

ETSI TS 183 010 V1.2.1 (2006-04)

Technical Specification

**Telecommunications and Internet converged Services and
Protocols for Advanced Networking (TISPAN);
NGN Signalling Control Protocol;
Communication HOLD (HOLD);
PSTN/ISDN simulation services**



Reference

RTS/TISPAN-03069-NGN-R1

Keywords

HOLD, supplementary service

ETSI

650 Route des Lucioles
F-06921 Sophia Antipolis Cedex - FRANCE

Tel.: +33 4 92 94 42 00 Fax: +33 4 93 65 47 16

Siret N° 348 623 562 00017 - NAF 742 C
Association à but non lucratif enregistrée à la
Sous-Préfecture de Grasse (06) N° 7803/88

Important notice

Individual copies of the present document can be downloaded from:

<http://www.etsi.org>

The present document may be made available in more than one electronic version or in print. In any case of existing or perceived difference in contents between such versions, the reference version is the Portable Document Format (PDF). In case of dispute, the reference shall be the printing on ETSI printers of the PDF version kept on a specific network drive within ETSI Secretariat.

Users of the present document should be aware that the document may be subject to revision or change of status. Information on the current status of this and other ETSI documents is available at

<http://portal.etsi.org/tb/status/status.asp>

If you find errors in the present document, please send your comment to one of the following services:

http://portal.etsi.org/chaicor/ETSI_support.asp

Copyright Notification

No part may be reproduced except as authorized by written permission.
The copyright and the foregoing restriction extend to reproduction in all media.

© European Telecommunications Standards Institute 2006.
All rights reserved.

DECTTM, **PLUGTESTS**TM and **UMTS**TM are Trade Marks of ETSI registered for the benefit of its Members.
TIPHONTM and the **TIPHON logo** are Trade Marks currently being registered by ETSI for the benefit of its Members.
3GPPTM is a Trade Mark of ETSI registered for the benefit of its Members and of the 3GPP Organizational Partners.

Contents

Intellectual Property Rights	4
Foreword.....	4
1 Scope	5
2 References	5
3 Definitions and abbreviations.....	5
3.1 Definitions	5
3.2 Abbreviations	5
4 Communication HOLD (HOLD)	6
4.1 Introduction	6
4.2 Description	6
4.2.1 General description	6
4.3 Operational requirements	6
4.3.1 Provision/withdrawal	6
4.3.2 Requirements on the originating network side.....	6
4.3.3 Requirements in the network	6
4.3.4 Requirements on the terminating network side.....	6
4.4 Coding requirements	6
4.5 Signalling requirements.....	7
4.5.1 Activation/deactivation/registration.....	7
4.5.2 Invocation and operation	7
4.5.2.1 Actions at the invoking UE	7
4.5.2.2 Actions at the P-CSCF of the invoking UE.....	7
4.5.2.3 Actions at the S-CSCF	7
4.5.2.4 Actions at the AS of the invoking UE.....	7
4.5.2.5 Actions at the incoming I-CSCF	8
4.5.2.6 Actions at the outgoing IBCF.....	8
4.5.2.7 Actions at the incoming IBCF.....	8
4.5.2.8 Actions at the P-CSCF of the held UE	8
4.5.2.9 Actions at the held UE	8
4.6 Interaction with other services.....	8
4.6.1 Communication HOLD (HOLD)	8
4.6.2 Terminating Identification Presentation (TIP).....	8
4.6.3 Terminating Identification Restriction (TIR).....	8
4.6.4 Originating Identification Presentation (OIP).....	8
4.6.5 Originating Identification Restriction (OIR).....	8
4.6.6 CONference calling (CONF)	8
4.6.7 Communication DIVersion services (CDIV).....	8
4.6.8 Malicious Communication IDentification (MCID)	8
4.6.9 Anonymous Communication Rejection and Communication Barring (ACR/CB)	9
4.6.10 Explicit Communication Transfer (ECT)	9
4.7 Interactions with other networks	9
4.7.1 Interaction with PSTN/ISDN	9
4.7.2 Interaction with PSTN/ISDN Emulation	9
4.7.3 Interaction with external IP networks	9
4.8 Parameter values (timers).....	9
Annex A (informative): Signalling Flows	10
A.1 HOLD communication	10
A.1.1 HOLD communication without announcement.....	10
A.1.2 HOLD communication with announcement.....	11
A.2 RESUME Communication	12
A.2.1 RESUME communication without announcement.....	12
A.2.2 RESUME communication with announcement.....	13
History	14

Intellectual Property Rights

IPRs essential or potentially essential to the present document may have been declared to ETSI. The information pertaining to these essential IPRs, if any, is publicly available for **ETSI members and non-members**, and can be found in ETSI SR 000 314: *"Intellectual Property Rights (IPRs); Essential, or potentially Essential, IPRs notified to ETSI in respect of ETSI standards"*, which is available from the ETSI Secretariat. Latest updates are available on the ETSI Web server (<http://webapp.etsi.org/IPR/home.asp>).

Pursuant to the ETSI IPR Policy, no investigation, including IPR searches, has been carried out by ETSI. No guarantee can be given as to the existence of other IPRs not referenced in ETSI SR 000 314 (or the updates on the ETSI Web server) which are, or may be, or may become, essential to the present document.

Foreword

This Technical Specification (TS) has been produced by ETSI Technical Committee Telecommunications and Internet converged Services and Protocols for Advanced Networking (TISPAN).

1 Scope

The present document specifies the, stage three, Protocol Description of the Communication Hold (HOLD) services, based on stage one and two of the ISDN HOLD (HOLD) supplementary services. Within the Next Generation Network (NGN) the stage 3 description is specified using the IP-Multimedia Call Control Protocol based on Session Initiation Protocol (SIP) and Session Description Protocol (SDP).

2 References

The following documents contain provisions which, through reference in this text, constitute provisions of the present document.

- References are either specific (identified by date of publication and/or edition number or version number) or non-specific.
- For a specific reference, subsequent revisions do not apply.
- For a non-specific reference, the latest version applies.

Referenced documents which are not found to be publicly available in the expected location might be found at <http://docbox.etsi.org/Reference>.

- [1] ETSI ES 283 003: "Telecommunications and Internet converged Services and Protocols for Advanced Networking (TISPAN); Endorsement of "IP Multimedia Call Control Protocol based on Session Initiation Protocol (SIP) and Session Description Protocol (SDP) Stage 3 (Release 6)" for NGN Release 1".
- [2] ETSI ES 283 027: "Telecommunications and Internet converged Services and Protocols for Advanced Networking (TISPAN); Interworking SIP-ISUP for TISPAN-IMS".
- [3] ETSI TS 129 163: "Digital cellular telecommunications system (Phase 2+); Universal Mobile Telecommunications System (UMTS); Interworking between the IP Multimedia (IM) Core Network (CN) subsystem and Circuit Switched (CS) networks (3GPP TS 29.163 Release 6)".
- [4] IETF RFC 3264: "An Offer/Answer Model with the Session Description Protocol (SDP)".
- [5] ETSI TS 181 002: "Telecommunications and Internet converged Services and Protocols for Advanced Networking (TISPAN); Multimedia Telephony with PSTN/ISDN simulation services".
- [6] ETSI TS 183 028: "Telecommunications and Internet converged Services and Protocols for Advanced Networking (TISPAN); Common Basic Communication procedures Protocol specification".

3 Definitions and abbreviations

3.1 Definitions

For the purposes of the present document, the terms and definitions given in TS 181 002 [5] apply.

3.2 Abbreviations

For the purposes of the present document, the following abbreviations apply:

ACR/CB	Anonymous Communication Rejection and Communication Barring
AS	Application Server
CDIV	Communication DIVersion
ECT	Explicit Communication Transfer
HOLD	Communication session HOLD

IBCF	Interconnection Border Control Function
I-CSCF	Interrogating-Call Server Control Function
IMS	IP Multimedia Subsystem
IP	Internet Protocol
ISDN	Integrated Service Data Network
MCID	Malicious Communication IDentification
NGN	Next Generation Network
OIP	Originating Identification Presentation
OIR	Originating Identification Restriction
P-CSCF	Proxy-Call Session Control Function
PSTN	Public Switched Telephone Network
RTP	Real-Time Transport Protocol
S-CSCF	Server-Call Session Control Function
SIP	Session Initiation Protocol
TIP	Terminating Identification Presentation
TIR	Terminating Identification Restriction
UE	User Equipment

4 Communication HOLD (HOLD)

4.1 Introduction

Not applicable.

4.2 Description

4.2.1 General description

The Communication HOLD supplementary service enables a user to suspend the media stream(s) of an established IP multimedia session, and resume the media stream(s) at a later time.

4.3 Operational requirements

4.3.1 Provision/withdrawal

The HOLD service that includes announcements shall be provided after prior arrangement with the service provider.

4.3.2 Requirements on the originating network side

No specific requirements are needed in the network.

4.3.3 Requirements in the network

No specific requirements are needed in the network.

4.3.4 Requirements on the terminating network side

No specific requirements are needed in the network.

4.4 Coding requirements

No specific coding requirements are needed.

4.5 Signalling requirements

4.5.1 Activation/deactivation/registration

Not applicable.

4.5.2 Invocation and operation

4.5.2.1 Actions at the invoking UE

In addition to the application of basic call procedures according to ES 283 003 [1] the following procedures shall be applied at the invoking UE in accordance with RFC 3264 [4].

If individual media streams are affected:

- For each media stream that shall be held, the invoking UE shall generate a new SDP offer that contains:
 - an "inactive" SDP attribute if the stream was previously set to "recvonly" media stream; or
 - a "sendonly" SDP attribute if the stream was previously set to "sendrecv" media stream.
- For each media stream that shall be resumed, the invoking UE shall generate a new SDP offer that contains:
 - a "recvonly" SDP attribute if the stream was previously an inactive media stream; or
 - a "sendrecv" SDP attribute if the stream was previously a sendonly media stream; or
 - the attribute may be omitted, since sendrecv is the default.

If all the media streams in the SDP are affected:

- For the media streams that shall be held, the invoking UE shall generate a session level direction attribute in the SDP that is set to:
 - "inactive" if the streams were previously set to "recvonly" media streams; or
 - "sendonly" if the streams were previously set to "sendrecv" media streams.
- For the media streams that shall be resumed, the invoking UE shall generate a session level direction attribute in the SDP that is set to:
 - "recvonly" if the streams were previously inactive media streams; or
 - "sendrecv" if the streams were previously sendonly media streams; or
 - the attribute may be omitted, since sendrecv is the default.

Then the UE shall send the generated SDP offer in a re-INVITE (or UPDATE) request to the held UE.

4.5.2.2 Actions at the P-CSCF of the invoking UE

Basic communication procedures according to ES 283 003 [1] shall apply.

4.5.2.3 Actions at the S-CSCF

Basic communication procedures according to ES 283 003 [1] shall apply.

4.5.2.4 Actions at the AS of the invoking UE

As a network option the AS of the invoking UE shall initiate the procedures for the provision of an announcement to the held user in accordance with TS 183 028 [6].

4.5.2.5 Actions at the incoming I-CSCF

Basic communication procedures according to ES 283 003 [1] shall apply.

4.5.2.6 Actions at the outgoing IBCF

Basic communication procedures according to ES 283 003 [1] shall apply.

4.5.2.7 Actions at the incoming IBCF

Basic communication procedures according to ES 283 003 [1] shall apply.

4.5.2.8 Actions at the P-CSCF of the held UE

Basic communication procedures according to ES 283 003 [1] shall apply.

4.5.2.9 Actions at the held UE

Basic communication procedures according to ES 283 003 [1] shall apply.

4.6 Interaction with other services

4.6.1 Communication HOLD (HOLD)

No impact, i.e. neither service shall affect the operation of the other service.

4.6.2 Terminating Identification Presentation (TIP)

No impact, i.e. neither service shall affect the operation of the other service.

4.6.3 Terminating Identification Restriction (TIR)

No impact, i.e. neither service shall affect the operation of the other service.

4.6.4 Originating Identification Presentation (OIP)

No impact, i.e. neither service shall affect the operation of the other service.

4.6.5 Originating Identification Restriction (OIR)

No impact, i.e. neither service shall affect the operation of the other service.

4.6.6 CONFerence calling (CONF)

If a participant of a conference invokes the HOLD service, it is not desirable to provide an announcement to the conference. Therefore if a communication to a remote URI shall be held by sending a re-INVITE (or UPDATE) request which includes the "isfocus" feature parameter in the Contact header, the AS of the invoking UE shall not initiate the procedures for the provision of an announcement to the held user.

4.6.7 Communication DIVersion services (CDIV)

No impact, i.e. neither service shall affect the operation of the other service.

4.6.8 Malicious Communication IDentification (MCID)

No impact, i.e. neither service shall affect the operation of the other service.

4.6.9 Anonymous Communication Rejection and Communication Barring (ACR/CB)

No impact, i.e. neither service shall affect the operation of the other service.

4.6.10 Explicit Communication Transfer (ECT)

No impact, i.e. neither service shall affect the operation of the other service.

4.7 Interactions with other networks

4.7.1 Interaction with PSTN/ISDN

The procedures of TS 129 163 [3], clause 7.4.10 shall apply with the additions of ES 283 027 [2].

NOTE: If the HOLD and Resume procedures are initiated from the PSTN/ISDN network side, only the UPDATE request is used to signal the new SDP, in accordance with ES 283 003 [1].

4.7.2 Interaction with PSTN/ISDN Emulation

For Further Study.

4.7.3 Interaction with external IP networks

The procedures of ES 283 003 [1] shall apply.

4.8 Parameter values (timers)

Not applicable.

Annex A (informative): Signalling Flows

A.1 HOLD communication

Assumption is that a session has been established between UE-A and UE-B using basic communication procedures according to ES 283 003 [1], therefore the following signalling flows do not apply to the initial INVITE.

A.1.1 HOLD communication without announcement

Figure A.1 shows a communication session put on hold using a reINVITE request, note that the same can be achieved by sending an UPDATE request.

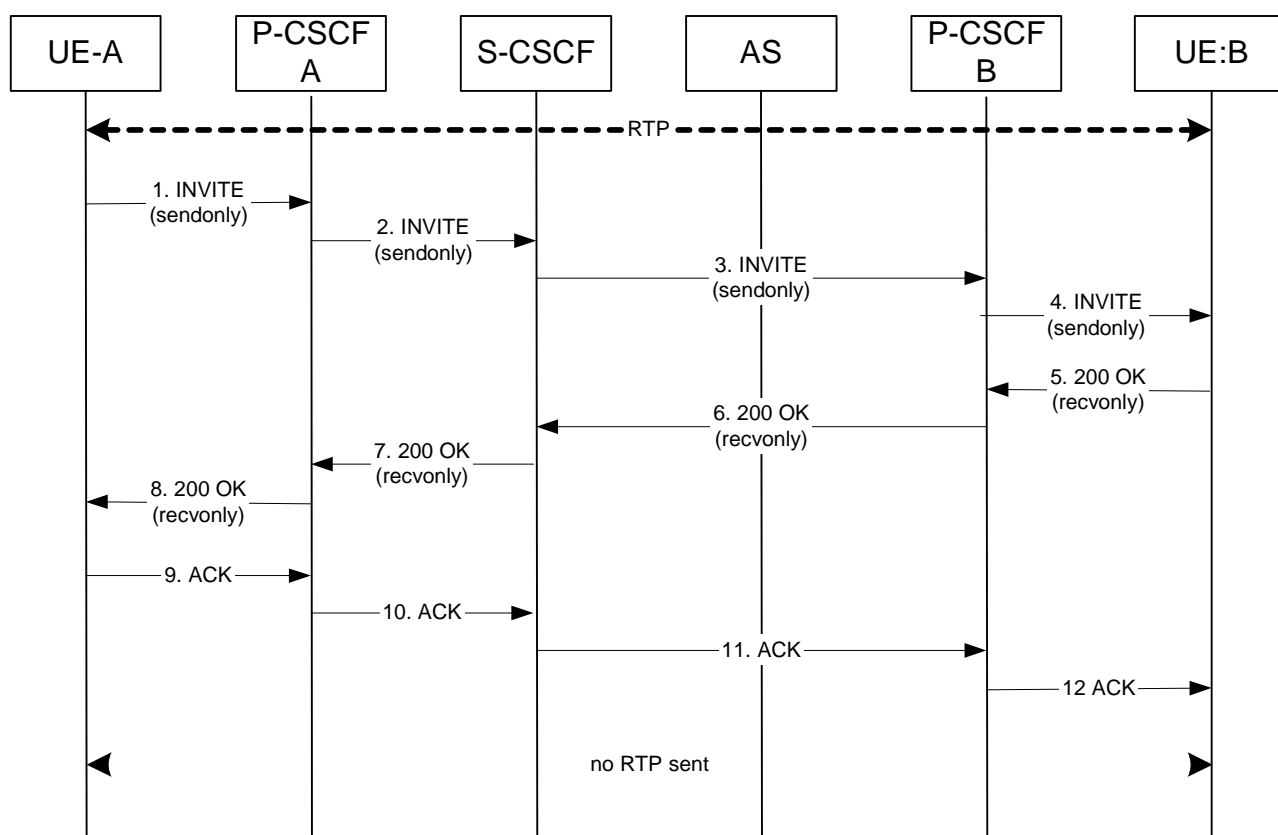

Figure A.1: HOLD communication without announcement to the held user

1. UE-A sends an INVITE to UE-B to hold the session. Hold is done by changing the SDP attribute.

- "a=sendonly", if the stream was previously a sendrecv media stream.
- "a=inactive", if the stream was previously a recvonly media stream.

A.1.2 HOLD communication with announcement

Figure A.2 shows a communication session put on hold using a reINVITE request, note that the same can be achieved by sending an UPDATE request.

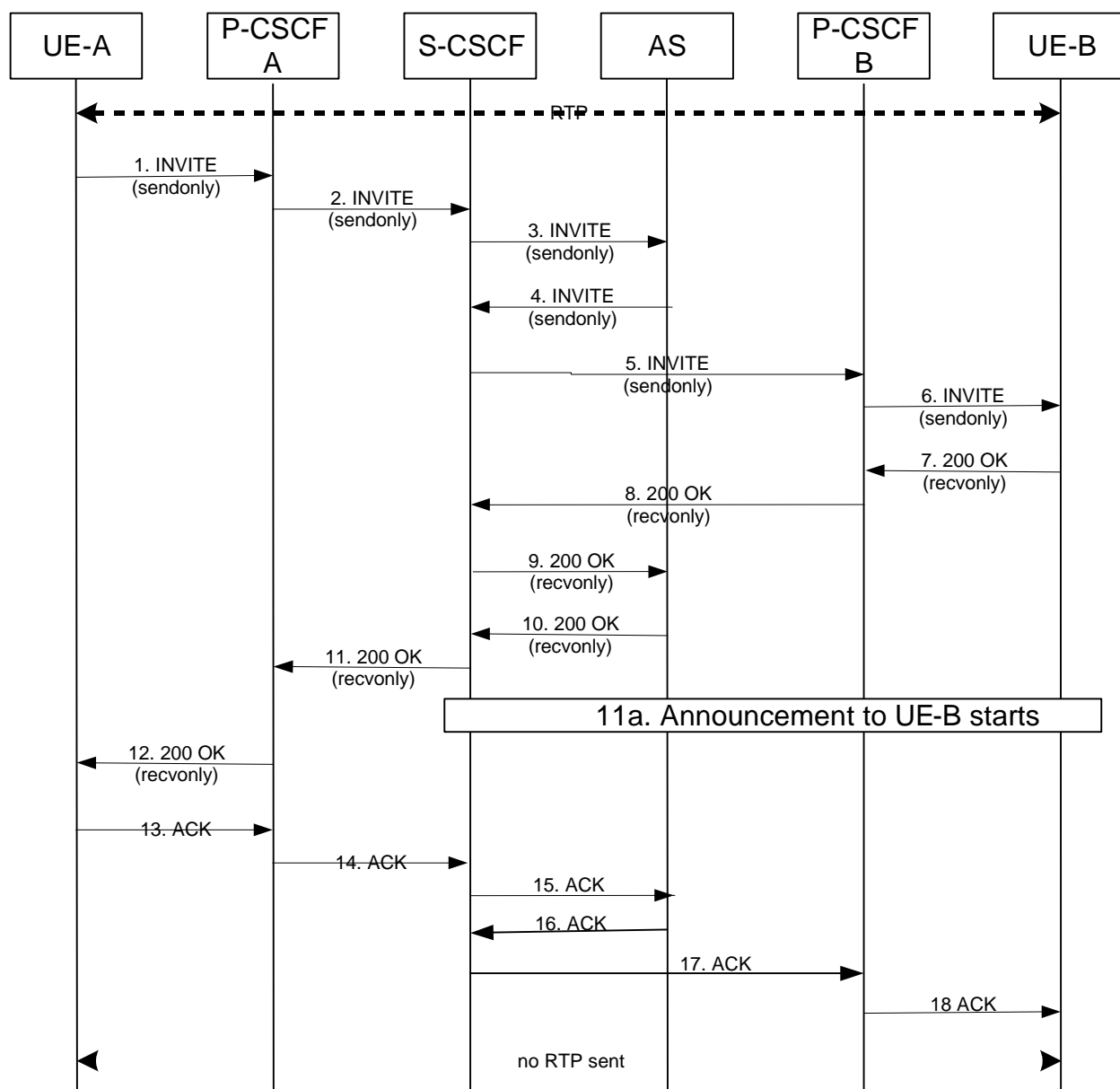

Figure A.2: HOLD communication with announcement to the held user

1. UE-A sends an INVITE to UE-B to hold the session. Hold is done by changing the SDP attribute.

- "a=sendonly", if the stream was previously a sendrecv media stream.
- "a=inactive", if the stream was previously a recvonly media stream.

A.2 RESUME Communication

A.2.1 RESUME communication without announcement

Figure A.3 shows how a communication session is resumed using a reINVITE request, note that the same can be achieved by sending an UPDATE request.

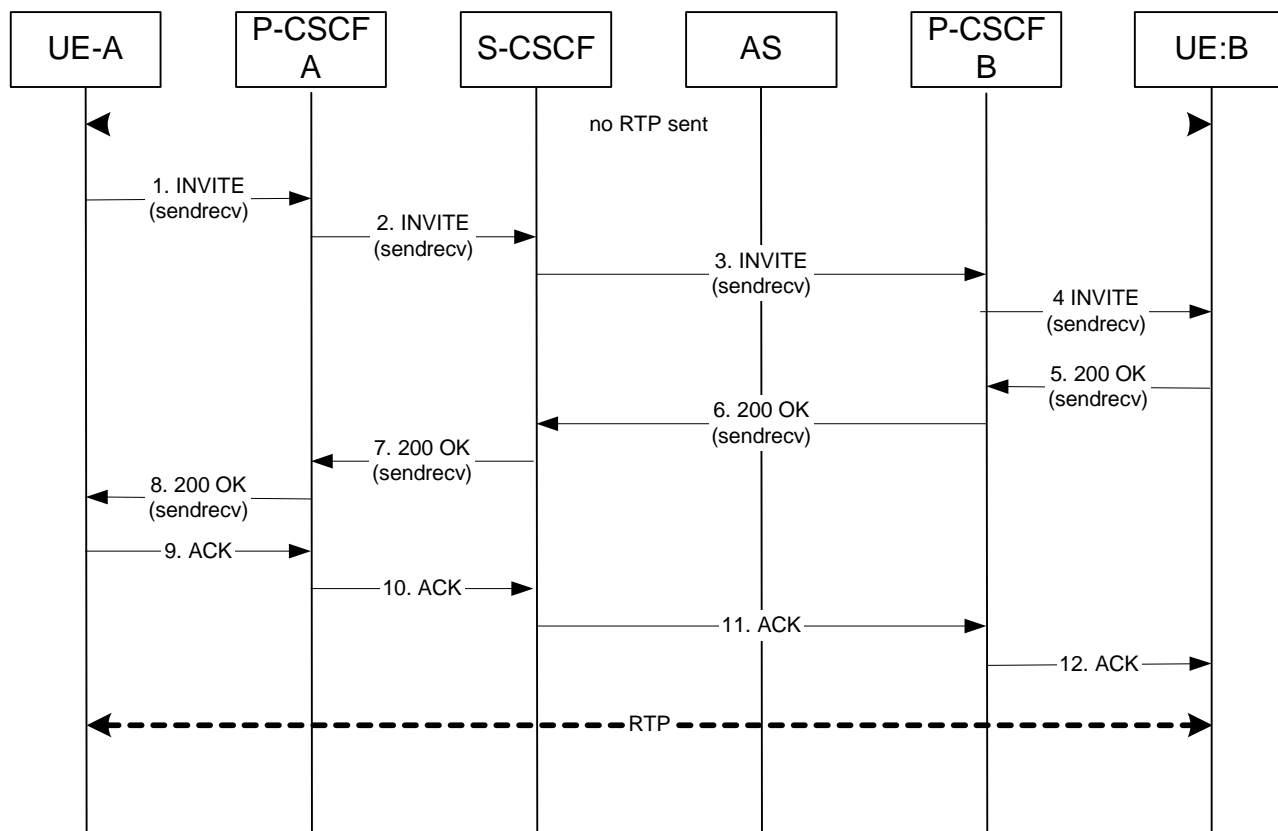

Figure A.3: RESUME communication without announcement to the held user

1. UE-A sends an INVITE to UE-B to resume the session. Resume is done by changing the SDP attribute.

- "a=sendrecv", if the stream was previously a recvonly media stream, or the attribute may be omitted, since sendrecv is the default.
- "a=recvonly", if the stream was previously an inactive media stream.

A.2.2 RESUME communication with announcement

Figure A.4 shows how a communication session is resumed using a reINVITE request, note that the same can be achieved by sending an UPDATE request.

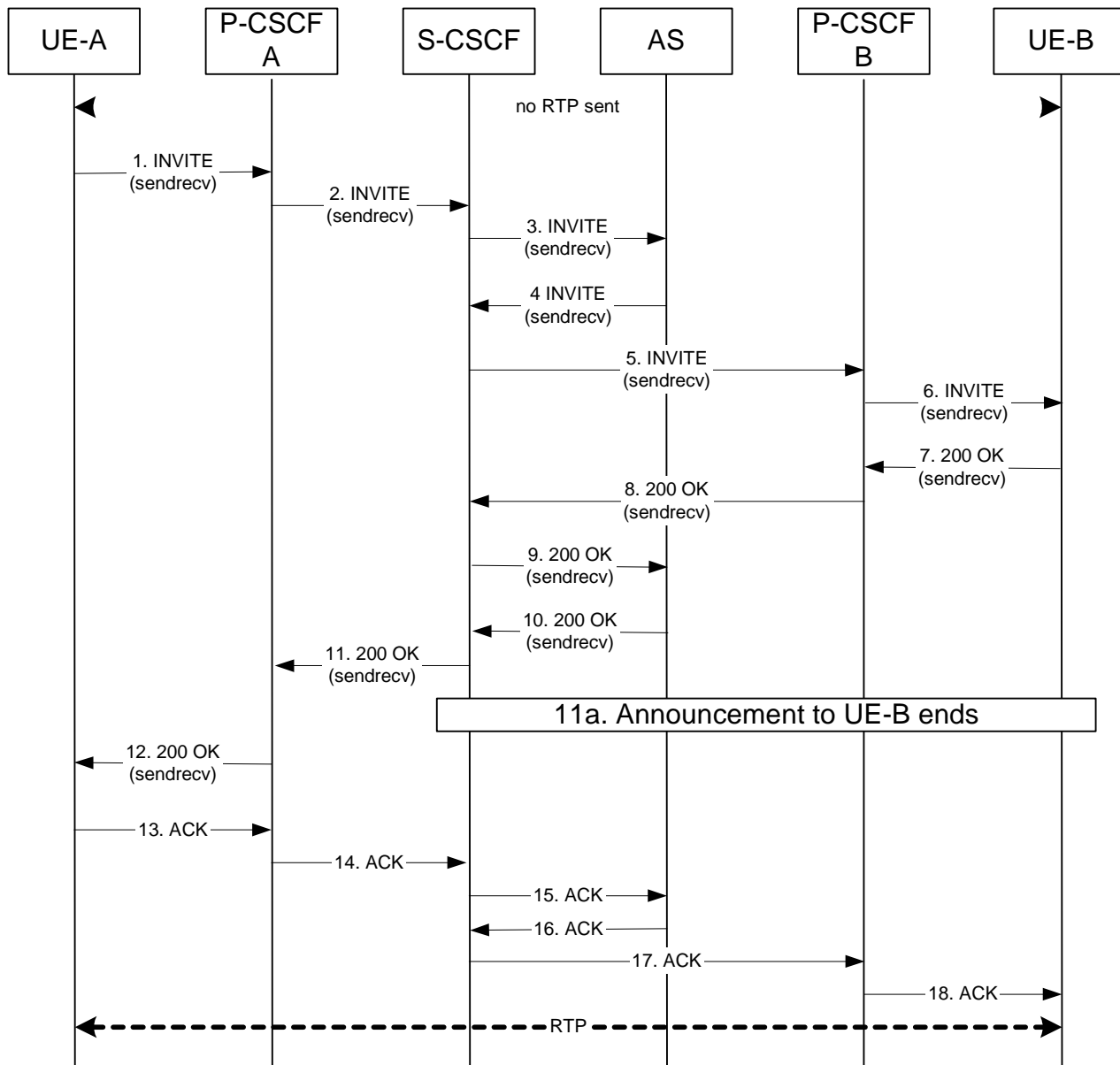

Figure A.4: RESUME communication with announcement to the held user

1. UE-A sends an INVITE to UE-B to resume the session. Resume is done by changing the SDP attribute.

- "a=sendrecv", if the stream was previously a recvonly media stream, or the attribute may be omitted, since sendrecv is the default.
- "a=recvonly", if the stream was previously an inactive media stream.

History

Document history		
V1.1.1	February 2005	Publication
V1.2.1	April 2006	Publication