

# ETSI TS 146 010 V15.0.0 (2018-07)



**Digital cellular telecommunications system (Phase 2+) (GSM);  
Full rate speech;  
Transcoding  
(3GPP TS 46.010 version 15.0.0 Release 15)**



---

Reference

RTS/TSGS-0446010vf00

---

Keywords

GSM

**ETSI**

650 Route des Lucioles  
F-06921 Sophia Antipolis Cedex - FRANCE

Tel.: +33 4 92 94 42 00 Fax: +33 4 93 65 47 16

Siret N° 348 623 562 00017 - NAF 742 C  
Association à but non lucratif enregistrée à la  
Sous-Préfecture de Grasse (06) N° 7803/88

---

**Important notice**

The present document can be downloaded from:

<http://www.etsi.org/standards-search>

The present document may be made available in electronic versions and/or in print. The content of any electronic and/or print versions of the present document shall not be modified without the prior written authorization of ETSI. In case of any existing or perceived difference in contents between such versions and/or in print, the only prevailing document is the print of the Portable Document Format (PDF) version kept on a specific network drive within ETSI Secretariat.

Users of the present document should be aware that the document may be subject to revision or change of status.

Information on the current status of this and other ETSI documents is available at

<https://portal.etsi.org/TB/ETSIDeliverableStatus.aspx>

If you find errors in the present document, please send your comment to one of the following services:

<https://portal.etsi.org/People/CommiteeSupportStaff.aspx>

---

**Copyright Notification**

No part may be reproduced or utilized in any form or by any means, electronic or mechanical, including photocopying and microfilm except as authorized by written permission of ETSI.

The content of the PDF version shall not be modified without the written authorization of ETSI.

The copyright and the foregoing restriction extend to reproduction in all media.

© ETSI 2018.

All rights reserved.

**DECT™**, **PLUGTESTS™**, **UMTS™** and the ETSI logo are trademarks of ETSI registered for the benefit of its Members.

**3GPP™** and **LTE™** are trademarks of ETSI registered for the benefit of its Members and of the 3GPP Organizational Partners.

**oneM2M** logo is protected for the benefit of its Members.

**GSM®** and the GSM logo are trademarks registered and owned by the GSM Association.

---

# Intellectual Property Rights

## Essential patents

IPRs essential or potentially essential to normative deliverables may have been declared to ETSI. The information pertaining to these essential IPRs, if any, is publicly available for **ETSI members and non-members**, and can be found in ETSI SR 000 314: *"Intellectual Property Rights (IPRs); Essential, or potentially Essential, IPRs notified to ETSI in respect of ETSI standards"*, which is available from the ETSI Secretariat. Latest updates are available on the ETSI Web server (<https://ipr.etsi.org/>).

Pursuant to the ETSI IPR Policy, no investigation, including IPR searches, has been carried out by ETSI. No guarantee can be given as to the existence of other IPRs not referenced in ETSI SR 000 314 (or the updates on the ETSI Web server) which are, or may be, or may become, essential to the present document.

## Trademarks

The present document may include trademarks and/or tradenames which are asserted and/or registered by their owners. ETSI claims no ownership of these except for any which are indicated as being the property of ETSI, and conveys no right to use or reproduce any trademark and/or tradename. Mention of those trademarks in the present document does not constitute an endorsement by ETSI of products, services or organizations associated with those trademarks.

---

# Foreword

This Technical Specification (TS) has been produced by ETSI 3rd Generation Partnership Project (3GPP).

The present document may refer to technical specifications or reports using their 3GPP identities, UMTS identities or GSM identities. These should be interpreted as being references to the corresponding ETSI deliverables.

The cross reference between GSM, UMTS, 3GPP and ETSI identities can be found under <http://webapp.etsi.org/key/queryform.asp>.

---

# Modal verbs terminology

In the present document "**shall**", "**shall not**", "**should**", "**should not**", "**may**", "**need not**", "**will**", "**will not**", "**can**" and "**cannot**" are to be interpreted as described in clause 3.2 of the [ETSI Drafting Rules](#) (Verbal forms for the expression of provisions).

"**must**" and "**must not**" are **NOT** allowed in ETSI deliverables except when used in direct citation.

# Contents

Intellectual Property Rights .....	2
Foreword.....	2
Modal verbs terminology.....	2
Foreword.....	6
1 Scope .....	7
1.1 References .....	7
1.1.1 Abbreviations.....	8
1.2 Outline description .....	8
1.3 Functional description of audio parts .....	8
1.4 PCM Format conversion .....	9
1.5 Principles of the RPE-LTP encoder.....	9
1.6 Principles of the RPE-LTP decoder.....	9
1.7 Sequence and subjective importance of encoded parameters .....	10
2 Transmission characteristics.....	13
2.1 Performance characteristics of the analogue/digital interfaces.....	13
2.2 Transcoder delay .....	13
3 Functional description of the RPE-LTP codec .....	13
3.1 Functional description of the RPE-LTP encoder .....	13
3.1.1 Offset compensation .....	14
3.1.2 Pre-emphasis.....	14
3.1.3 Segmentation .....	14
3.1.4 Autocorrelation .....	15
3.1.5 Schur Recursion.....	15
3.1.6 Transformation of reflection coefficients to Log.-Area Ratios.....	15
3.1.7 Quantization and coding of Log.-Area Ratios .....	15
3.1.8 Decoding of the quantized Log.-Area Ratios.....	16
3.1.9 Interpolation of Log.-Area Ratios.....	16
3.1.10 Transformation of Log.-Area Ratios into reflection coefficients.....	16
3.1.11 Short term analysis filtering.....	16
3.1.12 Sub-segmentation .....	16
3.1.13 Calculation of the LTP parameters .....	17
3.1.14 Coding/Decoding of the LTP lags .....	17
3.1.15 Coding/Decoding of the LTP gains .....	17
3.1.16 Long term analysis filtering .....	18
3.1.17 Long term synthesis filtering .....	18
3.1.18 Weighting Filter.....	18
3.1.19 Adaptive sample rate decimation by RPE grid selection .....	19
3.1.20 APCM quantization of the selected RPE sequence.....	19
3.1.21 APCM inverse quantization.....	20
3.1.22 RPE grid positioning.....	21
3.2 Decoder .....	21
3.2.1 RPE decoding clause .....	21
3.2.2 Long Term Prediction clause .....	21
3.2.3 Short term synthesis filtering clause .....	21
3.2.4 Post-processing .....	21
4 Codec homing .....	25
4.1 Functional description .....	25
4.2 Definitions .....	25
4.3 Encoder homing .....	26
4.4 Decoder homing .....	26
4.5 Encoder home state .....	27
4.6 Decoder home state .....	27
5 Computational details of the RPE-LTP codec.....	27
5.1 Data representation and arithmetic operations .....	27

5.2	Fixed point implementation of the RPE-LTP coder .....	29
5.2.0	Scaling of the input variable .....	30
5.2.1	Downscaling of the input signal .....	30
5.2.2	Offset compensation .....	30
5.2.3	Pre-emphasis .....	30
5.2.4	Autocorrelation .....	30
5.2.5	Computation of the reflection coefficients .....	31
5.2.6	Transformation of reflection coefficients to Log.-Area Ratios .....	32
5.2.7	Quantization and coding of the Log.-Area Ratios .....	33
5.2.8	Decoding of the coded Log.-Area Ratios .....	33
5.2.9	Computation of the quantized reflection coefficients .....	33
5.2.9.1	Interpolation of the LARpp[1..8] to get the LARp[1..8] .....	33
5.2.9.2	Computation of the rp[1..8] from the interpolated LARp[1..8] .....	34
5.2.10	Short term analysis filtering .....	34
5.2.11	Calculation of the LTP parameters .....	35
5.2.12	Long term analysis filtering .....	36
5.2.13	Weighting filter .....	36
5.2.14	RPE grid selection .....	37
5.2.15	APCM quantization of the selected RPE sequence .....	37
5.2.16	APCM inverse quantization .....	38
5.2.17	RPE grid positioning .....	39
5.2.18	Update of the reconstructed short term residual signal dp[-120..-1] .....	39
5.3	Fixed point implementation of the RPE-LTP decoder .....	39
5.3.1	RPE decoding clause .....	39
5.3.2	Long term synthesis filtering .....	39
5.3.3	Computation of the decoded reflection coefficients .....	40
5.3.4	Short term synthesis filtering clause .....	40
5.3.5	De-emphasis filtering .....	41
5.3.6	Upscaling of the output signal .....	41
5.3.7	Truncation of the output variable .....	41
5.4	Tables used in the fixed point implementation of the RPE-LTP coder and decoder .....	42
6	Digital test sequences .....	43
6.1	Input and output signals .....	43
6.2	Configuration for the application of the test sequences .....	43
6.2.1	Configuration 1 (encoder only) .....	43
6.2.2	Configuration 2 (decoder only) .....	44
6.3	Test sequences .....	44
6.3.1	Test sequences for configuration 1 .....	44
6.3.2	Test sequences for configuration 2 .....	45
6.3.3	Additional Test sequences for Codec Homing .....	49
6.3.3.1	Codec homing frames .....	49
6.3.3.2	Sequence for an extensive test of the decoder homing .....	49
6.3.3.3	Sequences for finding the 20 ms framing of the GSM full rate speech encoder .....	49
6.3.3.4	Formats and sizes of the synchronization sequences .....	50
<b>Annex A (informative):</b>	<b>Codec performance .....</b>	<b>52</b>
A.1	Performance of the RPE-LTP .....	52
A.1.1	Introduction .....	52
A.1.2	Speech performance .....	52
A.1.2.1	Single encoding .....	52
A.1.2.2	Speech performance when interconnected with coding systems on an analogue basis .....	53
A.1.2.2.1	Performance with 32 kbit/s ADPCM (G.721, superseded by G.726) .....	53
A.1.2.2.2	Performance with another RPE-LTP codec .....	53
A.1.2.2.3	Performance with encoding other than RPE-LTP and 32 kbit/s ADPCM (G.721, superseded by G.726) .....	53
A.1.3	Non-speech performance .....	53
A.1.3.1	Performance with single sine waves .....	53
A.1.3.2	Performance with DTMF tones .....	54
A.1.3.3	Performance with information tones .....	54
A.1.3.4	Performance with voice-band data .....	54
A.1.4	Delay .....	54

A.1.5	Bibliography.....	55
A.2	Subjective relevance of the speech coder output bits.....	56
A.3	Format for test sequence distribution.....	57
A.3.1	Type of files provided.....	57
A.3.2	File format description.....	58
<b>Annex B (informative):</b>	<b>Test sequence disks.....</b>	<b>60</b>
<b>Annex C (informative):</b>	<b>Change history.....</b>	<b>61</b>
History.....		62

---

# Foreword

This Technical Specification has been produced by the 3<sup>rd</sup> Generation Partnership Project (3GPP).

The present document specifies the full rate speech transcoding within the digital cellular telecommunications system.

NOTE: The present document is a reproduction of recommendation T/L/03/11 "13 kbit/s Regular Pulse Excitation - Long Term Prediction - Linear Predictive Coder for use in the digital cellular telecommunications system".

Archive en\_300961v080101p0.ZIP which accompanies the present document, contains test sequences, as described in clause 6 and annex A.3.

The archive contains the following:

Disk1.zip	Annex B: Test sequences for the GSM Full Rate speech codec; Test sequences SEQ01.xxx to SEQ05.xxx. (Disk1.zip contains LHA compressed files.)
Disk2.zip	Annex B: Test sequences for the GSM Full Rate speech codec with homing frames; Test sequences SEQ01H.* to SEQ02H.*.
Disk3.zip	Annex B: Test sequences for the GSM Full Rate speech codec with homing frames; Test sequences SEQ03H.* to SYNC159.COD.
Disk4.zip	Annex B: 8 bit A-law test sequences for the GSM Full Rate speech codec with and without homing frames (Disk4.zip contains self-extracting files).
Disk5.zip	Annex B: 8 bit $\mu$ -law test sequences for the GSM Full Rate speech codec with and without homing frames (Disk5.zip contains self-extracting files).

The contents of the present document are subject to continuing work within the TSG and may change following formal TSG approval. Should the TSG modify the contents of the present document, it will be re-released by the TSG with an identifying change of release date and an increase in version number as follows:

Version x.y.z

where:

- x the first digit:
  - 1 presented to TSG for information;
  - 2 presented to TSG for approval;
  - 3 or greater indicates TSG approved document under change control.
- y the second digit is incremented for all changes of substance, i.e. technical enhancements, corrections, updates, etc.
- z the third digit is incremented when editorial only changes have been incorporated in the document.

# 1 Scope

The transcoding procedure specified in the present document is applicable for the full-rate Traffic Channel (TCH) in the digital cellular telecommunications system. The use of this transcoding scheme for other applications has not been considered.

In GSM 06.01, a reference configuration for the speech transmission chain of the digital cellular telecommunications system is shown. According to this reference configuration, the speech encoder takes its input as a 13 bit uniform PCM signal either from the audio part of the mobile station or on the network side, from the PSTN via an 8 bit/A- or  $\mu$ -law (PCS 1900) to 13 bit uniform PCM conversion. The encoded speech at the output of the speech encoder is delivered to a channel encoder unit which is specified in GSM 05.03. In the receive direction, the inverse operations take place.

The present document describes the detailed mapping between input blocks of 160 speech samples in 13 bit uniform PCM format to encoded blocks of 260 bits and from encoded blocks of 260 bits to output blocks of 160 reconstructed speech samples. The sampling rate is 8000 sample/s leading to an average bit rate for the encoded bit stream of 13 kbit/s. The coding scheme is the so-called Regular Pulse Excitation - Long Term prediction - Linear Predictive Coder, here-after referred to as RPE-LTP.

The present document also specifies the conversion between A- and  $\mu$ -law (PCS 1900) PCM and 13 bit uniform PCM. Performance requirements for the audio input and output parts are included only to the extent that they affect the transcoder performance. The present document also describes the codec down to the bit level, thus enabling the verification of compliance to the present document to a high degree of confidence by use of a set of digital test sequences. These test sequences are described and are contained in archive en\_300961v080101p0.ZIP which accompanies the present document.

## 1.1 References

The following documents contain provisions which, through reference in this text, constitute provisions of the present document.

- References are either specific (identified by date of publication, edition number, version number, etc.) or non-specific.
- For a specific reference, subsequent revisions do not apply.
- For a non-specific reference, the latest version applies. In the case of a reference to a 3GPP document (including a GSM document), a non-specific reference implicitly refers to the latest version of that document *in the same Release as the present document*.

- [1] GSM 01.04: "Digital cellular telecommunications system (Phase 2+); Abbreviations and acronyms".
- [2] GSM 05.03: "Digital cellular telecommunications system (Phase 2+); Channel coding".
- [3] GSM 06.01: "Digital cellular telecommunications system (Phase 2+); Full rate speech; Processing functions".
- [4] GSM 11.10: "Digital cellular telecommunications system (Phase 2+); Mobile Station (MS) conformity specification".
- [5] Void.
- [6] ITU-T Recommendation G.711: "Pulse code modulation (PCM) of voice frequencies".
- [7] ITU-T Recommendation G.712: "Transmission performance characteristics of pulse code modulation".
- [8] ITU-T Recommendation G.726: "40, 32, 24, 16 kbit/s adaptive differential pulse code modulation (ADPCM)".
- [9] ITU-T Recommendation Q.35: "Technical characteristics of tones for the telephone service".
- [10] ITU-T Recommendation V.21: "300 bits per second duplex modem standardized for use in the general switched telephone network".



- [11] ITU-T Recommendation V.23: "600/1 200-band modem standardized for use in the general switched telephone network".
- [12] GSM 06.32: "Digital cellular telecommunications system (Phase 2+); Voice Activity Detector (VAD)".

### 1.1.1 Abbreviations

Abbreviations used in the present document are listed in GSM 01.04.

## 1.2 Outline description

The present document is structured as follows:

Subclause 1.3 contains a functional description of the audio parts including the A/D and D/A functions. Subclause 1.4 describes the conversion between 13 bit uniform and 8 bit A-law samples. Subclauses 1.5 and 1.6 present a simplified description of the principles of the RPE-LTP encoding and decoding process respectively. In clause 1.7, the sequence and subjective importance of encoded parameters are given.

Clause 2 deals with the transmission characteristics of the audio parts that are relevant for the performance of the RPE-LTP codec.

Some transmission characteristics of the RPE-LTP codec are also specified in clause 2. Clause 3 presents the functional description of the RPE-LTP coding and decoding procedures, whereas clause 4 describes the computational details of the algorithm. Procedures for the verification of the correct functioning of the RPE-LTP are described in clause 5.

Performance and network aspects of the RPE-LTP codec are contained in annex A.

## 1.3 Functional description of audio parts

The analogue-to-digital and digital-to-analogue conversion will in principle comprise the following elements:

### 1) Analogue to uniform digital:

- microphone;
- input level adjustment device;
- input anti-aliasing filter;
- sample-hold device sampling at 8 kHz;
- analogue-to-uniform digital conversion to 13 bits representation.

The uniform format shall be represented in two's complement.

### 2) Uniform digital to analogue:

- conversion from 13 bit /8 kHz uniform PCM to analogue;
- a hold device;
- reconstruction filter including  $x/\sin x$  correction;
- output level adjustment device;
- earphone or loudspeaker.

In the terminal equipment, the A/D function may be achieved either:

- by direct conversion to 13 bit uniform PCM format;
- or by conversion to 8 bit/A- or  $\mu$ -law (PCS 1900) companded format, based on a standard A- or  $\mu$ -law (PCS 1900) codec/filter according to ITU-T Recommendation G.711/714, followed by the 8-bit to 13-bit conversion according to the procedure specified in clause 1.4.

For the D/A operation, the inverse operations take place.

In the latter case it should be noted that the specifications in ITU-T recommendation G.714 (superseded by G.712) are concerned with PCM equipment located in the central parts of the network. When used in the terminal equipment, the present document does not on its own ensure sufficient out-of-band attenuation.

The specification of out-of-band signals is defined in clause 2 between the acoustic signal and the digital interface to take into account that the filtering in the terminal can be achieved both by electronic and acoustical design.

## 1.4 PCM Format conversion

The conversion between 8 bit A- or  $\mu$ -law (PCS 1900) companded format and the 13-bit uniform format shall be as defined in ITU-T Recommendation G.721 (superseded by G.726), clause 4.2.1, sub-block EXPAND and clause 4.2.7, sub-block COMPRESS. The parameter LAW = 1 should be used for A-law and LAW=0 should be used for  $\mu$ -law (PCS 1900).

## 1.5 Principles of the RPE-LTP encoder

A simplified block diagram of the RPE-LTP encoder is shown in figure 1.1. In this diagram the coding and quantization functions are not shown explicitly.

The input speech frame, consisting of 160 signal samples (uniform 13 bit PCM samples), is first pre-processed to produce an offset-free signal, which is then subjected to a first order pre-emphasis filter. The 160 samples obtained are then analysed to determine the coefficients for the short term analysis filter (LPC analysis). These parameters are then used for the filtering of the same 160 samples. The result is 160 samples of the short term residual signal. The filter parameters, termed reflection coefficients, are transformed to log.area ratios, LARs, before transmission.

For the following operations, the speech frame is divided into 4 sub-frames with 40 samples of the short term residual signal in each. Each sub-frame is processed blockwise by the subsequent functional elements.

Before the processing of each sub-block of 40 short term residual samples, the parameters of the long term analysis filter, the LTP lag and the LTP gain, are estimated and updated in the LTP analysis block, on the basis of the current sub-block of the present and a stored sequence of the 120 previous reconstructed short term residual samples.

A block of 40 long term residual signal samples is obtained by subtracting 40 estimates of the short term residual signal from the short term residual signal itself. The resulting block of 40 long term residual samples is fed to the Regular Pulse Excitation analysis which performs the basic compression function of the algorithm.

As a result of the RPE-analysis, the block of 40 input long term residual samples are represented by one of 4 candidate sub-sequences of 13 pulses each. The subsequence selected is identified by the RPE grid position (M). The 13 RPE pulses are encoded using Adaptive Pulse Code Modulation (APCM) with estimation of the sub-block amplitude which is transmitted to the decoder as side information.

The RPE parameters are also fed to a local RPE decoding and reconstruction module which produces a block of 40 samples of the quantized version of the long term residual signal.

By adding these 40 quantized samples of the long term residual to the previous block of short term residual signal estimates, a reconstructed version of the current short term residual signal is obtained.

The block of reconstructed short term residual signal samples is then fed to the long term analysis filter which produces the new block of 40 short term residual signal estimates to be used for the next sub-block thereby completing the feedback loop.

## 1.6 Principles of the RPE-LTP decoder

The simplified block diagram of the RPE-LTP decoder is shown in fig 1.2. The decoder includes the same structure as the feed-back loop of the encoder. In error-free transmission, the output of this stage will be the reconstructed short term residual samples. These samples are then applied to the short term synthesis filter followed by the de-emphasis filter resulting in the reconstructed speech signal samples.

## 1.7 Sequence and subjective importance of encoded parameters

As indicated in fig 1.1 the three different groups of data are produced by the encoder are:

- the short term filter parameters;
- the Long Term Prediction (LTP) parameters;
- the RPE parameters.

The encoder will produce this information in a unique sequence and format, and the decoder shall receive the same information in the same way. In table 1.1, the sequence of output bits b1 to b260 and the bit allocation for each parameter is shown.

The different parameters of the encoded speech and their individual bits have unequal importance with respect to subjective quality. Before being submitted to the channel encoding function the bits have to be rearranged in the sequence of importance as given in GSM 05.03. The ranking has been determined by subjective testing and the procedure used is described in annex A, clause A.2.

**Table 1.1: Encoder output parameters in order of occurrence and bit allocation within the speech frame of 260 bits/20 ms**

Parameter	Parameter number	Parameter name	Var. name	Number of bits	Bit no. (LSB-MSB)
	1		LAR 1	6	b1 - b6
	2		LAR 2	6	b7 - b12
FILTER	3	Log. Area ratios	LAR 3	5	b13 - b17
	4		LAR 4	5	b18 - b22
PARAMETERS	5	1 - 8	LAR 5	4	b23 - b26
	6		LAR 6	4	b27 - b30
	7		LAR 7	3	b31 - b33
	8		LAR 8	3	b34 - b36

### Sub-frame no.1

LTP	9	LTP lag	N1	7	b37 - b43
PARAMETERS	10	LTP gain	b1	2	b44 - b45
	11	RPE grid position	M1	2	b46 - b47
RPE	12	Block amplitude	Xmax1	6	b48 - b53
PARAMETERS	13	RPE-pulse no.1	x1(0)	3	b54 - b56
	14	RPE-pulse no.2	x1(1)	3	b57 - b59
	⋮	⋮	⋮	⋮	⋮
	25	RPE-pulse no.13	x1(12)	3	b90 - b92

### Sub-frame no.2

LTP	26	LTP lag	N2	7	b93 - b99
PARAMETERS	27	LTP gain	b2	2	b100- b101
	28	RPE grid position	M2	2	b102- b103
RPE	29	Block amplitude	Xmax2	6	b104- b109
PARAMETERS	30	RPE-pulse no.1	x2(0)	3	b110- b112
	31	RPE-pulse no.2	x2(1)	3	b113- b115
	⋮	⋮	⋮	⋮	⋮
	42	RPE-pulse no.13	x2(12)	3	b146- b148

**Table 1.1: Encoder output parameters in order of occurrence and bit allocation within the speech frame of 260 bits/20 ms**

**Sub-frame no.3**

LTP	43	LTP lag	N3	7	b149- b155
PARAMETERS	44	LTP gain	b3	2	b156- b157
	45	RPE grid position	M3	2	b158- b159
RPE	46	Block amplitude	Xmax3	6	b160- b165
PARAMETERS	47	RPE-pulse no.1	x3(0)	3	b166- b168
	48	RPE-pulse no.2	x3(1)	3	b169- b171
	..	...			...
	59	RPE-pulse no.13	x3(12)	3	b202- b204

**Sub-frame no.4**

LTP	60	LTP lag	N4	7	b205- b211
PARAMETERS	61	LTP gain	b4	2	b212- b213
	62	RPE grid position	M4	2	b214- b215
RPE	63	Block amplitude	Xmax4	6	b216- b221
PARAMETERS	64	RPE-pulse no.1	x4(0)	3	b222- b224
	65	RPE-pulse no.2	x4(1)	3	b225- b227
	..	...			...
	76	RPE-pulse no.13	x4(12)	3	b258- b260

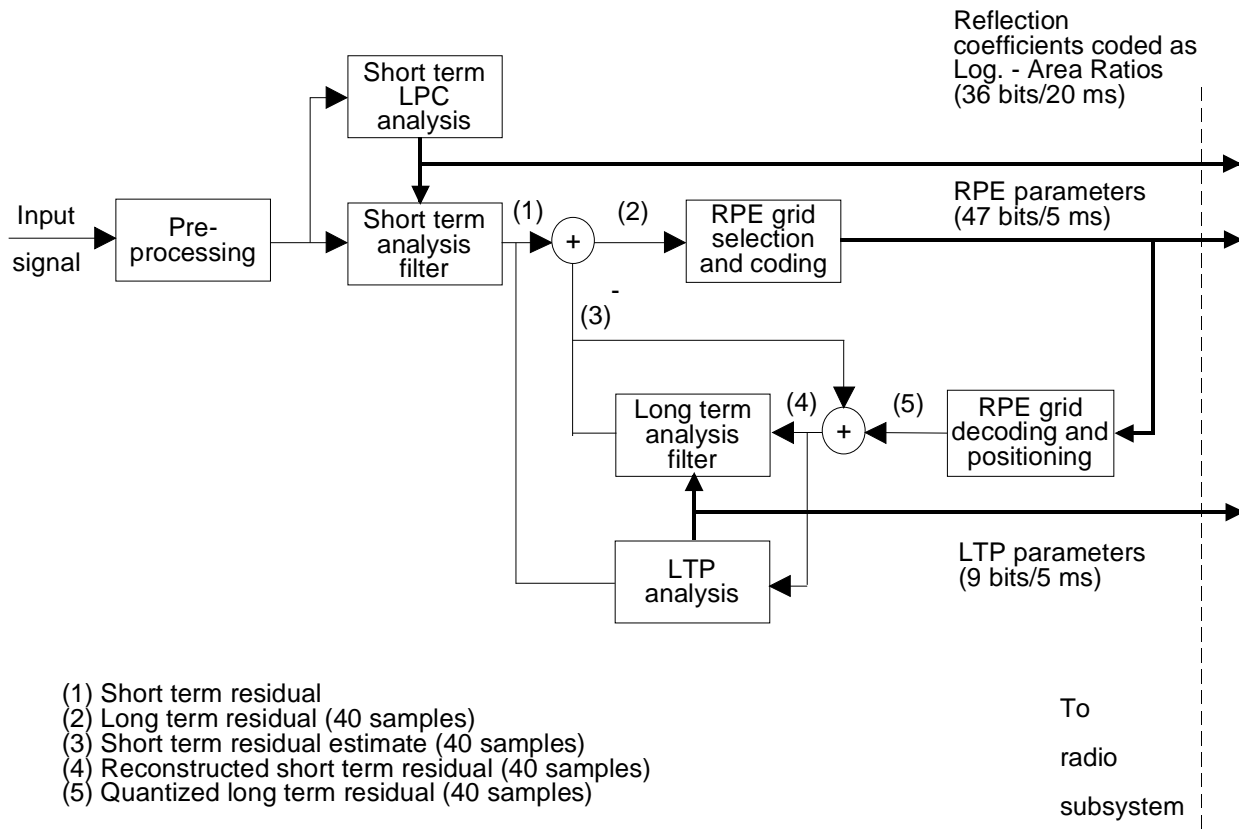

Figure 1.1: Simplified block diagram of the RPE - LTP encoder

Reflection coefficients coded as Log. - Area Ratios (36 bits/20 ms)

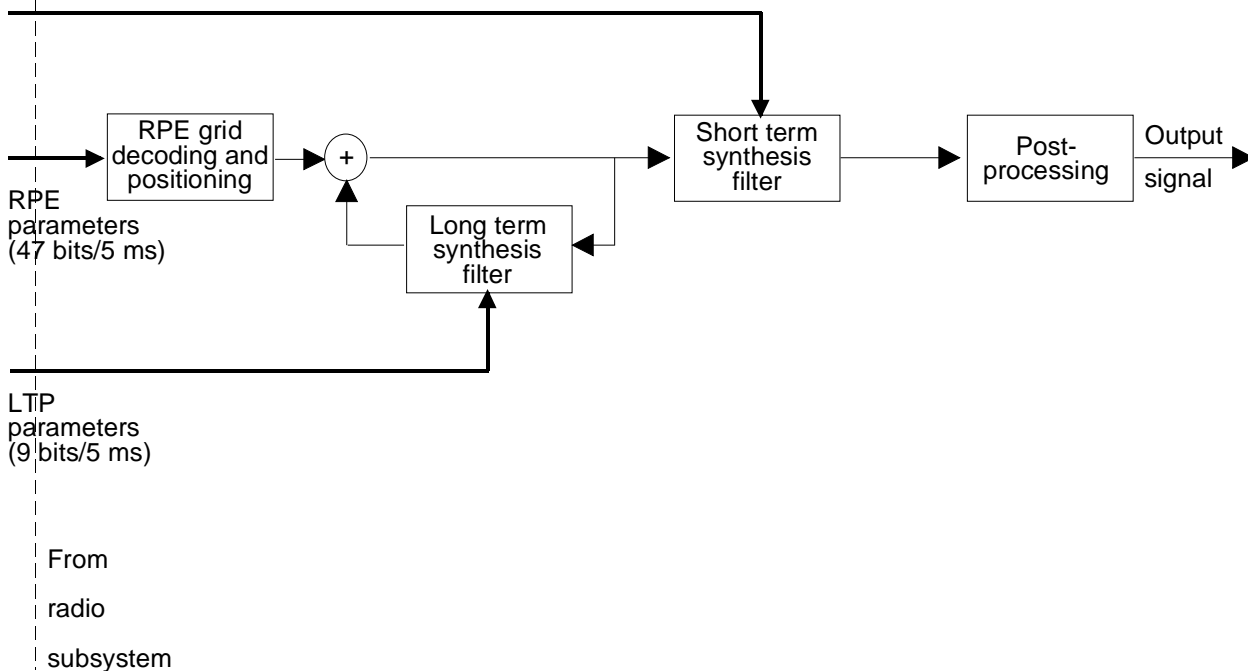

Figure 1.2: Simplified block diagram of the RPE - LTP decoder

---

## 2 Transmission characteristics

This clause specifies the necessary performance characteristics of the audio parts for proper functioning of the speech transcoder. Some transmission performance characteristics of the RPE-LTP transcoder are also given to assist the designer of the speech transcoder function. The information given here is redundant and the detailed specifications are contained in recommendation GSM 11.10.

The performance characteristics are referred to the 13 bit uniform PCM interface.

**NOTE:** To simplify the verification of the specifications, the performance limits may be referred to an A- or  $\mu$ -law (PCS 1900) measurement interface according to ITU-T Recommendation G.711. In this way, standard measuring equipments for PCM systems can be utilized for measurements. The relationship between the 13 bit format and the A- or  $\mu$ -law (PCS 1900) companded shall follow the procedures defined in clause 1.4.

### 2.1 Performance characteristics of the analogue/digital interfaces

Concerning 1) discrimination against out-of-band signals (sending) and 2) spurious out-of-band signals (receiving), the same requirements as defined in ETSI standard TE 04-15 (digital telephone, candidate NET33) apply.

### 2.2 Transcoder delay

Consider a back to back configuration where the parameters generated by the encoder are delivered to the speech decoder as soon as they are available.

The transcoder delay is defined as the time interval between the instant a speech frame of 160 samples has been received at the encoder input and the instant the corresponding 160 reconstructed speech samples have been out-put by the speech decoder at an 8 kHz sample rate.

The theoretical minimum delay which can be achieved is 20 ms. The requirement is that the transcoder delay should be less than 30 ms.

---

## 3 Functional description of the RPE-LTP codec

The block diagram of the RPE-LTP-coder is shown in figure 3.1. The individual blocks are described in the following clauses.

### 3.1 Functional description of the RPE-LTP encoder

The **Pre-processing clause** of the RPE-LTP encoder comprises the following two sub-blocks:

- Offset compensation (3.1.1);
- Pre-emphasis (3.1.2).

The **LPC analysis clause** of the RPE-LTP encoder comprises the following five sub-blocks:

- Segmentation (3.1.3);
- Auto-Correlation (3.1.4);
- Schur Recursion (3.1.5);
- Transformation of reflection coefficients to Log.-Area Ratios (3.1.6);
- Quantization and coding of Log.-Area Ratios (3.1.7).

The **Short term analysis filtering clause** of the RPE-LTP comprises the following four sub-blocks:

- Decoding of the quantized Log.-Area Ratios (LARs) (3.1.8);

- Interpolation of Log.-Area Ratios (3.1.9);
- Transformation of Log.-Area Ratios into reflection coefficients (3.1.10);
- Short term analysis filtering (3.1.11).

The **Long Term Predictor (LTP) clause** comprises 4 sub-blocks working on subsegments (3.1.12) of the short term residual samples:

- Calculation of LTP parameters (3.1.13);
- Coding of the LTP lags (3.1.14) and the LTP gains (3.1.15);
- Decoding of the LTP lags (3.1.14) and the LTP gains (3.1.15);
- Long term analysis filtering (3.1.16), and Long term synthesis filtering (3.1.17).

The **RPE encoding clause** comprises five different sub-blocks:

- Weighting filter (3.1.18);
- Adaptive sample rate decimation by RPE grid selection (3.1.19);
- APCM quantization of the selected RPE sequence (3.1.20);
- APCM inverse quantization (3.1.21);
- RPE grid positioning (3.1.22).

## Pre-processing clause

### 3.1.1 Offset compensation

Prior to the speech encoder an offset compensation, by a notch filter is applied in order to remove the offset of the input signal  $s_o$  to produce the offset-free signal  $s_{of}$ .

$$s_{of}(k) = s_o(k) - s_o(k-1) + \alpha * s_{of}(k-1) \quad (3.1.1)$$

$$\alpha = 32735 * 2^{-15}$$

### 3.1.2 Pre-emphasis

The signal  $s_{of}$  is applied to a first order FIR pre-emphasis filter leading to the input signal  $s$  of the analysis clause.

$$s(k) = s_{of}(k) - \beta * s_{of}(k-1) \quad (3.1.2)$$

$$\beta = 28180 * 2^{-15}$$

## LPC analysis clause

### 3.1.3 Segmentation

The speech signal  $s(k)$  is divided into non-overlapping frames having a length of  $T_0 = 20$  ms (160 samples). A new LPC-analysis of order  $p=8$  is performed for each frame.

### 3.1.4 Autocorrelation

The first  $p+1 = 9$  values of the Auto-Correlation function are calculated by:

$$\text{ACF}(k) = \sum_{i=k}^{159} s(i)s(i-k) \quad , k = 0, 1, \dots, 8 \quad (3.2)$$

### 3.1.5 Schur Recursion

The reflection coefficients are calculated as shown in figure 3.2 using the Schur Recursion algorithm. The term "reflection coefficient" comes from the theory of linear prediction of speech (LPC), where a vocal tract representation consisting of series of uniform cylindrical clauses is assumed. Such a representation can be described by the reflection coefficients or the area ratios of connected clauses.

### 3.1.6 Transformation of reflection coefficients to Log.-Area Ratios

The reflection coefficients  $r(i)$ , ( $i=1..8$ ), calculated by the Schur algorithm, are in the range:

$$-1 \leq r(i) \leq +1$$

Due to the favourable quantization characteristics, the reflection coefficients are converted into Log.-Area Ratios which are strictly defined as follows:

$$\text{Logarea}(i) = \log_{10} \left( \frac{1 + r(i)}{1 - r(i)} \right) \quad (3.3)$$

Since it is the companding characteristic of this transformation that is of importance, the following segmented approximation is used.

$$\text{LAR}(i) = \begin{cases} r(i) & ; |r(i)| < 0.675 \\ \text{sign}[r(i)] * [2|r(i)| - 0.675] & ; 0.675 \leq |r(i)| < 0.950 \\ \text{sign}[r(i)] * [8|r(i)| - 6.375] & ; 0.950 \leq |r(i)| \leq 1.000 \end{cases} \quad (3.4)$$

with the result that instead of having to divide and obtain the logarithm of particular values, it is merely necessary to multiply, add and compare these values.

The following equation (3.5) gives the inverse transformation.

$$r'(i) = \begin{cases} \text{LAR}'(i) & ; |\text{LAR}'(i)| < 0.675 \\ \text{sign}[\text{LAR}'(i)] * [0.500 * |\text{LAR}'(i)| + 0.337500] & ; 0.675 \leq |\text{LAR}'(i)| < 1.225 \\ \text{sign}[\text{LAR}'(i)] * [0.125 * |\text{LAR}'(i)| + 0.796875] & ; 1.225 \leq |\text{LAR}'(i)| \leq 1.625 \end{cases} \quad (3.5)$$

### 3.1.7 Quantization and coding of Log.-Area Ratios

The Log.-Area Ratios  $\text{LAR}(i)$  have different dynamic ranges and different asymmetric distribution densities. For this reason, the transformed coefficients  $\text{LAR}(i)$  are limited and quantized differently according to the following equation (3.6), with  $\text{LAR}_c(i)$  denoting the quantized and integer coded version of  $\text{LAR}(i)$ .

$$\text{LAR}_c(i) = \text{Nint}\{A(i) * \text{LAR}(i) + B(i)\} \quad (3.6)$$

with

$$\text{Nint}\{z\} = \text{int}\{z + \text{sign}\{z\} * 0.5\} \quad (3.6a)$$

Function  $\text{Nint}$  defines the rounding to the nearest integer value, with the coefficients  $A(i)$ ,  $B(i)$ , and different extreme values of  $\text{LAR}_c(i)$  for each coefficient  $\text{LAR}(i)$  given in table 3.1.



**Table 3.1: Quantization of the Log.-Area Ratios LAR(i)**

LAR No i	A(i)	B(i)	Minimum LAR <sub>c</sub> (i)	Maximum LAR <sub>c</sub> (i)
1	20.000	0.000	-32	+31
2	20.000	0.000	-32	+31
3	20.000	4.000	-16	+15
4	20.000	-5.000	-16	+15
5	13.637	0.184	- 8	+ 7
6	15.000	-3.500	- 8	+ 7
7	8.334	-0.666	- 4	+ 3
8	8.824	-2.235	- 4	+ 3

### Short-term analysis filtering clause

The current frame of the speech signal  $s$  is retained in memory until calculation of the LPC parameters LAR(i) is completed. The frame is then read out and fed to the short term analysis filter of order  $p=8$ . However, prior to the analysis filtering operation, the filter coefficients are decoded and pre-processed by interpolation.

### 3.1.8 Decoding of the quantized Log.-Area Ratios

In this block the quantized and coded Log.-Area Ratios (LAR<sub>c</sub>(i)) are decoded according to equation (3.7).

$$\text{LAR}'(i) = (\text{LAR}_c(i) - B(i)) / A(i) \quad (3.7)$$

### 3.1.9 Interpolation of Log.-Area Ratios

To avoid spurious transients which may occur if the filter coefficients are changed abruptly, two subsequent sets of Log.-Area Ratios are interpolated linearly. Within each frame of 160 analysed speech samples the short term analysis filter and the short term synthesis filter operate with four different sets of coefficients derived according to table 3.2.

**Table 3.2: Interpolation of LAR parameters (J=actual segment)**

k	LAR' <sub>J</sub> (i) =
0...12	$0.75 \cdot \text{LAR}'_{J-1}(i) + 0.25 \cdot \text{LAR}'_J(i)$
13...26	$0.50 \cdot \text{LAR}'_{J-1}(i) + 0.50 \cdot \text{LAR}'_J(i)$
27...39	$0.25 \cdot \text{LAR}'_{J-1}(i) + 0.75 \cdot \text{LAR}'_J(i)$
40..159	LAR' <sub>J</sub> (i)

### 3.1.10 Transformation of Log.-Area Ratios into reflection coefficients

The reflection coefficients are finally determined using the inverse transformation according to equation (3.5).

### 3.1.11 Short term analysis filtering

The Short term analysis filter is implemented according to the lattice structure depicted in figure 3.3.

$$d_0(k) = s(k) \quad (3.8a)$$

$$u_0(k) = s(k) \quad (3.8b)$$

$$d_i(k) = d_{i-1}(k) + r'_i \cdot u_{i-1}(k-1) \quad \text{with } i=1, \dots, 8 \quad (3.8c)$$

$$u_i(k) = u_{i-1}(k-1) + r'_i \cdot d_{i-1}(k) \quad \text{with } i=1, \dots, 8 \quad (3.8d)$$

$$d(k) = d_8(k) \quad (3.8e)$$

### Long-Term Predictor (LTP) clause

### 3.1.12 Sub-segmentation

Each input frame of the short term residual signal contains 160 samples, corresponding to 20 ms. The long term correlation is evaluated four times per frame, for each 5 ms subsegment. For convenience in the following, we note

$j=0,\dots,3$  the sub-segment number, so that the samples pertaining to the  $j$ -th sub-segment of the residual signal are now denoted by  $d(k_j+k)$  with  $j = 0,\dots,3$ ;  $k_j = k_0 + j*40$  and  $k = 0,\dots,39$  where  $k_0$  corresponds to the first value of the current frame.

### 3.1.13 Calculation of the LTP parameters

For each of the four sub-segments a long term correlation lag  $N_j$ , ( $j=0,\dots,3$ ), and an associated gain factor  $b_j$ , ( $j=0,\dots,3$ ) are determined. For each sub-segment, the determination of these parameters is implemented in three steps.

- 1) The first step is the evaluation of the cross-correlation  $R_j(\lambda)$  of the current sub-segment of short term residual signal  $d(k_j+i)$ , ( $i=0,\dots,39$ ) and the previous samples of the reconstructed short term residual signal  $d'(k_j+i)$ , ( $i=-120,\dots,-1$ ):

$$R_j(\lambda) = \sum_{i=0}^{39} d(k_j+i) * d'(k_j+i-\lambda); \quad \begin{array}{l} j = 0, \dots, 3 \\ \lambda = 40, \dots, 120 \end{array} \quad (3.9)$$

The cross-correlation is evaluated for lags  $\lambda$  greater than or equal to 40 and less than or equal to 120, i.e. corresponding to samples outside the current sub-segment and not delayed by more than two sub-segments.

- 2) The second step is to find the position  $N_j$  of the peak of the cross-correlation function within this interval:

$$R_j(N_j) = \max \{ R_j(\lambda); \lambda = 40..120 \}; \quad j = 0, \dots, 3 \quad (3.10)$$

- 3) The third step is the evaluation of the gain factor  $b_j$  according to:

$$b_j = R_j(N_j) / S_j(N_j); \quad j = 0, \dots, 3 \quad (3.11)$$

with

$$S_j(N_j) = \sum_{i=0}^{39} d'^2(k_j+i-N_j); \quad j = 0, \dots, 3 \quad (3.12)$$

It is clear that the last 120 samples of the reconstructed short term residual signal  $d'(k_j+i)$ , ( $i=-120,\dots,-1$ ) shall be retained until the next sub-segment so as to allow the evaluation of the relations (3.9),..., (3.12).

### 3.1.14 Coding/Decoding of the LTP lags

The long term correlation lags  $N_j$ , ( $j=0,\dots,3$ ) can have values in the range (40,...,120), and so shall be coded using 7 bits with:

$$N_{cj} = N_j; \quad j = 0, \dots, 3 \quad (3.13)$$

At the receiving end, assuming an error free transmission, the decoding of these values will restore the actual lags:

$$N_j' = N_{cj}; \quad j = 0, \dots, 3 \quad (3.14)$$

### 3.1.15 Coding/Decoding of the LTP gains

The long term prediction gains  $b_j$ , ( $j=0,\dots,3$ ) are encoded with 2 bits each, according to the following algorithm:

```

if          bj <= DLB(i) then bcj = 0; i=0
if DLB(i-1) < bj <= DLB(i) then bcj = i; i=1,2
if DLB(i-1) < bj          then bcj = 3; i=3

```

(3.15)

where DLB(i),(i=0,...,2) denotes the decision levels of the quantizer, and b<sub>cj</sub> represents the coded gain value. Decision levels and quantizing levels are given in table 3.3.

**Table 3.3: Quantization table for the LTP gain**

i	Decision level DLB(i)	Quantizing level QLB(i)
0	0.2	0.10
1	0.5	0.35
2	0.8	0.65
3		1.00

The decoding rule is implemented according to:

$$b_j' = \text{QLB}(b_{cj}) ; j = 0, \dots, 3 \quad (3.16)$$

where QLB(i),(i=0,...,3) denotes the quantizing levels, and b<sub>j</sub>' represents the decoded gain value (see table 3.3).

### 3.1.16 Long term analysis filtering

The short term residual signal d(k<sub>0</sub>+k),(k=0,...,159) is processed by sub-segments of 40 samples. From each of the four sub-segments (j=0,...,3) of short term residual samples, denoted here d(k<sub>j</sub>+k), (k=0,...,39), an estimate d''(k<sub>j</sub>+k), (k=0,...,39) of the signal is subtracted to give the long term residual signal e(k<sub>j</sub>+k), (k=0,...,39) (see figure 3.1):

$$\begin{aligned}
 e(k_j+k) &= d(k_j+k) - d''(k_j+k) & ; & \quad j = 0, \dots, 3 \\
 & & & \quad k = 0, \dots, 39 \\
 k_j &= k_0 + j*40
 \end{aligned} \quad (3.17)$$

Prior to this subtraction, the estimated samples d''(k<sub>j</sub>+k) are computed from the previously reconstructed short term residual samples d', adjusted to the current sub-segment LTP lag N<sub>j</sub>' and weighted with the sub-segment LTP gain b<sub>j</sub>':

$$\begin{aligned}
 d''(k_j+k) &= b_j' * d'(k_j+k-N_j') & ; & \quad j = 0, \dots, 3 \\
 & & & \quad k = 0, \dots, 39 \\
 k_j &= k_0 + j*40
 \end{aligned} \quad (3.18)$$

### 3.1.17 Long term synthesis filtering

The reconstructed long term residual signal e'(k<sub>0</sub>+k),(k=0,...,159) is processed by sub-segments of 40 samples. To each sub-segment, denoted here e'(k<sub>j</sub>+k), (k=0,...,39), the estimate d''(k<sub>j</sub>+k), (k=0,...,39) of the signal is added to give the reconstructed short term residual signal d'(k<sub>j</sub>+k),(k=0,...,39):

$$\begin{aligned}
 d'(k_j+k) &= e'(k_j+k) + d''(k_j+k) & ; & \quad j = 0, \dots, 3 \\
 & & & \quad k = 0, \dots, 39 \\
 k_j &= k_0 + j*40
 \end{aligned} \quad (3.19)$$

#### RPE encoding clause

### 3.1.18 Weighting Filter

A FIR "block filter" algorithm is applied to each sub-segment by convolving 40 samples e(k) with the impulse response H(i) ; i=0,...,10 (see table 3.4).

**Table 3.4: Impulse response of block filter (weighting filter)**

i	5	4 (6)	3 (7)	2 (8)	1 (9)	0 (10)
$H(i) \cdot 2^{13}$	8192	5741	2054	0	-374	-134

$$|H(\Omega=0)| = 2.779;$$

The conventional convolution of a sequence having 40 samples with an 11-tap impulse response would produce  $40+11-1=50$  samples. In contrast to this, the "block filter" algorithm produces the 40 central samples of the conventional convolution operation. For notational convenience the block filtered version of each sub-segment is denoted by  $x(k)$ ,  $k=0, \dots, 39$ .

$$x(k) = \sum_{i=0}^{10} H(i) * e^{(k+5-i)} \quad \text{with } k = 0, \dots, 39 \quad (3.20)$$

NOTE:  $e^{(k+5-i)} = 0$  for  $k+5-i < 0$  and  $k+5-i > 39$ .

### 3.1.19 Adaptive sample rate decimation by RPE grid selection

For the next step, the filtered signal  $x$  is down-sampled by a ratio of 3 resulting in 3 interleaved sequences of lengths 14, 13 and 13, which are split up again into 4 sub-sequences  $x_m$  of length 13:

$$x_m(i) = x(k_j + m + 3 \cdot i) \quad ; \quad i = 0, \dots, 12 \quad (3.21)$$

$$m = 0, \dots, 3$$

with  $m$  denoting the position of the decimation grid. According to the explicit solution of the RPE mean squared error criterion, the optimum candidate sub-sequence  $x_M$  is selected which is the one with the maximum energy:

$$E_M = \max_m \sum_{i=0}^{12} x_m^2(i) \quad ; \quad m = 0, \dots, 3 \quad (3.22)$$

The optimum grid position  $M$  is coded as  $M_c$  with 2 bits.

### 3.1.20 APCM quantization of the selected RPE sequence

The selected sub-sequence  $x_M(i)$  (RPE sequence) is quantized, applying APCM (Adaptive Pulse Code Modulation). For each RPE sequence consisting of a set of 13 samples  $x_M(i)$ , the maximum  $x_{\max}$  of the absolute values  $|x_M(i)|$  is selected and quantized logarithmically with 6 bits as  $x_{\max c}$  as given in table 3.5.

**Table 3.5: Quantization of the block maximum  $x_{\max}$** 

xmax	x'max	xmaxc	xmax	x'max	xmaxc
0 .. 31	31	0	2048 .. 2303	2303	32
32 .. 63	63	1	2304 .. 2559	2559	33
64 .. 95	95	2	2560 .. 2815	2815	34
96 .. 127	127	3	2816 .. 3071	3071	35
128 .. 159	159	4	3072 .. 3327	3327	36
160 .. 191	191	5	3328 .. 3583	3583	37
192 .. 223	223	6	3584 .. 3839	3839	38
224 .. 255	255	7	3840 .. 4095	4095	39
256 .. 287	287	8	4096 .. 4607	4607	40
288 .. 319	319	9	4608 .. 5119	5119	41
320 .. 351	351	10	5120 .. 5631	5631	42
352 .. 383	383	11	5632 .. 6143	6143	43
384 .. 415	415	12	6144 .. 6655	6655	44
416 .. 447	447	13	6656 .. 7167	7167	45
448 .. 479	479	14	7168 .. 7679	7679	46
480 .. 511	511	15	7680 .. 8191	8191	47
512 .. 575	575	16	8192 .. 9215	9215	48
576 .. 639	639	17	9216 .. 10239	10239	49
640 .. 703	703	18	10240 .. 11263	11263	50
704 .. 767	767	19	11264 .. 12287	12287	51
768 .. 831	831	20	12288 .. 13311	13311	52
832 .. 895	895	21	13312 .. 14335	14335	53
896 .. 959	959	22	14336 .. 15359	15359	54
960 .. 1023	1023	23	15360 .. 16383	16383	55
1024 .. 1151	1151	24	16384 .. 18431	18431	56
1152 .. 1279	1279	25	18432 .. 20479	20479	57
1280 .. 1407	1407	26	20480 .. 22527	22527	58
1408 .. 1535	1535	27	22528 .. 24575	24575	59
1536 .. 1663	1663	28	24576 .. 26623	26623	60
1664 .. 1791	1791	29	26624 .. 28671	28671	61
1792 .. 1919	1919	30	28672 .. 30719	30719	62
1920 .. 2047	2047	31	30720 .. 32767	32767	63

For the normalization, the 13 samples are divided by the decoded version  $x'_{\max}$  of the block maximum. Finally, the normalized samples:

$$x'(i) = x_M(i)/x'_{\max} ; \quad i=0, \dots, 12 \quad (3.23)$$

are quantized uniformly with three bits to  $x_{Mc}(i)$  as given in table 3.6.

**Table 3.6: Quantization of the normalized RPE-samples**

$x' \cdot 2^{15}$ (Interval-limits)	$\underline{x}_M' \cdot 2^{15}$	$x_{Mc}$ (Channel)
-32768 ... -24577	-28672	0 = 000
-24576 ... -16385	-20480	1 = 001
-16384 ... -8193	-12288	2 = 010
-8192 ... -1	-4096	3 = 011
0 ... 8191	4096	4 = 100
8192 ... 16383	12288	5 = 101
16384 ... 24575	20480	6 = 110
24576 ... 32767	28672	7 = 111

### 3.1.21 APCM inverse quantization

The  $x_{Mc}(i)$  are decoded to  $\underline{x}_M'(i)$  and denormalized using the decoded value  $x'_{\max}$  leading to the decoded sub-sequence  $x'_M(i)$ .

### 3.1.22 RPE grid positioning

The quantized sub-sequence is upsampled by a ratio of 3 by inserting zero values according to the grid position given with  $M_c$ .

## 3.2 Decoder

The decoder comprises the following 4 clauses. Most of the sub-blocks are also needed in the encoder and have been described already. Only the short term synthesis filter and the de-emphasis filter are added in the decoder as new sub-blocks.

- RPE decoding clause (3.2.1);
- Long Term Prediction clause (3.2.2);
- Short term synthesis filtering clause (3.2.3);
- Post-processing (3.2.4).

The complete block diagram for the decoder is shown in figure 3.4. The variables and parameters of the decoder are marked by the index  $r$  to distinguish the received values from the encoder values.

### 3.2.1 RPE decoding clause

The input signal of the long term synthesis filter (reconstruction of the long term residual signal) is formed by decoding and denormalizing the RPE-samples (APCM inverse quantization - 3.1.21) and by placing them in the correct time position (RPE grid positioning - 3.1.22). At this stage, the sampling frequency is increased by a factor of 3 by inserting the appropriate number of intermediate zero-valued samples.

### 3.2.2 Long Term Prediction clause

The reconstructed long term residual signal  $e_r'$  is applied to the long term synthesis filter (see 3.1.16 and 3.1.17) which produces the reconstructed short term residual signal  $d_r'$  for the short term synthesizer.

### 3.2.3 Short term synthesis filtering clause

The coefficients of the short term synthesis filter (see figure 3.5) are reconstructed applying the identical procedure to that in the encoder (3.1.8 - 3.1.10). The short term synthesis filter is implemented according to the lattice structure depicted in figure 3.5.

$$s_{r(0)}(k) = d_r'(k) \quad (3.24a)$$

$$s_{r(i)}(k) = s_{r(i-1)}(k) - r_{r'(9-i)} * v_{8-i}(k-1); \quad i=1, \dots, 8 \quad (3.24b)$$

$$v_{9-i}(k) = v_{8-i}(k-1) + r_{r'(9-i)} * s_{r(i)}(k); \quad i=1, \dots, 8 \quad (3.24c)$$

$$s_{r'}(k) = s_{r(8)}(k) \quad (3.24d)$$

$$v_0(k) = s_{r(8)}(k) \quad (3.24e)$$

### 3.2.4 Post-processing

The output of the synthesis filter  $s_r(k)$  is fed into the IIR- de-emphasis filter leading to the output signal  $s_{r0}$ .

$$s_{r0}(k) = s_r(k) + \text{beta} * s_{r0}(k-1); \quad \text{beta} = 28180 * 2^{-15} \quad (3.25)$$

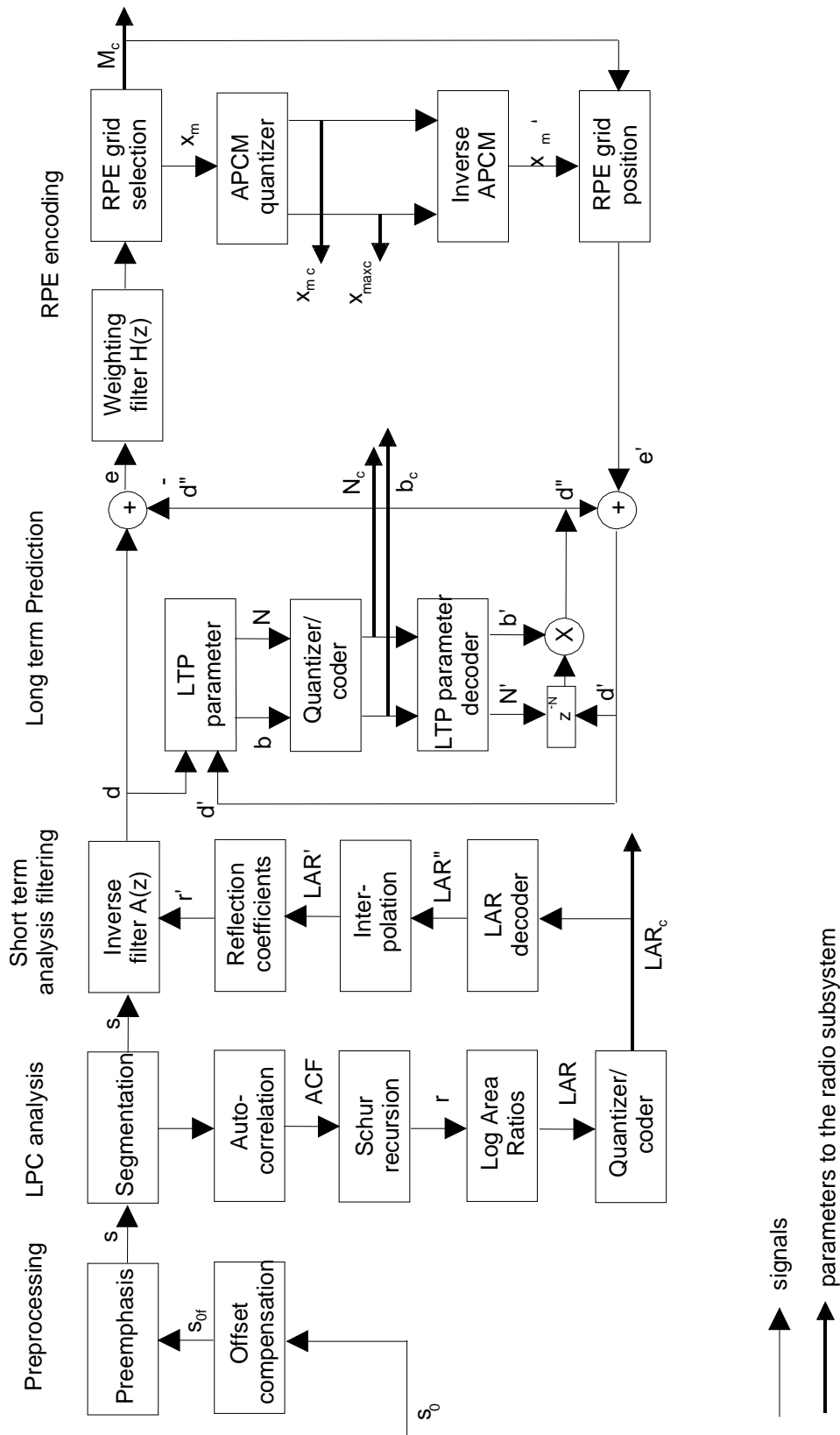

Figure 3.1: Block diagram of the RPE - LTP encoder

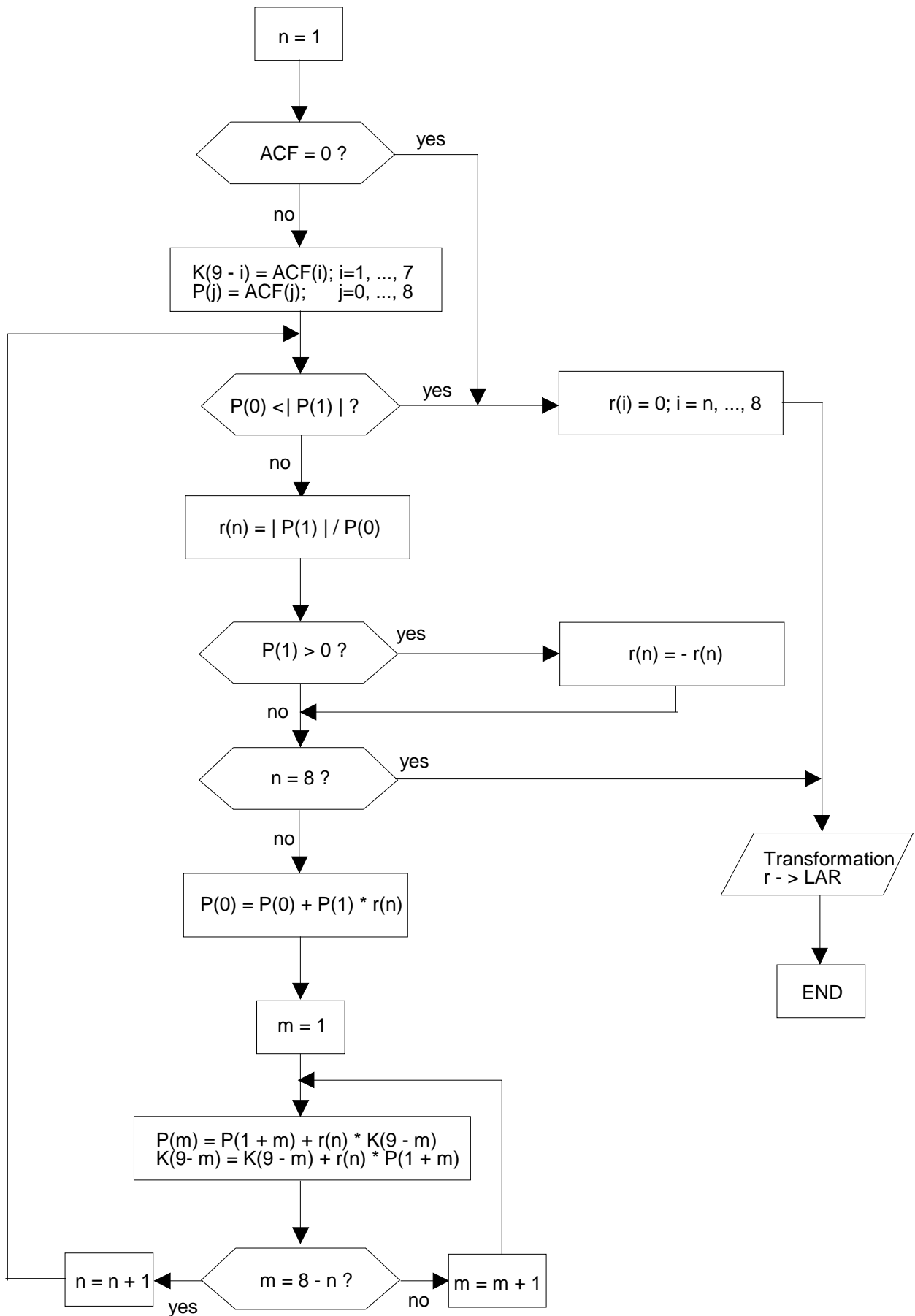

Figure 3.2: LPC analysis using Schur recursion



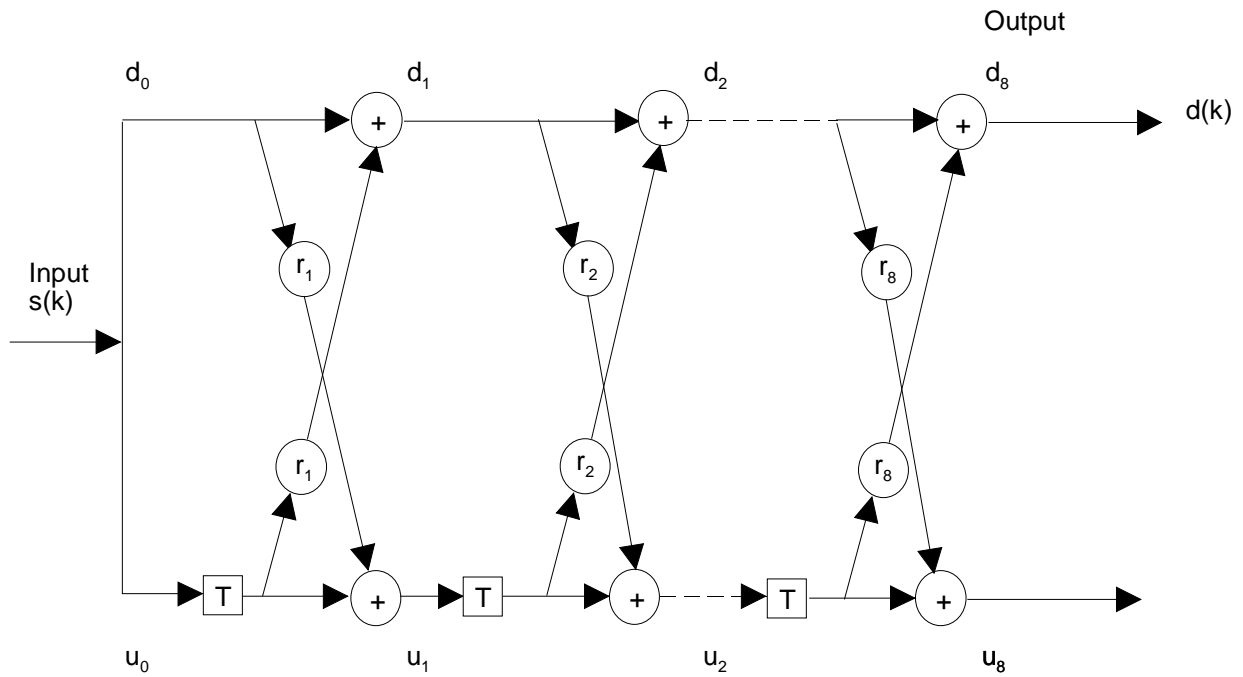

Figure 3.3: Short term analysis filter

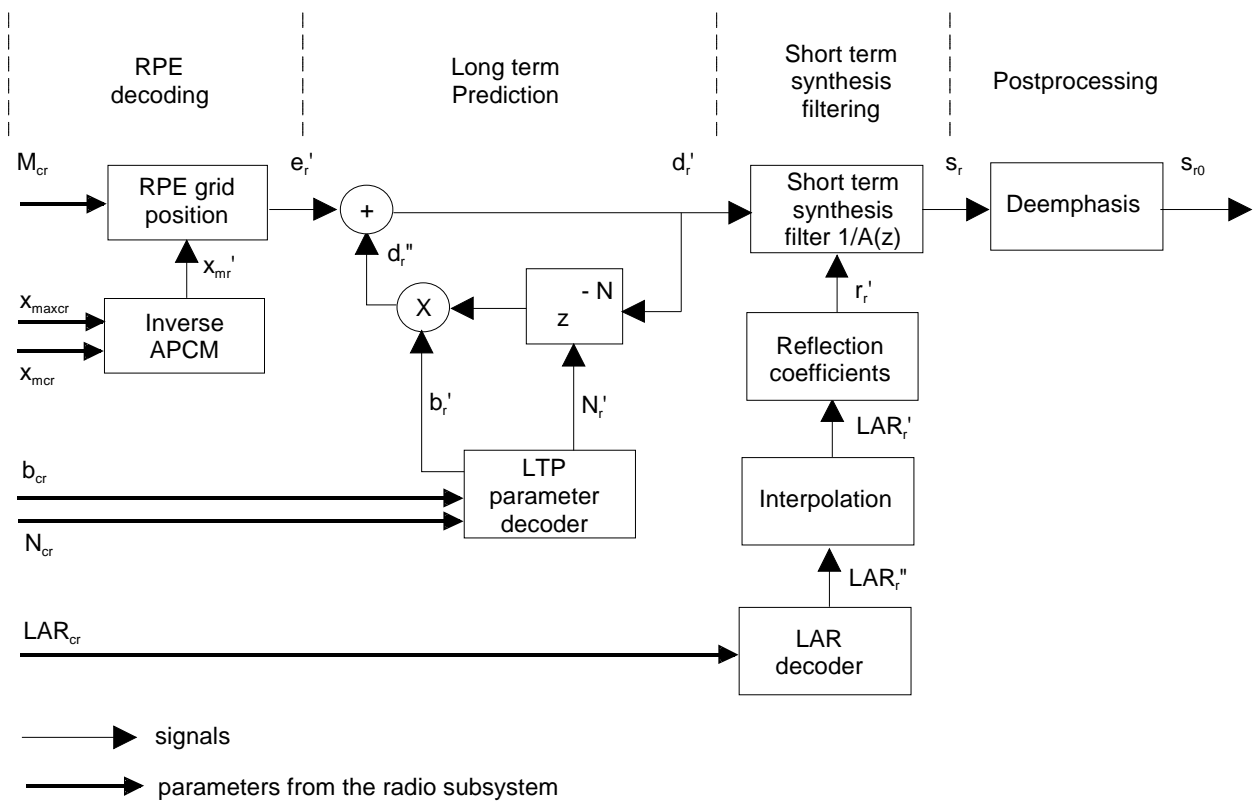

Figure 3.4: Block diagram of the RPE-LTP decoder

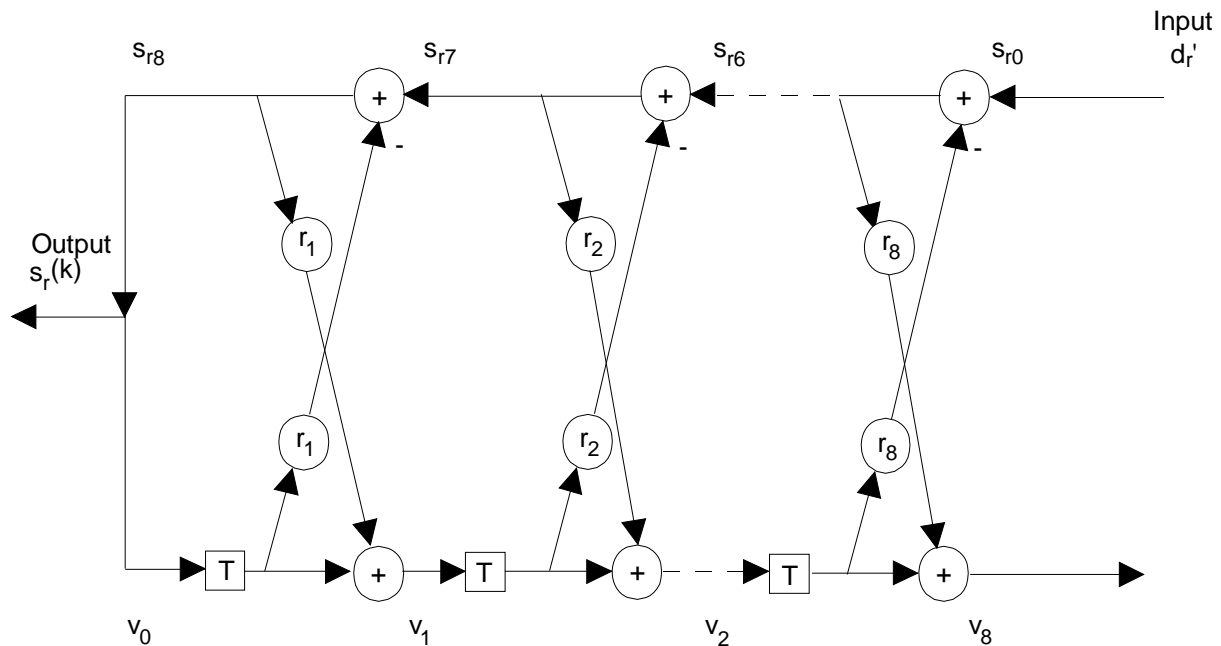

Figure 3.5: Short term synthesis filter

## 4 Codec homing

The below described codec homing procedure is introduced to the GSM Full Rate speech codec as an optional feature to simplify bit-exact codec tests. It is free to the manufacturers to implement this feature or not.

### 4.1 Functional description

The full rate speech codec is described in a bit-exact arithmetic to ease type approval as well as general testing purposes of the full rate speech codec.

The response of the codec to a predefined input sequence can only be foreseen if the internal state variables of the codec are in a predefined state at the beginning of the experiment. Therefore, the codec has to be put into a so called home state before a bit-exact test can be performed. This is usually done by a reset (a procedure in which the internal state variables of the codec are set to their defined initial values).

To allow a reset of the codec in remote locations, special homing frames have been defined for the encoder and the decoder, thus enabling a codec homing by inband signalling.

The codec homing procedure is defined in such a way, that in either direction (encoder or decoder) the homing functions are called after processing the homing frame that is input. The output corresponding to the first homing frame is therefore dependent on the codec state when receiving that frame and hence usually not known. The response to any further homing frame in one direction is by definition a homing frame of the other direction. This procedure allows homing of both, the encoder and decoder from either side, if a loop back configuration is implemented, taking proper framing into account.

### 4.2 Definitions

**Encoder-homing-frame:** The encoder-homing-frame consists of 160 identical samples, each 13 bits long, with the least significant bit set to "one" and all other bits set to "zero". When written to 16-bit words with left justification, the samples have a value of 0008 hex. The speech decoder has to produce this frame as a response to the second and any further decoder-homing-frame if at least two decoder-homing-frames were input to the decoder consecutively.

**Decoder-homing-frame:** The decoder-homing-frame has a fixed set of speech parameters as described in table 4.1 a/b. It is the natural response of the speech encoder to the second and any further encoder-homing-frame if at least two encoder-homing-frames were input to the encoder consecutively.

Table 4.1 a: LAR parameter values for the decoder-homing-frame

LARc[1]	LARc[2]	LARc[3]	LARc[4]	LARc[5]	LARc[6]	LARc[7]	LARc[8]
0x0009	0x0017	0x000F	0x0008	0x0007	0x0003	0x0003	0x0002

Table 4.1 b: Sub-frame parameter values for the decoder-homing-frame

Parameter		Sub-frame 1	Sub-frame 2	Sub-frame 3	Sub-frame 4
LTP lag	Nc	0x0028	0x0028	0x0028	0x0028
LTP gain	bc	0x0000	0x0000	0x0000	0x0000
RPE grid	Mc	0x0000	0x0000	0x0000	0x0000
block amplitude	xmaxc	0x0000	0x0000	0x0000	0x0000
RPE pulse 0	xMc[0]	0x0004	0x0004	0x0004	0x0004
RPE pulse 1	xMc[1]	0x0004	0x0004	0x0004	0x0004
RPE pulse 2	xMc[2]	0x0004	0x0004	0x0004	0x0004
RPE pulse 3	xMc[3]	0x0004	0x0004	0x0004	0x0004
RPE pulse 4	xMc[4]	0x0004	0x0004	0x0004	0x0003
RPE pulse 5	xMc[5]	0x0004	0x0004	0x0004	0x0004
RPE pulse 6	xMc[6]	0x0004	0x0004	0x0004	0x0004
RPE pulse 7	xMc[7]	0x0004	0x0004	0x0004	0x0004
RPE pulse 8	xMc[8]	0x0004	0x0004	0x0004	0x0004
RPE pulse 9	xMc[9]	0x0004	0x0004	0x0004	0x0004
RPE pulse 10	xMc[10]	0x0004	0x0004	0x0004	0x0004
RPE pulse 11	xMc[11]	0x0004	0x0004	0x0004	0x0004
RPE pulse 12	xMc[12]	0x0004	0x0004	0x0004	0x0004

### 4.3 Encoder homing

Whenever the full rate speech encoder receives at its input an encoder-homing-frame exactly aligned with its internal speech frame segmentation, the following events take place:

- Step 1: The speech encoder performs its normal operation including VAD and DTX and produces a speech parameter frame at its output which is in general unknown. If the speech encoder is already in its home state at the beginning of that frame, then the resulting speech parameter frame is identical to the decoder-homing-frame. This is how the decoder-homing-frame was constructed.
- Step 2: After successful completion of that operation, the speech encoder provokes the homing functions for all sub-modules including VAD and DTX and sets all state variables into their home state. On the reception of the next input frame, the speech encoder will start from its home state.

NOTE: Applying a sequence of N encoder-homing-frames will cause at least N-1 decoder-homing-frames at the output of the speech encoder.

### 4.4 Decoder homing

Whenever the speech decoder receives at its input a decoder-homing-frame (which is not marked as a bad frame), then the following events take place:

- Step 1: The speech decoder performs its normal operation and produces a speech frame at its output which is in general unknown. If the speech decoder is already in its home state at the beginning of that frame, then the resulting speech frame is replaced by the encoder-homing-frame. This would not naturally be the case but is forced by this definition here.
- Step 2: After successful completion of that operation, the speech decoder provokes the homing functions for all sub-modules including the comfort noise generator and sets all state variables into their home state. On the reception of the next input frame, the speech decoder will start from its home state.

NOTE 1: Applying a sequence of N decoder-homing-frames will cause at least N-1 encoder-homing-frames at the output of the speech decoder.

NOTE 2: By definition, the first frame of each decoder test sequence must differ from the decoder-homing-frame at least in one bit position within the parameters for LARs and first subframe. Therefore, if the decoder is in its home state, it is sufficient to check only these parameters to detect a subsequent decoder-homing-frame. This definition is made to support a delay-optimized implementation in the TRAU uplink direction.

## 4.5 Encoder home state

In table 4.2, a listing of all the encoder state variables with their predefined values when in the home state is given.

**Table 4.2: Initial values of the encoder state variables**

	Variable	Initial value
Offset compensation filter memory	z1	set to 0
Offset compensation filter memory	L_z2	set to 0
Pre-emphasis filter memory	mp	set to 0
LARs from previous frame	LARpp(j-1)[1...8]	all set to 0
Short term analysis filter memory	u[0...7]	all set to 0
LTP delay line	dp[-120...-1]	all set to 0

Initial values for variables used by the VAD algorithm are listed in GSM 06.32 [12]. In addition, the state variables of the DTX system have to be brought into their home state. As the DTX system is not specified in a bit-exact way, no common reset table can be given here.

## 4.6 Decoder home state

In table 4.3, a listing of all the decoder state variables with their predefined values when in the home state is given.

**Table 4.3: Initial values of the decoder state variables**

	Variable	Initial value
LTP lag from previous frame	nrp	set to 40
LTP delay line	drp[-120...-1]	all set to 0
LARs from previous frame	LARrpp(j-1)[1...8]	all set to 0
Short term synthesis filter memory	v[0...8]	all set to 0
De-emphasis filter memory	msr	set to 0

In addition, the state variables of the bad frame handling (error concealment) module and the comfort noise insertion module have to be brought into their home state. As these modules are not specified in a bit-exact way, no common reset table can be given here.

# 5 Computational details of the RPE-LTP codec

## 5.1 Data representation and arithmetic operations

Only two types of variables are used along the implementation of the RPE-LTP algorithm in fixed point arithmetic. These two types are:

Integer on 16 bits;

Long integer on 32 bits.

This assumption simplifies the detailed description and allows the maximum reach of precision.

In different places of the recommendation, different scaling factors are used according to different operations. To help the reader in the comparison of corresponding floating point and fixed point values given in clause 3 and 4 comments of the format:

```
/* var = integer( real_var * scalefactor ) */
```

are used at several points of clause 5. var is the rounded fixed point representation of the floating point representation of var (real\_var) using the given scaling factor.

In the description, input signal samples, coded parameters and output signal samples are represented by 16 bit words. At the receiving part it shall therefore be ensured that only valid bits (13 bits for samples signal and two to seven bits for coded parameters) are used. In verification tests, the testing system may introduce random bit at non valid places inside these samples (3 LSBs) or parameters (MSBs) to test this function. In the digital test sequences all non valid bits are set to 0.

The following part of this clause describes the required set of arithmetic operations to implement the RPE-LTP algorithm in fixed point.

For arithmetics operations or variables with a long integer type (32 bit) a prefix L\_ is used in order to distinguish them from the 16 bit variables or arithmetic operations.

All the names of the variables are identical to those of the functional description of the RPE-LTP Codec (clause 3) but variables like x', x'' are respectively called:

```
x'  '-----> xp
x'' '-----> xpp
```

in order to avoid any confusing notation.

NOTE: The x', x'' variables are examples but are not used within the following description.

The following notations are used in the arithmetic operations:

Square brackets ( [..] ) are used for arrays and when needed, the starting index and the ending index are put inside the bracket. For example x[0..159] means that x is an array of 160 words of 16 bits with beginning index 0 and ending index 159 and x[k] is an element of the array x[0..159].

All functions' names are underlined. For example add( x, y) means that we perform the addition of x and y.

- << n: denotes a n-bit arithmetic shift left operation (zero fill) on variables of type short or long; if n is less than 0, this operation becomes an arithmetic right shift of -n;
- >> n: denotes a n-bit arithmetic right shift operation (sign extension ) on variables of type short or long; if n is less than 0, this operation becomes an arithmetic left shift of -n (zero fill);
- a > b: denotes the "greater than" condition;
- a >= b: denotes the "greater than or equal" condition;
- a < b: denotes the "less than" condition;
- a <= b: denotes the "less than or equal" condition;
- a == b: denotes the "equal to" condition.

The basic structure of the FOR-NEXT loop is used in this description for loop computation; the declaration is:

```
== FOR k= start to end:
   inner computation;
== NEXT k:
```

Also the IF.. ELSE IF structure is used throughout this detailed description. The basic structure is:

```
IF (condition1) THEN statement1;
ELSE IF ( condition2) THEN statement2;
ELSE IF ( condition3) THEN statement3;
```

The word EXIT is used to exit immediately from a procedure.

The following arithmetic operations are defined:

add( var1, var2): performs the addition (var1+var2) with overflow control and saturation; the result is set at +32767 when overflow occurs or at -32768 when underflow occurs.

sub( var1, var2): performs the subtraction (var1-var2) with overflow control and saturation; the result is set at +32767 when overflow occurs or at -32768 when underflow occurs.

mult( var1, var2): performs the multiplication of var1 by var2 and gives a 16 bits result which is scaled i.e.  $\text{mult}(\text{var1}, \text{var2}) = (\text{var1 times var2}) \gg 15$  and  $\text{mult}(-32768, -32768) = 32767$

mult\_r( var1, var2): same as mult but with rounding i.e.  $\text{mult}_r(\text{var1}, \text{var2}) = ((\text{var1 times var2}) + 16384) \gg 15$  and  $\text{mult}_r(-32768, -32768) = 32767$

abs( var1 ): absolute value of var1;  $\text{abs}(-32768) = 32767$

div( var1, var2): div produces a result which is the fractional integer division of var1 by var2; var1 and var2 shall be positive and var2 shall be greater or equal to var1; The result is positive (leading bit equal to 0) and truncated to 16 bits. if var1 == var2 then  $\text{div}(\text{var1}, \text{var2}) = 32767$

L\_mult(var1, var2): L\_mult is a 32 bit result for the multiplication of var1 times var2 with a one bit shift left.  $\text{L\_mult}(\text{var1}, \text{var2}) = (\text{var1 times var2}) \ll 1$ . The condition L\_mult (-32768, -32768) does not occur in the algorithm.

L\_add(L\_var1, L\_var2): 32 bits addition of two 32 bits variables (L\_var1 + L\_var2) with overflow control and saturation; the result is set at 2147483647 when overflow occurs and at -2147483648 when underflow occurs.

L\_sub(L\_var1, L\_var2): 32 bits subtraction of two 32 bits variables (L\_var1 - L\_var2) with overflow control and saturation; the result is set at 2147483647 when overflow occurs and at -2147483648 when underflow occurs.

norm( L\_var1 ): norm produces the number of left shifts needed to normalize the 32 bits variable L\_var1 for positive values on the interval with minimum of 1073741824 and maximum of 2147483647 and for negative values on the interval with minimum of -2147483648 and maximum of -1073741824; in order to normalize the result, the following operation shall be done:  $\text{L\_norm\_var1} = \text{L\_var1} \ll \text{norm}(\text{L\_var1})$

$\text{L\_var2} = \text{var1}$ : deposit the 16 bits of var1 in the LSB 16 bits of L\_var2 with sign extension.

$\text{var2} = \text{L\_var1}$ : extract the 16 LSB bits of L\_var1 to put in var2.

When a constant is used in an operation on 32 bits, it shall be first sign-extended on 32 bits.

## 5.2 Fixed point implementation of the RPE-LTP coder

The RPE-LTP coder works on a frame by frame basis. The length of the frame is equal to 160 samples. Some computations are done once per frame (analysis) and some others for each of the four sub-segments (40 samples).

In the following detailed description, procedure 5.2.0 to 5.2.10 are done once per frame to produce at the output of the coder the LARc[1..8] parameters which are the coded LAR coefficients and also to realize the inverse filtering operation for the entire frame (160 samples of signal d[0..159]). These parts produce at the output of the coder:

```
| LARc[1..8]      : Coded LAR coefficients
|--> These parameters are calculated and sent once per frame.
```

Procedure 5.2.11 to 5.2.18 are to be executed four times per frame. That means once for each sub-segment RPE-LTP analysis of 40 samples. These parts produce at the output of the coder:

```
| Nc           : LTP lag;
| bc           : Coded LTP gain;
| Mc           : RPE grid selection;
| xmaxc        : Coded maximum amplitude of the RPE sequence;
| xMc[0..12]   : Codes of the normalized RPE samples;
|--> These parameters are calculated and sent four times per frame.
```

### Pre-processing clause

## 5.2.0 Scaling of the input variable

After A or  $\mu$ -law (PCS 1900) to linear conversion (or directly from the A to D converter) the following scaling is assumed for input to the RPE-LTP algorithm:

```
S.v.v.v.v.v.v.v.v.v.v.v.v.v.v.v.v.v.v.v.v.v.v.v.x.x.x ( 2's complement format).
Where S is the sign bit, v a valid bit, and x a "don't care" bit.
The original signal is called sop[..];
```

### 5.2.1 Downscaling of the input signal

```
|== FOR k=0 to 159:
|   so[k] = sop[k] >> 3;
|   so[k] = so[k] << 2;
|== NEXT k:
```

### 5.2.2 Offset compensation

This part implements a high-pass filter and requires extended arithmetic precision for the recursive part of this filter.

The input of this procedure is the array so[0..159] and the output the array sof[0..159].

```
|== FOR k = 0 to 159:

|   Compute the non-recursive part.
|   s1 = sub( so[k], z1 );
|   z1 = so[k];

|   Compute the recursive part.
|   L_s2 = s1;
|   L_s2 = L_s2 << 15;
|   Execution of a 31 by 16 bits multiplication.
|   msp = L_z2 >> 15;
|   lsp = L_sub( L_z2, ( msp << 15 ) );
|   temp = mult_r( lsp, 32735 );
|   L_s2 = L_add( L_s2, temp );
|   L_z2 = L_add( L_mult( msp, 32735 ) >> 1, L_s2 );

|   Compute sof[k] with rounding.
|   sof[k] = L_add( L_z2, 16384 ) >> 15;
|== NEXT k:
```

Keep z1 and L\_z2 in memory for the next frame.

Initial value: z1=0; L\_z2=0;

### 5.2.3 Pre-emphasis

```
|== FOR k=0 to 159:
|   s[k] = add( sof[k], mult_r( mp, -28180 ) );
|   mp = sof[k];
|== NEXT k:
```

Keep mp in memory for the next frame.

Initial value: mp=0;

#### LPC analysis clause

### 5.2.4 Autocorrelation

The goal is to compute the array L\_ACF[k]. The signal s[i] shall be scaled in order to avoid an overflow situation.

Dynamic scaling of the array s[0..159].

Search for the maximum.

```

smax = 0;
|== FOR k = 0 to 159:
|   temp = abs( s [k] );
|   IF ( temp > smax ) THEN smax = temp;
|== NEXT k;

```

Computation of the scaling factor.

```

IF ( smax == 0 ) THEN scalauto = 0;
ELSE scalauto = sub( 4, norm( smax << 16 ) );

```

Scaling of the array s[0..159].

```

IF ( scalauto > 0 ) THEN
|   temp = 16384 >> sub( scalauto,1);
|== FOR k = 0 to 159:
|   s[k] = mult_r( s[k], temp);
|== NEXT k;

```

Compute the L\_ACF[.].

```

|== FOR k=0 to 8:
|   L_ACF[k] = 0;
|==== FOR i=k to 159:
|   L_temp = L_mult( s[i], s[i-k] );
|   L_ACF[k] = L_add( L_ACF[k], L_temp );
|==== NEXT i:
|== NEXT k:

```

Rescaling of the array s[0..159].

```

IF ( scalauto > 0 ) THEN
|== FOR k = 0 to 159:
|   s[k] = s[k] << scalauto;
|== NEXT k;

```

## 5.2.5 Computation of the reflection coefficients

Schur recursion with 16 bits arithmetic.

```

IF( L_ACF[0] == 0 ) THEN
|== FOR i = 1 to 8:
|   r[i] = 0;
|== NEXT i:
|   EXIT; /continue with clause 5.2.6/
temp = norm( L_ACF[0] );
|== FOR k=0 to 8:
|   ACF[k] = ( L_ACF[k] << temp ) >> 16;
|== NEXT k:

```

Initialize array P[.] and K[.] for the recursion.

```

|== FOR i=1 to 7:
|   K[9-i] = ACF[i];
|== NEXT i:
|== FOR i=0 to 8:
|   P[i] = ACF[i];
|== NEXT i:

```

Compute reflection coefficients.

```

|== FOR n=1 to 8:

```



```

|   IF( P[0] < abs( P[1] ) ) THEN
|
|                                     |== FOR i = n to 8:
|                                     |   r[i] = 0;
|                                     |== NEXT i:
|                                     |   EXIT; /continue with
|                                     |   clause 5.2.6/
|   r[n] = div( abs( P[1] ), P[0] );
|   IF ( P[1] > 0 ) THEN r[n] = sub( 0, r[n] );
|
|   IF ( n == 8 ) THEN EXIT; /continue with
|                                     clause 5.2-6/

```

### Schur recursion.

```

|   P[0] = add( P[0], mult_r( P[1], r[n] ) );
|=== FOR m=1 to 8-n:
|   P[m] = add( P[m+1], mult_r( K[9-m], r[n] ) );
|   K[9-m] = add( K[9-m], mult_r( P[m+1], r[n] ) );
|=== NEXT m:
|
|== NEXT n:

```

NOTE: The following lines gives one correct implementation of the div(num, denum) arithmetic operation. Compute div which is the integer division of num by denum: with denum >= num > 0.

```

L_num = num;
L_denum = denum;
div = 0;
|== FOR k = 0 to 14:
|   div = div << 1;
|   L_num = L_num << 1;
|   IF ( L_num >= L_denum ) THEN
|
|                                     | L_num=L_sub(L_num, L_denum);
|                                     | div = add( div , 1 );
|== NEXT k:

```

## 5.2.6 Transformation of reflection coefficients to Log.-Area Ratios

The following scaling for r[..] and LAR[..] has been used:

```

/* r[..] = integer( real_r[..]*32768. );  -1. <= real_r < 1. */
/*
/* LAR[..] = integer( real_LAR[..]*16384. );
/*
/* with  -1.625 <= real_LAR <= 1.625
*/

```

### Computation of the LAR[1..8] from the r[1..8].

```

|== FOR i = 1 to 8:
|   temp = abs( r[i] );
|   IF ( temp < 22118 ) THEN temp = temp >> 1;
|   ELSE IF ( temp < 31130 ) THEN
|       temp = sub( temp, 11059 );
|   ELSE temp = sub( temp, 26112 ) << 2;
|   LAR[i] = temp;
|   IF ( r[i] < 0 ) THEN LAR[i] = sub( 0, LAR[i] );
|== NEXT i:

```

## 5.2.7 Quantization and coding of the Log.-Area Ratios

This procedure needs four tables; the following equations give the optimum scaling for the constants:

```
/* A[1..8]= integer( real_A[1..8]*1024); 8 values (see table5.1)*/
/*
/* B[1..8]= integer( real_B[1..8]*512); 8 values (see table5.1)*/
/*
/* MAC[1..8]= maximum of the LARc[1..8]; 8 values (see table5.1)*/
/*
/* MIC[1..8]= minimum of the LARc[1..8]; 8 values (see table5.1)*/
```

### Computation for quantizing and coding the LAR[1..8].

```
|== FOR i =1 to 8:
|   temp= mult( A[i], LAR[i] );
|   temp= add( temp, B[i] );
|   temp= add( temp, 256);      for rounding
|   LARc[i]= temp >> 9;
|
|   Check IF LARc[i] lies between MIN and MAX
|
|   IF ( LARc[i] > MAC[i] ) THEN LARc[i] = MAC[i];
|   IF ( LARc[i] < MIC[i] ) THEN LARc[i] = MIC[i];
|   LARc[i] = sub( LARc[i], MIC[i] ); /See note below/
|== NEXT i:
```

NOTE: The equation is used to make all the LARc[i] positive.

### Short term analysis filtering clause

## 5.2.8 Decoding of the coded Log.-Area Ratios

This procedure requires for efficient implementation two tables.

```
/* INVA[1..8]=integer((32768*8)/(real_A[1..8]));          */
/*
/*                                     8 values (table 5.2) */
/* MIC[1..8]=minimum value of the LARc[1..8];          */
/*
/*                                     8 values (table 5.1) */
```

### Compute the LARpp[1..8].

```
|== FOR i=1 to 8:
|   temp1 = add( LARc[i], MIC[i] ) << 10; /See note below/
|   temp2 = B[i] << 1;
|   temp1 = sub( temp1, temp2);
|   temp1 = mult_r( INVA[i], temp1);
|   LARpp[i] = add( temp1, temp1);
|== NEXT i:
```

NOTE: The addition of MIC[i] is used to restore the sign of LARc[i].

## 5.2.9 Computation of the quantized reflection coefficients

Within each frame of 160 analysed speech samples the short term analysis and synthesis filters operate with four different sets of coefficients, derived from the previous set of decoded LARs(LARpp(j-1)) and the actual set of decoded LARs (LARpp(j)).

### 5.2.9.1 Interpolation of the LARpp[1..8] to get the LARp[1..8]

For k\_start = 0 to k\_end = 12.

```
|==== FOR i= 1 to 8:
```

```

|     LARp[i] = add((LARpp(j-1)[i] >> 2),(LARpp(j)[i] >> 2));
|     LARp[i] = add( LARp[i] , ( LARpp(j-1)[i] >> 1 ) );
|==== NEXT i:

For k_start = 13 to k_end = 26.
|==== FOR i= 1 to 8:
|     LARp[i] = add((LARpp(j-1)[i] >> 1),(LARpp(j)[i] >> 1 ));
|==== NEXT i:

For k_start = 27 to k_end = 39.
|==== FOR i= 1 to 8:
|     LARp[i] = add((LARpp(j-1)[i] >> 2),(LARpp(j)[i] >> 2 ));
|     LARp[i] = add( LARp[i] , ( LARpp(j)[i] >> 1 ) );
|==== NEXT i:

For k_start = 40 to k_end = 159.
|==== FOR i= 1 to 8:
|     LARp[i] = LARpp(j)[i];
|==== NEXT i:

```

Initial value: LARpp(j-1)[1..8]=0;

### 5.2.9.2 Computation of the rp[1..8] from the interpolated LARp[1..8]

The input of this procedure is the interpolated LARp[1..8] array. The reflection coefficients, rp[i], are used in the analysis filter and in the synthesis filter.

```

|== FOR i=1 to 8:
|     temp = abs( LARp[i] );
|     IF ( temp < 11059 ) THEN temp = temp << 1;
|         ELSE IF (temp < 20070) THEN
|             temp = add(temp, 11059);
|             ELSE temp = add( (temp >> 2), 26112 );
|     rp[i] = temp;
|     IF ( LARp[i] < 0 ) THEN rp[i] = sub( 0, rp[i] );
|== NEXT i:

```

### 5.2.10 Short term analysis filtering

This procedure computes the short term residual signal d[.] to be fed to the RPE-LTP loop from the s[.] signal and from the local rp[.] array (quantized reflection coefficients). As the call of this procedure can be done in many ways (see the interpolation of the LAR coefficient), it is assumed that the computation begins with index k\_start (for arrays d[.] and s[.]) and stops with index k\_end (k\_start and k\_end are defined in 5.2.9.1). This procedure also needs to keep the array u[0..7] in memory for each call.

```

|== FOR k = k_start to k_end:
|     di = s[k]
|     sav = di;
|==== FOR i = 1 to 8:
|     temp = add( u[i-1], mult_r( rp[i], di ) );
|     di = add( di, mult_r( rp[i], u[i-1] ) );
|     u[i-1] = sav;
|     sav = temp;
|==== NEXT i:
|     d[k] = di;
|== NEXT k:

```

Keep the array u[0..7] in memory.

Initial value: u[0..7]=0;

**Long Term Predictor (LTP) clause**

## 5.2.11 Calculation of the LTP parameters

This procedure computes the LTP gain (bc) and the LTP lag (Nc) for the long term analysis filter. This is done by calculating a maximum of the cross-correlation function between the current sub-segment short term residual signal  $d[0..39]$  (output of the short term analysis filter; for simplification the index of this array begins at 0 and ends at 39 for each sub-segment of the RPE-LTP analysis) and the previous reconstructed short term residual signal  $dp[-120..-1]$ . A dynamic scaling shall be performed to avoid overflow.

### Search of the optimum scaling of $d[0..39]$ .

```

dmax = 0;
|== FOR k = 0 to 39:
|   temp = abs( d[k] );
|   IF ( temp > dmax ) THEN dmax = temp;
|== NEXT k:

temp = 0;
IF ( dmax == 0 ) THEN scal = 0;
  ELSE temp = norm( dmax << 16 );
IF ( temp > 6 ) THEN scal = 0;
  ELSE scal = sub( 6, temp );

```

### Initialization of a working array $wt[0..39]$ .

```

|== FOR k = 0 to 39:
|   wt[k] = d[k] >> scal;
|== NEXT k:

```

### Search for the maximum cross-correlation and coding of the LTP lag.

```

L_max = 0;
Nc = 40;   (index for the maximum cross-correlation)
|== FOR lambda = 40 to 120:
|   L_result = 0;
|=== FOR k = 0 to 39:
|     L_temp = L_mult( wt[k], dp[k-lambda] );
|     L_result = L_add( L_temp, L_result );
|=== NEXT k:
|   IF ( L_result > L_max ) THEN
|
|                                     | Nc = lambda;
|                                     | L_max = L_result ;
|== NEXT lambda:

```

### Rescaling of $L\_max$ .

```

L_max = L_max >> ( sub( 6, scal ) );

```

### Initialization of a working array $wt[0..39]$ .

```

|== FOR k = 0 to 39:
|   wt[k] = dp[k-Nc] >> 3;
|== NEXT k:

```

### Compute the power of the reconstructed short term residual signal $dp[.].$

```

L_power = 0;
|== FOR k = 0 to 39:
|   L_temp = L_mult( wt[k], wt[k] );
|   L_power = L_add( L_temp, L_power );
|== NEXT k:

```

### Normalization of $L\_max$ and $L\_power$ .

```

IF ( L_max <= 0 ) THEN
    | bc = 0;
    | EXIT; /cont. with 5.2.12/
IF ( L_max >= L_power ) THEN
    | bc = 3;
    | EXIT; /cont. with 5.2.12/
temp = norm( L_power );
R = ( L_max << temp ) >> 16;
S = ( L_power << temp ) >> 16;

```

### Coding of the LTP gain.

Table 5.3a shall be used to obtain the level DLB[i] for the quantization of the LTP gain b to get the coded version bc.

```

|== FOR bc = 0 to 2:
|     IF ( R <= mult(S, DLB[bc])) THEN EXIT; /cont. with
|                                     5.2.12/
|== NEXT bc;
bc = 3;

```

Initial value: dp[-120..-1]=0;

## 5.2.12 Long term analysis filtering

In this part, we have to decode the bc parameter to compute the samples of the estimate dpp[0..39]. The decoding of bc needs the use of table 5.3b. The long term residual signal e[0..39] is then calculated to be fed to the RPE encoding clause.

### Decoding of the coded LTP gain.

```
bp = QLB[bc];
```

### Calculating the array e[0..39] and the array dpp[0..39].

```

|== FOR k = 0 to 39:
|     dpp[k] = mult_r( bp, dp[k-Nc] );
|     e[k] = sub( d[k], dpp[k] );
|== NEXT k:

```

### **RPE encoding clause**

## 5.2.13 Weighting filter

The coefficients of the weighting filter are stored in a table (see table 5.4). The following scaling is used:

```
/* H[0..10] = integer( real_H[0..10]*8192 ); */
```

### Initialization of a temporary working array wt[0..49].

```

|== FOR k= 0 to 4:
|     wt[k] = 0;
|== NEXT k:

|== FOR k = 5 to 44:
|     wt[k] = e[k-5];
|== NEXT k:

|== FOR k= 45 to 49:
|     wt[k] = 0;
|== NEXT k:

```

Compute the signal  $x[0..39]$ .

```

|== FOR k= 0 to 39:
|   L_result = 8192; /rounding of the output
|                   of the filter/
|==== FOR i = 0 to 10:
|   L_temp = L_mult( wt[k+i], H[i] );
|   L_result = L_add( L_result, L_temp );
|==== NEXT i:
|   L_result = L_add(L_result,L_result); /scaling (x2)/
|   L_result = L_add(L_result,L_result); /scaling (x4)/
|   x[k] = L_result >> 16;
|== NEXT k:

```

## 5.2.14 RPE grid selection

The signal  $x[0..39]$  is used to select the RPE grid which is represented by  $M_c$ .

```

EM = 0;
Mc = 0;

|== FOR m = 0 to 3:
|   L_result = 0;
|==== FOR i = 0 to 12:
|   temp1 = x[m+(3*i)] >> 2;
|   L_temp = L_mult( temp1, temp1 );
|   L_result = L_add( L_temp, L_result );
|==== NEXT i:
|   IF ( L_result > EM ) THEN
|                                     | Mc = m;
|                                     | EM = L_result;
|== NEXT m:

```

Down-sampling by a factor 3 to get the selected  $x_M[0..12]$  RPE sequence.

```

|== FOR i = 0 to 12:
|   xM[i] = x[Mc +(3*i)];
|== NEXT i:

```

## 5.2.15 APCM quantization of the selected RPE sequence

Find the maximum absolute value  $x_{max}$  of  $x_M[0..12]$ .

```

xmax = 0;
|== FOR i = 0 to 12:
|   temp = abs( xM[i] );
|   IF ( temp > xmax ) THEN xmax = temp;
|== NEXT i:

```

Quantizing and coding of  $x_{max}$  to get  $x_{maxc}$ .

```

exp = 0;
temp = xmax >> 9;
itest = 0;
|== FOR i = 0 to 5:
|   IF ( temp <= 0 ) THEN itest = 1;
|   temp = temp >> 1;
|   IF ( itest == 0 ) THEN exp = add( exp, 1 );
|== NEXT i:

```

```
temp = add( exp, 5 ) ;
xmaxc = add( ( xmaxc >> temp ), ( exp << 3 ) ) ;
```

#### Quantizing and coding of the xM[0..12] RPE sequence to get the xMc[0..12].

This computation uses the fact that the decoded version of xmaxc can be calculated by using the exponent and the mantissa part of xmaxc (logarithmic table).

So, this method avoids any division and uses only a scaling of the RPE samples by a function of the exponent. A direct multiplication by the inverse of the mantissa (NRFAC[0..7] found in table 5.5) gives the 3 bit coded version xMc[0..12] of the RPE samples.

#### Compute exponent and mantissa of the decoded version of xmaxc.

```
exp = 0 ;
IF ( xmaxc > 15 ) THEN exp = sub( ( xmaxc >> 3 ), 1 ) ;
mant = sub( xmaxc , ( exp << 3 ) ) ;
```

#### Normalize mantissa 0 <= mant <= 7.

```
IF ( mant == 0 ) THEN | exp = -4;
                    | mant = 15;
ELSE | itest = 0;
    |== FOR i = 0 to 2:
    |   IF ( mant > 7 ) THEN itest = 1;
    |   IF ( itest == 0 ) THEN mant = add( ( mant << 1 ), 1 );
    |   IF ( itest == 0 ) THEN exp = sub( exp, 1 );
    |== NEXT i:
mant = sub( mant, 8 ) ;
```

#### Direct computation of xMc[0..12] using table 5.5.

```
temp1 = sub( 6, exp ); /normalization by the exponent/
temp2 = NRFAC[mant]; /see table 5.5 (inverse mantissa)/

|== FOR i = 0 to 12:
|   temp = xM[i] << temp1;
|   temp = mult( temp , temp2 );
|   xMc[i] = add( ( temp >> 12 ), 4 ); /See note below/
|== NEXT I:
```

NOTE: This equation is used to make all the xMc[i] positive.

Keep in memory exp and mant for the following inverse APCM quantizer.

## 5.2.16 APCM inverse quantization

This part is for decoding the RPE sequence of coded xMc[0..12] samples to obtain the xMp[0..12] array. Table 5.6 is used to get the mantissa of xmaxc (FAC[0..7]).

```
temp1 = FAC[mant]; see 5.2.15 for mant
temp2 = sub( 6, exp ); see 5.2.15 for exp
temp3 = 1 << sub( temp2, 1 );

|== FOR i = 0 to 12:
|   temp = sub( ( xMc[i] << 1 ), 7 ); /See note below/
|   temp = temp << 12;
|   temp = mult_r( temp1, temp );
|   temp = add( temp, temp3 );
|   xMp[i] = temp >> temp2;
|== NEXT i;
```

NOTE: This subtraction is used to restore the sign of  $x_{Mc}[i]$ .

## 5.2.17 RPE grid positioning

This procedure computes the reconstructed long term residual signal  $ep[0..39]$  for the LTP analysis filter. The inputs are the  $M_c$  which is the grid position selection and the  $x_{Mp}[0..12]$  decoded RPE samples which are upsampled by a factor of 3 by inserting zero values.

```

|== FOR k = 0 to 39:
|   ep[k] = 0;
|== NEXT k:

|== FOR i = 0 to 12:
|   ep[Mc +(3*i)] = xMp[i];
|== NEXT i:

```

## 5.2.18 Update of the reconstructed short term residual signal $dp[-120..-1]$

This procedure adds the reconstructed long term residual signal  $ep[0..39]$  to the estimated signal  $dpp[0..39]$  from the long term analysis filter to compute the reconstructed short term residual signal  $dp[-40..-1]$ ; also the reconstructed short term residual array  $dp[-120..-41]$  is updated.

```

|== FOR k = 0 to 79:
|   dp[-120+k] = dp[-80+k];
|== NEXT k:

|== FOR k = 0 to 39:
|   dp[-40+k] = add( ep[k], dpp[k] );
|== NEXT k:

```

Keep the array  $dp[-120..-1]$  in memory for the next sub-segment.

Initial value:  $dp[-120..-1]=0$ ;

## 5.3 Fixed point implementation of the RPE-LTP decoder

Only the synthesis filter and the de-emphasis procedure are different from the procedures found in the RPE-LTP coder. Procedures 5.3.1 and 5.3.2 are executed for each sub-segment (four times per frame). Procedures 5.3.3, 5.3.4 and 5.3.5 are executed once per frame.

### 5.3.1 RPE decoding clause

Procedures 5.2.15 (only the part to get mant and exp of  $x_{maxc}$ ), 5.2.16 and 5.2.17 are used to obtain the reconstructed long term residual signal  $erp[0..39]$  signal from the received parameters for each sub-segment (i.e.  $M_{cr}$ ,  $x_{maxcr}$ ,  $x_{mcr}[0..12]$ ).

### 5.3.2 Long term synthesis filtering

This procedure uses the  $b_{cr}$  and  $N_{cr}$  parameter to realize the long term synthesis filtering. The decoding of  $b_{cr}$  needs the use of table 5.3b.

- $N_r$  is the received and decoded LTP lag.
- An array  $drp[-120..39]$  is used in this procedure.

The elements for -120 to -1 of the array  $drp$  are kept in memory for the long term synthesis filter. For each sub-segment (40 samples), this procedure computes the  $drp[0..39]$  to be fed to the synthesis filter.

Check the limits of  $N_r$ .

```

Nr = Ncr;
IF ( Ncr < 40 ) THEN Nr = nrp;

```



```

IF ( Ncr > 120 ) THEN Nr = nrp;
nrp= Nr;

```

Keep the nrp value for the next sub-segment.

Initial value: nrp=40;

Decoding of the LTP gain bcr.

```

brp = QLB[bcr]

```

Computation of the reconstructed short term residual signal drp[0..39].

```

|== FOR k = 0 to 39:
|   drpp = mult_r( brp, drp[k-Nr] );
|   drp[k] = add( erp[k], drpp );
|== NEXT k:

```

Update of the reconstructed short term residual signal drp[-1..-120].

```

|== FOR k = 0 to 119:
|   drp[-120+k] = drp[-80+k];
|== NEXT k:

```

Keep the array drp[-120..-1] for the next sub-segment.

Initial value: drp[-120..-1]=0;

### 5.3.3 Computation of the decoded reflection coefficients

This procedure (which is executed once per frame) is the same as the one described in the CODER part. For decoding of the received LARcr[1..8], see procedure 5.2.8. For the interpolation of the decoded Log.-Area Ratios, see procedure 5.2.9.1 and for the computation of the reflection coefficients rrp[1..8], see procedure 5.2.9.2.

### 5.3.4 Short term synthesis filtering clause

This procedure uses the drp[0..39] signal and produces the sr[0..159] signal which is the output of the short term synthesis filter. For ease of explanation, a temporary array wt[0..159] is used.

Initialization of the array wt[0..159].

For the first sub-segment in a frame:

```

|== FOR k = 0 to 39:
|   wt[k] = drp[k];
|== NEXT k:

```

For the second sub-segment in a frame:

```

|== FOR k = 0 to 39:
|   wt[40+k] = drp[k];
|== NEXT k:

```

For the third sub-segment in a frame:

```

|== FOR k = 0 to 39:
|   wt[80+k] = drp[k];
|== NEXT k:

```

For the fourth sub-segment in a frame:

```

|== FOR k = 0 to 39:
|   wt[120+k] = drp[k];
|== NEXT k:

```



## 5.4 Tables used in the fixed point implementation of the RPE-LTP coder and decoder

**Table 5.1: Quantization of the Log.-Area Ratios**

<b>i</b>	<b>A[i]</b>	<b>B[i]</b>	<b>MIC[i]</b>	<b>MAC[i]</b>
1	20480	0	-32	31
2	20480	0	-32	31
3	20480	2048	-16	15
4	20480	-2560	-16	15
5	13964	94	-8	7
6	15360	-1792	-8	7
7	8534	-341	-4	3
8	9036	-1144	-4	3

**Table 5.2: Tabulation of 1/A[1..8]**

<b>i</b>	<b>INVA[i]</b>
1	13107
2	13107
3	13107
4	13107
5	19223
6	17476
7	31454
8	29708

**Table 5.3a: Decision level of the LTP gain quantizer**

<b>bc</b>	<b>DLB[bc]</b>
0	6554
1	16384
2	26214
3	32767

**Table 5.3b: Quantization levels of the LTP gain quantizer**

<b>bc</b>	<b>QLB[bc]</b>
0	3277
1	11469
2	21299
3	32767

**Table 5.4: Coefficients of the weighting filter**

<b>i</b>	<b>H[i]</b>
0	-134
1	-374
2	0
3	2054
4	5741
5	8192
6	5741
7	2054
8	0
9	-374
10	-134

**Table 5.5: Normalized inverse mantissa used to compute  $x_M/x_{max}$** 

i	NRFAC[i]
0	29128
1	26215
2	23832
3	21846
4	20165
5	18725
6	17476
7	16384

**Table 5.6: Normalized direct mantissa used to compute  $x_M/x_{max}$** 

i	FAC[i]
0	18431
1	20479
2	22527
3	24575
4	26623
5	28671
6	30719
7	32767

## 6 Digital test sequences

This clause provides information on the digital test sequences that have been designed to help in the verification of implementations of the RPE-LTP codec. Copies of these sequences are available (see annex A3). As the codec homing procedure (see clause 4) is an optional feature two sets of test vectors are provided, one set without codec homing frames and a second set with codec homing frames. In addition A-law and  $\mu$ -law compressed testsequences are provided for each set as a further option for TRAU testing.

### 6.1 Input and output signals

Table 6.1 defines the input and output signals for the test sequences. The words defined in this table use 16 bits. The left or right justification is indicated in the table. The codewords described in the table correspond to one frame of coder input or decoder output signal; i.e. for 20 ms of input signal the 76 codewords are obtained at the output of the coder and 76 codewords provided at the input of the decoder will yield 20 ms of output signal in the decoder. Three types of files are provided:

- speech encoder input samples, sop[...] \*.INP
- coded parameters (encoded speech data) \*.COD
- speech decoder output samples, srop[...] \*.OUT

### 6.2 Configuration for the application of the test sequences

Two configurations are appropriate in order to test an implementation of the RPE-LTP codec. The first is for testing the coder part of the RPE-LTP algorithm which means that a sop[...] signal (on files: \*.INP) is provided at the input of the encoder which responds with frames of coded parameters. The encoder output has to be checked against reference files (files: \*.COD). The other configuration is for testing the decoder part of the RPE-LTP algorithm. In this case, frames of coded parameters (see table 5.1, files: \*.COD) are sent to the RPE-LTP decoder which responds with the srop[...] signal. These samples have to be checked against reference files (files: \*.OUT).

#### 6.2.1 Configuration 1 (encoder only)

A reset signal (RS) shall be applied to the RPE-LTP encoder under test to set all internal variables to the exact states specified in clause 5 of this recommendation prior to the start of an input test sequence in order to obtain the correct output values for this test. But please note, this reset signal is only required for a codec implementation without codec

homing procedure. If codec homing is implemented the reset of the internal state variables is done by the means of software. This test shall be done in real-time with a sampling rate of 8 kHz at the input of the encoder under test (see figure 6.1). All the necessary hardware and software should be installed by the user in order to capture in real time the output coded parameters of the RPE-LTP encoder and to compare them to the dedicated reference file.

Codec homing not implemented:

In the case of a correct hardware implementation undergoing test, all speech encoder output frames must be identical to the corresponding frames in the \*.COD file.

Codec homing implemented:

Each \*.INP file includes two homing frames at the start of the test sequence. The function of these is to reset the speech encoder state variables to their initial value. In the case of a correct hardware implementation undergoing test, the first speech encoder output frame is undefined and need not be identical to the first frame in the \*.H.COD file. All subsequent speech encoder output frames must be identical to the corresponding frames in the \*.H.COD file.

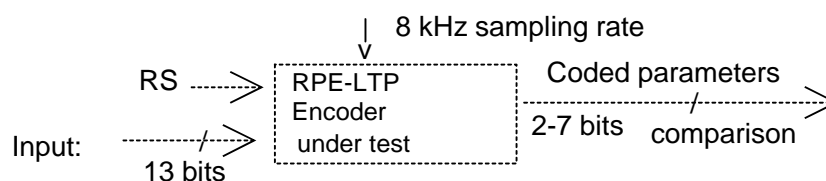

Figure 6.1: Configuration 1: RPE-LTP encoder under test

## 6.2.2 Configuration 2 (decoder only)

Figure 6.2 shows a RPE-LTP decoder under test. In the same way as described in the coder part, a reset signal (RS) shall be used before the processing of the first frame of coded parameters. But please note that also for the decoder this reset signal is only required if the codec homing procedure is not implemented. The decoder shall be tested for a continuous output with a sampling rate of 8 kHz. At the input of the decoder, the 76 parameters shall be sent in a time interval of 20 ms.

Codec homing not implemented:

In the case of a correct hardware implementation undergoing testing, all speech decoder output frames must be identical to the corresponding frames in the \*.OUT file.

Codec homing implemented:

Each \*.H.COD file includes two homing frames at the start of the test sequence. The function of these is to reset the speech decoder state variables to their initial value. In the case of a correct hardware implementation undergoing testing, the first speech decoder output frame is undefined and need not be identical to first frame in the \*.H.OUT file. All subsequent speech decoder output frames must be identical to the corresponding frames in the \*.H.OUT file.

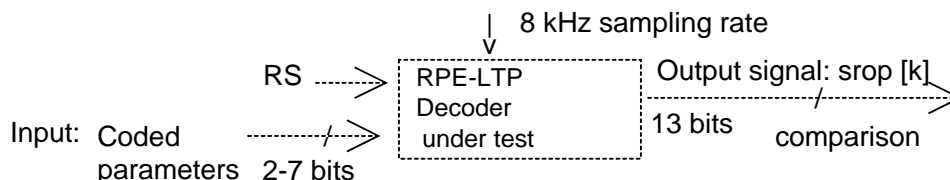

Figure 6.2: Configuration 2: RPE-LTP decoder under test

## 6.3 Test sequences

The letter 'H' at the end of a file name denotes a test sequences with codec homing frames.

### 6.3.1 Test sequences for configuration 1

For configuration 1, four different input test sequence are provided:

SRQ01/SEQ01H Sequence for testing the overflow controls in the encoder;

SEQ02/SEQ02H Sequence for testing the LPC part of the encoder;

SEQ03/SEQ03H Sequence for testing the LTP part of the encoder;

SEQ04/SEQ04H Sequence for testing various critical parts of the algorithm.

Sequence SEQ01/SEQ01H uses a large number of saturated samples. The residual LPC signal reaches very high values, which has two effects on the processing:

- occurrence of a large number of overflows in addition/subtraction operations. Table 6.2 describes each overflow point and the number of occurrences for each.
- the excitation RPE samples have a large dynamic range and the 64 codewords of the sub-block maximum are each obtained at least once on output.

Sequence SEQ02/SEQ02H focuses successively on each reflection coefficient calculated in the Schur recursion. Table 6.3 shows which frames deal with which reflection coefficient and its dynamic range. The Log.-Area codewords output by the coder cover the full range of their possible values except the 2nd LARc that does not reach the value 0 and 63 (min and max). The maximum value (63) is however obtained in sequence 4.

Sequence SEQ03/SEQ03H tests the long term predictor part of the algorithm. It has been generated by exciting a sharply resonant filter with a periodic train of impulses; this produces a pitched signal. Each part corresponding to a given pitch is 128 ms (4 blocks of 256 words) long. The pitch periods have been randomly drawn in the range [2,15] ms and the random order is shown in table 6.4.

Sequence SEQ04/SEQ04H accounts for various remaining non tested points of the algorithm where implementing errors may be suspected. Tables 6.5 and 6.6 summarize the critical points that this sequence has been designed to check (i.e. where the three previous sequences were ineffective). Table 6.5 shows the list of tested points where errors can be detected. Each tested error is described and the frame number corresponding to the first occurrence of a divergence between the exact and the degraded algorithm is also indicated.

Table 6.6 illustrates three paths of the algorithm that are never explored during the processing of the three previous sequences; the table shows which condition leads to each path and the number of associated occurrences in sequence SEQ04/SEQ04H.

Notice finally one point where special care shall be taken:

- A small degradation (i.e. +/- 1) of DLB[2] (the third decision level of the LTP gain quantizer (see table 5.3a) is unable to provide any noticeable effect on the output of the four sequences described above).

## 6.3.2 Test sequences for configuration 2

Five different input test sequence are provided for this configuration. Four sequences obtained in configuration 1 at the output of the encoder (coded parameters) are used as input for the decoder under test in configuration 2.

Table 6.7 gives the list of tested overflow points and their occurrence on sequence SEQ01/SEQ01H for this configuration.

Sequence SEQ05/SEQ05H is provided to scan all possible codes for each parameter. This sequence is an artificial sequence and does not correspond to any encoder output. The codewords have been randomly generated and cover the entire range of codewords values. Moreover, the delay value  $N_r$  belonging to [40,120] in an error-free transmission condition, takes in this sequence its value in [0,127]. In this case the decoder behaviour on non-allowed values of  $N_r$  will be tested.

**Table 6.1a: Signals used in digital test sequences (\*.INP)**

Name	Description	Justification
ENCODER INPUT		
sop[k]	13 bits: encoder input signal.	left

Table 6.1b: Signals used in digital test sequences (\*.COD)

Name	Description	Justification
<b>ENCODER OUTPUT / DECODER INPUT</b>		
LARc[1]	6 bits : 1st Log.-Area Ratio	right
LARc[2]	6 bits : 2nd Log.-Area Ratio	right
LARc[3]	5 bits : 3rd Log.-Area Ratio	right
LARc[4]	5 bits : 4th Log.-Area Ratio	right
LARc[5]	4 bits : 5th Log.-Area Ratio	right
LARc[6]	4 bits : 6th Log.-Area Ratio	right
LARc[7]	3 bits : 7th Log.-Area Ratio	right
LARc[8]	3 bits : 8th Log.-Area Ratio	right
<b>Sub-frame no 1</b>		
Nc	7 bits : LTP lag	right
bc	2 bits : LTP gain	right
Mc	2 bits : RPE grid position	right
xmaxc	6 bits : Block amplitude	right
xMc[0..12]	3 bits : RPE pulses index 0 to 12	right
<b>Sub-frame no 2</b>		
Nc	7 bits : LTP lag	right
bc	2 bits : LTP gain	right
Mc	2 bits : RPE grid position	right
xmaxc	6 bits : Block amplitude	right
xMc[0..12]	3 bits : RPE pulses index 0 to 12	right
<b>Sub-frame no 3</b>		
Nc	7 bits : LTP lag	right
bc	2 bits : LTP gain	right
Mc	2 bits : RPE grid position	right
xmaxc	6 bits : Block amplitude	right
xMc[0..12]	3 bits : RPE pulses index 0 to 12	right
<b>Sub-frame no 4</b>		
Nc	7 bits : LTP lag	right
bc	2 bits : LTP gain	right
Mc	2 bits : RPE grid position	right
xmaxc	6 bits : Block amplitude	right
xMc[0..12]	3 bits : RPE pulses index 0 to 12	right

Table 6.1c: Signals used in digital test sequences (\*.OUT)

Name	Description	Justification
<b>DECODER OUTPUT</b>		
srop[k]	13 bits: decoder output signal. The 3 LSB's of the 16 bits are equal to 0	left

**Table 6.2: List of tested overflow points for sequence 1 (coder part)**

Overflow point	No of occurrences
Short term analysis filter (5.2.10)	
1st add	1059
2nd add	134
LTP parameters computation (5.2.11)	
Abs( d[k] )	5
Long term analysis filter (5.2.12)	
sub	11
Weighting filter (5.2.13)	
scaling the result (both x2 and x4)	302
APCM quantizer ( 5 . 2 . 15 )	
Find max abs of xm: Abs	49
Update of Array dp of the long term analysis filter (5.2.18)	
add	126

**Table 6.3**

Reflection Coeff.	Frames	Dynamic range
1	1-135	-32564,32558
2	136-311	-32356,32242
3	316-423	-32157,32744
4	424-524	-31594,31960
5	525-633	-31697,31735
6	634-738	-30055,31575
7	739-839	-29090,31386
8	840-944	-31052,31208

Table 6.3 gives the position of the frames dedicated to the study of each reflection coefficient and dynamic range of the coefficient for sequence 2 in configuration 2.

**Table 6.4: Pitch periods of sequence 3 (configuration 1)**

86	56	68	120	52	93	20	66	82	115	114	60	42	45	17	64	16
88	83	63	90	73	23	77	100	33	29	106	35	67	57	103	116	30
71	69	81	47	32	97	65	62	111	49	109	25	96	50	54	91	85
99	70	76	46	26	34	104	108	107	22	119	48	58	37	72	110	27
24	36	87	51	59	38	21	44	113	39	61	53	18	40	94	105	55
112	75	98	118	41	80	31	74	28	84	89	79	43	101	95	19	78
117	92	102														



Table 6.5: Errors specially detected by sequence 4/Config 1

Test point	Error checked : incorrect / correct statement / statement	No of the 1st frame with error
Autocorrelation function (5.2.4)	k=0 to 158/k=0 to 159	27
Computation of the reflect. coefficients (5.2.5)	if( P[0] <= / if( P[0] < abs(P[1]) ) / abs(P[1]) )	514
Quantization and coding of the LARs (5.2.7)	A[4] + 1 / A[4]	21
	A[5] - 1 / A[5]	35
	A[5] + 1 / A[5]	430
	A[6] - 1 / A[6]	427
	A[8] - 1 / A[8]	8
	MAC[2] - 1 / MAC[2] MAC[2] + 1 / MAC[2]	24 516
Comput. of the rp from the interp. LARp (5.2.9)	11058 / 11059	19
	20069 / 20070	25
Calc. of the LTP parameters ->Search of the opt scaling (5.2.11)	k= 0 to 38 / k= 0 to 39	32
->Coding of the LTP gain (5.2.11)	mult_r/ mult	373
	DLB[0] + 1 / DLB[0]	511
	DLB[1] + 1 / DLB[1]	373
ADPCM inverse quantizer (5.2.16)	FAC[2] + 1 / FAC[2]	422
	FAC[3] - 1 / FAC[3]	179
	FAC[4] + 1 / FAC[4]	74
	FAC[5] - 1 / FAC[5]	439
	FAC[5] + 1 / FAC[5]	74
	FAC[6] - 1 / FAC[6]	479
	FAC[6] + 1 / FAC[6] FAC[7] - 1 / FAC[7]	330 139

Table 6.6: Paths specially explored by sequence 4/Config 1

Test point	Number of occurrences
Autocorrelation function (5.2.4) condition smax == 0	8
Computation of the reflection coefficients : -> condition L_ACF[0] == 0 (5.2.5) -> condition P[0] < abs(P[1])(5.2.5)	8
	4

**Table 6.7: List of tested overflows points for sequence 1 (decoder part)**

Overflow Point	Nb of occurrences		
	Sequence 1	Sequence 2	Sequence 3
Long term synthesis filter (5.3.2) : add	126	0	0
Short term synthesis filter : (5.3.4)			
1st add:	4499	0	0
2nd add:	405	1	0
De-emphasize filter (5.3.5): add	89	0	0
Scaling of the output signal (5.3.6): add	16691	339	19

### 6.3.3 Additional Test sequences for Codec Homing

The test sequences described below are only required if the codec homing procedure is implemented.

#### 6.3.3.1 Codec homing frames

In addition to the test sequences described above, two homing sequences are provided to assist in codec testing. SEQ06H.INP contains one encoder-homing-frame. SEQ06H.COD contains one decoder-homing-frame.

#### 6.3.3.2 Sequence for an extensive test of the decoder homing

If the decoder receives a complete decoder-homing-frame (which is not marked as a bad frame), then it is sufficient that the following frame contains only the LARs and the first subframe data of the decoder-homing-frame to cause a decoder reset and the output of the encoder-homing-frame. To check this behaviour the test sequence HOMING01.COD/OUT was produced. As the test sequences SEQ01H...05H the sequence HOMING01 contains 2 complete decoder-homing-frames at the beginning and inside there is a mixture of complete and fractional (incomplete) decoder-homing-frames.

#### 6.3.3.3 Sequences for finding the 20 ms framing of the GSM full rate speech encoder

When testing the decoder, alignment of the test sequences used to the decoder framing is achieved by the air interface (MS test) or can be reached easily on the  $A_{bis}$ -interface (test on network side).

When testing the encoder, usually there is no information available about where the encoder starts its 20 ms segments of speech input to the encoder.

In the following, a procedure is described to find the 20 ms framing of the encoder using special synchronization sequences. This procedure can be used for MS as well as for network side.

Synchronization can be achieved in two steps. First, bit synchronization has to be found. In a second step, frame synchronization can be determined. This procedure takes advantage of the codec homing feature of the full rate codec, which puts the codec in a defined home state after the reception of the first homing frame. On the reception of further homing frames, the output of the codec is predefined which can be used as a trigger reference.

#### **- Bit synchronization**

The input to the speech encoder is a series of 13 bit long words (104 kbits/s, 13 bit linear PCM). When starting to test the speech encoder, no knowledge is available of bit synchronization, i.e., where the encoder expects its least significant bits, and where it expects the most significant bits.

The encoder-homing-frame consists of 160 samples, all set to zero with the exception of the least significant bit, which is set to one (0 0000 0000 0001 binary, or 0x0008 hex if written into 16 bit words left justified). If two such encoder-homing-frames are input to the encoder consecutively, the decoder-homing-frame is expected at the output as a reaction of the second encoder-homing-frame.

Since there are only 13 possibilities for bit synchronization, after a maximum of 13 trials bit synchronization can be reached. In each trial three consecutive encoder-homing-frames are input to the encoder. If the decoder-homing-frame is not detected at the output, the relative bit position of the three input frames is shifted by one and another trial is performed. As soon as the decoder-homing-frame is detected at the output, bit synchronization is found, and the first step can be terminated.

The reason why three consecutive encoder-homing-frames are needed is that frame synchronization is not known at this stage. To be sure that the encoder reads two complete homing frames, three frames have to be input. Wherever the encoder has its 20 ms segmentation, it will always read at least two complete encoder-homing-frames.

An example of the 13 different frame triplets is given in sequence BITSYNC.INP.

#### **- Frame synchronization**

Once bit synchronization is found, frame synchronization can be found by inputting one special frame that delivers 160 different output frames, depending on the 160 different positions that this frame can possibly have with respect to the encoder framing.

This special synchronization frame was found by taking one input frame and shifting it through the positions 0 to 159. The corresponding 160 encoded speech frames were calculated and it was verified that all 160 output frames were different. When shifting the input synchronization frame, the samples at the beginning were set to 0x0008 hex, which corresponds to the samples of the encoder-homing-frame.

Before inputting this special synchronization frame to the encoder, again the encoder has to be reset by one encoder-homing-frame. A second encoder-homing-frame is needed to provoke a decoder-homing-frame at the output that can be used as a trigger reference. Since the framing of the encoder is not known at that stage, three encoder-homing-frames have to precede the special synchronization frame to ensure that the encoder reads at least two homing frames, and at least one decoder-homing-frame is produced at the output, serving as a trigger for recording.

The special synchronization frame preceded by the three encoder-homing-frames are given in SEQSYNC.INP. The corresponding 160 different output frames are given in SYNC000.COD through SYNC159.COD. The three digit number in the filename indicates the number of samples by which the input is retarded with respect to the encoder framing. By a corresponding shift in the opposite direction, alignment with the encoder framing can be attained.

### 6.3.3.4 Formats and sizes of the synchronization sequences

BIT SYNC.INP:

This sequence consists of 13 frame triplets. It has the format of the speech encoder input test sequences (13 bit left justified with the three least significant bits set to zero).

The size of it is therefore:

$$\text{SIZE (BITSYNC.INP)} = 13 * 3 * 160 * 2 \text{ bytes} = 12\,480 \text{ bytes}$$

SEQSYNC.INP:

This sequence consists of 3 encoder reset frames and the special synchronization frame. It has the format of the speech encoder input test sequences (13 bit left justified with the three least significant bits set to zero).

The size of it is therefore:

$$\text{SIZE (SEQSYNC.INP)} = 4 * 160 * 2 \text{ bytes} = 1\,280 \text{ bytes}$$

SYNCXXX.COD:

These sequences consists of 1 encoder output frame each. They have the format of the speech encoder output test sequences (16 bit words right justified).

The size of them is therefore:

$$\text{SIZE (SYNCXXX.COD)} = 76 * 2 \text{ bytes} = 152 \text{ bytes}$$

### Optional 8 bit Test Sequences

In addition to the test sequences with and without homing as described above, two complete sets of test sequences with A-law and  $\mu$ -law compressed are provided. These sequences allow the test of TRAU equipment by means of the A-Interface. On the A-Interface speech data is available as a 64 kbps PCM data stream of compressed samples with 8 bits each.

The usage of these 8 bit test sequences is exactly the same as described above for the 13 bit linear test sequences except that the A-Interface is used instead of feeding/taking them directly into/from the speech codec. Therefore bit synchronization is not necessary, too.

Provided are the encoder input sequences `_x.INP`, the encoder output sequences `_x.COD` and the decoder output sequences `_x.OUT`.

The `_x.INP` sequences are used at the encoder input and result in the `_x.COD` sequences at the encoder output.

The linear decoder input sequences `.COD` (without `-x` in their names) have to be used to force the 8 bit compressed decoder output sequences `-x.OUT`.

The format of the `_x.INP` and `_x.OUT` sequences is such that 160 samples of a speech frame are contained in one byte each. This results in a file size of half the size of the 13 bit linear test sequences.

The format of the `*.cod` files remains unchanged.

## Annex A (informative): Codec performance

### A.1 Performance of the RPE-LTP

#### A.1.1 Introduction

The purpose of this annex is to give a broad outline of the performance of the RPE-LTP codec with other parts of the digital network. Some general guidance is also offered on non-voice services.

#### A.1.2 Speech performance

Planning rules for digital processes are defined in terms of quantizing distortion units (qdu) which can be realized from the following formula (reference 1) using the assumption that the formula accuracy represents the determination of qdus from QN measurements:

$$QN = 37 - 15 \log_{10}(n) \quad , \text{where } n \text{ is the qdu} \quad (\text{A1.1})$$

By definition 1 qdu is the quantization distortion arising from one commercial PCM codec.

NOTE: The subjective testing methodology to determine QN for the RPE-LTP codec was consistent with current ITU-T methods (reference 2).

##### A.1.2.1 Single encoding

Under error-free transmission conditions the perceived quality of the RPE-LTP codec (see figure A.1.1) is lower than both codecs conforming to recommendations ITU-T G.711 and ITU-T G.721 (superseded by G.726). Table A.1.1 indicates the relative performance of the codec and can be compared with codecs conforming to recommendations ITU-T G.711 and ITU-T G.721 (superseded by G.726).

The performance of the RPE-LTP codec has been found to be substantially unaffected down to a carrier to interference (C/I) ratio of 10 dB, but may be considered to have acceptable performance down to 7 dB. Smaller C/I ratios produce unacceptable degradation of speech performance and should be avoided.

NOTE 1: It should be noted that there are doubts as to whether the simulations which generated the error pattern properly represent real operating conditions. The C/I values quoted should therefore only be considered as parameters of this simulation. They may not correspond to real radio interference conditions. Results from early GSM validation hardware show that the C/I values which give the performance quoted may be several dBs higher. Some error statistics of the simulations are shown in table A.1.2.

NOTE 2: The real condition C/I = 10 dB is believed to correspond to about 90 % coverage.

**Table A.1.1: Relative levels of speech performance under error-free conditions**

Codec	QN (dB)	qdu
G.711 (64 kbit/s, A- or $\mu$ -law (PCS 1900) PCM)	37	1
G.721 (superseded by G.726) (32 kbit/s, ADPCM)	29	3.5 (*)
RPE-LTP	23-25	7-8 (*)
(*) Commercial A- or $\mu$ -law (PCS 1900) PCM input and output circuitry included.		
NOTE: The qdu value for the RPE-LTP codec is a conservative estimate. At present there are no specific CCITT rules for determining qdus for encoding below 32 kbit/s.		

**Table A1.2: Bit error statistics for C/I test conditions**

Simulated C/I ratio:	10 dB	7 dB	4 dB
Total number of errors in class I (182 bits protected by a 1/2 rate code)	0.016%	0.61%	4.1%
Total number of errors in class II (78 bits unprotected)	4.5%	8.3%	13.0%
Number of "frame erasure" indications by CRC	1	15	95
Number of "frame erasures" not detected by CRC	1	14	76
NOTE: The total number of frames was 750. CRC means Cyclic Redundancy Check.			

### A.1.2.2 Speech performance when interconnected with coding systems on an analogue basis

#### A.1.2.2.1 Performance with 32 kbit/s ADPCM (G.721, superseded by G.726)

The speech performance of the RPE-LTP codec when interconnected with encoding at 32 kbit/s (see figure A.1.3 and A.1.4) decreases in accordance with the formula in clause A.1.2, and appears to obey the law of additivity when  $q_{dus}$  have been determined for the individual codecs.

#### A.1.2.2.2 Performance with another RPE-LTP codec

The speech performance of the RPE-LTP codec when interconnected with another codec of the same type (see figure A1.2) is lower than that of A1.2.2.1. It again appears to obey the law of additivity when  $q_{dus}$  have been determined for the individual codecs.

#### A.1.2.2.3 Performance with encoding other than RPE-LTP and 32 kbit/s ADPCM (G.721, superseded by G.726)

No information is available on this point, so great care shall be exercised when interconnection is made to codecs with encoding different from that of A.1.2.2.1 and A.1.2.2.2.

## A.1.3 Non-speech performance

It should be noted that the RPE-LTP speech codec is an adaptive system which has been optimized for speech inputs. Great care shall be taken when making measurements with non-speech signals because the normal assumptions of time invariance and linearity cannot be made.

### A.1.3.1 Performance with single sine waves

Detailed experiments have shown that the RPE-LTP codec will pass sine waves with segmental signal to noise ratios generally in excess of 20 dB in the frequency range of 100 - 2000 Hz. However, in some cases reproduction above 2000 Hz is not as good.

It should be noted that sine waves above 1300 Hz may be reproduced with significant fluctuations in amplitude and frequency due to the adaptive sub-sampling technique employed. This results in irregularities in the measured frequency response.

A typical frequency response measured with A-law PCM input circuitry is shown in figure A.1.5. If 13 bit linear PCM input circuitry is used, the irregularity is less.

### A.1.3.2 Performance with DTMF tones

It has been shown that the RPE-LTP codec transfers DTMF signals of 80 ms duration. However, questions like minimum allowable signal duration, pause duration and the behaviour in the presence of transmission errors have not been investigated.

### A.1.3.3 Performance with information tones

Experiments have shown that network originated signalling tones, conforming to recommendation ITU-T Q.35, are easily recognizable when passed through the RPE-LTP codec.

### A.1.3.4 Performance with voice-band data

Tests have shown that voice-band data transmission does not work satisfactorily with 1200 bit/s modems according to recommendation ITU-T V.23. Voice-band data according to recommendation ITU-T V.21 (300 bit/s) will not be subject to any significant degradation.

This behaviour has been tested for one RPE-LTP link (encoder-decoder). The effect of transmission errors has not been tested.

## A.1.4 Delay

The theoretical minimum delay of the RPE-LTP codec is 20 ms. However, practical realizations may have an additional processing time in the order of 3 - 8 ms.

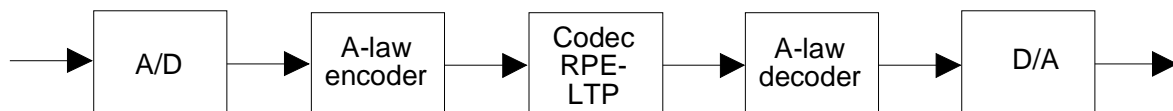

Figure A.1.1: One - transcoding scheme (A-law)

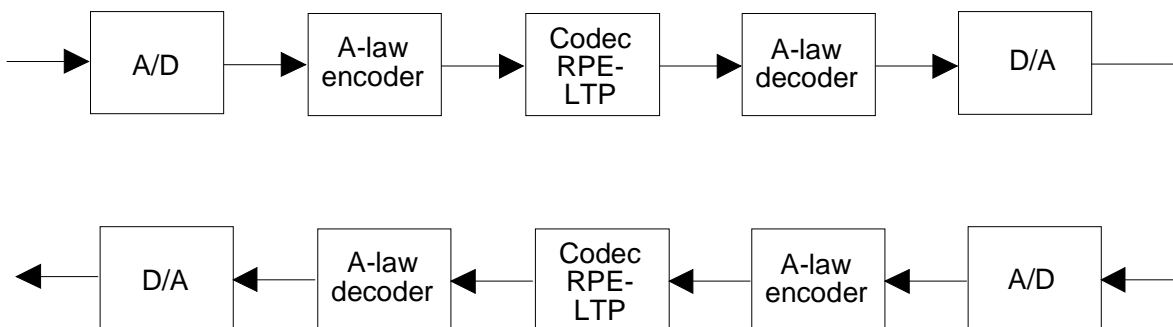

Figure A.1.2: Two - transcodings scheme (A-law)

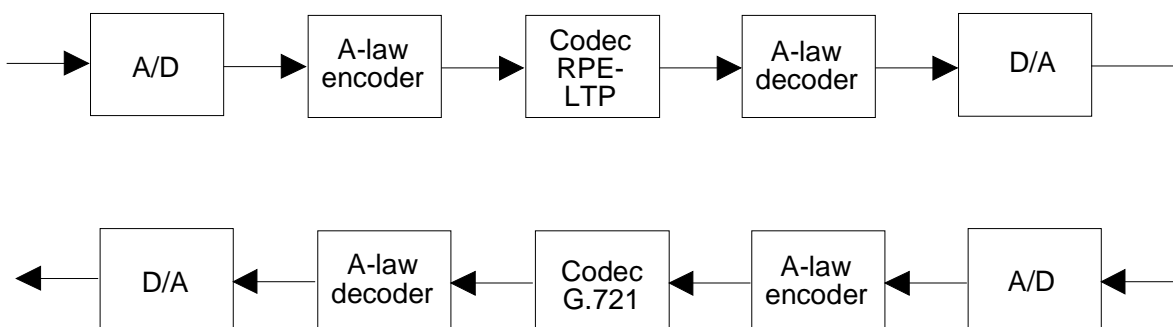

Figure A.1.3: Mixed transcodings - scheme 1 (A-law)

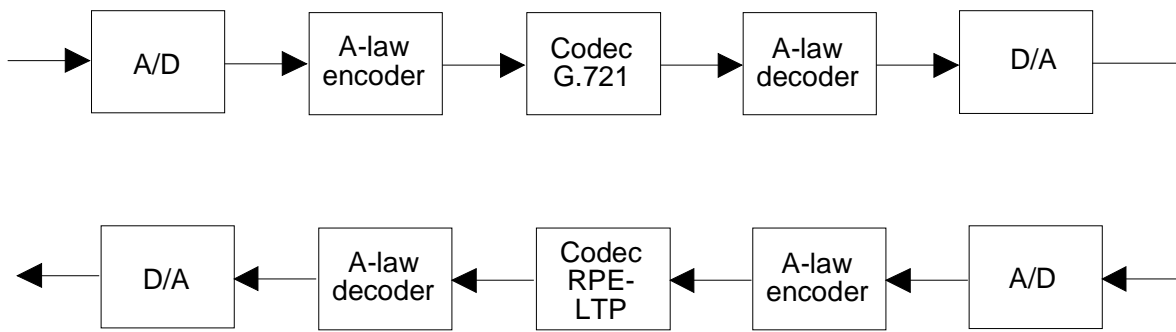

Figure A 1.4: Mixed transcodings - scheme 2 (A-law)

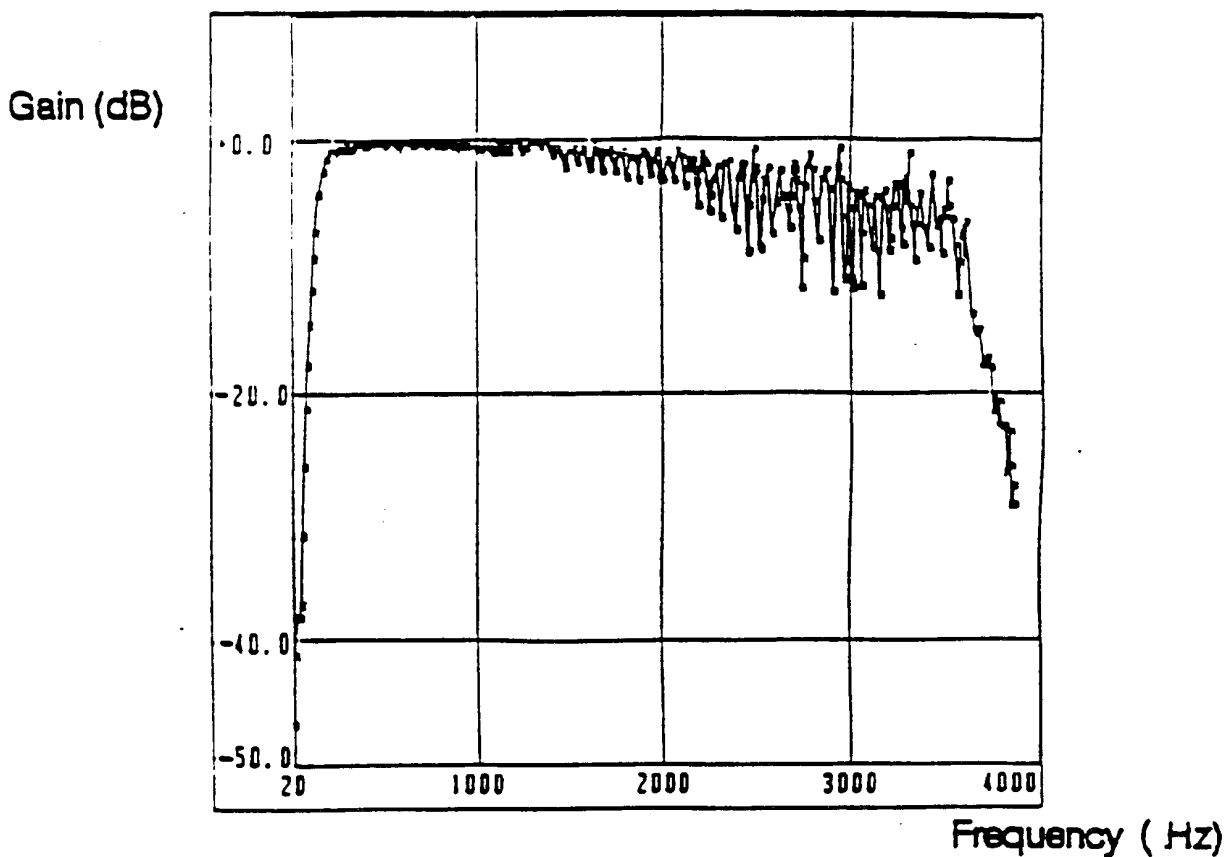

Figure A.1.5: Frequency response for RPE-LTP codec (with commercial A-law PCM input and output circuitry)

### A.1.5 Bibliography

- 1) ITU-T: "Subjective performance assessment of digital processes using the Modulated Noise Reference Unit (MNRU)", annex C, Supplement no 14, Red book, volume V, 1985.
- 2) ITU-T: "Subjective performance assessment of digital processes using the Modulated Noise Reference Unit (MNRU)", annex A, Supplement no 14, Red book, volume V, 1985.
- 3) ITU-T: "Technical characteristics of tones for the telephone service", recommendation Q.35, Red book, volume VI.1, 1985.



## A.2 Subjective relevance of the speech coder output bits

Since no valid objective quality criterion for speech signals is available, the only way to build up such a relevance table is to perform listening tests. The procedure described below was used to obtain the relevance classification given in table A.2.1 of the recommendation.

To classify a single bit, say bit  $i$  of parameter  $k$ , a short speech signal (2 sec) was encoded, then this bit was inverted in each frame (the other bits were left unchanged) and the resulting bit stream was fed into the speech decoder. The listeners had to compare the quality of the signal with the quality of six reference signals with different levels of distortion. Repeating this procedure for all bits would result in a subdivision of the 260 bits into six relevance classes. It can be observed that many of the bits have the same physical meaning and it can be expected that bits with the same meaning have the same relevance (e.g. the MSB's of the RPE samples). Relying on this assumption, only one of the equivalent parameters was considered. Since there are 13 parameters with different physical meaning with 56 bits in total, the number of tests is reduced from 260 to 56.

The reference signals were the same speech signal distorted by inverting one of the six bits of LAR coefficient number one. This resulted in an adequate quantization of distortion levels ranging from "not intelligible" (MSB inverted) to "negligible distortion" (LSB inverted).

The test was carried out using three listeners and one female speaker. Since the three listeners came to rather similar results, no more listeners were considered to be required. Averaging the three outcomes led to the relevance table given in table A.2.1, where the order of all bits between two successive bits of the first parameter (LAR 1) are arbitrarily chosen.

**Table A.2.1a: Subjective importance of encoded bits  
(the parameter and bit numbers refer to table 1.1)**

Importance class	Parameter name	Parameter number	Bit number
1	Log.area ratio 1 Block amplitude	1 12,29,46,63	b6 b53,b109,b165,b221
2	Log.area ratio 1 Log.area ratio 2 Log.area ratio 3	1 2 3	b5 b12 b17
3	Log.area ratio 1 Log.area ratio 2 Log.area ratio 3 Log.area ratio 4 LTP lag Block amplitude Log.area ratio 2,5,6 LTP lag LTP lag LTP lag LTP lag	1 2 3 4 9,26,43,60 12,29,46,63 2,5,6 9,26,43,60 9,26,43,60 9,26,43,60 9,26,43,60	b4 b11 b16 b22 b43,b99,b155,b211 b52,b108,b164,b220 b10,b26,b30 b42,b98,b154,b210 b41,b97,b153,b209 b40,b96,b152,b208 b39,b95,b151,b207
4	Block amplitude Log.area ratio 1 Log.area ratio 4 Log.area ratio 7 LTP lag Log.area ratio 5,6 LTP gain LTP lag Grid position	12,29,46,63 1 4 7 9,26,43,60 5,6 10,27,44,61 9,26,43,60 11,28,45,62	b51,b107,b163,b219 b3 b21 b33 b38,b94,b150,b206 b25,b29 b45,b101,b157,b213 b37,b93,b149,b205 b47,b103,b159,b215

**Table A.2.1b: Subjective importance of encoded bits  
(the parameter and bit numbers refer to table 1.1)**

Importance	Parameter class	Parameter name	Bit number
5	Log.area ratio 1	1	b2
	Log.area ratio 2,3,8,4	2,3,8,4	b9,b15,b36,b20
	Log.area ratio 5,7	5,7	b24,b32
	LTP gain	10,27,44,61	b44,b100,b156,b212
	Block amplitude	12,29,46,63	b50,b106,b162,b218
	RPE pulses	13..25	b56,b59,...,b92
	RPE pulses	30..42	b112,b115,...,b148
	RPE pulses	47..59	b168,b171,...,b204
	RPE pulses	64..76	b224,b227,...,b260
	Grid position	11,28,45,62	b46,b102,b158,b214
	Block amplitude	12,29,46,63	b49,b105,b161,b217
	RPE pulses	13..25	b55,b58,...,b91
	RPE pulses	30..42	b111,b114,...,b147
	RPE pulses	47..59	b167,b170,...,b203
	RPE pulses	64..67	b223,b226,b229,b232
RPE pulses	68..76	b235,b238,...,b259	
6	Log.area ratio 1	1	b1
	Log.area ratio 2,3,6	2,3,6	b8,b14,b28
	Log.area ratio 7	7	b31
	Log.area ratio 8	8	b35
	Log.area ratio 8,3	8,3	b34,b13
	Log.area ratio 4	4	b19
	Log.area ratio 4,5	4,5	b18,b23
	Block amplitude	12,29,46,63	b48,b104,b160,b216
	RPE pulses	13..25	b54,b57,...,b90
	RPE pulses	30..42	b110,b113,...,b146
	RPE pulses	47..59	b166,b169,...,b202
	RPE pulses	64..76	b222,b225,...,b258
	Log.area ratio 2,6	2,6	b7,b27

## A.3 Format for test sequence distribution

### A.3.1 Type of files provided

Three types of files are provided:

- Files for input of the encoder: \*.INP;
- Files for input of decoder or comparison with encoder output: \*.COD;
- Files for comparison with the decoder output: \*.OUT;

Five disks are provided containing all the digital test sequences. Disk1.zip contains all test sequences that are required for a codec implementation without codec homing while disk2.zip and disk3.zip contain the test sequences required for a codec implementation with codec homing. Disk4.zip and disk5.zip contain the 8 bit test sequences with A-law and  $\mu$ -law compression, respectively.

Disk1.zip contains the SEQ01.INP, SEQ01.COD, SEQ01.OUT, SEQ02.INP, SEQ02.COD, SEQ02.OUT, SEQ03.INP, SEQ03.COD, SEQ03.OUT, SEQ04.INP, SEQ04.COD, SEQ04.OUT, SEQ05.COD, SEQ05.OUT files. Disk2.zip contains the SEQ01H.INP, SEQ01H.COD, SEQ01H.OUT, SEQ02H.INP, SEQ02H.COD, SEQ02H.OUT files.

Disk3.zip contains the SEQ03H.INP, SEQ03H.COD, SEQ03H.OUT, SEQ04H.INP, SEQ04H.COD, SEQ04H.OUT, SEQ05H.COD, SEQ05H.OUT, SEQ06H.INP, SEQ06H.COD, HOMING01.COD, HOMING01.OUT, BITSYNC.INP, SEQSYNC.INP and SYNC000...159.COD files.

Disk4.zip contains the A-law compressed 8 bit test sequences with and without homing. All the files of disk1- 3.zip except for BITSYNC.INP, which is not necessary for TRAU testing, are on disk4.zip. The extension `_A` is added to the

filenames in order to indicate A-law. The files HOMING01, SEQSYN and SYNC000... are renamed to HOM01\_A, SEQSYN\_A and SYN000\_A, respectively.

Disk5.zip contains the  $\mu$ -law compressed 8 bit test sequences with and without homing similar to disk4.zip. The u in the filenames stands for  $\mu$ -law.

Table A.3.1a/b gives the contents of the five disks and also the size in bytes and the number of frames for each test sequence file.

## A.3.2 File format description

All the files with the linear 13 bit test sequences are written in binary using 16 bit words. This means that input samples (sop[k], on files: \*.INP), output samples (srop[k], on files: \*.OUT) and coded parameters (on files: \*.COD) use 2 bytes each. Hence the sizes of the files are directly related to the number of processed frames.

For files with linear 13 bit sequences and .INP or .OUT extension type:

$$\text{Size (in bytes)} = \text{No of frames} * 160 * 2;$$

All files x.INP and x.OUT with the compressed 8 bit test sequences are written in binary using 1 byte per sample.

For files with compressed 8 bit sequences and x.INP or x.OUT type:

$$\text{Size (in bytes)} = \text{No of frames} * 160 * ;$$

For all files with .COD extension type:

$$\text{Size (in bytes)} = \text{No of frames} * 76 * 2;$$

Table A.3.1 shows the size of all the 13 bit linear files written in direct binary format. The size of the files containing the optional 8 bit test sequences with type x.INP and x.OUT is half the size shown in the table (disk4.zip and disk5.zip).

**Table A.3.1a: Contents of disk1.zip (test sequences without codec homing frames and file sizes)**

Disk No.	Purpose of Sequence	Name of Sequence	No. Of Frames	Size in Bytes	Justification
1/5	Codec test sequence	SEQ01.INP	584	186 880	Left
1/5	Codec test sequence	SEQ01.COD	584	88 768	Right
1/5	Codec test sequence	SEQ01.OUT	584	186 880	Left
1/5	Codec test sequence	SEQ02.INP	947	303 040	Left
1/5	Codec test sequence	SEQ02.COD	947	143 944	Right
1/5	Codec test sequence	SEQ02.OUT	947	303 040	Left
1/5	Codec test sequence	SEQ03.INP	673	215 360	Left
1/5	Codec test sequence	SEQ03.COD	673	102 296	Right
1/5	Codec test sequence	SEQ03.OUT	673	215 360	Left
1/5	Codec test sequence	SEQ04.INP	520	166 400	Left
1/5	Codec test sequence	SEQ04.COD	520	79 040	Right
1/5	Codec test sequence	SEQ04.OUT	520	166 400	Left
1/5	Decoder test sequence	SEQ05.COD	64	9 728	Right
1/5	Decoder test sequence	SEQ05.OUT	64	20 480	Left

**Table A.3.1b: Contents of disk2.zip and disk3.zip (test sequences with codec homing frames and file sizes)**

Disk No.	Purpose of Sequence	Name of Sequence	No. Of Frames	Size in Bytes	Justification
2/5	Codec test sequence	SEQ01H.INP	586	187 520	Left
2/5	Codec test sequence	SEQ01H.COD	586	89 072	Right
2/5	Codec test sequence	SEQ01H.OUT	586	187 520	Left
2/5	Codec test sequence	SEQ02H.INP	949	303 680	Left
2/5	Codec test sequence	SEQ02H.COD	949	144 248	Right
2/5	Codec test sequence	SEQ02H.OUT	949	303 680	Left
3/5	Codec test sequence	SEQ03H.INP	675	216 000	Left
3/5	Codec test sequence	SEQ03H.COD	675	102 600	Right
3/5	Codec test sequence	SEQ03H.OUT	675	216 000	Left
3/5	Codec test sequence	SEQ04H.INP	522	167 040	Left
3/5	Codec test sequence	SEQ04H.COD	522	79 344	Right
3/5	Codec test sequence	SEQ04H.OUT	522	167 040	Left
3/5	Decoder test sequence	SEQ05H.COD	66	10 032	Right
3/5	Decoder test sequence	SEQ05H.OUT	66	21 120	Left
3/5	Encoder-homing-frame	SEQ06H.INP	1	320	Left
3/5	Decoder-homing-frame	SEQ06H.COD	1	152	Right
3/5	Decoder homing test	HOMING01.COD	100	15 200	Right
3/5	Decoder homing test	HOMING01.OUT	100	32 000	Left
3/5	Bit Synchronization	BITSYNC.INP	39	1 2480	Left
3/5	Frame Synchronization (input)	SEQSYNC.INP	4	1 280	Left
3/5	Frame Synchronization (output)	SYNC000.COD	1	152	Right
3/5		SYNC001.COD	1	152	Right
3/5		SYNC002.COD	1	152	Right
"		"	"	"	"
"		"	"	"	"
3/5		SYNC159.COD	1	152	Right

---

## Annex B (informative): Test sequence disks

Provided in archive en\_300961v080101p0.ZIP which accompanies the present document.

## Annex C (informative): Change history

SMG No.	TDoc. No.	CR. No.	Section affected	New version	Subject/Comments
SMG#07				4.0.2	ETSI Publication
SMG#20				5.0.1	Release 1996 version
SMG#23	97-737 97-741	A002 A003		5.1.1	UAP61 comments Introduction of Homing and 8 bit Test Sequences for Full Rate Speech Transcoding
SMG#27				6.0.0	Release 1997 version
SMG#28	P-99-138	A004	whole document	7.0.0	Addition of mu-law (PCS 1900)
				7.0.1	Update to Version 7.0.1 for OAP
				7.0.2	Update to Version 7.0.2 for Publication
				7.0.3	Inclusion of associated zip files
				7.0.4	Inclusion of present text
				8.0.0	Release 99 version
				8.0.1	Inclusion of present text file
SMG#32	P-00-272	A009		8.1.0	Correction of figure 3.1
				8.1.1	Update to Version 8.1.1 for Publication

Change history							
Date	TSG #	TSG Doc.	CR	Rev	Subject/Comment	Old	New
2001-03	11				Version for Release 4		4.0.0
2001-06	12	SP-010303	001		Correction of figure 3.2	4.0.0	4.1.0
2002-06	16				Version for Release 5	4.1.0	5.0.0
2004-12	26				Version for Release 6	5.0.0	6.0.0
2007-06	36				Version for Release 7	6.0.0	7.0.0
2008-12	42				Version for Release 8	7.0.0	8.0.0
2009-12	46				Version for Release 9	8.0.0	9.0.0
2011-03	51				Version for Release 10	9.0.0	10.0.0
2012-09	57				Version for Release 11	10.0.0	11.0.0
2013-12	62	SP-130568	0002		Correction to references	11.0.0	11.1.0
2014-09	65				Version for Release 12	11.1.0	12.0.0
2015-12	70				Version for Release 13	12.0.0	13.0.0

Change history							
Date	Meeting	TDoc	CR	Rev	Cat	Subject/Comment	New version
03-2017	SA#75					Version for Release 14	14.0.0
06-2018	SA#80	-	-	-	-	Version for Release 15	15.0.0

---

# History

<b>Document history</b>		
V15.0.0	July 2018	Publication