

ETSI TS 144 001 V12.0.0 (2014-10)



**Digital cellular telecommunications system (Phase 2+);
Mobile Station - Base Station System (MS - BSS) interface;
General aspects and principles
(3GPP TS 44.001 version 12.0.0 Release 12)**



ReferenceRTS/TSGC-0144001vc00

Keywords

GSM

ETSI

650 Route des Lucioles
F-06921 Sophia Antipolis Cedex - FRANCE

Tel.: +33 4 92 94 42 00 Fax: +33 4 93 65 47 16

Siret N° 348 623 562 00017 - NAF 742 C
Association à but non lucratif enregistrée à la
Sous-Préfecture de Grasse (06) N° 7803/88

Important notice

The present document can be downloaded from:

<http://www.etsi.org>

The present document may be made available in electronic versions and/or in print. The content of any electronic and/or print versions of the present document shall not be modified without the prior written authorization of ETSI. In case of any existing or perceived difference in contents between such versions and/or in print, the only prevailing document is the print of the Portable Document Format (PDF) version kept on a specific network drive within ETSI Secretariat.

Users of the present document should be aware that the document may be subject to revision or change of status. Information on the current status of this and other ETSI documents is available at

<http://portal.etsi.org/tb/status/status.asp>

If you find errors in the present document, please send your comment to one of the following services:

http://portal.etsi.org/chaicor/ETSI_support.asp

Copyright Notification

No part may be reproduced or utilized in any form or by any means, electronic or mechanical, including photocopying and microfilm except as authorized by written permission of ETSI.

The content of the PDF version shall not be modified without the written authorization of ETSI.

The copyright and the foregoing restriction extend to reproduction in all media.

© European Telecommunications Standards Institute 2014.

All rights reserved.

DECT™, **PLUGTESTS™**, **UMTS™** and the ETSI logo are Trade Marks of ETSI registered for the benefit of its Members. **3GPP™** and **LTE™** are Trade Marks of ETSI registered for the benefit of its Members and of the 3GPP Organizational Partners.

GSM® and the GSM logo are Trade Marks registered and owned by the GSM Association.

Intellectual Property Rights

IPRs essential or potentially essential to the present document may have been declared to ETSI. The information pertaining to these essential IPRs, if any, is publicly available for **ETSI members and non-members**, and can be found in ETSI SR 000 314: *"Intellectual Property Rights (IPRs); Essential, or potentially Essential, IPRs notified to ETSI in respect of ETSI standards"*, which is available from the ETSI Secretariat. Latest updates are available on the ETSI Web server (<http://ipr.etsi.org>).

Pursuant to the ETSI IPR Policy, no investigation, including IPR searches, has been carried out by ETSI. No guarantee can be given as to the existence of other IPRs not referenced in ETSI SR 000 314 (or the updates on the ETSI Web server) which are, or may be, or may become, essential to the present document.

Foreword

This Technical Specification (TS) has been produced by ETSI 3rd Generation Partnership Project (3GPP).

The present document may refer to technical specifications or reports using their 3GPP identities, UMTS identities or GSM identities. These should be interpreted as being references to the corresponding ETSI deliverables.

The cross reference between GSM, UMTS, 3GPP and ETSI identities can be found under <http://webapp.etsi.org/key/queryform.asp>.

Modal verbs terminology

In the present document "**shall**", "**shall not**", "**should**", "**should not**", "**may**", "**may not**", "**need**", "**need not**", "**will**", "**will not**", "**can**" and "**cannot**" are to be interpreted as described in clause 3.2 of the [ETSI Drafting Rules](#) (Verbal forms for the expression of provisions).

"**must**" and "**must not**" are **NOT** allowed in ETSI deliverables except when used in direct citation.

Contents

Intellectual Property Rights	2
Foreword.....	2
Modal verbs terminology.....	2
Foreword.....	4
0a Scope	5
0b References	5
0c Definitons and abbreviations.....	6
1 General	6
2 Interface applications	6
3 Interface technical specification objectives.....	7
4 Interface characteristics.....	7
5 Interface capabilities.....	8
6 Technical Specifications on GSM MS-BSS interfaces	8
7 Protocol modelling principles	8
Annex A (informative): Change History	11
History	12

Foreword

This Technical Specification has been produced by the 3rd Generation Partnership Project (3GPP).

The contents of the present document are subject to continuing work within the TSG and may change following formal TSG approval. Should the TSG modify the contents of the present document, it will be re-released by the TSG with an identifying change of release date and an increase in version number as follows:

Version x.y.z

where:

- x the first digit:
 - 1 presented to TSG for information;
 - 2 presented to TSG for approval;
 - 3 or greater indicates TSG approved document under change control.
- y the second digit is incremented for all changes of substance, i.e. technical enhancements, corrections, updates, etc.
- z the third digit is incremented when editorial only changes have been incorporated in the document.

0a Scope

The present document describes the general aspects and principles relating to the Technical Specifications for the GSM MS-BSS interface.

0b References

The following documents contain provisions which, through reference in this text, constitute provisions of the present document.

- References are either specific (identified by date of publication, edition number, version number, etc.) or non-specific.
- For a specific reference, subsequent revisions do not apply.
- For a non-specific reference, the latest version applies. In the case of a reference to a 3GPP document (including a GSM document), a non-specific reference implicitly refers to the latest version of that document *in the same Release as the present document*.

- [1] Void.
- [1a] 3GPP TR 21.905: "Vocabulary for 3GPP Specifications".
- [2] 3GPP TS 22.030: "Man-Machine Interface (MMI) of the User Equipment (UE)".
- [3] 3GPP TS 24.002: "GSM - UMTS Public Land Mobile Network (PLMN) access reference configuration".
- [4] 3GPP TS 44.003: "Mobile Station - Base Station System (MS - BSS) interface; Channel structures and access capabilities".
- [5] 3GPP TS 44.004: "Layer 1; General requirements".
- [6] 3GPP TS 44.005: "Data Link (DL) layer; General aspects".
- [7] 3GPP TS 44.006: "Mobile Station - Base Station System (MS - BSS) interface; Data Link (DL) layer specification".
- [8] 3GPP TS 24.007: "Mobile radio interface signalling layer 3; General aspects".
- [9] 3GPP TS 24.008: "Mobile radio interface; Layer 3 specification; Core network protocols; Stage 3".
- [10] 3GPP TS 24.010: "Mobile radio interface layer 3; Supplementary services specification; General aspects".
- [11] 3GPP TS 24.011: "Point-to-Point (PP) Short Message Service (SMS) support on mobile radio interface".
- [12] 3GPP TS 44.012: "Short Message Service Cell Broadcast (SMSCB) support on the mobile radio interface".
- [13] ITU-T Recommendation X.200: "Information technology - Open Systems Interconnection - Basic Reference Model: The basic model".
- [14] ITU-T Recommendation X.210: "Information technology - Open systems interconnection - Basic Reference Model: Conventions for the definition of OSI services".

0c Definitons and abbreviations

Abbreviations used in the present document are listed in 3GPP TR 21.905.

1 General

1.1

A GSM PLMN supports a wide range of services which a user accesses by a standard set of interfaces at a mobile station (MS). The mobile station is connected to the PLMN fixed infrastructure via a radio path to a base station, as shown in figure 1.

1.2

The MS-BSS interface on this radio path is specified in the 24- and 44-series of Technical Specifications in such a way as to permit user and network technologies and configurations to evolve separately.

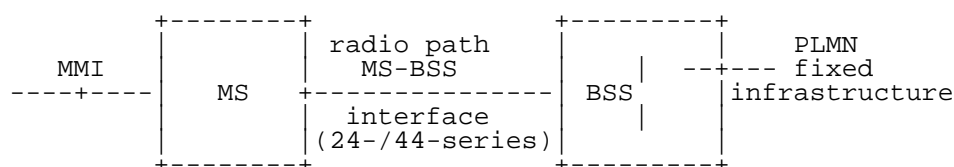

Figure 1: Basic interfaces for user access for a GSM PLMN

1.3

The principles and procedures for the man-machine interface (MMI) to the MS are described in Technical Specification 3GPP TS 22.030. The user may also use standard terminal interfaces within the MS. The reference configuration for the access is described in Technical Specification 3GPP TS 24.002.

2 Interface applications

Figure 2 shows some examples of the application of GSM MS-BSS interfaces. The following cases are shown:

- i) access of simple handportable or vehicle mounted MSs;
- ii) access of an MS with multiple terminal equipment installation;
- iii) access of a mobile PBX or LAN;

In addition, the figure identifies internetwork interfaces for connections to:

- iv) land-line ISDN networks;
- v) dedicated service networks.

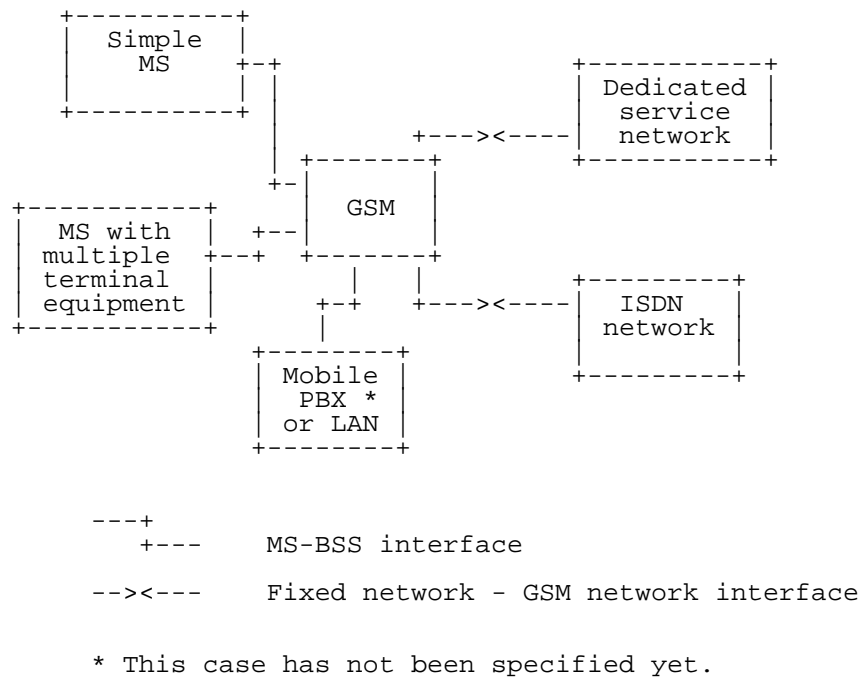

Figure 2: Examples of GSM interfaces

3 Interface technical specification objectives

MS-BSS interface Technical Specifications should allow:

- i) different types of mobile stations and terminal equipment to use the same standard interface;
- ii) portability of MSs within the system area of the GSM system;
- iii) separate evolution of both mobile stations and network equipment technologies and configurations;
- iv) calls to a terminal using the same code (call number) no matter in what country it is actually located;
- v) connections of an MS to the ISDN network so that only the radio channel capacity and the ISDN protocol are limiting factors.

4 Interface characteristics

The MS-BSS interface is specified by a comprehensive set of characteristics, including:

- i) channel structures and access capabilities;
- ii) user-network (MS-BSS) protocols;
- iii) maintenance and operation characteristics;
- iv) performance characteristics;
- v) service characteristics.

5 Interface capabilities

In addition to the multiservice capability, the GSM MS-BSS interface may allow for capabilities such as the following:

- i) multidrop and other multiple terminal arrangements;
- ii) choice of information bit rate, circuit or packet switching mode, layer 2 coding method, etc., on a call-by-call or other basis (e.g. semipermanent, or subscription time option), over the same interface according to the user's need;
- iii) capability for compatibility checking in order to check whether calling and called terminals can communicate with each other.

6 Technical Specifications on GSM MS-BSS interfaces

6.1

The reference configurations for the GSM MS-BSS interface define the terminology for various reference points. Technical Specification 3GPP TS 24.002 contains the GSM PLMN access reference configuration.

6.2

Technical Specification 3GPP TS 44.003 defines the channel structures and access capabilities for the MS-BSS interface. A distinction is necessary between the logical channel structure supported by the interface and the access capability supported by the radio path of the system.

6.3

The MS-BSS interface as defined in Technical Specifications 3GPP TS 44.004, 3GPP TS 44.005, 3GPP TS 44.006, 3GPP TS 24.007, 3GPP TS 24.008, 3GPP TS 24.010, 3GPP TS 24.011 and 3GPP TS 44.012 is applicable to a wide range of situations.

7 Protocol modelling principles

7.1

The signalling protocols on the MS-BSS Interface are specified using the concepts of the reference model of Open System Interconnection (OSI) given in ITU-T Recommendations X.200 and X.210.

7.2

The basic structuring technique in the OSI reference model is layering. According to this technique, communication among application processes is viewed as being logically partitioned into an ordered set of layers represented in a vertical sequence as shown in figure 3.

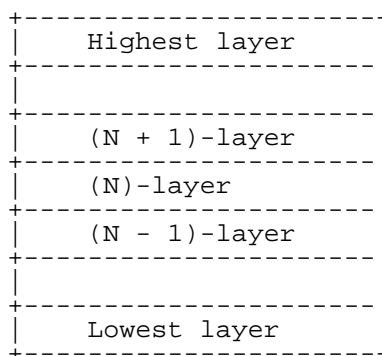

Figure 3: Layering

Entities exist in each layer. Entities in the same layer, but in different systems which must exchange information to achieve a common objective are called "peer entities". Entities in adjacent layers interact through their common boundary. The services provided by the (N + 1)-layer are the combination of the services and functions provided by the (N)-layer and all layers below the (N)-layer.

Management functions may also be required. They may include functions which are common for several layers and are not supported by the services provided by a specific layer. Examples of such functions are error reporting, status reporting and management of the operation of certain layers. Such management functions do not require that peer-to-peer messages are sent across the MS-BSS interface.

7.3

For signalling on the MS-BSS interface three layers are required as shown in figure 4.

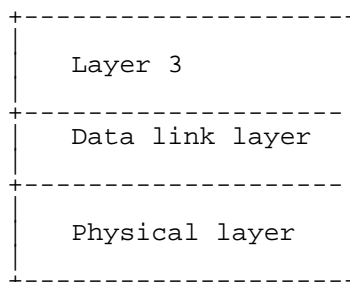

Figure 4: Layering on the MS-BSS interface

The layers are:

- PHYSICAL LAYER which corresponds to the lowest layer. The functions and protocols of the physical layer are defined in Technical Specification 3GPP TS 44.004.
- DATA LINK LAYER. The functions and protocols of the data link layer are defined in Technical Specifications 3GPP TS 44.005 and 3GPP TS 44.006.
- LAYER 3. The functions and protocols of layer 3 are defined in Technical Specifications 3GPP TS 24.007, 3GPP TS 24.008, 3GPP TS 24.010, 3GPP TS 24.011 and 3GPP TS 44.012.

7.4

Layer-to-layer interactions are specified in terms of service primitives. The primitives represent, in an abstract way, the logical exchange of information and control between adjacent layers. They do not specify or constrain implementation.

Primitives are also used to describe information exchange between layers and the mobile management entity.

The primitives that are exchanged between the (N + 1)-layer and the (N)-layer are of the following four types (see figure 5).

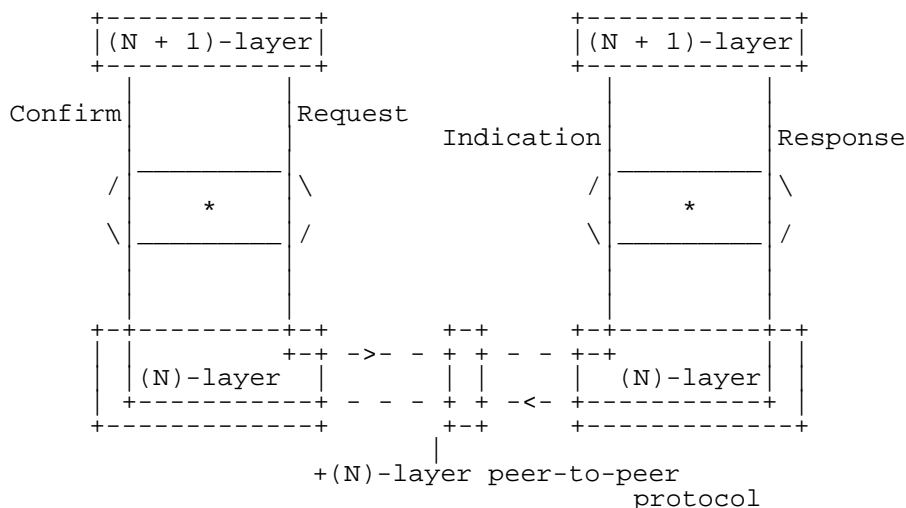

Figure 5: Primitive action sequence for peer-to-peer communication

The REQUEST primitive type is used when a higher layer is requesting a service from the next lower layer.

The INDICATION primitive type is used by a layer providing a service to notify the next higher layer of activities related to the primitive type REQUEST.

The RESPONSE primitive type is used by a layer to acknowledge receipt, from a lower layer, of the primitive type INDICATION.

The CONFIRM primitive type is used by the layer providing the requested service to confirm that the activity has been completed.

Annex A (informative): Change History

Meeting No.	TDoc. No.	CR. No.	Section affected	New version	Subject/Comments
SMG#07				4.0.4	Phase 2 version
SMG#20				5.0.0	Release 1996 version
SMG#27				6.0.0	Release 1997 version
SMG#29				7.0.0	Release 1998 version
SMG#31				8.0.0	Release 1999 version
CN#11				4.0.0	Release 4 version
NP-16	NP-020224	001		4.1.0	Various clean-up of wrong references
NP-16				5.0.0	Plenary decision to make this TS also for Rel-5.
NP-26				6.0.0	Plenary decision to make this TS also for Rel-6.
				7.0.0	Plenary decision to make this TS also for Rel-7.
CP-42				8.0.0	Plenary decision to make this TS also for Rel-8.
CP-46				9.0.0	Plenary decision to make this TS also for Rel-9.
CP-51				10.0.0	Plenary decision to make this TS also for Rel-10.
CP-57				11.0.0	Plenary decision to make this TS also for Rel-11.
CP-65				12.0.0	Plenary decision to make this TS also for Rel-12.

History

Document history		
V12.0.0	October 2014	Publication