

ETSI TS 143 130 V15.0.0 (2018-07)



**Digital cellular telecommunications system (Phase 2+) (GSM);
GSM/EDGE Iur-g interface;
Stage 2
(3GPP TS 43.130 version 15.0.0 Release 15)**



Reference

RTS/TSGR-0643130vf00

Keywords

GSM

ETSI

650 Route des Lucioles
F-06921 Sophia Antipolis Cedex - FRANCE

Tel.: +33 4 92 94 42 00 Fax: +33 4 93 65 47 16

Siret N° 348 623 562 00017 - NAF 742 C
Association à but non lucratif enregistrée à la
Sous-Préfecture de Grasse (06) N° 7803/88

Important notice

The present document can be downloaded from:

<http://www.etsi.org/standards-search>

The present document may be made available in electronic versions and/or in print. The content of any electronic and/or print versions of the present document shall not be modified without the prior written authorization of ETSI. In case of any existing or perceived difference in contents between such versions and/or in print, the only prevailing document is the print of the Portable Document Format (PDF) version kept on a specific network drive within ETSI Secretariat.

Users of the present document should be aware that the document may be subject to revision or change of status.

Information on the current status of this and other ETSI documents is available at

<https://portal.etsi.org/TB/ETSIDeliverableStatus.aspx>

If you find errors in the present document, please send your comment to one of the following services:

<https://portal.etsi.org/People/CommiteeSupportStaff.aspx>

Copyright Notification

No part may be reproduced or utilized in any form or by any means, electronic or mechanical, including photocopying and microfilm except as authorized by written permission of ETSI.

The content of the PDF version shall not be modified without the written authorization of ETSI.

The copyright and the foregoing restriction extend to reproduction in all media.

© ETSI 2018.

All rights reserved.

DECT™, **PLUGTESTS™**, **UMTS™** and the ETSI logo are trademarks of ETSI registered for the benefit of its Members.

3GPP™ and **LTE™** are trademarks of ETSI registered for the benefit of its Members and of the 3GPP Organizational Partners.

oneM2M logo is protected for the benefit of its Members.

GSM® and the GSM logo are trademarks registered and owned by the GSM Association.

Intellectual Property Rights

Essential patents

IPRs essential or potentially essential to normative deliverables may have been declared to ETSI. The information pertaining to these essential IPRs, if any, is publicly available for **ETSI members and non-members**, and can be found in ETSI SR 000 314: *"Intellectual Property Rights (IPRs); Essential, or potentially Essential, IPRs notified to ETSI in respect of ETSI standards"*, which is available from the ETSI Secretariat. Latest updates are available on the ETSI Web server (<https://ipr.etsi.org/>).

Pursuant to the ETSI IPR Policy, no investigation, including IPR searches, has been carried out by ETSI. No guarantee can be given as to the existence of other IPRs not referenced in ETSI SR 000 314 (or the updates on the ETSI Web server) which are, or may be, or may become, essential to the present document.

Trademarks

The present document may include trademarks and/or tradenames which are asserted and/or registered by their owners. ETSI claims no ownership of these except for any which are indicated as being the property of ETSI, and conveys no right to use or reproduce any trademark and/or tradename. Mention of those trademarks in the present document does not constitute an endorsement by ETSI of products, services or organizations associated with those trademarks.

Foreword

This Technical Specification (TS) has been produced by ETSI 3rd Generation Partnership Project (3GPP).

The present document may refer to technical specifications or reports using their 3GPP identities, UMTS identities or GSM identities. These should be interpreted as being references to the corresponding ETSI deliverables.

The cross reference between GSM, UMTS, 3GPP and ETSI identities can be found under <http://webapp.etsi.org/key/queryform.asp>.

Modal verbs terminology

In the present document "**shall**", "**shall not**", "**should**", "**should not**", "**may**", "**need not**", "**will**", "**will not**", "**can**" and "**cannot**" are to be interpreted as described in clause 3.2 of the [ETSI Drafting Rules](#) (Verbal forms for the expression of provisions).

"**must**" and "**must not**" are **NOT** allowed in ETSI deliverables except when used in direct citation.

Contents

Intellectual Property Rights	2
Foreword.....	2
Modal verbs terminology.....	2
Foreword.....	4
1 Scope	5
2 References	5
3 Definitions, symbols and abbreviations	5
3.1 Definitions	5
3.2 Symbols.....	6
3.3 Abbreviations	6
4 Motivation, principles and assumptions	6
4.1 Motivation	6
4.2 Principles.....	7
4.3 Void.....	7
5 General aspects.....	8
5.1 Network architecture	8
5.1.1 General.....	8
5.1.2 MS Identifiers in Iu mode	8
5.1.3 MS Identifiers in A/Gb mode	10
5.2 Iur-g interface capabilities.....	10
6 I _{ur} Interface Protocols	10
6.1 General	10
6.2 Functions of the Iur-g interface protocols	11
6.3 Iur-g Interface protocol structure.....	11
6.4 Radio signalling protocols.....	12
7 Radio Network Layer: RNSAP protocol.....	12
7.1 General	12
7.2 Basic mobility procedures	13
7.2.1 General.....	13
7.2.2 Paging	13
7.2.3 Cell Update	14
7.2.4 Registration Area Update.....	15
7.2.5 RRC Connection Release.....	16
7.2.6 Radio Resource Reserve Handover	16
7.2.6.1 General	16
7.2.6.2 Successful operation.....	17
7.2.6.3 Abnormal conditions.....	18
7.2.6.3.1 BSS Radio Resource Reservation Failure	18
7.2.6.3.2 Handover failure from MS/UE.....	19
7.3 Void.....	20
7.4 Global procedures.....	20
7.4.1 General.....	20
7.4.2 Error Indication.....	20
7.4.3 Common Measurement Functions	20
7.4.4 Information Exchange Functions.....	21
Annex A (Informative): Change history	22
History	23

Foreword

This Technical Specification has been produced by the 3rd Generation Partnership Project (3GPP).

The contents of the present document are subject to continuing work within the TSG and may change following formal TSG approval. Should the TSG modify the contents of the present document, it will be re-released by the TSG with an identifying change of release date and an increase in version number as follows:

Version x.y.z

where:

- x the first digit:
 - 1 presented to TSG for information;
 - 2 presented to TSG for approval;
 - 3 or greater indicates TSG approved document under change control.
- y the second digit is incremented for all changes of substance, i.e. technical enhancements, corrections, updates, etc.
- z the third digit is incremented when editorial only changes have been incorporated in the document.

1 Scope

The present document provides an overview of the Iur-g interface. It describes the motivation, principles and functionality of this interface. It does not contain the detailed description, which it is included in the stage 3 Technical Specifications.

2 References

The following documents contain provisions which, through reference in this text, constitute provisions of the present document.

- References are either specific (identified by date of publication, edition number, version number, etc.) or non-specific.
- For a specific reference, subsequent revisions do not apply.
- For a non-specific reference, the latest version applies. In the case of a reference to a 3GPP document (including a GSM document), a non-specific reference implicitly refers to the latest version of that document *in the same Release as the present document*.

- [1] 3GPP TR 21.905, "3rd Generation Partnership Project; Technical Specification Group Services and System Aspects; Vocabulary for 3GPP Specifications".
 - [2] 3GPP TS 23.236, "3rd Generation Partnership Project; Technical Specification Group Services and System Aspects; Intra-domain connection of Radio Access Network (RAN) nodes to multiple Core Network (CN) nodes".
 - [3] 3GPP TS 25.331, "3rd Generation Partnership Project; Technical Specification Group Radio Access Network; RRC Protocol Specification".
 - [4] 3GPP TS 25.420, "3rd Generation Partnership Project; Technical Specification Group Radio Access Network; UTRAN Iur Interface General Aspects and Principles".
 - [5] 3GPP TS 25.423, "3rd Generation Partnership Project; Technical Specification Group Radio Access Network; UTRAN Iur Interface RNSAP Signalling".
 - [6] 3GPP TS 43.051, "Technical Specification 3rd Generation Partnership Project; Technical Specification Group GSM/EDGE Radio Access Network; Overall description - Stage 2; (Release 5)".
 - [7] Void.
-

3 Definitions, symbols and abbreviations

3.1 Definitions

For the purposes of the present document, the terms and definitions given in 3GPP TR 21.905 [1] and the following ones apply:

A/Gb mode: mode of operation of the MS when connected to the Core Network via GERAN and the A and/or Gb interfaces.

MS: Unless stated otherwise, this refers with no distinction to both MS and UE.

Iu mode: mode of operation of the MS when connected to the Core Network via GERAN or UTRAN and the Iu interface.

RAN node: a BSS or a RNC.

3.2 Symbols

For the purposes of the present document, the following symbols apply:

A	Interface between a BSS and an MSC
Gb	Interface between a BSS and an SGSN
Iu	Interface between a BSS/RNC and the CN
Iur	Interface between two RNSs
Iur-g	Interface between two BSSs or between a BSS and an RNS
Um	Interface between a GERAN MS and a BSS
Uu	Interface between a UE and the RNS

3.3 Abbreviations

For the purposes of the present document, the following abbreviations apply:

BSC	Base Station Controller
BSS	Base Station Sub-system
CBSS	Controlling Base Station Sub-system
CN	Core Network
CRNC	Controlling Radio Network Controller
GERAN	GSM/EDGE Radio Access Network
GPRS	General Packet Radio Service
GRA	GERAN Registration Area
LA	Location Area
MS	Mobile Station
MSC	Mobile Switching Centre
NACC	Network Assisted Cell Change
NNSF	NAS Node Selection Function
RA	Routeing Area
RAN	Radio Access Network
RNC	Radio Network Controller
RNS	Radio Network Sub-system
RNSAP	Radio Network Subsystem Application Part
RNTI	Radio Network Temporary Identity
RRA	RAN Registration Area
RRM	Radio Resource Management
SBSC	Serving BSC
SBSS	Serving BSS
SGSN	Serving GPRS Support Node
SRNC	Serving RNC
TBSS	Target BSS
UE	User Equipment
UMTS	Universal Mobile Telephony System
URA	UTRAN Registration Area
UTRAN	UMTS Terrestrial Radio Access Network

4 Motivation, principles and assumptions

4.1 Motivation

As part of the work to connect GERAN via the Iu interface to the CN, the GRA and RNTI concepts have also been adopted for the GERAN. With these concepts, an inactive mobile in the RRC-GRA_PCH state will perform signalling to the network whenever it changes the GRA. Since GRAs need not be constrained by BSC coverage areas, it is possible that the MS reselects a cell on a different BSC but on the same GRA. In order maintain the ability to page the mobile in the GRA with the correct RNTI, as well as to enable a path for a GRA update procedure with the serving BSC, it is necessary to have an Iur-g interface between the BSSs.

The same principle applies for dual-RAN capable mobiles. The architecture specifications permit network operators to design networks that alleviate the potential problem caused by dual mode mobiles frequently toggling between UTRAN

and GERAN coverage areas (e.g. in indoor coverage situations): for instance, common LAIs and RAIs for GERAN and UTRAN cells in the same geographical area. Defining GERAN and UTRAN cells in common LAs and RAs permits an inactive mobile to change from GERAN to UTRAN coverage or, vice versa, without any signalling to the network. Prior to Release 5, this is possible because GSM/GPRS does not use the connection oriented Iu interface. From Release 5 on, an *inactive* MS would signal to the network when a cell change involving change of RAN takes place. To prevent this, operators may configure GRA IDs and URA IDs to indicate the same registration area. To enable paging across these registration areas, as well as to enable the possibility to perform GRA/URA update procedures with the serving BSC/RNC, it is necessary to have an Iur-g interface between the BSS and the RNC.

The definition of GRAs/URAs has the following benefits:

- It increases the MT call success rate: by reducing the frequency of updates, it reduces the time during which the MS is believed by the RAN to be in the old registration area, when paging requests would fail.
- It reduces the amount of signalling on the radio interface, since the mobile does not need to indicate cell changes when moving within a GRA/URA.
- For the same reason, it reduces the amount of signalling in the network, thus decreasing the number of updates and of SRNC/SBSC relocation procedures.

The Iur-g may bring other benefits:

- Support for the SRNC/SBSC relocation procedure: the current SRNS relocation procedure defined for UTRAN using the Iur interface could be reused, improving the performance of the procedure. The Cell Update and Relocation Commit messages could be transferred over this interface.

4.2 Principles

The Iur-g interface shall be designed based on the following principles:

- The Iur-g interface shall be open.
- From a logical standpoint, this interface is a point to point interface between one BSS and one BSS or RNC within a PLMN. From a physical point of view, the interface could share Iu or other transmission resources.
- The Iur-g interface is optional. The presence of the Iur-g shall be transparent to the MS: the 3GPP specifications shall ensure that all mobiles function correctly irrespective of the presence or absence of the Iur-g interface.
- This interface shall support the exchange of signalling information between a BSS and a BSC/RNC. The Iur-g interface shall not carry user information.
- A GRA contains one or more GERAN cells and zero or more UTRAN cells. A URA contains one or more UTRAN cells and zero or more GERAN cells.

NOTE: The term RAN Registration Area (RRA) is used in this document to refer to a registration area irrespective of whether it contains GERAN cells, UTRAN cells or both types of cells. The terms GRA and URA will be used in GERAN and UTRAN specifications, respectively, where GRAs may contain UTRAN cells and URAs may contain GERAN cells.

- In *Iu mode*, the BSC has been allocated an identifier (BSC-Id) from the same pool of numbers as the RNC-Id.

4.3 Void

5 General aspects

5.1 Network architecture

5.1.1 General

The Iur-g interface is the logical interface between two BSSs in *Iu mode* or between an RNS and a BSS in *Iu mode* or between a BSS in *A/Gb mode* and a UTRAN-NTDD RNS. The different Iur-g interface combinations are depicted in Figure 1 and Figure 1a.

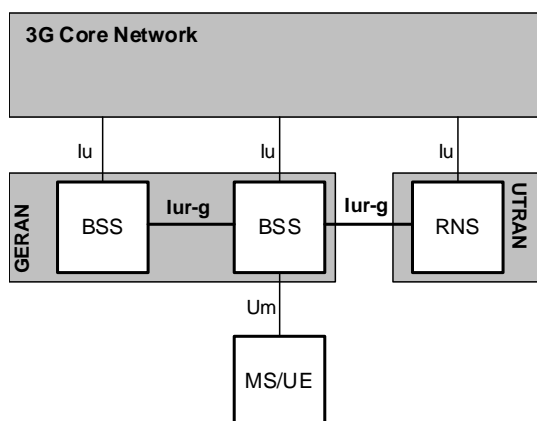

Figure 1: Reference architecture for the Iur-g interface (BSS in Iu mode).

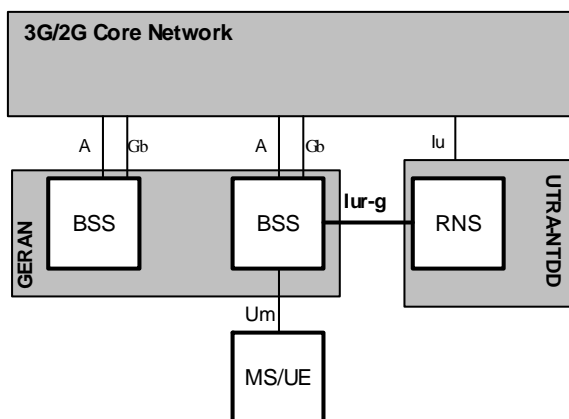

Figure 1a: Reference architecture for the Iur-g interface (BSS in A/Gb mode)

5.1.2 MS Identifiers in Iu mode

The Radio Network Temporary Identities (RNTI) are used as MS/UE identifiers within the GERAN/UTRAN and in signalling messages between MS/UE and GERAN. Four types of RNTI exist:

- 1) Serving BSS/RNC RNTI (S-RNTI);
- 2) Drift BSS/RNC RNTI (D-RNTI);
- 3) Cell RNTI (C-RNTI);
- 4) UTRAN RNTI (U-RNTI) or GERAN RNTI (G-RNTI);

The S-RNTI is used:

- by the MS/UE to identify itself to the Serving BSS/RNC;
- by the SBSS/SRNC to address the MS/UE; and
- by the DBSS/DRNC to identify the MS/UE to serving BSS/RNC.

The S-RNTI is allocated for all MSs/UEs having an RRC connection. It is allocated by the serving BSS/RNC and it is unique within the serving BSS/RNC. The S-RNTI is reallocated always when the serving BSS/RNC for the RRC connection is changed.

The D-RNTI is used by the serving BSS/RNC to identify the MS/UE to the drift BSS/RNC.

NOTE: The D-RNTI is never used on the Um/Uu interface.

The D-RNTI is allocated by the drift BSS/RNC upon drift MS/UE contexts establishment and it shall be unique within the drift BSS/RNC. Serving BSS/RNC shall know the mapping between the S-RNTI and the D-RNTIs allocated in the drift BSS for the same MS/UE. The drift BSS/RNC shall know the S-RNTI and SBSS-ID/RNC-ID related to the existing D-RNTI within the drift BSS/RNC.

The C-RNTI is used this identifier is used only in UTRAN:

- in case of the Iur-g interface between UTRAN and GERAN (specifically the case of a SBSS and DRNC);
- by the UE to identify itself to the controlling RNC; and
- by the controlling RNC to address the UE.

The C-RNTI is allocated by the controlling RNC upon UE accessing a new cell. The C-RNTI shall be unique within the accessed cell. The controlling RNC shall know the D-RNTI associated to the C-RNTI within the same logical RNC (if any).

The G-RNTI/U-RNTI is allocated to an MS/UE having an RRC connection and it identifies the MS/UE within GERAN/UTRAN. The G-RNTI/U-RNTI is composed of:

- SBSS/SRNC identity; and
- S-RNTI.

Each BSS/RNC has a unique identifier within the GERAN/UTRAN part of the PLMN, denoted by BSS/RNC identifier (BSS-ID/RNC-ID). This identifier is used to route GERAN/UTRAN interface messages to the correct BSS/RNC. The BSS-ID/RNC-ID of the serving BSS/RNC together with the S-RNTI is a unique identifier of the MS/UE in the GERAN/UTRAN part of the PLMN.

From this architecture, there are three possible scenarios for a particular MS/UE:

- a) Both the serving and the controlling RAN nodes are BSCs.
- b) The serving RAN node is a BSC and the controlling RAN node is an RNC.
- c) The serving RAN node is an RNC and the controlling RAN node is a BSC.

These scenarios are shown in Figure 2.

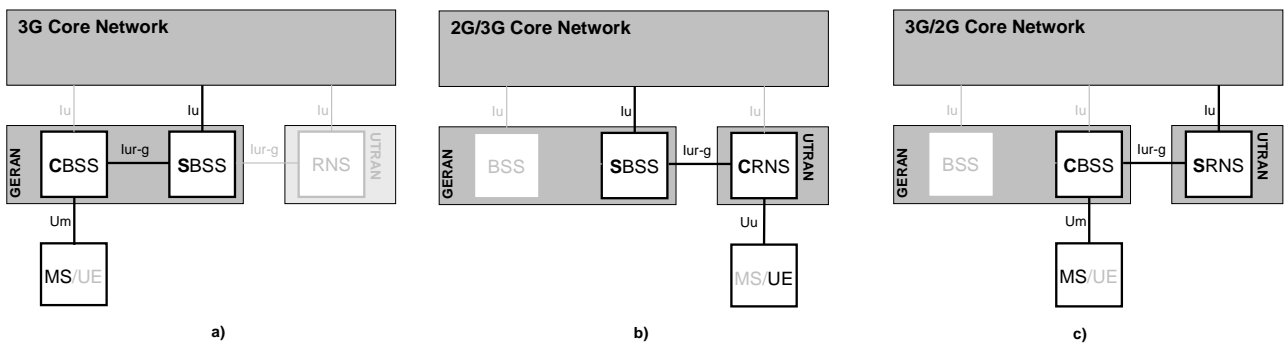

Figure 2: Scenarios using the Iur-g interface (BSS in *lu mode*)

5.1.3 MS Identifiers in A/Gb mode

The Radio Network Temporary Identity (RNTI) is used as a MS/UE identifier within the GERAN/UTRAN. One type of RNTI exists:

- Drift RNTI (D-RNTI)

The D-RNTI is allocated by the TBSS and is used to identify the MS/UE during a handover via the Iur-g interface.

There is one possible scenario in which the D-RNTI is used:

- a) The serving RAN node is a UTRA-NTDD RNC and the target RAN node is a BSS

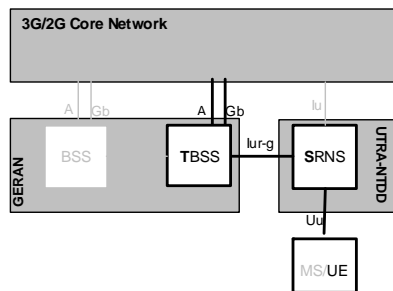

Figure 2a: Scenario using the Iur-g interface (BSS in *A/Gb mode*)

5.2 Iur-g interface capabilities

The Iur-g interface provides capability to support radio interface mobility between BSSs or between a BSS and an RNS of UEs having a connection with the GERAN or the UTRAN. This capability includes the support of paging, cell update, registration area update and handover between BSSs or between a BSS and an RNS. Further, Iur-g interface provides capability to support information exchange between two BSSs or between a BSS and RNS.

6 Iur Interface Protocols

6.1 General

There shall exist a clear separation between the Radio Network Layer and the Transport Layer. Therefore, the radio network signalling is separated from the data transport resource and traffic handling as shown in Figure 3. This separation is also present in the Iur interface (see 3GPP TS 25.420 [4]).

Since the Iur-g does not carry user data information, neither data transport resources nor Transport Signalling are present on this interface. These elements, present in the Iur interface but not in the Iur-g, are shown in dotted lines in Figure 3.

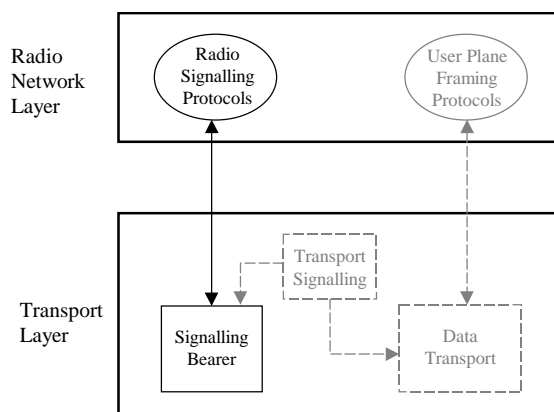

Figure 3: Separation of Radio Network Protocols and transport over Iur-g.

The following Table lists all stage 3 specifications that are used for Iur-g interface:

Table 1: Stage 3 Iur-g interface specifications

Spec. No	Spec. Name
TS 25.401	UTRAN Overall Description
TS 25.420	UTRAN Iur Interface: General Aspects and Principles
TS 25.421	UTRAN Iur interface Layer 1
TS 25.422	UTRAN Iur Interface Signalling Transport
TS 25.423	UTRAN Iur Interface RNSAP Signalling

6.2 Functions of the Iur-g interface protocols

The list of functions on the Iur-g interface is the following:

- **Paging.** This function allows the SBSS/SRNC to page a MS/UE in a GRA/URA or a cell in the DBSS/DRNS;
- **Relocation Execution.** This function allows the SBSS/SRNC to finalise a Relocation previously prepared via other interfaces;
- **Reporting of General Error Situations.** This function allows reporting of general error situations, for which function specific error messages have not been defined.
- **Measurements on Common Resources.** This function allows an BSS/RNC to request from another BSS/RNC to initiate measurements on Common Resources. The function also allows the requested BSS/RNC to report the result of the measurements.

Radio Resource Reserve Handover. This function allows the SRNC to request allocation of radio resources in the TBSS prior to the HANOVER REQUEST message is received from the Core Network.

6.3 Iur-g Interface protocol structure

The Iur interface protocol architecture consists of two functional layers:

- **Radio Network Layer:** it defines the procedures related to the interaction of two BSSs or between a BSS and an RNC within a PLMN. The radio network layer consists of a Radio Network Control Plane and a Radio Network User Plane. The functionality of the Radio Network User Plane of the Iur-g interface is null.
- **Transport Layer:** it consists of two planes:

- a) **Transport Network Control Plane:** it defines procedures for establishing physical connections between two BSSs or between a BSS and an RNC within a PLMN. The functionality of the Transport Network Control Plane of the Iur-g interface is null.
- b) **Transport Network User Plane:** it provides means for the transport of the Radio Network Layer information.

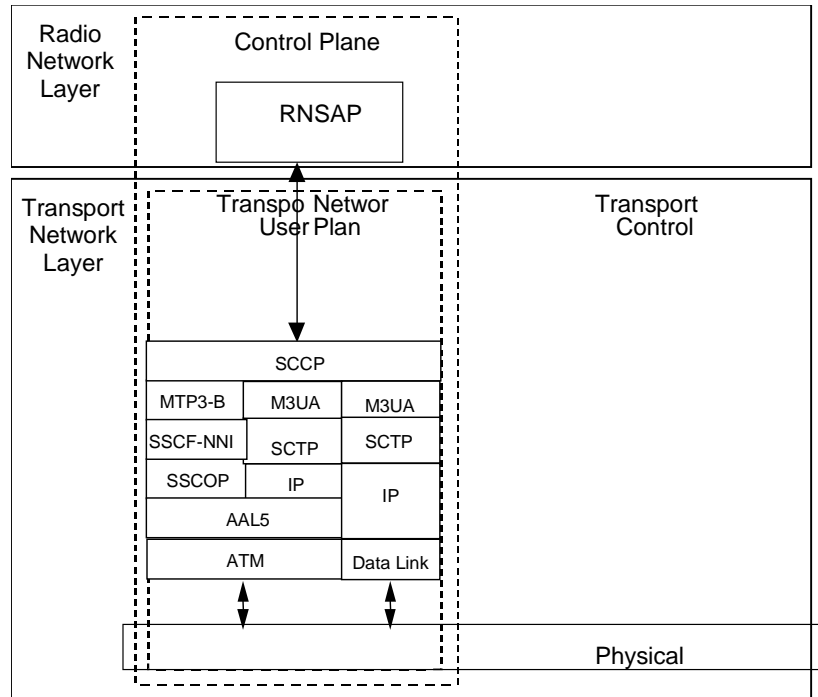

Figure 4: Iur-g interface protocol structure.

6.4 Radio signalling protocols

The protocol responsible for providing signalling information across the Iur-g interface is a sub-set of the Radio Network Subsystem Application Part (RNSAP) (see 3GPP TS 25.423 [5]). This subset of RNSAP is terminated by two BSSs or by the BSS and RNC inter-connected via the Iur-g interface.

The subset of RNSAP procedures applicable to the Iur-g interface are divided into two modules as follows:

1. **RNSAP Basic Mobility Procedures:** these procedures are used to handle the mobility within GERAN or between GERAN and UTRAN.
2. **RNSAP Global Procedures:** these procedures are not related to a specific MS. The procedures in this module are in contrast to the above module involving two peer CBSSs or a CBSS and a CRNC.

7 Radio Network Layer: RNSAP protocol

7.1 General

The following sub-clauses describe the applicability of the procedures that are supported on the Iur-g interface. The actual Iur-g interface procedures are further described in 3GPP TS 25.423 [5]. These sub-clauses show those procedures integrated with procedures on other interfaces and/or events in other network entities than the BSS or the RNC.

7.2 Basic mobility procedures

7.2.1 General

The Iur-g interface has no Radio Network User Plane functionality.

In Iu mode, SBSS/SRNS relocation is performed during every Cell Update procedure. Therefore, the only state when the MS is simultaneously known by two BSSs or one BSS and one RNC is in GERAN RRC-GRA_PCH state and UTRAN URA_PCH state.

In the GERAN RRC-GRA_PCH and UTRAN URA_PCH states, the following procedures related to the mobility of the MS are supported over the Iur-g interface:

- Paging;
- Cell Update;
- Registration Area Update; and
- RRC Connection Release.

In A/Gb mode, the following procedure related to the mobility of the MS is supported over the Iur-g interface:

- Radio Resource Reserve Handover.

The following sub-clauses describe how these procedures are performed over the Iur-g interface.

Elementary procedures over the Iur-g interface that support above mentioned mobility procedures are specified in 3GPP TS 25.423 [5] and are listed in the table below categorized by *Iu mode* and *A/Gb mode* respectively:

Table 2: Iur-g basic mobility procedures

Elementary Procedure	Initiating Message	Allowed Operating Mode for BSS
Uplink Signalling Transfer	GERAN UPLINK SIGNALLING TRANSFER INDICATION	Iu mode only
Downlink Signalling Transfer	DOWNLINK SIGNALLING TRANSFER REQUEST	Iu mode only
Relocation Commit	RELOCATION COMMIT	Both Iu mode and A/Gb mode
Paging	PAGING REQUEST	Iu mode only
Enhanced Relocation Resource Reserve	ENHANCED RELOCATION RESOURCE REQUEST	A/Gb mode only
Enhanced Relocation Resource Release	ENHANCED RELOCATION RESOURCE RELEASE COMMAND	A/Gb mode only

7.2.2 Paging

The MS/UE in the RRC-GRA_PCH and URA-PCH states may receive a CN initiated paging message. The Paging Request message received by the serving node (BSS or RNC) shall trigger paging over the registration area. In case registration area consists of cells belonging to different BSS/RNC, then the RNSAP Paging procedure over the Iur-g interface is used.. This procedure is used by the SBSS/SRNC to indicate to a CBSS/CRNC that an MS shall be paged in a cell or GRA/URA that is under the control of the CBSS/CRNC.

To illustrate further the usage of this procedure the following figure describes a scenario when the MS/UE has a context active towards PS domain and paging request is issued by the CS domain.

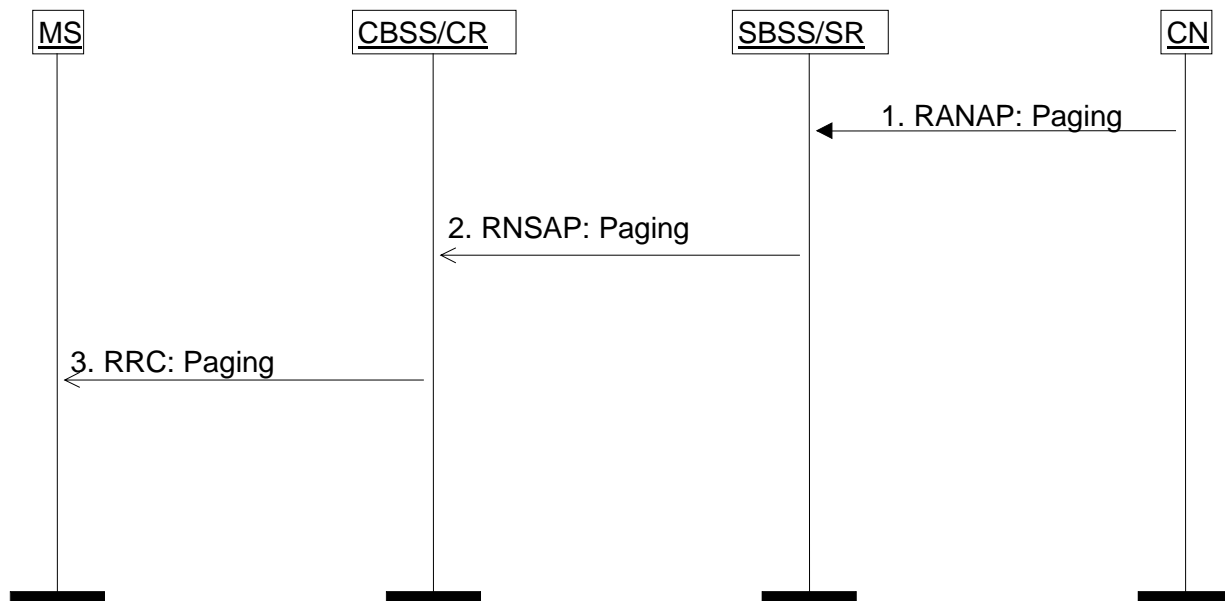

Figure 5: Example of Paging over Iur-g

7.2.3 Cell Update

In the RRC-GRA_PCH or URA_PCH states the MS/UE may initiate the Cell Update procedure for reasons of uplink activity, whether that is an answer to a page, periodic cell update or uplink data transfer. As explained in sub-clause 4.3, a Cell Update procedure shall always trigger the SRNC/SBSS relocation. The following figure describes the signalling flow for Cell Update procedure.

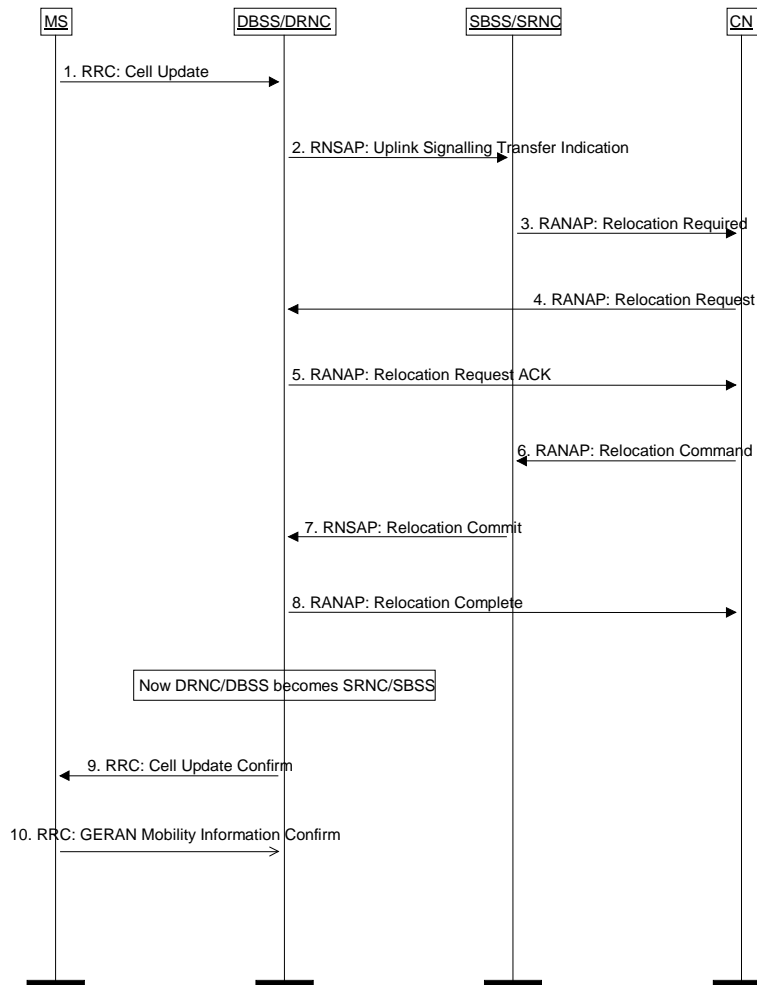

Figure 6: Cell Update with Relocation (Simplified)

1. MS/UE in RRC-GRA_PCH and URA_PCH states triggers the Cell Update procedure by sending RRC CELL UPDATE message to the DBSS/DRNC.
 - DBSS/DRNC will use RNSAP Uplink Signalling Transfer procedure to forward the Cell Update message to the SBSS/SRNC. The message that is used for this is GERAN Uplink Signalling Transfer Indication. The procedure and the contents of the message are described in 3GPP TS 25.423 [5]. There are two messages already defined one for FDD and one for TDD. In case of the Iur-g interface, RNSAP GERAN UPLINK SIGNALLING TRANSFER INDICATION message (GERAN message) is used.
2. Upon reception of CELL UPDATE message, the SBSS/SRNC shall trigger the SBB/SRNC relocation. Steps 4, 5, and 6 are not relevant for this discussion so they are omitted.
7. The Relocation Commit procedure is used by the source BSS/RNC to execute the relocation. This procedure is described in 3GPP TS 25.423 [5]. The procedure is triggered by the RELOCATION COMMIT message.
9. Assuming a successful relocation the former DBSS/DRNC, the SBSS/SRNC shall send the CELL UPDATE CONFIRM message to the UE/MS.

7.2.4 Registration Area Update

The MS/UE shall trigger the GRA/URA Update Procedure when there is a change in registration area, or based on the timers related to the periodic GRA/URA update. The following figure shows an example of a successful GRA/URA Update. This example assumes no SBSS/SRNC relocation.

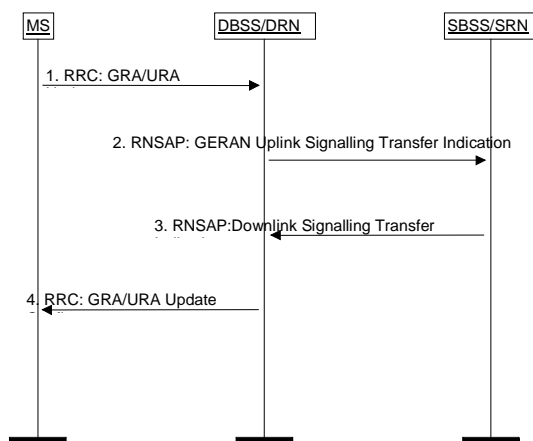

Figure 7: GRA Update, no relocation (Simplified)

1. The MS/UE in RRC-GRA or URA_PCH states triggers the GRA/URA Update procedure by sending RRC GRA/URA UPDATE message to the DBSS/DRNC.
 - The DBSS/DRNC uses RNSAP Uplink Signalling Transfer procedure to forward the GRA/URA UPDATE message to the SBSS/SRNC. The GERAN UPLINK SIGNALLING TRANSFER INDICATION message is used for this. The procedure and the contents of the message are described in 3GPP TS 25.423 [5].
2. Upon reception of the GERAN UPLINK SIGNALLING TRANSFER INDICATION message containing the RRC GRA/URA UPDATE message, the SBSS/SRNC shall include the GRA/URA UPDATE CONFIRM message and use the Downlink Signalling Transfer procedure to request the DRNC/DBSS the transfer of the message to the MS/UE. The Downlink Signalling Transfer procedure is specified in 3GPP TS 25.423 [5] and it is triggered by DOWNLINK SIGNALLING TRANSFER REQUEST message. The content of this message is specified in 3GPP TS 25.423 [5]. The content of the message should be the same in case of the Iur-g interface, except for C-Id IE. In case of a DRNC, the C-Id is used, while in case of a DBSS, the CI IE shall be used.
3. The DBSS/DRNC shall send the GRA/URA UPDATE CONFIRM message to the UE/MS.

7.2.5 RRC Connection Release

The SBSS/SRNC may trigger the RRC Connection Release procedure for an MS/UE in RRC-GRA_PCH or URA_PCH states. In order to release the RRC connection, the SBSS/SRNC shall first trigger the paging procedure. The SBSS/SRNC, in response to the Cell Update procedure, may then use the DOWNLINK SIGNALLING TRANSFER INDICATION message to relay the RRC CONNECTION RELEASE message to the MS/UE.

In addition, the SBSS/SRNC, in response to any Cell Update or GRA/URA Update procedures, may decide to trigger the release of RRC Connection. In that case the SBSS/SRNC shall use the DOWNLINK SIGNALLING TRANSFER INDICATION message to relay the RRC CONNECTION RELEASE message to the MS/UE.

7.2.6 Radio Resource Reserve Handover

7.2.6.1 General

This procedure applies to intra and inter-MSC handover in case of CS domain handover/relocation from UTRA-NTDD RNS to GERAN BSS operating in A/Gb mode and it is used on purpose to reduce the handover preparation time when an inter-system CS handover is triggered from an RNS to a BSS.

This procedure allows the SRNS to request allocation of radio resources in the TBSS for an inter-system CS handover prior to the HANDOVER REQUEST message is received from the Core Network, allowing the SRNS to start the handover command process towards the MS/UE before the reception of the RELOCATION COMMAND message from the Core Network.

7.2.6.2 Successful operation

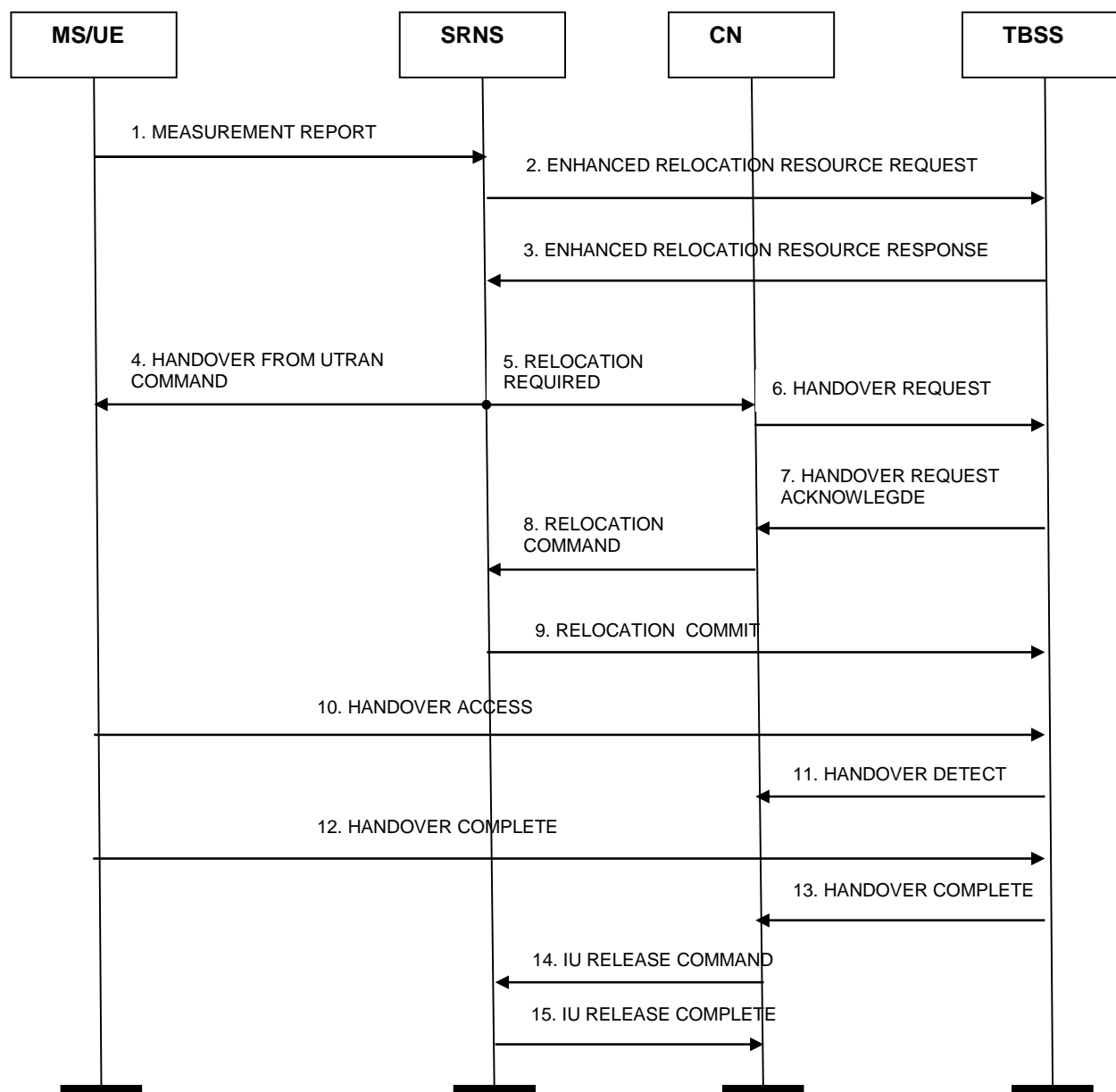

Figure 8: Iur-g HO with radio resource reservation in the TBSS

- 1) After receiving the measurement report from the MS/UE and having considered the GSM neighbor cells capacity and load information, the SRNS decides to handover the MS/UE to a neighbor GSM cell.
- 2) An Iur-g connection is established by the SRNS towards the BSS serving the targeted neighbour GSM cell. The SRNS sends the ENHANCED RELOCATION RESOURCE REQUEST message to the TBSS in order to reserve radio resources for the MS/UE.
- 3) At reception of the ENHANCED RELOCATION RESOURCE REQUEST message the TBSS allocates a D-RNTI (Drift-Radio Network Temporary Identity) for the MS/UE and reserves the radio resources according to the Speech Version parameter (the MS/UE preferences for GSM). The TBSS builds the *L3 Information Container IE* (containing the (RR) HANDOVER COMMAND message) and sends it together with the *D-RNTI IE* in the ENHANCED RELOCATION RESOURCE RESPONSE message to the SRNS.
- 4) Receiving the ENHANCED RELOCATION RESOURCE RESPONSE message the SRNS sends the (RR) HANDOVER COMMAND message included in the *L3 information container IE* to the MS/UE encapsulated in the HANDOVER FROM UTRAN COMMAND message.

- 5) SRNS sends the RELOCATION REQUIRED message to the CN with the D-RNTI encapsulated in the *Old BSS to New BSS IE*.
- 6) The CN sends the HANDOVER REQUEST message to the TBSS with the D-RNTI encapsulated in the *Old BSS to New BSS IE*. The TBSS correlates the received D-RNTI in the HANDOVER REQUEST message with the D-RNTI identifying the previously reserved radio resources.
- 7) The TBSS sends the HANDOVER REQUEST ACKNOWLEDGE message to the CN.
- 8) The CN sends the RELOCATION COMMAND message to the SRNS.
- 9) The SRNS sends the RELOCATION COMMIT message to the TBSS for the concerned MS/UE (and D-RNTI).
- 10) The MS/UE is accessing the target GSM cell by sending the HANDOVER ACCESS message to the TBSS.
- 11) The TBSS sends the HANDOVER DETECT message to the CN since it has already received the RELOCATION COMMIT message from the SRNS. Otherwise if the RELOCATION COMMIT message for concerned MS/UE is not received in the TBSS, then the TBSS shall not send the HANDOVER DETECT message to the CN. In this case the TBSS shall wait for the RELOCATION COMMIT message before sending the HANDOVER DETECT message to the CN.
- 12) The MS/UE sends the HANDOVER COMPLETE message to the TBSS.
- 13) The TBSS forwards the message to the CN.
- 14) The CN sends the IU RELEASE COMMAND message to the SRNS after receiving the HANDOVER COMPLETE message.
- 15) After releasing the UTRAN resources and the Iur-g connection towards the TBSS, the SRNC sends the IU RELEASE COMPLETE message to the CN.

7.2.6.3 Abnormal conditions

7.2.6.3.1 BSS Radio Resource Reservation Failure

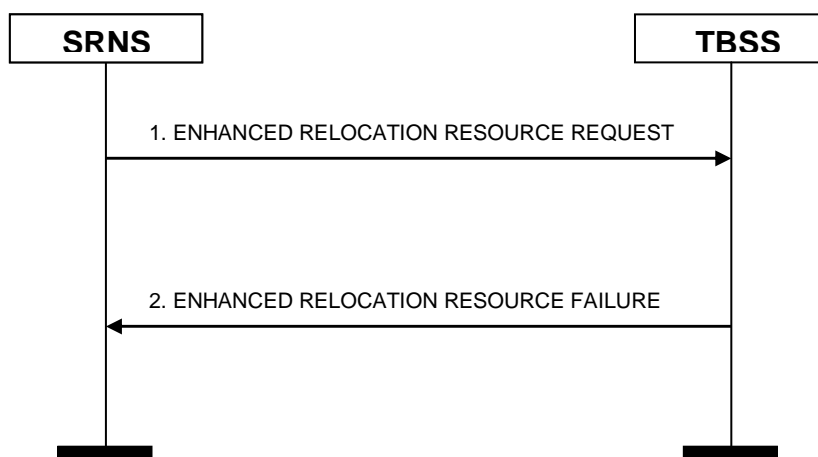
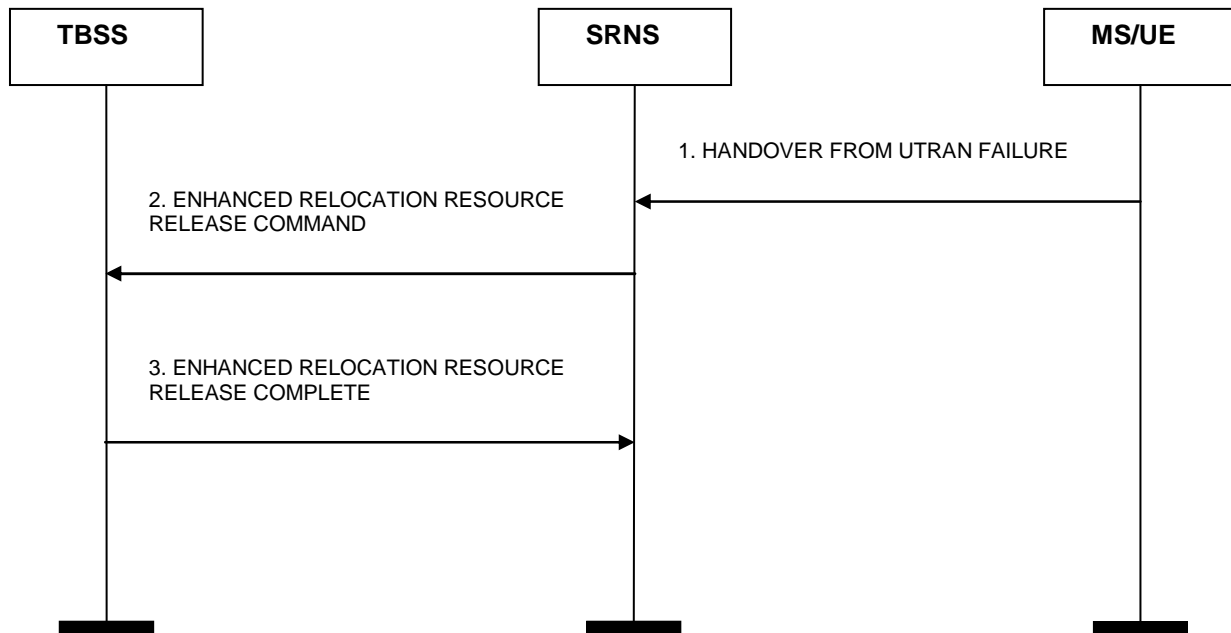

Figure 9: BSS Radio Resource Reservation Failure

1. SRNS sends the ENHANCED RELOCATION RESOURCE REQUEST message to the TBSS in order to reserve radio resources for the MS/UE.
2. If the TBSS can not reserve the requested radio resources, then the TBSS returns the ENHANCED RELOCATION RESOURCE FAILURE message to the SRNS with appropriate Cause value included in the message.
3. Upon reception of the ENHANCED RELOCATION RESOURCE FAILURE message the SRNS starts releasing the dedicated Iur-g connection towards the TBSS.

7.2.6.3.2 Handover failure from MS/UE

**Figure 10: MS/UE Handover Failure**

1. In case the handover process fails in the MS/UE, the MS/UE sends the HANDOVER FROM UTRAN FAILURE message to the SRNS.
2. The SRNS informs the TBSS of the handover failure by sending the ENHANCED RELOCATION RESOURCE RELEASE COMMAND message on the dedicated Iur-g connection. Upon reception of the ENHANCED RELOCATION RESOURCE RELEASE COMMAND message, the TBSS starts releasing the radio resources related to the MS/UE and returns the ENHANCED RELOCATION RESOURCE RELEASE COMPLETE message to the SRNS.
3. Upon reception of the ENHANCED RELOCATION RESOURCE RELEASE COMPLETE message, the SRNS starts releasing the dedicated Iur-g connection towards the TBSS.

7.3 Void

7.4 Global procedures

7.4.1 General

Table 3: Global procedures list

Elementary Procedure	Initiating Message	Allowed Operating Mode for BSS
Error Indication	ERROR INDICATION	Iu mode only
Common Measurement Initiation	COMMON MEASUREMENT INITIATION REQUEST	Both Iu mode and A/Gb mode
Common Measurement Reporting	COMMON MEASUREMENT REPORT	Both Iu mode and A/Gb mode
Common Measurement Termination	COMMON MEASUREMENT TERMINATION REQUEST	Both Iu mode and A/Gb mode
Common Measurement Failure	COMMON MEASUREMENT FAILURE INDICATION	Both Iu mode and A/Gb mode
Information Exchange Initiation	INFORMATION EXCHANGE INITIATION	Both Iu mode and A/Gb mode
Information Reporting	INFORMATION REPORT	Both Iu mode and A/Gb mode
Information Exchange Termination	INFORMATION EXCHANGE TERMINATION REQUEST	Both Iu mode and A/Gb mode
Information Exchange Failure	INFORMATION EXCHANGE FAILURE INDICATION	Both Iu mode and A/Gb mode

7.4.2 Error Indication

The Error Indication procedure is initiated by a node to report detected errors in a received message, provided they cannot be reported by an appropriate response message.

7.4.3 Common Measurement Functions

The Common Measurement function in the Iur-g interface is used to support the Improved RRM across BSS and BSS/RNC. This functionality is supported by adopting the Iur procedures for Common Measurements:

- **Common Measurement Initiation:** This procedure is used by an RNC/BSS to request the initiation of measurements of common resources to another RNC/BSS. For measurements made in GERAN cells, only the following measurement types are applicable:
 - Load
 - RT load
 - NRT load information
- **Common Measurement Reporting:** This procedure is used by an RNC/BSS to report the result of measurements requested by another RNC using the Common Measurement Initiation.
- **Common Measurement Termination:** This procedure is used by an RNC/BSS to terminate a measurement previously requested by the Common Measurement Initiation procedure.

- **Common Measurement Failure:** This procedure is used by an RNC/BSS to notify another RNC/BSS that a measurement previously requested by the Common Measurement Initiation procedure can no longer be reported.

7.4.4 Information Exchange Functions

This Information Exchange functions are used to initiate, maintain and terminate information exchange between two RNC/BSS nodes. This functionality is supported by adopting the Iur procedures for Information Exchange:

- **Information Exchange Initiation:** This procedure is used by a BSS/RNC to request the initiation of an information exchange with another BSS/RNC. The procedure is initiated with an INFORMATION EXCHANGE INITIATION REQUEST message sent from BSS1 to BSS2/RNC2 or by RNC1 to BSS2. Upon reception, the BSS2/RNC2 shall provide the requested information according to the parameters given in the request.
- **Information Reporting:** This procedure is used by a BSS/RNC to report the result of information requested by another BSS/RNC using the Information Exchange Initiation.
- **Information Exchange Termination:** This procedure is used by a BSS/RNC to terminate the information exchange requested using the Information Exchange Initiation.
- **Information Exchange Failure:** This procedure is used by a BSS/RNC to notify another that the information exchange it previously requested using the Information Exchange Initiation can no longer be reported.

The information which can be requested on the Iur and Iur-g interfaces is shown in the table below marked with "X". For information which is not applicable on the Iur-g interface, the BSS shall regard the Information Exchange Initiation procedure as failed.

Table 4: Allowed Information types on Iur and Iur-g interfaces

Information Type	Interface	
	Iur	Iur-g
IPDL Parameters	X	
DGPS Corrections	X	
GPS Information	X	
Cell Capacity Class	X	X

Cell capacity class for GERAN cells is defined by the number of configured carriers in specific GERAN cells which ranges from integer 1 to 100. The value 1 shall indicate the minimum cell capacity and the value 100 shall indicate the maximum cell capacity.

Annex A (Informative): Change history

Date / TSG #	TSG Doc.	CR	Rev	Subject/Comment	New
GP-11	-	-	-	Conversion to Technical Specification based upon TR 43.930 v5.1.0	5.0.0
GP-23				Version for Release 6	6.0.0
GP-35				Version for Release 7	7.0.0
GP-40				Version for Release 8	8.0.0
GP-44				Version for Release 9	9.0.0
GP-49	GP-110493	0001	1	Enhancements of lur-g interface	10.0.0
GP-55				Version for Release 11	11.0.0
GP-63				Version for Release 12 (frozen at SP-65)	12.0.0
GP-68				Version for Release 13 (frozen at SP-70)	13.0.0

Change history

Date	Meeting	TDoc	CR	Rev	Cat	Subject/Comment	New version
2017-09	75				-	Release 14 version (frozen at TSG-75)	14.0.0
2017-09		RP-171597	0004	-	A	Removal of references to TS 44.118	14.1.0
2018-06	80					Release 15 version (frozen at TSG-80)	15.0.0

History

Document history		
V15.0.0	July 2018	Publication