

# ETSI TS 143 129 V6.13.0 (2010-02)

---

*Technical Specification*

**Digital cellular telecommunications system (Phase 2+);  
Packed-switched handover for GERAN A/Gb mode;  
Stage 2  
(3GPP TS 43.129 version 6.13.0 Release 6)**



---

**Reference**

RTS/TSGG-0143129v6d0

---

**Keywords**

GSM

**ETSI**

650 Route des Lucioles  
F-06921 Sophia Antipolis Cedex - FRANCE

Tel.: +33 4 92 94 42 00 Fax: +33 4 93 65 47 16

Siret N° 348 623 562 00017 - NAF 742 C  
Association à but non lucratif enregistrée à la  
Sous-Préfecture de Grasse (06) N° 7803/88

---

**Important notice**

Individual copies of the present document can be downloaded from:

<http://www.etsi.org>

The present document may be made available in more than one electronic version or in print. In any case of existing or perceived difference in contents between such versions, the reference version is the Portable Document Format (PDF). In case of dispute, the reference shall be the printing on ETSI printers of the PDF version kept on a specific network drive within ETSI Secretariat.

Users of the present document should be aware that the document may be subject to revision or change of status. Information on the current status of this and other ETSI documents is available at

<http://portal.etsi.org/tb/status/status.asp>

If you find errors in the present document, please send your comment to one of the following services:

[http://portal.etsi.org/chaicor/ETSI\\_support.asp](http://portal.etsi.org/chaicor/ETSI_support.asp)

---

**Copyright Notification**

No part may be reproduced except as authorized by written permission.  
The copyright and the foregoing restriction extend to reproduction in all media.

© European Telecommunications Standards Institute 2010.  
All rights reserved.

**DECT™**, **PLUGTESTS™**, **UMTS™**, **TIPHON™**, the TIPHON logo and the ETSI logo are Trade Marks of ETSI registered for the benefit of its Members.

**3GPP™** is a Trade Mark of ETSI registered for the benefit of its Members and of the 3GPP Organizational Partners.

**LTE™** is a Trade Mark of ETSI currently being registered

for the benefit of its Members and of the 3GPP Organizational Partners.

**GSM®** and the GSM logo are Trade Marks registered and owned by the GSM Association.

---

## Intellectual Property Rights

IPRs essential or potentially essential to the present document may have been declared to ETSI. The information pertaining to these essential IPRs, if any, is publicly available for **ETSI members and non-members**, and can be found in ETSI SR 000 314: *"Intellectual Property Rights (IPRs); Essential, or potentially Essential, IPRs notified to ETSI in respect of ETSI standards"*, which is available from the ETSI Secretariat. Latest updates are available on the ETSI Web server (<http://webapp.etsi.org/IPR/home.asp>).

Pursuant to the ETSI IPR Policy, no investigation, including IPR searches, has been carried out by ETSI. No guarantee can be given as to the existence of other IPRs not referenced in ETSI SR 000 314 (or the updates on the ETSI Web server) which are, or may be, or may become, essential to the present document.

---

## Foreword

This Technical Specification (TS) has been produced by ETSI 3rd Generation Partnership Project (3GPP).

The present document may refer to technical specifications or reports using their 3GPP identities, UMTS identities or GSM identities. These should be interpreted as being references to the corresponding ETSI deliverables.

The cross reference between GSM, UMTS, 3GPP and ETSI identities can be found under <http://webapp.etsi.org/key/queryform.asp>.

# Contents

Intellectual Property Rights .....	2
Foreword.....	2
Foreword.....	6
Introduction .....	6
1 Scope .....	7
2 References .....	7
3 Definitions and abbreviations.....	8
3.1 Definitions .....	8
3.2 Void.....	8
3.3 Abbreviations .....	8
4 Architecture and principles .....	10
4.1 Reference architecture .....	10
4.2 Handover principles .....	10
4.2.1 General.....	10
4.2.2 PS Handover preparation phase .....	11
4.2.3 PS Handover execution phase.....	11
4.2.4 PS Handover Network Node Responsibilities .....	12
4.3 Protocol architecture.....	12
4.3.1 User plane overview .....	12
4.3.2 Control plane overview.....	12
4.3.3 Physical Layer .....	13
4.3.3.1 Shared Channels.....	13
4.3.3.1.1 General .....	13
4.3.4 RLC/MAC .....	13
4.3.5 Radio Resource (RR).....	13
4.3.6 BSSGP .....	13
4.3.7 Overview of PS Handover Signalling Messages .....	14
4.3.7.1 PS handover signalling messages on the Um interface .....	14
4.3.7.2 PS handover signalling messages on the Gb interface .....	14
4.3.7.3 PS handover signalling messages on the Gn interface .....	15
4.4 Identifiers .....	15
4.4.1 NSAPI, PFI, RAB ID relation during inter-RAT, inter-mode PS handover .....	16
5 Signalling procedures.....	17
5.1 GERAN ( <i>A/Gb mode</i> ) → GERAN ( <i>A/Gb mode</i> ) handover.....	17
5.1.1 Intra Cell.....	17
5.1.2 Intra BSS.....	17
5.1.2.1 General .....	17
5.1.2.2 Intra BSS HO; Preparation phase.....	18
5.1.2.3 Intra BSS HO; Execution phase .....	19
5.1.2.4 Intra BSS Handover - Optimised .....	20
5.1.3 Intra SGSN.....	22
5.1.3.1 Intra SGSN/Inter BSS HO, Preparation phase .....	22
5.1.3.2 Intra SGSN/Inter BSS HO, Execution phase .....	23
5.1.4 Inter SGSN.....	25
5.1.4.1 Inter SGSN HO, Preparation phase .....	25
5.1.4.2 Inter SGSN HO, Execution phase .....	28
5.2 Inter-RAT/mode handover (GERAN <i>A/Gb mode</i> → UTRAN/ GERAN <i>Iu mode</i> ) .....	32
5.2.1 Intra SGSN.....	32
5.2.1.1 Intra-SGSN GERAN <i>A/Gb mode</i> to UTRAN/GERAN <i>Iu mode</i> HO; Preparation phase .....	32
5.2.1.2 Intra-SGSN GERAN <i>A/Gb mode</i> to UTRAN/GERAN <i>Iu mode</i> HO; Execution phase .....	34
5.2.2 Inter SGSN.....	37
5.2.2.1 Inter-SGSN GERAN <i>A/Gb mode</i> to UTRAN/GERAN <i>Iu mode</i> HO; Preparation phase .....	37

5.2.2.2	Inter-SGSN GERAN A/Gb <i>mode</i> to UTRAN/GERAN Iu <i>mode</i> HO; Execution phase .....	39
5.3	Inter-RAT/mode Handover (UTRAN/GERAN Iu <i>mode</i> → GERAN A/Gb <i>mode</i> ).....	43
5.3.1	Intra SGSN.....	43
5.3.1.1	Inter RAT/mode UTRAN/GERAN Iu <i>mode</i> to GERAN A/Gb <i>mode</i> PS HO; Preparation phase .....	43
5.3.1.2	Inter RAT/mode UTRAN/GERAN Iu <i>mode</i> to GERAN A/Gb <i>mode</i> PS HO; Execution phase .....	45
5.3.2	Inter SGSN.....	48
5.3.2.1	Inter RAT/mode UTRAN/GERAN Iu <i>mode</i> to GERAN A/Gb <i>mode</i> PS HO; Preparation phase .....	48
5.3.2.2	Inter RAT UTRAN/GERAN Iu <i>mode</i> to GERAN A/Gb <i>mode</i> PS HO; Execution phase .....	50
5.4	Handover reject .....	54
5.4.1	General.....	54
5.4.2	Inter-SGSN HO Reject; Signalling procedure .....	54
5.5	Handover cancel.....	54
5.5.1	General.....	54
5.5.2	Signalling procedures .....	55
5.5.2.1	Inter-SGSN case, GERAN A/Gb <i>mode</i> → GERAN A/Gb <i>mode</i> .....	55
5.5.2.2	Inter-SGSN case, GERAN A/Gb <i>mode</i> → UTRAN/GERAN Iu <i>mode</i> .....	56
5.5.2.3	Inter-SGSN case, UTRAN/GERAN Iu <i>mode</i> → GERAN A/Gb <i>mode</i> .....	57
5.6	Container handling .....	57
5.6.1	Contents of the containers.....	58
5.6.1.1	Contents of the GERAN A/Gb <i>mode</i> → GERAN A/Gb Transparent Containers .....	59
5.6.1.1.1	Source BSS to Target BSS Transparent Container.....	59
5.6.1.1.2	Target BSS to Source BSS Transparent Container.....	59
5.6.1.2	Contents of the GERAN A/Gb <i>mode</i> → UTRAN Transparent Containers .....	59
5.6.1.2.1	Source RNC to Target RNC Transparent Container .....	59
5.6.1.2.2	Target RNC to Source RNC Transparent Container .....	60
5.6.1.3	Contents of the UTRAN → GERAN A/Gb Mode Transparent Containers.....	60
5.6.1.3.1	Source BSS to Target BSS Transparent Container.....	60
5.6.1.3.2	Target BSS to Source BSS Transparent Container.....	60
5.6.1.4	Contents of the GERAN A/Gb <i>mode</i> → GERAN Iu <i>mode</i> Transparent Containers .....	60
5.6.1.4.1	Source RNC to Target RNC Transparent Container .....	60
5.6.1.4.2	Target RNC to Source RNC Transparent Container .....	61
5.6.1.5	Content of GERAN Iu <i>mode</i> → GERAN A/Gb <i>mode</i> Transparent Containers .....	61
5.6.1.5.1	Source BSS to Target BSS Transparent Container.....	61
5.6.1.5.2	Target BSS to Source BSS Transparent Container.....	61
5.7	PS Handover Failure .....	61
5.7.1	Preparations Phase Failure Scenarios .....	62
5.7.1.1	PS Handover preparation phase failure scenarios on the Um interface.....	62
5.7.1.2	PS Handover preparation phase failure scenarios on the Gb interface.....	62
5.7.1.3	PS Handover preparation phase failure scenarios on the Gn interface.....	62
5.7.2	Execution Phase Failure Scenarios .....	63
5.7.2.1	Execution phase failures on the Um interface.....	63
5.7.2.1.1	Initial Access Failure in the Target Cell during PS handover.....	63
5.7.2.1.2	Radio contact with the MS is lost.....	64
5.7.2.2	Execution phase failures on the Gb interface .....	66
5.7.2.3	Execution phase failures on the Gn interface .....	67
6	Radio interface Signalling .....	67
6.1	PS Handover Signalling (Um).....	67
6.1.1	General.....	67
6.1.2	Overview of PS Handover messages .....	67
6.1.2.1	GERAN A/Gb <i>mode</i> to GERAN A/Gb <i>mode</i> PS Handover .....	67
6.1.2.2	UTRAN/GERAN Iu <i>mode</i> to GERAN A/Gb <i>mode</i> PS Handover.....	68
6.1.2.3	GERAN A/Gb <i>mode</i> to GERAN Iu <i>mode</i> PS Handover .....	68
6.1.2.4	GERAN A/Gb <i>mode</i> to UTRAN <i>mode</i> PS Handover.....	68
6.1.3	RLC/MAC segmentation .....	69
6.1.4	Inter RAT/mode PS Handover to GERAN A/Gb .....	69
6.1.5	Inter RAT/mode PS Handover from GERAN A/Gb.....	69
6.2	Mechanisms for Initial Access in the Target Cell .....	69
6.2.1	General.....	69
6.2.2	Synchronisation of handovers.....	69
6.2.3	Option 1 - Downlink Data sent after performing access in the target cell .....	70
6.2.3.1	Unsynchronised Networks Call Flow.....	70

6.2.3.2	Synchronised Networks Call Flow.....	70
6.2.4	Option 2 - Downlink Data sent before performing access in the target cell (Blind Transmission) .....	71
6.2.4.1	Unsynchronised Networks Call Flow.....	71
6.2.4.2	Synchronised Network Call Flow .....	72
6.3	Methods for triggering PS Handover.....	73
<b>Annex A (normative): Agreed handover principles.....</b>		<b>74</b>
A.1	Agreed handover principles.....	74
<b>Annex B (informative): PS Handover Primitives .....</b>		<b>76</b>
B.1	Overview .....	76
B.2	Primitives in Source BSS .....	76
B.3	Primitives in Old SGSN .....	77
B.5	Primitives in Target BSS.....	79
B.6	Primitives in MS.....	79
<b>Annex C (informative): Change history .....</b>		<b>80</b>
History .....		82

---

## Foreword

This Technical Specification has been produced by the 3<sup>rd</sup> Generation Partnership Project (3GPP).

The contents of the present document are subject to continuing work within the TSG and may change following formal TSG approval. Should the TSG modify the contents of the present document, it will be re-released by the TSG with an identifying change of release date and an increase in version number as follows:

Version x.y.z

where:

- x the first digit:
  - 1 presented to TSG for information;
  - 2 presented to TSG for approval;
  - 3 or greater indicates TSG approved document under change control.
- y the second digit is incremented for all changes of substance, i.e. technical enhancements, corrections, updates, etc.
- z the third digit is incremented when editorial only changes have been incorporated in the document.

---

## Introduction

Packet Switched (PS) handover is introduced in order to support real-time packet-switched with strict QoS requirements on low latency and packet loss. Packet switched handover reduces the service interruption of the user plane information at cell change compared to the cell-reselection and enables methods to improve buffer handling of user plane data in order to reduce packet loss at cell-change.

---

# 1 Scope

The present document defines the stage-2 service description for packet switched handover in GERAN *A/Gb mode*. ITU-T Recommendation I.130 [8] describes a three-stage method for characterisation of telecommunication services, and ITU-T Recommendation Q.65 [9] defines stage 2 of the method. The present document refers to packet switched handover in GERAN *A/Gb mode*, and therefore focuses on the corresponding radio protocol enhancements to the packet switched domain only i.e. when services are provided through the Gb interface.

---

# 2 References

The following documents contain provisions which, through reference in this text, constitute provisions of the present document.

- References are either specific (identified by date of publication, edition number, version number, etc.) or non-specific.
- For a specific reference, subsequent revisions do not apply.
- For a non-specific reference, the latest version applies. In the case of a reference to a 3GPP document (including a GSM document), a non-specific reference implicitly refers to the latest version of that document *in the same Release as the present document*.

- [1] 3GPP TR 21.905: "Vocabulary for 3GPP Specifications".
- [2] 3GPP TS 22.105: "Services and service capabilities".
- [3] 3GPP TS 22.060: "General Packet Radio Service (GPRS); Service description; Stage 1".
- [4] 3GPP TS 43.064: "Overall description of the GPRS radio interface; Stage 2".
- [5] 3GPP TS 25.922: "Radio Resource Management strategies".
- [6] 3GPP TS 23.107: "Quality of Service (QoS) concept and architecture".
- [7] 3GPP TS 44.060: "General Packet Radio Service (GPRS); Mobile Station (MS) - Base Station System (BSS) interface; Radio Link Control/Medium Access Control (RLC/MAC) protocol".
- [8] ITU-T Recommendations I.130: "Method for the characterization of telecommunication services supported by an ISDN and network capabilities of an ISDN".
- [9] ITU-T Recommendation Q.65: "The unified functional methodology for the characterization of services and network capabilities".
- [10] 3GPP TS 48.018: "General Packet Radio Service (GPRS); Base Station System (BSS) - Serving GPRS Support Node (SGSN); BSS GPRS Protocol".
- [11] 3GPP TS 29.060: "General Packet Radio Service (GPRS); GPRS Tunnelling Protocol (GTP) across the Gn and Gp interface".
- [12] 3GPP TS 23.003: "Numbering, addressing and identification".
- [13] 3GPP TS 25.401: "UTRAN overall description".
- [14] 3GPP TS 43.051: "GSM/EDGE Radio Access Network (GERAN) overall description; Stage 2".
- [15] 3GPP TS 24.008: "Mobile radio interface Layer 3 specification; Core network protocols; Stage 3".
- [16] 3GPP TS 44.118: "Mobile radio interface layer 3 specification, Radio Resource Control (RRC) protocol; Iu mode".
- [17] 3GPP TS 25.331: "Radio Resource Control (RRC) protocol specification".



- [18] 3GPP TS 24.007: "Mobile radio interface signalling layer 3; General Aspects".
- [19] 3GPP TS 23.060: "General Packet Radio Service (GPRS); Service description; Stage 2".
- [20] 3GPP TS 23.108: "Mobile radio interface layer 3 specification core network protocols; Stage 2 (structured procedures)".
- [21] 3GPP TS 44.064: "Mobile Station - Serving GPRS Support Node (MS-SGSN) Logical Link Control (LLC) Layer Specification".
- [22] 3GPP TS 23.236: "Intra-domain connection of Radio Access Network (RAN) nodes to multiple Core Network (CN) nodes".
- [23] 3GPP TS 25.413: "UTRAN Iu interface Radio Access Network Application Part (RANAP) signalling".
- [24] Void.
- [25] 3GPP TS 44.018: "Mobile radio interface layer 3 specification; Radio Resource Control (RRC) protocol".
- [26] 3GPP TS 45.010: "Radio subsystem synchronization".
- [27] 3GPP TS 33.102: 'Security architecture'.

---

## 3 Definitions and abbreviations

### 3.1 Definitions

For the purposes of the present document, the terms and definitions given in 3GPP TR 21.905 [1] and the following apply:

**Active PFCs:** that subset of the PFCs to be handed over, for which the source BSS has determined that resources should be allocated in the target cell during the PS Handover preparation phase.

**A/Gb mode:** mode of operation of the MS when connected to the Core Network via GERAN and the A and/or Gb interfaces.

**PFC subject to handover:** refers to an MS's PFC for which the packet switched handover procedure is to be initiated when a cell change is required. Whether a PFC needs handover or not is decided by the BSS. This decision criteria is not standardized.

### 3.2 Void

### 3.3 Abbreviations

For the purposes of the present document, the following abbreviations apply:

ATM	Asynchronous Transfer Mode
BSC	Base Station Controller
BSS	Base Station Sub-system
BSSGP	Base Station Subsystem GPRS Protocol
BTS	Base Transceiver Station
CN part	Core Network part
CN	Core Network
CS	Circuit Switched
DTM	Dual Transfer Mode
EDGE	Enhanced Data rates for GSM Evolution
FLO	Flexible Layer One

GboIP	Gb over IP
GERAN	GSM/EDGE Radio Access Network
GPRS	General Packet Radio Service
GSM	Global System for Mobile communications
GTP	GPRS Tunnelling Protocol
IMS	IP Multimedia Subsystem
IP	Internet Protocol
LLC	Logical Link Control
MAC	Medium Access Control
MS	Mobile Station
MSC	Mobile Switching Centre
MTU	Maximum Transfer Unit
PDP	Packet Data Protocol
PDTCH	Packet Data Traffic CHannel
PFC	Packet Flow Context
PFM	Packet Flow Management
PS	Packet Switched
PTCCH	Packet Timing advance Control CHannel
QoS	Quality of Service
RAB	Radio Access Bearer
RAN	Radio Access Network
RAT	Radio Access Technology
RAU	Routeing Area Update
RLC	Radio Link Control
RN part	Radio Network part
RNC	Radio Network Controller
ROHC	RObust Header Compression
RRM	Radio Resource Management
RTP	Real Time Protocol
SABM	Set Asynchronous Balanced Mode
SACCH	Standalone Associated Control CHannel
SAPI	Service Access Point Identifier
SGSN	Serving GPRS Support Node
SIP	Session Initiated Protocol
SNDCP	Sub-Network Dependent Convergence Protocol
TBF	Temporary Block Flow
TF	Transport Format
TFC	Transport Format Combination
TFCI	Transport Format Combination Indicator
TR	Technical Report
TS	Technical Specification
UA	Unnumbered Acknowledgement
UDP	User Datagram Protocol
UE	User Equipment
UMTS	Universal Mobile Telephony System
UTRAN	UMTS Terrestrial Radio Access Network
VoIP	Voice over IP
XID	eXchange IDentification

## 4 Architecture and principles

### 4.1 Reference architecture

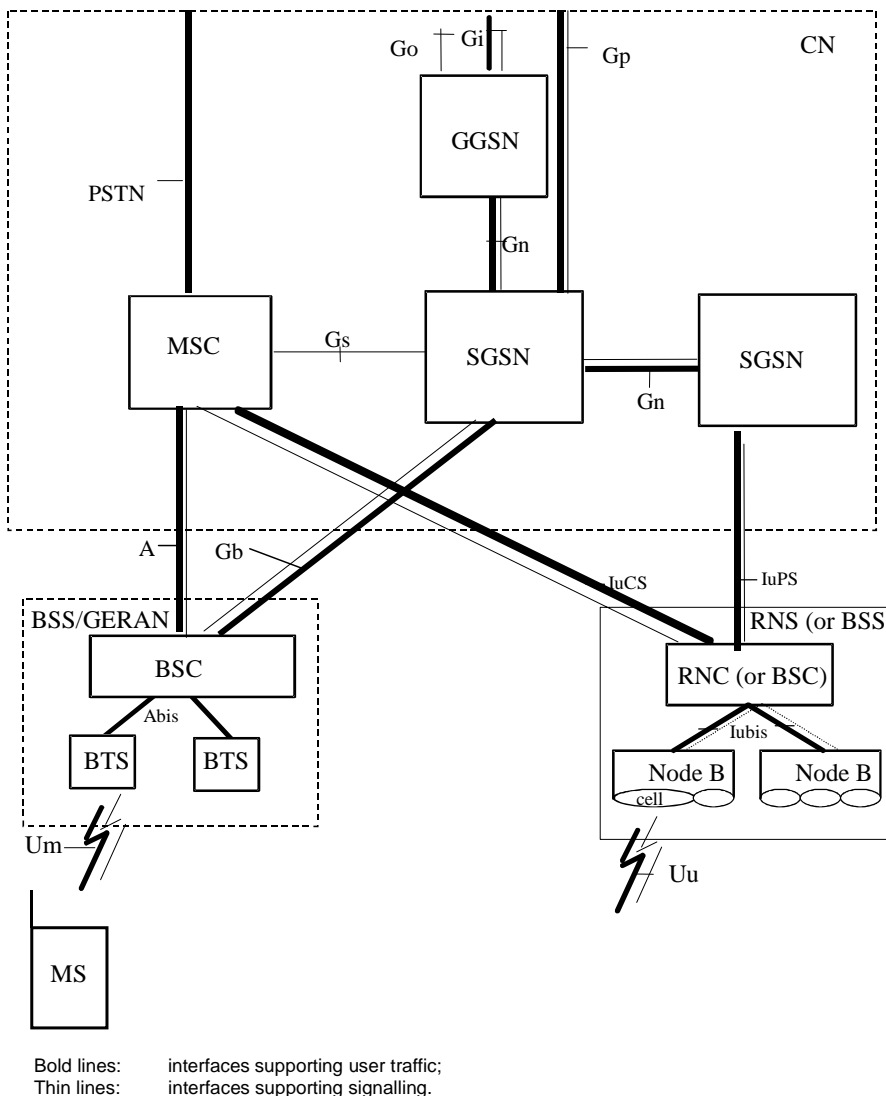

NOTE: The Iu interface is also supported by a GERAN BSS supporting Iu mode.

**Figure 1: Reference Architecture for PS handover in GERAN A/Gb mode**

## 4.2 Handover principles

### 4.2.1 General

The PS Handover procedure is used to handover an MS with one or more packet flows from a source cell to a target cell. The source and target cells can be located within either the same BSS (Intra BSS HO), different BSSs within the same SGSN (Intra SGSN HO) or belonging to different SGSNs (Inter SGSN HO), or systems with different radio access types (Inter RAT HO, Inter mode HO).

While the MS is still in the source cell:

- Radio resources in the target cell are allocated and signalled to the MS.
- System information of the target cell needed for access in the target cell is signalled to the MS.

For each scenario (Intra BSS HO, Intra SGSN HO, Inter SGSN HO and Inter RAT/mode HO) the PS handover procedure is divided into:

- a preparation phase; and
- an execution phase.

By using the Gs interface (together with NMO1) the interruption time for the PS Handover procedure would be shortened since using a combined LAU/RAU procedure would be possible.

## 4.2.2 PS Handover preparation phase

The PS handover preparation phase consists of the following consecutive steps:

- the decision by the source BSS to request a PS handover for an MS with one or more PFCs subject to handover:
  - the request from the source BSS to the old SGSN for the PS handover;
  - if the target BSS is not connected to the same SGSN the request from the old SGSN to the new SGSN to reserve resources;
- the reservation of resources in the target network nodes prior to ordering the MS to move to the target cell. This involves:
  - in case of Inter SGSN handover, the new SGSN reserving SNDCP/LLC resources and establishing Packet Flow Contexts;
  - in case of RA change the SGSN (which belongs to the RA) allocates a new P-TMSI and derives a new Local TLLI from this P-TMSI;
  - the target BSS reserving/allocating radio resources and Packet Flow Contexts in the target cell;
  - in case of Inter-SGSN handover, the definition of security related parameters for the new SGSN, e.g. ciphering algorithm, to be used in the target cell immediately in both uplink and downlink directions.

When handover has to be performed for an MS with multiple active PFCs, the SGSN requests the BSS to create one or more PFCs.

The target BSS may or may not establish radio resources for the created PFCs. If no radio resources at all are established the handover shall be rejected (see Section 5.4.2).

If not all the PFCs can be created successfully the target BSS indicates this to the new SGSN, which then informs the old SGSN/source BSS on the accepted and failed BSS PFCs.

PFCs with no radio resources reserved will be re-established upon arrival in the target cell.

## 4.2.3 PS Handover execution phase

The PS Handover execution phase consists of the following consecutive steps:

- packet forwarding by the old SGSN of the received DL packets both to the source BSS, new SGSN (if Inter SGSN HO) and the target BSS as soon as radio resources are reserved in the target BSS;
- the optional "blind" transmission by the target BSS of the DL RLC/MAC blocks over the reserved radio resources in the target cell is only valid for lossy type of services where unacknowledged LLC and RLC protocol modes are used;
- the command generated by the target BSS/RNS sent via the source BSS to order the MS to handover to the target cell;

- the notification by the MS of its presence in the target cell on the allocated radio resources;
- the redirection by the SGSN of the DL packets to the target BSS alone;
- the release of the resources on the source side including PFCs and radio resources.

### 4.2.4 PS Handover Network Node Responsibilities

This clause would reflect the Agreed Handover principles from the clause A.1 by listing the specific node responsibilities during PS handover.

## 4.3 Protocol architecture

This clause will contain information on the services and functions provided and required by each layer.

### 4.3.1 User plane overview

The user plane protocol architecture for GERAN A/Gb are depicted in figure 2.

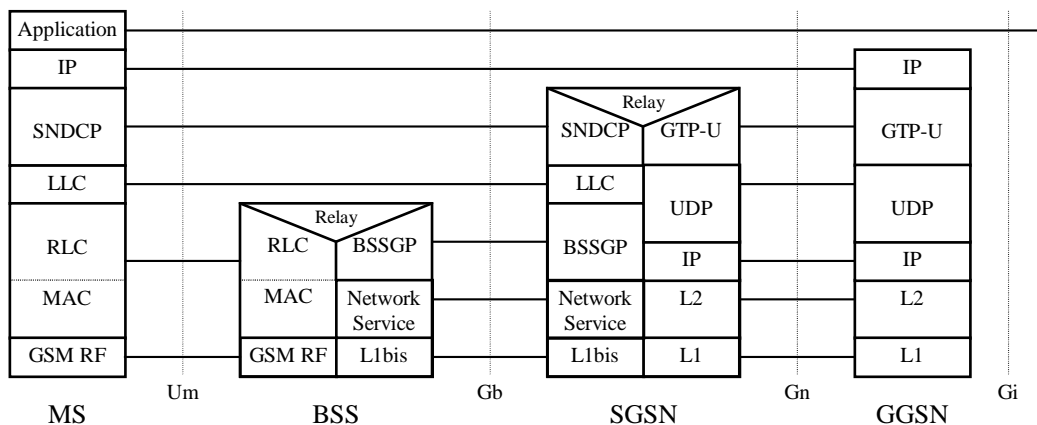

Figure 2: User Plane protocol architecture in A/Gb mode

### 4.3.2 Control plane overview

Figure 3 shows the protocol architecture for the control plane required to support PS Handover in A/Gb mode. Protocol entities on the network side under BSSGP are not shown, as the architecture remains the same as for the legacy A/Gb mode.

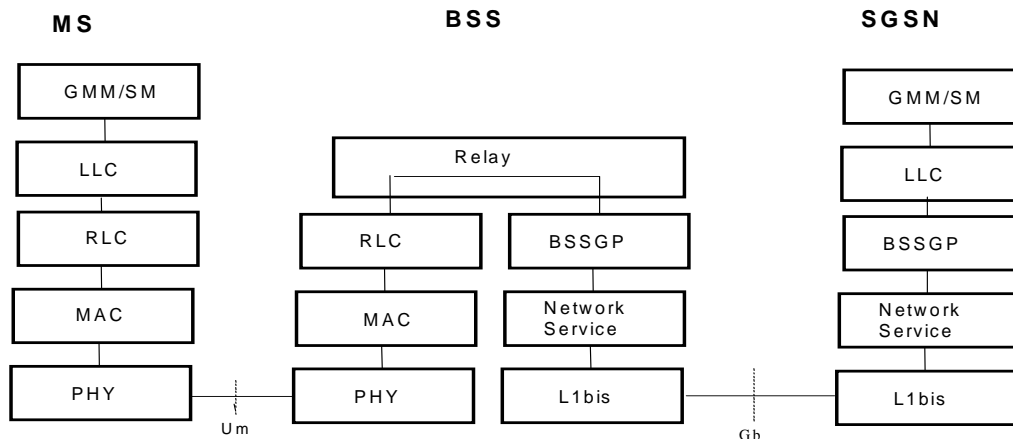

Figure 3: Control Plane Architecture in A/Gb mode

### 4.3.3 Physical Layer

#### 4.3.3.1 Shared Channels

##### 4.3.3.1.1 General

Radio resources on one or more shared channels may be assigned to an MS (according to its multislot capabilities) for exchange of user plane payload for any PFC between the BSS and the MS. The key characteristics of a service realized using a shared channel are as follows:

- RLC/MAC control messages are used to allocate the required uplink and downlink TBFs where both TBFs are associated with the same PFC and therefore are identified using the same PFI.
- Handover initiation decisions are made by the BSS and may be based on measurement reports or cell change notification information sent by the mobile station on PACCH.
- If the mobile station is allocated one or more shared channels in support of a PFC that is subject to handover, then the BSS may prohibit this MS from making autonomous cell re-selection decisions while that PFC is active.
- After the MS has moved to the target cell, initial uplink access in this cell is controlled by USF scheduling.

### 4.3.4 RLC/MAC

The services required from the RLC/MAC layer are:

- Data transfer in acknowledged mode.
- Data transfer in unacknowledged mode.
- Segmentation and reassembly.
- In-Sequence delivery of LLC PDUs (for a given PFC).
- Assignment, reconfiguration and release of TBFs and RLC instances (RLC/MAC control functions).
- Control of timing advance.
- Notification of unrecoverable errors to LLC.
- Handling of RLC/MAC control messages.

RLC/MAC services are required by radio resource management functions in order to send and receive messages to/from the MS and BSS relating to radio resource management.

RLC/MAC supports the following radio resource management features that are required for PS handover:

- Establishment of a TBF on one or more physical channel(s) in a given direction, for a given PFC.
- Reconfiguration of the radio resources assigned to one or more TBFs in downlink and/or uplink within a cell.
- Release of TBFs and associated radio resources following the corresponding service deactivation.
- Release of all TBFs and associated radio resources in the source cell, as a result of handover to a target cell.

### 4.3.5 Radio Resource (RR)

This clause will contain information on any impacts on the RR protocol related to support of PS Handover.

### 4.3.6 BSSGP

BSSGP is expected to provide the signalling channel for PS Handover related signalling between the CN and the BSS.

The services required from the BSSGP layer can therefore be summarised as:

- Transmission and reception of PS Handover related messages (i.e. PFM messages) over the Gb interface.
- Routing of PS Handover related messages to the PFM entity.
- Handling of PS Handover related messages with the appropriate priority.

## 4.3.7 Overview of PS Handover Signalling Messages

The signalling messages used during PS handover are divided into three groups depending on the utilized interface:

- PS handover signalling messages on the *Um* interface are RLC/MAC signalling blocks.
- PS handover signalling messages on the *Gb* interface are BSSGP signalling messages sent by the PFM entity.
- PS handover signalling messages on the *Gn* interface are GTP signalling messages.

### 4.3.7.1 PS handover signalling messages on the Um interface

The signalling messages used on the *Um* interface are:

- PS Handover Command (BSS -> MS).
- Packet Control Acknowledgement (MS -> BSS).
- PS Handover Access - Access Bursts (MS -> BSS).
- Packet Physical Information (BSS->MS).

### 4.3.7.2 PS handover signalling messages on the Gb interface

The Gb interface signalling messages are new signalling messages carried by the BSSGP. These signalling messages are to be defined in 3GPP TS 48.018 [10].

The signalling messages used on the *Gb* interface are:

- PS Handover Required (BSS->CN):
  - This message is sent from the BSS controlling the source cell to the SGSN to indicate that for a given MS which already has radio resource(s) assigned, a PS handover is required.
- PS Handover Request (CN->BSS):
  - This message is sent from the SGSN to the BSS controlling the target cell to request this BSS to reserve resources for the MS subject to PS Handover.
- PS Handover Request Acknowledge (BSS->CN):
  - This message is sent from the BSS controlling the target cell to the SGSN to report the outcome of the resource allocation for the requested BSS PFCs. This message indicates to the SGSN the successful resource allocation and the failure for one or more requested BSS PFCs.
- PS Handover Request Negative Acknowledge (BSS -> CN):
  - This message is sent from the BSS controlling the target cell to the SGSN to report the failure of the resource allocation for all the requested BSS PFCs.
- PS Handover Complete (BSS->CN):
  - This message is sent from the BSS controlling the target cell to the SGSN to notify the SGSN that the MS has made a successful access on the target cell. If PS Handover to UTRAN is supported by the MS and the BSS, it may also be used by the BSS to request the INTER RAT HANDOVER INFO from the SGSN.

- PS Handover Complete Ack (CN->BSS):
  - This message is sent from the SGSN to the BSS controlling the target cell to provide the MS inter-RAT terminal capabilities (INTER RAT HANDOVER INFO) if requested in the **PS Handover Complete** message.
- PS Handover Required Acknowledge (CN->BSS):
  - This message is sent from the SGSN to the BSS controlling the source cell to indicate that the MS can switch to the target cell.
- PS Handover Cancel (BSS->CN):
  - This message is sent from the BSS controlling the source cell to the SGSN to inform the SGSN to cancel an ongoing handover.
- PS Handover Required Negative Acknowledge (CN->BSS):
  - This message is sent from the SGSN to the BSS controlling the source cell to inform unsuccessful resource allocation or other PS handover failure in the target cell.

#### 4.3.7.3 PS handover signalling messages on the Gn interface

The Gn interface signalling messages are existing messages that will be used as described in 3GPP TS 29.060 [11].

The signalling messages used on the Gn interface between source SGSN and target SGSN are:

- Forward Relocation Request:
  - The old SGSN shall send a Forward Relocation Request message to the new SGSN to convey necessary information to perform the PS handover procedure between new SGSN and Target BSS.
- Forward Relocation Response:
  - The new SGSN shall send a Forward Relocation Response message to the old SGSN as a response to a previous Forward Relocation Request message.
- Forward Relocation Complete:
  - The new SGSN shall send a Forward Relocation Complete message to the old SGSN to indicate that the PS Handover procedure has been successfully finished.
- Forward Relocation Complete Acknowledge:
  - The old SGSN sends a Forward Relocation Complete Acknowledge message to the new SGSN as a response to Forward Relocation Complete message.
- Relocation Cancel Request:
  - The Relocation Cancel Request message is sent from the old SGSN to the new SGSN when the old SGSN is requested to cancel the PS Handover procedure by the source BSS by means of BSSGP message.
- Relocation Cancel Response:
  - The Relocation Cancel Response message is sent from the new SGSN to the old SGSN when the PS handover procedure has been cancelled in the old SGSN. This message is used as the response to the Relocation Cancel Request message.

GTP messages need to be enhanced with additional IE to support PS Handover.

## 4.4 Identifiers

The identifiers used in PS handover for GERAN A/Gb mode are the identities used by MS to connect via GERAN through the Gb interface as well as through the Iu interface to the Core Network.



A large number of these identities for GERAN A/Gb mode will be utilized in the PS handover procedure in GERAN A/Gb mode in the same manner as specified currently. However in order to support PS handover procedure new identifiers will be defined as well.

In order to enable data transmission and to address the resources allocated by the target system during the PS Handover procedure (i.e. for the case where the target cell belongs to another RA), before the MS moves to the target cell a new P-TMSI will be allocated by the SGSN associated with the RA the target cell belongs to. The new P-TMSI is a temporary and unique identifier in the new RA and is used to assign a local TLLI for the target cell.

NOTE: Further in this TS the term "local TLLI" refers to the Local TLLI derived from new P-TMSI assigned by the new SGSN and utilized in the target cell, whereas the term "old TLLI" refers to the Local TLLI utilized in the source cell that is derived from the P-TMSI assigned by the old SGSN.

In case of inter RAT PS Handover to/from UTRAN and inter-mode handover to/from GERAN Iu mode, existing UTRAN and GERAN Iu mode identifiers will be used.

The existing as well as new identifiers utilized in PS handover procedure for GERAN A/Gb mode are listed in table 1.

**Table 1: Identifiers utilized in PS handover in GERAN A/Gb mode**

Identifier	Specification reference
CI (Cell Identity)	3GPP TS 23.003 [12], 3GPP TS 25.401 [13], 3GPP TS 43.051 [14]
RAI (Routing Area Identity)	3GPP TS 23.003 [12]
LAI (Location Area Identity)	3GPP TS 24.008 [15]
IMSI (International Mobile Subscriber Identity)	3GPP TS 23.003 [12]
P-TMSI (Packet Temporary Mobile Subscriber Identity)	3GPP TS 23.003 [12]
TLLI (Temporary Logical Link Identity)	3GPP TS 23.003 [12]
RNTI (Radio Network Temporary Identity)	3GPP TS 44.118 [16], 3GPP TS 25.401 [13]
GRNTI (GERAN Radio Network Temporary Identity)	3GPP TS 25.401 [13]
U-RNTI (UTRAN-RNTI)	3GPP TS 25.401 [13]
TEID (Tunnel Endpoint Identifier)	3GPP TS 29.060 [11]
NSAPI (Network Service Access Point Identifier)	3GPP TS 29.060 [11]
TI (Transaction Identifier)	3GPP TS 24.007 [18]
SAPI (Service Access Point Identifier)	3GPP TS 29.060 [11]
PFI (Packet Flow Identifier)	3GPP TS 48.018 [10]
BVCI (BSSGP Virtual Connection Identifier)	3GPP TS 48.018 [10]
RAB Id (Radio Access Bearer Identifier)	3GPP TS 25.331 [17]
RB Id (Radio Bearer Identifier)	3GPP TS 25.331 [17]
TFI (Temporary Flow Identifier)	3GPP TS 44.060 [7]
USF (Uplink State Flag)	3GPP TS 44.060 [7]
Handover Reference	3GPP TS 44.018 [10]

#### 4.4.1 NSAPI, PFI, RAB ID relation during inter-RAT, inter-mode PS handover

During the inter-RAT and inter-mode PS handover to/from UTRAN/GERAN Iu there is a need to associate the MSs active PDP context with the BSS PFC and RABs in the respective SGSN(s).

As depicted in 3GPP TS 23.060 [19] NSAPI is a common identifier of the PDP context in all systems and as such it can be used by the MS to associate the active PDP contexts to the BSS PFC identified by the PFI and the RAB identified by the RAB Id during the inter-mode and inter-RAT PS handover. The MS has to associate the BSS PFC identified by the PFI utilized in GERAN A/Gb mode cell with a RAB identified by RAB Id utilized in the UTRAN /GERAN Iu mode cell. This is done through the relation with the NSAPI, which is the common identifier in both systems. MS performs this association based on the identifiers received by the network.

The information received by the MS/UE depends on the RAT of the target cell:

- In case of the UTRAN/GERAN Iu mode target cell and GERAN A/Gb mode source cell, the MS shall receive the RAB Id and associate this with its existing PFIs based on the relation with NSAPI.
- In case of the GERAN A/Gb mode target cell, UTRAN/GERAN Iu mode source cell, the UE shall receive the PFI for each of the accepted NSAPIs and associate them with its existing RAB IDs based on the relation with NSAPI. An SGSN supporting PS Handover to GERAN A/Gb mode shall always assign a SAPI and it shall

assign a valid PFI value if the UE has indicated the support of PS Handover procedures. The MS shall indicate in the MS network capability IE whether it supports "multiple TBFs". The SGSN may use this information when allocating the SAPI and PFI during PDP Context activation. During handover preparation the SAPI and PFI values shall be sent from the old SGSN to the new SGSN.

- If the old SGSN did not assign a valid PFI value for one or more PDP Contexts, the new SGSN shall after successful completion of the RAU initiate explicit SM procedure to allocate a PFI value according to its policy for each of the PDP Contexts for which no PFI is currently allocated. If none of the PDP Contexts forwarded from the old SGSN has a valid PFI allocated the new SGSN shall consider this as a failure case and the request for PS handover shall be rejected..

---

## 5 Signalling procedures

### 5.1 GERAN (*A/Gb mode*) → GERAN (*A/Gb mode*) handover

#### 5.1.1 Intra Cell

Intra Cell PS Handover will be needed in cases when a new channel is selected in the same cell to be used by the MS. This is handled by the BSS internally and if there are no changes in the new channel there is no need for BSS to notify the SGSN about the change of channel.

BSS/SGSN signalling will be needed in case the new channel has limited resources and cannot support the same QoS, for the BSS PFC as the old channel.

For these purpose existing modification procedures on the Um and Gb interface are used, e.g. PACKET TIMESLOT RECONFIGURE (3GPP TS 44.060 [7]) on the air interface and MODIFY BSS PFC (3GPP TS 48.018 [10]) procedure on the Gb interface.

If the modification procedures fail BSS may cancel the intra cell PS handover procedure.

#### 5.1.2 Intra BSS

##### 5.1.2.1 General

This clause is further split into two clauses. The first describes an intra-BSS handover procedure based largely on the inter-BSS handover procedure. The second section describes an optional optimised intra-BSS handover procedure. When the source and target cells are within the same BSS the handover can be either executed by the BSS itself (optimised handover) or by involving the SGSN in the preparation phase. In the latter case although handover is performed within one BSS the roles of source BSS and target BSS are the same as in Inter BSS Handover.

## 5.1.2.2 Intra BSS HO; Preparation phase

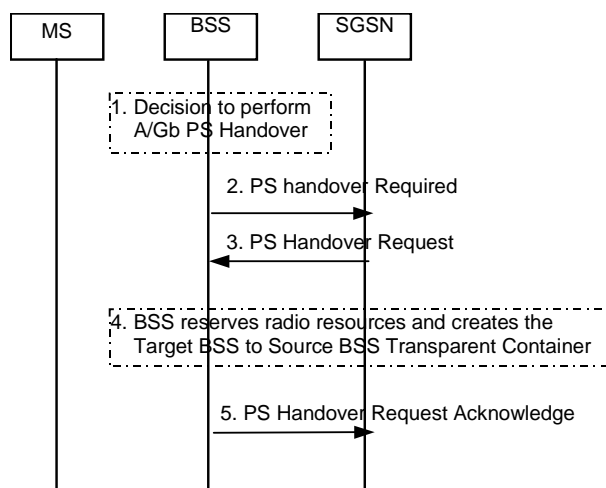

**Figure 4: PS Handover Preparation Phase; Intra-BSS case (GERAN A/Gb mode → GERAN A/Gb mode)**

1. The BSS decides to initiate a PS handover. At this point both uplink and downlink user data is transmitted via the following: TBFs between the MS and BSS, BSSGP PFCs tunnel(s) between the BSS and SGSN, GTP tunnel(s) between the SGSN and GGSN.
2. The BSS sends a **PS Handover Required** (Old TLLI, Cause, Source Cell Identifier, Target Cell Identifier, Source BSS to Target BSS Transparent Container (RN part), Active PFCs List) message to the SGSN.
3. The SGSN determines from the Target Cell Identifier the type of handover, i.e. intra-SGSN, inter-SGSN or inter-RAT/mode handover and whether the routing area has changed. In case of no change of routing area, the SGSN sends a **PS Handover Request** (TLLI, Cause, IMSI, Source Cell Identifier, Target Cell Identifier, PFCs To Be Set Up List, Source BSS to Target BSS Transparent Container (RN part)) message to the BSS. In case when the routing area changes the SGSN allocates a new P-TMSI for this MS and derives a local TLLI from this P-TMSI prior to the sending of the **PS Handover Request** message. The SGSN shall only request resources for PFCs that are included in the Active PFCs List.

NOTE: The BSS PFCs required to be set up are downloaded to the target BSS from the SGSN, i.e. all information required for PFC creation.

4. Based upon the ABQP for each PFC the BSS makes a decision about which PFCs to assign radio resources. The algorithm by which the BSS decides which PFCs that need resources is implementation specific. Due to resource limitations not all downloaded PFCs will necessarily receive resource allocation. The BSS allocates TBFs for each PFC that can be accommodated.

After allocating radio resources the target BSS shall prepare the Target BSS to Source BSS Transparent Container for the set up BSS PFCs.

5. The BSS shall send the **PS Handover Request Acknowledge** (TLLI, List of Set Up PFCs, Target BSS to Source BSS Transparent Container (PS Handover Command with RN part)) message to the SGSN. Upon sending the **PS Handover Request Acknowledge** message the BSS shall be prepared to receive downlink LLC PDUs directed to the new cell and associated with the accepted PFCs.

When the SGSN receives the **PS Handover Request Acknowledge** message and it decides to proceed with the handover, the preparation phase is finished and the execution phase will follow.

## 5.1.2.3 Intra BSS HO; Execution phase

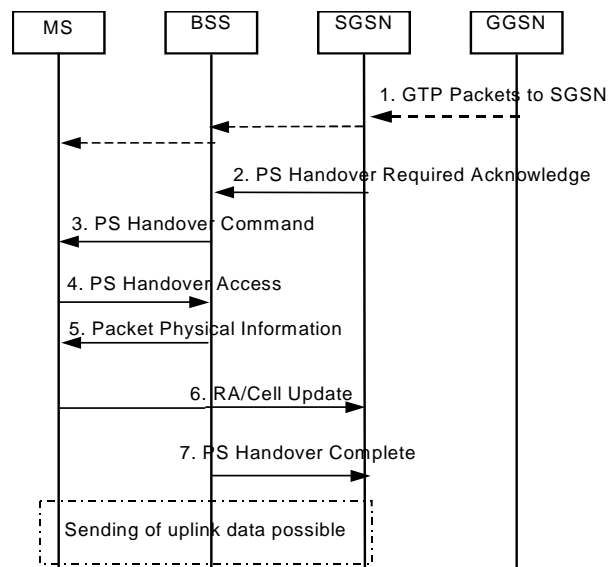

Figure 5: PS Handover Execution Phase; Intra-BSS case (GERAN A/Gb mode → GERAN A/Gb mode)

1. The SGSN continues to receive GTP packets from the GGSN (via GTP) and forwards the associated PDU payload to the MS via the BSS.

When receiving the **PS Handover Request Acknowledge** message the SGSN may, based on QoS, start duplication of LLC PDUs and forward those to the new cell in the BSS. If the SGSN forwards downlink packets to the new cell in the BSS, the BSS may start blind transmission of downlink user data towards the MS over the allocated radio channels.

2. The SGSN continues the PS Handover by sending a **PS Handover Required Acknowledge** (Old TLLI, List of Set Up PFCs, Target BSS to Source BSS Transparent Container (PS Handover Command with RN part)) message to the BSS.

Before sending the **PS Handover Required Acknowledge** message, the SGSN, based on QoS, may suspend downlink data transfer for any PDP contexts.

Before sending the **PS Handover Command** message to the MS the BSS, based on QoS, may try to empty the downlink BSS buffer for any BSS PFCs.

NOTE 1: Only PFI(s) for PFCs accepted by the target cell are included in the message.

3. The BSS sends the **PS Handover Command** (RN part) message to the MS by interrupting the transmission of LLC PDUs on any of the downlink TBFs. Following the transmission of this signalling message the BSS may resume LLC PDU transmission until it either has no more LLC PDUs to send or the PFC is released. Upon reception of the **PS Handover Command** the MS is not required to continue data reception in the source cell. The MS shall suspend the uplink transmission of user plane data. MS management of uplink N-PDUs following the reception of the **PS Handover Command** message is as follows:

- All uplink packets associated with a PFC receiving handover treatment that have not yet been fully transmitted might be buffered depending on the QoS class.
- Subsequent uplink packets that become available for transmission following the reception of the **PS Handover Command** message might also be buffered depending on the QoS class.
- The MS may discard uplink packets during the link interruption to preserve the real-time properties.

4. The MS tunes to the radio channel and the timeslot allocated in the target cell by the BSS and may send the **PS Handover Access** (Handover Reference) message in the form of four handover access bursts to the BSS on the allocated channel. The **PS Handover Command** message indicates whether or not the MS shall send **PS Handover Access** messages.

5. The BSS sends a **Packet Physical information** message to the MS containing update of the timing advance for the MS to synchronize.

NOTE 2: In the case of pre-synchronised handover the MS may receive the timing advance information to use in uplink in the target cell in the **PS Handover Command** message (if no timing advance information is included, the mobile station uses a default timing advance in the target cell). In a pre-synchronised or synchronised handover, the **Packet Physical information** message is not sent in the target cell.

6. The MS sends uplink LLC PDUs, e.g. a **Routing Area Update Request** message or uplink user data packets to the SGSN immediately after receiving the **Packet Physical Information** message or, in a synchronised or pre-synchronised handover, immediately if the **PS Handover Access** message is not required to be sent (see Section 6.2).

The MS shall resume the user data transfer only for those NSAPIs for which radio resources are allocated in the target cell. For NSAPIs using LLC ADM for which radio resources were not allocated in the target cell the MS may request radio resources using the legacy procedures.

7. Upon reception of the first correct RLC/MAC block (sent in normal burst format) from the MS the BSS sends a **PS Handover Complete** (TLLI, IMSI) message to inform the SGSN that the MS has arrived in the target cell. After the reception of the **PS Handover Complete** message the SGSN shall initiate the BSS PFC procedures to delete the BSS PFC in the BSS controlling the source cell and shall be prepared to receive data from the new cell. The source BSS initiates the release of the radio resources in the source cell after receiving the DELETE-BSS-PFC PDU from the SGSN.

If Routing Area Update occurs after completion of the execution phase, then the CAMEL procedure calls shall be performed according to 3GPP TS 23.060.

#### 5.1.2.4 Intra BSS Handover - Optimised

This clause describes the optimised intra-BSS PS handover procedures applicable for the case where the source and target cells are associated with the same Network Service Entity (NSE) and the same Routing Area (RA). The optimisation involves the BSS providing the data forwarding function and does not require any explicit signalling with the SGSN except the sending of PS Handover Complete at the end of PS Handover. Support for this procedure is optional for the BSS.

Supporting this procedure requires that the BSS be able to determine whether or not it manages PS resources for the target cell, whether or not the target cell is associated with the same NSE, that it can internally forward LLC PDUs from the source to the target cell and whether or not both cells are part of the same RA (i.e. the SGSN is not required to make this determination and relay this information). If the BSS cannot make these determinations it shall use the non-optimised intra-BSS PS handover procedures described in clauses 5.1.2.2 and 5.1.2.3.

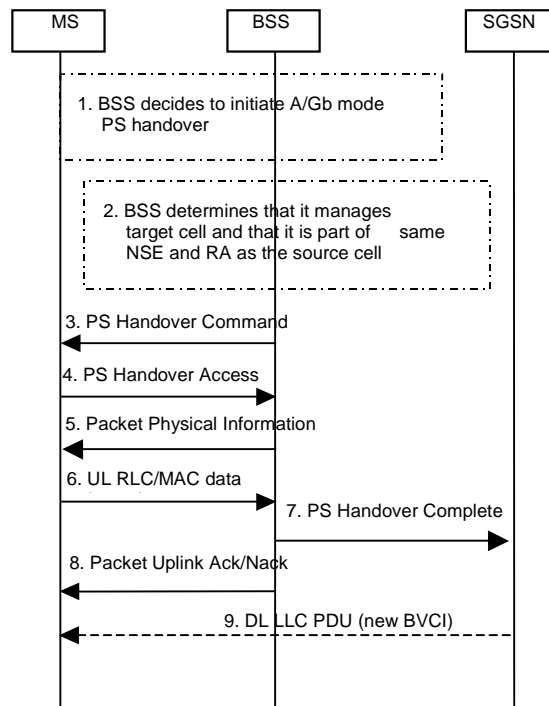

**Figure 6: Optimised Intra-BSS PS Handover (same NSE and same RA)**

1. The BSS decides that a handover is required based on e.g. received measurement reports.
2. The BSS determines that it manages resources for both cells and that they are associated with the same (NSE) and the same RA. The BSS applies data forwarding (from the old cell to the new cell) for PFCs that it determines are to receive PS handover treatment.

NOTE 1: The MS does not know if optimised or non-optimised intra-BSS PS handover procedures are used.

3. The BSS sends the **PS Handover Command** (RN part) message to the MS by interrupting the transmission of LLC PDUs on any of the downlink TBFs. Following the transmission of this signalling message the BSS may resume LLC PDU transmission until it either has no more LLC PDUs to send or the PFC is released. Upon reception of the **PS Handover Command** the MS is not required to continue data reception in the source cell. Upon reception of the **PS Handover Command** the MS shall suspend the uplink transmission of user plane data. MS management of uplink N-PDUs following the reception of the **PS Handover Command** message is as follows:

- All uplink packets associated with a PFC receiving handover treatment that have not yet been fully transmitted might be buffered depending on the QoS class.
- Subsequent uplink packets that become available for transmission following the reception of the **PS Handover Command** message might also be buffered depending on the QoS class.
- The MS may discard uplink packets during the link interruption to preserve the real-time properties.

4. The MS tunes to the radio channel and the timeslot allocated in the target cell by the BSS and if so required by the BSS (see sub-clause 6.2) sends the **PS Handover Access** (Handover Reference) message in the form of four handover access bursts to the BSS on the allocated channel. The **PS Handover Command** message indicates whether the **PS Handover Access** message shall be sent by the MS.
5. Upon receipt of the **PS Handover Access** message, based on the Handover Reference, the BSS sends the **Packet Physical Information** message, if needed (see sub-clause 6.2), with the timing advance to the MS for the MS to synchronise.

NOTE 2: In the case of pre-synchronised handover the MS may receive the timing advance information to use in uplink in the target cell in the **PS Handover Command** message (if no timing advance information is included, the mobile station uses a default timing advance in the target cell). In a pre-synchronised or synchronized handover the **Packet Physical information** message is not sent in the target cell.

6. The MS sends uplink LLC PDUs, e.g. uplink user data packets, in the allocated channel to the BSS.

The MS shall resume the user data transfer only for those NSAPIs for which there are radio resources allocated in the target cell. For NSAPIs using LLC ADM for which radio resources were not allocated in the target cell the MS may request radio resources using the legacy procedures.

7. Upon reception of the first correct RLC/MAC block (sent in normal burst format) from the MS, the BSS releases the radio resources in the source cell and sends, on the target cell BVCI, the **PS Handover Complete** (TLLI, IMSI, Target Cell Identifier) message to the SGSN in order to indicate that the BSS has performed an internal handover. In this case, the target cell is indicated in the **PS Handover Complete** message.
8. Once the BSS has correctly identified the MS, it sends a **Packet Uplink Ack/Nack** message (see 3GPP TS 44.060) indicating the status of the received RLC data blocks.
9. The reception of the **PS Handover Complete** message at the SGSN triggers the sending of downlink data to the new cell using a new BVCI. The first DL PDU received by the BSS with the new-BVCI allows the BSS to clear the relationship to the old BVCI.

The reception of the PS handover Complete message indicates to the SGSN that there is no need to wait for the Cell Update sent from the MS to the SGSN.

NOTE 3: It is assumed here that downlink flow control is carried out on a per PFC basis and that the PFC specific flow control parameters remain the same upon MS arrival in the target cell.

## 5.1.3 Intra SGSN

### 5.1.3.1 Intra SGSN/Inter BSS HO, Preparation phase

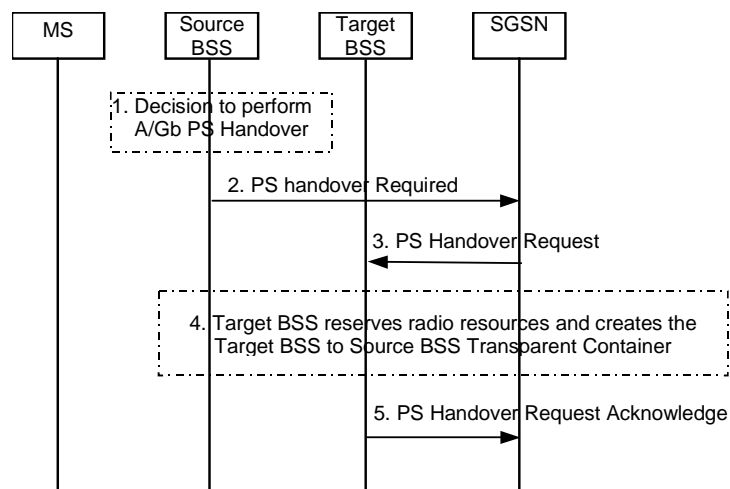

**Figure 7: PS Handover Preparation Phase; Intra-SGSN/Inter-BSS case (GERAN A/Gb mode → GERAN A/Gb mode)**

1. The source BSS decides to initiate a PS handover. At this point both uplink and downlink user data is transmitted via the following: TBFs between MS and source BSS, BSSGP PFCs tunnel(s) between the source BSS and SGSN, GTP tunnel(s) between the SGSN and GGSN.
2. The source BSS sends a **PS Handover Required** (Old TLLI, Cause, Source Cell Identifier, Target Cell Identifier, Source BSS to Target BSS Transparent Container (RN part), Active PFCs List, Reliable INTER RAT HANDOVER INFO) message to the SGSN.

The source BSS should always include the "Reliable INTER RAT HANDOVER INFO" indicator set to "1" in the **PS Handover Required** message if the INTER RAT HANDOVER INFO in the Source BSS to Target BSS Transparent Container was received from the SGSN in a **PS Handover Complete Ack** message or a **PS Handover Request** message with 'Reliable INTER RAT HANDOVER INFO' set to '1' or a **CREATE-BSS-PFC** message. It shall be set to "0" otherwise.

3. The SGSN determines from the Target Cell Identifier the type of handover, i.e. intra-SGSN, inter-SGSN or inter-RAT/mode handover and whether the routing area has changed. In case of no change of routing area, the SGSN sends a **PS Handover Request** (TLLI, Cause, IMSI, Source Cell Identifier, Target Cell Identifier, PFCs To Be Set Up List, Source BSS to Target BSS Transparent Container (RN part), Reliable INTER RAT HANDOVER INFO) message to the target BSS. In case of Intra-SGSN PS handover when the routing area changes, the SGSN shall assign a new P-TMSI for the MS and derive a local TLLI prior to the sending of the **PS Handover Request** message. The SGSN shall only request resources for PFCs that are included in the Active PFCs List. If received in a **PS Handover Required** message, the SGSN should forward the "Reliable INTER RAT HANDOVER INFO" indicator to the target BSS in the **PS Handover Request** message.

NOTE 1: The BSS PFCs required to be set up are downloaded to the target BSS from the SGSN, i.e. all information required for PFC creation.

4. Based upon the ABQP for each PFC the target BSS makes a decision about which PFCs to assign radio resources. The algorithm by which the BSS decides which PFCs that need resources is implementation specific. Due to resource limitations not all downloaded PFCs will necessarily receive resource allocation. The target BSS allocates TBFs for each PFC that can be accommodated by the target BSS.

After allocating radio resources the target BSS shall prepare the Target BSS to Source BSS Transparent Container for the set up BSS PFCs.

5. The target BSS sends the **PS Handover Request Acknowledge** (TLLI, List of Set Up PFCs, Target BSS to Source BSS Transparent Container (PS Handover Command with RN part)) message to the SGSN. Upon sending the **PS Handover Request Acknowledge** message the target BSS shall be prepared to receive downlink LLC PDUs from the SGSN for the accepted PFCs.

When the SGSN receives the **PS Handover Request Acknowledge** message and it decides to proceed with the handover, the preparation phase is finished and the execution phase will follow.

### 5.1.3.2 Intra SGSN/Inter BSS HO, Execution phase

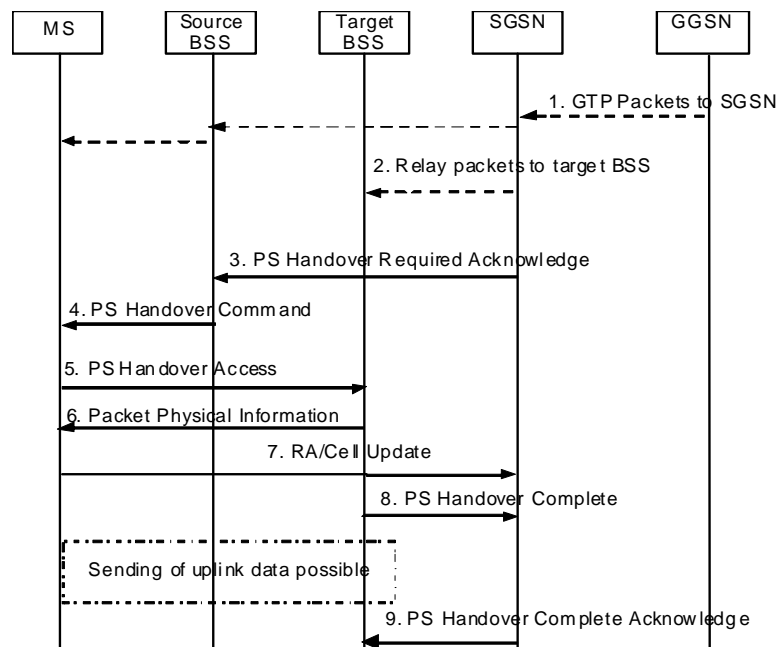

**Figure 8: PS Handover Execution Phase; Intra-SGSN/Inter-BSS case (GERAN A/Gb mode → GERAN A/Gb mode)**

1. The SGSN continues to receive GTP packets from the GGSN (via GTP) and forwards the associated PDU payload to the MS via the source BSS.
2. When receiving the **PS Handover Request Acknowledge** message the SGSN may, based on QoS, start duplication of LLC PDUs and forward those to the target BSS. If the SGSN forwards downlink packets to the



target BSS, the target BSS may start blind transmission of downlink user data towards the MS over the allocated radio channels.

3. The SGSN continues the PS Handover by sending a **PS Handover Required Acknowledge** (Old TLLI, List of Set Up PFCs, Target BSS to Source BSS Transparent Container (PS Handover Command with RN part)) message to the source BSS.

Before sending the **PS Handover Required Acknowledge** message, the SGSN, based on QoS, may suspend downlink data transfer for any PDP contexts.

Before sending the **PS Handover Command** message to the MS the source BSS, based on QoS, may try to empty the downlink BSS buffer for any BSS PFCs.

NOTE 1: Only PFI(s) for PFCs accepted by the target cell are included in the message.

4. The source BSS sends the **PS Handover Command** (RN part) message to the MS by interrupting the transmission of LLC PDUs on any of the downlink TBFs. Following the transmission of this signalling message the source BSS may resume LLC PDU transmission until it either has no more LLC PDUs to send or the PFC is released. Upon reception of the **PS Handover Command** message the MS is not required to continue data reception in the source cell. Upon reception of the **PS Handover Command** message the MS shall suspend the uplink transmission of user plane data. MS management of uplink N-PDUs following the reception of the **PS Handover Command** message is as follows:
  - All uplink packets associated with a PFC receiving handover treatment that have not yet been fully transmitted might be buffered depending on the QoS class.
  - Subsequent uplink packets that become available for transmission following the reception of the **PS Handover Command** message might also be buffered depending on the QoS class.
  - The MS may discard uplink packets during the link interruption to preserve the real-time properties.
5. The MS tunes to the radio channel and the timeslot allocated in the target cell by the BSS and may send the **PS Handover Access** (Handover Reference) message in the form of four handover access bursts to the BSS on the allocated channel. The **PS Handover Command** message indicates whether or not the MS shall send **PS Handover Access** messages.
6. The target BSS sends a **Packet Physical information** message to the MS containing the timing advance for the MS to synchronise.

NOTE 2: In the case of pre-synchronised handover the MS may receive the timing advance information to use in uplink in the target cell in the **PS Handover Command** message (if no timing advance information is included, the mobile station uses a default timing advance in the target cell). In a pre-synchronised or synchronised handover, the **Packet Physical Information** message is not sent in the target cell.

7. The MS sends uplink LLC PDUs, e.g. a **Routing Area Update Request** message or uplink user data packets to the SGSN immediately after receiving the **Packet Physical Information** message or, in a synchronised or pre-synchronised handover, immediately if the **PS Handover Access** message is not required to be sent (see Section 6.2).

The MS shall resume the user data transfer only for those NSAPIs for which there are radio resources allocated in the target cell. For NSAPIs using LLC ADM for which radio resources were not allocated in the target cell the MS may request for radio resources using the legacy procedures.

8. Upon reception of the first correct RLC/MAC block (sent in normal burst format) from the MS the target BSS sends a **PS Handover Complete** (TLLI, IMSI, Request for INTER RAT HANDOVER INFO) message to inform the SGSN that the MS has arrived in the target cell. After the reception of the **PS Handover Complete** message the SGSN shall initiate the BSS PFC procedures to delete the BSS PFC in the BSS controlling the source cell and shall be prepared to receive data from the new cell. The source BSS initiates the release of the radio resources in the source cell after receiving the DELETE-BSS-PFC PDU from the SGSN. The target BSS that supports inter-RAT PS handover to UTRAN should request the INTER RAT HANDOVER INFO from the SGSN if the "Reliable INTER RAT HANDOVER INFO" is missing or set to "0" in the **PS Handover Request** message or if it has not received the INTER RAT HANDOVER INFO as part of the Source BSS to Target BSS transparent container.

9. Upon reception of the **PS Handover Complete** message with the "Request for Inter RAT Handover Info" set to "1", the SGSN should send the **PS Handover Complete Acknowledge** (TLLI, INTER RAT HANDOVER INFO) message to the target BSS.

NOTE 3: An SGSN that does not recognize the 'Request for Inter RAT Handover Info' in the **PS Handover Complete** message will not send the **PS Handover Complete Acknowledge** message to the target BSS.

10. The target BSS receiving the **PS Handover Complete Acknowledge** message shall set the "Reliable INTER RAT HANDOVER" to "1" in the **PS Handover Required** message in any subsequent PS handover to GERAN *A/Gb mode*. The target BSS failing to receive the **PS Handover Complete Acknowledge** message shall set the "Reliable INTER RAT HANDOVER" to "0" in the **PS Handover Required** message in any subsequent PS handover to GERAN *A/Gb mode*. The target BSS shall, upon receipt of the INTER RAT HANDOVER INFO in the **PS Handover Complete Acknowledge** message, discard the INTER RAT HANDOVER INFO received from the source BSS during the preparation phase.

If Routing Area Update occurs after completion of the execution phase, then the CAMEL procedure calls shall be performed according to 3GPP TS 23.060.

## 5.1.4 Inter SGSN

### 5.1.4.1 Inter SGSN HO, Preparation phase

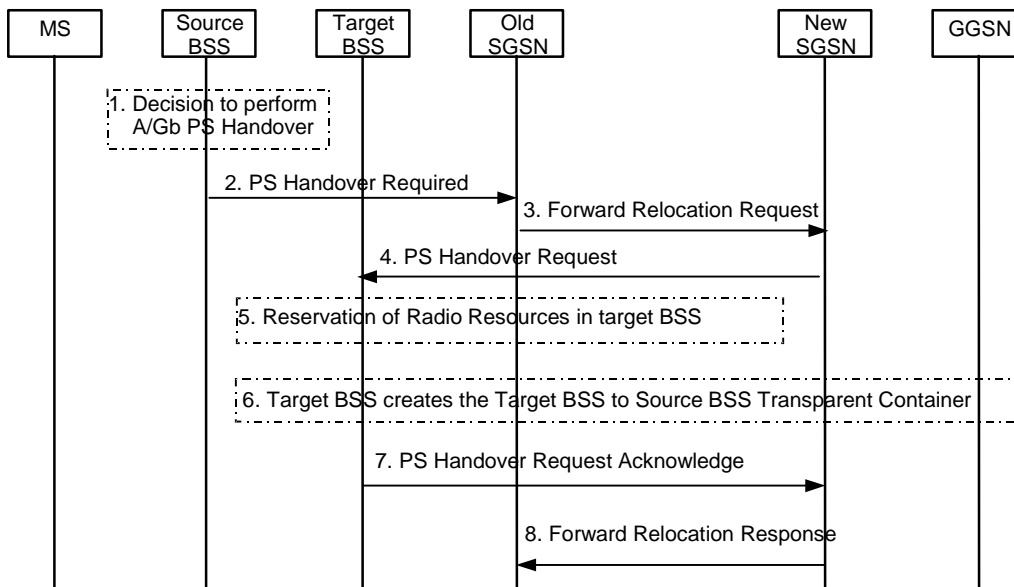

Figure 9: PS Handover Preparation Phase; Inter-SGSN case (GERAN *A/Gb mode* → GERAN *A/Gb mode*)

1. The source BSS decides to initiate a PS handover. At this point both uplink and downlink user data is transmitted via the following: TBFs between MS and source BSS, BSSGP PFCs tunnel(s) between source BSS and old SGSN, GTP tunnel(s) between old SGSN and GGSN.
2. The source BSS sends a **PS Handover Required** (Old TLLI, Cause, Source Cell Identifier, Target Cell Identifier, Source BSS to Target BSS Transparent Container (RN part), Active PFCs List, Reliable INTER RAT HANDOVER INFO) message to the old SGSN.

The source BSS should always include the "Reliable INTER RAT HANDOVER INFO" indicator set to "1" in the **PS Handover Required** message if the INTER RAT HANDOVER INFO in the Source BSS to Target BSS Transparent Container was received from the SGSN in a **PS Handover Complete Ack** message or a **PS Handover Request** message with 'Reliable INTER RAT HANDOVER INFO' set to '1' or a **CREATE-BSS-PFC** message. It shall be set to "0" otherwise.

3. The old SGSN determines from the Target Cell Identifier that the type of handover is inter-SGSN. In case of inter-SGSN PS Handover, the old SGSN initiates the PS Handover resource allocation procedure by sending a **Forward Relocation Request** (IMSI, Cause, Source Cell Identifier, Target Cell Identifier, MM Context, PDP

Contexts, Packet Flow ID, SNDCP XID parameters, LLC XID parameters, Tunnel Endpoint Identifier for the Control Plane, SGSN Address for the control plane, Source BSS to Target BSS Transparent Container (RN part) in the BSS container, PDP Context Prioritisation, "Reliable INTER RAT HANDOVER INFO") message to the new SGSN. The old SGSN sends all active PDP contexts to the new SGSN indicating the PFIs and the XID parameters related to those PDP contexts. Each PDP context contains the GGSN Address for the User Plane and the Uplink TEID for Data (to this GGSN Address and Uplink TEID for Data the old SGSN and the new SGSN send uplink packets).

The MM context contains security related information, e.g. used ciphering algorithm and ciphering key as described in 3GPP TS 29.060 [11]. The relation between GSM and UMTS security parameters is defined in 3GPP TS 33.102 [27].

The Ciphering key used by the old SGSN is reused by the new SGSN until a new authentication procedure is performed (see clause 5.1.4.2, bullet 13).

If the new SGSN does not support the indicated ciphering algorithm, the new SGSN has to select a new ciphering algorithm. This new algorithm will be sent transparently from the new SGSN to the MS. The IOV-UI parameter generated in the new SGSN and used as input to the ciphering procedure will also be transferred transparently from the new SGSN to the MS.

When the new SGSN receives the **Forward Relocation Request** message it extracts from the PDP Contexts the associated NSAPIs, SAPIs and PFIs to be used in the new SGSN. In case when the new SGSN does not support the same SAPI and PFI indicated by the old SGSN for a certain NSAPI, the new SGSN shall continue the PS handover procedure only for those NSAPIs for which it can support the same PFI and SAPI as the old SGSN and for which it can allocate resources. All PDP contexts for which no resources are allocated by the new SGSN or for which it cannot support the same SAPI and PFI (i.e. the corresponding NSAPIs are not addressed in the **Forward Relocation Response** message of the target SGSN), are maintained in the new SGSN and the related SAPIs and PFIs are kept. When this occurs the packet data transfer corresponding to PDP Contexts for which new SAPI and PFI values are needed are suspended. These PDP contexts may be modified or deactivated by the new SGSN via explicit SM procedures upon the completion of the routing area update (RAU) procedure. When the required PDP, MM, SNDCP and LLC contexts are established and the mapping between NSAPI, SAPI and PFI for each of these PDP Contexts is established, the corresponding packet data transfer can continue.

If for a given PDP Context the new SGSN does not receive a PFI from the old SGSN, it shall not request the target BSS to allocate TBF resources corresponding to that PDP Context.

If none of the PDP Contexts forwarded from the old SGSN has a valid PFI allocated the new SGSN shall consider this as a failure case and the request for PS handover shall be rejected.

The old SGSN shall indicate the current XID parameter settings (i.e. those used at the old SGSN) to the new SGSN. If the new SGSN can accept all XID parameters as indicated by the old SGSN, the new SGSN shall create a NAS container for PS HO indicating 'Reset to the old XID parameters'.

NOTE 1: 'Reset to the old XID parameters' means that the LLC and SNDCP layer are reset, except for the LLC XID parameters and SNDCP XID parameters which are re-initialized to the latest negotiated values, and the negotiated compression entities which are re-initialized.

NOTE 2: void

Otherwise the new SGSN shall create a NAS container for PS HO indicating Reset (i.e. reset to default parameters).

If received in a **PS Handover Required** message, the old SGSN should forward the "Reliable INTER RAT HANDOVER INFO" indicator to the new SGSN in the **Forward Relocation Request** message.

4. The new SGSN sends a **PS Handover Request** (Local TLLI, Cause, IMSI, Source Cell Identifier, Target Cell Identifier, Source BSS to Target BSS Transparent Container (RN part), PFCs To Be Set Up List, NAS container for PS HO, Reliable INTER RAT HANDOVER INFO) message to the target BSS. The new SGSN shall not request resources for PFCs associated with PDP contexts with a maximum bit rate for uplink and downlink of 0 kbit/s. If received in a **Forward Relocation Request** message, the new SGSN should forward the "Reliable INTER RAT HANDOVER INFO" indicator to the target BSS in the **PS Handover Request** message.

NOTE 3: The BSS PFCs required to be set up are downloaded to the target BSS from the new SGSN, i.e. all information required for PFC creation.

5. Based upon the ABQP for each PFC the target BSS makes a decision about which PFCs to assign radio resources. The algorithm by which the BSS decides which PFCs that need resources is implementation specific. Due to resource limitations not all downloaded PFCs will necessarily receive resource allocation. The target BSS allocates TBFs for each PFC that can be accommodated by the target BSS.
6. The target BSS shall prepare the Target BSS to Source BSS Transparent Container which contains a PS Handover Command including the CN part (NAS container for PS HO) and the RN part (PS Handover Radio Resources).
7. The target BSS shall send the **PS Handover Request Acknowledge** (Local TLLI, List of Set Up PFCs, Target BSS to Source BSS Transparent Container) message to the new SGSN. Upon sending the **PS Handover Request Acknowledge** message the target BSS shall be prepared to receive downlink LLC PDUs from the new SGSN for the accepted PFCs.
8. When the new SGSN receives the **PS Handover Request Acknowledge** message the **Forward Relocation Response** (Cause, List of Set Up PFCs, Target BSS to Source BSS Transparent Container in the BSS Container, Tunnel Endpoint Identifier Control Plane, SGSN Address for the control plane, Tunnel Endpoint Identifier Data II) message is sent from the new SGSN to the old SGSN. This message indicates that the new SGSN is ready to receive packets forwarded from the old SGSN. If the target BSS or the new SGSN failed to allocate resources this shall be indicated in the message. The Tunnel Endpoint Identifier Data II, one information for each PDP context, contains the tunnel endpoint of the new SGSN and the IP address of the new SGSN for data forwarding from the old to the new SGSN.

The new SGSN activates the allocated LLC/SNDCP engines as specified in 3GPP TS 44.064 [21] for an SGSN originated Reset or 'Reset to the old XID parameters'.

When the old SGSN receives the **Forward Relocation Response** message and it decides to proceed with the handover, the preparation phase is finished and the execution phase will follow.

5.1.4.2 Inter SGSN HO, Execution phase

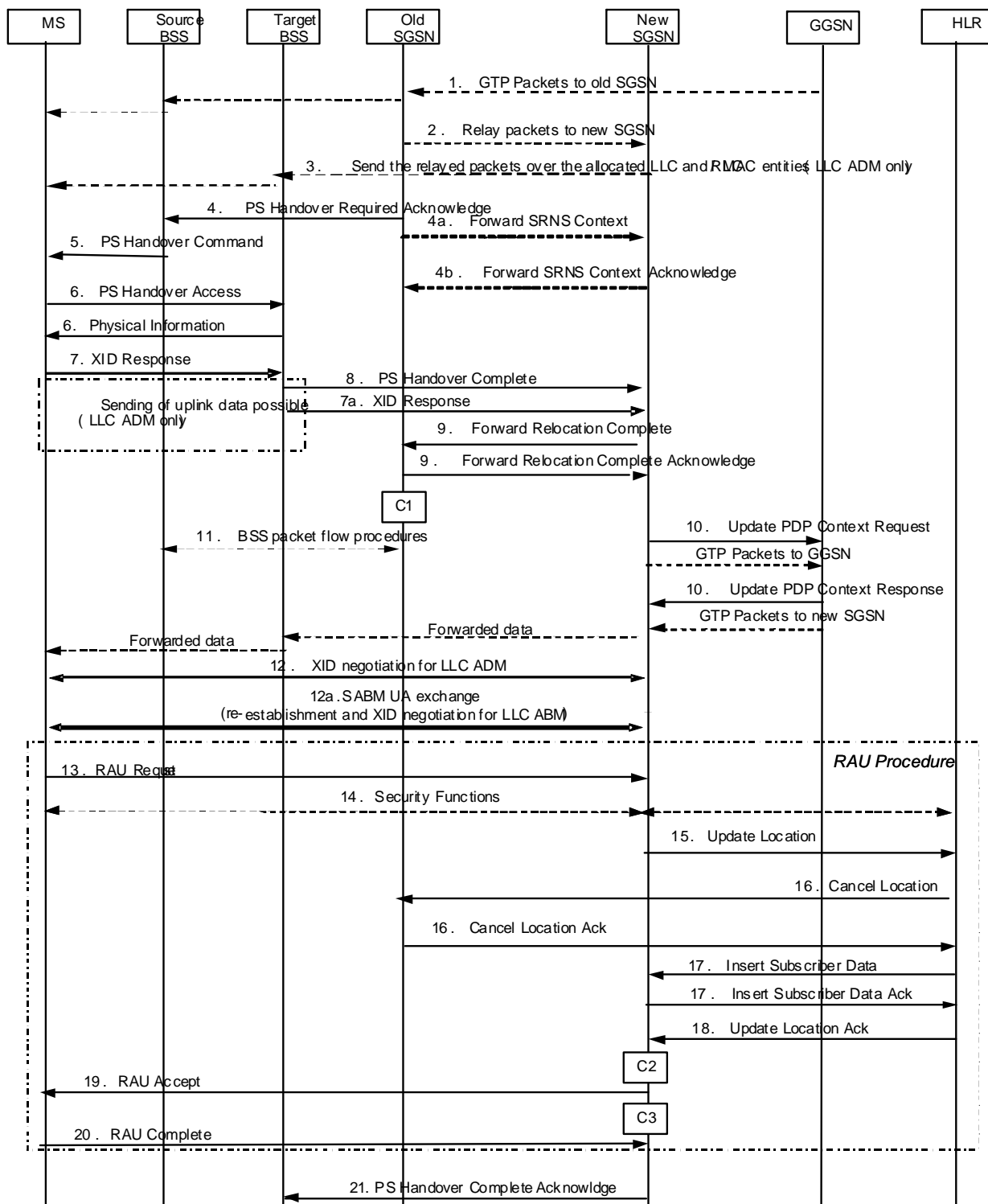

Figure 10: PS Handover Execution Phase; Inter-SGSN case (GERAN A/Gb mode → GERAN A/Gb mode)

1. The old SGSN continues to receive GTP packets from the GGSN (via GTP) and forwards the associated PDU payload to the MS via the source BSS.
2. If a Tunnel Endpoint is available the old SGSN may, based on QoS, start N-PDU relay and duplication to the new SGSN.

- For PDP context which uses LLC ADM in the old SGSN all new downlink N-PDUs received after completion of the PS handover preparation phase are relayed to the new SGSN. All such N-PDUs are encapsulated in a GTP-PDU when transmitted to the new SGSN.

NOTE 1: The order of steps, starting from step 2 onwards, does not necessarily reflect the order of events. For instance the old SGSN may start data forwarding (step 2), send the **PS Handover Required Acknowledge** message (step 4) and send the **Forward SRNS Context** message (step 4a) almost simultaneously.

3. The new SGSN may, based on QoS, proceed with the packet handling as follows:
  - For PDP context(s) which uses LLC ABM the new SGSN stores the N-PDUs associated with their number into the SMDCP queue. Data transfer prior the exchange of N-PDU SNs is not possible.
  - For PDP context(s) which uses LLC ADM the new SGSN either
    - a. forwards the received downlink N-PDUs to the target BSS;
    - b. stores the received data into the SMDCP queue for e.g. the PDU lifetime;
    - c. discards the received data until e.g. reception of the **PS Handover Complete** message.

If the new SGSN forwards downlink packets to the target BSS, the target BSS may start a blind transmission of downlink user data towards the MS over the allocated radio channels.

4. The old SGSN continues the PS Handover procedure by sending a **PS Handover Required Acknowledge** (Old TLLI, PFCs Set Up List, Target BSS to Source BSS Transparent Container (PS Handover Command with RN part and CN part)) message to the source BSS.

Before sending the **PS Handover Required Acknowledge** message, the old SGSN, based on QoS, may suspend downlink data transfer for any PDP contexts.

Before sending the **PS Handover Command** message to the MS the source BSS, based on QoS, may try to empty the downlink BSS buffer for any BSS PFCs.

NOTE 2: Only PFI(s) for PFCs accepted by the target cell are included in the message.

- 4a. The old SGSN shall send the **Forward SRNS Context** (NSAPI, DL GTP-U number, UL GTP-U number) message to the new SGSN if there is at least one PDP context which requires "delivery order" to be preserved. NSAPI identifies the PDP context to which the GTP-U numbers apply. The **Forward SRNS Context** message is then acknowledged by the **Forward SRNS Context Acknowledge** message. The **Forward SRNS Context** message contains the sequence numbers of the GTP-PDU next to be transmitted in the uplink and downlink direction. After the **Forward SRNS Context** message is sent, further uplink N-PDUs received by the old SGSN from the source BSS, relative to a PDP context which requires "delivery order" to be preserved, shall not be forwarded to the GGSN.

The GTP-U sequence numbers are only sent by the old SGSN for PDP context(s) requiring delivery order (QoS profile) to be preserved. If delivery order is to be preserved (QoS profile), consecutive GTP-PDU sequence numbering shall be maintained through the lifetime of the PDP context(s).

Therefore, during the entire PS Handover procedure for the PDP context(s) using delivery order required (QoS profile), the responsible GTP-U entities (SGSNs and GGSN) shall assign consecutive GTP-PDU sequence numbers to user packets belonging to the same PDP context uplink and downlink, respectively.

5. The source BSS sends the **PS Handover Command** (RN part, CN part) message to the MS by interrupting the transmission of LLC PDUs on any of the downlink TBFs. The RN part and the CN part are transparent information to the BSS. Following the transmission of this signalling message the source BSS may resume LLC PDU transmission until it either has no more LLC PDUs to send or the PFC is released. Upon reception of the **PS Handover Command** message the MS is not required to continue data reception in the source cell. Upon reception of the **PS Handover Command** message the MS shall suspend the uplink transmission of user plane data. The MS management of uplink N-PDUs following the reception of the **PS Handover Command** message is as follows:

- All uplink packets associated with a PFC receiving handover treatment that have not yet been fully transmitted may be buffered depending on the QoS class. If the buffered uplink packets are transmitted in the new cell, they need to be ciphered using the new IOV-UI after the handover.
  - Subsequent uplink packets that become available for transmission following the reception of the **PS Handover Command** message might also be buffered depending on the QoS class.
  - The MS may discard uplink packets during the link interruption to preserve the real-time properties.
6. The MS tunes to the radio channel and the timeslot allocated in the target cell by the target BSS and may send the **PS Handover Access** (Handover Reference) message in the form of four handover access bursts to the target BSS on the allocated channel. The **PS Handover Command** message indicates whether or not the MS shall send **PS Handover Access** message. The target BSS sends a **Packet Physical information** message to the MS containing the timing advance for the MS to synchronise.

NOTE 3: In the case of pre-synchronised handover the MS may receive the timing advance information to use in uplink in the target cell in the **PS Handover Command** message (if no timing advance information is included, the mobile station uses a default timing advance in the target cell). In a pre-synchronised or synchronised handover the **Packet Physical Information** message is not sent in the target cell.

- 7./7a. After accessing the cell using access bursts and receiving timing advance information from the BSS in step 6, the MS processes the NAS container and then sends one **XID Response** message to the new SGSN. The MS sends this message immediately after receiving the **Packet Physical Information** message or, in a synchronised or pre-synchronised handover, immediately if the **PS Handover Access** message is not required to be sent (see Section 6.2).

Upon sending the XID Response message the MS shall resume the user data transfer only for those NSAPIs for which there are radio resources allocated in the target cell. For NSAPIs using LLC ADM for which radio resources were not allocated in the target cell, the MS may request for radio resources using the legacy procedures.

NOTE 4: If the new SGSN indicated Reset (i.e. reset to default parameters) in the NAS container for PS HO included in the PS Handover Command, in order to avoid collision cases the mobile station may avoid triggering XID negotiation for any LLC SAPI used in LLC ADM, but wait for the SGSN to do so (see bullet 12). In any case the mobile station may avoid triggering XID negotiation for any LLC SAPI used in LLC ABM, but wait for the SGSN to do so (see bullet 12a).

8. Upon reception of the first correct RLC/MAC block (sent in normal burst format) from the MS the target BSS sends a **PS Handover Complete** (Local TLLI, IMSI, Request INTER RAT HANDOVER INFO) message to inform the new SGSN that the MS has arrived in the target cell. Each uplink N-PDU received by the new SGSN via the target BSS is then forwarded directly to the GGSN. The target BSS that supports inter-RAT PS handover to UTRAN should request the INTER RAT HANDOVER INFO from the SGSN if the "Reliable INTER RAT HANDOVER INFO" is missing or set to "0" in the **PS Handover Request** message or if it has not received the INTER RAT HANDOVER INFO as part of the Source BSS to Target BSS transparent container.
9. Upon receiving the **PS Handover Complete** message, the new SGSN sends a **Forward Relocation Complete** message to the old SGSN. The old SGSN responds with a **Forward Relocation Complete Acknowledge** message. Upon the reception of the **Forward Relocation Complete** message the old SGSN starts a packet forwarding timer. The old SGSN stops forwarding of data to the new SGSN after the packet forwarding timer expires.
10. The new SGSN sends an **Update PDP Context Request** (New SGSN Address, TEID, QoS Negotiated) message to the GGSN concerned. The GGSN updates the PDP context fields and returns an **Update PDP Context Response** (TEID) message. From now on the GGSN sends new incoming downlink IP packets to the new SGSN instead of to the old SGSN.
11. After the reception of the **Forward Relocation Complete** message the old SGSN deletes to BSS packet flow context towards the old cell. The source BSS initiates the release of the radio resources in the source cell.
12. If the new SGSN indicated Reset (i.e. reset to default parameters) in the NAS container for PS HO included in the PS Handover Command, then on receipt of the **PS Handover Complete** message the new SGSN initiates an LLC/SNDCP XID negotiation for each LLC SAPI used in LLC ADM. In this case if the SGSN wants to use the default parameters, it shall send an empty XID Command. If the new SGSN indicated 'Reset to the old XID

parameters' in the NAS container for PS HO, no further XID negotiation is required for LLC SAPIs used in LLC ADM only.

- 12a. The new SGSN re-establishes LLC ABM for the PDP contexts which use acknowledged information transfer. During the exchange of SABM and UA the SGSN shall perform LLC/SNDCP XID negotiation.
13. The MS sends a **Routing Area Update Request** message to the new SGSN informing it that the target cell belongs to a new routing area. The MS shall send this message immediately after message 7. The new SGSN knows that a handover has been performed for this MS and can therefore exclude the SGSN context procedures that normally are used within the RA Update procedure.
14. At this point the new SGSN may optionally invoke MS authentication (security function). The security function can be deferred and performed at any later time as well.

NOTE 5: During an authentication procedure the SGSN has to suspend the downlink transmission of user data.

15. The new SGSN informs the HLR of the change of SGSN by sending **Update Location** (SGSN Number, SGSN Address, IMSI) message to the HLR.
16. The HLR sends **Cancel Location** (IMSI, Cancellation Type) message to the old SGSN with Cancellation Type set to Update Procedure. The old SGSN acknowledges with a **Cancel Location Acknowledge** (IMSI) message. This message allows the old SGSN to know when to release the inter-SGSN tunnel.
17. The HLR sends **Insert Subscriber Data** (IMSI, GPRS subscription data) message to the new SGSN. The new SGSN validates the MS presence in the (new) RA. If all checks are successful then the new SGSN constructs an MM context for the MS and returns an **Insert Subscriber Data Acknowledge** (IMSI) message to the HLR. This message allows the new SGSN to know when to release the inter-SGSN tunnel.
18. The HLR acknowledges the Update Location by sending an **Update Location Acknowledge** (IMSI) message to the new SGSN.
19. The new SGSN validates the MS presence in the new RA. If the MS is allowed to be attached in this RA, the SGSN updates the MM context for and sends a **Routing Area Update Accept** (P-TMSI, TMSI, P-TMSI signature, Receive N-PDU number) message to the MS. The Receive N-PDU Number contains the acknowledgements for each acknowledged-mode NSAPI used by the SGSN, thereby confirming all mobile-originated N-PDUs successfully transferred before the start of the PS handover procedure.
20. The MS confirms the re-allocation of the new P-TMSI by responding the SGSN with a **Routing Area Update Complete** (Receive N-PDU number) message. The MS derives a new local TLLI from the new P-TMSI using current MM procedures. The Receive N-PDU Number contains the acknowledgements for each acknowledged-mode NSAPI used by the MS, thereby confirming all mobile-terminated N-PDUs successfully transferred before the start of the handover procedure. If Receive N-PDU Number confirms reception of N-PDUs that were forwarded from the old SGSN, these N-PDUs shall be discarded by the new SGSN.

The following CAMEL procedure calls shall be performed (see referenced procedures in TS 23.078 [8b])

- C1) CAMEL\_GPRS\_PDP\_Context\_Disconnection, CAMEL\_GPRS\_Detach and CAMEL\_PS\_Notification.

They are called in the following order:

- The CAMEL\_GPRS\_PDP\_Context\_Disconnection procedure is called several times: once per PDP context. The procedure returns as result "Continue".
- Then the CAMEL\_GPRS\_Detach procedure is called once. The procedure returns as result "Continue".
- Then the CAMEL\_PS\_Notification procedure is called once. The procedure returns as result "Continue".

- C2) CAMEL\_GPRS\_Routeing\_Area\_Update\_Session and CAMEL\_PS\_Notification.

They are called in the following order:

- The CAMEL\_GPRS\_Routeing\_Area\_Update\_Session procedure is called. The procedure returns as result "Continue".
- Then, the CAMEL\_PS\_Notification procedure is called. The procedure returns as result "Continue".



C3) CAMEL\_GPRS\_Routing\_Area\_Update\_Context.

This procedure is called several times: once per PDP context. It returns as result "Continue".

For C2 and C3: refer to Routing Area Update procedure description in 3GPP TS 23.060.

21. Upon reception of the **PS Handover Complete** message with the "Request for Inter RAT Handover Info" set to "1", the SGSN should send the **PS Handover Complete Acknowledge** (TLLI, INTER RAT HANDOVER INFO) message to the target BSS.

NOTE 5: An SGSN that does not recognize the 'Request for Inter RAT Handover Info' in the **PS Handover Complete** message will not send the **PS Handover Complete Acknowledge** message back to the BSS.

22. The target BSS receiving the **PS Handover Complete Acknowledge** message shall set the "Reliable INTER RAT HANDOVER" to "1" in the **PS Handover Required** message in any subsequent PS handover to GERAN *A/Gb mode*. The target BSS failing to receive the **PS Handover Complete Acknowledge** message shall set the "Reliable INTER RAT HANDOVER" to "0" in the **PS Handover Required** message in any subsequent PS handover to GERAN *A/Gb mode*. The Target BSS shall, upon receipt of the INTER RAT HANDOVER INFO in the **PS Handover Complete Acknowledge** message, discard the INTER RAT HANDOVER INFO received from the source BSS during the preparation phase.

## 5.2 Inter-RAT/mode handover (GERAN *A/Gb mode* → UTRAN/ GERAN *Iu mode*)

### 5.2.1 Intra SGSN

#### 5.2.1.1 Intra-SGSN GERAN *A/Gb mode* to UTRAN/GERAN *Iu mode* HO; Preparation phase

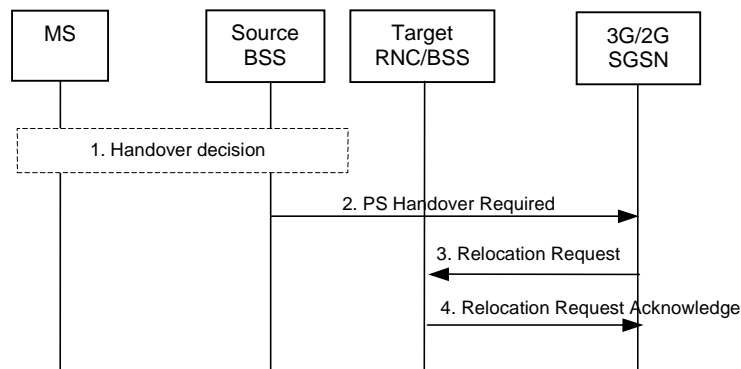

**Figure 11: PS Handover Preparation Phase; Inter-RAT/mode,  
Intra-SGSN case (GERAN *A/Gb mode* → UTRAN, GERAN *Iu mode*)**

1. The source BSS decides to initiate a PS handover. At this point both uplink and downlink user data is transmitted via the following: TBFs between MS and source BSS, BSSGP PFCs tunnel(s) between the source BSS and 3G/2G SGSN, GTP tunnel(s) between the 3G/2G SGSN and GGSN.
2. The source BSS sends a **PS Handover Required** (TLLI, Cause, Source Cell Identifier, Target RNC Identifier, Source RNC to Target RNC Transparent Container, Active PFCs List) message to the SGSN.
3. The 3G/2G SGSN determines from the Target RNC Identifier that the type of handover is inter-RAT/mode handover. In case of Inter-RAT/Intra-SGSN PS handover, the 3G/2G SGSN constructs a **Relocation Request** (Permanent NAS Identity, Cause, CN Domain Indicator, Integrity protection information (i.e. IK and allowed Integrity Protection algorithms, Encryption information (i.e. CK and allowed Ciphering algorithms), RABs To Be Set Up List, Source RNC to Target RNC Transparent Container, Iu Signalling connection identifier, Global CN-ID, SNA Access Information, UESBI-Iu) message to the target RNC/BSS.

For each RAB requested to be established, the RABs To Be Set Up List shall contain information such as RAB ID, RAB parameters, Transport Layer Address, and Iu Transport Association. The 3G/2G SGSN shall only request resources for RABs for which the corresponding PFC is included in the Active PFCs List. The RAB ID information element contains the NSAPI value, and the RAB parameters information element gives the QoS profile. The Transport Layer Address is the SGSN Address for user data, and the Iu Transport Association corresponds to the uplink Tunnel Endpoint Identifier Data.

Ciphering and integrity protection keys are sent to the target RNC/BSS to allow data transfer to continue in the new RAT/mode target cell without requiring a new AKA (Authentication and Key Agreement) procedure. Information that is required to be sent to the MS (either in the **PS Handover Command** message or after the handover completion message) from RRC in the target RNC/BSS shall be included in the RRC message sent from the target RNC/BSS to the MS via the transparent container.

In the target RNC/BSS radio and Iu user plane resources are reserved for the accepted RABs.

4. The target RNC/BSS sends the **Relocation Request Acknowledge** (Target RNC to Source RNC Transparent Container, RABs setup list, RABs failed to setup list) message to the 3G/2G SGSN. Upon sending the **Relocation Request Acknowledge** message the target RNC/BSS shall be prepared to receive downlink GTP PDUs from the 3G/2G SGSN for the accepted RABs.

Each RAB to be setup is defined by a Transport Layer Address, which is the target RNC/BSS Address for user data, and the Iu Transport Association, which corresponds to the downlink Tunnel Endpoint Identifier for user data.

NOTE: The information to be included in the containers differs for UTRAN and GERAN Iu mode. For UTRAN, the information included in the container is related to RAB setup and other IE similar to those in the **Handover to UTRAN** message defined in 3GPP TS 25.331 [17]. For GERAN Iu mode the **Radio Bearer Reconfiguration** message defined in 3GPP TS 44.118 [16] is the RRC message to be included.

When the 3G/2G SGSN receives the **Relocation Request Acknowledge** message and it decides to proceed with the handover, the preparation phase is finished and the execution phase will follow.

5.2.1.2 Intra-SGSN GERAN A/Gb mode to UTRAN/GERAN Iu mode HO; Execution phase

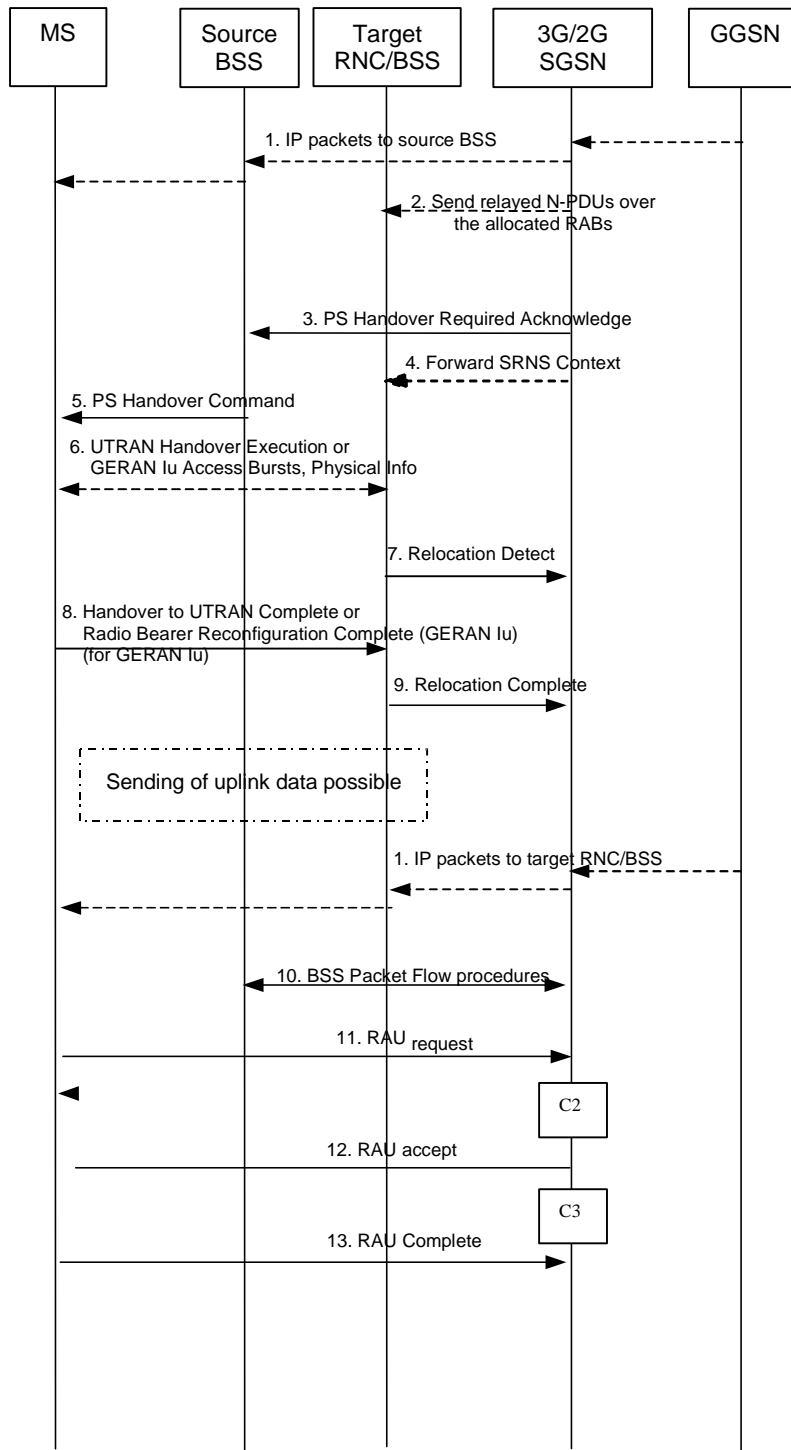

**Figure 12: PS Handover Execution Phase; Inter-RAT/mode, Intra-SGSN case (GERAN A/Gb mode → UTRAN, GERAN Iu mode)**

1. The 3G/2G SGSN continues to receive IP packets from the GGSN (via GTP) and forwards the associated PDU payload to the MS via the source BSS.
2. When receiving the **Relocation Request Acknowledge** message the 3G/2G SGSN may, based on QoS, start downlink N-PDU relay and duplication to the target RNC/BSS if a Tunnel Endpoint is available as follows:

- For PDP context, which uses LLC ADM, all new downlink N-PDUs received after completion of the PS handover preparation phase are relayed to the target RNC. All such N-PDUs are encapsulated in a GTP-PDU when transmitted to the target RNC/BSS.
  - If the 3G/2G SGSN forwards downlink packets to the target RNC/BSS, the target RNC/BSS may start blind transmission of downlink user data towards the MS over the allocated radio channels.
3. The 3G/2G SGSN continues the PS Handover by sending a **PS Handover Required Acknowledge** (TLLI, List of Set Up PFCs, Target RNC to Source RNC Transparent Container) message to the source BSS.

Before sending the **PS Handover Required Acknowledge** message, the 3G/2G SGSN, based on QoS, may suspend downlink data transfer for any PDP contexts.

Before sending the **PS Handover Command** message to the MS the source BSS, based on QoS, may try to empty the downlink BSS buffer for any BSS PFCs.

4. The 3G/2G SGSN shall send the **Forward SRNS Context** (NSAPIDL GTP-U number, UL GTP-U number) message to the target RNC/BSS if there is at least one PDP context which requires "delivery order" to be preserved..NSAPI identifies the PDP context to which the GTP-U numbers apply The **Forward SRNS Context** message contains the sequence numbers of the GTP-PDU next to be transmitted in the uplink and downlink direction. After the **Forward SRNS Context** message is sent, further uplink N-PDUs received by the 3G/2G SGSN from the source BSS, relative to a PDP context which requires "delivery order" to be preserved, shall not be forwarded to the GGSN.

The GTP-U numbers are only sent by the 3G/2G SGSN for PDP context(s) requiring delivery order (QoS profile) to be preserved. If delivery order is to be preserved (QoS profile), consecutive GTP-PDU sequence numbering shall be maintained through the lifetime of the PDP context(s).

Therefore, during the entire PS Handover procedure for the PDP context(s) using delivery order required (QoS profile), the responsible GTP-U entities (3G/2G SGSN, target RNC/BSS and GGSN) shall assign consecutive GTP-PDU sequence numbers to user packets belonging to the same PDP context uplink and downlink, respectively.

The target RNC/BSS proceed as follows:

- For RABs not requiring lossless PDCP the target RNC/BSS may, according the QoS profile of the PDP context, store the received data until it receives confirmation of MS presence in the target cell.

The further target RNC/BSS behaviour is as specified in 3GPP TS 23.060 [19] (Combined Hard Handover and SRNS Relocation).

5. The source BSS sends the **PS Handover Command** message containing the **Handover to UTRAN Command** message (as it is specified in 3GPP TS 25.331 [17]) or **Radio Bearer Reconfiguration** message (as it is specified in 3GPP TS 44.118 [16]) to the MS by interrupting the transmission of LLC PDUs on any of the downlink TBFs. Following the transmission of this signalling message the source BSS may resume LLC PDU transmission until it either has no more LLC PDUs to send or the PFC is released. Upon reception of the **PS Handover Command** the MS is not required to continue data reception in the source cell. Upon reception of the **PS Handover Command** the MS shall suspend the uplink transmission of user plane data. MS management of uplink N-PDUs following the reception of the **PS Handover Command** message is as follows:

- All N-PDUs associated with a PFC receiving handover treatment that have not yet been fully transmitted might be buffered depending on the QoS class.
- Subsequent uplink N-PDUs that become available for transmission following the reception of the **PS Handover Command** message might also be buffered depending on the QoS class.
- For real time services uplink N-PDUs may be discarded by the MS during the link interruption.

NOTE: Any buffering should be performed before the data is passed to SNDCP in order to avoid header compression on N-PDUs such that data delivery in the target cell may begin from the correct point in the sequence.

6. MS is in the target cell and performs access to UTRAN as defined in 3GPP TS 25.331 [17] and to GERAN Iu mode as defined in 3GPP TS 44.118 [16].

7. The target RNC/BSS sends a **Relocation Detect** message to the 3G/2G SGSN to indicate that the MS is in the target cell. The message shall be sent when the relocation execution trigger is received. For SRNS relocation type "UE Involved", the relocation execution trigger may be received from the Uu interface; i.e. when the target RNC detects the MS on the lower layers. When the **Relocation Detect** message is sent, the target RNC shall start serving RNC operation.
8. In UTRAN, the MS sends **Handover to UTRAN Complete** {Message Type, UE Information elements (Start List, CN Domain Identity, Start), RB Information Elements (Count-C Activation Time)} message to the target RNC (see 3GPP TS 25.331 [17]).

In GERAN Iu, the MS sends **Radio Bearer Reconfiguration Complete** {RRC Transaction Identifier, Integrity Check Info, Uplink Integrity Protection Activation Info, COUNT-C Activation Time, Radio Bearer Uplink Ciphering Activation Time Info, Mobile Observed Time Difference, Uplink Counter Synchronisation Info struct, START List, CN Domain Identity, START, RB with PDCP Information List, RB with PDCP Information} message to target BSS.

9. When the new source RNC-ID + S-RNTI are successfully exchanged with the MS, the target RNC/BSS shall send the **Relocation Complete** message to the new SGSN. The purpose of the Relocation Complete procedure is to indicate by the target RNC/BSS the completion of the relocation of the source BSS to the CN. After the reception of the **Relocation Complete** message the 3G/2G SGSN shall be prepared to receive data from the target RNC/BSS.
10. The 3G/2G SGSN shall initiate PFC Management procedures towards the source cell in order to trigger the release of resources in the source cell.
11. The MS sends a **Routing Area Update Request** (Old RAI, Old P-TMSI signature, Update Type) message to the 3G/2G SGSN. This is done even if the target cell belongs to the same routing area as the source cell. The MS shall send this message immediately after message 8. The 3G/2G SGSN knows that a handover has been performed for this MS and can therefore exclude the SGSN context procedures which normally are used within the RA Update procedure.
12. The 3G/2G SGSN validates the MS presence in the new RA. If the MS is allowed to be attached in this RA, the 3G/2G SGSN updates the MM context for and sends a **Routing Area Update Accept** message to the MS.
13. The MS may respond to the SGSN with a **Routing Area Update Complete** message.

The following CAMEL procedure calls shall be performed (see referenced procedures in TS 23.078 [8b]):

C2) CAMEL\_GPRS\_Routeing\_Area\_Update\_Session and CAMEL\_PS\_Notification.

They are called in the following order:

- The CAMEL\_GPRS\_Routeing\_Area\_Update\_Session procedure is called. The procedure returns as result "Continue".
- Then, the CAMEL\_PS\_Notification procedure is called. The procedure returns as result "Continue".

C3) CAMEL\_GPRS\_Routeing\_Area\_Update\_Context.

This procedure is called several times: once per PDP context. It returns as result "Continue".

For C2 and C3: refer to Routing Area Update procedure description in 3GPP TS 23.060.

## 5.2.2 Inter SGSN

### 5.2.2.1 Inter-SGSN GERAN A/Gb mode to UTRAN/GERAN Iu mode HO; Preparation phase

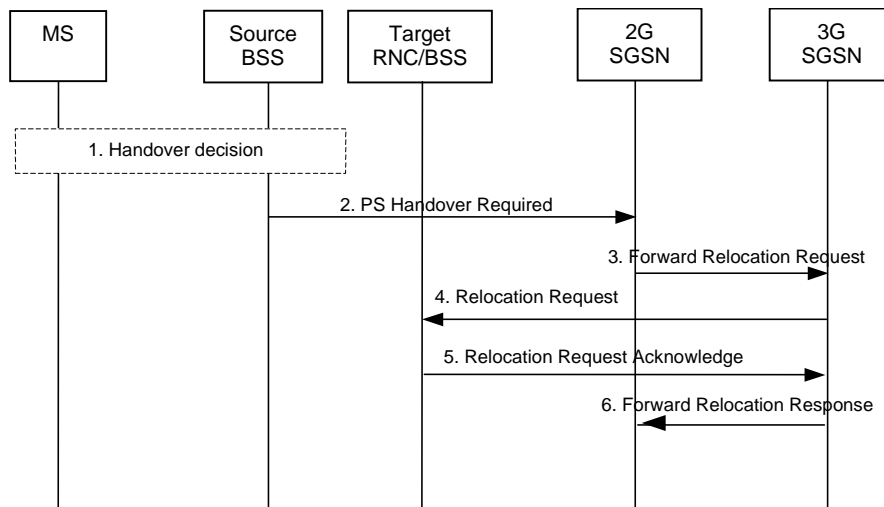

**Figure 13: PS Handover Preparation Phase; Inter-RAT/mode, Inter-SGSN case (GERAN A/Gb mode → UTRAN, GERAN Iu mode)**

1. The source BSS decides to initiate a PS handover. At this point both uplink and downlink user data is transmitted via the following: TBFs between MS and source BSS, BSSGP PFCs tunnel(s) between source BSS and old SGSN, GTP tunnel(s) between old SGSN and GGSN.
2. The source BSS sends a **PS Handover Required** (TLLI, Cause, Source Cell Identifier, Target RNC Identifier, Source RNC to Target RNC Transparent Container, Active PFCs List) message to the old SGSN.
3. The old SGSN determines from the Target RNC Identifier that the type of handover is inter-RAT/mode handover. In case of inter-SGSN inter-RAT/mode PS handover the old SGSN initiates the relocation resource allocation procedure by sending a **Forward Relocation Request** (IMSI, Target Identification, MM Context, PDP Context, PDP Context Prioritisation, Tunnel Endpoint Identifier Control Plane, SGSN Address for Control plane, Source RNC to Target RNC Transparent Container in the UTRAN Transparent Container, RANAP Cause, Packet Flow ID, SMDCP XID parameters, LLC XID parameters) message to the new SGSN.

The old SGSN sends all active PDP Contexts to the new SGSN indicating the PFIs and the XID parameters related to those PDP Contexts. Each PDP context contains the GGSN Address for the User Plane and the Uplink TEID for Data (to this GGSN Address and Uplink TEID for Data the old SGSN and the new SGSN send uplink packets).

The MM context contains security related information, e.g. supported ciphering algorithms as described in 3GPP TS 29.060 [11]. The relation between GSM and UMTS security parameters is defined in 3GPP TS 33.102 [27].

NOTE 1: For relocation to an area where Intra Domain Connection of RAN Nodes to Multiple CN Nodes is used, the old SGSN may - if it provides Intra Domain Connection of RAN Nodes to Multiple CN Nodes - have multiple new SGSNs for each handover target in a pool area, in which case the old SGSN will select one of them to become the new SGSN, as specified in 3GPP TS 23.236 [22].

Upon receipt of the message, the new SGSN establishes all MM and PDP contexts and initiates the RAB setup procedures for all PDP contexts received.

4. The new SGSN sends a **Relocation Request** (Permanent NAS Identity, Cause, CN Domain Indicator, Integrity protection information (i.e. IK and allowed Integrity Protection algorithms), Encryption information (i.e. CK and allowed Ciphering algorithms), RABs to be setup list, Source RNC to Target RNC Transparent Container, Iu Signalling connection identifier, Global CN-ID, SNA Access Information, UESBI-Iu) message to the target RNC/BSS.

For each RAB requested to be established, RABs To Be Setup shall contain information such as RAB ID, RAB parameters, Transport Layer Address, and Iu Transport Association. The new SGSN shall not request resources for RABs associated with PDP contexts with a maximum bit rate for uplink and downlink of 0 kbit/s. The RAB ID information element contains the NSAPI value, and the RAB parameters information element gives the QoS profile. The Transport Layer Address is the SGSN Address for user data, and the Iu Transport Association corresponds to the uplink Tunnel Endpoint Identifier Data.

Ciphering and integrity protection keys are sent to the target RNC/BSS to allow data transfer to continue in the new RAT/mode target cell without requiring a new AKA (Authentication and Key Agreement) procedure. Information that is required to be sent to the MS (either in the **PS Handover Command** message or after the handover completion message) from RRC in the target RNC/BSS shall be included in the RRC message sent from the target RNC/BSS to the MS via the transparent container.

In the target RNC/BSS radio and Iu user plane resources are reserved for the accepted RABs.

5. The target RNC/BSS sends the **Relocation Request Acknowledge** (Target RNC to Source RNC Transparent Container, RABs setup list, RABs failed to setup list) message to the new SGSN. Upon sending the **Relocation Request Acknowledge** message the target RNC/BSS shall be prepared to receive downlink GTP PDUs from the new SGSN for the accepted RABs.

Each RAB to be setup is defined by a Transport Layer Address, which is the target RNC/BSS Address for user data, and the Iu Transport Association, which corresponds to the downlink Tunnel Endpoint Identifier for user data.

NOTE 2: The information to be included in the containers differs for UTRAN and GERAN Iu mode. For UTRAN, the information included in the container is related to RAB setup and other IE similar to those in the **Handover to UTRAN** message defined in 3GPP TS 25.331 [17]. For GERAN *Iu mode* the **Radio Bearer Reconfiguration** message defined in 3GPP TS 44.118 [16] is the RRC message to be included.

6. When resources for the transmission of user data between target RNC/BSS and new SGSN have been allocated and the new SGSN is ready for the PS handover, the **Forward Relocation Response** (Cause, List of Set Up PFCs, Tunnel Endpoint Identifier Control Plane, SGSN Address for User Traffic, Tunnel Endpoint Identifier Data II, RANAP cause, SGSN Address for control plane, Target RNC to Source RNC Transparent Container in the UTRAN Transparent Container) message is sent from the new SGSN to the old SGSN. RAN Transparent Container and RANAP Cause contain information from the target RNC/BSS to be forwarded to the source BSS.

The Tunnel Endpoint Identifier Data II, one information for each PDP context, is the tunnel endpoint of the new SGSN and is used for data forwarding from the old SGSN, via the new SGSN, to the target RNC.

When the old SGSN receives the **Forward Relocation Response** message and it decides to proceed with the handover, the preparation phase is finished and the execution phase will follow.

5.2.2.2 Inter-SGSN GERAN A/Gb mode to UTRAN/GERAN Iu mode HO; Execution phase

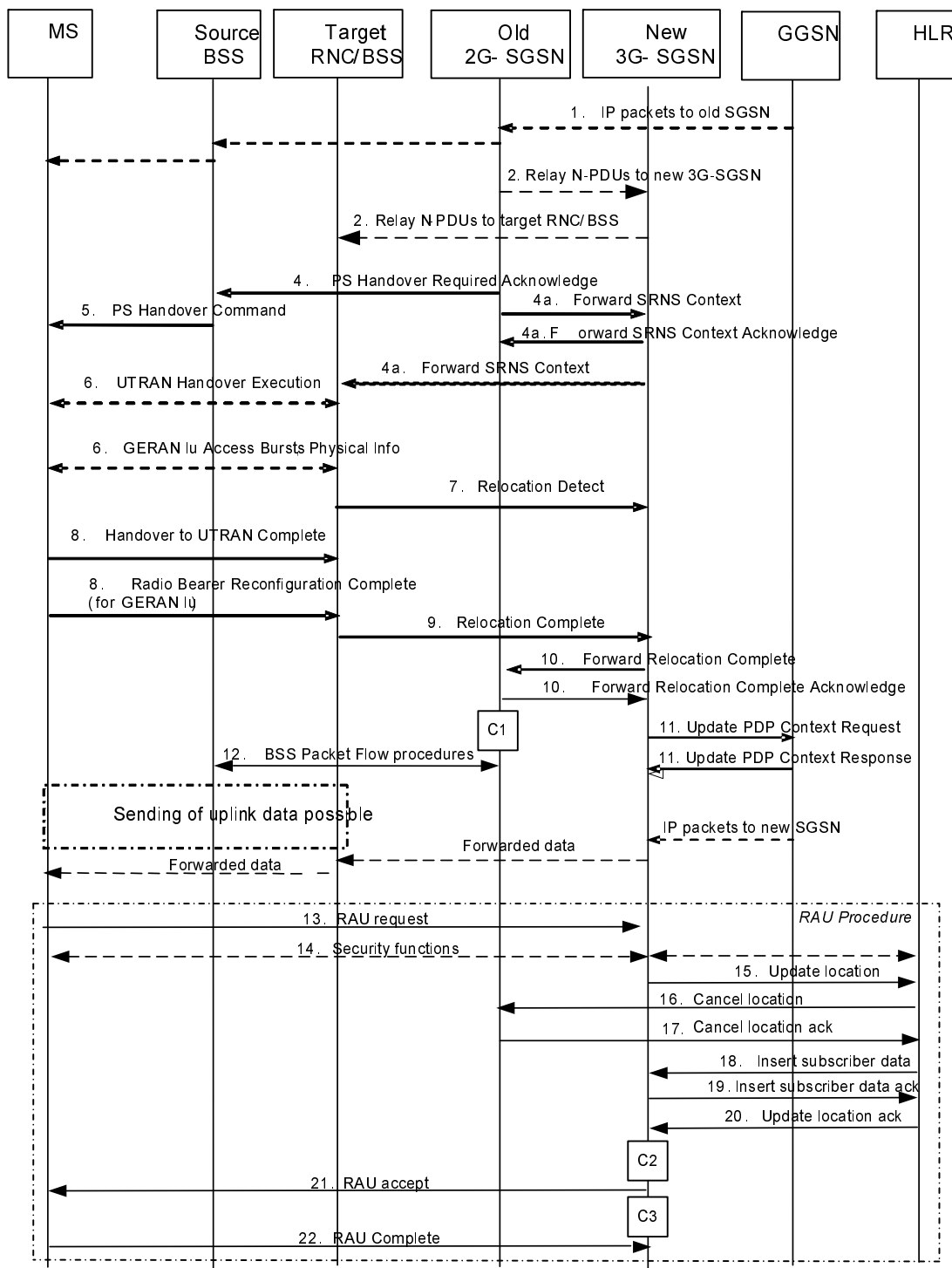

Figure 14: PS Handover Execution Phase; Inter-RAT/mode, Inter-SGSN case (GERAN A/Gb mode → UTRAN/GERAN Iu mode)

1. The old SGSN continues to receive IP packets from the GGSN (via GTP) and forwards the associated PDU payload to the MS via the source BSS.



2. When receiving the **Forward Relocation Response** message the old SGSN may, based on QoS, start downlink N-PDU relay and duplication to the target RNC/BSS via the new SGSN (if a Tunnel Endpoint is available) as follows:

- For PDP context, which uses LLC ADM in the old SGSN all new downlink N-PDUs received after completion of the PS handover preparation phase are relayed to the target RNC/BSS via the new SGSN. All such N-PDUs are encapsulated in a GTP-PDU when transmitted to the new SGSN.

If the old SGSN forwards downlink packets to the target RNC/BSS via the new SGSN, the target RNC/BSS may start blind transmission of downlink user data towards the MS over the allocated radio channels.

NOTE 1: The order of steps, starting from step 2 onwards, does not necessarily reflect the order of events. For instance the old SGSN may start data forwarding (step 2), send the **PS Handover Required Acknowledge** message (step 4) and send the Forward SRNS context message (step 4a) almost simultaneously.

3. Void

4. The old SGSN continues the PS Handover by sending a **PS Handover Required Acknowledge** (TLLI, List of Set Up PFCs, Target RNC to Source RNC Transparent Container) message to the source BSS.

Before sending the **PS Handover Required Acknowledge** message, the old SGSN, based on QoS, may suspend downlink data transfer for any PDP contexts.

Before sending the **PS Handover Command** message to the MS the source BSS, based on QoS, may try to empty the downlink BSS buffer for any BSS PFCs.

- 4a. The old SGSN shall send the **Forward SRNS Context** message (NSAPI, DL GTP-U number, UL GTP-U number) to the new SGSN if there is at least one PDP context which requires "delivery order" to be preserved. NSAPI identifies the PDP context to which the GTP-U numbers apply. The **Forward SRNS Context** message is then acknowledged by the **Forward SRNS Context Acknowledge** message. The **Forward SRNS Context** message contains the sequence numbers of the GTP-PDU next to be transmitted in the uplink and downlink direction. After the **Forward SRNS Context** message is sent, further uplink N-PDUs received by the old SGSN from the source BSS, relative to a PDP context which requires "delivery order" to be preserved, shall not be forwarded to the GGSN.

The GTP-U numbers are only sent by the old SGSN for PDP context(s) requiring delivery order (QoS profile) to be preserved. If delivery order is to be preserved (QoS profile), consecutive GTP-PDU sequence numbering shall be maintained through the lifetime of the PDP context(s).

Therefore, during the entire PS Handover procedure for the PDP context(s) using delivery order required (QoS profile), the responsible GTP-U entities (old SGSN, target RNC and GGSN) shall assign consecutive GTP-PDU sequence numbers to user packets belonging to the same PDP context uplink and downlink, respectively.

The target RNC proceed as follows:

- For RABs not requiring lossless PDCP the target RNC may, according the QoS profile of the PDP context, store the received data until it receives confirmation of MS presence in the target cell.

The further target RNC/BSS behaviour is as specified in 3GPP TS 23.060 [19] (Combined Hard Handover and SRNS Relocation).

5. The source BSS sends the **PS Handover Command** message containing the **Handover to UTRAN Command** message (as specified in 3GPP TS 25.331 [17]) or **Radio Bearer Reconfiguration** message (as specified in 3GPP TS 44.118 [16]) to the MS by interrupting the transmission of LLC PDUs on any of the downlink TBFs. Following the transmission of this signalling message the source BSS may resume LLC PDU transmission until it either has no more LLC PDUs to send or the PFC is released. Upon reception of the **PS Handover Command** message the MS is not required to continue data reception in the source cell. Upon reception of the **PS Handover Command** message the MS shall suspend the uplink transmission of user plane data. MS management of uplink N-PDUs following the reception of the **PS Handover Command** message is as follows:

- All N-PDUs associated with a PFC receiving handover treatment that have not yet been fully transmitted might be buffered depending on the QoS class.

- Subsequent uplink N-PDUs that become available for transmission following the reception of the **PS Handover Command** message might also be buffered depending on the QoS class.
- For real time services uplink N-PDUs may be discarded by the MS during the link interruption.

NOTE 2: Any buffering should be performed before the data is passed to SNDCP in order to avoid header compression on N-PDUs such that data delivery in the target cell may begin from the correct point in the sequence.

6. MS is in the target cell and performs access to UTRAN as defined in 3GPP TS 25.331 [17] and to GERAN Iu mode as defined in 3GPP TS 44.118 [16].
7. Target RNC/BSS sends a **Relocation Detect** message to the new SGSN to indicate that the MS is in the target cell. The message shall be sent when the relocation execution trigger is received. For SRNS relocation type "UE Involved", the relocation execution trigger may be received from the Uu interface; i.e. when the target RNC detects the MS on the lower layers. When the **Relocation Detect** message is sent, the target RNC shall start serving RNC operation.
8. In UTRAN, MS sends **Handover to UTRAN Complete** {Message Type, UE Information elements (Start List, CN Domain Identity, Start), RB Information Elements (Count-C Activation Time)} message to the target RNC (see 3GPP TS 25.331 [17]).

In GERAN Iu, MS sends **Radio Bearer Reconfiguration Complete** {RRC Transaction Identifier, Integrity Check Info, Uplink Integrity Protection Activation Info, COUNT-C Activation Time, Radio Bearer Uplink Ciphering Activation Time Info, Mobile Observed Time Difference, Uplink Counter Synchronisation Info struct, START List, CN Domain Identity, START, RB with PDCP Information List, RB with PDCP Information} message to target BSS.

9. When the new source RNC-ID + S-RNTI are successfully exchanged with the MS, the target RNC/BSS shall send the **Relocation Complete** message to the new SGSN. The purpose of the Relocation Complete procedure is to indicate by the target RNC/BSS the completion of the relocation of the source BSS to the CN. After the reception of the **Relocation Complete** message the new SGSN shall be prepared to receive data from the target RNC/BSS. Each uplink N-PDU received by the new SGSN is forwarded directly to the GGSN.
10. For inter-SGSN PS handover, the new SGSN sends a **Forward Relocation Complete** message to the old SGSN to indicate the success of the handover procedure. The old SGSN acknowledges this with a **Forward Relocation Complete Acknowledge** message. Upon the reception of the Forward Relocation Complete message the old SGSN starts a packet forwarding timer. The old SGSN stops forwarding of data to the new SGSN after the packet forwarding timer expires.
11. The new SGSN sends an **Update PDP Context Request** (new SGSN Address, TEID, QoS Negotiated) message to the GGSN concerned. The GGSN updates the PDP context fields and returns an **Update PDP Context Response** (TEID) message. From now on the GGSN sends new incoming downlink IP packets to the new SGSN instead of to the old SGSN.
12. The old SGSN shall initiate PFC Management procedures towards the source cell in order to trigger the release of resources in the source cell.
13. The MS sends a **Routing Area Update Request** (Old RAI, Old P-TMSI signature, Update Type) message to the new SGSN informing it that the target cell belongs to a new routing area. The MS shall send this message immediately after message 7. The new SGSN knows that a handover has been performed for this MS and can therefore exclude the SGSN context procedures which normally are used within the RA Update procedure.
14. At this point the new SGSN may optionally invoke MS authentication (security function). The security function can be deferred and performed at any later time as well.

NOTE 3: During an authentication procedure the SGSN has to suspend the downlink transmission of user data.

15. The new SGSN informs the HLR of the change of SGSN by sending **Update Location** (SGSN Number, SGSN Address, IMSI) message to the HLR.
16. The HLR sends **Cancel Location** (IMSI, Cancellation Type) message to the old SGSN with Cancellation Type set to Update Procedure.

17. The old SGSN acknowledges with a **Cancel Location Acknowledge** (IMSI) message. This message allows the old SGSN to know when to release the inter-SGSN tunnel.
18. The HLR sends **Insert Subscriber Data** (IMSI, GPRS subscription data) message to the new SGSN. The new SGSN validates the MS presence in the (new) RA.
19. If all checks are successful then the new SGSN constructs an MM context for the MS and returns an **Insert Subscriber Data Acknowledge** (IMSI) message to the HLR. This message allows the new SGSN to know when to release the inter-SGSN tunnel.
20. The HLR acknowledges the Update Location by sending an **Update Location Acknowledge** (IMSI) message to the new SGSN.
21. The new SGSN validates the MS presence in the new RA. If the MS is allowed to be attached in this RA, the SGSN updates the MM context for and sends a **Routing Area Update Accept** message to the MS.
22. The MS may respond to the SGSN with a **Routing Area Update Complete** message.

The following CAMEL procedure calls shall be performed (see referenced procedures in TS 23.078 [8b])

- C1) CAMEL\_GPRS\_PDP\_Context\_Disconnection, CAMEL\_GPRS\_Detach and CAMEL\_PS\_Notification.

They are called in the following order:

- The CAMEL\_GPRS\_PDP\_Context\_Disconnection procedure is called several times: once per PDP context. The procedure returns as result "Continue".
- Then the CAMEL\_GPRS\_Detach procedure is called once. The procedure returns as result "Continue".
- Then the CAMEL\_PS\_Notification procedure is called once. The procedure returns as result "Continue".

- C2) CAMEL\_GPRS\_Routeing\_Area\_Update\_Session and CAMEL\_PS\_Notification.

They are called in the following order:

- The CAMEL\_GPRS\_Routeing\_Area\_Update\_Session procedure is called. The procedure returns as result "Continue".
- Then, the CAMEL\_PS\_Notification procedure is called. The procedure returns as result "Continue".

- C3) CAMEL\_GPRS\_Routeing\_Area\_Update\_Context.

This procedure is called several times: once per PDP context. It returns as result "Continue".

For C2 and C3: refer to Routing Area Update procedure description in 3GPP TS 23.060.

## 5.3 Inter-RAT/mode Handover (UTRAN/GERAN Iu mode → GERAN A/Gb mode)

### 5.3.1 Intra SGSN

#### 5.3.1.1 Inter RAT/mode UTRAN/GERAN Iu mode to GERAN A/Gb mode PS HO; Preparation phase

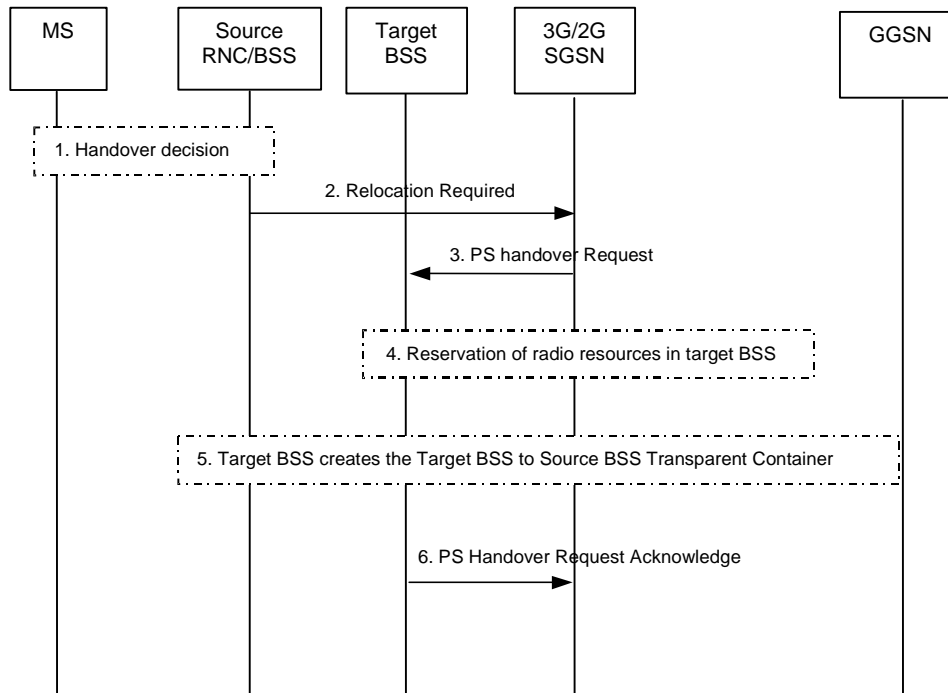

**Figure 15: PS Handover Preparation Phase; Inter-RAT/mode, Intra-SGSN case (UTRAN/GERAN Iu mode → GERAN A/Gb mode)**

- Based on measurement results and knowledge of the RAN topology, the source RNC/BSS decides to initiate an inter RAT/mode PS handover towards the GERAN A/Gb mode. At this point both uplink and downlink user data flows via the tunnel(s): Radio Bearer between the MS and the source RNC/BSS; GTP-U tunnel(s) between the source RNC/BSS and the 3G/2G SGSN; GTP-U tunnel(s) between the 3G/2G SGSN and the GGSN.

NOTE 1: The process leading to the handover decision is outside of the scope of this paper.

- The source RNC/BSS sends a **Relocation Required** (Relocation Type, Cause, Source ID, Target ID, Source BSS To Target BSS Transparent Container (RN part)) message to the 3G/2G SGSN. The source RNC/BSS shall set Relocation Type to "UE Involved in relocation of SRNS".

Target ID contains the identity of the target cell.

- The 3G/2G SGSN determines from the Target Cell Identifier that the type of handover is inter-RAT/mode handover. The 3G/2G SGSN sends a **PS Handover Request** (Local TLLI, IMSI, Cause, Target Cell Identifier, Source BSS to Target BSS Transparent Container (RN part), PFCs To Be Set Up List, NAS container for PS HO) message to the target BSS. The 3G/2G SGSN shall only request resources for PFCs for which, based on source side information, resources should be allocated in the target cell during the PS Handover preparation phase.

If the 3G/2G SGSN has negotiated XID parameters with the MS when the MS was in A/Gb mode before, or if the 3G/2G SGSN can accept all XID parameters as indicated by the old SGSN during a previous inter-SGSN PS handover, the 3G/2G SGSN shall create a NAS container for PS HO indicating 'Reset to the old XID parameters'. Otherwise the 3G/2G SGSN shall create a NAS container for PS HO indicating Reset (i.e. reset to default parameters).

4. Based upon the ABQP for each PFC the target BSS makes a decision about which PFCs to assign radio resources. The algorithm by which the BSS decides which PFCs that need resources is implementation specific. Due to resource limitations not all downloaded PFCs will necessarily receive resource allocation. The target BSS allocates TBFs for each PFC that can be accommodated by the target BSS.

After allocating radio resources the target BSS shall prepare the Target BSS to Source BSS Transparent Container for the set up BSS PFCs.

5. The target BSS shall prepare the Target BSS to Source BSS Transparent Container which contains a PS Handover Command including the CN part (NAS container for PS HO) and the RN part (PS Handover Radio Resources).
6. The target BSS shall send the **PS Handover Request Acknowledge** message (Local TLLI, List of Set Up PFCs, Target BSS to Source BSS Transparent Container) message to the 3G/2G SGSN. Upon sending the **PS Handover Request Acknowledge** message the target BSS shall be prepared to receive downlink LLC PDUs from the 3G/2G SGSN for the accepted PFCs.

Any PDP contexts for which a PFC was not established are maintained in the 3G/2G SGSN and the related SAPIs and PFIs are kept. These PDP contexts may be modified or deactivated by the 3G/2G SGSN via explicit SM procedures upon the completion of the routing area update (RAU) procedure.

When the 3G/2G SGSN receives the **PS Handover Request Acknowledge** message and it decides to proceed with the handover, the preparation phase is finished and the execution phase will follow.

5.3.1.2 Inter RAT/mode UTRAN/GERAN Iu mode to GERAN A/Gb mode PS HO; Execution phase

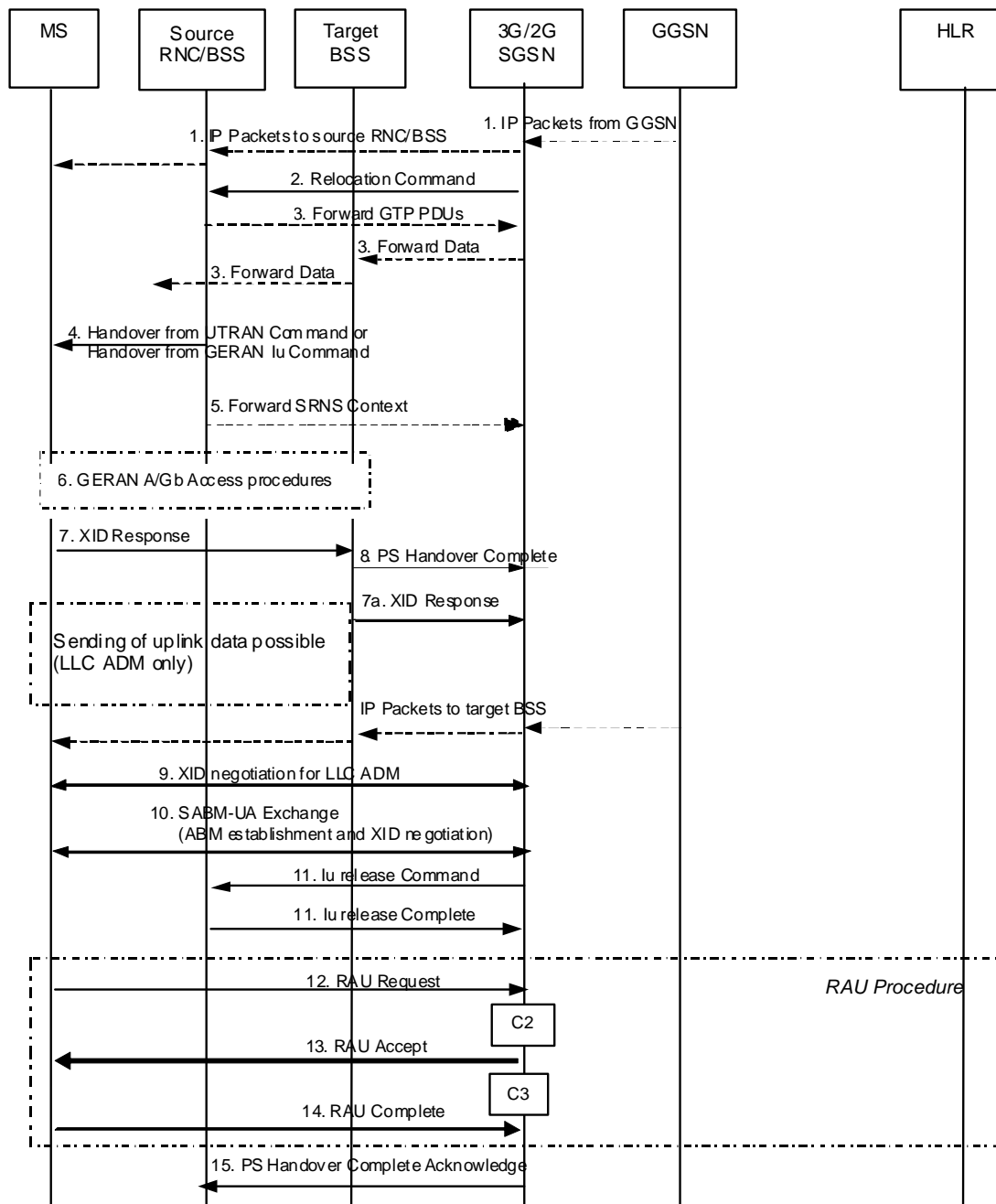

Figure 16: PS Handover Execution Phase; Inter-RAT/mode, Intra-SGSN case (UTRAN/GERAN Iu mode → GERAN A/Gb mode)

1. The 3G/2G SGSN continues to receive IP packets from the GGSN (via GTP) and forwards the associated PDU payload to the MS via the source RNC/BSS.
2. The 3G/2G SGSN continues the PS handover by sending a **Relocation Command** (Target BSS to Source BSS Transparent Container (PS Handover Command with RN part and CN part), RABs to be Released List, RABs Subject to Data Forwarding List) message to the source RNC/BSS. "RABs to be released list" will be the list of all NSAPIs (RAB Ids) for which a PFC was not established "RABs Subject to Data forwarding list" will be the list of all NSAPIs (RAB Ids) for which a PFC was established.
3. When receiving the **Relocation Command** message the source RNC may, based on QoS, begin the forwarding of data for the RABs subject to data forwarding to the 3G/2G SGSN according to the definition in 3GPP TS 23.060 [19]. The GTP-U sequence numbers are only sent by the source RNC for PDP context(s)

requiring delivery order (QoS profile) to be preserved. If delivery order is to be preserved (QoS profile), consecutive GTP-PDU sequence numbering shall be maintained through the lifetime of the PDP context(s).

The 3G/2G SGSN may, based on QoS, proceed with the packet handling as follows:

- For PDP contexts which use LLC ADM the 3G/2G SGSN either:
    - a. forwards the received downlink N-PDUs to the target BSS;
    - b. stores the received data into the SNDSCP queue for e.g. the PDU lifetime;
    - c. discards the received data until e.g. reception of the **PS Handover Complete** message.
  - If the 3G/2G SGSN forwards packets to the target BSS, the target BSS may start a blind transmission of downlink user data towards the MS over the allocated radio channels.
4. The RNC/BSS sends the **Handover from UTRAN Command** message (UTRAN) or the **Handover from GERAN Iu Command** message to the MS where each message includes a PS Handover Command (RN part and CN part) message. Before sending the message the uplink and downlink data transfer shall be suspended in the source RNC for the RABs that require delivery order.

Upon reception of the **Handover from UTRAN Command** message (UTRAN) or the **Handover from GERAN Iu Command** the MS shall suspend the uplink transmission of user plane data.

5. The source RNC/BSS continues the handover by sending a **Forward SRNS Context** (RAB contexts) message to the 3G/2G SGSN.

The source RNC/BSS behaviour is as specified in 3GPP TS 23.060 [19] (Combined Hard Handover and SRNS Relocation).

6. The MS executes the handover according to the parameters provided in the message delivered in step 4. The procedure is the same as in step 6 in subclause 5.1.4.2.
- 7./7a. After accessing the cell using access bursts and receiving timing advance information from the BSS in step 6, the MS processes the NAS container and then sends one **XID Response** message to the 3G/2G SGSN. The MS sends this message immediately after receiving the **Packet Physical Information** message containing the timing advance or, in the synchronised network case, immediately if the **PS Handover Access** message is not required to be sent (see Section 6.2).

The MS shall resume the user data transfer only for those NSAPIs for which there are radio resources allocated in the target cell. For NSAPIs using LLC ADM for which radio resources were not allocated in the target cell the MS may request for radio resources using the legacy procedures.

- NOTE: If the 3G/2G SGSN indicated Reset (i.e. reset to default parameters) in the NAS container for PS HO included in the **Handover from UTRAN Command** message (UTRAN) or the **Handover from GERAN Iu Command** message, in order to avoid collision cases the mobile station may avoid triggering XID negotiation for any LLC SAPI used in LLC ADM, but wait for the SGSN to do so (see bullet 9). In any case the mobile station may avoid triggering XID negotiation for any LLC SAPI used in LLC ABM, but wait for the SGSN to do so (see bullet 10).

8. Upon reception of the first correct RLC/MAC block (sent in normal burst format) from the MS the target BSS sends a **PS Handover Complete** (Local TLLI, IMSI, Request for INTER RAT HANDOVER INFO) message to inform the 3G/2G SGSN that the MS has arrived in the target cell. Each uplink N-PDU received by the 3G/2G SGSN via the target BSS is then forwarded directly to the GGSN. The target BSS should request the INTER RAT HANDOVER INFO from the SGSN by setting the "Request for INTER RAT HANDOVER INFO " to "1".
9. If the 3G/2G SGSN indicated Reset (i.e. reset to default parameters) in the NAS container for PS HO included in the **Handover from UTRAN Command** message (UTRAN) or the **Handover from GERAN Iu Command** message, then on receipt of the **PS Handover Complete** message the SGSN initiates an LLC/SNDSCP XID negotiation for each LLC SAPI used in LLC ADM. In this case if the SGSN wants to use the default parameters, it shall send an empty XID Command. If the SGSN indicated 'Reset to the old XID parameters' in the NAS container for PS HO, no further XID negotiation is required for LLC SAPIs used in LLC ADM only.

10. The 3G/2G SGSN (re-)establishes LLC ABM for the PDP contexts which use acknowledged information transfer. During the exchange of SABM and UA the SGSN shall perform LLC/SNDCP XID negotiation.
11. After the reception of the **PS Handover Complete** message the 3G/2G SGSN sends an **Iu Release Command** message to the source RNC/BSS commanding the source RNC/BSS to release all resources related to the Iu connection. When the RNC/BSS data forwarding timer has expired the source RNC/BSS responds with an **Iu Release Complete** (RAB Data Volume report list, RABs released list) message.
12. The MS sends a **Routing Area Update Request** (Old P-TMSI, Old RAI, Old P-TMSI signature, Update Type) message to the 3G/2G SGSN. This is done even if the target cell belongs to the same routing area as the source cell. The MS shall send this message immediately after message 7, see 3GPP TS 23.060 [19].

The 3G/2G SGSN knows that a handover has been performed for this MS and can therefore exclude the SGSN context procedures which normally are used within the RA Update procedure.

13. The 3G/2G SGSN validates the MS presence in the new RA. If the MS is allowed to be attached in this RA, the 3G/2G SGSN updates the MM context for and sends a **Routing Area Update Accept** (P-TMSI, TMSI, P-TMSI signature, Receive N-PDU number) message to the MS. The Receive N-PDU Number contains the acknowledgements for each acknowledged-mode NSAPI used by the 3G/2G SGSN, thereby confirming all mobile originated N-PDUs successfully transferred before the start of the PS handover procedure.
14. The MS confirms the re-allocation of the new P-TMSI by responding to the 3G/2G SGSN with a **Routing Area Update Complete** (Receive N-PDU number). The MS derives the TLLI from the new P-TMSI using the current MM procedures. The Receive N-PDU Number contains the acknowledgements for each acknowledged mode NSAPI used by the MS, thereby confirming all mobile terminated N-PDUs successfully transferred before the start of the handover procedure. If Receive N-PDU Number confirms reception of N-PDUs that were forwarded from the 3G/2G SGSN, these N-PDUs shall be discarded by the 3G/2G SGSN.

The following CAMEL procedure calls shall be performed (see referenced procedures in TS 23.078 [8b]):

C2) CAMEL\_GPRS\_Routeing\_Area\_Update\_Session and CAMEL\_PS\_Notification.

They are called in the following order:

- The CAMEL\_GPRS\_Routeing\_Area\_Update\_Session procedure is called. The procedure returns as result "Continue".
- Then, the CAMEL\_PS\_Notification procedure is called. The procedure returns as result "Continue".

C3) CAMEL\_GPRS\_Routeing\_Area\_Update\_Context.

This procedure is called several times: once per PDP context. It returns as result "Continue".

For C2 and C3: refer to Routing Area Update procedure description in 3GPP TS 23.060.

15. Upon reception of the **PS Handover Complete** message with the "Request for INTER RAT HANDOVER INFO" set to "1", the SGSN should send then **PS Handover Complete Acknowledge** (TLLI, INTER RAT HANDOVER INFO) message to the target BSS.

NOTE 2: An SGSN that does not recognize the 'Request for Inter RAT Handover Info' in the **PS Handover Complete** message will not send the **PS Handover Complete Acknowledge** message back to the BSS.

16. The target BSS receiving the **PS Handover Complete Acknowledge** message shall set the "Reliable INTER RAT HANDOVER" to "1" in the **PS Handover Required** message in any subsequent PS handover to GERAN *A/Gb mode*. The target BSS failing to receive the **PS Handover Complete Acknowledge** message shall set the "Reliable INTER RAT HANDOVER" to "0" in the **PS Handover Required** message in any subsequent PS handover to GERAN *A/Gb mode*. The Target BSS shall, upon receipt of the INTER RAT HANDOVER INFO in the **PS Handover Complete Acknowledge** message, discard the INTER RAT HANDOVER INFO received from the source RNC during the preparation phase.



## 5.3.2 Inter SGSN

### 5.3.2.1 Inter RAT/mode UTRAN/GERAN Iu mode to GERAN A/Gb mode PS HO; Preparation phase

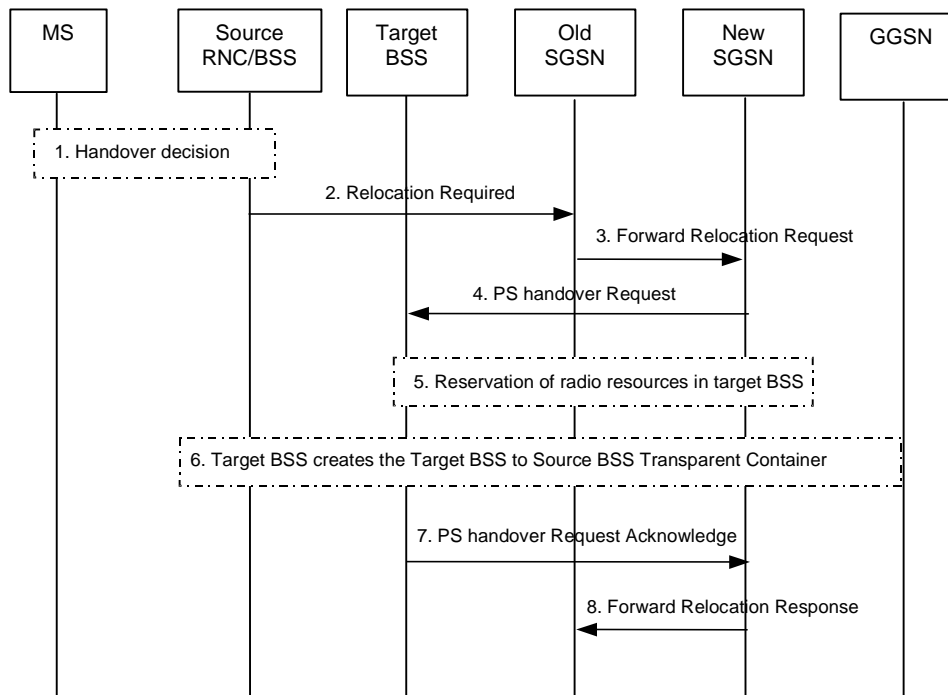

**Figure 17: PS Handover Preparation Phase; Inter-RAT/mode, Inter-SGSN case (UTRAN/GERAN Iu mode → GERAN A/Gb mode)**

1. Based on measurement results and knowledge of the RAN topology, the source RNC/BSS decides to initiate an inter RAT/mode PS handover towards the GERAN A/Gb mode. At this point both uplink and downlink user data flows via the tunnel(s): Radio Bearer between the MS and the source RNC/BSS; GTP-U tunnel(s) between the source RNC/BSS and the old SGSN; GTP-U tunnel(s) between the old SGSN and the GGSN.

NOTE 1: The process leading to the handover decision is outside of the scope of this paper.

2. The source RNC/BSS sends a **Relocation Required** (Relocation Type, Cause, Source ID, Target ID, Source BSS To Target BSS Transparent Container (RN part)) message to the old SGSN. The source RNC/BSS shall set Relocation Type to "UE Involved in relocation of SRNS".

Target ID contains the identity of the target cell.

3. The old SGSN determines from the Target Cell Identifier that the type of handover is inter-RAT/mode handover. In case of Inter-RAT/ mode Inter-SGSN PS handover, the old SGSN initiates the PS Handover resource allocation procedure by sending a **Forward Relocation Request** (IMSI, Tunnel Endpoint Identifier Control Plane, RANAP Cause, Target Cell Identifier, MM Context, PDP Contexts, Packet Flow ID, SMDCP XID parameters, LLC XID parameters, PDP Context Prioritisation, Source BSS To Target BSS Transparent Container [RN part] in the BSS Container, Source RNC Id, SGSN Address for control plane) message to the new SGSN. If the old SGSN supports PS handover procedures then it has to allocate a valid PFI according to subclause 4.4.1 during the PDP Context activation procedure. Each PDP context contains the GGSN Address for User Plane and the Uplink TEID for Data (to this GGSN Address and Uplink TEID for Data the old SGSN and the new SGSN send uplink packets).

The MM context contains security related information, e.g. supported ciphering algorithms as described in 3GPP TS 29.060 [11]. The relation between GSM and UMTS security parameters is defined in 3GPP TS 33.102 [27],

The new SGSN selects the ciphering algorithm to use. This algorithm will be sent transparently from the new SGSN to the MS. The IOV-UI parameter generated in the new SGSN and used, as input to the ciphering procedure will also be transferred transparently from the new SGSN to the MS.

When the new SGSN receives the **Forward Relocation Request** message the required PDP, MM, SNDCP and LLC contexts are established and a new P-TMSI is allocated for the MS. When this message is received by the new SGSN it begins the process of establishing PFCs for all PDP contexts.

When the new SGSN receives the **Forward Relocation Request** message it extracts from the PDP Contexts the NSAPIs and SAPIs and PFIs to be used in the new SGSN. If for a given PDP Context the new SGSN does not receive a PFI from the old SGSN, it shall not request the target BSS to allocate TBF resources corresponding to that PDP Context. If none of the PDP Contexts forwarded from the old SGSN has a valid PFI allocated the new SGSN shall consider this as a failure case and the request for PS handover shall be rejected.

In case when an SAPI and PFI was available at the old SGSN but the new SGSN does not support the same SAPI and PFI for a certain NSAPI as the old SGSN, the new SGSN shall continue the PS handover procedure only for those NSAPIs for which it can support the same PFI and SAPI as the old SGSN. All PDP contexts for which no resources are allocated by the new SGSN or for which it cannot support the same SAPI and PFI (i.e. the corresponding NSAPIs are not addressed in the response message of the target SGSN), are maintained and the related SAPIs and PFIs are kept. These PDP contexts may be modified or deactivated by the new SGSN via explicit SM procedures upon RAU procedure.

The old SGSN shall indicate the current XID parameter settings if available (i.e. those negotiated at the old SGSN when the MS was in A/Gb mode or received during a previous inter-SGSN PS handover) to the new SGSN. If the new SGSN can accept all XID parameters as indicated by the old SGSN, the new SGSN shall create a NAS container for PS HO indicating 'Reset to the old XID parameters'. Otherwise, if the new SGSN cannot accept all XID parameters indicated by the old SGSN or if no XID parameters were indicated by the old SGSN, the new SGSN shall create a NAS container for PS HO indicating Reset (i.e. reset to default parameters).

4. The new SGSN sends a **PS Handover Request** (Local TLLI, IMSI, Cause, Target Cell Identifier, Source BSS to Target BSS Transparent Container (RN part), PFCs To Be Set Up List, NAS container for PS HO) message to the target BSS. The new SGSN shall not request resources for PFCs associated with PDP contexts with maximum bit rate for uplink and downlink of 0 kbit/s.
5. Based upon the ABQP for each PFC the target BSS makes a decision about which PFCs to assign radio resources. The algorithm by which the BSS decides which PFCs that need resources is implementation specific. Due to resource limitations not all downloaded PFCs will necessarily receive resource allocation. The target BSS allocates TBFs for each PFC that it can accommodate.
6. The target BSS shall prepare the Target BSS to Source BSS Transparent Container which contains a PS Handover Command including the CN part (NAS container for PS HO) and the RN part (PS Handover Radio Resources).
7. Target BSS shall send the **PS Handover Request Acknowledge** message (Local TLLI, List of Set Up PFCs, Target BSS to Source BSS Transparent Container) message to the new SGSN. Upon sending the **PS Handover Request Acknowledge** message the target BSS shall be prepared to receive downlink LLC PDUs from the new SGSN for the accepted PFCs.

Any PDP contexts for which a PFC was not established are maintained in the new SGSN and the related SAPIs and PFIs are kept. These PDP contexts may be modified or deactivated by the new SGSN via explicit SM procedures upon the completion of the routing area update (RAU) procedure.

8. The new SGSN passes the assigned list of TEIDs for each PDP context for which a PFC was assigned in the RAB setup information IE in the **Forward Relocation Response** (Cause, List of Set Up PFCs, Target BSS to Source BSS Transparent Container) in the BSS Container, Tunnel Endpoint Identifier Control Plane, SGSN Address for User Traffic, Tunnel Endpoint Identifier Data II) message to the old SGSN. The NSAPIs of the active PDP Contexts received in the Forward Relocation Request message for which the PS handover continues, i.e. for which resources are allocated for the PFCs in the target BSS, are indicated in this message.

The Tunnel Endpoint Identifier Data II, one information for each PDP context, is the tunnel endpoint of the new SGSN and is used for data forwarding from the old SGSN, via the new SGSN, to the target BSS.

The new SGSN activates the allocated LLC/SNDCP engines as specified in 3GPP TS 44.064 [21] for an SGSN originated Reset or 'Reset to the old XID parameters'.

When the old SGSN receives the **Forward Relocation Response** message and it decides to proceed with the handover, the preparation phase is finished and the execution phase will follow.

5.3.2.2 Inter RAT UTRAN/GERAN Iu mode to GERAN A/Gb mode PS HO; Execution phase

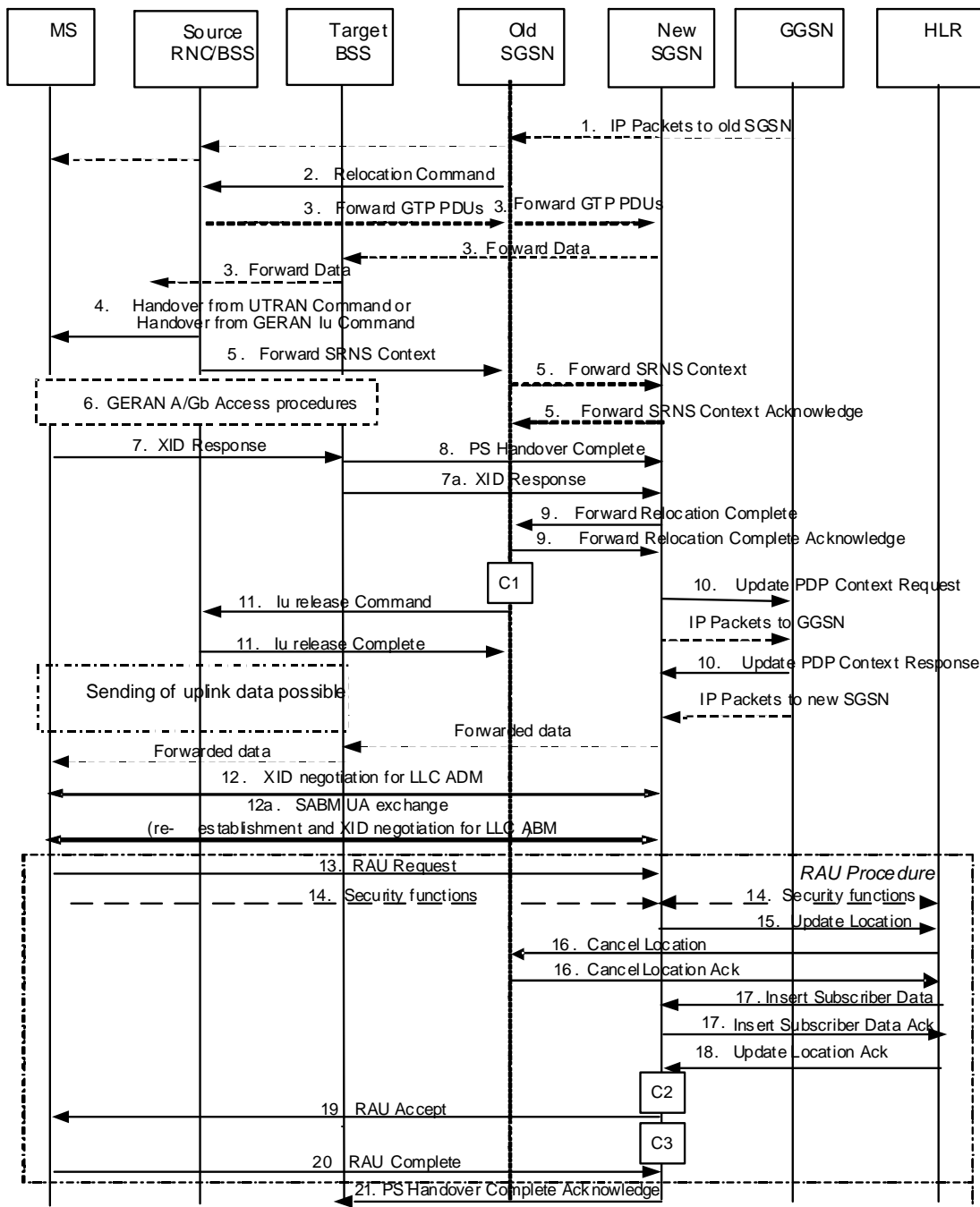

Figure 18: PS Handover Execution Phase; Inter-RAT/mode, Inter-SGSN case (UTRAN/GERAN Iu mode → GERAN A/Gb mode)

1. The old SGSN continues to receive IP packets from the GGSN (via GTP) and forwards the associated PDU payload to the MS via the source RNC/BSS.
2. The old SGSN continues the PS handover by sending a **Relocation Command** (Target BSS to Source BSS Transparent Container (PS Handover Command with RN part and CN part), RABs to be Released List, RABs Subject to Data Forwarding List) message to the source RNC/BSS. "RABs to be released list" will be the list of all NSAPIs (RAB Ids) for which a PFC was not established "RABs Subject to Data forwarding list" will be the list of all NSAPIs (RAB Ids) for which a PFC was established.

3. When receiving the **Relocation Command** message the source RNC/BSS may, based on QoS, begin the forwarding of data for the RABs subject to data forwarding to the new SGSN via the old SGSN (if a Tunnel Endpoint is available) according to the definition in 3GPP TS 23.060 [19]. The GTP-U sequence numbers are only sent by the source RNC for PDP context(s) requiring delivery order (QoS profile) to be preserved. If delivery order is to be preserved (QoS profile), consecutive GTP-PDU sequence numbering shall be maintained through the lifetime of the PDP context(s).

The new SGSN may, based on QoS, proceed with the packet handling as follows:

- For PDP contexts which use LLC ADM the new SGSN either:
  - a. forwards the received downlink N-PDUs to the target BSS;
  - b. stores the received data into the SNDCP queue for e.g. the PDU lifetime;
  - c. discards the received data until e.g. reception of the **PS Handover Complete** message.

If the new SGSN forwards packets to the target BSS, the target BSS may start a blind transmission of downlink user data towards the MS over the allocated radio channels.

NOTE 1: The order of steps, starting from step 3 onwards, does not necessarily reflect the order of events. For instance the source RNC may start data forwarding (step 3), send the RRC message (step 4) and send the **Forward SRNS Context** message (step 5) almost simultaneously.

4. The source RNC/BSS sends the **Handover from UTRAN Command** message (UTRAN) or the **Handover from GERAN Iu Command** message to the MS where each message includes a PS Handover Command (RN part and CN part). Before sending the message the uplink and downlink data transfer shall be suspended in the source RNC for the RABs that require delivery order.

Upon the reception of the **HANDOVER from UTRAN Command** message (UTRAN) or the **HANDOVER from GERAN Iu Command** message containing the PS Handover Command message, the MS shall associate its RAB IDs to the respective PFIs based on the relation with the NSAPI and shall suspend the uplink transmission of the user plane data.

5. The source RNC continues the handover by sending a **Forward SRNS Context** (RAB contexts) message to the new SGSN, via the old SGSN. The **Forward SRNS Context** message is acknowledged by the new SGSN with the **Forward SRNS Context Acknowledge** message to the old SGSN.

The source RNC/BSS behaviour is as specified in 3GPP TS 23.060 [19] (Combined Hard Handover and SRNS Relocation).

6. The MS executes the handover according to the parameters provided in the message delivered in step 4. The procedure is the same as in step 6 in subclause 5.1.4.2 with the additional function of association of the received PFI and existing RAB Id related to the particular NSAPI as described in clause 4.4.1.
- 7./7a. After accessing the cell using access bursts and receiving timing advance information from the BSS in step 6, the MS processes the NAS container and then sends one **XID Response** message to the new SGSN. The MS sends this message immediately after receiving the **Packet Physical Information** message containing the timing advance or, in the synchronised network case, immediately if the **PS Handover Access** message is not required to be sent (see Section 6.2).

Upon sending the **XID Response message**, the MS shall resume the user data transfer only for those NSAPIs for which there are radio resources allocated in the target cell. For NSAPIs using LLC ADM for which radio resources were not allocated in the target cell the MS may request for radio resources using the legacy procedures.

NOTE 2: If the new SGSN indicated Reset (i.e. reset to default parameters) in the NAS container for PS HO included in the the **Handover from UTRAN Command** message (UTRAN) or the **Handover from GERAN Iu Command** message, in order to avoid collision cases the mobile station may avoid triggering XID negotiation for any LLC SAPI used in LLC ADM, but wait for the SGSN to do so (see bullet 12). In any case the mobile station may avoid triggering XID negotiation for any LLC SAPI used in LLC ABM, but wait for the SGSN to do so (see bullet 12a).

8. Upon reception of the first correct RLC/MAC block (sent in normal burst format) from the MS the target BSS sends a **PS Handover Complete** (Local TLLI, Handover Complete Status, Request for INTER RAT

HANDOVER INFO) message to inform the new SGSN that the MS has arrived in the target cell. Each uplink N-PDU received by the new SGSN via the target BSS is then forwarded directly to the GGSN. The target BSS should request the INTER RAT HANDOVER INFO from the SGSN by setting the "Request for Inter RAT Handover Info" to "1".

9. Upon receiving the **PS Handover Complete** message, the new SGSN send a **Forward Relocation Complete** message to the old SGSN to indicate completion of the PS handover procedures. The old SGSN responds with a **Forward Relocation Complete Acknowledge** message.
10. The new SGSN sends an **Update PDP Context Request** (new SGSN Address, TEID, QoS Negotiated) message to the GGSN concerned. The GGSN updates the PDP context fields and returns an **Update PDP Context Response** (TEID) message. From now on the GGSN sends new incoming downlink IP packets to the new SGSN instead of to the old SGSN.
11. The old SGSN sends an **Iu Release Command** message to the source RNC/BSS commanding the source RNC/BSS to release all resources related to the Iu connection. When the RNC/BSS data forwarding timer has expired the source RNC/BSS responds with an **Iu Release Complete** (RAB Data Volume report list, RABs released list) message.
12. If the new SGSN indicated Reset (i.e. reset to default parameters) in the NAS container for PS HO included in the **Handover from UTRAN Command** message (UTRAN) or the **Handover from GERAN Iu Command** message, then on receipt of the PS Handover Complete the new SGSN initiates an LLC/SNDCP XID negotiation for each LLC SAPI used in LLC ADM. In this case if the SGSN wants to use the default parameters, it shall send an empty XID Command. If the new SGSN indicated 'Reset to the old XID parameters' in the NAS container for PS HO, no further XID negotiation is required for LLC SAPIs used in LLC ADM only.
- 12a. The new SGSN (re-)establishes LLC ABM for the PDP contexts which use acknowledged information transfer. During the exchange of SABM and UA the SGSN shall perform LLC/SNDCP XID negotiation.
13. The MS sends a **Routing Area Update Request** (Old P-TMSI, Old RAI, Old P-TMSI signature, Update Type) message to the new SGSN informing it that the source cell belongs to a new routing area. The MS shall send this message immediately after message 7, see 3GPP TS 23.060 [19].

The new SGSN knows that a handover has been performed for this MS and can therefore exclude the SGSN context procedures which normally are used within the RA Update procedure.

14. At this point the new SGSN may optionally invoke MS authentication (security function). The security function can be deferred and performed at any later time as well.

NOTE 3: During an authentication procedure the SGSN has to suspend the downlink transmission of user data.

15. The new SGSN informs the HLR of the change of SGSN by sending **Update Location** (SGSN Number, SGSN Address, IMSI) message to the HLR.
16. The HLR sends a **Cancel Location** (IMSI, Cancellation Type) message to the old SGSN with Cancellation Type set to Update Procedure. The old SGSN acknowledges with a **Cancel Location Acknowledge** (IMSI) message. This message allows the old SGSN to know when to release the inter-SGSN tunnel.
17. The HLR sends **Insert Subscriber Data** (IMSI, GPRS subscription data) message to the new SGSN. The new SGSN validates the MS presence in the (new) RA. If all checks are successful then the new SGSN constructs an MM context for the MS and returns an **Insert Subscriber Data Acknowledge** (IMSI) message to the HLR. This message allows the new SGSN to know when to release the inter-SGSN tunnel.
18. The HLR acknowledges the Update Location by sending an **Update Location Acknowledge** (IMSI) message to the new SGSN.
19. The new SGSN validates the MS presence in the new RA. If the MS is allowed to be attached in this RA, the SGSN updates the MM context for and sends a **Routing Area Update Accept** (P-TMSI, TMSI, P-TMSI signature, Receive N-PDU number) message to the MS. The Receive N-PDU Number contains the acknowledgements for each acknowledged-mode NSAPI used by the SGSN, thereby confirming all mobile originated N-PDUs successfully transferred before the start of the PS handover procedure.
20. The MS confirms the re-allocation of the new P-TMSI by responding to the SGSN with a **Routing Area Update Complete** (Receive N-PDU number) message. The MS derives the Local TLLI from the new P-TMSI

using the current MM procedures. The Receive N-PDU Number contains the acknowledgements for each acknowledged mode NSAPI used by the MS, thereby confirming all mobile terminated N-PDUs successfully transferred before the start of the handover procedure. If Receive N-PDU Number confirms reception of N-PDUs that were forwarded from the old SGSN, these N-PDUs shall be discarded by the new SGSN.

The following CAMEL procedure calls shall be performed (see referenced procedures in TS 23.078 [8b])

C1) CAMEL\_GPRS\_PDP\_Context\_Disconnection, CAMEL\_GPRS\_Detach and CAMEL\_PS\_Notification.

They are called in the following order:

- The CAMEL\_GPRS\_PDP\_Context\_Disconnection procedure is called several times: once per PDP context. The procedure returns as result "Continue".
- Then the CAMEL\_GPRS\_Detach procedure is called once. The procedure returns as result "Continue".
- Then the CAMEL\_PS\_Notification procedure is called once. The procedure returns as result "Continue".

C2) CAMEL\_GPRS\_Routeing\_Area\_Update\_Session and CAMEL\_PS\_Notification.

They are called in the following order:

- The CAMEL\_GPRS\_Routeing\_Area\_Update\_Session procedure is called. The procedure returns as result "Continue".
- Then, the CAMEL\_PS\_Notification procedure is called. The procedure returns as result "Continue".

C3) CAMEL\_GPRS\_Routeing\_Area\_Update\_Context.

This procedure is called several times: once per PDP context. It returns as result "Continue".

For C2 and C3: refer to Routing Area Update procedure description in 3GPP TS 23.060.

21. Upon reception of the **PS Handover Complete** message with the "Request for Inter RAT Handover Info" set to "1", the SGSN should send then **PS Handover Complete Acknowledge** (TLLI, INTER RAT HANDOVER INFO) message to the target BSS.

NOTE 4: An SGSN that does not recognize the 'Request for Inter RAT Handover Info' in the **PS Handover Complete** message will not send the **PS Handover Complete Acknowledge** message back to the BSS.

22. The target BSS receiving the **PS Handover Complete Acknowledge** message shall set the "Reliable INTER RAT HANDOVER" to "1" in the **PS Handover Required** message in any subsequent PS handover to GERAN *A/Gb mode*. The target BSS failing to receive the **PS Handover Complete Acknowledge** message shall set the "Reliable INTER RAT HANDOVER" to "0" in the **PS Handover Required** message in any subsequent PS handover to GERAN *A/Gb mode*. The Target BSS shall, upon receipt of the INTER RAT HANDOVER INFO in the **PS Handover Complete Acknowledge** message, discard the INTER RAT HANDOVER INFO received from the source RNC during the preparation phase.

## 5.4 Handover reject

### 5.4.1 General

The target BSS may reject the use of the PS Handover procedure in case none of the PFCs To Be Set Up in the **PS Handover Request** message could be granted the requested QoS, or, in case of a non-critical PS handover, if at least one of the PFCs To Be Set Up in the **PS Handover Request** message could not be granted the requested QoS. In this case no MS context will be established in the target BSS and no resources will be allocated. The target BSS will send a **PS Handover Request Negative Acknowledge** message to the new SGSN causing the new SGSN to release any allocated resources (e.g. P-TMSI, MS associated contexts) related to the specific MS. The signalling procedure for the Inter-SGSN HO Reject is shown in clause 5.4.2. Similar procedures are used in the other handover cases.

### 5.4.2 Inter-SGSN HO Reject; Signalling procedure

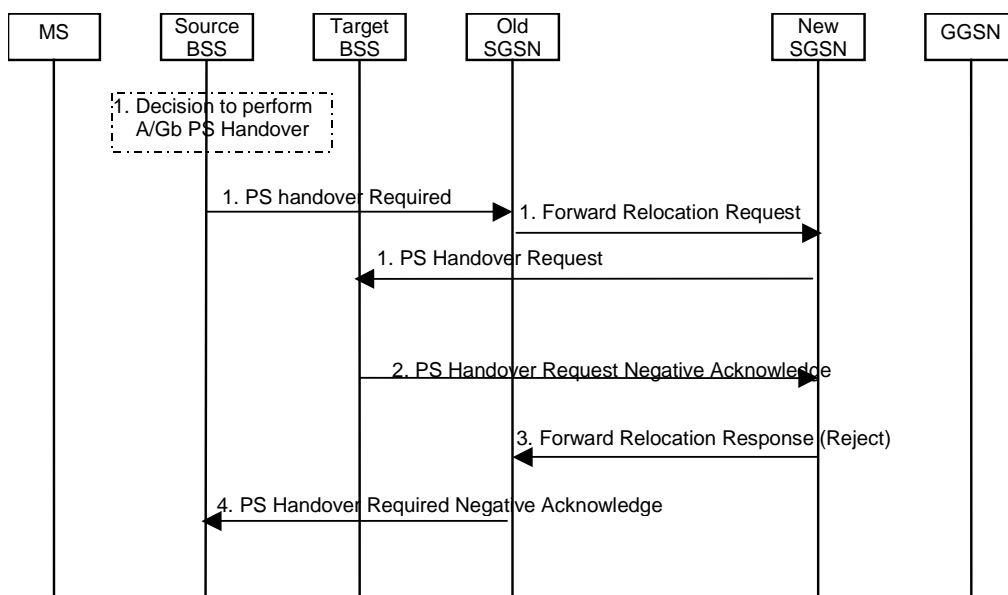

**Figure 19: PS Handover Reject; Inter-SGSN case (GERAN A/Gb mode → GERAN A/Gb mode)**

1. The first four steps in the flow are identical to the ones in clause 5.1.4.1.
2. In case the target BSS fails to allocate any resources for any of the requested PFCs it sends a **PS Handover Request Negative Acknowledge** (Cause, Source Cell Identifier, Target Cell Identifier) message to the new SGSN.
3. When the new SGSN receives the **PS Handover Request Negative Acknowledge** message it clears any reserved resources (e.g. PDP context, P-TMSI) for this mobile and sends the **Forward Relocation Response** (Cause, SGSN Address for control plane) message to the old SGSN.
4. When the old SGSN receives the **Forward Relocation Response** message it sends a **PS Handover Required Negative Acknowledge** (Old TLLI, Cause, Source Cell Identifier, Target Cell Identifier) message to the source BSS.

## 5.5 Handover cancel

### 5.5.1 General

Instead of performing the handover, the source BSS may at any time during the handover procedure, up to the time when the **PS Handover Command** message is sent to the mobile station cancel the handover. The reason for cancelling can be e.g. due to a timer expiration or due to other events within the source BSS and is initiated by sending a **PS Handover Cancel** PDU to the SGSN.

A **PS Handover Cancel** PDU shall also be sent by the source BSS after the **PS Handover Command** message is sent to the mobile station for the case where the PS Handover fails and the MS returns to the old cell or radio contact with the MS is lost. This is done in order to release the resources reserved for the PS Handover in the target system.

The radio contact with the MS is considered lost by the source BSS if, after transmission of the **PS Handover Command** message, for an implementation dependent period of time:

- the BSS does not receive a **Packet Cell Change Failure** message (see sub-clause 5.7.2) or any other RLC/MAC block (other than a Packet Control Acknowledgement message which acknowledges the receipt of the PS Handover Command) from the MS in the source cell, and either
  - the BSS does not receive any RLC/MAC block from the MS in the target cell, if the PS handover is an optimised intra-BSS handover, or
  - the BSS does not receive a DELETE-BSS-PFC PDU (including the TLLI of the MS) from the SGSN, if the PS handover is an inter-BSS handover, inter-RAT/mode or non-optimised intra-BSS handover.

The signalling procedures for the case when the handover is cancelled before the **PS Handover Command** message has been sent by the source BSS to the mobile station is shown in clause 5.5.2 below, as well as the case when the handover is cancelled in UTRAN/GERAN Iu mode by the source RNC/BSS. The signalling procedures for the cases that occur after the **PS Handover Command** message has been sent are shown in clause 5.7.2.1.

## 5.5.2 Signalling procedures

### 5.5.2.1 Inter-SGSN case, GERAN A/Gb mode → GERAN A/Gb mode

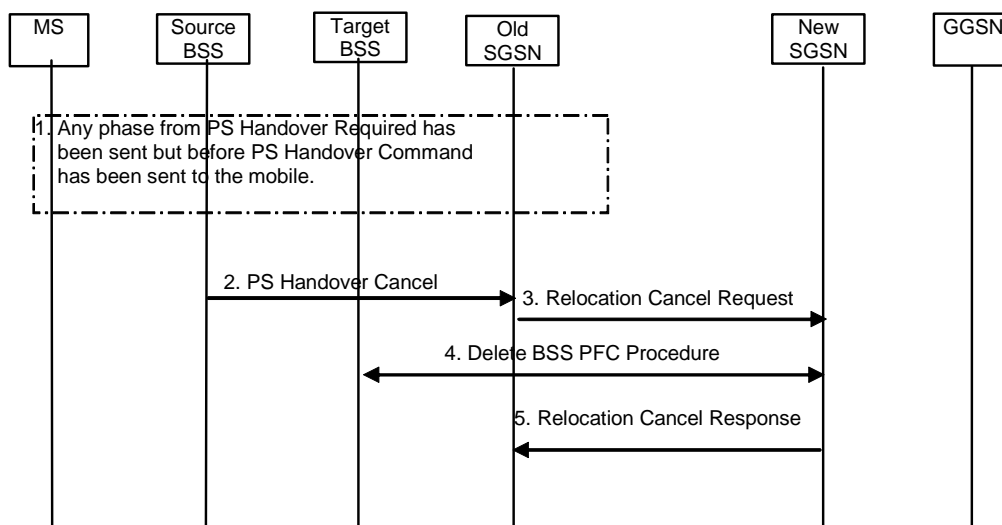

**Figure 20: PS Handover Cancel; Inter-SGSN case, GERAN A/Gb mode → GERAN A/Gb mode**

1. The source BSS decides to cancel the previously requested PS Handover. This may be due to initiation of a CS call during the preparation phase, not enough accepted PFCs, or any other reason.
2. The source BSS sends a **PS Handover Cancel** (TLLI, Cause, Source Cell Identifier, Target Cell Identifier) PDU to the old SGSN.

3. The old SGSN terminates the PS Handover to the target cell by sending a **Relocation Cancel Request** (IMSI) message to the new SGSN. The old SGSN also resumes operation on the resources in the source cell.

NOTE 1: If one new SGSN was chosen among a pool, then the **Relocation Cancel Request** message is sent to this SGSN.

4. The new SGSN triggers the release of resources in the target cell and also releases its own resources allocated for this handover.

5. The new SGSN acknowledges the release of all resources on the target side by returning a **Relocation Cancel Response** message to the old SGSN.



NOTE 2: In the intra-SGSN case, the messages **Relocation Cancel Request** and **Relocation Cancel Response** are not exchanged since the old and new SGSN are then the same node.

### 5.5.2.2 Inter-SGSN case, GERAN A/Gb mode → UTRAN/GERAN Iu mode

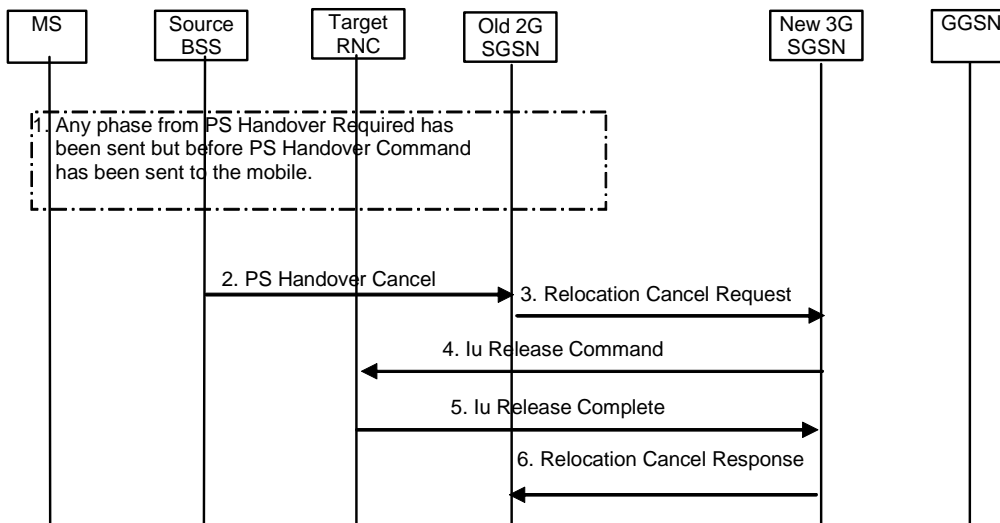

**Figure 20a: PS Handover Cancel; Inter-SGSN case, GERAN A/Gb mode → UTRAN/GERAN Iu mode**

1. The source BSS decides to cancel the previously requested PS handover. This may be due to initiation of a CS call during the preparation phase, not enough accepted PFCs, or any other reason.
2. The source BSS sends a **PS Handover Cancel** (TLLI, Cause, Source Cell Identifier, Target Cell Identifier) PDU to the old SGSN.
3. The old SGSN terminates the PS Handover to the target cell by sending a **Relocation Cancel Request** (IMSI) message to the new SGSN. The old SGSN also resumes operation on the resources in the source cell.

NOTE 1: If one new SGSN was chosen among a pool, then the **Relocation Cancel Request** message is sent to this SGSN.

4. The new SGSN triggers the release of resources in the target cell by sending an **Iu Release Command** message to the target RNC
5. The target RNC releases all resources allocated for this handover and returns an **Iu Release Complete** message to the new SGSN.
6. The new SGSN releases its own resources allocated for this handover and acknowledges the release of all resources on the target side by returning a **Relocation Cancel Response** message to the old SGSN.

NOTE 2: In the intra-SGSN case, the messages **Relocation Cancel Request** and **Relocation Cancel Response** are not exchanged since the old and new SGSN are then the same node.

### 5.5.2.3 Inter-SGSN case, UTRAN/GERAN Iu mode → GERAN A/Gb mode

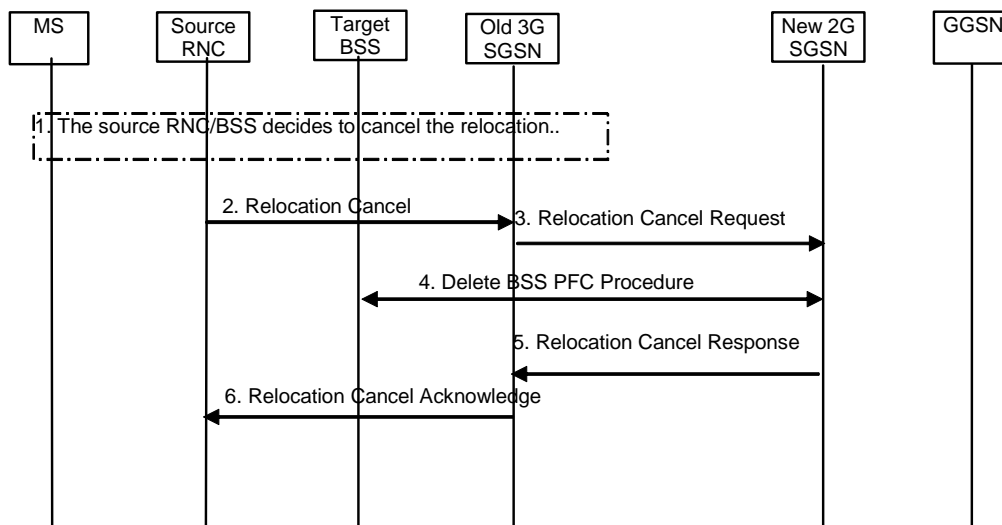

**Figure 20b: Relocation Cancel; Inter-SGSN case, UTRAN/GERAN Iu mode → GERAN A/Gb mode**

1. The source RNC/BSS decides to cancel the previously requested relocation of PS resources. This may be due to initiation of a CS call during the preparation phase, not enough accepted RABs, UE returned to source cell or any other reason.

2. The source RNC/BSS sends a **Relocation Cancel** (Cause) message to the old SGSN.

3. The old SGSN terminates the relocation to the target cell by sending a **Relocation Cancel Request** (IMSI) message to the new SGSN. The old SGSN also resumes operation on the resources in the source cell.

NOTE 1: If one new SGSN was chosen among a pool, then the **Relocation Cancel Request** message is sent to this SGSN.

4. The new SGSN triggers the release of resources in the target cell and also releases its own resources allocated for this handover.

5. The new SGSN acknowledges the release of all resources on the target side by returning a **Relocation Cancel Response** (Cause) message to the old SGSN.

6. The old SGSN returns a Relocation Cancel message to the source RNC/BSS.

NOTE 2: In the intra-SGSN case, the messages **Relocation Cancel Request** and **Relocation Cancel Response** are not exchanged since the old and new SGSN are then the same node.

## 5.6 Container handling

There are two transparent containers defined for the PS handover in GERAN A/Gb mode:

- Source BSS to Target BSS Transparent Container.
- Target BSS to Source BSS Transparent Container.

The Source BSS to Target BSS Transparent Container will carry the information to be transported transparently between the source BSS and the target BSS related to PS handover.

The Target BSS to Source BSS Transparent Container will carry the information to be transported transparently between the target BSS and the source BSS related to PS handover.

In case of the inter-RAT/mode PS handover the transparent containers defined for UTRAN/GERAN Iu mode (Source RNC to Target RNC Transparent Container and Target RNC to Source RNC Transparent Container) will be utilized and enhanced with new information elements to support PS handover.

The generic handling of the source cell (GERAN A/Gb mode or UTRAN/GERAN Iu mode) to target cell (GERAN A/Gb mode or UTRAN/GERAN Iu mode) radio-related container is as follows:

- Created by the source BSS or RNC.
- Processed by the target BSS or RNC.
- Forwarded transparently by the SGSNs.

The generic handling of the target cell (GERAN A/Gb mode or UTRAN/GERAN Iu mode) to source cell (GERAN A/Gb mode or UTRAN/GERAN Iu mode) radio-related container is as follows:

- Created by the target BSS or RNC.
- Processed by the source BSS or RNC.
- Forwarded transparently by the SGSNs.

## 5.6.1 Contents of the containers

The transparent container will consist of two parts:

- The **Radio Network part** (RN part) carrying radio interface related parameters relevant for the MS and the radio network (BSS/RNC) and sent transparently through the core network; This content is:
  - Created by the source BSS/RNC and carried in the Source BSS/RNC to Target BSS/RNC transparent container (i.e. the forward container).
  - Created by the target BSS/RNC and carried in the Target BSS/RNC to Source BSS/RNC transparent container (i.e. the reverse container).
  - Processed by the target BSS/RNC (forward container only)
  - Processed by the source BSS/RNC and MS (reverse container only).
- The **Core Network part** (CN part) carrying parameters relevant for the MS and the core network. This part is only needed from the new SGSN to the MS for PS handover to A/Gb mode and thus is only included in the Target BSS to Source BSS Transparent Container. This content is:
  - Created by the new SGSN.
  - Included in the Target BSS to Source BSS Transparent Container by the target BSS.

NOTE 1: The target BSS does not process the Core Network part.

- Forwarded transparently by the old SGSN and source BSS/RNC.
- Carried within the **PS Handover Command** sent from the source BSS to the MS for PS handover from A/Gb mode to A/Gb mode.
- Carried within the **PS Handover Command** included within a **Handover from UTRAN Command** message or the **Handover from GERAN Iu Command** message sent from the source RNC to the MS for PS handover from Iu mode to A/Gb mode.
- Processed by the MS.

The contents of the Radio Network part will depend on:

- Type of channels that are subject to PS handover, i.e. shared or dedicated.

NOTE 2: Currently dedicated channels are not considered in the PS handover in GERAN A/Gb mode.

- PS handover scenario, i.e. intra-mode or inter-RAT/mode.
- Whether it is sent in a forward container or a reverse container.

The contents of the Core Network part will depend on the PS handover scenario, i.e. intra-mode or inter-RAT/mode.

### 5.6.1.1 Contents of the GERAN A/Gb mode → GERAN A/Gb Transparent Containers

#### 5.6.1.1.1 Source BSS to Target BSS Transparent Container

In GERAN A/Gb mode → GERAN A/Gb mode the Source BSS to Target BSS Transparent Container is sent in the **PS Handover Required** message, the **Forward Relocation Request** message and the **PS Handover Request** message.

The Radio Network part consists of the following:

- MS RAC.
- START\_PS and UE RAC (for dual mode mobile stations).

NOTE 1: The START\_PS and UE RAC are needed to support PS Handover to UTRAN/GERAN Iu mode.

NOTE 2: The way of transferring START\_PS and UE RAC from the mobile station to the BSS, is to piggyback the RRC container INTER RAT HANDOVER INFO, which includes START\_PS and UE RAC, to the Attach Complete and Routing Area Update Complete messages from the mobile station to the SGSN. The SGSN will then include this container in every CREATE-BSS-PFC message sent to the BSS or in the **PS Handover Complete Acknowledge** message if requested by the BSS.

#### 5.6.1.1.2 Target BSS to Source BSS Transparent Container

In GERAN A/Gb mode → GERAN A/Gb mode the Target BSS to Source BSS Transparent Container is sent in the **PS Handover Request Acknowledge** message, **Forward Relocation Response** message and the **PS Handover Required Acknowledge** message.

The Radio Network part consists of the required information for access in the target cell and the information on allocated radio resources, uplink and downlink TBF parameters, Handover reference and generic parameters for access in the target cell (i.e. GPRS cell options, target cell "Cell Selection struct", global power control parameters, reference frequency lists, cell allocation, GPRS mobile allocation).

The Core Network part (i.e. NAS Container for PS HO) consists of the following parameters:

- an XID Command indicating Reset or 'Reset to old XID parameters' and the new IOV-UI for the target cell;
- the GPRS ciphering algorithm to be used in the target cell, if it is different from the ciphering algorithm used in the source cell.

### 5.6.1.2 Contents of the GERAN A/Gb mode → UTRAN Transparent Containers

#### 5.6.1.2.1 Source RNC to Target RNC Transparent Container

In GERAN A/Gb mode → UTRAN the Source RNC to Target RNC Transparent Container is sent from the source BSS to the target RNC in the **PS Handover Required** message and the **Relocation Request** message.

The Radio Network part consists of the following:

- RRC Container as defined in 3GPP TS 25.331 [17] will contain Inter RAT Handover Info (UTRAN specific information including START\_PS/UE RAC) and Inter RAT UE radio access capability including MS RAC from BSS to RNC.
- Target Cell Id.
- Number of Iu instances IE. The value of this IE is set to 1 as defined in 3GPP TS 25.413 [23].
- Relocation Type. The value of the IE is set to 'UE involved', as defined in 3GPP TS 25.413 [23].

### 5.6.1.2.2 Target RNC to Source RNC Transparent Container

In GERAN A/Gb mode -> UTRAN the Target RNC to Source RNC Transparent Container is sent from the target RNC to the source BSS in the **Relocation Request Acknowledge** message, **Forward Relocation Response** message and the **PS Handover Required Acknowledge** message.

The Radio Network part consists of the RRC message, i.e. the **Handover to UTRAN Command** message (as defined in 3GPP TS 25.331 [17]) used to perform handover from GERAN A/Gb mode to UTRAN. This message will be sent to the MS/UE within the **PS Handover Command** message.

### 5.6.1.3 Contents of the UTRAN → GERAN A/Gb Mode Transparent Containers

#### 5.6.1.3.1 Source BSS to Target BSS Transparent Container

In UTRAN -> GERAN A/Gb mode the Source BSS to Target BSS Transparent Container is sent from the source RNC to the target BSS in the **Relocation Required**, **Forward Relocation Request** message and the **PS Handover Request** message in order to support inter-RAT PS handover from UTRAN (CELL\_DCH state or CELL\_FACH state, only PS RABs established) to GERAN A/Gb mode.

The Radio Network part consists of the following information:

- MS RAC.
- INTER RAT HANDOVER INFO (defined in 3GPP TS 25.331) containing the START\_PS and UE RAC values.

NOTE: The START\_PS value received in the INTER RAT HANDOVER INFO is not always aligned with the START\_PS value stored in the MS after it has attached to the GSM network. The target BSS shall replace the value received in the container received from the source RNC with the value received from the MS via the SGSN (i.e. within a **CREATE-BSS-PFC** message or a **PS Handover Complete Acknowledge** message).

#### 5.6.1.3.2 Target BSS to Source BSS Transparent Container

In UTRAN -> GERAN A/Gb mode the Target BSS to Source BSS Transparent Container is sent from the target BSS to the source RNC in the **PS Handover Request Acknowledge** message, **Forward Relocation Response** message and the **Relocation Command** message in order to support inter-RAT PS handover from UTRAN (CELL\_DCH state or CELL\_FACH state, only PS RABs established) to GERAN A/Gb mode.

The Radio Network part consist of the required information for access in the target cell and the information on allocated radio resources: uplink and downlink TBF parameters, PS Handover reference and generic parameters for access in the target cell (i.e. GPRS cell options, target cell "Cell Selection struct", global power control parameters, reference frequency lists, cell allocation, GPRS mobile allocation). Over the air interface this radio network container is sent within the **Handover from UTRAN Command** message.

The Core Network part (i.e. NAS Container for PS HO) consist of the following parameters:

- an XID Command indicating Reset or 'Reset to old XID parameters' and the new IOV-UI for the target cell;
- the GPRS ciphering algorithm to be used in the target cell;

### 5.6.1.4 Contents of the GERAN A/Gb mode → GERAN Iu mode Transparent Containers

#### 5.6.1.4.1 Source RNC to Target RNC Transparent Container

In GERAN A/Gb mode -> GERAN Iu mode the Source RNC to Target RNC Transparent Container is sent from the source BSS to the target BSS (Iu) in the **PS Handover Required** message, **Forward Relocation Request** message and the **Relocation Request** message.

The Radio Network part consists of:

- RRC Container as defined in 3GPP TS 44.118 [16] shall contain START\_PS /MS GERAN IU capabilities.

- Target Cell Id.
- Number of Iu instances. The value of the IE is set to 1 as defined in 3GPP TS 25.413 [23].
- Relocation Type. The value of the IE is set to 'UE involved', as defined in 3GPP TS 25.413 [23].

#### 5.6.1.4.2 Target RNC to Source RNC Transparent Container

In GERAN A/Gb mode -> GERAN Iu mode the Target RNC to Source RNC Transparent Container is sent from the target BSS (Iu) to source BSS in the **Relocation Request Acknowledge** message, **Forward Relocation Response** message and the **PS Handover Required Acknowledge** message.

The Radio Network Part consist of the RRC message used in GERAN Iu mode to perform handover, i.e. **Radio Bearer Reconfiguration** message as defined in 3GPP TS 44.118 [16]. This message will be sent to the MS in the **PS Handover Command** message.

#### 5.6.1.5 Content of GERAN Iu mode → GERAN A/Gb mode Transparent Containers

##### 5.6.1.5.1 Source BSS to Target BSS Transparent Container

In GERAN Iu mode -> GERAN A/Gb mode the Source BSS to Target BSS Transparent Container is sent from the source BSS (Iu) to the target BSS in the **Relocation Required** message, **Forward Relocation Request** message and the **PS Handover Request** message.

The Radio Network part consists of the following:

- MS RAC.
- INTER RAT OR MODE HANDOVER INFO with MS capabilities as defined in 3GPP TS 44.118 [16].

NOTE: START\_PS and UE RAC shall be added to this IE.

##### 5.6.1.5.2 Target BSS to Source BSS Transparent Container

In GERAN Iu mode -> GERAN A/Gb mode the Target BSS to Source BSS Transparent Container is sent from the target BSS to the source BSS (Iu) in the **PS Handover Request Acknowledge** message, **Forward Relocation Response** message and the **Relocation Command** message in order to support PS handover to GERAN A/Gb mode from GERAN Iu mode (RRC Cell\_Dedicated state or RRC CELL\_Shared state, only PS RABs established).

The Radio Network part consists of the required information for access in the target cell and the information on allocated radio resources: Uplink and downlink TBF parameters, PS Handover reference and generic parameters for access in the target cell (i.e. GPRS cell options, target cell "Cell Selection struct", global power control parameters, reference frequency lists, cell allocation, GPRS mobile allocation). Over the air interface this information is sent in the **Handover from GERAN Iu mode Command** message.

The Core Network (i.e. NAS Container for PS HO) part consists of the following parameters:

- an XID Command indicating Reset or 'Reset to old XID parameters' and the new IOV-UI for the target cell;
- the GPRS ciphering algorithm to be used in the target cell;

## 5.7 PS Handover Failure

During the PS handover procedure several types of failures can be identified. The PS handover failures may be typical network and signalling failure occurrences such as failures related to the loss of signalling messages, incorrect information element in the signalling messages or failures due to network nodes failures or specific to abnormal cases occurring during PS handover procedures.

In general the PS handover failures can be divided into:

- Preparation Phase Failure Scenarios on the Um, Gb and Gn interface.

- Execution Phase Failure Scenarios on the Um, Gb and Gn interface.

NOTE: RAU procedure failures will be handled as specified in 3GPP TS 24.008 [15].

A list of appropriate cause values should be chosen/defined to indicate to the source cell and target cell nodes the cause of the **PS Handover Request Negative Acknowledge** and the **PS handover Cancel** messages.

## 5.7.1 Preparations Phase Failure Scenarios

### 5.7.1.1 PS Handover preparation phase failure scenarios on the Um interface

- No Resource Reservation / Allocation:
  - No radio resources available in the target cell.

### 5.7.1.2 PS Handover preparation phase failure scenarios on the Gb interface

- No Resource Reservation / Allocation on the target system:
  - No radio resources available in the target cell (see clause 5.4). Appropriate cause values are needed in the **PS Handover Request Negative Acknowledge** message.
- Insufficient resource allocation by the target system:
  - In case of insufficient resource allocation by the target side the source BSS may cancel the PS handover procedure (see clause 5.5).
- Feature "PS Handover" not supported:
  - A new cause value is needed for the Gb interface if the target BSS does not support the PS Handover procedure.
- Generic Causes:
  - Generic causes for the Gb interface failures are defined in 3GPP TS 48.018 [10]. The same cause values are applicable to the PS handover procedure on the Gb interface.

### 5.7.1.3 PS Handover preparation phase failure scenarios on the Gn interface

- Context Transfer Failure:
  - Context transfer failure may occur due to various causes defined in 3GPP TS 29.060 [11]. These cause values will be utilized during PS handover procedure. These values are to be utilized during PS handover procedure to indicate to the old SGSN the cause of the PS handover reject. Consequently an appropriate cause value should be chosen to allow the old SGSN to indicate to the source BSS the cause of failure.
- No Resource Reservation/ No Resource Allocation:
  - Resource Reservation/Allocation failure occurs when no radio resources are available in the target cell. Consequently an appropriate cause value should be chosen to allow the old SGSN to indicate to the source BSS the cause of failure.
- Procedure "PS Handover" not supported:
  - This occurs when the new SGSN does not support the PS Handover feature.
- Generic Causes:
  - In 3GPP TS 29.060 [11] a set of cause values are defined. The same cause values are applicable to the PS handover procedure on the Gn interface.

## 5.7.2 Execution Phase Failure Scenarios

### 5.7.2.1 Execution phase failures on the Um interface

#### 5.7.2.1.1 Initial Access Failure in the Target Cell during PS handover

In case of initial access failure in the target cell, including the case where the MS fails to acquire time alignment information (for the non-synchronised handover case), the MS is allowed to revert to the old cell. As is defined currently in 3GPP TS 44.060 [7], the MS shall return to the old cell and send a **Packet Cell Change Failure** message with the appropriate cause

If the MS was in packet transfer mode (or MAC-shared state) before the attempted handover it will, when going back to the old cell, send a **Packet Cell Change Failure** message and resume TBFs which were ongoing in the old cell. The source BSS will inform the old SGSN about this failure and consequently the old SGSN will inform the new SGSN about this failure, upon which the new SGSN will release the allocated resources and clear out any information and buffers related to this MS.

The signalling flows for this procedure are depicted in figure 21 and 21a.

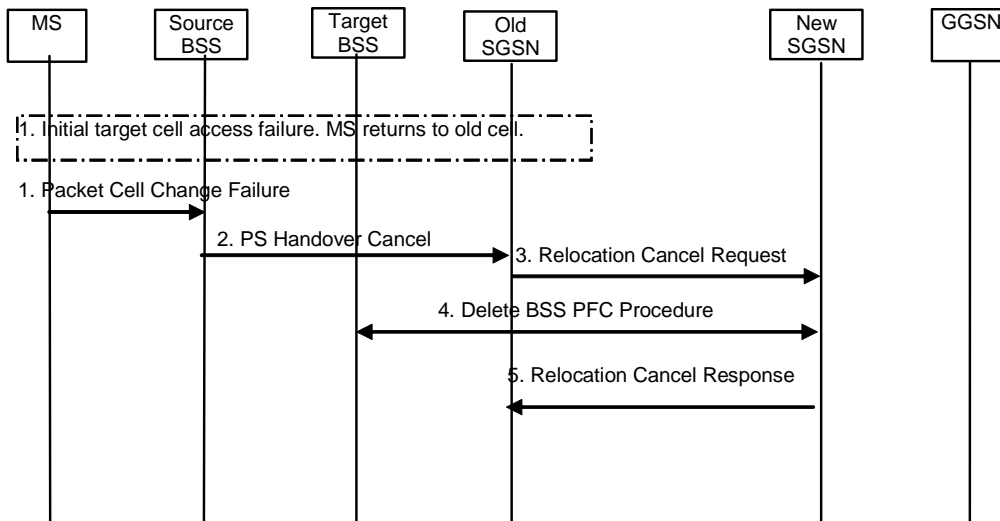

**Figure 21: MS returns to old cell; Inter-SGSN case, GERAN A/Gb mode → GERAN A/Gb mode**

1. The MS returns to the old cell and sends a **Packet Cell Change Failure** message to the source BSS.
2. The source BSS sends a **PS Handover Cancel** (TLLI, Cause = MS Back on old Channel, Source Cell Identifier, Target Cell Identifier) PDU to the old SGSN.

3. The old SGSN terminates the PS Handover to the target cell by sending a **Relocation Cancel Request** (IMSI) message to the new SGSN. The old SGSN also resumes operation on the resources in the source cell.

NOTE 1: If one new SGSN was chosen among a pool, then the **Relocation Cancel Request** message is sent to this SGSN.

4. The new SGSN triggers the release of resources in the target cell and also releases its own resources allocated for this handover.

5. The new SGSN acknowledges the release of all resources on the target side by returning a **Relocation Cancel Response** message to the old SGSN.

NOTE 2: In the intra-SGSN case, the messages **Relocation Cancel Request** and **Relocation Cancel Response** are not exchanged since the old and new SGSN are then the same node.



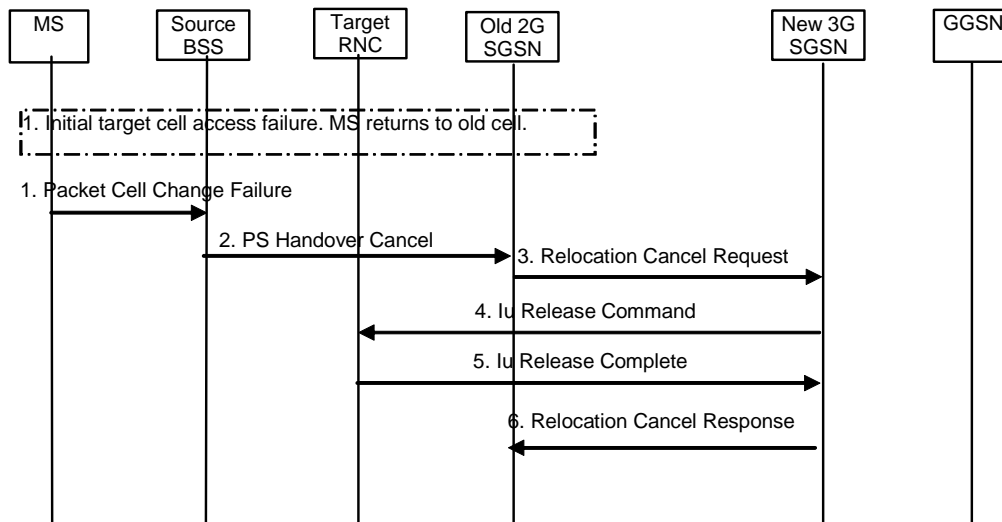

**Figure 21a: MS returns to old cell; Inter-SGSN case, GERAN A/Gb mode → UTRAN/GERAN Iu mode**

1. The MS returns to the old cell and sends a **Packet Cell Change Failure** message to the source BSS.
2. The source BSS sends a **PS Handover Cancel** (TLLI, Cause = MS Back on old Channel, Source Cell Identifier, Target Cell Identifier) PDU to the old SGSN.
3. The old SGSN terminates the PS Handover to the target cell by sending a **Relocation Cancel Request** (IMSI) message to the new SGSN. The old SGSN also resumes operation on the resources in the source cell.

NOTE 3: If one new SGSN was chosen among a pool, then the **Relocation Cancel Request** message is sent to this SGSN.

4. The new SGSN triggers the release of resources in the target cell by sending an **Iu Release Command** message to the target RNC
5. The target RNC releases all resources allocated for this handover and returns an **Iu Release Complete** message to the new SGSN.
6. The new SGSN releases its own resources allocated for this handover and acknowledges the release of all resources on the target side by returning a **Relocation Cancel Response** message to the old SGSN.

NOTE 4: In the intra-SGSN case, the messages **Relocation Cancel Request** and **Relocation Cancel Response** are not exchanged since the old and new SGSN are then the same node.

#### 5.7.2.1.2 Radio contact with the MS is lost

After sending a **PS Handover Command** message to the MS, if the source BSS detects that radio contact with the MS has been lost (see sub-clause 5.5.1):

- In case of optimised intra-BSS PS handover, the BSS shall release the assigned resource in both the source cell and target cell.
- In case of SGSN involved PS handover, the source BSS shall release the assigned resource in the source cell and initiate the PS Handover Cancel procedure to release the reserved resource in the target cell.

The signalling flows for this procedure are depicted in figures 21b and 21c.

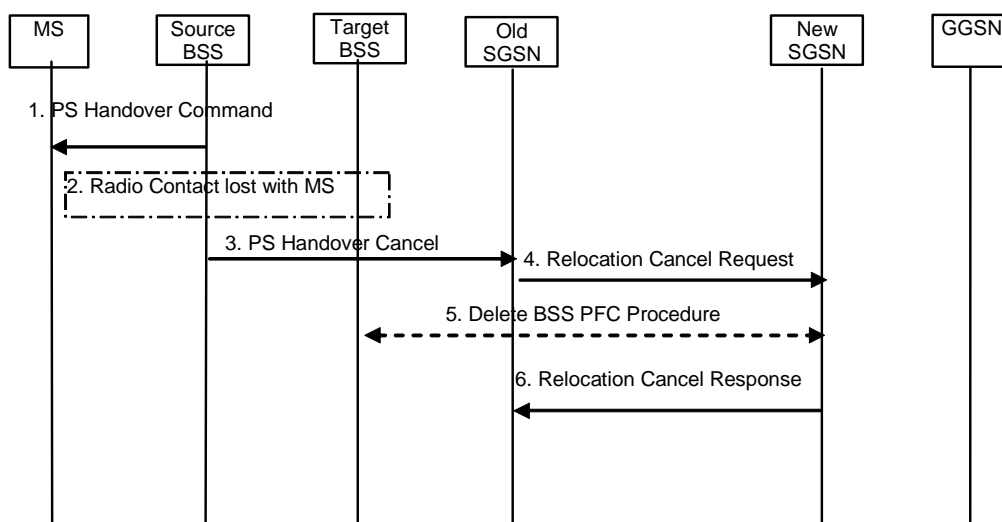

**Figure 21b: Radio Contact lost with MS; Inter-SGSN case, GERAN A/Gb mode→ GERAN A/Gb mode**

1. The source BSS sends a **PS Handover Command** message to the MS.
2. The source BSS receives no indication that the MS has made access in the target cell, nor that it has returned to the source cell.
3. The source BSS sends a **PS Handover Cancel** (TLLI, Cause = Radio Contact Lost with MS, Source Cell Identifier, Target Cell Identifier) PDU to the old SGSN.

NOTE 5: If the old SGSN has already received a **Forward Relocation Complete** message when the **PS Handover Cancel** PDU is received, the old SGSN ignores the **PS Handover Cancel** PDU.

4. The old SGSN terminates the PS Handover to the target cell by sending a **Relocation Cancel Request** (IMSI) message to the new SGSN.

NOTE 6: If one new SGSN was chosen among a pool, then the **Relocation Cancel Request** message is sent to this SGSN.

NOTE 7: If the MS has successfully made access on the target side when the **Relocation Cancel Request** message is received by the new SGSN, the new SGSN does not release any resources on the target side, but instead goes directly to step 6 below.

NOTE 8: If the resources on the target side have, due to some local decision on the target side, already been released when the **Relocation Cancel Request** message is received by the new SGSN, then the new SGSN goes directly to step 6 below.

5. The new SGSN triggers the release of resources in the target cell and also releases its own resources allocated for this handover.
6. The new SGSN returns a **Relocation Cancel Response** message to the old SGSN which then releases all its resources for this connection.

NOTE 9: In the intra-SGSN case, the messages **Relocation Cancel Request** and **Relocation Cancel Response** are not exchanged since the old and new SGSN are then the same node.

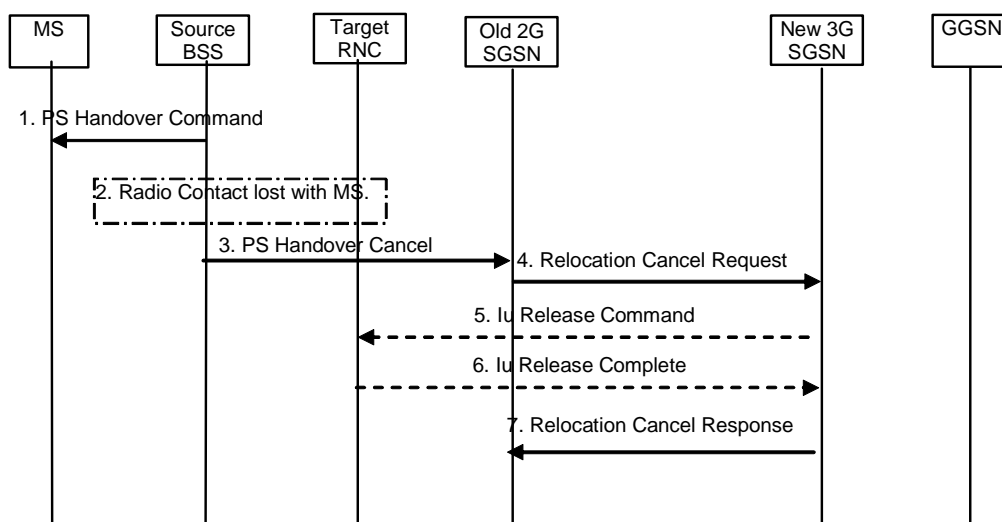

**Figure 21c: Radio Contact lost with MS; Inter-SGSN case, GERAN A/Gb mode→ UTRAN/GERAN Iu mode**

1. The source BSS sends a **PS Handover Command** message to the MS.
2. The source BSS receives no indication that the MS has made access in the target cell, nor that it has returned to the source cell.
3. The source BSS sends a **PS Handover Cancel** (TLLI, Cause = Radio Contact Lost with MS, Source Cell Identifier, Target Cell Identifier) PDU to the old SGSN.

NOTE 10: If the old SGSN has already received a **Forward Relocation Complete** message when the **PS Handover Cancel** PDU is received, the old SGSN ignores the **PS Handover Cancel** PDU.

4. The old SGSN terminates the PS Handover to the target cell by sending a **Relocation Cancel Request** (IMSI) message to the new SGSN.

NOTE 11: If one new SGSN was chosen among a pool, then the **Relocation Cancel Request** message is sent to this SGSN.

NOTE 12: If the MS has successfully made access on the target side when the **Relocation Cancel Request** message is received by the new SGSN, the new SGSN does not release any resources on the target side, but instead goes directly to step 7 below.

NOTE 13: If the resources on the target side have, due to some local decision on the target side, already been released when the **Relocation Cancel Request** message is received by the new SGSN, then the new SGSN goes directly to step 7 below.

5. The new SGSN triggers the release of resources in the target cell by sending an **Iu Release Command** message to the target RNC.
6. The target RNC releases all resources allocated for this handover and returns an **Iu Release Complete** message to the new SGSN which then releases its own resources allocated for this handover.
7. The new SGSN returns a **Relocation Cancel Response** message to the old SGSN which then releases all its resources for this connection.

NOTE 14: In the intra-SGSN case, the messages **Relocation Cancel Request** and **Relocation Cancel Response** are not exchanged since the old and new SGSN are then the same node.

### 5.7.2.2 Execution phase failures on the Gb interface

- Generic Causes:

- Generic causes for the Gb interface failures are defined in 3GPP TS 48.018 [10]. The same cause values are applicable to the PS handover procedure.

### 5.7.2.3 Execution phase failures on the Gn interface

- Update PDP Context failure:
  - As specified in 3GPP TS 29.060 [11] if the new SGSN receives an **Update PDP Context Response** message from the GGSN with a cause value other than 'Request accepted', it shall abort the update of the PDP context. Such a PDP context may be modified or deactivated by the new SGSN via explicit SM procedures upon the completion of the routing area update (RAU) procedure.

## 6 Radio interface Signalling

### 6.1 PS Handover Signalling (Um)

#### 6.1.1 General

PS Handover signalling includes the set of all air interface messages (Um signalling for A/Gb mode and Uu signalling for Iu mode) sent to or from the MS in the source and target cells during the PS handover procedure.

#### 6.1.2 Overview of PS Handover messages

##### 6.1.2.1 GERAN A/Gb mode to GERAN A/Gb mode PS Handover

When performing an inter-SGSN PS Handover from GERAN A/Gb mode to GERAN A/Gb mode the following information is sent over the Um interface.

- **PS Handover Command** message - sent to the MS in the source cell and includes the following:
  - optionally, the NAS container for PS HO
  - Indication of the radio resources for uplink and downlink TBFs to be used in the target cell for each PFC receiving PS handover treatment (i.e. the reverse path container created by target BSS/RNC).
  - Indication of a PS handover reference number to be used when the MS arrives in the target cell.
- **PS Handover Access** message - the MS sends 4 handover access bursts in the target cell using an uplink TBF provided by the PS Handover Command. If multiple uplink TBFs are provided by the **PS Handover Command** message the MS sends access bursts using just one of these TBFs (i.e. at minimum one uplink TBF must be provided in the **PS Handover Command** message). The handover reference number is included within each access burst. This message is always sent for the case of non-synchronised handover and may be sent for the case of synchronised or pre-synchronised handovers (determined by the target BSS during the PS handover preparation phase) to allow the target BSS to verify the accessing MS.
- **Packet Physical Information** message - sent by the target BSS to the MS in the target cell in response to the **PS Handover Access** message for the case of unsynchronised cells. Whether or not this message is sent in case of synchronised cells is indicated by the **PS Handover command** message (see 3GPP TS 44.018 [25]). It is sent using the downlink PACCH associated with the uplink TBF used to send the access bursts and provides the MS with physical layer information (i.e. Timing Advance). The time alignment information received in this message applies to all uplink TBFs allocated to the MS in the **PS Handover Command** message. The target BSS only sends this information if it receives the expected handover reference number in a **PS Handover Access** message.
- Uplink RLC Data Blocks - sent on uplink TBFs allocated by the **PS Handover Command** message after the MS receives **Packet Physical Information** message as follows:
  - For inter-SGSN PS handover the MS, prior to sending any uplink user plane payload for any PFC, shall send an **XID Response** message .

- Downlink RLC Data Blocks - sent on downlink TBFs allocated by the **PS Handover Command** message as follows:
  - For inter-SGSN PS handover for a given PFC the new SGSN may begin downlink N-PDU transmissions for that PFC prior to receiving a **PS Handover Complete** message (i.e. blind transmission may be used) or it may wait for a **PS Handover Complete** message before beginning downlink N-PDU transmissions for that PFC.

### 6.1.2.2 UTRAN/GERAN Iu mode to GERAN A/Gb mode PS Handover

When performing a PS Handover from UTRAN/GERAN Iu mode to GERAN A/Gb mode the following information is sent over the Uu and Um interfaces:

- RRC Message - sent to the MS in the source cell and includes the same information described for the PS Handover Command in clause 6.1.2.1.
- For PS handover from UTRAN the Handover from UTRAN Command (3GPP TS 25.331 [17]) message is used in CELL\_DCH and CELL\_FACH state when only PS RABs are established.
- For PS handover from GERAN Iu mode the HANDOVER FROM GERAN IU COMMAND message is used in RRC-Cell\_Dedicated (MAC Dedicated or MAC DTM state) or RRC-Cell\_Shared state when only PS RABs are established.
- **PS Handover Access** message - sent as described in clause 6.1.2.1.
- **Packet Physical Information** message - sent as described in clause 6.1.2.1.
- Uplink RLC Data Blocks - sent as described in clause 6.1.2.1.
- Downlink RLC Data Blocks - sent as described in clause 6.1.2.1.

### 6.1.2.3 GERAN A/Gb mode to GERAN Iu mode PS Handover

When performing a PS Handover from GERAN A/Gb mode to GERAN Iu mode the following information is sent over the Uu and Um interfaces:

- **PS Handover Command** message - sent to the MS in the source cell and includes the following:
  - System broadcast information applicable to the target cell.
  - Indication of the radio resources for uplink and downlink TBFs to be used in the target cell for each RAB receiving PS handover treatment (i.e. the reverse path container created by target BSS). Note that the MS will map the N-SAPI associated with each of its active PDP Contexts directly to a RABid (i.e. N-SAPI = RABid).
  - Indication of a PS handover reference number to be used when the MS arrives in the target cell.
- **PS Handover Access** message - sent as described in clause 6.1.2.1.
- **Packet Physical information** message - sent as described in clause 6.1.2.1.
- RRC message (e.g. Physical Channel Reconfiguration Complete) - content is GERAN Iu mode specific.
- Uplink RLC Data Blocks - sent on uplink TBFs allocated by the PS Handover Command after the MS receives Physical Layer Information (content is GERAN Iu mode specific).
- Downlink RLC Data Blocks - sent on downlink TBFs allocated by the PS Handover Command (content is GERAN Iu mode specific).

### 6.1.2.4 GERAN A/Gb mode to UTRAN mode PS Handover

When performing a PS Handover from GERAN A/Gb mode to UTRAN mode the following information is sent over the Uu and Um interfaces:

- PS HANDOVER COMMAND - an RLC/MAC control message sent to the MS in the source cell. It includes the reverse path container created by the target RNC that consists of the RRC message (i.e. the Handover to UTRAN Command) required to perform PS handover to UTRAN.
- MS Detected by Target RNC - exact procedure and information transfer is UTRAN specific.
- RRC message (e.g. Physical Channel Reconfiguration Complete) - information content is UTRAN specific.

### 6.1.3 RLC/MAC segmentation

RLC/MAC segmentation is a feature that provides an additional mechanism for sending control plane messages from the BSS to the MS. This feature can only be used after contention resolution is completed in the BSS and the BSS has to send an RLC/MAC control message that is from 3 to 9 radio blocks long.

### 6.1.4 Inter RAT/mode PS Handover to GERAN A/Gb

Void.

### 6.1.5 Inter RAT/mode PS Handover from GERAN A/Gb

Void.

## 6.2 Mechanisms for Initial Access in the Target Cell

### 6.2.1 General

This clause describes two possible approaches to the MS making access in the target cell. Both basic approaches assume that a handover procedure similar to that for the CS domain (Handover Access followed by Physical Information messages) takes place.

The effect of synchronised networks is examined for both approaches where the exchange of Handover Access and Physical Information is not required as the TA can be derived in advance.

The main assumptions applicable to the call flows are:

- USFs are required to schedule uplink data blocks.
- All identifiers and resources are known by the MS and target BSS before the MS makes the initial access in the target cell.

### 6.2.2 Synchronisation of handovers

The following synchronisation mechanisms are used for PS handover:

- Non-synchronised.
- Synchronised.
- Pre-Synchronised.

The non-synchronised cases are shown in figures 22 and 24 and are characterised by the requirement for the MS to obtain a valid uplink timing advance before it can transmit normal bursts. The MS shall notify its presence in the target cell through the transmission of access bursts to the BSS, and the BSS shall respond with a valid timing advance which in turn enables the MS to send normal bursts in uplink.

The synchronised and pre-synchronised cases are shown in figures 23 and 25 and have different mechanisms for the provision of the timing advance that are described in 3GPP TS 45.010 [26].

NOTE: The pseudo-synchronised case is not supported by the PS handover feature.

### 6.2.3 Option 1 - Downlink Data sent after performing access in the target cell

In this approach, downlink data is not transmitted until the BSS has been made aware of the presence of the MS via the reception of a **PS Handover Access** message.

#### 6.2.3.1 Unsynchronised Networks Call Flow

The message flow for this option is shown in figure 22. The MS starts by sending **PS Handover Access** messages as four access bursts to the network (through USF allocation). As there is no contention, the network should receive at least one of the access bursts. A Handover Reference parameter is allocated by the target BSS in the **PS Handover Command** message and included in the **PS Handover Access** message to verify that the correct MS is accessing the resources. This is similar to the Handover Reference in the CS handover case.

The BSS receives the **PS Handover Access** message and detects that the correct MS has now made access in the target cell. It sends a **Packet Physical Information** message to indicate that the MS has been detected. The main purpose of this message is to give the Timing Advance information to the MS.

Once the MS has received the **Packet Physical Information** message it sends uplink LLC PDUs (user or signalling data, depending on the scenario). When correctly receiving the first RLC data block from the MS the target BSS verifies the mobile station, generates a **PS Handover Complete** message and sends it to the new SGSN.

The MS can start sending uplink RLC/MAC data blocks on the pre-allocated resources when scheduled with its USF. When the **PS Handover Complete** message has been received by the new SGSN, it can start sending downlink data blocks.

NOTE: The downlink RLC data blocks can be sent for any PFC receiving PS handover treatment after the target BSS has confirmed that the correct MS is present and after the **PS Handover Complete** message has been received by the new SGSN.

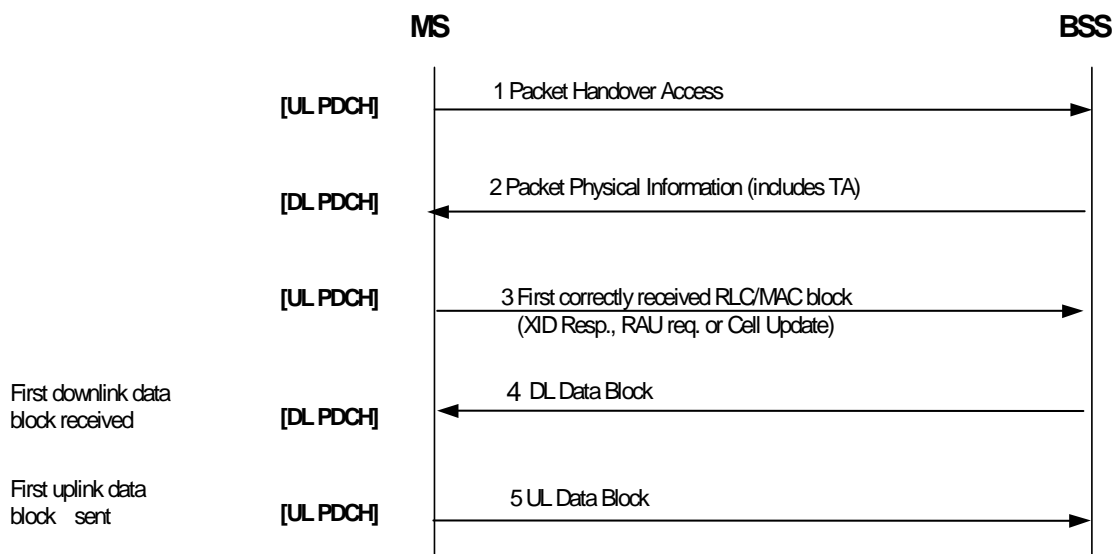

Figure 22: Option 1 - Downlink Data after MS contacts network

#### 6.2.3.2 Synchronised Networks Call Flow

In the case of synchronous networks it is possible for the MS to calculate the TA of the target cell before it moves from the source cell.

Figure 23 shows the call flow in the case of synchronous networks. In this case it is possible for the MS to start transmitting and receiving messages as soon as it switches to the target cell.

As described in 3GPP TS 44.018 [25], handover access bursts may optionally be sent if indicated in the handover command message. If no access bursts are sent the MS begins sending uplink LLC PDUs. These PDUs are only sent to

verify the MS's presence in the new cell but do not trigger the sending of **Packet Physical Information** message. As blind transmission in the downlink is not being used in this scenario, the BSS must wait until a first RLC/MAC block is received (through USF allocation) before transmitting data in the downlink.

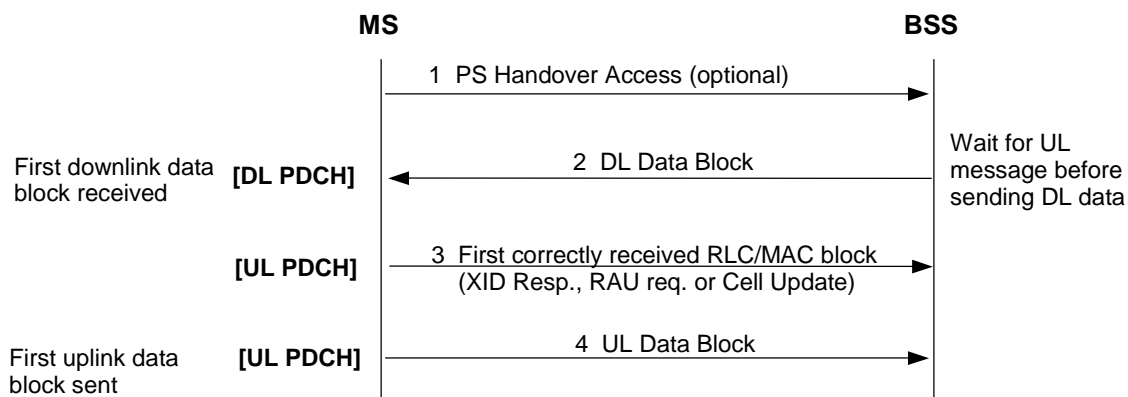

**Figure 23: Option 1 - Downlink Data after MS contacts network, Synchronous Networks**

## 6.2.4 Option 2 - Downlink Data sent before performing access in the target cell (Blind Transmission)

Blind transmission aims at minimising the interruption time on the downlink following handover. The target BSS starts transmitting downlink data on the newly reserved resources in the target cell before the MS has accessed this cell. The message flow for this scheme is shown in figure 24.

### 6.2.4.1 Unsynchronised Networks Call Flow

As the BSS must send the Packet Physical Information as an immediate response to the **Packet Handover Access** message, it is unable to send any downlink data at the same time. Therefore the BSS interrupts delivery of downlink data in order to send the Packet Physical Information to the MS.



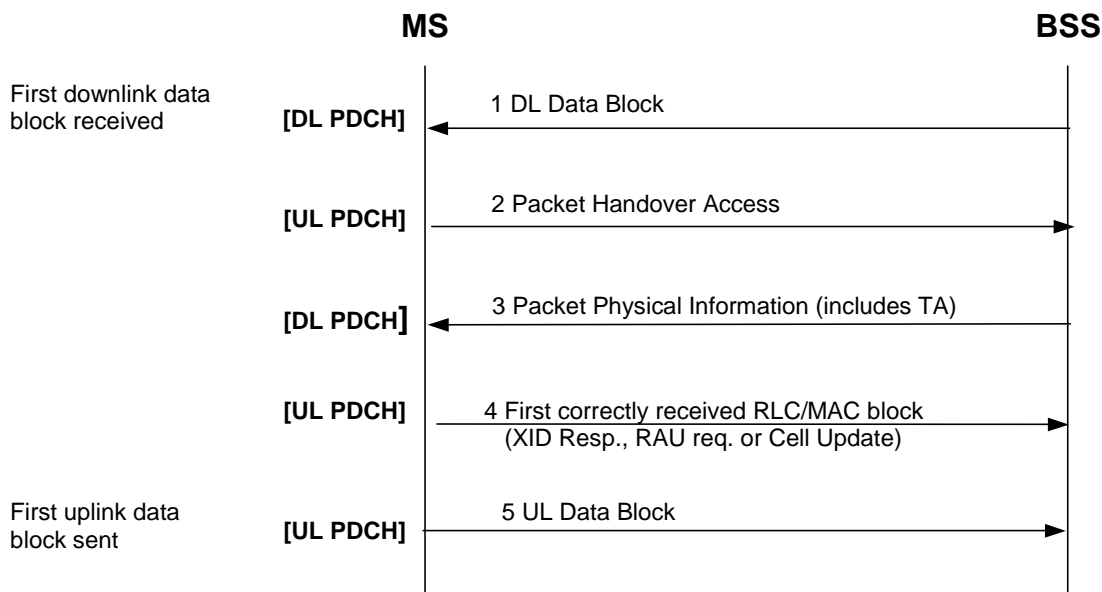

- NOTE 1: DL data is shown as being sent before the Packet Handover Access, but it may be sent by the target BSS at any time in the sequence. The **PS Handover Access** message is sent when being scheduled with the USF.
- NOTE 2: Blind transmission assumes that the downlink data flow for a PFC receiving PS handover treatment may begin before the new SGSN receives the associated **PS Handover Complete** message from the target BSS and before the RAU procedure has started.

Figure 24: Option 2 - Blind Transmission in target cell

### 6.2.4.2 Synchronised Network Call Flow

In the case of blind transmission with synchronous networks, downlink data can be sent at the earliest opportunity. This is similar to the case for blind transmission without synchronous networks. However, uplink data transfer is also sped-up as shown in the call flow of figure 25.

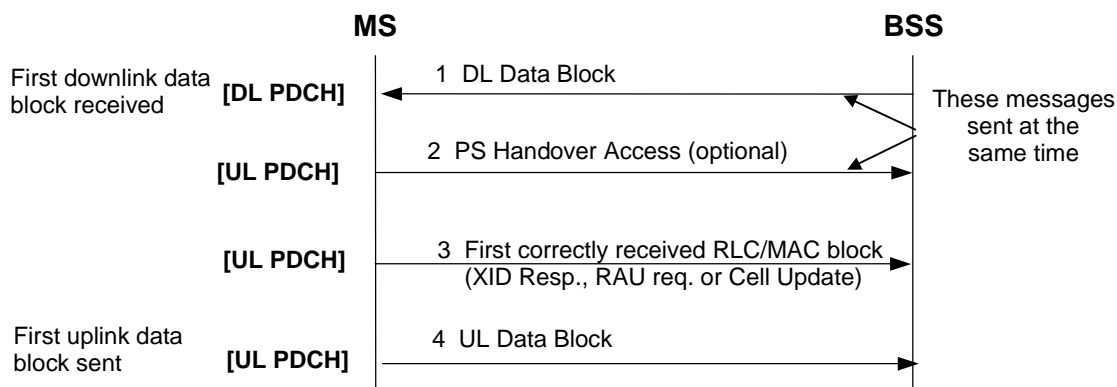

Figure 25: Option 2 - Blind Transmission in target cell, Synchronous Networks

The **PS Handover Access** message is the first uplink message sent if indicated in the handover command message as described in 3GPP TS44.018. Otherwise one or more RLC/MAC blocks that contain the **XID Response** message will be sent. This case is therefore the best in terms of reduced service interruption time.

- NOTE: Blind transmission assumes that the flow of downlink data for a PFC receiving PS handover treatment may begin before the new SGSN receives the **PS Handover Complete** message from the target BSS and before the RAU procedure has started.

## 6.3 Methods for triggering PS Handover

A PS Handover is triggered by the BSS based on the received measurement reports or initiated by the reception of the **Packet Cell Change Notification** message from the mobile station. The BSS controls which of the two methods to use for initiating the PS Handover.

When PS Handover is triggered by the BSS based on the measurement reports, the mobile station is in NC2 mode. The mobile station sends measurement reports to the network (BSS). When the network has found a new cell meeting the cell reselection criteria, and prepared for the PS Handover in that target cell, it sends the **PS Handover Command** message to the mobile station.

If not in NC2 mode, the mobile station may, by transmitting a **Packet Cell Change Notification** message according to the Cell Change Notification procedure, make the BSS aware it has found a new cell meeting the cell reselection criteria. The network then prepares for the PS Handover in the indicated target cell and sends the **PS Handover Command** message to the mobile station. In order to avoid that the mobile station performs autonomous cell reselection due to timeout of T3208, the network can order the mobile station to enter NC2 mode by transmitting the **Packet Measurement Order** message in response to the PCCN message. This will keep the mobile station in the cell until the **PS Handover Command** message is sent by the network, thus making it possible for the network to perform all necessary PS handover signalling and set up the radio resources in the target cell.

---

# Annex A (normative): Agreed handover principles

## A.1 Agreed handover principles

1. It is the mobile station that is handed over to a target cell when one or more of its PFCs are subject to handover.
2. The source BSS makes the decision to initiate the handover preparation phase when required for PFC(s) subject to handover.
3. Information pertaining to all PDP contexts and PFCs relating to the MS should be sent from the old SGSN to the target SGSN in the handover signalling regardless of their QoS.
4. The target BSS should make the final decision on which PFCs are subject to handover and to assign resources over the Um interface in the target cell. This decision is based on the target BSS being able to fulfil the QoS for these PFCs.
5. The old SGSN decides whether and when to forward data to the TEIDs provided by the new SGSN.
6. It is not required to have resources allocated in advance for bearers which themselves are not determined to be subject to handover by the target BSS.
7. How the target BSS decides which PFCs to accept and which to reject should be implementation specific.
8. For the PS Handover, forwarding of data is performed from the old SGSN either to the target BSS (intra BSS, intra SGSN-inter BSS) or to the new SGSN (inter SGSN); an optional optimisation for intra BSS handover will allow the BSS to decide how to handle the user data flow.
9. An explicit Routing Area Update procedure is performed (if required) when the handover procedure is terminated.
10. The explicit RAU may not contain the following message sequences that are performed already during the handover procedure:
  - Transfer of contexts between SGSNs (inter SGSN case).
  - Exchange of SMDCP sequence numbers (inter SGSN case).
  - Allocation of P-TMSI.
11. Uplink and downlink data transfer continues during the Routing Area Update procedure. This is possible because certain RAU centric functions are performed during the handover execution phase.
12. The PS Handover service shall support intra BSS, intra SGSN-inter BSS, inter SGSN and inter RAT scenarios.
13. Based on the quality of service parameters the MS or the network may throw away packets available for transmission in the uplink or downlink during the ongoing handover procedure.
14. The source BSS shall only request PS handover for one cell in each **PS Handover Required** message.
15. The PS handover procedure is only performed when the target BSS pre-allocates resource for at least one PFC. In case the target BSS cannot allocate resources for at least one PFC the target BSS shall reject the PS Handover request using the **PS Handover Request Negative Acknowledge** message.
16. In case the mobile fails to synchronize to the target cell within a timeout period after having received a PS Handover Command, shall revert to the source cell and the old "channels".
17. Optionally, in the case of Intra RAT/Mode PS handover, information pertaining to the radio resource realization of the PFCs subject to Handover can be transferred from the source BSS to the target BSS.

18. During the PS Handover preparation phase the new SGSN (assuming RA change) assigns a unique identifier (P-TMSI, Local TLLI) for data transmission in the target cell. This Local TLLI is used for data transfer between the target BSS and the new SGSN. This Local TLLI is not sent to the MS. After PS Handover Completion the MS triggers the RAU procedure. After P-TMSI reallocation, which is performed during Routing area update, a new Local TLLI will be derived from the P-TMSI using current MM procedures.
19. An SGSN supporting PS handover to GERAN *A/Gb mode* shall always assign a valid SAPI and PFI upon PDP Context activation for a PS Handover capable MS.

# Annex B (informative): PS Handover Primitives

## B.1 Overview

The set of figures below indicate the primitive exchanges that could occur during a successful PS handover procedure. All numbered primitives shown using bold font are further specified in either 3GPP TS 48.018, 3GPP TS 44.064 or 3GPP TS 44.065 whereas those shown using normal font are only provided for reasons of conceptual completeness (i.e. they provide an example of a primitive that could be implemented in support of the PS handover feature).

## B.2 Primitives in Source BSS

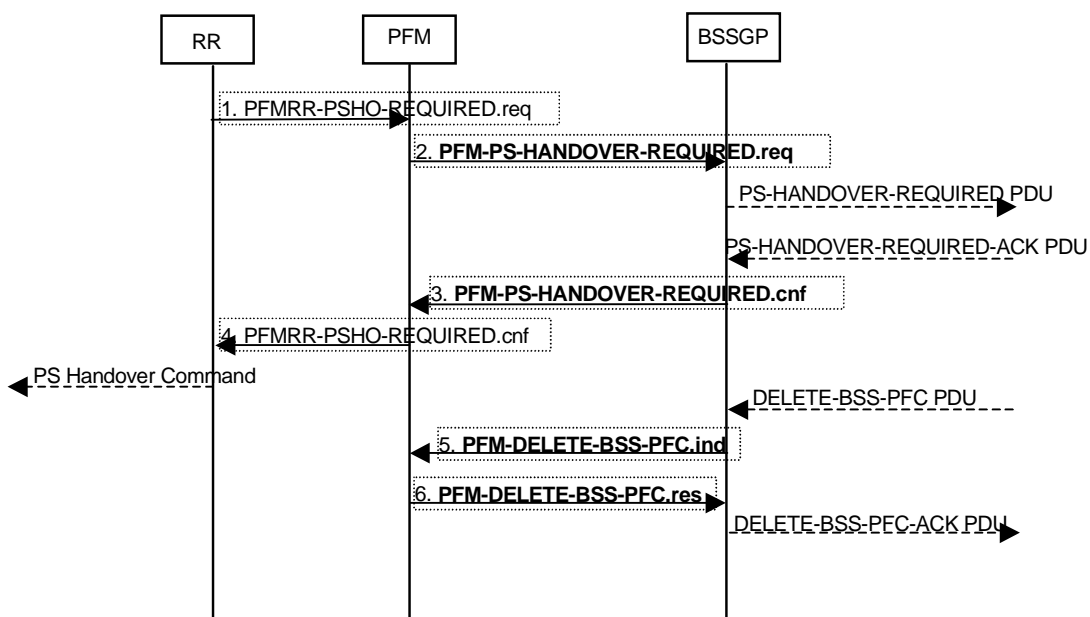

### B.3 Primitives in Old SGSN

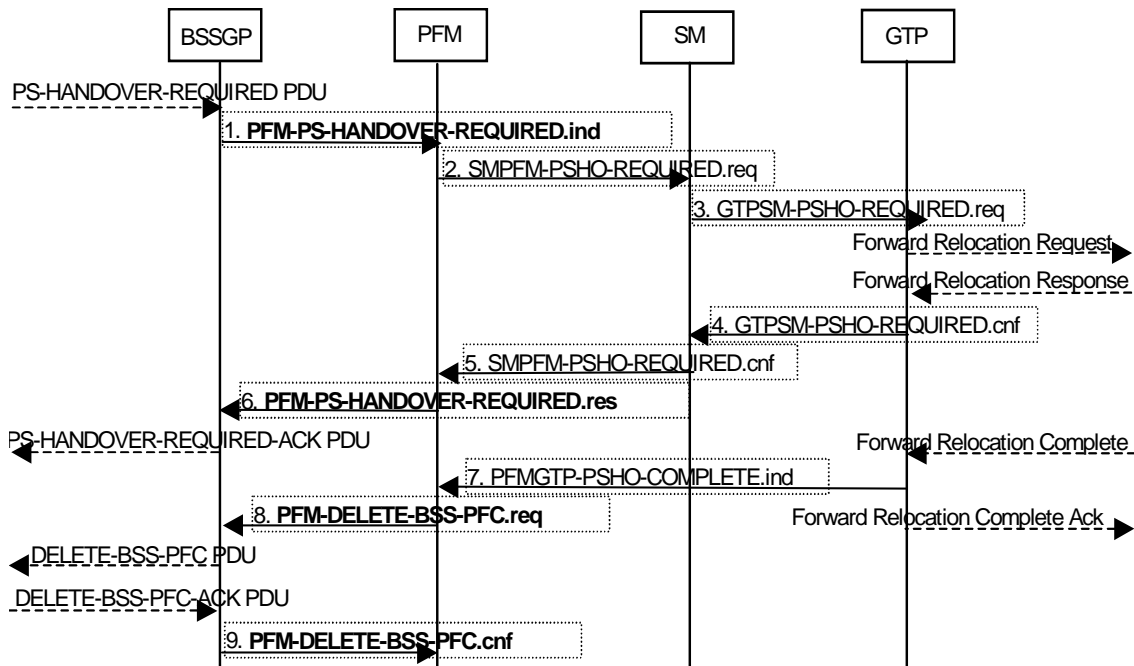

### B.4 Primitives in New SGSN

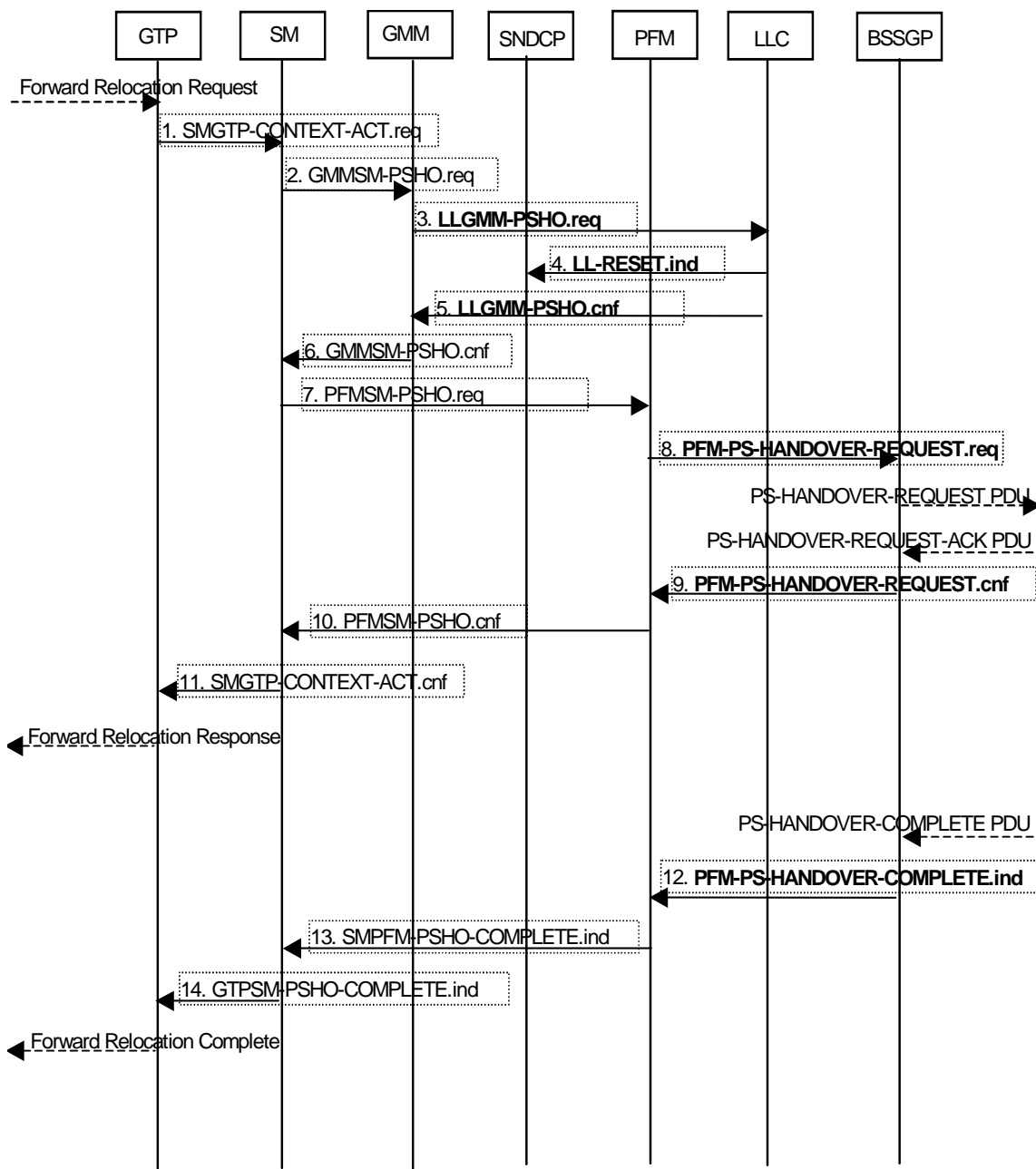

## B.5 Primitives in Target BSS

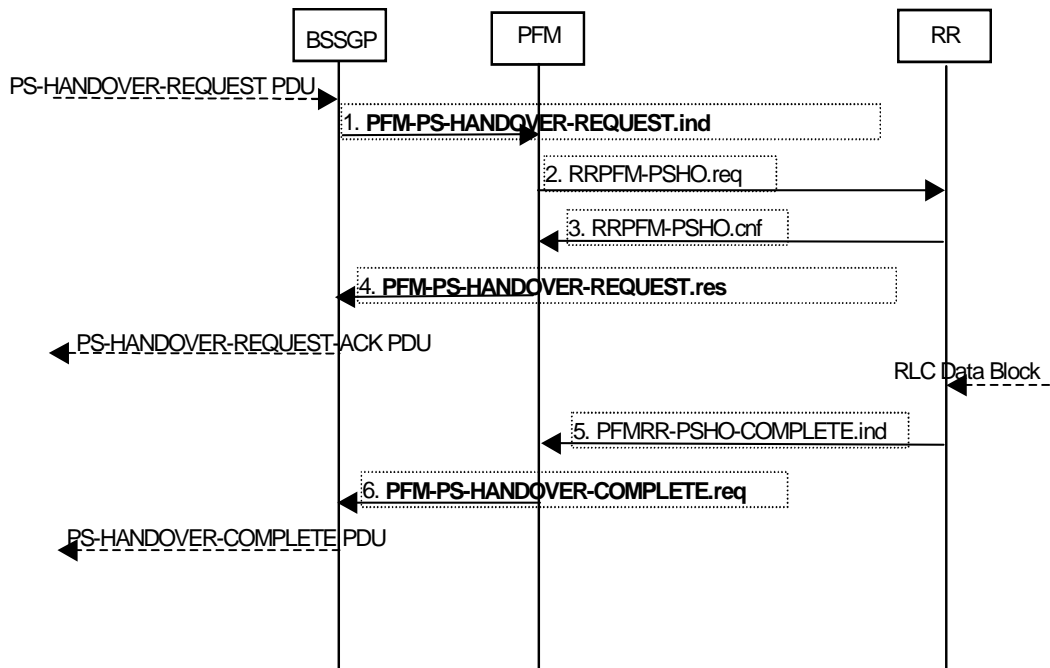

## B.6 Primitives in MS

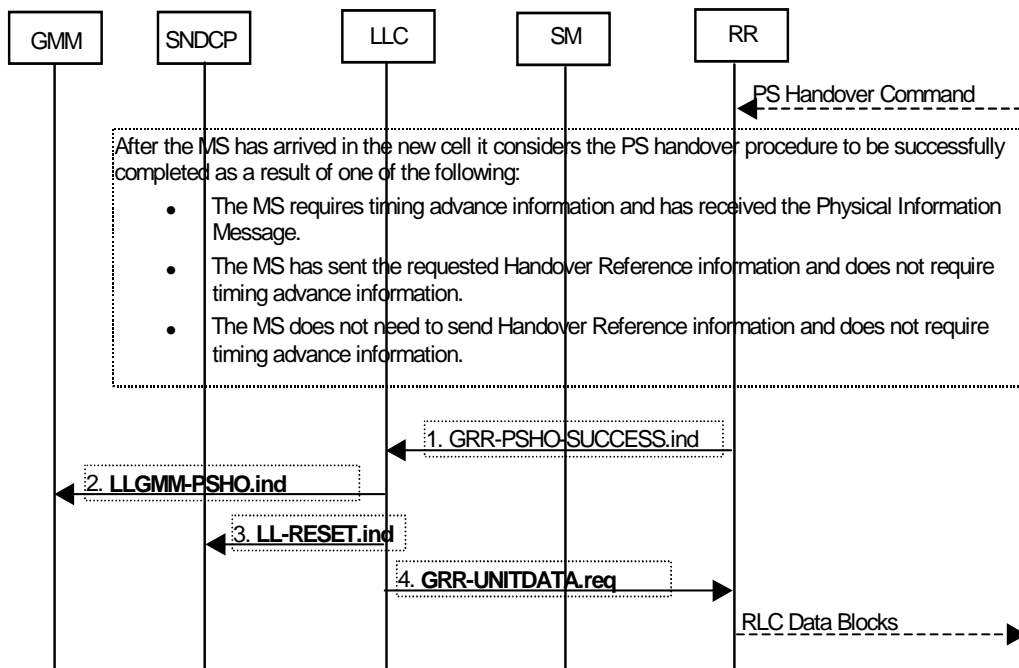



## Annex C (informative): Change history

Change history							
Date	TSG #	TSG Doc.	CR	Rev	Subject/Comment	Old	New
2004-11	22	GP-042904	-	-	Version for Release 6	-	6.0.0
2005-01	23	GP-050450	001	1	Correction of data forwarding in case of inter-RAT PS Handover	6.0.0	6.1.0
2005-01	23	GP-050323	002		'Layer 3 information' not used for PS Handover	6.0.0	6.1.0
2005-01	23	GP-050603	004	2	Clarification of PDP Context Suspension During Inter-SGSN GERAN A/Gb to GERAN A/Gb PS Handover	6.0.0	6.1.0
2005-01	23	GP-050326	005		PS Handover Cancel after failed PS Handover	6.0.0	6.1.0
2005-01	23	GP-050327	006		Addition of the SABM-UA exchange procedure	6.0.0	6.1.0
2005-04	24	GP-050894	009		Routing Area Update at every Inter-RAT PS Handover	6.1.0	6.2.0
2005-04	24	GP-051136	013	2	Introduction of the PS Handover Complete message in the intra-BSS optimised scenario	6.1.0	6.2.0
2005-04	24	GP-050940	015	2	Various Updates/Clarifications to TS43.129	6.1.0	6.2.0
2005-06	25	GP-051687	011	4	Simplification of PS Handover procedure	6.2.0	6.3.0
2005-06	25	GP-051689	012	2	Suspension of DL Data Transfer	6.2.0	6.3.0
2005-06	25	GP-051558	019		Updates to TS 43.129	6.2.0	6.3.0
2005-06	25	GP-051795	020	2	Removal of NSAPI/SAPI/PFI mapping in inter-RAT/inter-mode PS Handover to GERAN A/Gb mode	6.2.0	6.3.0
2005-09	26	GP-052311	0017	3	Clarification on the sending of PS Handover Access messages	6.3.0	6.4.0
2005-09	26	GP-052030	0022		Alignment of PDU names with TS 48.018	6.3.0	6.4.0
2005-09	26	GP-052218	0023	1	Annex for PS Handover Primitives	6.3.0	6.4.0
2005-09	26	GP-052033	0024		Clarification of CN part and RN part	6.3.0	6.4.0
2005-09	26	GP-052221	0025	1	Corrections to Forward SRNS Context procedures	6.3.0	6.4.0
2005-11	27	GP-052543	0008	4	Transferring of UE RAC and START PS from the MS to the BSC	6.4.0	6.5.0
2005-11	27	GP-052541	0026		Removal of FFSeS related to NAS container	6.4.0	6.5.0
2005-11	27	GP-052542	0027		Security clean-up	6.4.0	6.5.0
2005-11	27	GP-052800	0028	1	Various corrections to TS 43.129	6.4.0	6.5.0
2005-11	27	GP-052799	0029	1	Corrections of Source RNC to Target RNC container	6.4.0	6.5.0
2006-01	28	GP-060226	0031		Various updates to TS 43.129	6.5.0	6.6.0
2006-01	28	GP-060420	0033	2	User-Plane Data Forwarding for Inter-RAT PS Handover	6.5.0	6.6.0
2006-01	28	GP-060342	0034	1	Condition for UL data transfer	6.5.0	6.6.0
2006-01	28	GP-060459	0036	2	Correction of XID negotiation	6.5.0	6.6.0
2006-04	29	GP-060938	0037	2	Various editorial updates to PS Handover procedures	6.6.0	6.7.0
2006-04	29	GP-060828	0038	1	Various updates	6.6.0	6.7.0
2006-04	29	GP-060742	0039		Various corrections	6.6.0	6.7.0
2006-05					Make figures editable	6.7.0	6.7.1
2006-06	30	GP-061350	0040	1	Behaviour in case of failed Update PDP Context procedure	6.7.1	6.8.0
2006-06	30	GP-061258	0041		Behaviour in case of missing XID parameters	6.7.1	6.8.0
2006-09	31	GP-061871	0044	2	Resource release during PS handover when no response from mobile station	6.8.0	6.9.0
2006-11	32	GP-062114	0043	4	Introduction of CAMEL Trigger Points	6.9.0	6.10.0
2006-11	32	GP-062115	0047		Various updates to TS 43.129	6.9.0	6.10.0
2006-11	32	GP-062365	0048	1	Clarification of PS Handover Cancel behaviour	6.9.0	6.10.0
2006-11	32	GP-062415	0049	1	Improved behaviour in case of inactive PFCs/RABs	6.9.0	6.10.0
2006-11	32	GP-062190	0050		Definition of Lost MS	6.9.0	6.10.0
2006-11	32	GP-062418	0051	2	Non-critical PS handover reject	6.9.0	6.10.0
2006-11	32	GP-062373	0053	1	Clarification on the PS HO execution phase	6.9.0	6.10.0
2007-02	33	GP-070488	0056	2	Various updates on PS Handover	6.10.0	6.11.0
2007-02	33	GP-070339	0060		Correction of conditions for PS handover reject	6.10.0	6.11.0
2007-05	34	GP-070713	0064		Erroneous implementation of CR 0033 to TS 43.129	6.11.0	6.12.0
2009-11	44	GP-091875	0075	1	Introduction of PS Handover Complete Acknowledge	6.12.0	6.13.0

				Message		
--	--	--	--	---------	--	--

---

## History

<b>Document history</b>		
V6.1.0	January 2005	Publication
V6.2.0	April 2005	Publication
V6.3.0	June 2005	Publication
V6.4.0	September 2005	Publication
V6.5.0	November 2005	Publication
V6.6.0	January 2006	Publication
V6.7.1	April 2006	Publication
V6.8.0	June 2006	Publication
V6.9.0	September 2006	Publication
V6.10.0	November 2006	Publication
V6.11.0	February 2007	Publication
V6.12.0	May 2007	Publication
V6.13.0	February 2010	Publication