

ETSI TS 143 059 V4.7.0 (2006-04)

Technical Specification

**Digital cellular telecommunications system (Phase 2+);
Functional stage 2 description of
Location Services (LCS) in GERAN
(3GPP TS 43.059 version 4.7.0 Release 4)**



Reference

RTS/TSGG-0143059v470

Keywords

GSM

ETSI

650 Route des Lucioles
F-06921 Sophia Antipolis Cedex - FRANCE

Tel.: +33 4 92 94 42 00 Fax: +33 4 93 65 47 16

Siret N° 348 623 562 00017 - NAF 742 C
Association à but non lucratif enregistrée à la
Sous-Préfecture de Grasse (06) N° 7803/88

Important notice

Individual copies of the present document can be downloaded from:

<http://www.etsi.org>

The present document may be made available in more than one electronic version or in print. In any case of existing or perceived difference in contents between such versions, the reference version is the Portable Document Format (PDF). In case of dispute, the reference shall be the printing on ETSI printers of the PDF version kept on a specific network drive within ETSI Secretariat.

Users of the present document should be aware that the document may be subject to revision or change of status. Information on the current status of this and other ETSI documents is available at

<http://portal.etsi.org/tb/status/status.asp>

If you find errors in the present document, please send your comment to one of the following services:

http://portal.etsi.org/chaicor/ETSI_support.asp

Copyright Notification

No part may be reproduced except as authorized by written permission.
The copyright and the foregoing restriction extend to reproduction in all media.

© European Telecommunications Standards Institute 2006.
All rights reserved.

DECTTM, **PLUGTESTS**TM and **UMTS**TM are Trade Marks of ETSI registered for the benefit of its Members.
TIPHONTM and the **TIPHON logo** are Trade Marks currently being registered by ETSI for the benefit of its Members.
3GPPTM is a Trade Mark of ETSI registered for the benefit of its Members and of the 3GPP Organizational Partners.

Intellectual Property Rights

IPRs essential or potentially essential to the present document may have been declared to ETSI. The information pertaining to these essential IPRs, if any, is publicly available for **ETSI members and non-members**, and can be found in ETSI SR 000 314: "*Intellectual Property Rights (IPRs); Essential, or potentially Essential, IPRs notified to ETSI in respect of ETSI standards*", which is available from the ETSI Secretariat. Latest updates are available on the ETSI Web server (<http://webapp.etsi.org/IPR/home.asp>).

Pursuant to the ETSI IPR Policy, no investigation, including IPR searches, has been carried out by ETSI. No guarantee can be given as to the existence of other IPRs not referenced in ETSI SR 000 314 (or the updates on the ETSI Web server) which are, or may be, or may become, essential to the present document.

Foreword

This Technical Specification (TS) has been produced by ETSI 3rd Generation Partnership Project (3GPP).

The present document may refer to technical specifications or reports using their 3GPP identities, UMTS identities or GSM identities. These should be interpreted as being references to the corresponding ETSI deliverables.

The cross reference between GSM, UMTS, 3GPP and ETSI identities can be found under <http://webapp.etsi.org/key/queryform.asp> .

Contents

Intellectual Property Rights	2
Foreword.....	2
Foreword.....	6
1 Scope	7
2 References	7
3 Definitions and abbreviations.....	8
3.1 Definitions	8
3.2 Abbreviations	9
4 Main concepts	10
4.1 Assumptions	10
4.2 Standard LCS Methods	10
4.2.1 Timing Advance	10
4.2.2 Enhanced Observed Time Difference (E-OTD) positioning mechanism.....	10
4.2.3 Global Positioning System (GPS) positioning mechanism.....	10
5 GERAN LCS Architecture.....	11
5.1 LCS Operations	11
5.2 High-Level Functions.....	12
5.2.1 Co-ordination, Measurement and Calculation Functions.....	13
5.3 GERAN LCS Functional Entities.....	14
5.3.1 Internal Client Group.....	14
5.3.1.1 Internal GERAN Location Client Function (LCF).....	14
5.3.2 GERAN System Handling group.....	14
5.3.2.1 GERAN Location System Control Function (LSCF).....	14
5.3.2.2 GERAN Location System Operations Function (LSOF)	14
5.3.2.3 Location System Broadcast Function (LSBcF).....	14
5.3.3 Positioning group.....	15
5.3.3.1 GERAN Position Radio Co-ordination Function (PRCF).....	15
5.3.3.2 GERAN Position Calculation Function (PCF).....	15
5.3.3.3 GERAN Position Signal Measurement Function (PSMF)	16
5.3.3.4 GERAN Position Radio Resource Management (PRRM)	16
5.4 Assignment of LCS Functional Entities to GERAN Elements.....	16
5.5 Functional Description of GERAN LCS Network Elements	16
5.5.1 BSC.....	16
5.5.2 SMLC	16
5.5.3 CBC	17
5.5.4 LMU	17
5.5.5 MS	17
6 Signalling Protocols and Interfaces	17
6.1 Protocol layering in CS domain	17
6.1.1 Generic Signalling Model for LCS in CS Domain	17
6.1.2 Message Segmentation in CS Domain.....	18
6.1.2.1 Network Level Segmentation.....	18
6.1.2.2 Intermediate Level Segmentation.....	19
6.1.2.3 RRLP Pseudo-Segmentation	19
6.1.3 Signalling between an SMLC, MSC and BSC.....	19
6.1.4 Signaling between SMLC and MS	19
6.1.5 SMLC Signalling to a Type A LMU	20
6.1.5.1 Circuit Switched Signalling using an SDCCH.....	20
6.1.5.2 Signalling using a TCH.....	20
6.1.6 SMLC signaling to a Type B LMU	21
6.1.7 SMLC Signalling to a peer SMLC.....	22

7	GERAN Network Location Procedures	23
7.1	State description for SMLC	23
7.1.1	SMLC States	23
7.1.1.1	NULL State	23
7.1.1.2	LOCATION State	23
7.1.2	State Functionality	23
7.1.2.1	State Transitions	23
7.1.2.2	LOCATION Timer Function	24
7.2	State Description for the BSC	24
7.2.1	BSC States	24
7.2.1.1	IDLE State	24
7.2.1.2	LOCATION State	24
7.2.2	State Functionality	24
7.2.2.1	State Transitions	24
7.2.2.2	LOCATION Timer Function	25
7.3	Usage of SCCP Connection on the Lb interface	25
7.3.1	SCCP Connection for positioning of a target MS	25
7.3.2	SCCP connection to access a Type A LMU	25
8	Common Procedures to Support Positioning	26
8.1	Information Transfer between a SMLC and a Target MS	26
8.2	Information Transfer between a SMLC and a BSC	27
8.3	Common Procedures to Support Access to an LMU	27
8.3.1	Location Update Procedure between a SMLC and a Type A LMU	28
8.3.2	IMSI Detach Procedure between a SMLC and a Type A LMU	28
8.3.3	LCS Information Transfer between a SMLC and a Type A LMU	29
8.3.3.1	Information Transfer using an SDCCH	29
8.3.3.2	Information Transfer using a TCH	31
8.3.4	LCS Information Transfer between a SMLC and a Type B LMU	32
8.4	Common Control Procedures for LMUs	32
8.4.1	Reset Procedure	33
8.4.2	Status Query Procedure	33
8.4.3	Status Update Procedure	33
8.5	Exception Procedures	34
8.5.1	Procedures in the SMLC	34
8.5.2	Procedures in an LMU	35
8.5.3	Procedures in the BSC	35
8.5.3.1	General Procedures	35
8.5.3.2	Rejection of an SMLC Positioning Request	35
8.5.3.3	Interaction with Inter-BSC Handover	35
8.5.3.4	Interaction with Intra-BSC Handover and other RR Management Procedures	35
8.5.3.5	Priority of Handover and Other RR Management Procedures	36
8.5.3.6	Interaction with Segmentation	36
8.5.3.7	Overload	36
8.6	Procedures in the Target MS	36
8.7	Further Procedures for Handover	36
9	Positioning procedures	37
9.1	Positioning Procedure Initiation	37
9.1.1	Core Network Position Procedure Initiation over the A interface	37
9.1.2	Positioning Procedure Initiation from an Internal LCS Client	38
9.2	Common Positioning Procedure for CS Domain	38
9.3	TA Based Positioning in CS Domain	39
9.3.1	Definition of TA states	39
9.3.1.1	MS in IDLE State	39
9.3.1.2	MS in DEDICATED State	39
9.3.2	TA Positioning Procedure	40
9.3.3	Unsuccessful TA positioning procedure in BSC	40
9.4	E-OTD and GPS Positioning Procedures	40
9.4.1	General procedures	40
9.4.2	Positioning Request	41
9.4.3	Assistance Data Delivery	41

9.4.4	Error Handling for E-OTD and GPS in CS Domain.....	42
9.4.5	Error Handling for the SMLC.....	43
9.4.6	Broadcast of Assistance Data.....	43
9.4.6.1	Point-To-Multipoint Assistance Data Broadcast Flow.....	44
9.4.6.2	Ciphering.....	45
9.4.6.2.1	Algorithm	45
9.4.6.3	Deciphering key control and delivery to MS	46
10	Information storage	48
10.1	SMLC.....	48
10.2	Recovery and Restoration Procedures.....	49
Annex A (informative):	Change history	50
History		51

Foreword

This Technical Specification has been produced by the 3rd Generation Partnership Project (3GPP).

The contents of the present document are subject to continuing work within the TSG and may change following formal TSG approval. Should the TSG modify the contents of the present document, it will be re-released by the TSG with an identifying change of release date and an increase in version number as follows:

Version x.y.z

where:

- x the first digit:
 - 1 presented to TSG for information;
 - 2 presented to TSG for approval;
 - 3 or greater indicates TSG approved document under change control.
- y the second digit is incremented for all changes of substance, i.e. technical enhancements, corrections, updates, etc.
- z the third digit is incremented when editorial only changes have been incorporated in the document.

1 Scope

The present document specifies the stage 2 of the LoCation Services (LCS) feature in GERAN, which provides the mechanisms to support mobile location services for operators, subscribers and third party service providers.

The purpose of this stage 2 specification is to define the GERAN LCS architecture, functional entities and operations to support location methods. This description is confined to the aspects of LCS within the GERAN and does not define nor describe the LCS entities or operations within the Core Network.

Location Services may be considered as a network provided enabling technology consisting of standardised service capabilities, which enable the provision of location applications. The application(s) may be service provider specific. The description of the numerous and varied possible location applications which are enabled by this technology are outside the scope of the present document. However, clarifying examples of how the functionality being described may be used to provide specific location services may be included.

This stage 2 specification covers the GERAN LCS functional model and entities, the location methods, state descriptions, and message flows.

2 References

The following documents contain provisions which, through reference in this text, constitute provisions of the present document.

- References are either specific (identified by date of publication, edition number, version number, etc.) or non-specific.
- For a specific reference, subsequent revisions do not apply.
- For a non-specific reference, the latest version applies. In the case of a reference to a 3GPP document (including a GSM document), a non-specific reference implicitly refers to the latest version of that document *in the same Release as the present document*.

- [1] 3GPP TS 21.905: "Vocabulary for 3GPP Specifications".
- [2] 3GPP TS 22.071: "Location Services (LCS); Service description - Stage 1".
- [3] 3GPP TS 22.101: "Service principles".
- [4] 3GPP TS 23.007: "Restoration Procedures".
- [5] 3GPP TS 23.032: "Universal Geographical Area Description".
- [6] 3GPP TS 23.041: "Technical Realization of Cell Broadcast Service (CBS)".
- [7] 3GPP TS 23.271: "Functional stage 2 description of location services in UMTS and GSM".
- [8] 3GPP TS 24.008: "Mobile Radio Interface Layer 3 Specification (CC/MM); Layer 3 specification."
- [9] 3GPP TS 24.030: "Location Services (LCS); Supplementary Service Operations Stage 3".
- [10] 3GPP TS 24.080: "Location Services (LCS); Mobile Radio Interface Layer 3, Supplementary services Specification; Formats Encoding".
- [11] 3GPP TS 43.051: Overall Stage 2 Description for GSM/EDGE Radio Access Network (GERAN)
- [12] 3GPP TS 44.006: MS-BSS Interface Data Link (DL) Layer Specification
- [13] 3GPP TS 44.012: Short Message Service Cell Broadcast (SMSCB) Support on the Mobile Radio Interface
- [14] 3GPP TS 44.018: Mobile radio interface layer 3 specification; Radio Resource Control Protocol

- [15] 3GPP TS 44.031: Mobile Station (MS) - Serving Mobile Location Centre (SMLC) Radio Resource LCS Protocol (RRLP)
- [16] 3GPP TS 44.035: Location Services (LCS); Broadcast Network Assistance for Enhanced Observed Time Difference (E-OTD) and Global Positioning System (GPS) Positioning Methods
- [17] 3GPP TS 44.071: Mobile Radio Interface Layer 3 Location Services Specification (LCS); Formats and Coding
- [18] 3GPP TS 48.008: Mobile radio interface layer 3 specification; Layer 3 specification
- [19] 3GPP TS 48.031: Location Services (LCS); Serving Mobile Location Centre - Serving Mobile Location Centre (SMLC - SMLC); SMLCPP specification
- [20] 3GPP TS 48.058: Base Station Controller - Base Transceiver Station (BSC - BTS) interface; Layer 3 specification.
- [21] 3GPP TS 48.071: Location Services (LCS); Serving Mobile Location Center – Base Station Subsystem (SMLC-BSS) interface Layer 3 specification
- [22] 3GPP TS 49.031: Location Services (LCS); Base Station System Application Part LCS Extension (BSSAP-LE)
- [23] TIA/EIA/IS-J-STD-036 – Enhanced Wireless 9-1-1 Phase II, August 2000

3 Definitions and abbreviations

3.1 Definitions

For the purposes of the present document the following terms and definitions apply and the terms and definitions given in 3GPP TS 22.101 .

LCS (LoCation Services): LCS is a service concept in system standardisation. LCS specifies all the necessary network elements and entities, their functionality, interfaces, as well as communication messages, due to implement the positioning functionality in a cellular network. Note that LCS does not specify any location based (value added) services except locating of emergency calls

LCS Client: a software and/or hardware entity that interacts with a LCS Server for the purpose of obtaining location information for one or more Mobile Stations. LCS Clients subscribe to LCS in order to obtain location information. LCS Clients may or may not interact with human users. The LCS Client is responsible for formatting and presenting data and managing the user interface (dialogue). The LCS Client may reside in the Mobile Station (MS)

LCS Server: a software and/or hardware entity offering LCS capabilities. The LCS Server accepts requests, services requests, and sends back responses to the received requests. The LCS server consists of LCS components, which are distributed to one or more PLMN and/or service provider

Location Estimate: the geographic location of an MS and/or valid Mobile Equipment (ME), expressed in latitude and longitude data. The Location Estimate shall be represented in a well-defined universal format. Translation from this universal format to another geographic location system may be supported, although the details are considered outside the scope of the primitive services

Mobile Assisted positioning: any mobile centric positioning method (e.g. E-OTD, GPS) in which the MS provides position measurements to the network for computation of a location estimate by the network. The network may provide assistance data to the MS to enable position measurements and/or improve measurement performance

Mobile Based positioning: any mobile centric positioning method (e.g. E-OTD, GPS) in which the MS performs both position measurements and computation of a location estimate and where assistance data useful or essential to one or both of these functions is provided to the MS by the network. Position methods where an MS performs measurements and location computation without network assistance data are not considered within this category

Mobile Station: the mobile station (MS) consists of Mobile or User Equipment (ME or MS) with a valid SIM or USIM attached.

Positioning (/location detecting): positioning is a functionality, which detects a geographical location (of e.g. a mobile terminal)

Positioning technology (/locating technology): a technology or system concept including the specifications of RF interfaces, data types, etc. to process the estimation of a geographical location, e.g. GPS and E-OTD

Radio Interface Timing: Comprise Absolute Time Differences (ATDs) or Real Time Differences (RTDs) of the signals transmitted by Base Stations, where timing differences are measured relative to either some absolute time difference (ATD) or the signals of another Base Station (RTD).

RRLP pseudo-segmentation: The use of several RRLP data messages to deliver a large amount of assistance data

Target MS: the Mobile Station being positioned

Type A LMU: accessed exclusively over the air interface (Um interface): there is no wired connection to any other network element.

Type B LMU: is accessed over the Abis interface from a BSC. The LMU may be either a standalone network element addressed using some pseudo-cell ID or connected to or integrated in a BTS. Note, Abis interface is beyond the scope of this document.

3.2 Abbreviations

For the purposes of the present document, the abbreviations given in 3GPP TS 21.905 apply.

2G-	Second Generation
3G-	Third Generation
A	Interface between GERAN BSS and MSC
A-GPS	Assisted GPS
ATD	Absolute Time Difference
BSSLAP	Base Station System Application Part
BSSAP-LE	Base Station System Application Part LCS Extension
CBC-BSC	Interface between CBC and BSC
CBC-SMLC	Interface between CBC and SMLC
D-GPS	Differential GPS
E-OTD	Enhanced Observed Time Difference
Gb	Interface between GERAN BSS and SGSN
Lb	Interface between SMLC and BSC
LCCF	Location Client Control Function
LCF	Location Client Function
LSBcF	Location System Broadcast Function
LSCF	Location System Control Function
LSOF	Location System Operation Function
PCF	Position Calculation Function
PRCF	Positioning Radio Co-ordination Function
PRRM	Positioning Radio Resource Management
PSMF	Positioning Signal Measurement Function
RIT	Radio Interface Timing
RRLP	Radio Resource Link Protocol
RTD	Real Time Difference
SMSCB	Short Message Service Cell Broadcast
SMLCPP	Serving Mobile Location Center Peer Protocol
TA	Timing Advance
UDT	SCCP Unitdata message
Um	GERAN Air Interface
UTC	Universal Coordinated Time

4 Main concepts

A general description of location services and the service requirements is given in the specification 3GPP TS 22.071. By measuring radio signals the capability to determine the geographic location of the mobile station (MS) shall be provided. The location information may be requested by and reported to a client (application) associated with the MS, or by a client within or attached to the Core Network. The location information may also be utilised internally by GERAN, for example to support features such as home location billing. The location information shall be reported in standard formats, such as those for cell based or geographical coordinates of the location of the MS.

It shall be possible for the majority of the MS (active or idle) within a network to use the feature without compromising the radio transmission or signalling capabilities of the GERAN.

Three positioning mechanisms are supported for LCS: Timing Advance (TA), Enhanced Observed Time Difference (E-OTD), and Global Positioning System (GPS).

4.1 Assumptions

- SMLC is either an integrated functionality in BSC or a standalone network element within GERAN.
- LMU is either an integrated functionality in BTS (Type B LMU) or a standalone network element (Type A LMU) where communication is over the Um interface.
- Positioning not supported on Gb interface, but paging GPRS mobiles supported for Circuit Switched mode positioning.

4.2 Standard LCS Methods

4.2.1 Timing Advance

The TA is based on the existing Timing Advance (TA) parameter. The TA value is known for the serving BTS. To obtain TA values in case the MS is in idle mode a special procedure, not noticed by the GSM subscriber (no ringing tone), is set up. The cell-ID of the serving cell and the TA is returned as the result of the TA.

TA may be used to assist all positioning mechanisms and is a fall-back procedure.

4.2.2 Enhanced Observed Time Difference (E-OTD) positioning mechanism

The E-OTD method is based on measurements in the MS of the Enhanced Observed Time Difference of arrival of bursts of nearby pairs of BTSs. For E-OTD measurement synchronization, normal and dummy bursts are used. When the transmission frames of BTSs are not synchronized, the network needs to measure the Real or Absolute Time Differences (RTDs or ATDs) between them. To obtain accurate trilateration, E-OTD measurements and, for non-synchronized BTSs, RTD or ATD measurements are needed for at least three distinct pairs of geographically dispersed BTSs. Based on the measured E-OTD values the location of MS can be calculated either in the network or in the MS itself, if all the needed information is available in MS.

4.2.3 Global Positioning System (GPS) positioning mechanism

The Global Positioning System (GPS) method refers to any of several variants that make use of GPS signals or additional signals derived from GPS signals in order to calculate MS position. These variants give rise to a range of optional information flows between the MS and the network. One dimension of variation is where position calculation is performed at: a) MS-based PCF or b) network-based PCF. Another dimension is whether "assistance data" is required - irrespective of where position calculation is performed. Examples of assistance data include differential GPS data; lists of satellites in view based on approximate MS position, etc. A third dimension of variation is closely related to the preceding, namely, the origin and distribution of any assistance data. For example, even while assistance data may be required of a GPS method, it may be optional that the assistance data originates from and is distributed within and by the PLMN, VPLMN, etc.

5 GERAN LCS Architecture

Figure 1, shows the general arrangement of the Location Service feature. This illustrates, generally, the relation of LCS Clients and servers in the core network with the GERAN. The definition and operation of LCS entities operating in the core network is outside the scope of the present document. The LCS entities within the GERAN communicate with the Core Network (CN) across the A and Gb interfaces.

Communication among the GERAN LCS entities makes use of the messaging and signalling capabilities of the GERAN.

As part of their service or operation, the LCS Clients may request the location information of Mobile Station. There may be more than one LCS client. These may be associated with the core network, associated with the GERAN, operated as part of a MS application or accessed by the MS through its access to an application (e.g. through the Internet).

Within the GERAN, the BSC receives authenticated requests for LCS information from the core network across the A and Gb interfaces and passes these to the SMLC. The SMLC may be a standalone network element or functionality that is integrated to the BSC. LCS entities then manage the GERAN resources, including the base station, the LMU, the MS and calculation functions, to estimate the location of the MS and return the result to the Core Network.

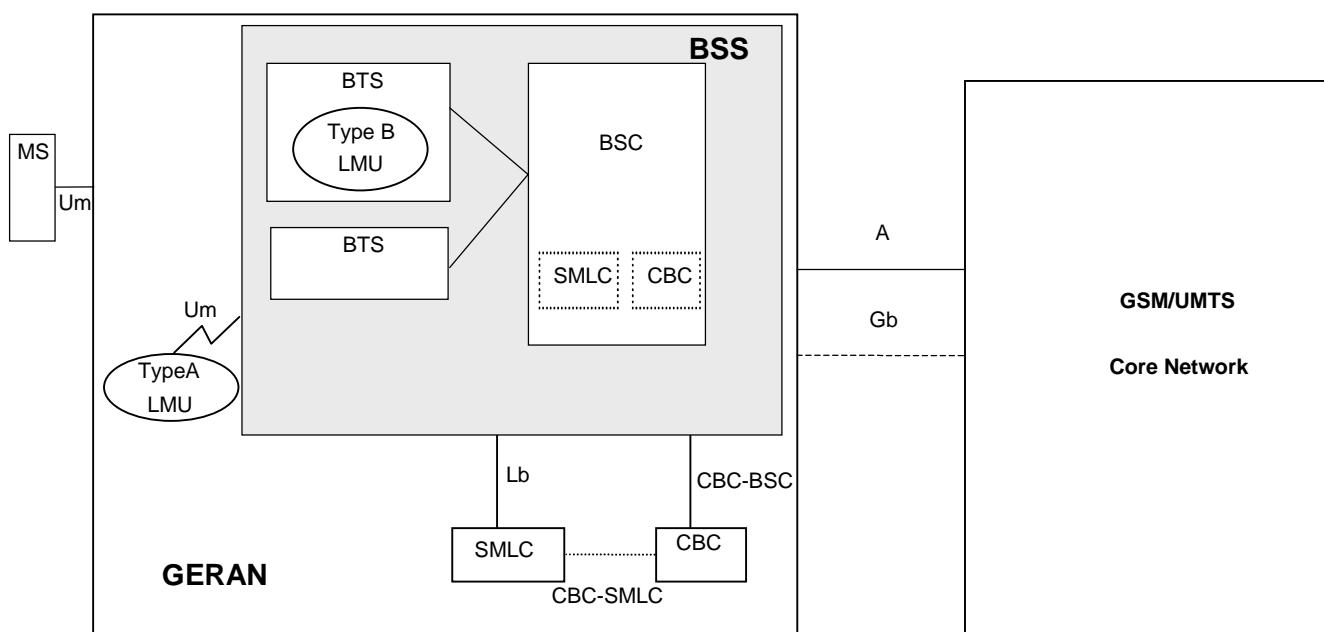

Figure 1: Functional LCS Architecture in GERAN

Note: Positioning not supported on Gb interface, but paging GPRS mobile supported for Circuit Switched mode positioning.

5.1 LCS Operations

The schematic functional description of LCS operations is defined in Figure 2.

Upon request from the LCS entities or for internal operations, the GERAN LCS functional entities will:

- request measurements, typically from the MS and/or one or more BTS radio apparatus;
- send the measurement results to the appropriate calculating function within GERAN;
- receive the result from the calculating function within GERAN;
- send the results to the LCS entities in the core network or to application entities within GERAN.

In the event that the client is internal to GERAN the request may be made directly to the GERAN LCS entities as the internal clients are considered to be "pre-authorised".

As part of its operation, the GERAN LCS calculating function may require additional information. This may be obtained by the function directly by communication with a database, or it may be through a request to GERAN LCS entities that will mediate the request and return of information from the appropriate database (or databases if more than one is needed to fulfil the requests).

There may possibly also be available independent information that is able to supply the location information directly, or may be able to supply auxiliary information to the calculation function. The GERAN LCS co-ordination function, as part of its activity to supervise the location process, may query the MS or other elements of the GERAN to determine their capabilities and use this information to select the mode of operation.

This general operation is outlined in the following (generic) sequence diagram Figure 2. This figure is not intended to show the complete LCS operation for GERAN, but to simply to outline the basis for operation. Location measurements may continually be taken in the background.

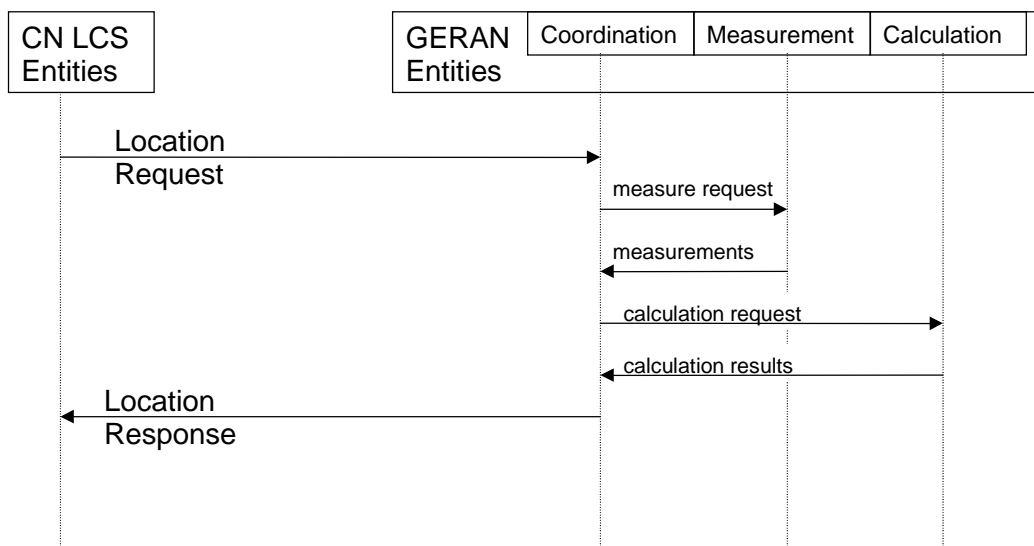

Figure 2: General sequence for LCS operation

5.2 High-Level Functions

Several functional groupings may be defined to describe the LCS. These groupings occur in both the Core Network and the GERAN. The overall LCS functional grouping is described in the system stage 2, 3GPP TS 23.271. Each grouping encompasses a number of functional components and functions.

The functions within the GERAN are described in more detail in the following subclauses of the present document.

Within GERAN the functional entities may be grouped as follows:

- the Internal Client group;
- the GERAN System Handling group;
- the Positioning group.

The LCS functional diagram shown in Figure 3 depicts the interaction of the LCS functional entities within the GERAN. The GERAN uses the various LCS components to provide the target MS Location Information to the internal LCS client.

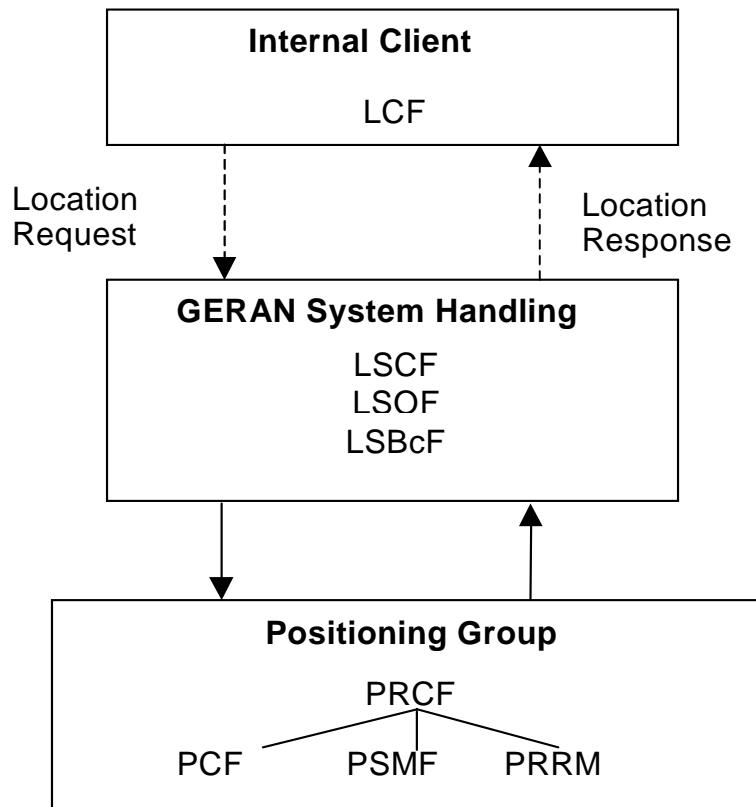

Figure 3: GERAN LCS Capability Functional Diagram

5.2.1 Co-ordination, Measurement and Calculation Functions

These GERAN functions (including functions in the System handling and Positioning groups) provide the co-ordination, measurement and calculation functions needed to provide a location estimate. The functions interface with the requesting application and select the appropriate location method and speed of response. The functions co-ordinate the operations of the radio and measurement equipment to transmit the needed signals and to make the needed measurements. The functions may also access databases or other sources of information appropriate for the location method. The functions also provide the calculation functions appropriate for the location method to estimate the MS location and the accuracy of the report. The functions also may record information on the usage of the LCS that may be used for administrative purposes (e.g. forwarded to a billing function in the Core Network). If needed by the location method, the functions will ensure the broadcast of information and gather and update information concerning GERAN operating parameters (e.g. timing of BTS transmissions) needed for LCS operations.

These entities are mainly concerned with the location method, controlling the radio equipment and performing the calculations to determine the location and thus may be associated with the SMLC in the GERAN. These functions may receive location requests from either the core network or from applications internal to the GERAN.

These functions communicate with the core network across the A and Gb interfaces, and with the BTS and LMU and with the MS across the Um interface.

5.3 GERAN LCS Functional Entities

5.3.1 Internal Client Group

5.3.1.1 Internal GERAN Location Client Function (LCF)

The Location Client Function (LCF) represents a logical interface between the internal GERAN LCS applications and the LCS BSC Handling entities (e.g. the Location System Control Function (LSCF) in the BSC).

NOTE: There is not necessarily a requirement for a LCCF (Location Client Control Function) for the GERAN Internal Client as is described for external clients in the system stage 2 specification, 3GPP TS 23.271.

The GERAN may make use of location information for internal operations such as location assisted handover. In such a case, a LCF representing the internal GERAN LCS application may communicate with the LSCF to request and receive the location information.

5.3.2 GERAN System Handling group

5.3.2.1 GERAN Location System Control Function (LSCF)

The GERAN Location System Control Function is responsible for co-ordinating location requests. This function manages call-related and non-call-related location requests and allocates network resources for handling them. This function "insulates" the Location clients in the Core Network from the detailed operation of the location method in order that the GERAN may be used by several types of core network and with several location methods.

The LSCF provides flow control between simultaneous location requests. Simultaneous location requests must be queued in a controlled manner to account for priority requests (e.g. for Emergency Clients). The details of the flow control, priority selection and queuing are beyond the scope of the present document.

The LSCF will select the appropriate location method based on the availability of resources and parameters of the location request. The LSCF coordinates resources and activities needed to obtain data (e.g. base station geographic coordinates) needed for the location method. It also records LCS usage data for the location service request that may be passed to a Location System Recording Function (LSRF) or O&M function in the Core Network.

5.3.2.2 GERAN Location System Operations Function (LSOF)

The Location System Operations Function (LSOF) is responsible for provisioning of data, location capabilities, data related to clients and subscription (LCS client data and MS data), fault management and performance management of LCS within the BSC.

An LSOF may be associated with each entity. The LSOF interacts with Internal (O&M) Clients for administration and maintenance of the data.

5.3.2.3 Location System Broadcast Function (LSBcF)

The Location System Broadcast Function (LSBcF) provides broadcast capability. The LSBcF capability is only used when broadcast data is required for E-OTD or A-GPS positioning methods. Broadcast information (such as the geographic coordinates of the base stations) may be required, for example, to support a Position Calculation Function (PCF) located in the mobile station. These broadcasts may also include other information (such as currently observable satellites) that may assist a MS in the use of external location services.

The information to be broadcast is selected based on the location techniques offered for use by the LCS and the needs of the MS. This broadcast information may be specially coded (i.e. encrypted) to ensure its availability only to subscribers of the service. The use of broadcasts or other methods for signalling to the MS may be selected based on the chosen location method.

The information to be broadcast includes for example:

1. E-OTD Assistance:

- Reference Time
- Neighbour Channel Time Slot Scheme
- Information about sectored neighbour channels
- Neighbour channel 51 Multiframe Offset values
- Neighbour channel BCC values
- RTD Drift Factor values (ciphered if active)
- Neighbour channel RTD values (ciphered if active)
- Serving cell and neighbour cell location information (ciphered if active)

2. GPS Assistance Data:

- Reference Time
- Reference Location
- Differential GPS Correction Data (DGPS)
- Ephemeris and Clock Correction Data
- Almanac and Other Data.

5.3.3 Positioning group

5.3.3.1 GERAN Position Radio Co-ordination Function (PRCF)

The GERAN Position Radio Control Function manages a location request for a MS through overall co-ordination and scheduling of resources to perform location measurements. This function interfaces with the PSMF, the PRRM and the PCF. The PRCF determines the location method to be used based on the location request, the QoS, the capabilities of the GERAN, and the MS's capabilities. The PRCF also manages the needed radio resources through the PRRM. It determines which PSMFs are to be involved, what to measure, and obtains processed signal measurements from the PSMF.

Some location methods may involve measurements made at the MS. In this case the PRCF interfaces with the MS to obtain the measurements (or the location results if they have been determined by the MS). Some location methods may involve measurements or information from several sources, including radio units at several BTSs and involve a series of transmissions and receptions. The PRCF entity also provides ancillary measurements in case of network-assisted location method. Ancillary information may be extracted from navigating systems like GPS.

The PRCF forwards the signal measurement data to the PCF.

It is the function of the PRCF to co-ordinate the sequence of activities and compensate for failures (if they occur) to provide the location estimate.

5.3.3.2 GERAN Position Calculation Function (PCF)

The GERAN Position Calculation Function is responsible for calculating the location of the MS. This function applies an algorithmic computation on the collected signal measurements to compute the final location estimate and accuracy.

It may obtain related data (e.g.: base station geographic coordinates) needed for the calculation. There may be more than one calculating function available within, or associated with, the calculation function of the GERAN.

The Position Calculation Function is also responsible for estimating the accuracy of the location estimate.

5.3.3.3 GERAN Position Signal Measurement Function (PSMF)

The GERAN Position Signal Measurement Function (PSMF) is responsible for performing and gathering uplink or downlink radio signal measurements for use in the calculation of a MS's location. These measurements can be location related or ancillary.

There may be one or more PSMF within a GERAN and they may be located at the MS or a Location Measurement Unit (LMU). The PSMF, generally, may provide measurement of signals (i.e. satellite signals) in addition to measurements of the GERAN radio transmissions. The measurements to be made will depend on the selected location method.

5.3.3.4 GERAN Position Radio Resource Management (PRRM)

The GERAN Position Radio Resource Management entity is responsible for managing the effect of LCS operations on the overall performance of the radio network. This may ensure, for example, that the operation of the PSMF does not degrade the QoS of other calls.

5.4 Assignment of LCS Functional Entities to GERAN Elements

The following Table 1 shows the generic configuration for different location methods, including network-based, mobile-based, mobile-assisted and network-assisted methods. With this approach both the network and the mobiles are able to measure the timing of signals and compute the mobile's location estimate. Depending on the applied location method it is possible to utilise the corresponding configuration containing all needed entities. For instance, if a network-based location method is applied, the entities that are involved in measuring the mobile's signal and calculating its location estimate are allocated to the network elements of the access network. On the other hand, in case mobile-based or network-assisted methods are used these entities should be allocated to the mobile station.

Table 1: Example Allocation of LCS Functional Entities to Network Elements

	MS	LMU	SMLC	BSC
LCF	X			X
LSBcF			X	
LSCF				X
PRCF			X	
PCF	X		X	
PRRM				X
PSMF	X	X		
LSOF		X	X	X

5.5 Functional Description of GERAN LCS Network Elements

5.5.1 BSC

The BSC receives authenticated requests for LCS information from the CN across A and Gb interfaces and passes these to the SMLC.

5.5.2 SMLC

The SMLC is either a separate network element of GERAN or integrated functionality in BSC that contains functionality required to support LCS. The SMLC manages the overall co-ordination and scheduling of resources required for the location of a mobile. It also calculates the final location estimate and estimates the achieved accuracy. The SMLC may control a number of LMUs for the purpose of obtaining radio interface measurements to locate or help locate MS subscribers in the area that it serves. The SMLC is administered with the capabilities and types of measurement produced by each of its LMUs. The radio interface timing measurement returned by an LMU to a SMLC has a generic status in usable for more than one location method.

5.5.3 CBC

For Location Services, when a Cell Broadcast Center (CBC) is associated with a BSC, the SMLC may interface to a CBC in order to broadcast assistance data using existing cell broadcast capabilities. The SMLC shall behave as a user, Cell Broadcast Entity, to the CBC (refer to 3GPP TS 23.041).

5.5.4 LMU

The LCS Measurement Unit (LMU) entity makes measurements (e.g. of radio signals) and communicates these measurements to the SMLC (e.g. the PRCF). The LMU contains a PSMF and may also perform calculations associated with the measurements. The LMU may make its measurements in response to requests (e.g. from the SMLC), or it may autonomously measure and report regularly (e.g. timing of BTS transmissions) or when there are significant changes in radio conditions (e.g. changes in the RTD). There may be one or more LMUs associated with the SMLC and an LCS request may involve measurements by one or more LMUs. LMU functionality may be integrated in a BTS.

An LMU makes radio measurements to support one or more positioning methods; these assistance measurements are specific to all MSs in a certain geographic area. All location and assistance measurements obtained by an LMU are supplied to the SMLC associated with the LMU. Instructions concerning the timing, the nature, and any periodicity of these measurements are either provided by the SMLC or are pre-administered in the LMU.

The following assistance measurement obtained by an LMU has a generic status usable by more than one position method:

Radio Interface Timing measurements – comprise Absolute Time Differences (ATDs) or Real Time Differences (RTDs) of the signals transmitted by Base Stations, where timing differences are measured relative to either some absolute time difference (ATD) or the signals of another Base Station (RTD).

5.5.5 MS

The MS interacts with the measurement co-ordination functions to make measurements of downlink signals. The measurements to be made will be determined by the chosen location method.

The MS may also contain LCS applications, or access an LCS application through communication with a network accessed by the MS or an application residing in the MS and/or satellite signals. The MS may include the needed measurement and calculation functions to determine the MS's location with or without assistance of the GERAN LCS entities.

6 Signalling Protocols and Interfaces

6.1 Protocol layering in CS domain

6.1.1 Generic Signalling Model for LCS in CS Domain

Figure 4 shows the generic signalling model applicable to LCS for signalling interaction in which an SMLC forms at least one of the signalling end points in the circuit switched domain.

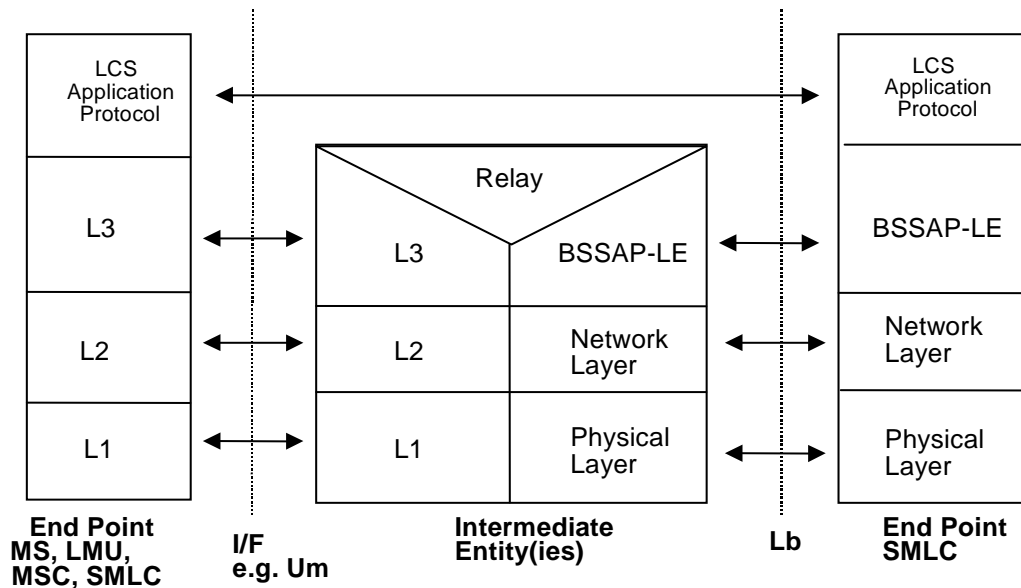

Figure 4: Generic Model for LCS Signalling to an SMLC for CS domain

The functions performed by each protocol layer are as follows:

- a) LCS application protocol – this depends on the other signaling end point (e.g. whether a target MS or LMU) and may be absent if supported in the BSSAP-LE layer. The application protocol supports specific LCS functions (e.g. positioning measurements, assistance measurements) and is independent of lower protocol layers.
- b) BSSAP-LE – this is an extension of BSSAP and carries the LCS application protocol signaling units. Necessary functions include identification of the LCS application protocol and identification, where not provided by the network layer, of the two end points. This layer can be relayed by an intermediate entity or mapped into an equivalent layer 3 protocol used by the other signaling end point. This layer supports segmentation of LCS application layer protocols.
- c) Network Layer – provides signaling transport between the SMLC and either the other end point or some intermediate entity at which the BSSAP-LE layer is relayed or mapped. The network layer may support connection oriented or connectionless signaling. For second generation circuit oriented applications, the network layer is provided using MTP and SCCP. This layer supports segmentation of LCS application layer protocols.
- d) Physical Layer – for second generation circuit oriented applications, SS7 signaling links are supported by the physical layer.
- e) L3 – a protocol layer compatible with or the same as BSSAP-LE.
- f) L2 – logical link layer for the other endpoint
- g) L1 – physical layer for the other end point.

6.1.2 Message Segmentation in CS Domain

Message segmentation is needed to transport any large LCS message that exceeds the message size limitation supported by any GSM interface over which transport is needed.

6.1.2.1 Network Level Segmentation

Segmentation and reassembly of large RRLP, SMLCPP and BSSLAP messages at the network (e.g. SCCP) level may be supported. For message transfer over any interface where network level segmentation is not supported, segmentation at the application level shall be used. This may require support of both network and intermediate level segmentation by certain intermediate entities. Intermediate Level Segmentation

6.1.2.2 Intermediate Level Segmentation

The segmentation of RRLP 3GPP TS 44.031, SMLCPP 3GPP TS 48.031, and BSSLAP 3GPP TS 48.071 messages is supported by segmentation mechanisms defined in 3GPP TS 48.008, 3GPP TS 24.008, 3GPP TS 44.018 and 3GPP TS 49.031. The sending, receiving and all intermediate entities supporting segmentation shall ensure reliable and sequenced delivery of the message segments by appropriate use of the capabilities supported by lower transport and network level protocols

6.1.2.3 RRLP Pseudo-Segmentation

The use of several RRLP messages to deliver a large amount of assistance data is called “RRLP pseudo-segmentation”. In order to avoid excessive delays for MM and CM layer procedures (call setup for example) it is recommended to utilize the “RRLP pseudo-segmentation” and limit the maximum size of individual RRLP messages (e.g. approximately 240 octets will avoid lower layer segmentation).

6.1.3 Signalling between an SMLC, MSC and BSC

A SMLC can either be separate logical entity or integrated functionality in the BSC. If the SMLC is a separate logical entity, the LCS signalling between SMLC and MSC is accomplished through the A and Lb interfaces. If the SMLC is integrated, the LCS signalling is accomplished through the A interface only. Figure 5 shows the protocol layers used to support LCS signaling between the SMLC, MSC and BSC.

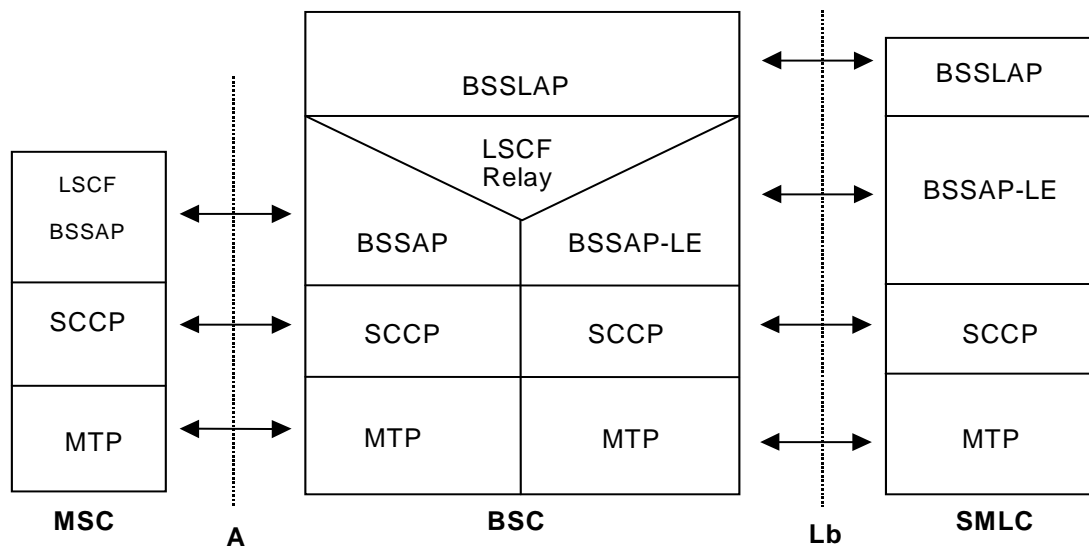

Figure 5: Signalling Protocols between SMLC, MSC and BSC

6.1.4 Signaling between SMLC and MS

SMLC Signalling to a target MS is accomplished through the Um interface. The figure below shows the protocol layers used to support signaling between an SMLC and target MS.

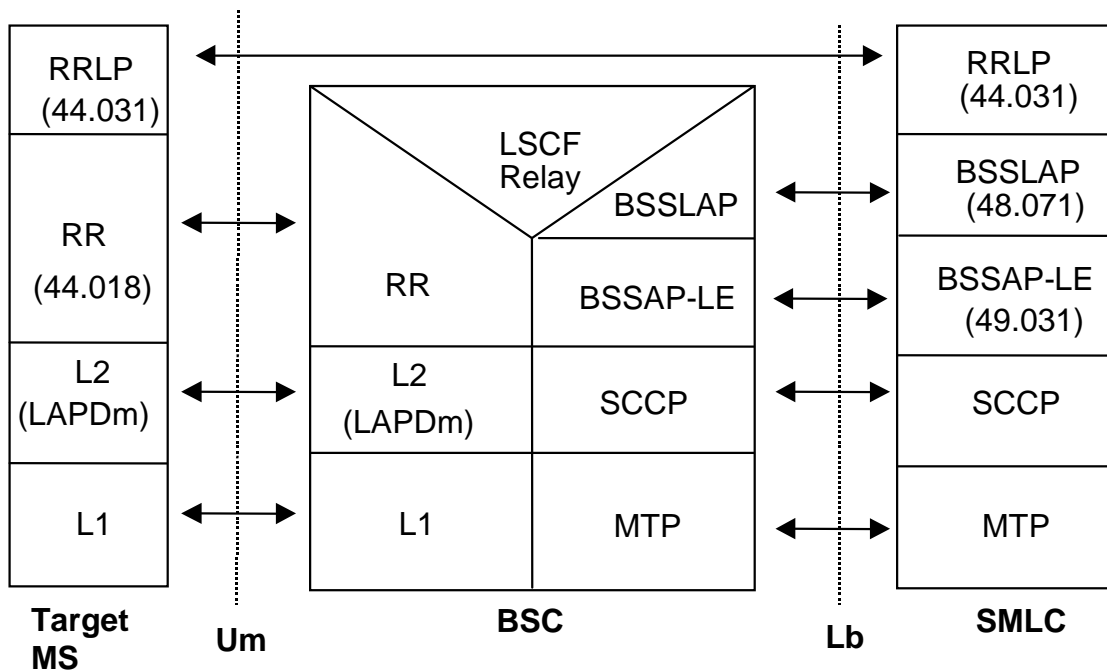

Figure 6: Signalling between an SMLC and Target MS

6.1.5 SMLC Signalling to a Type A LMU

6.1.5.1 Circuit Switched Signalling using an SDCCH

Figure 7 shows the protocol layers used to support signaling between an SMLC and a Type A LMU, using an SDCCH on the Um interface.

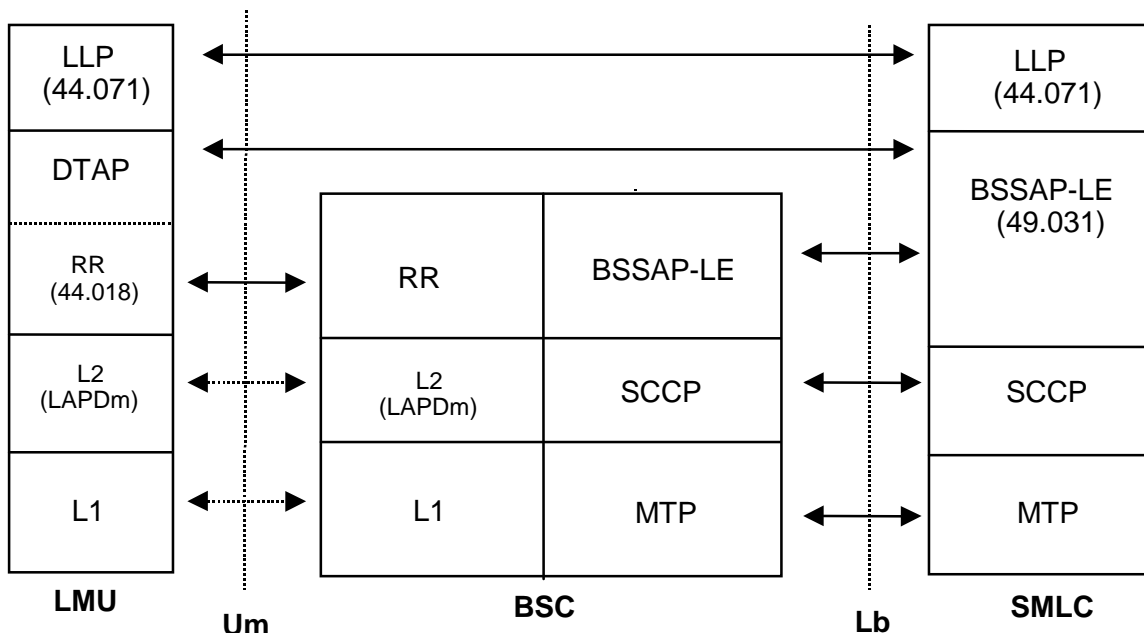

Figure 7: Signalling between an SMLC and Type A LMU using an SDCCH

6.1.5.2 Signalling using a TCH

Figure 8 shows the protocol layers that can be used to support signaling between an SMLC and a Type A LMU using a TCH on the Um interface. The TCH is assumed to support either transparent or non-transparent synchronous data and

may be provided in a multislot configuration. The main usage would be for O&M data and SW download – e.g. during offpeak hours.

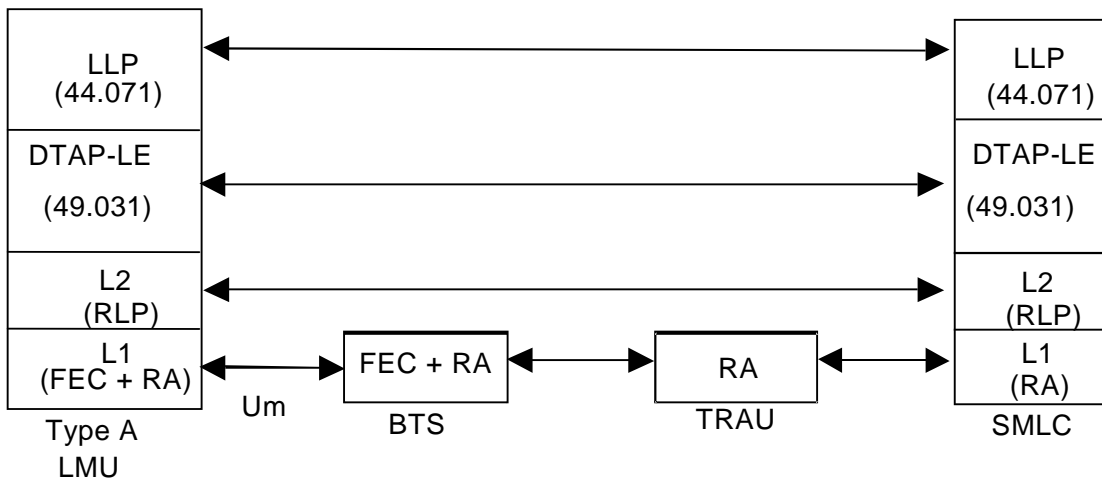

Figure 8: Signalling between an SMLC and a Type A LMU using a TCH

6.1.6 SMLC signaling to a Type B LMU

The protocol layers employed to enable signaling between the SMLC and a Type B LMU are shown in Figure 9. (Note 1)*: Abis interface is beyond the scope of this document.

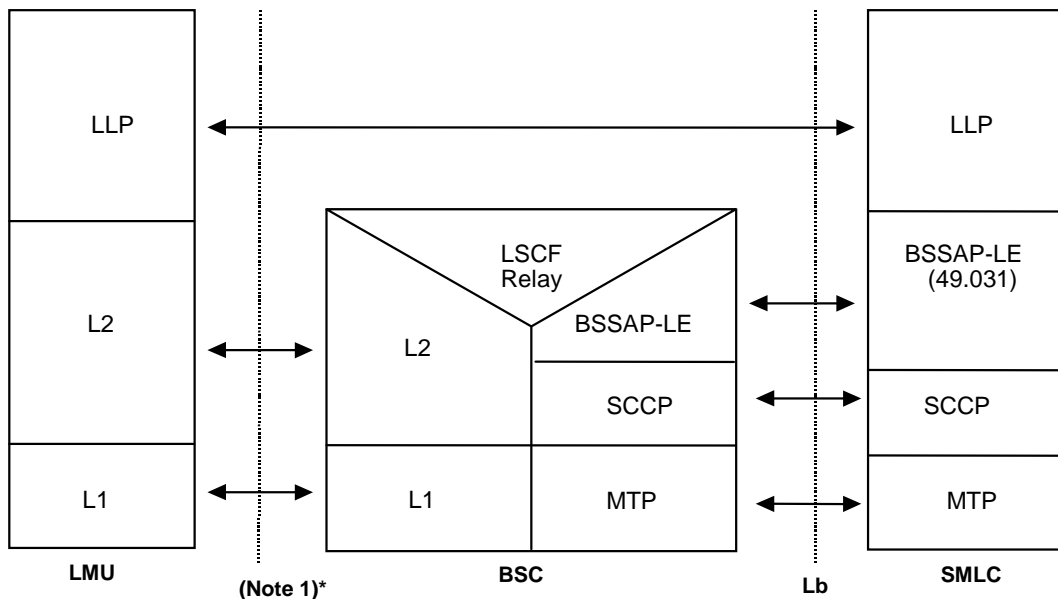

Figure 9: Signalling between an SMLC and Type B LMU

6.1.7 SMLC Signalling to a peer SMLC

The protocol layers used for SMLC to SMLC signaling are shown in Figure 10, where it is assumed that both SMLCs have SS7 link connections to STPs (or there is a direct SS7 link between the SMLCs).

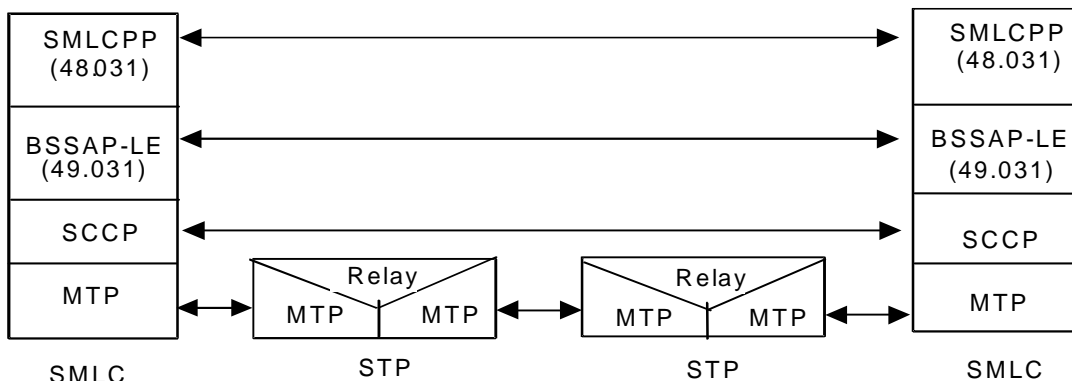

Figure 10: SMLC to SMLC Signalling via SS7 STPs

In the absence of either a direct link or links to an STP, signaling can go via attached BSCs and MSCs as shown in Figure 11 for signaling between the SMLCs sharing the same MSC.

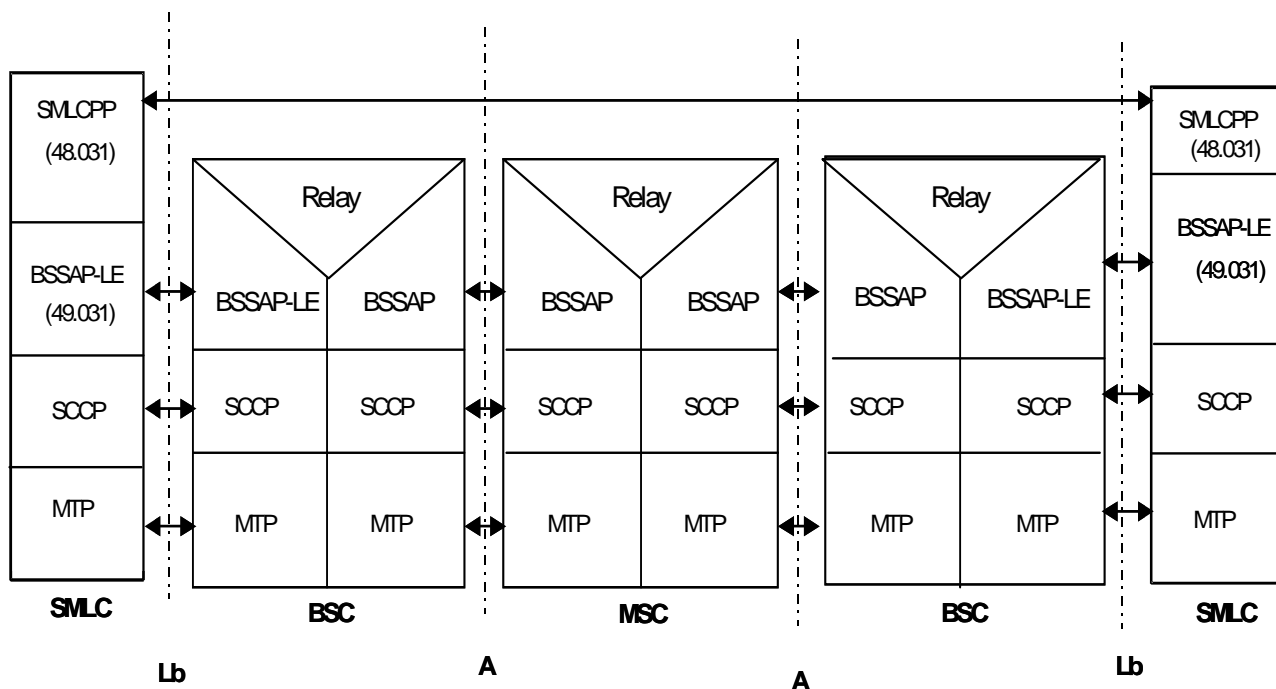

Figure 11: SMLC to SMLC Signalling via associated BSCs and MSC

7 GERAN Network Location Procedures

7.1 State description for SMLC

7.1.1 SMLC States

7.1.1.1 NULL State

This is a conceptual rather than actual state in which a certain location request from a particular Location Client, VMSC, SGSN or BSC either has not yet been received or has been completed.

7.1.1.2 LOCATION State

This state exists after the SMLC has received a location request from a BSC and persists while the SMLC is obtaining position measurements for a particular positioning method until such time as positioning measurements have been received and a location estimate has been computed and returned to the BSC.

When sufficient positioning measurement results have been received, the SMLC either evaluates them, if they include an already computed location estimate, or uses them to compute a location estimate. The SMLC then has the option of either reinitiating another positioning attempt, e.g. if the location estimate did not satisfy the required QoS and the requirement on response time permits another position attempt, or returning the location estimate to the BSC.

7.1.2 State Functionality

7.1.2.1 State Transitions

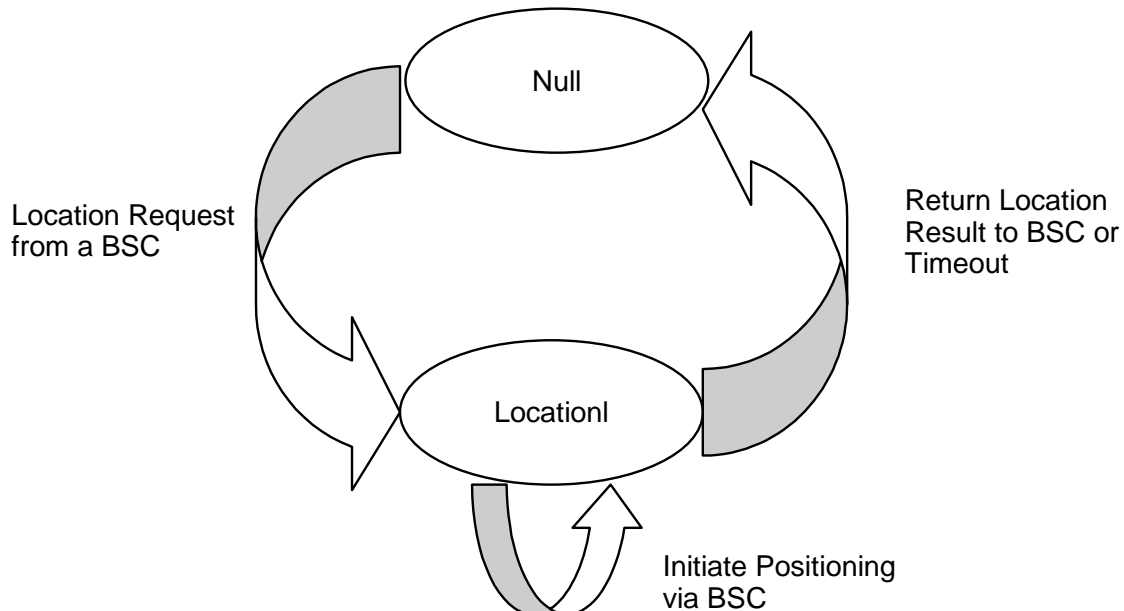

Figure 12: State Transitions in the SMLC

Moving from NULL to LOCATION state:

After a location request is received from the BSC, the SMLC enters the LOCATION state. It then chooses a positioning method and initiates the appropriate position measurements.

Moving from LOCATION to NULL state:

When the SMLC has obtained a location estimate that best meets the requested QoS parameters, it returns this to the BSC and re-enters the NULL state.

7.1.2.2 LOCATION Timer Function

The SMLC runs a timer while in the LOCATION state to limit the total amount of time that positioning can be active. This timer should be related to any response time indicated in the location request QoS parameters. If the timer expires before a final location estimate has been produced, the SMLC either returns the best existing location estimate to the BSC (e.g. an estimate based on the current cell ID) or returns a failure indication. It then re-enters the NULL state.

7.2 State Description for the BSC

7.2.1 BSC States

7.2.1.1 IDLE State

In this state, the BSC location service is inactive for a particular MS.

7.2.1.2 LOCATION State

In this state, the BSC is awaiting a response from a SMLC after requesting the location for a particular MS. In this state, a Radio Resource connection to the target MS will be active – allowing the SMLC and MS to exchange positioning related messages for mobile based and mobile assisted position methods. For certain position methods (e.g. network based position methods), the SMLC may invoke substates in the BSC during which other types of association or procedure are supported with the MS (e.g. temporary call establishment, handover). In this state, the BSC may transfer positioning related messages between the SMLC and the target MS and/or between the SMLC and certain LMUs served by the BSC.

7.2.2 State Functionality

7.2.2.1 State Transitions

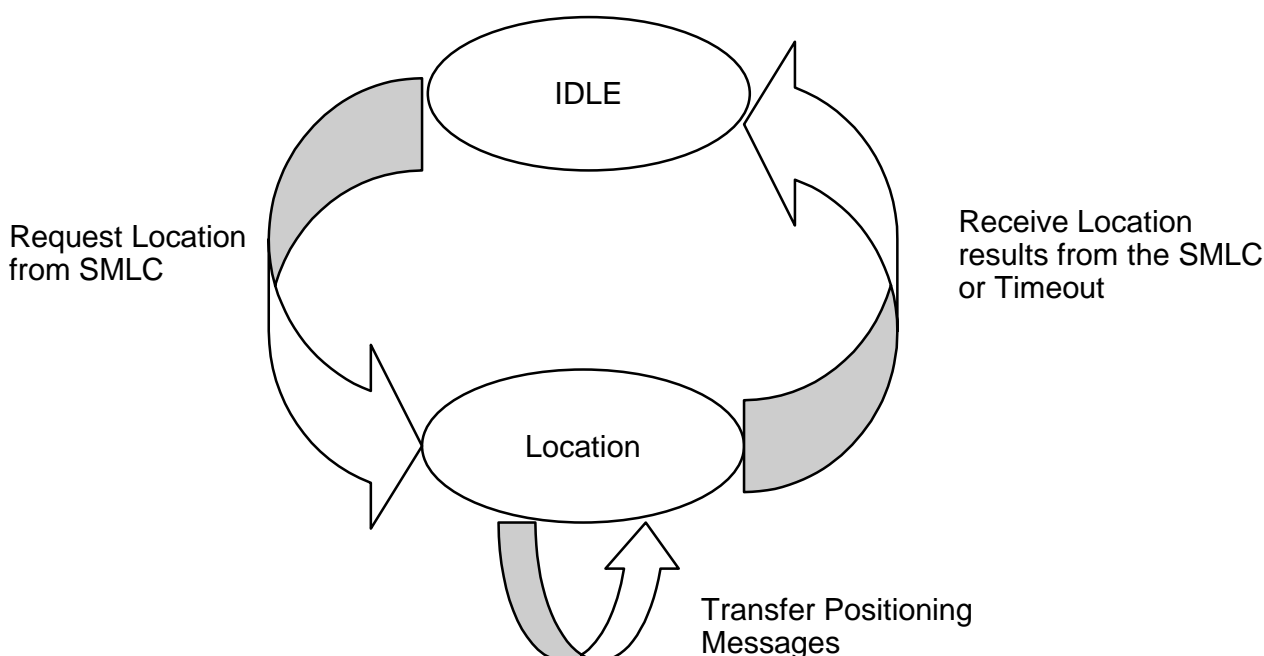

Figure 13: State Transitions in the BSC

Moving from IDLE to LOCATION state:

After a request has been received to locate a particular MS served by the BSC, a location request is sent to the SMLC associated with the serving cell: the BSC then enters the LOCATION state. Before entering this state, a Radio Resource connection to the MS must have been already established by the VMSC.

Moving from LOCATION to IDLE state:

After the return of a location estimate result from the SMLC, the BSC shall re-enter IDLE state.

7.2.2.2 LOCATION Timer Function

The BSC runs a timer while in the LOCATION state to limit the amount of time waiting for a location response from the SMLC. If the timer expires before such information is received, the BSC indicates a location failure to the original requesting entity and re-enters IDLE state.

7.3 Usage of SCCP Connection on the Lb interface

SCCP connection oriented signaling between a SMLC and a BSC is used to support SMLC signaling to a Type A LMU, a serving BSC, or a target MS. The types of SCCP connections are described below.

7.3.1 SCCP Connection for positioning of a target MS

The BSC establishes this connection when a request is received for a location estimate for a target MS. The BSC sends the BSSAP-LE Perform Location Request to the SMLC inside an SCCP Connection Request message. Signaling between the SMLC and target MS is then relayed by the BSC between this SCCP connection and the main signaling link to the MS. The same SCCP connection is also used to transfer BSSLAP messages between the SMLC and serving BSC. See figure below.

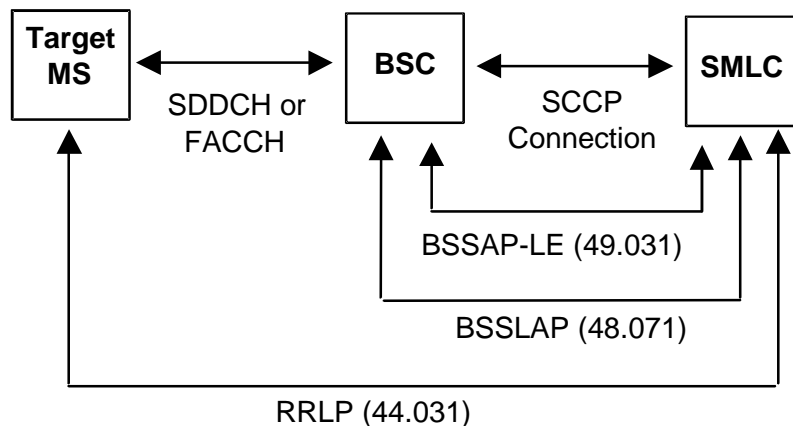

Figure 14: SCCP based signalling for MS positioning with a SMLC

7.3.2 SCCP connection to access a Type A LMU

The BSC or SMLC establishes this connection to enable LCS messages to be transferred to or from a Type A LMU. The BSC or SMLC sends a BSSAP-LE LMU Connection Request message inside an SCCP Connection Request message. Signaling is subsequently relayed through the BSC using this SCCP connection as shown in the figure below.

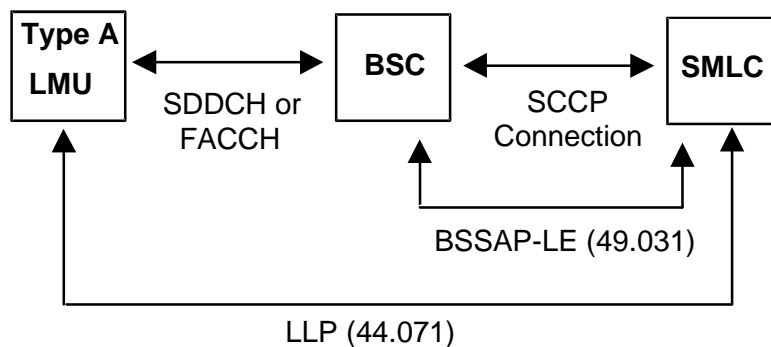

Figure 15: SCCP based signalling to access a TypeA LMU with a SMLC

8 Common Procedures to Support Positioning

The procedures described in this section enable an SMLC to obtain positioning related information or instigate positioning for a particular target MS. The procedures are applicable to all positioning methods after an SMLC receives a BSSAP-LE Perform Location request for a target MS until a BSSAP-LE Perform Location response is returned to the originator.

8.1 Information Transfer between a SMLC and a Target MS

A SMLC uses the procedure shown below in order to obtain positioning measurements from a target MS or transfer location assistance information to a target MS after a request has been received from the BSC serving the target MS. More details of the location information transfer procedure between the BSC and MS can be found in 3GPP TS 24.008.

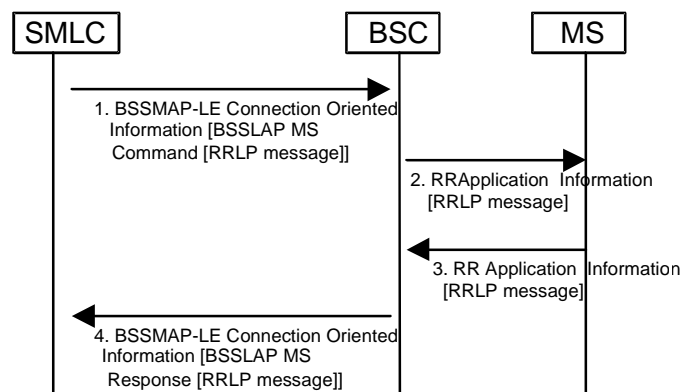

Figure 16: Information Transfer between a SMLC and a Target MS

- 1) The SMLC passes a BSSAP-LE Connection Oriented Information message to the serving BSC containing an embedded BSSLAP MS Position Command with an RRLP message parameter. The message is transferred using the SCCP connection established between the SMLC and BSC for positioning the target MS. If the BSSLAP message is too large to fit in a single BSSAP-LE Connection Oriented Information message, it may be segmented and transferred inside a sequence of BSSAP-LE messages with the last BSSAP-LE message containing a last segment indication and the last RRLP segment. The SMLC shall indicate in the first BSSLAP MS Position Command whether the embedded RRLP message contains a positioning command versus positioning assistance data.
- 2) The BSC transfers the embedded RRLP message to the target MS inside an RR Application Information message. If the BSSLAP message was segmented by the SMLC, onward transfer to the MS shall be deferred until all segments have arrived and the complete BSSLAP message is reassembled. The embedded RRLP message shall then be re-segmented if necessary with each RRLP segment transferred in a separate RR Application Information message with the last RR message indicating the last RRLP segment. No later than when the last RR Application Information message has been transferred, the BSC shall start a positioning supervision timer if none is already in progress or restart this if already in progress. If the timer expires before the final response in step 3 is received, the BSC shall return a BSSAP-LE Connection oriented Information message to the SMLC containing a BSSLAP Abort with a cause of BSC timeout.
- 3) When the target MS has positioning information to return to the SMLC, it sends an RR Application Information message to the BSC containing an embedded RRLP message. If the RRLP message is too large to fit in a single RR Application Information message, it may be segmented and carried in a sequence of RR Application Information messages with the last message indicating the last RRLP segment. The last RR Application Information message shall indicate if this is the final response from the MS.

- 4) If the timer started in step 2 has already expired, the BSC discards the RRLP message received in step 3. Otherwise, the BSC forwards the RRLP message to the SMLC inside a BSSLAP MS Positioning Response message contained in a BSSAP-LE Connection Oriented Information message. If the RRLP message was segmented, onward transfer to the SMLC shall be deferred until all segments have arrived and the complete RRLP message is reassembled. If the resulting BSSLAP message is too large to fit into a single BSSAP-LE Connection Oriented Information message (e.g. if the RRLP message was segmented), it shall be segmented. Each segment is then transferred in a separate BSSAP-LE message with the last message containing the last BSSLAP segment. If the SMLC indicated a positioning command in step 1 and the MS has indicated a final response, the BSC may add additional measurement information to the BSSLAP MS Position Response in the last BSSAP-LE message – if necessary, creating a new BSSAP-LE message if message size limitations would be exceeded. The BSC shall stop the supervision timer started in step 2 when the final segment of the final response from the MS has been transferred. If the MS did not indicate a final response in step 2, the SMLC may transfer a further RRLP message to the MS (e.g. containing assistance data) according to steps 1 and 2 and the MS may return a subsequent response according to steps 3 and 4.

8.2 Information Transfer between a SMLC and a BSC

A SMLC uses the procedure shown below in order to obtain positioning related information from the BSC serving a particular target MS after a positioning request has been received from the BSC.

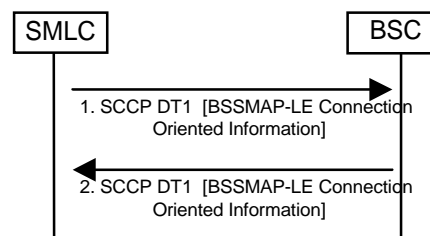

Figure 17: Information Transfer between a SMLC and a BSC

- 1) The SMLC passes a BSSAP-LE Connection Oriented Information message to the BSC containing an embedded BSSLAP message. The BSSAP-LE message is transferred using the SCCP connection previously established between the SMLC and BSC when the positioning request for the target MS was initially sent to the SMLC. The BSC recognizes that it is the final destination due to the presence of the embedded BSSLAP message.
- 2) When the BSC has positioning information for the target MS to return to the SMLC, it sends a BSSAP-LE Connection Oriented Information message to the SMLC containing an embedded BSSLAP message. The message is sent using the SCCP connection previously established for positioning the target MS.

8.3 Common Procedures to Support Access to an LMU

The procedures in this section support the transfer of positioning related information and O&M data between an SMLC and a particular LMU associated with the SMLC.

8.3.1 Location Update Procedure between a SMLC and a Type A LMU

The following procedure supports a normal location update from the perspective of a Type A LMU. The location update can occur periodically, on power up, following recovery from some failure condition and when an LMU in idle mode detects that its closest BTS is in another location area.

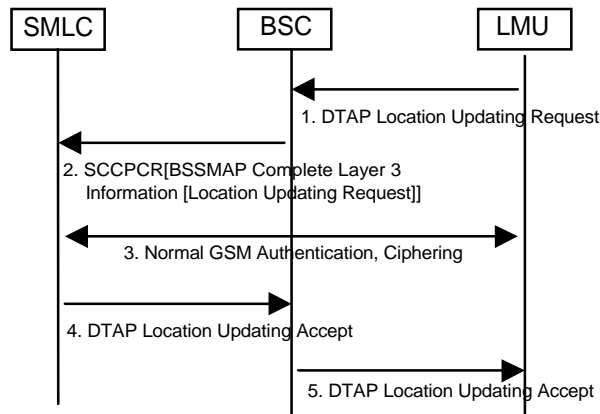

Figure 18: Location Update Procedure between a SMLC and a Type A LMU

- 1) If the LMU does not currently have a signaling link, it sends an RR Channel Request to the serving BTS to request a SDCCH. The RR Channel Request contains an establishment cause identifying an LMU. After assignment of the SDCCH, the LMU sends a DTAP Location Updating request to the BSC. This shall indicate that a follow on request is pending if the LMU has more data to send.
- 2) Because the BSC serving the LMU is associated with a SMLC and the Channel Request message contained an LMU establishment cause, the BSC forwards the Location Updating request to the SMLC rather than MSC. If there was previously no SDCCH, this is sent inside a BSSMAP Complete Layer 3 Information message that is contained in an SCCP Connection Request.
- 3) The SMLC performs normal authentication and ciphering if needed for the LMU. The SMLC shall not assign a TMSI to the LMU to avoid duplicating a TMSI assigned to a normal MS by a VLR.
- 4) The SMLC returns a DTAP Location Updating Accept to the BSC. Unless the LMU indicated a follow on request, the SMLC may then initiate release of the SDCCH.
- 5) The BSC forwards the DTAP message to the LMU.

8.3.2 IMSI Detach Procedure between a SMLC and a Type A LMU

The following procedure supports a normal IMSI Detach from the perspective of a Type A LMU. This may be instigated if the LMU is to be deactivated – e.g. for offline maintenance.

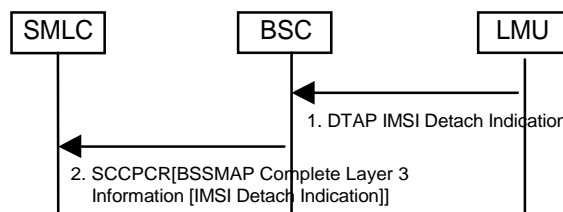

Figure 19: IMSI Detach Procedure between a SMLC and a Type A LMU

- 1) If the LMU does not currently have a signaling link, it sends an RR Channel Request to the serving BTS to request a SDCCH. The RR Channel Request contains an establishment cause identifying an LMU. After assignment of the SDCCH, the LMU sends a DTAP IMSI Detach Indication to the BSC.

- 2) Because the BSC serving the LMU is associated with a SMLC and the Channel Request message contained an LMU establishment cause, the BSC forwards the IMSI Detach Indication to the SMLC rather than MSC. If there was previously no SDCCH, this is sent inside a BSSAP Complete Layer 3 Information message that is contained in an SCCP Connection Request. The SMLC marks the LMU as temporarily inactive and initiates release of the SDCCH.

8.3.3 LCS Information Transfer between a SMLC and a Type A LMU

8.3.3.1 Information Transfer using an SDCCH

The following procedure supports information transfer between a SMLC and a Type A LMU.

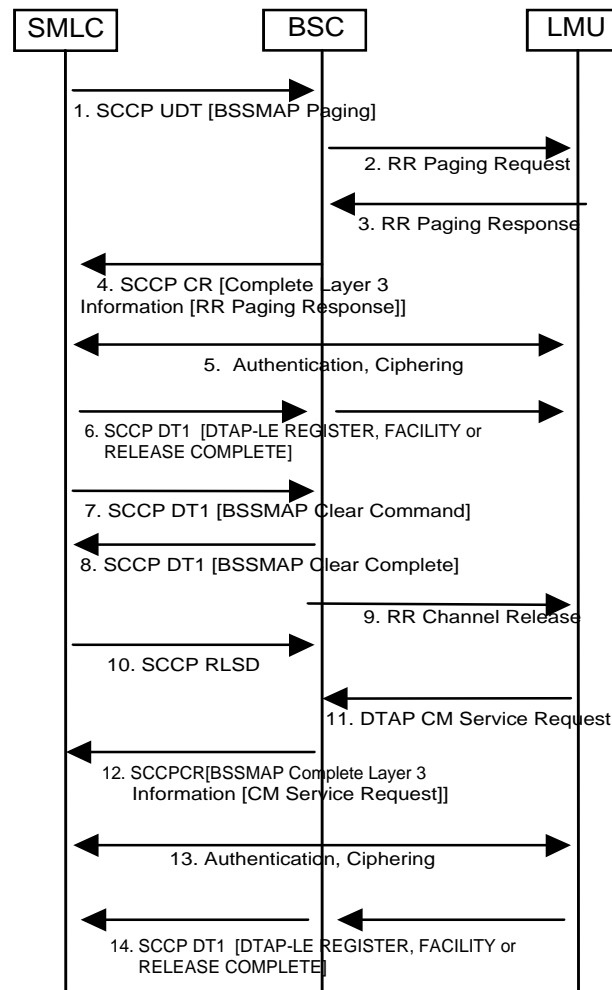

Figure 20: Information Transfer between a SMLC and a Type A LMU

- 1) If there is no signaling link yet for an LMU between the SMLC and the BSC serving the LMU, the SMLC sends a BSSAP Paging message to the serving BSC inside an SCCP Unitdata message.
- 2) The serving BSC broadcasts an RR Paging Request.
- 3) The LMU sends a Channel Request message containing an LMU establishment cause to request an SDCCH. After assignment of the SDCCH, the LMU returns an RR Paging Response.
- 4) Because the BSC serving the LMU is associated with a SMLC and the Channel Request message in step 3 contained an LMU establishment cause, the BSC transfers the Paging Response to the SMLC, rather than MSC, in a BSSAP Complete Layer 3 Information message contained in an SCCP Connection Request.
- 5) The SMLC performs normal authentication and ciphering if this is needed for the LMU. The SMLC shall not assign a TMSI to the LMU to avoid duplicating a TMSI assigned to a normal MS by a VLR.

- 6) If the SMLC needs to send data to the LMU, it may send one or more DTAP-LE REGISTER, FACILITY or RELEASE COMPLETE messages to the BSC. Each DTAP-LE message contains an embedded LLP message and an indication of whether release of the SDCCH by the LMU is forbidden. Each DTAP-LE message is transferred by the BSC to the LMU.
- 7) The SMLC may initiate release of the SDCCH to the LMU by sending a BSSAP Clear Command to the BSC.
- 8) The BSC returns a BSSAP Clear Complete.
- 9) The BSC orders release of the SDCCH by sending an RR Channel Release to the LMU.
- 10) The SMLC releases the SCCP connection to the BSC by sending an SCCP Released message.
- 11) When the LMU has LCS data to send and does not currently have a signaling link, it sends an RR Channel Request to the serving BTS to request an SDCCH. The RR Channel Request contains an establishment cause identifying an LMU. After assignment of the SDCCH, the LMU sends a DTAP CM Service request to the serving BSC.
- 12) Because the BSC serving the LMU is associated with a SMLC and the Channel Request message contained an LMU establishment cause, the BSC forwards the CM Service Request with an indication that this came from an LMU to the SMLC, rather than MSC, inside a BSSAP Complete Layer 3 Information message that is contained in an SCCP Connection Request.
- 13) The SMLC performs authentication and ciphering if needed for the LMU. Otherwise, a CM Service Accept is returned. The SMLC shall not assign a TMSI to the LMU to avoid duplicating a TMSI assigned to a normal MS by a VLR.
- 14) The LMU sends one or more DTAP-LE REGISTER, FACILITY or RELEASE COMPLETE messages to the serving BSC each containing an embedded LLP message. The BSC forwards each DTAP-LE message to the SMLC.

8.3.3.2 Information Transfer using a TCH

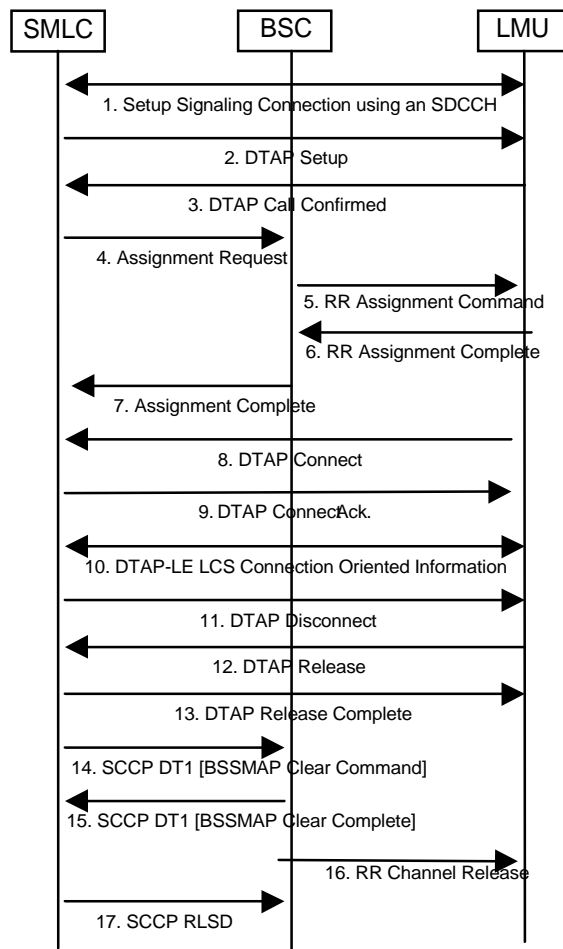

Figure 21: Information Transfer between a SMLC and a Type A LMU using a TCH

- 1) The SMLC establishes a signaling connection to the LMU using an SDCCH.
- 2) The SMLC sends a DTAP Setup to the LMU with the requested bearer capability.
- 3) The LMU returns a DTAP Call Confirmed.
- 4) The SMLC initiates traffic channel assignment by sending a BSSAP Assignment Request to the BSC.
- 5) The BSC requests channel activation in the BTS and then sends an RR Assignment Command to the LMU.
- 6) The LMU acknowledges TCH assignment.
- 7) The BSC confirms TCH assignment.
- 8) The LMU confirms call establishment.
- 9) The SMLC acknowledges the LMU confirm.
- 10) DTAP-LE Connection Oriented Information messages are transferred between the SMLC and LMU on the established TCH: these are transparent to the BSC.
- 11) The SMLC initiates release of the TCH by sending a DTAP Disconnect to the LMU
- 12) The LMU returns a DTAP Release.
- 13) The SMLC sends a DTAP Release Complete.
- 14) The SMLC initiates release of the TCH by sending a BSSAP Clear Command to the BSC.

- 15) The BSC returns a BSSAP Clear Complete.
- 16) The BSC orders release of the TCH by sending an RR Channel Release to the LMU.
- 17) The SMLC releases the SCCP connection to the BSC by sending an SCCP Released message.

8.3.4 LCS Information Transfer between a SMLC and a Type B LMU

A SMLC uses the procedure shown below in order to exchange LCS information with a TypeB LMU.

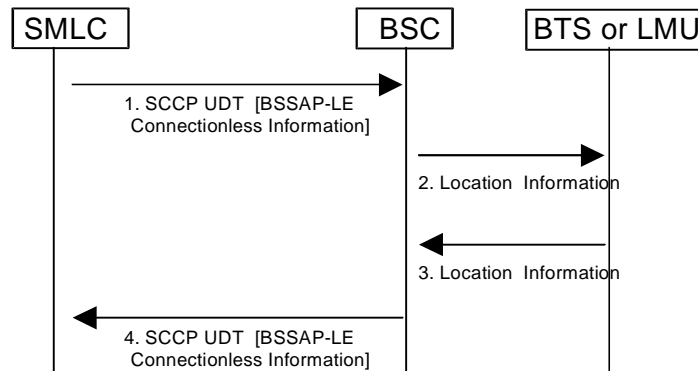

Figure 22: Information Transfer between a SMLC and a Type B LMU

- 1) The SMLC passes a BSSAP-LE Connectionless Information message to the BSC containing an embedded LLP message and the LAC/CI cell address identifying the LMU. The BSSAP-LE message is transferred inside an SCCP Unitdata message.
- 2) The BSC transfers the embedded LLP message to either the BTS associated with the LMU or the LMU itself inside a Location Information message. The BTS or LMU is identified using the LAC/CI received in step 1.
- 3) When the LMU has positioning information to return to the SMLC, either it or its associated BTS transfers this to the BSC inside a Location Information message..
- 4) The serving BSC forwards the LLP message to the SMLC inside a BSSAP-LE Connectionless Information message contained in an SCCP Unitdata message. The BSSAP-LE message contains the LAC/CI address identifying the LMU.

8.4 Common Control Procedures for LMUs

These procedures are applicable to any Type A LMU and may be used for any Type B LMU to enable control of the LMU by its associated SMLC. The procedures assume support for the establishment of a signaling link and the transfer of LLP messages between an SMLC and LMU that are defined in the common procedures to support access to an LMU, section 8.3. Consequently, details of signaling link establishment and message transfer by a BSC and BTS are not shown.

8.4.1 Reset Procedure

The reset procedure enables an SMLC to return an LMU to a known initial state in which no measurement or O&M operations are outstanding or being performed.

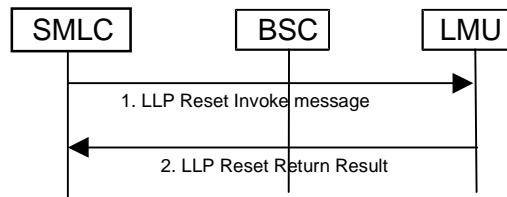

Figure 23: Reset Procedure for a Circuit Mode LMU

- 1) After first establishing a signaling connection to the LMU (see section 8.3), the SMLC sends an LLP Reset Invoke to the LMU via BSC.
- 2) The LMU cancels any LCS measurement and O&M tasks previously ordered by the SMLC. The LMU then returns an LLP Reset Return Result to the SMLC.

8.4.2 Status Query Procedure

The Status Query procedure enables an SMLC to verify the status of an associated LMU. The procedure may be instigated periodically or following any loss of communication with the LMU.

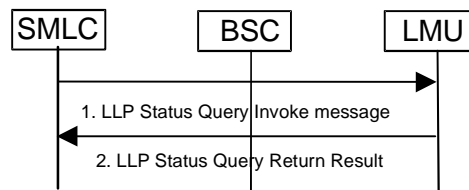

Figure 24: Status Query Procedure for a Circuit Mode LMU

- 1) After first establishing a signaling connection to the LMU (see section 8.3), the SMLC sends an LLP Status Query Invoke to the LMU via BSC.
- 2) The LMU returns an LLP Status Query return result, indicating the number of active measurement jobs for each type of measurement (e.g. RIT) and the number of active O&M jobs in the LMU that were previously ordered by the SMLC.

8.4.3 Status Update Procedure

The Status Update procedure enables an LMU to report status information to its associated SMLC. The procedure may be instigated for the following reasons:

1. Periodically
2. Power-on condition or recovery from failure with loss of memory
3. Impending availability or unavailability for O&M reasons
4. Location Update by a Type A LMU in a new Location Area.

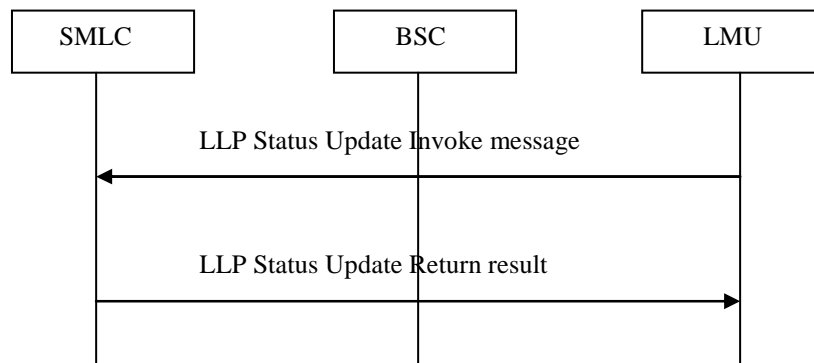

Figure 25: Status Update Procedure for a Circuit Mode LMU

- 1) After first establishing a signaling connection to the SMLC (see section 8.3), the LMU sends an LLP Status Update Invoke to the SMLC via BSC. This message shall include the reason for the Status Update, the number of active and outstanding jobs of each category in the LMU and the current hardware status.
- 2) The SMLC returns an LLP Status Update return result to acknowledge receipt of the Status Update.

8.5 Exception Procedures

The procedures in this section apply to all location procedures where a BSSAP-LE Perform Location Request has been sent to an SMLC by a BSC requesting some location service (e.g. provision of a location estimate for a target MS or transfer of assistance data to a target MS).

8.5.1 Procedures in the SMLC

When a request for a location estimate fails due to failure of a position method itself (e.g. due to inaccurate or insufficient position measurements and related data) and the SMLC is unable to instigate another positioning attempt (e.g. due to a requirement on response time), the SMLC may return a BSSAP-LE Perform Location response containing a less accurate location estimate (e.g. based on serving cell and timing advance). If a less accurate estimate is not available, the SMLC shall instead return a BSSAP-LE Perform Location response message containing no location estimate and indicating the cause of failure.

When a request for any other location service (e.g. transfer of assistance data to a target MS) fails for any reason and the SMLC is unable to reattempt the service, the SMLC shall return a BSSAP-LE Perform Location response message indicating the cause of failure.

When a location service request is interrupted by some other unrecoverable error event inside the SMLC, the SMLC shall immediately terminate the location service attempt and return a BSSAP Perform Location Response message containing the reason for the location service cancellation. In that case, any dialogue previously opened with an LMU or BSC for the purpose of instigating position measurements for any MS being located may also be aborted by the SMLC.

If the SMLC receives a BSSAP-LE Perform Location Abort indication for a previous location service request from the BSC, it shall immediately terminate the location service attempt and may abort any dialogues used for the location service attempt that may still exist with any LMUs. The circumstances of the abort may still ensure cancellation of any such procedure (see section on BSC).

If the SMLC has instigated any location related procedure in the Target MS or its serving BSC and receives a BSSLAP Reject, BSSLAP Abort or BSSLAP Reset indication from the BSC, it shall cancel the location service attempt and may abort any dialogues for this that currently exist with any LMUs. For a BSSLAP Abort, the SMLC shall then either return any location estimate already derived, if this was requested, or return a BSSAP-LE Perform Location response indicating failure of the location service and the cause of the failure in the BSSLAP Abort. For a BSSLAP Reject and BSSLAP Reset, the SMLC has the additional option of restarting the location service attempt and using the same or a different position method where a location estimate was requested. A decision to restart the location service shall take into account the cause of the location service failure as conveyed in the BSSLAP Reject or BSSLAP Reset and whether,

in the case of successful intra-BSC handover, the new cell for the target MS is still associated with the SMLC. If the SMLC receives a BSSLAP Reject or BSSLAP Reset with a cause indicating intra-BSC handover and with a new cell identity for the target MS that is not associated with the SMLC, the SMLC shall return a BSSAP-LE Perform Location response containing either a location estimate, if requested and available, or a failure cause indicating “intra-BSC” handover.

NOTE: In the case of an intra-BSC handover to a cell in a different PLMN (different MCC, MNC combination), the SMLC may receive a BSSLAP Reset containing the new location area code and new cell ID. The SMLC may then deduce the new MCC and MNC from the uniqueness, when this applies, of the combined values for the new location area code and cell ID compared to the corresponding values for neighbouring cells.

8.5.2 Procedures in an LMU

An LMU shall return an error indication to its controlling SMLC when location measurements previously ordered by the SMLC cannot be provided due to any error condition.

8.5.3 Procedures in the BSC

8.5.3.1 General Procedures

The BSC serving a target MS shall supervise any network or MS location service procedure, including transfer of positioning assistance data to an MS, and shall only allow one such procedure to be active at any time. If a new procedure is instigated by the SMLC for any target MS, the BSC shall cancel any previous procedure without notifying the SMLC or target MS. The new procedure shall then be treated according to the prevailing conditions. If a location information transfer to an MS initiated by an SMLC is not active, the BSC shall discard any RRLP message or message segment received from the MS. This precludes the initiation of any location service procedure from an MS.

Depending on the location procedure and its current state of execution, a serving BSC may choose to defer certain radio related events (e.g. handover) to avoid interference with location – refer to the later sections for each position method. A serving BSC shall abort all existing location related procedures for a particular target MS without notifying a target MS if the DCCH to the target MS or the SCCP connection to the SMLC is released. In the event of an abort with a SMLC, the BSC shall attempt to notify the SMLC using a BSSAP-LE Perform Location Abort.

8.5.3.2 Rejection of an SMLC Positioning Request

The BSC may reject any request from an SMLC for positioning or transfer of assistance data for a target MS if the request cannot be performed for reasons other than interaction with handover or other RR management. If the request is rejected, the BSC shall return a BSSLAP Reject to the SMLC containing the cause of rejection.

8.5.3.3 Interaction with Inter-BSC Handover

The BSC shall reject any request from an SMLC for positioning or transfer of assistance data while an inter-BSC handover procedure is ongoing and shall return a BSSLAP Abort to the SMLC.

The BSC shall terminate any network or MS positioning procedure or any transfer of RRLP assistance data already in progress if inter-BSC handover is needed and is not precluded by the particular location procedure and its current state. When a location procedure is terminated and there is an active BSSLAP transaction, the BSC shall return a BSSLAP Abort message to the SMLC after the BSSAP Handover Required has been sent to the serving MSC. The BSSLAP Abort shall contain the cause of the location procedure failure. When a location procedure is terminated and there is no active BSSLAP transaction, the BSC shall send a BSSAP-LE Perform Location Abort message to the SMLC after the BSSMAP Handover Required has been sent to the serving MSC.

8.5.3.4 Interaction with Intra-BSC Handover and other RR Management Procedures

The BSC shall reject any request from an SMLC for positioning or transfer of assistance data while an intra-BSC handover or other intra-BSC RR management procedure involving the target MS is ongoing and shall return a BSSLAP Reset to the SMLC when the handover or other RR management procedure is complete in the BSC. If the handover or other RR management procedure times out in the BSC, the BSC shall instead return either a BSSLAP Reset or a BSSLAP Abort to the SMLC.

The BSC shall terminate any network or MS positioning procedure or any transfer of RRLP assistance data already in progress if an intra-BSC handover or other intra-BSC RR management procedure is needed and is not precluded by the particular location procedure and its current state. When location procedure is terminated, the BSC shall return a BSSLAP Reset message to the SMLC after the intra-BSC handover or other RR management procedure is complete in the BSC. If the intra-BSC handover or other RR management procedure times out in the BSC, the BSC shall instead return either a BSSLAP Reset or a BSSLAP Abort to the SMLC.

A BSSLAP Reset shall contain a cause indication, the current serving cell identity, the current location area code if this has just changed due to intra-BSC handover and may contain measurement information for the target MS (e.g. TA value). A BSSLAP Reset shall also include the current location area code if there has been any change of location area since the location request for the target MS was first sent to the SMLC and if the current location area code was not yet reported to the SMLC in a previous BSSLAP Reset.

8.5.3.5 Priority of Handover and Other RR Management Procedures

If the transfer of RRLP messages between an SMLC and target MS is interrupted by intra-BSC handover, inter-BSC handover or any other intra-BSC RR management procedure, the BSC shall avoid delay to the handover or RR management procedure by employing the preemption capability defined in 3GPP TS 44.006 and 3GPP TS 24.008. This allows an RR Handover Command or other RR management command sent to the target MS to be assigned a “high” priority at the data link level enabling preemption of “low” priority RR Application Information messages (carrying RRLP messages) which may have been sent earlier. This procedure ensures that any RRLP data still untransmitted to the MS will be preempted (and discarded) by the data link layer in the BTS prior to transmission of the Handover Command or other RR Management command.

8.5.3.6 Interaction with Segmentation

When requested to transfer a segmented RRLP message between an SMLC and target MS, the BSC shall discard all received RRLP segments if the transfer procedure in the BSC cannot be supported or is aborted. The BSC need not wait until all RRLP segments are received before notifying the SMLC of the failure of the RRLP procedure with a BSSLAP Abort, Reject or Reset message.

If a location service procedure for a target MS is not currently underway or previously failed, the BSC shall discard all BSSLAP segments received from an SMLC for this MS until it receives the first or only segment of a new BSSLAP message. Once a location service procedure has been started involving RRLP message transfer to a target MS, the BSC shall discard all RRLP segments received from the MS until it receives the first or only segment of a new RRLP message. The new RRLP message shall then be treated according to the state of the RRLP message transfer as described in section 8.1.

Further details regarding transfer and segmentation of RRLP messages between a BSC and MS can be found in 3GPP TS 24.008.

8.5.3.7 Overload

The BSC may indicate an inability to support location due to overload by rejecting with a cause indicating congestion a BSSAP Perform Location request received from the MSC. If a SMLC has rejected a request from the BSC to perform location with a cause indicating congestion, the BSC shall convey the rejection and cause to the MSC if the request was MSC initiated. If the request was initiated by the BSC, the BSC may reduce the frequency of its location requests to the SMLC according to the rules in 3GPP TS 49.031, which give precedence to location service requests with a higher priority.

8.6 Procedures in the Target MS

A target MS shall terminate any positioning procedure or the transfer of RRLP positioning assistance data without sending any response to the SMLC if any RR message is received from the BSC that starts some other RR management procedure, including a new positioning procedure. The new RR procedure shall then be executed by the MS.

8.7 Further Procedures for Handover

Handover procedures are described in 3GPP TS 23.271.

9 Positioning procedures

The following section describes the positioning procedures for Timing Advance, Enhanced Observed Time Difference and Global Positioning System.

9.1 Positioning Procedure Initiation

9.1.1 Core Network Position Procedure Initiation over the A interface

This procedure is used by the Core Network to start the positioning procedure in GERAN over the A interface.

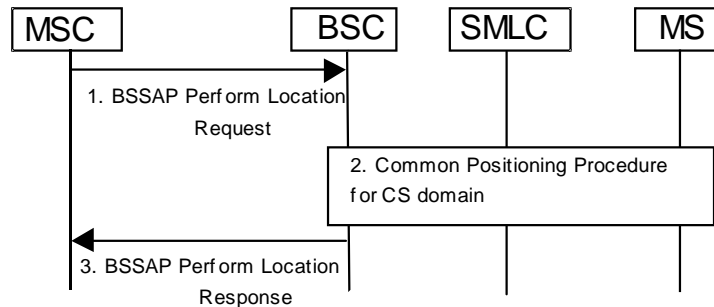

Figure 26: Positioning Procedure Initiation Over A Interface

- 1) The MSC sends the BSSAP Perform Location Request message on the existing SCCP connection for the target MS to request the BSC to start the positioning procedure. The Location Type is always included. Depending on the type of location request, additional parameters may be included to provide the Cell Identifier, Classmark Information Type 3, LCS Client Type, Chosen Channel, LCS Priority, Quality of service, GPS Assistance Data, and APDU.2.)
- 2) The common positioning procedures for CS domain are executed (see below).
- 3) The BSC sends the BSSAP Perform Location Response message to the MSC. A location estimate, positioning data, deciphering keys, or LCS Cause may be included.

9.1.2 Positioning Procedure Initiation from an Internal LCS Client

The figure below illustrates how a serving BSC may obtain the location of a target MS that is already in dedicated mode on behalf of some PLMN operator LCS client in GERAN – e.g. to support handover. The procedure is valid when local regulatory requirements do not require privacy checking for PLMN operator initiated location.

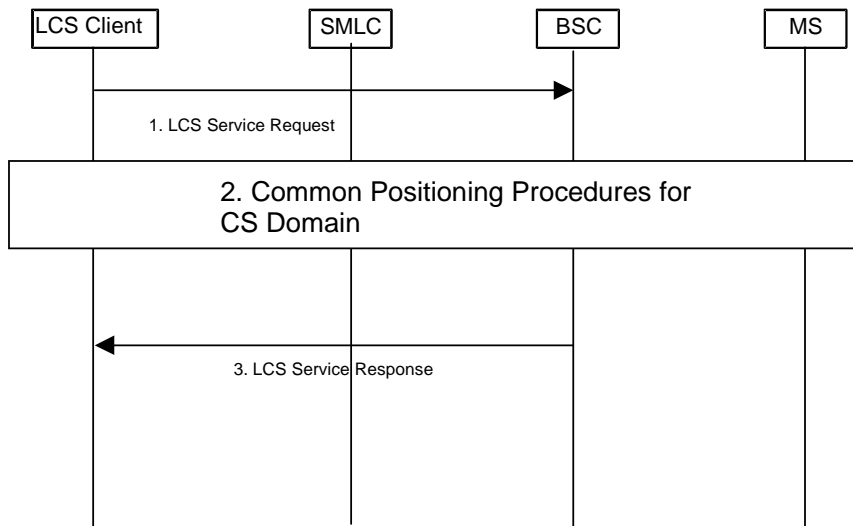

Figure 27: Positioning Procedure Initiation from an Internal LCS Client

- 1) An LCS client within the GERAN requests the current location of a target MS from the serving BSC
- 2) The common positioning procedures for CS domain are executed see Figure 28 below. The BSC returns the MS location estimate to the requesting LCS client.

9.2 Common Positioning Procedure for CS Domain

This procedure is common to all positioning methods in the CS domain.

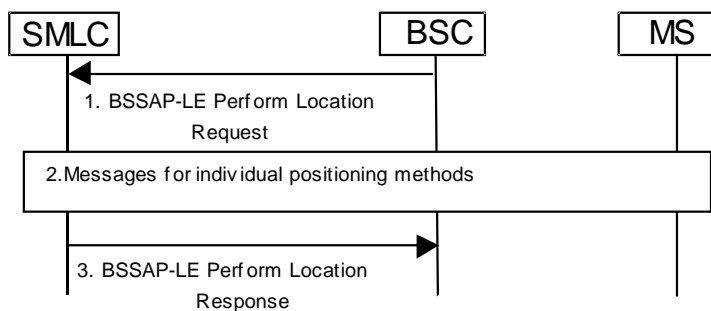

Figure 28: Common Positioning Procedure for CS Domain

- 1) The BSC sends the BSSAP-LE Perform Location Request message to request the SMLC to start the positioning procedure.

- 2) If location information is requested and the location accuracy within the QoS, if provided, can be satisfied by the reported cell ID and, if available, TA value, the SMLC may send a BSSAP-LE Perform Location Response message immediately. Otherwise, the SMLC determines the positioning method and instigates the particular message sequence for this method defined in subsequent sections. If the position method returns position measurements, the SMLC uses them to compute a location estimate. If there has been a failure to obtain position measurements, the SMLC may use the current cell ID and, if available, TA value to derive an approximate location estimate. If a computed location estimate is returned for an MS based position method, the SMLC may verify consistency with the current cell ID and, if available, TA value. If the location estimate so obtained does not satisfy the requested accuracy or the location attempt failed, e.g. due to missing data, and sufficient response time still remains, the SMLC may instigate a further location attempt using the same (e.g. providing more assistance data to MS) or a different position method. If there is insufficient response time for another position attempt, the SMLC shall return any location estimate already obtained even if not satisfying the requested accuracy. If a vertical location co-ordinate is requested but the SMLC can only obtain horizontal co-ordinates, these may be returned. Requirements on the geographic shape encoded within the 'position information' parameter may exist for certain LCS client types. The SMLC shall comply with any shape requirements defined in 3GPP. The SMLC in a certain country should attempt to comply with the shape requirements defined for a specific LCS client type in the relevant national standards of that country. If location assistance data is requested, the SMLC transfers this data to the MS as described in subsequent sections. The SMLC determines the exact location assistance data to transfer according to the type of data specified by the MS, the MS location capabilities and the current cell ID. If deciphering keys are requested the SMLC obtains the current keys.
- 3) The SMLC sends the BSSAP-LE Perform Location Response message to the BSC containing any location estimate or deciphering keys. In case of failure the cause value may be included.

9.3 TA Based Positioning in CS Domain

The TA is based on the existing Timing Advance (TA) parameter. The TA value is known for the serving BTS. To obtain TA values in case the MS is in idle mode a special call, not noticed by the GSM subscriber (no ringing tone), is set up. The cell-ID of the serving cell and the TA is returned as the result of the TA.

9.3.1 Definition of TA states

9.3.1.1 MS in IDLE State

In IDLE state the MS may be paged or may request an originating (e.g. emergency) call. The paging response message or CM Service Request, in each case respectively, received in COMPLETE_LAYER_3 message may contain location information that includes the TA value. If available, the TA value and other location information shall be provided to the SMLC by the requesting BSC along with the current serving cell ID in the BSSAP-LE Perform Location request. This enables TA based positioning in the SMLC without any further interactions.

9.3.1.2 MS in DEDICATED State

In DEDICATED state the SMLC shall send a TA_REQUEST to request the TA value from the serving BSC. The BSC shall respond with either a TA_RESPONSE carrying the TA value and possibly other radio measurements from the MS or a Reset. The associated procedure is described in the next section.

9.3.2 TA Positioning Procedure

This TA positioning procedure is generic for a standalone SMLC or integrate SMLC in the BSC.

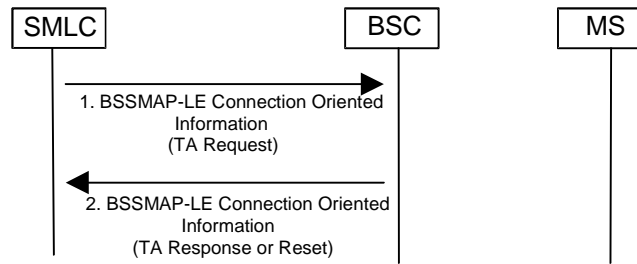

Figure 29: TA Positioning Procedure for the SMLC

- 1) The SMLC sends a BSSAP-LE Connection Oriented Information message to the BSC serving a particular target MS. The APDU parameter in this message contains a BSSLAP TA Request.
- 2) Provided the location area for the target MS has not changed or, if changed, was previously reported to the SMLC, the BSC returns the current TA value and current serving cell for the target MS to the SMLC in a BSSLAP TA response contained within a BSSAP-LE Connection Oriented Information message. The TA response may also include the latest measurement results received from the target MS for the serving and neighbouring cells. If the location area for the target MS has changed since the location request was first sent to the SMLC and if the new location area has not yet been reported to the SMLC, the BSC shall return a BSSLAP Reset to the SMLC within a BSSMAP-LE Connection Oriented Information message. The Reset shall include the current serving cell, the current location area code, a cause value indicating “intra-BSC handover” and the current TA value and may include the latest measurement results received from the target MS for the serving and neighboring cells. The SMLC then derives a location estimate for the target MS based on the received serving cell ID, location area code if included, TA value and other measurement results if included.

NOTE: In the case of a previous intra-BSC handover to a cell in a different PLMN (different MCC, MNC combination), the SMLC would receive a BSSLAP Reset containing the new location area code and new cell ID. The SMLC may then deduce the new MCC and MNC from the uniqueness, when this applies, of the combined values for the new location area code and cell ID compared to the corresponding values for neighbouring cells.

9.3.3 Unsuccessful TA positioning procedure in BSC

There are three messages defined to handle error scenarios during positioning procedure in BSC. The messages are 1) Reject, 2) Abort and 3) Reset. Refer to 3GPP TS 48.071 for details.

After receiving the BSSLAP TA Request in BSC, a Reject will be sent with proper cause value from BSC to SMLC in "BSSAP-LE Connection Oriented Information Message" if TA positioning cannot be performed in BSC at that time for reasons other than handover or another ongoing RR management procedure.

An Abort or Reset is possible if the TA positioning cannot be done in BSC during that time. Reset is sent to SMLC to indicate when the positioning needs to be restarted after temporary interruption due to intra BSC HO or other intra-BSC RR management. The contents of a Reset shall be as defined in step 2 in section 9.3.2. Abort is used to indicate to SMLC the failure of the current TA positioning attempt (e.g. due to inter-BSC handover) and allowing a new one from application level.

9.4 E-OTD and GPS Positioning Procedures

9.4.1 General procedures

For any location request where the highest priority level is assigned and MS-based GPS positioning is not used, the SMLC functionality shall provide sufficient assistance data to a target MS to enable a location estimate or location measurements to succeed according to the required QoS on the first attempt. The SMLC shall not assume in this case that the target MS already possesses assistance data. For a lower priority location request or when MS-based GPS positioning is used, the SMLC may reduce the assistance data provided to a target MS on the first location attempt.

In the high priority case with MS-assisted GPS for the first positioning attempt, acquisition assistance data shall be included in the RRLP measure position request message.

9.4.2 Positioning Request

This signaling flow is generic for all MS based or assisted location methods (MS Based E-OTD, MS Assisted E-OTD, MS Based GPS, and MS Assisted GPS) The signaling flow below applies to integrated and standalone SMLCs in a circuit switched network.

If the SMLC desires to avoid lower layer (e.g. BSSAP-LE) segmentation, see section 6.1.2, and transfer the LCS assistance data more reliably, this procedure may be preceded by an "Assistance Data Delivery" procedure. Note, that part of the entire set of assistance data may be included in the RRLP Measure Position Request even when the message is preceded by an "Assistance Data Delivery" procedure.

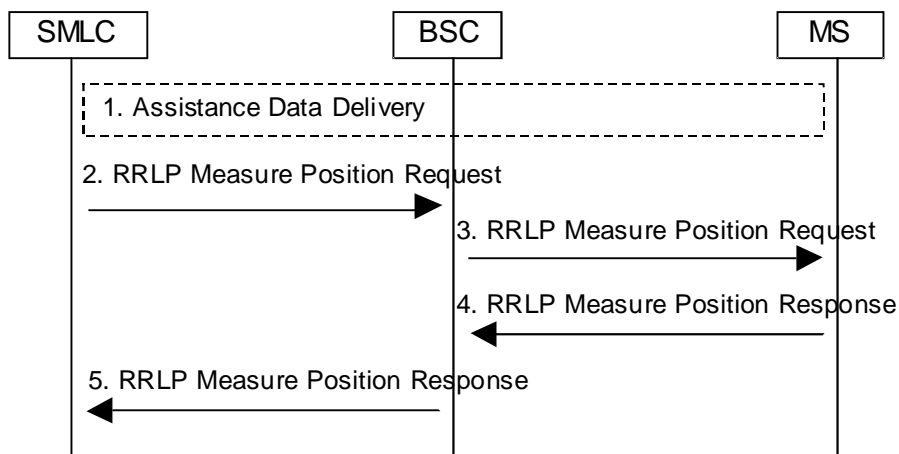

Figure 30: E-OTD or GPS Position Request Flow

- 1) The SMLC may precede the RRLP MEASURE POSITION REQUEST with an optional Assistance Data Delivery procedure.
- 2) The SMLC determines possible assistance data and sends RRLP MEASURE POSITION REQUEST to the BSC.
- 3) The BSC forwards the positioning request including the QoS and any assistance data to the MS in a RRLP MEASURE POSITION REQUEST.
- 4) The MS performs the requested E-OTD or GPS measurements, if needed assistance data is available in the MS. If the MS is able to calculate its own location and this is required and needed assistance data is available in MS, the MS computes a location estimate based on E-OTD or GPS measurements. In case of E-OTD, any data necessary to perform these operations will either be provided in the RRLP MEASURE POSITION REQUEST or available from broadcast sources. In case of Assisted GPS (both MS based GPS and MS assisted GPS) and first positioning attempt, a minimum set of GPS assistance data will be either provided in the RRLP MEASURE POSITION REQUEST or available from broadcast sources. For further positioning attempt (failure in first attempt due to missing assistance data), sufficient GPS assistance data, possibly excluding the assistance data sent in the first attempt, will be provided in the RRLP MEASURE POSITION REQUEST and possibly preceding RRLP ASSISTANCE DATA messages. The resulting E-OTD or GPS measurements or E-OTD or GPS location estimate are returned to the BSC in a RRLP MEASURE POSITION RESPONSE. If the MS was unable to perform the necessary measurements, or compute a location, a failure indication identifying the reason for failure (e.g. missing assistance data) is returned instead.
- 5) BSC forwards the RRLP MEASURE POSITION response to SMLC.

9.4.3 Assistance Data Delivery

This signalling flow is generic for all MS based or assisted location methods (MS Based and Assisted E-OTD, and MS Based or MS Assisted GPS) in a circuit switched network.

If the SMLC desires to avoid lower layer (e.g. BSSAP-LE) segmentation and transfer the LCS assistance data more reliably, the sequence 1-4 illustrated in the figure below may be repeated several times to deliver more assistance data than can be sent by one RRLP Assistance Data Delivery message. In this case, each individual message is independent such that the data received in one message is stored in the MS independently of the other RRLP Assistance Data messages (i.e. an error of delivery of one message does not require a retransmission of all the RRLP Assistance Data messages). The SMLC shall indicate in the RRLP ASSISTANCE DATA message if more RRLP ASSISTANCE DATA messages will be used after the current one in order to deliver the entire set of assistance data. Data that is specific to the current cell should be sent in the last message this is recommended so that assistance data for the correct cell is available to the MS after a handover.

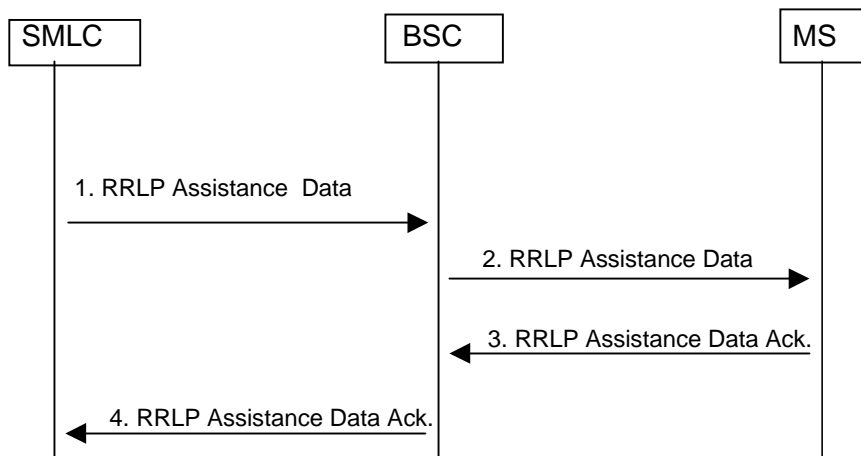

Figure 31: E-OTD or GPS Assistance Data Delivery Flow

- 1) The SMLC determines assistance data and sends it in the RRLP ASSISTANCE DATA message to the BSC.
- 2) The BSC forwards the assistance data to the MS in a RRLP ASSISTANCE DATA message.
- 3) The MS acknowledges the reception of complete assistance data to the BSC with a RRLP ASSISTANCE DATA Ack.
- 4) The BSC forwards the RRLP ASSISTANCE DATA Ack message to the SMLC.

9.4.4 Error Handling for E-OTD and GPS in CS Domain

This section describes error handling for positioning and transfer of assistance data for E-OTD and GPS. For a description of error handling involving segmentation and more details on usage of a BSSLAP Abort, Reject and Reset, refer to section 8.5 Exception Procedures.

- Case 1: When the RRLP request comes to BSC for E-OTD and GPS, The BSC will send a BSSLAP reject message to SMLC if the request cannot be supported in the BSC for reasons other than an ongoing intra BSC or inter BSC handover or other ongoing RR management procedure. For an ongoing intra BSC HO or other RR management procedure, the BSC shall return a BSSLAP Reset when the handover or RR management procedure is complete. The SMLC may then start the RRLP request (if there is time) again. For ongoing inter-BSC HO, the BSC shall return a BSSLAP Abort. The location service request may then restart from the LCS Client, VMSC or SGSN.

- Case 2: When the RRLP request comes to BSC from SMLC, BSC sends the "RRLP request" to the MS if there is no ongoing HO or other RR management procedure at that point. If an intra-BSC HO or other RR management procedure is initiated in BSC, the BSC sends the HO or other RR management command to MS. A timer will then be started in BSC, the duration of which is network dependent, but typically 6 (six) seconds. Upon receiving the HO or other RR management command, the MS will stop the location procedure and start on handover or other RR management procedure, since this has higher priority than location. The MS will then send the HO complete or other RR management response message to BSC. When this message is received before the expiration of BSC timer, a BSSLAP Reset message will be sent to SMLC from BSC. The Reset will tell SMLC to start another location service request if there is enough time.
- Case 3: During intra-BSC HO or other intra-BSC RR management procedure, if a HO complete or RR management procedure completion was not received in BSC and the corresponding timer expired. In this case a reset or abort message will be sent to SMLC indicating MS timeout. The location service may then restart from either the SMLC if a reset was sent or from the LCS Client, VMSC or SGSN if an abort was sent.
- Case 4: If an inter-BSC handover is needed during a location procedure or if the BSC times out on an RRLP response from the target MS, the BSC shall send a BSSLAP Abort to the SMLC. The location service attempt may then be restarted from the LCS Client, VMSC, or SGSN.

9.4.5 Error Handling for the SMLC

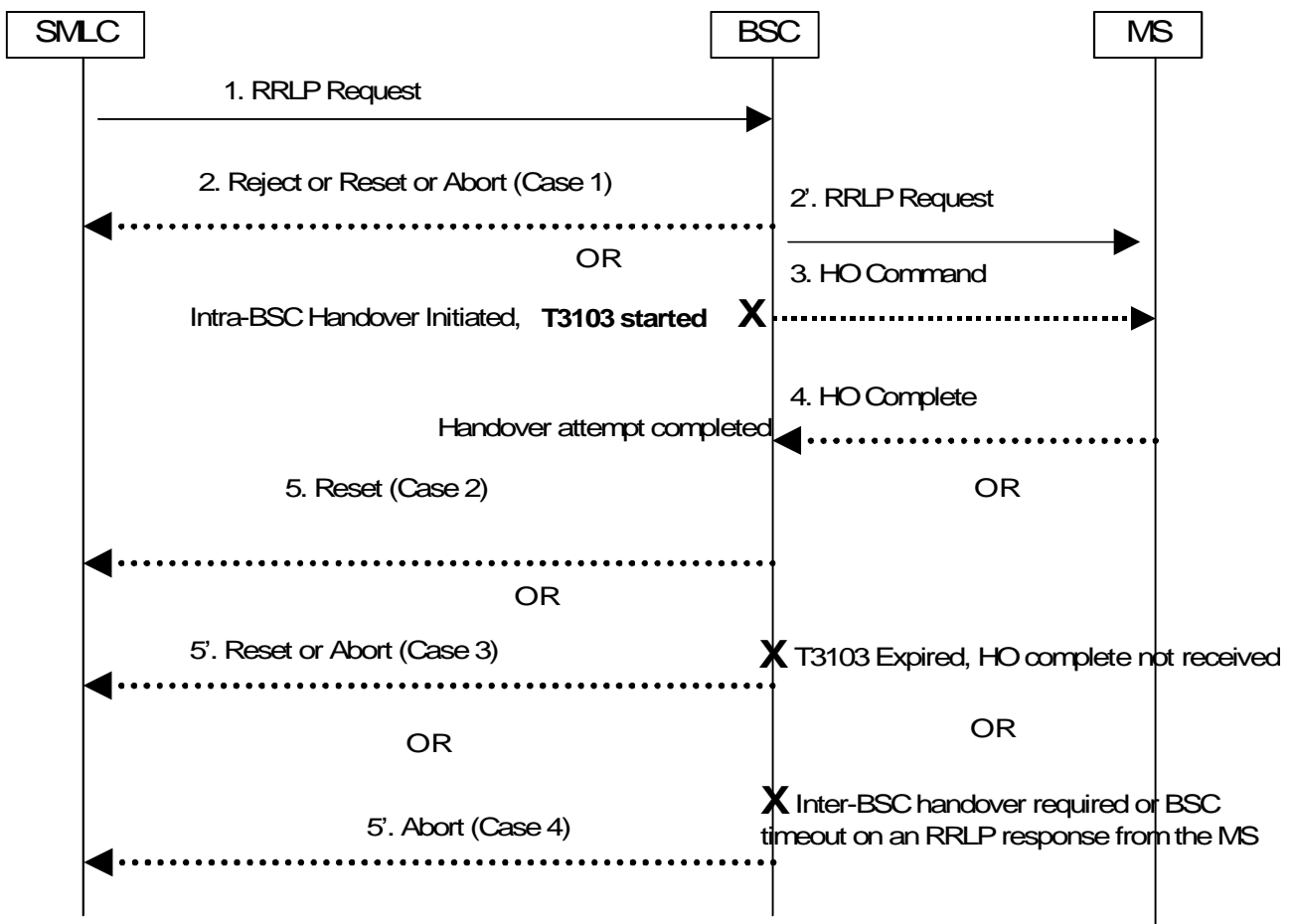

Figure 32: Error Handling for the SMLC

9.4.6 Broadcast of Assistance Data

In MS Based E-OTD, MS Based GPS and MS Assisted GPS systems, there may be a need for assistance data to be broadcast to the MS. The assistance data to be broadcast for MS Based E-OTD contains the Real Time Difference (RTD) values (in case of a non-synchronised network) and Base Transceiver Station (BTS) coordinates. In addition, the

broadcast data contains other information simplifying the E-OTD measurements. The broadcast of GPS assistance data makes available reference time, reference location, differential GPS (DGPS) correction data, ephemeris and clock correction data, almanac data, UTC offset, ionospheric delay, and satellite health status for GPS-based positioning. It improves the location accuracy for MS Based implementations, increases the sensitivity, enables LMU-independent GPS time dissemination and assists the acquisition of satellite signal for both MS Based and MS Assisted implementations.

The E-OTD assistance data to be broadcast is in compressed format where the redundant information is not included. The MS is capable to reconstruct the E-OTD assistance data using the message header information. The length of the message is depending on how many neighbours are included in the E-OTD assistance data as well as whether the redundant information can be removed from the message. The typical size of one broadcast message will be less than 82 octets. Part of the broadcast message (serving and neighbour base station coordinates) may be ciphered.

The GPS assistance data to be broadcast is under the same common message header with three types of data sets (or IEs), which may have different broadcast rates to minimise the bandwidth impact while still maintaining the same positioning capabilities. The first type consists of differential GPS (DGPS) correction data. The second type consists of ephemeris and clock correction data. The third type consists of almanac and other data. The length of this message is 82 octets and the data IE part may be ciphered.

The contents of the broadcast message for the E-OTD and GPS assistance data is described in 3GPP TS 44.035. The support for these broadcast messages is optional for network and MS.

The broadcast channel which is used to broadcast the E-OTD and GPS assistance data make use of the existing basic or extended CBCH and SMSCB DRX service. The LCS broadcast messages need to be either scheduled, or prioritised over other broadcast messages to avoid any delay.

9.4.6.1 Point-To-Multipoint Assistance Data Broadcast Flow

This signalling flow is generic for MS Based E-OTD, MS Based GPS and MS Assisted GPS methods. The E-OTD/GPS Assistance Data Broadcast Message is created in SMLC and the whole message including the ciphered parts and parameters to control the transfer are transferred with below flow from SMLC to MS. SMSCB DRX service is used for LCS assistance data broadcast. Prior receiving the first schedule message MS should read first block of each message lot to be able to receive the LCS Broadcast Data or the schedule message. After receiving the schedule message MS should receive the LCS Broadcast Data messages according the schedule information.

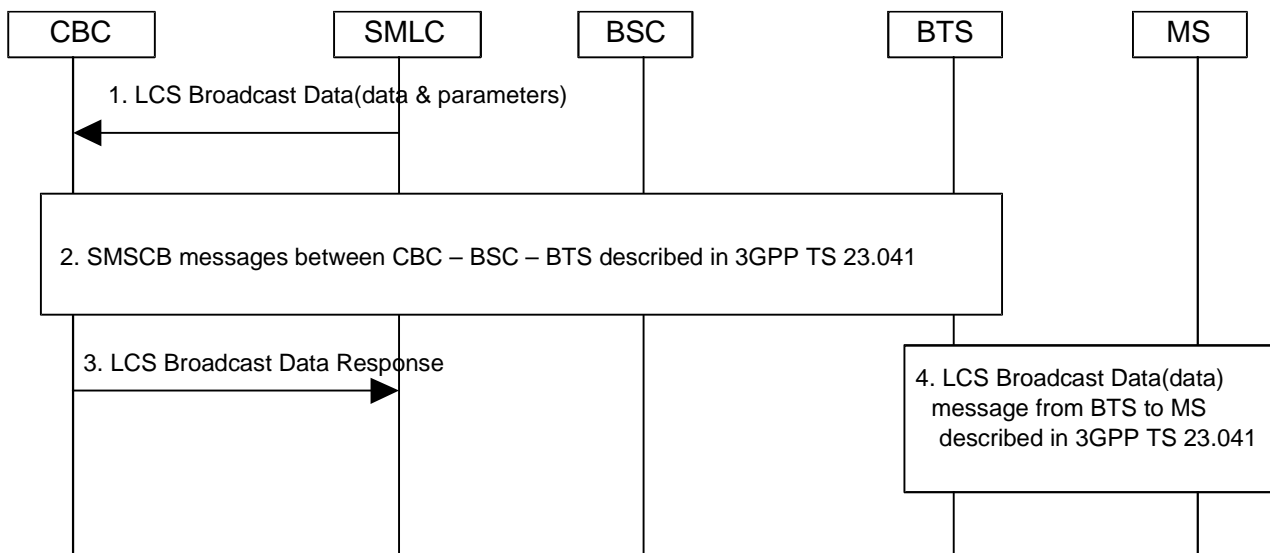

Figure 33: E-OTD/GPS Broadcast Data Flow

- 1) SMLC sends the complete broadcast message to CBC with LCS Broadcast Data message. This LCS Broadcast Data message contains the data to be broadcasted as well as parameters that indicate to which BTS the broadcast message is targeted and what time the broadcast should happen. LCS Broadcast Data (data & parameters) message may also contain the SMSCB scheduling information which can be utilised for the SMSCB DRX

feature specified in 3GPP TS 44.012 specification. SMS-SCB DRX operation is required in order that MS performance can be optimised.

- 2) CBC starts message transfer to BSC and BTS according to 3GPP TS 23.041
- 3) LCS Broadcast Data Response message from CBC to SMLC is used to indicate that the LCS Broadcast Data has been delivery request has been fulfilled. This message is not mandatory
- 4) BTS starts the message transfer to MS according to 3GPP TS 23.041.

Implementations that have SMLC and/or CBC integrated into BSC may use other message signalling.

9.4.6.2 Ciphering

In order for the operators to control the access to the assistance data, parts of the broadcast data may be ciphered. Ciphering is done with a specific key delivered by the network for this purpose. The deciphering keys may be requested by the MS as described in 3GPP TS 23.271. The LCS Broadcast Data, when ciphered, will be partially ciphered according to the LCS broadcast message definitions specified in 3GPP TS 44.035. The parts that will be ciphered in E-OTD LCS Broadcast Data message are neighbour RTD values, serving and neighbour BTS coordinates. For GPS, all assistance data may be ciphered, The MS is capable to decipher the broadcast message (ciphered parts) using the cipher key (56 bits) delivered from the Core Network to MS and using the Ciphering Serial Number (16 bits) included in the broadcast message.

9.4.6.2.1 Algorithm

The algorithm used for ciphering is the standard 56-bit DES algorithm. The deciphering of broadcast messages is done in the MS. SMLC ciphers the LCS Broadcast Data message (part of message is ciphered) using the deciphering keys (56 bits) and Ciphering Serial Number (16 bits) included in broadcast message using 56-bit DES algorithm.

The ciphered part is variable length with one bit resolution. From LCS Broadcast Data message header MS can compute what part of message is ciphered.

Inputs to the 56-bit DES algorithm are the following:

- 56-bit key K (deciphering key)
- 16-bit Ciphering Serial Number from broadcast message which is denoted here by IV (initialisation vector)
- plaintext bits (the ciphered part of broadcast message)

Encryption is done by producing a mask bit stream which is then added bit-by-bit to the plaintext data (XOR-operation) to obtain the ciphertext data. First IV is concatenated with 0-bits in order to achieve a 64-bit block I_1 . This block is then encrypted by the DES algorithm using the key K. Output is a 64-bit block I_2 . This constitutes the first 64 bits of the mask bit stream. If the message is longer than 64 bits, then more bits are needed. Those are produced by encrypting I_2 again by the DES algorithm using the key K. Output is a 64-bit block I_3 . This constitutes the next 64 bits of the mask bit stream. This iteration is continued until enough bits are produced. The unnecessary bits from the last 64-bit block I_j are discarded. Below Figure 34 describes the first two mask bit generations and the two ciphered 64-bit blocks.

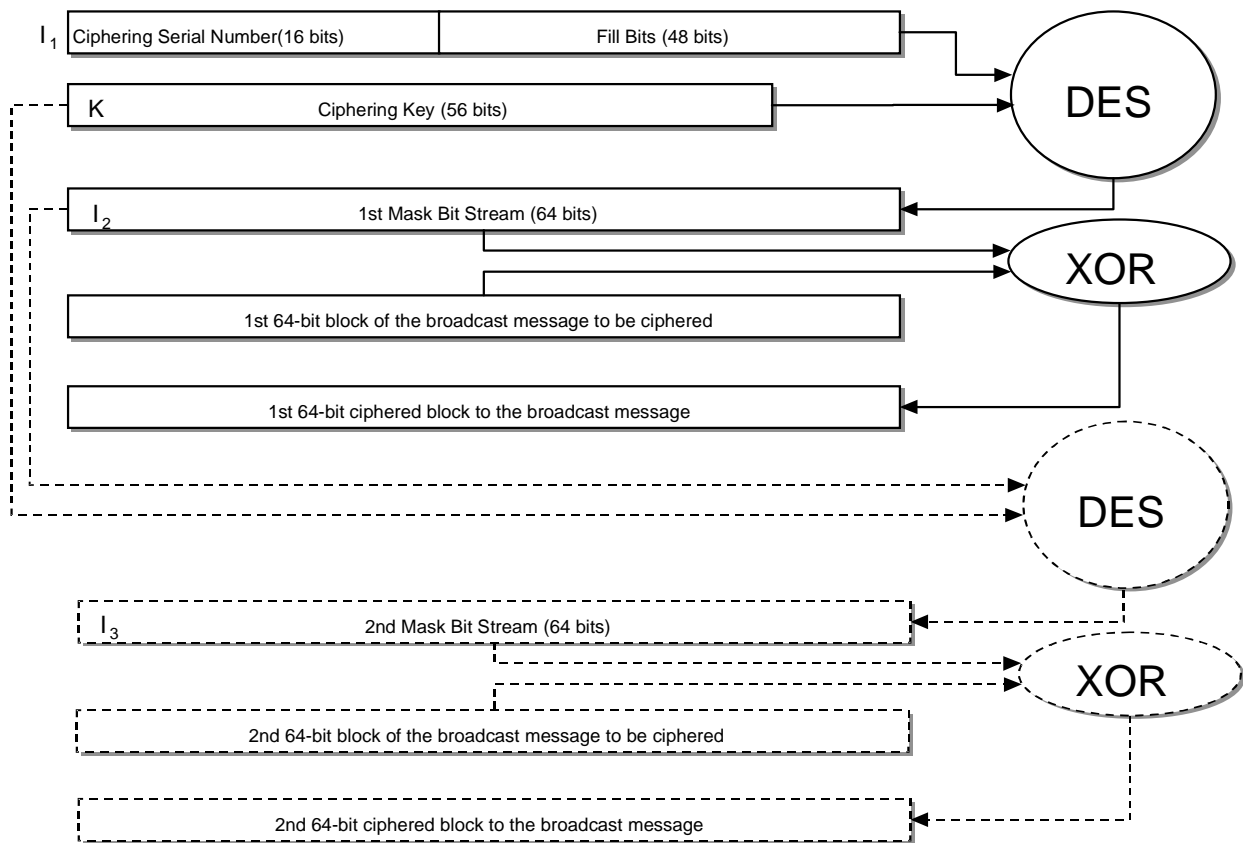

Figure 34 : CIPHERING ALGORITHM

Decryption is done similarly. The same mask bit stream is produced. This time the mask stream bits are added bit-by-bit (XORed) to the ciphertext data bits. The result will be the plain text data.

9.4.6.3 Deciphering key control and delivery to MS

The deciphering keys are needed in MS if the LCS Broadcast Data (ciphered parts) is ciphered. The deciphering keys' control system contains two keys (the Current Deciphering Key and the Next Deciphering Key) and the Ciphering Key Flag (indicating the current Ciphering Key Flag state in the location area in the time that the deciphering key set is delivered from SMLC to MS). Two Deciphering Keys are needed in order to overcome the problem of unsynchronised nature of the periodic location updates that MSs make in the location area. The SMLC controls the keys and there are following requirements related to the deciphering keys:

- Deciphering Key Set (Current and Next Deciphering Key, Ciphering Key Flag) are always location area specific.
- One SMLC controls the deciphering key set changes inside the location area and in case several SMLCs in the location area then one coordinating SMLC for the deciphering key set control must be nominated. The SMLC configuration is done with O&M procedures.
- The coordinating SMLC delivers the new deciphering key set to the other SMLCs with SMLCPP protocol when the deciphering key set changes. The Ciphering Key Flag in the LCS Broadcast Data message is changed only when the coordinating SMLC changes the deciphering key set and delivers the new set to other SMLCs in the same location area.
- The SMLCs upon receiving the new deciphering key set, start using immediately the new set in the LCS Broadcast Data message. The coordinating SMLC also starts using the new set same time.

The deciphering key set changes always following way when the new set is generated:

- The Next Deciphering Key comes to the Current Deciphering Key in the new set
- One new key is taken into use and named as the Next Deciphering Key
- The Ciphering Key Flag changes the state

The Ciphering Key Flag controls the MS key usage (Current/Next Deciphering Key) as follows:

- After receiving the new deciphering key set, MS starts using the new set immediately.
- The Ciphering Key Flag in the LCS Broadcast Data message and the one received returned to the MS should have same polarity. This means that MS starts using the Current Deciphering Key immediately.
- When the Ciphering Key Flag state changes in the LCS Broadcast Data message then MS starts to use the Next Deciphering Key for deciphering the broadcast message. The Next Deciphering Key becomes now the Current Deciphering Key in MS.

The following Figure 35 describes the deciphering key delivery mechanism.

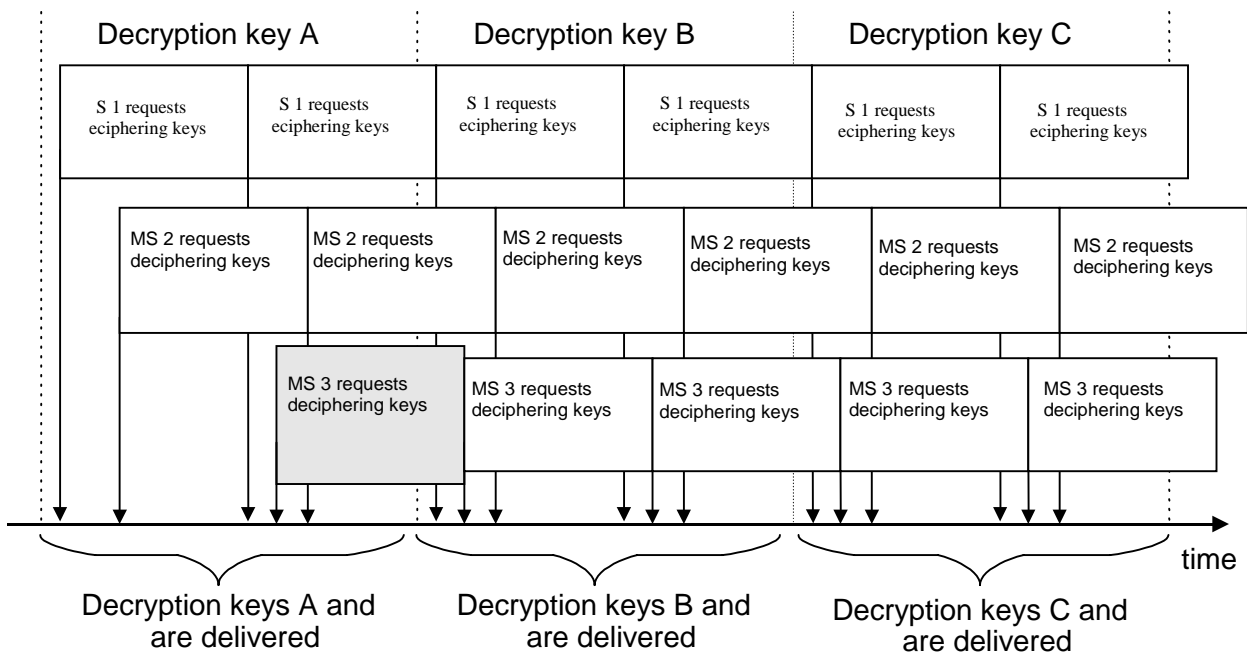

Figure 35: Deciphering key delivery

- First the key A is the Current Deciphering Key and key B is the Next Deciphering Key
- When the SMLC changes to use the key B (Next Deciphering Key) then the Deciphering Key Flag state is changed in the LCS Broadcast Data message. At this point the coordinating SMLC delivers the new deciphering key set to other SMLCs in the same location area as well as to MS when MS is requesting the keys during the location update (IMSI Attach, Normal or Periodic Location Update)
- The new deciphering key set contains now key B as the Current Deciphering Key, key C as new Next Deciphering Key and the Ciphering Key Flag currently in use in that location area.
- When the SMLC changes to use the key C (Next Deciphering Key) then the Ciphering Key Flag state is changed in the LCS Broadcast Data message. At this point the coordinating SMLC delivers the new deciphering key set to other SMLCs in same location area as well as to MS when MS is requesting the new set during the location update (IMSI Attach, Normal or Periodic Location Update)
- The new deciphering key set contains now key C as the Current Deciphering Key, key D as new Next Deciphering Key and the Ciphering Key Flag currently in use in that location area

The process continues as above when the keys are changed. The lifetime of one key (Current/Next Ciphering Key) is minimum one periodic location update period used in the location area.

10 Information storage

This section describes information storage structures that are mandatory (M), conditional (C) or optional (O) for LCS in GERAN, and the recovery and restoration procedures needed to maintain service if inconsistencies in databases occur and for lost or invalid database information.

10.1 SMLC

Common Data

The following table holds permanent BTS data:

Table 1: Permanent SMLC Data for a BTS

Permanent BTS Data Item	Status	Description
BTS position	M	BTS position (latitude/longitude) of the Serving BTS
CGI	M	Cell global identity.
BSIC	M	Base station identity code.
BCCH	M	Frequency of the broadcast carrier.

The SMLC holds data for its associated LMUs. The main key to LMU data in the SMLC is the IMSI for a Type A LMU and a cell site identifier for a Type B LMU. LMU data provides the location capabilities of the LMU (e.g. which location and assistance measurements are supported). The following permanent data shall be administered for any LMU:

Table 2: Permanent SMLC Data for an LMU

Permanent LMU Data Item	Status	Description
Type of LMU	M	Indicates if LMU is Type A or Type B
IMSI	C	Main key to data for a Type A LMU. Not applicable to a Type B LMU
LAC + CI	C	Cell site identifier to address a Type B LMU. Not applicable to a Type A LMU.
Signaling Access	M	Information regarding signalling access to the LMU including the following: <ul style="list-style-type: none"> - address of default serving BSC - SS7 link set to serving BSC (or to an intermediate STP)
Serving Cell	M	Identity of the cell in which the LMU is physically located
Geographic location	C	Latitude/longitude coordinates Storage of coordinates is mandatory for E-OTD if an LMU is not co-located with a BTS
Position measurement functions	O	List of supported position measurements For each type of position measurement, a list of associated capabilities – details are outside the scope of this specification
Assistance measurement functions	O	List of supported assistance measurements For each type of assistance measurement, a list of associated capabilities – details are outside the scope of this specification
Diagnostic functions	O	List of supported diagnostic functions – details are outside the scope of this specification

The SMLC also holds the following temporary data for each LMU for which there has been any previous signalling interaction.

Table 3: Temporary SMLC Data for an LMU

Temporary LMU Data Item	Status	Description
Position Measurements	O	Ongoing and scheduled position measurements ordered in the LMU by the SMLC – details are outside the scope of this specification
Assistance Measurements	O	Ongoing and scheduled assistance measurements ordered by the SMLC – details are outside the scope of this specification
O&M Activities	O	Ongoing and scheduled O&M activities ordered in the LMU by the SMLC – details are outside the scope of this specification

An LMU contains no mandatory data regarding its associated SMLC. An LMU shall contain permanent data regarding its measurement and O&M capabilities and may contain pre-administered data regarding location assistance measurements and O&M activities that the LMU is to perform without the need for any command from the SMLC. The content of such location measurement and O&M related data is outside the scope of this specification.

10.2 Recovery and Restoration Procedures

The LCS recovery and restoration procedures allow temporary data to be recovered or re-initialized following loss or corruption of data, such that normal LCS service is rapidly restored and inconsistency between the data held by different LCS network elements is removed. For a full description, refer to 3GPP TS 23.007.

Annex A (informative): Change history

Change history							
Date	TSG GERAN#	TSG Doc.	CR	Rev	Subject/Comment	Old	New
2001-04	04	GP-010942			Version for Release 4		4.0.0
2001-06	05	GP-010988	001		LCS error handling (Inter-BSC Handover)	4.0.0	4.1.0
2001-06	05	GP-011308	007		Geographic Shape Restriction	4.0.0	4.1.0
2001-08	06	GP-011935	010	2	Correct Faulty References to the BSSAP-LE and RR Specifications	4.1.0	4.2.0
2001-11	07	GP-011997	015		Correction of Inconsistent Text	4.2.0	4.3.0
2001-11	07	GP-012209	017		Error Handling for E-OTD and GPS	4.2.0	4.3.0
2002-02	08	GP-020436	024	1	Informing an SMLC of a change in the LAC for LCS using BSSLAP	4.3.0	4.4.0
2002-06	10	GP-021518	035		Correction of timing when SMLC enters LOCATION state	4.4.0	4.5.0
2004-04	19	GP-040681	048	1	Correction of GERAN location request procedure	4.5.0	4.6.0
2006-04	29	GP-060925	0061	1	Correction of State Update Procedure	4.6.0	4.7.0

History

Document history		
V4.0.0	April 2001	Publication
V4.1.0	June 2001	Publication
V4.2.0	August 2001	Publication
V4.3.0	November 2001	Publication
V4.4.0	February 2002	Publication
V4.5.0	June 2002	Publication
V4.6.0	April 2004	Publication
V4.7.0	April 2006	Publication