

ETSI TS 143 051 V17.0.0 (2022-05)



**Digital cellular telecommunications system (Phase 2+) (GSM);
GSM/EDGE Overall description;
Stage 2
(3GPP TS 43.051 version 17.0.0 Release 17)**



Reference

RTS/TSGR-0043051vh00

Keywords

GSM

ETSI

650 Route des Lucioles
F-06921 Sophia Antipolis Cedex - FRANCE

Tel.: +33 4 92 94 42 00 Fax: +33 4 93 65 47 16

Siret N° 348 623 562 00017 - APE 7112B
Association à but non lucratif enregistrée à la
Sous-Préfecture de Grasse (06) N° w061004871

Important notice

The present document can be downloaded from:

<http://www.etsi.org/standards-search>

The present document may be made available in electronic versions and/or in print. The content of any electronic and/or print versions of the present document shall not be modified without the prior written authorization of ETSI. In case of any existing or perceived difference in contents between such versions and/or in print, the prevailing version of an ETSI deliverable is the one made publicly available in PDF format at www.etsi.org/deliver.

Users of the present document should be aware that the document may be subject to revision or change of status.

Information on the current status of this and other ETSI documents is available at

<https://portal.etsi.org/TB/ETSIDeliverableStatus.aspx>

If you find errors in the present document, please send your comment to one of the following services:

<https://portal.etsi.org/People/CommitteeSupportStaff.aspx>

If you find a security vulnerability in the present document, please report it through our
Coordinated Vulnerability Disclosure Program:

<https://www.etsi.org/standards/coordinated-vulnerability-disclosure>

Notice of disclaimer & limitation of liability

The information provided in the present deliverable is directed solely to professionals who have the appropriate degree of experience to understand and interpret its content in accordance with generally accepted engineering or other professional standard and applicable regulations.

No recommendation as to products and services or vendors is made or should be implied.

No representation or warranty is made that this deliverable is technically accurate or sufficient or conforms to any law and/or governmental rule and/or regulation and further, no representation or warranty is made of merchantability or fitness for any particular purpose or against infringement of intellectual property rights.

In no event shall ETSI be held liable for loss of profits or any other incidental or consequential damages.

Any software contained in this deliverable is provided "AS IS" with no warranties, express or implied, including but not limited to, the warranties of merchantability, fitness for a particular purpose and non-infringement of intellectual property rights and ETSI shall not be held liable in any event for any damages whatsoever (including, without limitation, damages for loss of profits, business interruption, loss of information, or any other pecuniary loss) arising out of or related to the use of or inability to use the software.

Copyright Notification

No part may be reproduced or utilized in any form or by any means, electronic or mechanical, including photocopying and microfilm except as authorized by written permission of ETSI.

The content of the PDF version shall not be modified without the written authorization of ETSI.

The copyright and the foregoing restriction extend to reproduction in all media.

© ETSI 2022.
All rights reserved.

Intellectual Property Rights

Essential patents

IPRs essential or potentially essential to normative deliverables may have been declared to ETSI. The declarations pertaining to these essential IPRs, if any, are publicly available for **ETSI members and non-members**, and can be found in ETSI SR 000 314: "*Intellectual Property Rights (IPRs); Essential, or potentially Essential, IPRs notified to ETSI in respect of ETSI standards*", which is available from the ETSI Secretariat. Latest updates are available on the ETSI Web server (<https://ipr.etsi.org/>).

Pursuant to the ETSI Directives including the ETSI IPR Policy, no investigation regarding the essentiality of IPRs, including IPR searches, has been carried out by ETSI. No guarantee can be given as to the existence of other IPRs not referenced in ETSI SR 000 314 (or the updates on the ETSI Web server) which are, or may be, or may become, essential to the present document.

Trademarks

The present document may include trademarks and/or tradenames which are asserted and/or registered by their owners. ETSI claims no ownership of these except for any which are indicated as being the property of ETSI, and conveys no right to use or reproduce any trademark and/or tradename. Mention of those trademarks in the present document does not constitute an endorsement by ETSI of products, services or organizations associated with those trademarks.

DECT™, **PLUGTESTS™**, **UMTS™** and the ETSI logo are trademarks of ETSI registered for the benefit of its Members. **3GPP™** and **LTE™** are trademarks of ETSI registered for the benefit of its Members and of the 3GPP Organizational Partners. **oneM2M™** logo is a trademark of ETSI registered for the benefit of its Members and of the oneM2M Partners. **GSM®** and the GSM logo are trademarks registered and owned by the GSM Association.

Legal Notice

This Technical Specification (TS) has been produced by ETSI 3rd Generation Partnership Project (3GPP).

The present document may refer to technical specifications or reports using their 3GPP identities. These shall be interpreted as being references to the corresponding ETSI deliverables.

The cross reference between 3GPP and ETSI identities can be found under <http://webapp.etsi.org/key/queryform.asp>.

Modal verbs terminology

In the present document "**shall**", "**shall not**", "**should**", "**should not**", "**may**", "**need not**", "**will**", "**will not**", "**can**" and "**cannot**" are to be interpreted as described in clause 3.2 of the [ETSI Drafting Rules](#) (Verbal forms for the expression of provisions).

"**must**" and "**must not**" are **NOT** allowed in ETSI deliverables except when used in direct citation.

Contents

Intellectual Property Rights	2
Legal Notice	2
Modal verbs terminology.....	2
Foreword.....	7
1 Scope	8
2 References	8
2.1 Normative references	8
2.2 Informative references.....	9
3 Symbols and abbreviations.....	10
3.1 Symbols.....	10
3.2 Abbreviations	10
4 GERAN Architecture	11
4.1 GERAN Reference Architecture	11
4.2 UMTS Architecture applied to GERAN	12
4.3 Protocol architecture in PS domain	13
4.3.1 General.....	13
4.3.2 User plane.....	14
4.3.3 Control plane	14
4.4 Protocol architecture in CS domain.....	15
4.4.1 General.....	15
4.4.2 User plane	15
4.4.3 Control plane	15
4.5 Iur-g interface.....	16
4.5.1 General principles	16
4.5.2 Protocol architecture	17
4.5.3 RNSAP protocol	17
4.6 Support for MSC/SGSN in pool.....	18
4.7 CS services for GERAN Iu-mode	18
4.8 User Equipment Specific Behaviour Information (UESBI) in GERAN Iu mode	19
5 Radio Interface Protocol Architecture.....	19
5.1 Protocol Structure when connecting through Iu	19
5.2 Multiplexing Principles	21
5.2.1 Multiplexing of different types of radio access bearers for one MS	21
5.2.2 Multiplexing of user plane data from different core network interfaces.....	21
5.3 Iu vs A/Gb mode selection.....	22
5.3.1 Introduction.....	22
5.3.2 PLMN, cell and mode (re-)selection in GERAN	22
6 User and Control Plane Protocols	23
6.1 Identifiers in GERAN.....	23
6.1.1 IMSI, TMSI and P-TMSI.....	23
6.1.2 G-RNTI.....	23
6.1.3 NSAPI, RAB ID and RB ID	23
6.1.4 RB Id, RRB Id, and TFI.....	24
6.1.5 USF.....	24
6.1.6 SAI.....	24
6.1.7 BSC-id	24
6.1.8 LAI for 3G core network	24
6.1.9 RAI for the 3G core network	25
6.1.10 GRA Identity	25
6.1.11 GERAN internal Cell Identity	25
6.2 Relay	25
6.3 Radio Resource Control (RRC).....	25

6.3.1	RRC Functions.....	25
6.3.2	RRC Connection Levels	26
6.3.3	RRC Connection Modes	27
6.3.4	RRC Connection Mobility	27
6.3.4.1	RRC Connection mobility in RRC-Idle mode	27
6.3.4.2	RRC Connection mobility in RRC-Connected mode.....	27
6.3.5	RRC protocol and messages	28
6.3.6	Support of Radio Bearers in GERAN	28
6.4	Packet Data Convergence Protocol (PDCP).....	28
6.4.1	Services provided to upper layers	28
6.4.2	Services expected from RLC layer	29
6.4.3	PDCP Functions.....	29
6.4.3.1	Transparent Mode	29
6.4.3.2	Non-Transparent Mode	29
6.5	Radio Link Control (RLC)	30
6.5.1	Services provided to upper layer.....	30
6.5.2	RLC Functions.....	30
6.5.2.1	Transparent Mode	30
6.5.2.2	Non-Transparent Mode	30
6.5.2.2.1	Acknowledged Mode.....	30
6.5.2.2.2	Unacknowledged Mode.....	31
6.6	Medium Access Control (MAC)	31
6.6.1	Services provided to upper layers	31
6.6.2	MAC Functions	31
6.6.2.1	Additional functions for RLC transparent mode	32
6.6.2.2	Additional functions for RLC non-transparent mode.....	32
6.6.3	Model of MAC	32
6.6.4	MAC operation	33
6.6.4.1	General	33
6.6.4.2	TBF establishment	34
6.6.4.2.0	General	34
6.6.4.2.1	Uplink resource request from MAC-Idle state	35
6.6.4.2.1.1	Mobile Originated Transmission	35
6.6.4.2.1.2	Mobile Terminated Transmission	35
6.6.4.3	TBF multiplexing and scheduling	36
6.6.4.3.1	Multiplexing of RLC instances on TBFs.....	36
6.6.4.3.2	Scheduling of TBFs on physical-layer resources	36
6.6.4.4	TBF release	36
6.6.4.5	TBF reallocation	37
6.7	RLC/MAC PDU Formats for different protocol modes	37
6.7.1	Acknowledged RLC mode.....	37
6.7.2	Unacknowledged RLC mode.....	37
6.7.3	Transparent RLC mode.....	37
6.8	Physical Layer (Phy)	37
6.8.1	Definitions	38
6.8.2	Services provided to upper layer.....	38
6.8.2.1	Specific services of the physical layer in the MS.....	38
6.8.3	Logical Channels	38
6.8.3.1	Traffic channels.....	38
6.8.3.2	Control channels	39
6.8.3.2.1	Broadcast channels	39
6.8.3.2.2	Common control type channels	39
6.8.3.2.3	Dedicated control channels.....	39
6.8.3.2.4	Cell Broadcast Channel (CBCH).....	39
6.8.4	Basic Physical Subchannels	40
6.8.4.1	DBPSCH - Dedicated Basic Physical SubCHannel	40
6.8.4.2	SBPSCH - Shared Basic Physical SubCHannel.....	40
6.8.5	Mapping of logical channels onto basic physical subchannels	40
6.8.5.1	DBPSCH full rate.....	40
6.8.5.2	DBPSCH half rate.....	40
6.8.5.3	SBPSCH full rate	41
6.8.5.4	SBPSCH half rate.....	41

6.8.6	Physical Layer Functions	42
6.8.7	Channel Coding	42
6.6.8	Enhanced Power control procedure	44
6.8.8.1	MS implementation	45
6.8.8.1.1	MS power control	45
6.8.8.1.2	MS link quality measurement reports	45
6.8.8.2	BSS implementation	45
6.9	Flexible Layer One (FLO)	45
6.9.1	General	45
6.9.2	Definitions	45
6.9.3	Principles	45
6.9.3.1	General	45
6.9.3.2	Coding / multiplexing	46
7	Ciphering	47
7.1	Location of ciphering in the GERAN protocol architecture	47
7.2	Inputs to the ciphering algorithm	47
7.2.1	Ciphering Key	47
7.2.2	Bearer	48
7.2.3	Direction	48
7.2.4	Length	48
7.2.5	Parameter Settings	48
8	Integrity protection	49
8.1	Integrity protection on RRC messages	49
8.2	Integrity protection on RLC/MAC control messages	49
8.3	Calculation of message authentication code	49
9	Mobility Management and Session Management (MM and SM)	49
10	Sequence Diagrams Examples for Handover	49
Annex A (informative): Radio Access Bearer Realization		50
A.1	Conversational Radio Access Bearer	50
A.2	Streaming, Interactive, Background Radio Access Bearers	54
A.2.1	Streaming	54
A.2.2	Interactive	56
A.2.3	Background	57
Annex B (informative): RLC/MAC Header format Convention		58
B.1	GPRS RLC/MAC data block header	58
B.1.1	Downlink RLC/MAC data block header	58
B.1.2	Uplink RLC/MAC data block header	58
B.2	EGPRS RLC/MAC data block header	58
B.2.1	Downlink RLC/MAC data block header	58
B.2.2	Uplink RLC/MAC data block header	59
B.3	ECSD RLC/MAC data block header	60
B.3.1	Uplink and downlink RLC/MAC data block header	60
Annex C (informative): RRC States, MAC States and RRC Connection Mobility		62
C.1	Void	62
C.2	MAC states	62
C.2.1	MAC-Dedicated state	62
C.2.1.1	Transition from MAC-Dedicated state to MAC-Idle state	62
C.2.1.2	Transition from MAC-Dedicated state to MAC-Shared state	62
C.2.1.3	Transition from MAC-Dedicated state to MAC-DTM state	62
C.2.2	MAC-Shared state	63
C.2.2.1	Transition from MAC-Shared state to MAC-DTM state	63
C.2.2.2	Transition from MAC-Shared state to MAC-Idle state	63

C.2.2.3	Transition from MAC-Shared state to MAC-Dedicated state.....	63
C.2.3	MAC-Idle state	63
C.2.3.1	Transition from MAC-Idle state to MAC-Dedicated state.....	63
C.2.3.2	Transition from MAC-IDLE state to MAC-SHARED state	63
C.2.4	MAC-DTM state	63
C.2.4.1	Transition from MAC-DTM state to MAC-Dedicated state.....	63
C.2.4.2	Transition from MAC-DTM state to MAC-Shared state	63
C.3	Mapping between RRC States and MAC States	63
Annex D (informative):	Change history	65
History		68

Foreword

This Technical Specification has been produced by the 3rd Generation Partnership Project (3GPP).

The contents of the present document are subject to continuing work within the TSG and may change following formal TSG approval. Should the TSG modify the contents of the present document, it will be re-released by the TSG with an identifying change of release date and an increase in version number as follows:

Version x.y.z

where:

- x the first digit:
 - 1 presented to TSG for information;
 - 2 presented to TSG for approval;
 - 3 or greater indicates TSG approved document under change control.
- y the second digit is incremented for all changes of substance, i.e. technical enhancements, corrections, updates, etc.
- z the third digit is incremented when editorial only changes have been incorporated in the document.

1 Scope

The present document defines the stage 2 service description for a GSM/EDGE Radio Access Network (GERAN). ITU-T Recommendation I.130 describes a three-stage method for characterisation of telecommunication services, and CCITT Q.65 defines stage 2 of the method.

The present document illustrates how the services requested by a GSM/UMTS Core Network are realized by the GERAN.

The main focus of the present document is on functionality related to the Iu interfaces. The aim of the present document is not to describe functionality related to the A and Gb interfaces in details. There is no detailed description of the interfaces towards the core network and only references are given to the appropriate specifications.

2 References

The following documents contain provisions which, through reference in this text, constitute provisions of the present document.

- References are either specific (identified by date of publication, edition number, version number, etc.) or non-specific.
- For a specific reference, subsequent revisions do not apply.
- For a non-specific reference, the latest version applies. In the case of a reference to a 3GPP document (including a GSM document), a non-specific reference implicitly refers to the latest version of that document *in the same Release as the present document*.

2.1 Normative references

- [1] 3GPP TS 25.410: "UTRAN Iu Interface: General Aspects and Principles".
- [2] 3GPP TS 25.411: "UTRAN Iu interface Layer 1".
- [3] 3GPP TS 25.412: "UTRAN Iu interface signalling transport".
- [4] 3GPP TS 25.413: "UTRAN Iu interface RANAP signalling".
- [5] 3GPP TS 25.414: "UTRAN Iu interface data transport & transport signalling".
- [6] 3GPP TS 25.415: "UTRAN Iu interface user plane protocols".
- [7] 3GPP TS 48.014: "General Packet Radio Service (GPRS); Base Station System (BSS) - Serving GPRS Support Node (SGSN) interface; Gb interface Layer 1".
- [8] 3GPP TS 48.016: "General Packet Radio Service (GPRS); Base Station System (BSS) - Serving GPRS Support Node (SGSN) interface; Network Service".
- [9] 3GPP TS 48.018: "General Packet Radio Service (GPRS); Base Station System (BSS) - Serving GPRS Support Node (SGSN); BSS GPRS Protocol (BSSGP)".
- [10] 3GPP TS 45.001: "Digital cellular telecommunications system (Phase 2+); Physical layer on the radio path; General description".
- [11] 3GPP TS 45.002: "Digital cellular telecommunications system (Phase 2+); Multiplexing and multiple access on the radio path".
- [12] 3GPP TS 43.002: "Network Architecture".
- [13] 3GPP TS 48.001: "Base Station System - Mobile Services Switching Centre (BSS-MSC) Interface General Aspects".

- [14] 3GPP TS 48.002: "Base Station System - Mobile Services Switching Centre (BSS-MSC) Interface - Interface Principles".
- [15] 3GPP TS 48.004: "Base Station System - Mobile Services Switching Centre (BSS-MSC) Interface Layer 1 Specification".
- [16] 3GPP TS 48.006: "Signalling Transport Mechanism Specification for the Base Station System - Mobile Services Switching Centre (BSS-MSC) Interface".
- [17] 3GPP TS 48.008: "Mobile Switching Centre - Base Station system (MSC-BSS) Interface Layer 3 Specification".
- [18] 3GPP TS 48.063: "Inband Tandem Free Operation (TFO) of Speech Codecs; Service Description; Stage 3".
- [19] 3GPP TS 25.420: "UTRAN Iur Interface: General Aspects and principles".
- [20] 3GPP TS 25.421: "UTRAN Iur Interface Layer 1".
- [21] 3GPP TS 25.422: "UTRAN Iur Interface signalling transport".
- [22] 3GPP TS 25.423: "UTRAN Iur Interface RNSAP signalling".
- [23] 3GPP TS 24.022: "Radio Link Protocol (RLP) for Circuit Switched Bearer and Teleservices".
- [24] 3GPP TS 44.018: "Radio Resource Control Protocol".
- [25] 3GPP TS 24.008: "Mobile radio interface layer 3 specification; Core Network Protocols - Stage 3".
- [26] 3GPP TS 44.060: "Radio Link Control / Medium Access Control (RLC/MAC) protocol".
- [27] 3GPP TS 45.008: "Radio subsystem Link Control".
- [28] 3GPP TS 23.003: "Numbering, Addressing and Identification".
- [29] 3GPP TS 23.221: "Architectural requirements (Release 5)"
- [30] 3GPP TS 23.236: "Intra Domain Connection of RAN Nodes to Multiple CN Nodes"
- [31] 3GPP TS 23.195: "Provision of User Equipment Specific Behaviour Information (UESBI) to network entities"

2.2 Informative references

- [32] 3GPP TS 23.060: "General Packet Radio Service (GPRS); Service Description; Stage 2".
- [33] 3GPP TS 43.64: "General Packet Radio Service (GPRS); Overall description of the GPRS radio interface; Stage 2".
- [34] 3GPP TS 23.034: "High Speed Circuit Switched Data (HSCSD); Stage 2".
- [35] 3GPP TS 41.004: "Digital cellular telecommunications system (Phase 2+); Abbreviations and acronyms".
- [36] ITU-T Recommendation I.130: "Method for the characterization of telecommunication services supported by an ISDN and network capabilities of an ISDN".
- [37] ITU-T Recommendation Q.65: "The unified functional methodology for the characterization of services and network capabilities including alternative object-oriented techniques".
- [38] 3GPP TS 23.153: "Out of Band Transcoder Control"
- [39] 3GPP TR 45.902: "Flexible Layer One"

3 Symbols and abbreviations

3.1 Symbols

For the purposes of the present document, the following symbols apply:

A	Interface between a BSS and a 2G MSC
Gb	Interface between a BSS and a 2G SGSN
Iu-cs	Interface between a BSS and a 3G MSC
Iu-ps	Interface between a BSS and a 3G SGSN
Iur-g	Interface between two BSSs

NOTE: whether the Iur-g interface is also used between a BSS and an RNC is FFS.

Um	Interface between MS and BSS
----	------------------------------

3.2 Abbreviations

For the purposes of the present document, the following abbreviations apply. Additional applicable abbreviations can be found in 3GPP TS 41.004 [27] and 3GPP TS 43.064 [25].

ADCH	Associated Dedicated CHannel
ARQ	Automatic Repeat reQuest
AS	Access Stratum
BCCH	Broadcast Control CHannel
BSS	Base Station Subsystem
CBCH	Cell Broadcast CHannel
CC	Call Control
CDCH	Control-plane DCH
CN	Core Network
CPBCCH	COMPACT PBCCH
CS-i	GPRS Coding Scheme i
DC	Dedicated Control
DCH	Dedicated CHannel
DLC	Data Link Control
DBPSCH	Dedicated Basic Physical Sub CHannel
ECSD	Enhanced Circuit Switched Data
EDGE	Enhanced Data rates for Global Evolution
E-FACCH	Enhanced FACCH
E-IACCH	Enhanced Inband Associated Control CHannel
EGPRS	Enhanced GPRS
EPC	Enhanced Power Control
EPCCH	Enhanced Power Control CHannel
E-TCH	Enhanced TCH
FACCH	Fast Associated Control CHannel
FLO	Flexible Layer One
FPC	Fast Power Control
GC	General Control
GERAN	GSM/EDGE Radio Access Network
GPRS	General Packet Radio Service
GRA	GERAN Registration Area
G-RNTI	GERAN Radio Network Temporary Identity
GSM	Global System for Mobile Communications
IETF	Internet Engineering Task Force
IMSI	International Mobile Subscriber Identity
IP	Internet Protocol
LCS	LoCation Services
MAC	Medium Access Control
MCS-i	EGPRS Modulation and Coding Scheme i

MM	Mobility Management
MS	Mobile Station
NAS	Non Access Stratum
NSAPI	Network layer SAPI
Nt	Notification
O-FACCH	Octal FACCH
O-TCH	Octal TCH
PBCCH	Packet BCCH
PDCH	Packet Data CHannel
PDCP	Packet Data Convergence Protocol
PDP	Packet Data Protocol
PDTCH	Packet Data TCH
PDU	Packet Data Unit
PLMN	Public Land Mobile Network
PTCCH	Packet Timing advance Control CHannel
P-TMSI	Packet TMSI
PUESBINE	Provision of UE Specific Behaviour Information to Network Entities
QoS	Quality of Service
RAB	Radio Access Bearer
RANAP	Radio Access Network Application Part
RB	Radio Bearer
RLC	Radio Link Control
RNSAP	Radio Network Subsystem Application Part
ROHC	Robust Header Compression
RRC	Radio Resource Control
RTP	Real Time Protocol
SACCH	Slow Associated Control CHannel
SACCH/TP	SACCH for enhanced power control
SAP	Service Access Point
SAPI	Service Access Point Identifier
SDCCH	Stand-alone Dedicated Control CHannel
SDU	Service Data Unit
SBPSCH	Shared Basic Physical Sub CHannel
TB	Transport Block
TBF	Temporary Block Flow
TCH	Traffic Channel
TCP	Transmission Control Protocol
TFC	Transport Format Combination
TFCI	Transport Format Combination Indicator
TFCS	Transport Format Combination Set
TLLI	Temporary Logical Link Identifier
TMSI	Temporary Mobile Subscriber Identity
TrCH	Transport Channel
TTI	Transmission Time Interval
UDCH	User-plane DCH
UDP	User Datagram Protocol
UESBI	UE Specific Behaviour Information
UMTS	Universal Mobile Telecommunication System
USF	Uplink State Flag
UTRAN	UMTS Terrestrial Radio Access Network

4 GERAN Architecture

4.1 GERAN Reference Architecture

The reference architecture of GERAN is illustrated in Figure 1.

GERAN connects with 3 interfaces A, Gb and Iu interfaces to the core network. Any combination comprising one, two or three of these 3 interfaces is possible. Two Base Station Subsystems (BSS) may be connected to each other with an Iur-g interface. A BSS and an RNC may also be connected via an Iur-g interface.

The mobile station shall operate using **only the following modes**:

- a) **A/Gb mode**, e.g. for pre-Release 5 terminals, for Release 5 terminals when connected to a GERAN with no I_u interface towards the Core Network;
- b) **Iu mode** (i.e. I_{u-CS} and I_{u-PS}), e.g. for Release 5 terminals when connected to a GERAN with I_u interfaces towards the Core Network.

Both modes must be supported by the standard and no other modes (e.g. A / I_{u-PS} or I_{u-CS} / G_b) shall be allowed.

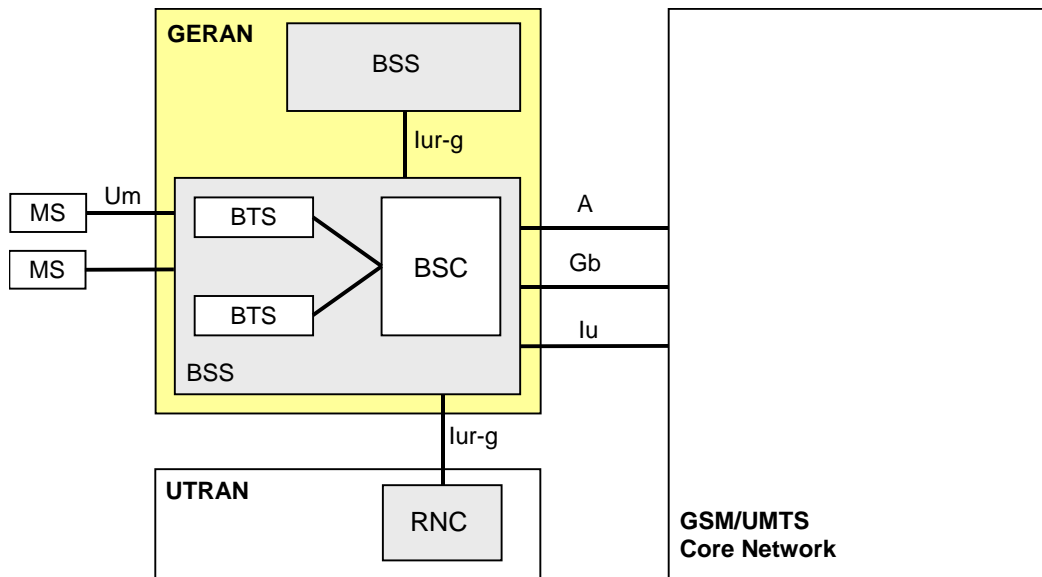

Figure 1: GERAN reference architecture

The functional split within a BSS is implementation-dependent.

4.2 UMTS Architecture applied to GERAN

This clause describes the GERAN architecture when it connects to the core network through an Iu interface. Figure 2 shows the assumed UMTS architecture as outlined in 3GPP TS 23.110. GERAN is shown instead of UTRAN. The figure below shows the UMTS architecture in terms of its entities Mobile Station, GERAN and Core Network. The respective reference points Um (Radio Interface) and Iu (CN-RAN reference) are shown. The figure illustrates furthermore the high-level functional grouping into the Access Stratum and the Non-Access Stratum.

The Access Stratum offers services through the following Service Access Points (SAP) to the Non-Access Stratum:

- General Control (GC) SAPs;
- Notification (Nt) SAPs; and
- Dedicated Control (DC) SAPs.

The SAPs are marked with circles in Figure 2.

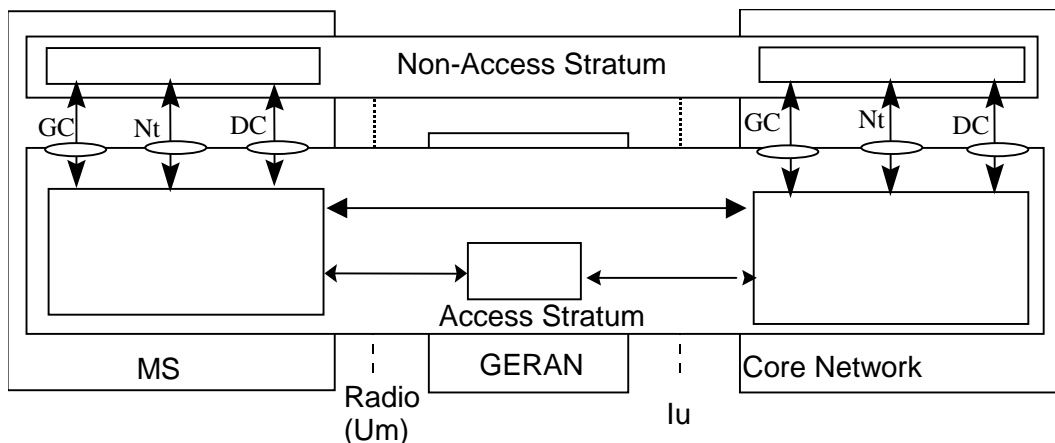

Figure 2: UMTS Architecture applied to GERAN

This model can be further refined to distinguish the end AS entities, which provide the services to higher layers, from the local entities, which provide services over respectively the Um and the Iu reference point. Figure 3 presents the refined model.

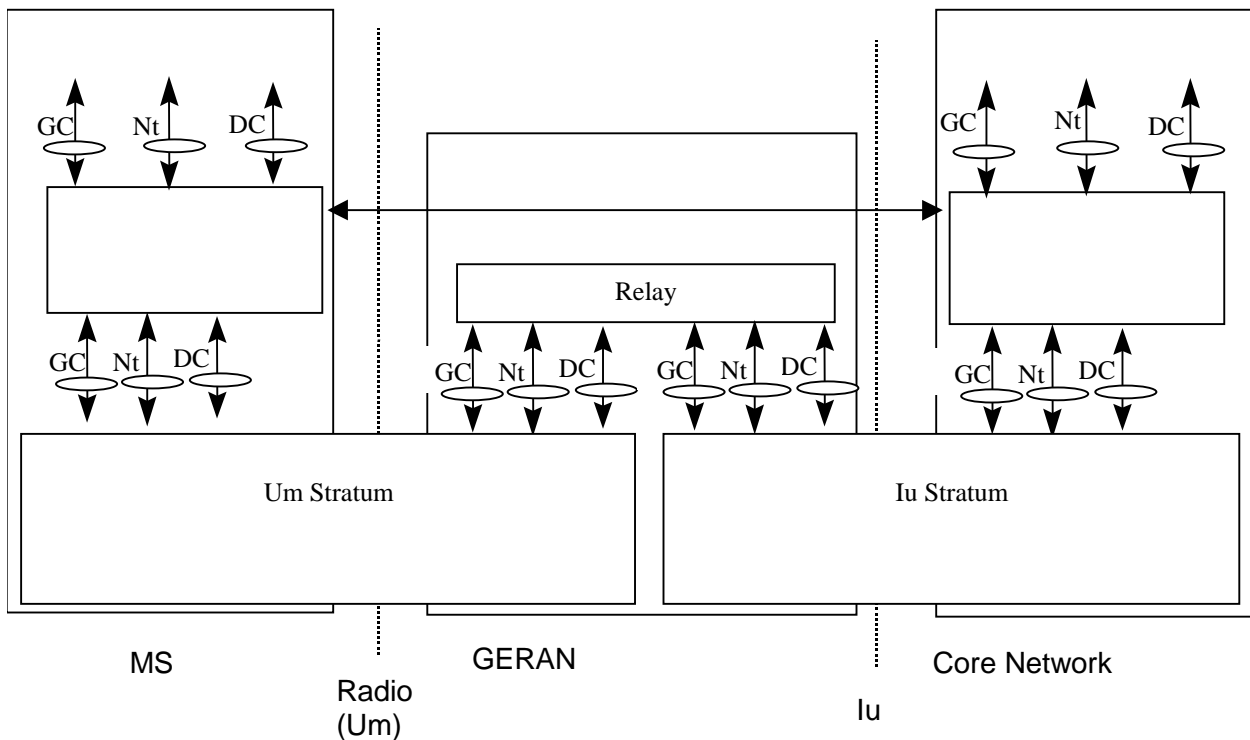

Figure 3: Assumed GERAN Model

4.3 Protocol architecture in PS domain

4.3.1 General

Specifications and more detailed descriptions of the Iu-ps interface protocols and architecture can be found in [1-6].

Specifications and more detailed descriptions of the Gb interface protocols and architecture can be found in [7-9].

The Um interface protocols are described in clauses 5 and 6.

4.3.2 User plane

Figure 4 shows the user plane for GERAN connected to a packet switched core network domain. For reference, GPRS and UMTS protocol stacks when connected to the packet switched core network domain are described in 3GPP TS 23.060 [24].

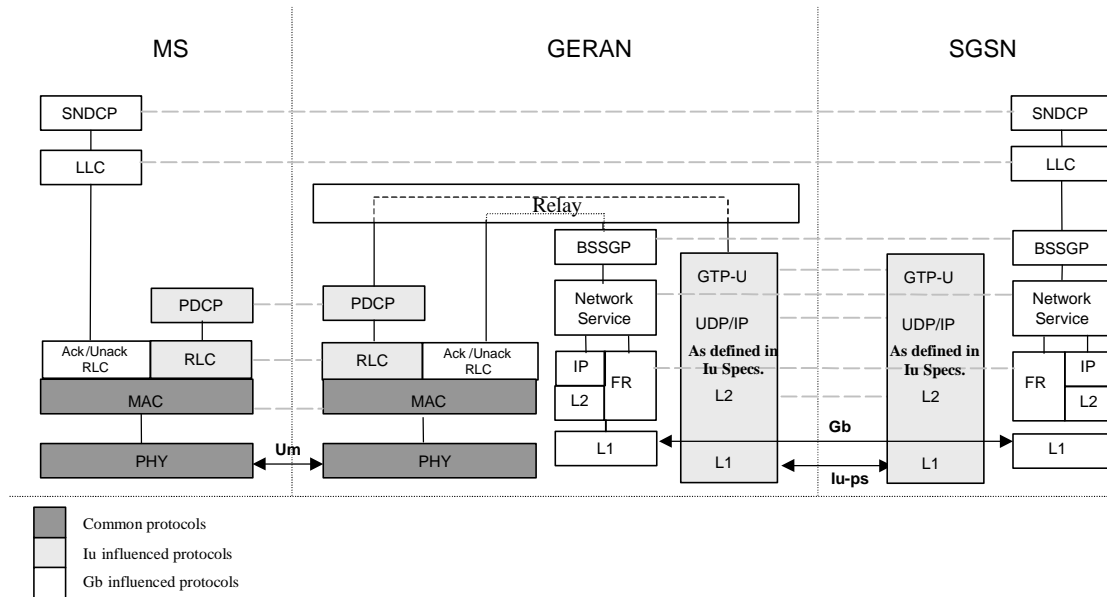

Figure 4: User Plane protocols towards Packet Switched Core Network domain

The Iu-ps protocol stack is inherited from UMTS specifications (Ref. 1-6). However, GERAN expects more transport layer options than ATM (3GPP Work Item "IP Transport in UTRAN").

4.3.3 Control plane

Figure 5 shows a high level view of the control plane for GERAN when connected to a packet switched core network domain. For reference, GPRS and UMTS Control Plane protocol stacks when connected to the packet switched core network domain are depicted in Figures 7 of [24] and 8 of [24] respectively.

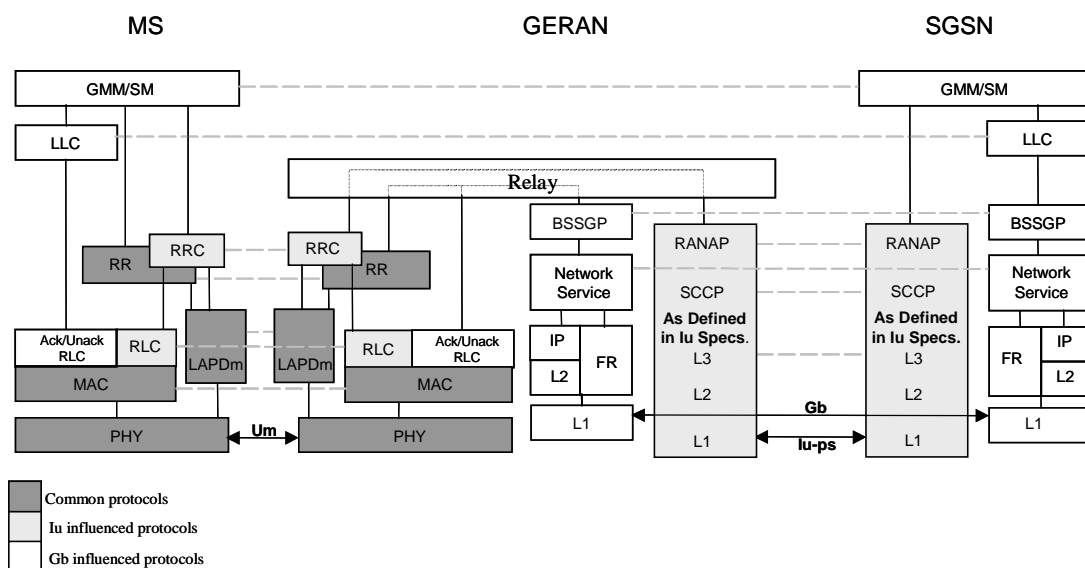

Figure 5: Control Plane protocols towards Packet Switched Core Network domain

NOTE: The Iu-ps protocol stack is inherited from UMTS specifications (Ref. 1-6). However, GERAN expects more transport layer options than ATM (3GPP Work Item "IP Transport in UTRAN").

NOTE: RRC uses the services of LAPDm only on broadcast control channels.

4.4 Protocol architecture in CS domain

4.4.1 General

Specifications and more detailed descriptions of the Iu-cs interface protocols and architecture can be found in [1-6].

Specifications and more detailed descriptions of the A interface protocols and architecture can be found in [13-18]. The RLP Protocol is found in [23].

The Um interface protocols are described in clauses 5 and 6.

Within GERAN, speech and data frames will be transmitted at the radio interface using a specific channel coding. As the support of transceivers with limited capabilities has to be assured, the capabilities provided by the GERAN have to be taken into account by the CN during call set-up and Relocation. Additionally, in case a RAB has to be established or relocated for CS services, it is required that the GERAN BSC receives specific information from the MSC-Server.

4.4.2 User plane

Figure 6 shows the user plane for GERAN connected to a circuit switched core network domain

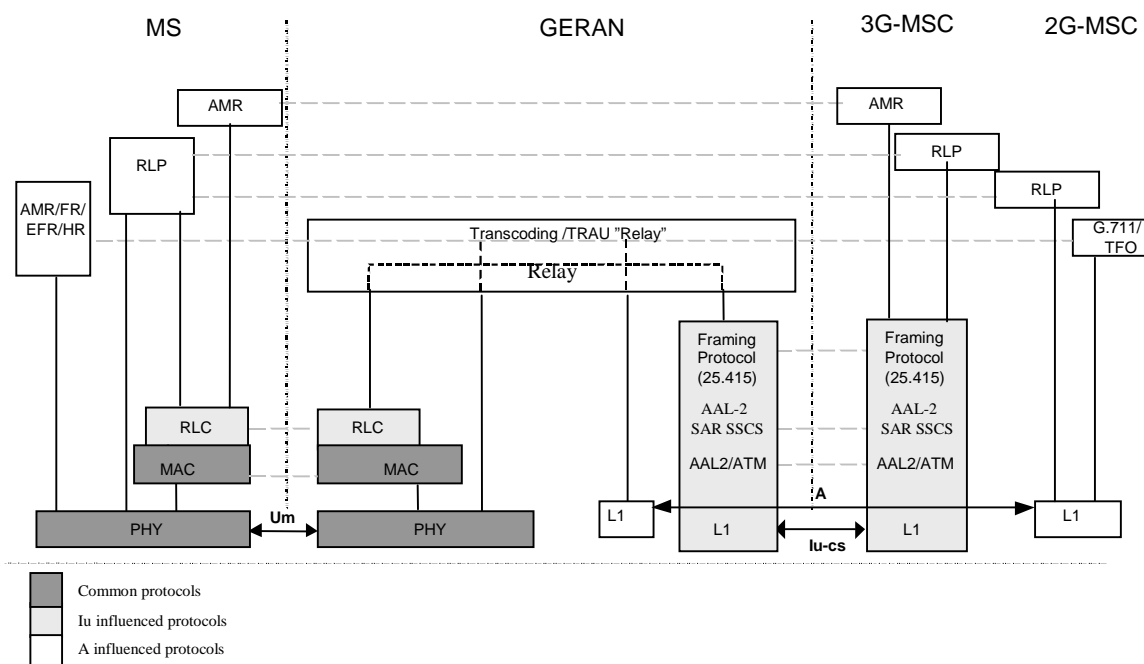

Figure 6: User Plane protocols towards Circuit-Switched Core Network domain

NOTE: The figure only shows existing Release 99 Transport layer options for A and Iu-cs.

NOTE: The Iu-cs protocol stack is inherited from UMTS specifications [1-6]. However, GERAN expects more transport layer options than ATM (3GPP Work Item "IP Transport in UTRAN").

4.4.3 Control plane

Figure 7 shows the control plane for GERAN connected to a circuit switched core network domain.

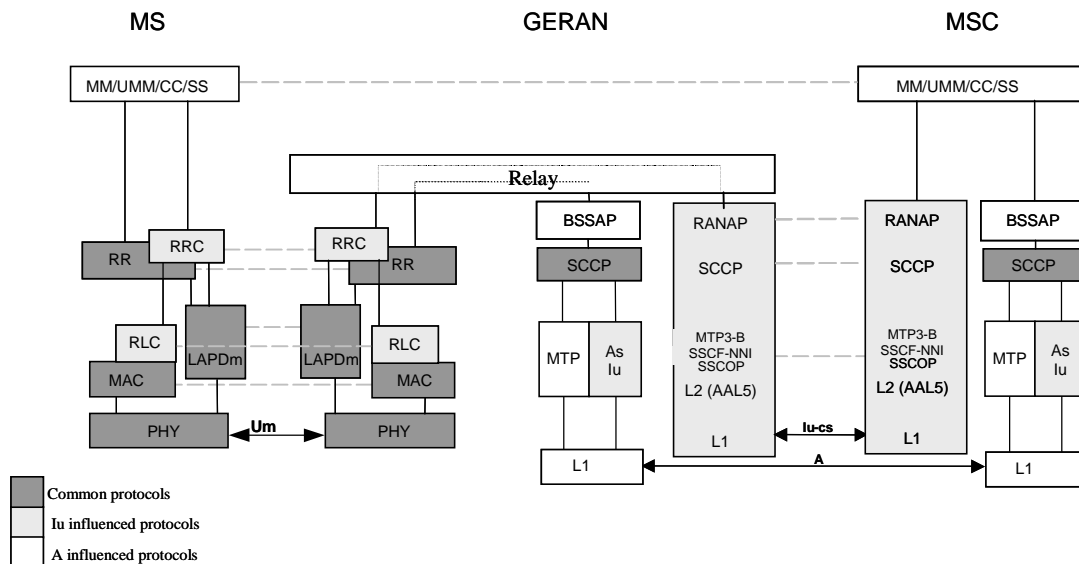

Figure 7: Control Plane Protocols towards Circuit-Switched Core Network Domain

NOTE: The Iu-cs protocol stack is inherited from UMTS specifications [1-6]. However, GERAN expects more transport layer options than ATM (3GPP Work Item "IP Transport in UTRAN").

NOTE: RRC uses the services of LAPDm only on broadcast control channels.

4.5 Iur-g interface

4.5.1 General principles

The support of the Iur-g interface in GERAN is optional. It should be noted however that this allows for registration areas to span across several BSS (and possibly RNS) areas. Registration areas may refer to GRAs or URAs.

The general principles for the specification of the Iur-g interface are as follows:

- the Iur-g interface should be open;
- the use of the Iur-g interface may be used for Mobile Stations operating in Iu mode but not for Mobile Stations operating in A/Gb mode;
- the Iur-g interface shall support the exchange of signaling information between two BSSs, or between a BSS and an RNC;
- from a logical standpoint, the Iur-g is a point to point interface between two BSSs or between a BSS and an RNC. A point to point logical interface should be feasible even in the absence of a physical direct connection between the two entities;
- the behaviour of the MS shall be independent of the presence of the Iur-g interface or of the presence of any of its planes.

When specifying the Iur-g interface, it is deemed necessary to introduce a separation between the Radio Network functionality and the Transport Network functionality to facilitate introduction of future technology (see Figure 8).

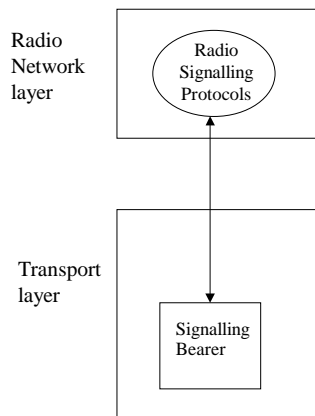

Figure 8: Separation of Radio Network Protocols and transport over the Iur-g interface

4.5.2 Protocol architecture

Figure 9 represents the protocol architecture for Iur-g interface. It is based on the UTRAN Iur protocol architecture, where only the control plane of the protocol is used for Iur-g. See [19-22].

The Radio Network Subsystem Application Part (RNSAP) for GERAN contains a sub-set of the UTRAN RNSAP procedures. However the contents of the messages used over Iur-g might differ.

NOTE: The Transport Network protocols shown here are adopted from UTRAN Release 99, although they are subject to change for GERAN Release 5 and this figure will be modified accordingly.

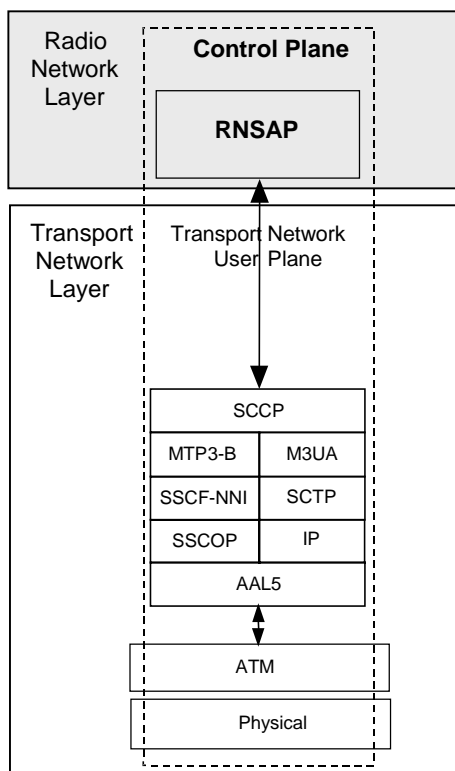

Figure 9: Iur-g Protocol Architecture

4.5.3 RNSAP protocol

The protocol responsible for providing signaling information across the Iur-g interface is called the Radio Network Subsystem Application Part (RNSAP). The RNSAP is terminated by the two BSSs or the BSS and the RNC interconnected via the Iur-g interface RNSAP Procedure Modules.

RNSAP procedures as defined in UTRAN are divided into four modules as follows:

1. RNSAP Basic Mobility Procedures;
2. RNSAP DCH Procedures;
3. RNSAP Common Transport Channel Procedures;
4. RNSAP Global Procedures.

In case of GERAN Iur-g, only RNSAP Basic Mobility Procedures and RNSAP Global Procedures are adopted from UTRAN and modified as necessary. Table 1 lists elementary procedures that are used with RNSAP in Iur-g interface. These are Class 2 procedures that do not require response and are always considered successful.

The Basic Mobility Procedures module contains procedures used to handle the mobility within GERAN, while the Global Procedures module contains procedures that are not related to a specific MS.

Table 1: Elementary Procedures

Elementary Procedure	Initiating Message
Uplink Signaling Transfer	UPLINK SIGNALLING TRANSFER INDICATION
Downlink Signaling Transfer	DOWNLINK SIGNALLING TRANSFER REQUEST
SRNS Relocation Commit	SRNS RELOCATION COMMIT
Paging	PAGING REQUEST
Error Indication	ERROR INDICATION

4.6 Support for MSC/SGSN in pool

The stage 2 description on how the MSC/SGSN in pool concept is supported in the BSS and MS in GERAN Iu mode is described in [31].

4.7 CS services for GERAN Iu-mode

Call Set-up:

In case of a call set-up towards the CS domain, the BSC shall provide GERAN specific capabilities in the "GERAN Classmark" within the INITIAL UE MESSAGE to the MSC-Server of the serving cell that have to be taken into account by the MSC-Server during call set-up (e.g. to negotiate a speech codec [38]).

To be able to set-up an appropriate RB with the corresponding channel coding for a CS service, the BSC will receive specific information within the "GERAN BSC Container" from the MSC-Server within the RAB ASSIGNMENT REQUEST message.

In case the MS moves to a new cell during the period between the transmission of the INITIAL UE MESSAGE and the reception of the RAB ASSIGNMENT REQUEST message, the RAB Assignment may fail, as the BSC may not be able to set-up the requested RB, because different capabilities are provided in that new cell. In this case the BSC shall report the unsuccessful RAB establishment to the CN by indicating an appropriate cause value within the RAB ASSIGNMENT RESPONSE message and shall include the "GERAN Classmark" of the new cell. Based on the received "GERAN Classmark" the MSC-Server may re-attempt the RAB Assignment procedure.

Relocation:

In case the whole RAN provides the same capabilities with regard to CS services, the exchange of the "GERAN Classmark" between RAN and CN is not required during the Relocation procedure.

In case the whole RAN does not provide the same capabilities with regard to CS services, the exchange of the "GERAN Classmark" between RAN and CN is required during the Relocation procedure to avoid that the CN has to store cell related information and to be able to reuse the existing Relocation procedure inside the CN. The exchange of the "GERAN Classmark" shall be performed as follows: In case of Relocation to GERAN Iu-mode, the Source RAN-node

shall transfer the "GERAN Classmark" of the GERAN target cell to the MSC-Server within the RELOCATION REQUIRED message, which has to be taken into account by the CN during the execution of the Relocation procedure.

To be able to set-up an appropriate RB with the corresponding channel coding in the target cell for a CS service, the Target BSC will receive the requested specific information within the "GERAN BSC Container" from the MSC-Server within the RELOCATION REQUEST message.

In case the target BSC cannot allocate radio resources corresponding to the "GERAN BSC Container" content, received within the RELOCATION REQUEST message, the BSC shall report this failure event by including an appropriate cause value within the RELOCATION FAILURE message to the MSC-Server. In this case the target BSC shall additionally include the "GERAN Classmark" of the target cell in the RELOCATION FAILURE message sent to the MSC-Server. If the MSC-Server receives a RELOCATION FAILURE message indicating "GERAN Iu-mode failure", the MSC-Server shall report this relocation failure to the source RAN node. Optionally, if the received "GERAN Classmark" shows that the requested CS service is incompatible with the transceiver capabilities of the target cell, the MSC-Server may initiate a second handover attempt towards the target BSC taking the received "GERAN Classmark" into account.

4.8 User Equipment Specific Behaviour Information (UESBI) in GERAN Iu mode

The Provision of User Equipment Specific Behaviour Information to network entities (PUESBINE) feature is described in 3GPP TS 23.195 [31]. The PUESBINE feature is supported in GERAN Iu mode as in UTRAN and in GERAN, it is applicable only to the UMTS functionality and GERAN to UTRAN handovers.

5 Radio Interface Protocol Architecture

The radio interface protocol architecture when GERAN connects to A or Gb interface is the same as defined in earlier releases. The clause below describes the protocol architecture when connecting through an Iu interface to the CN. Whether the protocol structure described in this clause (5) is also applicable for an evolved A interface is for further study. The multiplexing principles of data coming from the different CN interfaces (A, Gb and Iu) are illustrated in clause 5.3.

5.1 Protocol Structure when connecting through Iu

The radio interface is layered into three protocol layers:

- the physical layer (L1);
- the data link layer (L2);
- the network layer (L3).

Layer 2 is split into the following sublayers: Radio Link Control (RLC), Medium Access Control (MAC) protocol and Packet Data Convergence Protocol (PDCP). RLC/MAC is used as layer 2 in the control plane below RRC, except for operation on the BCCH, where DL is used. Whether the Broadcast/Multicast Control (BMC) protocol described in 25.301 is needed is for further study.

The protocol architecture is divided into Control (C-) and User (U-) planes. The RLC and MAC protocols and the physical layer carries data from both C- and U-plane. PDCP exists in the U-plane only.

In the C-plane, Layer 3 is partitioned into sublayers where the lowest sublayer, denoted as Radio Resource Control (RRC), interfaces with layer 2 and terminates in the GERAN. The next sublayer provides 'Duplication avoidance' functionality as specified in 3GPP TS 24.007. It terminates in the CN but is part of the Access Stratum; it provides the Access Stratum Services to higher layers. The higher layer signalling such as Mobility Management (MM) and Call Control (CC) are assumed to belong to the non-access stratum, and therefore not in the scope of 3GPP TSG GERAN. On the general level, the protocol architecture is similar to the current ITU-R protocol architecture, ITU-R M.1035.

Figure 10 shows the radio interface protocol architecture. Each block in Figure 10 represents an instance of the respective protocol. Service Access Points (SAP) for peer-to-peer communication are marked with circles at the

interface between sublayers. The SAP between MAC and the physical layer provides the logical channels when Flexible Layer One is not used, and transport channels when Flexible Layer One is used. In the C-plane, the interface between 'Duplication avoidance' and higher L3 sublayers (CC, MM) is defined by the General Control (GC), Notification (Nt) and Dedicated Control (DC) SAPs. A description of these SAPs can be found in 3GPP TS 23.110.

Also shown in the figure are connections between RRC and MAC as well as RRC and L1 providing local inter-layer control services. An equivalent control interface exists between RRC and the RLC sublayer, between RRC and the PDCP sublayer. These interfaces allow the RRC to control the configuration of the lower layers. For this purpose separate Control SAPs are defined between RRC and each lower layer (PDCP, RLC, MAC, and L1).

The GERAN can be requested by the CN to prevent loss of data according to the quality of service requirements [UMTS 23.107] of the bearer in question (i.e. independently of the handovers on the radio interface), as long as an inter-BSS handover does not take place. This is a basic requirement to be fulfilled by the GERAN retransmission functionality as provided by the RLC sublayer. However, in case of the inter-BSS handover, the prevention of the loss of data may not be guaranteed autonomously by the GERAN but relies on 'Duplication avoidance' functions in the CN.

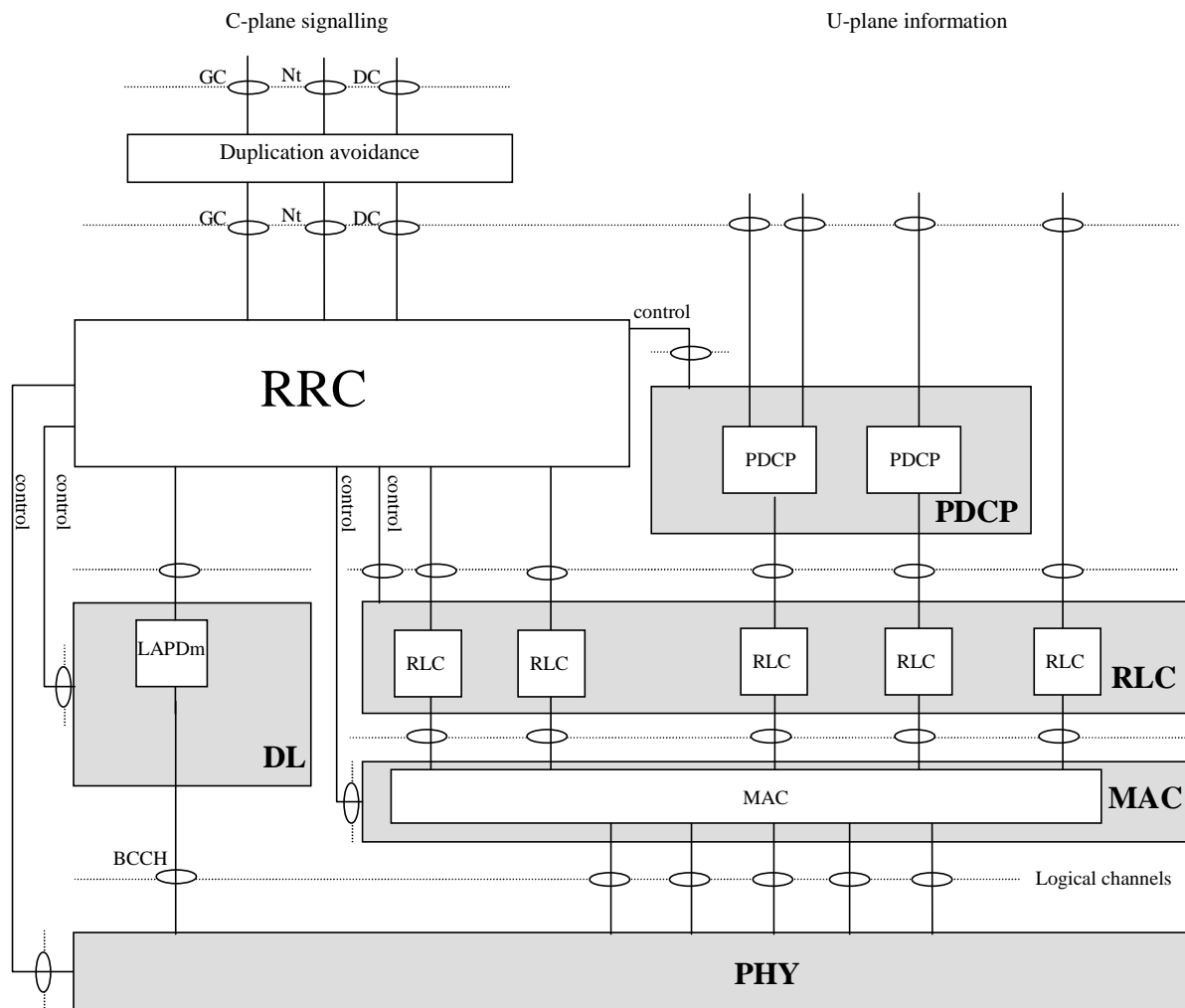

Figure 10: Radio Interface protocol architecture

Figure 10 reflects the radio interface protocol architecture when connecting to the Iu interface and the Flexible Layer One is not used.

Figure 11 below represents the radio interface protocol architecture in relation to the Flexible Layer One only.

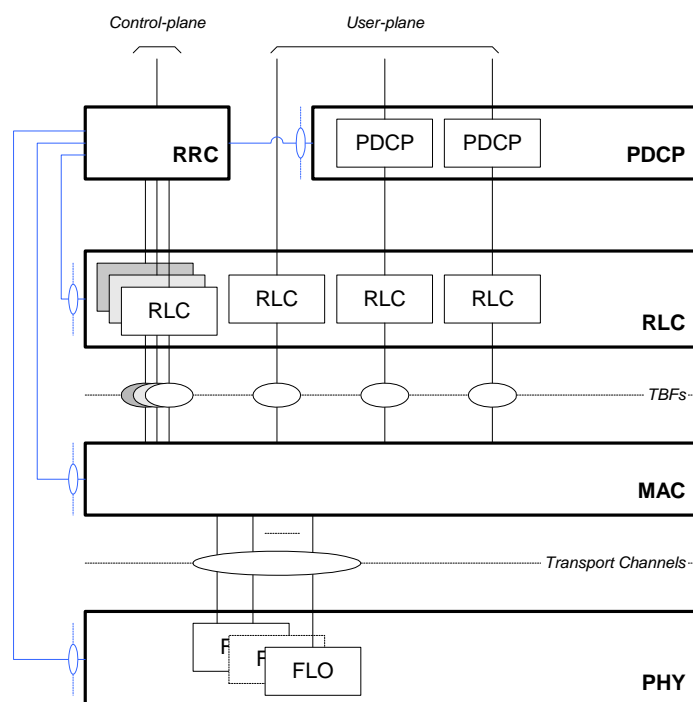

Figure 11: Radio Interface protocol architecture with FLO

5.2 Multiplexing Principles

5.2.1 Multiplexing of different types of radio access bearers for one MS

GERAN can allocate multiple dedicated and shared basic physical subchannels to a mobile station. The allocation shall be consistent with the mobile station's capability (See GSM 05.02 [11]).

Different types of Radio Access Bearer Services can be multiplexed for one MS using functionality of the MAC and/or the physical layers on one or more shared and/or dedicated basic physical subchannels. One radio bearer can only be mapped either on dedicated or shared basic physical subchannels.

5.2.2 Multiplexing of user plane data from different core network interfaces

Figure 12 shows the multiplexing principles on the network side of user plane data coming from different type of core network interfaces. User data from the Iu interface and user data from the Gb interface are multiplexed on MAC level, through shared basic physical subchannels, or on the physical layer, through different basic physical subchannels. User data coming from the A interface is multiplexed with user data from the Gb interface and user data from the Iu interface on the physical layer through different basic physical subchannels.

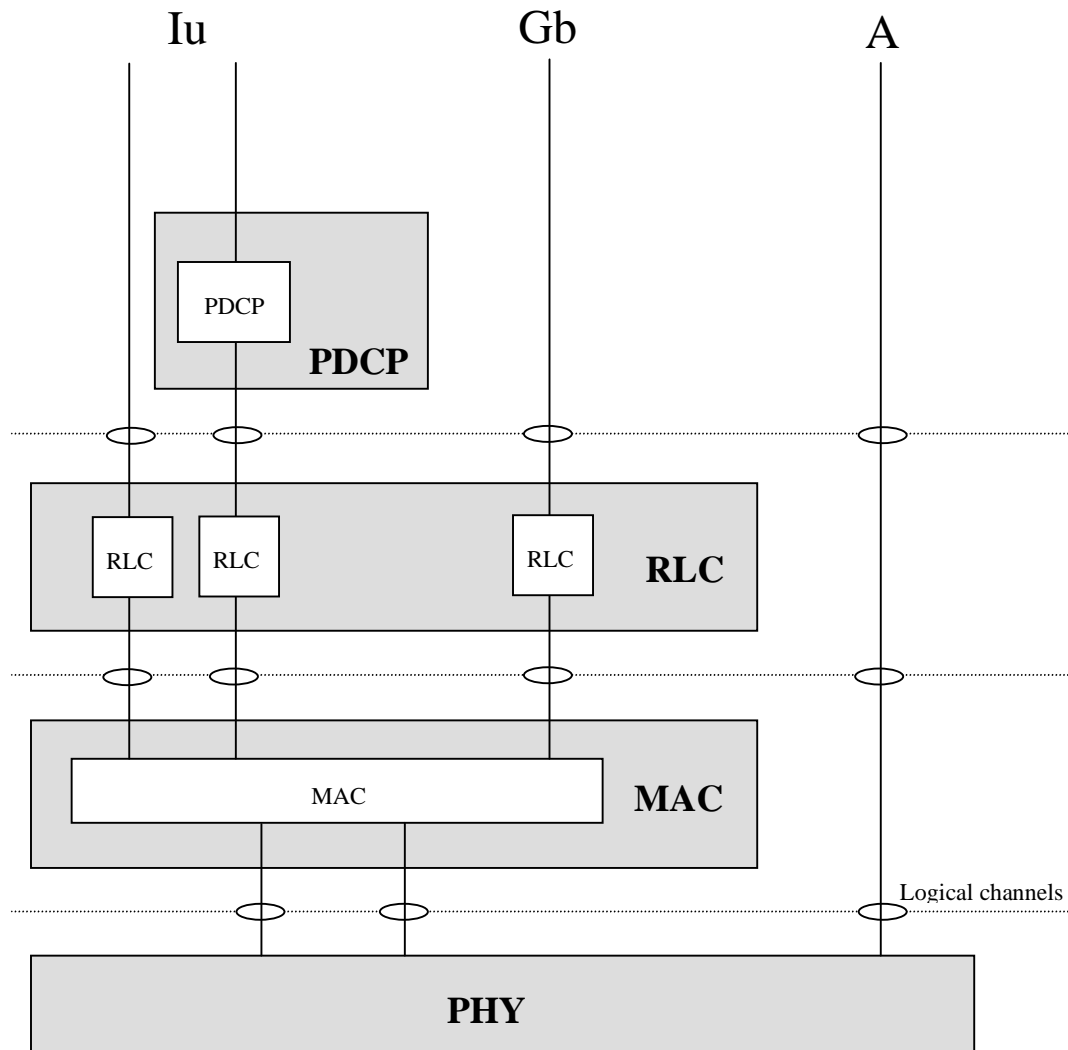

Figure 12: Multiplexing principles on the network side of user plane data flows coming from different interfaces

5.3 *Iu* vs *A/Gb* mode selection

5.3.1 Introduction

A GERAN cell can support either *A/Gb* mode only, or *Iu* mode only, or both modes. The support of each mode depends on the interfaces via which the GERAN is connected to the Core Network nodes.

The support of each mode of operation by a GERAN cell is indicated in the broadcast system information messages, see subclause 6.3.1.

Similarly, the mode(s) of operation a mobile station supports is indicated in information concerning radio aspects of the mobile station, made available to the radio access network, see [25]. *Iu* mode support may also be indicated implicitly at radio access by the mobile station. A mobile station can only operate either in *A/Gb* mode or in *Iu* mode at a given time.

5.3.2 PLMN, cell and mode (re-)selection in GERAN

The procedures for PLMN selection apply independently of the mode(s) supported by the cells belonging to the available PLMNs.

The procedures for cell re-selection defined in *A/Gb* mode apply also in *Iu* mode. The cell re-selection may be under the control of the network or the mobile station, see [26].

In case cell re-selection is under control of the mobile station, cell re-selection shall only be based on radio criteria and not on which mode is supported by the neighbour cells, see [27]. The *Iu mode* shall be selected in the target cell if supported by both the cell and the mobile station unless otherwise ordered by the network.

NOTE: The above text outlines the default mechanism of mode of operation selection and does not prohibit the introduction of a more flexible solution, which avoids unnecessary mode of operation changes, at a later stage.

In case cell re-selection is under control of the network, the mode to apply in the target cell is provided by the network.

NOTE: When a mobile station is allocated dedicated physical sub-channels, the maintenance of the radio resources is handled via handover procedures by the network. Irrespective of the mode of operation in the current cell, the network will select the mode of operation to apply in the target cell.

Once the mode of operation has been chosen in the new cell, the relevant procedures to *A/Gb* or *Iu mode* apply. Procedures will be defined in *A/Gb* or *Iu mode* to allow for changing mode without changing cell.

6 User and Control Plane Protocols

This clause provides an overview on the user and control plane protocols of GERAN. For detailed description of each of the layer, please refer to the corresponding specification (see below).

6.1 Identifiers in GERAN

The identities listed below shall be used for an MS connected, via GERAN through an Iu interface, to the CN. The identities for an MS connected, via GERAN through a Gb interface, to the CN are defined in Release 99 and can be found in 3GPP TS 23.060.

6.1.1 IMSI, TMSI and P-TMSI

The International Mobile Subscriber Identity (IMSI), Temporary Mobile Subscriber Identity (TMSI) and Packet Temporary Mobile Subscriber Identity (P-TMSI) are defined in 3GPP TS 23.003.

6.1.2 G-RNTI

A GERAN Radio Network Temporary Identity (G-RNTI) shall be allocated to a mobile station by the BSS when an RRC connection is established between this mobile station and the GERAN. It identifies the MS within GERAN and may be used the same way TLLI is currently used over the radio interface in (E)GPRS (*A/Gb mode*). The G-RNTI is defined in 3GPP TS 44.118. It is 32 bits in length and contains the serving BSC identity (SBSC-id) and the MS identity (S-RNTI) which is unique within the area of its serving BSC.

6.1.3 NSAPI, RAB ID and RB ID

The UMTS definitions and mapping amongst NSAPI, RAB ID and RB ID shall be used for GERAN 3GPP TS 23.060.

The Network layer Service Access Point Identifier (NSAPI) and IMSI are used for network layer routing. In the MS, NSAPI identifies the PDP-SAP. In the SGSN and GGSN, NSAPI identifies the PDP context associated with an MM context.

In communication with BSS across the Iu-ps and Um interfaces, the RAB ID is used to identify the radio access bearer and shall be identical to the NSAPI value. In the BSS, the RAB ID identifies the BSS RAB context. The RAB ID shall uniquely identify the RAB for a specific CN domain and a particular MS.

GERAN establishes exactly one radio bearer to realize each RAB. Within the MS and the GERAN, the RB ID shall uniquely identify the radio bearer for a particular MS.

6.1.4 RB Id, RRB Id, and TFI

An RB Id (Radio Bearer Identity) identifies an RB (Radio Bearer). An RB Id has one of 32 possible values. Signalling radio bearers use RB Ids 0 to 4; user radio bearers use the rest. RB Ids are assigned at RB establishment and remain assigned until the radio bearer or the RRC connection is released.

An RRB Id (Reduced Radio Bearer Identity) identifies a TBF on FACCH, SACCH, or SDCCH. An RRB Id has one of 8 possible values. For such TBFs carrying SRBs, RRB Ids are implicitly assigned when the DBPSCH is assigned. For such TBFs carrying URBs, the mapping between RB Id and RRB Id is given at RB setup.

A TFI (Temporary Flow Identity) identifies a TBF (Temporary Block Flow) on PDTCHs. A TFI has one of 32 possible values. For SBPSCHs, when a TBF is established, one unique TFI is assigned across all SBPSCHs that carry the TBF. Uplink and downlink TFIs are independent, *i.e.*, assignment of a TFI in one direction does not constrain the TFI used in the other direction. The GERAN establishes the association between RB Id and TFI when the TBF is established. For DBPSCHs, TFIs are implicitly assigned to TBFs when the corresponding RB is allocated on the DBPSCH, and remain assigned until the RB is deallocated from the DBPSCH. For each RB on a DBPSCH, the TFI equals the RB Id.

A TBF on one or more TCHs is the only user of the TCHs; hence, no specific MAC-layer identifier is needed.

6.1.5 USF

For a TBF on one or more PDTCHs, USF (Uplink State Flag) is sent in the downlink and identifies which TBF may use the next block (or blocks) on the uplink SBPSCH or DBPSCH. A USF has one of 8 values.

A unique USF is assigned per timeslot for the duration of the TBF. The GERAN establishes the association between TFI and USFs when the TBF is established.

6.1.6 SAI

The SAI (Service Area Identifier) identifies a Service Area that consists of one or more GERAN and UTRAN cells. It is defined in [25]. The SAI is unique within the PLMN. The SAI is used over the Iu interface for mechanism such as inter-system handover, location services, charging etc.

The SAI is constructed as follows:

$$\text{SAI} = \text{MCC} + \text{MNC} + \text{LAC} + \text{SAC}$$

6.1.7 BSC-id

Each BSC that supports the Iu interface will be allocated a BSC-id (Base Station Control Identifier). The BSC-id is constructed the same way as the RNC-id, which is defined in [25]. The BSC-id and the RNC-id are allocated from the same addressing space and are unique within the PLMN. The BSC-id together with the PLMN-id is used for addressing BSCs over the Iur-g and the Iu interface.

6.1.8 LAI for 3G core network

For the case the network does not support common Location Areas for the 2G and 3G CNs, a GERAN cell that supports Iu mode of operation needs to support an additional Location Area Identity (LAI) for the 3G CN [25] [26]. For the case the network supports common Location Areas for the 2G and 3G CN, a GERAN cell supporting both *A/Gb* and *Iu* modes of operation may not need an additional LAC for the 3G CN. The LAI is unique within the PLMN.

The LAI is constructed as follows:

$$\text{LAI} = \text{MCC} + \text{MNC} + \text{LAC}$$

NOTE: It is FFS whether the full LAC for the 3G CN needs to be broadcast in the cell. It might be possible to share part of it with the LAC for the 2G CN.

6.1.9 RAI for the 3G core network

For the case the network does not support common Routing Areas for the 2G and 3G CN, a GERAN cell that supports Iu mode of operation needs to support an additional Routing Area Identity for the 3G [25] [26]. For the case the network supports common Routing Areas for the 2G and 3G CN, a GERAN cell supporting both A/Gb and Iu modes of operation may not need an additional RAC for the 3G CN. The RAI is unique within the LAI.

The RAI is constructed as follows:

RAI = LAI + RAC

NOTE: It is FFS whether the full RAC for the 3G CN needs to be broadcast in the cell. It might be possible to share part of it with the RAC for the 2G CN.

6.1.10 GRA Identity

A GERAN Registration Area (GRA) is identified by the GRA Identity. GRAs consist of one or more cells and are allowed to overlap as well as to overlap BSCs/RNCs and LAs/RAs. One or more GRA Identities are broadcast in the cell.

6.1.11 GERAN internal Cell Identity

A GERAN cell identity (GC-id) will be used to address cells in GERAN. The GC-id consists of the BSC-id identifying the BSC controlling the cell and a cell identity CI unique within that BSC. The same CI is used to address the cell for both *A/Gb mode* and *Iu mode*.

NOTE: In GERAN A/Gb mode, the CI is unique within the Location Area and in GERAN Iu mode, the CI needs to be unique within the BSC Area.

6.2 Relay

The relay function of GERAN functionality and whether some functions need to be standardized are FFS.

6.3 Radio Resource Control (RRC)

RRC is a layer 3 control plane protocol for radio resource management.

6.3.1 RRC Functions

The Radio Resource Control (RRC) layer handles the control plane signalling of Layer 3 between the MSs and the GERAN. The RRC performs the following functions:

- **Broadcast of information provided by the non-access stratum (Core Network):** The RRC layer performs system information broadcasting from the network to all MSs. The system information is normally repeated on a regular basis. The RRC layer performs the scheduling, segmentation and repetition when such broadcasting is carried on BCCH. This function supports broadcast of higher layer (above RRC) information. This information may be cell specific or not. As an example RRC may broadcast Core Network location service area information related to some specific cells.
- **Broadcast of information related to the access stratum (GERAN):** The RRC layer performs system information broadcasting from the network to all MSs. The system information is normally repeated on a regular basis. The RRC layer performs the scheduling, segmentation and repetition when such broadcasting is carried on BCCH. This function supports broadcast of typically cell-specific information.
- **Establishment, re-establishment, maintenance and release of an RRC connection between the MS and the GERAN:** The establishment of an RRC connection is initiated by a request from higher layers at the MS side to establish the first Signalling Connection for the MS. The establishment of an RRC connection includes an optional cell re-selection, an admission control, and a layer 2 signalling link establishment. The release of an RRC connection can be initiated by a request from higher layers to release the last Signalling Connection for the MS or by the RRC layer itself in case of RRC connection failure. In case of connection loss, the MS

requests re-establishment of the RRC connection. In case of RRC connection failure, RRC releases resources associated with the RRC connection.

- **Establishment, reconfiguration and release of Radio Bearers:** The RRC layer can, on request from higher layers, perform the establishment, reconfiguration and release of Radio Bearers in the user plane. A number of Radio Bearers can be established to an MS at the same time. At establishment and reconfiguration, the RRC layer performs admission control and selects parameters describing the Radio Bearer processing in layer 2 and layer 1, based on information from higher layers.
- **Assignment, reconfiguration and release of radio resources for the RRC connection:** Depending on the RRC and MAC states, the RRC layer may handle the assignment of radio resources needed for the RRC connection including needs from both the control and user planes. The RRC layer may reconfigure radio resources during an established RRC connection. RRC indicates to the MS resource allocations for purposes of inter system handovers.
- **RRC connection mobility functions:** The RRC layer performs evaluation, decision and execution related to RRC connection mobility during an established RRC connection, such as handover, preparation of handover to UTRAN or other systems, cell re-selection and cell/GRA update procedures, based on e.g. measurements done by the MS.
- **Release of signalling connections:** The RRC layer provides the necessary functions for the GERAN or the MS to request the release of a signalling connection.
- **Paging/notification:** The RRC layer can broadcast paging information from the network to selected MSs on PCCCH making use of the MAC layer services. Higher layers on the network side can request paging and notification. The RRC layer can also initiate paging during an established RRC connection.
- **Listening to BCCH:** The RRC layer may need to listen to the BCCH of the serving cell for working out whether Iu mode is supported in this cell. The RRC layer listens to the BCCH of neighbouring cells for neighbour cell measurements; the RRC layer also receives paging information on the PCCCH.
- **Routing of higher layer PDUs:** This function performs at the MS side routing of higher layer PDUs to the correct higher layer entity, at the GERAN side to the correct RANAP entity.
- **Control of requested QoS:** This function shall ensure that the QoS requested for the Radio Bearers can be met. This includes the allocation of a sufficient number of radio resources.
- **MS measurement reporting and control of the reporting:** The measurements performed by the MS are controlled by the RRC layer including both GSM/EDGE air interface and other systems. The RRC layer is responsible for sending information that control the MS measurement reporting when using the SACCH channel. The RRC layer also performs the reporting of the measurements from the MS to the network using SACCH.
- **Power control:** The RRC layer controls parameters for normal power control, enhanced power control and fast power control.
- **Control of ciphering:** The RRC layer provides procedures for setting of ciphering (on/off) between the MS and GERAN.
- **Integrity protection:** This function controls integrity protection and performs integrity protection those RRC messages that are considered sensitive and/or contain sensitive information.
- **Support for Location Services.** Signaling between MS and GERAN to support positioning of an MS.
- **Timing advance control.** The RRC controls the operation of timing advance on dedicated basic physical subchannels.
- **Set-up, reconfiguration and release of the transport channels.** The RRC is responsible for the set-up, reconfiguration and release of the transport channels when FLO is used.

6.3.2 RRC Connection Levels

The different levels of RRC connection between MS and GERAN are listed below:

- No signalling connection exists
The MS has no relation to GERAN, only to CN. For data transfer, a signalling connection has to be established.
- A signalling connection exists
There is an RRC connection between the MS and GERAN. The MS position can be known on different levels:
 - GERAN Registration Area (GRA) level
The MS's position is known on GERAN registration area level. GRA is a specified set of cells, which can be identified in the PBCCH.
 - Cell level
The MS's position is known on cell level.

6.3.3 RRC Connection Modes

Two modes of operation are currently defined for the MS, RRC-Idle mode and RRC-Connected mode.

After power on, the MS in RRC-Idle mode may transmit a request to establish an RRC connection with the GERAN. In RRC-Idle mode the MS is identified by non-access stratum identities such as IMSI, TMSI and P-TMSI. In addition, the GERAN has no own information about the individual MSs in RRC-Idle mode, and can only address e.g. all MSs in a cell or all MSs monitoring a specific paging occasion.

The RRC-Connected mode is entered when the RRC connection is established between the MS and the GERAN. The MS is assigned a radio network temporary identity (G-RNTI) to be used as MS identity. MS is identified within a GERAN with the G-RNTI.

Three states are defined in RRC-Connected mode: RRC-Cell_Shared state, RRC-Cell_Dedicated state and RRC-GRA_PCH state.

In RRC-Cell_Shared state, no dedicated basic physical subchannel is allocated to the MS and the position of the MS is known by GERAN on cell level;

In RRC-Cell_Dedicated state, the MS is assigned one or more dedicated basic physical subchannels in the uplink and downlink, which it can use anytime. Furthermore, the MS may be assigned one or more shared basic physical subchannels. The position of the MS is known by GERAN on cell level.

In RRC-GRA_PCH state, no basic physical subchannel is allocated to the MS. No uplink activity is possible. The location of the MS is known on GERAN Registration area level.

The behaviour of the MS in each of these states is defined in 3GPP TS 44.118.

The MS leaves the RRC-connected mode and returns to RRC-idle mode when the RRC connection is released or at RRC connection failure.

6.3.4 RRC Connection Mobility

6.3.4.1 RRC Connection mobility in RRC-Idle mode

When the mobile station is in RRC-Idle mode, the CN knows the location of the mobile station at RA or LA level depending on the CN domain. There is no knowledge of the MS location within the BSS and paging is required to trigger an RRC connection establishment prior to any transfer with the MS. Such establishment moves the MS to RRC-Connected mode.

6.3.4.2 RRC Connection mobility in RRC-Connected mode

Handover procedures are used by the GERAN to control the mobility of the mobile station in RRC-Cell_Dedicated state. Such procedures are used to completely modify the channels allocated to the mobile station, e.g. when the cell is changed.

The GERAN is in charge of tracking the location of the mobile station, at cell or GRA level, when in RRC-Cell_Shared state or RRC-GRA_PCH state respectively. In such case, the CN to which a signalling connection is established knows

the location of the mobile station at the BSS level. Cell Update and GRA update procedures are defined to let the serving BSS know about any cell or GRA change.

Cell reselection to a new cell or new GRA may involve signalling exchanges between the mobile station and the source BSS through the Iur-g interface, depending on the mobile station's RRC state. A Serving BSS relocation may then be triggered by the source BSS.

Upon cell update, serving BSS relocation is triggered. Upon GRA update, it is an implementation issue whether to trigger a serving BSS relocation or not.

A cell can belong to several GRAs.

It is FFS whether RRAs may also be defined. An RRA could cover both GERAN and UTRAN cells. Cell/RRA updates may then not be triggered though the MS is moving from a GERAN/UTRAN cell to a UTRAN/GERAN cell.

6.3.5 RRC protocol and messages

The RRC protocol and the related RRC messages are defined in [24].

Service Areas are defined in GERAN. RRC procedures are identified by RRC Transaction Identifiers.

The procedures for inter-RAT cell change order between UTRAN and GERAN *A/Gb mode* are re-used when a cell change is ordered from/to a UTRAN cell to/from a GERAN cell in *Iu mode*.

The procedures for inter-RAT handover between UTRAN and GERAN *A/Gb mode* are re-used for inter-mode handover between GERAN *Iu mode* and GERAN *A/Gb mode*. Further consideration is however required to assess whether procedures for handover within GERAN *A/Gb mode* can be re-used.

6.3.6 Support of Radio Bearers in GERAN

The RRC layer is responsible for setting up radio bearers in the U-plane and the C-plane.

User Plane Radio Bearers are set-up when a Radio Access Bearer is required to be set-up by the Core Network.

Control Plane Radio Bearers are established when an RRC connection is set-up by a Mobile Station. Those comprise a set of five Signalling Radio Bearers:

- RB 0 is using DLC (as in Fig 10 of 43.051) and shall be used for all messages sent on the BCCH.
- RB 1 shall be used for all messages sent using RLC unacknowledged mode (RLC-UM).
- RB 2 shall be used for all messages sent using RLC acknowledged mode (RLC-AM), except for the RRC messages carrying higher layer (NAS) signalling.
- RB 3 and optionally RB 4 shall be used for all RRC messages carrying higher layer (NAS) signalling and sent using RLC acknowledged mode (RLC-AM).

Association of RBs 1 to 4 and logical channels is provided by the MAC protocol.

6.4 Packet Data Convergence Protocol (PDCP)

This clause provides an overview on services and functions provided by the Packet Data Convergence Protocol (PDCP). A detailed description of the PDCP is given in 3GPP TS 25.323.

6.4.1 Services provided to upper layers

The following services are provided by PDCP to upper layers:

- PDCP SDU delivery.

6.4.2 Services expected from RLC layer

- Data transfer in acknowledged mode.
- Data transfer in unacknowledged mode.
- Data transfer in transparent mode.
- Segmentation and reassembly.
- In-Sequence delivery.

6.4.3 PDCP Functions

For clarity reason, two PDCP modes are defined in the present document: transparent and non-transparent. The transparent and non-transparent modes relate respectively to the PDCP-no-header PDU and the PDCP-data PDU cases described in 3GPP TS 25.323.

The functions performed by the PDCP are dependent on the PDCP mode used.

6.4.3.1 Transparent Mode

The name "transparent" means that the PDCP layer does not change the incoming service data units (SDU), i.e. no header is added and possible TCP/IP or RTP/UDP/IP headers in the data are left untouched.

The functions of the transparent mode of PDCP are:

- **Transfer of user data;**
- **Relocation of PDCP buffer;**
- **PDCP SDU buffering.**

6.4.3.2 Non-Transparent Mode

The functions of the non-transparent mode of PDCP are:

- **Header adaptation** of the IP data streams;
- **Transfer of user data;**
- **PDCP SDU buffering;**
- **Relocation support appropriate to applicable QoS requirements;**
- **If adopted for UTRAN, multiplexing of radio bearers onto RLC entities.**

Different header adaptation mechanisms may be used by the PDCP:

- **Header compression:** Transport and network level headers (e.g. RTP/UDP/IP) are compressed in such a way that the decompressed headers are semantically identical to the original uncompressed headers. The IETF ROHC WG is responsible for standardising header compression schemes. Header compression is suited for standard internet applications that are not designed to work only with GERAN and especially for multimedia applications therefore the scheme will be used with generic realtime multimedia bearers.
- **Header removal:** Transport and network level headers (e.g. RTP/UDP/IP) are completely removed. Based on information submitted at call setup and based on information derived from lower layer (link & physical), the receiving entity can regenerate the headers. The primary application of header removal is the optimized speech bearer, and the regenerated header may not always be semantically identical to the original header.
- **No header adaptation:** Transport and network-level headers (e.g. RTP/UDP/IP) are forwarded.

6.5 Radio Link Control (RLC)

This clause provides an overview on services and functions provided by the Radio Link Control (RLC). A detailed description of the RLC is given in 3GPP TS 44.060 and 3GPP TS 44.160.

6.5.1 Services provided to upper layer

- **Transparent data transfer.** This service transmits higher layer PDUs without altering them nor adding any RLC protocol information.
- **Acknowledged data transfer.** This service transmits higher layer PDUs and guarantees delivery to the peer entity.
- **Unacknowledged data transfer.** This service transmits higher layer PDUs without guaranteeing delivery to the peer entity.
- **Notification of unrecoverable errors.** RLC notifies the upper layer of errors that cannot be resolved by RLC itself by normal exception handling procedures.
- **Notification of discard.** RLC notifies the upper layer of the higher layer PDUs (RLC SDUs) it discards.
- **A local suspend/resume function (FFS):** RLC operation may be suspended/resumed if requested by RRC. This service is used when the ciphering parameters need to be changed.
- **A stop/continue function (FFS):** RLC operation may be stopped/continued if requested by RRC. This service is used at Serving BSS relocation in order to synchronise the PDCP entities in the MS and BSS to realise a loss-less relocation.
- **A reset function (FFS)**

There is a single Radio Bearer per RLC instance.

6.5.2 RLC Functions

6.5.2.1 Transparent Mode

RLC has no functionality when operating in transparent mode. The incoming SDUs are transferred to the MAC layer without being altered. No upper layer protocol information is removed. No RLC protocol information is added. All necessary signalling is made out of band.

6.5.2.2 Non-Transparent Mode

In non-transparent mode, the RLC is responsible for ciphering user data blocks (RLC PDUs). This function prevents unauthorized acquisition of data.

6.5.2.2.1 Acknowledged Mode

RLC has support for the following functions in acknowledged mode. For a detailed description, see 3GPP TS 44.060 and 3GPP TS 44.160.

- **Segmentation** of upper layer PDUs into RLC data blocks.
- **Concatenation** of upper layer PDUs into RLC data blocks.
- **Padding** to fill out an RLC data block.
- **Backward Error Correction (BEC)** procedures enabling the selective retransmission of RLC data blocks. As for EGPRS R'99, either selective type I hybrid ARQ or selective type II hybrid ARQ (incremental redundancy) is used.
- **Discard** of RLC SDUs not yet segmented into RLC PDUs, according to the delay requirements of the associated Radio Bearer.

- **Reassembly** of RLC data blocks into upper layer PDUs.
- **In-sequence delivery** of upper layer PDUs.
- **Link Adaptation**.
- **Ciphering**.

6.5.2.2.2 Unacknowledged Mode

RLC has support for the following functions in unacknowledged mode. For a detailed description, see 3GPP TS 44.060 and 3GPP TS 44.160. No backward error correction procedure is supported in this mode.

- **Segmentation** of upper layer PDUs into RLC data blocks.
- **Concatenation** of upper layer PDUs into RLC data blocks.
- **Padding** to fill out an RLC data block.
- **Reassembly** of RLC data blocks into upper layer PDUs.
- **Sequence number check** to detect lost RLC blocks.
- **In-order delivery** of upper layer PDUs.
- **Link Adaptation**.
- **Ciphering**.

6.6 Medium Access Control (MAC)

This clause provides an overview on services and functions provided by the Medium Access Control (MAC). A detailed description of the MAC is given in 3GPP TS 44.060 and 3GPP TS 44.160.

6.6.1 Services provided to upper layers

The MAC layer allows the transmission over the physical layer of upper layer PDUs from one mobile station when operating on a dedicated basic physical subchannel, or one or more mobile stations when operating on a shared basic physical subchannel. The MAC layer handles the access to and multiplexing onto the basic physical subchannels. MAC does not allow for operation on shared basic physical subchannels using FLO.

- **Data transfer**. This service provides unacknowledged transfer of MAC SDUs between peer MAC entities. This service does not provide any data segmentation. Therefore, segmentation/reassembly function should be achieved by upper layer.

6.6.2 MAC Functions

The functions of MAC include:

- **Configuring the mapping between logical channels and basic physical subchannels**. The MAC is responsible for configuring the mapping of logical channel(s) onto the appropriate basic physical subchannel(s).
- **Defining logical channels to be used for each radio bearer service**. This function includes mapping of signalling radio bearers onto logical channels.
- **Assignment, reconfiguration and release of shared radio resources for a TBF**. The MAC layer may handle the assignment of radio resources on SBPSCH(s) needed for a TBF including needs from both the control and user plane. The MAC layer may reconfigure radio resources of a TBF on SBPSCH(s).
- **MS measurement reporting and control of the reporting**. The MAC layer is responsible for sending information that control the MS measurement reporting when using PBCCH or PACCH channels. The MAC layer also performs the reporting of the measurements from the MS to the network using PACCH.

- **Broadcasting/listening of/to PBCCH and PCCCH.** The MAC layer broadcasts/listens (to) the PBCCH of the serving cell for the sending/decoding of packet system information messages. The MAC layer also sends paging information on the PCCCH and monitors the paging occasions according to the DRX cycle. Within the Mobile Station, the MAC layer notifies the RRC layer when receiving a paging message; within the network, it is responsible for aggregating and sending paging messages addressed to one or more Mobile Stations when received from the RRC layer.
- **Timing advance control.** The MAC layer controls the operation of timing advance on shared basic physical subchannels.

The specific functions provided by the MAC protocol when FLO is used are listed below:

- **Mapping between TBFs and transport channels.** The MAC is responsible for mapping of TBF(s) onto the appropriate transport channel(s).
- **Selection of the appropriate transport format per transport channel.** The MAC is responsible for selecting the appropriate transport format for each transport channel within the transport format set configured by RRC so that the resulting transport format combination on the coded composite transport channel belongs to the transport format combination set configured by RRC.
- **Priority handling between data flows of one MS.**

6.6.2.1 Additional functions for RLC transparent mode

When MAC offers services to an RLC entity in transparent mode, the following function is also supported.

- **Ciphering.** The MAC is responsible for ciphering user data blocks (MAC SDUs).

6.6.2.2 Additional functions for RLC non-transparent mode

When MAC offers services to an RLC entity in non-transparent mode, the following functions are supported in addition to those listed in section 6.6.2.

- **Ciphering.** The MAC layer is responsible for ciphering layer 2 control blocks (RLC/MAC PDUs).
- **Identification of different traffic flows of one or more MSs on the basic physical subchannels.** Inband identification is needed to address a flow to an MS in the downlink or identify a flow from an MS in the uplink.
- **Multiplexing/demultiplexing of higher layer PDUs.** This function includes priority handling between data flows of one or more mobile stations, e.g. by attributes of Radio Bearer services.
- **Multiplexing/demultiplexing user and control plane data to/from the physical layer.** The MAC layer is responsible for multiplexing/demultiplexing RLC data blocks and RLC/MAC control blocks.
- **Scheduling of RLC/MAC data and control PDUs delivered to the physical layer on shared basic physical subchannels.** This includes USF and RRBP field monitoring for uplink transfer and sharing radio resources on the downlink.
- **Splitting/recombining.** This includes splitting/recombining of the RLC/MAC PDU flow belonging to one or more TBF(s) onto/from several shared logical channels. This function does not apply for RLC/MAC control blocks.

6.6.3 Model of MAC

The model presented in this section does not mandate how to implement the MAC layer.

In this model, the functions of MAC are controlled by a MAC control entity and a MAC common control entity.

The MAC control entity is specific to an MS. It is controlled by RRC; at RB establishment, the MAC control entity sets-up the functions needed to support the Radio Bearer. The MAC control entity can be in one of four states MAC-Idle state, MAC-Shared state, MAC-Dedicated state or MAC-DTM state, as defined in Annex C.2. The MAC functions listed in the above sub-sections do not apply in every MAC state.

There is one and only one MAC control entity on the MS side. On the network side, there is one MAC control entity per MS. Additionally, there is one MAC common control entity per cell, which is responsible for the control of common channels and procedures.

Figure 13 below shows an example of MAC model to realise a set of Radio Bearers on the MS side (user plane only), when FLO is not used. It shows the MAC Control Entity for that MS, together with some MAC functions that are used in this case.

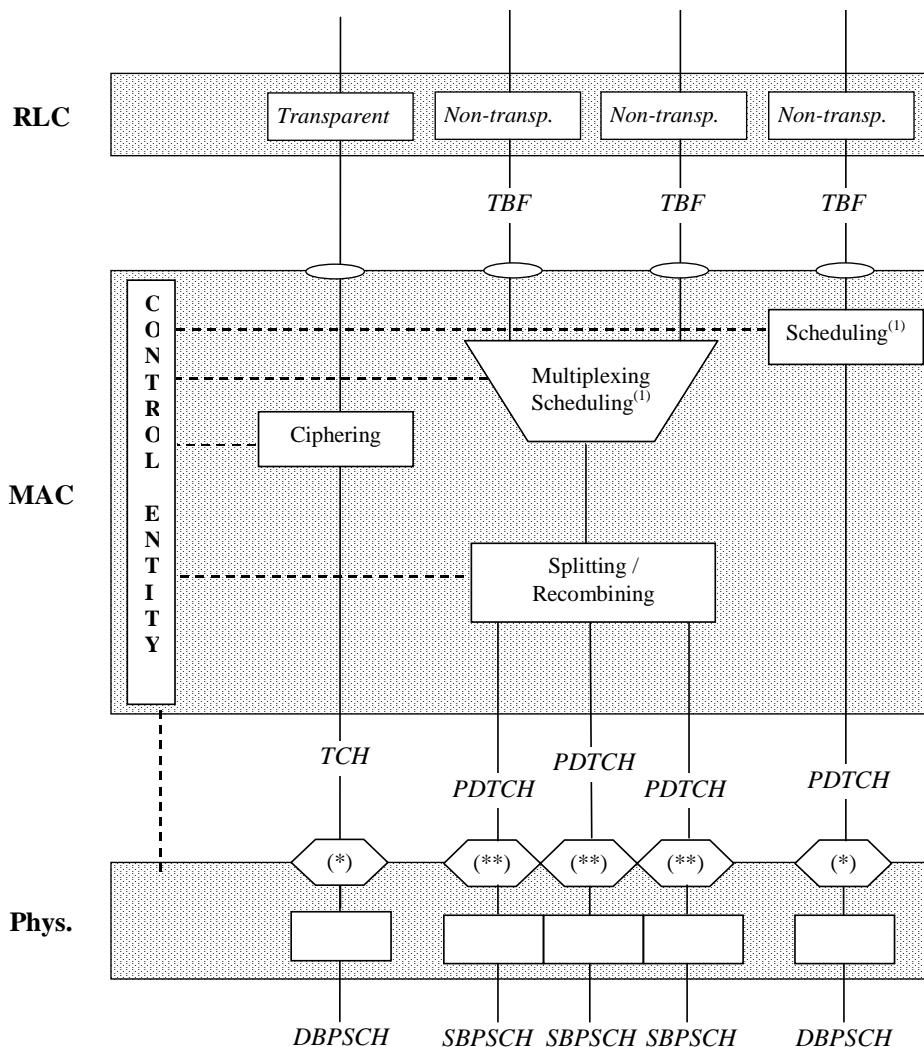

(*): Such a SAP is created, re-configured and released by RRC ——— User plane data
 (**): Such a SAP is created, re-configured and released by MAC - - - - - Control plane data
 (1): The scheduling function in this figure includes multiplexing user and control plane data and appending a MAC (possibly combined RLC/MAC) header to the MAC SDU.

Figure 13. Example of MAC functions for one user (MS side – user plane)

6.6.4 MAC operation

6.6.4.1 General

The MAC layer uses TBFs (Temporary Block Flows) to offer data transport between peer RLC instances. The MAC layer supports transport of data between multiple peer RLC instances established in a single MS and the GERAN.

When FLO is used [38], the MAC layer offers TBFs to the RLC layer. Three different DCHs are introduced, namely CDCH (Control-plane DCH), UDCH (User-plane DCH) and ADCH (Associated DCH). While CDCH and UDCH are used exclusively for transmission of RLC/MAC blocks for data transfer (from control-plane and user-plane,

respectively), ADCH is used exclusively for transmission of RLC/MAC control blocks. CDCH and ADCH use the signalling TFC(s) as follows:

- On a DBPSCH/F, one signalling TFC is used for all RLC/MAC blocks.
- On a DBPSCH/H, two signalling TFCs are used. The MAC layer transmits every RLC/MAC block twice in a row. The first and second transport blocks used by the RLC/MAC block use the first and second signalling TFCs, respectively.

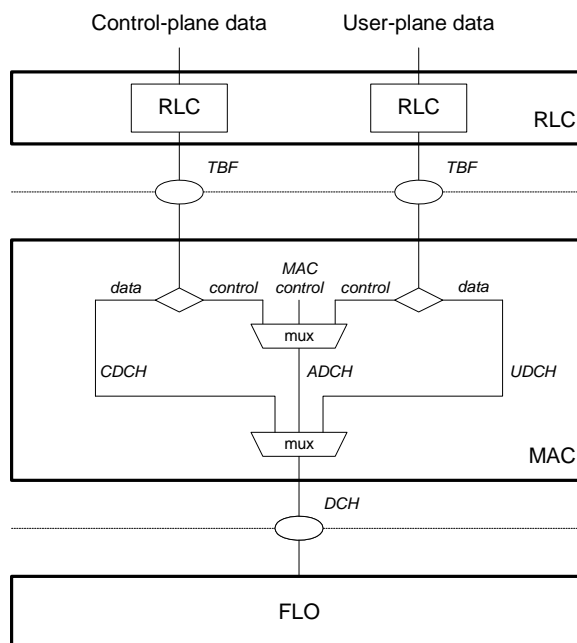

Figure 14: Logical Channels and Transport Channels

A TBF provides unidirectional data transport on one or more basic physical subchannels of the same type (either SBPSCH or DBPSCH). RRC may reconfigure a TBF from using one or more SBPSCHs to using one or more DBPSCHs (and vice versa). More than one TBF may be allocated to a single MS in any direction. A TBF may transport data for the following combination of RLC instances:

- A single RLC instance carrying data for a URB.
- A single RLC instance carrying data for an SRB.
- A single RLC instance carrying data for a URB or an SRB, and using TBF stealing, one or more RLC instances each carrying data for an SRB for which no specific TBF is currently established. This combination is only supported by TBFs on SBPSCH.

Multiple TBFs are supported on all logical channels except TCH and common control channels.

Any MS operating in *Iu mode* supports multiple TBFs in uplink and downlink. MSs supports 8 uplink TBFs and 8 downlink TBFs.

6.6.4.2 TBF establishment

6.6.4.2.0 General

Uplink TBFs on SBPSCHs are established as follows:

- An MS issues a MAC-layer request followed by the GERAN returning a MAC-layer assignment. This is used when the MS is in *MAC-Idle state*, *MAC-Shared state*, or *MAC-DTM state*.
- An MS issues an RRC-layer request followed by GERAN returning an RRC-layer message that assigns TBFs to existing RBs on an SBPSCH. This is used when the MS is in *MAC-Dedicated state*.

- The GERAN sends an RRC-layer message that sets up or reconfigures RBs on an SBPSCH. This is used when the MS is in *MAC-Shared state*, *MAC-Dedicated state*, or *MAC-DTM state*.

Uplink TBFs on DBPSCHs are established as follows:

- An MS issues a MAC-layer request followed by the GERAN returning a MAC-layer dedicated assignment. This implicitly establishes 4 TBFs for SRBs 1 through 4. This is used when the MS is in *MAC-Idle state*.
- The GERAN sends an RRC-layer message that sets up or reconfigures radio bearers on a DBPSCH. This implicitly establishes 4 TBFs for SRBs 1 through 4. It may also explicitly establish TBFs and USFs for URBs. This is used when the MS is in *MAC-Shared state*, *MAC-Dedicated state*, or *MAC-DTM state*.

Downlink TBFs on SBPSCHs are established as follows:

- The GERAN sends a MAC-layer assignment. This is used when the MS is in *MAC-Idle state*, *MAC-Shared state*, or *MAC-DTM state*.
- The GERAN sends an RRC-layer message that sets up or reconfigures RBs on an SBPSCH. This is used when the MS is in *MAC-Shared state*, *MAC-Dedicated state*, or *MAC-DTM state*.

Downlink TBFs on DBPSCHs are established as follows:

- The GERAN sends a MAC-layer dedicated assignment. This implicitly establishes 4 TBFs for SRBs 1 through 4. The GERAN may send the MAC-layer dedicated assignment in response to an MS issuing a MAC-layer request. This is used when the MS is in *MAC-Idle state*.
- The GERAN sends an RRC-layer message that sets up or reconfigures RBs on a DBPSCH. This implicitly establishes 4 TBFs for SRBs 1 through 4. It may also explicitly establish TBFs for URBs. This is used when the MS is in *MAC-Shared state*, *MAC-Dedicated state*, or *MAC-DTM state*.

6.6.4.2.1 Uplink resource request from MAC-Idle state

6.6.4.2.1.1 Mobile Originated Transmission

When the mobile station is in MAC-Idle state and requests the establishment of a TBF or dedicated resource, an RLC/MAC control message (PACKET CHANNEL REQUEST or EGPRS PACKET CHANNEL REQUEST message) is sent on the PRACH. In this message, the mobile station indicates one establishment cause from the following list:-

- "Single Block Without TBF Establishment", "One Phase Access Request", "One Phase Access Request in RLC unack mode", "Short Access Request", "Two Phase Access Request", "MM Procedure", "Dedicated channel request", "Emergency call"

To establish a TBF for a user radio bearer, one of the following is used:-

- "One Phase Access Request", "One Phase Access Request in RLC unack mode", "Short Access Request", "Two Phase Access Request"

To establish a TBF or dedicated resource for a signalling radio bearer, one of the following is used:-

- "Single Block Without TBF Establishment", "MM Procedure", "Dedicated channel request", "Emergency call"

Note that "Page Response" and "Cell Update" establishment causes are only to be used in A/Gb mode.

6.6.4.2.1.2 Mobile Terminated Transmission

For mobile terminated transmission, when a paging request message containing a paging cause is sent to the mobile station, the mobile station requests resources on the PRACH using one of two establishment causes as follows:-

To respond to paging causes "Terminating Conversational Call" or "Terminating Streaming Call" the mobile station indicates:-

- "Dedicated channel request"

To respond to paging causes "Terminating Interactive Call", "Terminating Background Call", "Terminating High Priority Signalling", "Terminating Low Priority Signalling", or "Terminating – cause unknown" the mobile station indicates:-

- "MM Procedure"

6.6.4.3 TBF multiplexing and scheduling

6.6.4.3.1 Multiplexing of RLC instances on TBFs

When one TBF carries data for one RLC instance, multiplexing is trivial. This case is analogous to REL-4 and previous releases.

When one TBF, in addition to a first RLC instance, carries data for one or more RLC instances, each carrying data of an SRB for which no specific TBF is currently established, the MAC layer uses TBF stealing to multiplex data from these RLC instances onto the TBF. This stealing mechanism allows the MAC layer to send SRB data without signalling to set up a separate TBF. To send data using this mechanism, the GERAN or MS MAC layer performs the following:

- It selects one of the TBFs currently established on an SBPSCH for the MS in question.
- It adds the SRBId to the RLC/MAC header to allow the receiving MAC entity to detect that TBF stealing is used and to forward the received data to the correct RLC instance.
- It sends the SRB-related data in the next scheduling opportunity for the selected TBF.

6.6.4.3.2 Scheduling of TBFs on physical-layer resources

TBFs are scheduled on a radio-block basis according to their QoS attributes.

An established uplink TBF is scheduled as follows:

- On an SBPSCH, the MS sends data for the TBF that corresponds to the received USF. If no TBF corresponds to the received USF, the MS does not send.
- On a DBPSCH with a PDTCH-type channel combination, if the MS has more than one TBF with data to send, the MS sends data for the TBF that corresponds to the received USF. If the MS has nothing to send for the scheduled TBF, and if the MS has data to send for one or more other TBFs mapped onto the same BPSCH, the MS sends data from one of these other TBFs.
- On a DBPSCH with a PDTCH-type channel combination, if the MS has only one TBF with data to send, the MS ignores the USF and sends data for that TBF. This allows the GERAN to reduce downlink interference by not transmitting if there is no downlink data to send.
- On a DBPSCH with a PDTCH-type channel combination, when a previously inactive TBF again has data to send, the MS shall send one data block for this TBF the next time the GERAN schedules any of the MS's TBFs. This notifies GERAN that this TBF has again become active. The GERAN decodes the TFI and then schedules this TBF according to its QoS attributes. To handle the case where the GERAN fails to decode the TFI in the data block from this TBF, a repetition scheme is standardized for the MS.
- On a DBPSCH with a TCH-type channel combination, the multiframe structure and MS stealing rules determine which TBFs are scheduled, analogous to CS operation for REL-4.

An established downlink TBF is scheduled by the GERAN.

6.6.4.4 TBF release

An uplink TBF is released as follows:

- On an SBPSCH, the GERAN releases the TBF by sending a PACKET UPLINK ACK/NACK with the *final ack indicator* set to 1.
- On a DBPSCH, the GERAN releases the TBF by releasing the DBPSCH, by releasing the corresponding radio bearer, or by reconfiguring the corresponding radio bearer to another BPSCH.

A downlink TBF is released as follows:

- On an SBPSCH, the GERAN initiates release by sending a data block with *final block indicator* set to 1. The MS acknowledges the release.
- On a DBPSCH, the GERAN releases the TBF by releasing the DBPSCH, by releasing the corresponding radio bearer, or by reconfiguring the corresponding radio bearer to another BPSCH.

6.6.4.5 TBF reallocation

Considering the mobile station's multislot capabilities, GERAN may reallocate one or more of a mobile station's TBFs:

- To a different radio frequency or a different hopping sequence. All of a mobile station's TBFs operate on one radio frequency or one hopping sequence.
- To different timeslots (the same number, more, or fewer).
- To use a different TFI for a given TBF.
- To use different USFs for a given uplink TBF.
- To use different coding schemes or modulation-and-coding schemes.

This reallocation may be in response to a mobile-station request.

When only SBPSCHs are allocated, GERAN MAC or GERAN RRC signals the reallocation.

When at least one DBPSCH is allocated, GERAN RRC signals the reallocation.

6.7 RLC/MAC PDU Formats for different protocol modes

6.7.1 Acknowledged RLC mode

The GPRS/EGPRS channel codes RLC/MAC header and coding schemes (CS-1, ... ,CS-4 and MCS-1, ... , MCS-9) are used. Other coding schemes are CSD/ECSD.

6.7.2 Unacknowledged RLC mode

The GPRS/EGPRS channel codes RLC/MAC header and coding schemes (CS-1, ... ,CS-4 and MCS-1, ... , MCS-9) are used. Other coding schemes are CSD/ECSD when operating on a dedicated basic physical subchannel.

6.7.3 Transparent RLC mode

The transparent mode is used for example to transmit voice in GERAN. The different channel coding schemes used for voice in GSM are used. New coding schemes for 8-PSK half rate and possibly full rate speech are also required. Other coding schemes like e.g. CSD/ECSD is FFS.

Since RLC is used in transparent mode, no RLC/MAC header has to be added.

6.8 Physical Layer (Phy)

The physical layer (layer 1) is the lowest layer in the OSI Reference Model and it supports all functions required for the transmission of bit streams on the physical medium. This clause provides an overview on services and functions provided by the Physical Layer. A detailed description of the physical layer is given in [Ref: 05 series]. The Flexible Layer One part of the physical layer is described in subclause 6.9.

6.8.1 Definitions

A **physical channel** uses a combination of frequency and time division multiplexing and is defined as a sequence of radio frequency channels and time slots. The complete definition of a particular physical channel consists of a description in the frequency domain, and a description in the time domain [11].

A **basic physical channel** is defined as a sequence of radio frequency channels and time slots. The basic physical channel uses the same timeslot in every TDMA frame. The TDMA frame number sequence is 0,1,.. FN_MAX, where FN_MAX is the maximum TDMA frame number for a hyperframe (i.e. all TDMA frames on a timeslot).

A **basic physical subchannel** is defined as a basic physical channel or a part of a basic physical channel and an associated multiframe structure. A basic physical subchannel can either be shared or dedicated. Example: DBPSCH/F.

A **logical channel** is defined by the type of data which is transferred and characterized by parameters such as channel coding and interleaving. It can be uni-directional or bi-directional [11]. Example: PDTCH/U, TCH/FS, FACCH/F.

A **channel combination** is defined as the combination of logical channels that is mapped on a certain basic physical subchannel. Example: TCH/FS+FACCH/F+SACCH/TF. The channel combination could also be mapped onto a basic physical channel, example: TCH/H(0,1)+FACCH/H(0,1)+SACCH/TH(0,1) [11].

6.8.2 Services provided to upper layer

The physical layer interfaces the Medium Access Control (MAC) sub-layer of Layer 2 and the Radio Resource Control (RRC) sub-layer of Layer 3. Through Service Access Points (SAP), the physical layer offers services described below:

- **Access capabilities:** the physical layer offers logical channels and the transmission services associated to higher layers. Logical channels are multiplexed either in a fixed predefined manner (multiframe structure) or dynamically by the MAC on basic physical subchannels. Basic physical subchannels are the units scheduled on the radio medium. Some are reserved by the network for common use (e.g. for use by a combination of PCCCH and PBCCH), others are assigned to dedicated connections with MSs (dedicated basic physical subchannels), or are assigned to a shared usage between MSs (shared basic physical subchannels).
- **Error detection:** the physical layer offers an error protected transmission service, it includes error detection functions and to a lower level, error correction functions. Erroneous received frames may be notified to upper layer and, depending on the need of the upper layer, offered to it. The probability of one or more errors in a physical block transferred by the physical layer is defined in 3GPP TS 45.005. Due to non specified methods of quality detection, the probability of residual errors in transferred blocks may vary between implementations.

6.8.2.1 Specific services of the physical layer in the MS

- Measurement of the signal strength of neighbouring base stations. Measurements are transferred to layer 3.
- Measurement of the signal quality of the basic physical subchannel used. Measurements are transferred to the MAC layer for reporting to the base station.
- Cell/PLMN selection in idle mode or in packet mode. In idle mode or in packet mode, the physical layer selects the best cell with its BCCH (CPBCCH only for COMPACT and for packet mode only) in close co-operation with layer 3, meeting requirements for PLMN selection specified in 3GPP TS 42.011.

6.8.3 Logical Channels

6.8.3.1 Traffic channels

Traffic channels of type TCH are intended to carry either encoded speech or user data on dedicated basic physical subchannel. TCH can be either full rate (TCH/F) or half rate (TCH/H).

Traffic channels of type O-TCH are intended to carry encoded speech on dedicated basic physical subchannel. O-TCH can be either full rate (O-TCH/F) or half rate (O-TCH/H).

Traffic channels of type E-TCH are intended to carry user data on dedicated basic physical subchannels.

Packet data traffic channels (PDTCH) are intended to carry user data on either dedicated or shared basic physical subchannels. PDTCH's can be either full rate (PDTCH/F) or half rate (PDTCH/H).

6.8.3.2 Control channels

Control channels carry signalling or synchronization data. Four categories of control channels are defined: broadcast, common, dedicated control channels and cell broadcast channels. Specific channels within these categories are defined in the clauses following.

6.8.3.2.1 Broadcast channels

GERAN shall reuse Release 99 broadcast channels. Any addition shall be made in a backwards compatible manner.

6.8.3.2.2 Common control type channels

GERAN common control type channels shall be based on Release 99 common control type channels. Any addition shall be made in a backwards compatible manner.

6.8.3.2.3 Dedicated control channels

On a dedicated basic physical subchannel:

- i) The Fast Associated Control channel (FACCH) associated to one TCH. FACCH can either be full rate (FACCH/F, E-FACCH/F, O-FACCH/F) or half rate (FACCH/H, O-FACCH/H) depending whether it is associated to a full rate or half rate TCH.
- ii) The Packet Associated Control channel (PACCH) associated to one PDTCH: The PACCH is bi-directional. PACCH/U is used for the uplink and PACCH/D for the downlink. PACCH can either be full rate (PACCH/F) or half rate (PACCH/H) depending whether it is associated to a full rate or half rate PDTCH.
- iii) The Slow Associated Control channel (SACCH) associated to one TCH or PDTCH. SACCH can either be full rate (SACCH/TF) or half rate (SACCH/TH) depending whether it is associated to a full rate or half rate TCH or PDTCH. Further, the SACCH can be associated either to a TCH or PDTCH where EPC is not deployed (SACCH/T) or a TCH or PDTCH where EPC is deployed (SACCH/TP).
- iv) The Enhanced Power Control channel (EPCCH) associated to one TCH or PDTCH. EPCCH can be either full rate (EPCCH/F) or half rate (EPCCH/H) depending on whether it is associated to a full rate or half rate TCH or PDTCH.
- v) The Stand-alone Dedicated Control Channel (SDCCH) is a bi-directional dedicated control channel whose allocation is not linked to the allocation of a TCH [UMTS 45.003].
- vi) The Enhanced Inband Associated Control Channel (E-IACCH/F) associated to one E-TCH/F.

On a shared basic physical subchannel:

- i) The Packet Associated Control channel (PACCH): The PACCH is bi-directional. PACCH/U is used for the uplink and PACCH/D for the downlink. PACCH can either be full rate (PACCH) or half rate (PACCH/H) depending whether it is associated to a full rate or half rate PDTCH.
- ii) The Packet Timing advance Control CHannel uplink (PTCCH/U): Used to transmit random access bursts to allow estimation of the timing advance for one MS in packet transfer mode.
- iii) The Packet Timing advance Control CHannel downlink (PTCCH/D): Used to transmit timing advance updates for several MS. One PTCCH/D is paired with several PTCCH/U's.

6.8.3.2.4 Cell Broadcast Channel (CBCH)

GERAN shall reuse Release 99 cell broadcast channel.

6.8.4 Basic Physical Subchannels

A basic physical subchannel can either be dedicated or shared.

All basic physical subchannels are bi-directional unless otherwise stated.

6.8.4.1 DBPSCH - Dedicated Basic Physical SubChannel

A DBPSCH is for only one user and it always has an associated SACCH. A DBPSCH can either be full rate or half rate.

6.8.4.2 SBPSCH - Shared Basic Physical SubChannel

A SBPSCH is for one or more users. A SBPSCH can either be full rate or half rate.

6.8.5 Mapping of logical channels onto basic physical subchannels

6.8.5.1 DBPSCH full rate

The following channel combinations are possible for a DBPSCH full rate:

- i) TCH/F + FACCH/F + SACCH/TF;
- ii) TCH/F + FACCH/F + SACCH/TPF + EPCCH/F;
- iii) PDTCH/F + PACCH/F + SACCH/TF;
- iv) PDTCH/F + PACCH/F + SACCH/TPF + EPCCH/F;
- v) E-TCH/F + E-FACCH/F + SACCH/TF + E-IACCH/F;
- vi) O-TCH/F + O-FACCH/F + SACCH/TF;
- vii) O-TCH/F + O-FACCH/F + SACCH/TPF + EPCCH/F.

Figure 13 shows the multiframe mapping of the logical channels for DBPSCH/F.

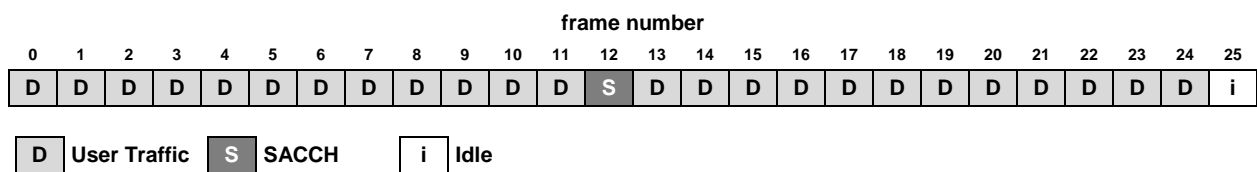

Figure 13: DBPSCH/F - Multiframe mapping of logical channels

Note: When EPC is used, the EPCCH is mapped on the bits of the SACCH bursts.

6.8.5.2 DBPSCH half rate

The following channel combinations are possible for a DBPSCH half rate:

- i) TCH/H + FACCH/H + SACCH/TH;
- ii) TCH/H + FACCH/H + SACCH/TPH + EPCCH/H;
- iii) O-TCH/H + O-FACCH/H + SACCH/TH;
- iv) O-TCH/H + O-FACCH/H + SACCH/TPH + EPCCH/H;
- v) PDTCH/H + PACCH/H + SACCH/TH;

vi) PDTCH/H + PACCH/H + SACCH/TPH + EPCCH/H.

Figure 14 shows the multiframe mapping of the logical channels for DBPSCH/H.

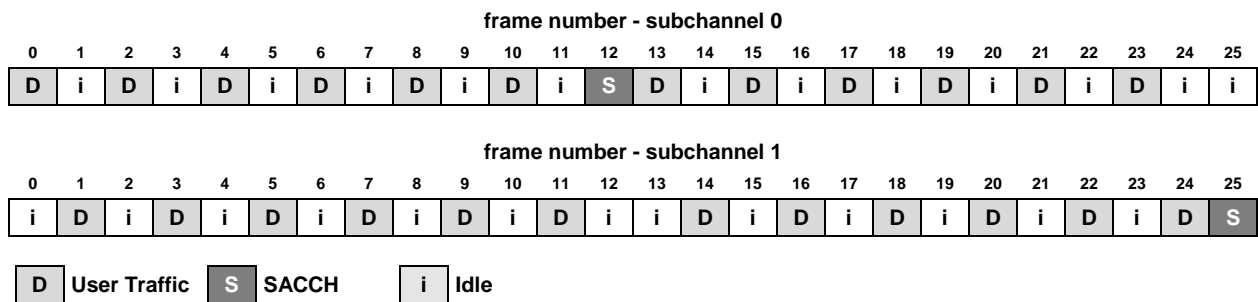

Figure 14: DBPSCH/H - Multiframe mapping of logical channels

Note: When EPC is used, the EPCCH is mapped on the bits of the SACCH bursts.

6.8.5.3 SBPSCH full rate

Excluding CBCH, broadcast channels and common control type channels, the following channel combination is possible for a SBPSCH full rate:

- PDTCH/F + PACCH/F + PTCCH/F.

Figure 15 shows the multiframe mapping of the logical channels for SBPSCH/F. Only half of the 52-multiframe is shown, the second half being identical to the first one.

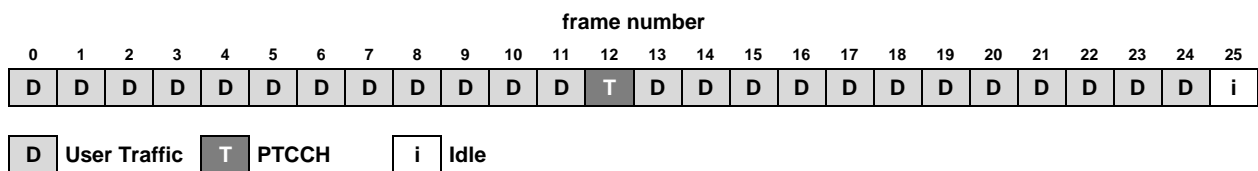

Figure 15: SBPSCH/F - Multiframe mapping of logical channels

6.8.5.4 SBPSCH half rate

The following channel combination is possible for a SBPSCH half rate:

- PDTCH/H + PACCH/H.

Figure 16 shows the multiframe mapping of the logical channels for SBPSCH/F. Only half of the 52-multiframe is shown, the second half being identical to the first one.

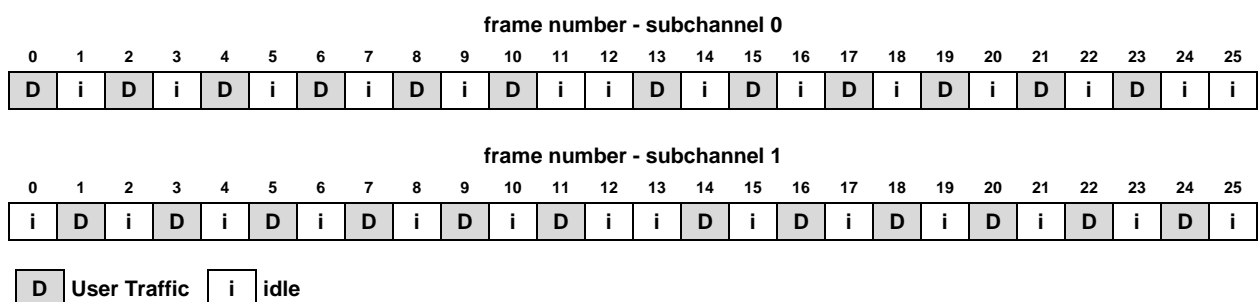

Figure 16: SBPSCH/H - Multiframe mapping of logical channels**6.8.6 Physical Layer Functions**

An overview of the functions which create the services of the physical layer can be found in 3GPP TS 45.001.

6.8.7 Channel Coding

Table 2 gives an overview of the logical traffic channels with the corresponding type of channel and their mapping to basic physical subchannel. The list shall be considered as the possible, but not mandatory, channels.

Table 2: Channel Coding

Logical Channel	Mod.	Radio Block / Frame Size (Bits)	SB	Channel Coding		Interleaving		Basic Physical Subchannel			
				Type	Rate	Type	Depth (bursts)				
TCH/FS [tbd] (2)	GMSK	464	8	CC	13 kbps	diag	8	DBPSCH/F			
TCH/EFS [tbd] (2)	GMSK	464	8	CC	12.2 kbps	diag	8	DBPSCH/F			
TCH/WFS [tbd] (3)	GMSK	464	8	CC	[tbc]	diag	8	DBPSCH/F			
O-TCH/WFS[tbd] (3)	8PSK	1392	24	CC	[tbc]	diag	8	DBPSCH/F			
O-TCH/WHS [tbd] (3)	8PSK	696	12	CC	[tbc]	diag	4	DBPSCH/H			
TCH/HS [tbd] (2)	GMSK	232	4	CC	5.6 kbps	diag	4	DBPSCH/H			
TCH/AFS	GMSK	464	8	CC	TCH/AFS4.75 TCH/AFS5.15 TCH/AFS5.90 TCH/AFS6.70 TCH/AFS7.40 TCH/AFS7.95 TCH/AFS10.2 TCH/AFS12.2	diag	8	DBPSCH/F			
TCH/AHS	GMSK	232	4	CC	TCH/AHS4.75 TCH/AHS5.15 TCH/AHS5.90 TCH/AHS6.70 TCH/AHS7.40 TCH/AHS7.95	diag	4	DBPSCH/H			
O-TCH/AHS	8PSK	696	12	CC	O-TCH/AHS4.75 O-TCH/AHS5.15 O-TCH/AHS5.90 O-TCH/AHS6.70 O-TCH/AHS7.40 O-TCH/AHS7.95 O-TCH/AHS10.2 O-TCH/AHS12.2	diag	4	DBPSCH/H			
TCH/F	GMSK	464	8	CC	TCH/F9.6 TCH/F14.4	diag	22	DBPSCH/F			
E-TCH/F	8PSK	1392	24	RS+C C CC	E-TCH/F28.8 E-TCH/F32.0 E-TCH/F43.2	diag	22	DBPSCH/F			
PDTCH/F	GMSK	464	8+4	CC	MCS1-4	rect	4	SBPSCH/F			
			8		CS1-4			DBPSCH/F			
			8+4		MCS1-4			ffs	ffs	DBPSCH/F	
			8		CS1-4						
			8+4		MCS1-4						
			8		CS1-4						
	8PSK	1392	8		MCS5-9	rect	4				SBPSCH/F
			8		MCS5-9	DBPSCH/F					
PDTCH/H	GMSK	464	8+4	CC	MCS1-4	rect	4	SBPSCH/H			
			8		CS1-4			DBPSCH/H			
			8+4		MCS1-4			ffs	ffs	DBPSCH/H	
			8		CS1-4						
			8+4		MCS1-4						
			8		CS1-4						
	8PSK	1392	8		MCS5-9	rect	4				SBPSCH/H
			8		MCS5-9	DBPSCH/H					
			8		MCS5-9	ffs	ffs	DBPSCH/H			

(2) The possibility to establish TCH/EFS, TCH/FS, TCH/HS speech channels is to be decided by 3GPP SA2
 CC: Convolutional Code.
 RS: Reed Solomon code.

The table above remains to be completed.

Except for the already existing logical channels, the 8PSK modulated logical channels are indicated by an "O-" prefix (as in Octal PSK).

Table 3 gives an overview of the logical control channels used for speech and circuit switched data, and their associated logical traffic channel.

Table 3: Control channel coding

Logical Channel	Mod.	Radio Block / Frame Size (Bits)	SB	Channel Coding		Interleaving		Associated logical traffic channel
				Type	Rate	Type	Depth (bursts)	
FACCH/F	GMSK	464	8	CC	9.2 kbps	diag	8	TCH/F
O-FACCH/F	8PSK	1392	24	CC	9.2 kbps	diag	8	O-TCH/F
FACCH/H	GMSK	464	8	CC	4.6 kbps	diag	6	TCH/H
O-FACCH/H	8PSK	1392	24	CC	4.6 kbps	diag	6	O-TCH/H
SACCH/F	GMSK	464	8	CC	184/480 kbps	block	4	TCH/F, E-TCH/F & O-TCH/F
SACCH/H	GMSK	464	8	CC	184/480 kbps	block	4	TCH/H & O-TCH/H
SACCH/TPF	GMSK	416	8	CC	184/480 kbps	block	4	TCH/F & O-TCH/F with EPC
SACCH/TPH	GMSK	416	8	CC	184/480 kbps	block	4	TCH/H & O-TCH/H with EPC
E-FACCH/F	GMSK	464	8	CC	9.2kbps	block	4	E-TCH/F
E-IACCH/F	8PSK	24	-	BC	3/20 kbps	-	4	E-TCH/F
EPCCH/F	GMSK	12	-	BC	3/120 kbps	-	1	TCH/F & O-TCH/F with EPC
EPCCH/H	GMSK	12	-	BC	3/120 kbps	-	1	TCH/H & O-TCH/H with EPC

CC: Convolutional Code.

BC: Block code

Except for the already existing logical channels, the 8PSK modulated logical channels are indicated by an "O-" prefix (as in Octal PSK).

6.6.8 Enhanced Power control procedure

In addition to the normal power control, an enhanced power control scheme (EPC) shall be supported by the MS and may optionally be supported by the BSS, when operating on a DBPSCH.

EPC has a reporting period of 26 TDMA frames (120 ms). A dedicated control channel, the EPCCH, is used for the purpose of EPC. For MS power control, EPC power commands are sent on the downlink EPCCH. For BTS power control, EPC measurement reports are sent on the uplink EPCCH.

If EPC is in use, the normal SACCH (SACCH/TF or SACCH/TH) is replaced by a modified SACCH (SACCH/TPF or SACCH/TPH). The EPCCH is multiplexed with the SACCH/TP. One EPCCH frame is multiplexed with each burst of the SACCH/TP. The multiplexing is done on the physical layer.

6.8.8.1 MS implementation

Enhanced power control shall be implemented in the MS.

When on a DBPSCH, the MS shall use EPC, if so indicated by the BSS in the ASSIGNMENT COMMAND or HANDOVER COMMAND (see 3GPP 44.018).

6.8.8.1.1 MS power control

If EPC is in use, the MS shall employ the most recently commanded EPC level on each uplink DBPSCH. The power level to be employed by the MS is indicated by means of the EPC power command sent via EPCCH once every EPC reporting period. The MS shall report, in the SACCH L1 header, the RF power level used at the end of the normal power control reporting period.

NOTE: The term "normal power control" is used in this specification for clarification and is otherwise referred to as "power control".

The enhanced power control scheme is based on differential control to adjust the employed RF power level. The possible EPC power commands are the same as for fast power control used for ECSD [3GPP TS 45.008].

6.8.8.1.2 MS link quality measurement reports

When employing EPC, the MS shall use the uplink EPCCH for EPC measurement reporting.

For each DBPSCH on which EPC is in use, the received signal quality shall be measured by the MS in a manner that can be related to the average BER before channel decoding, assessed over one EPC reporting period.

The average BER shall for every EPC reporting period be mapped to the RXQUAL scale according to 45.008 [], producing the parameter RXQUAL_EPC which is reported to the network via EPCCH.

6.8.8.2 BSS implementation

Enhanced power control may optionally be implemented in the BSS.

6.9 Flexible Layer One (FLO)

6.9.1 General

The Flexible Layer One belongs to the Physical Layer. It operates on DBPSCH only.

6.9.2 Definitions

Transport Block: block exchanged on a transport channel between the physical layer and the MAC sublayer. It contains an RLC/MAC block.

Transport Channel: a transport channel is offered by the physical layer to the MAC sublayer for exchange of transport blocks. A transport channel is used to carry with a certain quality of service, a data flow over the radio interface.

Transport Format: configuration of a transport channel, including CRC size, transport block length, etc.

Transport Format Combination: allowed combination of transport format(s) of the different transport channels that are multiplexed together on a basic physical subchannel.

6.9.3 Principles

6.9.3.1 General

The radio interface protocol architecture around the Flexible Layer One (FLO) is depicted in subclause 5.1. With FLO, the physical layer offers transport channels to the MAC sublayer. A transport channel is characterized by how the

information is transferred over the radio interface. The offered transport channels are Dedicated CHannels (DCH). A DCH is a channel dedicated to one MS.

Each transport channel can carry one data flow providing a certain Quality of Service (QoS). A number of transport channels can be multiplexed and sent on the same basic physical subchannel at the same time within the same TTI.

The configuration of a transport channel i.e. the number of input bits, CRC size etc. is denoted the Transport Format (TF). A number of different transport formats can be associated to one transport channel. The configuration of the transport formats is under control of the GERAN and signalled to the MS at call set-up. In both the MS and the BSS, the transport formats are used to configure the encoder and decoder units. When configuring a transport format, the GERAN can choose between a number of predefined CRC lengths and code types.

On transport channels, transport blocks (TB) are exchanged between the MAC layer and the physical layer on a transmission time interval (TTI) basis. For each TTI a transport format is chosen and indicated through the transport format indicator (TFIN). When a transport channel is inactive, a transport format with a transport block size of zero is selected.

Only a limited number of combinations of the transport formats of the different TrCH are allowed. A valid combination is called a Transport Format Combination (TFC). The set of valid TFCs on a basic physical subchannel is called the Transport Format Combination Set (TFCS). The TFCS is signalled through the Calculated Transport Format Combinations (CTFC).

In order to decode the received sequence the receiver needs to know the active TFC for a radio packet. This information is transmitted in the Transport Format Combination Indicator (TFCI) field. This field is basically a layer 1 header and has the same function as the stealing bits in GSM. Each of the TFC within a TFCS are assigned a unique TFCI value and when a radio packet is received this is the first to be decoded by the receiver. From the decoded TFCI value the transport formats for the different transport channels are known and the actual decoding can start.

In case of multislot operation, there shall be one FLO instance for each basic physical subchannel. Each FLO instance is configured independently by Layer 3 and as a result gets its own TFCS. The number of allocated basic physical subchannels depends on the multislot capabilities of the MS.

6.9.3.2 Coding / multiplexing

The coding/multiplexing unit of FLO is a combination of error detection, forward error correction, rate matching, multiplexing and interleaving of transport blocks (TB) in radio packet.

The following steps can be identified:

- CRC attachment: error detection is provided on each transport block through a cyclic redundancy check (CRC). Layer 3 configures the size of the CRC to be used. Code blocks are output from the CRC attachment.
- Channel coding: after CRC attachment, the code blocks are processed through channel coding (1/3 rate convolutional code), producing encoded blocks.
- Rate matching: in rate matching, bits of an encoded block on a transport channel are repeated or punctured. When the number of bits on a transport channel varies between different TTI, coded bits are repeated or punctured to ensure that the total bit rate after TrCH multiplexing is identical to the total channel bit rate of the allocated basic physical channel. Outputs from the rate matching are called radio frames. The rate matching produces one radio frame per encoded block, i.e. per TrCH.
- Multiplexing of transport channels: for every radio packet to be transmitted, one radio frame from each TrCH is delivered to the TrCH multiplexing. These radio frames are serially multiplexed into a Coded Composite Transport CHannel (CCTrCH).
- TFCI mapping: the coded TFCI is appended at the beginning of the CCTrCH.
- Interleaving: the coded TFCI and the CCTrCH are interleaved together on bursts. The interleaving can be either block diagonal or block rectangular and is configured by Layer 3.

7 Ciphering

The ciphering architecture is specified in 3GPP TS 33.102 and is identical to that of UTRAN (f8). The ciphering principle with input parameters to the algorithm is illustrated in figure 17.

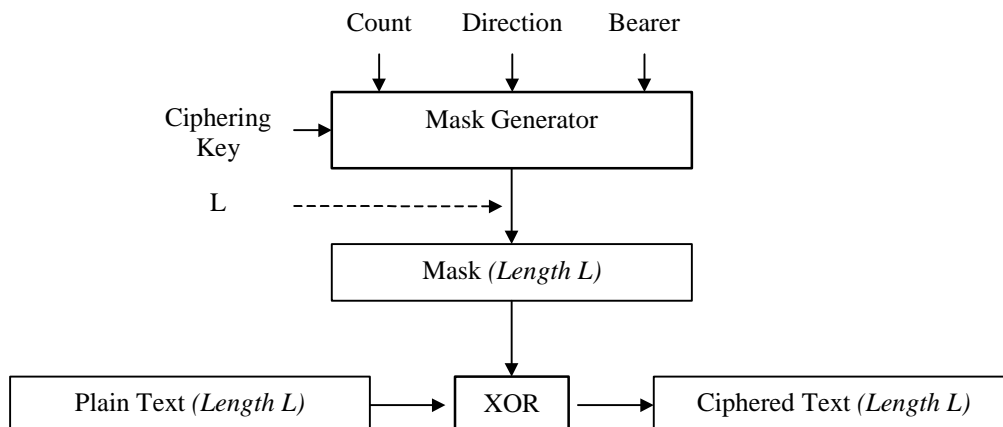

Figure 17: Ciphering Principle

Ciphering shall be applied after contention resolution has been performed provided the MS is under coverage of its serving BSS. It is FFS how it is performed when the controlling RAN node is not the serving RAN node.

7.1 Location of ciphering in the GERAN protocol architecture

The ciphering function is performed either in the RLC sub-layer or in the MAC sub-layer, according to the following rules:

- In case of non-transparent RLC mode (acknowledged or unacknowledged), ciphering is performed in the RLC sub-layer for layer 2 user data blocks only. Layer 2 signalling is ciphered in the MAC sub-layer.
- In case of transparent RLC mode, ciphering is performed in the MAC sub-layer.

According to this model, ciphering when applied is performed in the BSS and the MS, and the context needed for ciphering (input parameters) is only known in BSS and the MS.

7.2 Inputs to the ciphering algorithm

7.2.1 Ciphering Key

The ciphering key is 128 bit long.

The ciphering key is established between the MS and BSS during the authentication phase. In the two-key solution, the CS-domain user-plane bearers are ciphered with the most recent cipher key agreed between the user and the MSC (CK-CS). The PS-domain user-plane bearers are ciphered with the most recent cipher key agreed between the user and the SGSN (CK-PS).

The signalling radio bearers are used for transfer of signalling data for services delivered by both CS and PS service domains. These signalling radio bearers are ciphered using the CK of the service domain for which the most recent security mode negotiation took place. This may require that the cipher key of an (already ciphered) ongoing signalling connection has to be changed, when a new connection is established with another service domain, or when a security mode negotiation follows a re-authentication during an ongoing connection.

To ensure performing the right ciphering function at the RLC and MAC layers, three conditions must be met:

- A user-plane Radio Bearer is either from CS-domain or PS-domain, but not from both.

- RRC maps a given user-plane Radio Bearer to a given domain in order to derive the correct key to utilise for each RB.
- The RLC and MAC layers receive the Radio Bearer IDs and CKs they should use from RRC.

7.2.2 Bearer

This parameter indicates the radio bearer identity (when available), which shall be unique within a RRC connection. It is used as input parameter to the ciphering algorithm to ensure that the same ciphering mask is not applied to two or more parallel Radio Bearers having the same ciphering key and count. Each Radio Bearer is ciphered independently.

In case no radio bearer identity is available (layer 2 signalling), the data id shall be equal to a unique value.

To ensure that the same ciphering mask is not applied to layer 2 signalling (no RBid available) and layer 2 user data (RBid available), RBid indicator is used in the count parameter to inform whether RBid is available or not.

7.2.3 Direction

This parameter indicates the direction of transmission (uplink/downlink).

7.2.4 Length

This parameter indicates the length of the mask to be generated by the algorithm (this length is equal to that of the data to be ciphered). It is not an input to the mask generator.

7.2.5 Parameter Settings

The following tables defines how to set the input parameters to the ciphering algorithm that applies to layer 2 user data blocks and layer 2 signalling respectively:

Table 4: Input parameters for user data blocks

Input parameters	Size (bits)	Non-transparent RLC Mode	Transparent RLC Mode
Count	32	RLC Sequence Number: a) 7 bits or b) 11 bits a) 0...127 or b) 0...2047	Slot number: 3 bits 0...7
		RBid indicator: 1 bit 1 (RBid available)	
		HFN: 24 or 20 bits a) 0...16777215 or b) 0...1048575	TDMA Frame Number: 17 bits (see note 1) HFN: 11 bits 0...2047
Direction	1	1 bit 0 (Uplink) or 1 (Downlink)	
Bearer	5	Radio Bearer Identifier (RBid) 0...31	
Length	16	Length of the input data to be ciphered: the fields included in the input parameters shall not be ciphered. 0...65535	Full block size

NOTE 1: The construction of the 17-bit TDMA Frame Number is described in 3GPP TS 44.160.

Table 5: Input Parameters for layer 2 signalling

Input parameters	Size (bits)	Non-transparent RLC mode
Count	32	Slot number: 3 bits 0...7
		RBid indicator: 1 bit 0 (RBid not available)
		TDMA Frame Number: 17 bits (see note 1 in table 4)
		HFN: 11 bits 0...2047
Direction	1	1 bit 0 (Uplink) or 1 (Downlink)
Bearer	5	"00000"
Length	L	Full block size

8 Integrity protection

8.1 Integrity protection on RRC messages

Integrity protection with a 32-bit MAC-I shall be performed on all RRC messages, with the exceptions defined in 3GPP TS 44.118.

There may be one IK for CS connections (IK_{CS}), established between the CS service domain and the user and one IK for PS connections (IK_{PS}) established between the PS service domain and the user.

The data integrity of radio bearers for user data is not protected.

The signalling radio bearers are used for transfer of signalling data for services delivered by both CS and PS service domains. These signalling radio bearers are data integrity protected by the IK of the service domain for which the most recent security mode negotiation took place. This may require that the integrity key of an (already integrity protected) ongoing signalling connection has to be changed, when a new connection is established with another service domain, or when a security mode negotiation follow a re-authentication during an ongoing connection.

8.2 Integrity protection on RLC/MAC control messages

RLC/MAC control messages are not integrity protected.

8.3 Calculation of message authentication code

The MS shall calculate the message authentication code in accordance with 3GPP TS 33.102. The construction of the input parameter MESSAGE (3GPP TS 33.102) for the integrity algorithm is FFS.

9 Mobility Management and Session Management (MM and SM)

See 3GPP TS 24.008.

10 Sequence Diagrams Examples for Handover

See 3GPP TS 45.008, and 3GPP TS 25.931.

Annex A (informative): Radio Access Bearer Realization

This annex describes how the different protocols of the GERAN User Plane protocol stack are configured to provide the desired radio access bearer classes (conversational, streaming, interactive and background). Only the traffic over Iu-ps interface is considered.

A.1 Conversational Radio Access Bearer

In table A.1, case A represents optimized conversational RAB further described in clause A.1.2. Case B represents the generic conversational RAB.

Table A.1: Conversational RAB

PDCP	RLC	MAC	Physical Layer						
			Basic Physical SubChannel	Traffic Channel				Dedicated Control Channel	
				Type	Interleav. v.	Mod.	Coding		
Non Transparent <i>Header Removal</i>	Transp.	Dedicated	DBPSCH/F	TCH/F	8 diag	GMSK	UEP	As TCH/AF S	FACCH/F (2) SACCH/TF or SACCH/TPF + EPCCH/F
						8PSK (1)	UEP	ffs	FACCH/F (2) SACCH/TF or SACCH/TPF + EPCCH/F
			DBPSCH/H	TCH/H	4 diag	GMSK	UEP	As TCH/AH S	FACCH/H (2) SACCH/TH or SACCH/TPH + EPCCH/H
						8PSK	UEP	As TCH/AH S	FACCH/H (2) SACCH/TH or SACCH/TPH + EPCCH/H
Non Transparent <i>Header Compression or No Adaptation</i> Transparent	Unack	Dedicated	DBPSCH/F	PDTCH/F	4 rect	GMSK	EEP		SACCH/TF or SACCH/TPF + EPCCH/F PACCH/F
						8PSK	EEP		SACCH/TF or SACCH/TPF + EPCCH/F PACCH/F
			TCH/F (2)	ffs	GMSK	EEP		FACCH/F (2) SACCH/TF or SACCH/TPF + EPCCH/F	
					8PSK	EEP		FACCH/F (2) SACCH/TF or SACCH/TPF + EPCCH/F	

A

B

			DBPSCH/H	PDTCH/ H	4 rect	GMSK	EEP	SACCH/TH or SACCH/TPH + EPCCH/H PACCH/H
						8PSK	EEP	SACCH/TH or SACCH/TPH + EPCCH/H PACCH/H
				TCH/H	ffs	GMSK	EEP	FACCH/H SACCH/TH or SACCH/TPH + EPCCH/H

UEP Unequal Error Protection - EEP Equal Error Protection.
(1) This row is intended for the realization of wide-band speech codec and is ffs.
(2) Whether FACCH and PACCH are both needed is ffs.

A.2 Streaming, Interactive, Background Radio Access Bearers

A.2.1 Streaming

Table A.2: Streaming RAB

PDCP	RLC	MAC	Physical Layer						
			Basic Physical SubChannel	Traffic Channel				Dedicated Control Channel	
				Type	Interleav. v.	Mod.	Coding		
Non Transparent Header Compression or No Adaptation Transparent	Unack	Dedicated	DBPSCH/F	PDTCH/F	4 rect	GMSK	EEP	SACCH/TF or SACCH/TPF + EPCCH/F PACCH/F	A
						8PSK	EEP	SACCH/TF or SACCH/TPF + EPCCH/F PACCH/F	
				TCH/F	ffs	GMSK	EEP	FACCH/F (1) SACCH/TF or SACCH/TPF + EPCCH/F	
						8PSK	EEP	FACCH/F (1) SACCH/TF or SACCH/TPF + EPCCH/F	
			DBPSCH/H	PDTCH/H	4 rect	GMSK	EEP	SACCH/TH or SACCH/TPH + EPCCH/H PACCH/H	
						8PSK	EEP	SACCH/TH or SACCH/TPH + EPCCH/H PACCH/H	
				TCH/H	ffs	GMSK	EEP	FACCH/H (1) SACCH/TH or SACCH/TPH + EPCCH/H	
						GMSK	EEP	FACCH/H (1) SACCH/TH or SACCH/TPH + EPCCH/H	
Non Transparent Header Compression	Ack	Dedicated	DBPSCH/F	PDTCH/F	4 rect	GMSK	EEP	SACCH/TF or SACCH/TPF + EPCCH/F PACCH/F	B

PDCP	RLC	MAC	Physical Layer					
			Basic Physical SubChannel	Traffic Channel				Dedicated Control Channel
				Type	Interleav. v.	Mod.	Coding	
n or No Adaptation Transparent						8PSK	EEP	SACCH/TF or SACCH/TPF + EPCCH/F PACCH/F
			DBPSCH/H	PDTCH/H	4 rect	GMSK	EEP	SACCH/TH or SACCH/TPH + EPCCH/H PACCH/H
						8PSK	EEP	SACCH/TH or SACCH/TPH + EPCCH/H PACCH/H
Non Transparent Header Compression or No Adaptation Transparent	Unack	Shared	SBPSCH/F	PDTCH/F	4 rect	GMSK	EEP	PACCH/F PTCCH/F
						8PSK	EEP	PACCH/F PTCCH/F
			SBPSCH/H	PDTCH/H	4 rect	GMSK	EEP	PACCH/H PTCCH/H
						8PSK	EEP	PACCH/H PTCCH/H
Non Transparent Header Compression or No Adaptation Transparent	Ack	Shared	SBPSCH/F	PDTCH/F	4 rect	GMSK	EEP	PACCH/F PTCCH/F
						8PSK	EEP	PACCH/F PTCCH/F
			SBPSCH/H	PDTCH/H	4 rect	GMSK	EEP	PACCH/H PTCCH/H
						8PSK	EEP	PACCH/H PTCCH/H
UEP Unequal Error Protection - EEP Equal Error Protection - OS Operational Scenario Supported (1) Whether FACCH and PACCH are both needed when multiplexing PDTCH and TCH is FFS								

C

D

A.2.2 Interactive

Table A.3: Interactive RAB

PDCP	RLC	MAC	Physical Layer						TCH multiplexing case (clause 5.1.1)	
			Basic Physical SubChannel	Traffic Channel				Dedicated Control Channel		
				Type	Interleaving	Mod.	Coding			
Non Transparent Header Compression No Adaptation Transparent	Ack	Dedicated	DBPSCH/F	PDTCH/F	4 rect.	GMSK	EEP	PACCH/F SACCH/TF or SACCH/TPF + EPCCH/F	1-6	A
						8PSK	EEP	PACCH/F SACCH/TF or SACCH/TPF + EPCCH/F	1-6	
			DBPSCH/H	PDTCH/H	4 rect.	GMSK	EEP	PACCH/FH SACCH/TH or SACCH/TPH + EPCCH/H	1-6	
						8PSK	EEP	PACCH/H SACCH/TH or SACCH/TPH + EPCCH/H	1-6	
Non Transparent Header Compression No Adaptation Transparent	Ack	Shared	SBPSCH/F	PDTCH/F	4 rect.	GMSK	EEP	PACCH/F PTCCH/F	NA	B
						8PSK	EEP	PACCH/F PTCCH/F	NA	
			SBPSCH/H	PDTCH/H	4 rect.	GMSK	EEP	PACCH/H PTCCH/H	NA	
						8PSK	EEP	PACCH/H PTCCH/H	NA	

UEP Unequal Error Protection - EEP Equal Error Protection

A.2.3 Background

Table A.4: Background RAB

PDCP	RLC	MAC	Physical Layer					Dedicated Control Channel
			Basic Physical SubChannel	Traffic Channel				
				Type	Interleav. v.	Mod.	Coding	
Non Transparent Header Compression No Adaptation Transparent	Ack	Dedicated	DBPSCH/F	PDTCH/F	4 rect.	GMSK	EEP	PACCH/F SACCH/TF or SACCH/TPF + EPCCH/F
						8PSK	EEP	PACCH/F SACCH/TF or SACCH/TPF + EPCCH/F
			DBPSCH/H	PDTCH/H	4 rect.	GMSK	EEP	PACCH/FH SACCH/TH or SACCH/TPH + EPCCH/H
						8PSK	EEP	PACCH/H SACCH/TH or SACCH/TPH + EPCCH/H
Non Transparent Header Compression No Adaptation Transparent	Ack	Shared	SBPSCH/F	PDTCH/F	4 rect.	GMSK	EEP	PACCH/F PTCCH/F
						8PSK	EEP	PACCH/F PTCCH/F
			SBPSCH/H	PDTCH/H	4 rect.	GMSK	EEP	PACCH/H PTCCH/H
						8PSK	EEP	PACCH/H PTCCH/H

UEP Unequal Error Protection - EEP Equal Error Protection

Annex B (informative): RLC/MAC Header format Convention

B.1 GPRS RLC/MAC data block header

B.1.1 Downlink RLC/MAC data block header

The Downlink RLC/MAC data block header is formatted as shown in figure B.1.

		Bit					
8	7	6	5	4	3	2	1
Payload Type	RRBP		S/P	USF			
PR	TFI						FBI
BSN							E
Length indicator					M	E	
.							
.							
.							
Length indicator					M	E	

Figure B.1: Downlink RLC/MAC Data Block header (CS-1, CS-2, CS-3, CS-4)

B.1.2 Uplink RLC/MAC data block header

The Uplink RLC/MAC data block header is formatted as shown in figure B.2.

		Bit					
8	7	6	5	4	3	2	1
Payload Type	Countdown Value				SI	R	
Spare	TFI						TI
BSN							E
Length indicator					M	E	
.							
.							
.							
Length indicator					M	E	
TLLI							

Figure B.2: Uplink RLC/MAC Data Block Header (CS-1, CS-2, CS-3 and CS-4)

B.2 EGPRS RLC/MAC data block header

B.2.1 Downlink RLC/MAC data block header

The EGPRS combined downlink RLC/MAC header for MCS-7, MCS-8 and MCS-9 (header type 1) is formatted according to figure B.3.

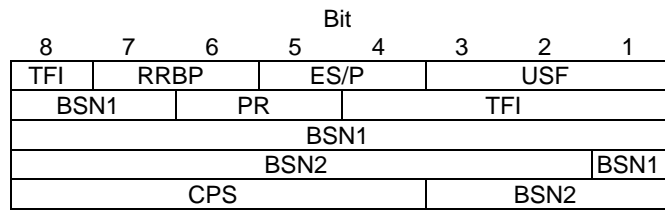

Figure B.3: Downlink RLC Data Block Header for MCS-7, MCS-8 and MCS-9

The EGPRS combined downlink RLC/MAC header for MCS-5 and MCS-6 (header type 2) is formatted according to figure B.4.

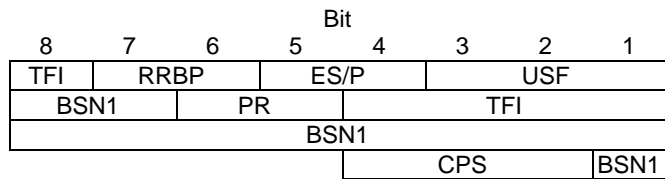

Figure B.4: Downlink RLC Data Block Header for MCS-5 and MCS-6

The EGPRS combined downlink RLC/MAC header for MCS-1, MCS-2, MCS-3 and MCS-4 (header type 3) is formatted according to figure B.5.

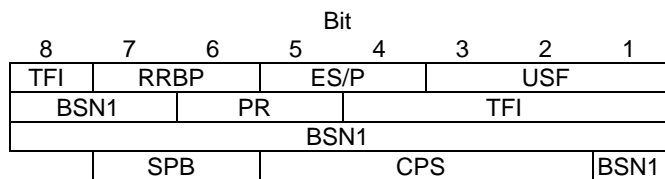

Figure B.5: Downlink RLC Data Block Header for MCS-1, MCS-2, MCS-3 and MCS-4

B.2.2 Uplink RLC/MAC data block header

The EGPRS combined uplink RLC/MAC header for MCS-7, MCS-8 and MCS-9 (header type 1) is formatted according to figure B.6.

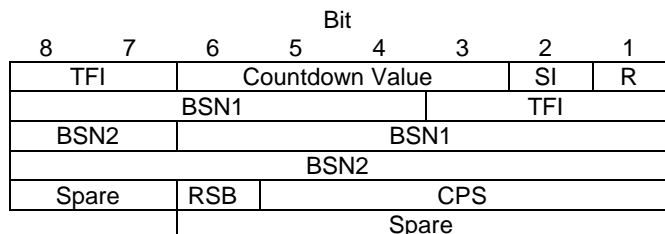

Figure B.6: Uplink RLC Data Block Header for MCS-7, MCS-8 and MCS-9

The EGPRS combined uplink RLC/MAC header for MCS-5 and MCS-6 (header type 2) is formatted according to figure B.7.

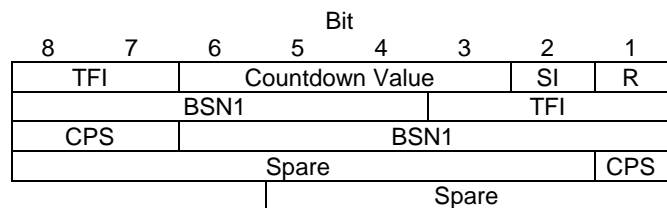

Figure B.7: Uplink RLC Data Block Header for MCS-5 and MCS-6

The EGPRS combined uplink RLC/MAC header for MCS-1, MCS-2, MCS-3 and MCS-4 (header type 3) is formatted according to figure B.8.

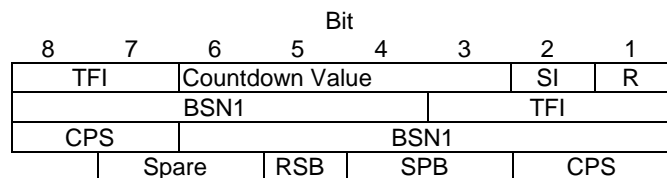

Figure B.8: Uplink RLC Data Block Header for MCS-1, MCS-2, MCS-3 and MCS-4

B.3 ECSD RLC/MAC data block header

The RLC/MAC data block headers for ECSD channel coding are identical in uplink and in downlink.

B.3.1 Uplink and downlink RLC/MAC data block header

The header formatting is depicted in Figure B-9.

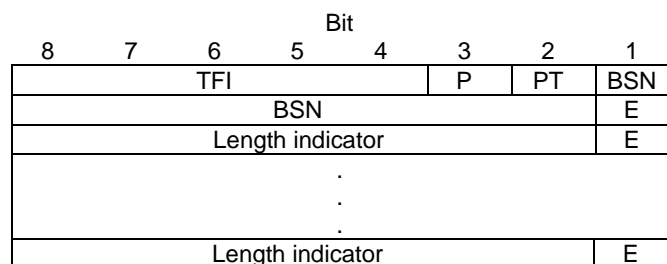

Figure B-9. Downlink and uplink RLC/MAC Data Block Header using ECSD.

All header-fields in Figure B-9 except the P- and PT-fields follows the specification of GPRS and EGPRS. The Length Indicator is identical to the EGPRS Length Indicator, and the TFI is identical to the GPRS/EGPRS TFI field. The specification of the P- and PT-fields is included below.

Polling bit. This bit is set if the receiver is polled for an ACK/NAK report. P=0 implies that polling should be ignored, while P=1 requires that the receiver sends an ACK/NAK report to the transmitter.

Payload type. If PT=1 then the RLC/MAC block contains user data, and if PT=0 then the RLC/MAC-block contains control information.

Block check sequences are also defined for data blocks on ECSD channels. However, they are not shown in Figure B-9 since they are not considered to be part of the header. An 8-bit block check sequence is mandatory for the header while a 16-bit block check sequence is optional for the payload.

Whether the block check sequence on the payload is used or not is negotiated during service setup.

Annex C (informative): RRC States, MAC States and RRC Connection Mobility

C.1 Void

C.2 MAC states

This clause describes the MAC state model for GERAN in *Iu mode*. The model shows the MAC state for the MAC control entity of an MS and not for individual radio bearers. What characterizes the different MAC states is how new radio resource allocation is performed i.e. by MAC or RRC, using PCCCH/PACCH/PDTCH or FACCH/SDCCH.

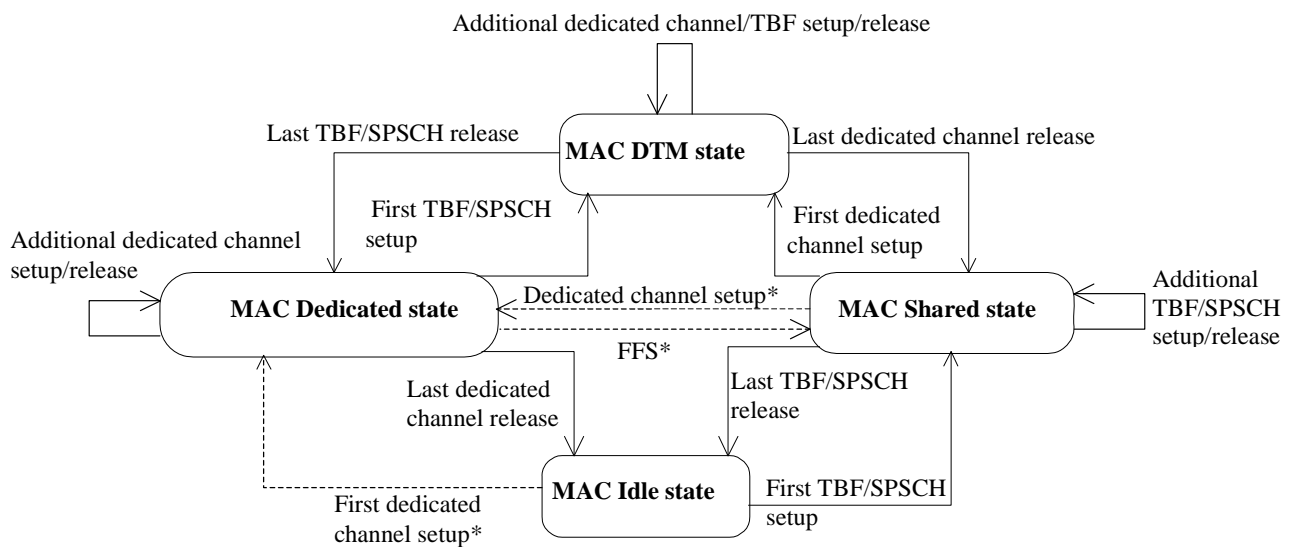

* Which way dedicated channel setup is carried out is FFS.

Figure C-2. States of the MAC Control Entity

C.2.1 MAC-Dedicated state

The MAC Control entity will be in MAC-Dedicated state when RRC is in RRC-Cell_Dedicated state and a dedicated basic physical subchannel is used and no shared basic physical subchannel is established. In MAC-Dedicated state MAC has no control functionality.

C.2.1.1 Transition from MAC-Dedicated state to MAC-Idle state

The transition occurs when the last dedicated basic physical subchannel is released.

C.2.1.2 Transition from MAC-Dedicated state to MAC-Shared state

This transition is FFS.

C.2.1.3 Transition from MAC-Dedicated state to MAC-DTM state

The transition occurs when a first TBF on shared basic physical subchannel(s) is established. The establishment of the TBF is handled by RRC.

C.2.2 MAC-Shared state

The MAC control entity is in MAC-Shared state when at least one TBF is ongoing but no dedicated basic physical subchannels have been allocated. The corresponding RRC state is RRC-Cell_Shared state.

C.2.2.1 Transition from MAC-Shared state to MAC-DTM state

The transition occurs when the first dedicated basic physical subchannel is set up while maintaining at least one of the ongoing TBFs on shared basic physical subchannel(s).

C.2.2.2 Transition from MAC-Shared state to MAC-Idle state

The transition occurs when all TBFs are released.

C.2.2.3 Transition from MAC-Shared state to MAC-Dedicated state

The transition occurs when the first dedicated channel is set up (on the same cell or a different cell) for the MS. TBFs from the shared mode are released at transition to dedicated mode. This transition is FFS.

C.2.3 MAC-Idle state

The MAC control entity of an MS is in MAC-Idle state when there are no dedicated or shared basic physical subchannels. RRC can be in RRC-Cell_Shared state, RRC-GRA_PCH state or RRC-Idle mode. In this state, the MS camps on the PCCCH.

C.2.3.1 Transition from MAC-Idle state to MAC-Dedicated state

The transition occurs when the first dedicated basic physical subchannel is established. This transition is FFS.

C.2.3.2 Transition from MAC-IDLE state to MAC-SHARED state

The transition occurs when the first TBF on shared basic physical subchannel(s) is established.

C.2.4 MAC-DTM state

The MAC control entity of an MS is in this state when it has one or more dedicated basic physical subchannel(s) and one or more shared basic physical subchannel(s) allocated. The corresponding RRC state is RRC-Cell_Dedicated state.

C.2.4.1 Transition from MAC-DTM state to MAC-Dedicated state

This transition occurs when the last shared basic physical subchannel is released.

C.2.4.2 Transition from MAC-DTM state to MAC-Shared state

This transition occurs when the last dedicated basic physical subchannel is released.

C.3 Mapping between RRC States and MAC States

In the following table, it is described the mapping between GERAN RRC and MAC states and possible channel combinations. RRC always handles the allocation of DBPSCH and it also controls which SBPSCHs MAC is allowed to use. MAC always allocates PDTCHs when using SBPSCHs. The table below shows which protocol is responsible for the different procedures in different scenarios.

Table C.3: Mapping between RRC and MAC states

Currently Allocated channel(s)		Allocation of new resources		Current Control Plane States	
TCH, SDCCH or PDTCH on DBPSCH	PDTCH on SBPSCH	TCH, SDCCH or PDTCH on DBPSCH	PDTCH on SBPSCH	MAC State	RRC State
1 (or more)	-	RRC	RRC	Dedicated	Cell_Dedicated
1 (or more)	1 (or more)		MAC	DTM	
	1 (or more)			Shared	Cell_Shared
-	-	NA (Note 1)	NA	Idle	GRA_PCH
-	-	NA (Note 2)			RRC-Idle Mode
-	-				

Note 1. A TCH or an SDCCH may be allocated by RRC in RRC-GRA_PCH state and in RRC-Cell_Shared state (when receiving a TCH or an SDCCH assignment on PAGCH, MAC enters the MAC_Dedicated state or the MAC_DTM state respectively and RRC enters the RRC-Cell_Dedicated state).

Note 2. A TCH or an SDCCH may be allocated by RRC through MAC (when receiving a TCH or an SDCCH assignment on PAGCH MAC enters the MAC-Dedicated state).

Annex D (informative): Change history

Change history							
Date	TSG #	TSG Doc.	CR	Rev	Subject/Comment	Old	New
Nov. 00	02	GP-000930			New specification approved by TSG-GERAN		4.0.0
Jan. 01	03	GP-010041	00 1		Editorial corrections of sections 2 and 3	4.0.0	5.0.0
Jan. 01	03	GP-010042	00 2		Corrections of section on GERAN architecture	4.0.0	5.0.0
Jan. 01	03	GP-010044	00 3		Changes to clause 6	4.0.0	5.0.0
Jan. 01	03	GP-010289	00 4	1	Clarification wrt TFI unicity	4.0.0	5.0.0
Jan. 01	03	GP-010051	00 5		Definition of the MAC functions	4.0.0	5.0.0
Jan. 01	03	GP-010290	00 6	1	Editorial corrections of Annex C	4.0.0	5.0.0
Jan. 01	03	GP-010137	00 7		RLC/MAC header formats for ECSD channels	4.0.0	5.0.0
Jan. 01	03	GP-010220	00 8		Change of MAC modes into MAC states; corrections related to PDTCH on DPSCCH	4.0.0	5.0.0
Jan. 01	03	GP-010221	00 9		Clarification of RRC functions	4.0.0	5.0.0
Apr. 01	04	GP-010891	01 1	1	Re-configuration of RB onto DPSCCH	5.0.0	5.1.0
Apr. 01	04	GP-010963	01 2	2	Working assumptions for RRC design	5.0.0	5.1.0
Apr. 01	04	GP-010964	01 3	2	Introduction of RRC connection mobility assumptions for GERAN	5.0.0	5.1.0
Apr. 01	04	GP-010883	01 5	1	Clarifications and corrections to section 6.3 and Annex C	5.0.0	5.1.0
Apr. 01	04	GP-010605	01 6		Removal of Physical Layer Multiplexing from 43.051	5.0.0	5.1.0
Apr. 01	04	GP-010887	01 7	1	Introduction of RLC SDU Discard	5.0.0	5.1.0
Apr. 01	04	GP-010762	01 8		Removal of the quarter rate channels	5.0.0	5.1.0
Apr. 01	04	GP-010603	01 9		Inclusion of the decision of adopting RLC/MAC as layer 2 on the control plane	5.0.0	5.1.0
June 01	05	GP-011021	02 0		Introduction of Iur-g between UTRAN and GERAN in the specification	5.1.0	5.2.0
June 01	05	GP-011411	02 1	1	Introduction of the definition of Signalling Radio Bearers	5.1.0	5.2.0
June 01	05	GP-011282	02 2	1	On security issues	5.1.0	5.2.0
June 01	05	GP-011024	02 3		Ciphering of signaling radio bearers	5.1.0	5.2.0
June 01	05	GP-011363	02 4	1	Introduction of Enhanced Power Control	5.1.0	5.2.0
June 01	05	GP-011026	02 5		Editorial Changes Related to Fast Power Control for ECSD and other minor clean-ups	5.1.0	5.2.0
June 01	05	GP-011373	02 6	2	Working assumption on mode selection	5.1.0	5.2.0
June 01	05	GP-011345	02 7	1	Introduction of area concept in GERAN	5.1.0	5.2.0
June 01	05	GP-011366	02 8	1	Changes of references to GERAN Release 4 and editorial changes	5.1.0	5.2.0
Aug. 01	06	GP-011678	03 0		Alignment with Physical Channel definition in 45.002	5.2.0	5.3.0
Nov. 01	07	GP-012834	03 4	2	Inclusion of GERAN Iu Internal Cell Identity CI	5.3.0	5.4.0
Nov. 01	07	GP-012705	03 5	1	Removal of Fast Random Access from GERAN Rel5 Iu	5.3.0	5.4.0
Feb. 02	08	GP-020253	03 3	2	Introduction of support for MSC/SGSN in pool in GERAN Iu mode	5.4.0	5.5.0
Feb. 02	08	GP-020268	03 7		Mandatoriness of the P channels and procedures on PCCCH	5.4.0	5.5.0

Feb. 02	08	GP-020461	04 0	1	Correction of alignment with physical channel definition in 45.002	5.4.0	5.5.0
Apr. 02	09	GP-021257	03 6	5	CS services for GERAN lu-mode	5.5.0	5.6.0
Apr. 02	09	GP-020711	03 8	1	Interfaces between GERAN and CN	5.5.0	5.6.0
Apr. 02	09	GP-020883	03 9	3	Integrity protection in GERAN	5.5.0	5.6.0
Apr. 02	09	GP-021147	04 2	1	Alignment of RLC Functions with stage 3	5.5.0	5.6.0
Apr. 02	09	GP-021146	04 4	1	Clean-up	5.5.0	5.6.0
Apr. 02	09	GP-020874	04 5		Count input to ciphering algorithm	5.5.0	5.6.0
Aug. 02	11	GP-022802	04 1	8	MAC multiplexing and scheduling	5.6.0	5.7.0
Aug. 02	11	GP-022799	04 9	2	TBF reallocation	5.6.0	5.7.0
Nov. 02	12	GP-023356	05 0	2	Principles of lu mode establishment causes	5.7.0	5.8.0
Apr. 03	14	GP-030822	05 2		Correction to SBPSCH and SBPSCH/H	5.8.0	5.9.0
Aug. 03	16	GP-032198	05 4	1	PUESBINE feature in GERAN lu mode	5.9.0	5.10.0
Nov. 03	17	GP-032805	05 3	5	Introduction of Flexible Layer One	5.10.0	6.0.0
Aug. 07	35				Version for Release 7	6.0.0	7.0.0
Dec. 08	40				Version for Release 8	7.0.0	8.0.0
Dec. 09	44				Version for Release 9	8.0.0	9.0.0
Mar. 11	49				Version for Release 10	9.0.0	10.0.0
Sep. 12	55				Version for Release 11	10.0.0	11.0.0
Sep. 14	63				Version for Release 12 (frozen at SP-65)	11.0.0	12.0.0
Dec. 15	68				Version for Release 13 (frozen at SP-70)	12.0.0	13.0.0

Change history							
Date	Meeting	TDoc	CR	Rev	Cat	Subject/Comment	New version
2017-03	RP-75					Release 14 version	14.0.0
2018-06	RP-80					Release 15 version	15.0.0
2020-07	RP-88e	-	-	-	-	Upgrade to Rel-16 version without technical change	16.0.0
2022-03	RP-95e	-	-	-	-	Upgrade to Rel-17 version without technical change	17.0.0

History

Document history		
V17.0.0	May 2022	Publication