

ETSI TS 138 551 V18.6.0 (2026-04)



TECHNICAL SPECIFICATION

**5G;
NR;
User Equipment (UE) Multiple Input Multiple Output (MIMO)
Over-the-Air (OTA) performance;
Conformance testing
(3GPP TS 38.551 version 18.6.0 Release 18)**



Reference

RTS/TSGR-0538551 vi60

Keywords

5G

ETSI

650 Route des Lucioles
F-06921 Sophia Antipolis Cedex - FRANCE

Tel.: +33 4 92 94 42 00 Fax: +33 4 93 65 47 16

Siret N° 348 623 562 00017 - APE 7112B
Association à but non lucratif enregistrée à la
Sous-Préfecture de Grasse (06) N° w061004871

Important notice

The present document can be downloaded from the
[ETSI Search & Browse Standards](#) application.

The present document may be made available in electronic versions and/or in print. The content of any electronic and/or print versions of the present document shall not be modified without the prior written authorization of ETSI. In case of any existing or perceived difference in contents between such versions and/or in print, the prevailing version of an ETSI deliverable is the one made publicly available in PDF format on [ETSI deliver](#) repository.

Users should be aware that the present document may be revised or have its status changed,
this information is available in the [Milestones listing](#).

If you find errors in the present document, please send your comments to
the relevant service listed under [Committee Support Staff](#).

If you find a security vulnerability in the present document, please report it through our
[Coordinated Vulnerability Disclosure \(CVD\)](#) program.

Notice of disclaimer & limitation of liability

The information provided in the present deliverable is directed solely to professionals who have the appropriate degree of experience to understand and interpret its content in accordance with generally accepted engineering or other professional standard and applicable regulations.

No recommendation as to products and services or vendors is made or should be implied.

No representation or warranty is made that this deliverable is technically accurate or sufficient or conforms to any law and/or governmental rule and/or regulation and further, no representation or warranty is made of merchantability or fitness for any particular purpose or against infringement of intellectual property rights.

In no event shall ETSI be held liable for loss of profits or any other incidental or consequential damages.

Any software contained in this deliverable is provided "AS IS" with no warranties, express or implied, including but not limited to, the warranties of merchantability, fitness for a particular purpose and non-infringement of intellectual property rights and ETSI shall not be held liable in any event for any damages whatsoever (including, without limitation, damages for loss of profits, business interruption, loss of information, or any other pecuniary loss) arising out of or related to the use of or inability to use the software.

Copyright Notification

No part may be reproduced or utilized in any form or by any means, electronic or mechanical, including photocopying and microfilm except as authorized by written permission of ETSI.

The content of the PDF version shall not be modified without the written authorization of ETSI.

The copyright and the foregoing restriction extend to reproduction in all media.

© ETSI 2026.
All rights reserved.

Intellectual Property Rights

Essential patents

IPRs essential or potentially essential to normative deliverables may have been declared to ETSI. The declarations pertaining to these essential IPRs, if any, are publicly available for **ETSI members and non-members**, and can be found in ETSI SR 000 314: "*Intellectual Property Rights (IPRs); Essential, or potentially Essential, IPRs notified to ETSI in respect of ETSI standards*", which is available from the ETSI Secretariat. Latest updates are available on the [ETSI IPR online database](#).

Pursuant to the ETSI Directives including the ETSI IPR Policy, no investigation regarding the essentiality of IPRs, including IPR searches, has been carried out by ETSI. No guarantee can be given as to the existence of other IPRs not referenced in ETSI SR 000 314 (or the updates on the ETSI Web server) which are, or may be, or may become, essential to the present document.

Trademarks

The present document may include trademarks and/or tradenames which are asserted and/or registered by their owners. ETSI claims no ownership of these except for any which are indicated as being the property of ETSI, and conveys no right to use or reproduce any trademark and/or tradename. Mention of those trademarks in the present document does not constitute an endorsement by ETSI of products, services or organizations associated with those trademarks.

DECT™, **PLUGTESTS™**, **UMTS™** and the ETSI logo are trademarks of ETSI registered for the benefit of its Members. **3GPP™**, **LTE™** and **5G™** logo are trademarks of ETSI registered for the benefit of its Members and of the 3GPP Organizational Partners. **oneM2M™** logo is a trademark of ETSI registered for the benefit of its Members and of the oneM2M Partners. **GSM®** and the GSM logo are trademarks registered and owned by the GSM Association.

Legal Notice

This Technical Specification (TS) has been produced by ETSI 3rd Generation Partnership Project (3GPP).

The present document may refer to technical specifications or reports using their 3GPP identities. These shall be interpreted as being references to the corresponding ETSI deliverables.

The cross reference between 3GPP and ETSI identities can be found at [3GPP to ETSI numbering cross-referencing](#).

Modal verbs terminology

In the present document "**shall**", "**shall not**", "**should**", "**should not**", "**may**", "**need not**", "**will**", "**will not**", "**can**" and "**cannot**" are to be interpreted as described in clause 3.2 of the [ETSI Drafting Rules](#) (Verbal forms for the expression of provisions).

"**must**" and "**must not**" are **NOT** allowed in ETSI deliverables except when used in direct citation.

Contents

Intellectual Property Rights	2
Legal Notice	2
Modal verbs terminology.....	2
Foreword.....	6
1 Scope	8
2 References	8
3 Definitions of terms, symbols, and abbreviations	9
3.1 Terms.....	9
3.2 Symbols.....	9
3.3 Abbreviations	9
4 General	10
4.1 Relationship between minimum requirements and test requirements	10
4.2 Applicability of minimum requirements	10
4.3 Applicability rules for testing of SA and NSA UEs.....	10
5 Frequency Bands	11
5.1 General	11
5.2 Operating bands.....	11
6 FR1 MIMO OTA Performance	14
6.1 General	14
6.1.1 Definition of MIMO throughput.....	14
6.1.2 Total Radiated Multi-Antenna Sensitivity (TRMS).....	14
6.2 Void.....	17
7 FR2 MIMO OTA requirements.....	17
7.1 General	17
7.1.1 MIMO Average Spherical Coverage (MASC)	17
Annex A (normative): FR1 Test methodology	20
A.1 General	20
A.2 Multi-Probe Anechoic Chamber (MPAC).....	20
A.2.1 System setup.....	20
A.2.2 Calibration procedure	22
A.2.3 Void.....	22
A.2.4 Minimum Range Length	22
A.3 EUT positioning	23
A.4 Reference coordinate system.....	25
Annex B (informative): Estimation of FR1 measurement uncertainty	27
B.1 MU budget of FR1 MPAC system	27
B.2 Measurement error contribution descriptions for MPAC.....	28
B.2.1 Mismatch for measurement process	28
B.2.2 Measurement distance uncertainty	28
B.2.3 Quality of quiet zone	28
B.2.4 Base Station simulator.....	28
B.2.5 Channel Emulator.....	28
B.2.6 Amplifier uncertainties.....	28
B.2.7 Random uncertainty	29
B.2.8 Throughput measurement: output level step resolution.....	29
B.2.9 Signal flatness	29

B.2.10	Mismatch for calibration process	30
B.2.11	Reference antenna positioning misalignment.....	30
B.2.12	Total Uncertainty of the Network Analyzer	30
B.2.13	Uncertainty of an absolute gain of the calibration antenna	30
B.2.14	Offset of the Phase Center of the Reference Antenna	30
Annex C (normative): FR1 Channel models and Validation procedure		31
C.1	FR1 Channel models	31
C.2	FR1 Base Station beam configuration.....	32
C.3	FR1 Channel model validation.....	33
C.3.1	General	33
C.3.2	Power Delay Profile (PDP)	34
C.3.3	Doppler/Temporal correlation.....	36
C.3.4	Spatial correlation.....	40
C.3.5	Cross-polarization	46
C.3.6	Power validation.....	49
C.4	Validation Pass/fail limit	50
C.4.1	General	50
C.4.2	Pass/Fail Criteria of PDP.....	50
C.4.3	Pass/Fail Criteria of Doppler/Temporal correlation	51
C.4.4	Pass/Fail Criteria of Spatial correlation.....	53
C.4.5	Pass/Fail Criteria of Cross-polarization.....	56
C.4.6	Pass/Fail Criteria of Power validation	57
Annex D (normative): gNB configurations.....		57
D.1	FR1 gNB configurations	57
D.2	FR2 gNB configurations	62
Annex E (normative): Environmental requirements		66
E.1	Scope	66
E.2	Ambient temperature.....	66
E.3	Operating voltage	66
Annex F (normative): Maximum uncertainty of test system and test tolerance.....		68
F.1	Maximum uncertainty of test system	68
F.2	Test tolerances.....	68
Annex G (normative): FR2 Test methodology.....		68
G.1	General	68
G.2	FR2 3D Multi-Probe Anechoic Chamber (3D-MPAC).....	69
G.2.1	System setup.....	69
G.2.2	Calibration procedure.....	71
G.2.3	Void.....	71
G.2.4	Minimum Range Length	71
G.2.5	Sample Device Orientations for Selected Test Points	72
G.3	Coordinate System and Device positioning	75
Annex H (informative): Estimation of FR2 measurement uncertainty		79
H.1	MU Budget for FR2 3D-MPAC system	79
H2	Measurement error contribution descriptions for 3D-MPAC	80
H.2.1	Mismatch for measurement process	80
H.2.2	Measurement distance uncertainty	80
H.2.3	Quality of quiet zone	80

H.2.4	Base Station simulator.....	80
H.2.5	Channel Emulator.....	80
H.2.6	Amplifier uncertainties.....	80
H.2.7	Random uncertainty	81
H.2.8	Throughput measurement: output level step resolution.....	81
H.2.9	Signal flatness	81
H.2.10	Mismatch for calibration process	82
H.2.11	Reference antenna positioning misalignment.....	82
H.2.12	Total Uncertainty of the Network Analyzer	82
H.2.13	Uncertainty of an absolute gain of the calibration antenna	82
H.2.14	Offset of the Phase Center of the Reference Antenna	82
Annex I (normative): FR2 Channel models and Validation procedure		82
I.1	FR2 Channel models	82
I.2	FR2 Base Station beam configuration.....	83
I.3	FR2 Channel model validation.....	84
I.3.1	General	84
I.3.2	FR2 Power Delay Profile (PDP).....	84
I.3.3	FR2 Doppler/Temporal correlation	86
I.3.4	FR2 PAS similarity percentage (PSP).....	88
I.3.5	FR2 Cross-polarization.....	92
I.3.6	FR2 Power validation.....	93
I.4	Validation Pass/fail limit	94
I.4.1	General	94
I.4.2	Pass/Fail Criteria of PDP.....	94
I.4.3	Pass/Fail Criteria of Doppler/Temporal correlation	94
I.4.4	Pass/Fail Criteria of PSP	95
I.4.5	Pass/Fail Criteria of Cross-polarization.....	96
I.4.6	Pass/Fail Criteria of Power validation.....	96
Annex J (informative): Change history		97
History		100

Foreword

This Technical Specification has been produced by the 3rd Generation Partnership Project (3GPP).

The contents of the present document are subject to continuing work within the TSG and may change following formal TSG approval. Should the TSG modify the contents of the present document, it will be re-released by the TSG with an identifying change of release date and an increase in version number as follows:

Version x.y.z

where:

- x the first digit:
 - 1 presented to TSG for information;
 - 2 presented to TSG for approval;
 - 3 or greater indicates TSG approved document under change control.
- y the second digit is incremented for all changes of substance, i.e. technical enhancements, corrections, updates, etc.
- z the third digit is incremented when editorial only changes have been incorporated in the document.

In the present document, modal verbs have the following meanings:

- shall** indicates a mandatory requirement to do something
- shall not** indicates an interdiction (prohibition) to do something

The constructions "shall" and "shall not" are confined to the context of normative provisions, and do not appear in Technical Reports.

The constructions "must" and "must not" are not used as substitutes for "shall" and "shall not". Their use is avoided insofar as possible, and they are not used in a normative context except in a direct citation from an external, referenced, non-3GPP document, or so as to maintain continuity of style when extending or modifying the provisions of such a referenced document.

- should** indicates a recommendation to do something
- should not** indicates a recommendation not to do something
- may** indicates permission to do something
- need not** indicates permission not to do something

The construction "may not" is ambiguous and is not used in normative elements. The unambiguous constructions "might not" or "shall not" are used instead, depending upon the meaning intended.

- can** indicates that something is possible
- cannot** indicates that something is impossible

The constructions "can" and "cannot" are not substitutes for "may" and "need not".

- will** indicates that something is certain or expected to happen as a result of action taken by an agency the behaviour of which is outside the scope of the present document
- will not** indicates that something is certain or expected not to happen as a result of action taken by an agency the behaviour of which is outside the scope of the present document
- might** indicates a likelihood that something will happen as a result of action taken by some agency the behaviour of which is outside the scope of the present document

might not indicates a likelihood that something will not happen as a result of action taken by some agency the behaviour of which is outside the scope of the present document

In addition:

is (or any other verb in the indicative mood) indicates a statement of fact

is not (or any other negative verb in the indicative mood) indicates a statement of fact

The constructions "is" and "is not" do not indicate requirements.

1 Scope

The present document establishes the Multiple Input Multiple Output (MIMO) Over-the-Air (OTA) performance requirements for NR UEs operating on frequency Range 1 and frequency range 2, for NR standalone (SA) and NR non-standalone (NSA) operation mode. The corresponding test methodologies are also presented in the Annex of this Technical Specification.

2 References

The following documents contain provisions which, through reference in this text, constitute provisions of the present document.

- References are either specific (identified by date of publication, edition number, version number, etc.) or non-specific.
- For a specific reference, subsequent revisions do not apply.
- For a non-specific reference, the latest version applies. In the case of a reference to a 3GPP document (including a GSM document), a non-specific reference implicitly refers to the latest version of that document *in the same Release as the present document*.

- [1] 3GPP TR 21.905: "Vocabulary for 3GPP Specifications".
- [2] 3GPP TS 38.101-1: "NR; User Equipment (UE) radio transmission and reception; Part 1: Range 1 Standalone".
- [3] 3GPP TS 38.101-3: "NR; User Equipment (UE) radio transmission and reception; Part 3: Range 1 and Range 2 Interworking operation with other radios".
- [4] 3GPP TS 38.508-1: "5GS; User Equipment (UE) conformance specification; Part 1: Common test environment".
- [5] 3GPP TR 38.901: "Study on channel model for frequencies from 0.5 to 100 GHz".
- [6] 3GPP TS 38.101-4: "NR; User Equipment (UE) radio transmission and reception; Part 4: Performance requirements".
- [7] 3GPP TS 38.151: "NR; User Equipment (UE) Multiple Input Multiple Output (MIMO) Over-the-Air (OTA) performance requirements".
- [8] 3GPP TS 38.561: "UE TRP (Total Radiated Power) and TRS (Total Radiated Sensitivity) requirements and test methodologies for FR1 (NR SA and EN-DC); User Equipment (UE) conformance specification".
- [9] IEEE Std 149-2021: "IEEE Recommended Practice for Antenna Measurements", IEEE.
- [10] 3GPP TR 38.827: "Study on radiated metrics and test methodology for the verification of multi-antenna reception performance of NR User Equipment (UE)".
- [11] 3GPP TS 38.101-2: "NR; User Equipment (UE) radio transmission and reception; Part 2: Range 2 Standalone".
- [12] 3GPP TS 38.508-2: "5GS; User Equipment (UE) conformance specification; Part 2: Common Implementation Conformance Statement (ICS) proforma".
- [13] 3GPP TS 38.521-2: "User Equipment (UE) conformance specification; Radio transmission and reception; Part 2: Range 2 Standalone".
- [14] 3GPP TR 38.903: "NR; Derivation of test tolerances and measurement uncertainty for User Equipment (UE) conformance test cases"

3 Definitions of terms, symbols, and abbreviations

3.1 Terms

For the purposes of the present document, the terms given in 3GPP TR 21.905 [1] and the following apply. A term defined in the present document takes precedence over the definition of the same term, if any, in 3GPP TR 21.905 [1].

Free Space (FS): UE used in a free space configuration

Handheld UE: UE intended to be used in hand held scenario.

MIMO Average Spherical Coverage: An averaged sensitivity of best 18 FR2 MIMO OTA sensitivity values within the 3D sphere with constant-density points for PC3 device.

Primary mechanical mode: mode that is most often used for a specific user scenario. Every terminal has at least one primary mechanical mode, if multiple modes are supported, different primary mechanical modes may be applicable for different user scenarios, e.g., different primary mechanical modes for Free Space and Hand phantom usage for the same UE.

PSP (PAS Similarity Percentage): The similarity of the PAS produced by the OTA system and the reference PAS, which is presented by the Total Variation Distance (TVD) of power angular spectrum (PAS). PSP is defined as $(1 - \text{TVD}) * 100\%$. PSP=100% denotes full similarity and PSP=0% denotes full dissimilarity.

3.2 Symbols

For the purposes of the present document, the following symbols apply:

$P_{RS-EPRE-MAX}$ Maximum downlink RS-EPRE

3.3 Abbreviations

For the purposes of the present document, the abbreviations given in 3GPP TR 21.905 [1] and the following apply. An abbreviation defined in the present document takes precedence over the definition of the same abbreviation, if any, in 3GPP TR 21.905 [1].

ACK	Acknowledgment
AOA	Azimuth angle Of Arrival
AOD	Azimuth angle Of Departure
ASA	Azimuth Spread of Arrival angles
ASD	Azimuth Spread of Departure angles
BS	Base Station
CASA	Cluster ASA
CASD	Cluster ASD
CDL	Clustered Delay Line
CIR	Channel Impulse Response
CSI	Channel state information
CSI-RS	CSI reference signal
CW	Continuous Wave
CZSA	Cluster ZSA
CZSD	Cluster ZSD
DML	Data Mode Landscape
DMP	Data Mode Portrait
DMRS	Demodulation reference signal
DMSU	Data Mode Screen Up
DUT	Device Under Test
EUT	Equipment Under Test
EVM	Error Vector Magnitude
FR1	Frequency Range 1
FR2	Frequency Range 2

FRC	Fixed Reference Measurement Channel
FS	Free Space
gNB	Next Generation Node B
HARQ	Hybrid automatic repeat request
MIMO	Multiple Input Multiple Output
MPAC	Multi-Probe Anechoic Chamber
MU	Measurement Uncertainty
NACK	Not Acknowledged
NR	New Radio
NSA	Non-Standalone a mode of operation where operation of a radio is assisted with another radio
OCNG	OFDMA Channel Noise Generator
OTA	Over The Air
PAS	Power Angular Spectrum
PDP	Power Delay Profile
PDSCH	Physical downlink shared channel
PRB	Physical resource block
PSP	PAS Similarity Percentage
RE	Resource Element
RS-EPRE	Reference Signal-Energy Per Resource Element
SCS	Subcarrier spacing
SNR	Signal to Noise Ratio
SS	System Simulator
SSS	Secondary Synchronization Signal
TBS	Transport Block Size
TCI	Transmission Configuration Indicator
TRMS	Total Radiated Multi-antenna Sensitivity
UE	User Equipment
UMa	Urban Macro
UMi	Urban Micro
VNA	Vector Network Analyser
XPR	Cross-Polarization Ratio
ZOA	Zenith angle Of Arrival
ZOD	Zenith angle Of Departure
ZSA	Zenith angle Spread of Arrival
ZSD	Zenith angle Spread of Departure

4 General

4.1 Relationship between minimum requirements and test requirements

The Minimum Requirements given in 3GPP TS 38.151 [7] make no allowance for Measurement Uncertainty (MU). The present document defines the MU and Test Tolerances in Annex B for FR1 MIMO OTA and Annex H for FR2 MIMO OTA. The test tolerances are used to relax the Minimum Requirements in 3GPP TS 38.151 [7] to create the Test Requirements.

4.2 Applicability of minimum requirements

The MIMO OTA minimum requirements apply only to the primary mechanical mode of UE which is declared by the manufacturer if the UE can support multiple mechanical modes.

The minimum requirements apply only to the UE under normal environmental conditions specified in Annex E.

4.3 Applicability rules for testing of SA and NSA UEs

The applicability and test coverage rules for Non-Standalone (NSA) only capable UEs shall include the following:

- For FR1 NSA (EN-DC) only capable UEs, testing is not required.
- For FR2 NSA (EN-DC) only capable UEs, for each FR2 NR band supported by the device, test the UE in EN-DC mode using any one example configuration containing that NR band or configuration declaration decision tree as per recommended MIMO OTA test procedures in this specification.

The applicability and test coverage rules for Standalone (SA) and NSA (EN-DC) capable UEs shall include the following:

- For FR1 UEs, for each NR band in a device, test the UE in Standalone Mode as per the TRMS test procedures in this specification. This shall also fulfil coverage for all EN-DC minimum performance requirements for that NR band and need not be retested in EN-DC mode.
- For FR2 UEs, for each FR2 NR band supported by the device, test the UE in any of SA modes including FR2 only mode, FR1+FR2 NR-DC mode and FR1+FR2 NR-CA mode using any one example configuration containing that NR band. This shall fulfil coverage for FR2 MIMO OTA requirements for that NR band and need not be retested in EN-DC mode.

5 Frequency Bands

5.1 General

NR MIMO OTA Requirements are defined separately for different Frequency Ranges (FR). The frequency ranges in which NR can operate according to this version of the specification are identified as described in Table 5.1-1.

Table 5.1-1: Definition of frequency ranges

Frequency range designation	Corresponding frequency range
FR1	410 MHz - 7125 MHz
FR2	24250 MHz - 52600 MHz

The present specification covers both FR1 and FR2 operating bands. For FR2, only FR2-1 bands are applicable.

5.2 Operating bands

NR is designed to operate in FR1 operating bands defined in 3GPP TS 38.101-1 [2] and FR2 operating bands defined in TS 38.101-2 [11]. NSA band combinations are defined in 3GPP TS 38.101-3 [3].

For FR2 EN-DC capable UEs, principle of EN-DC band combinations selection for FR2 MIMO OTA testing is as following:

- 1) Focus on the performance of the NR carrier and do not consider multiple permutations between different LTE bands and NR band under test, i.e., for each NR band, only select one EN-DC band combination.
- 2) For UE supporting multiple EN-DC band combinations for the same NR band, consider only those EN-DC configurations which have no MSD impact on either LTE or NR.

Table 5.2-1: Measurement parameters for example inter-band EN-DC band combinations (LTE + FR2, two bands)

EN-DC configuration	E-UTRA configurations	NR FR2 configurations
DC_66A_n261A	Mid channel	Mid channel

Table 5.2-2: Measurement parameters for example inter-band NR-DC band combinations (FR1 + FR2, two bands)

NR-DC configuration	NR FR1 configurations	NR FR2 configurations
DC_n66A_n261A	Mid channel	Mid channel

Table 5.2-3: Measurement parameters for example inter-band NR-CA band combinations (FR1 + FR2, two bands)

NR-CA configuration	NR FR1 configurations	NR FR2 configurations
CA-n66A_n261A	Mid channel	Mid channel

With the above basic principle and example band combination, the selection logic for testing is defined by the decision trees shown in Figure 5.2-1 and Figure 5.2-2.

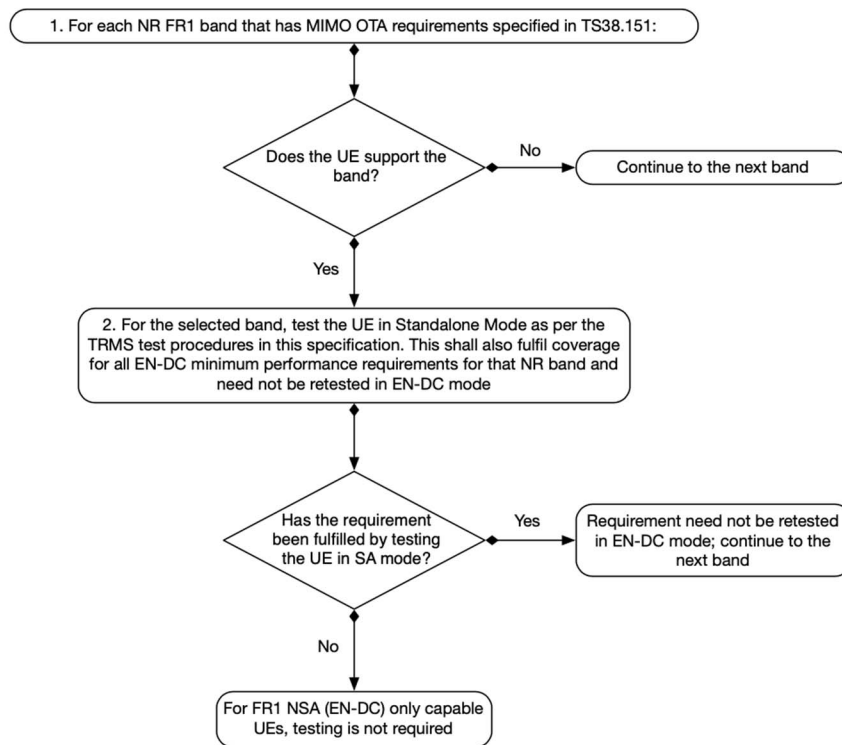

Figure 5.2-1: Decision tree for FR1 MIMO OTA testing

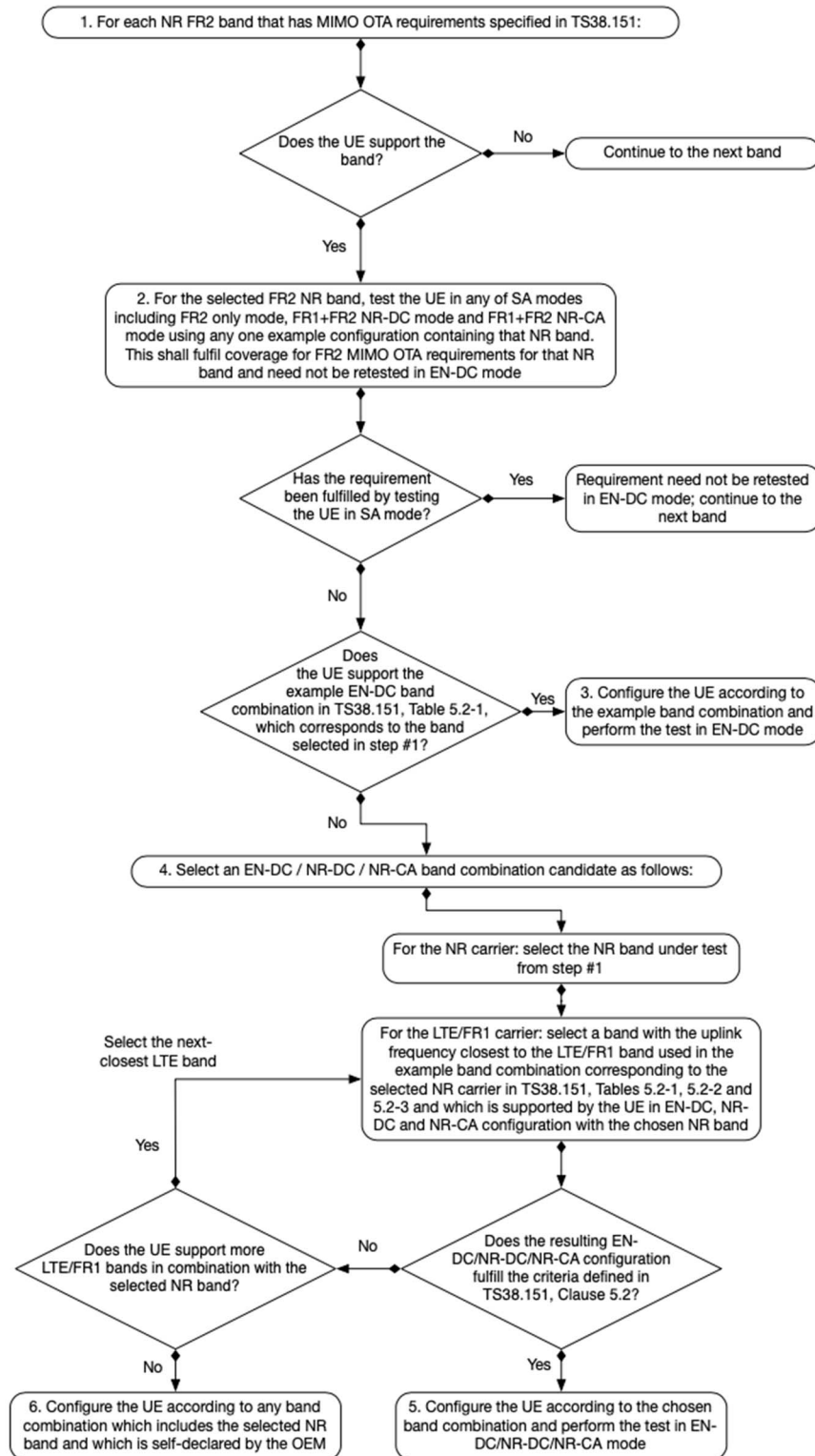

Figure 5.2-2: Decision tree for FR2 MIMO OTA testing

6 FR1 MIMO OTA Performance

6.1 General

6.1.1 Definition of MIMO throughput

The MIMO throughput is defined here as the time-averaged number of correctly received transport blocks in a communication system running an application, where a Transport Block is defined in the reference measurement channel. From OTA perspective, this is also called MIMO OTA throughput. It will be used as the baseline figure of merit for FR1 and FR2 MIMO OTA testing.

The MIMO OTA throughput is measured at the top of physical layer of NR system under the use of FRC, the SS transmit fixed-size payload bits to the DUT. The DUT signals back either ACK or NACK to the SS. The SS then records the following:

- number of ACKs;
- number of NACKs; and
- number of DTX slots.

Hence the MIMO (OTA) throughput can be calculated as:

$$MIMO\ (OTA)\ Throughput = \frac{Transmitted\ TBS \times Num\ of\ ACKs}{MeasurementTime}$$

Where Transmitted TBS is the Transport Block Size transmitted by the SS, which is fixed for an FRC during the measurement period. Measurement Time is the total composed of successful slots (ACK), unsuccessful slots (NACK) and DTX-symbols.

The time-averaging is to be taken over a time period sufficiently long to average out the variations due to the fading channel. Therefore, this is also called the average MIMO OTA throughput. The throughput should be measured at a time when eventual start-up transients in the system have evanesced.

6.1.2 Total Radiated Multi-Antenna Sensitivity (TRMS)

6.1.2.1 Test Purpose

The purpose of this test is to ensure that the UE meets the TRMS minimum performance requirements.

6.1.2.2 Test Applicability

This test case applies to all types of NR UE release 17 and forward. See clause 4.2 for additional applicability.

6.1.2.3 Minimum Conformance Requirements

Editor's Note: TRMS value for band n79 is pending in RAN4 spec TS38.151.

The average TRMS of free space data mode portrait (FS DMP), free space data mode landscape (FS DML), and free space data mode screen up (FS DMSU), is defined as the FR1 MIMO OTA requirement. The averaging shall be done in linear scale for the TRMS results at these DUT positions, according to the formula:

$$TRMS_{average,70} = 10 \log \left[3 / \left(\frac{1}{10^{S_{FS_DMP,70}/10}} + \frac{1}{10^{S_{FS_DML,70}/10}} + \frac{1}{10^{S_{FS_DMSU,70}/10}} \right) \right]$$

where

$$S_{MODE,70} = 10 \log \left[12 / \left(\frac{1}{10^{P_{MODE,70,0}/10}} + \frac{1}{10^{P_{MODE,70,1}/10}} + \dots + \frac{1}{10^{P_{MODE,70,11}/10}} \right) \right]$$

Such that *MODE* is one of {*FS_DMP*, *FS_DML*, *FS_DMSU*}, and { $P_{MODE,70,0}$, ..., $P_{MODE,70,11}$ } are the measured sensitivity values at each azimuth position at the 70% throughput outage.

The reported TRMS value shall be corrected by -0.5 dB output level step resolution of the final power step search and the correction shall be noted in the test report.

If 1 azimuth position does not result in a defined measured sensitivity at 70 % throughput, $S_{MODE,70}$ is calculated using the 11 measured sensitivities and the maximum downlink RS-EPRE $P_{RS-EPRE-MAX}$ (substitution approach) for the one missing result. $P_{RS-EPRE-MAX}$ is the maximum downlink RS-EPRE supported by the test system, and is defined as -80 dBm/15 kHz (or equivalent -77 dBm/30 kHz) for FR1 MIMO OTA.

The TRMS shall be measured at the mid channel as specified in 3GPP TS 38.508-1 [4], subclause 4.3.1. The average TRMS shall be lower than the average TRMS requirements specified in Table 6.1.2.3-1.

The additional criterion in azimuthal orientations shall be met:

- The EUT has to meet 70 % throughput in 11 of total 12 azimuthal orientations. If the EUT fails to meet this criterion even under maximum downlink power condition (i.e. $P_{RS-EPRE-MAX}$), the EUT shall fail the FR1 MIMO OTA test.
- The EUT has to meet 90 % throughput in 10 of total 12 azimuthal orientations for bands > 1 GHz, and 8 of total 12 azimuthal orientations for bands < 1 GHz. If the EUT fails to meet this criterion even under maximum downlink power condition (i.e. $P_{RS-EPRE-MAX}$), the EUT shall fail the FR1 MIMO OTA test.

FR1 TRMS minimum performance requirements for NR handheld UEs operating in SA mode in free space and the primary mechanical mode for 70% DL throughput with the corresponding measurement configurations (i.e. channel model and gNB configuration) specified in clause C.1 and clause E.1 are defined in Table 6.1.2.3-1.

Table 6.1.2.3-1: FR1 TRMS minimum performance requirements for NR handheld UEs operating on SA mode in free space and the primary mechanical mode

NR bands	Bandwidth (MHz)	MIMO layer	Channel model	Reference channel	TRMS _{average,70}
n1	10	4x4	FR1 UMa CDL-C	R.PDSCH.1-2.4 FDD	-96.0 dBm/15kHz
n5	10	2x2	FR1 UMi CDL-C	R.PDSCH.1-3.1 FDD	-88.0 dBm/15kHz
n28	10	2x2	FR1 UMi CDL-C	R.PDSCH.1-3.1 FDD	-84.6 dBm/15kHz
n41	40	4x4	FR1 UMa CDL-C	R.PDSCH.2-2.4 TDD	-93.3 dBm/30kHz
n78	40	4x4	FR1 UMa CDL-C	R.PDSCH.2-2.4 TDD	-94.8 dBm/30kHz
n79	40	4x4	FR1 UMa CDL-C	R.PDSCH.2-2.4 TDD	[...] dBm/30kHz

6.1.2.4 Test Description

6.1.2.4.1 Initial Conditions

Initial conditions are a set of test configurations the UE needs to be tested in and the steps for the SS to take with the UE to reach the correct measurement state.

A radio communications tester or a corresponding device is used as a gNB simulator to setup calls to the DUT according to Clause D.1.

Channel model shall be set according to Clause C.1 and the emulated BS beam configuration shall be set according to Clause C.2.

Chamber environment constraints shall be the same as described in Clause A.2.1. The coordinate system shall match that of Clause A.3.

Environmental conditions from Annex E shall apply.

The positioning of the device under test within the test volume shall be set as defined in Clause A.3.

The calibration procedure is specified in Clause A.2.2.

Initial conditions are a set of test configurations the UE shall be tested in and the steps for the SS to take with the UE to reach the correct measurement state for each test case.

- 1) Ensure environmental requirements of Annex E are met.
- 2) Configure the test system according to Annexes C and D for the applicable test case.
- 3) Verify the implementation of the channel model as specified in clause C.3.
- 4) Position the UE in the chamber according to clause A.3.
- 5) Power on the UE.
- 6) Set up the connection.

NOTE: For step 3, the verification of the channel model implementation is usually performed once for each channel model as part of the laboratory accreditation process and will remain valid as long as the setup and instruments remain unchanged. Otherwise, the channel model validation may need to be performed prior to starting each throughput test.

6.1.2.4.2 Test Procedure

For throughput testing, the following steps shall be followed in order to evaluate NR MIMO OTA performance of the DUT:

- 1) Measure MIMO OTA throughput from one measurement point, the maximum downlink power $P_{RS-EPRE-MAX}$ is defined in clause 6.1.2. MIMO OTA throughput is the minimum downlink signal power resulting in a pre-defined throughput value, i.e. 70 % and 90 % of the maximum theoretical throughput. The downlink signal power step size shall be no more than 0.5 dB when RF power level is near the NR MIMO sensitivity level.
- 2) Rotate the UE around vertical axis of the test system by 30 degrees and repeat from step 1 until one complete rotation has been measured i.e. 12 different UE azimuth rotations.
- 3) Repeat the test from step 1 for each specified device orientation. A list of orientations is given in clause A.3.
- 4) The postprocessing method to calculate the average MIMO Throughput is defined in clause 6.

NOTE: For step 1 of throughput testing, the measurement is not needed to start from maximum downlink power each time. To save testing time, the starting downlink power can be set as a proper value (lower than maximum downlink power supported by test system) as long as all the throughput curve curves at 12 different UE azimuth rotations can reach at least 90% of the maximum theoretical throughput.

6.1.2.4 Test Requirements

Editor's Note: TRMS value for band n79 is pending in RAN4 spec TS38.151.

The test requirements are shown in Table 6.1.2.4-1.

Table 6.1.2.4-1: FR1 TRMS test requirements for NR handheld UEs operating on SA mode in free space and the primary mechanical mode

NR bands	Bandwidth (MHz)	MIMO layer	Channel model	Reference channel	TRMS _{average,70}
n1	10	4x4	FR1 UMa CDL-C	R.PDSCH.1-2.4 FDD	-96.0 dBm/15kHz +TT
n5	10	2x2	FR1 UMi CDL-C	R.PDSCH.1-3.1 FDD	-88.0 dBm/15kHz +TT
n28	10	2x2	FR1 UMi CDL-C	R.PDSCH.1-3.1 FDD	-84.6 dBm/15kHz +TT
n41	40	4x4	FR1 UMa CDL-C	R.PDSCH.2-2.4 TDD	-93.3 dBm/30kHz + TT
n78	40	4x4	FR1 UMa CDL-C	R.PDSCH.2-2.4 TDD	-94.8 dBm/30kHz +TT
n79	40	4x4	FR1 UMa CDL-C	R.PDSCH.2-2.4 TDD	[...] dBm/30kHz +TT

6.2 Void

7 FR2 MIMO OTA requirements

7.1 General

7.1.1 MIMO Average Spherical Coverage (MASC)

The MIMO Average Spherical Coverage (MASC) is the Figure of Merit of FR2 MIMO OTA requirement. FR2 MIMO OTA is measured with 36 constant-density points within the 3D sphere. The MASC is determined by the averaging of the best 18 sensitivity values for power class 3 UE. The averaging shall be done in linear scale for the MASC result according to the formula:

$$MASC_{70} = 10 \log \left[\frac{18}{\left(\frac{1}{10^{-\frac{P_{70,1}}{10}}} + \frac{1}{10^{-\frac{P_{70,2}}{10}}} + \dots + \frac{1}{10^{-\frac{P_{70,18}}{10}}} \right)} \right]$$

Such that $\{P_{70,1}, \dots, P_{70,18}\}$ are the best 18 sensitivity values from all the 36 constant density measurement points, as defined in [7] Annex B.2.3.

The MASC is determined by the averaging of the best 5 sensitivity values for power class 1 UE. The averaging shall be done in linear scale for the MASC result according to the formula:

$$MASC_{70} = 10 \log \left[\frac{5}{\left(\frac{1}{10^{-\frac{P_{70,1}}{10}}} + \frac{1}{10^{-\frac{P_{70,2}}{10}}} + \dots + \frac{1}{10^{-\frac{P_{70,5}}{10}}} \right)} \right]$$

Such that $\{P_{70,1}, \dots, P_{70,5}\}$ are the best 5 sensitivity values from all the 36 constant density measurement points, as defined in [7] Annex B.2.3.

The MASC shall be measured at the mid channel as specified in TS 38.508-1 subclause 4.3.1 [4]. The MASC shall be lower than the requirements specified in Clause 7.2.

For FR2 MIMO OTA, $P_{RS-EPRE-MAX}$, i.e., the maximum downlink RS-EPRE supported by the test system, is defined as -79.1dBm/120kHz.

For power class 3 UE, if the number of test points where the UE can meet 70% maximum throughput outage even under maximum downlink power condition (i.e., -79.1dBm/120kHz) is less than 18, then UE fails the test. For power class 1 UE, if the number of test points where the UE can meet 70% maximum throughput outage even under maximum downlink power condition (i.e., -79.1dBm/120kHz) is less than 5, then UE fails the test.

Other criteria for FR2 are FFS.

7.1.1.1 Test Purpose

The purpose of this test is to ensure that the UE meets the MASC minimum performance requirements.

7.1.1.2 Test Applicability

This test case applies to all types of NR UE release 18 and forward. See clause 4.2 for additional applicability.

7.1.1.3 Minimum Conformance Requirements

Editor's Note: MASC values for bands n257/n258/n260 are pending in RAN4 spec TS38.151.

FR2 MASC minimum performance requirements for power class 3 NR handheld UEs in free space and the primary mechanical mode for averaging of the best 18 sensitivity values for 70% DL throughput with the corresponding measurement configurations (i.e., channel model and gNB configuration) specified in Annex I.1 and Annex E.2 are defined in Table 7.1.1.3-1.

Table 7.1.1.3-1: FR2 MASC minimum performance requirements for NR handheld UEs in free space and the primary mechanical mode

NR bands	Bandwidth [MHz]	MIMO layer	Channel model	Reference channel	MASC ₇₀ [dBm/120kHz]
n257	100	2x2	FR2 UMi CDL-C	R.PDSCH.5-2.2 TDD	[...]
n258	100	2x2	FR2 UMi CDL-C	R.PDSCH.5-2.2 TDD	[...]
n260	100	2x2	FR2 UMi CDL-C	R.PDSCH.5-2.2 TDD	[...]
n261	100	2x2	FR2 UMi CDL-C	R.PDSCH.5-2.2 TDD	-100.0

7.1.2 Test Description

7.1.2.1 Initial Conditions

Before throughput testing, the initial conditions shall be confirmed to reach the correct measurement state for each test case.

1. Ensure environmental requirements of Annex E are met.
2. Configure the test system according to Annex E.2 and Annex I.1 for the applicable test case.
3. Verify the implementation of the channel model as specified in Annex I.3.
4. Position the UE in the chamber according to Annex G.3.
5. Power on the UE.
6. Set up the connection.

Note: For step 3, the verification of the channel model implementation is usually performed once for each channel model and for each validation frequency listed in Table I.3.1-1 as part of the laboratory accreditation process, and will remain valid as long as the setup and instruments remain unchanged. Otherwise the channel model validation may need to be performed prior to starting each throughput test.

7.1.2.2 Test Procedure

For throughput testing, the following steps shall be followed in order to evaluate FR2 MIMO OTA performance of the DUT:

1. Position the DUT in the default P0 alignment option (Orientation 1), as defined in Clause G.3.
2. Measure MIMO OTA throughput, the maximum downlink power is -79.1dBm/120kHz, as defined in Clause 7.1.1. MIMO OTA throughput is the minimum downlink signal power resulting in a pre-defined throughput value (70%) of the maximum theoretical throughput. The downlink signal power step size shall be no more than 0.5 dB when RF power level is near the NR MIMO sensitivity level.
3. Rotate the UE to the next test point. Table 7.1.2.2-1 lists 36 evenly spaced test points determined using the charged particle approach and with test point #1 centred at (0,0). If the re-positioning concept is not applied, continue to position the device in DUT Orientation 1 as defined in Clause G.3. If the re-positioning concept is applied,
 - a) position the device in DUT Orientation 1 from Table G.3-1 for measurements within zenith range $0^\circ \leq \theta \leq 90^\circ$
 - b) position the device in DUT Orientation 2 (either Options 1 or 2) from Table G.3-1 for measurements within zenith range $90^\circ < \theta \leq 180^\circ$.
4. Repeat the test from step 2 for each specified test point.
5. The postprocessing method and the performance metric are defined in Clause 7.1.

Note: For step 2 of throughput testing, the measurement is not needed to start from maximum downlink power each time. To save testing time, the starting downlink power can be set as a proper value (lower than maximum downlink power supported by test system) as long as the throughput curve can reach at least 70% of the maximum theoretical throughput.

Table 7.1.2.2-1: Evenly spaced FR2 test points with a constant density

Test Point Number	θ [°]	ϕ [°]
1	0.0	0.0
2	33.5	139.7
3	33.9	49.7
4	35.5	-142.9
5	35.5	-76.9
6	37.6	-17.2
7	52.3	94.7
8	56.9	175.7
9	62.5	20.4
10	63.7	-99.8
11	67.1	-55.0
12	69.3	-139.5
13	69.5	130.1
14	70.3	60.8
15	72.1	-16.2
16	88.7	-167.5
17	88.7	98.5
18	89.3	157.0
19	93.9	-78.9
20	94.6	31.6
21	95.3	-115.6
22	99.6	-38.3
23	103.8	-1.1
24	104.4	66.3
25	110.1	127.5
26	115.1	-145.6
27	120.8	171.9
28	125.3	-60.7
29	128.2	-104.1
30	128.8	91.3
31	129.9	35.8
32	136.0	-13.4
33	145.8	138.1
34	150.2	-153.3
35	160.6	-67.4
36	161.7	59.1

7.1.2.3 Test Requirements

Editor's Note: MASC values for bands n257/n258/n260 are pending in RAN4 spec TS38.151.

The test requirements are shown in Table 7.1.2.3-1.

Table 7.1.2.3-1: FR2 MASC test requirements for NR handheld UEs in free space and the primary mechanical mode

NR bands	Bandwidth [MHz]	MIMO layer	Channel model	Reference channel	MASC ₇₀ [dBm/120kHz]
n257	100	2x2	FR2 UMi CDL-C	R.PDSCH.5-2.2 TDD	[...] +TT
n258	100	2x2	FR2 UMi CDL-C	R.PDSCH.5-2.2 TDD	[...] +TT
n260	100	2x2	FR2 UMi CDL-C	R.PDSCH.5-2.2 TDD	[...] +TT
n261	100	2x2	FR2 UMi CDL-C	R.PDSCH.5-2.2 TDD	-100.0 + TT

Annex A (normative): FR1 Test methodology

A.1 General

FR1 MIMO OTA requirement testing is based on UE-noise limited environmental condition, i.e. UE throughput characterized as a function of signal power incident to the DUT antennas.

The minimum test zone size for FR1 MIMO OTA test methods is 20cm. "Black-box" testing approach is adopted for NR MIMO OTA testing, the geometric centre of the EUT shall be placed in the centre of the test zone, the EUT shall be completely contained within the minimum test zone size.

FR1 MIMO OTA requirement testing should be performed under primary mechanical mode. The primary mechanical mode for devices having multiple mechanical modes shall be declared by the manufacturers. Single primary mechanical mode for each device should be declared for MIMO OTA conformance testing.

A.2 Multi-Probe Anechoic Chamber (MPAC)

A.2.1 System setup

MPAC test method is the reference methodology for FR NR MIMO OTA testing. By arranging an array of antennas around the Equipment Under Test (EUT), a spatial distribution of angles of arrival in MPAC system may be simulated to expose the EUT to a near field environment that appears to have originated from a complex multipath far field environment.

As illustrated schematically in Figure A.2.1-1, signals propagate from the base station/communication tester to the EUT through a simulated multipath environment known as a spatial channel model, where appropriate channel impairments such as Doppler and fading are applied to each path prior to injecting all of the directional signals into the chamber simultaneously through the antenna array. The resulting field distribution in the test zone is then integrated by the EUT antenna(s) and processed by the receiver(s) just as it would do so in any non-simulated multipath environment. MPAC system with 16 uniformly spaced dual-polarized probes is permitted for NR FR1 MIMO OTA testing.

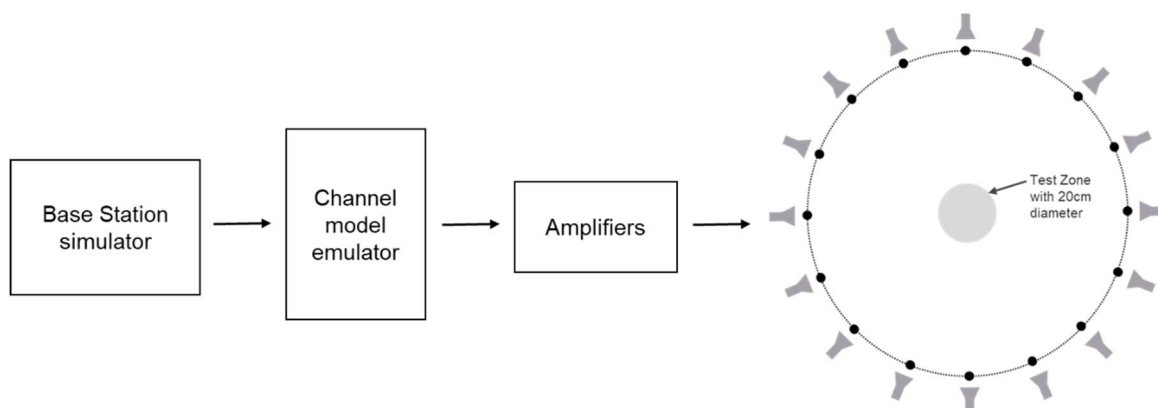

Figure A.2.1-1: MPAC system layout for NR FR1 MIMO OTA testing

For the selected environmental conditions modelled by the FR1 CDL channel models, the minimum setup configuration can be described as in Table A.2.1-1:

Table A.2.1-1: Example of a minimum setup for MPAC

	MPAC
Minimum number of antenna positions	16
Antenna spacing	22.5
Applicable channel model	FR1 UMi/UMa CDL-C

The setup of OTA chamber antennas with sixteen antenna positions is depicted in Figure A.2.1-2. The DUT is at the centre, and the antennas are aligned on a circle around the DUT with uniform spacing (e.g. 22.5° with 32 elements arranged in 16 positions, where each position contains a vertically and horizontally polarized antenna pair). Denoting directions of K OTA antennas with $\phi_k, k = 1 \dots K$, and antenna spacing of 22.5°. Each antenna is connected to a single fading emulator output port. In the figure, for example, antenna A_{1V} denotes the first OTA antenna position and Vertically (V) polarized element, A_{8H} denotes the eight OTA antenna position and horizontally (H) polarized element, etc.

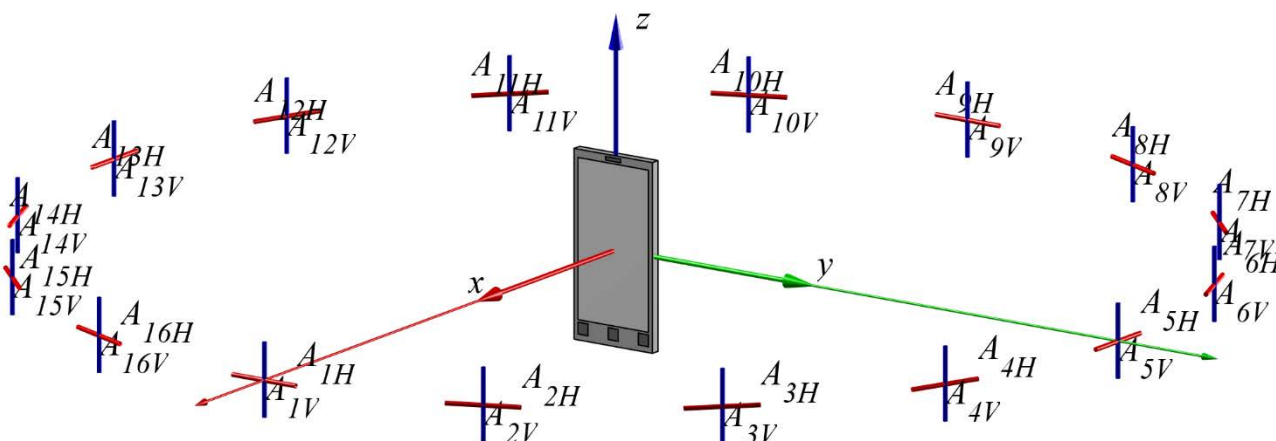

Figure A.2.1-2: OTA chamber antenna setup with sixteen uniformly spaced dual polarized chamber antennas

The OTA/channel model coordinate systems and probe placement are further clarified in Figure A.2.1-3. The x -axis of the coordinate system is aligned with the centre of probe #1 and the x, y , and z axes of the OTA coordinate system are aligned with the x_{CM}, y_{CM} , and z_{CM} axes of the channel model coordinate system.

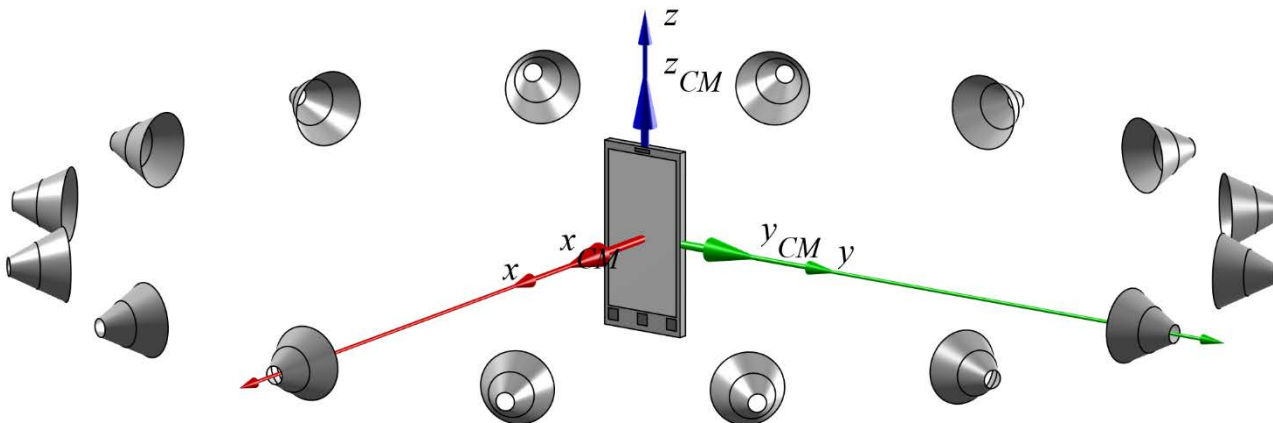

Figure A.2.1-3: Illustration of aligned OTA and channel model coordinate systems

A.2.2 Calibration procedure

The system needs to be calibrated by using a reference calibration antenna with known gain values in order to ensure that the downlink signal power is correct. In Non-Standalone (NSA) mode, the LTE link antenna provides a stable LTE signal without precise path loss or polarization control.

Unlike traditional TRP/TRS testing where the path loss corrections can all be applied as a post processing step to the measured data, the path loss for each probe in the MPAC system has to be balanced at test time in order to generate the desired channel model environment within the test zone of the chamber. The imbalance of each path during testing would result in an alteration of the angular dependence of the channel model (i.e. varied characteristics of generated channel model) within the test zone of the chamber:

- 1) Place a vertical reference dipole in the centre of the test zone, connected to a VNA port, with the other VNA port connected to the input of the channel emulator unit.
- 2) Configure the channel emulator for bypass mode.
- 3) Measure the response of each path from each vertical polarization probe to the reference antenna in the centre of test zone.
- 4) Adjust the power on all vertical polarization branches of the channel emulator so that the powers received at the centre are equal.
- 5) Repeat the steps 1 to 4 with the magnetic loop or horizontally polarized reference dipole instead and adjust the horizontal polarization branches of the channel emulator.
- 6) The worst-case path loss becomes the reference path loss of the entire system; this loss is used to compute the power in the centre of the test zone relative to the output power of the Base Station simulator. Besides, based on the reference path loss, the relative offset of each path loss shall be corrected.

NOTE: Calibration based on other antennas, e.g. horn antennas is not precluded.

This procedure shall be repeated on a regular basis, i.e., at least one per year, and any time the conducted and/or radiated signal paths have been affected, e.g., change in propagation conditions, replacement of cables, change in measurement antennas/probes, etc. It is recommended to perform this procedure rather frequently, e.g., monthly, to assess system stability.

A.2.3 Void

A.2.4 Minimum Range Length

The minimum range length of FR1 MPAC system is defined as the distance from the centre of the test zone to the aperture of the measurement probes/antennas, as illustrated in Figure A.2.4-1.

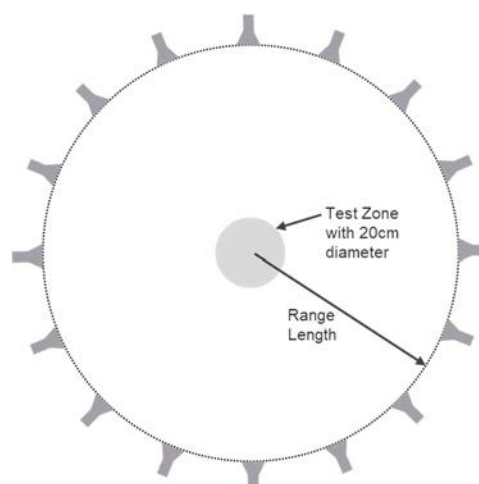

Figure A.2.4-1: Illustration of range length definition of FR1 MPAC

The minimum range length for NR FR1 MPAC OTA systems with 20cm test zone size is 1.2 m. While for MPAC systems, the far-field requirements do not have to apply, it was shown that the spatial correlation can be impacted significantly for distances below 1.2 m.

A.3 EUT positioning

This Clause defines the measurement coordinate system for the NR MIMO OTA.

For FR1 MIMO OTA, the DUT shall be tested under Free Space Data Mode Portrait (FS DMP), Free Space Data Mode Landscape (FS DML), and Free Space Data Mode Screen Up (FS DMSU), the DUT azimuthal rotation shall be performed over 360 degrees per orientation in 30 degree steps (12 total positions). The three different test and environment conditions for handsets are summarized in Table A.3-1.

The geometric centre of the DUT shall be aligned with the centre of the test zone/coordinate system and the DUT shall be fully contained within the test zone, i.e., a sphere with 20 cm diameter.

Table A.3-1: Summary of testing environment conditions for devices supporting DL MIMO data reception

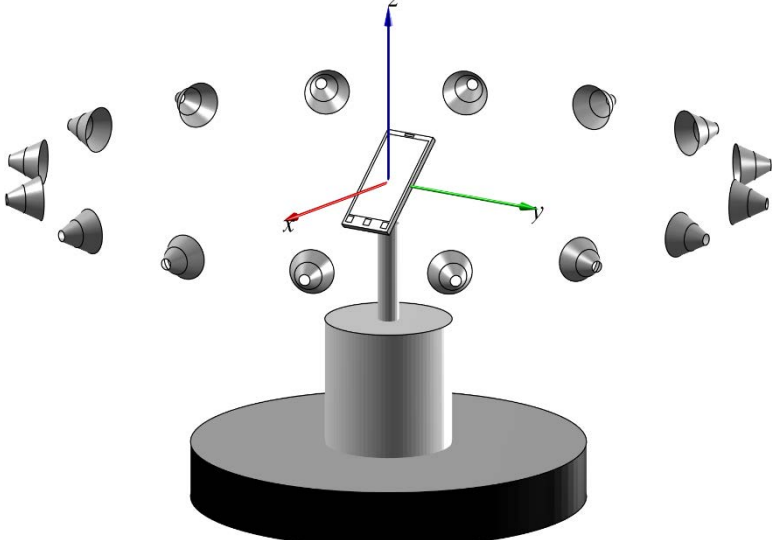
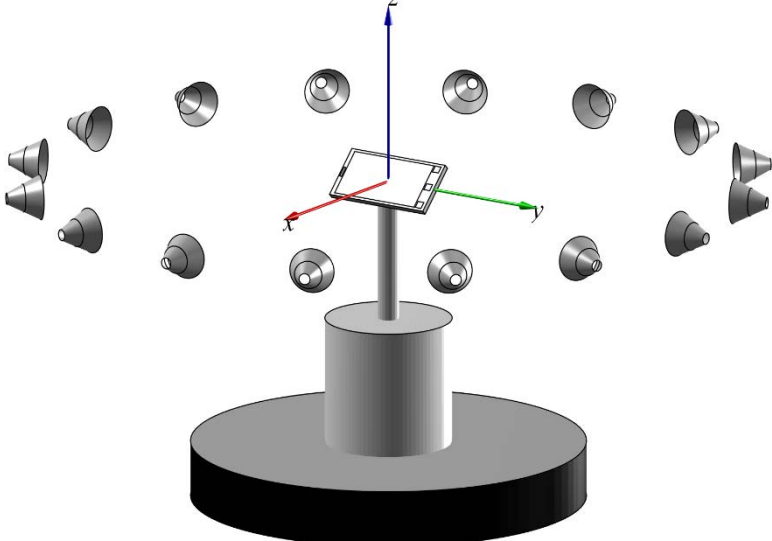
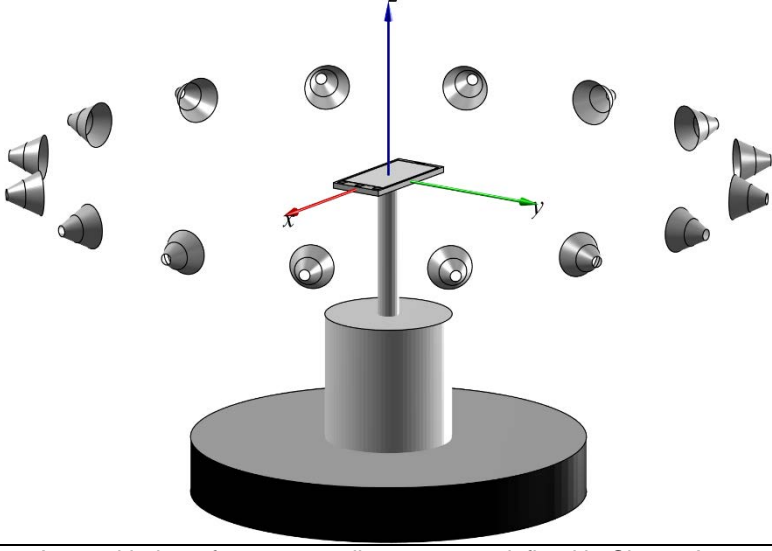
DUT type	Testing condition	DUT orientation angles	Diagram
Handset	FS DMP	$\Psi=0^\circ$ $\Theta=-45^\circ$ $\Phi=0^\circ$	
Handset	FS DML - Left Tilt	$\Psi=90^\circ$ $\Theta=-45^\circ$ $\Phi=0^\circ$	
Handset	FS DMSU	$\Psi=0^\circ$ $\Theta=-90^\circ$ $\Phi=0^\circ$	

NOTE: Rotation angles defined in Figure A.4-2 with the reference coordinate system defined in Clause A.4.

A.4 Reference coordinate system

This clause defines the measurement coordinate system for the NR UE. The reference coordinate system as defined in IEEE Std 149-2021 [9] is used as a baseline for provided Figure A.4-1 below, while Figure A.4-2 shows an example DUT in the default alignment, i.e., the DUT and the reference coordinate systems are aligned with $\theta = 0^\circ$ and $\phi = 0^\circ$ and $\psi = 0^\circ$ where θ , ϕ , and ψ describe the relative angles between the two coordinate systems.

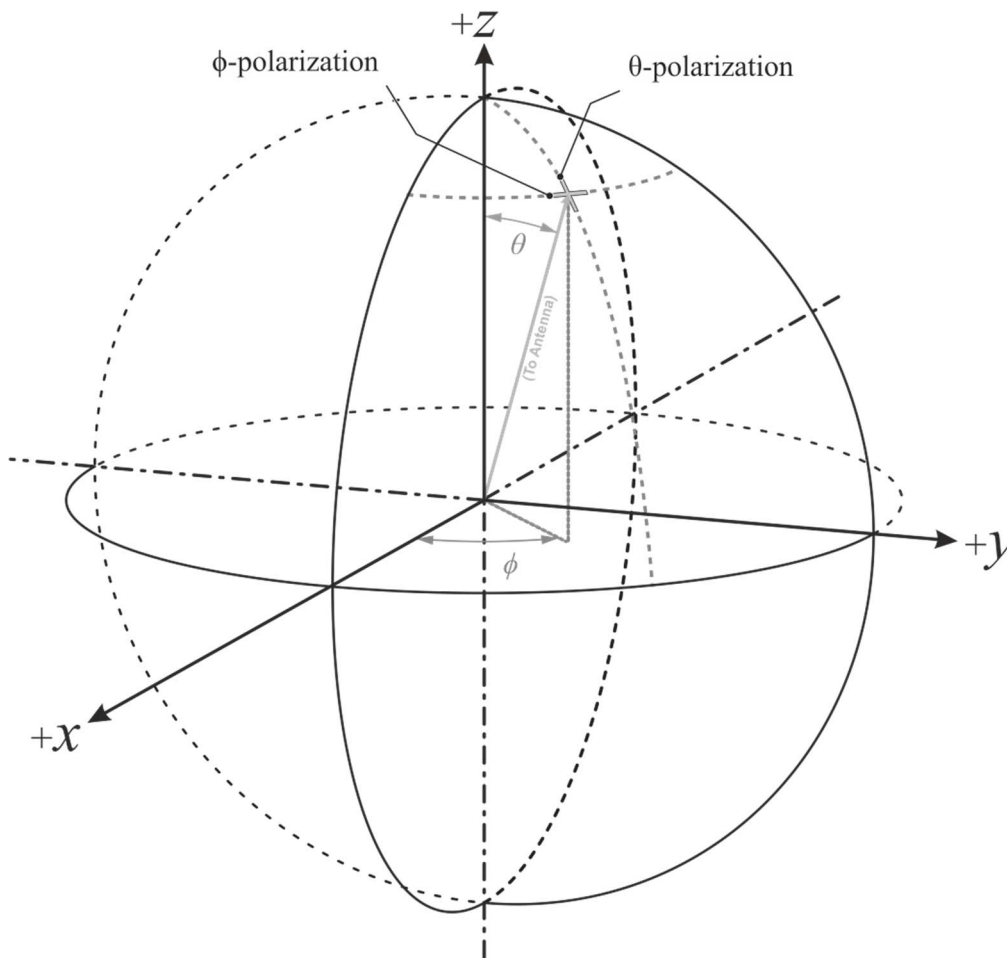

Figure A.4-1: Reference coordinate system

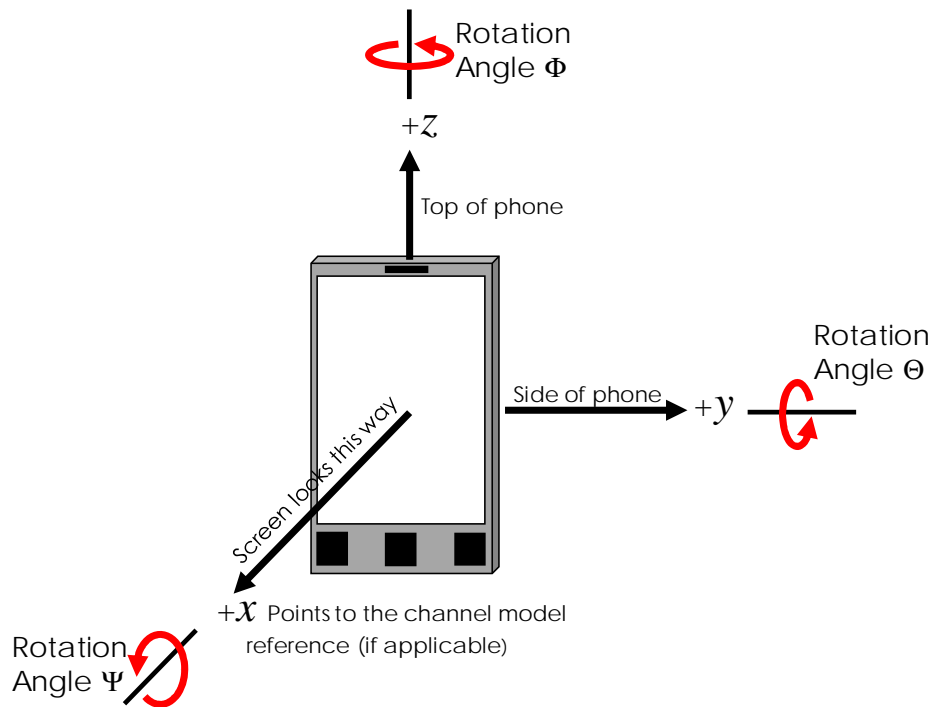

Figure A.4-2: DUT default alignment of example smartphone UE to coordinate system

The following aspects are necessary:

- A basic understanding of the top and bottom of the device is needed in order to define unambiguous DUT positioning requirements for the test, e.g., in the drawings used in this annex, the three buttons are on the bottom (front) of the device, the earpiece is on the upper (front) of the device and the camera is on the top of the device (back).
- An understanding of the origin and alignment the coordinate system inside the test system i.e. the directions in which the x , y , z -axes points inside the test chamber is needed in order to define unambiguous DUT orientation, DUT beam, signal, interference, and measurement angles

Annex B (informative): Estimation of FR1 measurement uncertainty

B.1 MU budget of FR1 MPAC system

This clause defines the measurement uncertainty (MU) for FR1 MPAC system, as shown in Table B.1-1.

Table B.1-1: Preliminary measurement uncertainty budget for FR1 MPAC system

UID	Description of uncertainty contribution	Example value (410 MHz < f ≤ 3 GHz) [dB]	Example value (3 GHz < f ≤ 7.125GHz) [dB]	Distribution of the probability	Std Uncertainty (410 MHz < f ≤ 3 GHz) [dB]	Std Uncertainty (3 GHz < f ≤ 7.125GHz) [dB]
Stage 2: DUT measurement						
1	Mismatch for measurement process	0	0	U-Shaped	0	0
2	Measure distance uncertainty	0	0	Normal	0	0
3	Quality of quiet zone	0.5	0.5	Actual	0.5	0.5
4	Base Station simulator	1.3	1.3	Normal	0.65	0.65
5	Channel Emulator			Normal	0.84	0.84
	- absolute output power	1.5	1.5	Rectangular		
	- output signal stability	0.5	0.5	Rectangular		
	- output stability with temperature	0.4	0.4			
6	Amplifier uncertainties	0.7	0.7	Rectangular	0.40	0.40
7	Random uncertainty	0.4	0.4	Normal	0.20	0.20
8	Throughput measurement: output level step resolution	0	0	Rectangular	0	0
9	Signal flatness	0	0	Normal	0	0
Stage 1: Calibration measurement						
10	Mismatch for calibration process - loopback cable path - system input path - reference antenna	0.2	0.2	U-Shaped	0.14	0.14
11	Reference antenna positioning misalignment	0	0	Normal	0	0
12	Quality of quiet zone	0.5	0.5	Rectangular	0.29	0.20
13	Total uncertainty of the Network Analyzer	0.2	0.5	Normal	0.10	0.25
14	Uncertainty of an absolute gain of the calibration antenna	0.58	0.58	Normal	0.29	0.29
15	Offset of the Phase Center of the Reference Antenna	0	0	Normal	0	0
Total Expanded Uncertainty, U, with 95 % Confidence Interval					2.61	2.65

The detailed descriptions of each measurement uncertainty contributor are defined in in clause B.2.

B.2 Measurement error contribution descriptions for MPAC

B.2.1 Mismatch for measurement process

This term comes from the mismatch between the system input cables connecting to the base station simulator output port. For more information, see clause A.4.2.1 of 3GPP TS 38.561 [8].

B.2.2 Measurement distance uncertainty

The cause of this uncertainty contributor is due to the reduction of distance between the measurement antenna and the DUT. Given that 1.2 m is defined as the minimum range length for FR1 MPAC system and the device is not offset from the axis(es) of rotation, this term could be set as 0 dB.

B.2.3 Quality of quiet zone

The quality of the quiet zone procedure characterizes the quiet zone performance of the anechoic chamber, specifically the effect of reflections within the anechoic chamber including any positioners and support structures. For FR1 quality of quiet zone measurements, reference antennas of sleeve dipole or magnetic loop are used. For more information, see clauses A.3.7 and A.4.2.8 of 3GPP TS 38.561 [8] with the exception that only the phi-axis ripple test is performed for MIMO OTA.

The ripple test shall be repeated when the RF/propagation conditions inside the chamber have changed, e.g., the chamber has been disassembled and reassembled, portions of the absorber been replaced, measurement antennas/probes been replaced, positioning system been replaced, etc.

B.2.4 Base Station simulator

gNB emulator is used to drive a signal to the channel emulator and then to the device under test. Generally there occurs uncertainty contribution from absolute level accuracy, non-linearity and frequency characteristic of the gNB emulator.

For practical reasons, in a case that a VNA is used as a calibration equipment, gNB emulator is connected to the system after the calibration measurement is performed by the VNA. Hence, the uncertainty on the absolute level of gNB emulator (transmitter device) cannot be assumed as systematic. This uncertainty will be determined from the manufacturer's datasheet and the distribution used shall match that provided in the datasheet which are commonly quoting MUs/accuracies with a "95 % confidence level" and/or a "coverage factor of 2". In the absence of a declared distribution in the datasheet, the rectangular distribution should be used. Furthermore, the uncertainty of the non-linearity is included in the absolute level uncertainty.

B.2.5 Channel Emulator

The channel emulator is also working as a signal source in the NR MIMO OTA system, therefore there occurs uncertainty contribution from absolute level accuracy, non-linearity, frequency characteristic and stability of the channel emulator. These uncertainty contributions shall be taken from the manufacturer's data sheet.

B.2.6 Amplifier uncertainties

Any components in the setup can potentially introduce measurement uncertainty. It is then needed to determine the uncertainty contributors associated with the use of such components. For the case of external amplifiers, the following uncertainties should be considered but the applicability is contingent to the measurement implementation and calibration procedure:

- Stability:

- An uncertainty contribution comes from the output level stability of the amplifier. Even if the amplifier is part of the system for both measurement and calibration, the uncertainty due to the stability shall be considered. This uncertainty can be either measured or determined by the manufacturers' data sheet for the operating conditions in which the system will be required to operate.
- Linearity:
 - An uncertainty contribution comes from the linearity of the amplifier since in most cases calibration and measurements are performed at two different input/output power levels. This uncertainty can be either measured or determined by the manufacturers' data sheet.
- Noise Figure:
 - When the signal goes into an amplifier, noise is added so that the SNR at the output is reduced with regard to the SNR of the signal at the input. This added noise introduces error on the signal which affects the Error Rate of the receiver thus the EVM (Error Vector Magnitude). An uncertainty can be calculated through the following formula:

$$\varepsilon_{EVM} = 20 \log_{10} \left(1 + 10^{\frac{-SNR}{20}} \right)$$
 - Where SNR is the signal to noise ratio in dB at the signal level used during the sensitivity measurement.
- Mismatch:
 - If the external amplifier is used for both stages, measurement and calibration the uncertainty contribution associated with it can be considered systematic and constant -> 0dB. If it is not the case, the mismatch uncertainty at its input and output shall be either measured or determined by the method described in 3GPP TR 38.901 [5].
- Gain:
 - If the external amplifier is used for both stages, measurement and calibration the uncertainty contribution associated with it can be considered systematic and constant -> 0 dB. If it is not the case, this uncertainty shall be considered.

B.2.7 Random uncertainty

This contribution is used to account for all the unknown, unquantifiable, etc. uncertainties associated with the measurements.

Random uncertainty MU contributions are normally distributed. The random uncertainty term, by definition, cannot be measured, or even isolated completely. A fixed value of 0.4 dB is suggested for TRMS measurements to include a digital error rate uncertainty and is aligned with the random uncertainty for TRS for NR FR1 (3GPP TS 38.561 [8]).

B.2.8 Throughput measurement: output level step resolution

When output power of the channel emulator is swept to reach the throughput target that defines the sensitivity threshold, the final power step resolution represents an asymmetric uncertainty contribution that can be corrected since this uncertainty is device and test system independent. The lab shall correct the TRMS results by *-0.5 output level step resolution* of the final power step search and note the correction in the test report. If the alternate DL signal power search procedure with linearization, detailed in clause A.2.3 is applied to assess the DL signal power at each grid point, no correction of TRMS shall be applied and no additional MU shall be considered.

B.2.9 Signal flatness

For wireless technologies with wide channel bandwidths, the test system might not have a flat frequency response across the entire channel. While the range calibration corrects for any variation of frequency response as a function of the centre frequency of the channel, the broadband delivered to the test zone will be a function of the entire channel bandwidth as opposed to just the centre frequency. For more information, see clause A.4.2.14 of 3GPP TS 38.561 [8].

B.2.10 Mismatch for calibration process

During calibration stage, there will be impedance mismatch between the various RF cables and components used within the system. Standing waves are created by the reflections between any two components and uncertainty in the signal level will be generated. In general, three mismatch for calibration process should be considered:

- Loopback cable path: This item comes from the mismatch between the reference cable and the loopback cable during the loopback cable measurement step.
- System input path: This item comes from the mismatch between the loopback cable and the system input cable (generally the output cable after BS simulator). The reflectivity of the source output port is measured at the end of the loopback cable connecting to the system input cable.
- Reference antenna: This item comes from the mismatch between the VNA input port and the reference antenna. The reflectivity of the VNA input port is measured at the end of the reference cable connecting to the reference antenna.

For more information, see clause A.4.2.1 of 3GPP TS 38.561 [8].

B.2.11 Reference antenna positioning misalignment

This contribution originates from reference antenna alignment and pointing error. In this measurement if the maximum gain directions of the reference antenna and the receiving antenna are aligned to each other, this contribution can be considered negligible and therefore set to zero.

B.2.12 Total Uncertainty of the Network Analyzer

This contribution originates from all uncertainties involved transmission magnitude measurement (including drift and frequency flatness) with a network analyser. will be determined from the manufacturer's datasheet which is now commonly quoting MUs/accuracies with a "95 % confidence level" and/or a "coverage factor of 2" and the distribution used shall match that provided in the datasheet. In the absence of a declared distribution in the datasheet, the rectangular distribution should be used.

B.2.13 Uncertainty of an absolute gain of the calibration antenna

The calibration antenna only appears in calibration phase (Stage 1). Therefore, the gain uncertainty has to be taken into account.

This uncertainty shall come from a calibration report (which is now commonly quoting MUs/accuracies with a "95 % confidence level" and/or a "coverage factor of 2") with traceability to a National Metrology Institute with measurement uncertainty budgets generated following the guidelines outlined in internationally accepted standards. In the absence of a declared distribution in the present document, the rectangular distribution should be used.

B.2.14 Offset of the Phase Center of the Reference Antenna

During range reference measurement, if a directional antenna is used, the uncertainty in the accuracy of positioning its phase center on the axis of rotation will directly generate an uncertainty in this part of the measurement. In practical measurement, sleeve dipoles and loops are used for FR1 calibration, then the uncertainty of this element should be 0 dB, since the phase center offset is negligible.

Annex C (normative): FR1 Channel models and Validation procedure

C.1 FR1 Channel models

The following channel models are required for FR1 MIMO OTA measurement.

The generic models are Table C.1-1 FR1 UMi CDL-C and Table C.1-2 FR1 UMa CDL-C, which do not include base station antenna filtering. UMi CDL-C and UMa CDL-C are selected to define 2x2 and 4x4 MIMO OTA requirements, respectively.

Therefore, in addition, the BS beam filtering effect defined in clause C.2 also apply when emulating the channel models.

Table C.1-1: Channel model parameters for UMi CDL-C at 3.5 GHz

Cluster #	Absolute Delay [ns]	Power in [dB]	AOD in [°]	AOA in [°]	ZOD in [°]	ZOA in [°]
1	0	-4.4215	-36.1891	-122.2815	98.9242	90
2	20.99	-1.25	-21.5937	125.831	99.1915	90
3	22.19	-3.4684	-21.5937	125.831	99.1915	90
4	23.29	-5.2294	-21.5937	125.831	99.1915	90
5	21.76	-2.5215	-32.5709	-143.6126	99.5732	90
6	63.66	0	-7.4275	166.4003	99.306	90
7	64.48	-2.2185	-7.4275	166.4003	99.306	90
8	65.6	-3.9794	-7.4275	166.4003	99.306	90
9	65.84	-7.4215	37.2175	73.8315	100.4513	90
10	79.35	-7.1215	-47.1664	82.7664	98.5616	90
11	82.13	-10.7215	41.5716	-79.6999	100.6231	90
12	93.36	-11.1215	-67.1585	66.9895	98.218	90
13	122.85	-5.1215	-41.5244	84.0543	100.165	90
14	130.83	-6.8215	-47.0437	-96.2818	100.2604	90
15	217.04	-8.7215	-55.7519	94.8406	98.1225	90
16	271.05	-13.2215	55.3698	53.9494	100.2604	90
17	425.89	-13.9215	53.2234	16.0364	98.4852	90
18	460.03	-13.9215	46.8456	32.2963	98.1416	90
19	549.02	-15.8215	-70.1021	18.2098	97.9698	90
20	560.77	-17.1215	48.9306	37.0455	100.7376	90
21	630.65	-16.0215	49.6052	33.7452	98.1225	90
22	663.74	-15.7215	57.7615	29.801	98.1034	90
23	704.27	-21.6215	65.6725	11.6092	100.4513	90
24	865.23	-22.8215	-83.5324	56.2837	100.9476	90
Per-Cluster Parameters						
Parameter	CASD in [°]	CASA in [°]	CZSD in [°]	CZSA in [°]	XPR in [dB]	
Value	1.2265	12.0742	0.5726	0	7	

Table C.1-2: Channel model parameters for UMa CDL-C at 3.5 GHz

Cluster #	Absolute Delay [ns]	Power in [dB]	AOD in [°]	AOA in [°]	ZOD in [°]	ZOA in [°]
1	0	-4.4215	-37.4195	-96.4031	96.7645	90
2	76.6135	-1.25	-21.7362	118.7405	98.4506	90
3	80.9935	-3.4684	-21.7362	118.7405	98.4506	90
4	85.0085	-5.2294	-21.7362	118.7405	98.4506	90
5	79.424	-2.5215	-33.5316	-124.0196	100.8594	90
6	232.359	0	-6.5142	171.2639	99.1732	90
7	235.352	-2.2185	-6.5142	171.2639	99.1732	90
8	239.44	-3.9794	-6.5142	171.2639	99.1732	90
9	240.316	-7.4215	41.4581	51.4188	106.3995	90
10	289.6275	-7.1215	-49.2149	62.9864	94.4761	90
11	299.7745	-10.7215	46.1367	-41.2744	107.4834	90
12	340.764	-11.1215	-70.697	42.5606	92.3083	90
13	448.4025	-5.1215	-43.1524	64.6538	104.5929	90
14	477.5295	-6.8215	-49.0831	-62.7423	105.1951	90
15	792.196	-8.7215	-58.4403	78.6184	91.7061	90
16	989.3325	-13.2215	60.9633	25.6781	105.1951	90
17	1554.4985	-13.9215	58.6569	-23.4063	93.9944	90
18	1679.1095	-13.9215	51.8037	-2.3553	91.8265	90
19	2003.923	-15.8215	-73.86	-20.5926	90.7426	90
20	2046.8105	-17.1215	54.0442	3.7933	108.2061	90
21	2301.8725	-16.0215	54.7691	-0.4794	91.7061	90
22	2422.651	-15.7215	63.5332	-5.5859	91.5856	90
23	2570.5855	-21.6215	72.0338	-29.1381	106.3995	90
24	3158.0895	-22.8215	-88.2912	28.7003	109.5309	90
Per-Cluster Parameters						
Parameter	CASD in [°]	CASA in [°]	CZSD in [°]	CZSA in [°]	XPR in [dB]	
Value	1.3179	15.632	3.6131	0	7	

C.2 FR1 Base Station beam configuration

The emulated BS beam configuration to be used for all emulation of channel models defined in Annex C.1 is specified in this clause.

The Base Station beam configuration includes basic antenna parameters and beamforming characteristic. The basic BS antenna parameters is defined in Table C.2-1.

Table C.2-1: BS Antenna Parameters

Parameter description	Symbol	Parameter value	
		FR1 ≤ 2.5GHz	FR1 > 2.5GHz
Antenna panels in vertical dimension	M_g	1	1
Antenna panels in horizontal dimension	N_g	1	1
Elements per panel in vertical dimension	M_e	4	8
Elements per panel in horizontal dimension	N_e	8	8
Number of polarizations per panel	P	2	2
Element spacing in horizontal dimension (λ)	d_H	0.5	0.5
Element spacing in vertical dimension (λ)	d_V	0.5	0.5

Antenna element radiation patterns, including orientation of the element main polarization components as well as orientation of the antenna array are as in the example pattern in Table 7.3-1 of 3GPP TR 38.901 [5]. The antenna element has $\pm 45^\circ$ polarization components and the radiation pattern parameters are $\theta_{3dB} = 65^\circ$, $\phi_{3dB} = 65^\circ$, $A_{max} = 30dB$, $SLA_V = 30dB$, $G_{E,max} = 8$ dBi.

The beamforming characteristic of the FR1 BS pattern is defined as follow:

- A code book of 60 fixed beams is constructed to a grid of five elevation angles from -20° to $+20^\circ$ with 10° steps and 12 azimuth angles from -80° to $+80^\circ$ with $\sim 15^\circ$ steps.
- For 4x4 MIMO OTA, two strongest transmitting beams are selected from the pre-defined beam grid based on their proximity to the strong clusters of each FR1 channel model. These beams should have different azimuth directions and can provide the highest receive power for UE.
- For 2x2 MIMO OTA, one strongest transmitting beam is selected from the pre-defined beam grid which provides the highest received power for UE based on the FR1 channel model.
- Beam directions for channels model given in clause C.1 are:
 - For UMa CDL-C, the beam directions are:
 - Strongest beam: AoD: -7.27° , ZoD: 100°
 - 2nd strongest beam: AoD: -21.82° , ZoD: 100°
 - For UMi CDL-C, the strongest beam direction is: AoD: -7.27° , ZoD: 100° .

C.3 FR1 Channel model validation

C.3.1 General

This clause describes the MIMO OTA validation measurements, in order to ensure that the channel models are correctly implemented and hence capable of generating the propagation environment, as described by the model, within the test zone.

The following measurements shall be done for FR1 channel model validation:

- Power Delay Profile (PDP).
- Doppler/Temporal correlation.
- Spatial correlation.
- Cross-polarization.
- Power validation.

Frequencies to be used to test for channel model validation.

Table C.3.1-1: Frequencies for PDP, Doppler, Spatial correlation and Cross-polarization validation

NR FR1 Bands	Range	Test frequency (MHz)
n71	Low	617 MHz
n12, n17, n29, n14, n28		722 MHz
n5, n8, n18, n20		836.5 MHz
n50, n51, n74	Mid	1575.42 MHz
n3, n2, n25, n39		1880 MHz
n1, n34, n65		2132.5 MHz
n7, n30, n41, n40, n38, [n90]		2450 MHz
n77, n78	High	3600 MHz
n79		[4700 MHz]

Table C.3.1-2: Frequencies for Power validation

NR FR1 Bands	Range	Test frequency (centre frequency of each band)
n71	Low	n71
n12, n17, n29, n14, n28		n28
n5, n8, n18, n20		n8
n50, n51, n74	Mid	n51
n3, n2, n25, n39		n3
n1, n34, n65		n1
n7, n30, n41, n40, n38, [n90]		n41
n77, n78	High	n78
n79		n79

C.3.2 Power Delay Profile (PDP)

This measurement checks that the resulting power delay profile (PDP) is in-line with the PDP defined for the channel model. For PDP validation measurement, only Vertical validation is required.

The PDP measurement is performed with a Vector Network Analyser (VNA). An example setup for PDP measurement is shown in Figure C.3.2-1. VNA transmits frequency sweep signals through the NR MIMO OTA test system. A reference antenna (i.e. dipole antenna), within the centre of the test zone, receives the signal and VNA analyses the frequency response of the system. A number of traces (frequency responses) are measured and recorded by VNA and analysed by a post processing SW, e.g. MATLAB®. Special care has to be taken into account to keep the fading conditions unchanged, i.e. frozen, during the short period of time of a single trace measurement. The fading may proceed only in between traces.

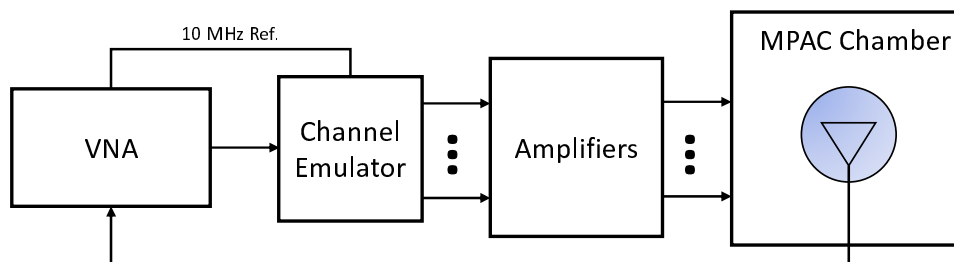

Figure C.3.2-1: Setup for PDP measurements

Step the emulation and store traces from VNA, i.e. run the emulation to CIR number 1, pause, measure VNA trace, run the emulation to CIR number 10, pause, measure VNA trace. Continue until 1000 VNA traces are measured.

VNA settings for PDP measurements are presented in Table C.3.2-1.

Table C.3.2-1: VNA settings for PDP measurements

Item	Unit	Value
Centre frequency	MHz	Downlink centre frequency in Table C.3.1-1
Span	MHz	200
Number of traces		1000
Number of points		1101
Averaging		1

Channel model specification for PDP measurements is presented in Table C.3.2-2.

Table C.3.2-2: Channel model specification for PDP measurements

Item	Unit	Value
Centre frequency	MHz	Downlink centre frequency in Table C.3.1-1
Distance between traces in channel model	wavelength (note)	> 2
Channel model		As specified in clause C.1
NOTE: Time [s] = distance [λ] / MS speed [λ/s]. MS speed [λ/s] = MS speed [m/s] / Speed of light [m/s] * Centre frequency [Hz].		

Method of measurement result analysis:

Measured VNA traces (frequency responses H(t,f)) are saved into a hard drive. The data is read into, e.g. MATLAB®. The analysis is performed by taking the Fourier transform of each FR. The resulting impulse responses h(t,τ) are averaged in power over time:

$$P(\tau) = \frac{1}{T} \sum_{t=1}^T |h(t, \tau)|^2$$

Finally the resulting PDP is shifted in delay, such that the first tap is on delay zero.

Beam-Specific Block Diagram

It is assumed that the beams are mapped to the inputs of the channel emulator as follows:

- Beam 1: Input 1 and Input 2.
- Beam 2: Input 3 and Input 4 (CDL-C UMa only).

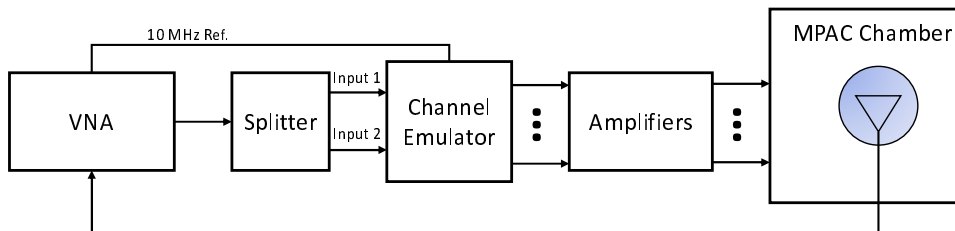

Figure C.3.2-2: Setup for Beam-Specific PDP measurements (Beam 1)

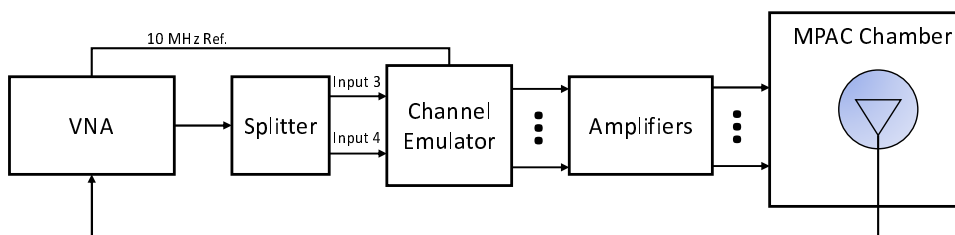

Figure C.3.2-3: Setup for Beam-Specific PDP measurements (Beam 2 CDL-C UMa only)

The detailed PDP reference value for CDL-C UMa and CDL-C UMi validation are defined in the following tables:

Table C.3.2-3: PDP Targets for CDL-C UMa beam 1 at ≤ 2.5 GHz

Combined Clusters index	Delay(ns)	Power(dB)
1	0	-34.3
2-5	80	-19.5
6-8	235	0.0
9-10	290	-33.0
11	450	-35.8
12	480	-34.0

Table C.3.2-4: PDP Targets for CDL-C UMa beam 2 at ≤ 2.5 GHz

Combined Clusters index	Delay(ns)	Power(dB)
1	0	-27.9
2-5	80	0.0
6-8	235	-18.4
9-10	290	-27.8
11	450	-27.9
12	480	-28.0

Table C.3.2-5: PDP Targets for CDL-C UMa beam 1 at > 2.5 GHz

Combined Clusters index	Delay(ns)	Power(dB)
1	0	-34.2
2-5	80	-19.3
6-8	235	0.0
9	290	-34.7
10	450	-35.8
11	480	-34.7

Table C.3.2-6: PDP Targets for CDL-C UMa beam 2 at > 2.5 GHz

Combined Clusters index	delay(ns)	power(dB)
1	0	-27.8
2-5	80	0.0
6-8	235	-18.3
9-10	290	-28.9
11	450	-28.1
12	480	-28.8

Table C.3.2-7: PDP Targets for CDL-C UMi at ≤ 2.5 GHz and > 2.5 GHz

Combined Clusters index	Delay(ns)	Power(dB)
1	0	-30.7
2-5	20	-19.2
6-10	65	0.0
11-12	130	-31.4

C.3.3 Doppler/Temporal correlation

This measurement checks the Doppler/temporal correlation. For Doppler/Temporal correlation validation measurement, only Vertical validation is required.

The Doppler spectrum is measured with a spectrum analyser as shown in Figure C.3.3-1. In this case a signal generator transmits CW signal through the NR MIMO OTA test system. The signal is received by a test antenna within the test area. Finally, the signal is analysed by a spectrum analyser and the measured spectrum is compared to the target spectrum. This setup can be used to measure Doppler Spectrum of the Channel models defined in clause C.1.

Method of measurement:

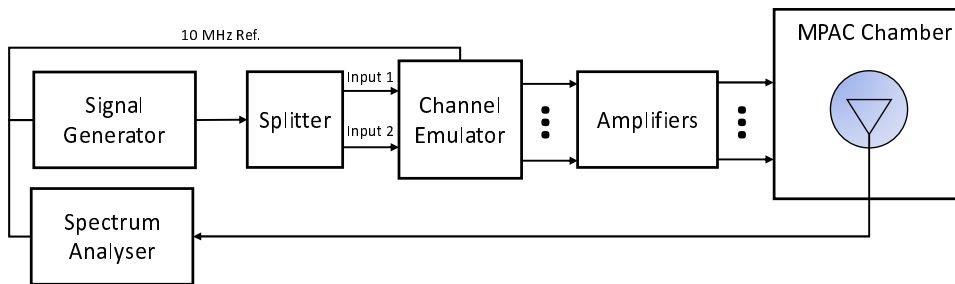

Figure C.3.3-1: Setup for Doppler measurements

Sine wave (CW, carrier wave) signal is transmitted from the signal generator. The signal is connected from the signal generator to fading emulator via cables. The fading emulator output signals are connected to power amplifier boxes via cables. The amplified signals are then transferred via cables to the probe antennas. The probe antennas radiate the signals over the air to the test antenna. The Doppler spectrum is measured by the spectrum analyser and the trace is saved.

Signal generator settings for Doppler/Temporal correlation measurements are presented in Table C.3.3-1.

Table C.3.3-1: Signal generator settings for Doppler/Temporal correlation measurements

Item	Unit	Value
Centre frequency	MHz	Downlink centre frequency in Table C.3.1-1
Modulation		OFF

Spectrum analyser settings for Doppler/Temporal correlation measurements are presented in Table C.3.3-2.

Table C.3.3-2: Spectrum analyser settings for Doppler/Temporal correlation measurements

Item	Unit	Value
Centre frequency	MHz	Downlink centre frequency in Table C.3.1-1
Minimum Span	Hz	4 kHz
RBW	Hz	1
VBW	Hz	1
Number of points		16001
Averaging		100

Channel model specification for Doppler/Temporal correlation measurements is presented in Table C.3.3-3.

Table C.3.3-3: Channel model specification for Doppler/Temporal correlation measurements

Item	Unit	Value
Centre frequency	MHz	Downlink centre frequency in Table C.3.1-1
Channel model		As specified in clause C.1
Mobile speed	km/h	100

Method of measurement result analysis: Measurement data file (Doppler power spectrum) is saved into hard drive. The data is read into, e.g. MATLAB®. The analysis is performed by taking the Fourier transformation of the Doppler spectrum. The resulting temporal correlation function $R_t(\Delta t)$ is normalized such that $\max(|R_t(\Delta t)|) = 1$. Then the function values left from the maximum i.e. the negative lags are cut out. Further on the function values after five periods are cut out.

Time Domain Alternate Method

Time domain techniques can also be used to validate the temporal correlation. The temporal correlation validation measurement setup is illustrated in Figure C.3.3-2. In this case a Signal generator transmits a CW signal through the MIMO test system. The signal is received by a test antenna within the test area. Finally, the signal is collected by a signal analyser and the measured signal is stored as IQ data format for postprocessing.

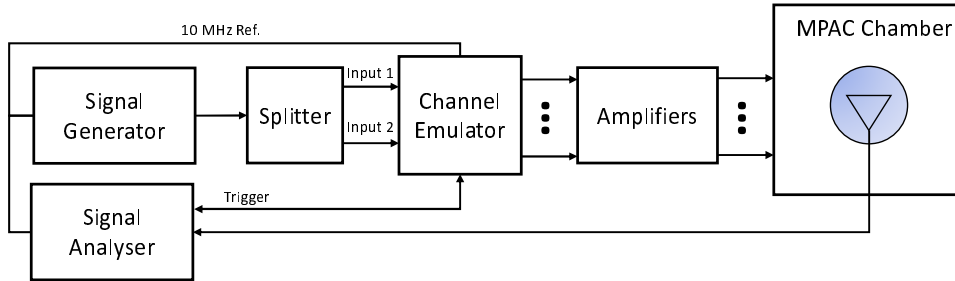

Figure C.3.3-2: Setup for Doppler measurements based on time domain technique

The time domain doppler spectrum is measured by the signal analyser and the trace in IQ format is saved. Follow the same procedure to post process the data and calculate the temporal correlation curve. Data recording is synchronized with the channel emulator trigger. Depending on CE implementation, the trigger direction between SAN and CE needs to be adjusted, i.e., from SAN to CE or from CE to SAN.

The settings for the signal analyser are in Table C.3.3-4.

Table C.3.3-4: Signal Analyser Settings

Item	Unit	Value
Centre frequency	MHz	Downlink centre frequency in Table C.3.1-1
Sampling	Hz	At least 15 times bigger than the max Doppler spread ($f_d=v/\lambda$)
Observation time	s	At least 16 s. Channel Model length should be the same or greater than the observation time

Beam-Specific Block Diagram

It is assumed that the beams are mapped to the inputs of the channel emulator as follows:

- Beam 1: Input 1 and Input 2.
- Beam 2: Input 3 and Input 4 (CDL-C UMa only).

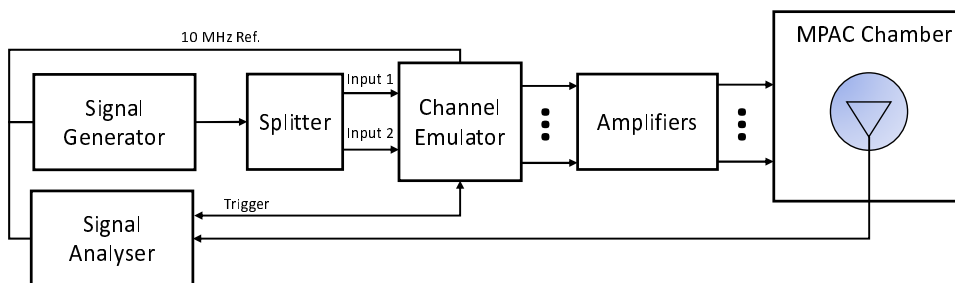

Figure C.3.3-3: Setup for Beam-Specific Doppler measurements (Beam 1)

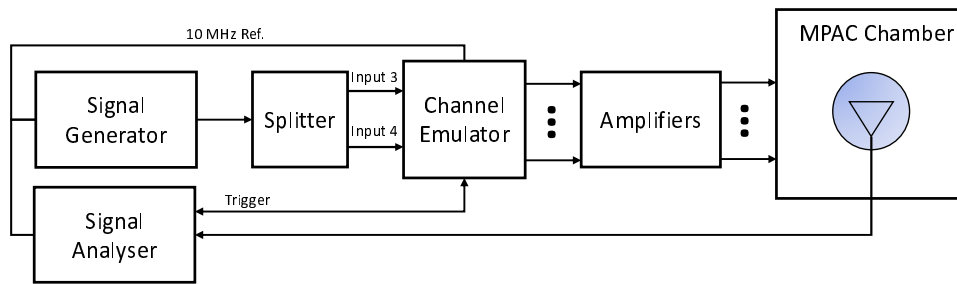

Figure C.3.3-4: Setup for Beam-Specific Doppler measurements (Beam 2 CDL-C UMa only)

The detailed Temporal correlation reference value for CDL-C UMa and CDL-C UMi channel model validation is defined in Table C.3.3-5.

Table C.3.3-5: Autocorrelation Targets

Lambda Separation	CDL-C UMa beam 1 at ≤ 2.5 GHz	CDL-C UMa beam 2 at ≤ 2.5 GHz	CDL-C UMa beam 1 at > 2.5 GHz	CDL-C UMa beam 2 at > 2.5 GHz	CDL-C UMi beam 1 at ≤ 2.5 GHz	CDL-C UMi beam 1 at > 2.5 GHz
0.0	1.000	1.000	1.000	1.000	1.000	1.000
0.1	0.986	0.974	0.985	0.973	0.995	0.995
0.2	0.945	0.907	0.942	0.904	0.982	0.982
0.3	0.882	0.832	0.874	0.825	0.962	0.961
0.4	0.801	0.776	0.787	0.765	0.936	0.935
0.5	0.709	0.738	0.689	0.723	0.906	0.905
0.6	0.613	0.695	0.586	0.675	0.872	0.871
0.7	0.518	0.623	0.486	0.599	0.834	0.834
0.8	0.430	0.525	0.394	0.496	0.793	0.793
0.9	0.353	0.426	0.315	0.391	0.750	0.749
1.0	0.289	0.360	0.252	0.319	0.705	0.704
1.1	0.240	0.335	0.206	0.290	0.659	0.658
1.2	0.204	0.320	0.174	0.273	0.614	0.612
1.3	0.181	0.287	0.154	0.239	0.569	0.568
1.4	0.167	0.233	0.143	0.185	0.527	0.525
1.5	0.159	0.176	0.137	0.129	0.487	0.485
1.6	0.155	0.141	0.135	0.096	0.450	0.448
1.7	0.153	0.135	0.134	0.092	0.417	0.415
1.8	0.150	0.137	0.134	0.095	0.387	0.385
1.9	0.144	0.132	0.130	0.093	0.361	0.358
2.0	0.135	0.117	0.122	0.089	0.337	0.335
2.1	0.121	0.097	0.109	0.086	0.316	0.313
2.2	0.105	0.076	0.090	0.076	0.296	0.293
2.3	0.085	0.062	0.069	0.064	0.277	0.274
2.4	0.065	0.071	0.047	0.067	0.258	0.255
2.5	0.048	0.090	0.031	0.088	0.239	0.236
2.6	0.039	0.099	0.033	0.103	0.219	0.216
2.7	0.038	0.088	0.046	0.099	0.198	0.195
2.8	0.042	0.058	0.057	0.073	0.178	0.175
2.9	0.043	0.037	0.062	0.038	0.158	0.154
3.0	0.041	0.067	0.060	0.045	0.138	0.135
3.1	0.037	0.103	0.050	0.080	0.120	0.116
3.2	0.036	0.120	0.036	0.100	0.103	0.100
3.3	0.044	0.115	0.019	0.099	0.089	0.085
3.4	0.056	0.097	0.010	0.081	0.076	0.073
3.5	0.068	0.082	0.019	0.061	0.066	0.063
3.6	0.075	0.083	0.029	0.053	0.057	0.055
3.7	0.076	0.090	0.034	0.060	0.051	0.049
3.8	0.068	0.089	0.036	0.073	0.046	0.044
3.9	0.051	0.079	0.044	0.091	0.042	0.041
4.0	0.027	0.068	0.062	0.111	0.039	0.038
4.1	0.007	0.063	0.090	0.127	0.037	0.035
4.2	0.036	0.062	0.123	0.133	0.036	0.034

4.3	0.067	0.057	0.155	0.129	0.038	0.036
4.4	0.093	0.052	0.182	0.126	0.043	0.040
4.5	0.111	0.055	0.200	0.131	0.051	0.048
4.6	0.119	0.063	0.207	0.139	0.061	0.058
4.7	0.116	0.066	0.200	0.138	0.073	0.070
4.8	0.101	0.058	0.180	0.117	0.085	0.082
4.9	0.078	0.047	0.149	0.079	0.096	0.093
5.0	0.051	0.048	0.110	0.034	0.107	0.104

C.3.4 Spatial correlation

This measurement checks whether the measured correlation curve follows the theoretical curve. For spatial correlation validation measurement, only Vertical validation measurement is required. Spatial correlation validation is only adopted for FR1 MIMO OTA.

The spatial correlation validation measurement setup is illustrated in Figure C.3.4-1. The network analyser transmits signals through the fading emulator and probes. The 16 probes radiate the signals within the anechoic chamber and a receiving test antenna is placed within the test zone. The test antenna is attached to a positioner that can move the antenna to pre-defined spatial locations on a fixed radius from the centre of the quiet zone. The received signal is measured with the network analyser.

The measurement and analysis procedure are as follows:

Set the target channel model to fading emulator:

- 1) For each position of the test antenna in the test zone, step & pause the emulator to different time instances. Measure the frequency responses $H(f, t) = H(m\Delta f, n\Delta T)$, $m = 0, \dots, M - 1$ for all stepped channel snapshots $n = 0, \dots, N - 1$, where the interval between frequency and time samples is Δf and ΔT , respectively. The number of channel snapshots N and frequency samples M should be sufficiently high so that the matrix can be estimated reliably.
- 2) Move the measurement antenna with a positioner to another location k and repeat step 2 to record frequency responses $H_k(m\Delta f, n\Delta T)$ of all stepped channel snapshots.
- 3) Repeat step 3 to record frequency responses at all $k = 1, \dots, K$ spatial sample points.
- 4) Stack measured time and frequency samples to a vector and calculate correlation between the first spatial sample point (i.e. $k = 1$) and other spatial points $k = 1, \dots, K$.
- 5) $\rho_k = \text{corr}[\text{vec}(H_1(m\Delta f, n\Delta T)), \text{vec}(H_k(m\Delta f, n\Delta T))]$.
- 6) Take the theoretical reference spatial correlation of the corresponding spatial sample points. Plot both the measured and theoretical curves.
- 7) Calculate the weighted RMS correlation error between the measured and the reference.

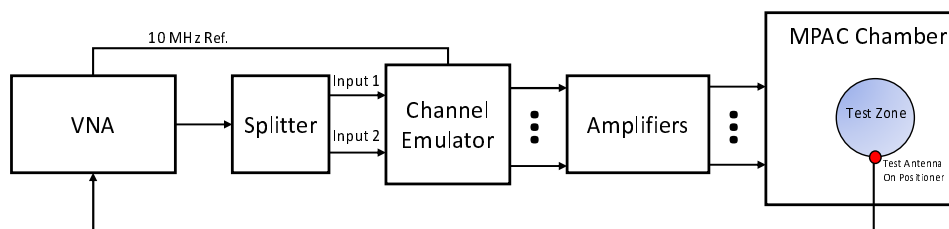

Figure C.3.4-1: Configuration for spatial correlation validation

Beam-Specific Block Diagram

It is assumed that the beams are mapped to the inputs of the channel emulator as follows:

- Beam 1: Input 1 and Input 2.
- Beam 2: Input 3 and Input 4 (CDL-C UMa only).

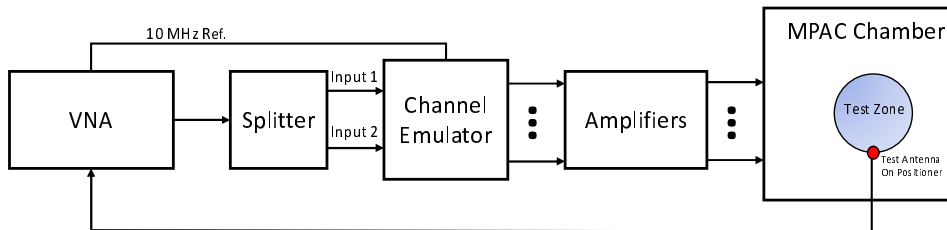

Figure C.3.4-2: Configuration for spatial correlation validation (CDL-C UMi)

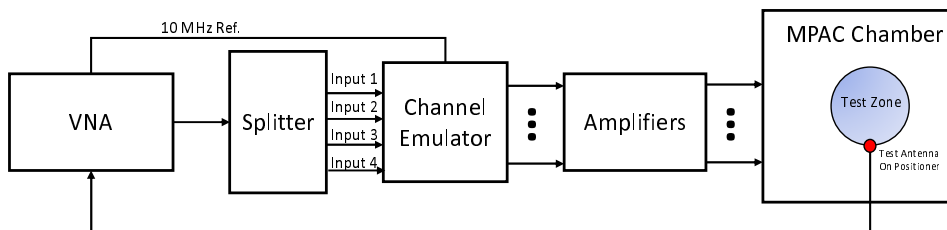

Figure C.3.4-3: Configuration for spatial correlation validation (CDL-C UMa)

Time and frequency samples

The number of temporal snapshots *N* and frequency samples *M* is shown in Table C.3.4-1. The channel model specification is presented in Table C.3.4-2.

Table C.3.4-1: VNA settings for spatial correlation

Item	Unit	Value
Centre frequency	MHz	Downlink centre frequency in Table C.3.1-1
Span	MHz	0 (see note 2)
RF output level	dBm	-15
Number of traces		1000
Distance between traces in channel model	Wavelength (see note 1)	> 2
Number of points		1 (or the smallest possible) (see note 2)
Averaging		1

NOTE1: Time in seconds = distance [λ] / MS speed [λ/s].
 MS speed [λ/s] = MS speed [m/s] / Speed of light [m/s] * Center frequency [Hz].
 NOTE 2: Span and number of points may be increased to estimate reliably.

Table C.3.4-2: Channel model specification

Item	Unit	Value
Centre frequency	MHz	Downlink centre frequency in Table C.3.1-1
Channel model samples	Wavelength	> 2000
Channel model		As specified in clause C.1
Mobile speed	km/h	30

Spatial samples

The spatial samples for the correlation validation measurement are on the circumference of the quiet zone, as illustrated in Figure C.3.4-4. The test zone is a circle with 20 cm diameter in the horizontal plane. The reference point (denoted by a red marker) is in AoA 270°. The mean AoAs of the CDL-C UMi and CDL-C UMa models are slightly different, but the underlying geometry for the CDL model indicates that the mean AoA (or assumed LoS direction) of the model is 180°. The reference point orientation of the validation measurement is proposed to be with 90° offset to the channel model reference AoA to enable accurate sampling of the main lobe of the spatial correlation curve. The reference point orientation has to be defined in the channel model coordinate system, see Figure A.2.1-3, instead of the chamber/probe coordinate system to enable optimization of OTA model implementation to achieve better alignment with the cluster AoAs and probe directions. In order to have spatial samples that yield reasonable measurement times and adequately capture the main lobe of the correlation curve, a non-uniform sampling is used where the first quadrant i.e. 270°-180°, is sampled with dense sampling compared to the rest of the circle. The spacing of the spatial samples is summarized in Table C.3.4-3 for test frequencies less than 1880 MHz and equal to or greater than 1880 MHz.

Table C.3.4-3: Spacing of Spatial Samples

Test Frequencies [MHz]	First quadrant of test zone circumference (270°-180°)	Remaining quadrants
617, 722, 836.5, 1575.42	$\lambda/15$	$\lambda/4$
1880, 2132.50, 2450, 3600, 4700	$\lambda/10$	$\lambda/2$

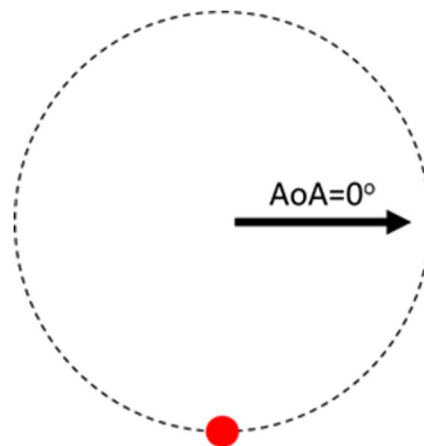

Figure C.3.4-4: Test zone interpretation with Angle of Arrival reference orientation

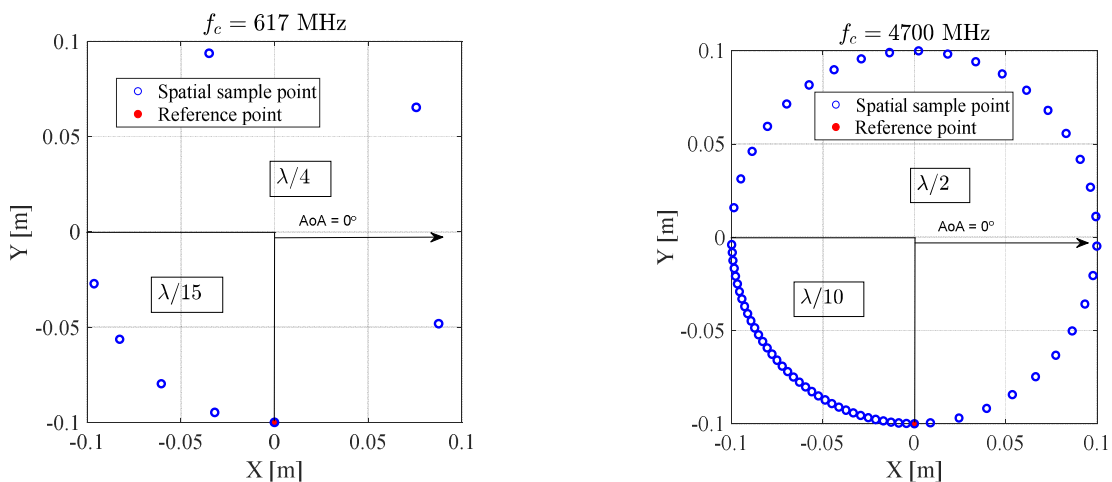

Figure C.3.4-5: Spatial sampling for spatial correlation validation measurement for test frequencies less than and equal to or greater than 1880 MHz: 617 MHz spatial sampling (left) and 4700 MHz spatial sampling (right)

Reference Spatial Correlation Curves

The spatial correlation validation reference curves are tabulated in Tables C.3.4-4 and C.3.4-5 for CDL-C UMi and CDL-C UMa, respectively, for a vertically polarized MPAC OTA setup with 16 uniformly spaced probes.

Table C.3.4-4: Spatial correlation reference curves for CDL-C UMi model for a vertically polarized MPAC OTA setup with 16 uniformly spaced probes at FR1 test frequencies

Azim [°]	$ \rho $ beam 1	Azim [°]	$ \rho $ beam 1	Azim [°]	$ \rho $ beam 1	Azim [°]	$ \rho $ beam 1	Azim [°]	$ \rho $ beam 1
617 MHz		722 MHz		836.5 MHz		1575.42 MHz		1880 MHz	
270.0	1.00	270.0	1.00	270.0	1.00	270.0	1.00	270.0	1.00
251.4	1.00	254.1	1.00	256.3	1.00	262.7	1.00	260.9	1.00
232.9	1.00	238.3	1.00	242.6	1.00	255.5	1.00	251.7	1.00
214.3	0.99	222.4	1.00	228.9	1.00	248.2	1.00	242.6	0.99
195.8	0.99	206.6	0.99	215.2	0.99	240.9	0.99	233.5	0.99
110.4	0.87	190.7	0.98	201.6	0.98	233.7	0.99	224.3	0.98
40.8	0.87	120.5	0.84	187.9	0.96	226.4	0.99	215.2	0.97
331.2	0.98	61.1	0.80	128.7	0.82	219.1	0.98	206.0	0.95
		1.6	0.91	77.3	0.73	211.9	0.97	196.9	0.91
		302.1	0.99	26.0	0.81	204.6	0.96	187.8	0.86
				334.7	0.95	197.3	0.94	134.3	0.32
				283.3	1.00	190.0	0.91	88.6	0.07
						182.8	0.87	43.0	0.17
						152.7	0.66	357.3	0.56
						125.5	0.44	311.6	0.92
						98.2	0.30		
						71.0	0.28		
						43.7	0.37		
						16.5	0.54		
						349.2	0.75		
						321.9	0.91		
						294.7	0.99		

Azim [°]	$ \rho $ beam 1	Azim [°]	$ \rho $ beam 1	Azim [°]	$ \rho $ beam 1	Azim [°]	$ \rho $ beam 1
2132.5 MHz		2450 MHz		3600 MHz		4700 MHz	
270.0	1.00	270.0	1.00	270.0	1.00	270.0	1.00
261.9	1.00	263.0	1.00	265.2	1.00	266.3	1.00
253.9	1.00	256.0	1.00	260.5	1.00	262.7	1.00
245.8	0.99	249.0	0.99	255.7	0.99	259.0	0.99
237.8	0.99	242.0	0.99	250.9	0.99	255.4	0.99
229.7	0.98	234.9	0.99	246.1	0.99	251.7	0.99
221.7	0.97	227.9	0.98	241.4	0.98	248.1	0.98
213.6	0.96	220.9	0.97	236.6	0.98	244.4	0.98
205.6	0.93	213.9	0.95	231.8	0.97	240.8	0.98
197.5	0.89	206.9	0.92	227.1	0.97	237.1	0.97
189.5	0.84	199.9	0.88	222.3	0.95	233.5	0.97
181.4	0.77	192.9	0.83	217.5	0.93	229.8	0.96
139.7	0.27	185.9	0.76	212.7	0.90	226.1	0.95
99.5	0.14	144.9	0.19	208.0	0.86	222.5	0.93
59.2	0.14	109.9	0.26	203.2	0.81	218.8	0.91
18.9	0.26	74.8	0.37	198.4	0.75	215.2	0.87
338.6	0.71	39.8	0.19	193.7	0.68	211.5	0.83
298.4	0.97	4.7	0.29	188.9	0.59	207.9	0.78
		329.7	0.74	184.1	0.49	204.2	0.72
		294.6	0.97	156.1	0.23	200.6	0.64
				132.3	0.62	196.9	0.56
				108.4	0.85	193.3	0.47
				84.6	0.93	189.6	0.37
				60.7	0.92	185.9	0.27
				36.9	0.79	182.3	0.18

Azim [°]	ρ beam 1	Azim [°]	ρ beam 1	Azim [°]	ρ beam 1	Azim [°]	ρ beam 1
2132.5 MHz		2450 MHz		3600 MHz		4700 MHz	
				13.0	0.42	161.7	0.51
				349.1	0.15	143.5	0.83
				325.3	0.60	125.2	0.95
				301.4	0.90	106.9	0.89
				277.6	1.00	88.6	0.80
						70.4	0.78
						52.1	0.88
						33.8	0.98
						15.5	0.91
						357.3	0.53
						339.0	0.09
						320.7	0.50
						302.4	0.82
						284.2	0.97

Table C.3.4-5: Spatial correlation reference curves for CDL-C UMa model for a vertically polarized MPAC OTA setup with 16 uniformly spaced probes at FR1 test frequencies

Azim [°]	ρ comb	Azim [°]	ρ comb	Azim [°]	ρ comb	Azim [°]	ρ comb	Azim [°]	ρ comb
617 MHz		722 MHz		836.5 MHz		1575.42 MHz		1880 MHz	
270.0	1.00	270.0	1.00	270.0	1.00	270.0	1.00	270.0	1.00
251.4	0.99	254.1	0.99	256.3	0.99	262.7	0.99	260.9	0.99
232.9	0.99	238.3	0.98	242.6	0.98	255.5	0.98	251.7	0.96
214.3	0.98	222.4	0.97	228.9	0.97	248.2	0.96	242.6	0.92
195.8	0.96	206.6	0.96	215.2	0.96	240.9	0.94	233.5	0.89
110.4	0.61	190.7	0.94	201.6	0.95	233.7	0.92	224.3	0.88
40.8	0.47	120.5	0.58	187.9	0.92	226.4	0.91	215.2	0.87
331.2	0.85	61.1	0.30	128.7	0.56	219.1	0.90	206.0	0.86
		1.6	0.56	77.3	0.19	211.9	0.89	196.9	0.83
		302.1	0.95	26.0	0.27	204.6	0.88	187.8	0.78
				334.7	0.70	197.3	0.87	134.3	0.20
				283.3	0.99	190.0	0.84	88.6	0.31
						182.8	0.79	43.0	0.19
						152.7	0.42	357.3	0.36
						125.5	0.13	311.6	0.54
						98.2	0.30		
						71.0	0.31		
						43.7	0.29		
						16.5	0.33		
						349.2	0.29		
						321.9	0.48		
						294.7	0.88		

Azim [°]	ρ comb	Azim [°]	ρ comb	Azim [°]	ρ comb	Azim [°]	ρ comb
2132.5 MHz		2450 MHz		3600 MHz		4700 MHz	
270.0	1.00	270.0	1.00	270.0	1.00	270.0	1.00
261.9	0.99	263.0	0.99	265.2	0.98	266.3	0.98
253.9	0.95	256.0	0.95	260.5	0.95	262.7	0.94
245.8	0.92	249.0	0.91	255.7	0.90	259.0	0.89
237.8	0.89	242.0	0.87	250.9	0.84	255.4	0.83
229.7	0.86	234.9	0.85	246.1	0.80	251.7	0.78
221.7	0.85	227.9	0.83	241.4	0.77	248.1	0.73
213.6	0.85	220.9	0.82	236.6	0.75	244.4	0.70
205.6	0.83	213.9	0.82	231.8	0.73	240.8	0.68
197.5	0.80	206.9	0.80	227.1	0.72	237.1	0.66
189.5	0.75	199.9	0.77	222.3	0.71	233.5	0.65
181.4	0.67	192.9	0.73	217.5	0.70	229.8	0.64
139.7	0.22	185.9	0.66	212.7	0.69	226.1	0.63
99.5	0.24	144.9	0.26	208.0	0.67	222.5	0.62
59.2	0.03	109.9	0.23	203.2	0.64	218.8	0.61

18.9	0.16	74.8	0.19	198.4	0.61	215.2	0.60
338.6	0.37	39.8	0.13	193.7	0.56	211.5	0.59
298.4	0.73	4.7	0.15	188.9	0.49	207.9	0.57
		329.7	0.38	184.1	0.41	204.2	0.55
		294.6	0.74	156.1	0.42	200.6	0.52
				132.3	0.19	196.9	0.48
				108.4	0.64	193.3	0.42
				84.6	0.47	189.6	0.35
				60.7	0.44	185.9	0.26
				36.9	0.28	182.3	0.18
				13.0	0.16	161.7	0.59
				349.1	0.16	143.5	0.26
				325.3	0.41	125.2	0.79
				301.4	0.40	106.9	0.43
				277.6	0.95	88.6	0.68
						70.4	0.63
						52.1	0.75
						33.8	0.87
						15.5	0.67
						357.3	0.09
						339.0	0.25
						320.7	0.32
						302.4	0.42
						284.2	0.73

Time Domain Alternative Method:

Time domain techniques can also be used to validate the spatial correlation. The spatial correlation validation measurement setup is illustrated in Figure C.3.4-3. In this case a Signal generator transmits a CW signal through the MIMO test system. The signal is received by a test antenna within the test area. Finally, the signal is collected by a signal analyser and the measured signal is stored for postprocessing.

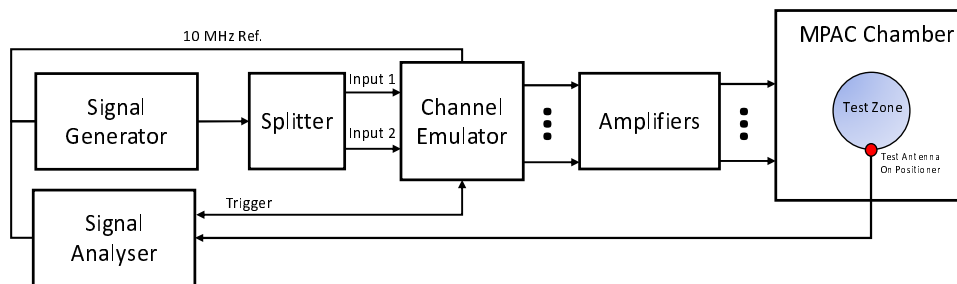

Figure C.3.4-6: Configuration for spatial correlation validation based on time domain techniques

For each spatial point, the channel emulator should issue a trigger signal each time fading is started. For each point collect a time domain trace with the signal analyser, when done, stop fading. Data recording is synchronized with the channel emulator trigger. Depending on CE implementation, the trigger direction between SAN and CE needs to be adjusted, i.e., from SAN to CE or from CE to SAN.

Follow the same procedure to postprocess the data and calculate the spatial correlation by setting m to 1. The settings for the Signal Generator and Signal Analyser are in Tables C.3.4-6 and C.3.4-7 respectively.

Table C.3.4-6: Signal Generator Settings

Item	Unit	Value
Centre frequency	MHz	Downlink centre frequency in Table C.3.1-1
Output power	dBm	Function of the CE. Sufficiently above Noise Floor

Table C.3.4-7: Signal Analyser Settings

Item	Unit	Value
Centre frequency	MHz	Downlink centre frequency in Table C.3.1-1
Sampling	Hz	At least 15 times bigger than the max Doppler spread ($f_d=v/\lambda$)
Observation time	s	At least 16 s. Channel Model length should be the same or greater than the observation time

Beam-Simultaneous Block Diagram

It is assumed that the beams are mapped to the inputs of the channel emulator as follows:

- Beam 1: Input 1 and Input 2.
- Beam 2: Input 3 and Input 4 (CDL-C UMa only).

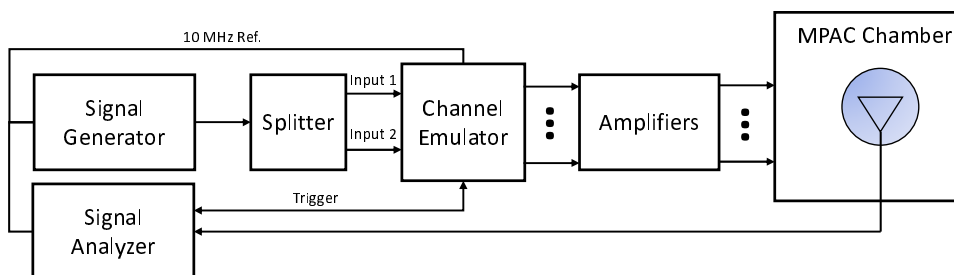

Figure C.3.4-7: Configuration for spatial correlation validation based on time domain techniques (CDL-C UMi)

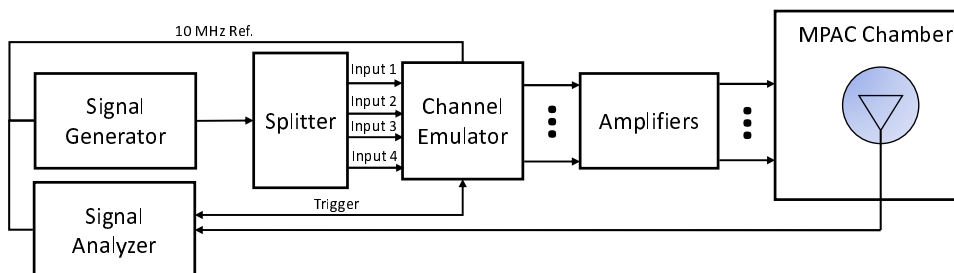

Figure C.3.4-8: Configuration for spatial correlation validation based on time domain techniques (CDL-C UMa)

C.3.5 Cross-polarization

This measurement checks how well the measured vertically or horizontally polarized power levels follow expected values. The test setup for cross-polarization is the same as PDP validation in Figure C.3.2-1.

Method of measurement: Step the emulation and store traces from VNA.

VNA settings for cross-polarization measurements are presented in Table C.3.5-1.

Table C.3.5-1: VNA settings for cross-polarization

Item	Unit	Value
Centre frequency	MHz	Downlink Centre Frequency in Table C.3.1-1
Span	MHz	40
Number of traces		1000
Number of points		802
Averaging		1

Channel model specification for cross-polarization measurements is presented in Table C.3.5-2.

Table C.3.5-2: Channel model specification for cross-polarization

Item	Unit	Value
Centre frequency	MHz	Downlink centre frequency in Table C.3.1-1
Distance between traces in channel model	wavelength (see note 1)	> 2
Channel model		As specified in clause C.1
Mobile speed (see note 2)	km/h	30

NOTE 1: Time [s] = distance [λ] / MS speed [λ /s].
 MS speed [λ /s] = MS speed [m /s] / Speed of light [m/s] * Centre frequency [Hz].
 NOTE 2: The mobile speed is valid for the Time Domain Alternative method only.

Measurement Procedure:

Step the emulation and store traces from VNA. i.e. run the emulation to CIR number 1, pause, measure VNA trace, run the emulation to CIR number 10, pause, measure VNA trace. Continue until 1000 VNA traces are measured. Ensure that the phase relationship at the inputs of the channel emulator do not produce destructive interference.

- a. Use a vertically polarized sleeve dipole to measure the V component.
- b. Use a horizontally polarized (vertically oriented) magnetic loop dipole, or a horizontally polarized sleeve dipole measured in four orthogonal horizontal positions and summed to measure the H component.

Method of measurement result analysis:

Measured VNA traces (frequency responses $H_V(t, f)$ and $H_H(t, f)$) are saved into a hard drive. The data is read into, e.g. MATLAB®. The frequency responses are averaged in power over time and frequency and the V/H ratio calculated as follows:

$$P_V = \sum_t \sum_f |H_V(t, f)|^2$$

$$P_H = \sum_t \sum_f |H_H(t, f)|^2$$

$$P_{V/H} [dB] = 10 \log_{10} \left(\frac{P_V}{P_H} \right)$$

Beam-Specific Block Diagram

It is assumed that the beams are mapped to the inputs of the channel emulator as follows:

- Beam 1: Input 1 and Input 2
- Beam 2: Input 3 and Input 4 (CDL-C UMa only)

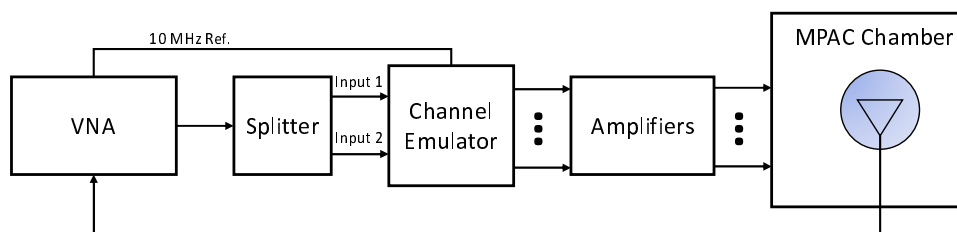

Figure C.3.5-1: Setup for Beam-Specific V/H measurements (Beam 1)

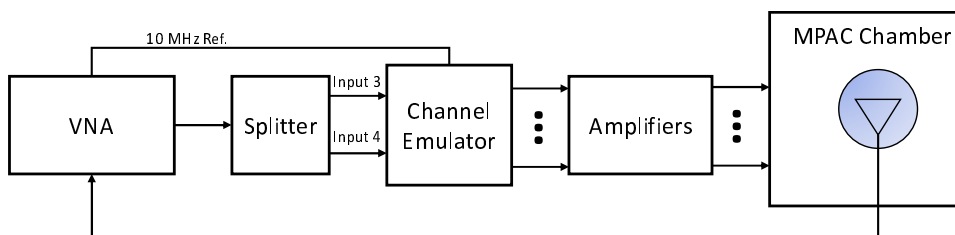

Figure C.3.5-2: Setup for Beam-Specific V/H measurements (Beam 2 CDL-C UMa only)

Time Domain Alternative Method:

The power in the Vertical and Horizontal polarizations can also be measured in time domain. The measurement setup for Beam-Specific are presented in Figures C.3.5-3, and C.3.5-4.

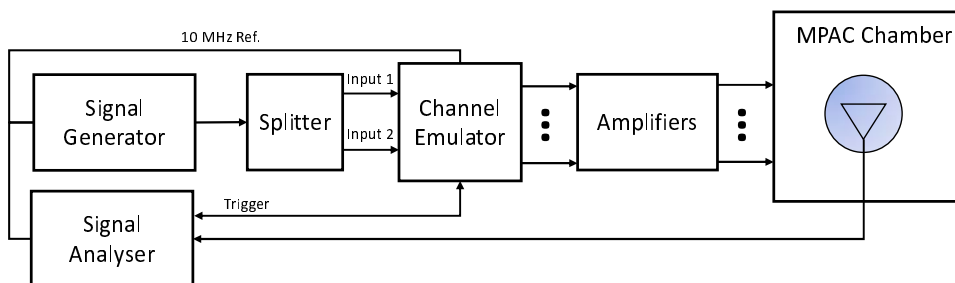

Figure C.3.5-3: Setup for Beam-Specific V/H measurements (Beam 1)

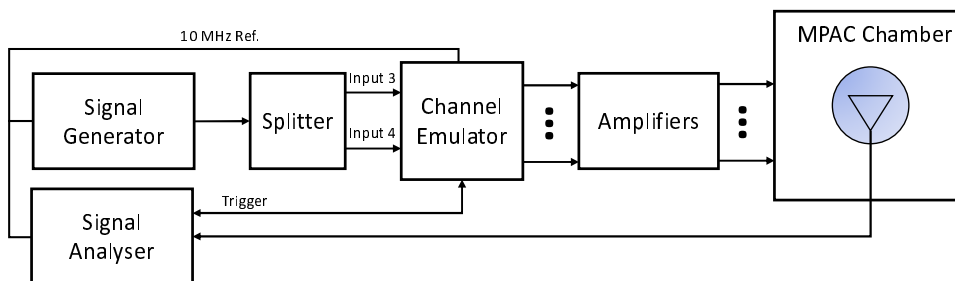

Figure C.3.5-4: Setup for Beam-Specific V/H measurements (Beam 2 CDL-C UMa only)

The instruments settings are the same as those in Tables C.3.4-6 and C.3.4-7. The measurement analysis is the same as that of the frequency domain method setting the summation over f to a single point.

The reference V/H-ratios for CDL-C UMa and CDL-C UMi channel model validation are defined in Tables C.3.5-3 and C.3.5-4, respectively.

Table C.3.5-3: Reference V/H-ratios for CDL-C UMa

UMa C, $f_c \leq 2.5$ GHz	Beam 1	Input 1+2: V/H = 0 dB
	Beam 2	Input 3+4: V/H = 0 dB
UMa C, $f_c > 2.5$ GHz	Beam 1	Input 1+2: V/H = 0 dB
	Beam 2	Input 3+4: V/H = 0 dB

Table C.3.5-4: Reference V/H-ratios for CDL-C UMi

UMi C, $f_c \leq 2.5$ GHz	Beam 1	Inputs 1+2: V/H = 0 dB
UMi C, $f_c > 2.5$ GHz	Beam 1	Inputs 1+2: V/H = 0 dB

C.3.6 Power validation

This measurement checks the total power in the centre of the test zone. The power validation is measured with a spectrum analyser as shown in Figure C.3.6-1.

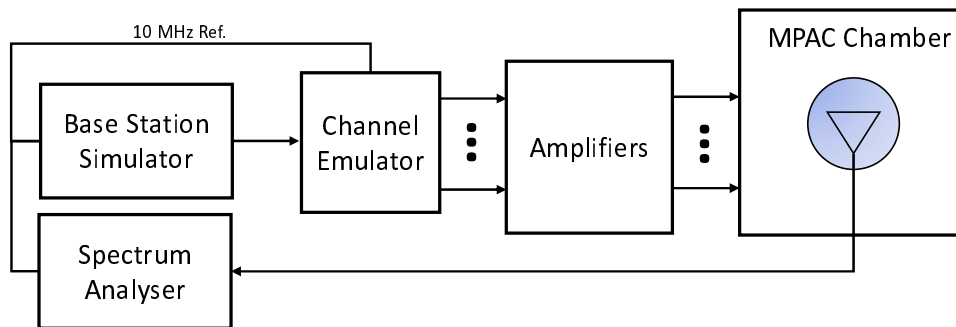

Figure C.3.6-1: Setup for power validation measurements

Spectrum analyser settings for power validation measurements are presented in Table C.3.6-1.

Table C.3.6-1: Spectrum analyser settings for power validation measurements

Item	Unit	Value
Centre frequency	MHz	Downlink centre frequency in Table C.3.1-2
Integrated Channel Span	Hz	40MHz
RBW	Hz	30 kHz
VBW	Hz	≥ 10 MHz
Number of points		≥ 400
Averaging		≥ 100
Detector		RMS

Measurement Procedure:

- 1) Place a vertical reference dipole in the centre of the test zone connected to a spectrum analyser (or power meter) via a cable.
- 2) Record the cable and reference dipole gains.
- 3) Load the target channel model into the channel emulator and play the model.
- 4) Start the NR FR1 signalling in the base station emulator with the required parameter identical to the measurements conditions.
- 5) Average the power received by the spectrum analyser for a sufficient amount of time to account for the fading channel - one full channel simulation might be unnecessary. The possibility to use an equipment capable to decode the NR signal for EPRE Power Validation is not precluded.
- 6) Repeat steps 1 to 4 with a magnetic loop for the horizontal polarization, or a horizontally polarized sleeve dipole measured in at least four orthogonal horizontal positions and average the summed orientations to get the H component.
- 7) Calculate the total power received at the test area as the sum of the power in the two polarizations.

NOTE: In step 6, if horizontally polarized sleeve dipole is used, the reference gain correction should be the average of the theta gain pattern cut of the dipole. Besides, more horizontal positions for averaging will improve the measurement accuracy but increase the total measurement time.

The power validation result is considered as systematic offset, which needs to be corrected on the UE final sensitivity value to further reduce measurement uncertainty.

The detailed power validation setup for CDL-C UMi and CDL-C UMa channel models are illustrated in Figure C.3.6-2 and Figure C.3.6-3.

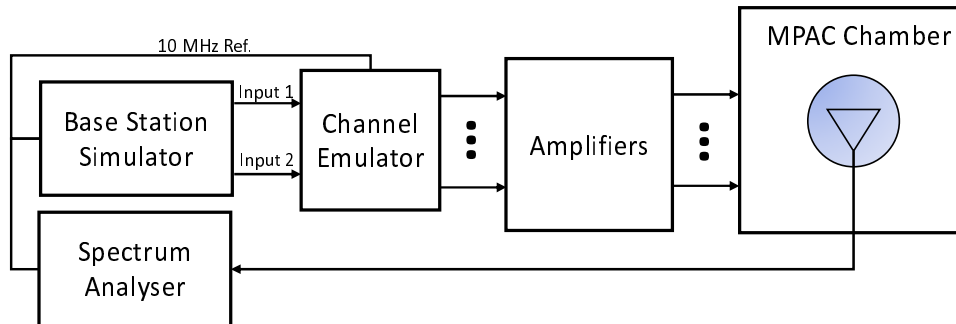

Figure C.3.6-2: Setup for power validation measurements for CDL-C UMi

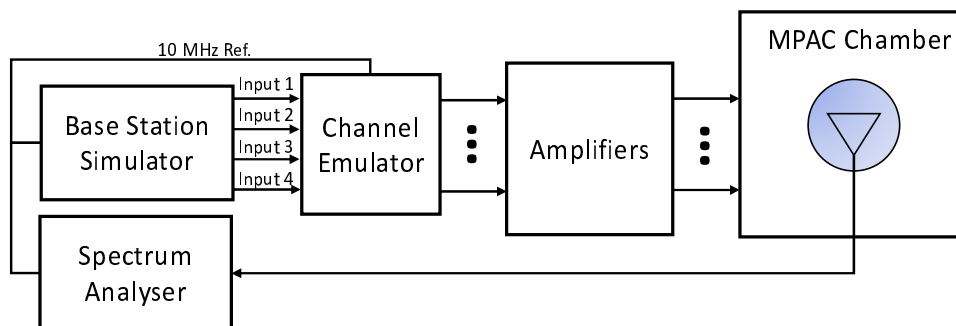

Figure C.3.6-3: Setup for power validation measurements for CDL-C UMa

C.4 Validation Pass/fail limit

C.4.1 General

This clause defines the pass/fail limit of FR1 MPAC system for FR1 channel model validation.

C.4.2 Pass/Fail Criteria of PDP

This clause defines the pass/fail criteria of PDP, this pass/fail limits apply for all FR1 frequency bands, for both combined and individual beams.

The detailed pass/fail limits for each cluster of CDL-C UMa and CDL-C UMi are defined in Table C.4.2-1.

CDL-C UMa beam 1 at ≤ 2.5 GHz		CDL-C UMa beam 2 at ≤ 2.5 GHz		CDL-C UMa beam 1 at > 2.5 GHz		CDL-C UMa beam 2 at > 2.5 GHz		CDL-C UMi beam 1 at ≤ 2.5 GHz		CDL-C UMi beam 1 at > 2.5 GHz	
Lower	Upper	Lower	Upper	Lower	Upper	Lower	Upper	Lower	Upper	Lower	Upper
0	0.3	0	0.3	0	0.3	0	0.3	0	0.3	0	0.3
0	0.3	0	0.3	0	0.3	0	0.3	0	0.3	0	0.3
0	0.3	0	0.3	0	0.3	0	0.3	0	0.3	0	0.3
0	0.3	0	0.3	0	0.3	0	0.3	0	0.3	0	0.3
0	0.3	0	0.3	0	0.3	0	0.3	0	0.3	0	0.3
0	0.3	0	0.3	0	0.3	0	0.3	0	0.3	0	0.3
0	0.3	0	0.3	0	0.3	0	0.3	0	0.3	0	0.3
0	0.3	0	0.3	0	0.3	0	0.3	0	0.3	0	0.3
0	0.3	0	0.3	0	0.3	0	0.3	0	0.3	0	0.3
0	0.3	0	0.3	0	0.3	0	0.3	0	0.3	0	0.3
0	0.3	0	0.3	0	0.3	0	0.3	0	0.3	0	0.3
0	0.3	0	0.3	0	0.3	0	0.3	0	0.3	0	0.3
0	0.3	0	0.3	0	0.3	0	0.3	0	0.3	0	0.3
0	0.3	0	0.3	0	0.3	0	0.3	0	0.3	0	0.3

Based on the value defined in Table C.4.3-1, Figure C.4.3-1 shows the pass/fail and reference curve of temporal correlation.

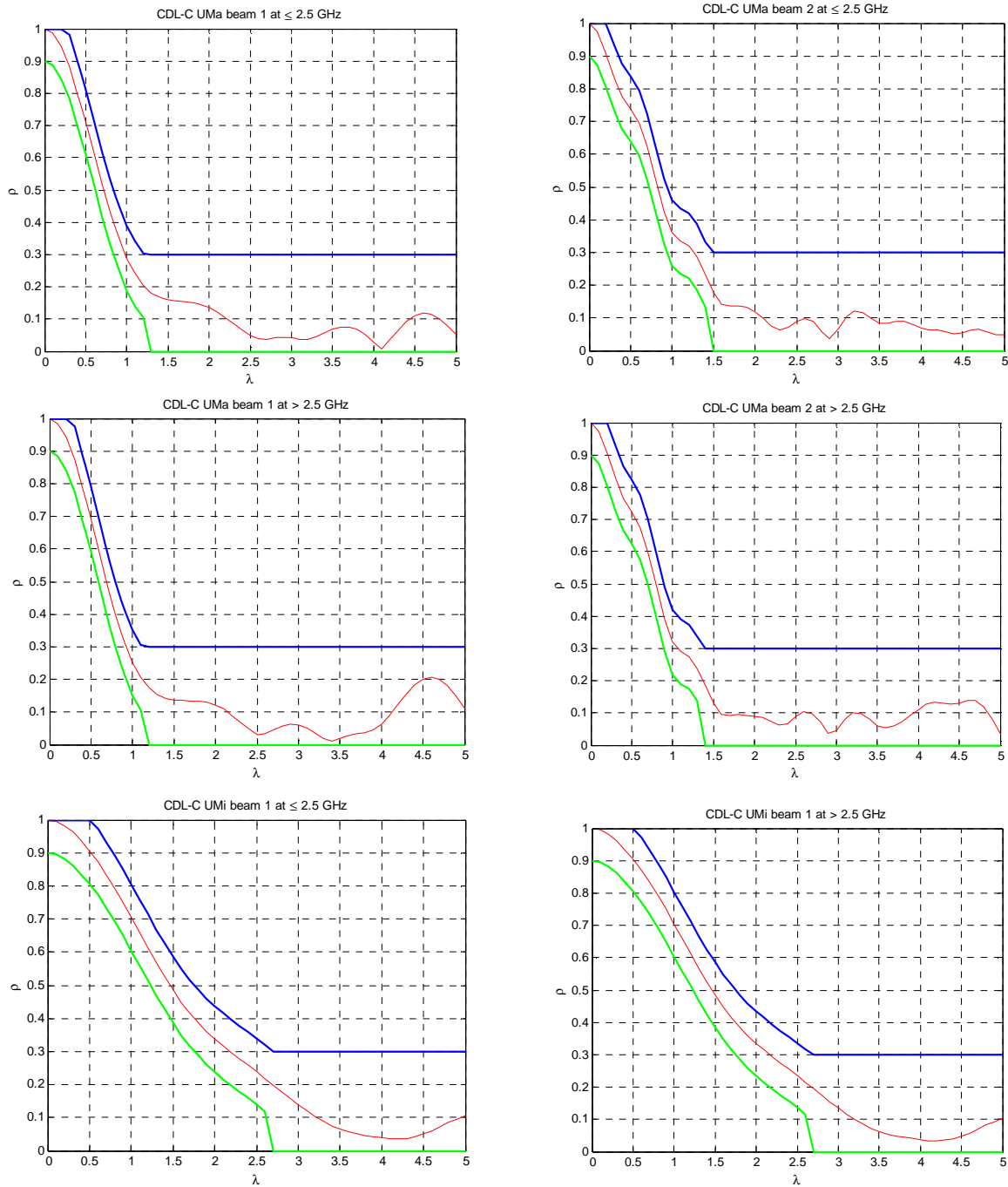

Figure C.4.3-1: Pass/fail limits and targets of Temporal correlation for CDL-C UMa and CDL-C UMi channel model: red curve (reference), blue (upper limit) and green (lower limit)

C.4.4 Pass/Fail Criteria of Spatial correlation

This clause defines the pass/fail criteria of spatial correlation, this general pass/fail limits principle apply for all channel models in all FR1 frequency bands, for both combined and individual beams.

The pass/fail limits for spatial correlation are formed as bands of $\pm 10\%$ of correlation capped at 100 % for the upper limit for target correlation defined in clause C.3.4 of 35 % (for CDL-C UMa @3600MHz, this value is 65 %) and above. For target correlations below 35 % (for CDL-C UMa @3600MHz, this value is 65 %), the band is widened to $\pm 20\%$ capped at 0 %.

For the detailed pass/fail limit, the values are defined in the Table C.4.4-1 and Table C.4.4-2, for CDL-C UMi and CDL-C UMa channel model, respectively.

Table C.4.4-1: Spatial correlation pass/fail limits for CDL-C UMi channel model

Lower	Upper	Lower	Upper	Lower	Upper	Lower	Upper	Lower	Upper
617 MHz		722 MHz		836.5 MHz		1575.42 MHz		1880 MHz	
0.90	1.00	0.90	1.00	0.90	1.00	0.90	1.00	0.90	1.00
0.90	1.00	0.90	1.00	0.90	1.00	0.90	1.00	0.90	1.00
0.90	1.00	0.90	1.00	0.90	1.00	0.90	1.00	0.90	1.00
0.90	1.00	0.90	1.00	0.90	1.00	0.90	1.00	0.89	1.00
0.89	1.00	0.89	1.00	0.89	1.00	0.89	1.00	0.89	1.00
0.88	1.00	0.88	1.00	0.88	1.00	0.89	1.00	0.88	1.00
0.74	0.94	0.74	0.94	0.86	1.00	0.89	1.00	0.87	1.00
0.70	0.90	0.70	0.90	0.72	0.92	0.88	1.00	0.85	1.00
		0.81	1.00	0.63	0.83	0.87	1.00	0.81	1.00
		0.89	1.00	0.71	0.91	0.86	1.00	0.76	0.96
				0.85	1.00	0.84	1.00	0.12	0.52
				0.90	1.00	0.81	1.00	0.00	0.27
						0.77	0.97	0.00	0.37
						0.56	0.76	0.46	0.66
						0.34	0.54	0.82	1.00
						0.10	0.50		
						0.08	0.48		
						0.27	0.47		
						0.44	0.64		
						0.65	0.85		
						0.81	1.00		
						0.89	1.00		

Lower	Upper	Lower	Upper	Lower	Upper	Lower	Upper
2132.5 MHz		2450 MHz		3600 MHz		4700 MHz	
0.90	1.00	0.90	1.00	0.90	1.00	0.90	1.00
0.90	1.00	0.90	1.00	0.90	1.00	0.90	1.00
0.90	1.00	0.90	1.00	0.90	1.00	0.90	1.00
0.89	1.00	0.89	1.00	0.89	1.00	0.89	1.00
0.89	1.00	0.89	1.00	0.89	1.00	0.89	1.00
0.88	1.00	0.89	1.00	0.89	1.00	0.89	1.00
0.87	1.00	0.88	1.00	0.88	1.00	0.88	1.00
0.86	1.00	0.87	1.00	0.88	1.00	0.88	1.00
0.83	1.00	0.85	1.00	0.87	1.00	0.88	1.00
0.79	0.99	0.82	1.00	0.87	1.00	0.87	1.00
0.74	0.94	0.78	0.98	0.85	1.00	0.87	1.00
0.67	0.87	0.73	0.93	0.83	1.00	0.86	1.00
0.07	0.47	0.66	0.86	0.80	1.00	0.85	1.00
0	0.34	0.00	0.39	0.76	0.96	0.83	1.00
0	0.34	0.06	0.46	0.71	0.91	0.81	1.00
0.06	0.46	0.27	0.47	0.65	0.85	0.77	0.97
0.61	0.81	0.00	0.39	0.58	0.78	0.73	0.93
0.87	1.00	0.09	0.49	0.49	0.69	0.68	0.88
		0.64	0.84	0.39	0.59	0.62	0.82
		0.87	1.00	0.03	0.43	0.54	0.74
				0.52	0.72	0.46	0.66
				0.75	0.95	0.37	0.57
				0.83	1.00	0.27	0.47
				0.82	1.00	0.07	0.47
				0.69	0.89	0.00	0.38
				0.32	0.52	0.41	0.61
				0.00	0.35	0.73	0.93
				0.50	0.70	0.85	1.00
				0.80	1.00	0.79	0.99
				0.90	1.00	0.70	0.90
						0.68	0.88
						0.78	0.98
						0.88	1.00
						0.81	1.00
						0.43	0.63
						0.00	0.29
						0.40	0.60
						0.72	0.92
						0.87	1.00

Table C.4.4-2: Spatial correlation pass/fail limits for CDL-C UMa channel model

Lower	Upper	Lower	Upper	Lower	Upper	Lower	Upper	Lower	Upper
617 MHz		722 MHz		836.5 MHz		1575.42 MHz		1800 MHz	
0.90	1.00	0.90	1.00	0.90	1.00	0.90	1.00	0.90	1.00
0.89	1.00	0.89	1.00	0.89	1.00	0.89	1.00	0.89	1.00
0.89	1.00	0.88	1.00	0.88	1.00	0.88	1.00	0.85	1.00
0.88	1.00	0.87	1.00	0.87	1.00	0.86	1.00	0.82	1.00
0.86	1.00	0.86	1.00	0.86	1.00	0.84	1.00	0.79	0.99
0.51	0.71	0.84	1.00	0.85	1.00	0.82	1.00	0.78	0.98
0.37	0.57	0.48	0.68	0.82	1.00	0.81	1.00	0.77	0.97
0.75	0.95	0.20	0.40	0.46	0.66	0.80	1.00	0.76	0.96
		0.46	0.66	0.09	0.29	0.79	0.99	0.73	0.93
		0.85	1.00	0.17	0.37	0.78	0.98	0.68	0.88
				0.60	0.80	0.77	0.97	0.00	0.40
				0.89	1.00	0.74	0.94	0.11	0.52
						0.69	0.89	0.00	0.39
						0.32	0.52	0.26	0.46
						0.00	0.33	0.44	0.64
						0.10	0.50		
						0.11	0.51		
						0.09	0.49		

Lower	Upper	Lower	Upper	Lower	Upper	Lower	Upper	Lower	Upper
617 MHz		722 MHz		836.5 MHz		1575.42 MHz		1800 MHz	
						0.13	0.53		
						0.09	0.49		
						0.38	0.58		
						0.78	0.98		

Lower	Upper	Lower	Upper	Lower	Upper	Lower	Upper
2132.5 MHz		2450 MHz		3600 MHz		4700 MHz	
0.90	1.00	0.90	1.00	0.90	1.00	0.90	1.00
0.89	1.00	0.89	1.00	0.88	1.00	0.88	1.00
0.86	1.00	0.85	1.00	0.85	1.00	0.84	1.00
0.83	1.00	0.81	1.00	0.80	1.00	0.79	0.99
0.80	1.00	0.77	0.97	0.74	0.94	0.73	0.93
0.79	0.99	0.75	0.95	0.70	0.90	0.68	0.88
0.78	0.98	0.73	0.93	0.67	0.87	0.63	0.83
0.77	0.97	0.72	0.92	0.65	0.85	0.60	0.80
0.74	0.94	0.72	0.92	0.63	0.83	0.58	0.78
0.69	0.89	0.70	0.90	0.62	0.82	0.56	0.76
0.00	0.36	0.67	0.87	0.61	0.81	0.55	0.75
0.10	0.50	0.63	0.83	0.60	0.80	0.54	0.74
0.02	0.42	0.56	0.76	0.59	0.79	0.53	0.73
0.26	0.46	0.06	0.46	0.57	0.77	0.52	0.72
0.47	0.67	0.03	0.43	0.44	0.84	0.51	0.71
0.90	1.00	0.00	0.39	0.41	0.81	0.50	0.70
0.89	1.00	0.00	0.33	0.36	0.76	0.49	0.69
0.86	1.00	0.00	0.35	0.29	0.69	0.47	0.67
		0.28	0.48	0.21	0.61	0.45	0.65
		0.64	0.84	0.22	0.62	0.42	0.62
				0.00	0.49	0.38	0.58
				0.44	0.84	0.32	0.52
				0.27	0.67	0.15	0.55
				0.24	0.64	0.06	0.46
				0.08	0.58	0.00	0.38
				0.00	0.46	0.49	0.69
				0.00	0.46	0.06	0.46
				0.21	0.61	0.69	0.89
				0.20	0.60	0.33	0.53
				0.85	1.00	0.58	0.78
						0.53	0.73
						0.65	0.85
						0.77	0.97
						0.57	0.77
						0.00	0.29
						0.05	0.45
						0.12	0.52
						0.32	0.52
						0.63	0.83

C.4.5 Pass/Fail Criteria of Cross-polarization

This clause defines the pass/fail criteria of cross-polarization, this pass/fail limits apply for all channel models in all FR1 frequency bands, for both combined and individual beams.

The cross-polarization ratio pass/fail limit is specified as ± 1 dB.

C.4.6 Pass/Fail Criteria of Power validation

This clause defines the pass/fail criteria of power validation, this pass/fail limits apply for all channel models in all FR1 frequency bands.

The power validation pass/fail limit is specified as ± 1.5 dB.

Annex D (normative): gNB configurations

D.1 FR1 gNB configurations

The gNodeB emulator parameters shall be set according to Table D.1-1 for FR1 common parameters, Table D.1-2 for FR1 FDD 2x2 test parameters, Table D.1-3 for FR1 TDD 2x2 test parameters, Table D.1-4 for FR1 FDD 4x4 test parameters, and Table D.1-5 for FR1 TDD 4x4 test parameters.

Table D.1-1: FR1 Common test parameters

Parameter		Unit	Value
PDSCH transmission scheme (Note 1)			Transmission scheme 1
Carrier configuration	Offset between Point A and the lowest usable subcarrier on this carrier (Note 2)	RBs	0
	Subcarrier spacing	kHz	15 or 30
DL BWP configuration #1	Cyclic prefix		Normal
	RB offset	RBs	0
	Number of contiguous PRB	PRBs	Maximum transmission bandwidth configuration as specified in clause 5.3.2 of 3GPP TS 38.101-1 [2] for tested channel bandwidth and subcarrier spacing
Common serving cell parameters	Physical Cell ID		0
	SSB position in burst		First SSB in Slot #0
	SSB periodicity	ms	20
	First DMRS position for Type A PDSCH mapping		2
PDCCH configuration	Slots for PDCCH monitoring		Each slot
	Symbols with PDCCH	Symbols	0, 1
	Number of PRBs in CORESET		Table 5.2-2 of 3GPP TS 38.101-4 [6] for tested channel bandwidth and subcarrier spacing
	Number of PDCCH candidates and aggregation levels		1/AL8
	CCE-to-REG mapping type		Non-interleaved
	DCI format		1_1
	TCI state		TCI state #1
Cross carrier scheduling			Not configured
CSI-RS for tracking	First subcarrier index in the PRB used for CSI-RS		$k_0=0$ for CSI-RS resource 1,2,3,4
	First OFDM symbol in the PRB used for CSI-RS		$l_0 = 6$ for CSI-RS resource 1 and 3 $l_0 = 10$ for CSI-RS resource 2 and 4
	Number of CSI-RS ports (X)		1 for CSI-RS resource 1,2,3,4
	CDM Type		'No CDM' for CSI-RS resource 1,2,3,4
	Density (p)		3 for CSI-RS resource 1,2,3,4
	CSI-RS periodicity	Slots	15 kHz SCS: 20 for CSI-RS resource 1,2,3,4 30 kHz SCS: 40 for CSI-RS resource 1,2,3,4
	CSI-RS offset	Slots	15 kHz SCS: 10 for CSI-RS resource 1 and 2 11 for CSI-RS resource 3 and 4

Parameter		Unit	Value
			30 kHz SCS: 20 for CSI-RS resource 1 and 2 21 for CSI-RS resource 3 and 4
	Frequency Occupation		Start PRB 0 Number of PRB = BWP size
	QCL info		TCI state #0
NZP CSI-RS for CSI acquisition	First subcarrier index in the PRB used for CSI-RS		$k_0 = 0$
	First OFDM symbol in the PRB used for CSI-RS		$l_0 = 12$
	Number of CSI-RS ports (X)		Same as number of transmit antenna
	CDM Type		'FD-CDM2'
	Density (ρ)		1
	CSI-RS periodicity	Slots	15 kHz SCS: 20 30 kHz SCS: 40
	CSI-RS offset	Slots	0
	Frequency Occupation		Start PRB 0 Number of PRB = BWP size
	QCL info		TCI state #1
ZP CSI-RS for CSI acquisition	First subcarrier index in the PRB used for CSI-RS		$k_0 = 4$
	First OFDM symbol in the PRB used for CSI-RS		$l_0 = 12$
	Number of CSI-RS ports (X)		4
	CDM Type		'FD-CDM2'
	Density (ρ)		1
	CSI-RS periodicity	Slots	15 kHz SCS: 20 30 kHz SCS: 40
	CSI-RS offset	Slots	0
	Frequency Occupation		Start PRB 0 Number of PRB = BWP size
PDSCH DMRS configuration	Antenna ports indexes		{1000, 1001} for Rank 2 tests {1000-1003} for Rank 4 tests
	Number of PDSCH DMRS CDM group(s) without data		1 for Rank 2 tests 2 for Rank 4 tests
TCI state #0	Type 1 QCL information	SSB index QCL Type	SSB #0 Type C
	Type 2 QCL information	SSB index QCL Type	N/A N/A
TCI state #1	Type 1 QCL information	CSI-RS resource QCL Type	CSI-RS resource 1 from 'CSI-RS for tracking' configuration Type A
	Type 2 QCL information	CSI-RS resource QCL Type	N/A N/A
PT-RS configuration			PT-RS is not configured
Maximum number of code block groups for ACK/NACK feedback			1
Maximum number of HARQ transmission			1
HARQ ACK/NACK bundling			Multiplexed
Redundancy version coding sequence			N.A
Precoding configuration			SP Type I, Random per slot with PRB bundling granularity
Symbols for all unused REs			OCNG clause A.5 of 3GPP TS 38.101-4 [9]
Minimum Number of Slots per Stream			20000 for 15kHz SCS 40000 for 30kHz SCS (Note 3)
Transmit Power Control		dBm	13
DL power level (RS EPRE of SSS)		dBm / SCS	Set at gNodeB simulator with correction from calibration
EPRE ratio of PDSCH to SSS		dB	0
Note 1: UE assumes that the TCI state for the PDSCH is identical to the TCI state applied for the PDCCH transmission.			
Note 2: Point A coincides with minimum guard band as specified in Table 5.3.3-1 from 3GPP TS 38.101-1 [2] for tested channel bandwidth and subcarrier spacing.			

Parameter	Unit	Value
Note 3: For FR1 MIMO OTA test lab alignments and FR1 MIMO OTA UE performance requirements, the following values can be used: For FR1 bands >1GHz: 20k for 30kHz SCS, 10k for 15kHz SCS; For FR1 bands <1GHz: [20k] for 15kHz SCS;		

Table D.1-2: Test parameters for FR1 FDD 2x2

Parameter	Unit	Value
Duplex mode		FDD
Reference channel		R.PDSCH.1-3.1 FDD (Note)
Bandwidth	MHz	10
SCS	kHz	15
Modulation DL		64QAM
Modulation UL		QPSK
Active DL BWP index		1
PDSCH configuration	Mapping type	Type A
	k0	0
	Starting symbol (S)	2
	Length (L)	12
	PDSCH aggregation factor	1
	PRB bundling type	Static
	PRB bundling size	2
	Resource allocation type	Type 0
	RBG size	Config2
	VRB-to-PRB mapping type	Non-interleaved
PDSCH DMRS configuration	DMRS Type	Type 1
	Number of additional DMRS	1
	Maximum number of OFDM symbols for DL front loaded DMRS	1
CSI-RS for tracking	CSI-RS periodicity	Slots 20
	CSI-RS offset	Slots Table 5.2-1 [3]
Number of HARQ Processes		4
The number of slots between PDSCH and corresponding HARQ-ACK information		2
Note: "R.PDSCH.1-3.1 FDD" is defined in Table A.3.2.1.1-3 of 3GPP TS 38.101-4 [6].		

Table D.1-3: Test parameters for FR1 TDD 2x2

Parameter		Unit	Value
Duplex mode			TDD
Reference channel			R.PDSCH.2-3.1 TDD (Note 1)
Bandwidth		MHz	40
SCS		kHz	30
Modulation DL			64QAM
Modulation UL			QPSK
Active DL BWP index			1
PDSCH configuration	Mapping type		Type A
	k0		0
	Starting symbol (S)		2
	Length (L)		Specific to each Reference channel
	PDSCH aggregation factor		1
	PRB bundling type		Static
	PRB bundling size		2
	Resource allocation type		Type 0
	RBG size		Config2
	VRB-to-PRB mapping type		Non-interleaved
PDSCH DMRS configuration	VRB-to-PRB mapping interleave bundle size		N/A
	DMRS Type		Type 1
	Number of additional DMRS		1
CSI-RS for tracking	Maximum number of OFDM symbols for DL front loaded DMRS		1
	First OFDM symbol in the PRB used for CSI-RS		Table 5.2-1 [3]
	CSI-RS periodicity	Slots	40
	CSI-RS offset	Slots	Table 5.2-1 [3]
Number of HARQ Processes			8
TDD UL-DL pattern			FR1.30-1 (Note 2)
Note 1: "R.PDSCH.2-3.1 TDD" is defined in Table A.3.2.2.2-3 of 3GPP TS 38.101-4 [6].			
Note 2: "FR1.30-1" is defined in Annex A.1.2 of 3GPP TS 38.101-4 [6].			

Table D.1-4: Test parameters for FR1 FDD 4x4

Parameter		Unit	Value
Duplex mode			FDD
Reference channel			R.PDSCH.1-2.4 FDD (Note)
Bandwidth		MHz	10
SCS		kHz	15
Modulation DL			16QAM
Modulation UL			QPSK
Active DL BWP index			1
PDSCH configuration	Mapping type		Type A
	k0		0
	Starting symbol (S)		2
	Length (L)		12
	PDSCH aggregation factor		1
	PRB bundling type		Static
	PRB bundling size		2
	Resource allocation type		Type 0
	RBG size		Config2
	VRB-to-PRB mapping type		Non-interleaved
VRB-to-PRB mapping interleave bundle size		N/A	
PDSCH DMRS configuration	DMRS Type		Type 1
	Number of additional DMRS		1
	Maximum number of OFDM symbols for DL front loaded DMRS		1
CSI-RS for tracking	CSI-RS periodicity	Slots	20
	CSI-RS offset	Slots	Table 5.2-1 [3]
Number of HARQ Processes			4
The number of slots between PDSCH and corresponding HARQ-ACK information			2
Note: "R.PDSCH.1-2.4 FDD" is defined in Table A.3.2.1.1-2 of 3GPP TS 38.101-4 [6].			

Table D.1-5: Test parameters for FR1 TDD 4x4

Parameter		Unit	Value
Duplex mode			TDD
Reference channel			R.PDSCH.2-2.4 TDD (Note 1)
Bandwidth		MHz	40
SCS		kHz	30
Modulation DL			16QAM
Modulation UL			QPSK
Active DL BWP index			1
PDSCH configuration	Mapping type		Type A
	k0		0
	Starting symbol (S)		2
	Length (L)		Specific to each Reference channel
	PDSCH aggregation factor		1
	PRB bundling type		Static
	PRB bundling size		2
	Resource allocation type		Type 0
	RBG size		Config2
	VRB-to-PRB mapping type		Non-interleaved
VRB-to-PRB mapping interleave bundle size		N/A	
PDSCH DMRS configuration	DMRS Type		Type 1
	Number of additional DMRS		1
	Maximum number of OFDM symbols for DL front loaded DMRS		1
CSI-RS for tracking	First OFDM symbol in the PRB used for CSI-RS		Table 5.2-1 [3]
	CSI-RS periodicity	Slots	40.
	CSI-RS offset	Slots	Table 5.2-1 [3]
Number of HARQ Processes			8
TDD UL-DL pattern			FR1.30-1 (Note 2)
Note 1: "R.PDSCH.2-2.4 TDD" is defined in Table A.3.2.2.2-2 of 3GPP TS 38.101-4 [6].			
Note 2: "FR1.30-1" is defined in clause A.1.2 of 3GPP TS 38.101-4 [6].			

D.2 FR2 gNB configurations

The gNodeB emulator parameters for FR2 MIMO OTA testing shall be set according to Table D.2-1 for FR2 common parameters and Table D.2-2 for FR2 TDD 2x2 test parameters.

Table D.2-1: FR2 Common test parameters

Parameter		Unit	Value
PDSCH transmission scheme (Note 1)			Transmission scheme 1
PTRS <i>epre</i> -Ratio			0
Actual carrier configuration	Offset between Point A and the lowest usable subcarrier on this carrier (Note 2)	RBs	0
	Subcarrier spacing	kHz	120
DL BWP configuration #1	Cyclic prefix		Normal
	RB offset	RBs	0
	Number of contiguous PRB	PRBs	Maximum transmission bandwidth configuration as specified in clause 5.3.2 of TS 38.101-2 [11] for tested channel bandwidth and subcarrier spacing
Common serving cell parameters	Physical Cell ID		0
	SSB position in burst		1
	SSB periodicity	ms	20
	First DMRS position for Type A PDSCH mapping		2
PDCCH configuration	Slots for PDCCH monitoring		Each slot
	Symbols with PDCCH		0
	Number of PRBs in CORESET		Table 7.2-2 of TS 38.101-4 [6] for tested channel bandwidth and subcarrier spacing
	Number of PDCCH candidates and aggregation levels		1/AL8
	CCE-to-REG mapping type		Non-interleaved
	DCI format		1_1
	TCI state		TCI state #1
Cross carrier scheduling			Not configured
CSI-RS for tracking	First subcarrier index in the PRB used for CSI-RS (k_0)		0 for CSI-RS resource 1,2,3,4
	First OFDM symbol in the PRB used for CSI-RS (l_0)		6 for CSI-RS resource 1 and 3 10 for CSI-RS resource 2 and 4
	Number of CSI-RS ports (X)		1 for CSI-RS resource 1,2,3,4
	CDM Type		'No CDM' for CSI-RS resource 1,2,3,4
	Density (ρ)		3 for CSI-RS resource 1,2,3,4
	CSI-RS periodicity	Slots	120 kHz SCS: 160 for CSI-RS resource 1,2,3,4
	CSI-RS offset	Slots	120 kHz SCS: 80 for CSI-RS resource 1 and 2 81 for CSI-RS resource 3 and 4
	Frequency Occupation		Start PRB 0 Number of PRB = BWP size
	QCL info		TCI state #0
NZP CSI-RS for CSI acquisition	First subcarrier index in the PRB used for CSI-RS (k_0)		0
	First OFDM symbol in the PRB used for CSI-RS (l_0)		12
	Number of CSI-RS ports (X)		2
	CDM Type		FD-CDM2
	Density (ρ)		1
	CSI-RS periodicity	Slots	120 kHz SCS: 160
	CSI-RS offset		0
	Frequency Occupation		Start PRB 0 Number of PRB = BWP size
QCL info		TCI state #1	

ZP CSI-RS for CSI acquisition	First subcarrier index in the PRB used for CSI-RS (k_0)		4
	First OFDM symbol in the PRB used for CSI-RS (l_0)		12
	Number of CSI-RS ports (X)		4
	CDM Type		FD-CDM2
	Density (ρ)		1
	CSI-RS periodicity	Slots	120 kHz SCS: 160
	CSI-RS offset		0
	Frequency Occupation		Start PRB 0 Number of PRB = BWP size
CSI-RS for beam refinement	First subcarrier index in the PRB used for CSI-RS		$k_0=0$ for CSI-RS resource 1,2
	First OFDM symbol in the PRB used for CSI-RS		$l_0 = 8$ for CSI-RS resource 1 $l_0 = 9$ for CSI-RS resource 2
	Number of CSI-RS ports (X)		1 for CSI-RS resource 1,2
	CDM Type		'No CDM' for CSI-RS resource 1,2
	Density (ρ)		3 for CSI-RS resource 1,2
	CSI-RS periodicity	Slots	60 kHz SCS: 80 for CSI-RS resource 1,2 120 kHz SCS: 160 for CSI-RS resource 1,2
	CSI-RS offset	Slots	0 for CSI-RS resource 1,2
	QCL info		TCI state #1
PDSCH DMRS configuration	Antenna ports indexes		{1000} for Rank 1 tests {1000, 1001} for Rank 2 tests
	Number of PDSCH DMRS CDM group(s) without data		1
TCI state #0	Type 1 QCL information	SSB index	SSB #0
		QCL Type	Type C
	Type 2 QCL information	SSB index	SSB #0
		QCL Type	Type D
TCI state #1	Type 1 QCL information	CSI-RS resource	CSI-RS resource 1 from 'CSI-RS for tracking' configuration
		QCL Type	Type A
	Type 2 QCL information	CSI-RS resource	CSI-RS resource 1 from 'CSI-RS for tracking' configuration
		QCL Type	Type D
PTRS configuration	Frequency density (K_{PT-RS})		2
	Time density (L_{PT-RS})		1
Maximum number of code block groups for ACK/NACK feedback			1
Maximum number of HARQ transmission			1
HARQ ACK/NACK bundling			Multiplexed
Redundancy version coding sequence			{0,2,3,1}
Precoding configuration			SP Type I, Random per slot with PRB bundling granularity
Symbols for all unused Res			OCNG in Annex A.5 of TS 38.101-4 [6]
Minimum Number of Slots per Stream			20000 for FR2 UMi CDL-C
Transmit Power Control		dBm	13 dBm
Note 1: UE assumes that the TCI state for the PDSCH is identical to the TCI state applied for the PDCCH transmission.			
Note 2: Point A coincides with minimum guard band as specified in Table 5.3.3-1 from TS 38.101-2 [11] for tested channel bandwidth and subcarrier spacing.			

Table D.2-2: Test parameters for FR2 TDD 2x2

Parameter		Unit	Value
Duplex mode			TDD
Reference channel			R.PDSCH.5-2.2 TDD (Note 1)
Bandwidth		MHz	100
SCS		kHz	120
Modulation DL			16QAM
Modulation UL			QPSK
Active DL BWP index			1
CSI-RS for tracking	First OFDM symbol in the PRB used for CSI-RS (l_0)		Table E.2-1
	CSI-RS offset	Slots	Table E.2-1
PDCCH configuration			Number of PDCCH candidates and aggregation levels 1/AL8
PDSCH configuration	Mapping type		Type A
	k_0		0
	Starting symbol (S)		1
	Length (L)		Specific to each Reference channel as defined in A.3.2.2 of TS 38.101-4 [6]
	PDSCH aggregation factor		1
	PRB bundling type		Static
	PRB bundling size		WB for Test 1-1, 2 for other tests
	Resource allocation type		Type 0
	RBG size		config2
	VRB-to-PRB mapping type		Non-interleaved
PDSCH DMRS configuration	DMRS Type		Type 1
	Number of additional DMRS		1
	Maximum number of OFDM symbols for DL front loaded DMRS		1
Number of HARQ Processes			8
TDD UL-DL pattern			FR2.120-1 (Note2)
Note 1: "R.PDSCH.5-2.2 TDD" is defined in Table A.3.2.2.5-2 of TS 38.101-4 [6]			
Note 2: "FR2.120-1" is defined in Annex A.1.3 of TS 38.101-4 [6]			

Annex E (normative): Environmental requirements

E.1 Scope

The requirements in this clause apply to all types of UE(s) in FR1 and FR2.

E.2 Ambient temperature

All the MIMO OTA requirements are applicable in room temperature e.g. 25°C.

E.3 Operating voltage

Editor's note: The following aspects should be considered in a future release:

- Test procedure (including associated vendor declaration), test setup and MU impact to enable testing with external cable in FR2 is FFS.
- An external cable, e.g., charging/automation cable, could be considered when test time for FR2 MIMO OTA conformance test cases increases, e.g.: more FR2 bands, more frequencies (L/M/H), and/or more applicable channel models.

For FR1 and FR2 MIMO OTA, all test cases shall be performed in the normal voltage condition with the DUT operated in stand-alone battery powered mode. No extreme voltage testing is required. It is recommended to start testing with a fully charged battery and conclude and/or pause testing before the battery has completely lost its charge.

Annex F (normative): Maximum uncertainty of test system and test tolerance

F.1 Maximum uncertainty of test system

The maximum acceptable uncertainty of the Test System is specified in Table F.1-1 for each test, where appropriate. The Test System shall enable each test to be measured with an uncertainty not exceeding the specified values. All ranges and uncertainties are absolute values and are valid for a confidence level of 95 %.

In Annex B and H, the estimation of measurement uncertainty is defined.

Table F.1-1: Maximum Test System uncertainties for MIMO OTA tests

Clause	Maximum Test System Uncertainty	Derivation of Test System Uncertainty
6.1.2 Total Radiated Multi-Antenna Sensitivity (TRMS)	± 2.61 dB for ≤ 3 GHz ± 2.65 dB for > 3 GHz	Refer to Annex B
7.1.1 MIMO Average Spherical Coverage (MASC)	± 5.05 dB for $26.5\text{GHz} \leq f \leq 29.5\text{GHz}$	Refer to Annex H

F.2 Test tolerances

Test tolerances in Table F.2-1 are used to relax the Minimum Requirements in the present document and to derive the Test Requirements.

Table F.2-1: Test Tolerances for OTA tests

Clause	Test Tolerance
6.1.2 Total Radiated Multi-Antenna Sensitivity (TRMS)	$0.62 \cdot \text{MU}$ (dB) for ≤ 3 GHz $0.62 \cdot \text{MU}$ (dB) for > 3 GHz
7.1.1 MIMO Average Spherical Coverage (MASC)	$0.62 \cdot \text{MU}$ (dB) for $26.5\text{GHz} \leq f \leq 29.5\text{GHz}$

Annex G (normative): FR2 Test methodology

G.1 General

FR2 MIMO OTA requirement testing is based on UE-noise limited environmental condition, i.e., UE throughput characterized as a function of signal power incident to the DUT antennas.

The minimum test zone size for FR2 MIMO OTA 3D-MPAC system is 20cm. "Black-box" testing approach is adopted for NR MIMO OTA testing, the physical centre of the EUT shall be placed in the centre of the test zone, the EUT shall be completely contained within the minimum test zone size.

FR2 MIMO OTA requirement testing should be performed under primary mechanical mode. The primary mechanical mode for devices having multiple mechanical modes shall be declared by the manufacturers. Single primary mechanical mode for each device should be declared for MIMO OTA conformance testing.

G.2 FR2 3D Multi-Probe Anechoic Chamber (3D-MPAC)

G.2.1 System setup

The 3D MPAC test method is the reference methodology for FR2 NR MIMO OTA testing. By arranging an array of antennas around the Equipment Under Test (EUT), a spatial distribution of angles of arrival in the 3D MPAC system may be simulated to expose the EUT to a near field environment that appears to have originated from a complex multipath far field environment.

As illustrated schematically in Figure G.2.1-1, signals propagate from the base station/communication tester to the EUT through a simulated multipath environment known as a spatial channel model, where appropriate channel impairments such as Doppler and fading are applied to each path prior to injecting all of the directional signals into the chamber simultaneously through the probe array. The resulting field distribution in the test zone is then integrated by the EUT antenna(s) and processed by the receiver(s) just as it would do so in any non-simulated multipath environment. The 3D MPAC system with 6 dual-polarized probes (illustrated with black dots in Figure G.2.1-1) placed on a sector with minimum radius of 0.75m from the centre of the test zone is permitted for NR FR2 MIMO OTA testing.

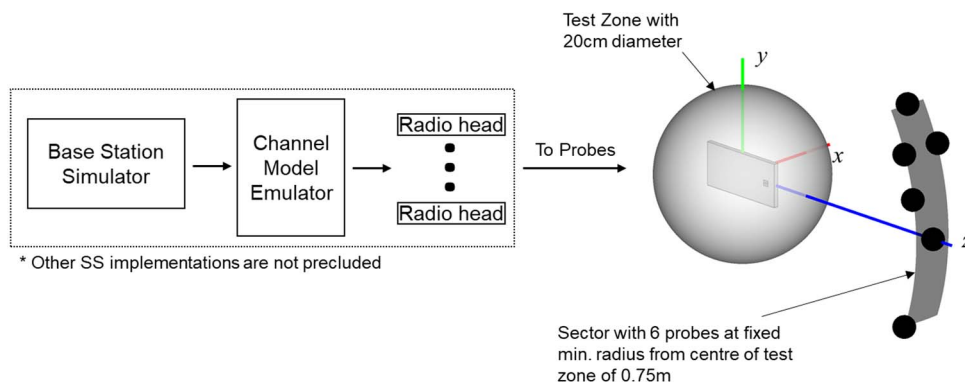

Figure G.2.1-1: 3D MPAC system layout for NR FR2 MIMO OTA testing

The exact probe locations with respect to the OTA test system coordinate system are tabulated in Table G.2.1-1.

Table G.2.1-1: FR2 3D MPAC Probe Locations in OTA test system coordinate system

Probe Number	Theta [deg]	Phi [deg]
1	0.0	0.0
2	11.2	116.7
3	20.6	-104.3
4	20.6	104.3
5	20.6	75.7
6	30.0	90.0

The 3D MPAC probes in Table G.2.1-1 can be implemented using conventional millimetre-wave probes as well as IFF-based probes as long as the same probe configuration and same number of probes is used.

The channel model parameters and probe locations for channel model implementation are defined in a channel model coordinate system, which is illustrated in figure G.2.1-2. The channel model coordinate axes x_{CM} , y_{CM} , and z_{CM} correspond to the OTA test system coordinate axes z , y , and $-x$, respectively.

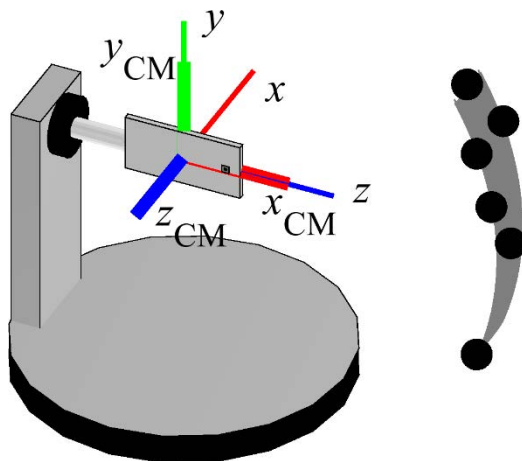

Figure G.2.1-2: Channel Model Coordinate Axes in FR2 3D-MPAC system

The probe locations with respect to channel model coordinate axes are tabulated in table G.2.1-2.

Table G.2.1-2: FR2 3D MPAC Probe Locations in Channel Model Coordinate System

Probe Number	Theta [deg]	Phi [deg]
1	90	0
2	85	10
3	85	-20
4	85	20
5	95	20
6	90	30

The channel model rotations assumed for this probe configuration are tabulated in Table G.2.1-3.

Table G.2.1-3: Channel Model Rotations

UMi CDL-C	
Phi [deg]	Theta [deg]
32	15.0

This channel model rotation assumes the relative orientations of BS and UE antennas displayed in Figure G.2.1-3, i.e., the DUT antenna is pointed towards the BS in channel model coordinate system.

In order to avoid positioning ambiguities, the turntable implementing the rotation in θ shall match the intended DUT θ for P0 Orientation 1 without the re-positioning approach, as defined in Clause G.3, applied. With the re-positioning approach applied, the relative orientation between the DUT and the probes for P0 Orientation 2 shall be the same the relative orientation between DUT and probes as for P0 Orientation 1.

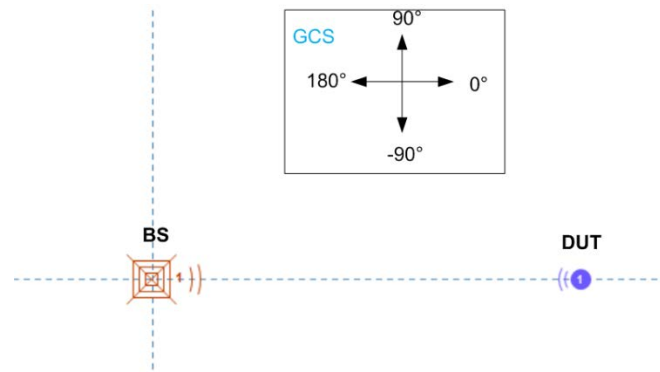

Figure G.2.1-3: Relative orientations of BS and UE antennas

Since the test points are uniformly spaced in 3D already, Table 7.1.2.4.2-1, there is no need to adjust/rotate the DUT rotations by the channel model rotations.

G.2.2 Calibration procedure

The system needs to be calibrated by using a reference calibration antenna with known gain values in order to ensure that the downlink signal power is correct. In non-standalone (NSA) mode, the LTE link antenna provides a stable LTE signal without precise path loss or polarization control.

The path loss for each probe in the 3D MPAC system must be calibrated at test time in order to generate the desired channel model environment within the test zone of the chamber. The imbalance of each path during testing would result in an alteration of the angular dependence of the channel model (i.e. varied characteristics of generated channel model) within the test zone of the chamber.

For the calibration measurement, the reference antenna is placed in the centre of the quiet zone, connected to a VNA port, with the other VNA port connected to the input of the channel emulator unit as illustrated schematically in Figure G.3.2-1. For each probe antenna, the reference antenna needs to be aligned in polarization, i.e., θ or ϕ , and direction with the probe antenna that corresponds to the respective path to be calibrated. For each calibration measurement, the channel emulator needs to be configured in bypass mode. The calibration process determines the composite loss, $L_{\text{path,pol}}$, of the entire receiver chain path gains (measurement antenna, amplification) and losses (switches, combiners, cables, path loss, etc.). The calibration measurement is repeated for each measurement path (two orthogonal polarizations and each signal path).

G.2.3 Void

G.2.4 Minimum Range Length

The minimum range length of FR2 MPAC system is defined as the distance from the centre of the test zone to the aperture of the measurement probes/antennas, as illustrated in Figure G.2.4-1.

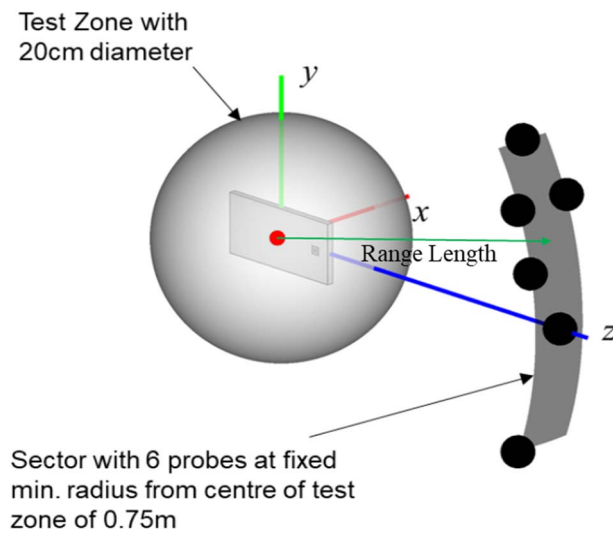

Figure G.2.4-1: Illustration of range length definition of FR2 3D-MPAC

The minimum range length for NR FR2 MPAC OTA systems with 20cm test zone size is 0.75m. It was shown that the PSP can be reduced significantly for distances below 0.75m.

G.2.5 Sample Device Orientations for Selected Test Points

Tables G.2.5-1 and G.2.5-2 include illustrations of device/positioner/probe configurations & orientations based on a sample MIMO OTA test system for various test points for $\theta < 90^\circ$ (Table G.2.5-1) and $\theta > 90^\circ$ (Table G.2.5-2), respectively.

Table G.2.5-1: Visualization of DUT Orientation of test points with $\theta < 90^\circ$

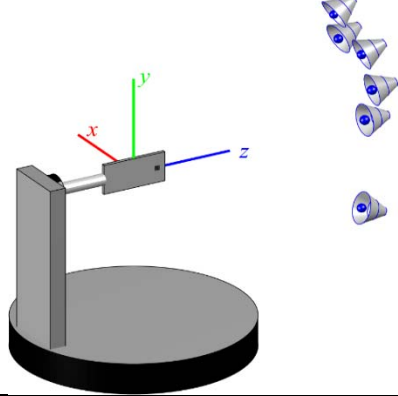
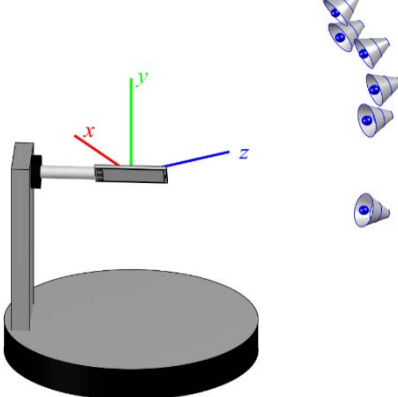
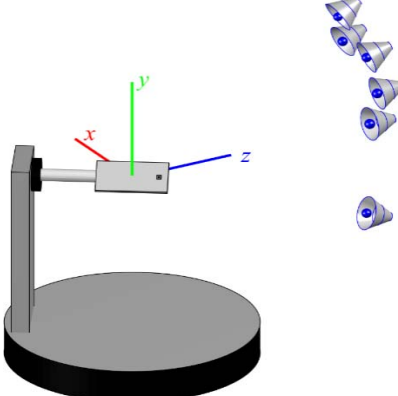
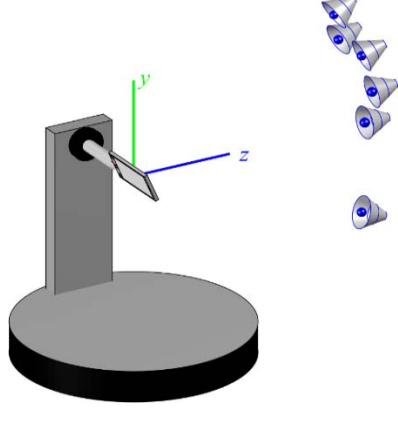
Test Point Number	θ [°]	ϕ [°]	Sample System/DUT Illustration with P0 – Orientation 1
1	0.0	0.0	
2	33.5	139.7	
3	33.9	49.7	
...			
18	89.3	157.0	

The illustrations in Table G.2.5-2 with $\theta > 90^\circ$ include the device and positioner orientations with the device placed in the P0 alignment option with Orientation 1 as well as Orientation 2 (Option 1 or Option 2) with the re-positioning approach as defined in Clause G.3.

Table G.2.5-2: Visualization of DUT Orientation of test points with $\theta > 90^\circ$

Test Point Number	θ [°]	ϕ [°]	Sample System/DUT Illustration with P0 – Orientation 1	Sample System/DUT Illustration with P0 – Orientation 2
19	93.9	-78.9		
...				
35	160.6	-67.4		
36	161.7	59.1		

G.3 Coordinate System and Device positioning

This Clause defines the measurement coordinate system and device positioning for NR FR2 MIMO OTA.

The reference coordinate system, as defined in [9], is provided in Figure A.4-1 while Figure G.3-1 shows the DUT in the default orientation.

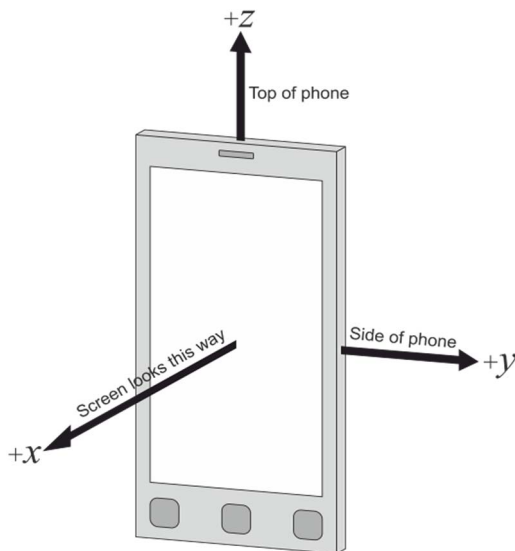

Figure G.3-1: DUT default orientation to coordinate system

For FR2 MIMO OTA, the DUT shall be tested using a 3D scan. With the DUT positioned in the default P0 alignment option, as defined in Table G.3-1, measurements on 36 evenly spaced test points, see Table 7.1.2.4.2-1, with a constant density shall be performed.

Table G.3-1: Summary of possible DUT positioning options

Testing condition	DUT orientation angles	Diagram
XY plane or P0 Orientation 1 (default)	$\alpha=0;$ $\beta=0;$ $\gamma=0$	

<p>P0 Orientation 2 – Option 1 (based on re-positioning approach)</p>	<p>$\alpha=180^\circ;$ $\beta=0;$ $\gamma=0$</p>	
<p>P0 Orientation 2 – Option 2 (based on re-positioning approach)</p>	<p>$\alpha=0;$ $\beta=180^\circ;$ $\gamma=0$</p>	

Near-field coupling effects between the antenna and the pedestals/positioners/fixtures generally cause increased signal ripples. Re-positioning the DUT by directing the beam peak away from those areas can reduce the effect of signal ripple on TP measurements. The images of Figure G.3-2 illustrate how to reposition the DUT when the near field coupling effects likely originate from the positioner/mast. In either case, Orientation 1, top image of Figure G.3-2, is used for the measurement of one hemisphere while Orientation 2 (Option 1, centre image or Option 2, bottom image) is used for the measurement of the opposite hemisphere. This re-positioning approach is applicable to FR2 only.

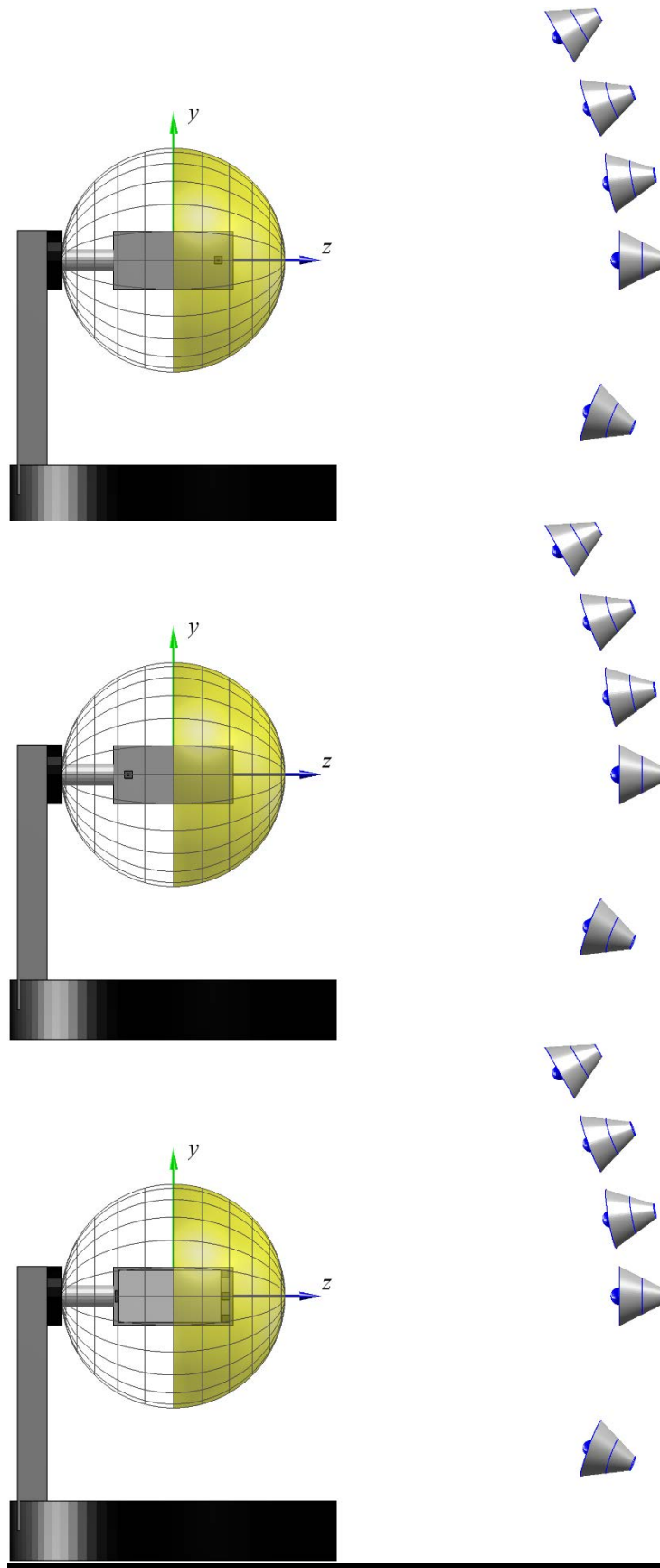

Figure G.3-2: Illustration of DUT re-positioning using a sample FR2 MPAC system (Top: P0 Orientation 1, Centre: Orientation 2 - Option 1, Bottom: Orientation 2 - Option 2). The region with reduced signal ripple is illustrated in yellow

Due to the non-commutative nature of rotations, the order of rotations is important and needs to be defined when multiple DUT orientations are tested.

The rotations around the x, y, and z axes can be defined with the following rotation matrices

$$R_x(\alpha) = \begin{bmatrix} 1 & 0 & 0 & 0 \\ 0 & \cos \alpha & -\sin \alpha & 0 \\ 0 & \sin \alpha & \cos \alpha & 0 \\ 0 & 0 & 0 & 1 \end{bmatrix}$$

$$R_y(\beta) = \begin{bmatrix} \cos \beta & 0 & \sin \beta & 0 \\ 0 & 1 & 0 & 0 \\ -\sin \beta & 0 & \cos \beta & 0 \\ 0 & 0 & 0 & 1 \end{bmatrix}$$

and

$$R_z(\gamma) = \begin{bmatrix} \cos \gamma & -\sin \gamma & 0 & 0 \\ \sin \gamma & \cos \gamma & 0 & 0 \\ 0 & 0 & 1 & 0 \\ 0 & 0 & 0 & 1 \end{bmatrix}$$

with the respective angles of rotation, α , β , γ and

$$\begin{bmatrix} x' \\ y' \\ z' \\ 1 \end{bmatrix} = R \begin{bmatrix} x \\ y \\ z \\ 1 \end{bmatrix}$$

Additionally, any translation of the DUT can be defined with the translation matrix

$$T(t_x, t_y, t_z) = \begin{bmatrix} 1 & 0 & 0 & t_x \\ 0 & 1 & 0 & t_y \\ 0 & 0 & 1 & t_z \\ 0 & 0 & 0 & 1 \end{bmatrix}$$

with offsets t_x , t_y , t_z in x, y, and z, respectively and with

$$\begin{bmatrix} x' \\ y' \\ z' \\ 1 \end{bmatrix} = T \begin{bmatrix} x \\ y \\ z \\ 1 \end{bmatrix}$$

The combination of rotations and translation is captured by the multiplication of rotation and translation matrices.

For instance, the matrix M

$$M = T(t_x, t_y, t_z) \cdot R_z(\gamma) \cdot R_y(\beta) \cdot R_x(\alpha)$$

describes an initial rotation of the DUT around the x axis with angle α , a subsequent rotation around the y axis with angle β , and a final rotation around the z axis with angle γ . After those rotations, the DUT is translated by t_x , t_y , t_z in x, y, and z, respectively.

Annex H (informative): Estimation of FR2 measurement uncertainty

H.1 MU Budget for FR2 3D-MPAC system

This clause defines the measurement uncertainty (MU) for FR2 3D-MPAC system, as shown in Table H.1-1.

Table H.1-1: Preliminary measurement uncertainty budget for FR2 3D-MPAC system

UID	Description of uncertainty contribution	Example value (26.5GHz≤f≤29.5GHz)	Example value (37GHz≤f≤40GHz)	Distribution of the probability	Std Uncertainty (26.5GHz≤f≤29.5GHz) [dB]	Std Uncertainty (37GHz≤f≤40GHz) [dB]
Stage 2: DUT measurement						
1	Mismatch for measurement process	1.30	TBD	Actual	1.30	TBD
2	Measure distance uncertainty	0.00	TBD	Rectangular	0.00	TBD
3	Quality of quiet zone	0.6	TBD	Actual	0.6	TBD
4	Base Station simulator	2.9	TBD	Normal	1.45	TBD
5	Channel Emulator -absolute value -stability -linearity	1.5dB 0.5dB 0.4dB	TBD	Actual (normal-power; rect-stability)	0.84	TBD
6	Amplifier uncertainties	2.10	TBD	Normal	1.05	TBD
7	Random uncertainty	0.50	TBD	Normal	0.25	TBD
8	Throughput measurement: output level step resolution	0.25	TBD	Rectangular	0.14	TBD
9	Signal flatness	0.00	0.00	Normal	0.00	TBD
Stage 1: Calibration measurement						
10	Mismatch for calibration process - loopback cable path - system input path - reference antenna	0.00	TBD	U-Shaped	0.00	TBD
11	Reference antenna positioning misalignment	0.01	TBD	Rectangular	0.01	TBD
12	Quality of quiet zone	0.60	TBD	Actual	0.60	TBD
13	Total uncertainty of the Network Analyzer	0.73	TBD	Normal	0.37	TBD
14	Uncertainty of an absolute gain of the calibration antenna	0.60	TBD	Normal	0.30	TBD
15	Offset of the Phase Center of the Reference Antenna	0.00	TBD	Rectangular	0.00	TBD
Total Expanded Uncertainty, U, with 95% Confidence Interval					5.05	TBD

The detailed descriptions of each measurement uncertainty contributor are defined in in clause H.2.

H2 Measurement error contribution descriptions for 3D-MPAC

H.2.1 Mismatch for measurement process

This term comes from the mismatch between the system input cables connecting to the base station simulator output port. For more information, see clause A.4.2.1 of 3GPP TS 38.561 [8].

H.2.2 Measurement distance uncertainty

The cause of this uncertainty contributor is due to the reduction of distance between the measurement antenna and the DUT. A minimum range length of 0.75m is required for testing. This MU can be considered 0dB as the range length is primarily dependent on the PSP.

H.2.3 Quality of quiet zone

The quality of the quiet zone procedure characterizes the quiet zone performance of the anechoic chamber, specifically the effect of reflections within the anechoic chamber including any positioners and support structures, see Annex O of 3GPP TS 38.521-2 [13].

The ripple test shall be repeated when the RF/propagation conditions inside the chamber have changed, e.g., the chamber has been disassembled and reassembled, portions of the absorber been replaced, measurement antennas/probes been replaced, positioning system been replaced, etc.

H.2.4 Base Station simulator

gNB emulator is used to drive a signal to the channel emulator and then to the device under test. Generally there occurs uncertainty contribution from absolute level accuracy, non-linearity and frequency characteristic of the gNB emulator.

For practical reasons, in a case that a VNA is used as a calibration equipment, gNB emulator is connected to the system after the calibration measurement is performed by the VNA. Hence, the uncertainty on the absolute level of gNB emulator (transmitter device) cannot be assumed as systematic. This uncertainty will be determined from the manufacturer's datasheet and the distribution used shall match that provided in the datasheet which are commonly quoting MUs/accuracies with a "95 % confidence level" and/or a "coverage factor of 2". In the absence of a declared distribution in the datasheet, the rectangular distribution should be used. Furthermore, the uncertainty of the non-linearity is included in the absolute level uncertainty.

H.2.5 Channel Emulator

The channel emulator is also working as a signal source in the NR MIMO OTA system, therefore there occurs uncertainty contribution from absolute level accuracy, non-linearity, frequency characteristic and stability of the channel emulator. These uncertainty contributions shall be taken from the manufacturer's data sheet.

H.2.6 Amplifier uncertainties

Any components in the setup can potentially introduce measurement uncertainty. It is then needed to determine the uncertainty contributors associated with the use of such components. For the case of external amplifiers, the following uncertainties should be considered but the applicability is contingent to the measurement implementation and calibration procedure:

- Stability:
 - An uncertainty contribution comes from the output level stability of the amplifier. Even if the amplifier is part of the system for both measurement and calibration, the uncertainty due to the stability shall be

considered. This uncertainty can be either measured or determined by the manufacturers' data sheet for the operating conditions in which the system will be required to operate.

- Linearity:
 - An uncertainty contribution comes from the linearity of the amplifier since in most cases calibration and measurements are performed at two different input/output power levels. This uncertainty can be either measured or determined by the manufacturers' data sheet.
- Noise Figure:
 - When the signal goes into an amplifier, noise is added so that the SNR at the output is reduced with regard to the SNR of the signal at the input. This added noise introduces error on the signal which affects the Error Rate of the receiver thus the EVM (Error Vector Magnitude). An uncertainty can be calculated through the following formula:

$$\varepsilon_{EVM} = 20 \log_{10} \left(1 + 10^{\frac{-SNR}{20}} \right)$$

- Where SNR is the signal to noise ratio in dB at the signal level used during the sensitivity measurement.
- Mismatch:
 - If the external amplifier is used for both stages, measurement and calibration the uncertainty contribution associated with it can be considered systematic and constant -> 0dB. If it is not the case, the mismatch uncertainty at its input and output shall be either measured or determined by the method described in 3GPP TR 38.901 [5].
- Gain:
 - If the external amplifier is used for both stages, measurement and calibration the uncertainty contribution associated with it can be considered systematic and constant -> 0 dB. If it is not the case, this uncertainty shall be considered.

H.2.7 Random uncertainty

This contribution is used to account for all the unknown, unquantifiable, etc. uncertainties associated with the measurements, see Annex B.2.2.9 of 3GPP TR 38.903 [14].

Random uncertainty MU contributions are normally distributed. The random uncertainty term, by definition, cannot be measured, or even isolated completely. A fixed value of 0.5 dB is suggested for MASC measurements to include a digital error rate uncertainty and is aligned with the random uncertainty for TRS for NR FR1 (3GPP TS 38.561 [8]).

H.2.8 Throughput measurement: output level step resolution

When output power of the communication tester is swept to reach the throughput target that defines the sensitivity threshold, the final power step resolution represents an asymmetric uncertainty contribution that can be corrected since this uncertainty is device and test system independent. The lab shall correct the MASC results by -0.5 output level step resolution of the final power step search and note the correction in the test report.

H.2.9 Signal flatness

For wireless technologies with wide channel bandwidths, the test system might not have a flat frequency response across the entire channel. While the range calibration corrects for any variation of frequency response as a function of the centre frequency of the channel, the broadband delivered to the test zone will be a function of the entire channel bandwidth as opposed to just the centre frequency. For more information, see clause A.4.2.14 of 3GPP TS 38.561 [8].

H.2.10 Mismatch for calibration process

During calibration stage, there will be impedance mismatch between the various RF cables and components used within the system. Standing waves are created by the reflections between any two components and uncertainty in the signal level will be generated. In general, three mismatch for calibration process should be considered:

- Loopback cable path: This item comes from the mismatch between the reference cable and the loopback cable during the loopback cable measurement step.
- System input path: This item comes from the mismatch between the loopback cable and the system input cable (generally the output cable after BS simulator). The reflectivity of the source output port is measured at the end of the loopback cable connecting to the system input cable.
- Reference antenna: This item comes from the mismatch between the VNA input port and the reference antenna. The reflectivity of the VNA input port is measured at the end of the reference cable connecting to the reference antenna.

For more information, see clause A.4.2.1 of 3GPP TS 38.561 [8].

H.2.11 Reference antenna positioning misalignment

This contribution originates from reference antenna alignment and pointing error.

H.2.12 Total Uncertainty of the Network Analyzer

This contribution originates from all uncertainties involved transmission magnitude measurement (including drift and frequency flatness) with a network analyser. will be determined from the manufacturer's datasheet which is now commonly quoting MUs/accuracies with a "95 % confidence level" and/or a "coverage factor of 2" and the distribution used shall match that provided in the datasheet. In the absence of a declared distribution in the datasheet, the rectangular distribution should be used.

H.2.13 Uncertainty of an absolute gain of the calibration antenna

The calibration antenna only appears in calibration phase (Stage 1). Therefore, the gain uncertainty has to be taken into account.

This uncertainty shall come from a calibration report (which is now commonly quoting MUs/accuracies with a "95 % confidence level" and/or a "coverage factor of 2") with traceability to a National Metrology Institute with measurement uncertainty budgets generated following the guidelines outlined in internationally accepted standards. In the absence of a declared distribution in the present document, the rectangular distribution should be used.

H.2.14 Offset of the Phase Center of the Reference Antenna

During range reference measurement, if a directional antenna is used, the uncertainty in the accuracy of positioning its phase centre on the axis of rotation will directly generate an uncertainty in this part of the measurement. In practical measurement, sleeve dipoles and loops are used for FR1 calibration, then the uncertainty of this element should be 0 dB, since the phase centre offset is negligible.

Annex I (normative): FR2 Channel models and Validation procedure

I.1 FR2 Channel models

The following channel model is required for FR2 MIMO OTA measurement.

The generic model is Table I.1-1 FR2 UMi CDL-C, which does not include base station antenna filtering. Therefore, in addition, the BS beam filtering effect defined in Annex I.2 also apply when emulating the channel models.

Table I.1-1: Channel model parameters for UMi CDL-C at 28 GHz

Cluster #	Absolute Delay [ns]	Power in [dB]	AOD in [°]	AOA in [°]	ZOD in [°]	ZOA in [°]
1	0	-4.4215	-30.4353	-134.4434	98.9242	83.3318
2	12.594	-1.25	-20.9269	129.1633	99.1915	72.5229
3	13.314	-3.4684	-20.9269	129.1633	99.1915	72.5229
4	13.974	-5.2294	-20.9269	129.1633	99.1915	72.5229
5	13.056	-2.5215	-28.0782	-152.8206	99.5732	71.1282
6	38.196	0	-11.6982	164.1145	99.306	74.7544
7	38.688	-2.2185	-11.6982	164.1145	99.306	74.7544
8	39.36	-3.9794	-11.6982	164.1145	99.306	74.7544
9	39.504	-7.4215	17.3861	84.3647	100.4513	69.2454
10	47.61	-7.1215	-37.5865	92.0623	98.5616	66.7349
11	49.278	-10.7215	20.2226	-97.7585	100.6231	72.0348
12	56.016	-11.1215	-50.6106	78.4702	98.218	64.4337
13	73.71	-5.1215	-33.911	93.1719	100.165	85.4238
14	78.498	-6.8215	-37.5066	-112.0441	100.2604	64.1548
15	130.224	-8.7215	-43.1797	102.4645	98.1225	64.7824
16	162.63	-13.2215	29.2116	67.2359	100.2604	92.467
17	255.534	-13.9215	27.8133	34.5731	98.4852	65.6889
18	276.018	-13.9215	23.6584	48.5813	98.1416	68.7572
19	329.412	-15.8215	-52.5282	36.4455	97.9698	59.1339
20	336.462	-17.1215	25.0168	52.6729	100.7376	65.3402
21	378.39	-16.0215	25.4562	49.8296	98.1225	58.4365
22	398.244	-15.7215	30.7697	46.4316	98.1034	65.2705
23	422.562	-21.6215	35.9234	30.759	100.4513	62.6903
24	519.138	-22.8215	-61.2775	69.2469	100.9476	61.993
Per-Cluster Parameters						
Parameter	CASD in [°]	CASA in [°]	CZSD in [°]	CZSA in [°]	XPR in [dB]	
Value	0.799	10.4021	0.5726	4.8814	7	

I.2 FR2 Base Station beam configuration

The emulated BS beam configuration to be used for emulation of channel model defined in Annex I.1 is specified in this clause.

The Base Station beam configuration includes basic antenna parameters and beamforming characteristic. The basic BS antenna parameters is defined in Table I.2-1.

Table I.2-1: FR2 BS Antenna Parameters

Parameter description	Symbol	Parameter value
		FR2
Antenna panels in vertical dimension	M_g	1
Antenna panels in horizontal dimension	N_g	1
Elements per panel in vertical dimension	M_e	8
Elements per panel in horizontal dimension	N_e	16
Number of polarizations per panel	P	2
Element spacing in horizontal dimension (λ)	d_H	0.5
Element spacing in vertical dimension (λ)	d_V	0.5

Antenna element radiation patterns, including orientation of the element main polarization components as well as orientation of the antenna array are as in the example pattern in Table 7.3-1 of TR 38.901 [5]. The antenna element has $\pm 45^\circ$ polarization components and the radiation pattern parameters are $\theta_{3dB} = 65^\circ$, $\phi_{3dB} = 65^\circ$, $A_{max} = 30dB$, $SLAV = 30dB$, $G_{E,max} = 8$ dBi.

The beamforming characteristic of the FR2 BS pattern is defined as follow:

- A code book of 128 fixed beams is constructed to a grid of eight elevation angles from -25° to $+25^\circ$ with $\sim 7.1^\circ$ step size and 16° azimuth angles from -60° to $+60^\circ$ with 8° step size;
- 1 strongest transmitting beam is generated from BS, the direction of this beam towards the strongest cluster of the FR2 channel model. Specifically, the direction in UMi CDL-C model is: AoD: -12° , ZoD: 100.71.

1.3 FR2 Channel model validation

1.3.1 General

This clause describes the FR2 MIMO OTA validation measurements, in order to ensure that the channel models are correctly implemented and hence capable of generating the propagation environment, as described by the model, within the test zone of the 3D-MPAC system.

The following measurements shall be done for FR2 channel model validation:

- Power Delay Profile (PDP)
- Doppler/Temporal correlation
- PAS similarity percentage (PSP)
- Cross-polarization
- Power validation

Frequencies to be used to test for FR2 channel model validation:

Table I.3.1-1: FR2 Channel model validation frequencies

NR FR2 Bands	Range	Test Frequency (MHz)
n257	Low	27750
n260	High	38500
n258	Low	25875
n261	Low	27925

1.3.2 FR2 Power Delay Profile (PDP)

This measurement checks that the resulting power delay profile (PDP) is in-line with the PDP defined for the channel model. For PDP validation measurement, only Vertical validation is required.

The PDP measurement is performed with a Vector Network Analyser (VNA). An example setup for PDP measurement is shown in Figure I.3.2-1. VNA transmits frequency sweep signals through the NR MIMO OTA test system. A reference antenna, within the centre of the test zone, receives the signal and VNA analyses the frequency response of the system. A number of traces (frequency responses) are measured and recorded by VNA and analysed by a post processing SW, e.g., MATLAB[®]. Special care has to be taken into account to keep the fading conditions unchanged, i.e. frozen, during the short period of time of a single trace measurement. The fading may proceed only in between traces.

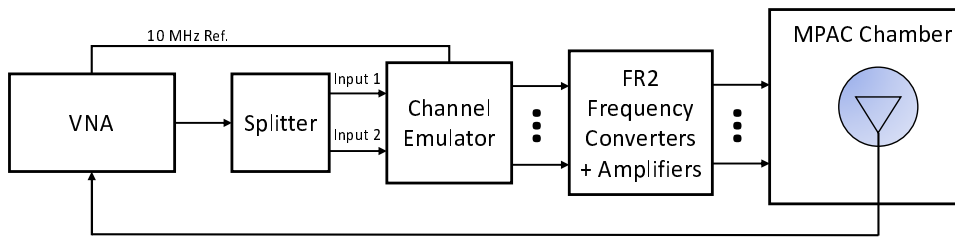

Figure I.3.2-1: Setup for PDP measurements (FR2)

Step the emulation and store traces from VNA. I.e. run the emulation to CIR number 1, pause, measure VNA trace, run the emulation to CIR number 10, pause, measure VNA trace. Continue until 1000 VNA traces are measured.

VNA settings:

Table I.3.2-1: VNA settings for FR2 PDP measurements

Item	Unit	Value
Centre frequency	MHz	Downlink centre frequency in Table I.3.1-1
Span	MHz	200
Number of traces		1000
Number of points		1101
Averaging		1

Channel model specification:

Table I.3.2-2: Channel model specification for FR2 PDP measurements

Item	Unit	Value
Centre frequency	MHz	Downlink centre frequency in Table I.3.1-1
Distance between traces in channel model	wavelength (Note)	> 2
Channel model		As specified in Annex I.1
NOTE: Time [s] = distance [λ] / MS speed [λ/s] MS speed [λ/s] = MS speed [m/s] / Speed of light [m/s] * Centre frequency [Hz]		

Method of measurement result analysis:

Measured VNA traces (frequency responses $H(t,f)$) are saved into a hard drive. The data is read into, e.g., MATLAB®. The analysis is performed by taking the Fourier transform of each trace. The resulting impulse responses $h(t,\tau)$ are averaged in power over time:

$$P(\tau) = \frac{1}{T} \sum_{t=1}^T |h(t, \tau)|^2$$

Finally, the resulting PDP is shifted in delay, such that the first tap is on delay zero.

The detailed PDP reference value for FR2 CDL-C UMi validation are defined in the following table:

Table I.3.2-3: PDP Targets for FR2 CDL-C UMi

Combined Clusters index	Delay(ns)	Power(dB)
1	0	-27.8
2-5	15	-18.3
6-11	40	0.0
13-14	75	-31.2

I.3.3 FR2 Doppler/Temporal correlation

This measurement checks the Doppler/temporal correlation. For Doppler/Temporal correlation validation measurement, only Vertical validation is required.

The Doppler spectrum is measured with a spectrum analyser as shown in Figure I.3.3-1. In this case a signal generator transmits CW signal through the NR MIMO OTA test system. The signal is received by a test antenna within the test area. Finally, the signal is analysed by a spectrum analyser and the measured spectrum is compared to the target spectrum. This setup can be used to measure Doppler Spectrum of the Channel models defined in Annex I.2.

Method of measurement:

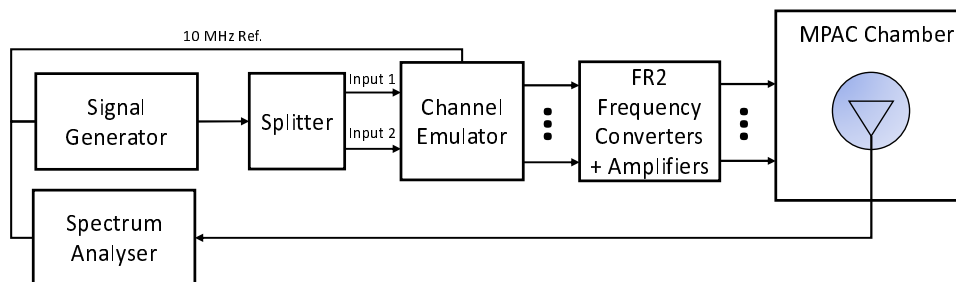

Figure I.3.3-1: Setup for FR2 Doppler measurements

Sine wave (CW, carrier wave) signal is transmitted from the signal generator. The signal is connected from the signal generator to fading emulator via cables. The fading emulator output signals are connected to frequency converter and power amplifier boxes via cables. The amplified signals are then transferred via cables to the probe antennas. The probe antennas radiate the signals over the air to the test antenna. The Doppler spectrum is measured by the spectrum analyser and the trace is saved.

Signal generator settings:

Table I.3.3-1: Signal generator settings for FR2 Doppler/Temporal correlation measurements

Item	Unit	Value
Centre frequency	MHz	Downlink centre frequency in Table I.3.1-1
Modulation		OFF

Spectrum analyser settings:

Table I.3.3-2: Spectrum analyser settings for FR2 Doppler/Temporal correlation measurements

Item	Unit	Value
Centre frequency	MHz	Downlink centre frequency in Table I.3.1-1
Minimum Span	Hz	4 kHz
RBW	Hz	1
VBW	Hz	1
Number of points		16002
Averaging		100

Channel model specification:

Table I.3.3-3: Channel model specification for FR2 Doppler/Temporal correlation measurements

Item	Unit	Value
Centre frequency	MHz	Downlink centre frequency in Table I.3.1-1
Channel model		As specified in Annex I.1
Mobile speed	km/h	12

Method of measurement result analysis: Measurement data file (Doppler power spectrum) is saved into hard drive. The data is read into, e.g., MATLAB®. The analysis is performed by taking the Fourier transformation of the Doppler spectrum. The resulting temporal correlation function $R_r(\Delta t)$ is normalized such that $\max(\text{abs}(R_r(\Delta t)))=1$. Then the function values left from the maximum is cut out. Further on the function values after, e.g. seven periods is cut out.

The detailed Temporal correlation reference value for FR2 CDL-C UMi channel model validation is defined in table I.3.3-4.

Table I.3.3-4: Temporal correlation Targets

Distance [λ]	X2V Corr.	Distance [λ]	X2V Corr.
0	1.0000	2.5	0.1769
0.1	0.9929	2.6	0.1717
0.2	0.9717	2.7	0.1649
0.3	0.9379	2.8	0.1564
0.4	0.8937	2.9	0.1456
0.5	0.8414	3	0.1327
0.6	0.7834	3.1	0.1177
0.7	0.7223	3.2	0.1011
0.8	0.6601	3.3	0.0829
0.9	0.5986	3.4	0.0638
1	0.5387	3.5	0.0449
1.1	0.4817	3.6	0.0272
1.2	0.4284	3.7	0.0121
1.3	0.3796	3.8	0.0023
1.4	0.3362	3.9	0.0079
1.5	0.2984	4	0.0104
1.6	0.2667	4.1	0.0083
1.7	0.2416	4.2	0.0026
1.8	0.2221	4.3	0.0095
1.9	0.2081	4.4	0.0235
2	0.1987	4.5	0.0397
2.1	0.1921	4.6	0.0572
2.2	0.1879	4.7	0.0738
2.3	0.1844	4.8	0.0890
2.4	0.1812	4.9	0.1018
		5	0.1109

Time Domain Alternate Method

Time domain techniques can also be used to validate the temporal correlation. The temporal correlation validation measurement setup is illustrated in Figure I.3.3-2. In this case a Signal generator transmits a CW signal through the MIMO test system. The signal is received by a test antenna within the test area. Finally, the signal is collected by a signal analyser and the measured signal is stored as IQ data format for postprocessing. Depending on CE implementation, the trigger direction between spectrum analyser (SAN) and CE needs to be adjusted, i.e., from SAN to CE or from CE to SAN.

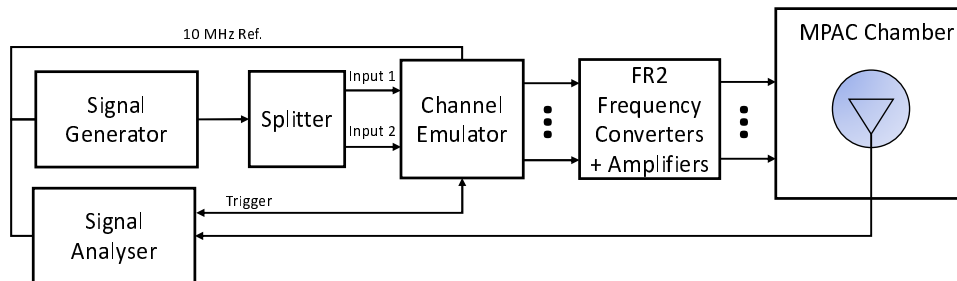

Figure I.3.3-2: Setup for Doppler measurements based on time domain technique

The time domain doppler spectrum is measured by the signal analyser and the trace in IQ format is saved. Follow the same procedure to post process the data and calculate the temporal correlation curve. Data recording is synchronized with the channel emulator trigger.

The settings for the signal analyser are in Table I.3.3-5:

Table I.3.3-5: Signal Analyser Settings

Item	Unit	Value
Centre frequency	MHz	Downlink centre frequency in Table I.3.1-1
Sampling	Hz	At least 15 times bigger than the max Doppler spread ($f_d=v/\lambda$)
Observation time	s	At least 16s. Channel Model length should be the same or greater than the observation time.

I.3.4 FR2 PAS similarity percentage (PSP)

The PSP validation measurements aim at evaluating PAS similarity percentage (PSP), which is one of the validation metrics for characterizing FR2 channel model under test in the quite zone of 3D-MPAC. For PSP validation measurement, only vertical polarization validation is required.

The measurement array is essentially a virtual array configuration realized in 3D-MPAC through a ϕ - θ positioning system. The measurement array is a semi-circle and sector array configuration illustrated in Figure I.3.4-1 where complex channel frequency response is measured at each antenna location 0.5λ apart using a vector network analyser (VNA) setup. The vertical sectors of the measurement array are limited to $60^\circ (\pm 30^\circ)$ and the horizontal sector to $180^\circ (\pm 90^\circ)$ with the broad side direction points towards the probes. Depending of the turntable architecture/implementation, the virtual array configuration for the PSP validation is composed of two alternative semi-circle arrangements (1 x horizontal and either 2 x crossed vertical or 2 x parallel vertical). The radius of the array element locations with respect to the centre of the test zone is 5 cm, which is equivalent to the half of the test zone radius at 28 GHz. For different frequency bands, the radius of the measurement array sector semi-circles remains fixed at 5 cm while the spatial sampling of the array varies. This measurement validates the proper angular behaviour in the test zone.

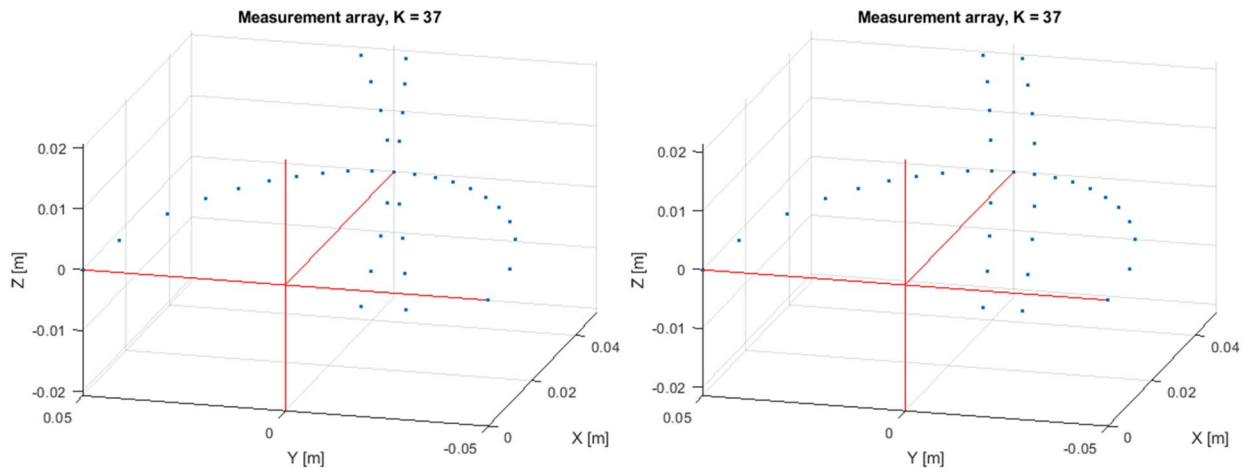

Figure I.3.4-1: Semi-circle measurement array configurations with $K = 37$ elements (at 28 GHz). On the left with two crossed vertical sectors, on the right with two parallel vertical sectors

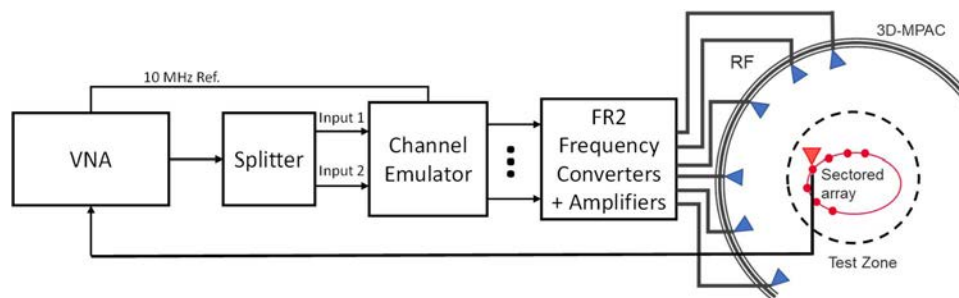

Figure I.3.4-2: Setup for FR2 PSP validation measurements

The PSP validation is measured with a vector network analyser as shown in Figure I.3.4-2 illustrating the PSP measurement setup. Port 1 of the VNA transmits signals through the fading emulator and radiate them through L probes within the anechoic chamber. The radiated signals are then received at the test antenna that is positioned inside the test zone. The test antenna is mounted on a ϕ - θ positioner which is capable of moving the antenna to pre-defined spatial locations on a fixed radius from the centre of the quiet zone according the measurement array configuration. Finally, the signal is received at port 2 of the VNA. The most suitable approach for the PSP validation is based on an omnidirectional antenna (omnidirectional pattern in AZ and wide BW in EL) as the test can be automated easily. Alternatively, a directional antenna could be used but requires frequent re-positioning.

The measurement and analysis procedure are given as follows:

1. Set the target channel model in the Channel Emulator.
2. For each position of the test antenna on the measurement array configuration in the test zone, step & pause the emulator to different time instances. Measure the complex frequency responses $H(f, t) = H(m\Delta f, n\Delta T)$, $m = 0, \dots, M - 1$ for all stepped channel snapshots $n = 0, \dots, N - 1$, where the interval between frequency and time samples is Δf and ΔT , respectively. The number of channel snapshots N and frequency samples M .
3. Move the measurement antenna with a positioner to another location k and repeat step 2 to record frequency responses $H_k(m\Delta f, n\Delta T)$ of all stepped channel snapshots.
4. Repeat step 3 to record frequency responses at all $k = 0, \dots, K$ spatial sample points.
5. Estimate the measured PAS through the following two- stage processing:

- a. In the first stage, calculate the discrete azimuth and elevation angles (DoA) for the measurement array configuration by applying the MUSIC algorithm. Estimate the powers from the DoA and auto-covariance matrix of the received signal acquired through VNA complex frequency response data.
- i) Compose an estimate of the covariance matrix $\mathbf{R}_H \in \mathbb{C}^{K \times K}$. The entry on the k th row and k' th column of \mathbf{R}_H is:

$$R_H(k, k') = \sum_{n=1}^N \sum_{m=1}^M H_k(m\Delta f, n\Delta T) \overline{H_{k'}(m\Delta f, n\Delta T)},$$

where $(\overline{})$ is the complex conjugate operator.

- ii) Compose pseudo-PAS of the chamber environment and channel model using the MUSIC algorithm. The intention of this step is to estimate DoAs of signals radiated by probes. Perform first the eigen decomposition of \mathbf{R}_H and pick the noise-subspace matrix \mathbf{V} . The matrix \mathbf{V} is obtained from the eigen decomposition by removing eigenvectors, i.e. columns that correspond to X strongest eigenvalues, where X is the number of active probes in the MPAC setup. The pseudo-PAS is:

$$P_{\text{MUSIC}}(\beta) = \frac{1}{\boldsymbol{\omega}(\beta) \mathbf{V} \mathbf{V}^H \boldsymbol{\omega}^H(\beta)},$$

where $()^H$ is the matrix Hermitean operator and the near-field array factor of the virtual array composed by K spatial measurement antenna locations is:

$$\boldsymbol{\omega}(\beta) = \frac{\lambda_0}{4\pi \|\vec{r}_k - R \vec{u}(\beta)\|} \exp\left(\frac{j2\pi \|\vec{r}_k - R \vec{u}(\beta)\|}{\lambda_0}\right),$$

where λ_0 is the wavelength at the carrier centre frequency, $\|\|$ is the norm of a vector, \vec{r}_k is a location vector of the k th virtual array element, $\vec{u}(\beta)$ is the unit vector to direction β , and R is the a priori known approximate range length [9]. Both vectors \vec{r}_k and $\vec{u}(\beta)$ are defined with respect to same origin, which is the centre of the test zone.

- iii) Find local maxima of $P_{\text{MUSIC}}(\beta)$ and pick directions $\beta_x, x = 1, \dots, X$ of the X highest peaks.
- iv) Perform Bartlett beamforming as defined in step 6 with the steering vector $\boldsymbol{\omega}(\beta_x)$ (instead of $a(\beta)$) to the X directions identified in iii). The output is X power estimates $P_{\text{est}}(\beta_x)$.
- b. In the second stage, use the angle and power estimates, i.e. the discrete PAS of X azimuth and elevation directions and power values in conjunction with a 4x4 DUT sampling array for beamforming with the conventional Bartlett beamformer to estimate the “measured PAS seen by DUT” for PSP calculation as follows:

$$\hat{P}_o(\beta) = a^H(\beta) \left(\sum_{x=1}^X a(\beta_x) P_{\text{est}}(\beta_x) a^H(\beta_x) \right) a(\beta),$$

where $a(\beta)$ is the array steering vector of the 4x4 DUT array.

6. Evaluate the reference OTA PAS for the 4x4 DUT array by applying the conventional Bartlett beamformer. The theoretical PAS as reference is calculated for the ideal channel model as:

$$\hat{P}_r(\beta) = a^H(\beta) \oint a(\beta') P(\beta') a^H(\beta') d\beta' a(\beta),$$

where $a(\beta)$ is the array steering vector of the 4x4 DUT array and $P(\beta')$ is the PAS of the reference channel model.

7. Calculate total variation distance (D_p) from the reference and measured PAS as follows:

$$D_p = \frac{1}{2} \int \left| \frac{\hat{P}_r(\beta)}{\int \hat{P}_r(\beta') d\beta'} - \frac{\hat{P}_o(\beta)}{\int \hat{P}_o(\beta') d\beta'} \right| d\beta$$

8. Calculate PSP values as $\text{PSP} = (1 - D_p) \times 100\%$.

VNA settings:

Table I.3.4-1: VNA settings for FR2 PSP measurements

Item	Unit	Value
Centre frequency	MHz	Downlink centre frequency in Table I.3.1-1
Span	MHz	0, or the minimum (Note 1)
Number of traces		1000
Number of points		1 (Note 1)
NOTE 1: Span and number of points may be increased to estimate reliably.		

Channel model specification:

Table I.3.4-2: Channel model specification for FR2 PSP measurements

Item	Unit	Value
Centre frequency	MHz	Downlink centre frequency in Table I.3.1-1
Distance between traces in channel model	wavelength (Note)	> 2
Channel model		As specified in Annex I.1
NOTE: Time [s] = distance [λ] / MS speed [λ /s] MS speed [λ /s] = MS speed [m/s] / Speed of light [m/s] * Centre frequency [Hz]		

Time Domain Alternative Method:

PSP validation can also be implemented using time-domain techniques using the testing setup presented in Figure I.3.4-3. The VNA is substituted by a signal generator, and a signal analyser. Depending on CE implementation, the trigger direction between SAN and CE needs to be adjusted, i.e., from SAN to CE or from CE to SAN.

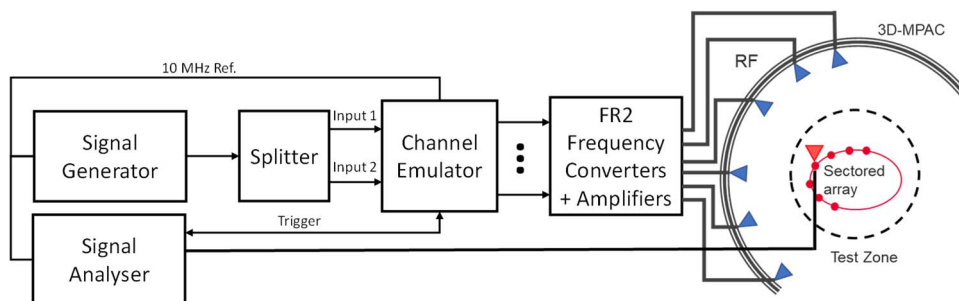

Figure I.3.4-3: Setup for FR2 PSP validation measurements based on time domain

Table I.3.4-3: Signal Generator Settings for FR2 PSP measurements based on time domain

Item	Unit	Value
Centre frequency	MHz	Downlink centre frequency in Table I.3.1-1
Output power	dBm	Function of the CE. Sufficiently above Noise Floor

Table I.3.4-4: Signal Analyser Settings for FR2 PSP measurements based on time domain

Item	Unit	Value
Centre frequency	MHz	Downlink centre frequency in Table I.3.1-1
Sampling	Hz	At least 10 times bigger than the max Doppler spread ($f_d=v/\lambda$)
Observation time	s	At least 32s

The measurement and analysis procedure are given as follows:

Follow the same procedure as before, but M is set to 1. The Channel Emulator is not stepped, but it is allowed to play in free run mode for each of the K spatial points.

1.3.5 FR2 Cross-polarization

This measurement checks how well the measured vertically or horizontally polarized power levels follow expected values. The test setup for cross-polarization is the same as PDP validation in Figure I.3.2-1.

Method of measurement: Step the emulation and store traces from VNA.

VNA settings:

Table I.3.5-1: VNA settings for FR2 cross-polarization

Item	Unit	Value
Centre frequency	MHz	Downlink Centre Frequency in Table I.3.1-1
Span	MHz	40
Number of traces		1000
Number of points		802
Averaging		1

Channel model specification:

Table I.3.5-2: Channel model specification for FR2 cross-polarization

Item	Unit	Value
Centre frequency	MHz	Downlink centre frequency in Table I.3.1-1
Distance between traces in channel model	wavelength (Note)	> 2
Channel model		As specified in Annex I.1
Mobile speed	km/h	30
NOTE: Time [s] = distance [λ] / MS speed [λ /s] MS speed [λ /s] = MS speed [m/s] / Speed of light [m/s] * Centre frequency [Hz]		

Measurement Procedure:

1. Play or step through the channel model listed in Annex I.1.
2. Measure the absolute power received at the centre of the test zone, averaged over a statistically significant number of fades.
 - a. Perform separate V-polarization and H-polarization measurements sequentially, e.g., by rotating a single-polarized horn antenna accordingly or with a use of a dual-polarized horn where the un-used polarization is terminated.
 - b. Measure input 1+2 first and then enable input at a time to measure input 1 and 2 separately
 - c. Disable all CE outputs and enable one output at a time. Get the VNA trace pointing the measurement horn antenna towards the active probe. Record frequency sweeps through the channel model. Repeat for all the probes.
3. Calculate the V/H ratio.
 - Measure VNA traces (frequency responses over time and probes $H_V(t, f, k_V)$ and $H_H(t, f, k_H)$) are saved into a hard drive. The data is read into, e.g., MATLAB®. The frequency responses are summed in power over time t , frequency f and probes k and the V/H ratio calculated as follows:

$$P_V = \sum_t \sum_f \sum_{k_V} |H_V(t, f, k_V)|^2$$

$$P_H = \sum_t \sum_f \sum_{k_H} |H_H(t, f, k_H)|^2$$

$$P_{V/H}[dB] = 10 \log_{10} \left(\frac{P_V}{P_H} \right)$$

4. Compare it with the theory value.

Reference target for FR2 CDL-C UMi:

- V/H FR2 CDL-C-UMi, X2+, fc=28 GHz
- Beam 1, Input 1: V/H = -0.45 dB
- Beam 1, Input 2: V/H = 0.49 dB
- Beam 1, Input 1+2: V/H = 0 dB

I.3.6 FR2 Power validation

This measurement checks the total power in the centre of the test zone. The power validation is measured with a spectrum analyser as shown in Figure I.3.6-1.

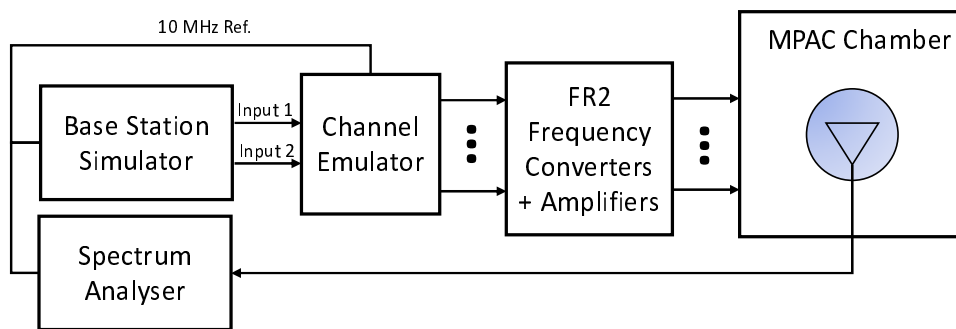

Figure I.3.6-1: Setup for FR2 power validation measurements

Spectrum analyser settings:

Table I.3.6-1: Spectrum analyser settings for FR2 power validation measurements

Item	Unit	Value
Centre frequency	MHz	Downlink centre frequency in Table I.3.1-1
Integrated Channel Span	Hz	20MHz
RBW	Hz	30 kHz
VBW	Hz	≥10MHz
Number of points		≥400
Averaging		≥100
Detector		RMS

Measurement Procedure:

1. Place a horn antenna in the centre of the test zone connected to a spectrum analyser (or power meter) via a cable. Point the horn to the first probe and initially select the V-polarization.
2. Record the cable and horn antenna gains.

3. Load the target channel model into the channel emulator.
4. Start the NR FR2 signalling in the base station emulator with the required parameter identical to the measurements conditions.
5. Disable all CE outputs and enable only the CE output that points towards the active probe with the polarization matching the polarization of the reference horn antenna.
6. Average the power received by the spectrum analyser to get ≥ 100 averages to account for the fading channel.
7. Repeat steps 5 to 6 for all six probe directions and perform separate V and H polarization measurements while matching the polarization of the horn antenna in the centre of the test zone with the polarization of the probe.
8. Calculate the total power received at the test area as the sum of the power over $k = 6$ probes in the two polarizations as follows:

$$P_V = 10 \log_{10} \sum_{k_V} 10^{\left(\frac{P_{k_V}[dB]}{10}\right)}$$

$$P_H = 10 \log_{10} \sum_{k_H} 10^{\left(\frac{P_{k_H}[dB]}{10}\right)}$$

$$P_{total}[dB] = 10 \log_{10} \left[\sum_{k_V} 10^{\left(\frac{P_{k_V}[dB]}{10}\right)} + \sum_{k_H} 10^{\left(\frac{P_{k_H}[dB]}{10}\right)} \right]$$

I.4 Validation Pass/fail limit

I.4.1 General

This clause defines the pass/fail limit of FR2 3D-MPAC system for FR2 channel model validation.

I.4.2 Pass/Fail Criteria of PDP

This clause defines the pass/fail criteria of PDP, this pass/fail limits apply for all FR2 frequency bands.

The detailed pass/fail limits for each cluster of FR2 CDL-C UMi are defined in Table I.4.2-1.

Table I.4.2-1: PDP pass/fail limits for FR2 CDL-C UMi channel model validation

	Power Tolerance	Delay Tolerance
Paths from 0dB to 10dB	± 1 dB	± 6 ns
Paths from 10dB to 30dB	± 5 dB	± 6 ns
Paths from 30dB to 40dB	± 10 dB	± 6 ns

I.4.3 Pass/Fail Criteria of Doppler/Temporal correlation

This clause defines the pass/fail criteria of doppler/temporal correlation validation, this pass/fail limits apply for all FR2 frequency bands.

The pass/fail limits for theoretical temporal correlation defined in Clause I.3.3 above 0.3 are formed as bands of ± 0.1 of correlation capped at 1 at the high end. Additionally, when the theoretical temporal correlation drops below 0.3, the limits are formed at bands of ± 0.3 of correlation capped at 0 at the low end.

Table I.4.3-1: pass/fail limits for temporal correlation

Distance [λ]	X2V Corr.		Distance [λ]	X2V Corr.	
	Lower	Upper		Lower	Upper
0	0.9000	1.0000	2.5	0.0000	0.3000
0.1	0.8929	1.0000	2.6	0.0000	0.3000
0.2	0.8717	1.0000	2.7	0.0000	0.3000
0.3	0.8379	1.0000	2.8	0.0000	0.3000
0.4	0.7937	0.9937	2.9	0.0000	0.3000
0.5	0.7414	0.9414	3	0.0000	0.3000
0.6	0.6834	0.8834	3.1	0.0000	0.3000
0.7	0.6223	0.8223	3.2	0.0000	0.3000
0.8	0.5601	0.7601	3.3	0.0000	0.3000
0.9	0.4986	0.6986	3.4	0.0000	0.3000
1	0.4387	0.6387	3.5	0.0000	0.3000
1.1	0.3817	0.5817	3.6	0.0000	0.3000
1.2	0.3284	0.5284	3.7	0.0000	0.3000
1.3	0.2796	0.4796	3.8	0.0000	0.3000
1.4	0.2362	0.4362	3.9	0.0000	0.3000
1.5	0.1984	0.3984	4	0.0000	0.3000
1.6	0.1667	0.3667	4.1	0.0000	0.3000
1.7	0.1416	0.3416	4.2	0.0000	0.3000
1.8	0.1221	0.3221	4.3	0.0000	0.3000
1.9	0.1081	0.3081	4.4	0.0000	0.3000
2	0.0000	0.3000	4.5	0.0000	0.3000
2.1	0.0000	0.3000	4.6	0.0000	0.3000
2.2	0.0000	0.3000	4.7	0.0000	0.3000
2.3	0.0000	0.3000	4.8	0.0000	0.3000
2.4	0.0000	0.3000	4.9	0.0000	0.3000
			5	0.0000	0.3000

Based on the value defined in Table I.4.3-1, Figure I.4.3-1 shows the pass/fail and reference curve of temporal correlation.

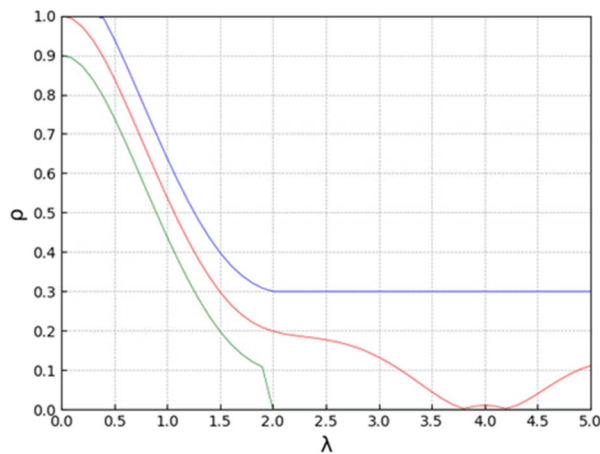

Figure I.4.3-1: Pass/fail limits and targets of Temporal correlation for CDL-C UMi channel model: red curve (reference), blue (upper limit) and green (lower limit)

I.4.4 Pass/Fail Criteria of PSP

This clause defines the pass/fail criteria of PSP, this general pass/fail limits principle apply for all FR2 frequency bands.

The PSP pass/fail limit is specified as 84%.

I.4.5 Pass/Fail Criteria of Cross-polarization

This clause defines the pass/fail criteria of cross-polarization, this pass/fail limits apply for all FR2 frequency bands.

The cross-polarization ratio pass/fail limit is specified as ± 1.5 dB.

I.4.6 Pass/Fail Criteria of Power validation

This clause defines the pass/fail criteria of power validation, this pass/fail limits apply for all FR2 bands.

The power validation pass/fail limit is specified as 1.5 dB.

Annex J (informative): Change history

Change history							
Date	Meeting	TDoc	CR	Rev	Cat	Subject/Comment	New version
2022-11	RAN5#97	R5-227308	-	-	-	Initial Skeleton	0.0.1
2023-03	RAN5#98	R5-230842 R5-230843 R5-230844 R5-231803 R5-230847 R5-230848 R5-231804	-	-	-	Implementation of pCRs into TS 38.551 V0.1.0	0.1.0
2023-05	RAN5#99	R5-232699 R5-232701 R5-232702 R5-232703 R5-232704	-	-	-	Implementation of pCRs into TS 38.551 V0.2.0	0.2.0
2023-08	RAN5#100	R5-234597 R5-234598 R5-234599 R5-234600 R5-234601 R5-234602 R5-234603 R5-234604	-	-	-	Implementation of pCRs into TS 38.551 V0.3.0	0.3.0
2023-11	RAN5#101	R5-237844 R5-237846 R5-236788 R5-237845	-	-	-	Implementation of pCRs into TS 38.551 V0.4.0	0.4.0
2023-12	RAN#102	RP-233639	-	-	-	presented at RAN#102 for 1-step approval	1.0.0
2023-12	RAN#102	-	-	-	-	put under revision control as v17.0.0 with small editorial changes	17.0.0
2024-03	RAN5#102	R5-240598	0002	-	F	Correction and alignment of Annex B title	17.1.0
2024-03	RAN5#102	R5-240599	0003	-	F	Further clarifications in Annex A such as MPAC description and coordinate system	17.1.0
2024-03	RAN5#102	R5-241416	0009	-	F	Add missing abbreviations	17.1.0
2024-03	RAN5#102	R5-241934	0001	1	F	Introduce Annex for maximum uncertainty of test system and test tolerance	17.1.0
2024-03	RAN5#102	R5-241935	0004	1	F	Align Test Case Structure to typical RAN5 spec	17.1.0
2024-03	RAN5#102	R5-241936	0005	1	F	Editorial update on Annex C	17.1.0
2024-03	RAN5#102	R5-241937	0006	1	F	Editorial update on Annex E	17.1.0
2024-03	RAN5#102	R5-241938	0007	1	F	Editorial update on clause 3	17.1.0
2024-03	RAN5#102	R5-241939	0008	1	F	Editorial update on clause 4	17.1.0
2024-06	RAN5#103	R5-243227	0011	-	F	CR to TS 38.551 on Annex C, editorial	17.2.0
2024-06	RAN5#103	R5-243230	0012	-	F	CR to TS 38.551 on Annex G, editorial	17.2.0
2024-06	RAN5#103	R5-243232	0013	-	F	CR to TS 38.551 on EUT positioning	17.2.0
2024-06	RAN5#103	R5-243233	0014	-	F	CR to TS 38.551 on section 6.1.2	17.2.0
2024-06	RAN5#103	R5-243312	0015	-	F	Clarification of Calibration and Ripple Test Procedures	17.2.0
2024-06	RAN5#103	R5-243313	0016	-	F	Clarification of Channel Model Coordinate System and Probe Placement	17.2.0
2024-06	RAN5#103	R5-243800	0010	1	F	CR to TS 38.551 on Annex A.2.3	17.2.0
2024-09	RAN#105	R5-244445	0018	-	F	Clarification of voltage environmental requirement	17.3.0
2024-09	RAN#105	R5-245428	0021	-	F	On General and frequency Bands update	18.0.0
2024-09	RAN#105	R5-245429	0022	-	F	On FR2 gNB configurations update	18.0.0
2024-09	RAN#105	R5-245430	0023	-	F	On FR1 estimation of MU update	18.0.0
2024-09	RAN#105	R5-245432	0025	-	F	On FR2 Test methodology	18.0.0
2024-09	RAN#105	R5-245433	0026	-	F	On MU of FR2 3D-MPAC system	18.0.0
2024-09	RAN#105	R5-245437	0028	-	F	On FR2 Channel models	18.0.0
2024-09	RAN#105	R5-245999	0020	1	F	On scope, references, terms and abbreviations update	18.0.0
2024-09	RAN#105	R5-246001	0024	1	F	On FR2 MIMO OTA requirements	18.0.0
2024-09	RAN#105	R5-246002	0027	1	F	On environmental requirements update	18.0.0
2024-12	RAN#106	R5-246533	0029	-	F	Correction of CM Validation Setups	18.1.0
2024-12	RAN#106	R5-247415	0033	-	F	On 38.551 Annex D	18.1.0
2024-12	RAN#106	R5-247416	0034	-	F	On 38.551 Annex I	18.1.0
2024-12	RAN#106	R5-247419	0036	-	F	On 38.551 MASC	18.1.0
2024-12	RAN#106	R5-247420	0037	-	F	On 38.551 Operating bands	18.1.0
2024-12	RAN#106	R5-247423	0039	-	F	On 38.551 TRMS	18.1.0
2024-12	RAN#106	R5-247967	0031	1	F	Device Positioning for FR2 MIMO OTA Testing	18.1.0
2024-12	RAN#106	R5-247968	0032	1	F	On 38.551 Annex C	18.1.0
2024-12	RAN#106	R5-247969	0035	1	F	On 38.551 Definition of terms	18.1.0
2024-12	RAN#106	R5-248007	0030	1	F	Charging Cable Verification Procedure	18.1.0
2025-03	RAN#107	R5-251725	0040	1	F	On Annex A.4, Reference coordinate system	18.2.0
2025-03	RAN#107	R5-251726	0041	1	F	On Annex C.3.5, FR1 Cross-Polarization	18.2.0
2025-03	RAN#107	R5-251727	0042	1	F	On Annex C.3.6, FR1 Power validation	18.2.0
2025-03	RAN#107	R5-251728	0043	1	F	On Annex D.2, FR2 gNB configurations	18.2.0
2025-03	RAN#107	R5-251729	0044	1	F	On Annex I.3.2, FR2 Power Delay Profile (PDP)	18.2.0

2025-03	RAN#107	R5-251730	0045	1	F	On Annex I.3.3, FR2 Doppler/Temporal correlation	18.2.0
2025-03	RAN#107	R5-251731	0046	1	F	On clause 7 FR2 MIMO OTA requirements	18.2.0
2025-03	RAN#107	R5-251732	0048	1	F	On clause 3.3 Abbreviations	18.2.0
2025-03	RAN#107	R5-251759	0047	2	F	On FR2 MIMO OTA tests with cable	18.2.0
2025-06	RAN#108	R5-252247	0050	-	F	Correction of SCF CM Validation Frequency for n3 and corresponding reference values and limits	18.3.0
2025-06	RAN#108	R5-252817	0053	-	F	On FR2 MIMO OTA requirements	18.3.0
2025-06	RAN#108	R5-252819	0054	-	F	On NR MIMO OTA Scope	18.3.0
2025-06	RAN#108	R5-252820	0055	-	F	On NR MIMO OTA Test Tolerance	18.3.0
2025-06	RAN#108	R5-252821	0056	-	F	On Operating Bands	18.3.0
2025-06	RAN#108	R5-252823	0057	-	F	On Terms and Abbreviations	18.3.0
2025-06	RAN#108	R5-252824	0058	-	F	On TRMS TT	18.3.0
2025-06	RAN#108	R5-253608	0052	1	F	On FR2 MIMO OTA MU	18.3.0
2025-06	RAN#108	R5-253609	0051	1	F	On FR1 Minimum Conformance Requirements	18.3.0
2025-09	RAN#109	R5-254050	0059	-	F	Correction of Test Equipment Reference	18.4.0
2025-12	RAN#110	R5-256480	0060	-	F	Editorial clarifications on FR1 and FR2 gNB configurations	18.5.0
2025-12	RAN#110	R5-256481	0061	-	F	Editorial correction on clause Operating voltage	18.5.0
2025-12	RAN#110	R5-256483	0062	-	F	Editorial updates on 38.551 clause General	18.5.0
2025-12	RAN#110	R5-256484	0063	-	F	Editorial updates on 38.551 References	18.5.0
2025-12	RAN#110	R5-256485	0064	-	F	On MU budget clarification of FR1 MPAC system	18.5.0
2025-12	RAN#110	R5-256486	0065	-	F	On Reference coordinate system clarifications	18.5.0
2026-03	RAN#111	R5-260675	0066	-	F	Clarification of Re-Positioning Concept for FR2 MIMO OTA	18.6.0
2026-03	RAN#111	R5-261571	0067	1	F	Editorial CR on FR2 PAS similarity percentage PSP	18.6.0

History

Version	Date	Status
V18.0.0	October 2024	Publication
V18.1.0	January 2025	Publication
V18.2.0	April 2025	Publication
V18.3.0	July 2025	Publication
V18.4.0	October 2025	Publication
V18.5.0	February 2026	Publication
V18.6.0	April 2026	Publication