

# ETSI TS 138 508-1 V17.9.0 (2023-08)



**LTE;  
5G;  
5GS;  
User Equipment (UE) conformance specification;  
Part 1: Common test environment  
(3GPP TS 38.508-1 version 17.9.0 Release 17)**



---

**Reference**

RTS/TSGR-0538508-1vh90

---

**Keywords**

5G,LTE

**ETSI**

650 Route des Lucioles  
F-06921 Sophia Antipolis Cedex - FRANCE

---

Tel.: +33 4 92 94 42 00 Fax: +33 4 93 65 47 16

Siret N° 348 623 562 00017 - APE 7112B  
Association à but non lucratif enregistrée à la  
Sous-Préfecture de Grasse (06) N° w061004871

---

**Important notice**

---

The present document can be downloaded from:

<https://www.etsi.org/standards-search>

The present document may be made available in electronic versions and/or in print. The content of any electronic and/or print versions of the present document shall not be modified without the prior written authorization of ETSI. In case of any existing or perceived difference in contents between such versions and/or in print, the prevailing version of an ETSI deliverable is the one made publicly available in PDF format at [www.etsi.org/deliver](http://www.etsi.org/deliver).

Users of the present document should be aware that the document may be subject to revision or change of status.

Information on the current status of this and other ETSI documents is available at

<https://portal.etsi.org/TB/ETSIDeliverableStatus.aspx>

If you find errors in the present document, please send your comment to one of the following services:

<https://portal.etsi.org/People/CommitteeSupportStaff.aspx>

If you find a security vulnerability in the present document, please report it through our  
Coordinated Vulnerability Disclosure Program:

<https://www.etsi.org/standards/coordinated-vulnerability-disclosure>

---

**Notice of disclaimer & limitation of liability**

---

The information provided in the present deliverable is directed solely to professionals who have the appropriate degree of experience to understand and interpret its content in accordance with generally accepted engineering or other professional standard and applicable regulations.

No recommendation as to products and services or vendors is made or should be implied.

No representation or warranty is made that this deliverable is technically accurate or sufficient or conforms to any law and/or governmental rule and/or regulation and further, no representation or warranty is made of merchantability or fitness for any particular purpose or against infringement of intellectual property rights.

In no event shall ETSI be held liable for loss of profits or any other incidental or consequential damages.

Any software contained in this deliverable is provided "AS IS" with no warranties, express or implied, including but not limited to, the warranties of merchantability, fitness for a particular purpose and non-infringement of intellectual property rights and ETSI shall not be held liable in any event for any damages whatsoever (including, without limitation, damages for loss of profits, business interruption, loss of information, or any other pecuniary loss) arising out of or related to the use of or inability to use the software.

---

**Copyright Notification**

---

No part may be reproduced or utilized in any form or by any means, electronic or mechanical, including photocopying and microfilm except as authorized by written permission of ETSI.

The content of the PDF version shall not be modified without the written authorization of ETSI.

The copyright and the foregoing restriction extend to reproduction in all media.

© ETSI 2023.  
All rights reserved.

---

## Intellectual Property Rights

### Essential patents

IPRs essential or potentially essential to normative deliverables may have been declared to ETSI. The declarations pertaining to these essential IPRs, if any, are publicly available for **ETSI members and non-members**, and can be found in ETSI SR 000 314: "*Intellectual Property Rights (IPRs); Essential, or potentially Essential, IPRs notified to ETSI in respect of ETSI standards*", which is available from the ETSI Secretariat. Latest updates are available on the ETSI Web server (<https://ipr.etsi.org/>).

Pursuant to the ETSI Directives including the ETSI IPR Policy, no investigation regarding the essentiality of IPRs, including IPR searches, has been carried out by ETSI. No guarantee can be given as to the existence of other IPRs not referenced in ETSI SR 000 314 (or the updates on the ETSI Web server) which are, or may be, or may become, essential to the present document.

### Trademarks

The present document may include trademarks and/or tradenames which are asserted and/or registered by their owners. ETSI claims no ownership of these except for any which are indicated as being the property of ETSI, and conveys no right to use or reproduce any trademark and/or tradename. Mention of those trademarks in the present document does not constitute an endorsement by ETSI of products, services or organizations associated with those trademarks.

**DECT™**, **PLUGTESTS™**, **UMTS™** and the ETSI logo are trademarks of ETSI registered for the benefit of its Members. **3GPP™** and **LTE™** are trademarks of ETSI registered for the benefit of its Members and of the 3GPP Organizational Partners. **oneM2M™** logo is a trademark of ETSI registered for the benefit of its Members and of the oneM2M Partners. **GSM®** and the GSM logo are trademarks registered and owned by the GSM Association.

---

## Legal Notice

This Technical Specification (TS) has been produced by the ETSI 3rd Generation Partnership Project (3GPP).

The present document may refer to technical specifications or reports using their 3GPP identities. These shall be interpreted as being references to the corresponding ETSI deliverables.

The cross reference between 3GPP and ETSI identities can be found under <https://webapp.etsi.org/key/queryform.asp>.

---

## Modal verbs terminology

In the present document "**shall**", "**shall not**", "**should**", "**should not**", "**may**", "**need not**", "**will**", "**will not**", "**can**" and "**cannot**" are to be interpreted as described in clause 3.2 of the [ETSI Drafting Rules](#) (Verbal forms for the expression of provisions).

"**must**" and "**must not**" are **NOT** allowed in ETSI deliverables except when used in direct citation.

# Contents

Intellectual Property Rights .....	2
Legal Notice .....	2
Modal verbs terminology.....	2
Foreword.....	29
1 Scope .....	30
2 References .....	30
3 Definitions, symbols and abbreviations .....	32
3.1 Definitions .....	32
3.2 Symbols.....	32
3.3 Abbreviations .....	33
4 Common test environments.....	33
4.1 Environmental conditions.....	33
4.1.1 Temperature.....	33
4.1.2 Voltage.....	34
4.2 Common requirements of test equipment.....	34
4.2.1 General functional requirements.....	34
4.2.2 Minimum functional requirements .....	35
4.2.2.1 Supported Cell Configuration .....	35
4.2.2.1.1 Supported Channels for an E-UTRA cell (NSA mode only).....	36
4.2.2.1.2 Supported Channels for a NR cell .....	36
4.2.2.1.2.1 Logical channels .....	36
4.2.2.1.2.2 Transport channels.....	36
4.2.2.1.2.3 Physical channels.....	36
4.2.2.1.2.4 Physical signals.....	36
4.3 Reference test conditions.....	37
4.3.1 Test frequencies .....	37
4.3.1.0 General.....	37
4.3.1.0A Mid test channel bandwidth .....	37
4.3.1.0B Low test channel bandwidth.....	40
4.3.1.0C High test channel bandwidth.....	42
4.3.1.0D Bandwidth part.....	45
4.3.1.0E Void.....	46
4.3.1.1 Test frequencies for NR operating bands in FR1 .....	47
4.3.1.1.1 NR operating bands in FR1 .....	47
4.3.1.1.1.1 Reference test frequencies for NR operating band n1.....	47
4.3.1.1.1.2 Reference test frequencies for NR operating band n2.....	54
4.3.1.1.1.3 Reference test frequencies for NR operating band n3.....	58
4.3.1.1.1.4 FFS.....	66
4.3.1.1.1.5 Reference test frequencies for NR operating band n5.....	66
4.3.1.1.1.6 FFS.....	69
4.3.1.1.1.7 Reference test frequencies for NR operating band n7.....	69
4.3.1.1.1.8 Reference test frequencies for NR operating band n8.....	74
4.3.1.1.1.9 to .....	
4.3.1.1.1.11 .....	FFS
.....	77
4.3.1.1.1.12 Reference test frequencies for NR operating band n12.....	77
4.3.1.1.1.13 Reference test frequencies for NR operating band n13.....	80
4.3.1.1.1.14 Reference test frequencies for NR operating band n14.....	81
4.3.1.1.1.15 to .....	
4.3.1.1.1.19 .....	FFS
.....	83
4.3.1.1.1.20 Reference test frequencies for NR operating band n20.....	83

4.3.1.1.1.21 to	4.3.1.1.1.23 .....	FFS
	.....	86
4.3.1.1.1.24	Reference test frequencies for NR operating band n24.....	86
4.3.1.1.1.25	Reference test frequencies for NR operating band n25.....	88
4.3.1.1.1.26	Reference test frequencies for NR operating band n26.....	92
4.3.1.1.1.27	FFS.....	95
4.3.1.1.1.28	Reference test frequencies for NR operating band n28.....	95
4.3.1.1.1.29	Reference test frequencies for NR operating band n29 (SDL) .....	101
4.3.1.1.1.30	Reference test frequencies for NR operating band n30.....	102
4.3.1.1.1.31 to	4.3.1.1.1.33 .....	FFS
	.....	103
4.3.1.1.1.34	Reference test frequencies for NR operating band n34.....	103
4.3.1.1.1.35 to	4.3.1.1.1.37 .....	FFS
	.....	105
4.3.1.1.1.38	Reference test frequencies for NR operating band n38.....	105
4.3.1.1.1.39	Reference test frequencies for NR operating band n39.....	109
4.3.1.1.1.40	Reference test frequencies for NR operating band n40.....	112
4.3.1.1.1.41	Reference test frequencies for NR operating band n41.....	116
4.3.1.1.1.42 to	4.3.1.1.1.45 .....	FFS
	.....	121
4.3.1.1.1.46	Reference test frequencies for NR operating band n46.....	121
4.3.1.1.1.47	FFS.....	124
4.3.1.1.1.48	Reference test frequencies for NR operating band n48.....	124
4.3.1.1.1.49	FFS.....	129
4.3.1.1.1.50	Reference test frequencies for NR operating band n50.....	129
4.3.1.1.1.51	Reference test frequencies for NR operating band n51.....	132
4.3.1.1.1.52	FFS.....	133
4.3.1.1.1.53	Reference test frequencies for NR operating band n53.....	133
4.3.1.1.1.54 to	4.3.1.1.1.64 .....	FFS
	.....	135
4.3.1.1.1.65	Reference test frequencies for NR operating band n65.....	135
4.3.1.1.1.66	Reference test frequencies for NR operating band n66.....	138
4.3.1.1.1.67 –	4.3.1.1.1.69 .....	FFS
	.....	151
4.3.1.1.1.70	Reference test frequencies for NR operating band n70.....	151
4.3.1.1.1.71	Reference test frequencies for NR operating band n71.....	159
4.3.1.1.1.72 – 4.3.1.1.1.73	.....	162
4.3.1.1.1.74	Reference test frequencies for NR operating band n74.....	162
4.3.1.1.1.75	Reference test frequencies for NR operating band n75 (SDL) .....	165
4.3.1.1.1.76	Reference test frequencies for NR operating band n76 (SDL) .....	167
4.3.1.1.1.77	Reference test frequencies for NR operating band n77.....	168
4.3.1.1.1.78	Reference test frequencies for NR operating band n78.....	172
4.3.1.1.1.79	Reference test frequencies for NR operating band n79.....	177
4.3.1.1.1.80	Reference test frequencies for NR operating band n80 (SUL) .....	181
4.3.1.1.1.81	Reference test frequencies for NR operating band n81 (SUL) .....	182
4.3.1.1.1.82	Reference test frequencies for NR operating band n82 (SUL) .....	183
4.3.1.1.1.83	Reference test frequencies for NR operating band n83 (SUL) .....	183
4.3.1.1.1.84	Reference test frequencies for NR operating band n84 (SUL) .....	184
4.3.1.1.1.85	FFS.....	186
4.3.1.1.1.86	Reference test frequencies for NR operating band n86 (SUL) .....	186
4.3.1.1.1.87 to	4.3.1.1.1.90 .....	FFS
	.....	187
4.3.1.1.1.91	Reference test frequencies for NR operating band n91.....	187
4.3.1.1.1.92	Reference test frequencies for NR operating band n92.....	188
4.3.1.1.1.93	Reference test frequencies for NR operating band n93.....	191

4.3.1.1.1.94	Reference test frequencies for NR operating band n94.....	192
4.3.1.1.1.95	Reference test frequencies for NR operating band n95 (SUL) .....	195
4.3.1.1.1.96	Reference test frequencies for NR operating band n96.....	196
4.3.1.1.1.97	Reference test frequencies for NR operating band n97 (SUL) .....	198
4.3.1.1.1.98	FFS.....	200
4.3.1.1.1.99	Reference test frequencies for NR operating band n99 (SUL) .....	200
4.3.1.1.2	NR inter-band CA configurations in FR1 .....	204
4.3.1.1.2.1	NR inter-band CA configurations in FR1 (two bands) .....	204
4.3.1.1.2.2	NR inter-band CA configurations in FR1 (three bands) .....	207
4.3.1.1.3	NR intra-band contiguous CA in FR1 .....	209
4.3.1.1.3.1 –		
	4.3.1.1.3.39 .....	FFS
	.....	209
4.3.1.1.3.40	NR Intra-band contiguous configurations CA_n40 .....	209
4.3.1.1.3.40.1	CA_n40B .....	209
4.3.1.1.3.41	NR Intra-band contiguous configurations CA_n41 .....	210
4.3.1.1.3.41.1	CA_n41C .....	211
4.3.1.1.3.42 –		
	4.3.1.1.3.47 .....	FFS
	.....	219
4.3.1.1.3.48	NR Intra-band contiguous configurations CA_n48 .....	219
4.3.1.1.3.48.1	CA_n48B .....	219
4.3.1.1.3.49 –		
	4.3.1.1.3.65 .....	FFS
	.....	245
4.3.1.1.3.66	NR Intra-band contiguous configurations CA_n66 .....	245
4.3.1.1.3.66.1	CA_n66B .....	245
4.3.1.1.3.67 –		
	4.3.1.1.3.76 .....	FFS
	.....	258
4.3.1.1.3.77	NR Intra-band contiguous configurations CA_n77 .....	258
4.3.1.1.3.77.1	CA_n77C .....	258
4.3.1.1.3.78	NR Intra-band contiguous configurations CA_n78 .....	275
4.3.1.1.3.78.1	CA_n78C .....	275
4.3.1.1.3.78.2	CA_n78B .....	281
4.3.1.1.4	Void.....	285
4.3.1.1.5	NR intra-band non-contiguous CA configurations in FR1 .....	285
4.3.1.1.5.1 –		
	4.3.1.1.5.47 .....	FFS
	.....	285
4.3.1.1.5.48	CA_n48(2A) .....	285
4.3.1.1.5.66	CA_n66(2A) .....	289
4.3.1.1.5.67 –		
	4.3.1.1.5.70 .....	FFS
	.....	297
4.3.1.1.5.71	CA_n71(2A) .....	297
4.3.1.1.5.77	CA_n77(2A) .....	298
4.3.1.1.6	NR Operating SUL band combinations in FR1 .....	307
4.3.1.1.7	NR inter-band NR-DC configurations in FR1 .....	308
4.3.1.1.7.1	NR inter-band NR-DC configurations in FR1 (two bands) .....	308
4.3.1.2	Test frequencies for NR operating bands in FR2 .....	309
4.3.1.2.1	NR operating bands in FR2 .....	309
4.3.1.2.1.1	Reference test frequencies for NR operating band n257.....	309
4.3.1.2.1.2	Reference test frequencies for NR operating band n258.....	310
4.3.1.2.1.3	Reference test frequencies for NR operating band n259.....	311
4.3.1.2.1.4	Reference test frequencies for NR operating band n260.....	313
4.3.1.2.1.5	Reference test frequencies for NR operating band n261.....	314
4.3.1.2.2	NR inter-band CA configurations in FR2.....	315
4.3.1.2.3	NR intra-band contiguous CA configurations in FR2 .....	315
4.3.1.2.3.1	NR Intra-band contiguous CA configurations for CA_n257 .....	315
4.3.1.2.3.1.1	CA_n257B.....	315
4.3.1.2.3.1.2	CA_n257C.....	316

4.3.1.2.3.1.3	CA_n257D .....	317
4.3.1.2.3.1.4	CA_n257E .....	317
4.3.1.2.3.1.5	CA_n257F .....	318
4.3.1.2.3.1.6	CA_n257G .....	318
4.3.1.2.3.1.7	CA_n257H .....	320
4.3.1.2.3.1.8	CA_n257I .....	323
4.3.1.2.3.1.9	CA_n257J .....	326
4.3.1.2.3.1.10	CA_n257K .....	327
4.3.1.2.3.1.11	CA_n257L .....	328
4.3.1.2.3.1.12	CA_n257M .....	329
4.3.1.2.3.2.3	CA_n258D .....	331
4.3.1.2.3.2.4	CA_n258E .....	333
4.3.1.2.3.2.5	CA_n258F .....	333
4.3.1.2.3.2.6	CA_n258G .....	333
4.3.1.2.3.2.7	CA_n258H .....	335
4.3.1.2.3.2.8	CA_n258I .....	336
4.3.1.2.3.2.9	CA_n258J .....	336
4.3.1.2.3.2.10	CA_n258K .....	337
4.3.1.2.3.2.11	CA_n258L .....	337
4.3.1.2.3.2.12	CA_n258M .....	337
4.3.1.2.3.3	FFS .....	337
4.3.1.2.3.4	NR Intra-band contiguous CA configurations for CA_n260 .....	337
4.3.1.2.3.4.1	CA_n260B .....	337
4.3.1.2.3.4.2	CA_n260C .....	337
4.3.1.2.3.4.3	CA_n260D .....	338
4.3.1.2.3.4.4	CA_n260E .....	338
4.3.1.2.3.4.5	CA_n260F .....	339
4.3.1.2.3.4.6	CA_n260G .....	339
4.3.1.2.3.4.7	CA_n260H .....	340
4.3.1.2.3.4.8	CA_n260I .....	342
4.3.1.2.3.4.9	CA_n260J .....	344
4.3.1.2.3.4.10	CA_n260K .....	347
4.3.1.2.3.4.11	CA_n260L .....	351
4.3.1.2.3.4.12	CA_n260M .....	357
4.3.1.2.3.4.13	CA_n260O .....	362
4.3.1.2.3.4.14	CA_n260P .....	363
4.3.1.2.3.4.15	CA_n260Q .....	364
4.3.1.2.3.5	NR Intra-band contiguous CA configurations for CA_n261 .....	364
4.3.1.2.3.5.1	CA_n261B .....	364
4.3.1.2.3.5.2	CA_n261C .....	364
4.3.1.2.3.5.3	CA_n261D .....	365
4.3.1.2.3.5.4	CA_n261E .....	366
4.3.1.2.3.5.5	CA_n261F .....	366
4.3.1.2.3.5.6	CA_n261G .....	366
4.3.1.2.3.5.7	CA_n261H .....	368
4.3.1.2.3.5.8	CA_n261I .....	370
4.3.1.2.3.5.9	CA_n261J .....	372
4.3.1.2.3.5.10	CA_n261K .....	374
4.3.1.2.3.5.11	CA_n261L .....	374
4.3.1.2.3.5.12	CA_n261M .....	374
4.3.1.2.3.5.13	CA_n261O .....	378
4.3.1.2.3.5.14	CA_n261P .....	379
4.3.1.2.3.5.15	CA_n261Q .....	380
4.3.1.2.4	NR intra-band non-contiguous CA configurations in FR2 .....	380
4.3.1.2.4.1	NR Intra-band non-contiguous CA configurations for CA_n257 .....	380
4.3.1.2.4.2	NR Intra-band non-contiguous CA configurations for CA_n258 .....	380
4.3.1.2.4.3	FFS .....	380
4.3.1.2.4.4	NR Intra-band non-contiguous CA configurations for CA_n260 .....	380
4.3.1.2.4.4.1	CA_n260(XA) .....	380
4.3.1.2.4.4.2	CA_n260(A-I) .....	380
4.3.1.2.4.5	NR Intra-band non-contiguous CA configurations for CA_n261 .....	381
4.3.1.2.4.5.1	CA_n261(XA) .....	381

4.3.1.3	Test frequencies for NR band combinations between FR1 and FR2.....	381
4.3.1.3.1	NR inter-band CA configurations between FR1 and FR2.....	381
4.3.1.3.2	Inter-band NR-DC configurations between FR1 and FR2 .....	382
4.3.1.3.2.1	NR-DC configurations between FR1 and FR2 (two bands).....	382
4.3.1.4	Test frequencies for EN-DC band combinations within FR1.....	383
4.3.1.4.1	Inter-band EN-DC configurations within FR1 .....	383
4.3.1.4.1.1	General.....	383
4.3.1.4.1.2	Inter-band EN-DC configurations within FR1 (two bands).....	384
4.3.1.4.1.3	Inter-band EN-DC configurations within FR1 (three bands).....	388
4.3.1.4.1.4	Inter-band EN-DC configurations within FR1 (four bands).....	395
4.3.1.4.1.6	Inter-band EN-DC configurations within FR1 (six bands).....	407
4.3.1.4.2	Intra-band contiguous EN-DC configurations within FR1 .....	408
4.3.1.4.2.1 –		
	4.3.1.4.2.40 .....	FFS
	.....	408
4.3.1.4.2.41	Intra-band contiguous EN-DC configurations DC_(n)41 .....	408
4.3.1.4.2.41.1	DC_(n)41AA.....	408
4.3.1.4.2.41.2	DC_(n)41CA.....	417
4.3.1.4.2.42.to 4.3.1.4.2.70	FFS.....	424
4.3.1.4.2.71.1	DC_(n)71AA.....	424
4.3.1.4.3	Intra-band non-contiguous EN-DC configurations within FR1.....	432
4.3.1.4.3.1 –		
	4.3.1.4.3.40.....	FFS
	.....	432
4.3.1.4.3.41	Intra-band non-contiguous EN-DC configurations DC_41_n41 .....	432
4.3.1.4.3.41.1	DC_41A_n41A.....	432
4.3.1.4.3.41.2	DC_41C_n41A.....	432
4.3.1.4a	Test frequencies for NE-DC band combinations within FR1.....	433
4.3.1.4a.1	Inter-band NE-DC configurations within FR1 .....	433
4.3.1.5	Test frequencies for EN-DC band combinations including FR2.....	434
4.3.1.5.1	Inter-band EN-DC configurations including FR2 .....	434
4.3.1.6	Test frequencies for EN-DC band combinations including FR1 and FR2 .....	473
4.3.1.6.1	Inter-band EN-DC configurations including FR1 and FR2 .....	473
4.3.1.7	Test frequencies for Non-3GPP Access .....	477
4.3.1.7.1	WLAN Test frequencies.....	477
4.3.1.7.2	Bluetooth Test frequencies .....	477
4.3.1.8	Test frequencies for NR Sidelink operating bands.....	477
4.3.1.8.1	Test frequencies for NR Sidelink operating bands in FR1 .....	477
4.3.1.8.2	Test frequencies for concurrent NR sidelink operation .....	478
4.3.1.9	Test frequencies for NR NTN operating bands.....	478
4.3.1.9.1	NR NTN operating bands .....	478
4.3.2	Radio conditions .....	485
4.3.2.1	FR1, normal propagation condition for connected.....	485
4.3.2.2	FR2, condition for OTA.....	485
4.3.3	Physical channel allocations .....	485
4.3.3.1	E-UTRA.....	485
4.3.3.2	NR.....	485
4.3.3.2.1	Antennas .....	485
4.3.3.2.2	Downlink physical channels and physical signals.....	485
4.3.3.2.3	Mapping of downlink physical channels and signals to physical resources .....	486
4.3.4	Signal levels.....	486
4.3.4.1	Signal levels for conducted testing.....	486
4.3.4.1.1	Downlink signal levels .....	486
4.3.4.2	Signal levels for OTA testing.....	486
4.3.5	Standard test signals.....	486
4.3.6	Physical layer parameters .....	486
4.3.6.1	Downlink physical layer parameters .....	486
4.3.6.1.1	Physical layer parameters for scheduling of PUSCH .....	486
4.3.6.1.1.1	Physical layer parameters for DCI format 0_0.....	486
4.3.6.1.1.2	Physical layer parameters for DCI format 0_1.....	487
4.3.6.1.1.3	Physical layer parameters for DCI format 0_2.....	488
4.3.6.1.2	Physical layer parameters for scheduling of PDSCH.....	490



4.3.6.1.2.1	Physical layer parameters for DCI format 1_0.....	490
4.3.6.1.2.2	Physical layer parameters for DCI format 1_1.....	491
4.3.6.1.2.3	Physical layer parameters for DCI format 1_2.....	493
4.3.6.1.3	Void.....	494
4.3.6.1.4	Physical layer parameters for scheduling of PSCCH/PSSCH .....	494
4.3.6.1.4.1	Physical layer parameters for DCI format 3_0.....	494
4.3.6.1.4.2	Physical layer parameters for DCI format 3_1.....	495
4.3.6.1.5	Physical layer parameters for scheduling of MBS.....	495
4.3.6.1.5.1	Physical layer parameters for DCI format 4_0.....	495
4.3.6.1.5.2	Physical layer parameters for DCI format 4_1.....	496
4.3.6.1.5.3	Physical layer parameters for DCI format 4_2.....	496
4.3.6.2	Sidelink physical layer parameters.....	497
4.3.6.2.1	Physical layer parameters for scheduling of PSSCH on PSCCH .....	497
4.3.6.2.1.1	Physical layer parameters for SCI format 1-A.....	497
4.3.6.2.2	Physical layer parameters for scheduling on PSSCH .....	498
4.3.6.2.2.1	Physical layer parameters for SCI format 2-A.....	498
4.3.6.2.2.2	Physical layer parameters for SCI format 2-B.....	499
4.4	Reference system configurations.....	499
4.4.1	Simulated network scenarios .....	499
4.4.1.1	Standalone cell network scenarios .....	499
4.4.1.1.1	Standalone E-UTRA single cell and multi cell network scenarios.....	499
4.4.1.1.2	Standalone NR single cell network scenarios.....	500
4.4.1.1.3	Standalone NR single mode multi cell network scenarios.....	500
4.4.1.1.4	Standalone NR dual mode multi cell network scenarios .....	500
4.4.1.1.5	Standalone NR 3GPP Inter-RAT network scenarios.....	500
4.4.1.2	Non-standalone cell network scenarios.....	500
4.4.1.2.1	Non-standalone E-UTRA single cell and NR single cell network scenarios.....	500
4.4.1.2.2	Non-standalone E-UTRA single cell and NR single mode multi cell network scenarios.....	500
4.4.1.2.3	Non-standalone E-UTRA single mode multi cell and NR single mode multi cell network scenarios .....	501
4.4.1.2.4	Non-standalone E-UTRA single cell and NR dual mode multi cell network scenarios .....	501
4.4.1.3	Non-3GPP Accesss network scenarios.....	501
4.4.1.3.1	WLAN network scenario.....	501
4.4.1.3.2	Bluetooth network scenario.....	502
4.4.2	Simulated cells.....	502
4.4.3	Common parameters for simulated NR cells .....	505
4.4.3.1	Common configurations of system information blocks .....	505
4.4.3.1.1	Combinations of system information blocks for E-UTRA standalone, EN-DC and NGEN-DC ..	505
4.4.3.1.2	Combinations of system information blocks for NR standalone and NE-DC .....	505
4.4.3.1.3	Scheduling of system information blocks.....	509
4.4A	Test states .....	514
4.4A.1	General.....	514
4.4A.2	Test states and associated 5GC and RRC protocol states .....	514
4.4A.3	Test state parameters.....	515
4.4A.4	Test state ID syntax.....	515
4.4A.5	Mapping of test state IDs and test parameters to generic procedures, generic procedure parameters and specific message conditions .....	516
4.5	Generic procedures.....	517
4.5.1	General.....	517
4.5.2	RRC_IDLE .....	518
4.5.2.1	Initiation.....	518
4.5.2.2	Procedures.....	519
4.5.2.3	Specific message contents.....	525
4.5.3	RRC_INACTIVE .....	526
4.5.3.1	Initiation.....	526
4.5.3.2	Procedures.....	526
4.5.4	RRC_CONNECTED .....	527
4.5.4.1	Initiation.....	527
4.5.4.2	Procedures.....	528
4.5.4.3	Specific message contents.....	531
4.5.5	SWITCHED_OFF .....	533
4.5.6	Void.....	534

4.5.7	Out of Coverage.....	534
4.5.7.1	Initiation.....	534
4.5.7.2	Procedures.....	534
4.5.7.3	Specific message contents.....	535
4.5A	Auxiliary procedures.....	536
4.5A.1	General.....	536
4.5A.2	UE-requested PDU session establishment procedure.....	536
4.5A.2A	UE-requested PDU session establishment procedure over Non 3GPP Access.....	539
4.5A.2B	Procedure to establish multiple additional PDN connections in S1.....	539
4.5A.2B.3	Specific message contents.....	541
4.5A.2C	Procedure for UE-requested PDU session modification after the first S1 to N1 mode change / Single-registration mode with N26.....	542
4.5A.3	Procedure for IP address allocation in the user plane.....	545
4.5A.4	Procedure for IMS signalling.....	546
4.5A.5	IPsec Tunnel Disconnection in 5GC / WLAN.....	546
4.5A.6	IPsec Tunnel Establishment in 5GC / WLAN.....	547
4.5B	Common test environment for Vertical UEs.....	547
4.5B.1	SNPN-only UEs.....	547
4.5B.2	RedCap UEs.....	548
4.6	Default NG-RAN RRC message and information elements contents.....	549
4.6.0	General.....	549
4.6.0.1	Global conditions.....	549
4.6.1	Contents of RRC messages.....	550
-	<i>CounterCheck</i> .....	550
-	<i>CounterCheckResponse</i> .....	550
-	<i>DedicatedSIBRequest</i> .....	551
-	<i>DL DedicatedMessageSegment</i> .....	551
-	<i>DLInformationTransfer</i> .....	551
-	<i>DLInformationTransferMRDC</i> .....	552
-	<i>FailureInformation</i> .....	552
-	<i>IABOtherInformation</i> .....	553
-	<i>LocationMeasurementIndication</i> .....	553
-	<i>LoggedMeasurementConfiguration</i> .....	553
-	<i>MBSBroadcastConfiguration</i> .....	554
-	<i>MBSInterestIndication</i> .....	555
-	<i>MCGFailureInformation</i> .....	555
-	<i>MeasurementReport</i> .....	555
-	<i>MIB</i> .....	555
-	<i>MobilityFromNRCommand</i> .....	556
-	<i>Paging</i> .....	557
-	<i>RRCReestablishment</i> .....	557
-	<i>RRCReestablishmentComplete</i> .....	558
-	<i>RRCReestablishmentRequest</i> .....	558
-	<i>RRCReconfiguration</i> .....	558
-	<i>RRCReconfigurationComplete</i> .....	562
-	<i>RRCReject</i> .....	562
-	<i>RRCRelease</i> .....	563
-	<i>RRCResume</i> .....	564
-	<i>RRCResumeComplete</i> .....	565
-	<i>RRCResumeRequest</i> .....	565
-	<i>RRCResumeRequest1</i> .....	566
-	<i>RRCSetup</i> .....	566
-	<i>RRCSetupComplete</i> .....	566
-	<i>RRCSetupRequest</i> .....	567
-	<i>RRCSystemInfoRequest</i> .....	567
-	<i>SCGFailureInformation</i> .....	567
-	<i>SCGFailureInformationEUTRA</i> .....	568
-	<i>SecurityModeCommand</i> .....	568
-	<i>SecurityModeComplete</i> .....	568
-	<i>SecurityModeFailure</i> .....	568
-	<i>SIB1</i> .....	569
-	<i>SidelinkUEInformationNR</i> .....	571

–	<i>SystemInformation</i> .....	572
–	<i>UEAssistanceInformation</i> .....	573
–	<i>UECapabilityEnquiry</i> .....	574
–	<i>UECapabilityInformation</i> .....	574
–	<i>UEInformationRequest</i> .....	574
–	<i>UEInformationResponse</i> .....	575
–	<i>ULDedicatedMessageSegment</i> .....	575
–	<i>ULInformationTransfer</i> .....	576
–	<i>ULInformationTransferIRAT</i> .....	576
–	<i>ULInformationTransferMRDC</i> .....	576
4.6.1A	Contents of PC5 RRC messages .....	577
–	<i>MasterInformationBlockSidelink</i> .....	577
–	<i>MeasurementReportSidelink</i> .....	577
–	<i>RemoteUEInformationSidelink</i> .....	578
–	<i>RRCReconfigurationSidelink</i> .....	578
–	<i>RRCReconfigurationCompleteSidelink</i> .....	580
–	<i>RRCReconfigurationFailureSidelink</i> .....	580
–	<i>UECapabilityEnquirySidelink</i> .....	581
–	<i>UECapabilityInformationSidelink</i> .....	582
–	<i>uuMessageTransferSidelink</i> .....	583
4.6.2	System information blocks .....	584
–	<i>SIB2</i> .....	584
–	<i>SIB3</i> .....	585
–	<i>SIB4</i> .....	585
–	<i>SIB5</i> .....	587
–	<i>SIB6</i> .....	588
–	<i>SIB7</i> .....	589
–	<i>SIB8</i> .....	590
–	<i>SIB9</i> .....	591
–	<i>SIB10</i> .....	592
–	<i>SIB11</i> .....	592
–	<i>SIB13</i> .....	593
–	<i>SIB14</i> .....	594
–	<i>SIB15</i> .....	594
–	<i>SIB16</i> .....	594
–	<i>SIB17</i> .....	594
–	<i>SIB18</i> .....	595
–	<i>SIB19</i> .....	595
–	<i>SIB20</i> .....	596
–	<i>SIB21</i> .....	596
4.6.2A	Positioning System information blocks .....	597
–	<i>PosSystemInformation-r16-IEs</i> .....	597
–	<i>PosSI-SchedulingInfo</i> .....	597
–	<i>SIBpos</i> .....	597
4.6.3	Radio resource control information elements .....	598
–	<i>AdditionalSpectrumEmission</i> .....	598
–	<i>Alpha</i> .....	598
–	<i>AMF-Identifier</i> .....	598
–	<i>ARFCN-ValueEUTRA</i> .....	598
–	<i>ARFCN-ValueNR</i> .....	598
–	<i>ARFCN-ValueUTRA-FDD</i> .....	599
–	<i>AvailabilityCombinationsPerCell</i> .....	599
–	<i>AvailabilityIndicator</i> .....	599
–	<i>BAP-Routing-ID</i> .....	600
–	<i>BeamFailureRecoveryConfig</i> .....	600
–	<i>BeamFailureRecoveryRSConfig</i> .....	601
–	<i>BetaOffsets</i> .....	601
–	<i>BetaOffsetsCrossPri</i> .....	601
–	<i>BH-RLC-ChannelConfig</i> .....	601
–	<i>BH-LogicalChannelIdentity</i> .....	602
–	<i>BH-LogicalChannelIdentity-Ext</i> .....	602
–	<i>BH-RLC-ChannelID</i> .....	602

–	<i>BSR-Config</i> .....	602
–	<i>BWP</i> .....	602
–	<i>BWP-Downlink</i> .....	603
–	<i>BWP-DownlinkCommon</i> .....	603
–	<i>BWP-DownlinkDedicated</i> .....	603
–	<i>BWP-Id</i> .....	604
–	<i>BWP-Uplink</i> .....	604
–	<i>BWP-UplinkCommon</i> .....	605
–	<i>BWP-UplinkDedicated</i> .....	605
–	<i>CandidateBeamRS</i> .....	606
–	<i>CellAccessRelatedInfo</i> .....	606
–	<i>CellAccessRelatedInfo-EUTRA-5GC</i> .....	607
–	<i>CellAccessRelatedInfo-EUTRA-EPC</i> .....	607
–	<i>CellGroupConfig</i> .....	607
–	<i>CellGroupId</i> .....	612
–	<i>CellIdentity</i> .....	612
–	<i>CellReselectionPriority</i> .....	613
–	<i>CellReselectionSubPriority</i> .....	613
–	<i>CFR-ConfigMulticast</i> .....	613
–	<i>CGI-InfoEUTRA</i> .....	613
–	<i>CGI-InfoEUTRALogging</i> .....	613
–	<i>CGI-InfoNR</i> .....	614
–	<i>CGI-Info-Logging</i> .....	614
–	<i>CLI-RSSI-Range</i> .....	614
–	<i>CodebookConfig</i> .....	614
–	<i>CommonLocationInfo</i> .....	615
–	<i>CondReconfigId</i> .....	615
–	<i>CondReconfigToAddModList</i> .....	615
–	<i>ConditionalReconfiguration</i> .....	615
–	<i>ConfiguredGrantConfig</i> .....	616
–	<i>ConfiguredGrantConfigIndex</i> .....	618
–	<i>ConfiguredGrantConfigIndexMAC</i> .....	618
–	<i>ConnEstFailureControl</i> .....	618
–	<i>ControlResourceSet</i> .....	618
–	<i>ControlResourceSetId</i> .....	619
–	<i>ControlResourceSetZero</i> .....	619
–	<i>CrossCarrierSchedulingConfig</i> .....	619
–	<i>CSI-AperiodicTriggerStateList</i> .....	619
–	<i>CSI-FrequencyOccupation</i> .....	620
–	<i>CSI-IM-Resource</i> .....	621
–	<i>CSI-IM-ResourceId</i> .....	621
–	<i>CSI-IM-ResourceSet</i> .....	621
–	<i>CSI-IM-ResourceSetId</i> .....	621
–	<i>CSI-MeasConfig</i> .....	622
–	<i>CSI-ReportConfig</i> .....	623
–	<i>CSI-ReportConfigId</i> .....	623
–	<i>CSI-ResourceConfig</i> .....	624
–	<i>CSI-ResourceConfigId</i> .....	624
–	<i>CSI-ResourcePeriodicityAndOffset</i> .....	624
–	<i>CSI-RS-ResourceConfigMobility</i> .....	624
–	<i>CSI-RS-ResourceMapping</i> .....	624
–	<i>CSI-SemiPersistentOnPUSCH-TriggerStateList</i> .....	625
–	<i>CSI-SSB-ResourceSet</i> .....	625
–	<i>CSI-SSB-ResourceSetId</i> .....	626
–	<i>DedicatedNAS-Message</i> .....	626
–	<i>DL-PPW-PreConfig</i> .....	626
–	<i>DMRS-BundlingPUCCH-Config</i> .....	626
–	<i>DMRS-BundlingPUSCH-Config</i> .....	626
–	<i>DMRS-DownlinkConfig</i> .....	626
–	<i>DMRS-UplinkConfig</i> .....	627
–	<i>DownlinkConfigCommon</i> .....	627
–	<i>DownlinkConfigCommonSIB</i> .....	627

-	<i>DownlinkPreemption</i> .....	628
-	<i>DRB-Identity</i> .....	628
-	<i>DRX-Config</i> .....	629
-	<i>DRX-ConfigSecondaryGroup</i> .....	629
-	<i>DRX-ConfigSL</i> .....	629
-	<i>EphemerisInfo</i> .....	629
-	<i>FeatureCombination</i> .....	630
-	<i>FeatureCombinationPreambles</i> .....	630
-	<i>FilterCoefficient</i> .....	631
-	<i>FreqBandIndicatorNR</i> .....	631
-	<i>FreqPriorityListDedicatedSlicing</i> .....	631
-	<i>FreqPriorityListSlicing</i> .....	631
-	<i>FrequencyInfoDL</i> .....	632
-	<i>FrequencyInfoDL-SIB</i> .....	632
-	<i>FrequencyInfoUL</i> .....	632
-	<i>FrequencyInfoUL-SIB</i> .....	633
-	<i>GapPriority</i> .....	633
-	<i>HighSpeedConfig</i> .....	633
-	<i>Hysteresis</i> .....	634
-	<i>HysteresisLocation</i> .....	634
-	<i>InvalidSymbolPattern</i> .....	634
-	<i>I-RNTI-Value</i> .....	634
-	<i>LBT-FailureRecoveryConfig</i> .....	635
-	<i>LocationInfo</i> .....	635
-	<i>LocationMeasurementInfo</i> .....	635
-	<i>LoggedMeasurementConfiguration</i> .....	635
-	<i>LogicalChannelConfig</i> .....	636
-	<i>LogicalChannelIdentity</i> .....	636
-	<i>LTE-NeighCellsCRS-AssistInfoList</i> .....	637
-	<i>MAC-CellGroupConfig</i> .....	637
-	<i>MeasConfig</i> .....	638
-	<i>MeasGapConfig</i> .....	639
-	<i>MeasGapId</i> .....	640
-	<i>MeasGapSharingConfig</i> .....	640
-	<i>MeasId</i> .....	641
-	<i>MeasIdleConfig</i> .....	641
-	<i>MeasIdToAddModList</i> .....	642
-	<i>MeasObjectCLI</i> .....	642
-	<i>MeasObjectEUTRA</i> .....	642
-	<i>MeasObjectId</i> .....	643
-	<i>MeasObjectNR</i> .....	643
-	<i>MeasObjectNR-SL</i> .....	644
-	<i>MeasObjectRxTxDiff</i> .....	644
-	<i>MeasObjectToAddModList</i> .....	644
-	<i>MeasObjectUTRA-FDD</i> .....	645
-	<i>MeasResultCellListSFTD-NR</i> .....	645
-	<i>MeasResultCellListSFTD-EUTRA</i> .....	645
-	<i>MeasResultForRSSI</i> .....	646
-	<i>MeasResults</i> .....	646
-	<i>MeasResult2EUTRA</i> .....	647
-	<i>MeasResult2NR</i> .....	648
-	<i>MeasResultIdleEUTRA</i> .....	648
-	<i>MeasResultIdleNR</i> .....	648
-	<i>MeasResultRxTxTimeDiff</i> .....	648
-	<i>MeasResultSCG-Failure</i> .....	648
-	<i>MeasResultsSL</i> .....	651
-	<i>MeasRSSI-ReportConfig</i> .....	652
-	<i>MeasTriggerQuantityEUTRA</i> .....	652
-	<i>MobilityStateParameters</i> .....	652
-	<i>MRB-Identity</i> .....	652
-	<i>MsgA-ConfigCommon</i> .....	652
-	<i>MsgA-PUSCH-Config</i> .....	653

–	<i>MultiFrequencyBandListNR</i> .....	653
–	<i>MultiFrequencyBandListNR-SIB</i> .....	653
–	<i>MUSIM-GapConfig</i> .....	654
–	<i>MUSIM-GapId</i> .....	654
–	<i>MUSIM-GapInfo</i> .....	654
–	<i>NeedForGapsConfigNR</i> .....	654
–	<i>NeedForGapsInfoNR</i> .....	654
–	<i>NeedForGapNCSG-ConfigEUTRA</i> .....	655
–	<i>NeedForGapNCSG-ConfigNR</i> .....	655
–	<i>NeedForGapNCSG-InfoEUTRA</i> .....	655
–	<i>NeedForGapNCSG-InfoNR</i> .....	655
–	<i>NextHopChainingCount</i> .....	655
–	<i>NG-5G-S-TMSI</i> .....	655
–	<i>NonCellDefiningSSB</i> .....	656
–	<i>NPN-Identity</i> .....	656
–	<i>NPN-IdentityInfoList</i> .....	656
–	<i>NR-DL-PRS-PDC-Info</i> .....	657
–	<i>NR-NS-PmaxList</i> .....	658
–	<i>NSAG-ID</i> .....	658
–	<i>NSAG-IdentityInfo</i> .....	658
–	<i>NTN-Config</i> .....	658
–	<i>NZP-CSI-RS-Resource</i> .....	659
–	<i>NZP-CSI-RS-ResourceId</i> .....	659
–	<i>NZP-CSI-RS-ResourceSet</i> .....	659
–	<i>NZP-CSI-RS-ResourceSetId</i> .....	660
–	<i>P-Max</i> .....	660
–	<i>PathlossReferenceRS</i> .....	660
–	<i>PathlossReferenceRS-Id</i> .....	660
–	<i>PCI-ARFCN-EUTRA</i> .....	661
–	<i>PCI-ARFCN-NR</i> .....	661
–	<i>PCI-List</i> .....	661
–	<i>PCI-Range</i> .....	661
–	<i>PCI-RangeElement</i> .....	661
–	<i>PCI-RangeIndex</i> .....	661
–	<i>PCI-RangeIndexList</i> .....	662
–	<i>PDCCH-Config</i> .....	662
–	<i>PDCCH-ConfigCommon</i> .....	663
–	<i>PDCCH-ConfigSIB1</i> .....	665
–	<i>PDCCH-ServingCellConfig</i> .....	665
–	<i>PDCP-Config</i> .....	665
–	<i>PDSCH-Config</i> .....	667
–	<i>PDSCH-ConfigCommon</i> .....	668
–	<i>PDSCH-ServingCellConfig</i> .....	668
–	<i>PDSCH-TimeDomainResourceAllocationList</i> .....	668
–	<i>PHR-Config</i> .....	669
–	<i>PhysCellId</i> .....	669
–	<i>PhysicalCellGroupConfig</i> .....	670
–	<i>PLMN-Identity</i> .....	670
–	<i>PLMN-IdentityInfoList</i> .....	671
–	<i>PLMN-IdentityList2</i> .....	671
–	<i>PRB-Id</i> .....	671
–	<i>PTRS-DownlinkConfig</i> .....	672
–	<i>PTRS-UplinkConfig</i> .....	672
–	<i>PUCCH-Config</i> .....	672
–	<i>PUCCH-ConfigCommon</i> .....	678
–	<i>PUCCH-ConfigurationList</i> .....	678
–	<i>PUCCH-PathlossReferenceRS-Id</i> .....	678
–	<i>PUCCH-PowerControl</i> .....	679
–	<i>PUCCH-SpatialRelationInfo</i> .....	679
–	<i>PUCCH-SpatialRelationInfo-Id</i> .....	679
–	<i>PUCCH-TPC-CommandConfig</i> .....	680
–	<i>PUSCH-Config</i> .....	680

-	<i>PUSCH-ConfigCommon</i> .....	681
-	<i>PUSCH-PowerControl</i> .....	681
-	<i>PUSCH-ServingCellConfig</i> .....	682
-	<i>PUSCH-TimeDomainResourceAllocationList</i> .....	682
-	<i>PUSCH-TPC-CommandConfig</i> .....	684
-	<i>Q-OffsetRange</i> .....	685
-	<i>Q-QualMin</i> .....	685
-	<i>Q-RxLevMin</i> .....	685
-	<i>QuantityConfig</i> .....	685
-	<i>RACH-ConfigCommon</i> .....	686
-	<i>RACH-ConfigCommonTwoStepRA</i> .....	687
-	<i>RACH-ConfigDedicated</i> .....	688
-	<i>RACH-ConfigGeneric</i> .....	689
-	<i>RACH-ConfigGenericTwoStepRA</i> .....	689
-	<i>RA-Prioritization</i> .....	689
-	<i>RA-PrioritizationForSlicing</i> .....	690
-	<i>RadioBearerConfig</i> .....	690
-	<i>RadioLinkMonitoringConfig</i> .....	694
-	<i>RadioLinkMonitoringRS-Id</i> .....	694
-	<i>RAN-AreaCode</i> .....	695
-	<i>RateMatchPattern</i> .....	695
-	<i>RateMatchPatternId</i> .....	695
-	<i>RateMatchPatternLTE-CRS</i> .....	695
-	<i>ReferenceLocation</i> .....	695
-	<i>ReferenceTimeInfo</i> .....	696
-	<i>RejectWaitTime</i> .....	696
-	<i>RepetitionSchemeConfig</i> .....	696
-	<i>ReportConfigId</i> .....	696
-	<i>ReportConfigInterRAT</i> .....	696
-	<i>ReportConfigNR</i> .....	699
-	<i>ReportConfigNR-SL</i> .....	702
-	<i>ReportConfigToAddModList</i> .....	703
-	<i>ReportInterval</i> .....	703
-	<i>ReselectionThreshold</i> .....	703
-	<i>ReselectionThresholdQ</i> .....	704
-	<i>ResumeCause</i> .....	704
-	<i>RLC-BearerConfig</i> .....	704
-	<i>RLC-Config</i> .....	705
-	<i>RLF-TimersAndConstants</i> .....	706
-	<i>RMTC-Config</i> .....	707
-	<i>RNTI-Value</i> .....	707
-	<i>RSRP-Range</i> .....	707
-	<i>RSRQ-Range</i> .....	707
-	<i>RSSI-Range</i> .....	708
-	<i>RxTxTimeDiff</i> .....	708
-	<i>SCellActivationRS-Config</i> .....	708
-	<i>SCellActivationRS-ConfigId</i> .....	708
-	<i>SCellIndex</i> .....	708
-	<i>SchedulingRequestConfig</i> .....	708
-	<i>SchedulingRequestId</i> .....	709
-	<i>SchedulingRequestResourceConfig</i> .....	709
-	<i>SchedulingRequestResourceId</i> .....	710
-	<i>ScramblingId</i> .....	710
-	<i>SCS-SpecificCarrier</i> .....	710
-	<i>SDAP-Config</i> .....	710
-	<i>SearchSpace</i> .....	711
-	<i>SearchSpaceId</i> .....	712
-	<i>SearchSpaceZero</i> .....	713
-	<i>SecurityAlgorithmConfig</i> .....	713
-	<i>SemiStaticChannelAccessConfig</i> .....	713
-	<i>SemiStaticChannelAccessConfigUE</i> .....	713
-	<i>Sensor-LocationInfo</i> .....	713

-	<i>ServingCellAndBWP-Id</i> .....	714
-	<i>ServCellIndex</i> .....	714
-	<i>ServingCellConfig</i> .....	714
-	<i>ServingCellConfigCommon</i> .....	716
-	<i>ServingCellConfigCommonSIB</i> .....	718
-	<i>ShortI-RNTI-Value</i> .....	719
-	<i>ShortMAC-I</i> .....	719
-	<i>SINR-Range</i> .....	719
-	<i>SI-RequestConfig</i> .....	719
-	<i>SI-SchedulingInfo</i> .....	720
-	<i>SK-Counter</i> .....	720
-	<i>SlotFormatCombinationsPerCell</i> .....	720
-	<i>SlotFormatIndicator</i> .....	720
-	<i>S-NSSAI</i> .....	721
-	<i>SpeedStateScaleFactors</i> .....	721
-	<i>SPS-Config</i> .....	721
-	<i>SPS-ConfigIndex</i> .....	721
-	<i>SPS-PUCCH-AN</i> .....	721
-	<i>SPS-PUCCH-AN-List</i> .....	721
-	<i>SRB-Identity</i> .....	722
-	<i>SRS-CarrierSwitching</i> .....	722
-	<i>SRS-Config</i> .....	722
-	<i>SRS-RSRP-Range</i> .....	724
-	<i>SRS-TPC-CommandConfig</i> .....	724
-	<i>SSB-Index</i> .....	724
-	<i>SSB-MTC</i> .....	724
-	<i>SSB-PositionQCL-Relation</i> .....	725
-	<i>SSB-ToMeasure</i> .....	725
-	<i>SS-RSSI-Measurement</i> .....	725
-	<i>SubcarrierSpacing</i> .....	725
-	<i>TAG-Config</i> .....	726
-	<i>TAR-Config</i> .....	726
-	<i>TCI-ActivatedConfig</i> .....	726
-	<i>TCI-State</i> .....	726
-	<i>TCI-StateId</i> .....	727
-	<i>TCI-UL-State</i> .....	727
-	<i>TCI-UL-StateId</i> .....	727
-	<i>TDD-UL-DL-ConfigCommon</i> .....	727
-	<i>TDD-UL-DL-ConfigDedicated</i> .....	728
-	<i>TrackingAreaCode</i> .....	729
-	<i>T-Reselection</i> .....	729
-	<i>TimeAlignmentTimer</i> .....	729
-	<i>TimeToTrigger</i> .....	729
-	<i>UAC-BarringInfoSetIndex</i> .....	729
-	<i>UAC-BarringInfoSetList</i> .....	729
-	<i>UAC-BarringPerCatList</i> .....	729
-	<i>UAC-BarringPerPLMN-List</i> .....	730
-	<i>UE-TimersAndConstants</i> .....	730
-	<i>UE-TimersAndConstantsRemoteUE</i> .....	730
-	<i>UL-DelayValueConfig</i> .....	730
-	<i>UL-ExcessDelayConfig</i> .....	730
-	<i>UL-GapFR2-Config</i> .....	731
-	<i>UplinkCancellation</i> .....	731
-	<i>UplinkConfigCommon</i> .....	731
-	<i>UplinkConfigCommonSIB</i> .....	731
-	<i>Uplink-PowerControl</i> .....	732
-	<i>Uu-RelayRLC-ChannelConfig</i> .....	732
-	<i>Uu-RelayRLC-ChannelID</i> .....	732
-	<i>UplinkTxDirectCurrentList</i> .....	733
-	<i>UplinkTxDirectCurrentMoreCarrierList</i> .....	733
-	<i>UplinkTxDirectCurrentTwoCarrierList</i> .....	733
-	<i>ZP-CSI-RS-Resource</i> .....	733



–	<i>ZP-CSI-RS-ResourceId</i> .....	734
–	<i>ZP-CSI-RS-ResourceSet</i> .....	734
–	<i>ZP-CSI-RS-ResourceSetId</i> .....	734
4.6.4	UE capability information elements .....	734
–	<i>AccessStratumRelease</i> .....	734
–	<i>AppLayerMeasParameters</i> .....	734
–	<i>BandCombinationList</i> .....	735
–	<i>BandCombinationListSidelinkEUTRA-NR</i> .....	735
–	<i>CA-BandwidthClassEUTRA</i> .....	735
–	<i>CA-BandwidthClassNR</i> .....	735
–	<i>CA-ParametersEUTRA</i> .....	736
–	<i>CA-ParametersNR</i> .....	736
–	<i>CA-ParametersNRDC</i> .....	736
–	<i>CarrierAggregationVariant</i> .....	736
–	<i>CodebookParameters</i> .....	737
–	<i>FeatureSetCombination</i> .....	738
–	<i>FeatureSetCombinationId</i> .....	738
–	<i>FeatureSetDownlink</i> .....	738
–	<i>FeatureSetDownlinkId</i> .....	739
–	<i>FeatureSetDownlinkPerCC</i> .....	739
–	<i>FeatureSetDownlinkPerCC-Id</i> .....	739
–	<i>FeatureSetEUTRA-DownlinkId</i> .....	739
–	<i>FeatureSetEUTRA-UplinkId</i> .....	739
–	<i>FeatureSets</i> .....	740
–	<i>FeatureSetUplink</i> .....	740
–	<i>FeatureSetUplinkId</i> .....	741
–	<i>FeatureSetUplinkPerCC</i> .....	741
–	<i>FeatureSetUplinkPerCC-Id</i> .....	741
–	<i>FreqBandIndicatorEUTRA</i> .....	741
–	<i>FreqBandList</i> .....	741
–	<i>FreqSeparationClass</i> .....	743
–	<i>FreqSeparationClassDL-Only</i> .....	743
–	<i>FR2-2-AccessParamsPerBand</i> .....	743
–	<i>HighSpeedParameters</i> .....	743
–	<i>IMS-Parameters</i> .....	743
–	<i>InterRAT-Parameters</i> .....	744
–	<i>MAC-Parameters</i> .....	744
–	<i>MeasAndMobParameters</i> .....	744
–	<i>MeasAndMobParametersMRDC</i> .....	745
–	<i>MIMO-Layers</i> .....	745
–	<i>MIMO-ParametersPerBand</i> .....	745
–	<i>ModulationOrder</i> .....	747
–	<i>MRDC-Parameters</i> .....	748
–	<i>NRDC-Parameters</i> .....	748
–	<i>NTN-Parameters</i> .....	749
–	<i>OLPC-SRS-Pos</i> .....	749
–	<i>PDCCP-Parameters</i> .....	749
–	<i>PDCCP-ParametersMRDC</i> .....	750
–	<i>Phy-Parameters</i> .....	750
–	<i>Phy-ParametersMRDC</i> .....	751
–	<i>Phy-ParametersSharedSpectrumChAccess</i> .....	752
–	<i>PosSRS-RRC-Inactive-OutsideInitialUL-BWP</i> .....	752
–	<i>PowSav-Parameters</i> .....	752
–	<i>ProcessingParameters</i> .....	752
–	<i>PRS-ProcessingCapabilityOutsideMGinPPWperType</i> .....	753
–	<i>RAT-Type</i> .....	753
–	<i>RedCapParameters</i> .....	753
–	<i>RF-Parameters</i> .....	753
–	<i>RF-ParametersMRDC</i> .....	756
–	<i>RLC-Parameters</i> .....	756
–	<i>SDAP-Parameters</i> .....	756
–	<i>SidelinkParameters</i> .....	757

–	<i>SimultaneousRxTxPerBandPair</i> .....	757
–	<i>SON-Parameters</i> .....	757
–	<i>SpatialRelationsSRS-Pos</i> .....	757
–	<i>SRS-AllPosResourcesRRC-Inactive</i> .....	757
–	<i>SRS-SwitchingTimeNR</i> .....	757
–	<i>SRS-SwitchingTimeEUTRA</i> .....	758
–	<i>SupportedBandwidth</i> .....	758
–	<i>UE-BasedPerfMeas-Parameters</i> .....	758
–	<i>UE-CapabilityRAT-ContainerList</i> .....	758
–	<i>UE-CapabilityRAT-RequestList</i> .....	759
–	<i>UE-CapabilityRequestFilterCommon</i> .....	760
–	<i>UE-CapabilityRequestFilterNR</i> .....	760
–	<i>UE-MRDC-Capability</i> .....	761
–	<i>UE-NR-Capability</i> .....	763
–	<i>UE-RadioPagingInfo</i> .....	766
–	<i>SharedSpectrumChAccessParamsPerBand</i> .....	767
4.6.5	Other information elements .....	767
–	<i>AbsoluteTimeInfo</i> .....	767
–	<i>AppLayerMeasConfig</i> .....	767
–	<i>AreaConfiguration</i> .....	767
–	<i>BT-NameList</i> .....	767
–	<i>DedicatedInfoF1c</i> .....	768
–	<i>EUTRA-AllowedMeasBandwidth</i> .....	768
–	<i>EUTRA-MBSFN-SubframeConfigList</i> .....	768
–	<i>EUTRA-MultiBandInfoList</i> .....	768
–	<i>EUTRA-NS-PmaxList</i> .....	769
–	<i>EUTRA-PhysCellId</i> .....	769
–	<i>EUTRA-PhysCellIdRange</i> .....	769
–	<i>EUTRA-PresenceAntennaPort1</i> .....	769
–	<i>EUTRA-Q-OffsetRange</i> .....	769
–	<i>IAB-IP-Address</i> .....	770
–	<i>IAB-IP-AddressIndex</i> .....	770
–	<i>IAB-IP-Usage</i> .....	770
–	<i>LoggingDuration</i> .....	770
–	<i>LoggingInterval</i> .....	770
–	<i>LogMeasResultListBT</i> .....	770
–	<i>LogMeasResultListWLAN</i> .....	771
–	<i>MeasConfigAppLayerId</i> .....	771
–	<i>OtherConfig</i> .....	771
–	<i>PhysCellIdUTRA-FDD</i> .....	772
–	<i>RRC-TransactionIdentifier</i> .....	772
–	<i>Sensor-NameList</i> .....	772
–	<i>TraceReference</i> .....	772
–	<i>UE-MeasurementsAvailable</i> .....	772
–	<i>UTRA-FDD-Q-OffsetRange</i> .....	773
–	<i>VisitedCellInfoList</i> .....	773
–	<i>WLAN-NameList</i> .....	773
4.6.6	Sidelink information elements .....	773
–	<i>SL-BWP-Config</i> .....	773
–	<i>SL-BWP-ConfigCommon</i> .....	774
–	<i>SL-BWP-PoolConfig</i> .....	774
–	<i>SL-BWP-PoolConfigCommon</i> .....	775
–	<i>SL-CBR-PriorityTxConfigList</i> .....	776
–	<i>SL-CBR-CommonTxConfigList</i> .....	776
–	<i>SL-ConfigDedicatedNR</i> .....	777
–	<i>SL-ConfiguredGrantConfig</i> .....	778
–	<i>SL-DestinationIdentity</i> .....	779
–	<i>SL-FreqConfig</i> .....	779
–	<i>SL-FreqConfigCommon</i> .....	780
–	<i>SL-LogicalChannelConfig</i> .....	780
–	<i>SL-L2RelayUE-Config</i> .....	781
–	<i>SL-L2RemoteUE-Config</i> .....	781

–	<i>SL-MeasConfigCommon</i> .....	781
–	<i>SL-MeasConfigInfo</i> .....	782
–	<i>SL-MeasIdList</i> .....	782
–	<i>SL-MeasObjectList</i> .....	782
–	<i>SL-PDCP-Config</i> .....	783
–	<i>SL-PSBCH-Config</i> .....	783
–	<i>SL-PSSCH-TxConfigList</i> .....	783
–	<i>SL-QoS-FlowIdentity</i> .....	784
–	<i>SL-QoS-Profile</i> .....	784
–	<i>SL-QuantityConfig</i> .....	784
–	<i>SL-RadioBearerConfig</i> .....	784
–	<i>SL-ReportConfigList</i> .....	784
–	<i>SL-ResourcePool</i> .....	785
–	<i>SL-RLC-BearerConfig</i> .....	787
–	<i>SL-RelayUE-Config</i> .....	787
–	<i>SL-RemoteUE-Config</i> .....	788
–	<i>SL-RLC-BearerConfigIndex</i> .....	788
–	<i>SL-RLC-ChannelID</i> .....	788
–	<i>SL-RLC-Config</i> .....	788
–	<i>SL-ScheduledConfig</i> .....	789
–	<i>SL-SDAP-Config</i> .....	789
–	<i>SL-SRAP-Config</i> .....	790
–	<i>SL-SyncConfig</i> .....	791
–	<i>SL-Thres-RSRP-List</i> .....	792
–	<i>SL-TxPower</i> .....	792
–	<i>SL-TypeTxSync</i> .....	792
–	<i>SL-UE-SelectedConfig</i> .....	792
–	<i>SL-ZoneConfig</i> .....	793
–	<i>SLRB-Uu-ConfigIndex</i> .....	793
4.6.7	MBS information elements .....	793
–	<i>CarrierFreqListMBS</i> .....	793
–	<i>CFR-ConfigMCCH-MTCH</i> .....	793
–	<i>DRX-ConfigPTM</i> .....	794
–	<i>MBS-NeighbourCellList</i> .....	794
–	<i>MBS-ServiceList</i> .....	794
–	<i>MBS-SessionInfoList</i> .....	794
–	<i>MTCH-SSB-MappingWindowList</i> .....	795
–	<i>PDSCH-ConfigBroadcast</i> .....	795
–	<i>TMGI</i> .....	796
4.7	Default 5GC NAS message and information elements contents .....	796
4.7.0	General .....	796
4.7.0.1	<i>Interpretation of IE presence and values</i> .....	796
4.7.0.2	<i>Security protected 5GS NAS messages</i> .....	796
4.7.1	Contents of 5GMM messages .....	797
–	<i>Authentication request</i> .....	797
–	<i>Authentication response</i> .....	797
–	<i>Authentication result</i> .....	798
–	<i>Authentication failure</i> .....	798
–	<i>Authentication reject</i> .....	799
–	<i>Registration request</i> .....	799
–	<i>Registration accept</i> .....	801
–	<i>Registration complete</i> .....	803
–	<i>Registration reject</i> .....	804
–	<i>UL NAS transport</i> .....	804
–	<i>DL NAS transport</i> .....	806
–	<i>De-registration request (UE originating de-registration)</i> .....	808
–	<i>De-registration accept (UE originating de-registration)</i> .....	808
–	<i>De-registration request (UE terminated de-registration)</i> .....	809
–	<i>De-registration accept (UE terminated de-registration)</i> .....	809
–	<i>Service request</i> .....	809
–	<i>Service accept</i> .....	810
–	<i>Service reject</i> .....	811

–	Configuration update command.....	811
–	Configuration update complete.....	812
–	Identity request.....	812
–	Identity response .....	813
–	Notification.....	813
–	Notification response .....	813
–	Security mode command .....	814
–	Security mode complete.....	815
–	Security mode reject.....	815
–	Security protected 5GS NAS message .....	816
–	5GMM status.....	817
–	Control plane service request .....	817
–	Network slice-specific authentication command.....	818
–	Network slice-specific authentication complete .....	818
–	Network slice-specific authentication result .....	819
–	Relay key request .....	819
–	Relay key accept.....	819
–	Relay key reject .....	820
–	Relay authentication request.....	820
–	Relay authentication response .....	820
4.7.2	Contents of 5GSM messages .....	821
–	PDU session establishment request .....	821
–	PDU session establishment accept.....	822
–	PDU session establishment reject .....	826
–	PDU session authentication command.....	827
–	PDU session authentication complete.....	827
–	PDU session authentication result .....	827
–	PDU session modification request .....	828
–	PDU session modification reject.....	828
–	PDU session modification command .....	829
–	PDU session modification complete .....	830
–	PDU session modification command reject .....	830
–	PDU session release request.....	831
–	PDU session release reject .....	831
–	PDU session release command.....	831
–	PDU session release complete .....	832
–	5GSM status .....	832
–	Service-level authentication command.....	832
–	Service-level authentication complete .....	833
–	Remote UE report .....	833
–	Remote UE report response .....	833
4.7.3	Contents of EAP-AKA' messages.....	833
4.7.3.1	EAP-AKA' message attributes .....	834
4.7.3.2	EAP-AKA' messages .....	836
4.7.4	Contents of V2X messages .....	838
–	DIRECT LINK ESTABLISHMENT REQUEST .....	838
–	DIRECT LINK ESTABLISHMENT ACCEPT.....	839
–	DIRECT LINK MODIFICATION REQUEST .....	840
–	DIRECT LINK MODIFICATION ACCEPT.....	841
–	DIRECT LINK RELEASE REQUEST .....	842
–	DIRECT LINK RELEASE ACCEPT.....	843
–	DIRECT LINK KEEPALIVE REQUEST.....	843
–	DIRECT LINK KEEPALIVE RESPONSE.....	844
–	DIRECT LINK AUTHENTICATION REQUEST.....	844
–	DIRECT LINK AUTHENTICATION RESPONSE.....	845
–	DIRECT LINK AUTHENTICATION REJECT .....	845
–	DIRECT LINK SECURITY MODE COMMAND .....	846
–	DIRECT LINK SECURITY MODE COMPLETE.....	846
–	DIRECT LINK SECURITY MODE REJECT .....	848
–	DIRECT LINK REKEYING REQUEST.....	848
–	DIRECT LINK REKEYING RESPONSE.....	849
–	DIRECT LINK IDENTIFIER UPDATE REQUEST.....	849

–	<i>DIRECT LINK IDENTIFIER UPDATE ACCEPT</i> .....	850
–	<i>DIRECT LINK IDENTIFIER UPDATE ACK</i> .....	851
–	<i>DIRECT LINK IDENTIFIER UPDATE REJECT</i> .....	852
–	<i>DIRECT LINK MODIFICATION REJECT</i> .....	852
–	<i>DIRECT LINK ESTABLISHMENT REJECT</i> .....	852
4.7.5	V2X information elements.....	853
4.7.5.1	Void.....	853
4.7.5.2	Void.....	853
4.7.5.3	Void.....	853
4.7.5.4	V2X information elements for UE policy part .....	853
–	<i>UE policy part when UE policy part type = {V2XP}</i> .....	853
–	<i>V2XP contents</i> .....	853
–	<i>V2XP info</i> .....	853
4.7.5.5	V2X information elements of UE policies for V2X communication over PC5 .....	854
–	<i>V2XP info = {UE policies for V2X communication over PC5}</i> .....	854
–	<i>Served by E-UTRA or served by NR</i> .....	854
–	<i>Authorized PLMN and RATs combinations</i> .....	855
–	<i>Authorized PLMN and RATs combination</i> .....	855
–	<i>PLMN ID</i> .....	855
–	<i>Not served by E-UTRA and not served by NR</i> .....	856
–	<i>Radio parameters per geographical area list</i> .....	856
–	<i>Radio parameters per geographical area info</i> .....	856
–	<i>Geographical area</i> .....	857
–	<i>Coordinate area</i> .....	857
–	<i>Radio parameters</i> .....	857
–	<i>V2X service identifier to PC5 RAT and Tx profiles mapping rules</i> .....	857
–	<i>V2X service identifier to PC5 RAT and Tx profiles mapping rule</i> .....	858
–	<i>V2X service identifiers</i> .....	858
–	<i>Privacy config</i> .....	858
–	<i>V2X services requiring privacy</i> .....	859
–	<i>V2X service requiring privacy</i> .....	859
–	<i>Geographical areas</i> .....	859
–	<i>V2X communication over PC5 in E-UTRA-PC5</i> .....	859
–	<i>V2X service identifier to destination layer-2 ID mapping rules</i> .....	860
–	<i>V2X service identifier to destination layer-2 ID mapping rule</i> .....	860
–	<i>PPPP to PDB mapping rules</i> .....	860
–	<i>PPPP to PDB mapping rule</i> .....	861
–	<i>V2X service identifier to V2X E-UTRA frequency mapping rules</i> .....	861
–	<i>V2X service identifier to V2X E-UTRA frequency mapping rule</i> .....	861
–	<i>V2X E-UTRA frequencies with geographical areas list</i> .....	861
–	<i>V2X E-UTRA frequencies with geographical areas info</i> .....	862
–	<i>V2X E-UTRA frequencies</i> .....	862
–	<i>V2X services authorized for PPPR</i> .....	862
–	<i>V2X service authorized for PPPR</i> .....	862
–	<i>V2X communication over PC5 in NR-PC5</i> .....	863
–	<i>V2X service identifier to V2X NR frequency mapping rules</i> .....	863
–	<i>V2X service identifier to V2X NR frequency mapping rule</i> .....	863
–	<i>V2X NR frequencies with geographical areas list</i> .....	864
–	<i>V2X NR frequencies with geographical areas info</i> .....	864
–	<i>V2X NR frequencies</i> .....	864
–	<i>V2X service identifier to destination layer-2 ID for broadcast mapping rules</i> .....	864
–	<i>V2X service identifier to destination layer-2 ID for broadcast mapping rule</i> .....	865
–	<i>V2X service identifier to destination layer-2 ID for groupcast mapping rules</i> .....	865
–	<i>V2X service identifier to destination layer-2 ID for groupcast mapping rule</i> .....	865
–	<i>V2X service identifier to destination layer-2 ID for unicast initial signalling mapping rules</i> .....	866
–	<i>V2X service identifier to destination layer-2 ID for unicast initial signalling mapping rule</i> .....	866
–	<i>V2X service identifier to PC5 QoS parameters mapping rules</i> .....	866
–	<i>V2X service identifier to PC5 QoS parameters mapping rule</i> .....	866
–	<i>AS configuration</i> .....	867
–	<i>SLRB mapping rules</i> .....	867
–	<i>SLRB mapping rule</i> .....	867
–	<i>PC5 QoS profile</i> .....	868

-	<i>NR-PC5 unicast security policies</i> .....	868
-	<i>NR-PC5 unicast security policy</i> .....	868
-	<i>Security policy</i> .....	869
-	<i>V2X service identifier to default mode of communication mapping rules</i> .....	869
-	<i>V2X service identifier to default mode of communication mapping rule</i> .....	869
4.7.6	Contents of UE Policy Delivery messages .....	870
-	<i>MANAGE UE POLICY COMMAND</i> .....	870
-	<i>MANAGE UE POLICY COMPLETE</i> .....	870
-	<i>MANAGE UE POLICY COMMAND REJECT</i> .....	871
-	<i>UE STATE INDICATION</i> .....	871
-	<i>UE POLICY PROVISIONING REQUEST</i> .....	872
-	<i>UE POLICY PROVISIONING REJECT</i> .....	872
4.7A	Default TC message and information element contents .....	873
4.7A.1	Test mode messages.....	873
-	<i>ACTIVATE TEST MODE COMPLETE</i> .....	873
-	<i>DEACTIVATE TEST MODE</i> .....	873
-	<i>DEACTIVATE TEST MODE COMPLETE</i> .....	873
4.7A.2	Test loop messages .....	873
-	<i>CLOSE UE TEST LOOP</i> .....	873
-	<i>CLOSE UE TEST LOOP COMPLETE</i> .....	874
-	<i>OPEN UE TEST LOOP</i> .....	874
-	<i>OPEN UE TEST LOOP COMPLETE</i> .....	874
4.7A.3	Beamlock messages .....	874
-	<i>ACTIVATE BEAMLOCK</i> .....	874
-	<i>ACTIVATE BEAMLOCK COMPLETE</i> .....	874
-	<i>DEACTIVATE BEAMLOCK</i> .....	875
-	<i>DEACTIVATE BEAMLOCK COMPLETE</i> .....	875
4.7A.4	UE SS-RSRP per receiver branch reporting messages .....	875
-	<i>SS-RSRP REPORT REQUEST</i> .....	875
-	<i>SS-RSRP REPORT RESPONSE</i> .....	875
4.7A.5	UE Positioning messages.....	875
-	<i>RESET UE POSITIONING STORED INFORMATION</i> .....	875
-	<i>UPDATE UE LOCATION INFORMATION</i> .....	875
4.7A.6	NSSAI delete messages .....	875
-	<i>NSSAI DELETE REQUEST</i> .....	875
-	<i>NSSAI DELETE RESPONSE</i> .....	876
4.7A.7	UE Power Limit Messages .....	876
-	<i>ACTIVATE POWER LIMIT REQUEST</i> .....	876
-	<i>ACTIVATE POWER LIMIT RESPONSE</i> .....	878
-	<i>DEACTIVATE POWER LIMIT REQUEST</i> .....	878
-	<i>DEACTIVATE POWER LIMIT RESPONSE</i> .....	879
4.7B	Default AT Command message and information element.....	879
-	<i>AT Command +CATM</i> .....	879
-	<i>AT Command +CCUTLE</i> .....	879
-	<i>AT Command +CUTCR</i> .....	879
-	<i>AT Command +CUSPCREQ</i> .....	880
4.8	Reference configurations.....	880
4.8.1	Radio configurations.....	880
4.8.2	5GC configurations.....	887
4.8.2.1	Reference QoS rules.....	887
4.8.2.2	Reference packet filters.....	891
4.8.2.3	Reference QoS flow descriptions .....	894
4.8.3	Common test UICC and USIM parameters .....	897
4.8.3.1	General .....	897
4.8.3.2	Default parameters for the test USIM and ISIM .....	897
4.8.3.3	Default settings for the Elementary Files (EFs) .....	897
4.8.3.3.1	Modified contents of the USIM Elementary Files .....	898
4.8.3.3.2	Contents of Elementary Files at the DF <sub>5GS</sub> level .....	898
4.8.3.3.3	Default settings of UICC and USIM for V2X .....	899
4.8.4	DNN/APN configurations.....	900
4.8.5	URSP configurations .....	901
4.8.5.1	General .....	901

4.8.5.2	UE Route Selection Policy Rules.....	901
4.8.5.3	Route Selection Descriptors.....	901
4.9	Test procedures.....	902
4.9.1	Test procedure to check user plane connectivity on DRB#n.....	902
4.9.2	Test procedure to activate UE Beamlock Test Function (UBF).....	903
4.9.3	Test procedure to deactivate UE Beamlock Test Function (UBF).....	904
4.9.4	Test procedure to check that UE is in state 5GC RRC_IDLE on a certain NR/NGC cell.....	905
4.9.5	Test procedure to check that UE is camped on a new NR/NGC cell belonging to a new TA.....	905
4.9.6	Test procedures for Switch off / Power off UE.....	906
4.9.6.1	Switch off / Power off procedure in RRC_IDLE.....	906
4.9.6.2	Switch off / Power off procedure in RRC_INACTIVE.....	907
4.9.6.3	Switch off / Power off procedure in RRC_CONNECTED.....	909
4.9.6.3A	Switch off / Power off procedure in RRC_CONNECTED with T3540 started.....	909
4.9.6.4	Switch off / Power off procedure in State DEREGISTERED.....	909
4.9.6.5	Switch off / Power off procedure in WLAN Isec_SA_Established.....	910
4.9.6.6	Switch off / Power off procedure in MA PDU session Established on NR and WLAN.....	910
4.9.7	Test procedure for UE for Tracking area updating / Inter-system change from N1 mode to S1 mode in 5GMM/EMM-IDLE mode.....	911
4.9.8	Test procedure for Registration Reject.....	915
4.9.9	Test procedure for UE for Tracking area updating / Inter-system change from S1 mode to N1 mode in 5GMM/EMM-IDLE mode.....	915
4.9.10	Test procedure to check that the UE is in RRC_CONNECTED state.....	921
4.9.11	Test procedure for IMS Emergency call or eCall over IMS establishment in 5GC with IMS emergency registration.....	921
4.9.12	Test procedure for IMS Emergency call establishment in 5GC without IMS emergency registration.....	925
4.9.12A	Test procedure for IMS MO Emergency call release.....	929
4.9.12B	Test procedure for IMS MT Emergency call release.....	932
4.9.13	Test procedure for no response to paging.....	934
4.9.14	Void.....	935
4.9.15	Test procedure for IMS MO speech call establishment in 5GC.....	935
4.9.16	Test procedure for IMS MT speech call establishment in 5GC.....	937
4.9.17	Test procedure for IMS MO call release in 5GC.....	939
4.9.18	Test procedure for IMS MT call release in 5GC.....	941
4.9.19	Test procedure for IMS MO SMS in 5GC.....	943
4.9.20	Test procedure for IMS MT SMS in 5GC.....	944
4.9.21	Test procedure for PDU Session Release.....	945
4.9.22	Test procedure for establishing unicast mode NR sidelink communication / Initiating UE side.....	946
4.9.23	Test procedure for establishing unicast mode NR sidelink communication / Peer UE side.....	949
4.9.24	Test procedure for IMS MO Video call establishment in 5GC.....	950
4.9.25	Test procedure for UE Configuration Update for transparent UE Policy delivery.....	953
4.9.26	Test procedure for IMS MT video call establishment in 5GC.....	953
4.9.27	Test procedure for adding video to a speech call in 5GC.....	956
4.9.28	Test procedure for removing video from an ongoing call in 5GC.....	958
4.9.29	Test Procedure for eCall over IMS establishment in 5GS: eCall Only Support.....	959
4.9.30	Test procedure for releasing unicast mode NR sidelink communication.....	960
4.9.31	Test procedure to check user plane connectivity on PC5 unicast link.....	961
4.9.32	Test procedure to activate UE Power Limit Function (UPLF).....	965
4.9.33	Test procedure to deactivate UE Power Limit Function (UPLF).....	967
4.9.34	Test procedure for MBS Multicast session join and session establishment.....	968
4.9.35	Test procedure for deleting configured S-NSSAI, default configured S-NSSAI and allowed S-NSSAI.....	972
4.9.36	Test procedure for registration of a MUSIM UE.....	974
4.9.37	Test procedure for MBS Multicast session release.....	975
4.9.38	Test procedure to check TMGI and associated MRB reception in a multicast MBS session.....	977
4.10	Reference configuration for V2X.....	979
4.10.1	Pre-configuration for V2X.....	979
4.11	GNSS Requirements for NR sidelink.....	980
4.11.1	General.....	980
4.11.2	GNSS Scenarios.....	980
5	Test environments for RF test.....	983
5.0	General.....	983

5.0.1	Single PDU configuration for RF testing.....	983
5.1	Requirements of test equipment .....	983
5.1.1	Requirements for transmission and reception tests.....	983
5.1.1.1	Requirements common for conducted and OTA tests.....	983
5.1.1.2	Requirements for conducted tests .....	983
5.1.1.3	Requirements for OTA tests.....	983
5.1.1.3.1	DFF and DFF with simplification for centre of beam measurements.....	983
5.1.1.3.2	IFF .....	984
5.1.1.3.3	NFTF .....	984
5.1.2	Requirements for performance tests .....	985
5.1.2.1	Void.....	985
5.1.2.2	Void.....	985
5.1.2.3	Requirements for OTA test method .....	985
5.2	Reference test conditions.....	985
5.2.1	Signal levels.....	985
5.2.1.1	Signal Levels for conducted testing .....	985
5.2.1.2	Signal Levels for OTA testing .....	985
5.2.1.2.1	Downlink Signal Levels .....	985
5.2.2	Test Frequencies .....	985
5.2.2.1	NR operating bands in FR1 .....	985
5.2.2.1.1	Reference test frequencies for NR operating band n1 .....	985
5.2.2.1.2	Reference test frequencies for NR operating band n2 .....	986
5.2.2.1.3	Reference test frequencies for NR operating band n3 .....	986
5.2.2.1.4	FFS .....	987
5.2.2.1.5	Reference test frequencies for NR operating band n5 .....	987
5.2.2.1.6	FFS .....	987
5.2.2.1.7	Reference test frequencies for NR operating band n7 .....	987
5.2.2.1.8	Reference test frequencies for NR operating band n8 .....	988
5.2.2.1.9 – 5.2.2.1.11	FFS .....	988
5.2.2.1.12	Reference test frequencies for NR operating band n12 .....	988
5.2.2.1.13	FFS .....	989
5.2.2.1.14	Reference test frequencies for NR operating band n14 .....	989
5.2.2.1.15 –	5.2.2.1.19.....	FFS
	.....	989
5.2.2.1.20	Reference test frequencies for NR operating band n20 .....	989
5.2.2.1.21 –	5.2.2.1.23.....	FFS
	.....	990
5.2.2.1.24	Reference test frequencies for NR operating band n24 .....	990
5.2.2.1.25	Reference test frequencies for NR operating band n25 .....	990
5.2.2.1.26	Reference test frequencies for NR operating band n26 .....	991
5.2.2.1.27	FFS .....	991
5.2.2.1.28	Reference test frequencies for NR operating band n28 .....	991
5.2.2.1.29	FFS .....	992
5.2.2.1.30	Reference test frequencies for NR operating band n30 .....	992
5.2.2.1.31 –	5.2.2.1.37.....	FFS
	.....	992
5.2.2.1.38	Reference test frequencies for NR operating band n38 .....	992
5.2.2.1.39	Reference test frequencies for NR operating band n39 .....	993
5.2.2.1.40	Reference test frequencies for NR operating band n40 .....	993
5.2.2.1.41	Reference test frequencies for NR operating band n41 .....	994
5.2.2.1.42 –	5.2.2.1.47.....	FFS
	.....	994
5.2.2.1.48	Reference test frequencies for NR operating band n48 .....	994
5.2.2.1.49	FFS .....	995
5.2.2.1.50	Reference test frequencies for NR operating band n50 .....	995
5.2.2.1.51 –	5.2.2.1.64.....	FFS
	.....	996



5.2.2.1.65	Reference test frequencies for NR operating band n65 .....	996
5.2.2.1.66	Reference test frequencies for NR operating band n66 .....	996
5.2.2.1.67 –		
	5.2.2.1.69 .....	FFS
	.....	997
5.2.2.1.70	Reference test frequencies for NR operating band n70 .....	997
5.2.2.1.71	Reference test frequencies for NR operating band n71 .....	997
5.2.2.1.72 –		
	5.2.2.1.73 .....	FFS
	.....	998
5.2.2.1.74	Reference test frequencies for NR operating band n74 .....	998
5.2.2.1.75 –		
	5.2.2.1.76 .....	FFS
	.....	998
5.2.2.1.77	Reference test frequencies for NR operating band n77 .....	998
5.2.2.1.78	Reference test frequencies for NR operating band n78 .....	999
5.2.2.1.79	Reference test frequencies for NR operating band n79 .....	999
5.2.2.2	NR operating bands in FR2 .....	1000
5.2.2.2.1	Reference test frequencies for NR operating band n257 .....	1000
5.2.2.2.2	Reference test frequencies for NR operating band n258 .....	1000
5.2.2.2.3	Reference test frequencies for NR operating band n259 .....	1001
5.2.2.2.4	Reference test frequencies for NR operating band n260 .....	1001
5.2.2.2.5	Reference test frequencies for NR operating band n261 .....	1002
5.3	Void .....	1002
5.4	Default NG-RAN RRC message and information elements contents .....	1002
5.4.1	Radio resource control information elements .....	1002
5.4.2	Radio resource control information elements for Demodulation Performance and CSI reporting tests .....	1008
5.4.2.0	Parameters common to all Demod and CSI tests .....	1008
5.4.2.1	Message contents for PDSCH Demodulation requirements .....	1026
5.4.2.2	Message contents for PDCCH Demodulation requirements .....	1028
5.4.2.3	Message contents for Sustained downlink data rate requirements .....	1030
5.4.2.4	Message contents for CQI reporting requirements .....	1038
5.4.2.5	Message contents for PMI reporting requirements .....	1045
5.4.2.6	Message contents for RI reporting requirements .....	1052
5.4.3	Sidelink information elements for Demodulation Performance tests .....	1059
5.5	Common procedures for RF testing .....	1060
5.5.1	Procedure to configure SCC for NR RF CA testing .....	1060
5.5.2	Procedure to configure SCC for EN-DC RF CA testing .....	1061
6	Test environments for Signalling test .....	1062
6.1	Requirements of test equipment .....	1062
6.1.1	Requirements common for conducted and OTA tests .....	1062
6.1.2	Requirements for conducted test method .....	1063
6.1.3	Requirements for OTA test method .....	1063
6.1.3.1	General .....	1063
6.1.3.2	Sample OTA Measurement Test Setup .....	1063
6.1.3.3	Procedure for selecting UE Orientation and for calibration .....	1064
6.1.3.4	Handling of Thresholds .....	1065
6.1.4	Requirements for timer tolerances .....	1065
6.2	Reference test conditions .....	1065
6.2.1	Physical Channel Allocations .....	1065
6.2.1.1	Antennas .....	1065
6.2.1.2	Downlink physical channels and physical signals .....	1065
6.2.1.3	Sidelink physical channels and physical signals .....	1066
6.2.2	Signal levels .....	1067
6.2.2.1	Signal Levels for conducted testing .....	1067
6.2.2.1.1	Measurement accuracy and side conditions .....	1069
6.2.2.2	Signal Levels for OTA testing .....	1069
6.2.2.2.1	General .....	1069
6.2.2.2.2	Signal Levels for FR2 OTA NR cells .....	1069
6.2.2.2.3	Signal Levels for FR1 OTA NR cell(s) with FR2 OTA NR cell(s) .....	1070
6.2.2.2.4	Signal Levels for OTA E-UTRA cell(s) with FR2 OTA NR cell(s) .....	1071

6.2.2.2.5	Signal Levels for OTA UTRA cell(s) with FR2 OTA NR cell(s) .....	1072
6.2.3	Default test frequencies .....	1073
6.2.3.1	Test frequencies for NR standalone signalling testing .....	1073
6.2.3.2	Test frequencies for EN-DC band combinations for signalling testing .....	1083
6.2.3.2.1	General .....	1083
6.2.3.2.2	E-UTRA 1CC and NR 1CC .....	1083
6.2.3.2.3	E-UTRA 1CC and NR CA 2CC .....	1085
6.2.3.2a	Test frequencies for NE-DC band combinations for signalling testing .....	1086
6.2.3.2a.1	General .....	1086
6.2.3.2a.2	NR 1CC and E-UTRA 1CC .....	1086
6.2.3.3	Test frequencies for NR and E-UTRA Inter-RAT signalling testing .....	1087
6.2.3.4	Test frequencies for NR CA configurations for signalling testing .....	1087
6.2.3.5	Test frequencies for MFBI signalling testing .....	1091
6.2.3.6	Test frequencies for NR DC configurations for signalling testing .....	1094
6.2.3.7	Test frequencies for NR sidelink configurations for signalling testing .....	1094
6.2.3.8	Test frequencies for NR NTN configurations for signalling testing .....	1094
6.3	Reference system configurations .....	1097
6.3.1	Default System Information configurations .....	1097
6.3.1.1	Intra-frequency neighbouring cell list in SIB3 for NR cells .....	1097
6.3.1.2	Inter-frequency carrier frequency list in SIB4 for NR cells .....	1097
6.3.1.3	E-UTRA carrier frequency list in SIB5 for NR cells .....	1097
6.3.2	Default configurations for NAS test cases .....	1098
6.3.2.1	Simulated network scenarios for NAS test cases .....	1098
6.3.2.2	Simulated NAS cells .....	1098
6.3.3	Cell configuration types .....	1100
6.3.3.1	Introduction .....	1100
6.3.3.2	SCell types .....	1100
6.4	Signalling Test Case specific USIM Configurations .....	1100
6.4.1	General .....	1100
7	Test environments for RRM tests .....	1107
7.0	General .....	1107
7.0.1	Single PDU configuration for RRM testing .....	1107
7.1	Test equipment requirements .....	1107
7.1.1	Void .....	1107
7.1.2	Void .....	1107
7.1.3	Requirements for OTA test method .....	1107
7.1.3.1	General .....	1107
7.1.3.2	RRM baseline setup .....	1107
7.1.3.2.1	General description .....	1107
7.1.3.2.2	Applicability criteria .....	1108
7.1.3.2.3	Measurement distance and quiet zone .....	1109
7.1.3.2.4	Quality of the quiet zone .....	1109
7.2	Reference test conditions .....	1110
7.2.1	Signal levels .....	1110
7.2.1.1	Void .....	1110
7.2.1.2	Void .....	1110
7.2.2	Physical layer parameters .....	1110
7.2.2.1	Downlink physical layer parameters .....	1110
7.2.3	Default test frequencies .....	1111
7.2.3.1	Default test frequencies FR1 NR operating bands .....	1111
7.2.3.2	Default test frequencies FR2 operating bands .....	1111
7.3	Default NG-RAN RRC message and information elements contents for RRM .....	1119
7.3.0	General definitions .....	1119
7.3.1	Radio resource control information elements for RRM .....	1119
-	<i>CSI-RS-ResourceMapping for ZP-CSI-RS</i> .....	1129
-	<i>PRB-Id</i> .....	1148
-	<i>ZP-CSI-RS-Resource-RRM</i> .....	1148
-	<i>ZP-CSI-RS-ResourceSet-RRM</i> .....	1149
-	<i>ZP-CSI-RS-ResourceSetId-RRM</i> .....	1149
7.3.2	Sidelink information elements for RRM .....	1149
-	<i>SL-BWP-ConfigCommon</i> .....	1149

–	<i>SL-BWP-PoolConfigCommon</i> .....	1150
–	<i>SL-ResourcePool</i> .....	1150
–	<i>SL-PSSCH-TxConfigList</i> .....	1150
–	<i>SL-UE-SelectedConfig</i> .....	1151
7.4	FFS .....	1151
7.5	Common procedures for RRM testing .....	1151
7.5.1	Procedure to configure SCC(s) for NR RRM CA testing .....	1151
7.5.2	Procedure to configure SCC(s) for EN-DC RRM CA testing .....	1151
<b>Annex A (informative): Connection Diagrams .....</b>		<b>1152</b>
A.1	Definition of Terms .....	1152
A.2	General Considerations on Connections Diagram .....	1153
A.3	Setup Diagrams .....	1154
A.3.1	Test Equipment Parts for Conducted Measurements .....	1154
A.3.1.1	Basic Transmitter/Receiver tests .....	1154
A.3.1.2	Transmitter tests using Spectrum Analyser .....	1158
A.3.1.3	Transmitter tests using Spectrum Analyser and Signal Generator .....	1162
A.3.1.4	Receiver tests using Signal Generator .....	1166
A.3.1.5	Receiver tests using Spectrum Analyser .....	1175
A.3.1.6	Receiver Performance tests .....	1177
A.3.1.7	Demodulation Performance and CSI reporting tests .....	1178
A.3.1.8	RRM tests with more than one NR cell .....	1192
A.3.1.9	Test Equipment supporting NR Sidelink .....	1198
A.3.2	User Equipment Parts for Conducted Measurements .....	1201
A.3.2.1	General .....	1201
A.3.2.2	One Antenna Connector .....	1202
A.3.2.3	Two Antenna Connectors .....	1203
A.3.2.4	Three Antenna Connectors .....	1210
A.3.2.5	Four Antenna Connectors .....	1211
A.3.2.6	Over Four Antenna Connectors .....	1215
A.3.2.7	User Equipment supporting NR Sidelink .....	1217
A.3.3	Test Equipment Parts for Radiated Measurements .....	1221
A.3.3.1	Transmitter/Receiver tests .....	1221
A.3.3.2	Demodulation and CSI tests .....	1224
A.3.3.3	RRM tests .....	1225
A.3.4	User Equipment Parts for Radiated Measurements .....	1226
A.3.4.1	Basic Transmitter/Receiver tests .....	1226
A.3.4.2	Demodulation and CSI tests .....	1227
A.3.4.3	RRM tests .....	1227
<b>Annex B (normative): Permitted test methods For OTA Testing .....</b>		<b>1228</b>
B.1	General .....	1228
B.2	Permitted Test Methods .....	1228
B.2.1	General .....	1228
B.2.2	Direct far field (DFF) .....	1228
B.2.2.1	Description .....	1228
B.2.2.2	Quiet zone dimension .....	1230
B.2.2.3	Quality of the quiet zone .....	1232
B.2.2.4	Measurement Distance .....	1232
B.2.3	Direct far field (DFF) setup simplification for centre of beam measurements .....	1234
B.2.3.1	Description .....	1234
B.2.3.2	Quiet zone dimension .....	1234
B.2.3.3	Quality of the quiet zone .....	1234
B.2.3.4	Measurement Distance .....	1234
B.2.4	Indirect far field (IFF): Compact Antenna Test Range (CATR) .....	1234
B.2.4.1	Description .....	1234
B.2.4.2	Quiet zone dimension .....	1235
B.2.4.3	Quality of the quiet zone .....	1236
B.2.4.4	Measurement Distance .....	1236

B.2.5	Near field to far field transform (NFTF) .....	1236
B.2.5.1	Description.....	1236
B.2.5.2	Quiet zone dimension .....	1238
B.2.5.3	Quality of the quiet zone.....	1238
B.2.5.4	Measurement Distance.....	1238
B.2.6	Enhanced IFF .....	1238
B.2.6.1	Description.....	1238
B.2.6.2	Quiet zone dimension .....	1239
B.2.6.3	Quality of the quiet zone.....	1239
B.2.6.4	Measurement Distance.....	1239
B.2.7	IFF+DFF .....	1239
B.2.7.1	Description.....	1239
B.2.7.2	Quiet zone dimension .....	1239
B.2.7.3	Quality of the quiet zone.....	1240
B.2.7.4	Measurement Distance.....	1240
<b>Annex C (informative): Calculation of test frequencies.....</b>		<b>1241</b>
C.0	General .....	1241
C.1	Definitions and Parameters .....	1241
C.2	Determination of test frequencies.....	1244
C.2.0	General .....	1244
C.2.1	Determination of test frequencies for symmetric NR bands and symmetric uplink and downlink channel bandwidth combinations.....	1244
C.2.1.1	Determination of test frequencies for Low-, Mid- and High-Range .....	1244
C.2.1.2	Determination test frequencies for of Mid-Low and Mid-High-Range for signalling tests .....	1244
C.2.2	Determination of test frequencies for asymmetric NR bands and symmetric uplink and downlink channel bandwidth combinations .....	1245
C.2.3	Determination of test frequencies for bands supporting asymmetric channel bandwidth combinations .....	1245
C.2.3.1	General.....	1245
C.2.3.2	Determination of Low-, Mid- and High-Range for bands supporting asymmetric uplink and downlink bandwidth combinations .....	1245
C.2.3.3	Determination of test frequencies for a Mid range adjacent inter-frequency cell for FR2 RRM multicell testing .....	1246
C.2.4	Frequency determination for NR CA and NR DC configurations.....	1246
C.2.4.1	Determination of test frequencies for NR Inter-band CA and NR DC .....	1246
C.2.4.2	Determination of test frequencies for NR Intra-band Contiguous CA.....	1246
C.2.4.2.1	General .....	1246
C.2.4.2.2	Determination of test frequencies for Low-, Mid- and High-Range .....	1247
C.2.4.2A	Determination of test frequencies for FR1 NR Intra-band Contiguous CA without UL CA for bands with uplink bandwidth less than downlink bandwidth.....	1247
C.2.4.2A.1	General .....	1247
C.2.4.2A.2	Determination of test frequencies for Low-, Mid- and High-Range .....	1247
C.2.4.3	Determination of test frequencies for NR Intra-band Non-Contiguous CA.....	1248
C.2.4.3.1	General .....	1248
C.2.4.3.1A	Selection of maximum frequency separation for FR1 .....	1249
C.2.4.3.1B	Selection of maximum frequency separation for FR2.....	1249
C.2.4.3.2	Determination of test frequencies for a sub-block combination.....	1249
C.2.4.3.3	Void.....	1250
C.2.5	Frequency determination for supplemental uplink .....	1250
C.2.5.1	General.....	1250
C.2.5.2	Determination of Low-, Mid- and High-Range for supplemental uplink bands .....	1250
C.2.6	Frequency determination for EN-DC configurations .....	1250
C.2.6.1	Determination of test frequencies for EN-DC Inter-band.....	1250
C.2.6.2	Determination of test frequencies for EN_DC Intra-band Contiguous CA .....	1250
C.2.6.2.1	General .....	1250
C.2.6.2.2	Determination of test frequencies for Low-, Mid- and High-Range with NR at band edges .....	1251
C.2.6.2.3	Determination of test frequencies for Low-, Mid- and High-Range with E-UTRA at band edges ...	1252
C.2.6.3	Determination of test frequencies for EN-DC Intra-band non-contiguous .....	1253
C.3	Determination of SSB and CORESET#0.....	1253

C.3.1	General .....	1253
C.3.2	Determination of SSB, CORESET#0 and signalling parameters for a PCell .....	1253
C.3.3	Determination of SSB and signalling parameters for a carrier without CORESET#0 .....	1255
C.4	Determination of SSB and CORESET#0 for RRM testing with SSB SCS 120 kHz and 240 kHz....	1256
C.4.1	General .....	1256
C.4.2	Determination of SSB, CORESET#0 and signalling parameters .....	1256
C.5	Determination of test frequencies and S-SSB for V2X bands.....	1257
C.5.1	General .....	1257
C.5.2	Determination of test frequencies and S-SSB for V2X bands.....	1259
<b>Annex D (informative):</b>	<b>Change history .....</b>	<b>1261</b>
History .....		1305

---

# Foreword

This Technical Specification has been produced by the 3rd Generation Partnership Project (3GPP).

The contents of the present document are subject to continuing work within the TSG and may change following formal TSG approval. Should the TSG modify the contents of the present document, it will be re-released by the TSG with an identifying change of release date and an increase in version number as follows:

Version x.y.z

where:

- x the first digit:
  - 1 presented to TSG for information;
  - 2 presented to TSG for approval;
  - 3 or greater indicates TSG approved document under change control.
- y the second digit is incremented for all changes of substance, i.e. technical enhancements, corrections, updates, etc.
- z the third digit is incremented when editorial only changes have been incorporated in the document.

The present document is part 1 of a multi-part deliverable covering the 5G System (5GS) User Equipment (UE) conformance specification, as identified below:

- 3GPP TS 38.508-1: "5GS; User Equipment (UE) conformance specification; Part 1: Common test environment" (the present document).
- 3GPP TS 38.508-2 [10]: "5GS; User Equipment (UE) conformance specification; Part 2: Common Implementation Conformance Statement (ICS) proforma".

---

# 1 Scope

The present document defines the test environment for the 5G System.

This specification covers all aspects, including NG-RAN, 5GC and interworking between 5GS and EPS used for conformance tests of User Equipment (UE).

---

# 2 References

The following documents contain provisions which, through reference in this text, constitute provisions of the present document.

- References are either specific (identified by date of publication, edition number, version number, etc.) or non-specific.
- For a specific reference, subsequent revisions do not apply.
- For a non-specific reference, the latest version applies. In the case of a reference to a 3GPP document (including a GSM document), a non-specific reference implicitly refers to the latest version of that document *in the same Release as the present document*.

- [1] 3GPP TR 21.905: "Vocabulary for 3GPP Specifications".
- [2] 3GPP TS 36.508: "Evolved Universal Terrestrial Radio Access (E-UTRA) and Evolved Packet Core (EPC); Common test environments for User Equipment (UE) conformance testing".
- [3] 3GPP TS 36.300: "Evolved Universal Terrestrial Radio Access (E-UTRA) and Evolved Universal Terrestrial Radio Access (E-UTRAN); Overall description; Stage 2".
- [4] 3GPP TS 36.331: "Evolved Universal Terrestrial Radio Access (E-UTRA); Radio Resource Control (RRC); Protocol specification".
- [5] 3GPP TS 38.300: "NR; Overall description; Stage 2".
- [6] 3GPP TS 38.331: "NR; Radio Resource Control (RRC); Protocol specification".
- [7] 3GPP TS 38.101-1: "NR; User Equipment (UE) radio transmission and reception; Part 1: Range 1 Standalone".
- [8] 3GPP TS 38.101-2: "NR; User Equipment (UE) radio transmission and reception; Part 2: Range 2 Standalone".
- [9] 3GPP TS 38.101-3: "NR; User Equipment (UE) radio transmission and reception; Part 3: Range 1 and Range 2 Interworking operation with other radios".
- [10] 3GPP TS 38.508-2: "5GS; User Equipment (UE) conformance specification; Part 2: Common Implementation Conformance Statement (ICS) proforma".
- [11] 3GPP TS 38.509: "5GS; Special conformance testing functions for User Equipment (UE)".
- [12] 3GPP TS 38.523-1: "5GS; User Equipment (UE) conformance specification; Part 1: Protocol".
- [13] 3GPP TS 38.133: "NR; Requirements for support of radio resource management".
- [14] 3GPP TS 38.521-1: "NR; User Equipment (UE) conformance specification; Radio transmission and reception; Part 1: Range 1 Standalone".
- [15] 3GPP TS 38.521-2: "NR; User Equipment (UE) conformance specification; Radio transmission and reception; Part 2: Range 2 Standalone".
- [16] 3GPP TS 38.521-3: "NR; User Equipment (UE) conformance specification; Radio transmission and reception; Part 3: Range 1 and Range 2 Interworking operation with other radios".

- [17] 3GPP TS 38.521-4: “NR; User Equipment (UE) conformance specification; Radio transmission and reception; Part 4: Performance”.
- [18] 3GPP TS 38.533: “NR; User Equipment (UE) conformance specification; Radio resource management”.
- [19] 3GPP TS 38.523-2: “5GS; User Equipment (UE) conformance specification; Part 2: Applicability of protocol test cases”.
- [20] 3GPP TS 38.321: “NR; Medium Access Control (MAC) protocol specification”.
- [21] 3GPP TS 38.214: “NR; Physical layer procedures for data”.
- [22] 3GPP TS 38.213: “NR; Physical layer procedures for control”.
- [23] 3GPP TS 38.523-3: "5GS; UE conformance specification; Part 3: Protocol Test Suites".
- [24] 3GPP TR 38.810: “NR; Study on test methods”
- [25] 3GPP TS 23.041: “Technical realization of Cell Broadcast Service (CBS)”
- [26] 3GPP TS 23.003: “Numbering, addressing and identification”
- [27] 3GPP TS 38.212: "NR; Multiplexing and channel coding"
- [28] 3GPP TS 24.501: “Non-Access-Stratum (NAS) protocol for 5G System (5GS);Stage 3”
- [29] 3GPP TS 38.211: "NR; Physical channels and modulation".
- [30] IETF RFC 4187: " Extensible Authentication Protocol Method for 3rd Generation Authentication and Key Agreement (EAP-AKA) ".
- [31] IETF RFC 5448: "Improved Extensible Authentication Protocol Method for 3rd Generation Authentication and Key Agreement (EAP-AKA)".
- [32] IETF RFC 3748: "Extensible Authentication Protocol (EAP)".
- [33] 3GPP TS 23.502: "Procedures for the 5G System (5GS); Stage 2".
- [34] IETF RFC 7296: "Internet Key Exchange Protocol Version 2 (IKEv2)".
- [35] 3GPP TS 24.502: “Access to the 3GPP 5G Core Network (5GCN) via Non-3GPP Access Networks (N3AN); Stage 3”
- [36] 3GPP TS 34.123-2: "User Equipment (UE) conformance specification; Part 2: Implementation Conformance Statement (ICS) proforma specification "
- [37] 3GPP TS 36.523-2: "Evolved Universal Terrestrial Radio Access (E-UTRA) and Evolved Packet Core (EPC); User Equipment (UE) conformance specification; Part 2: Implementation Conformance Statement (ICS) proforma specification".
- [38] 3GPP TR 38.903: “NR; Derivation of test tolerances and measurement uncertainty for User Equipment (UE) conformance test cases”
- [39] 3GPP TS 37.571-1: "Universal Terrestrial Radio Access (UTRA) and Evolved UTRA (E-UTRA) and Evolved Packet Core (EPC); User Equipment (UE) conformance specification for UE positioning; Part 1: Conformance test specification".
- [40] 3GPP TS 37.571-2: "Universal Terrestrial Radio Access (UTRA) and Evolved UTRA (E-UTRA) and Evolved Packet Core (EPC); User Equipment (UE) conformance specification for UE positioning; Part 2: Protocol conformance".
- [41] 3GPP TS 36.523-3: "Evolved Universal Terrestrial Radio Access (E-UTRA) and Evolved Packet Core (EPC); User Equipment (UE) conformance specification; Part 3: Test Suites".



- [42] 3GPP TS 36.523-1: "Evolved Universal Terrestrial Radio Access (E-UTRA) and Evolved Packet Core (EPC); User Equipment (UE) conformance specification; Part 1: Protocol conformance specification".
- [43] 3GPP TS 33.501: "Security architecture and procedures for 5G system".
- [44] 3GPP TS 34.229-1: "Internet Protocol (IP) multimedia call control protocol based on Session Initiation Protocol (SIP) and Session Description Protocol (SDP); User Equipment (UE) conformance specification; Part 1: Protocol conformance specification".
- [45] 3GPP TS 26.114: "IP Multimedia Subsystem (IMS);Multimedia Telephony;Media handling and interaction".
- [46] IETF RFC 4566: "SDP: Session Description Protocol".
- [47] 3GPP TS 34.229-5: "Internet Protocol (IP) multimedia call control protocol based on Session Initiation Protocol (SIP) and Session Description Protocol (SDP); User Equipment (UE) conformance specification; Part 5: Protocol conformance specification using 5G System (5GS)".
- [48] 3GPP TS 36.101: "Evolved Universal Terrestrial Radio Access (E-UTRA); User Equipment (UE) radio transmission and reception".
- [49] 3GPP TS 37.571-5: "User Equipment (UE) conformance specification for UE positioning; Part 5: Test scenarios and assistance data".
- [50] STANAG 4294: "NATO STANAG 4294. Navstar Global Positioning System (GPS) System Characteristics".
- [51] 3GPP TS 34.229-2: "Internet Protocol (IP) multimedia call control protocol based on Session Initiation Protocol (SIP) and Session Description Protocol (SDP);User Equipment (UE) conformance specification;Part 2: Implementation Conformance Statement (ICS) specification".
- [52] 3GPP TS 34.108: "Common Test Environments for User Equipment (UE); Conformance testing".
- [53] 3GPP TS 23.287: "Architecture enhancements for 5G System (5GS) to support Vehicle-to-Everything (V2X) services".
- [54] 3GPP TS 24.587: "Vehicle-to-Everything (V2X) services in 5G System (5GS)".
- [55] 3GPP TS 38.306: "User equipment (UE) radio access capabilities".
- [56] 3GPP TS 38.101-5: "NR; User Equipment (UE) radio transmission and reception; Part 5: Satellite access Radio Frequency (RF) and performance requirements".
- [57] 3GPP TS 38.521-5: "NR; User Equipment (UE) conformance specification; Radio transmission and reception; Part 5: Satellite access Radio Frequency (RF) and performance requirements".

---

## 3 Definitions, symbols and abbreviations

### 3.1 Definitions

For the purposes of the present document, the terms and definitions given in TR 21.905 [1] and the following apply. A term defined in the present document takes precedence over the definition of the same term, if any, in TR 21.905 [1].

**B:** a value followed by "B" is a binary value.

**H:** a value followed by "H" is a hexadecimal value.

### 3.2 Symbols

For the purposes of the present document, the following symbols apply:

## 3.3 Abbreviations

For the purposes of the present document, the abbreviations given in TR 21.905 [1] and the following apply. An abbreviation defined in the present document takes precedence over the definition of the same abbreviation, if any, in TR 21.905 [1].

5GC	5G Core Network
5GMM	5GS Mobility Management
5GS	5G System
5GSM	5GS Session Management
EN-DC	E-UTRA-NR Dual Connectivity
MCG	Master Cell Group
MR-DC	Multi-RAT Dual Connectivity
NE-DC	NR-E-UTRA Dual Connectivity
NGC	NG Core Network. Synonym of 5GC.
NGEN-DC	NG-RAN E-UTRA-NR Dual Connectivity
NG-RAN	NG Radio Access Network
NR	NR Radio Access
RedCap	Reduced Capability
RRC	Radio Resource Control
SCG	Secondary Cell Group
SS	System Simulator

---

## 4 Common test environments

### 4.1 Environmental conditions

The requirements in this clause apply to all types of UE(s).

#### 4.1.1 Temperature

Regarding FR1 the UE shall fulfil all the requirements in the full temperature range of:

**Table 4.1.1-1: Temperature conditions for FR1**

+15°C to +35°C	For normal conditions (with relative humidity up to 75 %)
-10°C to +55°C	For extreme conditions (see IEC publications 68-2-1 and 68-2-2)

Outside this temperature range the UE, if powered on, shall not make ineffective use of the radio frequency spectrum. In no case shall the UE exceed the transmitted levels as defined in TS 38.101-1 [7] clause 6.2 for extreme operation.

The normative reference for this requirement is TS 38.101-1 [7] Annex E.2.

All RF requirements for UEs operating in FR2 are defined over the air and can only be tested in an OTA chamber.

Regarding FR2 the UE shall fulfil all requirements in the temperature range defined in Table 4.1.1-2.

**Table 4.1.1-2: Temperature conditions for FR2**

+15°C to +35°C	For normal (room temperature) conditions with relative humidity up to 75%
-10°C to +55°C	For extreme conditions

Outside this temperature range the UE, if powered on, shall not make ineffective use of the radio frequency spectrum. In no case shall the UE exceed the transmitted levels as defined in TS 38.101-2[8] clause 6.2 for extreme operation.

The normative reference for this requirement is TS 38.101-2 [8] Annex E.2.

Some tests are performed also in extreme temperature conditions. These test conditions are denoted as TL (temperature low,  $-10^{\circ}\text{C}$ ) and TH (temperature high,  $+55^{\circ}\text{C}$ ).

## 4.1.2 Voltage

**Editor's Note:** This clause is incomplete. The following items are missing or are incomplete:

- Methodology to control the voltage in a case which a power cable is not connected to DUT is FFS since it is not agreed whether we can connect the power cable to DUT at the OTA measurement situation yet.

Regarding both FR1 and FR2 the UE shall fulfil all the requirements in the full voltage range, i.e. the voltage range between the extreme voltages.

The manufacturer shall declare the lower and higher extreme voltages and the approximate shutdown voltage. For the equipment that can be operated from one or more of the power sources listed below, the lower extreme voltage shall not be higher, and the higher extreme voltage shall not be lower than that specified below.

**Table 4.1.2-1: Voltage conditions**

Power source	Lower extreme voltage	Higher extreme voltage	Normal conditions voltage
AC mains	0.9 * nominal	1.1 * nominal	nominal
Regulated lead acid battery	0.9 * nominal	1.3 * nominal	1.1 * nominal
Non regulated batteries:			
Leclanché	0.85 * nominal	nominal	nominal
Lithium	0.95 * nominal	1.1 * nominal	1.1 * nominal
Mercury/nickel & cadmium	0.90 * nominal		nominal

Outside this voltage range the UE if powered on, shall not make ineffective use of the radio frequency spectrum. In no case shall the UE exceed the transmitted levels as defined in TS 38.101-1[7] and TS 38.101-2[8] clause 6.2 for extreme operation. In particular, the UE shall inhibit all RF transmissions when the power supply voltage is below the manufacturer declared shutdown voltage.

The normative reference for this requirement is TS 38.101-1 [7] Annex E.2 and TS 38.101-2 [8] Annex E.2.

Some tests are performed also in extreme voltage conditions. These test conditions are denoted as VL (lower extreme voltage) and VH (higher extreme voltage).

## 4.2 Common requirements of test equipment

Mobile conformance testing can be categorized into 3 distinct areas:

- RF Conformance Testing consisting of:
  - Transmission and Reception Conformance Testing.
  - Performance Conformance Testing.
- RRM Conformance Testing.
- Signalling Conformance Testing.

The test equipment required for each category of testing may or not be different, depending on the supplier of the test equipment. However, there will be some generic requirements of the test equipment that are essential for all three categories of test, and these are specified in this clause.

In addition, there will be requirements to test operation in multi-system configurations other than E-UTRA and NR dual connectivity (EN-DC). However, these would not form a common test equipment requirement for the three test areas and are not considered in the present document.

### 4.2.1 General functional requirements

**NOTE:** This clause has been written such that it does not constrain the implementation of different architectures and designs of test equipment.

All test equipment used to perform conformance testing for frequency range 1 on a UE shall provide the following minimum functionality:

- Conducted test method

All test equipment used to perform conformance testing for frequency range 2 on a UE shall provide the following minimum functionality:

- OTA test method

All test equipment used to perform conformance testing on a UE shall provide a platform suitable for testing UE's in at least one of the following connectivity values:

- NR; or
- EN-DC; or
- NE-DC; or
- NR-DC; or
- WLAN; or
- E-UTRA/EPC

All test equipment used to perform conformance testing on a UE shall provide a platform suitable for testing UE's that are either of following duplex mode for NR and E-UTRA (EN-DC or NE-DC connectivity values only) respectively.

- FDD Mode; or
- TDD Mode; or
- both FDD/TDD Modes; or
- HD-FDD Mode (NR RedCap only).

All test equipment shall provide the following minimum functionality.

- The capability of emulating a single NR cell and a single E-UTRA (for EN-DC or NE-DC connectivity values only) cell with the appropriate channels to allow the UE to register on the cell.
- The capability to allow the UE to set up an RRC connection with the system simulator, and to maintain the connection for the duration of the test.
- The capability (for the specific test):
  - to select and support an appropriate radio bearer for the downlink;
  - to set up and support the appropriate radio bearer for the uplink;

## 4.2.2 Minimum functional requirements

### 4.2.2.1 Supported Cell Configuration

The System Simulator shall provide the capability to simulate a minimum number of cells whose number and capabilities are governed by the test cases that need to be performed (test cases are defined in TS 38.523-1 [12] (Signalling), TS 38.521-1 [14], TS 38.521-2 [15], TS 38.521-3 [16] (TRx), TS 38.521-4 [17] (Performance), TS 38.533 [18] (RRM), TS 37.571-1 [39] and TS 37.571-2 [40] (Positioning)).

To perform test cases requiring multiple cell(s), the system simulator shall provide multiple cells offering the capabilities as required by the test case.

The type and number of channels (especially physical channels) constitute an important set of capabilities for a cell. The following clauses list possible channels that may be supported by the SS. Each channel type, however, and the minimum number of channels needed are only mandatory if specific test cases require them.

The mapping between Logical and Transport channels is as described in TS 38.321 [20]. Similarly, the mapping between Transport channels and Physical channels is as described in TS 38.211, TS 38.302 and TS 38.212. The reference measurement channels (mapping between Transport channels and Physical channels for PDSCH/PDCCH) are defined in TS 38.521-1 [14] annex A

#### 4.2.2.1.1 Supported Channels for an E-UTRA cell (NSA mode only)

Requirement for supported channels for E-UTRA cell is described in TS 36.508[2].

#### 4.2.2.1.2 Supported Channels for a NR cell

##### 4.2.2.1.2.1 Logical channels

Logical channel	Minimum number	Comments
BCCH	0 for EN-DC, 1 for SA	
CCCH	0 for EN-DC, 1 for SA	
DCCH	0 for EN-DC, 2 for SA	Split SRB or SRB3 is optional in EN-DC
PCCH	0 for EN-DC, 1 for SA	
DTCH	n	Depending on SS's support for RB service testing

##### 4.2.2.1.2.2 Transport channels

Transport channel	Minimum number	Comments
BCH	1	
PCH	N/A for EN-DC, 1 for SA	
RACH	1	
DL-SCH	1	
UL-SCH	1	

##### 4.2.2.1.2.3 Physical channels

Physical channel	Minimum number	Comments
PBCH	1	Physical Broadcast Channel
PDCCH	1	The physical downlink control channel carries scheduling assignments and other control information.
PDSCH	1	Physical Downlink Shared Channel
PUCCH	1	The physical uplink control channel carries uplink control information
PUSCH	1	Physical Uplink Shared Channel
PRACH	1	Physical Random Access Channel

##### 4.2.2.1.2.4 Physical signals

Physical signal	Minimum number	Comments
Demodulation reference signal	NA	UL
Sounding Reference signal	NA	UL, if applicable
Phase Tracking Reference Signal	NA	UL, if applicable
Demodulation reference signal(PDSCH)	NA	DL
Demodulation reference signal(PDCCH)	NA	DL
Demodulation reference signal(PBCH)	NA	DL
Phase Tracking Reference Signal	NA	DL, if applicable
CSI reference signal	NA	DL

Physical signal	Minimum number	Comments
Primary synchronisation signal	NA	DL
Secondary synchronisation signal	NA	DL

## 4.3 Reference test conditions

### 4.3.1 Test frequencies

Editor's Note: n7 (Mid: 25MHz, High: 50MHz), n8 (High: 35MHz), n25 (High: 45MHz), n40 (High: 100MHz), n65 (High: 50MHz), n66 (High: 45MHz), n71 (High: 35MHz), n75 (High: 50MHz), and n80 (High: 40MHz) are currently not yet included in the test channel bandwidth tables due to test frequency have not been defined yet. Further analysis is needed for the test coverage of these test channel bandwidths and bands.

#### 4.3.1.0 General

The test frequencies are based on operating bands defined in TS 38.101-1 [7], TS 38.101-2 [8] and TS 38.101-3 [9].

#### 4.3.1.0A Mid test channel bandwidth

The Mid test channel bandwidth definition for RF is given in Table 4.3.1.0A-1 and Table 4.3.1.0A-2 for FR1 and FR2 respectively.

**Table 4.3.1.0A-1: Mid Test Channel bandwidths for each NR band, FR1**

NR Band	UE Mid Test Channel bandwidth [MHz] <sup>1, 1a, 1b</sup>	RedCap UE Mid Test Channel bandwidth [MHz]
n1	25	15
n2	20	15
n3	20	15
n5	15	15
n7	15	15
n8	20	15
n12	10	10
n13	10	10
n14	10	10
n20	15	15
n24	10	10
n25	20	15
n26	10	15
n28	15	15
n29	10 <sup>2</sup>	N/A
n30	10	10
n34	10	10
n38	20	15
n39	20	15
n40	30	15
n41	60	15
n46	40	N/A
n48	20 <sup>4</sup> , 40 <sup>5</sup>	15
n50	20	15
n51	5	5
n53	10	10
n65	15	15
n66	20	10 <sup>8</sup>
n70	15	10
n71	10	10

n74	15	15
n75	15 <sup>2</sup>	N/A
n76	5 <sup>2</sup>	N/A
n77	50	15
n78	50	15
n79	50	20
n80	20 <sup>3</sup>	[15]
n81	15 <sup>3</sup>	[15]
n82	15 <sup>3</sup>	[15]
n83	15 <sup>3</sup>	[15]
n84	25 <sup>3</sup>	[15]
n86	20 <sup>3</sup>	[15]
n91	10 <sup>3</sup>	[10]
n92	15	[15]
n93	10 <sup>3</sup>	[10]
n94	15	[15]
n95	10 <sup>3</sup>	[10]
n96	60	N/A
n97	50 <sup>3</sup>	[15]
n99	10 <sup>3</sup>	[10]
n100	5	5
n101	10	10
<p>Note 1: Mid channel BW is the closest channel BW to the arithmetic average channel BW of all the possible channel BWs per band in Table 5.3.5-1 of TS 38.521-1 [14] among all SCSs. If there are two channel bandwidths that have same distance to the average value, the higher one is selected.</p> <p>In case such bandwidth is not applicable for a given subcarrier spacing, the closer bandwidth to the value in this table applicable for such subcarrier spacing shall be tested.</p> <p>In case such bandwidth is not defined in the UE release specification according to 38.101-1 [7] Table 5.3.5-1:</p> <ul style="list-style-type: none"> <li>- If the bandwidth listed above is equal or higher than maximum bandwidth supported in the UE release according to 38.101-1 [7] Table 5.3.5-1, the closest channel BW to the arithmetic average among the values supported in the UE release specification shall be tested.</li> <li>the closer bandwidth to the value in this table defined for that band in the UE release specification shall be tested.</li> </ul> <p>If there are two channel bandwidths that have same distance to the arithmetic average, the higher one is selected</p> <p>Note 1a: Values listed in this table assume that the (non-optional) channel bandwidths specified in Table 5.3.5-1 of TS 38.101-1 [7] lower than the maximum are supported. However, these channel bandwidths are mandatory with capability parameter as defined in [55] TS 38.306 clause 4.2.1 for <i>channelBWs-DL/channelBWs-UL</i> parameters. Hence the UE might indicate them as not supported. In such case, select the closest channel bandwidth in both DL and UL.</p> <p>Note 1b: For CA, DC, SDL and SUL, the mid-test channel bandwidth per component carrier is chosen to test the closest aggregated bandwidth to the mathematical centre between minimum and maximum aggregated bandwidth defined for and within a given bandwidth combination set. In case no set of channel bandwidths per component carrier supported by the UE can achieve such aggregated bandwidth, select one combination of bandwidths per component carrier within the bandwidth combination set that minimizes the difference to the target aggregated bandwidth.</p> <p>Note 2: This UE channel bandwidth is applicable only to downlink.</p> <p>Note 3: This UE channel bandwidth is applicable only to uplink.</p> <p>Note 4: Applicable when for use as single carrier, PCell in CA or PCell in DC configuration.</p> <p>Note 5: Applicable for use as SCell in CA or SCell in DC configuration.</p> <p>Note 6: Void</p> <p>Note 7: Void</p> <p>Note 8: Void</p> <p>Note 9: Void</p> <p>Note 10: This Mid test channel bandwidth is chosen since it is more commonly used.</p>		

Table 4.3.1.0A-2: Mid Test Channel bandwidths for each NR band, FR2

NR Band	UE Mid Test Channel bandwidth [MHz] <sup>1, 2, 3</sup>
n257	200
n258	200
n259	200
n260	200
n261	200
Note 1:	Mid channel BW is the closest channel BW to the arithmetic average channel BW of all the possible channel BWs per band in Table 5.3.5-1 of TS 38.521-1 [14] among all SCSs. If there are two channel bandwidths that have same distance to the average value, the higher one is selected. In case such bandwidth is not applicable for a given subcarrier spacing, the closer bandwidth to the value in this table applicable for such subcarrier spacing shall be tested. In case such bandwidth is not defined in the UE release specification according to 38.101-2 [8] Table 5.3.5-1, the closer bandwidth to the value in this table defined for that band in the UE release specification shall be tested. If there are two channel bandwidths that have same distance to the arithmetic average, the higher one is selected.
Note 2:	Values listed in this table assume that the (non-optional) channel bandwidths specified in Table 5.3.5-1 of TS 38.101-2 [8] lower than the maximum are supported. However, these channel bandwidths are mandatory with capability parameter as defined in [55] TS 38.306 clause 4.2.1 for <i>channelBWs-DL/channelBWs-UL</i> parameters. Hence the UE might indicate them as not supported. In such case, select the closest channel bandwidth in both DL and UL.
Note 3:	For CA and DC, the mid-test channel bandwidth per component carrier is chosen to test the closest aggregated bandwidth to the mathematical centre between minimum and maximum aggregated bandwidth defined for and within a given bandwidth combination set. In case no set of channel bandwidths per component carrier supported by the UE can achieve such aggregated bandwidth, select one combination of bandwidths per component carrier within the bandwidth combination set that minimizes the difference to the target aggregated bandwidth.

Table 4.3.1.0A-3: Mid Test Channel bandwidths for each NR band, NTN

NR Band	UE Mid Test Channel bandwidth [MHz] <sup>1, 2</sup>
n255	15
n256	15
Note 1:	Mid channel BW is the closest channel BW to the arithmetic average channel BW of all the possible channel BWs per band in Table 5.3.5-1 of TS 38.521-5 [57] among all SCSs. If there are two channel bandwidths that have same distance to the average value, the higher one is selected. In case such bandwidth is not applicable for a given subcarrier spacing, the closer bandwidth to the value in this table applicable for such subcarrier spacing shall be tested.
Note 2:	Values listed in this table assume that the (non-optional) channel bandwidths specified in Table 5.3.5-1 of TS 38.101-5 [56] lower than the maximum are supported. However, these channel bandwidths are mandatory with capability parameter as defined in TS 38.306 clause 4.2.1 [55] for <i>channelBWs-DL/channelBWs-UL</i> parameters. Hence the UE might indicate them as not supported. In such case, select the closest channel bandwidth in both DL and UL.



## 4.3.1.0B Low test channel bandwidth

The low test channel bandwidth definition for RF is given in Table 4.3.1.0B-1 and Table 4.3.1.0B-2 for FR1 and FR2 respectively.

**Table 4.3.1.0B-1: Low Test Channel bandwidths for each NR band, FR1**

NR Band	UE Low Test Channel bandwidth [MHz] <sup>1, 1a, 1b</sup>	RedCap UE Low Test Channel bandwidth [MHz]
n1	5	5
n2	5	5
n3	5	5
n5	5	5
n7	5	5
n8	5	5
n12	5	5
n13	5	5
n14	5	5
n20	5	5
n24	5	5
n25	5	5
n26	5	5
n28	5	5
n29	5 <sup>2</sup>	N/A
n30	5	5
n34	5	5
n38	5	5
n39	5	5
n40	5 <sup>4</sup> , 10 <sup>5</sup>	10
n41	10	10
n46	10	N/A
n48	5 <sup>4</sup> , 10 <sup>5</sup>	10
n50	5 <sup>4</sup> , 10 <sup>5</sup>	10
n51	5	5
n53	5	5
n65	5	5
n66	5	5
n70	5	5
n71	5	5
n74	5	5
n75	5 <sup>2</sup>	N/A
n76	5 <sup>2</sup>	N/A
n77	10	10
n78	10	10
n79	10	10
n80	5 <sup>3</sup>	[5]
n81	5 <sup>3</sup>	[5]
n82	5 <sup>3</sup>	[5]
n83	5 <sup>3</sup>	[5]
n84	5 <sup>3</sup>	[5]
n86	5 <sup>3</sup>	[5]
n91	5	[5]
n92	5	[5]
n93	5	[5]
n94	5	[5]
n95	5 <sup>3</sup>	[5]
n96	20	N/A
n97	5 <sup>3</sup>	[5]
n99	5 <sup>3</sup>	[5]
n100	5	5

n101	5	5
Note 1:	Minimum values among all the possible channel BW combinations per band in Table 5.3.5-1 of TS 38.521-1 [14] are listed. In case such bandwidth is not applicable for a given subcarrier spacing, the minimum bandwidth applicable for such subcarrier spacing shall be tested. In case such bandwidth is not defined in the UE release specification according to 38.101-1 [7] Table 5.3.5-1, the minimum bandwidth defined for that band in the UE release specification shall be tested.	
Note 1a:	Values listed in this table assume that the (non-optional) channel bandwidths specified in Table 5.3.5-1 of TS 38.101-1 [7] lower than the maximum are supported. However, these channel bandwidths are mandatory with capability parameter as defined in [55] TS 38.306 clause 4.2.1 for <i>channelBWs-DL/channelBWs-UL</i> parameters. Hence the UE might indicate them as not supported. In such case, select the closest channel bandwidth in both DL and UL.	
Note 1b:	For CA, DC, SDL and SUL, the low-test channel bandwidth per component carrier is chosen to allow minimum aggregated bandwidth defined for a given bandwidth combination set. In case no set of channel bandwidths per component carrier supported by the UE can achieve minimum aggregated bandwidth, select one combination of bandwidths per component carrier within the bandwidth combination set that minimizes the aggregated bandwidth.	
Note 2:	This UE channel bandwidth is applicable only to downlink.	
Note 3:	This UE channel bandwidth is applicable only to uplink.	
Note 4:	Applicable for use as SCell in CA or SCell in DC configuration.	
Note 5:	Applicable for use as single carrier, PCell in CA or PCell in DC configuration.	

Table 4.3.1.0B-2: Low Test Channel bandwidths for each NR band, FR2

NR Band	UE Low Test Channel bandwidth [MHz] <sup>1, 2, 3</sup>
n257	50
n258	50
n259	50
n260	50
n261	50
Note 1:	Minimum values among all the possible channel BW combinations per band in Table 5.3.5-1 of TS 38.521-2 [15] are listed. In case such bandwidth is not applicable for a given subcarrier spacing, the minimum bandwidth applicable for such subcarrier spacing shall be tested. In case such bandwidth is not defined in the UE release specification according to 38.101-2 [8] Table 5.3.5-1, the minimum bandwidth defined for that band in the UE release specification shall be tested.
Note 2:	Values listed in this table assume that the (non-optional) channel bandwidths specified in Table 5.3.5-1 of TS 38.101-2 [8] lower than the maximum are supported. However, these channel bandwidths are mandatory with capability parameter as defined in [55] TS 38.306 clause 4.2.1 for <i>channelBWs-DL/channelBWs-UL</i> parameters. Hence the UE might indicate them as not supported. In such case, select the closest channel bandwidth in both DL and UL.
Note 3:	For CA and DC, the low-test channel bandwidth per component carrier is chosen to allow minimum

aggregated bandwidth defined for a given bandwidth combination set. In case no set of channel bandwidths per component carrier supported by the UE can achieve minimum aggregated bandwidth, select one combination of bandwidths per component carrier within the bandwidth combination set that minimizes the aggregated bandwidth.

**Table 4.3.1.0B-3: Low Test Channel bandwidths for each NR band, NTN**

NR Band	UE Low Test Channel bandwidth [MHz] <sup>1, 2</sup>
n255	5
n256	5
Note 1:	Minimum values among all the possible channel BW combinations per band in Table 5.3.5-1 of TS 38.521-5 [57] are listed. In case such bandwidth is not applicable for a given subcarrier spacing, the minimum bandwidth applicable for such subcarrier spacing shall be tested.
Note 2:	Values listed in this table assume that the (non-optional) channel bandwidths specified in Table 5.3.5-1 of TS 38.101-5 [56] lower than the maximum are supported. However, these channel bandwidths are mandatory with capability parameter as defined in [55] TS 38.306 clause 4.2.1 for <i>channelBWs-DL/channelBWs-UL</i> parameters. Hence the UE might indicate them as not supported. In such case, select the closest channel bandwidth in both DL and UL.

#### 4.3.1.0C High test channel bandwidth

The high test channel bandwidth definition for RF is given in Table 4.3.1.0C-1 and Table 4.3.1.0C-2 for FR1 and FR2 respectively.

**Table 4.3.1.0C-1: High Test Channel bandwidths for each NR band, FR1**

NR Band	UE High Test Channel bandwidth [MHz] <sup>10, 11, 12</sup>	RedCap UE High Test Channel bandwidth [MHz]
n1	50	20
n2	40	20
n3	50	20
n5	20 <sup>1</sup> , 25 <sup>2</sup>	20
n7	20	20
n8	35	20
n12	15	15
n13	10	10
n14	10	10
n20	20	20
n24	10	10
n25	40 <sup>1</sup>	20
n26	20	20
n28	30	20
n29	10 <sup>2</sup>	N/A
n30	10	10
n34	15	15
n38	25, 40 <sup>13</sup>	15
n39	40	20
n40	80	20

n41	100	20
n46	80	N/A
n48	40 <sup>3</sup> , 100 <sup>4</sup>	20
n50	60 <sup>1</sup> , 80 <sup>2</sup>	20
n51	5	5
n53	10	10
n65	20	20
n66	40	20
n70	15 <sup>1</sup> , 25 <sup>2</sup>	15 <sup>1</sup> , 20 <sup>2</sup>
n71	20 <sup>1</sup>	20
n74	20	20
n75	20 <sup>2</sup>	N/A
n76	5 <sup>2</sup>	N/A
n77	100	20
n78	100	20
n79	100	20
n80	30 <sup>1</sup>	[20]
n81	20 <sup>1</sup>	[20]
n82	20 <sup>1</sup>	[20]
n83	30 <sup>1</sup>	[20]
n84	50 <sup>1</sup>	[20]
n86	40 <sup>1</sup>	[20]
n91	10 <sup>1</sup>	[10]
n92	20	[20]
n93	10 <sup>1</sup>	[10]
n94	20	[20]
n95	15 <sup>1</sup>	[15]
n96	80	N/A
n97	100 <sup>1</sup>	[20]
n99	10 <sup>1</sup>	[10]
n100	5	5
n101	10	10

- Note 1: This UE channel bandwidth is applicable only to uplink.
- Note 2: This UE channel bandwidth is applicable only to downlink.
- Note 3: Applicable for use as single carrier, PCell in CA or PCell in DC configuration.
- Note 4: Applicable for use as DL SCell in CA or DL SCell in DC configuration.
- Note 5: Void
- Note 6: Void
- Note 7: Void
- Note 8: Void
- Note 9: Void
- Note 10: Maximum values among all the possible channel BW combinations per band in Table 5.3.5-1 of TS 38.521-1 [14] are listed.  
In case such bandwidth is not applicable for a given subcarrier spacing, the maximum bandwidth applicable for such subcarrier spacing shall be tested.  
In case such bandwidth is not defined in the UE release specification according to 38.101-1 [7] Table 5.3.5-1, the maximum bandwidth defined for that band in the UE release specification shall be tested.  
In case such bandwidth is optional in the UE release specification according to 38.101-1 [7] Table 5.3.5-1 and not supported by the UE, the maximum non-optional bandwidth for the UE release specification shall be tested.
- Note 11: Values listed in this table assume that the maximum (non-optional) channel bandwidth specified in Table 5.3.5-1 of TS 38.101-1 [7] is mandatory without capability parameter (i.e., purely mandatory) as defined in [55] TS 38.306 clause 4.2.1 for *supportedBandwidthDL*/*supportedBandwidthUL* parameters in a band combination with a single band entry and a single CC entry (i.e., non-CA band combination).
- Note 12: For CA, DC, SDL and SUL, the High-test channel bandwidth per component carrier is chosen to allow maximum aggregated bandwidth defined for a given bandwidth combination set. In case no set of channel bandwidths per component carrier supported by the UE can achieve maximum aggregated bandwidths in CA, DC, SDL or SUL, some flexibility could be provided to the ecosystem for Rel-15 and Rel-16 so one combination of bandwidth per component carrier within the bandwidth combination set that maximizes the aggregated bandwidth is tested instead values described in Note 12 in Table 4.3.1.0C-1.
- Note 13: These UE channel bandwidths are applicable to sidelink operation.

NOTE 1 (Informative): In case values listed in table above are higher than those signalled by the UE in *supportedBandwidthDL/supportedBandwidthUL*, some flexibility could be provided to the ecosystem for Rel-15 and Rel-16 so the value signalled by the UE in *supportedBandwidthDL/supportedBandwidthUL* is used in single carrier operation instead values described in Table 4.3.1.0C-1.

**Table 4.3.1.0C-2: High Test Channel bandwidths for each NR band, FR2**

NR Band	UE High Test Channel bandwidth [MHz] <sup>1, 2, 3</sup>
n257	400
n258	400
n259	400
n260	400
n261	400
Note 1:	Maximum values among all the possible channel BW combinations per band in Table 5.3.5-1 of TS 38.521-2 [15] are listed. In case such bandwidth is not applicable for a given subcarrier spacing, the maximum bandwidth applicable for such subcarrier spacing shall be tested. In case such bandwidth is not defined in the UE release specification according to 38.101-2 [8] Table 5.3.5-1, the maximum bandwidth defined for that band in the UE release specification shall be tested. In case such bandwidth is optional in the UE release specification according to 38.101-2 [8] Table 5.3.5-1 and not supported by the UE, the maximum non-optional bandwidth for the UE release specification shall be tested.
Note 2:	Values listed in this table assume that the maximum (non-optional) channel bandwidth specified in Table 5.3.5-1 of TS 38.101-2 [8] is mandatory without capability parameter (i.e., purely mandatory) as defined in [55] TS 38.306 clause 4.2.1 for <i>supportedBandwidthDL/supportedBandwidthUL</i> parameters in a band combination with a single band entry and a single CC entry (i.e., non-CA band combination).
Note 3:	For CA and DC, the High-test channel bandwidth per component carrier is chosen to allow maximum aggregated bandwidth defined for a given bandwidth combination set. In case no set of channel bandwidths per component carrier supported by the UE can achieve maximum aggregated bandwidths in CA and DC, some flexibility could be provided to the ecosystem for Rel-15 and Rel-16 so one combination of bandwidth per component carrier within the bandwidth combination set that maximizes the aggregated bandwidth is tested instead values described in Note 3 in Table 4.3.1.0C-2.

NOTE 1 (Informative): In case values listed in table above are higher than those signalled by the UE in *supportedBandwidthDL/supportedBandwidthUL*, some flexibility could be provided to the ecosystem for Rel-15 and Rel-16 so the value signalled by the UE is used in single carrier operation instead values described in Table 4.3.1.0C-2.

**Table 4.3.1.0C-3: High Test Channel bandwidths for each NR band, NTN**

NR Band	UE High Test Channel bandwidth [MHz] <sup>1, 2</sup>
n255	20
n256	20
Note 1:	Maximum values among all the possible channel BW combinations per band in Table 5.3.5-1 of TS 38.521-5 [57] are listed.
Note 2:	Values listed in this table assume that the maximum (non-optional) channel bandwidth specified in Table 5.3.5-1 of TS 38.101-5 [56] is mandatory without capability parameter (i.e., purely mandatory) as defined in TS 38.306 clause 4.2,1 [55]

for supportedBandwidthDL/ supportedBandwidthUL parameters in a band combination with a single band entry and a single CC entry (i.e., non-CA band combination).

#### 4.3.1.0D Bandwidth part

The value of *locationAndBandwidth* in BWP for FR1 is given in Table 4.3.1.0D-1. The value of *locationAndBandwidth* in BWP for FR2 is given in Table 4.3.1.0D-2.

**Table 4.3.1.0D-1: *locationAndBandwidth* in BWP for FR1**

BW (MHz)	SCS (kHz)	$L_{RBs}$ (Note 2)	<i>locationAndBandwidth</i> (Note 1)
5	15	25	6600
5	30	11	2750
5	60	N/A	N/A
10	15	52	14025
10	30	24	6325
10	60	11	2750
15	15	79	21450
15	30	38	10175
15	60	18	4675
20	15	106	28875
20	30	51	13750
20	60	24	6325
25	15	133	36300
25	30	65	17600
25	60	31	8250
30	15	160	32174
30	30	78	21175
30	60	38	10175
35	15	188	24474
35	30	92	25025
35	60	44	11825
40	15	216	16774
40	30	106	28875
40	60	51	13750
45	15	242	9624
45	30	119	32450
45	60	58	15675
50	15	270	1924
50	30	133	36300
50	60	65	17600
60	15	N/A	N/A
60	30	162	31624
60	60	79	21450
70	15	N/A	N/A
70	30	189	24199
70	60	93	25300
80	15	N/A	N/A
80	30	217	16499
80	60	107	29150
90	15	N/A	N/A
90	30	245	8799
90	60	121	33000
100	15	N/A	N/A
100	30	273	1099
100	60	135	36850

Note 1: The value for *locationAndBandwidth* parameter is calculated as the RIV value in accordance to TS 38.214 [21] with  $N_{BWP}^{size} = 275$ ,  $RB_{start} = 0$  and  $L_{RBs}$  for each bandwidth and subcarrier spacing.

Note 2:  $L_{RBs} = \text{Max } N_{RB}$  is the default configuration, unless explicitly specified.

**Table 4.3.1.0D-2: *locationAndBandwidth* in BWP for FR2**

<b>BW (MHz)</b>	<b>SCS (kHz)</b>	<b><math>L_{RBs}</math> (Note 2)</b>	<b><i>locationAndBandwidth</i> (Note 1)</b>
50	60	66	17875
50	120	32	8525
100	60	132	36025
100	120	24 <sup>(Note 3)</sup>	6325
100	120	48 <sup>(Note 3)</sup>	12925
100	120	66	17875
200	60	264	3574
200	120	132	36025
400	60	N/A	N/A
400	120	264	3574
<p>Note 1: The value for <i>locationAndBandwidth</i> parameter is calculated as the RIV value in accordance to TS 38.214 [21] with <math>N_{BWP}^{size} = 275</math> and <math>RB_{start} = 0</math> for each bandwidth and subcarrier spacing.</p> <p>Note 2: <math>L_{RBs} = \text{Max } N_{RB}</math> is the default configuration, unless explicitly specified.</p> <p>Note 3: For configurations where the <math>L_{RBs}</math> is explicitly specified to be <math>L_{RBs} &lt; \text{Max } N_{RB}</math>.</p>			

4.3.1.0E Void

4.3.1.1 Test frequencies for NR operating bands in FR1

4.3.1.1.1 NR operating bands in FR1

4.3.1.1.1.1 Reference test frequencies for NR operating band n1

**Table 4.3.1.1.1.1-1: Test frequencies for NR operating band n1 and SCS 15 kHz**

CBW [MHz]	carrierBandwidth [PRBs]	Range		Carrier centre [MHz]	Carrier centre [ARFCN]	point A [MHz]	absoluteFrequencyPointA [ARFCN]	offsetToCarrier [Carrier PRBs]	SS block SCS [kHz]	GS CN	absoluteFrequencySSB [ARFCN]	$k_{SSB}$	Offset Carrier CORESET#0 [RBs] Note 2	CORESET#0 Index (Offset [RBs]) Note 1	offsetToPointA (SIB1) [PRBs] Note 1
5	25	Downlink	Low	211.25	422500	2110.25	422050	0	15	5279	422410	0	0	0 (0)	0
			Mid	2140	428000	2119.39	423878	102		5350	427970	8	1	0 (0)	103
			High	2167.5	433500	2074.53	414906	504		5418	433470	8	1	0 (0)	505
		Uplink	Low	192.25	384500	1920.25	384050	0	-	-	-	-	-	-	-
			Mid	1950	390000	1857.03	371406	504	-	-	-	-	-	-	-
			High	1977.5	395500	1974.17	394834	6	-	-	-	-	-	-	-
10	52	Downlink	Low	2115	423000	2110.32	422064	0	15	5280	422430	2	0	0 (0)	0
			Mid	2140	428000	2116.96	423392	102		5344	427490	10	1	0 (0)	103
			High	2165	433000	2069.6	413920	504		5405	432490	10	1	0 (0)	505
		Uplink	Low	1925	385000	1920.32	384064	0	-	-	-	-	-	-	-
			Mid	1950	390000	1854.6	370920	504	-	-	-	-	-	-	-
			High	1975	395000	1969.24	393848	6	-	-	-	-	-	-	-
15	79	Downlink	Low	2117.5	423500	2110.39	422078	0	15	5281	422450	4	0	0 (0)	0



			Mid	214 0	42800 0	2114 .53	422906	102		533 8	427010	0	0	1 (2)	104
			High	216 2.5	43250 0	2064 .67	412934	504		539 5	431570	8	1	1 (2)	507
			Uplink	Low	192 7.5	38550 0	1920 .39	384078		0	-	-	-	-	-
		Mid	195 0	39000 0	1852 .17	370434	504	-		-	-	-	-	-	
		High	197 2.5	39450 0	1964 .31	392862	6	-		-	-	-	-	-	
20	106	Downlink	Low	212 0	42400 0	2110 .46	422092	0	15	528 2	422650	6	1	2 (4)	5
			Mid	214 0	42800 0	2112 .1	422420	102		533 2	426530	2	0	1 (2)	104
			High	216 0	43200 0	2059 .74	411948	504		538 2	430590	10	1	1 (2)	507
		Uplink	Low	193 0	38600 0	1920 .46	384092	0	-	-	-	-	-	-	
			Mid	195 0	39000 0	1849 .74	369948	504	-	-	-	-	-	-	
			High	197 0	39400 0	1959 .38	391876	6	-	-	-	-	-	-	
25	133	Downlink	Low	212 2.5	42450 0	2110 .53	422106	0	15	528 3	422670	8	1	2 (4)	5
			Mid	214 0	42800 0	2109 .67	421934	102		532 6	426050	4	0	1 (2)	104
			High	215 7.5	43150 0	2054 .81	410962	504		536 9	429610	0	0	2 (4)	508
		Uplink	Low	193 2.5	38650 0	1920 .53	384106	0	-	-	-	-	-	-	
			Mid	195 0	39000 0	1847 .31	369462	504	-	-	-	-	-	-	
			High	196 7.5	39350 0	1954 .45	390890	6	-	-	-	-	-	-	
30	160	Downlink	Low	212 5	42500 0	2110 .6	422120	0	15	528 4	422690	10	1	2 (4)	5
			Mid	214 0	42800 0	2107 .24	421448	102		532 0	425570	6	0	1 (2)	104
			High	215 5	43100 0	2049 .88	409976	504		535 9	428690	10	1	2 (4)	509
		Uplink	Low	193 5	38700 0	1920 .6	384120	0	-	-	-	-	-	-	

			Mid	1950	390000	1844.88	368976	504		-	-	-	-	-	-
			High	1965	393000	1949.52	389904	6		-	-	-	-	-	-
40	216	Downlink	Low	2130	426000	2110.56	422112	0	15	5283	422670	6	1	2 (4)	5
			Mid	2140	428000	2102.2	420440	102		5308	424610	10	1	1 (2)	105
			High	2150	430000	2039.84	407968	504		5330	426490	6	0	0 (0)	504
		Uplink	Low	1940	388000	1920.56	384112	0	-	-	-	-	-	-	-
			Mid	1950	390000	1839.84	367968	504		-	-	-	-	-	-
			High	1960	392000	1939.48	387896	6		-	-	-	-	-	-
45	242	Downlink	Low	2132.5	426500	2110.72	422144	0	15	5284	422690	2	1	2(4)	5
			Mid	2140	428000	2099.86	419972	102		5302	424130	6	1	1(2)	105
			High	2147.5	429500	2035	407000	504		5320	425570	10	1	0(0)	505
		Uplink	Low	1942.5	388500	1920.72	384144	0	-	-	-	-	-	-	-
			Mid	1950	390000	1837.5	367500	504		-	-	-	-	-	-
			High	1957.5	391500	1934.64	386928	6		-	-	-	-	-	-
50	270	Downlink	Low	2135	427000	2110.7	422140	0	15	5282	422650	2	0	2 (4)	4
			Mid	2140	428000	2097.34	419468	102		5296	423650	2	0	2 (4)	106
			High	2145	429000	2029.98	405996	504		5307	424590	6	0	1 (2)	506
		Uplink	Low	1945	389000	1920.7	384140	0	-	-	-	-	-	-	-
			Mid	1950	390000	1834.98	366996	504		-	-	-	-	-	-
			High	1955	391000	1929.62	385924	6		-	-	-	-	-	-

Note 1: The CORESET#0 Index and the associated CORESET#0 Offset refers to Table 13-1 in TS 38.213 [22]. The value of CORESET#0 Index is signalled in controlResourceSetZero (pdcch-ConfigSIB1) in the MIB. The offsetToPointA IE is expressed in units of resource blocks assuming 15 kHz subcarrier spacing for FR1 and 60 kHz subcarrier spacing for FR2.

Note 2: The parameter Offset Carrier CORESET#0 specifies the offset from the lowest subcarrier of the carrier and the lowest subcarrier of CORESET#0. It corresponds to the parameter  $\Delta F_{\text{OffsetCORESET-0-Carrier}}$  in Annex C expressed in number of common RBs.

**Table 4.3.1.1.1-2: Test frequencies for NR operating band n1 and SCS 30 kHz**

CB W [MHz]	carrierBandwidth [PRBs]	Range		Carrier centre [MHz]	Carrier centre [ARFCN]	point A [MHz]	absoluteFrequencyPointA [ARFCN]	offsetToCarrier [Carrier PRBs]	SS block SCS [kHz]	GS CN	absoluteFrequencySSB [ARFCN]	$k_{SSB}$	Offset Carrier CORESET#0 [RBs] Note 2	CORESET#0 Index (Offset [RBs]) Note 1	offsetToPointA (SIB1) [PRBs] Note 1
10	24	Downlink	Low	211.5	42300.0	2110.68	422136	0	15	528.6	422910	18	0	0 (5)	10
			Mid	214.0	42800.0	2098.96	419792	102		535.0	427970	14	0	1 (6)	216
			High	216.5	43300.0	1979.24	395848	504		541.1	432970	14	0	1 (6)	1020
		Uplink	Low	192.5	38500.0	1920.68	384136	0	-	-	-	-	-	-	-
			Mid	195.0	39000.0	1764.24	352848	504	-	-	-	-	-	-	-
			High	197.5	39500.0	1968.52	393704	6	-	-	-	-	-	-	-
15	38	Downlink	Low	211.7.5	42350.0	2110.66	422132	0	15	528.7	422930	2	0	1 (6)	12
			Mid	214.0	42800.0	2096.44	419288	102		534.4	427490	22	0	1 (6)	216
			High	216.2.5	43250.0	1974.22	394844	504		540.1	432050	18	0	2 (7)	1022
		Uplink	Low	192.7.5	38550.0	1920.66	384132	0	-	-	-	-	-	-	-
			Mid	195.0	39000.0	1761.72	352344	504	-	-	-	-	-	-	-
			High	197.2.5	39450.0	1963.5	392700	6	-	-	-	-	-	-	-
20	51	Downlink	Low	212.0	42400.0	2110.82	422164	0	15	528.5	422890	2	0	0 (5)	10

		Uplink	Mid	2140	428000	2094.1	418820	102	-	5338	427010	18	0	1 (6)	216
			High	2160	432000	1969.38	393876	504		5388	431070	14	0	2 (7)	1022
			Low	1930	386000	1920.82	384164	0		-	-	-	-	-	-
			Mid	1950	390000	1759.38	351876	504		-	-	-	-	-	-
			High	1970	394000	1958.66	391732	6		-	-	-	-	-	-
25	65	Downlink	Low	2122.5	424500	2110.8	422160	0	15	5286	422910	10	0	0 (5)	10
			Mid	2140	428000	2091.58	418316	102		5332	426530	2	0	2 (7)	218
			High	2157.5	431500	1964.36	392872	504		5375	430090	22	0	2 (7)	1022
		Uplink	Low	1932.5	386500	1920.8	384160	0	-	-	-	-	-	-	
			Mid	1950	390000	1756.86	351372	504	-	-	-	-	-	-	
			High	1967.5	393500	1953.64	390728	6	-	-	-	-	-	-	
30	78	Downlink	Low	2125	425000	2110.96	422192	0	15	5287	422930	6	0	0 (5)	10
			Mid	2140	428000	2089.24	417848	102		5326	426050	22	0	1 (6)	216
			High	2155	431000	1959.52	391904	504		5362	428930	6	0	0 (5)	1018
		Uplink	Low	1935	387000	1920.96	384192	0	-	-	-	-	-	-	
			Mid	1950	390000	1754.52	350904	504	-	-	-	-	-	-	
			High	1965	393000	1948.8	389760	6	-	-	-	-	-	-	
40	106	Downlink	Low	2130	426000	2110.92	422184	0	15	5286	422910	2	0	0 (5)	10
			Mid	2140	428000	2084.2	416840	102		5314	425090	14	0	2 (7)	218
			High	2150	430000	1949.48	389896	504		5336	426970	22	0	0 (5)	1018
		Uplink	Low	1940	388000	1920.92	384184	0	-	-	-	-	-	-	

			Mi d	195 0	39000 0	1749 .48	349896	504		-	-	-	-	-	-
			Hi gh	196 0	39200 0	1938 .76	387752	6		-	-	-	-	-	-
45	119	Down link	Lo w	213 2.5	42650 0	2111 .08	422216	0	15	529 0	423170	6	0	3(8)	16
			Mi d	214 0	42800 0	2081 .86	416372	102		530 8	424610	10	0	2(7)	218
			Hi gh	214 7.5	42950 0	1944 .64	388928	504		532 6	426050	14	0	1(6)	1020
		Uplin k	Lo w	194 2.5	38850 0	1921 .08	384216	0	-	-	-	-	-	-	-
			Mi d	195 0	39000 0	1747 .14	349428	504		-	-	-	-	-	-
			Hi gh	195 7.5	39150 0	1933 .92	386784	6		-	-	-	-	-	-
50	133	Down link	Lo w	213 5	42700 0	2111 .06	422212	0	15	528 8	423130	18	0	2 (7)	14
			Mi d	214 0	42800 0	2079 .34	415868	102		530 2	424130	18	0	2 (7)	218
			Hi gh	214 5	42900 0	1939 .62	387924	504		531 3	425070	22	0	1 (6)	1020
		Uplin k	Lo w	194 5	38900 0	1921 .06	384212	0	-	-	-	-	-	-	-
			Mi d	195 0	39000 0	1744 .62	348924	504		-	-	-	-	-	-
			Hi gh	195 5	39100 0	1928 .9	385780	6		-	-	-	-	-	-

Note 1: The CORESET#0 Index and the associated CORESET#0 Offset refers to Table 13-2 in TS 38.213 [22]. The value of CORESET#0 Index is signalled in controlResourceSetZero (pdccch-ConfigSIB1) in the MIB. The offsetToPointA IE is expressed in units of resource blocks assuming 15 kHz subcarrier spacing for FR1 and 60 kHz subcarrier spacing for FR2.

Note 2: The parameter Offset Carrier CORESET#0 specifies the offset from the lowest subcarrier of the carrier and the lowest subcarrier of CORESET#0. It corresponds to the parameter  $\Delta F_{\text{OffsetCORESET-0-Carrier}}$  in Annex C expressed in number of common RBs.

Table 4.3.1.1.1-3: Test frequencies for NR operating band n1 and SCS 60 kHz without CORESET#0

CBW [MHz]	carrierBand width [PRBs]	Range		Carrier centre [MHz]	Carrier centre [ARFCN]	point A [MHz]	absolute FrequencyPoint A [ARFCN]	offsetTo Carrier [PRBs]	SS block SCS [kHz]	GSCN	absolute FrequencySSB [ARFCN]
10	11	Downlink	Low	2115	423000	2111.04	422208	0	15	-	422568
			Mid	2140	428000	2062.6	412520	102		-	427568
			High	2165	433000	1798.16	359632	504		-	432568
		Uplink	Low	1925	385000	1921.04	384208	0	-	-	-
			Mid	1950	390000	1583.16	316632	504		-	-
			High	1975	395000	1966.72	393344	6		-	-
15	18	Downlink	Low	2117.5	423500	2111.02	422204	0	15	-	422564
			Mid	2140	428000	2060.08	412016	102		-	427064
			High	2162.5	432500	1793.14	358628	504		-	431564
		Uplink	Low	1927.5	385500	1921.02	384204	0	-	-	-
			Mid	1950	390000	1580.64	316128	504		-	-
			High	1972.5	394500	1961.7	392340	6		-	-
20	24	Downlink	Low	2120	424000	2111.36	422272	0	15	-	422632
			Mid	2140	428000	2057.92	411584	102		-	426632
			High	2160	432000	1788.48	357696	504		-	430632
		Uplink	Low	1930	386000	1921.36	384272	0	-	-	-
			Mid	1950	390000	1578.48	315696	504		-	-
			High	1970	394000	1957.04	391408	6		-	-
25	31	Downlink	Low	2122.5	424500	2111.34	422268	0	15	-	422628
			Mid	2140	428000	2055.4	411080	102		-	426128
			High	2157.5	431500	1783.46	356692	504		-	429628
		Uplink	Low	1932.5	386500	1921.34	384268	0	-	-	-
			Mid	1950	390000	1575.96	315192	504		-	-
			High	1967.5	393500	1952.02	390404	6		-	-
30	38	Downlink	Low	2125	425000	2111.32	422264	0	15	-	422624
			Mid	2140	428000	2052.88	410576	102		-	425624
			High	2155	431000	1778.44	355688	504		-	428624
		Uplink	Low	1935	387000	1921.32	384264	0	-	-	-
			Mid	1950	390000	1573.44	314688	504		-	-
			High	1965	393000	1947	389400	6		-	-
40	51	Downlink	Low	2130	426000	2111.64	422328	0	15	-	422688
			Mid	2140	428000	2048.2	409640	102		-	424688
			High	2150	430000	1768.76	353752	504		-	426688
		Uplink	Low	1940	388000	1921.64	384328	0	-	-	

45	58	Downlink	Mid	1950	390000	1568.76	313752	504	15	-	-
			High	1960	392000	1937.32	387464	6		-	-
			Low	2132.5	426500	2111.62	422324	0		-	422684
		Mid	2140	428000	2045.68	409136	102	-		424184	
		High	2147.5	429500	1763.74	352748	504	-		425684	
		Uplink	Low	1942.5	388500	1921.62	384324	0		-	-
Mid	1950		390000	1566.24	313248	504	-	-			
High	1957.5		391500	1932.3	386460	6	-	-			
50	65	Downlink	Low	2135	427000	2111.6	422320	0	15	-	422680
			Mid	2140	428000	2043.16	408632	102		-	423680
			High	2145	429000	1758.72	351744	504		-	424680
		Uplink	Low	1945	389000	1921.6	384320	0		-	-
			Mid	1950	390000	1563.72	312744	504		-	-
			High	1955	391000	1927.28	385456	6		-	-
Note: FR1 carrier without CORESET#0 is indicated in the MIB by setting $k_{SSB}=31$ , $controlResourceSetZero=0$ and $searchSpaceZero=0$ (TS 38.213 [22], clause 13).											

4.3.1.1.1.2 Reference test frequencies for NR operating band n2

Table 4.3.1.1.1.2-1: Test frequencies for NR operating band n2 and SCS 15 kHz

CBW [MHz]	carrier Bandwidth [PRBs]	Range		Carrier centre [MHz]	Carrier centre [ARFCN]	point A [MHz]	absolute FrequencyPoint A [ARFCN]	offsetTo Carrier [Carrier PRBs]	SS block SCS [kHz]	GSCN	absolute FrequencySSB [ARFCN]	$k_{SSB}$	Offset Carrier CORE SET#0 [RBs] Note 2	CORE SET#0 Index (Offset [RBs]) Note 1	offsetTo PointA (SIB1) [PRBs] Note 1
5	25	Downlink	Low	1932.5	386500	1930.25	386050	0	15	4829	386410	0	0	0 (0)	0
			Mid	1960	392000	1939.39	387878	102		4900	391970	8	1	0 (0)	103
			High	1987.5	397500	1894.53	378906	504		4968	397470	8	1	0 (0)	505
		Uplink	Low	1852.5	370500	1850.25	370050	0	-	-	-	-	-	-	
			Mid	1880	376000	1787.03	357406	504	-	-	-	-	-	-	
			High	1907.5	381500	1904.17	380834	6	-	-	-	-	-	-	
10	52	Downlink	Low	1935	387000	1930.32	386064	0	15	4830	386430	2	0	0 (0)	0
			Mid	1960	392000	1936.96	387392	102		4894	391490	10	1	0 (0)	103
			High	1985	397000	1889.6	377920	504		4955	396490	10	1	0 (0)	505
		Uplink	Low	1855	371000	1850.32	370064	0	-	-	-	-	-	-	
			Mid	1880	376000	1784.6	356920	504	-	-	-	-	-	-	
			High	1905	381000	1899.24	379848	6	-	-	-	-	-	-	
15	79	Downlink	Low	1937.5	387500	1930.39	386078	0	15	4831	386450	4	0	0 (0)	0

		Uplink	Mid	1960	392000	1934.53	386906	102	-	4888	391010	0	0	1 (2)	104
			High	1982.5	396500	1884.67	376934	504		4945	395570	8	1	1 (2)	507
			Low	1857.5	371500	1850.39	370078	0		-	-	-	-	-	-
			Mid	1880	376000	1782.17	356434	504		-	-	-	-	-	-
			High	1902.5	380500	1894.31	378862	6		-	-	-	-	-	-
20	106	Downlink	Low	1940	388000	1930.46	386092	0	15	4832	386650	6	1	2 (4)	5
			Mid	1960	392000	1932.1	386420	102		4882	390530	2	0	1 (2)	104
			High	1980	396000	1879.74	375948	504		4932	394590	10	1	1 (2)	507
		Uplink	Low	1860	372000	1850.46	370092	0	-	-	-	-	-	-	-
			Mid	1880	376000	1779.74	355948	504		-	-	-	-	-	-
			High	1900	380000	1889.38	377876	6		-	-	-	-	-	-
25	133	Downlink	Low	1942.5	388500	1930.53	386106	0	15	4833	386670	8	1	2 (4)	5
			Mid	1960	392000	1929.67	385934	102		4876	390050	4	0	1 (2)	104
			High	1977.5	395500	1874.81	374962	504		4919	393610	0	0	2 (4)	508
		Uplink	Low	1862.5	372500	1850.53	370106	0	-	-	-	-	-	-	-
			Mid	1880	376000	1777.31	355462	504		-	-	-	-	-	-
			High	1897.5	379500	1884.45	376890	6		-	-	-	-	-	-
30	160	Downlink	Low	1945	389000	1930.6	386120	0	15	4834	386690	10	1	2 (4)	5
			Mid	1960	392000	1927.24	385448	102		4870	389570	6	0	1 (2)	104
			High	1975	395000	1869.88	373976	504		4909	392690	10	1	2 (4)	509
		Uplink	Low	1865	373000	1850.6	370120	0	-	-	-	-	-	-	-
			Mid	1880	376000	1774.88	354976	504		-	-	-	-	-	-
			High	1895	379000	1879.52	375904	6		-	-	-	-	-	-
40	216	Downlink	Low	1950	390000	1930.56	386112	0	15	4833	386670	6	1	2 (4)	5
			Mid	1960	392000	1922.2	384440	102		4858	388610	10	1	1 (2)	105
			High	1970	394000	1859.84	371968	504		4880	390490	6	0	0 (0)	504
		Uplink	Low	1870	374000	1850.56	370112	0	-	-	-	-	-	-	-
			Mid	1880	376000	1769.84	353968	504		-	-	-	-	-	-
			High	1890	378000	1869.48	373896	6		-	-	-	-	-	-

Note 1: The CORESET#0 Index and the associated CORESET#0 Offset refers to Table 13-1 in TS 38.213 [22]. The value of CORESET#0 Index is signalled in controlResourceSetZero (pdccch-ConfigSIB1) in the MIB. The offsetToPointA IE is expressed in units of resource blocks assuming 15 kHz subcarrier spacing for FR1 and 60 kHz subcarrier spacing for FR2.

Note 2: The parameter Offset Carrier CORESET#0 specifies the offset from the lowest subcarrier of the carrier and the lowest subcarrier of CORESET#0. It corresponds to the parameter  $\Delta F_{\text{OffsetCORESET-0-Carrier}}$  in Annex C expressed in number of common RBs.



Table 4.3.1.1.1.2-2: Test frequencies for NR operating band n2 and SCS 30 kHz

CBW [MHz]	carrier Bandwidth [PRBs]	Range		Carrier centre [MHz]	Carrier centre [ARFCN]	point A [MHz]	absolute Frequency Point A [ARFCN]	offsetTo Carrier [Carrier PRBs]	SS block SCS [kHz]	GSCN	absolute FrequencySSB [ARFCN]	$k_{SSB}$	Offset Carrier CORE SET#0 [RBs] Note 2	CORE SET#0 Index (Offset [RBs]) Note 1	offsetTo PointA (SIB1) [PRBs] Note 1	
10	24	Downlink	Low	1935	387000	1930.68	386136	0	15	4836	386910	18	0	0 (5)	10	
			Mid	1960	392000	1918.96	383792	102		4900	391970	14	0	1 (6)	216	
			High	1985	397000	1799.24	359848	504		4961	396970	14	0	1 (6)	1020	
		Uplink	Low	1855	371000	1850.68	370136	0	-	-	-	-	-	-	-	-
			Mid	1880	376000	1694.24	338848	504		-	-	-	-	-	-	-
			High	1905	381000	1898.52	379704	6		-	-	-	-	-	-	-
15	38	Downlink	Low	1937.5	387500	1930.66	386132	0	15	4837	386930	2	0	1 (6)	12	
			Mid	1960	392000	1916.44	383288	102		4894	391490	22	0	1 (6)	216	
			High	1982.5	396500	1794.22	358844	504		4951	396050	18	0	2 (7)	1022	
		Uplink	Low	1857.5	371500	1850.66	370132	0	-	-	-	-	-	-	-	-
			Mid	1880	376000	1691.72	338344	504		-	-	-	-	-	-	-
			High	1902.5	380500	1893.5	378700	6		-	-	-	-	-	-	-
20	51	Downlink	Low	1940	388000	1930.82	386164	0	15	4835	386890	2	0	0 (5)	10	
			Mid	1960	392000	1914.1	382820	102		4888	391010	18	0	1 (6)	216	
			High	1980	396000	1789.38	357876	504		4938	395070	14	0	2 (7)	1022	
		Uplink	Low	1860	372000	1850.82	370164	0	-	-	-	-	-	-	-	-
			Mid	1880	376000	1689.38	337876	504		-	-	-	-	-	-	-
			High	1900	380000	1888.66	377732	6		-	-	-	-	-	-	-
25	65	Downlink	Low	1942.5	388500	1930.8	386160	0	15	4836	386910	10	0	0 (5)	10	
			Mid	1960	392000	1911.58	382316	102		4882	390530	2	0	2 (7)	218	
			High	1977.5	395500	1784.36	356872	504		4925	394090	22	0	2 (7)	1022	
		Uplink	Low	1862.5	372500	1850.8	370160	0	-	-	-	-	-	-	-	-
			Mid	1880	376000	1686.86	337372	504		-	-	-	-	-	-	-
			High	1897.5	379500	1883.64	376728	6		-	-	-	-	-	-	-
30	78	Downlink	Low	1945	389000	1930.96	386192	0	15	4837	386930	6	0	0 (5)	10	
			Mid	1960	392000	1909.24	381848	102		4876	390050	22	0	1 (6)	216	
			High	1975	395000	1779.52	355904	504		4912	392930	6	0	0 (5)	1018	
		Uplink	Low	1865	373000	1850.96	370192	0	-	-	-	-	-	-	-	-
			Mid	1880	376000	1684.52	336904	504		-	-	-	-	-	-	-
			High	1895	379000	1878.8	375760	6		-	-	-	-	-	-	-
40	106	Downlink	Low	1950	390000	1930.92	386184	0	15	4836	386910	2	0	0 (5)	10	
			Mid	1960	392000	1904.2	380840	102		4864	389090	14	0	2 (7)	218	
			High	1970	394000	1769.48	353896	504		4886	390970	22	0	0 (5)	1018	

	Uplink	Low	1870	374000	1850.92	370184	0	-	-	-	-	-	-
		Mid	1880	376000	1679.48	335896	504	-	-	-	-	-	-
		High	1890	378000	1868.76	373752	6	-	-	-	-	-	-

Note 1: The CORESET#0 Index and the associated CORESET#0 Offset refers to Table 13-2 in TS 38.213 [22]. The value of CORESET#0 Index is signalled in controlResourceSetZero (pdcch-ConfigSIB1) in the MIB. The offsetToPointA IE is expressed in units of resource blocks assuming 15 kHz subcarrier spacing for FR1 and 60 kHz subcarrier spacing for FR2.

Note 2: The parameter Offset Carrier CORESET#0 specifies the offset from the lowest subcarrier of the carrier and the lowest subcarrier of CORESET#0. It corresponds to the parameter  $\Delta F_{\text{OffsetCORESET-0-Carrier}}$  in Annex C expressed in number of common RBs.

**Table 4.3.1.1.2-3: Test frequencies for NR operating band n2 and SCS 60 kHz without CORESET#0**

CBW [MHz]	carrierBand width [PRBs]	Range		Carrier centre [MHz]	Carrier centre [ARFCN]	point A [MHz]	absolute Frequency A [ARFCN]	offsetTo Carrier [PRBs]	SS block SCS [kHz]	GSCN	absolute FrequencySSB [ARFCN]
10	11	Downlink	Low	1935	387000	1931.04	386208	0	15	-	386568
			Mid	1960	392000	1882.6	376520	102		-	391568
			High	1985	397000	1618.16	323632	504		-	396568
		Uplink	Low	1855	371000	1851.04	370208	0	-	-	-
			Mid	1880	376000	1513.16	302632	504		-	-
			High	1905	381000	1896.72	379344	6		-	-
15	18	Downlink	Low	1937.5	387500	1931.02	386204	0	15	-	386564
			Mid	1960	392000	1880.08	376016	102		-	391064
			High	1982.5	396500	1613.14	322628	504		-	395564
		Uplink	Low	1857.5	371500	1851.02	370204	0	-	-	-
			Mid	1880	376000	1510.64	302128	504		-	-
			High	1902.5	380500	1891.7	378340	6		-	-
20	24	Downlink	Low	1940	388000	1931.36	386272	0	15	-	386632
			Mid	1960	392000	1877.92	375584	102		-	390632
			High	1980	396000	1608.48	321696	504		-	394632
		Uplink	Low	1860	372000	1851.36	370272	0	-	-	-
			Mid	1880	376000	1508.48	301696	504		-	-
			High	1900	380000	1887.04	377408	6		-	-
25	31	Downlink	Low	1942.5	388500	1931.34	386268	0	15	-	386628
			Mid	1960	392000	1875.4	375080	102		-	390128
			High	1977.5	395500	1603.46	320692	504		-	393628
		Uplink	Low	1862.5	372500	1851.34	370268	0	-	-	-
			Mid	1880	376000	1505.96	301192	504		-	-
			High	1897.5	379500	1882.02	376404	6		-	-
30	38	Downlink	Low	1945	389000	1931.32	386264	0	15	-	386624

40	51	Uplink	Mid	1960	392000	1872.88	374576	102	-	389624		
			High	1975	395000	1598.44	319688	504	-	392624		
			Low	1865	373000	1851.32	370264	0	-	-		
			Mid	1880	376000	1503.44	300688	504	-	-		
			High	1895	379000	1877	375400	6	-	-		
		Downlink	Low	1950	390000	1931.64	386328	0	15	-	386688	
			Mid	1960	392000	1868.2	373640	102	-	-	388688	
			High	1970	394000	1588.76	317752	504	-	-	390688	
			Uplink	Low	1870	374000	1851.64	370328	0	-	-	-
				Mid	1880	376000	1498.76	299752	504	-	-	-
High	1890	378000		1867.32	373464	6	-	-	-			

Note: FR1 carrier without CORESET#0 is indicated in the MIB by setting  $k_{SSB}=31$ ,  $controlResourceSetZero=0$  and  $searchSpaceZero=0$  (TS 38.213 [22], clause 13).

4.3.1.1.1.3 Reference test frequencies for NR operating band n3

Table 4.3.1.1.1.3-1: Test frequencies for NR operating band n3 and SCS 15 kHz

CBW [MHz]	carrierBandwidth [PRBs]	Range	Carrier centre [MHz]	Carrier centre [ARFCN]	point A [MHz]	absoluteFrequencyPointA [ARFCN]	offsetToCarrier [Carrier PRBs]	SS block SCS [kHz]	GS CN	absoluteFrequencySSB [ARFCN]	$k_{SSB}$	Offset Carrier CORESET#0 [RBs] Note 2	CORESET#0 Index (Offset [RBs]) Note 1	offsetToPointA (SIB1) [PRBs] Note 1	
5	25	Downlink	Low	1807.5	361500	1805.25	361050	0	15	4518	361470	8	1	0 (0)	1
			Mid	1842.5	368500	1821.89	364378	102		4604	368410	0	0	0 (0)	102
			High	1877.5	375500	1784.53	356906	504		4693	375410	0	0	0 (0)	504
		Uplink	Low	1712.5	342500	1710.25	342050	0	-	-	-	-	-	-	-
			Mid	1747.5	349500	1654.53	330906	504	-	-	-	-	-	-	-
			High	1782.5	356500	1779.17	355834	6	-	-	-	-	-	-	-
10	52	Downlink	Low	1810	362000	1805.32	361064	0	15	4519	361490	10	1	0 (0)	1

		Uplink	Mid	1842.5	368500	1819.46	363892	102	-	4598	367930	2	0	0 (0)	102
			High	18750	375000	1779.6	355920	504		4680	374430	2	0	0 (0)	504
			Low	17150	343000	1710.32	342064	0		-	-	-	-	-	-
			Mid	1747.5	349500	1652.1	330420	504		-	-	-	-	-	-
			High	17800	356000	1774.24	354848	6		-	-	-	-	-	-
15	79	Downlink	Low	1812.5	362500	1805.39	361078	0	15	4517	361450	4	0	0 (0)	0
			Mid	1842.5	368500	1817.03	363406	102		4592	367450	4	0	0 (0)	102
			High	1872.5	374500	1774.67	354934	504		4667	373450	4	0	0 (0)	504
		Uplink	Low	1717.5	343500	1710.39	342078	0		-	-	-	-	-	-
			Mid	1747.5	349500	1649.67	329934	504		-	-	-	-	-	-
			High	1777.5	355500	1769.31	353862	6		-	-	-	-	-	-
20	106	Downlink	Low	18150	363000	1805.46	361092	0	15	4518	361470	6	0	0 (0)	0
			Mid	1842.5	368500	1814.6	362920	102		4586	366970	6	0	0 (0)	102
			High	18700	374000	1769.74	353948	504		4657	372530	2	0	1 (2)	506
		Uplink	Low	17200	344000	1710.46	342092	0		-	-	-	-	-	-
			Mid	1747.5	349500	1647.24	329448	504		-	-	-	-	-	-
			High	17750	355000	1764.38	352876	6		-	-	-	-	-	-
25	133	Downlink	Low	1817.5	363500	1805.53	361106	0	15	4519	361490	8	0	0 (0)	0
			Mid	1842.5	368500	1812.17	362434	102		4580	366490	8	0	0 (0)	102
			High	1867.5	373500	1764.81	352962	504		4644	371550	4	0	1 (2)	506
		Uplink	Low	1722.5	344500	1710.53	342106	0		-	-	-	-	-	-

			Mid	1747.5	349500	1644.81	328962	504		-	-	-	-	-	-
			High	1772.5	354500	1759.45	351890	6		-	-	-	-	-	-
30	160	Downlink	Low	1820	364000	1805.6	361120	0	15	4520	361690	10	1	2 (4)	5
			Mid	1842.5	368500	1809.74	361948	102		4574	366010	10	0	0 (0)	102
			High	1865	373000	1759.88	351976	504		4631	370570	6	0	1 (2)	506
		Uplink	Low	1725	345000	1710.6	342120	0	-	-	-	-	-	-	-
			Mid	1747.5	349500	1642.38	328476	504		-	-	-	-	-	-
			High	1770	354000	1754.52	350904	6		-	-	-	-	-	-
35	188	Downlink	Low	1822.5	364500	1805.58	361116	0	15	4521	361710	6	2	2 (4)	6
			Mid	1842.5	368500	1807.22	361444	102		4568	365530	6	1	0 (0)	103
			High	1862.5	372500	1754.86	350972	504		4621	369650	10	0	2(4)	508
		Uplink	Low	1727.5	345500	1710.58	342116	0	-	-	-	-	-	-	-
			Mid	1747.5	349500	1639.86	327972	504		-	-	-	-	-	-
			High	1767.5	353500	1749.5	349900	6		-	-	-	-	-	-
40	216	Downlink	Low	1825	365000	1805.56	361112	0	15	4519	361490	6	0	0 (0)	0
			Mid	1842.5	368500	1804.7	360940	102		4562	365050	2	0	1 (2)	104
			High	1860	372000	1749.84	349968	504		4608	368670	6	1	2 (4)	509
		Uplink	Low	1730	346000	1710.56	342112	0	-	-	-	-	-	-	-
			Mid	1747.5	349500	1637.34	327468	504		-	-	-	-	-	-
			High	1765	353000	1744.48	348896	6		-	-	-	-	-	-
45	242	Downlink	Low	1827.5	365500	1805.72	361144	0	15	4520	361690	2	1	2 (4)	5

50	270	Uplink	Mi	1842	36850	1802	360472	102	-	455	364570	10	1	0 (0)	103	
			d	.5	0	.36					459	367690	2	1	2 (4)	509
			Hi	1857	37150	1745	349000	504								
		Uplink	Lo	1732	34650	1710	342144	0	-	-		-	-	-	-	-
			d	.5	0	.72										
			Hi	1762	35250	1739	347928	6								
		Downlink	Downlink	Lo	1830	36600	1805	361140	0	15	452	361710	10	1	2 (4)	5
				d	.5	0	.7				455	364090	6	0	1 (2)	104
				Hi	1855	37100	1739	347996	504		458	366530	10	0	0 (0)	504
Uplink	Lo		1735	34700	1710	342140	0	-	-		-	-	-	-		
	d		.5	0	.7											
	Hi		1760	35200	1734	346924	6									

Note 1: The CORESET#0 Index and the associated CORESET#0 Offset refers to Table 13-1 in TS 38.213 [22]. The value of CORESET#0 Index is signalled in controlResourceSetZero (pdcch-ConfigSIB1) in the MIB. The offsetToPointA IE is expressed in units of resource blocks assuming 15 kHz subcarrier spacing for FR1 and 60 kHz subcarrier spacing for FR2.

Note 2: The parameter Offset Carrier CORESET#0 specifies the offset from the lowest subcarrier of the carrier and the lowest subcarrier of CORESET#0. It corresponds to the parameter  $\Delta F_{\text{OffsetCORESET-0-Carrier}}$  in Annex C expressed in number of common RBs.

Table 4.3.1.1.3-2: Test frequencies for NR operating band n3 and SCS 30 kHz

CBW [MHz]	carrierBandwidth [PRBs]	Range	Carrier centre [MHz]	Carrier centre [ARFCN]	point A [MHz]	absoluteFrequencyPointA [ARFCN]	offsetToCarrier [Carrier PRBs]	SS block SCS [kHz]	GS CN	absoluteFrequencySSB [ARFCN]	$k_{SSB}$	Offset Carrier CORESET#0 [RBs] Note 2	CORESET#0 Index (Offset [RBs]) Note 1	offsetToPointA (SIB1) [PRBs] Note 1	
10	24	Downlink	Lo	1810	36200	1805	361136	0	15	452	361970	14	0	1 (6)	12
			d	.5	0	.68				460	368410	18	0	0 (5)	214

			High	1875	37500	1689	337848	504		468	374910	18	0	0 (5)	1018
		Uplink	Low	1715	34300	1710	342136	0	-	-	-	-	-	-	-
			Mid	1747	34950	1561	312348	504		-	-	-	-	-	-
			High	1780	35600	1773	354704	6		-	-	-	-	-	-
15	38	Downlink	Low	1812	36250	1805	361132	0	15	452	361930	2	0	1 (6)	12
			Mid	1842	36850	1798	359788	102		459	367930	2	0	1 (6)	216
			High	1872	37450	1684	336844	504		467	373930	2	0	1 (6)	1020
		Uplink	Low	1717	34350	1710	342132	0	-	-	-	-	-	-	-
			Mid	1747	34950	1559	311844	504		-	-	-	-	-	-
			High	1777	35550	1768	353700	6		-	-	-	-	-	-
20	51	Downlink	Low	1815	36300	1805	361164	0	15	452	361950	22	0	0 (5)	10
			Mid	1842	36850	1796	359320	102		459	367450	22	0	0 (5)	214
			High	1870	37400	1679	335876	504		466	373010	18	0	1 (6)	1020
		Uplink	Low	1720	34400	1710	342164	0	-	-	-	-	-	-	-
			Mid	1747	34950	1556	311376	504		-	-	-	-	-	-
			High	1775	35500	1763	352732	6		-	-	-	-	-	-
25	65	Downlink	Low	1817	36350	1805	361160	0	15	452	361970	6	0	1 (6)	12
			Mid	1842	36850	1794	358816	102		458	366970	6	0	1 (6)	216
			High	1867	37350	1674	334872	504		465	372030	2	0	2 (7)	1022
		Uplink	Low	1722	34450	1710	342160	0	-	-	-	-	-	-	-
			Mid	1747	34950	1554	310872	504		-	-	-	-	-	-

30	78	Down link	High	1772.5	354500	1758.64	351728	6	15	-	-	-	-	-	-
			Low	1820	364000	1805.96	361192	0		4523	361930	6	0	0 (5)	10
			Mid	1842.5	368500	1791.74	358348	102		4580	366490	2	0	1 (6)	216
		Uplink	High	1865	373000	1669.52	333904	504		4637	371050	22	0	1 (6)	1020
			Low	1725	345000	1710.96	342192	0		-	-	-	-	-	-
			Mid	1747.5	349500	1552.02	310404	504		-	-	-	-	-	-
35	92	Down link	High	1770	354000	1753.8	350760	6	15	-	-	-	-	-	-
			Low	1822.5	364500	1805.94	361188	0		4524	361950	14	0	0 (5)	10
			Mid	1842.5	368500	1789.22	357844	102		4574	366010	10	0	1 (6)	216
		Uplink	High	1862.5	372500	1664.5	332900	504		4627	370130	2	0	3 (8)	1024
			Low	1727.5	345500	1710.94	342188	0		-	-	-	-	-	-
			Mid	1747.5	349500	1549.5	309900	504		-	-	-	-	-	-
40	106	Down link	High	1767.5	353500	1748.78	349756	6	15	-	-	-	-	-	-
			Low	1825	365000	1805.92	361184	0		4525	361970	22	0	0 (5)	10
			Mid	1842.5	368500	1786.7	357340	102		4568	365530	18	0	1 (6)	216
		Uplink	High	1860	372000	1659.48	331896	504		4611	368910	2	0	0 (5)	1018
			Low	1730	346000	1710.92	342184	0		-	-	-	-	-	-
			Mid	1747.5	349500	1546.98	309396	504		-	-	-	-	-	-
45	119	Down link	High	1765	353000	1743.76	348752	6	15	-	-	-	-	-	-
			Low	1827.5	365500	1806.08	361216	0		4526	362170	6	0	3 (8)	16
			Mid	1842.5	368500	1784.36	356872	102		4562	365050	14	0	1 (6)	216



			High	1857.5	37150.0	1654.64	330928	504		460.1	368170	6	0	3 (8)	1024
		Uplink	Low	1732.5	34650.0	1711.08	342216	0	-	-	-	-	-	-	-
			Mid	1747.5	34950.0	1544.64	308928	504		-	-	-	-	-	-
			High	1762.5	35250.0	1738.92	347784	6		-	-	-	-	-	-
50	133	Downlink	Low	1830	36600.0	1806.06	361212	0	15	452.4	361950	6	0	0 (5)	10
			Mid	1842.5	36850.0	1781.84	356368	102		455.6	364570	22	0	1 (6)	216
			High	1855	37100.0	1649.62	329924	504		458.8	367010	2	0	1(6)	1020
		Uplink	Low	1735	34700.0	1711.06	342212	0	-	-	-	-	-	-	-
			Mid	1747.5	34950.0	1542.12	308424	504		-	-	-	-	-	-
			High	1760	35200.0	1733.9	346780	6		-	-	-	-	-	-
<p>Note 1: The CORESET#0 Index and the associated CORESET#0 Offset refers to Table 13-2 in TS 38.213 [22]. The value of CORESET#0 Index is signalled in controlResourceSetZero (pdcch-ConfigSIB1) in the MIB. The offsetToPointA IE is expressed in units of resource blocks assuming 15 kHz subcarrier spacing for FR1 and 60 kHz subcarrier spacing for FR2.</p> <p>Note 2: The parameter Offset Carrier CORESET#0 specifies the offset from the lowest subcarrier of the carrier and the lowest subcarrier of CORESET#0. It corresponds to the parameter <math>\Delta F_{\text{OffsetCORESET-0-Carrier}}</math> in Annex C expressed in number of common RBs.</p>															

Table 4.3.1.1.3-3: Test frequencies for NR operating band n3 and SCS 60 kHz without CORESET#0

CBW [MHz]	carrierBand width [PRBs]	Range		Carrier centre [MHz]	Carrier centre [ARFCN]	point A [MHz]	absolute FrequencyPoint A [ARFCN]	offsetTo Carrier [PRBs]	SS block SCS [kHz]	GSCN	absolute FrequencySSB [ARFCN]
10	11	Downlink	Low	1810	362000	1806.04	361208	0	15	-	361568
			Mid	1842.5	368500	1765.1	353020	102		-	368068
			High	1875	375000	1508.16	301632	504		-	374568
		Uplink	Low	1715	343000	1711.04	342208	0	-	-	-
			Mid	1747.5	349500	1380.66	276132	504		-	-
			High	1780	356000	1771.72	354344	6		-	-
15	18	Downlink	Low	1812.5	362500	1806.02	361204	0	15	-	361564
			Mid	1842.5	368500	1762.58	352516	102		-	367564

			High	1872.5	374500	1503.14	300628	504		-	373564
		Uplink	Low	1717.5	343500	1711.02	342204	0	-	-	-
			Mid	1747.5	349500	1378.14	275628	504		-	-
			High	1777.5	355500	1766.7	353340	6		-	-
20	24	Downlink	Low	1815	363000	1806.36	361272	0	15	-	361632
			Mid	1842.5	368500	1760.42	352084	102		-	367132
			High	1870	374000	1498.48	299696	504		-	372632
		Uplink	Low	1720	344000	1711.36	342272	0	-	-	-
			Mid	1747.5	349500	1375.98	275196	504		-	-
			High	1775	355000	1762.04	352408	6		-	-
25	31	Downlink	Low	1817.5	363500	1806.34	361268	0	15	-	361628
			Mid	1842.5	368500	1757.9	351580	102		-	366628
			High	1867.5	373500	1493.46	298692	504		-	371628
		Uplink	Low	1722.5	344500	1711.34	342268	0	-	-	-
			Mid	1747.5	349500	1373.46	274692	504		-	-
			High	1772.5	354500	1757.02	351404	6		-	-
30	38	Downlink	Low	1820	364000	1806.32	361264	0	15	-	361624
			Mid	1842.5	368500	1755.38	351076	102		-	366124
			High	1865	373000	1488.44	297688	504		-	370624
		Uplink	Low	1725	345000	1711.32	342264	0	-	-	-
			Mid	1747.5	349500	1370.94	274188	504		-	-
			High	1770	354000	1752	350400	6		-	-
35	44	Downlink	Low	1822.5	364500	1806.66	361332	0	15	-	361692
			Mid	1842.5	368500	1753.22	350644	102		-	365692
			High	1862.5	372500	1483.78	296756	504		-	369692
		Uplink	Low	1727.5	345500	1711.66	342332	0	-	-	-
			Mid	1747.5	349500	1368.78	273756	504		-	-
			High	1767.5	353500	1747.34	349468	6		-	-
40	51	Downlink	Low	1825	365000	1806.64	361328	0	15	-	361688
			Mid	1842.5	368500	1750.7	350140	102		-	365188
			High	1860	372000	1478.76	295752	504		-	368688
		Uplink	Low	1730	346000	1711.64	342328	0	-	-	-
			Mid	1747.5	349500	1366.26	273252	504		-	-
			High	1765	353000	1742.32	348464	6		-	-
45	58	Downlink	Low	1827.5	365500	1806.62	361324	0	15	-	361684
			Mid	1842.5	368500	1748.18	349636	102		-	364684
			High	1857.5	371500	1473.74	294748	504		-	367684
		Uplink	Low	1732.5	346500	1711.62	342324	0	-	-	-
			Mid	1747.5	349500	1363.74	272748	504		-	-
			High	1762.5	352500	1737.3	347460	6		-	-
50	65	Downlink	Low	1830	366000	1806.6	361320	0	15	-	361680

			Mid	1842.5	368500	1745.66	349132	102		-	364180
			High	1855	371000	1468.72	293744	504		-	366680
		Uplink	Low	1735	347000	1711.6	342320	0	-	-	-
			Mid	1747.5	349500	1361.22	272244	504		-	-
			High	1760	352000	1732.28	346456	6		-	-
Note: FR1 carrier without CORESET#0 is indicated in the MIB by setting $k_{SSB}=31$ , <i>controlResourceSetZero=0</i> and <i>searchSpaceZero = 0</i> (TS 38.213 [22], clause 13).											

4.3.1.1.1.4 FFS

4.3.1.1.1.5 Reference test frequencies for NR operating band n5

**Table 4.3.1.1.1.5-1: Test frequencies for NR operating band n5 and SCS 15 kHz**

CBW [MHz]	carrierBandwidth [PRBs]	Range		Carrier centre [MHz]	Carrier centre [ARFCN]	point A [MHz]	absoluteFrequencyPointA [ARFCN]	offsetToCarrier [Carrier PRBs]	SS block SCS [kHz]	GS CN	absoluteFrequencySSB [ARFCN]	$k_{SSB}$	Offset Carrier CORESET#0 [RBs] Note 2	CORESET#0 Index (Offset [RBs]) Note 1	offsetToPointA (SIB1) [PRBs] Note 1
5	25	Downlink	Low	871.5	174300	869.25	173850	0	15	2178	174270	8	1	0 (0)	1
			Mid	881.5	176300	860.89	172178	102		2203	176210	0	0	0 (0)	102
			High	891.5	178300	798.53	159706	504		2228	178330	4	1	1 (2)	507
		Uplink	Low	826.5	165300	824.25	164850	0	-	-	-	-	-	-	-
			Mid	836.5	167300	743.53	148706	504	-	-	-	-	-	-	-
			High	846.5	169300	843.17	168634	6	-	-	-	-	-	-	-
10	52	Downlink	Low	874	174800	869.32	173864	0	15	2179	174290	10	1	0 (0)	1
			Mid	881.5	176300	858.46	171692	102		2197	175730	2	0	0 (0)	102
			High	889	177800	793.6	158720	504		2218	177410	2	1	2 (4)	509
		Uplink	Low	829	165800	824.32	164864	0	-	-	-	-	-	-	

			Mid	836.5	167300	741.1	148220	504		-	-	-	-	-	-
			High	844	168800	838.24	167648	6		-	-	-	-	-	-
15	79	Downlink	Low	876.5	175300	869.39	173878	0	15	2177	174250	4	0	0 (0)	0
			Mid	881.5	176300	856.03	171206	102		2191	175250	4	0	0 (0)	102
			High	886.5	177300	788.67	157734	504		2205	176430	4	1	2 (4)	509
		Uplink	Low	831.5	166300	824.39	164878	0	-	-	-	-	-	-	-
			Mid	836.5	167300	738.67	147734	504		-	-	-	-	-	-
			High	841.5	168300	833.31	166662	6		-	-	-	-	-	-
20	106	Downlink	Low	879	175800	869.46	173892	0	15	2178	174270	6	0	0 (0)	0
			Mid	881.5	176300	853.6	170720	102		2185	174770	6	0	0 (0)	102
			High	884	176800	783.74	156748	504		2192	175450	6	1	2 (4)	509
		Uplink	Low	834	166800	824.46	164892	0	-	-	-	-	-	-	-
			Mid	836.5	167300	736.24	147248	504		-	-	-	-	-	-
			High	839	167800	828.38	165676	6		-	-	-	-	-	-
25	133	Downlink	Low	881.5	176300	869.53	173906	0	15	2179	174290	8	0	0 (0)	0
Note 3			Mid												
			High												
<p>Note 1: The CORESET#0 Index and the associated CORESET#0 Offset refers to Table 13-1 in TS 38.213 [22]. The value of CORESET#0 Index is signalled in controlResourceSetZero (pdccch-ConfigSIB1) in the MIB. The offsetToPointA IE is expressed in units of resource blocks assuming 15 kHz subcarrier spacing for FR1 and 60 kHz subcarrier spacing for FR2.</p> <p>Note 2: The parameter Offset Carrier CORESET#0 specifies the offset from the lowest subcarrier of the carrier and the lowest subcarrier of CORESET#0. It corresponds to the parameter <math>\Delta F_{\text{OffsetCORESET-0-Carrier}}</math> in Annex C expressed in number of common RBs.</p> <p>Note 3: This UE channel bandwidth is applicable only to downlink.</p>															

Table 4.3.1.1.1.5-2: Test frequencies for NR operating band n5 and SCS 30 kHz

CB W [MHz]	carrierBandwidth [PRBs]	Range		Carrier centre [MHz]	Carrier centre [ARFCN]	point A [MHz]	absoluteFrequencyPointA [ARFCN]	offsetToCarrier [Carrier PRBs]	SS block SCS [kHz]	GS CN	absoluteFrequencySSB [ARFCN]	$k_{SSB}$	Offset Carrier CORES ET#0 [RBs] Note 2	CORES ET#0 Index (Offset [RBs]) Note 1	offsetToPointA (SIB1) [PRBs] Note 1	
10	24	Downlink	Low	874	174800	869.68	173936	0	30	2185	174770	14	0	1 (1)	2	
			Mid	881.5	176300	840.46	168092	102		2203	176210	18	0	0 (0)	204	
			High	889	177800	703.24	140648	504		2224	177890	6	0	3 (3)	1014	
		Uplink	Low	829	165800	824.68	164936	0	-	-	-	-	-	-	-	-
			Mid	836.5	167300	650.74	130148	504		-	-	-	-	-	-	-
			High	844	168800	837.52	167504	6		-	-	-	-	-	-	-
15	38	Downlink	Low	876.5	175300	869.66	173932	0	30	2183	174730	2	0	1 (1)	2	
			Mid	881.5	176300	837.94	167588	102		2197	175730	2	0	1 (1)	206	
			High	886.5	177300	698.22	139644	504		2208	176670	6	0	0 (0)	1008	
		Uplink	Low	831.5	166300	824.66	164932	0	-	-	-	-	-	-	-	-
			Mid	836.5	167300	648.22	129644	504		-	-	-	-	-	-	-
			High	841.5	168300	832.5	166500	6		-	-	-	-	-	-	-
20	51	Downlink	Low	879	175800	869.82	173964	0	30	2184	174750	22	0	0 (0)	0	
			Mid	881.5	176300	835.6	167120	102		2191	175250	22	0	0 (0)	204	
			High	884	176800	693.38	138676	504		2195	175690	2	0	0 (0)	1008	
		Uplink	Low	834	166800	824.82	164964	0	-	-	-	-	-	-	-	

			Mid	836.5	167300	645.88	129176	504		-	-	-	-	-	-
			High	839	167800	827.66	165532	6		-	-	-	-	-	-
25	65	Down link	Low	881.5	176300	869.8	173960	0	30	2185	174770	6	0	1 (1)	2
Not e 3			Mid												
			High												
<p>Note 1: The CORESET#0 Index and the associated CORESET#0 Offset refers to Table 13-4 in TS 38.213 [22]. The value of CORESET#0 Index is signalled in controlResourceSetZero (pdccch-ConfigSIB1) in the MIB. The offsetToPointA IE is expressed in units of resource blocks assuming 15 kHz subcarrier spacing for FR1 and 60 kHz subcarrier spacing for FR2.</p> <p>Note 2: The parameter Offset Carrier CORESET#0 specifies the offset from the lowest subcarrier of the carrier and the lowest subcarrier of CORESET#0. It corresponds to the parameter <math>\Delta F_{\text{OffsetCORESET-0-Carrier}}</math> in Annex C expressed in number of common RBs.</p> <p>Note 3: This UE channel bandwidth is applicable only to downlink.</p>															

4.3.1.1.1.6 FFS

4.3.1.1.1.7 Reference test frequencies for NR operating band n7

**Table 4.3.1.1.1.7-1: Test frequencies for NR operating band n7 and SCS 15 kHz**

CB W [MHz]	carrierBandwidth [PRBs]	Range		Carrier centre [MHz]	Carrier centre [ARFCN]	point A [MHz]	absoluteFrequencyPointA [ARFCN]	offsetToCarrier [Carrier PRBs]	SS block SCS [kHz]	GS CN	absoluteFrequencySSB [ARFCN]	$k_{SSB}$	Offset Carrier CORESET#0 [RBs] Note 2	CORESET#0 Index (Offset [RBs]) Note 1	offsetToPointA (SIB1) [PRBs] Note 1
5	25	Down link	Low	2622.5	524500	2620.25	524050	0	15	6554	524410	0	0	0 (0)	0
			Mid	26550	531000	2634.39	526878	102		6636	530910	0	0	0 (0)	102
			High	2687.5	537500	2594.53	518906	504		6718	537410	0	0	0 (0)	504
		Uplink	Low	2502.5	500500	2500.25	500050	0	-	-	-	-	-	-	-
			Mid	25350	507000	2442.03	488406	504	-	-	-	-	-	-	-

			High	2567.5	513500	2564.17	512834	6		-	-	-	-	-	-
10	52	Down link	Low	2625	525000	2620.32	524064	0	15	6555	524430	2	0	0 (0)	0
			Mid	26550	531000	2631.96	526392	102		6630	530430	2	0	0 (0)	102
			High	26850	537000	2589.6	517920	504		6705	536430	2	0	0 (0)	504
		Uplink	Low	25050	501000	2500.32	500064	0	-	-	-	-	-	-	-
			Mid	25350	507000	2439.6	487920	504		-	-	-	-	-	-
			High	25650	513000	2559.24	511848	6		-	-	-	-	-	-
15	79	Down link	Low	2627.5	525500	2620.39	524078	0	15	6556	524450	4	0	0 (0)	0
			Mid	26550	531000	2629.53	525906	102		6624	529950	4	0	0 (0)	102
			High	2682.5	536500	2584.67	516934	504		6692	535450	4	0	0 (0)	504
		Uplink	Low	2507.5	501500	2500.39	500078	0	-	-	-	-	-	-	-
			Mid	25350	507000	2437.17	487434	504		-	-	-	-	-	-
			High	2562.5	512500	2554.31	510862	6		-	-	-	-	-	-
20	106	Down link	Low	2630	526000	2620.46	524092	0	15	6557	524650	6	1	2 (4)	5
			Mid	26550	531000	2627.1	525420	102		6618	529470	6	0	0 (0)	102
			High	26800	536000	2579.74	515948	504		6682	534530	2	0	1 (2)	506
		Uplink	Low	25100	502000	2500.46	500092	0	-	-	-	-	-	-	-
			Mid	25350	507000	2434.74	486948	504		-	-	-	-	-	-
			High	25600	512000	2549.38	509876	6		-	-	-	-	-	-
25	133	Down link	Low	2632.5	526500	2620.53	524106	0	15	6558	524670	8	1	2 (4)	5
			Mid	26550	531000	2624.67	524934	102	15	6612	528990	8	0	0 (0)	102

			High	2677.5	535500	2574.81	514962	504	15	6669	533550	4	0	1 (2)	506	
		Uplink	Low	2512.5	502500	2500.53	500106	0	-	-	-	-	-	-	-	
			Mid	25350	507000	2432.31	486462	504	-	-	-	-	-	-	-	
			High	2557.5	511500	2544.45	508890	6	-	-	-	-	-	-	-	
50	270	Downlink	Low	2645	529000	2620.7	524140	0	15	6557	524650	2	0	2 (4)	4	
			Mid	2655	531000	2612.34	522468	102	15	6582	526590	6	0	1 (2)	104	
			High	2665	533000	2549.98	509996	504	15	6607	528530	10	0	0 (0)	504	
		Uplink	Low	2525	505000	2500.7	500140	0	-	-	-	-	-	-	-	-
			Mid	2535	507000	2419.98	483996	504	-	-	-	-	-	-	-	-
			High	2545	509000	2519.62	503924	6	-	-	-	-	-	-	-	-
<p>Note 1: The CORESET#0 Index and the associated CORESET#0 Offset refers to Table 13-1 in TS 38.213 [22]. The value of CORESET#0 Index is controlResourceSetZero (pdcch-ConfigSIB1) in the MIB. The offsetToPointA IE is expressed in units of resource blocks assuming 15 kHz subcarrier spacing for FR1 and 60 kHz subcarrier spacing for FR2.</p> <p>Note 2: The parameter Offset Carrier CORESET#0 specifies the offset from the lowest subcarrier of the carrier and the lowest subcarrier of CORESET#0. It corresponds to the parameter <math>\Delta F_{\text{OffsetCORESET-0-Carrier}}</math> in Annex C expressed in number of common RBs.</p>																

Table 4.3.1.1.1.7-2: Test frequencies for NR operating band n7 and SCS 30 kHz

CBW [MHz]	carrierBandwidth [PRBs]	Range	Carrier centre [MHz]	Carrier centre [ARFCN]	point A [MHz]	absoluteFrequencyPointA [ARFCN]	offsetToCarrier [Carrier PRBs]	SS block SCS [kHz]	GS CN	absoluteFrequencySSB [ARFCN]	$k_{SSB}$	Offset Carrier CORESET#0 [RBs] Note 2	CORESET#0 Index (Offset [RBs]) Note 1	offsetToPointA (SIB1) [PRBs] Note 1	
10	24	Downlink	Low	2625	525000	2620.68	524136	0	15	6561	524910	18	0	0 (5)	10
			Mid	2655	531000	2613.96	522792	102		6636	530910	18	0	0 (5)	214
			High	2685	537000	2499.24	499848	504		6711	536910	18	0	0 (5)	1018



		Uplink	Low	2505	50100	2500	500136	0	-	-	-	-	-	-	
			Mid	2535	50700	2349	469848	504	-	-	-	-	-	-	
			High	2565	51300	2558	511704	6	-	-	-	-	-	-	
15	38	Downlink	Low	2627	52550	2620	524132	0	15	656	524930	2	0	1 (6)	12
			Mid	2655	53100	2611	522288	102		663	530430	2	0	1 (6)	216
			High	2682	53650	2494	498844	504		669	535930	2	0	1 (6)	1020
		Uplink	Low	2507	50150	2500	500132	0	-	-	-	-	-	-	
			Mid	2535	50700	2346	469344	504	-	-	-	-	-	-	
			High	2562	51250	2553	510700	6	-	-	-	-	-	-	
20	51	Downlink	Low	2630	52600	2620	524164	0	15	656	524890	2	0	0 (5)	10
			Mid	2655	53100	2609	521820	102		662	529950	22	0	0 (5)	214
			High	2680	53600	2489	497876	504		668	535010	18	0	1 (6)	1020
		Uplink	Low	2510	50200	2500	500164	0	-	-	-	-	-	-	
			Mid	2535	50700	2344	468876	504	-	-	-	-	-	-	
			High	2560	51200	2548	509732	6	-	-	-	-	-	-	
25	65	Downlink	Low	2632	52650	2620	524160	0	15	656	524910	10	0	0 (5)	10
			Mid	2655	53100	2606	521316	102	15	661	529470	6	0	1 (6)	216
			High	2677	53550	2484	496872	504	15	667	534030	2	0	2 (7)	1022
		Uplink	Low	2512	50250	2500	500160	0	-	-	-	-	-	-	
			Mid	2535	50700	2341	468372	504	-	-	-	-	-	-	
			High	2557	51150	2543	508728	6	-	-	-	-	-	-	

50	133	Downlink	Low	2645	529000	2621.06	524212	0	15	6563	525130	18	0	2 (7)	14		
			Mid	2655	531000	2594.34	518868	102	15	6588	527070	22	0	1 (6)	216		
			High	2665	533000	2459.62	491924	504	15	6613	529010	2	0	1 (6)	1020		
		Uplink	Low	2525	505000	2501.06	500212	0	-	-	-	-	-	-	-		
			Mid	2535	507000	2329.62	465924	504	-	-	-	-	-	-	-		
			High	2545	509000	2518.9	503780	6	-	-	-	-	-	-	-		
		<p>Note 1: The CORESET#0 Index and the associated CORESET#0 Offset refers to Table 13-2 in TS 38.213 [22]. The value of CORESET#0 Index is signalled in controlResourceSetZero (pdcc-ConfigSIB1) in the MIB. The offsetToPointA IE is expressed in units of resource blocks assuming 15 kHz subcarrier spacing for FR1 and 60 kHz subcarrier spacing for FR2.</p> <p>Note 2: The parameter Offset Carrier CORESET#0 specifies the offset from the lowest subcarrier of the carrier and the lowest subcarrier of CORESET#0. It corresponds to the parameter <math>\Delta F_{\text{OffsetCORESET-0-Carrier}}</math> in Annex C expressed in number of common RBs.</p>															

**Table 4.3.1.1.7-3: Test frequencies for NR operating band n7 and SCS 60 kHz without CORESET#0**

CBW [MHz]	carrierBand width [PRBs]	Range		Carrier centre [MHz]	Carrier centre [ARFCN]	point A [MHz]	absolute FrequencyPoint A [ARFCN]	offsetTo Carrier [PRBs]	SS block SCS [kHz]	GSCN	absolute FrequencySSB [ARFCN]
10	11	Downlink	Low	2625	525000	2621.04	524208	0	15	-	524568
			Mid	2655	531000	2577.6	515520	102		-	530568
			High	2685	537000	2318.16	463632	504		-	536568
		Uplink	Low	2505	501000	2501.04	500208	0	-	-	-
			Mid	2535	507000	2168.16	433632	504		-	-
			High	2565	513000	2556.72	511344	6		-	-
15	18	Downlink	Low	2627.5	525500	2621.02	524204	0	15	-	524564
			Mid	2655	531000	2575.08	515016	102		-	530064
			High	2682.5	536500	2313.14	462628	504		-	535564
		Uplink	Low	2507.5	501500	2501.02	500204	0	-	-	-
			Mid	2535	507000	2165.64	433128	504		-	-
			High	2562.5	512500	2551.7	510340	6		-	-
20	24	Downlink	Low	2630	526000	2621.36	524272	0	15	-	524632
			Mid	2655	531000	2572.92	514584	102		-	529632
			High	2680	536000	2308.48	461696	504		-	534632
		Uplink	Low	2510	502000	2501.36	500272	0	-	-	-

25	31	Downlink	Mid	2535	507000	2163.48	432696	504	15	-	-
			High	2560	512000	2547.04	509408	6		-	-
			Low	2632.5	526500	2621.34	524268	0		-	524628
		Mid	2655	531000	2570.4	514080	102	-		529128	
		High	2677.5	535500	2303.46	460692	504	-		533628	
		Uplink	Low	2512.5	502500	2501.34	500268	0		-	-
Mid	2535		507000	2160.96	432192	504	-	-			
High	2557.5		511500	2542.02	508404	6	-	-			
50	65	Downlink	Low	2645	529000	2621.6	524320	0	15	-	524680
			Mid	2655	531000	2558.16	511632	102		-	526680
			High	2665	533000	2278.72	455744	504		-	528680
		Uplink	Low	2525	505000	2501.6	500320	0		-	-
			Mid	2535	507000	2148.72	429744	504		-	-
			High	2545	509000	2517.28	503456	6		-	-
Note: FR1 carrier without CORESET#0 is indicated in the MIB by setting $k_{SSB}=31$ , $controlResourceSetZero=0$ and $searchSpaceZero=0$ (TS 38.213 [22], clause 13).											

4.3.1.1.1.8 Reference test frequencies for NR operating band n8

Table 4.3.1.1.1.8-1: Test frequencies for NR operating band n8 and SCS 15 kHz

CBW [MHz]	carrierBandwidth [PRBs]	Range		Carrier centre [MHz]	Carrier centre [ARFCN]	point A [MHz]	absoluteFrequencyPointA [ARFCN]	offsetToCarrier [Carrier PRBs]	SS block SCS [kHz]	GS CN	absoluteFrequencySSB [ARFCN]	$k_{SSB}$	Offset Carrier CORESET#0 [RBs] Note 2	CORESET#0 Index (Offset [RBs]) Note 1	offsetToPointA (SIB1) [PRBs] Note 1
5	25	Downlink	Low	927.5	185500	925.25	185050	0	15	2318	185530	4	1	1 (2)	3
			Mid	942.5	188500	921.89	184378	102		2354	188410	0	0	0 (0)	102
			High	957.5	191500	864.53	172906	504		2393	191530	4	1	1 (2)	507
		Uplink	Low	882.5	176500	880.25	176050	0	-	-	-	-	-	-	-
			Mid	897.5	179500	804.53	160906	504	-	-	-	-	-	-	-
			High	912.5	182500	909.17	181834	6	-	-	-	-	-	-	-

10	52	Down link	Lo w	930	18600 0	925. 32	185064	0	15	231 9	185550	6	1	1 (2)	3
			Mi d	942. 5	18850 0	919. 46	183892	102		234 8	187930	2	0	0 (0)	102
			Hi gh	955 0	19100 0	859. 6	171920	504		238 3	190610	2	1	2 (4)	509
		Uplink	Lo w	885 0	17700 0	880. 32	176064	0	-	-	-	-	-	-	
			Mi d	897. 5	17950 0	802. 1	160420	504	-	-	-	-	-	-	
			Hi gh	910 0	18200 0	904. 24	180848	6	-	-	-	-	-	-	
15	79	Down link	Lo w	932. 5	18650 0	925. 39	185078	0	15	232 0	185570	8	1	1 (2)	3
			Mi d	942. 5	18850 0	917. 03	183406	102		234 2	187450	4	0	0 (0)	102
			Hi gh	952. 5	19050 0	854. 67	170934	504		237 0	189630	4	1	2 (4)	509
		Uplink	Lo w	887. 5	17750 0	880. 39	176078	0	-	-	-	-	-	-	
			Mi d	897. 5	17950 0	799. 67	159934	504	-	-	-	-	-	-	
			Hi gh	907. 5	18150 0	899. 31	179862	6	-	-	-	-	-	-	
20	106	Down link	Lo w	935 0	18700 0	925. 46	185092	0	15	231 8	185530	2	0	1 (2)	2
			Mi d	942. 5	18850 0	914. 6	182920	102		233 6	186970	6	0	0 (0)	102
			Hi gh	950 0	19000 0	849. 74	169948	504		235 7	188650	6	1	2 (4)	509
		Uplink	Lo w	890 0	17800 0	880. 46	176092	0	-	-	-	-	-	-	
			Mi d	897. 5	17950 0	797. 24	159448	504	-	-	-	-	-	-	
			Hi gh	905 0	18100 0	894. 38	178876	6	-	-	-	-	-	-	
35	188	Down link	Lo w	942. 5	18850 0	925. 58	185116	0	15	231 8	185530	6	1	0 (0)	1
			Mi d	942. 5	18850 0	907. 22	185116	0	15	231 8	185530	6	1	0 (0)	1
			Hi gh	942. 5	18850 0	834. 86	185116	0	15	231 8	185530	6	1	0 (0)	1

Note 1: The CORESET#0 Index and the associated CORESET#0 Offset refers to Table 13-1 in TS 38.213 [22]. The value of CORESET#0 Index is signalled in controlResourceSetZero (pdcch-ConfigSIB1) in the MIB. The offsetToPointA IE is expressed in units of resource blocks assuming 15 kHz subcarrier spacing for FR1 and 60 kHz subcarrier spacing for FR2.

Note 2: The parameter Offset Carrier CORESET#0 specifies the offset from the lowest subcarrier of the carrier and the lowest subcarrier of CORESET#0. It corresponds to the parameter  $\Delta F_{\text{OffsetCORESET-0-Carrier}}$  in Annex C expressed in number of common RBs.

**Table 4.3.1.1.1.8-2: Test frequencies for NR operating band n8 and SCS 30 kHz**

CB W [MHz]	carrierBandwidth [PRBs]	Range		Carrier centre [MHz]	Carrier centre [ARFCN]	point A [MHz]	absoluteFrequencyPointA [ARFCN]	offsetToCarrier [Carrier PRBs]	SS block SCS [kHz]	GS CN	absoluteFrequencySSB [ARFCN]	$k_{SSB}$	Offset Carrier CORESET#0 [RBs] Note 2	CORESET#0 Index (Offset [RBs]) Note 1	offsetToPointA (SIB1) [PRBs] Note 1	
10	24	Downlink	Low	930	18600	925.68	185136	0	15	2325	186030	10	0	2 (7)	14	
			Mid	942.5	188500	901.46	180292	102		2354	188410	18	0	0 (5)	214	
			High	9550	191000	769.24	153848	504		2389	191090	6	0	3 (8)	1024	
		Uplink	Low	885	17700	880.68	176136	0	-	-	-	-	-	-	-	-
			Mid	897.5	179500	711.74	142348	504	-	-	-	-	-	-	-	-
			High	910	182000	903.52	180704	6	-	-	-	-	-	-	-	-
15	38	Downlink	Low	932.5	186500	925.66	185132	0	15	2326	186050	18	0	2 (7)	14	
			Mid	942.5	188500	898.94	179788	102		2348	187930	2	0	1 (6)	216	
			High	952.5	190500	764.22	152844	504		2373	189870	6	0	0 (5)	1018	
		Uplink	Low	887.5	177500	880.66	176132	0	-	-	-	-	-	-	-	
			Mid	897.5	179500	709.22	141844	504	-	-	-	-	-	-	-	
			High	907.5	181500	898.5	179700	6	-	-	-	-	-	-	-	
20	51	Downlink	Low	935	187000	925.82	185164	0	15	2324	186010	18	0	1 (6)	12	

			Mid	942.5	188500	896.6	179320	102		2342	187450	22	0	0 (5)	214
			High	950	190000	759.38	151876	504		2360	188890	2	0	0 (5)	1018
		Uplink	Low	890	178000	880.82	176164	0	-	-	-	-	-	-	-
			Mid	897.5	179500	706.88	141376	504		-	-	-	-	-	-
			High	905	181000	893.66	178732	6		-	-	-	-	-	-
35	92	Downlink	Low	942.5	188500	925.94	185188	0	15	2324	186010	10	0	1 (6)	12
			Mid	942.5	188500	889.22	185188	0	15	2324	186010	10	0	1 (6)	12
			High	942.5	188500	744.5	185188	0	15	2324	186010	10	0	1 (6)	12
<p>Note 1: The CORESET#0 Index and the associated CORESET#0 Offset refers to Table 13-2 in TS 38.213 [22]. The value of CORESET#0 Index is signalled in controlResourceSetZero (pdccch-ConfigSIB1) in the MIB. The offsetToPointA IE is expressed in units of resource blocks assuming 15 kHz subcarrier spacing for FR1 and 60 kHz subcarrier spacing for FR2.</p> <p>Note 2: The parameter Offset Carrier CORESET#0 specifies the offset from the lowest subcarrier of the carrier and the lowest subcarrier of CORESET#0. It corresponds to the parameter <math>\Delta F_{\text{OffsetCORESET-0-Carrier}}</math> in Annex C expressed in number of common RBs.</p>															

4.3.1.1.1.9 to 4.3.1.1.1.11 FFS

4.3.1.1.1.12 Reference test frequencies for NR operating band n12

**Table 4.3.1.1.12-1: Test frequencies for NR operating band n12 and SCS 15 kHz**

CBW [MHz]	carrierBandwidth [PRBs]	Range	Carrier centre [MHz]	Carrier centre [ARFCN]	point A [MHz]	absoluteFrequencyPointA [ARFCN]	offsetToCarrier [Carrier PRBs]	SS block SCS [kHz]	GS CN	absoluteFrequencySSB [ARFCN]	$k_{SSB}$	Offset Carrier CORESET#0 [RBs] Note 2	CORESET#0 Index (Offset [RBs]) Note 1	offsetToPointA (SIB1) [PRBs] Note 1
5	25	Downlink	Low	731.5	146300	729.25	145850	0	15	1828	146210	0	0 (0)	0
			Mid	737.5	147500	716.89	143378	102		1843	147410	0	0 (0)	102
			High	743.5	148700	650.53	130106	504		1858	148610	0	0 (0)	504

		Uplink	Low	701.5	140300	699.25	139850	0	-	-	-	-	-	-	
			Mid	707.5	141500	614.53	122906	504	-	-	-	-	-	-	
			High	713.5	142700	710.17	142034	6	-	-	-	-	-	-	
10	52	Downlink	Low	734	146800	729.32	145864	0	15	1829	146410	2	1	2 (4)	5
			Mid	737.5	147500	714.46	142892	102		1837	146930	2	0	0 (0)	102
			High	741	148200	645.6	129120	504		1845	147630	2	0	0 (0)	504
		Uplink	Low	704	140800	699.32	139864	0	-	-	-	-	-	-	
			Mid	707.5	141500	612.1	122420	504	-	-	-	-	-	-	
			High	711	142200	705.24	141048	6	-	-	-	-	-	-	
15	79	Downlink	Low	736.5	147300	729.39	145878	0	15	1830	146430	4	1	2 (4)	5
			Mid	737.5	147500	712.03	142406	102		1831	146450	4	0	0 (0)	102
			High	738.5	147700	640.67	128134	504		1832	146650	4	0	0 (0)	504
		Uplink	Low	706.5	141300	699.39	139878	0	-	-	-	-	-	-	
			Mid	707.5	141500	609.67	121934	504	-	-	-	-	-	-	
			High	708.5	141700	700.31	140062	6	-	-	-	-	-	-	

Note 1: The CORESET#0 Index and the associated CORESET#0 Offset refers to Table 13-1 in TS 38.213 [22]. The value of CORESET#0 Index is signalled in controlResourceSetZero (pdch-ConfigSIB1) in the MIB. The offsetToPointA IE is expressed in units of resource blocks assuming 15 kHz subcarrier spacing for FR1 and 60 kHz subcarrier spacing for FR2.

Note 2: The parameter Offset Carrier CORESET#0 specifies the offset from the lowest subcarrier of the carrier and the lowest subcarrier of CORESET#0. It corresponds to the parameter  $\Delta F_{\text{OffsetCORESET-0-Carrier}}$  in Annex C expressed in number of common RBs.

Table 4.3.1.1.12-2: Test frequencies for NR operating band n12 and SCS 30 kHz

CB W [MHz]	carrierBandwidth [PRBs]	Range		Carrier centre [MHz]	Carrier centre [ARFCN]	point A [MHz]	absoluteFrequencyPointA [ARFCN]	offsetToCarrier [Carrier PRBs]	SS block SCS [kHz]	GS CN	absoluteFrequencySSB [ARFCN]	$k_{SSB}$	Offset Carrier CORESET#0 [RBs] Note 2	CORESET#0 Index (Offset [RBs]) Note 1	offsetToPointA (SIB1) [PRBs] Note 1	
10	24	Downlink	Low	734	146800	729.68	145936	0	15	1835	146890	6	0	3 (8)	16	
			Mid	737.5	147500	696.46	139292	102		1843	147410	18	0	0 (5)	214	
			High	741	148200	555.24	111048	504		1851	148110	18	0	0 (5)	1018	
		Uplink	Low	704	140800	699.68	139936	0	-	-	-	-	-	-	-	-
			Mid	707.5	141500	521.74	104348	504		-	-	-	-	-	-	-
			High	711	142200	704.52	140904	6		-	-	-	-	-	-	-
15	38	Downlink	Low	736.5	147300	729.66	145932	0	15	1833	146670	6	0	0 (5)	10	
			Mid	737.5	147500	693.94	138788	102		1837	146930	2	0	1 (6)	216	
			High	738.5	147700	550.22	110044	504		1838	147130	2	0	1 (6)	1020	
		Uplink	Low	706.5	141300	699.66	139932	0	-	-	-	-	-	-	-	
			Mid	707.5	141500	519.22	103844	504		-	-	-	-	-	-	
			High	708.5	141700	699.5	139900	6		-	-	-	-	-	-	
<p>Note 1: The CORESET#0 Index and the associated CORESET#0 Offset refers to Table 13-2 in TS 38.213 [22]. The value of CORESET#0 Index is signalled in controlResourceSetZero (pdccch-ConfigSIB1) in the MIB. The offsetToPointA IE is expressed in units of resource blocks assuming 15 kHz subcarrier spacing for FR1 and 60 kHz subcarrier spacing for FR2.</p> <p>Note 2: The parameter Offset Carrier CORESET#0 specifies the offset from the lowest subcarrier of the carrier and the lowest subcarrier of CORESET#0. It corresponds to the parameter <math>\Delta F_{\text{OffsetCORESET-0-Carrier}}</math> in Annex C expressed in number of common RBs.</p>																



4.3.1.1.1.13 Reference test frequencies for NR operating band n13

Table 4.3.1.1.1.13-1: Test frequencies for NR operating band n13 and SCS 15 kHz

CBW [MHz]	carrierBandwidth [PRBs]	Range		Carrier centre [MHz]	Carrier centre [ARFCN]	point A [MHz]	absoluteFrequencyPointA [ARFCN]	offsetToCarrier [Carrier PRBs]	SS block SCS [kHz]	GS CN	absoluteFrequencySSB [ARFCN]	$k_{SSB}$	Offset Carrier CORESET#0 [RBs] Note 2	CORESET#0 Index (Offset [RBs]) Note 1	offsetToPointA (SIB1) [PRBs] Note 1	
5	25	Downlink	Low	748.5	149700	748.75	149750	0	15	1872	149790	0	1	2 (4)	5	
			Mid	751	150200	732.64	146528	102		1878	150270	0	1	2 (4)	107	
			High	753.5	150700	663.03	132606	504		1883	150730	4	1	1 (2)	507	
		Uplink	Low	779.5	155900	777.25	155450	0	-	-	-	-	-	-	-	-
			Mid	782	156400	689.03	156234	504	-	-	-	-	-	-	-	-
			High	784.5	156900	781.17	156234	6	-	-	-	-	-	-	-	-
10	52	Downlink	Low	751	150200	751.32	150264	0	15	1873	149810	2	1	2 (4)	5	
			Mid													
			High													
		Uplink	Low	782	156400	782.32	156464	0	-	-	-	-	-	-	-	
			Mid													
			High													
<p>Note 1: The CORESET#0 Index and the associated CORESET#0 Offset refers to Table 13-1 in TS 38.213 [22]. The value of CORESET#0 Index is signalled in controlResourceSetZero (pdcchConfigSIB1) in the MIB. The offsetToPointA IE is expressed in units of resource blocks assuming 15 kHz subcarrier spacing for FR1 and 60 kHz subcarrier spacing for FR2.</p> <p>Note 2: The parameter Offset Carrier CORESET#0 specifies the offset from the lowest subcarrier of the carrier and the lowest subcarrier of CORESET#0. It corresponds to the parameter <math>\Delta F_{\text{OffsetCORESET0Carrier}}</math> in Annex C expressed in number of common RBs.</p> <p>Note 3: 10 MHz test channel bandwidth is tested with Low range test frequency only. Low range test frequency shall be used instead of Mid range and High range test frequencies.</p>																

**Table 4.3.1.1.13-2: Test frequencies for NR operating band n13 and SCS 30 kHz**

CBW [MHz]	carrierBandwidth [PRBs]	Range		Carrier centre [MHz]	Carrier centre [ARFCN]	point A [MHz]	absoluteFrequencyPointA [ARFCN]	offsetToCarrier [Carrier PRBs]	SS block SCS [kHz]	GS CN	absoluteFrequencySSB [ARFCN]	$k_{SSB}$	Offset Carrier CORESET#0 [RBs] Note 2	CORESET#0 Index (Offset [RBs]) Note 1	offsetToPointA (SIB1) [PRBs] Note 1	
		Downlink	Uplink													
10	24	Downlink	Low	751	150200	747.36	149472	0	15	1878	150270	6	0	3 (8)	16	
			Mid													
			High													
		Uplink	Low	782	156400	778.36	155672	0	-	-	-	-	-	-	-	-
			Mid													
			High													

Note 1: The CORESET#0 Index and the associated CORESET#0 Offset refers to Table 13-2 in TS 38.213 [22]. The value of CORESET#0 Index is signalled controlResourceSetZero (pdchConfigSIB1 in the MIB. The offsetToPointA IE is expressed in units of resource blocks assuming 15 kHz subcarrier spacing for FR1 and 60 kHz subcarrier spacing for FR2.

Note 2: The parameter Offset Carrier CORESET#0 specifies the offset from the lowest subcarrier of the carrier and the lowest subcarrier of CORESET#0. It corresponds to the parameter  $\Delta F_{OffsetCORESET0Carrier}$  in Annex C expressed in number of common RBs.

Note 3: 10 MHz test channel bandwidth is tested with Low range test frequency only. Low range test frequency shall be used instead of Mid range and High range test frequencies.

4.3.1.1.14 Reference test frequencies for NR operating band n14

**Table 4.3.1.1.14-1: Test frequencies for NR operating band n14 and SCS 15 kHz**

CBW [MHz]	carrierBandwidth [PRBs]	Range	Carrier centre	Carrier centre	point A [MHz]	absoluteFrequencyPointA [ARFCN]	offsetToCarrier [Carrier PRBs]	SS block SCS	GS CN	absoluteFrequencySSB [ARFCN]	$k_{SSB}$	Offset Carrier CORESET#0 [RBs]	CORESET#0 Index (Offset [RBs])	offsetToPointA (SIB1) [PRBs] Note 1
-----------	-------------------------	-------	----------------	----------------	---------------	---------------------------------	--------------------------------	--------------	-------	------------------------------	-----------	--------------------------------	--------------------------------	-------------------------------------

				[MHz]	[ARFCN]				[kHz]				Note 2	Note 1		
5	25	Down link	Low	760.5	152100	758.25	151650	0	15	1902	152190	0	1	2 (4)	5	
			Mid	7630	152600	742.39	148478	102	1909	152690	0	1	2 (4)	107		
			High	765.5	153100	672.53	134506	504	1913	153130	4	1	1 (2)	507		
		Uplink	Low	790.5	158100	788.25	157650	0	-	-	-	-	-	-	-	-
			Mid	7930	158600	700.03	140006	504	-	-	-	-	-	-	-	-
			High	795.5	159100	792.17	158434	6	-	-	-	-	-	-	-	-
10	52	Down link	Low	7630	152600	758.32	151664	0	15	1903	152210	2	1	2 (4)	5	
			Mid													
			High													
		Uplink	Low	7930	158600	788.32	157664	0	-	-	-	-	-	-	-	-
			Mid													
			High													

Note 1: The CORESET#0 Index and the associated CORESET#0 Offset refers to Table 13-1 in TS 38.213 [22]. The value of CORESET#0 Index is signalled in controlResourceSetZero (pdcchConfigSIB1) in the MIB. The offsetToPointA IE is expressed in units of resource blocks assuming 15 kHz subcarrier spacing for FR1 and 60 kHz subcarrier spacing for FR2.

Note 2: The parameter Offset Carrier CORESET#0 specifies the offset from the lowest subcarrier of the carrier and the lowest subcarrier of CORESET#0. It corresponds to the parameter  $\Delta F_{\text{OffsetCORESET0Carrier}}$  in Annex C expressed in number of common RBs.

Note 3: 10 MHz test channel bandwidth is tested with Low range test frequency only. Low range test frequency shall be used instead of Mid range and High range test frequencies.

Table 4.3.1.1.14-2: Test frequencies for NR operating band n14 and SCS 30 kHz

CBW [MHz]	carrierBandwidth [PRBs]	Range	Carrier centre	Carrier centre	point A [MHz]	absoluteFrequencyPointA [ARFCN]	offsetToCarrier [Carrier PRBs]	SS block SCS	GS CN	absoluteFrequencySSB [ARFCN]	$k_{SSB}$	Offset Carrier CORESET#0 [RBs]	CORESET#0 Index (Offset [RBs])	offsetToPointA (SIB1) [PRBs] Note 1
-----------	-------------------------	-------	----------------	----------------	---------------	---------------------------------	--------------------------------	--------------	-------	------------------------------	-----------	--------------------------------	--------------------------------	-------------------------------------

				[MHz]	[ARFCN]				[kHz]				Note 2	Note 1			
10	24	Down link	Low	763	152600	758.68	151736	0	15	1909	152690	6	0	3 (8)	16		
			Mid														
			High														
		Uplink	Low	793	158600	788.68	157736	0	-	-	-	-	-	-	-	-	-
			Mid														
			High														
<p>Note 1: The CORESET#0 Index and the associated CORESET#0 Offset refers to Table 13-2 in TS 38.213 [22]. The value of CORESET#0 Index is signalled controlResourceSetZero (pdccchConfigSIB1) in the MIB. The offsetToPointA IE is expressed in units of resource blocks assuming 15 kHz subcarrier spacing for FR1 and 60 kHz subcarrier spacing for FR2.</p> <p>Note 2: The parameter Offset Carrier CORESET#0 specifies the offset from the lowest subcarrier of the carrier and the lowest subcarrier of CORESET#0. It corresponds to the parameter <math>\Delta F_{\text{OffsetCORESET0Carrier}}</math> in Annex C expressed in number of common RBs.</p> <p>Note 3: 10 MHz test channel bandwidth is tested with Low range test frequency only. Low range test frequency shall be used instead of Mid range and High range test frequencies.</p>																	

4.3.1.1.1.15 to 4.3.1.1.1.19 FFS

4.3.1.1.1.20 Reference test frequencies for NR operating band n20

**Table 4.3.1.1.1.20-1: Test frequencies for NR operating band n20 and SCS 15 kHz**

CBW [MHz]	carrierBandwidth [PRBs]	Range	Carrier centre [MHz]	Carrier centre [ARFCN]	point A [MHz]	absoluteFrequencyPointA [ARFCN]	offsetToCarrier [Carrier PRBs]	SS block SCS [kHz]	GS CN	absoluteFrequencySSB [ARFCN]	$k_{SSB}$	Offset Carrier CORESET#0 [RBs] Note 2	CORESET#0 Index (Offset [RBs]) Note 1	offsetToPointA (SIB1) [PRBs] Note 1	
5	25	Down link	Low	793.5	158700	791.25	158250	0	15	1983	158670	8	1	0 (0)	1
			Mid	806	161200	785.39	157078	102		2015	161290	0	1	2 (4)	107
			High	818.5	163700	725.53	145106	504		2047	163730	4	1	1 (2)	507

		Uplink	Low	834.5	166900	832.25	166450	0	-	-	-	-	-	-	-	
			Mid	847	169400	754.03	150806	504	-	-	-	-	-	-	-	-
			High	859.5	171900	856.17	171234	6	-	-	-	-	-	-	-	-
10	52	Downlink	Low	796	159200	791.32	158264	0	15	1984	158690	10	1	0 (0)	1	
			Mid	806	161200	782.96	156592	102		2009	160810	2	1	2 (4)	107	
			High	816	163200	720.6	144120	504		2034	162750	6	1	1 (2)	507	
		Uplink	Low	837	167400	832.32	166464	0	-	-	-	-	-	-	-	-
			Mid	847	169400	751.6	150320	504	-	-	-	-	-	-	-	-
			High	857	171400	851.24	170248	6	-	-	-	-	-	-	-	-
15	79	Downlink	Low	798.5	159700	791.39	158278	0	15	1982	158650	4	0	0 (0)	0	
			Mid	806	161200	780.53	156106	102		2003	160330	4	1	2 (4)	107	
			High	813.5	162700	715.67	143134	504		2021	161770	8	1	1 (2)	507	
		Uplink	Low	839.5	167900	832.39	166478	0	-	-	-	-	-	-	-	-
			Mid	847	169400	749.17	149834	504	-	-	-	-	-	-	-	-
			High	854.5	170900	846.31	169262	6	-	-	-	-	-	-	-	-
20	106	Downlink	Low	801	160200	791.46	158292	0	15	1983	158670	6	0	0 (0)	0	
			Mid	806	161200	778.1	155620	102		1997	159850	6	1	2 (4)	107	
			High	811	162200	710.74	142148	504		2011	160850	6	1	2 (4)	509	
		Uplink	Low	842	168400	832.46	166492	0	-	-	-	-	-	-	-	-
			Mid	847	169400	746.74	149348	504	-	-	-	-	-	-	-	-
			High	852	170400	841.38	168276	6	-	-	-	-	-	-	-	-

Note 1: The CORESET#0 Index and the associated CORESET#0 Offset refers to Table 13-1 in TS 38.213 [22]. The value of CORESET#0 Index is signalled in controlResourceSetZero (pdccch-ConfigSIB1) in the MIB. The offsetToPointA IE is expressed in units of resource blocks assuming 15 kHz subcarrier spacing for FR1 and 60 kHz subcarrier spacing for FR2.

Note 2: The parameter Offset Carrier CORESET#0 specifies the offset from the lowest subcarrier of the carrier and the lowest subcarrier of CORESET#0. It corresponds to the parameter  $\Delta F_{\text{OffsetCORESET-0-Carrier}}$  in Annex C expressed in number of common RBs.

**Table 4.3.1.1.1.20-2: Test frequencies for NR operating band n20 and SCS 30 kHz**

CB W [MHz]	carrierBandwidth [PRBs]	Range		Carrier centre [MHz]	Carrier centre [ARFCN]	point A [MHz]	absoluteFrequencyPointA [ARFCN]	offsetToCarrier [Carrier PRBs]	SS block SCS [kHz]	GS CN	absoluteFrequencySSB [ARFCN]	$k_{SSB}$	Offset Carrier CORESET#0 [RBs] Note 2	CORESET#0 Index (Offset [RBs]) Note 1	offsetToPointA (SIB1) [PRBs] Note 1	
10	24	Downlink	Low	796	159200	791.68	158336	0	15	1990	159170	14	0	1 (6)	12	
			Mid	806	161200	764.96	152992	102		2015	161290	6	0	3 (8)	220	
			High	816	163200	630.24	126048	504		2040	163230	10	0	2 (7)	1022	
		Uplink	Low	837	167400	832.68	166536	0	-	-	-	-	-	-	-	-
			Mid	847	169400	661.24	132248	504		-	-	-	-	-	-	-
			High	857	171400	850.52	170104	6		-	-	-	-	-	-	-
15	38	Downlink	Low	798.5	159700	791.66	158332	0	15	1988	159130	2	0	1 (6)	12	
			Mid	806	161200	762.44	152488	102		2006	160570	6	0	0 (5)	214	
			High	813.5	162700	625.22	125044	504		2027	162250	18	0	2 (7)	1022	
		Uplink	Low	839.5	167900	832.66	166532	0	-	-	-	-	-	-	-	-
			Mid	847	169400	658.72	131744	504		-	-	-	-	-	-	-
			High	854.5	170900	845.5	169100	6		-	-	-	-	-	-	-
20	51	Downlink	Low	801	160200	791.82	158364	0	15	1989	159150	22	0	0 (5)	10	

	Uplink	Mid	806	161200	760.1	152020	102	2000	160090	2	0	0 (5)	214
		High	811	162200	620.38	124076	504	2014	161090	2	0	0 (5)	1018
		Low	842	168400	832.82	166564	0	-	-	-	-	-	-
		Mid	847	169400	656.38	131276	504	-	-	-	-	-	-
		High	852	170400	840.66	168132	6	-	-	-	-	-	-

Note 1: The CORESET#0 Index and the associated CORESET#0 Offset refers to Table 13-2 in TS 38.213 [22]. The value of CORESET#0 Index is signalled controlResourceSetZero (pdccch-ConfigSIB1 in the MIB. The offsetToPointA IE is expressed in units of resource blocks assuming 15 kHz subcarrier spacing for FR1 and 60 kHz subcarrier spacing for FR2.

Note 2: The parameter Offset Carrier CORESET#0 specifies the offset from the lowest subcarrier of the carrier and the lowest subcarrier of CORESET#0. It corresponds to the parameter  $\Delta F_{\text{OffsetCORESET-0-Carrier}}$  in Annex C expressed in number of common RBs.

4.3.1.1.1.21 to 4.3.1.1.1.23 FFS

4.3.1.1.1.24 Reference test frequencies for NR operating band n24

**Table 4.3.1.1.1.24-1a: Test frequencies for NR operating band n24 and SCS 15 kHz**

UL/DL CBW [MHz]	carrier Bandwidth [PRBs]	Range		Carrier centre [MHz] Note 3	Carrier centre [ARFCN]	point A [MHz]	absolute FrequencyPoint A [ARFCN]	offsetTo Carrier [Carrier PRBs]	SS block SCS [kHz]	GSCN	absolute FrequencySSB [ARFCN]	$k_{SSB}$	Offset Carrier CORESET#0 [RBs] Note 2	CORE SET#0 Index (Offset [RBs]) Note 1	offsetTo PointA (SIB1) [PRBs] Note 1
5/5	25	Downlink	Low	1528.5	305700	1526.25	305250	0	15	3822	305790	0	1	2 (4)	5
			Mid	1533.5	306700	1512.89	302578	102		3833	306730	4	1	1 (2)	105
			High	1533.5	306700	1440.53	288106	504		3833	306730	4	1	1 (2)	507
		Uplink	Low	1630.0	326000	1627.75	325550	0	-	-	-	-	-	-	
			Mid	1635.0	327000	1542.03	308406	504	-	-	-	-	-	-	
			High	1654.0	330800	1650.67	330134	6	-	-	-	-	-	-	
10/5 (Note 4)	25	Downlink	Low	1528.5	305700	1526.25	305250	0	15	3822	305790	0	1	2 (4)	5
			Mid	1533.5	306700	1512.89	302578	102		3833	306730	4	1	1 (2)	105
			High	1533.5	306700	1440.53	288106	504		3833	306730	4	1	1 (2)	507
	52	Uplink	Low	1632.5	326500	1627.82	325564	0	-	-	-	-	-	-	
High			1651.5	330300	1645.74	329148	6	-	-	-	-	-	-		

10/10	52	Downlink	Low Mid	1531.0	306200	1526.32	305264	0	15	3823	305810	2	1	2 (4)	5
			High	1531.0	306200	1435.6	287120	504		3823	305810	2	1	2 (4)	509
		Uplink	Low Mid	1632.5	326500	1627.82	325564	0	-	-	-	-	-	-	-
			High	1651.5	330300	1645.74	329148	6	-	-	-	-	-	-	-

Note 1: The CORESET#0 Index and the associated CORESET#0 Offset refers to Table 13-1 in TS 38.213 [22]. The value of CORESET#0 Index is signalled in controlResourceSetZero (pdccch-ConfigSIB1) in the MIB. The offsetToPointA IE is expressed in units of resource blocks assuming 15 kHz subcarrier spacing for FR1 and 60 kHz subcarrier spacing for FR2.

Note 2: The parameter Offset Carrier CORESET#0 specifies the offset from the lowest subcarrier of the carrier and the lowest subcarrier of CORESET#0. It corresponds to the parameter  $\Delta F_{\text{OffsetCORESET-0-Carrier}}$  in Annex C expressed in number of common RBs.

Note 3: For symmetric CBW combinations, Low and Mid test frequencies are specified using Tx-Rx spacing of -101.5 MHz and High test frequency is specified using Tx-Rx spacing of -120.5 MHz

Note 4: For asymmetric CBW combination UL=10MHz and DL=5MHz, Low and Mid test frequencies are specified using Tx-Rx spacing of -104 MHz and High test frequency is specified using Tx-Rx spacing of -118 MHz.

**Table 4.3.1.1.1.24-2a: Test frequencies for NR operating band n24 and SCS 30 kHz**

CBW [MHz]	carrier Bandwidth [PRBs]	Range		Carrier centre [MHz] Note 3	Carrier centre [ARFCN]	point A [MHz]	absolute FrequencyPoint A [ARFCN]	offsetTo Carrier [Carrier PRBs]	SS block SCS [kHz]	GSCN	absolute FrequencySSB [ARFCN]	$k_{\text{SSB}}$	Offset Carrier CORE SET#0 [RBs] Note 2	CORE SET#0 Index (Offset [RBs]) Note 1	offsetTo PointA (SIB1) [PRBs] Note 1
10	24	Downlink	Low Mid	1531.0	306200	1526.68	305336	0	30	3829	306290	6	0	3 (3)	6
			High	1531.0	306200	1345.24	269048	504		3829	306290	6	0	3 (3)	1014
		Uplink	Low Mid	1632.5	326500	1628.18	325636	0	-	-	-	-	-	-	-
			High	1651.5	330300	1645.02	329004	6	-	-	-	-	-	-	-

Note 1: The CORESET#0 Index and the associated CORESET#0 Offset refers to Table 13-2 in TS 38.213 [22]. The value of CORESET#0 Index is signalled in controlResourceSetZero (pdccch-ConfigSIB1) in the MIB. The offsetToPointA IE is expressed in units of resource blocks assuming 15 kHz subcarrier spacing for FR1 and 60 kHz subcarrier spacing for FR2.

Note 2: The parameter Offset Carrier CORESET#0 specifies the offset from the lowest subcarrier of the carrier and the lowest subcarrier of CORESET#0. It corresponds to the parameter  $\Delta F_{\text{OffsetCORESET-0-Carrier}}$  in Annex C expressed in number of common RBs.

Note 3: Low and Mid test frequencies are specified using Tx-Rx spacing of -101.5 MHz and High test frequency is specified using Tx-Rx spacing of -120.5 MHz



**Table 4.3.1.1.1.24-3a: Test frequencies for NR operating band n24 and SCS 60 kHz without CORESET#0**

CBW [MHz]	carrierBand width [PRBs]	Range		Carrier centre [MHz] Note 2	Carrier centre [ARFCN]	point A [MHz]	absolute FrequencyPoint A [ARFCN]	offsetTo Carrier [PRBs]	SS block SCS [kHz]	GSCN	absolute FrequencySSB [ARFCN]
10	11	Downlink	Low Mid	1531.0	306200	1527.04	305408	0	15	-	305768
			High	1531.0	306200	1164.16	232832	504		-	305768
		Uplink	Low Mid	1632.5	326500	1628.54	325708	0	-	-	-
			High	1651.5	330300	1643.22	328644	6		-	-

Note 1: FR1 carrier without CORESET#0 is indicated in the MIB by setting  $k_{SSB}=31$ , *controlResourceSetZero=0* and *searchSpaceZero = 0* (TS 38.213 [22], clause 13).  
 Note 2: Low and Mid test frequencies are specified using Tx-Rx spacing of -101.5 MHz and High test frequency is specified using Tx-Rx spacing of -120.5 MHz

4.3.1.1.1.25

Reference test frequencies for NR operating band n25

**Table 4.3.1.1.1.25-1: Test frequencies for NR operating band n25 and SCS 15 kHz**

CBW [MHz]	carrier Bandwidth [PRBs]	Range		Carrier centre [MHz]	Carrier centre [ARFCN]	point A [MHz]	absolute FrequencyPoint A [ARFCN]	offsetTo Carrier [Carrier PRBs]	SS block SCS [kHz]	GSCN	absolute FrequencySSB [ARFCN]	$k_{SSB}$	Offset Carrier CORE SET#0 [RBs] Note 2	CORE SET#0 Index (Offset [RBs]) Note 1	offsetTo PointA (SIB1) [PRBs] Note 1
5	25	Downlink	Low	1932.5	386500	1930.25	386050	0	15	4829	386410	0	0	0 (0)	0
			Mid	1962.5	392500	1941.89	388378	102		4904	392410	0	0	0 (0)	102
			High	1992.5	398500	1899.53	379906	504		4979	398410	0	0	0 (0)	504
		Uplink	Low	1852.5	370500	1850.25	370050	0	-	-	-	-	-	-	-
			Mid	1882.5	376500	1789.53	357906	504		-	-	-	-	-	-
			High	1912.5	382500	1909.17	381834	6		-	-	-	-	-	-
10	52	Downlink	Low	1935	387000	1930.32	386064	0	15	4830	386430	2	0	0 (0)	0
			Mid	1962.5	392500	1939.46	387892	102		4898	391930	2	0	0 (0)	102
			High	1990	398000	1894.6	378920	504		4969	397490	10	1	0 (0)	505
		Uplink	Low	1855	371000	1850.32	370064	0	-	-	-	-	-	-	-
			Mid	1882.5	376500	1787.1	357420	504		-	-	-	-	-	-
			High	1910	382000	1904.24	380848	6		-	-	-	-	-	-
15	79	Downlink	Low	1937.5	387500	1930.39	386078	0	15	4831	386450	4	0	0 (0)	0

		Uplink	Mid	1962.5	392500	1937.03	387406	102	-	4892	391450	4	0	0 (0)	102
			High	1987.5	397500	1889.67	377934	504		4956	396510	0	0	1 (2)	506
			Low	1857.5	371500	1850.39	370078	0		-	-	-	-	-	-
			Mid	1882.5	376500	1784.67	356934	504		-	-	-	-	-	-
			High	1907.5	381500	1899.31	379862	6		-	-	-	-	-	-
20	106	Downlink	Low	1940	388000	1930.46	386092	0	15	4832	386650	6	1	2 (4)	5
			Mid	1962.5	392500	1934.6	386920	102		4886	390970	6	0	0 (0)	102
			High	1985	397000	1884.74	376948	504		4943	395530	2	0	1 (2)	506
		Uplink	Low	1860	372000	1850.46	370092	0	-	-	-	-	-	-	-
			Mid	1882.5	376500	1782.24	356448	504		-	-	-	-	-	-
			High	1905	381000	1894.38	378876	6		-	-	-	-	-	-
25	133	Downlink	Low	1942.5	388500	1930.53	386106	0	15	4833	386670	8	1	2 (4)	5
			Mid	1962.5	392500	1932.17	386434	102		4880	390490	8	0	0 (0)	102
			High	1982.5	396500	1879.81	375962	504		4933	394610	0	0	2 (4)	508
		Uplink	Low	1862.5	372500	1850.53	370106	0	-	-	-	-	-	-	-
			Mid	1882.5	376500	1779.81	355962	504		-	-	-	-	-	-
			High	1902.5	380500	1889.45	377890	6		-	-	-	-	-	-
30	160	Downlink	Low	1945	389000	1930.6	386120	0	15	4834	386690	10	1	2 (4)	5
			Mid	1962.5	392500	1929.74	385948	102		4874	390010	10	0	0 (0)	102
			High	1980	396000	1874.88	374976	504		4920	393630	2	0	2 (4)	508
		Uplink	Low	1865	373000	1850.6	370120	0	-	-	-	-	-	-	-
			Mid	1882.5	376500	1777.38	355476	504		-	-	-	-	-	-
			High	1900	380000	1884.52	376904	6		-	-	-	-	-	-
40	216	Downlink	Low	1950	390000	1930.56	386112	0	15	4833	386670	6	1	2 (4)	5
			Mid	1962.5	392500	1924.7	384940	102		4862	389050	2	0	1 (2)	104
			High	1975	395000	1864.84	372968	504		4894	391490	6	0	0 (0)	504
		Uplink	Low	1870	374000	1850.56	370112	0	-	-	-	-	-	-	-
			Mid	1882.5	376500	1772.34	354468	504		-	-	-	-	-	-
			High	1895	379000	1874.48	374896	6		-	-	-	-	-	-
45	242	Downlink	Low	1952.5	390500	1930.72	386144	0	15	4834	386690	2	1	2 (4)	5
			Mid	1962.5	392500	1922.36	384472	102	15	4856	388570	10	1	0 (0)	103
			High	1972.5	394500	1860	372000	504	15	4881	390510	2	0	0 (0)	504

Note 1: The CORESET#0 Index and the associated CORESET#0 Offset refers to Table 13-1 in TS 38.213 [22]. The value of CORESET#0 Index is signalled in controlResourceSetZero (pdcch-ConfigSIB1) in the MIB. The offsetToPointA IE is expressed in units of resource blocks assuming 15 kHz subcarrier spacing for FR1 and 60 kHz subcarrier spacing for FR2.

Note 2: The parameter Offset Carrier CORESET#0 specifies the offset from the lowest subcarrier of the carrier and the lowest subcarrier of CORESET#0. It corresponds to the parameter  $\Delta F_{\text{OffsetCORESET-0-Carrier}}$  in Annex C expressed in number of common RBs.

Table 4.3.1.1.1.25-2: Test frequencies for NR operating band n25 and SCS 30 kHz

CBW [MHz]	carrier Bandwidth [PRBs]	Range		Carrier centre [MHz]	Carrier centre [ARFCN]	point A [MHz]	absolute Frequency Point A [ARFCN]	offsetTo Carrier [Carrier PRBs]	SS block SCS [kHz]	GSCN	absolute FrequencySSB [ARFCN]	$k_{SSB}$	Offset Carrier CORE SET#0 [RBs] Note 2	CORE SET#0 Index (Offset [RBs]) Note 1	offsetTo PointA (SIB1) [PRBs] Note 1	
10	24	Downlink	Low	1935	387000	1930.68	386136	0	15	4836	386910	18	0	0 (5)	10	
			Mid	1962.5	392500	1921.46	384292	102		4904	392410	18	0	0 (5)	214	
			High	1990	398000	1804.24	360848	504		4975	397970	14	0	1 (6)	1020	
		Uplink	Low	1855	371000	1850.68	370136	0	-	-	-	-	-	-	-	-
			Mid	1882.5	376500	1696.74	339348	504		-	-	-	-	-	-	-
			High	1910	382000	1903.52	380704	6		-	-	-	-	-	-	-
15	38	Downlink	Low	1937.5	387500	1930.66	386132	0	15	4837	386930	2	0	1 (6)	12	
			Mid	1962.5	392500	1918.94	383788	102		4898	391930	2	0	1 (6)	216	
			High	1987.5	397500	1799.22	359844	504		4962	396990	22	0	1 (6)	1020	
		Uplink	Low	1857.5	371500	1850.66	370132	0	-	-	-	-	-	-	-	-
			Mid	1882.5	376500	1694.22	338844	504		-	-	-	-	-	-	-
			High	1907.5	381500	1898.5	379700	6		-	-	-	-	-	-	-
20	51	Downlink	Low	1940	388000	1930.82	386164	0	15	4835	386890	2	0	0 (5)	10	
			Mid	1962.5	392500	1916.6	383320	102		4892	391450	22	0	0 (5)	214	
			High	1985	397000	1794.38	358876	504		4949	396010	18	0	1 (6)	1020	
		Uplink	Low	1860	372000	1850.82	370164	0	-	-	-	-	-	-	-	-
			Mid	1882.5	376500	1691.88	338376	504		-	-	-	-	-	-	-
			High	1905	381000	1893.66	378732	6		-	-	-	-	-	-	-
25	65	Downlink	Low	1942.5	388500	1930.8	386160	0	15	4836	386910	10	0	0 (5)	10	
			Mid	1962.5	392500	1914.08	382816	102		4886	390970	6	0	1 (6)	216	
			High	1982.5	396500	1789.36	357872	504		4939	395090	22	0	2 (7)	1022	
		Uplink	Low	1862.5	372500	1850.8	370160	0	-	-	-	-	-	-	-	-
			Mid	1882.5	376500	1689.36	337872	504		-	-	-	-	-	-	-
			High	1902.5	380500	1888.64	377728	6		-	-	-	-	-	-	-
30	78	Downlink	Low	1945	389000	1930.96	386192	0	15	4837	386930	6	0	0 (5)	10	
			Mid	1962.5	392500	1911.74	382348	102		4880	390490	2	0	1 (6)	216	
			High	1980	396000	1784.52	356904	504		4926	394110	18	0	2 (7)	1022	
		Uplink	Low	1865	373000	1850.96	370192	0	-	-	-	-	-	-	-	-
			Mid	1882.5	376500	1687.02	337404	504		-	-	-	-	-	-	-
			High	1900	380000	1883.8	376760	6		-	-	-	-	-	-	-
40	106	Downlink	Low	1950	390000	1930.92	386184	0	15	4836	386910	2	0	0 (5)	10	
			Mid	1962.5	392500	1906.7	381340	102		4868	389530	18	0	1 (6)	216	
			High	1975	395000	1774.48	354896	504		4900	391970	22	0	0 (5)	1018	

45	119	Uplink	Low	1870	374000	1850.92	370184	0	-	-	-	-	-	-	
			Mid	1882.5	376500	1681.98	336396	504	-	-	-	-	-	-	
			High	1895	379000	1873.76	374752	6	-	-	-	-	-	-	
		Downlink	Low	1972.5	394500	1769.64	353928	504	15	4887	390990	18	0	0 (5)	1018
			Mid	1872.5	374500	1851.08	370216	0	-	-	-	-	-	-	-
			High	1882.5	376500	1679.64	335928	504	-	-	-	-	-	-	-

Note 1: The CORESET#0 Index and the associated CORESET#0 Offset refers to Table 13-2 in TS 38.213 [22]. The value of CORESET#0 Index is signalled in controlResourceSetZero (pdcch-ConfigSIB1) in the MIB. The offsetToPointA IE is expressed in units of resource blocks assuming 15 kHz subcarrier spacing for FR1 and 60 kHz subcarrier spacing for FR2.

Note 2: The parameter Offset Carrier CORESET#0 specifies the offset from the lowest subcarrier of the carrier and the lowest subcarrier of CORESET#0. It corresponds to the parameter  $\Delta F_{\text{OffsetCORESET-0-Carrier}}$  in Annex C expressed in number of common RBs.

**Table 4.3.1.1.1.25-3: Test frequencies for NR operating band n25 and SCS 60 kHz without CORESET#0**

CBW [MHz]	carrierBand width [PRBs]	Range	Carrier centre [MHz]	Carrier centre [ARFCN]	point A [MHz]	absolute FrequencyPoint A [ARFCN]	offsetTo Carrier [PRBs]	SS block SCS [kHz]	GSCN	absolute FrequencySSB [ARFCN]	
10	11	Downlink	Low	1935	387000	1931.04	386208	0	15	-	386568
			Mid	1962.5	392500	1885.1	377020	102		-	392068
			High	1990	398000	1623.16	324632	504		-	397568
		Uplink	Low	1855	371000	1851.04	370208	0	-	-	-
			Mid	1882.5	376500	1515.66	303132	504		-	-
			High	1910	382000	1901.72	380344	6		-	-
15	18	Downlink	Low	1937.5	387500	1931.02	386204	0	15	-	386564
			Mid	1962.5	392500	1882.58	376516	102		-	391564
			High	1987.5	397500	1618.14	323628	504		-	396564
		Uplink	Low	1857.5	371500	1851.02	370204	0	-	-	-
			Mid	1882.5	376500	1513.14	302628	504		-	-
			High	1907.5	381500	1896.7	379340	6		-	-
20	24	Downlink	Low	1940	388000	1931.36	386272	0	15	-	386632
			Mid	1962.5	392500	1880.42	376084	102		-	391132
			High	1985	397000	1613.48	322696	504		-	395632
		Uplink	Low	1860	372000	1851.36	370272	0	-	-	-
			Mid	1882.5	376500	1510.98	302196	504		-	-
			High	1905	381000	1892.04	378408	6		-	-
25	31	Downlink	Low	1942.5	388500	1931.34	386268	0	15	-	386628
			Mid	1962.5	392500	1877.9	375580	102		-	390628
			High	1982.5	396500	1608.46	321692	504		-	394628
		Uplink	Low	1862.5	372500	1851.34	370268	0	-	-	-

30	38	Downlink	Mid	1882.5	376500	1508.46	301692	504	15	-	-
			High	1902.5	380500	1887.02	377404	6		-	-
			Low	1945	389000	1931.32	386264	0		-	386624
		Uplink	Mid	1962.5	392500	1875.38	375076	102		-	390124
			High	1980	396000	1603.44	320688	504		-	393624
			Low	1865	373000	1851.32	370264	0		-	-
40	51	Downlink	Low	1950	390000	1931.64	386328	0	15	-	386688
			Mid	1962.5	392500	1870.7	374140	102		-	389188
			High	1975	395000	1593.76	318752	504		-	391688
		Uplink	Low	1870	374000	1851.64	370328	0		-	-
			Mid	1882.5	376500	1501.26	300252	504		-	-
			High	1895	379000	1872.32	374464	6		-	-
45	58	Downlink	Low	1952.5	390500	1931.62	386324	0	15	-	386684
			Mid	1962.5	392500	1868.18	373636	102		-	388684
			High	1972.5	394500	1588.74	317748	504		-	390684

Note: FR1 carrier without CORESET#0 is indicated in the MIB by setting  $k_{SSB}=31$ ,  $controlResourceSetZero=0$  and  $searchSpaceZero=0$  (TS 38.213 [22], clause 13).

4.3.1.1.1.26 Reference test frequencies for NR operating band n26

Table 4.3.1.1.1.26-1: Test frequencies for NR operating band n26 and SCS 15 kHz

CB W [MHz]	carrierBandwidth [PRBs]	Range		Carrier centre [MHz]	Carrier centre [ARFCN]	point A [MHz]	absoluteFrequencyPointA [ARFCN]	offsetToCarrier [Carrier PRBs]	SS block SCS [kHz]	GS CN	absoluteFrequencySSB [ARFCN]	$k_{SSB}$	Offset carrier CORESET#0 [RBs] Note 2	CORESET#0 Index (Offset [RBs]) Note 1	offsetToPointA (SIB1) [PRBs] Note 1
5	25	Downlink	Low	861.5	172300	859.25	171850	0	15	2153	172330	4	1	1 (2)	3
			Mid	876.5	175300	855.89	171178	102		2189	175210	0	0	0 (0)	102
			High	891.5	178300	798.53	159706	504		2228	178330	4	1	1 (2)	507
		Uplink	Low	816.5	163300	814.25	162850	0	-	-	-	-	-	-	

			Mid	831.5	166300	738.53	147706	504		-	-	-	-	-	-
			High	846.5	169300	843.17	168634	6		-	-	-	-	-	-
10	52	Downlink	Low	864	172800	859.32	171864	0	15	2154	172350	6	1	1 (2)	3
			Mid	876.5	175300	853.46	170692	102		2183	174730	2	0	0 (0)	102
			High	889	177800	793.6	158720	504		2218	177410	2	1	2 (4)	509
		Uplink	Low	819	163800	814.32	162864	0	-	-	-	-	-	-	-
			Mid	831.5	166300	736.1	147220	504		-	-	-	-	-	-
			High	844	168800	838.24	167648	6		-	-	-	-	-	-
15	79	Downlink	Low	866.5	173300	859.39	171878	0	15	2155	172370	8	1	1 (2)	3
			Mid	876.5	175300	851.03	170206	102		2177	174250	4	0	0 (0)	102
			High	886.5	177300	788.67	157734	504		2205	176430	4	1	2 (4)	509
		Uplink	Low	821.5	164300	814.39	162878	0	-	-	-	-	-	-	-
			Mid	831.5	166300	733.67	146734	504		-	-	-	-	-	-
			High	841.5	168300	833.31	166662	6		-	-	-	-	-	-
20	106	Downlink	Low	869	173800	859.46	171892	0	15	2153	172330	2	0	1 (2)	2
			Mid	876.5	175300	848.6	169720	102		2171	173770	6	0	0 (0)	102
			High	884	176800	783.74	156748	504		2192	175450	6	1	2 (4)	509
		Uplink	Low	824	164800	814.46	162892	0	-	-	-	-	-	-	-
			Mid	831.5	166300	731.24	146248	504		-	-	-	-	-	-
			High	839	167800	828.38	165676	6		-	-	-	-	-	-

Note 1: The CORESET#0 Index and the associated CORESET#0 Offset refers to Table 13-1 in TS 38.213 [22]. The value of CORESET#0 Index is signalled in controlResourceSetZero (pdccch-ConfigSIB1) in the MIB. The offsetToPointA IE is expressed in units of resource blocks assuming 15 kHz subcarrier spacing for FR1 and 60 kHz subcarrier spacing for FR2.

Note 2: The parameter Offset Carrier CORESET#0 specifies the offset from the lowest subcarrier of the carrier and the lowest subcarrier of CORESET#0. It corresponds to the parameter  $\Delta F_{\text{OffsetCORESET-0-Carrier}}$  in Annex C expressed in number of common RBs.

**Table 4.3.1.1.1.26-2: Test frequencies for NR operating band n26 and SCS 30 kHz**

CB W [MHz]	carrierBandwidth [PRBs]	Range		Carrier centre [MHz]	Carrier centre [ARFCN]	point A [MHz]	absoluteFrequencyPointA [ARFCN]	offsetToCarrier [Carrier PRBs]	SS block SCS [kHz]	GS CN	absoluteFrequencySSB [ARFCN]	$k_{SSB}$	Offset carrier CORESET#0 [RBs] Note 2	CORESET#0 Index (Offset [RBs]) Note 1	offsetToPointA (SIB1) [PRBs] Note 1	
10	24	Downlink	Low	864	172800	859.68	171936	0	15	2160	172830	10	0	2 (7)	14	
			Mid	876.5	175300	835.46	167092	102		2189	175210	18	0	0 (5)	214	
			High	889	177800	703.24	140648	504		2224	177890	6	0	3 (8)	1024	
		Uplink	Low	819	163800	814.68	162936	0	-	-	-	-	-	-	-	-
			Mid	831.5	166300	645.74	129148	504	-	-	-	-	-	-	-	-
			High	844	168800	837.52	167504	6	-	-	-	-	-	-	-	-
15	38	Downlink	Low	866.5	173300	859.66	171932	0	15	2161	172850	18	0	2 (7)	14	
			Mid	876.5	175300	832.94	166588	102		2183	174730	2	0	1 (6)	216	
			High	886.5	177300	698.22	139644	504		2208	176670	6	0	0 (5)	1018	
		Uplink	Low	821.5	164300	814.66	162932	0	-	-	-	-	-	-	-	-
			Mid	831.5	166300	643.22	128644	504	-	-	-	-	-	-	-	-
			High	841.5	168300	832.5	166500	6	-	-	-	-	-	-	-	-
20	51	Downlink	Low	869	173800	859.82	171964	0	15	2159	172810	18	0	1 (6)	12	

			Mid	876.5	175300	830.6	166120	102		2177	174250	22	0	0 (5)	214
			High	884	176800	693.38	138676	504		2195	175690	2	0	0 (5)	1018
		Uplink	Low	824	164800	814.82	162964	0	-	-	-	-	-	-	-
			Mid	831.5	166300	640.88	128176	504		-	-	-	-	-	-
			High	839	167800	827.66	165532	6		-	-	-	-	-	-
<p>Note 1: The CORESET#0 Index and the associated CORESET#0 Offset refers to Table 13-2 in TS 38.213 [22]. The value of CORESET#0 Index is signalled in controlResourceSetZero (pdccch-ConfigSIB1) in the MIB. The offsetToPointA IE is expressed in units of resource blocks assuming 15 kHz subcarrier spacing for FR1 and 60 kHz subcarrier spacing for FR2.</p> <p>Note 2: The parameter Offset Carrier CORESET#0 specifies the offset from the lowest subcarrier of the carrier and the lowest subcarrier of CORESET#0. It corresponds to the parameter <math>\Delta F_{\text{OffsetCORESET-0-Carrier}}</math> in Annex C expressed in number of common RBs.</p>															

4.3.1.1.1.27 FFS

4.3.1.1.1.28 Reference test frequencies for NR operating band n28

**Table 4.3.1.1.1.28-1: Test frequencies for NR operating band n28 and SCS 15 kHz when not used in EN-DC configuration DC\_21A\_n28A or in any EN-DC configuration of a higher order EN-DC configuration including DC\_21A\_n28A**

CBW [MHz]	carrierBandwidth [PRBs]	Range	Carrier centre [MHz]	Carrier centre [ARFCN]	point A [MHz]	absoluteFrequencyPointA [ARFCN]	offsetToCarrier [Carrier PRBs]	SS block SCS [kHz]	GS CN	absoluteFrequencySSB [ARFCN]	$k_{SSB}$	Offset Carrier CORESET#0 [RBs] Note 3	CORESET#0 Index (Offset [RBs]) Note 1	offsetToPointA (SIB1) [PRBs] Note 1	
5	25	Downlink	Low	760.5	152100	758.25	151650	0	15	1902	152190	0	1	2 (4)	5
			Mid	780.5	156100	759.89	151978	102		1949	156010	0	0	0 (0)	102
			High	800.5	160100	707.53	141506	504		2002	160130	4	1	1 (2)	507
		Uplink	Low	705.5	141100	703.25	140650	0	-	-	-	-	-	-	-
			Mid	725.5	145100	632.53	126506	504	-	-	-	-	-	-	-



			High	745.5	149100	742.17	148434	6		-	-	-	-	-	-
10	52	Downlink	Low	763	152600	758.32	151664	0	15	1903	152210	2	1	2 (4)	5
			Mid	780.5	156100	757.46	151492	102		1943	155530	2	0	0 (0)	102
			High	798	159600	702.6	140520	504		1989	159150	6	1	1 (2)	507
		Uplink	Low	708	141600	703.32	140664	0	-	-	-	-	-	-	-
			Mid	725.5	145100	630.1	126020	504		-	-	-	-	-	-
			High	743	148600	737.24	147448	6		-	-	-	-	-	-
15	79	Downlink	Low	765.5	153100	758.39	151678	0	15	1901	152170	8	1	1 (2)	3
			Mid	780.5	156100	755.03	151006	102		1937	155050	4	0	0 (0)	102
			High	795.5	159100	697.67	139534	504		1976	158170	8	1	1 (2)	507
		Uplink	Low	710.5	142100	703.39	140678	0	-	-	-	-	-	-	-
			Mid	725.5	145100	627.67	125534	504		-	-	-	-	-	-
			High	740.5	148100	732.31	146462	6		-	-	-	-	-	-
20 (Note 2)	106	Downlink	Low	768	153600	758.46	151692	0	15	1902	152190	10	1	1 (2)	3
			Mid	783	156600	755.1	151020	102		1938	155070	6	0	0 (0)	102
			High	793	158600	692.74	138548	504		1966	157250	6	1	2 (4)	509
		Uplink	Low	713	142600	703.46	140692	0	-	-	-	-	-	-	-
			Mid	728	145600	627.74	125548	504		-	-	-	-	-	-
			High	738	147600	727.38	145476	6		-	-	-	-	-	-
30	160	Downlink	Low	773	154600	758.6	151720	0	15	1901	152170	6	0	1 (2)	2

(Note 4)			Mid												
			High	788	157600	68288	136576	504	1940	155290	10	1	2 (4)	509	
		Uplink	Low	718	143600	7036	140720	0	-	-	-	-	-	-	
			Mid	733	146600	71752	143504	6	-	-	-	-	-	-	

Note 1: The CORESET#0 Index and the associated CORESET#0 Offset refers to Table 13-1 in TS 38.213 [22]. The value of CORESET#0 Index is signalled in controlResourceSetZero (pdccch-ConfigSIB1) in the MIB. The offsetToPointA IE is expressed in units of resource blocks assuming 15 kHz subcarrier spacing for FR1 and 60 kHz subcarrier spacing for FR2.

Note 2: Carrier centre frequency moved for Mid Range and CBW=20 MHz due to Note 7 in TS 38.101-1 [7], Table 5.3.5-1.

Note 3: The parameter Offset Carrier CORESET#0 specifies the offset from the lowest subcarrier of the carrier and the lowest subcarrier of CORESET#0. It corresponds to the parameter  $\Delta F_{\text{OffsetCORESET-0-Carrier}}$  in Annex C expressed in number of common RBs.

Note 4: No carrier centre frequency specified for Mid Range and CBW=30 MHz due to Note 7 in TS 38.101-1 [7], Table 5.3.5-1. For test cases specifying Mid range and CBW=30 MHz to be tested, use Low range and CBW=30 MHz instead.

**Table 4.3.1.1.28-1A: Test frequencies for NR operating band n28 and SCS 15 kHz when used in EN-DC configuration DC\_21A\_n28A or in any EN-DC configuration of a higher order EN-DC configuration including DC\_21A\_n28A**

CBW [MHz]	carrierBandwidth [PRBs]	Range		Carrier centre [MHz] (Note 5)	Carrier centre [ARFCN]	point A [MHz]	absoluteFrequencyPointA [ARFCN]	offsetToCarrier [Carrier PRBs]	SS block SCS [kHz]	GS CN	absoluteFrequencySSB [ARFCN]	$k_{SSB}$	Offset Carrier CORESET#0 [RBs] Note 3	CORESET#0 Index (Offset [RBs]) Note 1	offsetToPointA (SIB1) [PRBs] Note 1
5	25	Downlink	Low	785.5	157100	783.25	156650	0	15	1963	157010	0	0	0 (0)	0
			High	790.5	158100	697.53	139506	504			1977	158190	0	1	2 (4)
		Uplink	Low	730.5	146100	728.25	145650	0	-	-	-	-	-	-	-

			High	735.5	147100	732.17	146434	6		-	-	-	-	-	-
10	52	Downlink	Low Mid High	788	157600	764.96	152992	102	15	1964	157210	2	1	2 (4)	107
		Uplink	Low Mid High	733	146600	637.6	127520	504	-	-	-	-	-	-	-

Note 1: The CORESET#0 Index and the associated CORESET#0 Offset refers to Table 13-1 in TS 38.213 [22]. The value of CORESET#0 Index is signalled in controlResourceSetZero (pdcch-ConfigSIB1) in the MIB. The offsetToPointA IE is expressed in units of resource blocks assuming 15 kHz subcarrier spacing for FR1 and 60 kHz subcarrier spacing for FR2.

Note 2: Carrier centre frequency moved for Mid Range and CBW=20 MHz due to Note 7 in TS 38.101-1 [7], Table 5.3.5-1.

Note 3: The parameter Offset Carrier CORESET#0 specifies the offset from the lowest subcarrier of the carrier and the lowest subcarrier of CORESET#0. It corresponds to the parameter  $\Delta F_{\text{OffsetCORESET-0-Carrier}}$  in Annex C expressed in number of common RBs.

Note 4: No carrier centre frequency specified for Mid Range and CBW=30 MHz due to Note 7 in TS 38.101-1 [7], Table 5.3.5-1. For test cases specifying Mid range and CBW=30 MHz to be tested, use Low range and CBW=30 MHz instead.

Note 5: The frequency range in band n28 is restricted for this band combination to 728 - 738 MHz for the UL and 783 - 793 MHz for the DL. This restriction applies also for these band combinations when applicable EN-DC configuration is part of a higher order EN-DC configuration. (Reference: TS 38.101-3 [9], Table 5.5B.4.1-1 for DC\_21A\_n28 and Note 17)

**Table 4.3.1.1.28-2: Test frequencies for NR operating band n28 and SCS 30 kHz when not used in EN-DC configuration DC\_21A\_n28A or in any EN-DC configuration of a higher order EN-DC configuration including DC\_21A\_n28A**

CBW [MHz]	carrierBandwidth [PRBs]	Range		Carrier centre [MHz]	Carrier centre [ARFCN]	point A [MHz]	absoluteFrequencyPointA [ARFCN]	offsetToCarrier [Carrier PRBs]	SS block SCS [kHz]	GS CN	absoluteFrequencySSB [ARFCN]	$k_{SSB}$	Offset Carrier CORESET#0 [RBs] Note 3	CORESET#0 Index (Offset [RBs]) Note 1	offsetToPointA (SIB1) [PRBs] Note 1
10	24	Downlink	Low	763	152600	758.68	151736	0	15	1909	152690	6	0	3 (8)	16
			Mid	780.5	156100	739.46	147892	102		1949	156010	18	0	0 (5)	214
			High	798	159600	612.24	122448	504		1995	159630	10	0	2 (7)	1022

		Uplink	Low	708	141600	703.68	140736	0	-	-	-	-	-	-	-
			Mid	725.5	145100	539.74	107948	504	-	-	-	-	-	-	-
			High	743	148600	736.52	147304	6	-	-	-	-	-	-	-
15	38	Downlink	Low	765.5	153100	758.66	151732	0	15	1907	152650	18	0	2 (7)	14
			Mid	780.5	156100	736.94	147388	102		1943	155530	2	0	1 (6)	216
			High	795.5	159100	607.22	121444	504		1982	158650	18	0	2 (7)	1022
		Uplink	Low	710.5	142100	703.66	140732	0	-	-	-	-	-	-	-
			Mid	725.5	145100	537.22	107444	504	-	-	-	-	-	-	-
			High	740.5	148100	731.5	146300	6	-	-	-	-	-	-	-
20 (Note 2)	51	Downlink	Low	768	153600	758.82	151764	0	15	1908	152670	14	0	2 (7)	14
			Mid	783	156600	737.1	147420	102		1944	155550	22	0	0 (5)	214
			High	793	158600	602.38	120476	504		1969	157490	2	0	0 (5)	1018
		Uplink	Low	713	142600	703.82	140764	0	-	-	-	-	-	-	-
			Mid	728	145600	537.38	107476	504	-	-	-	-	-	-	-
			High	738	147600	726.66	145332	6	-	-	-	-	-	-	-
30 (Note 4)	78	Downlink	Low Mid	773	154600	758.96	151792	0	15	1907	152650	22	0	1 (6)	12
			High	788	157600	592.52	118504	504		1943	155530	6	0	0 (5)	1018
		Uplink	Low Mid	718	143600	703.96	140792	0	-	-	-	-	-	-	-

			High	733	14660 0	716. 8	143360	6		-	-	-	-	-	-
Note 1:	The CORESET#0 Index and the associated CORESET#0 Offset refers to Table 13-2 in TS 38.213 [22]. The value of CORESET#0 Index is signalled in controlResourceSetZero (pdcch-ConfigSIB1) in the MIB. The offsetToPointA IE is expressed in units of resource blocks assuming 15 kHz subcarrier spacing for FR1 and 60 kHz subcarrier spacing for FR2.														
Note 2:	Carrier centre frequency moved for Mid Range and CBW=20 MHz due to Note 7 in TS 38.101-1 [7], Table 5.3.5-1.														
Note 3:	The parameter Offset Carrier CORESET#0 specifies the offset from the lowest subcarrier of the carrier and the lowest subcarrier of CORESET#0. It corresponds to the parameter $\Delta F_{\text{OffsetCORESET-0-Carrier}}$ in Annex C expressed in number of common RBs.														
Note 4:	No carrier centre frequency specified for Mid Range and CBW=30 MHz due to Note 7 in TS 38.101-1 [7], Table 5.3.5-1.														

**Table 4.3.1.1.1.28-2A: Test frequencies for NR operating band n28 and SCS 30 kHz when used in EN-DC configuration DC\_21A\_n28A or in any EN-DC configuration of a higher order EN-DC configuration including DC\_21A\_n28A**

CBW [MHz]	carrierBandwidth [PRBs]	Range		Carrier centre [MHz]	Carrier centre [ARFCN]	point A [MHz]	absoluteFrequencyPointA [ARFCN]	offsetToCarrier [Carrier PRBs]	SS block SCS [kHz]	GS CN	absoluteFrequencySSB [ARFCN]	$k_{SSB}$	Offset Carrier CORESET#0 [RBs] Note 3	CORESET#0 Index (Offset [RBs]) Note 1	offsetToPointA (SIB1) [PRBs] Note 1
10	24	Downlink	Low Mid High	788	15760 0	746. 96	149392	102	15	197 0	157690	6	0	3 (8)	220
		Uplink	Low Mid High	733	14660 0	547. 24	109448	504	-	-	-	-	-	-	-
Note 1:	The CORESET#0 Index and the associated CORESET#0 Offset refers to Table 13-1 in TS 38.213 [22]. The value of CORESET#0 Index is signalled in controlResourceSetZero (pdcch-ConfigSIB1) in the MIB. The offsetToPointA IE is expressed in units of resource blocks assuming 15 kHz subcarrier spacing for FR1 and 60 kHz subcarrier spacing for FR2.														
Note 2:	Carrier centre frequency moved for Mid Range and CBW=20 MHz due to Note 7 in TS 38.101-1 [7], Table 5.3.5-1.														
Note 3:	The parameter Offset Carrier CORESET#0 specifies the offset from the lowest subcarrier of the carrier and the lowest subcarrier of CORESET#0. It corresponds to the parameter $\Delta F_{\text{OffsetCORESET-0-Carrier}}$ in Annex C expressed in number of common RBs.														
Note 4:	No carrier centre frequency specified for Mid Range and CBW=30 MHz due to Note 7 in TS 38.101-1 [7], Table 5.3.5-1. For test cases specifying Mid range and CBW=30 MHz to be tested, use Low range and CBW=30 MHz instead.														

Note 5: The frequency range in band n28 is restricted for this band combination to 728 - 738 MHz for the UL and 783 - 793 MHz for the DL. This restriction applies also for these band combinations when applicable EN-DC configuration is part of a higher order EN-DC configuration. (Reference: TS 38.101-3 [9], Table 5.5B.4.1-1 for DC\_21A\_n28 and Note 17)

4.3.1.1.1.29 Reference test frequencies for NR operating band n29 (SDL)

**Table 4.3.1.1.1.29-1: Test frequencies for NR operating band n29 and SCS 15 kHz without CORESET#0**

CBW [MHz]	carrierBand width [PRBs]	Range		Carrier centre [MHz]	Carrier centre [ARFCN]	point A [MHz]	absolute FrequencyPoint A [ARFCN]	offsetTo Carrier [PRBs]	SS block SCS [kHz]	GSCN	absolute FrequencySSB [ARFCN]
5	25	Downlink	Low	719.5	143900	717.25	143450	0	15	-	143810
			Mid	722.5	144500	701.89	140378	102		-	144410
			High	725.5	145100	632.53	126506	504		-	145010
10	52	Downlink	Low	722	144400	717.32	143464	0	15	-	143824
			Mid	722.5	144500	699.46	139892	102		-	143924
			High	723	144600	627.6	125520	504		-	144024
Note: FR1 carrier without CORESET#0 is indicated in the MIB by setting $k_{SSB}=31$ , <i>controlResourceSetZero</i> =0 and <i>searchSpaceZero</i> = 0 (TS 38.213 [22], clause 13).											

**Table 4.3.1.1.1.29-2: Test frequencies for NR operating band n29 and SCS 30 kHz without CORESET#0**

CBW [MHz]	carrierBand width [PRBs]	Range		Carrier centre [MHz]	Carrier centre [ARFCN]	point A [MHz]	absolute FrequencyPoint A [ARFCN]	offsetTo Carrier [PRBs]	SS block SCS [kHz]	GSCN	absolute FrequencySSB [ARFCN]
10	24	Downlink	Low	722	144400	717.68	143536	0	15	-	143896
			Mid	722.5	144500	681.46	136292	102		-	143996
			High	723	144600	537.24	107448	504		-	144096
Note: FR1 carrier without CORESET#0 is indicated in the MIB by setting $k_{SSB}=31$ , <i>controlResourceSetZero</i> =0 and <i>searchSpaceZero</i> = 0 (TS 38.213 [22], clause 13).											

4.3.1.1.1.30 Reference test frequencies for NR operating band n30

Table 4.3.1.1.1.30-1: Test frequencies for NR operating band n30 and SCS 15 kHz

CBW [MHz]	carrierBandwidth [PRBs]	Range		Carrier centre [MHz]	Carrier centre [ARFCN]	point A [MHz]	absoluteFrequencyPointA [ARFCN]	offsetToCarrier [Carrier PRBs]	SS block SCS [kHz]	GS CN	absoluteFrequencySSB [ARFCN]	$k_{SSB}$	Offset Carrier CORESET#0 [RBs] Note 2	CORESET#0 Index (Offset [RBs]) Note 1	offsetToPointA (SIB1) [PRBs] Note 1
5	25	Downlink	Low	2352.5	470500	2350.25	470050	0	15	5879	470410	0	0	0 (0)	0
			Mid	23550	471000	2334.39	466878	102		5886	470910	0	0	0 (0)	102
			High	2357.5	471500	2264.53	452906	504		5893	471410	0	0	0 (0)	504
		Uplink	Low	2307.5	461500	2305.25	461050	0	-	-	-	-	-	-	-
			Mid	23100	462000	2217.03	443406	504	-	-	-	-	-	-	-
			High	2312.5	462500	2309.17	461834	6	-	-	-	-	-	-	-
10	52	Downlink	Low	23550	471000	2350.32	470064	0	15	5880	470430	2	0	0 (0)	0
			Mid	23550	471000	2331.96	466392	102		5880	470430	2	0	0 (0)	102
			High	23550	471000	2259.6	451920	504		5880	470430	2	0	0 (0)	504
		Uplink	Low	23100	462000	2305.32	461064	0	-	-	-	-	-	-	-
			High												
<p>Note 1: The CORESET#0 Index and the associated CORESET#0 Offset refers to Table 13-1 in TS 38.213 [22]. The value of CORESET#0 Index is signalled in controlResourceSetZero (pdccch-ConfigSIB1) in the MIB. The offsetToPointA IE is expressed in units of resource blocks assuming 15 kHz subcarrier spacing for FR1 and 60 kHz subcarrier spacing for FR2.</p> <p>Note 2: The parameter Offset Carrier CORESET#0 specifies the offset from the lowest subcarrier of the carrier and the lowest subcarrier of CORESET#0. It corresponds to the parameter <math>\Delta F_{\text{OffsetCORESET-0-Carrier}}</math> in Annex C expressed in number of common RBs.</p>															

Table 4.3.1.1.1.30-2: Test frequencies for NR operating band n30 and SCS 30 kHz

CBW [MHz]	carrierBandwidth [PRBs]	Range		Carrier centre [MHz]	Carrier centre [ARFCN]	point A [MHz]	absoluteFrequencyPointA [ARFCN]	offsetToCarrier [Carrier PRBs]	SS block SCS [kHz]	GS CN	absoluteFrequencySSB [ARFCN]	$k_{SSB}$	Offset Carrier CORESET#0 [RBs] Note 2	CORESET#0 Index (Offset [RBs]) Note 1	offsetToPointA (SIB1) [PRBs] Note 1	
10	24	Downlink	Low	2355	471000	2350.68	470136	0	15	5886	470910	18	0	0 (5)	10	
			Mid	23550	471000	2313.96	462792	102			5886	470910	18	0	0 (5)	214
			High	23550	471000	2169.24	433848	504			5886	470910	18	0	0 (5)	1018
		Uplink	Low	2310	462000	2305.68	461136	0	-	-	-	-	-	-	-	
			Mid													
			High													
<p>Note 1: The CORESET#0 Index and the associated CORESET#0 Offset refers to Table 13-2 in TS 38.213 [22]. The value of CORESET#0 Index is signalled in controlResourceSetZero (pdcc-ConfigSIB1) in the MIB. The offsetToPointA IE is expressed in units of resource blocks assuming 15 kHz subcarrier spacing for FR1 and 60 kHz subcarrier spacing for FR2.</p> <p>Note 2: The parameter Offset Carrier CORESET#0 specifies the offset from the lowest subcarrier of the carrier and the lowest subcarrier of CORESET#0. It corresponds to the parameter <math>\Delta F_{\text{OffsetCORESET-0-Carrier}}</math> in Annex C expressed in number of common RBs.</p>																

4.3.1.1.1.31 to 4.3.1.1.1.33 FFS

4.3.1.1.1.34 Reference test frequencies for NR operating band n34

Table 4.3.1.1.1.34-1: Test frequencies for NR operating band n34 and SCS 15 kHz

CBW [MHz]	carrierBandwidth [PRBs]	Range		Carrier centre [MHz]	Carrier centre [ARFCN]	point A [MHz]	absoluteFrequencyPointA [ARFCN]	offsetToCarrier [Carrier PRBs]	SS block SCS [kHz]	GS CN	absoluteFrequencySSB [ARFCN]	$k_{SSB}$	Offset Carrier CORESET#0 [RBs] Note 2	CORESET#0 Index (Offset [RBs]) Note 1	offsetToPointA (SIB1) [PRBs] Note 1
5	25	Downlink	Low	2012.5	402500	2010.25	402050	0	15	5032	402530	4	1	1 (2)	3



		&	Mid	2017	40350	1996	399378	102		504	403470	8	1	0 (0)	103
			Uplink	High	.5	0	.89	385906		504	505	404410	0	0	0 (0)
10	52	Downlink &	Low	2015	40300	2010	402064	0	30	503	402970	2	3	0 (2)	5
			Uplink	Mid	.5	0	.46	398892		102	504	403470	2	3	0 (2)
15	79	Downlink &	High	2020	40400	1924	384920	504	30	505	403970	2	3	0 (2)	509
			Uplink	Low	.5	0	.39	402078		0	503	402990	4	3	0 (2)
			Mid												
			High												
<p>Note 1: The CORESET#0 Index and the associated CORESET#0 Offset refers to Table 13-1 in TS 38.213 [22]. The value of CORESET#0 Index is signalled in controlResourceSetZero (pdccch-ConfigSIB1) in the MIB. The offsetToPointA IE is expressed in units of resource blocks assuming 15 kHz subcarrier spacing for FR1 and 60 kHz subcarrier spacing for FR2.</p> <p>Note 2: The parameter Offset Carrier CORESET#0 specifies the offset from the lowest subcarrier of the carrier and the lowest subcarrier of CORESET#0. It corresponds to the parameter <math>\Delta F_{\text{OffsetCORESET-0-Carrier}}</math> in Annex C expressed in number of common RBs.</p>															

Table 4.3.1.1.1.34-2: Test frequencies for NR operating band n34 and SCS 30 kHz

CBW [MHz]	carrierBandwidth [PRBs]	Range	Carrier centre [MHz]	Carrier centre [ARFCN]	point A [MHz]	absoluteFrequencyPointA [ARFCN]	offsetToCarrier [Carrier PRBs]	SS block SCS [kHz]	GS CN	absoluteFrequencySSB [ARFCN]	$k_{SSB}$	Offset Carrier CORESET#0 [RBs] Note 2	CORESET#0 Index (Offset [RBs]) Note 1	offsetToPointA (SIB1) [PRBs] Note 1	
10	24	Downlink &	Low	2015	40300	2010	402136	0	30	503	402970	14	0	1 (1)	2
			Mid	.5	0	.46	395292	102		504	403470	14	0	1 (1)	206
		Uplink	High	2020	40400	1834	366848	504		505	403970	14	0	1 (1)	1010
15	38	Downlink &	Low	2017	40350	2010	402132	0	30	503	402990	22	0	1 (1)	2
			Mid	.5	0	.66									

			Uplink	High							
Note 1:	The CORESET#0 Index and the associated CORESET#0 Offset refers to Table 13-2 in TS 38.213 [22]. The value of CORESET#0 Index is signalled in controlResourceSetZero (pdccch-ConfigSIB1) in the MIB. The offsetToPointA IE is expressed in units of resource blocks assuming 15 kHz subcarrier spacing for FR1 and 60 kHz subcarrier spacing for FR2.										
Note 2:	The parameter Offset Carrier CORESET#0 specifies the offset from the lowest subcarrier of the carrier and the lowest subcarrier of CORESET#0. It corresponds to the parameter $\Delta F_{\text{OffsetCORESET-0-Carrier}}$ in Annex C expressed in number of common RBs.										

**Table 4.3.1.1.1.34-3: Test frequencies for NR operating band n34 and SCS 60 kHz without CORESET#0**

CBW [MHz]	carrierBand width [PRBs]	Range		Carrier centre [MHz]	Carrier centre [ARFCN]	point A [MHz]	absolute FrequencyPoint A [ARFCN]	offsetTo Carrier [PRBs]	SS block SCS [kHz]	GSCN	absolute FrequencySSB [ARFCN]
10	11	Downlink & Uplink	Low	2015	403000	2011.04	402208	0	15	-	402568
			Mid	2017.5	403500	1940.1	388020	102		-	403068
			High	2020	404000	1653.16	330632	504		-	403568
15	18	Downlink & Uplink	Low	2017.5	403500	2011.02	402204	0	15	-	402564
			Mid								
			High								
Note: FR1 carrier without CORESET#0 is indicated in the MIB by setting $k_{SSB}=31$ , $controlResourceSetZero=0$ and $searchSpaceZero = 0$ (TS 38.213 [22], clause 13).											

4.3.1.1.1.35 to 4.3.1.1.1.37 FFS

4.3.1.1.1.38 Reference test frequencies for NR operating band n38

**Table 4.3.1.1.1.38-1: Test frequencies for NR operating band n38 and SCS 15 kHz**

CBW [MHz]	carrierBand width [PRBs]	Range		Carrier centre [MHz]	Carrier centre [ARFCN]	point A [MHz]	absoluteFrequencyPointA [ARFCN]	offsetToCarrier [Carrier PRBs]	SS block SCS [kHz]	GSCN	absoluteFrequencySSB [ARFCN]	$k_{SSB}$	Offset Carrier CORESET#0 [RBs] Note 2	CORESET#0 Index (Offset [RBs]) Note 1	offsetToPointA (SIB1) [PRBs] Note 1
5	25	Downlink	Low	2572.5	514500	2570.25	514050	0	15	6432	514590	0	1	2 (4)	5

		&	Mid	2592 .5	51850 0	2571 .89	514378	102		647 9	518410	0	0	0 (0)	102
		Uplink	High	2617 .5	52350 0	2524 .53	504906	504		654 3	523470	8	1	0 (0)	505
10	52	Downlink &	Low	2575 0	51500 0	2570 .32	514064	0	30	643 9	515090	6	2	1 (6)	8
		Uplink	Mid	2595 0	51900 0	2571 .96	514392	102		648 6	518910	6	1	0 (2)	105
		Uplink	High	2615 0	52300 0	2519 .6	503920	504		653 6	522970	2	3	0 (2)	509
15	79	Downlink &	Low	2577 .5	51550 0	2570 .39	514078	0	30	643 7	515050	0	1	1 (6)	7
		Uplink	Mid	2595 0	51900 0	2569 .53	513906	102		648 0	518430	8	1	0 (2)	105
		Uplink	High	2612 .5	52250 0	2514 .67	502934	504		652 6	522050	0	1	1 (6)	511
20	106	Downlink &	Low	2580 0	51600 0	2570 .46	514092	0	30	643 8	515070	2	1	1 (6)	7
		Uplink	Mid	2595 0	51900 0	2567 .1	513420	102		647 4	517950	10	1	0 (2)	105
		Uplink	High	2610 0	52200 0	2509 .74	501948	504		651 3	521070	2	1	1 (6)	511
25	133	Downlink &	Low	2582 .5	51650 0	2570 .53	514106	0	30	643 9	515090	4	1	1 (6)	7
		Uplink	Mid	2595 0	51900 0	2564 .67	512934	102		646 8	517470	0	2	0 (2)	106
		Uplink	High	2607 .5	52150 0	2504 .81	500962	504		650 0	520090	4	1	1 (6)	511
30	160	Downlink &	Low	2585 0	51700 0	2570 .6	514120	0	30	643 7	515050	10	3	0 (2)	5
		Uplink	Mid	2595 0	51900 0	2562 .24	512448	102		646 2	516990	2	2	0 (2)	106
		Uplink	High	2605 0	52100 0	2499 .88	499976	504		648 7	518930	6	0	0 (2)	506
40	216	Downlink &	Low	2590 0	51800 0	2570 .56	514112	0	30	643 9	515090	2	1	1 (6)	7
		Uplink	Mid	2595 0	51900 0	2557 .2	511440	102		645 0	516030	6	3	0 (2)	107
		Uplink	High	2600 0	52000 0	2489 .84	497968	504		646 1	516970	10	1	0 (2)	507

Note 1: The CORESET#0 Index and the associated CORESET#0 Offset refers to Table 13-1 for SSB\_SCS = 15kHz and Table 13-3 for SSB\_SCS=30kHz in TS 38.213 [22]. The value of CORESET#0 Index is signalled in controlResourceSetZero (pdccch-ConfigSIB1) in the MIB. The offsetToPointA IE is expressed in units of resource blocks assuming 15 kHz subcarrier spacing for FR1 and 60 kHz subcarrier spacing for FR2.

Note 2: The parameter Offset Carrier CORESET#0 specifies the offset from the lowest subcarrier of the carrier and the lowest subcarrier of CORESET#0. It corresponds to the parameter  $\Delta F_{\text{OffsetCORESET-0-Carrier}}$  in Annex C expressed in number of common RBs.

**Table 4.3.1.1.1.38-2: Test frequencies for NR operating band n38 and SCS 30 kHz**

CBW [MHz]	carrierBandwidth [PRBs]	Range		Carrier centre [MHz]	Carrier centre [ARFCN]	point A [MHz]	absoluteFrequencyPointA [ARFCN]	offsetToCarrier [Carrier PRBs]	SS block SCS [kHz]	GS CN	absoluteFrequencySSB [ARFCN]	$k_{SSB}$	Offset Carrier CORESET#0 [RBs] Note 2	CORESET#0 Index (Offset [RBs]) Note 1	offsetToPointA (SIB1) [PRBs] Note 1
10	24	Downlink &	Low	2575	51500	2570	514136	0	30	643	515090	6	0	3 (3)	6
			Mid	2595	51900	2553	510792	102		648	518910	18	0	0 (0)	204
		Uplink	High	2615	52300	2429	485848	504		653	522970	14	0	1 (1)	1010
15	38	Downlink &	Low	2577	51550	2570	514132	0	30	643	515050	18	0	2 (2)	4
			Mid	2595	51900	2551	510288	102		648	518430	2	0	1 (1)	206
		Uplink	High	2612	52250	2424	484844	504		652	522050	18	0	2 (2)	1012
20	51	Downlink &	Low	2580	51600	2570	514164	0	30	643	515070	14	0	2 (2)	4
			Mid	2595	51900	2549	509820	102		647	517950	22	0	0 (0)	204
		Uplink	High	2610	52200	2419	483876	504		651	521070	14	0	2 (2)	1012
25	65	Downlink &	Low	2582	51650	2570	514160	0	30	643	515090	22	0	2 (2)	4
			Mid	2595	51900	2546	509316	102		646	517470	6	0	1 (1)	206
		Uplink	High	2607	52150	2414	482872	504		650	520090	22	0	2 (2)	1012
30	78	Downlink	Low	2585	51700	2570	514192	0	30	643	515050	22	0	1 (1)	2

40	106	Uplink &	Mid	2595	519000	2544.24	508848	102	30	6462	516990	2	0	1 (1)	206
			High	2605	521000	2409.52	481904	504		6487	518930	6	0	0 (0)	1008
		Downlink & Uplink	Low	2590	518000	2570.92	514184	0		6439	515090	14	0	2 (2)	4
			Mid	2595	519000	2539.2	507840	102		6450	516030	18	0	1 (1)	206
			High	2600	520000	2399.48	479896	504		6461	516970	22	0	0 (0)	1008
<p>Note 1: The CORESET#0 Index and the associated CORESET#0 Offset refers to Table 13-4 in TS 38.213 [22]. The value of CORESET#0 Index is signalled in controlResourceSetZero (pdcch-ConfigSIB1) in the MIB. The offsetToPointA IE is expressed in units of resource blocks assuming 15 kHz subcarrier spacing for FR1 and 60 kHz subcarrier spacing for FR2.</p> <p>Note 2: The parameter Offset Carrier CORESET#0 specifies the offset from the lowest subcarrier of the carrier and the lowest subcarrier of CORESET#0. It corresponds to the parameter <math>\Delta F_{\text{OffsetCORESET-0-Carrier}}</math> in Annex C expressed in number of common RBs.</p>															

**Table 4.3.1.1.1.38-3: Test frequencies for NR operating band n38 and SCS 60 kHz without CORESET#0**

CBW [MHz]	carrierBandwidth [PRBs]	Range	Carrier centre [MHz]	Carrier centre [ARFCN]	point A [MHz]	absoluteFrequency PointA [ARFCN]	offsetToCarrier [PRBs]	SS block SCS [kHz]	GSCN	absoluteFrequency SSB [ARFCN]	
10	11	Downlink & Uplink	Low	2575	515000	2571.04	514208	0	30	-	514928
			Mid	2595	519000	2517.6	503520	102		-	518928
			High	2615	523000	2248.16	449632	504		-	522928
15	18	Downlink & Uplink	Low	2577.5	515500	2571.02	514204	0	30	-	514924
			Mid	2595	519000	2515.08	503016	102		-	518424
			High	2612.5	522500	2243.14	448628	504		-	521924
20	24	Downlink & Uplink	Low	2580	516000	2571.36	514272	0	30	-	514992
			Mid	2595	519000	2512.92	502584	102		-	517992
			High	2610	522000	2238.48	447696	504		-	520992
25	31	Downlink & Uplink	Low	2582.5	516500	2571.34	514268	0	30	-	514988
			Mid	2595	519000	2510.4	502080	102		-	517488
			High	2607.5	521500	2233.46	446692	504		-	519888
30	38	Downlink & Uplink	Low	2585	517000	2571.32	514264	0	30	-	514984
			Mid	2595	519000	2507.88	501576	102		-	516984
			High	2605	521000	2228.44	445688	504		-	518984
40	51	Downlink & Uplink	Low	2590	518000	2571.64	514328	0	15	-	514688
			Mid	2595	519000	2503.2	500640	102		-	515688
			High	2600	520000	2218.76	443752	504		-	516688

Note: FR1 carrier without CORESET#0 is indicated in the MIB by setting  $k_{SSB} = 31$ ,  $controlResourceSetZero = 0$  and  $searchSpaceZero = 0$  (TS 38.213 [22], clause 13).

4.3.1.1.1.39 Reference test frequencies for NR operating band n39

**Table 4.3.1.1.1.39-1: Test frequencies for NR operating band n39 and SCS 15 kHz**

CBW [MHz]	carrierBandwidth [PRBs]	Range		Carrier centre [MHz]	Carrier centre [ARFCN]	point A [MHz]	absoluteFrequencyPointA [ARFCN]	offsetToCarrier [Carrier PRBs]	SS block SCS [kHz]	GS CN	absoluteFrequencySSB [ARFCN]	$k_{SSB}$	Offset Carrier CORESET#0 [RBs] Note 2	CORESET#0 Index (Offset [RBs]) Note 1	offsetToPointA (SIB1) [PRBs] Note 1
5	25	Downlink &	Low	1882.5	376500	1880.25	376050	0	15	4707	376590	0	1	2 (4)	5
			Mid	1899.1	379820	1878.49	375698	102		4747	379730	0	0	0 (0)	102
		Uplink	High	1917.5	383500	1824.53	364906	504		4793	383530	4	1	1 (2)	507
10	52	Downlink &	Low	1885	377000	1880.32	376064	0	30	4714	377090	6	2	1 (6)	8
			Mid	1900	380000	1876.96	375392	102		4750	379970	2	3	0 (2)	107
		Uplink	High	1915	383000	1819.6	363920	504		4789	383090	6	2	1 (6)	512
15	79	Downlink &	Low	1887.5	377500	1880.39	376078	0	30	4712	377050	0	1	1 (6)	7
			Mid	1900	380000	1874.53	374906	102		4744	379490	4	3	0 (2)	107
		Uplink	High	1912.5	382500	1814.67	362934	504		4773	381870	0	0	0 (2)	506
20	106	Downlink &	Low	1890	378000	1880.46	376092	0	30	4713	377070	2	1	1 (6)	7
			Mid	1900	380000	1872.1	374420	102		4738	379010	6	3	0 (2)	107
		Uplink	High	1910	382000	1809.74	361948	504		4760	380890	2	0	0 (2)	506
25	133	Downlink	Low	1892.5	378500	1880.53	376106	0	30	4714	377090	4	1	1 (6)	7

		&	Mid	1900	38000	1869	373934	102		473	378530	8	3	0 (2)	107
		Uplink	High	1907	38150	1804	360962	504		475	379970	0	2	0 (2)	508
30	160	Downlink &	Low	1895	37900	1880	376120	0	30	471	377050	10	3	0 (2)	5
		Uplink	Mid	1900	38000	1867	373448	102		472	378050	10	3	0 (2)	107
			High	1905	38100	1799	359976	504		473	378990	2	2	0 (2)	508
40	216	Downlink &	Low	1900	38000	1880	376112	0	30	471	377090	2	1	1 (6)	7
		Uplink	Mid												
			High												
<p>Note 1: The CORESET#0 Index and the associated CORESET#0 Offset refers to Table 13-1 for SSB_SCS = 15kHz and Table 13-3 for SSB_SCS=30kHz in TS 38.213 [22]. The value of CORESET#0 Index is signalled in controlResourceSetZero (pdcc-ConfigSIB1) in the MIB. The offsetToPointA IE is expressed in units of resource blocks assuming 15 kHz subcarrier spacing for FR1 and 60 kHz subcarrier spacing for FR2.</p> <p>Note 2: The parameter Offset Carrier CORESET#0 specifies the offset from the lowest subcarrier of the carrier and the lowest subcarrier of CORESET#0. It corresponds to the parameter <math>\Delta F_{\text{OffsetCORESET-0-Carrier}}</math> in Annex C expressed in number of common RBs.</p>															

Table 4.3.1.1.1.39-2: Test frequencies for NR operating band n39 and SCS 30 kHz

CBW [MHz]	carrierBandwidth [PRBs]	Range	Carrier centre [MHz]	Carrier centre [ARFCN]	point A [MHz]	absoluteFrequencyPointA [ARFCN]	offsetToCarrier [Carrier PRBs]	SS block SCS [kHz]	GS CN	absoluteFrequencySSB [ARFCN]	$k_{SSB}$	Offset Carrier CORESET#0 [RBs] Note 2	CORESET#0 Index (Offset [RBs]) Note 1	offsetToPointA (SIB1) [PRBs] Note 1	
10	24	Downlink &	Low	1885	37700	1880	376136	0	30	471	377090	6	0	3 (3)	6
		Uplink	Mid	1900	38000	1858	371792	102		475	379970	14	0	1 (1)	206
			High	1915	38300	1729	345848	504		478	383090	6	0	3 (3)	1014
15	38	Downlink &	Low	1887	37750	1880	376132	0	30	471	377050	18	0	2 (2)	4
			Mid	1900	38000	1856	371288	102		474	379490	22	0	1 (1)	206

		Uplink	High	1912.5	382500	1724.22	344844	504		4773	381870	6	0	0 (0)	1008
20	51	Downlink & Mid	Low	1890	378000	1880.82	376164	0	30	4713	377070	14	0	2 (2)	4
			Mid	1900	380000	1854.1	370820	102		4738	379010	18	0	1 (1)	206
		Uplink	High	1910	382000	1719.38	343876	504		4760	380890	2	0	0 (0)	1008
25	65	Downlink & Mid	Low	1892.5	378500	1880.8	376160	0	30	4714	377090	22	0	2 (2)	4
			Mid	1900	380000	1851.58	370316	102		4732	378530	2	0	2 (2)	208
		Uplink	High	1907.5	381500	1714.36	342872	504		4750	379970	6	0	1 (1)	1010
30	78	Downlink & Mid	Low	1895	379000	1880.96	376192	0	30	4712	377050	22	0	1 (1)	2
			Mid	1900	380000	1849.24	369848	102		4726	378050	22	0	1 (1)	206
		Uplink	High	1905	381000	1709.52	341904	504		4737	378990	2	0	1 (1)	1010
40	106	Downlink & Mid	Low	1900	380000	1880.92	376184	0	30	4714	377090	14	0	2 (2)	4
			Mid												
		Uplink	High												

Note 1: The CORESET#0 Index and the associated CORESET#0 Offset refers to Table 13-2 in TS 38.213 [22]. The value of CORESET#0 Index is signalled in controlResourceSetZero (pdcch-ConfigSIB1) in the MIB. The offsetToPointA IE is expressed in units of resource blocks assuming 15 kHz subcarrier spacing for FR1 and 60 kHz subcarrier spacing for FR2.

Note 2: The parameter Offset Carrier CORESET#0 specifies the offset from the lowest subcarrier of the carrier and the lowest subcarrier of CORESET#0. It corresponds to the parameter  $\Delta F_{\text{OffsetCORESET-0-Carrier}}$  in Annex C expressed in number of common RBs.

**Table 4.3.1.1.39-3: Test frequencies for NR operating band n39 and SCS 60 kHz without CORESET#0**

CBW [MHz]	carrierBand width [PRBs]	Range		Carrier centre [MHz]	Carrier centre [ARFCN]	point A [MHz]	absolute FrequencyPoint A [ARFCN]	offsetTo Carrier [PRBs]	SS block SCS [kHz]	GSCN	absolute FrequencySSB [ARFCN]
10	11	Downlink &	Low	1885	377000	1881.04	376208	0	30	-	376928
			Mid	1900	380000	1822.6	364520	102		-	379928



15	18	Uplink Downlink & Uplink	High	1915	383000	1548.16	309632	504	30	-	382928
			Low	1887.5	377500	1881.02	376204	0		-	376924
			Mid	1900	380000	1820.08	364016	102		-	379424
20	24	Downlink & Uplink	High	1912.5	382500	1543.14	308628	504	30	-	381924
			Low	1890	378000	1881.36	376272	0		-	376992
			Mid	1900	380000	1817.92	363584	102		-	378992
25	31	Downlink & Uplink	High	1910	382000	1538.48	307696	504	30	-	380992
			Low	1892.5	378500	1881.34	376268	0		-	376988
			Mid	1900	380000	1815.4	363080	102		-	378488
30	38	Downlink & Uplink	High	1907.5	381500	1533.46	306692	504	30	-	379988
			Low	1895	379000	1881.32	376264	0		-	376984
			Mid	1900	380000	1812.88	362576	102		-	377984
40	51	Downlink & Uplink	High	1905	381000	1528.44	305688	504	30	-	378984
			Low	1900	380000	1881.64	376328	0		-	377048
			Mid								

Note: FR1 carrier without CORESET#0 is indicated in the MIB by setting  $k_{SSB} = 31$ ,  $controlResourceSetZero = 0$  and  $searchSpaceZero = 0$  (TS 38.213 [22], clause 13).

4.3.1.1.1.40 Reference test frequencies for NR operating band n40

Table 4.3.1.1.1.40-1: Test frequencies for NR operating band n40 and SCS 15 kHz

CBW [MHz]	carrierBandwidth [PRBs]	Range		Carrier centre [MHz]	Carrier centre [ARFCN]	point A [MHz]	absoluteFrequencyPointA [ARFCN]	offsetToCarrier [Carrier PRBs]	SS block SCS [kHz]	GS CN	absoluteFrequencySSB [ARFCN]	$k_{SSB}$	Offset Carrier CORESET#0 [RBs] Note 2	CORESET#0 Index (Offset [RBs]) Note 1	offsetToPointA (SIB1) [PRBs] Note 1
5	25	Downlink	Low	2302.5	460500	2300.25	460050	0	(Note 3)	-	460770	-	-	-	-
			Mid	2350.0	470000	2329.39	465878	102		-	470270	-	-	-	-
		Uplink	High	2397.5	479500	2304.53	460906	504		-	479770	-	-	-	-
10	52	Downlink &	Low	2305.0	461000	2300.32	460064	0	30	5764	461090	6	2	1 (6)	8
			Mid	2350.0	470000	2326.96	465392	102		5875	469970	2	3	0 (2)	107

		Uplink	High	2395	479000	2299.6	459920	504		5989	479090	6	2	1 (6)	512
15	79	Downlink & Mid	Low	2307.5	461500	2300.39	460078	0	30	5762	461050	0	1	1 (6)	7
			High	2392.5	478500	2294.67	458934	504		5869	469490	4	3	0 (2)	107
		Uplink	High	2392.5	478500	2294.67	458934	504		5973	477870	0	0	0 (2)	506
20	106	Downlink & Mid	Low	2310	462000	2300.46	460092	0	30	5763	461070	2	1	1 (6)	7
			High	2390	478000	2289.74	457948	504		5863	469010	6	3	0 (2)	107
		Uplink	High	2390	478000	2289.74	457948	504		5960	476890	2	0	0 (2)	506
25	133	Downlink & Mid	Low	2312.5	462500	2300.53	460106	0	30	5764	461090	4	1	1 (6)	7
			High	2387.5	477500	2284.81	456962	504		5857	468530	8	3	0 (2)	107
		Uplink	High	2387.5	477500	2284.81	456962	504		5950	475970	0	2	0 (2)	508
30	160	Downlink & Mid	Low	2315	463000	2300.6	460120	0	30	5762	461050	10	3	0 (2)	5
			High	2385	477000	2279.88	455976	504		5851	468050	10	3	0 (2)	107
		Uplink	High	2385	477000	2279.88	455976	504		5937	474990	2	2	0 (2)	508
40	216	Downlink & Mid	Low	2320	464000	2300.56	460112	0	30	5764	461090	2	1	1 (6)	7
			High	2380	476000	2269.84	453968	504		5839	467090	2	1	1 (6)	109
		Uplink	High	2380	476000	2269.84	453968	504		5914	473090	2	1	1 (6)	511
50	270	Downlink & Mid	Low	2325	465000	2300.7	460140	0	30	5763	461070	10	3	0 (2)	5
			High	2375	475000	2259.98	451996	504		5827	466130	6	1	1 (6)	109
		Uplink	High	2375	475000	2259.98	451996	504		5888	471130	6	1	1 (6)	511
<p>Note 1: The CORESET#0 Index and the associated CORESET#0 Offset refers to Table 13-1 in TS 38.213 [22]. The value of CORESET#0 Index is signalled in controlResourceSetZero (pdccch-ConfigSIB1) in the MIB. The offsetToPointA IE is expressed in units of resource blocks assuming 15 kHz subcarrier spacing for FR1 and 60 kHz subcarrier spacing for FR2.</p>															

Note 2: The parameter Offset Carrier CORESET#0 specifies the offset from the lowest subcarrier of the carrier and the lowest subcarrier of CORESET#0. It corresponds to the parameter  $\Delta F_{\text{OffsetCORESET-0-Carrier}}$  in Annex C expressed in number of common RBs.  
 Note 3: No SS/PBCH block fits within the channel bandwidth. The channel bandwidth can only be used as SCell

**Table 4.3.1.1.1.40-2: Test frequencies for NR operating band n40 and SCS 30 kHz**

CB W [MHz]	carrierBandwidth [PRBs]	Range		Carrier centre [MHz]	Carrier centre [ARFCN]	point A [MHz]	absoluteFrequencyPointA [ARFCN]	offsetToCarrier [Carrier PRBs]	SS block SCS [kHz]	GS CN	absoluteFrequencySSB [ARFCN]	$k_{SSB}$	Offset Carrier CORESET#0 [RBs] Note 2	CORESET#0 Index (Offset [RBs]) Note 1	offsetToPointA (SIB1) [PRBs] Note 1
10	24	Downlink &	Low	2305	461000	2300.68	460136	0	30	5764	461090	6	0	3 (3)	6
			Mid	2350	470000	2308.96	461792	102		5875	469970	14	0	1 (1)	206
		Uplink	High	2395	479000	2209.24	441848	504		5989	479090	6	0	3 (3)	1014
15	38	Downlink &	Low	2307.5	461500	2300.66	460132	0	30	5762	461050	18	0	2 (2)	4
			Mid	2350	470000	2306.44	461288	102		5869	469490	22	0	1 (1)	206
		Uplink	High	2392.5	478500	2204.22	440844	504		5973	477870	6	0	0 (0)	1008
20	51	Downlink &	Low	2310	462000	2300.82	460164	0	30	5763	461070	14	0	2 (2)	4
			Mid	2350	470000	2304.1	460820	102		5863	469010	18	0	1 (1)	206
		Uplink	High	2390	478000	2199.38	439876	504		5960	476890	2	0	0 (0)	1008
25	65	Downlink &	Low	2312.5	462500	2300.8	460160	0	30	5764	461090	22	0	2 (2)	4
			Mid	2350	470000	2301.58	460316	102		5857	468530	2	0	2 (2)	208
		Uplink	High	2387.5	477500	2194.36	438872	504		5950	475970	6	0	1 (1)	1010
30	78	Downlink &	Low	2315	463000	2300.96	460192	0	30	5762	461050	22	0	1 (1)	2
			Mid	2350	470000	2299.24	459848	102		5851	468050	22	0	1 (1)	206

40	106	Uplink	High	2385	477000	2189.52	437904	504	30	5937	474990	2	0	1 (1)	1010
		Downlink &	Low	2320	464000	2300.92	460184	0		5764	461090	14	0	2 (2)	4
			Mid	2350	470000	2294.2	458840	102		5839	467090	14	0	2 (2)	208
50	133	Uplink	High	2380	476000	2179.48	435896	504	30	5914	473090	14	0	2 (2)	1012
		Downlink &	Low	2325	465000	2301.06	460212	0		5763	461070	22	0	1 (1)	2
			Mid	2350	470000	2289.34	457868	102		5827	466130	18	0	2 (2)	208
60	162	Uplink	High	2375	475000	2169.62	433924	504	30	5888	471130	18	0	2 (2)	1012
		Downlink &	Low	2330	466000	2300.84	460168	0		5762	461050	6	0	2 (2)	4
			Mid	2350	470000	2284.12	456824	102		5812	464930	14	0	0 (0)	204
80	217	Uplink	High	2370	474000	2159.4	431880	504	30	5862	468990	10	0	1 (1)	1010
		Downlink &	Low	2340	468000	2300.94	460188	0		5763	461070	6	0	2 (2)	4
			Mid	2350	470000	2274.22	454844	102		5788	463010	10	0	1 (1)	206
80	217	Uplink	High	2360	472000	2139.5	427900	504	30	5813	465130	2	0	3 (3)	1014

Note 1: The CORESET#0 Index and the associated CORESET#0 Offset refers to Table 13-2 in TS 38.213 [22]. The value of CORESET#0 Index is signalled in controlResourceSetZero (pdcch-ConfigSIB1) in the MIB. The offsetToPointA IE is expressed in units of resource blocks assuming 15 kHz subcarrier spacing for FR1 and 60 kHz subcarrier spacing for FR2.

Note 2: The parameter Offset Carrier CORESET#0 specifies the offset from the lowest subcarrier of the carrier and the lowest subcarrier of CORESET#0. It corresponds to the parameter  $\Delta F_{\text{OffsetCORESET-0-Carrier}}$  in Annex C expressed in number of common RBs.

**Table 4.3.1.1.40-3: Test frequencies for NR operating band n40 and SCS 60 kHz without CORESET#0**

CBW [MHz]	carrierBand width [PRBs]	Range		Carrier centre [MHz]	Carrier centre [ARFCN]	point A [MHz]	absolute FrequencyPoint A [ARFCN]	offsetTo Carrier [PRBs]	SS block SCS [kHz]	GSCN	absolute FrequencySSB [ARFCN]
10	11	Downlink &	Low	2305	461000	2301.04	460208	0	30	-	460928
			Mid	2350	470000	2272.6	454520	102		-	469928

15	18	Uplink Downlink & Uplink	High	2395	479000	2028.16	405632	504	30	-	478928
			Low	2307.5	461500	2301.02	460204	0		-	460924
			Mid	2350	470000	2270.08	454016	102		-	469424
20	24	Downlink & Uplink	High	2392.5	478500	2023.14	404628	504	30	-	477924
			Low	2310	462000	2301.36	460272	0		-	460992
			Mid	2350	470000	2267.92	453584	102		-	468992
25	31	Downlink & Uplink	High	2390	478000	2018.48	403696	504	30	-	476992
			Low	2312.5	462500	2301.34	460268	0		-	460988
			Mid	2350	470000	2265.4	453080	102		-	468488
30	38	Downlink & Uplink	High	2387.5	477500	2013.46	402692	504	30	-	475988
			Low	2315	463000	2301.32	460264	0		-	460984
			Mid	2350	470000	2262.88	452576	102		-	467984
40	51	Downlink & Uplink	High	2385	477000	2008.44	401688	504	30	-	474984
			Low	2320	464000	2301.64	460328	0		-	461048
			Mid	2350	470000	2258.2	451640	102		-	467048
50	65	Downlink & Uplink	High	2380	476000	1998.76	399752	504	30	-	473048
			Low	2325	465000	2301.6	460320	0		-	461040
			Mid	2350	470000	2253.16	450632	102		-	466040
60	79	Downlink & Uplink	High	2375	475000	1988.72	397744	504	30	-	471040
			Low	2330	466000	2301.56	460312	0		-	461032
			Mid	2350	470000	2248.12	449624	102		-	465032
80	107	Downlink & Uplink	High	2370	474000	1978.68	395736	504	30	-	469032
			Low	2340	468000	2301.48	460296	0		-	461016
			Mid	2350	470000	2238.04	447608	102		-	463016
			High	2360	472000	1958.6	391720	504		-	465016
Note: FR1 carrier without CORSESET#0 is indicated in the MIB by setting $k_{SSB}=31$ , <i>controlResourceSetZero</i> =0 and <i>searchSpaceZero</i> = 0 (TS 38.213 [22], clause 13).											

4.3.1.1.1.41 Reference test frequencies for NR operating band n41

Table 4.3.1.1.1.41-1: Test frequencies for NR operating band n41, SCS 15 kHz and  $\Delta F_{\text{Raster}}$  15 kHz

CBW [MHz]	carrierBandwidth [PRBs]	Range	Carrier centre [MHz]	Carrier centre [ARFCN]	point A [MHz]	absoluteFrequencyPointA [ARFCN]	offsetToCarrier [Carrier PRBs]	SS block SCS [kHz]	GS CN	absoluteFrequencySSB [ARFCN]	$k_{SSB}$	Offset Carrier CORESET#0 [RBs] Note 2	CORESET#0 Index (Offset [RBs]) Note 1	offsetToPointA (SIB1) [PRBs] Note 1
-----------	-------------------------	-------	----------------------	------------------------	---------------	---------------------------------	--------------------------------	--------------------	-------	------------------------------	-----------	---------------------------------------	---------------------------------------	-------------------------------------

10	52	Down link & Uplink	Low	2501.01	5002.02	2496.33	499266	0	15	6246	499710	4	0	1 (2)	2
			Mid	2593.005	5186.01	2569.965	513993	102		6477	518190	7	0	2 (4)	106
		High	2685.00	5370.00	2589.6	517920	504	6705		536430	2	0	0 (0)	504	
15	79	Down link & Uplink	Low	2503.5	5007.00	2496.39	499278	0	15	6246	499710	0	0	1 (2)	2
			Mid	2593.005	5186.01	2567.535	513507	102		6471	517710	9	0	2 (4)	106
		High	2682.495	5364.99	2584.665	516933	504	6693		535470	11	0	0 (0)	504	
20	106	Down link & Uplink	Low	2506.005	5012.01	2496.465	499293	0	15	6246	499710	7	1	0 (0)	1
			Mid	2593.005	5186.01	2565.105	513021	102		6465	517230	11	0	2 (4)	106
		High	2679.99	5359.98	2579.73	515946	504	6681		534510	8	1	0 (0)	505	
30	160	Down link & Uplink	Low	2511.00	5022.00	2496.6	499320	0	15	6246	499710	10	0	0 (0)	0
			Mid	2593.005	5186.01	2560.245	512049	102		6453	516270	3	1	2 (4)	107
		High	2674.995	5349.99	2569.875	513975	504	6657		532590	1	1	1 (2)	507	
40	216	Down link & Uplink	Low	2516.01	5032.02	2496.57	499314	0	15	6246	499710	0	1	0 (0)	1
			Mid	2593.005	5186.01	2555.205	511041	102		6441	515310	7	2	2 (4)	108
		High	2670.00	5340.00	2559.84	511968	504	6633		530670	6	1	2 (4)	509	
50	270	Down link & Uplink	Low	2521.005	5042.01	2496.705	499341	0	15	6246	499710	3	0	0 (0)	0
			Mid	2593.005	5186.01	2550.345	510069	102		6426	514110	3	0	0 (0)	102
		High	2664.99	5329.98	2549.97	509994	504	6606		528510	4	0	0 (0)	504	

Note 1: The CORESET#0 Index and the associated CORESET#0 Offset refers to Table 13-1 in TS 38.213 [22]. The value of CORESET#0 Index is signalled in controlResourceSetZero (pdcch-ConfigSIB1) in the MIB. The offsetToPointA IE is expressed in units of resource blocks assuming 15 kHz subcarrier spacing for FR1 and 60 kHz subcarrier spacing for FR2.

Note 2: The parameter Offset Carrier CORESET#0 specifies the offset from the lowest subcarrier of the carrier and the lowest subcarrier of CORESET#0. It corresponds to the parameter  $\Delta F_{\text{OffsetCORESET-0-Carrier}}$  in Annex C expressed in number of common RBs.

Table 4.3.1.1.1.41-2: Test frequencies for NR operating band n41, SCS 30 kHz and  $\Delta F_{\text{Raster}}$  30 kHz

CBW [MHz]	carrierBandwidth [PRBs]	Range		Carrier centre [MHz]	Carrier centre [ARFCN]	point A [MHz]	absoluteFrequencyPointA [ARFCN]	offsetToCarrier [Carrier PRBs]	SS block SCS [kHz]	GS CN	absoluteFrequencySSB [ARFCN]	$k_{\text{SSB}}$	Offset Carrier CORES ET#0 [RBs] Note 2	CORES ET#0 Index (Offset [RBs]) Note 1	offsetToPointA (SIB1) [PRBs] Note 1
10	24	Downlink &	Low	2501.01	500202	2496.69	499338	0	30	6252	500190	20	0	1 (1)	2
			Mid	2592.99	518598	2551.95	510390	102			518670	0	0	3 (3)	210
		Uplink	High	2685	537000	2499.24	499848	504			536910	18	0	0 (0)	1008
15	38	Downlink &	Low	2503.5	500700	2496.66	499332	0	30	6252	500190	22	0	1 (1)	2
			Mid	2592.99	518598	2549.43	509886	102			517950	0	0	0 (0)	204
		Uplink	High	2682.48	536496	2494.2	498840	504			535950	10	0	1 (1)	1010
20	51	Downlink &	Low	2506.02	501204	2496.84	499368	0	30	6252	500190	10	0	1 (1)	2
			Mid	2592.99	518598	2547.09	509418	102			517710	4	0	3 (3)	210
		Uplink	High	2679.99	535998	2489.37	497874	504			534990	12	0	1 (1)	1010
30	78	Downlink &	Low	2511	502200	2496.96	499392	0	30	6252	500190	2	0	1 (1)	2
			Mid	2592.99	518598	2542.23	508446	102			516510	0	0	0 (0)	204
		Uplink	High	2674.98	534996	2479.5	495900	504			533070	6	0	2 (2)	1012
40	106	Downlink &	Low	2516.01	503202	2496.93	499386	0	30	6252	500190	4	0	1 (1)	2
			Mid	2592.99	518598	2537.19	507438	102			515550	16	0	0 (0)	204
		Uplink	High	2670	534000	2469.48	493896	504			530910	2	0	0 (0)	1008
50	133	Downlink	Low	2521.02	504204	2497.08	499416	0	30	6252	500190	18	0	0 (0)	0

		&	Mid	2592 .99	51859 8	2532 .33	506466	102		643 2	514590	20	0	0 (0)	204
		Uplink	High	2664 .99	53299 8	2459 .61	491922	504		661 2	528990	20	0	0 (0)	1008
60	162	Downlink & Uplink	Low	2526	50520 0	2496 .84	499368	0	30	625 2	500190	10	0	1 (1)	2
			Mid	2592 .99	51859 8	2527 .11	505422	102		642 0	513630	0	0	2 (2)	208
			High	2659 .98	53199 6	2449 .38	489876	504		658 8	527070	14	0	2 (2)	1012
70	189	Downlink & Uplink	Low	2531 .01	50620 2	2496 .99	499398	0	30	625 2	500190	0	0	1 (1)	2
			Mid	2592 .99	51859 8	2522 .25	504450	102		640 8	512670	4	0	2 (2)	208
			High	2655	53100 0	2439 .54	487908	504		656 4	525150	6	0	3 (3)	1014
80	217	Downlink & Uplink	Low	2536 .02	50720 4	2496 .96	499392	0	30	625 2	500190	2	0	1 (1)	2
			Mid	2592 .99	51859 8	2517 .21	503442	102		639 6	511710	20	0	2 (2)	208
			High	2649 .99	52999 8	2429 .49	485898	504		653 7	522990	4	0	1 (1)	1010
90	245	Downlink & Uplink	Low	2541	50820 0	2496 .9	499380	0	30	625 2	500190	6	0	1 (1)	2
			Mid	2592 .99	51859 8	2512 .17	502434	102		638 1	510510	4	0	0 (0)	204
			High	2644 .98	52899 6	2419 .44	483888	504		651 3	521070	10	0	2 (2)	1012
100	273	Downlink & Uplink	Low	2546 .01	50920 2	2496 .87	499374	0	30	625 2	500190	8	0	1 (1)	2
			Mid	2592 .99	51859 8	2507 .13	501426	102		636 9	509550	20	0	0 (0)	204
			High	2640	52800 0	2409 .42	481884	504		648 6	518910	6	0	0 (0)	1008
<p>Note 1: The CORESET#0 Index and the associated CORESET#0 Offset refers to Table 13-4 in TS 38.213 [22]. The value of CORESET#0 Index is signalled in controlResourceSetZero (pdccch-ConfigSIB1) in the MIB. The offsetToPointA IE is expressed in units of resource blocks assuming 15 kHz subcarrier spacing for FR1 and 60 kHz subcarrier spacing for FR2.</p> <p>Note 2: The parameter Offset Carrier CORESET#0 specifies the offset from the lowest subcarrier of the carrier and the lowest subcarrier of CORESET#0. It corresponds to the parameter <math>\Delta F_{\text{OffsetCORESET-0-Carrier}}</math> in Annex C expressed in number of common RBs.</p>															



Table 4.3.1.1.1.41-3: Test frequencies for NR operating band n41, SCS 60 kHz and  $\Delta F_{\text{Raster}}$  15 kHz without CORESET#0

CBW [MHz]	carrierBand width [PRBs]	Range		Carrier centre [MHz]	Carrier centre [ARFCN]	point A [MHz]	absoluteFrequencyPointA [ARFCN]	offsetTo Carrier [PRBs]	SS block SCS [kHz]	GSCN	absolute FrequencySSB [ARFCN]
10	11	Downlink & Uplink	Low	2501.01	500202	2497.05	499410	0	15	-	499770
			Mid	2593.005	518601	2515.605	503121	102		-	518169
			High	2685	537000	2318.16	463632	504		-	536568
15	18	Downlink & Uplink	Low	2503.5	500700	2497.02	499404	0	15	-	499764
			Mid	2593.005	518601	2513.085	502617	102		-	517665
			High	2682.495	536499	2313.135	462627	504		-	535563
20	24	Downlink & Uplink	Low	2506.005	501201	2497.365	499473	0	15	-	499833
			Mid	2593.005	518601	2510.925	502185	102		-	517233
			High	2679.99	535998	2308.47	461694	504		-	534630
30	38	Downlink & Uplink	Low	2511	502200	2497.32	499464	0	15	-	499824
			Mid	2593.005	518601	2505.885	501177	102		-	516225
		Uplink	High	2674.995	534999	2298.435	459687	504		-	532623
40	51	Downlink & Uplink	Low	2516.01	503202	2497.65	499530	0	15	-	499890
			Mid	2593.005	518601	2501.205	500241	102		-	515289
			High	2670	534000	2288.76	457752	504		-	530688
50	65	Downlink & Uplink	Low	2521.005	504201	2497.605	499521	0	15	-	499881
			Mid	2593.005	518601	2496.165	499233	102		-	514281
			High	2664.99	532998	2278.71	455742	504		-	528678
60	79	Downlink & Uplink	Low	2526	505200	2497.56	499512	0	15	-	499872
			Mid	2593.005	518601	2491.125	498225	102		-	513273
			High	2659.995	531999	2268.675	453735	504		-	526671
70	93	Downlink & Uplink	Low	2531.01	506202	2497.53	499506	0	15	-	499866
			Mid	2593.005	518601	2486.085	497217	102		-	512265
			High	2655	531000	2258.64	451728	504		-	524664
80	107	Downlink & Uplink	Low	2536.005	507201	2497.485	499497	0	15	-	499857
			Mid	2593.005	518601	2481.045	496209	102		-	511257
			High	2649.99	529998	2248.59	449718	504		-	522654
90	121	Downlink & Uplink	Low	2541	508200	2497.44	499488	0	15	-	499848
			Mid	2593.005	518601	2476.005	495201	102		-	510249
			High	2644.995	528999	2238.555	447711	504		-	520647
100	135	Downlink & Uplink	Low	2546.01	509202	2497.41	499482	0	15	-	499842
			Mid	2593.005	518601	2470.965	494193	102		-	509241
			High	2640	528000	2228.52	445704	504		-	518640

Note: FR1 carrier without CORESET#0 is indicated in the MIB by setting  $k_{\text{SSB}}=31$ , *controlResourceSetZero*=0 and *searchSpaceZero* = 0 (TS 38.213 [22], clause 13).

4.3.1.1.1.42 to 4.3.1.1.1.45 FFS

4.3.1.1.1.46 Reference test frequencies for NR operating band n46

**Table 4.3.1.1.1.46-1: Test frequencies for NR operating band n46 and SCS 15 kHz (Note 3)**

CB W [MHz]	carrierBandwidth [PRBs]	Range		Carrier centre [MHz]	Carrier centre [ARFCN] Note 4	point A [MHz]	absoluteFrequencyPointA [ARFCN]	offsetToCarrier [Carrier PRBs]	SS block SCS [kHz]	GS CN	absoluteFrequencySSB [ARFCN]	$k_{SSB}$	Offset Carrier CORESET#0 [RBs] Note 2	CORESET#0 Index (Offset [RBs]) Note 1	offsetToPointA (SIB1) [PRBs] Note 1
10	52	Downlink & Uplink	Low	5730	782000	5725.32	781688	0	30	-	781928	31	-	-	-
			Mid							-					
		High	5830.02	788668	5734.62	782308	504	-		788596	31	-	-	-	
20	106	Downlink & Uplink	Low	5160	744000	5150.46	743364	0	30	-	743604	31	-	-	-
			Mid							5479.98					
		High	5905.02	793668	5804.76	786984	504	-		793272	31	-	-	-	
40	216	Downlink & Uplink	Low	5170.02	744668	5150.58	743372	0	30	-	743612	31	-	-	-
			Mid							5509.98					
		High	5895	793000	5784.84	785656	504	-		791944	31	-	-	-	

Note 1: The CORESET#0 Index and the associated CORESET#0 Offset refers to Table 13-3 in TS 38.213 [22]. The value of CORESET#0 Index is signalled in controlResourceSetZero (pdccch-ConfigSIB1) in the MIB. The offsetToPointA IE is expressed in units of resource blocks assuming 15 kHz subcarrier spacing for FR1 and 60 kHz subcarrier spacing for FR2.

Note 2: The parameter Offset Carrier CORESET#0 specifies the offset from the lowest subcarrier of the carrier and the lowest subcarrier of CORESET#0. It corresponds to the parameter  $\Delta F_{\text{OffsetCORESET-0-Carrier}}$  in Annex C expressed in number of common RBs.

Note 3: NR band n46 with SCS =15 kHz is restricted for operation when carrier is configured as an SCell part of a DC or CA configuration. As the bandwidth is limited to SCell then absence of CORESET#0 is indicated in the MIB by setting  $k_{SSB} = 31$ ,  $controlResourceSetZero = 0$  and  $searchSpaceZero = 0$  (TS 38.213 [22], clause 13).

Note 4: The selection of Low, Mid and High test frequencies are restricted to the limited allowed ARFCN values as specified in TS 38.101 [7], Table 5.4.2.3-2.

Table 4.3.1.1.1.46-2: Test frequencies for NR operating band n46 and SCS 30 kHz

CB W [MHz]	carrierBandwidth [PRBs]	Range		Carrier centre [MHz]	Carrier centre [ARFCN] Note 4	point A [MHz]	absoluteFrequencyPointA [ARFCN]	offsetToCarrier [Carrier PRBs]	SS block SCS [kHz]	GS CN	absoluteFrequencySSB [ARFCN]	$k_{SSB}$	Offset Carrier CORESET#0 [RBs] Note 2	CORESET#0 Index (Offset [RBs]) Note 1	offsetToPointA (SIB1) [PRBs] Note 1
10 Note 3	24	Downlink & Uplink	Low	5730	78200	5725.68	781712	0	30	-	781952	31	-	-	-
			Mid												
			High	5830.02	788668	5644.26	776284	504		-	788620	31	-	-	-
20	51	Downlink & Uplink	Low	5160	744000	5150.82	743388	0	30	8996	743712	12	0	3 (3)	6
			Mid	5479.98	765332	5434.08	762272	102		9218	765024	16	0	2 (2)	208
			High	5905.02	793668	5714.4	780960	504		9513	793344	0	0	2 (2)	1012
40	106	Downlink & Uplink	Low	5170.02	744668	5150.94	743396	0	30	8996	743712	4	0	3 (3)	6
			Mid	5509.98	767332	5454.18	763612	102		9232	766368	20	0	2 (2)	208
			High	5895	793000	5694.48	779632	504		9499	792000	8	0	1 (1)	1010
60	162	Downlink & Uplink	Low	5200.02	746668	5170.86	744724	0	30	9010	745056	20	0	3 (3)	6
			Mid	5500.02	766668	5434.14	762276	102		9218	765024	12	0	2 (2)	208
			High	5884.98	792332	5674.38	778292	504		9485	790656	4	0	1 (1)	1010
80	217	Downlink	Low	5190	746000	5150.94	743396	0	30	8996	743712	4	0	3 (3)	6

		&	Mid	5530,02	768668	5454,24	763616	102	9232	766368	16	0	2 (2)	208
	Uplink		High	5875,02	791668	5654,52	776968	504	9472	789408	8	1	3 (3)	1016

Note 1: The CORESET#0 Index and the associated CORESET#0 Offset refers to Table 13-4 in TS 38.213 [22]. The value of CORESET#0 Index is signalled in controlResourceSetZero (pdcc-ConfigSIB1) in the MIB. The offsetToPointA IE is expressed in units of resource blocks assuming 15 kHz subcarrier spacing for FR1 and 60 kHz subcarrier spacing for FR2.

Note 2: The parameter Offset Carrier CORESET#0 specifies the offset from the lowest subcarrier of the carrier and the lowest subcarrier of CORESET#0. It corresponds to the parameter  $\Delta F_{\text{OffsetCORESET-0-Carrier}}$  in Annex C expressed in number of common RBs.

Note 3: For this bandwidth, the minimum requirements are restricted to operation when carrier is configured as an SCell part of a DC or CA configuration. As the bandwidth is limited to SCell then absence of CORESET#0 is indicated in the MIB by setting  $k_{SSB}=31$ ,  $controlResourceSetZero=0$  and  $searchSpaceZero=0$  (TS 38.213 [22], clause 13).

Note 4: The selection of Low, Mid and High test frequencies are restricted to the limited allowed ARFCN values as specified in TS 38.101 [7], Table 5.4.2.3-2.

Note 5: The next lowest allowed ARFCN values has been selected as the lowest ARFCN value in TS 38.101 [7], Table 5.4.2.3-2 for CBW=60 MHz will cause the required guardband to exceed the bands lower edge.

**Table 4.3.1.1.46-3: Test frequencies for NR operating band n46 and SCS 60 kHz without CORESET#0 (Note 1)**

CBW [MHz]	carrierBand width [PRBs]	Range	Carrier centre [MHz]	Carrier centre [ARFCN] Note 2	point A [MHz]	absolute FrequencyPoint A [ARFCN]	offsetTo Carrier [PRBs]	SS block SCS [kHz]	GSCN	absolute FrequencySSB [ARFCN]							
10	11	Downlink & Uplink	Low	5730	782000	5726.04	781736	0	-	781976							
			Mid														
			High								5830.02	788668	5463.18	764212	504	-	788644
20	24	Downlink & Uplink	Low	5160	744000	5151.36	743424	0	-	743664							
			Mid								5479.98	765332	5397.9	759860	102	-	764996
			High								5905.02	793668	5533.5	768900	504	-	793332
40	51	Downlink & Uplink	Low	5170.02	744668	5151.66	743444	0	-	743684							
			Mid								5509.98	767332	5418.18	761212	102	-	766348
			High								5895	793000	5513.76	767584	504	-	792016
60	79	Downlink & Uplink	Low	5179.98	745332	5151.54	743436	0	-	743676							
			Mid								5500.02	766668	5398.14	759876	102	-	765012
			High								5884.98	792332	5493.66	766244	504	-	790676
80	107	Downlink & Uplink	Low	5190	746000	5151.48	743432	0	-	743672							
			Mid								5530,02	768668	5418,06	761204	102	-	766340
			High								5875,02	791668	5473,62	764908	504	-	789340

Note 1: FR1 carrier without CORESET#0 is indicated in the MIB by setting  $k_{SSB}=31$ , *controlResourceSetZero=0* and *searchSpaceZero = 0* (TS 38.213 [22], clause 13).  
 Note 2: The selection of Low, Mid and High test frequencies are restricted to the limited allowed ARFCN values as specified in TS 38.101 [7], Table 5.4.2.3-2.

4.3.1.1.1.47 FFS

4.3.1.1.1.48 Reference test frequencies for NR operating band n48

**Table 4.3.1.1.1.48-1: Test frequencies for NR operating band n48 and SCS 15 kHz**

CBW [MHz]	carrierBandwidth [PRBs]	Range		Carrier centre [MHz]	Carrier centre [ARFCN]	point A [MHz]	absoluteFrequencyPointA [ARFCN]	offsetToCarrier [Carrier PRBs]	SS block SCS [kHz]	GS CN	absoluteFrequencySSB [ARFCN]	$k_{SSB}$ (Note 4)	Offset Carrier CORESET#0 [RBs] Note 2	CORESET#0 Index (Offset [RBs]) Note 1	offsetToPointA (SIB1) [PRBs] Note 1
5	25	Downlink & Uplink	Low	3552.51	636834	3550.26	636684	0	(Note 3)	-	-	-	-	-	-
			Mid	3625.005	641667	3604.395	640293	102		-	-	-	-	-	
		High	3697.5	646500	3604.53	640302	504	-		-	-	-	-		
10	52	Downlink & Uplink	Low	3555	637000	3550.32	636688	0	30	7884	636960	8	0	0 (2)	2
			Mid	3624.99	641666	3601.95	640130	102		7933	641664	10	3	0 (2)	107
		High	3694.98	646332	3599.58	639972	504	7982		646368	0	3	1 (6)	513	
15	79	Downlink & Uplink	Low	3557.52	637168	3550.41	636694	0	30	7884	636960	2	0	0 (2)	2
			Mid	3624.99	641666	3599.52	639968	102		7931	641472	4	1	0 (2)	105
		High	3692.49	646166	3594.66	639644	504	7978		645984	4	2	0 (2)	508	
20	106	Downlink & Uplink	Low	3560.01	637334	3550.47	636698	0	30	7885	637056	10	3	1 (6)	9
			Mid	3624.99	641666	3597.09	639806	102		7930	641376	10	2	1 (6)	110

		Uplink	High	3690	646000	3589.74	639316	504		7975	645696	8	1	1 (6)	511
30	160	Downlink &	Low	3565.02	637668	3550.62	636708	0	30	7885	637056	0	3	1 (6)	9
			Mid	3624.99	641666	3592.23	639482	102		7926	640992	10	1	0 (2)	105
		Uplink	High	3684.99	645666	3579.87	638658	504		7968	645024	6	0	1 (6)	510
40	216	Downlink &	Low	3570	638000	3550.56	636704	0	30	7885	637056	4	3	1 (6)	9
			Mid	3624.99	641666	3587.19	639146	102		7923	640704	10	1	1 (6)	109
		Uplink	High	3679.98	645332	3569.82	637988	504		7961	644352	4	0	1 (6)	510
50	270	Downlink (Note 4)	Low	3575.01	638334	3550.71	636714	0	30		637056	31			
			Mid	3624.99	641666	3582.33	638822	102			640320	31			
		Uplink	High	3675	645000	3559.98	637332	504			643680	31			
<p>Note 1: The CORESET#0 Index and the associated CORESET#0 Offset refers to Table 13-3 in TS 38.213 [22]. The value of CORESET#0 Index is signalled in controlResourceSetZero (pdcch-ConfigSIB1) in the MIB. The offsetToPointA IE is expressed in units of resource blocks assuming 15 kHz subcarrier spacing for FR1 and 60 kHz subcarrier spacing for FR2.</p> <p>Note 2: The parameter OffsetCarrierCORESET#0 specifies the offset from the lowest subcarrier of the carrier and the lowest subcarrier of CORESET#0. It corresponds to the parameter <math>\Delta F_{\text{OffsetCORESET-0-Carrier}}</math> in Annex C expressed in number of common RBs.</p> <p>Note 3: No SS/PBCH block fits within the channel bandwidth. The channel bandwidth can only be used as SCell.</p> <p>Note 4: For this bandwidth, the minimum requirements are restricted to operation when carrier is configured as a downlink only SCell part of a CA configuration. As the bandwidth is limited to SCell then absence of CORESET#0 is indicated in the MIB by setting <math>k_{\text{SSB}}=31</math>, <math>\text{controlResourceSetZero}=0</math> and <math>\text{searchSpaceZero}=0</math> (TS 38.213 [22], clause 13).</p>															

Table 4.3.1.1.1.48-2: Test frequencies for NR operating band n48 and SCS 30 kHz

CBW [MHz]	carrierBandwidth [PRBs]	Range		Carrier centre [MHz]	Carrier centre [ARFCN]	point A [MHz]	absoluteFrequencyPointA [ARFCN]	offsetToCarrier [Carrier PRBs]	SS block SCS [kHz]	GS CN	absoluteFrequencySSB [ARFCN]	$k_{\text{SSB}}$	Offset Carrier CORESET#0 [RBs] Note 2	CORESET#0 Index (Offset [RBs]) Note 1	offsetToPointA (SIB1) [PRBs] Note 1
10	24	Downlink	Low	3555	637000	3550.68	636712	0	30	7884	636960	8	0	0 (0)	0

		&	Mi	3624	64166	3583	638930	102		793	641664	22	0	1 (1)	206
		Uplink	d	.99	6	.95				3					
			Hi	3694	64633	3509	633948	504		2	646368	12	0	3 (3)	1014
			gh	.98	2	.22				788					
15	38	Downlink & Uplink	Low	3557	63716	3550	636712	0	30	4	636960	8	0	0 (0)	0
			Mi	3624	64166	3581	638762	102		793	641472	22	0	0 (0)	204
			d	.99	6	.43				1					
			Hi	3692	64616	3504	633614	504		797	645984	10	0	1 (1)	1010
			gh	.49	6	.21				8					
20	51	Downlink & Uplink	Low	3560	63733	3550	636722	0	30	5	637056	22	0	3 (3)	6
			Mi	3624	64166	3579	638606	102		793	641376	10	0	3 (3)	210
			d	.99	6	.09				0					
			Hi	3690	64600	3499	633292	504		797	645696	20	0	2 (2)	1012
			gh	0	0	.38				5					
30	78	Downlink & Uplink	Low	3565	63766	3550	636732	0	30	5	637056	12	0	3 (3)	6
			Mi	3624	64166	3574	638282	102		792	640992	22	0	0 (0)	204
			d	.99	6	.23				6					
			Hi	3684	64566	3489	632634	504		796	645024	6	0	2 (2)	1012
			gh	.99	6	.51				8					
40	106	Downlink & Uplink	Low	3570	63800	3550	636728	0	30	5	637056	16	0	3 (3)	6
			Mi	3624	64166	3569	637946	102		792	640704	22	0	2 (2)	208
			d	.99	6	.19				3					
			Hi	3679	64533	3479	631964	504		796	644352	4	0	2 (2)	1012
			gh	.98	2	.46				1					
50	133	Downlink (Note 3) & Uplink (Note 3)	Low	3575	63833	3551	636738	0	30		637056	31			
			Mi	3624	64166	3564	637622	102			640320	31			
			d	.99	6	.33									
			Hi	3675	64500	3469	631308	504			643680	31			
			gh	0	0	.62									
60	162	Downlink (Note 3) & Uplink (Note 3)	Low	3580	63866	3550	636724	0	30		637056	31			
			Mi	3624	64166	3559	637274	102			640032	31			
			d	.99	6	.11									
			Hi	3669	64466	3459	630626	504			643008	31			
			gh	.99	6	.39									
70	189	Downlink	Low	3585	63900	3550	636732	0	30	-	637056	31	-	-	-
			w	0	0	.98									

		(Note 3)	Mid	3624.99	641666	3554.25	636950	102		-	639648	31	-	-	-
			High	3664.98	644332	3449.52	629968	504		-	642336	31	-	-	-
80	217	Downlink	Low	3590.01	639334	3550.95	636730	0	30		637056	31			
		(Note 3)	Mid	3624.99	641666	3549.21	636614	102			639360	31			
		(Note 3)	High	3660	644000	3439.5	629300	504			641664	31			
90	245	Downlink	Low	3595.02	639668	3550.92	636728	0	30		637056	31			
		(Note 3)	Mid	3624.99	641666	3544.17	636278	102			638976	31			
		(Note 3)	High	3654.99	643666	3429.45	628630	504			640992	31			
100	273	Downlink	Low	3600	640000	3550.86	636724	0	30		637056	31			
		(Note 3)	Mid	3624.99	641666	3539.13	635942	102			638688	31			
		(Note 3)	High	3649.98	643332	3419.4	627960	504			640320	31			
<p>Note 1: The CORESET#0 Index and the associated CORESET#0 Offset refers to Table 13-4 in TS 38.213 [22]. The value of CORESET#0 Index is signalled in controlResourceSetZero (pdcc-ConfigSIB1) in the MIB. The offsetToPointA IE is expressed in units of resource blocks assuming 15 kHz subcarrier spacing for FR1 and 60 kHz subcarrier spacing for FR2.</p> <p>Note 2: The parameter Offset Carrier CORESET#0 specifies the offset from the lowest subcarrier of the carrier and the lowest subcarrier of CORESET#0. It corresponds to the parameter <math>\Delta F_{\text{OffsetCORESET-0-Carrier}}</math> in Annex C expressed in number of common RBs.</p> <p>Note 3: For this bandwidth, the minimum requirements are restricted to operation when carrier is configured as a downlink only SCell part of a CA configuration. As the bandwidth is limited to SCell then absence of CORESET#0 is indicated in the MIB by setting <math>k_{\text{SSB}}=31</math>, <math>\text{controlResourceSetZero}=0</math> and <math>\text{searchSpaceZero} = 0</math> (TS 38.213 [22], clause 13).</p>															

Table 4.3.1.1.48-3: Test frequencies for NR operating band n48 and SCS 60 kHz without CORESET#0 (Note 1)

CBW [MHz]	carrierBand width [PRBs]	Range		Carrier centre [MHz]	Carrier centre [ARFCN]	point A [MHz]	absolute FrequencyPoint A [ARFCN]	offsetTo Carrier [PRBs]	SS block SCS [kHz]	GSCN	absolute FrequencySSB [ARFCN]
10	11	Downlink &	Low	3555	637000	3551.04	636736	0	30	-	636976
			Mid	3624.99	641666	3547.59	636506	102		-	641642



15	18	Uplink Downlink & Uplink	High	3694.98	646332	3328.14	621876	504	30	-	646308
			Low	3557.52	637168	3551.04	636736	0		-	636976
			Mid	3624.99	641666	3545.07	636338	102		-	641474
20	24	Downlink & Uplink	High	3692.49	646166	3323.13	621542	504	30	-	645974
			Low	3560.01	637334	3551.37	636758	0		-	636998
			Mid	3624.99	641666	3542.91	636194	102		-	641330
30	78	Downlink & Uplink	High	3690	646000	3318.48	621232	504	30	-	645664
			Low	3565.02	637668	3550.98	636732	0		7885	637056
			Mid	3624.99	641666	3574.23	638282	102		7926	640992
40	51	Downlink & Uplink	High	3684.99	645666	3489.51	632634	504	30	7968	645024
			Low	3570	638000	3551.64	636776	0		-	637016
			Mid	3624.99	641666	3533.19	635546	102		-	640682
50	65	Downlink (Note 2)	High	3679.98	645332	3298.74	619916	504	30	-	644348
			Low	3575.01	638334	3551.61	636774	0		-	637014
			Mid	3624.99	641666	3528.15	635210	102		-	640346
60	79	Downlink (Note 2)	High	3675	645000	3288.72	619248	504	30	-	643680
			Low	3580.02	638668	3551.58	636772	0		-	637012
			Mid	3624.99	641666	3523.11	634874	102		-	640010
70	93	Downlink (Note 2)	High	3669.99	644666	3278.67	618578	504	30	-	643010
			Low	3585	639000	3551.52	636768	0		-	637008
			Mid	3624.99	641666	3518.07	634538	102		-	639674
80	107	Downlink (Note 2)	High	3664.98	644332	3268.62	617908	504	30	-	642340
			Low	3590.01	639334	3551.49	636766	0		-	637006
			Mid	3624.99	641666	3513.03	634202	102		-	639338
90	121	Downlink (Note 2)	High	3660	644000	3258.6	617240	504	30	-	641672
			Low	3595.02	639668	3551.46	636764	0		-	637004
			Mid	3624.99	641666	3507.99	633866	102		-	639002
100	135	Downlink (Note 2)	High	3654.99	643666	3248.55	616570	504	30	-	641002
			Low	3600	640000	3551.4	636760	0		-	637000
			Mid	3624.99	641666	3502.95	633530	102		-	638666
			High	3649.98	643332	3238.5	615900	504		-	640332
<p>Note: FR1 carrier without CORESET#0 is indicated in the MIB by setting <math>k_{SSB}=31</math>, <i>controlResourceSetZero</i>=0 and <i>searchSpaceZero</i> = 0 (TS 38.213 [22], clause 13).</p> <p>Note 2: For this bandwidth, the minimum requirements are restricted to operation when carrier is configured as a downlink only SCell part of a CA configuration.</p>											

4.3.1.1.1.49 FFS

4.3.1.1.1.50 Reference test frequencies for NR operating band n50

**Table 4.3.1.1.1.50-1: Test frequencies for NR operating band n50 and SCS 15 kHz**

CB W [MHz]	carrierBandwidth [PRBs]	Range		Carrier centre [MHz]	Carrier centre [ARFCN]	point A [MHz]	absoluteFrequencyPointA [ARFCN]	offsetToCarrier [Carrier PRBs]	SS block SCS [kHz]	GS CN	absoluteFrequencySSB [ARFCN]	$k_{SSB}$	Offset Carrier CORESET#0 [RBs] Note 2	CORESET#0 Index (Offset [RBs]) Note 1	offsetToPointA (SIB1) [PRBs] Note 1
5	25	Downlink	Low	1434.5	286900	1432.25	286450	0	(Note 3)	-	287170	-	-	-	-
			&	Mid	1474.5	294900	1453.89	290778		102	-	295170	-	-	-
		Uplink	High	1514.5	302900	1421.53	284306	504		-	303170	-	-	-	-
10	52	Downlink	Low	1437	287400	1432.32	286464	0	30	3591	287310	6	1	0 (2)	3
			&	Mid	1474.5	294900	1451.46	290292		102	3687	294990	6	2	1 (6)
		Uplink	High	1512	302400	1416.6	283320	504		3780	302430	10	0	1 (6)	510
15	79	Downlink	Low	1439.5	287900	1432.39	286478	0	30	3592	287330	8	1	0 (2)	3
			&	Mid	1474.5	294900	1449.03	289806		102	3678	294270	0	0	0 (2)
		Uplink	High	1509.5	301900	1411.67	282334	504		3767	301450	0	1	1 (6)	511
20	106	Downlink	Low	1442	288400	1432.46	286492	0	30	3590	287290	2	0	0 (2)	2
			&	Mid	1474.5	294900	1446.6	289320		102	3672	293790	2	0	0 (2)
		Uplink	High	1507	301400	1406.74	281348	504		3754	300290	2	0	0 (2)	506
40	216	Downlink	Low	1452	290400	1432.56	286512	0	30	3591	287310	2	0	0 (2)	2

		&	Mid	1474.5	29490.0	1436.7	287340	102		3648	291870	10	1	0 (2)	105
		Uplink	High	1497	29940.0	1386.84	277368	504		3705	296430	6	3	0 (2)	509
50	270	Downlink & Uplink	Low	1457	29140.0	1432.7	286540	0	30	3593	287530	6	1	1 (6)	7
			Mid	1474.5	29490.0	1431.84	286368	102		3636	290910	2	2	0 (2)	106
			High	1492	29840.0	1376.98	275396	504		3682	294530	6	1	1 (6)	511
<p>Note 1: The CORESET#0 Index and the associated CORESET#0 Offset refers to Table 13-1 in TS 38.213 [22]. The value of CORESET#0 Index is signalled in controlResourceSetZero (pdccch-ConfigSIB1) in the MIB. The offsetToPointA IE is expressed in units of resource blocks assuming 15 kHz subcarrier spacing for FR1 and 60 kHz subcarrier spacing for FR2.</p> <p>Note 2: The parameter Offset Carrier CORESET#0 specifies the offset from the lowest subcarrier of the carrier and the lowest subcarrier of CORESET#0. It corresponds to the parameter <math>\Delta F_{\text{OffsetCORESET-0-Carrier}}</math> in Annex C expressed in number of common RBs.</p> <p>Note 3: No SS/PBCH block fits within the channel bandwidth. The channel bandwidth can only be used as SCell</p>															

Table 4.3.1.1.1.50-2: Test frequencies for NR operating band n50 and SCS 30 kHz

CBW [MHz]	carrierBandwidth [PRBs]	Range	Carrier centre [MHz]	Carrier centre [ARFCN]	point A [MHz]	absoluteFrequencyPointA [ARFCN]	offsetToCarrier [Carrier PRBs]	SS block SCS [kHz]	GS CN	absoluteFrequencySSB [ARFCN]	$k_{SS}$	Offset Carrier CORESET#0 [RBs] Note 2	CORESET#0 Index (Offset [RBs]) Note 1	offsetToPointA (SIB1) [PRBs] Note 1	
10	24	Downlink & Uplink	Low	1437	28740.0	1432.68	286536	0	30	3591	287310	18	0	0 (0)	0
			Mid	1474.5	29490.0	1433.46	286692	102		3687	294990	6	0	3 (3)	210
			High	1512	30240.0	1326.24	265248	504		3780	302430	10	0	2 (2)	1012
15	38	Downlink & Uplink	Low	1439	28790.0	1432.66	286532	0	30	3592	287330	2	0	1 (1)	2
			Mid	1474.5	29490.0	1430.94	286188	102		3678	294270	6	0	0 (0)	204
			High	1509.5	30190.0	1321.22	264244	504		3767	301450	18	0	2 (2)	1012
20	51	Downlink	Low	1442	28840.0	1432.82	286564	0	30	3590	287290	2	0	0 (0)	0

		&	Mid	1474.5	294900	1428.6	285720	102		3672	293790	2	0	0 (0)	204
		Uplink	High	1507	301400	1316.38	263276	504		3754	300290	2	0	0 (0)	1008
40	106	Downlink & Uplink	Low	1452	290400	1432.92	286584	0	30	3591	287310	2	0	0 (0)	0
			Mid	1474.5	294900	1418.7	283740	102		3648	291870	22	0	0 (0)	204
			High	1497	299400	1296.48	259296	504		3705	296430	18	0	1 (1)	1010
50	133	Downlink & Uplink	Low	1457	291400	1433.06	286612	0	30	3593	287530	18	0	2 (2)	4
			Mid	1474.5	294900	1413.84	282768	102		3636	290910	2	0	1 (1)	206
			High	1492	298400	1286.62	257324	504		3682	294530	18	0	2 (2)	1012
60	162	Downlink & Uplink	Low	1462	292400	1432.84	286568	0	30	3592	287330	14	0	0 (0)	0
			Mid	1474.5	294900	1408.62	281724	102		3624	289950	6	0	2 (2)	208
			High	1487	297400	1276.4	255280	504		3653	292330	14	0	0 (0)	1008
80 (Note 3)	217	Downlink	Low	1472	294400	1432.94	286588	0	30	3593	287530	2	0	3 (3)	6
			Mid	1474.5	294900	1398.72	279744	102		3600	288030	2	0	3 (3)	210
			High	1477	295400	1256.5	251300	504		3607	288530	2	0	3 (3)	1014

Note 1: The CORESET#0 Index and the associated CORESET#0 Offset refers to Table 13-2 in TS 38.213 [22]. The value of CORESET#0 Index is signalled in controlResourceSetZero (pdcch-ConfigSIB1) in the MIB. The offsetToPointA IE is expressed in units of resource blocks assuming 15 kHz subcarrier spacing for FR1 and 60 kHz subcarrier spacing for FR2.

Note 2: The parameter Offset Carrier CORESET#0 specifies the offset from the lowest subcarrier of the carrier and the lowest subcarrier of CORESET#0. It corresponds to the parameter  $\Delta F_{\text{OffsetCORESET-0-Carrier}}$  in Annex C expressed in number of common RBs.

Note 3: This UE channel bandwidth is applicable only to downlink (TS 38.101-1 table 5.3.5-1).

**Table 4.3.1.1.50-3: Test frequencies for NR operating band n50 and SCS 60 kHz without CORESET#0**

CBW [MHz]	carrierBand width [PRBs]	Range	Carrier centre [MHz]	Carrier centre [ARFCN]	point A [MHz]	absoluteFrequencyPointA [ARFCN]	offsetToCarrier [PRBs]	SS block SCS [kHz]	GSCN	absolute FrequencySSB
-----------	--------------------------	-------	----------------------	------------------------	---------------	---------------------------------	------------------------	--------------------	------	-----------------------

										[ARFCN]	
10	11	Downlink & Uplink	Low	1437	287400	1433.04	286608	0	30	-	287328
			Mid	1474.5	294900	1397.1	279420	102		-	294828
			High	1512	302400	1145.16	229032	504		-	302328
15	18	Downlink & Uplink	Low	1439.5	287900	1433.02	286604	0	30	-	287324
			Mid	1474.5	294900	1394.58	278916	102		-	294324
			High	1509.5	301900	1140.14	228028	504		-	301324
20	24	Downlink & Uplink	Low	1442	288400	1433.36	286672	0	30	-	287392
			Mid	1474.5	294900	1392.42	278484	102		-	293892
			High	1507	301400	1135.48	227096	504		-	300392
40	51	Downlink & Uplink	Low	1452	290400	1433.64	286728	0	30	-	287448
			Mid	1474.5	294900	1382.7	276540	102		-	291948
			High	1497	299400	1115.76	223152	504		-	296448
50	65	Downlink & Uplink	Low	1457	291400	1433.6	286720	0	30	-	287440
			Mid	1474.5	294900	1377.66	275532	102		-	290940
			High	1492	298400	1105.72	221144	504		-	294440
60	79	Downlink & Uplink	Low	1462	292400	1433.56	286712	0	30	-	287432
			Mid	1474.5	294900	1372.62	274524	102		-	289932
			High	1487	297400	1095.68	219136	504		-	292432
80 (Note 2)	107	Downlink	Low	1472	294400	1433.48	286696	0	30	-	287416
			Mid	1474.5	294900	1362.54	272508	102		-	287916
			High	1477	295400	1075.6	215120	504		-	288416

Note: FR1 carrier without CORESET#0 is indicated in the MIB by setting  $k_{SSB}=31$ , *controlResourceSetZero*=0 and *searchSpaceZero* = 0 (TS 38.213 [22], clause 13).

Note 2: This UE channel bandwidth is applicable only to downlink (TS 38.101-1 table 5.3.5-1).

4.3.1.1.1.51 Reference test frequencies for NR operating band n51

Table 4.3.1.1.1.51-1: Test frequencies for NR operating band n51 and SCS 15 kHz

[M Hz]	carrierBandwidth [PRBs]	Range		Carrier centre [MHz]	Carrier centre [ARFCN]	point A [MHz]	absoluteFrequencyPointA [ARFCN]	offsetToCarrier [Carrier PRBs]	SS block SCS [kHz]	GS CN	absoluteFrequencySSB [ARFCN]	$k_{SSB}$	Offset Carrier CORESET#0 [RBs] Note 2	CORESET#0 Index (Offset [RBs]) Note 1	offsetToPointA (SIB1) [PRBs] Note 1
5	25	Downlink	Low	1429.5	285900	1427.25	285450	0	15	3573	285870	8	1	0 (0)	1

			&	Mi d											
			Uplin k	Hi gh											

Note 1: The CORESET#0 Index and the associated CORESET#0 Offset refers to Table 13-1 in TS 38.213 [22]. The value of CORESET#0 Index is signalled in controlResourceSetZero (pdcch-ConfigSIB1) in the MIB. The offsetToPointA IE is expressed in units of resource blocks assuming 15 kHz subcarrier spacing for FR1 and 60 kHz subcarrier spacing for FR2.

Note 2: The parameter Offset Carrier CORESET#0 specifies the offset from the lowest subcarrier of the carrier and the lowest subcarrier of CORESET#0. It corresponds to the parameter  $\Delta F_{\text{OffsetCORESET-0-Carrier}}$  in Annex C expressed in number of common RBs.

4.3.1.1.1.52 FFS

4.3.1.1.1.53 Reference test frequencies for NR operating band n53

**Table 4.3.1.1.1.53-1: Test frequencies for NR operating band n53 and SCS 15 kHz**

CB W [MHz]	carrierBandwidth [PRBs]	Range		Carrier centre [MHz]	Carrier centre [ARFCN]	point A [MHz]	absoluteFrequencyPointA [ARFCN]	offsetToCarrier [Carrier PRBs]	SS block SCS [kHz]	GS CN	absoluteFrequencySSB [ARFCN]	$k_{SSB}$	Offset Carrier CORESET#0 [RBs] Note 2	CORESET#0 Index (Offset [RBs]) Note 1	offsetToPointA (SIB1) [PRBs] Note 1
5	25	Downlink &	Low	248.6	49720.0	2483.75	496750	0	15	621.5	497290	0	1	2 (4)	5
			Mid	248.93	49786.0	2468.69	493738	102			497770	0	0	0 (0)	102
		Uplink	High	249.25	49850.0	2399.53	479906	504			498530	4	1	1 (2)	507
10	52	Downlink &	Low	248.85	49770.0	2483.82	496764	0	15	621.6	497310	2	1	2 (4)	5
			Mid	248.93	49786.0	2466.6	493252	102			497290	2	0	0 (0)	102
		Uplink	High	249.0	49800.0	2394.6	478920	504			497550	6	1	1 (2)	507

Note 1: The CORESET#0 Index and the associated CORESET#0 Offset refers to Table 13-1 in TS 38.213 [22]. The value of CORESET#0 Index is signalled in controlResourceSetZero (pdcch-ConfigSIB1) in the MIB. The offsetToPointA IE is expressed in units of resource blocks assuming 15 kHz subcarrier spacing for FR1 and 60 kHz subcarrier spacing for FR2.

Note 2: The parameter Offset Carrier CORESET#0 specifies the offset from the lowest subcarrier of the carrier and the lowest subcarrier of CORESET#0. It corresponds to the parameter  $\Delta F_{\text{OffsetCORESET-0-Carrier}}$  in Annex C expressed in number of common RBs.

**Table 4.3.1.1.1.53-2: Test frequencies for NR operating band n53 and SCS 30 kHz**

CBW [MHz]	carrierBandwidth [PRBs]	Range		Carrier centre [MHz]	Carrier centre [ARFCN]	point A [MHz]	absoluteFrequencyPointA [ARFCN]	offsetToCarrier [Carrier PRBs]	SS block SCS [kHz]	GSCN	absoluteFrequencySSB [ARFCN]	$k_{SSB}$	Offset Carrier CORESET#0 [RBs] Note 2	CORESET#0 Index (Offset [RBs]) Note 1	offsetToPointA (SIB1) [PRBs] Note 1
10	24	Downlink &	Low	248.5	49770	2484.18	496836	0	15	622.2	497790	6	0	3 (8)	16
			Mid	248.9.3	49786.0	2448.26	489652	102		622.1	497770	18	0	0 (5)	214
		Uplink	High	249.0	49800.0	2304.24	460848	504		622.5	498030	10	0	2 (7)	1022
<p>Note 1: The CORESET#0 Index and the associated CORESET#0 Offset refers to Table 13-2 in TS 38.213 [22]. The value of CORESET#0 Index is signalled in controlResourceSetZero (pdccch-ConfigSIB1) in the MIB. The offsetToPointA IE is expressed in units of resource blocks assuming 15 kHz subcarrier spacing for FR1 and 60 kHz subcarrier spacing for FR2.</p> <p>Note 2: The parameter Offset Carrier CORESET#0 specifies the offset from the lowest subcarrier of the carrier and the lowest subcarrier of CORESET#0. It corresponds to the parameter <math>\Delta F_{\text{OffsetCORESET-0-Carrier}}</math> in Annex C expressed in number of common RBs.</p>															

**Table 4.3.1.1.1.53-3: Test frequencies for NR operating band n53 and SCS 60 kHz without CORESET#0**

CBW [MHz]	carrierBandwidth [PRBs]	Range		Carrier centre [MHz]	Carrier centre [ARFCN]	point A [MHz]	absoluteFrequencyPointA [ARFCN]	offsetToCarrier [PRBs]	SS block SCS [kHz]	GSCN	absoluteFrequencySSB [ARFCN]
10	11	Downlink &	Low	2488.5	497700	2484.54	496908	0	15	-	497268
			Mid	2489.3	497860	2411.9	482380	102		-	497428
		Uplink	High	2490	498000	2123.16	424632	504		-	497568
<p>Note: FR1 carrier without CORESET#0 is indicated in the MIB by setting <math>k_{SSB}=31</math>, <math>controlResourceSetZero=0</math> and <math>searchSpaceZero=0</math> (TS 38.213 [22], clause 13).</p>											

4.3.1.1.1.54 to 4.3.1.1.1.64 FFS

4.3.1.1.1.65 Reference test frequencies for NR operating band n65

**Table 4.3.1.1.1.65-1: Test frequencies for NR operating band n65 and SCS 15 kHz**

CB W [MHz]	carrierBandwidth [PRBs]	Range		Carrier centre [MHz]	Carrier centre [ARFCN]	point A [MHz]	absoluteFrequencyPointA [ARFCN]	offsetToCarrier [Carrier PRBs]	SS block SCS [kHz]	GS CN	absoluteFrequencySSB [ARFCN]	$k_{SSB}$	Offset Carrier CORESET#0 [RBs] Note 2	CORESET#0 Index (Offset [RBs]) Note 1	offsetToPointA (SIB1) [PRBs] Note 1	
5	25	Down link	Low	211.25	422500	2110.25	422050	0	15	5279	422410	0	0	0 (0)	0	
			Mid	215.5	431000	2134.39	426878	102		5389	431090	0	1	2 (4)	107	
			High	219.75	439500	2104.53	420906	504		5493	439470	8	1	0 (0)	505	
		Uplink	Low	192.25	384500	1920.25	384050	0	-	-	-	-	-	-	-	-
			Mid	196.5	393000	1872.03	374406	504		-	-	-	-	-	-	-
			High	200.75	401500	2004.17	400834	6		-	-	-	-	-	-	-
10	52	Down link	Low	211.5	423000	2110.32	422064	0	15	5280	422430	2	0	0 (0)	0	
			Mid	215.5	431000	2131.96	426392	102		5383	430610	2	1	2 (4)	107	
			High	219.5	439000	2099.6	419920	504		5480	438490	10	1	0 (0)	505	
		Uplink	Low	192.5	385000	1920.32	384064	0	-	-	-	-	-	-	-	
			Mid	196.5	393000	1869.6	373920	504		-	-	-	-	-	-	
			High	200.5	401000	1999.24	399848	6		-	-	-	-	-	-	
15	79	Down link	Low	211.75	423500	2110.39	422078	0	15	5281	422450	4	0	0 (0)	0	
			Mid	215.5	431000	2129.53	425906	102		5377	430130	4	1	2 (4)	107	



			Hi gh	219 2.5	43850 0	2094 .67	418934	504		547 0	437570	8	1	1 (2)	507
		Uplink	Lo w	192 7.5	38550 0	1920 .39	384078	0	-	-	-	-	-	-	-
			Mi d	196 5	39300 0	1867 .17	373434	504		-	-	-	-	-	-
			Hi gh	200 2.5	40050 0	1994 .31	398862	6		-	-	-	-	-	-
20	106	Down link	Lo w	212 0	42400 0	2110 .46	422092	0	15	528 2	422650	6	1	2 (4)	5
			Mi d	215 5	43100 0	2127 .1	425420	102		537 1	429650	6	1	2 (4)	107
			Hi gh	219 0	43800 0	2089 .74	417948	504		545 7	436590	10	1	1 (2)	507
		Uplink	Lo w	193 0	38600 0	1920 .46	384092	0	-	-	-	-	-	-	-
			Mi d	196 5	39300 0	1864 .74	372948	504		-	-	-	-	-	-
			Hi gh	200 0	40000 0	1989 .38	397876	6		-	-	-	-	-	-
<p>Note 1: The CORESET#0 Index and the associated CORESET#0 Offset refers to Table 13-1 in TS 38.213 [22]. The value of CORESET#0 Index is signalled in controlResourceSetZero (pdcc-ConfigSIB1) in the MIB. The offsetToPointA IE is expressed in units of resource blocks assuming 15 kHz subcarrier spacing for FR1 and 60 kHz subcarrier spacing for FR2.</p> <p>Note 2: The parameter Offset Carrier CORESET#0 specifies the offset from the lowest subcarrier of the carrier and the lowest subcarrier of CORESET#0. It corresponds to the parameter <math>\Delta F_{\text{OffsetCORESET-0-Carrier}}</math> in Annex C expressed in number of common RBs.</p>															

Table 4.3.1.1.1.65-2: Test frequencies for NR operating band n65 and SCS 30 kHz

CB W [MHz]	carrierBandwidth [PRBs]	Range	Carrier centre [MHz]	Carrier centre [ARFCN]	point A [MHz]	absoluteFrequencyPointA [ARFCN]	offsetToCarrier [Carrier PRBs]	SS block SCS [kHz]	GS CN	absoluteFrequencySSB [ARFCN]	$k_{SSB}$	Offset Carrier CORESET#0 [RBs] Note 2	CORESET#0 Index (Offset [RBs]) Note 1	offsetToPointA (SIB1) [PRBs] Note 1	
10	24	Down link	Lo w	211 5	42300 0	2110 .68	422136	0	15	528 6	422910	18	0	0 (5)	10
			Mi d	215 5	43100 0	2113 .96	422792	102		538 9	431090	6	0	3 (8)	220
			Hi gh	219 5	43900 0	2009 .24	401848	504		548 6	438970	14	0	1 (6)	1020

		Uplink	Low	1925	385000	1920.68	384136	0	-	-	-	-	-	-	
			Mid	1965	393000	1779.24	355848	504	-	-	-	-	-	-	
			High	2005	401000	1998.52	399704	6	-	-	-	-	-	-	
15	38	Downlink	Low	2117.5	423500	2110.66	422132	0	15	5287	422930	2	0	1 (6)	12
			Mid	2155	431000	2111.44	422288	102		5380	430370	6	0	0 (5)	214
			High	2192.5	438500	2004.22	400844	504		5476	438050	18	0	2 (7)	1022
		Uplink	Low	1927.5	385500	1920.66	384132	0	-	-	-	-	-	-	-
			Mid	1965	393000	1776.72	355344	504	-	-	-	-	-	-	-
			High	2002.5	400500	1993.5	398700	6	-	-	-	-	-	-	-
20	51	Downlink	Low	2120	424000	2110.82	422164	0	15	5285	422890	2	0	0 (5)	10
			Mid	2155	431000	2109.1	421820	102		5374	429890	2	0	0 (5)	214
			High	2190	438000	1999.38	399876	504		5463	437070	14	0	2 (7)	1022
		Uplink	Low	1930	386000	1920.82	384164	0	-	-	-	-	-	-	-
			Mid	1965	393000	1774.38	354876	504	-	-	-	-	-	-	-
			High	2000	400000	1988.66	397732	6	-	-	-	-	-	-	-

Note 1: The CORESET#0 Index and the associated CORESET#0 Offset refers to Table 13-2 in TS 38.213 [22]. The value of CORESET#0 Index is signalled in controlResourceSetZero (pdccch-ConfigSIB1) in the MIB. The offsetToPointA IE is expressed in units of resource blocks assuming 15 kHz subcarrier spacing for FR1 and 60 kHz subcarrier spacing for FR2.

Note 2: The parameter Offset Carrier CORESET#0 specifies the offset from the lowest subcarrier of the carrier and the lowest subcarrier of CORESET#0. It corresponds to the parameter  $\Delta F_{\text{OffsetCORESET-0-Carrier}}$  in Annex C expressed in number of common RBs.

**Table 4.3.1.1.65-3: Test frequencies for NR operating band n65 and SCS 60 kHz without CORESET#0**

CBW [MHz]	carrierBand width [PRBs]	Range	Carrier centre [MHz]	Carrier centre	point A [MHz]	absolute FrequencyPoint	offsetTo Carrier [PRBs]	SS block SCS [kHz]	GSCN	absolute FrequencySSB
-----------	--------------------------	-------	----------------------	----------------	---------------	-------------------------	-------------------------	--------------------	------	-----------------------

					[ARFCN]		A [ARFCN]				[ARFCN]
10	11	Downlink	Low	2115	423000	2111.04	422208	0	15	-	422568
			Mid	2155	431000	2077.6	415520	102		-	430568
			High	2195	439000	1828.16	365632	504		-	438568
		Uplink	Low	1925	385000	1921.04	384208	0	-	-	-
			Mid	1965	393000	1598.16	319632	504		-	-
			High	2005	401000	1996.72	399344	6		-	-
15	18	Downlink	Low	2117.5	423500	2111.02	422204	0	15	-	422564
			Mid	2155	431000	2075.08	415016	102		-	430064
			High	2192.5	438500	1823.14	364628	504		-	437564
		Uplink	Low	1927.5	385500	1921.02	384204	0	-	-	-
			Mid	1965	393000	1595.64	319128	504		-	-
			High	2002.5	400500	1991.7	398340	6		-	-
20	24	Downlink	Low	2120	424000	2111.36	422272	0	15	-	422632
			Mid	2155	431000	2072.92	414584	102		-	429632
			High	2190	438000	1818.48	363696	504		-	436632
		Uplink	Low	1930	386000	1921.36	384272	0	-	-	-
			Mid	1965	393000	1593.48	318696	504		-	-
			High	2000	400000	1987.04	397408	6		-	-
Note: FR1 carrier without CORESET#0 is indicated in the MIB by setting $k_{SSB}=31$ , <i>controlResourceSetZero</i> =0 and <i>searchSpaceZero</i> = 0 (TS 38.213 [22], clause 13).											

4.3.1.1.1.66 Reference test frequencies for NR operating band n66

Table 4.3.1.1.1.66-1: Test frequencies for NR operating band n66, uplink and downlink channel bandwidth combinations and SCS 15 kHz

UL/DLC BW Combination (Asymmetric BCS) Note 3	CBW [MHz]	carrierBandwidth [PRBs]	Range	Carrier centre [MHz]	Carrier centre [ARFCN]	point A [MHz]	absoluteFrequencyPointA [ARFCN]	offsetToCarrier [Carrier PRBs]	SS block SCS [kHz]	GS CN	absoluteFrequencySSB [ARFCN]	$k_{SSB}$	Offset Carrier CORESET#0 [RBs] Note 2	CORESET#0 Index (Offset [RBs]) Note 1	offsetToPointA (SIB1) [PRBs] Note 1	
5/5	5	25	Downlink	Low	2112.5	422500	2110.25	422050	0	15	5279	422410	0	0	0 (0)	0
				Mid	2145	429000	2124.39	424878	102		5361	428910	0	0	0 (0)	102

				High	217 7.5	4355 00	2084 .53	416906	504		544 3	435410	0	0	0 (0)	504
	5	25	Uplink	Low	171 2.5	3425 00	1710 .25	342050	0	-	-	-	-	-	-	-
				Mid	174 5	3490 00	1652 .03	330406	504		-	-	-	-	-	-
				High	177 7.5	3555 00	1774 .17	354834	6		-	-	-	-	-	-
5/20 (0,1)	20	106	Downdlink	Low	212 0	4240 00	2110 .46	422092	0	15	528 2	422650	6	1	2 (4)	5
				Mid	215 2.5	4305 00	2124 .6	424920	102		536 4	429150	6	1	2 (4)	107
				High	218 5	4370 00	2084 .74	416948	504		544 6	435650	6	1	2 (4)	509
	5	25	Uplink	Low	171 2.5	3425 00	1710 .25	342050	0	-	-	-	-	-	-	-
				Mid	174 5	3490 00	1652 .03	330406	504		-	-	-	-	-	-
				High	177 7.5	3555 00	1774 .17	354834	6		-	-	-	-	-	-
5/25 (1)	25	133	Downdlink	Low	212 2.5	4245 00	2110 .53	422106	0	15	528 3	422670	8	1	2 (4)	5
				Mid	215 5	4310 00	2124 .67	424934	102		536 5	429170	8	1	2 (4)	107
				High	218 7.5	4375 00	2084 .81	416962	504		544 4	435610	0	0	2 (4)	508
	5	25	Uplink	Low	171 2.5	3425 00	1710 .25	342050	0	-	-	-	-	-	-	-
				Mid	174 5	3490 00	1652 .03	330406	504		-	-	-	-	-	-
				High	177 7.5	3555 00	1774 .17	354834	6		-	-	-	-	-	-
5/30 (1)	30	160	Downdlink	Low	212 5	4250 00	2110 .6	422120	0	15	528 4	422690	10	1	2 (4)	5
				Mid	215 5	4310 00	2122 .24	424448	102		535 9	428690	10	1	2 (4)	107
				High	218 5	4370 00	2079 .88	415976	504		543 4	434690	10	1	2 (4)	509
	5	25	Uplink	Low	171 2.5	3425 00	1710 .25	342050	0	-	-	-	-	-	-	-
				Mid	174 2.5	3485 00	1649 .53	329906	504		-	-	-	-	-	-

5/40 (0,1)	40	216	Downlink	High	177 2.5	3545 00	1769 .17	353834	6	15	-	-	-	-	-	-
				Low	213 0	4260 00	2110 .56	422112	0		528 3	422670	6	1	2 (4)	5
				Mid	215 5	4310 00	2117 .2	423440	102		534 4	427490	6	0	0 (0)	102
	5	25	Uplink	High	218 0	4360 00	2069 .84	413968	504	-	540 5	432490	6	0	0 (0)	504
				Low	171 2.5	3425 00	1710 .25	342050	0		-	-	-	-	-	-
				Mid	173 7.5	3475 00	1644 .53	328906	504		-	-	-	-	-	-
10/10	10	52	Downlink	High	176 2.5	3525 00	1759 .17	351834	6	15	-	-	-	-	-	-
				Low	211 5	4230 00	2110 .32	422064	0		528 0	422430	2	0	0 (0)	0
				Mid	214 5	4290 00	2121 .96	424392	102		535 5	428430	2	0	0 (0)	102
	10	52	Uplink	High	217 5	4350 00	2079 .6	415920	504	-	543 0	434430	2	0	0 (0)	504
				Low	171 5	3430 00	1710 .32	342064	0		-	-	-	-	-	-
				Mid	174 5	3490 00	1649 .6	329920	504		-	-	-	-	-	-
10/20 (0,1)	20	106	Downlink	High	177 5	3550 00	1769 .24	353848	6	15	-	-	-	-	-	-
				Low	212 0	4240 00	2110 .46	422092	0		528 2	422650	6	1	2 (4)	5
				Mid	215 0	4300 00	2122 .1	424420	102		535 7	428650	6	1	2 (4)	107
	10	52	Uplink	High	218 0	4360 00	2079 .74	415948	504	-	543 2	434650	6	1	2 (4)	509
				Low	171 5	3430 00	1710 .32	342064	0		-	-	-	-	-	-
				Mid	174 5	3490 00	1649 .6	329920	504		-	-	-	-	-	-
10/25 (1)	25	133	Downlink	High	177 5	3550 00	1769 .24	353848	6	15	-	-	-	-	-	-
				Low	212 2.5	4245 00	2110 .53	422106	0		528 3	422670	8	1	2 (4)	5
				Mid	215 2.5	4305 00	2122 .17	424434	102		535 8	428670	8	1	2 (4)	107

				High	218 2.5	4365 00	2079 .81	415962	504		543 3	434670	8	1	2 (4)	509
	10	52	Uplink	Low	171 5	3430 00	1710 .32	342064	0	-	-	-	-	-	-	-
				Mid	174 5	3490 00	1649 .6	329920	504		-	-	-	-	-	-
				High	177 5	3550 00	1769 .24	353848	6		-	-	-	-	-	-
10/30 (1)	30	160	Downlink	Low	212 5	4250 00	2110 .6	422120	0	15	528 4	422690	10	1	2 (4)	5
				Mid	215 5	4310 00	2122 .24	424448	102		535 9	428690	10	1	2 (4)	107
				High	218 5	4370 00	2079 .88	415976	504		543 4	434690	10	1	2 (4)	509
	10	52	Uplink	Low	171 5	3430 00	1710 .32	342064	0	-	-	-	-	-	-	-
				Mid	174 5	3490 00	1649 .6	329920	504		-	-	-	-	-	-
				High	177 5	3550 00	1769 .24	353848	6		-	-	-	-	-	-
10/40 (0,1)	40	216	Downlink	Low	213 0	4260 00	2110 .56	422112	0	15	528 3	422670	6	1	2 (4)	5
				Mid	215 5	4310 00	2117 .2	423440	102		534 4	427490	6	0	0 (0)	102
				High	218 0	4360 00	2069 .84	413968	504		540 5	432490	6	0	0 (0)	504
	10	52	Uplink	Low	171 5	3430 00	1710 .32	342064	0	-	-	-	-	-	-	-
				Mid	174 0	3480 00	1644 .6	328920	504		-	-	-	-	-	-
				High	176 5	3530 00	1759 .24	351848	6		-	-	-	-	-	-
15/15	15	79	Downlink	Low	211 7.5	4235 00	2110 .39	422078	0	15	528 1	422450	4	0	0 (0)	0
				Mid	214 5	4290 00	2119 .53	423906	102		534 9	427950	4	0	0 (0)	102
				High	217 2.5	4345 00	2074 .67	414934	504		541 7	433450	4	0	0 (0)	504
	15	79	Uplink	Low	171 7.5	3435 00	1710 .39	342078	0	-	-	-	-	-	-	-
				Mid	174 5	3490 00	1647 .17	329434	504		-	-	-	-	-	-

				High	177 2.5	3545 00	1764 .31	352862	6		-	-	-	-	-	-	
20/20	20	106	Downlink	Low	212 0	4240 00	2110 .46	422092	0	15	528 2	422650	6	1	2 (4)	5	
				Mid	214 5	4290 00	2117 .1	423420	102		534 3	427470	6	0	0 (0)	102	
				High	217 0	4340 00	2069 .74	413948	504		540 7	432530	2	0	1 (2)	506	
	20	106	Uplink	Low	172 0	3440 00	1710 .46	342092	0	-	-	-	-	-	-	-	-
				Mid	174 5	3490 00	1644 .74	328948	504		-	-	-	-	-	-	
				High	177 0	3540 00	1759 .38	351876	6		-	-	-	-	-	-	
20/40 (0,1)	40	216	Downlink	Low	213 0	4260 00	2110 .56	422112	0	15	528 3	422670	6	1	2 (4)	5	
				Mid	215 5	4310 00	2117 .2	423440	102		534 4	427490	6	0	0 (0)	102	
				High	218 0	4360 00	2069 .84	413968	504		540 5	432490	6	0	0 (0)	504	
	20	106	Uplink	Low	172 0	3440 00	1710 .46	342092	0	-	-	-	-	-	-	-	-
				Mid	174 5	3490 00	1644 .74	328948	504		-	-	-	-	-	-	
				High	177 0	3540 00	1759 .38	351876	6		-	-	-	-	-	-	
25/25	25	133	Downlink	Low	212 2.5	4245 00	2110 .53	422106	0	15	528 3	422670	8	1	2 (4)	5	
				Mid	214 5	4290 00	2114 .67	422934	102		533 7	426990	8	0	0 (0)	102	
				High	216 7.5	4335 00	2064 .81	412962	504		539 4	431550	4	0	1 (2)	506	
	25	133	Uplink	Low	172 2.5	3445 00	1710 .53	342106	0	-	-	-	-	-	-	-	-
				Mid	174 5	3490 00	1642 .31	328462	504		-	-	-	-	-	-	
				High	176 7.5	3535 00	1754 .45	350890	6		-	-	-	-	-	-	
25/40 (1)	40	216	Downlink	Low	213 0	4260 00	2110 .56	422112	0	15	528 3	422670	6	1	2 (4)	5	
				Mid	215 2.5	4305 00	2114 .7	422940	102		533 7	426990	6	0	0 (0)	102	

				High	2175	435000	2064.84	412968	504		5394	431550	2	0	1 (2)	506
	25	133	Uplink	Low	1722.5	344500	1710.53	342106	0	-	-	-	-	-	-	-
				Mid	1745	349000	1642.31	328462	504		-	-	-	-	-	-
				High	1767.5	353500	1754.45	350890	6		-	-	-	-	-	-
30/30	30	160	Downdlink	Low	2125	425000	2110.6	422120	0	15	5284	422690	10	1	2 (4)	5
				Mid	2145	429000	2112.24	422448	102		5331	426510	10	0	0 (0)	102
				High	2165	433000	2059.88	411976	504		5381	430570	6	0	1 (2)	506
	30	160	Uplink	Low	1725	345000	1710.6	342120	0	-	-	-	-	-	-	-
				Mid	1745	349000	1639.88	327976	504		-	-	-	-	-	-
				High	1765	353000	1749.52	349904	6		-	-	-	-	-	-
30/40 (1)	40	216	Downdlink	Low	2130	426000	2110.56	422112	0	15	5283	422670	6	1	2 (4)	5
				Mid	2150	430000	2112.2	422440	102		5330	426490	6	0	0 (0)	102
				High	2170	434000	2059.84	411968	504		5383	430610	10	1	1 (2)	507
	30	160	Uplink	Low	1725	345000	1710.6	342120	0	-	-	-	-	-	-	-
				Mid	1745	349000	1639.88	327976	504		-	-	-	-	-	-
				High	1765	353000	1749.52	349904	6		-	-	-	-	-	-
40/40	40	216	Downdlink	Low	2130	426000	2110.56	422112	0	15	5283	422670	6	1	2 (4)	5
				Mid	2145	429000	2107.2	421440	102		5319	425550	2	0	1 (2)	104
				High	2160	432000	2049.84	409968	504		5358	428670	6	1	2 (4)	509
	40	216	Uplink	Low	1730	346000	1710.56	342112	0	-	-	-	-	-	-	-
				Mid	1745	349000	1634.84	326968	504		-	-	-	-	-	-



				High	1760	352000	1739.48	347896	6		-	-	-	-	-	-	
N.A./40 (Note4)	40	216	Downlink	High	2180	436000	2069.84	413968	504		5405	432490	6	0	0 (0)	504	
45/45	45	242	Downlink	Low	2132.5	426500	2110.72	422144	0	15	5284	422690	2	1	2 (4)	5	
				Mid	2145	429000	2104.86	420972	102	15	5313	425070	10	1	0 (0)	103	
				High	2157.5	431500	2045	409000	504	15	5345	427690	2	1	2 (4)	509	
	45	242	Uplink	Low	1732.5	346500	1710.72	342144	0	-	-	-	-	-	-	-	-
				Mid	1745	349000	1632.5	326500	504	-	-	-	-	-	-	-	-
				High	1757.5	351500	1734.64	346928	6	-	-	-	-	-	-	-	

Note 1: The CORESET#0 Index and the associated CORESET#0 Offset refers to Table 13-1 in TS 38.213 [22]. The value of CORESET#0 Index is signalled in controlResourceSetZero (pdccch-ConfigSIB1) in the MIB. The offsetToPointA IE is expressed in units of resource blocks assuming 15 kHz subcarrier spacing for FR1 and 60 kHz subcarrier spacing for FR2.

Note 2: The parameter Offset Carrier CORESET#0 specifies the offset from the lowest subcarrier of the carrier and the lowest subcarrier of CORESET#0. It corresponds to the parameter  $\Delta F_{\text{OffsetCORESET-0-Carrier}}$  in Annex C expressed in number of common RBs.

Note 3: Asymmetric CBW BCS refers to applicable asymmetric UL and DL channel bandwidth combination set as specified in TS 38.101-1 [7], Table 5.3.6-1 for NR band n66.

Note 4: Used only for non-contiguous CA x+40 combination with no UL configuration on the SB in Table 4.3.1.1.5.66-1

Table 4.3.1.1.1.66-1A: Void

Table 4.3.1.1.1.66-2: Test frequencies for NR operating band n66, uplink and downlink channel bandwidth combinations and SCS 30 kHz

UL/DLC BW Combination (Asymmetric BCS) Note 3	CBW [MHz]	carrierBandwidth [PRBs]	Range	Carrier centre [MHz]	Carrier centre [ARFCN]	point A [MHz]	absoluteFrequencyPointA [ARFCN]	offsetToCarrier [Carrier PRBs]	SS block SCS [kHz]	GS CN	absoluteFrequencySSB [ARFCN]	$k_{SSB}$	Offset Carrier CORESET#0 [RBs] Note 2	CORESET#0 Index (Offset [RBs]) Note 1	offsetToPointA (SIB1) [PRBs] Note 1	
10/10	10	24	Downlink	Low	2115	423000	2110.68	422136	0	15	5286	422910	18	0	0 (5)	10

	10	24	Uplink	Mid	2145	429000	2103.96	420792	102	-	5361	428910	18	0	0 (5)	214
				High	2175	435000	1989.24	397848	504		5436	434910	18	0	0 (5)	1018
				Low	1715	343000	1710.68	342136	0		-	-	-	-	-	-
				Mid	1745	349000	1559.24	311848	504		-	-	-	-	-	-
				High	1775	355000	1768.52	353704	6		-	-	-	-	-	-
				Low	2120	424000	2110.82	422164	0		15	5285	422890	2	0	0 (5)
10/20 (0,1)	20	51	Downlink	Mid	2150	430000	2104.1	420820	102	15	5360	428890	2	0	0 (5)	214
				High	2180	436000	1989.38	397876	504		5435	434890	2	0	0 (5)	1018
				Low	1715	343000	1710.68	342136	0		-	-	-	-	-	-
				Mid	1745	349000	1559.24	311848	504		-	-	-	-	-	-
				High	1775	355000	1768.52	353704	6		-	-	-	-	-	-
				Low	2120	424000	2110.82	422164	0		15	5285	422890	2	0	0 (5)
10/25 (1)	25	65	Downlink	Mid	2150	430500	2104.08	420816	102	15	5361	428910	10	0	0 (5)	214
				High	2180	436500	1989.36	397872	504		5436	434910	10	0	0 (5)	1018
				Low	1715	343000	1710.68	342136	0		-	-	-	-	-	-
				Mid	1745	349000	1559.24	311848	504		-	-	-	-	-	-
				High	1775	355000	1768.52	353704	6		-	-	-	-	-	-
				Low	2120	424000	2110.82	422164	0		15	5285	422890	2	0	0 (5)
10/30 (1)	30	78	Downlink	Mid	2150	431000	2104.24	420848	102	15	5362	428930	6	0	0 (5)	214
				High	2180	437000	1989.52	397904	504		5437	434930	6	0	0 (5)	1018
				Low	1715	343000	1710.68	342136	0		-	-	-	-	-	-
				Mid	1745	349000	1559.24	311848	504		-	-	-	-	-	-
				High	1775	355000	1768.52	353704	6		-	-	-	-	-	-
				Low	2120	424000	2110.82	422164	0		15	5285	422890	2	0	0 (5)
10/30 (1)	10	24	Uplink	Mid	2150	431000	2104.24	420848	102	15	5362	428930	6	0	0 (5)	214
				High	2180	437000	1989.52	397904	504		5437	434930	6	0	0 (5)	1018
				Low	1715	343000	1710.68	342136	0		-	-	-	-	-	-
				Mid	1745	349000	1559.24	311848	504		-	-	-	-	-	-
				High	1775	355000	1768.52	353704	6		-	-	-	-	-	-
				Low	2120	424000	2110.82	422164	0		15	5285	422890	2	0	0 (5)

				Mid	1745	349000	1559.24	311848	504		-	-	-	-	-	-	
				High	1775	355000	1768.52	353704	6		-	-	-	-	-	-	
10/40 (0,1)	40	106	Downlink	Low	2130	426000	2110.92	422184	0	15	5286	422910	2	0	0 (5)	10	
				Mid	2155	431000	2099.2	419840	102		5350	427970	22	0	0 (5)	214	
				High	2180	436000	1979.48	395896	504		5411	432970	22	0	0 (5)	1018	
	10	24	Uplink	Low	1715	343000	1710.68	342136	0	-	-	-	-	-	-	-	-
				Mid	1740	348000	1554.24	310848	504		-	-	-	-	-	-	
				High	1765	353000	1758.52	351704	6		-	-	-	-	-	-	
15/15	15	38	Downlink	Low	2117.5	423500	2110.66	422132	0	15	5287	422930	2	0	1 (6)	12	
				Mid	2145	429000	2101.44	420288	102		5355	428430	2	0	1 (6)	216	
				High	2172.5	434500	1984.22	396844	504		5423	433930	2	0	1 (6)	1020	
	15	38	Uplink	Low	1717.5	343500	1710.66	342132	0	-	-	-	-	-	-	-	-
				Mid	1745	349000	1556.72	311344	504		-	-	-	-	-	-	
				High	1772.5	354500	1763.5	352700	6		-	-	-	-	-	-	
20/20	20	51	Downlink	Low	2120	424000	2110.82	422164	0	15	5285	422890	2	0	0 (5)	10	
				Mid	2145	429000	2099.1	419820	102		5349	427950	22	0	0 (5)	214	
				High	2170	434000	1979.38	395876	504		5413	433010	18	0	1 (6)	1020	
	20	51	Uplink	Low	1720	344000	1710.82	342164	0	-	-	-	-	-	-	-	-
				Mid	1745	349000	1554.38	310876	504		-	-	-	-	-	-	
				High	1770	354000	1758.66	351732	6		-	-	-	-	-	-	
20/40	40	106	Downlink	Low	2130	426000	2110.92	422184	0	15	5286	422910	2	0	0 (5)	10	

(0,1)				Mid	215	4310	2099	419840	102		535	427970	22	0	0 (5)	214	
				High	218	4360	1979	395896	504		541	432970	22	0	0 (5)	1018	
				Low	172	3440	1710	342164	0	-	-	-	-	-	-	-	
	20	51	Uplink	Mid	174	3490	1554	310876	504		-	-	-	-	-	-	-
				High	177	3540	1758	351732	6		-	-	-	-	-	-	
				Low	212	4245	2110	422160	0	15	528	422910	10	0	0 (5)	10	
25/25	25	65	Downlink	Mid	214	4290	2096	419316	102		534	427470	6	0	1 (6)	216	
				High	216	4335	1974	394872	504		540	432030	2	0	2 (7)	1022	
				Low	172	3445	1710	342160	0	-	-	-	-	-	-	-	
	25	65	Uplink	Mid	174	3490	1551	310372	504		-	-	-	-	-	-	-
				High	176	3535	1753	350728	6		-	-	-	-	-	-	
				Low	213	4260	2110	422184	0	15	528	422910	2	0	0 (5)	10	
25/40 (1)	40	106	Downlink	Mid	215	4305	2096	419340	102		534	427470	22	0	0 (5)	214	
				High	217	4350	1974	394896	504		540	432030	18	0	1 (6)	1020	
				Low	172	3445	1710	342160	0	-	-	-	-	-	-	-	
	25	65	Uplink	Mid	174	3490	1551	310372	504		-	-	-	-	-	-	-
				High	176	3535	1753	350728	6		-	-	-	-	-	-	
				Low	212	4250	2110	422192	0	15	528	422930	6	0	0 (5)	10	
30/30	30	78	Downlink	Mid	214	4290	2094	418848	102		533	426990	2	0	1 (6)	216	
				High	216	4330	1969	393904	504		538	431050	22	0	1 (6)	1020	
				Low	172	3450	1710	342192	0	-	-	-	-	-	-	-	
	30	78	Uplink	Mid	215	4310	2099	419840	102		535	427970	22	0	0 (5)	214	
				High	218	4360	1979	395896	504		541	432970	22	0	0 (5)	1018	
				Low	172	3440	1710	342164	0	-	-	-	-	-	-	-	

				Mid	1745	349000	1549.52	309904	504		-	-	-	-	-	-	
				High	1765	353000	1748.8	349760	6		-	-	-	-	-	-	
30/40 (1)	40	106	Downlink	Low	2130	426000	2110.92	422184	0	15	5286	422910	2	0	0 (5)	10	
				Mid	2150	430000	2094.2	418840	102		5336	426970	22	0	0 (5)	214	
				High	2170	434000	1969.48	393896	504		5389	431090	14	0	2 (7)	1022	
	30	78	Uplink	Low	1725	345000	1710.96	342192	0	-	-	-	-	-	-	-	-
				Mid	1745	349000	1549.52	309904	504		-	-	-	-	-	-	
				High	1765	353000	1748.8	349760	6		-	-	-	-	-	-	
40/40	40	106	Downlink	Low	2130	426000	2110.92	422184	0	15	5286	422910	2	0	0 (5)	10	
				Mid	2145	429000	2089.2	417840	102		5325	426030	18	0	1 (6)	216	
				High	2160	432000	1959.48	391896	504		5361	428910	2	0	0 (5)	1018	
	40	106	Uplink	Low	1730	346000	1710.92	342184	0	-	-	-	-	-	-	-	-
				Mid	1745	349000	1544.48	308896	504		-	-	-	-	-	-	
				High	1760	352000	1738.76	347752	6		-	-	-	-	-	-	
N.A./40 (Note4)	40	106	Downlink	High	2180	436000	1979.48	395896	504		5411	432970	22	0	0 (5)	1018	
45/45	45	242	Downlink	Low	2132.5	426500	2110.72	422144	0	15	5284	422690	2	1	2 (4)	5	
				Mid	2145	429000	2104.86	420972	102		15	5313	425070	10	1	0 (0)	103
				High	2157.5	431500	2045	409000	504			5345	427690	2	1	2 (4)	509
	45	242	Uplink	Low	1732.5	346500	1710.72	342144	0	-	-	-	-	-	-	-	-
				Mid	1745	349000	1632.5	326500	504		-	-	-	-	-	-	-
				High	1757.5	351500	1734.64	346928	6		-	-	-	-	-	-	

- Note 1: The CORESET#0 Index and the associated CORESET#0 Offset refers to Table 13-2 in TS 38.213 [22]. The value of CORESET#0 Index is signalled in controlResourceSetZero (pdcch-ConfigSIB1) in the MIB. The offsetToPointA IE is expressed in units of resource blocks assuming 15 kHz subcarrier spacing for FR1 and 60 kHz subcarrier spacing for FR2.
- Note 2: The parameter Offset Carrier CORESET#0 specifies the offset from the lowest subcarrier of the carrier and the lowest subcarrier of CORESET#0. It corresponds to the parameter  $\Delta F_{\text{OffsetCORESET-0-Carrier}}$  in Annex C expressed in number of common RBs.
- Note 3: Asymmetric CBW BCS refers to applicable asymmetric UL and DL channel bandwidth combination set as specified in TS 38.101-1 [7], Table 5.3.6-1 for NR band n66.
- Note 4: Used only for non-contiguous CA x+40 combination with no UL configuration on the SB in Table 4.3.1.1.5.66-2

**Table 4.3.1.1.1.66-2A: Void**

**Table 4.3.1.1.1.66-3: Test frequencies for NR operating band n66, uplink and downlink channel bandwidth combinations and SCS 60 kHz without CORESET#0**

UL/DL CBW (Asymmetric BCS) Note 2	CBW [MHz]	carrier Bandwidth [PRBs]	Range	Carrier centre [MHz]	Carrier centre [ARFCN]	point A [MHz]	absoluteFreq uencyPointA [ARFCN]	offsetTo Carrier [Carrier PRBs]	SS block SCS [kHz]	GSCN	absolute FrequencySSB [ARFCN]	
10/10	10	11	Downlink	Low	2115	423000	2111.04	422208	0	15	-	422568
				Mid	2145	429000	2067.6	413520	102		-	428568
				High	2175	435000	1808.16	361632	504		-	434568
	10	11	Uplink	Low	1715	343000	1711.04	342208	0	-	-	-
				Mid	1745	349000	1378.16	275632	504		-	-
				High	1775	355000	1766.72	353344	6		-	-
10/20	20	24	Downlink	Low	2120	424000	2111.36	422272	0	15	-	422632
				Mid	2150	430000	2067.92	413584	102		-	428632
				High	2180	436000	1808.48	361696	504		-	434632
	10	11	Uplink	Low	1715	343000	1711.04	342208	0	-	-	-
				Mid	1745	349000	1378.16	275632	504		-	-
				High	1775	355000	1766.72	353344	6		-	-
10/25 (1)	25	31	Downlink	Low	2122.5	424500	2111.34	422268	0	15	-	422628
				Mid	2152.5	430500	2067.9	413580	102		-	428628
				High	2182.5	436500	1808.46	361692	504		-	434628
	10	11	Uplink	Low	1715	343000	1711.04	342208	0	-	-	-
				Mid	1745	349000	1378.16	275632	504		-	-
				High	1775	355000	1766.72	353344	6		-	-
10/30	30	38	Downlink	Low	2125	425000	2111.32	422264	0	15	-	422624

(1)	10	11	Uplink	Mid	2155	431000	2067.88	413576	102	-	428624	
				High	2185	437000	1808.44	361688	504	-	434624	
				Low	1715	343000	1711.04	342208	0	-	-	
				Mid	1745	349000	1378.16	275632	504	-	-	
				High	1775	355000	1766.72	353344	6	-	-	
10/40	40	51	Downlink	Low	2130	426000	2111.64	422328	0	15	-	422688
				Mid	2155	431000	2063.2	412640	102	-	427688	
				High	2180	436000	1798.76	359752	504	-	432688	
	10	11	Uplink	Low	1715	343000	1711.04	342208	0	-	-	
				Mid	1740	348000	1373.16	274632	504	-	-	
				High	1765	353000	1756.72	351344	6	-	-	
15/15	15	18	Downlink	Low	2117.5	423500	2111.02	422204	0	15	-	422564
				Mid	2145	429000	2065.08	413016	102	-	428064	
				High	2172.5	434500	1803.14	360628	504	-	433564	
	15	18	Uplink	Low	1717.5	343500	1711.02	342204	0	-	-	
				Mid	1745	349000	1375.64	275128	504	-	-	
				High	1772.5	354500	1761.7	352340	6	-	-	
20/20	20	24	Downlink	Low	2120	424000	2111.36	422272	0	15	-	422632
				Mid	2145	429000	2062.92	412584	102	-	427632	
				High	2170	434000	1798.48	359696	504	-	432632	
	20	24	Uplink	Low	1720	344000	1711.36	342272	0	-	-	
				Mid	1745	349000	1373.48	274696	504	-	-	
				High	1770	354000	1757.04	351408	6	-	-	
20/40	40	51	Downlink	Low	2130	426000	2111.64	422328	0	15	-	422688
				Mid	2155	431000	2063.2	412640	102	-	427688	
				High	2180	436000	1798.76	359752	504	-	432688	
	20	24	Uplink	Low	1720	344000	1711.36	342272	0	-	-	
				Mid	1745	349000	1373.48	274696	504	-	-	
				High	1770	354000	1757.04	351408	6	-	-	
25/25	25	31	Downlink	Low	2122.5	424500	2111.34	422268	0	15	-	422628
				Mid	2145	429000	2060.4	412080	102	-	427128	
				High	2167.5	433500	1793.46	358692	504	-	431628	
	25	31	Uplink	Low	1722.5	344500	1711.34	342268	0	-	-	
				Mid	1745	349000	1370.96	274192	504	-	-	
				High	1767.5	353500	1752.02	350404	6	-	-	
25/40 (1)	40	51	Downlink	Low	2130	426000	2111.64	422328	0	15	-	422688
				Mid	2152.5	430500	2060.7	412140	102	-	427188	
				High	2175	435000	1793.76	358752	504	-	431688	
	25	31	Uplink	Low	1722.5	344500	1711.34	342268	0	-	-	
				Mid	1745	349000	1370.96	274192	504	-	-	
				High	1767.5	353500	1752.02	350404	6	-	-	

30/30	30	38	Downlink	Low	2125	425000	2111.32	422264	0	15	-	422624
				Mid	2145	429000	2057.88	411576	102		-	426624
				High	2165	433000	1788.44	357688	504		-	430624
	30	38	Uplink	Low	1725	345000	1711.32	342264	0	-	-	-
				Mid	1745	349000	1368.44	273688	504		-	-
				High	1765	353000	1747	349400	6		-	-
30/40 (1)	40	51	Downlink	Low	2130	426000	2111.64	422328	0	15	-	422688
				Mid	2150	430000	2058.2	411640	102		-	426688
				High	2170	434000	1788.76	357752	504		-	430688
	30	38	Uplink	Low	1725	345000	1711.32	342264	0	-	-	-
				Mid	1745	349000	1368.44	273688	504		-	-
				High	1765	353000	1747	349400	6		-	-
40/40	40	51	Downlink	Low	2130	426000	2111.64	422328	0	15	-	422688
				Mid	2145	429000	2053.2	410640	102		-	425688
				High	2160	432000	1778.76	355752	504		-	428688
	40	51	Uplink	Low	1730	346000	1711.64	342328	0	-	-	-
				Mid	1745	349000	1363.76	272752	504		-	-
				High	1760	352000	1737.32	347464	6		-	-
45/45	45	58	Downlink	Low	2132.5	426500	2111.62	422324	0	15	-	422684
				Mid	2145	429000	2050.68	410136	102	15	-	425184
				High	2157.5	431500	1773.74	354748	504	15	-	427684
	45	58	Uplink	Low	1732.5	346500	1711.62	342324	0	-	-	-
				Mid	1745	349000	1361.24	272248	504	-	-	-
				High	1757.5	351500	1732.3	346460	6	-	-	-
<p>Note 1: FR1 carrier without CORESET#0 is indicated in the MIB by setting <math>k_{SSB}=31</math>, <i>controlResourceSetZero</i>=0 and <i>searchSpaceZero</i> = 0 (TS 38.213 [22], clause 13).</p> <p>Note 2: Asymmetric CBW BCS refers to applicable asymmetric UL and DL channel bandwidth combination set as specified in TS 38.101-1 [7], Table 5.3.6-1 for NR band n66.</p>												

**Table 4.3.1.1.1.66-3A: Void**

4.3.1.1.1.67 – 4.3.1.1.1.69 FFS

4.3.1.1.1.70 Reference test frequencies for NR operating band n70

Editor’s note: Test frequencies for the Tx-RX frequency separation of 295 Mhz option as specified in TS 38.101-1, Table 5.4.4-1 is FFS.



**Table 4.3.1.1.1.70-1: Test frequencies for NR operating band n70, default Tx-RX frequency separation 300MHz, uplink and downlink channel bandwidth combinations and SCS 15 kHz**

UL/DL Bandwidth combination	CBW [MHz]	carrier Bandwidth [PRBs]	Range	Carrier centre [MHz]	Carrier centre [ARFCN]	point A [MHz]	absoluteFrequencyPointA [ARFCN]	offsetToCarrier [Carrier PRBs]	SS block SCS [kHz]	GS CN	absoluteFrequencySSB [ARFCN]	$k_{SSB}$	Offset Carrier CORES ET#0 [RBs] Note 2	CORES ET#0 Index (Offset [RBs]) Note 1	offsetToPointA (SIB1) [PRBs] Note 1		
5/5	5	25	Downlink	Low	1997.5	399500	1995.25	399050	0	15	4993	399410	0	0	0 (0)	0	
				Mid	2002.5	400500	1981.89	396378	102		5007	400590	0	1	2 (4)	107	
				High	2007.5	401500	1914.53	382906	504		5018	401530	4	1	1 (2)	507	
	5	25	Uplink	Low	1697.5	339500	1695.25	339050	0	-	-	-	-	-	-	-	-
				Mid	1702.5	340500	1609.53	321906	504		-	-	-	-	-	-	-
				High	1707.5	341500	1704.17	340834	6		-	-	-	-	-	-	-
5/10	10	52	Downlink	Low	2000	400000	1995.32	399064	0	15	4994	399610	2	1	2 (4)	5	
				Mid	2005	401000	1981.96	396392	102		5008	400610	2	1	2 (4)	107	
				High	2010	402000	1914.6	382920	504		5019	401550	6	1	1 (2)	507	
	5	25	Uplink	Low	1697.5	339500	1695.25	339050	0	-	-	-	-	-	-	-	-
				Mid	1702.5	340500	1609.53	321906	504		-	-	-	-	-	-	-
				High	1707.5	341500	1704.17	340834	6		-	-	-	-	-	-	-
5/15	15	79	Downlink	Low	2002.5	400500	1995.39	399078	0	15	4995	399630	4	1	2 (4)	5	
				Mid	2007.5	401500	1982.03	396406	102		5006	400570	8	1	1 (2)	105	
				High	2012.5	402500	1914.67	382934	504		5020	401570	8	1	1 (2)	507	
	5	25	Uplink	Low	1697.5	339500	1695.25	339050	0	-	-	-	-	-	-	-	

				Mid	170 2.5	3405 00	160 9.53	321906	504		-	-	-	-	-	-
				High	170 7.5	3415 00	170 4.17	340834	6		-	-	-	-	-	-
5/20	20	106	Downlink	Low	200 5	4010 00	199 5.46	399092	0	15	499 6	399650	6	1	2 (4)	5
				Mid	200 7.5	4015 00	197 9.6	395920	102		500 0	400090	10	1	1 (2)	105
				High	201 0	4020 00	190 9.74	381948	504		500 7	400590	10	1	1 (2)	507
	5	25	Uplink	Low	169 7.5	3395 00	169 5.25	339050	0	-	-	-	-	-	-	-
				Mid	170 0	3400 00	160 7.03	321406	504		-	-	-	-	-	-
				High	170 2.5	3405 00	169 9.17	339834	6		-	-	-	-	-	-
5/25	25	133	Downlink	Low	200 7.5	4015 00	199 5.53	399106	0	15	499 4	399610	0	0	2 (4)	4
				Mid												
				High												
	5	25	Uplink	Low	169 7.5	3395 00	169 5.25	339050	0	-	-	-	-	-	-	-
				Mid												
				High												
10/10	10	52	Downlink	Low	200 0	4000 00	199 5.32	399064	0	15	499 4	399610	2	1	2 (4)	5
				Mid	200 2.5	4005 00	197 9.46	395892	102		500 1	400110	2	1	2 (4)	107
				High	200 5	4010 00	190 9.6	381920	504		500 8	400610	2	1	2 (4)	509
	10	52	Uplink	Low	170 0	3400 00	169 5.32	339064	0	-	-	-	-	-	-	-
				Mid	170 2.5	3405 00	160 7.1	321420	504		-	-	-	-	-	-
				High	170 5	3410 00	169 9.24	339848	6		-	-	-	-	-	-
10/20	20	106	Downlink	Low	200 5	4010 00	199 5.46	399092	0	15	499 6	399650	6	1	2 (4)	5

				Mid	200	4015	197	395920	102		500	400090	10	1	1 (2)	105	
				High	201	4020	190	381948	504		500	400590	10	1	1 (2)	507	
				Low	170	3400	169	339064	0		-	-	-	-	-	-	
				Mid	170	3405	160	321420	504		-	-	-	-	-	-	
10/25	25	133	Downlink	High	170	3410	169	339848	6	15	499	399610	0	0	2 (4)	4	
				Low	200	4015	199	399106	0		4	-	-	-	-		
				Mid													
				High													
	10	52	Uplink	Low	170	3400	169	339064	0		-	-	-	-	-	-	
				Mid													
				High													
				Low	200	4005	199	399078	0		15	499	399630	4	1	2 (4)	5
15/15	15	79	Downlink	Mid						15	5	-	-	-	-	-	
				High													
				Low	170	3405	169	339078	0		-	-	-	-	-	-	
				Mid													
	15	79	Uplink	High							-	-	-	-	-	-	
				Low	200	4010	199	399092	0		15	499	399650	6	1	2 (4)	5
				Mid													
				High													
15/20	20	106	Downlink	Low	200	4010	199	399092	0	15	6	-	-	-	-	-	
				Mid													
	15	79	Uplink	Low	170	3405	169	339078	0		-	-	-	-	-	-	

				Mid High												
15/25	25	133	Downlink	Low	200 7.5	4015 00	199 5.53	399106	0	15	499 4	399610	0	0	2 (4)	4
				Mid High												
	15	79	Uplink	Low	170 2.5	3405 00	169 5.39	339078	0	-	-	-	-	-	-	-
				Mid High												
<p>Note 1: The CORESET#0 Index and the associated CORESET#0 Offset refers to Table 13-1 in TS 38.213 [22]. The value of CORESET#0 Index is signalled in controlResourceSetZero (pdccch-ConfigSIB1) in the MIB. The offsetToPointA IE is expressed in units of resource blocks assuming 15 kHz subcarrier spacing for FR1 and 60 kHz subcarrier spacing for FR2.</p> <p>Note 2: The parameter Offset Carrier CORESET#0 specifies the offset from the lowest subcarrier of the carrier and the lowest subcarrier of CORESET#0. It corresponds to the parameter <math>\Delta F_{\text{OffsetCORESET-0-Carrier}}</math> in Annex C expressed in number of common RBs.</p>																

**Table 4.3.1.1.1.70-2: Test frequencies for NR operating band n70, default Tx-RX frequency separation 300MHz, uplink and downlink channel bandwidth combinations and SCS 30 kHz**

UL/DL Bandwidth combination	CBW [MHz]	carrier Bandwidth [PRBs]	Range	Carrier centre [MHz]	Carrier centre [ARFCN]	point A [MHz]	absoluteFrequencyPointA [ARFCN]	offsetToCarrier [Carrier PRBs]	SS block SCS [kHz]	GS CN	absoluteFrequencySSB [ARFCN]	$k_{SSB}$	Offset Carrier CORESET#0 [RBs] Note 2	CORESET#0 Index (Offset [RBs]) Note 1	offsetToPointA (SIB1) [PRBs] Note 1
10/10	10	24	Downlink	Low	2000	4000	199	399136	0	15	5000	6	0	3 (8)	16
				Mid	2002.5	400500	196	392292	102		5007	6	0	3 (8)	220
				High	2005	401000	181	363848	504		5014	6	0	3 (8)	1024
	10	24	Uplink	Low	1700	3400	169	339136	0	-	-	-	-	-	-

				Mid	170 2.5	3405 00	151 6.74	303348	504		-	-	-	-	-	-
				High	170 5	3410 00	169 8.52	339704	6		-	-	-	-	-	-
10/20	20	51	Downlink	Low	200 5	4010 00	199 5.82	399164	0	15	499 9	399890	2	0	0 (5)	10
				Mid	200 7.5	4015 00	196 1.6	392320	102		500 6	400570	14	0	2 (7)	218
				High	201 0	4020 00	181 9.38	363876	504		501 3	401070	14	0	2 (7)	1022
	10	24	Uplink	Low	170 0	3400 00	169 5.68	339136	0	-	-	-	-	-	-	-
				Mid	170 2.5	3405 00	151 6.74	303348	504		-	-	-	-	-	-
				High	170 5	3410 00	169 8.52	339704	6		-	-	-	-	-	-
10/25	25	65	Downlink	Low	200 7.5	4015 00	199 5.8	399160	0	15	500 0	400090	22	0	2 (7)	14
				Mid												
				High												
	10	24	Uplink	Low	170 0	3400 00	169 5.68	339136	0	-	-	-	-	-	-	-
				Mid												
				High												
15/15	15	38	Downlink	Low	200 2.5	4005 00	199 5.66	399132	0	15	499 8	399870	6	0	0 (5)	10
				Mid												
				High												
	15	38	Uplink	Low	170 2.5	3405 00	169 5.66	339132	0	-	-	-	-	-	-	-
				Mid												
				High												
15/20	20	51	Downlink	Low	200 5	4010 00	199 5.82	399164	0	15	499 9	399890	2	0	0 (5)	10

				Mid High												
	15	38	Uplink	Low	170 2.5	3405 00	169 5.66	339132	0	-	-	-	-	-	-	-
				Mid High												
15/25	25	65	Downlink	Low	200 7.5	4015 00	199 5.8	399160	0	15	500 0	400090	22	0	2 (7)	14
				Mid High												
	15	38	Uplink	Low	170 2.5	3405 00	169 5.66	339132	0	-	-	-	-	-	-	-
				Mid High												
<p>Note 1: The CORESET#0 Index and the associated CORESET#0 Offset refers to Table 13-2 in TS 38.213 [22]. The value of CORESET#0 Index is signalled in controlResourceSetZero (pdcch-ConfigSIB1 in the MIB. The offsetToPointA IE is expressed in units of resource blocks assuming 15 kHz subcarrier spacing for FR1 and 60 kHz subcarrier spacing for FR2.</p> <p>Note 2: The parameter Offset Carrier CORESET#0 specifies the offset from the lowest subcarrier of the carrier and the lowest subcarrier of CORESET#0. It corresponds to the parameter <math>\Delta F_{\text{OffsetCORESET-0-Carrier}}</math> in Annex C expressed in number of common RBs.</p>																

**Table 4.3.1.1.70-3: Test frequencies for NR operating band n70, default Tx-RX frequency separation 300MHz, uplink and downlink channel bandwidth combinations and SCS 60 kHz without CORESET#0**

UL/DL Band width combination	CBW [MHz]	carrier Bandwidth [PRBs]	Range	Carrier centre [MHz]	Carrier centre [ARFCN]	point A [MHz]	absolute FrequencyPoint A [ARFCN]	offsetTo Carrier [Carrier PRBs]	SS block SCS [kHz]	GSCN	absolute FrequencySSB [ARFCN]	
10/10	10	11	Downlink	Low	2000	400000	1996.04	399208	0	15	-	399568
				Mid	2002.5	400500	1925.1	385020	102		-	400068
				High	2005	401000	1638.16	327632	504		-	400568
10/10	10	11	Uplink	Low	1700	340000	1696.04	339208	0	-	-	-
				Mid	1702.5	340500	1335.66	267132	504		-	-

10/20	20	24	Downlink	High	1705	341000	1696.72	339344	6	15	-	-	
				Low	2005	401000	1996.36	399272	0		-	399632	
				Mid	2007.5	401500	1925.42	385084	102		-	400132	
	10	11	Uplink	High	2010	402000	1638.48	327696	504		-	400632	
				Low	1700	340000	1696.04	339208	0		-	-	
				Mid	1702.5	340500	1335.66	267132	504		-	-	
10/25	25	31	Downlink	High	1705	341000	1696.72	339344	6	15	-	-	
				Low	2007.5	401500	1996.34	399268	0		-	399628	
				Mid									
	10	11	Uplink	High									
				Low	1700	340000	1696.04	339208	0		-	-	
				Mid									
15/15	15	18	Downlink	High						15	-	-	
				Low	2002.5	400500	1996.02	399204	0		-	399564	
				Mid									
	15	18	Uplink	High									
				Low	1702.5	340500	1696.02	339204	0		-	-	
				Mid									
15/20	20	24	Downlink	High						15	-	-	
				Low	2005	401000	1996.36	399272	0		-	399632	
				Mid									
	15	18	Uplink	High									
				Low	1702.5	340500	1696.02	339204	0		-	-	
				Mid									
15/25	25	31	Downlink	High						15	-	-	
				Low	2007.5	401500	1996.34	399268	0		-	399628	
				Mid									
	15	18	Uplink	High									
				Low	1702.5	340500	1696.02	339204	0		-	-	
				Mid									

Note: FR1 carrier without CORESET#0 is indicated in the MIB by setting  $k_{SSB}=31$ ,  $controlResourceSetZero=0$  and  $searchSpaceZero=0$  (TS 38.213 [22], clause 13).

4.3.1.1.1.71 Reference test frequencies for NR operating band n71

Table 4.3.1.1.1.71-1: Test frequencies for NR operating band n71 and SCS 15 kHz

CBW [MHz]	carrierBandwidth [PRBs]	Range		Carrier centre [MHz]	Carrier centre [ARFCN]	point A [MHz]	absoluteFrequencyPointA [ARFCN]	offsetToCarrier [Carrier PRBs]	SS block SCS [kHz]	GS CN	absoluteFrequencySSB [ARFCN]	$k_{SSB}$	Offset Carrier CORESET#0 [RBs] Note 2	CORESET#0 Index (Offset [RBs]) Note 1	offsetToPointA (SIB1) [PRBs] Note 1
5	25	Downlink	Low	619.5	123900	617.25	123450	0	15	1548	123870	8	1	0 (0)	1
			Mid	634.5	126900	613.89	122778	102		1587	126990	0	1	2 (4)	107
			High	649.5	129900	556.53	111306	504		1623	129870	8	1	0 (0)	505
		Uplink	Low	665.5	133100	663.25	132650	0	-	-	-	-	-	-	-
			Mid	680.5	136100	587.53	117506	504	-	-	-	-	-	-	-
			High	695.5	139100	692.17	138434	6	-	-	-	-	-	-	-
10	52	Downlink	Low	622	124400	617.32	123464	0	15	1549	123890	10	1	0 (0)	1
			Mid	634.5	126900	611.46	122292	102		1581	126510	2	1	2 (4)	107
			High	647	129400	551.6	110320	504		1610	128890	10	1	0 (0)	505
		Uplink	Low	668	133600	663.32	132664	0	-	-	-	-	-	-	-
			Mid	680.5	136100	585.1	117020	504	-	-	-	-	-	-	-
			High	693	138600	687.24	137448	6	-	-	-	-	-	-	-
15	79	Downlink	Low	624.5	124900	617.39	123478	0	15	1547	123850	4	0	0 (0)	0
			Mid	634.5	126900	609.03	121806	102		1575	126030	4	1	2 (4)	107
			High	644.5	128900	546.67	109334	504		1600	127970	8	1	1 (2)	507



		Uplink	Low	670.5	134100	663.39	132678	0	-	-	-	-	-	-	
			Mid	680.5	136100	582.67	116534	504		-	-	-	-	-	
			High	690.5	138100	682.31	136462	6		-	-	-	-	-	
20	106	Downlink	Low	627	125400	617.46	123492	0	15	1548	123870	6	0	0 (0)	0
			Mid	634.5	126900	606.6	121320	102		1569	125550	6	1	2 (4)	107
			High	642	128400	541.74	108348	504		1587	126990	10	1	1 (2)	507
		Uplink	Low	673	134600	663.46	132692	0	-	-	-	-	-	-	-
			Mid	680.5	136100	580.24	116048	504	-	-	-	-	-	-	-
			High	688	137600	677.38	135476	6	-	-	-	-	-	-	-
<p>Note 1: The CORESET#0 Index and the associated CORESET#0 Offset refers to Table 13-1 in TS 38.213 [22]. The value of CORESET#0 Index is signalled in controlResourceSetZero (pdccch-ConfigSIB1) in the MIB. The offsetToPointA IE is expressed in units of resource blocks assuming 15 kHz subcarrier spacing for FR1 and 60 kHz subcarrier spacing for FR2.</p> <p>Note 2: The parameter Offset Carrier CORESET#0 specifies the offset from the lowest subcarrier of the carrier and the lowest subcarrier of CORESET#0. It corresponds to the parameter <math>\Delta F_{\text{OffsetCORESET-0-Carrier}}</math> in Annex C expressed in number of common RBs.</p>															

Table 4.3.1.1.1.71-2: Test frequencies for NR operating band n71 and SCS 30 kHz

CBW [MHz]	carrierBandwidth [PRBs]	Range	Carrier centre [MHz]	Carrier centre [ARFCN]	point A [MHz]	absoluteFrequencyPointA [ARFCN]	offsetToCarrier [Carrier PRBs]	SS block SCS [kHz]	GS CN	absoluteFrequencySSB [ARFCN]	$k_{SSB}$	Offset Carrier CORESET#0 [RBs] Note 2	CORESET#0 Index (Offset [RBs]) Note 1	offsetToPointA (SIB1) [PRBs] Note 1	
10	24	Downlink	Low	622	124400	617.68	123536	0	15	1555	124370	14	0	1 (6)	12
			Mid	634.5	126900	593.46	118692	102		1587	126990	6	0	3 (8)	220
			High	647	129400	461.24	92248	504		1616	129370	14	0	1 (6)	1020
		Uplink	Low	668	133600	663.68	132736	0	-	-	-	-	-	-	

			Mid	680.5	136100	494.74	98948	504		-	-	-	-	-	-	
			High	693	138600	686.52	137304	6		-	-	-	-	-	-	
15	38	Downlink	Low	624.5	124900	617.66	123532	0	15	1553	124330	2	0	1 (6)	12	
			Mid	634.5	126900	590.94	118188	102		1578	126270	6	0	0 (5)	214	
			High	644.5	128900	456.22	91244	504		1606	128450	18	0	2 (7)	1022	
		Uplink	Low	670.5	134100	663.66	132732	0	-	-	-	-	-	-	-	-
			Mid	680.5	136100	492.22	98444	504		-	-	-	-	-	-	-
			High	690.5	138100	681.5	136300	6		-	-	-	-	-	-	-
20	51	Downlink	Low	627	125400	617.82	123564	0	15	1554	124350	22	0	0 (5)	10	
			Mid	634.5	126900	588.6	117720	102		1572	125790	2	0	0 (5)	214	
			High	642	128400	451.38	90276	504		1593	127470	14	0	2 (7)	1022	
		Uplink	Low	673	134600	663.82	132764	0	-	-	-	-	-	-	-	
			Mid	680.5	136100	489.88	97976	504		-	-	-	-	-	-	
			High	688	137600	676.66	135332	6		-	-	-	-	-	-	

Note 1: The CORESET#0 Index and the associated CORESET#0 Offset refers to Table 13-2 in TS 38.213 [22]. The value of CORESET#0 Index is signalled in controlResourceSetZero (pdccch-ConfigSIB1) in the MIB. The offsetToPointA IE is expressed in units of resource blocks assuming 15 kHz subcarrier spacing for FR1 and 60 kHz subcarrier spacing for FR2.

Note 2: The parameter Offset Carrier CORESET#0 specifies the offset from the lowest subcarrier of the carrier and the lowest subcarrier of CORESET#0. It corresponds to the parameter  $\Delta F_{\text{OffsetCORESET-0-Carrier}}$  in Annex C expressed in number of common RBs.

4.3.1.1.1.72 – 4.3.1.1.1.73

4.3.1.1.1.74 Reference test frequencies for NR operating band n74

**Table 4.3.1.1.1.74-1: Test frequencies for NR operating band n74 and SCS 15 kHz**

CBW [MHz]	carrierBandwidth [PRBs]	Range		Carrier centre [MHz]	Carrier centre [ARFCN]	point A [MHz]	absoluteFrequencyPointA [ARFCN]	offsetToCarrier [Carrier PRBs]	SS block SCS [kHz]	GS CN	absoluteFrequencySSB [ARFCN]	$k_{SS}$	Offset Carrier CORESET#0 [RBs] Note 2	CORESET#0 Index (Offset [RBs]) Note 1	offsetToPointA (SIB1) [PRBs] Note 1
5	25	Downlink	Low	1477.5	29550	1475.25	295050	0	15	3693	295470	8	1	0 (0)	1
			Mid	1496.5	29930	1475.89	295178	102		3742	299330	4	1	1 (2)	105
			High	1515.5	30310	1422.53	284506	504		3788	303130	4	1	1 (2)	507
		Uplink	Low	1429.5	28590	1427.25	285450	0	-	-	-	-	-	-	-
			Mid	1448.5	28970	1355.53	271106	504	-	-	-	-	-	-	-
			High	1467.5	29350	1464.17	292834	6	-	-	-	-	-	-	-
10	52	Downlink	Low	1480	29600	1475.32	295064	0	15	3694	295490	10	1	0 (0)	1
			Mid	1496.5	29930	1473.46	294692	102		3736	298850	6	1	1 (2)	105
			High	1513	30260	1417.6	283520	504		3778	302210	2	1	2 (4)	509
		Uplink	Low	1432	28640	1427.32	285464	0	-	-	-	-	-	-	-
			Mid	1448.5	28970	1353.1	270620	504	-	-	-	-	-	-	-
			High	1465	29300	1459.24	291848	6	-	-	-	-	-	-	-
15	79	Downlink	Low	1482.5	29650	1475.39	295078	0	15	3692	295450	4	0	0 (0)	0
			Mid	1496.5	29930	1471.03	294206	102		3730	298370	8	1	1 (2)	105

			High	1510.5	302100	1412.67	282534	504		3765	301230	4	1	2 (4)	509
		Uplink	Low	1434.5	286900	1427.39	285478	0	-	-	-	-	-	-	-
			Mid	1448.5	289700	1350.67	270134	504		-	-	-	-	-	-
			High	1462.5	292500	1454.31	290862	6		-	-	-	-	-	-
20	106	Downlink	Low	1485	297000	1475.46	295092	0	15	3693	295470	6	0	0 (0)	0
			Mid	1496.5	299300	1468.6	293720	102		3724	297890	10	1	1 (2)	105
			High	1508	301600	1407.74	281548	504		3752	300250	6	1	2 (4)	509
		Uplink	Low	1437	287400	1427.46	285492	0	-	-	-	-	-	-	-
			Mid	1448.5	289700	1348.24	269648	504		-	-	-	-	-	-
			High	1460	292000	1449.38	289876	6		-	-	-	-	-	-
<p>Note 1: The CORESET#0 Index and the associated CORESET#0 Offset refers to Table 13-1 in TS 38.213 [22]. The value of CORESET#0 Index is signalled in controlResourceSetZero (pdcch-ConfigSIB1) in the MIB. The offsetToPointA IE is expressed in units of resource blocks assuming 15 kHz subcarrier spacing for FR1 and 60 kHz subcarrier spacing for FR2.</p> <p>Note 2: The parameter Offset Carrier CORESET#0 specifies the offset from the lowest subcarrier of the carrier and the lowest subcarrier of CORESET#0. It corresponds to the parameter <math>\Delta F_{\text{OffsetCORESET-0-Carrier}}</math> in Annex C expressed in number of common RBs.</p>															

Table 4.3.1.1.1.74-2: Test frequencies for NR operating band n74 and SCS 30 kHz

CBW [MHz]	carrierBandwidth [PRBs]	Range	Carrier centre [MHz]	Carrier centre [ARFCN]	point A [MHz]	absoluteFrequencyPointA [ARFCN]	offsetToCarrier [Carrier PRBs]	SS block SCS [kHz]	GS CN	absoluteFrequencySSB [ARFCN]	$k_{SSB}$	Offset Carrier CORESET#0 [RBs] Note 2	CORESET#0 Index (Offset [RBs]) Note 1	offsetToPointA (SIB1) [PRBs] Note 1
10	24	Downlink	Low	1480	296000	1475.68	295136	0	15	3700	14	0	1 (6)	12
			Mid	1496.5	299300	1455.46	291092	102		3742	10	0	2 (7)	218
			High	1513	302600	1327.24	265448	504		3784	6	0	3 (8)	1024

		Uplink	Low	1432	28640	1427	285536	0	-	-	-	-	-	-	
			Mid	1448	28970	1262	252548	504	-	-	-	-	-	-	
			High	1465	29300	1458	291704	6	-	-	-	-	-	-	
15	38	Downlink	Low	1482	29650	1475	295132	0	15	369	295930	2	0	1 (6)	12
			Mid	1496	29930	1452	290588	102		373	298850	18	0	2 (7)	218
			High	1510	30210	1322	264444	504		376	301470	6	0	0 (5)	1018
		Uplink	Low	1434	28690	1427	285532	0	-	-	-	-	-	-	-
			Mid	1448	28970	1260	252044	504	-	-	-	-	-	-	-
			High	1462	29250	1453	290700	6	-	-	-	-	-	-	-
20	51	Downlink	Low	1485	29700	1475	295164	0	15	369	295950	22	0	0 (5)	10
			Mid	1496	29930	1450	290120	102		373	298370	14	0	2 (7)	218
			High	1508	30160	1317	263476	504		375	300490	2	0	0 (5)	1018
		Uplink	Low	1437	28740	1427	285564	0	-	-	-	-	-	-	-
			Mid	1448	28970	1257	251576	504	-	-	-	-	-	-	-
			High	1460	29200	1448	289732	6	-	-	-	-	-	-	-

Note 1: The CORESET#0 Index and the associated CORESET#0 Offset refers to Table 13-2 in TS 38.213 [22]. The value of CORESET#0 Index is signalled in controlResourceSetZero (pdch-ConfigSIB1 in the MIB. The offsetToPointA IE is expressed in units of resource blocks assuming 15 kHz subcarrier spacing for FR1 and 60 kHz subcarrier spacing for FR2.

Note 2: The parameter Offset Carrier CORESET#0 specifies the offset from the lowest subcarrier of the carrier and the lowest subcarrier of CORESET#0. It corresponds to the parameter  $\Delta F_{\text{OffsetCORESET-0-Carrier}}$  in Annex C expressed in number of common RBs.

**Table 4.3.1.1.1.74-3: Test frequencies for NR operating band n74 and SCS 60 kHz without CORESET#0**

CBW [MHz]	carrier Bandwidth [PRBs]	Range		Carrier centre [MHz]	Carrier centre [ARFCN]	point A [MHz]	absolute FrequencyPoint A [ARFCN]	offsetTo Carrier [Carrier PRBs]	SS block SCS [kHz]	GSCN	absolute FrequencySSB [ARFCN]
10	11	Downlink	Low	1480	296000	1476.04	295208	0	15	-	295568
			Mid	1496.5	299300	1419.1	283820	102		-	298868
			High	1513	302600	1146.16	229232	504		-	302168
		Uplink	Low	1432	286400	1428.04	285608	0	-	-	-
			Mid	1448.5	289700	1081.66	216332	504		-	-
			High	1465	293000	1456.72	291344	6		-	-
15	18	Downlink	Low	1482.5	296500	1476.02	295204	0	15	-	295564
			Mid	1496.5	299300	1416.58	283316	102		-	298364
			High	1510.5	302100	1141.14	228228	504		-	301164
		Uplink	Low	1434.5	286900	1428.02	285604	0	-	-	-
			Mid	1448.5	289700	1079.14	215828	504		-	-
			High	1462.5	292500	1451.7	290340	6		-	-
20	24	Downlink	Low	1485	297000	1476.36	295272	0	15	-	295632
			Mid	1496.5	299300	1414.42	282884	102		-	297932
			High	1508	301600	1136.48	227296	504		-	300232
		Uplink	Low	1437	287400	1428.36	285672	0	-	-	-
			Mid	1448.5	289700	1076.98	215396	504		-	-
			High	1460	292000	1447.04	289408	6		-	-
Note: FR1 carrier without CORESET#0 is indicated in the MIB by setting $k_{SSB}=31$ , $controlResourceSetZero=0$ and $searchSpaceZero=0$ (TS 38.213 [22], clause 13).											

4.3.1.1.1.75 Reference test frequencies for NR operating band n75 (SDL)

**Table 4.3.1.1.1.75-1: Test frequencies for NR operating band n75 and SCS 15 kHz without CORESET#0**

CBW [MHz]	carrierBand width [PRBs]	Range		Carrier centre [MHz]	Carrier centre [ARFCN]	point A [MHz]	absolute FrequencyPoint A [ARFCN]	offsetTo Carrier [PRBs]	SS block SCS [kHz]	GSCN	absolute FrequencySSB [ARFCN]
5	25	Downlink	Low	1434.5	286900	1432.25	286450	0	15	-	286810
			Mid	1474.5	294900	1453.89	290778	102		-	294810
			High	1514.5	302900	1421.53	284306	504		-	302810

10	52	Downlink	Low	1437	287400	1432.32	286464	0	15	-	286824
			Mid	1474.5	294900	1451.46	290292	102		-	294324
			High	1512	302400	1416.6	283320	504		-	301824
15	79	Downlink	Low	1439.5	287900	1432.39	286478	0	15	-	286838
			Mid	1474.5	294900	1449.03	289806	102		-	293838
			High	1509.5	301900	1411.67	282334	504		-	300838
20	106	Downlink	Low	1442	288400	1432.46	286492	0	15	-	286852
			Mid	1474.5	294900	1446.6	289320	102		-	293352
			High	1507	301400	1406.74	281348	504		-	299852

Note: FR1 carrier without CORESET#0 is indicated in the MIB by setting  $k_{SSB}=31$ , *controlResourceSetZero*=0 and *searchSpaceZero* = 0 (TS 38.213 [22], clause 13).

**Table 4.3.1.1.1.75-2: Test frequencies for NR operating band n75 and SCS 30 kHz without CORESET#0**

CBW [MHz]	carrierBand width [PRBs]	Range	Carrier centre [MHz]	Carrier centre [ARFCN]	point A [MHz]	absolute FrequencyPoint A [ARFCN]	offsetTo Carrier [PRBs]	SS block SCS [kHz]	GSCN	absolute FrequencySSB [ARFCN]	
10	24	Downlink	Low	1437	287400	1432.68	286536	0	15	-	286896
			Mid	1474.5	294900	1433.46	286692	102		-	294396
			High	1512	302400	1326.24	265248	504		-	301896
15	38	Downlink	Low	1439.5	287900	1432.66	286532	0	15	-	286892
			Mid	1474.5	294900	1430.94	286188	102		-	293892
			High	1509.5	301900	1321.22	264244	504		-	300892
20	51	Downlink	Low	1442	288400	1432.82	286564	0	15	-	286924
			Mid	1474.5	294900	1428.6	285720	102		-	293424
			High	1507	301400	1316.38	263276	504		-	299924

Note: FR1 carrier without CORESET#0 is indicated in the MIB by setting  $k_{SSB}=31$ , *controlResourceSetZero*=0 and *searchSpaceZero* = 0 (TS 38.213 [22], clause 13).

Table 4.3.1.1.1.75-3: Test frequencies for NR operating band n75 and SCS 60 kHz without CORESET#0

CBW [MHz]	carrierBand width [PRBs]	Range		Carrier centre [MHz]	Carrier centre [ARFCN]	point A [MHz]	absolute FrequencyPoint A [ARFCN]	offsetTo Carrier [PRBs]	SS block SCS [kHz]	GSCN	absolute FrequencySSB [ARFCN]
10	11	Downlink	Low	1437	287400	1433.04	286608	0	15	-	286968
			Mid	1474.5	294900	1397.1	279420	102		-	294468
			High	1512	302400	1145.16	229032	504		-	301968
15	18	Downlink	Low	1439.5	287900	1433.02	286604	0	15	-	286964
			Mid	1474.5	294900	1394.58	278916	102		-	293964
			High	1509.5	301900	1140.14	228028	504		-	300964
20	24	Downlink	Low	1442	288400	1433.36	286672	0	15	-	287032
			Mid	1474.5	294900	1392.42	278484	102		-	293532
			High	1507	301400	1135.48	227096	504		-	300032

Note: FR1 carrier without CORESET#0 is indicated in the MIB by setting  $k_{SSB}=31$ , *controlResourceSetZero*=0 and *searchSpaceZero* = 0 (TS 38.213 [22], clause 13).

## 4.3.1.1.1.76 Reference test frequencies for NR operating band n76 (SDL)

Table 4.3.1.1.1.76-1: Test frequencies for NR operating band n76 and SCS 15 kHz without CORESET#0

Bandwidth [MHz]	carrierBand width [PRBs]	Range		Carrier centre [MHz]	Carrier centre [ARFCN]	point A [MHz]	absoluteFrequencyPointA [ARFCN]	offsetTo Carrier [PRBs]	SS block SCS [kHz]	GSCN	absolute FrequencySSB [ARFCN]
5	25	Downlink	Low, Mid, High	1429.5	285900	1427.25	285450	0	15	-	285810

Note: FR1 carrier without CORESET#0 is indicated in the MIB by setting  $k_{SSB}=31$ , *controlResourceSetZero*=0 and *searchSpaceZero* = 0 (TS 38.213 [22], clause 13).



4.3.1.1.1.77 Reference test frequencies for NR operating band n77

**Table 4.3.1.1.1.77-1: Test frequencies for NR operating band n77, SCS 15 kHz and  $\Delta F_{\text{Raster}}$  15 kHz**

CBW [MHz]	carrierBandwidth [PRBs]	Range		Carrier centre [MHz]	Carrier centre [ARFCN]	point A [MHz]	absoluteFrequencyPointA [ARFCN]	offsetToCarrier [Carrier PRBs]	SS block SCS [kHz]	GS CN	absoluteFrequencySSB [ARFCN]	$k_{\text{SSB}}$	Offset Carrier CORESET#0 [RBs] Note 2	CORESET#0 Index (Offset [RBs]) Note 1	offsetToPointA (SIB1) [PRBs] Note 1
10	52	Down link &	Low	3305.01	620334	3300.33	620022	0	30	7711	620352	6	1	1 (6)	7
			Mid	3750	650000	3726.96	648464	102		8020	650016	4	1	1 (6)	109
		Uplink	High	4194.99	679666	4099.59	673306	504		8329	679680	2	1	1 (6)	511
15	79	Down link &	Low	3307.5	620500	3300.39	620026	0	30	7711	620352	2	1	1 (6)	7
			Mid	3750	650000	3724.53	648302	102		8018	649824	10	2	0 (2)	106
		Uplink	High	4192.5	679500	4094.67	672978	504		8325	679296	6	0	0 (2)	506
20	106	Down link &	Low	3310.02	620668	3300.48	620032	0	30	7711	620352	8	0	1 (6)	6
			Mid	3750	650000	3722.1	648140	102		8016	649632	4	0	0 (2)	104
		Uplink	High	4189.995	679333	4089.735	672649	504		8322	679008	11	3	0 (2)	509
25	133	Down link &	Low	3312.51	620834	3300.54	620036	0	30	7711	620352	4	0	1 (6)	6
			Mid	3750	650000	3719.67	647978	102		8015	649536	10	1	1 (6)	109
		Uplink	High	4187.49	679166	4084.8	672320	504		8319	678720	4	3	1 (6)	513
30	160	Down link &	Low	3315	621000	3300.6	620040	0	30	7711	620352	0	0	1 (6)	6
			Mid	3750	650000	3717.24	647816	102		8013	649344	4	3	0 (2)	107
		Uplink	High	4185	679000	4079.88	671992	504		8315	678336	8	2	0 (2)	508

40	216	Down link & Uplink	Low	3320.01	621334	3300.57	620038	0	30	7711	620352	2	0	1 (6)	6
			Mid	3750	650000	3712.2	647480	102		8010	649056	4	3	1 (6)	111
		High	4179.99	678666	4069.83	671322	504	8308		677664	6	2	0 (2)	508	
50	270	Down link & Uplink	Low	3325.02	621668	3300.72	620048	0	30	7711	620352	4	3	0 (2)	5
			Mid	3750	650000	3707.34	647156	102		8006	648672	4	2	0 (2)	106
		High	4174.98	678332	4059.96	670664	504	8301		676992	4	1	0 (2)	507	
<p>Note 1: The CORESET#0 Index and the associated CORESET#0 Offset refers to Table 13-3 in TS 38.213 [22]. The value of CORESET#0 Index is signalled in controlResourceSetZero (pdccch-ConfigSIB1) in the MIB. The offsetToPointA IE is expressed in units of resource blocks assuming 15 kHz subcarrier spacing for FR1 and 60 kHz subcarrier spacing for FR2.</p> <p>Note 2: The parameter Offset Carrier CORESET#0 specifies the offset from the lowest subcarrier of the carrier and the lowest subcarrier of CORESET#0. It corresponds to the parameter <math>\Delta F_{\text{OffsetCORESET-0-Carrier}}</math> in Annex C expressed in number of common RBs.</p>															

Table 4.3.1.1.1.77-2: Test frequencies for NR operating band n77, SCS 30 kHz and  $\Delta F_{\text{Raster}}$  30 kHz

CBW [MHz]	carrierBandwidth [PRBs]	Range	Carrier centre [MHz]	Carrier centre [ARFCN]	point A [MHz]	absoluteFrequencyPointA [ARFCN]	offsetToCarrier [Carrier PRBs]	SS block SCS [kHz]	GS CN	absoluteFrequencySSB [ARFCN]	$k_{\text{SSB}}$	Offset Carrier CORESET#0 [RBs] Note 2	CORESET#0 Index (Offset [RBs]) Note 1	offsetToPointA (SIB1) [PRBs] Note 1	
10	24	Down link & Uplink	Low	3305.01	620334	3300.69	620046	0	30	7711	620352	18	0	2 (2)	4
			Mid	3750	65000	3708.96	647264	102		8020	650016	16	0	2 (2)	208
		High	4194.99	679666	4009.23	667282	504	8329		679680	14	0	2 (2)	1012	
15	38	Down link & Uplink	Low	3307.5	620500	3300.66	620044	0	30	7711	620352	20	0	2 (2)	4
			Mid	3750	650000	3706.44	647096	102		8018	649824	16	0	1 (1)	206
		High	4192.5	679500	4004.22	666948	504	8325		679296	12	0	0 (0)	1008	
20	51	Down link	Low	3310.02	620668	3300.84	620056	0	30	7711	620352	8	0	2 (2)	4

		&	Mid	3750	65000	3704	646940	102		801	649632	4	0	0 (0)	204
		Uplink	High	4189	67933	3999	666624	504		832	679008	0	0	2 (2)	1012
25	65	Downlink &	Low	3312	62083	3300	620054	0	30	771	620352	10	0	2 (2)	4
		Uplink	Mid	3750	65000	3701	646772	102		801	649536	4	0	3 (3)	210
			High	4187	67916	3994	666290	504		831	678720	22	0	3 (3)	1014
30	78	Downlink &	Low	3315	62100	3300	620064	0	30	771	620352	0	0	2 (2)	4
		Uplink	Mid	3750	65000	3699	646616	102		801	649344	16	0	1 (1)	206
			High	4185	67900	3989	665968	504		831	678336	8	0	1 (1)	1010
40	106	Downlink &	Low	3320	62133	3300	620062	0	30	771	620352	2	0	2 (2)	4
		Uplink	Mid	3750	65000	3694	646280	102		801	649056	16	0	3 (3)	210
			High	4179	67866	3979	665298	504		830	677664	6	0	1 (1)	1010
50	133	Downlink &	Low	3325	62166	3301	620072	0	30	771	620352	16	0	1 (1)	2
		Uplink	Mid	3750	65000	3689	645956	102		800	648672	4	0	1 (1)	206
			High	4174	67833	3969	664640	504		830	676992	16	0	0 (0)	1008
60	162	Downlink &	Low	3330	62200	3300	620056	0	30	771	620352	8	0	2 (2)	4
		Uplink	Mid	3750	65000	3684	645608	102		800	648384	16	0	3 (3)	210
			High	4170	67800	3959	663960	504		829	676320	0	0	1 (1)	1010
70	189	Downlink &	Low	3335	62233	3300	620066	0	30	771	620352	22	0	1 (1)	2
		Uplink	Mid	3750	65000	3679	645284	102		799	648000	4	0	1 (1)	206
			High	4164	67766	3949	663302	504		828	675648	10	0	0 (0)	1008
80	217	Downlink	Low	3340	62266	3300	620064	0	30	771	620352	0	0	2 (2)	4

		& Uplink	Mid	3750	650000	3674.22	644948	102	30	7996	647712	4	0	3 (3)	210
			High	4159.98	677332	3939.48	662632	504		8280	674976	8	0	0 (0)	1008
90	245	Downlink & Uplink	Low	33450	623000	3300.9	620060	0	30	7711	620352	4	0	2 (2)	4
			Mid	37500	650000	3669.18	644612	102		7992	647328	4	0	1 (1)	206
		High	41550	677000	3929.46	661964	504	8273		674304	4	0	0 (0)	1008	
100	273	Downlink & Uplink	Low	3350.01	623334	3300.87	620058	0	30	7711	620352	6	0	2 (2)	4
			Mid	37500	650000	3664.14	644276	102		7989	647040	4	0	3 (3)	210
		High	4149.99	676666	3919.41	661294	504	8266		673632	2	0	0 (0)	1008	
<p>Note 1: The CORESET#0 Index and the associated CORESET#0 Offset refers to Table 13-4 in TS 38.213 [22]. The value of CORESET#0 Index is signalled in controlResourceSetZero (pdccch-ConfigSIB1) in the MIB. The offsetToPointA IE is expressed in units of resource blocks assuming 15 kHz subcarrier spacing for FR1 and 60 kHz subcarrier spacing for FR2.</p> <p>Note 2: The parameter Offset Carrier CORESET#0 specifies the offset from the lowest subcarrier of the carrier and the lowest subcarrier of CORESET#0. It corresponds to the parameter <math>\Delta F_{\text{OffsetCORESET-0-Carrier}}</math> in Annex C expressed in number of common RBs.</p>															

**Table 4.3.1.1.77-3: Test frequencies for NR operating band n77, SCS 60 kHz and  $\Delta F_{\text{Raster}}$  30 kHz without CORESET#0**

CBW [MHz]	carrierBand width [PRBs]	Range		Carrier centre [MHz]	Carrier centre [ARFCN]	point A [MHz]	absolute FrequencyPoint A [ARFCN]	offsetTo Carrier [PRBs]	SS block SCS [kHz]	GSCN	absolute FrequencySSB [ARFCN]
10	11	Downlink & Uplink	Low	3305.01	620334	3301.05	620070	0	30	-	620310
			Mid	3750	650000	3672.6	644840	102		-	649976
			High	4194.99	679666	3828.15	655210	504		-	679642
15	18	Downlink & Uplink	Low	3307.5	620500	3301.02	620068	0	30	-	620308
			Mid	3750	650000	3670.08	644672	102		-	649808
			High	4192.5	679500	3823.14	654876	504		-	679308
20	24	Downlink & Uplink	Low	3310.02	620668	3301.38	620092	0	30	-	620332
			Mid	3750	650000	3667.92	644528	102		-	649664
			High	4189.98	679332	3818.46	654564	504		-	678996
25	31	Downlink & Uplink	Low	3312.51	620834	3301.35	620090	0	30	-	620330
			Mid	3750	650000	3665.4	644360	102		-	649496
			High	4187.49	679166	3813.45	654230	504		-	678662

30	38	Downlink & Uplink	Low	3315	621000	3301.32	620088	0	30	-	620328
			Mid	3750	650000	3662.88	644192	102		-	649328
			High	4185	679000	3808.44	653896	504		-	678328
40	51	Downlink & Uplink	Low	3320.01	621334	3301.65	620110	0	30	-	620350
			Mid	3750	650000	3658.2	643880	102		-	649016
			High	4179.99	678666	3798.75	653250	504		-	677682
50	65	Downlink & Uplink	Low	3325.02	621668	3301.62	620108	0	30	-	620348
			Mid	3750	650000	3653.16	643544	102		-	648680
			High	4174.98	678332	3788.7	652580	504		-	677012
60	79	Downlink & Uplink	Low	3330	622000	3301.56	620104	0	30	-	620344
			Mid	3750	650000	3648.12	643208	102		-	648344
			High	4170	678000	3778.68	651912	504		-	676344
70	93	Downlink	Low	3335.01	622334	3301.53	620102	0	30	-	620342
		&	Mid	3750	650000	3643.08	642872	102		-	648008
		Uplink	High	4164.99	677666	3768.63	651242	504		-	675674
80	107	Downlink & Uplink	Low	3340.02	622668	3301.5	620100	0	30	-	620340
			Mid	3750	650000	3638.04	642536	102		-	647672
			High	4159.98	677332	3758.58	650572	504		-	675004
90	121	Downlink & Uplink	Low	3345	623000	3301.44	620096	0	30	-	620336
			Mid	3750	650000	3633	642200	102		-	647336
			High	4155	677000	3748.56	649904	504		-	674336
100	135	Downlink & Uplink	Low	3350.01	623334	3301.41	620094	0	30	-	620334
			Mid	3750	650000	3627.96	641864	102		-	647000
			High	4149.99	676666	3738.51	649234	504		-	673666

Note: FR1 carrier without CORESET#0 is indicated in the MIB by setting  $k_{SSB}=31$ ,  $controlResourceSetZero=0$  and  $searchSpaceZero=0$  (TS 38.213 [22], clause 13).

4.3.1.1.1.78 Reference test frequencies for NR operating band n78

Table 4.3.1.1.1.78-1: Test frequencies for NR operating band n78, SCS 15 kHz and  $\Delta F_{Raster}$  15 kHz

CBW [MHz]	carrierBandwidth [PRBs]	Range		Carrier centre [MHz]	Carrier centre [ARFCN]	point A [MHz]	absoluteFrequencyPointA [ARFCN]	offsetToCarrier [Carrier PRBs]	SS block SCS [kHz]	GS CN	absoluteFrequencySSB [ARFCN]	$k_{SSB}$	Offset Carrier CORESET#0 [RBs] Note 2	CORESET#0 Index (Offset [RBs]) Note 1	offsetToPointA (SIB1) [PRBs] Note 1
10	52	Downlink	Low	3305.01	620334	3300.33	620022	0	30	7711	620352	6	1	1 (6)	7

		&	Mi	3549	63666	3526	635130	102		788	636672	6	0	1 (6)	108
		Uplink	d	.99	6	.95				1					
			Hi	3795	65300	3699	646640	504		805	652992	4	3	0 (2)	509
			gh		0	.6				1					
15	79	Down link &	Lo	3307	62050	3300	620026	0	30	771	620352	2	1	1 (6)	7
			w	.5	0	.39				1					
			Mi	3549	63666	3524	634968	102		787	636480	0	2	0 (2)	106
			d	.99	6	.52				9					
		Uplink	Hi	3792	65283	3694	646310	504		804	652704	10	2	1 (6)	512
			gh	.48	2	.65				8					
20	106	Down link &	Lo	3310	62066	3300	620032	0	30	771	620352	8	0	1 (6)	6
			w	.02	8	.48				1					
			Mi	3549	63666	3522	634806	102		787	636384	6	3	1 (6)	111
			d	.99	6	.09				8					
		Uplink	Hi	3789	65266	3689	645982	504		804	652320	2	2	0 (2)	508
			gh	.99	6	.73				4					
25	133	Down link &	Lo	3312	62083	3300	620036	0	30	771	620352	4	0	1 (6)	6
			w	.51	4	.54				1					
			Mi	3549	63666	3519	634644	102		787	636192	0	1	1 (6)	109
			d	.99	6	.66				6					
		Uplink	Hi	3787	65250	3684	645654	504		804	652032	6	1	1 (6)	511
			gh	.5	0	.81				1					
30	160	Down link &	Lo	3315	62100	3300	620040	0	30	771	620352	0	0	1 (6)	6
			w		0	.6				1					
			Mi	3549	63666	3517	634482	102		787	636000	6	2	0 (2)	106
			d	.99	6	.23				4					
		Uplink	Hi	3784	65233	3679	645324	504		803	651648	0	1	0 (2)	507
			gh	.98	2	.86				7					
40	216	Down link &	Lo	3320	62133	3300	620038	0	30	771	620352	2	0	1 (6)	6
			w	.01	4	.57				1					
			Mi	3549	63666	3512	634146	102		787	635712	6	2	1 (6)	110
			d	.99	6	.19				1					
		Uplink	Hi	3780	65200	3669	644656	504		803	650976	8	0	0 (2)	506
			gh		0	.84				0					
50	270	Down link &	Lo	3325	62166	3300	620048	0	30	771	620352	4	3	0 (2)	5
			w	.02	8	.72				1					
			Mi	3549	63666	3507	633822	102		786	635328	6	1	0 (2)	105
			d	.99	6	.33				7					
		Uplink	Hi	3774	65166	3659	643998	504		802	650400	6	3	1 (6)	513
			gh	.99	6	.97				4					

Note 1: The CORESET#0 Index and the associated CORESET#0 Offset refers to Table 13-3 in TS 38.213 [22]. The value of CORESET#0 Index is signalled in controlResourceSetZero (pdccch-ConfigSIB1) in the MIB. The offsetToPointA IE is expressed in units of resource blocks assuming 15 kHz subcarrier spacing for FR1 and 60 kHz subcarrier spacing for FR2.

Note 2: The parameter Offset Carrier CORESET#0 specifies the offset from the lowest subcarrier of the carrier and the lowest subcarrier of CORESET#0. It corresponds to the parameter  $\Delta F_{\text{OffsetCORESET-0-Carrier}}$  in Annex C expressed in number of common RBs.

**Table 4.3.1.1.178-2: Test frequencies for NR operating band n78, SCS 30 kHz and  $\Delta F_{\text{Raster}}$  30 kHz**

CB W [MHz]	carrierBandwidth [PRBs]	Range		Carrier centre [MHz]	Carrier centre [ARFCN]	point A [MHz]	absoluteFrequencyPointA [ARFCN]	offsetToCarrier [Carrier PRBs]	SS block SCS [kHz]	GS CN	absoluteFrequencySSB [ARFCN]	$k_{SSB}$	Offset Carrier CORESET#0 [RBs] Note 2	CORESET#0 Index (Offset [RBs]) Note 1	offsetToPointA (SIB1) [PRBs] Note 1
10	24	Downlink &	Low	3305.01	620334	3300.69	620046	0	30	7711	620352	18	0	2 (2)	4
			Mid	3549.99	636666	3508.95	633930	102		7881	636672	6	0	2 (2)	208
		Uplink	High	3795	653000	3609.24	640616	504		8051	652992	16	0	1 (1)	1010
15	38	Downlink &	Low	3307.5	620500	3300.66	620044	0	30	7711	620352	20	0	2 (2)	4
			Mid	3549.99	636666	3506.43	633762	102		7879	636480	6	0	1 (1)	206
		Uplink	High	3792.48	652832	3604.2	640280	504		8048	652704	16	0	3 (3)	1014
20	51	Downlink &	Low	3310.02	620668	3300.84	620056	0	30	7711	620352	8	0	2 (2)	4
			Mid	3549.99	636666	3504.09	633606	102		7878	636384	18	0	3 (3)	210
		Uplink	High	3789.99	652666	3599.37	639958	504		8044	652320	2	0	1 (1)	1010
25	65	Downlink &	Low	3312.51	620834	3300.81	620054	0	30	7711	620352	10	0	2 (2)	4
			Mid	3549.99	636666	3501.57	633438	102		7876	636192	18	0	2 (2)	208
		Uplink	High	3787.5	652500	3594.36	639624	504		8041	652032	0	0	3 (3)	1014
30	78	Downlink	Low	3315	621000	3300.96	620064	0	30	7711	620352	0	0	2 (2)	4

		&	Mid	3549 .99	63666 6	3499 .23	633282	102		787 4	636000	6	0	1 (1)	206
		Uplink	High	3784 .98	65233 2	3589 .5	639300	504		803 7	651648	12	0	0 (0)	1008
40	106	Downlink &	Low	3320 .01	62133 4	3300 .93	620062	0	30	771 1	620352	2	0	2 (2)	4
		Uplink	Mid	3549 .99	63666 6	3494 .19	632946	102		787 1	635712	6	0	3 (3)	210
			High	3780	65200 0	3579 .48	638632	504		803 0	650976	8	0	0 (0)	1008
50	133	Downlink &	Low	3325 .02	62166 8	3301 .08	620072	0	30	771 1	620352	16	0	1 (1)	2
		Uplink	Mid	3549 .99	63666 6	3489 .33	632622	102		786 7	635328	18	0	0 (0)	204
			High	3774 .99	65166 6	3569 .61	637974	504		802 4	650400	18	0	3 (3)	1014
60	162	Downlink &	Low	3330	62200 0	3300 .84	620056	0	30	771 1	620352	8	0	2 (2)	4
		Uplink	Mid	3549 .99	63666 6	3484 .11	632274	102		786 4	635040	6	0	3 (3)	210
			High	3769 .98	65133 2	3559 .38	637292	504		801 6	649632	4	0	0 (0)	1008
70	189	Downlink &	Low	3335 .01	62233 4	3300 .99	620066	0	30	771 1	620352	22	0	1 (1)	2
		Uplink	Mid	3549 .99	63666 6	3479 .25	631950	102		786 0	634656	18	0	0 (0)	204
			High	3765	65100 0	3549 .54	636636	504		801 0	649056	12	0	3 (3)	1014
80	217	Downlink &	Low	3340 .02	62266 8	3300 .96	620064	0	30	771 1	620352	0	0	2 (2)	4
		Uplink	Mid	3549 .99	63666 6	3474 .21	631614	102		785 7	634368	18	0	2 (2)	208
			High	3759 .99	65066 6	3539 .49	635966	504		800 3	648384	10	0	3 (3)	1014
90	245	Downlink &	Low	3345	62300 0	3300 .9	620060	0	30	771 1	620352	4	0	2 (2)	4
		Uplink	Mid	3549 .99	63666 6	3469 .17	631278	102		785 3	633984	18	0	0 (0)	204
			High	3754 .98	65033 2	3529 .44	635296	504		799 6	647712	8	0	3 (3)	1014
100	273	Downlink	Low	3350 .01	62333 4	3300 .87	620058	0	30	771 1	620352	6	0	2 (2)	4



		&	Mid	3549.99	636666	3464.13	630942	102	7850	633696	18	0	2 (2)	208
	Uplink		High	3750	650000	3519.42	634628	504	7989	647040	4	0	3 (3)	1014

Note 1: The CORESET#0 Index and the associated CORESET#0 Offset refers to Table 13-4 in TS 38.213 [22]. The value of CORESET#0 Index is signalled in controlResourceSetZero (pdcch-ConfigSIB1) in the MIB. The offsetToPointA IE is expressed in units of resource blocks assuming 15 kHz subcarrier spacing for FR1 and 60 kHz subcarrier spacing for FR2.

Note 2: The parameter Offset Carrier CORESET#0 specifies the offset from the lowest subcarrier of the carrier and the lowest subcarrier of CORESET#0. It corresponds to the parameter  $\Delta F_{\text{OffsetCORESET-0-Carrier}}$  in Annex C expressed in number of common RBs.

**Table 4.3.1.1.1.78-3: Test frequencies for NR operating band n78, SCS 60 kHz and  $\Delta F_{\text{Raster}}$  30 kHz without CORESET#0.**

CBW [MHz]	carrierBand width [PRBs]	Range	Carrier centre [MHz]	Carrier centre [ARFCN]	point A [MHz]	absoluteFrequencyPointA [ARFCN]	offsetToCarrier [PRBs]	SS block SCS [kHz]	GSCN	absoluteFrequencySSB [ARFCN]	
10	11	Downlink & Uplink	Low	3305.01	620334	3301.05	620070	0	30	-	620310
			Mid	3549.99	636666	3472.59	631506	102		-	636642
			High	3795	653000	3428.16	628544	504		-	652976
15	18	Downlink & Uplink	Low	3307.5	620500	3301.02	620068	0	30	-	620308
			Mid	3549.99	636666	3470.07	631338	102		-	636474
			High	3792.48	652832	3423.12	628208	504		-	652640
20	24	Downlink & Uplink	Low	3310.02	620668	3301.38	620092	0	30	-	620332
			Mid	3549.99	636666	3467.91	631194	102		-	636330
			High	3789.99	652666	3418.47	627898	504		-	652330
25	31	Downlink & Uplink	Low	3312.51	620834	3301.35	620090	0	30	-	620330
			Mid	3549.99	636666	3465.39	631026	102		-	636162
			High	3787.5	652500	3413.46	627564	504		-	651996
30	38	Downlink & Uplink	Low	3315	621000	3301.32	620088	0	30	-	620328
			Mid	3549.99	636666	3462.87	630858	102		-	635994
			High	3784.98	652332	3408.42	627228	504		-	651660
40	51	Downlink & Uplink	Low	3320.01	621334	3301.65	620110	0	30	-	620350
			Mid	3549.99	636666	3458.19	630546	102		-	635682
			High	3780	652000	3398.76	626584	504		-	651016
50	65	Downlink & Uplink	Low	3325.02	621668	3301.62	620108	0	30	-	620348
			Mid	3549.99	636666	3453.15	630210	102		-	635346
			High	3774.99	651666	3388.71	625914	504		-	650346
60	79	Downlink & Uplink	Low	3330	622000	3301.56	620104	0	30	-	620344
			Mid	3549.99	636666	3448.11	629874	102		-	635010
			High	3769.98	651332	3378.66	625244	504		-	649676
70	93		Low	3335.01	622334	3301.53	620102	0	30	-	620342

		Downlink & Uplink	Mid	3549.99	636666	3443.07	629538	102			634674
			High	3765	651000	3368.64	624576	504			649008
80	107	Downlink & Uplink	Low	3340.02	622668	3301.5	620100	0	30	-	620340
			Mid	3549.99	636666	3438.03	629202	102		-	634338
			High	3759.99	650666	3358.59	623906	504		-	648338
90	121	Downlink & Uplink	Low	3345	623000	3301.44	620096	0	30	-	620336
			Mid	3549.99	636666	3432.99	628866	102		-	634002
			High	3754.98	650332	3348.54	623236	504		-	647668
100	135	Downlink & Uplink	Low	3350.01	623334	3301.41	620094	0	30	-	620334
			Mid	3549.99	636666	3427.95	628530	102		-	633666
			High	3750	650000	3338.52	622568	504		-	647000
Note: FR1 carrier without CORESET#0 is indicated in the MIB by setting $k_{SSB}=31$ , <i>controlResourceSetZero</i> =0 and <i>searchSpaceZero</i> = 0 (TS 38.213 [22], clause 13).											

4.3.1.1.1.79 Reference test frequencies for NR operating band n79

**Table 4.3.1.1.1.79-1: Test frequencies for NR operating band n79, SCS 15 kHz and  $\Delta F_{\text{Raster}}$  15 kHz**

CBW [MHz]	carrierBandwidth [PRBs]	Range		Carrier centre [MHz]	Carrier centre [ARFCN]	point A [MHz]	absoluteFrequencyPointA [ARFCN]	offsetToCarrier [Carrier PRBs]	SS block SCS [kHz]	GS CN	absoluteFrequencySSB [ARFCN]	$k_{SSB}$	Offset Carrier CORESET#0 [RBs] Note 2	CORESET#0 Index (Offset [RBs]) Note 1	offsetToPointA (SIB1) [PRBs] Note 1
10 <sup>3</sup>	52	Downlink & Uplink	Low	4405.02	693668	4400.34	693356	0	30	8475	693696	4	4	0 (4)	8
			Mid (Note 4)	4700.13	713342	4677.09	711806	102		8680	713376	10	4	0 (4)	110
		Uplink	High (Note 4)	4994.76	732984	4899.36	726624	504		8884	732960	0	0	0 (4)	508
20	106	Downlink	Low	4410	694000	4400.46	693364	0	30	8476	693792	8	11	0 (4)	15

		&	Mid	4699 .98	71333 2	4672 .08	711472	102		867 6	712992	8	0	0 (4)	106
		Uplink	High	4989 .99	73266 6	4889 .73	725982	504		887 8	732384	6	5	0 (4)	513
40	216	Downlink &	Low	4420 .02	69466 8	4400 .58	693372	0	30	848 0	694176	0	43	0 (4)	47
			Mid	4699 .98	71333 2	4662 .18	710812	102		867 2	712608	8	23	0 (4)	129
		Uplink	High	4980 0	73200 0	4869 .84	724656	504		886 4	731040	0	4	0 (4)	512
50	270	Downlink &	Low	4425 0	69500 0	4400 .7	693380	0	30	848 0	694176	4	42	0 (4)	46
			Mid	4699 .98	71333 2	4657 .32	710488	102		867 2	712608	8	50	0 (4)	156
		Uplink	High	4974 .99	73166 6	4859 .97	723998	504		886 4	731040	10	58	0 (4)	566
<p>Note 1: The CORESET#0 Index and the associated CORESET#0 Offset refers to Table 13-5 in TS 38.213 [22]. The value of CORESET#0 Index is signalled in controlResourceSetZero (pdcch-ConfigSIB1) in the MIB. The offsetToPointA IE is expressed in units of resource blocks assuming 15 kHz subcarrier spacing for FR1 and 60 kHz subcarrier spacing for FR2.</p> <p>Note 2: The parameter Offset Carrier CORESET#0 specifies the offset from the lowest subcarrier of the carrier and the lowest subcarrier of CORESET#0. It corresponds to the parameter <math>\Delta F_{\text{OffsetCORESET-0-Carrier}}</math> in Annex C expressed in number of common RBs.</p> <p>Note 3: The High range frequency can't cover the two RBs at the right edge of band due to the limit of GSCN range in TS 38.101-1 table 5.4.3.3-1.</p> <p>Note 4: This frequency is obtained applying certain exceptions over general rules defined in annex C.3.2.</p>															

Table 4.3.1.1.1.79-2: Test frequencies for NR operating band n79, SCS 30 kHz and  $\Delta F_{\text{Raster}}$  30 kHz

CBW [MHz]	carrierBandwidth [PRBs]	Range	Carrier centre [MHz]	Carrier centre [ARFCN]	point A [MHz]	absoluteFrequencyPointA [ARFCN]	offsetToCarrier [Carrier PRBs]	SS block SCS [kHz]	GS CN	absoluteFrequencySSB [ARFCN]	$k_{\text{SSB}}$	Offset Carrier CORESET#0 [RBs] Note 2	CORESET#0 Index (Offset [RBs]) Note 1	offsetToPointA (SIB1) [PRBs] Note 1	
10	24	Downlink	Low (Note 3)	4405 .83	69372 2	4401 .51	693434	0	30	847 5	693696	22	0	0 (0)	0
		&	Mid	4699 .92	71332 8	4658 .88	710592	102		867 9	713280	0	0	0 (0)	204

		Uplink	High	4995	733000	4809.24	720616	504		8884	732960	8	0	0 (0)	1008
20	51	Downlink	Low	4410	694000	4400.82	693388	0	30	8475	693696	20	2	0 (0)	4
		&	Mid	4700.01	713334	4654.11	710274	102		8676	712992	6	1	0 (0)	206
		Uplink	High	4989.99	732666	4799.37	719958	504		8878	732384	18	3	0 (0)	1014
40	106	Downlink	Low	4420.02	694668	4400.94	693396	0	30	8480	694176	12	18	1 (4)	44
		&	Mid	4700.01	713334	4644.21	709614	102		8672	712608	18	8	1 (4)	228
		Uplink	High	4980	732000	4779.48	718632	504		8864	731040	0	3	0 (0)	1014
50	133	Downlink	Low	4425	695000	4401.06	693404	0	30	8480	694176	4	18	1 (4)	44
		&	Mid	4700.01	713334	4639.35	709290	102		8672	712608	6	22	1 (4)	256
		Uplink	High	4974.99	731666	4769.61	717974	504		8864	731040	10	26	1 (4)	1068
60	162	Downlink	Low	4430.01	695334	4400.85	693390	0	30	8480	694176	18	18	1 (4)	44
		&	Mid	4700.01	713334	4634.13	708942	102		8672	712608	18	36	1 (4)	284
		Uplink	High	4969.98	731332	4759.38	717292	504		8864	731040	20	54	1 (4)	1124
80	217	Downlink	Low	4440	696000	4400.94	693396	0	30	8480	694176	12	18	1 (4)	44
		&	Mid	4700.01	713334	4624.23	708282	102		8656	711072	6	0	1 (4)	212
		Uplink	High	4959.99	730666	4739.49	715966	504		8848	729504	2	46	1 (4)	1108
100	273	Downlink	Low	4450.02	696668	4400.88	693392	0	30	8480	694176	16	18	1 (4)	44
		&	Mid	4700.01	713334	4614.15	707610	102		8656	711072	6	28	1 (4)	268
		Uplink	High	4950	730000	4719.42	714628	504		8832	727968	20	37	1 (4)	1090

Note 1: The CORESET#0 Index and the associated CORESET#0 Offset refers to Table 13-6 in TS 38.213 [22]. The value of CORESET#0 Index is signalled in controlResourceSetZero (pdccch-ConfigSIB1) in the MIB. The offsetToPointA IE is expressed in units of resource blocks assuming 15 kHz subcarrier spacing for FR1 and 60 kHz subcarrier spacing for FR2.

Note 2: The parameter Offset Carrier CORESET#0 specifies the offset from the lowest subcarrier of the carrier and the lowest subcarrier of CORESET#0. It corresponds to the parameter  $\Delta F_{\text{OffsetCORESET-0-Carrier}}$  in Annex C expressed in number of common RBs.

Note 3: This frequency is obtained applying certain exceptions over general rules defined in annex C.3.2.

**Table 4.3.1.1.1.79-3: Test frequencies for NR operating band n79, SCS 60 kHz and  $\Delta F_{\text{Raster}}$  30 kHz without CORESET#0.**

CBW [MHz]	carrierBand width [PRBs]	Range		Carrier centre [MHz]	Carrier centre [ARFCN]	point A [MHz]	absoluteFreq PointA [ARFCN]	offsetTo Carrier [PRBs]	SS block SCS [kHz]	GSCN	absolute FrequencySSB [ARFCN]
10	11	Downlink & Uplink	Low	4405.02	693668	4401.06	693404	0	30	-	693644
			Mid	4700.01	713334	4622.61	708174	102		-	713310
			High	4995	733000	4628.16	708544	504		-	732976
20	24	Downlink & Uplink	Low	4410	694000	4401.36	693424	0	30	-	693664
			Mid	4700.01	713334	4617.93	707862	102		-	712998
			High	4989.99	732666	4618.47	707898	504		-	732330
40	51	Downlink & Uplink	Low	4420.02	694668	4401.66	693444	0	30	-	693684
			Mid	4700.01	713334	4608.21	707214	102		-	712350
			High	4980	732000	4598.76	706584	504		-	731016
50	65	Downlink & Uplink	Low	4425	695000	4401.6	693440	0	30	-	693680
			Mid	4700.01	713334	4603.17	706878	102		-	712014
			High	4974.99	731666	4588.71	705914	504		-	730346
60	79	Downlink & Uplink	Low	4430.01	695334	4401.57	693438	0	30	-	693678
			Mid	4700.01	713334	4598.13	706542	102		-	711678
			High	4969.98	731332	4578.66	705244	504		-	729676
80	107	Downlink & Uplink	Low	4440	696000	4401.48	693432	0	30	-	693672
			Mid	4700.01	713334	4588.05	705870	102		-	711006
			High	4959.99	730666	4558.59	703906	504		-	728338
100	135	Downlink & Uplink	Low	4450.02	696668	4401.42	693428	0	30	-	693668
			Mid	4700.01	713334	4577.97	705198	102		-	710334
			High	4950	730000	4538.52	702568	504		-	727000

Note: FR1 carrier without CORESET#0 is indicated in the MIB by setting  $k_{\text{SSB}}=31$ ,  $\text{controlResourceSetZero}=0$  and  $\text{searchSpaceZero} = 0$  (TS 38.213 [22], clause 13).

## 4.3.1.1.1.80 Reference test frequencies for NR operating band n80 (SUL)

Table 4.3.1.1.1.80-1: Test frequencies for NR operating band n80 and SCS 15 kHz

Bandwidth [MHz]	carrierBand width [PRBs]	Range		Carrier centre [MHz]	Carrier centre [ARFCN]	point A [MHz]	absoluteFrequency PointA [ARFCN]	offsetTo Carrier [PRBs]
5	25	Uplink	Low	1712.5	342500	1710.25	342050	0
			Mid	1747.5	349500	1654.53	330906	504
			High	1782.5	356500	1779.17	355834	6
10	52	Uplink	Low	1715	343000	1710.32	342064	0
			Mid	1747.5	349500	1652.1	330420	504
			High	1780	356000	1774.24	354848	6
15	79	Uplink	Low	1717.5	343500	1710.39	342078	0
			Mid	1747.5	349500	1649.67	329934	504
			High	1777.5	355500	1769.31	353862	6
20	106	Uplink	Low	1720	344000	1710.46	342092	0
			Mid	1747.5	349500	1647.24	329448	504
			High	1775	355000	1764.38	352876	6
25	133	Uplink	Low	1722.5	344500	1710.53	342106	0
			Mid	1747.5	349500	1644.81	328962	504
			High	1772.5	354500	1759.45	351890	6
30	160	Uplink	Low	1725	345000	1710.6	342120	0
			Mid	1747.5	349500	1642.38	328476	504
			High	1770	354000	1754.52	350904	6

Table 4.3.1.1.1.80-2: Test frequencies for NR operating band n80 and SCS 30 kHz

Bandwidth [MHz]	carrierBand width [PRBs]	Range		Carrier centre [MHz]	Carrier centre [ARFCN]	point A [MHz]	absoluteFrequency PointA [ARFCN]	offsetTo Carrier [PRBs]
10	24	Uplink	Low	1715	343000	1710.68	342136	0
			Mid	1747.5	349500	1561.74	312348	504
			High	1780	356000	1773.52	354704	6
15	38	Uplink	Low	1717.5	343500	1710.66	342132	0
			Mid	1747.5	349500	1559.22	311844	504
			High	1777.5	355500	1768.5	353700	6
20	51	Uplink	Low	1720	344000	1710.82	342164	0
			Mid	1747.5	349500	1556.88	311376	504
			High	1775	355000	1763.66	352732	6
25	65	Uplink	Low	1722.5	344500	1710.8	342160	0
			Mid	1747.5	349500	1554.36	310872	504
			High	1772.5	354500	1758.64	351728	6
30	78	Uplink	Low	1725	345000	1710.96	342192	0
			Mid	1747.5	349500	1552.02	310404	504
			High	1770	354000	1753.8	350760	6

Table 4.3.1.1.1.80-3: Test frequencies for NR operating band n80 and SCS 60 kHz

Bandwidth [MHz]	carrierBand width [PRBs]	Range	Carrier centre [MHz]	Carrier centre [ARFCN]	point A [MHz]	absoluteFrequency PointA [ARFCN]	offsetTo Carrier [PRBs]	
10	11	Uplink	Low	1715	343000	1711.04	342208	0
			Mid	1747.5	349500	1380.66	276132	504
			High	1780	356000	1771.72	354344	6
15	18	Uplink	Low	1717.5	343500	1711.02	342204	0
			Mid	1747.5	349500	1378.14	275628	504
			High	1777.5	355500	1766.7	353340	6
20	24	Uplink	Low	1720	344000	1711.36	342272	0
			Mid	1747.5	349500	1375.98	275196	504
			High	1775	355000	1762.04	352408	6
25	31	Uplink	Low	1722.5	344500	1711.34	342268	0
			Mid	1747.5	349500	1373.46	274692	504
			High	1772.5	354500	1757.02	351404	6
30	38	Uplink	Low	1725	345000	1711.32	342264	0
			Mid	1747.5	349500	1370.94	274188	504
			High	1770	354000	1752	350400	6

## 4.3.1.1.1.81 Reference test frequencies for NR operating band n81 (SUL)

Table 4.3.1.1.1.81-1: Test frequencies for NR operating band n81 and SCS 15 kHz

Bandwidth [MHz]	carrierBand width [PRBs]	Range	Carrier centre [MHz]	Carrier centre [ARFCN]	point A [MHz]	absoluteFrequency PointA [ARFCN]	offsetTo Carrier [PRBs]	
5	25	Uplink	Low	882.5	176500	880.25	176050	0
			Mid	897.5	179500	804.53	160906	504
			High	912.5	182500	909.17	181834	6
10	52	Uplink	Low	885	177000	880.32	176064	0
			Mid	897.5	179500	802.1	160420	504
			High	910	182000	904.24	180848	6
15	79	Uplink	Low	887.5	177500	880.39	176078	0
			Mid	897.5	179500	799.67	159934	504
			High	907.5	181500	899.31	179862	6
20	106	Uplink	Low	890	178000	880.46	176092	0
			Mid	897.5	179500	797.24	159448	504
			High	905	181000	894.38	178876	6

Table 4.3.1.1.1.81-2: Test frequencies for NR operating band n81 and SCS 30 kHz

Bandwidth [MHz]	carrierBand width [PRBs]	Range	Carrier centre [MHz]	Carrier centre [ARFCN]	point A [MHz]	absoluteFrequency PointA [ARFCN]	offsetTo Carrier [PRBs]	
10	24	Uplink	Low	885	177000	880.68	176136	0
			Mid	897.5	179500	711.74	142348	504
			High	910	182000	903.52	180704	6
15	38	Uplink	Low	887.5	177500	880.66	176132	0
			Mid	897.5	179500	709.22	141844	504
			High	907.5	181500	898.5	179700	6
20	51	Uplink	Low	890	178000	880.82	176164	0
			Mid	897.5	179500	706.88	141376	504

			High	905	181000	893.66	178732	6
--	--	--	------	-----	--------	--------	--------	---

## 4.3.1.1.1.82 Reference test frequencies for NR operating band n82 (SUL)

Table 4.3.1.1.1.82-1: Test frequencies for NR operating band n82 and SCS 15 kHz

Bandwidth [MHz]	carrierBand width [PRBs]	Range		Carrier centre [MHz]	Carrier centre [ARFCN]	point A [MHz]	absoluteFrequency PointA [ARFCN]	offsetTo Carrier [PRBs]
5	25	Uplink	Low	834.5	166900	832.25	166450	0
			Mid	847	169400	754.03	150806	504
			High	859.5	171900	856.17	171234	6
10	52	Uplink	Low	837	167400	832.32	166464	0
			Mid	847	169400	751.6	150320	504
			High	857	171400	851.24	170248	6
15	79	Uplink	Low	839.5	167900	832.39	166478	0
			Mid	847	169400	749.17	149834	504
			High	854.5	170900	846.31	169262	6
20	106	Uplink	Low	842	168400	832.46	166492	0
			Mid	847	169400	746.74	149348	504
			High	852	170400	841.38	168276	6

Table 4.3.1.1.1.82-2: Test frequencies for NR operating band n82 and SCS 30 kHz

Bandwidth [MHz]	carrierBand width [PRBs]	Range		Carrier centre [MHz]	Carrier centre [ARFCN]	point A [MHz]	absoluteFrequency PointA [ARFCN]	offsetTo Carrier [PRBs]
10	24	Uplink	Low	837	167400	832.68	166536	0
			Mid	847	169400	661.24	132248	504
			High	857	171400	850.52	170104	6
15	38	Uplink	Low	839.5	167900	832.66	166532	0
			Mid	847	169400	658.72	131744	504
			High	854.5	170900	845.5	169100	6
20	51	Uplink	Low	842	168400	832.82	166564	0
			Mid	847	169400	656.38	131276	504
			High	852	170400	840.66	168132	6

## 4.3.1.1.1.83 Reference test frequencies for NR operating band n83 (SUL)

Table 4.3.1.1.1.83-1: Test frequencies for NR operating band n83 and SCS 15 kHz

Bandwidth [MHz]	carrierBand width [PRBs]	Range		Carrier centre [MHz]	Carrier centre [ARFCN]	point A [MHz]	absoluteFrequency PointA [ARFCN]	offsetTo Carrier [PRBs]
5	25	Uplink	Low	705.5	141100	703.25	140650	0
			Mid	725.5	145100	632.53	126506	504
			High	745.5	149100	742.17	148434	6
10	52	Uplink	Low	708	141600	703.32	140664	0
			Mid	725.5	145100	630.1	126020	504
			High	743	148600	737.24	147448	6
15	79	Uplink	Low	710.5	142100	703.39	140678	0
			Mid	725.5	145100	627.67	125534	504
			High	740.5	148100	732.31	146462	6



20	106	Uplink	Low	713	142600	703.46	140692	0
			Mid	725.5	145100	625.24	125048	504
			High	738	147600	727.3	145476	6
30	160	Uplink	Low	718	143600	703.6	140720	0
(Note 1)			High	733	146600	717.52	143504	6

Note 1: No carrier centre frequency specified for Mid Range and CBW=30 MHz due to Note 7 in TS 38.101-1 [7], Table 5.3.5-1

Table 4.3.1.1.1.83-2: Test frequencies for NR operating band n83 and SCS 30 kHz

Bandwidth [MHz]	carrierBand width [PRBs]	Range	Carrier centre [MHz]	Carrier centre [ARFCN]	point A [MHz]	absoluteFrequency PointA [ARFCN]	offsetTo Carrier [PRBs]	
10	24	Uplink	Low	708	141600	703.68	140736	0
			Mid	725.5	145100	539.7	107948	504
			High	743	148600	736.52	147304	6
15	38	Uplink	Low	710.5	142100	703.66	140732	0
			Mid	725.5	145100	537.22	107444	504
			High	740.5	148100	731.5	146300	6
20	51	Uplink	Low	713	142600	703.82	140764	0
			Mid	725.5	145100	534.88	106976	504
			High	738	147600	726.66	145332	6
30	78	Uplink	Low	718	143600	703.96	140792	0
(Note 2)			High	733	146600	716.8	143360	6

Note 2: No carrier centre frequency specified for Mid Range and CBW=30 MHz due to Note 7 in TS 38.101-1 [7], Table 5.3.5-1

## 4.3.1.1.1.84

Reference test frequencies for NR operating band n84 (SUL)

Table 4.3.1.1.1.84-1: Test frequencies for NR operating band n84 and SCS 15 kHz

Bandwidth [MHz]	carrierBand width [PRBs]	Range	Carrier centre [MHz]	Carrier centre [ARFCN]	point A [MHz]	absoluteFrequency PointA [ARFCN]	offsetTo Carrier [PRBs]	
5	25	Uplink	Low	1922.5	384500	1920.25	384050	0
			Mid	1950	390000	1857.03	371406	504
			High	1977.5	395500	1974.17	394834	6
10	52	Uplink	Low	1925	385000	1920.32	384064	0
			Mid	1950	390000	1854.6	370920	504
			High	1975	395000	1969.24	393848	6
15	79	Uplink	Low	1927.5	385500	1920.39	384078	0
			Mid	1950	390000	1852.17	370434	504
			High	1972.5	394500	1964.31	392862	6
20	106	Uplink	Low	1930	386000	1920.46	384092	0
			Mid	1950	390000	1849.74	369948	504
			High	1970	394000	1959.38	391876	6
25	133	Uplink	Low	1932.5	386500	1920.53	384106	0
			Mid	1950	390000	1847.31	369462	504
			High	1967.5	393500	1954.45	390890	6
30	160	Uplink	Low	1935	387000	1920.6	384120	0
			Mid	1950	390000	1844.88	368976	504
			High	1965	393000	1949.52	389904	6
40	216	Uplink	Low	1940	388000	1920.56	384112	0
			Mid	1950	390000	1839.84	367968	504
			High	1960	392000	1939.48	387896	6
50	270	Uplink	Low	1945	389000	1920.7	384140	0
			Mid	1950	390000	1834.98	366996	504

			High	1955	391000	1929.62	385924	6
--	--	--	------	------	--------	---------	--------	---

Table 4.3.1.1.1.84-2: Test frequencies for NR operating band n84 and SCS 30 kHz

Bandwidth [MHz]	carrierBand width [PRBs]	Range		Carrier centre [MHz]	Carrier centre [ARFCN]	point A [MHz]	absoluteFrequency PointA [ARFCN]	offsetTo Carrier [PRBs]
10	24	Uplink	Low	1925	385000	1920.68	384136	0
			Mid	1950	390000	1764.24	352848	504
			High	1975	395000	1968.52	393704	6
15	38	Uplink	Low	1927.5	385500	1920.66	384132	0
			Mid	1950	390000	1761.72	352344	504
			High	1972.5	394500	1963.5	392700	6
20	51	Uplink	Low	1930	386000	1920.82	384164	0
			Mid	1950	390000	1759.38	351876	504
			High	1970	394000	1958.66	391732	6
25	65	Uplink	Low	1932.5	386500	1920.8	384160	0
			Mid	1950	390000	1756.86	351372	504
			High	1967.5	393500	1953.64	390728	6
30	78	Uplink	Low	1935	387000	1920.96	384192	0
			Mid	1950	390000	1754.52	350904	504
			High	1965	393000	1948.8	389760	6
40	106	Uplink	Low	1940	388000	1920.92	384184	0
			Mid	1950	390000	1749.48	349896	504
			High	1960	392000	1938.76	387752	6
50	133	Uplink	Low	1945	389000	1921.06	384212	0
			Mid	1950	390000	1744.62	348924	504
			High	1955	391000	1928.9	385780	6

Table 4.3.1.1.1.84-3: Test frequencies for NR operating band n84 and SCS 60 kHz

Bandwidth [MHz]	carrierBand width [PRBs]	Range		Carrier centre [MHz]	Carrier centre [ARFCN]	point A [MHz]	absoluteFrequency PointA [ARFCN]	offsetTo Carrier [PRBs]
10	11	Uplink	Low	1925	385000	1921.04	384208	0
			Mid	1950	390000	1583.16	316632	504
			High	1975	395000	1966.72	393344	6
15	18	Uplink	Low	1927.5	385500	1921.02	384204	0
			Mid	1950	390000	1580.64	316128	504
			High	1972.5	394500	1961.7	392340	6
20	24	Uplink	Low	1930	386000	1921.36	384272	0
			Mid	1950	390000	1578.48	315696	504
			High	1970	394000	1957.04	391408	6
25	31	Uplink	Low	1932.5	386500	1921.34	384268	0
			Mid	1950	390000	1575.96	315192	504
			High	1967.5	393500	1952.02	390404	6
30	38	Uplink	Low	1935	387000	1921.32	384264	0
			Mid	1950	390000	1573.44	314688	504
			High	1965	393000	1947	389400	6
40	51	Uplink	Low	1940	388000	1921.64	384328	0
			Mid	1950	390000	1568.76	313752	504
			High	1960	392000	1937.32	387464	6
50	65	Uplink	Low	1945	389000	1921.6	384320	0
			Mid	1950	390000	1563.72	312744	504
			High	1955	391000	1927.28	385456	6

4.3.1.1.1.85 FFS

4.3.1.1.1.86 Reference test frequencies for NR operating band n86 (SUL)

Table 4.3.1.1.1.86-1: Test frequencies for NR operating band n86 and SCS 15 kHz

Bandwidth [MHz]	carrierBand width [PRBs]	Range		Carrier centre [MHz]	Carrier centre [ARFCN]	point A [MHz]	absoluteFrequency PointA [ARFCN]	offsetTo Carrier [PRBs]
5	25	Uplink	Low	1712.5	342500	1710.25	342050	0
			Mid	1745	349000	1652.03	330406	504
			High	1777.5	355500	1774.17	354834	6
10	52	Uplink	Low	1715	343000	1710.32	342064	0
			Mid	1745	349000	1649.6	329920	504
			High	1775	355000	1769.24	353848	6
15	79	Uplink	Low	1717.5	343500	1710.39	342078	0
			Mid	1745	349000	1647.17	329434	504
			High	1772.5	354500	1764.31	352862	6
20	106	Uplink	Low	1720	344000	1710.46	342092	0
			Mid	1745	349000	1644.74	328948	504
			High	1770	354000	1759.38	351876	6
40	216	Uplink	Low	1730	346000	1710.56	342112	0
			Mid	1745	349000	1634.84	326968	504
			High	1760	352000	1739.48	347896	6

Table 4.3.1.1.1.86-2: Test frequencies for NR operating band n86 and SCS 30 kHz

Bandwidth [MHz]	carrierBand width [PRBs]	Range		Carrier centre [MHz]	Carrier centre [ARFCN]	point A [MHz]	absoluteFrequency PointA [ARFCN]	offsetTo Carrier [PRBs]
10	24	Uplink	Low	1715	343000	1710.68	342136	0
			Mid	1745	349000	1559.24	311848	504
			High	1775	355000	1768.52	353704	6
15	38	Uplink	Low	1717.5	343500	1710.66	342132	0
			Mid	1745	349000	1556.72	311344	504
			High	1772.5	354500	1763.5	352700	6
20	51	Uplink	Low	1720	344000	1710.82	342164	0
			Mid	1745	349000	1554.38	310876	504
			High	1770	354000	1758.66	351732	6
40	106	Uplink	Low	1730	346000	1710.92	342184	0
			Mid	1745	349000	1544.48	308896	504
			High	1760	352000	1738.76	347752	6

Table 4.3.1.1.1.86-3: Test frequencies for NR operating band n86 and SCS 60 kHz

Bandwidth [MHz]	carrierBand width [PRBs]	Range		Carrier centre [MHz]	Carrier centre [ARFCN]	point A [MHz]	absoluteFrequency PointA [ARFCN]	offsetTo Carrier [PRBs]
10	11	Uplink	Low	1715	343000	1711.04	342208	0
			Mid	1745	349000	1378.16	275632	504
			High	1775	355000	1766.72	353344	6
15	18	Uplink	Low	1717.5	343500	1711.02	342204	0
			Mid	1745	349000	1375.64	275128	504
			High	1772.5	354500	1761.7	352340	6

20	24	Uplink	Low	1720	344000	1711.36	342272	0
			Mid	1745	349000	1373.48	274696	504
			High	1770	354000	1757.04	351408	6
40	51	Uplink	Low	1730	346000	1711.64	342328	0
			Mid	1745	349000	1363.76	272752	504
			High	1760	352000	1737.32	347464	0

4.3.1.1.1.87 to 4.3.1.1.1.90 FFS

4.3.1.1.1.91 Reference test frequencies for NR operating band n91

Table 4.3.1.1.1.91-1: Test frequencies for NR operating band n91 and SCS 15 kHz

C B W [ M H z]	carrie rBand width [PRB s]	Range		C a r r i e r c e n t r e [M H z]	C a r r i e r c e n t r e [A R F C N ]	p o i n t A [M H z]	a b s o l u t e F r e q u e n c y P o i n t A [ARFCN]	o f f s e t T o C a r r i e r [C a r r i e r P R B s]	S S B C C S [k H z]	G S C N	a b s o l u t e F r e q u e n c y SSB [ARFCN ]	$k_{SS}$	O f f s e t C a r r i e r C O R E S E T# 0 [R B s] N o t e 2	C O R E S E T# 0 I n d e x (O f f s e t [R B s]) N o t e 1	o f f s e t T o P o i n t A (SIB1 ) [PRB s] N o t e 1	
		Down lin k	Up lin k													
5	25	Down lin k	Low	14 29 .5	28 59 00	14 27 .2 5	285450	0	1 5	3 5 7 3	285870	8	1	0 (0)	1	
			Mid													
			High													
		Up lin k	Low	83 4. 5	16 69 00	83 2. 25	166450	0	-	-	-	-	-	-		
			Mid	84 7	16 94 00	75 4. 03	150806	504	-	-	-	-	-	-		
			High	85 9. 5	17 19 00	85 6. 17	171234	6	-	-	-	-	-	-		
1 0	52	Up lin k	Low	83 7	16 74 00	83 2. 32	166464	0	(N o t e 3)	-	-	-	-	-	-	
			Mid	84 7	16 94 00	75 1. 6	150320	504		-	-	-	-	-		
			High	85 7	17 14 00	85 1. 24	170248	6		-	-	-	-	-		
<p>Note 1: The CORESET#0 Index and the associated CORESET#0 Offset refers to Table 13-1 in TS 38.213 [22]. The value of CORESET#0 Index is signalled in controlResourceSetZero (pdcch-ConfigSIB1) in the MIB. The offsetToPointA IE is expressed in units of resource blocks assuming 15 kHz subcarrier spacing for FR1 and 60 kHz subcarrier spacing for FR2.</p> <p>Note 2: The parameter Offset Carrier CORESET#0 specifies the offset from the lowest subcarrier of the carrier and the lowest subcarrier of CORESET#0. It corresponds to the parameter <math>\Delta F_{\text{OffsetCORESET-0-Carrier}}</math> in Annex C expressed in number of common RBs.</p> <p>Note 3: This UE channel bandwidth is applicable only to uplink (TS 38.101-1 table 5.3.5-1).</p>																

4.3.1.1.1.92 Reference test frequencies for NR operating band n92

Table 4.3.1.1.1.92-1: Test frequencies for NR operating band n92 and SCS 15 kHz

C B W [ M H z]	carrie rBand width [PRB s]	Range		C a r r i e r c e n t r e [ M H z]	C a r r i e r c e n t r e [ A R F C N ]	p o i n t A [ M H z ]	absolute F r e q u e n c y P o i n t A [ A R F C N ]	offse tToC a r r i e r [ C a r r i e r P R B s ]	S S C N	G S C N	absolut eF r e q u e n c y S S B [ A R F C N ]	$k_s$	Offs et C a r r i e r C O R E S E T# 0 [ R B s ] N o t e 2	C O R E S E T# 0 I n d e x (O f f s e t [ R B s ] N o t e 1	offset T o P o i n t A ( S I B 1 ) [ P R B s ] N o t e 1	
		Do w n l i n k	U p l i n k													
5	25	Do w n l i n k	L o w	14 34 .5	28 69 00	14 32 .2 5	286450	0	(N o t e 3)	-	287170	-	-	-	-	
			M i d	14 74 .5	29 49 00	14 53 .8 9	290778	102		-	295170	-	-	-	-	
			H i g h	15 14 .5	30 29 00	14 21 .5 3	284306	504		-	303170	-	-	-	-	
		U p l i n k	L o w	83 4. 5	16 69 00	83 2. 25	166450	0		-	-	-	-	-	-	-
			M i d	84 7 00	16 94 00	75 4. 03	150806	504		-	-	-	-	-	-	-
			H i g h	85 9. 5	17 19 00	85 6. 17	171234	6		-	-	-	-	-	-	-
1 0	52	Do w n l i n k	L o w	14 37	28 74 00	14 32 .3 2	286464	0	3 0	3 5 9 1	287310	6	1	0 (2)	3	
			M i d	14 74 .5	29 49 00	14 51 .4 6	290292	102		3 6 8 7	294990	6	2	1 (6)	110	
			H i g h	15 12	30 24 00	14 16 .6	283320	504		3 7 8 0	302430	1 0	0	1 (6)	510	
		U p l i n k	L o w	83 7	16 74 00	83 2. 32	166464	0		-	-	-	-	-	-	-
			M i d	84 7	16 94 00	75 1. 6	150320	504		-	-	-	-	-	-	-
			H i g h	85 7	17 14 00	85 1. 24	170248	6		-	-	-	-	-	-	-
1 5	79	Do w n l i n k	L o w	14 39 .5	28 79 00	14 32 .3 9	286478	0	3 0	3 5 9 2	287330	8	1	0 (2)	3	

			M i d	14 74 .5	29 49 00	14 49 .0 3	289806	102		3 6 7 8	294270	0	0	0 (2)	104
			H i g h	15 09 .5	30 19 00	14 11 .6 7	282334	504		3 7 6 7	301450	0	1	1 (6)	511
		Up lin k	L o w	83 9. 5	16 79 00	83 2. 39	166478	0	-	-	-	-	-	-	-
			M i d	84 7	16 94 00	74 9. 17	149834	504		-	-	-	-	-	-
			H i g h	85 4. 5	17 09 00	84 6. 31	169262	6		-	-	-	-	-	-
2 0	106	Do wn lin k	L o w	14 42	28 84 00	14 32 .4 6	286492	0	3 0	3 5 9 0	287290	2	0	0 (2)	2
			M i d	14 74 .5	29 49 00	14 46 .6	289320	102		3 6 7 2	293790	2	0	0 (2)	104
			H i g h	15 07	30 14 00	14 06 .7 4	281348	504		3 7 5 4	300290	2	0	0 (2)	506
		Up lin k	L o w	84 2	16 84 00	83 2. 46	166492	0	-	-	-	-	-	-	-
			M i d	84 7	16 94 00	74 6. 74	149348	504		-	-	-	-	-	-
			H i g h	85 2	17 04 00	84 1. 38	168276	6		-	-	-	-	-	-
<p>Note 1: The CORESET#0 Index and the associated CORESET#0 Offset refers to Table 13-1 in TS 38.213 [22]. The value of CORESET#0 Index is signalled in controlResourceSetZero (pdcch-ConfigSIB1) in the MIB. The offsetToPointA IE is expressed in units of resource blocks assuming 15 kHz subcarrier spacing for FR1 and 60 kHz subcarrier spacing for FR2.</p> <p>Note 2: The parameter Offset Carrier CORESET#0 specifies the offset from the lowest subcarrier of the carrier and the lowest subcarrier of CORESET#0. It corresponds to the parameter <math>\Delta F_{\text{OffsetCORESET-0-Carrier}}</math> in Annex C expressed in number of common RBs.</p> <p>Note 3: No SS/PBCH block fits within the channel bandwidth. The channel bandwidth can only be used as SCell</p>															

Table 4.3.1.1.1.92-2: Test frequencies for NR operating band n92 and SCS 30 kHz

C B W [ M H z]	carrie rBand width [PRB s]	Range		C a r r i e r c e n t r e [ M H z]	C a r r i e r c e n t r e [ A R F C N ]	p o i n t A [ M H z ]	a b s o l u t e F r e q u e n c y P o i n t A [ A R F C N ]	o f f s e t T o C a r r i e r [ C a r r i e r P R B s ]	S S C S [ k H z ]	G S C N	a b s o l u t e F r e q u e n c y S S B [ A R F C N ]	$k_s$	O f f s e t C a r r i e r C O R E S E T # 0 [ R B s ] N o t e 2	C O R E S E T # 0 I n d e x (O f f s e t [ R B s ]) N o t e 1	o f f s e t P o i n t A ( S I B 1 ) [ P R B s ] N o t e 1	
		Do w n l i n k	U p l i n k													
1 0	24	Do w n l i n k	L o w	14 37	28 74 00	14 32 .3 2	286464	0	3 0	3 5 9 1	287310	6	1	0 (2)	3	
			M i d	14 74 .5	29 49 00	14 51 .4 6	290292	102			3 6 8 7	294990	6	2	1 (6)	110
			H i g h	15 12	30 24 00	14 16 .6	283320	504			3 7 8 0	302430	1 0	0	1 (6)	510
		U p l i n k	L o w	83 7	16 74 00	83 2. 68	166536	0	-	-	-	-	-	-	-	-
			M i d	84 7	16 94 00	66 1. 24	132248	504	-	-	-	-	-	-	-	-
			H i g h	85 7	17 14 00	85 0. 52	170104	6	-	-	-	-	-	-	-	-
1 5	38	Do w n l i n k	L o w	14 39 .5	28 79 00	14 32 .3 9	286478	0	3 0	3 5 9 2	287330	8	1	0 (2)	3	
			M i d	14 74 .5	29 49 00	14 49 .0 3	289806	102			3 6 7 8	294270	0	0	0 (2)	104
			H i g h	15 09 .5	30 19 00	14 11 .6 7	282334	504			3 7 6 7	301450	0	1	1 (6)	511
		U p l i n k	L o w	83 9. 5	16 79 00	83 2. 66	166532	0	-	-	-	-	-	-	-	
			M i d	84 7	16 94 00	65 8. 72	131744	504	-	-	-	-	-	-	-	
			H i g h	85 4. 5	17 09 00	84 5. 5	169100	6	-	-	-	-	-	-	-	
2 0	51	Do w n l i n k	L o w	14 42	28 84 00	14 32 .4 6	286492	0	3 0	3 5 9 0	287290	2	0	0 (2)	2	
			M i d	14 74 .5	29 49 00	14 46 .6	289320	102			3 6 7 2	293790	2	0	0 (2)	104

			H i g h	15 07	30 14 00	14 06 .7 4	281348	504		3 7 5 4	300290	2	0	0 (2)	506
		Up lin k	L o w	84 2	16 84 00	83 2. 82	166564	0	-	-	-	-	-	-	-
			M i d	84 7	16 94 00	65 6. 38	131276	504		-	-	-	-	-	-
			H i g h	85 2	17 04 00	84 0. 66	168132	6		-	-	-	-	-	-

Note 1: The CORESET#0 Index and the associated CORESET#0 Offset refers to Table 13-1 in TS 38.213 [22]. The value of CORESET#0 Index is signalled in controlResourceSetZero (pdcc-ConfigSIB1) in the MIB. The offsetToPointA IE is expressed in units of resource blocks assuming 15 kHz subcarrier spacing for FR1 and 60 kHz subcarrier spacing for FR2.

Note 2: The parameter Offset Carrier CORESET#0 specifies the offset from the lowest subcarrier of the carrier and the lowest subcarrier of CORESET#0. It corresponds to the parameter  $\Delta F_{\text{OffsetCORESET-0-Carrier}}$  in Annex C expressed in number of common RBs.

4.3.1.1.1.93 Reference test frequencies for NR operating band n93

Table 4.3.1.1.1.93-1: Test frequencies for NR operating band n93 and SCS 15 kHz

C B W [ M H z]	carrie rBand width [PRB s]	Range	C a r r i e r c e n t r e [M H z]	C a r r i e r c e n t r e [A R F C N ]	po int A [M H z]	absolute Frequen cyPointA [ARFCN]	offse tToC arrier [Car rier PRB s]	S S b l o c k S C S [k H z]	G S C N	absolut eFrequ encySSB [ARFCN ]	$k_{SSB}$	Offs et Car rier CO RES ET# 0 [RB s] Not e 2	CO RES ET# 0 Inde x (Off set [RB s]) Not e 1	offse tToP ointA (SIB1 ) [PRB s] Note 1		
5	25	Do wn lin k	L o w	14 29 .5	28 59 00	14 27 .2 5	285450	0	1 5	3 5 7 3	8	1	0 (0)	1		
			M i d													
			H i g h													
		Up lin k	L o w	88 2. 5	17 65 00	88 0. 25	176050	0	-	-	-	-	-	-	-	-
			M i d	89 7. 5	17 95 00	80 4. 53	160906	504	-	-	-	-	-	-	-	-
			H i g h	91 2. 5	18 25 00	90 9. 17	181834	6	-	-	-	-	-	-	-	-
1 0	52	Up lin k	L o w	88 5 00	17 70 00	88 0. 32	176064	0	( N o t e 3)	-	-	-	-	-	-	
			M i d	89 7. 5	17 95 00	80 2. 1	160420	504	-	-	-	-	-	-	-	



			H i g h	91 0	18 20 00	90 4. 24	180848	6		-	-	-	-	-	-
<p>Note 1: The CORESET#0 Index and the associated CORESET#0 Offset refers to Table 13-1 in TS 38.213 [22]. The value of CORESET#0 Index is signalled in controlResourceSetZero (pdcch-ConfigSIB1) in the MIB. The offsetToPointA IE is expressed in units of resource blocks assuming 15 kHz subcarrier spacing for FR1 and 60 kHz subcarrier spacing for FR2.</p> <p>Note 2: The parameter Offset Carrier CORESET#0 specifies the offset from the lowest subcarrier of the carrier and the lowest subcarrier of CORESET#0. It corresponds to the parameter <math>\Delta F_{\text{OffsetCORESET-0-Carrier}}</math> in Annex C expressed in number of common RBs.</p> <p>Note 3: This UE channel bandwidth is applicable only to uplink (TS 38.101-1 table 5.3.5-1).</p>															

4.3.1.1.1.94 Reference test frequencies for NR operating band n94

Table 4.3.1.1.1.94-1: Test frequencies for NR operating band n94 and SCS 15 kHz

C B W [ M H z]	carrie rBand width [PRB s]	Range	C a r r i e r c e n t r e [ M H z]	C a r r i e r c e n t r e [ A R F C N ]	po i n t A [ M H z ]	absolu teFrequ encyPointA [ARFCN]	offse tToC arrier [Carr ier PRB s]	S S b l o c k S C S [ k H z]	G S C N	absolu teFrequ encySSB [ARFCN ]	$k_s$	Offs et Carr ier CO RES ET# 0 [RB s] Not e 2	CO RES ET# 0 Inde x (Off set [RB s]) Not e 1	offse tToP ointA (SIB1 ) [PRB s] Note 1	
5	25	Do wn lin k	L o w	14 34 .5	28 69 00	14 32 .2 5	286450	0	(N ote 3)	-	287170	-	-	-	-
			M i d	14 74 .5	29 49 00	14 53 .8 9	290778	102		-	295170	-	-	-	-
			H i g h	15 14 .5	30 29 00	14 21 .5 3	284306	504		-	303170	-	-	-	-
		Up lin k	L o w	88 2. 5	17 65 00	88 0. 25	176050	0	-	-	-	-	-	-	-
			M i d	89 7. 5	17 95 00	80 4. 53	160906	504	-	-	-	-	-	-	-
			H i g h	91 2. 5	18 25 00	90 9. 17	181834	6	-	-	-	-	-	-	-
1 0	52	Do wn lin k	L o w	14 37	28 74 00	14 32 .3 2	286464	0	3 0	3 5 9 1	287310	6	1	0 (2)	3
			M i d	14 74 .5	29 49 00	14 51 .4 6	290292	102		3 6 8 7	294990	6	2	1 (6)	110
			H i g h	15 12	30 24 00	14 16 .6	283320	504		3 7 8 0	302430	1 0	0	1 (6)	510

		Up link	L o w	88 5	17 70 00	88 0. 32	176064	0	-	-	-	-	-	-	
			M i d	89 7. 5	17 95 00	80 2. 1	160420	504		-	-	-	-	-	
			H i g h	91 0	18 20 00	90 4. 24	180848	6		-	-	-	-	-	
1 5	79	Do wn link	L o w	14 39 .5	28 79 00	14 32 .3 9	286478	0	3 0	3 5 9 2	287330	8	1	0 (2)	3
			M i d	14 74 .5	29 49 00	14 49 .0 3	289806	102		3 6 7 8	294270	0	0	0 (2)	104
			H i g h	15 09 .5	30 19 00	14 11 .6 7	282334	504		3 7 6 7	301450	0	1	1 (6)	511
		Up link	L o w	88 7. 5	17 75 00	88 0. 39	176078	0	-	-	-	-	-	-	
			M i d	89 7. 5	17 95 00	79 9. 67	159934	504		-	-	-	-	-	
			H i g h	90 7. 5	18 15 00	89 9. 31	179862	6		-	-	-	-	-	
2 0	106	Do wn link	L o w	14 42	28 84 00	14 32 .4 6	286492	0	3 0	3 5 9 0	287290	2	0	0 (2)	2
			M i d	14 74 .5	29 49 00	14 46 .6	289320	102		3 6 7 2	293790	2	0	0 (2)	104
			H i g h	15 07	30 14 00	14 06 .7 4	281348	504		3 7 5 4	300290	2	0	0 (2)	506
		Up link	L o w	89 0	17 80 00	88 0. 46	176092	0	-	-	-	-	-	-	
			M i d	89 7. 5	17 95 00	79 7. 24	159448	504		-	-	-	-	-	
			H i g h	90 5	18 10 00	89 4. 38	178876	6		-	-	-	-	-	

Note 1: The CORESET#0 Index and the associated CORESET#0 Offset refers to Table 13-1 in TS 38.213 [22]. The value of CORESET#0 Index is signalled in controlResourceSetZero (pdccch-ConfigSIB1) in the MIB. The offsetToPointA IE is expressed in units of resource blocks assuming 15 kHz subcarrier spacing for FR1 and 60 kHz subcarrier spacing for FR2.

Note 2: The parameter Offset Carrier CORESET#0 specifies the offset from the lowest subcarrier of the carrier and the lowest subcarrier of CORESET#0. It corresponds to the parameter  $\Delta F_{\text{OffsetCORESET-0-Carrier}}$  in Annex C expressed in number of common RBs.

Note 3: No SS/PBCH block fits within the channel bandwidth. The channel bandwidth can only be used as SCell

Table 4.3.1.1.1.94-2: Test frequencies for NR operating band n94 and SCS 30 kHz

C B W [ M H z]	carrie rBand width [PRB s]	Range		C a r r i e r c e n t r e [M H z]	C a r r i e r c e n t r e [A R F C N ]	p o i n t A [M H z ]	a b s o l u t e F r e q u e n c y P o i n t A [ARFCN]	o f f s e t T o C a r r i e r [C a r r i e r P R B s]	S S b l o c k S C S [k H z]	G S C N	a b s o l u t e F r e q u e n c y S S B [ARFCN ]	$k_s$	O f f s e t C a r r i e r C O R E S E T# 0 [R B s] N o t e 2	C O R E S E T# 0 I n d e x (O f f s e t [R B s]) N o t e 1	o f f s e t P o i n t A (SIB1 ) [PRB s] N o t e 1	
		Do w n l i n k	U p l i n k													
1 0	24	Do w n l i n k	L o w	14 37	28 74 00	14 32 .3 2	286464	0	3 0	3 5 9 1	287310	6	1	0 (2)	3	
			M i d	14 74 .5	29 49 00	14 51 .4 6	290292	102			3 6 8 7	294990	6	2	1 (6)	110
			H i g h	15 12	30 24 00	14 16 .6	283320	504			3 7 8 0	302430	1 0	0	1 (6)	510
		U p l i n k	L o w	88 5	17 70 00	88 0. 68	176136	0	-	-	-	-	-	-	-	-
			M i d	89 7. 5	17 95 00	71 1. 74	142348	504	-	-	-	-	-	-	-	-
			H i g h	91 0	18 20 00	90 3. 52	180704	6	-	-	-	-	-	-	-	-
1 5	38	Do w n l i n k	L o w	14 39 .5	28 79 00	14 32 .3 9	286478	0	3 0	3 5 9 2	287330	8	1	0 (2)	3	
			M i d	14 74 .5	29 49 00	14 49 .0 3	289806	102			3 6 7 8	294270	0	0	0 (2)	104
			H i g h	15 09 .5	30 19 00	14 11 .6 7	282334	504			3 7 6 7	301450	0	1	1 (6)	511
		U p l i n k	L o w	88 7. 5	17 75 00	88 0. 66	176132	0	-	-	-	-	-	-	-	-
			M i d	89 7. 5	17 95 00	70 9. 22	141844	504	-	-	-	-	-	-	-	-
			H i g h	90 7. 5	18 15 00	89 8. 5	179700	6	-	-	-	-	-	-	-	-
2 0	51	Do w n l i n k	L o w	14 42	28 84 00	14 32 .4 6	286492	0	3 0	3 5 9 0	287290	2	0	0 (2)	2	
			M i d	14 74 .5	29 49 00	14 46 .6	289320	102			3 6 7 2	293790	2	0	0 (2)	104

		H i g h	15 07	30 14 00	14 06 .7 4	281348	504		3 7 5 4	300290	2	0	0 (2)	506
	U p l i n k	L o w	89 0	17 80 00	88 0. 82	176164	0	-	-	-	-	-	-	-
		M i d	89 7. 5	17 95 00	70 6. 88	141376	504		-	-	-	-	-	-
		H i g h	90 5	18 10 00	89 3. 66	178732	6		-	-	-	-	-	-
<p>Note 1: The CORESET#0 Index and the associated CORESET#0 Offset refers to Table 13-1 in TS 38.213 [22]. The value of CORESET#0 Index is signalled in controlResourceSetZero (pdcch-ConfigSIB1) in the MIB. The offsetToPointA IE is expressed in units of resource blocks assuming 15 kHz subcarrier spacing for FR1 and 60 kHz subcarrier spacing for FR2.</p> <p>Note 2: The parameter Offset Carrier CORESET#0 specifies the offset from the lowest subcarrier of the carrier and the lowest subcarrier of CORESET#0. It corresponds to the parameter <math>\Delta F_{\text{OffsetCORESET-0-Carrier}}</math> in Annex C expressed in number of common RBs.</p>														

## 4.3.1.1.1.95 Reference test frequencies for NR operating band n95 (SUL)

Table 4.3.1.1.1.95-1: Test frequencies for NR operating band n95 and SCS 15 kHz

CBW [MHz]	carrierBand width [PRBs]	Range		Carrier centre [MHz]	Carrier centre [ARFCN]	point A [MHz]	absoluteFrequency PointA [ARFCN]	offsetTo Carrier [PRBs]
5	25	Uplink	Low	2012.5	402500	2010.25	402050	0
			Mid	2017.5	403500	1924.53	384906	504
			High	2022.5	404500	2019.17	403834	6
10	52	Uplink	Low	2015	403000	2010.32	402064	0
			Mid	2017.5	403500	1922.1	384420	504
			High	2020	404000	2014.24	402848	6
15	79	Uplink	Low, Mid, High	2017.5	403500	2010.39	402078	0

Table 4.3.1.1.1.95-2: Test frequencies for NR operating band n95 and SCS 30 kHz

CBW [MHz]	carrierBand width [PRBs]	Range		Carrier centre [MHz]	Carrier centre [ARFCN]	point A [MHz]	absoluteFrequency PointA [ARFCN]	offsetTo Carrier [PRBs]
10	24	Uplink	Low	2015	403000	2010.68	402136	0
			Mid	2017.5	403500	1831.74	366348	504
			High	2020	404000	2013.52	402704	6
15	38	Uplink	Low, Mid, High	2017.5	403500	2010.66	402132	0

Table 4.3.1.1.1.95-3: Test frequencies for NR operating band n95 and SCS 60 kHz

CBW [MHz]	carrierBand width [PRBs]	Range		Carrier centre [MHz]	Carrier centre [ARFCN]	point A [MHz]	absoluteFrequency PointA	offsetTo Carrier [PRBs]

							[ARFCN]	
10	11	Uplink	Low	2015	403000	2011.04	402208	0
			Mid	2017.5	403500	1650.66	330132	504
			High	2020	404000	2011.72	402344	6
15	18	Uplink	Low, Mid, High	2017.5	403500	2011.02	402204	0

## 4.3.1.1.1.96 Reference test frequencies for NR operating band n96

Table 4.3.1.1.1.96-1: Test frequencies for NR operating band n96 and SCS 15 kHz (Note 3)

C B W [ M H z]	carri erBand width [PRB s]	Range		Carri er ce ntr e [M Hz ]	Carri er ce ntr e [A R F C N ] No te 4	po int A [M Hz ]	absol ute Frequ ency PointA [ARFCN]	offse tToC arrier [Carr ier PRB s]	S S B C o c k S C S [k H z]	G S C N	absol ute Frequ encySSB [ARFCN ]	$k_{SS}$	Offs et Carr ier CO RES ET# 0 [RB s] Not e 2	CO RES ET# 0 Inde x (Off set [RB s]) Not e 1	offse tToP ointA (SIB1 ) [PRB s] Note 1
		Down link & Up link	Low Mid High												
200	106	Down link & Up link	Low	59 55	79 70 00	59 45 .4 6	796364	0	30	-	796604	31	-	-	-
			Mid	65 35 .0 2	83 56 68	65 07 .1 2	833808	102	-	835272	31	-	-	-	
			High	71 14 .9 8	87 43 32	70 14 .7 2	867648	504	-	873936	31	-	-	-	
400	216	Down link & Up link	Low	59 65 .0 2	79 76 68	59 45 .5 8	796372	0	30	-	796612	31	-	-	-
			Mid	65 25	83 50 00	64 87 .2	832480	102	-	833944	31	-	-	-	
			High	70 84 .9 8	87 23 32	69 74 .8 2	864988	504	-	871276	31	-	-	-	
<p>Note 1: The CORESET#0 Index and the associated CORESET#0 Offset refers to Table 13-3 in TS 38.213 [22]. The value of CORESET#0 Index is signalled in controlResourceSetZero (pdcch-ConfigSIB1) in the MIB. The offsetToPointA IE is expressed in units of resource blocks assuming 15 kHz subcarrier spacing for FR1 and 60 kHz subcarrier spacing for FR2.</p> <p>Note 2: The parameter Offset Carrier CORESET#0 specifies the offset from the lowest subcarrier of the carrier and the lowest subcarrier of CORESET#0. It corresponds to the parameter <math>\Delta F_{\text{OffsetCORESET-0-Carrier}}</math> in Annex C expressed in number of common RBs.</p> <p>Note 3: NR band n46 with SCS =15 kHz is restricted for operation when carrier is configured as an SCell part of a DC or CA configuration. As the bandwidth is limited to SCell then absence of CORESET#0 is indicated in the MIB by setting <math>k_{SSB}=31</math>, <i>controlResourceSetZero=0</i> and <i>searchSpaceZero = 0</i> (TS 38.213 [22], clause 13).</p> <p>Note 4: The selection of Low, Mid and High test frequencies are restricted to the limited allowed ARFCN values as specified in TS 38.101 [7], Table 5.4.2.3-3.</p>															

Table 4.3.1.1.1.96-2: Test frequencies for NR operating band n96 and SCS 30 kHz

C B W [ M H z]	carrie rBand width [PRB s]	Range		Carri er cent re [M Hz ]	Carri er cent re [A R F C N ] No te 3	po int A [M Hz ]	absolute Frequ ency PointA [ARFCN]	offse tToC arrier [Carr ier PRB s]	S S B o c k S C S [k H z]	G S C N	absolut eFrequ encySSB [ARFCN ]	$k_{SSB}$	Offs et Carr ier CO RES ET# 0 [RB s] Not e 2	CO RES ET# 0 Index (Off set [RB s]) Not e 1	offse tToP ointA (SIB 1) [PRB s] Note 1
		Down link & Up link	Low & High												
20	51	Down link & Up link	Low	59 55	79 70 00	59 45 .8 2	796388	0	30	9548	796704	22	0	0 (0)	0
			Mid	65 35 .0 2	83 56 68	64 89 .1 2	832608	102		9951	835392	22	0	1 (0)	204
		High	71 14 .9 8	87 43 32	69 24 .3 6	861624	504	10353		873984	22	0	0 (0)	1008	
40	106	Down link & Up link	Low	59 65 .0 2	79 76 68	59 45 .9 4	796396	0	30	9548	796704	22	0	0 (0)	0
			Mid	65 25	83 50 00	64 69 .2	831280	102		9937	834048	22	0	0 (0)	204
		High	70 84 .9 8	87 23 32	68 84 .4 6	858964	504	10339		872640	22	40	3 (3)	1112	
60	162	Down link & Up link	Low	59 74 .9 8	79 83 32	59 45 .8 2	796388	0	30	9548	796704	22	0	0 (0)	0
			Mid	69 85 .0 2	86 56 68	69 19 .1 4	861276	102		10256	864672	22	16	3 (3)	260
		High	70 95	87 30 00	68 84 .4	858960	504	10325		871296	0	0	0 (0)	1008	
80	217	Down link & Up link	Low	59 85	79 90 00	59 45 .9 4	796396	0	30	9548	796704	22	0	0 (0)	0
			Mid	65 44 .9 8	83 63 32	64 69 .2	831280	102		9937	834048	22	0	0 (0)	204
		High	70 24	86 83 32	68 04	853632	504	1002		866016	22	0	0 (0)	1008	

	g	.9	.4		7				
	h	8	8		0				
Note 1:	The CORESET#0 Index and the associated CORESET#0 Offset refers to Table 13-4 in TS 38.213 [22]. The value of CORESET#0 Index is signalled in controlResourceSetZero (pdccch-ConfigSIB1) in the MIB. The offsetToPointA IE is expressed in units of resource blocks assuming 15 kHz subcarrier spacing for FR1 and 60 kHz subcarrier spacing for FR2.								
Note 2:	The parameter Offset Carrier CORESET#0 specifies the offset from the lowest subcarrier of the carrier and the lowest subcarrier of CORESET#0. It corresponds to the parameter $\Delta F_{\text{OffsetCORESET-0-Carrier}}$ in Annex C expressed in number of common RBs.								
Note 3:	The selection of Low, Mid and High test frequencies are restricted to the limited allowed ARFCN values as specified in TS 38.101 [7], Table 5.4.2.3-3.								

**Table 4.3.1.1.96-3: Test frequencies for NR operating band n96 and SCS 60 kHz without CORESET#0 (Note 1)**

CB W [MHz]	carrierBandwidth [PRBs]	Range	Carrier centre [MHz]	Carrier centre [ARFCN] Note 2	point A [MHz]	absoluteFrequencyPointA [ARFCN]	offsetTo Carrier [PRBs]	SS block SCS [kHz]	GS CN	absoluteFrequencySSB [ARFCN]	
20	24	Downlink & Uplink	Low	5955	797000	5946.36	796424	0	30	-	796664
			Mid	6535.02	835668	6452.94	830196	102		-	835332
		High	7114.98	874332	6743.46	849564	504	-		873996	
40	51	Downlink & Uplink	Low	5965.02	797668	5946.66	796444	0	30	-	796684
			Mid	6525	835000	6433.2	828880	102		-	834016
		High	7084.98	872332	6703.74	846916	504	-		871348	
60	79	Downlink & Uplink	Low	5974.98	798332	5946.54	796436	0	30	-	796676
			Mid	6985.02	865668	6883.14	858876	102		-	864012
		High	7095	873000	6703.68	846912	504	-		871344	
80	107	Downlink & Uplink	Low	5985	799000	5946.48	796432	0	30	-	796672
			Mid	6544.98	836332	6433.02	828868	102		-	834004
		High	7024.98	868332	6623.58	841572	504	-		866004	
Note 1:	FR1 carrier without CORESET#0 is indicated in the MIB by setting $k_{\text{SSB}}=31$ , $\text{controlResourceSetZero}=0$ and $\text{searchSpaceZero}=0$ (TS 38.213 [22], clause 13).										
Note 2:	The selection of Low, Mid and High test frequencies are restricted to the limited allowed ARFCN values as specified in TS 38.101 [7], Table 5.4.2.3-3.										

## 4.3.1.1.1.97

Reference test frequencies for NR operating band n97 (SUL)

**Table 4.3.1.1.1.97-1: Test frequencies for NR operating band n97 and SCS 15 kHz**

CBW [MHz]	carrierBandwidth	Range	Carrier centre [MHz]	Carrier centre [ARFCN]	point A [MHz]	absoluteFrequencyPoint	offsetTo Carrier
-----------	------------------	-------	----------------------	------------------------	---------------	------------------------	------------------

	[PRBs]						A [ARFCN]	[Carrier PRBs]
5	25	Uplink	Low	2302.5	460500	2300.25	460050	0
			Mid	2350	470000	2329.39	465878	102
			High	2397.5	479500	2304.53	460906	504
10	52	Uplink	Low	2305	461000	2300.32	460064	0
			Mid	2350	470000	2326.96	465392	102
			High	2395	479000	2299.6	459920	504
15	79	Uplink	Low	2307.5	461500	2300.39	460078	0
			Mid	2350	470000	2324.53	464906	102
			High	2392.5	478500	2294.67	458934	504
20	106	Uplink	Low	2310	462000	2300.46	460092	0
			Mid	2350	470000	2322.1	464420	102
			High	2390	478000	2289.74	457948	504
25	133	Uplink	Low	2312.5	462500	2300.53	460106	0
			Mid	2350	470000	2319.67	463934	102
			High	2387.5	477500	2284.81	456962	504
30	160	Uplink	Low	2315	463000	2300.6	460120	0
			Mid	2350	470000	2317.24	463448	102
			High	2385	477000	2279.88	455976	504
40	216	Uplink	Low	2320	464000	2300.56	460112	0
			Mid	2350	470000	2312.2	462440	102
			High	2380	476000	2269.84	453968	504
50	270	Uplink	Low	2325	465000	2300.7	460140	0
			Mid	2350	470000	2307.34	461468	102
			High	2375	475000	2259.98	451996	504

Table 4.3.1.1.1.97-2: Test frequencies for NR operating band n97 and SCS 30 kHz

CBW [MHz]	carrier Bandw idth [PRBs]	Range	Carrier centre [MHz]	Carrier centre [ARFCN]	point A [MHz]	absolute Frequen cyPoint A [ARFCN]	offsetTo Carrier [Carrier PRBs]	
10	24	Uplink	Low	2305	461000	2300.68	460136	0
			Mid	2350	470000	2308.96	461792	102
			High	2395	479000	2209.24	441848	504
15	38	Uplink	Low	2307.5	461500	2300.66	460132	0
			Mid	2350	470000	2306.44	461288	102
			High	2392.5	478500	2204.22	440844	504
20	51	Uplink	Low	2310	462000	2300.82	460164	0
			Mid	2350	470000	2304.1	460820	102
			High	2390	478000	2199.38	439876	504
25	65	Uplink	Low	2312.5	462500	2300.8	460160	0
			Mid	2350	470000	2301.58	460316	102
			High	2387.5	477500	2194.36	438872	504
30	78	Uplink	Low	2315	463000	2300.96	460192	0
			Mid	2350	470000	2299.24	459848	102
			High	2385	477000	2189.52	437904	504
40	106	Uplink	Low	2320	464000	2300.92	460184	0
			Mid	2350	470000	2294.2	458840	102
			High	2380	476000	2179.48	435896	504
50	133	Uplink	Low	2325	465000	2301.06	460212	0
			Mid	2350	470000	2289.34	457868	102
			High	2375	475000	2169.62	433924	504
60	162	Uplink	Low	2330	466000	2300.84	460168	0
			Mid	2350	470000	2284.12	456824	102
			High	2370	474000	2159.4	431880	504
70	189	Uplink	Low	2335	467000	2300.98	460196	0
			Mid	2350	470000	2279.26	455852	102
			High	2365	473000	2149.54	429908	504
80	217	Uplink	Low	2340	468000	2300.94	460188	0
			Mid	2350	470000	2274.22	454844	102



90	245	Uplink	High	2360	472000	2139.5	427900	504
			Low	2345	469000	2300.9	460180	0
			Mid	2350	470000	2269.18	453836	102
			High	2355	471000	2129.46	425892	504
100	273	Uplink	Low	2350	470000	2300.86	460172	0
			Mid	2350	470000	2264.14	452828	102
			High	2350	470000	2119.42	423884	504

Table 4.3.1.1.1.97-3: Test frequencies for NR operating band n97 and SCS 60 kHz

CBW [MHz]	carrierBand width [PRBs]	Range		Carrier centre [MHz]	Carrier centre [ARFCN]	point A [MHz]	absolute FrequencyPoint A [ARFCN]	offsetTo Carrier [PRBs]
10	11	Uplink	Low	2305	461000	2301.04	460208	0
			Mid	2350	470000	2272.6	454520	102
			High	2395	479000	2028.16	405632	504
15	18	Uplink	Low	2307.5	461500	2301.02	460204	0
			Mid	2350	470000	2270.08	454016	102
			High	2392.5	478500	2023.14	404628	504
20	24	Uplink	Low	2310	462000	2301.36	460272	0
			Mid	2350	470000	2267.92	453584	102
			High	2390	478000	2018.48	403696	504
25	31	Uplink	Low	2312.5	462500	2301.34	460268	0
			Mid	2350	470000	2265.4	453080	102
			High	2387.5	477500	2013.46	402692	504
30	38	Uplink	Low	2315	463000	2301.32	460264	0
			Mid	2350	470000	2262.88	452576	102
			High	2385	477000	2008.44	401688	504
40	51	Uplink	Low	2320	464000	2301.64	460328	0
			Mid	2350	470000	2258.2	451640	102
			High	2380	476000	1998.76	399752	504
50	65	Uplink	Low	2325	465000	2301.6	460320	0
			Mid	2350	470000	2253.16	450632	102
			High	2375	475000	1988.72	397744	504
60	79	Uplink	Low	2330	466000	2301.56	460312	0
			Mid	2350	470000	2248.12	449624	102
			High	2370	474000	1978.68	395736	504
70	93	Uplink	Low	2335	467000	2301.52	460304	0
			Mid	2350	470000	2243.08	448616	102
			High	2365	473000	1968.64	393728	504
80	107	Uplink	Low	2340	468000	2301.48	460296	0
			Mid	2350	470000	2238.04	447608	102
			High	2360	472000	1958.6	391720	504
90	121	Uplink	Low	2345	469000	2301.44	460288	0
			Mid	2350	470000	2233	446600	102
			High	2355	471000	1948.56	389712	504
100	135	Uplink	Low	2350	470000	2301.4	460280	0
			Mid	2350	470000	2227.96	445592	102
			High	2350	470000	1938.52	387704	504

4.3.1.1.1.98 FFS

4.3.1.1.1.99 Reference test frequencies for NR operating band n99 (SUL)

Table 4.3.1.1.1.99-1: Test frequencies for NR operating band n99 and SCS 15 kHz

UL CBW [MHz]	carrier Bandwidth [PRBs]	Range	Carrier centre [MHz]	Carrier centre [ARFCN]	point A [MHz]	absolute FrequencyPoint A [ARFCN]	offsetTo Carrier [Carrier PRBs]
--------------	--------------------------	-------	----------------------	------------------------	---------------	-----------------------------------	---------------------------------

5	25	Uplink	Low	1630.0	326000	1627.75	325550	0
			Mid	1635.0	327000	1542.03	308406	504
			High	1654.0	330800	1650.67	330134	6
10	52	Uplink	Low	1632.5	326500	1627.82	325564	0
			Mid					
			High	1651.5	330300	1645.74	329148	6

Table 4.3.1.1.1.99-2: Test frequencies for NR operating band n99 and SCS 30 kHz

UL CBW [MHz]	carrier Bandwidth [PRBs]	Range		Carrier centre [MHz]	Carrier centre [ARFCN]	point A [MHz]	absolute FrequencyPoint A [ARFCN]	offsetTo Carrier [Carrier PRBs]
10	24	Uplink	Low	1632.5	326500	1627.82	325564	0
			Mid					
			High	1651.5	330300	1645.02	329004	6

Table 4.3.1.1.1.99-3: Test frequencies for NR operating band n99 and SCS 60 kHz

UL CBW [MHz]	carrier Bandwidth [PRBs]	Range		Carrier centre [MHz]	Carrier centre [ARFCN]	point A [MHz]	absolute FrequencyPoint A [ARFCN]	offsetTo Carrier [Carrier PRBs]
10	11	Uplink	Low	1632.5	326500	1628.54	325708	0
			Mid					
			High	1651.5	330300	1643.22	328644	6

4.3.1.1.1.100 Reference test frequencies for NR operating band n100

Table 4.3.1.1.1.100-1: Test frequencies for NR operating band n100 and SCS 15 kHz

CBW [MHz]	carrier Bandwidth [PRBs]	Range		Carrier centre [MHz]	Carrier centre [ARFCN]	point A [MHz]	absolute FrequencyPoint A [ARFCN]	offsetToCarrier [Carrier PRBs]	SSB block SCS [kHz]	SSB C N	absolute FrequencySSB [ARFCN]	$k_{SS}$	Offset Carrier CORESET#0 [RBs] Note 2	CORESET#0 Index (Offset [RBs]) Note 1	offsetToPointA (SIB1) [PRBs] Note 1
5	25	Downlink	Low	92.19	184380	91.65	183930	0	15	2303	184330	0	0	0(0)	0
			Mid	92.22	184440	91.59	180318	102		2305	184370	0	0	0(0)	102
			High	92.25	184500	91.53	165906	504		2307	184590	0	0	0(0)	504
		Uplink	Low	87.69	175380	87.44	174930	0	-	-	-	-	-	-	-

					6 5										
		M i d	87 7. 2	17 54 40	7 8 4. 2 3	156846	504		-	-	-	-	-	-	-
		H i g h	87 7. 5	17 55 00	8 7 4. 1 7	174834	6		-	-	-	-	-	-	-
<p>Note 1: The CORESET#0 Index and the associated CORESET#0 Offset refers to Table 13-1 in TS 38.213 [22]. The value of CORESET#0 Index is signalled in controlResourceSetZero (pdcch-ConfigSIB1) in the MIB. The offsetToPointA IE is expressed in units of resource blocks assuming 15 kHz subcarrier spacing for FR1 and 60 kHz subcarrier spacing for FR2.</p> <p>Note 2: The parameter Offset Carrier CORESET#0 specifies the offset from the lowest subcarrier of the carrier and the lowest subcarrier of CORESET#0. It corresponds to the parameter <math>\Delta F_{\text{OffsetCORESET-0-Carrier}}</math> in Annex C expressed in number of common RBs.</p>															

4.3.1.1.1.101 Reference test frequencies for NR operating band n101

Table 4.3.1.1.1.101-1: Test frequencies for NR operating band n101 and SCS 15 kHz

C B W [ M H z]	carrie rBand width [PRB s]	Range	C a r r i e r c e n t r e [ M H z]	C a r r i e r c e n t r e [ A R F C N ]	po i n t A [ M H z ]	absol ute Frequ ency PointA [ARFCN]	offse tToC arrier [Carr ier PRB s]	S S b l o c k S C S [ k H z]	G S C N	absol uteFrequ encySSB [ARFCN ]	$k_{SSB}$	Offs et Carr ier CO RES ET# 0 [RB s] Not e 2	CO RES ET# 0 Inde x (Off set [RB s]) Not e 1	offse tToP ointA (SIB1 ) [PRB s] Note 1	
5	25	Do wn lin k & Up lin k	L o w	19 02 .5	38 05 00	19 00 .2 5	380050	0	1 5	4 7 5 4	380410	0	1	2 (4)	5
			M i d	19 05	38 10 00	18 84 .3 9	376878	102	4 7 6 1	380910	0	0	0 (0)	102	
			H i g h	19 07 .5	38 15 00	18 14 .5 3	362906	504	4 7 6 8	381410	4	1	1 (2)	507	
10	52	Do wn lin k & Up lin k	L o w	19 05	38 10 00	19 00 .3 2	380064	0	1 5	4 7 5 5	380430	2	1	2 (4)	5
			M i d												
			H i g h												
<p>Note 1: The CORESET#0 Index and the associated CORESET#0 Offset refers to Table 13-1 in TS 38.213 [22]. The value of CORESET#0 Index is signalled in controlResourceSetZero (pdcch-ConfigSIB1) in the MIB. The offsetToPointA IE is expressed in units of resource blocks assuming 15 kHz subcarrier spacing for FR1 and 60 kHz subcarrier spacing for FR2.</p> <p>Note 2: The parameter Offset Carrier CORESET#0 specifies the offset from the lowest subcarrier of the carrier and the lowest subcarrier of CORESET#0. It corresponds to the parameter <math>\Delta F_{\text{OffsetCORESET-0-Carrier}}</math> in Annex C expressed in number of common RBs.</p>															

Table 4.3.1.1.1.101-2: Test frequencies for NR operating band n101 and SCS 30 kHz

C B W [ M H z]	carrie rBand width [PRB s]	Range		C a r r i e r c e n t r e [M H z]	C a r r i e r c e n t r e [A R F C N ]	p o i n t A [M H z]	absolute F r e q u e n c y P o i n t A [ARFCN]	offse tToC arrier [Carr ier PRB s]	S S b l o c k S C S [k H z]	G S C N	absolut eF r e q u e n c y S S B [ARFCN ]	$k_{S\alpha}$	Offs et C a r r i e r C O R E S E T# 0 [RB s] Not e 2	C O R E S E T# 0 I n d e x (O f f s e t [RB s]) Not e 1	offse tToP o i n t A (SIB1 ) [PRB s] Note 1
		Do w n l i n k & U p l i n k	L o w M i d H i g h												
1 0	24	Do w n l i n k & U p l i n k	L o w M i d H i g h	19 05	38 10 00	19 00 ,6 8	380136	0	1 5	4 7 6 2	380930	6	0	3 (8)	16
<p>Note 1: The CORESET#0 Index and the associated CORESET#0 Offset refers to Table 13-2 in TS 38.213 [22]. The value of CORESET#0 Index is signalled in controlResourceSetZero (pdcch-ConfigSIB1) in the MIB. The offsetToPointA IE is expressed in units of resource blocks assuming 15 kHz subcarrier spacing for FR1 and 60 kHz subcarrier spacing for FR2.</p> <p>Note 2: The parameter Offset Carrier CORESET#0 specifies the offset from the lowest subcarrier of the carrier and the lowest subcarrier of CORESET#0. It corresponds to the parameter <math>\Delta F_{\text{OffsetCORESET-0-Carrier}}</math> in Annex C expressed in number of common RBs.</p>															

## 4.3.1.1.2 NR inter-band CA configurations in FR1

## 4.3.1.1.2.1 NR inter-band CA configurations in FR1 (two bands)

**Table 4.3.1.1.2.1-1: Inter-band NR CA configurations (FR1, two bands)**

NR CA configuration	Uplink NR CA configuration	NR CA downlink configuration band 1 (Note 3)	NR CA downlink configuration band 2	NR CA uplink configuration band 1	NR CA uplink configuration band 2	Applicable for protocol testing (Note 2)
CA_n1A-n3A	CA_n1A-n3A	n1A	n3A	n1A	n3A	Yes
CA_n1A-n8A	CA_n1A-n8A	n1A	n8A	n1A	n8A	Yes
CA_n1(2A)-n3A	-	CA_n1(2A)	n3A	n1A	n3A	No
CA_n1(2A)-n5A	-	CA_n1(2A)	n5A	-	-	No
CA_n1(2A)-n8A	-	CA_n1(2A)	n8A	-	-	No
CA_n1A-n77A	-	n1A	n77A	-	-	Yes
CA_n1A-n78A	CA_n1A-n78A	n1A	n78A	n1A	n78A	Yes
CA_n1A-n78(2A)	CA_n1A-n78A	n1A	CA_n78(2A)	n1A	n78A	No
CA_n1A-n78C	CA_n1A-n78A	n1A	CA_n78C	n1A	n78A	No
CA_n1(2A)-n78A	-	CA_n1(2A)	n78A	-	-	No
CA_n1A-n79A	CA_n1A-n79A	n1A	n79A	n1A	n79A	Yes
CA_n2A-n5A	CA_n2A-n5A	n2A	n5A	n2A	n5A	Yes
CA_n2A-n48A	CA_n2A-n48A	n2A	n48A	n2A	n48A	Yes
CA_n2A-n66A	CA_n2A-n66A	n2A	n66A	n2A	n66A	Yes
CA_n2A-n77A	CA_n2A-n77A	n2A	n77A	n2A	n77A	Yes
CA_n3A-n5A	CA_n3A-n5A	n3A	n5A	n3A	n5A	Yes
CA_n3(2A)-n5A	-	CA_n3(2A)	n5A	-	-	No
CA_n3A-n8A	CA_n3A-n8A	n3A	n8A	n3A	n8A	Yes
CA_n3(2A)-n8A	-	CA_n3(2A)	n8A	-	-	No
CA_n3A-n41A	CA_n3A-n41A	n3A	n41A	n3A	n41A	Yes
CA_n3A-n78A	CA_n3A-n78A	n3A	n78A	n3A	n78A	Yes
CA_n3A-n78(2A)	CA_n3A-n78A	n3A	CA_n78(2A)	n3A	n78A	No
	CA_n78(2A)	n3A	CA_n78(2A)	-	CA_n78(2A)	No
CA_n3(2A)-n78A	-	CA_n3(2A)	n78A	-	-	No
CA_n5A-n7A	-	n5A	n7A	-	-	Yes
CA_n5A-n48A	CA_n5A-n48A	n5A	n48A	n5A	n48A	Yes
CA_n5A-n66A	CA_n5A-n66A	n5A	n66A	n5A	n66A	Yes
CA_n5A-n77A	CA_n5A-n77A	n5A	n77A	n5A	n77A	Yes
CA_n5A-n78A	-	n5A	n78A	-	-	Yes
CA_n5A-n78(2A)	CA_n5A-n78A	n5A	CA_n78(2A)	n5A	n78A	No

NR CA configuration	Uplink NR CA configuration	NR CA downlink configuration band 1 (Note 3)	NR CA downlink configuration band 2	NR CA uplink configuration band 1	NR CA uplink configuration band 2	Applicable for protocol testing (Note 2)
CA_n7A-n78A	-	n7A	n78A	-	-	Yes
CA_n8A-n78A	CA_n8A-n78A	n8A	n78A	n8A	n78A	Yes
CA_n8A-n78(2A)	CA_n8A-n78A	n8A	CA_n78(2A)	n8A	CA_n78(2A)	No
CA_n24A-n41A	CA_n24A-n41A	n24A	n41A	n24A	n41A	Yes
CA_n24A-n41(2A)	CA_n24A-n41A	n24A	CA_n41(2A)	n24A	n41A	No
CA_n24A-n48A	CA_n24A-n48A	n24A	n48A	n24A	n48A	Yes
CA_n24A-n48B	CA_n24A-n48A	n24A	CA_n48B	n24A	n48A	No
CA_n24A-n48(2A)	CA_n24A-n48A	n24A	CA_n48(2A)	n24A	n48A	No
CA_n24A-n77A	CA_n24A-n77A	n24A	n77A	n24A	n77A	Yes
CA_n24A-n77C	CA_n24A-n77A	n24A	CA_n77C	n24A	n77A	No
CA_n26A-n66A	CA_n26A-n66A	n26A	n66A	n26A	n66A	Yes
CA_n26A-n66(2A)	CA_n26A-n66A	n26A	CA_n66(2A)	n26A	n66A	No
CA_n26A-n70A	CA_n26A-n70A	n26A	n70A	n26A	n70A	Yes
CA_n28A-n41A	CA_n28A-n41A	n28A	n41A	n28A	n41A	Yes
CA_n28A-n78A	CA_n28A-n78A	n28A	n78A	n28A	n78A	Yes
CA_n28A-n79A	CA_n28A-n79A	n28A	n79A	n28A	n79A	Yes
CA_n29A-n66A	-	n29A	n66A (Note 1)	-	-	Yes
CA_n29B-n66B	-	n29A	CA_n66B (Note 1)	-	-	No
CA_n29A-n66(2A)	-	n29A	CA_n66(2A) (Note 1)	-	-	No
CA_n29A-n70A	-	n29A	n70A (Note 1)	-	-	Yes
CA_n29A-n71A	-	n29A	n71A (Note 1)	-	-	Yes
CA_n39A-n41A	CA_n39A-n41A	n39A	n41A	n39A	n41A	Yes
CA_n41A-n66A	-	n41A	n66A	-	-	Yes
CA_n41A-n71A	-	n41A	n71A	-	-	Yes
CA_n41A-n79A	CA_n41A-n79A	n41A	n79A	n41A	n79A	Yes
CA_n41C-n79A	CA_n41A-n79A	CA_n41C	n79A	n41A	n79A	No
	CA_n41C	CA_n41C	n79A	CA_n41C	-	No
CA_n48A-n66A	CA_n48A-n66A	n48A	n66A	n48A	n66A	Yes
CA_n48A-n66(2A)	CA_n48A-n66A	n48A	CA_n66(2A)	n48A	n66A	No
CA_n48A-n70A	CA_n48A-n70A	n48A	n70A	n48A	n70A	Yes
CA_n48A-n71A	CA_n48A-n71A	n48A	n71A	n48A	n71A	Yes

NR CA configuration	Uplink NR CA configuration	NR CA downlink configuration band 1 (Note 3)	NR CA downlink configuration band 2	NR CA uplink configuration band 1	NR CA uplink configuration band 2	Applicable for protocol testing (Note 2)
CA_n48A-n71(2A)	CA_n48A-n71A	n48A	CA_n71(2A)	n48A	n71A	No
CA_n48A-n77A	-	n48A	n77A	-	-	Yes
CA_n48B-n66A	CA_n48A-n66A	CA_n48B	n66A	n48A	n66A	No
CA_n48B-n70A	CA_n48A-n70A	CA_n48B	n70A	n48A	n70A	No
CA_n48B-n71A	CA_n48A-n71A	CA_n48B	n71A	n48A	n71A	No
CA_n48(2A)-n66A	CA_n48A-n66A	CA_n48(2A)	n66A	n48A	n66A	No
CA_n48(2A)-n66(2A)	CA_n48A-n66A	CA_n48(2A)	CA_n66(2A)	n48A	n66A	No
CA_n48(2A)-n70A	CA_n48A-n70A	CA_n48(2A)	n70A	n48A	n70A	No
CA_n48(2A)-n71A	CA_n48A-n71A	CA_n48(2A)	n71A	n48A	n71A	No
CA_n48(2A)-n71(2A)	CA_n48A-n71A	CA_n48(2A)	CA_n71(2A)	n48A	n71A	No
CA_n66A-n70A	-	n66A	n70A	-	-	Yes
CA_n66B-n70A	-	CA_n66B	n70A	-	-	No
CA_n66(2A)-n70A	-	CA_n66(2A)	n70A	-	-	No
CA_n66A-n71A	CA_n66A-n71A	n66A	n71A	n66A	n71A	Yes
CA_n66A-n71(2A)	CA_n66A-n71A	n66A	CA_n71(2A)	n66A	n71A	No
CA_n66B-n71A	CA_n66A-n71A	CA_n66B	n71A	n66A	n71A	No
CA_n66(2A)-n71A	CA_n66A-n71A	CA_n66(2A)	n71A	n66A	n71A	No
CA_n66(2A)-n71(2A)	CA_n66A-n71A	CA_n66(2A)	CA_n71(2A)	n66A	n71A	No
CA_n66A-n77A	CA_n66A-n77A	n66A	n77A	n66A	n77A	Yes
CA_n70A-n71A	CA_n70A-n71A	n70A	n71A	n70A	n71A	Yes
CA_n70A-n71(2A)	CA_n70A-n71A	n70A	CA_n71(2A)	n70A	n71A	No
CA_n71A-n77A	CA_n71A-n77A	n71A	n77A	n71A	n77A	Yes
CA_n77A-n79A	-	n77A	n79A	-	-	Yes
CA_n78A-n79A	-	n78A	n79A	-	-	Yes

Note 1: This band is used as PCell.

Note 2: Protocol testing is limited to NR CA configurations with 2CC.

Note 3: PCell is configured on this band unless otherwise stated.

4.3.1.1.2.2 NR inter-band CA configurations in FR1 (three bands)

**Table 4.3.1.1.2.2-1: Inter-band NR CA configurations within FR1 (three bands)**

NR CA configuration (Note 3)	Uplink NR CA configuration	NR CA downlink configuration band 1 (Note 4)	NR CA downlink configuration band 2	NR CA downlink configuration band 3	NR CA uplink configuration on band 1	NR CA uplink configuration on band 2	NR CA uplink configuration on band 3	Applicable for protocol testing (Note 2)
CA_n2A-n5A-n77A	CA_n2A-n5A	n2A	n5A	n77A	n2A	n5A	-	No
	CA_n2A-n77A	n2A	n5A	n77A	n2A	n77A	-	No
	CA_n5A-n77A	n2A	n5A	n77A	n5A	n77A	-	No
CA_n2A-n66A-n77A	CA_n2A-n66A	n2A	n66A	n77A	n2A	n66A	-	No
	CA_n2A-n77A	n2A	n66A	n77A	n2A	n77A	-	No
	CA_n66A-n77A	n2A	n66A	n77A	n66A	n77A	-	No
CA_n5A-n66A-n77A	CA_n5A-n66A	n5A	n66A	n77A	n5A	n66A	-	No
	CA_n5A-n77A	n5A	n66A	n77A	n5A	n77A	-	No
	CA_n66A-n77A	n5A	n66A	n77A	n66A	n77A	-	No
CA_n26A-n66A-n70A	CA_n26A-n66A	n26A	n66A	n70A	n26A	n66A	-	No
	CA_n26A-n70A	n26A	n66A	n70A	n26A	-	n70A	No
CA_n26A-n66(2A)-n70A	CA_n26A-n66A	n26A	CA_n66(2A)	n70A	n26A	n66A	-	No
	CA_n26A-n70A	n26A	CA_n66(2A)	n70A	n26A	-	n70A	No
CA_n29A-n66A-n70A	-	n29A (Note1)	n66A	n70A	-	-	-	No
CA_n29A-n66B-n70A	-	n29A (Note1)	CA_n66B	n70A	-	-	-	No
CA_n29A-n66(2A)-n70A	-	n29A (Note1)	CA_n66(2A)	n70A	-	-	-	No
CA_n41A-n66A-n71A	-	n41A	n66A	n71A	-	-	-	No
CA_n48A-n66A-n70A	CA_n48A-n66A	n48A	n66A	n70A	n48A	n66A	-	No
	CA_n48A-n70A	n48A	n66A	n70A	n48A	-	n70A	No
CA_n48A-n66A-n71A	CA_n48A-n66A	n48A	n66A	n71A	n48A	n66A	-	No
	CA_n48A-n71A	n48A	n66A	n71A	n48A	-	n71A	No
	CA_n66A-n71A	n48A	n66A	n71A	-	n66A	n71A	No
CA_n48A-n66A-n71(2A)	CA_n48A-n66A	n48A	n66A	CA_n71(2A)	n48A	n66A	-	No



NR CA configuration (Note 3)	Uplink NR CA configuration	NR CA downlink configuration band 1 (Note 4)	NR CA downlink configuration band 2	NR CA downlink configuration band 3	NR CA uplink configuration on band 1	NR CA uplink configuration on band 2	NR CA uplink configuration on band 3	Applicable for protocol testing (Note 2)
	CA_n48A-n71A	n48A	n66A	CA_n71(2A)	n48A	-	n71A	No
	CA_n66A-n71A	n48A	n66A	CA_n71(2A)	-	n66A	n71A	No
CA_n48A-n66(2A)-n70A	CA_n48A-n66A	n48A	CA_n66(2A)	n70A	n48A	n66A	-	No
	CA_n48A-n70A	n48A	CA_n66(2A)	n70A	n48A	-	n70A	No
CA_n48A-n66(2A)-n71A	CA_n48A-n66A	n48A	CA_n66(2A)	n71A	n48A	n66A	-	No
	CA_n48A-n71A	n48A	CA_n66(2A)	n71A	n48A	-	n71A	No
	CA_n66A-n71A	n48A	CA_n66(2A)	n71A	-	n66A	n71A	No
CA_n48A-n70A-n71A	CA_n48A-n70A	n48A	n70A	n71A	n48A	n70A	-	No
	CA_n48A-n71A	n48A	n70A	n71A	n48A	-	n71A	No
	CA_n70A-n71A	n48A	n70A	n71A	-	n70A	n71A	No
CA_n48A-n70A-n71(2A)	CA_n48A-n70A	n48A	n70A	CA_n71(2A)	n48A	n70A	-	No
	CA_n48A-n71A	n48A	n70A	CA_n71(2A)	n48A	-	n71A	No
	CA_n70A-n71A	n48A	n70A	CA_n71(2A)	-	n70A	n71A	No
CA_n48B-n66A-n70A	CA_n48A-n66A	CA_n48B	n66A	n70A	n48A	n66A	-	No
	CA_n48A-n70A	CA_n48B	n66A	n70A	n48A	-	n70A	No
CA_n48B-n66A-n71A	CA_n48A-n66A	CA_n48B	n66A	n71A	n48A	n66A	-	No
	CA_n48A-n71A	CA_n48B	n66A	n71A	n48A	-	n71A	No
	CA_n66A-n71A	CA_n48B	n66A	n71A	-	n66A	n71A	No
CA_n48B-n70A-n71A	CA_n48A-n70A	CA_n48B	n70A	n71A	n48A	n70A	-	No
	CA_n48A-n71A	CA_n48B	n70A	n71A	n48A	-	n71A	No
	CA_n70A-n71A	CA_n48B	n70A	n71A	-	n70A	n71A	No
CA_n48(2A)-n66A-n70A	CA_n48A-n66A	CA_n48(2A)	n66A	n70A	n48A	n66A	-	No
	CA_n48A-n70A	CA_n48(2A)	n66A	n70A	n48A	-	n70A	No
CA_n48(2A)-n66A-n71A	CA_n48A-n66A	CA_n48(2A)	n66A	n71A	n48A	n66A	-	No
	CA_n48A-n71A	CA_n48(2A)	n66A	n71A	n48A	-	n71A	No
	CA_n66A-n71A	CA_n48(2A)	n66A	n71A	-	n66A	n71A	No

NR CA configuration (Note 3)	Uplink NR CA configuration	NR CA downlink configuration band 1 (Note 4)	NR CA downlink configuration band 2	NR CA downlink configuration band 3	NR CA uplink configuration on band 1	NR CA uplink configuration on band 2	NR CA uplink configuration on band 3	Applicable for protocol testing (Note 2)
CA_n48(2A)-n70A-n71A	CA_n48A-n70A	CA_n48(2A)	n70A	n71A	n48A	n70A	-	No
	CA_n48A-n71A	CA_n48(2A)	n70A	n71A	n48A	-	n71A	No
	CA_n70A-n71A	CA_n48(2A)	n70A	n71A	-	n70A	n71A	No
CA_n66A-n70A-n71A	CA_n66A-n71A	n66A	n70A	n71A	n66A	-	n71A	No
	CA_n70A-n71A	n66A	n70A	n71A	-	n70A	n71A	No
CA_n66A-n70A-n71(2A)	CA_n66A-n71A	n66A	n70A	CA_n71(2A)	n66A	-	n71A	No
	CA_n70A-n71A	n66A	n70A	CA_n71(2A)	-	n70A	n71A	No
CA_n66B-n70A-n71A	CA_n66A-n71A	CA_n66B	n70A	n71A	n66A	-	n71A	No
	CA_n70A-n71A	CA_n66B	n70A	n71A	-	n70A	n71A	No
CA_n66(2A)-n70A-n71A	CA_n66A-n71A	CA_n66(2A)	n70A	n71A	n66A	-	n71A	No
	CA_n70A-n71A	CA_n66(2A)	n70A	n71A	-	n70A	n71A	No

Note 1: This band cannot be used as PCell.  
 Note 2: Protocol testing is limited to NR CA configurations with 3CC.  
 Note 3: The band with the lowest UL frequency is used as PCell if nothing else is specified for in the table or in the test case for the specific configuration.  
 Note 4: PCell is configured on this band unless otherwise stated.

4.3.1.1.3 NR intra-band contiguous CA in FR1

4.3.1.1.3.1 – 4.3.1.1.3.39 FFS

4.3.1.1.3.40 NR Intra-band contiguous configurations CA\_n40

4.3.1.1.3.40.1 CA\_n40B

Editor's note: CA\_n40B Test frequencies are FFS.

Table 4.3.1.1.3.40.1-1: NR Intra-Band contiguous CA configuration CA\_n40B (PCC=CC1 and SCC=CC2), CC1 SCS = 15kHz, CC2 SCS = 15kHz

CBW combination	C C	CB W	SC S	carrierBandwidth [PRBs]	Range	Carrier	Carrier	point A	absoluteFrequencyPointA [ARFCN]	offsetTo Carrier	SS block	GS CN	absoluteFrequencySSB [ARFCN]	$k_{SSB}$	Offset carrier CORES	CORES ET#0	offsetTo PointA (SIB1)
-----------------	-----	------	------	-------------------------	-------	---------	---------	---------	---------------------------------	------------------	----------	-------	------------------------------	-----------	----------------------	------------	------------------------

[MHz]	No te 2	[M Hz]	[k Hz ]			cen tre [MH z] Not e 2	centr e [ARF CN]	[M Hz]		[Carrier PRBs]	SC S [k Hz]				ET#0 [RBs] Note 3	Index (Offset [RBs]) Note 4	[PRBs] Note 4

Table 4.3.1.1.3.40.1-2: NR Intra-Band contiguous CA configuration CA\_n40B (PCC=CC1 and SCC=CC2), CC1 SCS = 30kHz, CC2 SCS = 30kHz

CBW combin ation [MHz]	C C No te 2	CB W [M Hz]	SC S [k Hz ]	carrierBa ndwidth [PRBs]	Ra nge	Car rier cen tre [MH z] Not e 2	Carri er centr e [ARF CN]	poi nt A [M Hz]	absoluteFreque ncyPointA [ARFCN]	offsetTo Carrier [Carrier PRBs]	SS blo ck SC S [k Hz]	GS CN	absoluteFreq uencySSB [ARFCN]	$k_{SSB}$	Offset carrier CORES ET#0 [RBs] Note 3	CORES ET#0 Index (Offset [RBs]) Note 4	offsetTo PointA (SIB1) [PRBs] Note 4

4.3.1.1.3.41 NR Intra-band contiguous configurations CA\_n41

4.3.1.1.3.41.1 CA\_n41C

Editor's note: Test frequencies for CA\_n41C with mixed numerology with SCS CC1=15 kHz and SCS CC2=30 kHz or 60 kHz; and SCS CC1=30 kHz and SCS CC2= 30 kHz or 60kHz is FFS.

Table 4.3.1.1.3.41.1-1: NR Intra-Band contiguous CA configuration CA\_n41C (PCC=CC1 and SCC=CC2), CC1 SCS = 30kHz, CC2 SCS = 30 kHz

CBW combination	CCN of 2	CBW [MHz]	SCS [kHz]	carrierBandwidth [PRBs]	Range		Carrier centre [MHz] Note 2	Carrier centre [ARFCN]	point A [MHz]	absoluteFrequencyPointA [ARFCN]	offsetToCarrier [Carrier PRBs]	SSB block SCS [kHz]	GSCN	absoluteFrequencySSB [ARFCN]	$k_s$	carrier CORE SET#0 [RBs] Note 3	CORE SET#0 Index (Offset [RBs]) Note 4	offsetToPointA (SIB1) [PRBs] Note 4	
					Downlink	Uplink													
40+80	CC1	40	30	106	Downlink	Low	251.6.01	5032.02	249.6.93	499386	0	30	62.52	500190	4	0	1 (1)	2	
						&	Mid	255.3	5106.00	249.7.2	499440			102	63.45	507630	18	0	1 (1)
					Uplink	High	259.0.17	5180.34	238.9.65	477930	504			64.38	515070	20	0	1 (1)	1010
	Channel spacing CC1-CC2=59.82 MHz (Note 1)																		
	CC2	80	30	217	Downlink	Low	257.5.83	5151.66	253.6.77	507354	0	30	63.51	508110	12	0	0 (0)	0	
						&	Mid	261.2.82	5225.64	253.7.04	507408			102	64.44	515550	2	0	1 (1)
Uplink					High	264.9.99	5299.98	242.9.49	485898	504	65.37			522990	4	0	1 (1)	1010	
40+100	CC1	40	30	106	Downlink	Low	251.6.01	5032.02	249.6.93	499386	0	30	62.52	500190	4	0	1 (1)	2	
						&	Mid	254.3.01	5086.02	248.7.21	497442			102	63.21	505710	20	0	2 (2)

					Uplink	High	257 0.28	5140 56	236 9.76	473952	504		63 87	510990	10	0	0 (0)	1008
Channel spacing CC1-CC2=69.72 MHz (Note 1)																		
	CC2	10 0	30	273	Downlink	Low	258 5.73	5171 46	253 6.59	507318	0	30	63 51	508110	0	0	1 (1)	2
					&	Mid	261 2.73	5225 46	252 6.87	505374	102		64 20	513630	16	0	2 (2)	208
					Uplink	High	264 0	5280 00	240 9.42	481884	504		64 86	518910	6	0	0 (0)	1008
50+60	CC1	50	30	133	Downlink	Low	252 1.02	5042 04	249 7.08	499416	0	30	62 52	500190	18	0	0 (0)	0
					&	Mid	256 2.99	5125 98	250 2.33	500466	102		63 57	508590	20	0	0 (0)	204
					Uplink	High	260 5.02	5210 04	239 9.64	479928	504		64 62	516990	18	0	0 (0)	1008
Channel spacing CC1-CC2=54.96 MHz (Note 1)																		
	CC2	60	30	162	Downlink	Low	257 5.98	5151 96	254 6.82	509364	0	30	63 78	510270	14	0	2 (2)	4
					&	Mid	261 7.95	5235 90	255 2.07	510414	102		64 83	518670	16	0	2 (2)	208
					Uplink	High	265 9.98	5319 96	244 9.38	489876	504		65 88	527070	14	0	2 (2)	1012
50+80	CC1	50	30	133	Downlink	Low	252 1.02	5042 04	249 7.08	499416	0	30	62 52	500190	18	0	0 (0)	0
					&	Mid	255 3	5106 00	249 2.34	498468	102		63 33	506670	22	0	1 (1)	206
					Uplink	High	258 5.13	5170 26	237 9.75	475950	504		64 14	513150	16	0	2 (2)	1012
Channel spacing CC1-CC2=64.86 MHz (Note 1)																		
	CC2	80	30	217	Downlink	Low	258 5.88	5171 76	254 6.82	509364	0	30	63 78	510270	14	0	2 (2)	4
					&	Mid	261 7.86	5235 72	254 2.08	508416	102		64 56	516510	10	0	0 (0)	204
					Uplink	High	264 9.99	5299 98	242 9.49	485898	504		65 37	522990	4	0	1 (1)	1010

50+100	CC1	50	30	133	Downlink	Low	252 1.02	5042 04	249 7.08	499416	0	30	62 52	500190	18	0	0 (0)	0	
					&	Mid	254 3.01	5086 02	248 2.35	496470	102		63 09	504750	0	0	3 (3)	210	
					Uplink	High	256 5.24	5130 48	235 9.86	471972	504		63 63	509070	6	0	1 (1)	1010	
	Channel spacing CC1-CC2=74.76 MHz (Note 1)																		
	CC2	100	30	273	Downlink	Low	259 5.78	5191 56	254 6.64	509328	0	30	63 78	510270	2	0	3(3)	6	
					&	Mid	261 7.77	5235 54	253 1.91	506382	102		64 32	514590	0	0	2(2)	208	
					Uplink	High	264 0	5280 00	240 9.42	481884	504		64 86	518910	6	0	0(0)	1008	
	60+50	CC1	60	30	162	Downlink	Low	252 6	5052 00	249 6.84	499368	0	30	62 52	500190	10	0	1 (1)	2
						&	Mid	256 8	5136 00	250 2.12	500424	102		63 57	508590	10	0	1 (1)	206
						Uplink	High	261 0.03	5220 06	239 9.43	479886	504		64 62	516990	8	0	1 (1)	1010
Channel spacing CC1-CC2=54.96 MHz (Note 1)																			
CC2		50	30	133	Downlink	Low	258 0.96	5161 92	255 7.02	511404	0	30	64 02	512190	22	0	0 (0)	0	
					&	Mid	262 2.96	5245 92	256 2.3	512460	102		65 07	520590	22	0	0 (0)	204	
					Uplink	High	266 4.99	5329 98	245 9.61	491922	504		66 12	528990	20	0	0 (0)	1008	
60+60		CC1	60	30	162	Downlink	Low	252 6	5052 00	249 6.84	499368	0	30	62 52	500190	10	0	1 (1)	2
						&	Mid	256 2.99	5125 98	249 7.11	499422	102		63 45	507630	0	0	2 (2)	208
						Uplink	High	259 9.98	5199 96	238 9.38	477876	504		64 38	515070	14	0	2 (2)	1012
	Channel spacing CC1-CC2=60 MHz (Note 1)																		
	CC2	60	30	162	Downlink	Low	258 6	5172 00	255 6.84	511368	0	30	64 02	512190	10	0	1 (1)	2	

60+80	C C 1	60	30	162	&	Mid	262 2.99	5245 98	255 7.11	511422	102	30	64 95	519630	0	0	2 (2)	208						
					Uplink	High	265 9.98	5319 96	244 9.38	489876	504		65 88	527070	14	0	2 (2)	1012						
					Downlink	Low	252 6	5052 00	249 6.84	499368	0		62 52	500190	10	0	1 (1)	2						
					&	Mid	255 3	5106 00	248 7.12	497424	102		63 21	505710	2	0	3 (3)	210						
					Uplink	High	258 0.09	5160 18	236 9.49	473898	504		63 87	510990	4	0	1 (1)	1010						
	Channel spacing CC1-CC2=69.9 MHz (Note 1)																							
	C C 2	80	30	217	Downlink	Low	259 5.9	5191 80	255 6.84	511368	0	30	64 02	512190	10	0	1 (1)	2						
					&	Mid	262 2.9	5245 80	254 7.12	509424	102		64 71	517710	2	0	3 (3)	210						
					Uplink	High	264 9.99	5299 98	242 9.49	485898	504		65 37	522990	4	0	1 (1)	1010						
	60+10 0	C C 1	60	30	162	Downlink	Low	252 6	5052 00	249 6.84	499368	0	30	62 52	500190	10	0	1 (1)	2					
&						Mid	254 3.01	5086 02	247 7.13	495426	102	62 94		503550	20	0	0 (0)	204						
Uplink						High	256 0.2	5120 40	234 9.6	469920	504	63 39		507150	2	0	3 (3)	1014						
Channel spacing CC1-CC2=79.8 MHz (Note 1)																								
C C 2						10 0	30	273	Downlink	Low	260 5.8	5211 60		255 6.66	511332	0	30	64 02	512190	22	0	1 (1)	2	
		&	Mid	262 2.81	5245 62				253 6.95	507390	102	64 44	515550	8	0	1 (1)		206						
		Uplink	High	264 0	5280 00				240 9.42	481884	504	64 86	518910	6	0	0 (0)		1008						
80+40		C C 1	80	30	217	Downlink	Low	253 6.02	5072 04	249 6.96	499392	0	30	62 52	500190	2	0	1 (1)	2					
						&	Mid	257 3.01	5146 02	249 7.23	499446	102		63 45	507630	16	0	1 (1)	206					
						Uplink	High	261 0.18	5220 36	238 9.68	477936	504		64 38	515070	18	0	1 (1)	1010					
	Channel spacing CC1-CC2=59.82 MHz (Note 1)																							

	C C 2	40	30	106	Downlink & Uplink	Low	259 5.84	5191 68	257 6.76	515352	0	30	64 53	516270	18	0	2 (2)	4
						Mid	263 2.83	5265 66	257 7.03	515406	102		65 43	523470	0	0	0 (0)	204
						High	267 0	5340 00	246 9.48	493896	504		66 36	530910	2	0	0 (0)	1008
80+50	C C 1	80	30	217	Downlink & Uplink	Low	253 6.02	5072 04	249 6.96	499392	0	30	62 52	500190	2	0	1 (1)	2
						Mid	256 8	5136 00	249 2.22	498444	102		63 33	506670	6	0	2 (2)	208
						High	260 0.13	5200 26	237 9.63	475926	504		64 14	513150	0	0	3 (3)	1014
Channel spacing CC1-CC2=64.86 MHz (Note 1)																		
	C C 2	50	30	133	Downlink & Uplink	Low	260 0.88	5201 76	257 6.94	515388	0	30	64 53	516270	6	0	2 (2)	4
						Mid	263 2.86	5265 72	257 2.2	514440	102		65 31	522510	2	0	0 (0)	204
						High	266 4.99	5329 98	245 9.61	491922	504		66 12	528990	20	0	0 (0)	1008
80+60	C C 1	80	30	217	Downlink & Uplink	Low	253 6.02	5072 04	249 6.96	499392	0	30	62 52	500190	2	0	1 (1)	2
						Mid	256 2.99	5125 98	248 7.21	497442	102		63 21	505710	20	0	2 (2)	208
						High	259 0.08	5180 16	236 9.58	473916	504		63 87	510990	22	0	0 (0)	1008
Channel spacing CC1-CC2=69.9 MHz (Note 1)																		
	C C 2	60	30	162	Downlink & Uplink	Low	260 5.92	5211 84	257 6.76	515352	0	30	64 53	516270	18	0	2 (2)	4
						Mid	263 2.89	5265 78	256 7.01	513402	102		65 19	521550	4	0	1 (1)	206
						High	265 9.98	5319 96	244 9.38	489876	504		65 88	527070	14	0	2 (2)	1012
80+80	C C 1	80	30	217	Downlink &	Low	253 6.02	5072 04	249 6.96	499392	0	30	62 52	500190	2	0	1 (1)	2
						Mid	255 3	5106 00	247 7.22	495444	102		62 94	503550	14	0	0 (0)	204



					Uplink	High	257 0.01	5140 02	234 9.51	469902	504		63 36	506910	0	0	0 (0)	1008
Channel spacing CC1-CC2=79.98 MHz (Note 1)																		
	CC2	80	30	217	Downlink	Low	261 6	5232 00	257 6.94	515388	0	30	64 53	516270	6	0	2 (2)	4
					&	Mid	263 2.98	5265 96	255 7.2	511440	102		64 95	519630	18	0	1 (1)	206
					Uplink	High	264 9.99	5299 98	242 9.49	485898	504		65 37	522990	4	0	1 (1)	1010
80+100	CC1	80	30	217	Downlink	Low	253 6.02	5072 04	249 6.96	499392	0	30	62 52	500190	2	0	1 (1)	2
					&	Mid	254 3.01	5086 02	246 7.23	493446	102		62 70	501630	16	0	1 (1)	206
					Uplink	High	255 0.12	5100 24	232 9.62	465924	504		62 88	503070	22	0	1 (1)	1010
Channel spacing CC1-CC2=89.88 MHz (Note 1)																		
	CC2	100	30	273	Downlink	Low	262 5.9	5251 80	257 6.76	515352	0	30	64 53	516270	18	0	2 (2)	4
					&	Mid	263 2.89	5265 78	254 7.03	509406	102		64 68	517470	0	0	0 (0)	204
					Uplink	High	264 0	5280 00	240 9.42	481884	504		64 86	518910	6	0	0 (0)	1008
100+40	CC1	100	30	273	Downlink	Low	254 6.01	5092 02	249 6.87	499374	0	30	62 52	500190	8	0	1 (1)	2
					&	Mid	257 3.01	5146 02	248 7.15	497430	102		63 21	505710	0	0	3 (3)	210
					Uplink	High	260 0.28	5200 56	236 9.7	473940	504		63 87	510990	14	0	0 (0)	1008
Channel spacing CC1-CC2=69.72 MHz (Note 1)																		
	CC2	40	30	106	Downlink	Low	261 5.73	5231 46	259 6.65	519330	0	30	65 01	520110	20	0	0 (0)	0
					&	Mid	264 2.73	5285 46	258 6.93	517386	102		65 70	525630	12	0	2 (2)	208
					Uplink	High	267 0	5340 00	246 9.48	493896	504		66 36	530910	2	0	0 (0)	1008

100+50	CC1	100	30	273	Downlink	Low	254 6.01	5092 02	249 6.87	499374	0	30	62 52	500190	8	0	1 (1)	2	
					&	Mid	256 8	5136 00	248 2.14	496428	102		63 06	504510	6	0	0 (0)	204	
					Uplink	High	259 0.23	5180 46	235 9.65	471930	504		63 63	509070	20	0	1 (1)	1010	
	Channel spacing CC1-CC2=74.76 MHz (Note 1)																		
	CC2	50	30	133	Downlink	Low	262 0.77	5241 54	259 6.83	519366	0	30	65 01	520110	8	0	0 (0)	0	
					&	Mid	264 2.76	5285 52	258 2.1	516420	102		65 58	524670	14	0	2 (2)	208	
					Uplink	High	266 4.99	5329 98	245 9.61	491922	504		66 12	528990	20	0	0 (0)	1008	
	100+60	CC1	100	30	273	Downlink	Low	254 6.01	5092 02	249 6.87	499374	0	30	62 52	500190	8	0	1 (1)	2
						&	Mid	256 2.99	5125 98	247 7.13	495426	102		62 94	503550	20	0	0 (0)	204
						Uplink	High	258 0.18	5160 36	234 9.6	469920	504		63 39	507150	2	0	3 (3)	1014
Channel spacing CC1-CC2=79.8 MHz (Note 1)																			
CC2		60	30	162	Downlink	Low	262 5.81	5251 62	259 6.65	519330	0	30	65 01	520110	20	0	0 (0)	0	
					&	Mid	264 2.79	5285 58	257 6.91	515382	102		65 43	523470	8	0	0 (0)	204	
					Uplink	High	265 9.98	5319 96	244 9.38	489876	504		65 88	527070	14	0	2 (2)	1012	
100+80		CC1	100	30	273	Downlink	Low	254 6.01	5092 02	249 6.87	499374	0	30	62 52	500190	8	0	1 (1)	2
						&	Mid	255 3	5106 00	246 7.14	493428	102		62 70	501630	22	0	1 (1)	206
						Uplink	High	256 0.11	5120 22	232 9.53	465906	504		62 88	503070	4	0	2 (2)	1012
	Channel spacing CC1-CC2=89.88 MHz (Note 1)																		
	CC2	80	30	217	Downlink	Low	263 5.89	5271 78	259 6.83	519366	0	30	65 01	520110	8	0	0 (0)	0	

					&	Mi d	264 2.88	5285 76	256 7.1	513420	102	65 19	521550	22	0	0 (0)	204
					Upli nk	Hi gh	264 9.99	5299 98	242 9.49	485898	504	65 37	522990	4	0	1 (1)	1010
<p>Note 1: Corresponds to nominal channel spacing in accordance with TS 38.101-1 [7], clause 5.4A.1 for the CC1 and CC2 channel bandwidth combination.</p> <p>Note 2: CCs are specified in increasing frequency order. CC1 is used as PCell if nothing else is specified in the test case.</p> <p>Note 3: The parameter Offset Carrier CORESET#0 specifies the offset from the lowest subcarrier of the carrier and the lowest subcarrier of CORESET#0. It corresponds to the parameter <math>\Delta F_{\text{OffsetCORESET-0-Carrier}}</math> in Annex C expressed in number of common RBs.</p> <p>Note 4: The CORESET#0 Index and the associated CORESET#0 Offset refers to Table 13-4 in TS 38.213 [22]. The value of CORESET#0 Index is signalled in controlResourceSetZero (pdcch-ConfigSIB1) in the MIB. The offsetToPointA IE is expressed in units of resource blocks assuming 15 kHz subcarrier spacing for FR1 and 60 kHz subcarrier spacing for FR2.</p>																	

4.3.1.1.3.42 – 4.3.1.1.3.47 FFS

4.3.1.1.3.48 NR Intra-band contiguous configurations CA\_n48

4.3.1.1.3.48.1 CA\_n48B

Editor's note: Test frequencies for CA\_n48B with mixed numerology with SCS CC1=15 kHz and SCS CC2=30 kHz or 60 kHz; and SCS CC1=30 kHz and SCS CC2= 15 kHz or 60kHz is FFS.

Table 4.3.1.1.3.48.1-1: NR Intra-Band contiguous CA configuration CA\_n48B (PCC=CC1 and SCC=CC2), CC1 SCS = 15kHz, CC2 SCS = 15kHz

CBW combination [MHz] (BCS)	CCN	CBW [MHz]	SCS [kHz]	carrierBandwidth [PRBs]	Range		Carrier centre [MHz] Note 2	Carrier centre [ARFCN]	point A [MHz]	absoluteFrequencyPointA [ARFCN]	offsetToCarrier [Carrier PRBs]	SS block SCS [kHz]	GS CN	absoluteFrequencySSB [ARFCN]	$k_{SS}$	Offset carrier CORE SET#0 [RBs] Note 3	CORE SET#0 Index (Offset [RBs]) Note 4	offsetToPointA (SIB1) [PRBs] Note 4	
10+10 (0,2) Note 6	CC1	10	15	52	Downlink	Low	3555	637000	3550.32	636688	0	30	7884	636960	8	0	0 (2)	2	
						&	Mid	3619.98	641332	3596.94	639796			102	7930	641376	8	3	1 (6)
					Uplink	High	3685.02	645668	3589.62	639308	504			7975	645696	4	2	1 (6)	512
	Channel spacing CC1-CC2=9.96 MHz (Note 1)																		
	CC2	10	15	52	Downlink	Low	3564.96	637664	3560.28	637352	0	30	7891	637632	4	1	0 (2)	3	
						&	Mid	3629.94	641996	3606.9	640460			102	7936	641952	4	0	0 (2)
Uplink					High	3694.98	646332	3599.58	639972	504	7982			646368	0	3	1 (6)	513	
10+15 (0,2)	CC1	10	15	52	Downlink	Low	3555	637000	3550.32	636688	0	30	7884	636960	8	0	0 (2)	2	
						&	Mid	3617.49	641166	3594.45	639630			102	7928	641184	6	1	1 (6)

Note 6					Uplink	High	3680.01	645334	3584.61	638974	504		7971	645312	2	2	0 (2)	508	
	Channel spacing CC1-CC2=12.48 MHz (Note 1)																		
	CC2	15	15	79	Downdlink	Low	3567.48	637832	3560.37	637358	0	30	7891	637632	10	0	0 (2)	2	
					&	Mid	3629.97	641998	3604.5	640300	102		7935	641856	8	1	1 (6)	109	
Uplink					High	3692.49	646166	3594.66	639644	504	7978		645984	4	2	0 (2)	508		
10+20 (0,2) Note 6	CC1	10	15	52	Downdlink	Low	3555	637000	3550.32	636688	0	30	7884	636960	8	0	0 (2)	2	
					&	Mid	3615	641000	3591.96	639464	102		7926	640992	4	3	0 (2)	107	
					Uplink	High	3675.36	645024	3579.96	638664	504		7968	645024	0	0	1 (6)	510	
	Channel spacing CC1-CC2=14.64 MHz (Note 1)																		
CC2	20	15	106	Downdlink	Low	3569.64	637976	3560.1	637340	0	30	7891	637632	4	2	0 (2)	4		
				&	Mid	3629.64	641976	3601.74	640116	102		7933	641664	0	1	1 (6)	109		
				Uplink	High	3690	646000	3589.74	639316	504		7975	645696	8	1	1 (6)	511		
10+30 (2)	CC1	10	15	52	Downdlink	Low	3555	637000	3550.32	636688	0	30	7884	636960	8	0	0 (2)	2	
					&	Mid	3609.99	640666	3586.95	639130	102		7923	640704	2	3	1 (6)	111	
					Uplink	High	3665.31	644354	3569.91	637994	504		7961	644352	10	3	0 (2)	509	
	Channel spacing CC1-CC2=19.68 MHz (Note 1)																		
CC2	30	15	160	Downdlink	Low	3574.68	638312	3560.28	637352	0	30	7891	637632	4	1	0 (2)	3		

					Mid	3629 .67	6419 78	3596 .91	639794	102		79 30	641376	10	3	1 (6)	111	
					High	3684 .99	6456 66	3579 .87	638658	504		79 68	645024	6	0	1 (6)	510	
10+40	CC1	10	15	52	Downlink	Low	3555	6370 00	3550 .32	636688	0	30	78 84	636960	8	0	0 (2)	2
(2)					&	Mid	3604 .98	6403 32	3581 .94	638796	102		79 19	640320	0	3	0 (2)	107
					Uplink	High	3655 .62	6437 08	3560 .22	637348	504		79 54	643680	8	1	0 (2)	507
Channel spacing CC1-CC2=24.36 MHz (Note 1)																		
	CC2	40	15	216	Downlink	Low	3579 .36	6386 24	3559 .92	637328	0	30	78 91	637632	4	3	0 (2)	5
						Mid	3629 .34	6419 56	3591 .54	639436	102		79 26	640992	8	1	1 (6)	109
						High	3679 .98	6453 32	3569 .82	637988	504		79 61	644352	4	0	1 (6)	510
10+50	CC1	10	15	52	Downlink	Low	3555	6370 00	3550 .32	636688	0	30	78 84	636960	8	0	0 (2)	2
(1,2)					&	Mid	3600	6400 00	3576 .96	638464	102		79 16	640032	8	2	1 (6)	110
					Uplink	High	3645 .6	6430 40	3550 .2	636680	504		79 47	643008	4	1	0 (2)	507
Channel spacing CC1-CC2=29.4 MHz (Note 1)																		
	CC2	50	15	270	Downlink	Low	3584 .4	6389 60	3560 .1	637340	0	30	78 91	637632	4	2	0 (2)	4
						Mid	3629 .4	6419 60	3586 .74	639116	102		79 22	640608	4	0	0 (2)	104
						High	3675	6450 00	3559 .98	637332	504		79 54	643680	0	3	0 (2)	509
15+5	CC1	15	15	79	Downlink	Low	3557 .52	6371 68	3550 .41	636694	0	30	78 84	636960	2	0	0 (2)	2

(0)					&	Mi d	3622 .5	6415 00	3597 .03	639802	102		79 30	641376	2	3	1 (6)	111	
					Upli nk	Hi gh	3687 .63	6458 42	3589 .8	639320	504		79 75	645696	4	1	1 (6)	511	
	Channel spacing CC1-CC2=9.855 MHz (Note 1)																		
	C C 2	5	15	25	Dow nlink	L o w	3567 .375	6378 25	3565 .125	637675	0	Not e	-	-	-	-	-	-	-
				&	Mi d	3632 .355	6421 57	3611 .745	640783	102	5	-	-	-	-	-	-	-	
				Upli nk	Hi gh	3697 .485	6464 99	3604 .515	640301	504		-	-	-	-	-	-	-	-
15+10  (0)	C C 1	15	15	79	Dow nlink	L o w	3557 .52	6371 68	3550 .41	636694	0	30	78 84	636960	2	0	0 (2)	2	
				&	Mi d	3619 .98	6413 32	3594 .51	639634	102	79 28		641184	2	1	1 (6)	109		
				Upli nk	Hi gh	3682 .5	6455 00	3584 .67	638978	504	79 71		645312	10	1	0 (2)	507		
	Channel spacing CC1-CC2=12.48 MHz (Note 1)																		
	C C 2	10	15	52	Dow nlink	L o w	3570	6380 00	3565 .32	637688	0	30	78 95	638016	4	1	1 (6)	7	
				&	Mi d	3632 .46	6421 64	3609 .42	640628	102	79 38		642144	4	2	0 (2)	106		
				Upli nk	Hi gh	3694 .98	6463 32	3599 .58	639972	504	79 82		646368	0	3	1 (6)	513		
15+15  (0,2)  Note 6	C C 1	15	15	79	Dow nlink	L o w	3557 .52	6371 68	3550 .41	636694	0	30	78 84	636960	2	0	0 (2)	2	
				&	Mi d	3617 .49	6411 66	3592 .02	639468	102	79 26		640992	0	3	0 (2)	107		
				Upli nk	Hi gh	3677 .49	6451 66	3579 .66	638644	504	79 68		645024	8	1	1 (6)	511		
	Channel spacing CC1-CC2=15 MHz (Note 1)																		

	C C 2	15	15	79	Dow nlink	L o w	3572 .52	6381 68	3565 .41	637694	0	30	78 95	638016	10	0	1 (6)	6
					&	Mi d	3632 .49	6421 66	3607 .02	640468	102		79 37	642048	8	3	1 (6)	111
					Upli nk	Hi g h	3692 .49	6461 66	3594 .66	639644	504		79 78	645984	4	2	0 (2)	508
15+20  (0,2)  Note 6	C C 1	15	15	79	Dow nlink	L o w	3557 .52	6371 68	3550 .41	636694	0	30	78 84	636960	2	0	0 (2)	2
					&	Mi d	3615 00	6410 00	3589 .53	639302	102		79 24	640800	10	0	0 (2)	104
					Upli nk	Hi g h	3672 .84	6448 56	3575 .01	638334	504		79 65	644736	6	3	1 (6)	513
Channel spacing CC1-CC2=17.16 MHz (Note 1)																		
	C C 2	20	15	106	Dow nlink	L o w	3574 .68	6383 12	3565 .14	637676	0	30	78 95	638016	4	2	1 (6)	8
					&	Mi d	3632 .16	6421 44	3604 .26	640284	102		79 35	641856	0	3	1 (6)	111
					Upli nk	Hi g h	3690	6460 00	3589 .74	639316	504		79 75	645696	8	1	1 (6)	511
15+30  (2)	C C 1	15	15	79	Dow nlink	L o w	3557 .52	6371 68	3550 .41	636694	0	30	78 84	636960	2	0	0 (2)	2
					&	Mi d	3609 .99	6406 66	3584 .52	638968	102		79 21	640512	8	0	1 (6)	108
					Upli nk	Hi g h	3662 .79	6441 86	3564 .96	637664	504		79 58	644064	4	3	1 (6)	513
Channel spacing CC1-CC2=22.2 MHz (Note 1)																		
	C C 2	30	15	160	Dow nlink	L o w	3579 .72	6386 48	3565 .32	637688	0	30	78 95	638016	4	1	1 (6)	7
					&	Mi d	3632 .19	6421 46	3599 .43	639962	102		79 31	641472	10	1	0 (2)	105
					Upli nk	Hi g h	3684 .99	6456 66	3579 .87	638658	504		79 68	645024	6	0	1 (6)	510



15+40  (0,1,2)  Note 6	C C 1	15	15	79	Dow nlink	L o w	3557 .52	6371 68	3550 .41	636694	0	30	78 84	636960	2	0	0 (2)	2	
					&	Mi d	3604 .98	6403 32	3579 .51	638634	102		79 17	640128	6	0	0 (2)	104	
					Upli nk	Hi g h	3653 .1	6435 40	3555 .27	637018	504		79 51	643392	2	1	1 (6)	511	
	Channel spacing CC1-CC2=26.88 MHz (Note 1)																		
	C C 2	40	15	216	Dow nlink	L o w	3584 .4	6389 60	3564 .96	637664	0	30	78 95	638016	4	3	1 (6)	9	
						Mi d	3631 .86	6421 24	3594 .06	639604	102		79 28	641184	8	3	1 (6)	111	
					Hi g h	3679 .98	6453 32	3569 .82	637988	504		79 61	644352	4	0	1 (6)	510		
15+50  (0,1,2)  Note 6	C C 1	15	15	79	Dow nlink	L o w	3557 .52	6371 68	3550 .41	636694	0	30	78 84	636960	2	0	0 (2)	2	
					&	Mi d	3600	6400 00	3574 .53	638302	102		79 14	639840	2	0	1 (6)	108	
					Upli nk	Hi g h	3643 .08	6428 72	3545 .25	636350	504		79 44	642720	10	0	1 (6)	510	
	Channel spacing CC1-CC2=31.92 MHz (Note 1)																		
	C C 2	50	15	270	Dow nlink	L o w	3589 .44	6392 96	3565 .14	637676	0	30	78 95	638016	4	2	1 (6)	8	
						Mi d	3631 .92	6421 28	3589 .26	639284	102		79 24	640800	4	2	0 (2)	106	
					Hi g h	3675	6450 00	3559 .98	637332	504		79 54	643680	0	3	0 (2)	509		
20+5  (0)	C C 1	20	15	106	Dow nlink	L o w	3560 .01	6373 34	3550 .47	636698	0	30	78 85	637056	10	3	1 (6)	9	
					&	Mi d	3622 .5	6415 00	3594 .6	639640	102		79 28	641184	8	0	1 (6)	108	
					Upli nk	Hi g h	3685 .2	6456 80	3584 .94	638996	504		79 71	645312	4	0	0 (2)	506	

Channel spacing CC1-CC2=12.285 MHz (Note 1)																		
	C C 2	5	15	25	Downlink & Uplink	Low	3572 .295	6381 53	3570 .045	638003	0	Note 5	-	-	-	-	-	-
						Mid	3634 .785	6423 19	3614 .175	640945	102		-	-	-	-	-	-
						High	3697 .485	6464 99	3604 .515	640301	504		-	-	-	-	-	-
20+10  (0,2)  Note 6	C C 1	20	15	106	Downlink & Uplink	Low	3560 .01	6373 34	3550 .47	636698	0	30	78 85	637056	10	3	1 (6)	9
						Mid	3619 .98	6413 32	3592 .08	639472	102		79 26	640992	8	2	0 (2)	106
						High	3680 .34	6453 56	3580 .08	638672	504		79 68	645024	4	3	0 (2)	509
Channel spacing CC1-CC2=14.64 MHz (Note 1)																		
	C C 2	10	15	52	Downlink & Uplink	Low	3574 .65	6383 10	3569 .97	637998	0	30	78 98	638304	6	3	0 (2)	5
						Mid	3634 .62	6423 08	3611 .58	640772	102		79 40	642336	4	2	1 (6)	110
						High	3694 .98	6463 32	3599 .58	639972	504		79 82	646368	0	3	1 (6)	513
20+15  (0,2)  Note 6	C C 1	20	15	106	Downlink & Uplink	Low	3560 .01	6373 34	3550 .47	636698	0	30	78 85	637056	10	3	1 (6)	9
						Mid	3617 .49	6411 66	3589 .59	639306	102		79 24	640800	6	0	0 (2)	104
						High	3675 .33	6450 22	3575 .07	638338	504		79 65	644736	2	3	1 (6)	513
Channel spacing CC1-CC2=17.16 MHz (Note 1)																		
	C C 2	15	15	79	Downlink &	Low	3577 .17	6384 78	3570 .06	638004	0	30	78 98	638304	0	3	0 (2)	5
						Mid	3634 .65	6423 10	3609 .18	640612	102		79 38	642144	8	3	0 (2)	107

					Uplink	High	3692.49	6461.66	3594.66	639644	504		7978	645984	4	2	0 (2)	508
20+20 (0,2) Note 6	CC1	20	15	106	Downdlink	Low	3560.01	6373.34	3550.47	636698	0	30	7885	637056	10	3	1 (6)	9
					&	Mid	3615	6410.00	3587.1	639140	102		7923	640704	4	2	1 (6)	110
					Uplink	High	3670.02	6446.68	3569.76	637984	504		7961	644352	8	0	1 (6)	510
					Channel spacing CC1-CC2=19.98 MHz (Note 1)													
	CC2	20	15	106	Downdlink	Low	3579.99	6386.66	3570.45	638030	0	30	7898	638304	10	0	0 (2)	2
&	Mid	3634.98	6423.32	3607.08	640472	102	7937	642048	4	3	1 (6)		111					
Uplink	High	3690	6460.00	3589.74	639316	504	7975	645696	8	1	1 (6)		511					
20+30 (2)	CC1	20	15	106	Downdlink	Low	3560.01	6373.34	3550.47	636698	0	30	7885	637056	10	3	1 (6)	9
					&	Mid	3609.99	6406.66	3582.09	638806	102		7919	640320	2	2	0 (2)	106
					Uplink	High	3660.03	6440.02	3559.77	637318	504		7954	643680	2	0	1 (6)	510
	Channel spacing CC1-CC2=24.96 MHz (Note 1)																	
	CC2	30	15	160	Downdlink	Low	3584.97	6389.98	3570.57	638038	0	30	7898	638304	2	0	0 (2)	2
					Mid	3634.95	6423.30	3602.19	640146	102	7933		641664	6	2	0 (2)	106	
					High	3684.99	6456.66	3579.87	638658	504	7968		645024	6	0	1 (6)	510	
30+30 (2)	CC1	30	15	160	Downdlink	Low	3565.02	6376.68	3550.62	636708	0	30	7885	637056	0	3	1 (6)	9
					&	Mid	3609.99	6406.66	3577.23	638482	102		7916	640032	2	1	1 (6)	109

					Uplink	High	3654.99	643666	3549.87	636658	504		7947	643008	2	3	0 (2)	509
Channel spacing CC1-CC2=30 MHz (Note 1)																		
	CC2	30	15	160	Downlink	Low	3595.02	639668	3580.62	638708	0	30	7905	638976	4	0	0 (2)	2
						Mid	3639.99	642666	3607.23	640482	102		7937	642048	6	2	1 (6)	110
						High	3684.99	645666	3579.87	638658	504		7968	645024	6	0	1 (6)	510
40+30	CC1	40	15	216	Downlink	Low	3570	638000	3550.56	636704	0	30	7885	637056	4	3	1 (6)	9
(2)					&	Mid	3609.99	640666	3572.19	638146	102		7912	639648	2	1	0 (2)	105
					Uplink	High	3650.31	643354	3540.15	636010	504		7940	642336	2	1	0 (2)	507
Channel spacing CC1-CC2=34.68 MHz (Note 1)																		
	CC2	30	15	160	Downlink	Low	3604.68	640312	3590.28	639352	0	30	7912	639648	8	2	0 (2)	4
						Mid	3644.67	642978	3611.91	640794	102		7940	642336	6	0	1 (6)	108
						High	3684.99	645666	3579.87	638658	504		7968	645024	6	0	1 (6)	510
20+40	CC1	20	15	106	Downlink	Low	3560.01	637334	3550.47	636698	0	30	7885	637056	10	3	1 (6)	9
(1,2)					&	Mid	3604.98	640332	3577.08	638472	102		7916	640032	0	2	1 (6)	110
					Uplink	High	3650.28	643352	3550.02	636668	504		7947	643008	4	2	0 (2)	508
Channel spacing CC1-CC2=29.7 MHz (Note 1)																		
	CC2	40	15	216	Downlink	Low	3589.71	639314	3570.27	638018	0	30	7898	638304	10	1	0 (2)	3

20+50  (1,2)					Mid	3634 .68	6423 12	3596 .88	639792	102		79 29	641280	0	0	0 (2)	104	
					High	3679 .98	6453 32	3569 .82	637988	504		79 61	644352	4	0	1 (6)	510	
	CC1	20	15	106	Downlink	Low	3560 .01	6373 34	3550 .47	636698	0	30	78 85	637056	10	3	1 (6)	9
					&	Mid	3600	6400 00	3572 .1	638140	102		79 12	639648	8	1	0 (2)	105
					Uplink	High	3640 .26	6426 84	3540	636000	504		79 40	642336	0	2	0 (2)	508
Channel spacing CC1-CC2=34.74 MHz (Note 1)																		
40+40  (1,2)	CC2	50	15	270	Downlink	Low	3594 .75	6396 50	3570 .45	638030	0	30	78 98	638304	10	0	0 (2)	2
						Mid	3634 .74	6423 16	3592 .08	639472	102		79 26	640992	8	2	0 (2)	106
						High	3675	6450 00	3559 .98	637332	504		79 54	643680	0	3	0 (2)	509
	CC1	40	15	216	Downlink	Low	3570	6380 00	3550 .56	636704	0	30	78 85	637056	4	3	1 (6)	9
					&	Mid	3604 .98	6403 32	3567 .18	637812	102		79 09	639360	0	1	1 (6)	109
				Uplink	High	3640 .02	6426 68	3529 .86	635324	504		79 33	641664	4	2	0 (2)	508	
Channel spacing CC1-CC2=39.96 MHz (Note 1)																		
40+50	CC2	40	15	216	Downlink	Low	3609 .96	6406 64	3590 .52	639368	0	30	79 12	639648	4	1	0 (2)	3
						Mid	3644 .94	6429 96	3607 .14	640476	102		79 37	642048	0	3	1 (6)	111
						High	3679 .98	6453 32	3569 .82	637988	504		79 61	644352	4	0	1 (6)	510
	CC1	40	15	216	Downlink	Low	3570	6380 00	3550 .56	636704	0	30	78 85	637056	4	3	1 (6)	9

(1,2)					&	Mid	3600	640000	3562.2	637480	102		7905	638976	8	0	0 (2)	104	
					Uplink	High	3630.06	642004	3519.9	634660	504		7926	640992	8	1	0 (2)	507	
	Channel spacing CC1-CC2=44.94 MHz (Note 1)																		
	CC2	50	15	270		Downlink	Low	3614.94	640996	3590.64	639376	0	30	7912	639648	8	0	0 (2)	2
							Mid	3644.94	642996	3602.28	640152	102		7933	641664	0	2	0 (2)	106
						High	3675.00	645000	3559.98	637332	504		7954	643680	0	3	0 (2)	509	
<p>Note 1: Corresponds to nominal channel spacing in accordance with TS 38.101-1 [7], clause 5.4A.1 for the CC1 and CC2 channel bandwidth combination.</p> <p>Note 2: CCs are specified in increasing frequency order. CC1 is used as PCell if nothing else is specified in the test case.</p> <p>Note 3: The parameter Offset Carrier CORESET#0 specifies the offset from the lowest subcarrier of the carrier and the lowest subcarrier of CORESET#0. It corresponds to the parameter <math>\Delta F_{\text{OffsetCORESET-0-Carrier}}</math> in Annex C expressed in number of common RBs.</p> <p>Note 4: The CORESET#0 Index and the associated CORESET#0 Offset refers to Table 13-3 in TS 38.213 [22]. The value of CORESET#0 Index is signalled in controlResourceSetZero (pdcch-ConfigSIB1) in the MIB. The offsetToPointA IE is expressed in units of resource blocks assuming 15 kHz subcarrier spacing for FR1 and 60 kHz subcarrier spacing for FR2.</p> <p>Note 5: No SS/PBCH block fits within the channel bandwidth. The channel bandwidth can only be used as SCell.</p> <p>Note 6: UL CA is only supported for BCS0. I.e.the test frequencies for uplink CC2 are only supported for BCS0.</p>																			

Table 4.3.1.1.3.48.1-2: NR Intra-Band contiguous CA configuration CA\_n48B (PCC=CC1 and SCC=CC2), CC1 SCS = 30kHz, CC2 SCS = 30kHz

CBW combination [MHz] (BCS)	CCN	CBW [MHz]	SCS [kHz]	carrierBandwidth [PRBs]	Range	Carrier centre [MHz] Note 2	Carrier centre [ARFCN]	point A [MHz]	absoluteFrequencyPointA [ARFCN]	offsetToCarrier [Carrier PRBs]	SS block SCS [kHz]	GS CN	absoluteFrequencySSB [ARFCN]	$k_{SS}$	Offset carrier CORESET#0 [RBs] Note 3	CORESET#0 Index (Offset [RBs]) Note 4	offsetToPointA (SIB1) [PRBs] Note 4		
10+10  (0,2)  Note 5	CC1	10	30	24	Downlink	Low	3555	637000	3550.68	636712	0	30	7884	636960	8	0	0 (0)	0	
						&	Mid	3620.01	641334	3578.97	638598		102	7930	641376	18	0	3 (3)	210
						Uplink	High	3685.02	645668	3499.26	633284		504	7975	645696	4	0	3 (3)	1014

Channel spacing CC1-CC2=9.96 MHz (Note 1)																		
	C C 2	10	30	24	Downlink & Uplink	Low	356 4.96	6376 64	356 0.64	637376	0	30	78 91	637632	16	0	0 (0)	0
						Mid	362 9.97	6419 98	358 8.93	639262	102		79 36	641952	2	0	0 (0)	204
						High	369 4.98	6463 32	350 9.22	633948	504		79 82	646368	12	0	3 (3)	1014
10+15 (0,2) Note 5	C C 1	10	30	24	Downlink & Uplink	Low	355 5	6370 00	355 0.68	636712	0	30	78 84	636960	8	0	0 (0)	0
						Mid	361 7.49	6411 66	357 6.45	638430	102		79 28	641184	18	0	2 (2)	208
						High	368 0.01	6453 34	349 4.25	632950	504		79 71	645312	2	0	1 (1)	1010
Channel spacing CC1-CC2=12.48 MHz (Note 1)																		
	C C 2	15	30	38	Downlink & Uplink	Low	356 7.48	6378 32	356 0.64	637376	0	30	78 91	637632	16	0	0 (0)	0
						Mid	362 9.97	6419 98	358 6.41	639094	102		79 35	641856	2	0	3 (3)	210
						High	369 2.49	6461 66	350 4.21	633614	504		79 78	645984	10	0	1 (1)	1010
10+20 (0,2) Note 5	C C 1	10	30	24	Downlink & Uplink	Low	355 5	6370 00	355 0.68	636712	0	30	78 84	636960	8	0	0 (0)	0
						Mid	361 5	6410 00	357 3.96	638264	102		79 26	640992	16	0	1 (1)	206
						High	367 5.36	6450 24	348 9.6	632640	504		79 68	645024	0	0	2 (2)	1012
Channel spacing CC1-CC2=14.64 MHz (Note 1)																		
	C C 2	20	30	51	Downlink & Uplink	Low	356 9.64	6379 76	356 0.46	637364	0	30	78 91	637632	4	0	1 (1)	2
						Mid	362 9.64	6419 76	358 3.74	638916	102		79 33	641664	12	0	2 (2)	208
						High	369 0	6460 00	349 9.38	633292	504		79 75	645696	20	0	2 (2)	1012
10+30	C C 1	10	30	24	Downlink	Low	355 5	6370 00	355 0.68	636712	0	30	78 84	636960	8	0	0 (0)	0

(2)					&	Mid	360 9.99	6406 66	356 8.95	637930	102		79 23	640704	14	0	3 (3)	210	
					Uplink	High	366 5.31	6443 54	347 9.55	631970	504		79 61	644352	22	0	1 (1)	1010	
	Channel spacing CC1-CC2=19.68 MHz (Note 1)																		
	CC2	30	30	78	Downlink	Low	357 4.68	6383 12	356 0.64	637376	0	30	78 91	637632	16	0	0 (0)	0	
						Mid	362 9.67	6419 78	357 8.91	638594	102		79 30	641376	22	0	3 (3)	210	
					High	368 4.99	6456 66	348 9.51	632634	504		79 68	645024	6	0	2 (2)	1012		
10+40	CC1	10	30	24	Downlink	Low	355 5	6370 00	355 0.68	636712	0	30	78 84	636960	8	0	0 (0)	0	
(2)					&	Mid	360 5.01	6403 34	356 3.97	637598	102		79 19	640320	10	0	1 (1)	206	
					Uplink	High	365 5.62	6437 08	346 9.86	631324	504		79 54	643680	20	0	0 (0)	1008	
	Channel spacing CC1-CC2=24.36 MHz (Note 1)																		
	CC2	40	30	106	Downlink	Low	357 9.36	6386 24	356 0.28	637352	0	30	78 91	637632	16	0	1 (1)	2	
						Mid	362 9.37	6419 58	357 3.57	638238	102		79 26	640992	18	0	2 (2)	208	
					High	367 9.98	6453 32	347 9.46	631964	504		79 61	644352	4	0	2 (2)	1012		
10+70	CC1	10	30	24	Downlink	Low	355 5	6370 00	355 0.68	636712	0	30	78 84	636960	8	0	0 (0)	0	
(2)					&	Mid	359 0.01	6393 34	354 8.97	636598	102		79 09	639360	2	0	3 (3)	210	
					Uplink	High	362 5.5	6417 00	343 9.74	629316	504		79 33	641664	12	0	0 (0)	1008	
	Channel spacing CC1-CC2=39.48 MHz (Note 1)																		
	CC2	70	30	189	Downlink	Low	359 4.48	6396 32	356 0.46	637364	0	30	78 91	637632	4	0	1 (1)	2	
						Mid	362 9.49	6419 66	355 8.75	637250	102		79 16	640032	22	0	3 (3)	210	
					High	366 4.98	6443 32	344 9.52	629968	504		79 40	642336	8	0	1 (1)	1010		



10+50  (1,2)	C C 1	10	30	24	Downlink	Low	355 5	6370 00	355 0.68	636712	0	30	78 84	636960	8	0	0 (0)	0	
					&	Mid	360 0	6400 00	355 8.96	637264	102		79 16	640032	8	0	3 (3)	210	
					Uplink	High	364 5.6	6430 40	345 9.84	630656	504		79 47	643008	16	0	0 (0)	1008	
	Channel spacing CC1-CC2=29.4 MHz (Note 1)																		
	C C 2	50	30	133	Downlink	Low	358 4.4	6389 60	356 0.46	637364	0	30	78 91	637632	4	0	1 (1)	2	
						Mid	362 9.4	6419 60	356 8.74	637916	102		79 22	640608	4	0	0 (0)	204	
						High	367 5	6450 00	346 9.62	631308	504		79 54	643680	12	0	1 (1)	1010	
10+60  (1,2)	C C 1	10	30	24	Downlink	Low	355 5	6370 00	355 0.68	636712	0	30	78 84	636960	8	0	0 (0)	0	
					&	Mid	359 4.99	6396 66	355 3.95	636930	102		79 12	639648	6	0	1 (1)	206	
					Uplink	High	363 5.55	6423 70	344 9.79	629986	504		79 40	642336	14	0	0 (0)	1008	
	Channel spacing CC1-CC2=34.44 MHz (Note 1)																		
	C C 2	60	30	162	Downlink	Low	358 9.44	6392 96	356 0.28	637352	0	30	78 91	637632	16	0	1 (1)	2	
						Mid	362 9.43	6419 62	356 3.55	637570	102		79 19	640320	14	0	2 (2)	208	
						High	366 9.99	6446 66	345 9.39	630626	504		79 47	643008	22	0	1 (1)	1010	
10+80  (1,2)	C C 1	10	30	24	Downlink	Low	355 5	6370 00	355 0.68	636712	0	30	78 84	636960	8	0	0 (0)	0	
					&	Mid	358 5	6390 00	354 3.96	636264	102		79 05	638976	0	0	1 (1)	206	
					Uplink	High	361 5.48	6410 32	342 9.72	628648	504		79 26	640992	8	0	0 (0)	1008	
	Channel spacing CC1-CC2=44.52 MHz (Note 1)																		
	C C 2	80	30	217	Downlink	Low	359 9.52	6399 68	356 0.46	637364	0	30	78 91	637632	4	0	1 (1)	2	

					Mid	362 9.52	6419 68	355 3.74	636916	102		79 12	639648	20	0	1 (1)	206	
					High	366 0	6440 00	343 9.5	629300	504		79 33	641664	4	0	1 (1)	1010	
10+90	CC1	10	30	24	Downlink	Low	355 5	6370 00	355 0.68	636712	0	30	78 84	636960	8	0	0 (0)	0
(1,2)					&	Mid	357 9.99	6386 66	353 8.95	635930	102		79 02	638688	22	0	2 (2)	208
					Uplink	High	360 5.43	6403 62	341 9.67	627978	504		79 19	640320	6	0	0 (0)	1008
Channel spacing CC1-CC2=49.56 MHz (Note 1)																		
	CC2	90	30	245	Downlink	Low	360 4.56	6403 04	356 0.46	637364	0	30	78 91	637632	4	0	1 (1)	2
						Mid	362 9.55	6419 70	354 8.73	636582	102		79 09	639360	18	0	3 (3)	210
						High	365 4.99	6436 66	342 9.45	628630	504		79 26	640992	2	0	1 (1)	1010
15+10	CC1	15	30	38	Downlink	Low	355 7.52	6371 68	355 0.68	636712	0	30	78 84	636960	8	0	0 (0)	0
(0,2)					&	Mid	362 0.01	6413 34	357 6.45	638430	102		79 28	641184	18	0	2 (2)	208
Note 5					Uplink	High	368 2.5	6455 00	349 4.22	632948	504		79 71	645312	4	0	1 (1)	1010
Channel spacing CC1-CC2=12.48 MHz (Note 1)																		
	CC2	10	30	24	Downlink	Low	357 0	6380 00	356 5.68	637712	0	30	78 95	638016	16	0	2 (2)	4
					&	Mid	363 2.49	6421 66	359 1.45	639430	102		79 38	642144	2	0	1 (1)	206
					Uplink	High	369 4.98	6463 32	350 9.22	633948	504		79 82	646368	12	0	3 (3)	1014
15+15	CC1	15	30	38	Downlink	Low	355 7.52	6371 68	355 0.68	636712	0	30	78 84	636960	8	0	0 (0)	0
(0,2)					&	Mid	361 7.49	6411 66	357 3.93	638262	102		79 26	640992	18	0	1 (1)	206
Note 5					Uplink	High	367 7.49	6451 66	348 9.21	632614	504		79 68	645024	2	0	3 (3)	1014
Channel spacing CC1-CC2=15 MHz (Note 1)																		

	C C 2	15	30	38	Downlink & Uplink	Low	357 2.52	6381 68	356 5.68	637712	0	30	78 95	638016	16	0	2 (2)	4
						Mid	363 2.49	6421 66	358 8.93	639262	102		79 36	641952	2	0	0 (0)	204
						High	369 2.49	6461 66	350 4.21	633614	504		79 78	645984	10	0	1 (1)	1010
15+20 (0,2) Note 5	C C 1	15	30	38	Downlink & Uplink	Low	355 7.52	6371 68	355 0.68	636712	0	30	78 84	636960	8	0	0 (0)	0
						Mid	361 5	6410 00	357 1.44	638096	102		79 24	640800	16	0	0 (0)	204
						High	367 2.84	6448 56	348 4.56	632304	504		79 64	644640	0	0	0 (0)	1008
Channel spacing CC1-CC2=17.16 MHz (Note 1)																		
	C C 2	20	30	51	Downlink & Uplink	Low	357 4.68	6383 12	356 5.5	637700	0	30	78 95	638016	4	0	3 (3)	6
						Mid	363 2.16	6421 44	358 6.26	639084	102		79 35	641856	12	0	3 (3)	210
						High	369 0	6460 00	349 9.38	633292	504		79 75	645696	20	0	2 (2)	1012
15+30 (2)	C C 1	15	30	38	Downlink & Uplink	Low	355 7.52	6371 68	355 0.68	636712	0	30	78 84	636960	8	0	0 (0)	0
						Mid	360 9.99	6406 66	356 6.43	637762	102		79 21	640512	14	0	2 (2)	208
						High	366 2.79	6441 86	347 4.51	631634	504		79 58	644064	22	0	3 (3)	1014
Channel spacing CC1-CC2=22.2 MHz (Note 1)																		
	C C 2	30	30	78	Downlink & Uplink	Low	357 9.72	6386 48	356 5.68	637712	0	30	78 95	638016	16	0	2 (2)	4
						Mid	363 2.19	6421 46	358 1.43	638762	102		79 31	641472	22	0	0 (0)	204
						High	368 4.99	6456 66	348 9.51	632634	504		79 68	645024	6	0	2 (2)	1012
15+70 (2)	C C 1	15	30	38	Downlink & Uplink	Low	355 7.52	6371 68	355 0.68	636712	0	30	78 84	636960	8	0	0 (0)	0
						Mid	359 0.01	6393 34	354 6.45	636430	102		79 07	639168	2	0	2 (2)	208

					Uplink	High	362 2.98	6415 32	343 4.7	628980	504		79 30	641376	12	0	2 (2)	1012
Channel spacing CC1-CC2=42 MHz (Note 1)																		
	CC2	70	30	189	Downlink	Low	359 9.52	6399 68	356 5.5	637700	0	30	78 95	638016	4	0	3 (3)	6
						Mid	363 2.01	6421 34	356 1.27	637418	102		79 17	640128	22	0	0 (0)	204
						High	366 4.98	6443 32	344 9.52	629968	504		79 40	642336	8	0	1 (1)	1010
15+40	CC1	15	30	38	Downlink	Low	355 7.52	6371 68	355 0.68	636712	0	30	78 84	636960	8	0	0 (0)	0
(1,2)					&	Mid	360 5.01	6403 34	356 1.45	637430	102		79 17	640128	10	0	0 (0)	204
					Uplink	High	365 3.1	6435 40	346 4.82	630988	504		79 51	643392	20	0	2 (2)	1012
Channel spacing CC1-CC2=26.88 MHz (Note 1)																		
	CC2	40	30	106	Downlink	Low	358 4.4	6389 60	356 5.32	637688	0	30	78 95	638016	16	0	3 (3)	6
						Mid	363 1.89	6421 26	357 6.09	638406	102		79 28	641184	18	0	3 (3)	210
						High	367 9.98	6453 32	347 9.46	631964	504		79 61	644352	4	0	2 (2)	1012
15+50	CC1	15	30	38	Downlink	Low	355 7.52	6371 68	355 0.68	636712	0	30	78 84	636960	8	0	0 (0)	0
(1,2)					&	Mid	360 0	6400 00	355 6.44	637096	102		79 14	639840	8	0	2 (2)	208
					Uplink	High	364 3.08	6428 72	345 4.8	630320	504		79 44	642720	16	0	2 (2)	1012
Channel spacing CC1-CC2=31.92 MHz (Note 1)																		
	CC2	50	30	133	Downlink	Low	358 9.44	6392 96	356 5.5	637700	0	30	78 95	638016	4	0	3 (3)	6
						Mid	363 1.92	6421 28	357 1.26	638084	102		79 24	640800	4	0	1 (1)	206
						High	367 5	6450 00	346 9.62	631308	504		79 54	643680	12	0	1 (1)	1010

15+60  (1,2)	C C 1	15	30	38	Downlink	Low	355 7.52	6371 68	355 0.68	636712	0	30	78 84	636960	8	0	0 (0)	0	
					&	Mid	359 4.99	6396 66	355 1.43	636762	102		79 10	639456	6	0	0 (0)	204	
					Uplink	High	363 3.03	6422 02	344 4.75	629650	504		79 37	642048	14	0	2 (2)	1012	
	Channel spacing CC1-CC2=36.96 MHz (Note 1)																		
	C C 2	60	30	162	Downlink	Low	359 4.48	6396 32	356 5.32	637688	0	30	78 95	638016	16	0	3 (3)	6	
						Mid	363 1.95	6421 30	356 6.07	637738	102		79 21	640512	14	0	3 (3)	210	
						High	366 9.99	6446 66	345 9.39	630626	504		79 47	643008	22	0	1 (1)	1010	
15+80  (1,2)	C C 1	15	30	38	Downlink	Low	355 7.52	6371 68	355 0.68	636712	0	30	78 84	636960	8	0	0 (0)	0	
					&	Mid	358 5	6390 00	354 1.44	636096	102		79 03	638784	0	0	0 (0)	204	
					Uplink	High	361 2.96	6408 64	342 4.68	628312	504		79 23	640704	8	0	2 (2)	1012	
	Channel spacing CC1-CC2=47.04 MHz (Note 1)																		
	C C 2	80	30	217	Downlink	Low	360 4.56	6403 04	356 5.5	637700	0	30	78 95	638016	4	0	3 (3)	6	
						Mid	363 2.04	6421 36	355 6.26	637084	102		79 14	639840	20	0	2 (2)	208	
						High	366 0	6440 00	343 9.5	629300	504		79 33	641664	4	0	1 (1)	1010	
20+10  (0,2)  Note 5	C C 1	20	30	51	Downlink	Low	356 0.01	6373 34	355 0.83	636722	0	30	78 85	637056	22	0	3 (3)	6	
					&	Mid	362 0.01	6413 34	357 4.11	638274	102		79 26	640992	6	0	1 (1)	206	
					Uplink	High	368 0.34	6453 56	348 9.72	632648	504		79 68	645024	16	0	1 (1)	1010	
	Channel spacing CC1-CC2=14.64 MHz (Note 1)																		
	C C 2	10	30	24	Downlink	Low	357 4.65	6383 10	357 0.33	638022	0	30	78 98	638304	18	0	1 (1)	2	

					&	Mi d	363 4.65	6423 10	359 3.61	639574	102		79 40	642336	2	0	3 (3)	210
					Uplink	Hi gh	369 4.98	6463 32	350 9.22	633948	504		79 82	646368	12	0	3 (3)	1014
20+15	C C 1	20	30	51	Downlink	Lo w	356 0.01	6373 34	355 0.83	636722	0	30	78 85	637056	22	0	3 (3)	6
(0,2)					&	Mi d	361 7.49	6411 66	357 1.59	638106	102		79 24	640800	6	0	0 (0)	204
Note 5					Uplink	Hi gh	367 5.33	6450 22	348 4.71	632314	504		79 65	644736	14	0	3 (3)	1014
Channel spacing CC1-CC2=17.16 MHz (Note 1)																		
	C C 2	15	30	38	Downlink	Lo w	357 7.17	6384 78	357 0.33	638022	0	30	78 98	638304	18	0	1 (1)	2
					&	Mi d	363 4.65	6423 10	359 1.09	639406	102		79 38	642144	2	0	2 (2)	208
					Uplink	Hi gh	369 2.49	6461 66	350 4.21	633614	504		79 78	645984	10	0	1 (1)	1010
20+20	C C 1	20	30	51	Downlink	Lo w	356 0.01	6373 34	355 0.83	636722	0	30	78 85	637056	22	0	3 (3)	6
(0,2)					&	Mi d	361 5	6410 00	356 9.1	637940	102		79 23	640704	4	0	3 (3)	210
Note 5					Uplink	Hi gh	367 0.02	6446 68	347 9.4	631960	504		79 61	644352	8	0	2 (2)	1012
Channel spacing CC1-CC2=19.98 MHz (Note 1)																		
	C C 2	20	30	51	Downlink	Lo w	357 9.99	6386 66	357 0.81	638054	0	30	78 98	638304	10	0	0 (0)	0
					&	Mi d	363 4.98	6423 32	358 9.08	639272	102		79 37	642048	16	0	3 (3)	210
					Uplink	Hi gh	369 0	6460 00	349 9.38	633292	504		79 75	645696	20	0	2 (2)	1012
20+30	C C 1	20	30	51	Downlink	Lo w	356 0.01	6373 34	355 0.83	636722	0	30	78 85	637056	22	0	3 (3)	6
(2)					&	Mi d	360 9.99	6406 66	356 4.09	637606	102		79 19	640320	2	0	1 (1)	206
					Uplink	Hi gh	366 0.03	6440 02	346 9.41	631294	504		79 54	643680	2	0	2 (2)	1012
Channel spacing CC1-CC2=24.96 MHz (Note 1)																		

	C C 2	30	30	78	Dow nlink	Lo w	358 4.97	6389 98	357 0.93	638062	0	30	78 98	638304	2	0	0 (0)	0
						Mi d	363 4.95	6423 30	358 4.19	638946	102		79 33	641664	6	0	1 (1)	206
						Hi gh	368 4.99	6456 66	348 9.51	632634	504		79 68	645024	6	0	2 (2)	1012
20+70  (2)	C C 1	20	30	51	Dow nlink	Lo w	356 0.01	6373 34	355 0.83	636722	0	30	78 85	637056	22	0	3 (3)	6
					&	Mi d	359 0.01	6393 34	354 4.11	636274	102		79 05	638976	14	0	0 (0)	204
					Uplin k	Hi gh	362 0.16	6413 44	342 9.54	628636	504		79 26	640992	20	0	0 (0)	1008
Channel spacing CC1-CC2=44.82 MHz (Note 1)																		
	C C 2	70	30	189	Dow nlink	Lo w	360 4.83	6403 22	357 0.81	638054	0	30	78 98	638304	10	0	0 (0)	0
						Mi d	363 4.83	6423 22	356 4.09	637606	102		79 19	640320	2	0	1 (1)	206
						Hi gh	366 4.98	6443 32	344 9.52	629968	504		79 40	642336	8	0	1 (1)	1010
30+10  (2)	C C 1	30	30	78	Dow nlink	Lo w	356 5.02	6376 68	355 0.98	636732	0	30	78 85	637056	12	0	3 (3)	6
					&	Mi d	362 0.01	6413 34	356 9.25	637950	102		79 23	640704	18	0	2 (2)	208
					Uplin k	Hi gh	367 5.3	6450 20	347 9.82	631988	504		79 61	644352	4	0	1 (1)	1010
Channel spacing CC1-CC2=19.68 MHz (Note 1)																		
	C C 2	10	30	24	Dow nlink	Lo w	358 4.7	6389 80	358 0.38	638692	0	30	79 05	638976	20	0	1 (1)	2
						Mi d	363 9.69	6426 46	359 8.65	639910	102		79 43	642624	2	0	1 (1)	206
						Hi gh	369 4.98	6463 32	350 9.22	633948	504		79 82	646368	12	0	3 (3)	1014
30+15  (2)	C C 1	30	30	78	Dow nlink	Lo w	356 5.02	6376 68	355 0.98	636732	0	30	78 85	637056	12	0	3 (3)	6
					&	Mi d	361 7.49	6411 66	356 6.73	637782	102		79 21	640512	18	0	1 (1)	206

					Uplink	High	367 0.29	6446 86	347 4.81	631654	504		79 58	644064	2	0	3 (3)	1014
Channel spacing CC1-CC2=22.2 MHz (Note 1)																		
	CC2	15	30	38	Downlink	Low	358 7.22	6391 48	358 0.38	638692	0	30	79 05	638976	20	0	1 (1)	2
						Mid	363 9.69	6426 46	359 6.13	639742	102		79 41	642432	2	0	0 (0)	204
						High	369 2.49	6461 66	350 4.21	633614	504		79 78	645984	10	0	1 (1)	1010
30+20	CC1	30	30	78	Downlink	Low	356 5.02	6376 68	355 0.98	636732	0	30	78 85	637056	12	0	3 (3)	6
(2)					&	Mid	361 5	6410 00	356 4.24	637616	102		79 19	640320	16	0	0 (0)	204
					Uplink	High	366 5.04	6443 36	346 9.56	631304	504		79 54	643680	16	0	1 (1)	1010
Channel spacing CC1-CC2=24.96 MHz (Note 1)																		
	CC2	20	30	51	Downlink	Low	358 9.98	6393 32	358 0.8	638720	0	30	79 05	638976	16	0	0 (0)	0
						Mid	363 9.96	6426 64	359 4.06	639604	102		79 40	642336	20	0	1 (1)	206
						High	369 0	6460 00	349 9.38	633292	504		79 75	645696	20	0	2 (2)	1012
30+30	CC1	30	30	78	Downlink	Low	356 5.02	6376 68	355 0.98	636732	0	30	78 85	637056	12	0	3 (3)	6
(2)					&	Mid	360 9.99	6406 66	355 9.23	637282	102		79 16	640032	14	0	2 (2)	208
					Uplink	High	365 4.99	6436 66	345 9.51	630634	504		79 47	643008	14	0	1 (1)	1010
Channel spacing CC1-CC2=30 MHz (Note 1)																		
	CC2	30	30	78	Downlink	Low	359 5.02	6396 68	358 0.98	638732	0	30	79 05	638976	4	0	0 (0)	0
						Mid	363 9.99	6426 66	358 9.23	639282	102		79 37	642048	6	0	3 (3)	210
						High	368 4.99	6456 66	348 9.51	632634	504		79 68	645024	6	0	2 (2)	1012



30+40  (2)	C C 1	30	30	78	Dow nlink	Lo w	356 5.02	6376 68	355 0.98	636732	0	30	78 85	637056	12	0	3 (3)	6	
					&	Mi d	360 5.01	6403 34	355 4.25	636950	102		79 12	639648	10	0	0 (0)	204	
					Uplin k	Hi gh	364 5.3	6430 20	344 9.82	629988	504		79 40	642336	12	0	0 (0)	1008	
	Channel spacing CC1-CC2=34.68 MHz (Note 1)																		
	C C 2	40	30	106	Dow nlink	Lo w	359 9.7	6399 80	358 0.62	638708	0	30	79 05	638976	4	0	1 (1)	2	
						Mi d	363 9.69	6426 46	358 3.89	638926	102		79 33	641664	2	0	2 (2)	208	
					Hi gh	367 9.98	6453 32	347 9.46	631964	504		79 61	644352	4	0	2 (2)	1012		
30+50  (2)	C C 1	30	30	78	Dow nlink	Lo w	356 5.02	6376 68	355 0.98	636732	0	30	78 85	637056	12	0	3 (3)	6	
					&	Mi d	360 0	6400 00	354 9.24	636616	102		79 09	639360	8	0	2 (2)	208	
					Uplin k	Hi gh	363 5.28	6423 52	343 9.8	629320	504		79 33	641664	8	0	0 (0)	1008	
	Channel spacing CC1-CC2=39.72 MHz (Note 1)																		
	C C 2	50	30	133	Dow nlink	Lo w	360 4.74	6403 16	358 0.8	638720	0	30	79 05	638976	16	0	0 (0)	0	
						Mi d	363 9.72	6426 48	357 9.06	638604	102		79 30	641376	12	0	3 (3)	210	
					Hi gh	367 5	6450 00	346 9.62	631308	504		79 54	643680	12	0	1 (1)	1010		
30+60  (2)	C C 1	30	30	78	Dow nlink	Lo w	356 5.02	6376 68	355 0.98	636732	0	30	78 85	637056	12	0	3 (3)	6	
					&	Mi d	359 4.99	6396 66	354 4.23	636282	102		79 05	638976	6	0	0 (0)	204	
					Uplin k	Hi gh	362 5.23	6416 82	342 9.75	628650	504		79 26	640992	6	0	0 (0)	1008	
	Channel spacing CC1-CC2=44.76 MHz (Note 1)																		
	C C 2	60	30	162	Dow nlink	Lo w	360 9.78	6406 52	358 0.62	638708	0	30	79 05	638976	4	0	1 (1)	2	

					Mid	363 9.75	6426 50	357 3.87	638258	102		79 26	640992	22	0	1 (1)	206	
					High	366 9.99	6446 66	345 9.39	630626	504		79 47	643008	22	0	1 (1)	1010	
30+70	CC1	30	30	78	Downlink	Low	356 5.02	6376 68	355 0.98	636732	0	30	78 85	637056	12	0	3 (3)	6
(2)					&	Mid	359 0.01	6393 34	353 9.25	635950	102		79 02	638688	2	0	2 (2)	208
					Uplink	High	361 5.18	6410 12	341 9.7	627980	504		79 19	640320	4	0	0 (0)	1008
Channel spacing CC1-CC2=49.8 MHz (Note 1)																		
	CC2	70	30	189	Downlink	Low	361 4.82	6409 88	358 0.8	638720	0	30	79 05	638976	16	0	0 (0)	0
						Mid	363 9.81	6426 54	356 9.07	637938	102		79 23	640704	6	0	3 (3)	210
						High	366 4.98	6443 32	344 9.52	629968	504		79 40	642336	8	0	1 (1)	1010
40+10	CC1	40	30	106	Downlink	Low	357 0	6380 00	355 0.92	636728	0	30	78 85	637056	16	0	3 (3)	6
(2)					&	Mid	362 0.01	6413 34	356 4.21	637614	102		79 19	640320	18	0	0 (0)	204
					Uplink	High	367 0.62	6447 08	347 0.1	631340	504		79 54	643680	4	0	0 (0)	1008
Channel spacing CC1-CC2=24.36 MHz (Note 1)																		
	CC2	10	30	24	Downlink	Low	359 4.36	6396 24	359 0.04	639336	0	30	79 12	639648	0	0	3 (3)	6
						Mid	364 4.37	6429 58	360 3.33	640222	102		79 46	642912	2	0	0 (0)	204
						High	369 4.98	6463 32	350 9.22	633948	504		79 82	646368	12	0	3 (3)	1014
40+15	CC1	40	30	106	Downlink	Low	357 0	6380 00	355 0.92	636728	0	30	78 85	637056	16	0	3 (3)	6
(2)					&	Mid	361 7.49	6411 66	356 1.69	637446	102		79 18	640224	18	0	3 (3)	210
					Uplink	High	366 5.61	6443 74	346 5.09	631006	504		79 51	643392	2	0	2 (2)	1012
Channel spacing CC1-CC2=26.88 MHz (Note 1)																		

	C C 2	15	30	38	Dow nlink	Lo w	359 6.88	6397 92	359 0.04	639336	0	30	79 12	639648	0	0	3 (3)	6
						Mi d	364 4.37	6429 58	360 0.81	640054	102		79 45	642816	2	0	3 (3)	210
						Hi gh	369 2.49	6461 66	350 4.21	633614	504		79 78	645984	10	0	1 (1)	1010
40+20  (2)	C C 1	40	30	106	Dow nlink	Lo w	357 0	6380 00	355 0.92	636728	0	30	78 85	637056	16	0	3 (3)	6
					&	Mi d	361 5	6410 00	355 9.2	637280	102		79 16	640032	16	0	2 (2)	208
					Uplin k	Hi gh	366 0.3	6440 20	345 9.78	630652	504		79 47	643008	20	0	0 (0)	1008
Channel spacing CC1-CC2=29.7 MHz (Note 1)																		
	C C 2	20	30	51	Dow nlink	Lo w	359 9.7	6399 80	359 0.52	639368	0	30	79 12	639648	16	0	1 (1)	2
						Mi d	364 4.7	6429 80	359 8.8	639920	102		79 43	642624	16	0	0 (0)	204
						Hi gh	369 0	6460 00	349 9.38	633292	504		79 75	645696	20	0	2 (2)	1012
40+30  (2)	C C 1	40	30	106	Dow nlink	Lo w	357 0	6380 00	355 0.92	636728	0	30	78 85	637056	16	0	3 (3)	6
					&	Mi d	360 9.99	6406 66	355 4.19	636946	102		79 12	639648	14	0	0 (0)	204
					Uplin k	Hi gh	365 0.31	6433 54	344 9.79	629986	504		79 40	642336	14	0	0 (0)	1008
Channel spacing CC1-CC2=34.68 MHz (Note 1)																		
	C C 2	30	30	78	Dow nlink	Lo w	360 4.68	6403 12	359 0.64	639376	0	30	79 12	639648	8	0	1 (1)	2
						Mi d	364 4.67	6429 78	359 3.91	639594	102		79 40	642336	6	0	2 (2)	208
						Hi gh	368 4.99	6456 66	348 9.51	632634	504		79 68	645024	6	0	2 (2)	1012
20+40  (1,2)	C C 1	20	30	51	Dow nlink	Lo w	356 0.01	6373 34	355 0.83	636722	0	30	78 85	637056	22	0	3 (3)	6
					&	Mi d	360 5.01	6403 34	355 9.11	637274	102		79 16	640032	22	0	2 (2)	208

				Uplink	High	365 0.28	6433 52	345 9.66	630644	504		79 47	643008	4	0	1 (1)	1010	
Channel spacing CC1-CC2=29.7 MHz (Note 1)																		
20+50  (1,2)	CC2	40	30	106	Downlink	Low	358 9.71	6393 14	357 0.63	638042	0	30	78 98	638304	22	0	0 (0)	0
						Mid	363 4.71	6423 14	357 8.91	638594	102		79 30	641376	22	0	3 (3)	210
						High	367 9.98	6453 32	347 9.46	631964	504		79 61	644352	4	0	2 (2)	1012
	CC1	20	30	51	Downlink	Low	356 0.01	6373 34	355 0.83	636722	0	30	78 85	637056	22	0	3 (3)	6
					&	Mid	360 0	6400 00	355 4.1	636940	102		79 12	639648	20	0	0 (0)	204
					Uplink	High	364 0.26	6426 84	344 9.64	629976	504		79 40	642336	0	0	1 (1)	1010
Channel spacing CC1-CC2=34.74 MHz (Note 1)																		
20+60  (1,2)	CC2	50	30	133	Downlink	Low	359 4.75	6396 50	357 0.81	638054	0	30	78 98	638304	10	0	0 (0)	0
						Mid	363 4.74	6423 16	357 4.08	638272	102		79 26	640992	8	0	1 (1)	206
						High	367 5	6450 00	346 9.62	631308	504		79 54	643680	12	0	1 (1)	1010
	CC1	20	30	51	Downlink	Low	356 0.01	6373 34	355 0.83	636722	0	30	78 85	637056	22	0	3 (3)	6
					&	Mid	359 4.99	6396 66	354 9.09	636606	102		79 09	639360	18	0	2 (2)	208
					Uplink	High	363 0.21	6420 14	343 9.59	629306	504		79 33	641664	22	0	0 (0)	1008
Channel spacing CC1-CC2=39.78 MHz (Note 1)																		
	CC2	60	30	162	Downlink	Low	359 9.79	6399 86	357 0.63	638042	0	30	78 98	638304	22	0	0 (0)	0
						Mid	363 4.77	6423 18	356 8.89	637926	102		79 23	640704	18	0	3 (3)	210
						High	366 9.99	6446 66	345 9.39	630626	504		79 47	643008	22	0	1 (1)	1010

20+80	C	20	30	51	Downlink	Low	356 0.01	6373 34	355 0.83	636722	0	30	78 85	637056	22	0	3 (3)	6
	C				&	Mid	358 5	6390 00	353 9.1	635940	102		79 02	638688	12	0	2 (2)	208
	C				Uplink	High	361 0.14	6406 76	341 9.52	627968	504		79 19	640320	16	0	0 (0)	1008
Channel spacing CC1-CC2=49.86 MHz (Note 1)																		
40+40	C	80	30	217	Downlink	Low	360 9.87	6406 58	357 0.81	638054	0	30	78 98	638304	10	0	0 (0)	0
	C					Mid	363 4.86	6423 24	355 9.08	637272	102		79 16	640032	0	0	3 (3)	210
	C					High	366 0	6440 00	343 9.5	629300	504		79 33	641664	4	0	1 (1)	1010
40+40	C	40	30	106	Downlink	Low	357 0	6380 00	355 0.92	636728	0	30	78 85	637056	16	0	3 (3)	6
	C				&	Mid	360 5.01	6403 34	354 9.21	636614	102		79 09	639360	10	0	2 (2)	208
	C				Uplink	High	364 0.02	6426 68	343 9.5	629300	504		79 33	641664	4	0	1 (1)	1010
Channel spacing CC1-CC2=39.96 MHz (Note 1)																		
40+50	C	40	30	106	Downlink	Low	360 9.96	6406 64	359 0.88	639392	0	30	79 12	639648	16	0	0 (0)	0
	C					Mid	364 4.97	6429 98	358 9.17	639278	102		79 37	642048	10	0	3 (3)	210
	C					High	367 9.98	6453 32	347 9.46	631964	504		79 61	644352	4	0	2 (2)	1012
40+50	C	40	30	106	Downlink	Low	357 0	6380 00	355 0.92	636728	0	30	78 85	637056	16	0	3 (3)	6
	C				&	Mid	360 0	6400 00	354 4.2	636280	102		79 05	638976	8	0	0 (0)	204
	C				Uplink	High	363 0.06	6420 04	342 9.54	628636	504		79 26	640992	20	0	0 (0)	1008
Channel spacing CC1-CC2=44.94 MHz (Note 1)																		
C	50	30	133	Downlink	Low	361 4.94	6409 96	359 1	639400	0	30	79 12	639648	8	0	0 (0)	0	

40+60 (1,2)					Mid	364 4.94	6429 96	358 4.28	638952	102		79 33	641664	0	0	1 (1)	206	
					High	367 5	6450 00	346 9.62	631308	504		79 54	643680	12	0	1 (1)	1010	
	CC1	40	30	106	Downlink	Low	357 0	6380 00	355 0.92	636728	0	30	78 85	637056	16	0	3 (3)	6
					&	Mid	359 4.99	6396 66	353 9.19	635946	102		79 02	638688	6	0	2 (2)	208
					Uplink	High	362 0.07	6413 38	341 9.55	627970	504		79 19	640320	14	0	0 (0)	1008
	Channel spacing CC1-CC2=49.92 MHz (Note 1)																	
	CC2	60	30	162	Downlink	Low	361 9.92	6413 28	359 0.76	639384	0	30	79 12	639648	0	0	1 (1)	2
						Mid	364 4.91	6429 94	357 9.03	638602	102		79 30	641376	14	0	3 (3)	210
						High	366 9.99	6446 66	345 9.39	630626	504		79 47	643008	22	0	1 (1)	1010
	Note 1:		Corresponds to nominal channel spacing in accordance with TS 38.101-1 [7], clause 5.4A.1 for the CC1 and CC2 channel bandwidth combination.															
Note 2:		CCs are specified in increasing frequency order. CC1 is used as PCell if nothing else is specified in the test case.																
Note 3:		The parameter Offset Carrier CORESET#0 specifies the offset from the lowest subcarrier of the carrier and the lowest subcarrier of CORESET#0. It corresponds to the parameter $\Delta F_{\text{OffsetCORESET-0-Carrier}}$ in Annex C expressed in number of common RBs.																
Note 4:		The CORESET#0 Index and the associated CORESET#0 Offset refers to Table 13-4 in TS 38.213 [22]. The value of CORESET#0 Index is signalled in controlResourceSetZero (pdcch-ConfigSIB1) in the MIB. The offsetToPointA IE is expressed in units of resource blocks assuming 15 kHz subcarrier spacing for FR1 and 60 kHz subcarrier spacing for FR2.																
Note 5:		UL CA is only supported for BCS0. I.e. the test frequencies for uplink CC2 are only supported for BCS0.																

4.3.1.1.3.49 – 4.3.1.1.3.65 FFS

4.3.1.1.3.66 NR Intra-band contiguous configurations CA\_n66

4.3.1.1.3.66.1 CA\_n66B

Editor's note: Test frequencies for CA\_n66B with mixed numerology with SCS CC1=15kHz and SCS CC2=30 kHz or 60kHz; and SCS CC1=30kHz and SCS CC2=15 kHz or 60 kHz is FFS.

Table 4.3.1.1.3.66.1-1: NR Intra-Band contiguous CA configuration CA\_n66B (PCC=CC1 and SCC=CC2), SCS 15 kHz

CBW combination	CC Number	CBW [MHz]	SCS [kHz]	carrierBandwidth [PRBs]	Range	Carrier centre [MHz] Note 2	Carrier centre [ARFCN]	point A [MHz]	absoluteFrequencyPointA [ARFCN]	offsetToCarrier [Carrier PRBs]	SS block SCS [kHz]	GS CN	absoluteFrequencySSB [ARFCN]	$k_{SSB}$	Offset carrier CORE SET#0 [RBs] Note 3	CORE SET#0 Index (Offset [RBs]) Note 4	offsetToPointA (SIB1) [PRBs] Note 4		
5+20	CC1	5	15	25	Downlink	Low	211.25	422500	211.025	422050	0	15	5279	422410	0	0	0 (0)	0	
						Middle	214.5	429000	212.439	424878	102		5361	428910	0	0	0 (0)	102	
						High	217.5	435500	208.453	416906	504		5443	435410	0	0	0 (0)	504	
					Uplink	Low	171.25	342500	171.025	342050	0		-	-	-	-	-	-	-
						Middle	174.5	349000	165.203	330406	504		-	-	-	-	-	-	
						High	177.5	355500	177.417	354834	6		-	-	-	-	-	-	
	Channel spacing CC1-CC2=12 MHz (Note 1)																		
	CC2	20	15	106	Downlink	Low	212.45	424900	211.496	422992	0	15	5291	423370	6	0	0 (0)	0	
						Middle	215.7	431400	212.91	425820	102		5373	429870	6	0	0 (0)	102	
						High	218.95	437900	208.924	417848	504		5455	436370	6	0	0 (0)	504	
	5+40	CC1	5	15	25	Downlink	Low	211.25	422500	211.025	422050	0	15	5279	422410	0	0	0 (0)	0
							Middle	213.53	427060	211.469	422938	102		5336	426970	0	0	0 (0)	102
High							215.81	431620	206.513	413026	504	5393		431530	0	0	0 (0)	504	
Uplink						Low	171.25	342500	171.025	342050	0	-		-	-	-	-	-	

						Mi d	173 5.3	3470 60	164 2.33	328466	504		-	-	-	-	-	-
						Hi gh	175 8.1	3516 20	175 4.77	350954	6		-	-	-	-	-	-
Channel spacing CC1-CC2=21.9 MHz (Note 1)																		
	C C 2	40	15	216	Dow nlink	Lo w	213 4.4	4268 80	211 4.96	422992	0	15	52 91	423370	6	0	0 (0)	0
						Mi d	215 7.2	4314 40	211 9.4	423880	102		53 48	427930	6	0	0 (0)	102
						Hi gh	218 0	4360 00	206 9.84	413968	504		54 05	432490	6	0	0 (0)	504
10+15	C C 1	10	15	52	Dow nlink	Lo w	211 5	4230 00	211 0.32	422064	0	15	52 80	422430	2	0	0 (0)	0
						Mi d	214 5	4290 00	212 1.96	424392	102		53 55	428430	2	0	0 (0)	102
						Hi gh	217 5	4350 00	207 9.6	415920	504		54 30	434430	2	0	0 (0)	504
					Uplin k	Lo w	171 5	3430 00	171 0.32	342064	0	-	-	-	-	-	-	-
						Mi d	174 5	3490 00	164 9.6	329920	504		-	-	-	-	-	-
						Hi gh	177 5	3550 00	176 9.24	353848	6		-	-	-	-	-	-
Channel spacing CC1-CC2=12.3 MHz (Note 1)																		
	C C 2	15	15	79	Dow nlink	Lo w	212 7.3	4254 60	212 0.19	424038	0	15	53 07	424590	4	1	2 (4)	5
						Mi d	215 7.3	4314 60	213 1.83	426366	102		53 82	430590	4	1	2 (4)	107
						Hi gh	218 7.3	4374 60	208 9.47	417894	504		54 57	436590	4	1	2 (4)	509
10+20	C C 1	10	15	52	Dow nlink	Lo w	211 5	4230 00	211 0.32	422064	0	15	52 80	422430	2	0	0 (0)	0
						Mi d	214 5	4290 00	212 1.96	424392	102		53 55	428430	2	0	0 (0)	102
						Hi gh	217 5	4350 00	207 9.6	415920	504		54 30	434430	2	0	0 (0)	504
					Uplin k	Lo w	171 5	3430 00	171 0.32	342064	0	-	-	-	-	-	-	-



						Mi d	174 5	3490 00	164 9.6	329920	504		-	-	-	-	-	-
						Hi gh	177 5	3550 00	176 9.24	353848	6		-	-	-	-	-	-
Channel spacing CC1-CC2=14.4 MHz (Note 1)																		
	C C 2	20	15	106	Dow nlink	Lo w	212 9.4	4258 80	211 9.86	423972	0	15	53 04	424350	6	0	0 (0)	0
						Mi d	215 9.4	4318 80	213 1.5	426300	102		53 79	430350	6	0	0 (0)	102
						Hi gh	218 9.4	4378 80	208 9.14	417828	504		54 54	436350	6	0	0 (0)	504
10+40	C C 1	10	15	52	Dow nlink	Lo w	211 5	4230 00	211 0.32	422064	0	15	52 80	422430	2	0	0 (0)	0
						Mi d	213 5.4	4270 80	211 2.36	422472	102		53 31	426510	2	0	0 (0)	102
						Hi gh	215 5.7	4311 40	206 0.3	412060	504		53 81	430570	2	0	0 (0)	504
					Upl ink	Lo w	171 5	3430 00	171 0.32	342064	0	-	-	-	-	-	-	-
						Mi d	173 5.4	3470 80	164 0	328000	504		-	-	-	-	-	-
						Hi gh	175 5.7	3511 40	174 9.94	349988	6		-	-	-	-	-	-
Channel spacing CC1-CC2=24.3 MHz (Note 1)																		
	C C 2	40	15	216	Dow nlink	Lo w	213 9.3	4278 60	211 9.86	423972	0	15	53 04	424350	6	0	0 (0)	0
						Mi d	215 9.7	4319 40	212 1.9	424380	102		53 55	428430	6	0	0 (0)	102
						Hi gh	218 0	4360 00	206 9.84	413968	504		54 05	432490	6	0	0 (0)	504
15+10	C C 1	15	15	79	Dow nlink	Lo w	211 7.5	4235 00	211 0.39	422078	0	15	52 81	422450	4	0	0 (0)	0
						Mi d	214 5	4290 00	211 9.53	423906	102		53 49	427950	4	0	0 (0)	102
						Hi gh	217 2.5	4345 00	207 4.67	414934	504		54 17	433450	4	0	0 (0)	504
					Upl ink	Lo w	171 7.5	3435 00	171 0.39	342078	0	-	-	-	-	-	-	-

						Mi d	174 5	3490 00	164 7.17	329434	504		-	-	-	-	-	-
						Hi gh	177 2.5	3545 00	176 4.31	352862	6		-	-	-	-	-	-
Channel spacing CC1-CC2=12.3 MHz (Note 1)																		
	C C 2	10	15	52	Dow nlink	Lo w	212 9.8	4259 60	212 5.12	425024	0	15	53 20	425570	2	1	2 (4)	5
						Mi d	215 7.3	4314 60	213 4.26	426852	102		53 88	431070	2	1	2 (4)	107
						Hi gh	218 4.8	4369 60	208 9.4	417880	504		54 56	436570	2	1	2 (4)	509
15+15	C C 1	15	15	79	Dow nlink	Lo w	211 7.5	4235 00	211 0.39	422078	0	15	52 81	422450	4	0	0 (0)	0
						Mi d	214 5	4290 00	211 9.53	423906	102		53 49	427950	4	0	0 (0)	102
						Hi gh	217 2.5	4345 00	207 4.67	414934	504		54 17	433450	4	0	0 (0)	504
					Uplin k	Lo w	171 7.5	3435 00	171 0.39	342078	0	-	-	-	-	-	-	-
						Mi d	174 5	3490 00	164 7.17	329434	504		-	-	-	-	-	-
						Hi gh	177 2.5	3545 00	176 4.31	352862	6		-	-	-	-	-	-
Channel spacing CC1-CC2=15 MHz (Note 1)																		
	C C 2	15	15	79	Dow nlink	Lo w	213 2.5	4265 00	212 5.39	425078	0	15	53 20	425570	8	1	1 (2)	3
						Mi d	216 0	4320 00	213 4.53	426906	102		53 88	431070	8	1	1 (2)	105
						Hi gh	218 7.5	4375 00	208 9.67	417934	504		54 56	436570	8	1	1 (2)	507
15+20	C C 1	15	15	79	Dow nlink	Lo w	211 7.5	4235 00	211 0.39	422078	0	15	52 81	422450	4	0	0 (0)	0
						Mi d	214 5	4290 00	211 9.53	423906	102		53 49	427950	4	0	0 (0)	102
						Hi gh	217 2.5	4345 00	207 4.67	414934	504		54 17	433450	4	0	0 (0)	504
					Uplin k	Lo w	171 7.5	3435 00	171 0.39	342078	0	-	-	-	-	-	-	-

						Mi d	174 5	3490 00	164 7.17	329434	504		-	-	-	-	-	-
						Hi gh	177 2.5	3545 00	176 4.31	352862	6		-	-	-	-	-	-
Channel spacing CC1-CC2=17.1 MHz (Note 1)																		
	C C 2	20	15	106	Dow nlink	Lo w	213 4.6	4269 20	212 5.06	425012	0	15	53 20	425570	6	1	2 (4)	5
						Mi d	216 2.1	4324 20	213 4.2	426840	102		53 88	431070	6	1	2 (4)	107
						Hi gh	218 9.6	4379 20	208 9.34	417868	504		54 56	436570	6	1	2 (4)	509
20+5	C C 1	20	15	106	Dow nlink	Lo w	212 0	4240 00	211 0.46	422092	0	15	52 82	422650	6	1	2 (4)	5
						Mi d	214 5	4290 00	211 7.1	423420	102		53 43	427470	6	0	0 (0)	102
						Hi gh	217 0	4340 00	206 9.74	413948	504		54 07	432530	2	0	1 (2)	506
					Uplin k	Lo w	172 0	3440 00	171 0.46	342092	0	-	-	-	-	-	-	-
						Mi d	174 5	3490 00	164 4.74	328948	504		-	-	-	-	-	-
						Hi gh	177 0	3540 00	175 9.38	351876	6		-	-	-	-	-	-
Channel spacing CC1-CC2=12 MHz (Note 1)																		
	C C 2	5	15	25	Dow nlink	Lo w	213 2	4264 00	212 9.75	425950	0	15	53 30	426490	0	1	2 (4)	5
						Mi d	215 7	4314 00	213 6.39	427278	102		53 91	431310	0	0	0 (0)	102
						Hi gh	218 2	4364 00	208 9.03	417806	504		54 55	436370	8	1	0 (0)	505
20+10	C C 1	20	15	106	Dow nlink	Lo w	212 0	4240 00	211 0.46	422092	0	15	52 82	422650	6	1	2 (4)	5
						Mi d	214 5	4290 00	211 7.1	423420	102		53 43	427470	6	0	0 (0)	102
						Hi gh	217 0	4340 00	206 9.74	413948	504		54 07	432530	2	0	1 (2)	506
					Uplin k	Lo w	172 0	3440 00	171 0.46	342092	0	-	-	-	-	-	-	-

						Mi d	174 5	3490 00	164 4.74	328948	504		-	-	-	-	-	-
						Hi gh	177 0	3540 00	175 9.38	351876	6		-	-	-	-	-	-
Channel spacing CC1-CC2=14.4 MHz (Note 1)																		
	C C 2	10	15	52	Dow nlink	Lo w	213 4.4	4268 80	212 9.72	425944	0	15	53 30	426490	2	1	2 (4)	5
						Mi d	215 9.4	4318 80	213 6.36	427272	102		53 91	431310	2	0	0 (0)	102
						Hi gh	218 4.4	4368 80	208 9	417800	504		54 55	436370	10	1	0 (0)	505
20+15	C C 1	20	15	106	Dow nlink	Lo w	212 0	4240 00	211 0.46	422092	0	15	52 82	422650	6	1	2 (4)	5
						Mi d	214 5	4290 00	211 7.1	423420	102		53 43	427470	6	0	0 (0)	102
						Hi gh	217 0	4340 00	206 9.74	413948	504		54 07	432530	2	0	1 (2)	506
					Uplin k	Lo w	172 0	3440 00	171 0.46	342092	0	-	-	-	-	-	-	-
						Mi d	174 5	3490 00	164 4.74	328948	504		-	-	-	-	-	-
						Hi gh	177 0	3540 00	175 9.38	351876	6		-	-	-	-	-	-
Channel spacing CC1-CC2=17.1 MHz (Note 1)																		
	C C 2	15	15	79	Dow nlink	Lo w	213 7.1	4274 20	212 9.99	425998	0	15	53 30	426490	8	1	1 (2)	3
						Mi d	216 2.1	4324 20	213 6.63	427326	102		53 94	431550	4	1	2 (4)	107
						Hi gh	218 7.1	4374 20	208 9.27	417854	504		54 55	436370	4	0	0 (0)	504
40+5	C C 1	40	15	216	Dow nlink	Lo w	213 0	4260 00	211 0.56	422112	0	15	52 83	422670	6	1	2 (4)	5
						Mi d	214 5	4290 00	210 7.2	421440	102		53 19	425550	2	0	1 (2)	104
						Hi gh	216 0	4320 00	204 9.84	409968	504		53 58	428670	6	1	2 (4)	509
					Uplin k	Lo w	173 0	3460 00	171 0.56	342112	0	-	-	-	-	-	-	-

						Mi d	174 5	3490 00	163 4.84	326968	504		-	-	-	-	-	-
						Hi gh	176 0	3520 00	173 9.48	347896	6		-	-	-	-	-	-
Channel spacing CC1-CC2=21.9 MHz (Note 1)																		
	C C 2	5	15	25	Dow nlink	Lo w	215 1.9	4303 80	214 9.65	429930	0	15	53 79	430350	8	1	0 (0)	1
						Mi d	216 6.9	4333 80	214 6.29	429258	102		54 18	433470	0	1	2 (4)	107
						Hi gh	218 1.9	4363 80	208 8.93	417786	504		54 54	436350	8	1	0 (0)	505
40+10	C C 1	40	15	216	Dow nlink	Lo w	213 0	4260 00	211 0.56	422112	0	15	52 83	422670	6	1	2 (4)	5
						Mi d	214 5	4290 00	210 7.2	421440	102		53 19	425550	2	0	1 (2)	104
						Hi gh	216 0	4320 00	204 9.84	409968	504		53 58	428670	6	1	2 (4)	509
					Upl ink	Lo w	173 0	3460 00	171 0.56	342112	0	-	-	-	-	-	-	-
						Mi d	174 5	3490 00	163 4.84	326968	504		-	-	-	-	-	-
						Hi gh	176 0	3520 00	173 9.48	347896	6		-	-	-	-	-	-
Channel spacing CC1-CC2=24.3 MHz (Note 1)																		
	C C 2	10	15	52	Dow nlink	Lo w	215 4.3	4308 60	214 9.62	429924	0	15	53 79	430350	10	1	0 (0)	1
						Mi d	216 9.3	4338 60	214 6.26	429252	102		54 18	433470	2	1	2 (4)	107
						Hi gh	218 4.3	4368 60	208 8.9	417780	504		54 54	436350	10	1	0 (0)	505
<p>Note 1: Corresponds to nominal channel spacing in accordance with TS 38.101-1 [7], clause 5.4A.1 for the CC1 and CC2 channel bandwidth combination.</p> <p>Note 2: CCs are specified in increasing frequency order. CC1 is used as PCell if nothing else is specified in the test case.</p> <p>Note 3: The parameter Offset Carrier CORESET#0 specifies the offset from the lowest subcarrier of the carrier and the lowest subcarrier of CORESET#0. It corresponds to the parameter <math>\Delta F_{\text{OffsetCORESET-0-Carrier}}</math> in Annex C expressed in number of common RBs.</p> <p>Note 4: The CORESET#0 Index and the associated CORESET#0 Offset refers to Table 13-1 in TS 38.213 [22]. The value of CORESET#0 Index is signalled in controlResourceSetZero (pdcch-ConfigSIB1) in the MIB. The offsetToPointA IE is expressed in units of resource blocks assuming 15 kHz subcarrier spacing for FR1 and 60 kHz subcarrier spacing for FR2.</p>																		

Table 4.3.1.1.3.66.1-2: NR Intra-Band contiguous CA configuration CA\_n66B (PCC=CC1 and SCC=CC2), SCS 30 kHz

CBW combination	CCN of 2	CBW [MHz]	SCS [kHz]	carrierBandwidth [PRBs]	Range		Carrier centre [MHz] Note 2	Carrier centre [ARFCN]	point A [MHz]	absoluteFrequencyPointA [ARFCN]	offsetToCarrier [Carrier PRBs]	SS block SCS [kHz]	GS CN	absoluteFrequencySSB [ARFCN]	$k_{SSB}$	Offset carrier CORE SET#0 [RBs] Note 3	CORE SET#0 Index (Offset [RBs]) Note 4	offsetToPointA (SIB1) [PRBs] Note 4		
10+15	CC1	10	30	24	Downlink	Low	211.5	4230.00	211.0.68	422136	0	15	52.86	422910	18	0	0 (5)	10		
						Mid	214.5	4290.00	210.3.96	420792	102			53.61	428910	18	0	0 (5)	214	
						High	217.5	4350.00	198.9.24	397848	504			54.36	434910	18	0	0 (5)	1018	
					Uplink	Low	171.5	3430.00	171.0.68	342136	0		-	-	-	-	-	-		
						Mid	174.5	3490.00	155.9.24	311848	504		-	-	-	-	-	-		
						High	177.5	3550.00	176.8.52	353704	6		-	-	-	-	-	-		
	Channel spacing CC1-CC2=12.3 MHz (Note 1)																			
	CC2	15	30	38	Downlink	Low	212.7.3	4254.60	212.0.46	424092	0	15	53.10	424830	6	0	0 (5)	10		
						Mid	215.7.3	4314.60	211.3.74	422748	102			53.85	430830	6	0	0 (5)	214	
						High	218.7.3	4374.60	199.9.02	399804	504			54.60	436830	6	0	0 (5)	1018	
	10+20	CC1	10	30	24	Downlink	Low	211.5	4230.00	211.0.68	422136	0	15	52.86	422910	18	0	0 (5)	10	
							Mid	214.5	4290.00	210.3.96	420792	102			53.61	428910	18	0	0 (5)	214
							High	217.5	4350.00	198.9.24	397848	504			54.36	434910	18	0	0 (5)	1018
Uplink						Low	171.5	3430.00	171.0.68	342136	0	-	-	-	-	-	-			

						Mid	174 5	3490 00	155 9.24	311848	504		-	-	-	-	-	-
						High	177 5	3550 00	176 8.52	353704	6		-	-	-	-	-	-
Channel spacing CC1-CC2=14.4 MHz (Note 1)																		
	CC2	20	30	51	Downlink	Low	212 9.4	4258 80	212 0.22	424044	0	15	53 10	424830	22	0	0 (5)	10
						Mid	215 9.4	4318 80	211 3.5	422700	102		53 85	430830	22	0	0 (5)	214
						High	218 9.4	4378 80	199 8.78	399756	504		54 60	436830	22	0	0 (5)	1018
10+40	CC1	10	30	24	Downlink	Low	211 5	4230 00	211 0.68	422136	0	15	52 86	422910	18	0	0 (5)	10
						Mid	213 5.4	4270 80	209 4.36	418872	102		53 37	426990	18	0	0 (5)	214
						High	215 5.7	4311 40	196 9.94	393988	504		53 87	431050	18	0	0 (5)	1018
					Uplink	Low	171 5	3430 00	171 0.68	342136	0	-	-	-	-	-	-	-
						Mid	173 5.4	3470 80	154 9.64	309928	504		-	-	-	-	-	-
						High	175 5.7	3511 40	174 9.22	349844	6		-	-	-	-	-	-
Channel spacing CC1-CC2=24.3 MHz (Note 1)																		
	CC2	40	30	106	Downlink	Low	213 9.3	4278 60	212 0.22	424044	0	15	53 10	424830	22	0	0 (5)	10
						Mid	215 9.7	4319 40	210 3.9	420780	102		53 61	428910	22	0	0 (5)	214
						High	218 0	4360 00	197 9.48	395896	504		54 11	432970	22	0	0 (5)	1018
15+10	CC1	15	30	38	Downlink	Low	211 7.5	4235 00	211 0.66	422132	0	15	52 87	422930	2	0	1 (6)	12
						Mid	214 5	4290 00	210 1.44	420288	102		53 55	428430	2	0	1 (6)	216
						High	217 2.5	4345 00	198 4.22	396844	504		54 23	433930	2	0	1 (6)	1020
					Uplink	Low	171 7.5	3435 00	171 0.66	342132	0	-	-	-	-	-	-	-

						Mid	174 5	3490 00	155 6.72	311344	504		-	-	-	-	-	-
						High	177 2.5	3545 00	176 3.5	352700	6		-	-	-	-	-	-
Channel spacing CC1-CC2=12.3 MHz (Note 1)																		
	CC2	10	30	24	Downlink	Low	212 9.8	4259 60	212 5.48	425096	0	15	53 26	426050	6	0	3 (8)	16
						Mid	215 7.3	4314 60	211 6.26	423252	102		53 94	431550	6	0	3 (8)	220
						High	218 4.8	4369 60	199 9.04	399808	504		54 62	437050	6	0	3 (8)	1024
15+15	CC1	15	30	38	Downlink	Low	211 7.5	4235 00	211 0.66	422132	0	15	52 87	422930	2	0	1 (6)	12
						Mid	214 5	4290 00	210 1.44	420288	102		53 55	428430	2	0	1 (6)	216
						High	217 2.5	4345 00	198 4.22	396844	504		54 23	433930	2	0	1 (6)	1020
					Uplink	Low	171 7.5	3435 00	171 0.66	342132	0	-	-	-	-	-	-	-
						Mid	174 5	3490 00	155 6.72	311344	504		-	-	-	-	-	-
						High	177 2.5	3545 00	176 3.5	352700	6		-	-	-	-	-	-
Channel spacing CC1-CC2=15 MHz (Note 1)																		
	CC2	15	30	38	Downlink	Low	213 2.5	4265 00	212 5.66	425132	0	15	53 26	426050	18	0	2 (7)	14
						Mid	216 0	4320 00	211 6.44	423288	102		53 94	431550	18	0	2 (7)	218
						High	218 7.5	4375 00	199 9.22	399844	504		54 62	437050	18	0	2 (7)	1022
15+20	CC1	15	30	38	Downlink	Low	211 7.5	4235 00	211 0.66	422132	0	15	52 87	422930	2	0	1 (6)	12
						Mid	214 5	4290 00	210 1.44	420288	102		53 55	428430	2	0	1 (6)	216
						High	217 2.5	4345 00	198 4.22	396844	504		54 23	433930	2	0	1 (6)	1020
					Uplink	Low	171 7.5	3435 00	171 0.66	342132	0	-	-	-	-	-	-	-



						Mid	174.5	3490.00	155.672	311344	504		-	-	-	-	-	-
						High	177.25	3545.00	176.3.5	352700	6		-	-	-	-	-	-
Channel spacing CC1-CC2=17.1 MHz (Note 1)																		
	CC2	20	30	51	Downlink	Low	213.4.6	4269.20	212.5.42	425084	0	15	53.23	425810	2	0	0 (5)	10
						Mid	216.2.1	4324.20	211.6.2	423240	102		53.91	431310	2	0	0 (5)	214
						High	218.9.6	4379.20	199.8.98	399796	504		54.59	436810	2	0	0 (5)	1018
20+10	CC1	20	30	51	Downlink	Low	212.0	4240.00	211.0.82	422164	0	15	52.85	422890	2	0	0 (5)	10
						Mid	214.5	4290.00	209.9.1	419820	102		53.49	427950	22	0	0 (5)	214
						High	217.0	4340.00	197.9.38	395876	504		54.13	433010	18	0	1 (6)	1020
					Uplink	Low	172.0	3440.00	171.0.82	342164	0	-	-	-	-	-	-	-
						Mid	174.5	3490.00	155.4.38	310876	504		-	-	-	-	-	-
						High	177.0	3540.00	175.8.66	351732	6		-	-	-	-	-	-
Channel spacing CC1-CC2=14.4 MHz (Note 1)																		
	CC2	10	30	24	Downlink	Low	213.4.4	4268.80	213.0.08	426016	0	15	53.36	426970	6	0	3 (8)	16
						Mid	215.9.4	4318.80	211.8.36	423672	102		53.97	431790	18	0	0 (5)	214
						High	218.4.4	4368.80	199.8.64	399728	504		54.61	436850	14	0	1 (6)	1020
20+15	CC1	20	30	51	Downlink	Low	212.0	4240.00	211.0.82	422164	0	15	52.85	422890	2	0	0 (5)	10
						Mid	214.5	4290.00	209.9.1	419820	102		53.49	427950	22	0	0 (5)	214
						High	217.0	4340.00	197.9.38	395876	504		54.13	433010	18	0	1 (6)	1020
					Uplink	Low	172.0	3440.00	171.0.82	342164	0	-	-	-	-	-	-	-

						Mid	1745	349000	1554.38	310876	504		-	-	-	-	-	-
						High	1770	354000	1758.66	351732	6		-	-	-	-	-	-
Channel spacing CC1-CC2=17.1 MHz (Note 1)																		
	CC2	15	30	38	Downlink	Low	2137.1	427420	2130.26	426052	0	15	5336	426970	18	0	2 (7)	14
						Mid	2162.1	432420	2118.54	423708	102		5397	431790	6	0	0 (5)	214
						High	2187.1	437420	1998.82	399764	504		5461	436850	2	0	1 (6)	1020
40+10	CC1	40	30	106	Downlink	Low	2130	426000	2110.92	422184	0	15	5286	422910	2	0	0 (5)	10
						Mid	2145	429000	2089.2	417840	102		5325	426030	18	0	1 (6)	216
						High	2160	432000	1959.48	391896	504		5361	428910	2	0	0 (5)	1018
					Uplink	Low	1730	346000	1710.92	342184	0	-	-	-	-	-	-	-
						Mid	1745	349000	1544.48	308896	504		-	-	-	-	-	-
						High	1760	352000	1738.76	347752	6		-	-	-	-	-	-
Channel spacing CC1-CC2=24.3 MHz (Note 1)																		
	CC2	10	30	24	Downlink	Low	2154.3	430860	2149.98	429996	0	15	5385	430830	14	0	1 (6)	12
						Mid	2169.3	433860	2128.26	425652	102		5424	433950	6	0	3 (8)	220
						High	2184.3	436860	1998.54	399708	504		5460	436830	14	0	1 (6)	1020
<p>Note 1: Corresponds to nominal channel spacing in accordance with TS 38.101-1 [7], clause 5.4A.1 for the CC1 and CC2 channel bandwidth combination.</p> <p>Note 2: CCs are specified in increasing frequency order. CC1 is used as PCell if nothing else is specified in the test case.</p> <p>Note 3: The parameter Offset Carrier CORESET#0 specifies the offset from the lowest subcarrier of the carrier and the lowest subcarrier of CORESET#0. It corresponds to the parameter <math>\Delta F_{\text{OffsetCORESET-0-Carrier}}</math> in Annex C expressed in number of common RBs.</p> <p>Note 4: The CORESET#0 Index and the associated CORESET#0 Offset refers to Table 13-2 in TS 38.213 [22]. The value of CORESET#0 Index is signalled in controlResourceSetZero (pdccch-ConfigSIB1) in the MIB. The offsetToPointA IE is expressed in units of resource blocks assuming 15 kHz subcarrier spacing for FR1 and 60 kHz subcarrier spacing for FR2.</p>																		

4.3.1.1.3.67 – 4.3.1.1.3.76 FFS

4.3.1.1.3.77 NR Intra-band contiguous configurations CA\_n77

4.3.1.1.3.77.1 CA\_n77C

Editor's note: Test frequencies for CA\_n78C with mixed numerology with SCS CC1=15kHz and SCS CC2=30 kHz or 60kHz; and SCS CC1=30kHz and SCS CC2=15 kHz or 60 kHz is FFS.

Table 4.3.1.1.3.77.1-1: NR Intra-Band contiguous CA configuration CA\_n77C (PCC=CC1 and SCC=CC2), SCS 30 kHz

CBW combination (BCS)	CCN	CBW [MHz]	SCS [kHz]	carrierBandwidth [PRBs]	Range		Carrier centre [MHz] Note 2	Carrier centre [ARFCN]	point A [MHz]	absoluteFrequencyPointA [ARFCN]	offsetToCarrier [Carrier PRBs]	SSB block SCS [kHz]	GSCN	absoluteFrequencySSB [ARFCN]	$k_s$	Offset carrier CORE SET#0 [RBs] Note 3	CORE SET#0 Index (Offset [RBs]) Note 4	offsetToPointA (SIB1) [PRBs] Note 4	
					Downlink	Uplink													
10+100 (1)	CC1	10	30	24	Downlink	Low	330	6203	330	620046	0	30	77	620352	18	0	2 (2)	4	
						Mid	369	6466	365	643930	102			79	646656	14	0	1 (1)	206
						Uplink	409	6730	390	660642	504			82	673056	6	0	3 (3)	1014
	Channel spacing CC1-CC2=54,6 MHz (Note 1)																		
	CC2	10	30	273	Downlink	Low	335	6239	331	620698	0	30	77	621024	14	0	3 (3)	6	
						Mid	375	6503	366	644582	102			79	647328	10	0	2 (2)	208
Uplink						414	6766	391	661294	504	82			673632	2	0	0 (0)	1008	

15+90  (1)	C C 1	15	30	38	Dow nlink  &  Upli nk	Lo w	330 7,5	6205 00	330 0,66	620044	0	30	77 11	620352	20	0	2 (2)	4	
						Mi d	370 5	6470 00	366 1,44	644096	102		79 87	646848	16	0	2 (2)	208	
						Hi gh	410 2,92	6735 28	391 4,64	660976	504		82 63	673344	8	0	1 (1)	1010	
	Channel spacing CC1-CC2=52,08 MHz (Note 1)																		
	C C 2	90	30	245	Dow nlink  &  Upli nk	Lo w	335 9,58	6239 72	331 5,48	621032	0	30	77 21	621312	16	0	1 (1)	2	
						Mi d	375 7,08	6504 72	367 6,26	645084	102		79 97	647808	12	0	1 (1)	206	
Hi gh						415 5	6770 00	392 9,46	661964	504	82 73		674304	4	0	0 (0)	1008		
15+10 0  (1)	C C 1	15	30	38	Dow nlink  &  Upli nk	Lo w	330 7,5	6205 00	330 0,66	620044	0	30	77 11	620352	20	0	2 (2)	4	
						Mi d	369 9,99	6466 66	365 6,43	643762	102		79 83	646464	14	0	0 (0)	204	
						Hi gh	409 2,87	6728 58	390 4,59	660306	504		82 56	672672	6	0	1 (1)	1010	
	Channel spacing CC1-CC2=57,12 MHz (Note 1)																		
	C C 2	10 0	30	273	Dow nlink  &  Upli nk	Lo w	336 4,62	6243 08	331 5,48	621032	0	30	77 21	621312	16	0	1 (1)	2	
						Mi d	375 7,11	6504 74	367 1,25	644750	102		79 94	647520	10	0	3 (3)	210	
Hi gh						414 9,99	6766 66	391 9,41	661294	504	82 66		673632	2	0	0 (0)	1008		
20+90  (1)	C C 1	20	30	51	Dow nlink  &  Upli nk	Lo w	331 0,02	6206 68	330 0,84	620056	0	30	77 11	620352	8	0	2 (2)	4	
						Mi d	370 5	6470 00	365 9,1	643940	102		79 85	646656	4	0	1 (1)	206	
						Hi gh	410 0,1	6733 40	390 9,48	660632	504		82 60	673056	16	0	3 (3)	1014	
	Channel spacing CC1-CC2=54,9 MHz (Note 1)																		
	C C 2	90	30	245	Dow nlink	Lo w	336 4,92	6243 28	332 0,82	621388	0	30	77 25	621696	20	0	2 (2)	4	

20+100 (1)	C C 1	20	30	51	&	Mid	375 9,9	6506 60	367 9,08	645272	102	30	79 99	648000	16	0	1 (1)	206	
					Uplink	High	415 5	6770 00	392 9,46	661964	504		82 73	674304	4	0	0 (0)	1008	
					Downdlink	Low	331 0,02	6206 68	330 0,84	620056	0		77 11	620352	8	0	2 (2)	4	
					&	Mid	369 9,99	6466 66	365 4,09	643606	102		79 82	646368	2	0	3 (3)	210	
	Uplink	High	409 0,05	6726 70	389 9,43	659962	504	82 53	672384	14	0	3 (3)	1014						
	Channel spacing CC1-CC2=59,94 MHz (Note 1)																		
	C C 2	10 0	30	273	Downdlink	Low	336 9,96	6246 64	332 0,82	621388	0	30	77 25	621696	20	0	2 (2)	4	
	&	Mid	375 9,93	6506 62	367 4,07	644938	102	79 96	647712	14	0	3 (3)	210						
	Uplink	High	414 9,99	6766 66	391 9,41	661294	504	82 66	673632	2	0	0 (0)	1008						
	25+80 (1)	C C 1	25	30	65	Downdlink	Low	331 2,51	6208 34	330 0,81	620054	0	30	77 11	620352	10	0	2 (2)	4
&						Mid	371 0,01	6473 34	366 1,59	644106	102	79 87	646848	6	0	2 (2)	208		
Uplink						High	410 7,66	6738 44	391 4,52	660968	504	82 63	673344	16	0	1 (1)	1010		
Channel spacing CC1-CC2=52,32 MHz (Note 1)																			
C C 2	80	30	217	Downdlink	Low	336 4,83	6243 22	332 5,77	621718	0	30	77 28	621984	2	0	1 (1)	2		
&	Mid	376 2,33	6508 22	368 6,55	645770	102	80 04	648480	22	0	0 (0)	204							
Uplink	High	415 9,98	6773 32	393 9,48	662632	504	82 80	674976	8	0	0 (0)	1008							
25+90 (1)	C C 1	25	30	65	Downdlink	Low	331 2,51	6208 34	330 0,81	620054	0	30	77 11	620352	10	0	2 (2)	4	
					&	Mid	370 5	6470 00	365 6,58	643772	102	79 83	646464	4	0	0 (0)	204		
					Uplink	High	409 7,64	6731 76	390 4,5	660300	504	82 56	672672	12	0	1 (1)	1010		
					Channel spacing CC1-CC2=57,36 MHz (Note 1)														

	C C 2	90	30	245	Dow nlink  &  Upli nk	Lo w	336 9,87	6246 58	332 5,77	621718	0	30	77 28	621984	2	0	1 (1)	2
						Mi d	376 2,36	6508 24	368 1,54	645436	102		80 01	648192	20	0	2 (2)	208
						Hi gh	415 5	6770 00	392 9,46	661964	504		82 73	674304	4	0	0 (0)	1008
25+10 0  (1)	C C 1	25	30	65	Dow nlink  &  Upli nk	Lo w	331 2,51	6208 34	330 0,81	620054	0	30	77 11	620352	10	0	2 (2)	4
						Mi d	369 9,99	6466 66	365 1,57	643438	102		79 80	646176	2	0	2 (2)	208
						Hi gh	408 7,59	6725 06	389 4,45	659630	504		82 49	672000	10	0	1 (1)	1010
Channel spacing CC1-CC2=62,4 MHz (Note 1)																		
	C C 2	10 0	30	273	Dow nlink  &  Upli nk	Lo w	337 4,91	6249 94	332 5,77	621718	0	30	77 28	621984	2	0	1 (1)	2
						Mi d	376 2,39	6508 26	367 6,53	645102	102		79 97	647808	18	0	0 (0)	204
						Hi gh	414 9,99	6766 66	391 9,41	661294	504		82 66	673632	2	0	0 (0)	1008
30+80  (1)	C C 1	30	30	78	Dow nlink  &  Upli nk	Lo w	331 5	6210 00	330 0,96	620064	0	30	77 11	620352	0	0	2 (2)	4
						Mi d	371 0,01	6473 34	365 9,25	643950	102		79 85	646656	18	0	0 (0)	204
						Hi gh	410 5,14	6736 76	390 9,66	660644	504		82 60	673056	4	0	3 (3)	1014
Channel spacing CC1-CC2=54,84 MHz (Note 1)																		
	C C 2	80	30	217	Dow nlink  &  Upli nk	Lo w	336 9,84	6246 56	333 0,78	622052	0	30	77 32	622368	4	0	3 (3)	6
						Mi d	376 4,85	6509 90	368 9,07	645938	102		80 06	648672	22	0	1 (1)	206
						Hi gh	415 9,98	6773 32	393 9,48	662632	504		82 80	674976	8	0	0 (0)	1008
30+90  (1)	C C 1	30	30	78	Dow nlink  &	Lo w	331 5	6210 00	330 0,96	620064	0	30	77 11	620352	0	0	2 (2)	4
						Mi d	370 5	6470 00	365 4,24	643616	102		79 82	646368	16	0	2 (2)	208

					Uplink	High	409 5,12	6730 08	389 9,64	659976	504		82 53	672384	0	0	3 (3)	1014	
Channel spacing CC1-CC2=59,88 MHz (Note 1)																			
	CC2	90	30	245	Downlink	Low	337 4,88	6249 92	333 0,78	622052	0	30	77 32	622368	4	0	3 (3)	6	
					&	Mid	376 4,88	6509 92	368 4,06	645604	102		80 03	648384	20	0	3 (3)	210	
					Uplink	High	415 5	6770 00	392 9,46	661964	504		82 73	674304	4	0	0 (0)	1008	
30+100 (1)	CC1	30	30	78	Downlink	Low	331 5	6210 00	330 0,96	620064	0	30	77 11	620352	0	0	2 (2)	4	
					&	Mid	369 9,99	6466 66	364 9,23	643282	102		79 78	645984	14	0	0 (0)	204	
					Uplink	High	408 5,07	6723 38	388 9,59	659306	504		82 46	671712	22	0	2 (2)	1012	
	Channel spacing CC1-CC2=64,92 MHz (Note 1)																		
		CC2	100	30	273	Downlink	Low	337 9,92	6253 28	333 0,78	622052	0	30	77 32	622368	4	0	3 (3)	6
						&	Mid	376 4,91	6509 94	367 9,05	645270	102		79 99	648000	18	0	1 (1)	206
					Uplink	High	414 9,99	6766 66	391 9,41	661294	504		82 66	673632	2	0	0 (0)	1008	
40+70 (1)	CC1	40	30	106	Downlink	Low	332 0,01	6213 34	330 0,93	620062	0	30	77 11	620352	2	0	2 (2)	4	
					&	Mid	371 4,99	6476 66	365 9,19	643946	102		79 85	646656	22	0	0 (0)	204	
					Uplink	High	411 0,15	6740 10	390 9,63	660642	504		82 60	673056	6	0	3 (3)	1014	
	Channel spacing CC1-CC2=54,84 MHz (Note 1)																		
		CC2	70	30	189	Downlink	Low	337 4,85	6249 90	334 0,83	622722	0	30	77 39	623040	6	0	3 (3)	6
						&	Mid	376 9,83	6513 22	369 9,09	646606	102		80 13	649344	2	0	2 (2)	208
					Uplink	High	416 4,99	6776 66	394 9,53	663302	504		82 87	675648	10	0	0 (0)	1008	

40+80  (1)	C C 1	40	30	106	Dow nlink  &  Upli nk	Lo w	332 0,01	6213 34	330 0,93	620062	0	30	77 11	620352	2	0	2 (2)	4	
						Mi d	371 0,01	6473 34	365 4,21	643614	102		79 82	646368	18	0	2 (2)	208	
						Hi gh	410 0,16	6733 44	389 9,64	659976	504		82 53	672384	0	0	3 (3)	1014	
	Channel spacing CC1-CC2=59,82 MHz (Note 1)																		
	C C 2	80	30	217	Dow nlink  &  Upli nk	Lo w	337 9,83	6253 22	334 0,77	622718	0	30	77 39	623040	10	0	3 (3)	6	
						Mi d	376 9,83	6513 22	369 4,05	646270	102		80 09	648960	2	0	0 (0)	204	
Hi gh						415 9,98	6773 32	393 9,48	662632	504	82 80		674976	8	0	0 (0)	1008		
40+90  (1)	C C 1	40	30	106	Dow nlink  &  Upli nk	Lo w	332 0,01	6213 34	330 0,93	620062	0	30	77 11	620352	2	0	2 (2)	4	
						Mi d	370 5	6470 00	364 9,2	643280	102		79 78	645984	16	0	0 (0)	204	
						Hi gh	409 0,2	6726 80	388 9,68	659312	504		82 46	671712	16	0	2 (2)	1012	
	Channel spacing CC1-CC2=64,8 MHz (Note 1)																		
	C C 2	90	30	245	Dow nlink  &  Upli nk	Lo w	338 4,81	6256 54	334 0,71	622714	0	30	77 39	623040	14	0	3 (3)	6	
						Mi d	376 9,8	6513 20	368 8,98	645932	102		80 06	648672	4	0	2 (2)	208	
Hi gh						415 5	6770 00	392 9,46	661964	504	82 73		674304	4	0	0 (0)	1008		
40+10 0  (1)	C C 1	40	30	106	Dow nlink  &  Upli nk	Lo w	332 0,01	6213 34	330 0,93	620062	0	30	77 11	620352	2	0	2 (2)	4	
						Mi d	369 9,99	6466 66	364 4,19	642946	102		79 75	645696	14	0	2 (2)	208	
						Hi gh	408 0,27	6720 18	387 9,75	658650	504		82 39	671040	6	0	2 (2)	1012	
	Channel spacing CC1-CC2=69,72 MHz (Note 1)																		
	C C 2	10 0	30	273	Dow nlink	Lo w	338 9,73	6259 82	334 0,59	622706	0	30	77 39	623040	22	0	3 (3)	6	



50+60 (0,1)	C C 1	50	30	133	&	Mid	376 9,71	6513 14	368 3,85	645590	102	30	80 02	648288	10	0	0 (0)	204
					Uplink	High	414 9,99	6766 66	391 9,41	661294	504		82 66	673632	2	0	0 (0)	1008
					Downdlink	Low	332 5,02	6216 68	330 1,08	620072	0		77 11	620352	16	0	1 (1)	2
					&	Mid	372 0	6480 00	365 9,34	643956	102		79 85	646656	12	0	0 (0)	204
					Uplink	High	411 5,04	6743 36	390 9,66	660644	504		82 60	673056	4	0	3 (3)	1014
					Channel spacing CC1-CC2=54,96 MHz (Note 1)													
	C C 2	60	30	162	Downdlink	Low	337 9,98	6253 32	335 0,82	623388	0	30	77 46	623712	12	0	3 (3)	6
					&	Mid	377 4,96	6516 64	370 9,08	647272	102		80 20	650016	8	0	2 (2)	208
					Uplink	High	417 0	6780 00	395 9,4	663960	504		82 94	676320	0	0	1 (1)	1010
	50+70 (1)	C C 1	50	30	133	Downdlink	Low	332 5,02	6216 68	330 1,08	620072	0	30	77 11	620352	16	0	1 (1)
&						Mid	371 4,99	6476 66	365 4,33	643622	102	79 82		646368	10	0	2 (2)	208
Uplink						High	410 5,11	6736 74	389 9,73	659982	504	82 53		672384	18	0	2 (2)	1012
Channel spacing CC1-CC2=59,88 MHz (Note 1)																		
C C 2		70	30	189	Downdlink	Low	338 4,9	6256 60	335 0,88	623392	0	30	77 46	623712	8	0	3 (3)	6
					&	Mid	377 4,87	6516 58	370 4,13	646942	102		80 16	649632	2	0	0 (0)	204
	Uplink				High	416 4,99	6776 66	394 9,53	663302	504	82 87		675648	10	0	0 (0)	1008	
50+80 (0,1)	C C 1	50	30	133	Downdlink	Low	332 5,02	6216 68	330 1,08	620072	0	30	77 11	620352	16	0	1 (1)	2
					&	Mid	371 0,01	6473 34	364 9,35	643290	102		79 78	645984	6	0	0 (0)	204
					Uplink	High	409 5,12	6730 08	388 9,74	659316	504		82 46	671712	12	0	2 (2)	1012
					Channel spacing CC1-CC2=64,86 MHz (Note 1)													

	C C 2	80	30	217	Dow nlink  &  Upli nk	Lo w	338 9,88	6259 92	335 0,82	623388	0	30	77 46	623712	12	0	3 (3)	6
						Mi d	377 4,87	6516 58	369 9,09	646606	102		80 13	649344	2	0	2 (2)	208
						Hi gh	415 9,98	6773 32	393 9,48	662632	504		82 80	674976	8	0	0 (0)	1008
50+90  (1)	C C 1	50	30	133	Dow nlink  &  Upli nk	Lo w	332 5,02	6216 68	330 1,08	620072	0	30	77 11	620352	16	0	1 (1)	2
						Mi d	370 5	6470 00	364 4,34	642956	102		79 75	645696	4	0	2 (2)	208
						Hi gh	408 5,16	6723 44	387 9,78	658652	504		82 39	671040	4	0	2 (2)	1012
Channel spacing CC1-CC2=69,84 MHz (Note 1)																		
	C C 2	90	30	245	Dow nlink  &  Upli nk	Lo w	339 4,86	6263 24	335 0,76	623384	0	30	77 46	623712	16	0	3 (3)	6
						Mi d	377 4,84	6516 56	369 4,02	646268	102		80 09	648960	4	0	0 (0)	204
						Hi gh	415 5	6770 00	392 9,46	661964	504		82 73	674304	4	0	0 (0)	1008
50+10 0  (0,1)	C C 1	50	30	133	Dow nlink  &  Upli nk	Lo w	332 5,02	6216 68	330 1,08	620072	0	30	77 11	620352	16	0	1 (1)	2
						Mi d	369 9,99	6466 66	363 9,33	642622	102		79 71	645312	2	0	0 (0)	204
						Hi gh	407 5,23	6716 82	386 9,85	657990	504		82 32	670368	18	0	1 (1)	1010
Channel spacing CC1-CC2=74,76 MHz (Note 1)																		
	C C 2	10 0	30	273	Dow nlink  &  Upli nk	Lo w	339 9,78	6266 52	335 0,64	623376	0	30	77 45	623616	0	0	0 (0)	0
						Mi d	377 4,75	6516 50	368 8,89	645926	102		80 06	648672	10	0	2 (2)	208
						Hi gh	414 9,99	6766 66	391 9,41	661294	504		82 66	673632	2	0	0 (0)	1008
60+60  (0,1)	C C 1	60	30	162	Dow nlink  &	Lo w	333 0	6220 00	330 0,84	620056	0	30	77 11	620352	8	0	2 (2)	4
						Mi d	372 0	6480 00	365 4,12	643608	102		79 82	646368	0	0	3 (3)	210

					Uplink	High	4110	674000	3899,4	659960	504		8253	672384	16	0	3 (3)	1014
Channel spacing CC1-CC2=60 MHz (Note 1)																		
	CC2	60	30	162	Downlink	Low	3390	626000	3360,84	624056	0	30	7753	624384	16	0	3 (3)	6
					&	Mid	3780	652000	3714,12	647608	102		8023	650304	8	0	0 (0)	204
					Uplink	High	4170	678000	3959,4	663960	504		8294	676320	0	0	1 (1)	1010
60+70	CC1	60	30	162	Downlink	Low	3330	622000	3300,84	620056	0	30	7711	620352	8	0	2 (2)	4
(1)					&	Mid	3714,99	647666	3649,11	643274	102		7978	645984	22	0	0 (0)	204
					Uplink	High	4100,07	673338	3889,47	659298	504		8246	671712	6	0	3 (3)	1014
Channel spacing CC1-CC2=64,92 MHz (Note 1)																		
	CC2	70	30	189	Downlink	Low	3394,92	626328	3360,9	624060	0	30	7753	624384	12	0	3 (3)	6
					&	Mid	3779,91	651994	3709,17	647278	102		8020	650016	2	0	2 (2)	208
					Uplink	High	4164,99	677666	3949,53	663302	504		8287	675648	10	0	0 (0)	1008
60+80	CC1	60	30	162	Downlink	Low	3330	622000	3300,84	620056	0	30	7711	620352	8	0	2 (2)	4
(0,1)					&	Mid	3710,01	647334	3644,13	642942	102		7975	645696	18	0	2 (2)	208
					Uplink	High	4090,08	672672	3879,48	658632	504		8239	671040	0	0	3 (3)	1014
Channel spacing CC1-CC2=69,9 MHz (Note 1)																		
	CC2	80	30	217	Downlink	Low	3399,9	626660	3360,84	624056	0	30	7753	624384	16	0	3 (3)	6
					&	Mid	3779,91	651994	3704,13	646942	102		8016	649632	2	0	0 (0)	204
					Uplink	High	4159,98	677332	3939,48	662632	504		8280	674976	8	0	0 (0)	1008

60+90 (1)	C C 1	60	30	162	Dow nlink  &  Upli nk	Lo w	333 0	6220 00	330 0,84	620056	0	30	77 11	620352	8	0	2 (2)	4
						Mi d	370 5	6470 00	363 9,12	642608	102		79 71	645312	16	0	0 (0)	204
						Hi gh	408 0,12	6720 08	386 9,52	657968	504		82 32	670368	16	0	2 (2)	1012
	Channel spacing CC1-CC2=74,88 MHz (Note 1)																	
C C 2	90	30	245	Dow nlink  &  Upli nk	Lo w	340 4,88	6269 92	336 0,78	624052	0	30	77 53	624384	20	0	3 (3)	6	
					Mi d	377 9,88	6519 92	369 9,06	646604	102		80 13	649344	4	0	2 (2)	208	
					Hi gh	415 5	6770 00	392 9,46	661964	504		82 73	674304	4	0	0 (0)	1008	
60+10 0 (0,1)	C C 1	60	30	162	Dow nlink  &  Upli nk	Lo w	333 0	6220 00	330 0,84	620056	0	30	77 11	620352	8	0	2 (2)	4
						Mi d	369 9,99	6466 66	363 4,11	642274	102		79 68	645024	14	0	2 (2)	208
						Hi gh	407 0,19	6713 46	385 9,59	657306	504		82 25	669696	6	0	2 (2)	1012
	Channel spacing CC1-CC2=79,8 MHz (Note 1)																	
C C 2	10 0	30	273	Dow nlink  &  Upli nk	Lo w	340 9,8	6273 20	336 0,66	624044	0	30	77 52	624288	4	0	0 (0)	0	
					Mi d	377 9,79	6519 86	369 3,93	646262	102		80 09	648960	10	0	0 (0)	204	
					Hi gh	414 9,99	6766 66	391 9,41	661294	504		82 66	673632	2	0	0 (0)	1008	
70+60 (1)	C C 1	70	30	189	Dow nlink  &  Upli nk	Lo w	333 5,01	6223 34	330 0,99	620066	0	30	77 11	620352	22	0	1 (1)	2
						Mi d	372 0	6480 00	364 9,26	643284	102		79 78	645984	12	0	0 (0)	204
						Hi gh	410 5,08	6736 72	388 9,62	659308	504		82 46	671712	20	0	2 (2)	1012
	Channel spacing CC1-CC2=64,92 MHz (Note 1)																	
C C 2	60	30	162	Dow nlink	Lo w	339 9,93	6266 62	337 0,77	624718	0	30	77 59	624960	2	0	0 (0)	0	

					&	Mid	378 4,92	6523 28	371 9,04	647936	102		80 27	650688	16	0	2 (2)	208
					Uplink	High	417 0	6780 00	395 9,4	663960	504		82 94	676320	0	0	1 (1)	1010
70+70 (1)	CC1	70	30	189	Downlink	Low	333 5,01	6223 34	330 0,99	620066	0	30	77 11	620352	22	0	1 (1)	2
					&	Mid	371 4,99	6476 66	364 4,25	642950	102		79 75	645696	10	0	2 (2)	208
					Uplink	High	409 5,03	6730 02	387 9,57	658638	504		82 39	671040	18	0	2 (2)	1012
Channel spacing CC1-CC2=69,96 MHz (Note 1)																		
	CC2	70	30	189	Downlink	Low	340 4,97	6269 98	337 0,95	624730	0	30	77 60	625056	14	0	3 (3)	6
					&	Mid	378 4,95	6523 30	371 4,21	647614	102		80 23	650304	2	0	0 (0)	204
					Uplink	High	416 4,99	6776 66	394 9,53	663302	504		82 87	675648	10	0	0 (0)	1008
70+80 (1)	CC1	70	30	189	Downlink	Low	333 5,01	6223 34	330 0,99	620066	0	30	77 11	620352	22	0	1 (1)	2
					&	Mid	371 0,01	6473 34	363 9,27	642618	102		79 71	645312	6	0	0 (0)	204
					Uplink	High	408 5,04	6723 36	386 9,58	657972	504		82 32	670368	12	0	2 (2)	1012
Channel spacing CC1-CC2=74,94 MHz (Note 1)																		
	CC2	80	30	217	Downlink	Low	340 9,95	6273 30	337 0,89	624726	0	30	77 60	625056	18	0	3 (3)	6
					&	Mid	378 4,95	6523 30	370 9,17	647278	102		80 20	650016	2	0	2 (2)	208
					Uplink	High	415 9,98	6773 32	393 9,48	662632	504		82 80	674976	8	0	0 (0)	1008
70+90 (1)	CC1	70	30	189	Downlink	Low	333 5,01	6223 34	330 0,99	620066	0	30	77 11	620352	22	0	1 (1)	2
					&	Mid	370 5	6470 00	363 4,26	642284	102		79 68	645024	4	0	2 (2)	208
					Uplink	High	407 5,08	6716 72	385 9,62	657308	504		82 25	669696	4	0	2 (2)	1012
Channel spacing CC1-CC2=79,92 MHz (Note 1)																		

	C C 2	90	30	245	Dow nlink  &  Upli nk	Lo w	341 4,93	6276 62	337 0,83	624722	0	30	77 60	625056	22	0	3 (3)	6
						Mi d	378 4,92	6523 28	370 4,1	646940	102		80 16	649632	4	0	0 (0)	204
						Hi gh	415 5	6770 00	392 9,46	661964	504		82 73	674304	4	0	0 (0)	1008
70+10 0  (1)	C C 1	70	30	189	Dow nlink  &  Upli nk	Lo w	333 5,01	6223 34	330 0,99	620066	0	30	77 11	620352	22	0	1 (1)	2
						Mi d	369 9,99	6466 66	362 9,25	641950	102		79 64	644640	2	0	0 (0)	204
						Hi gh	406 5,15	6710 10	384 9,69	656646	504		82 18	669024	18	0	1 (1)	1010
Channel spacing CC1-CC2=84,84 MHz (Note 1)																		
	C C 2	10 0	30	273	Dow nlink  &  Upli nk	Lo w	341 9,85	6279 90	337 0,71	624714	0	30	77 59	624960	6	0	0 (0)	0
						Mi d	378 4,83	6523 22	369 8,97	646598	102		80 13	649344	10	0	2 (2)	208
						Hi gh	414 9,99	6766 66	391 9,41	661294	504		82 66	673632	2	0	0 (0)	1008
80+60  (1)	C C 1	80	30	217	Dow nlink  &  Upli nk	Lo w	334 0,02	6226 68	330 0,96	620064	0	30	77 11	620352	0	0	2 (2)	4
						Mi d	372 0	6480 00	364 4,22	642948	102		79 75	645696	12	0	2 (2)	208
						Hi gh	410 0,1	6733 40	387 9,6	658640	504		82 39	671040	16	0	2 (2)	1012
Channel spacing CC1-CC2=69,9 MHz (Note 1)																		
	C C 2	60	30	162	Dow nlink  &  Upli nk	Lo w	340 9,92	6273 28	338 0,76	625384	0	30	77 66	625632	8	0	0 (0)	0
						Mi d	378 9,9	6526 60	372 4,02	648268	102		80 30	650976	20	0	0 (0)	204
						Hi gh	417 0	6780 00	395 9,4	663960	504		82 94	676320	0	0	1 (1)	1010
80+70  (1)	C C 1	80	30	217	Dow nlink  &	Lo w	334 0,02	6226 68	330 0,96	620064	0	30	77 11	620352	0	0	2 (2)	4
						Mi d	371 4,99	6476 66	363 9,21	642614	102		79 71	645312	10	0	0 (0)	204

					Uplink	High	409,05	672670	3869,55	657970	504		8232	670368	14	0	2 (2)	1012
Channel spacing CC1-CC2=74,94 MHz (Note 1)																		
	CC2	70	30	189	Downlink	Low	3414,96	627664	3380,94	625396	0	30	7767	625728	20	0	3 (3)	6
					&	Mid	3789,93	652662	3719,19	647946	102		8027	650688	6	0	2 (2)	208
					Uplink	High	4164,99	677666	3949,53	663302	504		8287	675648	10	0	0 (0)	1008
80+80	CC1	80	30	217	Downlink	Low	3340,02	622668	3300,96	620064	0	30	7711	620352	0	0	2 (2)	4
(0,1)					&	Mid	3710,01	647334	3634,23	642282	102		7968	645024	6	0	2 (2)	208
					Uplink	High	4080	672000	3859,5	657300	504		8225	669696	12	0	2 (2)	1012
Channel spacing CC1-CC2=79,98 MHz (Note 1)																		
	CC2	80	30	217	Downlink	Low	3420	628000	3380,94	625396	0	30	7767	625728	20	0	3 (3)	6
					&	Mid	3789,99	652666	3714,21	647614	102		8023	650304	2	0	0 (0)	204
					Uplink	High	4159,98	677332	3939,48	662632	504		8280	674976	8	0	0 (0)	1008
80+90	CC1	80	30	217	Downlink	Low	3340,02	622668	3300,96	620064	0	30	7711	620352	0	0	2 (2)	4
(1)					&	Mid	3705	647000	3629,22	641948	102		7964	644640	4	0	0 (0)	204
					Uplink	High	4070,04	671336	3849,54	656636	504		8218	669024	4	0	2 (2)	1012
Channel spacing CC1-CC2=84,96 MHz (Note 1)																		
	CC2	90	30	245	Downlink	Low	3424,98	628332	3380,88	625392	0	30	7766	625632	0	0	0 (0)	0
					&	Mid	3789,96	652664	3709,14	647276	102		8020	650016	4	0	2 (2)	208
					Uplink	High	4155	677000	3929,46	661964	504		8273	674304	4	0	0 (0)	1008

80+100 (0,1)	CC1	80	30	217	Downlink & Uplink	Low	334 0,02	6226 68	330 0,96	620064	0	30	77 11	620352	0	0	2 (2)	4
						Mid	369 9,99	6466 66	362 4,21	641614	102		79 61	644352	2	0	2 (2)	208
						High	406 0,11	6706 74	383 9,61	655974	504		82 11	668352	18	0	1 (1)	1010
	Channel spacing CC1-CC2=89,88 MHz (Note 1)																	
CC2	100	30	273	Downlink & Uplink	Low	342 9,9	6286 60	338 0,76	625384	0	30	77 66	625632	8	0	0 (0)	0	
					Mid	378 9,87	6526 58	370 4,01	646934	102		80 16	649632	10	0	0 (0)	204	
					High	414 9,99	6766 66	391 9,41	661294	504		82 66	673632	2	0	0 (0)	1008	
90+60 (1)	CC1	90	30	245	Downlink & Uplink	Low	334 5	6230 00	330 0,9	620060	0	30	77 11	620352	4	0	2 (2)	4
						Mid	372 0	6480 00	363 9,18	642612	102		79 71	645312	12	0	0 (0)	204
						High	409 5,12	6730 08	386 9,58	657972	504		82 32	670368	12	0	2 (2)	1012
	Channel spacing CC1-CC2=74,88 MHz (Note 1)																	
CC2	60	30	162	Downlink & Uplink	Low	341 9,88	6279 92	339 0,72	626048	0	30	77 73	626304	16	0	0 (0)	0	
					Mid	379 4,88	6529 92	372 9	648600	102		80 34	651360	0	0	3 (3)	210	
					High	417 0	6780 00	395 9,4	663960	504		82 94	676320	0	0	1 (1)	1010	
90+70 (1)	CC1	90	30	245	Downlink & Uplink	Low	334 5	6230 00	330 0,9	620060	0	30	77 11	620352	4	0	2 (2)	4
						Mid	371 4,99	6476 66	363 4,17	642278	102		79 68	645024	10	0	2 (2)	208
						High	408 5,07	6723 38	385 9,53	657302	504		82 25	669696	10	0	2 (2)	1012
	Channel spacing CC1-CC2=79,92 MHz (Note 1)																	
CC2	70	30	189	Downlink	Low	342 4,92	6283 28	339 0,9	626060	0	30	77 73	626304	4	0	0 (0)	0	



90+80  (1)	C C 1	90	30	245	& Uplink	Mid	379 4,91	6529 94	372 4,17	648278	102	30	80 30	650976	10	0	0 (0)	204					
						High	416 4,99	6776 66	394 9,53	663302	504		82 87	675648	10	0	0 (0)	1008					
						Downlink	Low	334 5	6230 00	330 0,9	620060		0	77 11	620352	4	0	2 (2)	4				
					& Uplink	Mid	371 0,01	6473 34	362 9,19	641946	102		79 64	644640	6	0	0 (0)	204					
						High	407 5,02	6716 68	384 9,48	656632	504		82 18	669024	8	0	2 (2)	1012					
						Channel spacing CC1-CC2=84,96 MHz (Note 1)																	
	C C 2	80	30	217	Downlink	Low	342 9,96	6286 64	339 0,9	626060	0	30	77 73	626304	4	0	0 (0)	0					
						& Uplink	Mid	379 4,97	6529 98	371 9,19	647946		102	80 27	650688	6	0	2 (2)	208				
						High	415 9,98	6773 32	393 9,48	662632	504		82 80	674976	8	0	0 (0)	1008					
	90+90  (1)	C C 1	90	30	245	& Uplink	Low	334 5	6230 00	330 0,9	620060	0	30	77 11	620352	4	0	2 (2)	4				
Mid							370 5	6470 00	362 4,18	641612	102	79 61		644352	4	0	2 (2)	208					
High							406 5	6710 00	383 9,46	655964	504	82 11		668352	4	0	2 (2)	1012					
Channel spacing CC1-CC2=90 MHz (Note 1)																							
C C 2						90	30	245	Downlink	Low	343 5	6290 00		339 0,9	626060	0	30	77 73	626304	4	0	0 (0)	0
										& Uplink	Mid	379 5		6530 00	371 4,18	647612		102	80 23	650304	4	0	0 (0)
		High	415 5	6770 00	392 9,46					661964	504	82 73	674304	4	0	0 (0)		1008					
C C 1		90	30	245	Downlink	Low	334 5	6230 00	330 0,9	620060	0	30	77 11	620352	4	0	2 (2)	4					
						& Uplink	Mid	369 9,99	6466 66	361 9,17	641278		102	79 57	643968	2	0	0 (0)	204				
						High	405 5,07	6703 38	382 9,53	655302	504		82 04	667680	18	0	1 (1)	1010					
Channel spacing CC1-CC2=94,92 MHz (Note 1)																							

	C C 2	10 0	30	273	Dow nlink  &  Upli nk	Lo w  Mi d  Hi gh	343 9,92  379 4,91  414 9,99	6293 28  6529 94  6766 66	339 0,78  370 9,05  391 9,41	626052   647270  661294	0   102  504	30	77 73  80 20  82 66	626304   650016  673632	12   10  2	0   0  0	0 (0)   2 (2)  0 (0)	0   208  1008
100+6 0  (1)	C C 1	10 0	30	273	Dow nlink  &  Upli nk	Lo w  Mi d  Hi gh	335 0,01  372 0  409 0,2	6233 34  6480 00  6726 80	330 0,87  363 4,14  385 9,62	620058   642276  657308	0   102  504	30	77 11  79 68  82 25	620352   645024  669696	6   12  4	0   0  0	2 (2)   2 (2)  2 (2)	4   208  1012
Channel spacing CC1-CC2=79,8 MHz (Note 1)																		
	C C 2	60	30	162	Dow nlink  &  Upli nk	Lo w  Mi d  Hi gh	342 9,81  379 9,8  417 0	6286 54  6533 20  6780 00	340 0,65  373 3,92  395 9,4	626710   648928  663960	0   102  504	30	77 80  80 37  82 94	626976   651648  676320	2   8  0	0   0  0	1 (1)   1 (1)  1 (1)	2   206  1010
100+7 0  (1)	C C 1	10 0	30	273	Dow nlink  &  Upli nk	Lo w  Mi d  Hi gh	335 0,01  371 4,99  408 0,15	6233 34  6476 66  6720 10	330 0,87  362 9,13  384 9,57	620058   641942  656638	0   102  504	30	77 11  79 64  82 18	620352   644640  669024	6   10  2	0   0  0	2 (2)   0 (0)  2 (2)	4   204  1012
Channel spacing CC1-CC2=84,84 MHz (Note 1)																		
	C C 2	70	30	189	Dow nlink  &  Upli nk	Lo w  Mi d  Hi gh	343 4,85  379 9,83  416 4,99	6289 90  6533 22  6776 66	340 0,83  372 9,09  394 9,53	626722   648606  663302	0   102  504	30	77 80  80 34  82 87	626976   651360  675648	14   18  10	0   0  0	0 (0)   2 (2)  0 (0)	0   208  1008
100+8 0  (1)	C C 1	10 0	30	273	Dow nlink  &	Lo w  Mi d	335 0,01  371 0,01	6233 34  6473 34	330 0,87  362 4,15	620058   641610	0   102	30	77 11  79 61	620352   644352	6   6	0   0	2 (2)   2 (2)	4   208

					Uplink	High	407,0,1	6713,40	383,9,52	655968	504		82,11	668352	0	0	2 (2)	1012
Channel spacing CC1-CC2=89,88 MHz (Note 1)																		
	CC2	80	30	217	Downlink	Low	343,9,89	6293,26	340,0,83	626722	0	30	77,80	626976	14	0	0 (0)	0
					&	Mid	379,9,89	6533,26	372,4,11	648274	102		80,30	650976	14	0	0 (0)	204
					Uplink	High	415,9,98	6773,32	393,9,48	662632	504		82,80	674976	8	0	0 (0)	1008
100+90	CC1	100	30	273	Downlink	Low	335,0,01	6233,34	330,0,87	620058	0	30	77,11	620352	6	0	2 (2)	4
(1)					&	Mid	370,5	6470,00	361,9,14	641276	102		79,57	643968	4	0	0 (0)	204
					Uplink	High	406,0,08	6706,72	382,9,5	655300	504		82,04	667680	20	0	1 (1)	1010
Channel spacing CC1-CC2=94,92 MHz (Note 1)																		
	CC2	90	30	245	Downlink	Low	344,4,93	6296,62	340,0,83	626722	0	30	77,80	626976	14	0	0 (0)	0
					&	Mid	379,9,92	6533,28	371,9,1	647940	102		80,27	650688	12	0	2 (2)	208
					Uplink	High	415,5	6770,00	392,9,46	661964	504		82,73	674304	4	0	0 (0)	1008
100+100	CC1	100	30	273	Downlink	Low	335,0,01	6233,34	330,0,87	620058	0	30	77,11	620352	6	0	2 (2)	4
(0,1)					&	Mid	369,9,99	6466,66	361,4,13	640942	102		79,54	643680	2	0	2 (2)	208
					Uplink	High	405,0,03	6700,02	381,9,45	654630	504		81,97	667008	18	0	1 (1)	1010
Channel spacing CC1-CC2=99,96 MHz (Note 1)																		
	CC2	100	30	273	Downlink	Low	344,9,97	6299,98	340,0,83	626722	0	30	77,80	626976	14	0	0 (0)	0
					&	Mid	379,9,95	6533,30	371,4,09	647606	102		80,23	650304	10	0	0 (0)	204
					Uplink	High	414,9,99	6766,66	391,9,41	661294	504		82,66	673632	2	0	0 (0)	1008

Note 1: Corresponds to nominal channel spacing in accordance with TS 38.101-1 [7], clause 5.4A.1 for the CC1 and CC2 channel bandwidth combination.

Note 2: CCs are specified in increasing frequency order. CC1 is used as PCell if nothing else is specified in the test case.

Note 3: The parameter Offset Carrier CORESET#0 specifies the offset from the lowest subcarrier of the carrier and the lowest subcarrier of CORESET#0. It corresponds to the parameter  $\Delta F_{\text{OffsetCORESET-0-Carrier}}$  in Annex C expressed in number of common RBs.

Note 4: The CORESET#0 Index and the associated CORESET#0 Offset refers to Table 13-4 in TS 38.213 [22]. The value of CORESET#0 Index is signalled in controlResourceSetZero (pdcc-ConfigSIB1) in the MIB. The offsetToPointA IE is expressed in units of resource blocks assuming 15 kHz subcarrier spacing for FR1 and 60 kHz subcarrier spacing for FR2.

4.3.1.1.3.78 NR Intra-band contiguous configurations CA\_n78

4.3.1.1.3.78.1 CA\_n78C

Editor's note: Test frequencies for CA\_n78C with mixed numerology with SCS CC1=15kHz and SCS CC2=30 kHz or 60kHz; and SCS CC1=30kHz and SCS CC2=15 kHz or 60 kHz is FFS.

Table 4.3.1.1.3.78.1-1: NR Intra-Band contiguous CA configuration CA\_n78C (PCC=CC1 and SCC=CC2), SCS 30 kHz

CBW combination	CCN	CBW [MHz]	SCS [kHz]	carrierBandwidth [PRBs]	Range		Carrier centre [MHz] Note 2	Carrier centre [ARFCN]	point A [MHz]	absoluteFrequencyPointA [ARFCN]	offsetToCarrier [Carrier PRBs]	SSB block SCS [kHz]	GSCN	absoluteFrequencySSB [ARFCN]	$k_s$	Offset carrier CORESET#0 [RBs] Note 3	CORESET#0 Index (Offset [RBs]) Note 4	offsetToPointA (SIB1) [PRBs] Note 4
					Downlink	Uplink												
50+60	C1	50	30	133	Downlink	Low	332 5.02	6216 68	330 1.08	620072	0	30	77 11	620352	16	0	1 (1)	2
					Uplink	Mid	351 9.99	6346 66	345 9.33	630622	102		78 46	633312	2	0	0 (0)	204
						High	371 5.02	6476 68	350 9.64	633976	504		79 82	646368	8	0	2 (2)	1012
Channel spacing CC1-CC2=54.96 MHz (Note 1)																		
	C2	60	30	162	Downlink	Low	337 9.98	6253 32	335 0.82	623388	0	30	77 46	623712	12	0	3 (3)	6

50+80	C C 1	50	30	133	&	Mid	357 4.95	6383 30	350 9.07	633938	102	30	78 81	636672	22	0	1 (1)	206	
					Uplink	High	376 9.98	6513 32	355 9.38	637292	504		80 16	649632	4	0	0 (0)	1008	
					Dow nlink	Low	332 5.02	6216 68	330 1.08	620072	0		77 11	620352	16	0	1 (1)	2	
					&	Mid	351 0	6340 00	344 9.34	629956	102		78 40	632736	20	0	3 (3)	210	
	Uplink	High	369 5.13	6463 42	348 9.75	632650	504	79 68	645024	14	0	1 (1)	1010						
	Channel spacing CC1-CC2=64.86 MHz (Note 1)																		
	C C 2	80	30	217	Dow nlink	Low	338 9.88	6259 92	335 0.82	623388	0	30	77 46	623712	12	0	3 (3)	6	
	&	Mid	357 4.86	6383 24	349 9.08	633272	102	78 74	636000	16	0	1 (1)	206						
	Uplink	High	375 9.99	6506 66	353 9.49	635966	504	80 03	648384	10	0	3 (3)	1014						
	50+10 0	C C 1	50	30	133	Dow nlink	Low	332 5.02	6216 68	330 1.08	620072	0	30	77 11	620352	16	0	1 (1)	2
&						Mid	350 0.01	6333 34	343 9.35	629290	102	78 33	632064	14	0	3 (3)	210		
Uplink						High	367 5.24	6450 16	346 9.86	631324	504	79 54	643680	20	0	0 (0)	1008		
Channel spacing CC1-CC2=74.76 MHz (Note 1)																			
C C 2	10 0	30	273	Dow nlink	Low	339 9.78	6266 52	335 0.64	623376	0	30	77 45	623616	0	0	0 (0)	0		
&	Mid	357 4.77	6383 18	348 8.91	632594	102	78 67	635328	22	0	1 (1)	206							
Uplink	High	375 0	6500 00	351 9.42	634628	504	79 89	647040	4	0	3 (3)	1014							
60+50	C C 1	60	30	162	Dow nlink	Low	333 0	6220 00	330 0.84	620056	0	30	77 11	620352	8	0	2 (2)	4	
					&	Mid	352 5	6350 00	345 9.12	630608	102	78 46	633312	16	0	0 (0)	204		
					Uplink	High	372 0.03	6480 02	350 9.43	633962	504	79 82	646368	22	0	2 (2)	1012		
Channel spacing CC1-CC2=54.96 MHz (Note 1)																			

	CC2	50	30	133	Downlink	Low	338 4.96	6256 64	336 1.02	624068	0	30	77 53	624384	4	0	3 (3)	6
					&	Mid	357 9.96	6386 64	351 9.3	634620	102		78 88	637344	12	0	1 (1)	206
					Uplink	High	377 4.99	6516 66	356 9.61	637974	504		80 24	650400	18	0	3 (3)	1014
60+60	CC1	60	30	162	Downlink	Low	333 0	6220 00	330 0.84	620056	0	30	77 11	620352	8	0	2 (2)	4
					&	Mid	351 9.99	6346 66	345 4.11	630274	102		78 43	633024	14	0	2 (2)	208
					Uplink	High	370 9.98	6473 32	349 9.38	633292	504		79 75	645696	20	0	2 (2)	1012
	Channel spacing CC1-CC2=60 MHz (Note 1)																	
	CC2	60	30	162	Downlink	Low	339 0	6260 00	336 0.84	624056	0	30	77 53	624384	16	0	3 (3)	6
					&	Mid	357 9.99	6386 66	351 4.11	634274	102		78 85	637056	22	0	3 (3)	210
					Uplink	High	376 9.98	6513 32	355 9.38	637292	504		80 16	649632	4	0	0 (0)	1008
60+80	CC1	60	30	162	Downlink	Low	333 0	6220 00	330 0.84	620056	0	30	77 11	620352	8	0	2 (2)	4
					&	Mid	351 0	6340 00	344 4.12	629608	102		78 36	632352	8	0	2 (2)	208
					Uplink	High	369 0.09	6460 06	347 9.49	631966	504		79 61	644352	2	0	2 (2)	1012
	Channel spacing CC1-CC2=69.9 MHz (Note 1)																	
	CC2	80	30	217	Downlink	Low	339 9.9	6266 60	336 0.84	624056	0	30	77 53	624384	16	0	3 (3)	6
					&	Mid	357 9.9	6386 60	350 4.12	633608	102		78 78	636384	16	0	3 (3)	210
					Uplink	High	375 9.99	6506 66	353 9.49	635966	504		80 03	648384	10	0	3 (3)	1014
60+100	CC1	60	30	162	Downlink	Low	333 0	6220 00	330 0.84	620056	0	30	77 11	620352	8	0	2 (2)	4
					&	Mid	350 0.01	6333 34	343 4.13	628942	102		78 29	631680	2	0	2 (2)	208

					Uplink	High	367 0.2	6446 80	345 9.6	630640	504		79 47	643008	8	0	1 (1)	1010	
Channel spacing CC1-CC2=79.8 MHz (Note 1)																			
	CC2	10 0	30	273	Downlink	Low	340 9.8	6273 20	336 0.66	624044	0	30	77 52	624288	4	0	0 (0)	0	
					&	Mid	357 9.81	6386 54	349 3.95	632930	102		78 71	635712	22	0	3 (3)	210	
					Uplink	High	375 0	6500 00	351 9.42	634628	504		79 89	647040	4	0	3 (3)	1014	
80+50	CC1	80	30	217	Downlink	Low	334 0.02	6226 68	330 0.96	620064	0	30	77 11	620352	0	0	2 (2)	4	
					&	Mid	352 5	6350 00	344 9.22	629948	102		78 39	632640	4	0	0 (0)	204	
					Uplink	High	371 0.13	6473 42	348 9.63	632642	504		79 68	645024	22	0	1 (1)	1010	
	Channel spacing CC1-CC2=64.86 MHz (Note 1)																		
		CC2	50	30	133	Downlink	Low	340 4.88	6269 92	338 0.94	625396	0	30	77 67	625728	20	0	3 (3)	6
						&	Mid	358 9.86	6393 24	352 9.2	635280	102		78 95	638016	0	0	2 (2)	208
					Uplink	High	377 4.99	6516 66	356 9.61	637974	504		80 24	650400	18	0	3 (3)	1014	
80+60	CC1	80	30	217	Downlink	Low	334 0.02	6226 68	330 0.96	620064	0	30	77 11	620352	0	0	2 (2)	4	
					&	Mid	351 9.99	6346 66	344 4.21	629614	102		78 36	632352	2	0	2 (2)	208	
					Uplink	High	370 0.08	6466 72	347 9.58	631972	504		79 61	644352	20	0	1 (1)	1010	
	Channel spacing CC1-CC2=69.9 MHz (Note 1)																		
		CC2	60	30	162	Downlink	Low	340 9.92	6273 28	338 0.76	625384	0	30	77 66	625632	8	0	0 (0)	0
						&	Mid	358 9.89	6393 26	352 4.01	634934	102		78 91	637632	10	0	0 (0)	204
					Uplink	High	376 9.98	6513 32	355 9.38	637292	504		80 16	649632	4	0	0 (0)	1008	

80+80	C C 1	80	30	217	Dow nlink  &  Upli nk	Lo w	334 0.02	6226 68	330 0.96	620064	0	30	77 11	620352	0	0	2 (2)	4	
						Mi d	351 0	6340 00	343 4.22	628948	102		78 29	631680	20	0	1 (1)	206	
						Hi gh	368 0.01	6453 34	345 9.51	630634	504		79 47	643008	14	0	1 (1)	1010	
	Channel spacing CC1-CC2=79.98 MHz (Note 1)																		
	C C 2	80	30	217	Dow nlink  &  Upli nk	Lo w	342 0	6280 00	338 0.94	625396	0	30	77 67	625728	20	0	3 (3)	6	
						Mi d	358 9.98	6393 32	351 4.2	634280	102		78 85	637056	16	0	3 (3)	210	
Hi gh						375 9.99	6506 66	353 9.49	635966	504	80 03		648384	10	0	3 (3)	1014		
80+10 0	C C 1	80	30	217	Dow nlink  &  Upli nk	Lo w	334 0.02	6226 68	330 0.96	620064	0	30	77 11	620352	0	0	2 (2)	4	
						Mi d	350 0.01	6333 34	342 4.23	628282	102		78 22	631008	14	0	1 (1)	206	
						Hi gh	366 0.12	6440 08	343 9.62	629308	504		79 33	641664	20	0	0 (0)	1008	
	Channel spacing CC1-CC2=89.88 MHz (Note 1)																		
	C C 2	10 0	30	273	Dow nlink  &  Upli nk	Lo w	342 9.9	6286 60	338 0.76	625384	0	30	77 66	625632	8	0	0 (0)	0	
						Mi d	358 9.89	6393 26	350 4.03	633602	102		78 78	636384	22	0	3 (3)	210	
Hi gh						375 0	6500 00	351 9.42	634628	504	79 89		647040	4	0	3 (3)	1014		
100+5 0	C C 1	10 0	30	273	Dow nlink  &  Upli nk	Lo w	335 0.01	6233 34	330 0.87	620058	0	30	77 11	620352	6	0	2 (2)	4	
						Mi d	352 5	6350 00	343 9.14	629276	102		78 32	631968	4	0	0 (0)	204	
						Hi gh	370 0.23	6466 82	346 9.65	631310	504		79 54	643680	10	0	1 (1)	1010	
	Channel spacing CC1-CC2=74.76 MHz (Note 1)																		
	C C 2	50	30	133	Dow nlink	Lo w	342 4.77	6283 18	340 0.83	626722	0	30	77 80	626976	14	0	0 (0)	0	



100+60	C C 1	10 0	30	273	& Uplink	Mid	359 9.76	6399 84	353 9.1	635940	102	30	79 02	638688	12	0	2 (2)	208	
						High	377 4.99	6516 66	356 9.61	637974	504		80 24	650400	18	0	3 (3)	1014	
					Downlink	Low	335 0.01	6233 34	330 0.87	620058	0		77 11	620352	6	0	2 (2)	4	
						& Uplink	Mid	351 9.99	6346 66	343 4.13	628942		102	78 29	631680	2	0	2 (2)	208
	Channel spacing CC1-CC2=79.8 MHz (Note 1)																		
		C C 2	60	30	162	Downlink	Low	342 9.81	6286 54	340 0.65	626710	0	30	77 80	626976	2	0	1 (1)	2
	& Uplink						Mid	359 9.79	6399 86	353 3.91	635594	102		78 98	638304	22	0	0 (0)	204
						High	376 9.98	6513 32	355 9.38	637292	504	80 16		649632	4	0	0 (0)	1008	
	100+80	C C 1	10 0	30	273	Downlink	Low	335 0.01	6233 34	330 0.87	620058	0	30	77 11	620352	6	0	2 (2)	4
& Uplink							Mid	351 0	6340 00	342 4.14	628276	102		78 22	631008	20	0	1 (1)	206
						High	367 0.11	6446 74	343 9.53	629302	504	79 33		641664	2	0	1 (1)	1010	
Channel spacing CC1-CC2=89.88 MHz (Note 1)																			
		C C 2	80	30	217	Downlink	Low	343 9.89	6293 26	340 0.83	626722	0	30	77 80	626976	14	0	0 (0)	0
& Uplink							Mid	359 9.88	6399 92	352 4.1	634940	102		78 91	637632	4	0	0 (0)	204
	High					375 9.99	6506 66	353 9.49	635966	504	80 03	648384		10	0	3 (3)	1014		
100+100	C C 1	10 0	30	273	Downlink	Low	335 0.01	6233 34	330 0.87	620058	0	30	77 11	620352	6	0	2 (2)	4	
						& Uplink	Mid	350 0.01	6333 34	341 4.15	627610		102	78 15	630336	14	0	1 (1)	206
						High	365 0.04	6433 36	341 9.46	627964	504		79 19	640320	20	0	0 (0)	1008	
Channel spacing CC1-CC2=99.96 MHz (Note 1)																			

CC2	10	30	273	Downlink & Uplink	Low	344 9.97	6299 98	340 0.83	626722	0	30	77 80	626976	14	0	0 (0)	0
					Mid	359 9.97	6399 98	351 4.11	634274	102		78 85	637056	22	0	3 (3)	210
					High	375 0	6500 00	351 9.42	634628	504		79 89	647040	4	0	3 (3)	1014

Note 1: Corresponds to nominal channel spacing in accordance with TS 38.101-1 [7], clause 5.4A.1 for the CC1 and CC2 channel bandwidth combination.  
 Note 2: CCs are specified in increasing frequency order. CC1 is used as PCell if nothing else is specified in the test case.  
 Note 3: The parameter Offset Carrier CORESET#0 specifies the offset from the lowest subcarrier of the carrier and the lowest subcarrier of CORESET#0. It corresponds to the parameter  $\Delta F_{\text{OffsetCORESET}\#0\text{-Carrier}}$  in Annex C expressed in number of common RBs.  
 Note 4: The CORESET#0 Index and the associated CORESET#0 Offset refers to Table 13-4 in TS 38.213 [22]. The value of CORESET#0 Index is signalled in controlResourceSetZero (pdcc-ConfigSIB1) in the MIB. The offsetToPointA IE is expressed in units of resource blocks assuming 15 kHz subcarrier spacing for FR1 and 60 kHz subcarrier spacing for FR2.

4.3.1.1.3.78.2 CA\_n78B

Editor's note: Test frequencies for CA\_n78B with mixed numerology with SCS CC1=15kHz and SCS CC2=30 kHz or 60kHz; and SCS CC1=30kHz and SCS CC2=15 kHz or 60 kHz is FFS.

Table 4.3.1.1.3.78.2-1: NR Intra-Band contiguous CA configuration CA\_n78B (PCC=CC1 and SCC=CC2), SCS 15 kHz and  $\Delta F_{\text{Raster}}$  15 kHz

CBW combination	CCN	CBW [MHz]	SCS [kHz]	carrierBandwidth [PRBs]	Range	Carrier centre [MHz]	Carrier centre [ARFCN]	point A [MHz]	absoluteFrequencyPointA [ARFCN]	offsetToCarrier [Carrier PRBs]	SS block SCS [kHz]	GS CN	absoluteFrequencySSB [ARFCN]	$k_{\text{SSB}}$	Offset carrier CORESET#0 [RBs] Note 3	CORE SET#0 Index (Offset [RBs]) Note 4	offsetToPointA (SIB1) [PRBs] Note 4	
20+50	CC1	20	15	106	Downlink	Low	3310 .005	6206 67	3300 .465	620031	0	30	77 11	620352	9	0	1 (6)	6
					&	Mid	3525	6350 00	3497 .1	633140	102		78 60	634656	4	2	0 (2)	106
					Uplink	High	3740 .25	6493 50	3639 .99	642666	504		80 10	649056	6	2	1 (6)	512

Channel spacing CC1-CC2=34.74 MHz (Note 1)

50+20	CC2	50	15	270	Downlink	Low	3344 .745	6229 83	3320 .445	621363	0	30	77 25	621696	9	1	1 (6)	7	
					&	Mid	3559 .74	6373 16	3517 .08	634472	102		78 74	636000	4	3	0 (2)	107	
					Uplink	High	3774 .99	6516 66	3659 .97	643998	504		80 24	650400	6	3	1 (6)	513	
	CC1	50	15	270	Downlink	Low	3325 .005	6216 67	3300 .705	620047	0	30	77 11	620352	5	3	0 (2)	5	
					&	Mid	3540	6360 00	3497 .34	633156	102		78 60	634656	0	1	0 (2)	105	
					Uplink	High	3755 .25	6503 50	3640 .23	642682	504		80 10	649056	2	1	1 (6)	511	
	Channel spacing CC1-CC2=34.74 MHz (Note 1)																		
	CC2	20	15	106	Downlink	Low	3359 .745	6239 83	3350 .205	623347	0	30	77 45	623616	5	0	0 (2)	2	
					&	Mid	3574 .74	6383 16	3546 .84	636456	102		78 95	638016	0	2	1 (6)	110	
Uplink					High	3789 .99	6526 66	3689 .73	645982	504	80 44		652320	2	2	0 (2)	508		
Note 1:		Corresponds to nominal channel spacing in accordance with TS 38.101-1 [7], clause 5.4A.1 for the CC1 and CC2 channel bandwidth combination.																	
Note 2:		CCs are specified in increasing frequency order. CC1 is used as PCell if nothing else is specified in the test case.																	
Note 3:		The parameter Offset Carrier CORESET#0 specifies the offset from the lowest subcarrier of the carrier and the lowest subcarrier of CORESET#0. It corresponds to the parameter $\Delta F_{\text{OffsetCORESET-0-Carrier}}$ in Annex C expressed in number of common RBs.																	
Note 4:		The CORESET#0 Index and the associated CORESET#0 Offset refers to Table 13-4 in TS 38.213 [22]. The value of CORESET#0 Index is signalled in controlResourceSetZero (pdcch-ConfigSIB1) in the MIB. The offsetToPointA IE is expressed in units of resource blocks assuming 15 kHz subcarrier spacing for FR1 and 60 kHz subcarrier spacing for FR2.																	

**Table 4.3.1.1.3.78.2-2: NR Intra-Band contiguous CA configuration CA\_n78B (PCC=CC1 and SCC=CC2), SCS 30 kHz and  $\Delta F_{\text{Raster}}$  30 kHz**

CBW combination	CCN	CBW [MHz]	SCS [kHz]	carrierBandwidth [PRBs]	Range	Carrier centre [MHz] Note 2	Carrier centre [ARFCN]	point A [MHz]	absoluteFrequencyPointA [ARFCN]	offsetToCarrier [Carrier PRBs]	SSB blocks	GSCN	absoluteFrequencySSB [ARFCN]	$k_s$	Offset carrier CORESET#0 [RBs] Note 3	CORESET#0 Index (Offset [RBs]) Note 4	offsetToPointA (SIB1) [PRBs] Note 4
-----------------	-----	-----------	-----------	-------------------------	-------	-----------------------------	------------------------	---------------	---------------------------------	--------------------------------	------------	------	------------------------------	-------	---------------------------------------	---------------------------------------	-------------------------------------

													C S [ k H z ]						
20+50	C C 1	20	30	51	Dow nlink  &  Upli nk	Lo w	331 0.02	6206 68	330 0.84	620056	0	30	77 11	620352	8	0	2 (2)	4	
						Mi d	352 5	6350 00	347 9.1	631940	102		78 60	634656	4	0	1 (1)	206	
						Hi gh	374 0.25	6493 50	354 9.63	636642	504		80 10	649056	6	0	3 (3)	1014	
	Channel spacing CC1-CC2=34.74 MHz (Note 1)																		
	C C 2	50	30	133	Dow nlink  &  Upli nk	Lo w	334 4.76	6229 84	332 0.82	621388	0	30	77 25	621696	20	0	2 (2)	4	
						Mi d	355 9.74	6373 16	349 9.08	633272	102		78 74	636000	16	0	1 (1)	206	
Hi gh						377 4.99	6516 66	356 9.61	637974	504	80 24		650400	18	0	3 (3)	1014		
50+20	C C 1	50	30	133	Dow nlink  &  Upli nk	Lo w	332 5.02	6216 68	330 1.08	620072	0	30	77 11	620352	16	0	1 (1)	2	
						Mi d	354 0	6360 00	347 9.34	631956	102		78 60	634656	12	0	0 (0)	204	
						Hi gh	375 5.25	6503 50	354 9.87	636658	504		80 10	649056	14	0	2 (2)	1012	
	Channel spacing CC1-CC2=34.74 MHz (Note 1)																		
	C C 2	20	30	51	Dow nlink  &  Upli nk	Lo w	335 9.76	6239 84	335 0.58	623372	0	30	77 45	623616	4	0	0 (0)	0	
						Mi d	357 4.74	6383 16	352 8.84	635256	102		78 95	638016	0	0	3 (3)	210	
Hi gh						378 9.99	6526 66	359 9.37	639958	504	80 44		652320	2	0	1 (1)	1010		
Note 1: Corresponds to nominal channel spacing in accordance with TS 38.101-1 [7], clause 5.4A.1 for the CC1 and CC2 channel bandwidth combination. Note 2: CCs are specified in increasing frequency order. CC1 is used as PCell if nothing else is specified in the test case. Note 3: The parameter Offset Carrier CORESET#0 specifies the offset from the lowest subcarrier of the carrier and the lowest subcarrier of CORESET#0. It corresponds to the parameter $\Delta F_{\text{OffsetCORESET-0-Carrier}}$ in Annex C expressed in number of common RBs.																			

Note 4: The CORESET#0 Index and the associated CORESET#0 Offset refers to Table 13-4 in TS 38.213 [22]. The value of CORESET#0 Index is signalled in controlResourceSetZero (pdcch-ConfigSIB1) in the MIB. The offsetToPointA IE is expressed in units of resource blocks assuming 15 kHz subcarrier spacing for FR1 and 60 kHz subcarrier spacing for FR2.

4.3.1.1.4 Void

4.3.1.1.5 NR intra-band non-contiguous CA configurations in FR1

4.3.1.1.5.1 – 4.3.1.1.5.47 FFS

4.3.1.1.5.48 CA\_n48(2A)

Editor's note: Test frequencies for CA\_n48(2A) with mixed numerology with SCS CC1=15kHz and SCS CC2=30 kHz or 60kHz; and SCS CC1=30kHz and SCS CC2=15 kHz or 60 kHz is FFS.

**Table 4.3.1.1.5.48-1: NR Intra-Band non-contiguous CA configuration CA\_n48(2A) without UL CA, SCS=15 kHz, Max Wgap**

SB CBW combination	SB	Band width [MHz]	carrier Bandw idth [PRBs]	Range (Note 1)	Gap	Test frequencies and signalling parameters
<b>CA_n48(2A); n48A (10MHz) + n48A (10-50MHz)</b>						
10+10	SB1	10	52	Downlink & Uplink	Max	Table 4.3.1.1.1.48-1: Low range for CBW=10 MHz
	SB2	10	52	Downlink & Uplink	Wgap	Table 4.3.1.1.1.48-1: High range for CBW=10 MHz
10+15	SB1	10	52	Downlink & Uplink	Max	Table 4.3.1.1.1.48-1: Low range for CBW=10 MHz
	SB2	15	79	Downlink & Uplink	Wgap	Table 4.3.1.1.1.48-1: High range for CBW=15 MHz
10+20	SB1	10	52	Downlink & Uplink	Max	Table 4.3.1.1.1.48-1: Low range for CBW=10 MHz
	SB2	20	106	Downlink & Uplink	Wgap	Table 4.3.1.1.1.48-1: High range for CBW=20 MHz
10+40	SB1	10	52	Downlink & Uplink	Max	Table 4.3.1.1.1.48-1: Low range for CBW=10 MHz
	SB2	40	216	Downlink & Uplink	Wgap	Table 4.3.1.1.1.48-1: High range for CBW=40 MHz
10+50	SB1	10	52	Downlink & Uplink	Max	Table 4.3.1.1.1.48-1: Low range for CBW=10 MHz
	SB2	50	270	Downlink & Uplink	Wgap	Table 4.3.1.1.1.48-1: High range for CBW=50 MHz
<b>CA_n48(2A); n48A (15MHz) + n48A (10-50MHz)</b>						
15+10	SB1	15	79	Downlink & Uplink	Max	Table 4.3.1.1.1.48-1: Low range for CBW=15 MHz
	SB2	10	52	Downlink & Uplink	Wgap	Table 4.3.1.1.1.48-1: High range for CBW=10 MHz
15+15	SB1	15	79	Downlink & Uplink	Max	Table 4.3.1.1.1.48-1: Low range for CBW=15 MHz
	SB2	15	79	Downlink & Uplink	Wgap	Table 4.3.1.1.1.48-1: High range for CBW=15 MHz
15+20	SB1	15	79	Downlink & Uplink	Max	Table 4.3.1.1.1.48-1: Low range for CBW=15 MHz
	SB2	20	106	Downlink & Uplink	Wgap	Table 4.3.1.1.1.48-1: High range for CBW=20 MHz
15+40	SB1	15	79	Downlink & Uplink	Max	Table 4.3.1.1.1.48-1: Low range for CBW=15 MHz
	SB2	40	216	Downlink & Uplink	Wgap	Table 4.3.1.1.1.48-1: High range for CBW=40 MHz
15+50	SB1	15	79	Downlink & Uplink	Max	Table 4.3.1.1.1.48-1: Low range for CBW=15 MHz
	SB2	50	270	Downlink & Uplink	Wgap	Table 4.3.1.1.1.48-1: High range for CBW=50 MHz
<b>CA_n48(2A); n48A (20MHz) + n48A (10-50MHz)</b>						
20+10	SB1	20	106	Downlink & Uplink	Max	Table 4.3.1.1.1.48-1: Low range for CBW=20 MHz
	SB2	10	52	Downlink & Uplink	Wgap	Table 4.3.1.1.1.48-1: High range for CBW=10 MHz
20+15	SB1	20	106	Downlink & Uplink	Max	Table 4.3.1.1.1.48-1: Low range for CBW=20 MHz
	SB2	15	79	Downlink & Uplink	Wgap	Table 4.3.1.1.1.48-1: High range for CBW=15 MHz
20+20	SB1	20	106	Downlink & Uplink	Max	Table 4.3.1.1.1.48-1: Low range for CBW=20 MHz
	SB2	20	106	Downlink & Uplink	Wgap	Table 4.3.1.1.1.48-1: High range for CBW=20 MHz
20+40	SB1	20	106	Downlink & Uplink	Max	Table 4.3.1.1.1.48-1: Low range for CBW=20 MHz
	SB2	40	216	Downlink & Uplink	Wgap	Table 4.3.1.1.1.48-1: High range for CBW=40 MHz
20+50	SB1	20	106	Downlink & Uplink	Max	Table 4.3.1.1.1.48-1: Low range for CBW=20 MHz
	SB2	50	270	Downlink & Uplink	Wgap	Table 4.3.1.1.1.48-1: High range for CBW=50 MHz
<b>CA_n48(2A); n48A (40MHz) + n48A (10-50MHz)</b>						
40+10	SB1	40	216	Downlink & Uplink	Max	Table 4.3.1.1.1.48-1: Low range for CBW=40 MHz
	SB2	10	52	Downlink & Uplink	Wgap	Table 4.3.1.1.1.48-1: High range for CBW=10 MHz
40+15	SB1	40	216	Downlink & Uplink	Max	Table 4.3.1.1.1.48-1: Low range for CBW=40 MHz
	SB2	15	79	Downlink & Uplink	Wgap	Table 4.3.1.1.1.48-1: High range for CBW=15 MHz
40+20	SB1	40	216	Downlink & Uplink	Max	Table 4.3.1.1.1.48-1: Low range for CBW=40 MHz
	SB2	20	106	Downlink & Uplink	Wgap	Table 4.3.1.1.1.48-1: High range for CBW=20 MHz
40+40	SB1	40	216	Downlink & Uplink	Max	Table 4.3.1.1.1.48-1: Low range for CBW=40 MHz
	SB2	40	216	Downlink & Uplink	Wgap	Table 4.3.1.1.1.48-1: High range for CBW=40 MHz
40+50	SB1	40	216	Downlink & Uplink	Max	Table 4.3.1.1.1.48-1: Low range for CBW=40 MHz
	SB2	50	270	Downlink & Uplink	Wgap	Table 4.3.1.1.1.48-1: High range for CBW=50 MHz

CA_n48(2A); n48A (50MHz) + n48A (10-50MHz)						
50+10	SB1	50	270	Downlink & Uplink	Max	Table 4.3.1.1.1.48-1: Low range for CBW=50 MHz
	SB2	10	52	Downlink & Uplink	Wgap	Table 4.3.1.1.1.48-1: High range for CBW=10 MHz
50+15	SB1	50	270	Downlink & Uplink	Max	Table 4.3.1.1.1.48-1: Low range for CBW=50 MHz
	SB2	15	79	Downlink & Uplink	Wgap	Table 4.3.1.1.1.48-1: High range for CBW=15 MHz
50+20	SB1	50	270	Downlink & Uplink	Max	Table 4.3.1.1.1.48-1: Low range for CBW=50 MHz
	SB2	20	106	Downlink & Uplink	Wgap	Table 4.3.1.1.1.48-1: High range for CBW=20 MHz
50+40	SB1	50	270	Downlink & Uplink	Max	Table 4.3.1.1.1.48-1: Low range for CBW=50 MHz
	SB2	40	216	Downlink & Uplink	Wgap	Table 4.3.1.1.1.48-1: High range for CBW=40 MHz
50+50	SB1	50	270	Downlink & Uplink	Max	Table 4.3.1.1.1.48-1: Low range for CBW=50 MHz
	SB2	50	270	Downlink & Uplink	Wgap	Table 4.3.1.1.1.48-1: High range for CBW=50 MHz

Note 1: CA\_n48(2A) is specified in [7] 38.101-1 without uplink CA. PCC is configured on SB1 unless otherwise stated. The test frequencies for both SB1 and SB2 have been specified for both downlink and uplink to enable that the CC of either SB1 or SB2 can be used as PCC.

**Table 4.3.1.1.5.48-2: NR Intra-Band non-contiguous CA configuration CA\_n48(2A) without UL CA, SCS=30 kHz, Max Wgap**

CBW combination	SB	Band width [MHz]	carrier Bandwidth [PRBs]	Range (Note 1)	Gap	Test frequencies and signalling parameters
<b>CA_n48(2A); n48A (10MHz) + n48A (10-100MHz)</b>						
10+10	SB1	10	24	Downlink & Uplink	Max	Table 4.3.1.1.1.48-2: Low range for CBW=10 MHz
	SB2	10	24	Downlink & Uplink	Wgap	Table 4.3.1.1.1.48-2: High range for CBW=10 MHz
10+15	SB1	10	24	Downlink & Uplink	Max	Table 4.3.1.1.1.48-2: Low range for CBW=10 MHz
	SB2	15	38	Downlink & Uplink	Wgap	Table 4.3.1.1.1.48-2: High range for CBW=15 MHz
10+20	SB1	10	24	Downlink & Uplink	Max	Table 4.3.1.1.1.48-2: Low range for CBW=10 MHz
	SB2	20	51	Downlink & Uplink	Wgap	Table 4.3.1.1.1.48-2: High range for CBW=20 MHz
10+40	SB1	10	24	Downlink & Uplink	Max	Table 4.3.1.1.1.48-2: Low range for CBW=10 MHz
	SB2	40	106	Downlink & Uplink	Wgap	Table 4.3.1.1.1.48-2: High range for CBW=40 MHz
10+50	SB1	10	24	Downlink & Uplink	Max	Table 4.3.1.1.1.48-2: Low range for CBW=10 MHz
	SB2	50	133	Downlink & Uplink	Wgap	Table 4.3.1.1.1.48-2: High range for CBW=50 MHz
10+60	SB1	10	24	Downlink & Uplink	Max	Table 4.3.1.1.1.48-2: Low range for CBW=10 MHz
	SB2	60	162	Downlink & Uplink	Wgap	Table 4.3.1.1.1.48-2: High range for CBW=60 MHz
10+80	SB1	10	24	Downlink & Uplink	Max	Table 4.3.1.1.1.48-2: Low range for CBW=10 MHz
	SB2	80	217	Downlink & Uplink	Wgap	Table 4.3.1.1.1.48-2: High range for CBW=80 MHz
10+90	SB1	10	24	Downlink & Uplink	Max	Table 4.3.1.1.1.48-2: Low range for CBW=10 MHz
	SB2	90	245	Downlink & Uplink	Wgap	Table 4.3.1.1.1.48-2: High range for CBW=90 MHz
10+100	SB1	10	24	Downlink & Uplink	Max	Table 4.3.1.1.1.48-2: Low range for CBW=10 MHz
	SB2	100	273	Downlink & Uplink	Wgap	Table 4.3.1.1.1.48-2: High range for CBW=100 MHz
<b>CA_n48(2A); n48A (15MHz) + n48A (10-100MHz)</b>						
15+10	SB1	15	38	Downlink & Uplink	Max	Table 4.3.1.1.1.48-2: Low range for CBW=15 MHz
	SB2	10	24	Downlink & Uplink	Wgap	Table 4.3.1.1.1.48-2: High range for CBW=10 MHz
15+15	SB1	15	38	Downlink & Uplink	Max	Table 4.3.1.1.1.48-2: Low range for CBW=15 MHz
	SB2	15	38	Downlink & Uplink	Wgap	Table 4.3.1.1.1.48-2: High range for CBW=15 MHz
15+20	SB1	15	38	Downlink & Uplink	Max	Table 4.3.1.1.1.48-2: Low range for CBW=15 MHz
	SB2	20	51	Downlink & Uplink	Wgap	Table 4.3.1.1.1.48-2: High range for CBW=20 MHz
15+40	SB1	15	38	Downlink & Uplink	Max	Table 4.3.1.1.1.48-2: Low range for CBW=15 MHz
	SB2	40	106	Downlink & Uplink	Wgap	Table 4.3.1.1.1.48-2: High range for CBW=40 MHz
15+50	SB1	15	38	Downlink & Uplink	Max	Table 4.3.1.1.1.48-2: Low range for CBW=15 MHz
	SB2	50	133	Downlink & Uplink	Wgap	Table 4.3.1.1.1.48-2: High range for CBW=50 MHz
15+60	SB1	15	38	Downlink & Uplink	Max	Table 4.3.1.1.1.48-2: Low range for CBW=15 MHz
	SB2	60	162	Downlink & Uplink	Wgap	Table 4.3.1.1.1.48-2: High range for CBW=60 MHz
15+80	SB1	15	38	Downlink & Uplink	Max	Table 4.3.1.1.1.48-2: Low range for CBW=15 MHz
	SB2	80	217	Downlink & Uplink	Wgap	Table 4.3.1.1.1.48-2: High range for CBW=80 MHz
15+90	SB1	15	38	Downlink & Uplink	Max	Table 4.3.1.1.1.48-2: Low range for CBW=15 MHz
	SB2	90	245	Downlink & Uplink	Wgap	Table 4.3.1.1.1.48-2: High range for CBW=90 MHz
15+100	SB1	15	38	Downlink & Uplink	Max	Table 4.3.1.1.1.48-2: Low range for CBW=15 MHz
	SB2	100	273	Downlink & Uplink	Wgap	Table 4.3.1.1.1.48-2: High range for CBW=100 MHz
<b>CA_n48(2A); n48A (20MHz) + n48A (10-100MHz)</b>						
20+10	SB1	20	51	Downlink & Uplink	Max	Table 4.3.1.1.1.48-2: Low range for CBW=20 MHz
	SB2	10	24	Downlink & Uplink	Wgap	Table 4.3.1.1.1.48-2: High range for CBW=10 MHz





60+80	SB2	60	162	Downlink & Uplink	Wgap	Table 4.3.1.1.1.48-2: High range for CBW=60 MHz
	SB1	60	162	Downlink & Uplink	Max	Table 4.3.1.1.1.48-2: Low range for CBW=60 MHz
	SB2	80	217	Downlink & Uplink	Wgap	Table 4.3.1.1.1.48-2: High range for CBW=80 MHz
<b>CA_n48(2A); n48A (80MHz) + n48A (10-60MHz)</b>						
80+10	SB1	80	217	Downlink & Uplink	Max	Table 4.3.1.1.1.48-2: Low range for CBW=80 MHz
	SB2	10	24	Downlink & Uplink	Wgap	Table 4.3.1.1.1.48-2: High range for CBW=10 MHz
80+15	SB1	80	217	Downlink & Uplink	Max	Table 4.3.1.1.1.48-2: Low range for CBW=80 MHz
	SB2	15	38	Downlink & Uplink	Wgap	Table 4.3.1.1.1.48-2: High range for CBW=15 MHz
80+20	SB1	80	217	Downlink & Uplink	Max	Table 4.3.1.1.1.48-2: Low range for CBW=80 MHz
	SB2	20	51	Downlink & Uplink	Wgap	Table 4.3.1.1.1.48-2: High range for CBW=20 MHz
80+40	SB1	80	217	Downlink & Uplink	Max	Table 4.3.1.1.1.48-2: Low range for CBW=80 MHz
	SB2	40	106	Downlink & Uplink	Wgap	Table 4.3.1.1.1.48-2: High range for CBW=40 MHz
80+50	SB1	80	217	Downlink & Uplink	Max	Table 4.3.1.1.1.48-2: Low range for CBW=80 MHz
	SB2	50	133	Downlink & Uplink	Wgap	Table 4.3.1.1.1.48-2: High range for CBW=50 MHz
80+60	SB1	80	217	Downlink & Uplink	Max	Table 4.3.1.1.1.48-2: Low range for CBW=80 MHz
	SB2	60	162	Downlink & Uplink	Wgap	Table 4.3.1.1.1.48-2: High range for CBW=60 MHz
<b>CA_n48(2A); n48A (90MHz) + n48A (10-50MHz)</b>						
90+10	SB1	90	245	Downlink & Uplink	Max	Table 4.3.1.1.1.48-2: Low range for CBW=90 MHz
	SB2	10	24	Downlink & Uplink	Wgap	Table 4.3.1.1.1.48-2: High range for CBW=10 MHz
90+15	SB1	90	245	Downlink & Uplink	Max	Table 4.3.1.1.1.48-2: Low range for CBW=90 MHz
	SB2	15	38	Downlink & Uplink	Wgap	Table 4.3.1.1.1.48-2: High range for CBW=15 MHz
90+20	SB1	90	245	Downlink & Uplink	Max	Table 4.3.1.1.1.48-2: Low range for CBW=90 MHz
	SB2	20	51	Downlink & Uplink	Wgap	Table 4.3.1.1.1.48-2: High range for CBW=20 MHz
90+40	SB1	90	245	Downlink & Uplink	Max	Table 4.3.1.1.1.48-2: Low range for CBW=90 MHz
	SB2	40	106	Downlink & Uplink	Wgap	Table 4.3.1.1.1.48-2: High range for CBW=40 MHz
90+50	SB1	90	245	Downlink & Uplink	Max	Table 4.3.1.1.1.48-2: Low range for CBW=90 MHz
	SB2	50	133	Downlink & Uplink	Wgap	Table 4.3.1.1.1.48-2: High range for CBW=50 MHz
<b>CA_n48(2A); n48A (100MHz) + n48A (10-40MHz)</b>						
100+10	SB1	100	273	Downlink & Uplink	Max	Table 4.3.1.1.1.48-2: Low range for CBW=100 MHz
	SB2	10	24	Downlink & Uplink	Wgap	Table 4.3.1.1.1.48-2: High range for CBW=10 MHz
100+15	SB1	100	273	Downlink & Uplink	Max	Table 4.3.1.1.1.48-2: Low range for CBW=100 MHz
	SB2	15	38	Downlink & Uplink	Wgap	Table 4.3.1.1.1.48-2: High range for CBW=15 MHz
100+20	SB1	100	273	Downlink & Uplink	Max	Table 4.3.1.1.1.48-2: Low range for CBW=100 MHz
	SB2	20	51	Downlink & Uplink	Wgap	Table 4.3.1.1.1.48-2: High range for CBW=20 MHz
100+40	SB1	100	273	Downlink & Uplink	Max	Table 4.3.1.1.1.48-2: Low range for CBW=100 MHz
	SB2	40	106	Downlink & Uplink	Wgap	Table 4.3.1.1.1.48-2: High range for CBW=40 MHz
Note 1: CA_n48(2A) is specified in [7] 38.101-1 without uplink CA. PCC is configured on SB1 unless otherwise stated. The test frequencies for both SB1 and SB2 have been specified for both downlink and uplink to enable that the CC of either SB1 or SB2 can be used as PCC.						

4.3.1.1.5.49 – 4.3.1.1.5.65 FFS

4.3.1.1.5.66 CA\_n66(2A)

Editor's note: Test frequencies for CA\_n66(2A) with mixed numerology with SCS CC1=15kHz and SCS CC2=30 kHz or 60kHz; and SCS CC1=30kHz and SCS CC2=15 kHz or 60 kHz is FFS.

**Table 4.3.1.1.5.66-1: NR Intra-Band non-contiguous CA configuration CA\_n66(2A) without UL CA, SCS=15 kHz, Max Wgap**

CBW combination (BCS)	SB	Bandwidth [MHz]	carrier Bandwidth [PRBs]	Range (Note 1)	Gap	Test frequencies and signalling parameters
<b>CA_n66(2A); n66A (5MHz) + n66A(5-40MHz)</b>						
5+5 (0,1,2)	SB1	5	25	Downlink & Uplink	Max Wgap	Table 4.3.1.1.1.66-1: Low range for UL/DL Bandwidth combination = 5/5
	SB2	5	25	Downlink & Uplink		Table 4.3.1.1.1.66-1: High range for UL/DL Bandwidth combination = 5/5
5+10 (0,1,2)	SB1	5	25	Downlink & Uplink	Max Wgap	Table 4.3.1.1.1.66-1: Low range for UL/DL Bandwidth combination = 5/5
	SB2	10	52	Downlink & Uplink		Table 4.3.1.1.1.66-1: High range for UL/DL Bandwidth combination = 10/10
5+15 (0,1,2)	SB1	5	25	Downlink & Uplink	Max Wgap	Table 4.3.1.1.1.66-1: Low range for UL/DL Bandwidth combination = 5/5
	SB2	15	79	Downlink & Uplink		Table 4.3.1.1.1.66-1: High range for UL/DL Bandwidth combination = 15/15
5+20 (0,1,2)	SB1	5	25	Downlink & Uplink	Max Wgap	Table 4.3.1.1.1.66-1: Low range for UL/DL Bandwidth combination = 5/5
	SB2	20	106	Downlink & Uplink		Table 4.3.1.1.1.66-1: High range for UL/DL Bandwidth combination = 5/20, 10/20 or 20/20 depending on required UL bandwidth
5+25 (1)	SB1	5	25	Downlink & Uplink	Max Wgap	Table 4.3.1.1.1.66-1: Low range for UL/DL Bandwidth combination = 5/5
	SB2	25	133	Downlink & Uplink		Table 4.3.1.1.1.66-1: High range for UL/DL Bandwidth combination = 5/25, 10/25 or 25/25 depending on required UL bandwidth
5+30 (1)	SB1	5	25	Downlink & Uplink	Max Wgap	Table 4.3.1.1.1.66-1: Low range for UL/DL Bandwidth combination = 5/5
	SB2	30	160	Downlink & Uplink		Table 4.3.1.1.1.66-1: High range for UL/DL Bandwidth combination = 5/30, 10/30 or 30/30 depending on required UL bandwidth
5+40 (0,1,2)	SB1	5	25	Downlink & Uplink	Max Wgap	Table 4.3.1.1.1.66-1: Low range for UL/DL Bandwidth combination = 5/5
	SB2	40	216	Downlink or Downlink & Uplink		If UL is not configured on SB2: Table 4.3.1.1.1.66-1: High range for N.A./40. Otherwise: Table 4.3.1.1.1.66-1: High range for UL/DL Bandwidth combination = 5/40, 10/40, 20/40 or 40/40 depending on required UL bandwidth
<b>CA_n66(2A); n66A (10MHz) + n66A(5-40MHz)</b>						
10+5 (0,1,2)	SB1	10	52	Downlink & Uplink	Max Wgap	Table 4.3.1.1.1.66-1: Low range for UL/DL Bandwidth combination = 10/10
	SB2	5	25	Downlink & Uplink		Table 4.3.1.1.1.66-1: High range for UL/DL Bandwidth combination = 5/5
10+10 (0,1,2)	SB1	10	52	Downlink & Uplink	Max Wgap	Table 4.3.1.1.1.66-1: Low range for UL/DL Bandwidth combination = 10/10
	SB2	10	52	Downlink & Uplink		Table 4.3.1.1.1.66-1: High range for UL/DL Bandwidth combination = 10/10
10+15 (0,1,2)	SB1	10	52	Downlink & Uplink	Max Wgap	Table 4.3.1.1.1.66-1: Low range for UL/DL Bandwidth combination = 10/10
	SB2	15	79	Downlink & Uplink		Table 4.3.1.1.1.66-1: High range for UL/DL Bandwidth combination = 15/15

10+20 (0,1,2)	SB1	10	52	Downlink & Uplink	Max Wgap	Table 4.3.1.1.1.66-1: Low range for UL/DL Bandwidth combination = 10/10
	SB2	20	106	Downlink & Uplink		Table 4.3.1.1.1.66-1: High range for UL/DL Bandwidth combination = 5/20, 10/20 or 20/20 depending on required UL bandwidth
10+25 (1)	SB1	10	52	Downlink & Uplink	Max Wgap	Table 4.3.1.1.1.66-1: Low range for UL/DL Bandwidth combination = 10/10
	SB2	25	133	Downlink & Uplink		Table 4.3.1.1.1.66-1: High range for UL/DL Bandwidth combination = 5/25, 10/25 or 25/25 depending on required UL bandwidth
10+30 (1)	SB1	10	52	Downlink & Uplink	Max Wgap	Table 4.3.1.1.1.66-1: Low range for UL/DL Bandwidth combination = 10/10
	SB2	30	160	Downlink & Uplink		Table 4.3.1.1.1.66-1: High range for UL/DL Bandwidth combination = 5/30, 10/30 or 30/30 depending on required UL bandwidth
10+40 (0,1,2)	SB1	10	52	Downlink & Uplink	Max Wgap	Table 4.3.1.1.1.66-1: Low range for UL/DL Bandwidth combination = 10/10
	SB2	40	216	Downlink or Downlink & Uplink		If UL is not configured on SB2: Table 4.3.1.1.1.66-1: High range for N.A./40. Otherwise: Table 4.3.1.1.1.66-1: High range for UL/DL Bandwidth combination = 5/40, 10/40, 20/40 or 40/40 depending on required UL bandwidth
<b>CA_n66(2A); n66A (15MHz) + n66A(5-40MHz)</b>						
15+5 (0,1,2)	SB1	15	79	Downlink & Uplink	Max Wgap	Table 4.3.1.1.1.66-1: Low range for UL/DL Bandwidth combination = 15/15
	SB2	5	25	Downlink & Uplink		Table 4.3.1.1.1.66-1: High range for UL/DL Bandwidth combination = 5/5
15+10 (0,1,2)	SB1	15	79	Downlink & Uplink	Max Wgap	Table 4.3.1.1.1.66-1: Low range for UL/DL Bandwidth combination = 15/15
	SB2	10	52	Downlink & Uplink		Table 4.3.1.1.1.66-1: High range for UL/DL Bandwidth combination = 10/10
15+15 (0,1,2)	SB1	15	79	Downlink & Uplink	Max Wgap	Table 4.3.1.1.1.66-1: Low range for UL/DL Bandwidth combination = 15/15
	SB2	15	79	Downlink & Uplink		Table 4.3.1.1.1.66-1: High range for UL/DL Bandwidth combination = 15/15
15+20 (0,1,2)	SB1	15	79	Downlink & Uplink	Max Wgap	Table 4.3.1.1.1.66-1: Low range for UL/DL Bandwidth combination = 15/15
	SB2	20	106	Downlink & Uplink		Table 4.3.1.1.1.66-1: High range for UL/DL Bandwidth combination = 5/20, 10/20 or 20/20 depending on required UL bandwidth
15+25 (1)	SB1	15	79	Downlink & Uplink	Max Wgap	Table 4.3.1.1.1.66-1: Low range for UL/DL Bandwidth combination = 15/15
	SB2	25	133	Downlink & Uplink		Table 4.3.1.1.1.66-1: High range for UL/DL Bandwidth combination = 5/25, 10/25 or 25/25 depending on required UL bandwidth
15+30 (1)	SB1	15	79	Downlink & Uplink	Max Wgap	Table 4.3.1.1.1.66-1: Low range for UL/DL Bandwidth combination = 15/15
	SB2	30	160	Downlink & Uplink		Table 4.3.1.1.1.66-1: High range for UL/DL Bandwidth combination = 5/30, 10/30 or 30/30 depending on required UL bandwidth
15+40 (0,1,2)	SB1	15	79	Downlink & Uplink	Max Wgap	Table 4.3.1.1.1.66-1: Low range for UL/DL Bandwidth combination = 15/15
	SB2	40	216	Downlink or Downlink & Uplink		If UL is not configured on SB2: Table 4.3.1.1.1.66-1: High range for N.A./40. Otherwise: Table 4.3.1.1.1.66-1: High range for UL/DL Bandwidth combination = 5/40, 10/40, 20/40 or 40/40 depending on required UL bandwidth
<b>CA_n66(2A); n66A (20MHz) + n66A(5-40MHz)</b>						
20+5 (0,1,2)	SB1	20	106	Downlink & Uplink	Max Wgap	Table 4.3.1.1.1.66-1: Low range for UL/DL Bandwidth combination = 5/20, 10/20 or 20/20 depending on required UL bandwidth
	SB2	5	25	Downlink & Uplink		Table 4.3.1.1.1.66-1: High range for UL/DL Bandwidth combination 5/5
20+10 (0,1,2)	SB1	20	106	Downlink & Uplink	Max Wgap	Table 4.3.1.1.1.66-1: Low range for UL/DL Bandwidth combination = 5/20, 10/20 or 20/20 depending on required UL bandwidth

	SB2	10	52	Downlink & Uplink		Table 4.3.1.1.1.66-1: High range for UL/DL Bandwidth combination 10/10
20+15 (0,1,2)	SB1	20	106	Downlink & Uplink	Max Wgap	Table 4.3.1.1.1.66-1: Low range for UL/DL Bandwidth combination = 5/20, 10/20 or 20/20 depending on required UL bandwidth
	SB2	15	79	Downlink & Uplink		Table 4.3.1.1.1.66-1: High range for UL/DL Bandwidth combination 15/15
20+20 (0,1,2)	SB1	20	106	Downlink & Uplink	Max Wgap	Table 4.3.1.1.1.66-1: Low range for UL/DL Bandwidth combination = 5/20, 10/20 or 20/20 depending on required UL bandwidth
	SB2	20	106	Downlink & Uplink		Table 4.3.1.1.1.66-1: High range for for UL/DL Bandwidth combination = 5/20, 10/20 or 20/20 depending on required UL bandwidth
20+25 (1)	SB1	20	106	Downlink & Uplink	Max Wgap	Table 4.3.1.1.1.66-1: Low range for UL/DL Bandwidth combination = 5/20, 10/20 or 20/20 depending on required UL bandwidth
	SB2	25	133	Downlink & Uplink		Table 4.3.1.1.1.66-1: High range for UL/DL Bandwidth combination = 5/25, 10/25 or 25/25 depending on required UL bandwidth
20+30 (1)	SB1	20	106	Downlink & Uplink	Max Wgap	Table 4.3.1.1.1.66-1: Low range for UL/DL Bandwidth combination = 5/20, 10/20 or 20/20 depending on required UL bandwidth
	SB2	30	160	Downlink & Uplink		Table 4.3.1.1.1.66-1: High range for UL/DL Bandwidth combination = 5/30, 10/30 or 30/30 depending on required UL bandwidth
20+40 (0,1,2)	SB1	20	106	Downlink & Uplink	Max Wgap	Table 4.3.1.1.1.66-1: Low range for UL/DL Bandwidth combination = 5/20, 10/20 or 20/20 depending on required UL bandwidth
	SB2	40	216	Downlink or Downlink & Uplink		If UL is not configured on SB2: Table 4.3.1.1.1.66-1: High range for N.A./40. Otherwise: Table 4.3.1.1.1.66-1: High range for UL/DL Bandwidth combination = 5/40, 10/40, 20/40 or 40/40 depending on required UL bandwidth
<b>CA_n66(2A); n66A (25MHz) + n66A(5-40MHz)</b>						
25+5 (1)	SB1	25	133	Downlink & Uplink	Max Wgap	Table 4.3.1.1.1.66-1: Low range for UL/DL Bandwidth combination = 5/25, 10/25 or 25/25 depending on required UL bandwidth
	SB2	5	25	Downlink & Uplink		Table 4.3.1.1.1.66-1: High range for UL/DL Bandwidth combination 5/5
25+10 (1)	SB1	25	133	Downlink & Uplink	Max Wgap	Table 4.3.1.1.1.66-1: Low range for UL/DL Bandwidth combination = 5/25, 10/25 or 25/25 depending on required UL bandwidth
	SB2	10	52	Downlink & Uplink		Table 4.3.1.1.1.66-1: High range for UL/DL Bandwidth combination 10/10
25+15 (1)	SB1	25	133	Downlink & Uplink	Max Wgap	Table 4.3.1.1.1.66-1: Low range for UL/DL Bandwidth combination = 5/25, 10/25 or 25/25 depending on required UL bandwidth
	SB2	15	79	Downlink & Uplink		Table 4.3.1.1.1.66-1: High range for UL/DL Bandwidth combination 15/15
25+20 (1)	SB1	25	133	Downlink & Uplink	Max Wgap	Table 4.3.1.1.1.66-1: Low range for UL/DL Bandwidth combination = 5/25, 10/25 or 25/25 depending on required UL bandwidth
	SB2	20	106	Downlink & Uplink		Table 4.3.1.1.1.66-1: High range for for UL/DL Bandwidth combination = 5/20, 10/20 or 20/20 depending on required UL bandwidth
25+25 (1)	SB1	25	133	Downlink & Uplink	Max Wgap	Table 4.3.1.1.1.66-1: Low range for UL/DL Bandwidth combination = 5/25, 10/25 or 25/25 depending on required UL bandwidth
	SB2	25	133	Downlink & Uplink		Table 4.3.1.1.1.66-1: High range for UL/DL Bandwidth combination = 5/25, 10/25 or 25/25 depending on required UL bandwidth
25+30 (1)	SB1	25	133	Downlink & Uplink	Max Wgap	Table 4.3.1.1.1.66-1: Low range for UL/DL Bandwidth combination = 5/25, 10/25 or 25/25 depending on required UL bandwidth

	SB2	30	160	Downlink & Uplink		Table 4.3.1.1.1.66-1: High range for UL/DL Bandwidth combination = 5/30, 10/30 or 30/30 depending on required UL bandwidth
25+40 (1)	SB1	25	133	Downlink & Uplink	Max Wgap	Table 4.3.1.1.1.66-1: Low range for UL/DL Bandwidth combination = 5/25, 10/25 or 25/25 depending on required UL bandwidth
	SB2	40	216	Downlink or Downlink & Uplink		If UL is not configured on SB2: Table 4.3.1.1.1.66-1: High range for N.A./40. Otherwise: Table 4.3.1.1.1.66-1: High range for UL/DL Bandwidth combination = 5/40, 10/40, 20/40 or 40/40 depending on required UL bandwidth
<b>CA_n66(2A); n66A (30MHz) + n66A(5-40MHz)</b>						
30+5 (1)	SB1	30	160	Downlink & Uplink	Max Wgap	Table 4.3.1.1.1.66-1: Low range for UL/DL Bandwidth combination = 5/30, 10/30 or 30/30 depending on required UL bandwidth
	SB2	5	25	Downlink & Uplink		Table 4.3.1.1.1.66-1: High range for UL/DL Bandwidth combination 5/5
30+10 (1)	SB1	30	160	Downlink & Uplink	Max Wgap	Table 4.3.1.1.1.66-1: Low range for UL/DL Bandwidth combination = 5/30, 10/30 or 30/30 depending on required UL bandwidth
	SB2	10	52	Downlink & Uplink		Table 4.3.1.1.1.66-1: High range for UL/DL Bandwidth combination 10/10
30+15 (1)	SB1	30	160	Downlink & Uplink	Max Wgap	Table 4.3.1.1.1.66-1: Low range for UL/DL Bandwidth combination = 5/30, 10/30 or 30/30 depending on required UL bandwidth
	SB2	15	79	Downlink & Uplink		Table 4.3.1.1.1.66-1: High range for UL/DL Bandwidth combination 15/15
30+20 (1)	SB1	30	160	Downlink & Uplink	Max Wgap	Table 4.3.1.1.1.66-1: Low range for UL/DL Bandwidth combination = 5/30, 10/30 or 30/30 depending on required UL bandwidth
	SB2	20	106	Downlink & Uplink		Table 4.3.1.1.1.66-1: High range for for UL/DL Bandwidth combination = 5/20, 10/20 or 20/20 depending on required UL bandwidth
30+25 (1)	SB1	30	160	Downlink & Uplink	Max Wgap	Table 4.3.1.1.1.66-1: Low range for UL/DL Bandwidth combination = 5/30, 10/30 or 30/30 depending on required UL bandwidth
	SB2	25	133	Downlink & Uplink		Table 4.3.1.1.1.66-1: High range for UL/DL Bandwidth combination = 5/25, 10/25 or 25/25 depending on required UL bandwidth
30+30 (1)	SB1	30	160	Downlink & Uplink	Max Wgap	Table 4.3.1.1.1.66-1: Low range for UL/DL Bandwidth combination = 5/30, 10/30 or 30/30 depending on required UL bandwidth
	SB2	30	160	Downlink & Uplink		Table 4.3.1.1.1.66-1: High range for UL/DL Bandwidth combination = 5/30, 10/30 or 30/30 depending on required UL bandwidth
30+40 (1)	SB1	30	160	Downlink & Uplink	Max Wgap	Table 4.3.1.1.1.66-1: Low range for UL/DL Bandwidth combination = 5/30, 10/30 or 30/30 depending on required UL bandwidth
	SB2	40	216	Downlink or Downlink & Uplink		If UL is not configured on SB2: Table 4.3.1.1.1.66-1: High range for N.A./40. Otherwise: Table 4.3.1.1.1.66-1: High range for UL/DL Bandwidth combination = 5/40, 10/40, 20/40 or 40/40 depending on required UL bandwidth
<b>CA_n66(2A); n66A (40MHz) + n66A(5-40MHz)</b>						
40+5 (1,2)	SB1	40	216	Downlink & Uplink	Max Wgap	Table 4.3.1.1.1.66-1: Low range for UL/DL Bandwidth combination = 5/40, 10/40, 20/40 or 40/40 depending on required UL bandwidth
	SB2	5	25	Downlink & Uplink		Table 4.3.1.1.1.66-1: High range for UL/DL Bandwidth combination 5/5
40+10 (1,2)	SB1	40	216	Downlink & Uplink	Max Wgap	Table 4.3.1.1.1.66-1: Low range for UL/DL Bandwidth combination = 5/40, 10/40, 20/40 or 40/40 depending on required UL bandwidth
	SB2	10	52	Downlink & Uplink		Table 4.3.1.1.1.66-1: High range for UL/DL Bandwidth combination 10/10

40+15 (1,2)	SB1	40	216	Downlink & Uplink	Max Wgap	Table 4.3.1.1.1.66-1: Low range for UL/DL Bandwidth combination = 5/40, 10/40, 20/40 or 40/40 depending on required UL bandwidth
	SB2	15	79	Downlink & Uplink		Table 4.3.1.1.1.66-1: High range for UL/DL Bandwidth combination 15/15
40+20 (1,2)	SB1	40	216	Downlink & Uplink	Max Wgap	Table 4.3.1.1.1.66-1: Low range for UL/DL Bandwidth combination = 5/40, 10/40, 20/40 or 40/40 depending on required UL bandwidth
	SB2	20	106	Downlink & Uplink		Table 4.3.1.1.1.66-1: High range for UL/DL Bandwidth combination = 5/20, 10/20 or 20/20 depending on required UL bandwidth
40+25 (1)	SB1	40	216	Downlink & Uplink	Max Wgap	Table 4.3.1.1.1.66-1: Low range for UL/DL Bandwidth combination = 5/40, 10/40, 20/40 or 40/40 depending on required UL bandwidth
	SB2	25	133	Downlink & Uplink		Table 4.3.1.1.1.66-1: High range for UL/DL Bandwidth combination = 5/25, 10/25 or 25/25 depending on required UL bandwidth
40+30 (1)	SB1	40	216	Downlink & Uplink	Max Wgap	Table 4.3.1.1.1.66-1: Low range for UL/DL Bandwidth combination = 5/40, 10/40, 20/40 or 40/40 depending on required UL bandwidth
	SB2	30	160	Downlink & Uplink		Table 4.3.1.1.1.66-1: High range for UL/DL Bandwidth combination = 5/30, 10/30 or 30/30 depending on required UL bandwidth
40+40 (1,2)	SB1	40	216	Downlink & Uplink	Max Wgap	Table 4.3.1.1.1.66-1: Low range for UL/DL Bandwidth combination = 5/40, 10/40, 20/40 or 40/40 depending on required UL bandwidth
	SB2	40	216	Downlink or Downlink & Uplink		If UL is not configured on SB2: Table 4.3.1.1.1.66-1: High range for N.A./40 Otherwise: Table 4.3.1.1.1.66-1: High range for UL/DL Bandwidth combination = 5/40, 10/40, 20/40 or 40/40 depending on required UL bandwidth
Note 1: CA_n66(2A) is specified in [7] 38.101-1 without uplink CA. PCC is configured on SB1 unless otherwise stated. The test frequencies for both SB1 and SB2 have been specified for both downlink and uplink to enable that the CC of either SB1 or SB2 can be used as PCC.						

**Table 4.3.1.1.5.66-2: NR Intra-Band non-contiguous CA configuration CA\_n66(2A) without UL CA, SCS=30 kHz, Max Wgap**

CBW combination (BCS)	SB	Band width [MHz]	carrier Bandwidth [PRBs]	Range	Gap	Test frequencies and signalling parameters
<b>CA_n66(2A); n66A (10MHz) + n66A(10-40MHz)</b>						
10+10 (0,1,2)	SB1	10	52	Downlink & Uplink	Max Wgap	Table 4.3.1.1.1.66-2: Low range for UL/DL Bandwidth combination = 10/10
	SB2	10	52	Downlink & Uplink		Table 4.3.1.1.1.66-2: High range for UL/DL Bandwidth combination = 10/10
10+15 (0,1,2)	SB1	10	52	Downlink & Uplink	Max Wgap	Table 4.3.1.1.1.66-2: Low range for UL/DL Bandwidth combination = 10/10
	SB2	15	79	Downlink & Uplink		Table 4.3.1.1.1.66-2: High range for UL/DL Bandwidth combination = 15/15
10+20 (0,1,2)	SB1	10	52	Downlink & Uplink	Max Wgap	Table 4.3.1.1.1.66-2: Low range for UL/DL Bandwidth combination = 10/10
	SB2	20	106	Downlink & Uplink		Table 4.3.1.1.1.66-2: High range for UL/DL Bandwidth combination = 10/20 or 20/20 depending on required UL bandwidth
10+25 (1)	SB1	10	52	Downlink & Uplink	Max Wgap	Table 4.3.1.1.1.66-2: Low range for UL/DL Bandwidth combination = 10/10
	SB2	25	133	Downlink & Uplink		Table 4.3.1.1.1.66-2: High range for UL/DL Bandwidth combination = 5/25, 10/25 or 25/25 depending on required UL bandwidth
10+30 (1)	SB1	10	52	Downlink & Uplink	Max Wgap	Table 4.3.1.1.1.66-2: Low range for UL/DL Bandwidth combination = 10/10

	SB2	30	160	Downlink & Uplink		Table 4.3.1.1.1.66-2: High range for UL/DL Bandwidth combination = 5/30, 10/30 or 30/30 depending on required UL bandwidth
10+40 (0,1,2)	SB1	10	24	Downlink & Uplink	Max Wgap	Table 4.3.1.1.1.66-2: Low range for UL/DL Bandwidth combination = 10/10
	SB2	40	106	Downlink or Downlink & Uplink		If UL is not configured on SB2: Table 4.3.1.1.1.66-2: High range for N.A./40. Otherwise: Table 4.3.1.1.1.66-2: High range for UL/DL Bandwidth combination = 20/40 or 40/40 depending on required UL bandwidth
<b>CA_n66(2A); n66A (15MHz) +n66A(10-40MHz)</b>						
15+10 (0,1,2)	SB1	15	79	Downlink & Uplink	Max Wgap	Table 4.3.1.1.1.66-2: Low range for UL/DL Bandwidth combination = 15/15
	SB2	10	52	Downlink & Uplink		Table 4.3.1.1.1.66-2: High range for UL/DL Bandwidth combination = 10/10
15+15 (0,1,2)	SB1	15	79	Downlink & Uplink	Max Wgap	Table 4.3.1.1.1.66-2: Low range for UL/DL Bandwidth combination = 15/15
	SB2	15	79	Downlink & Uplink		Table 4.3.1.1.1.66-2: High range for UL/DL Bandwidth combination = 15/15
15+20 (0,1,2)	SB1	15	79	Downlink & Uplink	Max Wgap	Table 4.3.1.1.1.66-2: Low range for UL/DL Bandwidth combination = 15/15
	SB2	20	106	Downlink & Uplink		Table 4.3.1.1.1.66-2: High range for UL/DL Bandwidth combination = 20/20
15+25 (1)	SB1	15	79	Downlink & Uplink	Max Wgap	Table 4.3.1.1.1.66-2: Low range for UL/DL Bandwidth combination = 15/15
	SB2	25	133	Downlink & Uplink		Table 4.3.1.1.1.66-2: High range for UL/DL Bandwidth combination = 5/25, 10/25 or 25/25 depending on required UL bandwidth
15+30 (1)	SB1	15	79	Downlink & Uplink	Max Wgap	Table 4.3.1.1.1.66-2: Low range for UL/DL Bandwidth combination = 15/15
	SB2	30	160	Downlink & Uplink		Table 4.3.1.1.1.66-2: High range for UL/DL Bandwidth combination = 5/30, 10/30 or 30/30 depending on required UL bandwidth
15+40 (0,1,2)	SB1	15	38	Downlink & Uplink	Max Wgap	Table 4.3.1.1.1.66-2: Low range for UL/DL Bandwidth combination = 15/15
	SB2	40	106	Downlink or Downlink & Uplink		If UL is not configured on SB2: Table 4.3.1.1.1.66-2: High range for N.A./40 Otherwise: Table 4.3.1.1.1.66-2: High range for UL/DL Bandwidth combination = 20/40 or 40/40 depending on required UL bandwidth
<b>CA_n66(2A); n66A (20MHz) + n66A(10-40MHz)</b>						
20+10 (0,1,2)	SB1	20	106	Downlink & Uplink	Max Wgap	Table 4.3.1.1.1.66-2: Low range for UL/DL Bandwidth combination = 10/20 or 20/20 depending on required UL bandwidth
	SB2	10	52	Downlink & Uplink		Table 4.3.1.1.1.66-2: High range for UL/DL Bandwidth combination 10/10
20+15 (0,1,2)	SB1	20	106	Downlink & Uplink	Max Wgap	Table 4.3.1.1.1.66-2: Low range for UL/DL Bandwidth combination = 10/20 or 20/20 depending on required UL bandwidth
	SB2	15	79	Downlink & Uplink		Table 4.3.1.1.1.66-2: High range for UL/DL Bandwidth combination 15/15
20+20 (0,1,2)	SB1	20	106	Downlink & Uplink	Max Wgap	Table 4.3.1.1.1.66-2: Low range for UL/DL Bandwidth combination = 10/20 or 20/20 depending on required UL bandwidth
	SB2	20	106	Downlink & Uplink		Table 4.3.1.1.1.66-2: High range for UL/DL Bandwidth combination = 10/20 or 20/20 depending on required UL bandwidth
20+25 (1)	SB1	20	106	Downlink & Uplink	Max Wgap	Table 4.3.1.1.1.66-2: Low range for UL/DL Bandwidth combination = 5/20, 10/20 or 20/20 depending on required UL bandwidth
	SB2	25	133	Downlink & Uplink		Table 4.3.1.1.1.66-2: High range for UL/DL Bandwidth combination = 5/25, 10/25 or 25/25 depending on required UL bandwidth
20+30 (1)	SB1	20	106	Downlink & Uplink	Max Wgap	Table 4.3.1.1.1.66-2: Low range for UL/DL Bandwidth combination = 5/20, 10/20 or 20/20 depending on required UL bandwidth

	SB2	30	160	Downlink & Uplink		Table 4.3.1.1.1.66-2: High range for UL/DL Bandwidth combination = 5/30, 10/30 or 30/30 depending on required UL bandwidth
20+40 (0,1,2)	SB1	20	51	Downlink & Uplink	Max Wgap	Table 4.3.1.1.1.66-2: Low range for UL/DL Bandwidth combination = 10/20 or 20/20 depending on required UL bandwidth
	SB2	40	106	Downlink or Downlink & Uplink		If UL is not configured on SB2: Table 4.3.1.1.1.66-2: High range for N.A./40 Otherwise: Table 4.3.1.1.1.66-2: High range for UL/DL Bandwidth combination = 20/40 or 40/40 depending on required UL bandwidth
<b>CA_n66(2A); n66A (25MHz) + n66A(10-40MHz)</b>						
25+10 (1)	SB1	25	133	Downlink & Uplink	Max Wgap	Table 4.3.1.1.1.66-2: Low range for UL/DL Bandwidth combination = 5/25, 10/25 or 25/25 depending on required UL bandwidth
	SB2	10	52	Downlink & Uplink		Table 4.3.1.1.1.66-2: High range for UL/DL Bandwidth combination 10/10
25+15 (1)	SB1	25	133	Downlink & Uplink	Max Wgap	Table 4.3.1.1.1.66-2: Low range for UL/DL Bandwidth combination = 5/25, 10/25 or 25/25 depending on required UL bandwidth
	SB2	15	79	Downlink & Uplink		Table 4.3.1.1.1.66-2: High range for UL/DL Bandwidth combination 15/15
25+20 (1)	SB1	25	133	Downlink & Uplink	Max Wgap	Table 4.3.1.1.1.66-2: Low range for UL/DL Bandwidth combination = 5/25, 10/25 or 25/25 depending on required UL bandwidth
	SB2	20	106	Downlink & Uplink		Table 4.3.1.1.1.66-2: High range for for UL/DL Bandwidth combination = 5/20, 10/20 or 20/20 depending on required UL bandwidth
25+25 (1)	SB1	25	133	Downlink & Uplink	Max Wgap	Table 4.3.1.1.1.66-2: Low range for UL/DL Bandwidth combination = 5/25, 10/25 or 25/25 depending on required UL bandwidth
	SB2	25	133	Downlink & Uplink		Table 4.3.1.1.1.66-2: High range for UL/DL Bandwidth combination = 5/25, 10/25 or 25/25 depending on required UL bandwidth
25+30 (1)	SB1	25	133	Downlink & Uplink	Max Wgap	Table 4.3.1.1.1.66-2: Low range for UL/DL Bandwidth combination = 5/25, 10/25 or 25/25 depending on required UL bandwidth
	SB2	30	160	Downlink & Uplink		Table 4.3.1.1.1.66-2: High range for UL/DL Bandwidth combination = 5/30, 10/30 or 30/30 depending on required UL bandwidth
25+40 (1)	SB1	25	65	Downlink & Uplink	Max Wgap	Table 4.3.1.1.1.66-2: Low range for UL/DL Bandwidth combination = 5/25, 10/25 or 25/25 depending on required UL bandwidth
	SB2	40	106	Downlink or Downlink & Uplink		If UL is not configured on SB2: Table 4.3.1.1.1.66-2: High range for N.A./40 Otherwise: Table 4.3.1.1.1.66-2: High range for UL/DL Bandwidth combination = 5/40, 10/40, 20/40 or 40/40 depending on required UL bandwidth
<b>CA_n66(2A); n66A (30MHz) + n66A(10-40MHz)</b>						
30+10 (1)	SB1	30	160	Downlink & Uplink	Max Wgap	Table 4.3.1.1.1.66-2: Low range for UL/DL Bandwidth combination = 5/30, 10/30 or 30/30 depending on required UL bandwidth
	SB2	10	52	Downlink & Uplink		Table 4.3.1.1.1.66-2: High range for UL/DL Bandwidth combination 10/10
30+15 (1)	SB1	30	160	Downlink & Uplink	Max Wgap	Table 4.3.1.1.1.66-2: Low range for UL/DL Bandwidth combination = 5/30, 10/30 or 30/30 depending on required UL bandwidth
	SB2	15	79	Downlink & Uplink		Table 4.3.1.1.1.66-2: High range for UL/DL Bandwidth combination 15/15
30+20 (1)	SB1	30	160	Downlink & Uplink	Max Wgap	Table 4.3.1.1.1.66-2: Low range for UL/DL Bandwidth combination = 5/30, 10/30 or 30/30 depending on required UL bandwidth
	SB2	20	106	Downlink & Uplink		Table 4.3.1.1.1.66-2: High range for for UL/DL Bandwidth combination = 5/20, 10/20 or 20/20 depending on required UL bandwidth



30+25 (1)	SB1	30	160	Downlink & Uplink	Max Wgap	Table 4.3.1.1.1.66-2: Low range for UL/DL Bandwidth combination = 5/30, 10/30 or 30/30 depending on required UL bandwidth
	SB2	25	133	Downlink & Uplink		Table 4.3.1.1.1.66-2: High range for UL/DL Bandwidth combination = 5/25, 10/25 or 25/25 depending on required UL bandwidth
30+30 (1)	SB1	30	160	Downlink & Uplink	Max Wgap	Table 4.3.1.1.1.66-2: Low range for UL/DL Bandwidth combination = 5/30, 10/30 or 30/30 depending on required UL bandwidth
	SB2	30	160	Downlink & Uplink		Table 4.3.1.1.1.66-2: High range for UL/DL Bandwidth combination = 5/30, 10/30 or 30/30 depending on required UL bandwidth
30+40 (1)	SB1	30	78	Downlink & Uplink	Max Wgap	Table 4.3.1.1.1.66-2: Low range for UL/DL Bandwidth combination = 5/30, 10/30 or 30/30 depending on required UL bandwidth
	SB2	40	106	Downlink or Downlink & Uplink		If UL is not configured on SB2: Table 4.3.1.1.1.66-2: High range for N.A./40 Otherwise: Table 4.3.1.1.1.66-2: High range for UL/DL Bandwidth combination = 5/40, 10/40, 20/40 or 40/40 depending on required UL bandwidth
<b>CA_n66(2A); n66A (40MHz) + n66A(10-40MHz)</b>						
40+10 (1,2)	SB1	40	216	Downlink & Uplink	Max Wgap	Table 4.3.1.1.1.66-2: Low range for UL/DL Bandwidth combination = 20/40 or 40/40 depending on required UL bandwidth
	SB2	10	52	Downlink & Uplink		Table 4.3.1.1.1.66-2: High range for UL/DL Bandwidth combination 10/10
40+15 (1,2)	SB1	40	216	Downlink & Uplink	Max Wgap	Table 4.3.1.1.1.66-2: Low range for UL/DL Bandwidth combination = 10/40 or 20/40 depending on required UL bandwidth
	SB2	15	79	Downlink & Uplink		Table 4.3.1.1.1.66-2: High range for UL/DL Bandwidth combination 15/15
40+20 (1,2)	SB1	40	216	Downlink & Uplink	Max Wgap	Table 4.3.1.1.1.66-2: Low range for UL/DL Bandwidth combination = 20/40 or 40/40 depending on required UL bandwidth
	SB2	20	106	Downlink & Uplink		Table 4.3.1.1.1.66-2: High range for UL/DL Bandwidth combination = 10/20 or 20/20 depending on required UL bandwidth
40+25 (1)	SB1	40	216	Downlink & Uplink	Max Wgap	Table 4.3.1.1.1.66-2: Low range for UL/DL Bandwidth combination = 5/40, 10/40, 20/40 or 40/40 depending on required UL bandwidth
	SB2	25	133	Downlink & Uplink		Table 4.3.1.1.1.66-2: High range for UL/DL Bandwidth combination = 5/25, 10/25 or 25/25 depending on required UL bandwidth
40+30 (1)	SB1	40	216	Downlink & Uplink	Max Wgap	Table 4.3.1.1.1.66-2: Low range for UL/DL Bandwidth combination = 5/40, 10/40, 20/40 or 40/40 depending on required UL bandwidth
	SB2	30	160	Downlink & Uplink		Table 4.3.1.1.1.66-2: High range for UL/DL Bandwidth combination = 5/30, 10/30 or 30/30 depending on required UL bandwidth
40+40 (1,2)	SB1	40	106	Downlink & Uplink	Max Wgap	Table 4.3.1.1.1.66-2: Low range for UL/DL Bandwidth combination = 5/40, 10/40, 20/40 or 40/40 depending on required UL bandwidth
	SB2	40	106	Downlink or Downlink & Uplink		If UL is not configured on SB2: Table 4.3.1.1.1.66-2: High range for N.A./40 Otherwise: Table 4.3.1.1.1.66-2: High range for UL/DL Bandwidth combination = 5/40, 10/40, 20/40 or 40/40 depending on required UL bandwidth
Note 1: CA_n66(2A) is specified in [7] 38.101-1 without uplink CA. PCC is configured on SB1 unless otherwise stated. The test frequencies for both SB1 and SB2 have been specified for both downlink and uplink to enable that the CC of either SB1 or SB2 can be used as PCC.						

4.3.1.1.5.67 – 4.3.1.1.5.70 FFS

4.3.1.1.5.71 CA\_n71(2A)

Editor's note: Test frequencies for CA\_n71(2A) with mixed numerology with SCS CC1=15kHz and SCS CC2=30 kHz; and SCS CC1=30kHz and SCS CC2=15 kHz is FFS.

**Table 4.3.1.1.5.71-1: NR Intra-Band non-contiguous CA configuration CA\_n71(2A) without UL CA, SCS=15 kHz, Max Wgap**

CBW combination	SB	Band width [MHz]	carrier Bandwidth [PRBs]	Range	Gap	Test frequencies and signalling parameters
<b>CA_n71(2A); n71A (5MHz) + n71A (5-20MHz)</b>						
5+5	SB1	5	25	Downlink & Uplink	Max	Table 4.3.1.1.1.71-1: Low range for CBW=5 MHz
	SB2	5	25	Downlink & Uplink	Wgap	Table 4.3.1.1.1.71-1: High range for CBW=5 MHz
5+10	SB1	5	25	Downlink & Uplink	Max	Table 4.3.1.1.1.71-1: Low range for CBW=5 MHz
	SB2	10	52	Downlink & Uplink	Wgap	Table 4.3.1.1.1.71-1: High range for CBW=10 MHz
5+15	SB1	5	25	Downlink & Uplink	Max	Table 4.3.1.1.1.71-1: Low range for CBW=5 MHz
	SB2	15	79	Downlink & Uplink	Wgap	Table 4.3.1.1.1.71-1: High range for CBW=15 MHz
5+20	SB1	5	25	Downlink & Uplink	Max	Table 4.3.1.1.1.71-1: Low range for CBW=5 MHz
	SB2	20	106	Downlink & Uplink	Wgap	Table 4.3.1.1.1.71-1: High range for CBW=20 MHz
<b>CA_n71(2A); n71A (10MHz) + n71A (5-20MHz)</b>						
10+5	SB1	10	52	Downlink & Uplink	Max	Table 4.3.1.1.1.71-1: Low range for CBW=10 MHz
	SB2	5	25	Downlink & Uplink	Wgap	Table 4.3.1.1.1.71-1: High range for CBW=5 MHz
10+10	SB1	10	52	Downlink & Uplink	Max	Table 4.3.1.1.1.71-1: Low range for CBW=10 MHz
	SB2	10	52	Downlink & Uplink	Wgap	Table 4.3.1.1.1.71-1: High range for CBW=10 MHz
10+15	SB1	10	52	Downlink & Uplink	Max	Table 4.3.1.1.1.71-1: Low range for CBW=10 MHz
	SB2	15	79	Downlink & Uplink	Wgap	Table 4.3.1.1.1.71-1: High range for CBW=15 MHz
10+20	SB1	10	52	Downlink & Uplink	Max	Table 4.3.1.1.1.71-1: Low range for CBW=10 MHz
	SB2	20	106	Downlink & Uplink	Wgap	Table 4.3.1.1.1.71-1: High range for CBW=20 MHz
<b>CA_n71(2A); n71A (15MHz) + n71A (5-15MHz)</b>						
15+5	SB1	15	79	Downlink & Uplink	Max	Table 4.3.1.1.1.71-1: Low range for CBW=15 MHz
	SB2	5	25	Downlink & Uplink	Wgap	Table 4.3.1.1.1.71-1: High range for CBW=5 MHz
15+10	SB1	15	79	Downlink & Uplink	Max	Table 4.3.1.1.1.71-1: Low range for CBW=15 MHz
	SB2	10	52	Downlink & Uplink	Wgap	Table 4.3.1.1.1.71-1: High range for CBW=10 MHz
15+15	SB1	15	79	Downlink & Uplink	Max	Table 4.3.1.1.1.71-1: Low range for CBW=15 MHz
	SB2	15	79	Downlink & Uplink	Wgap	Table 4.3.1.1.1.71-1: High range for CBW=15 MHz
<b>CA_n71(2A); n71A (20MHz) + n71A (5-10MHz)</b>						
20+5	SB1	20	106	Downlink & Uplink	Max	Table 4.3.1.1.1.71-1: Low range for CBW=20 MHz
	SB2	5	25	Downlink & Uplink	Wgap	Table 4.3.1.1.1.71-1: High range for CBW=5 MHz
20+10	SB1	20	106	Downlink & Uplink	Max	Table 4.3.1.1.1.71-1: Low range for CBW=20 MHz
	SB2	10	52	Downlink & Uplink	Wgap	Table 4.3.1.1.1.71-1: High range for CBW=10 MHz
Note 1: CA_n71(2A) is specified in [7] 38.101-1 without uplink CA. PCC is configured on SB1 unless otherwise stated. The test frequencies for both SB1 and SB2 have been specified for both downlink and uplink to enable that the CC of either SB1 or SB2 can be used as PCC.						

**Table 4.3.1.1.5.71-2: NR Intra-Band non-contiguous CA configuration CA\_n71(2A) without UL CA, SCS=30 kHz, Max Wgap**

SB CBW combination	SB	Band width [MHz]	carrier Bandwidth [PRBs]	Range	Gap	Test frequencies and signalling parameters
<b>CA_n71(2A); n71A (10MHz) + n71A (10-20MHz)</b>						
10+10	SB1	10	24	Downlink & Uplink	Max	Table 4.3.1.1.1.71-2: Low range for CBW=10 MHz
	SB2	10	24	Downlink & Uplink	Wgap	Table 4.3.1.1.1.71-2: High range for CBW=10 MHz
10+15	SB1	10	24	Downlink & Uplink	Max	Table 4.3.1.1.1.71-2: Low range for CBW=10 MHz
	SB2	15	38	Downlink & Uplink	Wgap	Table 4.3.1.1.1.71-2: High range for CBW=15 MHz
10+20	SB1	10	24	Downlink & Uplink	Max	Table 4.3.1.1.1.71-2: Low range for CBW=10 MHz
	SB2	20	51	Downlink & Uplink	Wgap	Table 4.3.1.1.1.71-2: High range for CBW=20 MHz
<b>CA_n71(2A); n71A (15MHz) + n71A (10-15MHz)</b>						
15+10	SB1	15	38	Downlink & Uplink	Max	Table 4.3.1.1.1.71-2: Low range for CBW=15 MHz

	SB2	10	24	Downlink & Uplink	Wgap	Table 4.3.1.1.1.71-2: High range for CBW=10 MHz
15+15	SB1	15	38	Downlink & Uplink	Max	Table 4.3.1.1.1.71-2: Low range for CBW=15 MHz
	SB2	15	38	Downlink & Uplink	Wgap	Table 4.3.1.1.1.71-2: High range for CBW=15 MHz
<b>CA_n71(2A); n71A (20MHz) + n71A (10MHz)</b>						
20+10	SB1	20	51	Downlink & Uplink	Max	Table 4.3.1.1.1.71-2: Low range for CBW=20 MHz
	SB2	10	24	Downlink & Uplink	Wgap	Table 4.3.1.1.1.71-2: High range for CBW=10 MHz
Note 1:	CA_n71(2A) is specified in [7] 38.101-1 without uplink CA. PCC is configured on SB1 unless otherwise stated. The test frequencies for both SB1 and SB2 have been specified for both downlink and uplink to enable that the CC of either SB1 or SB2 can be used as PCC.					

4.3.1.1.5.72 – 4.3.1.1.5.76 FFS

4.3.1.1.5.77 CA\_n77(2A)

Editor's note: Test frequencies for CA\_n77(2A) with mixed numerology with SCS CC1=15kHz and SCS CC2=30 kHz or 60kHz; and SCS CC1=30kHz and SCS CC2=15 kHz or 60 kHz is FFS.

**Table 4.3.1.1.5.77-1: NR Intra-Band non-contiguous CA configuration CA\_n77(2A) without UL CA, SCS=15 kHz, Max Wgap**

CBW combination	SB	Bandwidth [MHz]	Range (Note 1)	Gap	Test frequencies and signalling parameters
<b>CA_n77(2A); n77A(20-40MHz) + n77A(20-40MHz)</b>					
CBW1+CBW2	SB1	CBW1	Downlink & Uplink	Max Wgap	For CBW1, use Table 4.3.1.1.1.77-1: Low range for CBW = 20 OR 40 MHz
	SB2	CBW2	Downlink & Uplink		For CBW2, use Table 4.3.1.1.1.77-1: High range for CBW = 20 OR 40 MHz
Note 1: CA_n77(2A) BCS0 is specified in [7] 38.101-1 without uplink CA. PCC is configured on SB1 unless otherwise stated. The test frequencies for both SB1 and SB2 have been specified for both downlink and uplink to enable that the CC of either SB1 or SB2 can be used as PCC.					

**Table 4.3.1.1.5.77-2: NR Intra-Band non-contiguous CA configuration CA\_n77(2A) without UL CA, SCS=30 kHz, Max Wgap**

CBW combination	SB	Bandwidth [MHz]	Range (Note 1)	Gap	Test frequencies and signalling parameters
<b>CA_n77(2A); n77A(20-100MHz) + n77A(20-100MHz)</b>					
CBW1+CBW2	SB1	CBW1	Downlink & Uplink	Max Wgap	For CBW1, use Table 4.3.1.1.1.77-2: Low range for CBW = 20, 40, 80 OR 100 MHz
	SB2	CBW2	Downlink & Uplink		For CBW2, use Table 4.3.1.1.1.77-2: High range for CBW = 20, 40, 80 OR 100 MHz
Note 1: CA_n77(2A) BCS0 is specified in [7] 38.101-1 without uplink CA. PCC is configured on SB1 unless otherwise stated. The test frequencies for both SB1 and SB2 have been specified for both downlink and uplink to enable that the CC of either SB1 or SB2 can be used as PCC.					

Table 4.3.1.1.5.77-3: NR Intra-Band non-contiguous CA configuration CA\_n77(2A) with UL CA (PCC=CC1 and SCC=CC2), SCS 15kHz

CBW combination [MHz]	Range	CCN	CBW [MHz]	SCS [kHz]	carrierBandwidth [PRBs]	Carrier centre [MHz] Note 2	Carrier centre [ARFCN]	point A [MHz]	absoluteFrequencyPointA [ARFCN]	offsetToCarrier [Carrier PRBs]	SS block SCS [kHz]	GS CN	absoluteFrequencySSB [ARFCN]	$k_{SSB}$	Offset carrier CORE SET#0 [RBs] Note 3	CORE SET#0 Index (Offset [RBs]) Note 4	offsetTo PointA (SIB1) [PRBs] Note 4	
20+20	DL & UL	LOW	CC1	20	15	106	3310.02	620668	3300.48	620032	0	30	7711	620352	8	0	1 (6)	6
			MaxFsBW=100MHz, maxWgap = 60MHz															
	DL & UL	HIGH	CC2	20	15	106	3390	626000	3380.46	625364	0	30	7766	625632	4	0	1 (6)	2
			MaxFsBW=100MHz, maxWgap = 60MHz															
	DL & UL	HIGH	CC1	20	15	106	4110	674000	4019.28	667952	504	30	8273	674304	4	3	0 (2)	509
			MaxFsBW=100MHz, maxWgap = 60MHz															
DL & UL	HIGH	CC2	20	15	106	4189.995	679333	4089.735	672649	504	30	8322	679008	11	3	0 (2)	509	
		MaxFsBW=100MHz, maxWgap = 60MHz																
20+40	DL & UL	LOW	CC1	20	15	106	3310.02	620668	3300.48	620032	0	30	7711	620352	8	0	1 (6)	6
			MaxFsBW=100MHz, maxWgap = 40MHz															
	DL & UL	HIGH	CC2	40	15	216	3380.01	625334	3360.57	624038	0	30	7753	624384	10	2	1 (6)	8
			MaxFsBW=100MHz, maxWgap = 40MHz															
	DL & UL	HIGH	CC1	20	15	106	4110	674000	4019.28	667952	504	30	8273	674304	4	3	0 (2)	509
			MaxFsBW=100MHz, maxWgap = 40MHz															
DL & UL	HIGH	CC2	40	15	216	4179.99	678666	4069.83	671322	504	30	8308	677664	6	2	0 (2)	508	
		MaxFsBW=100MHz, maxWgap = 40MHz																
40+20	DL	LOW	CC1	40	15	216	3320.01	621334	3300.57	620038	0	30	7711	620352	2	0	1 (6)	6

	& U L	MaxFsBW=100MHz, maxWgap =40MHz															
		C C 2	20	15	106	3390	6260 00	3370 .56	624704	0	30	77 60	625056	4	3	1 (6)	9
		H I G H C 1	40	15	216	4119 .99	6746 66	4029 .27	668618	504	30	82 80	674976	10	3	0 (2)	509
		MaxFsBW=100MHz, maxWgap =40MHz															
		C C 2	20	15	106	4189 .995	6793 33	4089 .735	672649	504	30	83 22	679008	11	3	0 (2)	509
		40+40	D L & U L	L O W C 1	40	15	216	3320 .01	6213 34	3300 .57	620038	0	30	77 11	620352	2	0
MaxFsBW=100MHz, maxWgap =20MHz																	
C C 2	40	15		216	3380 .01	6253 34	3360 .57	624038	0	30	77 53	624384	10	2	1 (6)	8	
H I G H C 1	40	15		216	4119 .99	6746 66	4029 .27	668618	504	30	82 80	674976	10	3	0 (2)	509	
MaxFsBW=100MHz, maxWgap =20MHz																	
C C 2	40	15		216	4179 .99	6786 66	4069 .83	671322	504	30	83 08	677664	6	2	0 (2)	508	
<p>Note 1: CCs are specified in increasing frequency order. CC1 is used as PCell if nothing else is specified in the test case.</p> <p>Note 2: The parameter Offset Carrier CORESET#0 specifies the offset from the lowest subcarrier of the carrier and the lowest subcarrier of CORESET#0. It corresponds to the parameter <math>\Delta F_{\text{OffsetCORESET-0-Carrier}}</math> in Annex C expressed in number of common RBs.</p> <p>Note 3: The CORESET#0 Index and the associated CORESET#0 Offset refers to Table 13-2 in TS 38.213 [22]. The value of CORESET#0 Index is signalled in controlResourceSetZero (pdcch-ConfigSIB1) in the MIB. The offsetToPointA IE is expressed in units of resource blocks assuming 15 kHz subcarrier spacing for FR1 and 60 kHz subcarrier spacing for FR2</p>																	

**Table 4.3.1.1.5.77-4: NR Intra-Band non-contiguous CA configuration CA\_n77(2A) with UL CA (PCC=CC1 and SCC=CC2), SCS 30kHz**

CBW combination [MHz]	Range	C C N o t e 2	CB W [ M H z]	SC S [ k H z]	carrierBandwidth [PRBs]	Carrier centre [MHz] Note 2	Carrier centre [ARFCN]	point A [MHz]	absoluteFrequencyPointA [ARFCN]	offsetToCarrier [Carrier PRBs]	SS block SCS [kHz]	GS CN	absoluteFrequencySSB [ARFCN]	$k_{\text{SSB}}$	Offset carrier CORESET#0 [RBs] Note 3	CORE SET#0 Index (Offset [RBs]) Note 4	offsetToPointA (SIB1) [PRBs] Note 4
-----------------------	-------	---------------------------------	------------------------------	------------------------------	-------------------------	-----------------------------	------------------------	---------------	---------------------------------	--------------------------------	--------------------	-------	------------------------------	------------------	---------------------------------------	--	-------------------------------------

20+20	D L & U L	L O W	C C 1	20	30	51	331 0.02	6206 68	330 0.84	620056	0	30	77 11	620352	8	0	2 (2)	4	
			MaxFsBW=100MHz, maxWgap = 60MHz																
			C C 2	20	30	51	339 0	6260 00	338 0.82	625388	0	30	77 66	625632	4	0	0 (0)	0	
		H I G H	C C 1	20	30	51	411 0	6740 00	392 8.56	661904	504	30	82 73	674304	16	0	2 (2)	1012	
			MaxFsBW=100MHz, maxWgap = 60MHz																
			C C 2	20	30	51	418 9.98	6793 32	399 9.36	666624	504	30	83 22	679008	0	0	2 (2)	1012	
20+40	D L & U L	L O W	C C 1	20	30	51	331 0.02	6206 68	330 0.84	620056	0	30	77 11	620352	8	0	2 (2)	4	
			MaxFsBW=100MHz, maxWgap = 40MHz																
			C C 2	40	30	106	337 9.98	6253 32	336 0.9	624060	0	30	77 53	624384	12	3	0 (0)	6	
		H I G H	C C 1	20	30	51	411 0	6740 00	392 8.56	661904	504	30	82 73	674304	16	0	2 (2)	1012	
			MaxFsBW=100MHz, maxWgap = 40MHz																
			C C 2	40	30	106	417 9.99	6786 66	397 9.47	665298	504	30	83 08	677664	6	0	1 (1)	1010	
20+80	D L & U L	L O W	C C 1	20	30	51	331 0.02	6206 68	330 0.84	620056	0	30	77 11	620352	8	0	2 (2)	4	
			MaxFsBW=200MHz, maxWgap = 100MHz																
			C C 2	80	30	217	345 9.99	6306 66	342 0.93	628062	0	30	77 94	628320	18	0	0 (0)	0	
		H I G H	C C 1	20	30	51	401 0.01	6673 34	382 8.57	655238	504	30	82 03	667584	10	0	0 (0)	1008	
			MaxFsBW=200MHz, maxWgap = 100MHz																
			C C 2	80	30	217	415 9.98	6773 32	393 9.48	662632	504	30	82 80	674976	8	0	0 (0)	1008	

20+100	D L & U L	L O W	C C 1	20	30	51	331 0.02	6206 68	330 0.84	620056	0	30	77 11	620352	8	0	2 (2)	4	
			MaxFsBW=200MHz, maxWgap = 80MHz																
			C C 2	10 0	30	273	345 0	6300 00	340 0.86	626724	0	30	77 80	626976	12	0	0 (0)	0	
		H I G H	C C 1	20	30	51	401 0.01	6673 34	382 8.57	655238	504	30	82 03	667584	10	0	0 (0)	1008	
			MaxFsBW=200MHz, maxWgap = 80MHz																
			C C 2	10 0	30	273	414 9.99	6766 66	391 9.41	661294	504	30	82 66	673632	2	0	0 (0)	1008	
40+20	D L & U L	L O W	C C 1	40	30	106	332 0.01	6213 34	330 0.93	620062	0	30	77 11	620352	2	0	2 (2)	4	
			MaxFsBW=100MHz, maxWgap = 40MHz																
			C C 2	20	30	51	339 0	6260 00	338 0.82	625388	0	30	77 66	625632	4	0	0 (0)	0	
		H I G H	C C 1	40	30	106	412 0.02	6746 68	393 8.58	662572	504	30	82 80	674976	20	0	2 (2)	1012	
			MaxFsBW=100MHz, maxWgap = 40MHz																
			C C 2	20	30	51	418 9.98	6793 32	399 9.36	666624	504	30	83 22	679008	0	0	2 (2)	1012	
40+40	D L & U L	L O W	C C 1	40	30	106	332 0.01	6213 34	330 0.93	620062	0	30	77 11	620352	2	0	2 (2)	4	
			MaxFsBW=100MHz, maxWgap = 20MHz																
			C C 2	40	30	106	337 9.98	6253 32	336 0.9	624060	0	30	77 53	624384	12	3	0 (0)	6	
		H I G H	C C 1	40	30	106	412 0.02	6746 68	393 8.58	662572	504	30	82 80	674976	20	0	2 (2)	1012	
			MaxFsBW=100MHz, maxWgap = 20MHz																
			C C 2	40	30	106	417 9.99	6786 66	397 9.47	665298	504	30	83 08	677664	6	0	1 (1)	1010	

40+80	D L & U L	L O W	C C 1	40	30	106	332 0.01	6213 34	330 0.93	620062	0	30	77 11	620352	2	0	2 (2)	4	
			MaxFsBW=200MHz, maxWgap = 80MHz																
			C C 2	80	30	217	345 9.99	6306 66	342 0.93	628062	0	30	77 94	628320	18	0	0 (0)	0	
		H I G H	C C 1	40	30	106	402 0	6680 00	383 8.56	655904	504	30	82 10	668256	16	0	0 (0)	1008	
			MaxFsBW=200MHz, maxWgap = 80MHz																
			C C 2	80	30	217	415 9.98	6773 32	393 9.48	662632	504	30	82 80	674976	8	0	0 (0)	1008	
40+100	D L & U L	L O W	C C 1	40	30	106	332 0.01	6213 34	330 0.93	620062	0	30	77 11	620352	2	0	2 (2)	4	
			MaxFsBW=200MHz, maxWgap = 60MHz																
			C C 2	10 0	30	273	345 0	6300 00	340 0.86	626724	0	30	77 80	626976	12	0	0 (0)	0	
		H I G H	C C 1	40	30	106	402 0	6680 00	383 8.56	655904	504	30	82 10	668256	16	0	0 (0)	1008	
			MaxFsBW=200MHz, maxWgap = 60MHz																
			C C 2	10 0	30	273	414 9.99	6766 66	391 9.41	661294	504	30	82 66	673632	2	0	0 (0)	1008	
80+20	D L & U L	L O W	C C 1	80	30	217	334 0.02	6226 68	330 0.96	620064	0	30	77 11	620352	0	0	2 (2)	4	
			MaxFsBW=200MHz, maxWgap = 100MHz																
			C C 2	20	30	51	348 9.99	6326 66	348 0.81	632054	0	30	78 36	632352	10	0	2 (2)	4	
		H I G H	C C 1	80	30	217	404 0.01	6693 34	385 8.57	657238	504	30	82 24	669600	2	0	1 (1)	1010	
			MaxFsBW=200MHz, maxWgap = 100MHz																
			C C 2	20	30	51	418 9.98	6793 32	399 9.36	666624	504	30	83 22	679008	0	0	2 (2)	1012	



80+40	D L & U L	L O W	C C 1	80	30	217	334 0.02	6226 68	330 0.96	620064	0	30	77 11	620352	0	0	2 (2)	4	
			MaxFsBW=200MHz, maxWgap = 80MHz																
			C C 2	40	30	106	348 0	6320 00	346 0.92	630728	0	30	78 22	631008	16	0	1 (1)	2	
		H I G H	C C 1	80	30	217	404 0.01	6693 34	385 8.57	657238	504	30	82 24	669600	2	0	1 (1)	1010	
			MaxFsBW=200MHz, maxWgap = 80MHz																
			C C 2	40	30	106	417 9.99	6786 66	397 9.47	665298	504	30	83 08	677664	6	0	1 (1)	1010	
80+80	D L & U L	L O W	C C 1	80	30	217	334 0.02	6226 68	330 0.96	620064	0	30	77 11	620352	0	0	2 (2)	4	
			MaxFsBW=200MHz, maxWgap = 40MHz																
			C C 2	80	30	217	345 9.99	6306 66	342 0.93	628062	0	30	77 94	628320	18	0	0 (0)	0	
		H I G H	C C 1	80	30	217	404 0.01	6693 34	385 8.57	657238	504	30	82 24	669600	2	0	1 (1)	1010	
			MaxFsBW=200MHz, maxWgap = 40MHz																
			C C 2	80	30	217	415 9.98	6773 32	393 9.48	662632	504	30	82 80	674976	8	0	0 (0)	1008	
80+100	D L & U L	L O W	C C 1	80	30	217	334 0.02	6226 68	330 0.96	620064	0	30	77 11	620352	0	0	2 (2)	4	
			MaxFsBW=200MHz, maxWgap = 20MHz																
			C C 2	10 0	30	273	345 0	6300 00	340 0.86	626724	0	30	77 80	626976	12	0	0 (0)	0	
		H I G H	C C 1	80	30	217	404 0.01	6693 34	385 8.57	657238	504	30	82 24	669600	2	0	1 (1)	1010	
			MaxFsBW=200MHz, maxWgap = 20MHz																
			C C 2	10 0	30	273	414 9.99	6766 66	391 9.41	661294	504	30	82 66	673632	2	0	0 (0)	1008	

100+20	D L & U L	L O W	C C 1	10 0	30	273	335 0.01	6233 34	330 0.87	620058	0	30	77 11	620352	6	0	2 (2)	4		
			MaxFsBW=200MHz, maxWgap = 80MHz																	
			C C 2	20	30	51	348 9.99	6326 66	348 0.81	632054	0	30	78 36	632352	10	0	2 (2)	4		
		H I G H	C C 1	10 0	30	273	405 0	6700 00	386 8.56	657904	504	30	82 31	670272	8	0	1 (1)	1010		
			MaxFsBW=200MHz, maxWgap = 80MHz																	
			C C 2	20	30	51	418 9.98	6793 32	399 9.36	666624	504	30	83 22	679008	0	0	2 (2)	1012		
100+40	D L & U L	L O W	C C 1	10 0	30	273	335 0.01	6233 34	330 0.87	620058	0	30	77 11	620352	6	0	2 (2)	4		
			MaxFsBW=200MHz, maxWgap = 60MHz																	
			C C 2	40	30	106	348 0	6320 00	346 0.92	630728	0	30	78 22	631008	16	0	1 (1)	2		
		H I G H	C C 1	10 0	30	273	405 0	6700 00	386 8.56	657904	504	30	82 31	670272	8	0	1 (1)	1010		
			MaxFsBW=200MHz, maxWgap = 60MHz																	
			C C 2	40	30	106	417 9.99	6786 66	397 9.47	665298	504	30	83 08	677664	6	0	1 (1)	1010		
100+80	D L & U L	L O W	C C 1	10 0	30	273	335 0.01	6233 34	330 0.87	620058	0	30	77 11	620352	6	0	2 (2)	4		
			MaxFsBW=200MHz, maxWgap = 20MHz																	
			C C 2	80	30	217	345 9.99	6306 66	342 0.93	628062	0	30	77 94	628320	18	0	0 (0)	0		
		H I G H	C C 1	10 0	30	273	405 0	6700 00	386 8.56	657904	504	30	82 31	670272	8	0	1 (1)	1010		
			MaxFsBW=200MHz, maxWgap = 20MHz																	
			C C 2	80	30	217	415 9.98	6773 32	393 9.48	662632	504	30	82 80	674976	8	0	0 (0)	1008		

100+10 0	D L & U L	L O W	C C 1	10 0	30	273	335 0.01	6233 34	330 0.87	620058	0	30	77 11	620352	6	0	2 (2)	4	
			MaxFsBW=600MHz, maxWgap = 400MHz																
			C C 2	10 0	30	273	384 9.99	6566 66	380 0.85	653390	0	30	80 58	653664	10	0	1 (1)	2	
		H I G H	C C 1	10 0	30	273	365 0.01	6433 34	346 8.57	631238	504	30	79 53	643584	10	0	0 (0)	1008	
			MaxFsBW=600MHz, maxWgap = 400MHz																
			C C 2	10 0	30	273	414 9.99	6766 66	391 9.41	661294	504	30	82 66	673632	2	0	0 (0)	1008	
Note 1:		CCs are specified in increasing frequency order. CC1 is used as PCell if nothing else is specified in the test case.																	
Note 2:		The parameter Offset Carrier CORESET#0 specifies the offset from the lowest subcarrier of the carrier and the lowest subcarrier of CORESET#0. It corresponds to the parameter $\Delta F_{\text{OffsetCORESET-0-Carrier}}$ in Annex C expressed in number of common RBs.																	
Note 3:		The CORESET#0 Index and the associated CORESET#0 Offset refers to Table 13-2 in TS 38.213 [22]. The value of CORESET#0 Index is signalled in controlResourceSetZero (pdcch-ConfigSIB1) in the MIB. The offsetToPointA IE is expressed in units of resource blocks assuming 15 kHz subcarrier spacing for FR1 and 60 kHz subcarrier spacing for FR2																	

## 4.3.1.1.5.78 CA\_n78(2A)

Editor's note: Test frequencies for CA\_n78(2A) with mixed numerology with SCS CC1=15kHz and SCS CC2=30 kHz or 60kHz; and SCS CC1=30kHz and SCS CC2=15 kHz or 60 kHz is FFS.

**Table 4.3.1.1.5.78-1: NR Intra-Band non-contiguous CA configuration CA\_n78(2A) without UL CA, SCS=15 kHz, Max Wgap**

CBW combination	SB	Bandwidth [MHz]	Range	Gap	Test frequencies and signalling parameters
<b>CA_n78(2A); n78A(10-50MHz) + n78A(10-50MHz)</b>					
CBW1+CBW2	SB1	CBW1	Downlink & Uplink	Max Wgap	For CBW1, use Table 4.3.1.1.1.78-1: Low range for CBW = 10, 20, 25, 30, 40 OR 50 MHz
	SB2	CBW2	Downlink & Uplink		For CBW2, use Table 4.3.1.1.1.78-1: High range for CBW = 10, 20, 25, 30, 40 OR 50 MHz
Note 1: CA_n78(2A) is specified in [7] 38.101-1 with and without uplink CA. PCC is configured on SB1 unless otherwise stated. This table is applicable for the case of without UL CA but test frequencies for both SB1 and SB2 have been specified for both downlink and uplink to enable that the CC of either SB1 or SB2 can be used as PCC.					

**Table 4.3.1.1.5.78-1A: NR Intra-Band non-contiguous CA configuration CA\_n78(2A) with UL CA, SCS=15 kHz, Max Wgap**

FFS

**Table 4.3.1.1.5.78-2: NR Intra-Band non-contiguous CA configuration CA\_n78(2A) without UL CA, SCS=30 kHz, Max Wgap**

CBW combination	SB	Bandwidth [MHz]	Range	Gap	Test frequencies and signalling parameters
<b>CA_n78(2A); n78A(10-100MHz) + n78A(10-100MHz)</b>					
CBW1+CBW2	SB1	CBW1	Downlink & Uplink	Max Wgap	For CBW1, use Table 4.3.1.1.1.78-2: Low range for CBW = 10, 20, 25, 30, 40, 50, 60, 70, 80, 90 OR 100 MHz
	SB2	CBW2	Downlink & Uplink		For CBW2, use Table 4.3.1.1.1.78-2: High range for CBW = 10, 20, 25, 30, 40, 50, 60, 70, 80, 90 OR 100 MHz
Note 1: CA_n78(2A) is specified in [7] 38.101-1 with and without uplink CA. PCC is configured on SB1 unless otherwise stated. This table is applicable for the case of without UL CA but test frequencies for both SB1 and SB2 have been specified for both downlink and uplink to enable that the CC of either SB1 or SB2 can be used as PCC.					

**Table 4.3.1.1.5.78-2A: NR Intra-Band non-contiguous CA configuration CA\_n78(2A) with UL CA, SCS=30 kHz, Max Wgap**

FFS

## 4.3.1.1.6 NR Operating SUL band combinations in FR1

For SUL band combinations specified in TS 38.101-1 [7] Table 5.5C-1, the test frequencies and signalling parameters in clause 4.3.1.1.1 apply for each operating bands.

For SUL band combinations with intra-band non-contiguous CA specified in TS 38.101-1 [7] Table 5.5C-2, the test frequencies and signalling parameters in clause 4.3.1.1.1 apply for SUL band. The test frequencies and signalling parameters in clause 4.3.1.1.5 apply for each DL CA component carrier.

For SUL band combinations with intra-band contiguous CA specified in TS 38.101-1 [7] Table 5.5C-3, the test frequencies and signalling parameters in clause 4.3.1.1.1 apply for SUL band. The test frequencies and signalling parameters in clause 4.3.1.1.3 apply for each DL CA component carrier.

For SUL band combinations with inter-band CA specified in TS 38.101-1 [7] Table 5.5C-4, the test frequencies and signalling parameters in clause 4.3.1.1.1 apply for each operating bands.

## 4.3.1.1.7 NR inter-band NR-DC configurations in FR1

## 4.3.1.1.7.1 NR inter-band NR-DC configurations in FR1 (two bands)

**Table 4.3.1.1.7.1-1: Inter-band NR-DC configurations (FR1, two bands)**

NR-DC configuration	Uplink NR-DC configuration	NR-DC downlink configuration band 1	NR-DC downlink configuration band 2	NR-DC uplink configuration band 1	NR-DC uplink configuration band 2	Applicable for protocol testing (Note 1)
DC_n48A-n70A	DC_n48A-n70A	n48A	n70A	n48A	n70A	Yes
Note 1: Protocol testing is limited to NR-DC configurations with 2CC.						

4.3.1.2 Test frequencies for NR operating bands in FR2

4.3.1.2.1 NR operating bands in FR2

4.3.1.2.1.1 Reference test frequencies for NR operating band n257

**Table 4.3.1.2.1.1-1: Test frequencies for NR operating band n257, SCS 60 kHz and  $\Delta F_{\text{Raster}}$  60 kHz**

CBW [MHz]	carrier Bandwidth [PRBs]	Range		Carrier centre [MHz]	Carrier centre [ARFCN]	point A [MHz]	absolute Frequency Point A [ARFCN]	offsetTo Carrier [Carrier PRBs]	SS block SCS [kHz]	GSCN	absolute FrequencySSB [ARFCN]	$k_{\text{SSE}}$	Offset Carrier CORE SET#0 [RBs] Note 2	CORE SET#0 Index (Offset [RBs]) Note 1	offsetTo PointA (SIB1) [PRBs] Note 1
50	66	Downlink & Uplink	Low	26525.04	2054583	26501.28	2054187	0	120	22388	2054683	4	13	1 (8)	21
			Mid	27999.96	2079165	27902.76	2077545	102		22473	2079163	10	4	1 (8)	114
			High	29475	2103749	29088.36	2097305	504		22558	2103643	2	4	0 (0)	508
100	132	Downlink & Uplink	Low	26550	2054999	26502.48	2054207	0	120	22388	2054683	8	11	1 (8)	19
			Mid	27999.96	2079165	27879	2077149	102		22472	2078875	10	13	1 (8)	123
			High	29449.92	2103331	29039.52	2096491	504		22555	2102779	0	0	0 (0)	504
200	264	Downlink & Uplink	Low	26600.04	2055833	26505	2054249	0	120	22388	2054683	2	8	1 (8)	16
			Mid	27999.96	2079165	27831.48	2076357	102		22469	2078011	10	7	1 (8)	117
			High	29400	2102499	28942.08	2094867	504		22550	2101339	4	7	1 (8)	519

Note 1: The CORESET#0 Index and the associated CORESET#0 Offset refers to Table 13-7 in TS 38.213 [22]. The value of CORESET#0 Index is signalled controlResourceSetZero (pdcch-ConfigSIB1) in the MIB. The offsetToPointA IE is expressed in units of resource blocks assuming 15 kHz subcarrier spacing for FR1 and 60 kHz subcarrier spacing for FR2.

Note 2: The parameter Offset Carrier CORESET#0 specifies the offset from the lowest subcarrier of the carrier and the lowest subcarrier of CORESET#0. It corresponds to the parameter  $\Delta F_{\text{OffsetCORESET-0-Carrier}}$  in Annex C expressed in number of common RBs.

**Table 4.3.1.2.1.1-2: Test frequencies for NR operating band n257, SCS 120kHz and  $\Delta F_{\text{Raster}}$  120 kHz**

CBW [MHz]	carrier Bandwidth [PRBs]	Range		Carrier centre [MHz]	Carrier centre [ARFCN]	point A [MHz]	absolute Frequency Point A [ARFCN]	offsetTo Carrier [Carrier PRBs]	SS block SCS [kHz]	GSCN	absolute FrequencySSB [ARFCN]	$k_{\text{SSE}}$	Offset Carrier CORE SET#0 [RBs] Note 2	CORE SET#0 Index (Offset [RBs]) Note 1	offsetTo PointA (SIB1) [PRBs] Note 1
50	32	Downlink & Uplink	Low	26525.04	2054583	26502	2054199	0	120	22388	2054683	2	6	1 (4)	20
			Mid	27999.96	2079165	27830.04	2076333	102		22473	2079163	11	1	1 (4)	214
			High	29475	2103749	28726.2	2091269	504		22558	2103643	7	1	0 (0)	1010
100	66	Downlink & Uplink	Low	26550	2054999	26502.48	2054207	0	120	22388	2054683	10	5	1 (4)	18
			Mid	27999.96	2079165	27805.56	2075925	102		22472	2078875	11	6	1 (4)	224

200	132	Uplink	High	29449.92	2103331	28676.64	2090443	504	120	22555	2102779	0	0	0 (0)	1008
		Downlink & Uplink	Low	26600.04	2055833	26505	2054249	0		22388	2054683	1	4	1 (4)	16
			Mid	27999.96	2079165	27758.04	2075133	102		22469	2078011	11	3	1 (4)	218
			High	29400	2102499	28579.2	2088819	504		22550	2101339	8	3	1 (4)	1022
400	264	Downlink & Uplink	Low	26700	2057499	26509.92	2054331	0	120	22388	2054683	8	0	1 (4)	8
			Mid	27999.96	2079165	27663	2073549	102		22463	2076283	11	1	0 (0)	206
			High	29299.92	2100831	28384.08	2085567	504		22539	2098171	2	7	1 (4)	1030

Note 1: The CORESET#0 Index and the associated CORESET#0 Offset refers to Table 13-8 in TS 38.213 [22]. The value of CORESET#0 Index is signalled in controlResourceSetZero (pdccch-ConfigSIB1) in the MIB. The offsetToPointA IE is expressed in units of resource blocks assuming 15 kHz subcarrier spacing for FR1 and 60 kHz subcarrier spacing for FR2.

Note 2: The parameter Offset Carrier CORESET#0 specifies the offset from the lowest subcarrier of the carrier and the lowest subcarrier of CORESET#0. It corresponds to the parameter  $\Delta F_{\text{OffsetCORESET-0-Carrier}}$  in Annex C expressed in number of common RBs.

## 4.3.1.2.1.2

## Reference test frequencies for NR operating band n258

Table 4.3.1.2.1.2-1: Test frequencies for NR operating band n258, SCS 60 kHz and  $\Delta F_{\text{Raster}}$  60 kHz

CBW [MHz]	carrier Bandwidth [PRBs]	Range	Carrier centre [MHz]	Carrier centre [ARFCN]	point A [MHz]	absolute Frequency A [ARFCN]	offsetTo Carrier [Carrier PRBs]	SS block SCS [kHz]	GSCN	absolute FrequencySSB [ARFCN]	$k_{\text{SSE}}$	Offset Carrier CORESET#0 [RBs] Note 2	CORESET#0 Index (Offset [RBs]) Note 1	offsetToPointA (SIB1) [PRBs] Note 1	
50	66	Downlink & Uplink	Low	24275.04	2017083	24251.28	2016687	0	120	22257	2016955	4	2	0 (0)	2
			Mid	25875	2043749	25777.8	2042129	102		22350	2043739	2	4	1 (8)	114
			High	27474.96	2070415	27088.32	2063971	504		22443	2070523	0	14	1 (8)	526
100	132	Downlink & Uplink	Low	24300	2017499	24252.48	2016707	0	120	22257	2016955	8	0	0 (0)	0
			Mid	25875	2043749	25754.04	2041733	102		22349	2043451	2	13	1 (8)	123
			High	27450	2069999	27039.6	2063159	504		22440	2069659	8	9	1 (8)	521
200	264	Downlink & Uplink	Low	24350.04	2018333	24255	2016749	0	120	22258	2017243	2	13	1 (8)	21
			Mid	25875	2043749	25706.52	2040941	102		22346	2042587	2	7	1 (8)	117
			High	27399.96	2069165	26942.04	2061533	504		22434	2067931	2	1	1 (8)	513

Note 1: The CORESET#0 Index and the associated CORESET#0 Offset refers to Table 13-7 in TS 38.213 [22]. The value of CORESET#0 Index is signalled in controlResourceSetZero (pdccch-ConfigSIB1) in the MIB. The offsetToPointA IE is expressed in units of resource blocks assuming 15 kHz subcarrier spacing for FR1 and 60 kHz subcarrier spacing for FR2.

Note 2: The parameter Offset Carrier CORESET#0 specifies the offset from the lowest subcarrier of the carrier and the lowest subcarrier of CORESET#0. It corresponds to the parameter  $\Delta F_{\text{OffsetCORESET-0-Carrier}}$  in Annex C expressed in number of common RBs.

Table 4.3.1.2.1.2: Test frequencies for NR operating band n258, SCS 120kHz and  $\Delta F_{\text{Raster}}$  120 kHz

CBW [MHz]	carrierBandwidth [PRBs]	Range	Carrier centre [MHz]	Carrier centre [ARFCN]	point A [MHz]	absoluteFrequencyPointA [ARFCN]	offsetToCarrier [Carrier PRBs]	SS block SCS [kHz]	GSCN	absoluteFrequencySSB [ARFCN]	$k_{\text{SSE}}$	Offset Carrier CORESET#0 [RBs] Note 2	CORESET#0 Index (Offset [RBs]) Note 1	offsetToPointA (SIB1) [PRBs] Note 1	
50	32	Downlink & Uplink	Low	24275.04	2017083	24252	2016699	0	120	22257	2016955	8	0	0 (0)	0
			Mid	25875	2043749	25705.08	2040917	102		22350	2043739	7	1	1 (4)	214
			High	27474.96	2070415	26726.16	2057935	504		22443	2070523	6	6	1 (4)	1028
100	66	Downlink & Uplink	Low	24300	2017499	24252.48	2016707	0	120	22257	2016955	4	0	0 (0)	0
			Mid	25875	2043749	25680.6	2040509	102		22349	2043451	7	6	1 (4)	224
			High	27450	2069999	26676.72	2057111	504		22440	2069659	10	4	1 (4)	1024
200	132	Downlink & Uplink	Low	24350.04	2018333	24255	2016749	0	120	22258	2017243	7	6	1 (4)	20
			Mid	25875	2043749	25633.08	2039717	102		22346	2042587	7	3	1 (4)	218
			High	27399.96	2069165	26579.16	2055485	504		22434	2067931	7	0	1 (4)	1016
400	264	Downlink & Uplink	Low	24450	2019999	24259.92	2016831	0	120	22258	2017243	2	3	1 (4)	14
			Mid	25875	2043749	25538.04	2038133	102		22340	2040859	7	1	0 (0)	206
			High	27300	2067499	26384.16	2052235	504		22423	2064763	0	4	1 (4)	1024

Note 1: The CORESET#0 Index and the associated CORESET#0 Offset refers to Table 13-8 in TS 38.213 [22]. The value of CORESET#0 Index is signalled in controlResourceSetZero (pdcch-ConfigSIB1) in the MIB. The offsetToPointA IE is expressed in units of resource blocks assuming 15 kHz subcarrier spacing for FR1 and 60 kHz subcarrier spacing for FR2.

Note 2: The parameter Offset Carrier CORESET#0 specifies the offset from the lowest subcarrier of the carrier and the lowest subcarrier of CORESET#0. It corresponds to the parameter  $\Delta F_{\text{OffsetCORESET-0-Carrier}}$  in Annex C expressed in number of common RBs.

## 4.3.1.2.1.3

Reference test frequencies for NR operating band n259

Table 4.3.1.2.1.3-1: Test frequencies for NR operating band n259, SCS 60 kHz and  $\Delta F_{\text{Raster}}$  60 kHz

CBW [MHz]	carrierBandwidth [PRBs]	Range	Carrier centre [MHz]	Carrier centre [ARFCN]	point A [MHz]	absoluteFrequencyPointA [ARFCN]	offsetToCarrier [Carrier PRBs]	SS block SCS [kHz]	GSCN	absoluteFrequencySSB [ARFCN]	$k_{\text{SSE}}$	Offset Carrier CORESET#0 [RBs] Note 2	CORESET#0 Index (Offset [RBs]) Note 1	offsetToPointA (SIB1) [PRBs] Note 1	
50	66	Downlink & Uplink	Low	39525	2271249	39501.24	2270853	0	120	23140	2271259	10	5	1 (8)	13
			Mid	41499.96	2304165	41402.76	2302545	102		23254	2304091	10	6	0 (0)	108
			High	43474.92	2337081	43088.28	2330637	504		23369	2337211	10	15	1 (8)	527
100	132	Downlink & Uplink	Low	39550.08	2271667	39502.56	2270875	0	120	23140	2271259	0	4	1 (8)	12
			Mid	41499.96	2304165	41379	2302149	102		23253	2303803	10	7	1 (8)	117
			High	43449.96	2336665	43039.56	2329825	504		23366	2336347	6	11	1 (8)	523
200	264	Downlink	Low	39600	2272499	39504.96	2270915	0	120	23140	2271259	8	0	1 (8)	8



		& Uplink	Mid	41499.96	2304165	41331.48	2301357	102	23250	2302939	10	1	1 (8)	111
			High	43399.92	2335831	42942	2328199	504	23360	2334619	0	3	1 (8)	515
Note 1:	The CORESET#0 Index and the associated CORESET#0 Offset refers to Table 13-7 in TS 38.213 [22]. The value of CORESET#0 Index is signalled in controlResourceSetZero (pdcc-ConfigSIB1) in the MIB. The offsetToPointA IE is expressed in units of resource blocks assuming 15 kHz subcarrier spacing for FR1 and 60 kHz subcarrier spacing for FR2.													
Note 2:	The parameter Offset Carrier CORESET#0 specifies the offset from the lowest subcarrier of the carrier and the lowest subcarrier of CORESET#0. It corresponds to the parameter $\Delta F_{\text{OffsetCORESET-0-Carrier}}$ in Annex C expressed in number of common RBs.													

Table 4.3.1.2.1.3-2: Test frequencies for NR operating band n259, SCS 120kHz and  $\Delta F_{\text{Raster}}$  120 kHz

CBW [MHz]	carrier Bandwidth [PRBs]	Range	Carrier centre [MHz]	Carrier centre [ARFCN]	point A [MHz]	absolute Frequency PointA [ARFCN]	offsetToCarrier [Carrier PRBs]	SS block SCS [kHz]	GSCN	absolute Frequency SSB [ARFCN]	$k_{\text{SSB}}$	Offset Carrier CORESET#0 [RBs] Note 2	CORESET#0 Index (Offset [RBs]) Note 1	offsetToPointA (SIB1) [PRBs] Note 1	
50	32	Downlink & Uplink	Low	39525	2271249	39501.96	2270865	0	120	23140	2271259	5	2	1 (4)	12
			Mid	41499.96	2304165	41330.04	2301333	102		23254	2304091	11	2	0 (0)	208
			High	43474.92	2337081	42726.12	2324601	504		23369	2337211	5	7	1 (4)	1030
100	66	Downlink & Uplink	Low	39550.08	2271667	39502.56	2270875	0	120	23140	2271259	0	2	1 (4)	12
			Mid	41499.96	2304165	41305.56	2300925	102		23253	2303803	11	3	1 (4)	218
			High	43449.96	2336665	42676.68	2323777	504		23366	2336347	9	5	1 (4)	1026
200	132	Downlink & Uplink	Low	39600	2272499	39504.96	2270915	0	120	23140	2271259	4	0	1 (4)	8
			Mid	41499.96	2304165	41258.04	2300133	102		23250	2302939	11	0	1 (4)	212
			High	43399.92	2335831	42579.12	2322151	504		23360	2334619	6	1	1 (4)	1018
400	264	Downlink & Uplink	Low	39700.08	2274167	39510	2270999	0	120	23140	2271259	10	0	0 (0)	0
			Mid	41499.96	2304165	41163	2298549	102		23245	2301499	11	6	1 (4)	224
			High	43299.96	2334165	42384.12	2318901	504		23349	2331451	11	4	1 (4)	1024
Note 1:	The CORESET#0 Index and the associated CORESET#0 Offset refers to Table 13-8 in TS 38.213 [22]. The value of CORESET#0 Index is signalled in controlResourceSetZero (pdcc-ConfigSIB1) in the MIB. The offsetToPointA IE is expressed in units of resource blocks assuming 15 kHz subcarrier spacing for FR1 and 60 kHz subcarrier spacing for FR2.														
Note 2:	The parameter Offset Carrier CORESET#0 specifies the offset from the lowest subcarrier of the carrier and the lowest subcarrier of CORESET#0. It corresponds to the parameter $\Delta F_{\text{OffsetCORESET-0-Carrier}}$ in Annex C expressed in number of common RBs.														

Table 4.3.1.2.1.4-1: Test frequencies for NR operating band n260, SCS 60 kHz and  $\Delta F_{\text{Raster}}$  60 kHz

CBW [MHz]	carrier Bandwidth [PRBs]	Range		Carrier centre [MHz]	Carrier centre [ARFCN]	point A [MHz]	absolute Frequency Point A [ARFCN]	offsetToCarrier [Carrier PRBs]	SS block SCS [kHz]	GSCN	absolute Frequency SSB [ARFCN]	$k_{\text{SSE}}$	Offset Carrier CORESET#0 [RBs] Note 2	CORESET#0 Index (Offset [RBs]) Note 1	offsetToPointA (SIB1) [PRBs] Note 1
50	66	Downlink & Uplink	Low	37025.04	2229583	37001.28	2229187	0	120	22995	2229499	0	6	0 (0)	6
			Mid	38499.96	2254165	38402.76	2252545	102		23081	2254267	6	13	1 (8)	123
			High	39975	2278749	39588.36	2272305	504		23166	2278747	10	4	1 (8)	516
100	132	Downlink & Uplink	Low	37050	2229999	37002.48	2229207	0	120	22995	2229499	4	4	0 (0)	4
			Mid	38499.96	2254165	38379	2252149	102		23079	2253691	6	6	0 (0)	108
			High	39949.92	2278331	39539.52	2271491	504		23163	2277883	8	0	1 (8)	512
200	264	Downlink & Uplink	Low	37100.04	2230833	37005	2229249	0	120	22995	2229499	10	0	0 (0)	0
			Mid	38499.96	2254165	38331.48	2251357	102		23076	2252827	6	0	0 (0)	102
			High	39900	2277499	39442.08	2269867	504		23157	2276155	0	0	0 (0)	504

Note 1: The CORESET#0 Index and the associated CORESET#0 Offset refers to Table 13-7 in TS 38.213 [22]. The value of CORESET#0 Index is signalled in controlResourceSetZero (pdch-ConfigSIB1) in the MIB. The offsetToPointA IE is expressed in units of resource blocks assuming 15 kHz subcarrier spacing for FR1 and 60 kHz subcarrier spacing for FR2.

Note 2: The parameter Offset Carrier CORESET#0 specifies the offset from the lowest subcarrier of the carrier and the lowest subcarrier of CORESET#0. It corresponds to the parameter  $\Delta F_{\text{OffsetCORESET-0-Carrier}}$  in Annex C expressed in number of common RBs.

Table 4.3.1.2.1.4-2: Test frequencies for NR operating band n260, SCS 120kHz and  $\Delta F_{\text{Raster}}$  120 kHz

CBW [MHz]	carrier Bandwidth [PRBs]	Range		Carrier centre [MHz]	Carrier centre [ARFCN]	point A [MHz]	absolute Frequency Point A [ARFCN]	offsetToCarrier [Carrier PRBs]	SS block SCS [kHz]	GSCN	absolute Frequency SSB [ARFCN]	$k_{\text{SSE}}$	Offset Carrier CORESET#0 [RBs] Note 2	CORESET#0 Index (Offset [RBs]) Note 1	offsetToPointA (SIB1) [PRBs] Note 1
50	32	Downlink & Uplink	Low	37025.04	2229583	37002	2229199	0	120	22995	2229499	6	2	0 (0)	4
			Mid	38499.96	2254165	38330.04	2251333	102		23081	2254267	3	6	1 (4)	224
			High	39975	2278749	39226.2	2266269	504		23166	2278747	11	1	1 (4)	1018
100	66	Downlink & Uplink	Low	37050	2229999	37002.48	2229207	0	120	22995	2229499	2	2	0 (0)	4
			Mid	38499.96	2254165	38305.56	2250925	102		23079	2253691	3	3	0 (0)	210
			High	39949.92	2278331	39176.64	2265443	504		23163	2277883	4	0	1 (4)	1016
200	132	Downlink & Uplink	Low	37100.04	2230833	37005	2229249	0	120	22995	2229499	5	0	0 (0)	0
			Mid	38499.96	2254165	38258.04	2250133	102		23076	2252827	3	0	0 (0)	204
			High	39900	2277499	39079.2	2263819	504		23157	2276155	0	0	0 (0)	1008
400	264	Downlink	Low	37200	2232499	37009.92	2229331	0	120	22996	2229787	0	5	1 (4)	18

		& Uplink	Mid	38499.96	2254165	38163	2248549	102		23071	2251387	3	2	1 (4)	216
			High	39799.92	2275831	38884.08	2260567	504		23146	2272987	6	3	0 (0)	1014
Note 1:	The CORESET#0 Index and the associated CORESET#0 Offset refers to Table 13-8 in TS 38.213 [22]. The value of CORESET#0 Index is signalled in controlResourceSetZero (pdcch-ConfigSIB1) in the MIB. The offsetToPointA IE is expressed in units of resource blocks assuming 15 kHz subcarrier spacing for FR1 and 60 kHz subcarrier spacing for FR2.														
Note 2:	The parameter Offset Carrier CORESET#0 specifies the offset from the lowest subcarrier of the carrier and the lowest subcarrier of CORESET#0. It corresponds to the parameter $\Delta F_{\text{OffsetCORESET-0-Carrier}}$ in Annex C expressed in number of common RBs.														

## 4.3.1.2.1.5 Reference test frequencies for NR operating band n261

Table 4.3.1.2.1.5-1: Test frequencies for NR operating band n261, SCS 60 kHz and  $\Delta F_{\text{Raster}}$  60 kHz

CBW [MHz]	carrierBandwidth [PRBs]	Range		Carrier centre [MHz]	Carrier centre [ARFCN]	point A [MHz]	absoluteFrequencyPointA [ARFCN]	offsetToCarrier [Carrier PRBs]	SS block SCS [kHz]	GSCN	absoluteFrequencySSB [ARFCN]	$k_{\text{SSE}}$	Offset Carrier CORESET#0 [RBs] Note 2	CORESET#0 Index (Offset [RBs]) Note 1	offsetToPointA (SIB1) [PRBs] Note 1
50	66	Downlink & Uplink	Low	27525	2071249	27501.24	2070853	0	120	22446	2071387	6	16	1 (8)	24
			Mid	27924.96	2077915	27827.76	2076295	102		22469	2078011	0	13	1 (8)	123
			High	28324.92	2084581	27938.28	2078137	504		22492	2084635	6	9	1 (8)	521
100	132	Downlink & Uplink	Low	27550.08	2071667	27502.56	2070875	0	120	22446	2071387	8	14	1 (8)	22
			Mid	27924.96	2077915	27804	2075899	102		22467	2077435	0	6	0 (0)	108
			High	28299.96	2084165	27889.56	2077325	504		22489	2083771	2	5	1 (8)	517
200	264	Downlink & Uplink	Low	27600	2072499	27504.96	2070915	0	120	22446	2071387	4	11	1 (8)	19
			Mid	27924.96	2077915	27756.48	2075107	102		22464	2076571	0	0	0 (0)	102
			High	28249.92	2083331	27792	2075699	504		22483	2082043	8	4	0 (0)	508
Note 1:	The CORESET#0 Index and the associated CORESET#0 Offset refers to Table 13-7 in TS 38.213 [22]. The value of CORESET#0 Index is signalled in controlResourceSetZero (pdcch-ConfigSIB1) in the MIB. The offsetToPointA IE is expressed in units of resource blocks assuming 15 kHz subcarrier spacing for FR1 and 60 kHz subcarrier spacing for FR2.														
Note 2:	The parameter Offset Carrier CORESET#0 specifies the offset from the lowest subcarrier of the carrier and the lowest subcarrier of CORESET#0. It corresponds to the parameter $\Delta F_{\text{OffsetCORESET-0-Carrier}}$ in Annex C expressed in number of common RBs.														

Table 4.3.1.2.1.5-2: Test frequencies for NR operating band n261, SCS 120kHz and  $\Delta F_{\text{Raster}}$  120 kHz

CBW [MHz]	carrierBandwidth [PRBs]	Range		Carrier centre [MHz]	Carrier centre [ARFCN]	point A [MHz]	absoluteFrequencyPointA [ARFCN]	offsetToCarrier [Carrier PRBs]	SS block SCS [kHz]	GSCN	absoluteFrequencySSB [ARFCN]	$k_{\text{SSE}}$	Offset Carrier CORESET#0 [RBs] Note 2	CORESET#0 Index (Offset [RBs]) Note 1	offsetToPointA (SIB1) [PRBs] Note 1
50	32	Downlink	Low	27525	2071249	27501.96	2070865	0	120	22446	2071387	9	7	1 (4)	22

		& Uplink	Mid	27924.96	2077915	27755.04	2075083	102		22469	2078011	0	6	1 (4)	224
			High	28324.92	2084581	27576.12	2072101	504		22492	2084635	3	4	1 (4)	1024
100	66	Downlink & Uplink	Low	27550.08	2071667	27502.56	2070875	0	120	22446	2071387	4	7	1 (4)	22
			Mid	27924.96	2077915	27730.56	2074675	102		22467	2077435	0	3	0 (0)	210
			High	28299.96	2084165	27526.68	2071277	504		22489	2083771	7	2	1 (4)	1020
200	132	Downlink & Uplink	Low	27600	2072499	27504.96	2070915	0	120	22446	2071387	8	5	1 (4)	18
			Mid	27924.96	2077915	27683.04	2073883	102		22464	2076571	0	0	0 (0)	204
			High	28249.92	2083331	27429.12	2069651	504		22483	2082043	4	2	0 (0)	1012
400	264	Downlink & Uplink	Low	27700.08	2074167	27510	2070999	0	120	22446	2071387	2	2	1 (4)	12
			Mid	27924.96	2077915	27588	2072299	102		22459	2075131	0	2	1 (4)	216
			High	28149.96	2081665	27234.12	2066401	504		22472	2078875	9	1	1 (4)	1018

Note 1: The CORESET#0 Index and the associated CORESET#0 Offset refers to Table 13-8 in TS 38.213 [22]. The value of CORESET#0 Index is signalled in controlResourceSetZero (pdcc-ConfigSIB1) in the MIB. The offsetToPointA IE is expressed in units of resource blocks assuming 15 kHz subcarrier spacing for FR1 and 60 kHz subcarrier spacing for FR2.

Note 2: The parameter Offset Carrier CORESET#0 specifies the offset from the lowest subcarrier of the carrier and the lowest subcarrier of CORESET#0. It corresponds to the parameter  $\Delta F_{\text{OffsetCORESET-0-Carrier}}$  in Annex C expressed in number of common RBs.

## 4.3.1.2.2 NR inter-band CA configurations in FR2

Table 4.3.1.2.2-1: NR inter-band CA configurations in FR2

NR CA configuration	Uplink NR CA configuration	NR CA downlink configuration band 1	NR CA downlink configuration band 2	NR CA uplink configuration band 1	NR CA uplink configuration band 2	Applicable for protocol testing (Note 1)
CA_n260A-n261A	-	n260A	n261A	-	-	Yes

Note 1: Protocol testing is limited to NR CA configurations with 2CC.

## 4.3.1.2.3 NR intra-band contiguous CA configurations in FR2

## 4.3.1.2.3.1 NR Intra-band contiguous CA configurations for CA\_n257

## 4.3.1.2.3.1.1 CA\_n257B

Editor's note: CA\_n257B Test frequencies are FFS.

Table 4.3.1.2.3.1.1-1: NR Intra-Band contiguous CA configuration CA\_n257B, SCS=120 kHz,  $\Delta F_{\text{Raster}}$  120 kHz

CBW combination	CC Note 2	CBW [MHz]	SCS [kHz]	carrierBandwidth [PRBs]	Range	Carrier centre [MHz] Note 2	Carrier centre [ARFCN]	point A [MHz]	absoluteFrequencyPointA [ARFCN]	offsetToCarrier [Carrier PRBs]	SS block SCS [kHz]	GS CN	absoluteFrequencySSB [ARFCN]	$k_{\text{SSB}}$	Offset Carrier CORESET#0 [RBs] Note 3	CORESET#0 Index (Offset [RBs]) Note 4	offsetToPointA (SIB1) [PRBs] Note 4

4.3.1.2.3.1.2 CA\_n257C

Editor's note: CA\_n257C Test frequencies are FFS.

Table 4.3.1.2.3.1.2-1: NR Intra-Band contiguous CA configuration CA\_n257C, SCS=120 kHz,  $\Delta F_{\text{Raster}}$  120 kHz

CBW combination	CC Note 2	CBW [MHz]	SCS [kHz]	carrierBandwidth [PRBs]	Range	Carrier centre [MHz] Note 2	Carrier centre [ARFCN]	point A [MHz]	absoluteFrequencyPointA [ARFCN]	offsetToCarrier [Carrier PRBs]	SS block SCS [kHz]	GS CN	absoluteFrequencySSB [ARFCN]	$k_{\text{SSB}}$	Offset Carrier CORESET#0 [RBs] Note 3	CORESET#0 Index (Offset [RBs]) Note 4	offsetToPointA (SIB1) [PRBs] Note 4

4.3.1.2.3.1.3 CA\_n257D

Editor's note: CA\_n257D Test frequencies are FFS.

Table 4.3.1.2.3.1.3-1: NR Intra-Band contiguous CA configuration CA\_n257D, SCS=60 kHz,  $\Delta F_{\text{Raster}}$  60 kHz

CBW combination	CC Note 2	CBW [MHz]	SCS [kHz]	carrierBand width [PRBs]	Range	Carrier centre [MHz] Note 2	Carrier centre [ARFCN]	point A [MHz]	absoluteFrequencyPointA [ARFCN]	offsetToCarrier [Carrier PRBs]	SS block SCS [kHz]	GS CN	absoluteFrequencySSB [ARFCN]	$k_{\text{SSB}}$	Offset Carrier CORESET#0 [RBs] Note 3	CORESET#0 Index (Offset [RBs]) Note 4	offsetToPointA (SIB1) [PRBs] Note 4

Table 4.3.1.2.3.1.3-2: NR Intra-Band contiguous CA configuration CA\_n257D, SCS=120 kHz,  $\Delta F_{\text{Raster}}$  120 kHz

CBW combination	CC Note 2	CBW [MHz]	SCS [kHz]	carrierBand width [PRBs]	Range	Carrier centre [MHz] Note 2	Carrier centre [ARFCN]	point A [MHz]	absoluteFrequencyPointA [ARFCN]	offsetToCarrier [Carrier PRBs]	SS block SCS [kHz]	GS CN	absoluteFrequencySSB [ARFCN]	$k_{\text{SSB}}$	Offset Carrier CORESET#0 [RBs] Note 3	CORESET#0 Index (Offset [RBs]) Note 4	offsetToPointA (SIB1) [PRBs] Note 4

4.3.1.2.3.1.4 CA\_n257E

Table 4.3.1.2.3.1.4-1: NR Intra-Band contiguous CA configuration CA\_n257E, SCS=60 kHz,  $\Delta F_{\text{Raster}}$  60 kHz.

FFS

Table 4.3.1.2.3.1.4-2: NR Intra-Band contiguous CA configuration CA\_n257E, SCS=120 kHz,  $\Delta F_{\text{Raster}}$  120 kHz.

FFS

4.3.1.2.3.1.5 CA\_n257F

Table 4.3.1.2.3.1.5-1: NR Intra-Band contiguous CA configuration CA\_n257F, SCS=60 kHz, ΔF<sub>Raster</sub> 60 kHz.

FFS

Table 4.3.1.2.3.1.5-2: NR Intra-Band contiguous CA configuration CA\_n257F, SCS=120 kHz, ΔF<sub>Raster</sub> 120 kHz.

FFS

4.3.1.2.3.1.6 CA\_n257G

Table 4.3.1.2.3.1.6-1: Void

Table 4.3.1.2.3.1.6-2: NR Intra-Band contiguous CA configuration CA\_n257G, SCS=60 kHz, ΔF<sub>Raster</sub> 60 kHz, nominal channel spacing

CBW combination	CC Note 2	CBW [MHz]	SCS [kHz]	carrierBandwidth [PRBs]	Range		Carrier centre [MHz] Note 2	Carrier centre [ARFCN]	point A [MHz]	absoluteFrequencyPointA [ARFCN]	offsetToCarrier [Carrier PRBs]	SS block SCS [kHz]	GS CN	absoluteFrequencySSB [ARFCN]	<i>k</i> <sub>SSB</sub>	Offset Carrier CORESET#0 [RBs] Note 3	CORESET#0 Index (Offset [RBs]) Note 4	offsetToPointA (SIB1) [PRBs] Note 4	
50+100	CC 1	50	60	66	Downlink &	Low	26525.04	2054583	26501.28	2054187	0	120	22388	2054683	4	13	1 (8)	21	
						Mid	27949.92	2078331	27852.72	2076711	102		22470	2078299	4	2	1 (8)	112	
					Uplink	High	29375.52	2102091	28988.88	2095647	504		22553	2102203	4	14	1 (8)	526	
	Channel spacing CC1-CC2=74.40 MHz (Note 1)																		
	100+100	CC 2	100	60	132	Downlink &	Low	26599.44	2055823	26551.92	2055031	0	120	22391	2055547	0	15	1 (8)	23
							Mid	28024.32	2079571	27903.36	2077555	102		22473	2079163	0	4	1 (8)	114
Uplink						High	29449.92	2103331	29039.52	2096491	504	22555		2102779	0	0	0 (0)	504	
100+100	CC 1	100	60	132	Downlink &	Low	26550	2054999	26502.48	2054207	0	120	22388	2054683	8	11	1 (8)	19	
						Mid	27949.92	2078331	27828.96	2076315	102		22469	2078011	4	11	1 (8)	121	
					Uplink	High	29349	21016	28939	2094825	504		225	2101339	10	10	1 (8)	522	

		k	gh	.96	65	.56			50									
Channel spacing CC1-CC2=99.96 MHz (Note 1)																		
CC 2	100	60	132	Down link & Uplink	Low	26649.96	2056665	26602.44	2055873	0	120	22393	2056123	10	0	0 (0)	0	
					Mid	28049.88	2079997	27928.92	2077981	102		22474	2079451	6	0	0 (0)	102	
					High	29449.92	2103331	29039.52	2096491	504		22555	2102779	0	0	0 (0)	504	

Note 1: Corresponds to nominal channel spacing in accordance with TS 38.101-2 [8], clause 5.4A.1 for the channel bandwidths of the two respective NR component carriers.

Note 2: CCs are specified in increasing frequency order. CC1 is used as PCell if nothing else is specified in the test case.

Note 3: The parameter Offset Carrier CORESET#0 specifies the offset from the lowest subcarrier of the carrier and the lowest subcarrier of CORESET#0. It corresponds to the parameter  $\Delta F_{\text{OffsetCORESET-0-Carrier}}$  in Annex C expressed in number of common RBs.

Note 4: The CORESET#0 Index and the associated CORESET#0 Offset refers to Table 13-7 in TS 38.213 [22]. The value of CORESET#0 Index is signalled in controlResourceSetZero (pdcch-ConfigSIB1) in the MIB. The offsetToPointA IE is expressed in units of resource blocks assuming 15 kHz subcarrier spacing for FR1 and 60 kHz subcarrier spacing for FR2.

Table 4.3.1.2.3.1.6-3: Void

Table 4.3.1.2.3.1.6-4: NR Intra-Band contiguous CA configuration CA\_n257G, SCS=120 kHz,  $\Delta F_{\text{Raster}}$  120 kHz, nominal channel spacing

CBW combination	CC Note 2	CBW [MHz]	SCS [kHz]	carrierBandwidth [PRBs]	Range	Carrier centre [MHz]	Carrier centre [ARFCN]	point A [MHz]	absoluteFrequencyPointA [ARFCN]	offsetToCarrier [Carrier PRBs]	SS block SCS [kHz]	GS CN	absoluteFrequencySSB [ARFCN]	$k_{\text{SSB}}$	Offset Carrier CORESET#0 [RBs]	CORESET#0 Index (Offset [RBs])	offsetToPointA (SIB1) [PRBs]		
50+100	CC 1	50	120	32	Down link & Uplink	Low	26525.04	2054583	26502	2054199	0	120	22388	2054683	2	6	1 (4)	20	
						Mid	27950.04	2078333	27780.12	2075501	102		22470	2078299	7	0	1 (4)	212	
						High	29375.52	2102091	28626.72	2089611	504		22553	2102203	8	6	1 (4)	1028	
	Channel spacing CC1-CC2=74.40 MHz (Note 1)																		
	CC 2	100	120	66	Down link & Uplink	Low	26599.44	2055823	26551.92	2055031	0	120	22391	2055547	6	7	1 (4)	22	
						Mid	28024.44	2079573	27830.04	2076333	102		22473	2079163	11	1	1 (4)	214	
High						29449.92	2103331	28676.64	2090443	504	22555		2102779	0	0	0 (0)	1008		
100+100	CC 1	100	120	66	Down link	Low	26550	2054999	26502.48	2054207	0	120	22388	2054683	10	5	1 (4)	18	



					&	Mid	27950	20783	27755	2075093	102		224	2078011	7	5	1 (4)	222
					Uplink	High	29349	21016	28576	2088777	504		69					
							.04	33	.64				225	2101339	5	5	1 (4)	1026
							.96	65	.68				50					
Channel spacing CC1-CC2=99.96 MHz (Note 1)																		
CC	100	12	66	Down link &	Low	26649	20566	26602	2055873	0	120	223	2056123	5	0	0 (0)	0	
2		0			Mid	28050	20799	27855	2076759	102		93	2079451	2	0	0 (0)	204	
				Uplink	High	29449	21033	28676	2090443	504		74						
						.92	31	.64				225	2102779	0	0	0 (0)	1008	
												55						
<p>Note 1: Corresponds to nominal channel spacing in accordance with TS 38.101-2 [8], clause 5.4A.1 for the channel bandwidths of the two respective NR component carriers.</p> <p>Note 2: CCs are specified in increasing frequency order. CC1 is used as PCell if nothing else is specified in the test case.</p> <p>Note 3: The parameter Offset Carrier CORESET#0 specifies the offset from the lowest subcarrier of the carrier and the lowest subcarrier of CORESET#0. It corresponds to the parameter <math>\Delta F_{\text{OffsetCORESET-0-Carrier}}</math> in Annex C expressed in number of common RBs.</p> <p>Note 4: The CORESET#0 Index and the associated CORESET#0 Offset refers to Table 13-8 in TS 38.213 [22]. The value of CORESET#0 Index is signalled in controlResourceSetZero (pdccch-ConfigSIB1) in the MIB. The offsetToPointA IE is expressed in units of resource blocks assuming 15 kHz subcarrier spacing for FR1 and 60 kHz subcarrier spacing for FR2.</p>																		

4.3.1.2.3.1.7 CA\_n257H

Table 4.3.1.2.3.1.7-1: Void

Table 4.3.1.2.3.1.7-2: NR Intra-Band contiguous CA configuration CA\_n257H, SCS=60 kHz,  $\Delta F_{\text{Raster}}$  60 kHz, nominal channel spacing

CBW combination	CC Note 2	CBW [MHz]	SCS [kHz]	carrierBandwidth [PRBs]	Range	Carrier centre [MHz]	Carrier centre [ARFCN]	point A [MHz]	absoluteFrequencyPointA [ARFCN]	offsetToCarrier [Carrier PRBs]	SS block SCS [kHz]	GS CN	absoluteFrequencySSB [ARFCN]	$k_{\text{SSB}}$	Offset Carrier CORESET#0 [RBs]	CORESET#0 Index (Offset [RBs])	offsetToPointA (SIB1) [PRBs]	
50+100 +100	CC 1	50	60	66	Down link &	Low	26525	20545	26501	2054187	0	120	223	2054683	4	13	1 (8)	21
						Mid	27900	20774	27802	2075879	102		224	2077435	8	7	0 (0)	109
					Uplink	High	29275	21004	28888	2093981	504		225	2100475	2	9	1 (8)	521
Channel spacing CC1-CC2=74.40 MHz (Note 1)																		
CC 2	100	60	132	Down link	Low	26599	20558	26551	2055031	0	120	223	2055547	0	15	1 (8)	23	
						.44	23	.92				91						

					&	Mid	27974 .4	20787 39	27853 .44	2076723	102		224 70	2078299	4	1	1 (8)	111
					Uplink	High	29349 .96	21016 65	28939 .56	2094825	504		225 50	2101339	10	10	1 (8)	522
Channel spacing CC2-CC3=99.96 MHz (Note 1)																		
	CC 3	100	60	132	Down link &	Low	26699 .4	20574 89	26651 .88	2056697	0	120	223 96	2056987	2	4	0 (0)	4
						Mid	28074 .36	20804 05	27953 .4	2078389	102		224 76	2080027	6	6	1 (8)	116
					Uplink	High	29449 .92	21033 31	29039 .52	2096491	504		225 55	2102779	0	0	0 (0)	504
100+100 +100	CC 1	100	60	132	Down link &	Low	26550	20549 99	26502 .48	2054207	0	120	223 88	2054683	8	11	1 (8)	19
						Mid	27900	20774 99	27779 .04	2075483	102		224 66	2077147	8	8	1 (8)	118
					Uplink	High	29250	20999 99	28839 .6	2093159	504		225 44	2099611	8	5	1 (8)	517
Channel spacing CC1-CC2=99.96 MHz (Note 1)																		
	CC 2	100	60	132	Down link &	Low	26649 .96	20566 65	26602 .44	2055873	0	120	223 93	2056123	10	0	0 (0)	0
						Mid	27999 .96	20791 65	27879	2077149	102		224 72	2078875	10	13	1 (8)	123
					Uplink	High	29349 .96	21016 65	28939 .56	2094825	504		225 50	2101339	10	10	1 (8)	522
Channel spacing CC2-CC3=99.96 MHz (Note 1)																		
	CC 3	100	60	132	Down link &	Low	26749 .92	20583 31	26702 .4	2057539	0	120	223 99	2057851	0	6	0 (0)	6
						Mid	28099 .92	20808 31	27978 .96	2078815	102		224 77	2080315	0	3	0 (0)	105
					Uplink	High	29449 .92	21033 31	29039 .52	2096491	504		225 55	2102779	0	0	0 (0)	504
Note 1: Corresponds to nominal channel spacing in accordance with TS 38.101-2 [8], clause 5.4A.1 for the channel bandwidths of the two respective NR component carriers.																		
Note 2: CCs are specified in increasing frequency order. CC1 is used as PCell if nothing else is specified in the test case.																		
Note 3: The parameter Offset Carrier CORESET#0 specifies the offset from the lowest subcarrier of the carrier and the lowest subcarrier of CORESET#0. It corresponds to the parameter $\Delta F_{\text{OffsetCORESET-0-Carrier}}$ in Annex C expressed in number of common RBs.																		
Note 4: The CORESET#0 Index and the associated CORESET#0 Offset refers to Table 13-7 in TS 38.213 [22]. The value of CORESET#0 Index is signalled in controlResourceSetZero (pdcch-ConfigSIB1) in the MIB. The offsetToPointA IE is expressed in units of resource blocks assuming 15 kHz subcarrier spacing for FR1 and 60 kHz subcarrier spacing for FR2.																		

Table 4.3.1.2.3.1.7-3: Void

Table 4.3.1.2.3.1.7-4: NR Intra-Band contiguous CA configuration CA\_n257H, SCS=120 kHz, ΔF<sub>Raster</sub> 120 kHz, nominal channel spacing

CBW combination	CC Note 2	CBW [MHz]	SCS [kHz]	carrierBandwidth [PRBs]	Range	Carrier centre [MHz]	Carrier centre [ARFCN]	point A [MHz]	absoluteFrequencyPointA [ARFCN]	offsetToCarrier [Carrier PRBs]	SS block SCS [kHz]	GS CN	absoluteFrequencySSB [ARFCN]	k <sub>SSB</sub>	Offset Carrier CORES ET#0 [RBs]	CORES ET#0 Index (Offset [RBs])	offsetToPointA (SIB1) [PRBs]		
50+100 +100	CC 1	50	120	32	Downlink & Uplink	Low	26525.04	2054583	26502	2054199	0	120	22388	2054683	2	6	1 (4)	20	
						Mid	27900.99	2077499	27730.08	2074667	102		22467	2077435	4	3	0 (0)	210	
						High	29275.56	2100425	28526.76	2087945	504		22547	2100475	1	4	1 (4)	1024	
	Channel spacing CC1-CC2=74.40 MHz (Note 1)																		
	CC 2	100	120	66	Downlink & Uplink	Low	26599.44	2055823	26551.92	2055031	0	120	22391	2055547	6	7	1 (4)	22	
						Mid	27974.4	2078739	27780	2075499	102		22470	2078299	8	0	1 (4)	212	
						High	29349.96	2101665	28576.68	2088777	504		22550	2101339	5	5	1 (4)	1026	
	Channel spacing CC2-CC3=99.96 MHz (Note 1)																		
	CC 3	100	120	66	Downlink & Uplink	Low	26699.4	2057489	26651.88	2056697	0	120	22396	2056987	1	2	0 (0)	4	
						Mid	28074.36	2080405	27879.96	2077165	102		22476	2080027	3	3	1 (4)	218	
						High	29449.92	2103331	28676.64	2090443	504		22555	2102779	0	0	0 (0)	1008	
	100+100 +100	CC 1	100	120	66	Downlink & Uplink	Low	26550.99	2054999	26502.48	2054207	0	120	22388	2054683	10	5	1 (4)	18
Mid							27900.99	2077499	27705.6	2074259	102	22466		2077147	4	4	1 (4)	220	
High							29250.99	2099999	28476.72	2087111	504	22544		2099611	10	2	1 (4)	1020	
Channel spacing CC1-CC2=99.96 MHz (Note 1)																			
CC 2		100	120	66	Downlink & Uplink	Low	26649.96	2056665	26602.44	2055873	0	120	22393	2056123	5	0	0 (0)	0	
						Mid	27999.96	2079165	27805.56	2075925	102		22472	2078875	11	6	1 (4)	224	
						High	29349.96	2101665	28576.68	2088777	504		22550	2101339	5	5	1 (4)	1026	
Channel spacing CC2-CC3=99.96 MHz (Note 1)																			
CC 3		100	120	66	Downlink	Low	26749.92	2058331	26702.4	2057539	0	120	22399	2057851	0	3	0 (0)	6	

					&	Mid	28099.92	2080831	27905.52	2077591	102	22477	2080315	6	1	0 (0)	206
					Uplink	High	29449.92	2103331	28676.64	2090443	504	22555	2102779	0	0	0 (0)	1008

Note 1: Corresponds to nominal channel spacing in accordance with TS 38.101-2 [8], clause 5.4A.1 for the channel bandwidths of the two respective NR component carriers.

Note 2: CCs are specified in increasing frequency order. CC1 is used as PCell if nothing else is specified in the test case.

Note 3: The parameter Offset Carrier CORESET#0 specifies the offset from the lowest subcarrier of the carrier and the lowest subcarrier of CORESET#0. It corresponds to the parameter  $\Delta F_{\text{OffsetCORESET-0-Carrier}}$  in Annex C expressed in number of common RBs.

Note 4: The CORESET#0 Index and the associated CORESET#0 Offset refers to Table 13-8 in TS 38.213 [22]. The value of CORESET#0 Index is signalled in controlResourceSetZero (pdccch-ConfigSIB1) in the MIB. The offsetToPointA IE is expressed in units of resource blocks assuming 15 kHz subcarrier spacing for FR1 and 60 kHz subcarrier spacing for FR2.

4.3.1.2.3.1.8 CA\_n257I

Table 4.3.1.2.3.1.8-1: Void

Table 4.3.1.2.3.1.8-2: NR Intra-Band contiguous CA configuration CA\_n257I, SCS=60 kHz,  $\Delta F_{\text{Raster}}$  60 kHz, nominal channel spacing

CBW combination	CC Note 2	CBW [MHz]	SCS [kHz]	carrierBandwidth [PRBs]	Range	Carrier centre [MHz] Note 2	Carrier centre [ARFCN]	point A [MHz]	absoluteFrequencyPointA [ARFCN]	offsetToCarrier [Carrier PRBs]	SS block SCS [kHz]	GS CN	absoluteFrequencySSB [ARFCN]	$k_{\text{SSB}}$	Offset Carrier CORESET#0 [RBs] Note 3	CORESET#0 Index (Offset [RBs]) Note 4	offsetToPointA (SIB1) [PRBs] Note 4		
50+100 +100+100	CC 1	50	60	66	Downlink &	Low	26525.04	2054583	26501.28	2054187	0	120	22388	2054683	4	13	1 (8)	21	
						Mid	27849.96	2076665	27752.76	2075045	102		22464	2076571	2	5	0 (0)	107	
					Uplink	High	29175.6	2098759	28788.96	2092315	504		22541	2098747	0	4	1 (8)	516	
	Channel spacing CC1-CC2=74.40 MHz (Note 1)																		
	CC 2	100	60	132	Downlink &	Low	26599.44	2055823	26551.92	2055031	0	120	22391	2055547	0	15	1 (8)	23	
						Mid	27924.36	2077905	27803.4	2075889	102		22467	2077435	10	6	0 (0)	108	
					Uplink	High	29250.99	2099999	28839.6	2093159	504		22544	2099611	8	5	1 (8)	517	
	Channel spacing CC2-CC3=99.96 MHz (Note 1)																		
	CC 3	100	60	132	Downlink	Low	26699.4	2057489	26651.88	2056697	0	120	22396	2056987	2	4	0 (0)	4	

					&	Mid	28024	20795	27903	2077555	102	224	2079163	0	4	1 (8)	114	
					Uplink	High	29349	21016	28939	2094825	504	225	2101339	10	10	1 (8)	522	
							Channel spacing CC3-CC4=99.96 MHz (Note 1)											
	CC 4	100	60	132	Down link &	Low	26799	20591	26751	2058363	0	120	224	2058715	4	1	1 (8)	9
						Mid	28124	20812	28003	2079221	102		224	2080891	2	9	1 (8)	119
					Uplink	High	29449	21033	29039	2096491	504		225	2102779	0	0	0 (0)	504
100+100	CC 1	100	60	132	Down link &	Low	26550	20549	26502	2054207	0	120	223	2054683	8	11	1 (8)	19
+100+100						Mid	27849	20766	27729	2074649	102		224	2076283	2	6	1 (8)	116
					Uplink	High	29150	20983	28739	2091493	504		225	2097883	6	0	1 (8)	512
							Channel spacing CC1-CC2=99.96 MHz (Note 1)											
	CC 2	100	60	132	Down link &	Low	26649	20566	26602	2055873	0	120	223	2056123	10	0	0 (0)	0
						Mid	27949	20783	27828	2076315	102		224	2078011	4	11	1 (8)	121
					Uplink	High	29250	20999	28839	2093159	504		225	2099611	8	5	1 (8)	517
							Channel spacing CC2-CC3=99.96 MHz (Note 1)											
	CC 3	100	60	132	Down link &	Low	26749	20583	26702	2057539	0	120	223	2057851	0	6	0 (0)	6
						Mid	28049	20799	27928	2077981	102		224	2079451	6	0	0 (0)	102
					Uplink	High	29349	21016	28939	2094825	504		225	2101339	10	10	1 (8)	522
							Channel spacing CC3-CC4=99.96 MHz (Note 1)											
	CC 4	100	60	132	Down link &	Low	26849	20599	26802	2059205	0	120	224	2059579	2	3	1 (8)	11
						Mid	28149	20816	28028	2079647	102		224	2081179	8	5	0 (0)	107
					Uplink	High	29449	21033	29039	2096491	504		225	2102779	0	0	0 (0)	504

- Note 1: Corresponds to nominal channel spacing in accordance with TS 38.101-2 [8], clause 5.4A.1 for the channel bandwidths of the two respective NR component carriers.
- Note 2: CCs are specified in increasing frequency order. CC1 is used as PCell if nothing else is specified in the test case.
- Note 3: The parameter Offset Carrier CORESET#0 specifies the offset from the lowest subcarrier of the carrier and the lowest subcarrier of CORESET#0. It corresponds to the parameter  $\Delta F_{\text{OffsetCORESET-0-Carrier}}$  in Annex C expressed in number of common RBs.
- Note 4: The CORESET#0 Index and the associated CORESET#0 Offset refers to Table 13-7 in TS 38.213 [22]. The value of CORESET#0 Index is signalled in controlResourceSetZero (pdcch-ConfigSIB1) in the MIB. The offsetToPointA IE is expressed in units of resource blocks assuming 15 kHz subcarrier spacing for FR1 and 60 kHz subcarrier spacing for FR2.

Table 4.3.1.2.3.1.8-3: Void

Table 4.3.1.2.3.1.8-4: NR Intra-Band contiguous CA configuration CA\_n2571, SCS=120 kHz, ΔF<sub>Raster</sub> 120 kHz nominal channel spacing

CBW combination	CC Note 2	CBW [MHz]	SCS [kHz]	carrierBandwidth [PRBs]	Range		Carrier centre [MHz] Note 2	Carrier centre [ARFCN]	point A [MHz]	absoluteFrequencyPointA [ARFCN]	offsetToCarrier [Carrier PRBs]	SS block SCS [kHz]	GS CN	absoluteFrequencySSB [ARFCN]	k <sub>SSB</sub>	Offset Carrier CORES ET#0 [RBs] Note 3	CORES ET#0 Index (Offset [RBs]) Note 4	offsetToPointA (SIB1) [PRBs] Note 4	
50+100 +100+100	CC 1	50	120	32	Downlink & Uplink	Low	26525.04	2054583	26502	2054199	0	120	22388	2054683	2	6	1 (4)	20	
						Mid	27849.96	2076665	27680.04	2073833	102		22464	2076571	1	2	0 (0)	208	
						High	29175.6	2098759	28426.8	2086279	504		22541	2098747	6	1	1 (4)	1018	
	Channel spacing CC1-CC2=74.40 MHz (Note 1)																		
	CC 2	100	120	66	Downlink & Uplink	Low	26599.44	2055823	26551.92	2055031	0	120	22391	2055547	6	7	1 (4)	22	
						Mid	27924.36	2077905	27729.96	2074665	102		22467	2077435	5	3	0 (0)	210	
						High	29250	2099999	28476.72	2087111	504		22544	2099611	10	2	1 (4)	1020	
	Channel spacing CC2-CC3=99.96 MHz (Note 1)																		
	CC 3	100	120	66	Downlink & Uplink	Low	26699.4	2057489	26651.88	2056697	0	120	22396	2056987	1	2	0 (0)	4	
						Mid	28024.32	2079571	27829.92	2076331	102		22473	2079163	0	2	1 (4)	216	
						High	29349.96	2101665	28576.68	2088777	504		22550	2101339	5	5	1 (4)	1026	
	Channel spacing CC3-CC4=99.96 MHz (Note 1)																		
	CC 4	100	120	66	Downlink & Uplink	Low	26799.36	2059155	26751.84	2058363	0	120	22402	2058715	8	0	1 (4)	8	
						Mid	28124.28	2081237	27929.88	2077997	102		22479	2080891	7	4	1 (4)	220	
						High	29449.92	2103331	28676.64	2090443	504		22555	2102779	0	0	0 (0)	1008	
	100+100 +100+100	CC 1	100	120	66	Downlink & Uplink	Low	26550.99	2054999	26502.48	2054207	0	120	22388	2054683	10	5	1 (4)	18
Mid							27849	20766	27655	2073425	102	224		2076283	1	3	1 (4)	218	

0					Uplink	d	.96	65	.56			63						
					Uplink	High	29150	20983	28376	2085445	504	225	2097883	3	0	1 (4)	1016	
							.04	33	.76			38						
	Channel spacing CC1-CC2=99.96 MHz (Note 1)																	
	CC 2	100	120	66	Downlink & Uplink	Low	26649	20566	26602	2055873	0	120	22393	2056123	5	0	0 (0)	0
						Mid	27949	20783	27755	2075091	102		22469	2078011	8	5	1 (4)	222
					Uplink	High	29250	20999	28476	2087111	504		22544	2099611	10	2	1 (4)	1020
									.99									
	Channel spacing CC2-CC3=99.96 MHz (Note 1)																	
	CC 3	100	120	66	Downlink & Uplink	Low	26749	20583	26702	2057539	0	120	22399	2057851	0	3	0 (0)	6
						Mid	28049	20799	27855	2076757	102		22474	2079451	3	0	0 (0)	204
					Uplink	High	29349	21016	28576	2088777	504		22550	2101339	5	5	1 (4)	1026
								.96										
Channel spacing CC3-CC4=99.96 MHz (Note 1)																		
CC 4	100	120	66	Downlink & Uplink	Low	26849	20599	26802	2059205	0	120	22405	2059579	7	1	1 (4)	10	
					Mid	28149	20816	27955	2078423	102		22480	2081179	10	2	0 (0)	208	
				Uplink	High	29449	21033	28676	2090443	504		22555	2102779	0	0	0 (0)	1008	
								.92										

Note 1: Corresponds to nominal channel spacing in accordance with TS 38.101-2 [8], clause 5.4A.1 for the channel bandwidths of the two respective NR component carriers.  
 Note 2: CCs are specified in increasing frequency order. CC1 is used as PCell if nothing else is specified in the test case.  
 Note 3: The parameter Offset Carrier CORESET#0 specifies the offset from the lowest subcarrier of the carrier and the lowest subcarrier of CORESET#0. It corresponds to the parameter  $\Delta F_{\text{OffsetCORESET-0-Carrier}}$  in Annex C expressed in number of common RBs.  
 Note 4: The CORESET#0 Index and the associated CORESET#0 Offset refers to Table 13-8 in TS 38.213 [22]. The value of CORESET#0 Index is signalled in controlResourceSetZero (pdcch-ConfigSIB1) in the MIB. The offsetToPointA IE is expressed in units of resource blocks assuming 15 kHz subcarrier spacing for FR1 and 60 kHz subcarrier spacing for FR2.

4.3.1.2.3.1.9 CA\_n257J

Editor's note: CA\_n257J Test frequencies are FFS.

Table 4.3.1.2.3.1.9-1:Void

Table 4.3.1.2.3.1.9-2: NR Intra-Band contiguous CA configuration CA\_n257J, SCS=60 kHz,  $\Delta F_{\text{Raster}}$  60 kHz, nominal channel spacing

CBW	CC	CB	SC	carrierBand	Ran	Carri	Carrie	poi	absoluteFrequenc	offsetToC	SS	GS	absoluteFreque	$k_{SSB}$	Offset	CORESE	offsetToP
-----	----	----	----	-------------	-----	-------	--------	-----	------------------	-----------	----	----	----------------	-----------	--------	--------	-----------

combination	Note 2	W [MHz]	S [kHz]	width [PRBs]	ge	er centre [MHz] Note 2	r centre [ARFCN]	nt A [MHz]	yPointA [ARFCN]	arrier [Carrier PRBs]	block SC S [kHz]	CN	ncySSB [ARFCN]		Carrier CORESE T#0 [RBs] Note 3	T#0 Index (Offset [RBs]) Note 4	ointA (SIB1) [PRBs] Note 4

Table 4.3.1.2.3.1.9-3: Void

Table 4.3.1.2.3.1.9-4: NR Intra-Band contiguous CA configuration CA\_n257J, SCS=120 kHz, ΔF<sub>Raster</sub> 120 kHz, nominal channel spacing

CBW combination	CC Note 2	CB W [MHz]	SC S [kHz]	carrierBand width [PRBs]	Range	Carrier centre [MHz] Note 2	Carrier centre [ARFCN]	point A [MHz]	absoluteFrequencyPointA [ARFCN]	offsetToCarrier [Carrier PRBs]	SS block SC S [kHz]	GS CN	absoluteFrequencySSB [ARFCN]	<i>k</i> <sub>SSB</sub>	Offset Carrier CORESE T#0 [RBs] Note 3	CORESE T#0 Index (Offset [RBs]) Note 4	offsetToPointA (SIB1) [PRBs] Note 4

4.3.1.2.3.1.10 CA\_n257K

Editor's note: CA\_n257K Test frequencies are FFS.

Table 4.3.1.2.3.1.10-1: Void

Table 4.3.1.2.3.1.10-2: NR Intra-Band contiguous CA configuration CA\_n257K, SCS=60 kHz, ΔF<sub>Raster</sub> 60 kHz, nominal channel spacing

CBW combination	CC Note 2	CB W [MHz]	SC S [kHz]	carrierBand width [PRBs]	Range	Carrier centre [MHz] Note 2	Carrier centre [ARFCN]	point A [MHz]	absoluteFrequencyPointA [ARFCN]	offsetToCarrier [Carrier PRBs]	SS block SC S [kHz]	GS CN	absoluteFrequencySSB [ARFCN]	<i>k</i> <sub>SSB</sub>	Offset Carrier CORESE T#0 [RBs] Note 3	CORESE T#0 Index (Offset [RBs]) Note 4	offsetToPointA (SIB1) [PRBs] Note 4



Table 4.3.1.2.3.1.10-3: Void

Table 4.3.1.2.3.1.10-4: NR Intra-Band contiguous CA configuration CA\_n257K, SCS=120 kHz, ΔF<sub>Raster</sub> 120 kHz, nominal channel spacing

CBW combination	CC Note 2	CBW [MHz]	SCS [kHz]	carrierBandwidth [PRBs]	Range	Carrier centre [MHz] Note 2	Carrier centre [ARFCN]	point A [MHz]	absoluteFrequencyPointA [ARFCN]	offsetToCarrier [Carrier PRBs]	SS block SCS [kHz]	GS CN	absoluteFrequencySSB [ARFCN]	<i>k</i> <sub>SSB</sub>	Offset Carrier CORESET#0 [RBs] Note 3	CORESET#0 Index (Offset [RBs]) Note 4	offsetToPointA (SIB1) [PRBs] Note 4

4.3.1.2.3.1.11 CA\_n257L

Editor's note: CA\_n257L Test frequencies are FFS.

Table 4.3.1.2.3.1.11-1: Void

Table 4.3.1.2.3.1.11-2: NR Intra-Band contiguous CA configuration CA\_n257L, SCS=60 kHz, ΔF<sub>Raster</sub> 60 kHz, nominal channel

CBW combination	CC Note 2	CBW [MHz]	SCS [kHz]	carrierBandwidth [PRBs]	Range	Carrier centre [MHz] Note 2	Carrier centre [ARFCN]	point A [MHz]	absoluteFrequencyPointA [ARFCN]	offsetToCarrier [Carrier PRBs]	SS block SCS [kHz]	GS CN	absoluteFrequencySSB [ARFCN]	<i>k</i> <sub>SSB</sub>	Offset Carrier CORESET#0 [RBs] Note 3	CORESET#0 Index (Offset [RBs]) Note 4	offsetToPointA (SIB1) [PRBs] Note 4

Table 4.3.1.2.3.1.11-3: Void

Table 4.3.1.2.3.1.11-4: NR Intra-Band contiguous CA configuration CA\_n257L, SCS=120 kHz, ΔF<sub>Raster</sub> 120 kHz, nominal channel spacing

CBW combination	CC Note 2	CBW [MHz]	SCS [kHz]	carrierBand width [PRBs]	Range	Carrier centre [MHz] Note 2	Carrier centre [ARFCN]	point A [MHz]	absoluteFrequencyPointA [ARFCN]	offsetToCarrier [Carrier PRBs]	SS block SCS [kHz]	GS CN	absoluteFrequencySSB [ARFCN]	<i>k</i> <sub>SSB</sub>	Offset Carrier CORESE T#0 [RBs] Note 3	CORESE T#0 Index (Offset [RBs]) Note 4	offsetToPointA (SIB1) [PRBs] Note 4

4.3.1.2.3.1.12 CA\_n257M

Editor's note: CA\_n257M Test frequencies are FFS.

Table 4.3.1.2.3.1.12-1: Void

Table 4.3.1.2.3.1.12-2: NR Intra-Band contiguous CA configuration CA\_n257M, SCS=60 kHz, ΔF<sub>Raster</sub> 60 kHz, nominal channel

CBW combination	CC Note 2	CBW [MHz]	SCS [kHz]	carrierBand width [PRBs]	Range	Carrier centre [MHz] Note 2	Carrier centre [ARFCN]	point A [MHz]	absoluteFrequencyPointA [ARFCN]	offsetToCarrier [Carrier PRBs]	SS block SCS [kHz]	GS CN	absoluteFrequencySSB [ARFCN]	<i>k</i> <sub>SSB</sub>	Offset Carrier CORESE T#0 [RBs] Note 3	CORESE T#0 Index (Offset [RBs]) Note 4	offsetToPointA (SIB1) [PRBs] Note 4

Table 4.3.1.2.3.1.12-3: Void

Table 4.3.1.2.3.1.12-4: NR Intra-Band contiguous CA configuration CA\_n257M, SCS=120 kHz, ΔF<sub>Raster</sub> 120 kHz, nominal channel spacing

CBW combination	CC Note 2	CBW [MHz]	SCS [kHz]	carrierBand width [PRBs]	Range	Carrier centre	Carrier centre	point A [MHz]	absoluteFrequencyPointA [ARFCN]	offsetToCarrier [Carrier PRBs]	SS block SCS	GS CN	absoluteFrequencySSB [ARFCN]	<i>k</i> <sub>SSB</sub>	CORESE T#1 Offset from	CORESE T#0 Index (Offset	offsetToPointA (SIB1) [PRBs]

						[MHz] ] Note 2	[ARF CN]				S [kHz]				$N_{BW}^{start}$ [RBs]	[RBs] Note 1	Note 1

4.3.1.2.3.2 NR Intra-band contiguous CA configurations for CA\_n258

4.3.1.2.3.2.1 CA\_n258B

Table 4.3.1.2.3.2.1-1: Void

Table 4.3.1.2.3.2.1-2: NR Intra-Band contiguous CA configuration CA\_n258B (PCC=CC1 and SCC=CC2), SCS=120 kHz, nominal channel spacing

CBW combination	CC	CBW [MHz]	SCS [kHz]	carrier Bandwidth [PRBs]	Range	Carrier centre [MHz] Note 2	Carrier centre [ARFCN]	point A [MHz]	absoluteF requency PointA [ARFCN]	offsetT oCarrier [Carrier PRBs]	SS block SCS [kHz]	GSCN	absoluteF requency SSB [ARFCN]	$k_{SSB}$	Offset Carrier CORES ET#0 [RBs] Note 3	CORE SET#0 Index (Offset [RBs]) Note 4	offset ToPointA (SIB1) [PRBs] Note 4		
50+400	CC1	50	120	32	Downlink & Uplink	Low	24275.04	2017083	24252	2016699	0	120	22257	2016955	8	0	0 (0)	0	
						Mid	25674.96	2040415	25505.04	2037583	102		22338	2040283	6	0	0 (0)	204	
						High	27083.04	2063883	26334.24	2051403	504		22420	2063899	8	2	1 (4)	1020	
	Channel spacing CC1-CC2=216.96 MHz (Note 1)																		
	CC2	400	120	264	Downlink & Uplink	Low	24492	2020699	24301.92	2017531	0	120	22260	2017819	0	2	0 (0)	4	
						Mid	25891.92	2044031	25554.96	2038415	102		22341	2041147	10	1	0 (0)	206	
						High	27300	2067499	26384.16	2052235	504		22423	2064763	0	4	1 (4)	1024	
	100+400	CC1	100	120	66	Downlink & Uplink	Low	24300	2017499	24252.48	2016707	0	120	22257	2016955	4	0	0 (0)	0
							Mid	25674.96	2040415	25480.56	2037175	102		22337	2039995	6	1	1 (4)	214
High							27057.48	2063457	26284.2	2050569	504	22417		2063035	5	1	1 (4)	1018	
Channel spacing CC1-CC2=242.52 MHz (Note 1)																			
CC2		400	120	264	Downlink & Uplink	Low	24542.52	2021541	24352.44	2018373	0	120	22263	2018683	11	2	0 (0)	4	
						Mid	25917.48	2044457	25580.52	2038841	102		22343	2041723	1	4	1 (4)	220	
						High	27300	2067499	26384.16	2052235	504		22423	2064763	0	4	1 (4)	1024	
200+400		CC1	200	120	132	Downlink & Uplink	Low	24350.04	2018333	24255	2016749	0	120	22258	2017243	7	6	1 (4)	20
							Mid	25674.96	2040415	25433.04	2036383	102		22334	2039131	6	2	0 (0)	208
	High						27005.04	2062583	26184.24	2048903	504	22411		2061307	10	2	0 (0)	1012	
	Channel spacing CC1-CC2=294.96 MHz (Note 1)																		
	CC2	400	120	264	Downlink & Uplink	Low	24645	2023249	24454.92	2020081	0	120	22269	2020411	9	3	0 (0)	6	
						Mid	25969.92	2045331	25632.96	2039715	102		22346	2042587	8	3	1 (4)	218	

400+400	CC1	400	120	264	Uplink	High	27300	2067499	26384.16	2052235	504	120	22423	2064763	0	4	1 (4)	1024	
					Downlink & Uplink	Low	24450	2019999	24259.92	2016831	0		22258	2017243	2	3	1 (4)	14	
						Mid	25674.96	2040415	25338	2034799	102		22329	2037691	6	4	1 (4)	220	
						High	26900.04	2060833	25984.2	2045569	504		22400	2058139	9	5	1 (4)	1026	
	Channel spacing CC1-CC2=399.96 MHz (Note 1)																		
	CC2	400	120	264	Downlink & Uplink	Low	24849.96	2026665	24659.88	2023497	0	120	22281	2023867	5	1	1 (4)	10	
						Mid	26074.92	2047081	25737.96	2041465	102		22352	2044315	9	2	1 (4)	216	
						High	27300	2067499	26384.16	2052235	504		22423	2064763	0	4	1 (4)	1024	

Note 1: Corresponds to nominal channel spacing in accordance with TS 38.101-2 [8], clause 5.4A.1 for the channel bandwidths of the two respective NR component carriers.  
 Note 2: CCs are specified in increasing frequency order. CC1 is used as PCell if nothing else is specified in the test case.  
 Note 3: The parameter Offset Carrier CORESET#0 specifies the offset from the lowest subcarrier of the carrier and the lowest subcarrier of CORESET#0. It corresponds to the parameter  $\Delta F_{\text{OffsetCORESET-0-Carrier}}$  in Annex C expressed in number of common RBs.  
 Note 4: The CORESET#0 Index and the associated CORESET#0 Offset refers to Table 13-8 in TS 38.213 [22]. The value of CORESET#0 Index is signalled in controlResourceSetZero (pdcch-ConfigSIB1) in the MIB. The offsetToPointA IE is expressed in units of resource blocks assuming 15 kHz subcarrier spacing for FR1 and 60 kHz subcarrier spacing for FR2.

4.3.1.2.3.2.2 CA\_n258C

FFS

4.3.1.2.3.2.3 CA\_n258D

Table 4.3.1.2.3.2.3-1: NR Intra-Band contiguous CA configuration CA\_n258D (PCC=CC1 and SCC=CC2), SCS=60 kHz, nominal channel spacing

CBW combination	CC	CBW [MHz]	SCS [kHz]	carrierBandwidth [PRBs]	Range	Carrier centre [MHz] Note 2	Carrier centre [ARFCN]	point A [MHz]	absoluteFrequencyPointA [ARFCN]	offsetToCarrier [Carrier PRBs]	SS block SCS [kHz]	GSCN	absoluteFrequencySSB [ARFCN]	$k_{SSB}$	Offset Carrier CORESET#0 [RBs] Note 3	CORE SET#0 Index (Offset [RBs]) Note 4	offsetToPointA (SIB1) [PRBs] Note 4		
50+200	CC1	50	60	66	Downlink & Uplink	Low	24275.04	2017083	24251.28	2016687	0	120	22257	2016955	4	2	0 (0)	2	
						Mid	25774.92	2042081	25677.72	2040461	102		22344	2042011	2	7	0 (0)	109	
						High	27278.04	2067133	26891.4	2060689	504		22431	2067067	6	7	0 (0)	511	
	Channel spacing CC1-CC2=121.92 MHz (Note 1)																		
	CC2	200	60	264	Downlink & Uplink	Low	24396.96	2019115	24301.92	2017531	0	120	22260	2017819	0	4	0 (0)	4	
						Mid	25896.84	2044113	25728.36	2041305	102		22347	2042875	10	0	1 (8)	110	
						High	27399.96	2069165	26942.04	2061533	504		22434	2067931	2	1	1 (8)	513	
	100+200	CC1	100	60	132	Downlink & Uplink	Low	24300	2017499	24252.48	2016707	0	120	22257	2016955	8	0	0 (0)	0
							Mid	25774.92	2042081	25653.96	2040065	102		22343	2041723	2	8	1 (8)	118
							High	27252.48	2066707	26842.08	2059867	504		22428	2066203	0	4	0 (0)	508
Channel spacing CC1-CC2=147.48 MHz (Note 1)																			
CC2		200	60	264	Downlink	Low	24447.48	2019957	24352.44	2018373	0	120	22263	2018683	10	5	0 (0)	5	

200+200	CC1	200	60	264	& Uplink	Mid	25922.4	2044539	25753.92	2041731	102	120	22349	2043451	4	13	1 (8)	123	
						High	27399.96	2069165	26942.04	2061533	504		22434	2067931	2	1	1 (8)	513	
					& Uplink	Low	24350.04	2018333	24255	2016749	0		22258	2017243	2	13	1 (8)	21	
						Mid	25774.92	2042081	25606.44	2039273	102		22340	2040859	2	2	1 (8)	112	
						High	27200.04	2065833	26742.12	2058201	504		22423	2064763	10	14	1 (8)	526	
	Channel spacing CC1-CC2=199.92 MHz (Note 1)																		
	CC2	200	60	264	Downlink & Uplink	Low	24549.96	2021665	24454.92	2020081	0	120	22269	2020411	6	7	0 (0)	7	
						Mid	25974.84	2045413	25806.36	2042605	102		22352	2044315	6	12	1 (8)	122	
						High	27399.96	2069165	26942.04	2061533	504		22434	2067931	2	1	1 (8)	513	

Note 1: Corresponds to nominal channel spacing in accordance with TS 38.101-2 [8], clause 5.4A.1 for the channel bandwidths of the two respective NR component carriers.  
 Note 2: CCs are specified in increasing frequency order. CC1 is used as PCell if nothing else is specified in the test case.  
 Note 3: The parameter Offset Carrier CORESET#0 specifies the offset from the lowest subcarrier of the carrier and the lowest subcarrier of CORESET#0. It corresponds to the parameter  $\Delta f_{\text{OffsetCORESET-0-Carrier}}$  in Annex C expressed in number of common RBs.  
 Note 4: The CORESET#0 Index and the associated CORESET#0 Offset refers to Table 13-7 in TS 38.213 [22]. The value of CORESET#0 Index is signalled in controlResourceSetZero (pdcch-ConfigSIB1) in the MIB. The offsetToPointA IE is expressed in units of resource blocks assuming 15 kHz subcarrier spacing for FR1 and 60 kHz subcarrier spacing for FR2.

Table 4.3.1.2.3.2-2: NR Intra-Band contiguous CA configuration CA\_n258D (PCC=CC1 and SCC=CC2), SCS=120 kHz, nominal channel spacing

CBW combination	CC	CBW [MHz]	SCS [kHz]	carrierBandwidth [PRBs]	Range	Carrier centre [MHz] Note 2	Carrier centre [ARFCN]	point A [MHz]	absoluteFrequencyPointA [ARFCN]	offsetToCarrier [Carrier PRBs]	SS block SCS [kHz]	GSCN	absoluteFrequencySSB [ARFCN]	$k_{\text{SSB}}$	Offset Carrier CORESET#0 [RBs] Note 3	CORE SET#0 Index (Offset [RBs]) Note 4	offsetToPointA (SIB1) [PRBs] Note 4		
50+200	CC1	50	120	32	Downlink & Uplink	Low	24275.04	2017083	24252	2016699	0	120	22257	2016955	8	0	0 (0)	0	
						Mid	25775.04	2042083	25605.12	2039251	102		22344	2042011	0	3	0 (0)	210	
						High	27278.04	2067133	26529.24	2054653	504		22431	2067067	3	3	0 (0)	1014	
					Channel spacing CC1-CC2=121.92 MHz (Note 1)														
					CC2	200	120	132	Downlink & Uplink	Low	24396.96		2019115	24301.92	2017531	0	120	22260	2017819
	Mid	25896.96	2044115	25655.04						2040083	102	22347	2042875	4	0	1 (4)		212	
	High	27399.96	2069165	26579.16						2055485	504	22434	2067931	7	0	1 (4)		1016	
	100+200	CC1	100	120	66	Downlink & Uplink	Low	24300	2017499	24252.48	2016707	0	120	22257	2016955	4	0	0 (0)	0
							Mid	25775.04	2042083	25580.64	2038843	102		22343	2041723	0	4	1 (4)	220
							High	27252.48	2066707	26479.2	2053819	504		22428	2066203	0	2	0 (0)	1012
Channel spacing CC1-CC2=147.48 MHz (Note 1)																			
CC2						200	120	132	Downlink & Uplink	Low	24447.48	2019957		24352.44	2018373	0	120	22263	2018683
		Mid	25922.52	2044541	25680.6					2040509	102	22349	2043451	7	6	1 (4)		224	
		High	27399.96	2069165	26579.16					2055485	504	22434	2067931	7	0	1 (4)		1016	
200+200		CC1	200	120	132	Downlink & Uplink	Low	24350.04	2018333	24255	2016749	0	120	22258	2017243	7	6	1 (4)	20
							Mid	25775.04	2042083	25533.12	2038051	102		22340	2040859	0	1	1 (4)	214
							High	27200.04	2065833	26379.24	2052153	504		22423	2064763	5	7	1 (4)	1030
	Channel spacing CC1-CC2=199.92 MHz (Note 1)																		

	CC2	200	120	132	Downlink & Uplink	Low	24549.96	2021665	24454.92	2020081	0	120	22269	2020411	9	3	0 (0)	6	
						Mid	25974.96	2045415	25733.04	2041383	102			22352	2044315	2	6	1 (4)	224
						High	27399.96	2069165	26579.16	2055485	504			22434	2067931	7	0	1 (4)	1016

Note 1: Corresponds to nominal channel spacing in accordance with TS 38.101-2 [8], clause 5.4A.1 for the channel bandwidths of the two respective NR component carriers.  
 Note 2: CCs are specified in increasing frequency order. CC1 is used as PCell if nothing else is specified in the test case.  
 Note 3: The parameter Offset Carrier CORESET#0 specifies the offset from the lowest subcarrier of the carrier and the lowest subcarrier of CORESET#0. It corresponds to the parameter  $\Delta F_{\text{OffsetCORESET-0-Carrier}}$  in Annex C expressed in number of common RBs.  
 Note 4: The CORESET#0 Index and the associated CORESET#0 Offset refers to Table 13-8 in TS 38.213 [22]. The value of CORESET#0 Index is signalled in controlResourceSetZero (pdcc-ConfigSIB1) in the MIB. The offsetToPointA IE is expressed in units of resource blocks assuming 15 kHz subcarrier spacing for FR1 and 60 kHz subcarrier spacing for FR2.

4.3.1.2.3.2.4 CA\_n258E

FFS

4.3.1.2.3.2.5 CA\_n258F

FFS

4.3.1.2.3.2.6 CA\_n258G

**Table 4.3.1.2.3.2.6-1: NR Intra-Band contiguous CA configuration CA\_n258G (PCC=CC1 and SCC=CC2), SCS=60 kHz, nominal channel spacing**

CBW combination	CC	CBW [MHz]	SCS [kHz]	carrierBandwidth [PRBs]	Range	Carrier centre [MHz] Note 2	Carrier centre [ARFCN]	point A [MHz]	absoluteFrequencyPointA [ARFCN]	offsetToCarrier [Carrier PRBs]	SS block SCS [kHz]	GSCN	absoluteFrequencySSB [ARFCN]	$k_{SSB}$	Offset Carrier CORESET#0 [RBs] Note 3	CORE SET#0 Index (Offset [RBs]) Note 4	offsetToPointA (SIB1) [PRBs] Note 4		
50+100	CC1	50	60	66	Downlink & Uplink	Low	24275.04	2017083	24251.28	2016687	0	120	22257	2016955	4	2	0 (0)	2	
						Mid	25824.96	2042915	25727.76	2041295	102		22347	2042875	8	1	1 (8)	111	
						High	27375.6	2068759	26988.96	2062315	504		22437	2068795	0	8	1 (8)	520	
	Channel spacing CC1-CC2=74.4 MHz (Note 1)																		
	CC2	100	60	132	Downlink & Uplink	Low	24349.44	2018323	24301.92	2017531	0	120	22260	2017819	0	4	0 (0)	4	
						Mid	25899.36	2044155	25778.4	2042139	102		22350	2043739	4	3	1 (8)	113	
						High	27450	2069999	27039.6	2063159	504		22440	2069659	8	9	1 (8)	521	
	100+100	CC1	100	60	132	Downlink & Uplink	Low	24300	2017499	24252.48	2016707	0	120	22257	2016955	8	0	0 (0)	0
							Mid	25824.96	2042915	25704	2040899	102		22346	2042587	8	10	1 (8)	120
High							27350.04	2068333	26939.64	2061493	504	22434		2067931	6	4	1 (8)	516	
Channel spacing CC1-CC2=99.96 MHz (Note 1)																			
CC2		100	60	132	Downlink & Uplink	Low	24399.96	2019165	24352.44	2018373	0	120	22263	2018683	10	5	0 (0)	5	
						Mid	25924.92	2044581	25803.96	2042565	102		22352	2044315	10	15	1 (8)	125	

					Uplink	High	27450	2069999	27039.6	2063159	504		22440	2069659	8	9	1 (8)	521	
Note 1:	Corresponds to nominal channel spacing in accordance with TS 38.101-2 [8], clause 5.4A.1 for the channel bandwidths of the two respective NR component carriers.																		
Note 2:	CCs are specified in increasing frequency order. CC1 is used as PCell if nothing else is specified in the test case.																		
Note 3:	The parameter Offset Carrier CORESET#0 specifies the offset from the lowest subcarrier of the carrier and the lowest subcarrier of CORESET#0. It corresponds to the parameter $\Delta F_{\text{OffsetCORESET-0-Carrier}}$ in Annex C expressed in number of common RBs.																		
Note 4:	The CORESET#0 Index and the associated CORESET#0 Offset refers to Table 13-7 in TS 38.213 [22]. The value of CORESET#0 Index is signalled in controlResourceSetZero (pdccch-ConfigSIB1) in the MIB. The offsetToPointA IE is expressed in units of resource blocks assuming 15 kHz subcarrier spacing for FR1 and 60 kHz subcarrier spacing for FR2.																		

Table 4.3.1.2.3.2.6-2: NR Intra-Band contiguous CA configuration CA\_n258G (PCC=CC1 and SCC=CC2), SCS=120 kHz, nominal channel spacing

CBW combination	CC	CBW [MHz]	SCS [kHz]	carrierBandwidth [PRBs]	Range	Carrier centre [MHz]	Carrier centre [ARFCN]	point A [MHz]	absoluteFrequencyPointA [ARFCN]	offsetToCarrier [Carrier PRBs]	SS block SCS [kHz]	GSCN	absoluteFrequencySSB [ARFCN]	$k_{\text{SSB}}$	Offset Carrier CORESET#0 [RBs]	CORESET#0 Index (Offset [RBs])	offsetToPointA (SIB1) [PRBs]		
50+100	CC1	50	120	32	Downlink & Uplink	Low	24275.04	2017083	24252	2016699	0	120	22257	2016955	8	0	0 (0)	0	
						Mid	25824.96	2042915	25655.04	2040083	102		22347	2042875	4	0	1 (4)	212	
						High	27375.6	2068759	26626.8	2056279	504		22437	2068795	6	3	1 (4)	1022	
	Channel spacing CC1-CC2=74.4 MHz (Note 1)																		
	CC2	100	120	66	Downlink & Uplink	Low	24349.44	2018323	24301.92	2017531	0	120	22260	2017819	0	2	0 (0)	4	
						Mid	25899.36	2044155	25704.96	2040915	102		22350	2043739	8	1	1 (4)	214	
						High	27450	2069999	26676.72	2057111	504		22440	2069659	10	4	1 (4)	1024	
	100+100	CC1	100	120	66	Downlink & Uplink	Low	24300	2017499	24252.48	2016707	0	120	22257	2016955	4	0	0 (0)	0
							Mid	25824.96	2042915	25630.56	2039675	102		22346	2042587	4	5	1 (4)	222
High							27350.04	2068333	26576.76	2055445	504	22434		2067931	3	2	1 (4)	1020	
Channel spacing CC1-CC2=99.96 MHz (Note 1)																			
CC2		100	120	66	Downlink & Uplink	Low	24399.96	2019165	24352.44	2018373	0	120	22263	2018683	11	2	0 (0)	4	
						Mid	25924.92	2044581	25730.52	2041341	102		22352	2044315	11	7	1 (4)	226	
						High	27450	2069999	26676.72	2057111	504		22440	2069659	10	4	1 (4)	1024	

Note 1:	Corresponds to nominal channel spacing in accordance with TS 38.101-2 [8], clause 5.4A.1 for the channel bandwidths of the two respective NR component carriers.																		
Note 2:	CCs are specified in increasing frequency order. CC1 is used as PCell if nothing else is specified in the test case.																		
Note 3:	The parameter Offset Carrier CORESET#0 specifies the offset from the lowest subcarrier of the carrier and the lowest subcarrier of CORESET#0. It corresponds to the parameter $\Delta F_{\text{OffsetCORESET-0-Carrier}}$ in Annex C expressed in number of common RBs.																		
Note 4:	The CORESET#0 Index and the associated CORESET#0 Offset refers to Table 13-8 in TS 38.213 [22]. The value of CORESET#0 Index is signalled in controlResourceSetZero (pdccch-ConfigSIB1) in the MIB. The offsetToPointA IE is expressed in units of resource blocks assuming 15 kHz subcarrier spacing for FR1 and 60 kHz subcarrier spacing for FR2.																		

Table 4.3.1.2.3.2.7-1: NR Intra-Band contiguous CA configuration CA\_n258H (PCC=CC1 and SCC=CC2), SCS=60 kHz, nominal channel spacing

CBW combination	CC	CBW [MHz]	SCS [kHz]	carrier Bandwidth [PRBs]	Range		Carrier centre [MHz] Note 2	Carrier centre [ARFCN]	point A [MHz]	absolute Frequency PointA [ARFCN]	offset ToCarrier [Carrier PRBs]	SS block SCS [kHz]	GSCN	absolute Frequency SSB [ARFCN]	k <sub>SSB</sub>	Offset Carrier CORESET#0 [RBs] Note 3	CORE SET#0 Index (Offset [RBs]) Note 4	offset ToPointA (SIB1) [PRBs] Note 4	
					Downlink & Uplink	Low Mid High													
50+100+100	CC1	50	60	66	Downlink & Uplink	Low	24275.04	2017083	24251.28	2016687	0	120	22257	2016955	4	2	0 (0)	2	
						Mid	25774.92	2042081	25677.72	2040461	102		22344	2042011	2	7	0 (0)	109	
						High	27275.64	2067093	26889	2060649	504		22431	2067067	10	2	1 (8)	514	
	Channel spacing CC1-CC2=74.4 MHz (Note 1)																		
	CC2	100	60	132	Downlink & Uplink	Low	24349.44	2018323	24301.92	2017531	0	120	22260	2017819	0	4	0 (0)	4	
						Mid	25849.32	2043321	25728.36	2041305	102		22347	2042875	10	0	1 (8)	110	
						High	27350.04	2068333	26939.64	2061493	504		22434	2067931	6	4	1 (8)	516	
	Channel spacing CC2-CC3=99.96 MHz (Note 1)																		
	CC3	100	60	132	Downlink & Uplink	Low	24449.4	2019989	24401.88	2019197	0	120	22266	2019547	2	1	1 (8)	9	
						Mid	25949.28	2044987	25828.32	2042971	102		22353	2044603	0	6	1 (8)	116	
						High	27450	2069999	27039.6	2063159	504		22440	2069659	8	9	1 (8)	521	
	100+100+100	CC1	100	60	132	Downlink & Uplink	Low	24300	2017499	24252.48	2016707	0	120	22257	2016955	8	0	0 (0)	0
Mid							25774.92	2042081	25653.96	2040065	102	22343		2041723	2	8	1 (8)	118	
High							27250.08	2066667	26839.68	2059827	504	22428		2066203	4	7	0 (0)	511	
Channel spacing CC1-CC2=99.96 MHz (Note 1)																			
CC2		100	60	132	Downlink & Uplink	Low	24399.96	2019165	24352.44	2018373	0	120	22263	2018683	10	5	0 (0)	5	
						Mid	25874.88	2043747	25753.92	2041731	102		22349	2043451	4	13	1 (8)	123	
						High	27350.04	2068333	26939.64	2061493	504		22434	2067931	6	4	1 (8)	516	
Channel spacing CC2-CC3=99.96 MHz (Note 1)																			
CC3		100	60	132	Downlink & Uplink	Low	24499.92	2020831	24452.4	2020039	0	120	22269	2020411	0	3	1 (8)	11	
						Mid	25974.84	2045413	25853.88	2043397	102		22354	2044891	6	2	0 (0)	104	
						High	27450	2069999	27039.6	2063159	504		22440	2069659	8	9	1 (8)	521	

Note 1: Corresponds to nominal channel spacing in accordance with TS 38.101-2 [8], clause 5.4A.1 for the channel bandwidths of the two respective NR component carriers.  
 Note 2: CCs are specified in increasing frequency order. CC1 is used as PCell if nothing else is specified in the test case.  
 Note 3: The parameter Offset Carrier CORESET#0 specifies the offset from the lowest subcarrier of the carrier and the lowest subcarrier of CORESET#0. It corresponds to the parameter  $\Delta F_{\text{OffsetCORESET-0-Carrier}}$  in Annex C expressed in number of common RBs.  
 Note 4: The CORESET#0 Index and the associated CORESET#0 Offset refers to Table 13-7 in TS 38.213 [22]. The value of CORESET#0 Index is signalled in controlResourceSetZero (pdcch-ConfigSIB1) in the MIB. The offsetToPointA IE is expressed in units of resource blocks assuming 15 kHz subcarrier spacing for FR1 and 60 kHz subcarrier spacing for FR2.

Table 4.3.1.2.3.2.7-2: NR Intra-Band contiguous CA configuration CA\_n258H (PCC=CC1 and SCC=CC2), SCS=120 kHz, nominal channel spacing

CBW	CC	CBW	SCS	carrierB	Range	Carrier	Carrier	point A	absoluteF	offset	SS	GSCN	absoluteF	k <sub>SSB</sub>	Offset	CORE	offset
-----	----	-----	-----	----------	-------	---------	---------	---------	-----------	--------	----	------	-----------	------------------	--------	------	--------



combination		[MHz]	[kHz]	bandwidth [PRBs]		centre [MHz] Note 2	centre [ARFCN]	[MHz]	frequency PointA [ARFCN]	ToCarrier [Carrier PRBs]	block SCS [kHz]		frequency SSB [ARFCN]		Carrier CORESET#0 [RBs] Note 3	SET#0 Index (Offset [RBs]) Note 4	ToPointA (SIB1) [PRBs] Note 4		
50+100+100	CC1	50	120	32	Downlink & Uplink	Low	24275.04	2017083	24252	2016699	0	120	22257	2016955	8	0	0 (0)	0	
						Mid	25775.04	2042083	25605.12	2039251	102		22344	2042011	0	3	0 (0)	210	
						High	27275.64	2067093	26526.84	2054613	504		22431	2067067	11	0	1 (4)	1016	
	Channel spacing CC1-CC2=74.4 MHz (Note 1)																		
	CC2	100	120	66	Downlink & Uplink	Low	24349.44	2018323	24301.92	2017531	0	120	22260	2017819	0	2	0 (0)	4	
						Mid	25849.44	2043323	25655.04	2040083	102		22347	2042875	4	0	1 (4)	212	
						High	27350.04	2068333	26576.76	2055445	504		22434	2067931	3	2	1 (4)	1020	
	Channel spacing CC2-CC3=99.96 MHz (Note 1)																		
	CC3	100	120	66	Downlink & Uplink	Low	24449.4	2019989	24401.88	2019197	0	120	22266	2019547	7	0	1 (4)	8	
						Mid	25949.4	2044989	25755	2041749	102		22353	2044603	11	2	1 (4)	216	
						High	27450	2069999	26676.72	2057111	504		22440	2069659	10	4	1 (4)	1024	
	100+100+100	CC1	100	120	66	Downlink & Uplink	Low	24300	2017499	24252.48	2016707	0	120	22257	2016955	4	0	0 (0)	0
Mid							25775.04	2042083	25580.64	2038843	102	22343		2041723	0	4	1 (4)	220	
High							27250.08	2066667	26476.8	2053779	504	22428		2066203	8	3	0 (0)	1014	
Channel spacing CC1-CC2=99.96 MHz (Note 1)																			
CC2		100	120	66	Downlink & Uplink	Low	24399.96	2019165	24352.44	2018373	0	120	22263	2018683	11	2	0 (0)	4	
						Mid	25875	2043749	25680.6	2040509	102		22349	2043451	7	6	1 (4)	224	
						High	27350.04	2068333	26576.76	2055445	504		22434	2067931	3	2	1 (4)	1020	
Channel spacing CC2-CC3=99.96 MHz (Note 1)																			
CC3		100	120	66	Downlink & Uplink	Low	24499.92	2020831	24452.4	2020039	0	120	22269	2020411	6	1	1 (4)	10	
						Mid	25974.96	2045415	25780.56	2042175	102		22354	2044891	2	1	0 (0)	206	
						High	27450	2069999	26676.72	2057111	504		22440	2069659	10	4	1 (4)	1024	
Note 1: Corresponds to nominal channel spacing in accordance with TS 38.101-2 [8], clause 5.4A.1 for the channel bandwidths of the two respective NR component carriers.																			
Note 2: CCs are specified in increasing frequency order. CC1 is used as PCell if nothing else is specified in the test case.																			
Note 3: The parameter Offset Carrier CORESET#0 specifies the offset from the lowest subcarrier of the carrier and the lowest subcarrier of CORESET#0. It corresponds to the parameter $\Delta F_{\text{OffsetCORESET-0-Carrier}}$ in Annex C expressed in number of common RBs.																			
Note 4: The CORESET#0 Index and the associated CORESET#0 Offset refers to Table 13-8 in TS 38.213 [22]. The value of CORESET#0 Index is signalled in controlResourceSetZero (pdcch-ConfigSIB1) in the MIB. The offsetToPointA IE is expressed in units of resource blocks assuming 15 kHz subcarrier spacing for FR1 and 60 kHz subcarrier spacing for FR2.																			

4.3.1.2.3.2.8 CA\_n258I

FFS

4.3.1.2.3.2.9 CA\_n258J

FFS

4.3.1.2.3.2.10 CA\_n258K

FFS

4.3.1.2.3.2.11 CA\_n258L

FFS

4.3.1.2.3.2.12 CA\_n258M

FFS

4.3.1.2.3.3 FFS

4.3.1.2.3.4 NR Intra-band contiguous CA configurations for CA\_n260

4.3.1.2.3.4.1 CA\_n260B

Editor's note: CA\_n260B Test frequencies are FFS.

Table 4.3.1.2.3.4.1-1: NR Intra-Band contiguous CA configuration CA\_n260B (PCC=CC1 and SCC=CC2), SCS=120 kHz, nominal channel spacing

CBW combination	CC	CBW [MHz]	SCS [kHz]	carrier Band width [PRBs]	Range	Carrier centre [MHz] Note 2	Carrier centre [ARFCN]	point A [MHz]	absoluteFrequency PointA [ARFCN]	offsetToCarrier [Carrier PRBs]	SS block SCS [kHz]	GSCN	absoluteFrequency SSB [ARFCN]	$k_{SSB}$	Offset Carrier CORE SET#0 [RBs] Note 3	CORE SET#0 Index (Offset [RBs]) Note 4	offsetToPoint A (SIB1) [PRBs] Note 4

4.3.1.2.3.4.2 CA\_n260C

Editor's note: CA\_n260C Test frequencies are FFS.

Table 4.3.1.2.3.4.2-1: NR Intra-Band contiguous CA configuration CA\_n260C (PCC=CC1 and SCC=CC2, CC3), SCS=120 kHz, nominal channel spacing

CBW combination	CC	CBW [MHz]	SCS [kHz]	carrier Band width [PRBs]	Range	Carrier centre [MHz] Note 2	Carrier centre [ARFCN]	point A [MHz]	absoluteFrequency PointA [ARFCN]	offsetToCarrier [Carrier PRBs]	SS block SCS [kHz]	GSCN	absoluteFrequency SSB [ARFCN]	$k_{SSB}$	Offset Carrier CORE SET#0 [RBs]	CORE SET#0 Index (Offset [RBs])	offsetToPoint A (SIB1) [PRBs]

				<i>J</i>							<i>er</i> [PRBs]					[RBs] Note 3	t [RBs] Note 4	[PRBs] ] Note 4

4.3.1.2.3.4.3 CA\_n260D

Editor's note: CA\_n260D Test frequencies are FFS.

Table 4.3.1.2.3.4.3-1: NR Intra-Band contiguous CA configuration CA\_n260D (PCC=CC1 and SCC=CC2), SCS=60 kHz, nominal channel spacing

CBW combinati on	CC	CBW [MHz]	SCS [kHz]	<i>carrierB</i> <i>andwidd</i> <i>h</i> [PRBs]	Range	Carrier centre [MHz] Note 2	Carrier centre [ARFCN]	point A [MHz]	<i>absoluteF</i> <i>requency</i> <i>PointA</i> [ARFCN]	<i>offsetT</i> <i>oCarrie</i> <i>r</i> [Carrier PRBs]	SS block SCS [kHz]	GSCN	<i>absoluteF</i> <i>requency</i> <i>SSB</i> [ARFCN]	<i>k<sub>SSB</sub></i>	Offset Carrier CORES ET#0 [RBs] Note 3	CORE SET#0 Index (Offse t [RBs]) Note 4	offsetT oPoint A (SIB1) [PRBs] Note 4

Table 4.3.1.2.3.4.3-2: NR Intra-Band contiguous CA configuration CA\_n260D (PCC=CC1 and SCC=CC2), SCS=120 kHz, nominal channel spacing

CBW combinati on	CC	CBW [MHz]	SCS [kHz]	<i>carrierB</i> <i>andwidd</i> <i>h</i> [PRBs]	Range	Carrier centre [MHz] Note 2	Carrier centre [ARFCN]	point A [MHz]	<i>absoluteF</i> <i>requency</i> <i>PointA</i> [ARFCN]	<i>offsetT</i> <i>oCarrie</i> <i>r</i> [Carrier PRBs]	SS block SCS [kHz]	GSCN	<i>absoluteF</i> <i>requency</i> <i>SSB</i> [ARFCN]	<i>k<sub>SSB</sub></i>	Offset Carrier CORES ET#0 [RBs] Note 3	CORE SET#0 Index (Offse t [RBs]) Note 4	offsetT oPoint A (SIB1) [PRBs] Note 4

4.3.1.2.3.4.4 CA\_n260E

Table 4.3.1.2.3.4.4-1: NR Intra-Band contiguous CA configuration CA\_n260E (PCC=CC1 and SCC=CC2), SCS=60 kHz, nominal channel spacing

FFS

Table 4.3.1.2.3.4.4-2: NR Intra-Band contiguous CA configuration CA\_n260E (PCC=CC1 and SCC=CC2), SCS=120 kHz, nominal channel spacing

FFS

4.3.1.2.3.4.5 CA\_n260F

Table 4.3.1.2.3.4.5-1: NR Intra-Band contiguous CA configuration CA\_n260F (PCC=CC1 and SCC=CC2), SCS=60 kHz, nominal channel spacing

FFS

Table 4.3.1.2.3.4.5-2: NR Intra-Band contiguous CA configuration CA\_n260F (PCC=CC1 and SCC=CC2), SCS=120 kHz, nominal channel spacing

FFS

4.3.1.2.3.4.6 CA\_n260G

Table 4.3.1.2.3.4.6-1: NR Intra-Band contiguous CA configuration CA\_n260G (PCC=CC1 and SCC=CC2), SCS=60 kHz, nominal channel spacing

CBW combination	CC	CBW [MHz]	SCS [kHz]	carrier Bandwidth [PRBs]	Range		Carrier centre [MHz] Note 2	Carrier centre [ARFCN]	point A [MHz]	absolute Frequency Point A [ARFCN]	offsetToCarrier [Carrier PRBs]	SS block SCS [kHz]	GSCN	absolute Frequency SSB [ARFCN]	$k_{SSB}$	Offset Carrier CORESET#0 [RBs] Note 3	CORESET#0 Index (Offset [RBs]) Note 4	offsetToPoint A (SIB1) [PRBs] Note 4	
					Downlink & Uplink														
50+100	CC1	50	60	66	Downlink & Uplink	Low	37025.04	2229583	37001.28	2229187	0	120	22995	2229499	0	6	0 (0)	6	
						Mid	38449.92	2253331	38352.72	2251711	102		23078	2253403	0	11	1 (8)	121	
						High	39875.52	2277091	39488.88	2270647	504		23160	2277019	0	7	0 (0)	511	
	Channel spacing CC1-CC2=74.4 MHz (Note 1)																		
	CC2	100	60	132	Downlink & Uplink	Low	37099.44	2230823	37051.92	2230031	0	120	22998	2230363	8	7	0 (0)	7	
						Mid	38524.32	2254571	38403.36	2252555	102		23081	2254267	8	12	1 (8)	122	
						High	39949.92	2278331	39539.52	2271491	504		23163	2277883	8	0	1 (8)	512	
	100+100	CC1	100	60	132	Downlink & Uplink	Low	37050	2229999	37002.48	2229207	0	120	22995	2229499	4	4	0 (0)	4
							Mid	38449.92	2253331	38328.96	2251315	102		23076	2252827	0	4	0 (0)	106
High							39849.96	2276665	39439.56	2269825	504	23157		2276155	6	3	0 (0)	507	
Channel spacing CC1-CC2=99.96 MHz (Note 1)																			
CC2		100	60	132	Downlink & Uplink	Low	37149.96	2231665	37102.44	2230873	0	120	23001	2231227	6	1	1 (8)	9	
						Mid	38549.88	2254997	38428.92	2252981	102		23082	2254555	2	1	1 (8)	111	
						High	39949.92	2278331	39539.52	2271491	504		23163	2277883	8	0	1 (8)	512	

- Note 1: Corresponds to nominal channel spacing in accordance with TS 38.101-2 [8], clause 5.4A.1 for the channel bandwidths of the two respective NR component carriers.
- Note 2: CCs are specified in increasing frequency order. CC1 is used as PCell if nothing else is specified in the test case.
- Note 3: The parameter Offset Carrier CORESET#0 specifies the offset from the lowest subcarrier of the carrier and the lowest subcarrier of CORESET#0. It corresponds to the parameter  $\Delta F_{\text{OffsetCORESET-0-Carrier}}$  in Annex C expressed in number of common RBs.
- Note 4: The CORESET#0 Index and the associated CORESET#0 Offset refers to Table 13-7 in TS 38.213 [22]. The value of CORESET#0 Index is signalled in controlResourceSetZero (pdcch-ConfigSIB1) in the MIB. The offsetToPointA IE is expressed in units of resource blocks assuming 15 kHz subcarrier spacing for FR1 and 60 kHz subcarrier spacing for FR2.

Table 4.3.1.2.3.4.6-2: NR Intra-Band contiguous CA configuration CA\_n260G (PCC=CC1 and SCC=CC2), SCS=120 kHz, nominal channel spacing

CBW combination	CC	CBW [MHz]	SCS [kHz]	carrier bandwidth [PRBs]	Range		Carrier centre [MHz] Note 2	Carrier centre [ARFCN]	point A [MHz]	absolute frequency PointA [ARFCN]	offsetToCarrier [Carrier PRBs]	SS block SCS [kHz]	GSCN	absolute frequency SSB [ARFCN]	$k_{SSB}$	Offset Carrier CORESET#0 [RBs] Note 3	CORE SET#0 Index (Offset [RBs]) Note 1	offsetToPointA (SIB1) [PRBs] Note 1	
					Downlink & Uplink	Low Mid High													
50+100	CC1	50	120	32	Downlink & Uplink	Low	37025.04	2229583	37002	2229199	0	120	22995	2229499	6	2	0 (0)	4	
						Mid	38450.04	2253333	38280.12	2250501	102		23078	2253403	11	4	1 (4)	220	
						High	39875.52	2277091	39126.72	2264611	504		23160	2277019	0	3	0 (0)	1014	
	Channel spacing CC1-CC2=74.4 MHz (Note 1)																		
	CC2	100	120	66	Downlink & Uplink	Low	37099.44	2230823	37051.92	2230031	0	120	22998	2230363	10	3	0 (0)	6	
						Mid	38524.44	2254573	38330.04	2251333	102		23081	2254267	3	6	1 (4)	224	
						High	39949.92	2278331	39176.64	2265443	504		23163	2277883	4	0	1 (4)	1016	
	100+100	CC1	100	120	66	Downlink & Uplink	Low	37050	2229999	37002.48	2229207	0	120	22995	2229499	2	2	0 (0)	4
							Mid	38450.04	2253333	38255.64	2250093	102		23076	2252827	11	1	0 (0)	206
							High	39849.96	2276665	39076.68	2263777	504		23157	2276155	9	1	0 (0)	1010
Channel spacing CC1-CC2=99.96 MHz (Note 1)																			
CC2		100	120	66	Downlink & Uplink	Low	37149.96	2231665	37102.44	2230873	0	120	23001	2231227	9	0	1 (4)	8	
						Mid	38550	2254999	38355.6	2251759	102		23082	2254555	6	0	1 (4)	212	
						High	39949.92	2278331	39176.64	2265443	504		23163	2277883	4	0	1 (4)	1016	
Note 1: Corresponds to nominal channel spacing in accordance with TS 38.101-2 [8], clause 5.4A.1 for the channel bandwidths of the two respective NR component carriers.																			
Note 2: CCs are specified in increasing frequency order. CC1 is used as PCell if nothing else is specified in the test case.																			
Note 3: The parameter Offset Carrier CORESET#0 specifies the offset from the lowest subcarrier of the carrier and the lowest subcarrier of CORESET#0. It corresponds to the parameter $\Delta F_{\text{OffsetCORESET-0-Carrier}}$ in Annex C expressed in number of common RBs.																			
Note 4: The CORESET#0 Index and the associated CORESET#0 Offset refers to Table 13-8 in TS 38.213 [22]. The value of CORESET#0 Index is signalled in controlResourceSetZero (pdcch-ConfigSIB1) in the MIB. The offsetToPointA IE is expressed in units of resource blocks assuming 15 kHz subcarrier spacing for FR1 and 60 kHz subcarrier spacing for FR2.																			

4.3.1.2.3.4.7 CA\_n260H

Table 4.3.1.2.3.4.7-1: NR Intra-Band contiguous CA configuration CA\_n260H (PCC=CC1 and SCC=CC2, CC3), SCS=60 kHz, nominal channel spacing

CBW combination	CC	CBW [MHz]	SCS [kHz]	carrier bandwidth [PRBs]	Range		Carrier centre [MHz] Note 2	Carrier centre [ARFCN]	point A [MHz]	absolute frequency PointA [ARFCN]	offsetToCarrier [Carrier PRBs]	SS block SCS [kHz]	GSCN	absolute frequency SSB [ARFCN]	$k_{SSB}$	Offset Carrier CORESET#0 [RBs] Note 3	CORE SET#0 Index (Offset [RBs]) Note 4	offsetToPointA (SIB1) [PRBs] Note 4
					Downlink & Uplink	Low Mid												
50+100 +100	CC1	50	60	66	Downlink & Uplink	Low	37025.04	2229583	37001.28	2229187	0	120	22995	2229499	0	6	0 (0)	6
						Mid	38400	2252499	38302.8	2250879	102		23075	2252539	4	8	1 (8)	118

					Uplink	High	39775.56	2275425	39388.92	2268981	504		23154	2275291	10	1	0 (0)	505	
Channel spacing CC1-CC2=74.4 MHz (Note 1)																			
CC2	100	60	132	Downlink & Uplink	Low	37099.44	2230823	37051.92	2230031	0	120	22998	2230363	8	7	0 (0)	7		
					Mid	38474.4	2253739	38353.44	2251723	102		23078	2253403	0	10	1 (8)	120		
					High	39849.96	2276665	39439.56	2269825	504		23157	2276155	6	3	0 (0)	507		
Channel spacing CC2-CC3=99.96 MHz (Note 1)																			
CC3	100	60	132	Downlink & Uplink	Low	37199.4	2232489	37151.88	2231697	0	120	23004	2232091	10	4	1 (8)	12		
					Mid	38574.36	2255405	38453.4	2253389	102		23084	2255131	2	15	1 (8)	125		
					High	39949.92	2278331	39539.52	2271491	504		23163	2277883	8	0	1 (8)	512		
100+100 +100	CC1	100	60	132	Downlink & Uplink	Low	37050	2229999	37002.48	2229207	0	120	22995	2229499	4	4	0 (0)	4	
						Mid	38400	2252499	38279.04	2250483	102		23073	2251963	4	1	0 (0)	103	
						High	39750	2274999	39339.6	2268159	504		23152	2274715	4	14	1 (8)	526	
Channel spacing CC1-CC2=99.96 MHz (Note 1)																			
CC2	100	60	132	Downlink & Uplink	Low	37149.96	2231665	37102.44	2230873	0	120	23001	2231227	6	1	1 (8)	9		
					Mid	38499.96	2254165	38379	2252149	102		23079	2253691	6	6	0 (0)	108		
					High	39849.96	2276665	39439.56	2269825	504		23157	2276155	6	3	0 (0)	507		
Channel spacing CC2-CC3=99.96 MHz (Note 1)																			
CC3	100	60	132	Downlink & Uplink	Low	37249.92	2233331	37202.4	2232539	0	120	23007	2232955	8	6	1 (8)	14		
					Mid	38599.92	2255831	38478.96	2253815	102		23085	2255419	8	3	1 (8)	113		
					High	39949.92	2278331	39539.52	2271491	504		23163	2277883	8	0	1 (8)	512		

Note 1: Corresponds to nominal channel spacing in accordance with TS 38.101-2 [8], clause 5.4A.1 for the channel bandwidths of the two respective NR component carriers.

Note 2: CCs are specified in increasing frequency order. CC1 is used as PCell if nothing else is specified in the test case.

Note 3: The parameter Offset Carrier CORESET#0 specifies the offset from the lowest subcarrier of the carrier and the lowest subcarrier of CORESET#0. It corresponds to the parameter  $\Delta F_{\text{OffsetCORESET}0\text{-Carrier}}$  in Annex C expressed in number of common RBs.

Note 4: The CORESET#0 Index and the associated CORESET#0 Offset refers to Table 13-7 in TS 38.213 [22]. The value of CORESET#0 Index is signalled in controlResourceSetZero (pdcch-ConfigSIB1) in the MIB. The offsetToPointA IE is expressed in units of resource blocks assuming 15 kHz subcarrier spacing for FR1 and 60 kHz subcarrier spacing for FR2.

Table 4.3.1.2.3.4.7-2: NR Intra-Band contiguous CA configuration CA\_n260H (PCC=CC1 and SCC=CC2, CC3), SCS=120 kHz, nominal channel spacing

CBW combination	CC	CBW [MHz]	SCS [kHz]	carrierBandwidth [PRBs]	Range	Carrier centre [MHz] Note 2	Carrier centre [ARFCN]	point A [MHz]	absoluteFrequencyPointA [ARFCN]	offsetToCarrier [Carrier PRBs]	SS block SCS [kHz]	GSCN	absoluteFrequencySSB [ARFCN]	$k_{\text{SSB}}$	Offset Carrier CORESET#0 [RBs] Note 3	CORE SET#0 Index (Offset [RBs]) Note 4	offsetToPointA [PRBs] Note 4	
50+100 +100	CC1	50	120	32	Downlink & Uplink	Low	37025.04	2229583	37002	2229199	0	120	22995	2229499	6	2	0 (0)	4
						Mid	38400	2252499	38230.08	2249667	102		23075	2252539	8	3	1 (4)	218
						High	39775.56	2275425	39026.76	2262945	504		23154	2275291	5	0	0 (0)	1008
Channel spacing CC1-CC2=74.4 MHz (Note 1)																		
CC2	100	120	66	Downlink & Uplink	Low	37099.44	2230823	37051.92	2230031	0	120	22998	2230363	10	3	0 (0)	6	
					Mid	38474.4	2253739	38280	2250499	102		23078	2253403	0	5	1 (4)	222	
					High	39849.96	2276665	39076.68	2263777	504		23157	2276155	9	1	0 (0)	1010	

Channel spacing CC2-CC3=99.96 MHz (Note 1)																		
100+100 +100	CC3	100	120	66	Downlink & Uplink	Low	37199.4	2232489	37151.88	2231697	0	120	23004	2232091	5	2	1 (4)	12
						Mid	38574.36	2255405	38379.96	2252165	102		23084	2255131	7	7	1 (4)	226
						High	39949.92	2278331	39176.64	2265443	504		23163	2277883	4	0	1 (4)	1016
	CC1	100	120	66	Downlink & Uplink	Low	37050	2229999	37002.48	2229207	0	120	22995	2229499	2	2	0 (0)	4
						Mid	38400	2252499	38205.6	2249259	102		23073	2251963	8	0	0 (0)	204
						High	39750	2274999	38976.72	2262111	504		23152	2274715	2	7	1 (4)	1030
	Channel spacing CC1-CC2=99.96 MHz (Note 1)																	
	CC2	100	120	66	Downlink & Uplink	Low	37149.96	2231665	37102.44	2230873	0	120	23001	2231227	9	0	1 (4)	8
						Mid	38499.96	2254165	38305.56	2250925	102		23079	2253691	3	3	0 (0)	210
						High	39849.96	2276665	39076.68	2263777	504		23157	2276155	9	1	0 (0)	1010
	Channel spacing CC2-CC3=99.96 MHz (Note 1)																	
	CC3	100	120	66	Downlink & Uplink	Low	37249.92	2233331	37202.4	2232539	0	120	23007	2232955	4	3	1 (4)	14
Mid						38599.92	2255831	38405.52	2252591	102	23085		2255419	10	1	1 (4)	214	
High						39949.92	2278331	39176.64	2265443	504	23163		2277883	4	0	1 (4)	1016	

Note 1: Corresponds to nominal channel spacing in accordance with TS 38.101-2 [8], clause 5.4A.1 for the channel bandwidths of the two respective NR component carriers.

Note 2: CCs are specified in increasing frequency order. CC1 is used as PCell if nothing else is specified in the test case.

Note 3: The parameter Offset Carrier CORESET#0 specifies the offset from the lowest subcarrier of the carrier and the lowest subcarrier of CORESET#0. It corresponds to the parameter  $\Delta F_{\text{OffsetCORESET}0\text{-Carrier}}$  in Annex C expressed in number of common RBs.

Note 4: The CORESET#0 Index and the associated CORESET#0 Offset refers to Table 13-8 in TS 38.213 [22]. The value of CORESET#0 Index is signalled in controlResourceSetZero (pdcch-ConfigSIB1) in the MIB. The offsetToPointA IE is expressed in units of resource blocks assuming 15 kHz subcarrier spacing for FR1 and 60 kHz subcarrier spacing for FR2.

4.3.1.2.3.4.8 CA\_n260I

Table 4.3.1.2.3.4.8-1: NR Intra-Band contiguous CA configuration CA\_n260I (PCC=CC1, SCC=CC2, CC3, CC4), SCS=60 kHz, nominal channel spacing

CBW combination	CC	CBW [MHz]	SCS [kHz]	carrierBandwidth [PRBs]	Range	Carrier centre [MHz] Note 2	Carrier centre [ARFCN]	point A [MHz]	absoluteFrequencyPointA [ARFCN]	offsetToCarrier [Carrier PRBs]	SS block SCS [kHz]	GSCN	absoluteFrequencySSB [ARFCN]	$k_{SSB}$	Offset Carrier CORESET#0 [RBs] Note 3	CORE SET#0 Index (Offset [RBs]) Note 4	offsetToPointA (SIB1) [PRBs] Note 4	
50+100 +100+100	CC1	50	60	66	Downlink & Uplink	Low	37025.04	2229583	37001.28	2229187	0	120	22995	2229499	0	6	0 (0)	6
						Mid	38349.96	2251665	38252.76	2250045	102		23072	2251675	10	5	1 (8)	115
						High	39675.6	2273759	39288.96	2267315	504		23149	2273851	8	12	1 (8)	524
	Channel spacing CC1-CC2=74.4 MHz (Note 1)																	
	CC2	100	60	132	Downlink & Uplink	Low	37099.44	2230823	37051.92	2230031	0	120	22998	2230363	8	7	0 (0)	7
						Mid	38424.36	2252905	38303.4	2250889	102		23075	2252539	6	7	1 (8)	117
						High	39750	2274999	39339.6	2268159	504		23152	2274715	4	14	1 (8)	526
	Channel spacing CC2-CC3=99.96 MHz (Note 1)																	
	CC3	100	60	132	Downlink & Uplink	Low	37199.4	2232489	37151.88	2231697	0	120	23004	2232091	10	4	1 (8)	12
						Mid	38524.32	2254571	38403.36	2252555	102		23081	2254267	8	12	1 (8)	122

					Uplink	High	39849.96	2276665	39439.56	2269825	504		23157	2276155	6	3	0 (0)	507	
Channel spacing CC3-CC4=99.96 MHz (Note 1)																			
CC4	100	60	132	Downlink & Uplink	Low	37299.36	2234155	37251.84	2233363	0	120	23010	2233819	0	10	1 (8)	18		
					Mid	38624.28	2256237	38503.32	2254221	102	23086	2255707	10	1	0 (0)	103			
					High	39949.92	2278331	39539.52	2271491	504	23163	2277883	8	0	1 (8)	512			
100+100 +100+100	CC1	100	60	132	Downlink & Uplink	Low	37050	2229999	37002.48	2229207	0	120	22995	2229499	4	4	0 (0)	4	
						Mid	38349.96	2251665	38229	2249649	102	23071	2251387	10	14	1 (8)	124		
						High	39650.04	2273333	39239.64	2266493	504	23146	2272987	2	9	1 (8)	521		
Channel spacing CC1-CC2=99.96 MHz (Note 1)																			
CC2	100	60	132	Downlink & Uplink	Low	37149.96	2231665	37102.44	2230873	0	120	23001	2231227	6	1	1 (8)	9		
					Mid	38449.92	2253331	38328.96	2251315	102	23076	2252827	0	4	0 (0)	106			
					High	39750	2274999	39339.6	2268159	504	23152	2274715	4	14	1 (8)	526			
Channel spacing CC2-CC3=99.96 MHz (Note 1)																			
CC3	100	60	132	Downlink & Uplink	Low	37249.92	2233331	37202.4	2232539	0	120	23007	2232955	8	6	1 (8)	14		
					Mid	38549.88	2254997	38428.92	2252981	102	23082	2254555	2	1	1 (8)	111			
					High	39849.96	2276665	39439.56	2269825	504	23157	2276155	6	3	0 (0)	507			
Channel spacing CC3-CC4=99.96 MHz (Note 1)																			
CC4	100	60	132	Downlink & Uplink	Low	37349.88	2234997	37302.36	2234205	0	120	23013	2234683	10	11	1 (8)	19		
					Mid	38649.84	2256663	38528.88	2254647	102	23088	2256283	4	6	1 (8)	116			
					High	39949.92	2278331	39539.52	2271491	504	23163	2277883	8	0	1 (8)	512			

- Note 1: Corresponds to nominal channel spacing in accordance with TS 38.101-2 [8], clause 5.4A.1 for the channel bandwidths of the two respective NR component carriers.
- Note 2: CCs are specified in increasing frequency order. CC1 is used as PCell if nothing else is specified in the test case.
- Note 3: The parameter Offset Carrier CORESET#0 specifies the offset from the lowest subcarrier of the carrier and the lowest subcarrier of CORESET#0. It corresponds to the parameter  $\Delta F_{\text{OffsetCORESET-0-Carrier}}$  in Annex C expressed in number of common RBs.
- Note 4: The CORESET#0 Index and the associated CORESET#0 Offset refers to Table 13-7 in TS 38.213 [22]. The value of CORESET#0 Index is signalled in controlResourceSetZero (pdcch-ConfigSIB1) in the MIB. The offsetToPointA IE is expressed in units of resource blocks assuming 15 kHz subcarrier spacing for FR1 and 60 kHz subcarrier spacing for FR2.

Table 4.3.1.2.3.4.8-2: NR Intra-Band contiguous CA configuration CA\_n260I (PCC=CC1, SCC=CC2, CC3,CC4), SCS=120 kHz, nominal channel spacing

CBW combination	CC	CBW [MHz]	SCS [kHz]	carrierBandwidth [PRBs]	Range	Carrier centre [MHz] Note 2	Carrier centre [ARFCN]	point A [MHz]	absoluteFrequencyPointA [ARFCN]	offsetToCarrier [Carrier PRBs]	SS block SCS [kHz]	GSCN	absoluteFrequencySSB [ARFCN]	$k_{SSB}$	Offset Carrier CORESET#0 [RBs] Note 3	CORE SET#0 Index (Offset [RBs]) Note 4	offsetToPointA [PRBs] Note 4	
50+100 +100+100	CC1	50	120	32	Downlink & Uplink	Low	37025.04	2229583	37002	2229199	0	120	22995	2229499	6	2	0 (0)	4
						Mid	38349.96	2251665	38180.04	2248833	102	23072	2251675	5	2	1 (4)	216	
						High	39675.6	2273759	38926.8	2261279	504	23149	2273851	10	5	1 (4)	1026	
Channel spacing CC1-CC2=74.4 MHz (Note 1)																		
CC2	100	120	66	Downlink & Uplink	Low	37099.44	2230823	37051.92	2230031	0	120	22998	2230363	10	3	0 (0)	6	
					Mid	38424.36	2252905	38229.96	2249665	102	23075	2252539	9	3	1 (4)	218		
					High	39750	2274999	38976.72	2262111	504	23152	2274715	2	7	1 (4)	1030		



Channel spacing CC2-CC3=99.96 MHz (Note 1)																		
CC3	100	120	66	Downlink & Uplink	Low	37199.4	2232489	37151.88	2231697	0	120	23004	2232091	5	2	1 (4)	12	
					Mid	38524.32	2254571	38329.92	2251331	102		23081	2254267	4	6	1 (4)	224	
					High	39849.96	2276665	39076.68	2263777	504		23157	2276155	9	1	0 (0)	1010	
Channel spacing CC3-CC4=99.96 MHz (Note 1)																		
CC4	100	120	66	Downlink & Uplink	Low	37299.36	2234155	37251.84	2233363	0	120	23010	2233819	0	5	1 (4)	18	
					Mid	38624.28	2256237	38429.88	2252997	102		23086	2255707	11	0	0 (0)	204	
					High	39949.92	2278331	39176.64	2265443	504		23163	2277883	4	0	1 (4)	1016	
100+100 +100+100	CC1	100	120	66	Downlink & Uplink	Low	37050	2229999	37002.48	2229207	0	120	22995	2229499	2	2	0 (0)	4
						Mid	38349.96	2251665	38155.56	2248425	102		23071	2251387	5	7	1 (4)	226
						High	39650.04	2273333	38876.76	2260445	504		23146	2272987	7	4	1 (4)	1024
Channel spacing CC1-CC2=99.96 MHz (Note 1)																		
CC2	100	120	66	Downlink & Uplink	Low	37149.96	2231665	37102.44	2230873	0	120	23001	2231227	9	0	1 (4)	8	
					Mid	38449.92	2253331	38255.52	2250091	102		23076	2252827	0	2	0 (0)	208	
					High	39750	2274999	38976.72	2262111	504		23152	2274715	2	7	1 (4)	1030	
Channel spacing CC2-CC3=99.96 MHz (Note 1)																		
CC3	100	120	66	Downlink & Uplink	Low	37249.92	2233331	37202.4	2232539	0	120	23007	2232955	4	3	1 (4)	14	
					Mid	38549.88	2254997	38355.48	2251757	102		23082	2254555	7	0	1 (4)	212	
					High	39849.96	2276665	39076.68	2263777	504		23157	2276155	9	1	0 (0)	1010	
Channel spacing CC3-CC4=99.96 MHz (Note 1)																		
CC4	100	120	66	Downlink & Uplink	Low	37349.88	2234997	37302.36	2234205	0	120	23013	2234683	11	5	1 (4)	18	
					Mid	38649.84	2256663	38455.44	2253423	102		23088	2256283	2	3	1 (4)	218	
					High	39949.92	2278331	39176.64	2265443	504		23163	2277883	4	0	1 (4)	1016	

Note 1: Corresponds to nominal channel spacing in accordance with TS 38.101-2 [8], clause 5.4A.1 for the channel bandwidths of the two respective NR component carriers.

Note 2: CCs are specified in increasing frequency order. CC1 is used as PCell if nothing else is specified in the test case.

Note 3: The parameter Offset Carrier CORESET#0 specifies the offset from the lowest subcarrier of the carrier and the lowest subcarrier of CORESET#0. It corresponds to the parameter  $\Delta F_{\text{OffsetCORESET-0-Carrier}}$  in Annex C expressed in number of common RBs.

Note 4: The CORESET#0 Index and the associated CORESET#0 Offset refers to Table 13-8 in TS 38.213 [22]. The value of CORESET#0 Index is signalled in controlResourceSetZero (pdcch-ConfigSIB1) in the MIB. The offsetToPointA IE is expressed in units of resource blocks assuming 15 kHz subcarrier spacing for FR1 and 60 kHz subcarrier spacing for FR2.

4.3.1.2.3.4.9 CA\_n260J

Table 4.3.1.2.3.4.9-1: NR Intra-Band contiguous CA configuration CA\_n260J (PCC=CC1, SCC=CC2, CC3, CC4, CC5), SCS=60 kHz, nominal channel spacing

CBW combination	CC	CBW [MHz]	SCS [kHz]	carrierBandwidth [PRBs]	Range	Carrier centre [MHz] Note 2	Carrier centre [ARFCN]	point A [MHz]	absoluteFrequencyPointA [ARFCN]	offsetToCarrier [Carrier PRBs]	SS block SCS [kHz]	GSCN	absoluteFrequencySSB [ARFCN]	$k_{SSB}$	Offset Carrier CORESET#0 [RBs] Note 3	CORE SET#0 Index Note 4	offsetToPointA [PRBs] Note 4	
50+100 +100+100	CC1	50	60	66	Downlink &	Low	37025.04	2229583	37001.28	2229187	0	120	22995	2229499	0	6	0 (0)	6
						Mid	38299.92	2250831	38202.72	2249211	102		23069	2250811	4	3	1 (8)	113

+100					Uplink	High	39575.64	2272093	39189	2265649	504		23143	2272123	6	7	1 (8)	519	
	Channel spacing CC1-CC2=74.4 MHz (Note 1)																		
	CC2	100	60	132	Downlink & Uplink	Low	37099.44	2230823	37051.92	2230031	0	120	22998	2230363	8	7	0 (0)	7	
						Mid	38374.32	2252071	38253.36	2250055	102		23072	2251675	0	5	1 (8)	115	
						High	39650.04	2273333	39239.64	2266493	504		23146	2272987	2	9	1 (8)	521	
	Channel spacing CC2-CC3=99.96 MHz (Note 1)																		
	CC3	100	60	132	Downlink & Uplink	Low	37199.4	2232489	37151.88	2231697	0	120	23004	2232091	10	4	1 (8)	12	
						Mid	38474.28	2253737	38353.32	2251721	102		23078	2253403	2	10	1 (8)	120	
						High	39750	2274999	39339.6	2268159	504		23152	2274715	4	14	1 (8)	526	
	Channel spacing CC3-CC4=99.96 MHz (Note 1)																		
	CC4	100	60	132	Downlink & Uplink	Low	37299.36	2234155	37251.84	2233363	0	120	23010	2233819	0	10	1 (8)	18	
						Mid	38574.24	2255403	38453.28	2253387	102		23084	2255131	4	15	1 (8)	125	
						High	39849.96	2276665	39439.56	2269825	504		23157	2276155	6	3	0 (0)	507	
	Channel spacing CC4-CC5=99.96 MHz (Note 1)																		
	CC5	100	60	132	Downlink & Uplink	Low	37399.32	2235821	37351.8	2235029	0	120	23016	2235547	2	15	1 (8)	23	
Mid						38674.2	2257069	38553.24	2255053	102	23089		2256571	6	4	0 (0)	106		
High						39949.92	2278331	39539.52	2271491	504	23163		2277883	8	0	1 (8)	512		
100+100 +100+100 +100	CC1	100	60	132	Downlink & Uplink	Low	37050	2229999	37002.48	2229207	0	120	22995	2229499	4	4	0 (0)	4	
						Mid	38299.92	2250831	38178.96	2248815	102		23068	2250523	4	12	1 (8)	122	
						High	39550.08	2271667	39139.68	2264827	504		23140	2271259	0	4	1 (8)	516	
	Channel spacing CC1-CC2=99.96 MHz (Note 1)																		
	CC2	100	60	132	Downlink & Uplink	Low	37149.96	2231665	37102.44	2230873	0	120	23001	2231227	6	1	1 (8)	9	
						Mid	38399.88	2252497	38278.92	2250481	102		23073	2251963	6	1	0 (0)	103	
						High	39650.04	2273333	39239.64	2266493	504		23146	2272987	2	9	1 (8)	521	
	Channel spacing CC2-CC3=99.96 MHz (Note 1)																		
	CC3	100	60	132	Downlink & Uplink	Low	37249.92	2233331	37202.4	2232539	0	120	23007	2232955	8	6	1 (8)	14	
						Mid	38499.84	2254163	38378.88	2252147	102		23079	2253691	8	6	0 (0)	108	
						High	39750	2274999	39339.6	2268159	504		23152	2274715	4	14	1 (8)	526	
	Channel spacing CC3-CC4=99.96 MHz (Note 1)																		
	CC4	100	60	132	Downlink & Uplink	Low	37349.88	2234997	37302.36	2234205	0	120	23013	2234683	10	11	1 (8)	19	
						Mid	38599.8	2255829	38478.84	2253813	102		23085	2255419	10	3	1 (8)	113	
						High	39849.96	2276665	39439.56	2269825	504		23157	2276155	6	3	0 (0)	507	
Channel spacing CC4-CC5=99.96 MHz (Note 1)																			
CC5	100	60	132	Downlink & Uplink	Low	37449.84	2236663	37402.32	2235871	0	120	23018	2236123	0	1	0 (0)	1		
					Mid	38699.76	2257495	38578.8	2255479	102		23091	2257147	0	9	1 (8)	119		
					High	39949.92	2278331	39539.52	2271491	504		23163	2277883	8	0	1 (8)	512		
Note 1:	Corresponds to nominal channel spacing in accordance with TS 38.101-2 [8], clause 5.4A.1 for the channel bandwidths of the two respective NR component carriers.																		
Note 2:	CCs are specified in increasing frequency order. CC1 is used as PCell if nothing else is specified in the test case.																		
Note 3:	The parameter Offset Carrier CORESET#0 specifies the offset from the lowest subcarrier of the carrier and the lowest subcarrier of CORESET#0. It corresponds to the parameter $\Delta F_{\text{OffsetCORESET-0-Carrier}}$ in Annex C expressed in number of common RBs.																		
Note 4:	The CORESET#0 Index and the associated CORESET#0 Offset refers to Table 13-7 in TS 38.213 [22]. The value of CORESET#0 Index is signalled in controlResourceSetZero (pdcch-ConfigSIB1) in the MIB. The offsetToPointA IE is expressed in units of resource blocks assuming 15 kHz subcarrier spacing for FR1 and 60 kHz subcarrier spacing for FR2.																		

Table 4.3.1.2.3.4.9-2: NR Intra-Band contiguous CA configuration CA\_n260J (PCC=CC1, SCC=CC2, CC3, CC4, CC5), SCS=120 kHz, nominal channel spacing

CBW combination	CC	CBW [MHz]	SCS [kHz]	carrierBandwidth [PRBs]	Range	Carrier centre [MHz] Note 2	Carrier centre [ARFCN]	point A [MHz]	absoluteFrequencyPointA [ARFCN]	offsetToCarrier [Carrier PRBs]	SS block SCS [kHz]	GSCN	absoluteFrequencySSB [ARFCN]	$k_{SSB}$	Offset Carrier CORESET#0 [RBs] Note 3	CORE SET#0 Index (Offset [RBs]) Note 4	offsetToPointA (SIB1) [PRBs] Note 4		
50+100 +100+100 +100	CC1	50	120	32	Downlink & Uplink	Low	37025.04	2229583	37002	2229199	0	120	22995	2229499	6	2	0 (0)	4	
						Mid	38300.04	2250833	38130.12	2248001	102		23069	2250811	1	1	1 (4)	214	
						High	39575.64	2272093	38826.84	2259613	504		23143	2272123	3	3	1 (4)	1022	
	Channel spacing CC1-CC2=74.4 MHz (Note 1)																		
	CC2	100	120	66	Downlink & Uplink	Low	37099.44	2230823	37051.92	2230031	0	120	22998	2230363	10	3	0 (0)	6	
						Mid	38374.44	2252073	38180.04	2248833	102		23072	2251675	5	2	1 (4)	216	
						High	39650.04	2273333	38876.76	2260445	504		23146	2272987	7	4	1 (4)	1024	
	Channel spacing CC2-CC3=99.96 MHz (Note 1)																		
	CC3	100	120	66	Downlink & Uplink	Low	37199.4	2232489	37151.88	2231697	0	120	23004	2232091	5	2	1 (4)	12	
						Mid	38474.4	2253739	38280	2250499	102		23078	2253403	0	5	1 (4)	222	
						High	39750	2274999	38976.72	2262111	504		23152	2274715	2	7	1 (4)	1030	
	Channel spacing CC3-CC4=99.96 MHz (Note 1)																		
	CC4	100	120	66	Downlink & Uplink	Low	37299.36	2234155	37251.84	2233363	0	120	23010	2233819	0	5	1 (4)	18	
						Mid	38574.36	2255405	38379.96	2252165	102		23084	2255131	7	7	1 (4)	226	
						High	39849.96	2276665	39076.68	2263777	504		23157	2276155	9	1	0 (0)	1010	
	Channel spacing CC4-CC5=99.96 MHz (Note 1)																		
	CC5	100	120	66	Downlink & Uplink	Low	37399.32	2235821	37351.8	2235029	0	120	23016	2235547	7	7	1 (4)	22	
						Mid	38674.32	2257071	38479.92	2253831	102		23089	2256571	2	2	0 (0)	208	
						High	39949.92	2278331	39176.64	2265443	504		23163	2277883	4	0	1 (4)	1016	
	100+100 +100+100 +100	CC1	100	120	66	Downlink & Uplink	Low	37050	2229999	37002.48	2229207	0	120	22995	2229499	2	2	0 (0)	4
Mid							38300.04	2250833	38105.64	2247593	102	23068		2250523	1	6	1 (4)	224	
High							39550.08	2271667	38776.8	2258779	504	23140		2271259	0	2	1 (4)	1020	
Channel spacing CC1-CC2=99.96 MHz (Note 1)																			
CC2		100	120	66	Downlink & Uplink	Low	37149.96	2231665	37102.44	2230873	0	120	23001	2231227	9	0	1 (4)	8	
						Mid	38400	2252499	38205.6	2249259	102		23073	2251963	8	0	0 (0)	204	
						High	39650.04	2273333	38876.76	2260445	504		23146	2272987	7	4	1 (4)	1024	
Channel spacing CC2-CC3=99.96 MHz (Note 1)																			
CC3		100	120	66	Downlink & Uplink	Low	37249.92	2233331	37202.4	2232539	0	120	23007	2232955	4	3	1 (4)	14	
						Mid	38499.96	2254165	38305.56	2250925	102		23079	2253691	3	3	0 (0)	210	
						High	39750	2274999	38976.72	2262111	504		23152	2274715	2	7	1 (4)	1030	
Channel spacing CC3-CC4=99.96 MHz (Note 1)																			
CC4		100	120	66	Downlink & Uplink	Low	37349.88	2234997	37302.36	2234205	0	120	23013	2234683	11	5	1 (4)	18	
						Mid	38599.92	2255831	38405.52	2252591	102		23085	2255419	10	1	1 (4)	214	
						High	39849.96	2276665	39076.68	2263777	504		23157	2276155	9	1	0 (0)	1010	

Channel spacing CC4-CC5=99.96 MHz (Note 1)																	
CC5	100	120	66	Downlink & Uplink	Low	37449.84	2236663	37402.32	2235871	0	120	23018	2236123	6	0	0 (0)	0
					Mid	38699.88	2257497	38505.48	2254257	102		23091	2257147	5	4	1 (4)	220
					High	39949.92	2278331	39176.64	2265443	504		23163	2277883	4	0	1 (4)	1016

- Note 1: Corresponds to nominal channel spacing in accordance with TS 38.101-2 [8], clause 5.4A.1 for the channel bandwidths of the two respective NR component carriers.
- Note 2: CCs are specified in increasing frequency order. CC1 is used as PCell if nothing else is specified in the test case.
- Note 3: The parameter Offset Carrier CORESET#0 specifies the offset from the lowest subcarrier of the carrier and the lowest subcarrier of CORESET#0. It corresponds to the parameter  $\Delta F_{\text{OffsetCORESET-0-Carrier}}$  in Annex C expressed in number of common RBs.
- Note 4: The CORESET#0 Index and the associated CORESET#0 Offset refers to Table 13-8 in TS 38.213 [22]. The value of CORESET#0 Index is signalled in controlResourceSetZero (pdcch-ConfigSIB1) in the MIB. The offsetToPointA IE is expressed in units of resource blocks assuming 15 kHz subcarrier spacing for FR1 and 60 kHz subcarrier spacing for FR2.

4.3.1.2.3.4.10 CA\_n260K

**Table 4.3.1.2.3.4.10-1: NR Intra-Band contiguous CA configuration CA\_n260K (PCC=CC1, SCC=CC2, CC3, CC4, CC5, CC6), SCS=60 kHz, nominal channel spacing**

CBW combination	C C	CB W [MHz]	SC S [kHz]	carrierBandwidth [PRBs]	Range	Carrier centre [MHz]	Carrier centre [ARFCN]	point A [MHz]	absoluteFrequencyPointA [ARFCN]	offsetToCarrier [Carrier PRBs]	SS block SCS [kHz]	GS CN	absoluteFrequencySSB [ARFCN]	$k_{SSB}$	Offset Carrier CORESET#0 [RBs]	CORESET#0 Index Note 4	offsetToPointA (SIB1) [PRBs] Note 4	
50+100 +100+100 +100+100	C C1	50	60	66	Downlink &	Low	37025.04	2229583	37001.28	2229187	0	120	22995	2229499	0	6	0 (0)	6
						Mid	38250.99	2249999	38152.8	2248379	102		23066	2249947	8	0	1 (8)	110
					Uplink	High	39475.68	2270427	39089.04	2263983	504		23137	2270395	4	2	1 (8)	514
Channel spacing CC1-CC2=74.4 MHz (Note 1)																		
	C C2	100	60	132	Downlink &	Low	37099.44	2230823	37051.92	2230031	0	120	22998	2230363	8	7	0 (0)	7
						Mid	38324.4	2251239	38203.44	2249223	102		23069	2250811	4	2	1 (8)	112
					Uplink	High	39550.08	2271667	39139.68	2264827	504		23140	2271259	0	4	1 (8)	516
Channel spacing CC2-CC3=99.96 MHz (Note 1)																		
	C C3	100	60	132	Downlink &	Low	37199.4	2232489	37151.88	2231697	0	120	23004	2232091	10	4	1 (8)	12
						Mid	38424.36	2252905	38303.4	2250889	102		23075	2252539	6	7	1 (8)	117
					Uplink	High	39650.04	2273333	39239.64	2266493	504		23146	2272987	2	9	1 (8)	521
Channel spacing CC3-CC4=99.96 MHz (Note 1)																		

C C4	100	60	132	Down link	Lo w	37299 .36	22341 55	37251 .84	2233363	0	120	230 10	2233819	0	10	1 (8)	18	
				&	Mid	38524 .32	22545 71	38403 .36	2252555	102		230 81	2254267	8	12	1 (8)	122	
				Uplink	Hig h	39750	22749 99	39339 .6	2268159	504		231 52	2274715	4	14	1 (8)	526	
Channel spacing CC4-CC5=99.96 MHz (Note 1)																		
C C5	100	60	132	Down link	Lo w	37399 .32	22358 21	37351 .8	2235029	0	120	230 16	2235547	2	15	1 (8)	23	
				&	Mid	38624 .28	22562 37	38503 .32	2254221	102		230 86	2255707	10	1	0 (0)	103	
				Uplink	Hig h	39849 .96	22766 65	39439 .56	2269825	504		231 57	2276155	6	3	0 (0)	507	
Channel spacing CC5-CC6=99.96 MHz (Note 1)																		
C C6	100	60	132	Down link	Lo w	37499 .28	22374 87	37451 .76	2236695	0	120	230 21	2236987	4	4	0 (0)	4	
				&	Mid	38724 .24	22579 03	38603 .28	2255887	102		230 92	2257435	0	7	0 (0)	109	
				Uplink	Hig h	39949 .92	22783 31	39539 .52	2271491	504		231 63	2277883	8	0	1 (8)	512	
100+100 +100+100 +100+100	C C1	100	60	132	Down link	Lo w	37050	22299 99	37002 .48	2229207	0	120	229 95	2229499	4	4	0 (0)	4
					&	Mid	38250	22499 99	38129 .04	2247983	102		230 65	2249659	8	9	1 (8)	119
					Uplink	Hig h	39450 .12	22700 01	39039 .72	2263161	504		231 34	2269531	10	6	0 (0)	510
Channel spacing CC1-CC2=99.96 MHz (Note 1)																		
C C2	100	60	132	Down link	Lo w	37149 .96	22316 65	37102 .44	2230873	0	120	230 01	2231227	6	1	1 (8)	9	
				&	Mid	38349 .96	22516 65	38229 .96	2249649	102		230 71	2251387	10	14	1 (8)	124	
				Uplink	Hig h	39550 .08	22716 67	39139 .68	2264827	504		231 40	2271259	0	4	1 (8)	516	
Channel spacing CC2-CC3=99.96 MHz (Note 1)																		
C C3	100	60	132	Down link	Lo w	37249 .92	22333 31	37202 .4	2232539	0	120	230 07	2232955	8	6	1 (8)	14	
				&	Mid	38449 .92	22533 31	38328 .96	2251315	102		230 76	2252827	0	4	0 (0)	106	
				Uplink	Hig h	39650 .04	22733 33	39239 .64	2266493	504		231 46	2272987	2	9	1 (8)	521	
Channel spacing CC3-CC4=99.96 MHz (Note 1)																		
C C4	100	60	132	Down link	Lo w	37349 .88	22349 97	37302 .36	2234205	0	120	230 13	2234683	10	11	1 (8)	19	
				&	Mid	38549 .88	22549 97	38428 .92	2252981	102		230 82	2254555	2	1	1 (8)	111	

				Uplink	High	39750	2274999	393396	2268159	504		23152	2274715	4	14	1 (8)	526
Channel spacing CC4-CC5=99.96 MHz (Note 1)																	
C C5	100	60	132	Downlink &	Low	3744984	2236663	3740232	2235871	0	120	23018	2236123	0	1	0 (0)	1
					Mid	3864984	2256663	3852888	2254647	102		23088	2256283	4	6	1 (8)	116
				Uplink	High	3984996	2276665	3943956	2269825	504		23157	2276155	6	3	0 (0)	507
Channel spacing CC5-CC6=99.96 MHz (Note 1)																	
C C6	100	60	132	Downlink &	Low	3754980	2238329	3750228	2237537	0	120	23024	2237851	2	6	0 (0)	6
					Mid	3874980	2258329	3862884	2256313	102		23094	2258011	6	11	1 (8)	121
				Uplink	High	3994992	2278331	3953952	2271491	504		23163	2277883	8	0	1 (8)	512
<p>Note 1: Corresponds to nominal channel spacing in accordance with TS 38.101-2 [8], clause 5.4A.1 for the channel bandwidths of the two respective NR component carriers.</p> <p>Note 2: CCs are specified in increasing frequency order. CC1 is used as PCell if nothing else is specified in the test case.</p> <p>Note 3: The parameter Offset Carrier CORESET#0 specifies the offset from the lowest subcarrier of the carrier and the lowest subcarrier of CORESET#0. It corresponds to the parameter <math>\Delta F_{\text{OffsetCORESET-0-Carrier}}</math> in Annex C expressed in number of common RBs.</p> <p>Note 4: The CORESET#0 Index and the associated CORESET#0 Offset refers to Table 13-7 in TS 38.213 [22]. The value of CORESET#0 Index is signalled in controlResourceSetZero (pdcch-ConfigSIB1) in the MIB. The offsetToPointA IE is expressed in units of resource blocks assuming 15 kHz subcarrier spacing for FR1 and 60 kHz subcarrier spacing for FR2.</p>																	

**Table 4.3.1.2.3.4.10-2: NR Intra-Band contiguous CA configuration CA\_n260K (PCC=CC1, SCC=CC2, CC3, CC4, CC5, CC6), SCS=120 kHz, nominal channel spacing**

CBW combination	C	CBW [MHz]	SCS [kHz]	carrierBandwidth [PRBs]	Range	Carrier centre [MHz] Note 2	Carrier centre [ARFCN]	point A [MHz]	absoluteFrequencyPointA [ARFCN]	offsetToCarrier [Carrier PRBs]	SS block SCS [kHz]	GS CN	absoluteFrequencySSB [ARFCN]	$k_{SSB}$	Offset Carrier CORESET#0 [RBs] Note 3	CORESET#0 Index (Offset [RBs]) Note 4	offsetToPointA (SIB1) [PRBs] Note 4	
50+100 +100+100 +100+100	C C1	50	120	32	Downlink &	Low	3702583	2229583	37002	2229199	0	120	22995	2229499	6	2	0 (0)	4
						Mid	3825099	2249999	3808008	2247167	102		23066	2249947	10	3	0 (0)	210
					Uplink	High	3947568	2270427	3872688	2257947	504		23137	2270395	8	0	1 (4)	1016
Channel spacing CC1-CC2=74.4 MHz (Note 1)																		
C C2	100	120	66	Downlink &	Low	3709944	2230823	3705192	2230031	0	120	22998	2230363	10	3	0 (0)	6	
					Mid	38324	22512	38130	2247999	102		230	2250811	2	1	1 (4)	214	

				Uplink	d	.4	39				69							
					High	39550.08	2271667	38776.8	2258779	504	23140	2271259	0	2	1 (4)	1020		
Channel spacing CC2-CC3=99.96 MHz (Note 1)																		
C C3	100	120	66	Downlink &	Low	37199.4	2232489	37151.88	2231697	0	120	23004	2232091	5	2	1 (4)	12	
					Mid	38424.36	2252905	38229.96	2249665	102		23075	2252539	9	3	1 (4)	218	
				Uplink	High	39650.04	2273333	38876.76	2260445	504		23146	2272987	7	4	1 (4)	1024	
Channel spacing CC3-CC4=99.96 MHz (Note 1)																		
C C4	100	120	66	Downlink &	Low	37299.36	2234155	37251.84	2233363	0	120	23010	2233819	0	5	1 (4)	18	
					Mid	38524.32	2254571	38329.92	2251331	102		23081	2254267	4	6	1 (4)	224	
				Uplink	High	39750.99	2274999	38976.72	2262111	504		23152	2274715	2	7	1 (4)	1030	
Channel spacing CC4-CC5=99.96 MHz (Note 1)																		
C C5	100	120	66	Downlink &	Low	37399.32	2235821	37351.8	2235029	0	120	23016	2235547	7	7	1 (4)	22	
					Mid	38624.28	2256237	38429.88	2252997	102		23086	2255707	11	0	0 (0)	204	
				Uplink	High	39849.96	2276665	39076.68	2263777	504		23157	2276155	9	1	0 (0)	1010	
Channel spacing CC5-CC6=99.96 MHz (Note 1)																		
C C6	100	120	66	Downlink &	Low	37499.28	2237487	37451.76	2236695	0	120	23021	2236987	2	2	0 (0)	4	
					Mid	38724.24	2257903	38529.84	2254663	102		23092	2257435	6	3	0 (0)	210	
				Uplink	High	39949.92	2278331	39176.64	2265443	504		23163	2277883	4	0	1 (4)	1016	
100+100 +100+100 +100+100	C C1	100	120	66	Downlink &	Low	37050.99	2229999	37002.48	2229207	0	120	22995	2229499	2	2	0 (0)	4
						Mid	38250.99	2249999	38055.6	2246759	102		23065	2249659	10	4	1 (4)	220
					Uplink	High	39450.12	2270001	38676.84	2257113	504		23134	2269531	5	3	0 (0)	1014
Channel spacing CC1-CC2=99.96 MHz (Note 1)																		
C C2	100	120	66	Downlink &	Low	37149.96	2231665	37102.44	2230873	0	120	23001	2231227	9	0	1 (4)	8	
					Mid	38349.96	2251665	38155.56	2248425	102		23071	2251387	5	7	1 (4)	226	
				Uplink	High	39550.08	2271667	38776.8	2258779	504		23140	2271259	0	2	1 (4)	1020	
Channel spacing CC2-CC3=99.96 MHz (Note 1)																		

C C3	100	12 0	66	Down link &	Lo w	37249 .92	22333 31	37202 .4	2232539	0	120	230 07	2232955	4	3	1 (4)	14
					Mi d	38449 .92	22533 31	38255 .52	2250091	102		230 76	2252827	0	2	0 (0)	208
				Uplin k	Hi gh	39650 .04	22733 33	38876 .76	2260445	504		231 46	2272987	7	4	1 (4)	1024
Channel spacing CC3-CC4=99.96 MHz (Note 1)																	
C C4	100	12 0	66	Down link &	Lo w	37349 .88	22349 97	37302 .36	2234205	0	120	230 13	2234683	11	5	1 (4)	18
					Mi d	38549 .88	22549 97	38355 .48	2251757	102		230 82	2254555	7	0	1 (4)	212
				Uplin k	Hi gh	39750	22749 99	38976 .72	2262111	504		231 52	2274715	2	7	1 (4)	1030
Channel spacing CC4-CC5=99.96 MHz (Note 1)																	
C C5	100	12 0	66	Down link &	Lo w	37449 .84	22366 63	37402 .32	2235871	0	120	230 18	2236123	6	0	0 (0)	0
					Mi d	38649 .84	22566 63	38455 .44	2253423	102		230 88	2256283	2	3	1 (4)	218
				Uplin k	Hi gh	39849 .96	22766 65	39076 .68	2263777	504		231 57	2276155	9	1	0 (0)	1010
Channel spacing CC5-CC6=99.96 MHz (Note 1)																	
C C6	100	12 0	66	Down link &	Lo w	37549 .8	22383 29	37502 .28	2237537	0	120	230 24	2237851	1	3	0 (0)	6
					Mi d	38749 .8	22583 29	38555 .4	2255089	102		230 94	2258011	9	5	1 (4)	222
				Uplin k	Hi gh	39949 .92	22783 31	39176 .64	2265443	504		231 63	2277883	4	0	1 (4)	1016

- Note 1: Corresponds to nominal channel spacing in accordance with TS 38.101-2 [8], clause 5.4A.1 for the channel bandwidths of the two respective NR component carriers.
- Note 2: CCs are specified in increasing frequency order. CC1 is used as PCell if nothing else is specified in the test case.
- Note 3: The parameter Offset Carrier CORESET#0 specifies the offset from the lowest subcarrier of the carrier and the lowest subcarrier of CORESET#0. It corresponds to the parameter  $\Delta F_{\text{OffsetCORESET-0-Carrier}}$  in Annex C expressed in number of common RBs.
- Note 4: The CORESET#0 Index and the associated CORESET#0 Offset refers to Table 13-8 in TS 38.213 [22]. The value of CORESET#0 Index is signalled in controlResourceSetZero (pdcch-ConfigSIB1) in the MIB. The offsetToPointA IE is expressed in units of resource blocks assuming 15 kHz subcarrier spacing for FR1 and 60 kHz subcarrier spacing for FR2.

4.3.1.2.3.4.11 CA\_n260L

Table 4.3.1.2.3.4.11-1: NR Intra-Band contiguous CA configuration CA\_n260L (PCC=CC1, SCC=CC2, CC3, CC4, CC5, CC6, CC7), SCS=60 kHz, nominal channel spacing

CBW combination	C C	CB W [M]	SC S [kHz]	carrierBandwidth [PRBs]	Range	Carrier centr	Carrier centr	point A [MHz]	absoluteFrequencyPointA [ARFCN]	offsetToCarrier [Carrier]	SS block	GS CN	absoluteFrequencySSB [ARFCN]	$k_{SSB}$	Offset Carrier CORES	CORES ET#0 Index	offsetToPointA (SIB1)
--------------------	--------	----------------	------------------	----------------------------	-------	------------------	------------------	---------------------	------------------------------------	------------------------------	-------------	----------	---------------------------------	-----------	----------------------------	------------------------	--------------------------



		Hz]	z]			e [MHz] Note 2	e [ARF CN]			PRBs]	SC S [kHz z]				ET#0 [RBs] Note 3	Note 4	[PRBs] Note 4		
50+100 +100+100 +100+100 +100	C C1	50	60	66	Down link &	Lo w	37025 .04	22295 83	37001 .28	2229187	0	120	229 95	2229499	0	6	0 (0)	6	
						Mid	38199 .96	22491 65	38102 .76	2247545	102		230 63	2249083	2	6	0 (0)	108	
					Uplink	High	39375 .72	22687 61	38989 .08	2262317	504		231 31	2268667	2	5	0 (0)	509	
	Channel spacing CC1-CC2=74.4 MHz (Note 1)																		
	C C2	100	60	132	Down link &	Lo w	37099 .44	22308 23	37051 .92	2230031	0	120	229 98	2230363	8	7	0 (0)	7	
						Mid	38274 .36	22504 05	38153 .4	2248389	102		230 66	2249947	10	7	0 (0)	109	
					Uplink	High	39450 .12	22700 01	39039 .72	2263161	504		231 34	2269531	10	6	0 (0)	510	
	Channel spacing CC2-CC3=99.96 MHz (Note 1)																		
	C C3	100	60	132	Down link &	Lo w	37199 .4	22324 89	37151 .88	2231697	0	120	230 04	2232091	10	4	1 (8)	12	
						Mid	38374 .32	22520 71	38253 .36	2250055	102		230 72	2251675	0	5	1 (8)	115	
					Uplink	High	39550 .08	22716 67	39139 .68	2264827	504		231 40	2271259	0	4	1 (8)	516	
	Channel spacing CC3-CC4=99.96 MHz (Note 1)																		
C C4	100	60	132	Down link &	Lo w	37299 .36	22341 55	37251 .84	2233363	0	120	230 10	2233819	0	10	1 (8)	18		
					Mid	38474 .28	22537 37	38353 .32	2251721	102		230 78	2253403	2	10	1 (8)	120		
				Uplink	High	39650 .04	22733 33	39239 .64	2266493	504		231 46	2272987	2	9	1 (8)	521		
Channel spacing CC4-CC5=99.96 MHz (Note 1)																			
C C5	100	60	132	Down link &	Lo w	37399 .32	22358 21	37351 .8	2235029	0	120	230 16	2235547	2	15	1 (8)	23		
					Mid	38574 .24	22554 03	38453 .28	2253387	102		230 84	2255131	4	15	1 (8)	125		
				Uplink	High	39750 99	22749 99	39339 .6	2268159	504		231 52	2274715	4	14	1 (8)	526		
Channel spacing CC5-CC6=99.96 MHz (Note 1)																			
C C6	100	60	132	Down link &	Lo w	37499 .28	22374 87	37451 .76	2236695	0	120	230 21	2236987	4	4	0 (0)	4		
					Mid	38674 .2	22570 69	38553 .24	2255053	102		230 89	2256571	6	4	0 (0)	106		
				Uplink	High	39849 .96	22766 65	39439 .56	2269825	504		231 57	2276155	6	3	0 (0)	507		

Channel spacing CC6-CC7=99.96 MHz (Note 1)																		
C C7	100	60	132	Down link &	Lo w	37599 .24	22391 53	37551 .72	2238361	0	120	230 27	2238715	6	1	1 (8)	9	
					Mi d	38774 .16	22587 35	38653 .2	2256719	102		230 95	2258299	8	1	1 (8)	111	
				Upl ink	Hi gh	39949 .92	22783 31	39539 .52	2271491	504		231 63	2277883	8	0	1 (8)	512	
100+100 +100+100 +100+100 +100	C C1	100	60	132	Down link &	Lo w	37050	22299 99	37002 .48	2229207	0	120	229 95	2229499	4	4	0 (0)	4
						Mi d	38199 .96	22491 65	38079 .96	2247149	102		230 62	2248795	2	7	1 (8)	117
					Upl ink	Hi gh	39350 .16	22683 35	38939 .76	2261495	504		231 28	2267803	8	1	0 (0)	505
Channel spacing CC1-CC2=99.96 MHz (Note 1)																		
C C2	100	60	132	Down link &	Lo w	37149 .96	22316 65	37102 .44	2230873	0	120	230 01	2231227	6	1	1 (8)	9	
					Mi d	38299 .92	22508 31	38178 .96	2248815	102		230 68	2250523	4	12	1 (8)	122	
				Upl ink	Hi gh	39450 .12	22700 01	39039 .72	2263161	504		231 34	2269531	10	6	0 (0)	510	
Channel spacing CC2-CC3=99.96 MHz (Note 1)																		
C C3	100	60	132	Down link &	Lo w	37249 .92	22333 31	37202 .4	2232539	0	120	230 07	2232955	8	6	1 (8)	14	
					Mi d	38399 .88	22524 97	38278 .92	2250481	102		230 73	2251963	6	1	0 (0)	103	
				Upl ink	Hi gh	39550 .08	22716 67	39139 .68	2264827	504		231 40	2271259	0	4	1 (8)	516	
Channel spacing CC3-CC4=99.96 MHz (Note 1)																		
C C4	100	60	132	Down link &	Lo w	37349 .88	22349 97	37302 .36	2234205	0	120	230 13	2234683	10	11	1 (8)	19	
					Mi d	38499 .84	22541 63	38378 .88	2252147	102		230 79	2253691	8	6	0 (0)	108	
				Upl ink	Hi gh	39650 .04	22733 33	39239 .64	2266493	504		231 46	2272987	2	9	1 (8)	521	
Channel spacing CC4-CC5=99.96 MHz (Note 1)																		
C C5	100	60	132	Down link &	Lo w	37449 .84	22366 63	37402 .32	2235871	0	120	230 18	2236123	0	1	0 (0)	1	
					Mi d	38599 .8	22558 29	38478 .84	2253813	102		230 85	2255419	10	3	1 (8)	113	
				Upl ink	Hi gh	39750 .99	22749 99	39339 .6	2268159	504		231 52	2274715	4	14	1 (8)	526	
Channel spacing CC5-CC6=99.96 MHz (Note 1)																		
C C6	100	60	132	Down link &	Lo w	37549 .8	22383 29	37502 .28	2237537	0	120	230 24	2237851	2	6	0 (0)	6	
					Mi d	38699	22574	38578	2255479	102		230	2257147	0	9	1 (8)	119	

					Uplink	d	.76	95	.8			91						
					High	39849	22766	39439		2269825	504	231	2276155	6	3	0 (0)	507	
						.96	65	.56				57						
Channel spacing CC6-CC7=99.96 MHz (Note 1)																		
C7	100	60	132	Downlink &	Low	37649	22399	37602		2239203	0	120	23030	2239579	4	3	1 (8)	11
					Mid	38799	22591	38678		2257145	102		23097	2258875	2	14	1 (8)	124
				Uplink	High	39949	22783	39539		2271491	504		23163	2277883	8	0	1 (8)	512
						.72	61	.76										
						.92	31	.52										

Note 1: Corresponds to nominal channel spacing in accordance with TS 38.101-2 [8], clause 5.4A.1 for the channel bandwidths of the two respective NR component carriers.  
 Note 2: CCs are specified in increasing frequency order. CC1 is used as PCell if nothing else is specified in the test case.  
 Note 3: The parameter Offset Carrier CORESET#0 specifies the offset from the lowest subcarrier of the carrier and the lowest subcarrier of CORESET#0. It corresponds to the parameter  $\Delta F_{\text{OffsetCORESET-0-Carrier}}$  in Annex C expressed in number of common RBs.  
 Note 4: The CORESET#0 Index and the associated CORESET#0 Offset refers to Table 13-7 in TS 38.213 [22]. The value of CORESET#0 Index is signalled in controlResourceSetZero (pdcch-ConfigSIB1) in the MIB. The offsetToPointA IE is expressed in units of resource blocks assuming 15 kHz subcarrier spacing for FR1 and 60 kHz subcarrier spacing for FR2.

Table 4.3.1.2.3.4.11-2: NR Intra-Band contiguous CA configuration CA\_n260L (PCC=CC1, SCC=CC2, CC3, CC4, CC5, CC6, CC7), SCS=120 kHz, nominal channel spacing

CBW combination	CC	CBW [MHz]	SCS [kHz]	carrierBandwidth [PRBs]	Range	Carrier centre [MHz]	Carrier centre [ARFCN]	point A [MHz]	absoluteFrequencyPointA [ARFCN]	offsetToCarrier [Carrier PRBs]	SS block SCS [kHz]	GS CN	absoluteFrequencySSB [ARFCN]	$k_{SSB}$	Offset Carrier CORESET#0 [RBs]	CORESET#0 Index (Offset [RBs])	offsetToPointA (SIB1) [PRBs]	
50+100 +100+100 +100+100 +100	C1	50	120	32	Downlink &	Low	2229583	37002	2229199	0	120	22995	2229499	6	2	0 (0)	4	
						Mid	2249165	38030	2246333	102		23063	2249083	7	2	0 (0)	208	
					Uplink	High	2268761	38626	2256281	504		23131	2268667	1	2	0 (0)	1012	
	Channel spacing CC1-CC2=74.4 MHz (Note 1)																	
	C2	100	120	66	Downlink &	Low	2230823	37051	2230031	0	120	22998	2230363	10	3	0 (0)	6	
						Mid	2250405	38079	2247165	102		23066	2249947	11	3	0 (0)	210	
Uplink					High	2270001	38676	2257113	504	23134		2269531	5	3	0 (0)	1014		
Channel spacing CC2-CC3=99.96 MHz (Note 1)																		
C3	100	120	66	Downlink	Low	2232489	37151	2231697	0	120	23004	2232091	5	2	1 (4)	12		

				&	Mid	38374	22520	38179	2248831	102		230	2251675	6	2	1 (4)	216	
				Uplink	High	39550	22716	38776	2258779	504		231	2271259	0	2	1 (4)	1020	
Channel spacing CC3-CC4=99.96 MHz (Note 1)																		
C	100	12	66	Downlink &	Low	37299	22341	37251	2233363	0	120	230	2233819	0	5	1 (4)	18	
C4		0			Mid	38474	22537	38279	2250497	102		230	2253403	1	5	1 (4)	222	
				Uplink	High	39650	22733	38876	2260445	504		231	2272987	7	4	1 (4)	1024	
Channel spacing CC4-CC5=99.96 MHz (Note 1)																		
C	100	12	66	Downlink &	Low	37399	22358	37351	2235029	0	120	230	2235547	7	7	1 (4)	22	
C5		0			Mid	38574	22554	38379	2252163	102		230	2255131	8	7	1 (4)	226	
				Uplink	High	39750	22749	38976	2262111	504		231	2274715	2	7	1 (4)	1030	
Channel spacing CC5-CC6=99.96 MHz (Note 1)																		
C	100	12	66	Downlink &	Low	37499	22374	37451	2236695	0	120	230	2236987	2	2	0 (0)	4	
C6		0			Mid	38674	22570	38479	2253829	102		230	2256571	3	2	0 (0)	208	
				Uplink	High	39849	22766	39076	2263777	504		231	2276155	9	1	0 (0)	1010	
Channel spacing CC6-CC7=99.96 MHz (Note 1)																		
C	100	12	66	Downlink &	Low	37599	22391	37551	2238361	0	120	230	2238715	9	0	1 (4)	8	
C7		0			Mid	38774	22587	38579	2255495	102		230	2258299	10	0	1 (4)	212	
				Uplink	High	39949	22783	39176	2265443	504		231	2277883	4	0	1 (4)	1016	
100+100	C	100	12	66	Downlink &	Low	37050	22299	37002	2229207	0	120	229	2229499	2	2	0 (0)	4
+100+100	C1		0			Mid	38199	22491	38005	2245925	102		230	2248795	7	3	1 (4)	218
+100+100					Uplink	High	39350	22683	38576	2255447	504		231	2267803	10	0	0 (0)	1008
+100	Channel spacing CC1-CC2=99.96 MHz (Note 1)																	
	C	100	12	66	Downlink &	Low	37149	22316	37102	2230873	0	120	230	2231227	9	0	1 (4)	8
	C2		0			Mid	38299	22508	38105	2247591	102		230	2250523	2	6	1 (4)	224
					Uplink	High	39450	22700	38676	2257113	504		231	2269531	5	3	0 (0)	1014

Channel spacing CC2-CC3=99.96 MHz (Note 1)																	
C C3	100	12 0	66	Down link &	Lo w	37249 .92	22333 31	37202 .4	2232539	0	120	230 07	2232955	4	3	1 (4)	14
					Mid	38399 .88	22524 97	38205 .48	2249257	102		230 73	2251963	9	0	0 (0)	204
				Uplink	High	39550 .08	22716 67	38776 .8	2258779	504		231 40	2271259	0	2	1 (4)	1020
Channel spacing CC3-CC4=99.96 MHz (Note 1)																	
C C4	100	12 0	66	Down link &	Lo w	37349 .88	22349 97	37302 .36	2234205	0	120	230 13	2234683	11	5	1 (4)	18
					Mid	38499 .84	22541 63	38305 .44	2250923	102		230 79	2253691	4	3	0 (0)	210
				Uplink	High	39650 .04	22733 33	38876 .76	2260445	504		231 46	2272987	7	4	1 (4)	1024
Channel spacing CC4-CC5=99.96 MHz (Note 1)																	
C C5	100	12 0	66	Down link &	Lo w	37449 .84	22366 63	37402 .32	2235871	0	120	230 18	2236123	6	0	0 (0)	0
					Mid	38599 .8	22558 29	38405 .4	2252589	102		230 85	2255419	11	1	1 (4)	214
				Uplink	High	39750 .99	22749 99	38976 .72	2262111	504		231 52	2274715	2	7	1 (4)	1030
Channel spacing CC5-CC6=99.96 MHz (Note 1)																	
C C6	100	12 0	66	Down link &	Lo w	37549 .8	22383 29	37502 .28	2237537	0	120	230 24	2237851	1	3	0 (0)	6
					Mid	38699 .76	22574 95	38505 .36	2254255	102		230 91	2257147	6	4	1 (4)	220
				Uplink	High	39849 .96	22766 65	39076 .68	2263777	504		231 57	2276155	9	1	0 (0)	1010
Channel spacing CC6-CC7=99.96 MHz (Note 1)																	
C C7	100	12 0	66	Down link &	Lo w	37649 .76	22399 95	37602 .24	2239203	0	120	230 30	2239579	8	1	1 (4)	10
					Mid	38799 .72	22591 61	38605 .32	2255921	102		230 97	2258875	1	7	1 (4)	226
				Uplink	High	39949 .92	22783 31	39176 .64	2265443	504		231 63	2277883	4	0	1 (4)	1016

Note 1: Corresponds to nominal channel spacing in accordance with TS 38.101-2 [8], clause 5.4A.1 for the channel bandwidths of the two respective NR component carriers.

Note 2: CCs are specified in increasing frequency order. CC1 is used as PCell if nothing else is specified in the test case.

Note 3: The parameter Offset Carrier CORESET#0 specifies the offset from the lowest subcarrier of the carrier and the lowest subcarrier of CORESET#0. It corresponds to the parameter  $\Delta F_{\text{OffsetCORESET-0-Carrier}}$  in Annex C expressed in number of common RBs.

Note 4: The CORESET#0 Index and the associated CORESET#0 Offset refers to Table 13-8 in TS 38.213 [22]. The value of CORESET#0 Index is signalled in controlResourceSetZero (pdcch-ConfigSIB1) in the MIB. The offsetToPointA IE is expressed in units of resource blocks assuming 15 kHz subcarrier spacing for FR1 and 60 kHz subcarrier spacing for FR2.

4.3.1.2.3.4.12 CA\_n260M

**Table 4.3.1.2.3.4.12-1: NR Intra-Band contiguous CA configuration CA\_n260M (PCC=CC1, SCC=CC2, CC3, CC4, CC5, CC6, CC7, CC8), SCS=60 kHz, nominal channel spacing**

CBW combination	C C	CB W [MHz]	SC S [kHz]	carrierBandwidth [PRBs]	Range	Carrier centre [MHz] Note 2	Carrier centre [ARFCN]	point A [MHz]	absoluteFrequencyPointA [ARFCN]	offsetToCarrier [Carrier PRBs]	SS block SCS [kHz]	GS CN	absoluteFrequencySSB [ARFCN]	$k_{SSB}$	Offset Carrier CORES ET#0 [RBs] Note 3	CORES ET#0 Index Note 4	offsetToPointA (SIB1) [PRBs] Note 4	
50+100 +100+100 +100+100 +100+100	C C1	50	60	66	Downlink &	Low	37025.04	2229583	37001.28	2229187	0	120	22995	0	6	0 (0)	6	
						Mid	38149.92	2248331	38052.72	2246711	102		23060	8	3	0 (0)	105	
					Uplink	High	39275.76	2267095	38889.12	2260651	504		23125	0	0	0 (0)	504	
	Channel spacing CC1-CC2=74.4 MHz (Note 1)																	
	C C2	100	60	132	Downlink &	Low	37099.44	2230823	37051.92	2230031	0	120	22998	8	7	0 (0)	7	
						Mid	38224.32	2249571	38103.36	2247555	102		23063	4	5	0 (0)	107	
					Uplink	High	39350.16	2268335	38939.76	2261495	504		23128	8	1	0 (0)	505	
	Channel spacing CC2-CC3=99.96 MHz (Note 1)																	
	C C3	100	60	132	Downlink &	Low	37199.4	2232489	37151.88	2231697	0	120	23004	10	4	1 (8)	12	
						Mid	38324.28	2251237	38203.32	2249221	102		23069	6	2	1 (8)	112	
					Uplink	High	39450.12	2270001	39039.72	2263161	504		23134	10	6	0 (0)	510	
	Channel spacing CC3-CC4=99.96 MHz (Note 1)																	
C C4	100	60	132	Downlink &	Low	37299.36	2234155	37251.84	2233363	0	120	23010	0	10	1 (8)	18		
					Mid	38424.24	2252903	38303.28	2250887	102		23075	8	7	1 (8)	117		
				Uplink	High	39550.08	2271667	39139.68	2264827	504		23140	0	4	1 (8)	516		
Channel spacing CC4-CC5=99.96 MHz (Note 1)																		
C C5	100	60	132	Downlink &	Low	37399.32	2235821	37351.8	2235029	0	120	23016	2	15	1 (8)	23		
					Mid	38524.2	2254569	38403.24	2252553	102		23081	10	12	1 (8)	122		

				Uplink	High	39650.04	22733.33	39239.64	2266493	504		23146	2272987	2	9	1 (8)	521	
Channel spacing CC5-CC6=99.96 MHz (Note 1)																		
C C6	100	60	132	Downlink &	Low	37499.28	22374.87	37451.76	2236695	0	120	23021	2236987	4	4	0 (0)	4	
					Mid	38624.16	22562.35	38503.2	2254219	102		23086	2255707	0	2	0 (0)	104	
				Uplink	High	39750	22749.99	39339.6	2268159	504		23152	2274715	4	14	1 (8)	526	
Channel spacing CC6-CC7=99.96 MHz (Note 1)																		
C C7	100	60	132	Downlink &	Low	37599.24	22391.53	37551.72	2238361	0	120	23027	2238715	6	1	1 (8)	9	
					Mid	38724.12	22579.01	38603.16	2255885	102		23092	2257435	2	7	0 (0)	109	
				Uplink	High	39849.96	22766.65	39439.56	2269825	504		23157	2276155	6	3	0 (0)	507	
Channel spacing CC7-CC8=99.96 MHz (Note 1)																		
C C8	100	60	132	Downlink &	Low	37699.2	22408.19	37651.68	2240027	0	120	23033	2240443	8	6	1 (8)	N/A	
					Mid	38824.08	22595.67	38703.12	2257551	102		23098	2259163	4	4	1 (8)	114	
				Uplink	High	39949.92	22783.31	39539.52	2271491	504		23163	2277883	8	0	1 (8)	512	
100+100 +100+100 +100+100 +100+100	C C1	100	60	132	Downlink &	Low	37050	22299.99	37002.48	2229207	0	120	22995	2229499	4	4	0 (0)	4
						Mid	38149.92	22483.31	38028.96	2246315	102		23059	2247931	8	4	1 (8)	114
					Uplink	High	39250.2	22666.69	38839.8	2259829	504		23123	2266363	6	12	1 (8)	524
Channel spacing CC1-CC2=99.96 MHz (Note 1)																		
C C2	100	60	132	Downlink &	Low	37149.96	22316.65	37102.44	2230873	0	120	23001	2231227	6	1	1 (8)	9	
					Mid	38249.88	22499.97	38128.92	2247981	102		23065	2249659	10	9	1 (8)	119	
				Uplink	High	39350.16	22683.35	38939.76	2261495	504		23128	2267803	8	1	0 (0)	505	
Channel spacing CC2-CC3=99.96 MHz (Note 1)																		
C C3	100	60	132	Downlink &	Low	37249.92	22333.31	37202.4	2232539	0	120	23007	2232955	8	6	1 (8)	14	
					Mid	38349.84	22516.63	38228.88	2249647	102		23071	2251387	0	15	1 (8)	125	
				Uplink	High	39450.12	22700.01	39039.72	2263161	504		23134	2269531	10	6	0 (0)	510	
Channel spacing CC3-CC4=99.96 MHz (Note 1)																		

C C4	100	60	132	Down link &	Lo w	37349 .88	22349 97	37302 .36	2234205	0	120	230 13	2234683	10	11	1 (8)	19
					Mid	38449 .8	22533 29	38328 .84	2251313	102		230 76	2252827	2	4	0 (0)	106
				Uplink	High	39550 .08	22716 67	39139 .68	2264827	504		231 40	2271259	0	4	1 (8)	516
Channel spacing CC4-CC5=99.96 MHz (Note 1)																	
C C5	100	60	132	Down link &	Lo w	37449 .84	22366 63	37402 .32	2235871	0	120	230 18	2236123	0	1	0 (0)	1
					Mid	38549 .76	22549 95	38428 .8	2252979	102		230 82	2254555	4	1	1 (8)	111
				Uplink	High	39650 .04	22733 33	39239 .64	2266493	504		231 46	2272987	2	9	1 (8)	521
Channel spacing CC5-CC6=99.96 MHz (Note 1)																	
C C6	100	60	132	Down link &	Lo w	37549 .8	22383 29	37502 .28	2237537	0	120	230 24	2237851	2	6	0 (0)	6
					Mid	38649 .72	22566 61	38528 .76	2254645	102		230 88	2256283	6	6	1 (8)	116
				Uplink	High	39750 .99	22749 99	39339 .6	2268159	504		231 52	2274715	4	14	1 (8)	526
Channel spacing CC6-CC7=99.96 MHz (Note 1)																	
C C7	100	60	132	Down link &	Lo w	37649 .76	22399 95	37602 .24	2239203	0	120	230 30	2239579	4	3	1 (8)	11
					Mid	38749 .68	22583 27	38628 .72	2256311	102		230 94	2258011	8	11	1 (8)	121
				Uplink	High	39849 .96	22766 65	39439 .56	2269825	504		231 57	2276155	6	3	0 (0)	507
Channel spacing CC7-CC8=99.96 MHz (Note 1)																	
C C8	100	60	132	Down link &	Lo w	37749 .72	22416 61	37702 .2	2240869	0	120	230 36	2241307	6	8	1 (8)	N/A
					Mid	38849 .64	22599 93	38728 .68	2257977	102		230 99	2259451	10	0	0 (0)	102
				Uplink	High	39949 .92	22783 31	39539 .52	2271491	504		231 63	2277883	8	0	1 (8)	512

- Note 1: Corresponds to nominal channel spacing in accordance with TS 38.101-2 [8], clause 5.4A.1 for the channel bandwidths of the two respective NR component carriers.
- Note 2: CCs are specified in increasing frequency order. CC1 is used as PCell if nothing else is specified in the test case.
- Note 3: The parameter Offset Carrier CORESET#0 specifies the offset from the lowest subcarrier of the carrier and the lowest subcarrier of CORESET#0. It corresponds to the parameter  $\Delta F_{\text{OffsetCORESET-0-Carrier}}$  in Annex C expressed in number of common RBs.
- Note 4: The CORESET#0 Index and the associated CORESET#0 Offset refers to Table 13-7 in TS 38.213 [22]. The value of CORESET#0 Index is signalled in controlResourceSetZero (pdccch-ConfigSIB1) in the MIB. The offsetToPointA IE is expressed in units of resource blocks assuming 15 kHz subcarrier spacing for FR1 and 60 kHz subcarrier spacing for FR2.



Table 4.3.1.2.3.4.12-2: NR Intra-Band contiguous CA configuration CA\_n260M (PCC=CC1, SCC=CC2, CC3, CC4, CC5, CC6, CC7, CC8), SCS=120 kHz, nominal channel spacing

CBW combination	C C	CB W [MHz]	SC S [kHz]	carrierBandwidth [PRBs]	Range	Carrier centre [MHz] Note 2	Carrier centre [ARFCN]	point A [MHz]	absoluteFrequencyPointA [ARFCN]	offsetToCarrier [Carrier PRBs]	SS block SCS [kHz]	GS CN	absoluteFrequencySSB [ARFCN]	$k_{SSB}$	Offset Carrier CORES ET#0 [RBs] Note 3	CORES ET#0 Index (Offset [RBs]) Note 4	offsetToPointA (SIB1) [PRBs] Note 4				
50+100 +100+100 +100+100 +100+100	C C1	50	120	32	Downlink &	Low	37025.04	2229583	37002	2229199	0	120	22995	6	2	0 (0)	4				
						Mid	38150.04	2248333	37980.12	2245501	102		23060					2248219	3	1	0 (0)
					Uplink	High	39275.76	2267095	38526.96	2254615	504		23126					2267227	6	7	1 (4)
Channel spacing CC1-CC2=74.4 MHz (Note 1)																					
C C2	100	120	66	Downlink &	Low	37099.44	2230823	37051.92	2230031	0	120	22998	10	3	0 (0)	6					
					Mid	38224.44	2249573	38030.04	2246333	102		23063					2249083	7	2	0 (0)	208
				Uplink	High	39350.16	2268335	38576.88	2255447	504		23128					2267803	10	0	0 (0)	1008
Channel spacing CC2-CC3=99.96 MHz (Note 1)																					
C C3	100	120	66	Downlink &	Low	37199.4	2232489	37151.88	2231697	0	120	23004	5	2	1 (4)	12					
					Mid	38324.4	2251239	38130	2247999	102		23069					2250811	2	1	1 (4)	214
				Uplink	High	39450.12	2270001	38676.84	2257113	504		23134					2269531	5	3	0 (0)	1014
Channel spacing CC3-CC4=99.96 MHz (Note 1)																					
C C4	100	120	66	Downlink &	Low	37299.36	2234155	37251.84	2233363	0	120	23010	0	5	1 (4)	18					
					Mid	38424.36	2252905	38229.96	2249665	102		23075					2252539	9	3	1 (4)	218
				Uplink	High	39550.08	2271667	38776.8	2258779	504		23140					2271259	0	2	1 (4)	1020
Channel spacing CC4-CC5=99.96 MHz (Note 1)																					
C C5	100	120	66	Downlink &	Low	37399.32	2235821	37351.8	2235029	0	120	23016	7	7	1 (4)	22					
					Mid	38524.32	2254571	38329.92	2251331	102		23081					2254267	4	6	1 (4)	224
				Uplink	High	39650.04	2273333	38876.76	2260445	504		23146					2272987	7	4	1 (4)	1024

Channel spacing CC5-CC6=99.96 MHz (Note 1)																		
C C6	100	12 0	66	Down link &	Lo w	37499 .28	22374 87	37451 .76	2236695	0	120	230 21	2236987	2	2	0 (0)	4	
					Mid	38624 .28	22562 37	38429 .88	2252997	102		230 86	2255707	11	0	0 (0)	204	
				Uplink	High	39750	22749 99	38976 .72	2262111	504		231 52	2274715	2	7	1 (4)	1030	
Channel spacing CC6-CC7=99.96 MHz (Note 1)																		
C C7	100	12 0	66	Down link &	Lo w	37599 .24	22391 53	37551 .72	2238361	0	120	230 27	2238715	9	0	1 (4)	8	
					Mid	38724 .24	22579 03	38529 .84	2254663	102		230 92	2257435	6	3	0 (0)	210	
				Uplink	High	39849 .96	22766 65	39076 .68	2263777	504		231 57	2276155	9	1	0 (0)	1010	
Channel spacing CC7-CC8=99.96 MHz (Note 1)																		
C C8	100	12 0	66	Down link &	Lo w	37699 .2	22408 19	37651 .68	2240027	0	120	230 33	2240443	4	3	1 (4)	N/A	
					Mid	38824 .2	22595 69	38629 .8	2256329	102		230 98	2259163	1	2	1 (4)	216	
				Uplink	High	39949 .92	22783 31	39176 .64	2265443	504		231 63	2277883	4	0	1 (4)	1016	
100+100 +100+100 +100+100	C C1	100	12 0	66	Down link &	Lo w	37050	22299 99	37002 .48	2229207	0	120	229 95	2229499	2	2	0 (0)	4
						Mid	38150 .04	22483 33	37955 .64	2245093	102		230 59	2247931	3	2	1 (4)	216
					Uplink	High	39250 .2	22666 69	38476 .92	2253781	504		231 23	2266363	3	6	1 (4)	1028
Channel spacing CC1-CC2=99.96 MHz (Note 1)																		
C C2	100	12 0	66	Down link &	Lo w	37149 .96	22316 65	37102 .44	2230873	0	120	230 01	2231227	9	0	1 (4)	8	
					Mid	38250	22499 99	38055 .6	2246759	102		230 65	2249659	10	4	1 (4)	220	
				Uplink	High	39350 .16	22683 35	38576 .88	2255447	504		231 28	2267803	10	0	0 (0)	1008	
Channel spacing CC2-CC3=99.96 MHz (Note 1)																		
C C3	100	12 0	66	Down link &	Lo w	37249 .92	22333 31	37202 .4	2232539	0	120	230 07	2232955	4	3	1 (4)	14	
					Mid	38349 .96	22516 65	38155 .56	2248425	102		230 71	2251387	5	7	1 (4)	226	
				Uplink	High	39450 .12	22700 01	38676 .84	2257113	504		231 34	2269531	5	3	0 (0)	1014	
Channel spacing CC3-CC4=99.96 MHz (Note 1)																		
C C4	100	12 0	66	Down link	Lo w	37349 .88	22349 97	37302 .36	2234205	0	120	230 13	2234683	11	5	1 (4)	18	

				&	Mid	38449	22533	38255	2250091	102		230	2252827	0	2	0 (0)	208
				Uplink	High	39550	22716	38776	2258779	504		231	2271259	0	2	1 (4)	1020
Channel spacing CC4-CC5=99.96 MHz (Note 1)																	
C	100	12	66	Downlink	Low	37449	22366	37402	2235871	0	120	230	2236123	6	0	0 (0)	0
C5		0		&	Mid	38549	22549	38355	2251757	102		230	2254555	7	0	1 (4)	212
				Uplink	High	39650	22733	38876	2260445	504		231	2272987	7	4	1 (4)	1024
Channel spacing CC5-CC6=99.96 MHz (Note 1)																	
C	100	12	66	Downlink	Low	37549	22383	37502	2237537	0	120	230	2237851	1	3	0 (0)	6
C6		0		&	Mid	38649	22566	38455	2253423	102		230	2256283	2	3	1 (4)	218
				Uplink	High	39750	22749	38976	2262111	504		231	2274715	2	7	1 (4)	1030
Channel spacing CC6-CC7=99.96 MHz (Note 1)																	
C	100	12	66	Downlink	Low	37649	22399	37602	2239203	0	120	230	2239579	8	1	1 (4)	10
C7		0		&	Mid	38749	22583	38555	2255089	102		230	2258011	9	5	1 (4)	222
				Uplink	High	39849	22766	39076	2263777	504		231	2276155	9	1	0 (0)	1010
Channel spacing CC7-CC8=99.96 MHz (Note 1)																	
C	100	12	66	Downlink	Low	37749	22416	37702	2240869	0	120	230	2241307	3	4	1 (4)	N/A
C8		0		&	Mid	38849	22599	38655	2256755	102		230	2259451	4	0	0 (0)	204
				Uplink	High	39949	22783	39176	2265443	504		231	2277883	4	0	1 (4)	1016
Note 1: Corresponds to nominal channel spacing in accordance with TS 38.101-2 [8], clause 5.4A.1 for the channel bandwidths of the two respective NR component carriers.																	
Note 2: CCs are specified in increasing frequency order. CC1 is used as PCell if nothing else is specified in the test case.																	
Note 3: The parameter Offset Carrier CORESET#0 specifies the offset from the lowest subcarrier of the carrier and the lowest subcarrier of CORESET#0. It corresponds to the parameter $\Delta F_{\text{OffsetCORESET-0-Carrier}}$ in Annex C expressed in number of common RBs.																	
Note 4: The CORESET#0 Index and the associated CORESET#0 Offset refers to Table 13-8 in TS 38.213 [22]. The value of CORESET#0 Index is signalled in controlResourceSetZero (pdcch-ConfigSIB1) in the MIB. The offsetToPointA IE is expressed in units of resource blocks assuming 15 kHz subcarrier spacing for FR1 and 60 kHz subcarrier spacing for FR2.																	

## 4.3.1.2.3.4.13 CA\_n2600

Editor's note: CA\_n2600 Test frequencies are FFS.

Table 4.3.1.2.3.4.13-1: NR Intra-Band contiguous CA configuration CA\_n2600 (PCC=CC1 and SCC=CC2), SCS=60 kHz, nominal channel spacing

CBW combination	CC	CBW [MHz]	SCS [kHz]	carrierBand width [PRBs]	Range	Carrier centre [MHz] Note 2	Carrier centre [ARFCN]	point A [MHz]	absoluteFrequency PointA [ARFCN]	offsetToCarrier [Carrier PRBs]	SS block SCS [kHz]	GSCN	absoluteFrequency SSB [ARFCN]	$k_{SSB}$	Offset Carrier CORESET#0 [RBs] Note 3	CORE SET#0 Index (Offset [RBs]) Note 4	offsetToPoint A (SIB1) [PRBs] Note 4

Table 4.3.1.2.3.4.13-2: NR Intra-Band contiguous CA configuration CA\_n2600 (PCC=CC1 and SCC=CC2), SCS=120 kHz, nominal channel spacing

CBW combination	CC	CBW [MHz]	SCS [kHz]	carrierBand width [PRBs]	Range	Carrier centre [MHz] Note 2	Carrier centre [ARFCN]	point A [MHz]	absoluteFrequency PointA [ARFCN]	offsetToCarrier [Carrier PRBs]	SS block SCS [kHz]	GSCN	absoluteFrequency SSB [ARFCN]	$k_{SSB}$	Offset Carrier CORESET#0 [RBs] Note 3	CORE SET#0 Index (Offset [RBs]) Note 4	offsetToPoint A (SIB1) [PRBs] Note 4

4.3.1.2.3.4.14 CA\_n260P

Editor's note: CA\_n260P Test frequencies are FFS.

Table 4.3.1.2.3.4.14-1: NR Intra-Band contiguous CA configuration CA\_n260P (PCC=CC1 and SCC=CC2, CC3), SCS=60 kHz, nominal channel spacing

CBW combination	CC	CBW [MHz]	SCS [kHz]	carrierBand width [PRB]	Range	Carrier centre [MHz] Note 2	Carrier centre [ARFCN]	point A [MHz]	absoluteFrequency PointA [ARFCN]	offsetToCarrier [Carrier PRBs]	SS block SCS [kHz]	GSCN	absoluteFrequency SSB [ARFCN]	$k_{SSB}$	Offset Carrier CORESET#0 [RBs]	CORE SET#0 Index (Offset [RBs])	offsetToPoint A (SIB1)

				<i>s</i>							<i>PRBs</i>					[RBs] Note 3	t [RBs] Note 4	[PRBs] Note 4

Table 4.3.1.2.3.4.14-2: NR Intra-Band contiguous CA configuration CA\_n260P (PCC=CC1 and SCC=CC2, CC3), SCS=120 kHz, nominal channel spacing

CBW combination	CC	CBW [MHz]	SCS [kHz]	carrier Bandwidth [PRBs]	Range	Carrier centre [MHz] Note 2	Carrier centre [ARFCN]	point A [MHz]	absolute Frequency Point A [ARFCN]	offset to Carrier [Carrier PRBs]	SS block SCS [kHz]	GSCN	absolute Frequency SSB [ARFCN]	$k_{SSB}$	Offset Carrier CORESET#0 [RBs] Note 3	CORESET#0 Index (Offset) [RBs] Note 4	offset to Point A (SIB1) [PRBs] Note 4

4.3.1.2.3.4.15 CA\_n260Q

FFS

4.3.1.2.3.5 NR Intra-band contiguous CA configurations for CA\_n261

4.3.1.2.3.5.1 CA\_n261B

Editor's note: CA\_n261B Test frequencies are FFS.

Table 4.3.1.2.3.5.1-1: NR Intra-Band contiguous CA configuration CA\_n261B (PCC=CC1 and SCC=CC2), SCS=120 kHz, nominal channel spacing

CBW combination	CC	CBW [MHz]	SCS [kHz]	carrier Bandwidth [PRBs]	Range	Carrier centre [MHz] Note 2	Carrier centre [ARFCN]	point A [MHz]	absolute Frequency Point A [ARFCN]	offset to Carrier [Carrier PRBs]	SS block SCS [kHz]	GSCN	absolute Frequency SSB [ARFCN]	$k_{SSB}$	Offset Carrier CORESET#0 [RBs] Note 3	CORESET#0 Index Note 4	offset to Point A (SIB1) [PRBs] Note 4

4.3.1.2.3.5.2 CA\_n261C

Editor's note: CA\_n261C Test frequencies are FFS.

Table 4.3.1.2.3.5.2-1: NR Intra-Band contiguous CA configuration CA\_n261C (PCC=CC1 and SCC=CC2, CC3), SCS=120 kHz, nominal channel spacing

CBW combination	CC	CBW [MHz]	SCS [kHz]	carrier Bandwidth [PRBs]	Range	Carrier centre [MHz] Note 2	Carrier centre [ARFCN]	point A [MHz]	absoluteF requency PointA [ARFCN]	offset ToCarrier [Carrier PRBs]	SS block SCS [kHz]	GSCN	absoluteF requency SSB [ARFCN]	$k_{SSB}$	Offset Carrier CORE SET#0 [RBs] Note 3	CORE SET#0 Index (Offset [RBs]) Note 4	offset ToPointA (SIB1) [PRBs] Note 4
-----------------	----	-----------	-----------	--------------------------	-------	-----------------------------	------------------------	---------------	-----------------------------------	---------------------------------	--------------------	------	--------------------------------	-----------	--	--	--------------------------------------

4.3.1.2.3.5.3 CA\_n261D

Editor's note: CA\_n261D Test frequencies are FFS.

Table 4.3.1.2.3.5.3-1: NR Intra-Band contiguous CA configuration CA\_n261D (PCC=CC1 and SCC=CC2), SCS=60 kHz, nominal channel spacing

CBW combination	CC	CBW [MHz]	SCS [kHz]	carrier Bandwidth [PRBs]	Range	Carrier centre [MHz] Note 2	Carrier centre [ARFCN]	point A [MHz]	absoluteF requency PointA [ARFCN]	offset ToCarrier [Carrier PRBs]	SS block SCS [kHz]	GSCN	absoluteF requency SSB [ARFCN]	$k_{SSB}$	Offset Carrier CORE SET#0 [RBs] Note 3	CORE SET#0 Index (Offset [RBs]) Note 4	offset ToPointA (SIB1) [PRBs] Note 4
-----------------	----	-----------	-----------	--------------------------	-------	-----------------------------	------------------------	---------------	-----------------------------------	---------------------------------	--------------------	------	--------------------------------	-----------	--	--	--------------------------------------

Table 4.3.1.2.3.5.3-2: NR Intra-Band contiguous CA configuration CA\_n261D (PCC=CC1 and SCC=CC2), SCS=120 kHz, nominal channel spacing

CBW combination	CC	CBW [MHz]	SCS [kHz]	carrier Bandwidth [PRBs]	Range	Carrier centre [MHz] Note 2	Carrier centre [ARFCN]	point A [MHz]	absoluteF requency PointA [ARFCN]	offset ToCarrier [Carrier PRBs]	SS block SCS [kHz]	GSCN	absoluteF requency SSB [ARFCN]	$k_{SSB}$	Offset Carrier CORE SET#0 [RBs] Note 3	CORE SET#0 Index (Offset [RBs]) Note 4	offset ToPointA (SIB1) [PRBs] Note 4
-----------------	----	-----------	-----------	--------------------------	-------	-----------------------------	------------------------	---------------	-----------------------------------	---------------------------------	--------------------	------	--------------------------------	-----------	--	--	--------------------------------------

4.3.1.2.3.5.4 CA\_n261E

Table 4.3.1.2.3.5.4-1: NR Intra-Band contiguous CA configuration CA\_n261E (PCC=CC1 and SCC=CC2), SCS=60 kHz, nominal channel spacing.

FFS

Table 4.3.1.2.3.5.4-2: NR Intra-Band contiguous CA configuration CA\_n261E (PCC=CC1 and SCC=CC2), SCS=120 kHz, nominal channel spacing.

FFS

4.3.1.2.3.5.5 CA\_n261F

Table 4.3.1.2.3.5.5-1: NR Intra-Band contiguous CA configuration CA\_n261F (PCC=CC1 and SCC=CC2), SCS=60 kHz, nominal channel spacing.

FFS

Table 4.3.1.2.3.5.5-2: NR Intra-Band contiguous CA configuration CA\_n261F (PCC=CC1 and SCC=CC2), SCS=120 kHz, nominal channel spacing.

FFS

4.3.1.2.3.5.6 CA\_n261G

Table 4.3.1.2.3.5.6-1: NR Intra-Band contiguous CA configuration CA\_n261G (PCC=CC1 and SCC=CC2), SCS=60 kHz, nominal channel spacing

CBW combination	CC	CBW [MHz]	SCS [kHz]	carrier Bandwidth [PRBs]	Range	Carrier centre [MHz] Note 2	Carrier centre [ARFCN]	point A [MHz]	absolute Frequency PointA [ARFCN]	offsetT oCarrier [Carrier PRBs]	SS block SCS [kHz]	GSCN	absolute Frequency SSB [ARFCN]	$k_{SSB}$	Offset Carrier CORESET#0 [RBs] Note 3	CORE SET#0 Index (Offset [RBs]) Note 4	offsetT oPoint A (SIB1) [PRBs] Note 4		
50+100	CC1	50	60	66	Downlink & Uplink	Low	27525	2071249	27501.24	2070853	0	120	22446	2071387	6	16	1 (8)	24	
						Mid	27874.92	2077081	27777.72	2075461	102		22466	2077147	6	10	1 (8)	120	
						High	28225.56	2082925	27838.92	2076481	504		22486	2082907	6	3	1 (8)	515	
	Channel spacing CC1-CC2=74.4 MHz (Note 1)																		
	CC2	100	60	132	Downlink & Uplink	Low	27599.4	2072489	27551.88	2071697	0	120	22448	2071963	2	2	0 (0)	2	
						Mid	27949.32	2078321	27828.36	2076305	102		22469	2078011	2	12	1 (8)	122	
						High	28299.96	2084165	27889.56	2077325	504		22489	2083771	2	5	1 (8)	517	
	100+100	CC1	100	60	132	Downlink & Uplink	Low	27550.08	2071667	27502.56	2070875	0	120	22446	2071387	8	14	1 (8)	22
							Mid	27874.92	2077081	27753.96	2075065	102		22464	2076571	6	3	0 (0)	105
High							28200	2082499	27789.6	2075659	504	22483		2082043	0	0	1 (8)	512	
Channel spacing CC1-CC2=99.96 MHz (Note 1)																			
CC2		100	60	132	Downlink	Low	27650.04	2073333	27602.52	2072541	0	120	22451	2072827	10	3	0 (0)	3	
						High													

					&	Mid	27974.88	2078747	27853.92	2076731	102		22470	2078299	8	0	1 (8)	110
					Uplink	High	28299.96	2084165	27889.56	2077325	504		22489	2083771	2	5	1 (8)	517

Note 1: Corresponds to nominal channel spacing in accordance with TS 38.101-2 [8], clause 5.4A.1 for the channel bandwidths of the two respective NR component carriers.  
 Note 2: CCs are specified in increasing frequency order. CC1 is used as PCell if nothing else is specified in the test case.  
 Note 3: The parameter Offset Carrier CORESET#0 specifies the offset from the lowest subcarrier of the carrier and the lowest subcarrier of CORESET#0. It corresponds to the parameter  $\Delta F_{\text{OffsetCORESET-0-Carrier}}$  in Annex C expressed in number of common RBs.  
 Note 4: The CORESET#0 Index and the associated CORESET#0 Offset refers to Table 13-7 in TS 38.213 [22]. The value of CORESET#0 Index is signalled in controlResourceSetZero (pdcc-ConfigSIB1) in the MIB. The offsetToPointA IE is expressed in units of resource blocks assuming 15 kHz subcarrier spacing for FR1 and 60 kHz subcarrier spacing for FR2.

Table 4.3.1.2.3.5.6-2: NR Intra-Band contiguous CA configuration CA\_n261G (PCC=CC1 and SCC=CC2), SCS=120 kHz, nominal channel spacing

CBW combination	CC	CBW [MHz]	SCS [kHz]	carrier Bandwidth [PRBs]	Range	Carrier centre [MHz] Note 2	Carrier centre [ARFCN]	point A [MHz]	absoluteFrequency PointA [ARFCN]	offsetToCarrier [Carrier PRBs]	SS block SCS [kHz]	GSCN	absoluteFrequency SSB [ARFCN]	$k_{\text{SSB}}$	Offset Carrier CORESET#0 [RBs] Note 3	CORESET#0 Index (Offset [RBs]) Note 4	offsetToPointA (SIB1) [PRBs] Note 4		
50+100	CC1	50	120	32	Downlink & Uplink	Low	27525	2071249	27501.96	2070865	0	120	22446	2071387	9	7	1 (4)	22	
						Mid	27875.04	2077083	27705.12	2074251	102		22466	2077147	8	4	1 (4)	220	
						High	28225.56	2082925	27476.76	2070445	504		22486	2082907	3	1	1 (4)	1018	
	Channel spacing CC1-CC2=74.4 MHz (Note 1)																		
	CC2	100	120	66	Downlink & Uplink	Low	27599.4	2072489	27551.88	2071697	0	120	22448	2071963	1	1	0 (0)	2	
						Mid	27949.44	2078323	27755.04	2075083	102		22469	2078011	0	6	1 (4)	224	
						High	28299.96	2084165	27526.68	2071277	504		22489	2083771	7	2	1 (4)	1020	
	100+100	CC1	100	120	66	Downlink & Uplink	Low	27550.08	2071667	27502.56	2070875	0	120	22446	2071387	4	7	1 (4)	22
							Mid	27875.04	2077083	27680.64	2073843	102		22464	2076571	8	1	0 (0)	206
High							28200	2082499	27426.72	2069611	504	22483		2082043	0	0	1 (4)	1016	
Channel spacing CC1-CC2=99.96 MHz (Note 1)																			
CC2		100	120	66	Downlink & Uplink	Low	27650.04	2073333	27602.52	2072541	0	120	22451	2072827	11	1	0 (0)	2	
						Mid	27975	2078749	27780.6	2075509	102		22470	2078299	3	0	1 (4)	212	
						High	28299.96	2084165	27526.68	2071277	504		22489	2083771	7	2	1 (4)	1020	

Note 1: Corresponds to nominal channel spacing in accordance with TS 38.101-2 [8], clause 5.4A.1 for the channel bandwidths of the two respective NR component carriers.  
 Note 2: CCs are specified in increasing frequency order. CC1 is used as PCell if nothing else is specified in the test case.  
 Note 3: The parameter Offset Carrier CORESET#0 specifies the offset from the lowest subcarrier of the carrier and the lowest subcarrier of CORESET#0. It corresponds to the parameter  $\Delta F_{\text{OffsetCORESET-0-Carrier}}$  in Annex C expressed in number of common RBs.  
 Note 4: The CORESET#0 Index and the associated CORESET#0 Offset refers to Table 13-8 in TS 38.213 [22]. The value of CORESET#0 Index is signalled in controlResourceSetZero (pdcc-ConfigSIB1) in the MIB. The offsetToPointA IE is expressed in units of resource blocks assuming 15 kHz subcarrier spacing for FR1 and 60 kHz subcarrier spacing for FR2.



Table 4.3.1.2.3.5.7-1: NR Intra-Band contiguous CA configuration CA\_n261H (PCC=CC1 and SCC=CC2, CC3), SCS=60 kHz, nominal channel spacing

CBW combination	CC	CBW [MHz]	SCS [kHz]	carrier bandwidth [PRBs]	Range	Carrier centre [MHz] Note 2	Carrier centre [ARFCN]	point A [MHz]	absolute Frequency Point A [ARFCN]	offsetToCarrier [Carrier PRBs]	SS block SCS [kHz]	GSCN	absolute Frequency SSB [ARFCN]	$k_{SSB}$	Offset Carrier CORESET#0 [RBs] Note 3	CORESET#0 Index (Offset [RBs]) Note 4	offsetToPoint A (SIB1) [PRBs] Note 4		
50+100+100	CC1	50	60	66	Downlink & Uplink	Low	27525	2071249	27501.24	2070853	0	120	22446	2071387	6	16	1 (8)	24	
						Mid	27825	2076249	27727.8	2074629	102		22463	2076283	10	7	1 (8)	117	
						High	28125.6	2081259	27738.96	2074815	504		22480	2081179	4	6	0 (0)	510	
	Channel spacing CC1-CC2=74.4 MHz (Note 1)																		
	CC2	100	60	132	Downlink & Uplink	Low	27599.4	2072489	27551.88	2071697	0	120	22448	2071963	2	2	0 (0)	2	
						Mid	27899.4	2077489	27778.44	2075473	102		22466	2077147	6	9	1 (8)	119	
						High	28200	2082499	27789.6	2075659	504		22483	2082043	0	0	1 (8)	512	
	Channel spacing CC2-CC3=99.96 MHz (Note 1)																		
	CC3	100	60	132	Downlink & Uplink	Low	27699.36	2074155	27651.84	2073363	0	120	22454	2073691	4	7	0 (0)	7	
						Mid	27999.36	2079155	27878.4	2077139	102		22472	2078875	8	14	1 (8)	124	
						High	28299.96	2084165	27889.56	2077325	504		22489	2083771	2	5	1 (8)	517	
	100+100+100	CC1	100	60	132	Downlink & Uplink	Low	27550.08	2071667	27502.56	2070875	0	120	22446	2071387	8	14	1 (8)	22
Mid							27825	2076249	27704.04	2074233	102	22461		2075707	10	0	0 (0)	102	
High							28100.04	2080833	27689.64	2073993	504	22477		2080315	10	2	0 (0)	506	
Channel spacing CC1-CC2=99.96 MHz (Note 1)																			
CC2		100	60	132	Downlink & Uplink	Low	27650.04	2073333	27602.52	2072541	0	120	22451	2072827	10	3	0 (0)	3	
						Mid	27924.96	2077915	27804	2075899	102		22467	2077435	0	6	0 (0)	108	
						High	28200	2082499	27789.6	2075659	504		22483	2082043	0	0	1 (8)	512	
Channel spacing CC2-CC3=99.96 MHz (Note 1)																			
CC3		100	60	132	Downlink & Uplink	Low	27750	2074999	27702.48	2074207	0	120	22457	2074555	0	1	1 (8)	9	
						Mid	28024.92	2079581	27903.96	2077565	102		22473	2079163	2	3	1 (8)	113	
						High	28299.96	2084165	27889.56	2077325	504		22489	2083771	2	5	1 (8)	517	

Note 1: Corresponds to nominal channel spacing in accordance with TS 38.101-2 [8], clause 5.4A.1 for the channel bandwidths of the two respective NR component carriers.

Note 2: CCs are specified in increasing frequency order. CC1 is used as PCell if nothing else is specified in the test case.

Note 3: The parameter Offset Carrier CORESET#0 specifies the offset from the lowest subcarrier of the carrier and the lowest subcarrier of CORESET#0. It corresponds to the parameter  $\Delta F_{\text{OffsetCORESET-0-Carrier}}$  in Annex C expressed in number of common RBs.

Note 4: The CORESET#0 Index and the associated CORESET#0 Offset refers to Table 13-7 in TS 38.213 [22]. The value of CORESET#0 Index is signalled in controlResourceSetZero (pdcc-ConfigSIB1) in the MIB. The offsetToPointA IE is expressed in units of resource blocks assuming 15 kHz subcarrier spacing for FR1 and 60 kHz subcarrier spacing for FR2.

Table 4.3.1.2.3.5.7-2: NR Intra-Band contiguous CA configuration CA\_n261H (PCC=CC1 and SCC=CC2, CC3), SCS=120 kHz, nominal channel spacing

CBW combination	CC	CBW [MHz]	SCS [kHz]	carrier bandwidth [PRBs]	Range	Carrier centre [MHz] Note 2	Carrier centre [ARFCN]	point A [MHz]	absolute frequency PointA [ARFCN]	offsetToCarrier [Carrier PRBs]	SS block SCS [kHz]	GSCN	absolute frequency SSB [ARFCN]	$k_s$	Offset Carrier CORESET#0 [RBs] Note 3	CORESET#0 Index (Offset [RBs]) Note 4	offsetToPointA (SIB1) [PRBs] Note 4		
50+100+100	CC1	50	120	32	Downlink & Uplink	Low	27525	2071249	27501.96	2070865	0	120	22446	2071387	9	7	1 (4)	22	
						Mid	27825	2076249	27655.08	2073417	102		22463	2076283	5	3	1 (4)	218	
						High	28125.6	2081259	27376.8	2068779	504		22480	2081179	8	2	0 (0)	1012	
	Channel spacing CC1-CC2=74.4 MHz (Note 1)																		
	CC2	100	120	66	Downlink & Uplink	Low	27599.4	2072489	27551.88	2071697	0	120	22448	2071963	1	1	0 (0)	2	
						Mid	27899.4	2077489	27705	2074249	102		22466	2077147	9	4	1 (4)	220	
						High	28200	2082499	27426.72	2069611	504		22483	2082043	0	0	1 (4)	1016	
	Channel spacing CC2-CC3=99.96 MHz (Note 1)																		
	CC3	100	120	66	Downlink & Uplink	Low	27699.36	2074155	27651.84	2073363	0	120	22454	2073691	8	3	0 (0)	6	
						Mid	27999.36	2079155	27804.96	2075915	102		22472	2078875	4	7	1 (4)	226	
						High	28299.96	2084165	27526.68	2071277	504		22489	2083771	7	2	1 (4)	1020	
	100+100+100	CC1	100	120	66	Downlink & Uplink	Low	27550.08	2071667	27502.56	2070875	0	120	22446	2071387	4	7	1 (4)	22
Mid							27825	2076249	27630.6	2073009	102	22461		2075707	5	0	0 (0)	204	
High							28100.04	2080833	27326.76	2067945	504	22477		2080315	5	1	0 (0)	1010	
Channel spacing CC1-CC2=99.96 MHz (Note 1)																			
CC2		100	120	66	Downlink & Uplink	Low	27650.04	2073333	27602.52	2072541	0	120	22451	2072827	11	1	0 (0)	2	
						Mid	27924.96	2077915	27730.56	2074675	102		22467	2077435	0	3	0 (0)	210	
						High	28200	2082499	27426.72	2069611	504		22483	2082043	0	0	1 (4)	1016	
Channel spacing CC2-CC3=99.96 MHz (Note 1)																			
CC3		100	120	66	Downlink & Uplink	Low	27750	2074999	27702.48	2074207	0	120	22457	2074555	6	0	1 (4)	8	
						Mid	28024.92	2079581	27830.52	2076341	102		22473	2079163	7	1	1 (4)	214	
						High	28299.96	2084165	27526.68	2071277	504		22489	2083771	7	2	1 (4)	1020	

Note 1: Corresponds to nominal channel spacing in accordance with TS 38.101-2 [8], clause 5.4A.1 for the channel bandwidths of the two respective NR component carriers.

Note 2: CCs are specified in increasing frequency order. CC1 is used as PCell if nothing else is specified in the test case.

Note 3: The parameter Offset Carrier CORESET#0 specifies the offset from the lowest subcarrier of the carrier and the lowest subcarrier of CORESET#0. It corresponds to the parameter  $\Delta F_{\text{OffsetCORESET-0-Carrier}}$  in Annex C expressed in number of common RBs.

Note 4: The CORESET#0 Index and the associated CORESET#0 Offset refers to Table 13-8 in TS 38.213 [22]. The value of CORESET#0 Index is signalled in controlResourceSetZero (pdcc-ConfigSIB1) in the MIB. The offsetToPointA IE is expressed in units of resource blocks assuming 15 kHz subcarrier spacing for FR1 and 60 kHz subcarrier spacing for FR2.

Table 4.3.1.2.3.5.8-1: NR Intra-Band contiguous CA configuration CA\_n2611 (PCC=CC1, SCC=CC2, CC3, CC4), SCS=60 kHz, nominal channel spacing

CBW combination	CC	CBW [MHz]	SCS [kHz]	carrier Bandwidth [PRBs]	Range		Carrier centre [MHz] Note 2	Carrier centre [ARFCN]	point A [MHz]	absolute Frequency Point A [ARFCN]	offset to Carrier [Carrier PRBs]	SS block SCS [kHz]	GSCN	absolute Frequency SSB [ARFCN]	k <sub>s</sub>	Offset Carrier CORESET#0 [RBs] Note 3	CORESET#0 Index (Offset [RBs]) Note 4	offset to Point A (SIB1) [PRBs] Note 4	
					Downlink & Uplink	Low Mid High													
50+100 +100+100	CC1	50	60	66	Downlink & Uplink	Low	27525	2071249	27501.24	2070853	0	120	22446	2071387	6	16	1 (8)	24	
						Mid	27774.96	2075415	27677.76	2073795	102		22460	2075419	4	5	1 (8)	115	
						High	28025.64	2079593	27639	2073149	504		22474	2079451	2	1	0 (0)	505	
	Channel spacing CC1-CC2=74.4 MHz (Note 1)																		
	CC2	100	60	132	Downlink & Uplink	Low	27599.4	2072489	27551.88	2071697	0	120	22448	2071963	2	2	0 (0)	2	
						Mid	27849.36	2076655	27728.4	2074639	102		22463	2076283	0	7	1 (8)	117	
						High	28100.04	2080833	27689.64	2073993	504		22477	2080315	10	2	0 (0)	506	
	Channel spacing CC2-CC3=99.96 MHz (Note 1)																		
	CC3	100	60	132	Downlink & Uplink	Low	27699.36	2074155	27651.84	2073363	0	120	22454	2073691	4	7	0 (0)	7	
						Mid	27949.32	2078321	27828.36	2076305	102		22469	2078011	2	12	1 (8)	122	
						High	28200	2082499	27789.6	2075659	504		22483	2082043	0	0	1 (8)	512	
	Channel spacing CC3-CC4=99.96 MHz (Note 1)																		
	CC4	100	60	132	Downlink & Uplink	Low	27799.32	2075821	27751.8	2075029	0	120	22460	2075419	6	4	1 (8)	12	
						Mid	28049.28	2079987	27928.32	2077971	102		22474	2079451	4	1	0 (0)	103	
						High	28299.96	2084165	27889.56	2077325	504		22489	2083771	2	5	1 (8)	517	
	100+100 +100+100	CC1	100	60	132	Downlink & Uplink	Low	27550.08	2071667	27502.56	2070875	0	120	22446	2071387	8	14	1 (8)	22
Mid							27774.96	2075415	27654	2073399	102	22459		2075131	4	14	1 (8)	124	
High							28000.08	2079167	27589.68	2072327	504	22472		2078875	8	13	1 (8)	525	
Channel spacing CC1-CC2=99.96 MHz (Note 1)																			
CC2		100	60	132	Downlink & Uplink	Low	27650.04	2073333	27602.52	2072541	0	120	22451	2072827	10	3	0 (0)	3	
						Mid	27874.92	2077081	27753.96	2075065	102		22464	2076571	6	3	0 (0)	105	
						High	28100.04	2080833	27689.64	2073993	504		22477	2080315	10	2	0 (0)	506	
Channel spacing CC2-CC3=99.96 MHz (Note 1)																			
CC3		100	60	132	Downlink & Uplink	Low	27750	2074999	27702.48	2074207	0	120	22457	2074555	0	1	1 (8)	9	
						Mid	27974.88	2078747	27853.92	2076731	102		22470	2078299	8	0	1 (8)	110	
						High	28200	2082499	27789.6	2075659	504		22483	2082043	0	0	1 (8)	512	
Channel spacing CC3-CC4=99.96 MHz (Note 1)																			
CC4		100	60	132	Downlink & Uplink	Low	27849.96	2076665	27802.44	2075873	0	120	22463	2076283	2	6	1 (8)	14	
						Mid	28074.84	2080413	27953.88	2078397	102		22476	2080027	10	5	1 (8)	115	
						High	28299.96	2084165	27889.56	2077325	504		22489	2083771	2	5	1 (8)	517	

Note 1: Corresponds to nominal channel spacing in accordance with TS 38.101-2 [8], clause 5.4A.1 for the channel bandwidths of the two respective NR component carriers.  
 Note 2: CCs are specified in increasing frequency order. CC1 is used as PCell if nothing else is specified in the test case.  
 Note 3: The parameter Offset Carrier CORESET#0 specifies the offset from the lowest subcarrier of the carrier and the lowest subcarrier of CORESET#0. It corresponds to the parameter

Note 4:  $\Delta F_{\text{OffsetCORESET-0-Carrier}}$  in Annex C expressed in number of common RBs. The CORESET#0 Index and the associated CORESET#0 Offset refers to Table 13-7 in TS 38.213 [22]. The value of CORESET#0 Index is signalled in controlResourceSetZero (pdcch-ConfigSIB1) in the MIB. The offsetToPointA IE is expressed in units of resource blocks assuming 15 kHz subcarrier spacing for FR1 and 60 kHz subcarrier spacing for FR2.

Table 4.3.1.2.3.5.8-2: NR Intra-Band contiguous CA configuration CA\_n261l (PCC=CC1, SCC=CC2, CC3,CC4), SCS=120 kHz, nominal channel spacing

CBW combination	CC	CBW [MHz]	SCS [kHz]	carrier bandwidth [PRBs]	Range		Carrier centre [MHz] Note 2	Carrier centre [ARFCN]	point A [MHz]	absolute Frequency PointA [ARFCN]	offsetToCarrier [Carrier PRBs]	SS block SCS [kHz]	GSCN	absolute Frequency SSB [ARFCN]	$k_s$	Offset Carrier CORESET#0 [RBs] Note 3	CORESET#0 Index (Offset [RBs]) Note 4	offsetToPointA (SIB1) [PRBs] Note 4	
					Downlink & Uplink														
50+100+100+100	CC1	50	120	32	Downlink & Uplink	Low	27525	2071249	27501.96	2070865	0	120	22446	2071387	9	7	1 (4)	22	
						Mid	27774.96	2075415	27605.04	2072583	102		22460	2075419	2	2	1 (4)	216	
						High	28025.64	2079593	27276.84	2067113	504		22474	2079451	1	0	0 (0)	1008	
	Channel spacing CC1-CC2=74.4 MHz (Note 1)																		
	CC2	100	120	66	Downlink & Uplink	Low	27599.4	2072489	27551.88	2071697	0	120	22448	2071963	1	1	0 (0)	2	
						Mid	27849.36	2076655	27654.96	2073415	102		22463	2076283	6	3	1 (4)	218	
						High	28100.04	2080833	27326.76	2067945	504		22477	2080315	5	1	0 (0)	1010	
	Channel spacing CC2-CC3=99.96 MHz (Note 1)																		
	CC3	100	120	66	Downlink & Uplink	Low	27699.36	2074155	27651.84	2073363	0	120	22454	2073691	8	3	0 (0)	6	
						Mid	27949.32	2078321	27754.92	2075081	102		22469	2078011	1	6	1 (4)	224	
						High	28200	2082499	27426.72	2069611	504		22483	2082043	0	0	1 (4)	1016	
	Channel spacing CC3-CC4=99.96 MHz (Note 1)																		
CC4	100	120	66	Downlink & Uplink	Low	27799.32	2075821	27751.8	2075029	0	120	22460	2075419	3	2	1 (4)	12		
					Mid	28049.28	2079987	27854.88	2076747	102		22474	2079451	8	0	0 (0)	204		
					High	28299.96	2084165	27526.68	2071277	504		22489	2083771	7	2	1 (4)	1020		
100+100+100+100	CC1	100	120	66	Downlink & Uplink	Low	27550.08	2071667	27502.56	2070875	0	120	22446	2071387	4	7	1 (4)	22	
						Mid	27774.96	2075415	27580.56	2072175	102		22459	2075131	2	7	1 (4)	226	
						High	28000.08	2079167	27226.8	2066279	504		22472	2078875	10	6	1 (4)	1028	
	Channel spacing CC1-CC2=99.96 MHz (Note 1)																		
	CC2	100	120	66	Downlink & Uplink	Low	27650.04	2073333	27602.52	2072541	0	120	22451	2072827	11	1	0 (0)	2	
						Mid	27874.92	2077081	27680.52	2073841	102		22464	2076571	9	1	0 (0)	206	
						High	28100.04	2080833	27326.76	2067945	504		22477	2080315	5	1	0 (0)	1010	
	Channel spacing CC2-CC3=99.96 MHz (Note 1)																		
	CC3	100	120	66	Downlink & Uplink	Low	27750	2074999	27702.48	2074207	0	120	22457	2074555	6	0	1 (4)	8	
						Mid	27974.88	2078747	27780.48	2075507	102		22470	2078299	4	0	1 (4)	212	
						High	28200	2082499	27426.72	2069611	504		22483	2082043	0	0	1 (4)	1016	
	Channel spacing CC3-CC4=99.96 MHz (Note 1)																		
CC4	100	120	66	Downlink & Uplink	Low	27849.96	2076665	27802.44	2075873	0	120	22463	2076283	1	3	1 (4)	14		
					Mid	28074.84	2080413	27880.44	2077173	102		22476	2080027	11	2	1 (4)	216		
					High	28299.96	2084165	27526.68	2071277	504		22489	2083771	7	2	1 (4)	1020		

Note 1: Corresponds to nominal channel spacing in accordance with TS 38.101-2 [8], clause 5.4A.1 for the channel bandwidths of the two respective NR component carriers.  
 Note 2: CCs are specified in increasing frequency order. CC1 is used as PCell if nothing else is specified in the test case.  
 Note 3: The parameter Offset Carrier CORESET#0 specifies the offset from the lowest subcarrier of the carrier and the lowest subcarrier of CORESET#0. It corresponds to the parameter  $\Delta F_{\text{OffsetCORESET-0-Carrier}}$  in Annex C expressed in number of common RBs.  
 Note 4: The CORESET#0 Index and the associated CORESET#0 Offset refers to Table 13-8 in TS 38.213 [22]. The value of CORESET#0 Index is signalled in controlResourceSetZero (pdcch-ConfigSIB1) in the MIB. The offsetToPointA IE is expressed in units of resource blocks assuming 15 kHz subcarrier spacing for FR1 and 60 kHz subcarrier spacing for FR2.

4.3.1.2.3.5.9 CA\_n261J

Table 4.3.1.2.3.5.9-1: NR Intra-Band contiguous CA configuration CA\_n261J (PCC=CC1, SCC=CC2, CC3, CC4), SCS=60 kHz, nominal channel spacing

CBW combination	CC	CBW [MHz]	SCS [kHz]	carrier Bandwidth [PRBs]	Range		Carrier centre [MHz] Note 2	Carrier centre [ARFCN]	point A [MHz]	absolute Frequency PointA [ARFCN]	offsetToCarrier [Carrier PRBs]	SS block SCS [kHz]	GSCN	absolute Frequency SSB [ARFCN]	$k_s$	Offset Carrier CORESET#0 [RBs] Note 3	CORE SET#0 Index (Offset [RBs]) Note 4	offsetToPointA (SIB1) [PRBs] Note 4	
					Downlink & Uplink	Low Mid High													
50+100 +100+100 +100	CC1	50	60	66	Downlink & Uplink	Low	27525	2071249	27501.24	2070853	0	120	22446	2071387	6	16	1 (8)	24	
						Mid	27724.92	2074581	27627.72	2072961	102		22457	2074555	10	2	1 (8)	112	
						High	27925.68	2077927	27539.04	2071483	504		22469	2078011	0	12	1 (8)	524	
	Channel spacing CC1-CC2=74.4 MHz (Note 1)																		
	CC2	100	60	132	Downlink & Uplink	Low	27599.4	2072489	27551.88	2071697	0	120	22448	2071963	2	2	0 (0)	2	
						Mid	27799.32	2075821	27678.36	2073805	102		22460	2075419	6	4	1 (8)	114	
						High	28000.08	2079167	27589.68	2072327	504		22472	2078875	8	13	1 (8)	525	
	Channel spacing CC2-CC3=99.96 MHz (Note 1)																		
	CC3	100	60	132	Downlink & Uplink	Low	27699.36	2074155	27651.84	2073363	0	120	22454	2073691	4	7	0 (0)	7	
						Mid	27899.28	2077487	27778.32	2075471	102		22466	2077147	8	9	1 (8)	119	
						High	28100.04	2080833	27689.64	2073993	504		22477	2080315	10	2	0 (0)	506	
	Channel spacing CC3-CC4=99.96 MHz (Note 1)																		
	CC4	100	60	132	Downlink & Uplink	Low	27799.32	2075821	27751.8	2075029	0	120	22460	2075419	6	4	1 (8)	12	
						Mid	27999.24	2079153	27878.28	2077137	102		22472	2078875	10	14	1 (8)	124	
						High	28200	2082499	27789.6	2075659	504		22483	2082043	0	0	1 (8)	512	
Channel spacing CC4-CC5=99.96 MHz (Note 1)																			
CC5	100	60	132	Downlink & Uplink	Low	27899.28	2077487	27851.76	2076695	0	120	22466	2077147	8	9	1 (8)	17		
					Mid	28099.2	2080819	27978.24	2078803	102		22477	2080315	0	4	0 (0)	106		
					High	28299.96	2084165	27889.56	2077325	504		22489	2083771	2	5	1 (8)	517		
100+100 +100+100 +100	CC1	100	60	132	Downlink & Uplink	Low	27550.08	2071667	27502.56	2070875	0	120	22446	2071387	8	14	1 (8)	22	
						Mid	27724.92	2074581	27603.96	2072565	102		22456	2074267	10	11	1 (8)	121	
						High	27900.12	2077501	27489.72	2070661	504		22466	2077147	6	8	1 (8)	520	
	Channel spacing CC1-CC2=99.96 MHz (Note 1)																		
	CC2	100	60	132	Downlink & Uplink	Low	27650.04	2073333	27602.52	2072541	0	120	22451	2072827	10	3	0 (0)	3	
						Mid	27824.88	2076247	27703.92	2074231	102		22461	2075707	0	1	0 (0)	103	

				Uplink	High	28000.08	2079167	27589.68	2072327	504		22472	2078875	8	13	1 (8)	525
Channel spacing CC2-CC3=99.96 MHz (Note 1)																	
CC3	100	60	132	Downlink & Uplink	Low	27750	2074999	27702.48	2074207	0	120	22457	2074555	0	1	1 (8)	9
					Mid	27924.84	2077913	27803.88	2075897	102		22467	2077435	2	6	0 (0)	108
					High	28100.04	2080833	27689.64	2073993	504		22477	2080315	10	2	0 (0)	506
Channel spacing CC3-CC4=99.96 MHz (Note 1)																	
CC4	100	60	132	Downlink & Uplink	Low	27849.96	2076665	27802.44	2075873	0	120	22463	2076283	2	6	1 (8)	14
					Mid	28024.8	2079579	27903.84	2077563	102		22473	2079163	4	3	1 (8)	113
					High	28200	2082499	27789.6	2075659	504		22483	2082043	0	0	1 (8)	512
Channel spacing CC4-CC5=99.96 MHz (Note 1)																	
CC5	100	60	132	Downlink & Uplink	Low	27949.92	2078331	27902.4	2077539	0	120	22469	2078011	4	11	1 (8)	19
					Mid	28124.76	2081245	28003.8	2079229	102		22479	2080891	6	8	1 (8)	118
					High	28299.96	2084165	27889.56	2077325	504		22489	2083771	2	5	1 (8)	517
Note 1: Corresponds to nominal channel spacing in accordance with TS 38.101-2 [8], clause 5.4A.1 for the channel bandwidths of the two respective NR component carriers.																	
Note 2: CCs are specified in increasing frequency order. CC1 is used as PCell if nothing else is specified in the test case.																	
Note 3: The parameter Offset Carrier CORESET#0 specifies the offset from the lowest subcarrier of the carrier and the lowest subcarrier of CORESET#0. It corresponds to the parameter $\Delta F_{\text{OffsetCORESET-0-Carrier}}$ in Annex C expressed in number of common RBs.																	
Note 4: The CORESET#0 Index and the associated CORESET#0 Offset refers to Table 13-7 in TS 38.213 [22]. The value of CORESET#0 Index is signalled in controlResourceSetZero (pdcch-ConfigSIB1) in the MIB. The offsetToPointA IE is expressed in units of resource blocks assuming 15 kHz subcarrier spacing for FR1 and 60 kHz subcarrier spacing for FR2.																	

Table 4.3.1.2.3.5.9-2: NR Intra-Band contiguous CA configuration CA\_n261J (PCC=CC1, SCC=CC2, CC3, CC4), SCS=120 kHz, nominal channel spacing

CBW combination	CC	CBW [MHz]	SCS [kHz]	carrierBandwidth [PRBs]	Range	Carrier centre [MHz] Note 2	Carrier centre [ARFCN]	point A [MHz]	absoluteFrequency PointA [ARFCN]	offsetToCarrier [Carrier PRBs]	SS block SCS [kHz]	GSCN	absoluteFrequency SSB [ARFCN]	$k_s$	Offset Carrier CORESET#0 [RBs] Note 3	CORE SET#0 Index (Offset [RBs]) Note 4	offsetToPoint A (SIB1) [PRBs] Note 4	
50+100 +100+100 +100	CC1	50	120	32	Downlink & Uplink	Low	27525	2071249	27501.96	2070865	0	120	22446	2071387	9	7	1 (4)	22
						Mid	27725.04	2074583	27555.12	2071751	102		22457	2074555	10	0	1 (4)	212
						High	27925.68	2077927	27176.88	2065447	504		22469	2078011	6	5	1 (4)	1026
	Channel spacing CC1-CC2=74.4 MHz (Note 1)																	
	CC2	100	120	66	Downlink & Uplink	Low	27599.4	2072489	27551.88	2071697	0	120	22448	2071963	1	1	0 (0)	2
						Mid	27799.44	2075823	27605.04	2072583	102		22460	2075419	2	2	1 (4)	216
						High	28000.08	2079167	27226.8	2066279	504		22472	2078875	10	6	1 (4)	1028
	Channel spacing CC2-CC3=99.96 MHz (Note 1)																	
	CC3	100	120	66	Downlink & Uplink	Low	27699.36	2074155	27651.84	2073363	0	120	22454	2073691	8	3	0 (0)	6
Mid						27899.4	2077489	27705	2074249	102	22466		2077147	9	4	1 (4)	220	
High						28100.04	2080833	27326.76	2067945	504	22477		2080315	5	1	0 (0)	1010	
Channel spacing CC3-CC4=99.96 MHz (Note 1)																		
CC4	100	120	66	Downlink & Uplink	Low	27799.32	2075821	27751.8	2075029	0	120	22460	2075419	3	2	1 (4)	12	
					Mid	27999.36	2079155	27804.96	2075915	102		22472	2078875	4	7	1 (4)	226	

				Uplink	High	28200	2082499	27426.72	2069611	504		22483	2082043	0	0	1 (4)	1016	
Channel spacing CC4-CC5=99.96 MHz (Note 1)																		
	CC5	100	120	66	Downlink & Uplink	Low	27899.28	2077487	27851.76	2076695	0	120	22466	2077147	10	4	1 (4)	16
						Mid	28099.32	2080821	27904.92	2077581	102		22477	2080315	11	1	0 (0)	206
						High	28299.96	2084165	27526.68	2071277	504		22489	2083771	7	2	1 (4)	1020
100+100 +100+100 +100	CC1	100	120	66	Downlink & Uplink	Low	27550.08	2071667	27502.56	2070875	0	120	22446	2071387	4	7	1 (4)	22
						Mid	27725.04	2074583	27530.64	2071343	102		22456	2074267	10	5	1 (4)	222
						High	27900.12	2077501	27126.84	2064613	504		22466	2077147	3	4	1 (4)	1024
	Channel spacing CC1-CC2=99.96 MHz (Note 1)																	
	CC2	100	120	66	Downlink & Uplink	Low	27650.04	2073333	27602.52	2072541	0	120	22451	2072827	11	1	0 (0)	2
						Mid	27825	2076249	27630.6	2073009	102		22461	2075707	5	0	0 (0)	204
						High	28000.08	2079167	27226.8	2066279	504		22472	2078875	10	6	1 (4)	1028
	Channel spacing CC2-CC3=99.96 MHz (Note 1)																	
	CC3	100	120	66	Downlink & Uplink	Low	27750	2074999	27702.48	2074207	0	120	22457	2074555	6	0	1 (4)	8
						Mid	27924.96	2077915	27730.56	2074675	102		22467	2077435	0	3	0 (0)	210
						High	28100.04	2080833	27326.76	2067945	504		22477	2080315	5	1	0 (0)	1010
	Channel spacing CC3-CC4=99.96 MHz (Note 1)																	
	CC4	100	120	66	Downlink & Uplink	Low	27849.96	2076665	27802.44	2075873	0	120	22463	2076283	1	3	1 (4)	14
						Mid	28024.92	2079581	27830.52	2076341	102		22473	2079163	7	1	1 (4)	214
						High	28200	2082499	27426.72	2069611	504		22483	2082043	0	0	1 (4)	1016
Channel spacing CC4-CC5=99.96 MHz (Note 1)																		
CC5	100	120	66	Downlink & Uplink	Low	27949.92	2078331	27902.4	2077539	0	120	22469	2078011	8	5	1 (4)	18	
					Mid	28124.88	2081247	27930.48	2078007	102		22479	2080891	2	4	1 (4)	220	
					High	28299.96	2084165	27526.68	2071277	504		22489	2083771	7	2	1 (4)	1020	

Note 1: Corresponds to nominal channel spacing in accordance with TS 38.101-2 [8], clause 5.4A.1 for the channel bandwidths of the two respective NR component carriers.

Note 2: CCs are specified in increasing frequency order. CC1 is used as PCell if nothing else is specified in the test case.

Note 3: The parameter Offset Carrier CORESET#0 specifies the offset from the lowest subcarrier of the carrier and the lowest subcarrier of CORESET#0. It corresponds to the parameter  $\Delta F_{\text{OffsetCORESET-0-Carrier}}$  in Annex C expressed in number of common RBs.

Note 4: The CORESET#0 Index and the associated CORESET#0 Offset refers to Table 13-8 in TS 38.213 [22]. The value of CORESET#0 Index is signalled in controlResourceSetZero (pdcch-ConfigSIB1) in the MIB. The offsetToPointA IE is expressed in units of resource blocks assuming 15 kHz subcarrier spacing for FR1 and 60 kHz subcarrier spacing for FR2.

4.3.1.2.3.5.10 CA\_n261K

FFS

4.3.1.2.3.5.11 CA\_n261L

FFS

4.3.1.2.3.5.12 CA\_n261M

Table 4.3.1.2.3.5.12-1: NR Intra-Band contiguous CA configuration CA\_n261M (PCC=CC1, SCC=CC2, CC3, CC4, CC5, CC6, CC7, CC8), SCS=60 kHz, nominal channel spacing

CBW combination	CC	CBW [MHz]	SCS [kHz]	carrier bandwidth [PRBs]	Range	Carrier centre [MHz] Note 2	Carrier centre [ARFCN]	point A [MHz]	absoluteFrequency PointA [ARFCN]	offsetToCarrier [Carrier PRBs]	SS block SCS [kHz]	GSCN	absoluteFrequency SSB [ARFCN]	$k_{SSB}$	Offset Carrier CORES ET#0 [RBs] Note 3	CORE SET#0 Index Note 4	offsetToPointA (SIB1) [PRBs] Note 4		
50+100 +100+100 +100+100 +100+100	CC1	50	60	66	Downlink & Uplink	Low	27525	2071249	27501.24	2070853	0	120	22446	2071387	6	16	1 (8)	24	
						Mid	27574.92	2072081	27477.72	2070461	102		22448	2071963	2	3	0 (0)	105	
						High	27625.8	2072929	27239.16	2066485	504		22451	2072827	6	4	0 (0)	508	
	Channel spacing CC1-CC2=74.4 MHz (Note 1)																		
	CC2	100	60	132	Downlink & Uplink	Low	27599.4	2072489	27551.88	2071697	0	120	22448	2071963	2	2	0 (0)	2	
						Mid	27649.32	2073321	27528.36	2071305	102		22451	2072827	10	4	0 (0)	106	
						High	27700.2	2074169	27289.8	2067329	504		22454	2073691	2	6	0 (0)	510	
	Channel spacing CC2-CC3=99.96 MHz (Note 1)																		
	CC3	100	60	132	Downlink & Uplink	Low	27699.36	2074155	27651.84	2073363	0	120	22454	2073691	4	7	0 (0)	7	
						Mid	27749.28	2074987	27628.32	2072971	102		22457	2074555	0	2	1 (8)	112	
						High	27800.16	2075835	27389.76	2068995	504		22460	2075419	4	3	1 (8)	515	
	Channel spacing CC3-CC4=99.96 MHz (Note 1)																		
	CC4	100	60	132	Downlink & Uplink	Low	27799.32	2075821	27751.8	2075029	0	120	22460	2075419	6	4	1 (8)	12	
						Mid	27849.24	2076653	27728.28	2074637	102		22463	2076283	2	7	1 (8)	117	
						High	27900.12	2077501	27489.72	2070661	504		22466	2077147	6	8	1 (8)	520	
	Channel spacing CC4-CC5=99.96 MHz (Note 1)																		
	CC5	100	60	132	Downlink & Uplink	Low	27899.28	2077487	27851.76	2076695	0	120	22466	2077147	8	9	1 (8)	17	
						Mid	27949.2	2078319	27828.24	2076303	102		22469	2078011	4	12	1 (8)	122	
						High	28000.08	2079167	27589.68	2072327	504		22472	2078875	8	13	1 (8)	525	
	Channel spacing CC5-CC6=99.96 MHz (Note 1)																		
	CC6	100	60	132	Downlink & Uplink	Low	27999.24	2079153	27951.72	2078361	0	120	22472	2078875	10	14	1 (8)	22	
						Mid	28049.16	2079985	27928.2	2077969	102		22474	2079451	6	1	0 (0)	103	
						High	28100.04	2080833	27689.64	2073993	504		22477	2080315	10	2	0 (0)	506	
	Channel spacing CC6-CC7=99.96 MHz (Note 1)																		
CC7	100	60	132	Downlink & Uplink	Low	28099.2	2080819	28051.68	2080027	0	120	22477	2080315	0	4	0 (0)	4		
					Mid	28149.12	2081651	28028.16	2079635	102		22480	2081179	8	6	0 (0)	108		
					High	28200	2082499	27789.6	2075659	504		22483	2082043	0	0	1 (8)	512		
Channel spacing CC7-CC8=99.96 MHz (Note 1)																			
CC8	100	60	132	Downlink & Uplink	Low	28199.16	2082485	28151.64	2081693	0	120	22483	2082043	2	1	1 (8)	9		
					Mid	28249.08	2083317	28128.12	2081301	102		22486	2082907	10	3	1 (8)	113		
					High	28299.96	2084165	27889.56	2077325	504		22489	2083771	2	5	1 (8)	517		
100+100 +100+100 +100+100 +100+100	CC1	100	60	132	Downlink & Uplink	Low	27550.08	2071667	27502.56	2070875	0	120	22446	2071387	8	14	1 (8)	22	
						Mid	27574.92	2072081	27453.96	2070065	102		22447	2071675	2	4	1 (8)	114	
						High	27600.24	2072503	27189.84	2065663	504		22448	2071963	0	1	0 (0)	505	
Channel spacing CC1-CC2=99.96 MHz (Note 1)																			



CC2	100	60	132	Downlink & Uplink	Low	27650.04	2073333	27602.52	2072541	0	120	22451	2072827	10	3	0 (0)	3
					Mid	27674.88	2073747	27553.92	2071731	102		22453	2073403	4	9	1 (8)	119
					High	27700.2	2074169	27289.8	2067329	504		22454	2073691	2	6	0 (0)	510
Channel spacing CC2-CC3=99.96 MHz (Note 1)																	
CC3	100	60	132	Downlink & Uplink	Low	27750	2074999	27702.48	2074207	0	120	22457	2074555	0	1	1 (8)	9
					Mid	27774.84	2075413	27653.88	2073397	102		22459	2075131	6	14	1 (8)	124
					High	27800.16	2075835	27389.76	2068995	504		22460	2075419	4	3	1 (8)	515
Channel spacing CC3-CC4=99.96 MHz (Note 1)																	
CC4	100	60	132	Downlink & Uplink	Low	27849.96	2076665	27802.44	2075873	0	120	22463	2076283	2	6	1 (8)	14
					Mid	27874.8	2077079	27753.84	2075063	102		22464	2076571	8	3	0 (0)	105
					High	27900.12	2077501	27489.72	2070661	504		22466	2077147	6	8	1 (8)	520
Channel spacing CC4-CC5=99.96 MHz (Note 1)																	
CC5	100	60	132	Downlink & Uplink	Low	27949.92	2078331	27902.4	2077539	0	120	22469	2078011	4	11	1 (8)	19
					Mid	27974.76	2078745	27853.8	2076729	102		22470	2078299	10	0	1 (8)	110
					High	28000.08	2079167	27589.68	2072327	504		22472	2078875	8	13	1 (8)	525
Channel spacing CC5-CC6=99.96 MHz (Note 1)																	
CC6	100	60	132	Downlink & Uplink	Low	28049.88	2079997	28002.36	2079205	0	120	22474	2079451	6	0	0 (0)	0
					Mid	28074.72	2080411	27953.76	2078395	102		22476	2080027	0	6	1 (8)	116
					High	28100.04	2080833	27689.64	2073993	504		22477	2080315	10	2	0 (0)	506
Channel spacing CC6-CC7=99.96 MHz (Note 1)																	
CC7	100	60	132	Downlink & Uplink	Low	28149.84	2081663	28102.32	2080871	0	120	22480	2081179	8	5	0 (0)	5
					Mid	28174.68	2082077	28053.72	2080061	102		22482	2081755	2	11	1 (8)	121
					High	28200	2082499	27789.6	2075659	504		22483	2082043	0	0	1 (8)	512
Channel spacing CC7-CC8=99.96 MHz (Note 1)																	
CC8	100	60	132	Downlink & Uplink	Low	28249.8	2083329	28202.28	2082537	0	120	22486	2082907	10	2	1 (8)	10
					Mid	28274.64	2083743	28153.68	2081727	102		22487	2083195	4	0	0 (0)	102
					High	28299.96	2084165	27889.56	2077325	504		22489	2083771	2	5	1 (8)	517

- Note 1: Corresponds to nominal channel spacing in accordance with TS 38.101-2 [8], clause 5.4A.1 for the channel bandwidths of the two respective NR component carriers.
- Note 2: CCs are specified in increasing frequency order. CC1 is used as PCell if nothing else is specified in the test case.
- Note 3: The parameter Offset Carrier CORESET#0 specifies the offset from the lowest subcarrier of the carrier and the lowest subcarrier of CORESET#0. It corresponds to the parameter  $\Delta$ OffsetCORESET-0-Carrier in Annex C expressed in number of common RBs.
- Note 4: The CORESET#0 Index and the associated CORESET#0 Offset refers to Table 13-7 in TS 38.213 [22]. The value of CORESET#0 Index is signalled in controlResourceSetZero (pdcch-ConfigSIB1) in the MIB. The offsetToPointA IE is expressed in units of resource blocks assuming 15 kHz subcarrier spacing for FR1 and 60 kHz subcarrier spacing for FR2.

**Table 4.3.1.2.3.5.12-2: NR Intra-Band contiguous CA configuration CA\_n261M (PCC=CC1, SCC=CC2, CC3, CC4, CC5, CC6, CC7, CC8), SCS=120 kHz, nominal channel spacing**

CBW combination	CC	CBW [MHz]	SCS [kHz]	carrierBandwidth [PRBs]	Range	Carrier centre [MHz] Note 2	Carrier centre [ARFCN]	point A [MHz]	absoluteFrequencyPointA [ARFCN]	offsetToCarrier [Carrier PRBs]	SS block SCS [kHz]	GSCN	absoluteFrequencySSB [ARFCN]	$k_{SSB}$	Offset Carrier CORESET#0 [RBs] Note 3	CORE SET#0 Index (Offset) [RBs]	offsetToPointA (SIB1) [PRBs] Note 4
-----------------	----	-----------	-----------	-------------------------	-------	-----------------------------	------------------------	---------------	---------------------------------	--------------------------------	--------------------	------	------------------------------	-----------	---------------------------------------	---------------------------------	-------------------------------------

																	Note 4	
50+100 +100+100 +100+100 +100+100	CC1	50	120	32	Downlink & Uplink	Low	27525	2071249	27501.96	2070865	0	120	22446	2071387	9	7	1 (4)	22
						Mid	27575.04	2072083	27405.12	2069251	102		22448	2071963	0	1	0 (0)	206
						High	27625.8	2072929	26877	2060449	504		22451	2072827	9	1	0 (0)	1010
	Channel spacing CC1-CC2=74.4 MHz (Note 1)																	
	CC2	100	120	66	Downlink & Uplink	Low	27599.4	2072489	27551.88	2071697	0	120	22448	2071963	1	1	0 (0)	2
						Mid	27649.44	2073323	27455.04	2070083	102		22451	2072827	4	2	0 (0)	208
						High	27700.2	2074169	26926.92	2061281	504		22454	2073691	1	3	0 (0)	1014
	Channel spacing CC2-CC3=99.96 MHz (Note 1)																	
	CC3	100	120	66	Downlink & Uplink	Low	27699.36	2074155	27651.84	2073363	0	120	22454	2073691	8	3	0 (0)	6
						Mid	27749.4	2074989	27555	2071749	102		22457	2074555	11	0	1 (4)	212
						High	27800.16	2075835	27026.88	2062947	504		22460	2075419	8	1	1 (4)	1018
	Channel spacing CC3-CC4=99.96 MHz (Note 1)																	
	CC4	100	120	66	Downlink & Uplink	Low	27799.32	2075821	27751.8	2075029	0	120	22460	2075419	3	2	1 (4)	12
						Mid	27849.36	2076655	27654.96	2073415	102		22463	2076283	6	3	1 (4)	218
						High	27900.12	2077501	27126.84	2064613	504		22466	2077147	3	4	1 (4)	1024
	Channel spacing CC4-CC5=99.96 MHz (Note 1)																	
	CC5	100	120	66	Downlink & Uplink	Low	27899.28	2077487	27851.76	2076695	0	120	22466	2077147	10	4	1 (4)	16
						Mid	27949.32	2078321	27754.92	2075081	102		22469	2078011	1	6	1 (4)	224
						High	28000.08	2079167	27226.8	2066279	504		22472	2078875	10	6	1 (4)	1028
	Channel spacing CC5-CC6=99.96 MHz (Note 1)																	
	CC6	100	120	66	Downlink & Uplink	Low	27999.24	2079153	27951.72	2078361	0	120	22472	2078875	5	7	1 (4)	22
						Mid	28049.28	2079987	27854.88	2076747	102		22474	2079451	8	0	0 (0)	204
						High	28100.04	2080833	27326.76	2067945	504		22477	2080315	5	1	0 (0)	1010
	Channel spacing CC6-CC7=99.96 MHz (Note 1)																	
CC7	100	120	66	Downlink & Uplink	Low	28099.2	2080819	28051.68	2080027	0	120	22477	2080315	0	2	0 (0)	4	
					Mid	28149.24	2081653	27954.84	2078413	102		22480	2081179	3	3	0 (0)	210	
					High	28200	2082499	27426.72	2069611	504		22483	2082043	0	0	1 (4)	1016	
Channel spacing CC7-CC8=99.96 MHz (Note 1)																		
CC8	100	120	66	Downlink & Uplink	Low	28199.16	2082485	28151.64	2081693	0	120	22483	2082043	7	0	1 (4)	8	
					Mid	28249.2	2083319	28054.8	2080079	102		22486	2082907	10	1	1 (4)	214	
					High	28299.96	2084165	27526.68	2071277	504		22489	2083771	7	2	1 (4)	1020	
100+100 +100+100 +100+100 +100+100	CC1	100	120	66	Downlink & Uplink	Low	27550.08	2071667	27502.56	2070875	0	120	22446	2071387	4	7	1 (4)	22
						Mid	27575.04	2072083	27380.64	2068843	102		22447	2071675	0	2	1 (4)	216
						High	27600.24	2072503	26826.96	2059615	504		22448	2071963	6	0	0 (0)	1008
	Channel spacing CC1-CC2=99.96 MHz (Note 1)																	
	CC2	100	120	66	Downlink & Uplink	Low	27650.04	2073333	27602.52	2072541	0	120	22451	2072827	11	1	0 (0)	2
						Mid	27675	2073749	27480.6	2070509	102		22453	2073403	7	4	1 (4)	220
						High	27700.2	2074169	26926.92	2061281	504		22454	2073691	1	3	0 (0)	1014
	Channel spacing CC2-CC3=99.96 MHz (Note 1)																	
	CC3	100	120	66	Downlink & Uplink	Low	27750	2074999	27702.48	2074207	0	120	22457	2074555	6	0	1 (4)	8
						Mid	27774.96	2075415	27580.56	2072175	102		22459	2075131	2	7	1 (4)	226
						High	27800.16	2075835	27026.88	2062947	504		22460	2075419	8	1	1 (4)	1018
	Channel spacing CC3-CC4=99.96 MHz (Note 1)																	

CC4	100	120	66	Downlink & Uplink	Low	27849.96	2076665	27802.44	2075873	0	120	22463	2076283	1	3	1 (4)	14
					Mid	27874.92	2077081	27680.52	2073841	102		22464	2076571	9	1	0 (0)	206
					High	27900.12	2077501	27126.84	2064613	504		22466	2077147	3	4	1 (4)	1024
Channel spacing CC4-CC5=99.96 MHz (Note 1)																	
CC5	100	120	66	Downlink & Uplink	Low	27949.92	2078331	27902.4	2077539	0	120	22469	2078011	8	5	1 (4)	18
					Mid	27974.88	2078747	27780.48	2075507	102		22470	2078299	4	0	1 (4)	212
					High	28000.08	2079167	27226.8	2066279	504		22472	2078875	10	6	1 (4)	1028
Channel spacing CC5-CC6=99.96 MHz (Note 1)																	
CC6	100	120	66	Downlink & Uplink	Low	28049.88	2079997	28002.36	2079205	0	120	22474	2079451	3	0	0 (0)	0
					Mid	28074.84	2080413	27880.44	2077173	102		22476	2080027	11	2	1 (4)	216
					High	28100.04	2080833	27326.76	2067945	504		22477	2080315	5	1	0 (0)	1010
Channel spacing CC6-CC7=99.96 MHz (Note 1)																	
CC7	100	120	66	Downlink & Uplink	Low	28149.84	2081663	28102.32	2080871	0	120	22480	2081179	10	2	0 (0)	4
					Mid	28174.8	2082079	27980.4	2078839	102		22482	2081755	6	5	1 (4)	222
					High	28200	2082499	27426.72	2069611	504		22483	2082043	0	0	1 (4)	1016
Channel spacing CC7-CC8=99.96 MHz (Note 1)																	
CC8	100	120	66	Downlink & Uplink	Low	28249.8	2083329	28202.28	2082537	0	120	22486	2082907	5	1	1 (4)	10
					Mid	28274.76	2083745	28080.36	2080505	102		22487	2083195	1	0	0 (0)	204
					High	28299.96	2084165	27526.68	2071277	504		22489	2083771	7	2	1 (4)	1020

- Note 1: Corresponds to nominal channel spacing in accordance with TS 38.101-2 [8], clause 5.4A.1 for the channel bandwidths of the two respective NR component carriers.
- Note 2: CCs are specified in increasing frequency order. CC1 is used as PCell if nothing else is specified in the test case.
- Note 3: The parameter Offset Carrier CORESET#0 specifies the offset from the lowest subcarrier of the carrier and the lowest subcarrier of CORESET#0. It corresponds to the parameter  $\Delta F_{\text{OffsetCORESET-0-Carrier}}$  in Annex C expressed in number of common RBs.
- Note 4: The CORESET#0 Index and the associated CORESET#0 Offset refers to Table 13-8 in TS 38.213 [22]. The value of CORESET#0 Index is signalled in controlResourceSetZero (pdcch-ConfigSIB1) in the MIB. The offsetToPointA IE is expressed in units of resource blocks assuming 15 kHz subcarrier spacing for FR1 and 60 kHz subcarrier spacing for FR2.

4.3.1.2.3.5.13 CA\_n261O

Editor's note: CA\_n261O Test frequencies are FFS.

Table 4.3.1.2.3.5.13-1: NR Intra-Band contiguous CA configuration CA\_n261O (PCC=CC1 and SCC=CC2), SCS=60 kHz, nominal channel spacing

CBW combination	CC	CBW [MHz]	SCS [kHz]	carrier Bandwidth [PRBs]	Range	Carrier centre [MHz] Note 2	Carrier centre [ARFCN]	point A [MHz]	absolute Frequency PointA [ARFCN]	offsetToCarrier [Carrier PRBs]	SS block SCS [kHz]	GSCN	absolute Frequency SSB [ARFCN]	$k_s$	Offset Carrier CORESET#0 [RBs] Note 3	CORESET#0 Index (Offset [RBs]) Note 4	offsetToPointA (SIB1) [PRBs] Note 4

Table 4.3.1.2.3.5.13-2: NR Intra-Band contiguous CA configuration CA\_n261O (PCC=CC1 and SCC=CC2), SCS=120 kHz, nominal channel spacing

CBW combination	CC	CBW [MHz]	SCS [kHz]	carrierBand width [PRBs]	Range	Carrier centre [MHz] Note 2	Carrier centre [ARFCN]	point A [MHz]	absoluteFrequency PointA [ARFCN]	offsetToCarrier [Carrier PRBs]	SS block SCS [kHz]	GSCN	absoluteFrequency SSB [ARFCN]	$k_s$	Offset Carrier CORESET#0 [RBs] Note 3	CORE SET#0 Index (Offset [RBs]) Note 4	offsetToPoint A (SIB1) [PRBs] Note 4

4.3.1.2.3.5.14 CA\_n261P

Editor's note: CA\_n261P Test frequencies are FFS.

Table 4.3.1.2.3.5.14-1: NR Intra-Band contiguous CA configuration CA\_n261P (PCC=CC1 and SCC=CC2, CC3), SCS=60 kHz, nominal channel spacing

CBW combination	CC	CBW [MHz]	SCS [kHz]	carrierBand width [PRBs]	Range	Carrier centre [MHz] Note 2	Carrier centre [ARFCN]	point A [MHz]	absoluteFrequency PointA [ARFCN]	offsetToCarrier [Carrier PRBs]	SS block SCS [kHz]	GSCN	absoluteFrequency SSB [ARFCN]	$k_s$	Offset Carrier CORESET#0 [RBs] Note 3	CORE SET#0 Index (Offset [RBs]) Note 4	offsetToPoint A (SIB1) [PRBs] Note 4

Table 4.3.1.2.3.5.14-2: NR Intra-Band contiguous CA configuration CA\_n261P (PCC=CC1 and SCC=CC2, CC3), SCS=120 kHz, nominal channel spacing

CBW combination	CC	CBW [MHz]	SCS [kHz]	carrierBand width [PRBs]	Range	Carrier centre [MHz] Note 2	Carrier centre [ARFCN]	point A [MHz]	absoluteFrequency PointA [ARFCN]	offsetToCarrier [Carrier PRBs]	SS block SCS [kHz]	GSCN	absoluteFrequency SSB [ARFCN]	$k_s$	Offset Carrier CORESET#0 [RBs] Note 3	CORE SET#0 Index (Offset [RBs]) Note 4	offsetToPoint A (SIB1) [PRBs] Note 4

4.3.1.2.3.5.15 CA\_n261Q

FFS

4.3.1.2.4 NR intra-band non-contiguous CA configurations in FR2

4.3.1.2.4.1 NR Intra-band non-contiguous CA configurations for CA\_n257

4.3.1.2.4.2 NR Intra-band non-contiguous CA configurations for CA\_n258

4.3.1.2.4.3 FFS

4.3.1.2.4.4 NR Intra-band non-contiguous CA configurations for CA\_n260

4.3.1.2.4.4.1 CA\_n260(XA)

Editor's note: This clause is reserved for test frequencies for CA\_n260(XA) configurations where x is >= 2, e.g. CA\_n260(2A), CA\_n260(3A) and CA\_n260(4A)

4.3.1.2.4.4.2 CA\_n260(A-I)

Editor's note: CA\_n260(A-I) Test frequencies are FFS.

Table 4.3.1.2.4.4.2-1: NR Intra-Band non-contiguous CA configuration CA\_n260(A-I) without UL CA, SCS=120 kHz, Max Wgap

CBW combination	Sub-block Note 2	CC within Sub-Block Note 2	Bandwidth [MHz]	carrierBand width [PRBs]	Range	Carrier centre [MHz]	Carrier centre [ARFCN]	point A [MHz]	absoluteFrequencyPointA [ARFCN]	offsetToCarrier [Carrier PRBs]	SS block SCS [kHz]	GS CN	absoluteFrequencySSB [ARFCN]	$k_s$	carrier CORESET#0 [RBs] Note 3	CORESET#0 Index (Offset [RBs]) Note 4	offsetToPointA (SIB1) [PRBs] Note 4

Table 4.3.1.2.4.4.2-2: NR Intra-Band non-contiguous CA configuration CA\_n260(A-I) with UL CA, SCS=120 kHz, Max Wgap

CBW combination	Sub-block	CC within	Bandwidth [MHz]	carrierBand width [PRBs]	Range	Carrier centre	Carrier centre	point A [MHz]	absoluteFrequencyPointA [ARFCN]	offsetToCarrier [Carrier PRBs]	SS block	GS CN	absoluteFrequencySSB [ARFCN]	$k_s$	carrier CORESET#0	CORESET#0 Index	offsetToPointA (SIB1)

	ck Not e 2	Sub - Blo ck Not e 2				re [MH z]	e [ARF CN]	z]		PRBs]	SC S [kHz]				[RBs] Note 3	(Offset [RBs]) Note 4	[PRBs] Note 4

4.3.1.2.4.5 NR Intra-band non-contiguous CA configurations for CA\_n261

4.3.1.2.4.5.1 CA\_n261(XA)

**Table 4.3.1.2.4.5.1-1: NR Intra-Band non-contiguous CA configuration CA\_n261(2A), SCS=120 kHz, Max Wgap**

CBW combination	CC	Bandwidth [MHz]	Range		Test frequencies and signalling parameters
<b>CA_n261(2A); A (50-400MHz) - A (50-400MHz)</b>					
CBW1+ CBW2	CC1	CBW1	Downlink & Uplink	Max Wgap	Table 4.3.1.2.1.5-2: Low range for CBW=CBW1, where CBW1= 50 MHz, 100 MHz, 200 MHz or 400 MHz
	CC2	CBW2	Downlink & Uplink		Table 4.3.1.2.1.5-2: High range for CBW=CBW2, where CBW2= 50 MHz, 100 MHz, 200 MHz or 400 MHz

4.3.1.3 Test frequencies for NR band combinations between FR1 and FR2

4.3.1.3.1 NR inter-band CA configurations between FR1 and FR2

**Table 4.3.1.3.1-1: NR-CA configurations between FR1 and FR2 (two bands)**

NR-CA configuration	Uplink NR-CA configuration	NR FR1 downlink configuration	NR FR2 downlink configuration	NR FR1 uplink configuration	NR FR2 uplink configuration	Applicable for protocol testing (Note 1)
CA_n1A-n258A	CA_n1A-n258A	n1A	n258A	n1A	n258A	Yes
CA_n1A-n258D	CA_n1A-n258A	n1A	CA_n258D	n1A	n258A	No
CA_n1A-n258E	CA_n1A-n258A	n1A	CA_n258E	n1A	n258A	No
CA_n1A-n258F	CA_n1A-n258A	n1A	CA_n258F	n1A	n258A	No
CA_n1A-n258G	CA_n1A-n258A	n1A	CA_n258G	n1A	n258A	No

CA_n1A-n258H	CA_n1A-n258A	n1A	CA_n258H	n1A	n258A	No
CA_n1A-n258I	CA_n1A-n258A	n1A	CA_n258I	n1A	n258A	No
CA_n1A-n258J	CA_n1A-n258A	n1A	CA_n258J	n1A	n258A	No
CA_n1A-n258K	CA_n1A-n258A	n1A	CA_n258K	n1A	n258A	No
CA_n1A-n258L	CA_n1A-n258A	n1A	CA_n258L	n1A	n258A	No
CA_n1A-n258M	CA_n1A-n258A	n1A	CA_n258M	n1A	n258A	No
CA_n78A-n258D	CA_n78A-n258A	n78A	CA_n258D	n78A	n258A	No
CA_n78A-n258E	CA_n78A-n258A	n78A	CA_n258E	n78A	n258A	No
CA_n78A-n258F	CA_n78A-n258A	n78A	CA_n257F	n78A	n258A	No

Note 1: Protocol testing is limited to NR-CA configurations with 2CC.

## 4.3.1.3.2 Inter-band NR-DC configurations between FR1 and FR2

## 4.3.1.3.2.1 NR-DC configurations between FR1 and FR2 (two bands)

Table 4.3.1.3.2.1-1: NR-DC configurations between FR1 and FR2 (two bands)

NR-DC configuration	Uplink NR-DC configuration	NR FR1 downlink configuration	NR FR2 downlink configuration	NR FR1 uplink configuration	NR FR2 uplink configuration	Applicable for protocol testing (Note 1)
DC_n1A-n258A	DC_n1A-n258A	n1A	n258A	n1A	n258A	Yes
DC_n1A-n258G	DC_n1A-n258A	n1A	CA_n258G	n1A	n258A	Yes (NR CA 2CC)
DC_n1A-n258H	DC_n1A-n258A	n1A	CA_n258H	n1A	n258A	No
DC_n1A-n258I	DC_n1A-n258A	n1A	CA_n258I	n1A	n258A	No
DC_n1A-n258J	DC_n1A-n258A	n1A	CA_n258J	n1A	n258A	No
DC_n1A-n258K	DC_n1A-n258A	n1A	CA_n258K	n1A	n258A	No
DC_n1A-n258L	DC_n1A-n258A	n1A	CA_n258L	n1A	n258A	No
DC_n1A-n258M	DC_n1A-n258A	n1A	CA_n258M	n1A	n258A	No
DC_n78A-n257A	DC_n78A-n257A	n78A	n257A	n78A	n257A	Yes
DC_n78A-n257G	DC_n78A-n257A	n78A	CA_n257G	n78A	n257A	Yes (NR CA 2CC)
DC_n78A-n257H	DC_n78A-n257A	n78A	CA_n257H	n78A	n257A	No
DC_n78A-n257I	DC_n78A-n257A	n78A	CA_n257I	n78A	n257A	No
DC_n78A-n258A	DC_n78A-n258A	n78A	n258A	n78A	n258A	Yes
DC_n78A-n258G	DC_n78A-n258A	n78A	CA_n258G	n78A	n258A	Yes (NR CA 2CC)
DC_n78A-n258H	DC_n78A-n258A	n78A	CA_n258H	n78A	n258A	No
DC_n78A-n258I	DC_n78A-n258A	n78A	CA_n258I	n78A	n258A	No
DC_n78A-n258J	DC_n78A-n258A	n78A	CA_n258J	n78A	n258A	No
DC_n78A-n258K	DC_n78A-n258A	n78A	CA_n258K	n78A	n258A	No

NR-DC configuration	Uplink NR-DC configuration	NR FR1 downlink configuration	NR FR2 downlink configuration	NR FR1 uplink configuration	NR FR2 uplink configuration	Applicable for protocol testing (Note 1)
DC_n1A-n258A	DC_n1A-n258A	n1A	n258A	n1A	n258A	Yes
DC_n1A-n258G	DC_n1A-n258A	n1A	CA_n258G	n1A	n258A	Yes (NR CA 2CC)
DC_n1A-n258H	DC_n1A-n258A	n1A	CA_n258H	n1A	n258A	No
DC_n1A-n258I	DC_n1A-n258A	n1A	CA_n258I	n1A	n258A	No
DC_n1A-n258J	DC_n1A-n258A	n1A	CA_n258J	n1A	n258A	No
DC_n1A-n258K	DC_n1A-n258A	n1A	CA_n258K	n1A	n258A	No
DC_n1A-n258L	DC_n1A-n258A	n1A	CA_n258L	n1A	n258A	No
DC_n1A-n258M	DC_n1A-n258A	n1A	CA_n258M	n1A	n258A	No
DC_n78A-n257A	DC_n78A-n257A	n78A	n257A	n78A	n257A	Yes
DC_n78A-n258L	DC_n78A-n258A	n78A	CA_n258L	n78A	n258A	No
DC_n78A-n258M	DC_n78A-n258A	n78A	CA_n258M	n78A	n258A	No
DC_n79A-n257A	DC_n79A-n257A	n79A	n257A	n79A	n257A	Yes
DC_n79A-n257G	DC_n79A-n257A	n79A	CA_n257G	n79A	n257A	Yes (NR CA 2CC)
DC_n79A-n257H	DC_n79A-n257A	n79A	CA_n257H	n79A	n257A	No
DC_n79A-n257I	DC_n79A-n257A	n79A	CA_n257I	n79A	n257A	No

Note 1: Protocol testing is limited to NR-DC configurations with 2CC and NR-DC with NR CA 2CC.

#### 4.3.1.4 Test frequencies for EN-DC band combinations within FR1

##### 4.3.1.4.1 Inter-band EN-DC configurations within FR1

###### 4.3.1.4.1.1 General

For inter-band EN-DC configurations as listed in this clause, the following apply:

For the E-UTRA band and E-UTRA CA configurations, test frequencies as specified in TS 36.508 [2], clause 4.3.1 are used.

For the NR band and NR CA configurations, test frequencies as specified in clause 4.3.1.1 are used.

For the EN-DC inter-band configuration that includes an EN-DC contiguous configuration (e.g. DC\_2A-(n)71AA) the EN-DC contiguous configuration is listed in the NR configuration column and the test frequencies as specified in clause 4.3.1.4.2 are used.

For the secondary NR band in inter-band signalling test cases, the band selected is based on the subset of NR bands supported within the EN-DC configurations specified in Table 4.3.1.4.1.2-1 for NR FR1.



## 4.3.1.4.1.2

## Inter-band EN-DC configurations within FR1 (two bands)

Table 4.3.1.4.1.2-1: Inter-band EN-DC configurations within FR1 (two bands)

EN-DC configuration	Uplink EN-DC Configuration	E-UTRA downlink configuration	NR downlink configuration	E-UTRA uplink configuration	NR uplink configuration	Applicable for protocol testing (Note 1)
DC_1A_n3A	DC_1A_n3A	1A	n3A	1A	n3A	Yes
DC_1A_n5A	DC_1A_n5A	1A	n5A	1A	n5A	Yes
DC_1A_n7A	DC_1A_n7A	1A	n7A	1A	n7A	Yes
DC_1A_n28A	DC_1A_n28A	1A	n28A	1A	n28A	Yes
DC_1A_n41A	DC_1A_n41A	1A	n41A	1A	n41A	Yes
DC_1A_n77A	DC_1A_n77A	1A	n77A	1A	n77A	Yes
DC_1A_n78A	DC_1A_n78A	1A	n78A	1A	n78A	Yes
DC_1A_n78C	DC_1A_n78A	1A	CA_n78C	1A	n78A	Yes (NR 2CC)
DC_1A-1A_n78A	DC_1A_n78A	CA_1A-1A	n78A	1A	n78A	No
DC_1A_n79A	DC_1A_n79A	1A	n79A	1A	n79A	Yes
DC_1A_n79C	DC_1A_n79A	1A	CA_n79C	1A	n79A	FFS (NR 2CC)
DC_2A_n5A	DC_2A_n5A	2A	n5A	2A	n5A	Yes
DC_2A_n41A	DC_2A_n41A	2A	n41A	2A	n41A	Yes
DC_2C_n41A	DC_2A_n41A	CA_2C	n41A	2A	n41A	No
	DC_2C_n41A	CA_2C	n41A	CA_2C	n41A	No
DC_2A_n48A	DC_2A_n48A	2A	n48A	2A	n48A	Yes
DC_2A_n66A	DC_2A_n66A	2A	n66A	2A	n66A	Yes
DC_2A_n71A	DC_2A_n71A	2A	n71A	2A	n71A	Yes
DC_2A_n77A	DC_2A_n77A	2A	n77A	2A	n77A	Yes
DC_2A_n78A	DC_2A_n78A	2A	n78A	2A	n78A	Yes
DC_3A_n1A	DC_3A_n1A	3A	n1A	3A	n1A	Yes
DC_3A_n5A	DC_3A_n5A	3A	n5A	3A	n5A	Yes
DC_3A_n7A	DC_3A_n7A	3A	n7A	3A	n7A	Yes
DC_3A_n28A	DC_3A_n28A	3A	n28A	3A	n28A	Yes
DC_3A_n41A	DC_3A_n41A	3A	n41A	3A	n41A	Yes
DC_3A_n77A	DC_3A_n77A	3A	n77A	3A	n77A	Yes
DC_3A_n78A	DC_3A_n78A	3A	n78A	3A	n78A	Yes
DC_3A_n78C	DC_3A_n78A	3A	CA_n78C	3A	n78A	Yes (NR 2CC)
DC_3C_n78A	DC_3A_n78A	CA_3C	n78A	3A	n78A	No
DC_3A_n79A	DC_3A_n79A	3A	n79A	3A	n79A	Yes
DC_3A_n79C	DC_3A_n79A	3A	CA_n79C	3A	n79A	FFS (NR 2CC)
DC_5A_n2A	DC_5A_n2A	5A	n2A	5A	n2A	Yes
DC_5A_n66A	DC_5A_n66A	5A	n66A	5A	n66A	Yes
DC_5A_n77A	DC_5A_n77A	5A	n77A	5A	n77A	Yes
DC_5A_n78A	DC_5A_n78A	5A	n78A	5A	n78A	Yes
DC_5A_n78C	DC_5A_n78A	5A	CA_n78C	5A	n78A	Yes (NR 2CC)

EN-DC configuration	Uplink EN-DC Configuration	E-UTRA downlink configuration	NR downlink configuration	E-UTRA uplink configuration	NR uplink configuration	Applicable for protocol testing (Note 1)
DC_7A-7A_n78A	DC_7A_n78A	CA_7A-7A	n78A	7A	n78A	No
DC_7A_n1A	DC_7A_n1A	7A	n1A	7A	n1A	Yes
DC_7A_n3A	DC_7A_n3A	7A	n3A	7A	n3A	Yes
DC_7A_n5A	DC_7A_n5A	7A	n5A	7A	n5A	Yes
DC_7A_n28A	DC_7A_n28A	7A	n28A	7A	n28A	Yes
DC_7A_n66A	DC_7A_n66A	7A	n66A	7A	n66A	Yes
DC_7A_n78A	DC_7A_n78A	7A	n78A	7A	n78A	Yes
DC_7C_n66A	DC_7A_n66A	CA_7C	n66A	7A	n66A	No
DC_7C_n78A	DC_7A_n78A	CA_7C	n78A	7A	n78A	No
	DC_7C_n78A	CA_7C	n78A	7C	n78A	No
DC_8A_n1A	DC_8A_n1A	8A	n1A	8A	n1A	Yes
DC_8A_n3A	DC_8A_n3A	8A	n3A	8A	n3A	Yes
DC_8A_n20A	DC_8A_n20A	8A	n20A	8A	n20A	Yes
DC_8A_n41A	DC_8A_n41A	8A	n41A	8A	n41A	Yes
DC_8A_n77A	DC_8A_n77A	8A	n77A	8A	n77A	Yes
DC_8A_n78A	DC_8A_n78A	8A	n78A	8A	n78A	Yes
DC_11A_n77A	DC_11A_n77A	11A	n77A	11A	n77A	Yes
DC_11A_n78A	DC_11A_n78A	11A	n78A	11A	n78A	Yes
DC_11A_n79A	DC_11A_n79A	11A	n79A	11A	n79A	Yes
DC_12A_n2A	DC_12A_n2A	12A	n2A	12A	n2A	Yes
DC_12A_n5A	DC_12A_n5A	12A	n5A	12A	n5A	Yes
DC_12A_n66A	DC_12A_n66A	12A	n66A	12A	n66A	Yes
DC_12A_n78A	DC_12A_n78A	12A	n78A	12A	n78A	Yes
DC_13A_n2A	DC_13A_n2A	13A	n2A	13A	n2A	Yes
DC_13A_n66A	DC_13A_n66A	13A	n66A	13A	n66A	Yes
DC_13A_n77A	DC_13A_n77A	13A	n77A	13A	n77A	Yes
DC_14A_n2A	DC_14A_n2A	14A	n2A	14A	n2A	Yes
DC_14A_n66A	DC_14A_n66A	14A	n66A	14A	n66A	Yes
DC_18A_n77A	DC_18A_n77A	18A	n77A	18A	n77A	Yes
DC_18A_n78A	DC_18A_n78A	18A	n78A	18A	n78A	Yes
DC_18A_n79A	DC_18A_n79A	18A	n79A	18A	n79A	Yes
DC_19A_n1A	DC_19A_n1A	19A	n1A	19A	n1A	Yes
DC_19A_n77A	DC_19A_n77A	19A	n77A	19A	n77A	Yes
DC_19A_n77(2A)	DC_19A_n77A	19A	CA_n77(2A)	19A	n77A	Yes (NR 2CC)
DC_19A_n78A	DC_19A_n78A	19A	n78A	19A	n78A	Yes
DC_19A_n78(2A)	DC_19A_n78A	19A	CA_n78(2A)	19A	n78A	Yes (NR 2CC)
DC_19A_n78C	DC_19A_n78A	19A	CA_n78C	19A	n78A	Yes (NR 2CC)
DC_19A_n79A	DC_19A_n79A	19A	n79A	19A	n79A	Yes
DC_19A_n79C	DC_19A_n79A	19A	CA_n79C	19A	n79A	FFS (NR 2CC)
DC_20A_n1A	DC_20A_n1A	20A	n1A	20A	n1A	Yes

EN-DC configuration	Uplink EN-DC Configuration	E-UTRA downlink configuration	NR downlink configuration	E-UTRA uplink configuration	NR uplink configuration	Applicable for protocol testing (Note 1)
DC_20A_n3A	DC_20A_n3A	20A	n3A	20A	n3A	Yes
DC_20A_n7A	DC_20A_n7A	20A	n7A	20A	n7A	Yes
DC_20A_n8A	DC_20A_n8A	20A	n8A	20A	n8A	Yes
DC_20A_n28A	DC_20A_n28A	20A	n28A	20A	n28A	Yes
DC_20A_n78A	DC_20A_n78A	20A	n78A	20A	n78A	Yes
DC_21A_n1A	DC_21A_n1A	21A	n1A	21A	n1A	Yes
DC_21A_n28A	DC_21A_n28A	21A	n28A	21A	n28A	Yes
DC_21A_n77A	DC_21A_n77A	21A	n77A	21A	n77A	Yes
DC_21A_n77(2A)	DC_21A_n77A	21A	CA_n77(2A)	21A	n77A	Yes (NR 2CC)
DC_21A_n78A	DC_21A_n78A	21A	n78A	21A	n78A	Yes
DC_21A_n78(2A)	DC_21A_n78A	21A	CA_n78(2A)	21A	n78A	Yes (NR 2CC)
DC_21A_n78C	DC_21A_n78A	21A	CA_n78C	21A	n78A	Yes (NR 2CC)
DC_21A_n79A	DC_21A_n79A	21A	n79A	21A	n79A	Yes
DC_21A_n79C	DC_21A_n79A	21A	CA_n79C	21A	n79A	FFS (NR 2CC)
DC_25A_n41A	DC_25A_n41A	25A	n41A	25A	n41A	Yes
DC_26A_n41A	DC_26A_n41A	26A	n41A	26A	n41A	Yes
DC_26A_n77A	DC_26A_n77A	26A	n77A	26A	n77A	Yes
DC_26A_n78A	DC_26A_n78A	26A	n78A	26A	n78A	Yes
DC_26A_n79A	DC_26A_n79A	26A	n79A	26A	n79A	Yes
DC_28A_n3A	DC_28A_n3A	28A	n3A	28A	n3A	Yes
DC_28A_n5A	DC_28A_n5A	28A	n5A	28A	n5A	Yes
DC_28A_n7A	DC_28A_n7A	28A	n7A	28A	n7A	Yes
DC_28A_n77A	DC_28A_n77A	28A	n77A	28A	n77A	Yes
DC_28A_n78A	DC_28A_n78A	28A	n78A	28A	n78A	Yes
DC_28A_n78C	DC_28A_n78A	28A	CA_n78C	28A	n78A	Yes (NR 2CC)
DC_28A_n79A	DC_28A_n79A	28A	n79A	28A	n79A	Yes
DC_30A_n5A	DC_30A_n5A	30A	n5A	30A	n5A	Yes
DC_30A_n66A	DC_30A_n66A	30A	n66A	30A	n66A	Yes
DC_38A_n78A	-	38A	n78A	-	-	Yes
DC_39A_n41A	DC_39A_n41A	39A	n41A	39A	n41A	Yes
DC_39A_n79A	DC_39A_n79A	39A	n79A	39A	n79A	Yes
DC_40A_n1A	DC_40A_n1A	40A	n1A	40A	n1A	Yes
DC_40A_n41A	DC_40A_n41A	40A	n41A	40A	n41A	Yes
DC_40A_n78A	DC_40A_n78A	40A	n78A	40A	n78A	Yes
DC_40C_n78A	DC_40A_n78A	CA_40C	n78A	40A	n78A	No
	DC_40C_n78A	CA_40C	n78A	CA_40C	n78A	No
DC_40A_n79A	DC_40A_n79A	40A	n79A	40A	n79A	Yes
DC_40C_n79A	DC_40A_n79A	CA_40C	n79A	40A	n79A	No
DC_41A_n28A	DC_41A_n28A	41A	n28A	41A	n28A	Yes
DC_41A_n77A	DC_41A_n77A	41A	n77A	41A	n77A	Yes

EN-DC configuration	Uplink EN-DC Configuration	E-UTRA downlink configuration	NR downlink configuration	E-UTRA uplink configuration	NR uplink configuration	Applicable for protocol testing (Note 1)
DC_41C_n77A	DC_41A_n77A	CA_41C	n77A	41A	n77A	No
DC_41A_n78A	DC_41A_n78A	41A	n78A	41A	n78A	Yes
DC_41C_n78A	DC_41A_n78A	CA_41C	n78A	41A	n78A	No
DC_41A_n79A	DC_41A_n79A	41A	n79A	41A	n79A	Yes
DC_42A_n1A	DC_42A_n1A	42A	n1A	42A	n1A	Yes
DC_42C_n1A	DC_42C_n1A	CA_42C	n1A	CA_42C	n1A	No
DC_42A_n77A	-	42A	n77A	-	-	Yes
DC_42C_n77A	-	CA_42C	n77A	-	-	No
DC_42D_n77A	-	CA_42D	n77A	-	-	No
DC_42A_n78A	-	42A	n78A	-	-	Yes
DC_42A_n78C	-	42A	CA_n78C	-	-	Yes (NR 2CC)
DC_42C_n78A	-	CA_42C	n78A	-	-	No
DC_42C_n78C	-	CA_42C	CA_n78C	-	-	No
DC_42D_n78A	-	CA_42D	n78A	-	-	No
DC_42E_n78A	-	CA_42E	n78A	-	-	No
DC_42A_n79A	-	42A	n79A	-	-	Yes
DC_42A_n79C	-	42A	CA_n79C	-	-	FFS (NR 2CC)
DC_42C_n79A	-	CA_42C	n79A	-	-	No
DC_42C_n79C	-	CA_42C	CA_n79C	-	-	No
DC_42D_n79A	-	CA_42D	n79A	-	-	No
DC_42E_n79A	-	CA_42E	n79A	-	-	No
DC_48A_n5A	DC_48A_n5A	48A	n5A	48A	n5A	Yes
DC_48A_n66A	DC_48A_n66A	48A	n66A	48A	n66A	Yes
DC_66A_n2A	DC_66A_n2A	66A	n2A	66A	n2A	Yes
DC_66A_n5A	DC_66A_n5A	66A	n5A	66A	n5A	Yes
DC_66A_n41A	DC_66A_n41A	66A	n41A	66A	n41A	Yes
DC_66A_n71A	DC_66A_n71A	66A	n71A	66A	n71A	Yes
DC_66A_n77A	DC_66A_n77A	66A	n77A	66A	n77A	Yes
DC_66A_n78A	DC_66A_n78A	66A	n78A	66A	n78A	Yes
DC_71A_n2A	DC_71A_n2A	71A	n2A	71A	n2A	Yes
DC_71A_n66A	DC_71A_n66A	71A	n66A	71A	n66A	Yes

Note 1: Protocol testing is limited to EN-DC configurations with 1 CC E-UTRA and 1CC or 2CC NR configurations.

## 4.3.1.4.1.3

Inter-band EN-DC configurations within FR1 (three bands)

Table 4.3.1.4.1.3-1: Inter-band EN-DC configurations within FR1 (three bands)

EN-DC configuration	Uplink EN-DC Configuration	E-UTRA downlink configuration	NR downlink configuration	E-UTRA uplink configuration	NR uplink configuration	Applicable for protocol testing (Note 1)
DC_1A-3A_n28A	DC_1A_n28A	CA_1A-3A	n28A	1A	n28A	No
	DC_3A_n28A	CA_1A-3A	n28A	3A	n28A	No
DC_1A-3A_n41A	DC_1A_n41A	CA_1A-3A	n41A	1A	n41A	No
	DC_3A_n41A	CA_1A-3A	n41A	3A	n41A	No
DC_1A-3A_n77A	DC_1A_n77A	CA_1A-3A	n77A	1A	n77A	No
	DC_3A_n77A	CA_1A-3A	n77A	3A	n77A	No
DC_1A-3A_n78A	DC_1A_n78A	CA_1A-3A	n78A	1A	n78A	No
	DC_3A_n78A	CA_1A-3A	n78A	3A	n78A	No
DC_1A-3C_n78A	DC_1A_n78A	CA_1A-3C	n78A	1A	n78A	No
	DC_3A_n78A	CA_1A-3C	n78A	3A	n78A	No
DC_1A-3C_n78(2A)	DC_1A_n78A	CA_1A-3C	CA_n78(2A)	1A	n78A	No
	DC_3A_n78A	CA_1A-3C	CA_n78(2A)	3A	n78A	No
	DC_3C_n78A	CA_1A-3C	CA_n78(2A)	CA_3C	n78A	No
DC_1A-1A-3A_n78A	DC_1A_n78A	CA_1A-1A-3A	n78A	1A	n78A	No
	DC_3A_n78A	CA_1A-1A-3A	n78A	3A	n78A	No
DC_1A-1A-5A_n78A	DC_1A_n78A	CA_1A-1A-5A	n78A	1A	n78A	No
	DC_5A_n78A	CA_1A-1A-5A	n78A	5A	n78A	No
DC_1A-1A-3C_n78A	DC_1A_n78A	CA_1A-1A-3C	n78A	1A	n78A	No
	DC_3A_n78A	CA_1A-1A-3C	n78A	3A	n78A	No
	DC_3C_n78A	CA_1A-1A-3C	n78A	CA_3C	n78A	No
DC_1A-3A_n79A	DC_1A_n79A	CA_1A-3A	n79A	1A	n79A	No
	DC_3A_n79A	CA_1A-3A	n79A	3A	n79A	No
DC_1A-5A_n78C	DC_1A_n78A	CA_1A-5A	CA_n78C	1A	n78A	No
	DC_5A_n78A	CA_1A-5A	CA_n78C	5A	n78A	No
DC_1A-7A_n3A	DC_1A_n3A	CA_1A-7A	n3A	1A	n3A	No
	DC_7A_n3A	CA_1A-7A	n3A	7A	n3A	No
DC_1A-7A_n28A	DC_1A_n28A	CA_1A-7A	n28A	1A	n28A	No
	DC_7A_n28A	CA_1A-7A	n28A	7A	n28A	No
DC_1A-7A_n78A	DC_1A_n78A	CA_1A-7A	n78A	1A	n78A	No
	DC_7A_n78A	CA_1A-7A	n78A	7A	n78A	No
DC_1A-8A_n3A	DC_1A_n3A	CA_1A-8A	n3A	1A	n3A	No
	DC_8A_n3A	CA_1A-8A	n3A	8A	n3A	No
DC_1A-8A_n78A	DC_1A_n78A	CA_1A-8A	n78A	1A	n78A	No
	DC_8A_n78A	CA_1A-8A	n78A	8A	n78A	No
DC_1A-8A_n78(2A)	DC_1A_n78A	CA_1A-8A	CA_n78(2A)	1A	n78A	No
	DC_8A_n78A	CA_1A-8A	CA_n78(2A)	8A	n78A	No

EN-DC configuration	Uplink EN-DC Configuration	E-UTRA downlink configuration	NR downlink configuration	E-UTRA uplink configuration	NR uplink configuration	Applicable for protocol testing (Note 1)
DC_1A-18A_n77A	DC_1A_n77A	CA_1A-18A	n77A	1A	n77A	No
	DC_18A_n77A	CA_1A-18A	n77A	18A	n77A	No
DC_1A-19A_n77(2A)	DC_1A_n77A	CA_1A-19A	CA_n77(2A)	1A	n77A	No
	DC_19A_n77A	CA_1A-19A	CA_n77(2A)	19A	n77A	No
DC_1A-19A_n78A	DC_1A_n78A	CA_1A-19A	n78A	1A	n78A	No
	DC_19A_n78A	CA_1A-19A	n78A	19A	n78A	No
DC_1A-19A_n78(2A)	DC_1A_n78A	CA_1A-19A	CA_n78(2A)	1A	n78A	No
	DC_19A_n78A	CA_1A-19A	CA_n78(2A)	19A	n78A	No
DC_1A-19A_n79A	DC_1A_n79A	CA_1A-19A	n79A	1A	n79A	No
	DC_19A_n79A	CA_1A-19A	n79A	19A	n79A	No
DC_1A-20A_n3A	DC_1A_n3A	CA_1A-20A	n3A	1A	n3A	No
	DC_20A_n3A	CA_1A-20A	n3A	20A	n3A	No
DC_1A-20A_n8A	DC_1A_n8A	CA_1A-20A	n8A	1A	n8A	No
	DC_20A_n8A	CA_1A-20A	n8A	20A	n8A	No
DC_1A-20A_n28A	DC_1A_n28A	CA_1A-20A	n28A	1A	n28A	No
	DC_20A_n28A	CA_1A-20A	n28A	20A	n28A	No
DC_1A-20A_n78A	DC_1A_n78A	CA_1A-20A	n78A	1A	n78A	No
	DC_20A_n78A	CA_1A-20A	n78A	20A	n78A	No
DC_1A-21A_n28A	DC_1A_n28A	CA_1A-21A	n28A	1A	n28A	No
	DC_21A_n28A	CA_1A-21A	n28A	21A	n28A	No
DC_1A-21A_n77(2A)	DC_1A_n77A	CA_1A-21A	CA_n77(2A)	1A	n77A	No
	DC_21A_n77A	CA_1A-21A	CA_n77(2A)	21A	n77A	No
DC_1A-21A_n78A	DC_1A_n78A	CA_1A-21A	n78A	1A	n78A	No
	DC_21A_n78A	CA_1A-21A	n78A	21A	n78A	No
DC_1A-21A_n78(2A)	DC_1A_n78A	CA_1A-21A	CA_n78(2A)	1A	n78A	No
	DC_21A_n78A	CA_1A-21A	CA_n78(2A)	21A	n78A	No
DC_1A-21A_n79A	DC_1A_n79A	CA_1A-21A	n79A	1A	n79A	No
	DC_21A_n79A	CA_1A-21A	n79A	21A	n79A	No
DC_1A-28A_n3A	DC_1A_n3A	CA_1A-28A	n3A	1A	n3A	No
	DC_28A_n3A	CA_1A-28A	n3A	28A	n3A	No
DC_1A-28A_n5A <sup>2</sup>	DC_1A_n5A	CA_1A-28A	n5A	1A	n5A	No
	DC_28A_n5A	CA_1A-28A	n5A	28A	n5A	No
DC_1A-28A_n78C	DC_1A_n78A	CA_1A-28A	CA_n78C	1A	n78A	No
	DC_28A_n78A	CA_1A-28A	CA_n78C	28A	n78A	No
DC_1A_n28A-n78A	DC_1A_n28A	1A	CA_n28A-n78A	1A	n28A	Yes (NR 2CC)
	DC_1A_n78A	1A	CA_n28A-n78A	1A	n78A	No
DC_1A_n28A-n79A	DC_1A_n28A	1A	CA_n28A-n79A	1A	n28A	Yes (NR 2CC)
	DC_1A_n79A	1A	CA_n28A-n79A	1A	n79A	No
DC_1A-41A_n28A	DC_1A_n28A	CA_1A-41A	n28A	1A	n28A	No
	DC_41A_n28A	CA_1A-41A	n28A	41A	n28A	No

EN-DC configuration	Uplink EN-DC Configuration	E-UTRA downlink configuration	NR downlink configuration	E-UTRA uplink configuration	NR uplink configuration	Applicable for protocol testing (Note 1)
DC_1A-41C_n28A	DC_1A_n28A	CA_1A-41C	n28A	1A	n28A	No
	DC_41A_n28A	CA_1A-41C	n28A	41A	n28A	No
	DC_41C_n28A	CA_1A-41C	n28A	CA_41C	n28A	No
DC_1A-41A_n41A	DC_1A_n41A	CA_1A-41A	n41A	1A	n41A	No
DC_1A-41A_n77A	DC_1A_n77A	CA_1A-41A	n77A	1A	n77A	No
	DC_41A_n77A	CA_1A-41A	n77A	41A	n77A	No
DC_1A-42A_n78A	DC_1A_n78A	CA_1A-42A	n78A	1A	n78A	No
DC_1A-42C_n78A	DC_1A_n78A	CA_1A-42C	n78A	1A	n78A	No
DC_1A-42D_n78A	DC_1A_n78A	CA_1A-42D	n78A	1A	n78A	No
DC_1A-42E_n78A	DC_1A_n78A	CA_1A-42E	n78A	1A	n78A	No
DC_1A-42A_n79A	DC_1A_n79A	CA_1A-42A	n79A	1A	n79A	No
DC_1A-42C_n79A	DC_1A_n79A	CA_1A-42C	n79A	1A	n79A	No
DC_1A-42D_n79A	DC_1A_n79A	CA_1A-42D	n79A	1A	n79A	No
DC_1A-42E_n79A	DC_1A_n79A	CA_1A-42E	n79A	1A	n79A	No
DC_1A_n78A-n79A	DC_1A_n78A	1A	CA_n78A-n79A	1A	n78A	Yes (NR 2CC)
	DC_1A_n79A	1A	CA_n78A-n79A	1A	n79A	No
DC_2A-2A-14A_n66A	DC_2A_n66A	CA_2A-2A-14A	n66A	2A	n66A	No
	DC_14A_n66A	CA_2A-2A-14A	n66A	14A	n66A	No
DC_2A-14A_n2A	DC_2A_n2A	CA_2A-14A	n2A	2A	n2A	No
	DC_14A_n2A	CA_2A-14A	n2A	14A	n2A	No
DC_2A-14A_n66A	DC_2A_n66A	CA_2A-14A	n66A	2A	n66A	No
	DC_14A_n66A	CA_2A-14A	n66A	14A	n66A	No
DC_2A-66A_n5A	DC_2A_n5A	CA_2A-66A	n5A	2A	n5A	No
	DC_66A_n5A	CA_2A-66A	n5A	66A	n5A	No
DC_2A-66A_n41A	DC_2A_n41A	CA_2A-66A	n41A	2A	n41A	No
	DC_66A_n41A	CA_2A-66A	n41A	66A	n41A	No
DC_2A-66A_n71A	DC_2A_n71A	CA_2A-66A	n71A	2A	n71A	No
	DC_66A_n71A	CA_2A-66A	n71A	66A	n71A	No
DC_2A-(n)71AA	DC_2A_n71A	2A	DC_(n)71AA	2A	n71A	No
	DC_(n)71AA	2A	DC_(n)71AA	-	DC_(n)71AA	No
DC_3A-5A_n78C	DC_3A_n78A	CA_3A-5A	CA_n78C	3A	n78A	No
	DC_5A_n78A	CA_3A-5A	CA_n78C	5A	n78A	No
DC_3A_n1A-n78A	DC_3A_n1A	3A	CA_n1A-n78A	3A	n1A	Yes (NR 2CC)
	DC_3A_n78A	3A	CA_n1A-n78A	3A	n78A	No
DC_3A_n1A-n79A	DC_3A_n1A	3A	CA_n1A-n79A	3A	n1A	Yes (NR 2CC)
	DC_3A_n79A	3A	CA_n1A-n79A	3A	n79A	No
DC_3A-7A_n1A	DC_3A_n1A	CA_3A-7A	n1A	3A	n1A	No
	DC_7A_n1A	CA_3A-7A	n1A	7A	n1A	No
DC_3A-7A_n5A	DC_3A_n5A	CA_3A-7A	n5A	3A	n5A	No
	DC_7A_n5A	CA_3A-7A	n5A	7A	n5A	No

EN-DC configuration	Uplink EN-DC Configuration	E-UTRA downlink configuration	NR downlink configuration	E-UTRA uplink configuration	NR uplink configuration	Applicable for protocol testing (Note 1)
DC_3A-7A_n28A	DC_3A_n28A	CA_3A-7A	n28A	3A	n28A	No
	DC_7A_n28A	CA_3A-7A	n28A	7A	n28A	No
DC_3A-7A_n78A	DC_3A_n78A	CA_3A-7A	n78A	1A	n78A	No
	DC_7A_n78A	CA_3A-7A	n78A	7A	n78A	No
DC_3A-8A_n1A	DC_3A_n1A	CA_3A-8A	n1A	3A	n1A	No
	DC_8A_n1A	CA_3A-8A	n1A	8A	n1A	No
DC_3A-8A_n28A	DC_3A_n28A	CA_3A-8A	n28A	3A	n28A	No
	DC_8A_n28A	CA_3A-8A	n28A	8A	n28A	No
DC_3A-8A_n77A	DC_3A_n77A	CA_3A-8A	n77A	3A	n77A	No
	DC_8A_n77A	CA_3A-8A	n77A	8A	n77A	No
DC_3A-8A_n78A	DC_3A_n78A	CA_3A-8A	n78A	3A	n78A	No
	DC_8A_n78A	CA_3A-8A	n78A	8A	n78A	No
DC_3A-8A_n78(2A)	DC_3A_n78A	CA_3A-8A	CA_n78(2A)	3A	n78A	No
	DC_8A_n78A	CA_3A-8A	CA_n78(2A)	8A	n78A	No
DC_3A-18A_n77A	DC_3A_n77A	CA_3A-18A	n77A	3A	n77A	No
	DC_18A_n77A	CA_3A-18A	n77A	18A	n77A	No
DC_3A-18A_n78A	DC_3A_n78A	CA_3A-18A	n78A	3A	n78A	No
	DC_18A_n78A	CA_3A-18A	n78A	18A	n78A	No
DC_3A-19A_n1A	DC_3A_n1A	CA_3A-19A	n1A	3A	n1A	No
	DC_19A_n1A	CA_3A-19A	n1A	19A	n1A	No
DC_3A-19A_n77(2A)	DC_3A_n77A	CA_3A-19A	CA_n77(2A)	3A	n77A	No
	DC_19A_n77A	CA_3A-19A	CA_n77(2A)	19A	n77A	No
DC_3A-19A_n78A	DC_3A_n78A	CA_3A-19A	n78A	3A	n78A	No
	DC_19A_n78A	CA_3A-19A	n78A	19A	n78A	No
DC_3A-19A_n78(2A)	DC_3A_n78A	CA_3A-19A	CA_n78(2A)	3A	n78A	No
	DC_19A_n78A	CA_3A-19A	CA_n78(2A)	19A	n78A	No
DC_3A-19A_n79A	DC_3A_n79A	CA_3A-19A	n79A	3A	n79A	No
	DC_19A_n79A	CA_3A-19A	n79A	19A	n79A	No
DC_3A-20A_n1A	DC_3A_n1A	CA_3A-20A	n1A	3A	n1A	No
	DC_20A_n1A	CA_3A-20A	n1A	20A	n1A	No
DC_3A-20A_n28A	DC_3A_n28A	CA_3A-20A	n28A	3A	n28A	No
	DC_20A_n28A	CA_3A-20A	n28A	20A	n28A	No
DC_3A-21A_n1A	DC_3A_n1A	CA_3A-21A	n1A	3A	n1A	No
	DC_21A_n1A	CA_3A-21A	n1A	21A	n1A	No
DC_3A-21A_n28A	DC_3A_n28A	CA_3A-21A	n28A	3A	n28A	No
	DC_21A_n28A	CA_3A-21A	n28A	21A	n28A	No
DC_3A-21A_n77(2A)	DC_3A_n77A	CA_3A-21A	CA_n77(2A)	3A	n77A	No
	DC_21A_n77A	CA_3A-21A	CA_n77(2A)	21A	n77A	No
DC_3A-21A_n78A	DC_3A_n78A	CA_3A-21A	n78A	3A	n78A	No
	DC_21A_n78A	CA_3A-21A	n78A	21A	n78A	No



EN-DC configuration	Uplink EN-DC Configuration	E-UTRA downlink configuration	NR downlink configuration	E-UTRA uplink configuration	NR uplink configuration	Applicable for protocol testing (Note 1)
DC_3A-21A_n78(2A)	DC_3A_n78A	CA_3A-21A	CA_n78(2A)	3A	n78A	No
	DC_21A_n78A	CA_3A-21A	CA_n78(2A)	21A	n78A	No
DC_3A-21A_n79A	DC_3A_n79A	CA_3A-21A	n79A	3A	n79A	No
	DC_21A_n79A	CA_3A-21A	n79A	21A	n79A	No
DC_3A-28A_n78A	DC_3A_n78A	CA_3A-28A	n78A	3A	n78A	No
	DC_28A_n78A	CA_3A-28A	n78A	28A	n78A	No
DC_3A_n28A-n78A	DC_3A_n28A	3A	CA_n28A-n78A	3A	n28A	Yes (NR 2CC)
	DC_3A_n78A	3A	CA_n28A-n78A	3A	n78A	No
DC_3A_n28A-n79A	DC_3A_n28A	3A	CA_n28A-n79A	3A	n28A	Yes (NR 2CC)
	DC_3A_n79A	3A	CA_n28A-n79A	3A	n79A	No
DC_3A-40A_n1A	DC_3A_n1A	CA_3A-40A	n1A	3A	n1A	No
	DC_40A_n1A	CA_3A-40A	n1A	40A	n1A	No
DC_3A-41A_n28A	DC_3A_n28A	CA_3A-41A	n28A	3A	n28A	No
	DC_41A_n28A	CA_3A-41A	n28A	41A	n28A	No
DC_3A-41C_n28A	DC_3A_n28A	CA_3A-41C	n28A	3A	n28A	No
	DC_41A_n28A	CA_3A-41C	n28A	41A	n28A	No
	DC_41C_n28A	CA_3A-41C	n28A	CA_41C	n28A	No
DC_3A-41A_n41A	DC_3A_n41A	CA_3A-41A	n41A	3A	n41A	No
DC_3A-41A_n77A	DC_3A_n77A	CA_3A-41A	n77A	3A	n77A	No
	DC_41A_n77A	CA_3A-41A	n77A	41A	n77A	No
DC_3A-41A_n77(2A)	DC_3A_n77A	CA_3A-41A	CA_n77(2A)	3A	n77A	No
	DC_41A_n77A	CA_3A-41A	CA_n77(2A)	41A	n77A	No
DC_3A-41C_n77A	DC_3A_n77A	CA_3A-41C	n77A	3A	n77A	No
	DC_41A_n77A	CA_3A-41C	n77A	CA_41C	n77A	No
DC_3A-42A_n1A	DC_3A_n1A	CA_3A-42A	n1A	3A	n1A	No
DC_3A-42C_n1A	DC_3A_n1A	CA_3A-42C	n1A	3A	n1A	No
DC_3A-42A_n78A	DC_3A_n78A	CA_3A-42A	n78A	3A	n78A	No
DC_3A-42C_n78A	DC_3A_n78A	CA_3A-42C	n78A	3A	n78A	No
DC_3A-42D_n78A	DC_3A_n78A	CA_3A-42D	n78A	3A	n78A	No
DC_3A-42E_n78A	DC_3A_n78A	CA_3A-42E	n78A	3A	n78A	No
DC_3A-42A_n79A	DC_3A_n79A	CA_3A-42A	n79A	3A	n79A	No
DC_3A-42C_n79A	DC_3A_n79A	CA_3A-42C	n79A	3A	n79A	No
DC_3A-42D_n79A	DC_3A_n79A	CA_3A-42D	n79A	3A	n79A	No
DC_3A-42E_n79A	DC_3A_n79A	CA_3A-42E	n79A	3A	n79A	No
DC_3A_n78A-n79A	DC_3A_n78A	3A	CA_n78A-n79A	3A	n78A	Yes (NR 2CC)
	DC_3A_n79A	3A	CA_n78A-n79A	3A	n79A	No
DC_5A-7A_n78A	DC_5A_n78A	CA_5A-7A	n78A	5A	n78A	No
	DC_7A_n78A	CA_5A-7A	n78A	7A	n78A	No
DC_7A-8A_n1A	DC_7A_n1A	CA_7A-8A	n1A	7A	n1A	No
	DC_8A_n1A	CA_7A-8A	n1A	8A	n1A	No

EN-DC configuration	Uplink EN-DC Configuration	E-UTRA downlink configuration	NR downlink configuration	E-UTRA uplink configuration	NR uplink configuration	Applicable for protocol testing (Note 1)
DC_7A-8A_n3A	DC_7A_n3A	CA_7A-8A	n3A	7A	n3A	No
	DC_8A_n3A	CA_7A-8A	n3A	8A	n3A	No
DC_7A-20A_n1A	DC_7A_n1A	CA_7A-20A	n1A	7A	n1A	No
	DC_20A_n1A	CA_7A-20A	n1A	20A	n1A	No
DC_7A-20A_n3A	DC_7A_n3A	CA_7A-20A	n3A	7A	n3A	No
	DC_20A_n3A	CA_7A-20A	n3A	20A	n3A	No
DC_7A-20A_n8A	DC_7A_n8A	CA_7A-20A	n8A	7A	n8A	No
	DC_20A_n8A	CA_7A-20A	n8A	20A	n8A	No
DC_7A-20A_n28A	DC_7A_n28A	CA_7A-20A	n28A	7A	n28A	No
	DC_20A_n28A	CA_7A-20A	n28A	20A	n28A	No
DC_7A-20A_n78A	DC_7A_n78A	CA_7A-20A	n78A	7A	n78A	No
	DC_20A_n78A	CA_7A-20A	n78A	20A	n78A	No
DC_7A-28A_n3A	DC_7A_n3A	CA_7A-28A	n3A	7A	n3A	No
	DC_28A_n3A	CA_7A-28A	n3A	28A	n3A	No
DC_7A-28A_n5A <sup>2</sup>	DC_7A_n5A	CA_7A-28A	n5A	7A	n5A	No
	DC_28A_n5A	CA_7A-28A	n5A	28A	n5A	No
DC_7A_n5A-n78A	DC_7A_n5A	7A	CA_n5A-n78A	7A	n5A	Yes (NR 2CC)
	DC_7A_n78A	7A	CA_n5A-n78A	7A	n78A	No
DC_7A_n28A-n78A	DC_7A_n28A	7A	CA_n28A-n78A	7A	n28A	Yes (NR 2CC)
	DC_7A_n78A	7A	CA_n28A-n78A	7A	n78A	No
DC_7C_n5A-n78A	DC_7A_n5A	CA_7C	CA_n5A-n78A	7A	n5A	No
	DC_7A_n78A	CA_7C	CA_n5A-n78A	7A	n78A	No
	DC_7C_n5A	CA_7C	CA_n5A-n78A	CA_7C	n5A	No
	DC_7C_n78A	CA_7C	CA_n5A-n78A	CA_7C	n78A	No
	DC_7C_n28A-n78A	DC_7A_n28A	CA_7C	CA_n28A-n78A	7A	n28A
	DC_7A_n78A	CA_7C	CA_n28A-n78A	7A	n78A	No
	DC_7C_n28A	CA_7C	CA_n28A-n78A	CA_7C	n28A	No
	DC_7C_n78A	CA_7C	CA_n28A-n78A	CA_7C	n78A	No
	DC_14A-66A_n2A	DC_14A_n2A	CA_14A-66A	n2A	14A	n2A
	DC_66A_n2A	CA_14A-66A	n2A	66A	n2A	No
	DC_14A-66A_n66A	DC_14A_n66A	CA_14A-66A	n66A	14A	n66A
	DC_66A_n66A	CA_14A-66A	n66A	66A	n66A	No
	DC_14A-66A-66A_n2A	DC_14A_n2A	CA_14A-66A-66A	n2A	14A	n2A
	DC_66A_n2A	CA_14A-66A-66A	n2A	66A	n2A	No
	DC_18A-41C_n3A	DC_18A_n3A	CA_18A-41C	n3A	18A	n3A
	DC_41A_n3A	CA_18A-41C	n3A	41A	n3A	No
	DC_41C_n3A	CA_18A-41C	n3A	CA_41C	n3A	No
DC_18A-41A_n77A	DC_18A_n77A	CA_18A-41A	n77A	18A	n77A	No

EN-DC configuration	Uplink EN-DC Configuration	E-UTRA downlink configuration	NR downlink configuration	E-UTRA uplink configuration	NR uplink configuration	Applicable for protocol testing (Note 1)
	DC_41A_n77A	CA_18A-41A	n77A	41A	n77A	No
DC_18A-41C_n77A	DC_18A_n77A	CA_18A-41C	n77A	18A	n77A	No
	DC_41A_n77A	CA_18A-41C	n77A	41A	n77A	No
	DC_41C_n77A	CA_18A-41C	n77A	CA_41C	n77A	No
DC_18A-41A_n78A	DC_18A_n78A	CA_18A-41A	n78A	18A	n78A	No
	DC_41A_n78A	CA_18A-41A	n78A	41A	n78A	No
DC_18A-41C_n78A	DC_18A_n78A	CA_18A-41C	n78A	18A	n78A	No
	DC_41A_n78A	CA_18A-41C	n78A	41A	n78A	No
	DC_41C_n78A	CA_18A-41C	n78A	CA_41C	n78A	No
DC_19A_n1A-n78A	DC_19A_n1A	19A	CA_n1A-n78A	19A	n1A	Yes (NR 2CC)
	DC_19A_n78A	19A	CA_n1A-n78A	19A	n78A	No
DC_19A_n1A-n79A	DC_19A_n1A	19A	CA_n1A-n79A	19A	n1A	Yes (NR 2CC)
	DC_19A_n79A	19A	CA_n1A-n79A	19A	n79A	No
DC_19A-21A_n1A	DC_19A_n1A	CA_19A-21A	n1A	19A	n1A	No
	DC_21A_n1A	CA_19A-21A	n1A	21A	n1A	No
DC_19A-21A_n77(2A)	DC_19A_n77A	CA_19A-21A	CA_n77(2A)	19A	n77A	No
	DC_21A_n77A	CA_19A-21A	CA_n77(2A)	21A	n77A	No
DC_19A-21A_n78A	DC_19A_n78A	CA_19A-21A	n78A	19A	n78A	No
	DC_21A_n78A	CA_19A-21A	n78A	21A	n78A	No
DC_19A-21A_n78(2A)	DC_19A_n78A	CA_19A-21A	CA_n78(2A)	19A	n78A	No
	DC_21A_n78A	CA_19A-21A	CA_n78(2A)	21A	n78A	No
DC_19A-21A_n79A	DC_19A_n79A	CA_19A-21A	n79A	19A	n79A	No
	DC_21A_n79A	CA_19A-21A	n79A	21A	n79A	No
DC_19A-42A_n1A	DC_19A_n1A	CA_19A-42A	n1A	19A	n1A	No
DC_19A-42A_n78A	DC_19A_n78A	CA_19A-42A	n78A	19A	n78A	No
DC_19A-42A_n79A	DC_19A_n79A	CA_19A-42A	n79A	19A	n79A	No
DC_19A-42C_n1A	DC_19A_n1A	CA_19A-42C	n1A	19A	n1A	No
DC_19A-42C_n78A	DC_19A_n78A	CA_19A-42C	n78A	19A	n78A	No
DC_19A-42C_n79A	DC_19A_n79A	CA_19A-42C	n79A	19A	n79A	No
DC_19A_n78A-n79A	DC_19A_n78A	19A	CA_n78A-n79A	19A	n78A	Yes (NR 2CC)
	DC_19A_n79A	19A	CA_n78A-n79A	19A	n79A	No
DC_20A_n28A-n78A	DC_20A_n28A	20A	CA_n28A-n78A	20A	n28A	Yes (NR 2CC)
	DC_20A_n78A	20A	CA_n28A-n78A	20A	n78A	No
DC_21A_n1A-n78A	DC_21A_n1A	21A	CA_n1A-n78A	21A	n1A	Yes (NR 2CC)
	DC_21A_n78A	21A	CA_n1A-n78A	21A	n78A	No
DC_21A_n1A-n79A	DC_21A_n1A	21A	CA_n1A-n79A	21A	n1A	Yes (NR 2CC)
	DC_21A_n79A	21A	CA_n1A-n79A	21A	n79A	No
DC_21A_n28A-n77A	DC_21A_n28A	21A	CA_n28A-n77A	21A	n28A	Yes (NR 2CC)
	DC_21A_n77A	21A	CA_n28A-n77A	21A	n77A	No
DC_21A_n28A-n78A	DC_21A_n28A	21A	CA_n28A-n78A	21A	n28A	Yes (NR 2CC)

EN-DC configuration	Uplink EN-DC Configuration	E-UTRA downlink configuration	NR downlink configuration	E-UTRA uplink configuration	NR uplink configuration	Applicable for protocol testing (Note 1)
	DC_21A_n78A	21A	CA_n28A-n78A	21A	n78A	No
DC_21A_n28A-n79A	DC_21A_n28A	21A	CA_n28A-n79A	21A	n28A	Yes (NR 2CC)
	DC_21A_n79A	21A	CA_n28A-n79A	21A	n79A	No
DC_21A-42A_n1A	DC_21A_n1A	CA_21A-42A	n1A	21A	n1A	No
DC_21A-42C_n1A	DC_21A_n1A	CA_21A-42C	n1A	21A	n1A	No
DC_21A-42A_n78A	DC_21A_n78A	CA_21A-42A	n78A	21A	n78A	No
DC_21A-42C_n78A	DC_21A_n78A	CA_21A-42C	n78A	21A	n78A	No
DC_21A-42A_n79A	DC_21A_n79A	CA_21A-42A	n79A	21A	n79A	No
DC_21A-42C_n79A	DC_21A_n79A	CA_21A-42C	n79A	21A	n79A	No
DC_21A_n78A-n79A	DC_21A_n78A	21A	CA_n78A-n79A	21A	n78A	Yes (NR 2CC)
	DC_21A_n79A	21A	CA_n78A-n79A	21A	n79A	No
DC_28A_n7A-n78A	DC_28A_n7A	28A	CA_n7A-n78A	28A	n7A	Yes (NR 2CC)
	DC_28A_n7A	28A	CA_n7A-n78A	28A	n78A	No
DC_66A_(n)71AA	DC_66A_n71A	66A	DC_(n)71AA	66A	n71A	No
	DC_(n)71AA	66A	DC_(n)71AA	-	DC_(n)71AA	No

Note 1: Protocol testing is limited to EN-DC configurations with 1 CC E-UTRA and 1CC or 2CC NR configurations.  
Note 2: The frequency range in band 28 is restricted for this band combination to 703-733 MHz for the UL and 758 – 788 MHz for the DL.

## 4.3.1.4.1.4

Inter-band EN-DC configurations within FR1 (four bands)

Table 4.3.1.4.1.4-1: Inter-band EN-DC configurations within FR1 (four bands)

EN-DC configuration	Uplink EN-DC Configuration	E-UTRA downlink configuration	NR downlink configuration	E-UTRA uplink configuration	NR uplink configuration	Applicable for protocol testing (Note 1)
DC_1A-3A-7A_n28A	DC_1A_n28A	CA_1A-3A-7A	n28A	1A	n28A	No
	DC_3A_n28A	CA_1A-3A-7A	n28A	3A	n28A	No
	DC_7A_n28A	CA_1A-3A-7A	n28A	7A	n28A	No
DC_1A-3A-7A_n78A	DC_1A_n78A	CA_1A-3A-7A	n78A	1A	n78A	No
	DC_3A_n78A	CA_1A-3A-7A	n78A	3A	n78A	No
	DC_7A_n78A	CA_1A-3A-7A	n78A	7A	n78A	No
DC_1A-3A-8A_n77A	DC_1A_n77A	CA_1A-3A-8A	n77A	1A	n77A	No
	DC_3A_n77A	CA_1A-3A-8A	n77A	3A	n77A	No
	DC_8A_n77A	CA_1A-3A-8A	n77A	8A	n77A	No
DC_1A-3A-8A_n78A	DC_1A_n78A	CA_1A-3A-8A	n78A	1A	n78A	No
	DC_3A_n78A	CA_1A-3A-8A	n78A	3A	n78A	No
	DC_8A_n78A	CA_1A-3A-8A	n78A	8A	n78A	No

EN-DC configuration	Uplink EN-DC Configuration	E-UTRA downlink configuration	NR downlink configuration	E-UTRA uplink configuration	NR uplink configuration	Applicable for protocol testing (Note 1)
DC_1A-3A-19A_n77(2A)	DC_1A_n77A	CA_1A-3A-19A	CA_n77A(2A)	1A	n77A	No
	DC_3A_n77A	CA_1A-3A-19A	CA_n77A(2A)	3A	n77A	No
	DC_19A_n77A	CA_1A-3A-19A	CA_n77A(2A)	19A	n77A	No
DC_1A-3A-19A_n78A	DC_1A_n78A	CA_1A-3A-19A	n78A	1A	n78A	No
	DC_3A_n78A	CA_1A-3A-19A	n78A	3A	n78A	No
	DC_19A_n78A	CA_1A-3A-19A	n78A	19A	n78A	No
DC_1A-3A-19A_n78(2A)	DC_1A_n78A	CA_1A-3A-19A	CA_n78A(2A)	1A	n78A	No
	DC_3A_n78A	CA_1A-3A-19A	CA_n78A(2A)	3A	n78A	No
	DC_19A_n78A	CA_1A-3A-19A	CA_n78A(2A)	19A	n78A	No
DC_1A-3A-19A_n79A	DC_1A_n79A	CA_1A-3A-19A	n79A	1A	n79A	No
	DC_3A_n79A	CA_1A-3A-19A	n79A	3A	n79A	No
	DC_19A_n79A	CA_1A-3A-19A	n79A	19A	n79A	No
DC_1A-3A-20A_n28A	DC_1A_n28A	CA_1A-3A-20A	n28A	1A	n28A	No
	DC_3A_n28A	CA_1A-3A-20A	n28A	3A	n28A	No
	DC_20A_n28A	CA_1A-3A-20A	n28A	20A	n28A	No
DC_1A-3A-20A_n78A	DC_1A_n78A	CA_1A-3A-20A	n78A	1A	n78A	No
	DC_3A_n78A	CA_1A-3A-20A	n78A	3A	n78A	No
	DC_20A_n78A	CA_1A-3A-20A	n78A	20A	n78A	No
DC_1A-3A-21A_n77(2A)	DC_1A_n77A	CA_1A-3A-21A	CA_n77A(2A)	1A	n77A	No
	DC_3A_n77A	CA_1A-3A-21A	CA_n77A(2A)	3A	n77A	No
	DC_21A_n77A	CA_1A-3A-21A	CA_n77A(2A)	21A	n77A	No
DC_1A-3A-21A_n78A	DC_1A_n78A	CA_1A-3A-21A	n78A	1A	n78A	No
	DC_3A_n78A	CA_1A-3A-21A	n78A	3A	n78A	No
	DC_21A_n78A	CA_1A-3A-21A	n78A	21A	n78A	No
DC_1A-3A-21A_n78(2A)	DC_1A_n78A	CA_1A-3A-21A	CA_n78A(2A)	1A	n78A	No
	DC_3A_n78A	CA_1A-3A-21A	CA_n78A(2A)	3A	n78A	No
	DC_21A_n78A	CA_1A-3A-21A	CA_n78A(2A)	21A	n78A	No
DC_1A-3A-21A_n79A	DC_1A_n79A	CA_1A-3A-21A	n79A	1A	n79A	No
	DC_3A_n79A	CA_1A-3A-21A	n79A	3A	n79A	No
	DC_21A_n79A	CA_1A-3A-21A	n79A	21A	n79A	No
DC_1A-3A-28A_n78A	DC_1A_n78A	CA_1A-3A-28A	n78A	1A	n78A	No
	DC_3A_n78A	CA_1A-3A-28A	n78A	3A	n78A	No
	DC_28A_n78A	CA_1A-3A-28A	n78A	28A	n78A	No
DC_1A-3A_n28A-n78A	DC_1A_n28A	CA_1A-3A	CA_n28A-n78A	1A	n28A	No
	DC_1A_n78A	CA_1A-3A	CA_n28A-n78A	1A	n78A	No
	DC_3A_n28A	CA_1A-3A	CA_n28A-n78A	3A	n28A	No
	DC_3A_n78A	CA_1A-3A	CA_n28A-n78A	3A	n78A	No
DC_1A-3A-42A_n78A	DC_1A_n78A	CA_1A-3A-42A	n78A	1A	n78A	No
	DC_3A_n78A	CA_1A-3A-42A	n78A	3A	n78A	No
DC_1A-3A-42C_n78A	DC_1A_n78A	CA_1A-3A-42C	n78A	1A	n78A	No

EN-DC configuration	Uplink EN-DC Configuration	E-UTRA downlink configuration	NR downlink configuration	E-UTRA uplink configuration	NR uplink configuration	Applicable for protocol testing (Note 1)
	DC_3A_n78A	CA_1A-3A-42C	n78A	3A	n78A	No
DC_1A-3A-42D_n78A	DC_1A_n78A	CA_1A-3A-42D	n78A	1A	n78A	No
	DC_3A_n78A	CA_1A-3A-42D	n78A	3A	n78A	No
DC_1A-3A-42A_n79A	DC_1A_n79A	CA_1A-3A-42A	n79A	1A	n79A	No
	DC_3A_n79A	CA_1A-3A-42A	n79A	3A	n79A	No
DC_1A-3A-42C_n79A	DC_1A_n79A	CA_1A-3A-42C	n79A	1A	n79A	No
	DC_3A_n79A	CA_1A-3A-42C	n79A	3A	n79A	No
DC_1A-3A-42D_n79A	DC_1A_n79A	CA_1A-3A-42D	n79A	1A	n79A	No
	DC_3A_n79A	CA_1A-3A-42D	n79A	3A	n79A	No
DC_1A-7A-20A_n28A	DC_1A_n28A	CA_1A-7A-20A	n28A	1A	n28A	No
	DC_7A_n28A	CA_1A-7A-20A	n28A	7A	n28A	No
	DC_20A_n28A	CA_1A-7A-20A	n28A	20A	n28A	No
DC_1A-7A-20A_n78A	DC_1A_n78A	CA_1A-7A-20A	n78A	1A	n78A	No
	DC_7A_n78A	CA_1A-7A-20A	n78A	7A	n78A	No
	DC_20A_n78A	CA_1A-7A-20A	n78A	20A	n78A	No
DC_1A-7A-28A_n78A	DC_1A_n78A	CA_1A-7A-28A	n78A	1A	n78A	No
	DC_7A_n78A	CA_1A-7A-28A	n78A	7A	n78A	No
	DC_28A_n78A	CA_1A-7A-28A	n78A	28A	n78A	No
DC_1A-7A_n28A-n78A	DC_1A_n28A	CA_1A-7A	CA_n28A-n78A	1A	n28A	No
	DC_1A_n78A	CA_1A-7A	CA_n28A-n78A	1A	n78A	No
	DC_7A_n28A	CA_1A-7A	CA_n28A-n78A	7A	n28A	No
	DC_7A_n78A	CA_1A-7A	CA_n28A-n78A	7A	n78A	No
DC_1A-19A-21A_n77(2A)	DC_1A_n77A	CA_1A-19A-21A	CA_n77(2A)	1A	n77A	No
	DC_19A_n77A	CA_1A-19A-21A	CA_n77(2A)	19A	n77A	No
	DC_21A_n77(2A)	CA_1A-19A-21A	CA_n77(2A)	21A	n77A	No
DC_1A-19A-21A_n78A	DC_1A_n78A	CA_1A-19A-21A	n78A	1A	n78A	No
	DC_19A_n78A	CA_1A-19A-21A	n78A	19A	n78A	No
	DC_21A_n78A	CA_1A-19A-21A	n78A	21A	n78A	No
DC_1A-19A-21A_n78(2A)	DC_1A_n78A	CA_1A-19A-21A	CA_n78(2A)	1A	n78A	No
	DC_19A_n78A	CA_1A-19A-21A	CA_n78(2A)	19A	n78A	No
	DC_21A_n78(2A)	CA_1A-19A-21A	CA_n78(2A)	21A	n78A	No
DC_1A-19A-21A_n79A	DC_1A_n79A	CA_1A-19A-21A	n79A	1A	n79A	No
	DC_19A_n79A	CA_1A-19A-21A	n79A	19A	n79A	No
	DC_21A_n79A	CA_1A-19A-21A	n79A	21A	n79A	No
DC_1A-19A-42A_n78A	DC_1A_n78A	CA_1A-19A-42A	n78A	1A	n78A	No
	DC_19A_n78A	CA_1A-19A-42A	n78A	19A	n78A	No
DC_1A-19A-42C_n78A	DC_1A_n78A	CA_1A-19A-42C	n78A	1A	n78A	No
	DC_19A_n78A	CA_1A-19A-42C	n78A	19A	n78A	No
DC_1A-19A-42A_n79A	DC_1A_n79A	CA_1A-19A-42A	n79A	1A	n79A	No
	DC_19A_n79A	CA_1A-19A-42A	n79A	19A	n79A	No

EN-DC configuration	Uplink EN-DC Configuration	E-UTRA downlink configuration	NR downlink configuration	E-UTRA uplink configuration	NR uplink configuration	Applicable for protocol testing (Note 1)
DC_1A-19A-42C_n79A	DC_1A_n79A	CA_1A-19A-42C	n79A	1A	n79A	No
	DC_19A_n79A	CA_1A-19A-42C	n79A	19A	n79A	No
DC_1A-20A_n28A-n78A	DC_1A_n28A	CA_1A-20A	CA_n28A-n78A	1A	n28A	No
	DC_1A_n78A	CA_1A-20A	CA_n28A-n78A	1A	n78A	No
	DC_20A_n28A	CA_1A-20A	CA_n28A-n78A	20A	n28A	No
	DC_20A_n78A	CA_1A-20A	CA_n28A-n78A	20A	n78A	No
DC_1A-21A-42A_n78A	DC_1A_n78A	CA_1A-21A-42A	n78A	1A	n78A	No
	DC_21A_n78A	CA_1A-21A-42A	n78A	21A	n78A	No
DC_1A-21A-42C_n78A	DC_1A_n78A	CA_1A-21A-42C	n78A	1A	n78A	No
	DC_21A_n78A	CA_1A-21A-42C	n78A	21A	n78A	No
DC_1A-21A-42A_n79A	DC_1A_n79A	CA_1A-21A-42A	n79A	1A	n79A	No
	DC_21A_n79A	CA_1A-21A-42A	n79A	21A	n79A	No
DC_1A-21A-42C_n79A	DC_1A_n79A	CA_1A-21A-42C	n79A	1A	n79A	No
	DC_21A_n79A	CA_1A-21A-42C	n79A	21A	n79A	No
DC_2A-2A-14A-66A_n66A	DC_2A_n66A	CA_2A-2A-14A-66A	n66A	2A	n66A	No
	DC_14A_n66A	CA_2A-2A-14A-66A	n66A	14A	n66A	No
	DC_66A_n66A	CA_2A-2A-14A-66A	n66A	66A	n66A	No
DC_2A-7A-7A-13A_n66A	DC_2A_n66A	CA_2A-7A-7A-13A	n66A	2A	n66A	No
	DC_7A_n66A	CA_2A-7A-7A-13A	n66A	7A	n66A	No
	DC_13A_n66A	CA_2A-7A-7A-13A	n66A	13A	n66A	No
DC_2A-7A-7A-66A_n66A	DC_2A_n66A	CA_2A-7A-7A-66A	n66A	2A	n66A	No
	DC_7A_n66A	CA_2A-7A-7A-66A	n66A	7A	n66A	No
	DC_66A_n66A	CA_2A-7A-7A-66A	n66A	66A	n66A	No
DC_2A-7A-7A-66A_n78A	DC_2A_n78A	CA_2A-7A-7A-66A	n78A	2A	n78A	No
	DC_7A_n78A	CA_2A-7A-7A-66A	n78A	7A	n78A	No
	DC_66A_n78A	CA_2A-7A-7A-66A	n78A	66A	n78A	No
DC_2A-7A-13A_n66A	DC_2A_n66A	CA_2A-7A-13A	n66A	2A	n66A	No
	DC_7A_n66A	CA_2A-7A-13A	n66A	7A	n66A	No
	DC_13A_n66A	CA_2A-7A-13A	n66A	13A	n66A	No
DC_2A-7A-66A_n66A	DC_2A_n66A	CA_2A-7A-66A	n66A	2A	n66A	No
	DC_7A_n66A	CA_2A-7A-66A	n66A	7A	n66A	No
	DC_66A_n66A	CA_2A-7A-66A	n66A	66A	n66A	No
DC_2A-7C-13A_n66A	DC_2A_n66A	CA_2A-7C-13A	n66A	2A	n66A	No
	DC_7A_n66A	CA_2A-7C-13A	n66A	7A	n66A	No
	DC_13A_n66A	CA_2A-7C-13A	n66A	13A	n66A	No
DC_2A-7C-66A_n66A	DC_2A_n66A	CA_2A-7C-66A	n66A	2A	n66A	No
	DC_7A_n66A	CA_2A-7C-66A	n66A	7A	n66A	No

EN-DC configuration	Uplink EN-DC Configuration	E-UTRA downlink configuration	NR downlink configuration	E-UTRA uplink configuration	NR uplink configuration	Applicable for protocol testing (Note 1)
	DC_66A_n66A	CA_2A-7C-66A	n66A	66A	n66A	No
DC_2A-7C-66A_n78A	DC_2A_n78A	CA_2A-7C-66A	n78A	2A	n78A	No
	DC_7A_n78A	CA_2A-7C-66A	n78A	7A	n78A	No
	DC_66A_n78A	CA_2A-7C-66A	n78A	66A	n78A	No
DC_2A-14A-66A_n2A	DC_2A_n2A	CA_2A-14A-66A	n2A	2A	n2A	No
	DC_14A_n2A	CA_2A-14A-66A	n2A	14A	n2A	No
	DC_66A_n2A	CA_2A-14A-66A	n2A	66A	n2A	No
DC_2A-14A-66A-66A_n2A	DC_2A_n2A	CA_2A-14A-66A-66A	n2A	2A	n2A	No
	DC_14A_n2A	CA_2A-14A-66A-66A	n2A	14A	n2A	No
	DC_66A_n2A	CA_2A-14A-66A-66A	n2A	66A	n2A	No
DC_2A-14A-66A_n66A	DC_2A_n66A	CA_2A-14A-66A	n66A	2A	n66A	No
	DC_14A_n66A	CA_2A-14A-66A	n66A	14A	n66A	No
	DC_66A_n66A	CA_2A-14A-66A	n66A	66A	n66A	No
DC_2A-66A-(n)71AA	DC_2A_n71A	CA_2A-66A	DC-(n)71AA	2A	n71A	No
	DC_66A_n71A	CA_2A-66A	DC-(n)71AA	66A	n71A	No
	DC_(n)71AA	CA_2A-66A	DC-(n)71AA	-	(n)71AA	No
DC_3A-7A-20A_n1A	DC_3A_n1A	CA_3A-7A-20A	n1A	3A	n1A	No
	DC_7A_n1A	CA_3A-7A-20A	n1A	7A	n1A	No
	DC_20A_n1A	CA_3A-7A-20A	n1A	20A	n1A	No
DC_3A-7A-20A_n8A	DC_3A_n8A	CA_3A-7A-20A	n8A	3A	n8A	No
	DC_7A_n8A	CA_3A-7A-20A	n8A	7A	n8A	No
	DC_20A_n8A	CA_3A-7A-20A	n8A	20A	n8A	No
DC_3A-7A-20A_n28A	DC_3A_n28A	CA_3A-7A-20A	n28A	3A	n28A	No
	DC_7A_n28A	CA_3A-7A-20A	n28A	7A	n28A	No
	DC_20A_n28A	CA_3A-7A-20A	n28A	20A	n28A	No
DC_3A-7A-20A_n78A	DC_3A_n78A	CA_3A-7A-20A	n78A	3A	n78A	No
	DC_7A_n78A	CA_3A-7A-20A	n78A	7A	n78A	No
	DC_20A_n78A	CA_3A-7A-20A	n78A	20A	n78A	No
DC_3A-7A-28A_n78A	DC_3A_n78A	CA_3A-7A-28A	n78A	3A	n78A	No
	DC_7A_n78A	CA_3A-7A-28A	n78A	7A	n78A	No
	DC_28A_n78A	CA_3A-7A-28A	n78A	28A	n78A	No
DC_3A-7A_n28A-n78A	DC_3A_n28A	CA_3A-7A	CA_n28A-n78A	3A	n28A	No
	DC_3A_n78A	CA_3A-7A	CA_n28A-n78A	3A	n78A	No
	DC_7A_n28A	CA_3A-7A	CA_n28A-n78A	7A	n28A	No
	DC_7A_n78A	CA_3A-7A	CA_n28A-n78A	7A	n78A	No
DC_3A-19A_n1A-n78A	DC_3A_n1A	CA_3A-19A	CA_n1A-n78A	3A	n1A	No
	DC_3A_n78A	CA_3A-19A	CA_n1A-n78A	3A	n78A	No



EN-DC configuration	Uplink EN-DC Configuration	E-UTRA downlink configuration	NR downlink configuration	E-UTRA uplink configuration	NR uplink configuration	Applicable for protocol testing (Note 1)
	DC_19A_n1A	CA_3A-19A	CA_n1A-n78A	19A	n1A	No
	DC_19A_n78A	CA_3A-19A	CA_n1A-n78A	19A	n78A	No
DC_3A-19A_n1A-n79A	DC_3A_n1A	CA_3A-19A	CA_n1A-n79A	3A	n1A	No
	DC_3A_n79A	CA_3A-19A	CA_n1A-n79A	3A	n79A	No
	DC_19A_n1A	CA_3A-19A	CA_n1A-n79A	19A	n1A	No
	DC_19A_n79A	CA_3A-19A	CA_n1A-n79A	19A	n79A	No
DC_3A-19A-21A_n78A	DC_3A_n78A	CA_3A-19A-21A	n78A	3A	n78A	No
	DC_19A_n78A	CA_3A-19A-21A	n78A	19A	n78A	No
	DC_21A_n78A	CA_3A-19A-21A	n78A	21A	n78A	No
DC_3A-19A-21A_n79A	DC_3A_n79A	CA_3A-19A-21A	n79A	3A	n79A	No
	DC_19A_n79A	CA_3A-19A-21A	n79A	19A	n79A	No
	DC_21A_n79A	CA_3A-19A-21A	n79A	21A	n79A	No
DC_3A-19A-42A_n1A	DC_3A_n1A	CA_3A-19A-42A	n1A	3A	n1A	No
	DC_19A_n1A	CA_3A-19A-42A	n1A	19A	n1A	No
DC_3A-19A-42C_n1A	DC_3A_n1A	CA_3A-19A-42C	n1A	3A	n1A	No
	DC_19A_n1A	CA_3A-19A-42C	n1A	19A	n1A	No
DC_3A-19A-42A_n78A	DC_3A_n78A	CA_3A-19A-42A	n78A	3A	n78A	No
	DC_19A_n78A	CA_3A-19A-42A	n78A	19A	n78A	No
DC_3A-19A-42C_n78A	DC_3A_n78A	CA_3A-19A-42C	n78A	3A	n78A	No
	DC_19A_n78A	CA_3A-19A-42C	n78A	19A	n78A	No
DC_3A-19A-42A_n79A	DC_3A_n79A	CA_3A-19A-42A	n79A	3A	n79A	No
	DC_19A_n79A	CA_3A-19A-42A	n79A	19A	n79A	No
DC_3A-19A-42C_n79A	DC_3A_n79A	CA_3A-19A-42C	n79A	3A	n79A	No
	DC_19A_n79A	CA_3A-19A-42C	n79A	19A	n79A	No
DC_3A-20A_n28A-n78A	DC_3A_n28A	CA_3A-20A	CA_n28A-n78A	3A	n28A	No
	DC_3A_n78A	CA_3A-20A	CA_n28A-n78A	3A	n78A	No
	DC_20A_n28A	CA_3A-20A	CA_n28A-n78A	20A	n28A	No
	DC_20A_n78A	CA_3A-20A	CA_n28A-n78A	20A	n78A	No
DC_3A-21A_n1A-n78A	DC_3A_n1A	CA_3A-21A	CA_n1A-n78A	3A	n1A	No
	DC_3A_n78A	CA_3A-21A	CA_n1A-n78A	3A	n78A	No
	DC_21A_n1A	CA_3A-21A	CA_n1A-n78A	21A	n1A	No
	DC_21A_n78A	CA_3A-21A	CA_n1A-n78A	21A	n78A	No
DC_3A-21A_n1A-n79A	DC_3A_n1A	CA_3A-21A	CA_n1A-n79A	3A	n1A	No
	DC_3A_n79A	CA_3A-21A	CA_n1A-n79A	3A	n79A	No
	DC_21A_n1A	CA_3A-21A	CA_n1A-n79A	21A	n1A	No
	DC_21A_n79A	CA_3A-21A	CA_n1A-n79A	21A	n79A	No
DC_3A-21A-42A_n78A	DC_3A_n78A	CA_3A-21A-42A	n78A	3A	n78A	No
	DC_21A_n78A	CA_3A-21A-42A	n78A	21A	n78A	No
DC_3A-21A-42C_n78A	DC_3A_n78A	CA_3A-21A-42C	n78A	3A	n78A	No
	DC_21A_n78A	CA_3A-21A-42C	n78A	21A	n78A	No

EN-DC configuration	Uplink EN-DC Configuration	E-UTRA downlink configuration	NR downlink configuration	E-UTRA uplink configuration	NR uplink configuration	Applicable for protocol testing (Note 1)
DC_3A-21A-42A_n79A	DC_3A_n79A	CA_3A-21A-42A	n79A	3A	n79A	No
	DC_21A_n79A	CA_3A-21A-42A	n79A	21A	n79A	No
DC_3A-21A-42C_n79A	DC_3A_n79A	CA_3A-21A-42C	n79A	3A	n79A	No
	DC_21A_n79A	CA_3A-21A-42C	n79A	21A	n79A	No
DC_3A-42A_n1A-n78A	DC_3A_n1A	CA_3A-42A	n1A	3A	n1A	No
	DC_3A_n78A	CA_3A-42A	n78A	3A	n78A	No
DC_3A-42C_n1A-n78A	DC_3A_n1A	CA_3A-42C	n1A	3A	n1A	No
	DC_3A_n78A	CA_3A-42C	n78A	3A	n78A	No
DC_3A-42A_n1A-n79A	DC_3A_n1A	CA_3A-42A	n1A	3A	n1A	No
	DC_3A_n79A	CA_3A-42A	n79A	3A	n79A	No
DC_3A-42C_n1A-n79A	DC_3A_n1A	CA_3A-42C	n1A	3A	n1A	No
	DC_3A_n79A	CA_3A-42C	n79A	3A	n79A	No
DC_7A-20A_n28A-n78A	DC_7A_n28A	CA_7A-20A	CA_n28A-n78A	7A	n28A	No
	DC_7A_n78A	CA_7A-20A	CA_n28A-n78A	7A	n78A	No
	DC_20A_n28A	CA_7A-20A	CA_n28A-n78A	20A	n28A	No
	DC_20A_n78A	CA_7A-20A	CA_n28A-n78A	20A	n78A	No
DC_19A-21A_n1A-n78A	DC_19A_n1A	CA_19A-21A	CA_n1A-n78A	19A	n1A	No
	DC_19A_n78A	CA_19A-21A	CA_n1A-n78A	19A	n78A	No
	DC_21A_n1A	CA_19A-21A	CA_n1A-n78A	21A	n1A	No
	DC_21A_n78A	CA_19A-21A	CA_n1A-n78A	21A	n78A	No
DC_19A-21A_n1A-n79A	DC_19A_n1A	CA_19A-21A	CA_n1A-n79A	19A	n1A	No
	DC_19A_n79A	CA_19A-21A	CA_n1A-n79A	19A	n79A	No
	DC_21A_n1A	CA_19A-21A	CA_n1A-n79A	21A	n1A	No
	DC_21A_n79A	CA_19A-21A	CA_n1A-n79A	21A	n79A	No
DC_19A-21A-42A_n1A	DC_19A_n1A	CA_19A-21A-42A	n1A	19A	n1A	No
	DC_21A_n1A	CA_19A-21A-42A	n1A	21A	n1A	No
DC_19A-21A-42C_n1A	DC_19A_n1A	CA_19A-21A-42C	n1A	19A	n1A	No
	DC_21A_n1A	CA_19A-21A-42C	n1A	21A	n1A	No
DC_19A-21A-42A_n78A	DC_19A_n78A	CA_19A-21A-42A	n78A	19A	n78A	No
	DC_21A_n78A	CA_19A-21A-42A	n78A	21A	n78A	No
DC_19A-21A-42C_n78A	DC_19A_n78A	CA_19A-21A-42C	n78A	19A	n78A	No
	DC_21A_n78A	CA_19A-21A-42C	n78A	21A	n78A	No
DC_19A-21A-42A_n79A	DC_19A_n79A	CA_19A-21A-42A	n79A	19A	n79A	No
	DC_21A_n79A	CA_19A-21A-42A	n79A	21A	n79A	No
DC_19A-21A-42C_n79A	DC_19A_n79A	CA_19A-21A-42C	n79A	19A	n79A	No
	DC_21A_n79A	CA_19A-21A-42C	n79A	21A	n79A	No
DC_19A-42A_n1A-n78A	DC_19A_n1A	CA_19A-42A	n1A	19A	n1A	No
	DC_19A_n78A	CA_19A-42A	n78A	19A	n78A	No
DC_19A-42C_n1A-n78A	DC_19A_n1A	CA_19A-42C	n1A	19A	n1A	No
	DC_19A_n78A	CA_19A-42C	n78A	19A	n78A	No

EN-DC configuration	Uplink EN-DC Configuration	E-UTRA downlink configuration	NR downlink configuration	E-UTRA uplink configuration	NR uplink configuration	Applicable for protocol testing (Note 1)
DC_19A-42A_n1A-n79A	DC_19A_n1A	CA_19A-42A	n1A	19A	n1A	No
	DC_19A_n79A	CA_19A-42A	n79A	19A	n79A	No
DC_19A-42C_n1A-n79A	DC_19A_n1A	CA_19A-42C	n1A	19A	n1A	No
	DC_19A_n79A	CA_19A-42C	n79A	19A	n79A	No
DC_21A-42A_n1A-n78A	DC_21A_n1A	CA_21A-42A	n1A	21A	n1A	No
	DC_21A_n78A	CA_21A-42A	n78A	21A	n78A	No
DC_21A-42C_n1A-n78A	DC_21A_n1A	CA_21A-42C	n1A	21A	n1A	No
	DC_21A_n78A	CA_21A-42C	n78A	21A	n78A	No
DC_21A-42A_n1A-n79A	DC_21A_n1A	CA_21A-42A	n1A	21A	n1A	No
	DC_21A_n79A	CA_21A-42A	n79A	21A	n79A	No
DC_21A-42C_n1A-n79A	DC_21A_n1A	CA_21A-42C	n1A	21A	n1A	No
	DC_21A_n79A	CA_21A-42C	n79A	21A	n79A	No

Note 1: Protocol testing is limited to EN-DC configurations with 1 CC E-UTRA and 1CC or 2CC NR configurations.

## 4.3.1.4.1.5

Inter-band EN-DC configurations within FR1 (five bands)

Table 4.3.1.4.1.5-1: Inter-band EN-DC configurations within FR1 (five bands)

EN-DC configuration	Uplink EN-DC Configuration	E-UTRA downlink configuration	NR downlink configuration	E-UTRA uplink configuration	NR uplink configuration	Applicable for protocol testing (Note 1)
DC_1A-3A-7A-20A_n28A	DC_1A_n28A	CA_1A-3A-7A-20A	n28A	1A	n28A	No
	DC_3A_n28A	CA_1A-3A-7A-20A	n28A	3A	n28A	No
	DC_7A_n28A	CA_1A-3A-7A-20A	n28A	7A	n28A	No
	DC_20A_n28A	CA_1A-3A-7A-20A	n28A	20A	n28A	No
DC_1A-3A-7A-20A_n78A	DC_1A_n78A	CA_1A-3A-7A-20A	n78A	1A	n78A	No
	DC_3A_n78A	CA_1A-3A-7A-20A	n78A	3A	n78A	No
	DC_7A_n78A	CA_1A-3A-7A-20A	n78A	7A	n78A	No
	DC_20A_n78A	CA_1A-3A-7A-20A	n78A	20A	n78A	No
DC_1A-3A-7A-28A_n78A	DC_1A_n78A	CA_1A-3A-7A-28A	n78A	1A	n78A	No
	DC_3A_n78A	CA_1A-3A-7A-28A	n78A	3A	n78A	No
	DC_7A_n78A	CA_1A-3A-7A-28A	n78A	7A	n78A	No
	DC_28A_n78A	CA_1A-3A-7A-28A	n78A	28A	n78A	No
DC_1A-3A-7A_n28A-n78A	DC_1A_n28A	CA_1A-3A-7A	CA_n28A-n78A	1A	n28A	No
	DC_1A_n78A	CA_1A-3A-7A	CA_n28A-n78A	1A	n78A	No
	DC_3A_n28A	CA_1A-3A-7A	CA_n28A-n78A	3A	n28A	No
	DC_3A_n78A	CA_1A-3A-7A	CA_n28A-n78A	3A	n78A	No
	DC_7A_n28A	CA_1A-3A-7A	CA_n28A-n78A	7A	n28A	No

EN-DC configuration	Uplink EN-DC Configuration	E-UTRA downlink configuration	NR downlink configuration	E-UTRA uplink configuration	NR uplink configuration	Applicable for protocol testing (Note 1)
	DC_7A_n78A	CA_1A-3A-7A	CA_n28A-n78A	7A	n78A	No
DC_1A-3A-19A-42A_n78A	DC_1A_n78A	CA_1A-3A-19A-42A	n78A	1A	n78A	No
	DC_3A_n78A	CA_1A-3A-19A-42A	n78A	3A	n78A	No
	DC_19A_n78A	CA_1A-3A-19A-42A	n78A	19A	n78A	No
DC_1A-3A-19A-42C_n78A	DC_1A_n78A	CA_1A-3A-19A-42C	n78A	1A	n78A	No
	DC_3A_n78A	CA_1A-3A-19A-42C	n78A	3A	n78A	No
	DC_19A_n78A	CA_1A-3A-19A-42C	n78A	19A	n78A	No
DC_1A-3A-19A-42A_n79A	DC_1A_n79A	CA_1A-3A-19A-42A	n79A	1A	n79A	No
	DC_3A_n79A	CA_1A-3A-19A-42A	n79A	3A	n79A	No
	DC_19A_n79A	CA_1A-3A-19A-42A	n79A	19A	n79A	No
DC_1A-3A-19A-42C_n79A	DC_1A_n79A	CA_1A-3A-19A-42C	n79A	1A	n79A	No
	DC_3A_n79A	CA_1A-3A-19A-42C	n79A	3A	n79A	No
	DC_19A_n79A	CA_1A-3A-19A-42C	n79A	19A	n79A	No
DC_1A-3A-20A_n28A-n78A	DC_1A_n28A	CA_1A-3A-20A	CA_n28A-n78A	1A	n28A	No
	DC_1A_n78A	CA_1A-3A-20A	CA_n28A-n78A	1A	n78A	No
	DC_3A_n28A	CA_1A-3A-20A	CA_n28A-n78A	3A	n28A	No
	DC_3A_n78A	CA_1A-3A-20A	CA_n28A-n78A	3A	n78A	No
	DC_20A_n28A	CA_1A-3A-20A	CA_n28A-n78A	20A	n28A	No
	DC_20A_n78A	CA_1A-3A-20A	CA_n28A-n78A	20A	n78A	No
DC_1A-3A-21A-42A_n78A	DC_1A_n78A	CA_1A-3A-21A-42A	n78A	1A	n78A	No
	DC_3A_n78A	CA_1A-3A-21A-42A	n78A	3A	n78A	No
	DC_21A_n78A	CA_1A-3A-21A-42A	n78A	21A	n78A	No
DC_1A-3A-21A-42C_n78A	DC_1A_n78A	CA_1A-3A-21A-42C	n78A	1A	n78A	No
	DC_3A_n78A	CA_1A-3A-21A-42C	n78A	3A	n78A	No

EN-DC configuration	Uplink EN-DC Configuration	E-UTRA downlink configuration	NR downlink configuration	E-UTRA uplink configuration	NR uplink configuration	Applicable for protocol testing (Note 1)
	DC_21A_n78A	CA_1A-3A-21A-42C	n78A	21A	n78A	No
DC_1A-3A-21A-42A_n79A	DC_1A_n79A	CA_1A-3A-21A-42A	n79A	1A	n79A	No
	DC_3A_n79A	CA_1A-3A-21A-42A	n79A	3A	n79A	No
	DC_21A_n79A	CA_1A-3A-21A-42A	n79A	21A	n79A	No
DC_1A-3A-21A-42C_n79A	DC_1A_n79A	CA_1A-3A-21A-42C	n79A	1A	n79A	No
	DC_3A_n79A	CA_1A-3A-21A-42C	n79A	3A	n79A	No
	DC_21A_n79A	CA_1A-3A-21A-42C	n79A	21A	n79A	No
DC_1A-7A-20A_n28A-n78A	DC_1A_n28A	CA_1A-7A-20A	CA_n28A-n78A	1A	n28A	No
	DC_1A_n78A	CA_1A-7A-20A	CA_n28A-n78A	1A	n78A	No
	DC_7A_n28A	CA_1A-7A-20A	CA_n28A-n78A	7A	n28A	No
	DC_7A_n78A	CA_1A-7A-20A	CA_n28A-n78A	7A	n78A	No
	DC_20A_n28A	CA_1A-7A-20A	CA_n28A-n78A	20A	n28A	No
	DC_20A_n78A	CA_1A-7A-20A	CA_n28A-n78A	20A	n78A	No
DC_1A-19A-21A-42A_n78A	DC_1A_n78A	CA_1A-19A-21A-42A	n78A	1A	n78A	No
	DC_19A_n78A	CA_1A-19A-21A-42A	n78A	19A	n78A	No
	DC_21A_n78A	CA_1A-19A-21A-42A	n78A	21A	n78A	No
DC_1A-19A-21A-42C_n78A	DC_1A_n78A	CA_1A-19A-21A-42C	n78A	1A	n78A	No
	DC_19A_n78A	CA_1A-19A-21A-42C	n78A	19A	n78A	No
	DC_21A_n78A	CA_1A-19A-21A-42C	n78A	21A	n78A	No
DC_1A-19A-21A-42A_n79A	DC_1A_n79A	CA_1A-19A-21A-42A	n79A	1A	n79A	No
	DC_19A_n79A	CA_1A-19A-21A-42A	n79A	19A	n79A	No
	DC_21A_n79A	CA_1A-19A-21A-42A	n79A	21A	n79A	No
DC_1A-19A-21A-42C_n79A	DC_1A_n79A	CA_1A-19A-21A-42C	n79A	1A	n79A	No
	DC_19A_n79A	CA_1A-19A-21A-	n79A	19A	n79A	No

EN-DC configuration	Uplink EN-DC Configuration	E-UTRA downlink configuration	NR downlink configuration	E-UTRA uplink configuration	NR uplink configuration	Applicable for protocol testing (Note 1)
		42C				
	DC_21A_n79A	CA_1A-19A-21A-42C	n79A	21A	n79A	No
DC_3A-7A-20A_n28A-n78A	DC_3A_n28A	CA_3A-7A-20A	CA_n28A-n78A	3A	n28A	No
	DC_3A_n78A	CA_3A-7A-20A	CA_n28A-n78A	3A	n78A	No
	DC_7A_n28A	CA_3A-7A-20A	CA_n28A-n78A	7A	n28A	No
	DC_7A_n78A	CA_3A-7A-20A	CA_n28A-n78A	7A	n78A	No
	DC_20A_n28A	CA_3A-7A-20A	CA_n28A-n78A	20A	n28A	No
	DC_20A_n78A	CA_3A-7A-20A	CA_n28A-n78A	20A	n78A	No
DC_3A-19A-21A-42A_n78A	DC_3A_n78A	CA_3A-19A-21A-42A	n78A	3A	n78A	No
	DC_19A_n78A	CA_3A-19A-21A-42A	n78A	19A	n78A	No
	DC_21A_n78A	CA_3A-19A-21A-42A	n78A	21A	n78A	No
DC_3A-19A-21A-42C_n78A	DC_3A_n78A	CA_3A-19A-21A-42C	n78A	3A	n78A	No
	DC_19A_n78A	CA_3A-19A-21A-42C	n78A	19A	n78A	No
	DC_21A_n78A	CA_3A-19A-21A-42C	n78A	21A	n78A	No
DC_3A-19A-21A-42A_n79A	DC_3A_n79A	CA_3A-19A-21A-42A	n79A	3A	n79A	No
	DC_19A_n79A	CA_3A-19A-21A-42A	n79A	19A	n79A	No
	DC_21A_n79A	CA_3A-19A-21A-42A	n79A	21A	n79A	No
DC_3A-19A-21A-42C_n79A	DC_3A_n79A	CA_3A-19A-21A-42C	n79A	3A	n79A	No
	DC_19A_n79A	CA_3A-19A-21A-42C	n79A	19A	n79A	No
	DC_21A_n79A	CA_3A-19A-21A-42C	n79A	21A	n79A	No
DC_3A-19A-42A_n1A-n78A	DC_3A_n1A	CA_3A-19A-42A	CA_n1A-n78A	3A	n1A	No
	DC_3A_n78A	CA_3A-19A-42A	CA_n1A-n78A	3A	n78A	No
	DC_19A_n1A	CA_3A-19A-42A	CA_n1A-n78A	19A	n1A	No
	DC_19A_n78A	CA_3A-19A-42A	CA_n1A-n78A	19A	n78A	No
DC_3A-19A-42C_n1A-n78A	DC_3A_n1A	CA_3A-19A-42C	CA_n1A-n78A	3A	n1A	No
	DC_3A_n78A	CA_3A-19A-42C	CA_n1A-n78A	3A	n78A	No
	DC_19A_n1A	CA_3A-19A-42C	CA_n1A-n78A	19A	n1A	No
	DC_19A_n78A	CA_3A-19A-42C	CA_n1A-n78A	19A	n78A	No

EN-DC configuration	Uplink EN-DC Configuration	E-UTRA downlink configuration	NR downlink configuration	E-UTRA uplink configuration	NR uplink configuration	Applicable for protocol testing (Note 1)
DC_3A-19A-42A_n1A-n79A	DC_3A_n1A	CA_3A-19A-42A	CA_n1A-n79A	3A	n1A	No
	DC_3A_n79A	CA_3A-19A-42A	CA_n1A-n79A	3A	n79A	No
	DC_19A_n1A	CA_3A-19A-42A	CA_n1A-n79A	19A	n1A	No
	DC_19A_n79A	CA_3A-19A-42A	CA_n1A-n79A	19A	n79A	No
DC_3A-19A-42C_n1A-n79A	DC_3A_n1A	CA_3A-19A-42C	CA_n1A-n79A	3A	n1A	No
	DC_3A_n79A	CA_3A-19A-42C	CA_n1A-n79A	3A	n79A	No
	DC_19A_n1A	CA_3A-19A-42C	CA_n1A-n79A	19A	n1A	No
	DC_19A_n79A	CA_3A-19A-42C	CA_n1A-n79A	19A	n79A	No
DC_3A-21A-42A_n1A-n78A	DC_3A_n1A	CA_3A-21A-42A	CA_n1A-n78A	3A	n1A	No
	DC_3A_n78A	CA_3A-21A-42A	CA_n1A-n78A	3A	n78A	No
	DC_21A_n1A	CA_3A-21A-42A	CA_n1A-n78A	21A	n1A	No
	DC_21A_n78A	CA_3A-21A-42A	CA_n1A-n78A	21A	n78A	No
DC_3A-21A-42C_n1A-n78A	DC_3A_n1A	CA_3A-21A-42C	CA_n1A-n78A	3A	n1A	No
	DC_3A_n78A	CA_3A-21A-42C	CA_n1A-n78A	3A	n78A	No
	DC_21A_n1A	CA_3A-21A-42C	CA_n1A-n78A	21A	n1A	No
	DC_21A_n78A	CA_3A-21A-42C	CA_n1A-n78A	21A	n78A	No
DC_3A-21A-42A_n1A-n79A	DC_3A_n1A	CA_3A-21A-42A	CA_n1A-n79A	3A	n1A	No
	DC_3A_n79A	CA_3A-21A-42A	CA_n1A-n79A	3A	n79A	No
	DC_21A_n1A	CA_3A-21A-42A	CA_n1A-n79A	21A	n1A	No
	DC_21A_n79A	CA_3A-21A-42A	CA_n1A-n79A	21A	n79A	No
DC_3A-21A-42C_n1A-n79A	DC_3A_n1A	CA_3A-21A-42C	CA_n1A-n79A	3A	n1A	No
	DC_3A_n79A	CA_3A-21A-42C	CA_n1A-n79A	3A	n79A	No
	DC_21A_n1A	CA_3A-21A-42C	CA_n1A-n79A	21A	n1A	No
	DC_21A_n79A	CA_3A-21A-42C	CA_n1A-n79A	21A	n79A	No
DC_19A-21A-42A_n1A-n78A	DC_19A_n1A	CA_19A-21A-42A	CA_n1A-n78A	19A	n1A	No
	DC_19A_n78A	CA_19A-21A-42A	CA_n1A-n78A	19A	n78A	No
	DC_21A_n1A	CA_19A-21A-42A	CA_n1A-n78A	21A	n1A	No
	DC_21A_n78A	CA_19A-21A-42A	CA_n1A-n78A	21A	n78A	No
DC_19A-21A-42C_n1A-n78A	DC_19A_n1A	CA_19A-21A-42C	CA_n1A-n78A	19A	n1A	No
	DC_19A_n78A	CA_19A-21A-42C	CA_n1A-n78A	19A	n78A	No
	DC_21A_n1A	CA_19A-21A-42C	CA_n1A-n78A	21A	n1A	No
	DC_21A_n78A	CA_19A-21A-42C	CA_n1A-n78A	21A	n78A	No
DC_19A-21A-42A_n1A-n79A	DC_19A_n1A	CA_19A-21A-42A	CA_n1A-n79A	19A	n1A	No
	DC_19A_n79A	CA_19A-21A-42A	CA_n1A-n79A	19A	n79A	No
	DC_21A_n1A	CA_19A-21A-42A	CA_n1A-n79A	21A	n1A	No
	DC_21A_n79A	CA_19A-21A-42A	CA_n1A-n79A	21A	n79A	No

Note 1: Protocol testing is limited to EN-DC configurations with 1 CC E-UTRA and 1CC or 2CC NR configurations.

**Table 4.3.1.4.1.6-1: Inter-band EN-DC configurations within FR1 (six bands)**

EN-DC configuration	Uplink EN-DC Configuration	E-UTRA downlink configuration	NR downlink configuration	E-UTRA uplink configuration	NR uplink configuration	Applicable for protocol testing (Note 1)
DC_1A-3A-7A-20A_n28A-n78A	DC_1A_n28A	CA_1A-3A-7A-20A	CA_n28A-n78A	1A	n28A	No
	DC_1A_n78A	CA_1A-3A-7A-20A	CA_n28A-n78A	1A	n78A	No
	DC_3A_n28A	CA_1A-3A-7A-20A	CA_n28A-n78A	3A	n28A	No
	DC_3A_n78A	CA_1A-3A-7A-20A	CA_n28A-n78A	3A	n78A	No
	DC_7A_n28A	CA_1A-3A-7A-20A	CA_n28A-n78A	7A	n28A	No
	DC_7A_n78A	CA_1A-3A-7A-20A	CA_n28A-n78A	7A	n78A	No
	DC_20A_n28A	CA_1A-3A-7A-20A	CA_n28A-n78A	20A	n28A	No
DC_20A_n78A	CA_1A-3A-7A-20A	CA_n28A-n78A	20A	n78A	No	
Note 1: Protocol testing is limited to EN-DC configurations with 1 CC E-UTRA and 1CC or 2CC NR configurations.						



4.3.1.4.2 Intra-band contiguous EN-DC configurations within FR1

4.3.1.4.2.1 – 4.3.1.4.2.40 FFS

4.3.1.4.2.41 Intra-band contiguous EN-DC configurations DC\_(n)41

4.3.1.4.2.41.1 DC\_(n)41AA

**Table 4.3.1.4.2.41.1-1: EN-DC combination DC\_(n)41AA, intra-band contiguous, SCS 15 kHz, 15 kHz NR raster, NR CC at the band edges**

EN-DC channel bandwidth combination	CC	Bandwidth [MHz]	carrierBandwidth [PRBs]	Range	Carrier centre [MHz] Note 2	Carrier centre [ARFCN]	point A [MHz]	absolute FrequencyPointA [ARFCN]	offset ToCarrier [Carrier PRBs]	SS block SCS [kHz]	GSCN	absoluteFrequencySSB [ARFCN]	$k_{SSB}$	Offset Carrier CORES ET#0 [RBs] Note 3	CORES ET#0 Index (Offset [RBs]) Note 1	offsetToPointA (SIB1) [PRBs] Note 1	
E-UTRA: 10MHz + NR: 20MHz	E-UTRA CC1	10	50	Downlink & Uplink	Low	2521.200	39902	-	-	-	-	-	-	-	-	-	
					Mid	2603.100	40721	-	-	-	-	-	-	-	-	-	
					High	2664.900	41339	-	-	-	-	-	-	-	-	-	
	Channel spacing E-UTRA CC1- NR CC1 = 15 MHz (Note 2)																
	NR CC1	20	106	Downlink & Uplink	Low	2506.200	501240	2496.66	499332	0	15	6246	499710	6	0	0 (0)	0
					Mid	2588.100	517620	2560.2	512040	102		6453	516270	6	1	2 (4)	107
					High	2679.900	535980	2579.64	515928	504		6681	534510	2	0	1 (2)	506
E-UTRA: 10MHz + NR: 40MHz	E-UTRA CC1	10	50	Downlink & Uplink	Low	2541.300	40103	-	-	-	-	-	-	-	-	-	
					Mid	2613.000	40820	-	-	-	-	-	-	-	-	-	
					High	2644.800	41138	-	-	-	-	-	-	-	-	-	
	Channel spacing E-UTRA CC1- NR CC1 = 25.005 MHz (Note 2)																
	NR CC1	40	216	Downlink & Uplink	Low	2516.295	503259	2496.855	499371	0	15	6249	499950	1	2	2 (4)	6
					Mid	2587.995	517599	2550.195	510039	102		6426	514110	1	1	0 (0)	103
					High	2669.805	533961	2559.645	511929	504		6633	530670	7	2	2 (4)	510
E-UTRA: 10MHz + NR: 50MHz	E-UTRA CC1	10	50	Downlink & Uplink	Low	2551.200	40202	-	-	-	-	-	-	-	-	-	
					Mid	2618.100	40871	-	-	-	-	-	-	-	-	-	
					High	2634.900	41039	-	-	-	-	-	-	-	-	-	
	NR CC1	50	270	Downlink & Uplink	Low	2521.200	504240	2496.9	499380	0	15	6249	499950	10	1	2 (4)	5
					Mid	2588.100	517620	2545.44	509088	102		6414	513150	10	0	0 (0)	102
					High	2664.900	532980	2549.88	509976	504		6606	528510	10	0	0 (0)	504
	E-UTRA: 20MHz + NR: 10MHz	E-UTRA CC1	20	100	Downlink & Uplink	Low	2516.100	39851	-	-	-	-	-	-	-	-	-
Mid						2598.000	40670	-	-	-	-	-	-	-	-	-	
High						2670.000	41390	-	-	-	-	-	-	-	-	-	
Channel spacing E-UTRA CC1- NR CC1 = 15 MHz (Note 2)																	

	NR CC1	10	52	Downlink & Uplink	Low	2501.100	500220	2496.42	499284	0	15	6246	499710	10	1	0 (0)	1
					Mid	2583.000	516600	2559.96	511992	102		6450	516030	2	0	0 (0)	102
					High	2685.000	537000	2589.6	517920	504		6705	536430	2	0	0 (0)	504
E-UTRA: 20MHz + NR: 20MHz	E-UTRA CC1	20	100	Downlink & Uplink	Low	2526.000	39950	-	-	-		-	-	-	-	-	-
					Mid	2603.100	40721	-	-	-		-	-	-	-	-	
					High	2659.800	41288	-	-	-		-	-	-	-	-	
Channel spacing E-UTRA CC1- NR CC1=19.995 MHz (Note 2)																	
	NR CC1	20	106	Downlink & Uplink	Low	2506.005	501201	2496.465	499293	0	15	6246	499710	7	1	0 (0)	1
					Mid	2583.105	516621	2555.205	511041	102		6441	515310	7	2	2 (4)	108
					High	2679.795	535959	2579.535	515907	504		6681	534510	9	0	1 (2)	506
E-UTRA: 20MHz + NR: 40MHz	E-UTRA CC1	20	100	Downlink & Uplink	Low	2546.100	40151	-	-	-		-	-	-	-	-	-
					Mid	2613.000	40820	-	-	-		-	-	-	-	-	
					High	2640.000	41090	-	-	-		-	-	-	-	-	
Channel spacing E-UTRA CC1- NR CC1=30 MHz (Note 2)																	
	NR CC1	40	216	Downlink & Uplink	Low	2516.100	503220	2496.66	499332	0	15	6246	499710	6	0	0 (0)	0
					Mid	2583.000	516600	2545.2	509040	102		6414	513150	2	0	1 (2)	104
					High	2670.000	534000	2559.84	511968	504		6633	530670	6	1	2 (4)	509
E-UTRA: 20MHz + NR: 50MHz	E-UTRA CC1	20	100	Downlink & Uplink	Low	2556.000	40250	-	-	-		-	-	-	-	-	-
					Mid	2618.100	40871	-	-	-		-	-	-	-	-	
					High	2629.800	40988	-	-	-		-	-	-	-	-	
Channel spacing E-UTRA CC1- NR CC1=34.995 MHz (Note 2)																	
	NR CC1	50	270	Downlink & Uplink	Low	2521.005	504201	2496.705	499341	0	15	6246	499710	3	0	0 (0)	0
					Mid	2583.105	516621	2540.445	508089	102		6402	512190	11	1	0 (0)	103
					High	2664.795	532959	2549.775	509955	504		6606	528510	5	1	0 (0)	505
Note 1: The CORESET#0 Index and the associated CORESET#0 Offset refers to Table 13-1 in TS 38.213 [22]. The value of CORESET#0 Index is signalled in controlResourceSetZero (pdccch-ConfigSIB1) in the MIB. The offsetToPointA IE is expressed in units of resource blocks assuming 15 kHz subcarrier spacing for FR1 and 60 kHz subcarrier spacing for FR2.																	
Note 2: The nominal carrier spacing between the E-UTRA and the NR carriers is set in accordance to TS 38.101-3 [9], clause 5.4B.1.																	

Table 4.3.1.4.2.41.1-1A: EN-DC combination DC\_(n)41AA, intra-band contiguous, SCS 15 kHz, 15 kHz NR raster, E-UTRA CC at the band edges

EN-DC channel bandwidth combination	CC	Band width [MHz )	carrierBandwidth [PRBs]	Range	Carrier centre [MHz] Note 2	Carrier centre [ARFCN]	point A [MHz]	absoluteFrequency PointA [ARFCN]	offset ToCarrier [Carrier PRBs]	SS block SCS [kHz]	GSCN	absoluteFrequency SSB [ARFCN]	$k_{SSB}$	Offset Carrier CORESET#0 [RBs] Note 3	CORESET#0 Index (Offset [RBs]) Note 1	offsetToPointA (SIB1) [PRBs] Note 1	
E-UTRA: 20MHz + NR: 40MHz	E-UTRA CC1	20	100	Downlink & Uplink	Low	2506.200	39752	-	-	-	-	-	-	-	-	-	
					Mid	2613.000	40820	-	-	-	-	-	-	-	-		
					High	2679.900	41489	-	-	-	-	-	-	-	-		
Channel spacing E-UTRA CC1- NR CC1=30 MHz (Note 2)																	
	NR CC1	40	216	Downlink & Uplink	Low	2536.200	507240	2516.76	503352	0	15	6297	503790	2	0	1 (2)	2
					Mid	2583.000	516600	2545.2	509040	102		6414	513150	2	0	1 (2)	104
					High	2649.900	529980	2539.74	507948	504		6582	526590	10	1	1 (2)	512

Note 1: The CORESET#0 Index and the associated CORESET#0 Offset refers to Table 13-1 in TS 38.213 [22]. The value of CORESET#0 Index is signalled in controlResourceSetZero (pdccch.ConfigSIB1) in the MIB. The offsetToPointA IE is expressed in units of resource blocks assuming 15 kHz subcarrier spacing for FR1 and 60 kHz subcarrier spacing for FR2.

Note 2: The nominal carrier spacing between the E-UTRA and the NR carriers is set in accordance to TS 38.101-3 [9], clause 5.4B.1.

Note 3: The parameter Offset Carrier CORESET#0 specifies the offset from the lowest subcarrier of the carrier and the lowest subcarrier of CORESET#0. It corresponds to the parameter  $\Delta F_{\text{OffsetCORESET-0-Carrier}}$  in Annex C expressed in number of common RBs.

**Table 4.3.1.4.2.41.1-2: EN-DC combination DC\_(n)41AA, intra-band contiguous, SCS 30 kHz, 30 kHz NR raster, NR CC at the band edges**

EN-DC channel bandwidth combination	CC	Bandwidth [MHz]	carrierBandwidth [PRBs]	Range	Carrier centre [MHz] Note 2	Carrier centre [ARFCN]	point A [MHz]	absoluteFrequencyPointA [ARFCN]	offsetToCarrier [Carrier PRBs]	SS block SCS [kHz]	GSCN	absoluteFrequencySSB [ARFCN]	$k_{SSB}$	Offset Carrier CORESET#0 [RBs] Note 3	CORESET#0 Index (Offset [RBs]) Note 1	offsetToPointA (SIB1) [PRBs] Note 1	
E-UTRA: 10MHz + NR: 20MHz	E-UTRA CC1	10	50	Downlink & Uplink	Low	2521.200	39902	-	-	-	-	-	-	-	-	-	
					Mid	2603.100	40721	-	-	-	-	-	-	-	-	-	-
					High	2664.900	41339	-	-	-	-	-	-	-	-	-	-
	Channel spacing E-UTRA CC1- NR CC1=15 MHz (Note 2)																
NR CC1	20	51	Downlink & Uplink	Low	2506.200	501240	2497.02	499404	0	30	6252	500190	22	0	0 (0)	0	
				Mid	2588.100	517620	2542.2	508440	102		6456	516510	2	0	0 (0)	204	
				High	2679.900	535980	2489.28	497856	504		6687	534990	18	0	1 (1)	1010	
E-UTRA: 10MHz + NR: 40MHz	E-UTRA CC1	10	50	Downlink & Uplink	Low	2541.000	40100	-	-	-	-	-	-	-	-	-	
					Mid	2613.000	40820	-	-	-	-	-	-	-	-	-	-
					High	2644.800	41138	-	-	-	-	-	-	-	-	-	-
	Channel spacing E-UTRA CC1- NR CC1=24.99 MHz (Note 2)																
NR CC1	40	106	Downlink & Uplink	Low	2516.010	503202	2496.93	499386	0	30	6252	500190	4	0	1 (1)	2	
				Mid	2588.010	517602	2532.21	506442	102		6432	514590	4	0	1 (1)	206	
				High	2669.790	533958	2469.27	493854	504		6636	530910	16	0	0 (0)	1008	
E-UTRA: 10MHz + NR: 50MHz	E-UTRA CC1	10	50	Downlink & Uplink	Low	2551.200	40202	-	-	-	-	-	-	-	-	-	
					Mid	2618.100	40871	-	-	-	-	-	-	-	-	-	-
					High	2634.900	41039	-	-	-	-	-	-	-	-	-	-
	Channel spacing E-UTRA CC1- NR CC1=30 MHz (Note 2)																
NR CC1	50	133	Downlink & Uplink	Low	2521.200	504240	2497.26	499452	0	30	6252	500190	6	0	0 (0)	0	
				Mid	2588.100	517620	2527.44	505488	102		6420	513630	2	0	1 (1)	206	
				High	2664.900	532980	2459.52	491904	504		6612	528990	2	0	1 (1)	1010	
E-UTRA: 10MHz + NR: 60MHz	E-UTRA CC1	10	50	Downlink & Uplink	Low	2561.100	40301	-	-	-	-	-	-	-	-	-	
					Mid	2622.900	40919	-	-	-	-	-	-	-	-	-	-
					High	2624.700	40937	-	-	-	-	-	-	-	-	-	-
	Channel spacing E-UTRA CC1- NR CC1=35.01 MHz (Note 2)																
NR CC1	60	162	Downlink & Uplink	Low	2526.090	505218	2496.93	499386	0	30	6252	500190	4	0	1 (1)	2	
				Mid	2587.890	517578	2522.01	504402	102		6408	512670	20	0	2 (2)	208	
				High	2659.710	531942	2449.11	489822	504		6585	526830	0	0	0 (0)	1008	
E-UTRA:	E-UTRA	10	50	Downlink	Low	2581.200	40502	-	-	-	-	-	-	-	-		

10MHz + NR: 80MHz	CC1			& Uplink	Mid	2633.100	41021	-	-	-	-	-	-	-	-	-	
					High	2604.900	40739	-	-	-	-	-	-	-	-	-	
	Channel spacing E-UTRA CC1- NR CC1=45 MHz (Note 2)																
	NR CC1	80	217	Downlink & Uplink	Low	2536.200	507240	2497.14	499428	0	30	6252	500190	14	0	0 (0)	0
Mid					2588.100	517620	2512.32	502464	102	6384		510750	2	0	3 (3)	210	
High					2649.900	529980	2429.4	485880	504	6537		522990	10	0	1 (1)	1010	
E-UTRA: 10MHz + NR: 100MHz	E-UTRA CC1	10	50	Downlink & Uplink	Low	2601.000	40700	-	-	-	-	-	-	-	-	-	
					Mid	2643.000	41120	-	-	-	-	-	-	-	-	-	
					High	2584.800	40538	-	-	-	-	-	-	-	-	-	
	Channel spacing E-UTRA CC1- NR CC1=54.99 MHz (Note 2)																
NR CC1	100	273	Downlink & Uplink	Low	2546.010	509202	2496.87	499374	0	30	6252	500190	8	0	1 (1)	2	
				Mid	2588.010	517602	2502.15	500430	102		6357	508590	8	0	1 (1)	206	
				High	2639.790	527958	2409.21	481842	504		6486	518910	20	0	0 (0)	1008	
E-UTRA: 20MHz + NR: 10MHz	E-UTRA CC1	20	100	Downlink & Uplink	Low	2516.100	39851	-	-	-	-	-	-	-	-	-	
					Mid	2598.000	40670	-	-	-	-	-	-	-	-	-	
					High	2670.000	41390	-	-	-	-	-	-	-	-	-	
	Channel spacing E-UTRA CC1- NR CC1=15 MHz (Note 2)																
NR CC1	10	24	Downlink & Uplink	Low	2501.100	500220	2496.78	499356	0	30	6252	500190	14	0	1 (1)	2	
				Mid	2583.000	516600	2541.96	508392	102		6456	516510	18	0	0 (0)	204	
				High	2685.000	537000	2499.24	499848	504		6711	536910	18	0	0 (0)	1008	
E-UTRA: 20MHz + NR: 20MHz	E-UTRA CC1	20	100	Downlink & Uplink	Low	2526.300	39953	-	-	-	-	-	-	-	-	-	
					Mid	2603.100	40721	-	-	-	-	-	-	-	-	-	
					High	2659.800	41288	-	-	-	-	-	-	-	-	-	
	Channel spacing E-UTRA CC1- NR CC1=20.01 MHz (Note 2)																
NR CC1	20	51	Downlink & Uplink	Low	2506.290	501258	2497.11	499422	0	30	6252	500190	16	0	0 (0)	0	
				Mid	2583.090	516618	2537.19	507438	102		6444	515550	16	0	0 (0)	204	
				High	2679.810	535962	2489.19	497838	504		6687	534990	0	0	2 (2)	1012	
E-UTRA: 20MHz + NR: 40MHz	E-UTRA CC1	20	100	Downlink & Uplink	Low	2546.100	40151	-	-	-	-	-	-	-	-	-	
					Mid	2613.000	40820	-	-	-	-	-	-	-	-	-	
					High	2640.000	41090	-	-	-	-	-	-	-	-	-	
	Channel spacing E-UTRA CC1- NR CC1=30 MHz (Note 2)																
NR CC1	40	106	Downlink & Uplink	Low	2516.100	503220	2497.02	499404	0	30	6252	500190	22	0	0 (0)	0	
				Mid	2583.000	516600	2527.2	505440	102		6420	513630	18	0	1 (1)	206	
				High	2670.000	534000	2469.48	493896	504		6636	530910	2	0	0 (0)	1008	
E-UTRA: 20MHz + NR: 50MHz	E-UTRA CC1	20	100	Downlink & Uplink	Low	2556.300	40253	-	-	-	-	-	-	-	-	-	
					Mid	2618.100	40871	-	-	-	-	-	-	-	-	-	
					High	2629.800	40988	-	-	-	-	-	-	-	-	-	
	Channel spacing E-UTRA CC1- NR CC1=35.01 MHz (Note 2)																
NR CC1	50	133	Downlink & Uplink	Low	2521.290	504258	2497.35	499470	0	30	6252	500190	0	0	0 (0)	0	
				Mid	2583.090	516618	2522.43	504486	102		6408	512670	16	0	1 (1)	206	
				High	2664.810	532962	2459.43	491886	504		6612	528990	8	0	1 (1)	1010	
E-UTRA: 20MHz + NR: 60MHz	E-UTRA CC1	20	100	Downlink & Uplink	Low	2566.200	40352	-	-	-	-	-	-	-	-	-	
					Mid	2622.900	40919	-	-	-	-	-	-	-	-	-	
					High	2619.900	40889	-	-	-	-	-	-	-	-	-	

Channel spacing E-UTRA CC1- NR CC1=39.99 MHz (Note 2)																	
E-UTRA: 20MHz + NR: 80MHz	E-UTRA CC1	20	100	Downlink & Uplink	Low	2526.210	505242	2497.05	499410	0	30	6252	500190	20	0	0 (0)	0
					Mid	2582.910	516582	2517.03	503406	102		6393	511470	0	0	0 (0)	204
					High	2659.890	531978	2449.29	489858	504		6588	527070	20	0	2 (2)	1012
Channel spacing E-UTRA CC1- NR CC1=50.01 MHz (Note 2)																	
E-UTRA: 20MHz + NR: 100MHz	E-UTRA CC1	20	100	Downlink & Uplink	Low	2536.290	507258	2497.23	499446	0	30	6252	500190	8	0	0 (0)	0
					Mid	2583.090	516618	2507.31	501462	102		6369	509550	8	0	0 (0)	204
					High	2649.810	529962	2429.31	485862	504		6537	522990	16	0	1 (1)	1010
Channel spacing E-UTRA CC1- NR CC1=60 MHz (Note 2)																	
E-UTRA: 20MHz + NR: 100MHz	E-UTRA CC1	100	273	Downlink & Uplink	Low	2546.100	509220	2496.96	499392	0	30	6252	500190	2	0	1 (1)	2
					Mid	2583.000	516600	2497.14	499428	102		6345	507630	22	0	1 (1)	206
					High	2640.000	528000	2409.42	481884	504		6486	518910	6	0	0 (0)	1008

Note 1: The CORESET#0 Index and the associated CORESET#0 Offset refers to Table 13-4 in TS 38.213 [22]. The value of CORESET#0 Index is signalled in controlResourceSetZero (pdccch. ConfigSIB1) in the MIB. The offsetToPointA IE is expressed in units of resource blocks assuming 15 kHz subcarrier spacing for FR1 and 60 kHz subcarrier spacing for FR2.

Note 2: The nominal carrier spacing between the E-UTRA and the NR carriers is set in accordance to TS 38.101-3 [9], clause 5.4B.1.

Note 3: The parameter Offset Carrier CORESET#0 specifies the offset from the lowest subcarrier of the carrier and the lowest subcarrier of CORESET#0. It corresponds to the parameter  $\Delta F_{\text{OffsetCORESET-0-Carrier}}$  in Annex C expressed in number of common RBs.

**Table 4.3.1.4.2.41.1-2A: EN-DC combination DC\_(n)41AA, intra-band contiguous, SCS 30 kHz, 30 kHz NR raster, E-UTRA CC at the band edges**

EN-DC channel bandwidth combination	CC	Band width [MHz]	carrierBandwidth [PRBs]	Range	Carrier centre [MHz] Note 2	Carrier centre [ARFCN]	point A [MHz]	absoluteFrequencyPointA [ARFCN]	offsetToCarrier [Carrier PRBs]	SS block SCS [kHz]	GSCN	absoluteFrequencySSB [ARFCN]	$k_{SSB}$	Offset Carrier CORESET#0 [RBs] Note 3	CORESET#0 Index (Offset [RBs]) Note 1	offsetToPointA (SIB1) [PRBs] Note 1		
E-UTRA: 20MHz + NR: 40MHz	E-UTRA CC1	20	100	Downlink & Uplink	Low	2506.200	39752	-	-	-	-	-	-	-	-	-		
					Mid	2613.000	40820	-	-	-	-	-	-	-	-	-	-	
					High	2679.900	41489	-	-	-	-	-	-	-	-	-	-	-
Channel spacing E-UTRA CC1- NR CC1=30 MHz (Note 2)																		
E-UTRA: 20MHz + NR: 60MHz	E-UTRA CC1	40	106	Downlink & Uplink	Low	2536.200	507240	2517.12	503424	0	30	6303	504270	18	0	1 (1)	2	
					Mid	2583.000	516600	2527.2	505440	102		6420	513630	18	0	1 (1)	206	
					High	2649.900	529980	2449.38	489876	504		6588	527070	14	0	2 (2)	1012	
Channel spacing E-UTRA CC1- NR CC1=39.99 MHz (Note 2)																		
E-UTRA: 20MHz + NR: 60MHz	E-UTRA CC1	20	100	Downlink & Uplink	Low	2506.200	39752	-	-	-	-	-	-	-	-	-	-	
					Mid	2622.900	40919	-	-	-	-	-	-	-	-	-	-	-
					High	2679.900	41489	-	-	-	-	-	-	-	-	-	-	-

NR CC1	60	162	Downlink & Uplink	Low	2546.190	509238	2517.03	503406	0	30	6303	504270	0	0	2 (2)	4
				Mid	2582.910	516582	2517.03	503406	102		6393	511470	0	0	0 (0)	204
				High	2639.910	527982	2429.31	485862	504		6537	522990	16	0	1 (1)	1010
E-UTRA: 20MHz + NR: 80MHz	E-UTRA CC1	20	100	Downlink & Uplink	Low	2506.200	39752	-	-	-	-	-	-	-	-	-
					Mid	2633.100	41021	-	-	-	-	-	-	-	-	-
					High	2679.900	41489	-	-	-	-	-	-	-	-	-
Channel spacing E-UTRA CC1- NR CC1=50.01 MHz (Note 2)																
NR CC1	80	217	Downlink & Uplink	Low	2556.210	511242	2517.15	503430	0	30	6303	504270	16	0	1 (1)	2
				Mid	2583.090	516618	2507.31	501462	102		6369	509550	8	0	0 (0)	204
				High	2629.890	525978	2409.39	481878	504		6486	518910	8	0	0 (0)	1008
E-UTRA: 20MHz + NR: 100MHz	E-UTRA CC1	20	100	Downlink & Uplink	Low	2506.200	39752	-	-	-	-	-	-	-	-	-
					Mid	2643.000	41120	-	-	-	-	-	-	-	-	-
					High	2679.900	41489	-	-	-	-	-	-	-	-	-
Channel spacing E-UTRA CC1- NR CC1=60 MHz (Note 2)																
NR CC1	100	273	Downlink & Uplink	Low	2566.200	513240	2517.06	503412	0	30	6303	504270	22	0	1 (1)	2
				Mid	2583.000	516600	2497.14	499428	102		6345	507630	22	0	1 (1)	206
				High	2619.900	523980	2389.32	477864	504		6438	515070	18	0	2 (2)	1012
Note 1: The CORESET#0 Index and the associated CORESET#0 Offset refers to Table 13-4 in TS 38.213 [22]. The value of CORESET#0 Index is signalled in controlResourceSetZero (pdccch. ConfigSIB1) in the MIB. The offsetToPointA IE is expressed in units of resource blocks assuming 15 kHz subcarrier spacing for FR1 and 60 kHz subcarrier spacing for FR2.																
Note 2: The nominal carrier spacing between the E-UTRA and the NR carriers is set in accordance to TS 38.101-3 [9], clause 5.4B.1.																
Note 3: The parameter Offset Carrier CORESET#0 specifies the offset from the lowest subcarrier of the carrier and the lowest subcarrier of CORESET#0. It corresponds to the parameter $\Delta F_{\text{OffsetCORESET-0-Carrier}}$ in Annex C expressed in number of common RBs.																

**Table 4.3.1.4.2.41.1-3: EN-DC combination DC\_(n)41AA, intra-band contiguous, SCS 60 kHz, 15 kHz NR raster, NR CC at the band edges without CORESET#0**

EN-DC channel bandwidth combination	CC	Bandwidth [MHz]	carrierBandwidth [PRBs]	Range	Carrier centre [MHz] Note 1	Carrier centre [ARFCN]	point A [MHz]	absoluteFrequencyPointA [ARFCN]	offsetToCarrier [Carrier PRBs]	SS block SCS [kHz]	GSCN	absoluteFrequencySSB [ARFCN]
E-UTRA: 10MHz + NR: 20MHz	E-UTRA CC1	10	50	Downlink & Uplink	Low	2521.200	39902	-	-	-	-	-
					Mid	2603.100	40721	-	-	-	-	
					High	2664.900	41339	-	-	-	-	
Channel spacing E-UTRA CC1- NR CC1=15 MHz (Note 2)												
NR CC1	20	24	Downlink & Uplink	Low	2506.200	501240	2497.56	499512	0	15	-	499872
				Mid	2588.100	517620	2506.02	501204	102		-	516252
				High	2679.900	535980	2308.38	461676	504		-	534612
E-UTRA: 10MHz + NR: 40MHz	E-UTRA CC1	10	50	Downlink & Uplink	Low	2541.300	40103	-	-	-	-	-
					Mid	2613.000	40820	-	-	-	-	-
					High	2644.800	41138	-	-	-	-	
Channel spacing E-UTRA CC1- NR CC1=25.005 MHz (Note 2)												

	NR CC1	40	51	Downlink & Uplink	Low	2516.295	503259	2497.935	499587	0	15	-	499947	
					Mid	2587.995	517599	2496.195	499239	102		-	514287	
					High	2669.805	533961	2288.565	457713	504		-	530649	
E-UTRA: 10MHz + NR: 50MHz	E-UTRA CC1	10	50	Downlink & Uplink	Low	2551.200	40202	-	-	-		-	-	
					Mid	2618.100	40871	-	-	-		-	-	
					High	2634.900	41039	-	-	-		-	-	
	Channel spacing E-UTRA CC1- NR CC1=30 MHz (Note 2)													
	NR CC1	50	65	Downlink & Uplink	Low	2521.200	504240	2497.8	499560	0	15	-	499920	
					Mid	2588.100	517620	2491.26	498252	102		-	513300	
High					2664.900	532980	2278.62	455724	504	-		528660		
E-UTRA: 10MHz + NR: 60MHz	E-UTRA CC1	10	50	Downlink & Uplink	Low	2561.100	40301	-	-	-		-	-	
					Mid	2622.900	40919	-	-	-		-	-	
					High	2625.000	40940	-	-	-		-	-	
	Channel spacing E-UTRA CC1- NR CC1=34.995 MHz (Note 2)													
	NR CC1	60	79	Downlink & Uplink	Low	2526.105	505221	2497.665	499533	0	15	-	499893	
					Mid	2587.905	517581	2486.025	497205	102		-	512253	
High					2659.995	531999	2268.675	453735	504	-		526671		
E-UTRA: 10MHz + NR: 80MHz	E-UTRA CC1	10	50	Downlink & Uplink	Low	2581.200	40502	-	-	-		-	-	
					Mid	2633.100	41021	-	-	-		-	-	
					High	2604.900	40739	-	-	-		-	-	
	Channel spacing E-UTRA CC1- NR CC1=45 MHz (Note 2)													
	NR CC1	80	107	Downlink & Uplink	Low	2536.200	507240	2497.68	499536	0	15	-	499896	
					Mid	2588.100	517620	2476.14	495228	102		-	510276	
High					2649.900	529980	2248.5	449700	504	-		522636		
E-UTRA: 10MHz + NR: 100MHz	E-UTRA CC1	10	50	Downlink & Uplink	Low	2601.300	40703	-	-	-		-	-	
					Mid	2643.000	41120	-	-	-		-	-	
					High	2584.800	40538	-	-	-		-	-	
	Channel spacing E-UTRA CC1- NR CC1=55.005 MHz (Note 2)													
	NR CC1	100	135	Downlink & Uplink	Low	2546.295	509259	2497.695	499539	0	15	-	499899	
					Mid	2587.995	517599	2465.955	493191	102		-	508239	
High					2639.805	527961	2228.325	445665	504	-		518601		
E-UTRA: 20MHz + NR: 10MHz	E-UTRA CC1	20	100	Downlink & Uplink	Low	2516.100	39851	-	-	-		-	-	
					Mid	2598.000	40670	-	-	-		-	-	
					High	2670.000	41390	-	-	-		-	-	
	Channel spacing E-UTRA CC1- NR CC1=15 MHz (Note 2)													
	NR CC1	10	11	Downlink & Uplink	Low	2501.100	500220	2497.14	499428	0	15	-	499788	
					Mid	2583.000	516600	2505.6	501120	102		-	516168	
High					2685.000	537000	2318.16	463632	504	-		536568		
E-UTRA: 20MHz + NR: 20MHz	E-UTRA CC1	20	100	Downlink & Uplink	Low	2526.000	39950	-	-	-		-	-	
					Mid	2603.100	40721	-	-	-		-	-	
					High	2659.800	41288	-	-	-		-	-	
	Channel spacing E-UTRA CC1- NR CC1=19.995 MHz (Note 2)													
	NR CC1	20	24	Downlink &	Low	2506.005	501201	2497.365	499473	0	15	-	499833	
					Mid	2583.105	516621	2501.025	500205	102		-	515253	

E-UTRA: 20MHz + NR: 40MHz	E-UTRA CC1	20	100	Uplink	High	2679.795	535959	2308.275	461655	504	-	534591	
				Downlink & Uplink	Low	2546.100	40151	-	-	-	-	-	
					Mid	2613.000	40820	-	-	-	-	-	
					High	2640.000	41090	-	-	-	-	-	
	Channel spacing E-UTRA CC1- NR CC1=30 MHz (Note 2)												
NR CC1	40	51	Downlink & Uplink	Low	2516.100	503220	2497.74	499548	0	15	-	499908	
				Mid	2583.000	516600	2491.2	498240	102	-	513288		
				High	2670.000	534000	2288.76	457752	504	-	530688		
E-UTRA: 20MHz + NR: 50MHz	E-UTRA CC1	20	100	Downlink & Uplink	Low	2556.000	40250	-	-	-	-	-	
					Mid	2618.100	40871	-	-	-	-	-	
					High	2629.800	40988	-	-	-	-	-	
				Channel spacing E-UTRA CC1- NR CC1=34.995 MHz (Note 2)									
	NR CC1	50	65	Downlink & Uplink	Low	2521.005	504201	2497.605	499521	0	15	-	499881
Mid					2583.105	516621	2486.265	497253	102	-	512301		
High					2664.795	532959	2278.515	455703	504	-	528639		
E-UTRA: 20MHz + NR: 60MHz	E-UTRA CC1	20	100	Downlink & Uplink	Low	2566.200	40352	-	-	-	-	-	
					Mid	2622.900	40919	-	-	-	-	-	
					High	2619.900	40889	-	-	-	-	-	
				Channel spacing E-UTRA CC1- NR CC1=40.005 MHz (Note 2)									
	NR CC1	60	79	Downlink & Uplink	Low	2526.195	505239	2497.755	499551	0	15	-	499911
Mid					2582.895	516579	2481.015	496203	102	-	511251		
High					2659.905	531981	2268.585	453717	504	-	526653		
E-UTRA: 20MHz + NR: 80MHz	E-UTRA CC1	20	100	Downlink & Uplink	Low	2586.000	40550	-	-	-	-	-	
					Mid	2633.100	41021	-	-	-	-	-	
					High	2599.800	40688	-	-	-	-	-	
				Channel spacing E-UTRA CC1- NR CC1=49.995 MHz (Note 2)									
	NR CC1	80	107	Downlink & Uplink	Low	2536.005	507201	2497.485	499497	0	15	-	499857
Mid					2583.105	516621	2471.145	494229	102	-	509277		
High					2649.795	529959	2248.395	449679	504	-	522615		
E-UTRA: 20MHz + NR: 100MHz	E-UTRA CC1	20	100	Downlink & Uplink	Low	2606.100	40751	-	-	-	-	-	
					Mid	2643.000	41120	-	-	-	-	-	
					High	2580.000	40490	-	-	-	-	-	
				Channel spacing E-UTRA CC1- NR CC1=60 MHz (Note 2)									
	NR CC1	100	135	Downlink & Uplink	Low	2546.100	509220	2497.5	499500	0	15	-	499860
Mid					2583.000	516600	2460.96	492192	102	-	507240		
High					2640.000	528000	2228.52	445704	504	-	518640		
Note 1: The nominal carrier spacing between the E-UTRA and the NR carriers is set in accordance to TS 38.101-3 [9], clause 5.4B1.													
Note 2: FR1 carrier without CORESET#0 is indicated in the MIB by setting $k_{SSB} = 31$ , $controlResourceSetZero = 0$ and $searchSpaceZero = 0$ (TS 38.213 [22], clause 13).													



Table 4.3.1.4.2.41.1-3A: EN-DC combination DC\_(n)41AA, intra-band contiguous, SCS 60 kHz, 15 kHz NR raster, E-UTRA CC at the band edges without CORESET#0

EN-DC channel bandwidth combination	CC	Bandwidth [MHz]	carrierBandwidth [PRBs]	Range	Carrier centre [MHz] Note 1	Carrier centre [ARFCN]	point A [MHz]	absoluteFrequencyPointA [ARFCN]	offsetToCarrier [Carrier PRBs]	SS block SCS [kHz]	GSCN	absoluteFrequencySSB [ARFCN]	
E-UTRA: 20MHz + NR: 40MHz	E-UTRA CC1	20	100	Downlink & Uplink	Low	2506.200	39752	-	-	-	-	-	
					Mid	2613.000	40820	-	-	-	-		
					High	2679.900	41489	-	-	-	-		
	Channel spacing E-UTRA CC1- NR CC1=30 MHz (Note 2)												
	NR CC1	40	51	Downlink & Uplink	Low	2536.200	507240	2517.84	503568	0	15	-	503928
					Mid	2583.000	516600	2491.2	498240	102	-	513288	
					High	2649.900	529980	2268.66	453732	504	-	526668	
E-UTRA: 20MHz + NR: 60MHz	E-UTRA CC1	20	100	Downlink & Uplink	Low	2506.200	39752	-	-	-	-	-	
					Mid	2622.900	40919	-	-	-	-		
					High	2679.900	41489	-	-	-	-		
	Channel spacing E-UTRA CC1- NR CC1=40.005 MHz (Note 2)												
	NR CC1	60	79	Downlink & Uplink	Low	2546.205	509241	2517.765	503553	0	15	-	503913
					Mid	2582.895	516579	2481.015	496203	102	-	511251	
					High	2639.895	527979	2248.575	449715	504	-	522651	
E-UTRA: 20MHz + NR: 80MHz	E-UTRA CC1	20	100	Downlink & Uplink	Low	2506.200	39752	-	-	-	-	-	
					Mid	2633.100	41021	-	-	-	-		
					High	2679.900	41489	-	-	-	-		
	Channel spacing E-UTRA CC1- NR CC1=49.995 MHz (Note 2)												
	NR CC1	80	107	Downlink & Uplink	Low	2556.195	511239	2517.675	503535	0	15	-	503895
					Mid	2583.105	516621	2471.145	494229	102	-	509277	
					High	2629.905	525981	2228.505	445701	504	-	518637	
E-UTRA: 20MHz + NR: 100MHz	E-UTRA CC1	20	100	Downlink & Uplink	Low	2506.200	39752	-	-	-	-	-	
					Mid	2643.000	41120	-	-	-	-		
					High	2679.900	41489	-	-	-	-		
	Channel spacing E-UTRA CC1- NR CC1=60 MHz (Note 2)												
	NR CC1	100	135	Downlink & Uplink	Low	2566.200	513240	2517.6	503520	0	15	-	503880
					Mid	2583.000	516600	2460.96	492192	102	-	507240	
					High	2619.900	523980	2208.42	441684	504	-	514620	
Note 1: The nominal carrier spacing between the E-UTRA and the NR carriers is set in accordance to TS 38.101-3 [9], clause 5.4B1.													
Note 2: FR1 carrier without CORESET#0 is indicated in the MIB by setting $k_{SSB} = 31$ , $controlResourceSetZero = 0$ and $searchSpaceZero = 0$ (TS 38.213 [22], clause 13).													

Table 4.3.1.4.2.41.2-1: EN-DC combination DC\_(n)41CA, intra-band contiguous, SCS 15 kHz, 15 kHz NR raster, NR CC at the band edges

EN-DC channel bandwidth combination	CC	Band width [MHz]	carrierBandwidth [PRBs]	Range		Carrier centre [MHz] Note 2	Carrier centre [ARFCN]	point A [MHz]	absoluteFrequencyPointA [ARFCN]	offsetToCarrier [Carrier PRBs]	SS block SCS [kHz]	GSCN	absoluteFrequencySSB [ARFCN]	$k_{SSB}$	Offset Carrier CORESET#0 [RBs] Note 3	CORESET#0 Index (Offset [RBs]) Note 1	offsetToPointA (SIB1) [PRBs] Note 1	
E-UTRA: 20MHz + 20MHz + NR: 40MHz	E-UTRA CC1	20	100	Downlink & Uplink	Low	2546.100	40151	-	-	-	-	-	-	-	-	-	-	
					Mid	2603.100	40721	-	-	-	-	-	-	-	-	-	-	
					High	2620.2	40892	-	-	-	-	-	-	-	-	-	-	
	Channel spacing E-UTRA CC1- E-UTRA CC2=19.8 MHz (Note 4)																	
	E-UTRA CC2	20	100	Downlink & Uplink	Low	2565.900	40349	-	-	-	-	-	-	-	-	-	-	-
					Mid	2622.900	40919	-	-	-	-	-	-	-	-	-	-	
					High	2640.000	41090	-	-	-	-	-	-	-	-	-	-	
	Channel spacing E-UTRA CC2- NR CC1=30 MHz (Note 2)																	
	NR CC1	40	216	Downlink & Uplink	Low	2516.100	503220	2496.66	499332	0	15	6246	499710	6	0	0 (0)	0	
					Mid	2573.100	514620	2535.30	507060	102		6390	511230	10	1	1 (2)	105	
High					2670.000	534000	2559.84	511968	504	6633		530670	6	1	2 (4)	509		
E-UTRA: 20MHz + 20MHz + NR: 50MHz	E-UTRA CC1	20	100	Downlink & Uplink	Low	2556.000	40250	-	-	-	-	-	-	-	-	-	-	
					Mid	2608.100	40771	-	-	-	-	-	-	-	-	-	-	
					High	2610.00	40790	-	-	-	-	-	-	-	-	-	-	
	Channel spacing E-UTRA CC1- E-UTRA CC2=19.8 MHz (Note 4)																	
	E-UTRA CC2	20	100	Downlink & Uplink	Low	2575.800	40448	-	-	-	-	-	-	-	-	-	-	-
					Mid	2627.900	40969	-	-	-	-	-	-	-	-	-	-	
					High	2629.800	40988	-	-	-	-	-	-	-	-	-	-	
	Channel spacing E-UTRA CC2- NR CC1=34.995 MHz (Note 2)																	
	NR CC1	50	270	Downlink & Uplink	Low	2521.005	504201	2496.705	499341	0	15	6246	499710	3	0	0 (0)	0	
					Mid	2573.1	514620	2530.440	506088	102		6738	510270	2	0	2 (4)	106	
High					2664.795	532959	2549.775	509955	504	6606		528510	5	1	0 (0)	505		
Note 1: The CORESET#0 Index and the associated CORESET#0 Offset refers to Table 13-1 in TS 38.213 [22]. The value of CORESET#0 Index is signalled in controlResourceSetZero (pdccch. ConfigSIB1) in the MIB. The offsetToPointA IE is expressed in units of resource blocks assuming 15 kHz subcarrier spacing for FR1 and 60 kHz subcarrier spacing for FR2.																		
Note 2: The nominal carrier spacing between the E-UTRA and the NR carriers is set in accordance to TS 38.101-3 [9], clause 5.4B.1.																		
Note 3: The parameter Offset Carrier CORESET#0 specifies the offset from the lowest subcarrier of the carrier and the lowest subcarrier of CORESET#0. It corresponds to the parameter $\Delta F_{\text{OffsetCORESET}0\text{-Carrier}}$ in Annex C expressed in number of common RBs.																		
Note 4: The nominal carrier spacing between the E-UTRA carriers is set in accordance to TS 36.101 [48], clause 5.7.1A.																		

Table 4.3.1.4.2.41.2-1A: EN-DC combination DC\_(n)41CA, intra-band contiguous, SCS 15 kHz, 15 kHz NR raster, E-UTRA CC at the band edges

EN-DC channel	CC	Band width	carrierBandwidth	Range		Carrier centre	Carrier centre	point A [MHz]	absoluteFrequency	offsetToCarrier	SS block	GSCN	absoluteFrequency	$k_{SSB}$	Offset Carrier	CORESET#0	offsetToPointA
---------------	----	------------	------------------	-------	--	----------------	----------------	---------------	-------------------	-----------------	----------	------	-------------------	-----------	----------------	-----------	----------------

bandwidth combination		[MHz]	[PRBs]			[MHz] Note 2	[ARFCN]		PointA [ARFCN]	rier [Carrier PRBs]	SCS [kHz]		SSB [ARFCN]		CORES ET#0 [RBs] Note 3	Index (Offset [RBs]) Note 1	(SIB1) [PRBs] Note 1					
E-UTRA: 20MHz + 20MHz + NR: 40MHz	E-UTRA CC1	20	100	Downlink & Uplink	Low	2506.200	39752	-	-	-	-	-	-	-	-	-	-					
					Mid	2603.100	40721	-	-	-	-	-	-	-	-	-						
					High	2659.800	41288	-	-	-	-	-	-	-	-	-						
	Channel spacing E-UTRA CC1- E-UTRA CC2=19.8 MHz (Note 4)																					
	E-UTRA CC2	20	100	Downlink & Uplink	Low	2526.000	39950	-	-	-	-	-	-	-	-	-	-	-				
					Mid	2622.900	40919	-	-	-	-	-	-	-	-	-						
					High	2679.600	41486	-	-	-	-	-	-	-	-	-						
	Channel spacing E-UTRA CC2- NR CC1=30 MHz (Note 2)																					
	NR CC1	40	216	Downlink & Uplink	Low	2556.000	511200	2536.56	507312	0	15	6348	507870	6	1	2 (4)	5					
					Mid	2573.100	514620	2535.3	507060	102								6390	511230	10	1	1 (2)
High					2629.800	525960	2519.64	503928	504	6531												

Note 1: The CORESET#0 Index and the associated CORESET#0 Offset refers to Table 13-1 in TS 38.213 [22]. The value of CORESET#0 Index is signalled in controlResourceSetZero (pdcc-ConfigSIB1) in the MIB. The offsetToPointA IE is expressed in units of resource blocks assuming 15 kHz subcarrier spacing for FR1 and 60 kHz subcarrier spacing for FR2.

Note 2: The nominal carrier spacing between the E-UTRA and the NR carriers is set in accordance to TS 38.101-3 [9], clause 5.4B.1.

Note 3: The parameter Offset Carrier CORESET#0 specifies the offset from the lowest subcarrier of the carrier and the lowest subcarrier of CORESET#0. It corresponds to the parameter  $\Delta F_{\text{OffsetCORESET-0-Carrier}}$  in Annex C expressed in number of common RBs.

Note 4: The nominal carrier spacing between the E-UTRA carriers is set in accordance to TS 36.101 [48], clause 5.7.1A.

Table 4.3.1.4.2.41.2-2: EN-DC combination DC\_(n)41CA, intra-band contiguous, SCS 30 kHz, 30 kHz NR raster, NR CC at the band edges

EN-DC channel bandwidth combination	CC	Bandwidth [MHz]	carrierBandwidth [PRBs]	Range	Carrier centre [MHz] Note 2	Carrier centre [ARFCN]	point A [MHz]	absoluteFrequencyPointA [ARFCN]	offsetToCarrier [Carrier PRBs]	SS block SCS [kHz]	GSCN	absoluteFrequencySSB [ARFCN]	$k_{SSB}$	Offset Carrier CORESET#0 [RBs] Note 3	CORES ET#0 Index (Offset [RBs]) Note 1	offsetToPointA (SIB1) [PRBs] Note 1						
E-UTRA: 20MHz + 20MHz + NR: 40MHz	E-UTRA CC1	20	100	Downlink & Uplink	Low	2546.100	40151	-	-	-	-	-	-	-	-	-						
					Mid	2603.100	40721	-	-	-	-	-	-	-	-	-						
					High	2620.200	40892	-	-	-	-	-	-	-	-	-						
	Channel spacing E-UTRA CC1- E-UTRA CC2=19.8 MHz (Note 4)																					
	E-UTRA CC2	20	100	Downlink & Uplink	Low	2565.900	40349	-	-	-	-	-	-	-	-	-	-					
					Mid	2622.900	40919	-	-	-	-	-	-	-	-	-						
					High	2640.000	41090	-	-	-	-	-	-	-	-	-						
	Channel spacing E-UTRA CC2- NR CC1=30 MHz (Note 2)																					
	NR CC1	40	106	Downlink & Uplink	Low	2516.100	503220	2497.02	499404	0	30	6252	500190	22	0	0 (0)	0					
					Mid	2573.100	514620	2517.30	503460	102								6396	511710	14	0	2 (2)
High					2670.000	534000	2469.48	493896	504	6636												

| E-UTRA: 20MHz + | E-UTRA CC1 | 20 | 100 | Downlink & | Low | 2556.300 | 40253 | - | - | - | - | - | - | - | - | - |
| Mid | 2608.100 | 40771 | - | - | - | - | - | - | - | - | - | - | - |

20MHz + NR: 50MHz				Uplink	High	2610.000	40790	-	-	-	-	-	-	-	-	-	-	
	Channel spacing E-UTRA CC1- E-UTRA CC2=19.8 MHz (Note 4)																	
	E-UTRA CC2	20	100	Downlink & Uplink	Downlink	Low	2576.100	40451	-	-	-	-	-	-	-	-	-	-
					Mid	2627.900	40969	-	-	-	-	-	-	-	-	-		
					Uplink	High	2629.800	40988	-	-	-	-	-	-	-	-		
	Channel spacing E-UTRA CC2- NR CC1=35.01 MHz (Note 2)																	
	NR CC1	50	133	Downlink & Uplink	Downlink	Low	2521.290	504258	2497.35	499470	0	30	6252	500190	0	0	0 (0)	0
					Mid	2573.100	514620	2512.44	502488	102	6384		510750	18	0	2 (2)	208	
					High	2664.810	532962	2459.43	491886	504	6612		528990	8	0	1 (1)	1010	
	E-UTRA: 20MHz + 20MHz + NR: 60MHz	E-UTRA CC1	20	100	Downlink & Uplink	Downlink	Low	2566.200	40352	-	-	-	-	-	-	-	-	-
Mid						2573.100	514620	-	-	-	-	-	-	-	-	-		
High						2600.100	40691	-	-	-	-	-	-	-	-	-		
Channel spacing E-UTRA CC1- E-UTRA CC2=19.8 MHz (Note 4)																		
E-UTRA CC2		20	100	Downlink & Uplink	Downlink	Low	2586.000	40550	-	-	-	-	-	-	-	-	-	-
					Mid	2632.900	41019	-	-	-	-	-	-	-	-	-		
					High	2619.900	40889	-	-	-	-	-	-	-	-	-		
Channel spacing E-UTRA CC2- NR CC1=39.99 MHz (Note 2)																		
NR CC1		60	162	Downlink & Uplink	Downlink	Low	2526.210	505242	2497.05	499410	0	30	6252	500190	20	0	0 (0)	0
					Mid	2573.100	514620	2507.22	501444	102	6369		509550	14	0	0 (0)	204	
	High				2659.890	531978	2449.29	489858	504	6588	527070		20	0	2 (2)	1012		
E-UTRA: 20MHz + 20MHz + NR: 80MHz	E-UTRA CC1	20	100	Downlink & Uplink	Downlink	Low	2586.300	40553	-	-	-	-	-	-	-	-	-	
					Mid	2623.100	40921	-	-	-	-	-	-	-	-	-		
					High	2580.000	40490	-	-	-	-	-	-	-	-	-		
	Channel spacing E-UTRA CC1- E-UTRA CC2=19.8 MHz (Note 4)																	
	E-UTRA CC2	20	100	Downlink & Uplink	Downlink	Low	2606.100	40751	-	-	-	-	-	-	-	-	-	-
					Mid	2642.900	41119	-	-	-	-	-	-	-	-	-		
					High	2599.800	40688	-	-	-	-	-	-	-	-	-		
	Channel spacing E-UTRA CC2- NR CC1=50.01 MHz (Note 2)																	
	NR CC1	80	217	Downlink & Uplink	Downlink	Low	2536.290	507258	2497.23	499446	0	30	6252	500190	8	0	0 (0)	0
					Mid	2573.100	514620	2497.32	499464	102	6345		507630	10	0	1 (1)	206	
High					2649.810	529962	2429.31	485862	504	6537	522990		16	0	1 (1)	1010		
E-UTRA: 20MHz + 20MHz + NR: 100MHz	E-UTRA CC1	20	100	Downlink & Uplink	Downlink	Low	2606.100	40751	-	-	-	-	-	-	-	-	-	
					Mid	2633.100	41021	-	-	-	-	-	-	-	-	-		
					High	2560.200	40292	-	-	-	-	-	-	-	-	-		
	Channel spacing E-UTRA CC1- E-UTRA CC2=19.8 MHz (Note 4)																	
	E-UTRA CC2	20	100	Downlink & Uplink	Downlink	Low	2625.900	40949	-	-	-	-	-	-	-	-	-	-
					Mid	2652.900	41219	-	-	-	-	-	-	-	-	-		
					High	2580.000	40490	-	-	-	-	-	-	-	-	-		
	Channel spacing E-UTRA CC2- NR CC1=60 MHz (Note 2)																	
	NR CC1	100	273	Downlink & Uplink	Downlink	Low	2546.100	509220	2496.96	499392	0	30	6252	500190	2	0	1 (1)	2
					Mid	2573.100	514620	2487.24	497448	102	6321		505710	18	0	2 (2)	208	
High					2640.000	528000	2409.42	481884	504	6486	518910		6	0	0 (0)	1008		

- Note 1: The CORESET#0 Index and the associated CORESET#0 Offset refers to Table 13-4 in TS 38.213 [22]. The value of CORESET#0 Index is signalled in controlResourceSetZero (pdccch-ConfigSIB1) in the MIB. The offsetToPointA IE is expressed in units of resource blocks assuming 15 kHz subcarrier spacing for FR1 and 60 kHz subcarrier spacing for FR2.
- Note 2: The nominal carrier spacing between the E-UTRA and the NR carriers is set in accordance to TS 38.101-3 [9], clause 5.4B.1.
- Note 3: The parameter Offset Carrier CORESET#0 specifies the offset from the lowest subcarrier of the carrier and the lowest subcarrier of CORESET#0. It corresponds to the parameter  $\Delta F_{\text{OffsetCORESET-0-Carrier}}$  in Annex C expressed in number of common RBs.
- Note 4: The nominal carrier spacing between the E-UTRA carriers is set in accordance to TS 36.101 [48], clause 5.7.1A.

**Table 4.3.1.4.2.41.2-2A: EN-DC combination DC\_(n)41CA, intra-band contiguous, SCS 30 kHz, 30 kHz NR raster, E-UTRA CC at the band edges**

EN-DC channel bandwidth combination	CC	Bandwidth [MHz]	carrierBandwidth [PRBs]	Range		Carrier centre [MHz] Note 2	Carrier centre [ARFCN]	point A [MHz]	absoluteFrequencyPointA [ARFCN]	offsetToCarrier [Carrier PRBs]	SS block SCS [kHz]	GSCN	absoluteFrequencySSB [ARFCN]	$k_{SSB}$	Offset Carrier CORESET#0 [RBs] Note 3	CORESET#0 Index (Offset [RBs]) Note 1	offsetToPointA (SIB1) [PRBs] Note 1	
																		Low
E-UTRA: 20MHz + 20MHz + NR: 40MHz	E-UTRA CC1	20	100	Downlink & Uplink	Low	2506.200	39752	-	-	-	-	-	-	-	-	-	-	
					Mid	2603.100	40721	-	-	-	-	-	-	-	-	-	-	-
					High	2659.800	41288	-	-	-	-	-	-	-	-	-	-	-
	Channel spacing E-UTRA CC1- E-UTRA CC2=19.8 MHz (Note 4)																	
	E-UTRA CC2	20	100	Downlink & Uplink	Low	2526.000	39950	-	-	-	-	-	-	-	-	-	-	-
					Mid	2622.900	40919	-	-	-	-	-	-	-	-	-	-	-
					High	2679.600	41486	-	-	-	-	-	-	-	-	-	-	-
	Channel spacing E-UTRA CC2- NR CC1=30 MHz (Note 2)																	
	NR CC1	40	106	Downlink & Uplink	Low	2556.000	511200	2536.92	507384	0	30	6351	508110	16	0	0 (0)	0	
					Mid	2573.100	514620	2517.3	503460	102		6396	511710	14	0	2 (2)	208	
High					2629.800	525960	2429.28	485856	504	6537		522990	16	0	0 (0)	1008		
E-UTRA: 20MHz + 20MHz + NR: 60MHz	E-UTRA CC1	20	100	Downlink & Uplink	Low	2506.500	39755	-	-	-	-	-	-	-	-	-	-	
					Mid	2613.100	40821	-	-	-	-	-	-	-	-	-	-	
					High	2659.800	41288	-	-	-	-	-	-	-	-	-	-	
	Channel spacing E-UTRA CC1- E-UTRA CC2=19.8 MHz (Note 4)																	
	E-UTRA CC2	20	100	Downlink & Uplink	Low	2526.300	39953	-	-	-	-	-	-	-	-	-	-	-
					Mid	2632.900	41019	-	-	-	-	-	-	-	-	-	-	
					High	2679.600	41486	-	-	-	-	-	-	-	-	-	-	
	Channel spacing E-UTRA CC2- NR CC1=39.99 MHz (Note 2)																	
	NR CC1	60	162	Downlink & Uplink	Low	2566.290	513258	2537.13	507426	0	30	6354	508350	20	0	2 (2)	4	
					Mid	2573.1	514620	2507.22	501444	102		6369	509550	14	0	0 (0)	204	
High					2619.810	523962	2409.21	481842	504	6486		518910	20	0	0 (0)	1008		
E-UTRA: 20MHz + 20MHz + NR: 80MHz	E-UTRA CC1	20	100	Downlink & Uplink	Low	2506.200	39752	-	-	-	-	-	-	-	-	-	-	
					Mid	2623.100	40921	-	-	-	-	-	-	-	-	-	-	
					High	2659.800	41288	-	-	-	-	-	-	-	-	-	-	
	Channel spacing E-UTRA CC1- E-UTRA CC2=19.8 MHz (Note 4)																	
E-UTRA	20	100	Downlink	Low	2526.000	39950	-	-	-	-	-	-	-	-	-	-	-	

	CC2			& Uplink	Mid	2642.9	41119	-	-	-	-	-	-	-	-	-	
					High	2679.600	41486	-	-	-	-	-	-	-	-	-	
Channel spacing E-UTRA CC2- NR CC1=50.01 MHz (Note 2)																	
NR CC1	80	217	Downlink & Uplink	Low	2576.010	515202	2536.95	507390	0	30	6351	508110	0	0	0 (0)	0	
				Mid	2573.1	514620	2497.32	499464	102		6345	576300	10	0	1 (1)	206	
				High	2609.790	521958	2389.29	477858	504		6438	515070	20	0	2 (2)	1012	
E-UTRA: 20MHz + 20MHz + NR: 100MHz	E-UTRA CC1	20	100	Downlink & Uplink	Low	2506.200	39752	-	-	-	-	-	-	-	-	-	
					Mid	2633.100	41021	-	-	-	-	-	-	-	-	-	
					High	2659.800	41288	-	-	-	-	-	-	-	-	-	
	Channel spacing E-UTRA CC1- E-UTRA CC2=19.8 MHz (Note 4)																
	E-UTRA CC2	20	100	Downlink & Uplink	Low	2526.000	39950	-	-	-	-	-	-	-	-	-	-
					Mid	2652.900	41219	-	-	-	-	-	-	-	-	-	
					High	2679.600	41486	-	-	-	-	-	-	-	-	-	
	Channel spacing E-UTRA CC2- NR CC1=60 MHz (Note 2)																
	NR CC1	100	273	Downlink & Uplink	Low	2586.000	517200	2536.86	507372	0	30	6351	508110	6	0	0 (0)	0
					Mid	2573.100	514620	2487.24	497448	102		6321	505710	18	0	2 (2)	208
High					2599.800	519960	2369.22	473844	504	6387		510990	22	0	1 (1)	1010	
Note 1: The CORESET#0 Index and the associated CORESET#0 Offset refers to Table 13-4 in TS 38.213 [22]. The value of CORESET#0 Index is signalled in controlResourceSetZero (pdcc. ConfigSIB1) in the MIB. The offsetToPointA IE is expressed in units of resource blocks assuming 15 kHz subcarrier spacing for FR1 and 60 kHz subcarrier spacing for FR2.																	
Note 2: The nominal carrier spacing between the E-UTRA and the NR carriers is set in accordance to TS 38.101-3 [9], clause 5.4B.1.																	
Note 3: The parameter Offset Carrier CORESET#0 specifies the offset from the lowest subcarrier of the carrier and the lowest subcarrier of CORESET#0. It corresponds to the parameter $\Delta F_{\text{OffsetCORESET}0\text{-Carrier}}$ in Annex C expressed in number of common RBs.																	
Note 4: The nominal carrier spacing between the E-UTRA carriers is set in accordance to TS 36.101 [48], clause 5.7.1A.																	

Table 4.3.1.4.2.41.2-3: EN-DC combination DC\_(n)41CA, intra-band contiguous, SCS 60 kHz, 15 kHz NR raster, NR CC at the band edges without CORESET#0

EN-DC channel bandwidth combination	CC	Band width [MHz]	carrierBandwidth [PRBs]	Range	Carrier centre [MHz] Note 1	Carrier centre [ARFCN]	point A [MHz]	absoluteFrequencyPointA [ARFCN]	offsetToCarrier [Carrier PRBs]	SS block SCS [kHz]	GSCN	absoluteFrequencySSB [ARFCN]	
E-UTRA: 20MHz + 20MHz + NR: 40MHz	E-UTRA CC1	20	100	Downlink & Uplink	Low	2546.100	40151	-	-	-	-	-	
					Mid	2603.100	40721	-	-	-	-	-	
					High	2620.200	40892	-	-	-	-		
	Channel spacing E-UTRA CC1- E-UTRA CC2=19.8 MHz (Note 3)												
	E-UTRA CC2	20	100	Downlink & Uplink	Low	2565.900	40349						
					Mid	2622.900	40919						
					High	2640.000	41090						
	Channel spacing E-UTRA CC2- NR CC1=30 MHz (Note 2)												
	NR CC1	40	51	Downlink & Uplink	Low	2516.100	503220	2497.74	499548	0	15	-	499908
					Mid	2573.100	514620	2481.3	496260	102		-	511308

E-UTRA: 20MHz + 20MHz + NR: 50MHz	E-UTRA CC1	20	100	Uplink	High	2670.000	534000	2288.76	457752	504	-	530688	
					Downlink & Uplink	Low	2556.000	40250	-	-	-	-	
						Mid	2608.100	40771	-	-	-	-	
						High	2610.000	40790	-	-	-	-	
	Channel spacing E-UTRA CC1- E-UTRA CC2=19.8 MHz (Note 3)												
	E-UTRA CC2	20	100	Downlink & Uplink	Low	2575.800	40448						
					Mid	2627.900	40969						
					High	2629.800	40988						
	Channel spacing E-UTRA CC2- NR CC1=34.995 MHz (Note 2)												
	NR CC1	50	65	Downlink & Uplink	Low	2521.005	504201	2497.605	499521	0	15	-	499881
Mid					2573.100	514620	2476.26	495252	102	-		510300	
High					2664.795	532959	2278.515	455703	504	-		528639	
E-UTRA: 20MHz + 20MHz + NR: 60MHz	E-UTRA CC1	20	100	Downlink & Uplink	Low	2566.200	40352	-	-	-	-	-	
					Mid	2613.100	40821	-	-	-	-		
					High	2600.100	40691	-	-	-	-		
					Channel spacing E-UTRA CC1- E-UTRA CC2=19.8 MHz (Note 3)								
	E-UTRA CC2	20	100	Downlink & Uplink	Low	2586.000	40550	-	-	-	-	-	
					Mid	2632.9	41019	-	-	-	-		
					High	2619.900	40889	-	-	-	-		
	Channel spacing E-UTRA CC2- NR CC1=40.005 MHz (Note 2)												
	NR CC1	60	79	Downlink & Uplink	Low	2526.195	505239	2497.755	499551	0	15	-	499911
					Mid	2573.1	514620	2471.22	494244	102		-	509292
High					2659.905	531981	2268.585	453717	504	-		526653	
E-UTRA: 20MHz + 20MHz + NR: 80MHz	E-UTRA CC1	20	100	Downlink & Uplink	Low	2586.000	40550	-	-	-	-	-	
					Mid	2623.100	40921	-	-	-	-		
					High	2580.000	40490	-	-	-	-		
					Channel spacing E-UTRA CC1- E-UTRA CC2=19.8 MHz (Note 3)								
	E-UTRA CC2	20	100	Downlink & Uplink	Low	2605.800	40748	-	-	-	-	-	
					Mid	2642.900	41119	-	-	-	-		
					High	2599.800	40688	-	-	-	-		
	Channel spacing E-UTRA CC2- NR CC1=49.995 MHz (Note 2)												
	NR CC1	80	107	Downlink & Uplink	Low	2536.005	507201	2497.485	499497	0	15	-	499857
					Mid	2573.1	514620	2461.14	492228	102		-	507276
High					2649.795	529959	2248.395	449679	504	-		522615	
E-UTRA: 20MHz + 20MHz + NR: 100MHz	E-UTRA CC1	20	100	Downlink & Uplink	Low	2606.100	40751	-	-	-	-	-	
					Mid	2633.100	41021	-	-	-	-		
					High	2560.2	40292	-	-	-	-		
					Channel spacing E-UTRA CC1- E-UTRA CC2=19.8 MHz (Note 3)								
	E-UTRA CC2	20	100	Downlink & Uplink	Low	2625.900	40949	-	-	-	-	-	
					Mid	2652.900	41219	-	-	-	-		
					High	2580.000	40490	-	-	-	-		
	Channel spacing E-UTRA CC2- NR CC1=60 MHz (Note 2)												
	NR	100	135	Downlink	Low	2546.100	509220	2497.5	499500	0	15	-	499860

	CC1			&	Mid	2573.100	514620	2451.06	490212	102		-	505260
				Uplink	High	2640.000	528000	2228.52	445704	504		-	518640
Note 1: The nominal carrier spacing between the E-UTRA and the NR carriers is set in accordance to TS 38.101-3 [9], clause 5.4B1.													
Note 2: FR1 carrier without CORESET#0 is indicated in the MIB by setting $k_{SSB} = 31$ , $controlResourceSetZero = 0$ and $searchSpaceZero = 0$ (TS 38.213 [22], clause 13).													
Note 3: The nominal carrier spacing between the E-UTRA carriers is set in accordance to TS 36.101 [48], clause 5.7.1A.													

**Table 4.3.1.4.2.41.2-3A: EN-DC combination DC\_(n)41CA, intra-band contiguous, SCS 60 kHz, 15 kHz NR raster, E-UTRA CC at the band edges without CORESET#0**

EN-DC channel bandwidth combination	CC	Band width [MHz]	carrierBandwidth [PRBs]	Range		Carrier centre [MHz] Note 1	Carrier centre [ARFCN]	point A [MHz]	absoluteFrequency PointA [ARFCN]	offset ToCarrier [Carrier PRBs]	SS block SCS [kHz]	GSCN	absoluteFrequency SSB [ARFCN]	
														Low
E-UTRA: 20MHz + 20MHz + NR: 40MHz	E-UTRA CC1	20	100	Downlink & Uplink	Low	2506.200	39752	-	-	-	-	-	-	
					Mid	2603.100	40721	-	-	-	-	-		
					High	2659.800	41288	-	-	-	-	-		
	Channel spacing E-UTRA CC1- E-UTRA CC2=19.8 MHz (Note 3)													
	E-UTRA CC2	20	100	Downlink & Uplink	Low	2526.000	39950	-	-	-	-	-	-	-
					Mid	2622.900	40919	-	-	-	-	-	-	
					High	2679.600	41486	-	-	-	-	-		
	Channel spacing E-UTRA CC2- NR CC1=30 MHz (Note 2)													
	NR CC1	40	51	Downlink & Uplink	Low	2556.000	511200	2537.64	507528	0	15	-	507888	
					Mid	2573.100	514620	2481.3	496260	102	-	511308		
High					2629.800	525960	2248.56	449712	504	-	522648			
E-UTRA: 20MHz + 20MHz + NR: 60MHz	E-UTRA CC1	20	100	Downlink & Uplink	Low	2506.200	39752	-	-	-	-	-	-	
					Mid	2613.100	40821	-	-	-	-	-	-	
					High	2659.800	41288	-	-	-	-	-		
	Channel spacing E-UTRA CC1- E-UTRA CC2=19.8 MHz (Note 3)													
	E-UTRA CC2	20	100	Downlink & Uplink	Low	2526.000	39950	-	-	-	-	-	-	-
					Mid	2632.9	41019	-	-	-	-	-	-	
					High	2679.600	41486	-	-	-	-	-		
	Channel spacing E-UTRA CC2- NR CC1=40.005 MHz (Note 2)													
	NR CC1	60	79	Downlink & Uplink	Low	2566.005	513201	2537.565	507513	0	15	-	507873	
					Mid	2573.1	514620	2471.22	494244	102	-	510300		
High					2619.795	523959	2228.475	445695	504	-	518631			
E-UTRA:	E-UTRA	20	100	Downlink	Low	2506.500	39755	-	-	-	-	-	-	



20MHz + 20MHz + NR: 80MHz	CC1			& Uplink	Mid	2623.100	40921	-	-	-	-	-	-	
					High	2659.800	41288	-	-	-	-	-		
					Channel spacing E-UTRA CC1- E-UTRA CC2=19.8 MHz (Note 3)									
	E-UTRA CC2	20	100	Downlink & Uplink	Low	2526.300	39953	-	-	-	-	-	-	
					Mid	2642.9	41119	-	-	-	-	-		
					High	2679.600	41486	-	-	-	-	-		
	Channel spacing E-UTRA CC2- NR CC1=49.995 MHz (Note 2)													
	NR CC1	80	107	Downlink & Uplink	Low	2576.295	515259	2537.775	507555	0	15	-	507915	
					Mid	2573.1	514620	2461.14	492228	102		-	507276	
					High	2609.805	521961	2208.405	441681	504		-	514617	
E-UTRA: 20MHz + 20MHz + NR: 100MHz	E-UTRA CC1	20	100	Downlink & Uplink	Low	2506.200	39752	-	-	-	-	-	-	
					Mid	2633.100	41021	-	-	-	-	-		
					High	2659.800	41288	-	-	-	-	-		
	Channel spacing E-UTRA CC1- E-UTRA CC2=19.8 MHz (Note 3)													
	E-UTRA CC2	20	100	Downlink & Uplink	Low	2526.000	39950	-	-	-	-	-	-	
					Mid	2652.900	41219	-	-	-	-	-		
					High	2679.600	41486	-	-	-	-	-		
	Channel spacing E-UTRA CC2- NR CC1=60 MHz (Note 2)													
	NR CC1	100	135	Downlink & Uplink	Low	2586.000	517200	2537.4	507480	0	15	-	507840	
					Mid	2573.100	514620	2451.06	490212	102		-	505260	
High					2599.800	519960	2188.32	437664	504	-		510600		

Note 1: The nominal carrier spacing between the E-UTRA and the NR carriers is set in accordance to TS 38.101-3 [9], clause 5.4B1.  
 Note 2: FR1 carrier without CORESET#0 is indicated in the MIB by setting  $k_{SSB} = 31$ ,  $controlResourceSetZero = 0$  and  $searchSpaceZero = 0$  (TS 38.213 [22], clause 13).  
 Note 3: The nominal carrier spacing between the E-UTRA carriers is set in accordance to TS 36.101 [48], clause 5.7.1A.

4.3.1.4.2.42.to 4.3.1.4.2.70 FFS

4.3.1.4.2.71 Intra-band contiguous EN-DC configurations DC\_(n)71

4.3.1.4.2.71.1 DC\_(n)71AA

Table 4.3.1.4.2.71.1-1: EN-DC combination DC\_(n)71AA, intra-band contiguous, SCS 15 kHz, 100 kHz NR raster, NR CC at the band edges

EN-DC channel bandwidth combination	CC	Band width [MHz]	carrierBandwidth [PRBs]	Range	Carrier centre [MHz] Note 2	Carrier centre [ARFCN]	point A [MHz]	absoluteFrequencyPointA [ARFCN]	offsetToCarrier [Carrier]	SS block SCS [kHz]	GSCN	absoluteFrequencySSB [ARFCN]	$k_{SSB}$	Offset Carrier CORESET#0 [RBs]	CORESET#0 Index (Offset[	offsetToPointA (SIB1) [PRBs] Note 1
-------------------------------------	----	------------------	-------------------------	-------	-----------------------------	------------------------	---------------	---------------------------------	---------------------------	--------------------	------	------------------------------	-----------	--------------------------------	--------------------------	-------------------------------------

										PRBs]					Note 3	RBs]) Note 1		
E-UTRA: 5MHz + NR: 5MHz	E-UTRA CC1	5	25	Downlink	Low	624.500	68661	-	-	-	-	-	-	-	-	-	-	
					Mid	637.000	68786	-	-	-	-	-	-	-	-	-		
					High	644.500	68861	-	-	-	-	-	-	-	-	-		
		Uplink	Low	670.500	133197	-	-	-	-	-	-	-	-	-	-	-	-	-
			Mid	683.000	133322	-	-	-	-	-	-	-	-	-	-	-	-	-
			High	690.500	133397	-	-	-	-	-	-	-	-	-	-	-	-	-
	NR CC1	5	25	Downlink	Low	619.500	123900	617.25	123450	0	15	1548	123870	8	1	0 (0)	1	
					Mid	632.000	126400	611.39	122278	102		1580	126490	0	1	2 (4)	107	
					High	649.500	129900	556.53	111306	504		1623	129870	8	1	0 (0)	505	
Uplink		Low	665.500	133100	663.25	132650	0	-	-	-	-	-	-	-	-	-		
		Mid	678.000	135600	585.03	117006	504	-	-	-	-	-	-	-	-	-		
		High	695.500	139100	692.17	138434	6	-	-	-	-	-	-	-	-	-		
E-UTRA: 5MHz + NR: 10MHz	E-UTRA CC1	5	25	Downlink	Low	629.500	68711	-	-	-	-	-	-	-	-	-	-	
					Mid	639.500	68811	-	-	-	-	-	-	-	-	-	-	-
					High	639.500	68811	-	-	-	-	-	-	-	-	-	-	-
		Uplink	Low	675.500	133247	-	-	-	-	-	-	-	-	-	-	-	-	
			Mid	685.500	133347	-	-	-	-	-	-	-	-	-	-	-	-	
			High	685.500	133347	-	-	-	-	-	-	-	-	-	-	-	-	
	NR CC1	10	52	Downlink	Low	622.000	124400	617.32	123464	0	15	1549	123890	10	1	0 (0)	1	
					Mid	632.000	126400	608.96	121792	102		1574	126010	2	1	2 (4)	107	
					High	647.000	129400	551.6	110320	504		1610	128890	10	1	0 (0)	505 (0)	
Uplink		Low	668.000	133600	663.32	132664	0	-	-	-	-	-	-	-	-			
		Mid	678.000	135600	582.6	116520	504	-	-	-	-	-	-	-	-			
		High	693.000	138600	687.24	137448	6	-	-	-	-	-	-	-				
E-UTRA: 5MHz + NR: 15MHz	E-UTRA CC1	5	25	Downlink	Low	634.500	68761	-	-	-	-	-	-	-	-	-	-	
					Mid	642.000	68836	-	-	-	-	-	-	-	-	-	-	
					High	634.500	68761	-	-	-	-	-	-	-	-	-	-	
		Uplink	Low	680.500	133297	-	-	-	-	-	-	-	-	-	-	-		
			Mid	688.000	133372	-	-	-	-	-	-	-	-	-	-	-		
			High	680.500	133297	-	-	-	-	-	-	-	-	-	-	-		
	NR CC1	15	79	Downlink	Low	624.500	124900	617.39	123478	0	15	1547	123850	4	0	0	0	
					Mid	632.000	126400	606.53	121306	102		1568	125530	4	1	2 (4)	107	
					High	644.500	128900	546.67	109334	504		1600	127970	8	1	1 (2)	507 (0)	
Uplink		Low	670.500	134100	663.39	132678	0	-	-	-	-	-	-	-				
		Mid	678.000	135600	580.17	116034	504	-	-	-	-	-	-	-				
		High	690.500	138100	682.31	136462	6	-	-	-	-	-	-					
E-UTRA: 5MHz + NR: 20MHz	E-UTRA CC1	5	25	Downlink	Low	639.500	68811	-	-	-	-	-	-	-	-	-	-	
					Mid	644.500	68861	-	-	-	-	-	-	-	-	-	-	
					High	629.500	68711	-	-	-	-	-	-	-	-	-	-	
		Uplink	Low	685.500	133347	-	-	-	-	-	-	-	-	-	-	-		
			Mid	690.500	133397	-	-	-	-	-	-	-	-	-	-			
			High	675.500	133247	-	-	-	-	-	-	-	-	-	-			

	NR CC1	20	106	Downlink	Low	627.000	125400	617.46	123492	0	15	1548	123870	6	0	0	0
					Mid	632.000	126400	604.1	120820	102		1562	125050	6	1	2 (4)	107
					High	642.000	128400	541.74	108348	504		1587	126990	10	1	1 (2)	507
				Uplink	Low	673.000	134600	663.46	132692	0	-	-	-	-	-	-	-
					Mid	678.000	135600	577.74	115548	504		-	-	-	-	-	-
					High	688.000	137600	677.38	135476	6		-	-	-	-	-	-
E-UTRA: 10MHz + NR: 5MHz	E-UTRA CC1	10	50	Downlink	Low	627.000	68686	-	-	-	-	-	-	-	-	-	-
					Mid	637.000	68786	-	-	-		-	-	-	-	-	-
					High	642.000	68836	-	-	-		-	-	-	-	-	-
				Uplink	Low	673.000	133222	-	-	-	-	-	-	-	-	-	-
					Mid	683.000	133322	-	-	-		-	-	-	-	-	-
					High	688.000	133372	-	-	-		-	-	-	-	-	-
	NR CC1	5	25	Downlink	Low	619.500	123900	617.25	123450	0	15	1548	123870	8	1	0 (0)	1 (0)
					Mid	629.500	125900	608.89	121778	102		1573	125810	0	0	0	102
					High	649.500	129900	556.53	111306	504		1623	129870	8	1	0 (0)	505
Uplink	Low	665.500	133100	663.25	132650	0	-	-	-	-	-	-	-				
	Mid	675.500	135100	582.53	116506	504		-	-	-	-	-	-				
	High	695.500	139100	692.17	138434	6		-	-	-	-	-	-				
E-UTRA: 10MHz + NR: 10MHz	E-UTRA CC1	10	50	Downlink	Low	632.000	68736	-	-	-	-	-	-	-	-	-	-
					Mid	639.500	68811	-	-	-		-	-	-	-	-	-
					High	637.000	68786	-	-	-		-	-	-	-	-	-
				Uplink	Low	678.000	133272	-	-	-	-	-	-	-	-	-	-
					Mid	685.500	133347	-	-	-		-	-	-	-	-	-
					High	683.000	133322	-	-	-		-	-	-	-	-	-
	NR CC1	10	52	Downlink	Low	622.000	124400	617.32	123464	0	15	1549	123890	10	1	0 (0)	1 (0)
					Mid	629.500	125900	606.46	121292	102		1567	125330	2	0	0	102
					High	647.000	129400	551.6	110320	504		1610	128890	10	1	0 (0)	505
Uplink	Low	668.000	133600	663.32	132664	0	-	-	-	-	-	-	-				
	Mid	675.500	135100	580.1	116020	504		-	-	-	-	-	-				
	High	693.000	138600	687.24	137448	6		-	-	-	-	-	-				
E-UTRA: 10MHz + NR: 15MHz	E-UTRA CC1	10	50	Downlink	Low	637.000	68786	-	-	-	-	-	-	-	-	-	-
					Mid	642.000	68836	-	-	-		-	-	-	-	-	-
					High	632.000	68736	-	-	-		-	-	-	-	-	-
				Uplink	Low	683.000	133322	-	-	-	-	-	-	-	-	-	-
					Mid	688.000	133372	-	-	-		-	-	-	-	-	-
					High	678.000	133272	-	-	-		-	-	-	-	-	-
	NR CC1	15	79	Downlink	Low	624.500	124900	617.39	123478	0	15	1547	123850	4	0	0 (0)	0
					Mid	629.500	125900	604.03	120806	102		1561	124850	4	0	0 (0)	102
					High	644.500	128900	546.67	109334	504		1600	127970	8	1	1 (1)	507
Uplink	Low	670.500	134100	663.39	132678	0	-	-	-	-	-	-	-				
	Mid	675.500	135100	577.67	115534	504		-	-	-	-	-	-				
	High	690.500	138100	682.31	136462	6		-	-	-	-	-	-				
E-UTRA: 15MHz +	E-UTRA CC1	15	75	Downlink	Low	629.500	68711	-	-	-	-	-	-	-	-	-	-
					Mid	637.000	68786	-	-	-		-	-	-	-	-	-

NR: 5MHz	NR CC1	5	25	Uplink	High	639.500	68811	-	-	-	-	-	-	-	-	-			
					Low	675.500	133247	-	-	-	-	-	-	-	-	-			
					Mid	683.000	133322	-	-	-	-	-	-	-	-	-			
				Downlink	High	685.500	133347	-	-	-	-	-	-	-	-	-	-	-	-
					Low	619.500	123900	617.25	123450	0	15	1548	123870	8	1	0 (0)	1		
					Mid	627.000	125400	606.39	121278	102	-	1566	125310	0	0	0 (0)	102		
					High	649.500	129900	556.53	111306	504	-	1623	129870	8	1	0 (0)	505		
					Uplink	Low	665.500	133100	663.25	132650	0	-	-	-	-	-	-	-	
						Mid	673.000	134600	580.03	116006	504	-	-	-	-	-	-	-	
High	695.500	139100	692.17	138434		6	-	-	-	-	-	-	-						

Note 1: The CORESET#0 Index and the associated CORESET#0 Offset refers to Table 13-2 in TS 38.213 [22]. The value of CORESET#0 Index is signalled in controlResourceSetZero (pdccch ConfigSIB1) in the MIB. The offsetToPointA IE is expressed in units of resource blocks assuming 15 kHz subcarrier spacing for FR1 and 60 kHz subcarrier spacing for FR2.

Note 2: The nominal carrier spacing between the E-UTRA and the NR carriers is set in accordance to TS 38.101-3 [9], clause 5.4B1.

Note 3: The parameter Offset Carrier CORESET#0 specifies the offset from the lowest subcarrier of the carrier and the lowest subcarrier of CORESET#0. It corresponds to the parameter  $\Delta F_{\text{OffsetCORESET-0-Carrier}}$  in Annex C expressed in number of common RBs.

Table 4.3.1.4.2.71.1-1A: EN-DC combination DC\_(n)71AA, intra-band contiguous, SCS 15 kHz, 100 kHz NR raster, E-UTRA CC at the band edges

EN-DC channel bandwidth combination	CC	Bandwidth [MHz]	carrierBandwidth [PRBs]	Range	Carrier centre [MHz] Note 2	Carrier centre [ARFCN]	point A [MHz]	absoluteFrequencyPointA [ARFCN]	offsetToCarrier [Carrier PRBs]	SS block SCS [kHz]	GSCN	absoluteFrequencySSB [ARFCN]	$k_{SSB}$	Offset Carrier CORESET#0 [RBs] Note 3	CORESET#0 Index (Offset [RBs]) Note 1	offsetToPointA (SIB1) [PRBs] Note 1	
E-UTRA: 5MHz + NR: 5MHz	E-UTRA CC1	5	25	Downlink	Low	619.500	68611	-	-	-	-	-	-	-	-	-	
					Mid	637.000	68786	-	-	-	-	-	-	-	-	-	
					High	649.500	68911	-	-	-	-	-	-	-	-	-	
				Uplink	Low	665.500	133147	-	-	-	-	-	-	-	-	-	-
					Mid	683.000	133322	-	-	-	-	-	-	-	-	-	-
					High	695.500	133447	-	-	-	-	-	-	-	-	-	-
NR	5	25	Downlink	Low	624.500	124900	622.25	124450	0	15	1559	124810	0	0	0 (0)	0	

	CC1				Mid	632.000	126400	611.39	122278	102		1580	126490	0	1	2 (4)	112
					High	644.500	128900	551.53	110306	504		1612	128930	4	1	1 (2)	507
					Uplink	Low	670.500	134100	668.25	133650	0	-	-	-	-	-	-
						Mid	678.000	135600	585.03	117006	504	-	-	-	-	-	-
						High	690.500	138100	687.17	137434	6	-	-	-	-	-	-
					E-UTRA: 5MHz + NR: 15MHz	E-UTRA CC1	5	25	Downlink	Low	619.500	68611	-	-	-	-	-
Mid	642.000	68836	-	-						-	-	-	-	-	-	-	
High	649.500	68911	-	-						-	-	-	-	-	-	-	
Uplink	Low	665.500	133147	-					-	-	-	-	-	-	-	-	
	Mid	688.000	133372	-					-	-	-	-	-	-	-	-	
	High	695.500	133447	-					-	-	-	-	-	-	-	-	
NR CC1	15	79	Downlink	Low		629.500	125900	622.39	124478	0	15	1561	124850	4	0	0 (0)	0
				Mid		632.000	126400	606.53	121306	102		1568	125530	4	1	2 (4)	107
				High		639.500	127900	541.67	108334	504		1586	126970	8	1	1 (2)	507
			Uplink	Low		675.500	135100	668.39	133678	0	-	-	-	-	-	-	
				Mid		678.000	135600	580.17	116034	504	-	-	-	-	-	-	
				High		685.500	137100	677.31	135462	6	-	-	-	-	-	-	
E-UTRA: 10MHz + NR: 10MHz	E-UTRA CC1	10	50	Downlink	Low	622.000	68636	-	-	-	-	-	-	-	-	-	
					Mid	639.500	68811	-	-	-	-	-	-	-	-	-	
					High	647.000	68886	-	-	-	-	-	-	-	-	-	
				Uplink	Low	668.000	133172	-	-	-	-	-	-	-	-	-	
					Mid	685.500	133347	-	-	-	-	-	-	-	-	-	
					High	693.000	133422	-	-	-	-	-	-	-	-	-	
	NR CC1	10	52	Downlink	Low	632.000	126400	627.32	125464	0	15	1574	126010	2	1	2 (4)	5
					Mid	629.500	125900	606.46	121292	102		1567	125330	2	0	0 (0)	102
					High	637.000	127400	541.6	108320	504		1588	127010	2	1	2 (4)	509
				Uplink	Low	678.000	135600	673.32	134664	0	-	-	-	-	-	-	
					Mid	675.500	135100	580.1	116020	504	-	-	-	-	-	-	
					High	683.000	136600	677.24	135448	6	-	-	-	-	-	-	
E-UTRA: 15MHz + NR: 5MHz	E-UTRA CC1	15	75	Downlink	Low	624.500	68661	-	-	-	-	-	-	-	-		
					Mid	637.000	68786	-	-	-	-	-	-	-	-	-	
					High	644.500	68861	-	-	-	-	-	-	-	-	-	
				Uplink	Low	670.500	133197	-	-	-	-	-	-	-	-	-	
					Mid	683.000	133322	-	-	-	-	-	-	-	-	-	
					High	690.500	133397	-	-	-	-	-	-	-	-	-	
	NR CC1	5	25	Downlink	Low	634.500	126900	632.25	126450	0	15	1587	126990	0	1	2 (4)	5
					Mid	627.000	125400	606.39	121278	102		1566	125310	0	0	0 (0)	102
					High	634.500	126900	541.53	108306	504		1587	126990	0	1	2 (4)	509
				Uplink	Low	680.500	136100	678.25	135650	0	-	-	-	-	-	-	
					Mid	673.000	134600	580.03	116006	504	-	-	-	-	-	-	
					High	680.500	136100	677.17	135434	6	-	-	-	-	-	-	

Note 1: The CORESET#0 Index and the associated CORESET#0 Offset refers to Table 13-2 in TS 38.213 [22]. The value of CORESET#0 Index is signalled in controlResourceSetZero (pdccch-ConfigSIB1) in the MIB. The offsetToPointA IE is expressed in units of resource blocks assuming 15 kHz subcarrier spacing for FR1 and 60 kHz subcarrier spacing for FR2.

Note 2: The nominal carrier spacing between the E-UTRA and the NR carriers is set in accordance to TS 38.101-3 [9], clause 5.4B1.

Note 3: The parameter Offset Carrier CORESET#0 specifies the offset from the lowest subcarrier of the carrier and the lowest subcarrier of CORESET#0. It corresponds to the parameter  $\Delta F_{\text{OffsetCORESET-0-Carrier}}$  in Annex C expressed in number of common RBs.

Table 4.3.1.4.2.71.1-2: EN-DC combination DC\_(n)71AA, intra-band contiguous, SCS 30 kHz, 100 kHz NR raster, NR CC at the band edge

EN-DC channel bandwidth combination	CC	Bandwidth [MHz]	carrierBandwidth [PRBs]	Range		Carrier centre [MHz] Note 2	Carrier centre [ARFCN]	point A [MHz]	absoluteFrequencyPointA [ARFCN]	offsetToCarrier [Carrier PRBs]	SS block SCS [kHz]	GSCN	absoluteFrequencySSB [ARFCN]	$k_{SSB}$	Offset Carrier CORESET#0 [RBs] Note 3	CORESET#0 Index (Offset [RBs]) Note 1	offsetToPointA (SIB1) [PRBs] Note 1		
																		Low	Mid
E-UTRA: 5MHz + NR: 10MHz	E-UTRA CC1	5	25	Downlink	Low	629.500	68711	-	-	-	-	-	-	-	-	-	-		
					Mid	639.500	68811	-	-	-	-	-	-	-	-	-	-		
					High	639.500	68811	-	-	-	-	-	-	-	-	-	-		
				Uplink	Low	675.500	133247	-	-	-	-	-	-	-	-	-	-	-	-
					Mid	685.500	133347	-	-	-	-	-	-	-	-	-	-	-	-
					High	685.500	133347	-	-	-	-	-	-	-	-	-	-	-	-
	NR CC1	10	24	Downlink	Low	622.000	124400	617.68	123536	0	15	1555	124370	14	0	1 (6)	12		
					Mid	632.000	126400	590.96	118192	102		1580	126490	6	0	3 (8)	220		
					High	647.000	129400	461.24	92248	504		1616	129370	14	0	1 (6)	1020		
				Uplink	Low	668.000	133600	663.68	132736	0	-	-	-	-	-	-	-	-	
					Mid	678.000	135600	492.24	98448	504	-	-	-	-	-	-	-	-	
					High	693.000	138600	686.52	137304	6	-	-	-	-	-	-	-	-	
E-UTRA: 5MHz + NR: 15MHz	E-UTRA CC1	5	25	Downlink	Low	634.500	68761	-	-	-	-	-	-	-	-	-	-		
					Mid	642.000	68836	-	-	-	-	-	-	-	-	-	-		
					High	634.500	68761	-	-	-	-	-	-	-	-	-	-		
				Uplink	Low	680.500	133297	-	-	-	-	-	-	-	-	-	-	-	
					Mid	688.000	133372	-	-	-	-	-	-	-	-	-	-	-	
					High	680.500	133297	-	-	-	-	-	-	-	-	-	-	-	
	NR CC1	15	38	Downlink	Low	624.500	124900	617.66	123532	0	15	1553	124330	2	0	1 (6)	12		
					Mid	632.000	126400	588.44	117688	102		1571	125770	6	0	0 (5)	214		
					High	644.500	128900	456.22	91244	504		1606	128450	18	0	2 (7)	1022		
				Uplink	Low	670.500	134100	663.66	132732	0	-	-	-	-	-	-	-		
					Mid	678.000	135600	489.72	97944	504	-	-	-	-	-	-	-		
					High	690.500	138100	681.5	136300	6	-	-	-	-	-	-	-		
E-UTRA: 5MHz + NR: 20MHz	E-UTRA CC1	5	25	Downlink	Low	639.500	68811	-	-	-	-	-	-	-	-	-			
					Mid	644.500	68861	-	-	-	-	-	-	-	-	-			
					High	629.500	68711	-	-	-	-	-	-	-	-	-			
				Uplink	Low	685.500	133347	-	-	-	-	-	-	-	-	-	-		
					Mid	690.500	133397	-	-	-	-	-	-	-	-	-	-		
					High	675.500	133247	-	-	-	-	-	-	-	-	-	-		
	NR CC1	20	51	Downlink	Low	627.000	125400	617.82	123564	0	15	1554	124350	22	0	0 (5)	10		
					Mid	632.000	126400	586.1	117220	102		1565	125290	2	0	0 (5)	214		

E-UTRA: 10MHz + NR: 10MHz	E-UTRA CC1	10	50	Uplink	High	642.000	128400	451.38	90276	504	-	1593	127470	14	0	2 (7)	1022
					Low	673.000	134600	663.82	132764	0	-	-	-	-	-	-	
					Mid	678.000	135600	487.38	97476	504	-	-	-	-	-	-	
				Downlink	High	688.000	137600	676.66	135332	6	-	-	-	-	-	-	
					Low	632.000	68736	-	-	-	-	-	-	-	-	-	
					Mid	639.500	68811	-	-	-	-	-	-	-	-	-	
	Uplink	High	637.000	68786	-	-	-	-	-	-	-	-	-				
		Low	678.000	133272	-	-	-	-	-	-	-	-	-				
		Mid	685.500	133347	-	-	-	-	-	-	-	-	-				
NR CC1	Downlink	10	24	Downlink	Low	622.000	124400	617.68	123536	0	15	1555	124370	14	0	1 (6)	12
					Mid	629.500	125900	588.46	117692	102	-	1573	125810	18	0	0 (5)	214
					High	647.000	129400	461.24	92248	504	-	1616	129370	14	0	1 (6)	1020
	Uplink	Low	668.000	133600	663.68	132736	0	-	-	-	-	-	-				
		Mid	675.500	135100	489.74	97948	504	-	-	-	-	-	-				
		High	693.000	138600	686.52	137304	6	-	-	-	-	-	-				
E-UTRA: 10MHz + NR: 15MHz	E-UTRA CC1	10	50	Downlink	Low	637.000	68786	-	-	-	-	-	-	-	-	-	-
					Mid	642.000	68836	-	-	-	-	-	-	-	-	-	
					High	632.000	68736	-	-	-	-	-	-	-	-	-	
				Uplink	Low	683.000	133322	-	-	-	-	-	-	-	-	-	
					Mid	688.000	133372	-	-	-	-	-	-	-	-	-	
					High	678.000	133272	-	-	-	-	-	-	-	-	-	
	NR CC1	15	38	Downlink	Low	624.500	124900	617.66	123532	0	15	1553	124330	2	0	1 (6)	12
					Mid	629.500	125900	585.94	117188	102	-	1567	125330	2	0	1 (6)	216
					High	644.500	128900	456.22	91244	504	-	1606	128450	18	0	2 (7)	1022
Uplink	Low	670.500	134100	663.66	132732	0	-	-	-	-	-	-					
	Mid	675.500	135100	487.22	97444	504	-	-	-	-	-	-					
	High	690.500	138100	681.5	136300	6	-	-	-	-	-	-					
E-UTRA: 15MHz + NR: 10MHz	E-UTRA CC1	15	75	Downlink	Low	634.500	68761	-	-	-	-	-	-	-	-	-	
					Mid	639.500	68811	-	-	-	-	-	-	-	-	-	
					High	634.500	68761	-	-	-	-	-	-	-	-	-	
				Uplink	Low	680.500	133297	-	-	-	-	-	-	-	-	-	
					Mid	685.500	133347	-	-	-	-	-	-	-	-	-	
					High	680.500	133297	-	-	-	-	-	-	-	-	-	
	NR CC1	10	24	Downlink	Low	622.000	124400	617.68	123536	0	15	1555	124370	14	0	1 (6)	12
					Mid	627.000	125400	585.96	117192	102	-	1566	125310	18	0	0 (5)	214
					High	647.000	129400	461.24	92248	504	-	1616	129370	14	0	1 (6)	1020
Uplink	Low	668.000	133600	663.68	132736	0	-	-	-	-	-	-					
	Mid	673.000	134600	487.24	97448	504	-	-	-	-	-	-					
	High	693.000	138600	686.52	137304	6	-	-	-	-	-	-					

Note 1: The CORESET#0 Index and the associated CORESET#0 Offset refers to Table 13-2 in TS 38.213 [22]. The value of CORESET#0 Index is signalled in controlResourceSetZero (pdccch.ConfigSIB1) in the MIB. The offsetToPointA IE is expressed in units of resource blocks assuming 15 kHz subcarrier spacing for FR1 and 60 kHz subcarrier spacing for FR2.

Note 2: The nominal carrier spacing between the E-UTRA and the NR carriers is set in accordance to TS 38.101-3 [9], clause 5.4B1.

Note 3: The parameter Offset Carrier CORESET#0 specifies the offset from the lowest subcarrier of the carrier and the lowest subcarrier of CORESET#0. It corresponds to the parameter

$\Delta_{\text{OffsetCORESET-0-Carrier}}$  in Annex C expressed in number of common RBs.

Table 4.3.1.4.2.71.1-2A: EN-DC combination DC\_(n)71AA, intra-band contiguous, SCS 30 kHz, 100 kHz NR raster, E-UTRA CC at the band edge

EN-DC channel bandwidth combination	CC	Bandwidth [MHz]	carrierBandwidth [PRBs]	Range	Carrier centre [MHz] Note 2	Carrier centre [ARFCN]	point A [MHz]	absoluteFrequencyPointA [ARFCN]	offsetToCarrier [Carrier PRBs]	SS block SCS [kHz]	GSCN	absoluteFrequencySSB [ARFCN]	$k_{\text{SSB}}$	Offset Carrier CORESET#0 [RBs] Note 3	CORESET#0 (Offset [RBs]) Index Note 1	offsetToPointA (SIB1) [PRBs] Note 1		
E-UTRA: 5MHz + NR: 15MHz	E-UTRA CC1	5	25	Downlink	Low	619.500	68611	-	-	-	-	-	-	-	-	-		
					Mid	642.000	68836	-	-	-	-	-	-	-	-	-	-	
					High	649.500	68911	-	-	-	-	-	-	-	-	-	-	
				Uplink	Low	665.500	133147	-	-	-	-	-	-	-	-	-	-	-
					Mid	688.000	133372	-	-	-	-	-	-	-	-	-	-	-
					High	695.500	133447	-	-	-	-	-	-	-	-	-	-	-
	NR CC1	15	38	Downlink	Low	629.500	125900	622.66	124532	0	15	1567	125330	2	0	1 (6)	12	
					Mid	632.000	126400	588.44	117688	102		1571	125770	6	0	0 (5)	214	
					High	639.500	127900	451.22	90244	504		1592	127450	18	0	2 (7)	1022	
Uplink				Low	675.500	135100	668.66	133732	0	-	-	-	-	-	-	-	-	
				Mid	678.000	135600	489.72	97944	504		-	-	-	-	-	-	-	
				High	685.500	137100	676.5	135300	6		-	-	-	-	-	-	-	

Note 1: The CORESET#0 Index and the associated CORESET#0 Offset refers to Table 13-2 in TS 38.213 [22]. The value of CORESET#0 Index is signalled in controlResourceSetZero (pdccch-ConfigSIB1) in the MIB. The offsetToPointA IE is expressed in units of resource blocks assuming 15 kHz subcarrier spacing for FR1 and 60 kHz subcarrier spacing for FR2.

Note 2: The nominal carrier spacing between the E-UTRA and the NR carriers is set in accordance to TS 38.101-3 [9], clause 5.4B1.



## 4.3.1.4.3 Intra-band non-contiguous EN-DC configurations within FR1

## 4.3.1.4.3.1 – 4.3.1.4.3.40 FFS

## 4.3.1.4.3.41 Intra-band non-contiguous EN-DC configurations DC\_41\_n41

## 4.3.1.4.3.41.1 DC\_41A\_n41A

**Table 4.3.1.4.41.1-1: Test frequencies for EN-DC combination DC\_41A\_n41A, Max Wgap**

Test Frequency ID	NR channel bandwidth [MHz]	NR SCS [kHz]	NR test frequency range (Note 1)	E-UTRA channel bandwidth [MHz]	E-UTRA frequency range (Note 2)	
Low with maxWgap (NR – E-UTRA)	40	30	Low	20	High	
	50					
	60					
	80					
	100					
High with maxWgap (E-UTRA - NR)	40		30	High	20	Low
	50					
	60					
	80					
	100					
Low with maxWgap (NR – E-UTRA)	40	60		Low	20	High
	50					
	60					
	80					
	100					
High with maxWgap (E-UTRA - NR)	40		60	High	20	Low
	50					
	60					
	80					
	100					

Note 1: The NR test frequencies are specified in clause 4.3.1.1.1.41 for the NR Channel Bandwidth, NR SCS and NR test frequency range as given in the table.

Note 2: The E-UTRA test frequencies are specified in TS 36.508 [2], clause 4.3.1.2.9 for the E-UTRA channel bandwidth and E-UTRA test frequency range as given in the table.

## 4.3.1.4.3.41.2 DC\_41C\_n41A

**Table 4.3.1.4.41.2-1: Test frequencies for EN-DC combination DC\_41C\_n41A, SCS=30kHz, Max Wgap**

Test Frequency ID	NR channel bandwidth [MHz]	NR SCS [kHz]	NR test frequency range (Note 1)	E-UTRA CC Combo / N <sub>RB_agg</sub> [MHz]	E-UTRA frequency range (Note 2)	
Low with maxWgap (NR – E-UTRA)	40	30	Low	20 + 20	High	
	50					
	60					
	80					
	100					
High with maxWgap (E-UTRA - NR)	40		30	High	20 + 20	Low
	50					
	60					
	80					
	100					
Low with maxWgap (NR – E-UTRA)	40	60		Low	20 + 20	High
	50					
	60					
	80					
	100					

High with maxWgap (E-UTRA - NR)	40	High	20 + 20	Low
	50			
	60			
	80			
	100			
Note 1: The NR test frequencies are specified in clause 4.3.1.1.1.41 for the NR Channel Bandwidth, NR SCS and NR test frequency range as given in the table. Note 2: The E-UTRA test frequencies are specified in TS 36.508 [2], clause 4.3.1.2.9A for the E-UTRA CC Combo and E-UTRA test frequency range as given in the table.				

4.3.1.4.3.41.3 DC\_41D\_n41A

**Table 4.3.1.4.41.3-1: Test frequencies for EN-DC combination DC\_41D\_n41A, SCS=30kHz, Max Wgap**

Test Frequency ID	NR channel bandwidth [MHz]	NR SCS [kHz]	NR test frequency range (Note 1)	E-UTRA CC Combo / N <sub>RB_agg</sub> [MHz]	E-UTRA frequency range (Note 2)	
Low with maxWgap (NR – E-UTRA)	40	30	Low	20 + 20 + 20	High	
	50					
	60					
	80					
	100					
High with maxWgap (E-UTRA - NR)	40		High		20 + 20 + 20	Low
	50					
	60					
	80					
	100					
Low with maxWgap (NR – E-UTRA)	40	60	Low	20 + 20 + 20	High	
	50					
	60					
	80					
	100					
High with maxWgap (E-UTRA - NR)	40		High		20 + 20 + 20	Low
	50					
	60					
	80					
	100					
Note 1: The NR test frequencies are specified in clause 4.3.1.1.1.41 for the NR Channel Bandwidth, NR scs and NR test frequency range as given in the table. Note 2: The E-UTRA test frequencies are specified in TS 36.508 [2], clause 4.3.1.2.9A for the E-UTRA CC Combo and E-UTRA test frequency range as given in the table.						

4.3.1.4a Test frequencies for NE-DC band combinations within FR1

4.3.1.4a.1 Inter-band NE-DC configurations within FR1

4.3.1.4a.1.1 General

For inter-band NE-DC configurations as listed in this clause, the following apply:

For the NR band and NR CA configurations, test frequencies as specified in clause 4.3.1.1 are used.

For the E-UTRA band and E-UTRA CA configurations, test frequencies as specified in TS 36.508 [2], clause 4.3.1 are used.

For the primary NR band in inter-band signalling test cases, the band selected is based on the subset of NR bands supported within the NE-DC configurations specified in Table 4.3.1.4a.1.2-1 for NR FR1.

## 4.3.1.4a.1.2 Inter-band NE-DC configurations within FR1 (two bands)

**Table 4.3.1.4a.1.2-1: Inter-band NE-DC configurations within FR1 (two bands)**

NE-DC configuration	Uplink NE-DC Configuration	NR downlink configuration	E-UTRA downlink configuration	NR uplink configuration	E-UTRA uplink configuration	Applicable for protocol testing (Note 1)
DC_n28A_3A	DC_n28A_3A	n28A	3A	n28A	3A	Yes
DC_n28A_3C	DC_n28A_3A	n28A	CA_3C	n28A	3A	No
DC_n28A_39A	DC_n28A_39A	n28A	39A	n28A	39A	Yes
DC_n28A_39C	DC_n28A_39A	n28A	CA_39C	n28A	39A	No

## 4.3.1.5 Test frequencies for EN-DC band combinations including FR2

## 4.3.1.5.1 Inter-band EN-DC configurations including FR2

## 4.3.1.5.1.1 General

For inter-band EN-DC configurations as listed in this clause, the following apply:

For the E-UTRA band and E-UTRA CA configurations, test frequencies as specified in TS 36.508 [2], clause 4.3.1 are used.

For the NR band and NR CA configurations, test frequencies as specified in clause 4.3.1.2 are used.

For the secondary NR band in inter-band signalling test cases, the band selected is based on the subset of NR bands supported within the EN-DC configurations specified in Table 4.3.1.4.1.2-1 for NR FR1 and 4.3.1.5.1.2-1 for NR FR2.

## 4.3.1.5.1.2 Inter-band EN-DC configurations including FR2 (two bands)

Table 4.3.1.5.1.2-1: Inter-band EN-DC configurations including FR2 (two bands)

EN-DC configuration	Uplink EN-DC Configuration	E-UTRA downlink configuration	NR downlink configuration	E-UTRA uplink configuration	NR uplink configuration	Applicable for protocol testing (Note 1)
DC_1A_n257A	DC_1A_n257A	1A	n257A	1A	n257A	Yes
DC_1A_n257G	DC_1A_n257A	1A	CA_n257G	1A	n257A	Yes (NR 2CC)
	DC_1A_n257G	1A	CA_n257G	1A	CA_n257G	No
DC_1A_n257H	DC_1A_n257A	1A	CA_n257H	1A	n257A	No
	DC_1A_n257G	1A	CA_n257H	1A	CA_n257G	No
	DC_1A_n257H	1A	CA_n257H	1A	CA_n257H	No
DC_1A_n257I	DC_1A_n257A	1A	CA_n257I	1A	n257A	No
	DC_1A_n257G	1A	CA_n257I	1A	CA_n257G	No
	DC_1A_n257H	1A	CA_n257I	1A	CA_n257H	No
	DC_1A_n257I	1A	CA_n257I	1A	CA_n257I	No
DC_2A_n257A	DC_2A_n257A	2A	n257A	2A	n257A	Yes
DC_2A_n257(2A)	DC_2A_n257A	2A	CA_n257(2A)	2A	n257A	FFS (NR 2CC)
DC_2A_n260A	DC_2A_n260A	2A	n260A	2A	n260A	Yes
DC_2A_n260G	DC_2A_n260A	2A	CA_n260G	2A	n260A	Yes (NR 2CC)
DC_2A_n260H	DC_2A_n260A	2A	CA_n260H	2A	n260A	No
DC_2A_n260I	DC_2A_n260A	2A	CA_n260I	2A	n260A	No
DC_2A_n260J	DC_2A_n260A	2A	CA_n260J	2A	n260A	No
DC_2A_n260K	DC_2A_n260A	2A	CA_n260K	2A	n260A	No
DC_2A_n260L	DC_2A_n260A	2A	CA_n260L	2A	n260A	No
DC_2A_n260M	DC_2A_n260A	2A	CA_n260M	2A	n260A	No
DC_2C_n260A	DC_2A_n260A	CA_2C	n260A	2A	n260A	No
DC_2A_n260(2A)	DC_2A_n260A	2A	CA_n260(2A)	2A	n260A	FFS (NR 2CC)
DC_2A-2A_n260A	DC_2A_n260A	CA_2A-2A	n260A	2A	n260A	No
DC_2A-2A_n260G	DC_2A_n260A	CA_2A-2A	CA_n260G	2A	n260A	No
DC_2A-2A_n260H	DC_2A_n260A	CA_2A-2A	CA_n260H	2A	n260A	No
DC_2A-2A_n260I	DC_2A_n260A	CA_2A-2A	CA_n260I	2A	n260A	No
DC_2A-2A_n260J	DC_2A_n260A	CA_2A-2A	CA_n260J	2A	n260A	No
DC_2A-2A_n260K	DC_2A_n260A	CA_2A-2A	CA_n260K	2A	n260A	No
DC_2A-2A_n260L	DC_2A_n260A	CA_2A-2A	CA_n260L	2A	n260A	No
DC_2A-2A_n260M	DC_2A_n260A	CA_2A-2A	CA_n260M	2A	n260A	No
DC_3A_n257A	DC_3A_n257A	3A	n257A	3A	n257A	Yes
DC_3A_n257D	DC_3A_n257A	3A	CA_n257D	3A	n257A	FFS (NR 2CC)
DC_3A_n257G	DC_3A_n257A	3A	CA_n257G	3A	n257A	Yes (NR 2CC)
	DC_3A_n257B	3A	CA_n257G	3A	CA_n257B	No
	DC_3A_n257D	3A	CA_n257G	3A	CA_n257D	No

EN-DC configuration	Uplink EN-DC Configuration	E-UTRA downlink configuration	NR downlink configuration	E-UTRA uplink configuration	NR uplink configuration	Applicable for protocol testing (Note 1)
DC_3A_n257H	DC_3A_n257G	3A	CA_n257G	3A	CA_n257G	No
	DC_3A_n257A	3A	CA_n257H	3A	n257A	No
	DC_3A_n257B	3A	CA_n257H	3A	CA_n257B	No
	DC_3A_n257D	3A	CA_n257H	3A	CA_n257D	No
	DC_3A_n257G	3A	CA_n257H	3A	CA_n257G	No
DC_3A_n257I	DC_3A_n257H	3A	CA_n257H	3A	CA_n257H	No
	DC_3A_n257A	3A	CA_n257I	3A	n257A	No
	DC_3A_n257B	3A	CA_n257I	3A	CA_n257B	No
	DC_3A_n257D	3A	CA_n257I	3A	CA_n257D	No
	DC_3A_n257G	3A	CA_n257I	3A	CA_n257G	No
DC_5A_n260A	DC_3A_n257H	3A	CA_n257I	3A	CA_n257H	No
	DC_3A_n257I	3A	CA_n257I	3A	CA_n257I	No
DC_5A_n257A	DC_5A_n257A	5A	n257A	5A	n257A	Yes
DC_5A_n260A	DC_5A_n260A	5A	n260A	5A	n260A	Yes
DC_5A_n260B	DC_5A_n260A	5A	CA_n260B	5A	n260A	FFS (NR 2CC)
DC_5A_n260C	DC_5A_n260A	5A	CA_n260C	5A	n260A	No
DC_5A_n260D	DC_5A_n260A	5A	CA_n260D	5A	n260A	FFS (NR 2CC)
DC_5A_n260E	DC_5A_n260A	5A	CA_n260E	5A	n260A	No
DC_5A_n260F	DC_5A_n260A	5A	CA_n260F	5A	n260A	No
DC_5A_n260G	DC_5A_n260A	5A	CA_n260G	5A	n260A	Yes (NR 2CC)
DC_5A_n260H	DC_5A_n260A	5A	CA_n260H	5A	n260A	No
DC_5A_n260I	DC_5A_n260A	5A	CA_n260I	5A	n260A	No
DC_5A_n260J	DC_5A_n260A	5A	CA_n260J	5A	n260A	No
DC_5A_n260K	DC_5A_n260A	5A	CA_n260K	5A	n260A	No
DC_5A_n260L	DC_5A_n260A	5A	CA_n260L	5A	n260A	No
DC_5A_n260M	DC_5A_n260A	5A	CA_n260M	5A	n260A	No
DC_5A_n260O	DC_5A_n260A	5A	CA_n260O	5A	n260A	FFS (NR 2CC)
DC_5B_n260A	DC_5A_n260A	CA_5B	n260A	5A	n260A	No
	DC_5B_n260A	CA_5B	n260A	CA_5B	n260A	No
DC_5A_n260(2A)	DC_5A_n260A	5A	CA_n260(2A)	5A	n260A	FFS (NR 2CC)
DC_5A_n260(3A)	DC_5A_n260A	5A	CA_n260(3A)	5A	n260A	No
DC_5A_n260(4A)	DC_5A_n260A	5A	n260(4A)	5A	n260A	No
DC_5A_n260(A-I)	DC_5A_n260A	5A	CA_n260(A-I)	5A	n260A	No
DC_5A_n260(G-I)	DC_5A_n260A	5A	CA_n260(G-I)	5A	n260A	No
DC_5A-5A_n260A	DC_5A_n260A	CA_5A-5A	n260A	5A	n260A	No
DC_5A_n261A	DC_5A_n261A	5A	n261A	5A	n261A	Yes
DC_5A_n261B	DC_5A_n261A	5A	CA_n261B	5A	n261A	FFS (NR 2CC)
DC_5A_n261C	DC_5A_n261A	5A	CA_n261C	5A	n261A	No
DC_5A_n261D	DC_5A_n261A	5A	CA_n261D	5A	n261A	FFS (NR 2CC)
DC_5A_n261E	DC_5A_n261A	5A	CA_n261E	5A	n261A	No

EN-DC configuration	Uplink EN-DC Configuration	E-UTRA downlink configuration	NR downlink configuration	E-UTRA uplink configuration	NR uplink configuration	Applicable for protocol testing (Note 1)
DC_5A_n261F	DC_5A_n261A	5A	CA_n261F	5A	n261A	No
DC_5A_n261G	DC_5A_n261A	5A	CA_n261G	5A	n261A	Yes (NR 2CC)
DC_5A_n261H	DC_5A_n261A	5A	CA_n261H	5A	n261A	No
DC_5A_n261I	DC_5A_n261A	5A	CA_n261I	5A	n261A	No
DC_5A_n261J	DC_5A_n261A	5A	CA_n261J	5A	n261A	No
DC_5A_n261K	DC_5A_n261A	5A	CA_n261K	5A	n261A	No
DC_5A_n261L	DC_5A_n261A	5A	CA_n261L	5A	n261A	No
DC_5A_n261M	DC_5A_n261A	5A	CA_n261M	5A	n261A	No
DC_5A_n261O	DC_5A_n261A	5A	CA_n261O	5A	n261A	FFS (NR 2CC)
DC_5A_n261P	DC_5A_n261A	5A	CA_n261P	5A	n261A	No
DC_5A_n261Q	DC_5A_n261A	5A	CA_n261Q	5A	n261A	No
DC_5A_n261(2A)	DC_5A_n261A	5A	CA_n261(2A)	5A	n261A	Yes (NR 2CC)
DC_5A_n261(3A)	DC_5A_n261A	5A	CA_n261(3A)	5A	n261A	No
DC_5A_n261(4A)	DC_5A_n261A	5A	CA_n261(4A)	5A	n261A	No
DC_5A_n261(D-G)	DC_5A_n261A	5A	CA_n261(D-G)	5A	n261A	No
DC_5A_n261(D-H)	DC_5A_n261A	5A	CA_n261(D-H)	5A	n261A	No
DC_5A_n261(D-I)	DC_5A_n261A	5A	CA_n261(D-I)	5A	n261A	No
DC_5A_n261(D-O)	DC_5A_n261A	5A	CA_n261(D-O)	5A	n261A	No
DC_5A_n261(D-P)	DC_5A_n261A	5A	CA_n261(D-P)	5A	n261A	No
DC_5A_n261(D-Q)	DC_5A_n261A	5A	CA_n261(D-Q)	5A	n261A	No
DC_5A_n261(E-O)	DC_5A_n261A	5A	CA_n261(E-O)	5A	n261A	No
DC_5A_n261(E-P)	DC_5A_n261A	5A	CA_n261(E-P)	5A	n261A	No
DC_5A_n261(E-Q)	DC_5A_n261A	5A	CA_n261(E-Q)	5A	n261A	No
DC_7A_n257A	DC_7A_n257A	7A	n257A	7A	n257A	Yes
DC_7A-7A_n257A	DC_7A_n257A	CA_7A-7A	n257A	7A	n257A	No
DC_8A_n257A	DC_8A_n257A	8A	n257A	8A	n257A	Yes
DC_8A_n257D	DC_8A_n257A	8A	CA_n257D	8A	n257A	FFS (NR 2CC)
DC_8A_n257E	DC_8A_n257A	8A	CA_n257E	8A	n257A	No
DC_8A_n257F	DC_8A_n257A	8A	CA_n257F	8A	n257A	No
DC_8A_n257G	DC_8A_n257A	8A	CA_n257G	8A	n257A	Yes (NR 2CC)
DC_8A_n257H	DC_8A_n257A	8A	CA_n257H	8A	n257A	No
DC_8A_n257I	DC_8A_n257A	8A	CA_n257I	8A	n257A	No
DC_8A_n257J	DC_8A_n257A	8A	CA_n257J	8A	n257A	No
DC_8A_n257K	DC_8A_n257A	8A	CA_n257K	8A	n257A	No
DC_8A_n257L	DC_8A_n257A	8A	CA_n257L	8A	n257A	No
DC_8A_n257M	DC_8A_n257A	8A	CA_n257M	8A	n257A	No
DC_8A_n258A	DC_8A_n258A	8A	n258A	8A	n258A	Yes
DC_11A_n257A	DC_11A_n257A	11A	n257A	11A	n257A	Yes
DC_12A_n260A	DC_12A_n260A	12A	n260A	12A	n260A	Yes
DC_14A_n260A	DC_14A_n260A	14A	n260A	14A	n260A	Yes

EN-DC configuration	Uplink EN-DC Configuration	E-UTRA downlink configuration	NR downlink configuration	E-UTRA uplink configuration	NR uplink configuration	Applicable for protocol testing (Note 1)
DC_14A_n260G	DC_14A_n260A	14A	CA_n260G	14A	n260A	Yes (NR 2CC)
	DC_14A_n260G	14A	CA_n260G	14A	CA_n260G	No
DC_14A_n260H	DC_14A_n260A	14A	CA_n260H	14A	n260A	No
	DC_14A_n260G	14A	CA_n260H	14A	CA_n260G	No
	DC_14A_n260H	14A	CA_n260H	14A	CA_n260H	No
DC_14A_n260I	DC_14A_n260A	14A	CA_n260I	14A	n260A	No
	DC_14A_n260G	14A	CA_n260I	14A	CA_n260G	No
	DC_14A_n260H	14A	CA_n260I	14A	CA_n260H	No
	DC_14A_n260I	14A	CA_n260I	14A	CA_n260I	No
DC_12A_n260G	DC_12A_n260A	12A	CA_n260G	12A	n260A	Yes (NR 2CC)
DC_12A_n260H	DC_12A_n260A	12A	CA_n260H	12A	n260A	No
DC_12A_n260I	DC_12A_n260A	12A	CA_n260I	12A	n260A	No
DC_12A_n260J	DC_12A_n260A	12A	CA_n260J	12A	n260A	No
DC_12A_n260K	DC_12A_n260A	12A	CA_n260K	12A	n260A	No
DC_12A_n260L	DC_12A_n260A	12A	CA_n260L	12A	n260A	No
DC_12A_n260M	DC_12A_n260A	12A	CA_n260M	12A	n260A	No
DC_13A_n257A	DC_13A_n257A	13A	n257A	13A	n257A	Yes
DC_13A_n260A	DC_13A_n260A	13A	n260A	13A	n260A	Yes
DC_18A_n257A	DC_18A_n257A	18A	n257A	18A	n257A	Yes
DC_19A_n257A	DC_19A_n257A	19A	n257A	19A	n257A	Yes
DC_19A_n257D	DC_19A_n257A	19A	CA_n257D	19A	n257A	FFS (NR 2CC)
DC_19A_n257G	DC_19A_n257A	19A	CA_n257G	19A	n257A	Yes (NR 2CC)
	DC_19A_n257G	19A	CA_n257G	19A	CA_n257G	No
DC_19A_n257H	DC_19A_n257A	19A	CA_n257H	19A	n257A	No
	DC_19A_n257G	19A	CA_n257H	19A	CA_n257G	No
	DC_19A_n257H	19A	CA_n257H	19A	CA_n257H	No
DC_19A_n257I	DC_19A_n257A	19A	CA_n257I	19A	n257A	No
	DC_19A_n257G	19A	CA_n257I	19A	CA_n257G	No
	DC_19A_n257H	19A	CA_n257I	19A	CA_n257H	No
	DC_19A_n257I	19A	CA_n257I	19A	CA_n257I	No
DC_20A_n257A	DC_20A_n257A	20A	n257A	20A	n257A	Yes
DC_21A_n257A	DC_21A_n257A	21A	n257A	21A	n257A	Yes
DC_21A_n257D	DC_21A_n257A	21A	CA_n257D	21A	n257A	FFS (NR 2CC)
DC_21A_n257G	DC_21A_n257A	21A	CA_n257G	21A	n257A	Yes (NR 2CC)
	DC_21A_n257G	21A	CA_n257G	21A	CA_n257G	No
DC_21A_n257H	DC_21A_n257A	21A	CA_n257H	21A	n257A	No
	DC_21A_n257G	21A	CA_n257H	21A	CA_n257G	No
	DC_21A_n257H	21A	CA_n257H	21A	CA_n257H	No
DC_21A_n257I	DC_21A_n257A	21A	CA_n257I	21A	n257A	No
	DC_21A_n257G	21A	CA_n257I	21A	CA_n257G	No

EN-DC configuration	Uplink EN-DC Configuration	E-UTRA downlink configuration	NR downlink configuration	E-UTRA uplink configuration	NR uplink configuration	Applicable for protocol testing (Note 1)
	DC_21A_n257H	21A	CA_n257I	21A	CA_n257H	No
	DC_21A_n257I	21A	CA_n257I	21A	CA_n257I	No
DC_28A_n257A	DC_28A_n257A	28A	n257A	28A	n257A	Yes
DC_30A_n260A	DC_30A_n260A	30A	n260A	30A	n260A	Yes
DC_30A_n260G	DC_30A_n260A	30A	CA_n260G	30A	n260A	Yes (NR 2CC)
DC_30A_n260H	DC_30A_n260A	30A	CA_n260H	30A	n260A	No
DC_30A_n260I	DC_30A_n260A	30A	CA_n260I	30A	n260A	No
DC_30A_n260J	DC_30A_n260A	30A	CA_n260J	30A	n260A	No
DC_30A_n260K	DC_30A_n260A	30A	CA_n260K	30A	n260A	No
DC_30A_n260L	DC_30A_n260A	30A	CA_n260L	30A	n260A	No
DC_30A_n260M	DC_30A_n260A	30A	CA_n260M	30A	n260A	No
DC_41A_n257A	DC_41A_n257A	41A	n257A	41A	n257A	Yes
DC_42A_n257A	DC_42A_n257A	42A	n257A	42A	n257A	Yes
DC_42C_n257A	DC_42A_n257A	CA_42C	n257A	42A	n257A	No
	DC_42C_n257A	CA_42C	n257A	CA_42C	n257A	No
DC_42A_n257D	DC_42A_n257A	42A	CA_n257D	42A	n257A	FFS (NR 2CC)
DC_42C_n257D	DC_42A_n257A	CA_42C	CA_n257D	42A	n257A	No
	DC_42C_n257A	CA_42C	CA_n257D	CA_42C	n257A	No
DC_42D_n257A	DC_42A_n257A	CA_42D	n257A	42A	n257A	No
	DC_42C_n257A	CA_42D	n257A	CA_42C	n257A	No
DC_42E_n257A	DC_42A_n257A	CA_42E	n257A	42A	n257A	No
	DC_42C_n257A	CA_42E	n257A	CA_42C	n257A	No
DC_48A_n260A	DC_48A_n260A	48A	n260A	48A	n260A	Yes
DC_48C_n260A	DC_48A_n260A	CA_48C	n260A	48A	n260A	No
	DC_48C_n260A	CA_48C	n260A	CA_48C	n260A	No
DC_66A_n257A	DC_66A_n257A	66A	n257A	66A	n257A	Yes
DC_66A_n257(2A)	DC_66A_n257A	66A	CA_n257(2A)	66A	n257A	FFS (NR 2CC)
DC_66A-66A_n257A	DC_66A_n257A	CA_66A-66A	n257A	66A	n257A	No
DC_66A_n260A	DC_66A_n260A	66A	n260A	66A	n260A	Yes
DC_66A_n260D	DC_66A_n260A	66A	CA_n260D	66A	n260A	FFS (NR 2CC)
DC_66A_n260E	DC_66A_n260A	66A	CA_n260E	66A	n260A	No
DC_66A_n260F	DC_66A_n260A	66A	CA_n260F	66A	n260A	No
DC_66A_n260G	DC_66A_n260A	66A	CA_n260G	66A	n260A	Yes (NR 2CC)
DC_66A_n260H	DC_66A_n260A	66A	CA_n260H	66A	n260A	No
DC_66A_n260I	DC_66A_n260A	66A	CA_n260I	66A	n260A	No
DC_66A_n260J	DC_66A_n260A	66A	CA_n260J	66A	n260A	No
DC_66A_n260K	DC_66A_n260A	66A	CA_n260K	66A	n260A	No
DC_66A_n260L	DC_66A_n260A	66A	CA_n260L	66A	n260A	No
DC_66A_n260M	DC_66A_n260A	66A	CA_n260M	66A	n260A	No
DC_66A_n260O	DC_66A_n260A	66A	CA_n260O	66A	n260A	FFS (NR 2CC)



EN-DC configuration	Uplink EN-DC Configuration	E-UTRA downlink configuration	NR downlink configuration	E-UTRA uplink configuration	NR uplink configuration	Applicable for protocol testing (Note 1)
DC_66A_n260(2A)	DC_66A_n260A	66A	CA_n260(2A)	66A	n260A	FFS (NR 2CC)
DC_66A_n260(3A)	DC_66A_n260A	66A	CA_n260(3A)	66A	n260A	No
DC_66A_n260(4A)	DC_66A_n260A	66A	CA_n260(4A)	66A	n260A	No
DC_66A_n260(A-I)	DC_66A_n260A	66A	CA_n260(A-I)	66A	n260A	No
DC_66A_n260(G-I)	DC_66A_n260A	66A	CA_n260(G-I)	66A	n260A	No
DC_66A-66A_n260A	DC_66A_n260A	CA_66A-66A	n260A	66A	n260A	No
DC_66A-66A_n260G	DC_66A_n260A	CA_66A-66A	CA_n260G	66A	n260A	No
DC_66A-66A_n260H	DC_66A_n260A	CA_66A-66A	CA_n260H	66A	n260A	No
DC_66A-66A_n260I	DC_66A_n260A	CA_66A-66A	CA_n260I	66A	n260A	No
DC_66A-66A_n260J	DC_66A_n260A	CA_66A-66A	CA_n260J	66A	n260A	No
DC_66A-66A_n260K	DC_66A_n260A	CA_66A-66A	CA_n260K	66A	n260A	No
DC_66A-66A_n260L	DC_66A_n260A	CA_66A-66A	CA_n260L	66A	n260A	No
DC_66A-66A_n260M	DC_66A_n260A	CA_66A-66A	CA_n260M	66A	n260A	No
DC_66A_n261A	DC_66A_n261A	66A	n261A	66A	n261A	Yes
DC_66A_n261D	DC_66A_n261A	66A	CA_n261D	66A	n261A	FFS (NR 2CC)
DC_66A_n261E	DC_66A_n261A	66A	CA_n261E	66A	n261A	No
DC_66A_n261F	DC_66A_n261A	66A	CA_n261F	66A	n261A	No
DC_66A_n261G	DC_66A_n261A	66A	CA_n261G	66A	n261A	Yes (NR 2CC)
DC_66A_n261H	DC_66A_n261A	66A	CA_n261H	66A	n261A	No
DC_66A_n261I	DC_66A_n261A	66A	CA_n261I	66A	n261A	No
DC_66A_n261J	DC_66A_n261A	66A	CA_n261J	66A	n261A	No
DC_66A_n261K	DC_66A_n261A	66A	CA_n261K	66A	n261A	No
DC_66A_n261L	DC_66A_n261A	66A	CA_n261L	66A	n261A	No
DC_66A_n261M	DC_66A_n261A	66A	CA_n261M	66A	n261A	No
DC_66A_n261O	DC_66A_n261A	66A	CA_n261O	66A	n261A	FFS (NR 2CC)
DC_66A_n261P	DC_66A_n261A	66A	CA_n261P	66A	n261A	No
DC_66A_n261Q	DC_66A_n261A	66A	CA_n261Q	66A	n261A	No
DC_66A_n261(2A)	DC_66A_n261A	66A	CA_n261(2A)	66A	n261A	Yes (NR 2CC)
DC_66A_n261(3A)	DC_66A_n261A	66A	CA_n261(3A)	66A	n261A	No
DC_66A_n261(4A)	DC_66A_n261A	66A	CA_n261(4A)	66A	n261A	No
DC_66A_n261(D-G)	DC_66A_n261A	66A	CA_n261(D-G)	66A	n261A	No
DC_66A_n261(D-H)	DC_66A_n261A	66A	CA_n261(D-H)	66A	n261A	No
DC_66A_n261(D-I)	DC_66A_n261A	66A	CA_n261(D-I)	66A	n261A	No
DC_66A_n261(D-O)	DC_66A_n261A	66A	CA_n261(D-O)	66A	n261A	No
DC_66A_n261(D-P)	DC_66A_n261A	66A	CA_n261(D-P)	66A	n261A	No
DC_66A_n261(D-Q)	DC_66A_n261A	66A	CA_n261(D-Q)	66A	n261A	No
DC_66A_n261(E-O)	DC_66A_n261A	66A	CA_n261(E-O)	66A	n261A	No
DC_66A_n261(E-P)	DC_66A_n261A	66A	CA_n261(E-P)	66A	n261A	No
DC_66A_n261(E-Q)	DC_66A_n261A	66A	CA_n261(E-Q)	66A	n261A	No

Note 1: Protocol testing is limited to EN-DC configurations with 1 CC E-UTRA and 1CC or 2CC NR configurations.

## 4.3.1.5.1.3 Inter-band EN-DC configurations including FR2 (three bands)

Table 4.3.1.5.1.3-1: Inter-band EN-DC configurations including FR2 (three bands)

EN-DC configuration	Uplink EN-DC Configuration	E-UTRA downlink configuration	NR downlink configuration	E-UTRA uplink configuration	NR uplink configuration	Applicable for protocol testing (Note 1)
DC_1A-3A_n257A	DC_1A_n257A	CA_1A-3A	n257A	1A	n257A	No
	DC_3A_n257A	CA_1A-3A	n257A	3A	n257A	No
DC_1A-3A_n257G	DC_1A_n257A	CA_1A-3A	CA_n257G	1A	n257A	No
	DC_1A_n257D	CA_1A-3A	CA_n257G	1A	CA_n257D	No
	DC_3A_n257A	CA_1A-3A	CA_n257G	3A	n257A	No
	DC_3A_n257D	CA_1A-3A	CA_n257G	3A	CA_n257D	No
	DC_3A_n257G	CA_1A-3A	CA_n257G	3A	CA_n257G	No
DC_1A-3A_n257H	DC_1A_n257A	CA_1A-3A	CA_n257H	1A	n257A	No
	DC_1A_n257D	CA_1A-3A	CA_n257H	1A	CA_n257D	No
	DC_3A_n257A	CA_1A-3A	CA_n257H	3A	n257A	No
	DC_3A_n257D	CA_1A-3A	CA_n257H	3A	CA_n257D	No
	DC_3A_n257G	CA_1A-3A	CA_n257H	3A	CA_n257G	No
DC_1A-3A_n257I	DC_1A_n257A	CA_1A-3A	CA_n257I	1A	n257A	No
	DC_1A_n257D	CA_1A-3A	CA_n257I	1A	CA_n257D	No
	DC_3A_n257A	CA_1A-3A	CA_n257I	3A	n257A	No
	DC_3A_n257D	CA_1A-3A	CA_n257I	3A	CA_n257D	No
	DC_3A_n257G	CA_1A-3A	CA_n257I	3A	CA_n257G	No
	DC_3A_n257H	CA_1A-3A	CA_n257I	3A	CA_n257H	No
	DC_3A_n257I	CA_1A-3A	CA_n257I	3A	CA_n257I	No
DC_1A-18A_n257A	DC_1A_n257A	CA_1A-18A	n257A	1A	n257A	No
	DC_18A_n257A	CA_1A-18A	n257A	18A	n257A	No
DC_1A-19A_n257A	DC_1A_n257A	CA_1A-19A	n257A	1A	n257A	No
	DC_19A_n257A	CA_1A-19A	n257A	19A	n257A	No
DC_1A-19A_n257G	DC_1A_n257A	CA_1A-19A	CA_n257G	1A	n257A	No
	DC_1A_n257D	CA_1A-19A	CA_n257G	1A	CA_n257D	No
	DC_1A_n257G	CA_1A-19A	CA_n257G	1A	CA_n257G	No
	DC_19A_n257A	CA_1A-19A	CA_n257G	19A	n257A	No
	DC_19A_n257D	CA_1A-19A	CA_n257G	19A	CA_n257D	No
DC_1A-19A_n257H	DC_1A_n257A	CA_1A-19A	CA_n257H	1A	n257A	No
	DC_1A_n257D	CA_1A-19A	CA_n257H	1A	CA_n257D	No
	DC_1A_n257G	CA_1A-19A	CA_n257H	1A	CA_n257G	No
	DC_1A_n257H	CA_1A-19A	CA_n257H	1A	CA_n257H	No
	DC_19A_n257A	CA_1A-19A	CA_n257H	19A	n257A	No

EN-DC configuration	Uplink EN-DC Configuration	E-UTRA downlink configuration	NR downlink configuration	E-UTRA uplink configuration	NR uplink configuration	Applicable for protocol testing (Note 1)
DC_1A-19A_n257I	DC_19A_n257D	CA_1A-19A	CA_n257H	19A	CA_n257D	No
	DC_1A_n257A	CA_1A-19A	CA_n257I	1A	n257A	No
	DC_1A_n257D	CA_1A-19A	CA_n257I	1A	CA_n257D	No
	DC_1A_n257G	CA_1A-19A	CA_n257I	1A	CA_n257G	No
	DC_1A_n257H	CA_1A-19A	CA_n257I	1A	CA_n257H	No
	DC_1A_n257I	CA_1A-19A	CA_n257I	1A	CA_n257I	No
	DC_19A_n257A	CA_1A-19A	CA_n257I	19A	n257A	No
DC_1A-21A_n257A	DC_19A_n257D	CA_1A-19A	CA_n257I	19A	CA_n257D	No
	DC_1A_n257A	CA_1A-21A	n257A	1A	n257A	No
DC_1A-21A_n257G	DC_21A_n257A	CA_1A-21A	n257A	21A	n257A	No
	DC_1A_n257A	CA_1A-21A	CA_n257G	1A	n257A	No
DC_1A-21A_n257G	DC_1A_n257G	CA_1A-21A	CA_n257G	1A	CA_n257G	No
	DC_21A_n257A	CA_1A-21A	CA_n257G	21A	n257A	No
	DC_21A_n257G	CA_1A-21A	CA_n257G	21A	CA_n257G	No
	DC_1A_n257H	CA_1A-21A	CA_n257H	1A	n257A	No
DC_1A-21A_n257H	DC_1A_n257G	CA_1A-21A	CA_n257H	1A	CA_n257G	No
	DC_1A_n257H	CA_1A-21A	CA_n257H	1A	CA_n257H	No
	DC_21A_n257A	CA_1A-21A	CA_n257H	21A	n257A	No
	DC_21A_n257G	CA_1A-21A	CA_n257H	21A	CA_n257G	No
	DC_21A_n257H	CA_1A-21A	CA_n257H	21A	CA_n257H	No
	DC_1A_n257A	CA_1A-21A	CA_n257I	1A	n257A	No
DC_1A-21A_n257I	DC_1A_n257G	CA_1A-21A	CA_n257I	1A	CA_n257G	No
	DC_1A_n257H	CA_1A-21A	CA_n257I	1A	CA_n257H	No
	DC_1A_n257I	CA_1A-21A	CA_n257I	1A	CA_n257I	No
	DC_21A_n257A	CA_1A-21A	CA_n257I	21A	n257A	No
	DC_21A_n257G	CA_1A-21A	CA_n257I	21A	CA_n257G	No
	DC_21A_n257H	CA_1A-21A	CA_n257I	21A	CA_n257H	No
	DC_21A_n257I	CA_1A-21A	CA_n257I	21A	CA_n257I	No
	DC_1A-41A_n257A	DC_1A_n257A	CA_1A-41A	n257A	1A	n257A
DC_1A-42A_n257A	DC_41A_n257A	CA_1A-41A	n257A	41A	n257A	No
	DC_1A_n257A	CA_1A-42A	n257A	1A	n257A	No
DC_1A-42A_n257G	DC_42A_n257A	CA_1A-42A	n257A	42A	n257A	No
	DC_1A_n257A	CA_1A-42A	CA_n257G	1A	n257A	No
	DC_1A_n257D	CA_1A-42A	CA_n257G	1A	CA_n257D	No
	DC_1A_n257G	CA_1A-42A	CA_n257G	1A	n257A	No
	DC_1A_n257G	CA_1A-42A	CA_n257G	1A	CA_n257G	No
	DC_42A_n257A	CA_1A-42A	CA_n257G	42A	n257A	No
	DC_42A_n257D	CA_1A-42A	CA_n257G	42A	CA_n257D	No
DC_1A-42A_n257H	DC_1A_n257A	CA_1A-42A	CA_n257H	1A	n257A	No
	DC_1A_n257D	CA_1A-42A	CA_n257H	1A	CA_n257D	No

EN-DC configuration	Uplink EN-DC Configuration	E-UTRA downlink configuration	NR downlink configuration	E-UTRA uplink configuration	NR uplink configuration	Applicable for protocol testing (Note 1)
	DC_1A_n257A	CA_1A-42A	CA_n257H	1A	n257A	No
	DC_1A_n257G	CA_1A-42A	CA_n257H	1A	CA_n257G	No
	DC_1A_n257H	CA_1A-42A	CA_n257H	1A	CA_n257H	No
	DC_42A_n257A	CA_1A-42A	CA_n257H	42A	n257A	No
	DC_42A_n257D	CA_1A-42A	CA_n257H	42A	CA_n257D	No
DC_1A-42A_n257I	DC_1A_n257A	CA_1A-42A	CA_n257I	1A	n257A	No
	DC_1A_n257D	CA_1A-42A	CA_n257I	1A	CA_n257D	No
	DC_1A_n257A	CA_1A-42A	CA_n257I	1A	n257A	No
	DC_1A_n257G	CA_1A-42A	CA_n257I	1A	CA_n257G	No
	DC_1A_n257H	CA_1A-42A	CA_n257I	1A	CA_n257H	No
	DC_1A_n257I	CA_1A-42A	CA_n257I	1A	CA_n257I	No
	DC_42A_n257A	CA_1A-42A	CA_n257I	42A	n257A	No
	DC_42A_n257D	CA_1A-42A	CA_n257I	42A	CA_n257D	No
	DC_1A-42C_n257A	DC_1A_n257A	CA_1A-42C	n257A	1A	n257A
DC_42A_n257A		CA_1A-42C	n257A	42A	n257A	No
DC_1A-42D_n257A	DC_1A_n257A	CA_1A-42D	n257A	1A	n257A	No
	DC_42A_n257A	CA_1A-42D	n257A	42A	n257A	No
DC_1A-42E_n257A	DC_1A_n257A	CA_1A-42E	n257A	1A	n257A	No
	DC_42A_n257A	CA_1A-42E	n257A	42A	n257A	No
DC_1A-42E_n257G	DC_1A_n257A	CA_1A-42E	CA_n257G	1A	n257A	No
	DC_1A_n257D	CA_1A-42E	CA_n257G	1A	CA_n257D	No
	DC_1A_n257A	CA_1A-42E	CA_n257G	1A	n257A	No
	DC_1A_n257G	CA_1A-42E	CA_n257G	1A	CA_n257G	No
	DC_42A_n257A	CA_1A-42E	CA_n257G	42A	n257A	No
DC_1A-42E_n257H	DC_42A_n257D	CA_1A-42E	CA_n257G	42A	CA_n257D	No
	DC_1A_n257A	CA_1A-42E	CA_n257H	1A	n257A	No
	DC_1A_n257D	CA_1A-42E	CA_n257H	1A	CA_n257D	No
	DC_1A_n257A	CA_1A-42E	CA_n257H	1A	n257A	No
	DC_1A_n257G	CA_1A-42E	CA_n257H	1A	CA_n257G	No
	DC_1A_n257H	CA_1A-42E	CA_n257H	1A	CA_n257H	No
	DC_42A_n257A	CA_1A-42E	CA_n257H	42A	n257A	No
DC_42A_n257D	CA_1A-42E	CA_n257H	42A	CA_n257D	No	
DC_1A-42E_n257I	DC_1A_n257A	CA_1A-42E	CA_n257I	1A	n257A	No
	DC_1A_n257D	CA_1A-42E	CA_n257I	1A	CA_n257D	No
	DC_1A_n257A	CA_1A-42E	CA_n257I	1A	n257A	No
	DC_1A_n257G	CA_1A-42E	CA_n257I	1A	CA_n257G	No
	DC_1A_n257H	CA_1A-42E	CA_n257I	1A	CA_n257H	No
	DC_1A_n257I	CA_1A-42E	CA_n257I	1A	CA_n257I	No
	DC_42A_n257A	CA_1A-42E	CA_n257I	42A	n257A	No
	DC_42A_n257D	CA_1A-42E	CA_n257I	42A	CA_n257D	No

EN-DC configuration	Uplink EN-DC Configuration	E-UTRA downlink configuration	NR downlink configuration	E-UTRA uplink configuration	NR uplink configuration	Applicable for protocol testing (Note 1)
DC_2A-5A_n257A	DC_2A_n257A	CA_2A-5A	n257A	2A	n257A	No
	DC_5A_n257A	CA_2A-5A	n257A	5A	n257A	No
DC_2A-5A_n260A	DC_2A_n260A	CA_2A-5A	n260A	2A	n260A	No
	DC_5A_n260A	CA_2A-5A	n260A	5A	n260A	No
DC_2A-12A_n260A	DC_2A_n260A	CA_2A-12A	n260A	2A	n260A	No
	DC_12A_n260A	CA_2A-12A	n260A	12A	n260A	No
DC_2A-14A_n260A	DC_2A_n260A	CA_2A-14A	n260A	2A	n260A	No
	DC_14A_n260A	CA_2A-14A	n260A	14A	n260A	No
DC_2A-14A_n260G	DC_2A_n260A	CA_2A-14A	CA_n260G	2A	n260A	No
	DC_2A_n260G	CA_2A-14A	CA_n260G	2A	CA_n260G	No
	DC_14A_n260A	CA_2A-14A	CA_n260G	14A	n260A	No
	DC_14A_n260G	CA_2A-14A	CA_n260G	14A	CA_n260G	No
DC_2A-14A_n260H	DC_2A_n260A	CA_2A-14A	CA_n260H	2A	n260A	No
	DC_2A_n260G	CA_2A-14A	CA_n260H	2A	CA_n260G	No
	DC_2A_n260H	CA_2A-14A	CA_n260H	2A	CA_n260H	No
	DC_14A_n260A	CA_2A-14A	CA_n260H	14A	n260A	No
	DC_14A_n260G	CA_2A-14A	CA_n260H	14A	CA_n260G	No
	DC_14A_n260H	CA_2A-14A	CA_n260H	14A	CA_n260H	No
DC_2A-14A_n260I	DC_2A_n260A	CA_2A-14A	CA_n260I	2A	n260A	No
	DC_2A_n260G	CA_2A-14A	CA_n260I	2A	CA_n260G	No
	DC_2A_n260H	CA_2A-14A	CA_n260I	2A	CA_n260H	No
	DC_2A_n260I	CA_2A-14A	CA_n260I	2A	CA_n260I	No
	DC_14A_n260A	CA_2A-14A	CA_n260I	14A	n260A	No
	DC_14A_n260G	CA_2A-14A	CA_n260I	14A	CA_n260G	No
	DC_14A_n260H	CA_2A-14A	CA_n260I	14A	CA_n260H	No
	DC_14A_n260I	CA_2A-14A	CA_n260I	14A	CA_n260I	No
DC_2A-2A-14A_n260A	DC_2A_n260A	CA_2A-2A-14A	n260A	2A	n260A	No
	DC_14A_n260A	CA_2A-2A-14A	n260A	14A	n260A	No
DC_2A-2A-14A_n260G	DC_2A_n260A	CA_2A-2A-14A	CA_n260G	2A	n260A	No
	DC_2A_n260G	CA_2A-2A-14A	CA_n260G	2A	CA_n260G	No
	DC_14A_n260A	CA_2A-2A-14A	CA_n260G	14A	n260A	No
	DC_14A_n260G	CA_2A-2A-14A	CA_n260G	14A	CA_n260G	No
DC_2A-2A-14A_n260H	DC_2A_n260A	CA_2A-2A-14A	CA_n260H	2A	n260A	No
	DC_2A_n260G	CA_2A-2A-14A	CA_n260H	2A	CA_n260G	No
	DC_2A_n260H	CA_2A-2A-14A	CA_n260H	2A	CA_n260H	No
	DC_14A_n260A	CA_2A-2A-14A	CA_n260H	14A	n260A	No
	DC_14A_n260G	CA_2A-2A-14A	CA_n260H	14A	CA_n260G	No
	DC_14A_n260H	CA_2A-2A-14A	CA_n260H	14A	CA_n260H	No
DC_2A-2A-14A_n260I	DC_2A_n260A	CA_2A-2A-14A	CA_n260I	2A	n260A	No
	DC_2A_n260G	CA_2A-2A-14A	CA_n260I	2A	CA_n260G	No

EN-DC configuration	Uplink EN-DC Configuration	E-UTRA downlink configuration	NR downlink configuration	E-UTRA uplink configuration	NR uplink configuration	Applicable for protocol testing (Note 1)
	DC_2A_n260H	CA_2A-2A-14A	CA_n260I	2A	CA_n260H	No
	DC_2A_n260I	CA_2A-2A-14A	CA_n260I	2A	CA_n260I	No
	DC_14A_n260A	CA_2A-2A-14A	CA_n260I	14A	n260A	No
	DC_14A_n260G	CA_2A-2A-14A	CA_n260I	14A	CA_n260G	No
	DC_14A_n260H	CA_2A-2A-14A	CA_n260I	14A	CA_n260H	No
	DC_14A_n260I	CA_2A-2A-14A	CA_n260I	14A	CA_n260I	No
DC_2A-30A_n260A	DC_2A_n260A	CA_2A-30A	n260A	2A	n260A	No
	DC_30A_n260A	CA_2A-30A	n260A	30A	n260A	No
DC_2A-66A_n257A	DC_2A_n257A	CA_2A-66A	n257A	2A	n257A	No
	DC_66A_n257A	CA_2A-66A	n257A	66A	n257A	No
DC_2A-66A_n260A	DC_2A_n260A	CA_2A-66A	n260A	2A	n260A	No
	DC_66A_n260A	CA_2A-66A	n260A	66A	n260A	No
DC_3A-18A_n257A	DC_3A_n257A	CA_3A-18A	n257A	3A	n257A	No
	DC_18A_n257A	CA_3A-18A	n257A	18A	n257A	No
DC_3A-19A_n257A	DC_3A_n257A	CA_3A-19A	n257A	3A	n257A	No
	DC_19A_n257A	CA_3A-19A	n257A	19A	n257A	No
DC_3A-19A_n257G	DC_3A_n257A	CA_3A-19A	CA_n257G	3A	n257A	No
	DC_3A_n257D	CA_3A-19A	CA_n257G	3A	CA_n257D	No
	DC_3A_n257G	CA_3A-19A	CA_n257G	3A	CA_n257G	No
	DC_19A_n257A	CA_3A-19A	CA_n257G	19A	n257A	No
	DC_19A_n257D	CA_3A-19A	CA_n257G	19A	CA_n257D	No
DC_3A-19A_n257H	DC_3A_n257A	CA_3A-19A	CA_n257H	3A	n257A	No
	DC_3A_n257D	CA_3A-19A	CA_n257H	3A	CA_n257D	No
	DC_3A_n257G	CA_3A-19A	CA_n257H	3A	CA_n257G	No
	DC_3A_n257H	CA_3A-19A	CA_n257H	3A	CA_n257H	No
	DC_19A_n257A	CA_3A-19A	CA_n257H	19A	n257A	No
	DC_19A_n257D	CA_3A-19A	CA_n257H	19A	CA_n257D	No
DC_3A-19A_n257I	DC_3A_n257A	CA_3A-19A	CA_n257I	3A	n257A	No
	DC_3A_n257D	CA_3A-19A	CA_n257I	3A	CA_n257D	No
	DC_3A_n257G	CA_3A-19A	CA_n257I	3A	CA_n257G	No
	DC_3A_n257H	CA_3A-19A	CA_n257I	3A	CA_n257H	No
	DC_3A_n257I	CA_3A-19A	CA_n257I	3A	CA_n257I	No
	DC_19A_n257A	CA_3A-19A	CA_n257I	19A	n257A	No
DC_3A-21A_n257A	DC_3A_n257A	CA_3A-21A	n257A	3A	n257A	No
	DC_21A_n257A	CA_3A-21A	n257A	21A	n257A	No
DC_3A-21A_n257G	DC_3A_n257A	CA_3A-21A	CA_n257G	3A	n257A	No
	DC_3A_n257D	CA_3A-21A	CA_n257G	3A	CA_n257D	No
	DC_3A_n257G	CA_3A-21A	CA_n257G	3A	CA_n257G	No
	DC_21A_n257A	CA_3A-21A	CA_n257G	21A	n257A	No

EN-DC configuration	Uplink EN-DC Configuration	E-UTRA downlink configuration	NR downlink configuration	E-UTRA uplink configuration	NR uplink configuration	Applicable for protocol testing (Note 1)
DC_3A-21A_n257H	DC_21A_n257D	CA_3A-21A	CA_n257G	21A	CA_n257D	No
	DC_3A_n257A	CA_3A-21A	CA_n257H	3A	n257A	No
	DC_3A_n257D	CA_3A-21A	CA_n257H	3A	CA_n257D	No
	DC_3A_n257G	CA_3A-21A	CA_n257H	3A	CA_n257G	No
	DC_3A_n257H	CA_3A-21A	CA_n257H	3A	CA_n257H	No
	DC_21A_n257A	CA_3A-21A	CA_n257H	21A	n257A	No
DC_3A-21A_n257I	DC_21A_n257D	CA_3A-21A	CA_n257H	21A	CA_n257D	No
	DC_3A_n257A	CA_3A-21A	CA_n257I	3A	n257A	No
	DC_3A_n257D	CA_3A-21A	CA_n257I	3A	CA_n257D	No
	DC_3A_n257G	CA_3A-21A	CA_n257I	3A	CA_n257G	No
	DC_3A_n257H	CA_3A-21A	CA_n257I	3A	CA_n257H	No
	DC_3A_n257I	CA_3A-21A	CA_n257I	3A	CA_n257I	No
DC_3A-41A_n257A	DC_21A_n257A	CA_3A-21A	CA_n257I	21A	n257A	No
	DC_21A_n257D	CA_3A-21A	CA_n257I	21A	CA_n257D	No
DC_3A-41A_n257A	DC_3A_n257A	CA_3A-41A	n257A	3A	n257A	No
	DC_41A_n257A	CA_3A-41A	n257A	41A	n257A	No
DC_3A-42A_n257A	DC_3A_n257A	CA_3A-42A	n257A	3A	n257A	No
	DC_42A_n257A	CA_3A-42A	n257A	42A	n257A	No
DC_3A-42A_n257G	DC_3A_n257A	CA_3A-42A	CA_n257G	3A	n257A	No
	DC_3A_n257D	CA_3A-42A	CA_n257G	3A	CA_n257D	No
	DC_3A_n257G	CA_3A-42A	CA_n257G	3A	CA_n257G	No
	DC_42A_n257A	CA_3A-42A	CA_n257G	42A	n257A	No
	DC_42A_n257D	CA_3A-42A	CA_n257G	42A	CA_n257D	No
DC_3A-42A_n257H	DC_3A_n257A	CA_3A-42A	CA_n257H	3A	n257A	No
	DC_3A_n257D	CA_3A-42A	CA_n257H	3A	CA_n257D	No
	DC_3A_n257G	CA_3A-42A	CA_n257H	3A	CA_n257G	No
	DC_3A_n257H	CA_3A-42A	CA_n257H	3A	CA_n257H	No
	DC_42A_n257A	CA_3A-42A	CA_n257H	42A	n257A	No
	DC_42A_n257D	CA_3A-42A	CA_n257H	42A	CA_n257D	No
DC_3A-42A_n257I	DC_3A_n257A	CA_3A-42A	CA_n257I	3A	n257A	No
	DC_3A_n257D	CA_3A-42A	CA_n257I	3A	CA_n257D	No
	DC_3A_n257G	CA_3A-42A	CA_n257I	3A	CA_n257G	No
	DC_3A_n257H	CA_3A-42A	CA_n257I	3A	CA_n257H	No
	DC_3A_n257I	CA_3A-42A	CA_n257I	3A	CA_n257I	No
	DC_42A_n257A	CA_3A-42A	CA_n257I	42A	n257A	No
	DC_42A_n257D	CA_3A-42A	CA_n257I	42A	CA_n257D	No
DC_3A-42C_n257A	DC_3A_n257A	CA_3A-42C	n257A	3A	n257A	No
	DC_42A_n257A	CA_3A-42C	n257A	42A	n257A	No
DC_3A-42C_n257G	DC_3A_n257A	CA_3A-42C	CA_n257G	3A	n257A	No
	DC_3A_n257D	CA_3A-42C	CA_n257G	3A	CA_n257D	No

EN-DC configuration	Uplink EN-DC Configuration	E-UTRA downlink configuration	NR downlink configuration	E-UTRA uplink configuration	NR uplink configuration	Applicable for protocol testing (Note 1)
	DC_3A_n257G	CA_3A-42C	CA_n257G	3A	CA_n257G	No
	DC_42A_n257A	CA_3A-42C	CA_n257G	42A	n257A	No
	DC_42A_n257D	CA_3A-42C	CA_n257G	42A	CA_n257D	No
DC_3A-42C_n257H	DC_3A_n257A	CA_3A-42C	CA_n257H	3A	n257A	No
	DC_3A_n257D	CA_3A-42C	CA_n257H	3A	CA_n257D	No
	DC_3A_n257G	CA_3A-42C	CA_n257H	3A	CA_n257G	No
	DC_3A_n257H	CA_3A-42C	CA_n257H	3A	CA_n257H	No
	DC_42A_n257A	CA_3A-42C	CA_n257H	42A	n257A	No
	DC_42A_n257D	CA_3A-42C	CA_n257H	42A	CA_n257D	No
	DC_42A_n257G	CA_3A-42C	CA_n257H	42A	CA_n257G	No
DC_3A-42C_n257I	DC_3A_n257A	CA_3A-42C	CA_n257I	3A	n257A	No
	DC_3A_n257D	CA_3A-42C	CA_n257I	3A	CA_n257D	No
	DC_3A_n257G	CA_3A-42C	CA_n257I	3A	CA_n257G	No
	DC_3A_n257H	CA_3A-42C	CA_n257I	3A	CA_n257H	No
	DC_3A_n257I	CA_3A-42C	CA_n257I	3A	CA_n257I	No
	DC_42A_n257A	CA_3A-42C	CA_n257I	42A	n257A	No
	DC_42A_n257D	CA_3A-42C	CA_n257I	42A	CA_n257D	No
DC_3A-42D_n257G	DC_3A_n257A	CA_3A-42D	CA_n257G	3A	n257A	No
	DC_3A_n257D	CA_3A-42D	CA_n257G	3A	CA_n257D	No
	DC_3A_n257G	CA_3A-42D	CA_n257G	3A	CA_n257G	No
	DC_42A_n257A	CA_3A-42D	CA_n257G	42A	n257A	No
	DC_42A_n257D	CA_3A-42D	CA_n257G	42A	CA_n257D	No
DC_3A-42D_n257H	DC_3A_n257A	CA_3A-42D	CA_n257H	3A	n257A	No
	DC_3A_n257D	CA_3A-42D	CA_n257H	3A	CA_n257D	No
	DC_3A_n257G	CA_3A-42D	CA_n257H	3A	CA_n257G	No
	DC_3A_n257H	CA_3A-42D	CA_n257H	3A	CA_n257H	No
	DC_42A_n257A	CA_3A-42D	CA_n257H	42A	n257A	No
	DC_42A_n257D	CA_3A-42D	CA_n257H	42A	CA_n257D	No
DC_3A-42D_n257I	DC_3A_n257A	CA_3A-42D	CA_n257I	3A	n257A	No
	DC_3A_n257D	CA_3A-42D	CA_n257I	3A	CA_n257D	No
	DC_3A_n257G	CA_3A-42D	CA_n257I	3A	CA_n257G	No
	DC_3A_n257H	CA_3A-42D	CA_n257I	3A	CA_n257H	No
	DC_3A_n257I	CA_3A-42D	CA_n257I	3A	CA_n257I	No
	DC_42A_n257A	CA_3A-42D	CA_n257I	42A	n257A	No
	DC_42A_n257D	CA_3A-42D	CA_n257I	42A	CA_n257D	No
DC_3A-42E_n257G	DC_3A_n257A	CA_3A-42E	CA_n257G	3A	n257A	No
	DC_3A_n257D	CA_3A-42E	CA_n257G	3A	CA_n257D	No
	DC_3A_n257G	CA_3A-42E	CA_n257G	3A	CA_n257G	No
	DC_42A_n257A	CA_3A-42E	CA_n257G	42A	n257A	No
	DC_42A_n257D	CA_3A-42E	CA_n257G	42A	CA_n257D	No
DC_3A-42E_n257H	DC_3A_n257A	CA_3A-42E	CA_n257H	3A	n257A	No



EN-DC configuration	Uplink EN-DC Configuration	E-UTRA downlink configuration	NR downlink configuration	E-UTRA uplink configuration	NR uplink configuration	Applicable for protocol testing (Note 1)
	DC_3A_n257D	CA_3A-42E	CA_n257H	3A	CA_n257D	No
	DC_3A_n257G	CA_3A-42E	CA_n257H	3A	CA_n257G	No
	DC_3A_n257H	CA_3A-42E	CA_n257H	3A	CA_n257H	No
	DC_42A_n257A	CA_3A-42E	CA_n257H	42A	n257A	No
	DC_42A_n257D	CA_3A-42E	CA_n257H	42A	CA_n257D	No
DC_3A-42E_n257I	DC_3A_n257A	CA_3A-42E	CA_n257I	3A	n257A	No
	DC_3A_n257D	CA_3A-42E	CA_n257I	3A	CA_n257D	No
	DC_3A_n257G	CA_3A-42E	CA_n257I	3A	CA_n257G	No
	DC_3A_n257H	CA_3A-42E	CA_n257I	3A	CA_n257H	No
	DC_3A_n257I	CA_3A-42E	CA_n257I	3A	CA_n257I	No
	DC_42A_n257A	CA_3A-42E	CA_n257I	42A	n257A	No
	DC_42A_n257D	CA_3A-42E	CA_n257I	42A	CA_n257D	No
DC_5A-7A_n257A	DC_5A_n257A	CA_5A-7A	n257A	5A	n257A	No
	DC_7A_n257A	CA_5A-7A	n257A	7A	n257A	No
DC_5A-30A_n260A	DC_5A_n260A	CA_5A-30A	n260A	5A	n260A	No
	DC_30A_n260A	CA_5A-30A	n260A	30A	n260A	No
DC_5A-66A_n257A	DC_5A_n257A	CA_5A-66A	n257A	5A	n257A	No
	DC_66A_n257A	CA_5A-66A	n257A	66A	n257A	No
DC_5A-66A_n260A	DC_5A_n260A	CA_5A-66A	n260A	5A	n260A	No
	DC_66A_n260A	CA_5A-66A	n260A	66A	n260A	No
DC_12A-30A_n260A	DC_12A_n260A	CA_12A-30A	n260A	12A	n260A	No
	DC_30A_n260A	CA_12A-30A	n260A	30A	n260A	No
DC_12A-66A_n260A	DC_12A_n260A	CA_12A-66A	n260A	12A	n260A	No
	DC_66A_n260A	CA_12A-66A	n260A	66A	n260A	No
DC_14A-30A_n260A	DC_14A_n260A	CA_14A-30A	n260A	14A	n260A	No
	DC_30A_n260A	CA_14A-30A	n260A	30A	n260A	No
DC_14A-30A_n260G	DC_14A_n260A	CA_14A-30A	CA_n260G	14A	n260A	No
	DC_14A_n260G	CA_14A-30A	CA_n260G	14A	CA_n260G	No
	DC_30A_n260A	CA_14A-30A	CA_n260G	30A	n260A	No
	DC_30A_n260G	CA_14A-30A	CA_n260G	30A	CA_n260G	No
DC_14A-30A_n260H	DC_14A_n260A	CA_14A-30A	CA_n260H	14A	n260A	No
	DC_14A_n260G	CA_14A-30A	CA_n260H	14A	CA_n260G	No
	DC_14A_n260H	CA_14A-30A	CA_n260H	14A	CA_n260H	No
	DC_30A_n260A	CA_14A-30A	CA_n260H	30A	n260A	No
	DC_30A_n260G	CA_14A-30A	CA_n260H	30A	CA_n260G	No
	DC_30A_n260H	CA_14A-30A	CA_n260H	30A	CA_n260H	No
DC_14A-30A_n260I	DC_14A_n260A	CA_14A-30A	CA_n260I	14A	n260A	No
	DC_14A_n260G	CA_14A-30A	CA_n260I	14A	CA_n260G	No
	DC_14A_n260H	CA_14A-30A	CA_n260I	14A	CA_n260H	No
	DC_14A_n260I	CA_14A-30A	CA_n260I	14A	CA_n260I	No

EN-DC configuration	Uplink EN-DC Configuration	E-UTRA downlink configuration	NR downlink configuration	E-UTRA uplink configuration	NR uplink configuration	Applicable for protocol testing (Note 1)
	DC_30A_n260A	CA_14A-30A	CA_n260I	30A	n260A	No
	DC_30A_n260G	CA_14A-30A	CA_n260I	30A	CA_n260G	No
	DC_30A_n260H	CA_14A-30A	CA_n260I	30A	CA_n260H	No
	DC_30A_n260I	CA_14A-30A	CA_n260I	30A	CA_n260I	No
DC_14A-66A_n260A	DC_14A_n260A	CA_14A-66A	n260A	14A	n260A	No
	DC_66A_n260A	CA_14A-66A	n260A	66A	n260A	No
DC_14A-66A_n260G	DC_14A_n260A	CA_14A-66A	CA_n260G	14A	n260A	No
	DC_14A_n260G	CA_14A-66A	CA_n260G	14A	CA_n260G	No
	DC_66A_n260A	CA_14A-66A	CA_n260G	66A	n260A	No
	DC_66A_n260G	CA_14A-66A	CA_n260G	66A	CA_n260G	No
DC_14A-66A_n260H	DC_14A_n260A	CA_14A-66A	CA_n260H	14A	n260A	No
	DC_14A_n260G	CA_14A-66A	CA_n260H	14A	CA_n260G	No
	DC_14A_n260H	CA_14A-66A	CA_n260H	14A	CA_n260H	No
	DC_66A_n260A	CA_14A-66A	CA_n260H	66A	n260A	No
	DC_66A_n260G	CA_14A-66A	CA_n260H	66A	CA_n260G	No
	DC_66A_n260H	CA_14A-66A	CA_n260H	66A	CA_n260H	No
DC_14A-66A_n260I	DC_14A_n260A	CA_14A-66A	CA_n260I	14A	n260A	No
	DC_14A_n260G	CA_14A-66A	CA_n260I	14A	CA_n260G	No
	DC_14A_n260H	CA_14A-66A	CA_n260I	14A	CA_n260H	No
	DC_14A_n260I	CA_14A-66A	CA_n260I	14A	CA_n260I	No
	DC_66A_n260A	CA_14A-66A	CA_n260I	66A	n260A	No
	DC_66A_n260G	CA_14A-66A	CA_n260I	66A	CA_n260G	No
	DC_66A_n260H	CA_14A-66A	CA_n260I	66A	CA_n260H	No
DC_14A-66A-66A_n260A	DC_14A_n260A	CA_14A-66A-66A	n260A	14A	n260A	No
	DC_66A_n260A	CA_14A-66A-66A	n260A	66A	n260A	No
DC_14A-66A-66a_n260G	DC_14A_n260A	CA_14A-66A-66A	CA_n260G	14A	n260A	No
	DC_14A_n260G	CA_14A-66A-66A	CA_n260G	14A	CA_n260G	No
	DC_66A_n260A	CA_14A-66A-66A	CA_n260G	66A	n260A	No
	DC_66A_n260G	CA_14A-66A-66A	CA_n260G	66A	CA_n260G	No
DC_14A-66A-66a_n260H	DC_14A_n260A	CA_14A-66A-66A	CA_n260H	14A	n260A	No
	DC_14A_n260G	CA_14A-66A-66A	CA_n260H	14A	CA_n260G	No

EN-DC configuration	Uplink EN-DC Configuration	E-UTRA downlink configuration	NR downlink configuration	E-UTRA uplink configuration	NR uplink configuration	Applicable for protocol testing (Note 1)
	DC_14A_n260H	CA_14A-66A-66A	CA_n260H	14A	CA_n260H	No
	DC_66A_n260A	CA_14A-66A-66A	CA_n260H	66A	n260A	No
	DC_66A_n260G	CA_14A-66A-66A	CA_n260H	66A	CA_n260G	No
	DC_66A_n260H	CA_14A-66A-66A	CA_n260H	66A	CA_n260H	No
DC_14A-66A-66A_n260I	DC_14A_n260A	CA_14A-66A-66A	CA_n260I	14A	n260A	No
	DC_14A_n260G	CA_14A-66A-66A	CA_n260I	14A	CA_n260G	No
	DC_14A_n260H	CA_14A-66A-66A	CA_n260I	14A	CA_n260H	No
	DC_14A_n260I	CA_14A-66A-66A	CA_n260I	14A	CA_n260I	No
	DC_66A_n260A	CA_14A-66A-66A	CA_n260I	66A	n260A	No
	DC_66A_n260G	CA_14A-66A-66A	CA_n260I	66A	CA_n260G	No
	DC_66A_n260H	CA_14A-66A-66A	CA_n260I	66A	CA_n260H	No
	DC_66A_n260I	CA_14A-66A-66A	CA_n260I	66A	CA_n260I	No
DC_19A-21A_n257A	DC_19A_n257A	CA_19A-21A	n257A	19A	n257A	No
	DC_21A_n257A	CA_19A-21A	n257A	21A	n257A	No
DC_19A-21A_n257G	DC_19A_n257A	CA_19A-21A	CA_n257G	19A	n257A	No
	DC_19A_n257D	CA_19A-21A	CA_n257G	19A	CA_n257D	No
	DC_21A_n257A	CA_19A-21A	CA_n257G	21A	n257A	No
	DC_21A_n257D	CA_19A-21A	CA_n257G	21A	CA_n257D	No
	DC_21A_n257G	CA_19A-21A	CA_n257G	21A	CA_n257G	No
DC_19A-21A_n257H	DC_19A_n257A	CA_19A-21A	CA_n257H	19A	n257A	No
	DC_19A_n257D	CA_19A-21A	CA_n257H	19A	CA_n257D	No
	DC_21A_n257A	CA_19A-21A	CA_n257H	21A	n257A	No
	DC_21A_n257D	CA_19A-21A	CA_n257H	21A	CA_n257D	No
	DC_21A_n257G	CA_19A-21A	CA_n257H	21A	CA_n257G	No
	DC_21A_n257H	CA_19A-21A	CA_n257H	21A	CA_n257H	No
DC_19A-21A_n257I	DC_19A_n257A	CA_19A-21A	CA_n257I	19A	n257A	No
	DC_19A_n257D	CA_19A-21A	CA_n257I	19A	CA_n257D	No
	DC_21A_n257A	CA_19A-21A	CA_n257I	21A	n257A	No
	DC_21A_n257D	CA_19A-21A	CA_n257I	21A	CA_n257D	No

EN-DC configuration	Uplink EN-DC Configuration	E-UTRA downlink configuration	NR downlink configuration	E-UTRA uplink configuration	NR uplink configuration	Applicable for protocol testing (Note 1)
	DC_21A_n257G	CA_19A-21A	CA_n257I	21A	CA_n257G	No
	DC_21A_n257H	CA_19A-21A	CA_n257I	21A	CA_n257H	No
	DC_21A_n257I	CA_19A-21A	CA_n257I	21A	CA_n257I	No
DC_19A-42A_n257A	DC_19A_n257A	CA_19A-42A	n257A	19A	n257A	No
	DC_42A_n257A	CA_19A-42A	n257A	42A	n257A	No
DC_19A-42A_n257G	DC_19A_n257A	CA_19A-42A	CA_n257G	19A	n257A	No
	DC_19A_n257D	CA_19A-42A	CA_n257G	19A	CA_n257D	No
	DC_19A_n257G	CA_19A-42A	CA_n257G	19A	CA_n257G	No
	DC_42A_n257A	CA_19A-42A	CA_n257G	42A	n257A	No
	DC_42A_n257D	CA_19A-42A	CA_n257G	42A	CA_n257D	No
	DC_42A_n257G	CA_19A-42A	CA_n257G	42A	CA_n257G	No
DC_19A-42A_n257H	DC_19A_n257A	CA_19A-42A	CA_n257H	19A	n257A	No
	DC_19A_n257D	CA_19A-42A	CA_n257H	19A	CA_n257D	No
	DC_19A_n257G	CA_19A-42A	CA_n257H	19A	CA_n257G	No
	DC_19A_n257H	CA_19A-42A	CA_n257H	19A	CA_n257H	No
	DC_42A_n257A	CA_19A-42A	CA_n257H	42A	n257A	No
	DC_42A_n257D	CA_19A-42A	CA_n257H	42A	CA_n257D	No
	DC_42A_n257G	CA_19A-42A	CA_n257H	42A	CA_n257G	No
	DC_42A_n257H	CA_19A-42A	CA_n257H	42A	CA_n257H	No
DC_19A-42A_n257I	DC_19A_n257A	CA_19A-42A	CA_n257I	19A	n257A	No
	DC_19A_n257D	CA_19A-42A	CA_n257I	19A	CA_n257D	No
	DC_19A_n257G	CA_19A-42A	CA_n257I	19A	CA_n257G	No
	DC_19A_n257H	CA_19A-42A	CA_n257I	19A	CA_n257H	No
	DC_19A_n257I	CA_19A-42A	CA_n257I	19A	CA_n257I	No
	DC_42A_n257A	CA_19A-42A	CA_n257I	42A	n257A	No
	DC_42A_n257D	CA_19A-42A	CA_n257I	42A	CA_n257D	No
	DC_42A_n257G	CA_19A-42A	CA_n257I	42A	CA_n257G	No
	DC_42A_n257H	CA_19A-42A	CA_n257I	42A	CA_n257H	No
	DC_42A_n257I	CA_19A-42A	CA_n257I	42A	CA_n257I	No
DC_19A-42C_n257A	DC_19A_n257A	CA_19A-42C	n257A	19A	n257A	No
	DC_42A_n257A	CA_19A-42C	n257A	42A	n257A	No
DC_19A-42C_n257G	DC_19A_n257A	CA_19A-42C	CA_n257G	19A	n257A	No
	DC_19A_n257D	CA_19A-42C	CA_n257G	19A	CA_n257D	No
	DC_19A_n257G	CA_19A-42C	CA_n257G	19A	CA_n257G	No
	DC_42A_n257A	CA_19A-42C	CA_n257G	42A	n257A	No
	DC_42A_n257D	CA_19A-42C	CA_n257G	42A	CA_n257D	No
	DC_42A_n257G	CA_19A-42C	CA_n257G	42A	CA_n257G	No
DC_19A-42C_n257H	DC_19A_n257A	CA_19A-42C	CA_n257H	19A	n257A	No
	DC_19A_n257D	CA_19A-42C	CA_n257H	19A	CA_n257D	No
	DC_19A_n257G	CA_19A-42C	CA_n257H	19A	CA_n257G	No

EN-DC configuration	Uplink EN-DC Configuration	E-UTRA downlink configuration	NR downlink configuration	E-UTRA uplink configuration	NR uplink configuration	Applicable for protocol testing (Note 1)
	DC_19A_n257H	CA_19A-42C	CA_n257H	19A	CA_n257H	No
	DC_42A_n257A	CA_19A-42C	CA_n257H	42A	n257A	No
	DC_42A_n257D	CA_19A-42C	CA_n257H	42A	CA_n257D	No
	DC_42A_n257G	CA_19A-42C	CA_n257H	42A	CA_n257G	No
	DC_42A_n257H	CA_19A-42C	CA_n257H	42A	CA_n257H	No
DC_19A-42C_n257I	DC_19A_n257A	CA_19A-42C	CA_n257I	19A	n257A	No
	DC_19A_n257D	CA_19A-42C	CA_n257I	19A	CA_n257D	No
	DC_19A_n257G	CA_19A-42C	CA_n257I	19A	CA_n257G	No
	DC_19A_n257H	CA_19A-42C	CA_n257I	19A	CA_n257H	No
	DC_19A_n257I	CA_19A-42C	CA_n257I	19A	CA_n257I	No
	DC_42A_n257A	CA_19A-42C	CA_n257I	42A	n257A	No
	DC_42A_n257D	CA_19A-42C	CA_n257I	42A	CA_n257D	No
	DC_42A_n257G	CA_19A-42C	CA_n257I	42A	CA_n257G	No
	DC_42A_n257H	CA_19A-42C	CA_n257I	42A	CA_n257H	No
DC_21A-42A_n257A	DC_21A_n257A	CA_21A-42A	n257A	21A	n257A	No
	DC_42A_n257A	CA_21A-42A	n257A	42A	n257A	No
DC_21A-42A_n257G	DC_21A_n257A	CA_21A-42A	CA_n257G	21A	n257A	No
	DC_21A_n257D	CA_21A-42A	CA_n257G	21A	CA_n257D	No
	DC_42A_n257A	CA_21A-42A	CA_n257G	42A	n257A	No
	DC_42A_n257D	CA_21A-42A	CA_n257G	42A	CA_n257D	No
	DC_21A_n257G	CA_21A-42A	CA_n257G	21A	CA_n257G	No
DC_21A-42A_n257H	DC_21A_n257A	CA_21A-42A	CA_n257H	21A	n257A	No
	DC_21A_n257D	CA_21A-42A	CA_n257H	21A	CA_n257D	No
	DC_42A_n257A	CA_21A-42A	CA_n257H	42A	n257A	No
	DC_42A_n257D	CA_21A-42A	CA_n257H	42A	CA_n257D	No
	DC_21A_n257G	CA_21A-42A	CA_n257H	21A	CA_n257G	No
	DC_21A_n257H	CA_21A-42A	CA_n257H	21A	CA_n257H	No
DC_21A-42A_n257I	DC_21A_n257A	CA_21A-42A	CA_n257I	21A	n257A	No
	DC_21A_n257D	CA_21A-42A	CA_n257I	21A	CA_n257D	No
	DC_42A_n257A	CA_21A-42A	CA_n257I	42A	n257A	No
	DC_42A_n257D	CA_21A-42A	CA_n257I	42A	CA_n257D	No
	DC_21A_n257G	CA_21A-42A	CA_n257I	21A	CA_n257G	No
	DC_21A_n257H	CA_21A-42A	CA_n257I	21A	CA_n257H	No
	DC_21A_n257I	CA_21A-42A	CA_n257I	21A	CA_n257I	No
DC_21A-42C_n257A	DC_21A_n257A	CA_21A-42C	n257A	21A	n257A	No
	DC_42A_n257A	CA_21A-42C	n257A	42A	n257A	No
DC_21A-42C_n257G	DC_21A_n257A	CA_21A-42C	CA_n257G	21A	n257A	No
	DC_21A_n257D	CA_21A-42C	CA_n257G	21A	CA_n257D	No
	DC_42A_n257A	CA_21A-42C	CA_n257G	42A	n257A	No

EN-DC configuration	Uplink EN-DC Configuration	E-UTRA downlink configuration	NR downlink configuration	E-UTRA uplink configuration	NR uplink configuration	Applicable for protocol testing (Note 1)
	DC_42A_n257D	CA_21A-42C	CA_n257G	42A	CA_n257D	No
	DC_21A_n257G	CA_21A-42C	CA_n257G	21A	CA_n257G	No
DC_21A-42C_n257H	DC_21A_n257A	CA_21A-42C	CA_n257H	21A	n257A	No
	DC_21A_n257D	CA_21A-42C	CA_n257H	21A	CA_n257D	No
	DC_42A_n257A	CA_21A-42C	CA_n257H	42A	n257A	No
	DC_42A_n257D	CA_21A-42C	CA_n257H	42A	CA_n257D	No
	DC_21A_n257G	CA_21A-42C	CA_n257H	21A	CA_n257G	No
	DC_21A_n257H	CA_21A-42C	CA_n257H	21A	CA_n257H	No
DC_21A-42C_n257I	DC_21A_n257A	CA_21A-42C	CA_n257I	21A	n257A	No
	DC_21A_n257D	CA_21A-42C	CA_n257I	21A	CA_n257D	No
	DC_42A_n257A	CA_21A-42C	CA_n257I	42A	n257A	No
	DC_42A_n257D	CA_21A-42C	CA_n257I	42A	CA_n257D	No
	DC_21A_n257G	CA_21A-42C	CA_n257I	21A	CA_n257G	No
	DC_21A_n257H	CA_21A-42C	CA_n257I	21A	CA_n257H	No
	DC_21A_n257I	CA_21A-42C	CA_n257I	21A	CA_n257I	No

Note 1: Protocol testing is limited to EN-DC configurations with 1 CC E-UTRA and 1CC or 2CC NR configurations.

## 4.3.1.5.1.4

## Inter-band EN-DC configurations including FR2 (four bands)

Table 4.3.1.5.1.4-1: Inter-band EN-DC configurations including FR2 (four bands)

EN-DC Configuration	Uplink EN-DC configuration	E-UTRA downlink configuration	NR downlink configuration	E-UTRA uplink configuration	NR uplink configuration	Applicable for protocol testing (Note 1)
DC_1A-3A-18A_n257A	DC_1A_n257A	CA_1A-3A-18A	n257A	1A	n257A	No
	DC_3A_n257A	CA_1A-3A-18A	n257A	3A	n257A	No
	DC_18A_n257A	CA_1A-3A-18A	n257A	18A	n257A	No
DC_1A-3A-19A_n257A	DC_1A_n257A	CA_1A-3A-19A	n257A	1A	n257A	No
	DC_3A_n257A	CA_1A-3A-19A	n257A	3A	n257A	No
	DC_19A_n257A	CA_1A-3A-19A	n257A	19A	n257A	No
DC_1A-3A-19A_n257G	DC_1A_n257A	CA_1A-3A-19A	CA_n257G	1A	n257A	No
	DC_3A_n257A	CA_1A-3A-19A	CA_n257G	3A	n257A	No
	DC_3A_n257A	CA_1A-3A-19A	CA_n257G	3A	n257A	No
	DC_3A_n257G	CA_1A-3A-19A	CA_n257G	3A	CA_n257G	No
DC_1A-3A-19A_n257H	DC_1A_n257A	CA_1A-3A-19A	CA_n257G	19A	n257A	No
	DC_19A_n257A	CA_1A-3A-19A	CA_n257G	19A	n257A	No
	DC_3A_n257H	CA_1A-3A-19A	CA_n257H	3A	CA_n257H	No
	DC_3A_n257H	CA_1A-3A-19A	CA_n257H	3A	CA_n257H	No
DC_1A-3A-19A_n257I	DC_1A_n257A	CA_1A-3A-19A	CA_n257H	1A	n257A	No
	DC_3A_n257A	CA_1A-3A-19A	CA_n257H	3A	n257A	No
	DC_3A_n257A	CA_1A-3A-19A	CA_n257H	3A	n257A	No
	DC_3A_n257G	CA_1A-3A-19A	CA_n257H	3A	CA_n257G	No
	DC_3A_n257H	CA_1A-3A-19A	CA_n257H	3A	CA_n257H	No
	DC_19A_n257A	CA_1A-3A-19A	CA_n257H	19A	n257A	No
DC_1A-3A-19A_n257I	DC_1A_n257A	CA_1A-3A-19A	CA_n257I	1A	n257A	No
	DC_3A_n257A	CA_1A-3A-19A	CA_n257I	3A	n257A	No
	DC_3A_n257A	CA_1A-3A-19A	CA_n257I	3A	n257A	No
	DC_3A_n257G	CA_1A-3A-19A	CA_n257I	3A	CA_n257G	No
	DC_3A_n257H	CA_1A-3A-19A	CA_n257I	3A	CA_n257H	No
	DC_3A_n257I	CA_1A-3A-19A	CA_n257I	3A	CA_n257I	No
DC_1A-3A-21A_n257A	DC_1A_n257A	CA_1A-3A-19A	CA_n257I	19A	n257A	No
	DC_19A_n257A	CA_1A-3A-19A	CA_n257I	19A	n257A	No
	DC_21A_n257A	CA_1A-3A-21A	n257A	21A	n257A	No
DC_1A-3A-21A_n257G	DC_1A_n257A	CA_1A-3A-21A	n257A	1A	n257A	No
	DC_3A_n257A	CA_1A-3A-21A	n257A	3A	n257A	No
	DC_21A_n257A	CA_1A-3A-21A	n257A	21A	n257A	No
DC_1A-3A-21A_n257G	DC_1A_n257A	CA_1A-3A-21A	CA_n257G	1A	n257A	No
	DC_3A_n257A	CA_1A-3A-21A	CA_n257G	3A	n257A	No
	DC_3A_n257G	CA_1A-3A-21A	CA_n257G	3A	CA_n257G	No
	DC_21A_n257A	CA_1A-3A-21A	CA_n257G	21A	n257A	No
DC_1A-3A-21A_n257H	DC_1A_n257A	CA_1A-3A-21A	CA_n257H	1A	n257A	No
	DC_3A_n257A	CA_1A-3A-21A	CA_n257H	3A	n257A	No
	DC_3A_n257G	CA_1A-3A-21A	CA_n257H	3A	CA_n257G	No
	DC_3A_n257H	CA_1A-3A-21A	CA_n257H	3A	CA_n257H	No
	DC_21A_n257A	CA_1A-3A-21A	CA_n257H	21A	n257A	No
DC_1A-3A-21A_n257I	DC_1A_n257A	CA_1A-3A-21A	CA_n257I	1A	n257A	No
	DC_3A_n257A	CA_1A-3A-21A	CA_n257I	3A	n257A	No
	DC_3A_n257G	CA_1A-3A-21A	CA_n257I	3A	CA_n257G	No
	DC_3A_n257H	CA_1A-3A-21A	CA_n257I	3A	CA_n257H	No
	DC_3A_n257I	CA_1A-3A-21A	CA_n257I	3A	CA_n257I	No
	DC_21A_n257A	CA_1A-3A-21A	CA_n257I	21A	n257A	No
DC_1A-3A-41A_n257A	DC_1A_n257A	CA_1A-3A-21A	CA_n257I	1A	n257A	No
	DC_3A_n257A	CA_1A-3A-21A	CA_n257I	3A	n257A	No
	DC_41A_n257A	CA_1A-3A-41A	n257A	41A	n257A	No
DC_1A-3A-42A_n257A	DC_1A_n257A	CA_1A-3A-41A	n257A	1A	n257A	No
	DC_3A_n257A	CA_1A-3A-41A	n257A	3A	n257A	No
	DC_42A_n257A	CA_1A-3A-42A	n257A	42A	n257A	No

EN-DC Configuration	Uplink EN-DC configuration	E-UTRA downlink configuration	NR downlink configuration	E-UTRA uplink configuration	NR uplink configuration	Applicable for protocol testing (Note 1)
DC_1A-3A-18A_n257A	DC_1A_n257A	CA_1A-3A-18A	n257A	1A	n257A	No
	DC_3A_n257A	CA_1A-3A-18A	n257A	3A	n257A	No
	DC_18A_n257A	CA_1A-3A-18A	n257A	18A	n257A	No
DC_1A-3A-42A_n257G	DC_1A_n257A	CA_1A-3A-42A	CA_n257G	1A	n257A	No
	DC_1A_n257G	CA_1A-3A-42A	CA_n257G	1A	CA_n257G	No
	DC_3A_n257A	CA_1A-3A-42A	CA_n257G	3A	n257A	No
	DC_3A_n257G	CA_1A-3A-42A	CA_n257G	3A	CA_n257G	No
DC_1A-3A-42A_n257H	DC_1A_n257A	CA_1A-3A-42A	CA_n257H	1A	n257A	No
	DC_1A_n257G	CA_1A-3A-42A	CA_n257H	1A	CA_n257G	No
	DC_1A_n257H	CA_1A-3A-42A	CA_n257H	1A	CA_n257H	No
	DC_3A_n257A	CA_1A-3A-42A	CA_n257H	3A	n257A	No
	DC_3A_n257G	CA_1A-3A-42A	CA_n257H	3A	CA_n257G	No
	DC_3A_n257H	CA_1A-3A-42A	CA_n257H	3A	CA_n257H	No
	DC_3A_n257I	CA_1A-3A-42A	CA_n257I	3A	CA_n257I	No
DC_1A-3A-42A_n257I	DC_1A_n257A	CA_1A-3A-42A	CA_n257I	1A	n257A	No
	DC_1A_n257G	CA_1A-3A-42A	CA_n257I	1A	CA_n257G	No
	DC_1A_n257H	CA_1A-3A-42A	CA_n257I	1A	CA_n257H	No
	DC_1A_n257I	CA_1A-3A-42A	CA_n257I	1A	CA_n257I	No
	DC_3A_n257A	CA_1A-3A-42A	CA_n257I	3A	n257A	No
	DC_3A_n257G	CA_1A-3A-42A	CA_n257I	3A	CA_n257G	No
	DC_3A_n257H	CA_1A-3A-42A	CA_n257I	3A	CA_n257H	No
DC_1A-3A-42C_n257A	DC_1A_n257A	CA_1A-3A-42C	n257A	1A	n257A	No
	DC_3A_n257A	CA_1A-3A-42C	n257A	3A	n257A	No
	DC_42A_n257A	CA_1A-3A-42C	n257A	42A	n257A	No
	DC_42A_n257G	CA_1A-3A-42C	CA_n257G	1A	n257A	No
DC_1A-3A-42C_n257G	DC_1A_n257A	CA_1A-3A-42C	CA_n257G	1A	CA_n257G	No
	DC_1A_n257G	CA_1A-3A-42C	CA_n257G	1A	CA_n257G	No
	DC_3A_n257A	CA_1A-3A-42C	CA_n257G	3A	n257A	No
	DC_3A_n257G	CA_1A-3A-42C	CA_n257G	3A	CA_n257G	No
DC_1A-3A-42C_n257H	DC_1A_n257A	CA_1A-3A-42C	CA_n257H	1A	n257A	No
	DC_1A_n257G	CA_1A-3A-42C	CA_n257H	1A	CA_n257G	No
	DC_1A_n257H	CA_1A-3A-42C	CA_n257H	1A	CA_n257H	No
	DC_3A_n257A	CA_1A-3A-42C	CA_n257H	3A	n257A	No
	DC_3A_n257G	CA_1A-3A-42C	CA_n257H	3A	CA_n257G	No
	DC_3A_n257H	CA_1A-3A-42C	CA_n257H	3A	CA_n257H	No
DC_1A-3A-42C_n257I	DC_1A_n257A	CA_1A-3A-42C	CA_n257I	1A	n257A	No
	DC_1A_n257G	CA_1A-3A-42C	CA_n257I	1A	CA_n257G	No
	DC_1A_n257H	CA_1A-3A-42C	CA_n257I	1A	CA_n257H	No
	DC_1A_n257I	CA_1A-3A-42C	CA_n257I	1A	CA_n257I	No
	DC_3A_n257A	CA_1A-3A-42C	CA_n257I	3A	n257A	No
	DC_3A_n257G	CA_1A-3A-42C	CA_n257I	3A	CA_n257G	No
	DC_3A_n257H	CA_1A-3A-42C	CA_n257I	3A	CA_n257H	No
DC_1A-3A-42D_n257G	DC_1A_n257A	CA_1A-3A-42D	CA_n257G	1A	n257A	No
	DC_1A_n257G	CA_1A-3A-42D	CA_n257G	1A	CA_n257G	No
	DC_3A_n257A	CA_1A-3A-42D	CA_n257G	3A	n257A	No
	DC_3A_n257G	CA_1A-3A-42D	CA_n257G	3A	CA_n257G	No
DC_1A-3A-42D_n257H	DC_1A_n257A	CA_1A-3A-42D	CA_n257H	1A	n257A	No
	DC_1A_n257G	CA_1A-3A-42D	CA_n257H	1A	CA_n257G	No
	DC_1A_n257H	CA_1A-3A-42D	CA_n257H	1A	CA_n257H	No
	DC_3A_n257A	CA_1A-3A-42D	CA_n257H	3A	n257A	No
	DC_3A_n257G	CA_1A-3A-42D	CA_n257H	3A	CA_n257G	No
	DC_3A_n257H	CA_1A-3A-42D	CA_n257H	3A	CA_n257H	No
DC_1A-3A-	DC_1A_n257A	CA_1A-3A-42D	CA_n257I	1A	n257A	No



EN-DC Configuration	Uplink EN-DC configuration	E-UTRA downlink configuration	NR downlink configuration	E-UTRA uplink configuration	NR uplink configuration	Applicable for protocol testing (Note 1)
DC_1A-3A-18A_n257A	DC_1A_n257A	CA_1A-3A-18A	n257A	1A	n257A	No
	DC_3A_n257A	CA_1A-3A-18A	n257A	3A	n257A	No
	DC_18A_n257A	CA_1A-3A-18A	n257A	18A	n257A	No
42D_n257I						
	DC_1A_n257G	CA_1A-3A-42D	CA_n257I	1A	CA_n257G	No
	DC_1A_n257H	CA_1A-3A-42D	CA_n257I	1A	CA_n257H	No
	DC_1A_n257I	CA_1A-3A-42D	CA_n257I	1A	CA_n257I	No
	DC_3A_n257A	CA_1A-3A-42D	CA_n257I	3A	n257A	No
	DC_3A_n257G	CA_1A-3A-42D	CA_n257I	3A	CA_n257G	No
	DC_3A_n257H	CA_1A-3A-42D	CA_n257I	3A	CA_n257H	No
DC_1A-19A-21A_n257A	DC_1A_n257A	CA_1A-19A-21A	n257A	1A	n257A	No
	DC_19A_n257A	CA_1A-19A-21A	n257A	19A	n257A	No
	DC_21A_n257A	CA_1A-19A-21A	n257A	21A	n257A	No
DC_1A-19A-21A_n257G	DC_1A_n257A	CA_1A-19A-21A	CA_n257G	1A	n257A	No
	DC_1A_n257G	CA_1A-19A-21A	CA_n257G	1A	CA_n257G	No
	DC_19A_n257A	CA_1A-19A-21A	CA_n257G	19A	n257A	No
	DC_21A_n257A	CA_1A-19A-21A	CA_n257G	21A	n257A	No
	DC_21A_n257G	CA_1A-19A-21A	CA_n257G	21A	CA_n257G	No
DC_1A-19A-21A_n257H	DC_1A_n257A	CA_1A-19A-21A	CA_n257H	1A	n257A	No
	DC_1A_n257G	CA_1A-19A-21A	CA_n257H	1A	CA_n257G	No
	DC_1A_n257H	CA_1A-19A-21A	CA_n257H	1A	CA_n257H	No
	DC_19A_n257A	CA_1A-19A-21A	CA_n257H	19A	n257A	No
	DC_21A_n257A	CA_1A-19A-21A	CA_n257H	21A	n257A	No
	DC_21A_n257G	CA_1A-19A-21A	CA_n257H	21A	CA_n257G	No
DC_1A-19A-21A_n257I	DC_1A_n257A	CA_1A-19A-21A	CA_n257I	1A	n257A	No
	DC_1A_n257G	CA_1A-19A-21A	CA_n257I	1A	CA_n257G	No
	DC_1A_n257H	CA_1A-19A-21A	CA_n257I	1A	CA_n257H	No
	DC_1A_n257I	CA_1A-19A-21A	CA_n257I	1A	CA_n257I	No
	DC_19A_n257A	CA_1A-19A-21A	CA_n257I	19A	n257A	No
	DC_21A_n257A	CA_1A-19A-21A	CA_n257I	21A	n257A	No
	DC_21A_n257G	CA_1A-19A-21A	CA_n257I	21A	CA_n257G	No
	DC_21A_n257H	CA_1A-19A-21A	CA_n257I	21A	CA_n257H	No
	DC_21A_n257I	CA_1A-19A-21A	CA_n257I	21A	CA_n257I	No
DC_1A-19A-42A_n257A	DC_1A_n257A	CA_1A-19A-42A	n257A	1A	n257A	No
	DC_19A_n257A	CA_1A-19A-42A	n257A	19A	n257A	No
	DC_42A_n257A	CA_1A-19A-42A	n257A	42A	n257A	No
DC_1A-19A-42A_n257G	DC_1A_n257A	CA_1A-19A-42A	CA_n257G	1A	n257A	No
	DC_1A_n257G	CA_1A-19A-42A	CA_n257G	1A	CA_n257G	No
	DC_19A_n257A	CA_1A-19A-42A	CA_n257G	19A	n257A	No
	DC_42A_n257A	CA_1A-19A-42A	CA_n257G	42A	n257A	No
DC_1A-19A-42A_n257H	DC_1A_n257A	CA_1A-19A-42A	CA_n257H	1A	n257A	No
	DC_1A_n257G	CA_1A-19A-42A	CA_n257H	1A	CA_n257G	No
	DC_1A_n257H	CA_1A-19A-42A	CA_n257H	1A	CA_n257H	No
	DC_19A_n257A	CA_1A-19A-42A	CA_n257H	19A	n257A	No
DC_1A-19A-42A_n257I	DC_1A_n257A	CA_1A-19A-42A	CA_n257I	1A	n257A	No
	DC_1A_n257G	CA_1A-19A-42A	CA_n257I	1A	CA_n257G	No
	DC_1A_n257H	CA_1A-19A-42A	CA_n257I	1A	CA_n257H	No
	DC_1A_n257I	CA_1A-19A-42A	CA_n257I	1A	CA_n257I	No
	DC_19A_n257A	CA_1A-19A-42A	CA_n257I	19A	n257A	No
DC_1A-19A-42A_n257I	DC_1A_n257A	CA_1A-19A-42A	CA_n257I	1A	n257A	No
	DC_1A_n257G	CA_1A-19A-42A	CA_n257I	1A	CA_n257G	No
	DC_1A_n257H	CA_1A-19A-42A	CA_n257I	1A	CA_n257H	No
	DC_1A_n257I	CA_1A-19A-42A	CA_n257I	1A	CA_n257I	No
	DC_19A_n257A	CA_1A-19A-42A	CA_n257I	19A	n257A	No
DC_1A-19A-	DC_1A_n257A	CA_1A-19A-42C	n257A	1A	n257A	No

EN-DC Configuration	Uplink EN-DC configuration	E-UTRA downlink configuration	NR downlink configuration	E-UTRA uplink configuration	NR uplink configuration	Applicable for protocol testing (Note 1)
DC_1A-3A-18A_n257A	DC_1A_n257A	CA_1A-3A-18A	n257A	1A	n257A	No
	DC_3A_n257A	CA_1A-3A-18A	n257A	3A	n257A	No
	DC_18A_n257A	CA_1A-3A-18A	n257A	18A	n257A	No
42C_n257A						
	DC_19A_n257A	CA_1A-19A-42C	n257A	19A	n257A	No
	DC_42A_n257A	CA_1A-19A-42C	n257A	42A	n257A	No
DC_1A-19A-42C_n257G	DC_1A_n257A	CA_1A-19A-42C	CA_n257G	1A	n257A	No
	DC_1A_n257G	CA_1A-19A-42C	CA_n257G	1A	CA_n257G	No
	DC_19A_n257A	CA_1A-19A-42C	CA_n257G	19A	n257A	No
DC_1A-19A-42C_n257H	DC_1A_n257A	CA_1A-19A-42C	CA_n257G	42A	n257A	No
	DC_1A_n257G	CA_1A-19A-42C	CA_n257H	1A	CA_n257G	No
	DC_1A_n257H	CA_1A-19A-42C	CA_n257H	1A	CA_n257H	No
DC_1A-19A-42C_n257H	DC_19A_n257A	CA_1A-19A-42C	CA_n257H	19A	n257A	No
	DC_42A_n257A	CA_1A-19A-42C	CA_n257H	42A	n257A	No
	DC_1A_n257A	CA_1A-19A-42C	CA_n257I	1A	n257A	No
	DC_1A_n257G	CA_1A-19A-42C	CA_n257I	1A	CA_n257G	No
DC_1A-19A-42C_n257I	DC_1A_n257H	CA_1A-19A-42C	CA_n257I	1A	CA_n257H	No
	DC_1A_n257I	CA_1A-19A-42C	CA_n257I	1A	CA_n257I	No
	DC_19A_n257A	CA_1A-19A-42C	CA_n257I	19A	n257A	No
DC_1A-21A-42A_n257A	DC_42A_n257A	CA_1A-19A-42C	CA_n257I	42A	n257A	No
	DC_1A_n257A	CA_1A-21A-42A	n257A	1A	n257A	No
	DC_21A_n257A	CA_1A-21A-42A	n257A	21A	n257A	No
DC_1A-21A-42A_n257A	DC_42A_n257A	CA_1A-21A-42A	n257A	42A	n257A	No
	DC_1A_n257A	CA_1A-21A-42A	CA_n257G	1A	n257A	No
	DC_21A_n257A	CA_1A-21A-42A	CA_n257G	21A	n257A	No
DC_1A-21A-42A_n257G	DC_1A_n257G	CA_1A-21A-42A	CA_n257G	1A	CA_n257G	No
	DC_21A_n257A	CA_1A-21A-42A	CA_n257G	21A	n257A	No
	DC_21A_n257G	CA_1A-21A-42A	CA_n257G	21A	CA_n257G	No
	DC_42A_n257A	CA_1A-21A-42A	CA_n257G	42A	n257A	No
	DC_42A_n257D	CA_1A-21A-42A	CA_n257G	42A	CA_n257D	No
	DC_1A_n257A	CA_1A-21A-42A	CA_n257H	1A	n257A	No
DC_1A-21A-42A_n257H	DC_1A_n257G	CA_1A-21A-42A	CA_n257H	1A	CA_n257G	No
	DC_1A_n257H	CA_1A-21A-42A	CA_n257H	1A	CA_n257H	No
	DC_21A_n257A	CA_1A-21A-42A	CA_n257H	21A	n257A	No
	DC_21A_n257G	CA_1A-21A-42A	CA_n257H	21A	CA_n257G	No
	DC_21A_n257H	CA_1A-21A-42A	CA_n257H	21A	CA_n257H	No
	DC_42A_n257A	CA_1A-21A-42A	CA_n257H	42A	n257A	No
	DC_42A_n257D	CA_1A-21A-42A	CA_n257H	42A	CA_n257D	No
DC_1A-21A-42A_n257I	DC_1A_n257A	CA_1A-21A-42A	CA_n257I	1A	n257A	No
	DC_1A_n257G	CA_1A-21A-42A	CA_n257I	1A	CA_n257G	No
	DC_1A_n257H	CA_1A-21A-42A	CA_n257I	1A	CA_n257H	No
	DC_1A_n257I	CA_1A-21A-42A	CA_n257I	1A	CA_n257I	No
	DC_21A_n257A	CA_1A-21A-42A	CA_n257I	21A	n257A	No
	DC_21A_n257G	CA_1A-21A-42A	CA_n257I	21A	CA_n257G	No
	DC_21A_n257H	CA_1A-21A-42A	CA_n257I	21A	CA_n257H	No
	DC_21A_n257I	CA_1A-21A-42A	CA_n257I	21A	CA_n257I	No
	DC_42A_n257A	CA_1A-21A-42A	CA_n257I	42A	n257A	No
DC_42A_n257D	CA_1A-21A-42A	CA_n257I	42A	CA_n257D	No	
DC_1A-21A-42C_n257A	DC_1A_n257A	CA_1A-21A-42C	n257A	1A	n257A	No
	DC_21A_n257A	CA_1A-21A-42C	n257A	21A	n257A	No
	DC_42A_n257A	CA_1A-21A-42C	n257A	42A	n257A	No
DC_1A-21A-42C_n257G	DC_1A_n257A	CA_1A-21A-42C	CA_n257G	1A	n257A	No
	DC_1A_n257G	CA_1A-21A-42C	CA_n257G	1A	CA_n257G	No

EN-DC Configuration	Uplink EN-DC configuration	E-UTRA downlink configuration	NR downlink configuration	E-UTRA uplink configuration	NR uplink configuration	Applicable for protocol testing (Note 1)
DC_1A-3A-18A_n257A	DC_1A_n257A	CA_1A-3A-18A	n257A	1A	n257A	No
	DC_3A_n257A	CA_1A-3A-18A	n257A	3A	n257A	No
	DC_18A_n257A	CA_1A-3A-18A	n257A	18A	n257A	No
	DC_21A_n257A	CA_1A-21A-42C	CA_n257G	21A	n257A	No
	DC_21A_n257G	CA_1A-21A-42C	CA_n257G	21A	CA_n257G	No
	DC_42A_n257A	CA_1A-21A-42C	CA_n257G	42A	n257A	No
	DC_42A_n257D	CA_1A-21A-42C	CA_n257G	42A	CA_n257D	No
DC_1A-21A-42C_n257H	DC_1A_n257A	CA_1A-21A-42C	CA_n257H	1A	n257A	No
	DC_1A_n257G	CA_1A-21A-42C	CA_n257H	1A	CA_n257G	No
	DC_1A_n257H	CA_1A-21A-42C	CA_n257H	1A	CA_n257H	No
	DC_21A_n257A	CA_1A-21A-42C	CA_n257H	21A	n257A	No
	DC_21A_n257G	CA_1A-21A-42C	CA_n257H	21A	CA_n257G	No
	DC_21A_n257H	CA_1A-21A-42C	CA_n257H	21A	CA_n257H	No
	DC_42A_n257A	CA_1A-21A-42C	CA_n257H	42A	n257A	No
DC_42A_n257D	CA_1A-21A-42C	CA_n257H	42A	CA_n257D	No	
DC_1A-21A-42C_n257I	DC_1A_n257A	CA_1A-21A-42C	CA_n257I	1A	n257A	No
	DC_1A_n257G	CA_1A-21A-42C	CA_n257I	1A	CA_n257G	No
	DC_1A_n257H	CA_1A-21A-42C	CA_n257I	1A	CA_n257H	No
	DC_1A_n257I	CA_1A-21A-42C	CA_n257I	1A	CA_n257I	No
	DC_21A_n257A	CA_1A-21A-42C	CA_n257I	21A	n257A	No
	DC_21A_n257G	CA_1A-21A-42C	CA_n257I	21A	CA_n257G	No
	DC_21A_n257H	CA_1A-21A-42C	CA_n257I	21A	CA_n257H	No
	DC_21A_n257I	CA_1A-21A-42C	CA_n257I	21A	CA_n257I	No
DC_42A_n257A	CA_1A-21A-42C	CA_n257I	42A	n257A	No	
DC_42A_n257D	CA_1A-21A-42C	CA_n257I	42A	CA_n257D	No	
DC_2A-2A-14A-66A_n260A	DC_2A_n260A	CA_2A-2A-14A-66A	n260A	2A	n260A	No
	DC_14A_n260A	CA_2A-2A-14A-66A	n260A	14A	n260A	No
	DC_66A_n260A	CA_2A-2A-14A-66A	n260A	66A	n260A	No
DC_2A-2A-14A-66A_n260G	DC_2A_n260A	CA_2A-2A-14A-66A	CA_n260G	2A	n260A	No
	DC_2A_n260G	CA_2A-2A-14A-66A	CA_n260G	2A	CA_n260G	No
	DC_14A_n260A	CA_2A-2A-14A-66A	CA_n260G	14A	n260A	No
	DC_14A_n260G	CA_2A-2A-14A-66A	CA_n260G	14A	CA_n260G	No
	DC_66A_n260A	CA_2A-2A-14A-66A	CA_n260G	66A	n260A	No
	DC_66A_n260G	CA_2A-2A-14A-66A	CA_n260G	66A	CA_n260G	No
DC_2A-2A-14A-66A_n260H	DC_2A_n260A	CA_2A-2A-14A-66A	CA_n260H	2A	n260A	No
	DC_2A_n260G	CA_2A-2A-14A-66A	CA_n260H	2A	CA_n260G	No
	DC_2A_n260H	CA_2A-2A-14A-66A	CA_n260H	2A	CA_n260H	No
	DC_14A_n260A	CA_2A-2A-14A-66A	CA_n260H	14A	n260A	No
	DC_14A_n260G	CA_2A-2A-14A-66A	CA_n260H	14A	CA_n260G	No
	DC_14A_n260H	CA_2A-2A-14A-66A	CA_n260H	14A	CA_n260H	No
	DC_66A_n260A	CA_2A-2A-14A-66A	CA_n260H	66A	n260A	No
	DC_66A_n260G	CA_2A-2A-14A-66A	CA_n260H	66A	CA_n260G	No
	DC_66A_n260H	CA_2A-2A-14A-66A	CA_n260H	66A	CA_n260H	No

EN-DC Configuration	Uplink EN-DC configuration	E-UTRA downlink configuration	NR downlink configuration	E-UTRA uplink configuration	NR uplink configuration	Applicable for protocol testing (Note 1)
DC_1A-3A-18A_n257A	DC_1A_n257A	CA_1A-3A-18A	n257A	1A	n257A	No
	DC_3A_n257A	CA_1A-3A-18A	n257A	3A	n257A	No
	DC_18A_n257A	CA_1A-3A-18A	n257A	18A	n257A	No
DC_2A-2A-14A-66A_n260I	DC_2A_n260A	66A CA_2A-2A-14A-66A	CA_n260I	2A	n260A	No
	DC_2A_n260G	CA_2A-2A-14A-66A	CA_n260I	2A	CA_n260G	No
	DC_2A_n260H	CA_2A-2A-14A-66A	CA_n260I	2A	CA_n260H	No
	DC_2A_n260I	CA_2A-2A-14A-66A	CA_n260I	2A	CA_n260I	No
	DC_14A_n260A	CA_2A-2A-14A-66A	CA_n260I	14A	n260A	No
	DC_14A_n260G	CA_2A-2A-14A-66A	CA_n260I	14A	CA_n260G	No
	DC_14A_n260H	CA_2A-2A-14A-66A	CA_n260I	14A	CA_n260H	No
	DC_14A_n260I	CA_2A-2A-14A-66A	CA_n260I	14A	CA_n260I	No
	DC_66A_n260A	CA_2A-2A-14A-66A	CA_n260I	66A	n260A	No
	DC_66A_n260G	CA_2A-2A-14A-66A	CA_n260I	66A	CA_n260G	No
	DC_66A_n260H	CA_2A-2A-14A-66A	CA_n260I	66A	CA_n260H	No
	DC_66A_n260I	CA_2A-2A-14A-66A	CA_n260I	66A	CA_n260I	No
DC_2A-14A-30A_n260A	DC_2A_n260A	CA_2A-14A-30A	n260A	2A	n260A	No
	DC_14A_n260A	CA_2A-14A-30A	n260A	14A	n260A	No
	DC_30A_n260A	CA_2A-14A-30A	n260A	30A	n260A	No
DC_2A-14A-30A_n260G	DC_2A_n260A	CA_2A-14A-30A	CA_n260G	2A	n260A	No
	DC_2A_n260G	CA_2A-14A-30A	CA_n260G	2A	CA_n260G	No
	DC_14A_n260A	CA_2A-14A-30A	CA_n260G	14A	n260A	No
	DC_14A_n260G	CA_2A-14A-30A	CA_n260G	14A	CA_n260G	No
	DC_30A_n260A	CA_2A-14A-30A	CA_n260G	30A	n260A	No
	DC_30A_n260G	CA_2A-14A-30A	CA_n260G	30A	CA_n260G	No
DC_2A-14A-30A_n260H	DC_2A_n260A	CA_2A-14A-30A	CA_n260H	2A	n260A	No
	DC_2A_n260G	CA_2A-14A-30A	CA_n260H	2A	CA_n260G	No
	DC_2A_n260H	CA_2A-14A-30A	CA_n260H	2A	CA_n260H	No
	DC_14A_n260A	CA_2A-14A-30A	CA_n260H	14A	n260A	No
	DC_14A_n260G	CA_2A-14A-30A	CA_n260H	14A	CA_n260G	No
	DC_14A_n260H	CA_2A-14A-30A	CA_n260H	14A	CA_n260H	No
	DC_30A_n260A	CA_2A-14A-30A	CA_n260H	30A	n260A	No
	DC_30A_n260G	CA_2A-14A-30A	CA_n260H	30A	CA_n260G	No
DC_30A_n260H	CA_2A-14A-30A	CA_n260H	30A	CA_n260H	No	
DC_2A-14A-30A_n260I	DC_2A_n260A	CA_2A-14A-30A	CA_n260I	2A	n260A	No
	DC_2A_n260G	CA_2A-14A-30A	CA_n260I	2A	CA_n260G	No
	DC_2A_n260H	CA_2A-14A-30A	CA_n260I	2A	CA_n260H	No
	DC_2A_n260I	CA_2A-14A-30A	CA_n260I	2A	CA_n260I	No
	DC_14A_n260A	CA_2A-14A-30A	CA_n260I	14A	n260A	No
	DC_14A_n260G	CA_2A-14A-30A	CA_n260I	14A	CA_n260G	No
	DC_14A_n260H	CA_2A-14A-30A	CA_n260I	14A	CA_n260H	No
	DC_14A_n260I	CA_2A-14A-30A	CA_n260I	14A	CA_n260I	No
	DC_30A_n260A	CA_2A-14A-30A	CA_n260I	30A	n260A	No
	DC_30A_n260G	CA_2A-14A-30A	CA_n260I	30A	CA_n260G	No
	DC_30A_n260H	CA_2A-14A-30A	CA_n260I	30A	CA_n260H	No
DC_30A_n260I	CA_2A-14A-30A	CA_n260I	30A	CA_n260I	No	

EN-DC Configuration	Uplink EN-DC configuration	E-UTRA downlink configuration	NR downlink configuration	E-UTRA uplink configuration	NR uplink configuration	Applicable for protocol testing (Note 1)
DC_1A-3A-18A_n257A	DC_1A_n257A	CA_1A-3A-18A	n257A	1A	n257A	No
	DC_3A_n257A	CA_1A-3A-18A	n257A	3A	n257A	No
	DC_18A_n257A	CA_1A-3A-18A	n257A	18A	n257A	No
DC_2A-14A-66A_n260A	DC_2A_n260A	CA_2A-14A-66A	n260A	2A	n260A	No
	DC_14A_n260A	CA_2A-14A-66A	n260A	14A	n260A	No
	DC_66A_n260A	CA_2A-14A-66A	n260A	66A	n260A	No
DC_2A-14A-66A_n260G	DC_2A_n260A	CA_2A-14A-66A	CA_n260G	2A	n260A	No
	DC_2A_n260G	CA_2A-14A-66A	CA_n260G	2A	CA_n260G	No
	DC_14A_n260A	CA_2A-14A-66A	CA_n260G	14A	n260A	No
	DC_14A_n260G	CA_2A-14A-66A	CA_n260G	14A	CA_n260G	No
	DC_66A_n260A	CA_2A-14A-66A	CA_n260G	66A	n260A	No
	DC_66A_n260G	CA_2A-14A-66A	CA_n260G	66A	CA_n260G	No
DC_2A-14A-66A_n260H	DC_2A_n260A	CA_2A-14A-66A	CA_n260H	2A	n260A	No
	DC_2A_n260G	CA_2A-14A-66A	CA_n260H	2A	CA_n260G	No
	DC_2A_n260H	CA_2A-14A-66A	CA_n260H	2A	CA_n260H	No
	DC_14A_n260A	CA_2A-14A-66A	CA_n260H	14A	n260A	No
	DC_14A_n260G	CA_2A-14A-66A	CA_n260H	14A	CA_n260G	No
	DC_14A_n260H	CA_2A-14A-66A	CA_n260H	14A	CA_n260H	No
	DC_66A_n260A	CA_2A-14A-66A	CA_n260H	66A	n260A	No
	DC_66A_n260G	CA_2A-14A-66A	CA_n260H	66A	CA_n260G	No
DC_2A-14A-66A_n260I	DC_2A_n260A	CA_2A-14A-66A	CA_n260I	2A	n260A	No
	DC_2A_n260G	CA_2A-14A-66A	CA_n260I	2A	CA_n260G	No
	DC_2A_n260H	CA_2A-14A-66A	CA_n260I	2A	CA_n260H	No
	DC_2A_n260I	CA_2A-14A-66A	CA_n260I	2A	CA_n260I	No
	DC_14A_n260A	CA_2A-14A-66A	CA_n260I	14A	n260A	No
	DC_14A_n260G	CA_2A-14A-66A	CA_n260I	14A	CA_n260G	No
	DC_14A_n260H	CA_2A-14A-66A	CA_n260I	14A	CA_n260H	No
	DC_14A_n260I	CA_2A-14A-66A	CA_n260I	14A	CA_n260I	No
	DC_66A_n260A	CA_2A-14A-66A	CA_n260I	66A	n260A	No
	DC_66A_n260G	CA_2A-14A-66A	CA_n260I	66A	CA_n260G	No
DC_2A-14A-66A-66A_n260A	DC_2A_n260A	CA_2A-14A-66A-66A	n260A	2A	n260A	No
	DC_14A_n260A	CA_2A-14A-66A-66A	n260A	14A	n260A	No
	DC_66A_n260A	CA_2A-14A-66A-66A	n260A	66A	n260A	No
DC_2A-14A-66A-66A_n260G	DC_2A_n260A	CA_2A-14A-66A-66A	CA_n260G	2A	n260A	No
	DC_2A_n260G	CA_2A-14A-66A-66A	CA_n260G	2A	CA_n260G	No
	DC_14A_n260A	CA_2A-14A-66A-66A	CA_n260G	14A	n260A	No
	DC_14A_n260G	CA_2A-14A-66A-66A	CA_n260G	14A	CA_n260G	No
	DC_66A_n260A	CA_2A-14A-66A-66A	CA_n260G	66A	n260A	No
	DC_66A_n260G	CA_2A-14A-66A-66A	CA_n260G	66A	CA_n260G	No
DC_2A-14A-66A-66A_n260H	DC_2A_n260A	CA_2A-14A-66A-66A	CA_n260H	2A	n260A	No
	DC_2A_n260G	CA_2A-14A-66A-66A	CA_n260H	2A	CA_n260G	No
	DC_2A_n260H	CA_2A-14A-66A-66A	CA_n260H	2A	CA_n260H	No
	DC_14A_n260A	CA_2A-14A-66A-66A	CA_n260H	14A	n260A	No

EN-DC Configuration	Uplink EN-DC configuration	E-UTRA downlink configuration	NR downlink configuration	E-UTRA uplink configuration	NR uplink configuration	Applicable for protocol testing (Note 1)
DC_1A-3A-18A_n257A	DC_1A_n257A	CA_1A-3A-18A	n257A	1A	n257A	No
	DC_3A_n257A	CA_1A-3A-18A	n257A	3A	n257A	No
	DC_18A_n257A	CA_1A-3A-18A	n257A	18A	n257A	No
		66A				
	DC_14A_n260G	CA_2A-14A-66A-66A	CA_n260H	14A	CA_n260G	No
	DC_14A_n260H	CA_2A-14A-66A-66A	CA_n260H	14A	CA_n260H	No
	DC_66A_n260A	CA_2A-14A-66A-66A	CA_n260H	66A	n260A	No
	DC_66A_n260G	CA_2A-14A-66A-66A	CA_n260H	66A	CA_n260G	No
	DC_66A_n260H	CA_2A-14A-66A-66A	CA_n260H	66A	CA_n260H	No
DC_2A-14A-66A-66A_n260I	DC_2A_n260A	CA_2A-14A-66A-66A	CA_n260I	2A	n260A	No
	DC_2A_n260G	CA_2A-14A-66A-66A	CA_n260I	2A	CA_n260G	No
	DC_2A_n260H	CA_2A-14A-66A-66A	CA_n260I	2A	CA_n260H	No
	DC_2A_n260I	CA_2A-14A-66A-66A	CA_n260I	2A	CA_n260I	No
	DC_14A_n260A	CA_2A-14A-66A-66A	CA_n260I	14A	n260A	No
	DC_14A_n260G	CA_2A-14A-66A-66A	CA_n260I	14A	CA_n260G	No
	DC_14A_n260H	CA_2A-14A-66A-66A	CA_n260I	14A	CA_n260H	No
	DC_14A_n260I	CA_2A-14A-66A-66A	CA_n260I	14A	CA_n260I	No
	DC_66A_n260A	CA_2A-14A-66A-66A	CA_n260I	66A	n260A	No
	DC_66A_n260G	CA_2A-14A-66A-66A	CA_n260I	66A	CA_n260G	No
	DC_66A_n260H	CA_2A-14A-66A-66A	CA_n260I	66A	CA_n260H	No
	DC_66A_n260I	CA_2A-14A-66A-66A	CA_n260I	66A	CA_n260I	No
DC_3A-19A-21A_n257A	DC_3A_n257A	CA_3A-19A-21A	n257A	3A	n257A	No
	DC_19A_n257A	CA_3A-19A-21A	n257A	19A	n257A	No
	DC_21A_n257A	CA_3A-19A-21A	n257A	21A	n257A	No
DC_3A-19A-42A_n257A	DC_3A_n257A	CA_3A-19A-42A	n257A	3A	n257A	No
	DC_19A_n257A	CA_3A-19A-42A	n257A	19A	n257A	No
	DC_42A_n257A	CA_3A-19A-42A	n257A	42A	n257A	No
DC_3A-19A-42A_n257G	DC_3A_n257A	CA_3A-19A-42A	CA_n257G	3A	n257A	No
	DC_3A_n257D	CA_3A-19A-42A	CA_n257G	3A	CA_n257D	No
	DC_3A_n257G	CA_3A-19A-42A	CA_n257G	3A	CA_n257G	No
	DC_19A_n257A	CA_3A-19A-42A	CA_n257G	19A	n257A	No
	DC_19A_n257D	CA_3A-19A-42A	CA_n257G	19A	CA_n257D	No
	DC_19A_n257G	CA_3A-19A-42A	CA_n257G	19A	CA_n257G	No
	DC_42A_n257A	CA_3A-19A-42A	CA_n257G	42A	n257A	No
	DC_42A_n257D	CA_3A-19A-42A	CA_n257G	42A	CA_n257D	No
DC_42A_n257G	CA_3A-19A-42A	CA_n257G	42A	CA_n257G	No	
DC_3A-19A-42A_n257H	DC_3A_n257A	CA_3A-19A-42A	CA_n257H	3A	n257A	No
	DC_3A_n257D	CA_3A-19A-42A	CA_n257H	3A	CA_n257D	No
	DC_3A_n257G	CA_3A-19A-42A	CA_n257H	3A	CA_n257G	No
	DC_3A_n257H	CA_3A-19A-42A	CA_n257H	3A	CA_n257H	No
	DC_19A_n257A	CA_3A-19A-42A	CA_n257H	19A	n257A	No

EN-DC Configuration	Uplink EN-DC configuration	E-UTRA downlink configuration	NR downlink configuration	E-UTRA uplink configuration	NR uplink configuration	Applicable for protocol testing (Note 1)
DC_1A-3A-18A_n257A	DC_1A_n257A	CA_1A-3A-18A	n257A	1A	n257A	No
	DC_3A_n257A	CA_1A-3A-18A	n257A	3A	n257A	No
	DC_18A_n257A	CA_1A-3A-18A	n257A	18A	n257A	No
	DC_19A_n257D	CA_3A-19A-42A	CA_n257H	19A	CA_n257D	No
	DC_19A_n257G	CA_3A-19A-42A	CA_n257H	19A	CA_n257G	No
	DC_19A_n257H	CA_3A-19A-42A	CA_n257H	19A	CA_n257H	No
	DC_42A_n257A	CA_3A-19A-42A	CA_n257H	42A	n257A	No
	DC_42A_n257D	CA_3A-19A-42A	CA_n257H	42A	CA_n257D	No
	DC_42A_n257G	CA_3A-19A-42A	CA_n257H	42A	CA_n257G	No
	DC_42A_n257H	CA_3A-19A-42A	CA_n257H	42A	CA_n257H	No
DC_3A-19A-42A_n257I	DC_3A_n257A	CA_3A-19A-42A	CA_n257I	3A	n257A	No
	DC_3A_n257D	CA_3A-19A-42A	CA_n257I	3A	CA_n257D	No
	DC_3A_n257G	CA_3A-19A-42A	CA_n257I	3A	CA_n257G	No
	DC_3A_n257H	CA_3A-19A-42A	CA_n257I	3A	CA_n257H	No
	DC_3A_n257I	CA_3A-19A-42A	CA_n257I	3A	CA_n257I	No
	DC_19A_n257A	CA_3A-19A-42A	CA_n257I	19A	n257A	No
	DC_19A_n257D	CA_3A-19A-42A	CA_n257I	19A	CA_n257D	No
	DC_19A_n257G	CA_3A-19A-42A	CA_n257I	19A	CA_n257G	No
	DC_19A_n257H	CA_3A-19A-42A	CA_n257I	19A	CA_n257H	No
	DC_19A_n257I	CA_3A-19A-42A	CA_n257I	19A	CA_n257I	No
	DC_42A_n257A	CA_3A-19A-42A	CA_n257I	42A	n257A	No
	DC_42A_n257D	CA_3A-19A-42A	CA_n257I	42A	CA_n257D	No
	DC_42A_n257G	CA_3A-19A-42A	CA_n257I	42A	CA_n257G	No
	DC_42A_n257H	CA_3A-19A-42A	CA_n257I	42A	CA_n257H	No
	DC_42A_n257I	CA_3A-19A-42A	CA_n257I	42A	CA_n257I	No
DC_3A-19A-42C_n257A	DC_3A_n257A	CA_3A-19A-42C	n257A	3A	n257A	No
	DC_19A_n257A	CA_3A-19A-42C	n257A	19A	n257A	No
	DC_42A_n257A	CA_3A-19A-42C	n257A	42A	n257A	No
DC_3A-19A-42C_n257G	DC_3A_n257A	CA_3A-19A-42C	CA_n257G	3A	n257A	No
	DC_3A_n257D	CA_3A-19A-42C	CA_n257G	3A	CA_n257D	No
	DC_3A_n257G	CA_3A-19A-42C	CA_n257G	3A	CA_n257G	No
	DC_19A_n257A	CA_3A-19A-42C	CA_n257G	19A	n257A	No
	DC_19A_n257D	CA_3A-19A-42C	CA_n257G	19A	CA_n257D	No
	DC_19A_n257G	CA_3A-19A-42C	CA_n257G	19A	CA_n257G	No
	DC_42A_n257A	CA_3A-19A-42C	CA_n257G	42A	n257A	No
	DC_42A_n257D	CA_3A-19A-42C	CA_n257G	42A	CA_n257D	No
	DC_42A_n257G	CA_3A-19A-42C	CA_n257G	42A	CA_n257G	No
DC_3A-19A-42C_n257H	DC_3A_n257A	CA_3A-19A-42C	CA_n257H	3A	n257A	No
	DC_3A_n257D	CA_3A-19A-42C	CA_n257H	3A	CA_n257D	No
	DC_3A_n257G	CA_3A-19A-42C	CA_n257H	3A	CA_n257G	No
	DC_3A_n257H	CA_3A-19A-42C	CA_n257H	3A	CA_n257H	No
	DC_19A_n257A	CA_3A-19A-42C	CA_n257H	19A	n257A	No
	DC_19A_n257D	CA_3A-19A-42C	CA_n257H	19A	CA_n257D	No
	DC_19A_n257G	CA_3A-19A-42C	CA_n257H	19A	CA_n257G	No
	DC_19A_n257H	CA_3A-19A-42C	CA_n257H	19A	CA_n257H	No
	DC_42A_n257A	CA_3A-19A-42C	CA_n257H	42A	n257A	No
	DC_42A_n257D	CA_3A-19A-42C	CA_n257H	42A	CA_n257D	No
	DC_42A_n257G	CA_3A-19A-42C	CA_n257H	42A	CA_n257G	No
DC_42A_n257H	CA_3A-19A-42C	CA_n257H	42A	CA_n257H	No	
DC_3A-19A-42C_n257I	DC_3A_n257A	CA_3A-19A-42C	CA_n257I	3A	n257A	No
	DC_3A_n257D	CA_3A-19A-42C	CA_n257I	3A	CA_n257D	No
	DC_3A_n257G	CA_3A-19A-42C	CA_n257I	3A	CA_n257G	No
	DC_3A_n257H	CA_3A-19A-42C	CA_n257I	3A	CA_n257H	No
	DC_3A_n257I	CA_3A-19A-42C	CA_n257I	3A	CA_n257I	No
	DC_19A_n257A	CA_3A-19A-42C	CA_n257I	19A	n257A	No
	DC_19A_n257D	CA_3A-19A-42C	CA_n257I	19A	CA_n257D	No
DC_19A_n257G	CA_3A-19A-42C	CA_n257I	19A	CA_n257G	No	

EN-DC Configuration	Uplink EN-DC configuration	E-UTRA downlink configuration	NR downlink configuration	E-UTRA uplink configuration	NR uplink configuration	Applicable for protocol testing (Note 1)
DC_1A-3A-18A_n257A	DC_1A_n257A	CA_1A-3A-18A	n257A	1A	n257A	No
	DC_3A_n257A	CA_1A-3A-18A	n257A	3A	n257A	No
	DC_18A_n257A	CA_1A-3A-18A	n257A	18A	n257A	No
	DC_19A_n257H	CA_3A-19A-42C	CA_n257I	19A	CA_n257H	No
	DC_19A_n257I	CA_3A-19A-42C	CA_n257I	19A	CA_n257I	No
	DC_42A_n257A	CA_3A-19A-42C	CA_n257I	42A	n257A	No
	DC_42A_n257D	CA_3A-19A-42C	CA_n257I	42A	CA_n257D	No
	DC_42A_n257G	CA_3A-19A-42C	CA_n257I	42A	CA_n257G	No
	DC_42A_n257H	CA_3A-19A-42C	CA_n257I	42A	CA_n257H	No
	DC_42A_n257I	CA_3A-19A-42C	CA_n257I	42A	CA_n257I	No
DC_3A-21A-42A_n257A	DC_3A_n257A	CA_3A-21A-42A	n257A	3A	n257A	No
	DC_21A_n257A	CA_3A-21A-42A	n257A	21A	n257A	No
	DC_42A_n257A	CA_3A-21A-42A	n257A	42A	n257A	No
DC_3A-21A-42A_n257G	DC_3A_n257A	CA_3A-21A-42A	CA_n257G	3A	n257A	No
	DC_3A_n257D	CA_3A-21A-42A	CA_n257G	3A	CA_n257D	No
	DC_3A_n257G	CA_3A-21A-42A	CA_n257G	3A	CA_n257G	No
	DC_21A_n257A	CA_3A-21A-42A	CA_n257G	21A	n257A	No
	DC_21A_n257D	CA_3A-21A-42A	CA_n257G	21A	CA_n257D	No
	DC_21A_n257G	CA_3A-21A-42A	CA_n257G	21A	CA_n257G	No
	DC_42A_n257A	CA_3A-21A-42A	CA_n257G	42A	n257A	No
	DC_42A_n257D	CA_3A-21A-42A	CA_n257G	42A	CA_n257D	No
DC_42A_n257G	CA_3A-21A-42A	CA_n257G	42A	CA_n257G	No	
DC_3A-21A-42A_n257H	DC_3A_n257A	CA_3A-21A-42A	CA_n257H	3A	n257A	No
	DC_3A_n257D	CA_3A-21A-42A	CA_n257H	3A	CA_n257D	No
	DC_3A_n257G	CA_3A-21A-42A	CA_n257H	3A	CA_n257G	No
	DC_3A_n257H	CA_3A-21A-42A	CA_n257H	3A	CA_n257H	No
	DC_21A_n257A	CA_3A-21A-42A	CA_n257H	21A	n257A	No
	DC_21A_n257D	CA_3A-21A-42A	CA_n257H	21A	CA_n257D	No
	DC_21A_n257G	CA_3A-21A-42A	CA_n257H	21A	CA_n257G	No
	DC_21A_n257H	CA_3A-21A-42A	CA_n257H	21A	CA_n257H	No
	DC_42A_n257A	CA_3A-21A-42A	CA_n257H	42A	n257A	No
	DC_42A_n257D	CA_3A-21A-42A	CA_n257H	42A	CA_n257D	No
DC_42A_n257G	CA_3A-21A-42A	CA_n257H	42A	CA_n257G	No	
DC_42A_n257H	CA_3A-21A-42A	CA_n257H	42A	CA_n257H	No	
DC_3A-21A-42A_n257I	DC_3A_n257A	CA_3A-21A-42A	CA_n257I	3A	n257A	No
	DC_3A_n257D	CA_3A-21A-42A	CA_n257I	3A	CA_n257D	No
	DC_3A_n257G	CA_3A-21A-42A	CA_n257I	3A	CA_n257G	No
	DC_3A_n257H	CA_3A-21A-42A	CA_n257I	3A	CA_n257H	No
	DC_3A_n257I	CA_3A-21A-42A	CA_n257I	3A	CA_n257I	No
	DC_21A_n257A	CA_3A-21A-42A	CA_n257I	21A	n257A	No
	DC_21A_n257D	CA_3A-21A-42A	CA_n257I	21A	CA_n257D	No
	DC_21A_n257G	CA_3A-21A-42A	CA_n257I	21A	CA_n257G	No
	DC_21A_n257H	CA_3A-21A-42A	CA_n257I	21A	CA_n257H	No
	DC_21A_n257I	CA_3A-21A-42A	CA_n257I	21A	CA_n257I	No
	DC_42A_n257A	CA_3A-21A-42A	CA_n257I	42A	n257A	No
	DC_42A_n257D	CA_3A-21A-42A	CA_n257I	42A	CA_n257D	No
	DC_42A_n257G	CA_3A-21A-42A	CA_n257I	42A	CA_n257G	No
DC_42A_n257H	CA_3A-21A-42A	CA_n257I	42A	CA_n257H	No	
DC_42A_n257I	CA_3A-21A-42A	CA_n257I	42A	CA_n257I	No	
DC_3A-21A-42C_n257A	DC_3A_n257A	CA_3A-21A-42C	n257A	3A	n257A	No
	DC_21A_n257A	CA_3A-21A-42C	n257A	21A	n257A	No
	DC_42A_n257A	CA_3A-21A-42C	n257A	42A	n257A	No
DC_3A-21A-42C_n257G	DC_3A_n257A	CA_3A-21A-42C	CA_n257G	3A	n257A	No
	DC_3A_n257D	CA_3A-21A-42C	CA_n257G	3A	CA_n257D	No
	DC_3A_n257G	CA_3A-21A-42C	CA_n257G	3A	CA_n257G	No
	DC_21A_n257A	CA_3A-21A-42C	CA_n257G	21A	n257A	No



EN-DC Configuration	Uplink EN-DC configuration	E-UTRA downlink configuration	NR downlink configuration	E-UTRA uplink configuration	NR uplink configuration	Applicable for protocol testing (Note 1)
DC_1A-3A-18A_n257A	DC_1A_n257A	CA_1A-3A-18A	n257A	1A	n257A	No
	DC_3A_n257A	CA_1A-3A-18A	n257A	3A	n257A	No
	DC_18A_n257A	CA_1A-3A-18A	n257A	18A	n257A	No
	DC_21A_n257D	CA_3A-21A-42C	CA_n257G	21A	CA_n257D	No
	DC_21A_n257G	CA_3A-21A-42C	CA_n257G	21A	CA_n257G	No
	DC_42A_n257A	CA_3A-21A-42C	CA_n257G	42A	n257A	No
	DC_42A_n257D	CA_3A-21A-42C	CA_n257G	42A	CA_n257D	No
	DC_42A_n257G	CA_3A-21A-42C	CA_n257G	42A	CA_n257G	No
DC_3A-21A-42C_n257H	DC_3A_n257A	CA_3A-21A-42C	CA_n257H	3A	n257A	No
	DC_3A_n257D	CA_3A-21A-42C	CA_n257H	3A	CA_n257D	No
	DC_3A_n257G	CA_3A-21A-42C	CA_n257H	3A	CA_n257G	No
	DC_3A_n257H	CA_3A-21A-42C	CA_n257H	3A	CA_n257H	No
	DC_21A_n257A	CA_3A-21A-42C	CA_n257H	21A	n257A	No
	DC_21A_n257D	CA_3A-21A-42C	CA_n257H	21A	CA_n257D	No
	DC_21A_n257G	CA_3A-21A-42C	CA_n257H	21A	CA_n257G	No
	DC_21A_n257H	CA_3A-21A-42C	CA_n257H	21A	CA_n257H	No
	DC_42A_n257A	CA_3A-21A-42C	CA_n257H	42A	n257A	No
	DC_42A_n257D	CA_3A-21A-42C	CA_n257H	42A	CA_n257D	No
DC_3A-21A-42C_n257I	DC_3A_n257A	CA_3A-21A-42C	CA_n257I	3A	n257A	No
	DC_3A_n257D	CA_3A-21A-42C	CA_n257I	3A	CA_n257D	No
	DC_3A_n257G	CA_3A-21A-42C	CA_n257I	3A	CA_n257G	No
	DC_3A_n257H	CA_3A-21A-42C	CA_n257I	3A	CA_n257H	No
	DC_3A_n257I	CA_3A-21A-42C	CA_n257I	3A	CA_n257I	No
	DC_21A_n257A	CA_3A-21A-42C	CA_n257I	21A	n257A	No
	DC_21A_n257D	CA_3A-21A-42C	CA_n257I	21A	CA_n257D	No
	DC_21A_n257G	CA_3A-21A-42C	CA_n257I	21A	CA_n257G	No
	DC_21A_n257H	CA_3A-21A-42C	CA_n257I	21A	CA_n257H	No
	DC_21A_n257I	CA_3A-21A-42C	CA_n257I	21A	CA_n257I	No
	DC_42A_n257A	CA_3A-21A-42C	CA_n257I	42A	n257A	No
	DC_42A_n257D	CA_3A-21A-42C	CA_n257I	42A	CA_n257D	No
	DC_42A_n257G	CA_3A-21A-42C	CA_n257I	42A	CA_n257G	No
DC_14A-30A-66A_n260A	DC_14A_n260A	CA_14A-30A-66A	n260A	14A	n260A	No
	DC_30A_n260A	CA_14A-30A-66A	n260A	30A	n260A	No
	DC_66A_n260A	CA_14A-30A-66A	n260A	66A	n260A	No
DC_14A-30A-66A_n260G	DC_14A_n260A	CA_14A-30A-66A	CA_n260G	14A	n260A	No
	DC_14A_n260G	CA_14A-30A-66A	CA_n260G	14A	CA_n260G	No
	DC_30A_n260A	CA_14A-30A-66A	CA_n260G	30A	n260A	No
	DC_30A_n260G	CA_14A-30A-66A	CA_n260G	30A	CA_n260G	No
	DC_66A_n260A	CA_14A-30A-66A	CA_n260G	66A	n260A	No
	DC_66A_n260G	CA_14A-30A-66A	CA_n260G	66A	CA_n260G	No
DC_14A-30A-66A_n260H	DC_14A_n260A	CA_14A-30A-66A	CA_n260H	14A	n260A	No
	DC_14A_n260G	CA_14A-30A-66A	CA_n260H	14A	CA_n260G	No
	DC_14A_n260H	CA_14A-30A-66A	CA_n260H	14A	CA_n260H	No
	DC_30A_n260A	CA_14A-30A-66A	CA_n260H	30A	n260A	No
	DC_30A_n260G	CA_14A-30A-66A	CA_n260H	30A	CA_n260G	No
	DC_30A_n260H	CA_14A-30A-66A	CA_n260H	30A	CA_n260H	No
	DC_66A_n260A	CA_14A-30A-66A	CA_n260H	66A	n260A	No
	DC_66A_n260G	CA_14A-30A-66A	CA_n260H	66A	CA_n260G	No
DC_14A-30A-66A_n260I	DC_14A_n260A	CA_14A-30A-66A	CA_n260I	14A	n260A	No
	DC_14A_n260G	CA_14A-30A-66A	CA_n260I	14A	CA_n260G	No
	DC_14A_n260H	CA_14A-30A-66A	CA_n260I	14A	CA_n260H	No

EN-DC Configuration	Uplink EN-DC configuration	E-UTRA downlink configuration	NR downlink configuration	E-UTRA uplink configuration	NR uplink configuration	Applicable for protocol testing (Note 1)
DC_1A-3A-18A_n257A	DC_1A_n257A	CA_1A-3A-18A	n257A	1A	n257A	No
	DC_3A_n257A	CA_1A-3A-18A	n257A	3A	n257A	No
	DC_18A_n257A	CA_1A-3A-18A	n257A	18A	n257A	No
	DC_14A_n260I	CA_14A-30A-66A	CA_n260I	14A	CA_n260I	No
	DC_30A_n260A	CA_14A-30A-66A	CA_n260I	30A	n260A	No
	DC_30A_n260G	CA_14A-30A-66A	CA_n260I	30A	CA_n260G	No
	DC_30A_n260H	CA_14A-30A-66A	CA_n260I	30A	CA_n260H	No
	DC_30A_n260I	CA_14A-30A-66A	CA_n260I	30A	CA_n260I	No
	DC_66A_n260A	CA_14A-30A-66A	CA_n260I	66A	n260A	No
	DC_66A_n260G	CA_14A-30A-66A	CA_n260I	66A	CA_n260G	No
	DC_66A_n260H	CA_14A-30A-66A	CA_n260I	66A	CA_n260H	No
DC_14A-30A-66A-66A_n260A	DC_14A_n260A	CA_14A-30A-66A-66A	n260A	14A	n260A	No
	DC_30A_n260A	CA_14A-30A-66A-66A	n260A	30A	n260A	No
	DC_66A_n260A	CA_14A-30A-66A-66A	n260A	66A	n260A	No
DC_14A-30A-66A-66A_n260G	DC_14A_n260A	CA_14A-30A-66A-66A	CA_n260G	14A	n260A	No
	DC_14A_n260G	CA_14A-30A-66A-66A	CA_n260G	14A	CA_n260G	No
	DC_30A_n260A	CA_14A-30A-66A-66A	CA_n260G	30A	n260A	No
	DC_30A_n260G	CA_14A-30A-66A-66A	CA_n260G	30A	CA_n260G	No
	DC_66A_n260A	CA_14A-30A-66A-66A	CA_n260G	66A	n260A	No
	DC_66A_n260G	CA_14A-30A-66A-66A	CA_n260G	66A	CA_n260G	No
DC_14A-30A-66A-66A_n260H	DC_14A_n260A	CA_14A-30A-66A-66A	CA_n260H	14A	n260A	No
	DC_14A_n260G	CA_14A-30A-66A-66A	CA_n260H	14A	CA_n260G	No
	DC_14A_n260H	CA_14A-30A-66A-66A	CA_n260H	14A	CA_n260H	No
	DC_30A_n260A	CA_14A-30A-66A-66A	CA_n260H	30A	n260A	No
	DC_30A_n260G	CA_14A-30A-66A-66A	CA_n260H	30A	CA_n260G	No
	DC_30A_n260H	CA_14A-30A-66A-66A	CA_n260H	30A	CA_n260H	No
	DC_66A_n260A	CA_14A-30A-66A-66A	CA_n260H	66A	n260A	No
	DC_66A_n260G	CA_14A-30A-66A-66A	CA_n260H	66A	CA_n260G	No
	DC_66A_n260H	CA_14A-30A-66A-66A	CA_n260H	66A	CA_n260H	No
DC_14A-30A-66A-66A_n260I	DC_14A_n260A	CA_14A-30A-66A-66A	CA_n260I	14A	n260A	No
	DC_14A_n260G	CA_14A-30A-66A-66A	CA_n260I	14A	CA_n260G	No
	DC_14A_n260H	CA_14A-30A-66A-66A	CA_n260I	14A	CA_n260H	No
	DC_14A_n260I	CA_14A-30A-66A-66A	CA_n260I	14A	CA_n260I	No
	DC_30A_n260A	CA_14A-30A-66A-66A	CA_n260I	30A	n260A	No
	DC_30A_n260G	CA_14A-30A-66A-66A	CA_n260I	30A	CA_n260G	No
	DC_30A_n260H	CA_14A-30A-66A-66A	CA_n260I	30A	CA_n260H	No
	DC_30A_n260I	CA_14A-30A-66A-66A	CA_n260I	30A	CA_n260I	No

EN-DC Configuration	Uplink EN-DC configuration	E-UTRA downlink configuration	NR downlink configuration	E-UTRA uplink configuration	NR uplink configuration	Applicable for protocol testing (Note 1)
DC_1A-3A-18A_n257A	DC_1A_n257A	CA_1A-3A-18A	n257A	1A	n257A	No
	DC_3A_n257A	CA_1A-3A-18A	n257A	3A	n257A	No
	DC_18A_n257A	CA_1A-3A-18A	n257A	18A	n257A	No
		66A				
	DC_66A_n260A	CA_14A-30A-66A-66A	CA_n260I	66A	n260A	No
	DC_66A_n260G	CA_14A-30A-66A-66A	CA_n260I	66A	CA_n260G	No
	DC_66A_n260H	CA_14A-30A-66A-66A	CA_n260I	66A	CA_n260H	No
DC_19A-21A-42A_n257A	DC_19A_n257A	CA_19A-21A-42A	n257A	19A	n257A	No
	DC_21A_n257A	CA_19A-21A-42A	n257A	21A	n257A	No
	DC_42A_n257A	CA_19A-21A-42A	n257A	42A	n257A	No
DC_19A-21A-42A_n257G	DC_19A_n257A	CA_19A-21A-42A	CA_n257G	19A	n257A	No
	DC_19A_n257D	CA_19A-21A-42A	CA_n257G	19A	CA_n257D	No
	DC_19A_n257G	CA_19A-21A-42A	CA_n257G	19A	CA_n257G	No
	DC_21A_n257A	CA_19A-21A-42A	CA_n257G	21A	n257A	No
	DC_21A_n257D	CA_19A-21A-42A	CA_n257G	21A	CA_n257D	No
	DC_21A_n257G	CA_19A-21A-42A	CA_n257G	21A	CA_n257G	No
	DC_42A_n257A	CA_19A-21A-42A	CA_n257G	42A	n257A	No
	DC_42A_n257D	CA_19A-21A-42A	CA_n257G	42A	CA_n257D	No
DC_19A-21A-42A_n257H	DC_19A_n257A	CA_19A-21A-42A	CA_n257H	19A	n257A	No
	DC_19A_n257D	CA_19A-21A-42A	CA_n257H	19A	CA_n257D	No
	DC_19A_n257G	CA_19A-21A-42A	CA_n257H	19A	CA_n257G	No
	DC_19A_n257H	CA_19A-21A-42A	CA_n257H	19A	CA_n257H	No
	DC_21A_n257A	CA_19A-21A-42A	CA_n257H	21A	n257A	No
	DC_21A_n257D	CA_19A-21A-42A	CA_n257H	21A	CA_n257D	No
	DC_21A_n257G	CA_19A-21A-42A	CA_n257H	21A	CA_n257G	No
	DC_21A_n257H	CA_19A-21A-42A	CA_n257H	21A	CA_n257H	No
	DC_42A_n257A	CA_19A-21A-42A	CA_n257H	42A	n257A	No
	DC_42A_n257D	CA_19A-21A-42A	CA_n257H	42A	CA_n257D	No
DC_19A-21A-42A_n257I	DC_19A_n257A	CA_19A-21A-42A	CA_n257I	19A	n257A	No
	DC_19A_n257D	CA_19A-21A-42A	CA_n257I	19A	CA_n257D	No
	DC_19A_n257G	CA_19A-21A-42A	CA_n257I	19A	CA_n257G	No
	DC_19A_n257H	CA_19A-21A-42A	CA_n257I	19A	CA_n257H	No
	DC_19A_n257I	CA_19A-21A-42A	CA_n257I	19A	CA_n257I	No
	DC_21A_n257A	CA_19A-21A-42A	CA_n257I	21A	n257A	No
	DC_21A_n257D	CA_19A-21A-42A	CA_n257I	21A	CA_n257D	No
	DC_21A_n257G	CA_19A-21A-42A	CA_n257I	21A	CA_n257G	No
	DC_21A_n257H	CA_19A-21A-42A	CA_n257I	21A	CA_n257H	No
	DC_21A_n257I	CA_19A-21A-42A	CA_n257I	21A	CA_n257I	No
	DC_42A_n257A	CA_19A-21A-42A	CA_n257I	42A	n257A	No
	DC_42A_n257D	CA_19A-21A-42A	CA_n257I	42A	CA_n257D	No
DC_19A-21A-42C_n257A	DC_19A_n257A	CA_19A-21A-42C	n257A	19A	n257A	No
	DC_21A_n257A	CA_19A-21A-42C	n257A	21A	n257A	No
	DC_42A_n257A	CA_19A-21A-42C	n257A	42A	n257A	No
DC_19A-21A-42C_n257G	DC_19A_n257A	CA_19A-21A-42C	CA_n257G	19A	n257A	No
	DC_19A_n257D	CA_19A-21A-42C	CA_n257G	19A	CA_n257D	No

EN-DC Configuration	Uplink EN-DC configuration	E-UTRA downlink configuration	NR downlink configuration	E-UTRA uplink configuration	NR uplink configuration	Applicable for protocol testing (Note 1)
DC_1A-3A-18A_n257A	DC_1A_n257A	CA_1A-3A-18A	n257A	1A	n257A	No
	DC_3A_n257A	CA_1A-3A-18A	n257A	3A	n257A	No
	DC_18A_n257A	CA_1A-3A-18A	n257A	18A	n257A	No
	DC_19A_n257G	CA_19A-21A-42C	CA_n257G	19A	CA_n257G	No
	DC_21A_n257A	CA_19A-21A-42C	CA_n257G	21A	n257A	No
	DC_21A_n257D	CA_19A-21A-42C	CA_n257G	21A	CA_n257D	No
	DC_21A_n257G	CA_19A-21A-42C	CA_n257G	21A	CA_n257G	No
	DC_42A_n257A	CA_19A-21A-42C	CA_n257G	42A	n257A	No
	DC_42A_n257D	CA_19A-21A-42C	CA_n257G	42A	CA_n257D	No
	DC_42A_n257G	CA_19A-21A-42C	CA_n257G	42A	CA_n257G	No
DC_19A-21A-42C_n257H	DC_19A_n257A	CA_19A-21A-42C	CA_n257H	19A	n257A	No
	DC_19A_n257D	CA_19A-21A-42C	CA_n257H	19A	CA_n257D	No
	DC_19A_n257G	CA_19A-21A-42C	CA_n257H	19A	CA_n257G	No
	DC_19A_n257H	CA_19A-21A-42C	CA_n257H	19A	CA_n257H	No
	DC_21A_n257A	CA_19A-21A-42C	CA_n257H	21A	n257A	No
	DC_21A_n257D	CA_19A-21A-42C	CA_n257H	21A	CA_n257D	No
	DC_21A_n257G	CA_19A-21A-42C	CA_n257H	21A	CA_n257G	No
	DC_21A_n257H	CA_19A-21A-42C	CA_n257H	21A	CA_n257H	No
	DC_42A_n257A	CA_19A-21A-42C	CA_n257H	42A	n257A	No
	DC_42A_n257D	CA_19A-21A-42C	CA_n257H	42A	CA_n257D	No
DC_42A_n257G	CA_19A-21A-42C	CA_n257H	42A	CA_n257G	No	
DC_42A_n257H	CA_19A-21A-42C	CA_n257H	42A	CA_n257H	No	
DC_19A-21A-42C_n257I	DC_19A_n257A	CA_19A-21A-42C	CA_n257I	19A	n257A	No
	DC_19A_n257D	CA_19A-21A-42C	CA_n257I	19A	CA_n257D	No
	DC_19A_n257G	CA_19A-21A-42C	CA_n257I	19A	CA_n257G	No
	DC_19A_n257H	CA_19A-21A-42C	CA_n257I	19A	CA_n257H	No
	DC_19A_n257I	CA_19A-21A-42C	CA_n257I	19A	CA_n257I	No
	DC_21A_n257A	CA_19A-21A-42C	CA_n257I	21A	n257A	No
	DC_21A_n257D	CA_19A-21A-42C	CA_n257I	21A	CA_n257D	No
	DC_21A_n257G	CA_19A-21A-42C	CA_n257I	21A	CA_n257G	No
	DC_21A_n257H	CA_19A-21A-42C	CA_n257I	21A	CA_n257H	No
	DC_21A_n257I	CA_19A-21A-42C	CA_n257I	21A	CA_n257I	No
	DC_42A_n257A	CA_19A-21A-42C	CA_n257I	42A	n257A	No
	DC_42A_n257D	CA_19A-21A-42C	CA_n257I	42A	CA_n257D	No
	DC_42A_n257G	CA_19A-21A-42C	CA_n257I	42A	CA_n257G	No
DC_42A_n257H	CA_19A-21A-42C	CA_n257I	42A	CA_n257H	No	
DC_42A_n257I	CA_19A-21A-42C	CA_n257I	42A	CA_n257I	No	

Note 1: Protocol testing is limited to EN-DC configurations with 1 CC E-UTRA and 1CC or 2CC NR configurations.

## 4.3.1.5.1.5 Inter-band EN-DC configurations including FR2 (five bands)

Table 4.3.1.5.1.5-1: Inter-band EN-DC configurations including FR2 (five bands)

EN-DC Configuration	Uplink EN-DC configuration	E-UTRA downlink configuration	NR downlink configuration	E-UTRA uplink configuration	NR uplink configuration	Applicable for protocol testing (Note 1)
DC_1A-3A-19A-42A_n257A	DC_1A_n257A	CA_1A-3A-19A-42A	n257A	1A	n257A	No
	DC_3A_n257A	CA_1A-3A-19A-42A	n257A	3A	n257A	No
	DC_19A_n257A	CA_1A-3A-19A-42A	n257A	19A	n257A	No
	DC_42A_n257A	CA_1A-3A-19A-42A	n257A	42A	n257A	No
DC_1A-3A-19A-42A_n257G	DC_1A_n257A	CA_1A-3A-19A-42A	CA_n257G	1A	n257A	No
	DC_3A_n257A	CA_1A-3A-19A-42A	CA_n257G	3A	n257A	No
	DC_3A_n257G	CA_1A-3A-19A-42A	CA_n257G	3A	CA_n257G	No
	DC_19A_n257A	CA_1A-3A-19A-42A	CA_n257G	19A	n257A	No
	DC_42A_n257A	CA_1A-3A-19A-42A	CA_n257G	42A	n257A	No
DC_1A-3A-19A-42C_n257A	DC_1A_n257A	CA_1A-3A-19A-42C	n257A	1A	n257A	No
	DC_3A_n257A	CA_1A-3A-19A-42C	n257A	3A	n257A	No
	DC_19A_n257A	CA_1A-3A-19A-42C	n257A	19A	n257A	No
	DC_42A_n257A	CA_1A-3A-19A-42C	n257A	42A	n257A	No
DC_1A-3A-19A-42C_n257G	DC_1A_n257A	CA_1A-3A-19A-42C	CA_n257G	1A	n257A	No
	DC_3A_n257A	CA_1A-3A-19A-42C	CA_n257G	3A	n257A	No
	DC_3A_n257G	CA_1A-3A-19A-42C	CA_n257G	3A	CA_n257G	No
	DC_19A_n257A	CA_1A-3A-19A-42C	CA_n257G	19A	n257A	No
	DC_42A_n257A	CA_1A-3A-19A-42C	CA_n257G	42A	n257A	No
DC_1A-3A-19A-42C_n257H	DC_1A_n257A	CA_1A-3A-19A-42C	CA_n257H	1A	n257A	No
	DC_3A_n257A	CA_1A-3A-19A-42C	CA_n257H	3A	n257A	No
	DC_3A_n257G	CA_1A-3A-19A-42C	CA_n257H	3A	CA_n257G	No
	DC_3A_n257H	CA_1A-3A-19A-42C	CA_n257H	3A	CA_n257H	No
	DC_19A_n257A	CA_1A-3A-19A-42C	CA_n257H	19A	n257A	No
	DC_42A_n257A	CA_1A-3A-19A-42C	CA_n257H	42A	n257A	No
DC_1A-3A-19A-42C_n257I	DC_1A_n257A	CA_1A-3A-19A-42C	CA_n257I	1A	n257A	No
	DC_3A_n257A	CA_1A-3A-19A-42C	CA_n257I	3A	n257A	No
	DC_3A_n257G	CA_1A-3A-19A-42C	CA_n257I	3A	CA_n257G	No
	DC_3A_n257H	CA_1A-3A-19A-42C	CA_n257I	3A	CA_n257H	No
	DC_3A_n257I	CA_1A-3A-19A-42C	CA_n257I	3A	CA_n257I	No
	DC_19A_n257A	CA_1A-3A-19A-42C	CA_n257I	19A	n257A	No

EN-DC Configuration	Uplink EN-DC configuration	E-UTRA downlink configuration	NR downlink configuration	E-UTRA uplink configuration	NR uplink configuration	Applicable for protocol testing (Note 1)
	DC_42A_n257A	CA_1A-3A-19A-42C	CA_n257I	42A	n257A	No
DC_1A-3A-21A-42A_n257A	DC_1A_n257A	CA_1A-3A-21A-42A	n257A	1A	n257A	No
	DC_3A_n257A	CA_1A-3A-21A-42A	n257A	3A	n257A	No
	DC_21A_n257A	CA_1A-3A-21A-42A	n257A	21A	n257A	No
	DC_42A_n257A	CA_1A-3A-21A-42A	n257A	42A	n257A	No
DC_1A-3A-21A-42C_n257A	DC_1A_n257A	CA_1A-3A-21A-42C	n257A	1A	n257A	No
	DC_3A_n257A	CA_1A-3A-21A-42C	n257A	3A	n257A	No
	DC_21A_n257A	CA_1A-3A-21A-42C	n257A	21A	n257A	No
	DC_42A_n257A	CA_1A-3A-21A-42C	n257A	42A	n257A	No
DC_1A-3A-21A-42C_n257G	DC_1A_n257A	CA_1A-3A-21A-42C	CA_n257G	1A	n257A	No
	DC_3A_n257A	CA_1A-3A-21A-42C	CA_n257G	3A	n257A	No
	DC_3A_n257G	CA_1A-3A-21A-42C	CA_n257G	3A	CA_n257G	No
	DC_21A_n257A	CA_1A-3A-21A-42C	CA_n257G	21A	n257A	No
	DC_42A_n257A	CA_1A-3A-21A-42C	CA_n257G	42A	n257A	No
DC_1A-3A-21A-42C_n257H	DC_1A_n257A	CA_1A-3A-21A-42C	CA_n257H	1A	n257A	No
	DC_3A_n257A	CA_1A-3A-21A-42C	CA_n257H	3A	n257A	No
	DC_3A_n257G	CA_1A-3A-21A-42C	CA_n257H	3A	CA_n257G	No
	DC_3A_n257H	CA_1A-3A-21A-42C	CA_n257H	3A	CA_n257H	No
	DC_21A_n257A	CA_1A-3A-21A-42C	CA_n257H	21A	n257A	No
	DC_42A_n257A	CA_1A-3A-21A-42C	CA_n257H	42A	n257A	No
DC_1A-3A-21A-42C_n257I	DC_1A_n257A	CA_1A-3A-21A-42C	CA_n257I	1A	n257A	No
	DC_3A_n257A	CA_1A-3A-21A-42C	CA_n257I	3A	n257A	No
	DC_3A_n257G	CA_1A-3A-21A-42C	CA_n257I	3A	CA_n257G	No
	DC_3A_n257H	CA_1A-3A-21A-42C	CA_n257I	3A	CA_n257H	No
	DC_3A_n257I	CA_1A-3A-21A-42C	CA_n257I	3A	CA_n257I	No
	DC_21A_n257A	CA_1A-3A-21A-42C	CA_n257I	21A	n257A	No
	DC_42A_n257A	CA_1A-3A-21A-42C	CA_n257I	42A	n257A	No
DC_1A-19A-21A-42A_n257A	DC_1A_n257A	CA_1A-19A-21A-42A	n257A	1A	n257A	No
	DC_19A_n257A	CA_1A-19A-21A-42A	n257A	19A	n257A	No
	DC_21A_n257A	CA_1A-19A-21A-42A	n257A	21A	n257A	No
	DC_42A_n257A	CA_1A-19A-21A-42A	n257A	42A	n257A	No
DC_1A-19A-21A-42A_n257G	DC_1A_n257A	CA_1A-19A-21A-42A	CA_n257G	1A	n257A	No
	DC_1A_n257G	CA_1A-19A-21A-42A	CA_n257G	1A	CA_n257G	No

EN-DC Configuration	Uplink EN-DC configuration	E-UTRA downlink configuration	NR downlink configuration	E-UTRA uplink configuration	NR uplink configuration	Applicable for protocol testing (Note 1)
	DC_19A_n257A	CA_1A-19A-21A-42A	CA_n257G	19A	n257A	No
	DC_21A_n257A	CA_1A-19A-21A-42A	CA_n257G	21A	n257A	No
	DC_21A_n257G	CA_1A-19A-21A-42A	CA_n257G	21A	CA_n257G	No
	DC_42A_n257A	CA_1A-19A-21A-42A	CA_n257G	42A	n257A	No
DC_1A-19A-21A-42A_n257H	DC_1A_n257A	CA_1A-19A-21A-42A	CA_n257H	1A	n257A	No
	DC_1A_n257G	CA_1A-19A-21A-42A	CA_n257H	1A	CA_n257G	No
	DC_1A_n257H	CA_1A-19A-21A-42A	CA_n257H	1A	CA_n257H	No
	DC_19A_n257A	CA_1A-19A-21A-42A	CA_n257H	19A	n257A	No
	DC_21A_n257A	CA_1A-19A-21A-42A	CA_n257H	21A	n257A	No
	DC_21A_n257G	CA_1A-19A-21A-42A	CA_n257H	21A	CA_n257G	No
	DC_21A_n257H	CA_1A-19A-21A-42A	CA_n257H	21A	CA_n257H	No
	DC_42A_n257A	CA_1A-19A-21A-42A	CA_n257H	42A	n257A	No
DC_1A-19A-21A-42A_n257I	DC_1A_n257A	CA_1A-19A-21A-42A	CA_n257I	1A	n257A	No
	DC_1A_n257G	CA_1A-19A-21A-42A	CA_n257I	1A	CA_n257G	No
	DC_1A_n257H	CA_1A-19A-21A-42A	CA_n257I	1A	CA_n257H	No
	DC_1A_n257I	CA_1A-19A-21A-42A	CA_n257I	1A	CA_n257I	No
	DC_19A_n257A	CA_1A-19A-21A-42A	CA_n257I	19A	n257A	No
	DC_21A_n257A	CA_1A-19A-21A-42A	CA_n257I	21A	n257A	No
	DC_21A_n257G	CA_1A-19A-21A-42A	CA_n257I	21A	CA_n257G	No
	DC_21A_n257H	CA_1A-19A-21A-42A	CA_n257I	21A	CA_n257H	No
	DC_21A_n257I	CA_1A-19A-21A-42A	CA_n257I	21A	CA_n257I	No
DC_1A-19A-21A-42C_n257A	DC_1A_n257A	CA_1A-19A-21A-42C	n257A	1A	n257A	No
	DC_19A_n257A	CA_1A-19A-21A-42C	n257A	19A	n257A	No
	DC_21A_n257A	CA_1A-19A-21A-42C	n257A	21A	n257A	No
	DC_42A_n257A	CA_1A-19A-21A-42C	n257A	42A	n257A	No
DC_1A-19A-21A-42A_n257G	DC_1A_n257A	CA_1A-19A-21A-42A	CA_n257G	1A	n257A	No
	DC_1A_n257G	CA_1A-19A-21A-42A	CA_n257G	1A	CA_n257G	No
	DC_19A_n257A	CA_1A-19A-21A-42A	CA_n257G	19A	n257A	No
	DC_21A_n257A	CA_1A-19A-21A-42A	CA_n257G	21A	n257A	No
	DC_21A_n257G	CA_1A-19A-21A-42A	CA_n257G	21A	CA_n257G	No
	DC_42A_n257A	CA_1A-19A-21A-42A	CA_n257G	42A	n257A	No
DC_1A-19A-21A-42A_n257H	DC_1A_n257A	CA_1A-19A-21A-42A	CA_n257H	1A	n257A	No
	DC_1A_n257G	CA_1A-19A-21A-42A	CA_n257H	1A	CA_n257G	No
	DC_1A_n257H	CA_1A-19A-21A-42A	CA_n257H	1A	CA_n257H	No

EN-DC Configuration	Uplink EN-DC configuration	E-UTRA downlink configuration	NR downlink configuration	E-UTRA uplink configuration	NR uplink configuration	Applicable for protocol testing (Note 1)
	DC_19A_n257A	CA_1A-19A-21A-42A	CA_n257H	19A	n257A	No
	DC_21A_n257A	CA_1A-19A-21A-42A	CA_n257H	21A	n257A	No
	DC_21A_n257G	CA_1A-19A-21A-42A	CA_n257H	21A	CA_n257G	No
	DC_21A_n257H	CA_1A-19A-21A-42A	CA_n257H	21A	CA_n257H	No
	DC_42A_n257A	CA_1A-19A-21A-42A	CA_n257H	42A	n257A	No
DC_1A-19A-21A-42A_n257I	DC_1A_n257A	CA_1A-19A-21A-42A	CA_n257I	1A	n257A	No
	DC_1A_n257G	CA_1A-19A-21A-42A	CA_n257I	1A	CA_n257G	No
	DC_1A_n257H	CA_1A-19A-21A-42A	CA_n257I	1A	CA_n257H	No
	DC_1A_n257I	CA_1A-19A-21A-42A	CA_n257I	1A	CA_n257I	No
	DC_19A_n257A	CA_1A-19A-21A-42A	CA_n257I	19A	n257A	No
	DC_21A_n257A	CA_1A-19A-21A-42A	CA_n257I	21A	n257A	No
	DC_21A_n257G	CA_1A-19A-21A-42A	CA_n257I	21A	CA_n257G	No
	DC_21A_n257H	CA_1A-19A-21A-42A	CA_n257I	21A	CA_n257H	No
	DC_21A_n257I	CA_1A-19A-21A-42A	CA_n257I	21A	CA_n257I	No
DC_42A_n257A	CA_1A-19A-21A-42A	CA_n257I	42A	n257A	No	
DC_1A-19A-21A-42C_n257G	DC_1A_n257A	CA_1A-19A-21A-42C	CA_n257G	1A	n257A	No
	DC_1A_n257G	CA_1A-19A-21A-42C	CA_n257G	1A	CA_n257G	No
	DC_19A_n257A	CA_1A-19A-21A-42C	CA_n257G	19A	n257A	No
	DC_21A_n257A	CA_1A-19A-21A-42C	CA_n257G	21A	n257A	No
	DC_21A_n257G	CA_1A-19A-21A-42C	CA_n257G	21A	CA_n257G	No
	DC_42A_n257A	CA_1A-19A-21A-42C	CA_n257G	42A	n257A	No
DC_1A-19A-21A-42C_n257H	DC_1A_n257A	CA_1A-19A-21A-42C	CA_n257H	1A	n257A	No
	DC_1A_n257G	CA_1A-19A-21A-42C	CA_n257H	1A	CA_n257G	No
	DC_1A_n257H	CA_1A-19A-21A-42C	CA_n257H	1A	CA_n257H	No
	DC_19A_n257A	CA_1A-19A-21A-42C	CA_n257H	19A	n257A	No
	DC_21A_n257A	CA_1A-19A-21A-42C	CA_n257H	21A	n257A	No
	DC_21A_n257G	CA_1A-19A-21A-42C	CA_n257H	21A	CA_n257G	No
	DC_21A_n257H	CA_1A-19A-21A-42C	CA_n257H	21A	CA_n257H	No
	DC_42A_n257A	CA_1A-19A-21A-42C	CA_n257H	42A	n257A	No
DC_1A-19A-21A-42C_n257I	DC_1A_n257A	CA_1A-19A-21A-42C	CA_n257I	1A	n257A	No
	DC_1A_n257G	CA_1A-19A-21A-42C	CA_n257I	1A	CA_n257G	No
	DC_1A_n257H	CA_1A-19A-21A-42C	CA_n257I	1A	CA_n257H	No
	DC_1A_n257I	CA_1A-19A-21A-42C	CA_n257I	1A	CA_n257I	No
	DC_19A_n257A	CA_1A-19A-21A-42C	CA_n257I	19A	n257A	No
	DC_21A_n257A	CA_1A-19A-21A-42C	CA_n257I	21A	n257A	No
	DC_21A_n257G	CA_1A-19A-21A-42C	CA_n257I	21A	CA_n257G	No
	DC_21A_n257H	CA_1A-19A-21A-42C	CA_n257I	21A	CA_n257H	No



EN-DC Configuration	Uplink EN-DC configuration	E-UTRA downlink configuration	NR downlink configuration	E-UTRA uplink configuration	NR uplink configuration	Applicable for protocol testing (Note 1)
	DC_21A_n257H	CA_1A-19A-21A-42C	CA_n257I	21A	CA_n257H	No
	DC_21A_n257I	CA_1A-19A-21A-42C	CA_n257I	21A	CA_n257I	No
	DC_42A_n257A	CA_1A-19A-21A-42C	CA_n257I	42A	n257A	No
DC_2A-14A-30A-66A_n260A	DC_2A_n260A	CA_2A-14A-30A-66A	n260A	2A	n260A	No
	DC_14A_n260A	CA_2A-14A-30A-66A	n260A	14A	n260A	No
	DC_30A_n260A	CA_2A-14A-30A-66A	n260A	30A	n260A	No
	DC_66A_n260A	CA_2A-14A-30A-66A	n260A	66A	n260A	No
DC_2A-14A-30A-66A_n260G	DC_2A_n260A	CA_2A-14A-30A-66A	CA_n260G	2A	n260A	No
	DC_2A_n260G	CA_2A-14A-30A-66A	CA_n260G	2A	CA_n260G	No
	DC_14A_n260A	CA_2A-14A-30A-66A	CA_n260G	14A	n260A	No
	DC_14A_n260G	CA_2A-14A-30A-66A	CA_n260G	14A	CA_n260G	No
	DC_30A_n260A	CA_2A-14A-30A-66A	CA_n260G	30A	n260A	No
	DC_30A_n260G	CA_2A-14A-30A-66A	CA_n260G	30A	CA_n260G	No
	DC_66A_n260A	CA_2A-14A-30A-66A	CA_n260G	66A	n260A	No
	DC_66A_n260G	CA_2A-14A-30A-66A	CA_n260G	66A	CA_n260G	No
DC_2A-14A-30A-66A_n260H	DC_2A_n260A	CA_2A-14A-30A-66A	CA_n260H	2A	n260A	No
	DC_2A_n260G	CA_2A-14A-30A-66A	CA_n260H	2A	CA_n260G	No
	DC_2A_n260H	CA_2A-14A-30A-66A	CA_n260H	2A	CA_n260H	No
	DC_14A_n260A	CA_2A-14A-30A-66A	CA_n260H	14A	n260A	No
	DC_14A_n260G	CA_2A-14A-30A-66A	CA_n260H	14A	CA_n260G	No
	DC_14A_n260H	CA_2A-14A-30A-66A	CA_n260H	14A	CA_n260H	No
	DC_30A_n260A	CA_2A-14A-30A-66A	CA_n260H	30A	n260A	No
	DC_30A_n260G	CA_2A-14A-30A-66A	CA_n260H	30A	CA_n260G	No
	DC_30A_n260H	CA_2A-14A-30A-66A	CA_n260H	30A	CA_n260H	No
	DC_66A_n260A	CA_2A-14A-30A-66A	CA_n260H	66A	n260A	No
DC_66A_n260G	CA_2A-14A-30A-66A	CA_n260H	66A	CA_n260G	No	
DC_66A_n260H	CA_2A-14A-30A-66A	CA_n260H	66A	CA_n260H	No	
DC_2A-14A-30A-66A_n260I	DC_2A_n260A	CA_2A-14A-30A-66A	CA_n260I	2A	n260A	No
	DC_2A_n260G	CA_2A-14A-30A-66A	CA_n260I	2A	CA_n260G	No
	DC_2A_n260H	CA_2A-14A-30A-66A	CA_n260I	2A	CA_n260H	No
	DC_2A_n260I	CA_2A-14A-30A-66A	CA_n260I	2A	CA_n260I	No
	DC_14A_n260A	CA_2A-14A-30A-66A	CA_n260I	14A	n260A	No
	DC_14A_n260G	CA_2A-14A-30A-66A	CA_n260I	14A	CA_n260G	No
	DC_14A_n260H	CA_2A-14A-30A-66A	CA_n260I	14A	CA_n260H	No
	DC_14A_n260I	CA_2A-14A-30A-66A	CA_n260I	14A	CA_n260I	No
DC_30A_n260A	CA_2A-14A-30A-66A	CA_n260I	30A	n260A	No	

EN-DC Configuration	Uplink EN-DC configuration	E-UTRA downlink configuration	NR downlink configuration	E-UTRA uplink configuration	NR uplink configuration	Applicable for protocol testing (Note 1)
	DC_30A_n260G	CA_2A-14A-30A-66A	CA_n260I	30A	CA_n260G	No
	DC_30A_n260H	CA_2A-14A-30A-66A	CA_n260I	30A	CA_n260H	No
	DC_30A_n260I	CA_2A-14A-30A-66A	CA_n260I	30A	CA_n260I	No
	DC_66A_n260A	CA_2A-14A-30A-66A	CA_n260I	66A	n260A	No
	DC_66A_n260G	CA_2A-14A-30A-66A	CA_n260I	66A	CA_n260G	No
	DC_66A_n260H	CA_2A-14A-30A-66A	CA_n260I	66A	CA_n260H	No
	DC_66A_n260I	CA_2A-14A-30A-66A	CA_n260I	66A	CA_n260I	No

Note 1: Protocol testing is limited to EN-DC configurations with 1 CC E-UTRA and 1CC or 2CC NR configurations.

#### 4.3.1.5.1.6 Inter-band EN-DC configurations including FR2 (six bands)

**Table 4.3.1.5.1.6-1: Inter-band EN-DC configurations including FR2 (six bands)**

EN-DC Configuration	Uplink EN-DC configuration	E-UTRA downlink configuration	NR downlink configuration	E-UTRA uplink configuration	NR uplink configuration	Applicable for protocol testing (Note 1)
FFS	FFS	FFS	FFS	FFS	FFS	FFS

#### 4.3.1.6 Test frequencies for EN-DC band combinations including FR1 and FR2

##### 4.3.1.6.1 Inter-band EN-DC configurations including FR1 and FR2

###### 4.3.1.6.1.1 General

For inter-band EN-DC configurations as listed in this clause, the following apply:

For the E-UTRA band and E-UTRA CA configurations, test frequencies as specified in TS 36.508 [2], clause 4.3.1 are used.

For the NR band and NR CA configurations, test frequencies as specified in clause 4.3.1 for FR1 and 4.3.2 for FR2 are used.

## 4.3.1.6.1.2

Inter-band EN-DC configurations including FR1 and FR2 (three bands)

**Table 4.3.1.6.1.2-1: Inter-band EN-DC including FR1 and FR2 (three bands)**

EN-DC Configuration	Uplink EN-DC configuration	E-UTRA downlink configuration	NR downlink configuration	E-UTRA uplink configuration	NR uplink configuration	Applicable for protocol testing (Note 1)
DC_1A_n78A-n257A	DC_1A_n78A	1A	CA_n78A-n257A	1A	n78A	Yes (NR 2CC)
	DC_1A_n257A	1A	CA_n78A-n257A	1A	n257A	No
	DC_1A_n78A-n257A	1A	CA_n78A-n257A	1A	CA_n78A-n257A	Yes (NR 2CC)
DC_1A_n79A-n257A	DC_1A_n79A	1A	CA_n79A-n257A	1A	n79A	Yes (NR 2CC)
	DC_1A_n257A	1A	CA_n79A-n257A	1A	n257A	No
	DC_1A_n79A-n257A	1A	CA_n79A-n257A	1A	CA_n79A-n257A	Yes (NR 2CC)
DC_3A_n78A-n257A	DC_3A_n78A	3A	CA_n78A-n257A	3A	n78A	Yes (NR 2CC)
	DC_3A_n257A	3A	CA_n78A-n257A	3A	n257A	No
	DC_3A_n78A-n257A	3A	CA_n78A-n257A	3A	CA_n78A-n257A	Yes (NR 2CC)
DC_3A_n79A-n257A	DC_3A_n79A	3A	CA_n79A-n257A	3A	n79A	Yes (NR 2CC)
	DC_3A_n257A	3A	CA_n79A-n257A	3A	n257A	No
	DC_3A_n79A-n257A	3A	CA_n79A-n257A	3A	CA_n79A-n257A	Yes (NR 2CC)
DC_19A_n78A-n257A	DC_19A_n78A	19A	CA_n78A-n257A	19A	n78A	Yes (NR 2CC)
	DC_19A_n257A	19A	CA_n78A-n257A	19A	n257A	No
	DC_19A_n78A-n257A	19A	CA_n78A-n257A	19A	CA_n78A-n257A	Yes (NR 2CC)
DC_19A_n79A-n257A	DC_19A_n79A	19A	CA_n79A-n257A	19A	n79A	Yes (NR 2CC)
	DC_19A_n257A	19A	CA_n79A-n257A	19A	n257A	No
	DC_19A_n79A-n257A	19A	CA_n79A-n257A	19A	CA_n79A-n257A	Yes (NR 2CC)

Note 1: Protocol testing is limited to EN-DC configurations with 1 CC E-UTRA and 1CC or 2CC NR configurations.

## 4.3.1.6.1.3

Inter-band EN-DC configurations including FR1 and FR2 (four bands)

**Table 4.3.1.6.1.3-1: Inter-band EN-DC including FR1 and FR2 (four bands)**

EN-DC Configuration	Uplink EN-DC configuration	E-UTRA downlink configuration	NR downlink configuration	E-UTRA uplink configuration	NR uplink configuration	Applicable for protocol testing (Note 1)
DC_1A-3A_n78A-n257A	DC_1A_n78A	CA_1A-3A	CA_n78A-n257A	1A	n78A	No
	DC_1A_n257A	CA_1A-3A	CA_n78A-n257A	1A	n257A	No
	DC_3A_n78A	CA_1A-3A	CA_n78A-n257A	3A	n78A	No
	DC_3A_n257A	CA_1A-3A	CA_n78A-n257A	3A	n257A	No

EN-DC Configuration	Uplink EN-DC configuration	E-UTRA downlink configuration	NR downlink configuration	E-UTRA uplink configuration	NR uplink configuration	Applicable for protocol testing (Note 1)
DC_1A-3A_n78A-n257G	DC_1A_n78A	CA_1A-3A	CA_n78A-n257G	1A	n78A	No
	DC_1A_n257A	CA_1A-3A	CA_n78A-n257G	1A	n257A	No
	DC_1A_n257D	CA_1A-3A	CA_n78A-n257G	1A	CA_n257D	No
	DC_1A_n257G	CA_1A-3A	CA_n78A-n257G	1A	CA_n257G	No
	DC_3A_n78A	CA_1A-3A	CA_n78A-n257G	3A	n78A	No
	DC_3A_n257A	CA_1A-3A	CA_n78A-n257G	3A	n257A	No
	DC_3A_n257D	CA_1A-3A	CA_n78A-n257G	3A	CA_n257D	No
	DC_3A_n257G	CA_1A-3A	CA_n78A-n257G	3A	CA_n257G	No
DC_1A-3A_n78A-n257H	DC_1A_n78A	CA_1A-3A	CA_n78A-n257H	1A	n78A	No
	DC_1A_n257A	CA_1A-3A	CA_n78A-n257H	1A	n257A	No
	DC_1A_n257D	CA_1A-3A	CA_n78A-n257H	1A	CA_n257D	No
	DC_1A_n257G	CA_1A-3A	CA_n78A-n257H	1A	CA_n257G	No
	DC_1A_n257H	CA_1A-3A	CA_n78A-n257H	1A	CA_n257H	No
	DC_3A_n78A	CA_1A-3A	CA_n78A-n257H	3A	n78A	No
	DC_3A_n257A	CA_1A-3A	CA_n78A-n257H	3A	n257A	No
	DC_3A_n257D	CA_1A-3A	CA_n78A-n257H	3A	CA_n257D	No
	DC_3A_n257G	CA_1A-3A	CA_n78A-n257H	3A	CA_n257G	No
	DC_3A_n257H	CA_1A-3A	CA_n78A-n257H	3A	CA_n257H	No
DC_1A-3A_n78A-n257I	DC_1A_n78A	CA_1A-3A	CA_n78A-n257I	1A	n78A	No
	DC_1A_n257A	CA_1A-3A	CA_n78A-n257I	1A	n257A	No
	DC_1A_n257D	CA_1A-3A	CA_n78A-n257I	1A	CA_n257D	No
	DC_1A_n257G	CA_1A-3A	CA_n78A-n257I	1A	CA_n257G	No
	DC_1A_n257H	CA_1A-3A	CA_n78A-n257I	1A	CA_n257H	No
	DC_1A_n257I	CA_1A-3A	CA_n78A-n257I	1A	CA_n257I	No
	DC_3A_n78A	CA_1A-3A	CA_n78A-n257I	3A	n78A	No
	DC_3A_n257A	CA_1A-3A	CA_n78A-n257I	3A	n257A	No
	DC_3A_n257D	CA_1A-3A	CA_n78A-n257I	3A	CA_n257D	No
	DC_3A_n257G	CA_1A-3A	CA_n78A-n257I	3A	CA_n257G	No
	DC_3A_n257H	CA_1A-3A	CA_n78A-n257I	3A	CA_n257H	No
DC_3A_n257I	CA_1A-3A	CA_n78A-n257I	3A	CA_n257I	No	

Note 1: Protocol testing is limited to EN-DC configurations with 1 CC E-UTRA and 1CC or 2CC NR configurations.

## 4.3.1.6.1.4 Inter-band EN-DC configurations including FR1 and FR2 (five bands)

Table 4.3.1.6.1.4-1: Inter-band EN-DC including FR1 and FR2 (five bands)

EN-DC Configuration	Uplink EN-DC configuration	E-UTRA downlink configuration	NR downlink configuration	E-UTRA uplink configuration	NR uplink configuration	Applicable for protocol testing (Note 1)
---------------------	----------------------------	-------------------------------	---------------------------	-----------------------------	-------------------------	--

EN-DC Configuration	Uplink EN-DC configuration	E-UTRA downlink configuration	NR downlink configuration	E-UTRA uplink configuration	NR uplink configuration	Applicable for protocol testing (Note 1)
FFS	FFS	FFS	FFS	FFS	FFS	FFS
Note 1: Protocol testing is limited to EN-DC configurations with 1 CC E-UTRA and 1CC or 2CC NR configurations.						

## 4.3.1.6.1.5 Inter-band EN-DC configurations including FR1 and FR2 (six bands)

**Table 4.3.1.6.1.5-1: Inter-band EN-DC including FR1 and FR2 (six bands)**

EN-DC Configuration	Uplink EN-DC configuration	E-UTRA downlink configuration	NR downlink configuration	E-UTRA uplink configuration	NR uplink configuration	Applicable for protocol testing (Note 1)
FFS	FFS	FFS	FFS	FFS	FFS	FFS
Note 1: Protocol testing is limited to EN-DC configurations with 1 CC E-UTRA and 1CC or 2CC NR configurations.						

4.3.1.7 Test frequencies for Non-3GPP Access

4.3.1.7.1 WLAN Test frequencies

The same WLAN test frequencies as in TS 36.508 [2] clause 4.3.1.6 applies.

4.3.1.7.2 Bluetooth Test frequencies

The same Bluetooth test frequencies as in TS 36.508 [2] clause 4.3.1.7 applies.

4.3.1.8 Test frequencies for NR Sidelink operating bands

4.3.1.8.1 Test frequencies for NR Sidelink operating bands in FR1

4.3.1.8.1.1 Reference test frequencies for NR Sidelink operating band n38

FFS

4.3.1.8.1.2 Reference test frequencies for NR Sidelink operating band n47

**Table 4.3.1.8.1.2-1: Test frequencies for NR operating band n47 and SCS 15 kHz**

CBW [MHz]	carrierBand width [PRBs]	Range	Carrier centre [MHz]	Carrier centre [ARFCN]	point A [MHz]	sl-absolute FrequencyPoint A [ARFCN]	offsetToCarrier [Carrier PRBs]	sl-absoluteFrequencySSB [ARFCN] (NOTE)		
								S-SSB Low	S-SSB Mid	S-SSB High
10	52	Low	5860.005	790667	5855.325	790355	0	790421	790673	790913
		Mid	5889.99	792666	5794.59	786306	504	792420	792672	792912
		High	5919.99	794666	5914.23	794282	6	794420	794672	794912
20	106	Low	5865	791000	5855.46	790364	0	790430	791006	791570
		Mid	5889.99	792666	5789.73	785982	504	792096	792672	793236
		High	5914.995	794333	5904.375	793625	6	793763	794339	794903
30	160	Low	5870.01	791334	5855.61	790374	0	790440	791340	792228
		Mid	5889.99	792666	5784.87	785658	504	791772	792672	793560
		High	5910	794000	5894.52	792968	6	793106	794006	794894
40	216	Low	5875.005	791667	5855.565	790371	0	790437	791673	792897
		Mid	5889.99	792666	5779.83	785322	504	791436	792672	793896
		High	5904.99	793666	5884.47	792298	6	792436	793672	794896

NOTE: S-SSB Mid is the default S-SSB frequency unless explicitly indicated.

**Table 4.3.1.8.1.2-2: Test frequencies for NR operating band n47 and SCS 30 kHz**

CBW [MHz]	carrierBand width [PRBs]	Range	Carrier centre [MHz]	Carrier centre [ARFCN]	point A [MHz]	sl-absolute FrequencyPoint A [ARFCN]	offsetToCarrier [Carrier PRBs]	sl-absoluteFrequencySSB [ARFCN] (NOTE)		
								S-SSB Low	S-SSB Mid	S-SSB High
10	24	Low	5860.005	790667	5855.685	790379	0	790511	790679	790823
		Mid	5889.99	792666	5704.23	780282	504	792510	792678	792822
		High	5919.99	794666	5913.51	794234	6	794510	794678	794822
20	51	Low	5865	791000	5855.82	790388	0	790520	791000	791480
		Mid	5889.99	792666	5699.37	779958	504	792186	792666	793146
		High	5914.995	794333	5903.655	793577	6	793853	794333	794813
30	78	Low	5870.01	791334	5855.97	790398	0	790530	791346	792138
		Mid	5889.9	792666	5694.51	779634	504	791862	792678	793470
		High	5910	794000	5893.8	792920	6	793196	794012	794804
40	106	Low	5875.005	791667	5855.925	790395	0	790527	791679	792807
		Mid	5889.99	792666	5689.47	779298	504	791526	792678	793806

		High	5904.99	793666	5883.75	792250	6	792526	793678	794806
--	--	------	---------	--------	---------	--------	---	--------	--------	--------

NOTE: S-SSB Mid is the default S-SSB frequency unless explicitly indicated.

**Table 4.3.1.8.1.2-3: Test frequencies for NR operating band n47 and SCS 60 kHz**

CBW [MHz]	carrierBand width [PRBs]	Range	Carrier centre [MHz]	Carrier centre [ARFCN]	point A [MHz]	sl-absolute FrequencyPoint A [ARFCN]	offsetT oCarrier [Carrier PRBs]	sl-absoluteFrequencySSB [ARFCN] (NOTE)		
								S-SSB Low	S-SSB Mid	S-SSB High
10	11	Low	5860.005	790667	5856.045	790403	0	790667	790667	790667
		Mid	5889.99	792666	5523.15	768210	504	792666	792666	792666
		High	5919.99	794666	5911.71	794114	6	794666	794666	794666
20	24	Low	5865	791000	5856.36	790424	0	790688	791024	791312
		Mid	5889.99	792666	5518.47	767898	504	792354	792690	792978
		High	5914.995	794333	5902.035	793469	6	794021	794357	794645
30	38	Low	5870.01	791334	5856.33	790422	0	790686	791358	791982
		Mid	5889.99	792666	5513.43	767562	504	792018	792690	793314
		High	5910	794000	5892	792800	6	793352	794024	794648
40	51	Low	5875.005	791667	5856.645	790443	0	790707	791667	792627
		Mid	5889.99	792666	5508.75	767250	504	791706	792666	793626
		High	5904.99	793666	5882.31	792154	6	792706	793666	794626

NOTE: S-SSB Mid is the default S-SSB frequency unless explicitly indicated.

4.3.1.8.2 Test frequencies for concurrent NR sidelink operation

4.3.1.8.2.1 Reference test frequencies for Inter-band concurrent NR sidelink configurations

For inter-band concurrent NR sidelink configurations as listed in this clause, the following apply:

For the NR Uu band, test frequencies as specified in clause 4.3.1.1 for FR1 are used.

For the NR PC5 band, test frequencies as specified in clause 4.3.1.8.1 for FR1 are used.

**Table 4.3.1.8.2.1-1: Test frequencies for Inter-band concurrent NR sidelink operating bands**

Inter-band concurrent NR sidelink configuration	Operating band for NR uplink	Operating band for NR downlink	Operating band for NR sidelink	Applicable for protocol testing
V2X_n71-n47	n71	n71	n47	Yes

4.3.1.9 Test frequencies for NR NTN operating bands

4.3.1.9.1 NR NTN operating bands

4.3.1.9.1.1 Reference test frequencies for NR NTN operating band n256

**Table 4.3.1.9.1.1-1: Test frequencies for NR operating band n256 and SCS 15 kHz**

CBW [MHz]	carrierBand width [PRBs]	Range	Carrier centre [MHz]	Carrier centre [ARFCN]	point A [MHz]	absoluteFrequencyPoint A [ARFCN]	offsetT oCarrier [Carrier PRBs]	SSB block SCS [kHz]	GSN	absoluteFrequencySSB [ARFCN]	$k_{SS}$	Offset Carrier CORE SET# 0 [RBs] Note 2	CORE SET# 0 Index (Offset) [RBs] Note 1	offsetT oPoint A (SIB1) [PRBs] Note 1

5	25	Downlink	L	21 72.5	434 500	217 0.25	434050	0	15	54 29	434410	0	0	0(0)	0		
			M	21 85	437 000	216 4.39	432878	102		54 64	437090	0	1	2(4)	107		
			H	21 97.5	439 500	210 4.53	420906	504		54 93	439470	8	1	0(0)	505		
		Uplink	L	19 82.5	396 500	198 0.25	396050	0	-	-	-	-	-	-	-		
			M	19 95	399 000	190 2.03	380406	504	-	-	-	-	-	-	-		
			H	20 07.5	401 500	200 4.17	400834	6	-	-	-	-	-	-	-		
		10	52	Downlink	L	21 75	435 000	217 0.32	434064	0	15	54 30	434430	2	0	0(0)	0
					M	21 85	437 000	216 1.96	432392	102		54 58	436610	2	1	2(4)	107
					H	21 95	439 000	209 9.6	419920	504		54 80	438490	10	1	0(0)	505
Uplink	L			19 85	397 000	198 0.32	396064	0	-	-	-	-	-	-	-		
	M			19 95	399 000	189 9.6	379920	504	-	-	-	-	-	-	-		
	H			20 05	401 000	199 9.24	399848	6	-	-	-	-	-	-	-		
15	79			Downlink	L	21 77.5	435 500	217 0.39	434078	0	15	54 31	434450	4	0	0(0)	0
					M	21 85.0	437 000	215 9.53	431906	102		54 52	436130	4	1	2(4)	107
					H	21 92.5	438 500	209 4.67	418934	504		54 70	437570	8	1	1(2)	507
		Uplink	L	19 87.5	397 500	198 0.39	396078	0	-	-	-	-	-	-	-		
			M	19 95	399 000	189 7.17	379434	504	-	-	-	-	-	-	-		
			H	20 02.5	400 500	199 4.31	398862	6	-	-	-	-	-	-	-		
		20	106	Downlink	L	21 80	436 000	217 0.46	434092	0	15	54 32	434650	6	1	2(4)	5
					M	21 85	437 000	215 7.1	431420	102		54 46	435650	6	1	2(4)	107
					H	21 90	438 000	208 9.74	417948	504		54 57	436590	10	1	1(2)	507
Uplink	L			19 90	398 000	198 0.46	396092	0	-	-	-	-	-	-	-		
	M			19 95	399 000	189 4.7	378948	504	-	-	-	-	-	-	-		



				4										
		High	2000	40000	1989.38	397876	6		-	-	-	-	-	-

Note 1: The CORESET#0 Index and the associated CORESET#0 Offset refers to Table 13-1 in TS 38.213 [22]. The value of CORESET#0 Index is signalled in controlResourceSetZero (pdcch-ConfigSIB1) in the MIB. The offsetToPointA IE is expressed in units of resource blocks assuming 15 kHz subcarrier spacing for FR1 and 60 kHz subcarrier spacing for FR2.

Note 2: The parameter Offset Carrier CORESET#0 specifies the offset from the lowest subcarrier of the carrier and the lowest subcarrier of CORESET#0. It corresponds to the parameter  $\Delta F_{\text{OffsetCORESET-0-Carrier}}$  in Annex C expressed in number of common RBs.

**Table 4.3.1.9.1.1-2: Test frequencies for NR operating band n256 and SCS 30 kHz**

C B W [MHz]	carrierBandwidth [PRBs]	Range	Carrier centre [MHz]	Carrier centre [ARFCN]	point A [MHz]	absoluteFrequencyPoint A [ARFCN]	offsetToCarrier [Carrier PRBs]	SSB block SCS [kHz]	SSC N	absoluteFrequencySSB [ARFCN]	$k_{SS}$	OffsetCarrier CORESET#0 [RBs] Note 2	CORE SET#0 Index (Offset [RBs]) Note 1	offsetToPoint A (SIB1) [PRBs] Note 1	
10	52	Downlink	Low	2175	435000	2165.64	433128	0	15	5424	433950	10	0	1(6)	12
			Mid	2185	437000	2138.92	427784	102		5449	435890	14	0	0(5)	214
			High	2195	439000	2004.2	400840	504		5474	438010	6	0	2(7)	1022
		Uplink	Low	1985	397000	1975.64	395128	0	-	-	-	-	-	-	-
			Mid	1995	399000	1804.2	360840	504	-	-	-	-	-	-	-
			High	2005	401000	1993.48	398696	6	-	-	-	-	-	-	-
15	79	Downlink	Low	2175	435500	2163.28	432656	0	15	5419	433490	14	0	1(6)	12
			Mid	2185	437000	2134.06	426812	102		5437	434930	18	0	0(5)	2146
			High	2192.5	438500	1996.84	399368	504		5458	436610	6	0	3(8)	1024
		Uplink	Low	1987.5	397500	1973.28	394656	0	-	-	-	-	-	-	-
			Mid	1995	399000	1799.34	359868	504	-	-	-	-	-	-	-
			High	2002.5	400500	1986.12	397224	6	-	-	-	-	-	-	-
20	106	Downlink	Low	2180	436000	2160.92	432184	0	15	5411	432970	22	0	0(5)	10
			Mid	2185	437000	2129.2	425840	102		5425	433970	22	0	0(5)	214
			High	2192	438000	1986.12	397896	504		5454	434910	2	0	0(5)	1018

		igh	90	000	9.48				36					
	Uplink	Low	1990	398000	1970.92	394184	0	-	-	-	-	-	-	-
		Mid	1995	399000	1794.48	358896	504		-	-	-	-	-	-
		High	2000	400000	1978.76	395752	6		-	-	-	-	-	-
<p>Note 1: The CORESET#0 Index and the associated CORESET#0 Offset refers to Table 13-2 in TS 38.213 [22]. The value of CORESET#0 Index is signalled in controlResourceSetZero (pdcch-ConfigSIB1) in the MIB. The offsetToPointA IE is expressed in units of resource blocks assuming 15 kHz subcarrier spacing for FR1 and 60 kHz subcarrier spacing for FR2.</p> <p>Note 2: The parameter Offset Carrier CORESET#0 specifies the offset from the lowest subcarrier of the carrier and the lowest subcarrier of CORESET#0. It corresponds to the parameter <math>\Delta F_{\text{OffsetCORESET-0-Carrier}}</math> in Annex C expressed in number of common RBs.</p>														

Table 4.3.1.9.1.1-3: Test frequencies for NR operating band n256 and SCS 60 kHz

CBW [MHz]	carrierBand width [PRBs]	Range	Carrier centre [MHz]	Carrier centre [ARFCN]	point A [MHz]	absoluteFrequencyPointA [ARFCN]	offsetToCarrier [PRBs]	SS block SCS [kHz]	GS CN	absoluteFrequencySSB [ARFCN]	
10	11	Downlink	Low	2175	435000	2171.04	434208	0	15	-	434568
			Mid	2185	437000	2107.6	421520	102		-	436568
			High	2195	439000	1828.16	365632	504		-	438568
		Uplink	Low	1985	397000	1981.04	396208	0		-	-
			Mid	1995	399000	1628.16	325632	504		-	-
			High	2005	401000	1996.72	399344	6		-	-
15	18	Downlink	Low	2177.5	435500	2171.02	434204	0	15	-	434564
			Mid	2185	437000	2105.08	421016	102		-	436064
			High	2192.5	438500	1823.14	364628	504		-	437564
		Uplink	Low	1987.5	397500	1981.02	396204	0		-	-
			Mid	1995	399000	1625.64	325128	504		-	-
			High	2002.5	400500	1991.7	398340	6		-	-
20	24	Downlink	Low	2180	436000	2171.36	434272	0	15	-	434632
			Mid	2185	437000	2102.92	420584	102		-	435632
			High	2190	438000	1818.48	363696	504		-	436632
		Uplink	Low	1990	398000	1981.36	396272	0		-	-
			Mid	1995	399000	1623.48	324696	504		-	-
			High	2000	400000	1987.04	397408	6		-	-

Note: FR1 carrier without CORESET#0 is indicated in the MIB by setting  $k_{SSB}=31$ ,  $controlResourceSetZero=0$  and

$searchSpaceZero = 0$  (TS 38.213 [22], clause 13).

4.3.1.9.1.2 Reference test frequencies for NR NTN operating band n255

**Table 4.3.1.9.1.2-1: Test frequencies for NR operating band n255 with SCS 15 kHz and SSB SCS 15 kHz**

C B W [M Hz ]	carrierB andwidth [PRBs]	Range		Car rier cen tre [M Hz]	Car rier cen tre [AR FC N]	poi nt A [M Hz]	absoluteFre quencyPoint A [ARFCN]	offsetT oCarrie r [Carrie r PRBs]	S S b l o c k S C S [k H z]	G S C N	absoluteFr equencySS B [ARFCN]	$k_{SS}$	Offset Carrie r CORE SET# 0 [RBs] Note 2	CORE SET# 0 Index (Offse t [RBs] ) Note 1	offsetT oPoint A (SIB1) [PRBs] Note 1
5	25	Do wnli nk	L ow	15 27. 5	305 500	152 5.2 5	305050	0	15	38 18	305530	4	1	1(2)	3
			M id	15 42	308 400	152 1.3 9	304278	102		38 55	308430	4	1	1(2)	105
			H igh	15 56. 5	311 300	146 3.5 3	292706	504		38 92	311330	4	1	1(2)	507
		Upli nk	L ow	16 29	325 800	162 6.7 5	325350	0	-	-	-	-	-	-	-
			M id	16 43. 5	328 700	155 0.5 3	310106	504	-	-	-	-	-	-	-
			H igh	16 58	331 600	165 4.6 7	330934	6	-	-	-	-	-	-	-
10	52	Do wnli nk	L ow	15 30	306 000	152 5.3 2	305064	0	15	38 19	305550	6	1	1(2)	3
			M id	15 42	308 400	151 8.9 6	303792	102		38 49	307950	6	1	1(2)	105
			H igh	15 54	310 800	145 8.6	291720	504		38 79	310350	6	1	1(2)	507
		Upli nk	L ow	16 31. 5	326 300	162 6.8 2	325364	0	-	-	-	-	-	-	-
			M id	16 43. 5	328 700	154 8.1	309620	504	-	-	-	-	-	-	-
			H igh	16 55. 5	331 100	164 9.7 4	329948	6	-	-	-	-	-	-	-
15	79	Do wnli nk	L ow	15 32. 5	306 500	152 5.3 9	305078	0	15	38 20	305570	8	1	1(2)	3
			M id	15 42	308 400	151 6.5 3	303306	102		38 43	307470	8	1	1(2)	105
			H igh	15 51. 5	310 300	145 3.6 7	290734	504		38 66	309370	8	1	1(2)	507
		Upli nk	L ow	16 34	326 800	162 6.8 9	325378	0	-	-	-	-	-	-	

			M id	16 43. 5	328 700	154 5.6 7	309134	504		-	-	-	-	-	-
			H igh	16 53	330 600	164 4.8 1	328962	6		-	-	-	-	-	-
20	106	Do wnli nk	L ow	15 35	307 000	152 5.4 6	305092	0	15	38 18	305530	2	0	1(2)	2
			M id	15 42	308 400	151 4.1	302820	102		38 37	306990	10	1	1(2)	105
			H igh	15 49	309 800	144 8.7 4	289748	504		38 56	308450	6	1	2(4)	509
		Upli nk	L ow	16 36. 5	327 300	162 6.9 6	325392	0	-	-	-	-	-	-	-
			M id	16 43. 5	328 700	154 3.2 4	308648	504	-	-	-	-	-	-	-
			H igh	16 50. 5	330 100	163 9.8 8	327976	6	-	-	-	-	-	-	-
<p>Note 1: The CORESET#0 Index and the associated CORESET#0 Offset refers to Table 13-1 in TS 38.213 [22]. The value of CORESET#0 Index is signalled in controlResourceSetZero (pdcch-ConfigSIB1) in the MIB. The offsetToPointA IE is expressed in units of resource blocks assuming 15 kHz subcarrier spacing for FR1 and 60 kHz subcarrier spacing for FR2.</p> <p>Note 2: The parameter Offset Carrier CORESET#0 specifies the offset from the lowest subcarrier of the carrier and the lowest subcarrier of CORESET#0. It corresponds to the parameter <math>\Delta F_{\text{OffsetCORESET-0-Carrier}}</math> in Annex C expressed in number of common RBs.</p>															

**Table 4.3.1.9.1.2-2: Test frequencies for NR operating band n255 with SCS 30 kHz and SSB SCS 15 kHz**

C B W [M Hz ]	carrierB andwidth h [PRBs]	Range	Ca rri er ce ntr e [M Hz]	Car rier cen tre [AR FC N]	poi nt A [M Hz]	absoluteFre quencyPoint A [ARFCN]	offsetT oCarrie r [Carrie r PRBs]	S S B C S C S [k H z]	S S B C S C S [k H z]	absoluteFr equencySS B [ARFCN]	$k_{SSB}$	Offset Carrie r CORE SET# 0 [RBs] Note 2	CORE SET# 0 Index (Offse t ) Note 1	offsetT oPoint A (SIB1) [PRBs] Note 1	
10	52	Do wnli nk	L ow	15 30	306 000	152 0.6 4	304128	0	15	38 13	305070	2	0	3(8)	16
			M id	15 42	308 400	149 5.9 2	299184	102		38 43	307470	2	0	3(8)	220
			H igh	15 54	310 800	136 3.2	272640	504		38 73	309870	2	0	3(8)	1024
		Upli nk	L ow	16 31. 5	326 300	162 2.1 4	324428	0	-	-	-	-	-	-	-
			M id	16 43. 5	328 700	145 2.7	290540	504	-	-	-	-	-	-	-
			H igh	16 55. 5	331 100	164 3.9 8	328796	6	-	-	-	-	-	-	-
15	79	Do wnli nk	L ow	15 32. 5	306 500	151 8.2 8	303656	0	15	38 08	304610	6	0	3(8)	16

			M id	15 42	308 400	149 1.0 6	298212	102		38 31	306510	6	0	3(8)	220
			H igh	15 51. 5	310 300	135 5.8 4	271168	504		38 54	308410	6	0	3(8)	1024
		Upli nk	L ow	16 34	326 800	161 9.7 8	323956	0	-	-	-	-	-	-	-
			M id	16 43. 5	328 700	144 7.8 4	289568	504		-	-	-	-	-	-
			H igh	16 53	330 600	163 6.6 2	327324	6		-	-	-	-	-	-
20	106	Do wnli nk	L ow	15 35	307 000	151 5.9 2	303184	0	15	38 00	304090	14	0	2(7)	14
			M id	15 42	308 400	148 6.2	297240	102		38 16	305310	2	0	0(5)	214
			H igh	15 49	309 800	134 8.4 8	269696	504		38 35	306770	22	0	0(5)	1018
		Upli nk	L ow	16 36. 5	327 300	161 7.4 2	323484	0	-	-	-	-	-	-	-
			M id	16 43. 5	328 700	144 2.9 8	288596	504		-	-	-	-	-	-
			H igh	16 50. 5	330 100	162 9.2 6	325852	6		-	-	-	-	-	-
<p>Note 1: The CORESET#0 Index and the associated CORESET#0 Offset refers to Table 13-2 in TS 38.213 [22]. The value of CORESET#0 Index is signalled in controlResourceSetZero (pdcch-ConfigSIB1) in the MIB. The offsetToPointA IE is expressed in units of resource blocks assuming 15 kHz subcarrier spacing for FR1 and 60 kHz subcarrier spacing for FR2.</p> <p>Note 2: The parameter Offset Carrier CORESET#0 specifies the offset from the lowest subcarrier of the carrier and the lowest subcarrier of CORESET#0. It corresponds to the parameter <math>\Delta F_{\text{OffsetCORESET-0-Carrier}}</math> in Annex C expressed in number of common RBs.</p>															

**Table 4.3.1.9.1.2-3: Test frequencies for NR operating band n255 with SCS 60 kHz and SSB SCS 15 kHz**

CB W [MH z]	carrierBand width [PRBs]	Range	Carr ier cent re [MH z]	Carrie r cent re [ARF CN]	point A [MH z]	absoluteFrequen cyPointA [ARFCN]	offsetToC arrier [PRBs]	SS blo ck SC S [kH z]	GS CN	absoluteFrequen cySSB [ARFCN]	
10	11	Down link	Lo w	1530	30600 0	1526. 04	305208	0	15	-	305568
			Mi d	1542	30840 0	1464. 6	292920	102		-	307968
			Hi gh	1554	31080 0	1187. 16	237432	504		-	310368
		Uplink	Lo w	1631 .5	32630 0	1627. 54	325508	0	-	-	-
			Mi d	1643 .5	32870 0	1276. 66	255332	504	-	-	-
			Hi gh	1655 .5	33110 0	1647. 22	329444	6	-	-	-
15	18	Down link	Lo w	1532 .5	30650 0	1526. 02	305204	0	15	-	305564
			Mi d	1542	30840 0	1462. 08	292416	102		-	307464

			High	1551.5	310300	1182.14	236428	504		-	309364
		Uplink	Low	1634	326800	1627.52	325504	0	-	-	-
			Mid	1643.5	328700	1274.14	254828	504		-	-
			High	1653	330600	1642.2	328440	6		-	-
20	24	Downlink	Low	1535	307000	1526.36	305272	0	15	-	305632
			Mid	1542	308400	1459.92	291984	102		-	307032
			High	1549	309800	1177.48	235496	504		-	308432
		Uplink	Low	1636.5	327300	1627.86	325572	0		-	-
			Mid	1643.5	328700	1271.98	254396	504		-	-
			High	1650.5	330100	1637.54	327508	6		-	-

Note: FR1 carrier without CORESET#0 is indicated in the MIB by setting  $k_{SSB}=31$ , *controlResourceSetZero=0* and *searchSpaceZero=0* (TS 38.213 [22], clause 13).

## 4.3.2 Radio conditions

### 4.3.2.1 FR1, normal propagation condition for connected

The downlink connection between the System Simulator and the UE is without Additive White Gaussian Noise, and has no fading or multipath effects.

The uplink connection between the UE and System Simulator is without Additive White Gaussian Noise, and has no fading or multipath effects.

### 4.3.2.2 FR2, condition for OTA

FFS

## 4.3.3 Physical channel allocations

### 4.3.3.1 E-UTRA

The same physical channel allocations as in TS 36.508 [2] clause 4.3.3 applies.

### 4.3.3.2 NR

#### 4.3.3.2.1 Antennas

For FR1 testing, if the UE has two or four Rx antennas, the same downlink signal is applied to each antenna. All UE Rx antennas shall be connected unless otherwise stated in the test case.

#### 4.3.3.2.2 Downlink physical channels and physical signals

**Table 4.3.3.2.2-1: Power allocation for OFDM symbols and reference signals**

Parameter	Unit	Value
SSS transmit power	W	Test specific (Note 1)
EPRE ratio of PSS to SSS	dB	0
EPRE ratio of PBCH DMRS to SSS	dB	0
EPRE ratio of PBCH to PBCH DMRS	dB	0

EPRE ratio of PDCCH DMRS to SSS	dB	0
EPRE ratio of PDCCH to PDCCH DMRS	dB	0
EPRE ratio of PDSCH DMRS to SSS	dB	0
EPRE ratio of PDSCH to PDSCH DMRS	dB	0
EPRE ratio of PTRS to PDSCH	dB	0
EPRE ratio of CSI-RS to SSS	dB	0
Note 1: For signalling test cases the power allocation according to clause 6.2.1.2 applies.		

#### 4.3.3.2.3 Mapping of downlink physical channels and signals to physical resources

Parameters for mapping of downlink physical channels and signals are specified as follows.

Normal Cyclic Prefix

$N_{ID}^{cell}$ , Physical layer cell identity = 0 is used as the default physical layer cell identity

For Signalling testing, the same subcarrier spacing (SCS) is used for carrier and SS blocks; the tables in clause 6.2.3.1 specify which SCS to use for a particular NR band. In general, SCS=15kHz is used for FR1 FDD, SCS=15kHz or SCS=30kHz is used for FR1 TDD and SCS=120kHz is used for FR2.

For Signalling testing, the default channel bandwidth is specified in clause 6.2.3.1 for each NR band.

For Signalling testing, single SS Tx antenna is used, in FR1, unless specified otherwise in the test case.

For RF testing, the mapping of DL physical channels to resource element is defined in Annex C of TS 38.101-1 [7] and TS 38.101-2 [8] and TS 38.101-3 [9].

### 4.3.4 Signal levels

#### 4.3.4.1 Signal levels for conducted testing

##### 4.3.4.1.1 Downlink signal levels

For E-UTRA cell in EN-DC with FR1 NR, the downlink power setting specified in Table 4.3.4.1-1 of TS 36.508[2] are used unless otherwise specified in a test case.

##### 4.3.4.2 Signal levels for OTA testing

As defined in clause 5.2.1.2 for RF tests.

As defined in clause 6.2.1.2 for Signalling tests.

As defined in clause 7.2.1.2 for RRM tests.

### 4.3.5 Standard test signals

### 4.3.6 Physical layer parameters

#### 4.3.6.1 Downlink physical layer parameters

##### 4.3.6.1.1 Physical layer parameters for scheduling of PUSCH

###### 4.3.6.1.1.1 Physical layer parameters for DCI format 0\_0

DCI format 0\_0 is used for the scheduling of PUSCH in one cell.

Default physical layer parameters for DCI format 0\_0 are specified in table 4.3.6.1.1.1-1.

**Table 4.3.6.1.1.1-1: Physical layer parameters for DCI format 0\_0**

Parameter	Value	Value in binary
Identifier for DCI formats	Indicating an UL DCI format	"0"
Frequency domain resource assignment	Dependent on test parameters	-
Time domain resource assignment	Indicating the first entry of PUSCH-TimeDomainResourceAllocationList to be used	"0000"
Frequency hopping flag	w/o hopping	"0"
Modulation and coding scheme	Dependent on test parameters	
New data indicator	Set for every data transmission/retransmission according to the rules specified in TS 38.321	-
Redundancy version	Dependent on test parameters	-
HARQ process number	Dependent on test parameters	-
TPC command for scheduled PUSCH	0 dB (accumulated TPC) as per Table 7.1.1-1 in TS 38.213	"01"
UL/SUL indicator	Not present (0 bit for UEs not configured with SUL in the cell)	-

#### 4.3.6.1.1.2 Physical layer parameters for DCI format 0\_1

DCI format 0\_1 is used for the scheduling of PUSCH in one cell.

Default physical layer parameters for DCI format 0\_1 are specified in table 4.3.6.1.1.2-1.

**Table 4.3.6.1.1.2-1: Physical layer parameters for DCI format 0\_1**

Parameter	Value	Value in binary	Condition
Carrier indicator	Not present	-	
UL/SUL indicator	Not present (0 bit for UEs not configured with SUL in the cell)	-	
	1	1	SUL
Identifier for DCI formats	Indicating an UL DCI format	"0"	
Bandwidth part indicator	Not present (indicating active BWP, not present in case of only one <i>BWP-Id</i> as per Table 4.6.3-8)	-	
Frequency domain resource assignment	Dependent on test parameters	-	
Time domain resource assignment	Indicating the first entry of PUSCH-TimeDomainResourceAllocationList to be used	"0000"	
Frequency hopping flag	Not present	-	
Modulation and coding scheme	Dependent on test parameters	-	
New data indicator	Set for every data transmission / retransmission according to the rules specified in TS 38.321 [20]	-	
Redundancy version	Dependent on test parameters	-	
HARQ process number	Dependent on test parameters	-	
1 <sup>st</sup> downlink assignment index	Dependent on test parameters		
2 <sup>nd</sup> downlink assignment index	Not present (0 bit if one HARQ-ACK sub-codebook)	-	
TPC command for scheduled PUSCH	0 dB (accumulated TPC) as per Table 7.1.1-1 in TS 38.213 [22]	"01"	
SRS resource indicator	Not present	-	
Precoding information and number of layers	Not present (0 bits for 1 antenna port and if the higher layer parameter <i>txConfig</i> = Codebook as per clause 7.3.1.1.2 TS 38.212 [27])	-	



	2	"10"	2TX_UL_MIMO or ULFPTx_Mode1
	Dependent on UE reported full power PMI	1 bit as per Table 7.3.1.1.2-5 in TS 38.212	ULFPTx_Mode2
	0 or 1	1 bit	ULFPTx_ModeFull
Antenna ports	Port 0 (NOTE 2)	"000"	
		"00"	TRANSFORM_PRECODER_ENABLED
SRS request	No aperiodic SRS resource set triggered as per Table 7.3.1.1.2-24 in TS 38.212 (no SUL configured)	"00"	
CSI request	Not present	-	
CBG transmission information	Not present	-	
PTRS-DMRS association	DMRS port 0	"00"	PTRS_UL_CONFIG
	Not present	-	
beta_offset indicator	Not present (0 bit if the higher layer parameter dynamic in uci-on-PUSCH is not configured)	-	
DMRS sequence initialization	$n_{SCII} = 0$ (ScramblingID0 is not present as per Table 4.6.3-50)	"0"	
	Not present	-	TRANSFORM_PRECODER_ENABLED
UL-SCH indicator	Dependent on test parameters 1 bit. A value of "1" indicates UL-SCH shall be transmitted on the PUSCH and a value of "0" indicates UL-SCH shall not be transmitted on the PUSCH.	-	
ChannelAccess-CPext-CAPC	Not present	-	
Open-loop power control parameter set indication	Not present	-	
Priority indicator	Not present	-	
Invalid symbol pattern indicator	Not present	-	
Minimum applicable scheduling offset indicator	Not present	-	
SCell dormancy indication	Not present	-	
Sidelink assignment index	Dependent on test parameters 2 bits		SL_Mode1
NOTE 1: codebookSubset = nonCoherent, 2 layers, TPMI = 0 as specified in TS 38.212 [27] Table 7.3.1.1.2-4			
NOTE 2: Bitsize depends on transform precoder being enabled/disabled (PUSCH_Config, Table 4.6.3-118) and on dmrs-Type and maxLength (DMRS-UplinkConfig, Table 4.6.3-51); 3 bits (transform precoder disabled) or 2 bits (transform precoder enabled) for DMRS type 1 and len1			

Condition	Explanation
2TX_UL_MIMO	UL-MIMO test cases with 2 Tx antenna ports
PTRS_UL_CONFIG	When PTRS Uplink is configured
TRANSFORM_PRECODER_ENABLED	Transform precoding is enabled (PUSCH_Config, Table 4.6.3-118)
SUL	On the SUL carrier when supplementary carrier is configured
ULFPTx_Mode1	UL-MIMO test cases with UEs supporting UL full power transmission Mode-1
ULFPTx_Mode2	UL-MIMO test cases with UEs supporting UL full power transmission Mode-2
ULFPTx_ModeFull	UL-MIMO test cases with UEs supporting UL full power transmission Mode-full power
SL_Mode1	For SL mode 1 transmission test cases.

#### 4.3.6.1.1.3 Physical layer parameters for DCI format 0\_2

DCI format 0\_2 is used for the scheduling of PUSCH in one cell.

Default physical layer parameters for DCI format 0\_2 are specified in table 4.3.6.1.1.3-1.

**Table 4.3.6.1.1.3-1: Physical layer parameters for DCI format 0\_2**

Parameter	Value	Value in binary	Condition
Identifier for DCI formats	Indicating an UL DCI format	"0"	
Carrier indicator	Not present	-	
UL/SUL indicator	Not present (0 bit for UEs not configured with SUL in the cell)	-	
Bandwidth part indicator	Not present (indicating active BWP, not present in case of only one <i>BWP-Id</i> as per Table 4.6.3-8)	-	
Frequency domain resource assignment	Dependent on test parameters	-	
Time domain resource assignment	Indicating the first entry of PUSCH-TimeDomainResourceAllocationList to be used	"0000"	
Frequency hopping flag	Not present (0 bit if the higher layer parameter frequencyHoppingDCI-0-2 is not configured)	-	
Modulation and coding scheme	Dependent on test parameters	-	
New data indicator	Set for every data transmission / retransmission according to the rules specified in TS 38.321 [20]	-	
Redundancy version	Dependent on test parameters	-	
HARQ process number	Dependent on test parameters	-	
Downlink assignment index	Not present (0 bit if the higher layer parameter downlinkAssignmentIndexDCI-0-2 is not configured)		
TPC command for scheduled PUSCH	0 dB (accumulated TPC) as per Table 7.1.1-1 in TS 38.213 [22]	"01"	
SRS resource indicator	Not present	-	
Precoding information and number of layers	Not present (0 bits for 1 antenna port and if the higher layer parameter txConfig = Codebook as per clause 7.3.1.1.2 TS 38.212 [27])	-	
Antenna ports	Not present (0 bit if higher layer parameter antennaPortsFieldPresenceDCI-0-2 is not configured)	-	
SRS request	Not present (0 bit if the higher layer parameter <i>srs-RequestDCI-0-2</i> is not configured)	-	
CSI request	Not present	-	
PTRS-DMRS association	DMRS port 0	"00"	PTRS_UL_CONFIG
	Not present	-	
beta_offset indicator	Not present (0 bit if the higher layer parameter betaOffsets = semiStatic)	-	
DMRS sequence initialization	Not present (0 bit if the higher layer parameter dmrs-SequenceInitializationDCI-0-2 is not configured or if transform precoder is enabled)	-	
UL-SCH indicator	Dependent on test parameters 1 bit. A value of "1" indicates UL-SCH shall be transmitted on the PUSCH and a value of "0" indicates UL-SCH shall not be transmitted on the PUSCH.	-	
Open-loop power control parameter set indication	Not present (0 bit if the higher layer parameter p0-PUSCH-SetList is not configured)	-	
Priority indicator	Not present (0 bit if higher layer parameter priorityIndicatorDCI-0-2 is not configured)	-	
Invalid symbol pattern indicator	Not present (0 bit if higher layer parameter invalidSymbolPatternIndicatorDCI-0-2 is not configured)	-	

NOTE 1: codebookSubset = nonCoherent, 2 layers, TPMI = 0 as specified in TS 38.212 [27] Table 7.3.1.1.2-4  
 NOTE 2: Bitsize depends on transform precoder being enabled/disabled (PUSCH\_Config, Table 4.6.3-118) and on dmrs-Type and maxLength (DMRS-UplinkConfig, Table 4.6.3-51); 3 bits (transform precoder disabled) or 2 bits (transform precoder enabled) for DMRS type 1 and len1

Condition	Explanation
PTRS_UL_CONFIG	When PTRS Uplink is configured
TRANSFORM_PRECODER_ENABLED	Transform precoding is enabled (PUSCH_Config, Table 4.6.3-118)

#### 4.3.6.1.2 Physical layer parameters for scheduling of PDSCH

##### 4.3.6.1.2.1 Physical layer parameters for DCI format 1\_0

DCI format 1\_0 is used for the scheduling of PDSCH in one cell.

Default physical layer parameters for DCI format 1\_0 are specified in table 4.3.6.1.2.1-1 to 4.3.6.1.2.1-4.

**Table 4.3.6.1.2.1-1: Physical layer parameters for DCI format 1\_0**

Parameter	Value	Value in binary
Identifier for DCI formats	Indicating a DL DCI format	"01"
Frequency domain resource assignment	Dependent on test parameters	-
Time domain resource assignment	Indicating the first entry of PDSCH-TimeDomainResourceAllocationList to be used	"0000"
VRB-to-PRB mapping	Non-interleaved	"0"
Modulation and coding scheme	Dependent on test parameters	-
New data indicator	Set for every data transmission/retransmission according to the rules specified in TS 38.321	-
Redundancy version	Dependent on test parameters	-
HARQ process number	Dependent on test parameters	-
Downlink assignment index	Dependent on test parameters	-
TPC command for scheduled PUCCH	0 dB (accumulated TPC) as per Table 7.2.1-1 in TS 38.213	"01"
PUCCH resource indicator	$PUCCH-ResourceId[7] = 6$ in pucch-ResourceSetID[1] or $PUCCH-ResourceId[7] = 14$ in pucch-ResourceSetID[2] as defined in Table 4.6.3-112 (Mapping as per Table 9.2.3-2 in TS 38.213)	"110"
PDSCH-to-HARQ_feedback timing indicator	$K_1$ slots as specified in 9.2.3 in TS 38.213 $\mu=0$ (SCS=15kHz): $K_1=7$ $\mu=1$ (SCS=30kHz): $K_1=5$ $\mu=3$ (SCS=120kHz): $K_1=8$	'110'B '100'B '111'B

**Table 4.3.6.1.2.1-2: Physical layer parameters for DCI format 1\_0 for paging**

Parameter	Value	Value in binary
Short Messages Indicator	Only scheduling information for Paging is present in the DCI	"01"
Short Messages	Reserved	-
Frequency domain resource assignment	Dependent on test parameters	-
Time domain resource assignment	Indicating the first entry of PDSCH-TimeDomainResourceAllocationList to be used	"0000"
VRB-to-PRB mapping	Non-interleaved	"0"
Modulation and coding scheme	Dependent on test parameters	-

TB scaling	Scaling factor S=1 as defined in Table 5.1.3.2-2 in TS 38.214)	"00"
Reserved bits	Reserved 6 bits	-

**Table 4.3.6.1.2.1-3: Physical layer parameters for DCI format 1\_0 for SI**

Parameter	Value	Value in binary	Condition
Frequency domain resource assignment	Dependent on test parameters	-	-
Time domain resource assignment	Indicating the first entry of Table 5.1.2.1.1-2 in TS 38.214 [21] to be used	"0000"	SIB1
	Indicating the first entry of PDSCH-TimeDomainResourceAllocationList to be used	"0000"	SI
VRB-to-PRB mapping	Non-interleaved	"0"	-
Modulation and coding scheme	Dependent on test parameters	-	-
Redundancy version	Dependent on test parameters	-	-
System information indicator	SIB1	"0"	SIB1
	SI message	"1"	SI
Reserved bits	Reserved 15 bits	-	-

Condition	Explanation
SIB1	Used for DCI format 1_0 for SIB1
SI	Used for DCI format 1_0 for SI

**Table 4.3.6.1.2.1-4: Physical layer parameters for DCI format 1\_0 for random access**

Parameter	Value	Value in binary
Frequency domain resource assignment	Dependent on test parameters	-
Time domain resource assignment	Indicating the first entry of PDSCH-TimeDomainResourceAllocationList to be used	"0000"
VRB-to-PRB mapping	Non-interleaved	"0"
Modulation and coding scheme	Dependent on test parameters	-
Redundancy version	Dependent on test parameters	-
TB scaling	Scaling factor S=[1] as defined in Table 5.1.3.2-2 in TS 38.214)	"00"
Reserved bits	Reserved 16 bits	-

#### 4.3.6.1.2.2 Physical layer parameters for DCI format 1\_1

DCI format 1\_1 is used for the scheduling of PDSCH in one cell.

Default physical layer parameters for DCI format 1\_1 are specified in table 4.3.6.1.2.2-1.

**Table 4.3.6.1.2.2-1: Physical layer parameters for DCI format 1\_1**

Parameter	Value	Value in binary	Condition
Carrier indicator	Not present	-	
Identifier for DCI formats	Indicating a DL DCI format	"1"	
Bandwidth part indicator	Not present	-	
Frequency domain resource assignment	Dependent on test parameters	-	
Time domain resource assignment	Indicating the first entry of PDSCH-TimeDomainResourceAllocationList to be used	"0000"	
VRB-to-PRB mapping	Non-interleaved	"0"	
PRB bundling size indicator	Not present (semi-static PRB_bundling)	-	
Rate matching indicator	Not present	-	
ZP CSI-RS trigger	Not present	-	

Modulation and coding scheme (TB1)	Dependent on test parameters	-	
New data indicator (TB1)	Set for every data transmission/retransmission according to the rules specified in TS 38.321 [20]	-	
Redundancy version (TB1)	Dependent on test parameters	-	
Modulation and coding scheme (TB2)	Dependent on test parameters	-	
New data indicator (TB2)	Set for every data transmission/retransmission according to the rules specified in TS 38.321 [20]	-	
Redundancy version (TB2)	Dependent on test parameters	-	
HARQ process number	Dependent on test parameters	-	
Downlink assignment index	Dependent on test parameters	-	
TPC command for scheduled PUCCH	0 dB (accumulated TPC) as per Table 7.2.1-1 in TS 38.213 [22]	"01"	
PUCCH resource indicator	<i>PUCCH-ResourceId</i> [7] = 6 in <i>pucch-ResourceSetID</i> [1] or <i>PUCCH-ResourceId</i> [7] = 14 in <i>pucch-ResourceSetID</i> [2] as defined in Table 4.6.3-112 (Mapping as per Table 9.2.3-2 in TS 38.213 [22])	"110"	
PDSCH-to-HARQ_feedback timing indicator	corresponding to K1 slots as per Table 9.2.3-1 in TS 38.213 [22] and dl-DataToUL-ACK in Table 4.6.3-112 $\mu=0$ (SCS=15kHz): K1=7 $\mu=1$ (SCS=30kHz): K1=5 $\mu=3$ (SCS=120kHz): K1=8	"101" "011" "110"	
	corresponding to K1 slots as per Table 9.2.3-1 in TS 38.213 [22] and dl-DataToUL-ACK in Table 4.6.3-112 For 60KHz SCS K1 = 4 if $\text{mod}(i,5) = 0$ K1 = 3 if $\text{mod}(i,5) = 1$ K1 = 7 if $\text{mod}(i,5) = 2$ where $i$ is slot index per frame; $i = \{0, \dots, 39\}$  For 120KHz SCS K1 = 4 if $\text{mod}(i,5) = 0$ K1 = 3 if $\text{mod}(i,5) = 1$ K1 = 7 if $\text{mod}(i,5) = 2$ where $i$ is slot index per frame; $i = \{0, \dots, 79\}$		RF_FR2_DL
	corresponding to K1 slots as per Table 9.2.3-1 in TS 38.213 [22] and dl-DataToUL-ACK in Table 4.6.3-112  For TDD K1 = 4 if $\text{mod}(i,5) = 0$ K1 = 3 if $\text{mod}(i,5) = 1$ K1 = 2 if $\text{mod}(i,5) = 2$ where $i$ is slot index per frame; $i = \{0, \dots, 9\}$  For FDD K1 = 2		RF_FR1_15kHz

	<p>For TDD                      corresponding to K1 slots as per Table 9.2.3-1 in TS 38.213 [22] and dl-DataToUL-ACK in Table 4.6.3-112  <math>K1 = 8</math> if <math>\text{mod}(i,10) = 0</math>  <math>K1 = 7</math> if <math>\text{mod}(i,10) = 1</math>  <math>K1 = 6</math> if <math>\text{mod}(i,10) = 2</math>  <math>K1 = 5</math> if <math>\text{mod}(i,10) = 3</math>  <math>K1 = 4</math> if <math>\text{mod}(i,10) = 4</math>  <math>K1 = 3</math> if <math>\text{mod}(i,10) = 5</math>  <math>K1 = 2</math> if <math>\text{mod}(i,10) = 6</math>                      where <math>i</math> is slot index per frame; <math>i = \{0, \dots, 19\}</math>                      For FDD  <math>K1 = 2</math></p>		RF_FR1_30kHz
	<p>corresponding to K1 slots as per Table 9.2.3-1 in TS 38.213 [22] and dl-DataToUL-ACK in Table 4.6.3-112                      For TDD  <math>K1 = 13</math> if <math>\text{mod}(i,20) = 2</math>  <math>K1 = 12</math> if <math>\text{mod}(i,20) = 3</math>  <math>K1 = 11</math> if <math>\text{mod}(i,20) = 4</math>  <math>K1 = 10</math> if <math>\text{mod}(i,20) = 5</math>  <math>K1 = 9</math> if <math>\text{mod}(i,20) = 6</math>  <math>K1 = 8</math> if <math>\text{mod}(i,20) = 7</math>  <math>K1 = 7</math> if <math>\text{mod}(i,20) = 8</math>  <math>K1 = 6</math> if <math>\text{mod}(i,20) = 9</math>  <math>K1 = 6</math> if <math>\text{mod}(i,20) = 10</math>  <math>K1 = 6</math> if <math>\text{mod}(i,20) = 11</math>  <math>K1 = 6</math> if <math>\text{mod}(i,20) = 12</math>  <math>K1 = 6</math> if <math>\text{mod}(i,20) = 13</math>                      where <math>i</math> is slot index per frame; <math>i = \{0, \dots, 39\}</math>                      For FDD  <math>K1 = 2</math></p>		RF_FR1_60kHz
Antenna port(s)	DMRS port 0 as per Table 7.3.1.2.2-1 in TS 38.212 [27] ( <i>dmrs-Type</i> = DMRS type 1 and <i>maxLength</i> = len1 as per Table 4.6.3-50)	"0000"	
		"0011"	RF
Transmission configuration indication	Not present (0 bits, <i>tcj-PresentInDCI</i> = Not present as per Table 4.6.3-28)	-	
SRS request	No aperiodic SRS resource set triggered as per Table 7.3.1.1.2-24 in TS 38.212 [27] (no SUL configured)	"00"	
CBG transmission information	Not present	-	
CBG flushing out information	Not present	-	
DMRS sequence initialization	fix length of 1 bit; '0'B for DMRS-DownlinkConfig.scramblingID0 (or physCellId if scramblingID0 is not present); see Table 4.6.3-50	"0"	

Condition	Explanation
RF_FR1_15kHz	RF testing in TS 38.521-x for FR1. SCS is set to 15kHz.
RF_FR1_30kHz	RF testing in TS 38.521-x for FR1. SCS is set to 30kHz.
RF_FR1_60kHz	RF testing in TS 38.521-x for FR1. SCS is set to 60kHz.
RF_FR2_DL	RF testing in TS 38.521-x for FR2. SCS is set to 60kHz or 120kHz
RF	RF testing in TS 38.521-x for FR1 and FR2.

4.3.6.1.2.3 Physical layer parameters for DCI format 1\_2

DCI format 1\_2 is used for the scheduling of PDSCH in one cell.

Default physical layer parameters for DCI format 1\_2 are specified in table 4.3.6.1.2.3-1.

Table 4.3.6.1.2.3-1: Physical layer parameters for DCI format 1\_2

Parameter	Value	Value in binary	Condition
Identifier for DCI formats	Indicating a DL DCI format	"1"	
Carrier indicator	Not present		
Bandwidth part indicator	Not present	-	
Frequency domain resource assignment	Dependent on test parameters	-	
Time domain resource assignment	Indicating the first entry of PDSCH-TimeDomainResourceAllocationList to be used	"0000"	
VRB-to-PRB mapping	Non-interleaved	"0"	
PRB bundling size indicator	Not present (semi-static PRB_bundling)	-	
Rate matching indicator	Not present	-	
ZP CSI-RS trigger	Not present	-	
Modulation and coding scheme	Dependent on test parameters	-	
New data indicator	Set for every data transmission/retransmission according to the rules specified in TS 38.321 [20]	-	
Redundancy version	Dependent on test parameters	-	
HARQ process number	Dependent on test parameters	-	
Downlink assignment index	Dependent on test parameters	-	
TPC command for scheduled PUCCH	0 dB (accumulated TPC) as per Table 7.2.1-1 in TS 38.213 [22]	"01"	
PUCCH resource indicator	$PUCCH-ResourceId[7] = 6$ in $pucch-ResourceSetID[1]$ or $PUCCH-ResourceId[7] = 14$ in $pucch-ResourceSetID[2]$ as defined in Table 4.6.3-112 (Mapping as per Table 9.2.3-2 in TS 38.213 [22])	"110"	
PDSCH-to-HARQ_feedback timing indicator	corresponding to K1 slots as per Table 9.2.3-1 in TS 38.213 [22] and dl-DataToUL-ACK in Table 4.6.3-112 $\mu=0$ (SCS=15kHz): K1=7 $\mu=1$ (SCS=30kHz): K1=5 $\mu=3$ (SCS=120kHz): K1=8	"101" "011" "110"	
Antenna port(s)	Not present (0 bit if higher layer parameter $antennaPortsFieldPresenceDCI-1-2$ is not configured)	-	
Transmission configuration indication	Not present (0 bits, $tcI-PresentInDCI =$ Not present as per Table 4.6.3-28)	-	
SRS request	Not present (0 bit if higher layer parameter $srs-RequestDCI-1-2$ is not configured)	-	
DMRS sequence initialization	Not present (0 bit if higher layer parameter $dmrs-SequenceInitializationDCI-1-2$ is not configured)	-	
Priority indicator	Not present (0 bit if higher layer parameter $priorityIndicatorDCI-1-2$ is not configured)	-	

4.3.6.1.3 Void

4.3.6.1.4 Physical layer parameters for scheduling of PSCCH/PSSCH

4.3.6.1.4.1 Physical layer parameters for DCI format 3\_0

DCI format 3\_0 is used to schedule PSCCH/PSSCH transmission on NR sidelink.

Default physical layer parameters for DCI format 3\_0 are specified in Table 4.3.6.1.4.1-1.

**Table 4.3.6.1.4.1-1: Physical layer parameters for DCI format 3\_0**

Parameter	Value	Value in binary	Condition
Resource pool index	Not present	-	
Time gap	Indicating the first entry of sl-DCI-ToSL-Trans to be used	"000"B	
HARQ process number	Dependent on test parameters	-	
New data indicator	Set for every data transmission/retransmission according to the rules specified in TS 38.321[20]	-	
Lowest index of the subchannel allocation to the initial transmission	Dependent on test parameters	-	
Frequency resource assignment	Dependent on test parameters	-	
Time resource assignment	only one PSCCH/PSSCH occasion is scheduled per grant	"00000"B	
PSFCH-to-HARQ feedback timing indicator	Indicating the first entry of sl-PSFCH-ToPUCCH to be used	"000"B	
PUCCH resource indicator	Indicating the first entry of sl-PUCCH-Config to be used	"000"B	
Configuration index	Not present	-	SL-RNTI
	Indicating the first entry of sl-ConfiguredGrantConfigList to be used	"000"	SL-CS-RNTI
Counter sidelink assignment index	PDCCH monitoring occasions in which DCI format 3_0 scheduling PSSCH transmissions with corresponding PSFCH reception occasions is present, denoted as Y, satisfies $(Y-1) \bmod 4 = 0$ , as specified in 38.213 Table 16.5.2.1-1	"00"	

Condition	Explanation
SL-RNTI	UE is configured to monitor DCI format 3_0 with CRC scrambled by SL-RNTI, i.e. dynamic sidelink grant
SL-CS-RNTI	UE is configured to monitor DCI format 3_0 with CRC scrambled by SL-CS-RNTI, i.e. configured sidelink grant

#### 4.3.6.1.4.2 Physical layer parameters for DCI format 3\_1

DCI format 3\_1 is used to schedule PSCCH/PSSCH transmission on E-UTRA V2X sidelink.

FFS

#### 4.3.6.1.5 Physical layer parameters for scheduling of MBS

##### 4.3.6.1.5.1 Physical layer parameters for DCI format 4\_0

DCI format 4\_0 is used for the scheduling of PDSCH for broadcast in DL cell.

Default physical layer parameters for DCI format 4\_0 are specified in Table 4.3.6.1.5.1-1.

**Table 4.3.6.1.5.1-1: Physical layer parameters for DCI format 4\_0**

Parameter	Value	Value in binary	Condition
Frequency domain resource assignment	Dependent on test parameters	-	
Time domain resource assignment	Indicating the first entry of PDSCH-TimeDomainResourceAllocationList to be used	"0000"	
VRB-to-PRB mapping	Non-interleaved	"0"	
Modulation and coding scheme	Dependent on test parameters	-	



Redundancy version	Dependent on test parameters	-	
MCCH change notification	MSB indicates no new MBS service(s) start. LSB indicates no modification of MCCH information other than the change caused by start of new MBS service(s).	"00"	MCCH-RNTI
	Not present	-	G-RNTI
NOTE: Zeros shall be appended to DCI format 4_0 until the payload size equals that of DCI format 1_0 monitored in common search space in the same serving cell.			

Condition	Explanation
MCCH-RNTI	UE is configured to monitor DCI format 4_0 with CRC scrambled by MCCH-RNTI
G-RNTI	UE is configured to monitor DCI format 4_0 with CRC scrambled by G-RNTI for MTCH

#### 4.3.6.1.5.2 Physical layer parameters for DCI format 4\_1

DCI format 4\_1 is used for the scheduling of PDSCH for multicast in DL cell.

Default physical layer parameters for DCI format 4\_1 are specified in Table 4.3.6.1.5.2-1.

**Table 4.3.6.1.5.2-1: Physical layer parameters for DCI format 4\_1**

Parameter	Value	Value in binary
Frequency domain resource assignment	Dependent on test parameters	-
Time domain resource assignment	Indicating the first entry of PDSCH-TimeDomainResourceAllocationList to be used	"0000"
VRB-to-PRB mapping	Non-interleaved	"0"
Modulation and coding scheme	Dependent on test parameters	-
New data indicator	Set for every data transmission/retransmission according to the rules specified in TS 38.321	-
Redundancy version	Dependent on test parameters	-
HARQ process number	Dependent on test parameters	-
Downlink assignment index	Dependent on test parameters	-
PUCCH resource indicator	$PUCCH-ResourceId[7] = 6$ in $pucch-ResourceSetID[1]$ or $PUCCH-ResourceId[7] = 14$ in $pucch-ResourceSetID[2]$ as defined in Table 4.6.3-112 (Mapping as per Table 9.2.3-2 in TS 38.213)	"110"
PDSCH-to-HARQ_feedback timing indicator	$K_1$ slots, $dl-DataToUL-ACK-MulticastDciFormat4-1$ is not provided, as specified in 9.2.3 in TS 38.213 $\mu=0$ (SCS=15kHz): $K_1=7$ $\mu=1$ (SCS=30kHz): $K_1=5$ $\mu=3$ (SCS=120kHz): $K_1=8$	'110'B '100'B '111'B
Reserved bits	Reserved 3 bits	-

#### 4.3.6.1.5.3 Physical layer parameters for DCI format 4\_2

DCI format 4\_2 is used for the scheduling of PDSCH in DL cell.

Default physical layer parameters for DCI format 4\_2 are specified in Table 4.3.6.1.5.3-1.

**Table 4.3.6.1.5.3-1: Physical layer parameters for DCI format 4\_2**

Parameter	Value	Value in binary
Frequency domain resource assignment	Dependent on test parameters	-

Time domain resource assignment	Indicating the first entry of PDSCH-TimeDomainResourceAllocationList to be used	"0000"
VRB-to-PRB mapping	Non-interleaved	"0"
PRB bundling size indicator	Not present (semi-static PRB bundling)	-
Rate matching indicator	Not present	-
ZP CSI-RS trigger	Not present	-
Modulation and coding scheme (TB1)	Dependent on test parameters	-
New data indicator (TB1)	Set for every data transmission/retransmission according to the rules specified in TS 38.321 [20]	-
Redundancy version (TB1)	Dependent on test parameters	-
Modulation and coding scheme (TB2)	Dependent on test parameters	-
New data indicator (TB2)	Set for every data transmission/retransmission according to the rules specified in TS 38.321 [20]	-
Redundancy version (TB2)	Dependent on test parameters	-
HARQ process number	Dependent on test parameters	-
Downlink assignment index	Dependent on test parameters	-
PUCCH resource indicator	$PUCCH-ResourceId[7] = 6$ in $pucch-ResourceSetID[1]$ or $PUCCH-ResourceId[7] = 14$ in $pucch-ResourceSetID[2]$ as defined in Table 4.6.3-112 (Mapping as per Table 9.2.3-2 in TS 38.213 [22])	"110"
PDSCH-to-HARQ_feedback timing indicator	corresponding to K1 slots as per Table 9.2.3-1 in TS 38.213 [22] and $d/ -DataToUL-ACK$ in Table 4.6.3-112 $\mu=0$ (SCS=15kHz): K1=7 $\mu=1$ (SCS=30kHz): K1=5 $\mu=3$ (SCS=120kHz): K1=8	"101" "011" "110"
Antenna port(s)	DMRS port 0 as per Table 7.3.1.2.2-1 in TS 38.212 [27] ( $dmrs-Type = DMRS$ type 1 and $maxLength = len1$ as per Table 4.6.3-50)	"0000"
Transmission configuration indication	Not present (0 bit, $tci-PresentInDCI$ in $PDCCH-Config-Multicast$ is not enabled as per Table 4.6.3-FFS)	-
DMRS sequence initialization	Fix length of 1 bit (configured to $physCellId$ as $scramblingID0$ is not present in Table 4.6.3-50.	$physCellId$
Priority indicator	Not present (0 bit, $priorityIndicatorDCI-4-2-r17$ is not configured in $PDSCH-Config-Multicast$ as per Table 4.6.3-FFS)	-
Enabling/disabling HARQ-ACK feedback indication	Not present (0 bit, $harq-FeedbackEnablerMulticast$ does not indicate $dci-enable$ as per Table 4.6.3-FFS)	-
NOTE:	The size of DCI format 4_2 is configurable by higher layer parameter $sizeDCI-4-2$ from 20 bits and up to 140 bits.	

## 4.3.6.2 Sidelink physical layer parameters

### 4.3.6.2.1 Physical layer parameters for scheduling of PSSCH on PSCCH

#### 4.3.6.2.1.1 Physical layer parameters for SCI format 1-A

SCI format 1-A is used to schedule PSSCH transmission.

Default physical layer parameters for SCI format 1-A are specified in Table 4.3.6.2.1.1-1.

**Table 4.3.6.2.1.1-1: Physical layer parameters for SCI format 1-A**

Parameter	Value	Value in binary	Condition
-----------	-------	-----------------	-----------

Priority	Dependent on test parameters	-	
Frequency resource assignment	Dependent on test parameters	-	
Time domain resource assignment	only one PSCCH/PSSCH occasion is scheduled per grant	"0000"B	
Resource reservation period	Not present	-	
DMRS pattern	Indicating the first entry of sl-PSSCH-DMRS-TimePatternList-r16 to be used	"0"B	
2 <sup>nd</sup> -stage SCI format	SCI format 2-A	"00"B	
	SCI format 2-B	"01"B	DISTANCE-BASED HARQ
Beta_offset indicator	Indicating the first entry of sl-BetaOffsets2ndSCI to be used	"00"B	
Number of DMRS port	Single port p = 1000 is used	"0"B	
	Two ports p = 1000 and 1001 are used	"1"B	SL MIMO
Modulation and coding scheme	Dependent on test parameters	-	
Additional MCS table indicator	Not present	-	
PSFCH overhead indication	"1"B if mod (i, n <sub>PSFCH</sub> ) = 0 "0"B if mod (i, n <sub>PSFCH</sub> ) ≠ 0  where i is the logical slot index belong to resource pool per 1024 frame as specified in 38.214 [21] clause 8.	-	n <sub>PSFCH</sub> = 2 OR n <sub>PSFCH</sub> = 4 (Note 1)
	Not present		
Reserved	Number of reserved bits is given by sl-NumReservedBits-r16	"00"	
Note 1: n <sub>PSFCH</sub> is the PSFCH period (in slots) provided by sl-PSFCH-Period-r16. n <sub>PSFCH</sub> = 0 if sl-PSFCH-Period-r16 is not configured.			

Condition	Explanation
DISTANCE-BASED HARQ	For distance-based HARQ test
SL MIMO	For SL MIMO test

#### 4.3.6.2.2 Physical layer parameters for scheduling on PSSCH

##### 4.3.6.2.2.1 Physical layer parameters for SCI format 2-A

SCI format 2-A is used to provide HARQ information, to provide Source/Destination L1 ID or to trigger CSI reporting.

Default physical layer parameters for SCI format 2-A are specified in Table 4.3.6.2.2.1-1.

**Table 4.3.6.2.2.1-1: Physical layer parameters for SCI format 2-A**

Parameter	Value	Value in binary	Condition
HARQ process number	Dependent on test parameters		
New data indicator	Set for every data transmission/retransmission according to the rules specified in TS 38.321	-	
Redundancy version	Dependent on test parameters	-	
Source ID	Dependent on test parameters	-	
Destination ID	Dependent on test parameters	-	
HARQ feedback enabled/disabled indicator	HARQ feedback is enabled	"1"B	
Cast type indicator	broadcast	"00"B	BROADCAST
	groupcast with ACK/NACK HARQ	"01"B	GROUPCAST_ ACK_NACK
	unicast	"10"B	UNICAST
	groupcast with NACK-only HARQ	"11"B	GROUPCAST_ NACK_ONLY
CSI request	Not ask for SL CSI report	"0"B	
	Ask for SL CSI report	"1"B	SL_CSI

Condition	Explanation
BROADCAST	For broadcast SL communication test
GROUPCAST_ACK_NACK	For groupcast SL communication with ACK/NACK HARQ feedback test
GROUPCAST_NACK_ONLY	For groupcast SL communication with NACK-only HARQ feedback test
UNICAST	For unicast SL communication test
SL_CSI	For SL CSI reporting test

#### 4.3.6.2.2.2 Physical layer parameters for SCI format 2-B

SCI format 2-B is used to provide HARQ information, Source/Destination L1 ID or distance-based HARQ related parameters.

Default physical layer parameters for SCI format 2-B are specified in Table 4.3.6.2.2.2-1.

**Table 4.3.6.2.2.2-1: Physical layer parameters for SCI format 2-B**

Parameter	Value	Value in binary
HARQ process number	Dependent on test parameters	-
New data indicator	Set for every data transmission/retransmission according to the rules specified in TS 38.321	-
Redundancy version	Dependent on test parameters	-
Source ID	Dependent on test parameters	-
Destination ID	Dependent on test parameters	-
HARQ feedback enabled/disabled indicator	HARQ feedback enabled	"1"B
Zone ID	Dependent on test parameters	-
Communication range requirement	Indicating the first entry of sl-ZoneConfigMCR-List to be used	"0000"B

## 4.4 Reference system configurations

The reference system configurations specified in this sub clause apply to all test cases unless otherwise specified.

### 4.4.1 Simulated network scenarios

The simulated network scenarios will simulate UE operation in either standalone NR, standalone E-UTRA or in non-standalone NR and E-UTRA networks. For non-standalone case either the NR or the E-UTRA radio access acts as the master anchor node. For both standalone and non-standalone cases, the simulated networks may be single mode networks (FDD or TDD) or dual mode networks (FDD+TDD). For the standalone NR case the simulated networks may also be inter-RAT networks ((FDD or TDD) + (E-UTRA FDD or E-UTRA TDD or UTRA FDD)).

Simulated network scenarios to be tested are listed in this sub clause.

NOTE 1: The number of cells specified does not necessarily correspond to the maximum number of resources to be configured simultaneously in test equipment. Please refer to clause 6.1 for such information.

NOTE 2: For NAS test cases see sub clause 6.3.2.

#### 4.4.1.1 Standalone cell network scenarios

##### 4.4.1.1.1 Standalone E-UTRA single cell and multi cell network scenarios

For standalone E-UTRA FDD or TDD single cell environment see TS 36.508 [2], clause 4.4.1.1.

For standalone E-UTRA FDD or TDD multi cell network scenarios see TS 36.508 [2], clause 4.4.1.2.

#### 4.4.1.1.2 Standalone NR single cell network scenarios

For standalone NR FDD or TDD single cell environment, NR Cell 1 is used.

#### 4.4.1.1.3 Standalone NR single mode multi cell network scenarios

For standalone NR FDD or TDD intra-frequency multi cell environment, NR Cell 1, NR Cell 2 and NR Cell 4 are used.

For standalone NR FDD or TDD inter-frequency multi cell environment, NR Cell 1, NR Cell 3 and NR Cell 6 are used.

For standalone NR FDD or TDD inter-band cell environment, NR Cell 1 and NR Cell 10 are used.

For standalone NR FDD or TDD multi tracking area intra-frequency multi cell environment, NR Cell 1 and NR Cell 11 are used.

For standalone NR FDD or TDD multi tracking area inter-frequency multi cell environment, NR Cell 1 and NR Cell 23 are used.

For standalone NR FDD or TDD multi PLMN inter-frequency multi cell environment, NR Cell 1, NR Cell 12, NR Cell 13 and NR Cell 14 are used.

#### 4.4.1.1.4 Standalone NR dual mode multi cell network scenarios

For standalone NR FDD and TDD multi cell environment, NR Cell 1, NR Cell 10 and NR Cell 31 are used.

For standalone NR FDD and TDD multi PLMN multi cell environment, NR Cell 1, NR Cell 28, NR Cell 29 and NR Cell 30 are used.

In addition, standalone NR single mode multi cell network scenarios defined in clause 4.4.1.1.3 are combined with the dual mode scenarios defined in this clause when additional intra or inter-frequency cells are used.

#### 4.4.1.1.5 Standalone NR 3GPP Inter-RAT network scenarios

For standalone NR FDD or TDD single cell with E-UTRA FDD, E-UTRA TDD or UTRA FDD single cell inter-RAT environment:

- NR Cell 1 is used for the NR cell; and
- Cell 1, as specified in TS 36.508 [2] clause 4.4.1.1, is used for the E-UTRA cell; or
- Cell 5, as specified in TS 36.508 [2] clause 4.4.2, is used for the UTRA cell.

For standalone NR FDD or TDD single cell with E-UTRA FDD or E-UTRA TDD multi cell inter-RAT environment:

- NR Cell 1 is used for the NR cell; and
- Cell 1, Cell 2 and Cell 4, as specified in TS 36.508 [2] clause 4.4.1.2, is used for the E-UTRA cell; and

#### 4.4.1.2 Non-standalone cell network scenarios

##### 4.4.1.2.1 Non-standalone E-UTRA single cell and NR single cell network scenarios

For non-standalone NR FDD or TDD single cell and E-UTRA FDD or TDD single cell environment:

- Cell 1, as specified in TS 36.508 [2] clause 4.4.1.1, is used for the E-UTRA cell; and
- NR Cell 1 is used for the NR cell.

##### 4.4.1.2.2 Non-standalone E-UTRA single cell and NR single mode multi cell network scenarios

For non-standalone E-UTRA single cell and FDD or TDD NR intra-frequency single mode multi cell environment:

- Cell 1, as specified in TS 36.508 [2] clause 4.4.1.1, is used for the E-UTRA cell; and

- NR Cell 1, NR Cell 2 and NR Cell 4 are used for NR cells.

For non-standalone E-UTRA single cell and FDD or TDD NR inter-frequency single mode multi cell environment:

- Cell 1, as specified in TS 36.508 [2] clause 4.4.1.1, is used for the E-UTRA cell; and
- NR Cell 1, NR Cell 3 and NR Cell 6 are used for the NR cells.

For non-standalone E-UTRA single cell and FDD or TDD NR inter-band single mode multi cell environment:

- Cell 1, as specified in TS 36.508 [2] clause 4.4.1.1, is used for the E-UTRA cell; and
- NR Cell 1 and NR Cell 10 are used for the NR cells.

#### 4.4.1.2.3 Non-standalone E-UTRA single mode multi cell and NR single mode multi cell network scenarios

For non-standalone E-UTRA intra-frequency single mode multi cell and FDD or TDD NR intra-frequency single mode multi cell environment:

- E-UTRA Cell 1, Cell 2 and Cell 4, as specified in TS 36.508 [2] clause 4.4.1.2, is used for the E-UTRA cell; and
- NR Cell 1, NR Cell 2 and NR Cell 4 are used for NR cells.

For non-standalone FDD or TDD E-UTRA intra-frequency single mode multi cell and FDD or TDD NR inter-frequency single mode multi cell environment:

- E-UTRA Cell 1, Cell 2 and Cell 4, as specified in TS 36.508 [2] clause 4.4.1.2, is used for the E-UTRA cell; and
- NR Cell 1, NR Cell 3 and NR Cell 6 are used for the NR cells.

For non-standalone FDD or TDD E-UTRA inter-frequency single mode multi cell and FDD or TDD NR inter-frequency single mode multi cell environment:

- E-UTRA Cell 1, Cell 3 and Cell 6, as specified in TS 36.508 [2] clause 4.4.1.2, is used for the E-UTRA cell; and
- NR Cell 1, NR Cell 3 and NR Cell 6 are used for the NR cells.

For non-standalone single E-UTRA cell and FDD or TDD NR inter-band single mode multi cell environment:

- E-UTRA Cell 1, Cell 2 and Cell 4, as specified in TS 36.508 [2] clause 4.4.1.2, is used for the E-UTRA cell; and
- NR Cell 1 and NR Cell 10 are used for the NR cells.

#### 4.4.1.2.4 Non-standalone E-UTRA single cell and NR dual mode multi cell network scenarios

**Editor's note: It is FFS if the NR dual mode multi cell environment needs to include multiple E-UTRA cells in addition to the multiple NR cells.**

For non-standalone single E-UTRA cell and FDD and TDD NR dual mode multi cell environment:

- Cell 1, as specified in TS 36.508 [2] clause 4.4.1.1, is used for the E-UTRA cell; and
- NR Cell 1, NR Cell 10 and NR Cell 31 are used for the NR cells.

In addition, standalone NR single mode multi cell network scenarios defined in clause 4.4.1.2.2 are combined with the dual mode scenarios defined in this clause when additional intra or inter-frequency NR cells are used.

### 4.4.1.3 Non-3GPP Access network scenarios

#### 4.4.1.3.1 WLAN network scenario

For non-3GPP access over WLAN single cell environment Cell 27, Cell 27a and Cell 27b as specified in TS 36.508 [2] clauses 4.4.2 and 4.4.8 with condition 'IMSoWLAN' is used.

#### 4.4.1.3.2 Bluetooth network scenario

For non-3GPP access over Bluetooth single cell environment Cell 40 and Cell 41, as specified in TS 36.508 [2] clauses 4.4.2.

### 4.4.2 Simulated cells

NOTE 1: For NAS test cases see clause 6.3.2.

NOTE 2: Test frequency and range defined in table 4.4.2-1 do not apply to TS 38.521-1, TS 38.521-2 and TS 38.521-3 test cases.

Test frequencies and simulated NR cells are defined in table 4.4.2-1. Test frequencies and simulated E-UTRA and UTRA cells are defined in TS 36.508 [2] table 4.4.2-1.

For NR cells, NRf1 is the default test frequency. For UTRA cells, f8 as specified in TS 36.508 [2] table 4.2.2-1 is the default test frequency. For E-UTRA cells, f1 as specified in TS 36.508 [2] table 4.2.2-1 is the default test frequency.

Default parameters for simulated NR cells are specified in table 4.4.2-2 and table 4.4.2-3.

Default parameters for simulated E-UTRA cells are specified in TS 36.508 [2] table 4.4.2-1A and table 4.4.2-2.

Default parameters for simulated UTRA cells are specified in TS 36.508 [2] clause 4.4.4.

Common parameters for NR simulated cells are specified in clauses 4.4.3.

Other cell specific parameters are specified in TS 36.508 [2] clause 4.4.3 to 4.4.7.

**Table 4.4.2-1: Definition of test frequencies and simulated NR cells**

Test frequency	RAT	Operating band	Range	Simulated NR cells
NRf1	NR	Operating band under test	Mid (Note 1, Note 3)	NR Cell 1, NR Cell 2, NR Cell 4, NR Cell 11, NR Cell 489
NRf2	NR	Operating band under test	High (Note 1, Note 3)	NR Cell 3, NR Cell 12, NR Cell 23
NRf3	NR	Operating band under test	Low (Note 1, Note 3)	NR Cell 6, NR Cell 13
NRf4	NR	Operating band under test	(Note 1)	NR Cell 14
NRf5	NR	Operating band for inter-band cells	Mid (Note 1)	NR Cell 10, NR Cell 30, NR Cell 31
NRf6	NR	Operating band for inter-band cells	High (Note 1)	NR Cell 28, NR Cell 29
NRf7	NR	Operating band for inter-band cells	Low (Note 1)	
NRf8	NR	Operating band for SDL cell	Mid (Note 1)	NR Cell 32
NRf9	NR	Operating band for SUL cell	Mid (Note 1)	NR Cell 33
NRf10	NR	Operating band for inter-band cells	Mid (Note bb)	NR Cell 500
Note 1:	For signalling test, see clause 6.2.3.			
Note 2:	Void.			
Note 3:	For RRM test with NR intra-band non-contiguous CA, the test frequencies for the set of non-contiguous component carriers are specified in clauses 4.3.1.1.4 for FR1 and in clause 4.3.1.2.4 for FR2 without any regard to range. Thus "Low", "Mid" and "High" information in this table does not apply. Unless otherwise stated, test point with maximum Wgap is chosen.			
Note 4:	For signalling test with NR inter-band CA three bands only, the test band is different from the Operating band for NRf1 and the Operating band for NRf5.			

Table 4.4.2-2: Default NR parameters for simulated NR cells

cell ID	NR Cell Identifier		Physical layer cell identity	PRACH-rootSequenceIndex FDD	PRACH-rootSequenceIndex TDD	SSB-Index <sup>2,3</sup>
	gNB Identifier	Cell Identity		$L_{RA}=139$ Note 1	$L_{RA}=139$ Note 1	
NR Cell 1	'00 0000 0000 0000 0000 0000 0001'B	'00 0000 0000'B	0	0	0	1
NR Cell 2	'00 0000 0000 0000 0000 0000 0001'B	'00 0000 0010'B	2	32	32	0
NR Cell 3	'00 0000 0000 0000 0000 0000 0010'B	'00 0000 0011'B	3	0	0	1
NR Cell 4	'00 0000 0000 0000 0000 0000 0011'B	'00 0000 0100'B	4	64	64	1
NR Cell 6	'00 0000 0000 0000 0000 0000 0100'B	'00 0000 0110'B	6	0	0	1
NR Cell 10	'00 0000 0000 0000 0000 0000 0101'B	'00 0000 1010'B	10	0	0	1
NR Cell 11	'00 0000 0000 0000 0000 0000 0110'B	'00 0000 1011'B	11	96	96	0
NR Cell 12	'00 0000 0000 0000 0000 0000 0010'B	'00 0000 1100'B	12	32	32	0
NR Cell 13	'00 0000 0000 0000 0000 0000 0100'B	'00 0000 1101'B	13	32	32	0
NR Cell 14	'00 0000 0000 0000 0000 0000 0111'B	'00 0000 1110'B	14	0	0	1
NR Cell 23	'00 0000 0000 0000 0000 0000 0110'B	'00 0001 0111'B	23	64	64	1
NR Cell 28	'00 0000 0000 0000 0000 0000 0010'B	'00 0001 1100'B	28	0	0	1
NR Cell 29	'00 0000 0000 0000 0000 0000 0100'B	'00 0001 1101'B	29	32	32	0
NR Cell 30	'00 0000 0000 0000 0000 0000 0111'B	'00 0001 1110'B	30	32	32	0
NR Cell 31	'00 0000 0000 0000 0000 0000 0110'B	'00 0001 1111'B	31	64	64	1
NR Cell	'00 0000	'00 0010	32	-	-	1



32	0000 0000 0000 0001'B	0000'B				
NR Cell 33	'00 0000 0000 0000 0000 0001'B	'00 0010 0001'B	33	-	-	-
NR Cell 489	'00 0000 0000 0000 0000 0000 0001'B	'01 1110 1001'B	489	128	128	0
NR Cell 500	'00 0000 0000 0000 0000 0000 1000'B	'00 0000 0111'B	500	0	0	1

Note 1: To avoid collision of the preambles between intra-frequency cells, with the default *zeroCorrelationZoneConfig* value set to 15, the *PRACH-rootSequenceIndex* values have been separated by 32 root sequences per intra-frequency cell.

Note 2: This SSB-Index does not apply for RRM test cases in TS 38.533 [18]. RRM test cases shall use the SSB index defined in A.3 of TS 38.533 [18].

Note 3: For signalling test, simultaneous co-existence of active NR cells defined on the same frequency and same SSB-Index is not recommended due to the same timing used for intra-frequency NR cells in TS 38.523-3 [23].

**Table 4.4.2-3: Default NAS parameters for simulated NR cells**

cell ID	Tracking Area			TA# list (Note 1)	5G-GUTI (Note 2)			5G-TMSI	
	TA#	PLMN			TAC	AMF Identifier			
		MCC	MNC			AMF region ID	AMF Set ID		AMF Pointer
NR Cell 1	TAI-1	(Note 3)		1	TAI-1	254	1	1	Arbitrarily selected according to TS 23.003 [26] clause 2.10
NR Cell 2	TAI-1	(Note 3)		1	TAI-1	254	1	1	
NR Cell 3	TAI-1	(Note 3)		1	TAI-1	254	1	1	
NR Cell 4	TAI-1	(Note 3)		1	TAI-1	254	1	1	
NR Cell 6	TAI-1	(Note 3)		1	TAI-1	254	1	1	
NR Cell 10	TAI-1	(Note 3)		1	TAI-1	254	1	1	
NR Cell 11	TAI-2	(Note 3)		2	TAI-2	254	1	1	
NR Cell 23	TAI-2	(Note 3)		2	TAI-2	254	1	1	
NR Cell 12, NR Cell 28	TAI-3	002	11	1	TAI-3	253	1	1	
NR Cell 13, NR Cell 29	TAI-4	003	21	1	TAI-4	252	1	1	
NR Cell 14, NR Cell 30	TAI-5	004	31	1	TAI-5	251	1	1	
NR Cell 31	TAI-2	(Note 3)		2	TAI-2	254	1	1	
NR Cell 489	TAI-1	(Note 3)		1	TAI-1	254	1	1	
NR Cell 500	TAI-1	(Note 3)		1	TAI-1	254	1	1	

Note 1: The value(s) in the column TA# list indicates TAI(s) included in the response messages of the registration procedure (REGISTRATION ACCEPT) when the UE performs the registration procedure on a corresponding cell.

Note 2: The value in the column 5G-GUTI indicates 5G-GUTI included in the response messages of the registration procedure (REGISTRATION ACCEPT) when the UE performs the registration procedure on a corresponding cell.

Note 3: Set to the same Mobile Country Code and Mobile Network Code stored in EF<sub>IMSI</sub> on the test USIM card (subclause 4.9.3).

**Table 4.4.2-4: Default parameters for simulated SNPN cells**

cell ID	Network Identifier (NID)	
	Assignment mode (Note 1)	NID value
NR Cell 1	1	1
NR Cell 2	1	2
NR Cell 3	1	3
NR Cell 4	1	4
NR Cell 6	1	6

NR Cell 10	1	10
NR Cell 11	1	11
NR Cell 12	1	12
NR Cell 13	1	13
NR Cell 14	1	14
NR Cell 23	1	23
NR Cell 28	1	28
NR Cell 29	1	29
NR Cell 30	1	30
NR Cell 31	1	32
NR Cell 32	1	32
NR Cell 33	1	33
NR Cell 489	1	489
NR Cell 500	1	500
Note 1: As per TS 23.003 [26] clause 12.7.1, Network Identifier comprises of Assignment mode (one hexadecimal digit) and NID value (10 hexadecimal digits). Self-assignment NIDs are chosen by setting the assignment mode to value 1.		

### 4.4.3 Common parameters for simulated NR cells

The parameters specified in this sub clause apply to the simulated NR cells in standalone NR and non-standalone network scenarios unless otherwise specified.

The common parameters for the simulated E-UTRA cells for standalone E-UTRA and non-standalone network scenarios are specified in TS 36.508 [2] clause 4.4.3 unless otherwise specified.

#### 4.4.3.1 Common configurations of system information blocks

##### 4.4.3.1.1 Combinations of system information blocks for E-UTRA standalone, EN-DC and NGEN-DC

The combination of system information blocks for standalone E-UTRA, EN-DC and NGEN-DC network scenarios are specified in TS 36.508 [2] clause 4.4.3.1.

For EN-DC and NGEN-DC network scenarios the SS shall in addition to broadcasting the E-UTRA system information blocks also broadcast the NR MIB on the NR cell(s).

##### 4.4.3.1.2 Combinations of system information blocks for NR standalone and NE-DC

The combination of system information blocks required by a test case depends on the test case scenario. In this clause, several combinations of system information blocks are defined.

Regardless of the combination of system information blocks indicated as being used by a test case, the SS shall broadcast only the NR MIB on the NR Cell(s) configured on an SDL band and on NR SCell(s) configured on a band having no uplink frequency specified.

For NE-DC network scenario the SS shall in addition to broadcasting the NR system information blocks also broadcast the E-UTRA system information combination 1 on the E-UTRA cell(s) as specified in TS 36.508 [2].

Combination NR-1 is the default combination which applies to the following test case scenarios:

- NR FDD single cell scenario except RRM test case scenarios
- NR TDD single cell scenario except RRM test case scenarios
- NR FDD inter-band DC component carriers cell scenario
- NR TDD inter-band DC component carriers cell scenario
- NR FDD and NR TDD inter-band DC component carriers cell scenario

Combination NR-2 applies to the following test case scenarios:

- NR FDD intra-frequency multi cell scenario
- NR TDD intra-frequency multi cell scenario
- NR FDD and NR TDD dual mode multi cell roaming scenario
- NR FDD single cell RRM test case scenario
- NR TDD single cell RRM test case scenario

Combination NR-3 applies to the following test case scenarios:

- NR FDD intra-frequency multi cell scenario with neighbouring cell related information
- NR TDD intra-frequency multi cell scenario with neighbouring cell related information

Combination NR-4 applies to the following test case scenarios:

- NR FDD inter-frequency multi cell scenario
- NR TDD inter-frequency multi cell scenario
- NR FDD inter-band multi cell scenario
- NR TDD inter-band multi cell scenario
- NR FDD and NR TDD dual mode multi cell non-roaming scenario
- NR FDD intra-band carrier aggregation component carriers cell scenario
- NR FDD inter-band carrier aggregation component carriers cell scenario
- NR TDD intra-band carrier aggregation component carriers cell scenario
- NR FDD and NR TDD inter-band carrier aggregation component carriers cell scenario

Combination NR-5 applies to the following test case scenarios:

- NR FDD intra-band carrier aggregation component carriers cell scenario + NR FDD intra-frequency neighbour.
- NR FDD inter-band carrier aggregation component carriers cell scenario+ NR FDD intra-frequency neighbour.
- NR TDD intra-band carrier aggregation component carriers cell scenario+ NR FDD intra-frequency neighbour.
- NR FDD and NR TDD inter-band carrier aggregation component carriers cell scenario+ NR FDD intra-frequency neighbour.

Combination NR-6 applies to the following test case scenarios:

- 3GPP inter-RAT NR FDD + E-UTRA FDD multi cell scenario
- 3GPP inter-RAT NR TDD + E-UTRA TDD multi cell scenario
- 3GPP inter-RAT NR TDD + E-UTRA FDD multi cell scenario

Combination NR-7 applies to the following test case scenarios:

- NR FDD inter-frequency + 3GPP inter-RAT E-UTRA multi-cell scenario
- NR TDD inter-frequency + 3GPP inter-RAT E-UTRA multi-cell scenario

Combination NR-8 applies to the following test case scenarios:

- NR FDD ETWS single cell scenario
- NR TDD ETWS single cell scenario

Combination NR-9 applies to the following test case scenarios:

- 3GPP NR FDD + CMAS single cell scenario
- 3GPP NR TDD + CMAS single cell scenario

Combination NR-10 applies to the following test case scenarios:

- 3GPP NR FDD + ETWS primary notification single cell scenario
- 3GPP NR TDD + ETWS primary notification single cell scenario

Combination NR-11 applies to the following test case scenarios:

- 3GPP NR FDD + ETWS secondary notification single cell scenario
- 3GPP NR TDD + ETWS secondary notification single cell scenario

Combination NR-12 applies to the following test case scenarios:

- 3GPP NR FDD + SNPN only single cell scenario
- 3GPP NR TDD + SNPN only single cell scenario

Combination NR-13 applies to the following test case scenarios:

- 3GPP NR FDD + CAG cell multi cell scenario
- 3GPP NR TDD + CAG cell multi cell scenario

Combination NR-14 applies to the following test case scenarios:

- 3GPP NR FDD single cell scenario + NR sidelink communication with or without network scheduling.
- 3GPP NR TDD single cell scenario + NR sidelink communication with or without network scheduling.
- 3GPP NR FDD intra-frequency multi cell scenario + NR sidelink communication with or without network scheduling.
- 3GPP NR TDD intra-frequency multi cell scenario + NR sidelink communication with or without network scheduling.
- 3GPP NR FDD inter-frequency multi cell scenario + NR sidelink communication with or without network scheduling.
- 3GPP NR TDD inter-frequency multi cell scenario + NR sidelink communication with or without network scheduling.
- 3GPP NR FDD inter-band multi cell scenario + NR sidelink communication with or without network scheduling.
- 3GPP NR TDD inter-band multi cell scenario + NR sidelink communication with or without network scheduling.

Combination NR-15 applies to the following test case scenarios:

- 3GPP NR FDD single cell scenario + positioning test case which require posSIBs.
- 3GPP NR TDD single cell scenario + positioning test case which require posSIBs.

Combination NR-16 applies to the following test case scenarios:

- 3GPP NR FDD intra-frequency multi cell scenario + positioning test case which require posSIBs.
- 3GPP NR TDD intra-frequency multi cell scenario + positioning test case which require posSIBs.

Combination NR-17 applies to the following test case scenarios:

- 3GPP NR FDD inter-frequency multi cell scenario + positioning test case which require posSIBs.
- 3GPP NR TDD inter-frequency multi cell scenario + positioning test case which require posSIBs.

Combination NR-18 applies to the following test case scenarios:

- 3GPP NR FDD inter-frequency multi cell scenario + idle/inactive measurements.
- 3GPP NR TDD inter-frequency multi cell scenario + idle/inactive measurements.

Combination NR-19 applies to the following test case scenarios:

- 3GPP NR FDD + Extended field in SI scenario
- 3GPP NR TDD + Extended field in SI scenario

Combination NR-20 applies to the following test case scenarios:

- 3GPP NR FDD single cell scenario + MBS data.
- 3GPP NR TDD single cell scenario + MBS data.
- 3GPP NR FDD intra-frequency multi cell scenario + MBS data.
- 3GPP NR TDD intra-frequency multi cell scenario + MBS data.

Combination NR-21 applies to the following test case scenarios:

- 3GPP NR FDD intra-frequency multi cell scenario + MBS Service Continuity.
- 3GPP NR TDD intra-frequency multi cell scenario + MBS Service Continuity.

Combination NR-22 applies to the following test case scenarios:

- 3GPP NR FDD intra-frequency multi cell scenario + MBS data + MBS Service Continuity.
- 3GPP NR TDD intra-frequency multi cell scenario + MBS data + MBS Service Continuity.

Combination NR-23 applies to the following test case scenarios:

- 3GPP NR FDD inter-frequency multi cell scenario + MBS data
- 3GPP NR TDD inter-frequency multi cell scenario + MBS data.

Combination NR-24 applies to the following test case scenarios:

- 3GPP NR FDD inter-frequency multi cell scenario + MBS Service Continuity.
- 3GPP NR TDD inter-frequency multi cell scenario + MBS Service Continuity.

Combination NR-25 applies to the following test case scenarios:

- 3GPP NR FDD inter-frequency multi cell scenario + MBS data + MBS Service Continuity.
- 3GPP NR TDD inter-frequency multi cell scenario + MBS data + MBS Service Continuity.

Combination NR-26 applies to the following test case scenarios:

- 3GPP NR FDD + eNPN single cell scenario
- 3GPP NR TDD + eNPN single cell scenario

Combination NR-27 applies to the following test case scenarios:

- 3GPP NR FDD + eNPN multi cell scenario
- 3GPP NR TDD + eNPN multi cell scenario

Combination NR-28 applies to the following test case scenarios:

- 3GPP NR FDD single NTN cell scenario

Combination NR-29 applies to the following test case scenarios:

- 3GPP NR FDD intra-frequency multi NTN cell scenario

Combination NR-30 applies to the following test case scenarios:

- 3GPP NR FDD inter-frequency multi cell scenario + slice-based cell reselection in idle/inactive state
- 3GPP NR TDD inter-frequency multi cell scenario + slice-based cell reselection in idle/inactive state

**Table 4.4.3.1.2-1: Combinations of system information blocks**

Combination No.	System information block type																			
	SI B1	SI B2	SI B3	SI B4	SI B5	SI B6	SI B7	SI B8	SI B9	SIB 10	SIB 11	SIB 12	SIB 13	SIB 14	SIB 16	posS IBs	SIB 18	SIB 19	SIB 20	SI B 21
NR-1	X																			
NR-2	X	X																		
NR-3	X	X	X																	
NR-4	X	X		X																
NR-5	X	X	X	X																
NR-6	X	X			X															
NR-7	X	X		X	X															
NR-8	X					X	X													
NR-9	X							X												
NR-10	X					X														
NR-11	X						X													
NR-12	X									X										
NR-13	X	X								X										
NR-14	X	X		X							X									
NR-15	X															X				
NR-16	X	X														X				
NR-17	X	X		X												X				
NR-18	X			X						X										
NR-19	X	X								X										
NR-20	X	X																	X	
NR-21	X	X																		X
NR-22	X	X																	X	X
NR-23	X	X		X															X	
NR-24	X	X		X																X
NR-25	X	X		X															X	X
NR-26	X									X							X			
NR-27	X	X								X							X			
NR-28	X																	X		
NR-29	X	X																X		
NR-30	X	X		X											X					

4.4.3.1.3 Scheduling of system information blocks

The scheduling configurations for combinations of system information blocks are defined in the following tables. There is no scheduling information for combination NR-1.

**Table 4.4.3.1.3-1: Scheduling for combination NR-2**

Scheduling Information No.	Periodicity [radio frames]	Mapping of system information blocks
1	32	SIB2

**Table 4.4.3.1.3-2: Scheduling for combination NR-3**

Scheduling Information No.	Periodicity [radio frames]	Mapping of system information blocks
1	32	SIB2
2	64	SIB3

**Table 4.4.3.1.3-3: Scheduling for combination NR-4**

Scheduling Information No.	Periodicity [radio frames]	Mapping of system information blocks
1	32	SIB2
2	64	SIB4

**Table 4.4.3.1.3-4: Scheduling for combination NR-5**

Scheduling Information No.	Periodicity [radio frames]	Mapping of system information blocks
1	32	SIB2
2	64	SIB3
3	64	SIB4

**Table 4.4.3.1.3-5: Scheduling for combination NR-6**

Scheduling Information No.	Periodicity [radio frames]	Mapping of system information blocks
1	32	SIB2
2	64	SIB5

**Table 4.4.3.1.3-6: Scheduling for combination NR-7**

Scheduling Information No.	Periodicity [radio frames]	Mapping of system information blocks
1	32	SIB2
2	64	SIB4, SIB5

**Table 4.4.3.1.3-7: Scheduling for combination NR-8**

Scheduling Information No.	Periodicity [radio frames]	Mapping of system information blocks
1	32	SIB6
2	32	SIB7

**Table 4.4.3.1.3-8: Scheduling for combination NR-9**

Scheduling Information No.	Periodicity [radio frames]	Mapping of system information blocks
1	32	SIB8

**Table 4.4.3.1.3-9: Scheduling for combination NR-10**

Scheduling Information No.	Periodicity [radio frames]	Mapping of system information blocks
	32	SIB6

**Table 4.4.3.1.3-10: Scheduling for combination NR-11**

Scheduling Information No.	Periodicity [radio frames]	Mapping of system information blocks
1	32	SIB7

Table 4.4.3.1.3-11: Scheduling for combination NR-12

Scheduling Information No.	Periodicity [radio frames]	Mapping of system information blocks
1	64	SIB10

Table 4.4.3.1.3-12: Scheduling for combination NR-13

Scheduling Information No.	Periodicity [radio frames]	Mapping of system information blocks
1	32	SIB2
2	64	SIB10

Table 4.4.3.1.3-13: Scheduling for combination NR-14

Scheduling Information No.	Periodicity [radio frames]	Mapping of system information blocks
1	32	SIB2
2	64	SIB4
3	64	SIB12

Table 4.4.3.1.3-14: Scheduling for combination NR-15

Scheduling Information No.	Periodicity [radio frames]	Mapping of system information blocks
1	32	posSibType1-1, posSibType1-2, posSibType1-3 (Note 1)
	32	posSibType4-1 (Note 2)
	32	posSibType5-1 (Note 3)
	32	posSibType1-5, posSibType1-6, posSibType1-7 (Note 5)
	32	posSibType1-8 (Note 6)
2..N+1	32	posSibType2-1, posSibType2-3, posSibType2-6, posSibType2-7, posSibType2-8, posSibType2-9 (Note 4)
	32	posSibType2-12, posSibType2-13 (Note 7)
	32	posSibType2-17, posSibType2-18, posSibType2-19, posSibType2-20, posSibType2-21, posSibType2-22, posSibType2-23 (Note 8)
Note 1:	Content of SI message 1 when UE supports GNSS as defined in TS 37.571-2 [20] Table 8.1-1: Sub-test 25.	
Note 2:	Content of SI message 1 when UE supports Sensor as defined in TS 37.571-2 [20] Table 8.1-1: Sub-test 24.	
Note 3:	Content of SI message 1 when UE supports MBS as defined in TS 37.571-2 [20] Table 8.1-1: Sub-test 23.	
Note 4:	Content of SI messages 2..N, only present when UE supports GNSS as defined in TS 37.571-2 [20] Table 8.1-1: Sub-test 25. If UE supports N GNSS systems, N SIs are broadcasted, one SI per each GNSS system.	
Note 5:	Content of SI message 1 when UE supports RTK corrections	
Note 6:	Content of SI message 1 when UE supports SSR corrections	
Note 7:	Content of SI messages 2..N, only present when UE supports RTK corrections. . If UE supports N GNSS systems, N SIs are broadcasted, one SI per each GNSS system. The posSibType2-13 must only be present when GLONASS is supported.	
Note 8:	Content of SI messages 2..N, only present when UE supports SSR corrections. If UE supports N GNSS systems, N SIs are broadcasted, one SI per each GNSS system.	



**Table 4.4.3.1.3-15: Scheduling for combination NR-16**

Scheduling Information No.	Periodicity [radio frames]	Mapping of system information blocks
1	32	SIB2
2	32	posSibType6-1

**Table 4.4.3.1.3-16: Scheduling for combination NR-17**

Scheduling Information No.	Periodicity [radio frames]	Mapping of system information blocks
1	32	SIB2
2	64	SIB4
3	32	posSibType6-1

**Table 4.4.3.1.3-17: Scheduling for combination NR-18**

Scheduling Information No.	Periodicity [radio frames]	Mapping of system information blocks
1	64	SIB4
2	64	SIB11

**Table 4.4.3.1.3-18: Scheduling for combination NR-19**

Scheduling Information No.	Periodicity [radio frames]	Mapping of system information blocks
1	32	SIB2, SIB11

**Table 4.4.3.1.3-19: Void****Table 4.4.3.1.3-20: Scheduling for combination NR-20**

Scheduling Information No.	Periodicity [radio frames]	Mapping of system information blocks
1	32	SIB2
2	64	SIB20

**Table 4.4.3.1.3-21: Scheduling for combination NR-21**

Scheduling Information No.	Periodicity [radio frames]	Mapping of system information blocks
1	32	SIB2
2	64	SIB21

**Table 4.4.3.1.3-22: Scheduling for combination NR-22**

Scheduling Information No.	Periodicity [radio frames]	Mapping of system information blocks
1	32	SIB2
2	64	SIB20
2	64	SIB21

**Table 4.4.3.1.3-23: Scheduling for combination NR-23**

Scheduling Information No.	Periodicity [radio frames]	Mapping of system information blocks
----------------------------	----------------------------	--------------------------------------

1	32	SIB2
2	64	SIB4
3	64	SIB20

**Table 4.4.3.1.3-24: Scheduling for combination NR-24**

Scheduling Information No.	Periodicity [radio frames]	Mapping of system information blocks
1	32	SIB2
2	64	SIB4
3	64	SIB21

**Table 4.4.3.1.3-25: Scheduling for combination NR-25**

Scheduling Information No.	Periodicity [radio frames]	Mapping of system information blocks
1	32	SIB2
2	64	SIB4
3	64	SIB20
4	64	SIB21

**Table 4.4.3.1.3-26: Scheduling for combination NR-26**

Scheduling Information No.	Periodicity [radio frames]	Mapping of system information blocks
1	64	SIB10, SIB18

**Table 4.4.3.1.3-27: Scheduling for combination NR-27**

Scheduling Information No.	Periodicity [radio frames]	Mapping of system information blocks
1	32	SIB2
2	64	SIB10, SIB18

**Table 4.4.3.1.3-28: Scheduling for combination NR-28**

Scheduling Information No.	Periodicity [radio frames]	Mapping of system information blocks
1	64	SIB19

**Table 4.4.3.1.3-29: Scheduling for combination NR-29**

Scheduling Information No.	Periodicity [radio frames]	Mapping of system information blocks
1	32	SIB2
2	64	SIB19

**Table 4.4.3.1.3-30: Scheduling for combination NR-30**

Scheduling Information No.	Periodicity [radio frames]	Mapping of system information blocks
1	32	SIB2
2	64	SIB4
3	64	SIB16

## 4.4A Test states

### 4.4A.1 General

The purpose of the test states is to get the UE into specific 5GC and RRC protocol states in the initial condition of test cases. Each test state is identified by a test state ID. The syntax used for test state IDs is described in sub-clause 4.4A.4. The list of defined test states and the associated UE 5GC and RRC/ N3AN protocol states are specified in sub-clause 4.4A.2.

A test case may request that one or more test functions and/or configurations are activated/configured by the SS as part of the procedure used for the requested test state. The test case requests the additional test functions and/or configurations by specifying one or more test state parameters. The list of defined test state parameters is specified in sub-clause 4.4A.3.

### 4.4A.2 Test states and associated 5GC and RRC protocol states

**Table 4.4A.2-0: 5GC and RRC/N3AN protocol states for UE Switched Off**

5GS state ID	Connectivity	RRC/N3AN state	5GMM modes	5GMM sublayer	5GSM sublayer	Comments
0-A	-	-	-	-	-	UE switched off. No change to PLMN stored in the USIM
0N-B	NR	-	-	-	-	UE switched off with the PLMN under test stored in the USIM
0E-B	E-UTRA	-	-	-	-	
0W-B	WLAN	-	-	-	-	

**Table 4.4A.2-1: 5GC and RRC/N3AN protocol states for IDLE**

5GS state ID	Connectivity	RRC/N3AN state	5GMM modes	5GMM sublayer	5GSM sublayer
1N-A	NR	NR RRC_IDLE	5GMM-IDLE	5GMM-REGISTERED	PDU SESSION INACTIVE
					PDU SESSION ACTIVE
1E-A	E-UTRA	EUTRA RRC_IDLE	5GMM-IDLE	5GMM-REGISTERED	PDU SESSION INACTIVE
					PDU SESSION ACTIVE
1W-A	WLAN	Ipsec_SA_Released	5GMM-IDLE	5GMM-REGISTERED	PDU SESSION INACTIVE
					PDU SESSION ACTIVE
1N-B	NR	NR RRC_IDLE	5GMM-IDLE	5GMM-REGISTERED	PDU SESSION INACTIVE
					PDU SESSION ACTIVE

**Table 4.4A.2-2: 5GC and RRC protocol states for INACTIVE**

5GS state ID	Connectivity	RRC state	5GMM modes	5GMM sublayer	5GSM sublayer
2N-A	NR	NR RRC_INACTIVE	5GMM-CONNECTED	5GMM-REGISTERED	PDU SESSION INACTIVE
					PDU SESSION ACTIVE

2E-A	E-UTRA	EUTRA RRC_ INACTIVE	5GMM- CONNECTED	5GMM- REGISTERED	PDU SESSION INACTIVE
					PDU SESSION ACTIVE

Table 4.4A.2-3: 5GC and RRC/N3AN protocol states for CONNECTED

5GS state ID	Connectivity	RRC/N3AN state	5GMM modes	5GMM sublayer	5GSM sublayer
3N-A	NR	NR RRC_ CONNECTED	5GMM- CONNECTED	5GMM- REGISTERED	PDU SESSION INACTIVE
					PDU SESSION ACTIVE
3E-A	E-UTRA	EUTRA RRC_ CONNECTED	5GMM- CONNECTED	5GMM- REGISTERED	PDU SESSION INACTIVE
					PDU SESSION ACTIVE
3W-A	WLAN	Ipsec_SA_Established	5GMM- CONNECTED	5GMM- REGISTERED	PDU SESSION INACTIVE
					PDU SESSION ACTIVE
3N-B	NR	NR RRC_ CONNECTED	5GMM- CONNECTED	5GMM- REGISTERED	PDU SESSION INACTIVE
					PDU SESSION ACTIVE

Table 4.4A.2-4: 5GC and RRC/N3AN protocol states for Out of Coverage

5GS state ID	Connectivity	RRC/N3AN state	5GMM modes	5GMM sublayer	5GSM sublayer
4-A	-	-	-	-	-

### 4.4A.3 Test state parameters

Table 4.4A.3-1 lists the test functions and configurations that a test case can request to be activated/configured. A test case requests a test function or configuration to be used in the preamble by including the test state parameter text in the preamble statement of the test case in *italics*.

Editor's Note: The test state parameters are currently limited to test functions required by standalone NR. Additional test state parameters will be added in future as needed. E.g. for EN-DC, NE-DC and NGEN-DC there will be a need for parameters for bearer type (MCG and SCG, MCG and split or MCG only).

Table 4.4A.3-1: Test state parameters

Test state parameter	Description
<i>UE test loop mode &lt;X&gt; prepared</i>	If included the UE test mode is activated in the preamble indicating that UE test loop mode <X> will be activated in the test case test procedure, where <X> is A, B or E. (Note 1, Note 2, Note 3, Note 4)
<i>UE test loop mode &lt;X&gt; active</i>	If included the UE Test Mode and UE test loop mode <X> will be activated in the preamble, where <X> is A, B or E. (Note 1, Note 2, Note 3, Note 4)
Note 1:	See TS 38.509 [11], clause 5.2.2 for details of UE test mode.
Note 2:	See TS 38.509 [11], clause 5.3.4.1 for details of UE test loop mode A.
Note 3:	See TS 38.509 [11], clause 5.3.4.2.2 for details of UE test loop mode B.
Note 4:	See TS 38.509 [11], clause 5.3.4.3 for details of UE test loop mode E.

### 4.4A.4 Test state ID syntax

A test state ID is defined as:

<RRC state><Connectivity>-<Variant>

, where <RRC state>, <Connectivity> and <Variant> are defined in Table 4.4A.2-1.

**Table 4.4A.4-1: Test state fields**

Test state field	Value	Description
<RRC state>	0	Indicates that the requested test state will end up in SWITCHED_OFF state.
	1	Indicates that the requested test state will end up in RRC_IDLE/Ipsec_SA_Released state.
	2	Indicates that the requested test state will end up in RRC_INACTIVE state.
	3	Indicates that the requested test state will end up in RRC_CONNECTED/Ipsec_SA_Released state.
	4	Indicates that the requested test state will end up in Out_of_Coverage state.
<Connectivity>	E	E-UTRA is used as the initial access.
	N	NR is used as the initial access.
	W	Un trusted non 3GPP Access over WLAN is used as the initial access
<Variant>	A	A, B, C etc. used to represent different variants within a <RRC state><Connectivity> group of test states.

#### 4.4A.5 Mapping of test state IDs and test parameters to generic procedures, generic procedure parameters and specific message conditions

Depending on the test case preamble requested test state ID and test parameters the SS shall:

- 1> use the applicable generic procedure as specified in Table 4.4A.5-1 using the:
  - 2> applicable generic procedure parameters as specified in Table 4.4A.5-1 and Table 4.4A.5-2; and
  - 2> applicable message conditions as specified in Table 4.4A.5-2.

**Table 4.4A.5-1: Test state ID mapping to generic procedures and Connectivity generic procedure parameter**

Test state ID			Generic Procedure		
RRC state field	Connectivity field	Variant field	Name	Generic procedure parameter (Note 1)	Clause
0	-	A	SWITCHED_OFF		4.5.5
0	N	B	SWITCHED_OFF	Connectivity=NR	4.5.5
0	E	B	SWITCHED_OFF	Connectivity=E-UTRA	4.5.5
0	W	B	SWITCHED_OFF	Connectivity=WLAN	4.5.5
1	N	A	RRC_IDLE	Connectivity=NR	4.5.2
1	E	A	RRC_IDLE	Connectivity=E-UTRA	4.5.2
1	W	A	Ipsec_SA_Released	Connectivity=WLAN	4.5.2
1	N	B	RRC_IDLE_with_SL	Connectivity=NR, Sidelink = On	4.5.2
2	N	A	RRC_INACTIVE	Connectivity=NR	4.5.3
2	E	A	RRC_INACTIVE	Connectivity=E-UTRA	4.5.3
3	N	A	RRC_CONNECTED	Connectivity=NR	4.5.4
3	E	A	RRC_CONNECTED	Connectivity=E-UTRA	4.5.4
3	W	A	Ipsec_SA_Established	Connectivity=WLAN	4.5.4
3	N	B	RRC_CONNECTED_w ith_SL	Connectivity=NR, Sidelink = On	4.5.4
4	-	A	Out_of_Coverage	Sidelink = On	4.5.7

Note 1: In addition to the Connectivity parameter specified in this table the applicable additional generic procedure parameters and conditions as stated in Table 4.4A.5-2 shall be used

**Table 4.4A.5-2: Additional generic procedure parameters and message conditions**

Test state parameter	Additional generic procedure parameter(s)	Specific message conditions	
		Message	Condition

<i>UE test loop mode A prepared</i>	Test Mode= <i>On</i>	Note 1	Note 1
<i>UE test loop mode B prepared</i>	Test Mode= <i>On</i>	ACTIVATE UE TEST MODE (see subclause 4.7A.1)	UE test loop mode B
<i>UE test loop mode E prepared</i>	Test Mode= <i>On</i>	ACTIVATE UE TEST MODE (ee subclause 4.7A.1)	UE test loop mode E
<i>UE test loop mode A active</i>	Test Loop Function= <i>On</i>	Note 1	Note 1
<i>UE test loop mode B active</i>	Test Loop Function= <i>On</i>	ACTIVATE UE TEST MODE (see subclause 4.7A.1)	UE test loop mode B
		CLOSE UE TEST LOOP (see subclause 4.7A.2)	UE test loop mode B
<i>UE test loop mode E active</i>	Test Loop Function= <i>On</i>	ACTIVATE UE TEST MODE (see subclause 4.7A.1)	UE test loop mode E
		CLOSE UE TEST LOOP (see subclause 4.7A.2)	UE test loop mode E
Note 1: For test state parameters <i>UE test loop mode A prepared</i> and <i>UE test loop mode A active</i> there is no specific message conditions needed as the default UE test loop mode in the messages ACTIVATE UE TEST MODE and CLOSE UE TEST LOOP is UE test loop mode A.			

## 4.5 Generic procedures

### 4.5.1 General

The generic procedures are used by test cases to get UE under test into SWITCHED\_OFF, RRC\_IDLE/Ipsec SA not established, RRC\_INACTIVE, RRC\_CONNECTED/Ipsec SA or Out of Coverage established state.

A test case controls the SS by specifying the required RRC state and a set of generic procedure parameters applicable for the intended testing.

The connectivity values *EN-DC* and *E-UTRA/EPC* are both a UE connected to the EPC. The connectivity values *E-UTRA/5GC*, *NR*, *NGEN-DC*, *NE-DC* and *NR-DC* are all a UE connected to the 5GC.

**Table 4.5.1-1: Generic procedure parameters**

Parameter	Values	Description	Parameter condition
Connectivity	<i>E-UTRA/5GC</i>	E-UTRA connected to 5GC	Mandatory. For value <i>NR</i> see note 1.
	<i>NR</i>	NR connected to 5GC	
	<i>EN-DC</i>	E-UTRA-NR Dual Connectivity with E-UTRA connected to EPC	
	<i>NGEN-DC</i>	E-UTRA-NR Dual Connectivity with E-UTRA connected to 5GC	
	<i>NE-DC</i>	NR E-UTRA Dual Connectivity	
	<i>NR-DC</i>	NR-NR Dual Connectivity	
	<i>WLAN</i>	Un trusted non 3GPP access over WLAN	
	<i>E-UTRA/EPC</i>	E-UTRA connected to EPC	
Bearers	<i>MCG(s) and SCG</i>	MCG and SCG	Mandatory when Connectivity is set to <i>EN-DC</i> , <i>NGEN-DC</i> , <i>NE-DC</i> and <i>NR-DC</i> and when the generic procedures are used by test cases to get UE under test into RRC_CONNECTED state. s=1 if MULTI_PDN= FALSE and s=2 if MULTI_PDN=TRUE. N/A otherwise.
	<i>MCG(s) and split</i>	MCG and split	
Test Mode	<i>On</i>	UE test mode active as specified in TS 38.509 [11], clause 5.2.2.	Optional
Test Loop Function	<i>On</i>	UE test mode active with one of the UE test loop modes activated as specified in TS	Optional

		38.509 [11], clauses 5.2.2 and 5.3.2.	
Connected without release	<i>On</i>	Enter RRC_Connected with Ipsec_SA_Established and without any release.	Optional N/A for <i>NR-DC</i> .
Interworking without N26 interface supported	<i>On</i>	The NWK sets the REGISTRATION ACCEPT message, IE 5GS network feature support, IWK N26 (octet 3, bit 7) = 1	Optional, Depends on test case scenario. Default message content for REGISTRATION ACCEPT is set to Interworking without N26 interface NOT supported
Unrestricted nr PDN	<i>On</i>	Allow unrestricted numbers of PDNs.	Optional for Connectivity <i>E-UTRA/EPC</i> . N/A otherwise.
Sidelink	<i>On</i>	NR sidelink	Optional
Cast type	<i>Unicast</i>	To establish unicast sidelink and PC5-RRC connection.	Optional
GNSS Sync	<i>On</i>	To use GNSS as the synchronization reference source.	Optional
SL MIMO	<i>On</i>	To transmit PSSCH with 2 spatial layers, i.e. SL MIMO	Optional
Note 1: The TS 38.331 [6] abbreviation for NR connected to 5GC is NR/5GC.			

**Editor's Note:** The following values are not available to use in the current version of this specification because details are still FFS: Connectivity (E-UTRA/5GC and NGEN-DC).

## 4.5.2 RRC\_IDLE

### 4.5.2.1 Initiation

The SS shall:

- 1> if connectivity is *EN-DC*:
  - 2> use 1 E-UTRA cell and 1 NR cell, default parameters;
  - 2> if connected without release is not present:
    - 3> perform according to the table 4.5.2.2-1: E-UTRA RRC\_IDLE;
- 1> if connectivity is *E-UTRA/EPC*:
  - 2> use 1 E-UTRA cell, default parameters;
  - 2> if unrestricted nr PDN is not present:
    - 3> perform according to the table 4.5.2.2-1: E-UTRA RRC\_IDLE;
  - 2> else:
    - 3> perform according to the table 4.5.2.2-5: E-UTRA RRC\_IDLE Unrestricted nr PDN;
    - 3> if *pc\_noOf\_PDNsNewConnection* > 0:
      - 4> perform according to the table 4.5.2.2-6: E-UTRA RRC\_IDLE Unrestricted nr PDN Extension;
- 1> if connectivity is *NR*:
  - 2> use 1 NR cell, default parameters;
  - 2> if sidelink is *On*
    - 3> use 1 NR-SS-UE;
    - 3> if GNSS Sync is *On*

- 4> use 1 GNSS simulator.
- 2> perform according to the table 4.5.2.2-2: NR RRC\_IDLE;
- 2> if  $pc\_noOf\_PDUsNewConnection > 0$ 
  - 3> perform according to the table 4.5.2.2-4: NR RRC\_IDLE Extension;
- 1> if connectivity is *WLAN*:
  - 2> use 1 WLAN cell, default parameters;
  - 2> if connected without release is not present:
    - 3> perform according to the table 4.5.2.2-3: WLAN Ipsec\_SA\_Released;
  - 2> else:
    - 3> Not defined:
- 1> if connectivity is *NR-DC*:
  - 2> use 2 NR cells, default parameters;
  - 2> perform according to the table 4.5.2.2-2: NR RRC\_IDLE.
- 1> if connectivity is *NE-DC*:
  - 2> use 1 E-UTRA cell and 1 NR cell, default parameters;
  - 2> perform according to the table 4.5.2.2-2: NR RRC\_IDLE.

#### 4.5.2.2 Procedures

**Table 4.5.2.2-1: E-UTRA RRC\_IDLE**

St	Procedure	Message Sequence		TP	Verdict
		U - S	Message		
1-9a2	Same as TS 36.508 [2] table 4.5.2.3-1, steps 1-9a2.	-	-	-	-
-	EXCEPTION: Steps 10a1 to 10b8 describe behaviour which depends on procedure parameters; the "lower case letter" identifies a step sequence that take place if a procedure parameter has a particular value.	-	-	-	-
10a1-10a10	IF Test Mode = On OR Test Loop Function = On THEN steps 10-19 as defined in TS 36.508 [2] table 4.5.2A.3-1, are performed. The ACTIVATE TEST MODE is using the associated condition for the test loop.	-	-	-	-
10b1-10b8	ELSE steps 10-17 as defined in TS 36.508 [2], table 4.5.2.3-1 are performed.	-	-	-	-

**Table 4.5.2.2-2: NR RRC\_IDLE**

St	Procedure	Message Sequence		TP	Verdict
		U - S	Message		
1	-	<--	NR RRC: SYSTEM INFORMATION (BCCH)	-	-
2	The UE transmits an <i>RRCSetupRequest</i> message.	-->	NR RRC: <i>RRCSetupRequest</i>	-	-
3	The SS transmits an <i>RRCSetup</i> message.	<--	NR RRC: <i>RRCSetup</i>	-	-
4	The UE transmits an <i>RRCSetupComplete</i> message and a REGISTRATION REQUEST message.	-->	NR RRC: <i>RRCSetupComplete</i> 5GMM: REGISTRATION REQUEST	-	-
5	The SS transmits a <i>DLInformationTransfer</i>	<--	NR RRC: <i>DLInformationTransfer</i>	-	-



	message and an AUTHENTICATION REQUEST message.		5GMM: AUTHENTICATION REQUEST		
6	The UE transmits an <i>ULInformationTransfer</i> message and an AUTHENTICATION RESPONSE message.	-->	NR RRC: <i>ULInformationTransfer</i> 5GMM: AUTHENTICATION RESPONSE	-	-
7	Void	-	-	-	-
8	The SS transmits a <i>DLInformationTransfer</i> message and a SECURITY MODE COMMAND message.	<--	NR RRC: <i>DLInformationTransfer</i> 5GMM: SECURITY MODE COMMAND	-	-
9	The UE transmits an <i>ULInformationTransfer</i> message and a SECURITY MODE COMPLETE message.	-->	NR RRC: <i>ULInformationTransfer</i> 5GMM: SECURITY MODE COMPLETE	-	-
-	EXCEPTION: Step 9Aa1 to 9Aa2 describes behaviour that depends on the UE capability; the "lower case letter" identifies a step sequence that takes place if a capability is supported and the procedure parameter Interworking without N26 interface supported is not present.	-	-	-	-
9Aa1	IF UE_S1_SUPPORTED the SS transmits a <i>DLInformationTransfer</i> message and a SECURITY MODE COMMAND message.	<--	NR RRC: <i>DLInformationTransfer</i> 5GMM: SECURITY MODE COMMAND	-	-
9Aa2	The UE transmits an <i>ULInformationTransfer</i> message and a SECURITY MODE COMPLETE message.	-->	NR RRC: <i>ULInformationTransfer</i> 5GMM: SECURITY MODE COMPLETE	-	-
-	EXCEPTION: Steps 9a1 to 9a2 describe the SS sequence depending on procedure parameters; the "lower case letter" identifies a step sequence that take place if a procedure parameter has a particular value	-	-	-	-
9a1	IF Test Mode = <i>On</i> OR Test Loop Function = <i>On</i> , the SS transmits an ACTIVATE TEST MODE message to activate UE radio bearer test mode procedure. The ACTIVATE TEST MODE message is using the associated condition for the test loop.	<--	RRC: <i>DLInformationTransfer</i> TC: ACTIVATE TEST MODE	-	-
9a2	The UE transmits an ACTIVATE TEST MODE COMPLETE message.	-->	RRC: <i>ULInformationTransfer</i> TC: ACTIVATE TEST MODE COMPLETE	-	-
10	The SS transmits a <i>SecurityModeCommand</i> message.	<--	NR RRC: <i>SecurityModeCommand</i>	-	-
11	The UE transmits a <i>SecurityModeComplete</i> message.	-->	NR RRC: <i>SecurityModeComplete</i>	-	-
12	The SS transmits a <i>UECapabilityEnquiry</i> message.	<--	NR RRC: <i>UECapabilityEnquiry</i>	-	-
13	The UE transmits a <i>UECapabilityInformation</i> message.	-->	NR RRC: <i>UECapabilityInformation</i>	-	-
14	The SS transmits a <i>DLInformationTransfer</i> message and a REGISTRATION ACCEPT message.	<--	NR RRC: <i>DLInformationTransfer</i> 5GMM: REGISTRATION ACCEPT	-	-
15	The UE transmits an <i>ULInformationTransfer</i> message and a REGISTRATION COMPLETE message.	-->	NR RRC: <i>ULInformationTransfer</i> 5GMM: REGISTRATION COMPLETE	-	-
16	Void	-	-	-	-
17	Void	-	-	-	-
18	Void	-	-	-	-
-	EXCEPTION: Step 19a1 describes behaviour depending UE implementation; the "lower case letter" identifies a step sequence that take place if the UE performs a specific action.	-	-	-	-
19a1	IF <i>pc_noOf_PDUsSameConnection</i> > 0 THEN the generic procedure for UE-requested PDU session establishment, specified in subclause 4.5A.2, takes place performing establishment of UE-requested PDU session(s) with <i>ExpectedNumberOfNewPDUSessions</i> = <i>pc_noOf_PDUsSameConnection</i> .	-	-	-	-

-	EXCEPTION: Steps 19Aa1 to 19Aa2 describe behaviour which depends on the SS sequence depending on procedure parameters; the "lower case letter" identifies a step sequence that take place if a procedure parameter has a particular value.	-	-	-	-
19Aa1	IF <i>connected without release</i> is <i>On</i> AND Test Loop Function= <i>On</i> AND <i>pc_noOf_PDUsNewConnection</i> =0 THEN the SS transmits a CLOSE UE TEST LOOP message to enter the UE test loop mode. The CLOSE UE TEST LOOP is using the associated condition for the test loop.	<--	NR RRC: <i>DLInformationTransfer</i> TC: CLOSE UE TEST LOOP	-	-
19Aa2	The UE transmits a CLOSE UE TEST LOOP COMPLETE message to confirm that loopback entities for the radio bearer(s) have been created and loop back is activated.	-->	NR RRC: <i>ULInformationTransfer</i> TC: CLOSE UE TEST LOOP COMPLETE	-	-
-	EXCEPTION: Step 20a1 depends on the SS sequence depending on procedure parameters; the "lower case letter" identifies a step sequence that take place if a procedure parameter has a particular value.	-	-	-	-
20a1	IF <i>connected without release</i> is not present THEN, the SS transmits an <i>RRCRelease</i> message.	<--	NR RRC: <i>RRCRelease</i>	-	-
-	EXCEPTION: Step 20Aa1 depends on the SS sequence depending on procedure parameters; the "lower case letter" identifies a step sequence that take place if a procedure parameter has a particular value.	-	-	-	-
20Aa1	IF GNSS Sync = <i>On</i> THEN trigger UE to reset or clear the current UTC time that has been calculated from GNSS.  NOTE: The UTC time can be reset or clear on the UE using AT command (+CUTCR).	-	-	-	-
-	EXCEPTION: Step 21a1 and 21b1 depend on the SS sequence depending on procedure parameters; the "lower case letter" identifies a step sequence that take place if a procedure parameter has a particular value.	-	-	-	-
21a1	IF Sidelink = <i>On</i> AND Cast type = <i>Unicast</i> AND UE initiated unicast mode NR sidelink communication THEN generic procedure specified in subclause 4.9.22 is performed to establish unicast mode sidelink communication between the UE and the NR-SS-UE.				
21b1	ELSE IF Sidelink = <i>On</i> AND Cast type = <i>Unicast</i> AND NR-SS-UE initiated unicast mode NR sidelink communication THEN generic procedure specified in subclause 4.9.23 is performed to establish unicast mode sidelink communication between the UE and the NR-SS-UE.				
22a1	Void	-	-	-	-

Table 4.5.2.2-3: WLAN Ipsec\_SA\_Released

St	Procedure	Message Sequence		TP	Verdict
		U - S	Message		
1	The UE associates with the WLAN AP and obtains the local IP address.	-	-	-	-
2	The UE performs a dynamic selection of N3IWF using DNS query	-	-	-	-
-	Exception: The UE establishes an IPsec tunnel in parallel to 5GC registration steps 3 to 7 as	-	-	-	-

	per the IKEv2 protocol as defined in TS 23.502 [33] clause 4.12.2.2 figure 4.12.2.2-1.				
3	The UE transmits a REGISTRATION REQUEST message.	-->	5GMM: REGISTRATION REQUEST	-	-
4	The SS transmits an AUTHENTICATION REQUEST message including EAP-Request/AKA'-Challenge or 5G AKA Challenge.	<--	5GMM: AUTHENTICATION REQUEST	-	-
5	The UE transmits an AUTHENTICATION RESPONSE message including EAP-Response/AKA'-Challenge or 5G AKA Response.	-->	5GMM: AUTHENTICATION RESPONSE	-	-
6	The SS transmits a SECURITY MODE COMMAND message including EAP-Success if EAP-AKA' used.	<--	5GMM: SECURITY MODE COMMAND	-	-
7	The UE transmits a SECURITY MODE COMPLETE message.	-->	5GMM: SECURITY MODE COMPLETE	-	-
8	The SS transmits a REGISTRATION ACCEPT message.	<--	5GMM: REGISTRATION ACCEPT	-	-
9	The UE transmits a REGISTRATION COMPLETE message.	-->	5GMM: REGISTRATION COMPLETE	-	-
10	The generic procedure for UE-requested PDU session establishment, specified in subclause 4.5A.2A, takes place performing establishment of UE-requested PDU session.	-	-	-	-
-	EXCEPTION: Step 11a1 depends on the SS sequence depending on procedure parameters; the "lower case letter" identifies a step sequence that take place if a procedure parameter has a particular value.	-	-	-	-
11a1	IF <i>connected without release</i> is not present THEN generic procedure for SS-requested IPsec Secure tunnel disconnection, specified in subclause 4.5A.5, takes place performing disconnection of security association.	-	-	-	-

Note: The current procedure assumes UE establishes a single PDU session over Non 3GPP Access.

Table 4.5.2.2-4: NR RRC\_IDLE Extension

St	Procedure	Message Sequence		TP	Verdict
		U - S	Message		
0	Wait for 10 sec to allow the UE to start PDU session establishment automatically. IF it does THEN stop the 10 sec timer and continue with the steps from step 2 onwards. IF it does not and the 10 sec timer expires THEN go to step 1.	-	-	-	-
-	EXCEPTION: Step 1a1 and 1b1 depends on the status of the UE; the "lower case letter" identifies a step sequence that take place if a PDU connection is already active.	-	-	-	-
1a1	IF there is no PDU connection already active THEN Trigger the UE to perform PDU session establishment via AT or MMI command. NOTE: For the DNN name in the AT command, check the default PDU type from the value the ICS parameter <i>pc_APN_Default_Configuration</i> and take the value of the corresponding ICS parameter. If it is set to 'none' then use <i>pc_APN_ID_Internet</i> .	-	-	-	-
1b1	ELSE skip the steps 2-9a1	-	-	-	-
2-6	Steps 2-6 from Table 4.5.4.2-3 are performed.	-	-	-	-
7	The SS transmits a SERVICE ACCEPT message.	<--	NR RRC: <i>DLInformationTransfer</i> 5GMM: SERVICE ACCEPT	-	-
8	The generic procedure for UE-requested PDU session establishment, specified in subclause 4.5A.2, takes place performing establishment of	-	-	-	-

	UE-requested PDU session(s) with ExpectedNumberOfNewPDUSessions = pc_noOf_PDUsNewConnection.				
-	EXCEPTION: Steps 8Aa1 to 8Aa2 describe behaviour which depends on the SS sequence depending on procedure parameters; the "lower case letter" identifies a step sequence that take place if a procedure parameter has a particular value.	-	-	-	-
8Aa1	IF connected without release is <i>On</i> AND Test Loop Function= <i>On</i> THEN the SS transmits a CLOSE UE TEST LOOP message to enter the UE test loop mode. The CLOSE UE TEST LOOP is using the associated condition for the test loop.	<--	NR RRC: <i>DLInformationTransfer</i> TC: CLOSE UE TEST LOOP	-	-
8Aa2	The UE transmits a CLOSE UE TEST LOOP COMPLETE message to confirm that loopback entities for the radio bearer(s) have been created and loop back is activated.	-->	NR RRC: <i>ULInformationTransfer</i> TC: CLOSE UE TEST LOOP COMPLETE	-	-
-	EXCEPTION: Step 9a1 depends on the SS sequence depending on procedure parameters; the "lower case letter" identifies a step sequence that take place if a procedure parameter has a particular value.	-	-	-	-
9a1	IF <i>connected without release</i> is not present THEN, the SS transmits an <i>RRCRelease</i> message.	<--	NR RRC: <i>RRCRelease</i>	-	-

Table 4.5.2.2-5: E-UTRA RRC\_IDLE Unrestricted nr PDN

St	Procedure	Message Sequence		TP	Verdict
		U - S	Message		
1-9a2	Steps 1 to 9a2 of the generic procedure for UE Registration (State 2) as specified in TS 36.508 [2], table 4.5.2.3-1 take place.	-	-	-	-
-	EXCEPTION: Steps 10a1 to 10b8 describe behaviour which depends on procedure parameters; the "lower case letter" identifies a step sequence that take place if a procedure parameter has a particular value.	-	-	-	-
10a1-10a8	IF Test Mode = <i>On</i> OR Test Loop Function = <i>On</i> THEN steps 10-17 of the generic procedure for UE Registration, UE Test Mode Activated (State 2A) as specified in TS 36.508 [2] table 4.5.2A.3-1, take place. The ACTIVATE TEST MODE is using the associated condition for the test loop.	-	-	-	-
10b1-10b6	ELSE steps 10-15 as defined in TS 36.508 [2], table 4.5.2.3-1 take place.	-	-	-	-
-	EXCEPTION: IF the 'IP address allocation' for the APN for which the PDN connection is established is set to "Yes" in Table 4.8.4-1 THEN, in parallel to the event described in step 10A below the generic procedure for IP address allocation in the U-plane specified in TS 36.508 [2], subclause 4.5A.1 takes place performing IP address allocation in the U-plane if requested by the UE.	-	-	-	-
-	EXCEPTION: IF the 'IMS registration' for the APN for which the PDN connection is established is set to "Yes" in Table 4.8.4-1, THEN in parallel to the event described in step 10A below the relevant generic procedure for IMS signalling in the U-plane specified in Table 4.8.4-1 takes place.	-	-	-	-
10A	This message includes the ATTACH	-->	RRC: <i>ULInformationTransfer</i>	-	-

	COMPLETE message. The ACTIVATE DEFAULT EPS BEARER CONTEXT ACCEPT message is piggybacked in ATTACH COMPLETE.		NAS: ATTACH COMPLETE NAS: ACTIVATE DEFAULT EPS BEARER CONTEXT ACCEPT		
11	The Generic Test Procedure to establish multiple additional PDN connections as specified in subclause 4.5A.2B takes place, ExpectedNumberOfNewPDNConnections=pc_noOf_PDNsSameConnection.	-	-	-	-
-	EXCEPTION: Steps 11Aa1 to 11Aa2 describe behaviour which depends on the SS sequence depending on procedure parameters; the "lower case letter" identifies a step sequence that take place if a procedure parameter has a particular value.	-	-	-	-
11Aa1	IF connected without release is On AND Test Loop Function=On AND pc_noOf_PDUsNewConnection =0 THEN the SS transmits a CLOSE UE TEST LOOP message to enter the UE test loop mode. The CLOSE UE TEST LOOP is using the associated condition for the test loop.	<--	RRC: DLInformationTransfer TC: CLOSE UE TEST LOOP	-	-
11Aa2	The UE transmits a CLOSE UE TEST LOOP COMPLETE message to confirm that loopback entities for the radio bearer(s) have been created and loop back is activated.	-->	RRC: ULInformationTransfer TC: CLOSE UE TEST LOOP COMPLETE	-	-
-	EXCEPTION: Step 12a1 depends on procedure parameters; the "lower case letter" identifies a step sequence that take place if a procedure parameter has a particular value.	-	-	-	-
12a1	IF <i>connected without release</i> is not present THEN, the SS transmits an <i>RRCConnectionRelease</i> message to release RRC connection and move to E-UTRA RRC_IDLE (State 2).	<--	RRC: <i>RRCConnectionRelease</i>	-	-

**Table 4.5.2.2-6: E-UTRA RRC\_IDLE Unrestricted nr PDN Extension**

St	Procedure	Message Sequence		TP	Verdict
		U - S	Message		
0	Wait for 10 sec to allow the UE to start PDN connection establishment automatically. IF it does THEN stop the 10 sec timer and continue with the steps from step 2 onwards. IF it does not and the 10 sec timer expires THEN go to step 1.	-	-	-	-
-	EXCEPTION: Step 1a1 and 1b1 depends on the status of the UE; the "lower case letter" identifies a step sequence that take place if a PDU connection is already active.	-	-	-	-
1a1	IF there is no PDN connection already active THEN Trigger the UE to perform PDN connection establishment via AT or MMI command. NOTE: For the DNN name in the AT command, check the default PDU type from the value the ICS parameter pc_APN_Default_Configuration and take the value of the corresponding ICS parameter. If it is set to 'none' then use pc_APN_ID_Internet.	-	-	-	-
1b1	ELSE skip the steps 2-8a1	-	-	-	-
2-6	Steps 3 to 7 of the generic procedure specified in TS 36.508 [2], table 4.5.3.3-1 take place.	-	-	-	-
7	The Generic Test Procedure to establish multiple additional PDN connections as specified in subclause 4.5A.2B takes place,	-	-	-	-

	ExpectedNumberOfNewPDNConnections=pc_n oOf_PDNsNewConnection.				
-	EXCEPTION: Steps 7Aa1 to 7Aa2 describe behaviour which depends on the SS sequence depending on procedure parameters; the "lower case letter" identifies a step sequence that take place if a procedure parameter has a particular value.	-	-	-	-
7Aa1	IF connected without release is On AND Test Loop Function=On THEN the SS transmits a CLOSE UE TEST LOOP message to enter the UE test loop mode. The CLOSE UE TEST LOOP is using the associated condition for the test loop.	<--	RRC: DLInformationTransfer TC: CLOSE UE TEST LOOP	-	-
7Aa2	The UE transmits a CLOSE UE TEST LOOP COMPLETE message to confirm that loopback entities for the radio bearer(s) have been created and loop back is activated.	-->	RRC: ULInformationTransfer TC: CLOSE UE TEST LOOP COMPLETE	-	-
-	EXCEPTION: Step 18a1 depends on procedure parameters; the "lower case letter" identifies a step sequence that take place if a procedure parameter has a particular value.	-	-	-	-
8a1	IF <i>connected without release</i> is not present THEN, the SS transmits an <i>RRConnectionRelease</i> message to release RRC connection and move to E-UTRA RRC_IDLE (State 2).	<--	RRC: <i>RRConnectionRelease</i>	-	-

### 4.5.2.3 Specific message contents

All specific message contents shall be according clause 4.6 and 4.7 and TS 36.508 [2] clause 4.6 and 4.7 with the following exception(s).

**Table 4.5.2.3-1: SECURITY MODE COMMAND (Step 9Aa1, Table 4.5.2.2-2)**

Derivation path: Table 4.7.1-25 with condition UE\_S1\_SUPPORTED

**Table 4.5.2.3-2: SERVICE REQUEST (Step 4, Table 4.5.2.2-4)**

Derivation Path: Table 4.7.1-16.

Information Element	Value/remark	Comment	Condition
Service type	'0000'B	signalling	

**Table 4.5.2.3-3: Message PDN CONNECTIVITY REQUEST (step 4, Table 4.5.2.2-5)**

Derivation path: TS 36.508 [2], Table 4.7.3-20.

Information Element	Value/Remark	Comment	Condition
Access point name	Not present or One of the provided APN(s) in the Table 4.8.4-1	If present, the SS shall initialise the APN_Default=False If not present NOTE 2	

NOTE 1: Unless explicitly specified otherwise, the SS uses the Access point name value to address the entry of Table 4.8.4-1 to be used for the subsequent signalling of the PDN connectivity establishment and verifying specific UE behaviour e.g. depending on the type of the APN the UE may perform some actions.  
NOTE 2: The SS uses pc\_APN\_Default\_Configuration to address the entry of Table 4.8.4-1 to be used for the subsequent signalling of the PDN connectivity establishment.

**Table 4.5.2.3-4: Message ESM INFORMATION RESPONSE (step 9a2, Table 4.5.2.2-5)**

Derivation path: TS 36.508 [2], Table 4.7.3-14.

Information Element	Value/Remark	Comment	Condition
Access point name	Not present or One of the provided APN(s) in the Table 4.8.4-1	If present, the SS shall initialise the APN_Default=False If not present NOTE 2	
NOTE 1: Unless explicitly specified otherwise, the SS uses the Access point name value to address the entry of Table 4.8.4-1 to be used for the subsequent signalling of the PDN connectivity establishment and verifying specific UE behaviour e.g. depending on the type of the APN the UE may perform some actions. NOTE 2: The SS uses pc_APN_Default_Configuration to address the entry of Table 4.8.4-1 to be used for the subsequent signalling of the PDN connectivity establishment.			

**Table 4.5.2.3-5: Message ACTIVATE DEFAULT EPS BEARER CONTEXT REQUEST (Steps 10a5, 10b7, Table 4.5.2.2-5)**

Derivation path: TS 36.508 [2], Table 4.7.3-6 with CONDITION Interworking_with_5GS.			
Information Element	Value/Remark	Comment	Condition
EPS QoS	The EPC default bearer context of the entry in Table 4.8.4-1 which has been determined at step 1		
Access point name	IF the UE provided an Access point name in step 1 THEN the SS returns this name; OTHERWISE the SS includes the DNN/APN ID value of the entry in Table 4.8.4-1 which has been determined at step 1.		
Container ID n+3	'001C'H		
Length of container ID n+3 contents			
Container ID n+3 contents	5GC QoS rule of the entry in Table 4.8.4-1 which has been determined at step 1		
Container ID n+4	'001F'H		
Length of container ID n+4 contents			
Container ID n+4 contents	As per the relevant QoS rule (Container ID n+3)		

## 4.5.3 RRC\_INACTIVE

### 4.5.3.1 Initiation

The SS shall:

- 1> if connectivity is *NR*
- 2> use 1 NR cell, default parameters;
- 2> perform according to the table 4.5.3.2-1: NR RRC\_INACTIVE;

### 4.5.3.2 Procedures

**Table 4.5.3.2-1: NR RRC\_INACTIVE**

St	Procedure	Message Sequence		TP	Verdict
		U - S	Message		
1-19a1	Same as table 4.5.2.2-2, steps 1-19a1.	-	-	-	-
-	EXCEPTION: Steps 19Aa1-19Ab9 describes	-	-	-	-

	behaviour depending UE implementation; the "lower case letter" identifies a step sequence that take place if the UE performs a specific action.				
19Aa1	IF <i>pc_noOf_PDUsNewConnection</i> = 0 AND Test Loop Function=On, table 4.5.2.2-2 steps 19Aa1-19Aa2 take place.	-	-	-	-
19Ab1	IF <i>pc_noOf_PDUsNewConnection</i> > 0 THEN the SS transmits an <i>RRCRelease</i> message	<--	NR RRC: <i>RRCRelease</i>	-	-
19Ab2-Ab9	Steps 1-8 of the NR RRC_IDLE extension procedure specified in table 4.5.2.2-4, take place.	-	-	-	-
20	The SS transmits an <i>RRCRelease</i> message with suspend.	<--	NR RRC: <i>RRCRelease</i>	-	-

## 4.5.4 RRC\_CONNECTED

### 4.5.4.1 Initiation

The SS shall:

- 1> perform according to clause 4.5.2 RRC\_IDLE;
- 1> if connectivity is *EN-DC*:
  - 2> use 1 E-UTRA cell and 1 NR cell, default parameters;
  - 2> if connected without release is *On*:
    - 3> perform according to the table 4.5.4.2-2: RF E-UTRA RRC\_CONNECTED;
  - 2> else:
    - 3> perform according to the table 4.5.4.2-1: E-UTRA RRC\_CONNECTED;
- 1> if connectivity is *E-UTRA/EPC*:
  - 2> use 1 E-UTRA cell, default parameters;
  - 2> perform according to the table 4.5.4.2-1: E-UTRA RRC\_CONNECTED;
- 1> if connectivity is *NR*:
  - 2> use 1 NR cell, default parameters;
  - 2> if sidelink is *On*
    - 3> use 1 NR-SS-UE;
    - 3> if GNSS Sync is *On*
      - 4> use 1 GNSS simulator.
  - 2> if connected without release is not present:
    - 3> perform according to the table 4.5.4.2-3: NR RRC\_CONNECTED;
- 1> if connectivity is *WLAN*:
  - 2> use 1 WLAN cell, default parameters;
  - 2> if connected without release is not present:
    - 3> perform according to the table 4.5.4.2-4: WLAN IPsec\_SA\_Established;
  - 2> else:



3> Not defined;

1> if connectivity is *NR-DC*:

2> use 2 NR cells, default parameters;

2> perform according to the table 4.5.4.2-5: NR-DC RRC\_CONNECTED;

1> if connectivity is *NE-DC*:

2> use 1 E-UTRA cell and 1 NR cell, default parameters;

2> perform according to the table 4.5.4.2-6: NE-DC RRC\_CONNECTED;

#### 4.5.4.2 Procedures

**Table 4.5.4.2-1: E-UTRA RRC\_CONNECTED**

St	Procedure	Message Sequence		TP	Verdict
		U - S	Message		
1-6	Same as TS 36.508 [2] table 4.5.3.3-1, steps 2-7.	-	-	-	-
7	Same as TS 36.508 [2] table 4.5.3.3-1, step 8. The <i>RRCConnectionReconfiguration</i> is using condition EN-DC_SRB2-DRB for connectivity <i>EN-DC</i> and bearers <i>MCG(s) and SCG</i> or connectivity <i>E-UTRA/EPC</i> . The <i>RRCConnectionReconfiguration</i> is using an associated condition <i>MCG_and_SCG</i> for bearers <i>MCG(s) and SCG</i> or condition <i>MCG_and_split</i> for bearers <i>MCG(s) and split</i> . For connectivity <i>E-UTRA/EPC</i> there's no associated condition.	<--	<i>RRC:</i> <i>RRCConnectionReconfiguration</i> <i>NAS:</i> ACTIVATE DEDICATED EPS BEARER CONTEXT REQUEST	-	-
-	EXCEPTION: IF <i>MCG(s) and SCG</i> or <i>MCG(s) and split</i> . In parallel to steps 8-9 the UE performs a C-RNTI based Contention Based Random Access (CBRA) procedure on the NR cell.	-	-	-	-
8-9	Same as TS 36.508 [2] table 4.5.3.3-1, steps 9-10a1	-	-	-	-
10a1-10a2	IF Test Loop Function= <i>On</i> , same as TS 36.508 [2] table 4.5.4.3-1, steps 1-2. The CLOSE UE TEST LOOP is using the associated condition for the test loop.	-	-	-	-

**Table 4.5.4.2-2: RF E-UTRA RRC\_CONNECTED**

St	Procedure	Message Sequence		TP	Verdict
		U - S	Message		
1-9	Same as table 4.5.2.2-1, steps 1-9.	-	-	-	-
10a1-10a2	IF Test Mode = <i>On</i> OR Test Loop Function = <i>On</i> THEN same as TS 36.508 [2] table 4.5.2A.3-1, steps 10-11. The ACTIVATE TEST MODE is using the associated condition for the test loop.	-	-	-	-
-	EXCEPTION: Steps 11a1 to 11b8 describe the SS sequence depending on procedure parameters; the "lower case letter" identifies a step sequence that take place if a procedure parameter has a particular value.	-	-	-	-
11a1-11a8	IF Test Mode = <i>On</i> OR Test Loop Function = <i>On</i> THEN same as TS 36.508 [2] table 4.5.2A.3-1, steps 12-18.	-	-	-	-
11b1-11b8	ELSE, same as TS 36.508 [2] table 4.5.2.3-1, steps 10-16.	-	-	-	-
12	The SS transmits an	<--	<i>RRC:</i>	-	-

	<i>RRCConnectionReconfiguration</i> for connectivity <i>EN-DC</i> and bearers <i>MCG(s)</i> and <i>SCG</i> . The <i>RRCConnectionReconfiguration</i> is using an associated condition <i>MCG_and_SCG</i> for bearers <i>MCG(s)</i> and <i>SCG</i> or condition <i>MCG_and_split</i> for bearers <i>MCG(s)</i> and <i>split</i> .		RRCConnectionReconfiguration NAS: ACTIVATE DEDICATED EPS BEARER CONTEXT REQUEST		
-	EXCEPTION: In parallel to steps 13-14 the UE performs a C-RNTI based Contention Based Random Access (CBRA) procedure on the NR cell.	-	-	-	-
-	EXCEPTION: the steps 13 and 14 happen in any order.	-	-	-	-
13	The UE transmits an <i>RRCConnectionReconfigurationComplete</i>	-->	RRC: RRCConnectionReconfigurationComplete		
14	The UE transmits an ACTIVATE DEDICATED EPS BEARER CONTEXT ACCEPT message	-->	RRC: ULInformationTransfer NAS: ACTIVATE DEDICATED EPS BEARER CONTEXT ACCEPT		
15a1- 15a2	IF Test Loop Function= <i>On</i> , same as TS 36.508 [2] table 4.5.4.3-1, steps 1-2. The CLOSE UE TEST LOOP is using the associated condition for the test loop.	-	-	-	-

Table 4.5.4.2-3: NR RRC\_CONNECTED

St	Procedure	Message Sequence		TP	Verdict
		U - S	Message		
1	The SS transmits a <i>Paging</i> message.	<--	NR RRC: <i>Paging</i>	-	-
2	The UE transmits an <i>RRCSetupRequest</i> message.	-->	NR RRC: <i>RRCSetupRequest</i>	-	-
3	The SS transmits an <i>RRCSetup</i> message.	<--	NR RRC: <i>RRCSetup</i>	-	-
4	The UE transmits an <i>RRCSetupComplete</i> message and a SERVICE REQUEST message.	-->	NR RRC: <i>RRCSetupComplete</i> 5GMM: SERVICE REQUEST	-	-
5	The SS transmits a <i>SecurityModeCommand</i> message.	<--	NR RRC: <i>SecurityModeCommand</i>	-	-
6	The UE transmits a <i>SecurityModeComplete</i> message.	-->	NR RRC: <i>SecurityModeComplete</i>	-	-
7	The SS transmits an <i>RRCReconfiguration</i> message and a SERVICE ACCEPT message to establish SRB2 and DRB(s). The <i>RRCReconfiguration</i> message is configured using <i>RRCReconfiguration-SRB2-DRB(n, m)</i> where n and m are the number of DRB(s) configured with RLC-AM and RLC-UM respectively.	<--	NR RRC: <i>RRCReconfiguration</i> 5GMM: SERVICE ACCEPT	-	-
8	The UE transmits an <i>RRCReconfigurationComplete</i> message.	-->	NR RRC: <i>RRCReconfigurationComplete</i>	-	-
-	EXCEPTION: Steps 9a1 to 9a2 describe behaviour which depends on the SS sequence depending on procedure parameters; the "lower case letter" identifies a step sequence that take place if a procedure parameter has a particular value.	-	-	-	-
9a1	IF Test Loop Function= <i>On</i> , the SS transmits a CLOSE UE TEST LOOP message to enter the UE test loop mode. The CLOSE UE TEST LOOP is using the associated condition for the test loop.	<--	NR RRC: <i>DLInformationTransfer</i> TC: CLOSE UE TEST LOOP	-	-
9a2	The UE transmits a CLOSE UE TEST LOOP COMPLETE message to confirm that loopback entities for the radio bearer(s) have been created and loop back is activated.	-->	NR RRC: <i>ULInformationTransfer</i> TC: CLOSE UE TEST LOOP COMPLETE	-	-

Table 4.5.4.2-4: WLAN IPsec\_SA\_Established

St	Procedure	Message Sequence		TP	Verdict
		U - S	Message		
1	Trigger UE to initiate IPsec SA.	-	-	-	-
2	The generic procedure for UE-requested IPsec Secure tunnel establishment, specified in subclause 4.5A.64, takes place performing establishment of security association and one child security association.	-	-	-	-

Table 4.5.4.2-5: NR-DC RRC\_CONNECTED

St	Procedure	Message Sequence		TP	Verdict
		U - S	Message		
1-8	Same as table 4.5.4.2-3, steps 1-8.	-	-	-	-
8A	The SS transmits an <i>RRCReconfiguration</i> message and a PDU SESSION MODIFICATION COMMAND to add a new SCG DRB or a new split DRB	<--	NR RRC: <i>RRCReconfiguration</i> 5GMM: DL NAS TRANSPORT 5GSM: PDU SESSION MODIFICATION COMMAND	-	-
-	EXCEPTION: In parallel to steps 8B and 8C the UE performs a C-RNTI based Contention Based Random Access (CBRA) procedure on the PSCell.	-	-	-	-
-	EXCEPTION: Depending upon UE implementation, step 8B and 8C can occur in any order	-	-	-	-
8B	The UE transmits an <i>RRCReconfigurationComplete</i> message including nr-SCG-Response.	-->	NR RRC: <i>RRCReconfigurationComplete</i>	-	-
8C	The UE transmits a <i>ULInformationTransfer</i> message and an PDU SESSION MODIFICATION COMPLETE message.	-->	NR RRC: <i>ULInformationTransfer</i> 5GMM: UL NAS TRANSPORT 5GSM: PDU SESSION MODIFICATION COMPLETE	-	-
-	EXCEPTION: Steps 9a1 to 9a2 describe behaviour which depends on the SS sequence depending on procedure parameters; the "lower case letter" identifies a step sequence that take place if a procedure parameter has a particular value.	-	-	-	-
9a1	IF Test Loop Function= <i>On</i> , the SS transmits a CLOSE UE TEST LOOP message to enter the UE test loop mode. The CLOSE UE TEST LOOP is using the associated condition for the test loop.	<--	NR RRC: <i>DLInformationTransfer</i> TC: CLOSE UE TEST LOOP	-	-
9a2	The UE transmits a CLOSE UE TEST LOOP COMPLETE message to confirm that loopback entities for the radio bearer(s) have been created and loop back is activated.	-->	NR RRC: <i>ULInformationTransfer</i> TC: CLOSE UE TEST LOOP COMPLETE	-	-

Table 4.5.4.2-6: NE-DC RRC\_CONNECTED

St	Procedure	Message Sequence		TP	Verdict
		U - S	Message		
1-8	Same as table 4.5.4.2-3, steps 1-8.	-	-	-	-
8A	The SS transmits an <i>RRCReconfiguration</i> message and a PDU SESSION MODIFICATION COMMAND to add a new SCG DRB or a new split DRB	<--	NR RRC: <i>RRCReconfiguration</i> 5GMM: DL NAS TRANSPORT 5GSM: PDU SESSION MODIFICATION COMMAND	-	-
-	EXCEPTION: In parallel to steps 8B and 8C the UE performs a C-RNTI based Contention Free Random Access (CFRA) procedure on the PSCell.	-	-	-	-
8B	The UE transmits an <i>RRCReconfigurationComplete</i> message	-->	NR RRC: <i>RRCReconfigurationComplete</i>	-	-

	including eutra-SCG-Response.				
8C	The UE transmits a <i>ULInformationTransfer</i> message and an PDU SESSION MODIFICATION COMPLETE message.	-->	NR RRC: <i>ULInformationTransfer</i> 5GMM: UL NAS TRANSPORT 5GSM: PDU SESSION MODIFICATION COMPLETE	-	-
-	EXCEPTION: Steps 9a1 to 9a2 describe behaviour which depends on the SS sequence depending on procedure parameters; the "lower case letter" identifies a step sequence that take place if a procedure parameter has a particular value.	-	-	-	-
9a1	IF Test Loop Function= <i>On</i> , the SS transmits a CLOSE UE TEST LOOP message to enter the UE test loop mode. The CLOSE UE TEST LOOP is using the associated condition for the test loop.	<--	NR RRC: <i>DLInformationTransfer</i> TC: CLOSE UE TEST LOOP	-	-
9a2	The UE transmits a CLOSE UE TEST LOOP COMPLETE message to confirm that loopback entities for the radio bearer(s) have been created and loop back is activated.	-->	NR RRC: <i>ULInformationTransfer</i> TC: CLOSE UE TEST LOOP COMPLETE	-	-

#### 4.5.4.3 Specific message contents

All specific message contents shall be according clause 4.6 and 4.7 and TS 36.508 [2] clause 4.6 and 4.7 with the exceptions below.

**Table 4.5.4.3-0: RRCConnectionReconfiguration (step 7, Table 4.5.4.2-1)**

Derivation Path: 36.508 table 4.6.1-8			
Information Element	Value/remark	Comment	Condition
RRCConnectionReconfiguration ::= SEQUENCE {			
criticalExtensions CHOICE {			
c1 CHOICE {			
rrcConnectionReconfiguration-r8 SEQUENCE {			
dedicatedInfoNASList	Not present	no NAS message	
dedicatedInfoNASList SEQUENCE (SIZE(1..maxDRB)) OF	1 entry		MCG_and_S CG OR MCG_and_s plit
dedicatedInfoNAS [1]	OCTET STRING including ACTIVATE DEDICATED EPS BEARER CONTEXT REQUEST	according to table 4.5.4.3-1	
}			
}			
}			
}			

**Table 4.5.4.3-1: Message ACTIVATE DEDICATED EPS BEARER CONTEXT REQUEST (step 7, Table 4.5.4.2-1)**

Derivation path: TS 36.508 [2] Table 4.7.3-3			
Information Element	Value/Remark	Comment	Condition
Linked EPS bearer identity	12		
EPS QoS	According to reference dedicated EPS bearer context #6 - in TS 36.508 [2] table 6.6.2-1A		
TFT	According to reference dedicated EPS bearer context #6 - in TS 36.508 [2] table 6.6.2-1A		
Negotiated QoS	According to reference dedicated EPS bearer		

	context #6 - in TS 36.508 [2] table 6.6.2-1A		
Negotiated LLC SAPI	According to reference dedicated EPS bearer context #6 - in TS 36.508 [2] table 6.6.2-1A		
Radio priority	According to reference dedicated EPS bearer context #6 - in TS 36.508 [2] table 6.6.2-1A		
Protocol configuration options	According to reference dedicated EPS bearer context #6 - in TS 36.508 [2] table 6.6.2-1A		
Extended protocol configuration options	According to reference dedicated EPS bearer context #6 - in TS 36.508 [2] table 6.6.2-1A		

**Table 4.5.4.3-1A: RRCConnectionReconfiguration (step 12, Table 4.5.4.2-2)**

Derivation Path: 36.508 table 4.6.1-8			
Information Element	Value/remark	Comment	Condition
RRCConnectionReconfiguration ::= SEQUENCE {			
criticalExtensions CHOICE {			
c1 CHOICE {			
rrcConnectionReconfiguration-r8 SEQUENCE {			
dedicatedInfoNASList SEQUENCE (SIZE(1..maxDRB)) OF	1 entry		
dedicatedInfoNAS [1]	OCTET STRING including ACTIVATE DEDICATED EPS BEARER CONTEXT REQUEST	according to table 4.5.4.3-1B	
}			
}			
}			

**Table 4.5.4.3-1B: Message ACTIVATE DEDICATED EPS BEARER CONTEXT REQUEST (step 12, Table 4.5.4.2-2)**

Derivation path: TS 36.508 [2] Table 4.7.3-3			
Information Element	Value/Remark	Comment	Condition
Linked EPS bearer identity	5		
EPS QoS	According to reference dedicated EPS bearer context #6 - in TS 36.508 [2] table 6.6.2-1A		
TFT	According to reference dedicated EPS bearer context #6 - in TS 36.508 [2] table 6.6.2-1A		
Negotiated QoS	According to reference dedicated EPS bearer context #6 - in TS 36.508 [2] table 6.6.2-1A		
Negotiated LLC SAPI	According to reference dedicated EPS bearer context #6 - in TS 36.508 [2] table 6.6.2-1A		
Radio priority	According to reference dedicated EPS bearer context #6 - in TS 36.508 [2] table 6.6.2-1A		
Protocol configuration options	According to reference		

	dedicated EPS bearer context #6 - in TS 36.508 [2] table 6.6.2-1A		
Extended protocol configuration options	According to reference dedicated EPS bearer context #6 - in TS 36.508 [2] table 6.6.2-1A		

**Table 4.5.4.3-2: RRCReconfiguration (step 7, Table 4.5.4.2-3)**

Derivation Path: TS 38.508-1, table 4.8.1-1B

**Table 4.5.4.3-3: Void****Table 4.5.4.3-4: PDU SESSION MODIFICATION COMMAND (step 8A, Table 4.5.4.2-5 and Table 4.5.4.2-6)**

Derivation Path: Table 4.7.2-9.

Information Element	Value/remark	Comment	Condition
PDU session ID	The same as the PDU session ID in PDU SESSION ESTABLISHMENT REQUEST associated with the Internet PDU session if available or with the first PDU session		
Authorized QoS rules	One entry		
QoS rule [1]	Reference QoS rule #5 as defined in Table 4.8.2.1-5.	QFI=5	
Authorized QoS flow descriptions	One entry		
QoS flow [1]	Reference QoS flow #5 as defined in Table 4.8.2.3-5.	QFI=5	

**Table 4.5.4.3-5: RRCReconfiguration (step 8A, Table 4.5.4.2-5)**

Derivation Path: TS 38.508-1, table 4.8.1-1CA

**Table 4.5.4.3-6: RRCReconfigurationComplete (step 8B, Table 4.5.4.2-5)**

Derivation Path: TS 38.508-1, table 4.6.1-14 with condition NR-DC

**Table 4.5.4.3-7: RRCReconfiguration (step 8A, Table 4.5.4.2-6)**

Derivation Path: TS 38.508-1, table 4.8.1-1CB

**Table 4.5.4.3-8: RRCReconfigurationComplete (step 8B, Table 4.5.4.2-6)**

Derivation Path: TS 38.508-1, table 4.6.1-14 with condition NE-DC

## 4.5.5 SWITCHED\_OFF

### 4.5.5.1 Initiation

The SS shall:

1> if Test State ID=0-A:

2> Do nothing;

1> else if Test State ID=0N-B:

2> use 1 NR cell, default parameters;

2> perform the procedure according to the table 4.5.5.2-1: NR SWITCHED\_OFF\_0\_B;

1> else if Test State ID=0E-B:

2> FFS

NOTE: The procedure for State 0N-B is used as default.

4.5.5.2 Procedures

**Table 4.5.5.2-1: NR SWITCHED\_OFF\_ON\_B**

St	Procedure	Message Sequence		TP	Verdict
		U - S	Message		
1-20	Same as table 4.5.2.2-2, steps 1-20.	-	-	-	-
21-26	Same as table 4.9.6.1-1, steps 1a1-1b1	-	-	-	-

4.5.5.3 Specific message contents

All specific message contents shall be according clause 4.6 and 4.7.

NOTE: The procedure refers to default messages content. If a test case requires specific parameters to be set during the procedure e.g. list with ePLMNs or/and TAIs is stored, new or not 5G-GUTI, etc. then, this needs to be specified in the test case, which uses the procedure.

4.5.6 Void

4.5.7 Out of Coverage

4.5.7.1 Initiation

The SS shall:

1> If sidelink is *On*

2> use neither NR cell nor E-UTRA cell;

2> use 1 GNSS simulator;

2> use 1 NR-SS-UE;

2> perform the procedure according to the table 4.5.7.2-1: Out of Coverage (NR sidelink).

4.5.7.2 Procedures

**Table 4.5.7.2-1: Out of Coverage (NR sidelink)**

St	Procedure	Message Sequence		TP	Verdict
		U - S	Message		
-	EXCEPTION: Steps 1a1 describe the SS sequence depending on procedure parameters; the "lower case letter" identifies a step sequence that take place if a procedure parameter has a particular value.	-	-	-	-

1a1	IF Test Mode = <i>On</i> OR Test Loop Function = <i>On</i> THEN the SS triggers UE to activate UE test mode E.  NOTE: The activation of UE test mode may be performed by MMI or AT command (+CATM).	-	-	-	-
1A	Trigger UE to reset or clear the current UTC time that has been calculated from GNSS.  NOTE: The UTC time can be reset or clear on the UE using AT command (+CUTCR).	-	-	-	-
-	EXCEPTION: Steps 2a1 and 2b1 describe the SS sequence depending on procedure parameters; the "lower case letter" identifies a step sequence that take place if a procedure parameter has a particular value.	-	-	-	-
2a1	IF Cast type = <i>Unicast</i> AND UE initiated unicast mode NR sidelink communication THEN generic procedure specified in subclause 4.9.22 is performed to establish unicast mode sidelink communication between the UE and the NR-SS-UE.				
2b1	ELSE IF Cast type = <i>Unicast</i> AND NR-SS-UE initiated unicast mode NR sidelink communication THEN generic procedure specified in subclause 4.9.23 is performed to establish unicast mode sidelink communication between the UE and the NR-SS-UE.				
-	EXCEPTION: Steps 3a1 and 3b1 describe the SS sequence depending on procedure parameters; the "lower case letter" identifies a step sequence that take place if a procedure parameter has a particular value.	-	-	-	-
3a1	IF Test Loop Function = <i>On</i> AND the NR-SS-UE is configured as transmitting UE THEN the SS triggers UE to close UE test loop mode E (Receive Mode).  NOTE: Closing of UE test loop mode E may be performed by MMI or AT command (+CCUTLE).				
3b1	IF Test Loop Function = <i>On</i> AND NR-SS-UE is configured as receiving UE AND SL MIMO ≠ <i>On</i> THEN the SS triggers UE to close UE test loop mode E (Transmit Mode).  NOTE: Closing of UE test loop mode E may be performed by MMI or AT command (+CCUTLE).				
3c1	IF Test Loop Function = <i>On</i> AND NR-SS-UE is configured as receiving UE AND SL MIMO = <i>On</i> THEN the SS triggers UE to close UE test loop mode E (Transmit Mode with SL-MIMO).  NOTE: Closing of UE test loop mode E may be performed by MMI or AT command (+CCUTLE).				
4	Void	-	-	-	-

#### 4.5.7.3 Specific message contents

All specific message contents shall be according subclause 4.7B with the exceptions below.

**Table 4.5.7.3-1: +CATM (Table 4.5.7.2-1, Step 1a1)**

Derivation Path: +CATM specified in subclause 4.7B with condition Activation
--



**Table 4.5.7.3-2: +CCUTLE (Table 4.5.7.2-1, Step 3a1)**

Derivation Path: Table 4.7B-1 with condition Close and Receive

**Table 4.5.7.3-3: +CCUTLE (Table 4.5.7.2-1, Step 3b1)**

Derivation Path: Table 4.7B-1 with condition Close and Transmit

**Table 4.5.7.3-4: +CCUTLE (Table 4.5.7.2-1, Step 3c1)**

Derivation Path: Table 4.7B-1 with condition Close, Transmit and SL\_MIMO

## 4.5A Auxiliary procedures

### 4.5A.1 General

### 4.5A.2 UE-requested PDU session establishment procedure

#### 4.5A.2.1 Scope

The purpose of this procedure is to establish UE-requested PDU session(s).

**Table 4.5A.2.1-1: Conditions and other parameters**

Condition	Explanation
ExpectedNumberOfNewPDUSessions	<p><b>Usage:</b> Parameter determining procedure sequence. A value for this parameter shall be provided when the procedure is called. Unless the test requires specific number of PDU sessions to be established the value should be either <code>pc_noOf_PDUsSameConnection</code> or <code>pc_noOf_PDUsNewConnection</code> ([23]).</p> <p><b>Meaning:</b> The number of PDU sessions which are expected to happen. Depends on the UE configuration and/or the context in which the procedure is used.</p>
K	<p><b>Usage:</b> Parameter determining procedure sequence.</p> <p><b>Meaning:</b> The number of PDU SESSION ESTABLISHMENT REQUEST messages already processed including the one that is currently being processed.</p>
L	<p><b>Usage:</b> Parameter determining procedure sequence.</p> <p><b>Meaning:</b> The number of PDU SESSION ESTABLISHMENT REQUEST messages being received so far.</p>
N	<p><b>Usage:</b> Parameter determining procedure sequence. The parameter is initialised with the value of <code>ExpectedNumberOfNewPDUSessions</code></p> <p><b>Meaning:</b> Loop (step sequence repetition) control.</p>
IMS_PDU	<p><b>Usage:</b> Condition determining specific message contents.</p> <p><b>Meaning:</b> PDU session establishment for IMS. Whether a PDU session is for IMS is determined by the DNN/APN type of the entry in Table 4.8.4-1 which itself has been determined by the DNN IE in the UL NAS TRANSPORT message which carried the corresponding PDU SESSION ESTABLISHMENT REQUEST or by <code>pc_APN_Default_Configuration</code> if the DNN IE was not present</p>

#### 4.5A.2.2 Procedure description

##### 4.5A.2.2.1 Initial conditions

The UE is in RRC\_CONNECTED state.

## 4.5A.2.2.2 Procedure sequence

Table 4.5A.2.2.2-1: PDU session establishment procedure

St	Procedure	Message Sequence		Verdict
		U - S	Message	
0	Set K = 0, L = 0, N = ExpectedNumberOfNewPDUSessions	-	-	-
1	The procedure specified in Table 4.5A.2.2.2-2 takes place.	-	-	-
2	Set K = K + 1	-	-	-
-	EXCEPTION: In parallel to the events described in steps 3-6a1 below the events specified in Table 4.5A.2.2.2-2 may take place.	-	-	-
3	The SS transmits an <i>RRCReconfiguration</i> message and an PDU SESSION ESTABLISHMENT ACCEPT	<--	NR RRC: <i>RRCReconfiguration</i> 5GMM: DL NAS TRANSPORT 5GSM: PDU SESSION ESTABLISHMENT ACCEPT	-
4	The UE transmits an <i>RRCReconfigurationComplete</i> message.	-->	NR RRC: <i>RRCReconfigurationComplete</i>	-
-	EXCEPTION: Step 5a1 describes behaviour depending UE implementation; the "lower case letter" identifies a step sequence that take place if the UE performs a specific action.	-	-	-
5a1	IF the 'IP address allocation' for the DNN for which the PDU session is established is set to "Yes" in Table 4.8.4-1 THEN, the generic procedure for IP address allocation in the user plane, specified in subclause 4.5A.3, takes place performing IP address allocation in the user plane.	-	-	-
-	EXCEPTION: Step 6a1 describes behaviour depending UE implementation; the "lower case letter" identifies a step sequence that take place if the UE performs a specific action.	-	-	-
6a1	IF the 'IMS registration' for the DNN for which the PDU session is established is set to "Yes" in Table 4.8.4-1, THEN the generic procedure for IMS signalling in the U-plane specified in subclause 4.5A.4 takes place.	-	-	-
-	EXCEPTION: Steps 7a1 to 7b2 describe behaviour depending UE implementation; the "lower case letter" identifies a step sequence that take place if the UE performs a specific action.	-	-	-
7a1	IF L > K (NOTE 1) THEN repeat from step 2	-	-	-
7b1	ELSE IF K < N (NOTE 2) THEN repeat from step 1.	-	-	-
NOTE 1: One (or more) further PDU SESSION ESTABLISHMENT REQUEST message has been received in parallel.				
NOTE 2: Less PDU SESSION ESTABLISHMENT REQUEST messages than expected have been received and processed so far -> further request are expected from the UE.				

Table 4.5A.2.2.2-2: Reception of PDU SESSION ESTABLISHMENT REQUEST message

St	Procedure	Message Sequence		Verdict
		U - S	Message	
1	Start Wait_Timer = 8 sec. NOTE: 8s were chosen to cater for T3540 being set to 10s.	-	-	-
-	EXCEPTION: Steps 2a1 to 2b1 describe behaviour depending UE implementation; the "lower case letter" identifies a step sequence that take place if the UE performs a specific action.	-	-	-
2a1	The UE transmits an <i>ULInformationTransfer</i> message and a PDU SESSION ESTABLISHMENT REQUEST	-->	NR RRC: <i>ULInformationTransfer</i> 5GMM: UL NAS TRANSPORT 5GSM: PDU SESSION ESTABLISHMENT REQUEST	-
2a2	Stop Wait_Timer.	-	-	-

2a3	Set L = L +1.	-	-	-
2a4	Check: Does the L>N? (NOTE 1)	-	-	F
2b1	Check: Does Wait_Timer expire? (NOTE 2)	-	-	F
NOTE 1: The SS shall raise a fail verdict when there are more PDU SESSION ESTABLISHMENT REQUEST messages than expected and terminate the test. The reason for such a behaviour can be e.g. wrongly set Ixit with which the ExpectedNumberOfNewPDNConnections was initiated,				
NOTE 2: Unless this is specified explicitly otherwise e.g. in a test procedure which calls the procedure specified in the present table, the SS shall raise a fail verdict when there are less PDN CONNECTIVITY REQUEST messages than expected received at this point and terminate the test. The reason for such a behaviour can be e.g. wrongly set PICS with which the ExpectedNumberOfNewPDUSessions was initiated.				

4.5A.2.2.3 Specific message contents

All specific message contents shall be according clause 4.6 and 4.7 with the exceptions below.

**Table 4.5A.2.2.3-1: RRCReconfiguration (step 3, Table 4.5A.2.2.2-1)**

Derivation Path: Table 4.6.1-13 and condition NR if SRB2 is not yet established			
Information Element	Value/remark	Comment	Condition
RRCReconfiguration ::= SEQUENCE {			
criticalExtensions CHOICE {			
rrcReconfiguration ::= SEQUENCE {			
radioBearerConfig	RadioBearerConfig with conditions SRB2 and DRB2		NOT IMS_PDU
nonCriticalExtension SEQUENCE {			
masterCellGroup	CellGroupConfig with condition SRB2_DRB2		NOT IMS_PDU
dedicatedNAS-MessageList SEQUENCE (SIZE(1..maxDRB)) OF DedicatedNAS-Message {}	DedicatedNAS-Message		
}			
}			
}			
}			

**Table 4.5A.2.2.3-2: RRCReconfiguration (step 3, Table 4.5A.2.2.2-1)**

Derivation Path: Table 4.6.1-13 and condition NR if SRB2 is already established			
Information Element	Value/remark	Comment	Condition
RRCReconfiguration ::= SEQUENCE {			
criticalExtensions CHOICE {			
rrcReconfiguration ::= SEQUENCE {			
radioBearerConfig	RadioBearerConfig with condition DRBn	n is chosen as the next available number higher or equal to 2	
	RadioBearerConfig with condition DRB1		IMS_PDU
nonCriticalExtension SEQUENCE {			
masterCellGroup	CellGroupConfig with condition DRBn	n is set to the same value as for the radioBearerConfig IE above	
	CellGroupConfig with condition DRB1		IMS_PDU
dedicatedNAS-MessageList SEQUENCE (SIZE(1..maxDRB)) OF DedicatedNAS-Message {}	DedicatedNAS-Message		
}			
}			
}			
}			

## 4.5A.2A UE-requested PDU session establishment procedure over Non 3GPP Access

### 4.5A.2A.1 Scope

The purpose of this procedure is to establish UE-requested PDU session.

### 4.5A.2A.2 Procedure description

#### 4.5A.2A.2.1 Initial conditions

The UE has established an IPsec security association

#### 4.5A.2A.2.2 Procedure sequence

**Table 4.5A.2A.2.2-1: PDU session establishment procedure over Non 3GPP Access**

St	Procedure	Message Sequence	
		U – S	Message
1	The UE transmits a PDU SESSION ESTABLISHMENT REQUEST	-->	5GMM: UL NAS TRANSPORT 5GSM: PDU SESSION ESTABLISHMENT REQUEST
2	The SS establishes an IPsec child security association according to the IKEv2 specification in RFC 7296 [34]		
3	The SS transmits an PDU SESSION ESTABLISHMENT ACCEPT	<--	5GMM: DL NAS TRANSPORT 5GSM: PDU SESSION ESTABLISHMENT ACCEPT

Note 1: The current procedure assumes UE establishes a single PDU session over Non 3GPP Access.

### 4.5A.2A.3 Specific message contents

None

## 4.5A.2B Procedure to establish multiple additional PDN connections in S1

### 4.5A.2B.1 Scope

The present procedure is intended for test scenarios where it is desirable, due to the tested requirements (e.g. intersystem change between S1 and N1 mode), to allow the UE to set up as many as it may want, and in any order, PDN connections after the first PDN connection is established during the ATTACH to EPS procedure (i.e. when the UE is operating in S1 mode).

**Table 4.5A.2B.1-1: Conditions and other parameters**

Condition	Explanation
ExpectedNumberOfNewPDNConnections	<b>Usage:</b> Parameter determining procedure sequence. A value for this parameter shall be provided when the procedure is called. Unless the test requires specific number of PDN connections to be established the value should be either pc_noOf_PDNsSameConnection or pc_noOf_PDNsNewConnection ([19]). <b>Meaning:</b> The number of PDN connections which are expected to happen. Depends on the UE configuration and/or the context in which the procedure is used.
K	<b>Usage:</b> Parameter determining procedure sequence. <b>Meaning:</b> The number of PDN CONNECTIVITY REQUEST messages already processed including the one that is currently being processed.
L	<b>Usage:</b> Parameter determining procedure sequence. <b>Meaning:</b> The number of PDN CONNECTIVITY REQUEST messages being received so far.

N	<p><b>Usage:</b> Parameter determining procedure sequence. The parameter is initialised with the value of ExpectedNumberOfNewPDNConnections</p> <p><b>Meaning:</b> Loop (step sequence repetition) control.</p>
---	---

4.5A.2B.2 Procedure description

4.5A.2B.2.1 Initial conditions

System Simulator:

- 1 cell, default parameters.
- The procedure shall be performed under ideal radio conditions as defined in clause 5.

User Equipment:

- The UE is in Registered, RRC\_CONNECTED state (State 2).

The default system information messages are used.

4.5A.2B.2.2 Procedure sequence

**Table 4.5A.2B.2.2-1: Establishment of additional PDN connectivity**

St	Procedure	Message Sequence		Verdict
		U - S	Message	
0	Set K = 0, L = 0, N = ExpectedNumberOfNewPDNConnections	-	-	-
1	The procedure specified in Table 4.5A.2B.2.2-2 takes place.	-	-	-
2	Set K = K + 1.	-	-	-
-	EXCEPTION: In parallel to the events described in steps 3-6a1 below the events specified in Table 4.5A.2B.2.2-2 may take place.	-	-	-
3-4	Step 2-3 as defined in TS 36.508 [2], Table 4.5A.16.3-1, Generic Test Procedure to establish additional PDN connectivity take place.	-	-	-
-	EXCEPTION: IF the 'IP address allocation' for the APN for which the PDN connection is established is set to "Yes" in Table 4.8.4-1 THEN, in parallel to the event described in step 5 below the generic procedure for IP address allocation in the U-plane specified in TS 36.508 [2], subclause 4.5A.1 takes place performing IP address allocation in the U-plane if requested by the UE.	-	-	-
-	EXCEPTION: IF the 'IMS registration' for the APN for which the PDN connection is established is set to "Yes" in Table 4.8.4-1, THEN in parallel to the event described in step 5 below the relevant generic procedure for IMS signalling in the U-plane specified in Table 4.8.4-1 takes place.	-	-	-
5	Step 4 as defined in TS 36.508 [2], Table 4.5A.16.3-1, Generic Test Procedure to establish additional PDN connectivity takes place.	-	-	-
-	EXCEPTION: Steps 6a1 to 6b1 describe behaviour depending UE implementation; the "lower case letter" identifies a step sequence that take place if the UE performs a specific action.	-	-	-
6a1	IF L > K (NOTE 1) THEN repeat from step 2.	-	-	-
6b1	ELSE IF K < N (NOTE 2) THEN repeat from step 1.	-	-	-
NOTE 1: One (or more) further PDN CONNECTIVITY REQUEST message has been received in parallel.				
NOTE 2: Less PDN CONNECTIVITY REQUEST messages than expected have been received and processed so far and consequently further requests are expected from the UE.				

Table 4.5A.2B.2.2-2: Reception of PDN CONNECTIVITY REQUEST message

St	Procedure	Message Sequence		Verdict
		U - S	Message	
1	Start Wait_Timer = 10 sec. NOTE: 10 sec is an arbitrary value.	-	-	-
-	EXCEPTION: Steps 2a1 to 2b1 describe behaviour depending UE implementation; the "lower case letter" identifies a step sequence that take place if the UE performs a specific action.	-	-	-
2a1	Step 1 as defined in Table 4.5A.16.3-1, specified in TS 36.508 [2], subclause 4.5A.16 Generic Test Procedure to establish additional PDN connectivity takes place. The UE transmits a PDN CONNECTIVITY REQUEST message to request an additional PDN.	-->	PDN CONNECTIVITY REQUEST	-
2a2	Stop Wait_Timer.	-	-	-
2a3	Set L = L +1.	-	-	-
2a4	Check: Does the L>N? (NOTE 1)	-	-	F
2b1	Check: Does Wait_Timer expire? (NOTE 2)	-	-	F
NOTE 1: The SS shall raise a fail verdict when there are more PDN CONNECTIVITY REQUEST messages received than expected (L>N) and terminate the test. The reason for such a behaviour can be e.g. wrongly set PICS with which the ExpectedNumberOfNewPDNConnections was initiated,				
NOTE 2: Unless this is specified explicitly otherwise, e.g. in a test procedure which calls the procedure specified in the present table, the SS shall raise a fail verdict when there are less PDN CONNECTIVITY REQUEST messages than expected received at this point (note that when this procedure is called from the main behaviour K < N). The reason for such a behaviour can be e.g. wrongly set PICS with which the ExpectedNumberOfNewPDNConnections was initiated.				

### 4.5A.2B.3 Specific message contents

All specific message contents shall be referred to TS 36.508 [2] subclauses 4.6 and 4.7 with the exceptions specified below.

Table 4.5A.2B.3-1: Message PDN CONNECTIVITY REQUEST (step 2a1, Table 4.5A.2B.2.2-2)

Derivation path: TS 36.508 [2], Table 4.7.3-20.			
Information Element	Value/Remark	Comment	Condition
Access point name	Not present or One of the provided APN(s) in the Table 4.8.4-1	If present, the SS shall initialise the APN_Default=False If not present NOTE 2	
NOTE 1: Unless explicitly specified otherwise, the SS uses the Access point name value to address the entry of Table 4.8.4-1 to be used for the subsequent signalling of the PDN connectivity establishment and verifying specific UE behaviour e.g. depending on the type of the APN the UE may perform some actions.			
NOTE 2: The SS uses pc_APN_Default_Configuration to address the entry of Table 4.8.4-1 to be used for the subsequent signalling of the PDN connectivity establishment.			

Table 4.5A.2B.3-2: Message ACTIVATE DEFAULT EPS BEARER CONTEXT REQUEST (step 3, Table 4.5A.2B.2.2-1; Step 2, Table 4.5A.16.3-1 TS 36.508 [2])

Derivation path: TS 36.508 [2], Table 4.7.3-6 with CONDITION Interworking_with_5GS.			
Information Element	Value/Remark	Comment	Condition
EPS QoS	The EPC default bearer context of the entry in Table 4.8.4-1 which has been determined at step 1		
Access point name	IF the UE provided an Access point name in step 1 THEN the SS returns		

	this name; OTHERWISE the SS includes the DNN/APN ID value of the entry in Table 4.8.4-1 which has been determined at step 1.		
Container ID n+3	'001C'H		
Length of container ID n+3 contents			
Container ID n+3 contents	5GC QoS rule of the entry in Table 4.8.4-1 which has been determined at step 1		
Container ID n+4	'001F'H		
Length of container ID n+4 contents			
Container ID n+4 contents	As per the relevant QoS rule (Container ID n+3)		

### 4.5A.2C Procedure for UE-requested PDU session modification after the first S1 to N1 mode change / Single-registration mode with N26

#### 4.5A.2C.1 Scope

The purpose of this procedure is to handle UE-requested PDU session modification after the first S1 to N1 mode change in the scenario of Single-registration mode, 'Interworking without N26 interface not supported'.

**Table 4.5A.2C.1-1: Conditions and other parameters**

Condition	Explanation
ExpectedNumberOfPDUSessionModifications	<b>Usage:</b> Parameter determining procedure sequence. A value for this parameter shall be provided when the procedure is called. Unless the test requires specific number of PDU modifications to take place the value should be set to pc_noOf_PDNsSameConnection + pc_noOf_PDNsNewConnection + 1 ([19]). <b>Meaning:</b> The number of PDU sessions which are expected to happen. Depends on the UE configuration and/or the context in which the procedure is used.
K	<b>Usage:</b> Parameter determining procedure sequence. <b>Meaning:</b> The number of PDN SESSION MODIFICATION REQUEST messages already processed including the one that is currently being processed.
L	<b>Usage:</b> Parameter determining procedure sequence. <b>Meaning:</b> The number of PDN SESSION MODIFICATION REQUEST being received so far.
N	<b>Usage:</b> Parameter determining procedure sequence. The parameter is initialised with the value of ExpectedNumberOfPDUSessionModifications <b>Meaning:</b> Loop (step sequence repetition) control.

#### 4.5A.2C.2 Procedure description

##### 4.5A.2C.2.1 Initial conditions

The UE is in RRC\_CONNECTED state.

##### 4.5A.2C.2.2 Procedure sequence

**Table 4.5A.2C.2.2-1: Procedure for UE-requested PDU session modification after the first S1 to N1 mode change**

St	Procedure	Message Sequence		Verdict
		U - S	Message	
0	Set K = 0, L = 0, N = (ExpectedNumberOfPDUSessionModifications).	-	-	-
1	The procedure specified in Table 4.5A.2C.2.2-2 takes	-	-	-

	place.			
2	Set $K = K + 1$ .	-	-	-
-	EXCEPTION: In parallel to the events described in steps 3-5a1 below the events specified in Table 4.5A.2C.2.2-2 may take place.	-	-	-
3	The SS transmits a <i>RRCReconfiguration</i> message and a PDU SESSION MODIFICATION COMMAND.	<--	NR RRC: <i>RRCReconfiguration</i> 5GMM: DL NAS TRANSPORT 5GSM: PDU SESSION MODIFICATION COMMAND	-
-	EXCEPTION: Depending upon UE implementation, step 4 and 4A can occur in any order	-	-	-
4	The UE transmits a <i>RRCReconfigurationComplete</i> message.	-->	NR RRC: <i>RRCReconfigurationComplete</i>	-
4A	The UE transmits a PDU SESSION MODIFICATION COMPLETE message.	-->	5GMM: UL NAS TRANSPORT 5GSM: PDU SESSION MODIFICATION COMPLETE	-
-	EXCEPTION: Steps 5a1 to 5b1 describe behaviour depending UE implementation; the "lower case letter" identifies a step sequence that take place if the UE performs a specific action.	-	-	-
5a1	IF $L > K$ (NOTE 1) THEN repeat from step 2.	-	-	-
5b1	ELSE IF $K < N$ (NOTE 2) THEN repeat from step 1.	-	-	-
NOTE 1: One (or more) further PDU SESSION MODIFICATION REQUEST message has been received in parallel.				
NOTE 2: Less PDU SESSION MODIFICATION REQUEST messages than expected have been received and processed so far -> Further request are expected from the UE.				

Table 4.5A.2C.2.2-2: Reception of PDU SESSION MODIFICATION REQUEST message

St	Procedure	Message Sequence		Verdict
		U - S	Message	
1	Start Wait_Timer = 8 sec. NOTE: 8s were chosen to cater for T3540 being set to 10s.	-	-	-
-	EXCEPTION: Steps 2a1 to 2b1 describe behaviour depending UE implementation; the "lower case letter" identifies a step sequence that take place if the UE performs a specific action.	-	-	-
2a1	The UE transmits an <i>ULInformationTransfer</i> message and a PDU SESSION MODIFICATION REQUEST with PDU session ID which has been associated with a default EPS bearer set up during the UE operation in S1.	-->	NR RRC: <i>ULInformationTransfer</i> 5GSM: PDU SESSION MODIFICATION REQUEST	-
2a2	Stop Wait_Timer.	-	-	-
2a3	Set $L = L + 1$ .	-	-	-
2a4	Check: Does the $L > N$ ? (NOTE 1)	-	-	F
2b1	Check: Does Wait_Timer expire? (NOTE 2)	-	-	F
NOTE 1: The SS shall raise a fail verdict when there are more PDU SESSION MODIFICATION REQUEST messages received than expected and terminate the test. The reason for such a behaviour can be e.g. wrongly set PICS with which the ExpectedNumberOfNewPDNConnections was initiated.				
NOTE 2: Unless this is specified explicitly otherwise e.g. in a test procedure which calls the procedure specified in the present table, the SS shall raise a fail verdict when there are less PDU SESSION MODIFICATION REQUEST messages than expected received at this point and terminate the test. The reason for such a behaviour can be e.g. wrongly set PICS with which the ExpectedNumberOfNewPDUSessions was initiated,				

## 4.5A.2C.2.3 Specific message contents

All specific message contents shall be according clause 4.6 and 4.7 with the below exceptions:

Table 4.5A.2C.2.3-1: UL NAS TRANSPORT (Step 1, Table 4.5A.2C.2.2-2)

Derivation Path: Table 4.7.1-10.
----------------------------------



Information Element	Value/remark	Comment	Condition
Request type	'101'B	"modification request"	

**Table 4.5A.2C.2.3-2: PDU SESSION MODIFICATION REQUEST (Step 1, Table 4.5A.2C.2.2-2)**

Derivation Path: Table 4.7.2-7.			
Information Element	Value/remark	Comment	Condition
PDU session ID	The PDU session ID associated with the default EPS bearer of the PDN connection which is being transferred into PDU session and for which the UE needs to indicate its capabilities via the modification procedure. (NOTE 1)		
5GSM capability	Present. Contents not checked.		
Integrity protection maximum data rate	Present. Contents not checked.		
NOTE 1: The PDU session ID was provided in the ACTIVATE DEFAULT EPS BEARER CONTEXT ACCEPT when the UE attached in S1. If the UE provides here an unknown PDU session ID then the SS shall set an Inconclusive verdict.			

**Table 4.5A.2C.2.3-3: RRCReconfiguration (step 3, Table 4.5A.2C.2.2-1)**

Derivation Path: Table 4.6.1-13 and condition NR if SRB2 is not yet established			
Information Element	Value/remark	Comment	Condition
RRCReconfiguration ::= SEQUENCE {			
criticalExtensions CHOICE {			
rrcReconfiguration ::= SEQUENCE {			
radioBearerConfig	RadioBearerConfig with conditions SRB2 and DRB2		NOT IMS_PDU
nonCriticalExtension SEQUENCE {			
masterCellGroup	CellGroupConfig with condition SRB2_DRB2		NOT IMS_PDU
}			
}			
}			
}			

**Table 4.5A.2C.2.3-4: RRCReconfiguration (step 3, 4.5A.2C.2.2-1)**

Derivation Path: Table 4.6.1-13 and condition NR if SRB2 is already established			
Information Element	Value/remark	Comment	Condition
RRCReconfiguration ::= SEQUENCE {			
criticalExtensions CHOICE {			
rrcReconfiguration ::= SEQUENCE {			
radioBearerConfig	RadioBearerConfig with condition DRBn	n is chosen as the next available number higher or equal to 2	
	RadioBearerConfig with condition DRB1		IMS_PDU
nonCriticalExtension SEQUENCE {			
masterCellGroup	CellGroupConfig with condition DRBn	n is set to the same value as for the radioBearerConfig IE above	
	CellGroupConfig with condition DRB1		IMS_PDU
}			
}			
}			
}			

### 4.5A.3 Procedure for IP address allocation in the user plane

#### 4.5A.3.1 Scope

The purpose of this procedure is to allow the successful completion of IP address allocation if it is initiated by the UE therefore the result from the execution of the Procedure for IP address allocation in the user plane shall not lead to assignment of a verdict.

Depending on the UE configuration there may be unpredictable delay in the start of the procedure. A guarding time of 1.2 sec is suggested within which the procedure is expected to start. If the timer expires then the test procedure, from which the Procedure for IP address allocation in the user plane is called, shall advance to the next specified step.

#### 4.5A.3.2 Procedure description

##### 4.5A.3.2.1 Initial conditions

N/A

##### 4.5A.3.2.2 Procedure sequence

**Table 4.5A.3.2.2-1: Procedure for IP address allocation in the user plane**

Step	Procedure	Message Sequence	
		U - S	Message
-	EXCEPTION: Step 1 below and Step 1 in Table 4.5A.3.2.2-2 describe behaviour that depends on the contents of the latest PDU SESSION ESTABLISHMENT REQUEST message sent by the UE prior to this procedure.	-	-
-	EXCEPTION: In parallel to the event described in step 1 below the step specified in Table 4.5A.3.2.2-2 may take place.	-	-
1	If the "PDU session type" in the latest PDU SESSION ESTABLISHMENT REQUEST message prior to this procedure was 'IPv4' or 'IPv4v6' then, IPv4 address allocation by DHCPv4 may occur on the user plane bearer established for the QoS flow of the default QoS rule.	-	-

**Table 4.5A.3.2.2-2: Procedure for IP address allocation in the user plane, parallel behaviour**

Step	Procedure	Message Sequence	
		U - S	Message
1	If the "PDU session type" in the latest PDU SESSION ESTABLISHMENT REQUEST message prior to this procedure was 'IPv6' or 'IPv4v6' then stateless address auto configuration occurs on the user plane bearer established for the QoS flow of the default QoS rule.	-	-

##### 4.5A.3.2.3 Specific message contents

None

## 4.5A.4 Procedure for IMS signalling

### 4.5A.4.1 Scope

The purpose of this procedure is to allow the successful completion of IMS signalling.

The procedure is applicable for UEs with IMS support (TS 38.508-2 A.4.4-1/2).

### 4.5A.4.2 Procedure description

#### 4.5A.4.2.1 Initial conditions

N/A

#### 4.5A.4.2.2 Procedure sequence

**Table 4.5A.4.2.2-1: Procedure for IMS signalling**

Step	Procedure	Message Sequence	
		U - S	Message
-	EXCEPTION: Steps 1a1 to 1a2b1 describe a transaction that depends on the UE capability	-	-
1a1	IF pc_IMS_5GS then the SS starts timer Timer_1 = 10 s (Note 1)	-	-
-	EXCEPTION: Steps 1a2a1 to 1a2b1 describe a transaction that depends on the UE implementation	-	-
1a2a1	Registration procedure according TS 34.229-5 [47] subclause A.2 (steps 1-8).	-	-
1a2a8	Note: SS cancels timer Timer_1 at step 1a2a1	-	-
1a2b1	Timer_1 expires	-	-
Note 1: Depending on the UE configuration there may be unpredictable delay in the start of the procedure. A guarding time of [10] sec is suggested within which the procedure is expected to start. If the timer expires then the test procedure, from which the Procedure for IMS signalling U-plane is called, shall advance to the next specified step			

#### 4.5A.4.2.3 Specific message contents

None

## 4.5A.5 IPsec Tunnel Disconnection in 5GC / WLAN

### 4.5A.5.1 Scope

The purpose of this procedure is to disconnect an Ipsec tunnel.

### 4.5A.5.2 Procedure description

#### 4.5A.5.2.1 Initial conditions

The UE has established an IPsec security association

#### 4.5A.5.2.2 Procedure sequence

**Table 4.5A.5.2.2-1: IPsec Tunnel Disconnection in 5GC / WLAN**

St	Procedure	Message Sequence	
		U - S	Message
1	The SS initiated disconnection from the existing IPsec tunnel as defined in TS 24.502 [35] clause 7.4.2	-	-

NOTE: It is assumed that the WLAN AP association remains throughout the procedure.
--

#### 4.5A.5.3 Specific message contents

None

### 4.5A.6 IPsec Tunnel Establishment in 5GC / WLAN

#### 4.5A.6.1 Scope

The purpose of this procedure is to establish an Ipsec tunnel and NAS signalling connection.

#### 4.5A.6.2 Procedure description

##### 4.5A.6.2.1 Initial conditions

The UE has Registered to 5GC with a PDU session established and IPsec security association is released

##### 4.5A.6.2.2 Procedure sequence

**Table 4.5A.6.2.2-1: IPsec Tunnel Establishment in 5GC / WLAN**

St	Procedure	Message Sequence	
		U – S	Message
-	Exception: In parallel to steps 1 to 2, the UE initiates an IPsec security association and one child security association as defined in TS 24.502 [35] clause 7.3.2	-	-
1	The UE transmits a SERVICE REQUEST message.	-->	5GMM: SERVICE REQUEST
2	The SS transmits a SERVICE Accept message.	<--	5GMM: SERVICE ACCEPT
Note 1: The current procedure assumes UE establishes a single PDU session over Non 3GPP Access.			

#### 4.5A.6.3 Specific message contents

**Table 4.5A.6.3-1: SERVICE REQUEST (step 1, Table 4.5A.6.2.2-1)**

Derivation Path: 38.508-1 [4], Table 4.7.1-16			
Information Element	Value/remark	Comment	Condition
Service type			
Service type value	'0000'B	signalling	

## 4.5B Common test environment for Vertical UEs

### 4.5B.1 SNPN-only UEs

This clause defines the test environment which applies to all test cases listed in TS 38.523-2 [19], clause 4.3 and executed for SNPN-only UEs (TS 38.508-2 [10] A.4.1-5/3), unless otherwise specified.

- Each configured NR Cell is an SNPN cell, i.e., condition 'SNPN' (Standalone NPN cell) applies in the default message contents.
- The SIB1 of each NR Cell includes the NPN-Identity-r16 set to snpn-r16 with the PLMN of the cell and the nid-List-r16 IE configured with only one entry of NID with Assignment mode = 1 and NID value = 0.
- UE's "list of subscriber data" is pre-configured with the list of all PLMNs and NID value = 0.

NOTE: PLMNs are specified in Table 4.4.2-3 or clause 6.3.2 unless specified otherwise in the test case.

## 4.5B.2 RedCap UEs

This clause defines the test environment which applies to all test cases executed against RedCap UEs, unless otherwise specified.

- The test channel bandwidth is reduced, to a maximum of 20MHz for FR1 and 100MHz for FR2.
- The following ASN.1 types are configured with condition `pc_supportOfRedCap_r17 = TRUE`:
  - *SIB1* in Table 4.6.1-28,
  - *RLC-Config* in Table 4.6.3-149, and
  - *PDCP-Config* in Table 4.6.3-99.
- In case of HD-FDD mode, the following ASN.1 type is configured with condition `pc_halfDuplexFDD_TypeA_RedCap_r17 = TRUE`:
  - *SIB1* in Table 4.6.1-28.

## 4.5C UE Position Requirements for NTN testing

### 4.5C.1 General

This clause defines the UE positioning requirements which apply for all NR NTN cases.

- UE's positioning engine (e.g., standalone GNSS receiver) shall be enabled to allow it to acquire the position. UE position during the test is stationary. Below position shall be used to pre-configure UE position:
  - Latitude: 25.08439333
  - Longitude: 121.56076999
  - Altitude: 0

## 4.6 Default NG-RAN RRC message and information elements contents

### 4.6.0 General

#### 4.6.0.1 Global conditions

Groups of RRC and 5GMM conditions including always one and only one condition set to true per table, unless explicitly stated.

**Table 4.6.0.1-1: Signalling, RF/RRM/Performance**

Condition	Explanation
SIG	Used for signalling test cases
RF	Used for RF/Performance test cases
RRM	Used for RRM test cases

**Table 4.6.0.1-2: NR operating bands**

Condition	Explanation
FR1	410 MHz – 7125 MHz
FR2	24250 MHz – 52600 MHz

**Table 4.6.0.1-3: FDD/TDD**

Condition	Explanation
FDD	Frequency Division Duplex
TDD	Time Division Duplex

**Table 4.6.0.1-4: Subcarrier spacing**

Condition	Explanation
SCS15	15kHz
SCS30	30kHz
SCS60	60kHz
SCS120	120kHz
SCS240	240kHz

**Table 4.6.0.1-5: SST**

Condition	Explanation
SST_eMBB	Slice suitable for the handling of 5G enhanced Mobile Broadband.
SST_URLLC	Slice suitable for the handling of ultra- reliable low latency communications.
SST_MIoT	Slice suitable for the handling of massive IoT.
SST_V2X	Slice suitable for the handling of V2X services.
NOTE:	For the conditions in this table, one or more conditions are set to true.

**Table 4.6.0.1-6: Channel bandwidth**

Condition	Explanation
BW5	5mhz
BW10	10mhz
BW15	15mhz
BW20	20mhz
BW25	25mhz

BW30	30mhz
BW40	40mhz
BW50	50mhz
BW60	60mhz
BW80	80mhz
BW100	100mhz

#### 4.6.1 Contents of RRC messages

##### – CounterCheck

**Table 4.6.1-1: CounterCheck**

Derivation Path: TS 38.331 [6], clause 6.2.2			
Information Element	Value/remark	Comment	Condition
CounterCheck ::= SEQUENCE {			
rrc-TransactionIdentifier	RRC-TransactionIdentifier		
criticalExtensions CHOICE {			
counterCheck SEQUENCE {			
drb-CountMSB-InfoList SEQUENCE (SIZE (1..maxDRB)) OF DRB-CountMSB-Info	1 entry		
DRB-CountMSB-Info[1] SEQUENCE {		entry 1	
drb-Identity	DRB-Identity		
countMSB-Uplink	0		
countMSB-Downlink	0		
}			
}			
lateNonCriticalExtension	Not present		
nonCriticalExtension	Not present		
}			
}			

##### – CounterCheckResponse

**Table 4.6.1-2: CounterCheckResponse**

Derivation Path: TS 38.331 [6], clause 6.2.2			
Information Element	Value/remark	Comment	Condition
CounterCheckResponse ::= SEQUENCE {			
rrc-TransactionIdentifier	RRC-TransactionIdentifier		
criticalExtensions CHOICE {			
counterCheckResponse SEQUENCE {			
drb-CountInfoList SEQUENCE (SIZE (0..maxDRB)) OF DRB-CountInfo {	1 entry		
DRB-CountInfo[1] SEQUENCE {		entry 1	
drb-Identity	DRB-Identity		
count-Uplink	Not checked		
count-Downlink	Not checked		
}			
}			
lateNonCriticalExtension	Not checked		
nonCriticalExtension	Not checked		
}			
}			

– *DedicatedSIBRequest*

**Table 4.6.1-2A: *DedicatedSIBRequest***

Derivation Path: TS 38.331 [6], clause 6.2.2			
Information Element	Value/remark	Comment	Condition
DedicatedSIBRequest-r16 ::= SEQUENCE {			
criticalExtensions CHOICE {			
dedicatedSIBRequest-r16 SEQUENCE {			
onDemandSIB-RequestList-r16 SEQUENCE {			
requestedSIB-List-r16	Not checked		
requestedPosSIB-List-r16	Not checked		
}			
lateNonCriticalExtension	Not checked		
nonCriticalExtension	Not checked		
}			
}			
}			

– *DLDedicatedMessageSegment*

**Table 4.6.1-2B: *DLDedicatedMessageSegment***

Derivation Path: TS 38.331 [6], clause 6.2.2			
Information Element	Value/remark	Comment	Condition
DLDedicatedMessageSegment-r16 ::= SEQUENCE {			
criticalExtensions CHOICE {			
dLDedicatedMessageSegment-r16 SEQUENCE {			
segmentNumber-r16	0		firstSegment
	1		lastSegment
rrc-MessageSegmentContainer-r16	Set according to specific message content	OCTET STRING including segmented RRCReconfiguration or RRCResume message	
rrc-MessageSegmentType-r16	notLastSegment		firstSegment
	lastSegment		lastSegment
lateNonCriticalExtension	Not present		
nonCriticalExtension	Not present		
}			
}			
}			

Condition	Explanation
firstSegment	The first segment of the RRCReconfiguration or RRCResume message
lastSegment	The last segment of the RRCReconfiguration or RRCResume message

– *DLInformationTransfer*

**Table 4.6.1-3: *DLInformationTransfer***

Derivation Path: TS 38.331 [6], clause 6.2.2			
Information Element	Value/remark	Comment	Condition
DLInformationTransfer ::= SEQUENCE {			
rrc-TransactionIdentifier	RRC-TransactionIdentifier		
criticalExtensions CHOICE {			



dlInformationTransfer SEQUENCE {			
dedicatedNAS-Message	DedicatedNAS-Message		
lateNonCriticalExtension SEQUENCE {	Not present		
referenceTimeInfo-r16	ReferenceTimeInfo		
nonCriticalExtension	Not present		
}			
nonCriticalExtension	Not present		
}			
}			
}			

Condition	Explanation
TSC	For test cases requiring TSC (Time Sensitive Communication) functions enabled.

– *DLInformationTransferMRDC*

**Table 4.6.1-3A: DLInformationTransferMRDC**

Derivation Path: TS 38.331 [6], clause 6.2.2			
Information Element	Value/remark	Comment	Condition
DLInformationTransferMRDC-r16 ::= SEQUENCE {			
FFS			
}			

– *FailureInformation*

**Table 4.6.1-4: FailureInformation**

Derivation Path: TS 38.331 [6], clause 6.2.2			
Information Element	Value/remark	Comment	Condition
FailureInformation ::= SEQUENCE {			
criticalExtensions CHOICE {			
failureInformation SEQUENCE {			
failureInfoRLC-Bearer SEQUENCE {			
cellGroupId	Not checked		
logicalChannelIdentity	Not checked		
failureType	Not checked		
}			
lateNonCriticalExtension	Not checked		
nonCriticalExtension	Not checked		
nonCriticalExtension SEQUENCE {			DAPS_HOF
failureInfoDAPS-r16 SEQUENCE {			
failureType-r16	daps-failure	Indicate handover failure type is DAPS handover failure	
}			
nonCriticalExtension	Not checked		
}			
}			
}			
}			

Condition	Explanation
DAPS_HOF	DAPS handover failure

– *IABOtherInformation***Table 4.6.1-4A: IABOtherInformation**

Derivation Path: TS 38.331 [6], clause 6.2.2			
Information Element	Value/remark	Comment	Condition
IABOtherInformation-r16 ::= SEQUENCE {			
FFS			
}			

– *LocationMeasurementIndication***Table 4.6.1-5: LocationMeasurementIndication**

Derivation Path: TS 38.331 [6], clause 6.2.2			
Information Element	Value/remark	Comment	Condition
LocationMeasurementIndication ::= SEQUENCE {			
criticalExtensions CHOICE {			
locationMeasurementIndication SEQUENCE {			
measurementIndication CHOICE {			
setup	LocationMeasurementInfo		
}			
lateNonCriticalExtension	Not checked		
nonCriticalExtension	Not checked		
}			
}			
}			

– *LoggedMeasurementConfiguration***Table 4.6.1-5AA: LoggedMeasurementConfiguration (Thres1)**

Derivation Path: TS 38.331 [6], clause 6.2.2			
Information Element	Value/remark	Comment	Condition
LoggedMeasurementConfiguration-r16 ::= SEQUENCE {			
criticalExtensions CHOICE {			
loggedMeasurementConfiguration-r16 SEQUENCE {			
traceReference-r16 SEQUENCE {			
plmn-Identity-r16	plmn-Identity in USIM	MCC/MNC=MCC/MNC in USIM	
traceId-r16	'0EF'H	OCTET STRING (SIZE (3))	
}			
traceRecordingSessionRef-r16	'1A'H	OCTET STRING (SIZE (2))	
tce-Id-r16	'5'H	OCTET STRING (SIZE (1))	
absoluteTimeInfo-r16	Set to value corresponding to the absolute time when the message is sent	BIT STRING (SIZE (48))	
areaConfiguration-r16	Not present		
plmn-IdentityList-r16	Not present		
bt-NameList-r16	Not present		
wlan-NameList-r16	Not present		
sensor-NameList-r16	Not present		
loggingDuration-r16	min120		
reportType CHOICE {			

periodical SEQUENCE {			PERIODICAL
loggingInterval-r16	ms2560	2.56s	
}			
eventTriggered SEQUENCE {			EVENT
eventType-r16 CHOICE {			
outOfCoverage	NULL		OUT-OF-COVERAGE
eventL1 SEQUENCE {			EVENTL1
l1-Threshold CHOICE {			
rsrp	Thres1	Thres is an entry value into a mapping table in TS 38.133 [13].	
}			
hysteresis	0		
timeToTrigger	ms100	0.1s	
}			
}			
loggingInterval-r16	ms2560	2.56s	
}			
}			
lateNonCriticalExtension	Not present		
nonCriticalExtension	Not present		
}	LoggedMeasurementConfiguration-v1700-IEs		LOG-MEAS-R17
}			
}			
}			

Condition	Explanation
PERIODICAL	Configuration of LoggedPeriodicalReport
EVENT	Configuration of LoggedEventTrigger
OUT-OF-COVERAGE	Configuration of outOfCoverage
EVENTL1	Configuration of eventL1
LOG-MEAS-R17	Configuration of LoggedMeasurement in R17

– *MBSBroadcastConfiguration*

**Table 4.6.1-5ABA: MBSBroadcastConfiguration**

Derivation Path: TS 38.331 [6], clause 6.2.2			
Information Element	Value/remark	Comment	Condition
MBSBroadcastConfiguration-r17 ::= SEQUENCE {			
criticalExtensions CHOICE {			
mbsBroadcastConfiguration-r17 SEQUENCE {			
mbs-SessionInfoList-r17	MBS-SessionInfoList		
mbs-NeighbourCellList-r17	Not present		
drx-ConfigPTM-List-r17	Not present		
drx-ConfigPTM-List-r17 SEQUENCE (SIZE (1..maxNrofDRX-ConfigPTM-r17)) OF DRX-ConfigPTM-r17 {	1 entry		DRX_MBS_Broadcast
DRX-ConfigPTM-r17[1]	DRX-ConfigPTM	entry 1	
}			
pdsch-ConfigMTCH-r17	Not present		
mtch-SSB-MappingWindowList-r17	Not present		
lateNonCriticalExtension	Not present		
nonCriticalExtension	Not present		
}			
}			
}			
}			

Condition	Explanation
DRX_MBS_Broadcast	DRX is used for MBS Broadcast test

– *MBSInterestIndication*

**Table 4.6.1-5ABB: MBSInterestIndication**

Derivation Path: TS 38.331 [6], clause 6.2.2			
Information Element	Value/remark	Comment	Condition
MBSInterestIndication-r17 ::= SEQUENCE {			
criticalExtensions CHOICE {			
mbsInterestIndication-r17 SEQUENCE {			
mbs-FreqList-r17[n] SEQUENCE (SIZE (1..maxFreqMBS-r17)) OF ARFCN-ValueNR	The number of entries is set according to specific message content.		
mbs-Priority-r17	Not checked		
mbs-ServiceList-r17	Not checked		
lateNonCriticalExtension	Not checked		
nonCriticalExtension	Not checked		
}			
}			

– *MCGFailureInformation*

**Table 4.6.1-5AB: MCGFailureInformation**

Derivation Path: TS 38.331 [6], clause 6.2.2			
Information Element	Value/remark	Comment	Condition
MCGFailureInformation-r16 ::= SEQUENCE {			
FFS			
}			

– *MeasurementReport*

**Table 4.6.1-5A: MeasurementReport**

Derivation Path: TS 38.331 [6], clause 6.2.2			
Information Element	Value/remark	Comment	Condition
MeasurementReport ::= SEQUENCE {			
criticalExtensions CHOICE {			
measurementReport SEQUENCE {			
measResults	MeasResults		
lateNonCriticalExtension	Not checked		
nonCriticalExtension	Not checked		
}			
}			

– *MIB*

**Table 4.6.1-6: MIB**

Derivation Path: TS 38.331 [6], clause 6.2.2			
Information Element	Value/remark	Comment	Condition
MIB ::= SEQUENCE {			
systemFrameNumber	A valid value as defined in TS 38.331 [6]		

subCarrierSpacingCommon	scs15or60	For signalling test cases see clause 6.2.3, otherwise see clause 4.3.1.	SCS15or60
	scs30or120	For signalling test cases see clause 6.2.3, otherwise see clause 4.3.1.	SCS30or120
ssb-subcarrierOffset	Set to the integer value of the 4 LSB of kSSB defined for the frequency of the cell	For signalling test cases see clause 6.2.3, otherwise see clause 4.3.1.	
dmrs-TypeA-Position	pos2		
pdccch-ConfigSIB1	PDCCH-ConfigSIB1		
cellBarred	notBarred		
intraFreqReselection	allowed		
spare	0		
}			

Condition	Explanation
SCS15or60	SCS is 15kHz or 60kHz
SCS30or120	SCS is 30kHz or 120kHz.

– *MobilityFromNRCommand*

**Table 4.6.1-8: *MobilityFromNRCommand***

Derivation Path: TS 38.331 [6], clause 6.2.2			
Information Element	Value/remark	Comment	Condition
MobilityFromNRCommand ::= SEQUENCE {			
rrc-TransactionIdentifier	RRC-TransactionIdentifier		
criticalExtensions CHOICE {			
mobilityFromNRCommand SEQUENCE {			
targetRAT-Type	eutra ultra-fdd-v1610		HO-TO-UTRA_FDD
targetRAT-MessageContainer	OCTET STRING including the RRCConnectionReconfiguration message according TS 36.508 [2], table 4.6.1-8 with condition HO-TO-EUTRA OCTET STRING including the Handover TO UTRAN message specified in TS 36.508 [2] Table 4.7B.1-1 with condition UTRA FDD PS RB		HO-TO-UTRA_FDD
nas-SecurityParamFromNR	The 4 LSB of the downlink NAS COUNT		
lateNonCriticalExtension	Not present		
nonCriticalExtension	Not present		
}			
}			
}			

Condition	Explanation
HO-TO-UTRA_FDD	For Handover from NR to UTRA FDD

– *Paging*

**Table 4.6.1-9: Paging**

Derivation Path: TS 38.331 [6], clause 6.2.2			
Information Element	Value/remark	Comment	Condition
Paging ::= SEQUENCE {			
pagingRecordList SEQUENCE	1 entry		
(SIZE(1..maxNrofPageRec)) OF PagingRecord {			
PagingRecord[1] SEQUENCE {		entry 1	
ue-Identity CHOICE {			
ng-5G-S-TMSI	NG-5G-S-TMSI		
fullI-RNTI	I-RNTI-Value		NR_RRC_R ESUME
}			
accessType	Not present		
}			
}			
lateNonCriticalExtension	Not present		
nonCriticalExtension	Not present		
nonCriticalExtension SEQUENCE {			TMGI
pagingRecordList-v1700	Not present		
pagingGroupList-r17 SEQUENCE	1 entry		
(SIZE(1..maxNrofPageGroup-r17)) OF TMGI-r17 {			
TMGI-r17[1]	TMGI-r17	entry 1	
nonCriticalExtension	Not present		
}			
}			
}			
}			

Condition	Explanation
NR_RRC_RESUME	To page a UE in RRC_INACTIVE state to request RRC connection resumption
TMGI	TMGI is used as paging identity

– *RRCReestablishment*

**Table 4.6.1-10: RRCReestablishment**

Derivation Path: TS 38.331 [6], clause 6.2.2			
Information Element	Value/remark	Comment	Condition
RRCReestablishment ::= SEQUENCE {			
rrc-TransactionIdentifier	RRC-TransactionIdentifier		
criticalExtensions CHOICE {			
rrcReestablishment SEQUENCE {			
nextHopChainingCount	NextHopChainingCount		
lateNonCriticalExtension	Not present		
nonCriticalExtension	Not present		
nonCriticalExtension SEQUENCE {			L2RemoteU E
sl-L2RemoteUE-Config-r17 CHOICE {			
setup	SL-L2RemoteUE-Config-r17		
nonCriticalExtension	Not present		
}			
}			
}			
}			
}			
}			
}			

Condition	Explanation
L2RemoteUE	For L2 U2N Remote UE test cases.

– *RRCReestablishmentComplete*

**Table 4.6.1-11: RRCReestablishmentComplete**

Derivation Path: TS 38.331 [6], clause 6.2.2			
Information Element	Value/remark	Comment	Condition
RRCReestablishmentComplete ::= SEQUENCE {			
rrc-TransactionIdentifier	RRC-TransactionIdentifier		
criticalExtensions CHOICE {			
rrcReestablishmentComplete SEQUENCE {			
lateNonCriticalExtension	Not checked		
nonCriticalExtension	Not checked		
}			
}			
}			

– *RRCReestablishmentRequest*

**Table 4.6.1-12: RRCReestablishmentRequest**

Derivation Path: TS 38.331 [6], clause 6.2.2			
Information Element	Value/remark	Comment	Condition
RRCReestablishmentRequest ::= SEQUENCE {			
ue-Identity SEQUENCE {			
c-RNTI	RNTI-Value		
physCellId	PhysCellId	The physical cell identity of the PCell the UE was connected to prior to the failure	
shortMAC-I	ShortMAC-I		
}			
reestablishmentCause	Not checked		
spare	Present but contents not checked		
}			

– *RRCReconfiguration*

**Table 4.6.1-13: RRCReconfiguration**

Derivation Path: TS 38.331 [6], clause 6.2.2			
Information Element	Value/remark	Comment	Condition
RRCReconfiguration ::= SEQUENCE {			
rrc-TransactionIdentifier	RRC-TransactionIdentifier		
criticalExtensions CHOICE {			
rrcReconfiguration SEQUENCE {			
radioBearerConfig	Not present		
	RadioBearerConfig with conditions SRB2 and DRB1		NR, NR-DC
	RadioBearerConfig with conditions SRB2 and REEST		REEST
}			
}			

secondaryCellGroup	CellGroupConfig	OCTET STRING (CONTAINING CellGroupConfig)	EN-DC
	CellGroupConfig with condition NR-DC_SCG	OCTET STRING (CONTAINING CellGroupConfig)	NR-DC_SCG
	CellGroupConfig with conditions EN-DC and PSCell_change	OCTET STRING (CONTAINING CellGroupConfig)	EN-DC_HO
	CellGroupConfig with condition MEAS	OCTET STRING (CONTAINING CellGroupConfig)	EN-DC_MEAS
	CellGroupConfig with condition SCell_add	OCTET STRING (CONTAINING CellGroupConfig)	EN-DC_SCell_add
	Not present		
measConfig	Not present		
	MeasConfig	Measurements configuration	NR_MEAS, EN-DC_MEAS, IRAT_MEAS
lateNonCriticalExtension	Not present		
nonCriticalExtension	Not present		
nonCriticalExtension SEQUENCE {			NR, SCell_add, NR_MEAS, NR-DC, SIDELINK, DAPS_HO_ReleaseSource, CHO, CPC, REEST, L2RelayUE, L2RemoteUE
masterCellGroup	CellGroupConfig with condition SRB2_DRB1	OCTET STRING (CONTAINING CellGroupConfig)	NR, NR-DC
	CellGroupConfig with condition SCell_add	OCTET STRING (CONTAINING CellGroupConfig)	SCell_add
	CellGroupConfig with condition MEAS	OCTET STRING (CONTAINING CellGroupConfig)	NR_MEAS
	CellGroupConfig with condition REEST	OCTET STRING (CONTAINING CellGroupConfig)	REEST
	CellGroupConfig with condition RELAY	OCTET STRING (CONTAINING CellGroupConfig)	RELAY
fullConfig	Not present		
dedicatedNAS-MessageList	Not present		
dedicatedNAS-MessageList SEQUENCE (SIZE(1..maxDRB)) OF DedicatedNAS-Message {	1 entry		NR
DedicatedNAS-Message[1]	DedicatedNAS-Message	entry 1 A sequence of OCTET STRING(s) containing one or more DedicatedNAS-Message(s)	
}			
masterKeyUpdate	Not present		
masterKeyUpdate SEQUENCE {			MasterKeyChange
keySetChangeIndicator	true		



nextHopChainingCount	NextHopChainingCount		
nas-Container	Not present		
	OCTET STRING including the 10 Octets value generated according to TS 24.501 [28] clause 9.11.2.9		Inter_Sys_HO
}			
dedicatedSIB1-Delivery	Not present		
dedicatedSystemInformationDelivery	Not present		
otherConfig	Not present		
nonCriticalExtension	Not present		
nonCriticalExtension SEQUENCE {			NR-DC, SIDELINK, DAPS_HO_ReleaseSource, CHO, CPC, NE-DC, L2Relay UE, L2RemoteUE
otherConfig-v1540	Not present		
nonCriticalExtension SEQUENCE {			
mrdc-SecondaryCellGroupConfig	Not present		
mrdc-SecondaryCellGroupConfig CHOICE {			NR-DC, NE-DC
setup SEQUENCE {			
mrdc-ReleaseAndAdd	Not present		
mrdc-SecondaryCellGroup CHOICE {			
nr-SCG	RRCReconfiguration with condition NR-DC_SCG	OCTET STRING (CONTAINING RRCReconfiguration)	NR-DC
eutra-SCG	RRCConnectionReconfiguration according TS 36.508 [2], table 4.6.1-8 with condition NE-DC	OCTET STRING (CONTAINING RRCConnectionReconfiguration)	NE-DC
}			
}			
}			
radioBearerConfig2	Not present		NE-DC
	RadioBearerConfig with condition DRBn and SecondaryKeys	OCTET STRING (CONTAINING RadioBearerConfig)	NR-DC
sk-Counter	SK-Counter		
nonCriticalExtension	Not present		
nonCriticalExtension SEQUENCE {			SIDELINK, DAPS_HO_ReleaseSource, CHO, CPC, L2Relay UE, L2RemoteUE
otherConfig-v1610	Not present		
bap-Config-r16	Not present		
iab-IP-AddressConfigurationList-r16	Not present		
conditionalReconfiguration-r16	Not present		
	ConditionalReconfiguration		CHO, CPC
daps-SourceRelease-r16	Not present		



MasterKeyChange	MasterKeyUpdate when performing ReconfigurationWithSync and indicating a change of the AS security algorithms associated to the master key
Inter_Sys_HO	Used during inter-system handover to NR procedure
REEST	The first RRCReconfiguration message after successful completion of the RRC re-establishment procedure
SIDELINK	For NR sidelink dedicated configuration
DAPS_HO_ReleaseSource	The source cell part of DAPS operation is to be stopped and the source cell part of DAPS configuration is to be released.
CHO	Conditional handover
CPC	Conditional PSCell change
NE-DC	NR E-UTRA Dual Connectivity
L2RelayUE	For L2 U2N Relay UE test cases.
L2RemoteUE	For L2 U2N Remote UE test cases.
RELAY	Add Uu Relay RLC channel configuration
NR-FR2-Upink-Gaps	Configure Uplink Gaps for NR FR2

– *RRCReconfigurationComplete*

**Table 4.6.1-14: RRCReconfigurationComplete**

Derivation Path: TS 38.331 [6], clause 6.2.2			
Information Element	Value/remark	Comment	Condition
RRCReconfigurationComplete ::= SEQUENCE {			
rrc-TransactionIdentifier	Not checked		
criticalExtensions CHOICE {			
rrcReconfigurationComplete SEQUENCE {			
lateNonCriticalExtension	Not checked		
nonCriticalExtension	Not checked		
nonCriticalExtension SEQUENCE {			NR-DC, NE-DC
uplinkTxDirectCurrentList	Not checked		
nonCriticalExtension SEQUENCE {			
scg-Response CHOICE {			
nr-SCG-Response	RRCReconfigurationComplete	OCTET STRING (CONTAINING RRCReconfigurationComplete)	NR-DC
eutra-SCG-Response	RRCConnectionReconfigurationComplete	OCTET STRING	NE-DC
}			
nonCriticalExtension	Not checked		
}			
}			
nonCriticalExtension	Not checked		
}			
}			

Condition	Explanation
NR-DC	Used in NR-DC configuration
NE-DC	NR E-UTRA Dual Connectivity is configured

– *RRCReject*

**Table 4.6.1-15: RRCReject**

Derivation Path: TS 38.331 [6], clause 6.2.2			
Information Element	Value/remark	Comment	Condition
RRCReject ::= SEQUENCE {			
criticalExtensions CHOICE {			

rrcReject SEQUENCE {			
waitTime	1		
lateNonCriticalExtension	Not present		
nonCriticalExtension	Not present		
}			
}			

– RRCRelease

Table 4.6.1-16: RRCRelease

Derivation Path: TS 38.331 [6], clause 6.2.2			
Information Element	Value/remark	Comment	Condition
RRCRelease ::= SEQUENCE {			
rrc-TransactionIdentifier	RRC-TransactionIdentifier		
criticalExtensions CHOICE {			
rrcRelease SEQUENCE {			
redirectedCarrierInfo	Not present		
cellReselectionPriorities	Not present		
suspendConfig	Not present		
suspendConfig SEQUENCE {			NR_RRC_I NACTIVE
fullI-RNTI	I-RNTI-Value		
shortI-RNTI	ShortI-RNTI-Value		
ran-PagingCycle	rf32		
ran-NotificationAreaInfo CHOICE {			
cellList SEQUENCE (SIZE (1..maxPLMNIdentities)) OF PLMN-RAN-AreaCell {	1 entry		
PLMN-RAN-AreaCellList[1] SEQUENCE {		entry 1	
plmn-Identity	Not present		
ran-AreaCells SEQUENCE (SIZE (1..32)) OF CellIdentity {	1 entry		
CellIdentity[1]	CellIdentity	entry 1 Cellidentity for the used cell.	
}			
}			
}			
}			
}			
}			
t380	Not present		
nextHopChainingCount	NextHopChainingCount		
sl-UEIdentityRemote-r17	Not present		
sl-UEIdentityRemote-r17	RNTI-Value		L2RemoteUE
sdt-Config-r17	Not present		
sdt-Config-r17 CHOICE {			SDT
setup SEQUENCE {			
sdt-DRB-List-r17 SEQUENCE (SIZE (0..maxDRB)) OF DRB-Identity {	1 entry		
DRB-Identity	DRB-Identity using condition DRB1		
}			
sdt-SRB2-Indication-r17	Not present		
	allowed		pc_srb_SDT_r17
sdt-MAC-PHY-CG-Config-r17 CHOICE {			
setup SEQUENCE {			
cg-SDT-ConfigLCH-RestrictionToAddModList-r17 SEQUENCE (SIZE(1..maxLC-ID)) OF CG-SDT-Config-LCH-restriction-r17 {	1 entry		

logicalChannelIdentity-r17	LogicalChannelIdentity with condition DRB1		
configuredGrantType1Allowed-r17	true		
allowedCG-List-r17	Not present		
}			
cg-SDT-ConfigLCH-RestrictionToReleaseList-r17	Not present		
cg-SDT-ConfigInitialBWP-NUL-r17	Not present		
cg-SDT-ConfigInitialBWP-SUL-r17	Not present		
cg-SDT-ConfigInitialBWP-DL-r17	Not present		
cg-SDT-TimeAlignmentTimer-r17	ms750		
cg-SDT-RSRP-ThresholdSSB-r17	66		
cg-SDT-TA-ValidationConfig-r17	Not present		
cg-SDT-CS-RNTI-r17	Not present		
}			
}			
sdt-DRB-ContinueROHC-r17	Not present		
}			
}			
srs-PosRRC-Inactive-r17	Not present		
ran-ExtendedPagingCycle-r17	Not present		
}			
deprioritisationReq	Not present		
lateNonCriticalExtension	Not present		
nonCriticalExtension	Not present		
}			
}			
}			

Condition	Explanation
NR_RRC_INACTIVE	NR RRC state RRC_INACTIVE
SDT	For SDT test cases
L2RemoteUE	For L2 U2N Remote UE test cases.

– *RRCResume*

**Table 4.6.1-17: RRCResume**

Derivation Path: TS 38.331 [6], clause 6.2.2			
Information Element	Value/remark	Comment	Condition
RRCResume ::= SEQUENCE {			
rrc-TransactionIdentifier	RRC-TransactionIdentifier		
criticalExtensions CHOICE {			
rrcResume SEQUENCE {			
radioBearerConfig	RadioBearerConfig with condition RESUME		
masterCellGroup	CellGroupConfig with condition RESUME	OCTET STRING (CONTAINING CellGroupConfig)	
measConfig	Not present		
fullConfig	Not present		
lateNonCriticalExtension	Not present		
nonCriticalExtension	Not present		
nonCriticalExtension SEQUENCE {			L2RemoteUE
radioBearerConfig2	Not present		
sk-Counter	Not present		
nonCriticalExtension SEQUENCE {			
idleModeMeasurementReq-r16	Not present		
restoreMCG-SCells-r16	Not present		
restoreSCG-r16	Not present		
mrdc-SecondaryCellGroup-r16	Not present		

needForGapsConfigNR-r16	Not present		
nonCriticalExtension SEQUENCE {			
sl-ConfigDedicatedNR-r17	Not present		
sl-L2RemoteUE-Config-r17 CHOICE {			
setup	SL-L2RemoteUE-Config-r17		
}			
needForGapNCSG-ConfigNR-r17	Not present		
needForGapNCSG-ConfigEUTRA-r17	Not present		
scg-State-r17	Not present		
appLayerMeasConfig-r17	Not present		
nonCriticalExtension	Not present		
}			
}			
}			
}			
}			

Condition	Explanation
L2RemoteUE	For L2 U2N Remote UE test cases.

– *RRCResumeComplete*

**Table 4.6.1-18: RRCResumeComplete**

Derivation Path: TS 38.331 [6], clause 6.2.2			
Information Element	Value/remark	Comment	Condition
RRCResumeComplete ::= SEQUENCE {			
rrc-TransactionIdentifier	RRC-TransactionIdentifier		
criticalExtensions CHOICE {			
rrcResumeComplete SEQUENCE {			
dedicatedNAS-Message	Not checked		
selectedPLMN-Identity	Not checked		
uplinkTxDirectCurrentList	Not checked		
lateNonCriticalExtension	Not checked		
nonCriticalExtension	Not checked		
}			
}			
}			
}			

– *RRCResumeRequest*

**Table 4.6.1-19: RRCResumeRequest**

Derivation Path: TS 38.331 [6], clause 6.2.2			
Information Element	Value/remark	Comment	Condition
RRCResumeRequest ::= SEQUENCE {			
rrcResumeRequest SEQUENCE {			
resumeIdentity	ShortI-RNTI-Value		
resumeMAC-I	Not checked		
resumeCause	ResumeCause		
spare	Not checked		
}			
}			

– *RRCResumeRequest1*Table 4.6.1-20: *RRCResumeRequest1*

Derivation Path: TS 38.331 [6], clause 6.2.2			
Information Element	Value/remark	Comment	Condition
RRCResumeRequest1 ::= SEQUENCE {			
rrcResumeRequest1 SEQUENCE {			
resumeIdentity	I-RNTI-Value		
resumeMAC-I	Not checked		
resumeCause	ResumeCause		
spare	Not checked		
}			
}			

– *RRCSetup*Table 4.6.1-21: *RRCSetup*

Derivation Path: TS 38.331 [6], clause 6.2.2			
Information Element	Value/remark	Comment	Condition
RRCSetup ::= SEQUENCE {			
rrc-TransactionIdentifier	RRC-TransactionIdentifier		
criticalExtensions CHOICE {			
rrcSetup SEQUENCE {			
radioBearerConfig	RadioBearerConfig with condition SRB1		
masterCellGroup	CellGroupConfig with condition SRB1	OCTET STRING (CONTAINING CellGroupConfig)	
lateNonCriticalExtension	Not present		
nonCriticalExtension	Not present		
nonCriticalExtension SEQUENCE {			L2RemoteUE
sl-ConfigDedicatedNR-r17	Not present		
sl-L2RemoteUE-Config-r17	SL-L2RemoteUE-Config with condition SL-SRBO and SL-SRB1		
nonCriticalExtension	Not present		
}			
}			
}			

Condition	Explanation
L2RemoteUE	For L2 U2N Remote UE test cases.

– *RRCSetupComplete*Table 4.6.1-22: *RRCSetupComplete*

Derivation Path: TS 38.331 [6], clause 6.2.2			
Information Element	Value/remark	Comment	Condition
RRCSetupComplete ::= SEQUENCE {			
rrc-TransactionIdentifier	RRC-TransactionIdentifier		
criticalExtensions CHOICE {			
rrcSetupComplete SEQUENCE {			
selectedPLMN-Identity	Not checked		
registeredAMF	Not checked		
}			
}			

guami-Type	Not checked		
s-nssai-List	Not checked		
dedicatedNAS-Message	DedicatedNAS-Message		
ng-5G-S-TMSI-Value	Not checked		
lateNonCriticalExtension	Not checked		
nonCriticalExtension	Not checked		
}			
}			
}			

– *RRCSetupRequest*

**Table 4.6.1-23: RRCSetupRequest**

Derivation Path: TS 38.331 [6], clause 6.2.2			
Information Element	Value/remark	Comment	Condition
RRCSetupRequest ::= SEQUENCE {			
rrcSetupRequest SEQUENCE {			
ue-Identity CHOICE {			
randomValue	Not checked		
}			
establishmentCause	Not checked		
spare	Not checked		
}			
}			

– *RRCSystemInfoRequest*

**Table 4.6.1-24: RRCSystemInfoRequest**

Derivation Path: TS 38.331 [6], clause 6.2.2			
Information Element	Value/remark	Comment	Condition
RRCSystemInfoRequest ::= SEQUENCE {			
criticalExtensions CHOICE {			
rrcSystemInfoRequest SEQUENCE {			
requested-SI-List	Not checked		
spare	Not checked		
}			
}			
}			

– *SCGFailureInformation*

**Table 4.6.1-24A: SCGFailureInformation**

Derivation Path: TS 38.331 [6], clause 6.2.2			
Information Element	Value/remark	Comment	Condition
SCGFailureInformation ::= SEQUENCE {			
criticalExtensions CHOICE {			
scgFailureInformation SEQUENCE {			
failureReportSCG	Not checked		
nonCriticalExtension	Not checked		
}			
}			
}			



– SCGFailureInformationEUTRA

**Table 4.6.1-24B: SCGFailureInformationEUTRA**

Derivation Path: TS 38.331 [6], clause 6.2.2			
Information Element	Value/remark	Comment	Condition
SCGFailureInformationEUTRA ::= SEQUENCE {			
criticalExtensions CHOICE {			
scgFailureInformationEUTRA SEQUENCE {			
failureReportSCG-EUTRA	Not checked		
nonCriticalExtension	Not checked		
}			
}			
}			

– SecurityModeCommand

**Table 4.6.1-25: SecurityModeCommand**

Derivation Path: TS 38.331 [6], clause 6.2.2			
Information Element	Value/remark	Comment	Condition
SecurityModeCommand ::= SEQUENCE {			
rrc-TransactionIdentifier	RRC-TransactionIdentifier		
criticalExtensions CHOICE {			
securityModeCommand SEQUENCE {			
securityConfigSMC SEQUENCE {			
securityAlgorithmConfig	SecurityAlgorithmConfig		
}			
lateNonCriticalExtension	Not present		
nonCriticalExtension	Not present		
}			
}			
}			

– SecurityModeComplete

**Table 4.6.1-26: SecurityModeComplete**

Derivation Path: TS 38.331 [6], clause 6.2.2			
Information Element	Value/remark	Comment	Condition
SecurityModeComplete ::= SEQUENCE {			
rrc-TransactionIdentifier	RRC-TransactionIdentifier		
criticalExtensions CHOICE {			
securityModeComplete SEQUENCE {			
lateNonCriticalExtension	Not checked		
nonCriticalExtension	Not checked		
}			
}			
}			

– SecurityModeFailure

**Table 4.6.1-27: SecurityModeFailure**

Derivation Path: TS 38.331 [6], clause 6.2.2			
Information Element	Value/remark	Comment	Condition
SecurityModeFailure ::= SEQUENCE {			

rrc-TransactionIdentifier	RRC-TransactionIdentifier		
criticalExtensions CHOICE {			
securityModeFailure SEQUENCE {			
lateNonCriticalExtension	Not checked		
nonCriticalExtension	Not checked		
}			
}			
}			

– SIB1

Table 4.6.1-28: SIB1

Derivation Path: TS 38.331 [6], clause 6.2.2			
Information Element	Value/remark	Comment	Condition
SIB1 ::= SEQUENCE {			
cellSelectionInfo SEQUENCE {			
q-RxLevMin	-70	-140 dBm	RF OR RRM
	-55	-110 dBm	SIG AND FR1
	ROUND((-110+Delta(NRfs))/2)	-110+Delta(NRfs)	SIG AND FR2
q-RxLevMinOffset	Not present		
q-RxLevMinSUL	Not Present		
	-70	-140 dBm	SUL AND (RF OR RRM)
	-55	-110 dBm	SUL AND SIG
q-QualMin	-20	-20dB	QBASED
	Not present		
q-QualMinOffset	Not present		
}			
cellAccessRelatedInfo	CellAccessRelatedInfo		
connEstFailureControl	ConnEstFailureControl		
si-SchedulingInfo	Not present		NR_1
	SI-SchedulingInfo		
servingCellConfigCommon	ServingCellConfigCommonSIB		
	ServingCellConfigCommonSIB with condition PEI		PEI
ims-EmergencySupport	Not present		
	true	Indicates the cell supports IMS emergency bearer services for UEs in limited service mode.	SIG
eCallOverIMS-Support	Not present		
	true	Support of eCall over IMS services	eCalloverIMSforNR
ue-TimersAndConstants	UE-TimersAndConstants		
uac-BarringInfo	Not present		
useFullResumeID	Not present		
lateNonCriticalExtension	Not present		
nonCriticalExtension	Not present		
nonCriticalExtension SEQUENCE {			EMR_EUTRA, EMR_NR, posSIB, pc_supportOfRedCap_r17, SDT

idleModeMeasurementsEUTRA-r16	Not present		
	true		EMR_EUTRA
idleModeMeasurementsNR-r16	Not present		
	true		EMR_NR
posSI-SchedulingInfo-r16	PosSI-SchedulingInfo-r16		
	PosSI-SchedulingInfo-r16		posSIB
nonCriticalExtension SEQUENCE { uac-BarringInfo-v1630	Not present		
nonCriticalExtension SEQUENCE { hsdn-Cell-r17	Not present		
uac-BarringInfo-v1700	Not present		
sdt-ConfigCommon-r17	Not present		
sdt-ConfigCommon-r17 SEQUENCE { sdt-RSRP-Threshold-r17	66		SDT
sdt-LogicalChannelSR-DelayTimer-r17	Not present		
sdt-DataVolumeThreshold-r17	byte1000		
t319a-r17	ms1000		
}			
redCap-ConfigCommon-r17	Not present		
redCap-ConfigCommon-r17 SEQUENCE {  halfDuplexRedCapAllowed-r17	true		pc_halfDuplexFDD_TypeA_RedCap_r17 AND FDD
cellBarredRedCap-r17	Not present		
}			
featurePriorities-r17	Not present		
si-SchedulingInfo-v1700	Not present		
hyperSFN-r17	Not present		
eDRX-AllowedIdle-r17	Not present		
eDRX-AllowedInactive-r17	Not present		
intraFreqReselectionRedCap-r17	Not present		
	allowed		pc_supportOfRedCap_r17
cellBarredNTN-r17	Not present		
	notBarred		NTN
nonCriticalExtension	Not present		
}			
}			
}			
NOTE 1: Delta(NRfs) is derived based on calibration procedure defined in the clause 6.1.3.3. NRfs is NR frequency on which SIB1 is broadcasted.			
NOTE 2: ROUND is rounded off to the nearest integer. As an example, '1 to 1.49' set to '1' while '1.5 to 2' to '2' and '-2.0 to 1.5' set to '-2' while '-1.49 to -1' set to '-1'.			

Condition	Explanation
SUL	For test cases using SUL frequency for the serving cell, Qrxlevmin is obtained from q-RxLevMinSUL.
QBASED	This condition applies to Quality based signalling test cases.
NR_1	System information combination NR-1 according table 4.4.3.1.2-1 is applied.
SIG	Used for signalling test cases.
eCalloverIMSforNR	Used for eCall over IMS test cases (TS 38.523-1[12], TS 34.229-5[47])
posSIB	For test cases using posSIBs in system information.
EMR_EUTRA	For E-UTRA idle/inactive measurement test cases.
EMR_NR	For NR idle/inactive measurement test cases.
SDT	For SDT test cases
NTN	For NTN test cases

PEI	Paging Early Indication is configured in the cell.
-----	--

– *SidelinkUEInformationNR*

**Table 4.6.1-28A: SidelinkUEInformationNR**

Derivation Path: TS 38.331 [6], clause 6.2.2			
Information Element	Value/remark	Comment	Condition
SidelinkUEInformationNR-r16 ::= SEQUENCE {			
criticalExtensions CHOICE {			
sidelinkUEInformationNR-r16 SEQUENCE {			
sl-RxInterestedFreqList-r16	Not present		
sl-RxInterestedFreqList-r16 SEQUENCE (SIZE (1..maxNrofFreqSL-r16)) OF INTEGER {	1 entry		SIDELINK_RX
INTEGER[1]	1	entry 1	
}			
sl-TxResourceReqList-r16	Not present		
sl-TxResourceReqList-r16 SEQUENCE (SIZE (1..maxNrofSL-Dest-r16)) OF SL-TxResourceReq-r16 {	1 entry		SIDELINK_TX
SL-TxResourceReq-r16[1] SEQUENCE {		entry 1	
sl-DestinationIdentity-r16	SL-DestinationIdentity-r16		
sl-CastType-r16	unicast		
sl-RLC-ModeIndicationList-r16	Not present		
sl-QoS-InfoList-r16 SEQUENCE (SIZE (1..maxNrofSL-QFIsPerDest-r16)) OF SL-QoS-Info-r16 {	1 entry		
SL-QoS-Info-r16[1] SEQUENCE {		entry 1	
sl-QoS-FlowIdentity-r16	SL-QoS-FlowIdentity-r16		
sl-QoS-Profile-r16	SL-QoS-Profile-r16		
}			
}			
sl-TypeTxSyncList-r16 SEQUENCE (SIZE (1..maxNrofFreqSL-r16)) OF SL-TypeTxSync-r16 {	1 entry		
SL-TypeTxSync-r16[1]	SL-TypeTxSync-r16	entry 1	
}			
sl-TxInterestedFreqList-r16 SEQUENCE (SIZE (1..maxNrofFreqSL-r16)) OF INTEGER {	1 entry		
INTEGER[1]	1	entry 1	
}			
sl-CapabilityInformationSidelink-r16[1]	Not present		
}			
sl-FailureList-r16	Not present		
lateNonCriticalExtension	Not present		
nonCriticalExtension	Not present		
nonCriticalExtension SEQUENCE {			L2RelayUE
sl-TxResourceReqList-v1700	Not checked		
sl-RxDRX-ReportList-v1700	Not checked		
sl-RxInterestedGC-BC-DestList-r17	Not checked		
sl-RxInterestedFreqListDisc-r17	Not checked		
sl-TxResourceReqListDisc-r17	Not checked		
sl-TxResourceReqListCommRelay-r17 SEQUENCE (SIZE (1..maxNrofSL-Dest-r16)) OF SL-TxResourceReqCommRelayInfo-r17 {			
SL-TxResourceReqCommRelayInfo-r17 [1] SEQUENCE {		entry 1	
sl-RelayDRXConfig-r17	Not checked		
sl-TxResourceReqCommRelay-r17 CHOICE {			
sl-TxResourceReqL2U2N-Relay-r17 SEQUENCE {			
sl-DestinationIdentityL2U2N-r17	SL-DestinationIdentity-r16		

sl-TxInterestedFreqListL2U2N-r17 SEQUENCE (SIZE (1..maxNrofFreqSL-r16)) OF INTEGER {			
INTEGER[1]	1		
}			
sl-TypeTxSyncListL2U2N-r17 SEQUENCE (SIZE (1..maxNrofFreqSL-r16)) OF SL-TypeTxSync-r16 {			
SL-TypeTxSync-r16[1]	SL-TypeTxSync-r16	entry 1	
}			
sl-LocalID-Request-r17	true		
sl-PagingIdentityRemoteUE-r17 SEQUENCE {			
ng-5G-S-TMSI-r17	NG-5G-S-TMSI		
fullI-RNTI-r17	Not checked		
}			
sl-CapabilityInformationSidelink-r17	OCTET STRING containing UECapabilityInformation Sidelink specified in Table 4.6.1A-7 with condition RX		
}			
}			
}			
ue-Type-r17	relayUE		
sl-SourceIdentityRemoteUE-r17	Not checked		
nonCriticalExtension	Not present		
}			
}			
}			
}			

Condition	Explanation
SIDELINK_TX	Used when UE indicates its interest on sidelink transmission.
SIDELINK_RX	Used when UE indicates its interest on sidelink reception.
L2RelayUE	For L2 U2N Relay UE test cases.

– *SystemInformation*

**Table 4.6.1-29: SystemInformation**

Derivation Path: TS 38.331 [6], clause 6.2.2			
Information Element	Value/remark	Comment	Condition
SystemInformation ::= SEQUENCE {			
criticalExtensions CHOICE {			
systemInformation SEQUENCE {			
sib-TypeAndInfo SEQUENCE (SIZE (1..maxSIB)) OF CHOICE	See subclause 4.4.3.1.3		
sibX	"X" denotes the SIB number		
...			
sibY	"Y" denotes the SIB number		
}			
lateNonCriticalExtension	Not present		
nonCriticalExtension	Not present		
}			
criticalExtensionsFuture-r16 CHOICE {			posSIB
posSystemInformation-r16	PosSystemInformation-r16-IEs		
}			

}			
}			

Condition	Explanation
posSIB	For test cases using posSIBs in system information.

– UEAssistanceInformation

Table 4.6.1-30: UEAssistanceInformation

Derivation Path: TS 38.331 [6], clause 6.2.2			
Information Element	Value/remark	Comment	Condition
UEAssistanceInformation ::= SEQUENCE {			
criticalExtensions CHOICE {			
ueAssistanceInformation SEQUENCE {			
delayBudgetReport CHOICE {			
type1	Not checked		
}			
lateNonCriticalExtension	Not checked		
nonCriticalExtension	Not checked		
nonCriticalExtension SEQUENCE {			SIDELINK
overheatingAssistance	Not checked		
nonCriticalExtension SEQUENCE {			
idc-Assistance-r16	Not checked		
drx-Preference-r16	Not checked		
maxBW-Preference-r16	Not checked		
maxCC-Preference-r16	Not checked		
maxMIMO-LayerPreference-r16	Not checked		
minSchedulingOffsetPreference-r16	Not checked		
releasePreference-r16	Not checked		
sl-UE-AssistanceInformationNR-r16	Not checked		
sl-UE-AssistanceInformationNR-r16	1 entry		SIDELINK
SEQUENCE (SIZE (1..maxNrofTrafficPattern-r16))			
OF SL-TrafficPatternInfo-r16 {			
SL-TrafficPatternInfo-r16[1] SEQUENCE {		entry 1	
trafficPeriodicity-r16	FFS		
timingOffset-r16	FFS		
messageSize-r16	FFS		
sl-QoS-FlowIdentity-r16	SL-QoS-FlowIdentity-r16		
}			
}			
referenceTimeInfoPreference-r16	Not checked		
nonCriticalExtension	Not checked		
nonCriticalExtension SEQUENCE {			SDT
ul-GapFR2-Preference-r17	Not checked		
musim-Assistance-r17	Not checked		
overheatingAssistance-r17	Not checked		
maxBW-PreferenceFR2-2-r17	Not checked		
maxMIMO-LayerPreferenceFR2-2-r17	Not checked		
minSchedulingOffsetPreferenceExt-r17	Not checked		
rlm-MeasRelaxationState-r17	Not checked		
bfd-MeasRelaxationState-r17	Not checked		
nonSDT-DataIndication-r17 SEQUENCE {			SDT
resumeCause-r17	mo-Data		
}			
scg-DeactivationPreference	Not checked		
uplinkData-r17	Not checked		
rrm-MeasRelaxationFulfilment-r17	Not checked		
propagationDelayDifference-r17	Not checked		
nonCriticalExtension	Not checked		
}			
}			
}			
}			

}			
}			
}			

Condition	Explanation
SIDELINK	For NR sidelink dedicated configuration
SDT	For SDT test cases

– *UECapabilityEnquiry*

**Table 4.6.1-31: UECapabilityEnquiry**

Derivation Path: TS 38.331 [6], clause 6.2.2			
Information Element	Value/remark	Comment	Condition
UECapabilityEnquiry ::= SEQUENCE {			
rrc-TransactionIdentifier	RRC-TransactionIdentifier		
criticalExtensions CHOICE {			
ueCapabilityEnquiry SEQUENCE {			
ue-CapabilityRAT-RequestList	UE-CapabilityRAT-RequestList		
lateNonCriticalExtension	Not present		
ue-CapabilityEnquiryExt	Not present		
}			
}			
}			

– *UECapabilityInformation*

**Table 4.6.1-32: UECapabilityInformation**

Derivation Path: TS 38.331 [6], clause 6.2.2			
Information Element	Value/remark	Comment	Condition
UECapabilityInformation ::= SEQUENCE {			
rrc-TransactionIdentifier	RRC-TransactionIdentifier		
criticalExtensions CHOICE {			
ueCapabilityInformation SEQUENCE {			
ue-CapabilityRAT-ContainerList	UE-CapabilityRAT-ContainerList		
lateNonCriticalExtension	Not checked		
nonCriticalExtension	Not checked		
}			
}			
}			

– *UEInformationRequest*

**Table 4.6.1-32A: UEInformationRequest**

Derivation Path: TS 38.331 [6], clause 6.2.2			
Information Element	Value/remark	Comment	Condition
UEInformationRequest-r16 ::= SEQUENCE {			
rrc-TransactionIdentifier	RRC-TransactionIdentifier		
criticalExtensions CHOICE {			
ueInformationRequest-r16 SEQUENCE {			

idleModeMeasurementReq-r16	Not present		
	true		IDLE
logMeasReportReq-r16	Not present		
	true		LOG
connEstFailReportReq-r16	true		
ra-ReportReq-r16	Not present		
	true		RA
rfl-ReportReq-r16	Not present		
	true		RLF
mobilityHistoryReportReq-r16	Not present		
	true		HISTORY
lateNonCriticalExtension	Not present		
nonCriticalExtension	Not present		
}			
}			
}			

Condition	Explanation
IDLE	Idle/inactive measurement information reporting
LOG	Logged measurement information reporting
RA	Random access procedure information reporting
RLF	Radio link failure information reporting
HISTORY	Mobility history information reporting

– *UEInformationResponse*

**Table 4.6.1-32B: UEInformationResponse**

Derivation Path: TS 38.331 [6], clause 6.2.2			
Information Element	Value/remark	Comment	Condition
UEInformationResponse-r16 ::= SEQUENCE {			
rrc-TransactionIdentifier	RRC-TransactionIdentifier		
criticalExtensions CHOICE {			
ueInformationResponse-r16 SEQUENCE {			
measResultIdleEUTRA-r16	Not checked		
measResultIdleNR-r16	Not checked		
logMeasReport-r16	Not checked		
connEstFailReport-r16	Not checked		
ra-ReportList-r16	Not checked		
rfl-Report-r16	Not checked		
mobilityHistoryReport-r16	Not checked		
lateNonCriticalExtension	Not checked		
nonCriticalExtension	Not checked		
}			
}			
}			

– *ULDedicatedMessageSegment*

**Table 4.6.1-32C: ULDedicatedMessageSegment**

Derivation Path: TS 38.331 [6], clause 6.2.2			
Information Element	Value/remark	Comment	Condition
ULDedicatedMessageSegment-r16 ::= SEQUENCE {			
criticalExtensions CHOICE {			
ulDedicatedMessageSegment-r16 SEQUENCE {			
segmentNumber-r16	Any allowed value between 0 to 15		
rrc-MessageSegmentContainer-r16	Not Checked	OCTET STRING including	



		segmented UECapabilityInfor mation message	
rrc-MessageSegmentType-r16	Not Checked		
lateNonCriticalExtension	Not checked		
nonCriticalExtension	Not checked		
}			
}			
}			

– *ULInformationTransfer*

**Table 4.6.1-33: *ULInformationTransfer***

Derivation Path: TS 38.331 [6], clause 6.2.2			
Information Element	Value/remark	Comment	Condition
ULInformationTransfer ::= SEQUENCE {			
criticalExtensions CHOICE {			
ullInformationTransfer SEQUENCE {			
dedicatedNAS-Message	DedicatedNAS-Message		
lateNonCriticalExtension	Not checked		
nonCriticalExtension	Not checked		
}			
}			
}			

– *ULInformationTransferIRAT*

**Table 4.6.1-33A: *ULInformationTransferIRAT***

Derivation Path: TS 38.331 [6], clause 6.2.2			
Information Element	Value/remark	Comment	Condition
ULInformationTransferIRAT-r16 ::= SEQUENCE {			
FFS			
}			

– *ULInformationTransferMRDC*

**Table 4.6.1-34: *ULInformationTransferMRDC***

Derivation Path: TS 38.331 [6], clause 6.2.2			
Information Element	Value/remark	Comment	Condition
ULInformationTransferMRDC ::= SEQUENCE {			
criticalExtensions CHOICE {			
c1 CHOICE {			
ullInformationTransferMRDC SEQUENCE {			
ul-DCCH-MessageNR	Not checked		
ul-DCCH-MessageEUTRA	Not checked		
lateNonCriticalExtension	Not checked		
nonCriticalExtension	Not checked		
}			
}			
}			
}			

### 4.6.1A Contents of PC5 RRC messages

– *MasterInformationBlockSidelink*

**Table 4.6.1A-1: *MasterInformationBlockSidelink***

Derivation Path: TS 38.331 [6], clause 6.6.2			
Information Element	Value/remark	Comment	Condition
MasterInformationBlockSidelink ::= SEQUENCE {			
sl-TDD-Config-r16	111111111111		
inCoverage-r16	true		RX AND (GNSS_SYNC OR NB_SYNC)
	false		RX AND (UE_SYNC OR INTERNAL_SYNC)
	Not Checked		TX
directFrameNumber-r16	DFN of the radio frame in which the S-SSB containing this message is transmitted		
slotIndex-r16	slot index of the slot in which the S-SSB containing this message is transmitted		
reservedBits-r16	00		
}			

Condition	Explanation
GNSS_SYNC	GNSS is used as the synchronization reference source
NB_SYNC	gNB or eNB is used as the synchronization reference source
UE_SYNC	SyncRef UE is used as the synchronization reference source
INTERNAL_SYNC	Internal clock is used as the synchronization reference source
TX	UE transmits and NR-SS-UE receives.
RX	UE receives and NR-SS-UE transmits.

– *MeasurementReportSidelink*

**Table 4.6.1A-2: *MeasurementReportSidelink***

Derivation Path: TS 38.331 [6], clause 6.6.2			
Information Element	Value/remark	Comment	Condition
MeasurementReportSidelink ::= SEQUENCE {			
criticalExtensions CHOICE {			
measurementReportSidelink-r16 SEQUENCE {			
sl-measResults-r16 SEQUENCE {			
sl-MeasId-r16	1		
sl-MeasResult-r16 SEQUENCE {			
sl-ResultDMRS-r16 SEQUENCE {			
sl-RSRP-r16	(0..127)		TX
	71	actual value is (71-156) = -85dBm	RX
}			
}			
}			
}			
}			
lateNonCriticalExtension	Not checked		TX

	Not present		RX
nonCriticalExtension	Not checked		TX
	Not present		RX
}			
}			
}			

Condition	Explanation
TX	UE transmits and NR-SS-UE receives.
RX	UE receives and NR-SS-UE transmits.

– RemoteUEInformationSidelink

**Table 4.6.1A-2A: RemoteUEInformationSidelink**

Derivation Path: TS 38.331 [6], clause 6.6.2			
Information Element	Value/remark	Comment	Condition
RemoteUEInformationSidelink-r17 ::= SEQUENCE {			
criticalExtensions CHOICE {			
remoteUEInformationSidelink-r17 SEQUENCE {			
sl-RequestedSIB-List-r17 {			
setup	Set according to parameter given in test case		
}			
sl-PagingInfo-RemoteUE-r17	Not present		
lateNonCriticalExtension	Not checked		
nonCriticalExtension	Not checked		
}			
}			
}			

– RRCReconfigurationSidelink

**Table 4.6.1A-3: RRCReconfigurationSidelink**

Derivation Path: TS 38.331 [6], clause 6.6.2			
Information Element	Value/remark	Comment	Condition
RRCReconfigurationSidelink ::= SEQUENCE {			
rrc-TransactionIdentifier-r16	RRC-TransactionIdentifier (0..3)		RX
			TX
criticalExtensions CHOICE {			
rrcReconfigurationSidelink-r16 SEQUENCE {			
slrb-ConfigToAddModList-r16	Not present		
slrb-ConfigToAddModList-r16 SEQUENCE (SIZE (1..maxNrofSLRB-r16)) OF SLRB-Config-r16 {	1 entry		SL_DRB
SLRB-Config-r16[1] SEQUENCE {		entry 1	
slrb-PC5-ConfigIndex-r16	Not checked		TX
	1		RX
sl-SDAP-ConfigPC5-r16	Set according to parameter given in test case		TX
sl-SDAP-ConfigPC5-r16 SEQUENCE {			RX
sl-MappedQoS-FlowsToAddList-r16 SEQUENCE (SIZE (1.. maxNrofSL-QFIsPerDest-r16)) OF SL-PQFI-r16 {	1 entry		
SL-PQFI-r16[1]	1	entry 1	

}			
sl-MappedQoS-FlowsToReleaseList-r16	Not present		
sl-SDAP-Header-r16	absent		
}			
sl-PDCP-ConfigPC5-r16	Set according to parameter given in test case		TX
sl-PDCP-ConfigPC5-r16 SEQUENCE {			RX
sl-PDCP-SN-Size-r16	len12bits		
sl-OutOfOrderDelivery-r16	Not present		
}			
sl-RLC-ConfigPC5-r16	Set according to parameter given in test case		TX
sl-RLC-ConfigPC5-r16 CHOICE {			RX
sl-AM-RLC-r16 SEQUENCE {			
sl-SN-FieldLengthAM-r16	size12		
}			
}			
sl-MAC-LogicalChannelConfigPC5-r16	Set according to parameter given in test case		TX
sl-MAC-LogicalChannelConfigPC5-r16 SEQUENCE {			RX
sl-LogicalChannelIdentity-r16	LogicalChannelIdentity with condition DRB1		
}			
}			
}			
slrb-ConfigToReleaseList-r16	Not present		
sl-MeasConfig-r16	Not present		
sl-MeasConfig-r16 CHOICE {			SL_MEAS
setup	Set according to parameter given in test case		TX
setup SEQUENCE {			RX
sl-MeasObjectToRemoveList-r16	Not present		
sl-MeasObjectToAddModList-r16	SL-MeasObjectList-		
sl-ReportConfigToRemoveList-r16	Not present		
sl-ReportConfigToAddModList-r16	SL-ReportConfigList		
sl-MeasIdToRemoveList-r16	Not present		
sl-MeasIdToAddModList-r16	SL-MeasIdList		
sl-QuantityConfig-r16	SL-QuantityConfig		
}			
}			
sl-CSI-RS-Config-r16	Not present		
sl-CSI-RS-Config-r16 CHOICE {			SL_CSI
setup	Set according to parameter given in test case		TX
setup SEQUENCE {			RX
sl-CSI-RS-FreqAllocation-r16 CHOICE {			
sl-OneAntennaPort-r16	000000000001		
}			
sl-CSI-RS-FirstSymbol-r16	6		
}			
}			
sl-ResetConfig-r16	Not present		
sl-LatencyBoundCSI-Report-r16	Not present		
	160		SL_CSI
lateNonCriticalExtension	Not checked		TX
	Not present		RX
nonCriticalExtension	Not checked		TX
	Not present		RX
}			
}			

}		
---	--	--

Condition	Explanation
SL_DRB	To provide peer UE SL DRB related configuration via PC5 RRC
SL_MEAS	To provide peer UE SL RSRP measurement and reporting related configuration via PC5 RRC
SL_CSI	To provide peer UE SL CSI reporting related configuration via PC5 RRC
TX	UE transmits and NR-SS-UE receives.
RX	UE receives and NR-SS-UE transmits.

– *RRCReconfigurationCompleteSidelink*

**Table 4.6.1A-4: RRCReconfigurationCompleteSidelink**

Derivation Path: TS 38.331 [6], clause 6.6.2			
Information Element	Value/remark	Comment	Condition
RRCReconfigurationCompleteSidelink ::= SEQUENCE {			
rrc-TransactionIdentifier-r16	RRC-TransactionIdentifier		TX
	Set to the same value as the rrc-TransactionIdentifier-r16 field in corresponding RRCConfigurationSidelink message		RX
criticalExtensions CHOICE {			
rrcReconfigurationCompleteSidelink-r16 SEQUENCE {			
lateNonCriticalExtension	Not checked		TX
	Not present		RX
nonCriticalExtension	Not checked		TX
	Not present		RX
}			
}			
}			

Condition	Explanation
TX	UE transmits and NR-SS-UE receives.
RX	UE receives and NR-SS-UE transmits.

– *RRCReconfigurationFailureSidelink*

**Table 4.6.1A-5: RRCReconfigurationFailureSidelink**

Derivation Path: TS 38.331 [6], clause 6.6.2			
Information Element	Value/remark	Comment	Condition
RRCReconfigurationFailureSidelink ::= SEQUENCE {			
rrc-TransactionIdentifier-r16	RRC-TransactionIdentifier		TX
	Set to the same value as the rrc-TransactionIdentifier-r16 field in corresponding RRCConfigurationSidelink message		RX
criticalExtensions CHOICE {			
rrcReconfigurationFailureSidelink-r16 SEQUENCE {			
lateNonCriticalExtension	Not checked		TX
	Not present		RX
nonCriticalExtension	Not checked		TX

	Not present		RX
}			
}			
}			

Condition	Explanation
TX	UE transmits and NR-SS-UE receives.
RX	UE receives and NR-SS-UE transmits.

– *UECapabilityEnquirySidelink*

**Table 4.6.1A-6: UECapabilityEnquirySidelink**

Derivation Path: TS 38.331 [6], clause 6.6.2			
Information Element	Value/remark	Comment	Condition
UECapabilityEnquirySidelink ::= SEQUENCE {			
rrc-TransactionIdentifier-r16	RRC-TransactionIdentifier (0..3)		RX TX
criticalExtensions CHOICE {			
ueCapabilityEnquirySidelink-r16 SEQUENCE {			
frequencyBandListFilterSidelink-r16	Not checked		TX
frequencyBandListFilterSidelink-r16 SEQUENCE (SIZE (1..maxBandsMRDC)) OF FreqBandInformation {	1 entry		RX
FreqBandInformation[1] CHOICE {		entry 1	
bandInformationNR SEQUENCE {			
bandNR	FreqBandIndicatorNR of the PC5 operating band		
maxBandwidthRequestedDL	Not present		
maxBandwidthRequestedUL	Not present		
maxCarriersRequestedDL	Not present		
maxCarriersRequestedUL	Not present		
}			
}			
}			
}			
ue-CapabilityInformationSidelink-r16	Not present Not checked		TWO_WAY_ENQUIRY AND TX
	OCTET STRING containing UECapabilityInformationSidelink specified in Table 4.6.1A-7 with condition RX		TWO_WAY_ENQUIRY AND RX
lateNonCriticalExtension	Not checked Not present		TX RX
nonCriticalExtension	Not checked Not present		TX RX
}			
}			
}			

Condition	Explanation
TWO_WAY_ENQUIRY	For two-way SL UE capability enquiry procedure
TX	UE transmits and NR-SS-UE receives.
RX	UE receives and NR-SS-UE transmits.

– *UECapabilityInformationSidelink*

**Table 4.6.1A-7: UECapabilityInformationSidelink**

Derivation Path: TS 38.331 [6], clause 6.6.2			
Information Element	Value/remark	Comment	Condition
UECapabilityInformationSidelink ::= SEQUENCE {			
rrc-TransactionIdentifier-r16	RRC-TransactionIdentifier		TX
	Set to the same value as the rrc-TransactionIdentifier-r16 field in corresponding UECapabilityEnquirySidelink message		RX
criticalExtensions CHOICE {			
ueCapabilityInformationSidelink-r16 SEQUENCE {			
accessStratumReleaseSidelink-r16	rel16		
pdcp-ParametersSidelink-r16	Not checked		TX
pdcp-ParametersSidelink-r16 SEQUENCE {			RX
outOfOrderDeliverySidelink-r16	supported		
}			
rlc-ParametersSidelink-r16	Not checked		TX
rlc-ParametersSidelink-r16 SEQUENCE {			RX
am-WithLongSN-Sidelink-r16	supported		
um-WithLongSN-Sidelink-r16	supported		
}			
supportedBandCombinationListSidelinkNR-r16	Not checked		TX
supportedBandCombinationListSidelinkNR-r16 SEQUENCE (SIZE (1..maxBandComb)) OF BandCombinationParametersSidelinkNR-r16 {	1 entry		RX
BandCombinationParametersSidelinkNR-r16[1] SEQUENCE (SIZE (1..maxSimultaneousBands)) OF BandParametersSidelink-r16 {	1 entry	entry 1	
BandParametersSidelink-r16[1] SEQUENCE {		entry 1	
freqBandSidelink-r16	first FreqBandIndicatorNR contained in frequencyBandListFilterSidelink-r16 of corresponding UECapabilityEnquirySidelink message		
}			
}			
}			
supportedBandListSidelink-r16	Not checked		TX
supportedBandListSidelink-r16 SEQUENCE (SIZE (1..maxBands)) OF BandSidelinkPC5-r16 {	1 entry		RX
BandSidelinkPC5-r16[1] SEQUENCE {		entry 1	
freqBandSidelink-r16	first FreqBandIndicatorNR contained in frequencyBandListFilterSidelink-r16 of corresponding UECapabilityEnquirySidelink message		
sl-Reception-r16 SEQUENCE {			
harq-RxProcessSidelink-r16	n16		
pscch-RxSidelink-r16	value1		
scs-CP-PatternRxSidelink-r16 CHOICE {			
fr1-r16 SEQUENCE {			
scs-15kHz-r16	0101011000000000		
scs-30kHz-r16	0101011000000000		
scs-60kHz-r16	0101011000000000		

}			
}			
extendedCP-RxSidelink-r16	supported		
}			
sl-Tx-256QAM-r16	supported		
lowSE-64QAM-MCS-TableSidelink-r16	supported		
csi-ReportSidelink-r16 SEQUENCE {			
csi-RS-PortsSidelink-r16	p2		
}			
rankTwoReception-r16	supported		
sl-openLoopPC-RSRP-ReportSidelink-r16	supported		
sl-Rx-256QAM-r16	supported		
}			
}			
appliedFreqBandListFilter-r16	Not checked		TX
	Set to the same value as the frequencyBandListFilterSidelink-r16 of corresponding UECapabilityEnquirySidelink message		RX
lateNonCriticalExtension	Not checked		TX
	Not present		RX
nonCriticalExtension	Not checked		TX
	Not present		RX
}			
}			
}			

Condition	Explanation
TX	UE transmits and NR-SS-UE receives.
RX	UE receives and NR-SS-UE transmits.

– *uuMessageTransferSidelink*

**Table 4.6.1A-8: uuMessageTransferSidelink**

Derivation Path: TS 38.331 [6], clause 6.2.2			
Information Element	Value/remark	Comment	Condition
uuMessageTransferSidelink ::= SEQUENCE {			
criticalExtensions CHOICE {			
uuMessageTransferSidelink-r17 SEQUENCE {			
sl-PagingDelivery-r17	Not present FFS		Paging
sl-SIB1-Delivery-r17	Not present OCTET STRING containing SIB1 specified in Table 4.6.1-28		SIB1
sl-SystemInformationDelivery-r17	Not present OCTET STRING containing SystemInformation specified in Table 4.6.1-29		SystemInformation
lateNonCriticalExtension	Not present		
nonCriticalExtension	Not present		
}			
}			
}			



Condition	Explanation
Paging	PagingRecord relevant to the L2 U2N Remote UE is transferred
SIB1	SIB1 relevant to the L2 U2N Remote UE is transferred
SystemInformation	SIBs relevant to the L2 U2N Remote UE is transferred

## 4.6.2 System information blocks

### – SIB2

Table 4.6.2-1: SIB2

Derivation Path: TS 38.331 [6], clause 6.3.1			
Information Element	Value/remark	Comment	Condition
SIB2 ::= SEQUENCE {			
cellReselectionInfoCommon SEQUENCE {			
nrofSS-BlocksToAverage	2		
absThreshSS-BlocksConsolidation SEQUENCE {			
thresholdRSRP	RSRP-Range	Table 4.6.3-152	
thresholdRSRQ	Not present		
thresholdSINR	Not present		
}			
rangeToBestCell	dB0		
q-Hyst	dB0	To reduce interference between intra-frequency multiple cells	
speedStateReselectionPars	Not present		
}			
cellReselectionServingFreqInfo SEQUENCE {			
s-NonIntraSearchP	Not present		
s-NonIntraSearchQ	Not present		
threshServingLowP	0	Actual value of threshold = field value * 2 [dB]	
threshServingLowQ	Not present		
	3	3dB	QBASED
cellReselectionPriority	4	A middle value in the range has been selected	
cellReselectionSubPriority	Not present		
}			
intraFreqCellReselectionInfo SEQUENCE {			
q-RxLevMin	-70	-140dBm	
	-55	-110dBm	SIG
q-RxLevMinSUL	Not Present		
	-70	-140dBm	SUL
	-55	-110dBm	SUL AND SIG
q-QualMin	Not present		
	-20	-20dB	QBASED
s-IntraSearchP	31	Actual value of threshold = field value * 2 [dB]	
s-IntraSearchQ	Not present		
t-ReselectionNR	0		
frequencyBandList	Not present		
frequencyBandListSUL	Not present		
p-Max	Not present		
smtc	SSB-MTC	Table 4.6.3-185	

ss-RSSI-Measurement	Not present		
ssb-ToMeasure	SSB-ToMeasure		
deriveSSB-IndexFromCell	false		FDD
	true		TDD
t-ReselectionNR-SF	Not present		
smtc2-LP-r16	Not present		
ssb-PositionQCL-Common-r16	Not present		
}			
relaxedMeasurement-r16	Not present		
}			

Condition	Explanation
SUL	For test cases using SUL frequency for the serving cell, Qrxlevmin is obtained from <i>q-RxLevMin-sul</i> .
QBASED	This condition applies to Quality based signalling test cases.

– **SIB3**

**Table 4.6.2-2: SIB3**

Derivation Path: TS 38.331 [6], clause 6.3.1			
Information Element	Value/remark	Comment	Condition
SIB3 ::= SEQUENCE {			
intraFreqNeighCellList	Not present	Not required unless Qoffset configuration is tested. When Qoffset configuration is tested, see table 6.3.1.1-1	
intraFreqExcludedCellList	Not present	Not required unless list of exclude-listed intra-frequency neighbouring cells is tested. When exclude-listed cell list configuration is tested, see table 6.3.1.1-1	
lateNonCriticalExtension	Not present		
}			

– **SIB4**

**Table 4.6.2-3: SIB4**

Derivation Path: TS 38.331 [6], clause 6.3.1			
Information Element	Value/remark	Comment	Condition
SIB4 ::= SEQUENCE {			
interFreqCarrierFreqList SEQUENCE (SIZE (1..maxFreq)) OF InterFreqCarrierFreqInfo {	The same number of entries as the configured inter-freq carriers defined in table 6.3.1.2-1	<i>n</i> denotes the index of the entry	
InterFreqCarrierFreqInfo[ <i>n</i> ] SEQUENCE {		entry <i>n</i>	
dl-CarrierFreq	Downlink NR SSB ARFCN. See table 6.3.1.2-1		
frequencyBandList	MultiFrequencyBandList NR-SIB		
frequencyBandListSUL	Not present		

nrofSS-BlocksToAverage	2		
absThreshSS-BlocksConsolidation SEQUENCE			
{			
thresholdRSRP	RSRP-Range	Table 4.6.3-152	
thresholdRSRQ	Not present		
thresholdSINR	Not present		
}			
smtc	SSB-MTC	Table 4.6.3-185	
ssbSubcarrierSpacing	SubcarrierSpacing	Table 4.6.3-188	
ssb-ToMeasure	SSB-ToMeasure		
deriveSSB-IndexFromCell	false		FDD
	true		TDD
ss-RSSI-Measurement	Not present		
q-RxLevMin	-70	-140dBm	
	-55	-110dBm	SIG and FR1
	$\text{ROUND}((\text{-110} + \Delta(\text{NRfn}))/2)$	NOTE1 and NOTE2.	SIG and FR2
q-RxLevMinSUL	-70	-140dBm, For RF/RRM test cases	SUL
	Not present		
	-55	-110dBm	SUL and SIG
q-QualMin	Not present		
	-20	-20dB	QBASED
p-Max	Not present		
t-ReselectionNR	0		
t-ReselectionNR-SF	Not present	Not required unless speed-dependent cell re-selection is tested.	
threshX-HighP	2	4dB, this value should be higher than threshServingLow of the serving cell to avoid ping-pong with lower priority cells.	
threshX-LowP	1	2dB	
threshX-Q	Not present		
threshX-Q SEQUENCE {			QBASED
threshX-HighQ	5	5dB	
threshX-LowQ	5	5dB	
}			
cellReselectionPriority	4	The same priority as the one used for serving cell in SIB 2.	
cellReselectionSubPriority	Not present	The same subpriority as the one used for serving cell in SIB 2.	
q-OffsetFreq	$\text{dBXY with XY} = (\text{FLOOR}((\Delta(\text{NRfn}) - \Delta(\text{NRfs}))/2)) * 2$ (NOTE 3)	This value is type of Q-OffsetRange in TS 38.331 [6] which must be even value when its absolute value is larger than dB5.	FR2 AND NOT AbsoluteValue_Within_dB5
	$\text{dBXY with XY} = \Delta(\text{NRfn}) - \Delta(\text{NRfs})$		FR2 AND AbsoluteValue_Within_dB5

	dB0		
interFreqNeighCellList	Not present	Not required unless Qoffset configuration is tested.	
interFreqExcludedCellList	Not present	Not required unless Excluded cell list configuration is tested.	
}			
}			
lateNonCriticalExtension	Not present		
}			
NOTE 1: Delta(NRfn) and Delta(NRfs) is derived based on calibration procedure defined in the clause 6.1.3.3. NRfn and NRfs are NR frequencies in dl-CarrierFreq[n] and serving cell frequency on which SIB4 is broadcasted.			
NOTE 2: ROUND is rounded off to the nearest integer. As an example, '1 to 1.49' set to '1' while '1.5 to 2' to '2' and '-2.0 to 1.5' set to '-2' while '-1.49 to -1' set to '-1'.			
NOTE 3: FLOOR is rounded off to the smaller integer. As an example, '1.0 to 1.99' set to 1, '-1.01 to -2.00' set to -2.			

Condition	Explanation
SUL	For test cases using SUL frequency for the serving cell, Qrxlevmin is obtained from $q-RxLevMin-sul$ .
QBASED	This condition applies to Quality based signalling test cases.
AbsoluteValue_Within_dB5	$-5dB \leq (\Delta(NRfn) - \Delta(NRfs)) \leq 5dB$ .

## SIB5

Table 4.6.2-4: SIB5

Derivation Path: TS 38.331 [6], clause 6.3.1			
Information Element	Value/remark	Comment	Condition
SIB5 ::= SEQUENCE {			
carrierFreqListEUTRA SEQUENCE (SIZE (1..maxEUTRA-Carrier)) OF CarrierFreqEUTRA {	The same number of entries as the configured E-UTRA carriers. For Signalling test cases, see table 6.3.1.3-1.	$n$ denotes the index of the entry	
CarrierFreqEUTRA[n] SEQUENCE {		entry $n$	
carrierFreq	Downlink E-UTRA ARFCN under test. For Signalling test cases, see table 6.3.1.3-1.		
eutra-multiBandInfoList	Not present		
eutra-FreqNeighCellList	Not present	Not required unless EUTRA Qoffset configuration is tested.	
eutra-ExcludedCellList	Not present	Not required unless Excluded cell list configuration is tested.	
allowedMeasBandwidth	EUTRA-AllowedMeasBandwidth	The value of EUTRA-AllowedMeasBandwidth in Table 4.6.5-1.	
presenceAntennaPort1	FALSE		
	TRUE	At least two cell-specific antenna ports are used in	All neighCells with port1

		all neighbouring cells.	
cellReselectionPriority	3		
cellReselectionSubPriority	Not Present		
threshX-High	2 (4 dB)		
threshX-Low	1 (2 dB)		
q-RxLevMin	-70 (-140 dBm)	For RF/RRM test cases	
	-55(-110dBm)	For signalling test cases	
q-QualMin	-20 (-20dB)		
p-MaxEUTRA	23		
threshX-Q	Not present		
threshX-Q SEQUENCE {			QBASED
threshX-HighQ	9 (9dB)		
threshX-LowQ	9 (9dB)		
}			
}			
}			
t-ReselectionEUTRA	0		
t-ReselectionEUTRA-SF	Not present	Not required unless speed-dependent cell re-selection is tested.	
lateNonCriticalExtension	Not present		
}			

Condition	Explanation
QBASED	This condition applies to Quality based cell (re)selection signalling test cases.
All neighCells with port1	Used for all neighbouring cells with at least two cell-specific antenna ports

*SIB6*

**Table 4.6.2-5: SIB6**

Derivation Path: TS 38.331 [6], clause 6.3.1			
Information Element	Value/remark	Comment	Condition
SIB6 ::= SEQUENCE {			
messageIdentifier	'0001 0001 0000 0010'B	ETWS message identifier for earthquake and tsunami message (see TS 23.041 [25])	
serialNumber	'0011 0000 0000 0000'B	Note 1	
warningType	'0000 0101 1000 0000'B	Note 2	
lateNonCriticalExtension	Not present		
}			
<p>Note 1: Geographical Scope (Octet 1 bit 7 ~ 6) set to 'Cell wide',  Emergency User Alert (Octet 1 bit 5) set to 'Activate emergency user alert',  Popup (Octet 1 bit 4) set to 'Activate popup',  Update Number (Octet 2 bits 3~0) for each update, incremented by one, See TS 23.041 [25].</p> <p>Note 2: Warning Type Value (Octet 1 bit 7 ~ 1) set to 'Earthquake and Tsunami',  Emergency User Alert (Octet 1 bit 0) set to 'Activate emergency user alert',  Popup (Octet 2 bit 7) set to 'Activate Popup', see TS 23.041 [25],  Padding (Octet 2 bit 6 ~ 0) set to '000 0000'B.</p>			

## SIB7

Table 4.6.2-6: SIB7 (1<sup>st</sup> Segment)

Derivation Path: TS 38.331 [6], clause 6.3.1			
Information Element	Value/remark	Comment	Condition
SIB7 ::= SEQUENCE {			
messageIdentifier	'0001 0001 0000 0010'B	ETWS message identifier for earthquake and tsunami message (see TS 23.041 [25])	
serialNumber	'0011 0000 0000 0000'B	Note 1	
warningMessageSegmentType	notLastSegment		
warningMessageSegmentNumber	0		
warningMessageSegment	Octetstring of N	Where $N \geq 1$ and less than 1246 (see TS 23.041 [25])	
dataCodingScheme	Bitstring (8) ID of the alphabet/coding and the applied language	see TS 23.041 [25]	Segment 1
lateNonCriticalExtension	Not present		
}			
Note 1: Geographical Scope (Octet 1 bit 7 ~ 6) set to 'Cell wide', Emergency User Alert (Octet 1 bit 5) set to 'Activate emergency user alert', Popup (Octet 1 bit 4) set to 'Activate popup', Update Number (Octet 2 bits 3-0) for each update, incremented by one, See TS 23.041 [25].			

Condition	Explanation
Segment1	The field is mandatory present in the first segment of SIB7, otherwise it is not present.

Table 4.6.2-7: SIB7 (2<sup>nd</sup> Segment)

Derivation Path: TS 38.331 [6], clause 6.3.1			
Information Element	Value/remark	Comment	Condition
SIB7 ::= SEQUENCE {			
messageIdentifier	'0001 0001 0000 0010'B	ETWS message identifier for earthquake and tsunami message (see TS 23.041 [25])	
serialNumber	'0011 0000 0000 0000'B	Note 1	
warningMessageSegmentType	notLastSegment		
warningMessageSegmentNumber	1		
warningMessageSegment	Octetstring of N	Where $N \geq 1$ and less than 1246 (see TS 23.041 [25])	
dataCodingScheme	Not present		
lateNonCriticalExtension	Not present		
}			
Note 1: Geographical Scope (Octet 1 bit 7 ~ 6) set to 'Cell wide', Emergency User Alert (Octet 1 bit 5) set to 'Activate emergency user alert', Popup (Octet 1 bit 4) set to 'Activate popup', Update Number (Octet 2 bits 3-0) for each update, incremented by one, See TS 23.041 [25].			

Table 4.6.2-8: SIB7 (3<sup>rd</sup> Segment)

Derivation Path: TS 38.331 [6], clause 6.3.1			
--	--	--	--

Information Element	Value/remark	Comment	Condition
SIB7 ::= SEQUENCE {			
messageIdentifier	'0001 0001 0000 0010'B	ETWS message identifier for earthquake and tsunami message (see TS 23.041 [25])	
serialNumber	'0011 0000 0000 0000'B	Note 1	
warningMessageSegmentType	LastSegment		
warningMessageSegmentNumber	2		
warningMessageSegment	Octetstring of N	Where N ≥ 1 and less than 1246 (see TS 23.041 [25])	
dataCodingScheme	Not present		
lateNonCriticalExtension	Not present		
}			
Note 1: Geographical Scope (Octet 1 bit 7 ~ 6) set to 'Cell wide', Emergency User Alert (Octet 1 bit 5) set to 'Activate emergency user alert', Popup (Octet 1 bit 4) set to 'Activate popup', Update Number (Octet 2 bits 3-0) for each update, incremented by one, See TS 23.041 [25].			

**SIB8**

**Table 4.6.2-9: SIB8 (1<sup>st</sup> Segment)**

Derivation Path: TS 38.331 [6], clause 6.3.1			
Information Element	Value/remark	Comment	Condition
SIB8 ::= SEQUENCE {			
messageIdentifier	'0001 0001 0001 0010'B	CMAS CBS Message Identifier for CMAS Presidential Level Alerts (see TS 23.041 [25])	
serialNumber	'0011 0000 0000 0000'B	Note 1	
warningMessageSegmentType	notLastSegment		
warningMessageSegmentNumber	0		
warningMessageSegment	Octetstring of N	Where N ≥ 1 and less than 1246 (see TS 23.041 [25])	
dataCodingScheme	Bitstring (8) ID of the alphabet/coding and the applied language	see TS 23.041 [25]	Segment 1
warningAreaCoordinatesSegment	Not present		
lateNonCriticalExtension	Not present		
}			
Note 1: Geographical Scope (Octet 1 bit 7 ~ 6) set to 'Cell wide', Emergency User Alert (Octet 1 bit 5) set to 'Activate emergency user alert', Popup (Octet 1 bit 4) set to 'Activate popup', Update Number (Octet 2 bits 3-0) for each update, incremented by one, See TS 23.041 [25].			

Condition	Explanation
Segment1	The field is mandatory present in the first segment of SIB8, otherwise it is not present.

**Table 4.6.2-10: SIB8 (2<sup>nd</sup> Segment)**

Derivation Path: TS 38.331 [6], clause 6.3.1			
Information Element	Value/remark	Comment	Condition
SIB8 ::= SEQUENCE {			

messageIdentifier	'0001 0001 0001 0010'B	CMAS CBS Message Identifier for CMAS Presidential Level Alerts (see TS 23.041 [25])	
serialNumber	'0011 0000 0000 0000'B	Note 1	
warningMessageSegmentType	notLastSegment		
warningMessageSegmentNumber	1		
warningMessageSegment	Octetstring of N	Where N ≥ 1 and less than 1246 (see TS 23.041 [25])	
dataCodingScheme	Not present		
warningAreaCoordinatesSegment	Not present		
lateNonCriticalExtension	Not present		
}			
Note 1: Geographical Scope (Octet 1 bit 7 ~ 6) set to 'Cell wide', Emergency User Alert (Octet 1 bit 5) set to 'Activate emergency user alert', Popup (Octet 1 bit 4) set to 'Activate popup', Update Number (Octet 2 bits 3~0) for each update, incremented by one, See TS 23.041 [25].			

**Table 4.6.2-11: SIB8 (3<sup>rd</sup> Segment)**

Derivation Path: TS 38.331 [6], clause 6.3.1			
Information Element	Value/remark	Comment	Condition
SIB8 ::= SEQUENCE {			
messageIdentifier	'0001 0001 0001 0010'B	CMAS CBS Message Identifier for CMAS Presidential Level Alerts (see TS 23.041 [25])	
serialNumber	'0011 0000 0000 0000'B	Note 1	
warningMessageSegmentType	LastSegment		
warningMessageSegmentNumber	2		
warningMessageSegment	Octetstring of N	Where N ≥ 1 and less than 1246 (see TS 23.041 [25])	
dataCodingScheme	Not present		
warningAreaCoordinatesSegment	Not present		
lateNonCriticalExtension	Not present		
}			
Note 1: Geographical Scope (Octet 1 bit 7 ~ 6) set to 'Cell wide', Emergency User Alert (Octet 1 bit 5) set to 'Activate emergency user alert', Popup (Octet 1 bit 4) set to 'Activate popup', Update Number (Octet 2 bits 3~0) for each update, incremented by one, See TS 23.041 [25].			

**SIB9**

**Table 4.6.2-11A: SIB9**

Derivation Path: TS 38.331 [6], clause 6.3.1			
Information Element	Value/remark	Comment	Condition
SIB9 ::= SEQUENCE {			
timeInfo ::= SEQUENCE {			
FFS			
}			
lateNonCriticalExtension	Not present		
referenceTimeInfo-r16	ReferenceTimeInfo		TSC
}			



Condition	Explanation
TSC	For test cases requiring TSC (Time Sensitive Communication) functions enabled.

– SIB10

Table 4.6.2-12: SIB10

Derivation Path: TS 38.331 [6], clause 6.3.2			
Information Element	Value/remark	Comment	Condition
SIB10-r16 ::= SEQUENCE {			
hrnn-List-r16 SEQUENCE (SIZE (1..maxNPN-r16))			
OF HRNN-r16 {			
HRNN-r16[1] SEQUENCE {		1 entry	
hrnn-r16	“3gppTest”	charstring “3gppTest” converted to OCTETSTRING	
}			
}			
lateNonCriticalExtension	Not present		
}			

– SIB11

Table 4.6.2-13: SIB11

Derivation Path: TS 38.331 [6], clause 6.3.2			
Information Element	Value/remark	Comment	Condition
SIB11-r16 ::= SEQUENCE {			
measIdleConfigSIB-r16	MeasIdleConfigSIB-r16		
lateNonCriticalExtension	Not present		
}			

– SIB12

Table 4.6.2-14: SIB12

Derivation Path: TS 38.331 [6], clause 6.3.1			
Information Element	Value/remark	Comment	Condition
SIB12-r16 ::= SEQUENCE {			
segmentNumber-r16	index of the segment contained in segmentContainer-r16		
segmentType-r16	notLastSegment		NOT_LAST_SEG
	lastSegment		LAST_SEG
segmentContainer-r16	OCTET STRING (CONTAINING SIB12-IEs or segment of SIB12-IEs)	Note 1	
}			

Note 1: Size of the SIB12-IEs-r16 or segment of SIB12-IEs-r16 contained in segmentContainer-r16 shall not exceed the maximum TBS size of the SI. For signalling test cases, the size is defined in TS 38.523-3[23] clause 7.3.3.2.

Condition	Explanation
NOT_LAST_SEG	Used when SIB12-IEs is segmented and the segment contained in segmentContainer-r16 is not the last segment
LAST_SEG	Used when SIB12-IEs is not segmented, or SIB12-IEs is segmented and the segment contained in segmentContainer-r16 is the last segment

Table 4.6.2-14A: SIB12-IEs

Derivation Path: TS 38.331 [6], clause 6.3.2			
Information Element	Value/remark	Comment	Condition
SIB12-IEs-r16 ::= SEQUENCE {			
sl-ConfigCommonNR-r16 SEQUENCE {			
sl-FreqInfoList-r16 SEQUENCE (SIZE (1..maxNrofFreqSL-r16)) OF SL-FreqConfigCommon-r16 {	1 entry		
SL-FreqConfigCommon-r16[1]	SL-FreqConfigCommon	entry 1	
}			
sl-UE-SelectedConfig-r16	SL-UE-SelectedConfig		
sl-NR-AnchorCarrierFreqList-r16	Not present		
sl-EUTRA-AnchorCarrierFreqList-r16	Not present		
sl-RadioBearerConfigList-r16 SEQUENCE (SIZE (1..maxNrofSLRB-r16)) OF SL-RadioBearerConfig-r16 {	1 entry		
SL-RadioBearerConfig-r16[1]	SL-RadioBearerConfig	entry 1	
}			
sl-RLC-BearerConfigList-r16 SEQUENCE (SIZE (1..maxSL-LCID-r16)) OF SL-RLC-BearerConfig-r16 {	1 entry		
SL-RLC-BearerConfig-r16[1]	SL-RLC-BearerConfig	entry 1	
}			
sl-MeasConfigCommon-r16	SL-MeasConfigCommon		
sl-CSI-Acquisition-r16	Not present		
sl-OffsetDFN-r16	Not present		
t400-r16	ms1000		
sl-MaxNumConsecutiveDTX-r16	Not present		
sl-SSB-PriorityNR-r16	1		
}			
lateNonCriticalExtension	Not present		
sl-DRX-ConfigCommonGC-BC-r17	Not present		
sl-DiscConfigCommon-r17	Not present		
sl-DiscConfigCommon-r17 SEQUENCE {			L2RemoteUE, L2RelayUE
sl-RelayUE-ConfigCommon-r17	SL-RelayUE-Config		
sl-RemoteUE-ConfigCommon-r17	SL-RemoteUE-Config		
}			
sl-L2U2N-Relay-r17	Not present		
sl-L2U2N-Relay-r17	enabled		L2RemoteUE, L2RelayUE
sl-NonRelayDiscovery-r17	Not present		
sl-L3U2N-RelayDiscovery-r17	Not present		
sl-TimersAndConstantsRemoteUE-r17	Not present		
}			

Condition	Explanation
L2RemoteUE	For L2 U2N Remote UE test cases.
L2RelayUE	For L2 U2N Relay UE test cases.

## – SIB13

Table 4.6.2-15: SIB13

Derivation Path: TS 38.331 [6], clause 6.3.2			
Information Element	Value/remark	Comment	Condition
SIB13-r16 ::= SEQUENCE {			
FFS			
}			

## – SIB14

Table 4.6.2-16: SIB14

Derivation Path: TS 38.331 [6], clause 6.3.2			
Information Element	Value/remark	Comment	Condition
SIB14-r16 ::= SEQUENCE {			
FFS			
}			

## – SIB15

Table 4.6.2-17: SIB15

Derivation Path: TS 38.331 [6], clause 6.3.2			
Information Element	Value/remark	Comment	Condition
SIB15-r17 ::= SEQUENCE {			
FFS			
}			

## – SIB16

Table 4.6.2-18: SIB16

Derivation Path: TS 38.331 [6], clause 6.3.1			
Information Element	Value/remark	Comment	Condition
SIB16-r17 ::= SEQUENCE {			
freqPriorityListSlicing-r17	FreqPriorityListSlicing-r17		
lateNonCriticalExtension	Not present		
}			

## – SIB17

Table 4.6.2-18A: SIB17

Derivation Path: TS 38.331 [6], clause 6.3.1			
Information Element	Value/remark	Comment	Condition
SIB17-r17 ::= SEQUENCE {			
segmentNumber-r17	0		
segmentType-r17	lastSegment		
segmentContainer-r17	OCTET STRING (CONTAINING SIB17-IEs)	SIB17-IEs	
}			

Table 4.6.2-18AA: SIB17-IEs

Derivation Path: TS 38.331 [6], clause 6.3.1			
Information Element	Value/remark	Comment	Condition
SIB17-IEs-r17 ::= SEQUENCE {			
trs-ResourceSetConfig-r17 SEQUENCE (SIZE (1..maxNrofTRS-ResourceSets-r17)) OF TRS-ResourceSet-r17 {	1 entry		
TRS-ResourceSet-r17 [1] SEQUENCE {		Entry 1	
powerControlOffsetSS-r17	db-3		
scramblingID-Info-r17 CHOICE {			

scramblingIDforCommon-r17	0		
}			
firstOFDMSymbolInTimeDomain-r17	4		
startingRB-r17	0		
nrofRBs-r17	24		
ssb-Index-r17	0		
periodicityAndOffset-r17 CHOICE {			
slots20	10		
}			
frequencyDomainAllocation-r17	'0000'B		
indBitID-r17	0		
nrofResources-r17	n4		
}			
}			
validityDuration-r17	Not Present		
lateNonCriticalExtension	Not Present		
}			

– **SIB18**

**Table 4.6.2-18B: SIB18**

Derivation Path: TS 38.331 [6], clause 6.3.1			
Information Element	Value/remark	Comment	Condition
SIB18-r17 ::= SEQUENCE {			
gin-ElementList-r17 SEQUENCE (SIZE (1..maxGIN-r17)) OF GIN-Element-r17 {	1 entry		
GIN-Element-r17[1] SEQUENCE {		entry 1	
plmn-Identity-r17	PLMN-Identity		
nid-List-r17 SEQUENCE (SIZE (1..maxGIN-r17)) OF NID-r16 {	1 entry		
NID-r16[1]	See table 4.4.2-4	entry 1; NID is coded as a BITSTRING based on TS 38.508-1 Table 4.4.2-4	
}			
}			
gins-PerSNPN-List-r17	Not present	Not present if there is only a single SNPN in <i>snpn-AccessInfoList</i> in SIB1	
lateNonCriticalExtension	Not present		
}			

– **SIB19**

**Table 4.6.2-18C: SIB19**

Derivation Path: TS 38.331 [6], clause 6.3.1			
Information Element	Value/remark	Comment	Condition
SIB19-r17 ::= SEQUENCE {			
ntn-Config-r17	NTN-Config with condition GSO		GSO
	NTN-Config with condition NGSO		NGSO
t-Service-r17	Not Present		
referenceLocation-r17	Not present		

distanceThresh-r17	Not present		
ntn-NeighCellConfigList-r17	Not present		
lateNonCriticalExtension	Not present		
}			

Condition	Explanation
GSO	Geosynchronous Orbit scenario
NGSO	Non-geosynchronous Orbit scenario

– SIB20

Table 4.6.2-19: SIB20

Derivation Path: TS 38.331 [6], clause 6.3.1			
Information Element	Value/remark	Comment	Condition
SIB20-r17 ::= SEQUENCE {			
mcch-Config-r17 SEQUENCE {			
mcch-RepetitionPeriodAndOffset-r17 CHOICE {			
rf2-r17	0		
}			
mcch-WindowStartSlot-r17	2		
mcch-WindowDuration-r17	sl8		
mcch-ModificationPeriod-r17	rf8		
}			
cfr-ConfigMCCH-MTCH-r17	Not present		
lateNonCriticalExtension	Not present		
}			

– SIB21

Table 4.6.2-20: SIB21

Derivation Path: TS 38.331 [6], clause 6.3.1			
Information Element	Value/remark	Comment	Condition
SIB21-r17 ::= SEQUENCE {			
mbs-FSAI-IntraFreq-r17 SEQUENCE (SIZE (1..maxFSAI-MBS-r17)) OF MBS-FSAI-r17 {	1 entry		
MBS-FSAI-r17[1]	'000000'H	entry 1 OCTET STRING (SIZE (3))	
}			
mbs-FSAI-InterFreqList-r17	Not present		
mbs-FSAI-InterFreqList-r17 SEQUENCE (SIZE (1..maxFreq)) OF MBS-FSAI-InterFreq-r17 {	1 entry		MBS_interFreq
MBS-FSAI-InterFreq-r17[1] SEQUENCE {		entry 1	
dl-CarrierFreq-r17	ARFCN-ValueNR with condition DL_SSB		
mbs-FSAI-List-r17 SEQUENCE (SIZE (1..maxFSAI-MBS-r17)) OF MBS-FSAI-r17 {	1 entry		
MBS-FSAI-r17[1]	'000001'H	entry 1 OCTET STRING (SIZE (3))	
}			
}			
}			
lateNonCriticalExtension	Not present		
}			

Condition	Explanation
-----------	-------------

MBS_interFreq	SIB21 transmitted for a MBS inter-frequency cell environment (MBS service provided on multiple frequencies within a band).
---------------	--

## 4.6.2A Positioning System information blocks

### – *PosSystemInformation-r16-IEs*

**Table 4.6.2a-1: *PosSystemInformation-r16-IEs***

Derivation Path: TS 38.331 [6], clause 6.3.1a			
Information Element	Value/remark	Comment	Condition
PosSystemInformation-r16-IEs ::= SEQUENCE {			
posSIB-TypeAndInfo-r16 SEQUENCE (SIZE (1..maxSIB))	n entries	The number of entries depends on the sub-test, as specified in TS 37.571-2 [40]	
lateNonCriticalExtension	Not present		
nonCriticalExtension	Not present		
}			

### – *PosSI-SchedulingInfo*

**Table 4.6.2a-2: *PosSI-SchedulingInfo***

Derivation Path: TS 38.331 [6], clause 6.3.1a			
Information Element	Value/remark	Comment	Condition
PosSI-SchedulingInfo-r16 ::= SEQUENCE {			
posSchedulingInfoList-r16 SEQUENCE (SIZE (1..maxSI-Message)) OF PosSchedulingInfo-r16 {	n entries	The size of PosSchedulingInfo-r16 is depending on the sub-tests, as specified in TS 37.571-2 [40]	
PosSchedulingInfo-r16[n] SEQUENCE {		entry n	
offsetToSI-Used-r16	Not present		
posSI-Periodicity-r16	rf32		
posSI-BroadcastStatus-r16	broadcasting		
posSIB-MappingInfo-r16 SEQUENCE (SIZE (1..maxSIB)) OF PosSIB-Type-r16 {	n entries	The number of entries depends on the sub-test, as specified in TS 37.571-2 [40]	
PosSIB-Type-r16[n]			
}			
}			
}			
posSI-RequestConfig-r16	Not present		
posSI-RequestConfigSUL-r16	Not present		
}			

### – *SIBpos*

**Table 4.6.2a-3: *SIBpos***

Derivation Path: TS 38.331 [6], clause 6.3.1a			
Information Element	Value/remark	Comment	Condition
SIBpos-r16 ::= SEQUENCE {			

assistanceDataSIB-Element-r16	OCTET STRING containing AssistanceDataSIBelement as specified in TS 37.571-2 [40]		
lateNonCriticalExtension	Not present		
}			

### 4.6.3 Radio resource control information elements

#### – *AdditionalSpectrumEmission*

**Table 4.6.3-1: AdditionalSpectrumEmission**

Derivation Path: TS 38.331 [6], clause 6.3.2			
Information Element	Value/remark	Comment	Condition
AdditionalSpectrumEmission	0		

#### – *Alpha*

**Table 4.6.3-2: Alpha**

Derivation Path: TS 38.331 [6], clause 6.3.2			
Information Element	Value/remark	Comment	Condition
Alpha	alpha0		

#### – *AMF-Identifier*

**Table 4.6.3-3: AMF-Identifier**

Derivation Path: TS 38.331 [6], clause 6.3.2			
Information Element	Value/remark	Comment	Condition
AMF-Identifier	FFS		

#### – *ARFCN-ValueEUTRA*

**Table 4.6.3-4: ARFCN-ValueEUTRA**

Derivation Path: TS 38.331 [6], clause 6.3.2			
Information Element	Value/remark	Comment	Condition
ARFCN-ValueEUTRA	The ARFCN value for the E-UTRA carrier frequency.	For signalling test cases see subclause 6.2.3. Otherwise, see subclause 4.3.1.	

#### – *ARFCN-ValueNR*

**Table 4.6.3-5: ARFCN-ValueNR**

Derivation Path: TS 38.331 [6], clause 6.3.2			
Information Element	Value/remark	Comment	Condition
ARFCN-ValueNR	absoluteFrequencySSB as defined for the frequency of the cell	For signalling test cases see subclause 6.2.3.	DL_SSB

		Otherwise, see subclause 4.3.1.	
	absoluteFrequencyPoint A as defined for the DL frequency of the cell	For signalling test cases see subclause 6.2.3. Otherwise, see subclause 4.3.1.	DL_PointA
	absoluteFrequencyPoint A as defined for the UL frequency of the cell	For signalling test cases see subclause 6.2.3. Otherwise, see subclause 4.3.1.	UL_PointA
	sl-absoluteFrequencySSB as defined for the SL NRf1 carrier	For signalling test cases see subclause 6.2.3.7. Otherwise, see subclause 4.3.1.8.	SL_SSB
	sl-AbsoluteFrequencyPoint A as defined for the SL NRf1 carrier	For signalling test cases see subclause 6.2.3.7. Otherwise, see subclause 4.3.1.8.	SL_PointA

Condition	Explanation
DL_SSB	IE absoluteFrequencySSB for downlink
SL_SSB	IE sl-absoluteFrequencySSB for sidelink
DL_PointA	IE absoluteFrequencyPointA for downlink
UL_PointA	IE absoluteFrequencyPointA for uplink
SL_PointA	IE sl-absoluteFrequencyPointA for sidelink

– *ARFCN-ValueUTRA-FDD*

**Table 4.6.3-5A: ARFCN-ValueUTRA-FDD**

Derivation Path: TS 38.331 [6], clause 6.3.2			
Information Element	Value/remark	Comment	Condition
ARFCN-ValueUTRA-FDD-r16	FFS		

– *AvailabilityCombinationsPerCell*

**Table 4.6.3-5B: AvailabilityCombinationsPerCell**

Derivation Path: TS 38.331 [6], clause 6.3.2			
Information Element	Value/remark	Comment	Condition
AvailabilityCombinationsPerCell-r16 ::= SEQUENCE {			
FFS			
}			

– *AvailabilityIndicator*

**Table 4.6.3-5C: AvailabilityIndicator**

Derivation Path: TS 38.331 [6], clause 6.3.2			
Information Element	Value/remark	Comment	Condition
AvailabilityIndicator-r16 ::= SEQUENCE {			
FFS			
}			



– *BAP-Routing-ID***Table 4.6.3-5D: BAP-Routing-ID**

Derivation Path: TS 38.331 [6], clause 6.3.2			
Information Element	Value/remark	Comment	Condition
BAP-Routing-ID-r16 ::= SEQUENCE {			
FFS			
}			

– *BeamFailureRecoveryConfig***Table 4.6.3-6: BeamFailureRecoveryConfig**

Derivation Path: TS 38.331 [6], clause 6.3.2			
Information Element	Value/remark	Comment	Condition
BeamFailureRecoveryConfig SEQUENCE {			
rootSequenceIndex-BFR	Set according to the PRACH-rootSequenceIndex given in Table 4.4.2-2		
rach-ConfigBFR	RACH-ConfigGeneric		
rsrp-ThresholdSSB	57	Actual value = 100 dBm	
candidateBeamRSList SEQUENCE (SIZE(1..maxNrofCandidateBeams)) OF PRACH-ResourceDedicatedBFR {	1 entry		
PRACH-ResourceDedicatedBFR[1] CHOICE {		entry 1	
ssb SEQUENCE {			SSB
ssb	SSB-Index for BFR		
ra-PreambleIndex	56		
}			
}			
csi-rs[1] SEQUENCE {			CSI-RS
csi-rs	NZP-CSI-RS-ResourceId for BFR		
ra-OccasionList	Not present	The RA occasion associated with the SSB that is QCLed with this CSI-RS is used	
ra-PreambleIndex	Not present	The preamble index associated with the SSB that is QCLed with CSI-RS is used	
}			
ssb-perRACH-Occasion	one		
ra-ssb-OccasionMaskIndex	0		
recoverySearchSpaceId	searchSpaceId for BFR search space	The CORESET associated with the BFR search space can not be associated with another search space according to 38.331 [6]	
ra-Prioritization	RA-Prioritization		
beamFailureRecoveryTimer	ms200		
msg1-SubcarrierSpacing	SubcarrierSpacing		
}			

Condition	Explanation
SSB	SSB is used as reference signal for BFR
CSI-RS	CSI-RS is used as reference signal for BFR

– *BeamFailureRecoveryRSConfig*

**Table 4.6.3-6AA: *BeamFailureRecoveryRSConfig***

Derivation Path: TS 38.331 [6], clause 6.3.2			
Information Element	Value/remark	Comment	Condition
BeamFailureRecoveryRSConfig-r16 ::= SEQUENCE {			
FFS			
}			

**Table 4.6.3-6AB: *Void***

– *BetaOffsets*

**Table 4.6.3-6A: *BetaOffsets***

Derivation Path: TS 38.331 [6], clause 6.3.2			
Information Element	Value/remark	Comment	Condition
BetaOffsets ::= SEQUENCE {			
betaOffsetACK-Index1	9		
betaOffsetACK-Index2	9		
betaOffsetACK-Index3	9		
betaOffsetCSI-Part1-Index1	6		
betaOffsetCSI-Part1-Index2	6		
betaOffsetCSI-Part2-Index1	6		
betaOffsetCSI-Part2-Index2	6		
}			

– *BetaOffsetsCrossPri*

**Table 4.6.3-6BA: *BetaOffsetsCrossPri***

Derivation Path: TS 38.331 [6], clause 6.3.2			
Information Element	Value/remark	Comment	Condition
BetaOffsetsCrossPri-r17	FFS		

– *BH-RLC-ChannelConfig*

**Table 4.6.3-6B: *BH-RLC-ChannelConfig***

Derivation Path: TS 38.331 [6], clause 6.3.2			
Information Element	Value/remark	Comment	Condition
BH-RLC-ChannelConfig-r16 ::= SEQUENCE {			
FFS			
}			

– *BH-LogicalChannelIdentity***Table 4.6.3-6C: BH-LogicalChannelIdentity**

Derivation Path: TS 38.331 [6], clause 6.3.2			
Information Element	Value/remark	Comment	Condition
BH-LogicalChannelIdentity-r16 ::= CHOICE {			
FFS			
}			

– *BH-LogicalChannelIdentity-Ext***Table 4.6.3-6D: BH-LogicalChannelIdentity-Ext**

Derivation Path: TS 38.331 [6], clause 6.3.2			
Information Element	Value/remark	Comment	Condition
BH-LogicalChannelIdentity-Ext-r16	FFS		

– *BH-RLC-ChannelID***Table 4.6.3-6E: BH-RLC-ChannelID**

Derivation Path: TS 38.331 [6], clause 6.3.2			
Information Element	Value/remark	Comment	Condition
BH-RLC-ChannelID-r16	FFS		

– *BSR-Config***Table 4.6.3-7: BSR-Config**

Derivation Path: TS 38.331 [6], clause 6.3.2			
Information Element	Value/remark	Comment	Condition
BSR-Config ::= SEQUENCE {			
periodicBSR-Timer	sf1		
retxBSR-Timer	sf80		
logicalChannelSR-DelayTimer	Not present		
}			

– *BWP***Table 4.6.3-8: BWP**

Derivation Path: TS 38.331 [6], clause 6.3.2			
Information Element	Value/remark	Comment	Condition
BWP ::= SEQUENCE {			
locationAndBandwidth	Set to value of locationAndBandwidth in Table 4.3.1.0D-1 for the bandwidth and subcarrier spacing under test		FR1
	Set to value of locationAndBandwidth in Table 4.3.1.0D-2 for the bandwidth and subcarrier spacing under test		FR2
subcarrierSpacing	SubcarrierSpacing		
cyclicPrefix	Not present		
}			

– *BWP-Downlink*

**Table 4.6.3-9: BWP-Downlink**

Derivation Path: TS 38.331 [6], clause 6.3.2			
Information Element	Value/remark	Comment	Condition
BWP-Downlink ::= SEQUENCE {			
bwp-Id	BWP-Id with condition BWP-Id1		
bwp-Common	BWP-DownlinkCommon with condition BWP-Id1		
bwp-Dedicated	BWP-DownlinkDedicated		
}			

– *BWP-DownlinkCommon*

**Table 4.6.3-10: BWP-DownlinkCommon**

Derivation Path: TS 38.331 [6], clause 6.3.2			
Information Element	Value/remark	Comment	Condition
BWP-DownlinkCommon ::= SEQUENCE {			
genericParameters	BWP		
pdcch-ConfigCommon CHOICE {			
setup	PDCCH-ConfigCommon with condition SCell_add		SCell_Add
	PDCCH-ConfigCommon with condition InitialBWP_SIB		InitialBWP_SIB
	PDCCH-ConfigCommon with condition BWP-Id1		BWP-Id1
	PDCCH-ConfigCommon with condition PEI		PEI
}			
pdsch-ConfigCommon CHOICE {			
setup	PDSCH-ConfigCommon		
}			
}			

Condition	Explanation
InitialBWP_SIB	Configured via DownlinkConfigCommonSIB
BWP-Id1	Additional BWP 1
PEI	Paging Early Indication is configured in the cell.

– *BWP-DownlinkDedicated*

**Table 4.6.3-11: BWP-DownlinkDedicated**

Derivation Path: TS 38.331 [6], clause 6.3.2			
Information Element	Value/remark	Comment	Condition
BWP-DownlinkDedicated ::= SEQUENCE {			
pdcch-Config CHOICE {			
setup	PDCCH-Config		
}			
pdsch-Config CHOICE {			
setu	PDSCH-Config		
}			
sps-Config	Not present		

radioLinkMonitoringConfig	Not present		Scell_Add
radioLinkMonitoringConfig CHOICE {			
setup	RadioLinkMonitoringConfig		
}			
sps-ConfigToAddModList-r16	Not present		
sps-ConfigToReleaseList-r16	Not present		
sps-ConfigDeactivationStateList-r16	Not present		
beamFailureRecoverySCellConfig-r16	Not present		
sl-PDCCH-Config-r16	Not present		
sl-PDCCH-Config-r16 CHOICE {			SIDELINK
setup	PDCCH-Config with condition SLSS		
}			
sl-V2X-PDCCH-Config-r16	Not present		
preConfGapStatus-r17	Not present		
beamFailureRecoverySpCellConfig-r17	Not present		
harq-FeedbackEnablingforSPSActive-r17	Not present		
cfr-ConfigMulticast-r17	Not present		
cfr-ConfigMulticast-r17 CHOICE {			MBS_Multicast
setup	CFR-ConfigMulticast		
}			
dl-PPW-PreConfigToAddModList-r17	Not present		
dl-PPW-PreConfigToReleaseList-r17	Not present		
nonCellDefiningSSB-r17	Not present		
servingCellIMO-r17	Not present		
}			

Condition	Explanation
SIDELINK	Used for sidelink communication
Scell_Add	Add SCell
MBS_Multicast	Used for MBS Multicast reception

– *BWP-Id*

**Table 4.6.3-12: BWP-Id**

Derivation Path: TS 38.331 [6], clause 6.3.2			
Information Element	Value/remark	Comment	Condition
BWP-Id	0	Initial BWP	
	1		BWP-Id1

Condition	Explanation
BWP-Id1	Additional BWP 1

– *BWP-Uplink*

**Table 4.6.3-13: BWP-Uplink**

Derivation Path: TS 38.331 [6], clause 6.3.2			
Information Element	Value/remark	Comment	Condition
BWP-Uplink ::= SEQUENCE {			
bwp-Id	BWP-Id with condition BWP-Id1		
bwp-Common	BWP-UplinkCommon		
bwp-Dedicated	BWP-UplinkDedicated		
}			

*BWP-UplinkCommon*

**Table 4.6.3-14: BWP-UplinkCommon**

Derivation Path: TS 38.331 [6], clause 6.3.2			
Information Element	Value/remark	Comment	Condition
BWP-UplinkCommon ::= SEQUENCE {			
genericParameters	BWP		
rach-ConfigCommon CHOICE {			
setup	RACH-ConfigCommon		
}			
rach-ConfigCommon	Not present		SUL_SUL AND (RF OR RRM), RF AND SCell_Add
pusch-ConfigCommon CHOICE {			
setup	PUSCH-ConfigCommon		
}			
pucch-ConfigCommon CHOICE {			
setup	PUCCH-ConfigCommon		
}			
pucch-ConfigCommon	Not present		RF AND SCell_Add
enableRA-PrioritizationForSlicing-r17	Not present		
additionalRACH-ConfigList-r17	true		Slice_RACH
rsrp-ThresholdMsg3-r17	Not present		
numberOfMsg3-RepetitionsList-r17	Not present		
mcs-Msg3-Repetitions-r17	Not present		
}			

Condition	Explanation
SUL_SUL	On the SUL carrier when supplementary carrier is configured
SCell_Add	Add SCell
Slice_RACH	Slice specific RACH configuration

*BWP-UplinkDedicated*

**Table 4.6.3-15: BWP-UplinkDedicated**

Derivation Path: TS 38.331 [6], clause 6.3.2			
Information Element	Value/remark	Comment	Condition
BWP-UplinkDedicated ::= SEQUENCE {			
pucch-Config CHOICE {			
setup	PUCCH-Config		
}			
pucch-Config	Not present		SUL_NUL, RF AND SCell_Add
pusch-Config	Not present		RESUME
pusch-Config CHOICE {			
setup	PUSCH-Config		
}			
configuredGrantConfig	Not present		
configuredGrantConfig	ConfiguredGrantConfig		CG_Config
srs-Config	Not present		Short_DCI
srs-Config	SRS-Config		
beamFailureRecoveryConfig	Not present		
sl-PUCCH-Config-r16	Not present		
sl-PUCCH-Config-r16 CHOICE {			
setup	PUCCH-Config		SIDELINK
}			

cp-ExtensionC2-r16	Not present		
cp-ExtensionC3-r16	Not present		
useInterfacePUCCH-PUSCH-r16	Not present		
pucch-ConfigurationList-r16	Not present		
lbt-FailureRecoveryConfig-r16	Not present		
lbt-FailureRecoveryConfig-r16 CHOICE {			SharedSpec trum
setup	LBT- FailureRecoveryConfig		
}			
configuredGrantConfigToAddModList-r16	Not present		
configuredGrantConfigToReleaseList-r16	Not present		
configuredGrantConfigType2DeactivationStateList- r16	Not present		
}			

Condition	Explanation
Short_DCI	Used in test scenarios requiring DCI formats 0-0 and 1-0 on USS
SUL_NUL	On the NUL carrier when supplementary carrier is configured
RESUME	Used in RRCResume Message
SIDELINK	Used for sidelink communication
SCell_add	Add SCell
SharedSpectrum	Operation with shared spectrum channel access
CG_Config	Configured Grant Configuration

– *CandidateBeamRS*

**Table 4.6.3-15A: CandidateBeamRS**

Derivation Path: TS 38.331 [6], clause 6.3.2			
Information Element	Value/remark	Comment	Condition
CandidateBeamRS-r16 ::= SEQUENCE {			
FFS			
}			

– *CellAccessRelatedInfo*

**Table 4.6.3-16: CellAccessRelatedInfo**

Derivation Path: TS 38.331 [6], clause 6.3.2			
Information Element	Value/remark	Comment	Condition
CellAccessRelatedInfo ::= SEQUENCE {			
plmn-IdentityInfoList	PLMN-IdentityInfoList		
cellReservedForOtherUse	Not present		
	true		SNPN, CAG
cellReservedForFutureUse-r16	Not present		
npn-IdentityInfoList-r16	Not present		
	NPN-IdentityInfoList-r16		SNPN, CAG
snpn-AccessInfoList-r17	Not present		
snpn-AccessInfoList-r17 SEQUENCE (SIZE (1..maxNPN-r16)) OF SNPN-AccessInfo-r17 {	1 entry		eNPN
SNPN-AccessInfo-r17[1] SEQUENCE {		entry 1	
extCH-Supported-r17	true		
extCH-WithoutConfigAllowed-r17	true		
onboardingEnabled-r17	true		
imsEmergencySupportForSNPN-r17	true		
}			
}			
}			

Condition	Explanation
SNPN	Standalone NPN cell
CAG	PNI-NPN
eNPN	Rel-17 enhanced NPN cell

– *CellAccessRelatedInfo-EUTRA-5GC*

**Table 4.6.3-17: CellAccessRelatedInfo-EUTRA-5GC**

Derivation Path: TS 38.331 [6], clause 6.3.2			
Information Element	Value/remark	Comment	Condition
CellAccessRelatedInfo-EUTRA-5GC ::= SEQUENCE {			
FFS			
}			

– *CellAccessRelatedInfo-EUTRA-EPC*

**Table 4.6.3-18: CellAccessRelatedInfo-EUTRA-EPC**

Derivation Path: TS 38.331 [6], clause 6.3.2			
Information Element	Value/remark	Comment	Condition
CellAccessRelatedInfo-EUTRA-EPC ::= SEQUENCE {			
FFS			
}			

– *CellGroupConfig*

**Table 4.6.3-19: CellGroupConfig**

Derivation Path: TS 38.331 [6], clause 6.3.2			
Information Element	Value/remark	Comment	Condition
CellGroupConfig ::= SEQUENCE {			
cellGroupId	CellGroupId CellGroupId condition NR-DC_SCG		NR-DC_SCG
rlc-BearerToAddModList SEQUENCE (SIZE(1..maxLCH)) OF RLC-BearerConfig {	1 entry		EN-DC
RLC-BearerConfig[1]	RLC-BearerConfig with conditions AM and DRB2	entry 1	
}	RLC-BearerConfig with conditions AM and DRB2 and Re-establish_RLC		PSCell_change
rlc-BearerToAddModList SEQUENCE (SIZE(1..maxLCH)) OF RLC-BearerConfig {	1 entry		SRB1
RLC-BearerConfig[1]	RLC-BearerConfig with condition SRB1	entry 1	
}			
rlc-BearerToAddModList SEQUENCE (SIZE(1..maxLCH)) OF RLC-BearerConfig {	2 entries		SRB2_DRB 1
RLC-BearerConfig[1]	RLC-BearerConfig with condition SRB2	entry 1	
RLC-BearerConfig[2]	RLC-BearerConfig with conditions AM and DRB1	entry 2	
}			
rlc-BearerToAddModList SEQUENCE (SIZE(1..maxLCH)) OF RLC-BearerConfig {	2 entries		SRB2_DRB 2
RLC-BearerConfig[1]	RLC-BearerConfig with condition SRB2	entry 1	



RLC-BearerConfig[2]	RLC-BearerConfig with conditions AM and DRB2	entry 2	
}			
rlc-BearerToAddModList SEQUENCE (SIZE(1..maxLCH)) OF RLC-BearerConfig {	1 entry		DRBn, NR-DC_SCG
RLC-BearerConfig[1]	RLC-BearerConfig with conditions AM and DRBn	entry 1 DRBn is allocated according to internal TTCN mapping	
}			
rlc-BearerToAddModList SEQUENCE (SIZE(1..maxLCH)) OF RLC-BearerConfig {	3 entries		PCell_change
RLC-BearerConfig[1]	RLC-BearerConfig with conditions SRB1 and Re-establish_RLC	entry 1	
RLC-BearerConfig[2]	RLC-BearerConfig with conditions SRB2 and Re-establish_RLC	entry 2	
RLC-BearerConfig[3]	RLC-BearerConfig with conditions AM, DRB1 and Re-establish_RLC	entry 3	
}			
rlc-BearerToAddModList SEQUENCE (SIZE(1..maxLCH)) OF RLC-BearerConfig {	1+n entries	n is the number of DRBs established before RRC resume	RESUME
RLC-BearerConfig[1]	RLC-BearerConfig with condition SRB2 and RESUME	entry 1	
RLC-BearerConfig[k+1, k=1..n]	RLC-BearerConfig with condition DRBk and RESUME	entry [k+1, k=1..n]	
}			
rlc-BearerToAddModList SEQUENCE (SIZE(1..maxLCH)) OF RLC-BearerConfig {	2+n entries	n is the number of DRBs established before RRC re-establishment	REEST
RLC-BearerConfig[1]	RLC-BearerConfig with condition SRB1	entry 1	
RLC-BearerConfig[2]	RLC-BearerConfig with condition SRB2 and Re-establish_RLC	entry 2	
RLC-BearerConfig[k+2, k=1..n]	RLC-BearerConfig with condition DRBk and Re-establish_RLC	entry [k+2, k=1..n]	
}			
rlc-BearerToAddModList SEQUENCE (SIZE(1..maxLCH)) OF RLC-BearerConfig {	1 entry		MRBm AND (AM_PTP OR UM_bi_PTP OR UM_PTP OR UM_PTM)
RLC-BearerConfig[1]	RLC-BearerConfig with conditions AM and PTP	entry 1	AM_PTP
	RLC-BearerConfig with conditions UM and PTP		UM_bi_PTP
	RLC-BearerConfig with conditions UM_DLonly and PTP		UM_PTP
	RLC-BearerConfig with conditions UM_DLonly and PTM		UM_PTM
}			

rlc-BearerToAddModList SEQUENCE (SIZE(1..maxLCH)) OF RLC-BearerConfig {	2 entries		MRBm_DR Bn AND (AM_PTP OR UM_bi_PTP OR UM_PTP OR UM_PTM)
RLC-BearerConfig[1]	RLC-BearerConfig with conditions AM and PTP and MRBm	entry 1	AM_PTP
	RLC-BearerConfig with conditions UM and PTP and MRBm		UM_bi_PTP
	RLC-BearerConfig with conditions UM_DLonly and PTP and MRBm		UM_PTP
	RLC-BearerConfig with conditions UM_DLonly and PTM and MRBm		UM_PTM
RLC-BearerConfig[2]	RLC-BearerConfig with conditions AM and DRBn	entry 2 DRBn is allocated according to internal TTCN mapping	
}			
rlc-BearerToAddModList SEQUENCE (SIZE(1..maxLCH)) OF RLC-BearerConfig {	2 entries		MRBm AND (AMPTP_U MPTM OR UMPTP_UM PTM)
RLC-BearerConfig[1]	RLC-BearerConfig with conditions AM and PTP and MRBm	entry 1	AMPTP_UM PTM
	RLC-BearerConfig with conditions UM_DLonly and PTP and MRBm		UMPTP_UM PTM
RLC-BearerConfig[2]	RLC-BearerConfig with conditions UM_DLonly and PTM and MRBm	entry 2	AMPTP_UM PTM, UMPTP_UM PTM
}			
rlc-BearerToAddModList SEQUENCE (SIZE(1..maxLCH)) OF RLC-BearerConfig {	3 entries		MRBm_DR Bn AND (AMPTP_U MPTM OR UMPTP_UM PTM)
RLC-BearerConfig[1]	RLC-BearerConfig with conditions AM and PTP and MRBm	entry 1	AMPTP_UM PTM
	RLC-BearerConfig with conditions UM_DLonly and PTP and MRBm		UMPTP_UM PTM
RLC-BearerConfig[2]	RLC-BearerConfig with conditions UM_DLonly and PTM and MRBm	entry 2	AMPTP_UM PTM, UMPTP_UM PTM
RLC-BearerConfig[3]	RLC-BearerConfig with conditions AM and DRBn	entry 3 DRBn is allocated according to internal TTCN mapping	
}			
rlc-BearerToAddModList	Not present		
rlc-BearerToReleaseList	Not present		

mac-CellGroupConfig	MAC-CellGroupConfig		
	MAC-CellGroupConfig with condition MBS_Multicast		AMPTP_UM PTM, UMPTP_UM PTM, UM_PT M
	Not present		SRB2_DRB 1, MEAS, SRB2_DRB 2, SCell_add
physicalCellGroupConfig	PhysicalCellGroupConfig		
	Not present		SRB2_DRB 1, MEAS, SRB2_DRB 2, SCell_add, MRBm, MRBm_DR Bn
spCellConfig	Not present		SRB2_DRB 1, SRB2_DRB 2, SCell_add, AM_PTP, UM_bi_PTP, UM_PTP
spCellConfig SEQUENCE {			
servCellIndex	Not present		
	ServCellIndex		EN-DC, EN-DC AND MEAS
	ServCellIndex with condition NR-DC_SCG		NR-DC_SCG
reconfigurationWithSync	Not present		
reconfigurationWithSync SEQUENCE {			EN-DC, PCell_change, PSCell_change, NR-DC_SCG
spCellConfigCommon	ServingCellConfigCommon		
newUE-Identity	RNTI-Value		
	RNTI-Value with condition NR-DC_SCG		NR-DC_SCG
t304	ms1000		
rach-ConfigDedicated	Not present		
rach-ConfigDedicated CHOICE {			CFRA
uplink	RACH-ConfigDedicated		
supplementaryUplink	RACH-ConfigDedicated		SUL AND SIG
}			
}			
rfl-TimersAndConstants CHOICE {			
setup	RLF-TimersAndConstants		
}			
rfl-TimersAndConstants	Not present		MEAS, RESUME
rlmInSyncOutOfSyncThreshold	Not present		
spCellConfigDedicated	ServingCellConfig		EN-DC, SRB1, PCell_change, PSCell_cha

			nge, NR-DC_SCG, REEST
	Not present		
	ServingCellConfig with condition MEAS		MEAS
	ServingCellConfig with condition RESUME		RESUME
	ServingCellConfig with condition MBS_Multicast		AMPTP_UM PTM, UMPTP_UM PTM, UM_PTM
}			
sCellToAddModList	Not present		
sCellToAddModList SEQUENCE (SIZE (1..maxNrofSCells)) OF SCellConfig {	1 entry		SCell_add
SCellConfig[1] SEQUENCE {		entry 1	
sCellIndex	SCellIndex		
sCellConfigCommon	ServingCellConfigCommon with condition No_UL and SCell_add		
	ServingCellConfigCommon with condition SCell_add		RF AND UL_CA
sCellConfigDedicated	ServingCellConfig with condition No_UL and SCell_Add		
	ServingCellConfig with condition SCell_Add		RF AND UL_CA
}			
}			
sCellToReleaseList	Not present		
reportUplinkTxDirectCurrent	Not present		
bap-Address-r16	Not present		
bh-RLC-ChannelToAddModList-r16	Not present		
bh-RLC-ChannelToReleaseList-r16	Not present		
f1c-TransferPath-r16	Not present		
simultaneousTCI-UpdateList1-r16	Not present		
simultaneousTCI-UpdateList2-r16	Not present		
simultaneousSpatial-UpdatedList1-r16	Not present		
simultaneousSpatial-UpdatedList2-r16	Not present		
uplinkTxSwitchingOption-r16	Not present		
uplinkTxSwitchingPowerBoosting-r16	Not present		
reportUplinkTxDirectCurrentTwoCarrier-r16	Not present		
f1c-TransferPathNRDC-r17	Not present		
uplinkTxSwitching-2T-Mode-r17	Not present		
uplinkTxSwitching-DualUL-TxState-r17	Not present		
uu-RelayRLC-ChannelToAddModList-r17	Not present		
uu-RelayRLC-ChannelToAddModList-r17 SEQUENCE (SIZE (1.. maxUu-RelayRLC-ChannelID-r17)) OF Uu-RelayRLC-ChannelConfig-r17{			RELAY
Uu-RelayRLC-ChannelConfig-r17[1]	Uu-RelayRLC-ChannelConfig		
}			
uu-RelayRLC-ChannelToReleaseList-r17	Not present		
simultaneousU-TCI-UpdateList1-r17	Not present		
simultaneousU-TCI-UpdateList2-r17	Not present		
simultaneousU-TCI-UpdateList3-r17	Not present		
simultaneousU-TCI-UpdateList4-r17	Not present		
rlc-BearerToReleaseListExt-r17	Not present		
iab-ResourceConfigToAddModList-r17	Not present		
iab-ResourceConfigToReleaseList-r17	Not present		
reportUplinkTxDirectCurrentMoreCarrier-r17	Not present		
}			

Condition	Explanation
EN-DC	E-UTRA-NR Dual Connectivity with E-UTRA connected to EPC
CFRA	This condition applies when CFRA is configured
SUL	Supplementary Uplink
SRB1	Establishment of SRB1
SRB2_DRB1	Establishment of SRB2 and DRB1
SRB2_DRB2	Establishment of SRB2 and DRB2
DRBn	Establishment of DRBn
PCell_change	Intra-NR PCell change NR)
PSCell_change	NR PSCell change (EN-DC)
SCell_add	Add SCell
MEAS	A NR or EN-DC measurement is configured
NR-DC_SCG	Add SCG (NR-DC)
RESUME	Used in RRCResume Message
REEST	The first RRCReconfiguration message after successful completion of the RRC re-establishment procedure.
UL_CA	Uplink CA
MRBm	Establishment of MRBm
MRBm_DRBn	Establishment of MRBm and DRBn
AM_PTP	Multicast MRB with RLC-AM entity configuration for receiving PTP transmission
UM_bi_PTP	Multicast MRB with bidirectional RLC-UM configuration for receiving PTP transmission
UM_PTP	Multicast MRB with DL only RLC-UM configuration for receiving PTP transmission
UM_PTM	Multicast MRB with DL only RLC-UM entity for receiving PTM transmission
AMPTP_UMPTM	Multicast MRB with two RLC entities, one RLC-AM entity for receiving PTP transmission and the other DL only RLC-UM entity for receiving PTM transmission
UMPTP_UMPTM	Multicast MRB with two RLC-UM entities, one DL only RLC-UM entity for receiving PTP transmission and the other DL only RLC-UM entity for receiving PTM transmission
RELAY	This condition applies when Relay UE is configured

– *CellGroupId*

**Table 4.6.3-20: CellGroupId**

Derivation Path: TS 38.331 [6], clause 6.3.2			
Information Element	Value/remark	Comment	Condition
CellGroupId	0		
	1		EN-DC, NR-DC_SCG

Condition	Explanation
EN-DC	E-UTRA-NR Dual Connectivity with E-UTRA connected to EPC
NR-DC_SCG	Add SCG (NR-DC)

– *CellIdentity*

**Table 4.6.3-21: CellIdentity**

Derivation Path: TS 38.331 [6], clause 6.3.2			
Information Element	Value/remark	Comment	Condition
CellIdentity	Set to NR Cell Identifier defined in table 4.4.2-2	BIT STRING (SIZE (36))	

– *CellReselectionPriority***Table 4.6.3-22: CellReselectionPriority**

Derivation Path: TS 38.331 [6], clause 6.3.2			
Information Element	Value/remark	Comment	Condition
CellReselectionPriority	4		
	5		Priority_5

Condition	Explanation
Priority_5	Priority 5

– *CellReselectionSubPriority***Table 4.6.3-23: CellReselectionSubPriority**

Derivation Path: TS 38.331 [6], clause 6.3.2			
Information Element	Value/remark	Comment	Condition
CellReselectionSubPriority	FFS		

– *CFR-ConfigMulticast***Table 4.6.3-23AA: CFR-ConfigMulticast**

Derivation Path: TS 38.331 [6], clause 6.3.2			
Information Element	Value/remark	Comment	Condition
CFR-ConfigMulticast-r17 ::= SEQUENCE {			
locationAndBandwidthMulticast-r17	Not present		
pdcch-ConfigMulticast-r17	PDCCH-Config with condition MSS		
pdsch-ConfigMulticast-r17	PDSCH-Config with condition MBS_Multicast		
sps-ConfigMulticastToAddModList-r17	Not present		
sps-ConfigMulticastToReleaseList-r17	Not present		
}			

– *CGI-InfoEUTRA***Table 4.6.3-23A: CGI-InfoEUTRA**

Derivation Path: TS 38.331 [6], clause 6.3.2			
Information Element	Value/remark	Comment	Condition
CGI-InfoEUTRA	FFS		

– *CGI-InfoEUTRALogging***Table 4.6.3-23B: CGI-InfoEUTRALogging**

Derivation Path: TS 38.331 [6], clause 6.3.2			
Information Element	Value/remark	Comment	Condition
CGI-InfoEUTRALogging ::= SEQUENCE {			
FFS			
}			

– CGI-InfoNR

**Table 4.6.3-24: CGI-InfoNRo**

Derivation Path: TS 38.331 [6], clause 6.3.2			
Information Element	Value/remark	Comment	Condition
CGI-InfoNR	FFS		

– CGI-Info-Logging

**Table 4.6.3-24A: CGI-Info-Logging**

Derivation Path: TS 38.331 [6], clause 6.3.2			
Information Element	Value/remark	Comment	Condition
CGI-Info-Logging-r16 ::= SEQUENCE {			
FFS			
}			

– CLI-RSSI-Range

**Table 4.6.3-24B: CLI-RSSI-Range**

Derivation Path: TS 38.331 [6], clause 6.3.2			
Information Element	Value/remark	Comment	Condition
CLI-RSSI-Range-r16	FFS		

– CodebookConfig

**Table 4.6.3-25: CodebookConfig**

Derivation Path: TS 38.331 [6], clause 6.3.2			
Information Element	Value/remark	Comment	Condition
CodebookConfig ::= SEQUENCE {			
codebookType CHOICE {			
type1 SEQUENCE {			
subType CHOICE {			
type1-SinglePanel SEQUENCE {			
nrOfAntennaPorts CHOICE {			
two SEQUENCE {			2TX
twoTX-CodebookSubsetRestriction	111111		
moreThanTwo SEQUENCE {			
n1-n2 CHOICE {			
two-one-Type1-SinglePanel-Restriction	11111111		FR2
four-one-Type1-SinglePanel-Restriction	11111111 11111111		FR1
type1-SinglePanel-codebookSubsetRestriction-i2	Not present		
}			
}			
type1-SinglePanel-ri-Restriction	11111111		
}			
codebookMode	1		
}			
}			

Condition	Explanation
-----------	-------------

2TX	2 Tx CSI-RS configuration.
-----	----------------------------

– *CommonLocationInfo*

**Table 4.6.3-25A: CommonLocationInfo**

Derivation Path: TS 38.331 [6], clause 6.3.2			
Information Element	Value/remark	Comment	Condition
CommonLocationInfo-r16 ::= SEQUENCE {			
gnss-TOD-msec-r16	Not checked	OCTET STRING	
locationTimestamp-r16	Not checked	OCTET STRING	
locationCoordinate-r16	Not checked	OCTET STRING	
locationError-r16	Not checked	OCTET STRING	
locationSource-r16	Not checked	OCTET STRING	
velocityEstimate-r16	Not checked	OCTET STRING	
}			

– *CondReconfigId*

**Table 4.6.3-25B: CondReconfigId**

Derivation Path: TS 38.331 [6], clause 6.3.2			
Information Element	Value/remark	Comment	Condition
CondReconfigId-r16	1		

– *CondReconfigToAddModList*

**Table 4.6.3-25C: CondReconfigToAddModList**

Derivation Path: TS 38.331 [6], clause 6.3.2			
Information Element	Value/remark	Comment	Condition
CondReconfigToAddModList-r16 ::= SEQUENCE (SIZE (1.. maxNrofCondCells-r16)) OF CondReconfigToAddMod-r16 {	1 entry		
CondReconfigToAddMod-r16[1] ::= SEQUENCE {		entry 1	
condReconfigId-r16	CondReconfigId-r16		
condExecutionCond-r16 ::= SEQUENCE {			
MeasId [1]	1	identify a measurement configuration	
}			
condRRCReconfig-r16	RRCReconfiguration-HO	Table 4.8.1-1A	
}			

– *ConditionalReconfiguration*

**Table 4.6.3-25D: ConditionalReconfiguration**

Derivation Path: TS 38.331 [6], clause 6.3.2			
Information Element	Value/remark	Comment	Condition
ConditionalReconfiguration-r16 ::= SEQUENCE {			
attemptCondReconfig-r16	true		
condReconfigToRemoveList-r16	Not present		
condReconfigToAddModList-r16	CondReconfigToAddModList-r16		
}			



– *ConfiguredGrantConfig*

**Table 4.6.3-26: ConfiguredGrantConfig**

Derivation Path: TS 38.331 [6], clause 6.3.2			
Information Element	Value/remark	Comment	Condition
ConfiguredGrantConfig ::= SEQUENCE {			
frequencyHopping	Not present		
cg-DMRS-Configuration	DMRS-UplinkConfig		
mcs-Table	Not present		
mcs-TableTransformPrecoder	Not present		
uci-OnPUSCH	Not present		
resourceAllocation	resourceAllocationType1		
rbg-Size	Not present		
powerControlLoopToUse	n0		
p0-PUSCH-Alpha	0		
transformPrecoder	Not present		
nrofHARQ-Processes	16		
repK	n1		
repK-RV	Not present		
periodicity	Sym40x14	40ms	SCS15
	Sym80x14	40ms	SCS30
	Sym160x14	40ms	SCS60
	Sym320x14	40ms	SCS120
configuredGrantTimer	Not present		
rrc-ConfiguredUplinkGrant	Not present		
rrc-ConfiguredUplinkGrant SEQUENCE {			CG_Config_Type1
timeDomainOffset	9		
timeDomainAllocation	0		
frequencyDomainAllocation	BIT STRING (SIZE(18))	Equals to NBWPsize * (NBWPsize – LRB + 1) + (NBWPsize -1 - RBstart), where LRB = 24 PRB, RBstart = 0, NBWPsize is the size [PRBs] of the carrier bandwidth and contained in TS.38.508-1 [4] clause 6.2.3.1	
	BIT STRING (SIZE(18))	Equal to NBWPsize * (LRB-1) + RBstart), where LRB = 24 PRB, RBstart = 0, NBWPsize is the size [PRBs] of the carrier bandwidth and contained in TS.38.508-1 [4] clause 6.2.3.1	
antennaPort	2		
dmrs-SeqInitialization	Not present		
precodingAndNumberOfLayers	1		
srs-ResourceIndicator	Not present		
mcsAndTBS	1		
frequencyHoppingOffset	Not present		
pathlossReferenceIndex	0		
pusch-RepTypeIndicator-r16	Not present		
frequencyHoppingPUSCH-RepTypeB-r16	Not present		
timeReferenceSFN-r16	Not present		

pathlossReferenceIndex2-r17	Not present		
srs-ResourceIndicator2-r17	Not present		
precodingAndNumberOfLayers2-r17	Not present		
timeDomainAllocation-v1710	Not present		
timeDomainOffset-r17	Not present		
cg-SDT-Configuration-r17	Not present		
cg-SDT-Configuration-r17 SEQUENCE {			pc_cg_SDT_r17
cg-SDT-RetransmissionTimer	Not present		
sdt-SSB-Subset-r17	Not present	If this field is absent, UE assumes the SSB set includes all actually transmitted SSBs configured by SIB1.	
sdt-SSB-PerCG-PUSCH-r17	one		
sdt-P0-PUSCH-r17	0		
sdt-Alpha-r17	alpha08		
sdt-DMRS-Ports-r17 CHOICE {			
dmrsType1-r17	'100000000000'B	Port0	
}			
sdt-NrofDMRS-Sequences-r17	1		
}			
cg-RetransmissionTimer-r16	Not present		
cg-minDFI-Delay-r16	Not present		
cg-nrofPUSCH-InSlot-r16	Not present		
cg-nrofSlots-r16	Not present		
cg-StartingOffsets-r16	Not present		
cg-UCI-Multiplexing-r16	Not present		
cg-COT-SharingOffset-r16	Not present		
betaOffsetCG-UCI-r16	Not present		
cg-COT-SharingList-r16	Not present		
harq-ProclD-Offset-r16	Not present		
harq-ProclD-Offset2-r16	Not present		
configuredGrantConfigIndex-r16	Not present		
configuredGrantConfigIndexMAC-r16	Not present		
periodicityExt-r16	Not present		
startingFromRV0-r16	Not present		
phy-PriorityIndex-r16	Not present		
autonomousTx-r16	Not present		
cg-betaOffsetsCrossPri0-r17	Not present		
cg-betaOffsetsCrossPri1-r17	Not present		
mappingPattern-r17	Not present		
sequenceOffsetForRV-r17	Not present		
p0-PUSCH-Alpha2-r17	Not present		
powerControlLoopToUse2-r17	Not present		
cg-COT-SharingList-r17	Not present		
periodicityExt-r17	Not present		
repK-v1710	Not present		
nrofHARQ-Processes-v1700	Not present		
harq-ProclD-Offset2-v1700	Not present		
configuredGrantTimer-v1700	Not present		
cg-minDFI-Delay-v1710	Not present		
harq-ProclD-Offset-v1730	Not present		
cg-nrofSlots-r17	Not present		
}			

Condition	Explanation
CG_Config_Type1	Configured Grant Configuration Type1

– *ConfiguredGrantConfigIndex*

**Table 4.6.3-26A: ConfiguredGrantConfigIndex**

Derivation Path: TS 38.331 [6], clause 6.3.2			
Information Element	Value/remark	Comment	Condition
ConfiguredGrantConfigIndex-r16	FFS		

– *ConfiguredGrantConfigIndexMAC*

**Table 4.6.3-26B: ConfiguredGrantConfigIndexMAC**

Derivation Path: TS 38.331 [6], clause 6.3.2			
Information Element	Value/remark	Comment	Condition
ConfiguredGrantConfigIndexMAC-r16	FFS		

– *ConnEstFailureControl*

**Table 4.6.3-27: ConnEstFailureControl**

Derivation Path: TS 38.331 [6], clause 6.3.2			
Information Element	Value/remark	Comment	Condition
ConnEstFailureControl ::= SEQUENCE {			
connEstFailCount	n1		
connEstFailOffsetValidity	s30		
connEstFailOffset	1		
}			

– *ControlResourceSet*

**Table 4.6.3-28: ControlResourceSet**

Derivation Path: TS 38.331 [6], clause 6.3.2			
Information Element	Value/remark	Comment	Condition
ControlResourceSet ::= SEQUENCE {			
controlResourceSetId	ControlResourceSetId		
frequencyDomainResources	11110000 00000000 00000000 00000000 00000000 00000	CORESET to use the least significant 24 RBs of the BWP	
duration	2	SearchSpace duration of 2 symbols	
cce-REG-MappingType CHOICE {			
nonInterleaved	null		
}			
precoderGranularity	sameAsREG-bundle		
tci-StatesPDCCH-ToAddList	Not present		
tci-StatesPDCCH-ToReleaseList	Not present		
tci-PresentInDCI	Not present		
pdcch-DMRS-ScramblingID	Not present		
rb-Offset-r16	Not present		
tci-PresentDCI-1-2-r16	Not present		
coresetPoolIndex-r16	Not present		
controlResourceSetId-v1610	Not present		
}			

– *ControlResourceSetId*

**Table 4.6.3-29: ControlResourceSetId**

Derivation Path: TS 38.331 [6], clause 6.3.2			
Information Element	Value/remark	Comment	Condition
ControlResourceSetId	1		
	0		Common0

Condition	Explanation
Common0	CommonCORESET#0

– *ControlResourceSetZero*

**Table 4.6.3-30: ControlResourceSetZero**

Derivation Path: TS 38.331 [6], clause 6.3.2			
Information Element	Value/remark	Comment	Condition
ControlResourceSetZero	Set to CORESET#0 Index as defined for the frequency of the cell	For signalling test cases see subclause 6.2.3. Otherwise, see subclause 4.3.1.	

– *CrossCarrierSchedulingConfig*

**Table 4.6.3-31: CrossCarrierSchedulingConfig**

Derivation Path: TS 38.331 [6], clause 6.3.2			
Information Element	Value/remark	Comment	Condition
CrossCarrierSchedulingConfig ::= SEQUENCE {			
FFS			
}			

– *CSI-AperiodicTriggerStateList*

**Table 4.6.3-32: CSI-AperiodicTriggerStateList**

Derivation Path: TS 38.331 [6], clause 6.3.2			
Information Element	Value/remark	Comment	Condition
CSI-AperiodicTriggerStateList ::= SEQUENCE (SIZE (1..maxNrOfCSI-AperiodicTriggers)) OF CSI-AperiodicTriggerState {	1 entry		
CSI-AperiodicTriggerState[1] SEQUENCE {		entry 1	
associatedReportConfigInfoList SEQUENCE (SIZE(1..maxNrofReportConfigPerAperiodicTrigger)) OF CSI-AssociatedReportConfigInfo {	1 entry		
CSI-AssociatedReportConfigInfo[1] SEQUENCE {		entry 1	
reportConfigId	CSI-ReportConfigId		
resourcesForChannel CHOICE {			
nzp-CSI-RS SEQUENCE {			
resourceSet	8		FR1
	16		FR2
qcl-info SEQUENCE (SIZE(1..maxNrofAP-CSI-RS-ResourcesPerSet)) OF TCI-StateId {	1 entry		
TCI-StateId[1]	TCI-StateId	entry 1	
}			
}			
}			

csi-IM-ResourcesforInteference	8		FR1
	16		FR2
nzp-CSI-RS-ResourcesforInterference	8		FR1
	16		FR2
}			
}			
}			
}			

– CSI-FrequencyOccupation

**Table 4.6.3-33: CSI-FrequencyOccupation**

Derivation Path: TS 38.331 [6], clause 6.3.2			
Information Element	Value/remark	Comment	Condition
CSI-FrequencyOccupation ::= SEQUENCE {			
startingRB	0		
nrofRBs	160		FR1 AND BW60
	216		FR1 AND BW80
	108		FR1 AND BW40
	52		FR1 AND BW10
	276		FR1 AND BW100
	64		FR2 AND BW100
	52		TRS
	40		TRS AND ((FR1 AND BW15 AND SCS30) OR (FR1 AND BW30AND SCS60))
	32		TRS AND ((FR1 AND BW25 AND SCS60) OR (FR2 AND BW50 AND SCS120))
	28		TRS AND FR1 AND BW5 AND SCS15
	24		TRS AND ((FR1 AND BW5 AND SCS30) OR (FR1 AND BW10 AND SCS30) OR (FR1 AND BW10 AND SCS60) OR (FR1 AND BW15 AND SCS60) OR (FR1 AND BW20 AND SCS60))

	64		
}			

Condition	Explanation
TRS	Tracking-Reference Signal

– *CSI-IM-Resource*

**Table 4.6.3-34: CSI-IM-Resource**

Derivation Path: TS 38.331 [6], clause 6.3.2			
Information Element	Value/remark	Comment	Condition
CSI-IM-Resource ::= SEQUENCE {			
csi-IM-ResourceId	CSI-IM-ResourceId		
csi-IM-ResourceElementPattern CHOICE {			
pattern1 SEQUENCE {			
subcarrierLocation-p1	s4		
symbolLocation-p1	3		FR1
	4		FR2
}			
}			
freqBand	CSI-FrequencyOccupation		
periodicityAndOffset	Not present		
}			

– *CSI-IM-ResourceId*

**Table 4.6.3-35: CSI-IM-ResourceId**

Derivation Path: TS 38.331 [6], clause 6.3.2			
Information Element	Value/remark	Comment	Condition
CSI-IM-ResourceId	7		FR1
	31		FR2

– *CSI-IM-ResourceSet*

**Table 4.6.3-36: CSI-IM-ResourceSet**

Derivation Path: TS 38.331 [6], clause 6.3.2			
Information Element	Value/remark	Comment	Condition
CSI-IM-ResourceSet ::= SEQUENCE {			
csi-IM-ResourceSetId	CSI-IM-ResourceSetId		
csi-IM-Resources SEQUENCE (SIZE(1..maxNrofCSI-IM-ResourcesPerSet)) OF CSI-IM-ResourceId {	1 entry		
CSI-IM-ResourceId[1]	CSI-IM-ResourceId	entry 1	
}			
}			

– *CSI-IM-ResourceSetId*

**Table 4.6.3-37: CSI-IM-ResourceSetId**

Derivation Path: TS 38.331 [6], clause 6.3.2			
Information Element	Value/remark	Comment	Condition
CSI-IM-ResourceSetId	0		

– *CSI-MeasConfig***Table 4.6.3-38: CSI-MeasConfig**

Derivation Path: TS 38.331 [6], clause 6.3.2			
Information Element	Value/remark	Comment	Condition
CSI-MeasConfig ::= SEQUENCE {			
nzp-CSI-RS-ResourceToAddModList SEQUENCE (SIZE (1..maxNrofNzp-CSI-RS-Resources)) OF Nzp-CSI-RS-Resource {	1 entry		
Nzp-CSI-RS-Resource[1]	Nzp-CSI-RS-Resource	entry 1	
}			
nzp-CSI-RS-ResourceToReleaseList	Not present		
nzp-CSI-RS-ResourceSetToAddModList SEQUENCE (SIZE (1..maxNrofNzp-CSI-RS-ResourceSets)) OF Nzp-CSI-RS-ResourceSetId {	1 entry		
Nzp-CSI-RS-ResourceSet[1]	Nzp-CSI-RS-ResourceSet	entry 1	
}			
nzp-CSI-RS-ResourceSetToReleaseList	Not present		
csi-IM-ResourceToAddModList SEQUENCE (SIZE (1..maxNrofCSI-IM-Resources)) OF CSI-IM-Resource {	1 entry		
CSI-IM-Resource[1]	CSI-IM-Resource	entry 1	
}			
csi-IM-ResourceToReleaseList	Not present		
csi-IM-ResourceSetToAddModList SEQUENCE (SIZE (1..maxNrofCSI-SSB-ResourceSets)) OF CSI-SSB-ResourceSet {	1 entry		
CSI-IM-ResourceSet[1]	CSI-IM-ResourceSet	entry 1	
}			
csi-IM-ResourceSetToReleaseList	Not present		
csi-SSB-ResourceSetToAddModList SEQUENCE (SIZE (1..maxNrofCSI-SSB-ResourceSets)) OF CSI-SSB-ResourceSet {	1 entry		
CSI-SSB-ResourceSet[1]	CSI-SSB-ResourceSet	entry 1	
}			
csi-SSB-ResourceSetToReleaseList	Not present		
csi-ResourceConfigToAddModList SEQUENCE (SIZE (1..maxNrofCSI-ResourceConfigurations)) OF CSI-ResourceConfig {	1 entry		
CSI-ResourceConfig[1]	CSI-ResourceConfig	entry 1	
}			
csi-ResourceConfigToReleaseList	Not present		
csi-ReportConfigToAddModList SEQUENCE (SIZE (1..maxNrofCSI-ReportConfigurations)) OF CSI-ReportConfig {	1 entry		
CSI-ReportConfig[1]	CSI-ReportConfig	entry 1	
}			
csi-ReportConfigToReleaseList	Not present		
reportTriggerSize	0		
aperiodicTriggerStateList CHOICE {			
setup	CSI-AperiodicTriggerStateList		
}			
semiPersistentOnPUSCH-TriggerStateList	Not present		
reportTriggerSizeDCI-0-2-r16	Not present		
}			

– *CSI-ReportConfig*

**Table 4.6.3-39: CSI-ReportConfig**

Derivation Path: TS 38.331 [6], clause 6.3.2			
Information Element	Value/remark	Comment	Condition
CSI-ReportConfig ::= SEQUENCE {			
reportConfigId	CSI-ReportConfigId		
carrier	ServCellIndex		
resourcesForChannelMeasurement	CSI-ResourceConfigId		
csi-IM-ResourcesForInterference	CSI-ResourceConfigId		
nzp-CSI-RS-ResourcesForInterference	CSI-ResourceConfigId		
reportConfigType CHOICE {			
aperiodic SEQUENCE {			
reportSlotOffsetList SEQUENCE (SIZE (1..maxNrofUL-Allocations)) OF INTEGER {	1 entry		
INTEGER[1]	14	entry 1	
}			
}			
reportQuantity CHOICE {			
cri-RI-PMI-CQI	NULL,		FR1
cri-RI-LI-PMI-CQI	NULL		FR2
}			
reportFreqConfiguration SEQUENCE {			
cqi-FormatIndicator	widebandCQI		
pmi-FormatIndicator	widebandPMI		
csi-ReportingBand	Not present		
}			
timeRestrictionForChannelMeasurements	notConfigured		
timeRestrictionForInterferenceMeasurements	notConfigured		
codebookConfig	CodebookConfig		
dummy	Not present		
groupBasedBeamReporting CHOICE {			
disabled SEQUENCE {			
nrofReportedRS	n1		
}			
}			
cqi-Table	table1	64QAM	
	table2		256QAM
subbandSize	value2		
non-PMI-PortIndication	Not present		
semiPersistentOnPUSCH-v1530	Not present		
semiPersistentOnPUSCH-v1610	Not present		
aperiodic-v1610	Not present		
reportQuantity-r16	Not present		
codebookConfig-r16	Not present		
}			

Condition	Explanation
256QAM	Test cases using 256QAM for PDSCH

– *CSI-ReportConfigId*

**Table 4.6.3-40: CCSI-ReportConfigId**

Derivation Path: TS 38.331 [6], clause 6.3.2			
Information Element	Value/remark	Comment	Condition
CSI-ReportConfigID	0		



– *CSI-ResourceConfig***Table 4.6.3-41: CSI-ResourceConfig**

Derivation Path: TS 38.331 [6], clause 6.3.2			
Information Element	Value/remark	Comment	Condition
CSI-ResourceConfig ::= SEQUENCE {			
csi-ResourceConfigId	CSI-ResourceConfigId		
csi-RS-ResourceSetList CHOICE {			
nzp-CSI-RS-SSB SEQUENCE {			
nzp-CSI-RS-ResourceSetList SEQUENCE (SIZE (1..maxNrofNZP-CSI-RS-ResourceSetsPerConfig)) OF NZP-CSI-RS-ResourceSetId {	2 entries		
NZP-CSI-RS-ResourceSetId[1]	0	entry 1	
NZP-CSI-RS-ResourceSetId[2]	1	entry 2	
}			
csi-SSB-ResourceSetList	Not present		
}			
}			
bwp-Id	BWP-Id		
resourceType	periodic		
}			

– *CSI-ResourceConfigId***Table 4.6.3-42: CSI-ResourceConfigId**

Derivation Path: TS 38.331 [6], clause 6.3.2			
Information Element	Value/remark	Comment	Condition
CSI-ResourceConfigId	0		

– *CSI-ResourcePeriodicityAndOffset***Table 4.6.3-43: CSI-ResourcePeriodicityAndOffset**

Derivation Path: TS 38.331 [6], clause 6.3.2			
Information Element	Value/remark	Comment	Condition
CSI-ResourcePeriodicityAndOffset ::= CHOICE {			
slots80	10		FR1
slots320	40		FR2
}			

– *CSI-RS-ResourceConfigMobility***Table 4.6.3-44: CSI-RS-ResourceConfigMobility**

Derivation Path: TS 38.331 [6], clause 6.3.2			
Information Element	Value/remark	Comment	Condition
CSI-RS-ResourceConfigMobility ::= SEQUENCE {			
subcarrierSpacing	SubcarrierSpacing		
csi-RS-CellList-Mobility	FFS		
}			

– *CSI-RS-ResourceMapping***Table 4.6.3-45: CSI-RS-ResourceMapping**

Derivation Path: TS 38.331 [6], clause 6.3.2			
--	--	--	--

Information Element	Value/remark	Comment	Condition
CSI-RS-ResourceMapping ::= SEQUENCE {			
frequencyDomainAllocation CHOICE {			
row1	1000		(FR1 AND TRS) OR (FR2 AND TRS)
row4	010		FR2
other	011110		FR1
}			
nrofPorts	p8		FR1
	p4		FR2
	p1		(FR1 AND TRS) OR (FR2 AND TRS)
firstOFDMSymbolInTimeDomain	3		FR1
	13		FR2
	4		(FR1 AND TRS) OR (FR2 AND TRS)
firstOFDMSymbolInTimeDomain2	Not present		
cdm-Type	fd-CDM2		
	noCDM		TRS
density CHOICE {			
one	NULL		
three	NULL		TRS
}			
freqBand	CSI-FrequencyOccupation		
}			

Condition	Explanation
TRS	Tracking-Reference Signal is configured.

– *CSI-SemiPersistentOnPUSCH-TriggerStateList*

**Table 4.6.3-46: CSI-SemiPersistentOnPUSCH-TriggerStateList**

Derivation Path: TS 38.331 [6], clause 6.3.2			
Information Element	Value/remark	Comment	Condition
CSI-SemiPersistentOnPUSCH-TriggerStateList ::= SEQUENCE {			
FFS			
}			

– *CSI-SSB-ResourceSet*

**Table 4.6.3-47: CSI-SSB-ResourceSet**

Derivation Path: TS 38.331 [6], clause 6.3.2			
Information Element	Value/remark	Comment	Condition
CSI-SSB-ResourceSet ::= SEQUENCE {			
csi-SSB-ResourceSetId	CSI-SSB-ResourceSetId		
csi-SSB-ResourceList SEQUENCE (SIZE (1..maxNrofCSI-SSB-ResourcePerSet)) OF SSB-Index {	1 entry		
SSB-Index[1]	SSB-Index	entry 1	
}			
}			

– *CSI-SSB-ResourceSetId***Table 4.6.3-48: CSI-SSB-ResourceSetId**

Derivation Path: TS 38.331 [6], clause 6.3.2			
Information Element	Value/remark	Comment	Condition
CSI-SSB-ResourceSetId	0		

**Table 4.6.3-48A: Void**– *DedicatedNAS-Message***Table 4.6.3-49: DedicatedNAS-Message**

Derivation Path: TS 38.331 [6], clause 6.3.2			
Information Element	Value/remark	Comment	Condition
DedicatedNAS-Message	Set according to specific message content		

– *DL-PPW-PreConfig***Table 4.6.3-49A: DL-PPW-PreConfig**

Derivation Path: TS 38.331 [6], clause 6.3.2			
Information Element	Value/remark	Comment	Condition
DL-PPW-PreConfig-r17 ::= SEQUENCE {			
FFS			
}			

– *DMRS-BundlingPUCCH-Config***Table 4.6.3-49B: DMRS-BundlingPUCCH-Config**

Derivation Path: TS 38.331 [6], clause 6.3.2			
Information Element	Value/remark	Comment	Condition
DMRS-BundlingPUCCH-Config-r17 ::= SEQUENCE {			
FFS			
}			

– *DMRS-BundlingPUSCH-Config***Table 4.6.3-49C: DMRS-BundlingPUSCH-Config**

Derivation Path: TS 38.331 [6], clause 6.3.2			
Information Element	Value/remark	Comment	Condition
DMRS-BundlingPUSCH-Config-r17 ::= SEQUENCE {			
FFS			
}			

– *DMRS-DownlinkConfig***Table 4.6.3-50: DMRS-DownlinkConfig**

Derivation Path: TS 38.331 [6], clause 6.3.2			
--	--	--	--

Information Element	Value/remark	Comment	Condition
DMRS-DownlinkConfig ::= SEQUENCE {			
dmrs-Type	Not present	DMRS type 1	
dmrs-AdditionalPosition	pos1		FR1
	pos0		FR2
maxLength	Not present	len1	
scramblingID0	Not present		
scramblingID1	Not present		
phaseTrackingRS	Not present		FR1
phaseTrackingRS CHOICE {			FR2
setup	PTRS-DownlinkConfig		
}			
}			

– *DMRS-UplinkConfig*

**Table 4.6.3-51: DMRS-UplinkConfig**

Derivation Path: TS 38.331 [6], clause 6.3.2			
Information Element	Value/remark	Comment	Condition
DMRS-UplinkConfig ::= SEQUENCE {			
dmrs-Type	Not present	DMRS type 1	
dmrs-AdditionalPosition	pos1		FR1
	pos0		FR2
phaseTrackingRS	Not present		
phaseTrackingRS CHOICE {			PTRS_UL_CONFIG
setup	PTRS-UplinkConfig		
}			
maxLength	Not present	len1	
transformPrecodingDisabled SEQUENCE {			
scramblingID0	Not present		
scramblingID1	Not present		
}			
transformPrecodingEnabled	Not present		
}			

Condition	Explanation
PTRS_UL_CONFIG	When PTRS Uplink is configured

– *DownlinkConfigCommon*

**Table 4.6.3-52: DownlinkConfigCommon**

Derivation Path: TS 38.331 [6], clause 6.3.2			
Information Element	Value/remark	Comment	Condition
DownlinkConfigCommon ::= SEQUENCE {			
frequencyInfoDL	FrequencyInfoDL		
initialDownlinkBWP	BWP-DownlinkCommon		
	BWP-DownlinkCommon with condition SCell_add		SCell_Add
}			

– *DownlinkConfigCommonSIB*

**Table 4.6.3-53: DownlinkConfigCommonSIB**

Derivation Path: TS 38.331 [6], clause 6.3.2			
Information Element	Value/remark	Comment	Condition

DownlinkConfigCommonSIB ::= SEQUENCE {			
frequencyInfoDL	FrequencyInfoDL-SIB		
initialDownlinkBWP	BWP-DownlinkCommon with condition InitialBWP_SIB		
	BWP-DownlinkCommon with condition PEI		PEI
bcch-Config SEQUENCE {			
modificationPeriodCoeff	n4		
}			
pcch-Config SEQUENCE {			
defaultPagingCycle	rf128		
nAndPagingFrameOffset CHOICE {			
halfT	0		
	1		PEI
}			
ns	one		
	two		PEI
firstPDCCH-MonitoringOccasionOfPO	Not present		
nrofPDCCH-MonitoringOccasionPerSSB-InPO-r16	Not present		
}			
pei-Config-r17	Not present		
pei-Config-r17 SEQUENCE {			PEI
po-NumPerPEI-r17	po2		
payloadSizeDCI-2-7-r17	22		
pei-FrameOffset-r17	3		
subgroupConfig-r17 SEQUENCE {			
subgroupsNumPerPO-r17	2		
subgroupsNumForUEID-r17	2		
}			
lastUsedCellOnly-r17	Not present		
}			
initialDownlinkBWP-RedCap-r17	Not present		
}			

Condition	Explanation
PEI	Paging Early Indication is configured in the cell.

– *DownlinkPreemption*

**Table 4.6.3-54: DownlinkPreemption**

Derivation Path: TS 38.331 [6], clause 6.3.2			
Information Element	Value/remark	Comment	Condition
DownlinkPreemption ::= SEQUENCE {			
FFS			
}			

– *DRB-Identity*

**Table 4.6.3-55: DRB-Identity**

Derivation Path: TS 38.331 [6], clause 6.3.2			
Information Element	Value/remark	Comment	Condition
DRB-Identity	n		DRBn

Condition	Explanation
DRBn	DRB-Identity n

– *DRX-Config***Table 4.6.3-56: DRX-Config**

Derivation Path: TS 38.331 [6], clause 6.3.2			
Information Element	Value/remark	Comment	Condition
DRX-Config ::= SEQUENCE {			
drx-onDurationTimer CHOICE {			
milliSeconds	ms6		
}			
drx-InactivityTimer	ms1280		
drx-HARQ-RTT-TimerDL	56		
drx-HARQ-RTT-TimerUL	56		
drx-RetransmissionTimerDL	sl16		FR1
	sl64		FR2
drx-RetransmissionTimerUL	sl16		FR1
	sl64		FR2
drx-LongCycleStartOffset CHOICE {			
ms10240	0		
}			
shortDRX	not present		
drx-SlotOffset	0		
}			

– *DRX-ConfigSecondaryGroup***Table 4.6.3-56A: DRX-ConfigSecondaryGroup**

Derivation Path: TS 38.331 [6], clause 6.3.2			
Information Element	Value/remark	Comment	Condition
DRX-ConfigSecondaryGroup-r16 ::= SEQUENCE {			
FFS			
}			

– *DRX-ConfigSL***Table 4.6.3-56B: DRX-ConfigSL**

Derivation Path: TS 38.331 [6], clause 6.3.2			
Information Element	Value/remark	Comment	Condition
RX-ConfigSL-r17 ::= SEQUENCE {			
FFS			
}			

– *EphemerisInfo***Table 4.6.3-56C: EphemerisInfo**

Derivation Path: TS 38.331 [6], clause 6.3.2			
Information Element	Value/remark	Comment	Condition
EphemerisInfo-r17 ::= CHOICE {			
positionVelocity-r17 SEQUENCE {			GSO
positionX-r17	-16976014		
positionY-r17	27636499		
positionZ-r17	0		
velocityVX-r17	0		
velocityVY-r17	0		
velocityVZ-r17	0		
}			
orbital-r17 SEQUENCE {			NGSO

semiMajorAxis-r17	FFS		
eccentricity-r17	FFS		
periapsis-r17	FFS		
longitude-r17	FFS		
inclination-r17	FFS		
meanAnomaly-r17	FFS		
}			
}			

Condition	Explanation
GSO	Geosynchronous Orbit scenario
NGSO	Non-geosynchronous Orbit scenario

– *FeatureCombination*

**Table 4.6.3-56D: FeatureCombination**

Derivation Path: TS 38.331 [6], clause 6.3.2			
Information Element	Value/remark	Comment	Condition
FeatureCombination-r17 ::= SEQUENCE {			
redCap-r17	Not present		
smallData-r17	Not present		
nsag-r17 SEQUENCE (SIZE (1..maxSliceInfo-r17)) OF NSAG-ID-r17{	n entries	n is the number of NSAG values associated with the preambles indicated in FeatureCombinationPreambles	Slice_RACH
NSAG-ID-r17[k, k=1..n]	Set to the corresponding NSAG value used in the test case	entry [k, k=1..n]	
}			
msg3-Repetitions-r17	Not present		
}			

Condition	Explanation
Slice_RACH	Slice specific RACH configuration

– *FeatureCombinationPreambles*

**Table 4.6.3-56E: FeatureCombinationPreambles**

Derivation Path: TS 38.331 [6], clause 6.3.2			
Information Element	Value/remark	Comment	Condition
FeatureCombinationPreambles-r17 ::= SEQUENCE {			
featureCombination-r17	FeatureCombination-r17		
startPreambleForThisPartition-r17	FFS		
numberOfPreamblesPerSSB-ForThisPartition-r17	FFS		
ssb-SharedRO-MaskIndex-r17	Not present		
groupBconfigured-r17	Not present		
separateMsgA-PUSCH-Config-r17	Not present		
msgA-RSRP-Threshold-r17	RSRP-Range		
rsrp-ThresholdSSB-r17	RSRP-Range		
deltaPreamble-r17	Not present		
}			

– *FilterCoefficient*

**Table 4.6.3-57: FilterCoefficient**

Derivation Path: TS 38.331 [6], clause 6.3.2			
Information Element	Value/remark	Comment	Condition
FilterCoefficient	fc4		

– *FreqBandIndicatorNR*

**Table 4.6.3-58: FreqBandIndicatorNR**

Derivation Path: TS 38.331 [6], clause 6.3.2			
Information Element	Value/remark	Comment	Condition
FreqBandIndicatorNR	Operating band of the frequency as specified in Table 4.4.2-1		
	Secondary band under test		CA-InterBand, NR-DC-SecondaryB and

Condition	Explanation
CA-InterBand	Used in CA interBand test cases
NR-DC-SecondaryBand	Used in NR-DC test cases

– *FreqPriorityListDedicatedSlicing*

**Table 4.6.3-58AA: FreqPriorityListDedicatedSlicing**

Derivation Path: TS 38.331 [6], clause 6.3.2			
Information Element	Value/remark	Comment	Condition
FreqPriorityDedicatedSlicing-r17 ::= SEQUENCE {			
FFS			
}			

– *FreqPriorityListSlicing*

**Table 4.6.3-58A: FreqPriorityListSlicing**

Derivation Path: TS 38.331 [6], clause 6.3.2			
Information Element	Value/remark	Comment	Condition
FreqPriorityListSlicing-r17 ::= SEQUENCE (SIZE (1..maxFreqPlus1)) OF FreqPrioritySlicing-r17 {	2 entries		
FreqPrioritySlicing-r17[1] SEQUENCE {		entry 1	
dl-ImplicitCarrierFreq-r17	1		
sliceInfoList-r17 SEQUENCE (SIZE (1..maxSliceInfo-r17)) OF SliceInfo-r17 {	1 entry		
SliceInfo-r17[1] SEQUENCE {		entry 1	
nsag-IdentityInfo-r17	NSAG-IdentityInfo		
nsag-CellReselectionPriority-r17	CellReselectionPriority		
nsag-CellReselectionSubPriority-r17	Not present		
sliceCellListNR-r17	Not present		
}			
}			
}			
FreqPrioritySlicing-r17[2] SEQUENCE {		entry 2	
dl-ImplicitCarrierFreq-r17	2		



sliceInfoList-r17 SEQUENCE (SIZE (1..maxSliceInfo-r17)) OF SliceInfo-r17 {	1 entry		
SliceInfo-r17[1] SEQUENCE {		entry 1	
nsag-IdentityInfo-r17	NSAG-IdentityInfo		
nsag-CellReselectionPriority-r17	CellReselectionPriority with condition Priority_5		
nsag-CellReselectionSubPriority-r17	Not present		
sliceCellListNR-r17	Not present		
}			
}			
}			
}			

– *FrequencyInfoDL*

**Table 4.6.3-59: FrequencyInfoDL**

Derivation Path: TS 38.331 [6], clause 6.3.2			
Information Element	Value/remark	Comment	Condition
FrequencyInfoDL ::= SEQUENCE {			
absoluteFrequencySSB	ARFCN-ValueNR with condition DL_SSB		
frequencyBandList	MultiFrequencyBandList NR		
absoluteFrequencyPointA	ARFCN-ValueNR with condition DL_PointA		
scs-SpecificCarrierList SEQUENCE (SIZE (1..maxSCSs)) OF SCS-SpecificCarrier {	1 entry		
SCS-SpecificCarrier[1]	SCS-SpecificCarrier with condition DL_PointA	entry 1	
}			
}			

– *FrequencyInfoDL-SIB*

**Table 4.6.3-60: FrequencyInfoDL-SIB**

Derivation Path: TS 38.331 [6], clause 6.3.2			
Information Element	Value/remark	Comment	Condition
FrequencyInfoDL-SIB ::= SEQUENCE {			
frequencyBandList	MultiFrequencyBandList NR-SIB		
offsetToPointA	For signalling test cases see subclause 6.2.3. Otherwise, see subclause 4.3.1.		
scs-SpecificCarrierList SEQUENCE (SIZE (1..maxSCSs)) OF SCS-SpecificCarrier {	1 entry		
SCS-SpecificCarrier[1]	SCS-SpecificCarrier with condition DL_PointA	entry 1	
}			
}			

– *FrequencyInfoUL*

**Table 4.6.3-61: FrequencyInfoUL**

Derivation Path: TS 38.331 [6], clause 6.3.2			
Information Element	Value/remark	Comment	Condition
FrequencyInfoUL ::= SEQUENCE {			

frequencyBandList	MultiFrequencyBandList NR		FDD
	Not present		TDD
absoluteFrequencyPointA	ARFCN-ValueNR with condition UL_PointA		FDD
	Not present		TDD
scs-SpecificCarriers SEQUENCE (SIZE (1..maxSCSs)) OF SCS-SpecificCarrier { SCS-SpecificCarrier1	1 entry		
	SCS-SpecificCarrier with condition UL_PointA	entry 1	
}			
additionalSpectrumEmission	AdditionalSpectrumEmission		
p-Max	P-Max		
frequencyShift7p5khz	Not present		
	true		DSS
}			

Condition	Explanation
DSS	Dynamic Spectrum Sharing

– *FrequencyInfoUL-SIB*

**Table 4.6.3-62: FrequencyInfoUL-SIB**

Derivation Path: TS 38.331 [6], clause 6.3.2			
Information Element	Value/remark	Comment	Condition
FrequencyInfoUL-SIB ::= SEQUENCE {			
frequencyBandList	MultiFrequencyBandList NR-SIB		FDD
	Not present		TDD
absoluteFrequencyPointA	ARFCN-ValueNR with condition UL_PointA		FDD
	Not present		TDD
scs-SpecificCarrierList SEQUENCE (SIZE (1..maxSCSs)) OF SCS-SpecificCarrier { SCS-SpecificCarrier[1]	1 entry		
	SCS-SpecificCarrier with condition UL_PointA	entry 1	
}			
p-Max	P-Max		
frequencyShift7p5khz	Not present		
	true		DSS
}			

– *GapPriority*

**Table 4.6.3-62AA: GapPriority**

Derivation Path: TS 38.331 [6], clause 6.3.2			
Information Element	Value/remark	Comment	Condition
GapPriority-r17	FFS		

– *HighSpeedConfig*

**Table 4.6.3-62A: HighSpeedConfig-r16**

Derivation Path: TS 38.331 [6], clause 6.3.2			
Information Element	Value/remark	Comment	Condition
HighSpeedConfig-r16 ::= SEQUENCE {			
highSpeedMeasFlag-r16	Not present		

highSpeedDemodFlag-r16	Not present		
}			

**Table 4.6.3-62B: HighSpeedConfig-v1700**

Derivation Path: TS 38.331 [6], clause 6.3.2			
Information Element	Value/remark	Comment	Condition
HighSpeedConfig-v1700 ::= SEQUENCE {			
highSpeedMeasCA-Scell-r17	Not present		
highSpeedMeasInterFreq-r17	Not present		
highSpeedDemodCA-Scell-r17	Not present		
}			

**Table 4.6.3-62C: HighSpeedConfigFR2**

Derivation Path: TS 38.331 [6], clause 6.3.2			
Information Element	Value/remark	Comment	Condition
HighSpeedConfigFR2-r17 ::= SEQUENCE {			
highSpeedMeasFlagFR2-r17	set2		
highSpeedDeploymentTypeFR2-r17	bidirectional		
highSpeedLargeOneStepUL-TimingFR2-r17	true		
}			

– *Hysteresis*

**Table 4.6.3-63: Hysteresis**

Derivation Path: TS 38.331 [6], clause 6.3.2			
Information Element	Value/remark	Comment	Condition
Hysteresis	4		

– *HysteresisLocation*

**Table 4.6.3-63AA: HysteresisLocation**

Derivation Path: TS 38.331 [6], clause 6.3.2			
Information Element	Value/remark	Comment	Condition
HysteresisLocation-r17	FFS		

– *InvalidSymbolPattern*

**Table 4.6.3-63A: InvalidSymbolPattern**

Derivation Path: TS 38.331 [6], clause 6.3.2			
Information Element	Value/remark	Comment	Condition
InvalidSymbolPattern-r16 ::= SEQUENCE {			
FFS			
}			

– *I-RNTI-Value*

**Table 4.6.3-64: I-RNTI-Value**

Derivation Path: TS 38.331 [6], clause 6.3.2			
Information Element	Value/remark	Comment	Condition

I-RNTI-Value	SS arbitrarily selects a value between '00 0000 0001'H and 'FF FFFF FFFF'H.	BIT STRING (SIZE(40))	
--------------	---	-----------------------	--

– *LBT-FailureRecoveryConfig*

**Table 4.6.3-64A: LBT-FailureRecoveryConfig**

Derivation Path: TS 38.331 [6], clause 6.3.2			
Information Element	Value/remark	Comment	Condition
LBT-FailureRecoveryConfig-r16 ::= SEQUENCE {			
lbt-FailureInstanceMaxCount-r16	n4		
lbt-FailureDetectionTimer-r16	ms80		
}			

– *LocationInfo*

**Table 4.6.3-64B: LocationInfo**

Derivation Path: TS 38.331 [6], clause 6.3.2			
Information Element	Value/remark	Comment	Condition
LocationInfo-r16 ::= SEQUENCE {			
commonLocationInfo-r16	CommonLocationInfo-r16		MDT_LocationInfo
bt-LocationInfo-r16	LogMeasResultListBT-r16		MDT_BT
wlan-LocationInfo-r16	LogMeasResultListWLAN-r16		MDT_WLAN
sensor-LocationInfo-r16	Sensor-LocationInfo-r16		MDT_Sensor
}			

Condition	Explanation
MDT_LocationInfo	Used for CommonLocationInfo included in MDT (Minimized Driving Test)
MDT_BT	Used for Bluetooth measurement in MDT (Minimized Driving Test) services
MDT_WLAN	Used for WLAN measurement in MDT (Minimized Driving Test) services
MDT_Sensor	Used for Sensor measurement in MDT (Minimized Driving Test) services

– *LocationMeasurementInfo*

**Table 4.6.3-65: LocationMeasurementInfo**

Derivation Path: TS 38.331 [6], clause 6.3.2			
Information Element	Value/remark	Comment	Condition
LocationMeasurementInfo ::= CHOICE {			
eutra-RSTD SEQUENCE (SIZE (1..maxInterRAT-RSTD-Freq)) OF EUTRA-RSTD-Info {	1 entry		
EUTRA-RSTD-Info[1] SEQUENCE {		entry 1	
carrierFreq	ARFCN-ValueEUTRA		
measPRS-Offset	FFS		
}			
}			
}			

– *LoggedMeasurementConfiguration*

**Table 4.6.3-65A: LoggedMeasurementConfiguration-v1700-IEs**

Derivation Path: TS 38.331 [6], clause 6.2.2			
Information Element	Value/remark	Comment	Condition

LoggedMeasurementConfiguration-v1700-IEs ::= SEQUENCE {			
sigLoggedMeasType-r17	Not present		
	true		SigLogMDT
earlyMeasIndication-r17	Not present		
	true		EarlyMeas
areaConfiguration-v1700	Not present		
nonCriticalExtension	Not present		
}			

Condition	Explanation
SigLogMDT	Signalling based logged measurements
EarlyMeas	Log measurements on early measurement

– *LogicalChannelConfig*

**Table 4.6.3-66: LogicalChannelConfig**

Derivation Path: TS 38.331 [6], clause 6.3.2			
Information Element	Value/remark	Comment	Condition
LogicalChannelConfig ::= SEQUENCE {			
ul-SpecificParameters SEQUENCE {			
priority	1		
	3		SRB2
prioritisedBitRate	infinity		
bucketSizeDuration	ms50		
allowedServingCells	Not present		
allowedSCS-List	Not present		
maxPUSCH-Duration	Not present		
configuredGrantType1Allowed	Not present		
logicalChannelGroup	1		HI
	2		LO
	0		SRB1, SRB2, SRB3
schedulingRequestID	SchedulingRequestID		
logicalChannelSR-Mask	false		
logicalChannelSR-DelayTimerApplied	false		
bitRateQueryProhibitTimer	Not present		
}			
}			

Condition	Explanation
HI	Used for DRBs with high logical channel priority
LO	Used for DRBs with low logical channel priority
SRB1	Establishment of SRB1
SRB2	Establishment of SRB2
SRB3	Establishment of SRB3

– *LogicalChannelIdentity*

**Table 4.6.3-67: LogicalChannelIdentity**

Derivation Path: TS 38.331 [6], clause 6.3.2			
Information Element	Value/remark	Comment	Condition
LogicalChannelIdentity	1		SRB1
LogicalChannelIdentity	2		SRB2
LogicalChannelIdentity	3		SRB3
LogicalChannelIdentity	n+3		DRBn
LogicalChannelIdentity	2m+18		MRBm AND PTP

LogicalChannelIdentity	2m+19		MRBm AND PTM
------------------------	-------	--	--------------

Condition	Explanation
SRB1	Establishment of SRB1
SRB2	Establishment of SRB2
SRB3	Establishment of SRB3
DRBn	Establishment of DRBn; n=1..16
MRBm	Establishment of MRBm; m = 1.. (16-n)
PTM	RLC entity is used for receiving PTM transmission
PTP	RLC entity is used for receiving PTP transmission

– *LTE-NeighCellsCRS-AssistInfoList*

**Table 4.6.3-67A: LTE-NeighCellsCRS-AssistInfoList**

Derivation Path: TS 38.331 [6], clause 6.3.2			
Information Element	Value/remark	Comment	Condition
LTE-NeighCellsCRS-AssistInfoList-r17 ::= SEQUENCE (SIZE (1..maxNrofCRS-IM-InterfCell-r17)) OF LTE-NeighCellsCRS-AssistInfo-r17 {			
FFS			
}			

– *MAC-CellGroupConfig*

**Table 4.6.3-68: MAC-CellGroupConfig**

Derivation Path: TS 38.331 [6], clause 6.3.2			
Information Element	Value/remark	Comment	Condition
MAC-CellGroupConfig ::= SEQUENCE {			
drx-Config	Not present		
drx-Config CHOICE {			DRX
setup	DRX-Config		
}			
schedulingRequestConfig	SchedulingRequestConfig		
bsr-Config	BSR-Config		
tag-Config	TAG-Config		
phr-Config CHOICE {			
setup	PHR-Config		
}			
skipUplinkTxDynamic	false		
csi-Mask	Not present		
dataInactivityTimer	Not present		
usePreBSR-r16	Not present		
schedulingRequestID-LBT-SCell-r16	Not present		
lch-BasedPrioritization-r16	Not present		
schedulingRequestID-BFR-SCell-r16	Not present		
drx-ConfigSecondaryGroup-r16	Not present		
enhancedSkipUplinkTxDynamic-r16	Not present		
enhancedSkipUplinkTxConfigured-r16	Not present		
intraCG-Prioritization-r17	Not present		
drx-ConfigSL-r17	Not present		
drx-ConfigExt-v1700	Not present		
schedulingRequestID-BFR-r17	Not present		
schedulingRequestID-BFR2-r17	Not present		
schedulingRequestConfig-v1700	Not present		
tar-Config-r17	Not present		
g-RNTI-ConfigToAddModList-r17	Not present		

g-RNTI-ConfigToAddModList-r17 SEQUENCE (SIZE (1..maxG-RNTI-r17)) OF MBS-RNTI-SpecificConfig-r17 {	1 entry		MBS_Multicast
MBS-RNTI-SpecificConfig-r17[1] SEQUENCE {		entry 1	
mbs-RNTI-SpecificConfigId-r17	0		
groupCommon-RNTI-r17 CHOICE {			
g-RNTI	RNTI-Value		
}			
drx-ConfigPTM-r17	Not present		
drx-ConfigPTM-r17 CHOICE {			DRX_MBS_Multicast
setup	DRX-ConfigPTM		
}			
harq-FeedbackEnablerMulticast-r17	Not present		
dcI-enabler			DCI
enabled			RRC_Enable_HARQFeedback
harq-FeedbackOptionMulticast-r17	Not present		
ack-nack			ACK_NACK
nack-only			NACK_ONLY
pdsch-AggregationFactor-r17	Not present		
}			
g-RNTI-ConfigToReleaseList-r17	Not present		
g-CS-RNTI-ConfigToAddModList-r17	Not present		
g-CS-RNTI-ConfigToReleaseList-r17	Not present		
allowCSI-SRS-Tx-MulticastDRX-Active-r17	Not present		
schedulingRequestID-PosMG-Request-r17	Not present		
drx-LastTransmissionUL-r17	Not present		
}			

Condition	Explanation
DRX	This condition applies when DRX is configured
MBS_Multicast	Used for MBS Multicast reception
DRX_MBS_Multicast	DRX is used for MBS Multicast reception test
DCI	HARQ feedback for MBS multicast is indicated by DCI
RRC_Enable_HARQFeedback	HARQ feedback for MBS multicast is enabled by RRC
ACK_NACK	ACK/NACK based HARQ-ACK feedback
NACK_ONLY	NACK-only based HARQ-ACK feedback

– *MeasConfig*

**Table 4.6.3-69: MeasConfig**

Derivation Path: TS 38.331 [6], clause 6.3.2			
Information Element	Value/remark	Comment	Condition
MeasConfig ::= SEQUENCE {			
measObjectToRemoveList	Not present		
measObjectToAddModList	MeasObjectToAddModList		
reportConfigToRemoveList	Not present		
reportConfigToAddModList	ReportConfigToAddModList		
measIdToRemoveList	Not present		
measIdToAddModList	MeasIdToAddModList		
s-MeasureConfig	Not present		
quantityConfig	QuantityConfig		
measGapConfig	Not present		
measGapSharingConfig	Not present		
}			

– *MeasGapConfig***Table 4.6.3-70: MeasGapConfig**

Derivation Path: TS 38.331 [6], clause 6.3.2			
Information Element	Value/remark	Comment	Condition
MeasGapConfig ::= SEQUENCE {			
gapFR2	Not present		
gapFR2 CHOICE {			GAP_FR2
setup SEQUENCE {			
gapOffset	159		
mgl	ms3dot5		
mgrp	ms160		
mgta	ms0		
}			
}			
gapFR1	Not present		
gapFR1 CHOICE {			GAP_FR1
setup SEQUENCE {			
gapOffset	39		
	9		SIG AND INTER-FREQ_ODD
mgl	ms6		
mgrp	ms40		
mgta	ms0		
refServCellIndicator	Not present		
refFR2ServCellAsyncCA-r16	Not present		
mgl-r16	Not present		
	ms10		PRS
}			
gapUE	Not present		GAP_FR1 OR GAP_FR2
gapUE CHOICE {			
setup SEQUENCE {			
gapOffset	39		
	9		SIG AND INTER-FREQ_ODD
mgl	ms6		
mgrp	ms40		
mgta	ms0		
refServCellIndicator	Not present		
refFR2ServCellAsyncCA-r16	Not present		
mgl-r16	Not present		
	ms10		PRS
}			
}			
gapToAddModList-r17	Not present		
gapToAddModList-r17 SEQUENCE (SIZE (1..maxNrofGapId-r17)) OF GapConfig-r17 {	1 entry		GAP_ADD
GapConfig-r17[1] SEQUENCE {			entry 1
measGapId-r17	MeasGapId		
gapType-r17	perUE		
gapOffset-r17	39		
mgl-r17	ms6		
mgrp-r17	ms40		
mgta-r17	ms0		
refServCellIndicator-r17	Not present		
refFR2-ServCellAsyncCA-r17	Not present		
preConfigInd-r17	Not present		
	true		Pre-config
ncsgInd-r17	Not present		
	true		NCSG



gapAssociationPRS-r17	Not present		
	true		PRS
gapSharing-r17	Not present		
gapPriority-r17	Not present		
}			
gapToReleaseList-r17	Not present		
gapToReleaseList-r17 SEQUENCE (SIZE (1..maxNrofGapId-r17)) OF MeasGapId-r17 {	1 entry		GAP_RELEASE
MeasGapId-r17[1]	1		entry 1
}			
posMeasGapPreConfigToAddModList-r17	Not present		
posMeasGapPreConfigToAddModList-r17 SEQUENCE (SIZE (1..maxNrofPreConfigPosGapId-r17)) OF PosGapConfig-r17 {	1 entry		PRS_GAP_ADD
PosGapConfig-r17[1] SEQUENCE {			entry 1
measPosPreConfigGapId-r17	1		
gapOffset-r17	39		
mgl-r17	ms6		
mgrp-r17	ms40		
mgtA-r17	ms0		
gapType-r17	perUE		
}			
posMeasGapPreConfigToReleaseList-r17	Not present		
posMeasGapPreConfigToReleaseList-r17 SEQUENCE (SIZE (1..maxNrofPreConfigPosGapId-r17)) OF MeasPosPreConfigGapId-r17 {	1 entry		PRS_GAP_RELEASE
MeasPosPreConfigGapId-r17[1]	1		entry 1
}			
}			

Condition	Explanation
GAP_FR1	Configuration for FR1 per-FR gaps
GAP_FR2	Configuration for FR2 per-FR gaps
INTER-FREQ_ODD	When the SFNoffset of inter frequency neighbour cell is odd number. SFNoffset is defined in TS 38.523-3 [23]Table 7.1.5.2-1
GAP_ADD	Addition or modification of measurement gaps
GAP_RELEASE	Release of measurement gaps
PRS	PRS measurement
PRS_GAP_ADD	Addition or modification of preconfigured measurement gap for positioning
PRS_GAP_RELEASE	Addition or modification of preconfigured measurement gap for positioning

– *MeasGapId*

**Table 4.6.3-70A: MeasGapId**

Derivation Path: TS 38.331 [6], clause 6.3.2			
Information Element	Value/remark	Comment	Condition
MeasGapId-r17	1		

– *MeasGapSharingConfig*

**Table 4.6.3-71: MeasGapSharingConfig**

Derivation Path: TS 38.331 [6], clause 6.3.2			
Information Element	Value/remark	Comment	Condition
MeasGapSharingConfig ::= SEQUENCE {			
gapSharingFR2	Not present		
}			

– *MeasId***Table 4.6.3-72: MeasId**

Derivation Path: TS 38.331 [6], clause 6.3.2			
Information Element	Value/remark	Comment	Condition
MeasId	1		

– *MeasIdleConfig***Table 4.6.3-72A: MeasIdleConfig**

Derivation Path: TS 38.331 [6], clause 6.3.2			
Information Element	Value/remark	Comment	Condition
MeasIdleConfigSIB-r16 ::= SEQUENCE {			
measIdleCarrierListNR-r16	Not present		
measIdleCarrierListNR-r16 SEQUENCE (SIZE (1..maxFreqIdle-r16)) OF MeasIdleCarrierNR-r16 {	The same number of entries as NR cells configured for measurements	Serving cell not included	EMR_NR_S IB4, EMR_NR_S IB11
MeasIdleCarrierNR-r16[n] SEQUENCE {		entry n	
carrierFreq-r16	ARFCN-ValueEUTRA		
ssbSubcarrierSpacing-r16	SubcarrierSpacing	Table 4.6.3-188	
frequencyBandList	Not present		
measCellListNR-r16	Not present		
reportQuantities-r16	both		
qualityThreshold-r16	Not present		
ssb-MeasConfig-r16	Not present		EMR_NR_S IB4
ssb-MeasConfig-r16 SEQUENCE {			EMR_NR_S IB11
nrofSS-BlocksToAverage-r16	2		
absThreshSS-BlocksConsolidation-r16 SEQUENCE {			
thresholdRSRP	RSRP-Range	Table 4.6.3-152	
thresholdRSRQ	Not present		
thresholdSINR	Not present		
}			
smtc-r16	SSB-MTC	Table 4.6.3-185	
ssb-ToMeasure-r16	SSB-ToMeasure	Table 4.6.3-187	
deriveSSB-IndexFromCell-r16	false		
	true		FR1_TDD, FR2_TDD
ss-RSSI-Measurement-r16	Not present		
}			
beamMeasConfigIdle-r16	Not present		
}			
measIdleCarrierListEUTRA-r16	Not present		
measIdleCarrierListEUTRA-r16 SEQUENCE (SIZE (1..maxFreqIdle-r16)) OF MeasIdleCarrierEUTRA-r16 {	The same number of entries as E-UTRA cells configured for measurements	Serving cell not included	EMR_EUTR A_SIB11
MeasIdleCarrierEUTRA-r16[n] SEQUENCE {		entry n	
carrierFreqEUTRA-r16	ARFCN-ValueEUTRA		
allowedMeasBandwidth-r16	EUTRA-AllowedMeasBandwidth	Table 4.6.5-1.	
measCellListEUTRA-r16 SEQUENCE (SIZE (1..maxCellMeasIdle-r16)) OF EUTRA-PhysCellIdRange {	1 entry		

EUTRA-PhysCellIdRange	EUTRA-PhysCellIdRange	entry 1	
}			
reportQuatitiesEUTRA-r16	both		
qualityThresholdEUTRA-r16	Not present		
}			
}			
}			

Condition	Explanation
EMR_NR_SIB4	FFS
EMR_NR_SIB11	FFS

– *MeasIdToAddModList*

**Table 4.6.3-73: MeasIdToAddModList**

Derivation Path: TS 38.331 [6], clause 6.3.2			
Information Element	Value/remark	Comment	Condition
MeasIdToAddModList ::= SEQUENCE (SIZE (1..maxNrofMeasId)) OF MeasIdToAddMod {	1 entry		
MeasIdToAddMod[1] SEQUENCE {		entry 1	
measId	MeasId		
measObjectId	MeasObjectId		
reportConfigId	ReportConfigId		
}			

– *MeasObjectCLI*

**Table 4.6.3-73A: MeasObjectCLI**

Derivation Path: TS 38.331 [6], clause 6.3.2			
Information Element	Value/remark	Comment	Condition
MeasObjectCLI-r16 ::= SEQUENCE {			
FFS			
}			

– *MeasObjectEUTRA*

**Table 4.6.3-74: MeasObjectEUTRA**

Derivation Path: TS 38.331 [6], clause 6.3.2			
Information Element	Value/remark	Comment	Condition
MeasObjectEUTRA ::= SEQUENCE {			
carrierFreq	Downlink EARFCN for Freq		
allowedmeasBandwidth	Set according to TS 36.508 [2] Table 4.4.3.4-1 for E-UTRA cell	row 'measurement Bandwidth'	
cellsToRemoveListEUTRAN	Not present		
cellsToAddModListEUTRAN	Not present		
excludedCellsToRemoveListEUTRAN	Not present		
excludedCellsToAddModListEUTRAN	Not present		
eutra-PresenceAntennaPort1	false		
	true	at least two cell-specific antenna ports are used in all neighbouring cells	All neighCells with port1
eutra-Q-OffsetRange	Not present		

widebandRSRQ-Meas	false		
}			

Condition	Explanation
All neighCells with port1	Used for all neighbouring cells with at least two cell-specific antenna ports

– *MeasObjectId*

**Table 4.6.3-75: *MeasObjectId***

Derivation Path: TS 38.331 [6], clause 6.3.2			
Information Element	Value/remark	Comment	Condition
MeasObjectId	1		

– *MeasObjectNR*

**Table 4.6.3-76: *MeasObjectNR(Thres)***

Derivation Path: TS 38.331 [6], clause 6.3.2			
Information Element	Value/remark	Comment	Condition
MeasObjectNR ::= SEQUENCE {			
ssbFrequency	ARFCN-ValueNR with condition DL_SSB		
ssbSubcarrierSpacing	SubcarrierSpacing		
smtc1	SSB-MTC		
smtc2	Not present		
refFreqCSI-RS	Not present		
referenceSignalConfig SEQUENCE {			
ssb-ConfigMobility SEQUENCE {			
ssb-ToMeasure CHOICE {			
setup	SSB-ToMeasure		
}			
deriveSSB-IndexFromCell	false		FDD
	true		TDD
ssb-PositionQCL-Common-r16	Not present		
	SSB-PositionQCL-Relation		SharedSpec trum
ssb-PositionQCL-CellsToAddModList-r16	Not present		
ssb-PositionQCL-CellsToRemoveList-r16	Not present		
ss-RSSI-Measurement	Not present		
}			
csi-rs-ResourceConfigMobility	Not present		
}			
absThreshSS-BlocksConsolidation SEQUENCE {			
thresholdRSRP	Thres	Thres is an entry value into a mapping table in TS 38.133 [13].	
thresholdRSRQ	Not present		
thresholdSINR	Not present		
}			
absThreshCSI-RS-Consolidation	Not present		
nrofSS-BlocksToAverage	2		
nrofCSI-RS-ResourcesToAverage	Not present		
quantityConfigIndex	1		
offsetMO SEQUENCE {			
rsrpOffsetSSB	dB0		
rsrqOffsetSSB	dB0		
sinrOffsetSSB	dB0		
rsrpOffsetCSI-RS	dB0		

rsrqOffsetCSI-RS	dB0		
sinrOffsetCSI-RS	dB0		
}			
cellsToRemoveList	Not present		
cellsToAddModList	Not present		
excludedCellsToRemoveList	Not present		
excludedCellsToAddModList	Not present		
allowedCellsToRemoveList	Not present		
allowedCellsToAddModList	Not present		
freqBandIndicatorNR	FreqBandIndicatorNR		
rmtc-Config-r16	Not present		
	RMTC-Config		SharedSpec trum
}			

Condition	Explanation
SharedSpectrum	Operation with shared spectrum channel access

– *MeasObjectNR-SL*

**Table 4.6.3-76A: MeasObjectNR-SL**

Derivation Path: TS 38.331 [6], clause 6.3.2			
Information Element	Value/remark	Comment	Condition
MeasObjectNR-SL-r16 ::= SEQUENCE {			
tx-PoolMeasToRemoveList-r16	Not present		
tx-PoolMeasToAddModList-r16 SEQUENCE (SIZE (1..maxNrofSL-PoolToMeasureNR-r16)) OF SL-ResourcePoolID-r16{	1 entry		
SL-ResourcePoolID-r16[1]	1	entry 1	
}			
}			

– *MeasObjectRxTxDiff*

**Table 4.6.3-76B: MeasObjectRxTxDiff**

Derivation Path: TS 38.331 [6], clause 6.3.2			
Information Element	Value/remark	Comment	Condition
MeasObjectRxTxDiff-r17 ::= SEQUENCE {			
dl-Ref-r17 CHOICE {			
prs-Ref-r17	NULL		PRS_REF
csi-RS-Ref-r17	NULL		CSI- RS_REF
}			

Condition	Explanation
PRS_REF	Test cases using PRS reference signal to measure Rx-Tx time difference
CSI-RS_REF	Test cases using CSI-RS for tracking to measure Rx-Tx time difference

– *MeasObjectToAddModList*

**Table 4.6.3-77: MeasObjectToAddModList**

Derivation Path: TS 38.331 [6], clause 6.3.2			
Information Element	Value/remark	Comment	Condition
MeasObjectToAddModList ::= SEQUENCE (SIZE (1..maxNrofMeasId)) OF MeasObjectToAddMod {	1 entry		

MeasObjectToAddMod[1] SEQUENCE {		entry 1	
measObjectId	MeasObjectId		
measObject CHOICE {			
measObjectNR	MeasObjectNR		
}			
}			
MeasObjectToAddModList ::= SEQUENCE (SIZE (1..maxNrofMeasId)) OF MeasObjectToAddMod {	2 entries		InterRAT
MeasObjectToAddMod[1] SEQUENCE {		entry 1	
measObjectId	1		
measObject CHOICE {			
measObjectNR	MeasObjectNR		
}			
}			
MeasObjectToAddMod[2] SEQUENCE {		entry 2	
measObjectId	2		
measObject CHOICE {			
measObjectEUTRA	MeasObjectEUTRA		
}			
}			
}			
}			

Condition	Explanation
InterRAT	Configuration with at least one NR PCell and one or more E-UTRA neighbour cell(s)

– *MeasObjectUTRA-FDD*

**Table 4.6.3-77A: MeasObjectUTRA-FDD**

Derivation Path: TS 38.331 [6], clause 6.3.2			
Information Element	Value/remark	Comment	Condition
MeasObjectUTRA-FDD-r16 ::= SEQUENCE {			
carrierFreq-r16	ARFCN-ValueUTRA-FDD-r16		
utra-FDD-Q-OffsetRange-r16	UTRA-FDD-Q-OffsetRange-r16		
cellsToRemoveList-r16	Not present		
cellsToAddModList-r16	Not present		
}			

– *MeasResultCellListSFTD-NR*

**Table 4.6.3-78: MeasResultCellListSFTD-NR**

Derivation Path: TS 38.331 [6], clause 6.3.2			
Information Element	Value/remark	Comment	Condition
MeasResultCellListSFTD-NR ::= SEQUENCE {			
FFS			
}			

– *MeasResultCellListSFTD-EUTRA*

**Table 4.6.3-78A: MeasResultCellListSFTD-EUTRA**

Derivation Path: TS 38.331 [6], clause 6.3.2			
Information Element	Value/remark	Comment	Condition
MeasResultCellListSFTD-EUTRA ::= SEQUENCE {			
FFS			

}			
---	--	--	--

– *MeasResultForRSSI*

**Table 4.6.3-78AA: MeasResultForRSSI**

Derivation Path: TS 38.331 [6], clause 6.3.2			
Information Element	Value/remark	Comment	Condition
MeasResultForRSSI ::= SEQUENCE {			
rssi-Result-r16	FFS		
channelOccupancy-r16	FFS		
}			

– *MeasResults*

**Table 4.6.3-79: MeasResults**

Derivation Path: TS 38.331 [6], clause 6.3.2			
Information Element	Value/remark	Comment	Condition
MeasResults ::= SEQUENCE {			
measId	MeasId		
measResultServingMOList	Not checked		SFTD_NEIG HBOUR or SFTD_PSC ELL
measResultServingMOList SEQUENCE (SIZE (1.. maxNrofServingCells)) OF MeasResultServMO {	1 entry		
MeasResultServMO[1] SEQUENCE {		entry 1	
servCellId	ServCellIndex		
measResultServingCell SEQUENCE {			
physCellId	PhysCellId		
measResult SEQUENCE {			
cellResults SEQUENCE {			
resultsSSB-Cell SEQUENCE {			
rsrp	Not checked		
rsrq	Not checked		
sinr	Not checked		
}			
resultsCSI-RS-Cell	Not present		
}			
rsIndexResults	Not present		
}			
cgi-Info	Not present		
}			
measResultBestNeighCell	Not present		
}			
measResultNeighCells	Not present		A1, A2, SFTD_NEIG HBOUR or SFTD_PSC ELL, SFTD_EUT RA
measResultNeighCells CHOICE {			
measResultListNR	Set according to specific message content		A3, A4, A5, A6
measResultListEUTRA	Set according to specific message content		B1, B2
measResultListUTRA-FDD-r16	Set according to specific message content		B1_UTRA, B2_UTRA
}			

measResultServFreqListEUTRA-SCG	Not present		
measResultServFreqListNR-SCG	Not checked		
measResultSFTD-EUTRA	Not present		
measResultSFTD-EUTRA SEQUENCE {			SFTD_EUTRA
eutra-PhysCellId	PhysCellId of E-UTRA Cell 1		
sfn-OffsetResult	(0..1023)		
frameBoundaryOffsetResult	(-30720..30719)		
rsrp-Result	Not checked		
}			
measResultSFTD-NR	Not present		
measResultSFTD-NR SEQUENCE {			SFTD_PSCCELL
physCellId	PhysCellId of PSCell		
sfn-OffsetResult	Not checked		
frameBoundaryOffsetResult	Not checked		
rsrp-Result	Not checked		
}			
measResultCellListSFTD-NR	Not present		
measResultCellListSFTD-NR SEQUENCE (SIZE (1..maxCellSFTD)) OF MeasResultCellSFTD-NR {	1 entry		SFTD_NEIGHBOUR
MeasResultCellSFTD-NR[1] SEQUENCE {		entry 1	
physCellId	PhysCellId		
sfn-OffsetResult	Not checked		
frameBoundaryOffsetResult	Not checked		
rsrp-Result	Not checked		
}			
}			
measResultForRSSI-r16	Not present		
	MeasResultForRSSI		SharedSpectrum
locationInfo-r16	Not present		
ul-PDCP-DelayValueResultList-r16	Not present		
measResultsSL-r16	Not present		
measResultCLI-r16	Not present		
}			

Condition	Explanation
A1	If event trigger Id in corresponding Measurement Configuration was Event A1
A2	If event trigger Id in corresponding Measurement Configuration was Event A2
A3	If event trigger Id in corresponding Measurement Configuration was Event A3
A4	If event trigger Id in corresponding Measurement Configuration was Event A4
A5	If event trigger Id in corresponding Measurement Configuration was Event A5
A6	If event trigger Id in corresponding Measurement Configuration was Event A6
B1	If event trigger Id in corresponding Measurement Configuration was Event B1
B2	If event trigger Id in corresponding Measurement Configuration was Event B2
B1_UTRA	If event trigger Id in corresponding Measurement Configuration was Event B1-UTRA-FDD
B2_UTRA	If event trigger Id in corresponding Measurement Configuration was Event B2-UTRA-FDD
SFTD_NEIGHBOUR	Measurement reporting triggered by SFTD measurement on NR neighbour
SFTD_PSCCELL	Measurement reporting triggered by SFTD measurement on NR PSCell
SharedSpectrum	Operation with shared spectrum channel access
SFTD-EUTRA	Measurement reporting triggered by SFTD measurement on E-UTRA PSCell

– *MeasResult2EUTRA*

**Table 4.6.3-79A: *MeasResult2EUTRA***

Derivation Path: TS 38.331 [6], clause 6.3.2



Information Element	Value/remark	Comment	Condition
MeasResult2EUTRA ::= SEQUENCE {			
FFS			
}			

– *MeasResult2NR*

**Table 4.6.3-79B: *MeasResult2NR***

Derivation Path: TS 38.331 [6], clause 6.3.2			
Information Element	Value/remark	Comment	Condition
MeasResult2NR ::= SEQUENCE {			
FFS			
}			

– *MeasResultIdleEUTRA*

**Table 4.6.3-79C: *MeasResultIdleEUTRA***

Derivation Path: TS 38.331 [6], clause 6.3.2			
Information Element	Value/remark	Comment	Condition
MeasResultIdleEUTRA-r16 ::= SEQUENCE {			
FFS			
}			

– *MeasResultIdleNR*

**Table 4.6.3-79D: *MeasResultIdleNR***

Derivation Path: TS 38.331 [6], clause 6.3.2			
Information Element	Value/remark	Comment	Condition
MeasResultIdleNR-r16 ::= SEQUENCE {			
FFS			
}			

– *MeasResultRxTxTimeDiff*

**Table 4.6.3-79E: *MeasResultRxTxTimeDiff***

Derivation Path: TS 38.331 [6], clause 6.3.2			
Information Element	Value/remark	Comment	Condition
MeasResultRxTxTimeDiff-r17 ::= SEQUENCE {			
rxTxTimeDiff-ue-r17 SEQUENCE {			
result-k5-r17	INTEGER (0..61565)	Integer value for result-k5 measurements	
}			
}			

– *MeasResultSCG-Failure*

**Table 4.6.3-80: *MeasResultSCG-Failure***

Derivation Path: TS 38.331 [6], clause 6.3.2			
Information Element	Value/remark	Comment	Condition

MeasResultSCG-Failure ::= SEQUENCE {		<i>measResultPerMOList</i> for each <i>MeasObjectNR</i> for which a <i>measId</i> is configured (by the NR <i>RRCConfiguration</i> message) and measurement results are available include an entry	
<i>measResultPerMOList</i> SEQUENCE (SIZE (1.. <i>maxFreq</i> )) OF <i>MeasResult2NR</i> {	<i>n</i> entries of <i>MeasResult2NR</i>	MOList [1]  <i>n</i> denotes the number of non-serving frequencies being measured	
<i>MeasResult2NR</i> [1] SEQUENCE {		entry 1	
<i>ssbFrequency</i>	ARFCN-ValueNR with condition DL_SSB	the ARFCN if there is a <i>measId</i> configured with the <i>MeasObjectNR</i> and a <i>reportConfig</i> which has <i>rsType</i> set to <i>ssb</i>	
<i>refFreqCSI-RS</i>	INTEGER (0..3279165)	the ARFCN if there is a <i>measId</i> configured with the <i>MeasObjectNR</i> and a <i>reportConfig</i> which has <i>rsType</i> set to <i>csi-rs</i>	
<i>measResultServingCell</i> SEQUENCE {		if a serving cell is associated with the <i>MeasObjectNR</i>	
<i>physCellId</i>	INTEGER (0..1007)	the <i>physCellId</i> configured for this serving cell	
<i>measResult</i> SEQUENCE {			
<i>cellResults</i> SEQUENCE {			
<i>resultsSSB-Cell</i> SEQUENCE {			
<i>rsrp</i>	as specified in Table 4.6.3-152	Integer value for RSRP measurements	
<i>rsrq</i>	as specified in Table 4.6.3-153	Integer value for RSRQ measurements	
<i>sinr</i>	as specified in Table 4.6.3-172	Integer value for SINR measurements	
}			
<i>resultsCSI-RS-Cell</i> SEQUENCE {			
<i>rsrp</i>	as specified in Table 4.6.3-152	Integer value for RSRP measurements	
<i>rsrq</i>	as specified in Table 4.6.3-153	Integer value for RSRQ measurements	

sinr	as specified in Table 4.6.3-172	Integer value for SINR measurements	
}			
}			
rsIndexResults SEQUENCE {			
resultsSSB-Indexes SEQUENCE (SIZE (1..maxNrofSSBs)) OF ResultsPerSSB-Index {	<i>n</i> entires of ResultsPerSSB-Index	<i>ResultsPerSSB-IndexList</i>	
ResultsPerSSB-Index[1] SEQUENCE {		entry 1	
ssb-Index	SSB-Index	an SS-Block within an SS-Burst	
}		<i>MeasQuantityResults</i>	
}			
rsrp	as specified in Table 4.6.3-152	Integer value for RSRP measurements	
rsrq	as specified in Table 4.6.3-153	Integer value for RSRQ measurements	
sinr	as specified in Table 4.6.3-172	Integer value for SINR measurements	
}			
}			
		<i>ResultsPerSSB-Index</i> entry [x] if any	
}			
resultsCSI-RS-Indexes SEQUENCE (SIZE (1..maxNrofCSI-RS)) OF ResultsPerCSI-RS-Index {	<i>n</i> entires of ResultsPerCSI-RS-Index	<i>ResultsPerCSI-RS-IndexList</i>	
ResultsPerCSI-RS-Index[1] SEQUENCE {		entry 1	
csi-RS-Index	INTEGER (0..maxNrofCSI-RS-ResourcesRRM-1)	CSI-RS resource index associated to the measurement information to be reported	
}		<i>MeasQuantityResults</i>	
csi-RS-Results SEQUENCE {			
rsrp	as specified in Table 4.6.3-152	Integer value for RSRP measurements	
rsrq	as specified in Table 4.6.3-153	Integer value for RSRQ measurements	
sinr	as specified in Table 4.6.3-172	Integer value for SINR measurements	
}			
}			
		<i>ResultsPerCSI-RS-Index</i> entry [x] if any	
}			
}			
}			
}			
measResultNeighCellListNR SEQUENCE (SIZE (1..maxCellReport)) OF MeasResultNR {	<i>n</i> entires of MeasResultNR	include the best measured cells, ordered such that the best cell is listed first, and based on measurements collected up to the moment the UE	

		detected the failure	
MeasResultNR[1] SEQUENCE {		entry 1	
physCellId	INTEGER (0..1007)	the <i>physCellId</i> configured for the measured cell	
measResult SEQUENCE {			
cellResults SEQUENCE {			
resultsSSB-Cell SEQUENCE {			
rsrp	as specified in Table 4.6.3-152	Integer value for RSRP measurements	
rsrq	as specified in Table 4.6.3-153	Integer value for RSRQ measurements	
sinr	as specified in Table 4.6.3-172	Integer value for SINR measurements	
}			
resultsCSI-RS-Cell SEQUENCE {			
rsrp	as specified in Table 4.6.3-152	Integer value for RSRP measurements	
rsrq	as specified in Table 4.6.3-153	Integer value for RSRQ measurements	
sinr	as specified in Table 4.6.3-172	Integer value for SINR measurements	
}			
}			
}			
}			
}			
}		<i>MeasResultNR</i> entry [x] if any	
}			
}		<i>MeasResult2NR</i> entry [x] if any	
}			
}		MOList [x] if any	
}			
}			
}			

– *MeasResultsSL*

**Table 4.6.3-80A: *MeasResultsSL***

Derivation Path: TS 38.331 [6], clause 6.3.2			
Information Element	Value/remark	Comment	Condition
MeasResultsSL-r16 ::= SEQUENCE {			
measResultsListSL-r16 CHOICE {			
measResultNR-SL-r16 SEQUENCE {			
measResultListCBR-NR-r16 SEQUENCE (SIZE (1.. maxNrofSL-PoolToMeasureNR-r16)) OF MeasResultCBR-NR-r16 {	1 entry		
MeasResultCBR-NR-r16[1] SEQUENCE {		entry 1	
sl-poolReportIdentity-r16	1		
sl-CBR-ResultsNR-r16	(0..100)		
}			
}			
}			
}			
}			
}			
}			
}			

– *MeasRSSI-ReportConfig***Table 4.6.3-80AA: MeasRSSI-ReportConfig**

Derivation Path: TS 38.331 [6], clause 6.3.2			
Information Element	Value/remark	Comment	Condition
MeasRSSI-ReportConfig-r16 ::= SEQUENCE {			
channelOccupancyThreshold-r16	FFS		
}			

– *MeasTriggerQuantityEUTRA***Table 4.6.3-80B: MeasTriggerQuantityEUTRA**

Derivation Path: TS 38.331 [6], clause 6.3.2			
Information Element	Value/remark	Comment	Condition
MeasTriggerQuantityEUTRA-r16 ::= SEQUENCE {			
FFS			
}			

– *MobilityStateParameters***Table 4.6.3-81: MobilityStateParameters**

Derivation Path: TS 38.331 [6], clause 6.3.2			
Information Element	Value/remark	Comment	Condition
MobilityStateParameters ::= SEQUENCE {			
FFS			
}			

– *MRB-Identity***Table 4.6.3-81AA: MRB-Identity**

Derivation Path: TS 38.331 [6], clause 6.3.2			
Information Element	Value/remark	Comment	Condition
MRB-Identity-r17	m		MRBm

Condition	Explanation
MRBm	Establishment of MRBm

– *MsgA-ConfigCommon***Table 4.6.3-81A: MsgA-ConfigCommon**

Derivation Path: TS 38.331 [6], clause 6.3.2			
Information Element	Value/remark	Comment	Condition
MsgA-ConfigCommonL-r16 ::= SEQUENCE {			
rach-ConfigCommonTwoStepRA-r16	RACH-ConfigCommonTwoStepRA		
msgA-PUSCH-Config-r16	MsgA-PUSCH-Config		
}			

– *MsgA-PUSCH-Config***Table 4.6.3-81B: MsgA-PUSCH-Config**

Derivation Path: TS 38.331 [6], clause 6.3.2			
Information Element	Value/remark	Comment	Condition
MsgA-PUSCH-Config-r16 ::= SEQUENCE {			
MsgA-PUSCH-Resource-r16 SEQUENCE {			
msgA-MCS-r16	1		
nrofSlotsMsgA-PUSCH-r16	1		
nrofMsgA-PO-PerSlot-r16	one		
msgA-PUSCH-TimeDomainOffset-r16	4		
msgA-PUSCH-TimeDomainAllocation-r16	Not present		
startSymbolAndLengthMsgA-PO-r16	32		
mappingTypeMsgA-PUSCH-r16	typeA		
guardPeriodMsgA-PUSCH-r16	0		
guardBandMsgA-PUSCH-r16	0		
frequencyStartMsgA-PUSCH-r16	1		
nrofPRBs-PerMsgA-PO-r16	1		
nrofMsgA-PO-FDM-r16	one		
msgA-IntraSlotFrequencyHopping-r16	Not present		
msgA-HoppingBits-r16	Not present		
MsgA-DMRS-Config-r16 SEQUENCE {			
msgA-DMRS-AdditionalPosition-r16	pos0		
msgA-MaxLength-r16	Len2		
msgA-PUSCH-DMRS-CDM-Group-r16	0		
msgA-PUSCH-NrofPorts-r16	0		
msgA-ScramblingID0-r16	Not present		
msgA-ScramblingID1-r16	Not present		
}			
nrofDMRS-Sequences-r16	1		
msgA-Alpha-r16	alpha0		
interlaceIndexFirstPO-MsgA-PUSCH-r16	1		
nrofInterlacesPerMsgA-PO-r16	1		
}			
msgA-PUSCH-ResourceGroupB-r16	Not present		
msgA-TransformPrecoder-r16	enabled		
msgA-DataScramblingIndex-r16	Not present		
msgA-DeltaPreamble-r16	1		
}			

– *MultiFrequencyBandListNR***Table 4.6.3-82: MultiFrequencyBandListNR**

Derivation Path: TS 38.331 [6], clause 6.3.2			
Information Element	Value/remark	Comment	Condition
MultiFrequencyBandListNR ::= SEQUENCE (SIZE (1..maxNrofMultiBands)) OF FreqBandIndicatorNR {	1 entry		
FreqBandIndicatorNR[1]	FreqBandIndicatorNR	entry 1	
}			

– *MultiFrequencyBandListNR-SIB***Table 4.6.3-82A: MultiFrequencyBandListNR-SIB**

Derivation Path: TS 38.331 [6], clause 6.3.2			
Information Element	Value/remark	Comment	Condition
MultiFrequencyBandListNR-SIB ::= SEQUENCE (SIZE (1.. maxNrofMultiBands)) OF NR-MultiBandInfo {	1 entry		
NR-MultiBandInfo[1] SEQUENCE {		entry 1	

freqBandIndicatorNR	FreqBandIndicatorNR		
nr-NS-PmaxList	NR-NS-PmaxList		
}			
}			

– *MUSIM-GapConfig*

**Table 4.6.3-82BA: *MUSIM-GapConfig***

Derivation Path: TS 38.331 [6], clause 6.3.2			
Information Element	Value/remark	Comment	Condition
MUSIM-GapConfig-r17 ::= SEQUENCE {			
FFS			
}			

– *MUSIM-GapId*

**Table 4.6.3-82BB: *MUSIM-GapId***

Derivation Path: TS 38.331 [6], clause 6.3.2			
Information Element	Value/remark	Comment	Condition
MUSIM-GapId-r17	FFS		

– *MUSIM-GapInfo*

**Table 4.6.3-82BC: *MUSIM-GapInfo***

Derivation Path: TS 38.331 [6], clause 6.3.2			
Information Element	Value/remark	Comment	Condition
MUSIM-GapInfo-r17 ::= SEQUENCE {			
FFS			
}			

– *NeedForGapsConfigNR*

**Table 4.6.3-82B: *NeedForGapsConfigNR***

Derivation Path: TS 38.331 [6], clause 6.3.2			
Information Element	Value/remark	Comment	Condition
NeedForGapsConfigNR-r16 ::= SEQUENCE {			
FFS			
}			

– *NeedForGapsInfoNR*

**Table 4.6.3-82C: *NeedForGapsInfoNR***

Derivation Path: TS 38.331 [6], clause 6.3.2			
Information Element	Value/remark	Comment	Condition
NeedForGapsInfoNR-r16 ::= SEQUENCE {			
FFS			
}			

– *NeedForGapNCSG-ConfigEUTRA***Table 4.6.3-82D: NeedForGapNCSG-ConfigEUTRA**

Derivation Path: TS 38.331 [6], clause 6.3.2			
Information Element	Value/remark	Comment	Condition
NeedForGapNCSG-ConfigEUTRA-r17 ::= SEQUENCE {			
FFS			
}			

– *NeedForGapNCSG-ConfigNR***Table 4.6.3-82E: NeedForGapNCSG-ConfigNR**

Derivation Path: TS 38.331 [6], clause 6.3.2			
Information Element	Value/remark	Comment	Condition
NeedForGapNCSG-ConfigNR-r17 ::= SEQUENCE {			
FFS			
}			

– *NeedForGapNCSG-InfoEUTRA***Table 4.6.3-82F: NeedForGapNCSG-InfoEUTRA**

Derivation Path: TS 38.331 [6], clause 6.3.2			
Information Element	Value/remark	Comment	Condition
NeedForGapNCSG-InfoEUTRA-r17 ::= SEQUENCE {			
FFS			
}			

– *NeedForGapNCSG-InfoNR***Table 4.6.3-82G: NeedForGapNCSG-InfoNR**

Derivation Path: TS 38.331 [6], clause 6.3.2			
Information Element	Value/remark	Comment	Condition
NeedForGapNCSG-InfoNR-r17 ::= SEQUENCE {			
FFS			
}			

– *NextHopChainingCount***Table 4.6.3-83: NextHopChainingCount**

Derivation Path: TS 38.331 [6], clause 6.3.2			
Information Element	Value/remark	Comment	Condition
NextHopChainingCount	0		

– *NG-5G-S-TMSI***Table 4.6.3-84: NG-5G-S-TMSI**

Derivation Path: TS 38.331 [6], clause 6.3.2			
Information Element	Value/remark	Comment	Condition



NG-5G-S-TMSI	Set to the value of the NG-5G-S-TMSI of the UE	BIT STRING (SIZE(40))	
--------------	--	-----------------------	--

– *NonCellDefiningSSB*

**Table 4.6.3-84AAA: NonCellDefiningSSB**

Derivation Path: TS 38.331 [6], clause 6.3.2			
Information Element	Value/remark	Comment	Condition
NonCellDefiningSSB-r17 ::= SEQUENCE {			
FFS			
}			

– *NPN-Identity*

**Table 4.6.3-84AA: NPN-Identity**

Derivation Path: TS 38.331 [6], clause 6.3.2			
Information Element	Value/remark	Comment	Condition
NPN-Identity-r16 ::= CHOICE {			
pni-npn-r16 SEQUENCE {			CAG
plmn-identity-r16	PLMN-Identity		
cag-identityList-r16 SEQUENCE (SIZE (1..maxNPN-r16)) OF CAG-IdentityInfo-r16 {	1 entry		
cag-identity-r16[1]	1	cag-identity is coded as a 32 bit BITSTRING	
manualCAGselectionAllowed-r16	true		
}			
snpn-r16 SEQUENCE {			SNPN
plmn-identity-r16	PLMN-Identity		
nid-List-r16 SEQUENCE (SIZE (1..maxNPN-r16)) OF NID-r16{	1 entry		
NID-r16[1]	See table 4.4.2-4	NID is coded as a BITSTRING based on TS 38.508-1 Table 4.4.2-4	
}			
}			
}			

Condition	Explanation
CAG	PNI-NPN
SNPN	Standalone NPN cell

– *NPN-IdentityInfoList*

**Table 4.6.3-84AB: NPN-IdentityInfoList**

Derivation Path: TS 38.331 [6], clause 6.3.2			
Information Element	Value/remark	Comment	Condition
NPN-IdentityInfoList-r16 ::= SEQUENCE (SIZE (1..maxNPN-r16)) OF NPN-IdentityInfo-r16 {	1 entry		
NPN-IdentityInfo-r16[1] SEQUENCE {			
npn-identityList-r16 SEQUENCE (SIZE (1..maxNPN-r16)) OF NPN-Identity-r16 {	1 entry		
NPN-Identity-r16[1]	NPN-Identity with condition CAG		CAG

	NPN-Identity with condition SNPN		SNPN
}			
trackingAreaCode-r16	TrackingAreaCode		
ranac-r16	RAN-AreaCode		
cellIdentity-r16	CellIdentity		
cellReservedForOperatorUse-r16	notReserved		
iab-Support-r16	Not present		
}			
}			

Condition	Explanation
CAG	PNI-NPN
SNPN	Standalone NPN cell

– NR-DL-PRS-PDC-Info

Table 4.6.3-84AC: NR-DL-PRS-PDC-Info

Derivation Path: TS 38.331 [6], clause 6.3.2			
Information Element	Value/remark	Comment	Condition
NR-DL-PRS-PDC-Info-r17 ::= SEQUENCE {			
NR-DL-PRS-PDC-ResourceSet-r17 SEQUENCE {			
periodicityAndOffset-r17 CHOICE {			
scs15-r17 CHOICE {		entry 1	SCS15
n160-r17	10		
}			
scs30-r17 CHOICE {		entry 2	SCS30
n160-r17	10		
}			
scs120-r17 CHOICE {		entry 3	SCS120
n160-r17	10		
}			
}			
numSymbols-r17	n4		
dl-PRS-ResourceBandwidth-r17	8		SCS15
	22		SCS30
	11		SCS120
dl-PRS-StartPRB-r17	0		
resourceList-r17 SEQUENCE (SIZE (1..maxNrofPRS-ResourcesPerSet-r17)) OF NR-DL-PRS-Resource-r17 {	1 entry		
NR-DL-PRS-Resource-r17[1] SEQUENCE {		entry 1	
nr-DL-PRS-ResourceID-r17	0		
dl-PRS-SequenceID-r17	0		
dl-PRS-CombSizeN-AndReOffset-r17 CHOICE {			
n4-r17	0		SCS15 OR SCS30
n2-r17	0		SCS120
}			
dl-PRS-ResourceSlotOffset-r17	4		
dl-PRS-ResourceSymbolOffset-r17	0		
dl-PRS-QCL-Info-r17 CHOICE {			
ssb-r17 SEQUENCE {			SCS120
ssb-Index-r17	0	SSB#0	
rs-Type-r17	typeD		
}			
dl-PRS-r17 SEQUENCE {			SCS15 OR SCS30
qcl-DL-PRS-ResourceID-r17	0		
}			
}			

repFactorAndTimeGap-r17 SEQUENCE {			
repetitionFactor-r17	n2		
timeGap-r17	s1		
}			
}			

– *NR-NS-PmaxList*

**Table 4.6.3-84A: NR-NS-PmaxList**

Derivation Path: TS 38.331 [6], clause 6.3.2			
Information Element	Value/remark	Comment	Condition
NR-NS-PmaxList ::= SEQUENCE (SIZE (1.. maxNrofMultiBands)) OF NR-NS-PmaxValue {	1 entry		
NR-NS-PmaxValue[1] SEQUENCE {		entry 1	
additionalPmax	Not present		
additionalSpectrumEmission	AdditionalSpectrumEmission		
}			
}			

– *NSAG-ID*

**Table 4.6.3-84BA: NSAG-ID**

Derivation Path: TS 38.331 [6], clause 6.3.2			
Information Element	Value/remark	Comment	Condition
NSAG-ID-r17	Set according to specific message content		

– *NSAG-IdentityInfo*

**Table 4.6.3-84B: NSAG-IdentityInfo**

Derivation Path: TS 38.331 [6], clause 6.3.2			
Information Element	Value/remark	Comment	Condition
NSAG-IdentityInfo-r17 ::= SEQUENCE {			
nsag-ID-r17	NSAG-ID		
trackingAreaCode-r17	Not present		
}			

– *NTN-Config*

**Table 4.6.3-84C: NTN-Config**

Derivation Path: TS 38.331 [6], clause 6.3.2			
Information Element	Value/remark	Comment	Condition
NTN-Config-r17 ::= SEQUENCE {			
epochTime-r17	Not present		GSO
epochTime-r17 SEQUENCE {			NGSO
sfn-r17	FFS		
subFrameNR-r17	FFS		
}			
ntn-UISyncValidityDuration-r17	s240		
cellSpecificKoffset-r17	550		
kmac-r17	Not present		
ta-Info-r17	FFS		

ntn-PolarizationDL-r17	linear		
ntn-PolarizationUL-r17	linear		
ephemerisInfo-r17	EphemerisInfo with condition GSO		GSO
	EphemerisInfo with condition NGSO		NGSO
ta-Report-r17	Not present		
}			

Condition	Explanation
GSO	Geosynchronous Orbit scenario
NGSO	Non-geosynchronous Orbit scenario

– *NZP-CSI-RS-Resource*

**Table 4.6.3-85: NZP-CSI-RS-Resource**

Derivation Path: TS 38.331 [6], clause 6.3.2			
Information Element	Value/remark	Comment	Condition
NZP-CSI-RS-Resource ::= SEQUENCE {			
nzp-CSI-RS-ResourceId	NZP-CSI-RS-ResourceId		
resourceMapping	CSI-RS-ResourceMapping		
powerControlOffset	-3		
powerControlOffsetSS	Not present		
scramblingID	ScramblingId		
periodicityAndOffset	CSI-ResourcePeriodicityAndOffset		
qcl-InfoPeriodicCSI-RS	TCI-StateId		
}			

– *NZP-CSI-RS-ResourceId*

**Table 4.6.3-86: NZP-CSI-RS-ResourceId**

Derivation Path: TS 38.331 [6], clause 6.3.2			
Information Element	Value/remark	Comment	Condition
NZP-CSI-RS-ResourceId	0		

– *NZP-CSI-RS-ResourceSet*

**Table 4.6.3-87: NZP-CSI-RS-ResourceSet**

Derivation Path: TS 38.331 [6], clause 6.3.2			
Information Element	Value/remark	Comment	Condition
NZP-CSI-RS-ResourceSet ::= SEQUENCE {			
nzp-CSI-ResourceSetId	NZP-CSI-RS-ResourceSetId		
nzp-CSI-RS-Resources SEQUENCE (SIZE (1..maxNrofNZP-CSI-RS-ResourcesPerSet)) OF NZP-CSI-RS-ResourceId {	1 entry		
NZP-CSI-RS-ResourceId[1]	NZP-CSI-RS-ResourceId	entry 1	
}			
repetition	off		
	Not present		TRS
aperiodicTriggeringOffset	Not present		
trs-Info	Not present		
	true		TRS

}			

Condition	Explanation
TRS	Tracking-Reference Signal

– *NZP-CSI-RS-ResourceSetId*

**Table 4.6.3-88: NZP-CSI-RS-ResourceSetId**

Derivation Path: TS 38.331 [6], clause 6.3.2			
Information Element	Value/remark	Comment	Condition
NZP-CSI-RS-ResourceSetId	0		

– *P-Max*

NOTE: Exceptions in clause 5.4.1 shall be applied for RF test cases.

**Table 4.6.3-89: P-Max**

Derivation Path: TS 38.331 [6], clause 6.3.2			
Information Element	Value/remark	Comment	Condition
P-Max	23		NR OR (EN-DC AND pc_dynamic PowerSharing)
	20		EN-DC AND (NOT pc_dynamic PowerSharing)

Condition	Explanation
NR	NR connected to 5GC
EN-DC	E-UTRA-NR Dual Connectivity with E-UTRA connected to EPC

– PathlossReferenceRS

**Table 4.6.3-89AA: PathlossReferenceRS**

Derivation Path: TS 38.331 [6], clause 6.3.2			
Information Element	Value/remark	Comment	Condition
PathlossReferenceRS-r17 ::= SEQUENCE {			
FFS			
}			

– PathlossReferenceRS-Id

**Table 4.6.3-89AB: PathlossReferenceRS-Id**

Derivation Path: TS 38.331 [6], clause 6.3.2			
Information Element	Value/remark	Comment	Condition
PathlossReferenceRS-Id-r17	FFS		

– *PCI-ARFCN-EUTRA***Table 4.6.3-89A: PCI-ARFCN-EUTRA**

Derivation Path: TS 38.331 [6], clause 6.3.2			
Information Element	Value/remark	Comment	Condition
PCI-ARFCN-EUTRA-r16 ::= SEQUENCE {			
FFS			
}			

– *PCI-ARFCN-NR***Table 4.6.3-89B: PCI-ARFCN-NR**

Derivation Path: TS 38.331 [6], clause 6.3.2			
Information Element	Value/remark	Comment	Condition
PCI-ARFCN-NR-r16 ::= SEQUENCE {			
FFS			
}			

– *PCI-List***Table 4.6.3-90: PCI-List**

Derivation Path: TS 38.331 [6], clause 6.3.2			
Information Element	Value/remark	Comment	Condition
PCI-List ::= SEQUENCE {			
FFS			
}			

– *PCI-Range***Table 4.6.3-91: PCI-Range**

Derivation Path: TS 38.331 [6], clause 6.3.2			
Information Element	Value/remark	Comment	Condition
PCI-Range ::= SEQUENCE {			
start	PhysCellId		
range	FFS		
}			

– *PCI-RangeElement***Table 4.6.3-92: PCI-RangeElement**

Derivation Path: TS 38.331 [6], clause 6.3.2			
Information Element	Value/remark	Comment	Condition
PCI-RangeElement ::= SEQUENCE {			
FFS			
}			

– *PCI-RangeIndex***Table 4.6.3-93: PCI-RangeIndex**

Derivation Path: TS 38.331 [6], clause 6.3.2			
--	--	--	--

Information Element	Value/remark	Comment	Condition
PCI-RangeIndex	0		

– PCI-RangeIndexList

Table 4.6.3-94: PCI-RangeIndexList

Derivation Path: TS 38.331 [6], clause 6.3.2			
Information Element	Value/remark	Comment	Condition
PCI-RangeIndexList ::= SEQUENCE {			
FFS			
}			

– PDCCH-Config

Table 4.6.3-95: PDCCH-Config

Derivation Path: TS 38.331 [6], clause 6.3.2			
Information Element	Value/remark	Comment	Condition
PDCCH-Config ::= SEQUENCE {			
controlResourceSetToAddModList	Not present		EN-DC, MSS
controlResourceSetToAddModList SEQUENCE(SIZE (1..3)) OF ControlResourceSet {	1 entry		
ControlResourceSet[1]	ControlResourceSet	entry 1	
}			
controlResourceSetToReleaseList	Not present		
searchSpacesToAddModList SEQUENCE(SIZE (1..10)) OF SearchSpace {	1 entry		
SearchSpace[1]	SearchSpace with condition USS	entry 1	
	SearchSpace with condition MSS	entry 1	MSS
	SearchSpace with condition SLSS	entry 1	SLSS
	SearchSpace with condition DCI_2_6	entry 1	DCI_2_6
}			
searchSpacesToReleaseList	Not present		
downlinkPreemption	Not present		
tpc-PUSCH	Not present		
tpc-PUCCH	Not present		
tpc-SRS	Not present		
controlResourceSetToAddModListSizeExt-v1610	Not present		
controlResourceSetToReleaseListSizeExt-r16	Not present		
searchSpacesToAddModListExt-r16	Not present		
searchSpacesToAddModListExt-r16 SEQUENCE(SIZE (1..10)) OF SearchSpaceExt-r16 {	1 entry		DCI_2_6
SearchSpaceExt-r16[1] SEQUENCE{		entry 1	
controlResourceSetId-r16	ControlResourceSetId		
searchSpaceType-r16 SEQUENCE {			
common-r16 SEQUENCE {			
dci-Format2-4-r16	Not present		
dci-Format2-5-r16	Not present		
dci-Format2-6-r16 SEQUENCE {			
}			
}			
}			
searchSpaceGroupIdList-r16	Not present		
freqMonitorLocations-r16	Not present		
}			
}			

uplinkCancellation-r16	Not present		
monitoringCapabilityConfig-r16	Not present		
searchSpaceSwitchConfig-r16	Not present		
searchSpacesToAddModListExt-v1700	Not present		
searchSpacesToAddModListExt-v1700 SEQUENCE(SIZE (1..10)) OF SearchSpaceExt-v1700 {	1 entry		MSS
SearchSpaceExt-v1700[1] SEQUENCE {		entry 1	
monitoringSlotPeriodicityAndOffset-v1710	Not present		
monitoringSlotsWithinSlotGroup-r17	Not present		
duration-r17	Not present		
searchSpaceType-r17 SEQUENCE {			
common-r17 SEQUENCE {			
dci-Format4-0-r17	Not present		
dci-Format4-1-r17	Not present		
dci-Format4-2-r17	Not present		
dci-Format4-1-AndFormat4-2-r17 SEQUENCE {			
{			
}			
dci-Format2-7-r17	Not present		
}			
}			
searchSpaceGroupIdList-r17	Not present		
searchSpaceLinkingId-r17	Not present		
}			
monitoringCapabilityConfig-v1710	Not present		
searchSpaceSwitchConfig-r17	Not present		
pdccch-SkippingDurationList-r17	Not present		
}			

Condition	Explanation
MSS	SearchSpace for MBS Multicast reception
SLSS	SearchSpace for SL mode 1 transmission
DCI_2_6	Transmission of DCI_2_6 is required

*PDCCH-ConfigCommon*

**Table 4.6.3-96: PDCCH-ConfigCommon**

Derivation Path: TS 38.331 [6], clause 6.3.2			
Information Element	Value/remark	Comment	Condition
PDCCH-ConfigCommon ::= SEQUENCE {			
controlResourceSetZero	ControlResourceSetZero	Initial BWP	
	Not present		SCell_Add InitialBWP_SIB, BWP-Id1
commonControlResourceSet	ControlResourceSet		EN-DC
	Not present		
searchSpaceZero	SearchSpaceZero	Initial BWP	
	Not present		SCell_Add InitialBWP_SIB, BWP-Id1
commonSearchSpaceList SEQUENCE (SIZE (1..4)) OF SearchSpace {	2 entries		
	3 entries		PEI
SearchSpace[1]	SearchSpace with condition CSS	entry 1	
SearchSpace[2]	SearchSpace with condition SISS	entry 2	



SearchSpace[3]	SearchSpace with condition PEI	entry 3	PEI
}			
commonSearchSpaceList SEQUENCE (SIZE (1..4)) OF SearchSpace {	1 entry		EN-DC
SearchSpace[1]	SearchSpace with condition CSS	entry 1	
}			
commonSearchSpaceList	Not present		SCell_Add
searchSpaceSIB1	0		
	Not present		EN-DC, SCell_Add
searchSpaceOtherSystemInformation	SearchSpaceId with condition SISS		
	Not present		EN-DC, SCell_Add
pagingSearchSpace	0		
	Not present		EN-DC, SCell_Add
ra-SearchSpace	SearchSpaceId with condition CSS		
	Not present		SCell_Add
firstPDCCH-MonitoringOccasionOfPO	Not present		
commonSearchSpaceListExt-r16	Not present		
sdt-SearchSpace-r17	Not present		
sdt-SearchSpace-r17 CHOICE {			SDT
existingSearchSpace	SearchSpaceId with condition CSS		
}			
searchSpaceMCCH-r17	Not present		
searchSpaceMCCH-r17	SearchSpaceId with condition CSS		MBS_Broad cast
searchSpaceMTCH-r17	Not present		
commonSearchSpaceListExt2-r17	Not present		
commonSearchSpaceListExt2-r17 SEQUENCE(SIZE (1..4)) OF SearchSpaceExt-v1700 {	2 entries		MBS_Broad cast
SearchSpaceExt-v1700[1] SEQUENCE {		entry 1	
monitoringSlotPeriodicityAndOffset-v1710	Not present		
monitoringSlotsWithinSlotGroup-r17	Not present		
duration-r17	Not present		
searchSpaceType-r17 SEQUENCE {			
common-r17 SEQUENCE {			
dci-Format4-0-r17 SEQUENCE {			
}			
dci-Format4-1-r17	Not present		
dci-Format4-2-r17	Not present		
dci-Format4-1-AndFormat4-2-r17	Not present		
dci-Format2-7-r17	Not present		
}			
}			
}			
searchSpaceGroupIdList-r17	Not present		
searchSpaceLinkingId-r17	Not present		
}			
SearchSpaceExt-v1700[2] SEQUENCE {		entry 2	
monitoringSlotPeriodicityAndOffset-v1710	Not present		
monitoringSlotsWithinSlotGroup-r17	Not present		
duration-r17	Not present		
searchSpaceType-r17	Not present		
searchSpaceGroupIdList-r17	Not present		
searchSpaceLinkingId-r17	Not present		
}			
}			
firstPDCCH-MonitoringOccasionOfPO-v1710	Not present		
pei-ConfigBWP-r17	Not present		
pei-ConfigBWP-r17 SEQUENCE {			PEI

pei-SearchSpace-r17	SearchSpaceId with condition PEI		
firstPDCCH-MonitoringOccasionOfPEI-O-r17			
CHOICE {			
sCS15KHzZoneT[1]	0		
sCS15KHzZoneT[2]	1		
}			
followUnifiedTCIstate-v1720	Not present		
}			

Condition	Explanation
EN-DC	E-UTRA-NR Dual Connectivity with E-UTRA connected to EPC
SCell_Add	Add SCell
InitialBWP_SIB	Configured via DownlinkConfigCommonSIB
BWP-Id1	Additional BWP 1
SDT	For SDT test cases
PEI	Paging Early Indication is configured in the cell.
MBS_Broadcast	NR Cell provide MBS Broadcast service

– *PDCCH-ConfigSIB1*

**Table 4.6.3-97: PDCCH-ConfigSIB1**

Derivation Path: TS 38.331 [6], clause 6.3.2			
Information Element	Value/remark	Comment	Condition
PDCCH-ConfigSIB1 ::= SEQUENCE {			
controlResourceSetZero	ControlResourceSetZero		
searchSpaceZero	SearchSpaceZero		
}			

– *PDCCH-ServingCellConfig*

**Table 4.6.3-98: PDCCH-ServingCellConfig**

Derivation Path: TS 38.331 [6], clause 6.3.2			
Information Element	Value/remark	Comment	Condition
PDCCH-ServingCellConfig ::= SEQUENCE {			
slotFormatIndicator	Not present		
}			

– *PDCP-Config*

**Table 4.6.3-99: PDCP-Config**

Derivation Path: TS 38.331 [6], clause 6.3.2			
Information Element	Value/remark	Comment	Condition
PDCP-Config ::= SEQUENCE {			
drb SEQUENCE {			
discardTimer	infinity		
pdcp-SN-Size-UL	len18bits len12bits		pc_support OfRedCap_r 17
pdcp-SN-Size-DL	len18bits len12bits		MRBm pc_support OfRedCap_r 17
}			

headerCompression CHOICE {			
notUsed	NULL		
}			
integrityProtection	Not present		
statusReportRequired	true	AM is default	
	Not present		UM, UM_MRB
outOfOrderDelivery	Not present		
}			
drb	Not present		SRB, Split_SRB
moreThanOneRLC	Not present		
moreThanOneRLC SEQUENCE {			Split, Split_SRB, NR_split
primaryPath SEQUENCE {			
cellGroup	CellGroupId		
	0	MCG path	Split_SRB, NR_split
logicalChannel	LogicalChannelIdentity		
}			
ul-DataSplitThreshold	infinity		
	Not present		Split_SRB
pdcp-Duplication	false		
	Not present	one UL path	Split_SRB
}			
t-Reordering	Not present		
	80ms		UM, UM_MRB
cipheringDisabled	Not present		
discardTimerExt-r16	Not present		
moreThanTwoRLC-DRB-r16	Not present		
ethernetHeaderCompression-r16	Not present		
survivalTimeStateSupport-r17	Not present		
uplinkDataCompression-r17	Not present		
uplinkDataCompression-r17 CHOICE {			UDC
setup CHOICE {			
newSetup CHOICE {			
bufferSize-r17	kbyte2		
dictionary-r17	Not present		
}			
}			
}			
discardTimerExt2-r17	Not present		
initialRX-DELIV-r17	Not present		
	0		MRB_Initiali zation
}			

Condition	Explanation
Split	More than one RLC
SRB	SRB
UM	RLC UM DRB
Split_SRB	SRB with more than one RLC
NR_split	MCG and split for NR-DC.
UDC	RLC AM DRB with uplinkDataCompression
MRB_Initialization	Multicast MRB setup or PDCP re-establishment for multicast MRB
UM_MRB	UM multicast MRB
MRBm	Establishment of MRBm

## – PDSCH-Config

Table 4.6.3-100: PDSCH-Config

Derivation Path: TS 38.331 [6], clause 6.3.2			
Information Element	Value/remark	Comment	Condition
PDSCH-Config ::= SEQUENCE {			
dataScramblingIdentityPDSCH	0		
dmrs-DownlinkForPDSCH-MappingTypeA CHOICE			
{			
setup	DMRS-DownlinkConfig		
}			
dmrs-DownlinkForPDSCH-MappingTypeB	Not present		
tci-StatesToAddModList	Not present		MBS_Multicast
tci-StatesToAddModList SEQUENCE(SIZE (1..maxNrofTCI-States)) OF TCI-State {	1 entry		
TCI-State[1]	TCI-State	entry 1	
}			
tci-StatesToReleaseList	Not present		
vrb-ToPRB-Interleaver	Not present		
resourceAllocation	resourceAllocationType1 resourceAllocationType0		Used_for_Type0
pdsch-TimeDomainAllocationList	Not present		
pdsch-AggregationFactor	Not present		
rateMatchPatternToAddModList	Not present		
rateMatchPatternToReleaseList	Not present		
rateMatchPatternGroup1	Not present		
rateMatchPatternGroup2	Not present		
rbg-Size	config1		
mcs-Table	Not present	qam64 per default	
maxNrofCodeWordsScheduledByDCI	Not present		
prb-BundlingType CHOICE {			
staticBundling SEQUENCE {			
bundleSize	wideband		
}			
}			
zp-CSI-RS-ResourceToAddModList	Not present		
zp-CSI-RS-ResourceToReleaseList	Not present		
aperiodic-ZP-CSI-RS-ResourceSetsToAddModList	Not present		
aperiodic-ZP-CSI-RS-ResourceSetsToReleaseList	Not present		
sp-ZP-CSI-RS-ResourceSetsToAddModList	Not present		
sp-ZP-CSI-RS-ResourceSetsToReleaseList	Not present		
p-ZP-CSI-RS-ResourceSet	Not present		
maxMIMO-Layers-r16	Not present		
minimumSchedulingOffsetK0-r16	Not present		
antennaPortsFieldPresenceDCI-1-2-r16	Not present		
aperiodicZP-CSI-RS-ResourceSetsToAddModListDCI-1-2-r16	Not present		
aperiodicZP-CSI-RS-ResourceSetsToReleaseListDCI-1-2-r16	Not present		
dmrs-DownlinkForPDSCH-MappingTypeA-DCI-1-2-r16	Not present		
dmrs-DownlinkForPDSCH-MappingTypeB-DCI-1-2-r16	Not present		
dmrs-SequenceInitializationDCI-1-2-r16	Not present		
harq-ProcessNumberSizeDCI-1-2-r16	Not present		
mcs-TableDCI-1-2-r16	Not present		
numberOfBitsForRV-DCI-1-2-r16	Not present		
pdsch-TimeDomainAllocationListDCI-1-2-r16	Not present		
prb-BundlingTypeDCI-1-2-r16	Not present		
priorityIndicatorDCI-1-2-r16	Not present		
rateMatchPatternGroup1DCI-1-2-r16	Not present		
rateMatchPatternGroup2DCI-1-2-r16	Not present		

resourceAllocationType1GranularityDCI-1-2-r16	Not present		
vrb-ToPRB-InterleaverDCI-1-2-r16	Not present		
referenceOfSLIVDCI-1-2-r16	Not present		
resourceAllocationDCI-1-2-r16	Not present		
priorityIndicatorDCI-1-1-r16	Not present		
dataScramblingIdentityPDSCH2-r16	Not present		
pdsch-TimeDomainAllocationList-r16	Not present		
repetitionSchemeConfig-r16	Not present		
repetitionSchemeConfig-v1630	Not present		
}			

Condition	Explanation
Used_for_Type0	Used for RF performance test cases
MBS_Multicast	Used for MBS Multicast reception

– *PDSCH-ConfigCommon*

**Table 4.6.3-101: PDSCH-ConfigCommon**

Derivation Path: TS 38.331 [6], clause 6.3.2			
Information Element	Value/remark	Comment	Condition
PDSCH-ConfigCommon ::= SEQUENCE {			
pdsch-TimeDomainAllocationList	PDSCH-TimeDomainResourceAllocationList		
}			

– *PDSCH-ServingCellConfig*

**Table 4.6.3-102: PDSCH-ServingCellConfig**

Derivation Path: TS 38.331 [6], clause 6.3.2			
Information Element	Value/remark	Comment	Condition
PDSCH-ServingCellConfig ::= SEQUENCE {			
codeBlockGroupTransmission	Not present		
xOverhead	Not present		
nrofHARQ-ProcessesForPDSCH	n4		RF AND FDD
	n16		RRM AND FDD
	Not present	Default value: 8 HARQ processes	
pucch-Cell	Not present		
maxMIMO-Layers	Not present		
processingType2Enabled	Not present		
pdsch-CodeBlockGroupTransmissionList-r16	Not present		
}			

– *PDSCH-TimeDomainResourceAllocationList*

**Table 4.6.3-103: PDSCH-TimeDomainResourceAllocationList**

Derivation Path: TS 38.331 [6], clause 6.3.2			
Information Element	Value/remark	Comment	Condition
PDSCH-TimeDomainResourceAllocationList ::= SEQUENCE(SIZE(1..maxNrofDL-Allocations)) OF PDSCH-TimeDomainResourceAllocation {	2 entries		FR1
PDSCH-TimeDomainResourceAllocation[1] SEQUENCE {		entry 1	

k0	Not present		
mappingType	typeA		
startSymbolAndLength	53	Start symbol(S)=2, Length(L)=12	
}			
PDSCH-TimeDomainResourceAllocation[2]		entry 2	
SEQUENCE {			
k0	Not present		
mappingType	typeA		
startSymbolAndLength	72	S=2, L=6	
}			
}			
PDSCH-TimeDomainResourceAllocationList SEQUENCE (SIZE(1..maxNrofDL-Allocations)) OF PDSCH-TimeDomainResourceAllocation {	1 entry		FR2
PDSCH-TimeDomainResourceAllocation[1]		entry 1	
SEQUENCE {			
k0	Not present		
mappingType	typeA		
startSymbolAndLength	53	S=2, L=12	
}			
}			

– PHR-Config

Table 4.6.3-104: PHR-Config

Derivation Path: TS 38.331 [6], clause 6.3.2			
Information Element	Value/remark	Comment	Condition
PHR-Config ::= CHOICE {			
setup SEQUENCE {			
phr-PeriodicTimer	sf10		
phr-ProhibitTimer	sf0		
phr-Tx-PowerFactorChange	dB1		
multiplePHR	false		MR-DC OR NR-CA
	true		
dummy	false		
Phr-Type2OtherCell	false		
phr-ModeOtherCG	real		
}			
}			

Condition	Explanation
MR-DC	EN-DC, NGEN-DC, NE-DC or NR-DC.
NR-CA	UL CA for NR

– PhysCellId

Table 4.6.3-105: PhysCellId

Derivation Path: TS 38.331 [6], clause 6.3.2			
Information Element	Value/remark	Comment	Condition
PhysCellId	Set according to table 4.4.2-2 for the NR Cell.		

– *PhysicalCellGroupConfig***Table 4.6.3-106: *PhysicalCellGroupConfig***

Derivation Path: TS 38.331 [6], clause 6.3.2			
Information Element	Value/remark	Comment	Condition
PhysicalCellGroupConfig ::= SEQUENCE {			
harq-ACK-SpatialBundlingPUCCH	Not present		
harq-ACK-SpatialBundlingPUSCH	Not present		
p-NR-FR1	P-Max		
pdsch-HARQ-ACK-Codebook	dynamic		
tpc-SRS-RNTI	Not present		
tpc-PUCCH-RNTI	Not present		
tpc-PUSCH-RNTI	Not present		
sp-CSI-RNTI	Not present		
cs-RNTI	Not present		
dcp-Config-r16	Not present		
dcp-Config-r16 CHOICE {			DCP
setup SEQUENCE {			
ps-RNTI-r16	RNTI-Value		
ps-Offset-r16	120		
sizeDCI-2-6-r16	6		
ps-PositionDCI-2-6-r16	0		
ps-WakeUp-r16	Not present		
ps-TransmitPeriodicL1-RSRP-r16	Not present		
ps-TransmitOtherPeriodicCSI-r16	Not present		
}			
}			
harq-ACK-SpatialBundlingPUCCH-secondaryPUCCHgroup-r16	Not present		
harq-ACK-SpatialBundlingPUSCH-secondaryPUCCHgroup-r16	Not present		
pdsch-HARQ-ACK-Codebook-secondaryPUCCHgroup-r16	Not present		
p-NR-FR2-r16	Not present		
p-UE-FR2-r16	Not present		
nrhc-PCmode-FR1-r16	Not present		
nrhc-PCmode-FR2-r16	Not present		
pdsch-HARQ-ACK-Codebook-r16	Not present		
nfi-TotalDAI-Included-r16	Not present		
ul-TotalDAI-Included-r16	Not present		
pdsch-HARQ-ACK-OneShotFeedback-r16	Not present		
pdsch-HARQ-ACK-OneShotFeedbackNDI-r16	Not present		
pdsch-HARQ-ACK-OneShotFeedbackCBG-r16	Not present		
downlinkAssignmentIndexDCI-0-2-r16	Not present		
downlinkAssignmentIndexDCI-1-2-r16	Not present		
pdsch-HARQ-ACK-CodebookList-r16	Not present		
ackNackFeedbackMode-r16	Not present		
pdcch-BlindDetectionCA-ComblIndicator-r16	Not present		
pdcch-BlindDetection2-r16	Not present		
pdcch-BlindDetection3-r16	Not present		
bdFactorR-r16	Not present		
}			

Condition	Explanation
DCP	This condition applies when DCP is configured

– *PLMN-Identity***Table 4.6.3-107: *PLMN-Identity***

Derivation Path: TS 38.331 [6], clause 6.3.2
--

Information Element	Value/remark	Comment	Condition
PLMN-Identity ::= SEQUENCE {			
mcc SEQUENCE (SIZE (3)) OF MCC-MNC-Digit	See table 4.4.2-3		
mnc SEQUENCE (SIZE (2..3)) OF MCC-MNC-Digit	See table 4.4.2-3		
}			

– *PLMN-IdentityInfoList*

**Table 4.6.3-108: *PLMN-IdentityInfoList***

Derivation Path: TS 38.331 [6], clause 6.3.2			
Information Element	Value/remark	Comment	Condition
PLMN-IdentityInfoList ::= SEQUENCE (SIZE (1..maxPLMN)) OF PLMN-IdentityInfo {	1 entry		
PLMN-IdentityInfo[1] SEQUENCE {		entry 1	
plmn-IdentityList SEQUENCE (SIZE (1..maxPLMN)) OF PLMN-Identity {	1 entry		
PLMN-Identity[1]	PLMN-Identity	entry 1	
}			
trackingAreaCode	TrackingAreaCode		
ranac	RAN-AreaCode		
cellIdentity	CellIdentity		
cellReservedForOperatorUse	notReserved		
}			
}			

– *PLMN-IdentityList2*

**Table 4.6.3-108A: *PLMN-IdentityList2***

Derivation Path: TS 38.331 [6], clause 6.3.2			
Information Element	Value/remark	Comment	Condition
PLMN-IdentityList2-r16 ::= SEQUENCE {			
FFS			
}			

– *PRB-Id*

**Table 4.6.3-109: *PRB-Id***

Derivation Path: TS 38.331 [6], clause 6.3.2			
Information Element	Value/remark	Comment	Condition
PRB-Id	0		
	Set to value of the <i>L_RBs</i> - <i>nrofPRBs</i> where <i>L_RBs</i> is found in Table 4.3.1.0D-1 or Table 4.3.1.0D-2 for the bandwidth and SCS configured and <i>nrofPRBs</i> is defined for the corresponding <i>PUCCH-Resource</i> (1 otherwise).		secondHop PRB

Condition	Explanation
secondHopPRB	The IE secondHopPRB in PUCCH-Resource is now set.



– *PTRS-DownlinkConfig***Table 4.6.3-110: PTRS-DownlinkConfig**

Derivation Path: TS 38.331 [6], clause 6.3.2			
Information Element	Value/remark	Comment	Condition
PTRS-DownlinkConfig ::= SEQUENCE {			
frequencyDensity	Not present		
timeDensity	Not present		
epre-Ratio	0		
resourceElementOffset	Not present		
}			

– *PTRS-UplinkConfig***Table 4.6.3-111: PTRS-UplinkConfig**

Derivation Path: TS 38.331 [6], clause 6.3.2			
Information Element	Value/remark	Comment	Condition
PTRS-UplinkConfig ::= SEQUENCE {			
transformPrecoderDisabled SEQUENCE {			
frequencyDensity	Not present		
timeDensity	Not present		
maxNrofPorts	n1		
resourceElementOffset	Not present		
ptrs-Power	p00		
}			
transformPrecoderEnabled SEQUENCE {			
sampleDensity SEQUENCE (SIZE (5)) OF INTEGER {	5 entries		
INTEGER[1]	1	entry 1	
INTEGER[2]	8	entry 2	
INTEGER[3]	32	entry 3	
INTEGER[4]	32	entry 4	
INTEGER[5]	108	entry 5	
}			
timeDensityTransformPrecoding	Not present		
}			
}			

– *PUCCH-Config***Table 4.6.3-112: PUCCH-Config**

Derivation Path: TS 38.331 [6], clause 6.3.2			
Information Element	Value/remark	Comment	Condition
PUCCH-Config ::= SEQUENCE {			
resourceSetToAddModList SEQUENCE (SIZE (1..maxNrofPUCCH-ResourceSets)) OF PUCCH-ResourceSet {	2 entries		
PUCCH-ResourceSet[1] SEQUENCE {		entry 1	
pucch-ResourceSetId	0		
resourceList SEQUENCE (SIZE (0..maxNrofPUCCH-ResourcesPerSet)) OF PUCCH-ResourceId {	8 entries		
PUCCH-ResourceId[1]	0	entry 1	
PUCCH-ResourceId[2]	1	entry 2	
PUCCH-ResourceId[3]	2	entry 3	
PUCCH-ResourceId[4]	3	entry 4	
PUCCH-ResourceId[5]	4	entry 5	
PUCCH-ResourceId[6]	5	entry 6	
PUCCH-ResourceId[7]	6	entry 7	
}			
}			
}			

PUCCH-ResourceId[8]	7	entry 8	
}			
maxPayloadSize	Not present		
}			
PUCCH-ResourceSet[2] SEQUENCE {		entry 2	
pucch-ResourceSetId	1		
resourceList SEQUENCE (SIZE (8..maxNrofPUCCH-ResourcesPerSet)) OF PUCCH-ResourceId {	8 entries		
PUCCH-ResourceId[1]	8	entry 1	
PUCCH-ResourceId[2]	9	entry 2	
PUCCH-ResourceId[3]	10	entry 3	
PUCCH-ResourceId[4]	11	entry 4	
PUCCH-ResourceId[5]	12	entry 5	
PUCCH-ResourceId[6]	13	entry 6	
PUCCH-ResourceId[7]	14	entry 7	
PUCCH-ResourceId[8]	15	entry 8	
}			
maxPayloadSize	Not present		
}			
}			
resourceSetToReleaseList	Not present		
resourceToAddModList SEQUENCE (SIZE (1..maxNrofPUCCH-Resources)) OF PUCCH-Resource {	16 entries		
PUCCH-Resource[1] SEQUENCE {		entry 1	
pucch-ResourceId	0		
startingPRB	PRB-Id		
intraSlotFrequencyHopping	enabled		
	Not present		RF OR RRM
secondHopPRB	PRB-Id with condition secondHopPRB		
	Not present		RF OR RRM
format CHOICE {			
format0 SEQUENCE {			
initialCyclicShift	0		
nrofSymbols	2		
startingSymbolIndex	0		
}			
}			
}			
PUCCH-Resource[2] SEQUENCE {		entry 2	
pucch-ResourceId	1		
startingPRB	PRB-Id		
intraSlotFrequencyHopping	enabled		
	Not present		RF OR RRM
secondHopPRB	PRB-Id with condition secondHopPRB		
	Not present		RF OR RRM
format CHOICE {			
format0 SEQUENCE {			
initialCyclicShift	0		
nrofSymbols	2		
startingSymbolIndex	2		
}			
}			
}			
PUCCH-Resource[3] SEQUENCE {		entry 3	
pucch-ResourceId	2		
startingPRB	PRB-Id		
intraSlotFrequencyHopping	enabled		
	Not present		RF OR RRM
secondHopPRB	PRB-Id with condition secondHopPRB		
	Not present		RF OR RRM
format CHOICE {			

format0 SEQUENCE {			
initialCyclicShift	0		
nrofSymbols	2		
startingSymbolIndex	4		
}			
}			
PUCCH-Resource[4] SEQUENCE {		entry 4	
pucch-ResourceId	3		
startingPRB	PRB-Id		
intraSlotFrequencyHopping	enabled		
	Not present		RF OR RRM
secondHopPRB	PRB-Id with condition secondHopPRB		
	Not present		RF OR RRM
format CHOICE {			
format0 SEQUENCE {			
initialCyclicShift	0		
nrofSymbols	2		
startingSymbolIndex	6		
}			
}			
}			
PUCCH-Resource[5] SEQUENCE {		entry 5	
pucch-ResourceId	4		
startingPRB	PRB-Id		
intraSlotFrequencyHopping	enabled		
	Not present		RF OR RRM
secondHopPRB	PRB-Id with condition secondHopPRB		
	Not present		RF OR RRM
format CHOICE {			
format0 SEQUENCE {			
initialCyclicShift	0		
nrofSymbols	2		
startingSymbolIndex	8		
}			
}			
}			
PUCCH-Resource[6] SEQUENCE {		entry 6	
pucch-ResourceId	5		
startingPRB	PRB-Id		
intraSlotFrequencyHopping	enabled		
	Not present		RF OR RRM
secondHopPRB	PRB-Id with condition secondHopPRB		
	Not present		RF OR RRM
format CHOICE {			
format0 SEQUENCE {			
initialCyclicShift	0		
nrofSymbols	2		
startingSymbolIndex	10		
}			
}			
}			
PUCCH-Resource[7] SEQUENCE {		entry 7	
pucch-ResourceId	6		
startingPRB	PRB-Id		
intraSlotFrequencyHopping	enabled		
	Not present		RF OR RRM
secondHopPRB	PRB-Id with condition secondHopPRB		
	Not present		RF OR RRM
format CHOICE {			
format0 SEQUENCE {			
initialCyclicShift	0		

nrofSymbols	2		
startingSymbolIndex	12		
}			
}			
PUCCH-Resource[8] SEQUENCE {		entry 8	
pucch-ResourceId	7		
startingPRB	PRB-Id		
intraSlotFrequencyHopping	enabled		
	Not present		RF OR RRM
secondHopPRB	PRB-Id with condition secondHopPRB		
	Not present		RF OR RRM
format CHOICE {			
format1 SEQUENCE {			
initialCyclicShift	0		
nrofSymbols	14		
startingSymbolIndex	0		
timeDomainOCC	0		
}			
}			
}			
PUCCH-Resource[9] SEQUENCE {		entry 9	
pucch-ResourceId	8		
startingPRB	PRB-Id		
intraSlotFrequencyHopping	enabled		
	Not present		RF OR RRM
secondHopPRB	PRB-Id with condition secondHopPRB		
	Not present		RF OR RRM
format CHOICE {			
format2 SEQUENCE {			
nrofPRBs	6		
nrofSymbols	2		
startingSymbolIndex	0		
}			
}			
}			
PUCCH-Resource[10] SEQUENCE {		entry 10	
pucch-ResourceId	9		
startingPRB	PRB-Id		
intraSlotFrequencyHopping	enabled		
	Not present		RF OR RRM
secondHopPRB	PRB-Id with condition secondHopPRB		
	Not present		RF OR RRM
format CHOICE {			
format2 SEQUENCE {			
nrofPRBs	6		
nrofSymbols	2		
startingSymbolIndex	2		
}			
}			
}			
PUCCH-Resource[11] SEQUENCE {		entry 11	
pucch-ResourceId	10		
startingPRB	PRB-Id		
intraSlotFrequencyHopping	enabled		
	Not present		RF OR RRM
secondHopPRB	PRB-Id with condition secondHopPRB		
	Not present		RF OR RRM
format CHOICE {			
format2 SEQUENCE {			
nrofPRBs	6		
nrofSymbols	2		

startingSymbolIndex	4		
}			
}			
PUCCH-Resource[12] SEQUENCE {		entry 12	
pucch-ResourceId	11		
startingPRB	PRB-Id		
intraSlotFrequencyHopping	enabled		
	Not present		RF OR RRM
secondHopPRB	PRB-Id with condition secondHopPRB		
	Not present		RF OR RRM
format CHOICE {			
format2 SEQUENCE {			
nrofPRBs	6		
nrofSymbols	2		
startingSymbolIndex	6		
}			
}			
PUCCH-Resource[13] SEQUENCE {		entry 13	
pucch-ResourceId	12		
startingPRB	PRB-Id		
intraSlotFrequencyHopping	enabled		
	Not present		RF OR RRM
secondHopPRB	PRB-Id with condition secondHopPRB		
	Not present		RF OR RRM
format CHOICE {			
format2 SEQUENCE {			
nrofPRB	6		
nrofSymbols	2		
startingSymbolIndex	8		
}			
}			
PUCCH-Resource[14] SEQUENCE {		entry 14	
pucch-ResourceId	13		
startingPRB	PRB-Id		
intraSlotFrequencyHopping	enabled		
	Not present		RF OR RRM
secondHopPRB	PRB-Id with condition secondHopPRB		
	Not present		RF OR RRM
format CHOICE {			
format2 SEQUENCE {			
nrofPRBsinitial	6		
nrofSymbols	2		
startingSymbolIndex	10		
}			
}			
PUCCH-Resource[15] SEQUENCE {		entry 15	
pucch-ResourceId	14		
startingPRB	PRB-Id		
intraSlotFrequencyHopping	enabled		
	Not present		RF OR RRM
secondHopPRB	PRB-Id with condition secondHopPRB		
	Not present		RF OR RRM
format CHOICE {			
format2 SEQUENCE {			
nrofPRB	6		
nrofSymbols	2		
startingSymbolIndex	12		
}			

}			
}			
PUCCH-Resource[16] SEQUENCE {		entry 16	
pucch-ResourceId	15		
startingPRB	PRB-Id		
intraSlotFrequencyHopping	enabled		
	Not present		RF OR RRM
secondHopPRB	PRB-Id with condition secondHopPRB		
	Not present		RF OR RRM
format CHOICE {			
format3 SEQUENCE {			
nrofPRBs	1		
nrofSymbols	14		
startingSymbolIndex	0		
}			
}			
}			
resourceToReleaseList	Not present		
format1 CHOICE {			
setup SEQUENCE {			
interslotFrequencyHopping	enabled		
additionalDMRS	Not Present		
maxCodeRate	Not Present		
nrofSlots	Not present		
pi2BPSK	Not present		
simultaneousHARQ-ACK-CSI	Not Present		
}			
}			
format2 CHOICE {			
setup SEQUENCE {			
interslotFrequencyHopping	Not Present		
additionalDMRS	Not Present		
maxCodeRate	zeroDot25		
nrofSlots	Not present		
pi2BPSK	Not present		
simultaneousHARQ-ACK-CSI	True		
}			
}			
format3 CHOICE {			
setup SEQUENCE {			
interslotFrequencyHopping	enabled		
additionalDMRS	True		
maxCodeRate	zeroDot25		
nrofSlots	Not present		
pi2BPSK	Not present		
simultaneousHARQ-ACK-CSI	true		
}			
}			
format4	Not present		
schedulingRequestResourceToAddModList SEQUENCE (SIZE (1..maxNrofSR-Resources)) OF SchedulingRequestResourceConfig {	1 entry		
SchedulingRequestResourceConfig[1]	SchedulingRequestResourceConfig	entry 1	
}			
schedulingRequestResourceToReleaseList	Not present		
multi-CSI-PUCCH-ResourceList	Not present		
dl-DataToUL-ACK SEQUENCE (SIZE (1..8)) OF INTEGER {	8 entries		
INTEGER[1]	2	entry 1	
INTEGER[2]	3	entry 2	
INTEGER[3]	4	entry 3	
INTEGER[4]	5	entry 4	
INTEGER[5]	6	entry 5	

INTEGER[6]	7	entry 6	
INTEGER[7]	8	entry 7	
INTEGER[8]	9	entry 8	
}			
dl-DataToUL-ACK	Not present		Short_DCI
spatialRelationInfoToAddModList	Not present		
spatialRelationInfoToReleaseList	Not present		
pucch-PowerControl	PUCCH-PowerControl		
resourceToAddModListExt-r16	Not present		
dl-DataToUL-ACK-r16	Not present		
ul-AccessConfigListDCI-1-1-r16	Not present		
subslotLengthForPUCCH-r16	Not present		
dl-DataToUL-ACK-DCI-1-2-r16	Not present		
numberOfBitsForPUCCH-ResourceIndicatorDCI-1-2-r16	Not present		
dmrs-UplinkTransformPrecodingPUCCH-r16	Not present		
spatialRelationInfoToAddModListSizeExt-v1610	Not present		
spatialRelationInfoToReleaseListSizeExt-v1610	Not present		
spatialRelationInfoToAddModListExt-v1610	Not present		
spatialRelationInfoToReleaseListExt-v1610	Not present		
resourceGroupToAddModList-r16	Not present		
resourceGroupToReleaseList-r16	Not present		
sps-PUCCH-AN-List-r16	Not present		
schedulingRequestResourceToAddModListExt-v1610	Not present		
}			

Condition	Explanation
Short_DCI	Used in test scenarios requiring DCI formats 0-0 and 1-0 on USS

– *PUCCH-ConfigCommon*

**Table 4.6.3-113: PUCCH-ConfigCommon**

Derivation Path: TS 38.331 [6], clause 6.3.2			
Information Element	Value/remark	Comment	Condition
PUCCH-ConfigCommon ::= SEQUENCE {			
pucch-ResourceCommon	0		
pucch-GroupHopping	enable		
hoppingId	Not present		
p0-nominal	-90		
}			

– *PUCCH-ConfigurationList*

**Table 4.6.3-113A: PUCCH-ConfigurationList**

Derivation Path: TS 38.331 [6], clause 6.3.2			
Information Element	Value/remark	Comment	Condition
PUCCH-ConfigurationList-r16 ::= SEQUENCE {			
FFS			
}			

– *PUCCH-PathlossReferenceRS-Id*

**Table 4.6.3-114: PUCCH-PathlossReferenceRS-Id**

Derivation Path: TS 38.331 [6], clause 6.3.2			
Information Element	Value/remark	Comment	Condition

PUCCH-PathlossReferenceRS-Id	0		
------------------------------	---	--	--

– *PUCCH-PowerControl*

**Table 4.6.3-115: PUCCH-PowerControl**

Derivation Path: TS 38.331 [6], clause 6.3.2			
Information Element	Value/remark	Comment	Condition
PUCCH-PowerControl ::= SEQUENCE {			
deltaF-PUCCH-f0	0		
deltaF-PUCCH-f1	0		
deltaF-PUCCH-f2	0		
deltaF-PUCCH-f3	0		
deltaF-PUCCH-f4	0		
p0-Set	Not present		
pathlossReferenceRSs SEQUENCE (SIZE (1..maxNrofPUCCH-PathlossReferenceRSs)) OF PUCCH-PathlossReferenceRS {	1 entry		
PUCCH-PathlossReferenceRS[1] SEQUENCE {		entry 1	
pucch-PathlossReferenceRS-Id	PUCCH-PathlossReferenceRS-Id		
referenceSignal CHOICE {			
ssb-Index	SSB-Index		
}			
}			
twoPUCCH-PC-AdjustmentStates	Not present		
}			

– *PUCCH-SpatialRelationInfo*

**Table 4.6.3-116: PUCCH-SpatialRelationInfo**

Derivation Path: TS 38.331 [6], clause 6.3.2			
Information Element	Value/remark	Comment	Condition
PUCCH-SpatialRelationInfo ::= SEQUENCE {			
pucch-SpatialRelationInfoId	1		
servingCellId	ServCellIndex		
referenceSignal CHOICE {			
ssb-Index	SSB-Index		
}			
pucch-PathlossReferenceRS-Id	PUCCH-PathlossReferenceRS-Id		
p0-PUCCH-Id	1		
closedLoopIndex	i0		
}			

– *PUCCH-SpatialRelationInfo-Id*

**Table 4.6.3-116A: PUCCH-SpatialRelationInfo-Id**

Derivation Path: TS 38.331 [6], clause 6.3.2			
Information Element	Value/remark	Comment	Condition
PUCCH-SpatialRelationInfoId ::= SEQUENCE {			
FFS			
}			



– *PUCCH-TPC-CommandConfig***Table 4.6.3-117: PUCCH-TPC-CommandConfig**

Derivation Path: TS 38.331 [6], clause 6.3.2			
Information Element	Value/remark	Comment	Condition
PUCCH-TPC-CommandConfig ::= SEQUENCE {			
FFS			
}			

– *PUSCH-Config***Table 4.6.3-118: PUSCH-Config**

Derivation Path: TS 38.331 [6], clause 6.3.2			
Information Element	Value/remark	Comment	Condition
PUSCH-Config ::= SEQUENCE {			
dataScramblingIdentityPUSCH	Not present		
txConfig	Not Present		Short_DCI
codebook			
dmrs-UplinkForPUSCH-MappingTypeA CHOICE {			
setup	DMRS-UplinkConfig		
}			
dmrs-UplinkForPUSCH-MappingTypeB	Not present		
pusch-PowerControl	PUSCH-PowerControl		
frequencyHopping	Not present		
frequencyHoppingOffsetLists	Not present		
resourceAllocation	resourceAllocationType1		
pusch-TimeDomainAllocationList	Not present		
pusch-AggregationFactor	Not present		
mcs-Table	Not present		
mcs-TableTransformPrecoder	Not present		
transformPrecoder	enabled		TRANSFORM_P RECORDER_ENABL ED
	Not present	TRANSFORM_P RECORDER_DISA BLED	
codebookSubset	Not present		Short_DCI
	nonCoherent		
maxRank	Not present		Short_DCI
	1		
	2		2TX_UL_MI MO
rbg-Size	Not present		
uci-OnPUSCH CHOICE {			
setup SEQUENCE {			
betaOffsets CHOICE {			
semiStatic	BetaOffsets		
}			
scaling	f1		
}			
tp-pi2BPSK	Not present		
minimumSchedulingOffsetK2-r16	Not present		
ul-AccessConfigListDCI-0-1-r16	Not present		
harq-ProcessNumberSizeDCI-0-2-r16	Not present		
dmrs-SequenceInitializationDCI-0-2-r1	Not present		
numberOfBitsForRV-DCI-0-2-r16	Not present		
antennaPortsFieldPresenceDCI-0-2-r16	Not present		
dmrs-UplinkForPUSCH-MappingTypeA-DCI-0-2-r16	Not present		
dmrs-UplinkForPUSCH-MappingTypeB-DCI-0-2-r16	Not present		
frequencyHoppingDCI-0-2-r16	Not present		

frequencyHoppingOffsetListsDCI-0-2-r16	Not present		
codebookSubsetDCI-0-2-r16	Not present		
invalidSymbolPatternIndicatorDCI-0-2-r16	Not present		
maxRankDCI-0-2-r16	Not present		
mcs-TableDCI-0-2-r16	Not present		
mcs-TableTransformPrecoderDCI-0-2-r16	Not present		
priorityIndicatorDCI-0-2-r16	Not present		
pusch-RepTypeIndicatorDCI-0-2-r16	Not present		
resourceAllocationDCI-0-2-r16	Not present		
resourceAllocationType1GranularityDCI-0-2-r16	Not present		
uci-OnPUSCH-ListDCI-0-2-r16	Not present		
pusch-TimeDomainAllocationListDCI-0-2-r16	Not present		
pusch-TimeDomainAllocationListDCI-0-1-r16	Not present		
invalidSymbolPatternIndicatorDCI-0-1-r16	Not present		
priorityIndicatorDCI-0-1-r16	Not present		
pusch-RepTypeIndicatorDCI-0-1-r16	Not present		
frequencyHoppingDCI-0-1-r16	Not present		
uci-OnPUSCH-ListDCI-0-1-r16	Not present		
invalidSymbolPattern-r16	Not present		
pusch-PowerControl-v1610	Not present		
ul-FullPowerTransmission-r16	Not present		
pusch-TimeDomainAllocationListForMultiPUSCH-r16	Not present		
numberOfInvalidSymbolsForDL-UL-Switching-r16	Not present		
}			

Condition	Explanation
TRANSFORM_PRECODER_ENABLED	Transform precoding is enabled (DFT-s-OFDM UL waveform is configured)
2TX_UL_MIMO	UL-MIMO test cases with 2 Tx antenna ports
Short_DCI	Used in test scenarios requiring DCI formats 0-0 and 1-0 on USS

– *PUSCH-ConfigCommon*

**Table 4.6.3-119: PUSCH-ConfigCommon**

Derivation Path: TS 38.331 [6], clause 6.3.2			
Information Element	Value/remark	Comment	Condition
PUSCH-ConfigCommon ::= SEQUENCE {			
groupHoppingEnabledTransformPrecoding	Not present		
pusch-TimeDomainAllocationList	PUSCH-TimeDomainResourceAllocationList		
msg3-DeltaPreamble	1		
p0-NominalWithGrant	-90		
}			

– *PUSCH-PowerControl*

**Table 4.6.3-120: PUSCH-PowerControl**

Derivation Path: TS 38.331 [6], clause 6.3.2			
Information Element	Value/remark	Comment	Condition
PUSCH-PowerControl ::= SEQUENCE {			
tpc-Accumulation	Not present		
msg3-Alpha	alpha08		
p0-NominalWithoutGrant	-90		
p0-AlphaSets SEQUENCE (SIZE (1..maxNrofP0-PUSCH-AlphaSets)) OF P0-PUSCH-AlphaSet {	1 entry		
P0-PUSCH-AlphaSet[1] SEQUENCE {		entry 1	

p0-PUSCH-AlphaSetId	0		
p0	0		
alpha	alpha08		
}			
}			
pathlossReferenceRSToAddModList SEQUENCE (SIZE (1..maxNrofPUSCH-PathlossReferenceRSs)) OF PUSCH-PathlossReferenceRS {	1 entry		
PUSCH-PathlossReferenceRS[1] SEQUENCE {		entry 1	
pusch-PathlossReferenceRS-Id	0		
referenceSignal CHOICE{			
ssb-Index	SSB-Index		
}			
}			
}			
pathlossReferenceRSToReleaseList	Not present		
twoPUSCH-PC-AdjustmentStates	Not present		
deltaMCS	Not present		
sri-PUSCH-MappingToAddModList SEQUENCE (SIZE (1..maxNrofSRI-PUSCH-Mappings)) OF SRI-PUSCH-PowerControl {	1 entry		
SRI-PUSCH-PowerControl[1] SEQUENCE {		entry 1	
sri-PUSCH-PowerControlId	0		
sri-PUSCH-PathlossReferenceRS-Id	0		
sri-P0-PUSCH-AlphaSetId	0		
sri-PUSCH-ClosedLoopIndex	i0		
}			
}			
sri-PUSCH-MappingToReleaseList	Not present		
}			

– PUSCH-ServingCellConfig

Table 4.6.3-121: PUSCH-ServingCellConfig

Derivation Path: TS 38.331 [6], clause 6.3.2			
Information Element	Value/remark	Comment	Condition
PUSCH-ServingCellConfig ::= SEQUENCE {			
codeBlockGroupTransmission	Not present		
rateMatching	Not present		
xOverhead	Not present		
maxMIMO-Layers	Not present		
processingType2Enabled	Not present		
maxMIMO-LayersDCI-0-2-r16	Not present		
}			

– PUSCH-TimeDomainResourceAllocationList

Table 4.6.3-122: PUSCH-TimeDomainResourceAllocationList

Derivation Path: TS 38.331 [6], clause 6.3.2			
Information Element	Value/remark	Comment	Condition
PUSCH-TimeDomainResourceAllocationList ::= SEQUENCE (SIZE(1..maxNrofUL-Allocations)) OF PUSCH-TimeDomainResourceAllocation {	2 entries		
PUSCH-TimeDomainResourceAllocation[1] SEQUENCE {		entry 1	
k2	4		
	2		(RF OR RRM) AND (FR1 AND (SCS15 OR

			SCS30)) OR (FR2 AND SCS60 AND (DL OR RRM))
	3		((RF AND DL) OR RRM) AND FR2 AND SCS120
	6		((RF AND DL) OR RRM) AND FR1 AND SCS60
	4		RF AND FR2 AND SCS60 AND UL
	8		RF_FR2_12 0kHz_UL
mappingType	typeA		
startSymbolAndLength	27	Start symbol(S)=0, Length(L)=14	
}			
PUSCH-TimeDomainResourceAllocation[2] SEQUENCE {		entry 2 addressed by Msg3 PUSCH time resource allocation field of the Random Access Response acc. to TS 38.213 [22] Table 8.2-1.	
k2	Not present		
	2	K2+ Δ=4 acc. to TS 38.214 [21] Table 6.1.2.1.1-5 (NOTE 1)	FR1 AND SCS15
	6	K2+ Δ=9 acc. to TS 38.214 [21] Table 6.1.2.1.1-5 (NOTE 1)	FR1 AND SCS30
	3	K2+ Δ=9 acc. to TS 38.214 [21] Table 6.1.2.1.1-5 (NOTE 1)	FR2
mappingType	typeA		
startSymbolAndLength	27	Start symbol(S)=0, Length(L)=14	
}			
}			
NOTE 1: Values are chosen so that first slot of a TDD-UL-DL slot configuration period can be used for the Random Access Response and the last slot (of the same or another period) for the corresponding Msg3.			

Condition	Explanation
DL	RF Rx measurements.
UL	RF UL measurements.

*PUSCH-TimeDomainResourceAllocationList-r16*

**Table 4.6.3-122A: PUSCH-TimeDomainResourceAllocationList-r16**

Derivation Path: TS 38.331 [6], clause 6.3.2			
Information Element	Value/remark	Comment	Condition
PUSCH-TimeDomainResourceAllocationList-r16 ::= SEQUENCE (SIZE(1..maxNrofUL-Allocations-r16)) OF PUSCH-TimeDomainResourceAllocation-r16	2 entries		
PUSCH-TimeDomainResourceAllocation-r16[1] SEQUENCE {		entry 1	
k2-r16	4		
puschAllocationList-r16 SEQUENCE (SIZE(1..maxNrofMultiplePUSCHs-r16)) OF PUSCH-Allocation-r16 {	1 entry		
PUSCH-Allocation-r16[1] SEQUENCE {		entry 1	
mappingType-r16	typeA		
startSymbolAndLength-r16	27	start symbol(S)=0, Length(L)=14	
startSymbol-r16	Not present		
length-r16	Not present		
numberOfRepetitions-r16	Not present		
numberOfRepetitionsExt-r17	Not present		
numberOfSlotsTBoMS-r17	Not present		
extendedK2-r17	Not present		
}			
}			
}			
PUSCH-TimeDomainResourceAllocation-r16[2] SEQUENCE {		entry 2	
k2-r16	4		
puschAllocationList-r16 SEQUENCE (SIZE(1..maxNrofMultiplePUSCHs-r16)) OF PUSCH-Allocation-r16 {	1 entry		
PUSCH-Allocation-r16[1] SEQUENCE {		entry 1	
mappingType-r16	typeA		
startSymbolAndLength-r16	27	start symbol(S)=0, Length(L)=14	
startSymbol-r16	Not present		
length-r16	Not present		
numberOfRepetitions-r16	Not present		
numberOfRepetitionsExt-r17	Not present		
numberOfSlotsTBoMS-r17	Not present		
extendedK2-r17	Not present		
}			
}			
}			
}			

*PUSCH-TPC-CommandConfig*

**Table 4.6.3-123: PUSCH-TPC-CommandConfig**

Derivation Path: TS 38.331 [6], clause 6.3.2			
Information Element	Value/remark	Comment	Condition
PUSCH-TPC-CommandConfig ::= SEQUENCE {			
tpc-Index	Not present		
tpc-IndexSUL	Not present		
targetCell	Not present		
}			

– *Q-OffsetRange***Table 4.6.3-124: Q-OffsetRange**

Derivation Path: TS 38.331 [6], clause 6.3.2			
Information Element	Value/remark	Comment	Condition
Q-OffsetRange	dB0		

– *Q-QualMin***Table 4.6.3-125: Q-QualMin**

Derivation Path: TS 38.331 [6], clause 6.3.2			
Information Element	Value/remark	Comment	Condition
Q-QualMin	FFS		

– *Q-RxLevMin***Table 4.6.3-126: Q-RxLevMin**

Derivation Path: TS 38.331 [6], clause 6.3.2			
Information Element	Value/remark	Comment	Condition
Q-RxLevMin	FFS		

– *QuantityConfig***Table 4.6.3-127: QuantityConfig**

Derivation Path: TS 38.331 [6], clause 6.3.2			
Information Element	Value/remark	Comment	Condition
QuantityConfig ::= SEQUENCE {			
quantityConfigNR-List SEQUENCE (SIZE (1..maxNrofQuantityConfig)) OF QuantityConfigNR {	2 entries		
QuantityConfigNR[1] SEQUENCE {		entry 1	
quantityConfigCell SEQUENCE {			
ssb-FilterConfig SEQUENCE {			
filterCoefficientRSRP	FilterCoefficient		
filterCoefficientRSRQ	FilterCoefficient		
filterCoefficientRS-SINR	FilterCoefficient		
}			
csi-RS-FilterConfig SEQUENCE {			
filterCoefficientRSRP	FilterCoefficient		
filterCoefficientRSRQ	FilterCoefficient		
filterCoefficientRS-SINR	FilterCoefficient		
}			
}			
quantityConfigRS-Index SEQUENCE {			
ssb-FilterConfig SEQUENCE {			
filterCoefficientRSRP	FilterCoefficient		
filterCoefficientRSRQ	FilterCoefficient		
filterCoefficientRS-SINR	FilterCoefficient		
}			
csi-RS-FilterConfig SEQUENCE {			
filterCoefficientRSRP	FilterCoefficient		
filterCoefficientRSRQ	FilterCoefficient		
filterCoefficientRS-SINR	FilterCoefficient		
}			
}			
}			
QuantityConfigNR[2] SEQUENCE {		entry 2	

quantityConfigCell SEQUENCE {			
ssb-FilterConfig SEQUENCE {			
filterCoefficientRSRP	FilterCoefficient		
filterCoefficientRSRQ	FilterCoefficient		
filterCoefficientRS-SINR	FilterCoefficient		
}			
csi-RS-FilterConfig SEQUENCE {			
filterCoefficientRSRP	FilterCoefficient		
filterCoefficientRSRQ	FilterCoefficient		
filterCoefficientRS-SINR	FilterCoefficient		
}			
}			
quantityConfigRS-Index SEQUENCE {			
ssb-FilterConfig SEQUENCE {			
filterCoefficientRSRP	FilterCoefficient		
filterCoefficientRSRQ	FilterCoefficient		
filterCoefficientRS-SINR	FilterCoefficient		
}			
csi-RS-FilterConfig SEQUENCE {			
filterCoefficientRSRP	FilterCoefficient		
filterCoefficientRSRQ	FilterCoefficient		
filterCoefficientRS-SINR	FilterCoefficient		
}			
}			
}			
}			
quantityConfigEUTRA	Not present		
quantityConfigEUTRA SEQUENCE {			INTER-RAT
filterCoefficientRSRP	FilterCoefficient		
filterCoefficientRSRQ	FilterCoefficient		
filterCoefficientRS-SINR	FilterCoefficient		
}			
quantityConfigUTRA-FDD-r16	Not present		
quantityConfigUTRA-FDD-r16 SEQUENCE {			INTER-RAT_UTRA
filterCoefficientRSCP-r16	FilterCoefficient		
filterCoefficientEcNO-r16	FilterCoefficient		
}			
quantityConfigCLI-r16	Not present		
}			

Condition	Explanation
INTER-RAT	Configuration for EUTRA inter-RAT measurements
INTER-RAT_UTRA	Configuration for UTRA inter-RAT measurements

– RACH-ConfigCommon

Table 4.6.3-128: RACH-ConfigCommon

Derivation Path: TS 38.331 [6], clause 6.3.2			
Information Element	Value/remark	Comment	Condition
RACH-ConfigCommon ::= SEQUENCE {			
rach-ConfigGeneric	RACH-ConfigGeneric		
totalNumberOfRA-Preambles	Not present		
ssb-perRACH-OccasionAndCB-PreamblesPerSSB CHOICE {			
one	n8		FR1
	n4		FR2
}			
groupBconfigured	Not present		
ra-ContentionResolutionTimer	sf64		
rsrp-ThresholdSSB	RSRP-Range		
rsrp-ThresholdSSB-SUL	Not present		

	RSRP-Range		SUL
prach-RootSequenceIndex CHOICE { 1139 }	Set according to table 4.4.2-2 for the NR Cell.		
msg1-SubcarrierSpacing	SubcarrierSpacing		
restrictedSetConfig	unrestrictedSet		
msg3-transformPrecoder	Not present	transform precoding is disabled for Msg3 PUSCH transmission and any PUSCH transmission scheduled with DCI format 0_0	
ra-PrioritizationForAccessIdentity-r16	Not present		
prach-RootSequenceIndex-r16	Not present		
ra-PrioritizationForSlicing-r17	Not present		
	RA-PrioritizationForSlicing-r17		Slice_RACH
featureCombinationPreambles-r17 SEQUENCE (SIZE(1..maxFeatureCombPreamblesPerRACHResource-r17)) OF FeatureCombinationPreambles-r17{}	Not present		
	FeatureCombinationPreambles-r17		Slice_RACH
}			

Condition	Explanation
SUL	Supplementary uplink
Slice_RACH	Slice specific RACH configuration

– RACH-ConfigCommonTwoStepRA

Table 4.6.3-128A: RACH-ConfigCommonTwoStepRA

Derivation Path: TS 38.331 [6], clause 6.3.2			
Information Element	Value/remark	Comment	Condition
RACH-ConfigCommonTwoStepRA-r16 ::= SEQUENCE {			
rach-ConfigGenericTwoStepRA-r16	RACH-ConfigGenericTwoStepRA		
msgA-TotalNumberOfRA-Preambles-r16	Not present		
msgA-SSB-PerRACH-OccasionAndCB-PreamblesPerSSB-r16 CHOICE {	Not present		
one	n8		FR1
}	n4		FR2
}			
msgA-CB-PreamblesPerSSB-PerSharedRO-r16	Not present		
msgA-SSB-SharedRO-MaskIndex-r16	Not present		
groupB-ConfiguredTwoStepRA-r16	Not present		
msgA-PRACH-RootSequenceIndex-r16 CHOICE {}	Not present		
msgA-TransMax-r16	N8		
msgA-RSRP-Threshold-r16	RSRP-Range		
msgA-RSRP-ThresholdSSB-r16	RSRP-Range		
msgA-SubcarrierSpacing-r16	Not present		
msgA-RestrictedSetConfig-r16	Not present		
ra-PrioritizationForAccessIdentityTwoStep-r16 SEQUENCE {			
ra-Prioritization-r16	RA-Prioritization		
ra-PrioritizationForAI-r16	'10'B		
}			



ra-ContentionResolutionTimer-r16	sf32		
ra-PrioritizationForSlicingTwoStep-r17	Not present		
	RA-PrioritizationForSlicing		Slice_RACH
featureCombinationPreamblesList-r17 SEQUENCE (SIZE(1..maxFeatureCombPreamblesPerRACHResource-r17)) OF FeatureCombinationPreambles-r17{	Not present		
	FeatureCombinationPreambles		Slice_RACH
}			

Condition	Explanation
Slice_RACH	Slice specific RACH configuration

– RACH-ConfigDedicated

Table 4.6.3-129: RACH-ConfigDedicated

Derivation Path: TS 38.331 [6], clause 6.3.2			
Information Element	Value/remark	Comment	Condition
RACH-ConfigDedicated ::= SEQUENCE {			
cfra SEQUENCE {			
occasions SEQUENCE {			
rach-ConfigGeneric	RACH-ConfigGeneric		
ssb-perRACH-Occasion	one		
}			
resources CHOICE {			
ssb SEQUENCE {			
ssb-ResourceList SEQUENCE (SIZE(1..maxRA-SSB-Resources)) OF CFRA-SSB-Resource {	1 entry		
CFRA-SSB-Resource[1] SEQUENCE {		entry 1	
ssb	SSB-Index		
ra-PreambleIndex	8		
}			
}			
ra-ssb-OccasionMaskIndex	0		
}			
}			
ra-Prioritization	Not present		
ra-PrioritizationTwoStep-r16	Not present		
cfra-TwoStep-r16 SEQUENCE {	Not present		
}			2-step RA
occasionsTwoStepRA-r16 SEQUENCE {			
rach-ConfigGenericTwoStepRA-r16	RACH-ConfigGenericTwoStepRA		
ssb-PerRACH-OccasionTwoStepRA-r16			
}			
msgA-CFRA-PUSCH-r16	MsgA-PUSCH-Resource		
msgA-TransMax-r16	N10		
resourcesTwoStep-r16 SEQUENCE {			
ssb-ResourceList SEQUENCE (SIZE(1..maxRA-SSB-Resources)) OF CFRA-SSB-Resource {			
ssb	0		
ra-PreambleIndex	52	Randomly selected	
msgA-PUSCH-Resource-Index-r16	Not present		
}			
ra-ssb-OccasionMaskIndex	0		
}			
}			

--	--	--

Condition	Explanation
2-step RA	2-step RA type Random Access

– *RACH-ConfigGeneric*

**Table 4.6.3-130: RACH-ConfigGeneric**

Derivation Path: TS 38.331 [6], clause 6.3.2			
Information Element	Value/remark	Comment	Condition
RACH-ConfigGeneric ::= SEQUENCE {			
prach-ConfigurationIndex	160		FR1
	157		FR1 AND HD_FDD
	149		FR2
msg1-FDM	four		FR1
	one		FR2
msg1-FrequencyStart	0		
zeroCorrelationZoneConfig	15		
preambleReceivedTargetPower	-118		
preambleTransMax	n7		
powerRampingStep	dB4		
ra-ResponseWindow	sl20		
	sl10		FR1 AND SCS15
}			

Condition	Explanation
HD_FDD	SIG AND pc_halfDuplexFDD_TypeA_RedCap_r17 (i.e HD_FDD UE are performing signaling test on FDD band)

– *RACH-ConfigGenericTwoStepRA*

**Table 4.6.3-130A: RACH-ConfigGenericTwoStepRA**

Derivation Path: TS 38.331 [6], clause 6.3.2			
Information Element	Value/remark	Comment	Condition
RACH-ConfigGenericTwoStepRA-r16 ::= SEQUENCE {			
msgA-PRACH-ConfigurationIndex-r16	120		
msgA-RO-FDM-r16	four		
msgA-RO-FrequencyStart-r16	0		
msgA-ZeroCorrelationZoneConfig-r16	15		
msgA-PreamblePowerRampingStep-r16	dB0		
msgA-PreambleReceivedTargetPower-r16	-118		
msgB-ResponseWindow-r16	sl2		
preambleTransMax-r16	n10		
}			

– *RA-Prioritization*

**Table 4.6.3-131: RA-Prioritization**

Derivation Path: TS 38.331 [6], clause 6.3.2			
Information Element	Value/remark	Comment	Condition
RA-Prioritization ::= SEQUENCE {			
powerRampingStepHighPriority	dB0		

	FFS		Slice_RACH
scalingFactorBI	zero	zero corresponds to 0	
	FFS		Slice_RACH
}			

Condition	Explanation
Slice_RACH	Slice specific RACH configuration

– *RA-PrioritizationForSlicing*

**Table 4.6.3-131A: RA-PrioritizationForSlicing**

Derivation Path: TS 38.331 [6], clause 6.3.2			
Information Element	Value/remark	Comment	Condition
RA-PrioritizationForSlicing-r17 ::= SEQUENCE {			
ra-PrioritizationSlicelInfoList-r17 SEQUENCE (SIZE (1..maxSlicelInfo-r17)) OF RA-PrioritizationSlicelInfo-r17 {	1 entry		
RA-PrioritizationSlicelInfo-r17[1] SEQUENCE{		entry 1	
nsagIDList-r17 SEQUENCE (SIZE (1..maxSlicelInfo-r17)) OF NSAG-ID-r17 {	n entries	n is the number of NSAG values associated with the configured set of RA resources	
NSAG-ID-r17[k, k=1..n]	Set to the corresponding NSAG value used in the test case	entry [k, k=1..n]	
}			
}	RA-Prioritization		
}			

– *RadioBearerConfig*

**Table 4.6.3-132: RadioBearerConfig**

Derivation Path: TS 38.331 [6], clause 6.3.2			
Information Element	Value/remark	Comment	Condition
RadioBearerConfig ::= SEQUENCE {			
srb-ToAddModList	Not present		
srb-ToAddModList SEQUENCE (SIZE (1..2)) OF SRB-ToAddMod {	1 entry		SRB1
SRB-ToAddMod[1] SEQUENCE {		entry 1	
SRB-Identity	SRB-Identity with condition SRB1		
reestablishPDCP	Not present		
discardOnPDCP	Not present		
pdcpc-Config	Not present	Default	
}			
}			
srb-ToAddModList SEQUENCE (SIZE (1..2)) OF SRB-ToAddMod {	1 entry		SRB2, RESUME
SRB-ToAddMod[1] SEQUENCE {		entry 1	
SRB-Identity	SRB-Identity with condition SRB2		
reestablishPDCP	Not present		
discardOnPDCP	true		RESUME
}	Not present		

pdcp-Config	Not present	Default	
}			
}			
srb-ToAddModList SEQUENCE (SIZE (1..2)) OF SRB-ToAddMod {	1 entry		SRB3
SRB-ToAddMod[1] SEQUENCE {		entry 1	
srb-Identity	SRB-Identity with condition SRB3		
reestablishPDCP	Not present		
discardOnPDCP	Not present		
pdcp-Config	Not present	Default	
}			
}			
srb-ToAddModList SEQUENCE (SIZE (1..2)) OF SRB-ToAddMod {	2 entries		SRB_NR_P DCP REEST
SRB-ToAddMod[1] SEQUENCE {		entry 1	
SRB-Identity	SRB-Identity with condition SRB1		
reestablishPDCP	Not present true		SRB_NR_P DCP AND Re-establish_P DCP
discardOnPDCP	Not present		
pdcp-Config	Not present	Default	
}			
SRB-ToAddMod[2] SEQUENCE {		entry 2	
SRB-Identity	SRB-Identity with condition SRB2		
reestablishPDCP	Not present true		SRB_NR_P DCP AND Re-establish_P DCP, REEST
discardOnPDCP	Not present		
pdcp-Config	Not present	Default	
}			
}			
srb3-ToRelease	Not present		
drb-ToAddModList	Not present		
drb-ToAddModList SEQUENCE (SIZE (1..maxDRB)) OF DRB-ToAddMod {	1 entry		EN-DC_DRB
DRB-ToAddMod[1] SEQUENCE {		entry 1	
cnAssociation CHOICE {			
eps-BearerIdentity	6		
}			
drb-Identity	DRB-Identity using condition DRB2		
reestablishPDCP	Not present true		EN-DC_DRB AND Re-establish_P DCP
recoverPDCP	Not present true		EN-DC_DRB AND Recover_PDCP
pdcp-Config	PDCP-Config		
}			

}			
drb-ToAddModList SEQUENCE (SIZE (1..maxDRB)) OF DRB-ToAddMod {	1 entry		MCG_NR_P DCP
DRB-ToAddMod[1] SEQUENCE {		entry 1	
cnAssociation CHOICE {			
eps-BearerIdentity	12	EPS Bearer Id of default MCG DRB	
}			
drb-Identity	8	DRB Id of default MCG DRB	
reestablishPDCP	Not present		
recoverPDCP	Not present		
pdcp-Config	PDCP-Config		
}			
drb-ToAddModList SEQUENCE (SIZE (1..maxDRB)) OF DRB-ToAddMod {	1 entry		DRB1
DRB-ToAddMod[1] SEQUENCE {		entry 1	
cnAssociation CHOICE {			
sdap-Config	SDAP-Config		
}			
drb-Identity	DRB-Identity using condition DRB1		
reestablishPDCP	Not present true		DRB1 AND Re- establish_P DCP
recoverPDCP	Not present true		DRB1 AND Recover_PD CP
pdcp-Config	PDCP-Config		
daps-Config-r16	Not present true		DRB1 AND DAPS_PDC P
}			
}			
drb-ToAddModList SEQUENCE (SIZE (1..maxDRB)) OF DRB-ToAddMod {	1 entry		DRB2
DRB-ToAddMod[1] SEQUENCE {		entry 1	
cnAssociation CHOICE {			
sdap-Config	SDAP-Config		
}			
drb-Identity	DRB-Identity using condition DRB2		
reestablishPDCP	Not present true		DRB2 AND Re- establish_P DCP
recoverPDCP	Not present true		DRB2 AND Recover_PD CP
pdcp-Config	PDCP-Config		
daps-Config-r16	Not present		
}			
}			
drb-ToAddModList SEQUENCE (SIZE (1..maxDRB)) OF DRB-ToAddMod {	n entries	n is the number of DRBs established before RRC resume or RRC re-establishment	RESUME, REEST
DRB-ToAddMod[k, k=1..n] SEQUENCE {		entry [k, k=1..n]	

cnAssociation	Not present		
drb-Identity	DRB-Identity with condition DRBk		
reestablishPDCP	true		
recoverPDCP	Not present		
pdcp-Config	Not present		
daps-Config-r16	Not present		
}			
}			
drb-ToAddModList SEQUENCE (SIZE (1..maxDRB)) OF DRB-ToAddMod {	1 entry		DRBn
DRB-ToAddMod[1] SEQUENCE {		entry 1	
cnAssociation CHOICE {			
sdap-Config	SDAP-Config SDAP-Config with conditionNo-defaultDRB		SCG_DRB
}			
drb-Identity	DRB-Identity with condition DRBn		
reestablishPDCP	Not present		
recoverPDCP	Not present		
pdcp-Config	PDCP-Config PDCP-Config with condition Split		Split
}			
}			
drb-ToReleaseList	Not present		
securityConfig	Not present		SRB1
securityConfig SEQUENCE {			
securityAlgorithmConfig	SecurityAlgorithmConfig		
keyToUse	master secondary		SRB3, EN-DC_DRB, SecondaryKeys
}			
mrb-ToAddModList-r17	Not present		
mrb-ToAddModList-r17 SEQUENCE (SIZE (1..maxDRB)) OF MRB-ToAddMod-r17 {	1 entry		MRBm
MRB-ToAddMod-r17 [1] SEQUENCE {		entry 1	
mbs-SessionId-r17	TMGI		
mrb-Identity-r17	MRB-Identity with condition MRBm		
mrb-IdentityNew-r17	Not present		
reestablishPDCP-r17	Not present		
recoverPDCP-r17	Not present		
pdcp-Config-r17	PDCP-Config with condition MRB_Initialization and UM_MRB and MRBm PDCP-Config with condition MRB_Initialization and MRBm		UM_bi_PTP, UM_PTP, UM_PTM, UMPTP_UMPTM
}			
}			
mrb-ToReleaseList-r17	Not present		
srb4-ToAddMod-r17	Not present		
srb4-ToRelease-r17	Not present		
}			

Condition	Explanation
SRB3	Establishment of SRB3
MCG_NR_PDCP	EN-DC MCG DRB configured or reconfigured with NR PDCP

SRB_Nr_PDCP	EN-DC and NR SRB1 and SRB2 configured with NR PDCP
SRB1	Establishment of SRB1
SRB2	Establishment of SRB2
DRB1	Establishment of DRB1
DRB2	Establishment of DRB2
DRBn	Establishment of DRBn
EN-DC_DRB	EN-DC DRB configured on SCG
Re-establish_PDCP	Re-establishment of PDCP
Recover_PDCP	Recovery of PDCP
RESUME	Used in RRCResume Message
REEST	The first RRCReconfiguration message after successful completion of the RRC re-establishment procedure.
SecondaryKeys	NR-DC SCG or MCG DRB configured or reconfigured with secondary security keys
Split	Split PDCP: more than one RLC
DAPS_PDCP	Used when the bearer is configured as DAPS bearer
SCG_DRB	Used when the bearer is configured as an SCG bearer in either NR-DC or NE-DC
MRBm	Establishment of MRBm
UM_bi_PTP	Multicast MRB with bidirectional RLC-UM configuration for receiving PTP transmission
UM_PTP	Multicast MRB with DL only RLC-UM configuration for receiving PTP transmission
UM_PTM	Multicast MRB with DL only RLC-UM entity for receiving PTM transmission
UMPTP_UMPTM	Multicast MRB with two RLC-UM entities, one DL only RLC-UM entity for receiving PTP transmission and the other DL only RLC-UM entity for receiving PTM transmission

– *RadioLinkMonitoringConfig*

**Table 4.6.3-133: RadioLinkMonitoringConfig**

Derivation Path: TS 38.331 [6], clause 6.3.2			
Information Element	Value/remark	Comment	Condition
RadioLinkMonitoringConfig ::= SEQUENCE {			
failureDetectionResourcesToAddModList	1 entry		
SEQUENCE (SIZE(1..maxNrofFailureDetectionResources)) OF			
RadioLinkMonitoringRS {			
RadioLinkMonitoringRS[1] SEQUENCE {		entry 1	
radioLinkMonitoringRS-Id	RadioLinkMonitoringRS-Id		
purpose	rlf		
detectionResource CHOICE {			
ssb-Index	SSB-Index		
}			
}			
}			
failureDetectionResourcesToReleaseList	Not present		
beamFailureInstanceMaxCount	Not present		
beamFailureDetectionTimer	Not present		
}			

– *RadioLinkMonitoringRS-Id*

**Table 4.6.3-134: RadioLinkMonitoringRS-Id**

Derivation Path: TS 38.331 [6], clause 6.3.2			
Information Element	Value/remark	Comment	Condition
RadioLinkMonitoringRS-Id	0		

– *RAN-AreaCode***Table 4.6.3-135: RAN-AreaCode**

Derivation Path: TS 38.331 [6], clause 6.3.2			
Information Element	Value/remark	Comment	Condition
RAN-AreaCode	1		

– *RateMatchPattern***Table 4.6.3-136: RateMatchPattern**

Derivation Path: TS 38.331 [6], clause 6.3.2			
Information Element	Value/remark	Comment	Condition
RateMatchPattern ::= SEQUENCE {			
rateMatchPatternId	RateMatchPatternId		
patternType CHOICE {			
controlResourceSet	ControlResourceSetId		
}			
subcarrierSpacing	SubcarrierSpacing		
dummy	semiStatic	Dummy IE value	
}			

– *RateMatchPatternId***Table 4.6.3-137: RateMatchPatternId**

Derivation Path: TS 38.331 [6], clause 6.3.2			
Information Element	Value/remark	Comment	Condition
RateMatchPatternId	0		

– *RateMatchPatternLTE-CRS***Table 4.6.3-138: RateMatchPatternLTE-CRS**

Derivation Path: TS 38.331 [6], clause 6.3.2			
Information Element	Value/remark	Comment	Condition
RateMatchPatternLTE-CRS ::= SEQUENCE {			
FFS			
}			

– *ReferenceLocation***Table 4.6.3-138AA: ReferenceLocation**

Derivation Path: TS 38.331 [6], clause 6.3.2			
Information Element	Value/remark	Comment	Condition
ReferenceLocation-r17	FFS		



– *ReferenceTimeInfo***Table 4.6.3-138A: ReferenceTimeInfo**

Derivation Path: TS 38.331 [6], clause 6.3.2			
Information Element	Value/remark	Comment	Condition
ReferenceTimeInfo-r16 ::= SEQUENCE {			
time-r16 ::= SEQUENCE {			
refDays-r16	obtained from the local clock		
refSeconds-r16	obtained from the local clock		
refMilliSeconds-r16	obtained from the local clock		
refTenNanoSeconds-r16	obtained from the local clock		
}			
uncertainty-r16	not present		
timeInfoType-r16	localClock		
referenceSFN-r16	SFN of PCell		
}			

– *RejectWaitTime***Table 4.6.3-139: RejectWaitTime**

Derivation Path: TS 38.331 [6], clause 6.3.2			
Information Element	Value/remark	Comment	Condition
RejectWaitTime	1		

– *RepetitionSchemeConfig***Table 4.6.3-139A: RepetitionSchemeConfig**

Derivation Path: TS 38.331 [6], clause 6.3.2			
Information Element	Value/remark	Comment	Condition
RepetitionSchemeConfig-r16 ::= CHOICE {			
FFS			
}			

– *ReportConfigId***Table 4.6.3-140: ReportConfigId**

Derivation Path: TS 38.331 [6], clause 6.3.2			
Information Element	Value/remark	Comment	Condition
ReportConfigId	1		

– *ReportConfigInterRAT***Table 4.6.3-141: ReportConfigInterRAT (InterRAT-Thres, NR-Thres)**

Derivation Path: TS 38.331 [6], clause 6.3.2			
Information Element	Value/remark	Comment	Condition
ReportConfigInterRAT ::= SEQUENCE {			
reportType CHOICE {			
periodical SEQUENCE {			PERIODICAL

			OR PERIODICA L_UTRA
reportInterval	ReportInterval		
reportAmount	infinity		
reportQuantity SEQUENCE {		UE shall ignore the value(s) provided in reportQuantity if reportQuantityUTRA-FDD-r16 is configured.	
rsrp	true		
rsrq	true		
sinr	false		
}			
maxReportCells	8		
reportQuantityUTRA-FDD-r16	Not present		
reportQuantityUTRA-FDD-r16 SEQUENCE {			PERIODICA L_UTRA
cpich-RSCP	true		
cpich-EcN0	false		
}			
includeCommonLocationInfo-r16	Not present		
includeBT-Meas-r16	Not present		
includeWLAN-Meas-r16	Not present		
}			
eventTriggered SEQUENCE {			EVENT_B1 OR EVENT_B2 OR EVENT_B1_ UTRA OR EVENT_B2_ UTRA
eventId CHOICE {			
eventB1 SEQUENCE {			EVENT_B1
b1-ThresholdEUTRA CHOICE {			
rsrp	InterRAT-Thres	INTEGER (0..97)	
}			
reportOnLeave	false		
Hysteresis	0 (0 dB)	The actual value is field value * 0.5 dB	
timeToTrigger	ms0		
}			
eventB2 SEQUENCE {			EVENT_B2
b2-Threshold1 CHOICE {			
rsrp	NR-Thres	INTEGER(0..127)	
}			
b2-Threshold2EUTRA CHOICE {			
rsrp	InterRAT-Thres	INTEGER (0..97)	
}			
reportOnLeave	FALSE		
Hysteresis	3 (1.5dB)	The actual value is field value * 0.5 dB	
timeToTrigger	ms1024		
}			
eventB1-UTRA-FDD-r16 SEQUENCE {			EVENT_B1_ UTRA
b1-ThresholdUTRA-FDD-r16 CHOICE {			
utra-FDD-EcN0-r16	InterRAT-Thres		
}			
reportOnLeave-r16	false		
hysteresis-r16	0		

timeToTrigger-r16	ms0		
}			
eventB2-UTRA-FDD-r16 SEQUENCE {			EVENT_B2_ UTRA
b2-Threshold1-r16 CHOICE {			
rsrp	NR-Thres	INTEGER(0..127)	
}			
b2-Threshold2UTRA-FDD-r16 CHOICE {			
utra-FDD-EcN0-r16	InterRAT-Thres		
}			
reportOnLeave-r16	false		
hysteresis-r16	0		
timeToTrigger-r16	ms0		
}			
}			
rsType	ssb		
reportInterval	ms120		
reportAmount	r2		
reportQuantity SEQUENCE {		UE shall ignore the value(s) provided in reportQuantity if reportQuantityUTRA-FDD-r16 is configured.	
Rsrp	true		
rsrq	true		
sinr	false		
}			
maxReportCells	8		
reportQuantityUTRA-FDD-r16	Not present		
reportQuantityUTRA-FDD-r16 SEQUENCE {			EVENT_B1_ UTRA OR EVENT_B2_ UTRA
cpich-RSCP	false		
cpich-EcN0	true		
}			
includeCommonLocationInfo-r16	Not present		
includeBT-Meas-r16	Not present		
includeWLAN-Meas-r16	Not present		
includeSensor-Meas-r16	Not present		
}			
reportCGI SEQUENCE {			CGI
cellForWhichToReportCGI	EUTRA-PhysCellId		
}			
reportSFTD SEQUENCE {			SFTD- EUTRA
reportSFTD-Meas	true		
reportRSRP	false		
}			
}			
}			

Condition	Explanation
EVENT_B1	Configuration of Event B1 on E-UTRA carrier
EVENT_B2	Configuration of Event B2 on E-UTRA carrier
EVENT_B1_UTRA	Configuration of Event B1 on UTRA carrier
EVENT_B2_UTRA	Configuration of Event B2 on UTRA carrier
CGI	Configuration of CGI measurement
PERIODICAL	Configuration of periodical reporting on E-UTRA carrier
PERIODICAL_UTRA	Configuration of periodical reporting on UTRA carrier
SFTD-EUTRA	Configuration of SFTD measurement on E-UTRA PSCell

– *ReportConfigNR*Table 4.6.3-142: *ReportConfigNR*(Thres1, Thres2)

Derivation Path: TS 38.331 [6], clause 6.3.2			
Information Element	Value/remark	Comment	Condition
ReportConfigNR ::= SEQUENCE {			
reportType CHOICE {			
periodical SEQUENCE {			PERIODICAL
rsType	ssb		
reportInterval	ReportInterval		
reportAmount	infinity		
reportQuantityCell SEQUENCE {			
rsrp	true		
rsrq	true		
sinr	false		
	true		pc_ss_SINR_Meas
}			
}			
maxReportCells	8		
reportQuantityRS-Indexes	Not present		
maxNrofRS-IndexesToReport	Not present		
includeBeamMeasurements	false		
useAllowedCellList	false		
measRSSI-ReportConfig-r16	Not present		
includeCommonLocationInfo-r16	Not present		
includeBT-Meas-r16	Not present		
includeBT-Meas-r16 CHOICE {			MDT_BT
setup	BT-NameList		
}			
includeWLAN-Meas-r16	Not present		
includeWLAN-Meas-r16 CHOICE {			MDT_WLAN
setup	WLAN-NameList		
}			
includeSensor-Meas-r16	Not present		
includeSensor-Meas-r16 CHOICE {			MDT_SENSOR
setup	Sensor-NameList		
}			
ul-DelayValueConfig-r16	Not present		
ul-DelayValueConfig-r16 CHOICE {			MDT_DELAY
setup	UL-DelayValueConfig		
}			
reportAddNeighMeas-r16	Not present		
}			
eventTriggered SEQUENCE {			
eventId CHOICE {			
eventA1 SEQUENCE {			EVENT_A1
a1-Threshold CHOICE {			
rsrp	Thres1	Thres is an entry value into a mapping table in TS 38.133 [13].	
}			
}			
reportOnLeave	false		
hysteresis	Hysteresis		
timeToTrigger	TimeToTrigger		
}			
eventA2 SEQUENCE {			EVENT_A2
a2-Threshold CHOICE {			
rsrp	Thres1	Thres is an entry value into a mapping table in TS 38.133 [13].	

}			
reportOnLeave	false		
hysteresis	Hysteresis		
timeToTrigger	TimeToTrigger		
}			
eventA3 SEQUENCE {			EVENT_A3
a3-Offset CHOICE {			
rsrp	Thres1	Thres is an entry value into a mapping table in TS 38.133 [13].	
}			
reportOnLeave	false		
hysteresis	Hysteresis		
timeToTrigger	TimeToTrigger		
useAllowedCellList	false		
}			
eventA4 SEQUENCE {			EVENT_A4
a4-Threshold CHOICE {			
rsrp	Thres1	Thres is an entry value into a mapping table in TS 38.133 [13].	
}			
reportOnLeave	false		
hysteresis	Hysteresis		
timeToTrigger	TimeToTrigger		
useAllowedCellList	false		
}			
eventA5 SEQUENCE {			EVENT_A5
a5-Threshold1 CHOICE {			
rsrp	Thres1	Thres is an entry value into a mapping table in TS 38.133 [13].	
}			
a5-Threshold2 CHOICE {			
rsrp	Thres2	Thres is an entry value into a mapping table in TS 38.133 [13].	
}			
reportOnLeave	false		
hysteresis	Hysteresis		
timeToTrigger	TimeToTrigger		
useAllowedCellList	false		
}			
eventA6 SEQUENCE {			EVENT_A6
a6-Offset CHOICE {			
rsrp	Thres1	Thres is an entry value into a mapping table in TS 38.133 [13].	
}			
reportOnLeave	false		
hysteresis	Hysteresis		
timeToTrigger	TimeToTrigger		
useAllowedCellList	false		
}			
rsType	ssb		
reportInterval	ReportInterval		
reportAmount	r2		
reportQuantityCell SEQUENCE {			
rsrp	true		
rsrq	true		

sinr	false		
	true		pc_ss_SINR_Meas
}			
maxReportCells	8		
reportQuantityRS-Indexes	Not present		
maxNrofRS-IndexesToReport	Not present		
includeBeamMeasurements	false		
reportAddNeighMeas	Not present		
measRSSI-ReportConfig-r16	Not present		
	MeasRSSI-ReportConfig		SharedSpec trum
useT312-r16	Not present		
includeCommonLocationInfo-r16	Not present		MDT
includeBT-Meas-r16	Not present		
includeBT-Meas-r16 CHOICE {			MDT_BT
setup	BT-NameList		
}			
includeWLAN-Meas-r16	Not present		
includeWLAN-Meas-r16 CHOICE {			MDT_WLAN
setup	WLAN-NameList		
}			
includeSensor-Meas-r16	Not present		
includeSensor-Meas-r16 CHOICE {			MDT_SENS OR
setup	Sensor-NameList		
}			
}			
reportCGI SEQUENCE {			CGI
cellForWhichToReportCGI	PhysCellId		
}			
reportSFTD SEQUENCE {			SFTD_NEIG HBOUR or SFTD_PSC ELL
reportSFTD-Meas	false		SFTD_NEIG HBOUR
	true		SFTD_PSC ELL
reportRSRP	false		
reportSFTD-NeighMeas	true		SFTD_NEIG HBOUR
	Not present		SFTD_PSC ELL
drx-SFTD-NeighMeas	Not present		
cellsForWhichToReportSFTD	Not present		
}			
condTriggerConfig SEQUENCE {			CHO, CPC
condEventId CHOICE {			
condEventA3 SEQUENCE {			CHO AND EVENT_A3
a3-Offset CHOICE {			
rsrp	Thres1	Thres is an entry value into a mapping table in TS 38.133 [13].	
}			
hysteresis	Hysteresis		
timeToTrigger	TimeToTrigger		
}			
condEventA5 SEQUENCE {			CHO AND EVENT_A5
a5-Threshold1 CHOICE {			
rsrp	Thres1	Thres is an entry value into a	

		mapping table in TS 38.133 [13].	
}			
a5-Threshold2 CHOICE {			
rsp	Thres2	Thres is an entry value into a mapping table in TS 38.133 [13].	
}			
hysteresis	Hysteresis		
timeToTrigger	TimeToTrigger		
}			
rsType-r16	ssb		
}			
}			

Condition	Explanation
EVENT_A1	Configuration of Event A1
EVENT_A2	Configuration of Event A2
EVENT_A3	Configuration of Event A3
EVENT_A4	Configuration of Event A4
EVENT_A5	Configuration of Event A5
EVENT_A6	Configuration of Event A6
PERIODICAL	Configuration of periodical reporting
CGI	Configuration of CGI measurement
CHO	Configuration of conditional handover
CPC	Conditional PScell change
MDT	Configuration of MDT
MDT_BT	Configuration of MDT including Bluetooth measurements
MDT_WLAN	Configuration of MDT including WLAN measurements
MDT_SENSOR	Configuration of MDT including Sensor measurements
MDT_DELAY	Configuration of UL PDCP Packet Delay per DRB
SFTD_NEIGHBOUR	Configurations of SFTD measurement on NR neighbour
SFTD_PSCCELL	Configurations of SFTD measurement on NR PSCell
SharedSpectrum	Operation with shared spectrum channel access

– *ReportConfigNR-SL*

**Table 4.6.3-142A: ReportConfigNR-SL (Thres)**

Derivation Path: TS 38.331 [6], clause 6.3.2			
Information Element	Value/remark	Comment	Condition
ReportConfigNR-SL-r16 ::= SEQUENCE {			
reportType-r16 CHOICE {			
periodical-r16 SEQUENCE {			PERIODICAL
reportInterval-r16	ReportInterval		
reportAmount-r16	r2		
reportQuantity-r16 SEQUENCE {			
cbr-r16	true		
}			
eventTriggered-r16 SEQUENCE {			EVENT_C1, EVENT_C2
eventId-r16 CHOICE {			
eventC1 SEQUENCE {			EVENT_C1
c1-Threshold-r16	100*Thres	The actual CBR threshold is 100*Thres %	
hysteresis-r16	Hysteresis		
timeToTrigger-r16	TimeToTrigger		
}			

eventC2 SEQUENCE {			EVENT_C2
c2-Threshold-r16	100*Thres	The actual CBR threshold is 100*Thres %	
hysteresis-r16	Hysteresis		
timeToTrigger-r16	TimeToTrigger		
}			
}			
reportInterval-r16	ReportInterval		
reportAmount-r16	r2		
reportQuantity-r16 SEQUENCE {			
cbr-r16	true		
}			
}			
}			
}			
}			

Condition	Explanation
PERIODICAL	Configuration of periodical reporting
EVENT_C1	Configuration of Event C1
EVENT_C2	Configuration of Event C2

– *ReportConfigToAddModList*

**Table 4.6.3-143: ReportConfigToAddModList**

Derivation Path: TS 38.331 [6], clause 6.3.2			
Information Element	Value/remark	Comment	Condition
ReportConfigToAddModList ::= SEQUENCE(SIZE (1..maxReportConfigId)) OF ReportConfigToAddMod {	1 entry		
ReportConfigToAddMod[1] SEQUENCE {		entry 1	
reportConfigId	ReportConfigId		
reportConfig CHOICE {			
reportConfigNR	ReportConfigNR		
reportConfigInterRAT	ReportConfigInterRAT		InterRAT
}			
}			
}			
}			

Condition	Explanation
InterRAT	Configuration with at least one NR PCell and one or more E-UTRA neighbour cell(s)

– *ReportInterval*

**Table 4.6.3-144: ReportInterval**

Derivation Path: TS 38.331 [6], clause 6.3.2			
Information Element	Value/remark	Comment	Condition
ReportInterval	ms480		

– *ReselectionThreshold*

**Table 4.6.3-145: ReselectionThreshold**

Derivation Path: TS 38.331 [6], clause 6.3.2			
Information Element	Value/remark	Comment	Condition
ReselectionThreshold	FFS		



– *ReselectionThresholdQ***Table 4.6.3-146: ReselectionThresholdQ**

Derivation Path: TS 38.331 [6], clause 6.3.2			
Information Element	Value/remark	Comment	Condition
ReselectionThresholdQ	FFS		

– *ResumeCause***Table 4.6.3-147: ResumeCause**

Derivation Path: TS 38.331 [6], clause 6.3.2			
Information Element	Value/remark	Comment	Condition
ResumeCause	mt-Access		

– *RLC-BearerConfig***Table 4.6.3-148: RLC-BearerConfig**

Derivation Path: TS 38.331 [6], clause 6.3.2			
Information Element	Value/remark	Comment	Condition
RLC-BearerConfig ::= SEQUENCE {			
logicalChannelIdentity	LogicalChannelIdentity with condition DRBn		DRBn
	LogicalChannelIdentity with condition SRB1		SRB1
	LogicalChannelIdentity with condition SRB2		SRB2
	LogicalChannelIdentity with condition SRB3		SRB3
	LogicalChannelIdentity with condition MRBm and PTP		MRBm AND PTP
	LogicalChannelIdentity with condition MRBm and PTM		MRBm AND PTM
servedRadioBearer CHOICE {			
srb-Identity	SRB-Identity with condition SRB1		SRB1
	SRB-Identity with condition SRB2		SRB2
	SRB-Identity with condition SRB3		SRB3
drb-Identity	DRB-Identity with condition DRBn		DRBn
}			
servedRadioBearer	Not present		RESUME, MRBm
reestablishRLC	Not present		
	true		Re-establish_RLC, RESUME
rlc-Config	RLC-Config using condition AM		AM
	RLC-Config using condition UM.		UM
	RLC-Config using condition UM_DLonly		UM_DLonly

	Not present	Use default parameters as per TS 38.331 [6] clause 9.2.1	SRB1, SRB2, SRB3, RESUME
mac-LogicalChannelConfig	LogicalChannelConfig using condition HI		AM
	LogicalChannelConfig using condition LO		UM, UM_DLonly
	LogicalChannelConfig using condition SRBn	n= 1, 2, 3 for SRB1, SRB2, SRB3 resp.	SRB1, SRB2, SRB3, RESUME
rlc-Config-v1610	Not present		
rlc-Config-v1700	Not present		
logicalChannelIdentityExt-r17	Not present		
multicastRLC-BearerConfig-r17	Not present		
multicastRLC-BearerConfig-r17 SEQUENCE {			MRBm
servedMBS-RadioBearer-r17	MRB-Identity with condition MRBm		
isPTM-Entity-r17	true		PTM
	Not present		PTP
}			
servedRadioBearerSRB4-r17	Not present		
}			

Condition	Explanation
AM	RLC AM DRB
UM	RLC UM DRB
SRB1	Establishment of SRB1
SRB2	Establishment of SRB2
SRB3	Establishment of SRB3
DRBn	Establishment of DRBn
Re-establish_RLC	Re-establishment of RLC
RESUME	Used in RRCResume Message
MRBm	Establishment of MRBm
PTM	RLC entity is used for receiving PTM transmission
PTP	RLC entity is used for receiving PTP transmission
UM_DLonly	DL only RLC UM

– RLC-Config

Table 4.6.3-149: RLC-Config

Derivation Path: TS 38.331 [6], clause 6.3.2			
Information Element	Value/remark	Comment	Condition
RLC-Config ::= CHOICE {			
am SEQUENCE {			AM
ul-AM-RLC SEQUENCE {			
sn-FieldLength	size18		
	size12		pc_support OfRedCap_r 17
t-PollRetransmit	ms80		FR1
	ms30		FR2
pollPDU	p32768		
pollByte	kB750		
maxRetxThreshold	t8		
}			
dl-AM-RLC SEQUENCE {			
sn-FieldLength	size18		
	size12		pc_support OfRedCap_r 17

t-Reassembly	ms80		FR1
	ms30		FR2
t-StatusProhibit	ms30		
}			
um-Bi-Directional SEQUENCE {			UM
ul-UM-RLC SEQUENCE {			
sn-FieldLength	size12		pc_um_With LongSN
	size6		NOT pc_um_With LongSN AND pc_um_With ShortSN
}			
dl-UM-RLC SEQUENCE {			
sn-FieldLength	size12		pc_um_With LongSN
	size6		NOT pc_um_With LongSN AND pc_um_With ShortSN
t-Reassembly	ms80		FR1
	ms30		FR2
}			
}			
um-Uni-Directional-DL SEQUENCE {			UM_DLonly
dl-UM-RLC SEQUENCE {			
sn-FieldLength	size12		pc_um_With LongSN
	size6		NOT pc_um_With LongSN AND pc_um_With ShortSN
t-Reassembly	ms80		FR1
	ms30		FR2
}			
}			

Condition	Explanation
AM	RLC AM
UM	RLC UM
UM_DLonly	DL only RLC UM

– RLF-TimersAndConstants

Table 4.6.3-150: RLF-TimersAndConstants

Derivation Path: TS 38.331 [6], clause 6.3.2			
Information Element	Value/remark	Comment	Condition
RLF-TimersAndConstants ::= SEQUENCE {			
t310	ms1000		
n310	n1		
n311	n1		
t311	ms1000		
}			

– *RMTC-Config*

**Table 4.6.3-150A: Void**

– *RNTI-Value*

**Table 4.6.3-151: *RNTI-Value***

Derivation Path: TS 38.331 [6], clause 6.3.2			
Information Element	Value/remark	Comment	Condition
RNTI-Value	SS arbitrarily selects a value between '0001'H and 'FFEF'H		
	SS arbitrarily selects a value between '0001'H and 'FFEF'H different from the MCG RNTI-Value.		NR-DC_SCG

Condition	Explanation
NR-DC_SCG	Add SCG (NR-DC)

– *RSRP-Range*

**Table 4.6.3-152: *RSRP-Range***

Derivation Path: TS 38.331 [6], clause 6.3.2			
Information Element	Value/remark	Comment	Condition
RSRP-Range	0	For measurements, 0 means L3 SS-RSRP<-156dBm according to Table 10.1.6.1-1 in TS 38.133 [13]. For thresholds, 0 means -156dBm.	

– *RSRQ-Range*

**Table 4.6.3-153: *RSRQ-Range***

Derivation Path: TS 38.331 [6], clause 6.3.2			
Information Element	Value/remark	Comment	Condition
RSRQ-Range	0	For measurements, 0 means SS-RSRQ<-43dB according to Table 10.1.11.1-1 in TS 38.133 [14]. For thresholds, 0 means -43.5dB.	

– *RSSI-Range*

**Table 4.6.3-153A: *RSSI-Range***

Derivation Path: TS 38.331 [6], clause 6.3.2			
Information Element	Value/remark	Comment	Condition
RSSI-Range-r16	FFS		

– *RxTxTimeDiff*

**Table 4.6.3-153B: *RxTxTimeDiff***

Derivation Path: TS 38.331 [6], clause 6.3.2			
Information Element	Value/remark	Comment	Condition
RxTxTimeDiff-r17 ::= SEQUENCE {			
FFS			
}			

– *SCellActivationRS-Config*

**Table 4.6.3-153C: *SCellActivationRS-Config***

Derivation Path: TS 38.331 [6], clause 6.3.2			
Information Element	Value/remark	Comment	Condition
SCellActivationRS-Config-r17 ::= SEQUENCE {			
FFS			
}			

– *SCellActivationRS-ConfigId*

**Table 4.6.3-153D: *SCellActivationRS-ConfigId***

Derivation Path: TS 38.331 [6], clause 6.3.2			
Information Element	Value/remark	Comment	Condition
SCellActivationRS-ConfigId-r17	FFS		

– *SCellIndex*

**Table 4.6.3-154: *SCellIndex***

Derivation Path: TS 38.331 [6], clause 6.3.2			
Information Element	Value/remark	Comment	Condition
SCellIndex	1		
	2		EN-DC

Condition	Explanation
EN-DC	E-UTRA-NR Dual Connectivity with E-UTRA connected to EPC

– *SchedulingRequestConfig*

**Table 4.6.3-155: *SchedulingRequestConfig***

Derivation Path: TS 38.331 [6], clause 6.3.2			
Information Element	Value/remark	Comment	Condition
SchedulingRequestConfig ::= SEQUENCE {			

schedulingRequestToAddModList SEQUENCE (SIZE(1..maxNrofSR-ConfigPerCellGroup)) OF SSchedulingRequestToAddMod {	1 entry		
SchedulingRequestToAddMod[1] SEQUENCE {		entry 1	
schedulingRequestId	SchedulingRequestId		
sr-ProhibitTimer	Not present		
sr-TransMax	n16		
}			
}			
schedulingRequestToReleaseList	Not present		
}			

– *SchedulingRequestId*

**Table 4.6.3-156: SchedulingRequestId**

Derivation Path: TS 38.331 [6], clause 6.3.2			
Information Element	Value/remark	Comment	Condition
SchedulingRequestId	0		

– *SchedulingRequestResourceConfig*

**Table 4.6.3-157: SchedulingRequestResourceConfig**

Derivation Path: TS 38.331 [6], clause 6.3.2			
Information Element	Value/remark	Comment	Condition
SchedulingRequestResourceConfig ::= SEQUENCE {			
schedulingRequestResourceCellId	SchedulingRequestResourceCellId		
schedulingRequestID	SchedulingRequestId		
periodicityAndOffset CHOICE {			
sl10	9	With SCS = kHz15 results in repetition every 10 ms	SCS15
sl20	9	With SCS = kHz30 results in repetition every 10 ms	SCS30
sl40	19	With SCS = kHz60 results in repetition every 10 ms	FR1 AND SCS60
sl40	9	With SCS = kHz60 results in repetition every 10 ms	FR2 AND SCS60
sl80	9	With SCS = kHz120 results in repetition every 10 ms	SCS120
}			
resource	0	ID of the PUCCH resource as configured by PUCCH-Config (Table 4.6.3-84)	
}			

– *SchedulingRequestResourceId*

**Table 4.6.3-158: SchedulingRequestResourceId**

Derivation Path: TS 38.331 [6], clause 6.3.2			
Information Element	Value/remark	Comment	Condition
SchedulingRequestResourceId	1		

– *ScramblingId*

**Table 4.6.3-159: ScramblingId**

Derivation Path: TS 38.331 [6], clause 6.3.2			
Information Element	Value/remark	Comment	Condition
ScramblingId	0		

– *SCS-SpecificCarrier*

**Table 4.6.3-160: SCS-SpecificCarrier**

Derivation Path: TS 38.331 [6], clause 6.3.2			
Information Element	Value/remark	Comment	Condition
SCS-SpecificCarrier ::= SEQUENCE {			
offsetToCarrier	offsetToCarrier as defined for the DL frequency of the cell	For signalling test cases see subclause 6.2.3. Otherwise, see subclause 4.3.1.	DL_PointA
	offsetToCarrier as defined for the UL frequency of the cell	For signalling test cases see subclause 6.2.3. Otherwise, see subclause 4.3.1.	UL_PointA
	offsetToCarrier as defined for the SL NRf1 frequency	For signalling test cases see subclause 6.2.3.7. Otherwise, see subclause 4.3.1.8.	SL_PointA
subcarrierSpacing	SubcarrierSpacing		
carrierBandwidth	carrierBandwidth as defined for the frequency of the cell	For signalling test cases see subclause 6.2.3. Otherwise, see subclause 4.3.1.	
txDirectCurrentLocation	Not present		
}			

Condition	Explanation
DL_PointA	IE absoluteFrequencyPointA for downlink
UL_PointA	IE absoluteFrequencyPointA for uplink
SL_PointA	IE absoluteFrequencyPointA for sidelink

– *SDAP-Config*

**Table 4.6.3-161: SDAP-Config**

Derivation Path: TS 38.331 [6], clause 6.3.2			
Information Element	Value/remark	Comment	Condition
SDAP-Config ::= SEQUENCE {			

pdu-Session	The same value as the PDU session ID IE of the contained message		
sdap-HeaderDL	absent		
sdap-HeaderUL	present		
defaultDRB	true		
	false		No-defaultDRB
mappedQoS-FlowsToAdd SEQUENCE (SIZE (1..maxNrofQFIs)) OF QFI {	n entries		
QFI[n]	The list of QFIs of the Authorized QoS flow descriptions IE of the contained 5GSM message	entry n	
}			
mappedQoS-FlowsToRelease	Not present		
}			

Condition	Explanation
No-defaultDRB	The defaultDRB value is false.

– SearchSpace

Table 4.6.3-162: SearchSpace

Derivation Path: TS 38.331 [6], clause 6.3.2			
Information Element	Value/remark	Comment	Condition
SearchSpace ::= SEQUENCE {			
searchSpaceId	SearchSpaceId with condition CSS		CSS
	SearchSpaceId with condition USS		USS
	SearchSpaceId with condition SISS		SISS
	SearchSpaceId with condition MSS		MSS
	SearchSpaceId with condition SLSS		SLSS
	SearchSpace with condition DCI_2_6		DCI_2_6
controlResourceSetId	ControlResourceSetId		
	ControlResourceSetId with condition Common0		CSS, SISS, PEI
monitoringSlotPeriodicityAndOffset CHOICE {			
s1	NULL		
s5	0		(CSS OR USS) AND HD_FDD
s10	5		SISS
}			
duration	Not present	1 slot per default	
	2		SISS
	4		(CSS OR USS) AND HD_FDD
monitoringSymbolsWithinSlot	10000000000000		
nrofCandidates SEQUENCE {			
aggregationLevel1	n0		
aggregationLevel2	n4		FR1
	n3		FR2
aggregationLevel4	n2		
aggregationLevel8	n1		
aggregationLevel16	n0		



}			
searchSpaceType	Not present		MSS
searchSpaceType CHOICE {			
common SEQUENCE {			CSS, SISS, DCI_2_6
dci-Format0-0-AndFormat1-0 SEQUENCE {			
}			
dci-Format2-0	Not present		
dci-Format2-1	Not present		
dci-Format2-2	Not present		
dci-Format2-3	Not present		
}			
ue-Specific SEQUENCE {			USS, SLSS
dci-Formats	formats0-0-And-1-0		Short_DCI
dci-Formats	formats0-1-And-1-1		
dci-Formats-MT-r16	Not present		
dci-FormatsSL-r16	formats3-0		SLSS
dci-FormatsExt-r16	Not present		
}			
}			
}			

Condition	Explanation
CSS	Common SearchSpace
USS	UE-Specific SearchSpace
Short_DCI	Used in test scenarios requiring DCI formats 0-0 and 1-0 on USS
SISS	SearchSpace for SI
MSS	SearchSpace for MBS Multicast reception
PEI	Paging Early Indication is configured in the cell.
SLSS	SearchSpace for SL mode 1 transmission
DCI_2_6	Transmission of DCI_2_6 is required
HD_FDD	SIG AND pc_halfDuplexFDD_TypeA_RedCap_r17 (i.e HD_FDD UE are performing signalling test on FDD band)

– SearchSpaceId

Table 4.6.3-163: SearchSpaceId

Derivation Path: TS 38.331 [6], clause 6.3.2			
Information Element	Value/remark	Comment	Condition
SearchSpaceId	1		CSS
	2		USS
	3		SISS
	4		PEI
	5		MSS
	6		SLSS
	7		DCI_2_6

Condition	Explanation
CSS	Common SearchSpace
USS	UE-Specific SearchSpace
SISS	SearchSpace for SI
PEI	Paging Early Indication is configured in the cell.
MSS	SearchSpace for MBS Multicast reception.
SLSS	SearchSpace for SL mode 1 transmission
DCI_2_6	Transmission of DCI_2_6 is required

– *SearchSpaceZero*

**Table 4.6.3-164: SearchSpaceZero**

Derivation Path: TS 38.331 [6], clause 6.3.2			
Information Element	Value/remark	Comment	Condition
SearchSpaceZero	0	Index addressing SearchSpace#0 parameter set in Tables 13.11 .. 13.15 of TS 38.213 [22]	

– *SecurityAlgorithmConfig*

**Table 4.6.3-165: SecurityAlgorithmConfig**

Derivation Path: TS 38.331 [6], clause 6.3.2			
Information Element	Value/remark	Comment	Condition
SecurityAlgorithmConfig ::= SEQUENCE {			
cipheringAlgorithm	nea0 Set according to PIXIT px_NR_CipheringAlgorithm	see TS 38.523-3 [23]	RF OR RRM SIG
integrityProtAlgorithm	nia2 Set according to PIXIT px_NR_IntegrityProtAlgorithm	see TS 38.523-3 [23]	SIG
}			

– *SemiStaticChannelAccessConfig*

**Table 4.6.3-165A: SemiStaticChannelAccessConfig**

Derivation Path: TS 38.331 [6], clause 6.3.2			
Information Element	Value/remark	Comment	Condition
SemiStaticChannelAccessConfig-r16 ::= SEQUENCE {			
FFS			
}			

– *SemiStaticChannelAccessConfigUE*

**Table 4.6.3-165BA: SemiStaticChannelAccessConfigUE**

Derivation Path: TS 38.331 [6], clause 6.3.2			
Information Element	Value/remark	Comment	Condition
SemiStaticChannelAccessConfigUE-r17 ::= SEQUENCE {			
FFS			
}			

– *Sensor-LocationInfo*

**Table 4.6.3-165B: Sensor-LocationInfo**

Derivation Path: TS 38.331 [6], clause 6.3.2			
Information Element	Value/remark	Comment	Condition
Sensor-LocationInfo-r16 ::= SEQUENCE {			

sensor-MeasurementInformation-r16	Not checked	OCTET STRING	
sensor-MotionInformation-r16	Not checked	OCTET STRING	
}			

– *ServingCellAndBWP-Id*

**Table 4.6.3-165C: *ServingCellAndBWP-Id***

Derivation Path: TS 38.331 [6], clause 6.3.2			
Information Element	Value/remark	Comment	Condition
ServingCellAndBWP-Id -r17 ::= SEQUENCE {			
FFS			
}			

– *ServCellIndex*

**Table 4.6.3-166: *ServCellIndex***

Derivation Path: TS 38.331 [6], clause 6.3.2			
Information Element	Value/remark	Comment	Condition
ServCellIndex	0		
	1		EN-DC, NR-DC_SCG

Condition	Explanation
EN-DC	E-UTRA-NR Dual Connectivity with E-UTRA connected to EPC
NR-DC_SCG	Add SCG (NR-DC)

– *ServingCellConfig*

**Table 4.6.3-167: *ServingCellConfig***

Derivation Path: TS 38.331 [6], clause 6.3.2			
Information Element	Value/remark	Comment	Condition
ServingCellConfig ::= SEQUENCE {			
tdd-UL-DL-ConfigurationDedicated	Not present		
initialDownlinkBWP	BWP-DownlinkDedicated		
	BWP-DownlinkDedicated with condition Scell_Add		Scell_Add
	BWP-DownlinkDedicated with condition MBS_Multicast		MBS_Multicast
	Not present		MEAS, RESUME
downlinkBWP-ToReleaseList	Not present		
downlinkBWP-ToAddModList	Not present		
downlinkBWP-ToAddModList SEQUENCE (SIZE (1..maxNrofBWPs)) OF SEQUENCE {	1 entry		DLBWP_add
BWP-Downlink[1]	BWP-Downlink		
}			
firstActiveDownlinkBWP-Id	BWP-Id		
	Not present		MEAS
bwp-InactivityTimer	Not present		
defaultDownlinkBWP-Id	BWP-Id		
	Not present		MEAS, RESUME
uplinkConfig	Not present		MEAS, No_UL
uplinkConfig SEQUENCE {			

initialUplinkBWP	BWP-UplinkDedicated		
	BWP-UplinkDedicated with condition SUL_NUL		PUSCH_PU CCH_ON_S UL
	BWP-UplinkDedicated with condition RESUME		RESUME
uplinkBWP-ToReleaseList	Not present		
uplinkBWP-ToAddModList	Not present		
uplinkBWP-ToAddModList SEQUENCE (SIZE (1..maxNrofBWPs)) OF SEQUENCE {	1 entry		ULBWP_ad d
BWP-Uplink[1]	BWP-Uplink		
}			
firstActiveUplinkBWP-Id	BWP-Id		
pusch-ServingCellConfig	Not present		RESUME
pusch-ServingCellConfig CHOICE {			
setup	PUSCH- ServingCellConfig		
}			
carrierSwitching	Not present		
powerBoostPi2BPSK	Not present		
uplinkChannelBW-PerSCS-List	Not present		
enablePL-RS-UpdateForPUSCH-SRS-r16	Not present		
enableDefaultBeamPL-ForPUSCH0-0-r16	Not present		
enableDefaultBeamPL-ForPUCCH-r16	Not present		
enableDefaultBeamPL-ForSRS-r16	Not present		
uplinkTxSwitching-r16	Not present		
mpr-PowerBoost-FR2-r16	Not present		
}			
supplementaryUplink	Not present		
supplementaryUplink SEQUENCE {			PUSCH_PU CCH_ON_S UL
initialUplinkBWP	BWP-UplinkDedicated		
	BWP-UplinkDedicated with condition RESUME		RESUME
uplinkBWP-ToReleaseList	Not present		
uplinkBWP-ToAddModList	Not present		
firstActiveUplinkBWP-Id	BWP-Id		
pusch-ServingCellConfig CHOICE {			
setup	PUSCH- ServingCellConfig		
}			
carrierSwitching	Not present		
powerBoostPi2BPSK	Not present		
uplinkChannelBW-PerSCS-List	Not present		
enablePL-RS-UpdateForPUSCH-SRS-r16	Not present		
enableDefaultBeamPL-ForPUSCH0-0-r16	Not present		
enableDefaultBeamPL-ForPUCCH-r16	Not present		
enableDefaultBeamPL-ForSRS-r16	Not present		
uplinkTxSwitching-r16	Not present		
mpr-PowerBoost-FR2-r16	Not present		
}			
pdccch-ServingCellConfig CHOICE {			
setup	PDCCH- ServingCellConfig		
}			
pdccch-ServingCellConfig	Not present		MEAS, RESUME
pdsch-ServingCellConfig CHOICE {			
setup	PDSCH- ServingCellConfig		
}			
pdsch-ServingCellConfig	Not present		MEAS, RESUME
csi-MeasConfig	Not present		
sCellDeactivationTimer	Not present		

crossCarrierSchedulingConfig	Not present		
tag-Id	0		
dummy1	Not present		
pathlossReferenceLinking	Not present		
servingCellMO	Not present		
	MeasObjectId		MEAS
}			

Condition	Explanation
PUSCH_PUCCH_ON_SUL	For the purpose of SUL test under condition that supplementary uplink is configured with both PUSCH and PUCCH on SUL carrier.
MEAS	A NR or EN-DC measurement is configured.
No_UL	No uplink CA
RESUME	Used in RRCResume Message
Scell_Add	Add SCell
MBS_Multicast	Used for MBS Multicast reception
DLBWP_add	A dedicated DL BWP is configured
ULBWP_add	A dedicated UL BWP is configured

*ServingCellConfigCommon*

**Table 4.6.3-168: ServingCellConfigCommon**

Derivation Path: TS 38.331 [6], clause 6.3.2			
Information Element	Value/remark	Comment	Condition
ServingCellConfigCommon ::= SEQUENCE {			
physCellId	PhysCellId		
downlinkConfigCommon	DownlinkConfigCommon		
	DownlinkConfigCommon with condition SCell_add		SCell_add
uplinkConfigCommon	UplinkConfigCommon		
	Not present		No_UL
supplementaryUplinkConfig	Not present		
n-TimingAdvanceOffset	Not present		
ssb-PositionsInBurst CHOICE {			
shortBitmap	0100		FR1 AND SSB#1 AND (1.88GHz<FREQ<=3GHz AND (FDD OR (TDD AND SCS15)) OR FREQ<=1.88GHz)
	1000		FR1 AND SSB#0 AND (1.88GHz<FREQ<=3GHz AND (FDD OR (TDD AND SCS15)) OR FREQ<=1.88GHz)
mediumBitmap	01000000		FR1 AND SSB#1 AND (1.88GHz<FREQ<=3GHz AND (TDD AND

			SCS30) OR FREQ>3GH z)
	10000000		FR1 AND SSB#0 AND (1.88GHz<F REQ<=3GH z AND (TDD AND SCS30) OR FREQ>3GH z)
longBitmap	01000000000000000000 00000000000000000000 00000000000000000000 0000		FR2 AND SSB#1
	10000000000000000000 00000000000000000000 00000000000000000000 0000		FR2 AND SSB#0
}			
ssb-periodicityServingCell	ms20		
dmrs-TypeA-Position	pos2		
lte-CRS-ToMatchAround	Not present		
rateMatchPatternToAddModList	Not present		
rateMatchPatternToReleaseList	Not present		
ssbSubcarrierSpacing	SubcarrierSpacing	For signalling test cases see subclause 6.2.3. Otherwise, see subclause 4.3.1. Value SS block SCS.	
tdd-UL-DL-ConfigurationCommon	TDD-UL-DL-ConfigCommon		TDD
	Not present		FDD
ss-PBCH-BlockPower	0		
channelAccessMode-r16	Not present		
channelAccessMode-r16 CHOICE {			SharedSpec trum
dynamic	NULL		
}			
discoveryBurstWindowLength-r16	Not present		
ssb-PositionQCL-r16	Not present		
	SSB-PositionQCL-Relation-r16		SharedSpec trum
highSpeedConfig-r16	Not present		
	HighSpeedConfig-r16		R16 HST OR R17 HST FR1
highSpeedConfig-v1700	Not present		
	HighSpeedConfig-v1700		R17 HST FR1
channelAccessMode2-r17	Not present		
discoveryBurstWindowLength-r17	Not present		
ssb-PositionQCL-r17	Not present		
highSpeedConfigFR2-r17	Not present		
uplinkConfigCommon-v1700	Not present		
ntn-Config-r17	Not present		
	NTN-Config		GSO, NGSO
featurePriorities-r17	Not present		
}			

Condition	Explanation
-----------	-------------

FREQ<=1.88GHz	Frequency range <= 1.88GHz
1.88GHz<FREQ<=3GHz	Frequency range > 1.88GHz and <= 3GHz
FREQ>3GHz	Frequency range > 3GHz
No_UL	No uplink CA
SSB#N	Cell configured with SSB-Index set to N as defined in Table 4.4.2-2
SharedSpectrum	Operation with shared spectrum channel access in FR1
R16 HST	For R16 HST test
R17 HST FR1	For R17 HST FR1 test
GSO	Geosynchronous Orbit scenario
NGSO	Non-geosynchronous Orbit scenario

– *ServingCellConfigCommonSIB*

**Table 4.6.3-169: *ServingCellConfigCommonSIB***

Derivation Path: TS 38.331 [6], clause 6.3.2			
Information Element	Value/remark	Comment	Condition
ServingCellConfigCommonSIB ::= SEQUENCE {			
downlinkConfigCommon	DownlinkConfigCommon SIB		
	DownlinkConfigCommon SIB with condition PEI		PEI
uplinkConfigCommon	UplinkConfigCommonSIB		
supplementaryUplink	Not present		
	UplinkConfigCommonSIB with condition SUL_SUL		SUL
n-TimingAdvanceOffset	Not present		
ssb-PositionsInBurst SEQUENCE {			
inOneGroup	'0100 0000'B	When carrier frequency is smaller than or equal to 3 GHz, only the 4 leftmost bits are valid	SSB#1
	'1000 0000'B		SSB#0
groupPresence	Not present		FR1
	'1000 0000'B		FR2
}			
ssb-PeriodicityServingCell	ms20		
tdd-UL-DL-ConfigurationCommon	TDD-UL-DL-ConfigCommon		TDD
	Not present		FDD
ss-PBCH-BlockPower	0		
channelAccessMode-r16	Not present		
channelAccessMode-r16 CHOICE {			Shared Spectrum
dynamic	NULL		
}			
discoveryBurstWindowLength-r16	Not present		
highSpeedConfig-r16	Not present		
	HighSpeedConfig-r16		R16 HST OR R17 HST
channelAccessMode2-r17	Not present		
discoveryBurstWindowLength-v1700	Not present		
highSpeedConfigFR2-r17	Not present		
	HighSpeedConfigFR2-r17		R17 HST AND FR2
uplinkConfigCommon-v1700	Not present		
}			

Condition	Explanation
SUL	Supplementary uplink

SSB#N	Cell configured with SSB-Index set to N as defined in Table 4.4.2-2
SharedSpectrum	Operation with shared spectrum channel access
R16 HST	For R16 HST test
R17 HST	For R17 HST test
PEI	Paging Early Indication is configured in the cell.

– *ShortI-RNTI-Value*

**Table 4.6.3-170: ShortI-RNTI-Value**

Derivation Path: TS 38.331 [6], clause 6.3.2			
Information Element	Value/remark	Comment	Condition
ShortI-RNTI-Value	SS arbitrarily selects a value between '00 0001'H and 'FF FFFF'H.	BIT STRING (SIZE(24))	

– *ShortMAC-I*

**Table 4.6.3-171: ShortMAC-I**

Derivation Path: TS 38.331 [6], clause 6.3.2			
Information Element	Value/remark	Comment	Condition
ShortMAC-I	The 16 least significant bits of the MAC-I calculated using the security configuration of the source PCell.		

– *SINR-Range*

**Table 4.6.3-172: SINR-Range**

Derivation Path: TS 38.331 [6], clause 6.3.2			
Information Element	Value/remark	Comment	Condition
SINR-Range	0	For measurements, 0 means SS-SINR<-23dB according to Table 10.1.16.1-1 in TS 38.133 [14]. For thresholds, 0 means -23dB.	

– *SI-RequestConfig*

**Table 4.6.3-172A: SI-RequestConfig**

Derivation Path: TS 38.331 [6], clause 6.3.2			
Information Element	Value/remark	Comment	Condition
SI-RequestConfig ::= SEQUENCE {			
FFS			
}			



– *SI-SchedulingInfo*

**Table 4.6.3-173: SI-SchedulingInfo**

Derivation Path: TS 38.331 [6], clause 6.3.2			
Information Element	Value/remark	Comment	Condition
SI-SchedulingInfo ::= SEQUENCE {			
schedulingInfoList SEQUENCE (SIZE (1..maxSI-Message)) OF SchedulingInfo {	n entries See subclause 4.4.3.1		
SchedulingInfo[n] SEQUENCE {		entry n	
si-BroadcastStatus	broadcasting		
si-Periodicity	See subclause 4.4.3.1		
sib-MappingInfo SEQUENCE (SIZE (1..maxSIB)) OF SIB-TypeInfo {	n entries		
SIB-TypeInfo[1] SEQUENCE {		entry n	
type	See subclause 4.4.3.1		
valueTag	0		
areaScope	Not present		
}			
}			
}			
si-WindowLength	s80		FR1
	s160		FR2
si-RequestConfig	Not present		
si-RequestConfigSUL	Not present		
systemInformationAreaID	'0000 0000 0000 0000 0000 0001'B		
}			

– *SK-Counter*

**Table 4.6.3-173A: SK-Counter**

Derivation Path: TS 38.331 [6], clause 6.3.2			
Information Element	Value/remark	Comment	Condition
SK-Counter	0		

– *SlotFormatCombinationsPerCell*

**Table 4.6.3-174: SlotFormatCombinationsPerCell**

Derivation Path: TS 38.331 [6], clause 6.3.2			
Information Element	Value/remark	Comment	Condition
SlotFormatCombinationsPerCell ::= SEQUENCE {			
FFS			
}			

– *SlotFormatIndicator*

**Table 4.6.3-175: SlotFormatIndicator**

Derivation Path: TS 38.331 [6], clause 6.3.2			
Information Element	Value/remark	Comment	Condition
SlotFormatIndicator ::= SEQUENCE {			
FFS			
}			

– *S-NSSAI***Table 4.6.3-176: S-NSSAI**

Derivation Path: TS 38.331 [6], clause 6.3.2			
Information Element	Value/remark	Comment	Condition
S-NSSAI ::= CHOICE {			
FFS			
}			

– *SpeedStateScaleFactors***Table 4.6.3-177: SpeedStateScaleFactors**

Derivation Path: TS 38.331 [6], clause 6.3.2			
Information Element	Value/remark	Comment	Condition
SpeedStateScaleFactors ::= SEQUENCE {			
FFS			
}			

– *SPS-Config***Table 4.6.3-179: SPS-Config**

Derivation Path: TS 38.331 [6], clause 6.3.2			
Information Element	Value/remark	Comment	Condition
SPS-Config ::= SEQUENCE {			
FFS			
}			

– *SPS-ConfigIndex***Table 4.6.3-179A: SPS-ConfigIndex**

Derivation Path: TS 38.331 [6], clause 6.3.2			
Information Element	Value/remark	Comment	Condition
SPS-ConfigIndex-r16	FFS		

– *SPS-PUCCH-AN***Table 4.6.3-179B: SPS-PUCCH-AN**

Derivation Path: TS 38.331 [6], clause 6.3.2			
Information Element	Value/remark	Comment	Condition
SPS-PUCCH-AN-r16 ::= SEQUENCE {			
FFS			
}			

– *SPS-PUCCH-AN-List***Table 4.6.3-179C: SPS-PUCCH-AN-List**

Derivation Path: TS 38.331 [6], clause 6.3.2			
Information Element	Value/remark	Comment	Condition
SPS-PUCCH-AN-List-r16 ::= SEQUENCE {			
FFS			

}		
---	--	--

– *SRB-Identity*

**Table 4.6.3-180: SRB-Identity**

Derivation Path: TS 38.331 [6], clause 6.3.2			
Information Element	Value/remark	Comment	Condition
SRB-Identity	1		SRB1
	2		SRB2
	3		SRB3

Condition	Explanation
SRB1	SRB1
SRB2	SRB2
SRB3	SRB3

– *SRS-CarrierSwitching*

**Table 4.6.3-181: SRS-CarrierSwitching**

Derivation Path: TS 38.331 [6], clause 6.3.2			
Information Element	Value/remark	Comment	Condition
SRS-CarrierSwitching ::= SEQUENCE {			
FFS			
}			

– *SRS-Config*

**Table 4.6.3-182: SRS-Config**

Derivation Path: TS 38.331 [6], clause 6.3.2			
Information Element	Value/remark	Comment	Condition
SRS-Config ::= SEQUENCE {			
srs-ResourceSetToReleaseList	Not present		
srs-ResourceSetToAddModList SEQUENCE (SIZE(0..maxNrofSRS-ResourceSets)) OF SRS-ResourceSet {	1 entry		
SRS-ResourceSet[1] SEQUENCE {		entry 1	
srs-ResourceSetId	0		
srs-ResourceSetIdList SEQUENCE (SIZE(1..maxNrofSRS-ResourcesPerSet)) OF SRS-ResourceSetId {	1 entry		
SRS-ResourceSetId[1]	0	entry 1	
}			
resourceType CHOICE {			
aperiodic SEQUENCE {			
aperiodicSRS-ResourceTrigger	1		
csi-RS	Not present		
slotOffset	7		FR1
	4		FR2
}			
}			
usage	codebook		
alpha	Alpha		
p0	0		
pathlossReferenceRS CHOICE {			
ssb-Index	SSB-Index		
}			

srs-PowerControlAdjustmentStates	Not present		
}			
srs-ResourceToReleaseList	Not present		
srs-ResourceToAddModList SEQUENCE (SIZE(1..maxNrofSRS-Resources)) OF SRS-Resource {	1 entry		
SRS-Resource[1] SEQUENCE {		entry 1	
srs-ResourceId	0		
nrofSRS-Ports	ports2		2TX_UL_MIMO
	port1		
ptrs-PortIndex	Not present		
transmissionComb CHOICE {			
n2 SEQUENCE {			
combOffset-n2	0		
cyclicShift-n2	0		
}			
}			
resourceMapping SEQUENCE {			
startPosition	0		
nrofSymbols	n1		
repetitionFactor	n1		
}			
freqDomainPosition	0		
freqDomainShift	0		
freqHopping SEQUENCE {			
c-SRS	0		
	63		FR1_100MHz
	17		FR2_100MHz
b-SRS	0		
b-hop	0		
}			
groupOrSequenceHopping	groupHopping		
resourceType CHOICE {			
aperiodic SEQUENCE {			
}			
}			
sequenceId	0		
spatialRelationInfo SEQUENCE {	SRS-SpatialRelationInfo		
servingCellId	Not present		
referenceSignal CHOICE {			
ssb-Index	SSB-Index		
}			
}			
}			
}			
tpc-Accumulation	Not present		
srs-RequestDCI-1-2-r16	Not present		
srs-RequestDCI-0-2-r16	Not present		
srs-ResourceSetToAddModListDCI-0-2-r16	Not present		
srs-ResourceSetToReleaseListDCI-0-2-r16	Not present		
srs-PosResourceSetToReleaseList-r16	Not present		
srs-PosResourceSetToAddModList-r16	Not present		
srs-PosResourceToReleaseList-r16	Not present		
srs-PosResourceToAddModList-r16	Not present		
}			

Condition	Explanation
2TX_UL_MIMO	UL-MIMO test cases with 2 Tx antenna ports
FR1_100MHz	FR1 is used under the test. CBW is set to 100MHz.
FR2_100MHz	FR2 is used under the test. CBW is set to 100MHz.

– *SRS-RSRP-Range*

**Table 4.6.3-182A: SRS-RSRP-Range**

Derivation Path: TS 38.331 [6], clause 6.3.2			
Information Element	Value/remark	Comment	Condition
SRS-RSRP-Range-r16	FFS		

– *SRS-TPC-CommandConfig*

**Table 4.6.3-183: SRS-TPC-CommandConfig**

Derivation Path: TS 38.331 [6], clause 6.3.2			
Information Element	Value/remark	Comment	Condition
SRS-TPC-CommandConfig ::= SEQUENCE {			
FFS			
}			

– *SSB-Index*

**Table 4.6.3-184: SSB-Index**

Derivation Path: TS 38.331 [6], clause 6.3.2			
Information Element	Value/remark	Comment	Condition
SSB-Index	Set according to Table 4.4.2-2 for the NR Cell		

– *SSB-MTC*

**Table 4.6.3-185: SSB-MTC**

Derivation Path: TS 38.331 [6], clause 6.3.2			
Information Element	Value/remark	Comment	Condition
SSB-MTC ::= SEQUENCE {			
periodicityAndOffset CHOICE {			
sf20	0		
	10		SIG AND INTER-FREQ_ODD
}			
duration	sf2		FR1
	sf3		FR2
}			

Condition	Explanation
INTER-FREQ_ODD	When the (SFNoffset of inter frequency neighbour cell - SFNoffset of serving cell) is odd number. SFNoffset is defined in TS 38.523-3 [23] Table 7.1.5.2-1

**Table 4.6.3-186: SSB-MTC2**

Derivation Path: TS 38.331 [6], clause 6.3.2			
Information Element	Value/remark	Comment	Condition
SSB-MTC2 ::= SEQUENCE {			
FFS			
}			

– *SSB-PositionQCL-Relation*

**Table 4.6.3-186A: SSB-PositionQCL-Relation**

Derivation Path: TS 38.331 [6], clause 6.3.2			
Information Element	Value/remark	Comment	Condition
SSB-PositionQCL-Relation-r16	n1		

– *SSB-ToMeasure*

**Table 4.6.3-187: SSB-ToMeasure**

Derivation Path: TS 38.331 [6], clause 6.3.2			
Information Element	Value/remark	Comment	Condition
SSB-ToMeasure ::= CHOICE {			
shortBitmap	1100		FR1 AND (1.88GHz<FREQ<=3GHz AND (FDD OR (TDD AND SCS15)) OR FREQ<=1.88GHz)
mediumBitmap	11000000		FR1 AND (1.88GHz<FREQ<=3GHz AND (TDD AND SCS30) OR FREQ>3GHz)
longBitmap	11000000 00000000 00000000 00000000 00000000 00000000 00000000 00000000		FR2
}			

Condition	Explanation
FREQ<=1.88GHz	Frequency range <= 1.88GHz
1.88GHz<FREQ<=3GHz	Frequency range > 1.88GHz and <= 3GHz
FREQ>3GHz	Frequency range > 3GHz

– *SS-RSSI-Measurement*

**Table 4.6.3-187A: SS-RSSI-Measurement**

Derivation Path: TS 38.331 [6], clause 6.3.2			
Information Element	Value/remark	Comment	Condition
SS-RSSI-Measurement ::= SEQUENCE {			
FFS			
}			

– *SubcarrierSpacing*

**Table 4.6.3-188: SubcarrierSpacing**

Derivation Path: TS 38.331 [6], clause 6.3.2			
Information Element	Value/remark	Comment	Condition

SubcarrierSpacing	According to clause 6.2.3 for signalling test cases and clause 4.3.1 otherwise.		
-------------------	---	--	--

– *TAG-Config*

**Table 4.6.3-189: TAG-Config**

Derivation Path: TS 38.331 [6], clause 6.3.2			
Information Element	Value/remark	Comment	Condition
TAG-Config ::= SEQUENCE {			
tag-ToReleaseList	Not present		
tag-ToAddModList SEQUENCE (SIZE (1..maxNrofTAGs)) OF TAG {	1 entry		
TAG[1] SEQUENCE {		entry 1	
tag-Id	0		
timeAlignmentTimer	infinity		
}			
}			
}			

– *TAR-Config*

**Table 4.6.3-189AA: TAR-Config**

Derivation Path: TS 38.331 [6], clause 6.3.2			
Information Element	Value/remark	Comment	Condition
TAR-Config-r17 ::= SEQUENCE {			
FFS			
}			

– *TCI-ActivatedConfig*

**Table 4.6.3-189A: TCI-ActivatedConfig**

Derivation Path: TS 38.331 [6], clause 6.3.2			
Information Element	Value/remark	Comment	Condition
TCI-ActivatedConfig-r17 ::= SEQUENCE {			
FFS			
}			

– *TCI-State*

**Table 4.6.3-190: TCI-State**

Derivation Path: TS 38.331 [6], clause 6.3.2			
Information Element	Value/remark	Comment	Condition
TCI-State ::= SEQUENCE {			
tci-StateId	TCI-StateId		
qcl-Type1 SEQUENCE {			
cell	Not present		
bwp-Id	Not present		
referenceSignal CHOICE {			
ssb	SSB-Index		
}			
qcl-Type	typeD		

}			
qcl-Type2	Not present		
}			

– *TCI-StateId*

**Table 4.6.3-191: *TCI-StateId***

Derivation Path: TS 38.331 [6], clause 6.3.2			
Information Element	Value/remark	Comment	Condition
TCI-StateId	0		

– *TCI-UL-State*

**Table 4.6.3-191A: *TCI-UL-State***

Derivation Path: TS 38.331 [6], clause 6.3.2			
Information Element	Value/remark	Comment	Condition
TCI-UL-State-r17 ::= SEQUENCE {			
FFS			
}			

– *TCI-UL-StateId*

**Table 4.6.3-191B: *TCI-UL-StateId***

Derivation Path: TS 38.331 [6], clause 6.3.2			
Information Element	Value/remark	Comment	Condition
TCI-UL-State-Id-r17	FFS		

– *TDD-UL-DL-ConfigCommon*

**Table 4.6.3-192: *TDD-UL-DL-ConfigCommon***

Derivation Path: TS 38.331 [6], clause 6.3.2			
Information Element	Value/remark	Comment	Condition
TDD-UL-DL-ConfigCommon ::= SEQUENCE {			
referenceSubcarrierSpacing	SubcarrierSpacing		
pattern1 SEQUENCE {			
dl-UL-TransmissionPeriodicity	ms5		FR1
	ms0p625		SIG AND FR2
	ms2		RF AND FR2
nrofDownlinkSlots	7		(FR1 AND SCS30) OR (RF AND FR2 AND SCS120)
	3		(FR1 AND SCS15) OR (FR2 AND SCS60) OR (SIG AND FR2 AND SCS120)
	14		FR1 AND SCS60



nrofDownlinkSymbols	6		FR1 AND SCS30
	10		(FR1 AND SCS15) OR (SIG AND FR2 AND (SCS60 OR SCS120))
	12		(FR1 AND SCS60) OR (RF AND FR2 AND SCS120)
	4		RF AND FR2 AND SCS60
nrofUplinkSlots	2		FR1 AND SCS30
	1		(FR1 AND SCS15) OR (SIG AND FR2 AND (SCS60 OR SCS120))
	4		(FR1 AND SCS60) OR ((RF AND FR2 AND SCS60)
	8		RF AND FR2 AND SCS120
nrofUplinkSymbols	4		(FR1 AND SCS30) OR (RF AND FR2 AND SCS60)
	2		(FR1 AND SCS15) OR (SIG AND FR2 AND (SCS60 OR SCS120))
	8		FR1 AND SCS60
	0		RF AND FR2 AND SCS120
}			
pattern2	Not present		
}			

– *TDD-UL-DL-ConfigDedicated*

**Table 4.6.3-192A: TDD-UL-DL-ConfigDedicated**

Derivation Path: TS 38.331 [6], clause 6.3.2			
Information Element	Value/remark	Comment	Condition
TDD-UL-DL-ConfigDedicated ::= SEQUENCE {			
FFS			
}			

– *TrackingAreaCode***Table 4.6.3-193: TrackingAreaCode**

Derivation Path: TS 38.331 [6], clause 6.3.2			
Information Element	Value/remark	Comment	Condition
TrackingAreaCode	See table 4.4.2-3	BIT STRING (SIZE (24))	

– *T-Reselection***Table 4.6.3-194: T-Reselection**

Derivation Path: TS 38.331 [6], clause 6.3.2			
Information Element	Value/remark	Comment	Condition
T-Reselection	FFS		

– *TimeAlignmentTimer***Table 4.6.3-194A: TimeAlignmentTimer**

Derivation Path: TS 38.331 [6], clause 6.3.2			
Information Element	Value/remark	Comment	Condition
TimeAlignmentTimer	FFS		

– *TimeToTrigger***Table 4.6.3-195: TimeToTrigger**

Derivation Path: TS 38.331 [6], clause 6.3.2			
Information Element	Value/remark	Comment	Condition
TimeToTrigger	ms320		

– *UAC-BarringInfoSetIndex***Table 4.6.3-196: UAC-BarringInfoSetIndex**

Derivation Path: TS 38.331 [6], clause 6.3.2			
Information Element	Value/remark	Comment	Condition
UAC-BarringInfoSetIndex	FFS		

– *UAC-BarringInfoSetList***Table 4.6.3-197: UAC-BarringInfoSetList**

Derivation Path: TS 38.331 [6], clause 6.3.2			
Information Element	Value/remark	Comment	Condition
UAC-BarringInfoSetList	FFS		

– *UAC-BarringPerCatList***Table 4.6.3-198: UAC-BarringPerCatList**

Derivation Path: TS 38.331 [6], clause 6.3.2			
Information Element	Value/remark	Comment	Condition

UAC-BarringPerCatList	FFS		
-----------------------	-----	--	--

– *UAC-BarringPerPLMN-List*

**Table 4.6.3-199: UAC-BarringPerPLMN-List**

Derivation Path: TS 38.331 [6], clause 6.3.2			
Information Element	Value/remark	Comment	Condition
UAC-BarringPerPLMN-List	FFS		

– *UE-TimersAndConstants*

**Table 4.6.3-200: UE-TimersAndConstants**

Derivation Path: TS 38.331 [6], clause 6.3.2			
Information Element	Value/remark	Comment	Condition
UE-TimersAndConstants ::= SEQUENCE {			
t300	ms1000		
t301	ms1000		
t310	ms1000		
n310	n1		
t311	ms30000		
n311	n1		
t319	ms1000		
}			

– *UE-TimersAndConstantsRemoteUE*

**Table 4.6.3-200AA: UE-TimersAndConstantsRemoteUE**

Derivation Path: TS 38.331 [6], clause 6.3.2			
Information Element	Value/remark	Comment	Condition
UE-TimersAndConstantsRemoteUE-r17 ::= SEQUENCE {			
FFS			
}			

– *UL-DelayValueConfig*

**Table 4.6.3-200A: UL-DelayValueConfig**

Derivation Path: TS 38.331 [6], clause 6.3.2			
Information Element	Value/remark	Comment	Condition
UL-DelayValueConfig-r16 ::= SEQUENCE {			
delay-DRBlist	Set according to specific message content		
}			

– *UL-ExcessDelayConfig*

**Table 4.6.3-200BA: UL-ExcessDelayConfig**

Derivation Path: TS 38.331 [6], clause 6.3.2			
Information Element	Value/remark	Comment	Condition
UL-ExcessDelayConfig-r17 ::= SEQUENCE {			
FFS			
}			

– *UL-GapFR2-Config***Table 4.6.3-200BB: UE UL-GapFR2-Config**

Derivation Path: TS 38.331 [6], clause 6.3.2			
Information Element	Value/remark	Comment	Condition
UL-GapFR2-Config-r17 ::= SEQUENCE {			
gapOffset-r17	0		
ugl-r17	ms1		
ugrp-r17	ms40		
refFR2ServCellAsyncCA-r17	Not Present		
refFR2ServCellAsyncCA-r17 CHOICE {			AsyncCA
setup	0	Optional ServCellIndex with condition AsyncCA	
}			

Condition	Explanation
AsyncCA	Used only when configuring the FR2 UL gap pattern to UE in NGEN-DC, NR, EN-DC, NE-DC or NR-DC without FR2-FR2 band combination, with asynchronous CA involving FR2 carriers. Otherwise, it is absent.

– *UplinkCancellation***Table 4.6.3-200B: UplinkCancellation**

Derivation Path: TS 38.331 [6], clause 6.3.2			
Information Element	Value/remark	Comment	Condition
UplinkCancellation-r16 ::= SEQUENCE {			
FFS			
}			

– *UplinkConfigCommon***Table 4.6.3-201: UplinkConfigCommon**

Derivation Path: TS 38.331 [6], clause 6.3.2			
Information Element	Value/remark	Comment	Condition
UplinkConfigCommon ::= SEQUENCE {			
frequencyInfoUL	FrequencyInfoUL		
initialUplinkBWP	BWP-UplinkCommon		
timeAlignmentTimerCommon	infinity		
}			

– *UplinkConfigCommonSIB***Table 4.6.3-202: UplinkConfigCommonSIB**

Derivation Path: TS 38.331 [6], clause 6.3.2			
Information Element	Value/remark	Comment	Condition
UplinkConfigCommonSIB SEQUENCE {			
frequencyInfoUL	FrequencyInfoUL-SIB		
initialUplinkBWP	BWP-UplinkCommon		

	BWP-UplinkCommon with confition SUL_SUL		SUL_SUL
timeAlignmentTimerCommon	infinity		
}			

Condition	Explanation
SUL_SUL	On the SUL carrier when supplementary carrier is configured

– *Uplink-PowerControl*

**Table 4.6.3-202A: Uplink-PowerControl**

Derivation Path: TS 38.331 [6], clause 6.3.2			
Information Element	Value/remark	Comment	Condition
Uplink-PowerControl-r17 ::= SEQUENCE {			
FFS			
}			

– *Uu-RelayRLC-ChannelConfig*

**Table 4.6.3-202B: Uu-RelayRLC-ChannelConfig**

Derivation Path: TS 38.331 [6], clause 6.3.2			
Information Element	Value/remark	Comment	Condition
Uu-RelayRLC-ChannelConfig-r17 ::= SEQUENCE {			
uu-LogicalChannelIdentity-r17	LogicalChannelIdentity with condition SRB1		SRB1
	LogicalChannelIdentity with condition SRB2		SRB2
	LogicalChannelIdentity with condition DRB1		DRB1
uu-RelayRLC-ChannelID-r17	Uu-RelayRLC-ChannelID with condition SL-SRB1		SRB1
	Uu-RelayRLC-ChannelID with condition SL-SRB2		SRB2
	Uu-RelayRLC-ChannelID with condition SL- DRB1		DRB1
reestablishRLC-r17	true		
rlc-Config-r17	Not present		SRB1
	RLC-Config with condition AM		SRB2,DRB1
mac-LogicalChannelConfig-r17	LogicalChannelConfig with condition SRB1		SRB1
	LogicalChannelConfig with condition SRB2		SRB2
}			

Condition	Explanation
SRB1	Establishment of SRB1
SRB2	Establishment of SRB2
DRB1	Establishment of DRB1

– *Uu-RelayRLC-ChannelID*

**Table 4.6.3-202C: Uu-RelayRLC-ChannelID**

Derivation Path: TS 38.331 [6], clause 6.3.2			
Information Element	Value/remark	Comment	Condition
Uu-RelayRLC-ChannelID-r17	n+1		SL-SRBn

	n+4		SL-DRBn
--	-----	--	---------

Condition	Explanation
SL-SRBn	Establishment of Sidelink SRBn; n=0..3
SL-DRBn	Establishment of Sidelink DRBn; n=1..16

– *UplinkTxDirectCurrentList*

**Table 4.6.3-203: UplinkTxDirectCurrentList**

Derivation Path: TS 38.331 [6], clause 6.3.2			
Information Element	Value/remark	Comment	Condition
UplinkTxDirectCurrentList ::= SEQUENCE (SIZE (1..maxNrofServingCells)) OF UplinkTxDirectCurrentCell {	1 entry		
UplinkTxDirectCurrentCell[1] SEQUENCE {		entry 1	
FFS			
}			
}			

– *UplinkTxDirectCurrentMoreCarrierList*

**Table 4.6.3-203A: UplinkTxDirectCurrentMoreCarrierList**

Derivation Path: TS 38.331 [6], clause 6.3.2			
Information Element	Value/remark	Comment	Condition
UplinkTxDirectCurrentMoreCarrierList-r17 ::= SEQUENCE (SIZE (1..maxNrofCC-Group-r17)) OF CC-Group-r17 {			
FFS			
}			

– *UplinkTxDirectCurrentTwoCarrierList*

**Table 4.6.3-203B: UplinkTxDirectCurrentTwoCarrierList**

Derivation Path: TS 38.331 [6], clause 6.3.2			
Information Element	Value/remark	Comment	Condition
UplinkTxDirectCurrentTwoCarrierList-r16 ::= SEQUENCE (SIZE (1..maxNrofTxDC-TwoCarrier-r16)) OF UplinkTxDirectCurrentTwoCarrier-r16 {			
FFS			
}			

– *ZP-CSI-RS-Resource*

**Table 4.6.3-204: ZP-CSI-RS-Resource**

Derivation Path: TS 38.331 [6], clause 6.3.2			
Information Element	Value/remark	Comment	Condition
ZP-CSI-RS-Resource ::= SEQUENCE {			
zp-CSI-RS-ResourceId	ZP-CSI-RS-ResourceId		
resourceMapping	CSI-RS-ResourceMapping		
periodicityAndOffset	CSI-ResourcePeriodicityAndOffset		
}			

– *ZP-CSI-RS-ResourceId***Table 4.6.3-204A: ZP-CSI-RS-ResourceId**

Derivation Path: TS 38.331 [6], clause 6.3.2			
Information Element	Value/remark	Comment	Condition
ZP-CSI-RS-ResourceId	0		

– *ZP-CSI-RS-ResourceSet***Table 4.6.3-205: ZP-CSI-RS-ResourceSet**

Derivation Path: TS 38.331 [6], clause 6.3.2			
Information Element	Value/remark	Comment	Condition
ZP-CSI-RS-ResourceSet ::= SEQUENCE {			
zp-CSI-RS-ResourceSetId	ZP-CSI-RS-ResourceSetId		
zp-CSI-RS-ResourceIdList SEQUENCE (SIZE(1..maxNrofZP-CSI-RS-ResourcesPerSet)) OF ZP-CSI-RS-ResourceId {	1 entry		
ZP-CSI-RS-ResourceId[1]	FFS	entry 1	
}			
}			

– *ZP-CSI-RS-ResourceSetId***Table 4.6.3-206: ZP-CSI-RS-ResourceSetId**

Derivation Path: TS 38.331 [6], clause 6.3.2			
Information Element	Value/remark	Comment	Condition
ZP-CSI-RS-ResourceSetId	0		

## 4.6.4 UE capability information elements

– *AccessStratumRelease***Table 4.6.4-1: AccessStratumRelease**

Derivation Path: TS 38.331 [6], clause 6.3.3			
Information Element	Value/remark	Comment	Condition
AccessStratumRelease	Same as indicated in TC applicability in TS 38.523-2 [19]		

– *AppLayerMeasParameters***Table 4.6.4-1A: AppLayerMeasParameters**

Derivation Path: TS 38.331 [6], clause 6.3.3			
Information Element	Value/remark	Comment	Condition
AppLayerMeasParameters-r17 ::= SEQUENCE {			
FFS			
}			

– *BandCombinationList*

**Table 4.6.4-2: BandCombinationList**

Derivation Path: TS 38.331 [6], clause 6.3.3			
Information Element	Value/remark	Comment	Condition
BandCombinationList ::= SEQUENCE (SIZE (1..maxBandComb)) OF BandCombination {	At least 1 entry		
BandCombination[1] SEQUENCE {		entry 1	
bandList SEQUENCE (SIZE (1..maxSimultaneousBands)) OF BandParameters {	1 entry		
BandParameters[1] CHOICE {		entry 1	
eutra SEQUENCE {			
bandEUTRA	FreqBandIndicatorEUTRA		
ca-BandwidthClassDL-EUTRA	Not checked		
ca-BandwidthClassUL-EUTRA	Not checked		
}			
nr SEQUENCE {			
bandNR	FreqBandIndicatorNR		
ca-BandwidthClassDL-NR	Not checked		
ca-BandwidthClassUL-NR	Not checked		
}			
}			
featureSetCombination	Not checked		
ca-ParametersEUTRA	Not checked		
ca-ParametersNR	Not checked		
mrdc-Parameters	Not checked		
supportedBandwidthCombinationSet	BIT STRING (SIZE (1..32))		
powerClass-v1530	Not Checked		
}			
}			

– *BandCombinationListSidelinkEUTRA-NR*

**Table 4.6.4-2A: BandCombinationListSidelinkEUTRA-NR**

Derivation Path: TS 38.331 [6], clause 6.3.3			
Information Element	Value/remark	Comment	Condition
BandParametersSidelinkEUTRA-NR-r16 ::= SEQUENCE {			
FFS			
}			

– *CA-BandwidthClassEUTRA*

**Table 4.6.4-3: CA-BandwidthClassEUTRA**

Derivation Path: TS 38.331 [6], clause 6.3.3			
Information Element	Value/remark	Comment	Condition
CA-BandwidthClassEUTRA	Not checked		

– *CA-BandwidthClassNR*

**Table 4.6.4-4: CA-BandwidthClassNR**

Derivation Path: TS 38.331 [6], clause 6.3.3			
Information Element	Value/remark	Comment	Condition



CA-BandwidthClassNR	Not checked		
---------------------	-------------	--	--

– *CA-ParametersEUTRA*

**Table 4.6.4-5: CA- ParametersEUTRA**

Derivation Path: TS 38.331 [6], clause 6.3.3			
Information Element	Value/remark	Comment	Condition
CA-ParametersEUTRA ::= SEQUENCE {			
multipleTimingAdvance	Not checked		
simultaneousRx-Tx	Not checked		
supportedNAICS-2CRS-AP	Not checked		
additionalRx-Tx-PerformanceReq	Not checked		
ue-CA-PowerClass-N	Not checked		
supportedBandwidthCombinationSetEUTRA-v1530	Not checked		
}			

– *CA-ParametersNR*

**Table 4.6.4-6: CA- ParametersNR**

Derivation Path: TS 38.331 [6], clause 6.3.3			
Information Element	Value/remark	Comment	Condition
CA-ParametersNR ::= SEQUENCE {			
dummy	Not checked		
parallelTxSRS-PUCCH-PUSCH	Not checked		
parallelTxPRACH-SRS-PUCCH-PUSCH	Not checked		
simultaneousRxTxInterBandCA	Not checked		
simultaneousRxTxSUL	Not checked		
diffNumerologyAcrossPUCCH-Group	Not checked		
diffNumerologyWithinPUCCH-GroupSmallerSCS	Not checked		
supportedNumberTAG	Not checked		
}			

– *CA-ParametersNRDC*

**Table 4.6.4-6AA: CA- ParametersNRDC**

Derivation Path: TS 38.331 [6], clause 6.3.3			
Information Element	Value/remark	Comment	Condition
CA-ParametersNRDC ::= SEQUENCE {			
ca-ParametersNR-ForDC	Not checked		
ca-ParametersNR-ForDC-v1540	Not checked		
ca-ParametersNR-ForDC-v1550	Not checked		
ca-ParametersNR-ForDC-v1560	Not checked		
featureSetCombinationDC	Not checked		
}			

– *CarrierAggregationVariant*

**Table 4.6.4-6AB: CarrierAggregationVariant**

Derivation Path: TS 38.331 [6], clause 6.3.3			
Information Element	Value/remark	Comment	Condition
CarrierAggregationVariant ::= SEQUENCE {			
FFS			
}			

CodebookParameters

Table 4.6.4-6A: CodebookParameters

Derivation Path: TS 38.331 [6], clause 6.3.3			
Information Element	Value/remark	Comment	Condition
CodebookParameters ::= SEQUENCE {			
type1 SEQUENCE {			
singlePanel SEQUENCE {			
supportedCSI-RS-ResourceList SEQUENCE (SIZE (1.. maxNrofCSI-RS-Resources)) OF SupportedCSI-RS-Resource {	1 entry		
SupportedCSI-RS-Resource[1] SEQUENCE {		entry 1	
maxNumberTxPortsPerResource	Not checked		
maxNumberResourcesPerBand	Not checked		
totalNumberTxPortsPerBand	Not checked		
}			
}			
modes	Not checked		
maxNumberCSI-RS-PerResourceSet	Not checked		
}			
multiPanel SEQUENCE {			
supportedCSI-RS-ResourceList SEQUENCE (SIZE (1.. maxNrofCSI-RS-Resources)) OF SupportedCSI-RS-Resource {	1 entry		
SupportedCSI-RS-Resource[1] SEQUENCE {		entry 1	
maxNumberTxPortsPerResource	Not checked		
maxNumberResourcesPerBand	Not checked		
totalNumberTxPortsPerBand	Not checked		
}			
}			
modes	Not checked		
nrofPanels	Not checked		
maxNumberCSI-RS-PerResourceSet	Not checked		
}			
}			
type2 SEQUENCE {			
supportedCSI-RS-ResourceList SEQUENCE (SIZE (1.. maxNrofCSI-RS-Resources)) OF SupportedCSI-RS-Resource {	1 entry		
SupportedCSI-RS-Resource[1] SEQUENCE {		entry 1	
maxNumberTxPortsPerResource	Not checked		
maxNumberResourcesPerBand	Not checked		
totalNumberTxPortsPerBand	Not checked		
}			
}			
parameterLx	Not checked		
amplitudeScalingType	Not checked		
amplitudeSubsetRestriction	Not checked		
}			
type2-PortSelection SEQUENCE {			
supportedCSI-RS-ResourceList SEQUENCE (SIZE (1.. maxNrofCSI-RS-Resources)) OF SupportedCSI-RS-Resource {	1 entry		
SupportedCSI-RS-Resource[1] SEQUENCE {		entry 1	
maxNumberTxPortsPerResource	Not checked		
maxNumberResourcesPerBand	Not checked		
totalNumberTxPortsPerBand	Not checked		
}			
}			
parameterLx	Not checked		
amplitudeScalingType	Not checked		
}			
}			

– *FeatureSetCombination*

Table 4.6.4-7: FeatureSetCombination

Derivation Path: TS 38.331 [6], clause 6.3.3			
Information Element	Value/remark	Comment	Condition
FeatureSetCombination ::= SEQUENCE (SIZE (1..maxSimultaneousBands)) OF FeatureSetsPerBand {	1 entry		
FeatureSetsPerBand[1] SEQUENCE (SIZE (1..maxFeatureSetsPerBand)) OF FeatureSet {	1 entry	entry 1	
FeatureSet[1] CHOICE {		entry 1	
nr SEQUENCE {			
downlinkSetNR	Not checked		
uplinkSetNR	Not checked		
}			
}			
}			
}			

– *FeatureSetCombinationId*

Table 4.6.4-8: FeatureSetCombinationId

Derivation Path: TS 38.331 [6], clause 6.3.3			
Information Element	Value/remark	Comment	Condition
FeatureSetCombinationId	Not checked		

– *FeatureSetDownlink*

Table 4.6.4-9: FeatureSetDownlink

Derivation Path: TS 38.331 [6], clause 6.3.3			
Information Element	Value/remark	Comment	Condition
FeatureSetDownlink ::= SEQUENCE {			
featureSetListPerDownlinkCC SEQUENCE (SIZE (1..maxNrofServingCells)) OF FeatureSetDownlinkPerCC-Id {	1 entry		
FeatureSetDownlinkPerCC-Id[1]	Not checked	entry 1	
}			
intraBandFreqSeparationDL	FreqSeparationClass		
scalingFactor	Not checked		
crossCarrierSchedulingDL-OtherSCS	Not checked		
scellWithoutSSB	Not checked		
csi-RS-MeasSCellWithoutSSB	Not checked		
dummy1	Not checked		
type1-3-CSS	Not checked		
pdcchMonitoringAnyOccasions	Not checked		
dummy2	Not checked		
ue-SpecificUL-DL-Assignment	Not checked		
searchSpaceSharingCA-DL	Not checked		
timeDurationForQCL SEQUENCE {			
scs-60kHz	Not checked		
scsh-120kHz	Not checked		
}			
pdsch- ProcessingType1-DifferentTB-PerSlot SEQUENCE {			
scs-15kHz	Not checked		
scs-30kHz	Not checked		
scs-60kHz	Not checked		
scs-120kHz	Not checked		
}			

dummy3	Not checked		
dummy4	Not checked		
dummy5	Not checked		
dummy6	Not checked		
dummy7	Not checked		
}			

– *FeatureSetDownlinkId*

**Table 4.6.4-10: FeatureSetDownlinkId**

Derivation Path: TS 38.331 [6], clause 6.3.3			
Information Element	Value/remark	Comment	Condition
FeatureSetDownlinkId	Not checked		

– *FeatureSetDownlinkPerCC*

**Table 4.6.4-11: FeatureSetDownlinkPerCC**

Derivation Path: TS 38.331 [6], clause 6.3.3			
Information Element	Value/remark	Comment	Condition
FeatureSetDownlinkPerCC ::= SEQUENCE {			
supportedSubcarrierSpacingDL	Not checked		
supportedBandwidthDL	SupportedBandwidth		
channelBW-90mhz	Not checked		
maxNumberMIMO-LayersPDSCH	MIMO-LayersDL		
supportedModulationOrderDL	ModulationOrder		
}			

– *FeatureSetDownlinkPerCC-Id*

**Table 4.6.4-12: FeatureSetDownlinkPerCC-Id**

Derivation Path: TS 38.331 [6], clause 6.3.3			
Information Element	Value/remark	Comment	Condition
FeatureSetDownlinkPerCC-Id	Not checked		

– *FeatureSetEUTRA-DownlinkId*

**Table 4.6.4-13: FeatureSetEUTRA-DownlinkId**

Derivation Path: TS 38.331 [6], clause 6.3.3			
Information Element	Value/remark	Comment	Condition
FeatureSetEUTRA-DownlinkId	Not checked		

– *FeatureSetEUTRA-UplinkId*

**Table 4.6.4-14: FeatureSetEUTRA-UplinkId**

Derivation Path: TS 38.331 [6], clause 6.3.3			
Information Element	Value/remark	Comment	Condition
FeatureSetEUTRA-UplinkId	Not checked		

– *FeatureSets*Table 4.6.4-15: *FeatureSets*

Derivation Path: TS 38.331 [6], clause 6.3.3			
Information Element	Value/remark	Comment	Condition
FeatureSets ::= SEQUENCE {			
featureSetsDownlink SEQUENCE (SIZE (1..maxDownlinkFeatureSets)) OF FeatureSetDownlink {	1 entry		
FeatureSetDownlink[1]	FeatureSetDownlink	entry 1	
}			
featureSetsDownlinkPerCC SEQUENCE (SIZE (1..maxPerCC-FeatureSets)) OF FeatureSetDownlinkPerCC {	1 entry		
FeatureSetDownlinkPerCC[1]	FeatureSetDownlinkPerCC	entry 1	
}			
featureSetsUplink SEQUENCE (SIZE (1..maxUplinkFeatureSets)) OF FeatureSetUplink {	1 entry		
FeatureSetUplink[1]	FeatureSetUplink	entry 1	
}			
featureSetsUplinkPerCC SEQUENCE (SIZE (1..maxPerCC-FeatureSets)) OF FeatureSetUplinkPerCC {	1 entry		
FeatureSetUplinkPerCC[1]	FeatureSetUplinkPerCC	entry 1	
}			
}			

– *FeatureSetUplink*Table 4.6.4-16: *FeatureSetUplink*

Derivation Path: TS 38.331 [6], clause 6.3.3			
Information Element	Value/remark	Comment	Condition
FeatureSetUplink ::= SEQUENCE {			
featureSetListPerUplinkCC SEQUENCE (SIZE (1..maxNrofServingCells)) OF FeatureSetUplinkPerCC-Id {	1 entry		
FeatureSetUplinkPerCC-Id[1]	Not checked	entry 1	
}			
scalingFactor	Not checked		
crossCarrierSchedulingUL-OtherSCS	Not checked		
intraBandFreqSeparationUL	FreqSeparationClass		
searchSpaceSharingCA-UL	Not checked		
dummy1	Not checked		
supportedSRS-Resources SEQUENCE {			
maxNumberAperiodicSRS-PerBWP	Not Checked		
maxNumberAperiodicSRS-PerBWP-PerSlot	Not Checked		
maxNumberPeriodicSRS-PerBWP	Not Checked		
maxNumberPeriodicSRS-PerBWP-PerSlot	Not Checked		
maxNumberSemiPersistentSRS-PerBWP	Not Checked		
maxNumberSemiPersistentSRS-PerBWP-PerSlot	Not Checked		
maxNumberSRS-Ports-PerResource	Not Checked		
}			
twoPUCCH-Group	Not checked		
dynamicSwitchSUL	Not checked		
pusch- ProcessingType1-DifferentTB-PerSlot SEQUENCE {			
scs-15kHz	Not checked		
scs-30kHz	Not checked		
scs-60kHz	Not checked		
scs-120kHz	Not checked		
}			

dummy2	Not checked		
}			

– *FeatureSetUplinkId*

**Table 4.6.4-17: FeatureSetUplinkId**

Derivation Path: TS 38.331 [6], clause 6.3.3			
Information Element	Value/remark	Comment	Condition
FeatureSetUplinkId	Not checked		

– *FeatureSetUplinkPerCC*

**Table 4.6.4-18: FeatureSetUplinkPerCC**

Derivation Path: TS 38.331 [6], clause 6.3.3			
Information Element	Value/remark	Comment	Condition
FeatureSetUplinkPerCC ::= SEQUENCE {			
supportedSubcarrierSpacingUL	Not checked		
supportedBandwidthUL	SupportedBandwidth		
channelBW-90mhz	Not checked		
mimo-CB-PUSCH SEQUENCE {			
maxNumberMIMO-LayersCB-PUSCH	MIMO-LayersUL		
maxNumberSRS-ResourcePerSet	Not checked		
}			
maxNumberMIMO-LayersNonCB-PUSCH	MIMO-LayersUL		
supportedModulationOrderUL	ModulationOrder		
}			

– *FeatureSetUplinkPerCC-Id*

**Table 4.6.4-19: FeatureSetUplinkPerCC-Id**

Derivation Path: TS 38.331 [6], clause 6.3.3			
Information Element	Value/remark	Comment	Condition
FeatureSetUplinkPerCC-Id	Not checked		

– *FreqBandIndicatorEUTRA*

**Table 4.6.4-20: FreqBandIndicatorEUTRA**

Derivation Path: TS 38.331 [6], clause 6.3.3			
Information Element	Value/remark	Comment	Condition
FreqBandIndicatorEUTRA	EUTRA Operating band under test		

– *FreqBandList*

**Table 4.6.4-21: FreqBandList**

Derivation Path: TS 38.331 [6], clause 6.3.3			
Information Element	Value/remark	Comment	Condition
FreqBandList ::= SEQUENCE (SIZE (1..maxBandsMRDC)) OF FreqBandInformation {	Number of entries depends on the conditions		
FreqBandInformation[1] CHOICE {		entry 1	EN-DC, NE-DC

bandInformationEUTRA SEQUENCE {			
bandEUTRA	FreqBandIndicatorEUTRA		
ca-BandwidthClassDL-EUTRA	Not checked		
ca-BandwidthClassUL-EUTRA	Not checked		
}			
FreqBandInformation[2] CHOICE {		entry 2	
bandInformationNR SEQUENCE {			
bandNR	FreqBandIndicatorNR		
maxBandwidthRequestedDL	Not checked		
maxBandwidthRequestedUL	Not checked		
maxCarriersRequestedDL	Not checked		
maxCarriersRequestedUL	Not checked		
}			
FreqBandInformation[3] CHOICE {		entry 3	EN-DC AND CA-InterBand
bandInformationNR SEQUENCE {			
bandNR	FreqBandIndicatorNR with condition CA-InterBand		
maxBandwidthRequestedDL	Not checked		
maxBandwidthRequestedUL	Not checked		
maxCarriersRequestedDL	Not checked		
maxCarriersRequestedUL	Not checked		
}			
FreqBandInformation[1] CHOICE {		entry 1	NR
bandInformationNR SEQUENCE {			
bandNR	FreqBandIndicatorNR		
maxBandwidthRequestedDL	Not checked		
maxBandwidthRequestedUL	Not checked		
maxCarriersRequestedDL	Not checked		
maxCarriersRequestedUL	Not checked		
}			
FreqBandInformation[2] CHOICE {		entry 2	NR AND CA-InterBand
bandInformationNR SEQUENCE {			
bandNR	FreqBandIndicatorNR with condition CA-InterBand		
maxBandwidthRequestedDL	Not checked		
maxBandwidthRequestedUL	Not checked		
maxCarriersRequestedDL	Not checked		
maxCarriersRequestedUL	Not checked		
}			
FreqBandInformation[2] CHOICE {		entry 2	NR-DC
bandInformationNR SEQUENCE {			
bandNR	FreqBandIndicatorNR with condition NR-DC-SecondaryBand		
maxBandwidthRequestedDL	Not checked		
maxBandwidthRequestedUL	Not checked		
maxCarriersRequestedDL	Not checked		
maxCarriersRequestedUL	Not checked		
}			
}			

Condition	Explanation
-----------	-------------

EN-DC	E-UTRA-NR Dual Connectivity with E-UTRA connected to EPC
CA-InterBand	Used in NR CA Inter-band test cases
NR	NG-RAN NR Radio Access
NR-DC	NR-NR Dual Connectivity
NE-DC	NR E-UTRA Dual Connectivity

– *FreqSeparationClass*

**Table 4.6.4-22: FreqSeparationClass**

Derivation Path: TS 38.331 [6], clause 6.3.3			
Information Element	Value/remark	Comment	Condition
FreqSeparationClass	Not checked		

– *FreqSeparationClassDL-Only*

**Table 4.6.4-22A: FreqSeparationClassDL-Only**

Derivation Path: TS 38.331 [6], clause 6.3.3			
Information Element	Value/remark	Comment	Condition
FreqSeparationClassDL-Only-r16	FFS		

– *FR2-2-AccessParamsPerBand*

**Table 4.6.4-22BA: FR2-2-AccessParamsPerBand**

Derivation Path: TS 38.331 [6], clause 6.3.3			
Information Element	Value/remark	Comment	Condition
FR2-2-AccessParamsPerBand-r17 ::= SEQUENCE {			
FFS			
}			

– *HighSpeedParameters*

**Table 4.6.4-22B: HighSpeedParameters**

Derivation Path: TS 38.331 [6], clause 6.3.3			
Information Element	Value/remark	Comment	Condition
HighSpeedParameters-r16 ::= SEQUENCE {			
FFS			
}			

– *IMS-Parameters*

**Table 4.6.4-23: IMS-Parameters**

Derivation Path: TS 38.331 [6], clause 6.3.3			
Information Element	Value/remark	Comment	Condition
IMS-Parameters ::= SEQUENCE {			
ims-ParametersCommon SEQUENCE {			
voiceOverEUTRA-5GC	Not Checked		
}			
ims-ParametersFRX-Diff SEQUENCE {			
voiceOverNR	Not Checked		
}			
}			



– *InterRAT-Parameters*

**Table 4.6.4-24: InterRAT-Parameters**

Derivation Path: TS 38.331 [6], clause 6.3.3			
Information Element	Value/remark	Comment	Condition
InterRAT-Parameters ::= SEQUENCE {			
eutra SEQUENCE {			
supportedBandListEUTRA SEQUENCE (SIZE (1..maxBandsEUTRA)) OF FreqBandIndicatorEUTRA {	1 entry		
FreqBandIndicatorEUTRA[1]	FreqBandIndicatorEUTRA	entry 1	
}	A		
}			
eutra-ParametersCommon SEQUENCE {			
mfbf-EUTRA	Not Checked		
modifiedMPR-BehaviorEUTRA	Not Checked		
multiNS-Pmax-EUTRA	Not Checked		
rs-SINR-MeasEUTRA	Not Checked		
ne-DC	Not Checked		
nr-HO-ToEN-DC-r16	Not Checked		>=Rel16
}			
eutra-ParametersXDD-Diff SEQUENCE {			
rsrqMeasWidebandEUTRA	Not Checked		
}			
}			
}			
}			

– *MAC-Parameters*

**Table 4.6.4-25: MAC-Parameters**

Derivation Path: TS 38.331 [6], clause 6.3.3			
Information Element	Value/remark	Comment	Condition
MAC-Parameters ::= SEQUENCE {			
mac-ParametersCommon SEQUENCE {			
lcp-Restriction	Not checked		
dummy	Not checked		
lch-ToSCellRestriction	Not checked		
}			
mac-ParametersXDD-Diff SEQUENCE {			
skipUplinkTxDynamic	Not checked		
logicalChannelSR-DelayTimer	Not checked		
longDRX-Cycle	Not checked		
shortDRX-Cycle	Not checked		
multipleSR-Configurations	Not checked		
multipleConfiguredGrants	Not checked		
}			
}			

– *MeasAndMobParameters*

**Table 4.6.4-26: MeasAndMobParameters**

Derivation Path: TS 38.331 [6], clause 6.3.3			
Information Element	Value/remark	Comment	Condition
MeasAndMobParameters ::= SEQUENCE {			
measAndMobParametersCommon SEQUENCE {			
supportedGapPattern	Not checked		

ssb-RLM	Not checked		
ssb-AndCSI-RS-RLM	Not checked		
eutra-CGI-Reporting	Not checked		
nr-CGI-Reporting	Not checked		
nr-CGI-Reporting-ENDC	Not checked		
eutra-CGI-Reporting-NEDC	Not checked		
eutra-CGI-Reporting-NRDC	Not checked		
nr-CGI-Reporting-NEDC	Not checked		
nr-CGI-Reporting-NRDC	Not checked		
}			
measAndMobParametersXDD-Diff SEQUENCE {			
intraAndInterF-MeasAndReport	Not checked		
eventA-MeasAndReport	Not checked		
}			
MeasAndMobParametersFRX-Diff SEQUENCE {			
ss-SINR-Meas	Not checked		
csi-RSRP-AndRSRQ-MeasWithSSB	Not checked		
csi-RSRP-AndRSRQ-MeasWithoutSSB	Not checked		
csi-SINR-Meas	Not checked		
csi-RS-RLM	Not checked		
}			
}			

– *MeasAndMobParametersMRDC*

**Table 4.6.4-27: MeasAndMobParametersMRDC**

Derivation Path: TS 38.331 [6], clause 6.3.3			
Information Element	Value/remark	Comment	Condition
MeasAndMobParametersMRDC ::= SEQUENCE {			
measAndMobParametersMRDC-Common SEQUENCE			
{			
independentGapConfig	Not checked		
}			
measAndMobParametersMRDC-XDD-Diff SEQUENCE			
{			
sftd-MeasPSCell	Not checked		
sftd-MeasNR-Cell	Not checked		
}			
measAndMobParametersMRDC-FRX-Diff SEQUENCE			
{			
simultaneousRxDataSSB-DiffNumerology	Not checked		
}			
}			

– *MIMO-Layers*

**Table 4.6.4-28: MIMO-Layers**

Derivation Path: TS 38.331 [6], clause 6.3.3			
Information Element	Value/remark	Comment	Condition
MIMO-LayersDL	Not checked		
MIMO-LayersUL	Not checked		

– *MIMO-ParametersPerBand*

**Table 4.6.4-29: MIMO-ParametersPerBand**

Derivation Path: TS 38.331 [6], clause 6.3.3			
Information Element	Value/remark	Comment	Condition

MIMO-ParametersPerBand ::= SEQUENCE {			
tci-StatePDSCH SEQUENCE {			
maxNumberConfiguredTCIstatesPerCC	Not checked		
maxNumberActiveTCI-PerBWP	Not checked		
}			
additionalActiveTCI-StatePDCCH	Not checked		
pusch-TransCoherence	Not checked		
beamCorrespondenceWithoutUL-BeamSweeping	Not checked		
periodicBeamReport	Not checked		
aperiodicBeamReport	Not checked		
sp-BeamReportPUCCH	Not checked		
sp-BeamReportPUSCH	Not checked		
dummy1	Not checked		
maxNumberRxBeam	Not checked		
maxNumberRxTxBeamSwitchDL SEQUENCE {			
scs-15kHz	Not checked		
scs-30kHz	Not checked		
scs-60kHz	Not checked		
scs-120kHz	Not checked		
scs-240kHz	Not checked		
}			
maxNumberNonGroupBeamReporting	Not checked		
groupBeamReporting	Not checked		
uplinkBeamManagement SEQUENCE {			
maxNumberSRS-ResourcePerSet	Not checked		
maxNumberSRS-ResourceSet	Not checked		
}			
maxNumberCSI-RS-BFD	Not checked		
maxNumbeSSB-BFD	Not checked		
maxNumberCSI-RS-SSB-CBD	Not checked		
dummy2	Not checked		
twoPortsPTRS-UL	Not checked		
dummy5	Not checked		
dummy3	Not checked		
beamReportTiming SEQUENCE {			
scs-15kHz	Not checked		
scs-30kHz	Not checked		
scs-60kHz	Not checked		
scs-120kHz	Not checked		
}			
ptrs-DensityRecommendationSetDL SEQUENCE {			
scs-15kHz			
frequencyDensity1	Not checked		
frequencyDensity2	Not checked		
timeDensity1	Not checked		
timeDensity2	Not checked		
timeDensity3	Not checked		
}			
scs-30kHz			
frequencyDensity1	Not checked		
frequencyDensity2	Not checked		
timeDensity1	Not checked		
timeDensity2	Not checked		
timeDensity3	Not checked		
}			
scs-60kHz			
frequencyDensity1	Not checked		
frequencyDensity2	Not checked		
timeDensity1	Not checked		
timeDensity2	Not checked		
timeDensity3	Not checked		
}			
scs-120kHz			
frequencyDensity1	Not checked		
frequencyDensity2	Not checked		

timeDensity1	Not checked		
timeDensity2	Not checked		
timeDensity3	Not checked		
}			
}			
ptrs-DensityRecommendationSetUL SEQUENCE {			
scs-15kHz SEQUENCE {			
frequencyDensity1	Not checked		
frequencyDensity2	Not checked		
timeDensity1	Not checked		
timeDensity2	Not checked		
timeDensity3	Not checked		
sampleDensity1	Not checked		
sampleDensity2	Not checked		
sampleDensity3	Not checked		
sampleDensity4	Not checked		
sampleDensity5	Not checked		
}			
scs-30kHz SEQUENCE {			
frequencyDensity1	Not checked		
frequencyDensity2	Not checked		
timeDensity1	Not checked		
timeDensity2	Not checked		
timeDensity3	Not checked		
sampleDensity1	Not checked		
sampleDensity2	Not checked		
sampleDensity3	Not checked		
sampleDensity4	Not checked		
sampleDensity5	Not checked		
scs-60kHz SEQUENCE {			
frequencyDensity1	Not checked		
frequencyDensity2	Not checked		
timeDensity1	Not checked		
timeDensity2	Not checked		
timeDensity3	Not checked		
sampleDensity1	Not checked		
sampleDensity2	Not checked		
sampleDensity3	Not checked		
sampleDensity4	Not checked		
sampleDensity5	Not checked		
scs-120kHz SEQUENCE {			
frequencyDensity1	Not checked		
frequencyDensity2	Not checked		
timeDensity1	Not checked		
timeDensity2	Not checked		
timeDensity3	Not checked		
sampleDensity1	Not checked		
sampleDensity2	Not checked		
sampleDensity3	Not checked		
sampleDensity4	Not checked		
sampleDensity5	Not checked		
}			
dummy4	Not checked		
aperiodicTRS	Not checked		
}			

– *ModulationOrder*

**Table 4.6.4-30: ModulationOrder**

Derivation Path: TS 38.331 [6], clause 6.3.3			
Information Element	Value/remark	Comment	Condition
ModulationOrder	Not checked		

## – MRDC-Parameters

Table 4.6.4-31: MRDC-Parameters

Derivation Path: TS 38.331 [6], clause 6.3.3			
Information Element	Value/remark	Comment	Condition
MRDC-Parameters ::= SEQUENCE {			
singleUL-Transmission	Not checked		
dynamicPowerSharingENDC	Not checked		
tdm-Pattern	Not checked		
ul-SharingEUTRA-NR	Not checked		
ul-SwitchingTimeEUTRA-NR	Not checked		
simultaneousRxTxInterBandENDC	Not checked		
asynIntraBandENDC	Not checked		
}			

## – NRDC-Parameters

Table 4.6.4-31A: NRDC-Parameters

Derivation Path: TS 38.331 [6], clause 6.3.3			
Information Element	Value/remark	Comment	Condition
NRDC-Parameters ::= SEQUENCE {			
measAndMobParametersNRDC	Not checked		
generalParametersNRDC SEQUENCE {			
splitSRB-WithOneUL-Path	Not checked		
splitDRB-withUL-Both-MCG-SCG	Not checked		
srb3	Not checked		
v2x-EUTRA	Not checked		
}			
fdd-Add-UE-NRDC-Capabilities SEQUENCE {			
measAndMobParametersMRDC-XDD-Diff SEQUENCE {			
sftd-MeasPSCell	Not checked		
sftd-MeasNR-Cell	Not checked		
}			
generalParametersMRDC SEQUENCE {			
splitSRB-WithOneUL-Path	Not checked		
splitDRB-withUL-Both-MCG-SCG	Not checked		
srb3	Not checked		
v2x-EUTRA-v1530	Not checked		
}			
}			
tdd-Add-UE-NRDC-Capabilities SEQUENCE {			
measAndMobParametersMRDC-XDD-Diff SEQUENCE {			
sftd-MeasPSCell	Not checked		
sftd-MeasNR-Cell	Not checked		
}			
generalParametersMRDC SEQUENCE {			
splitSRB-WithOneUL-Path	Not checked		
splitDRB-withUL-Both-MCG-SCG	Not checked		
srb3	Not checked		
v2x-EUTRA-v1530	Not checked		
}			
}			
fr1-Add-UE-NRDC-Capabilities SEQUENCE {	UE-MRDC-CapabilityAddFRX-Mode		
measAndMobParametersMRDC-FRX-Diff SEQUENCE {			
simultaneousRxDataSSB-DiffNumerology	Not checked		
}			
}			

fr2-Add-UE-NRDC-Capabilities SEQUENCE {			
measAndMobParametersMRDC-FRX-Diff			
SEQUENCE {			
simultaneousRxDataSSB-DiffNumerology	Not checked		
}			
}			
lateNonCriticalExtension	Not checked		
nonCriticalExtension	Not checked		
}			

– *NTN-Parameters*

**Table 4.6.4-31BA: NTN-Parameters**

Derivation Path: TS 38.331 [6], clause 6.3.3			
Information Element	Value/remark	Comment	Condition
NTN-Parameters-r17 ::= SEQUENCE {			
FFS			
}			

– *OLPC-SRS-Pos*

**Table 4.6.4-31B: OLPC-SRS-Pos**

Derivation Path: TS 38.331 [6], clause 6.3.3			
Information Element	Value/remark	Comment	Condition
OLPC-SRS-Pos-r16 ::= SEQUENCE {			
FFS			
}			

– *PDCP-Parameters*

**Table 4.6.4-32: PDCP-Parameters**

Derivation Path: TS 38.331 [6], clause 6.3.3			
Information Element	Value/remark	Comment	Condition
PDCP-Parameters ::= SEQUENCE {			
supportedROHC-Profiles SEQUENCE {			
profile0x0000	Not checked		
profile0x0001	Not checked		
profile0x0002	Not checked		
profile0x0003	Not checked		
profile0x0004	Not checked		
profile0x0006	Not checked		
profile0x0101	Not checked		
profile0x0102	Not checked		
profile0x0103	Not checked		
profile0x0104	Not checked		
}			
maxNumberROHC-ContextSessions	Not checked		
uplinkOnlyROHC-Profiles	Not checked		
continueROHC-Context	Not checked		
outOfOrderDelivery	Not checked		
shortSN	Not checked		
pdcP-DuplicationSRB	Not checked		
pdcP-DuplicationMCG-OrSCG-DRB	Not checked		
}			

– *PDCP-ParametersMRDC***Table 4.6.4-33: PDCP-ParametersMRDC**

Derivation Path: TS 38.331 [6], clause 6.3.3			
Information Element	Value/remark	Comment	Condition
PDCP-ParametersMRDC ::= SEQUENCE {			
pdcp-DuplicationSplitSRB	Not checked		
pdcp-DuplicationSplitDRB	Not checked		
}			

– *Phy-Parameters***Table 4.6.4-34: Phy-Parameters**

Derivation Path: TS 38.331 [6], clause 6.3.3			
Information Element	Value/remark	Comment	Condition
Phy-Parameters ::= SEQUENCE {			
phy-ParametersCommon SEQUENCE {			
csi-RS-CFRA-ForHO	Not checked		
dynamicPRB-BundlingDL	Not checked		
sp-CSI-ReportPUCCH	Not checked		
sp-CSI-ReportPUSCH	Not checked		
nzp-CSI-RS-IntefMgmt	Not checked		
type2-SP-CSI-Feedback-LongPUCCH	Not checked		
precoderGranularityCORESET	Not checked		
dynamicHARQ-ACK-Codebook	Not checked		
semiStaticHARQ-ACK-Codebook	Not checked		
spatialBundlingHARQ-ACK	Not checked		
dynamicBetaOffsetInd-HARQ-ACK-CSI	Not checked		
pucch-Repetition-F1-3-4	Not checked		
ra-Type0-PUSCH	Not checked		
dynamicSwitchRA-Type0-1-PDSCH	Not checked		
dynamicSwitchRA-Type0-1-PUSCH	Not checked		
pdsch-MappingTypeA	Not checked		
pdsch-MappingTypeB	Not checked		
interleavingVRB-ToPRB-PDSCH	Not checked		
interSlotFreqHopping-PUSCH	Not checked		
type1-PUSCH-RepetitionMultiSlots	Not checked		
type2-PUSCH-RepetitionMultiSlots	Not checked		
pusch-RepetitionMultiSlots	Not checked		
pdsch-RepetitionMultiSlots	Not checked		
downlinkSPS	Not checked		
configuredUL-GrantType1	Not checked		
configuredUL-GrantType2	Not checked		
pre-EmptIndication-DL	Not checked		
cbg-TransIndication-DL	Not checked		
cbg-TransIndication-UL	Not checked		
cbg-FlushIndication-DL	Not checked		
dynamicHARQ-ACK-CodeB-CBG-Retx-DL	Not checked		
rateMatchingResrcSetSemi-Static	Not checked		
rateMatchingResrcSetDynamic	Not checked		
bwp-SwitchingDelay	Not checked		
}			
phy-ParametersXDD-Diff SEQUENCE {			
dynamicSFI	Not checked		
twoPUCCH-F0-2-ConsecSymbols	Not checked		
twoDifferentTPC-Loop-PUSCH	Not checked		
twoDifferentTPC-Loop-PUCCH	Not checked		
}			
phy-ParametersFRX-Diff SEQUENCE {			
dynamicSFI	Not checked		
dummy1	Not checked		

twoFL-DMRS	Not checked		
dummy2	Not checked		
dummy3	Not checked		
supportedDMRS-TypeDL	Not checked		
supportedDMRS-TypeUL	Not checked		
semiOpenLoopCSI	Not checked		
csi-ReportWithoutPMI	Not checked		
csi-ReportWithoutCQI	Not checked		
onePortsPTRS	Not checked		
twoPUCCH-F0-2-ConsecSymbols	Not checked		
pucch-F2-WithFH	Not checked		
pucch-F3-WithFH	Not checked		
pucch-F4-WithFH	Not checked		
freqHoppingPUCCH-F0-2	Not checked		
freqHoppingPUCCH-F1-3-4	Not checked		
mux-SR-HARQ-ACK-CSI-PUCCH- MultiPerSlot	Not checked		
uci-CodeBlockSegmentation	Not checked		
onePUCCH-LongAndShortFormat	Not checked		
twoPUCCH-AnyOthersInSlot	Not checked		
intraSlotFreqHopping-PUSCH	Not checked		
pusch-LBRM	Not checked		
pdccch-BlindDetectionCA	Not checked		
tpc-PUSCH-RNTI	Not checked		
tpc-PUCCH-RNTI	Not checked		
tpc-SRS-RNTI	Not checked		
absoluteTPC-Command	Not checked		
twoDifferentTPC-Loop-PUSCH	Not checked		
twoDifferentTPC-Loop-PUCCH	Not checked		
pusch-HalfPi-BPSK	Not checked		
pucch-F3-4-HalfPi-BPSK	Not checked		
almostContiguousCP-OFDM-UL	Not checked		
sp-CSI-RS	Not checked		
sp-CSI-IM	Not checked		
tdd-MultiDL-UL-SwitchPerSlot	Not checked		
multipleCORESET	Not checked		
}			
phy-ParametersFR1 SEQUENCE {			
pdccchMonitoringSingleOccasion	Not checked		
scs-60kHz	Not checked		
pdsch-256QAM-FR1	Not checked		
pdsch-RE-MappingFR1- PerSymbol	Not checked		
}			
phy-ParametersFR2 SEQUENCE {			
dummy	Not checked		
pdsch-RE-MappingFR2- PerSymbol	Not checked		
}			
}			

– *Phy-ParametersMRDC*

**Table 4.6.4-35: *Phy-ParametersMRDC***

Derivation Path: TS 38.331 [6], clause 6.3.3			
Information Element	Value/remark	Comment	Condition
Phy-ParametersMRDC ::= SEQUENCE {			
naics-Capability-List SEQUENCE (SIZE (1..maxNrofNAICS-Entries)) OF NAICS-Capability-Entry {	1 entry		
NAICS-Capability-Entry[1] SEQUENCE {		entry 1	
numberOfNAICS-CapableCC	Not checked		
numberOfAggregatedPRB	Not checked		
}			
}			



– *Phy-ParametersSharedSpectrumChAccess*

**Table 4.6.4-35AA: *Phy-ParametersSharedSpectrumChAccess***

Derivation Path: TS 38.331 [6], clause 6.3.3			
Information Element	Value/remark	Comment	Condition
Phy-ParametersSharedSpectrumChAccess-r16 ::= SEQUENCE {			
FFS			
ss-SINR-Meas-r16			
sp-CSI-ReportPUCCH-r16	Not checked		
sp-CSI-ReportPUSCH-r16	Not checked		
dynamicSFI-r16	Not checked		
mux-SR-HARQ-ACK-CSI-PUCCH-OncePerSlot-r16 SEQUENCE {			
sameSymbol-r16	Not checked		
diffSymbol-r16	Not checked		
}	Not checked		
mux-SR-HARQ-ACK-PUCCH-r16	Not checked		
mux-SR-HARQ-ACK-CSI-PUCCH-MultiPerSlot-r16	Not checked		
mux-HARQ-ACK-PUSCH-DiffSymbol-r16	Not checked		
pucch-Repetition-F1-3-4-r16	Not checked		
type1-PUSCH-RepetitionMultiSlots-r16	Not checked		
type2-PUSCH-RepetitionMultiSlots-r16	Not checked		
pusch-RepetitionMultiSlots-r16	Not checked		
pdsch-RepetitionMultiSlots-r16	Not checked		
downlinkSPS-r16	Not checked		
configuredUL-GrantType1-r16	Not checked		
configuredUL-GrantType2-r16	Not checked		
pre-EmptIndication-DL-r16	Not checked		
}			

– *PosSRS-RRC-Inactive-OutsideInitialUL-BWP*

**Table 4.6.4-35AB: *PosSRS-RRC-Inactive-OutsideInitialUL-BWP***

Derivation Path: TS 38.331 [6], clause 6.3.3			
Information Element	Value/remark	Comment	Condition
PosSRS-RRC-Inactive-OutsideInitialUL-BWP-r17 ::= SEQUENCE {			
FFS			
}			

– *PowSav-Parameters*

**Table 4.6.4-35A: *PowSav-Parameters***

Derivation Path: TS 38.331 [6], clause 6.3.3			
Information Element	Value/remark	Comment	Condition
PowSav-Parameters-r16 ::= SEQUENCE {			
FFS			
}			

– *ProcessingParameters*

**Table 4.6.4-36: *ProcessingParameters***

Derivation Path: TS 38.331 [6], clause 6.3.3			
Information Element	Value/remark	Comment	Condition
ProcessingParameters ::= SEQUENCE {			

fallback	Not checked		
differentTB-PerSlot SEQUENCE {			
upto1	Not checked		
upto2	Not checked		
upto4	Not checked		
upto7	Not checked		
}			
}			

– *PRS-ProcessingCapabilityOutsideMGinPPWperType*

**Table 4.6.4-36A: PRS-ProcessingCapabilityOutsideMGinPPWperType**

Derivation Path: TS 38.331 [6], clause 6.3.3			
Information Element	Value/remark	Comment	Condition
PRS-ProcessingCapabilityOutsideMGinPPWperType-r17 ::= SEQUENCE {			
FFS			
}			

– *RAT-Type*

**Table 4.6.4-37: RAT-Type**

Derivation Path: TS 38.331 [6], clause 6.3.3			
Information Element	Value/remark	Comment	Condition
RAT-Type	nr		
	eutra-nr		EN-DC, NE-DC

Condition	Explanation
EN-DC	E-UTRA-NR Dual Connectivity with E-UTRA connected to EPC
NE-DC	NR E-UTRA Dual Connectivity

– *RedCapParameters*

**Table 4.6.4-37A: RedCapParameters**

Derivation Path: TS 38.331 [6], clause 6.3.3			
Information Element	Value/remark	Comment	Condition
RedCapParameters-r17 ::= SEQUENCE {			
FFS			
}			

– *RF-Parameters*

**Table 4.6.4-38: RF-Parameters**

Derivation Path: TS 38.331 [6], clause 6.3.3			
Information Element	Value/remark	Comment	Condition
RF-Parameters ::= SEQUENCE {			
supportedBandListNR SEQUENCE (SIZE (1..maxBands)) OF BandNR {	At least 1 entry		
BandNR[1] SEQUENCE {		entry 1	
bandNR	FreqBandIndicatorNR with condition NR		
modifiedMPR-Behaviour	Not checked		
mimo-ParametersPerBand	Not checked		

extendedCP	Not checked		
multipleTCI	Not checked		
bwp-WithoutRestriction	Not checked		
bwp-SameNumerology	Not checked		
bwp-DiffNumerology	Not checked		
crossCarrierScheduling-SameSCS	Not checked		
pdsch-256QAM-FR2	Not checked		
pusch-256QAM	Not checked		
ue-PowerClass	Not checked		
rateMatchingLTE-CRS	Not checked		
channelBWs-DL CHOICE {			
fr1 SEQUENCE {			
scs-15kHz	Not checked		
scs-30kHz	Not checked		
scs-60kHz	Not checked		
}			
fr2 SEQUENCE {			
scs-60kHz	Not checked		
scs-120kHz	Not checked		
}			
}			
channelBWs-UL CHOICE {			
fr1 SEQUENCE {			
scs-15kHz	Not checked		
scs-30kHz	Not checked		
scs-60kHz	Not checked		
}			
fr2 SEQUENCE {			
scs-60kHz	Not checked		
scs-120kHz	Not checked		
}			
}			
BandNR[2] SEQUENCE {		entry 2	NR-DC-SecondaryB and NR_CA-InterBand
bandNR	FreqBandIndicatorNR with condition NR-DC-SecondaryBand		NR-DC-SecondaryB and
	FreqBandIndicatorNR with condition NR_CA-InterBand		NR_CA-InterBand
modifiedMPR-Behaviour	Not checked		
mimo-ParametersPerBand	Not checked		
extendedCP	Not checked		
multipleTCI	Not checked		
bwp-WithoutRestriction	Not checked		
bwp-SameNumerology	Not checked		
bwp-DiffNumerology	Not checked		
crossCarrierScheduling-SameSCS	Not checked		
pdsch-256QAM-FR2	Not checked		
pusch-256QAM	Not checked		
ue-PowerClass	Not checked		
rateMatchingLTE-CRS	Not checked		
channelBWs-DL CHOICE {			
fr1 SEQUENCE {			
scs-15kHz	Not checked		
scs-30kHz	Not checked		
scs-60kHz	Not checked		
}			
fr2 SEQUENCE {			
scs-60kHz	Not checked		
scs-120kHz	Not checked		
}			
}			



supportedBandCombinationList	Not checked		
appliedFreqBandListFilter	Not present		
	FreqBandList		FILTER_RE QUESTED
}			

Condition	Explanation
FILTER_REQUESTED	This condition shall be set to true when UE is requested to filter the information via 'capabilityRequestFilter' IE in the NR5GC UECapabilityEnquiry message or via 'requestedFreqBandsNR-MRDC' IE in the EN-DC UECapabilityEnquiry message
NR-DC-SecondaryBand	Used in NR-DC test cases
NR_CA-InterBand	NG-RAN NR Radio Access using NR CA Inter-band test cases

– *RF-ParametersMRDC*

**Table 4.6.4-39: RF-ParametersMRDC**

Derivation Path: TS 38.331 [6], clause 6.3.3			
Information Element	Value/remark	Comment	Condition
RF-ParametersMRDC ::= SEQUENCE {			
supportedBandCombinationList	BandCombinationList		
appliedFreqBandListFilter	FreqBandList with condition EN-DC		EN-DC
	FreqBandList with condition NE-DC		NE-DC
	FreqBandList with condition EN-DC and CA-InterBand		ENDC_CA-InterBand
}			

Condition	Explanation
EN-DC	E-UTRA-NR Dual Connectivity
EN-DC_CA-InterBand	E-UTRA-NR Dual Connectivity used in NR CA Inter-band test cases
NE-DC	NR E-UTRA Dual Connectivity

– *RLC-Parameters*

**Table 4.6.4-40: RLC-Parameters**

Derivation Path: TS 38.331 [6], clause 6.3.3			
Information Element	Value/remark	Comment	Condition
RLC-Parameters ::= SEQUENCE {			
am-WithShortSN	Not checked		
um-WithShortSN	Not checked		
um-WithLongSN	Not checked		
}			

– *SDAP-Parameters*

**Table 4.6.4-41: SDAP-Parameters**

Derivation Path: TS 38.331 [6], clause 6.3.3			
Information Element	Value/remark	Comment	Condition
SDAP-Parameters ::= SEQUENCE {			
as-ReflectiveQoS	Not checked		
}			

– *SidelinkParameters***Table 4.6.4-41A: *SidelinkParameters***

Derivation Path: TS 38.331 [6], clause 6.3.3			
Information Element	Value/remark	Comment	Condition
SidelinkParameters-r16 ::= SEQUENCE {			
FFS			
}			

– *SimultaneousRxTxPerBandPair***Table 4.6.4-41BA: *SimultaneousRxTxPerBandPair***

Derivation Path: TS 38.331 [6], clause 6.3.3			
Information Element	Value/remark	Comment	Condition
SimultaneousRxTxPerBandPair	FFS		

– *SON-Parameters***Table 4.6.4-41B: *SON-Parameters***

Derivation Path: TS 38.331 [6], clause 6.3.3			
Information Element	Value/remark	Comment	Condition
SON-Parameters-r16 ::= SEQUENCE {			
FFS			
}			

– *SpatialRelationsSRS-Pos***Table 4.6.4-41C: *SpatialRelationsSRS-Pos***

Derivation Path: TS 38.331 [6], clause 6.3.3			
Information Element	Value/remark	Comment	Condition
SpatialRelationsSRS-Pos-r16 ::= SEQUENCE {			
FFS			
}			

– *SRS-AllPosResourcesRRC-Inactive***Table 4.6.4-41D: *SRS-AllPosResourcesRRC-Inactive***

Derivation Path: TS 38.331 [6], clause 6.3.3			
Information Element	Value/remark	Comment	Condition
SRS-AllPosResourcesRRC-Inactive-r17 ::= SEQUENCE {			
FFS			
}			

– *SRS-SwitchingTimeNR***Table 4.6.4-42: *SRS-SwitchingTimeNR***

Derivation Path: TS 38.331 [6], clause 6.3.3			
Information Element	Value/remark	Comment	Condition
SRS-SwitchingTimeNR ::= SEQUENCE {			

switchingTimeDL	Not checked		
switchingTimeUL	Not checked		
}			

– *SRS-SwitchingTimeEUTRA*

**Table 4.6.4-43: SRS-SwitchingTimeEUTRA**

Derivation Path: TS 38.331 [6], clause 6.3.3			
Information Element	Value/remark	Comment	Condition
SRS-SwitchingTimeEUTRA ::= SEQUENCE {			
switchingTimeDL	Not checked		
switchingTimeUL	Not checked		
}			

– *SupportedBandwidth*

**Table 4.6.4-44: SupportedBandwidth**

Derivation Path: TS 38.331 [6], clause 6.3.3			
Information Element	Value/remark	Comment	Condition
SupportedBandwidth ::= CHOICE {			
fr1	Not checked		FR1
fr2	Not checked		FR2
}			

– *UE-BasedPerfMeas-Parameters*

**Table 4.6.4-44A: UE-BasedPerfMeas-Parameters**

Derivation Path: TS 38.331 [6], clause 6.3.3			
Information Element	Value/remark	Comment	Condition
UE-BasedPerfMeas-Parameters-r16 ::= SEQUENCE {			
FFS			
}			

– *UE-CapabilityRAT-ContainerList*

**Table 4.6.4-45: UE-CapabilityRAT-ContainerList**

Derivation Path: TS 38.331 [6], clause 6.3.3			
Information Element	Value/remark	Comment	Condition
UE-CapabilityRAT-ContainerList ::= SEQUENCE (SIZE (0.. maxRAT-CapabilityContainers)) OF UE-CapabilityRAT-Container {	n entries		
UE-CapabilityRAT-Container[1] SEQUENCE {		entry 1	
rat-Type	RAT-Type		
ue-CapabilityRAT-Container	UE-NR-Capability with condition NR		
	UE-NR-Capability with condition NR-DC		NR-DC
	UE-NR-Capability with condition NR_CA-InterBand		NR_CA-InterBand
}			
UE-CapabilityRAT-Container[2] SEQUENCE {		entry 2	EN-DC, NE-DC, EN-

			DC_CA-InterBand
rat-Type	RAT-Type with condition NE-DC		
ue-CapabilityRAT-Container	UE-MRDC-Capability with condition EN-DC		EN-DC
	UE-MRDC-Capability with condition NE-DC		NE-DC
	UE-MRDC-Capability with condition EN-DC_CA-InterBand		EN-DC_CA-InterBand
}			
}			

Condition	Explanation
EN-DC	E-UTRA-NR Dual Connectivity
EN-DC_CA-InterBand	E-UTRA-NR Dual Connectivity using NR CA Inter-band test cases
NE-DC	NR E-UTRA Dual Connectivity
NR_CA-InterBand	NG-RAN NR Radio Access using NR CA Inter-band test cases
NR-DC	Used in NR-DC test cases

– *UE-CapabilityRAT-RequestList*

**Table 4.6.4-46: UE-CapabilityRAT-RequestList**

Derivation Path: TS 38.331 [6], clause 6.3.3			
Information Element	Value/remark	Comment	Condition
UE-CapabilityRAT-RequestList ::= SEQUENCE (SIZE (0.. maxRAT-CapabilityContainers)) OF UE-CapabilityRAT-Request {	n entries		
UE-CapabilityRAT-Request[1] SEQUENCE {		entry 1	NR, NR-DC, NR_CA-InterBand
rat-Type	RAT-Type		
capabilityRequestFilter	UE-CapabilityRequestFilterNR with condition NR	OCTET STRING (CONTAINING UE-CapabilityRequestFilterNR)	
	UE-CapabilityRequestFilterNR with condition NR-DC	OCTET STRING (CONTAINING UE-CapabilityRequestFilterNR)	NR-DC
	UE-CapabilityRequestFilterNR with condition NR_CA-InterBand	OCTET STRING (CONTAINING UE-CapabilityRequestFilterNR)	NR_CA-InterBand
}			
UE-CapabilityRAT-Request[1] SEQUENCE {		entry 1	NE-DC, EN-DC, EN-DC_CA-InterBand
rat-Type	RAT-Type with condition NR		
capabilityRequestFilter	UE-CapabilityRequestFilterNR with condition NR	OCTET STRING (CONTAINING UE-CapabilityRequestFilterNR)	
}			
UE-CapabilityRAT-Request[2] SEQUENCE {		entry 2	NE-DC



rat-Type	RAT-Type with condition NE-DC		
capabilityRequestFilter	UE-CapabilityRequestFilterNR with condition NE-DC	OCTET STRING (CONTAINING UE-CapabilityRequestFilterNR)	
}			
UE-CapabilityRAT-Request[2] SEQUENCE {		entry 2	EN-DC, EN-DC_CA-InterBand
rat-Type	RAT-Type with condition EN-DC		
capabilityRequestFilter	UE-CapabilityRequestFilterNR with condition EN-DC	OCTET STRING (CONTAINING UE-CapabilityRequestFilterNR)	
	UE-CapabilityRequestFilterNR with condition EN-DC_CA-InterBand		
}			
}			

Condition	Explanation
EN-DC	E-UTRA-NR Dual Connectivity
EN-DC_CA-InterBand	E-UTRA-NR Dual Connectivity using NR CA Inter-band test cases
NR	NG-RAN NR Radio Access
NR-DC	Used in NR-DC test cases
NR_CA-InterBand	NG-RAN NR Radio Access using NR CA Inter-band test cases
NE-DC	NR E-UTRA Dual Connectivity

– *UE-CapabilityRequestFilterCommon*

**Table 4.6.4-46A: UE-CapabilityRequestFilterCommon**

Derivation Path: TS 38.331 [6], clause 6.3.3			
Information Element	Value/remark	Comment	Condition
UE-CapabilityRequestFilterCommon ::= SEQUENCE {			
mrdc-Request SEQUENCE {			
omitEN-DC	Not checked		
includeNR-DC	Not checked		
includeNE-DC	Not checked		
}			
}			

– *UE-CapabilityRequestFilterNR*

**Table 4.6.4-47: UE-CapabilityRequestFilterNR**

Derivation Path: TS 38.331 [6], clause 6.3.3			
Information Element	Value/remark	Comment	Condition
UE-CapabilityRequestFilterNR ::= SEQUENCE {			
frequencyBandListFilter	FreqBandList with condition NR		NR
	FreqBandList with condition EN-DC		EN-DC
	FreqBandList with condition EN-DC AND CA-InterBand		EN-DC_CA-InterBand

	FreqBandList with condition NR AND CA-InterBand		NR_CA-InterBand
	FreqBandList with condition NR and NR-DC		NR-DC
	FreqBandList with condition NR and NE-DC		NE-DC
nonCriticalExtension SEQUENCE {	Not present		
srs-SwitchingTimeRequest	Not present		
nonCriticalExtension SEQUENCE {			
srs-SwitchingTimeRequest	Not present		
nonCriticalExtension	Not present		
}			
}			
}			

Condition	Explanation
EN-DC	E-UTRA-NR Dual Connectivity
EN-DC_CA-InterBand	E-UTRA-NR Dual Connectivity using NR CA Inter-band test cases
NR_CA-InterBand	NG-RAN NR Radio Access using NR CA Inter-band test cases
NR	NG-RAN NR Radio Access
NR-DC	Used in NR-DC test cases
NE-DC	NR E-UTRA Dual Connectivity

– *UE-MRDC-Capability*

**Table 4.6.4-48: UE-MRDC-Capability**

Derivation Path: TS 38.331 [6], clause 6.3.3			
Information Element	Value/remark	Comment	Condition
UE-MRDC-Capability ::= SEQUENCE {			
measAndMobParametersMRDC	Not checked		
phy-ParametersMRDC-v1530	Not checked		
rf-ParametersMRDC	RF-ParametersMRDC with condition EN-DC		
	RF-ParametersMRDC with condition NE-DC		NE-DC
	RF-ParametersMRDC with condition EN-DC_CA-InterBand		EN-DC_CA-InterBand
generalParametersMRDC SEQUENCE {			
splitSRB-WithOneUL-Path	Not checked		
splitDRB-withUL-Both-MCG-SCG	Not checked		
srb3	Not checked		
v2x-EUTRA	Not checked		
}			
fdd-Add-UE-MRDC-Capabilities SEQUENCE {			
measAndMobParametersMRDC-XDD-Diff SEQUENCE {			
sftd-MeasPSCell	Not checked		
sftd-MeasNR-Cell	Not checked		
}			
generalParametersMRDC SEQUENCE {			
splitSRB-WithOneUL-Path	Not checked		
splitDRB-withUL-Both-MCG-SCG	Not checked		
srb3	Not checked		
v2x-EUTRA-v1530	Not checked		
}			
}			
tdd-Add-UE-MRDC-Capabilities SEQUENCE {			

measAndMobParametersMRDC-XDD-Diff SEQUENCE {			
sftd-MeasPSCell	Not checked		
sftd-MeasNR-Cell	Not checked		
}			
generalParametersMRDC SEQUENCE {			
splitSRB-WithOneUL-Path	Not checked		
splitDRB-withUL-Both-MCG-SCG	Not checked		
srb3	Not checked		
v2x-EUTRA-v1530	Not checked		
}			
}			
fr1-Add-UE-MRDC-Capabilities SEQUENCE {			
measAndMobParametersMRDC-FRX-Diff SEQUENCE {			
simultaneousRxDataSSB-DiffNumerology	Not checked		
}			
}			
fr2-Add-UE-MRDC-Capabilities			
measAndMobParametersMRDC-FRX-Diff SEQUENCE {			
simultaneousRxDataSSB-DiffNumerology	Not checked		
}			
}			
featureSetCombinations	Not checked		
pdcp-ParametersMRDC-v1530	Not checked		
lateNonCriticalExtension	Not checked		
nonCriticalExtension SEQUENCE {			
UE-MRDC-Capability-v1560 SEQUENCE {			
receivedFilters	Not checked		
measAndMobParametersMRDC-v1560 SEQUENCE {			
measAndMobParametersMRDC-XDD-Diff-v1560 SEQUENCE {			
sftd-MeasPSCell-NEDC	Not checked		
}			
}			
}			
fdd-Add-UE-MRDC-Capabilities-v1560 SEQUENCE {			
measAndMobParametersMRDC-XDD-Diff-v1560 SEQUENCE {			
sftd-MeasPSCell-NEDC	Not checked		
}			
}			
tdd-Add-UE-MRDC-Capabilities-v1560 SEQUENCE {			
measAndMobParametersMRDC-XDD-Diff-v1560 SEQUENCE {			
sftd-MeasPSCell-NEDC	Not checked		
}			
}			
nonCriticalExtension	Not checked		
}			
}			
}			

Condition	Explanation
EN-DC	E-UTRA-NR Dual Connectivity
EN-DC_CA-InterBand	E-UTRA-NR Dual Connectivity used in NR CA Inter-band test cases
NE-DC	NR E-UTRA Dual Connectivity

## – UE-NR-Capability

Table 4.6.4-49: UE-NR-Capability

Derivation Path: TS 38.331 [6], clause 6.3.3			
Information Element	Value/remark	Comment	Condition
UE-NR-Capability ::= SEQUENCE {			
accessStratumRelease	AccessStratumRelease		
pdcp-Parameters	Not checked		
rlc-Parameters	Not checked		
mac-Parameters	Not checked		
phy-Parameters	Not checked		
rf-Parameters	RF-Parameters		
	RF-Parameters with condition NR-DC		NR-DC
	RF-Parameters with condition NR_CA-InterBand		NR_CA-InterBand
measAndMobParameters	Not checked		
fdd-Add-UE-NR-Capabilities SEQUENCE {			
phy-ParametersXDD-Diff SEQUENCE {			
dynamicSFI	Not checked		
twoPUCCH-F0-2-ConsecSymbols	Not checked		
twoDifferentTPC-Loop-PUSCH	Not checked		
twoDifferentTPC-Loop-PUCCH	Not checked		
}			
mac-ParametersXDD-Diff SEQUENCE {			
skipUplinkTxDynamic	Not checked		
logicalChannelSR-DelayTimer	Not checked		
longDRX-Cycle	Not checked		
shortDRX-Cycle	Not checked		
multipleSR-Configurations	Not checked		
multipleConfiguredGrants	Not checked		
}			
measAndMobParametersXDD-Diff SEQUENCE {			
intraAndInterF-MeasAndReport	Not checked		
eventA-MeasAndReport	Not checked		
}			
}			
tdd-Add-UE-NR-Capabilities SEQUENCE {			
phy-ParametersXDD-Diff SEQUENCE {			
dynamicSFI	Not checked		
twoPUCCH-F0-2-ConsecSymbols	Not checked		
twoDifferentTPC-Loop-PUSCH	Not checked		
twoDifferentTPC-Loop-PUCCH	Not checked		
}			
mac-ParametersXDD-Diff SEQUENCE {			
skipUplinkTxDynamic	Not checked		
logicalChannelSR-DelayTimer	Not checked		
longDRX-Cycle	Not checked		
shortDRX-Cycle	Not checked		
multipleSR-Configurations	Not checked		
multipleConfiguredGrants	Not checked		
}			
measAndMobParametersXDD-Diff SEQUENCE {			
intraAndInterF-MeasAndReport	Not checked		
eventA-MeasAndReport	Not checked		
}			
fr1-Add-UE-NR-Capabilities SEQUENCE {			
phy-ParametersFRX-Diff SEQUENCE {			
dynamicSFI	Not checked		
oneFL-DMRS-TwoAdditionalDMRS	Not checked		
twoFL-DMRS	Not checked		
twoFL-DMRS-TwoAdditionalDMRS	Not checked		
}			

oneFL-DMRS-ThreeAdditionalDMRS	Not checked		
supportedDMRS-TypeDL	Not checked		
supportedDMRS-TypeUL	Not checked		
semiOpenLoopCSI	Not checked		
csi-ReportWithoutPMI	Not checked		
csi-ReportWithoutCQI	Not checked		
onePortsPTRS	Not checked		
twoPUCCH-F0-2-ConsecSymbols	Not checked		
pucch-F2-WithFH	Not checked		
pucch-F3-WithFH	Not checked		
pucch-F4-WithFH	Not checked		
freqHoppingPUCCH-F0-2	Not checked		
freqHoppingPUCCH-F1-3-4	Not checked		
mux-SR-HARQ-ACK-CSI-PUCCH	Not checked		
uci-CodeBlockSegmentation	Not checked		
onePUCCH-LongAndShortFormat	Not checked		
twoPUCCH-AnyOthersInSlot	Not checked		
intraSlotFreqHopping-PUSCH	Not checked		
pusch-LBRM	Not checked		
pdccch-BlindDetectionCA	Not checked		
tpc-PUSCH-RNTI	Not checked		
tpc-PUCCH-RNTI	Not checked		
tpc-SRS-RNTI	Not checked		
absoluteTPC-Command	Not checked		
twoDifferentTPC-Loop-PUSCH	Not checked		
twoDifferentTPC-Loop-PUCCH	Not checked		
pusch-HalfPi-BPSK	Not checked		
pucch-F3-4-HalfPi-BPSK	Not checked		
almostContiguousCP-OFDM-UL	Not checked		
sp-CSI-RS	Not checked		
sp-CSI-IM	Not checked		
tdd-MultiDL-UL-SwitchPerSlot	Not checked		
multipleCORESET	Not checked		
}			
measAndMobParametersFRX-Diff SEQUENCE {			
ss-SINR-Meas	Not checked		
csi-RSRP-AndRSRQ-MeasWithSSB	Not checked		
csi-RSRP-AndRSRQ-MeasWithoutSSB	Not checked		
csi-SINR-Meas	Not checked		
csi-RS-RLM	Not checked		
}			
}			
fr2-Add-UE-NR-Capabilities SEQUENCE {			
phy-ParametersFRX-Diff SEQUENCE {	Not checked		
dynamicSFI	Not checked		
oneFL-DMRS-TwoAdditionalDMRS	Not checked		
twoFL-DMRS	Not checked		
twoFL-DMRS-TwoAdditionalDMRS	Not checked		
oneFL-DMRS-ThreeAdditionalDMRS	Not checked		
supportedDMRS-TypeDL	Not checked		
supportedDMRS-TypeUL	Not checked		
semiOpenLoopCSI	Not checked		
csi-ReportWithoutPMI	Not checked		
csi-ReportWithoutCQI	Not checked		
onePortsPTRS	Not checked		
twoPUCCH-F0-2-ConsecSymbols	Not checked		
pucch-F2-WithFH	Not checked		
pucch-F3-WithFH	Not checked		
pucch-F4-WithFH	Not checked		
freqHoppingPUCCH-F0-2	Not checked		
freqHoppingPUCCH-F1-3-4	Not checked		
mux-SR-HARQ-ACK-CSI-PUCCH	Not checked		
uci-CodeBlockSegmentation	Not checked		
onePUCCH-LongAndShortFormat	Not checked		
twoPUCCH-AnyOthersInSlot	Not checked		

intraSlotFreqHopping-PUSCH	Not checked		
pusch-LBRM	Not checked		
pdcc-BlindDetectionCA	Not checked		
tpc-PUSCH-RNTI	Not checked		
tpc-PUCCH-RNTI	Not checked		
tpc-SRS-RNTI	Not checked		
absoluteTPC-Command	Not checked		
twoDifferentTPC-Loop-PUSCH	Not checked		
twoDifferentTPC-Loop-PUCCH	Not checked		
pusch-HalfPi-BPSK	Not checked		
pucch-F3-4-HalfPi-BPSK	Not checked		
almostContiguousCP-OFDM-UL	Not checked		
sp-CSI-RS	Not checked		
sp-CSI-IM	Not checked		
tdd-MultiDL-UL-SwitchPerSlot	Not checked		
multipleCORESET	Not checked		
}			
measAndMobParametersFRX-Diff SEQUENCE {			
ss-SINR-Meas	Not checked		
csi-RSRP-AndRSRQ-MeasWithSSB	Not checked		
csi-RSRP-AndRSRQ-MeasWithoutSSB	Not checked		
csi-SINR-Meas	Not checked		
csi-RS-RLM	Not checked		
}			
featureSets	Not checked		
featureSetCombinations	Not checked		
lateNonCriticalExtension	Not checked		
nonCriticalExtension SEQUENCE {			
fdd-Add-UE-NR-Capabilities-1530 SEQUENCE {			
eutra-ParametersXDD-Diff SEQUENCE {			
rsrqMeasWidebandEUTRA	Not checked		
}			
}			
tdd-Add-UE-NR-Capabilities-v1530 SEQUENCE {			
eutra-ParametersXDD-Diff SEQUENCE {			
rsrqMeasWidebandEUTRA	Not Checked		
}			
}			
dummy	Not checked		
interRAT-Parameters	Not checked		
inactiveState	Not checked		
delayBudgetReporting	Not checked		
nonCriticalExtension SEQUENCE {			
sdap-Parameters	Not checked		
overheatingInd	Not checked		
ims-Parameters	Not checked		
fr1-Add-UE-NR-Capabilities-v1540 SEQUENCE {			
ims-ParametersFRX-Diff SEQUENCE {			
voiceOverNR	Not checked		
}			
}			
fr2-Add-UE-NR-Capabilities-v1540 SEQUENCE {			
ims-ParametersFRX-Diff SEQUENCE {			
voiceOverNR	Not checked		
}			
}			
fr1-fr2-Add-UE-NR-Capabilities SEQUENCE {			
phy-ParametersFRX-Diff SEQUENCE {			
dynamicSFI	Not checked		
dummy1	Not checked		
twoFL-DMRS	Not checked		
dummy2	Not checked		
dummy3	Not checked		
supportedDMRS-TypeDL	Not checked		

supportedDMRS-TypeUL	Not checked		
semiOpenLoopCSI	Not checked		
csi-ReportWithoutPMI	Not checked		
csi-ReportWithoutCQI	Not checked		
onePortsPTRS	Not checked		
twoPUCCH-F0-2-ConsecSymbols	Not checked		
pucch-F2-WithFH	Not checked		
pucch-F3-WithFH	Not checked		
pucch-F4-WithFH	Not checked		
freqHoppingPUCCH-F0-2	Not checked		
freqHoppingPUCCH-F1-3-4	Not checked		
mux-SR-HARQ-ACK-CSI-PUCCH- MultiPerSlot	Not checked		
uci-CodeBlockSegmentation	Not checked		
onePUCCH-LongAndShortFormat	Not checked		
twoPUCCH-AnyOthersInSlot	Not checked		
intraSlotFreqHopping-PUSCH	Not checked		
pusch-LBRM	Not checked		
pdccch-BlindDetectionCA	Not checked		
tpc-PUSCH-RNTI	Not checked		
tpc-PUCCH-RNTI	Not checked		
tpc-SRS-RNTI	Not checked		
absoluteTPC-Command	Not checked		
twoDifferentTPC-Loop-PUSCH	Not checked		
twoDifferentTPC-Loop-PUCCH	Not checked		
pusch-HalfPi-BPSK	Not checked		
pucch-F3-4-HalfPi-BPSK	Not checked		
almostContiguousCP-OFDM-UL	Not checked		
sp-CSI-RS	Not checked		
sp-CSI-IM	Not checked		
tdd-MultiDL-UL-SwitchPerSlot	Not checked		
multipleCORESET	Not checked		
}			
measAndMobParametersFRX-Diff SEQUENCE {			
ss-SINR-Meas	Not checked		
csi-RSRP-AndRSRQ-MeasWithSSB	Not checked		
csi-RSRP-AndRSRQ-MeasWithoutSSB	Not checked		
csi-SINR-Meas	Not checked		
csi-RS-RLM	Not checked		
}			
}			
nonCriticalExtension SEQUENCE {	Not checked		
reducedCP-Latency	Not checked		
nonCriticalExtension SEQUENCE {			
nrdc-Parameters	Not checked		
receivedFilters	Not checked		
nonCriticalExtension	Not checked		
}			
}			
}			
}			
}			

Condition	Explanation
NR-DC	Used in NR-DC test cases
NR_CA-InterBand	NG-RAN NR Radio Access using NR CA Inter-band test cases

– UE-RadioPagingInfo

Table 4.6.4-49A: UE-RadioPagingInfo

Derivation Path: TS 38.331 [6], clause 6.3.3			
Information Element	Value/remark	Comment	Condition
UE-RadioPagingInfo-r17 ::= SEQUENCE {			

FFS			
}			

– *SharedSpectrumChAccessParamsPerBand*

**Table 4.6.4-50: SharedSpectrumChAccessParamsPerBand**

Derivation Path: TS 38.331 [6], clause 6.3.3			
Information Element	Value/remark	Comment	Condition
SharedSpectrumChAccessParamsPerBand-r16 ::= SEQUENCE {			
FFS			
}			

## 4.6.5 Other information elements

– *AbsoluteTimeInfo*

**Table 4.6.5-0A: AbsoluteTimeInfo**

Derivation Path: TS 38.331 [6], clause 6.3.4			
Information Element	Value/remark	Comment	Condition
AbsoluteTimeInfo-r16	FFS		

– *AppLayerMeasConfig*

**Table 4.6.5-0BA: AppLayerMeasConfig**

Derivation Path: TS 38.331 [6], clause 6.3.4			
Information Element	Value/remark	Comment	Condition
AppLayerMeasConfig-r17 ::= SEQUENCE {			
FFS			
}			

– *AreaConfiguration*

**Table 4.6.5-0B: AreaConfiguration**

Derivation Path: TS 38.331 [6], clause 6.3.4			
Information Element	Value/remark	Comment	Condition
AreaConfiguration-r16 ::= SEQUENCE {			
FFS			
}			

– *BT-NameList*

**Table 4.6.5-0C: BT-NameList**

Derivation Path: TS 38.331 [6], clause 6.3.4			
Information Element	Value/remark	Comment	Condition
BT-NameList-r16 ::= SEQUENCE (SIZE (1..maxBT-Name-r16)) OF {	1 entry		
BT-Name-r16[1]	Set according to specific message content	OCTET STRING (SIZE (1..248))	
}			



– *DedicatedInfoF1c*

**Table 4.6.5-0D: *DedicatedInfoF1c***

Derivation Path: TS 38.331 [6], clause 6.3.4			
Information Element	Value/remark	Comment	Condition
DedicatedInfoF1c-r17	FFS		

– *EUTRA-AllowedMeasBandwidth*

**Table 4.6.5-1: *EUTRA-AllowedMeasBandwidth***

Derivation Path: TS 38.331 [6], clause 6.3.4			
Information Element	Value/remark	Comment	Condition
EUTRA-AllowedMeasBandwidth	Set according to TS 36.508 [2] Table 4.4.3.4-1 for E-UTRA cell	row 'measurement Bandwidth'	

– *EUTRA-MBSFN-SubframeConfigList*

**Table 4.6.5-2: *EUTRA-MBSFN-SubframeConfigList***

Derivation Path: TS 38.331 [6], clause 6.3.4			
Information Element	Value/remark	Comment	Condition
EUTRA-MBSFN-SubframeConfigList ::= SEQUENCE (SIZE (1..maxMBSFN-Allocations)) OF EUTRA-MBSFN-SubframeConfig {	1 entry		
MBSFN-SubframeConfig[1] SEQUENCE {		entry 1	
radioframeAllocationPeriod	FFS		
radioframeAllocationOffset	FFS		
subframeAllocation1 CHOICE {			
oneFrame	FFS		
fourFrames	FFS		
}			
subframeAllocation2 CHOICE {			
oneFrame	FFS		
fourFrames	FFS		
}			
}			
}			
}			

– *EUTRA-MultiBandInfoList*

**Table 4.6.5-3: *EUTRA-MultiBandInfoList***

Derivation Path: TS 38.331 [6], clause 6.3.4			
Information Element	Value/remark	Comment	Condition
EUTRA-MultiBandInfoList ::= SEQUENCE (SIZE (1..maxMultiBands)) OF EUTRA-MultiBandInfo {	1 entry		
EUTRA-MultiBandInfo[1] SEQUENCE {		entry 1	
eutra-FreqBandIndicator	FreqBandIndicatorEUTRA		
eutra-NS-PmaxList	EUTRA-NS-PmaxList		
}			
}			

– *EUTRA-NS-PmaxList***Table 4.6.5-4: EUTRA-NS-PmaxList**

Derivation Path: TS 38.331 [6], clause 6.3.4			
Information Element	Value/remark	Comment	Condition
EUTRA-NS-PmaxList ::= SEQUENCE (SIZE (1..maxEUTRA-NS-Pmax)) OF EUTRA-NS-PmaxValue {	1 entry		
EUTRA-NS-PmaxValue[1] SEQUENCE {		entry 1	
additionalPmax	FFS		
additionalSpectrumEmission	FFS		
}			
}			

– *EUTRA-PhysCellId***Table 4.6.5-5: EUTRA-PhysCellId**

Derivation Path: TS 38.331 [6], clause 6.3.4			
Information Element	Value/remark	Comment	Condition
EUTRA-PhysCellId	Set according to TS 36.508 [2] Table 4.4.2-1A for E-UTRA cell		

– *EUTRA-PhysCellIdRange***Table 4.6.5-6: EUTRA-PhysCellIdRange**

Derivation Path: TS 38.331 [6], clause 6.3.4			
Information Element	Value/remark	Comment	Condition
EUTRA-PhysCellIdRange ::= SEQUENCE {			
start	EUTRA-PhysCellId		
range	Not present		
}			

– *EUTRA-PresenceAntennaPort1***Table 4.6.5-7: EUTRA-PresenceAntennaPort1**

Derivation Path: TS 38.331 [6], clause 6.3.4			
Information Element	Value/remark	Comment	Condition
EUTRA-PresenceAntennaPort1	FFS		

– *EUTRA-Q-OffsetRange***Table 4.6.5-8: EUTRA-Q-OffsetRange**

Derivation Path: TS 38.331 [6], clause 6.3.4			
Information Element	Value/remark	Comment	Condition
EUTRA-Q-OffsetRange	FFS		

Table 4.6.5-9: *Void*Table 4.6.5-10: *Void*– *IAB-IP-Address*Table 4.6.5-10A: *IAB-IP-Address*

Derivation Path: TS 38.331 [6], clause 6.3.4			
Information Element	Value/remark	Comment	Condition
IAB-IP-Address-r16 ::= SEQUENCE {			
FFS			
}			

– *IAB-IP-AddressIndex*Table 4.6.5-10B: *IAB-IP-AddressIndex*

Derivation Path: TS 38.331 [6], clause 6.3.4			
Information Element	Value/remark	Comment	Condition
IAB-IP-AddressIndex-r16	FFS		

– *IAB-IP-Usage*Table 4.6.5-10C: *IAB-IP-Usage*

Derivation Path: TS 38.331 [6], clause 6.3.4			
Information Element	Value/remark	Comment	Condition
IAB-IP-Usage-r16	FFS		

– *LoggingDuration*Table 4.6.5-10D: *LoggingDuration*

Derivation Path: TS 38.331 [6], clause 6.3.4			
Information Element	Value/remark	Comment	Condition
LoggingDuration-r16	FFS		

– *LoggingInterval*Table 4.6.5-10E: *LoggingInterval*

Derivation Path: TS 38.331 [6], clause 6.3.4			
Information Element	Value/remark	Comment	Condition
LoggingInterval-r16	FFS		

– *LogMeasResultListBT*Table 4.6.5-10F: *LogMeasResultListBT*

Derivation Path: TS 38.331 [6], clause 6.3.4			
Information Element	Value/remark	Comment	Condition
LogMeasResultListBT-r16 ::= SEQUENCE {			
LogMeasResultBT-r16 ::= SEQUENCE {			
bt-Addr-r16	Not checked	BIT STRING (SIZE (48))	

rsi-BT-r16	Not checked	INTEGER (-128..127)	
}			
}			

– *LogMeasResultListWLAN*

**Table 4.6.5-10G: LogMeasResultListWLAN**

Derivation Path: TS 38.331 [6], clause 6.3.4			
Information Element	Value/remark	Comment	Condition
LogMeasResultListWLAN-r16 ::= SEQUENCE (SIZE (1..maxWLAN-Id-Report-r16)) OF LogMeasResultWLAN-r16 {			
LogMeasResultWLAN-r16 SEQUENCE {			
wlan-Identifiers-r16 SEQUENCE {			
ssid-r16	Not checked	OCTET STRING (SIZE (1..32))	
bssid-r16	Not checked	OCTET STRING (SIZE (6))	
hessid-r16	Not checked	OCTET STRING (SIZE (6))	
}			
rsiWLAN-r16	Not checked	INTEGER(0..141)	
rtt-WLAN-r16 SEQUENCE {			
rttValue-r16	Not checked	INTEGER (0..16777215)	
rttUnits-r16	Not checked		
rttAccuracy-r16	Not checked	INTEGER (0..255)	
}			
}			

– *MeasConfigAppLayerId*

**Table 4.6.5-10H: MeasConfigAppLayerId**

Derivation Path: TS 38.331 [6], clause 6.3.4			
Information Element	Value/remark	Comment	Condition
MeasConfigAppLayerId-r17	FFS		

– *OtherConfig*

**Table 4.6.5-11: OtherConfig**

Derivation Path: TS 38.331 [6], clause 6.3.4			
Information Element	Value/remark	Comment	Condition
OtherConfig ::=SEQUENCE {			
delayBudgetReportingConfig CHOICE{			
release	FFS		
setup SEQUENCE {			
delayBudgetReportingProhibitTimer	FFS		
}			
}			
}			

– *PhysCellIdUTRA-FDD***Table 4.6.5-11A: PhysCellIdUTRA-FDD**

Derivation Path: TS 38.331 [6], clause 6.3.4			
Information Element	Value/remark	Comment	Condition
PhysCellIdUTRA-FDD-r16	FFS		

– *RRC-TransactionIdentifier***Table 4.6.5-12: RRC-TransactionIdentifier**

Derivation Path: TS 38.331 [6], clause 6.3.4			
Information Element	Value/remark	Comment	Condition
RRC-TransactionIdentifier	0		

– *Sensor-NameList***Table 4.6.5-13: Sensor-NameList**

Derivation Path: TS 38.331 [6], clause 6.3.4			
Information Element	Value/remark	Comment	Condition
Sensor-NameList-r16 ::= SEQUENCE {			
measUncomBarPre-r16	Set according to specific message content		
measUeSpeed	Set according to specific message content		
measUeOrientation	Set according to specific message content		
}			

– *TraceReference***Table 4.6.5-14: TraceReference**

Derivation Path: TS 38.331 [6], clause 6.3.4			
Information Element	Value/remark	Comment	Condition
TraceReference-r16 ::= SEQUENCE {			
FFS			
}			

– *UE-MeasurementsAvailable***Table 4.6.5-15: UE-MeasurementsAvailable**

Derivation Path: TS 38.331 [6], clause 6.3.4			
Information Element	Value/remark	Comment	Condition
UE-MeasurementsAvailable-r16 ::= SEQUENCE {			
logMeasAvailable-r16	Not checked true		LOG
logMeasAvailableBT-r16	Not checked true		BT
logMeasAvailableWLAN-r16	Not checked true		WLAN
connEstFailInfoAvailable-r16	Not checked true		CEF
rlf-InfoAvailable-r16	Not checked true		RLF

..successHO-InfoAvailable-r17	Not checked		
	true		SHR
..sigLogMeasConfigAvailable-r17	Not checked		
	true		sig_LOG
}			

Condition	Explanation
LOG	Logged measurement information reporting
BT	Bluetooth measurement information reporting
WLAN	WLAN measurement information reporting
CEF	Connection failure information reporting
RLF	Radio link failure information reporting
SHR	Successful handover reporting
sig_LOG	Signalling based logged measurements information reporting

– *UTRA-FDD-Q-OffsetRange*

**Table 4.6.5-16: UTRA-FDD-Q-OffsetRange**

Derivation Path: TS 38.331 [6], clause 6.3.4			
Information Element	Value/remark	Comment	Condition
UTRA-FDD-Q-OffsetRange-r16	dB0		

– *VisitedCellInfoList*

**Table 4.6.5-17: VisitedCellInfoList**

Derivation Path: TS 38.331 [6], clause 6.3.4			
Information Element	Value/remark	Comment	Condition
VisitedCellInfoList-r16 ::= SEQUENCE {			
FFS			
}			

– *WLAN-NameList*

**Table 4.6.5-18: WLAN-NameList**

Derivation Path: TS 38.331 [6], clause 6.3.4			
Information Element	Value/remark	Comment	Condition
WLAN-NameList-r16 ::= SEQUENCE (SIZE (1..maxWLAN-Name-r16)) OF {	1 entry		
WLAN-Name-r16[1]	Set according to specific message content	OCTET STRING (SIZE (1..32))	
}			

4.6.6 Sidelink information elements

– *SL-BWP-Config*

**Table 4.6.6-1: SL-BWP-Config**

Derivation Path: TS 38.331 [6], clause 6.3.5			
Information Element	Value/remark	Comment	Condition
SL-BWP-Config-r16 ::= SEQUENCE {			
sl-BWP-Id	BWP-Id		
sl-BWP-Config-r16 SEQUENCE {			
sl-BWP-r16	BWP		

sl-LengthSymbols-r16	sym14	All symbols in slot are used for SL	
	sym12	All symbols in slot are used for SL	EXTENDED
sl-StartSymbol-r16	sym0		
sl-PSBCH-Config-r16	Not present		
sl-TxDirectCurrentLocation-r16	Not present		
}			
sl-BWP-PoolConfig-r16	SL-BWP-PoolConfig with condition SCHEDULING		
}			

Condition	Explanation
EXTENDED	When cyclicPrefix is configured in sl-BWP-r16, i.e. extended CP is used

– *SL-BWP-ConfigCommon*

**Table 4.6.6-2: SL-BWP-ConfigCommon**

Derivation Path: TS 38.331 [6], clause 6.3.5

Information Element	Value/remark	Comment	Condition
SL-BWP-ConfigCommon-r16 ::= SEQUENCE {			
sl-BWP-Generic-r16 SEQUENCE {			
sl-BWP-r16	BWP		
sl-LengthSymbols-r16	sym14	All symbols in slot are used for SL	
	sym12	All symbols in slot are used for SL	EXTENDED
sl-StartSymbol-r16	sym0		
sl-PSBCH-Config-r16	Not present		
sl-TxDirectCurrentLocation-r16	Not present		
}			
sl-BWP-PoolConfigCommon-r16	SL-BWP-PoolConfigCommon with RXPOOL and SELECTED		
}			

Condition	Explanation
EXTENDED	When cyclicPrefix is configured in sl-BWP-r16, i.e. extended CP is used

– *SL-BWP-PoolConfig*

**Table 4.6.6-3: SL-BWP-PoolConfig**

Derivation Path: TS 38.331 [6], clause 6.3.5

Information Element	Value/remark	Comment	Condition
SL-BWP-PoolConfig-r16 ::= SEQUENCE {			
sl-RxPool-r16	Not present		
sl-TxPoolSelectedNormal-r16	Not present		
sl-TxPoolSelectedNormal-r16 SEQUENCE {			SELECTED
sl-PoolToReleaseList-r16	Not present		
sl-PoolToAddModList-r16 SEQUENCE (SIZE (1..maxNrofTXPool-r16)) OF SL-ResourcePoolConfig-r16 {	1 entry		
SL-ResourcePoolConfig-r16[1] SEQUENCE {		entry 1	
sl-ResourcePoolID-r16	1	Index of the resource pool for normal case	
sl-ResourcePool-r16	SL-ResourcePool with condition SL_HARQ		

}			
}			
}			
sl-TxPoolScheduling-r16	Not present		
sl-TxPoolScheduling-r16 SEQUENCE {			SCHEDULING
sl-PoolToReleaseList-r16	Not present		
sl-PoolToAddModList-r16 SEQUENCE (SIZE (1..maxNrofTXPool-r16)) OF SL-ResourcePoolConfig-r16 {	1 entry		
SL-ResourcePoolConfig-r16[1] SEQUENCE {		entry 1	
sl-ResourcePoolID-r16	1	Index of the resource pool used for normal case	
sl-ResourcePool-r16	SL-ResourcePool with condition SL_HARQ		
}			
}			
}			
sl-TxPoolExceptional-r16	Not present		
sl-TxPoolExceptional-r16 SEQUENCE {			EXCEPTIONAL
sl-ResourcePoolID-r16	2	Index of the pool used during exceptional cases	
sl-ResourcePool-r16	SL-ResourcePool with condition EXCEPTIONAL and SL_HARQ		
}			
}			

Condition	Explanation
SCHEDULING	To configure Tx resource pool for Mode 1 SL transmission
SELECTED	To configure Tx resource pool for Mode 2 SL transmission
EXCEPTIONAL	To configure Tx resource pool for exceptional cases such as HO, re-establishment etc.

– SL-BWP-PoolConfigCommon

Table 4.6.6-4: SL-BWP-PoolConfigCommon

Derivation Path: TS 38.331 [6], clause 6.3.5			
Information Element	Value/remark	Comment	Condition
SL-BWP-PoolConfigCommon-r16 ::= SEQUENCE {			
sl-RxPool-r16	Not present		
sl-RxPool-r16 SEQUENCE (SIZE (1..maxNrofRXPool-r16)) OF SL-ResourcePool-r16 {	1 entry		RXPOOL
SL-ResourcePool-r16[1]	SL-ResourcePool with condition SL_HARQ	entry 1	
}			
sl-TxPoolSelectedNormal-r16	Not present		
sl-TxPoolSelectedNormal-r16 SEQUENCE (SIZE (1..maxNrofTXPool-r16)) OF SL-ResourcePoolConfig-r16 {	1 entry		SELECTED
SL-ResourcePoolConfig-r16[1] SEQUENCE {		entry 1	
sl-ResourcePoolID-r16	1	Index of the resource pool for normal case	
sl-ResourcePool-r16	SL-ResourcePool with condition SL_HARQ		
}			
}			
sl-TxPoolExceptional-r16	Not present		



sl-TxPoolExceptional-r16 SEQUENCE {			EXCEPTIO NAL
sl-ResourcePoolID-r16	2	Index of the resource pool used for normal case	
sl-ResourcePool-r16	SL-ResourcePool with condition EXCEPTIONAL and SL_HARQ		
}			

Condition	Explanation
RXPOOL	To configure Rx resource pool
SELECTED	To configure Tx resource pool for Mode 2 SL transmission
EXCEPTIONAL	To configure Tx resource pool for exceptional cases such as HO, re-establishment etc.

– *SL-CBR-PriorityTxConfigList*

**Table 4.6.6-5: SL-CBR-PriorityTxConfigList**

Derivation Path: TS 38.331 [6], clause 6.3.5			
Information Element	Value/remark	Comment	Condition
SL-CBR-PriorityTxConfigList-r16 ::= SEQUENCE (SIZE (1..8)) OF SL-PriorityTxConfigIndex-r16 {	8 entries		
SL-PriorityTxConfigIndex-r16[k, k=1..8] SEQUENCE {		entry k	
sl-PriorityThreshold-r16	k	priority value = k	
sl-DefaultTxConfigIndex-r16	0	PSSCH Tx configuration corresponding to the first CBR level is used by UE when UE has no available CBR results.	
sl-CBR-ConfigIndex-r16	0	1st CBR level table is used	
sl-Tx-ConfigIndexList-r16 SEQUENCE (SIZE (1..maxCBR-Level-r16)) OF SL-TxConfigIndex-r16 {	2 entries		
SL-TxConfigIndex-r16[1]	0	entry 1 for CBR level corresponding to the first entry in sl-CBR-RangeConfigList	
SL-TxConfigIndex-r16[2]	0	entry 2 for CBR level corresponding to the second entry in sl-CBR-RangeConfigList	
}			
}			
}			

– *SL-CBR-CommonTxConfigList*

**Table 4.6.6-6: SL-CBR-CommonTxConfigList**

Derivation Path: TS 38.331 [6], clause 6.3.5			
Information Element	Value/remark	Comment	Condition
SL-CBR-CommonTxConfigList-r16 ::= SEQUENCE {			

sl-CBR-RangeConfigList-r16 SEQUENCE (SIZE (1..maxCBR-Config-r16)) OF SL-CBR-LevelsConfig-r16 {	1 entry		
SL-CBR-LevelsConfig-r16[1] SEQUENCE (SIZE (1..maxCBR-Level-r16)) OF SL-CBR-r16 {	2 entries		
SL-CBR-r16[1]	50	entry 1 0<=CBR<0.5	
SL-CBR-r16[2]	100	entry 2 0.5<=CBR<1	
}			
}			
sl-CBR-PSSCH-TxConfigList-r16 SEQUENCE (SIZE (1..maxTxConfig-r16)) OF SL-CBR-PSSCH-TxConfig-r16 {	1 entry		
SL-CBR-PSSCH-TxConfig-r16 SEQUENCE {			
sl-CR-Limit-r16	10000	CR limit = 100%	
sl-TxParameters-r16 SEQUENCE {			
sl-MinMCS-PSSCH-r16	0		
sl-MaxMCS-PSSCH-r16	26		
sl-MinSubChannelNumPSSCH-r16	1		
sl-MaxSubchannelNumPSSCH-r16	27		
sl-MaxTxTransNumPSSCH-r16	4		
sl-MaxTxPower-r16	Not present		
}			
}			
}			
}			

– *SL-ConfigDedicatedNR*

**Table 4.6.6-7: SL-ConfigDedicatedNR**

Derivation Path: TS 38.331 [6], clause 6.3.5			
Information Element	Value/remark	Comment	Condition
SL-ConfigDedicatedNR-r16 ::= SEQUENCE {			
sl-PHY-MAC-RLC-Config-r16	Not present		
sl-PHY-MAC-RLC-Config-r16 SEQUENCE {			SCHEDULING, SELECTED
sl-ScheduledConfig-r16	Not present		
sl-ScheduledConfig-r16 CHOICE {			SCHEDULING
setup	SL-ScheduledConfig		
}			
sl-UE-SelectedConfig-r16	Not present		
sl-UE-SelectedConfig-r16 CHOICE {			SELECTED
setup	SL-UE-SelectedConfig		
}			
sl-FreqInfoToReleaseList-r16	Not present		
sl-FreqInfoToAddModList-r16	Not present		
sl-FreqInfoToAddModList-r16 SEQUENCE (SIZE (1..maxNrofFreqSL-r16)) OF SL-FreqConfig-r16 {	1 entry		SCHEDULING, SELECTED
SL-FreqConfig-r16[1]	SL-FreqConfig	entry 1	
}			
sl-RLC-BearerToReleaseList-r16	Not present		
sl-RLC-BearerToAddModList-r16	Not present		
sl-RLC-BearerToAddModList-r16 SEQUENCE (SIZE (1..maxSL-LCID-r16)) OF SL-RLC-BearerConfig-r16 {	1 entry		SL_DRB
SL-RLC-BearerConfig-r16[1]	SL-RLC-BearerConfig	entry 1	
}			
sl-MaxNumConsecutiveDTX-r16	Not present		
sl-CSI-Acquisition-r16	Not present		

	enabled		SL_CSI_RE PORT
sl-CSI-SchedulingRequestId-r16	Not present		
sl-SSB-PriorityNR-r16	1		
networkControlledSyncTx-r16	off	UE doesn't send SL SSB by default	
}			
sl-RadioBearerToReleaseList-r16	Not present		
sl-RadioBearerToAddModList-r16	Not present		
sl-RadioBearerToAddModList-r16 SEQUENCE (SIZE (1..maxNrofSLRB-r16)) OF SL- RadioBearerConfig-r16 {	1 entry		SL_DRB
SL-RadioBearerConfig-r16[1]	SL-RadioBearerConfig		
}			
sl-MeasConfigInfoToReleaseList-r16	Not present		
sl-MeasConfigInfoToAddModList-r16	Not present		
sl-MeasConfigInfoToAddModList-r16 SEQUENCE (SIZE (1..maxNrofSL-Dest-r16)) OF SL- MeasConfigInfo-r16 {	1 entry		SL_MEAS
SL-MeasConfigInfo-r16[1]	SL-MeasConfigInfo		
}			
t400-r16	ms2000		
}			

Condition	Explanation
SCHEDULING	To configure UE performing mode 1 SL transmission
SELECTED	To configure UE performing mode 2 SL transmission
SL_DRB	To establish SL DRB
SL_MEAS	To configure UE performing measurements based on RS sent by peer UE
SL_CSI_REPORT	To configure UE performing SL CSI reporting

– *SL-ConfiguredGrantConfig*

**Table 4.6.6-8: SL-ConfiguredGrantConfig**

Derivation Path: TS 38.331 [6], clause 6.3.5			
Information Element	Value/remark	Comment	Condition
SL-ConfiguredGrantConfig-r16 ::= SEQUENCE {			
sl-ConfigIndexCG-r16	1		
sl-PeriodCG-r16 CHOICE {			
sl-PeriodCG1-r16	ms100		
}			
sl-NrofHARQ-Processes-r16	4		
sl-HARQ-ProclD-offset-r16	1		
sl-CG-MaxTransNumList-r16 SEQUENCE (SIZE (1..8)) OF SL-CG-MaxTransNum-r16	8 entries		
SL-CG-MaxTransNum-r16[k, k=1..8] SEQUENCE {		entry k	
sl-Priority-r16	k		
sl-MaxTransNum-r16	8	max Tx number = 8 for all priorities	
}			
}			
rrc-ConfiguredSidelinkGrant-r16	Not present	TYPE 2 CG is configured by default	
rrc-ConfiguredSidelinkGrant-r16 SEQUENCE {			TYPE 1
sl-TimeResourceCG-Type1-r16	a TRIV chosen by SS from the range 0 to 496 as specified in 38.214		
sl-StartSubchannelCG-Type1-r16	0		
sl-FreqResourceCG-Type1-r16	a FRIV chosen by SS from the range 0 to 6929 as specified in 38.214		

sl-TimeOffsetCG-Type1-r16	0		
sl-N1PUCCH-AN-r16	Not present		
	PUCCH-ResourceId		SL_HARQ_VIA_UU
sl-PSFCH-ToPUCCH-CG-Type1-r16	Not present		
	1		SL_HARQ_VIA_UU
sl-ResourcePoolID-r16	1	Resource pool for normal case is used	
sl-TimeReferenceSFN-Type1-r16	Not present	Default value sfno is used	
}			
}			

Condition	Explanation
TYPE 1	To configure a type 1 SL configured grant for UE
SL HARQ_VIA_UU	to report HARQ-ACK information that the UE generates based on PSFCH reception via UL

– *SL-DestinationIdentity*

**Table 4.6.6-9: SL-DestinationIdentity**

Derivation Path: TS 38.331 [6], clause 6.3.5			
Information Element	Value/remark	Comment	Condition
SL-DestinationIdentity-r16	24 bits destination ID chosen by SS		

– *SL-FreqConfig*

**Table 4.6.6-10: SL-FreqConfig**

Derivation Path: TS 38.331 [6], clause 6.3.5			
Information Element	Value/remark	Comment	Condition
SL-FreqConfig-r16 ::= SEQUENCE {			
sl-Freq-Id-r16	1		
sl-SCS-SpecificCarrierList-r16 SEQUENCE (SIZE (1..maxSCSs)) OF SCS-SpecificCarrier {	1 entry		
SCS-SpecificCarrier[1]	SCS-SpecificCarrier with condition SL_PointA	entry 1	
}			
sl-AbsoluteFrequencyPointA-r16	ARFCN-ValueNR with condition SL_PointA		
sl-AbsoluteFrequencySSB-r16	ARFCN-ValueNR with condition SL_SSB		
frequencyShift7p5khzSL-r16	Not present		
valueN-r16	0		
sl-BWP-ToReleaseList-r16	Not present		
sl-BWP-ToAddModList-r16 SEQUENCE (SIZE (1..maxNrofSL-BWPs-r16)) OF SL-BWP-Config-r16 {	1 entry		
SL-BWP-Config-r16[1]	SL-BWP-Config	entry 1	
}			
sl-SyncConfigList-r16 SEQUENCE (SIZE (1..maxSL-SyncConfig-r16)) OF SL-SyncConfig-r16 {	1 entry		
SL-SyncConfig-r16[1]	SL-SyncConfig	entry 1	
}			
sl-SyncPriority-r16	gnss		
}			

– *SL-FreqConfigCommon*

**Table 4.6.6-11: SL-FreqConfigCommon**

Derivation Path: TS 38.331 [6], clause 6.3.5			
Information Element	Value/remark	Comment	Condition
SL-FreqConfigCommon-r16 ::= SEQUENCE {			
sl-SCS-SpecificCarrierList-r16 SEQUENCE (SIZE (1..maxSCSs)) OF SCS-SpecificCarrier {	1 entry		
SCS-SpecificCarrier[1]	SCS-SpecificCarrier with condition SL_PointA	entry 1	
}			
sl-AbsoluteFrequencyPointA-r16	ARFCN-ValueNR with condition SL_PointA		
sl-AbsoluteFrequencySSB-r16	ARFCN-ValueNR with condition SL_SSB		
frequencyShift7p5khzSL-r16	Not present		
valueN-r16	0		
sl-BWP-List-r16 SEQUENCE (SIZE (1..maxNrofSL-BWPs-r16)) OF SL-BWP-ConfigCommon-r16 {	1 entry		
SL-BWP-ConfigCommon-r16[1]	SL-BWP-ConfigCommon		
}			
sl-SyncPriority-r16	gnss		
sl-NbAsSync-r16	Not present		
sl-SyncConfigList-r16 SEQUENCE (SIZE (1..maxSL-SyncConfig-r16)) OF SL-SyncConfig-r16 {	1 entry		
SL-SyncConfig-r16[1] SEQUENCE (SIZE (1..maxSL-SyncConfig-r16)) OF SL-SyncConfig-r16	1 entry	entry 1	
SL-SyncConfig-r16[1]	SL-SyncConfig	entry 1	
}			
}			

– *SL-LogicalChannelConfig*

**Table 4.6.6-12: SL-LogicalChannelConfig**

Derivation Path: TS 38.331 [6], clause 6.3.5			
Information Element	Value/remark	Comment	Condition
SL-LogicalChannelConfig-r16 ::= SEQUENCE {			
sl-Priority-r16	1		
sl-PrioritisedBitRate-r16	infinity		
sl-BucketSizeDuration-r16	ms50		
sl-ConfiguredGrantType1Allowed-r16	Not present		
sl-HARQ-FeedbackEnabled-r16	enabled		
sl-AllowedCG-List-r16	Not present		
sl-AllowedSCS-List-r16	Not present		
sl-MaxPUSCH-Duration-r16	Not present		
sl-LogicalChannelGroup-r16	1	Avoiding using LCG #0, which is reserved for SL SRB	
	5	Avoiding using LCG #0, which s reserved for SL SRB	LO
sl-SchedulingRequestId-r16	SchedulingRequestId		
sl-LogicalChannelSR-DelayTimerApplied-r16	Not present		
}			

Condition	Explanation
LO	LCG of the lower priority logical channels mapped to SL DRBs

– *SL-L2RelayUE-Config*

Table 4.6.6-12A: SL-L2RelayUE-Config

Derivation Path: TS 38.331 [6], clause 6.3.5			
Information Element	Value/remark	Comment	Condition
SL-L2RelayUE-Config-r17 ::= SEQUENCE {			
sl-RemoteUE-ToAddModList-r17 SEQUENCE (SIZE (1..maxNrofRemoteUE-r17)) OF SL-RemoteUE-ToAddMod-r17{	1 entry		
SL-RemoteUE-ToAddMod-r17[1] ::= SEQUENCE {		entry 1	
sl-L2IdentityRemote-r17	SL-DestinationIdentity-r16		
sl-SRAP-ConfigRelay-r17	SL-SRAP-Config with condition SL-SRBn		SL-SRBn
	SL-SRAP-Config with condition SL-DRBn		SL-DRBn
}			
}			
sl-RemoteUE-ToReleaseList-r17	Not present		
}			

Condition	Explanation
SL-SRBn	Establishment of Sidelink SRBn;n=0..3
SL-DRBn	Establishment of Sidelink DRBn;n=1..16

– *SL-L2RemoteUE-Config*

Table 4.6.6-12B: SL-L2RemoteUE-Config

Derivation Path: TS 38.331 [6], clause 6.3.5			
Information Element	Value/remark	Comment	Condition
SL-L2RemoteUE-Config-r17 ::= SEQUENCE {			
sl-SRAP-ConfigRemote-r17	SL-SRAP-Config with condition SL-SRBn		SL-SRBn
	SL-SRAP-Config with condition SL-DRBn		SL-DRBn
sl-UEIdentityRemote-r17	RNTI-Value		
}			

Condition	Explanation
SL-SRBn	Establishment of Sidelink SRBn; n=0..3
SL-DRBn	Establishment of Sidelink DRBn; n=1..16

– *SL-MeasConfigCommon*

Table 4.6.6-13: SL-MeasConfigCommon

Derivation Path: TS 38.331 [6], clause 6.3.5			
Information Element	Value/remark	Comment	Condition
SL-MeasConfigCommon-r16 ::= SEQUENCE {			
sl-MeasObjectListCommon-r16	SL-MeasObjectList		
sl-ReportConfigListCommon-r16	SL-ReportConfigList with condition PERIODICAL		
sl-MeasIdListCommon-r16	SL-MeasIdList		
sl-QuantityConfigCommon-r16	SL-QuantityConfig		
}			

*SL-MeasConfigInfo*

**Table 4.6.6-14: SL-MeasConfigInfo**

Derivation Path: TS 38.331 [6], clause 6.3.5			
Information Element	Value/remark	Comment	Condition
SL-MeasConfigInfo-r16 ::= SEQUENCE {			
sl-DestinationIndex-r16	0	The first destination UE reported in sl-TxResourceReqList in SidelinkUEInformationNR	
sl-MeasConfig-r16 SEQUENCE {			
sl-MeasObjectToRemoveList-r16	Not present		
sl-MeasObjectToAddModList-r16	SL-MeasObjectList		
sl-ReportConfigToRemoveList-r16	Not present		
sl-ReportConfigToAddModList-r16	SL-ReportConfigList with condition PERIODICAL		
sl-MeasIdToRemoveList-r16	Not present		
sl-MeasIdToAddModList-r16	SL-MeasIdList		
sl-QuantityConfig-r16	SL-QuantityConfig		
}			
}			

*SL-MeasIdList*

**Table 4.6.6-15: SL-MeasIdList**

Derivation Path: TS 38.331 [6], clause 6.3.5			
Information Element	Value/remark	Comment	Condition
SL-MeasIdList-r16 ::= SEQUENCE (SIZE (1..maxNrofSL-MeasId-r16)) OF SL-MeasIdInfo-r16	1 entry		
SL-MeasIdInfo-r16[1] SEQUENCE {		entry 1	
sl-MeasId-r16	1		
sl-MeasObjectId-r16	1		
sl-ReportConfigId-r16	1		
}			
}			

*SL-MeasObjectList*

**Table 4.6.6-16: SL-MeasObjectList**

Derivation Path: TS 38.331 [6], clause 6.3.5			
Information Element	Value/remark	Comment	Condition
SL-MeasObjectList-r16 ::= SEQUENCE (SIZE (1..maxNrofSL-ObjectId-r16)) OF SL-MeasObjectInfo-r16 {	1 entry		
SL-MeasObjectInfo-r16[1] SEQUENCE {		entry 1	
sl-MeasObjectId-r16	1		
sl-MeasObject-r16 SEQUENCE {			
frequencyInfoSL-r16	ARFCN-ValueNR of the DMRS used for SL-RSRP measurement  Note: How to set frequencyInfoSL-r16 is FFS.		
}			
}			

}		
---	--	--

– *SL-PDCP-Config*

**Table 4.6.6-17: SL-PDCP-Config**

Derivation Path: TS 38.331 [6], clause 6.3.5			
Information Element	Value/remark	Comment	Condition
SL-PDCP-Config-r16 ::= SEQUENCE {			
sl-DiscardTimer-r16	infinity		
sl-PDCP-SN-Size-r16	len12bits		
sl-OutOfOrderDelivery	Not present		
}			

– *SL-PSBCH-Config*

**Table 4.6.6-18: SL-PSBCH-Config**

Derivation Path: TS 38.331 [6], clause 6.3.5			
Information Element	Value/remark	Comment	Condition
SL-PSBCH-Config-r16 ::= SEQUENCE {			
dl-P0-PSBCH-r16	0		
dl-Alpha-PSBCH-r16	Not present	Default value 1 is used	
}			

– *SL-PSSCH-TxConfigList*

**Table 4.6.6-19: SL-PSSCH-TxConfigList**

Derivation Path: TS 38.331 [6], clause 6.3.5			
Information Element	Value/remark	Comment	Condition
SL-PSSCH-TxConfigList-r16 ::= SEQUENCE (SIZE (1..maxPSSCH-TxConfig-r16)) OF SL-PSSCH-TxConfig-r16 {	1 entry		
SL-PSSCH-TxConfig-r16[1] SEQUENCE {		entry 1	
sl-TypeTxSync-r16	Not present	Applicable for all synchronization reference types	
sl-ThresUE-Speed-r16	kmph60		
sl-ParametersAboveThres-r16 SEQUENCE {			
sl-MinMCS-PSSCH-r16	0		
sl-MaxMCS-PSSCH-r16	15		
sl-MinSubChannelNumPSSCH-r16	1		
sl-MaxSubchannelNumPSSCH-r16	27		
sl-MaxTxTransNumPSSCH-r16	4		
sl-MaxTxPower-r16	Not present		
}			
sl-ParametersBelowThres-r16 SEQUENCE {			
sl-MinMCS-PSSCH-r16	16		
sl-MaxMCS-PSSCH-r16	26		
sl-MinSubChannelNumPSSCH-r16	1		
sl-MaxSubchannelNumPSSCH-r16	27		
sl-MaxTxTransNumPSSCH-r16	4		
sl-MaxTxPower-r16	Not present		
}			
}			
}			



– *SL-QoS-FlowIdentity***Table 4.6.6-20: SL-QoS-FlowIdentity**

Derivation Path: TS 38.331 [6], clause 6.3.5			
Information Element	Value/remark	Comment	Condition
SL-QoS-FlowIdentity-r16	1		

– *SL-QoS-Profile***Table 4.6.6-21: SL-QoS-Profile**

Derivation Path: TS 38.331 [6], clause 6.3.5			
Information Element	Value/remark	Comment	Condition
SL-QoS-Profile-r16 ::= SEQUENCE {			
sl-PQI-r16 CHOICE {			
sl-StandardizedPQI-r16	0		
}			
sl-GFBR-r16	500		
sl-MFBR-r16	1000		
sl-Range-r16	Not present		
}			

– *SL-QuantityConfig***Table 4.6.6-22: SL-QuantityConfig**

Derivation Path: TS 38.331 [6], clause 6.3.5			
Information Element	Value/remark	Comment	Condition
SL-QuantityConfig-r16 ::= SEQUENCE {			
sl-FilterCoefficientDMRS-r16	fc4		
}			

– *SL-RadioBearerConfig***Table 4.6.6-23: SL-RadioBearerConfig**

Derivation Path: TS 38.331 [6], clause 6.3.5			
Information Element	Value/remark	Comment	Condition
SL-RadioBearerConfig-r16 ::= SEQUENCE {			
slrb-Uu-ConfigIndex-r16	SLRB-Uu-ConfigIndex		
sl-SDAP-Config-r16	SL-SDAP-Config		
sl-PDCP-Config-r16	SL-PDCP-Config		
sl-TransRange-r16	Not present		
}			

– *SL-ReportConfigList***Table 4.6.6-24: SL-ReportConfigList (Thres)**

Derivation Path: TS 38.331 [6], clause 6.3.5			
Information Element	Value/remark	Comment	Condition
SL-ReportConfigList-r16 ::= SEQUENCE (SIZE (1..maxNrofSL-ReportConfigId-r16)) OF SL-ReportConfigInfo-r16 {	1 entry		
SL-ReportConfigInfo-r16[1] SEQUENCE {		entry 1	
sl-ReportConfigId-r16	1		
sl-ReportConfig-r16 SEQUENCE {			

sl-ReportType-r16 CHOICE {			
sl-Periodical-r16 SEQUENCE {			PERIODICAL
sl-ReportInterval-r16	ReportInterval		
sl-ReportAmount-r16	infinity		
sl-ReportQuantity-r16 CHOICE {			
sl-RSRP-r16	true		
}			
sl-RS-Type-r16	dmrs		
}			
sl-EventTriggered-r16 SEQUENCE {			EVENT_S1, EVENT_S2
sl-EventId-r16 CHOICE {			
eventS1-r16 SEQUENCE {			EVENT_S1
s1-Threshold-r16 CHOICE {			
sl-RSRP-r16	Thres + 156	Thres is the actual value of event S1 threshold (in dBm)	
}			
sl-ReportOnLeave-r16	false		
sl-Hysteresis-r16	Hysteresis		
sl-TimeToTrigger-r16	TimeToTrigger		
}			
eventS2-r16 SEQUENCE {			EVENT_S2
s2-Threshold-r16 CHOICE {			
sl-RSRP-r16	Thres + 156	Thres is the actual value of event S2 threshold (in dBm)	
}			
sl-ReportOnLeave-r16	false		
sl-Hysteresis-r16	Hysteresis		
sl-TimeToTrigger-r16	TimeToTrigger		
}			
sl-ReportInterval-r16	ReportInterval		
sl-ReportAmount-r16	r2		
sl-ReportQuantity-r16 CHOICE {			
sl-RSRP-r16	true		
}			
sl-RS-Type-r16	dmrs		
}			
}			
}			
}			
}			

Condition	Explanation
EVENT_S1	Configuration of event S1 triggered reptring
EVENT_S2	Configuration of event S2 triggered reptring
PERIODICAL	Configuration of periodical reporting

– *SL-ResourcePool*

**Table 4.6.6-25: SL-ResourcePool**

Derivation Path: TS 38.331 [6], clause 6.3.5			
Information Element	Value/remark	Comment	Condition
SL-ResourcePool-r16 ::= SEQUENCE {			
sl-PSCCH-Config-r16 CHOICE {			
setup SEQUENCE {			
sl-TimeResourcePSCCH-r16	n2		
sl-FreqResourcePSCCH-r16	n10		
sl-DMRS-ScrambleID-r16	0		

sl-NumReservedBits-r16	2		
}			
}			
sl-PSSCH-Config-r16 CHOICE {			
setup SEQUENCE {			
sl-PSSCH-DMRS-TimePatternList-r16	2 entries		
SEQUENCE (SIZE (1..3)) OF INTEGER (2..4) {			
INTEGER[1]	2	entry 1	
INTEGER[2]	4	entry 2	
}			
sl-BetaOffsets2ndSCI-r16 SEQUENCE (SIZE (4))	4 entries		
OF SL-BetaOffsets-r16 {			
SL-BetaOffsets-r16[k, k=1..4]	1	entry k	
}			
sl-Scaling-r16	f1		
}			
}			
sl-PSFCH-Config-r16	Not present		
sl-PSFCH-Config-r16 CHOICE {			SL_HARQ
setup SEQUENCE {			
sl-PSFCH-Period-r16	sl4		
sl-PSFCH-RB-Set-r16	bitstring of length n, The leftmost p*floor(m/p)*floor(n/m) bits are set to "1" and the rest are set to "0"	Note 1, Note 2, Note 3	
sl-NumMuxCS-Pair-r16	n2		
sl-MinTimeGapPSFCH-r16	sl2		
sl-PSFCH-HopID-r16	Not present	Default frequency hopping ID 0 is used	
sl-PSFCH-CandidateResourceType-r16	startSubCH		
}			
}			
sl-SyncAllowed-r16 SEQUENCE {			
gnss-Sync-r16	true		
gnbEnb-Sync-r16	true		
ue-Sync-r16	true		
}			
sl-SubchannelSize-r16	n10		
dummy	Not present		
sl-StartRB-Subchannel-r16	0	start RB of BWP	
sl-NumSubchannel-r16	floor(n/m)	Note 1, Note 2	
sl-Additional-MCS-Table-r16	Not present		
sl-ThreshS-RSSI-CBR-r16	0	actual value is -112 dBm	
sl-TimeWindowSizeCBR-r16	slot100		
sl-TimeWindowSizeCR-r16	slot1000		
sl-PTRS-Config-r16	Not present		
sl-UE-SelectedConfigRP-r16 SEQUENCE {			
sl-CBR-PriorityTxConfigList-r16	SL-CBR-PriorityTxConfigList		
sl-Thres-RSRP-List-r16	SL-Thres-RSRP-List		
sl-MultiReserveResource-r16	Not present		
sl-MaxNumPerReserve-r16	n2		
sl-SensingWindow-r16	ms100		
sl-SelectionWindowList-r16 SEQUENCE (SIZE (8))	8 entries		
OF SL-SelectionWindowConfig-r16 {			
SL-SelectionWindowConfig-r16[k, k=1..8]		entry k	
SEQUENCE {			
sl-Priority-r16	k		
sl-SelectionWindow-r16	n10		
}			
}			
sl-ResourceReservePeriodList-r16	Not present		

sl-RS-ForSensing-r16	pssch		
sl-CBR-PriorityTxConfigList-v1650	Not present		
}			
sl-RxParametersNcell-r16	Not present		
sl-ZoneConfigMCR-List-r16	Not present		
sl-FilterCoefficient-r16	fc4		
sl-RB-Number-r16	10*floor(n/10)	Note 1	
sl-PreemptionEnable-r16	Not present		
sl-PriorityThreshold-UL-URLLC-r16	Not present		
sl-PriorityThreshold-r16	Not present		
sl-X-Overhead-r16	Not present	Default value n0 is used	
sl-PowerControl-r16	Not present		
sl-TxPercentageList-r16 SEQUENCE (SIZE (8)) OF SL-TxPercentageConfig-r16 {	8 entries		
SL-TxPercentageConfig-r16[k, k=1..8] SEQUENCE {		entry k	
sl-Priority-r16	k		
sl-TxPercentage-r16	p50		
}			
}			
sl-MinMaxMCS-List-r16	Not present		
sl-TimeResource-r16	1111111100	First 8 of every 10 logical slots	
	0000000011	Last 2 of every 10 logical slots	EXCEPTIONAL
}			
<p>Note 1: n is the bandwidth of active SL BWP (in RB). n is determined in Table 4.3.1.0D-1 and Table 4.3.1.0D-2 for FR1 and FR2 respectively.</p> <p>Note 2: m is subchannel size configured by sl-SubchannelSize-r16.</p> <p>Note 3: p is the PSFCH period configured by sl-PSFCH-Period-r16</p>			

Condition	Explanation
SL_HARQ	To enable SL HARQ feedback
EXCEPTIONAL	For exceptional resource pool

– *SL-RLC-BearerConfig*

**Table 4.6.6-26: SL-RLC-BearerConfig**

Derivation Path: TS 38.331 [6], clause 6.3.5			
Information Element	Value/remark	Comment	Condition
SL-RLC-BearerConfig-r16 ::= SEQUENCE {			
sl-RLC-BearerConfigIndex-r16	SL-RLC-BearerConfigIndex		
sl-ServedRadioBearer-r16	SLRB-Uu-ConfigIndex		
sl-RLC-Config-r16	SL-RLC-Config with condition AM		
sl-MAC-LogicalChannelConfig-r16	SL-LogicalChannelConfig		
}			

– *SL-RelayUE-Config*

**Table 4.6.6-26A: SL-RelayUE-Config**

Derivation Path: TS 38.331 [6], clause 6.3.5			
Information Element	Value/remark	Comment	Condition
SL-RelayUE-Config-r17 ::= SEQUENCE {			
threshHighRelay-r1	Not present		
threshLowRelay-r17	RSRP-Range		

hystMaxRelay-r17	Not present		
hystMinRelay-r17	Not present		
}			

– SL-RemoteUE-Config

**Table 4.6.6-26B: SL-RemoteUE-Config**

Derivation Path: TS 38.331 [6], clause 6.3.5			
Information Element	Value/remark	Comment	Condition
SL-RemoteUE-Config-r17 ::= SEQUENCE {			
threshHighRemote-r17	36		
hystMaxRemote-r17	Not present		
sl-ReselectionConfig-r17 SEQUENCE {			
sl-RSRP-Thresh-r17	4		
sl-FilterCoefficientRSRP-r17	Not present		
sl-HystMin-r17	Not present		
}			
}			

– SL-RLC-BearerConfigIndex

**Table 4.6.6-27: SL-RLC-BearerConfigIndex**

Derivation Path: TS 38.331 [6], clause 6.3.5			
Information Element	Value/remark	Comment	Condition
SL-RLC-BearerConfigIndex-r16	1		

– SL-RLC-ChannelID

**Table 4.6.6-27A: SL-RLC-ChannelID**

Derivation Path: TS 38.331 [6], clause 6.3.5			
Information Element	Value/remark	Comment	Condition
SL-RLC-ChannelID-r17	n+1		SL-SRBn
	n+4		SL-DRBn

Condition	Explanation
SL-SRBn	Establishment of sidelink SRBn; n=0..3
SL-DRBn	Establishment of sidelink DRBn; n=1..16

– SL-RLC-Config

**Table 4.6.6-28: SL-RLC-Config**

Derivation Path: TS 38.331 [6], clause 6.3.5			
Information Element	Value/remark	Comment	Condition
SL-RLC-Config-r16 ::= CHOICE {			
sl-AM-RLC-r16 SEQUENCE {			AM
sl-SN-FieldLengthAM-r16	size12		
sl-T-PollRetransmit-r16	ms80		
sl-PollPDU-r16	p32768		
sl-PollByte-r16	kB750		
sl-MaxRetxThreshold-r16	t8		
}			

sl-UM-RLC-r16 SEQUENCE {			UM
sl-SN-FieldLengthUM-r16	size6		
}			
}			

Condition	Explanation
AM	RLC AM
UM	RLC UM

– *SL-ScheduledConfig*

**Table 4.6.6-29: SL-ScheduledConfig**

Derivation Path: TS 38.331 [6], clause 6.3.5			
Information Element	Value/remark	Comment	Condition
SL-ScheduledConfig-r16 ::= SEQUENCE {			
sl-RNTI-r16	RNTI-Value		
mac-MainConfigSL-r16 SEQUENCE {			
sl-BSR-Config-r16	BSR-Config		
ul-PrioritizationThres-r16	Not present		
sl-PrioritizationThres-r16	Not present		
}			
sl-CS-RNTI-r16	Not present		
	RNTI-Value which is different with sl-RNTI-r16		SL_CG
sl-PSFCH-ToPUCCH-r16	Not present		
sl-PSFCH-ToPUCCH-r16 SEQUENCE (SIZE (1..8)) OF INTEGER {	1 entry		SL HARQ_VIA_UU
INTEGER[1]	4	entry 1	
}			
sl-ConfiguredGrantConfigList-r16	Not present		
sl-ConfiguredGrantConfigList-r16 SEQUENCE {			SL_CG
sl-ConfiguredGrantConfigToReleaseList-r16	Not present		
sl-ConfiguredGrantConfigToAddModList-r16 SEQUENCE (SIZE (1..maxNrofCG-SL-r16)) OF SL-ConfiguredGrantConfig-r16 {	1 entry		
SL-ConfiguredGrantConfig-r16[1]	SL-ConfiguredGrantConfig	entry 1	
}			
}			
sl-DCI-ToSL-Trans-r16 SEQUENCE (SIZE (1..8)) OF INTEGER {	1 entry		
INTEGER[1]	4	entry 1	
}			
}			

Condition	Explanation
SL_CG	To provide UE SL configured grant
SL HARQ_VIA_UU	to report HARQ-ACK information that the UE generates based on PSFCH reception via PUCCH/PUSCH

– *SL-SDAP-Config*

**Table 4.6.6-30: SL-SDAP-Config**

Derivation Path: TS 38.331 [6], clause 6.3.5			
Information Element	Value/remark	Comment	Condition
SL-SDAP-Config-r16 ::= SEQUENCE {			
sl-SDAP-Header-r16	present		

sl-DefaultRB-r16	true		
sl-MappedQoS-Flows-r16	Not present	All PC5 QoS flows are mapped to default SL DRB	
sl-CastType-r16	Unicast		
}			

– *SL-SRAP-Config*

**Table 4.6.6-30A: SL-SRAP-Config**

Derivation Path: TS 38.331 [6], clause 6.3.5			
Information Element	Value/remark	Comment	Condition
SL-SRAP-Config-r17 ::= SEQUENCE {			
sl-LocalIdentity-r17	1		
sl-MappingToAddModList-r17	Not present		
sl-MappingToAddModList-r17 SEQUENCE (SIZE (1..maxLC-ID)) OF SL-MappingToAddMod-r17[1] SEQUENCE {	1 entry		SL-SRB0
sl-RemoteUE-RB-Identity-r17 CHOICE {			
srb-Identity-r17	0		
}			
sl-EgressRLC-ChannelUu-r17	Not present		
sl-EgressRLC-ChannelUu-r17	Uu-RelayRLC-ChannelID using condition SL-SRB0		L2RelayUE
sl-EgressRLC-ChannelPC5-r17	Not present		
sl-EgressRLC-ChannelPC5-r17	SL-RLC-ChannelID using condition SL-SRB0		L2RemoteUE
}			
sl-MappingToAddModList-r17 SEQUENCE (SIZE (1..maxLC-ID)) OF SL-MappingToAddMod-r17[1] SEQUENCE {	1 entry		SL-SRB1
sl-RemoteUE-RB-Identity-r17 CHOICE {			
srb-Identity-r17	1		
}			
sl-EgressRLC-ChannelUu-r17	Not present		
sl-EgressRLC-ChannelUu-r17	Uu-RelayRLC-ChannelID using condition SL-SRB1		L2RelayUE
sl-EgressRLC-ChannelPC5-r17	Not present		
sl-EgressRLC-ChannelPC5-r17	SL-RLC-ChannelID using condition SL-SRB1		L2RemoteUE
}			
sl-MappingToAddModList-r17 SEQUENCE (SIZE (1..maxLC-ID)) OF SL-MappingToAddMod-r17[1] SEQUENCE {	1 entry		SL-SRB2
sl-RemoteUE-RB-Identity-r17 CHOICE {			
srb-Identity-r17	2		
}			
sl-EgressRLC-ChannelUu-r17	Not present		
sl-EgressRLC-ChannelUu-r17	Uu-RelayRLC-ChannelID using condition SL-SRB2		L2RelayUE
sl-EgressRLC-ChannelPC5-r17	Not present		
sl-EgressRLC-ChannelPC5-r17	SL-RLC-ChannelID using condition SL-SRB2		L2RemoteUE
}			
sl-MappingToAddModList-r17 SEQUENCE (SIZE (1..maxLC-ID)) OF SL-MappingToAddMod-r17[1] SEQUENCE {	1 entry		SL-DRB1
sl-RemoteUE-RB-Identity-r17 CHOICE {			
drb-Identity-r17	DRB-Identity using condition DRB1		

}			
sl-EgressRLC-ChannelUu-r17	Uu-RelayRLC-ChannelID using condition SL-DRB1		L2RelayUE
sl-EgressRLC-ChannelPC5-r17	Not present		
sl-EgressRLC-ChannelPC5-r17	SL-RLC-ChannelID using condition SL-DRB1		L2RemoteUE
}			
sl-MappingToAddModList-r17 SEQUENCE (SIZE (1..maxLC-ID)) OF SL-MappingToAddMod-r17[1] SEQUENCE {	1 entry		SL-DRB2
sl-RemoteUE-RB-Identity-r17 CHOICE {			
drb-Identity-r17	DRB-Identity using condition DRB2		
}			
sl-EgressRLC-ChannelUu-r17	Not present		
sl-EgressRLC-ChannelUu-r17	Uu-RelayRLC-ChannelID using condition SL-DRB2		L2RelayUE
sl-EgressRLC-ChannelPC5-r17	Not present		
sl-EgressRLC-ChannelPC5-r17	SL-RLC-ChannelID using condition SL-DRB2		L2RemoteUE
}			
sl-MappingToReleaseList-r1	Not present		
}			

Condition	Explanation
SL-SRB0	Establishment of Sidelink SRB0
SL-SRB1	Establishment of Sidelink SRB1
SL-SRB2	Establishment of Sidelink SRB2
SL-DRB1	Establishment of Sidelink DRB1
SL-DRB2	Establishment of Sidelink DRB2
L2RelayUE	For L2 U2N Relay UE test cases
L2RemoteUE	For L2 U2N Remote UE test cases

– SL-SyncConfig

Table 4.6.6-31: SL-SyncConfig

Derivation Path: TS 38.331 [6], clause 6.3.5			
Information Element	Value/remark	Comment	Condition
SL-SyncConfig-r16 ::= SEQUENCE {			
sl-SyncRefMinHyst-r16	dB3		
sl-SyncRefDiffHyst-r16	dB3		
sl-filterCoefficient-r16	fc4		
sl-SSB-TimeAllocation1-r16 SEQUENCE {			
sl-NumSSB-WithinPeriod-r16	n1		SCS15
	n2		SCS30, SCS60, SCS120
sl-TimeOffsetSSB-r16	0		
sl-TimeInterval-r16	Not present		SCS15
	1		SCS30, SCS60, SCS120
}			
sl-SSB-TimeAllocation2-r16 SEQUENCE {			
sl-NumSSB-WithinPeriod-r16	n1		SCS15
	n2		SCS30, SCS60, SCS120



sl-TimeOffsetSSB-r16	80		
sl-TimeInterval-r16	Not present		SCS15
	1		SCS30, SCS60, SCS120
}			
sl-SSB-TimeAllocation3-r16	Not present		
sl-SSID-r16	Arbitrarily chosen by SS from the range 1 to 335		
txParameters-r16 SEQUENCE {			
syncTxThreshIC-r16	Not present		
syncTxThreshOoC-r16	4	actual threshold is -100 dBm	
syncInfoReserved-r16	00		
}			
gnss-Sync-r16	Not present		
}			

– *SL-Thres-RSRP-List*

**Table 4.6.6-32: SL-Thres-RSRP-List**

Derivation Path: TS 38.331 [6], clause 6.3.5			
Information Element	Value/remark	Comment	Condition
SL-Thres-RSRP-List-r16 ::= SEQUENCE (SIZE (64)) OF INTEGER {	64 entries		
INTEGER[k, k=1..64]	0	entry k	
}			

– *SL-TxPower*

**Table 4.6.6-33: SL-TxPower**

Derivation Path: TS 38.331 [6], clause 6.3.5			
Information Element	Value/remark	Comment	Condition
SL-TxPower-r16 ::= CHOICE {			
txPower-r16	23	23dBm	
}			

– *SL-TypeTxSync*

**Table 4.6.6-34: SL-TypeTxSync**

Derivation Path: TS 38.331 [6], clause 6.3.5			
Information Element	Value/remark	Comment	Condition
SL-TypeTxSync-r16	gnss		

– *SL-UE-SelectedConfig*

**Table 4.6.6-35: SL-UE-SelectedConfig**

Derivation Path: TS 38.331 [6], clause 6.3.5			
Information Element	Value/remark	Comment	Condition
SL-UE-SelectedConfig-r16 ::= SEQUENCE {			
sl-PSSCH-TxConfigList-r16	SL-PSSCH-TxConfigList		
sl-ProbResourceKeep-r16	v0		
sl-ReselectAfter-r16	n9		

sl-CBR-CommonTxConfigList-r16	SL-CBR-CommonTxConfigList		
ul-PrioritizationThres-r16	Not present		
sl-PrioritizationThres-r16	Not present		
}			

– *SL-ZoneConfig*

**Table 4.6.6-36: *SL-ZoneConfig***

Derivation Path: TS 38.331 [6], clause 6.3.5			
Information Element	Value/remark	Comment	Condition
SL-ZoneConfig-r16 ::= SEQUENCE {			
sl-ZoneLength-r16	m50		
}			

– *SLRB-Uu-ConfigIndex*

**Table 4.6.6-37: *SLRB-Uu-ConfigIndex***

Derivation Path: TS 38.331 [6], clause 6.3.5			
Information Element	Value/remark	Comment	Condition
SLRB-Uu-ConfigIndex-r16	1		

#### 4.6.7 MBS information elements

– *CarrierFreqListMBS*

**Table 4.6.7-1: *CarrierFreqListMBS***

Derivation Path: TS 38.331 [6], clause 6.3.6			
Information Element	Value/remark	Comment	Condition
CarrierFreqListMBS-r17 ::= SEQUENCE {			
FFS			
}			

– *CFR-ConfigMCCH-MTCH*

**Table 4.6.7-2: *CFR-ConfigMCCH-MTCH***

Derivation Path: TS 38.331 [6], clause 6.3.6			
Information Element	Value/remark	Comment	Condition
CFR-ConfigMCCH-MTCH-r17 ::= SEQUENCE {			
locationAndBandwidthBroadcast-r17	Not present		
locationAndBandwidthBroadcast-r17 CHOICE {			SIB1_BWP
sameAsSib1ConfiguredLocationAndBW	NULL		
}			
pdsch-ConfigMCCH-r17	Not present		
commonControlResourceSetExt-r17	Not present		
}			

Condition	Explanation
SIB1_BWP	CFR for broadcast has the same location and size as the <i>locationAndBandwidth</i> for initial BWP configured in SIB1

– *DRX-ConfigPTM*

**Table 4.6.7-3: DRX-ConfigPTM**

Derivation Path: TS 38.331 [6], clause 6.3.6			
Information Element	Value/remark	Comment	Condition
DRX-ConfigPTM-r17 ::= SEQUENCE {			
drx-onDurationTimerPTM-r17 CHOICE {			
milliSeconds	ms6		
}			
drx-InactivityTimerPTM-r17	ms1280		
drx-HARQ-RTT-TimerDL-PTM-r17	Not present		
	56		HARQ_Feedback
drx-RetransmissionTimerDL-PTM-r17	Not present		
	sl16		FR1 and HARQ_Feedback
	sl64		FR2 and HARQ_Feedback
drx-LongCycleStartOffsetPTM-r17 CHOICE {			
ms10240	0		
}			
drx-SlotOffsetPTM-r17	0		
}			

Condition	Explanation
HARQ_Feedback	HARQ feedback is enabled for a G-RNTI associated with this DRX configuration

– *MBS-NeighbourCellList*

**Table 4.6.7-4: MBS-NeighbourCellList**

Derivation Path: TS 38.331 [6], clause 6.3.6			
Information Element	Value/remark	Comment	Condition
MBS-NeighbourCellList-r17 ::= SEQUENCE {			
FFS			
}			

– *MBS-ServiceList*

**Table 4.6.7-5: MBS-ServiceList**

Derivation Path: TS 38.331 [6], clause 6.3.6			
Information Element	Value/remark	Comment	Condition
MBS-ServiceList-r17 ::= SEQUENCE {			
FFS			
}			

– *MBS-SessionInfoList*

**Table 4.6.7-6: MBS-SessionInfoList**

Derivation Path: TS 38.331 [6], clause 6.3.6			
Information Element	Value/remark	Comment	Condition

MBS-SessionInfoList-r17 ::= SEQUENCE (SIZE (0..maxNrofMBS-Session-r17)) OF MBS-SessionInfo-r17 {	1 entry		
MBS-SessionInfo-r17[1] SEQUENCE {			
mbs-SessionId-r17	TMGI with condition MBS_Broadcast		
g-RNTI-r17	RNTI-Value		
mrb-ListBroadcast-r17 SEQUENCE (SIZE (1..maxNrofMRB-Broadcast-r17)) OF MRB-InfoBroadcast-r17 {	1 entry		
MRB-InfoBroadcast-r17[1] SEQUENCE {		entry 1	
pdcpc-Config-r17 SEQUENCE {			
pdcpc-SN-SizeDL-r17	Not present		
headerCompression-r17 CHOICE {			
notUsed	NULL		
}			
t-Reordering-r17	Not present		
}			
rlc-Config-r17 SEQUENCE {			
logicalChannelIdentity-r17	1		
sn-FieldLength-r17	Not present		
t-Reassembly-r17	Not present		
}			
}			
}			
mtch-SchedulingInfo-r17	Not present 0		DRX_MBS_Broadcast
mtch-NeighbourCell-r17	Not present		
pdsch-ConfigIndex-r17	Not present		
mtch-SSB-MappingWindowIndex-r17	Not present		
}			
}			

Condition	Explanation
DRX_MBS_Broadcast	DRX is used for MBS Broadcast test
MBS_Broadcast	MBS Broadcast service

– *MTCH-SSB-MappingWindowList*

**Table 4.6.7-7: MTCH-SSB-MappingWindowList**

Derivation Path: TS 38.331 [6], clause 6.3.6			
Information Element	Value/remark	Comment	Condition
MTCH-SSB-MappingWindowList-r17 ::= SEQUENCE {			
FFS			
}			

– *PDSCH-ConfigBroadcast*

**Table 4.6.7-8: PDSCH-ConfigBroadcast**

Derivation Path: TS 38.331 [6], clause 6.3.6			
Information Element	Value/remark	Comment	Condition
PDSCH-ConfigBroadcast-r17 ::= SEQUENCE {			
FFS			
}			

– TMGI

Table 4.6.7-9: TMGI

Derivation Path: TS 38.331 [6], clause 6.3.6			
Information Element	Value/remark	Comment	Condition
TMGI-r17 ::= SEQUENCE {			
plmn-Id-r17 CHOICE {			
plmn-Index-r17	1		
}			
serviceId-r17	'000001'H	OCTET STRING (SIZE (3))	MBS_Broad cast
	'000101'H	OCTET STRING (SIZE (3))	
}			

Condition	Explanation
MBS_Broadcast	MBS Broadcast service

## 4.7 Default 5GC NAS message and information elements contents

### 4.7.0 General

#### 4.7.0.1 Interpretation of IE presence and values

For Uplink NAS messages, the following terms and their meanings shall be used to determine how to test specific IEs:

- "Not present": test cases fail if IE is present.
- "Present but contents not checked": test cases fail if IE is not present. No requirements regarding contents of the IE.
- "If present: contents not checked": IE may or may not be present. No requirements regarding contents of the IE.
- "If present: <specific values>": IE may or may not be present. If present, its contents shall be as specified.
- "<specific values>": test cases fail if IE is not present. Its contents shall be as specified.
- "Present if <condition>: contents not checked: test cases fail if condition is fulfilled and IE is not present. Contents of IE are not checked, even if present.
- "Present if <condition>: <specific values>": test cases fail if condition is fulfilled and IE is not present. When IE shall be present, its contents shall be as specified.

#### 4.7.0.2 Security protected 5GS NAS messages

In subclause 4.7.1, all 5GS NAS messages are described in the plain 5GS NAS message format.

When a 5GS NAS message is security protected, the message shall be contained by SECURITY PROTECTED 5GS NAS MESSAGE unless contained by another NAS message.

The default contents of SECURITY PROTECTED 5GS NAS MESSAGE message is defined in table 4.7.1-28.

## 4.7.1 Contents of 5GMM messages

### – Authentication request

**Table 4.7.1-1: AUTHENTICATION REQUEST**

Derivation Path: 24.501 clause 8.2.1			
Information Element	Value/remark	Comment	Condition
Extended protocol discriminator	'0111 1110'B	5GS mobility management messages	
Security header type	'0000'B	Plain 5GS NAS message, not security protected	
Spare half octet	'0000'B		
Authentication request message identity	'0101 0110'B		
ngKSI			
NAS key set identifier	An arbitrarily selected value between '000'B and '110'B, different from the valid NAS key set identifier of the UE if such a value exists.		
TSC	'0'B	native security context (for KSI <sub>AMF</sub> )	
Spare half octet	'0000'B		
ABBA	'0000 0000 0000 0000'B		
Authentication parameter RAND (5G authentication challenge)	Not Present		EAP-AKA
	An arbitrarily selected 128 bits value		5G-AKA
Authentication parameter AUTN (5G authentication challenge)	Not Present		EAP-AKA
	128 bits value generated according to TS 24.501 [28] subclause 9.11.3.15		5G-AKA
EAP message	Not Present		5G-AKA
EAP message	EAP-request/AKA'-challenge	See Table 4.7.3.2-01	EAP-AKA

Condition	Explanation
EAP_AKA	EAP based primary authentication and key agreement procedure
5G-AKA	5G AKA based primary authentication and key agreement procedure

NOTE: Within a test execution this message is sent without integrity protection before NAS security mode control procedure has been successfully completed; and sent integrity protected and ciphered within SECURITY PROTECTED 5GS NAS MESSAGE message after 5GS NAS security mode control procedure has been successfully completed. SS does not maintain information for 5GS NAS security mode control procedure after a TC is completed.

### – Authentication response

**Table 4.7.1-2: AUTHENTICATION RESPONSE**

Derivation Path: 24.501 clause 8.2.2			
Information Element	Value/remark	Comment	Condition
Extended protocol discriminator	5GMM		
Security header type	'0000'B	Plain 5GS NAS message, not security protected	
Spare half octet	'0000'B		
Authentication response message identity	'0101 0111'B		

Authentication response parameter	16 octets RES* value calculated according to TS 24.501 [28] subclause 9.11.3.17		5G-AKA
	Not Present		EAP-AKA
EAP message	EAP-response/AKA'-challenge	See Table 4.7.3.2-02	EAP-AKA

Condition	Explanation
EAP-AKA	EAP based primary authentication and key agreement procedure
5G-AKA	5G AKA based primary authentication and key agreement procedure

NOTE: When sent in response to an AUTHENTICATION REQUEST message which is not integrity protected and not ciphered, the AUTHENTICATION RESPONSE message is sent integrity protected when a valid security context exists and without integrity protection and ciphering otherwise.

– *Authentication result*

**Table 4.7.1-3: AUTHENTICATION RESULT**

Derivation Path: 24.501 clause 8.2.3			
Information Element	Value/remark	Comment	Condition
Extended protocol discriminator	5GMM		
Security header type	'0000'B	Plain 5GS NAS message, not security protected	
Spare half octet	'0000'B		
Authentication result message identity	'0101 1010'B		
ngKSI	The same value as the last AUTHENTICATION REQUEST message		
Spare half octet	'0000'B		
EAP message	EAP-Success	See Table 4.7.3.2-03	
ABBA	'0000 0000 0000 0000'B		

NOTE: The security protection of this message is the same as the previous AUTHENTICATION REQUEST message.

– *Authentication failure*

**Table 4.7.1-4: AUTHENTICATION FAILURE**

Derivation Path: 24.501 clause 8.2.4			
Information Element	Value/remark	Comment	Condition
Extended protocol discriminator	5GMM		
Security header type	'0000'B	Plain 5GS NAS message, not security protected	
Spare half octet	'0000'B		
Authentication failure message identity	'0101 1001'B		
5GMM cause	Present but contents not checked		
Authentication failure parameter	If present: contents not checked		

NOTE: The security protection of this message is the same as the previous AUTHENTICATION REQUEST message.

– *Authentication reject***Table 4.7.1-5: AUTHENTICATION REJECT**

Derivation Path: 24.501 clause 8.2.5			
Information Element	Value/remark	Comment	Condition
Extended protocol discriminator	5GMM		
Security header type	'0000'B	Plain 5GS NAS message, not security protected	
Spare half octet	'0000'B		
Authentication reject message identity	'0101 1000'B		
EAP message	Not present		
EAP message	EAP-Response/AKA-Authentication-Reject	See Table 4.7.3.2-04	EAP-AKA

Condition	Explanation
EAP-AKA	EAP based primary authentication and key agreement procedure

NOTE: This message is sent without integrity protection.

– *Registration request***Table 4.7.1-6: REGISTRATION REQUEST**

Derivation Path: 24.501 clause 8.2.6			
Information Element	Value/remark	Comment	Condition
Extended protocol discriminator	'0111 1110'B	5GS mobility management messages	
Security header type	'0000'B	Plain 5GS NAS message, not security protected	
Spare half octet	'0000'B		
Registration request message identity	'0100 0001'B		
5GS registration type			
5GS registration type value	'001'B	Initial registration	
	'010'B		MOBILITY
	'011'B		PERIODIC
	'100'B		EMERGENCY
FOR	Present but contents not checked		
FOR	'1'B	Follow-on request pending	EMERGENCY
ngKSI	Present but contents not checked		
5GS mobile identity	Present but contents not checked		
Non-current native NAS key set identifier	If present: contents not checked		NON_CLEAR TEXT_IE
5GMM capability	If present: contents not checked		NON_CLEAR TEXT_IE
UE security capability	If present: contents not checked		
Requested NSSAI	If present: contents not checked		NON_CLEAR TEXT_IE
Last visited registered TAI	If present: contents not checked		NON_CLEAR TEXT_IE
S1 UE network capability	If present: contents not checked		NON_CLEAR TEXT_IE



Uplink data status	If present: contents not checked		NON_CLEAR TEXT_IE
PDU session status	If present: contents not checked		NON_CLEAR TEXT_IE
MICO indication	If present: contents not checked		NON_CLEAR TEXT_IE
UE status	If present: contents not checked		
Additional GUTI	If present: contents not checked		
Allowed PDU session status	If present: contents not checked		NON_CLEAR TEXT_IE
UE's usage setting	If present: contents not checked		NOT pc_IMS AND NON_CLEAR TEXT_IE
UE's usage setting	Present but contents not checked		NON_CLEAR TEXT_IE
Requested DRX parameters	If present: contents not checked		NON_CLEAR TEXT_IE
EPS NAS message container	If present: contents not checked		
LADN indication	If present: contents not checked		NON_CLEAR TEXT_IE
Payload container type	If present: '0101'B	UE policy container	NON_CLEAR TEXT_IE
Payload container	If present: contents not checked		NON_CLEAR TEXT_IE
Network slicing indication	If present: contents not checked		NON_CLEAR TEXT_IE
5GS update type	If present: contents not checked		NON_CLEAR TEXT_IE
Mobile station classmark 2	If present: contents not checked		NON_CLEAR TEXT_IE
Supported codecs	If present: contents not checked		NON_CLEAR TEXT_IE
NAS message container	The complete, ciphered, REGISTRATION REQUEST message including all IEs.		CIPHERED_MESSAGE
EPS bearer context status	If present: contents not checked		NON_CLEAR TEXT_IE
Requested extended DRX parameters	If present: contents not checked		NON_CLEAR TEXT_IE
T3324 value	If present: contents not checked		NON_CLEAR TEXT_IE
UE radio capability ID	If present: contents not checked		NON_CLEAR TEXT_IE
Requested mapped NSSAI	If present: contents not checked		NON_CLEAR TEXT_IE
Additional information requested	If present: contents not checked		NON_CLEAR TEXT_IE
Requested WUS assistance information	If present: contents not checked		NON_CLEAR TEXT_IE
N5GC indication	If present: contents not checked		NON_CLEAR TEXT_IE
Requested NB-N1 mode DRX parameters	If present: contents not checked		NON_CLEAR TEXT_IE
UE request type	If present: contents not checked		NON_CLEAR TEXT_IE
Paging restriction	If present: contents not checked		NON_CLEAR TEXT_IE
Service-level-AA container	If present: contents not checked		NON_CLEAR TEXT_IE
NID	If present: contents not checked		NON_CLEAR TEXT_IE

MS determined PLMN with disaster condition	If present: contents not checked		NON_CLEAR TEXT_IE
Requested PEIPS assistance information	If present: contents not checked		NON_CLEAR TEXT_IE

Condition	Explanation
INITIAL	Initial registration
MOBILITY	Mobility registration updating
PERIODIC	Periodic registration updating
EMERGENCY	Emergency registration
NON_CLEARTEXT_IE	An information element that is not allowed to be sent in cleartext and shall only be included in the complete REGISTRATION REQUEST message in the NAS message container IE.
CIPHERED_MESSAGE	If any of the IEs marked with the condition NON_CLEARTEXT_IE is present, and the UE has a valid 5G NAS security context, this condition applies.

NOTE: This message is sent integrity protected when a valid security context exists otherwise sent without integrity protection, including only cleartext IEs.

– *Registration accept*

**Table 4.7.1-7: REGISTRATION ACCEPT**

Derivation Path: 24.501 clause 8.2.7			
Information Element	Value/remark	Comment	Condition
Extended protocol discriminator	'0111 1110'B	5GS mobility management messages	
Security header type	'0000'B	Plain 5GS NAS message, not security protected	
Spare half octet	'0000'B		
Registration accept message identity	'0100 0010'B		
5GS registration result			
5GS registration result value	'001'B	3GPP access	
SMS allowed	'0'B	SMS over NAS not allowed	
5G-GUTI	See Table 4.4.2-3	For 5GC NAS test cases see Table 6.3.2.2-1	
Equivalent PLMNs	Not Present		
TAI list			
Length of tracking area identity list contents	'0000 0111'B	7 octets	
Partial tracking area identity list 1			
Number of elements	'0 0000'B	1 element	
Type of list	'00'B	list of TACs belonging to one PLMN, with non-consecutive TAC values	
MCC	See Table 4.4.2-3	For 5GC NAS test cases see Table 6.3.2.2-1	
MNC	See Table 4.4.2-3	For 5GC NAS test cases see Table 6.3.2.2-1	
TAC 1	See Table 4.4.2-3	For 5GC NAS test cases see Table 6.3.2.2-1	
Allowed NSSAI			
Length of NSSAI contents	4 entries	Equal to the number of S-	

		NSSAI values included	
S-NSSAI			
Length of S-NSSAI contents	'0000 0001'B	SST	
SST	'0000 0001'B	SST value 1 (eMBB)	
S-NSSAI			
Length of S-NSSAI contents	'0000 0001'B	SST	
SST	'0000 0010'B	SST value 2 (URLLC)	
S-NSSAI			
Length of S-NSSAI contents	'0000 0001'B	SST	
SST	'0000 0011'B	SST value 3 (MIoT)	
S-NSSAI			
Length of S-NSSAI contents	'0000 0001'B	SST	
SST	'0000 0100'B	SST value 4 (V2X)	
Rejected NSSAI	Not Present		
Configured NSSAI	Not Present		
5GS network feature support	'0000 1101 0000 0000 0000 0000'B	IMS voice over PS session supported over 3GPP access, Emergency services supported in NR connected to 5GCN and E-UTRA connected to 5GCN. All other features set to "not supported" including the 'Interworking without N26 interface not supported'.	
5GS network feature support	Not Present		SST_URLLC OR SST_V2X OR SST_MIOT
PDU session status	The same value as the PDU session status IE of the most recently received REGISTRATION REQUEST message		
PDU session reactivation result	Not Present		
PDU session reactivation result error cause	Not Present		
LADN information	Not Present		
MICO indication	Not Present		
Network slicing indication	Not Present		
Service area list	Not Present		
T3512 value			INITIAL
Timer value	'0 0000'B		
Unit	'111'B	value indicates that the timer is deactivated	
T3512 value	Not Present		
Non-3GPP de-registration timer value	Not Present		
T3502 value	Not Present		
Emergency number list	Not Present		
Extended emergency number list	Not Present		
SOR Transparent container	Not Present		

EAP message	Not Present		
NSSAI inclusion mode	Not Present		
Operator-defined access category definitions	Not Present		
Negotiated DRX parameters	Not Present		
Non-3GPP NW policies	Not Present		
EPS bearer context status	The same value as the EPS bearer context status IE of the most recently received REGISTRATION REQUEST message		
Negotiated extended DRX parameters	Not Present		
T3447 value	Not Present		
T3448 value	Not Present		
T3324 value	Not Present		
UE radio capability ID	Not Present		
UE radio capability ID	The same value as received in UE radio capability ID; if any of the REGISTRATION REQUEST message		pc_5GC_RA CS
UE radio capability ID deletion indication	Not Present		
Pending NSSAI	Not Present		
Ciphering key data	Not Present		
CAG information list	Not Present		
Truncated 5G-S-TMSI configuration	Not Present		
Negotiated WUS assistance information	Not Present		
Negotiated NB-N1 mode DRX parameters	Not Present		
Extended rejected NSSAI	Not Present		
Service-level-AA container	Not Present		
Negotiated PEIPS assistance information	Not Present		
5GS additional request result	Not Present		
NSSRG information	Not Present		
Disaster roaming wait range	Not Present		
Disaster return wait range	Not Present		
List of PLMNs to be used in disaster condition	Not Present		
Forbidden TAI(s) for the list of "5GS forbidden tracking areas for roaming"	Not Present		
Forbidden TAI(s) for the list of "5GS forbidden tracking areas for regional provision of service"	Not Present		
Extended CAG information list	Not Present		
NSAG information	Not Present		

Condition	Explanation
INITIAL	Initial registration

NOTE: This message is always sent within SECURITY PROTECTED 5GS NAS MESSAGE message.

– *Registration complete*

**Table 4.7.1-8: REGISTRATION COMPLETE**

Derivation Path: 24.501 clause 8.2.8			
Information Element	Value/remark	Comment	Condition
Extended protocol discriminator	'0111 1110'B	5GS mobility management messages	
Security header type	'0000'B	Plain 5GS NAS message, not security protected	
Spare half octet	'0000'B		
Registration complete message identity	'0100 0011'B		

SOR transparent container	If present: contents not checked		
---------------------------	----------------------------------	--	--

NOTE: This message is always sent within SECURITY PROTECTED 5GS NAS MESSAGE message.

– *Registration reject*

**Table 4.7.1-9: REGISTRATION REJECT**

Derivation Path: 24.501 clause 8.2.9			
Information Element	Value/remark	Comment	Condition
Extended protocol discriminator	'0111 1110'B	5GS mobility management messages	
Security header type	'0000'B	Plain 5GS NAS message, not security protected	
Spare half octet	'0000'B		
Registration reject message identity	'0100 0100'B		
5GMM cause	Set according to specific message content		
T3346 value	Not Present		
T3502 value	Not Present		
EAP message	Not Present		
Rejected NSSAI	Not Present		
CAG information list	Not Present		
Extended rejected NSSAI	Not Present		
Disaster return wait range	Not Present		
Extended CAG information list	Not Present		
Lower bound timer value	Not Present		
Forbidden TAI(s) for the list of "5GS forbidden tracking areas for roaming"	Not Present		
Forbidden TAI(s) for the list of "5GS forbidden tracking areas for regional provision of service"	Not Present		

NOTE: This message is sent without integrity protection before the secure exchange of NAS messages has been established and sent within SECURITY PROTECTED 5GS NAS MESSAGE message after the secure exchange of NAS messages has been established.

– *UL NAS transport*

**Table 4.7.1-10: UL NAS TRANSPORT**

Derivation Path: 24.501 clause 8.2.10			
Information Element	Value/remark	Comment	Condition
Extended protocol discriminator	'0111 1110'B	5GS mobility management messages	
Security header type	'0000'B	Plain 5GS NAS message, not security protected	
Spare half octet	'0000'B		
UL NAS TRANSPORT message identity	'0110 0111'B		
Payload container type	Set according to specific message content		
Payload container type	'0001'B	N1 SM information	INITIAL_PD_U_REQUEST
Payload container type	'0100'B	SOR transparent container	5GS_SOR_CMCI
Spare half octet	'0000'B		
Payload container	Set according to specific message content		

Payload container	Present	The SOR transparent container in the payload container IE carries steering of roaming information.	5GS_SOR_CMCI
Length of payload container contents		2 octet	
Payload container contents			
SOR transparent container	Present	The SOR transparent container carries steering of roaming information.	
Length of SOR transparent container contents		2 octet	
SOR header		1 octet	
SOR data type	1	The SOR transparent container carries acknowledgement of successful reception of the steering of roaming information.	
ME support of SOR-CMCI indicator (MSSI) value	If present: contents not checked		
ME support of SOR-CMCI indicator (MSSI) value	1	SOR-CMCI supported by the ME	
ME support of SOR-SNPNSI indicator (MSSNPNSI) value	If present: contents not checked		
SOR-MAC-IAUSF	Set to match the calculated SoR-MAC-IAUS as the way defined in TS 33.501 A.17		
Payload container	PDU SESSION ESTABLISHMENT REQUEST message		INITIAL_PDU_REQUEST
PDU session ID	If present: contents not checked		
PDU session ID	Same PDU session ID as defined in the PDU SESSION ESTABLISHMENT REQUEST message in the Payload container		INITIAL_PDU_REQUEST
Old PDU session ID	If present: contents not checked		
Request type	If present: contents not checked		
Request type	'001'B	initial request	INITIAL_PDU_REQUEST
S-NSSAI	If present: contents not checked		
DNN	If present: contents not checked	(NOTE 1)	
Additional information	If present: contents not checked		
MA PDU session information	If present: contents not checked		
Release assistance indication	If present: contents not checked		

NOTE 1: Although the contents of the IE is not required to be verified for PASS/FAIL purposes, the provided information shall be taken into account e.g. for the building the content of messages and allowing for specific UE behaviour as specified in Table 4.8.4-1.

Condition	Explanation
INITIAL_PDU_REQUEST	The UL NAS TRANSPORT message is used to transport a PDU SESSION ESTABLISHMENT REQUEST message to establish a new PDU session.
5GS_SOR_CMCI	Used in Rel-17 SOR-CMCI test cases (TS 38.523-1 [12])

NOTE: This message is always sent within SECURITY PROTECTED 5GS NAS MESSAGE message.

### DL NAS transport

Table 4.7.1-11: DL NAS TRANSPORT

Derivation Path: 24.501 clause 8.2.11			
Information Element	Value/remark	Comment	Condition
Extended protocol discriminator	'0111 1110'B	5GS mobility management messages	
Security header type	'0000'B	Plain 5GS NAS message, not security protected	
Spare half octet	'0000'B		
DL NAS TRANSPORT message identity	'0110 1000'B		
Payload container type	Set according to specific message content		
Payload container type	'0001'B	N1 SM information	5GSM_MES SAGE
Payload container type	'0100'B	SOR transparent container	5GS_SOR_CMCI
Spare half octet	'0000'B		
Payload container	Set according to specific message content		
Payload container	5GSM message		5GSM_MES SAGE
Payload container	Present	The SOR transparent container in the payload container IE carries steering of roaming information.	5GS_SOR_CMCI
Length of payload container contents		2 octet	
Payload container contents			
SOR transparent container	Present	The SOR transparent container carries steering of roaming information.	
Length of SOR transparent container contents		2 octet	
SOR header		1 octet	
SOR data type	0	The SOR transparent container carries steering of roaming information.	
List indication value	1	List of preferred PLMN/access technology	

		combinations is provided	
List type	1	The list type is a "PLMN ID and access technology list"	
Acknowledgement (ACK) value	1	Acknowledgement requested	
Additional parameters (AP) value	0	Additional parameters not included	
Additional parameters (AP) value	1	Additional parameters included	
SOR-MAC-IAUSF	Set to match the calculated SoR-MAC-IAUS as the way defined in TS 33.501 A.17		
CounterSOR	Value generated as per TS 33.501 Cl 6.14.2.3		
Length of PLMN ID and access technology list		1 octet	
PLMN ID and access technology list		Values determined by test implementation	
SOR-CMCI indicator (SI) value	0	SOR-CMCI absent	
SOR-CMCI indicator (SI) value	1	SOR-CMCI present	
Store SOR-CMCI in ME indicator (SSCMI) value		Value determined by test implementation	
SOR-SNPNI-SI indicator (SSSI) value	0	subscribed SNPNI or HPLMN indication that 'no change of the SOR-SNPNI-SI stored in the UE is needed and thus no SOR-SNPNI-SI is provided'	
SOR-CMCI	Present		
Length of SOR-CMCI contents		Length value determined by test implementation	
SOR-CMCI rule 1		Value determined by test implementation	
Length of SOR-CMCI rule contents		Length value determined by test implementation	
Tsor-cm timer value	00100001	60s	
Criterion type		Value determined by test implementation	
Criterion value		Value determined by test implementation	
SOR-SNPNI-SI	Not Present		
PDU session ID	Not Present		
PDU session ID	Set to the same value as the PDU session ID of the 5GSM message in the Payload container.		5GSM_MES SAGE
Additional information	Not Present		
5GMM cause	Not Present		
Back-off timer value	Not Present		
Lower bound timer value	Not Present		



Condition	Explanation
5GSM_MESSAGE	The DL NAS TRANSPORT message is used to transport a 5GSM message
5GS_SOR_CMCI	Used in Rel-17 SOR-CMCI test cases (TS 38.523-1 [12])

NOTE: This message is always sent within SECURITY PROTECTED 5GS NAS MESSAGE message.

– *De-registration request (UE originating de-registration)*

**Table 4.7.1-12: DEREGISTRATION REQUEST\_1**

Derivation Path: 24.501 clause 8.2.12			
Information Element	Value/remark	Comment	Condition
Extended protocol discriminator	'0111 1110'B	5GS mobility management messages	
Security header type	'0000'B	Plain 5GS NAS message, not security protected	
Spare half octet	'0000'B		
De-registration request message identity	'0100 0101'B		
De-registration type			
Switch off	'0'B		NORMAL
	'1'B		SWITCH_OFF
Re-registration required	'0'B		
Access type	'01'B	3GPP access	
ngKSI	Present but contents not checked		
5GS mobile identity	Present but contents not checked		

Condition	Explanation
NORMAL	Normal de-registration
SWITCH_OFF	Switch off

NOTE: If this message is sent as an initial NAS message, it is sent with integrity protection but without ciphering. Otherwise it is sent without integrity protection and ciphering before SS has started the ciphering and integrity and ciphered protected after SS has started the ciphering.

– *De-registration accept (UE originating de-registration)*

**Table 4.7.1-13: DEREGISTRATION ACCEPT\_1**

Derivation Path: 24.501 clause 8.2.13			
Information Element	Value/remark	Comment	Condition
Extended protocol discriminator	'0111 1110'B	5GS mobility management messages	
Security header type	'0000'B	Plain 5GS NAS message, not security protected	
Spare half octet	'0000'B		
De-registration accept message identity	'0100 0110'B		

NOTE: This message is sent using the same security protection as in the previous DETACH REQUEST message received from the UE.

– *De-registration request (UE terminated de-registration)***Table 4.7.1-14: DEREGISTRATION REQUEST\_2**

Derivation Path: 24.501 clause 8.2.14			
Information Element	Value/remark	Comment	Condition
Extended protocol discriminator	'0111 1110'B	5GS mobility management messages	
Security header type	'0000'B	Plain 5GS NAS message, not security protected	
Spare half octet	'0000'B		
De-registration request message identity	'0100 0111'B		
De-registration type	Set according to specific message content		
Spare half octet	'0000'B		
5GMM cause	Not Present		
T3346 value	Not Present		
Rejected NSSAI	Not Present		
CAG information list	Not Present		
Extended rejected NSSAI	Not Present		
Disaster return wait range	Not Present		
Extended CAG information list	Not Present		
Lower bound timer value	Not Present		
Forbidden TAI(s) for the list of "5GS forbidden tracking areas for roaming"	Not Present		
Forbidden TAI(s) for the list of "5GS forbidden tracking areas for regional provision of service"	Not Present		

NOTE: This message is always sent within SECURITY PROTECTED 5GS NAS MESSAGE message.

– *De-registration accept (UE terminated de-registration)***Table 4.7.1-15: DEREGISTRATION ACCEPT\_2**

Derivation Path: 24.501 clause 8.2.15			
Information Element	Value/remark	Comment	Condition
Extended protocol discriminator	'0111 1110'B	5GS mobility management messages	
Security header type	'0000'B	Plain 5GS NAS message, not security protected	
Spare half octet	'0000'B		
De-registration accept message identity	'0100 1000'B		

NOTE: This message is always sent within SECURITY PROTECTED 5GS NAS MESSAGE message.

– *Service request***Table 4.7.1-16: SERVICE REQUEST**

Derivation Path: 24.501 clause 8.2.16			
Information Element	Value/remark	Comment	Condition
Extended protocol discriminator	'0111 1110'B	5GS mobility management messages	
Security header type	'0000'B	Plain 5GS NAS message, not security protected	
Spare half octet	'0000'B		

Service request message identity	'0100 1100'B		
ngKSI			
NAS key set identifier	The valid NAS key set identifier of the UE		
TSC	'0'B	native security context (for KSI <sub>AMF</sub> )	
Service type	'0010'B	mobile terminated services	
5G-S-TMSI	The valid 5G-S-TMSI of the UE		
Uplink data status	If present: contents not checked		NON_CLEARTTEXT_IE
PDU session status	If present: contents not checked		NON_CLEARTTEXT_IE
Allowed PDU session status	If present: contents not checked		NON_CLEARTTEXT_IE
NAS message container	If present, the complete, ciphered, SERVICE REQUEST message including all IEs.		CIPHERED_MESSAGE
UE request type	If present: contents not checked		NON_CLEARTTEXT_IE
Paging restriction	If present: contents not checked		NON_CLEARTTEXT_IE

Condition	Explanation
NON_CLEARTTEXT_IE	An information element that is not allowed to be sent in cleartext and shall only be included in the complete SERVICE REQUEST message in the NAS message container IE. NOTE: This condition is only applicable if the SERVICE REQUEST message is sent as an initial NAS message.
CIPHERED_MESSAGE	If any of the IEs marked with the condition NON_CLEARTTEXT_IE is present, this condition applies. NOTE: This condition is only applicable if the SERVICE REQUEST message is sent as an initial NAS message.

NOTE: This message is sent without integrity protection, including only cleartext IEs, before NAS security mode control procedure has been successfully completed and sent within SECURITY PROTECTED 5GS NAS MESSAGE message after NAS security mode control procedure has been successfully completed

– *Service accept*

**Table 4.7.1-17: SERVICE ACCEPT**

Derivation Path: 24.501 clause 8.2.17			
Information Element	Value/remark	Comment	Condition
Extended protocol discriminator	'0111 1110'B	5GS mobility management messages	
Security header type	'0000'B	Plain 5GS NAS message, not security protected	
Spare half octet	'0000'B		
Service accept message identity	'0100 1110'B		
PDU session status	The same value as the PDU session status IE of the most recently received SERVICE REQUEST message		
PDU session reactivation result	Not Present		
PDU session reactivation result error cause	Not Present		
EAP message	Not Present		
T3448 value	Not Present		

5GS additional request result	Not Present		
Forbidden TAI(s) for the list of "5GS forbidden tracking areas for roaming"	Not Present		
Forbidden TAI(s) for the list of "5GS forbidden tracking areas for regional provision of service"	Not Present		

NOTE: This message is always sent within SECURITY PROTECTED 5GS NAS MESSAGE message.

– *Service reject*

**Table 4.7.1-18: SERVICE REJECT**

Derivation Path: 24.501 clause 8.2.18			
Information Element	Value/remark	Comment	Condition
Extended protocol discriminator	'0111 1110'B	5GS mobility management messages	
Security header type	'0000'B	Plain 5GS NAS message, not security protected	
Spare half octet	'0000'B		
Service reject message identity	'0100 1101'B		
5GMM cause	The value is set according to specific message content		
PDU session status	Not Present		
T3346 value	Not Present		
EAP message	Not Present		
T3448 value	Not Present		
CAG information list	Not Present		
Disaster return wait range	Not Present		
Extended CAG information list	Not Present		
Lower bound timer value	Not Present		
Forbidden TAI(s) for the list of "5GS forbidden tracking areas for roaming"	Not Present		
Forbidden TAI(s) for the list of "5GS forbidden tracking areas for regional provision of service"	Not Present		

NOTE: This message is sent without integrity protection before NAS security mode control procedure has been successfully completed and sent within SECURITY PROTECTED 5GS NAS MESSAGE message after NAS security mode control procedure has been successfully completed

– *Configuration update command*

**Table 4.7.1-19: CONFIGURATION UPDATE COMMAND**

Derivation Path: 24.501 clause 8.2.19			
Information Element	Value/remark	Comment	Condition
Extended protocol discriminator	'0111 1110'B	5GS mobility management messages	
Security header type	'0000'B	Plain 5GS NAS message, not security protected	
Spare half octet	'0000'B		
Configuration update command message identity	'0101 0100'B		
Configuration update indication	Not Present		
5G-GUTI	Not Present		
TAI list	Not Present		
Allowed NSSAI	Not Present		
Service area list	Not Present		
Full name for network	Not Present		
Short name for network	Not Present		

Local time zone	Not Present		
Universal time and local time zone	Not Present		
Network daylight saving time	Not Present		
LADN information	Not Present		
MICO indication	Not Present		
Network slicing indication	Not Present		
Configured NSSAI	Not Present		
Rejected NSSAI	Not Present		
Operator-defined access category definitions	Not Present		
SMS indication	Not Present		
T3447 value	Not Present		
CAG information list	Not Present		
UE radio capability ID	Not Present		
UE radio capability ID deletion indication	Not Present		
5GS registration result	Not Present		
Truncated 5G-S-TMSI configuration	Not Present		
Additional configuration indication	Not Present		
Extended rejected NSSAI	Not Present		
Service-level-AA container	Not Present		
NSSRG information	Not Present		
Disaster roaming wait range	Not Present		
Disaster return wait range	Not Present		
List of PLMNs to be used in disaster condition	Not Present		
Extended CAG information list	Not Present		
Updated PEIPS assistance information	Not Present		
NSAG information	Not Present		
Priority indicator	Not Present		

NOTE: This message is always sent within SECURITY PROTECTED 5GS NAS MESSAGE message.

– *Configuration update complete*

**Table 4.7.1-20: CONFIGURATION UPDATE COMPLETE**

Derivation Path: 24.501 clause 8.2.20			
Information Element	Value/remark	Comment	Condition
Extended protocol discriminator	'0111 1110'B	5GS mobility management messages	
Security header type	'0000'B	Plain 5GS NAS message, not security protected	
Spare half octet	'0000'B		
Configuration update complete message identity	'0101 0101'B		

NOTE: This message is always sent within SECURITY PROTECTED 5GS NAS MESSAGE message.

– *Identity request*

**Table 4.7.1-21: IDENTITY REQUEST**

Derivation Path: 24.501 clause 8.2.21			
Information Element	Value/remark	Comment	Condition
Extended protocol discriminator	'0111 1110'B	5GS mobility management messages	
Security header type	'0000'B	Plain 5GS NAS message, not security protected	
Spare half octet	'0000'B		
Identity request message identity	'0101 1011'B		

Identity type	Set according to specific message contents		
Spare half octet	'0000'B		

NOTE: This message is sent without integrity protection before 5GS NAS security mode control procedure has been successfully completed and sent within SECURITY PROTECTED 5GS NAS MESSAGE message after 5GS NAS security mode control procedure has been successfully completed.

– *Identity response*

**Table 4.7.1-22: IDENTITY RESPONSE**

Derivation Path: 24.501 clause 8.2.22			
Information Element	Value/remark	Comment	Condition
Extended protocol discriminator	'0111 1110'B	5GS mobility management messages	
Security header type	'0000'B	Plain 5GS NAS message, not security protected	
Spare half octet	'0000'B		
Identity response message identity	0101 1100'B		
Mobile identity	Present but contents not checked		

NOTE: This message is sent without integrity protection before 5GS NAS security mode control procedure has been successfully completed and sent within SECURITY PROTECTED 5GS NAS MESSAGE message after 5GS NAS security mode control procedure has been successfully completed.

– *Notification*

**Table 4.7.1-23: NOTIFICATION**

Derivation Path: 24.501 clause 8.2.23			
Information Element	Value/remark	Comment	Condition
Extended protocol discriminator	'0111 1110'B	5GS mobility management messages	
Security header type	'0000'B	Plain 5GS NAS message, not security protected	
Spare half octet	'0000'B		
Notification message identity	'0110 0101'B		
Access type	'01'B	3GPP access	
Spare half octet	'0000'B		

NOTE: This message is always sent within SECURITY PROTECTED 5GS NAS MESSAGE message.

– *Notification response*

**Table 4.7.1-24: NOTIFICATION RESPONSE**

Derivation Path: 24.501 clause 8.2.24			
Information Element	Value/remark	Comment	Condition
Extended protocol discriminator	'0111 1110'B	5GS mobility management messages	
Security header type	'0000'B	Plain 5GS NAS message, not security protected	
Spare half octet	'0000'B		

Notification response message identity	'0110 0110'B		
PDU session status	If present: contents not checked		

NOTE: This message is always sent within SECURITY PROTECTED 5GS NAS MESSAGE message.

### – Security mode command

**Table 4.7.1-25: SECURITY MODE COMMAND**

Derivation Path: 24.501 clause 8.2.25			
Information Element	Value/remark	Comment	Condition
Extended protocol discriminator	'0111 1110'B	5GS mobility management messages	
Security header type	'0000'B	Plain 5GS NAS message, not security protected	
Spare half octet	'0000'B		
Security mode command message identity	'0101 1101'B		
Selected NAS security algorithms			
Type of ciphering algorithm	Set according to PIXIT px_NAS_5GC_CipheringAlgorithm for default ciphering algorithm		
Type of ciphering algorithm	'0000'B	5G encryption algorithm 5G EAO (null ciphering algorithm)	For RF
Type of integrity protection algorithm	Set according to PIXIT px_NAS_5GC_IntegrityProtAlgorithm for default integrity protection algorithm	This value should not be equal to the null integrity algorithm.	
ngKSI			
NAS key set identifier	The valid NAS key set identifier		
TSC	'0'B	native security context (for KSI <sub>AMF</sub> )	
Spare half octet	'0000'B		
Replayed UE security capabilities	Set according to the received UE security capabilities		
IMEISV request	Not Present		
Selected EPS NAS security algorithms	Not Present		
Selected EPS NAS security algorithms			UE_S1_SUPPORTED
Type of ciphering algorithm	Set according to PIXIT px_NAS_CipheringAlgorithm for default ciphering algorithm	The px_NAS_CipheringAlgorithm PIXIT is defined in TS 36.523-3 [x]	
Type of integrity protection algorithm	Set according to PIXIT px_NAS_IntegrityProtAlgorithm for default integrity protection algorithm	The px_NAS_IntegrityProtAlgorithm is defined in TS 36.523-3 [x]	
Additional 5G security information	Not Present		
Additional 5G security information			NO_VALID_SS_SECURITY_CONTEXT
RINMR	'1'B	Retransmission of the initial NAS	

		message requested	
HDP	'0'B	K <sub>AMF</sub> derivation is not required	
EAP message	Not Present		
EAP message	EAP-Success	See Table 4.7.3.2-03	EAP-AKA
ABBA	'0000 0000 0000 0000'B		EAP-AKA
Replayed S1 UE security capabilities	Not Present		
Replayed S1 UE security capabilities	Set according to the received UE security capabilities in the last REGISTRATION REQUEST message		UE_S1_SUPPORTED

Condition	Explanation
NO_VALID_SS_SECURITY_CONTEXT	If the SS doesn't have a valid security context
EAP_AKA	EAP based primary authentication and key agreement procedure
For RF	Used for RF/RRM test cases
UE_S1_SUPPORTED	The UE indicated support of S1 in the last REGISTRATION REQUEST message

NOTE: This message is always sent integrity protected with new 5GS NAS security context.

– *Security mode complete*

**Table 4.7.1-26: SECURITY MODE COMPLETE**

Derivation Path: 24.501 clause 8.2.26			
Information Element	Value/remark	Comment	Condition
Extended protocol discriminator	'0111 1110'B	5GS mobility management messages	
Security header type	'0000'B	Plain 5GS NAS message, not security protected	
Spare half octet	'0000'B		
Security mode complete message identity	'0101 1110'B		
IMEISV	Not present		
NAS message container	Not present		
	Complete initial NAS message		RINMR_INDICATED
non-IMEISV PEI	Not present		

Condition	Explanation
RINMR_INDICATED	The SS requested retransmission of the initial NAS message in the last SECURITY MODE COMMAND

NOTE: This message is always sent within SECURITY PROTECTED 5GS NAS MESSAGE message with new 5GS NAS security context.

– *Security mode reject*

**Table 4.7.1-27: SECURITY MODE REJECT**

Derivation Path: 24.501 clause 8.2.27			
Information Element	Value/remark	Comment	Condition
Extended protocol discriminator	'0111 1110'B	5GS mobility management messages	



Security header type	'0000'B	Plain 5GS NAS message, not security protected	
Spare half octet	'0000'B		
Security mode reject message identity	'0101 1111'B		
5GMM cause	The value is set according to specific message content		

NOTE: This message is sent without integrity protection before 5GS NAS security mode control procedure has been successfully completed and sent within SECURITY PROTECTED 5GS NAS MESSAGE message after 5GS NAS security mode control procedure has been successfully completed.

– *Security protected 5GS NAS message*

**Table 4.7.1-28: SECURITY PROTECTED 5GS NAS MESSAGE**

Derivation Path: 24.501 clause 8.2.28			
Information Element	Value/remark	Comment	Condition
Extended protocol discriminator	5GMM		
Security header type	'0001'B	Integrity protected	UNCIPHERED
	'0010'B	Integrity protected and ciphered	CIPHERED
	'0011'B	Integrity protected with new 5G NAS security context	UNCIPHERED-NEW
	'0100'B	Integrity protected and ciphered with new 5G NAS security context	CIPHERED-NEW
Spare half octet	'0000'B		
Message authentication code	The calculated value of MAC-I for this message.	The value of MAC-I is calculated by SS using Sequence number sent by UE.	SENT-BY-SS
	The same value as the XMAC-I value calculated by SS.		SENT-BY-UE
Sequence number	The internal counter of the SS		SENT-BY-SS
	Any allowed value		SENT-BY-UE
Plain 5GS NAS message	Set according to specific message content		

Condition	Explanation
UNCIPHERED	This condition applies to unciphered NAS message exchange
CIPHERED	This condition applies to ciphered NAS message exchange
UNCIPHERED-NEW	This condition applies to unciphered NAS message exchange with new 5G NAS security context
CIPHERED-NEW	This condition applies to ciphered NAS message exchange with new 5G NAS security context
SENT-BY-SS	Use for the message sent from SS to UE
SENT-BY-UE	Use for the message sent from UE to SS

## – 5GMM status

Table 4.7.1-29: 5GMM STATUS

Derivation Path: 24.501 clause 8.2.29			
Information Element	Value/remark	Comment	Condition
Extended protocol discriminator	5GMM		
Security header type	'0000'B	Plain 5GS NAS message, not security protected	
Spare half octet	'0000'B		
5GMM STATUS message identity	'0110 0100'B		
5GMM cause	'0110 1111'B	Protocol error, unspecified	SENT-BY-SS
	Present but contents not checked		SENT-BY-UE

Condition	Explanation
SENT-BY-SS	Use for the message sent from SS to UE
SENT-BY-UE	Use for the message sent from UE to SS

NOTE: This message is always sent within SECURITY PROTECTED 5GS NAS MESSAGE message.

## – Control plane service request

Table 4.7.1-30: CONTROL PLANE SERVICE REQUEST

Derivation Path: 24.501 clause 8.2.30			
Information Element	Value/remark	Comment	Condition
Extended protocol discriminator	'0111 1110'B	5GS mobility management messages	
Security header type	'0000'B	Plain 5GS NAS message, not security protected	
Spare half octet	'0000'B		
Control plane service request message identity	'0100 1111'B		
Control plane service type	'001'B	mobile terminated request	
ngKSI			
NAS key set identifier	The valid NAS key set identifier of the UE		
TSC	'0'B	native security context (for KSI <sub>AMF</sub> )	
CIoT small data container	If present: contents not checked		NON_CLEARTEXT_IE
Payload container type	If present: contents not checked		NON_CLEARTEXT_IE
Payload container	If present: contents not checked		NON_CLEARTEXT_IE
PDU session ID	If present: contents not checked		NON_CLEARTEXT_IE
PDU session status	If present: contents not checked		NON_CLEARTEXT_IE
Release assistance indication	If present: contents not checked		NON_CLEARTEXT_IE
Uplink data status	If present: contents not checked		NON_CLEARTEXT_IE
NAS message container	If present: contents not checked		CIPHERED_MESSAGE
Additional information	If present: contents not checked		NON_CLEARTEXT_IE

Allowed PDU session status	If present: contents not checked		NON_CLEARTEXT_IE
UE request type	If present: contents not checked		NON_CLEARTEXT_IE
Paging restriction	If present: contents not checked		NON_CLEARTEXT_IE

Condition	Explanation
NON_CLEARTEXT_IE	An information element that is not allowed to be sent in cleartext and shall only be included in the complete CONTROL PLANE SERVICE REQUEST message in the NAS message container IE. NOTE: This condition is only applicable if the CONTROL PLANE SERVICE REQUEST message is sent as an initial NAS message.
CIPHERED_MESSAGE	If any of the IEs marked with the condition NON_CLEARTEXT_IE is present, this condition applies. NOTE: This condition is only applicable if the CONTROL PLANE SERVICE REQUEST message is sent as an initial NAS message.

NOTE: This message is sent without integrity protection, including only cleartext IEs, before NAS security mode control procedure has been successfully completed and sent within SECURITY PROTECTED 5GS NAS MESSAGE message after NAS security mode control procedure has been successfully completed

– *Network slice-specific authentication command*

**Table 4.7.1-31: NETWORK SLICE-SPECIFIC AUTHENTICATION COMMAND**

Derivation Path: 24.501 clause 8.2.31			
Information Element	Value/remark	Comment	Condition
Extended protocol discriminator	'0111 1110'B	5GS mobility management messages	
Security header type	'0000'B	Plain 5GS NAS message, not security protected	
Spare half octet	'0000'B		
NETWORK SLICE-SPECIFIC AUTHENTICATION COMMAND message identity	'0101 0000'B		
S-NSSAI	Set according to specific message content		
EAP message	Set according to Table 4.7.3.2-1	See TS 24.501 [25] subclause 9.11.2.2	

NOTE: This message is always sent within SECURITY PROTECTED 5GS NAS MESSAGE message.

– *Network slice-specific authentication complete*

**Table 4.7.1-32: NETWORK SLICE-SPECIFIC AUTHENTICATION COMPLETE**

Derivation Path: 24.501 clause 8.2.32			
Information Element	Value/remark	Comment	Condition
Extended protocol discriminator	'0111 1110'B	5GS mobility management messages	
Security header type	'0000'B	Plain 5GS NAS message, not security protected	
Spare half octet	'0000'B		
NETWORK SLICE-SPECIFIC AUTHENTICATION COMPLETE message identity	'0101 0001'B		
S-NSSAI	Set according to specific message content		

EAP message	Set according to Table 4.7.3.2-2	See TS 24.501 [25] subclause 9.11.2.2	
-------------	----------------------------------	---------------------------------------	--

NOTE: This message is always sent within SECURITY PROTECTED 5GS NAS MESSAGE message.

– *Network slice-specific authentication result*

**Table 4.7.1-33: NETWORK SLICE-SPECIFIC AUTHENTICATION RESULT**

Derivation Path: 24.501 clause 8.2.33			
Information Element	Value/remark	Comment	Condition
Extended protocol discriminator	'0111 1110'B	5GS mobility management messages	
Security header type	'0000'B	Plain 5GS NAS message, not security protected	
Spare half octet	'0000'B		
NETWORK SLICE-SPECIFIC AUTHENTICATION COMPLETE message identity	'0101 0010'B		
S-NSSAI	Set according to specific message content		
EAP message	EAP-Success	See Table 4.7.3.2-3	NSSAA Success
	EAP-Failure	See Table 4.7.3.2-6	NSSAA Failure

Condition	Explanation
NSSAA Success	Network slice-specific authentication succeeds
NSSAA Failure	Network slice-specific authentication fails

NOTE: This message is always sent within SECURITY PROTECTED 5GS NAS MESSAGE message.

– *Relay key request*

**Table 4.7.1-34: RELAY KEY REQUEST**

Derivation Path: 24.501 clause 8.2.34			
Information Element	Value/remark	Comment	Condition
Extended protocol discriminator	'0111 1110'B	5GS mobility management messages	
Security header type	'0000'B	Plain 5GS NAS message, not security protected	
Spare half octet	'0000'B		
Relay key request message identity	'0110 1001'B		
PRTI	FFS		
Relay key request parameters	FFS		

NOTE: This message is always sent within SECURITY PROTECTED 5GS NAS MESSAGE message.

– *Relay key accept*

**Table 4.7.1-35: RELAY KEY ACCEPT**

Derivation Path: 24.501 clause 8.2.35			
Information Element	Value/remark	Comment	Condition

Extended protocol discriminator	'0111 1110'B	5GS mobility management messages	
Security header type	'0000'B	Plain 5GS NAS message, not security protected	
Spare half octet	'0000'B		
Relay key accept message identity	'0110 1010'B		
PRTI	FFS		
Relay key response parameters	FFS		
EAP message	FFS		

NOTE: This message is always sent within SECURITY PROTECTED 5GS NAS MESSAGE message.

– *Relay key reject*

**Table 4.7.1-36: RELAY KEY REJECT**

Derivation Path: 24.501 clause 8.2.36			
Information Element	Value/remark	Comment	Condition
Extended protocol discriminator	'0111 1110'B	5GS mobility management messages	
Security header type	'0000'B	Plain 5GS NAS message, not security protected	
Spare half octet	'0000'B		
Relay key reject message identity	'0110 1011'B		
PRTI	FFS		
EAP message	FFS		

NOTE: This message is always sent within SECURITY PROTECTED 5GS NAS MESSAGE message.

– *Relay authentication request*

**Table 4.7.1-37: RELAY AUTHENTICATION REQUEST**

Derivation Path: 24.501 clause 8.2.37			
Information Element	Value/remark	Comment	Condition
Extended protocol discriminator	'0111 1110'B	5GS mobility management messages	
Security header type	'0000'B	Plain 5GS NAS message, not security protected	
Spare half octet	'0000'B		
Relay authentication request message identity	'0110 1100'B		
PRTI	FFS		
EAP message	FFS		

NOTE: This message is always sent within SECURITY PROTECTED 5GS NAS MESSAGE message.

– *Relay authentication response*

**Table 4.7.1-38: RELAY AUTHENTICATION RESPONSE**

Derivation Path: 24.501 clause 8.2.37			
Information Element	Value/remark	Comment	Condition
Extended protocol discriminator	'0111 1110'B	5GS mobility management messages	

Security header type	'0000'B	Plain 5GS NAS message, not security protected	
Spare half octet	'0000'B		
Relay authentication response message identity	'0110 1101'B		
PRTI	FFS		
EAP message	FFS		

NOTE: This message is always sent within SECURITY PROTECTED 5GS NAS MESSAGE message.

## 4.7.2 Contents of 5GSM messages

### – PDU session establishment request

**Table 4.7.2-1: PDU SESSION ESTABLISHMENT REQUEST**

Derivation Path: 24.501 clause 8.3.1			
Information Element	Value/remark	Comment	Condition
Extended protocol discriminator	'0010 1110'B	5GS session management messages	
PDU session ID	Any value according to TS 24.501 [25] subclause 9.4		
PTI	Any value from 1 to 254		
PDU SESSION ESTABLISHMENT REQUEST message identity	'1100 0001'B		
Integrity protection maximum data rate	Present but contents not checked		
PDU session type	Any value between '001'B, '010'B, '011'B and '101'B	The allowed values are respectively IPv4, IPv6, IPv4v6 and Ethernet (EtherType as defined in IEEE 802.3)	
SSC mode	If present: contents not checked		
5GSM capability	If present: contents not checked		
Maximum number of supported packet filters	If present: contents not checked		
Always-on PDU session requested	If present: contents not checked		
Always-on PDU session requested			SST_URLLC
APSR	'1'B	Always-on PDU session requested	
SM PDU DN request container	If present: contents not checked		
Extended protocol configuration options	If present: contents not checked	The SS shall remember if this IE is present and its contents because this affects subsequent SS behaviour, e.g. coding of PDU SESSION ESTABLISHMENT ACCEPT.	

Extended protocol configuration options	Present including at least the following container		DATA_OFF
Container ID n	'0017'H	3GPP PS data off UE status	
Length of container ID n contents		1 octet	
Container ID n contents	'01'H	'deactivated'	
IP header compression configuration	If present: contents not checked		
DS-TT Ethernet port MAC address	If present: contents not checked		
DS-TT Ethernet port MAC address	Any value according to TS 24.501 [25] subclause 9.11.4.25		Ethernet
UE-DS-TT residence time	If present: contents not checked		
Port management information container	If present: contents not checked		
Ethernet header compression configuration	If present: contents not checked		
Ethernet header compression configuration	Any value according to TS 24.501 [25] subclause 9.11.4.28		Ethernet
Suggested interface identifier	If present: contents not checked		
Service-level-AA container	If present: contents not checked		
Requested MBS container	If present: contents not checked		
PDU session pair ID	If present: contents not checked		
RSN	If present: contents not checked		

Condition	Explanation
DATA_OFF	If the UE supports 3GPP PS data off as specified in TS 38.508-2 [10], Table A.4.3.7-1/xx
Ethernet	If the PDU session type = '101'B.

– *PDU session establishment accept*

**Table 4.7.2-2: PDU SESSION ESTABLISHMENT ACCEPT**

Derivation Path: 24.501 clause 8.3.2			
Information Element	Value/remark	Comment	Condition
Extended protocol discriminator	'0010 1110'B	5GS session management messages	
PDU session ID	The same value as the value set in PDU SESSION ESTABLISHMENT REQUEST message		
PTI	The same value as the value set in PDU SESSION ESTABLISHMENT REQUEST message		
PDU SESSION ESTABLISHMENT ACCEPT message identity	'1100 0010'B		
Selected PDU session type	'001'B		IPv4
	'010'B		IPv6
	'011'B		IPv4v6
	'101'B		Ethernet
Selected SSC mode	'001'B	SSC mode 1	

Authorized QoS rules	5GC QoS rule of the entry in Table 4.8.4-1 which has been determined by the DNN IE in the UL NAS TRANSPORT message which carried the corresponding PDU SESSION ESTABLISHMENT REQUEST or by pc-APN_Default_Configuration if the DNN IE was not present		
Session AMBR			
Unit for Session-AMBR for downlink	'000 00101'	Value is incremented in multiples of 256 Kbps	
Session-AMBR for downlink	'0000 0000 0000 0100'B	1024 Kbps	
Unit for Session-AMBR for uplink	'000 00101'	Value is incremented in multiples of 256 Kbps	
Session-AMBR for uplink	'0000 0000 0000 0100'B	1024 Kbps	
5GSM cause	Not Present		
PDU address			IPv4
Length of PDU address contents	5 octets		
PDU type value	'001'B	IPv4	
PDU address information	IPv4 address	The SS provides a valid IPv4 address	NOT IPv4-DHCP
	0.0.0.0	DHCPv4 is to be used to allocate the IPv4 address	IPv4-DHCP
PDU address			IPv6
Length of PDU address contents	9 octets		
PDU type value	'010'B	IPv6	
PDU address information	IPv6 interface identifier	The SS provides a valid IPv6 interface identifier	
PDU address			IPv4v6
Length of PDU address contents	13 octets		
PDU type value	'011'B	IPv4v6	
PDU address information (Octets 4 to 11)	IPv6 interface identifier	The SS provides a valid IPv6 interface identifier	
PDU address information (Octets 12 to 15)	IPv4 address	The SS provides a valid IPv4 address	NOT IPv4-DHCP
	0.0.0.0	DHCPv4 is to be used to allocate the IPv4 address	IPv4-DHCP
RQ timer value	Not Present		
S-NSSAI			
Length of S-NSSAI contents	'0000 0001'B	SST	
SST	'0000 0001'B	SST value 1 (eMBB)	SST_eMBB
SST	'0000 0010'B	SST value 2 (URLLC)	SST_URLLC
SST	'0000 0011'B	SST value 3 (MIoT)	SST_MIoT
SST	'0000 0100'B	SST value 4 (V2X)	SST_V2X
Always-on PDU session indication	Not Present		
Always-on PDU session indication			



APSI	'0'B	Always-on PDU session not allowed	Always_On_Requested
APSI	'1'B	Always-on PDU session required	Always_On_Requested AND SST_URLLC
Mapped EPS bearer contexts	Not Present		
Mapped EPS bearer contexts			Interworking_with_EPS
Mapped EPS bearer context			
EPS bearer identity	The same value as the one specified in the Reference QoS flow referred to from the Reference QoS rule indicated in the IE Authorized QoS rules		
Operation code	'001'B	Create new EPS bearer	
E bit	'1'B	Parameters list is included	
Number of EPS parameters	'0001'B	1 parameter	
Mapped EPS QoS parameters	EPC default bearer context of the entry in Table 4.8.4-1 which has been determined by the DNN IE in the UL NAS TRANSPORT message which carried the corresponding PDU SESSION ESTABLISHMENT REQUEST or by pc-APN-Default-Configuration if the DNN IE was not present		
EAP message	Not Present		
Authorized QoS flow descriptions	The QoS flow referred to in the relevant Authorized QoS rules IE		
Extended protocol configuration options	Not Present		
Extended protocol configuration options			P-CSCF_IPv6 OR P-CSCF_IPv4
Container ID 1	'0001'H		P-CSCF_IPv6
Length of container ID 1 contents		Length value determined by test implementation	
Container ID 1 contents	IPv6 address	P-CSCF IPv6 Address	
Container ID 2	'000C'H		P-CSCF_IPv4
Length of container ID 2 contents		Length value determined by test implementation	
Container ID 2 contents	IPv4 address	P-CSCF IPv4 Address	
Container ID 3	'0001'H		Additional_P-CSCF_IPv6
Length of container ID 3 contents		Length value determined by	

		test implementation	
Container ID 3 contents	IPv6 address	Additional P-CSCF IPv6 Address	
Container ID 4	'000C'H		Additional_P-CSCF_IPv4
Length of container ID 4 contents		Length value determined by test implementation	
Container ID 4 contents	IPv4 address	Additional P-CSCF IPv4 Address	
Container ID n	'0003'H	n assigned to next available number	DNS IPv6 AND XCAP
Length of container ID n contents		Length value determined by the TTCN implementation	
Container ID n contents	IPv6 address	DNS IPv6 address	
Container ID n+1	'000D'H	n assigned to next available number	DNS IPv4 AND XCAP
Length of container ID n contents		Length value determined by the TTCN implementation	
Container ID n contents	IPv4 address	DNS IPv4 address	
DNN	The DNN/APN ID of the entry in Table 4.8.4-1 which has been determined by the DNN IE in the UL NAS TRANSPORT message which carried the corresponding PDU SESSION ESTABLISHMENT REQUEST or by pc_APN_Default_Configuration if the DNN IE was not present		
5GSM network feature support	Not Present		
Serving PLMN rate control	Not Present		
ATSSS container	Not Present		
Control plane only indication	Not Present		
IP header compression configuration	Not Present		
Ethernet header compression configuration	Not Present		
Ethernet header compression configuration	Any value according to TS 24.501 [25] subclause 9.11.4.28		Ethernet
Service-level-AA container	Not Present		
Received MBS container	Not Present		

Condition	Explanation
IPv4	If in the last PDU SESSION ESTABLISHMENT REQUEST sent prior to this message, the PDU session type = '001'B
IPv6	If in the last PDU SESSION ESTABLISHMENT REQUEST sent prior to this message, the PDU session type = '010'B
IPv4v6	If in the last PDU SESSION ESTABLISHMENT REQUEST sent prior to this message, the PDU session type = '011'B
IPv4-DHCP	If in the last PDU SESSION ESTABLISHMENT REQUEST sent prior to this message, the IE Extended protocol configuration options contains a configuration protocol option = '000BH' ("IPv4 address allocation via DHCPv4", length of contents = 0).

	Note: This condition is used in conjunction with IPv4 or IPv4v6 as indicated in the "PDU address information" just above.
Ethernet	If in the last PDU SESSION ESTABLISHMENT REQUEST sent prior to this message, the PDU session type = '101'B.
Always_On_Requested	If the last PDU SESSION ESTABLISHMENT REQUEST message included the Always-on PDU session requested IE
P-CSCF_IPv6	If in the last PDU SESSION ESTABLISHMENT REQUEST sent prior to this message the IE Extended protocol configuration options contains a configuration protocol option = '0001H' ("P-CSCF IPv6 Address Request", length of contents = 0)
P-CSCF_IPv4	If in the last PDU SESSION ESTABLISHMENT REQUEST sent prior to this message the IE Extended protocol configuration options contains a configuration protocol option = '000CH' ("P-CSCF IPv4 Address Request", length of contents = 0)
Interworking_with_EPS	If the UE has indicated support of S1, then the SS shall include this IE to provide details for the interworking with EPS being supported for a PDU session. This requirement is set up for the purpose of facilitating the test description. It is not mandatory for the Network to support Mapped EPS bearer contexts.
Additional_P-CSCF_IPv6	P-CSCF_IPv6 AND SS requires to be configured with second P-CSCF Ipv6 address
Additional_P-CSCF_IPv4	P-CSCF_IPv6 AND SS requires to be configured with second P-CSCF Ipv4 address
DNS IPv6	If in the last PDU Session Establishment REQUEST the Extended protocol configuration options was included with a "DNS IPv6 Address Request".
DNS IPv4	If in the last PDU Session Establishment REQUEST the Extended protocol configuration options was included with a "DNS IPv4 Address Request".
XCAP	Used for test cases (TS 34.229-5[47]) involving signalling between UE and XCAP server to activate or deactivate a supplementary service.

– *PDU session establishment reject*

**Table 4.7.2-3: PDU SESSION ESTABLISHMENT REJECT**

Derivation Path: 24.501 clause 8.3.3			
Information Element	Value/remark	Comment	Condition
Extended protocol discriminator	'0010 1110'B	5GS session management messages	
PDU session ID	The same value as the value set in PDU SESSION ESTABLISHMENT REQUEST message		
PTI	The same value as the value set in PDU SESSION ESTABLISHMENT REQUEST message		
PDU SESSION ESTABLISHMENT REJECT message identity	'1100 0011'B		
5GSM cause	The value is set according to specific message content		
Back-off timer value	Not Present		
Allowed SSC mode	Not Present		
EAP message	Not Present		
5GSM congestion re-attempt indicator	Not Present		
Extended protocol configuration options	Not Present		
Re-attempt indicator	Not Present		
Service-level-AA container	Not Present		

– *PDU session authentication command***Table 4.7.2-4: PDU SESSION AUTHENTICATION COMMAND**

Derivation Path: 24.501 clause 8.3.4			
Information Element	Value/remark	Comment	Condition
Extended protocol discriminator	'0010 1110'B	5GS session management messages	
PDU session ID	Set according to specific message content		
PTI	'0000 0000'B	No procedure transaction identity assigned	
PDU SESSION AUTHENTICATION COMMAND message identity	'1100 0101'B		
EAP message	Set according to TS 38.508 Table 4.7.3.2-1	See TS 24.501 [25] subclause 9.11.2.2	
Extended protocol configuration options	Not Present		

– *PDU session authentication complete***Table 4.7.2-5: PDU SESSION AUTHENTICATION COMPLETE**

Derivation Path: 24.501 clause 8.3.5			
Information Element	Value/remark	Comment	Condition
Extended protocol discriminator	'0010 1110'B	5GS session management messages	
PDU session ID	The value indicated in PDU SESSION AUTHENTICATION COMMAND message		
PTI	'0000 0000'B	No procedure transaction identity assigned	
PDU SESSION AUTHENTICATION COMPLETE message identity	'1100 0110'B		
EAP message	Set according to TS 38.508 Table 4.7.3.2-2	See TS 24.501 [25] subclause 9.11.2.2	
Extended protocol configuration options	If present: contents not checked		

– *PDU session authentication result***Table 4.7.2-6: PDU SESSION AUTHENTICATION RESULT**

Derivation Path: 24.501 clause 8.3.6			
Information Element	Value/remark	Comment	Condition
Extended protocol discriminator	'0010 1110'B	5GS session management messages	
PDU session ID	The value indicated in PDU SESSION AUTHENTICATION COMMAND message		
PTI	'0000 0000'B	No procedure transaction identity assigned	
PDU SESSION AUTHENTICATION RESULT message identity	'1100 0111'B		

EAP message	Set according to specific message content	See TS 24.501 [25] subclause 9.11.2.2	
Extended protocol configuration options	Not Present		

– *PDU session modification request*

**Table 4.7.2-7: PDU SESSION MODIFICATION REQUEST**

Derivation Path: 24.501 clause 8.3.7			
Information Element	Value/remark	Comment	Condition
Extended protocol discriminator	'0010 1110'B	5GS session management messages	
PDU session ID	The value indicated in PDU SESSION ESTABLISHMENT REQUEST message		
PTI	Any value from 1 to 254		
PDU SESSION MODIFICATION REQUEST message identity	'1100 1001'B		
5GSM capability	If present: contents not checked		
5GSM cause	If present: contents not checked		
Maximum number of supported packet filters	If present: contents not checked		
Always-on PDU session requested	If present: contents not checked		
Integrity protection maximum data rate	If present: contents not checked		
Requested QoS rules	If present: contents not checked		
Requested QoS flow descriptions	If present: contents not checked		
Mapped EPS bearer contexts	If present: contents not checked		
Extended protocol configuration options	If present: contents not checked		
Port management information container	If present: contents not checked		
IP header compression configuration	If present: contents not checked		
Ethernet header compression configuration	If present: contents not checked		
Requested MBS container	If present: contents not checked		
Service-level-AA container	If present: contents not checked		

– *PDU session modification reject*

**Table 4.7.2-8: PDU SESSION MODIFICATION REJECT**

Derivation Path: 24.501 clause 8.3.8			
Information Element	Value/remark	Comment	Condition
Extended protocol discriminator	'0010 1110'B	5GS session management messages	
PDU session ID	The value indicated in PDU SESSION MODIFICATION REQUEST message.		

PTI	The value indicated in PDU SESSION MODIFICATION REQUEST message.		
PDU SESSION MODIFICATION REJECT message identity	'1100 1010'B		
5GSM cause	Set according to specific message content.		
Back-off timer value	Not Present		
5GSM congestion re-attempt indicator	Not Present		
Extended protocol configuration options	Not Present		
Re-attempt indicator	Not Present		

– *PDU session modification command*

**Table 4.7.2-9: PDU SESSION MODIFICATION COMMAND**

Derivation Path: 24.501 clause 8.3.9			
Information Element	Value/remark	Comment	Condition
Extended protocol discriminator	'0010 1110'B	5GS session management messages	
PDU session ID	Set according to specific message content.		
PDU session ID	The value indicated in PDU SESSION MODIFICATION REQUEST message.		UE_Initiated_Modification
PTI	'0000 0000'B	No procedure transaction identity assigned	
PTI	The value indicated in PDU SESSION MODIFICATION REQUEST message.		UE_Initiated_Modification
PDU SESSION MODIFICATION COMMAND message identity	'1100 1011'B		
5GSM cause	Not Present		
Session AMBR	Not Present		
RQ timer value	Not Present		
Always-on PDU session indication	Not Present		
Always-on PDU session indication			
APSI	'0'B	Always-on PDU session not allowed	Always_On_Requested
APSI	'1'B	Always-on PDU session required	Always_On_Requested AND SST_URLLC
Authorized QoS rules	Not Present		
Mapped EPS bearer contexts	Not Present		
Authorized QoS flow descriptions	Not Present		
Extended protocol configuration options	Not Present		
ATSSS container	Not Present		
IP header compression configuration	Not Present		
Port management information container	Not Present		
Serving PLMN rate control	Not Present		
Ethernet header compression configuration	Not Present		
Received MBS container	Not Present		
Service-level-AA container	Not Present		

Condition	Explanation
-----------	-------------

Always_On_Requested	If the last PDU SESSION MODIFICATION REQUEST message included the Always-on PDU session requested IE
UE_Initiated_Modification	If this message was triggered by a PDU SESSION MODIFICATION REQUEST message sent by the UE

– *PDU session modification complete*

**Table 4.7.2-10: PDU SESSION MODIFICATION COMPLETE**

Derivation Path: 24.501 clause 8.3.10			
Information Element	Value/remark	Comment	Condition
Extended protocol discriminator	'0010 1110'B	5GS session management messages	
PDU session ID	The value indicated in PDU SESSION MODIFICATION COMMAND message		
PTI	'0000 0000'B	No procedure transaction identity assigned	
PTI	The value indicated in PDU SESSION MODIFICATION REQUEST message.		UE_Initiated_Modification
PDU SESSION MODIFICATION COMPLETE message identity	'1100 1100'B		
Extended protocol configuration options	If present: contents not checked		
Port management information container	If present: contents not checked		

Condition	Explanation
UE_Initiated_Modification	If this message was triggered by a PDU SESSION MODIFICATION REQUEST message sent by the UE

– *PDU session modification command reject*

**Table 4.7.2-11: PDU SESSION MODIFICATION COMMAND REJECT**

Derivation Path: 24.501 clause 8.3.11			
Information Element	Value/remark	Comment	Condition
Extended protocol discriminator	'0010 1110'B	5GS session management messages	
PDU session ID	The value indicated in PDU SESSION MODIFICATION COMMAND message		
PTI	'0000 0000'B	No procedure transaction identity assigned	
PDU SESSION MODIFICATION COMMAND REJECT message identity	'1100 1101'B		
5GSM cause	If present: contents not checked		
Extended protocol configuration options	If present: contents not checked		

– *PDU session release request***Table 4.7.2-12: PDU SESSION RELEASE REQUEST**

Derivation Path: 24.501 clause 8.3.12			
Information Element	Value/remark	Comment	Condition
Extended protocol discriminator	'0010 1110'B	5GS session management messages	
PDU session ID	The value indicated in PDU SESSION ESTABLISHMENT REQUEST message		
PTI	Any value from 1 to 254		
PDU SESSION RELEASE REQUEST message identity	'1101 0001'B		
5GSM cause	If present: contents not checked		
Extended protocol configuration options	If present: contents not checked		

– *PDU session release reject***Table 4.7.2-13: PDU SESSION RELEASE REJECT**

Derivation Path: 24.501 clause 8.3.13			
Information Element	Value/remark	Comment	Condition
Extended protocol discriminator	'0010 1110'B	5GS session management messages	
PDU session ID	The value indicated in PDU SESSION RELEASE REQUEST message.		
PTI	The value indicated in PDU SESSION RELEASE REQUEST message.		
PDU SESSION RELEASE REJECT message identity	'1101 0010'B		
5GSM cause	Set according to specific message content.		
Extended protocol configuration options	Not Present		

– *PDU session release command***Table 4.7.2-14: PDU SESSION RELEASE COMMAND**

Derivation Path: 24.501 clause 8.3.14			
Information Element	Value/remark	Comment	Condition
Extended protocol discriminator	'0010 1110'B	5GS session management messages	
PDU session ID	Set according to specific message content.		
PTI	'0000 0000'B	No procedure transaction identity assigned	
PDU SESSION RELEASE COMMAND message identity	'1101 0011'B		
5GSM cause	'0001 1010'B	Insufficient resources	
Back-off timer value	Not Present		
EAP message	Not Present		



5GSM congestion re-attempt indicator	Not Present		
Extended protocol configuration options	Not Present		
Access type	Not Present		
Service-level-AA container	Not Present		

– *PDU session release complete*

**Table 4.7.2-15: PDU SESSION RELEASE COMPLETE**

Derivation Path: 24.501 clause 8.3.15			
Information Element	Value/remark	Comment	Condition
Extended protocol discriminator	'0010 1110'B	5GS session management messages	
PDU session ID	The value indicated in PDU SESSION RELEASE COMMAND message.		
PTI	'0000 0000'B	No procedure transaction identity assigned	
PDU SESSION RELEASE COMPLETE message identity	'1101 0100'B		
5GSM cause	If present: contents not checked		
Extended protocol configuration options	If present: contents not checked		

– *5GSM status*

**Table 4.7.2-16: 5GSM STATUS**

Derivation Path: 24.501 clause 8.3.16			
Information Element	Value/remark	Comment	Condition
Extended protocol discriminator	'0010 1110'B	5GS session management messages	
PDU session ID	Set according to specific message content.		
PTI	Set according to specific message content.		
5GSM STATUS message identity	'1101 0110'B		
5GSM cause	Set according to specific message content.		

– *Service-level authentication command*

**Table 4.7.2-17: SERVICE-LEVEL AUTHENTICATION COMMAND**

Derivation Path: 24.501 clause 8.3.17			
Information Element	Value/remark	Comment	Condition
Extended protocol discriminator	'0010 1110'B	5GS session management messages	
PDU session ID	Set according to specific message content.		
PTI	Set according to specific message content.		
SERVICE-LEVEL AUTHENTICATION COMMAND message identity	'1101 1000'B		
Service-level-AA container	FFS		

– *Service-level authentication complete***Table 4.7.2-18: SERVICE-LEVEL AUTHENTICATION COMPLETE**

Derivation Path: 24.501 clause 8.3.18			
Information Element	Value/remark	Comment	Condition
Extended protocol discriminator	'0010 1110'B	5GS session management messages	
PDU session ID	Set according to specific message content.		
PTI	Set according to specific message content.		
SERVICE-LEVEL AUTHENTICATION COMPLETE message identity	'1101 1001'B		
Service-level-AA container	FFS		

– *Remote UE report***Table 4.7.2-19: REMOTE UE REPORT**

Derivation Path: 24.501 clause 8.3.19			
Information Element	Value/remark	Comment	Condition
Extended protocol discriminator	'0010 1110'B	5GS session management messages	
PDU session ID	Set according to specific message content.		
PTI	Set according to specific message content.		
REMOTE UE REPORT message identity	'1101 1010'B		
Remote UE context connected	FFS		
Remote UE context disconnected	FFS		

– *Remote UE report response***Table 4.7.2-20: REMOTE UE REPORT RESPONSE**

Derivation Path: 24.501 clause 8.3.20			
Information Element	Value/remark	Comment	Condition
Extended protocol discriminator	'0010 1110'B	5GS session management messages	
PDU session ID	Set according to specific message content.		
PTI	Set according to specific message content.		
REMOTE UE REPORT RESPONSE message identity	'1101 1011'B		

### 4.7.3 Contents of EAP-AKA' messages

For all the message definitions below, the acceptable order and syntax of attributes and fields within these attributes must be according to IETF RFCs where those attributes have been defined. Typically the order of attributes is not significant, but there could be well defined exceptions where the order is important.

The contents of the messages described in the present Annex is not complete - only the attributes required to be checked or generated by SS are listed here. The messages sent by the UE may contain additional attributes which are not checked and must thus be ignored by SS.

#### 4.7.3.1 EAP-AKA' message attributes

**Table 4.7.3.1-1: AT\_RAND\_Def**

Derivation Path: IETF RFC 4187 [30] clause 10.6			
Information Element	Value/remark	Comment	Condition
AT_RAND	'0000 0001'B	1	
Length	'0000 0101'B	5	
Reserved	'0000 0000 0000 0000'B		
RAND	An arbitrarily selected 128 bits value		

**Table 4.7.3.1-2: AT\_AUTN\_Def**

Derivation Path: IETF RFC 4187 [30] clause 10.7			
Information Element	Value/remark	Comment	Condition
AT_AUTN	'0000 0010'B	2	
Length	'0000 0101'B	5	
Reserved	'0000 0000 0000 0000'B		
AUTN	128 bits value generated according to TS 24.501 [28] subclause 9.11.3.15		

**Table 4.7.3.1-3: AT\_KDF\_Def**

Derivation Path: IETF RFC 5448 [31] clause 3.3			
Information Element	Value/remark	Comment	Condition
AT_KDF	'0001 1000'B	24	
Length	'0000 0001'B	1	
KDF	'0000 0000 0000 0001'	1: EAP_AKA'	

**Table 4.7.3.1-4: AT\_KDF\_INPUT\_Def**

Derivation Path: IETF RFC 5448 [31] clause 3.2			
Information Element	Value/remark	Comment	Condition
AT_KDF_INPUT	'0001 0111'B	23	
Length	Set to the Length of attribute AT_KDF_INPUT in 4 bytes		
Actual Network Name Length	Set to the actual length of 'Network Name' in bytes excluding any appended all zero bytes at end		
Network Name	Value generated according to TS 24.501 [28] clause 9.12.1 and shall be a multiple of 4 bytes (appended with 1,2 or 3 bytes of all zero bits when necessary)		

**Table 4.7.3.1-5: AT\_MAC\_Def**

Derivation Path: IETF RFC 4187 [30] clause 10.15			
Information Element	Value/remark	Comment	Condition
AT_MAC	'0000 1011'B	11	
Length	'0000 0101'B	5	

Reserved	'0000 0000 0000 0000'B		
MAC	128 bits value generated according to RFC 4187 [30] subclause 10.15		

Table 4.7.3.1-6: AT\_RES\_Def

Derivation Path: IETF RFC 4187 [30] clause 10.08			
Information Element	Value/remark	Comment	Condition
AT_RES	'0000 0011'B	3	
Length	Set to Length of AT_RES attribute in 4 bytes.	1 byte	
RES_LENGTH	Set to the actual length of 'RES' in bytes excluding any appended all zero bytes at end		
RES	RES* value calculated according to TS 24.501 [28] clause 9.11.3.17, possibly appended with 1,2 or 3 bytes of all zero bits to make length multiple of 4 bytes.		

Table 4.7.3.1-7: AT\_AUTS\_Def

Derivation Path: IETF RFC 4187 [30] clause 10.08			
Information Element	Value/remark	Comment	Condition
AT_AUTS	'0000 0100'B	4	
Length	'0000 0100'B	4	
AUTS	14 octets RES* value not checked		

Table 4.7.3.1-8: AT\_PERMANENT\_ID\_Def

Derivation Path: IETF RFC 4187 [30] clause 10.2			
Information Element	Value/remark	Comment	Condition
AT_PERMANENT_ID_REQ	'0000 1010'B	10	
Length	'0000 0001'B	1	
Reserved	'0000 0000 0000 0000'B		

Table 4.7.3.1-9: AT\_ANY\_ID\_REQ\_Def

Derivation Path: IETF RFC 4187 [30] clause 10.3			
Information Element	Value/remark	Comment	Condition
AT_ANY_ID_REQ	'0000 1101'B	13	
Length	'0000 0001'B	1	
Reserved	'0000 0000 0000 0000'B		

Table 4.7.3.1-10: AT\_FULLAUTH\_ID\_Def

Derivation Path: IETF RFC 4187 [30] clause 10.4			
Information Element	Value/remark	Comment	Condition
AT_FULLAUTH_ID_REQ	'0001 0001'B	17	
Length	'0000 0001'B	1	
Reserved	'0000 0000 0000 0000'B		

Table 4.7.3.1-11: AT\_IDENTITY\_Def

Derivation Path: IETF RFC 4187 [30] clause 10.5			
Information Element	Value/remark	Comment	Condition
AT_IDENTITY	'0000 1110'B	14	
Length	Set to the Length of AT_IDENTITY attribute in 4 bytes		
Actual Identity Length	Set to the actual length of 'identity' in bytes excluding any appended all zero bytes at end		
Identity	Value generated according to TS 24.501 [28] clause 9.11.3.4 and shall be a multiple of 4 bytes (appended with 1,2 or 3 bytes of all zero bits when necessary)		

Table 4.7.3.1-12: AT\_NOTIFICATION\_Def

Derivation Path: IETF RFC 4187 [30] clause 10.19			
Information Element	Value/remark	Comment	Condition
AT_NOTIFICATION	'0000 1100'B	12	
Length	'0000 0001'B	1	
Notification Code	16 bits value generated according to RFC 4187 [30] subclause 10.19.		

#### 4.7.3.2 EAP-AKA' messages

Table 4.7.3.2-1: EAP-Request/AKA'-Challenge

Derivation Path: IETF RFC 4187 [30] clause 9.3, RFC 3748 [32] clause 4			
Information Element	Value/remark	Comment	Condition
Code	1	Request	
Length	Set to length of EAP packet		
Data			
AT_RANDOM	AT_RANDOM_Def		
AT_AUTN	AT_AUTN_Def		
AT_KDF	AT_KDF_Def		
AT_KDF_INPUT	AT_KDF_INPUT_Def		
AT_MAC	AT_MAC_Def		

Table 4.7.3.2-2: EAP-Response/AKA'-Challenge

Derivation Path: IETF RFC 4187 [30] clause 9.4, RFC 3748 [32] clause 4			
Information Element	Value/remark	Comment	Condition
Code	2	Response	
Length	Set to length of EAP packet		
Data			
AT_Res	AT_Res_Def		
AT_MAC	AT_MAC_Def		

Table 4.7.3.2-3: EAP-Success

Derivation Path: IETF RFC 4187 [30] clause 6.3.4, RFC 3748 [32] clause 4			
Information Element	Value/remark	Comment	Condition

Code	3	Success	
Length	Set to length of EAP packet		
Data	Not present	Specific attributes not present	

**Table 4.7.3.2-4: EAP-Response/AKA-Authentication-Reject**

Derivation Path: IETF RFC 4187 [30] clause 9.5, RFC 3748 [32] clause 4			
Information Element	Value/remark	Comment	Condition
Code	4	Failure	
Length	Set to length of EAP packet		
Data	Not checked		

**Table 4.7.3.2-5: EAP-Response/AKA-Synchronization-Failure**

Derivation Path: IETF RFC 4187 [30] clause 9.6, RFC 3748 [32] clause 4			
Information Element	Value/remark	Comment	Condition
Code	4	Failure	
Length	Set to length of EAP packet		
Data			
AT_AUTS	AT_AUTS_Def		

**Table 4.7.3.2-6: EAP-Failure**

Derivation Path: IETF RFC 4187 [30] clause 6.3.3, RFC 3748 [32] clause 4			
Information Element	Value/remark	Comment	Condition
Code	4	Failure	
Length	Set to length of EAP packet		
Data	Not present	Specific attributes not present	

**Table 4.7.3.2-7: EAP-Request/AKA-Identity**

Derivation Path: IETF RFC 4187 [30] clause 9.1, RFC 3748 [32] clause 4			
Information Element	Value/remark	Comment	Condition
Code	1	Request	
Length	Set to length of EAP packet		
Data			
AT_PERMANENT_ID_REQ	AT_PERMANENT_ID_REQ_Def		SS requests that the UE send its permanent identity.
AT_ANY_ID_REQ	AT_ANY_ID_REQ_Def		SS does not specify which kind of an identity the UE should return.
AT_FULLAUTH_ID_REQ	AT_FULLAUTH_ID_REQ_Def		SS requests either the permanent identity or a pseudonym identity.

**Table 4.7.3.2-8: EAP-Response/AKA-Identity**

Derivation Path: IETF RFC 4187 [30] clause 9.2, RFC 3748 [32] clause 4			
Information Element	Value/remark	Comment	Condition
Code	2	Response	
Length	Set to length of EAP packet		
Data			
AT_IDENTITY	AT_IDENTITY_Def		

**Table 4.7.3.2-9: EAP-Request/AKA-Notification**

Derivation Path: IETF RFC 4187 [30] clause 9.10, RFC 3748 [32] clause 4			
Information Element	Value/remark	Comment	Condition
Code	1	Request	
Length	Set to length of EAP packet		
Data			
AT_NOTIFICATION	AT_NOTIFICATION_Def		

**Table 4.7.3.2-10: EAP-Response/AKA-Notification**

Derivation Path: IETF RFC 4187 [30] clause 9.11, RFC 3748 [32] clause 4			
Information Element	Value/remark	Comment	Condition
Code	2	Response	
Length	Set to length of EAP packet		
Data	Not present	Specific attributes not present	

## 4.7.4 Contents of V2X messages

**Table 4.7.4-1 to -6: Void**

– *DIRECT LINK ESTABLISHMENT REQUEST*

**Table 4.7.4-7: DIRECT LINK ESTABLISHMENT REQUEST**

Derivation Path: TS 24.587 [54] Table 7.3.1.1.1			
Information Element	Value/remark	Comment	Condition
DIRECT LINK ESTABLISHMENT REQUEST message identity	'0000 0001'B		
Sequence number	Not Checked	0~255, uniquely identify a PC5 signalling message being sent or received	Tx
	Incremented by TTCN by 1 for each outgoing new PC5 Signalling message.	0~255, uniquely identify a PC5 signalling message being sent or received	Rx
V2X service identifiers			
Length of V2X service identifier contents	'04'H		
V2X service identifier 1	'00 00 00 01'H		
Source user info			
Length of Application layer ID contents	'04'H		
Application Layer ID 1	'00 00 01 00'H	Application Layer ID in initiating UE side	

UE security capabilities			
Length of UE security capabilities contents	'02'H		
5G-EA algorithms	'1000 0000'B	5G-EA0 supported	
5G-IA algorithms	'1000 0000'B	5G-IA0 supported	
UE PC5 unicast signalling security policy	'0000 0000'B	Signalling integrity protection not needed, Signalling ciphering not needed.	
Key establishment information container	Not Present		
Nonce_1	Not Present		
MSBs of K <sub>NRP-<i>sess</i></sub> ID	Not Present		
Target user info	Not Checked		Tx
Target user info			Rx
Application layer ID IEI	'28'H		
Length of Application layer ID contents	'04'H		
Application layer ID contents	'00 00 11 00'H		
K <sub>NRP</sub> ID	Not Present		

Condition	Explanation
Tx	UE transmits and NR-SS-UE receives
Rx	UE receives and NR-SS-UE transmits

– *DIRECT LINK ESTABLISHMENT ACCEPT*

**Table 4.7.4-8: DIRECT LINK ESTABLISHMENT ACCEPT**

Derivation Path: TS 24.587 [54] Table 7.3.1.1.1			
Information Element	Value/remark	Comment	Condition
DIRECT LINK ESTABLISHMENT ACCEPT message identity	'0000 0010'B		
Sequence number	Not Checked	0~255, uniquely identify a PC5 signalling message being sent or received	Tx
	Incremented by TTCN by 1 for each outgoing new PC5 Signalling message.	0~255, uniquely identify a PC5 signalling message being sent or received	Rx
Source user info			
Length of Application layer ID contents	'04'H		
Application Layer ID 1	'00 00 02 00'H	Application Layer ID in target UE side	
QoS flow descriptions			
Length of PC5 QoS flow descriptions contents	Set to the actual length of 'PC5 QoS flow descriptions contents' in bytes		
PC5 QoS flow description 1			
PQFI	'00 0001'B		
Operation Code	'001'B	Create new PC5 QoS flow description	
Number of parameters	5		
E	1	parameters list is included	
Associated V2X service identifiers			
Length of V2X service identifier contents	'04'H		
V2X service identifier 1	'00 00 00 01'H		



Parameters list			
Parameter 1			
Parameter identifier	'01'H	PQI	
Length of parameter contents	1		
Parameter contents	22	Sensor sharing, See Table 5.4.4-1 in TS 23.287[xx]	
Parameter 2			
Parameter identifier	'02'H	GFBR	
Length of parameter contents	3		
Parameter contents	'0000 0110 0000 0000 0000 1010'B	10 * 1Mbps = 10Mbps.	
Parameter 3			
Parameter identifier	'03'H	MFBR	
Length of parameter contents	3		
Parameter contents	'0000 0110 0000 0000 0001 0100'B	20 * 1Mbps = 20Mbps.	
Parameter 4			
Parameter identifier	'04'H	Averaging window	
Length of parameter contents	2		
Parameter contents	'0000 0111 1101 0000'B	2000ms	
Parameter 5			
Parameter identifier	'06'H	Default priority level	
Length of parameter contents	1		
Parameter contents	4		
Configuration of UE PC5 unicast user plane security protection	'0000 0000'B	User plane integrity protection and ciphering is off	
IP address configuration	Not Checked		Tx
IP address configuration			Rx
IP address configuration IEI	'57'H		
IP address configuration content	'0000 0001'B	IPv6 Router	
Link local IPv6 address	Not Present		

Condition	Explanation
Tx	UE transmits and NR-SS-UE receives
Rx	UE receives and NR-SS-UE transmits

## DIRECT LINK MODIFICATION REQUEST

**Table 4.7.4-9: DIRECT LINK MODIFICATION REQUEST**

Derivation Path: TS 24.587 [54] Table 7.3.4.1.1			
Information Element	Value/remark	Comment	Condition
DIRECT LINK MODIFICATION REQUEST message identity	'0000 0100'B		
Sequence number	Not Checked	0~255, uniquely identify a PC5 signalling message being sent or received	Tx
	Incremented by TTCN by 1 for each outgoing new PC5 Signalling message.	0~255, uniquely identify a PC5 signalling message being sent or received	Rx
Link modification operation code	'0000 0011'B	Add new PC5 QoS flow(s) to the existing PC5 unicast link	
QoS flow descriptions			

Length of PC5 QoS flow descriptions contents	Set to the actual length of 'PC5 QoS flow descriptions contents' in bytes		
PC5 QoS flow description 1			
PQFI	'00 0010'B		
Operation Code	'001'B	Create new PC5 QoS flow description	
Number of parameters	5		
E	1	parameters list is included	
Associated V2X service identifiers			
Length of V2X service identifier contents	'04'H		
V2X service identifier 1	'00 00 00 02'H		
Parameters list			
Parameter 1			
Parameter identifier	'01'H	PQI	
Length of parameter contents	1		
Parameter contents	23	Platooning between UEs, See Table 5.4.4-1 in TS 23.287[xx]	
Parameter 2			
Parameter identifier	'02'H	GFBR	
Length of parameter contents	3		
Parameter contents	'0000 0111 0000 0000 0000 1010'B	10 * 4Mbps = 40Mbps.	
Parameter 3			
Parameter identifier	'03'H	MFBR	
Length of parameter contents	3		
Parameter contents	'0000 0111 0000 0000 0001 0100'B	20 * 4Mbps = 80Mbps.	
Parameter 4			
Parameter identifier	'04'H	Averaging window	
Length of parameter contents	2		
Parameter contents	'0000 0111 1101 0000'B	2000ms	
Parameter 5			
Parameter identifier	'06'H	Default priority level	
Length of parameter contents	1		
Parameter contents	3		

Condition	Explanation
Tx	UE transmits and NR-SS-UE receives
Rx	UE receives and NR-SS-UE transmits

– *DIRECT LINK MODIFICATION ACCEPT*

**Table 4.7.4-10: DIRECT LINK MODIFICATION ACCEPT**

Derivation Path: TS 24.587 [54] Table 7.3.5.1.1			
Information Element	Value/remark	Comment	Condition
DIRECT LINK MODIFICATION ACCEPT message identity	'0000 0101'B		
Sequence number	Not Checked	0~255, uniquely identify a PC5 signalling message being sent or received	Tx
	Incremented by TTCN by 1 for each outgoing new PC5 Signalling message.	0~255, uniquely identify a PC5 signalling	Rx

		message being sent or received	
QoS flow descriptions			
PC5 QoS flow descriptions IEI	'79'H		
Length of PC5 QoS flow descriptions contents	Set to the actual length of 'PC5 QoS flow descriptions contents' in bytes		
PC5 QoS flow description 1			
PQFI	'00 0010'B		
Operation Code	'001'B	Create new PC5 QoS flow description	
Number of parameters	5		
E	1	parameters list is included	
Associated V2X service identifiers			
Length of V2X service identifier contents	'04'H		
V2X service identifier 1	'00 00 00 02'H		
Parameters list			
Parameter 1			
Parameter identifier	'01'H	PQI	
Length of parameter contents	1		
Parameter contents	23	Platooning between UEs, See Table 5.4.4-1 in TS 23.287[xx]	
Parameter 2			
Parameter identifier	'02'H	GFBR	
Length of parameter contents	3		
Parameter contents	'0000 0111 0000 0000 0000 1010'B	10 * 4Mbps = 40Mbps.	
Parameter 3			
Parameter identifier	'03'H	MFBR	
Length of parameter contents	3		
Parameter contents	'0000 0111 0000 0000 0001 0100'B	20 * 4Mbps = 80Mbps.	
Parameter 4			
Parameter identifier	'04'H	Averaging window	
Length of parameter contents	2		
Parameter contents	'0000 0111 1101 0000'B	2000ms	
Parameter 5			
Parameter identifier	'06'H	Default priority level	
Length of parameter contents	1		
Parameter contents	3		

Condition	Explanation
Tx	UE transmits and NR-SS-UE receives
Rx	UE receives and NR-SS-UE transmits

*DIRECT LINK RELEASE REQUEST*

**Table 4.7.4-11: DIRECT LINK RELEASE REQUEST**

Derivation Path: TS 24.587 [54] Table 7.3.6.1.1			
Information Element	Value/remark	Comment	Condition
DIRECT LINK RELEASE REQUEST message identity	'0000 0111'B		
Sequence number	Not Checked	0~255, uniquely identify a PC5 signalling	Tx

		message being sent or received	
	Incremented by TTCN by 1 for each outgoing new PC5 Signalling message.	0~255, uniquely identify a PC5 signalling message being sent or received	Rx
PC5 signalling protocol cause	'0110 1111'B	Protocol error, unspecified	Rx
	Not Checked		Tx
MSB of KNRP ID	Not Checked		Tx
	'00 00'H		Rx

Condition	Explanation
Tx	UE transmits and NR-SS-UE receives
Rx	UE receives and NR-SS-UE transmits

– *DIRECT LINK RELEASE ACCEPT*

**Table 4.7.4-12: DIRECT LINK RELEASE ACCEPT**

Derivation Path: TS 24.587 [54] Table 7.3.7.1.1			
Information Element	Value/remark	Comment	Condition
DIRECT LINK RELEASE ACCEPT message identity	'0000 1000'B		
Sequence number	Not Checked	0~255, uniquely identify a PC5 signalling message being sent or received	Tx
	Incremented by TTCN by 1 for each outgoing new PC5 Signalling message.	0~255, uniquely identify a PC5 signalling message being sent or received	Rx
LSB of KNRP ID	Not Checked		Tx
	'00 00'H		Rx

Condition	Explanation
Tx	UE transmits and NR-SS-UE receives
Rx	UE receives and NR-SS-UE transmits

– *DIRECT LINK KEEPALIVE REQUEST*

**Table 4.7.4-13: DIRECT LINK KEEPALIVE REQUEST**

Derivation Path: TS 24.587 [54] Table 7.3.8.1.1			
Information Element	Value/remark	Comment	Condition
DIRECT LINK KEEPALIVE REQUEST message identity	'0000 1001'B		
Sequence number	Not Checked	0~255, uniquely identify a PC5 signalling message being sent or received	Tx
	Incremented by TTCN by 1 for each outgoing new PC5 Signalling message.	0~255, uniquely identify a PC5 signalling message being sent or received	Rx

Keep-alive counter	'00 00 00 00'H	Increase by 1 after each keep-alive procedure.	
Maximum inactivity period	Not Checked		Tx
Maximum inactivity period			Rx
Maximum inactivity period IEI	'55'H		
Maximum inactivity period contents	'00 00 00 06'H	6 seconds, higher value than T5003=5s	

Condition	Explanation
Tx	UE transmits and NR-SS-UE receives
Rx	UE receives and NR-SS-UE transmits

## DIRECT LINK KEEPALIVE RESPONSE

Table 4.7.4-14: DIRECT LINK KEEPALIVE RESPONSE

Derivation Path: TS 24.587 [54] Table 7.3.9.1.1			
Information Element	Value/remark	Comment	Condition
DIRECT LINK KEEPALIVE RESPONSE message identity	'0000 1010'B		
Sequence number	Not Checked	0~255, uniquely identify a PC5 signalling message being sent or received	Tx
	Incremented by TTCN by 1 for each outgoing new PC5 Signalling message.	0~255, uniquely identify a PC5 signalling message being sent or received	Rx
Keep-alive counter	'00 00 00 01'H		

Condition	Explanation
Tx	UE transmits and NR-SS-UE receives
Rx	UE receives and NR-SS-UE transmits

## DIRECT LINK AUTHENTICATION REQUEST

Table 4.7.4-15: DIRECT LINK AUTHENTICATION REQUEST

Derivation Path: TS 24.587 [54] Table 7.3.10.1.1			
Information Element	Value/remark	Comment	Condition
DIRECT LINK AUTHENTICATION REQUEST message identity	'0000 1011'B		
Sequence number	Not Checked	0~255, uniquely identify a PC5 signalling message being sent or received	Tx
	Incremented by TTCN by 1 for each outgoing new PC5 Signalling message.	0~255, uniquely identify a PC5 signalling message being sent or received	Rx
Key establishment information container			
Length of key establishment information container contents	Not checked		Tx
	'00'H		Rx
Key establishment information container contents	Not checked		Tx

	Not Present		Rx
--	-------------	--	----

Condition	Explanation
Tx	UE transmits and NR-SS-UE receives
Rx	UE receives and NR-SS-UE transmits

– *DIRECT LINK AUTHENTICATION RESPONSE*

**Table 4.7.4-16: DIRECT LINK AUTHENTICATION RESPONSE**

Derivation Path: TS 24.587 [54] Table 7.3.11.1.1			
Information Element	Value/remark	Comment	Condition
DIRECT LINK AUTHENTICATION RESPONSE message identity	'0000 1100'B		
Sequence number	Not Checked	0~255, uniquely identify a PC5 signalling message being sent or received	Tx
	Incremented by TTCN by 1 for each outgoing new PC5 Signalling message.	0~255, uniquely identify a PC5 signalling message being sent or received	Rx
Key establishment information container			
Length of key establishment information container contents	Not checked		Tx
	'00'H		Rx
Key establishment information container contents	Not checked		Tx
	Not Present		Rx

Condition	Explanation
Tx	UE transmits and NR-SS-UE receives
Rx	UE receives and NR-SS-UE transmits

– *DIRECT LINK AUTHENTICATION REJECT*

**Table 4.7.4-17: DIRECT LINK AUTHENTICATION REJECT**

Derivation Path: TS 24.587 [54] Table 7.3.12.1.1			
Information Element	Value/remark	Comment	Condition
DIRECT LINK AUTHENTICATION REJECT message identity	'0000 1101'B		
Sequence number	Not Checked	0~255, uniquely identify a PC5 signalling message being sent or received	Tx
	Incremented by TTCN by 1 for each outgoing new PC5 Signalling message.	0~255, uniquely identify a PC5 signalling message being sent or received	Rx
PC5 signalling protocol cause value	'0110 1111'B	Protocol error, unspecified	

Condition	Explanation
Tx	UE transmits and NR-SS-UE receives
Rx	UE receives and NR-SS-UE transmits

– *DIRECT LINK SECURITY MODE COMMAND*

**Table 4.7.4-18: DIRECT LINK SECURITY MODE COMMAND**

Derivation Path: TS 24.587 [54] Table 7.3.13.1.1			
Information Element	Value/remark	Comment	Condition
DIRECT LINK SECURITY MODE COMMAND message identity	'0000 1110'B		
Sequence number	Not Checked	0~255, uniquely identify a PC5 signalling message being sent or received	Tx
	Incremented by TTCN by 1 for each outgoing new PC5 Signalling message.	0~255, uniquely identify a PC5 signalling message being sent or received	Rx
Selected security algorithms	'0000 0000'B		
UE security capabilities			
Length of UE security capabilities contents	'02'H		
5G-EA algorithms	'1000 0000'B	5G-EA0 supported	
5G-IA algorithms	'1000 0000'B	5G-IA0 supported	
UE PC5 unicast signalling security policy			
UE PC5 unicast signalling security policy IE1	'59'H		
Signalling integrity protection policy	'000'B	Signalling integrity protection not needed	
Signalling ciphering policy	'000'B	Signalling ciphering not needed.	
Nonce_2	Not Checked		Tx
	Not Present		Rx
LSBs of K <sub>NR-P-sess</sub> ID	Not Checked		Tx
	Not Present		Rx
Key establishment information container	Not Checked		Tx
	Not Present		Rx
MSBs of K <sub>NR-P</sub> ID	Not Checked		Tx
	Not Present		Rx

Condition	Explanation
Tx	UE transmits and NR-SS-UE receives
Rx	UE receives and NR-SS-UE transmits

– *DIRECT LINK SECURITY MODE COMPLETE*

**Table 4.7.4-19: DIRECT LINK SECURITY MODE COMPLETE**

Derivation Path: TS 24.587 [54] Table 7.3.14.1.1			
Information Element	Value/remark	Comment	Condition
DIRECT LINK SECURITY MODE COMPLETE message identity	'0000 1111'B		
Sequence number	Not Checked	0~255, uniquely identify a PC5 signalling message being sent or received	Tx
	Incremented by TTCN by 1 for each outgoing new PC5 Signalling message.	0~255, uniquely identify a PC5 signalling message being sent or received	Rx

QoS flow descriptions			
Length of PC5 QoS flow descriptions contents	Set to the actual length of 'PC5 QoS flow descriptions contents' in bytes		
PC5 QoS flow description 1			
PQFI	'00 0001'B		
Operation Code	'001'B	Create new PC5 QoS flow description	
Number of parameters	5		
E	1	parameters list is included	
Associated V2X service identifiers			
Length of V2X service identifier contents	'04'H		
V2X service identifier 1	'00 00 00 01'H		
Parameters list			
Parameter 1			
Parameter identifier	'01'H	PQI	
Length of parameter contents	1		
Parameter contents	22	Sensor sharing, See Table 5.4.4-1 in TS 23.287[xx]	
Parameter 2			
Parameter identifier	'02'H	GFBR	
Length of parameter contents	3		
Parameter contents	'0000 0110 0000 0000 0000 1010'B	10 * 1Mbps = 10Mbps.	
Parameter 3			
Parameter identifier	'03'H	MFBR	
Length of parameter contents	3		
Parameter contents	'0000 0110 0000 0000 0001 0100'B	20 * 1Mbps = 20Mbps.	
Parameter 4			
Parameter identifier	'04'H	Averaging window	
Length of parameter contents	2		
Parameter contents	'0000 0111 1101 0000'B	2000ms	
Parameter 5			
Parameter identifier	'06'H	Default priority level	
Length of parameter contents	1		
Parameter contents	4		
UE PC5 unicast user plane security policy	'0000 0000'B	Signalling integrity protection not needed, Signalling ciphering not needed.	
IP address configuration	Not Checked		Tx
IP address configuration			Rx
IP address configuration IEI	'57'H		
IP address configuration content	'0000 0001'B	IPv6 Router	
Link local IPv6 address	Not Present		Rx
	Not Checked		Tx
LSBs of KNRP ID	Not Checked		Tx
	Not present		Rx

Condition	Explanation
Tx	UE transmits and NR-SS-UE receives
Rx	UE receives and NR-SS-UE transmits



– *DIRECT LINK SECURITY MODE REJECT*

**Table 4.7.4-20: DIRECT LINK SECURITY MODE REJECT**

Derivation Path: TS 24.587 [54] Table 7.3.15.1.1			
Information Element	Value/remark	Comment	Condition
DIRECT LINK SECURITY MODE REJECT message identity	'0001 0000'B		
Sequence number	Not Checked	0~255, uniquely identify a PC5 signalling message being sent or received	Tx
	Incremented by TTCN by 1 for each outgoing new PC5 Signalling message.	0~255, uniquely identify a PC5 signalling message being sent or received	Rx
PC5 signalling protocol cause	'0110 1111'B	Protocol error, unspecified	

Condition	Explanation
Tx	UE transmits and NR-SS-UE receives
Rx	UE receives and NR-SS-UE transmits

– *DIRECT LINK REKEYING REQUEST*

**Table 4.7.4-21: DIRECT LINK REKEYING REQUEST**

Derivation Path: TS 24.587 [54] Table 7.3.16.1.1			
Information Element	Value/remark	Comment	Condition
DIRECT LINK REKEYING REQUEST message identity	'0001 0001'B		
Sequence number	Not Checked	0~255, uniquely identify a PC5 signalling message being sent or received	Tx
	Incremented by TTCN by 1 for each outgoing new PC5 Signalling message.	0~255, uniquely identify a PC5 signalling message being sent or received	Rx
UE security capabilities			
Length of UE security capabilities contents	'02'H		
5G-EA algorithms	'1000 0000'B	5G-EA0 supported	
5G-IA algorithms	'1000 0000'B	5G-IA0 supported	
Key establishment information container	Not Checked		
Nonce_1	Not Checked		
MSBs of K <sub>NRP-<small>sess</small></sub> ID	Not Checked		
Re-authentication indication			
Re-authentication indication IEI	'56'H		
Re-authentication indication contents	'0000 0000'B	K <sub>NRP</sub> is not requested to be refreshed	

Condition	Explanation
Tx	UE transmits and NR-SS-UE receives
Rx	UE receives and NR-SS-UE transmits

– *DIRECT LINK REKEYING RESPONSE*

**Table 4.7.4-22: DIRECT LINK REKEYING RESPONSE**

Derivation Path: TS 24.587 [54] Table 7.3.17.1.1			
Information Element	Value/remark	Comment	Condition
DIRECT LINK REKEYING RESPONSE message identity	'0001 0010'B		
Sequence number	Not Checked	0~255, uniquely identify a PC5 signalling message being sent or received	Tx
	Incremented by TTCN by 1 for each outgoing new PC5 Signalling message.	0~255, uniquely identify a PC5 signalling message being sent or received	Rx

Condition	Explanation
Tx	UE transmits and NR-SS-UE receives
Rx	UE receives and NR-SS-UE transmits

– *DIRECT LINK IDENTIFIER UPDATE REQUEST*

**Table 4.7.4-23: DIRECT LINK IDENTIFIER UPDATE REQUEST**

Derivation Path: TS 24.587 [54] Table 7.3.18.1.1			
Information Element	Value/remark	Comment	Condition
DIRECT LINK IDENTIFIER UPDATE REQUEST message identity	'0001 0011'B		
Sequence number	Not Checked	0~255, uniquely identify a PC5 signalling message being sent or received	Tx
	Incremented by TTCN by 1 for each outgoing new PC5 Signalling message.	0~255, uniquely identify a PC5 signalling message being sent or received	Rx
MSB of K <sub>NRP-sess</sub> ID	Not checked		Tx
	'00'H		Rx
Source layer-2 ID	Not checked		Tx
	'00 00 10'H	New Layer-2 ID in initiating UE side	Rx
Source user info	Not checked		Tx
Source layer-2 ID	Not checked		Tx
Application layer ID IEI	'57'H		
Length of Application layer ID contents	'04'H		
Application Layer ID 1	'00 00 03 00'H	New application Layer ID in initiating UE side	
Source link local IPv6 address	Not present		

Condition	Explanation
Tx	UE transmits and NR-SS-UE receives
Rx	UE receives and NR-SS-UE transmits

## – DIRECT LINK IDENTIFIER UPDATE ACCEPT

Table 4.7.4-24: DIRECT LINK IDENTIFIER UPDATE ACCEPT

Derivation Path: TS 24.587 [54] Table 7.3.19.1.1			
Information Element	Value/remark	Comment	Condition
DIRECT LINK IDENTIFIER UPDATE ACCEPT message identity	'0001 0100'B		
Sequence number	Not Checked	0~255, uniquely identify a PC5 signalling message being sent or received	Tx
	Incremented by TTCN by 1 for each outgoing new PC5 Signalling message.	0~255, uniquely identify a PC5 signalling message being sent or received	Rx
LSB of K <sub>NRP-sess</sub> ID	Not checked		Tx
	'00'H		Rx
MSB of K <sub>NRP-sess</sub> ID	Not checked		Tx
	'00'H		Rx
Source layer-2 ID	Not checked		Tx
	'00 00 20'H		Rx
Target layer-2 ID	'00 00 10'H		Tx
	Same as the source layer-2 ID in DIRECT LINK IDENTIFIER UPDATE REQUEST message with Tx condition		Rx
Target user info			Tx
Application layer ID IEI	'28'H		
Length of Application layer ID contents	'04'H		
Application Layer ID 1	'00 00 03 00'H	New application Layer ID in initiating UE side	
Target user info	Not Present		Rx AND (NOT Update_user_info)
Target user info			Rx AND Update_user_info
Application layer ID IEI	'28'H		
Length of Application layer ID contents	'04'H		
Application Layer ID 1	Same as the source user info in DIRECT LINK IDENTIFIER UPDATE REQUEST message with Tx condition	New application Layer ID in initiating UE side	
Target link local IPv6 address	Not Present		
Source user info	Not checked		Tx
Source user info			Rx
Application layer ID IEI	'57'H		
Length of Application layer ID contents	'04'H		
Application Layer ID 1	'00 00 04 00'H	New application Layer ID in target UE side	
Source link local IPv6 address	Not Present		

Condition	Explanation
Tx	UE transmits and NR-SS-UE receives
Rx	UE receives and NR-SS-UE transmits

Update_user_info	NR-SS-UE receives the source user info in the DIRECT LINK IDENTIFIER UPDATE REQUEST.
------------------	--

– **DIRECT LINK IDENTIFIER UPDATE ACK**

**Table 4.7.4-25: DIRECT LINK IDENTIFIER UPDATE ACK**

Derivation Path: TS 24.587 [54] Table 7.3.20.1.1			
Information Element	Value/remark	Comment	Condition
DIRECT LINK IDENTIFIER UPDATE ACK message identity	'0001 0101'B		
Sequence number	Not Checked	0~255, uniquely identify a PC5 signalling message being sent or received	Tx
	Incremented by TTCN by 1 for each outgoing new PC5 Signalling message.	0~255, uniquely identify a PC5 signalling message being sent or received	Rx
LSB of K <sub>NRP-<i>sess</i></sub> ID	Not checked		Tx
	'00'H		Rx
Target layer-2 ID	'00 00 20'H		Tx
	Same as the source layer-2 ID in DIRECT LINK IDENTIFIER UPDATE ACCEPT message with Tx condition		Rx
Target user info			Tx
Application layer ID IEI	'28'H		
Length of Application layer ID contents	'04'H		
Application Layer ID 1	'00 00 04 00'H	New application Layer ID in target UE side	
Target user info	Not Present		Rx AND (NOT Update_user_info)
Target user info			Rx AND Update_user_info
Application layer ID IEI	'28'H		
Length of Application layer ID contents	'04'H		
Application Layer ID 1	Same as the source user info in DIRECT LINK IDENTIFIER UPDATE ACCEPT message with Tx condition	New application Layer ID in target UE side	
Target link local IPv6 address	Not Present		

Condition	Explanation
Tx	UE transmits and NR-SS-UE receives
Rx	UE receives and NR-SS-UE transmits
Update_user_info	NR-SS-UE receives the source user info in the DIRECT LINK IDENTIFIER UPDATE ACCEPT

– *DIRECT LINK IDENTIFIER UPDATE REJECT*

**Table 4.7.4-26: DIRECT LINK IDENTIFIER UPDATE REJECT**

Derivation Path: TS 24.587 [54] Table 7.3.21.1.1			
Information Element	Value/remark	Comment	Condition
DIRECT LINK IDENTIFIER UPDATE REJECT message identity	'0001 0110'B		
Sequence number	Not Checked	0~255, uniquely identify a PC5 signalling message being sent or received	Tx
	Incremented by TTCN by 1 for each outgoing new PC5 Signalling message.	0~255, uniquely identify a PC5 signalling message being sent or received	Rx
PC5 signalling protocol cause	'0110 1111'B	Protocol error, unspecified	

Condition	Explanation
Tx	UE transmits and NR-SS-UE receives
Rx	UE receives and NR-SS-UE transmits

– *DIRECT LINK MODIFICATION REJECT*

**Table 4.7.4-27: DIRECT LINK MODIFICATION REJECT**

Derivation Path: TS 24.587 [54] Table 7.3.22.1.1			
Information Element	Value/remark	Comment	Condition
DIRECT LINK MODIFICATION REJECT message identity	'0000 0110'B		
Sequence number	Not Checked	0~255, uniquely identify a PC5 signalling message being sent or received	Tx
	Incremented by TTCN by 1 for each outgoing new PC5 Signalling message.	0~255, uniquely identify a PC5 signalling message being sent or received	Rx
PC5 signalling protocol cause	'0110 1111'B	Protocol error, unspecified	

Condition	Explanation
Tx	UE transmits and NR-SS-UE receives
Rx	UE receives and NR-SS-UE transmits

– *DIRECT LINK ESTABLISHMENT REJECT*

**Table 4.7.4-28: DIRECT LINK ESTABLISHMENT REJECT**

Derivation Path: TS 24.587 [54] Table 7.3.23.1.1			
Information Element	Value/remark	Comment	Condition
DIRECT LINK ESTABLISHMENT REJECT message identity	'0000 0011'B		
Sequence number	Not Checked	0~255, uniquely identify a PC5 signalling	Tx

		message being sent or received	
	Incremented by TTCN by 1 for each outgoing new PC5 Signalling message.	0~255, uniquely identify a PC5 signalling message being sent or received	Rx
PC5 signalling protocol cause	'0110 1111'B	Protocol error, unspecified	

Condition	Explanation
Tx	UE transmits and NR-SS-UE receives
Rx	UE receives and NR-SS-UE transmits

### 4.7.5 V2X information elements

4.7.5.1 Void

4.7.5.2 Void

4.7.5.3 Void

4.7.5.4 V2X information elements for UE policy part

– *UE policy part when UE policy part type = {V2XP}*

**Table 4.7.5.4-1: UE policy part when UE policy part type = {V2XP}**

Derivation Path: TS 24.588 Figure 5.2.1.1			
Information Element	Value/remark	Comment	Condition
UE policy part contents length	Set to the actual length of 'UE policy part contents' in bytes		
UE policy part type	'0001'B	UE policy part type={ V2XP }	
Spare	'0000'B		
UE policy part contents={V2XP contents}	See Table 4.7.5.4-2		

– *V2XP contents*

**Table 4.7.5.4-2: V2XP contents**

Derivation Path: TS 24.588 Figure 5.2.1.2			
Information Element	Value/remark	Comment	Condition
V2XP info #1	See Table 4.7.5.4-3		
V2XP info #2	FFS		

– *V2XP info*

**Table 4.7.5.4-3: V2XP info**

Derivation Path: TS 24.588 Figure 5.3.1.1			
Information Element	Value/remark	Comment	Condition

V2XP info type	'0001'B	UE policies for V2X communication over PC5	
Spare	'0000'B		
Length of V2XP info contents	Set to the actual length of 'V2XP info contents' in bytes		
V2XP info contents	See Table 4.7.5.5-1		

#### 4.7.5.5 V2X information elements of UE policies for V2X communication over PC5

– *V2XP info = {UE policies for V2X communication over PC5}*

**Table 4.7.5.5-1: V2XP info = {UE policies for V2X communication over PC5}**

Derivation Path: TS 24.588 Figure 5.3.1.1			
Information Element	Value/remark	Comment	Condition
V2XP info type	'0001'B	UE policies for V2X communication over PC5	
Length of V2XP info contents	Set to the actual length of 'V2XP info contents' in bytes		
Validity timer	'FF FF FF FF FF FF FF FF FF FF'H	5 bytes, Expiration UTC time of validity of the UE policies, in seconds since midnight UTC of January 1, 1970 (not counting leap seconds)	
VSITPMRI	'1'B	'V2X service identifier to PC5 RAT and Tx profiles mapping rules' is present	
Served by E-UTRA or served by NR	See Table 4.7.5.5-2		
Not served by E-UTRA and not served by NR	See Table 4.7.5.5-6		
V2X service identifier to PC5 RAT and Tx profiles mapping rules	See Table 4.7.5.5-12		
Privacy config	See Table 4.7.5.5-15		
V2X communication over PC5 in E-UTRA-PC5	See Table 4.7.5.5-19		
V2X communication over PC5 in NR-PC5	See Table 4.7.5.5-31		

– *Served by E-UTRA or served by NR*

**Table 4.7.5.5-2: Served by E-UTRA or served by NR**

Derivation Path: TS 24.588 Figure 5.3.1.2			
Information Element	Value/remark	Comment	Condition
Length of served by E-UTRA or served by NR contents	Set to the actual length of 'served by E-UTRA or served by NR contents' in bytes		
Authorized PLMN and RATs combinations	See Table 4.7.5.5-3		

– *Authorized PLMN and RATs combinations***Table 4.7.5.5-3: Authorized PLMN and RATs combinations**

Derivation Path: TS 24.588 Figure 5.3.1.3			
Information Element	Value/remark	Comment	Condition
Length of authorized PLMN and RATs combinations contents	Set to the actual length of 'authorized PLMN and RATs combinations contents' in bytes		
Authorized PLMN and RATs combination 1	See Table 4.7.5.5-4		
Authorized PLMN and RATs combination 2	FFS		

– *Authorized PLMN and RATs combination***Table 4.7.5.5-4: Authorized PLMN and RATs combination**

Derivation Path: TS 24.588 Figure 5.3.1.4			
Information Element	Value/remark	Comment	Condition
PLMN ID	Set according to parameter given in test case		
NPIEN	'1'B	UE is authorized to use V2X communication over NR-PC5 when served by E-UTRA or served by NR	
EPIEN	'1'B	UE is authorized to use V2X communication over E-UTRA-PC5 when served by E-UTRA or served by NR	

– *PLMN ID***Table 4.7.5.5-5: PLMN ID**

Derivation Path: TS 24.588 Figure 5.3.1.5			
Information Element	Value/remark	Comment	Condition
MCC digit 1	Set according to parameter given in test case		
MCC digit 2	Set according to parameter given in test case		
MCC digit 3	Set according to parameter given in test case		
MNC digit 3	Set according to parameter given in test case		
MNC digit 1	Set according to parameter given in test case		
MNC digit 2	Set according to parameter given in test case		



– *Not served by E-UTRA and not served by NR*

**Table 4.7.5.5-6: Not served by E-UTRA and not served by NR**

Derivation Path: TS 24.588 Figure 5.3.1.6			
Information Element	Value/remark	Comment	Condition
Length of not served by E-UTRA and not served by NR contents	Set to the actual length of 'not served by E-UTRA and not served by NR contents' in bytes		
VPNENNI	'1'B	UE is authorized to use V2X communication over PC5	
NPINENN	'1'B	UE is authorized to use V2X communication over NR-PC5 when not served by E-UTRA and not served by NR	
EPINENN	'1'B	UE is authorized to use V2X communication over E-UTRA-PC5 when not served by E-UTRA and not served by NR	
E-UTRA radio parameters per geographical area list	See Table 4.7.5.5-7		
NR radio parameters per geographical area list	See Table 4.7.5.5-7		

– *Radio parameters per geographical area list*

**Table 4.7.5.5-7: Radio parameters per geographical area list**

Derivation Path: TS 24.588 Figure 5.3.1.7			
Information Element	Value/remark	Comment	Condition
Length of radio parameters per geographical area list contents	Set to the actual length of 'radio parameters per geographical area list contents' in bytes		
Radio parameters per geographical area info 1	See Table 4.7.5.5-8		
Radio parameters per geographical area info 2	FFS		

– *Radio parameters per geographical area info*

**Table 4.7.5.5-8: Radio parameters per geographical area info**

Derivation TS 24.588 Figure 5.3.1.8			
Information Element	Value/remark	Comment	Condition
Length of radio parameters per geographical area contents	Set to the actual length of 'radio parameters per geographical area contents' in bytes		
Geographical area	See Table 4.7.5.5-9		
Radio parameters	See Table 4.7.5.5-11		
MI	'1'B	Operator managed	

– *Geographical area***Table 4.7.5.5-9: Geographical area**

Derivation Path: TS 24.588 Figure 5.3.1.9			
Information Element	Value/remark	Comment	Condition
Length of geographical area contents	Set to the actual length of 'geographical area contents' in bytes		
Coordinate 1	See Table 4.7.5.5-10		
Coordinate 2	See Table 4.7.5.5-10		
Coordinate 3	See Table 4.7.5.5-10		

– *Coordinate area***Table 4.7.5.5-10: Coordinate area**

Derivation Path: TS 24.588 Figure 5.3.1.10			
Information Element	Value/remark	Comment	Condition
Latitude	35.753056		Coordinate 1
	35.735278		Coordinate 2
	35.744167		Coordinate 3
Longitude	139.689167		Coordinate 1
	139.689167		Coordinate 2
	139.709167		Coordinate 3

– *Radio parameters***Table 4.7.5.5-11: Radio parameters**

Derivation Path: TS 24.588 Figure 5.3.1.11			
Information Element	Value/remark	Comment	Condition
Length of radio parameters contents	Set to the actual length of 'radio parameters contents' in bytes		
Radio parameters contents	See Table 4.10.1.1-1: SL-V2X-Preconfiguration in TS 36.508 [2]		E-UTRAN V2X
	See Table 4.10.1-1: SL-PreconfigurationNR		NR V2X

– *V2X service identifier to PC5 RAT and Tx profiles mapping rules***Table 4.7.5.5-12: V2X service identifier to PC5 RAT and Tx profiles mapping rules**

Derivation Path: TS 24.588 Figure 5.3.1.12			
Information Element	Value/remark	Comment	Condition
Length of V2X service identifier to PC5 RAT and Tx profiles mapping rules contents	Set to the actual length of 'V2X service identifier to PC5 RAT and Tx profiles mapping rules contents' in bytes		
V2X service identifier to PC5 RAT and Tx profiles mapping rule 1	See Table 4.7.5.5-13		

V2X service identifier to PC5 RAT and Tx profiles mapping rule 2	FFS		
--	-----	--	--

– *V2X service identifier to PC5 RAT and Tx profiles mapping rule*

**Table 4.7.5.5-13: V2X service identifier to PC5 RAT and Tx profiles mapping rule**

Derivation Path: TS 24.588 Figure 5.3.1.13			
Information Element	Value/remark	Comment	Condition
Length of V2X service identifier to PC5 RAT and Tx profiles mapping rule contents	Set to the actual length of 'V2X service identifier to PC5 RAT and Tx profiles mapping rule contents' in bytes		
V2X service identifiers	See Table 4.7.5.5-14		
PC5 RAT	'00'B		E-UTRA-PC5
	'01'B		NR-PC5
Length of E-UTRA-PC5 Tx profiles	Set to the actual length of 'E-UTRA-PC5 Tx profiles' in bytes		E-UTRA-PC5
E-UTRA-PC5 Tx profiles	rel14	UE shall use Release 14 compatible format (i.e. using MCS table in Table 8.6.1-1 with 64 QAM indices overridden by 16QAM in TS 36.213 [23] and not Rel-15 feature) to transmit the corresponding V2X packet, Refer to IE v2x-TxProfileList in TS 36.331	E-UTRA-PC5

– *V2X service identifiers*

**Table 4.7.5.5-14: V2X service identifiers**

Derivation Path: TS 24.588 Figure 5.3.1.14			
Information Element	Value/remark	Comment	Condition
Length of V2X service identifiers contents	Set to the actual length of 'V2X service identifiers contents' in bytes		
V2X service identifier 1	'00 00 00 01'H	4 bytes for each V2X service identifier	
V2X service identifier 2	'00 00 00 02'H		

– *Privacy config*

**Table 4.7.5.5-15: Privacy config**

Derivation Path: TS 24.588 Figure 5.3.1.15			
Information Element	Value/remark	Comment	Condition

Length of privacy config contents	Set to the actual length of 'privacy config contents' in bytes		
V2X services requiring privacy	See Table 4.7.5.5-16		
Privacy timer	'FF FF'H	Expressed in units of seconds, after which the UE shall change the source Layer-2 ID self-assigned by the UE	

– *V2X services requiring privacy*

**Table 4.7.5.5-16: V2X services requiring privacy**

Derivation Path: TS 24.588 Figure 5.3.1.16			
Information Element	Value/remark	Comment	Condition
Length of V2X services requiring privacy contents	Set to the actual length of 'V2X services requiring privacy contents' in bytes		
V2X service requiring privacy 1	See Table 4.7.5.5-17		
V2X service requiring privacy 2	FFS		

– *V2X service requiring privacy*

**Table 4.7.5.5-17: V2X service requiring privacy**

Derivation Path: TS 24.588 Figure 5.3.1.17			
Information Element	Value/remark	Comment	Condition
Length of V2X service requiring privacy contents	Set to the actual length of 'V2X service requiring privacy contents' in bytes		
V2X service identifiers	See Table 4.7.5.5-14		
Geographical areas	See Table 4.7.5.5-18		

– *Geographical areas*

**Table 4.7.5.5-18: Geographical areas**

Derivation Path: TS 24.588 Figure 5.3.1.18			
Information Element	Value/remark	Comment	Condition
Length of geographical areas contents	Set to the actual length of 'geographical areas contents' in bytes		
Geographical area 1	See Table 4.7.5.5-9		
Geographical area 2	FFS		

– *V2X communication over PC5 in E-UTRA-PC5*

**Table 4.7.5.5-19: V2X communication over PC5 in E-UTRA-PC5**

Derivation Path: TS 24.588 Figure 5.3.1.19			
Information Element	Value/remark	Comment	Condition
Length of V2X communication over PC5 in E-UTRA-PC5 contents	Set to the actual length of 'V2X communication over PC5 in E-UTRA-PC5 contents' in bytes		

PPMR	'1'B	PPPP to PDB mapping rules field is present	
VSAPI	'1'B	V2X services authorized for PPPR field is present	
VSIEFMRI	'1'B	V2X service identifier to V2X E-UTRA frequency mapping rules field is present	
DDL2II	'1'B	Default destination layer-2 ID field is present	
V2X service identifier to destination layer-2 ID mapping rules	See Table 4.7.5.5-20		
PPPP to PDB mapping rules	See Table 4.7.5.5-22		
V2X service identifier to V2X E-UTRA frequency mapping rules	See Table 4.7.5.5-24		
V2X services authorized for PPPR	See Table 4.7.5.5-29		
Default destination layer-2 ID	'00 00 40'H	3 bytes, Random value	

– *V2X service identifier to destination layer-2 ID mapping rules*

**Table 4.7.5.5-20: V2X service identifier to destination layer-2 ID mapping rules**

Derivation Path: TS 24.588 Figure 5.3.1.20			
Information Element	Value/remark	Comment	Condition
Length of V2X service identifier to destination layer-2 ID mapping rules contents	Set to the actual length of 'V2X service identifier to destination layer-2 ID mapping rules contents' in bytes		
V2X service identifier to destination layer-2 ID mapping rule 1	See Table 4.7.5.5-21		
V2X service identifier to destination layer-2 ID mapping rule 2	FFS		

– *V2X service identifier to destination layer-2 ID mapping rule*

**Table 4.7.5.5-21: V2X service identifier to destination layer-2 ID mapping rule**

Derivation Path: TS 24.588 Figure 5.3.1.21			
Information Element	Value/remark	Comment	Condition
Length of V2X service identifier to destination layer-2 ID mapping rule contents	Set to the actual length of 'V2X service identifier to destination layer-2 ID mapping rule contents' in bytes		
V2X service identifiers	See Table 4.7.5.5-14		
Destination layer-2 ID	'00 00 41'H		

– *PPPP to PDB mapping rules*

**Table 4.7.5.5-22: PPPP to PDB mapping rules**

Derivation Path: TS 24.588 Figure 5.3.1.22			
Information Element	Value/remark	Comment	Condition

Length of PPPP to PDB mapping rules contents	Set to the actual length of 'PPPP to PDB mapping rules contents' in bytes		
PPPP to PDB mapping rule 1	See Table 4.7.5.5-23		
PPPP to PDB mapping rule 2	FFS		

– *PPPP to PDB mapping rule*

**Table 4.7.5.5-23: PPPP to PDB mapping rule**

Derivation Path: TS 24.588 Figure 5.3.1.23			
Information Element	Value/remark	Comment	Condition
PPPP	'000'B	PPPP value 1	
PDB	'00 32'H	50ms	

– *V2X service identifier to V2X E-UTRA frequency mapping rules*

**Table 4.7.5.5-24: V2X service identifier to V2X E-UTRA frequency mapping rules**

Derivation Path: TS 24.588 Figure 5.3.1.24			
Information Element	Value/remark	Comment	Condition
Length of V2X service identifier to V2X E-UTRA frequency mapping rules contents	Set to the actual length of 'V2X service identifier to V2X E-UTRA frequency mapping rules contents' in bytes		
V2X service identifier to V2X E-UTRA frequency mapping rule 1	See Table 4.7.5.5-25		
V2X service identifier to V2X E-UTRA frequency mapping rule 2	FFS		

– *V2X service identifier to V2X E-UTRA frequency mapping rule*

**Table 4.7.5.5-25: V2X service identifier to V2X E-UTRA frequency mapping rule**

Derivation Path: TS 24.588 Figure 5.3.1.25			
Information Element	Value/remark	Comment	Condition
Length of V2X service identifier to V2X E-UTRA frequency mapping rule contents	Set to the actual length of 'V2X service identifier to V2X E-UTRA frequency mapping rule contents' in bytes		
V2X service identifiers	See Table 4.7.5.5-14		
V2X E-UTRA frequencies with geographical areas list	See Table 4.7.5.5-26		

– *V2X E-UTRA frequencies with geographical areas list*

**Table 4.7.5.5-26: V2X E-UTRA frequencies with geographical areas list**

Derivation Path: TS 24.588 Figure 5.3.1.26			
Information Element	Value/remark	Comment	Condition
Length of V2X E-UTRA frequencies with geographical areas list contents	Set to the actual length of 'V2X E-UTRA frequencies with geographical areas list contents' in bytes		
V2X E-UTRA frequencies with geographical areas info 1	See Table 4.7.5.5-27		

V2X E-UTRA frequencies with geographical areas info 2	FFS		
---	-----	--	--

– *V2X E-UTRA frequencies with geographical areas info*

**Table 4.7.5.5-27: V2X E-UTRA frequencies with geographical areas info**

Derivation Path: TS 24.588 Figure 5.3.1.27			
Information Element	Value/remark	Comment	Condition
Length of V2X E-UTRA frequencies with geographical areas info contents	Set to the actual length of 'V2X E-UTRA frequencies with geographical areas info contents' in bytes		
V2X E-UTRA frequencies	See Table 4.7.5.5-28		
Geographical areas	See Table 4.7.5.5-18		

– *V2X E-UTRA frequencies*

**Table 4.7.5.5-28: V2X E-UTRA frequencies**

Derivation Path: TS 24.588 Figure 5.3.1.28			
Information Element	Value/remark	Comment	Condition
Length of V2X E-UTRA frequencies contents	Set to the actual length of 'V2X E-UTRA frequencies contents' in bytes		
V2X E-UTRA frequency 1	Downlink E-UTRA ARFCN under test. f5 of Table 6.2.3.5-1 in TS 36.508 [2]		SIG
	Downlink E-UTRA ARFCN under test. Mid Range EARFCN value of Table 4.3.1.2.15-1 in TS 36.508 [2].		
V2X E-UTRA frequency 2	FFS		

– *V2X services authorized for PPPR*

**Table 4.7.5.5-29: V2X services authorized for PPPR**

Derivation Path: TS 24.588 Figure 5.3.1.29			
Information Element	Value/remark	Comment	Condition
Length of V2X services authorized for PPPR contents	Set to the actual length of 'V2X services authorized for PPPR contents' in bytes		
V2X service authorized for PPPR 1	See Table 4.7.5.5-30		
V2X service authorized for PPPR 2	FFS		

– *V2X service authorized for PPPR*

**Table 4.7.5.5-30: V2X service authorized for PPPR**

Derivation Path: TS 24.588 Figure 5.3.1.30			
Information Element	Value/remark	Comment	Condition
Length of V2X service authorized for PPPR contents	Set to the actual length of 'V2X service authorized		

	for PPPR contents' in bytes		
V2X service identifiers	See Table 4.7.5.5-14		
PPPR	'000'B	PPPR value 1	

– *V2X communication over PC5 in NR-PC5*

**Table 4.7.5.5-31: V2X communication over PC5 in NR-PC5**

Derivation Path: TS 24.588 Figure 5.3.1.31			
Information Element	Value/remark	Comment	Condition
Length of V2X communication over PC5 in NR-PC5 contents	Set to the actual length of 'V2X communication over PC5 in NR-PC5 contents' in bytes		
VSINFMRI	'1'B	V2X service identifier to V2X NR frequency mapping rules field is present	
DDL2IBI	'1'B	Default destination layer-2 ID for broadcast field is present	
V2X service identifier to V2X NR frequency mapping rules	See Table 4.7.5.5-32		
V2X service identifier to destination layer-2 ID for broadcast mapping rules	See Table 4.7.5.5-37		
V2X service identifier to destination layer-2 ID for groupcast mapping rules	See Table 4.7.5.5-39		
V2X service identifier to destination layer-2 ID for unicast initial signalling mapping rules	See Table 4.7.5.5-41		
V2X service identifier to PC5 QoS parameters mapping rules	See Table 4.7.5.5-43		
AS configuration	See Table 4.7.5.5-45		
Default destination layer-2 ID for broadcast	'00 00 50'H		
NR-PC5 unicast security policies	See Table 4.7.5.5-49		
V2X service identifier to default mode of communication mapping rules	See Table 4.7.5.5-52		

– *V2X service identifier to V2X NR frequency mapping rules*

**Table 4.7.5.5-32: V2X service identifier to V2X NR frequency mapping rules**

Derivation Path: TS 24.588 Figure 5.3.1.32			
Information Element	Value/remark	Comment	Condition
Length of V2X service identifier to V2X NR frequency mapping rules contents	Set to the actual length of 'V2X service identifier to V2X NR frequency mapping rules contents' in bytes		
V2X service identifier to V2X NR frequency mapping rule 1	See Table 4.7.5.5-33		
V2X service identifier to V2X NR frequency mapping rule 2	FFS		

– *V2X service identifier to V2X NR frequency mapping rule*

**Table 4.7.5.5-33: V2X service identifier to V2X NR frequency mapping rule**

Derivation Path: TS 24.588 Figure 5.3.1.33
--



Information Element	Value/remark	Comment	Condition
Length of V2X service identifier to V2X NR frequency mapping rule contents	Set to the actual length of 'V2X service identifier to V2X NR frequency mapping rule contents' in bytes		
V2X service identifiers	See Table 4.7.5.5-14		
V2X NR frequencies with geographical areas list	See Table 4.7.5.5-34		

– *V2X NR frequencies with geographical areas list*

**Table 4.7.5.5-34: V2X NR frequencies with geographical areas list**

Derivation Path: TS 24.588 Figure 5.3.1.34			
Information Element	Value/remark	Comment	Condition
Length of V2X NR frequencies with geographical areas list contents	Set to the actual length of 'V2X NR frequencies with geographical areas list contents' in bytes		
V2X NR frequencies with geographical areas info 1	See Table 4.7.5.5-35		
V2X NR frequencies with geographical areas info 2	FFS		

– *V2X NR frequencies with geographical areas info*

**Table 4.7.5.5-35: V2X NR frequencies with geographical areas info**

Derivation Path: TS 24.588 Figure 5.3.1.35			
Information Element	Value/remark	Comment	Condition
Length of V2X NR frequencies with geographical areas info contents	Set to the actual length of 'V2X NR frequencies with geographical areas info contents' in bytes		
V2X NR frequencies	See Table 4.7.5.5-36		
Geographical areas	See Table 4.7.5.5-18		

– *V2X NR frequencies*

**Table 4.7.5.5-36: V2X NR frequencies**

Derivation Path: TS 24.588 Figure 5.3.1.36			
Information Element	Value/remark	Comment	Condition
Length of V2X NR frequencies contents	Set to the actual length of 'V2X NR frequencies contents' in bytes		
V2X NR frequency 1	ARFCN-ValueNR with condition SL_SSB in Table 4.6.3-5		
V2X NR frequency 2	FFS		

– *V2X service identifier to destination layer-2 ID for broadcast mapping rules*

**Table 4.7.5.5-37: V2X service identifier to destination layer-2 ID for broadcast mapping rules**

Derivation Path: TS 24.588 Figure 5.3.1.37			
Information Element	Value/remark	Comment	Condition
Length of V2X service identifier to destination layer-2 ID for broadcast mapping rules contents	Set to the actual length of 'V2X service identifier to destination layer-2 ID for		

	broadcast mapping rules contents' in bytes		
V2X service identifier to destination layer-2 ID for broadcast mapping rule 1	See Table 4.7.5.5-38		
V2X service identifier to destination layer-2 ID for broadcast mapping rule 2	FFS		

– *V2X service identifier to destination layer-2 ID for broadcast mapping rule*

**Table 4.7.5.5-38: V2X service identifier to destination layer-2 ID for broadcast mapping rule**

Derivation Path: TS 24.588 Figure 5.3.1.38			
Information Element	Value/remark	Comment	Condition
Length of V2X service identifier to destination layer-2 ID for broadcast mapping rule contents	Set to the actual length of 'V2X service identifier to destination layer-2 ID for broadcast mapping rule contents' in bytes		
V2X service identifiers	See Table 4.7.5.5-14		
Destination layer-2 ID for broadcast	'00 00 51'H		

– *V2X service identifier to destination layer-2 ID for groupcast mapping rules*

**Table 4.7.5.5-39: V2X service identifier to destination layer-2 ID for groupcast mapping rules**

Derivation Path: TS 24.588 Figure 5.3.1.39			
Information Element	Value/remark	Comment	Condition
Length of V2X service identifier to destination layer-2 ID for groupcast mapping rules contents	Set to the actual length of 'V2X service identifier to destination layer-2 ID for groupcast mapping rules contents' in bytes		
V2X service identifier to destination layer-2 ID for groupcast mapping rule 1	See Table 4.7.5.5-40		
V2X service identifier to destination layer-2 ID for groupcast mapping rule 2	FFS		

– *V2X service identifier to destination layer-2 ID for groupcast mapping rule*

**Table 4.7.5.5-40: V2X service identifier to destination layer-2 ID for groupcast mapping rule**

Derivation Path: TS 24.588 Figure 5.3.1.40			
Information Element	Value/remark	Comment	Condition
Length of V2X service identifier to destination layer-2 ID for groupcast mapping rule contents	Set to the actual length of 'V2X service identifier to destination layer-2 ID for groupcast mapping rule contents' in bytes		
V2X service identifiers	See Table 4.7.5.5-14		
Destination layer-2 ID for groupcast	'00 00 52'H		

- *V2X service identifier to destination layer-2 ID for unicast initial signalling mapping rules*

**Table 4.7.5.5-41: V2X service identifier to destination layer-2 ID for unicast initial signalling mapping rules**

Derivation Path: TS 24.588 Figure 5.3.1.41			
Information Element	Value/remark	Comment	Condition
Length of V2X service identifier to destination layer-2 ID for unicast initial signalling mapping rules contents	Set to the actual length of 'V2X service identifier to destination layer-2 ID for unicast initial signalling mapping rules contents' in bytes		
V2X service identifier to destination layer-2 ID for unicast initial signalling mapping rule 1	See Table 4.7.5.5-42		
V2X service identifier to destination layer-2 ID for unicast initial signalling mapping rule 2	FFS		

- *V2X service identifier to destination layer-2 ID for unicast initial signalling mapping rule*

**Table 4.7.5.5-42: V2X service identifier to destination layer-2 ID for unicast initial signalling mapping rule**

Derivation Path: TS 24.588 Figure 5.3.1.42			
Information Element	Value/remark	Comment	Condition
Length of V2X service identifier to destination layer-2 ID for unicast initial signalling mapping rule contents	Set to the actual length of 'V2X service identifier to destination layer-2 ID for unicast initial signalling mapping rule contents' in bytes		
V2X service identifiers	See Table 4.7.5.5-14		
Destination layer-2 ID for unicast initial signalling	'00 00 53'H		

- *V2X service identifier to PC5 QoS parameters mapping rules*

**Table 4.7.5.5-43: V2X service identifier to PC5 QoS parameters mapping rules**

Derivation Path: TS 24.588 Figure 5.3.1.43			
Information Element	Value/remark	Comment	Condition
Length of V2X service identifier to PC5 QoS parameters mapping rules contents	Set to the actual length of 'V2X service identifier to PC5 QoS parameters mapping rules contents' in bytes		
V2X service identifier to PC5 QoS parameters mapping rule 1	See Table 4.7.5.5-44		
V2X service identifier to PC5 QoS parameters mapping rule 2	FFS		

- *V2X service identifier to PC5 QoS parameters mapping rule*

**Table 4.7.5.5-44: V2X service identifier to PC5 QoS parameters mapping rule**

Derivation Path: TS 24.588 Figure 5.3.1.46			
Information Element	Value/remark	Comment	Condition
Length of V2X service identifier to PC5 QoS parameters mapping rule contents	Set to the actual length of 'V2X service identifier to		

	PC5 QoS parameters mapping rule contents' in bytes		
V2X service identifiers	See Table 4.7.5.5-14		
RI	'1'B	Range field is present	
PLAMBRI	'1'B	Per-link aggregate maximum bit rate field is present	
MFBR1	'1'B	Maximum flow bit rate field is present	
GFBR1	'1'B	Guaranteed flow bit rate field is present	
PQI	22	See Table 5.4.4-1 in TS 23.287 [xx]	
Guaranteed flow bit rate	'0000 0110 0000 0000 0000 1010'B	10 * 1Mbps = 10Mbps.	
Maximum flow bit rate	'0000 0110 0000 0000 0001 0100'B	20 * 1Mbps = 20Mbps.	
Per-link aggregate maximum bit rate	'0000 0110 0000 0000 0000 0010'B	2 * 1Mbps = 2Mbps.	
Range	'0000 0001 1111 0100'B	500 meters	

– *AS configuration*

**Table 4.7.5.5-45: AS configuration**

Derivation Path: TS 24.588 Figure 5.3.1.46a			
Information Element	Value/remark	Comment	Condition
Length of AS configuration contents	Set to the actual length of 'AS configuration contents' in bytes		
SLRB mapping rules	See Table 4.7.5.5-46		

– *SLRB mapping rules*

**Table 4.7.5.5-46: SLRB mapping rules**

Derivation Path: TS 24.588 Figure 5.3.1.47			
Information Element	Value/remark	Comment	Condition
Length of SLRB mapping rules contents	Set to the actual length of 'SLRB mapping rules contents' in bytes		
SLRB mapping rule 1	See Table 4.7.5.5-47		
SLRB mapping rule 2	FFS		

– *SLRB mapping rule*

**Table 4.7.5.5-47: SLRB mapping rule**

Derivation Path: TS 24.588 Figure 5.3.1.48			
Information Element	Value/remark	Comment	Condition
Length of SLRB mapping rule contents	Set to the actual length of 'SLRB mapping rule contents' in bytes		
PC5 QoS profile	See Table 4.7.5.5-48		
Length of SLRB	Set to the actual length of 'SLRB' in bytes		
SLRB	See Table 4.10.1-1		

– *PC5 QoS profile***Table 4.7.5.5-48: PC5 QoS profile**

Derivation Path: TS 24.588 Figure 5.3.1.49			
Information Element	Value/remark	Comment	Condition
Length of PC5 QoS profile contents	Set to the actual length of 'PC5 QoS profile contents' in bytes		
MDBVI	'0'B	Maximum data burst volume field is absent	
AWI	'1'B	Averaging window field is present	
PLOI	'1'B	The octet of the priority level is present	
RI	'1'B	Range field is present	
PLAMBRI	'1'B	Per-link aggregate maximum bit rate field is present	
MFBRI	'1'B	Maximum flow bit rate field is present	
GFBR	'1'B	Guaranteed flow bit rate field is present	
PQI	22	See Table 5.4.4-1 in TS 23.287[xx]	
Guaranteed flow bit rate	'0000 0110 0000 0000 0000 1010'B	10 * 1Mbps = 10Mbps.	
Maximum flow bit rate	'0000 0110 0000 0000 0001 0100'B	20 * 1Mbps = 20Mbps.	
Per-link aggregate maximum bit rate	'0000 0110 0000 0000 0000 0010'B	2 * 1Mbps = 2Mbps.	
Range	'0000 0001 1111 0100'B	500 meters	
Priority level	4		
Averaging window	'0000 0111 1101 0000'B	2000ms	
Maximum data burst volume	Not Present		

– *NR-PC5 unicast security policies***Table 4.7.5.5-49: NR-PC5 unicast security policies**

Derivation Path: TS 24.588 Figure 5.3.1.50			
Information Element	Value/remark	Comment	Condition
Length of NR-PC5 unicast security policies contents	Set to the actual length of 'NR-PC5 unicast security policies contents' in bytes		
NR-PC5 unicast security policy 1	See Table 4.7.5.5-50		
NR-PC5 unicast security policy 2	FFS		

– *NR-PC5 unicast security policy***Table 4.7.5.5-50: NR-PC5 unicast security policy**

Derivation Path: TS 24.588 Figure 5.3.1.51			
Information Element	Value/remark	Comment	Condition

Length of NR-PC5 unicast security policy contents	Set to the actual length of 'NR-PC5 unicast security policy contents' in bytes		
V2X service identifiers	See Table 4.7.5.5-14		
Security policy	See Table 4.7.5.5-51		
Geographical areas	See Table 4.7.5.5-18		

– *Security policy*

**Table 4.7.5.5-51: Security policy**

Derivation Path: TS 24.588 Figure 5.3.1.52			
Information Element	Value/remark	Comment	Condition
Signalling integrity protection policy	'000'B	Signalling integrity protection not needed	
Spare	'0'B		
Signalling ciphering policy	'000'B	Signalling ciphering not needed	
Spare	'0'B		
User plane integrity protection policy	'000'B	User plane integrity protection not needed	
Spare	'0'B		
User plane ciphering policy	'000'B	User plane ciphering not needed	
Spare	'0'B		

– *V2X service identifier to default mode of communication mapping rules*

**Table 4.7.5.5-52: V2X service identifier to default mode of communication mapping rules**

Derivation Path: TS 24.588 Figure 5.3.1.53			
Information Element	Value/remark	Comment	Condition
Length of V2X service identifier to default mode of communication mapping rules contents	'Set to the actual length of 'V2X service identifier to default mode of communication mapping rules contents' in bytes		
V2X service identifier to default mode of communication mapping rule 1	See Table 4.7.5.5-53		
V2X service identifier to default mode of communication mapping rule 2	FFS		

– *V2X service identifier to default mode of communication mapping rule*

**Table 4.7.5.5-53: V2X service identifier to default mode of communication mapping rule**

Derivation Path: TS 24.588 Figure 5.3.1.54			
Information Element	Value/remark	Comment	Condition
Length of V2X service identifier to default mode of communication mapping rule contents	'Set to the actual length of 'V2X service identifier to default mode of communication mapping rule contents' in bytes		
V2X service identifiers	See Table 4.7.5.5-14		
DMC	'00'B	Default mode of communication is set to unicast	
Spare	'0000 00'B		

## 4.7.6 Contents of UE Policy Delivery messages

### – *MANAGE UE POLICY COMMAND*

**Table 4.7.6-1: MANAGE UE POLICY COMMAND**

Derivation Path: TS 24.501 Table D.5.1.1.1			
Information Element	Value/remark	Comment	Condition
PTI	Any value from 1 to 254		
MANAGE UE POLICY COMMAND message identity	'0000 0001'B	MANAGE UE POLICY COMMAND message	
UE policy section management list			
Length of UE policy section management list contents	Set to the actual length of 'UE policy section management list contents' in bytes		
UE policy section management list contents	1 entry		
UE policy section management sublist (PLMN-1)			
Length of UE policy section management sublist	Set to the actual length of 'UE policy section management sublist' in bytes		
PLMN ID	Set to the PLMN value used in the test case		
UE policy section management sublist contents			
Instruction 1			
Instruction contents length	Set to the actual length of 'Instruction contents' in bytes		
UPSC	'00 01'H	2 bytes, value set by PCF	
UE policy section contents			
UE policy part 1			
UE policy part contents length	Set to the actual length of 'UE policy part contents' in bytes		
Spare	'0000'B		
UE policy part type	'0001'B		URSP
	'0010'B		ANDSP
	'0011'B		V2XP
UE policy part contents	See Table 4.8.5.1-1		URSP
	FFS		ANDSP
	See Table 4.7.5.4-1		V2XP

Condition	Explanation
URSP	UE Route Selection Policy (URSP)
ANDSP	UE Access Network Discovery and Selection Policy (ANDSP)
V2XP	UE policies for V2X (V2XP)

### – *MANAGE UE POLICY COMPLETE*

**Table 4.7.6-2: MANAGE UE POLICY COMPLETE**

Derivation Path: TS 24.501 Table D.5.2.1.1			
Information Element	Value/remark	Comment	Condition
PTI	The same value as the value set in MANAGE UE POLICY COMMAND message.		

MANAGE UE POLICY COMPLETE message identity	'0000 0010'B	MANAGE UE POLICY COMPLETE message	
--	--------------	-----------------------------------	--

– *MANAGE UE POLICY COMMAND REJECT*

**Table 4.7.6-3: MANAGE UE POLICY COMMAND REJECT**

Derivation Path: TS 24.501 Table D.5.3.1.1			
Information Element	Value/remark	Comment	Condition
PTI	The same value as the value set in MANAGE UE POLICY COMMAND message.		
MANAGE UE POLICY COMMAND REJECT message identity	'0000 0011'B	MANAGE UE POLICY COMMAND REJECT message	
UE policy section management result			
Length of UE policy section management result contents	Set to the actual length of 'UE policy section management result contents' in bytes		
UE policy section management list contents	1 entry		
UE policy section management subresult (PLMN 1)			
Number of results	1		
PLMN ID	Set to the PLMN value used in the test case		
UE policy section management subresult contents	1 entry		
Result 1			
UPSC	'00 01'H		
Failed instruction order	Set according to specific message content.		
Cause	Set according to specific message content.		

– *UE STATE INDICATION*

**Table 4.7.6-4: UE STATE INDICATION**

Derivation Path: TS 24.501 Table D.5.4.1.1			
Information Element	Value/remark	Comment	Condition
PTI	Any value from 1 to 254		
UE STATE INDICATION message identity	'0000 0100'B		
UPSI list	1 entry		
Length of UPSI list contents	Set to the actual length of 'UPSI list contents' in bytes		
UPSI sublist (PLMN 1)	1 entry		
Length of UPSI sublist	Set to the actual length of 'UPSI sublist' in bytes		
PLMN ID	Set to the PLMN value used in the test case		
UPSC 1	Set according to specific message content.		
UE policy classmark	Not checked		



Length of Policy information contents	Set to the actual length of 'Policy information contents' in bytes		
Spare	'0000 000'B		
SupportANDSP	'1'B		ANDSP
	Not checked		
UE OS Id			
Length of OS Id information contents	Set to the actual length of 'OS Id information contents' in bytes		
OS Id_1	Set according to parameter given in test case		

Condition	Explanation
ANDSP	UE Access Network Discovery and Selection Policy (ANDSP)

– *UE POLICY PROVISIONING REQUEST*

**Table 4.7.6-5: UE POLICY PROVISIONING REQUEST**

Derivation Path: TS 24.587 Table 7.2.1.1.1			
Information Element	Value/remark	Comment	Condition
PTI	Any value from 1 to 254		
UE POLICY PROVISIONING REQUEST message identity	'0000 0101'B		
Requested UE policies			
Length of Requested UE policies contents	2		
Requested UE policies contents	'0000 0001 0000 0000'B	UE policies for V2X communication over PC5 requested	

– *UE POLICY PROVISIONING REJECT*

**Table 4.7.6-6: UE POLICY PROVISIONING REJECT**

Derivation Path: TS 24.587 Table 7.2.2.1.1			
Information Element	Value/remark	Comment	Condition
PTI	The same value as the value set in UE POLICY PROVISIONING REQUEST message.		
UE POLICY PROVISIONING REJECT message identity	'0000 0110'B		
UPDS cause	'0001 1111'B	Request rejected, unspecified	

## 4.7A Default TC message and information element contents

This clause contains the default values of common TC (Test Control, see [11]) messages and information elements, which apply to all test cases unless otherwise specified. All the messages and information elements are listed in alphabetical order.

### 4.7A.1 Test mode messages

- *ACTIVATE TEST MODE* with the following exception:

- The supported test modes for 5GS are limited to those specified in subclause 38.509 [11] 5.3.4.

Same as TS 36.508 [2], Table 4.7A-1.

- *ACTIVATE TEST MODE COMPLETE*

Same as TS 36.508 [2], Table 4.7A-2.

- *DEACTIVATE TEST MODE*

Same as TS 36.508 [2], Table 4.7A-5.

- *DEACTIVATE TEST MODE COMPLETE*

Same as TS 36.508 [2], Table 4.7A-6.

### 4.7A.2 Test loop messages

- *CLOSE UE TEST LOOP*

Same as TS 36.508 [2], Table 4.7A-3 with the following exception:

- The supported test modes for 5GS are limited to those specified in subclause 38.509 [11] 5.3.4.

Derivation Path: 38.509 [11] clause 6.3			
Information Element	Value/remark	Comment	Condition
UE test loop mode	'0 0 0 0 0 0 1 0'B	UE test loop mode C	(UE TEST LOOP MODE C) AND (Broadcast MRB)
UE test loop mode A LB setup	Not present		
UE test loop mode B LB setup	Not present		
UE test loop mode C LB setup		MRB ID	
MRB ID	'0 0 0 0 0 0 0 1 0 0 0 0 0 0 0 0 0 0 0 0 0 0 0 0'B	Bit1 of Octet1 = 1: Broadcast MRB. Bit4 – bit1 of Octet2 = 0 0 0 0 and bit8 of Octet3 = 0: Identity of the logical channel of broadcast MTCH is 1.	
UE test loop mode D LB setup	Not present		
UE test loop mode E LB setup	Not present		
UE test loop mode F setup	Not present		(UE TEST LOOP MODE C) AND (Multicast MRB)
UE test loop mode	'0 0 0 0 0 0 1 0'B	UE test loop mode C	
UE test loop mode A LB setup	Not present		
UE test loop mode B LB setup	Not present		
UE test loop mode C LB setup		MRB ID	
MRB ID	'0 0'B	Bit1 of Octet1 = 0: Multicast MRB Bit8 - bit1 of Octet2 = 0 0 0 0 0 0 0 0 0 and bit8 of Octet3 = 0: MRB- Identity is 1	
UE test loop mode D LB setup	Not present		

UE test loop mode E LB setup	Not present		
UE test loop mode F setup	Not present		

Condition	Explanation
Broadcast MRB	Trigger the UE to count the MBS packet on Broadcast MRB of the Identity of the logical channel of broadcast MTCH
Multicast MRB	Trigger the UE to count the MBS packet on Multicast MRB of the MRB-Identity

- **CLOSE UE TEST LOOP COMPLETE**

Same as TS 36.508 [2], Table 4.7A-4.

- **OPEN UE TEST LOOP**

Same as TS 36.508 [2], Table 4.7A-7.

- **OPEN UE TEST LOOP COMPLETE**

Same as TS 36.508 [2], Table 4.7A-8.

### 4.7A.3 Beamlock messages

- **ACTIVATE BEAMLOCK**

This message is only sent in the direction SS to UE, embedded in a RRC *DLInformationTransfer* message.

**Table 4.7A.3-1: ACTIVATE BEAMLOCK**

Derivation Path: 38.509 clause 6.4.1			
Information Element	Value/remark	Comment	Condition
Protocol discriminator	1 1 1 1		
Skip indicator	0 0 0 0		
Message type	1 0 1 0 0 0 0 0		
UE Beamlock test Function	0 0 0 0 0 0 0 1		Tx Only
UE Beamlock test Function	0 0 0 0 0 0 1 0		Rx Only
UE Beamlock test Function	0 0 0 0 0 0 1 1		Tx and Rx

Condition	Explanation
Tx Only	Activation UE beamlock function for Tx only
Rx Only	Activation UE beamlock function for Rx only
Tx and Rx	Activation UE beamlock function for both Tx and Rx

- **ACTIVATE BEAMLOCK COMPLETE**

This message is only sent in the direction UE to SS, embedded in a RRC *ULInformationTransfer* message.

**Table 4.7A.3-2: ACTIVATE BEAMLOCK COMPLETE**

Derivation Path: 38.509 clause 6.4.2			
Information Element	Value/remark	Comment	Condition
Protocol discriminator	1 1 1 1		
Skip indicator	0 0 0 0		
Message type	1 0 1 0 0 0 0 1		

- *DEACTIVATE BEAMLOCK*

This message is only sent in the direction SS to UE, embedded in a RRC *DLInformationTransfer* message.

**Table 4.7A.3-3: DEACTIVATE BEAMLOCK**

Derivation Path: 38.509 clause 6.4.3			
Information Element	Value/remark	Comment	Condition
Protocol discriminator	1 1 1 1		
Skip indicator	0 0 0 0		
Message type	1 0 1 0 0 0 1 0		

- *DEACTIVATE BEAMLOCK COMPLETE*

This message is only sent in the direction UE to SS, embedded in a RRC *ULInformationTransfer* message.

**Table 4.7A.3-4: DEACTIVATE BEAMLOCK COMPLETE**

Derivation Path: 38.509 clause 6.4.4			
Information Element	Value/remark	Comment	Condition
Protocol discriminator	1 1 1 1		
Skip indicator	0 0 0 0		
Message type	1 0 1 0 0 0 1 1		

#### 4.7A.4 UE SS-RSRP per receiver branch reporting messages

- *SS-RSRPB REPORT REQUEST*

FFS

- *SS-RSRPB REPORT RESPONSE*

FFS

#### 4.7A.5 UE Positioning messages

- *RESET UE POSITIONING STORED INFORMATION*

FFS

- *UPDATE UE LOCATION INFORMATION*

FFS

#### 4.7A.6 NSSAI delete messages

- *NSSAI DELETE REQUEST*

This message is only sent in the direction SS to UE, embedded in a RRC *DLInformationTransfer* message.

**Table 4.7A.6-1: NSSAI DELETE REQUEST**

Derivation Path: 38.509 clause 6.7.1			
Information Element	Value/remark	Comment	Condition
Protocol discriminator	1 1 1 1		
Skip indicator	0 0 0 0		
Message type	1 0 0 0 0 1 1 0		

Delete NSSAI type	Set according to specific message contents		
Configured NSSAI	Set according to specific message contents		
Allowed NSSAI	Set according to specific message contents		

## - NSSAI DELETE RESPONSE

This message is only sent in the direction UE to SS, embedded in a RRC *ULInformationTransfer* message.

**Table 4.7A.6-2: NSSAI DELETE RESPONSE**

Derivation Path: 38.509 clause 6.7.2			
Information Element	Value/remark	Comment	Condition
Protocol discriminator	1 1 1 1		
Skip indicator	0 0 0 0		
Message type	1 0 1 0 0 1 1 1		

## 4.7A.7 UE Power Limit Messages

### - ACTIVATE POWER LIMIT REQUEST

This Message is only sent in the direction SS to UE, embedded in a RRC *DLInformationTransfer* message.

**Table 4.7A.7-1: ACTIVATE POWER LIMIT REQUEST**

Derivation Path: 38.509 clause 6.11.1			
Information Element	Value/remark	Comment	Condition
Protocol discriminator	1 1 1 1		
Skip indicator	0 0 0 0		
Message type	1 0 1 0 1 1 1 0		
TOTAL NR AGGREGATED BANDWIDTH	0 0 0 0 0 0 1 0		TOT NR AGG BW 100
TOTAL NR AGGREGATED BANDWIDTH	0 0 0 0 0 0 1 1		TOT NR AGG BW 150
TOTAL NR AGGREGATED BANDWIDTH	0 0 0 0 0 1 0 0		TOT NR AGG BW 200
TOTAL NR AGGREGATED BANDWIDTH	0 0 0 0 0 1 0 1		TOT NR AGG BW 250
TOTAL NR AGGREGATED BANDWIDTH	0 0 0 0 0 1 1 0		TOT NR AGG BW 300
TOTAL NR AGGREGATED BANDWIDTH	0 0 0 0 0 1 1 1		TOT NR AGG BW 350
TOTAL NR AGGREGATED BANDWIDTH	0 0 0 0 1 0 0 0		TOT NR AGG BW 400
TOTAL NR AGGREGATED BANDWIDTH	0 0 0 0 1 0 0 1		TOT NR AGG BW 450
TOTAL NR AGGREGATED BANDWIDTH	0 0 0 0 1 0 1 0		TOT NR AGG BW 500
TOTAL NR AGGREGATED BANDWIDTH	0 0 0 0 1 0 1 1		TOT NR AGG BW 550

TOTAL NR AGGREGATED BANDWIDTH	0 0 0 0 1 1 0 0		TOT NR AGG BW 600
TOTAL NR AGGREGATED BANDWIDTH	0 0 0 0 1 1 0 1		TOT NR AGG BW 650
TOTAL NR AGGREGATED BANDWIDTH	0 0 0 0 1 1 1 0		TOT NR AGG BW 700
TOTAL NR AGGREGATED BANDWIDTH	0 0 0 0 1 1 1 1		TOT NR AGG BW 750
TOTAL NR AGGREGATED BANDWIDTH	0 0 0 1 0 0 0 0		TOT NR AGG BW 800
TOTAL NR AGGREGATED BANDWIDTH	0 0 0 1 0 0 0 1		TOT NR AGG BW 850
TOTAL NR AGGREGATED BANDWIDTH	0 0 0 1 0 0 1 0		TOT NR AGG BW 900
TOTAL NR AGGREGATED BANDWIDTH	0 0 0 1 0 0 1 1		TOT NR AGG BW 950
TOTAL NR AGGREGATED BANDWIDTH	0 0 0 1 0 1 0 0		TOT NR AGG BW 1000
TOTAL NR AGGREGATED BANDWIDTH	0 0 0 1 0 1 0 1		TOT NR AGG BW 1050
TOTAL NR AGGREGATED BANDWIDTH	0 0 0 1 0 1 1 0		TOT NR AGG BW 1100
TOTAL NR AGGREGATED BANDWIDTH	0 0 0 1 0 1 1 1		TOT NR AGG BW 1150
TOTAL NR AGGREGATED BANDWIDTH	0 0 0 1 1 0 0 0		TOT NR AGG BW 1200
TOTAL NR AGGREGATED BANDWIDTH	0 0 0 1 1 0 0 1		TOT NR AGG BW 1250
TOTAL NR AGGREGATED BANDWIDTH	0 0 0 1 1 0 1 0		TOT NR AGG BW 1300
TOTAL NR AGGREGATED BANDWIDTH	0 0 0 1 1 0 1 1		TOT NR AGG BW 1350
TOTAL NR AGGREGATED BANDWIDTH	0 0 0 1 1 1 0 0		TOT NR AGG BW 1400
TOTAL NR AGGREGATED BANDWIDTH	0 0 0 1 1 1 0 1		TOT NR AGG BW 1450
TOTAL NR AGGREGATED BANDWIDTH	0 0 0 1 1 1 1 0		TOT NR AGG BW 1500
TOTAL NR AGGREGATED BANDWIDTH	0 0 0 1 1 1 1 1		TOT NR AGG BW 1550
TOTAL NR AGGREGATED BANDWIDTH	0 0 1 0 0 0 0 0		TOT NR AGG BW 1600
PCELL NR BANDWIDTH	0 0 0 0 0 0 0 1		PCELL NR BW 50
PCELL NR BANDWIDTH	0 0 0 0 0 0 1 0		PCELL NR BW 100

PCELL NR BANDWIDTH	0 0 0 0 1 0 0	PCELL NR BW 200
PCELL NR BANDWIDTH	0 0 0 0 1 0 0 0	PCELL NR BW 400

Condition	Explanation
TOT NR AGG BW 100	Total NR aggregated Bandwidth equal to 100 MHz
TOT NR AGG BW 150	Total NR aggregated Bandwidth equal to 150 MHz
TOT NR AGG BW 200	Total NR aggregated Bandwidth equal to 200 MHz
TOT NR AGG BW 250	Total NR aggregated Bandwidth equal to 250 MHz
TOT NR AGG BW 300	Total NR aggregated Bandwidth equal to 300 MHz
TOT NR AGG BW 350	Total NR aggregated Bandwidth equal to 350 MHz
TOT NR AGG BW 400	Total NR aggregated Bandwidth equal to 400 MHz
TOT NR AGG BW 450	Total NR aggregated Bandwidth equal to 450 MHz
TOT NR AGG BW 500	Total NR aggregated Bandwidth equal to 500 MHz
TOT NR AGG BW 550	Total NR aggregated Bandwidth equal to 550 MHz
TOT NR AGG BW 600	Total NR aggregated Bandwidth equal to 600 MHz
TOT NR AGG BW 650	Total NR aggregated Bandwidth equal to 650 MHz
TOT NR AGG BW 700	Total NR aggregated Bandwidth equal to 700 MHz
TOT NR AGG BW 750	Total NR aggregated Bandwidth equal to 750 MHz
TOT NR AGG BW 800	Total NR aggregated Bandwidth equal to 800 MHz
TOT NR AGG BW 850	Total NR aggregated Bandwidth equal to 850 MHz
TOT NR AGG BW 900	Total NR aggregated Bandwidth equal to 900 MHz
TOT NR AGG BW 950	Total NR aggregated Bandwidth equal to 950 MHz
TOT NR AGG BW 1000	Total NR aggregated Bandwidth equal to 1000 MHz
TOT NR AGG BW 1050	Total NR aggregated Bandwidth equal to 1050 MHz
TOT NR AGG BW 1100	Total NR aggregated Bandwidth equal to 1100 MHz
TOT NR AGG BW 1150	Total NR aggregated Bandwidth equal to 1150 MHz
TOT NR AGG BW 1200	Total NR aggregated Bandwidth equal to 1200 MHz
TOT NR AGG BW 1250	Total NR aggregated Bandwidth equal to 1250 MHz
TOT NR AGG BW 1300	Total NR aggregated Bandwidth equal to 1300 MHz
TOT NR AGG BW 1350	Total NR aggregated Bandwidth equal to 1350 MHz
TOT NR AGG BW 1400	Total NR aggregated Bandwidth equal to 1400 MHz
TOT NR AGG BW 1450	Total NR aggregated Bandwidth equal to 1450 MHz
TOT NR AGG BW 1500	Total NR aggregated Bandwidth equal to 1500 MHz
TOT NR AGG BW 1550	Total NR aggregated Bandwidth equal to 1550 MHz
TOT NR AGG BW 1600	Total NR aggregated Bandwidth equal to 1600 MHz
PCELL NR BW 50	PCC NR Bandwidth equal to 50 MHz
PCELL NR BW 100	PCC NR Bandwidth equal to 100 MHz
PCELL NR BW 200	PCC NR Bandwidth equal to 200 MHz
PCELL NR BW 400	PCC NR Bandwidth equal to 400 MHz

- **ACTIVATE POWER LIMIT RESPONSE**

This message is only sent in the direction UE to SS, embedded in a RRC *ULInformationTransfer* message.

**Table 4.7A.7-2: ACTIVATE POWER LIMIT RESPONSE**

Derivation Path: 38.509 clause 6.11.2			
Information Element	Value/remark	Comment	Condition
Protocol discriminator	1 1 1 1		
Skip indicator	0 0 0 0		
Message type	1 0 1 0 1 1 1 1		

- **DEACTIVATE POWER LIMIT REQUEST**

This message is only sent in the direction SS to UE, embedded in a RRC *DLInformationTransfer* message.

**Table 4.7A.7-3: DEACTIVATE POWER LIMIT REQUEST**

Derivation Path: 38.509 clause 6.11.3
---------------------------------------

Information Element	Value/remark	Comment	Condition
Protocol discriminator	1 1 1 1		
Skip indicator	0 0 0 0		
Message type	1 0 1 1 0 0 0 0		

## - DEACTIVATE POWER LIMIT RESPONSE

This message is only sent in the direction UE to SS, embedded in a RRC *ULInformationTransfer* message.

- Table 4.7A.7-3: DEACTIVATE POWER LIMIT RESPONSE

Derivation Path: 38.509 clause 6.11.4			
Information Element	Value/remark	Comment	Condition
Protocol discriminator	1 1 1 1		
Skip indicator	0 0 0 0		
Message type	1 0 1 1 0 0 0 1		

## 4.7B Default AT Command message and information element

### - AT Command +CATM

Same as TS 36.508 [2], Table 4.7I-1.

### - AT Command +CCUTLE

This AT Command is sent by the SS to the UE.

Table 4.7B-1: +CCUTLE

Derivation Path: 27.007 clause 15.3			
Field	Value/remark	Comment	Condition
+ CCUTLE =			
<status>	1		Open
<status>	0		Close
<direction>	1		Transmit
<sl_mimo>	0		Transmit
	1		Transmit AND SL_MIMO
<direction>	0		Receive
<format>	1		Receive
<length>	1		Receive
<monitor_list>	HEX '0000AA'		Receive

Condition	Explanation
Open	Open UE test loop back mode E.
Close	Close UE test loop back mode E
Transmit	UE is configured to transmit V2X communication packets
Receive	UE is configured to receive V2X communication packets
SL_MIMO	UE is configured to transmit PSSCH with 2 spatial layers, i.e. SL MIMO

### - AT Command +CUTCR

Same as TS 36.508 [2], Table 4.7I-3.



- *AT Command +CUSPCREQ*

Same as TS 36.508 [2], Table 4.7I-4.

## 4.8 Reference configurations

### 4.8.1 Radio configurations

- *RRCReconfiguration-DRB(n, m)*

**Table 4.8.1-1: RRCReconfiguration-DRB (n, m)**

Derivation Path: Table 4.6.1-13 with condition NR.			
Information Element	Value/remark	Comment	Condition
RRCReconfiguration ::= SEQUENCE {			
criticalExtensions CHOICE {			
c1 CHOICE {			
rrcReconfiguration SEQUENCE {			
radioBearerConfig	RadioBearerConfig-DRB-NR(n,m)		
}			
nonCriticalExtension SEQUENCE {			
masterCellGroup	CellGroupConfig-DRB(n, m)	OCTET STRING (CONTAINING CellGroupConfig)	
}			
}			
}			
}			

- *RRCReconfiguration-HO*

**Table 4.8.1-1A: RRCReconfiguration-HO**

Derivation Path: Table 4.6.1-13.			
Information Element	Value/remark	Comment	Condition
RRCReconfiguration ::= SEQUENCE {			
criticalExtensions CHOICE {			
rrcReconfiguration SEQUENCE {			
radioBearerConfig	RadioBearerConfig with conditions SRB_NR_PDCP and DRBn and Re-establish_PDCP		RBConfig_KeyChange
	RadioBearerConfig with conditions DRBn and Recover_PDCP		RBConfig_NoKeyChange
secondaryCellGroup	Not present		
nonCriticalExtension SEQUENCE {			
masterCellGroup	CellGroupConfig with conditions PCell_change	OCTET STRING (CONTAINING CellGroupConfig)	
masterKeyUpdate	Not present		
masterKeyUpdate SEQUENCE {			RBConfig_KeyChange
keySetChangeIndicator	false	Horizontal key derivation	
nextHopChainingCount	NextHopChainingCount		
nas-Container	Not present		
}			
}			
}			

}			
}			

Condition	Explanation
RBConfig_KeyChange	RadioBearerConfig to perform Intra-NR handover with security key change
RBConfig_NoKeyChange	RadioBearerConfig to perform Intra-NR handover without security key change

– *RRCReconfiguration-SRB2-DRB(n, m)*

**Table 4.8.1-1B: RRCReconfiguration-SRB2-DRB(n, m)**

Derivation Path: Table 4.6.1-13 with condition NR.			
Information Element	Value/remark	Comment	Condition
RRCReconfiguration ::= SEQUENCE {			
criticalExtensions CHOICE {			
c1 CHOICE {			
rrcReconfiguration SEQUENCE {			
radioBearerConfig	RadioBearerConfig-SRB2-DRB(n,m)		
}			
nonCriticalExtension SEQUENCE {			
masterCellGroup	CellGroupConfig-SRB2-DRB(n, m)	OCTET STRING (CONTAINING CellGroupConfig)	
}			
}			
}			

– *RRCReconfiguration-NR-DC-DRB*

**Table 4.8.1-1CA: RRCReconfiguration-NR-DC-DRB**

Derivation Path: Table 4.6.1-13 with condition NR-DC.			
Information Element	Value/remark	Comment	Condition
RRCReconfiguration ::= SEQUENCE {			
criticalExtensions CHOICE {			
c1 CHOICE {			
rrcReconfiguration SEQUENCE {			
radioBearerConfig	Not present		
}			
nonCriticalExtension SEQUENCE {			
masterCellGroup	Not present		MCG(s) and SCG
	CellGroupConfig with condition DRB(n+m+1)	OCTET STRING (CONTAINING CellGroupConfig)	MCG(s) and split
nonCriticalExtension SEQUENCE {			
nonCriticalExtension SEQUENCE {			
radioBearerConfig2	RadioBearerConfig with conditions DRB(n+m+1) and SCG_DRB and SecondaryKeys	OCTET STRING (CONTAINING RadioBearerConfig) DRB(n,m) already configured on MCG	MCG(s) and SCG
	RadioBearerConfig with conditions DRB(n+m+1) and SCG_DRB and Split and SecondaryKeys	OCTET STRING (CONTAINING RadioBearerConfig)	MCG(s) and split

		DRB(n,m) already configured on MCG	
}			
}			
}			
}			
}			
}			

*RRCReconfiguration-NE-DC-DRB*

**Table 4.8.1-1CB: RRCReconfiguration-NE-DC-DRB**

Derivation Path: Table 4.6.1-13 with condition NE-DC.			
Information Element	Value/remark	Comment	Condition
RRCReconfiguration ::= SEQUENCE {			
criticalExtensions CHOICE {			
c1 CHOICE {			
rrcReconfiguration SEQUENCE {			
radioBearerConfig	Not present		
}			
nonCriticalExtension SEQUENCE {			
masterCellGroup	Not present		MCG(s) and SCG
	CellGroupConfig with condition DRB(n+m+1)	OCTET STRING (CONTAINING CellGroupConfig)	MCG(s) and split
}			
}			
nonCriticalExtension SEQUENCE {			
nonCriticalExtension SEQUENCE {			
radioBearerConfig2	RadioBearerConfig with conditions DRB(n+m+1) and SCG_DRB and SecondaryKeys	OCTET STRING (CONTAINING RadioBearerConfig) DRB(n,m) already configured on MCG	MCG(s) and SCG
	RadioBearerConfig with conditions DRB(n+m+1) and SCG_DRB and Split and SecondaryKeys	OCTET STRING (CONTAINING RadioBearerConfig) DRB(n,m) already configured on MCG	MCG(s) and split
}			
}			
}			
}			
}			
}			
}			
}			

*RRCReconfiguration-Speech*

**Table 4.8.1-1C: RRCReconfiguration-Speech**

Derivation Path: Table 4.6.1-13 with condition NR.			
Information Element	Value/remark	Comment	Condition
RRCReconfiguration ::= SEQUENCE {			
criticalExtensions CHOICE {			
c1 CHOICE {			
rrcReconfiguration SEQUENCE {			
radioBearerConfig	RadioBearerConfig-Speech		

}			
nonCriticalExtension SEQUENCE {			
masterCellGroup	CellGroupConfig-DRB(0.1)	OCTET STRING (CONTAINING CellGroupConfig)	
}			
}			
}			
}			

– *RRCReconfiguration-Video*

**Table 4.8.1-1D: RRCReconfiguration-Video**

Derivation Path: Table 4.6.1-13 with condition NR.			
Information Element	Value/remark	Comment	Condition
RRCReconfiguration ::= SEQUENCE {			
criticalExtensions CHOICE {			
c1 CHOICE {			
rrcReconfiguration SEQUENCE {			
radioBearerConfig	RadioBearerConfig-Video		
}			
nonCriticalExtension SEQUENCE {			
masterCellGroup	CellGroupConfig-DRB(0,2)	OCTET STRING (CONTAINING CellGroupConfig)	
}			
}			
}			

– *CellGroupConfig-DRB(n, m)*

**Table 4.8.1-2: CellGroupConfig-DRB(n, m)**

Derivation Path: Table 4.6.3-19: CellGroupConfig (the same conditions are applicable as for table 4.6.3-19).			
Information Element	Value/remark	Comment	Condition
CellGroupConfig ::= SEQUENCE {			
rlc-BearerToAddModList SEQUENCE (SIZE(1..maxLCH)) OF RLC-BearerConfig {	n+m entries	BID is the total number of established DRBs in the UE, before applying the contents of this IE	
RLC-BearerConfig[k, k=1..n]	RLC-BearerConfig with conditions AM and DRB <sub>j</sub> (with j=BID+k)	entry (1..n+1)	n>0
RLC-BearerConfig[k, k=n+1..n+m]	RLC-BearerConfig with conditions UM and DRB <sub>j</sub> (with j=BID+k)	entry (n+1..n+m)	m>0
}			
}			

Condition	Explanation
n>0	n is greater than zero
m>0	m is greater than zero

– *CellGroupConfig-SRB3*

**Table 4.8.1-2A: CellGroupConfig-SRB3**

Derivation Path: Table 4.6.3-19: CellGroupConfig with condition EN-DC.			
Information Element	Value/remark	Comment	Condition
CellGroupConfig ::= SEQUENCE {			
rlc-BearerToAddModList SEQUENCE (SIZE(1..maxLCH)) OF RLC-BearerConfig {	2 entries		
RLC-BearerConfig[1]	RLC-BearerConfig with conditions AM and DRB2	entry 1	
RLC-BearerConfig[2]	RLC-BearerConfig with condition SRB3	entry 2	
}			
}			

– *CellGroupConfig-SRB2-DRB(n, m)*

**Table 4.8.1-2B: CellGroupConfig-SRB2-DRB(n, m)**

Derivation Path: Table 4.6.3-19: CellGroupConfig			
Information Element	Value/remark	Comment	Condition
CellGroupConfig ::= SEQUENCE {			
rlc-BearerToAddModList SEQUENCE (SIZE(1..maxLCH)) OF RLC-BearerConfig {	1+n+m entries		
RLC-BearerConfig[1]	RLC-BearerConfig with condition SRB2	entry 1	
RLC-BearerConfig[k, k=2..n+1]	RLC-BearerConfig with conditions AM and DRBj	entry (2..n+1) j is allocated according to internal TTCN mapping	n>0
...		...	
RLC-BearerConfig[k, k=n+2..n+m+1]	RLC-BearerConfig with conditions UM and DRBj	entry (n+2..n+m+1) j is allocated according to internal TTCN mapping	m>0
}			
mac-CellGroupConfig	Not present		
physicalCellGroupConfig	Not present		
spCellConfig	Not present		
}			

– *RadioBearerConfig-DRB (n, m)*

**Table 4.8.1-3: RadioBearerConfig-DRB (n, m)**

Derivation Path: Table 4.6.3-132 and condition EN-DC.			
Information Element	Value/remark	Comment	Condition
RadioBearerConfig ::= SEQUENCE {			
drb-ToAddModList SEQUENCE (SIZE (1..maxDRB)) OF DRB-ToAddMod {	n+m entries	BID is the total number of established DRBs in the UE, before applying the contents of this IE	
DRB-ToAddMod[k=1..n+m] SEQUENCE {		entry (1..n+m)	
cnAssociation CHOICE {			
eps-BearerIdentity	l, l=BID+5..BID+4+n+m		
}			
drb-Identity	l, l=BID+1..BID+n+m		

reestablishPDCP	Not present		
recoverPDCP	Not present		
pdcp-Config	PDCP-Config		k ≤ n
	PDCP-Config with condition UM		k > n
}			
}			
}			

*RadioBearerConfig-DRB-NR(n, m)*

**Table 4.8.1-3A: RadioBearerConfig-DRB-NR(n, m)**

Derivation Path: Table 4.6.3-132.

Information Element	Value/remark	Comment	Condition
RadioBearerConfig ::= SEQUENCE {			
drb-ToAddModList SEQUENCE (SIZE (1..maxDRB)) OF DRB-ToAddMod {	n+m entries	BID is the total number of established DRBs in the UE, before applying the contents of this IE entry (1..n+m)	
DRB-ToAddMod[k=1..n+m] SEQUENCE {			
cnAssociation CHOICE {			
sdap-Config	SDAP-Config		
}			
drb-Identity	BID+k	k=1..n+m	
reestablishPDCP	Not present		
recoverPDCP	Not present		
pdcp-Config	PDCP-Config		k ≤ n
	PDCP-Config with condition UM		k > n
}			
}			
}			

*RadioBearerConfig-SRB2-DRB (n, m)*

**Table 4.8.1-4: RadioBearerConfig-SRB2-DRB (n, m)**

Derivation Path: Table 4.6.3-132 and condition SRB2.

Information Element	Value/remark	Comment	Condition
RadioBearerConfig ::= SEQUENCE {			
drb-ToAddModList SEQUENCE (SIZE (1..maxDRB)) OF DRB-ToAddMod {	n+m entries		
DRB-ToAddMod[k=1..n+m] := SEQUENCE {		entry (1..n+m)	
cnAssociation CHOICE {			
sdap-Config	SDAP-Config	SDAP-Config is configured according to internal TTCN mapping (Note 1)	
}			
drb-Identity	j	j is allocated according to internal TTCN mapping	
reestablishPDCP	Not present		
recoverPDCP	Not present		
pdcp-Config	PDCP-Config		(1 < k ≤ n) OR (k=1 AND NOT NR_split)

	PDCP-Config with condition UM		k > n
	PDCP-Config with condition NR_split		k=1 AND NR_split
}			
}			
}			
}			
Note 1: Configure a default DRB or configure QoS flow to DRB mapping rule.			

*RadioBearerConfig-Speech*

**Table 4.8.1-5: RadioBearerConfig-Speech**

Derivation Path: Table 4.6.3-132 and condition SRB2.			
Information Element	Value/remark	Comment	Condition
RadioBearerConfig ::= SEQUENCE {			
drb-ToAddModList SEQUENCE (SIZE (1..maxDRB))	1 entry		
OF DRB-ToAddMod {			
DRB-ToAddMod[1] SEQUENCE {			
cnAssociation CHOICE {			
sdap-Config SEQUENCE {	SDAP-Config		
defaultDRB	false		
}			
}			
drb-Identity	j	j is allocated according to internal TTCN mapping	
reestablishPDCP	Not present		
recoverPDCP	Not present		
pdcp-Config	PDCP-Config with condition UM		
}			
}			
}			

*RadioBearerConfig-Video*

**Table 4.8.1-6: RadioBearerConfig-Video**

Derivation Path: Table 4.6.3-132 and condition SRB2.			
Information Element	Value/remark	Comment	Condition
RadioBearerConfig ::= SEQUENCE {			
drb-ToAddModList SEQUENCE (SIZE (1..maxDRB))	2 entries		
OF DRB-ToAddMod {			
DRB-ToAddMod [1] SEQUENCE {		entry 1	
cnAssociation CHOICE {			
sdap-Config SEQUENCE {	SDAP-Config		
defaultDRB	false		
}			
}			
drb-Identity	j	j is allocated according to internal TTCN mapping	
reestablishPDCP	Not present		
recoverPDCP	Not present		
pdcp-Config	PDCP-Config with condition UM		
}			
DRB-ToAddMod [2] SEQUENCE {		entry 2	
cnAssociation CHOICE {			

sdap-Config SEQUENCE {	SDAP-Config		
defaultDRB	false		
}			
}			
drb-Identity	k	k is allocated according to internal TTCN mapping	
reestablishPDCP	Not present		
recoverPDCP	Not present		
pdcpc-Config	PDCP-Config with condition UM		
}			
}			
}			

## 4.8.2 5GC configurations

### 4.8.2.1 Reference QoS rules

**Table 4.8.2.1-1: Reference QoS rule #1**

Derivation Path: TS 24.501, table 9.11.4.13			
Information Element	Value/remark	Comment	Condition
QoS rules			
QoS rule			
QoS rule identifier	'0000 0001'B	1 (unique per PDU session)	
Rule operation code	'001'B	Create new QoS rule	
DQR bit	'1'B	The QoS rule is the default QoS rule.	
Number of packet filters	'0001'B	1 packet filters	
Packet filter list	See table 4.8.2.2-1	Packet filter list #1	
QoS rule precedence	'1111 1111'B	255 (unique per PDU session; If the default QoS rule contains a match-all packet filter, then the highest precedence value shall be used for the default QoS rule.)	
Spare bit	'0'B		
Segregation	'0'B	Spare	
QoS flow identifier (QFI)	'00 0001'B	QFI 1 (Table 4.8.2.3-1)	

**Table 4.8.2.1-2: Reference QoS rule #2**

Derivation Path: TS 24.501, table 9.11.4.13			
Information Element	Value/remark	Comment	Condition
QoS rules			
QoS rule			
QoS rule identifier	'0000 0010'B	2 (unique per PDU session)	
Rule operation code	'001'B	Create new QoS rule	



DQR bit	'1'B	The QoS rule is the default QoS rule.	
Number of packet filters	'0001'B	1 packet filter	
Packet filter list	See table 4.8.2.2-1	Packet filter list #1	
QoS rule precedence	'1111 1111'B	255 (unique per PDU session; If the default QoS rule contains a match-all packet filter, then the highest precedence value shall be used for the default QoS rule.)	
Spare bit	'0'B		
Segregation	'0'B	Spare	
QoS flow identifier (QFI)	'00 0010'B	QFI 2 (Table 4.8.2.3-2)	

Table 4.8.2.1-3: Reference QoS rule #3

Derivation Path: TS 24.501, table 9.11.4.13			
Information Element	Value/remark	Comment	Condition
QoS rules			
QoS rule			
QoS rule identifier	'0000 0011'B	3 (unique per PDU session)	
Rule operation code	'001'B	Create new QoS rule	
DQR bit	'0'B	The QoS rule is the non-default QoS rule.	
Number of packet filters	'0001'B	1 packet filter	
Packet filter list	See table 4.8.2.2-2	Packet filter list #2	
QoS rule precedence	'0000 0011'B	3 (unique per PDU session)	
Spare bit	'0'B		
Segregation	'0'B	Spare	
QoS flow identifier (QFI)	'00 0001'B	QFI 1 (Table 4.8.2.3-1)	

Table 4.8.2.1-4: Reference QoS rule #4

Derivation Path: TS 24.501, table 9.11.4.13			
Information Element	Value/remark	Comment	Condition
QoS rules			
QoS rule			
QoS rule identifier	'0000 0100'B	4 (unique per PDU session)	
Rule operation code	'001'B	Create new QoS rule	
DQR bit	'1'B	The QoS rule is the default QoS rule.	
Number of packet filters	'0001'B	1 packet filter	
Packet filter list	See table 4.8.2.2-3	Packet filter list #3	
QoS rule precedence	'0000 00100'B	4 (unique per PDU session)	
Spare bit	'0'B		
Segregation	'0'B	Spare	
QoS flow identifier (QFI)	'00 0010'B	QFI 2 (Table 4.8.2.3-2)	

Table 4.8.2.1-4a: Reference QoS rule #4a

Derivation Path: TS 24.501, table 9.11.4.13			
Information Element	Value/remark	Comment	Condition
QoS rules			
QoS rule			
QoS rule identifier	'0000 1111'B	15 (unique per PDU session)	
Rule operation code	'001'B	Create new QoS rule	
DQR bit	'0'B	The QoS rule is the non-default QoS rule.	
Number of packet filters	'0001'B	1 packet filter	
Packet filter list	See table 4.8.2.2-3a	Packet filter list #3a	
QoS rule precedence	'0000 1111'B	15 (unique per PDU session)	
Spare bit	'0'B		
Segregation	'0'B	Spare	
QoS flow identifier (QFI)	'00 0100'B	QFI 4 (Table 4.8.2.3-2a)	

Table 4.8.2.1-5: Reference QoS rule #5

Derivation Path: TS 24.501, table 9.11.4.13			
Information Element	Value/remark	Comment	Condition
QoS rules			
QoS rule			
QoS rule identifier	'0000 0101'B	5 (unique per PDU session)	
Rule operation code	'001'B	Create new QoS rule	
DQR bit	'0'B	The QoS rule is the non-default QoS rule.	
Number of packet filters	'0001'B	1 packet filter	
Packet filter list	See table 4.8.2.2-4	Packet filter list #4	
QoS rule precedence	'0000 0101'B	5 (unique per PDU session)	
Spare bit	'0'B		
Segregation	'0'B	Spare	
QoS flow identifier (QFI)	'00 0101'B	QFI 5 (Table 4.8.2.3-3)	

Table 4.8.2.1-6: Reference QoS rule #6

Derivation Path: TS 24.501, table 9.11.4.13			
Information Element	Value/remark	Comment	Condition
QoS rules			
QoS rule			
QoS rule identifier	'0000 0110'B	6 (unique per PDU session)	
Rule operation code	'001'B	Create new QoS rule	
DQR bit	'0'B	The QoS rule is the non-default QoS rule.	
Number of packet filters	'0001'B	1 packet filter	
Packet filter list	See table 4.8.2.2-5	Packet filter list #5	
QoS rule precedence	'0000 0110'B	6 (unique per PDU session)	

Spare bit	'0'B		
Segregation	'0'B	Spare	
QoS flow identifier (QFI)	'00 0110'B	QFI 6 (Table 4.8.2.3-4)	

Table 4.8.2.1-7: Reference QoS rule #7

Derivation Path: TS 24.501, table 9.11.4.13			
Information Element	Value/remark	Comment	Condition
QoS rules			
QoS rule			IMS_VOICE
QoS rule identifier	'0000 0011'B	3 (unique per PDU session)	
Rule operation code	'001'B	Create new QoS rule	
DQR bit	'0'B	The QoS rule a non-default QoS rule.	
Number of packet filters	'0001'B	1 packet filter	
Packet filter list	See table 4.8.2.2-6	Packet filter list #6	
QoS rule precedence	'0000 0001'B	1 (unique per PDU session)	
Spare bit	'0'B		
Segregation	'0'B	Spare	
QoS flow identifier (QFI)	'00 0111'B	QFI 7 (Table 4.8.2.3-5)	
QoS rule			IMS_VIDEO
QoS rule identifier	'0000 0100'B	4 (unique per PDU session)	
Rule operation code	'001'B	Create new QoS rule	
DQR bit	'0'B	The QoS rule a non-default QoS rule.	
Number of packet filters	'0001'B	1 packet filter	
Packet filter list	See table 4.8.2.2-7	Packet filter list #7	
QoS rule precedence	'0000 0010'B	2 (unique per PDU session)	
Spare bit	'0'B		
Segregation	'0'B	Spare	
QoS flow identifier (QFI)	'00 1000'B	QFI 8 (Table 4.8.2.3-6)	

Condition	Explanation
IMS_VOICE	If this QoS rule is used to setup an IMS voice session
IMS_VIDEO	If this QoS rule is used to setup an IMS video session

Table 4.8.2.1-8: Reference QoS rule #8

Derivation Path: TS 24.501, table 9.11.4.13			
Information Element	Value/remark	Comment	Condition
QoS rules			
QoS rule			
QoS rule identifier	'0000 0111'B	7 (unique per PDU session)	
Rule operation code	'001'B	Create new QoS rule	
DQR bit	'1'B	The QoS rule is the default QoS rule.	
Number of packet filters	'0001'B	1 packet filter	
Packet filter list	See table 4.8.2.2-1	Packet filter list #1	

QoS rule precedence	'1111 1111'B	255 (unique per PDU session; If the default QoS rule contains a match-all packet filter, then the highest precedence value shall be used for the default QoS rule.)	
Spare bit	'0'B		
Segregation	'0'B	Spare	
QoS flow identifier (QFI)	'00 1001'B	QFI 9 (Table 4.8.2.3-7)	

**Table 4.8.2.1-XX: Reference QoS rule #9**

Derivation Path: TS 24.501, table 9.11.4.13			
Information Element	Value/remark	Comment	Condition
QoS rules			
QoS rule			
QoS rule identifier	'0000 1000'B	8 (unique per PDU session)	
Rule operation code	'001'B	Create new QoS rule	
DQR bit	'1'B	The QoS rule is the default QoS rule.	
Number of packet filters	'0001'B	1 packet filter	
Packet filter list	See table 4.8.2.2-1	Packet filter list #1	
QoS rule precedence	'1111 1111'B	255 (unique per PDU session; If the default QoS rule contains a match-all packet filter, then the highest precedence value shall be used for the default QoS rule.)	
Spare bit	'0'B		
Segregation	'0'B	Spare	
QoS flow identifier (QFI)	'00 1100'B	QFI 10 (Table 4.8.2.3-YY)	

#### 4.8.2.2 Reference packet filters

**Table 4.8.2.2-1: Packet filter list #1**

Derivation Path: TS 24.501, table 9.11.4.13			
Information Element	Value/remark	Comment	Condition
Packet filter list			
Packet filter direction	'11'B	bidirectional	
Packet filter identifier	'0001'B	Id 1	
Component type 1 ID	'0000 0001'B	Match-all type	

**Table 4.8.2.2-2: Packet filter list #2**

Derivation Path: TS 24.501, table 9.11.4.13			
Information Element	Value/remark	Comment	Condition
Packet filter list			

Packet filter direction	'11'B	bidirectional	
Packet filter identifier	'0010'B	Id 2	
Component type 1 ID	0 0 0 1 0 0 0 0	IPv4 remote address type	remotelPv4
	0 0 1 0 0 0 0 1	IPv6 remote address type/prefix length type	remotelPv6
Component type 1 Value	10.10.10.2 255.255.255.255	See Note 1	remotelPv4
	C0C0:C0C0:C0C0:C002 C0C0:C0C0:C0C0:C0C0/ 64	See Note 1	remotelPv6
Note 1: This IP address is also the address of an IP server able to send a flow of downlink IP packets to the UE. remotelPv4 applies if the UE has acquired an IPv4 address only, remotelPv6 applies if the UE has acquired an IPv6 address only, or both an IPv6 and an IPv4 address.			

Table 4.8.2.2-3: Packet filter list #3

Derivation Path: TS 24.501, table 9.11.4.13			
Information Element	Value/remark	Comment	Condition
Packet filter list			
Packet filter direction	'11'B	bidirectional	
Packet filter identifier	'0011'B	Id 3	
Component type 1 ID	0 0 0 1 0 0 0 0	IPv4 remote address type	remotelPv4
	0 0 1 0 0 0 0 1	IPv6 remote address type/prefix length type	remotelPv6
Component type 1 Value	10.10.10.3 255.255.255.255	See Note 1	remotelPv4
	C0C0:C0C0:C0C0:C003 C0C0:C0C0:C0C0:C0C0/ 64	See Note 1	remotelPv6
Note 1: This IP address is also the address of an IP server able to send a flow of downlink IP packets to the UE. remotelPv4 applies if the UE has acquired an IPv4 address only, remotelPv6 applies if the UE has acquired an IPv6 address only, or both an IPv6 and an IPv4 address.			

Table 4.8.2.2-3a: Packet filter list #3a

Derivation Path: TS 24.501, table 9.11.4.13			
Information Element	Value/remark	Comment	Condition
Packet filter list			
Packet filter direction	'11'B	bidirectional	
Packet filter identifier	'1111'B	Id 15	
Component type 1 ID	0 0 0 1 0 0 0 0	IPv4 remote address type	remotelPv4
	0 0 1 0 0 0 0 1	IPv6 remote address type/prefix length type	remotelPv6
Component type 1 Value	10.10.10.30 255.255.255.255	See Note 1	remotelPv4
	C0C0:C0C0:C0C0:C030 C0C0:C0C0:C0C0:C0C0/ 64	See Note 1	remotelPv6
Note 1: This IP address is also the address of an IP server able to send a flow of downlink IP packets to the UE. remotelPv4 applies if the UE has acquired an IPv4 address only, remotelPv6 applies if the UE has acquired an IPv6 address only, or both an IPv6 and an IPv4 address.			

Table 4.8.2.2-4: Packet filter list #4

Derivation Path: TS 24.501, table 9.11.4.13			
Information Element	Value/remark	Comment	Condition
Packet filter list			
Packet filter direction	'11'B	bidirectional	
Packet filter identifier	'0100'B	Id 4	
Component type 1 ID	0 0 0 1 0 0 0 0	IPv4 remote address type	remotelPv4
	0 0 1 0 0 0 0 1	IPv6 remote address type/prefix length type	remotelPv6
Component type 1 Value	10.10.10.4 255.255.255.255	See Note 1	remotelPv4
	C0C0:C0C0:C0C0:C004 C0C0:C0C0:C0C0:C0C0/ 64	See Note 1	remotelPv6
Note 1: This IP address is also the address of an IP server able to send a flow of downlink IP packets to the UE. remotelPv4 applies if the UE has acquired an IPv4 address only, remotelPv6 applies if the UE has acquired an IPv6 address only, or both an IPv6 and an IPv4 address.			

Table 4.8.2.2-5: Packet filter list #5

Derivation Path: TS 24.501, table 9.11.4.13			
Information Element	Value/remark	Comment	Condition
Packet filter list			
Packet filter direction	'11'B	bidirectional	
Packet filter identifier	'0101'B	Id 5	
Component type 1 ID	0 0 0 1 0 0 0 0	IPv4 remote address type	remotelPv4
	0 0 1 0 0 0 0 1	IPv6 remote address type/prefix length type	remotelPv6
Component type 1 Value	10.10.10.5 255.255.255.255	See Note 1	remotelPv4
	C0C0:C0C0:C0C0:C005 C0C0:C0C0:C0C0:C0C0/ 64	See Note 1	remotelPv6
Note 1: This IP address is also the address of an IP server able to send a flow of downlink IP packets to the UE. remotelPv4 applies if the UE has acquired an IPv4 address only, remotelPv6 applies if the UE has acquired an IPv6 address only, or both an IPv6 and an IPv4 address.			

Table 4.8.2.2-6: Packet filter list #6

Derivation Path: TS 24.501, table 9.11.4.13			
Information Element	Value/remark	Comment	Condition
Packet filter list			
Packet filter direction	'11'B	bidirectional	
Packet filter identifier	0110'B	Id 6	
Component type 1 ID	0 1 0 1 0 0 0 1	Remote port range type	
Component type 1 Value	media port	SS speech media port as used in the SDP negotiation (RTP remote port); see Note 1	
	media port + 1	RTCP remote port; see Note 1	
Component type 2 ID	0 0 1 1 0 0 0 0	Protocol identifier/Next header type	
Component type 2 Value	17	UDP	

Note 1: According to TS 26.114 [45] and RFC 4566 [46] a "media port" can be understood as the transport port to which a media stream is sent.

Table 4.8.2.2-7: Packet filter list #7

Derivation Path: TS 24.501, table 9.11.4.13			
Information Element	Value/remark	Comment	Condition
Packet filter list			
Packet filter direction	'11'B	bidirectional	
Packet filter identifier	0111'B	Id 7	
Component type 1 ID	0 1 0 1 0 0 0 1	Remote port range type	
Component type 1 Value	media port	SS video media port as used in the SDP negotiation (RTP remote port); see Note 1	
	media port + 1	RTCP remote port; see Note 1	
Component type 2 ID	0 0 1 1 0 0 0 0	Protocol identifier/Next header type	
Component type 2 Value	17	UDP	
Note 1: According to TS 26.114 [45] and RFC 4566 [46] a "media port" can be understood as the transport port to which a media stream is sent.			

#### 4.8.2.3 Reference QoS flow descriptions

Table 4.8.2.3-1: Reference QoS flow #1

Derivation Path: TS 24.501, table 9.11.4.12			
Information Element	Value/remark	Comment	Condition
QoS flow descriptions			
QoS flow description			
QFI	'00 0001'B	QFI 1	
Operation code	'001'B	Create new QoS flow description	
E bit	'1'B	Parameters list is included	
Number of parameters	'00 0001'B	1 parameter	
Number of parameters	'00 0010'B	2 parameters	Interworking_with_EPS
5QI	'0000 1001'B	5QI 9	
EPS bearer identity	Any not yet assigned value different to '5'		Interworking_with_EPS

Condition	Explanation
Interworking_with_EPS	If this flow is used in the Authorized QoS flow descriptions IE of a PDU SESSION ESTABLISHMENT ACCEPT message or PDU SESSION MODIFICATION COMMAND message also including the Mapped EPS bearer context IE.

Table 4.8.2.3-2: Reference QoS flow #2

Derivation Path: TS 24.501, table 9.11.4.12			
Information Element	Value/remark	Comment	Condition
QoS flow descriptions			
QoS flow description			
QFI	'00 0010'B	QFI 2	
Operation code	'001'B	Create new QoS flow description	

E bit	'1'B	Parameters list is included	
Number of parameters	'00 0001'B	1 parameter	
Number of parameters	'00 0010'B	2 parameters	Interworking _with_EPS
5QI	'0000 0101'B	5QI 5	
EPS bearer identity	'0101 0000'B	EBI 5	Interworking _with_EPS
EPS bearer identity	Any not yet assigned value different from '5'		Emergency Session AND Interworking _with_EPS

Condition	Explanation
Interworking_with_EPS	If this flow is used in the Authorized QoS flow descriptions IE of a PDU SESSION ESTABLISHMENT ACCEPT message or PDU SESSION MODIFICATION COMMAND message also including the Mapped EPS bearer context IE.
EmergencySession	If this flow is used in the Authorized QoS flow descriptions IE of a PDU Session Establishment Accept message for an emergency PDU session

Table 4.8.2.3-2a: Reference QoS flow #2a

Derivation Path: TS 24.501, table 9.11.4.12			
Information Element	Value/remark	Comment	Condition
QoS flow descriptions			
QoS flow description			
QFI	'00 0100'B	QFI 4	
Operation code	'001'B	Create new QoS flow description	
E bit	'1'B	Parameters list is included	
Number of parameters	'00 0001'B	1 parameter	
5QI	'0000 0101'B	5QI 5	

Table 4.8.2.3-3: Reference QoS flow #3

Derivation Path: TS 24.501, table 9.11.4.12			
Information Element	Value/remark	Comment	Condition
QoS flow descriptions			
QoS flow description			
QFI	'00 0101'B	QFI 5	
Operation code	'001'B	Create new QoS flow description	
E bit	'1'B	Parameters list is included	
Number of parameters	'00 0001'B	1 parameter	
5QI	'0000 0101'B	5QI 5	

Table 4.8.2.3-4: Reference QoS flow #4

Derivation Path: TS 24.501, table 9.11.4.12			
Information Element	Value/remark	Comment	Condition
QoS flow descriptions			
QoS flow description			
QFI	'00 0110'B	QFI 6	
Operation code	'001'B	Create new QoS flow description	
E bit	'1'B	Parameters list is included	



Number of parameters	'00 0001'B	1 parameter	
5QI	'0000 0101'B	5QI 5	

Table 4.8.2.3-5: Reference QoS flow #5

Derivation Path: TS 24.501, table 9.11.4.12			
Information Element	Value/remark	Comment	Condition
QoS flow descriptions			
QoS flow description			
QFI	'00 0111'B	QFI 7	
Operation code	'001'B	Create new QoS flow description	
E bit	'1'B	Parameters list is included	
Number of parameters	'00 0101'B	5 parameter	
Number of parameters	'00 0110'B	6 parameters	Interworking with_EPS
5QI	'0000 0001'B	5QI 1	
GFBR uplink	'040002'H	128 Kbps	
GFBR downlink	'040002'H	128 Kbps	
MFBR uplink	'040005'H	320 Kbps	
MFBR downlink	'040005'H	320 Kbps	
EPS bearer identity	Any not yet assigned value different to '5'	EBI 6	Interworking with_EPS

Condition	Explanation
Interworking_with_EPS	If this flow is used in the Authorized QoS flow descriptions IE of a PDU SESSION ESTABLISHMENT ACCEPT message or PDU SESSION MODIFICATION COMMAND message also including the Mapped EPS bearer context IE.

Table 4.8.2.3-6: Reference QoS flow #6

Derivation Path: TS 24.501, table 9.11.4.12			
Information Element	Value/remark	Comment	Condition
QoS flow descriptions			
QoS flow description			
QFI	'00 1000'B	QFI 8	
Operation code	'001'B	Create new QoS flow description	
E bit	'1'B	Parameters list is included	
Number of parameters	'00 0101'B	5 parameter	
Number of parameters	'00 0110'B	6 parameters	Interworking with_EPS
5QI	'0000 0010'B	5QI 2	
GFBR uplink	'020012'H	72 Kbps	
GFBR downlink	'020012'H	72 Kbps	
MFBR uplink	'030033'H	816 Kbps	
MFBR downlink	'030033'H	816 Kbps	
EPS bearer identity	Any not yet assigned value different to '5'	EBI 7	Interworking with_EPS

Condition	Explanation
Interworking_with_EPS	If this flow is used in the Authorized QoS flow descriptions IE of a PDU SESSION ESTABLISHMENT ACCEPT message or PDU SESSION MODIFICATION COMMAND message also including the Mapped EPS bearer context IE.

Table 4.8.2.3-7: Reference QoS flow #7

Derivation Path: TS 24.501, table 9.11.4.12			
Information Element	Value/remark	Comment	Condition
QoS flow descriptions			
QoS flow description			
QFI	'00 1001'B	QFI 9	
Operation code	'001'B	Create new QoS flow description	
E bit	'1'B	Parameters list is included	
Number of parameters	'00 0001'B	1 parameter	
5QI	'0101 0010'B	5QI 82	

Table 4.8.2.3-YY: Reference QoS flow #8

Derivation Path: TS 24.501, table 9.11.4.12			
Information Element	Value/remark	Comment	Condition
QoS flow descriptions			
QoS flow description			
QFI	'00 1001'B	QFI 10	
Operation code	'001'B	Create new QoS flow description	
E bit	'1'B	Parameters list is included	
Number of parameters	'00 0001'B	1 parameter	
5QI	'0101 0010'B	5QI 9	

## 4.8.3 Common test UICC and USIM parameters

This clause defines default parameters for programming the elementary files of the test UICC when running conformance test cases defined in 3GPP TS 38.523-1[12].

### 4.8.3.1 General

See clause 4.9.1 in 3GPP TS 36.508 [2] for the definition of test algorithm for

- authentication via EPC;
- authentication via 5GC using 5G AKA based primary authentication and key agreement procedure.
- authentication via 5GC using EAP-AKA' based primary authentication and key agreement procedure, further the Derivation of MSK, EMSK and other keys shall be as derived as clause 3.3 of IETF RFC 5448 [31], using Key derivation function HMAC-SHA-256 algorithm.

### 4.8.3.2 Default parameters for the test USIM and ISIM

Same as clause 4.9.2 in 3GPP TS 36.508 [2] for

- authentication via EPC;
- authentication via 5GC using 5G AKA based primary authentication and key agreement procedure.
- authentication via 5GC using EAP-AKA' based primary authentication and key agreement procedure.

### 4.8.3.3 Default settings for the Elementary Files (EFs)

Same as clause 4.9.3 in 3GPP TS 36.508 [2] for

- authentication via EPC;
- authentication via 5GC using 5G AKA based primary authentication and key agreement procedure

- authentication via 5GC using EAP-AKA' based primary authentication and key agreement procedure.

#### 4.8.3.3.1 Modified contents of the USIM Elementary Files

**Table 4.8.3.3.1-1: EF<sub>UST</sub> (USIM Service Table)**

Services		Activated	Version	Condition
Service n°122	5GS Mobility Management Information	Optional		5GC
Service n°123	5GS Security Parameters	Optional		5GC
Service n°124	Subscription identifier privacy support	Optional		5GC
Service n°125	SUCI calculation by the USIM	Optional		5GC
Service n°126	UAC Access Identities Configuration	Optional		5GC
Service n°127	Control plane-based steering of UE in VPLMN	Optional		5GC
Service n°128	Call control on PDU Session by USIM	Optional		
Service n°129	5GS Operator PLMN List	Optional		
Note: Only 5GS related services indicated				

Condition	Explanation
5GC	Authentication via 5GC

#### 4.8.3.3.2 Contents of Elementary Files at the DF<sub>5GS</sub> level

This clause defines the default contents of Elementary Files (EF) that are specific for 5GS and which are grouped in Data File (DF) structure 5GS.

##### EF<sub>5GS3GPPLOCi</sub> (5GS 3GPP location information)

File size: 20 Bytes

Default values: Bytes 1 to 13 (HEX): FF FF FF FF FF FF FF FF FF FF FF FF FF (5G-GUTI)

Bytes 14 to 19 (HEX): 42 F6 18 FF FF FE (Last visited registered TAI in 5GS for 3GPP access)

Byte 20 (BIN): 00000001 (5GS update status for 3GPP access = "5U2 not updated")

Bytes 14 to 19: TAI-MCC = 246 (bytes 14 to 15) and TAI-MNC = 81 (byte 16) are frequently used. The TAC (bytes 17 to 19) is set to "FF FF FE" since this, in conjunction with byte 20 setting of "01", is used to ensure that the UE performs registration at the beginning of a test.

Bytes in this file (e.g. GUTI in bytes 1 to 13) may be updated as a result of a registration attempt by the UE.

##### EF<sub>5GSN3GPPLOCi</sub> (5GS non-3GPP location information)

File size: 20 Bytes

Default values: Bytes 1 to 13 (HEX): FF FF FF FF FF FF FF FF FF FF FF FF FF (5G-GUTI)

Bytes 14 to 19 (HEX): 42 F6 18 FF FF FE (Last visited registered TAI in 5GS for non-3GPP access)

Byte 20 (BIN): 00000001 (5GS update status for non-3GPP access = "5U2 not updated")

Bytes 14 to 19: TAI-MCC = 246 (bytes 14 to 15) and TAI-MNC = 81 (byte 16) are frequently used. The TAC (bytes 17 to 19) is set to "FF FF FE" since this, in conjunction with byte 20 setting of "01", is used to ensure that the UE performs registration at the beginning of a test.

Bytes in this file (e.g. GUTI in bytes 1 to 13) may be updated as a result of a registration attempt by the UE.

##### EF<sub>5GS3GPPNSC</sub> (5GS 3GPP Access NAS Security Context)

The programming of this EF follows default parameter written in 3GPP TS 31.102 [33], annex E.

**EF<sub>5GSN3GPPNSC</sub>** (5GS non-3GPP Access NAS Security Context)

The programming of this EF follows default parameter written in 3GPP TS 31.102 [33], annex E.

**EF<sub>5GAUTHKEYS</sub>** (5G authentication keys)

The programming of this EF follows default parameter written in 3GPP TS 31.102 [33], annex E.

**EF<sub>UAC\_AIC</sub>** (UAC Access Identities Configuration)

The programming of this EF is a test house option.

**EF<sub>SUCI\_Calc\_Info</sub>** (Subscription Concealed Identifier Calculation Information EF)

The programming of this EF is a test house option.

**EF<sub>OPL5G</sub>** (5GS Operator PLMN List)

The programming of this EF follows default parameter written in 3GPP TS 31.102 [33], annex E.

**4.8.3.3.3 Default settings of UICC and USIM for V2X****EF<sub>UST</sub>** (USIM Service Table):

Same as clause 4.9.3.4 of TS 36.508 [2].

**EF<sub>VST</sub>** (V2X Service Table)

If service n°119 is "available" in the USIM Service Table, this file shall be present. This EF indicates the coding of the V2X management objects and which V2X services are available.

File size: 2 Bytes

Default values: Bytes 1 to 2 (HEX): 01 02

Coding of the V2X management objects is according to 3GPP TS 24.588 [113].

Service n°2 V2X policy configuration data over PC5 is supported.

**NOTE:** The default value for NR support of V2X services is different from that for LTE V2X in clause 4.9.3.4 of TS 36.508 [2].

**EF<sub>V2XP\_PC5</sub>** (V2X data policy over PC5)

If service n°2 is "available" in EF<sub>VST</sub>, this file shall be present. This EF contains V2X in 5GS UE policies over PC5. The format of the V2X in 5GS UE policies over PC5 are specified in 3GPP TS 24.588 [113].

The V2X in 5GS UE policies over PC5 contents:

**Table 4.8.3.3.3-1: V2X data policy over PC5**

Description	Value	M/O	Length (bytes)
V2X data policy over PC5 Tag	'A0'	M	1
Length	Note 1	M	Note 2
Validity timer	'FF FF FF FF FF FF FF FF FF FF'H	M	X1
Indicator bits	'1000 0000'B	M	1
Served by E-UTRA or served by NR Tag	'80'	M	1
Length	X2	M	Note 2
Served by E-UTRA or served by NR information	See Table 4.7.5.5-2	M	X2

Not served by E-UTRA and not served by NR Tag	'81'	O	1
Length	X3	O	Note 2
Not served by E-UTRA and not served by NR information	See Table 4.7.5.5-6	O	X3
V2X service identifier to Tx profiles mapping rules Tag	'82'	O	1
Length	X4	O	Note 2
V2X service identifier to Tx profiles mapping rules information	See Table 4.7.5.5-12		X4
Privacy config Tag	'83'	O	1
Length	X5	O	Note 2
Privacy config information	See Table 4.7.5.5-15		X5
V2X communication over PC5 in E-UTRA Tag	'84'	O	1
Length	X6	O	Note 2
V2X communication over PC5 in E-UTRA information	See Table 4.7.5.5-19	O	X6
V2X communication over PC5 in NR Tag	'85'	O	1
Length	X7	O	Note 2
V2X communication over PC5 in NR Information	See Table 4.7.5.5-31	O	X7
Note 1: This is the total size of the constructed TLV object.			
Note 2: The length is coded according to ISO/IEC 8825-1 [35].			

#### 4.8.4 DNN/APN configurations

The present subclause provides DNN/APN configurations required for flexible PDU/PDN handling. Table 4.8.4-1 provides configurations for the types on DNN/APN handled in the present version of the test specification. If in the future new PDU types need to be handled, then new DNN/APN configuration(s) may be added.

**Table 4.8.4-1: DNN/APN configurations, first set**

Configurations	Config #1	Config #2	Config #3
DNN/APN type	internet	ims	urllc
DNN/APN ID	pc_APN_ID_Internet	pc_APN_ID_IMS	pc_APN_ID_URLLC
5GC QoS rule	Reference QoS rule #1 as specified in subclause 4.8.2.1.	Reference QoS rule #2 as specified in subclause 4.8.2.1.	Reference QoS rule #8 as specified in subclause 4.8.2.1.
EPC default bearer context	Reference default EPS bearer context #1 as specified in TS 36.508 [10], Table 6.6.1-1.	Reference default EPS bearer context #2 as specified in TS 36.508 [10], Table 6.6.1-1.	N/A
EPC dedicated bearer context	Reference dedicated EPS bearer context #1 as specified in TS 36.508 [10], Table 6.6.2-1.	Reference dedicated EPS bearer context #4 as specified in TS 36.508 [10], Table 6.6.2-1.	N/A
IP address allocation	Yes	Yes	Yes
IMS registration	No	Yes NOTE 1	No
SST condition (NOTE 2)	SST_eMBB	SST_eMBB	SST_URLLC
NOTE 1: For PDN establishment the Procedure for IMS signalling according to TS 36.508 [2], subclause 4.5A.3 applies; for PDU establishment the Procedure for IMS signalling according to TS 34.229-5 [47], Annex A.2 applies.			
NOTE 2: The possible values of the SST condition are defined in Table 4.6.0.1-5.			

**Table 4.8.4-2: DNN/APN configurations, second set**

Configurations	Config #4	Config #5	Config #6	Config #7
----------------	-----------	-----------	-----------	-----------

DNN/APN type	miot	v2x	ethernet	mbs
DNN/APN ID	pc_APN_ID_MIoT	pc_APN_ID_V2X	pc_APN_ID_Ethernet	pc_APN_ID_MBS
5GC QoS rule	FFS	FFS	Reference QoS rule #1 as specified in subclause 4.8.2.1.	Reference QoS rule #9 as specified in subclause 4.8.2.1.
EPC default bearer context	N/A	N/A	N/A	N/A
EPC dedicated bearer context	N/A	N/A	N/A	N/A
IP address allocation	Yes	Yes	No	Yes
IMS registration	No	No	No	No
SST condition (NOTE 1)	SST_MIoT	SST_V2X	SST_URLLC	SST_eMBB
NOTE 1: The possible values of the SST condition are defined in Table 4.6.0.1-5.				

## 4.8.5 URSP configurations

### 4.8.5.1 General

FFS

### 4.8.5.2 UE Route Selection Policy Rules

**Table 4.8.5.2-1: UE Route Selection Policy Rule #1**

Derivation Path: TS 24.526, Figure 5.2.1			
Information Element	Value/remark	Comment	Condition
URSP rules	1 entry		
URSP rule			
Rule Precedence	1		
Traffic descriptor			
Traffic descriptor component type identifier	'1000 1000'B	DNN type	
Traffic descriptor component			
Application descriptors	Not present		
IP descriptors	Not present		
Domain descriptors	Not present		
Non-IP descriptors	Not present		
DNN	FFS		
Connection Capabilities	Not present		
List of Route Selection Descriptors	Route Selection Descriptor #1	Table 4.8.5.3-1	

### 4.8.5.3 Route Selection Descriptors

**Table 4.8.5.3-1: Route Selection Descriptor #1**

Derivation Path: TS 24.526, Figure 5.2.4			
Information Element	Value/remark	Comment	Condition
Route Selection Descriptor Precedence	1		
Route selection descriptor contents			
Route selection descriptor component type identifier	'0000 0010'B '0000 0100'B		S-NSSAI type DNN type
Route selection descriptor component			
SSC Mode Selection	Not present		
Network Slice Selection	FFS		S-NSSAI type
DNN Selection	FFS		DNN type
PDU Session Type Selection	Not present		
Non-Seamless Offload indication	Not present		
Access Type preference	Not present		

Condition	Explanation
S-NSSAI type	The Route selection descriptor component type is S-NSSAI
DNN type	The Route selection descriptor component type is DNN

## 4.9 Test procedures

### 4.9.1 Test procedure to check user plane connectivity on DRB#n

This procedure aims at checking whether the UE User Plane Access Stratum is capable of exchanging data on DRB#n (#n is the DRB Id specified in the test case when the present procedure is called). In case the UE supports IP, it is also checked that the UE IP stack is connected to the UE User Plane Access Stratum.

**Table 4.9.1-1: Test procedure sequence**

St	Procedure	Message Sequence		TP	Verdict
		U - S	Message/PDU/SDU		
-	EXCEPTION: Steps 1a1 to 1c2 describe behaviour that depends on the UE implementation; the "lower case letter" identifies a step sequence that take place depending on the UE implementation.	-	-	-	-
1a1	IF (pc_IP_Ping = TRUE AND pc_IPv4 = TRUE) THEN, the SS sends an ICMP Echo request to the IPv4 address assigned to the UE on DRB#n.	<--	ICMP ECHO REQUEST (NOTE 3)	-	-
1a2	Check: Does the UE send an ICMP Echo reply on DRB#n?	-->	ICMP ECHO REPLY	-	P
1b1	ELSE IF (pc_IP_Ping = TRUE AND (pc_IPv4 = FALSE AND pc_IPv6 = TRUE)) THEN, the SS sends an ICMPv6 Echo request to the IPv6 address assigned to the UE on DRB#n.	<--	ICMPv6 ECHO REQUEST (NOTE 3)	-	-
1b2	Check: Does the UE send an ICMPv6 Echo reply on DRB#n?	-->	ICMPv6 ECHO REPLY	-	P
1c1	ELSE, the SS transmits one IP Packet to verify data path on DRB#n. See NOTE 1, 2.	-	-	-	-
1c2	Check: Does UE send the IP Packet on DRB#n in the uplink?	-	-	-	P
NOTE 1: A Test Loop is assumed to already have been closed.					
NOTE 2: When DRB#n is a dedicated bearer, the IP Packet shall match the packet filters as configured for DRB#n. When DRB#n is a default bearer, the IP Packet shall match none of the dedicated bearers associated to DRB#n (if any). (NOTE 4)					
NOTE 3: When DRB#n is a dedicated bearer, the source address of the ICMP/ICMPv6 ECHO REQUEST shall be the same as the remote address of the DL/UL packet filters. When DRB#n is a default bearer, the source address of the ICMP/ICMPv6 ECHO REQUEST shall be different than the remote address of the DL/UL packet filters for an associated dedicated bearer (if any). (NOTE 4)					
NOTE 4: For 5GC QoS rules and the associated packet filters are specified in clause 4.8.2. For EPC the TFTs and associated packet filters are specified in clause 6.6.2 of TS 36.508 [2] and the IP packet shall be as according to clause 7.14.2 of TS 36.523-3 [41].					

**Table 4.9.1-1A: Test procedure sequence for Data path check for CA tests**

St	Procedure	Message Sequence		TP	Verdict
		U - S	Message/PDU/SDU		
-	EXCEPTION: Step 1 is only performed if SCell is not yet activated.	-	-	-	-
1	The SS transmits an Activation MAC control element to activate SCell.	<--	MAC PDU (Activation (C <sub>1</sub> =1))		
-	EXCEPTION: Steps 2a1 to 2c2 describe behaviour that depends on the UE implementation; the "lower case letter"	-	-	-	-

	identifies a step sequence that take place depending on the UE implementation.				
2a1	IF (pc_IP_Ping = TRUE AND pc_IPv4 = TRUE) THEN, the SS sends an ICMP Echo request to the IPv4 address assigned to the UE on DRB#n on the SCell.	<--	ICMP ECHO REQUEST (NOTE 3)	-	-
2a2	Check: Does the UE send an ICMP Echo reply on DRB#n on the SpCell?	-->	ICMP ECHO REPLY	-	P
2b1	ELSE IF (pc_IP_Ping = TRUE AND (pc_IPv4 = FALSE AND pc_IPv6 = TRUE)) THEN, the SS sends an ICMPv6 Echo request to the IPv6 address assigned to the UE on DRB#n on the SCell.	<--	ICMPv6 ECHO REQUEST (NOTE 3)	-	-
2b2	Check: Does the UE send an ICMPv6 Echo reply on DRB#n on the SpCell?	-->	ICMPv6 ECHO REPLY	-	P
2c1	ELSE, the SS transmits one IP Packet to verify data path on DRB#n on the SCell. See NOTE 1, 2.	-	-	-	-
2c2	Check: Does UE send the IP Packet on DRB#n in the uplink on the SpCell?	-	-	-	P
<p>NOTE 1: A Test Loop is assumed to already have been closed.</p> <p>NOTE 2: When DRB#n is a dedicated bearer, the IP Packet shall match the packet filters as configured for DRB#n. When DRB#n is a default bearer, the IP Packet shall match none of the dedicated bearers associated to DRB#n (if any). (NOTE 4)</p> <p>NOTE 3: When DRB#n is a dedicated bearer, the source address of the ICMP/ICMPv6 ECHO REQUEST shall be the same as the remote address of the DL/UL packet filters. When DRB#n is a default bearer, the source address of the ICMP/ICMPv6 ECHO REQUEST shall be different than the remote address of the DL/UL packet filters for an associated dedicated bearer (if any). (NOTE 4)</p> <p>NOTE 4: For 5GC QoS rules and the associated packet filters are specified in clause 4.8.2. For EPC the TFTs and associated packet filters are specified in clause 6.6.2 of TS 36.508 [2] and the IP packet shall be as according to clause 7.14.2 of TS 36.523-3 [41].</p>					

## 4.9.2 Test procedure to activate UE Beamlock Test Function (UBF)

### 4.9.2.1 Initiation

UE is operating in FR2 in RRC\_CONNECTED state.

### 4.9.2.2 Procedure

**Table 4.9.2.2-1: Test procedure Sequence**

St	Procedure	Message Sequence		TP	Verdict
		U - S	Message/PDU/SDU		
1	SS request UE to activate UE beamlock function.	<--	ACTIVATE BEAMLOCK	-	-
2	UE confirms that UE beamlock function is activated	-->	ACTIVATE BEAMLOCK COMPLETE	-	-

### 4.9.2.3 Specific Message contents

**Table 4.9.2.3-1: ACTIVATE BEAMLOCK**

Derivation Path: 38.509 clause 6.4.1			
Information Element	Value/remark	Comment	Condition
Protocol discriminator	1 1 1 1		
Skip indicator	0 0 0 0		
Message type	1 0 1 0 0 0 0 0		
UE Beamlock test Function	0 0 0 0 0 0 0 1		Tx Only
UE Beamlock test Function	0 0 0 0 0 0 1 0		Rx Only
UE Beamlock test Function	0 0 0 0 0 0 1 1		Tx and Rx



Condition	Explanation
Tx Only	Activation UE beamlock function for Tx only
Rx Only	Activation UE beamlock function for Rx only
Tx and Rx	Activation UE beamlock function for both Tx and Rx

**Table 4.9.2.3-2: ACTIVATE BEAMLOCK COMPLETE**

Derivation Path: 38.509 clause 6.4.2			
Information Element	Value/remark	Comment	Condition
Protocol discriminator	1 1 1 1		
Skip indicator	0 0 0 0		
Message type	1 0 1 0 0 0 1		

### 4.9.3 Test procedure to deactivate UE Beamlock Test Function (UBF)

#### 4.9.3.1 Initiation

UE is operating in FR2 in RRC\_CONNECTED state with UE beamlock test function activated.

#### 4.9.3.2 Procedure

**Table 4.9.3.2-1: Test procedure Sequence**

St	Procedure	Message Sequence		TP	Verdict
		U - S	Message/PDU/SDU		
1	SS request UE to deactivate UE beamlock function.	<--	DEACTIVATE BEAMLOCK	-	-
2	UE confirms that UE beamlock function is activated	-->	DEACTIVATE BEAMLOCK COMPLETE	-	-

#### 4.9.3.3 Specific Message contents

**Table 4.9.3.3-1: DEACTIVATE BEAMLOCK**

Derivation Path: 38.509 clause 6.4.3			
Information Element	Value/remark	Comment	Condition
Protocol discriminator	1 1 1 1		
Skip indicator	0 0 0 0		
Message type	1 0 1 0 0 0 1 0		

**Table 4.9.3.3-2: DEACTIVATE BEAMLOCK COMPLETE**

Derivation Path: 38.509 clause 6.4.4			
Information Element	Value/remark	Comment	Condition
Protocol discriminator	1 1 1 1		
Skip indicator	0 0 0 0		
Message type	1 0 1 0 0 0 1 1		

## 4.9.4 Test procedure to check that UE is in state 5GC RRC\_IDLE on a certain NR/NGC cell

### 4.9.4.1 Scope

This procedure aims at checking whether the UE is in state 5GC RRC\_IDLE on a certain cell (as specified in the test case).

### 4.9.4.2 Procedure description

#### 4.9.4.2.1 Initial conditions

As specified in the TC which calls the procedure in its entirety or refers to parts of it.

#### 4.9.4.2.2 Procedure

**Table 4.9.4.2.2-1: Test procedure sequence**

St	Procedure	Message Sequence		TP	Verdict
		U - S	Message/PDU/SDU		
1	Step 1 of Generic procedure for bringing the UE in RRC_CONNECTED state with connectivity NR as specified in Table 4.5.4.2-3 is performed.	-	-	-	-
2	Check: Does the UE transmit an <i>RRCSetupRequest</i> message on the cell specified in the test case?	-->	NR RRC: <i>RRCSetupRequest</i>	-	P
3-8	Steps 3-8 of Generic procedure for bringing the UE in RRC_CONNECTED state with connectivity NR as specified in Table 4.5.4.2-3 are performed.	-	-	-	-
-	EXCEPTION: Step 9a1 describes a step sequence depending on procedure parameters; the "lower case letter" identifies a step sequence that take place if a procedure parameter has a particular value	-	-	-	-
9a1	IF ' <i>connected without release</i> ' is not present THEN the SS transmits an <i>RRCRelease</i> message to release RRC connection and move the UE to RRC_IDLE.	<--	NR RRC: <i>RRCRelease</i>	-	-

#### 4.9.4.2.3 Specific Message content

As specified in the TC which calls the procedure in its entirety or refers to parts of it.

## 4.9.5 Test procedure to check that UE is camped on a new NR/NGC cell belonging to a new TA

### 4.9.5.1 Scope

This procedure aims at checking whether the UE performs a mobility registration updating (Tracking Area (TA) update) procedure when it camps on a new cell (as specified in the test case) belonging to a new TA.

### 4.9.5.2 Procedure description

#### 4.9.5.2.1 Initial conditions

As specified in the TC which calls the procedure in its entirety or refers to parts of it.

4.9.5.2.2 Procedure sequence

**Table 4.9.5.2.2-1: Test procedure sequence mobility registration updating (TA update)**

St	Procedure	Message Sequence		TP	Verdict
		U - S	Message/PDU/SDU		
-	EXCEPTION: Unless otherwise stated all the messages below are transmitted on the cell specified in the test case.	-	-	-	-
1	The UE transmits an <i>RRCSetupRequest</i> message.	-->	NR RRC: <i>RRCSetupRequest</i>	-	-
2	SS transmit an <i>RRCSetup</i> message.	<--	NR RRC: <i>RRCSetup</i>	-	-
3	The UE transmits an <i>RRCSetupComplete</i> message to confirm the successful completion of the connection establishment and a REGISTRATION REQUEST message indicating "mobility registration updating" is sent to update the registration of the actual tracking area.	-->	NR RRC: <i>RRCSetupComplete</i> 5GMM: REGISTRATION REQUEST	-	-
4	SS sends a REGISTRATION ACCEPT message containing a 5G-GUTI. (NOTE 1, NOTE 2)	<--	NR RRC: <i>DLInformationTransfer</i> 5GMM: REGISTRATION ACCEPT	-	-
5	Check: Does the UE send a REGISTRATION COMPLETE?	-->	NR RRC: <i>ULInformationTransfer</i> 5GMM: REGISTRATION COMPLETE	-	P
-	EXCEPTION: Step 6a1 describes a step sequence depending on procedure parameters; the "lower case letter" identifies a step sequence that take place if a procedure parameter has a particular value	-	-	-	-
6a1	IF <i>'connected without release'</i> is not present THEN the SS transmits an <i>RRCRelease</i> message to release RRC connection and move the UE to RRC_IDLE.	<--	NR RRC: <i>RRCRelease</i>	-	-
NOTE 1: If a PDU session status IE was included in the REGISTRATION REQUEST message then the SS includes a PDU session status IE in the REGISTRATION ACCEPT message indicating that all the PDU sessions are active. NOTE 2: If the UE has indicated S1 mode supported then the SS shall indicate in the 5GS network feature support IE in the REGISTRATION ACCEPT message the IWK N26 bit set to "interworking without N26 not supported". The setting of the "interworking without N26 not supported" has been chosen to ensure that the UE is operating in the single-registration mode allowing for a clearly pre-determined UE behaviour.					

4.9.5.2.3 Specific Message content

As specified in the TC which calls the procedure in its entirety or refers to parts of it.

4.9.6 Test procedures for Switch off / Power off UE

4.9.6.1 Switch off / Power off procedure in RRC\_IDLE

**Table 4.9.6.1-1: Switch off procedure in RRC\_IDLE**

Step	Procedure	Message Sequence	
		U - S	Message
-	EXCEPTION: Steps 1a1 to 1b1 describe behaviour that depends on the UE capability; the "lower case letter" identifies a step sequence that take place if [36] <i>pc_SwitchOnOff</i> or [37] <i>pc_USIM_Removal</i> is supported	-	-
1a1	IF <i>pc_SwitchOnOff</i> THEN switch off UE, IF <i>pc_USIM_Removal</i> THEN remove the USIM (Note 1)	-	-

1a2	UE transmits an <i>RRCSetupRequest</i> message.	-->	RRC: <i>RRCSetupRequest</i>
1a3	SS transmit an <i>RRCSetup</i> message.	<--	RRC: <i>RRCSetup</i>
-	EXCEPTION: Steps 1a4Aa1 to 1a4Aa5b1 specify optional behaviour if the UE has previously performed IMS registration	-	-
1a4Aa 1	The UE transmits an <i>RRCSetupComplete</i> message to confirm the successful completion of the connection establishment and to initiate the IMS signalling procedure by including the SERVICE REQUEST message.	-->	RRC: <i>RRCSetupComplete</i> 5GMM: SERVICE REQUEST
1a4Aa 2	The SS transmits a <i>SecurityModeCommand</i> message to activate AS security.	<--	RRC: <i>SecurityModeCommand</i>
1a4Aa 3	The UE transmits a <i>SecurityModeComplete</i> message and establishes the initial security configuration.	-->	RRC: <i>SecurityModeComplete</i>
1a4Aa 4	The SS transmits an <i>RRCReconfiguration</i> message and a SERVICE ACCEPT message to establish SRB2 and DRB.	<--	RRC: <i>RRCReconfiguration</i> 5GMM: SERVICE ACCEPT
-	EXCEPTION: In parallel to the event described in step 1a4Aa5 below, the generic test procedure in TS 34.229-5 [47] Annex A.11 may be performed.	-	-
1a4Aa 5	The UE transmits an <i>RRCReconfigurationComplete</i> message.	-->	RRC: <i>RRCReconfigurationComplete</i>
-	EXCEPTION: Steps 1a4Aa5a1 - 1a4Aa5b1 may be performed depending on UE implementation	-	-
-	EXCEPTION: Steps 1a4Aa5a1 - 1a4Aa5a2 may be repeated for all active PDU sessions	-	-
1a4Aa 5a1	The UE transmits a PDU SESSION RELEASE REQUEST message.	-->	PDU SESSION RELEASE REQUEST
1a4Aa 5a2	PDU session release procedure defined in clause 4.9.21 of TS 38.508-1 [4] is performed	-	-
1a4Aa 5a3	The UE transmits a DEREGISTRATION REQUEST message.	-->	5GMM: DEREGISTRATION REQUEST
1a4Aa 5b1	The UE transmits a DEREGISTRATION REQUEST message	-	5GMM: DEREGISTRATION REQUEST
-	EXCEPTION: Step 1a4Ab1 below specifies the behaviour if the UE has not previously performed IMS registration	-	-
1a4Ab 1	The UE transmits an <i>RRCSetupComplete</i> message including the DEREGISTRATION REQUEST message.	-->	RRC: <i>RRCSetupComplete</i> 5GMM: DEREGISTRATION REQUEST
1a4	Void	-	-
1a5	The SS transmits an <i>RRCRelease</i> message	<--	RRC: <i>RRCRelease</i>
1b1	ELSE power off UE (Note 2)	-	-
Note 1: USIM removal is a feasible alternative to switch off UE. Note 2: Power off is used when UE don't support switch off or USIM removal, in which case no UE originated deregistration procedure is expected.			

### 4.9.6.2 Switch off / Power off procedure in RRC\_INACTIVE

#### 4.9.6.2.1 Procedure

**Table 4.9.6.2.1-1: Switch off procedure in RRC\_INACTIVE**

Step	Procedure	Message Sequence	
		U - S	Message
-	EXCEPTION: Steps 1a1 to 1b1 describe behaviour that depends on the UE capability; the "lower case letter" identifies a step sequence that take place if [36] pc_SwitchOnOff or [37] pc_USIM_Removal is supported	-	-

1a1	IF pc_SwitchOnOff THEN switch off UE, IF pc_USIM_Removal THEN remove the USIM (Note 1)	-	-
1a2	UE transmits an <i>RRCResumeRequest</i> message.	-->	NR RRC: <i>RRCResumeRequest</i>
1a3	SS transmit an <i>RRCResume</i> message.	<--	NR RRC: <i>RRCResume</i>
	EXCEPTION: Steps 1a3Aa1 to 1a3Ab1 describe behaviour that depends on the UE implementation; the "lower case letter" identifies a step sequence that take place depending on the UE implementation.		
1a3Aa1	The UE transmits an <i>RRCResumeComplete</i> message to confirm the successful resumption of the RRC connection not including any 5G NAS message	-->	NR RRC: <i>RRCResumeComplete</i>
1a4Aa1-1a4Aa5	Void	-	-
-	EXCEPTION: The generic test procedure in TS 34.229-5 [47] Annex A.11 may be performed depending on UE implementation.	-	-
-	EXCEPTION: Steps 1a3Aa2a1 - 1a3Aa3 may be performed depending on UE implementation	-	-
-	EXCEPTION: Steps 1a3Aa2a1 - 1a3Aa2a2 may be repeated for all active PDU sessions	-	-
1a3Aa2a1	The UE transmits a PDU SESSION RELEASE REQUEST message.	-->	PDU SESSION RELEASE REQUEST
1a3Aa2a2	PDU session release procedure defined in clause 4.9.21 of TS 38.508-1 [4] is performed	-	-
1a3Aa3	The UE transmits a DEREGISTRATION REQUEST message	-	5GMM: DEREGISTRATION REQUEST
1a3Ab1	The UE transmits an <i>RRCResumeComplete</i> message to confirm the successful resumption of the RRC connection, including the DEREGISTRATION REQUEST message	-->	NR RRC: <i>RRCResumeComplete</i> 5GMM : DEREGISTRATION REQUEST
1a4	Void	-	-
1a5	The SS transmits an <i>RRCRelease</i> message	<--	NR RRC: <i>RRCRelease</i>
1b1	ELSE power off UE (Note 2)	-	-
Note 1: USIM removal is a feasible alternative to switch off UE.			
Note 2: Power off is used when UE don't support switch off or USIM removal, in which case no UE originated deregistration procedure is expected.			

4.9.6.2.2 Specific Message contents

Table 4.9.6.2.2-1: RRCResumeRequest

Derivation Path: TS 38.331 [6], clause 6.2.2			
Information Element	Value/remark	Comment	Condition
RRCResumeRequest ::= SEQUENCE {			
rrcResumeRequest SEQUENCE {			
resumeIdentity	Not checked		
resumeMAC-I	Not checked		
resumeCause	Not checked		
spare	Not checked		
}			
}			

## 4.9.6.3 Switch off / Power off procedure in RRC\_CONNECTED

Table 4.9.6.3-1: Switch off procedure in RRC\_CONNECTED

Step	Procedure	Message Sequence	
		U - S	Message
1a1-1a3	Void	-	-
2-4	Void	-	-
-	EXCEPTION: Steps 5a1 to 5b1 describe behaviour that depends on the UE implementation; the "lower case letter" identifies a step sequence that take place if a particular implementation is under test.	-	-
5a1	IF pc_SwitchOnOff THEN switch off UE, IF pc_USIM_Removal THEN remove the USIM (Note 1)	-	-
-	EXCEPTION: Step 5a1Aa1 to 5a2Ab1 below specifies optional behaviour if the UE has previously performed IMS registration	-	-
5a1Aa1	The UE may perform the generic test procedure described in TS 34.229-5 [47] Annex A.11	-	-
-	EXCEPTION: Steps 5a2Aa1a1 – 5a2Ab1 may be performed depending on UE implementation	-	-
-	EXCEPTION: Steps 5a2Aa1a1 - 5a2Aa1a2 may be repeated for all active PDU sessions	-	-
5a2Aa1a1	The UE transmits a PDU SESSION RELEASE REQUEST message.	-->	PDU SESSION RELEASE REQUEST
5a2Aa1a2	PDU session release procedure defined in clause 4.9.21 of TS 38.508-1 [4] is performed	-	-
5a2Aa1a3	The UE transmits a DEREGISTRATION REQUEST message.	-->	5GMM: DEREGISTRATION REQUEST
5a2Ab1	The UE transmits a DEREGISTRATION REQUEST message.	-->	5GMM: DEREGISTRATION REQUEST
5a3	The SS transmits an RRCRelease message.	<--	NR RRC: <i>RRCRelease</i>
5b1	ELSE power off UE (Note 2)	-	-
Note 1:	USIM removal is a feasible alternative to switch off UE.		
Note 2:	Power off is used when UE don't support switch off or USIM removal, in which case no UE originated deregistration procedure is expected.		

## 4.9.6.3A Switch off / Power off procedure in RRC\_CONNECTED with T3540 started

Table 4.9.6.3A-1: Switch off procedure in RRC\_CONNECTED with T3540 started

Step	Procedure	Message Sequence	
		U - S	Message
1	SS starts timer1 = T3540 (10 sec).	-	-
2	The SS locally releases the RRC connection.	-	-
3	SS waits for Timer1 expires. NOTE: On expiry of T3540 UE shall locally release the established N1 NAS signalling connection	-	-
4	The test procedure as described in Table 4.9.6.1-1: Switch off procedure in RRC_IDLE take place.	-	-

## 4.9.6.4 Switch off / Power off procedure in State DEREGISTERED

Table 4.9.6.4-1: Switch off procedure in State DEREGISTERED

Step	Procedure	Message Sequence
------	-----------	------------------

		U - S		Message
-	EXCEPTION: Steps 1a1 to 1b1 describe behaviour that depends on the UE capability; the "lower case letter" identifies a step sequence that take place if [36] pc_SwitchOnOff or [37] pc_USIM_Removal is supported	-	-	
1a1	IF pc_SwitchOnOff THEN switch off UE (Note 1)	-	-	
1b1	ELSE power off UE (Note 2)	-	-	
Note 1: USIM removal is a feasible alternative to switch off UE.				
Note 2: Power off is used when UE don't support switch off or USIM removal.				

4.9.6.5 Switch off / Power off procedure in WLAN Ipsec\_SA\_Established

Table 4.9.6.5-1: Switch off procedure in Ipsec\_SA\_Established

Step	Procedure	Message Sequence	
		U - S	Message
-	EXCEPTION: Steps 1a1 to 1b1 describe behaviour that depends on the UE capability; the "lower case letter" identifies a step sequence that take place if [30] pc_SwitchOnOff or [31] pc_USIM_Removal is supported	-	-
1a1	IF pc_SwitchOnOff THEN switch off UE (Note 1)	-	-
1a2	The UE transmits a DEREGISTRATION REQUEST message.	-->	5GMM: DEREGISTRATION REQUEST
1a3	The generic procedure for SS-requested IPsec Secure tunnel disconnection, specified in subclause 4.5A.5, takes place performing disconnection of security association	-	-
1b1	ELSE power off UE (Note 2)	-	-
Note 1: USIM removal is a feasible alternative to switch off UE.			
Note 2: Power off is used when UE don't support switch off or USIM removal, in which case no UE originated deregistration procedure is expected.			

4.9.6.6 Switch off / Power off procedure in MA PDU session Established on NR and WLAN

Table 4.9.6.6-1: Switch off procedure in MA PDU session Established

Step	Procedure	Message Sequence	
		U - S	Message
-	EXCEPTION: Steps 1a1 to 1b1 describe behaviour that depends on the UE capability; the "lower case letter" identifies a step sequence that take place if [30] pc_SwitchOnOff or [31] pc_USIM_Removal is supported	-	-
1a1	IF pc_SwitchOnOff THEN switch off UE (Note 1)	-	-
-	EXCEPTION: The Step 5a1Aa1 to 5a3 specified in Table 4.9.6.3-1 may take place on the NR Cell before or after the events described in steps 1a2-1a3 below.	-	-
1a2	The UE transmits a DEREGISTRATION REQUEST message on the WLAN cell.	-->	5GMM: DEREGISTRATION REQUEST
1a3	The generic procedure for SS-requested IPsec Secure tunnel disconnection, specified in subclause 4.5A.5, takes place performing	-	-

	disconnection of security association on the WLAN cell.		
1b1	ELSE power off UE (Note 2)	-	-
Note 1:	USIM removal is a feasible alternative to switch off UE.		
Note 2:	Power off is used when UE don't support switch off or USIM removal, in which case no UE originated deregistration procedure is expected.		

## 4.9.7 Test procedure for UE for Tracking area updating / Inter-system change from N1 mode to S1 mode in 5GMM/EMM-IDLE mode

### 4.9.7.1 Scope

This procedure aims at verifying that the UE performs a Tracking Area Update (TAU) procedure when it performs inter-system change from N1 mode to S1 mode in 5GMM/EMM-IDLE.

This procedure is only relevant when the parameter *Interworking without N26 interface supported* is FALSE.

The procedure provides different security context handling options based on the condition parameters defined in Table 4.9.7.1-1.

**Table 4.9.7.1-1: Condition parameters**

Condition	Explanation
new security context	When this parameter is present the SS will establish and take into account a new security context.
existing EPS security context	When this parameter is present the SS will take into account an existing EPS security context. A prerequisite for using this condition is the existence of an EPS security context
NOTE 1: If none of the defined condition parameters is present when the procedure is referred to then the SS will apply mapped 5G security context. A prerequisite for using this condition is the existence of 5G security context.	

### 4.9.7.2 Procedure description

#### 4.9.7.2.1 Initial conditions

System Simulator:

- 1 E-UTRA cell connected to EPC, default parameters, system information combination 31 as defined in TS 36.508 [2], subclause 4.4.3.1.1.

NOTE: Details about the NGC cell from which the UE will move to the E-UTRA cell are to be specified in the test.

User Equipment:

- The Test UICC shall be inserted. It shall provide relevant details on the EPC and 5GC.

All details required shall be explicitly specified in the TC which calls the procedure in its entirety or refers to parts of it.

#### 4.9.7.2.2 Procedure sequence

**Table 4.9.7.2.2-1: Test procedure sequence UE Tracking area updating / inter-system change from N1 mode to S1 mode in EMM-IDLE mode**

St	Procedure	Message Sequence		TP	Verdict
		U - S	Message/PDU/SDU		
-	EXCEPTION: Unless otherwise stated all the messages below are transmitted on the cell specified in the test case.	-	-	-	-



1	The UE transmits an <i>RRCConnectionRequest</i> message on the cell specified in the test case.	-->	RRC: <i>RRCConnectionRequest</i>	-	-
2	SS transmits an <i>RRCConnectionSetup</i> message.	<--	RRC: <i>RRCConnectionSetup</i>	-	-
3	The UE transmits an <i>RRCConnectionSetupComplete</i> message to confirm the successful completion of the connection establishment and a TRACKING AREA UPDATE REQUEST message is sent to update the registration of the actual tracking area. For some consequences related to the content of the TRACKING AREA UPDATE REQUEST message see the Notes in Table 4.9.7.2.3-1.	-->	RRC: <i>RRCConnectionSetupComplete</i> NAS: TRACKING AREA UPDATE REQUEST	-	-
-	EXCEPTION: Steps 4a1-4b2 describe a step sequence depending on procedure parameters; the "lower case letter" identifies a step sequence that take place if a procedure parameter has a particular value	-	-	-	-
4a1	IF <i>'new security context</i> THEN the SS transmits an AUTHENTICATION REQUEST message to initiate the EPS authentication and AKA procedure.	<--	RRC: <i>DLInformationTransfer</i> NAS: AUTHENTICATION REQUEST	-	-
4a2	The UE transmits an AUTHENTICATION RESPONSE message and establishes mutual authentication.	-->	RRC: <i>ULInformationTransfer</i> NAS: AUTHENTICATION RESPONSE	-	-
4a3	The SS transmits a NAS SECURITY MODE COMMAND message to activate NAS security.	<--	RRC: <i>DLInformationTransfer</i> NAS: SECURITY MODE COMMAND	-	-
4a4	The UE transmits a NAS SECURITY MODE COMPLETE message and establishes the initial security configuration.	-->	RRC: <i>ULInformationTransfer</i> NAS: SECURITY MODE COMPLETE	-	-
4b1	IF <i>'existing EPS security context</i> THEN the SS transmits a NAS SECURITY MODE COMMAND message to activate NAS security.	<--	RRC: <i>DLInformationTransfer</i> NAS: SECURITY MODE COMMAND	-	-
4b2	The UE transmits a NAS SECURITY MODE COMPLETE message and establishes the initial security configuration.	-->	RRC: <i>ULInformationTransfer</i> NAS: SECURITY MODE COMPLETE	-	-
-	EXCEPTION: If none of the branches 4a or 4b takes place then the SS shall apply mapped 5G security context, otherwise the SS shall apply the security context depending on the branch.	-	-	-	-
5	SS responds with TRACKING AREA UPDATE ACCEPT message.	<--	RRC: <i>DLInformationTransfer</i> NAS: TRACKING AREA UPDATE ACCEPT	-	-
6	Check: Does the UE transmit TRACKING AREA UPDATE COMPLETE?	-->	RRC: <i>ULInformationTransfer</i> NAS: TRACKING AREA UPDATE COMPLETE	-	P
7a1 – 8a1	Void	-	-	-	-
8b1	The generic procedure for UE-requested PDN connection establishment, specified in subclause 4.5A.2B, takes place performing establishment of UE-requested PDN connection(s) with ExpectedNumberOfNewPDNConnections = pc_noOf_PDNsSameConnection with the exception that IF step 2b1, Table 4.5A.2B.2.2-2 takes place THEN the SS shall not assign Fail but continue with the next step in the test sequence not expecting any additional connection establishment to take place (NOTE 2).	-	-	-	-
-	EXCEPTION: Steps 8b2a1 to 8b2b1 describe a step sequence depending on test case scenario; the right-most "lower case letter"	-	-	-	-

	identifies a step sequence that take place if the UE performs a specific action.				
8b2a 1	IF <i>pc_noOf_PDNsNewConnection</i> >0 THEN the SS transmits an <i>RRCConnectionRelease</i> message to release RRC connection and moves the UE to RRC_IDLE.	<--	RRC: <i>RRCConnectionRelease</i>	-	-
8b2a 2	The procedure E-UTRA RRC_IDLE Unrestricted nr PDN Extension as specified in table 4.5.2.2-6 takes place.  For the referred in step 7, Table 4.5.2.2-6, generic procedure for UE-requested PDN connection establishment, specified in subclause 4.5A.2B, IF step 2b1, Table 4.5A.2B.2.2-2 takes place THEN the SS shall not assign Fail but continue with the next step in the test sequence not expecting any additional connection establishment to take place (NOTE 2).	-	-	-	-
8b2b 1	ELSE IF <i>connected without release</i> is not present THEN, the SS transmits an <i>RRCConnectionRelease</i> message to release RRC connection and move to E-UTRA RRC_IDLE (State 2).	<--	RRC: <i>RRCConnectionRelease</i>	-	-
<p>NOTE 1: Void</p> <p>NOTE 2: Depending on UE implementation and/or NWK behaviour, the UE may transfer some PDU sessions into PDN connections without re-establishing those utilising the relevant mapped QoS provided in the PDU SESSION ESTABLISHMENT ACCEPT message when the UE was on the NR cell. This will result in the number of established PDNs, if any, being lower than the <i>pc_noOf_PDNsSameConnection</i> or the <i>pc_noOf_PDNsNewConnection</i> which the UE will establish upon initial attach to the EPS.</p>					

#### 4.9.7.2.3 Specific Message content

Default message contents as specified in TS 36.508 [2] with the following exceptions.

**Table 4.9.7.2.3-1: TRACKING AREA UPDATE REQUEST (Step 3, Table 4.9.7.2.2-1)**

Derivation Path: TS 36.508 [2], Table 4.7.2-27, condition NR.			
Information Element	Value/remark	Comment	Condition
EPS update type			
EPS update type Value	'000'B or '001'B or '010'B	'TA updating' or 'combined TA/LA updating' or 'combined TA/LA updating with IMSI attach'	
"Active" flag	Any value		
NAS key set identifier	the eKSI indicating the 5G NAS security context value assigned at the initial registration when the UE entered N1		
Old GUTI	GUTI, mapped from the 5G-GUTI assigned at the initial registration when the UE entered N1		
Additional GUTI	Not present or any allowed value		
Last visited registered TAI	The TAI the last visited E-UTRA Cell belonged to, if any. Not included if the UE does not have last stored EPC TAI.		
UE radio capability information update needed	'1'B	UE radio capability	First-N1-to-S1

		information update needed	
EPS bearer context status	Present, Content not checked	EBI corresponding to active PDN connections (transferred PDU Sessions) need to be set to 1 (NOTE 2)	
Old GUTI type	"Native GUTI"		
UE status	"UE is in 5GMM-REGISTERED state"		
<p>NOTE 1: The message shall be integrity protected using the 5GS security context available in the UE.</p> <p>NOTE 2: There will be no PDN connection establishment nor explicit bearer configuration for the transferred PDU sessions. This means that the UE has created locally the default bearer context and the dedicated bearer context(s) based on the parameters of the mapped bearer contexts or the associations between QoS flow and mapped bearer in the PDU session. Although the contents of the IE is not required to be verified for PASS/FAIL purposes, the provided information shall be taken into account for building any subsequent RRC Reconfiguration message, and can be used e.g. for SS configuration purposes as well.</p>			

Condition	Explanation
First-N1-to-S1	First N1 to S1 transition following UE registration in N1 mode

**Table 4.9.7.2.3-2: AUTHENTICATION REQUEST (Step 4a1, Table 4.9.7.2.2-1)**

Derivation Path: TS 36.508 [2], Table 4.7.2-7.			
Information Element	Value/remark	Comment	Condition
NAS key set identifier <sub>ASME</sub>			
NAS key set identifier	An arbitrarily selected value between '000'B and '110'B, different from the valid NAS key set identifier of the UE if such a value exists.	Value shall be different to the 5G NAS security context value if there is one assigned	

**Table 4.9.7.2.3-3: SECURITY MODE COMMAND (Step 4a3, Table 4.9.7.2.2-1)**

Derivation Path: TS 36.508 [2], Table 4.7.2-19.			
Information Element	Value/remark	Comment	Condition
NAS key set identifier <sub>ASME</sub>			
NAS key set identifier	The 4G NAS key set identifier assigned in step 4a1.		

**Table 4.9.7.2.3-4: SECURITY MODE COMMAND (Step 4b1, Table 4.9.7.2.2-1)**

Derivation Path: TS 36.508 [2], Table 4.7.2-19.			
Information Element	Value/remark	Comment	Condition
NAS key set identifier <sub>ASME</sub>			
NAS key set identifier	The 4G NAS key set identifier assigned in the latest Authentication procedure.		

**Table 4.9.7.2.3-5: Void**

## 4.9.8 Test procedure for Registration Reject

### 4.9.8.1 Scope

The purpose of this procedure is to reject the registration request, with a specific cause value, which may allow fields to be cleared in the USIM.

### 4.9.8.2 Procedure description

#### 4.9.8.2.1 Initial conditions

As specified in the TC which calls the procedure in its entirety or refers to parts of it.

#### 4.9.8.2.2 Procedure sequence

**Table 4.9.8.2.2-1: Procedure for Registration Reject**

St	Procedure	Message Sequence	
		U – S	Message
1	The UE transmits an <i>RRCSetupRequest</i> message.	-->	NR RRC: <i>RRCSetupRequest</i>
2	The SS transmits an <i>RRCSetup</i> message.	<--	NR RRC: <i>RRCSetup</i>
3	The UE transmits an <i>RRCSetupComplete</i> message and a REGISTRATION REQUEST message.	-->	NR RRC: <i>RRCSetupComplete</i> 5GMM: REGISTRATION REQUEST
4	The SS transmits an AUTHENTICATION REQUEST message including EAP-Request/AKA'-Challenge or 5G AKA Challenge.	<--	5GMM: AUTHENTICATION REQUEST
5	The UE transmits an AUTHENTICATION RESPONSE message including EAP-Response/AKA'-Challenge or 5G AKA Response.	-->	5GMM: AUTHENTICATION RESPONSE
6	The SS transmits a SECURITY MODE COMMAND message including EAP-Success if EAP-AKA' used.	<--	5GMM: SECURITY MODE COMMAND
7	The UE transmits a SECURITY MODE COMPLETE message.	-->	5GMM: SECURITY MODE COMPLETE
8	The SS transmits a REGISTRATION REJECT message with the cause value set to <i>Reject Cause</i> .	<--	5GMM: REGISTRATION REJECT
9	The SS transmits an <i>RRCRelease</i> message	<--	RRC: <i>RRCRelease</i>
10	Test procedure for Switch off / Power off in State Deregistered as specified in subclause 4.9.6.4		

#### 4.9.8.2.3 Specific message contents

**Table 4.9.8.2.3-1: REGISTRATION REJECT**

Derivation Path: table 4.7.1-9			
Information Element	Value/remark	Comment	Condition
5GMM cause	Set according to <i>Reject Cause</i>	<i>Reject Cause</i> set to #6 Illegal ME as default	

## 4.9.9 Test procedure for UE for Tracking area updating / Inter-system change from S1 mode to N1 mode in 5GMM/EMM-IDLE mode

### 4.9.9.1 Scope

This procedure aims at verifying that the UE performs a Mobility and periodic registration update procedure when it performs inter-system change from S1 mode to N1 mode in 5GMM/EMM-IDLE.

## 4.9.9.2 Procedure description

## 4.9.9.2.1 Initial conditions

## System Simulator:

- 1 NGC Cell connected to 5GC, default parameters, system information combination NR-6 as defined in subclause 4.4.3.1.2.

NOTE: Details about the E-UTRA cell from which the UE will move to the NGC cell are to be specified in the test.

## User Equipment:

- The Test UICC shall be inserted. It shall provide relevant details on the EPC and 5GC.

All details required shall be explicitly specified in the TC which calls the procedure in its entirety or refers to parts of it.

## 4.9.9.2.2 Procedure sequence

**Table 4.9.9.2.2-1: Test procedure sequence UE Tracking area updating / inter-system change from S1 mode to N1 mode in 5GMM/EMM-IDLE mode**

St	Procedure	Message Sequence		TP	Verdict
		U - S	Message/PDU/SDU		
-	EXCEPTION: Unless otherwise stated all the messages below are transmitted on the cell specified in the test case.	-	-	-	-
1-3	Steps 1-3 from the mobility and periodic registration update procedure as described in Table 4.9.5.2.2-1 are performed. For some consequences related to the content of the REGISTRATION REQUEST message sent in step 1 see the Notes in Table 4.9.9.2.3-1.	-	-	-	-
4	The SS transmits a DLInformationTransfer message and an AUTHENTICATION REQUEST message.	<--	NR RRC: DLInformationTransfer 5GMM: AUTHENTICATION REQUEST	-	-
5	The UE transmits a ULInformationTransfer message and an AUTHENTICATION RESPONSE message.	-->	NR RRC: ULInformationTransfer 5GMM: AUTHENTICATION RESPONSE	-	-
6	The SS transmits a DLInformationTransfer message and a SECURITY MODE COMMAND message.	<--	NR RRC: DLInformationTransfer 5GMM: SECURITY MODE COMMAND	-	-
7	The UE transmits a ULInformationTransfer message and a SECURITY MODE COMPLETE message.	-->	NR RRC: ULInformationTransfer 5GMM: SECURITY MODE COMPLETE	-	-
8	The SS transmits a SecurityModeCommand message.	<--	NR RRC: SecurityModeCommand	-	-
9	The UE transmits a SecurityModeComplete message.	-->	NR RRC: SecurityModeComplete	-	-
10-11	Steps 4-5 of Table 4.9.5.2.2-1 of the test procedure are performed.	-	-	-	-
12a1 - 13a1	Void	-	-	-	-
-	EXCEPTION: Steps 14a1 to 14b2b1 describe a step sequence depending on test case scenario; the "lower case letter" identifies a step sequence that take place if the test procedure is called in a particular scenario. (NOTE 1)	-	-	-	-
14a1	IF <i>Interworking without N26 interface supported</i> THEN	-	-	-	-

	The generic procedure for UE-requested PDU session establishment, specified in subclause 4.5A.2, takes place performing establishment of UE-requested PDU session(s) with ExpectedNumberOfNewPDUSessions = pc_noOf_PDUsSameConnection. The UE may attempt to transfer some of the existing in S1 PDN connection(s) in which case in the PDU SESSION ESTABLISHMENT REQUEST message the request type shall be set to "existing PDU session" (NOTE 3).				
-	EXCEPTION: Steps 14a2a1 to 14a2b1 describe a step sequence depending on test case scenario; the "lower case letter" identifies a step sequence that take place if the UE performs a specific action.	-	-	-	-
14a2 a1	IF pc_noOf_PDUsNewConnection > 0 THEN the SS transmits an <i>RRCRelease</i> message to release RRC connection and moves the UE to RRC_IDLE.	<--	NR RRC: <i>RRCRelease</i>	-	-
14a2 a2	The procedure NR RRC_IDLE Extension as specified in table 4.5.2.2-4 takes place.	-	-	-	-
14a2 b1	ELSE IF <i>connected without release</i> is not present THEN, the SS transmits an <i>RRCConnectionRelease</i> message to release RRC connection and move the UE to RRC_IDLE.	<--	NR RRC: <i>RRCRelease</i>	-	-
-	EXCEPTION: In parallel to the events described in step 14b1 below, the steps specified in Table 4.9.9.2.2-2 may take place.	-	-	-	-
14b1	ELSE (i.e. 'Interworking without N26 interface not supported') The generic procedure for UE-requested PDU session establishment, specified in subclause 4.5A.2, takes place performing establishment of UE-requested PDU session(s) with ExpectedNumberOfNewPDUSessions = pc_noOf_PDUsSameConnection with the exception that IF step 2b1, Table 4.5A.2.2.2-2 takes place THEN the SS shall not assign Fail but continue with the next step in the test sequence not expecting any additional session establishment to take place (NOTE 2).	-	-	-	-
-	EXCEPTION: Steps 14b2a1 to 14b2b1 describe a step sequence depending on test case scenario; the "lower case letter" identifies a step sequence that take place if the UE performs a specific action.	-	-	-	-
14b2 a1	IF pc_noOf_PDUsNewConnection > 0 THEN the SS transmits an <i>RRCRelease</i> message to release RRC connection and move the UE to RRC_IDLE.	<--	NR RRC: <i>RRCRelease</i>	-	-
14b2 a2	The procedure NR RRC_IDLE Extension as specified in Table 4.5.2.2-4 takes place.  For the referred in step 8, Table 4.5.2.2-4, generic procedure for UE-requested PDU session establishment, specified in subclause 4.5A.2, IF step 2b1, Table 4.5A.2.2.2-2 takes place THEN the SS shall not assign Fail but continue with the next step in the test sequence not expecting any additional session establishment to take place (NOTE 2).	-	-	-	-
14b2 b1	ELSE IF <i>connected without release</i> is not present THEN, the SS transmits an <i>RRCRelease</i> message to release RRC connection and move the UE to RRC_IDLE.	<--	NR RRC: <i>RRCRelease</i>	-	-

NOTE 1: The NWK will indicated whether Interworking without N26 interface is supported in the REGISTRATION ACCEPT message, IE '5GS network feature support', IWK N26 bit. Consequently which branch would the procedure sequence go through will depend on the content of the REGISTRATION ACCEPT message applicable to e.g. the test case which calls the present test procedure.

NOTE 2: Depending on UE implementation and/or NWK behaviour, the UE may transfer some PDN connections into PDU sessions without re-establishing them with the relevant mapping provided in the ACTIVATE DEFAULT EPS BEARER CONTEXT REQUEST message. This will result in the number of connection modifications, if any, being lower than the pc\_noOf\_PDUsSameConnection or the pc\_noOf\_PDUsNewConnection which the UE will establish upon initial attach to the 5GS.

NOTE 3: Since the MME does not provide the UE with the mapped PDU session for a PDN connection, the UE does not know whether interworking to 5GS is supported for a PDN connection for which the UE assigned a PDU Session identity before attempting to transfer the PDN connection from S1 mode to N1 mode. It is up to UE implementation to decide which PDN connection(s) to be attempted to transfer from S1 mode to N1 mode, e.g. based on UE policy or UE local configuration. (see TS 24.501 [22], subclause 6.1.4.2)

**Table 4.9.9.2.2-2: Parallel behaviour**

St	Procedure	Message Sequence		TP	Verdict
		U - S	Message		
-	EXCEPTION: Step 1 describe a step sequence depending on test case scenario; the "lower case letter" identifies a step sequence that take place if the UE performs a specific action. NOTE 2, NOTE 3	-	-	-	-
1	IF this is the first time in a test case that the UE moves from S1 to N1 THEN  the generic procedure for Procedure for UE-requested PDU session modification after the first S1 to N1 mode change / Single-registration mode with N26, specified in subclause 4.5A.2C, takes place with ExpectedNumberOfPDUSessionModification s=(pc_noOf_PDUsSameConnection+pc_noOf_PDUsNewConnection), with the exception that IF step 2b1, Table 4.5A.2C.2.2-2 takes place THEN the SS shall not assign Fail but continue with the next step in the test sequence not expecting any additional session modifications to take place (NOTE 1).				
<p>NOTE 1: Depending on UE implementation and/or NWK behaviour, the UE may transfer with modification some PDN connections into PDU sessions without re-establishing them with the relevant mapping provided in the ACTIVATE DEFAULT EPS BEARER CONTEXT REQUEST message. This will result in the number of session modifications, if any, being lower than the pc_noOf_PDUsSameConnection+pc_noOf_PDUsNewConnection.</p> <p>NOTE 2: Whether this is the first time in a test case that the UE moves from S1 to N1 depends on the test scenario (including what happens in the preamble of the test).</p> <p>NOTE 3: It is assumed that the PDU session modification for all transferred PDUs will happen on the same connection with the mobility and periodic registration update procedure.</p> <p>NOTE 4: For PDN connections which will be transferred, tests calling the present procedure shall ensure that: - For each PDN connection established during the UE registration to the EPS, the ACTIVATE DEFAULT EPS BEARER CONTEXT REQUEST message which corresponds to the default EPS bearer of the PDN connectivity being activated, contains the Protocol configuration options IE or the Extended protocol configuration options IE with mapped 5GS PDU a session-AMBR and QoS rule(s).</p>					

4.9.9.2.3 Specific Message content

**Table 4.9.9.2.3-1: REGISTRATION REQUEST (step 1, Table 4.9.9.2.2-1; step 3, Table 4.9.5.2.2-1)**

Derivation Path: Table 4.7.1-6.			
Information Element	Value/remark	Comment	Condition

5GS registration type	'x010'B	mobility registration updating x - not checked	
ngKSI			
NAS key set identifier	KSI <sub>AMF</sub> that was created when the UE last registered to 5GCN		Registered_Previously_on_5GCN
	'111'B	No key	Not_Registered_Previously_on_5GCN
TSC	'0'B	native security context (for KSI <sub>AMF</sub> )	Registered_Previously_on_5GCN
	Not applicable	TSC does not apply for NAS key set identifier value "111"	Not_Registered_Previously_on_5GCN
5GS mobile identity	5G-GUTI mapped from the 4G-GUTI assigned when the UE last registered to EPC E-UTRA		
Non-current native NAS key set identifier	Not present		
5GMM capability	'1'	S1 mode supported	
Last visited registered TAI	The TAI the last visited NGC Cell belonged to, if any. Not included if the UE does not have last stored 5GC TAI.		
S1 UE network capability			
All octets with the exception of octet 8, bit 8 and octet 9, bit 6	Not checked		
Extended protocol configuration options (ePCO) (octet 8, bit 8)	'1'	Extended protocol configuration options IE supported	
N1 mode supported (N1mode) (octet 9, bit 6)	'1'	N1 mode supported	
PDU session status	Any allowed value	(NOTE 1)	
UE status	"UE is in EMM-REGISTERED state"		
Additional GUTI	5G-GUTI assigned when the UE last registered to 5GCN		Registered_Previously_on_5GCN
	Not present		Not_Registered_Previously_on_5GCN
EPS NAS message container	TRACKING AREA UPDATE REQUEST message	See Table 4.9.9.2.3-2	
EPS bearer context status	Not present	(NOTE 2)	
<p>NOTE 1: The UE includes the PDU session status IE indicating the status of the PDU session(s) mapped during the inter-system change from S1 mode to N1 mode from the PDN connection(s) for which the EPS indicated that interworking to 5GS is supported, if any. This means that the UE has created locally the default bearer context and the dedicated bearer context(s) based on the parameters of the mapped bearer contexts or the associations between QoS flow and mapped bearer in the PDN connection. Although the contents of the IE is not required to be verified for PASS/FAIL purposes, the provided information shall be taken into account for building any subsequent RRC Reconfiguration message, and can be used e.g. for SS configuration purposes as well.</p> <p>NOTE 2: The UE is assumed NOT to have locally deactivated EPS bearer context(s) for which interworking to 5GS is supported while the UE was in S1 mode without notifying the network.</p>			



Condition	Explanation
Not_Registered_Previously_on_5GCN	UE has not_registered_previously_on_5GCN. UE does not have valid 5G NAS security context and 5G-GUTI.
Registered_Previously_on_5GCN	UE has registered_previously_on_5GCN. UE have valid 5G NAS security context and 5G-GUTI

Table 4.9.9.2.3-2: TRACKING AREA UPDATE REQUEST (Table 4.9.9.2.3-1)

Derivation Path: TS 36.508 [2], Table 4.7.2-27.			
Information Element	Value/remark	Comment	Condition
EPS update type			
EPS update type Value	'000'B	TA updating	
"Active" flag	'0'B	No Bearer Establishment requested	
NAS key set identifier	the eKSI for the current EPS security context		
TSC	'0'B		Mapped EPS security context
	'1'B		
Old GUTI	4G-GUTI assigned when the UE last registered to EPC E-UTRA		
UE network capability	Not present		
Last visited registered TAI	Not present		
DRX parameter	Not present		
UE radio capability information update needed	Not present		
EPS bearer context status	Not present		
MS network capability	Not present		
Old location area identification	Not present		
TMSI status	Not present		
Mobile station classmark 2	Not present		
Mobile station classmark 3	Not present		
Supported Codecs	Not present		
Additional update type	Not present		
Voice domain preference and UE's usage setting	Not present		
Old GUTI type	Not present		
Device properties	Not present		
MS network feature support	Not present		
TMSI based NRI container	Not present		
T3324 value	Not present		
T3412 extended value	Not present		
Extended DRX parameters	Not present		
UE additional security capability	Not present		
UE status	Not present		
Additional information requested	Not present		
NOTE: The message shall be integrity protected using the current EPS security context.			

Condition	Explanation
Mapped EPS security context	When explicitly specified by the test case in which the message is used.

Table 4.9.9.2.3-3: REGISTRATION ACCEPT (step 10, Table 4.9.9.2.2-1; step 4, Table 4.9.5.2.2-1)

Derivation Path: Table 4.7.1-7.			
Information Element	Value/remark	Comment	Condition
5GS network feature support	The IWK N26 (octet 4, bit 7) set to '1'		<i>Interworking without N26 interface supported</i>

## 4.9.10 Test procedure to check that the UE is in RRC\_CONNECTED state

### 4.9.10.1 Scope

This procedure aims at checking whether the UE is in the RRC\_CONNECTED state.

### 4.9.10.2 Procedure description

#### 4.9.10.2.1 Initial conditions

As specified in the TC which calls the procedure in its entirety or refers to parts of it.

#### 4.9.10.2.2 Procedure

**Table 4.9.10.2.2-1: Test procedure sequence**

St	Procedure	Message Sequence		TP	Verdict
		U - S	Message/PDU/SDU		
1	The SS sends <i>UECapabilityEnquiry</i> message to the UE.	<--	NR RRC: <i>UECapabilityEnquiry</i>	-	-
2	Check: Does the UE send a <i>UECapabilityInformation</i> message?	-->	NR RRC: <i>UECapabilityInformation</i>		P

#### 4.9.10.2.3 Specific Message content

None.

## 4.9.11 Test procedure for IMS Emergency call or eCall over IMS establishment in 5GC with IMS emergency registration

### 4.9.11.1 Scope

This procedure aims at verifying the UE establishment of IMS Emergency call or an eCall in 5GC when the UE is in 5GMM-IDLE and when IMS emergency registration is required e.g. under Normal Service conditions.

The procedure provides different emergency or eCall establishment options based on the condition parameters defined in Table 4.9.11.1-1.

**Table 4.9.11.1-1: Condition parameters**

Condition	Explanation
emergency call	When this parameter is present the TC has triggered the UE to initiate an emergency call. (NOTE)
eCall	When this parameter is present the TC has triggered the UE to initiate an eCall.
NOTE:	If this generic procedure is referred in test case without any condition, emergency call shall be used as default.

The trigger to initiate MO call will be part of test case from where the generic procedure is called.

### 4.9.11.2 Procedure description

#### 4.9.11.2.1 Initial conditions

System Simulator:

- 1 NR Cell connected to 5GC, default parameters.

User Equipment:

- The Test UICC shall be inserted. It shall provide Emergency Numbers.

The procedure assumes that the UE is in test state 1N-A, subclause 4.4A.2 on the NR Cell. All necessary details required shall be explicitly specified in the TC which calls the procedure in its entirety or refers to parts of it.

#### 4.9.11.2.2 Procedure sequence

**Table 4.9.11.2.2-1: Test procedure sequence UE IMS Emergency call or eCall over IMS establishment in 5GC with IMS emergency registration**

St	Procedure	Message Sequence		TP	Verdict
		U - S	Message/PDU/SDU		
-	EXCEPTION: Unless otherwise stated all the messages below are transmitted on the cell specified in the test case.	-	-	-	-
1	The UE transmits an <i>RRCSetupRequest</i> message with 'establishmentCause' set to 'emergency'.	-->	NR RRC: <i>RRCSetupRequest</i>	-	P
2	The SS transmits an <i>RRCSetup</i> message.	<--	NR RRC: <i>RRCSetup</i>	-	-
3	The UE transmits an <i>RRCSetupComplete</i> message and a SERVICE REQUEST message with 'Service type' set to 'emergency services'.	-->	NR RRC: <i>RRCSetupComplete</i> 5GMM: SERVICE REQUEST	-	P
4	The SS transmits a <i>SecurityModeCommand</i> message.	<--	NR RRC: <i>SecurityModeCommand</i>	-	-
5	The UE transmits a <i>SecurityModeComplete</i> message.	-->	NR RRC: <i>SecurityModeComplete</i>	-	-
6	The SS transmits an <i>RRCReconfiguration</i> message and a SERVICE ACCEPT message to establish SRB2 and DRB.	<--	NR RRC: <i>RRCReconfiguration</i> 5GMM: SERVICE ACCEPT	-	-
-	EXCEPTION: Depending upon UE implementation, steps 7 and 8 can occur in any order.	-	-	-	-
7	The UE transmits an <i>RRCReconfigurationComplete</i> message.	-->	NR RRC: <i>RRCReconfigurationComplete</i>	-	-
8	The UE transmits an UL NAS TRANSPORT message with 'Request type' set to 'initial emergency request', and, a PDU SESSION ESTABLISHMENT REQUEST.	-->	NR RRC: <i>ULInformationTransfer</i> 5GMM: UL NAS TRANSPORT 5GSM: PDU SESSION ESTABLISHMENT REQUEST	-	P
-	EXCEPTION: In parallel to the events described in steps 9-10 below the events specified in steps 1a1 to 2 of Table 4.9.11.2.2-2 take place.	-	-	-	-
9	The SS transmits an <i>RRCReconfiguration</i> message and an PDU SESSION ESTABLISHMENT ACCEPT.	<--	NR RRC: <i>RRCReconfiguration</i> 5GMM: DL NAS TRANSPORT 5GSM: PDU SESSION ESTABLISHMENT ACCEPT	-	-
10	The UE transmits an <i>RRCReconfigurationComplete</i> message.	-->	NR RRC: <i>RRCReconfigurationComplete</i>	-	-
-	EXCEPTION: In parallel to the events described in steps 11-13 below the events specified in steps 3 of Table 4.9.11.2.2-2 take place.	-	-	-	-
11	The SS transmits an <i>RRCReconfiguration</i> message and an PDU SESSION MODIFICATION COMMAND.	<--	NR RRC: <i>RRCReconfiguration</i> 5GMM: DL NAS TRANSPORT 5GSM: PDU SESSION MODIFICATION COMMAND	-	-
-	EXCEPTION: Depending upon UE implementation, steps 12 and 13 can occur in any order.	-	-	-	-
12	The UE transmits an <i>RRCReconfigurationComplete</i> message.	-->	NR RRC: <i>RRCReconfigurationComplete</i>	-	-
13	The UE transmits an <i>ULInformationTransfer</i> message and an PDU SESSION MODIFICATION COMPLETE message.	-->	NR RRC: <i>ULInformationTransfer</i> 5GMM: UL NAS TRANSPORT	-	P

			5GSM: PDU SESSION MODIFICATION COMPLETE		
--	--	--	--	--	--

**Table 4.9.11.2.2-2: IMS signalling and Emergency call establishment**

St	Procedure	Message Sequence		TP	Verdict
		U - S	Message/PDU/SDU		
-	EXCEPTION: Step 1a1 describes behaviour depending on UE implementation; the "lower case letter" identifies a step sequence that take place if the UE performs a specific action.	-	-	-	-
1a1	The generic procedure for IP address allocation in the user plane specified in subclause 4.5A.3 takes place.	-	-	-	-
2	Generic Test Procedure for IMS Emergency registration / 5GS as defined in TS 34.229-5 [47], annex A.3 is performed.	-	-	-	-
-	EXCEPTION: Steps 3a1-3b1 describe a step sequence depending on procedure parameters; the "lower case letter" identifies a step sequence that take place if a procedure parameter has a particular value.	-	-	-	-
3a1	IF 'emergency call' THEN Generic test procedure for setting up IMS Emergency Voice Call / 5G as defined in TS 34.229-5 [47], annex A.6 is performed.	-	-	-	-
3b1	IF 'eCall' THEN Generic test procedure for NR eCall Setup and MSD Update, steps 1-3, as defined in Annex A.23 of TS 34.229-5 [47] is performed.	-	-	-	-

#### 4.9.11.2.3 Specific Message content

All specific message contents shall be according subclause 4.6 and 4.7 with the exceptions below.

**Table 4.9.11.2.3-1: SIB1 (at any time prior and during the procedure, Table 4.9.11.2.2-1)**

Derivation Path: Table 4.6.1-28.			
Information Element	Value/remark	Comment	Condition
SIB1 ::= SEQUENCE {			
ims-EmergencySupport	Present	true	
}			

**Table 4.9.11.2.3-2: RRCSetupRequest (step 1, Table 4.9.11.2.2-1)**

Derivation Path: Table 4.6.1-23.			
Information Element	Value/remark	Comment	Condition
RRCSetupRequest ::= SEQUENCE {			
rrcSetupRequest SEQUENCE {			
establishmentCause	emergency		
}			
}			

**Table 4.9.11.2.3-3: SERVICE REQUEST (step 3, Table 4.9.11.2.2-1)**

Derivation Path: Table 4.7.1-16.			
Information Element	Value/remark	Comment	Condition
Service type	'0011'B	emergency services	

**Table 4.9.11.2.3-4: UL NAS TRANSPORT (step 8, Table 4.9.11.2.2-1)**

Derivation Path: Table 4.7.1-10, condition INITIAL_PDU_REQUEST.			
Information Element	Value/remark	Comment	Condition
Request type	'011'B	initial emergency request	
S-NSSAI	Not Present		
DNN	Not Present		

**Table 4.9.11.2.3-5: PDU SESSION ESTABLISHMENT REQUEST (step 8, Table 4.9.11.2.2-1)**

Derivation Path: Table 4.7.2-1.			
Information Element	Value/remark	Comment	Condition
PDU session ID	A value that is not currently being used by another PDU session		
PTI	A value currently not used		
SSC mode	'001'B	SSC mode 1	

**Table 4.9.11.2.3-6: DL NAS TRANSPORT (step 9, Table 4.9.11.2.2-1)**

Derivation Path: Table 4.7.1-11, condition 5GSM_MESSAGE.			
--	--	--	--

**Table 4.9.11.2.3-7: PDU SESSION ESTABLISHMENT ACCEPT (step 9, Table 4.9.11.2.2-1)**

Derivation Path: Table 4.7.2-2.			
Information Element	Value/remark	Comment	Condition
Selected SSC mode	'001'B	SSC mode 1	
Authorized QoS rules	Reference QoS rule #2 as defined in Table 4.8.2.1-2.		
Authorized QoS flow descriptions	Reference QoS flow #2 as defined in Table 4.8.2.3-2.		
DNN	Not Present		

**Table 4.9.11.2.3-8: RRCReconfiguration (step 9, Table 4.9.11.2.2-1)**

Derivation Path: Table 4.8.1-1: RRCReconfiguration-DRB (1, 0)			
---	--	--	--

**Table 4.9.11.2.3-9: PDU SESSION MODIFICATION COMMAND (step 11, Table 4.9.11.2.2-1)**

Derivation Path: Table 4.7.2-2.			
Information Element	Value/remark	Comment	Condition
PDU session ID	Same value as sent in PDU SESSION ESTABLISHMENT REQUEST message.		
Authorized QoS rules	Reference QoS rule #7 as defined in Table 4.8.2.1-7 using condition IMS_VOICE.		
Authorized QoS flow descriptions	Reference QoS flow #5 as defined in Table 4.8.2.3-5.		

**Table 4.9.11.2.3-10: RRCReconfiguration (step 11, Table 4.9.11.2.2-1)**

Derivation Path: 4.8.1-1C RRCReconfiguration-Speech			
---	--	--	--

**Table 4.9.11.2.3-11: INVITE (step 3a1, Table 4.9.11.2.2-2)**

Derivation Path: TS 34.229-5 [47], Annex A.6, Step 1 with conditions A7 and A28
---

## 4.9.12 Test procedure for IMS Emergency call establishment in 5GC without IMS emergency registration

### 4.9.12.1 Scope

This procedure aims at verifying the UE establishment of IMS Emergency call in 5GC without the need for IMS emergency registration to take place beforehand e.g. under Limited Service or SIM/USIM not available, the SIM/USIM is considered invalid by the UE conditions.

### 4.9.12.2 Procedure description

#### 4.9.12.2.1 Initial conditions

#### System Simulator:

- 1 NR Cell connected to 5GC, default parameters unless specified otherwise. PLMN/TAI which the cell belongs to, shall be explicitly specified in the TC which calls the procedure in its entirety or refers to parts of it

#### User Equipment:

- Whether the Test UICC shall be inserted or not, and, its settings e.g. in regard to the provision of Emergency Numbers, shall be explicitly specified in the TC which calls the procedure in its entirety or refers to parts of it.

#### 4.9.12.2.2 Procedure sequence

**Table 4.9.12.2.2-1: Test procedure sequence UE IMS Emergency call establishment in 5GC without IMS emergency registration**

St	Procedure	Message Sequence		TP	Verdict
		U - S	Message/PDU/SDU		
-	EXCEPTION: Unless otherwise stated all the messages below are transmitted on the cell specified in the test case.	-	-	-	-
1	Check: Does the UE transmits an <i>RRCSetupRequest</i> message with 'establishmentCause' set to 'emergency'?	-->	NR RRC: <i>RRCSetupRequest</i>	-	P
2	The SS transmits an <i>RRCSetup</i> message.	<--	NR RRC: <i>RRCSetup</i>	-	-
3	Check: Does the UE transmits an <i>RRCSetupComplete</i> message and a REGISTRATION REQUEST message with 'Service type' set to 'emergency services'?	-->	NR RRC: <i>RRCSetupComplete</i> 5GMM: REGISTRATION REQUEST	-	P
4	The SS transmits a <i>DLInformationTransfer</i> message and a SECURITY MODE COMMAND message with 'Selected NAS security algorithms' set to "null integrity protection algorithm" (5G-IA0), "null ciphering algorithm" (5G-EA0).	<--	NR RRC: <i>DLInformationTransfer</i> 5GMM: SECURITY MODE COMMAND	-	-
5	The UE transmits an <i>ULInformationTransfer</i> message and a SECURITY MODE COMPLETE message.	-->	NR RRC: <i>ULInformationTransfer</i> 5GMM: SECURITY MODE COMPLETE	-	P
6	The SS transmits a <i>SecurityModeCommand</i> message with cipheringAlgorithm set to 'NULL' ciphering algorithm (nea0) and integrityProtAlgorithm set to 'NULL' integrity protection algorithm (nia0).	<--	NR RRC: <i>SecurityModeCommand</i>	-	-

7	The UE transmits a <i>SecurityModeComplete</i> message.	-->	NR RRC: <i>SecurityModeComplete</i>	-	P
8	The SS transmits a <i>UECapabilityEnquiry</i> message.	<--	NR RRC: <i>UECapabilityEnquiry</i>	-	-
9	The UE transmits a <i>UECapabilityInformation</i> message.	-->	NR RRC: <i>UECapabilityInformation</i>	-	-
10	The SS transmits a <i>DLInformationTransfer</i> message and a REGISTRATION ACCEPT message.	<--	NR RRC: <i>DLInformationTransfer</i> 5GMM: REGISTRATION ACCEPT	-	-
11	The UE transmits an <i>ULInformationTransfer</i> message and a REGISTRATION COMPLETE message.	-->	NR RRC: <i>ULInformationTransfer</i> 5GMM: REGISTRATION COMPLETE	-	-
12	Void	-	-	-	-
13	Check: Does the UE transmits an UL NAS TRANSPORT message with 'Request type' set to 'initial emergency request', and, a PDU SESSION ESTABLISHMENT REQUEST?	-->	NR RRC: <i>ULInformationTransfer</i> 5GMM: UL NAS TRANSPORT 5GSM: PDU SESSION ESTABLISHMENT REQUEST	-	P
-	EXCEPTION: In parallel to the events described in steps 14-15 below the events specified in steps 1a1 of Table 4.9.12.2.2-2 take place.	-	-	-	-
14	The SS transmits an <i>RRCReconfiguration</i> message and an PDU SESSION ESTABLISHMENT ACCEPT to establish SRB2 and DRB.	<--	NR RRC: <i>RRCReconfiguration</i> 5GMM: DL NAS TRANSPORT 5GSM: PDU SESSION ESTABLISHMENT ACCEPT	-	-
15	The UE transmits an <i>RRCReconfigurationComplete</i> message.	-->	NR RRC: <i>RRCReconfigurationComplete</i>	-	-
-	EXCEPTION: In parallel to the events described in steps 16-18 below the events specified in steps 2 of Table 4.9.12.2.2-2 take place.	-	-	-	-
16	The SS transmits an <i>RRCReconfiguration</i> message and an PDU SESSION MODIFICATION COMMAND.	<--	NR RRC: <i>RRCReconfiguration</i> 5GMM: DL NAS TRANSPORT 5GSM: PDU SESSION MODIFICATION COMMAND	-	-
-	EXCEPTION: Depending upon UE implementation, steps 17 and 18 can occur in any order.	-	-	-	-
17	The UE transmits an <i>RRCReconfigurationComplete</i> message.	-->	NR RRC: <i>RRCReconfigurationComplete</i>	-	-
18	Check: Does the UE transmits an <i>ULInformationTransfer</i> message and an PDU SESSION MODIFICATION COMPLETE message?	-->	NR RRC: <i>ULInformationTransfer</i> 5GMM: UL NAS TRANSPORT 5GSM: PDU SESSION MODIFICATION COMPLETE	-	P

Table 4.9.12.2.2-2: IMS signalling and Emergency call establishment

St	Procedure	Message Sequence		TP	Verdict
		U - S	Message/PDU/SDU		
-	EXCEPTION: Step 1a1 describes behaviour depending UE implementation; the "lower case letter" identifies a step sequence that take place if the UE performs a specific action.	-	-	-	-
1a1	The generic procedure for IP address allocation in the user plane specified in subclause 4.5A.3 takes place.	-	-	-	-
2	Generic test procedure for setting up IMS Emergency Voice Call as defined in TS 34.229-5 [47] annex A.6 is performed.	-	-	-	-

#### 4.9.12.2.3 Specific Message content

All specific message contents shall be according subclause 4.6 and 4.7 with the exceptions below.

NOTE: Some of the specific message contents provided below assume that the UE is in the state 5GMM-DEREGISTERED.LIMITED-SERVICE or 5GMM-REGISTERED.LIMITED-SERVICE (e.g. the selected cell over 3GPP access is in a forbidden PLMN or is in a forbidden tracking area respectively), or, in 5GMM-DEREGISTERED.NO-SUPI as defined in TS 24.501 [28], subclauses 5.1.3.2.1.3.3 and 5.1.3.2.1.3.6 respectively. All necessary details required shall be explicitly specified in the TC which calls the procedure in its entirety or refers to parts of it.

**Table 4.9.12.2.3-1: SIB1 (at any time prior and during the procedure, Table 4.9.12.2.2-1)**

Derivation Path: Table 4.6.1-28.			
Information Element	Value/remark	Comment	Condition
SIB1 ::= SEQUENCE {			
ims-EmergencySupport	Present	true	
}			

**Table 4.9.12.2.3-2: RRCSetupRequest (step 1, Table 4.9.12.2.2-1)**

Derivation Path: Table 4.6.1-23.			
Information Element	Value/remark	Comment	Condition
RRCSetupRequest ::= SEQUENCE {			
rrcSetupRequest SEQUENCE {			
establishmentCause	emergency		
}			
}			

**Table 4.9.12.2.3-3: REGISTRATION REQUEST (step 3, Table 4.9.12.2.2-1)**

Derivation Path: Table 4.7.1-6, condition EMERGENCY.			
--	--	--	--

**Table 4.9.12.2.3-4: SECURITY MODE COMMAND (step 4, Table 4.9.12.2.2-1)**

Derivation Path: Table 4.7.1-25.			
Information Element	Value/remark	Comment	Condition
Selected NAS security algorithms			
Type of ciphering algorithm	5G-EA0	null ciphering algorithm	
Type of integrity protection algorithm	5G-IA0	null integrity protection algorithm	
ngKSI			
NAS key set identifier	'000'B		

**Table 4.9.12.2.3-5: SecurityModeCommand (step 6, Table 4.9.12.2.2-1)**

Derivation Path: Table 4.6.1-25.			
Information Element	Value/remark	Comment	Condition
SecurityModeCommand ::= SEQUENCE {			
criticalExtensions CHOICE {			
securityModeCommand SEQUENCE {			
securityConfigSMC SEQUENCE {			
securityAlgorithmConfig SEQUENCE {			
cipheringAlgorithm	nea0	'NULL' ciphering algorithm	
integrityProtAlgorithm	nia0	'NULL' integrity protection algorithm	
}			
}			
}			
}			
}			



**Table 4.9.12.2.3-6: REGISTRATION ACCEPT (step 10, Table 4.9.12.2.2-1)**

Derivation Path: Table 4.7.1-7, condition EMERGENCY.
--

**Table 4.9.12.2.3-7: UL NAS TRANSPORT (step 13, Table 4.9.12.2.2-1)**

Derivation Path: Table 4.7.1-10, condition INITIAL_PDU_REQUEST.			
Information Element	Value/remark	Comment	Condition
Request type	'011'B	initial emergency request	
S-NSSAI	Not Present		
DNN	Not Present		

**Table 4.9.12.2.3-8: PDU SESSION ESTABLISHMENT REQUEST (step 13, Table 4.9.12.2.2-1)**

Derivation Path: Table 4.7.2-1.			
Information Element	Value/remark	Comment	Condition
PDU session ID	A value that is not currently being used by another PDU session		
PTI	A value currently not used		
SSC mode	'001'B	SSC mode 1	

**Table 4.9.12.2.3-9: DL NAS TRANSPORT (step 14, Table 4.9.12.2.2-1)**

Derivation Path: Table 4.7.1-11, condition 5GSM_MESSAGE.
--

**Table 4.9.12.2.3-10: PDU SESSION ESTABLISHMENT ACCEPT (step 14, Table 4.9.12.2.2-1)**

Derivation Path: Table 4.7.2-2.			
Information Element	Value/remark	Comment	Condition
Selected SSC mode	'001'B	SSC mode 1	
Authorized QoS rules	Reference QoS rule #2 as defined in Table 4.8.2.1-2.		
Authorized QoS flow descriptions	Reference QoS flow #2 as defined in Table 4.8.2.3-2.		

**Table 4.9.12.2.3-11: RRCReconfiguration (step 14, Table 4.9.12.2.2-1)**

Derivation Path: Table 4.8.1-1: RRCReconfiguration-SRB2-DRB (1, 0)
--

**Table 4.9.12.2.3-12: PDU SESSION MODIFICATION COMMAND (step 16, Table 4.9.12.2.2-1)**

Derivation Path: Table 4.7.2-2.			
Information Element	Value/remark	Comment	Condition
PDU session ID	Same value as sent in PDU SESSION ESTABLISHMENT REQUEST message.		
Authorized QoS rules	Reference QoS rule #7 as defined in Table 4.8.2.1-7 using condition IMS_VOICE.		

Authorized QoS flow descriptions	Reference QoS flow #5 as defined in Table 4.8.2.3-5.		
----------------------------------	--	--	--

**Table 4.9.12.2.3-13: RRCReconfiguration (step 16, Table 4.9.12.2.2-1)**

Derivation Path: 4.8.1-1C RRCReconfiguration-Speech
---

**Table 4.9.12.2.3-14: INVITE (step 2, Table 4.9.12.2.2-2)**

Derivation Path: TS 34.229-5 [47], Annex A.6, Step 1 with conditions A6 and A28
---

## 4.9.12A Test procedure for IMS MO Emergency call release

### 4.9.12A.1 Scope

This procedure aims at verifying the UE initiated release of an ongoing IMS Emergency call in 5GC.

The procedure provides different handling options of the emergency PDU session based on the condition parameter defined in Table 4.9.12A.1-1.

**Table 4.9.12A.1-1: Condition parameters**

Condition	Explanation
release emergency PDU session	When this parameter is present the SS will release the emergency PDU session even if not requested by the UE after the release of the emergency call.
keep emergency PDU session	When this parameter is present the SS will only release the emergency PDU session if requested by the UE, if not it will release the voice QoS after the release of the emergency call.
NOTE 1: If the defined condition parameter is not present when the procedure is referred to then the default value 'release emergency PDU session' will apply.	

### 4.9.12A.2 Procedure description

#### 4.9.12A.2.1 Initial conditions

System Simulator:

- 1 NR Cell connected to 5GC, default parameters.

User Equipment:

- The Test UICC shall be inserted. It shall provide Emergency Numbers.

The procedure assumes that the UE is in test state 3N-A, subclause 4.4A.2 on the NR Cell with an active IMS emergency call. All necessary details required shall be explicitly specified in the TC which calls the procedure in its entirety or refers to parts of it.

#### 4.9.12A.2.2 Procedure sequence

**Table 4.9.12A.2.2-1: Test procedure sequence IMS MO Emergency call release**

St	Procedure	Message Sequence		TP	Verdict
		U - S	Message/PDU/SDU		
1	Generic test procedure for MO Release of Voice Call / 5GS, as defined in Annex A.7 of TS 34.229-5 [47], is performed.	-	-	-	-
2-3	Void	-	-	-	-

3A1	SS starts timer T1 = 5 seconds.	-	-	-	-
-	EXCEPTION: Steps 3Ba1 to 3Bb2b3 describe a transaction that depends on the UE behaviour; the "lower case letter" identifies a step sequence that takes place if a specific behaviour happens.	-	-	-	-
3Ba1	The UE transmits a PDU SESSION RELEASE REQUEST message.	-->	NR RRC: <i>ULInformationTransfer</i> 5GMM: UL NAS TRANSPORT 5GSM: PDU SESSION RELEASE REQUEST	-	-
3Ba2	Stop timer T1.	-	-	-	-
3Ba3	Test procedure for PDU Session Release specified in subclause 4.9.21 takes place.	-	-	-	-
3Bb1	Timer T1 expires.	-	-	-	-
-	EXCEPTION: Steps 3Bb2a1 – 3Bb2b3 describe a step sequence depending on procedure parameters; the "lower case letter" identifies a step sequence that take place if a procedure parameter has a particular value.	-	-	-	-
3Bb2 a1	IF 'release emergency PDU session' THEN test procedure for PDU Session Release specified in subclause 4.9.21 takes place.	-	-	-	-
3Bb2 b1	ELSE (i.e. 'keep emergency PDU session') THEN the SS transmits a RRCReconfiguration message and a PDU SESSION MODIFICATION COMMAND message.	<--	NR RRC: <i>RRCReconfiguration</i> 5GMM: DL NAS TRANSPORT 5GSM: PDU SESSION MODIFICATION COMMAND	-	-
-	EXCEPTION: Steps 3Bb2b2 and 3Bb2b3 can occur in any order.	-	-	-	-
3Bb2 b2	The UE transmits a RRCReconfigurationComplete.	-	NR RRC: <i>RRCReconfigurationComplete</i>	-	-
3Bb2 b3	Check: Does the UE transmit a PDU SESSION MODIFICATION COMPLETE message?	-->	NR RRC: <i>ULInformationTransfer</i> 5GMM: UL NAS TRANSPORT 5GSM: PDU SESSION MODIFICATION COMPLETE	-	P
4-5	Void	-	-	-	-

#### 4.9.12A.2.3 Specific Message content

All specific message contents shall be according subclause 4.6 and 4.7 with the exceptions below.

**Table 4.9.12A.2.3-1: RRCReconfiguration (step 3Ba3, step 3Bb2a1, Table 4.9.12A.2.2-1; step 1 Table 4.9.21.2.2-1)**

Derivation Path: Table 4.6.1-13.			
Information Element	Value/remark	Comment	Condition
RRCReconfiguration ::= SEQUENCE {			
criticalExtensions CHOICE {			
rrcReconfiguration SEQUENCE {			
radioBearerConfig SEQUENCE {			
drb-ToReleaseList SEQUENCE (SIZE (1..maxDRB)) OF DRB-Identity {	2 entries		
DRB-Identity[1]	DRB-Identity linked to the IMS emergency signalling bearer	entry 1	
DRB-Identity[2]	DRB-Identity linked to the IMS emergency speech bearer	entry 2	
}			
}			
nonCriticalExtension SEQUENCE {			
masterCellGroup SEQUENCE {			
rlc-BearerToReleaseList SEQUENCE (SIZE (1..maxLC-ID)) OF LogicalChannelIdentity {	2 entries		
logicalChannelIdentity[1]	Same value as drb-Identity[1] above	entry 1	

logicalChannelIdentity[2]	Same value as drb-Identity[2] above	entry 2	
}			
}			
}			
}			
}			
}			

**Table 4.9.12A.2.3-2: PDU SESSION RELEASE COMMAND (step 3Ba2, step 3Bb2a1, Table 4.9.12A.2.2-1; step 1 Table 4.9.21.2.2-1)**

Derivation Path: Table 4.7.1-14.			
Information Element	Value/remark	Comment	Condition
PDU session ID	Set according to the Emergency session ID.		
5GSM cause	'0010 0100'B	Regular deactivation	

**Table 4.9.12A.2.3-3: PDU SESSION RELEASE REQUEST (step 3Ba1, Table 4.9.12A.2.2-1)**

Derivation Path: Table 4.7.1-14.			
Information Element	Value/remark	Comment	Condition
PDU session ID	Set according to the Emergency session ID.		
PTI	Any value from 1 to 254		

**Table 4.9.12A.2.3-4: RRCReconfiguration (step 3Bb2b1, Table 4.9.12A.2.2-1)**

Derivation Path: Table 4.6.1-13.			
Information Element	Value/remark	Comment	Condition
RRCReconfiguration ::= SEQUENCE {			
criticalExtensions CHOICE {			
rrcReconfiguration SEQUENCE {			
radioBearerConfig SEQUENCE {			
drb-ToReleaseList SEQUENCE (SIZE (1..maxDRB)) OF DRB-Identity {	1 entry		
DRB-Identity	DRB-Identity linked to the IMS speech bearer		
}			
}			
nonCriticalExtension SEQUENCE {			
masterCellGroup SEQUENCE {			
rlc-BearerToReleaseList SEQUENCE (SIZE (1..maxLC-ID)) OF LogicalChannelIdentity {	1 entry		
LogicalChannelIdentity	Same value as drb-Identity above		
}			
}			
}			
}			
}			

**Table 4.9.12A.2.3-5: PDU SESSION MODIFICATION COMMAND (step 3Bb2b1, Table 4.9.12A.2.2-1)**

Derivation Path: Table 4.7.2-9.			
Information Element	Value/remark	Comment	Condition
PDU session ID	Set according to the Emergency session ID		
Authorized QoS rules			

QoS rule			
QoS rule identifier	'00000011'B	QoS rule 3	
Rule operation code	'010'B	Delete existing QoS rule	
Authorized QoS flow descriptions			
QoS flow descriptions			
QFI	'00000111'B	QFI 7	
Operation code	'010'B	Delete existing QoS flow	

## 4.9.12B Test procedure for IMS MT Emergency call release

### 4.9.12B.1 Scope

This procedure aims at verifying the network initiated release of an ongoing IMS Emergency call in 5GC.

The procedure provides different handling options of the emergency PDU session based on the condition parameter defined in Table 4.9.12B.1-1.

**Table 4.9.12B.1-1: Condition parameters**

Condition	Explanation
release emergency PDU session	When this parameter is present the SS will release the emergency PDU session after the release of the emergency call.
keep emergency PDU session	When this parameter is present the SS will release the voice QoS, but not release the emergency PDU session after the release of the emergency call.
NOTE 1: If the defined condition parameter is not present when the procedure is referred to then the default value 'release emergency PDU session' will apply.	

### 4.9.12B.2 Procedure description

#### 4.9.12B.2.1 Initial conditions

System Simulator:

- 1 NR Cell connected to 5GC, default parameters.

User Equipment:

- The Test UICC shall be inserted. It shall provide Emergency Numbers.

The procedure assumes that the UE is in test state 3N-A, subclause 4.4A.2 on the NR Cell with an active IMS emergency call. All necessary details required shall be explicitly specified in the TC which calls the procedure in its entirety or refers to parts of it.

#### 4.9.12B.2.2 Procedure sequence

**Table 4.9.12B.2.2-1: Test procedure sequence IMS MT Emergency call release**

St	Procedure	Message Sequence		TP	Verdict
		U - S	Message/PDU/SDU		
1-2	Generic test procedure for MT release of speech call, steps 1-2, as defined in Annex A.8 of TS 34.229-5 [47] is performed.	-	-	-	-
-	EXCEPTION: Steps 3a1 – 3b3 describe a step sequence depending on procedure parameters; the "lower case letter" identifies a step sequence that take place if a procedure parameter has a particular value.	-	-	-	-

3a1	IF 'release emergency PDU session' THEN test procedure for PDU Session Release specified in subclause 4.9.21 takes place.	-	-	-	-
3b1	ELSE (i.e. 'keep emergency PDU session') THEN the SS transmits a RRCReconfiguration message and a PDU SESSION MODIFICATION COMMAND message.	<--	NR RRC: RRCReconfiguration 5GMM: DL NAS TRANSPORT 5GSM: PDU SESSION MODIFICATION COMMAND	-	-
-	EXCEPTION: Steps 3b2 and 3b3 can occur in any order.	-	-	-	-
3b2	The UE transmits a RRCReconfigurationComplete.	-	NR RRC: RRCReconfigurationComplete	-	-
3b3	Check: Does the UE transmit a PDU SESSION MODIFICATION COMPLETE message?	-->	NR RRC: ULInformationTransfer 5GMM: UL NAS TRANSPORT 5GSM: PDU SESSION MODIFICATION COMPLETE	-	P
4	Void	-	-	-	-

4.9.12B.2.3 Specific Message content

All specific message contents shall be according subclause 4.6 and 4.7 with the exceptions below.

**Table 4.9.12B.2.3-1: RRCReconfiguration (step 3a1, Table 4.9.12B.2.2-1; step 1 Table 4.9.21.2.2-1)**

Derivation Path: Table 4.6.1-13.			
Information Element	Value/remark	Comment	Condition
RRCReconfiguration ::= SEQUENCE {			
criticalExtensions CHOICE {			
rrcReconfiguration SEQUENCE {			
radioBearerConfig SEQUENCE {			
drb-ToReleaseList SEQUENCE (SIZE (1..maxDRB)) OF DRB-Identity {	2 entries		
DRB-Identity[1]	DRB-Identity linked to the IMS emergency signalling bearer	entry 1	
DRB-Identity[2]	DRB-Identity linked to the IMS emergency speech bearer	entry 2	
}			
}			
nonCriticalExtension SEQUENCE {			
masterCellGroup SEQUENCE {			
rlc-BearerToReleaseList SEQUENCE (SIZE (1..maxLC-ID)) OF LogicalChannelIdentity {	2 entries		
LogicalChannelIdentity[1]	Same value as drb-Identity[1] above	entry 1	
LogicalChannelIdentity[2]	Same value as drb-Identity[2] above	entry 2	
}			
}			
}			
}			
}			
}			

**Table 4.9.12B.2.3-2: PDU SESSION RELEASE COMMAND (step 3a1, Table 4.9.12B.2.2-1; step 1 Table 4.9.21.2.2-1)**

Derivation Path: Table 4.7.1-14.			
Information Element	Value/remark	Comment	Condition
PDU session ID	Set according to the Emergency session ID.		
5GSM cause	'0010 0100'B	Regular deactivation	

**Table 4.9.12B.2.3-3: RRCReconfiguration (step 3b1, Table 4.9.12B.2.2-1)**

Derivation Path: Table 4.6.1-13.			
Information Element	Value/remark	Comment	Condition
RRCReconfiguration ::= SEQUENCE {			
criticalExtensions CHOICE {			
rrcReconfiguration SEQUENCE {			
radioBearerConfig SEQUENCE {			
drb-ToReleaseList SEQUENCE (SIZE (1..maxDRB)) OF DRB-Identity {	1 entry		
DRB-Identity	DRB-Identity linked to the IMS speech bearer		
}			
}			
nonCriticalExtension SEQUENCE {			
masterCellGroup SEQUENCE {			
rlc-BearerToReleaseList SEQUENCE (SIZE (1..maxLC-ID)) OF LogicalChannelIdentity {	1 entry		
LogicalChannelIdentity	Same value as drb-Identity above		
}			
}			
}			
}			
}			

**Table 4.9.12B.2.3-4: PDU SESSION MODIFICATION COMMAND (step 3b1, Table 4.9.12B.2.2-1)**

Derivation Path: Table 4.7.2-9.			
Information Element	Value/remark	Comment	Condition
PDU session ID	Set according to the Emergency session ID		
Authorized QoS rules			
QoS rule			
QoS rule identifier	'00000011'B	QoS rule 3	
Rule operation code	'010'B	Delete existing QoS rule	
Authorized QoS flow descriptions			
QoS flow descriptions			
QFI	'00000111'B	QFI 7	
Operation code	'010'B	Delete existing QoS flow	

## 4.9.13 Test procedure for no response to paging

### 4.9.13.1 Scope

This procedure aims at checking that the UE ignores paging messages with a specified identity.

### 4.9.13.2 Procedure description

#### 4.9.13.2.1 Initial conditions

As specified in the TC which calls the procedure in its entirety or refers to parts of it.

#### 4.9.13.2.2 Procedure sequence

**Table 4.9.13.2.2-1: Test procedure sequence**

St	Procedure	Message Sequence	TP	Verdict
----	-----------	------------------	----	---------

		U - S	Message		
1	The SS transmits a paging message using the NG-5G-S-TMSI which is specified in the referring test step, and on the cell which is specified in the referring test step.	<--	Paging	-	-
2	Check: Does the UE send an <i>RRCSetupRequest</i> message on the cell where the paging was transmitted within the next 3s?	-->	<i>RRCSetupRequest</i>	-	F

#### 4.9.13.3 Specific Message content

None.

#### 4.9.14 Void

#### 4.9.15 Test procedure for IMS MO speech call establishment in 5GC

##### 4.9.15.1 Scope

The purpose of this procedure is to establish an IMS MO speech call.

##### 4.9.15.2 Procedure description

###### 4.9.15.2.1 Initial conditions

System Simulator:

- 1 NR Cell connected to 5GC, default parameters.

User Equipment:

- The UE is in state 1N-A and registered to the IMS.

###### 4.9.15.2.2 Procedure sequence

**Table 4.9.15.2.2-1: IMS MO speech call establishment in 5GC**

St	Procedure	Message Sequence		TP	Verdict
		U - S	Message		
1	Make the UE attempt an IMS speech call.	-	-	-	-
2	Check: Does the UE transmit an <i>RRCSetupRequest</i> message with 'establishmentCause' set to 'mo-VoiceCall'?	-->	NR RRC: <i>RRCSetupRequest</i>	-	P
3	SS transmit an <i>RRCSetup</i> message.	<--	NR RRC: <i>RRCSetup</i>	-	-
4	Check: Does the UE transmit an <i>RRCSetupComplete</i> message to confirm the successful completion of the connection establishment and to initiate the session management procedure by including the SERVICE REQUEST message?	-->	NR RRC: <i>RRCSetupComplete</i> 5GMM: SERVICE REQUEST	-	P
5	The SS transmits a <i>SecurityModeCommand</i> message to activate AS security.	<--	NR RRC: <i>SecurityModeCommand</i>	-	-
6	Check: Does the UE transmit a <i>SecurityModeComplete</i> message and establish the initial security configuration?	-->	NR RRC: <i>SecurityModeComplete</i>	-	P
7	The SS transmits an <i>RRCReconfiguration</i> message and a SERVICE ACCEPT message to establish SRB2 and DRB(s).	<--	NR RRC: <i>RRCReconfiguration</i> 5GMM: SERVICE ACCEPT	-	-
-	EXCEPTION: In parallel to step 8 below, the steps specified in Table 4.9.15.2.2-2 take place.	-	-	-	-



8	The UE transmits an <i>RRCReconfigurationComplete</i> message.	-->	NR RRC: <i>RRCReconfigurationComplete</i>	-	-
-	EXCEPTION: Steps 9a1 to 9b4 describe behaviour that depends on UE configuration; the "lower case letter" identifies a step sequence that takes place if such configuration was conducted.	-	-	-	-
9a1-9a4	IF the UE is configured to use preconditions THEN steps 2-5 of Annex A.4.1 of TS 34.229-5 [47] take place.	-	-	-	-
9b1-9b4	ELSE steps 2-5 of Annex A.4.2 of TS 34.229-5 [47] take place.	-	-	-	-
10	The SS transmits an <i>RRCReconfiguration</i> message and a PDU SESSION MODIFICATION COMMAND message.	<--	NR RRC: <i>RRCReconfiguration</i> 5GMM: DL NAS TRANSPORT 5GSM: PDU SESSION MODIFICATION COMMAND	-	-
-	EXCEPTION: In parallel to steps 11 and 12 below, step 13a1 or 13b1 occur.	-	-	-	-
11	The UE transmits an <i>RRCReconfigurationComplete</i> message.	-->	NR RRC: <i>RRCReconfigurationComplete</i>	-	-
12	Check: Does the UE transmit an <i>ULInformationTransfer</i> message, an UL NAS TRANSPORT message and a PDU SESSION MODIFICATION COMPLETE message?	-->	NR RRC: <i>ULInformationTransfer</i> 5GMM: UL NAS TRANSPORT 5GSM: PDU SESSION MODIFICATION COMPLETE	-	P
-	EXCEPTION: Steps 13a1 to 13b3 describe behaviour that depends on UE configuration; the "lower case letter" identifies a step sequence that takes place if such configuration was conducted.	-	-	-	-
13a1-13a7	IF the UE is configured to use preconditions THEN steps 6-12 of Annex A.4.1 of TS 34.229-5 [47] take place.	-	-	-	-
13b1-13b3	ELSE steps 6-8 of Annex A.4.2 of TS 34.229-5 [47] take place.	-	-	-	-

Table 4.9.15.2.2-2: Parallel Behaviour

St	Procedure	Message Sequence		TP	Verdict
		U - S	Message		
-	EXCEPTION: Steps 1a1 to 1b1 describe behaviour that depends on UE configuration; the "lower case letter" identifies a step sequence that takes place if such configuration was conducted.	-	-	-	-
1a1	IF the UE is configured to use preconditions THEN step 1 of Annex A.4.1 of TS 34.229-5 [47] takes place.	-	-	-	-
1b1	ELSE step 1 of Annex A.4.2 of TS 34.229-5 [47] takes place.	-	-	-	-

4.9.15.3 Specific message contents

Table 4.9.15.3-1: *RRCSetupRequest* (step 2, Table 4.9.15.2.2-1)

Derivation Path: Table 4.6.1-23			
Information Element	Value/remark	Comment	Condition
<i>RRCSetupRequest</i> ::= SEQUENCE {			
<i>rrcSetupRequest</i> SEQUENCE {			
<i>establishmentCause</i>	mo-VoiceCall		
}			
}			

**Table 4.9.15.3-2: SERVICE REQUEST (step 4, Table 4.9.15.2.2-1)**

Derivation Path: Table 4.7.1-16			
Information Element	Value/remark	Comment	Condition
Service type			
Service type value	'0001'B	data	

**Table 4.9.15.3-3: PDU SESSION MODIFICATION COMMAND (step 10, Table 4.9.15.2.2-1)**

Derivation Path: Table 4.7.2-9			
Information Element	Value/remark	Comment	Condition
PDU session ID	Same value as sent in PDU SESSION ESTABLISHMENT REQUEST message.		
Authorized QoS rules	Reference QoS rule #7 as defined in Table 4.8.2.1-7 using condition IMS_VOICE.		
Authorized QoS flow descriptions	Reference QoS flow #5 as defined in Table 4.8.2.3-5.		

**Table 4.9.15.3-4: RRCReconfiguration (step 10, Table 4.9.15.2.2-1)**

Derivation Path: Table 4.8.1-1C
---------------------------------

## 4.9.16 Test procedure for IMS MT speech call establishment in 5GC

### 4.9.16.1 Scope

The purpose of this procedure is to establish an IMS MT speech call.

### 4.9.16.2 Procedure description

#### 4.9.16.2.1 Initial conditions

System Simulator:

- 1 NR Cell connected to 5GC, default parameters.

User Equipment:

- The UE is in state 1N-A and registered to the IMS.

#### 4.9.16.2.2 Procedure sequence

**Table 4.9.16.2.2-1: IMS MT speech call establishment in 5GC**

St	Procedure	Message Sequence		TP	Verdict
		U – S	Message		
1	The SS transmits a <i>Paging</i> message.	<--	NR RRC: <i>Paging</i>	-	-
2	Check: Does the UE transmit an <i>RRCSetupRequest</i> message with 'establishmentCause' set to 'mt-Access'?	-->	NR RRC: <i>RRCSetupRequest</i>	-	P
3	The SS transmits an <i>RRCSetup</i> message.	<--	NR RRC: <i>RRCSetup</i>	-	-
4	Check: Does the UE transmit an <i>RRCSetupComplete</i> message and a SERVICE REQUEST message?	-->	NR RRC: <i>RRCSetupComplete</i> 5GMM: SERVICE REQUEST	-	P

5	The SS transmits a <i>SecurityModeCommand</i> message.	<--	NR RRC: <i>SecurityModeCommand</i>	-	-
6	The UE transmits a <i>SecurityModeComplete</i> message.	-->	NR RRC: <i>SecurityModeComplete</i>	-	-
7	The SS transmits an <i>RRCReconfiguration</i> message and a SERVICE ACCEPT message to establish SRB2 and DRB(s). The <i>RRCReconfiguration</i> message is configured using <i>RRCReconfiguration-SRB2-DRB(n, m)</i> where n and m are the number of DRB(s) configured with RLC-AM and RLC-UM respectively.	<--	NR RRC: <i>RRCReconfiguration</i> 5GMM: SERVICE ACCEPT	-	-
8	Check: Does the UE transmit an <i>RRCReconfigurationComplete</i> message?	-->	NR RRC: <i>RRCReconfigurationComplete</i>	-	P
-	EXCEPTION: Steps 9a1 to 9b5 describe behaviour that depends on UE configuration; the "lower case letter" identifies a step sequence that takes place if such configuration was conducted.	-	-	-	-
9a1-9a5	IF the UE is configured to use preconditions THEN steps 1-5 of Annex A.5.1 of TS 34.229-5 [47] take place.	-	-	-	-
9b1-9b5	ELSE steps 1-5 of Annex A.5.2 of TS 34.229-5 [47] take place.	-	-	-	-
10	The SS transmits an <i>RRCReconfiguration</i> message and a PDU SESSION MODIFICATION COMMAND message.	<--	NR RRC: <i>RRCReconfiguration</i> 5GMM: DL NAS TRANSPORT 5GSM: PDU SESSION MODIFICATION COMMAND	-	-
-	EXCEPTION: Depending upon UE implementation, steps 11 and 12 can occur in any order	-	-	-	-
11	The UE transmits an <i>RRCReconfigurationComplete</i> message	-->	NR RRC: <i>RRCReconfigurationComplete</i>	-	-
12	Check: Does the UE transmit a <i>ULInformationTransfer</i> message, an UL NAS TRANSPORT message and an PDU SESSION MODIFICATION COMPLETE message?	-->	NR RRC: <i>ULInformationTransfer</i> 5GMM: UL NAS TRANSPORT 5GSM: PDU SESSION MODIFICATION COMPLETE	-	P
-	EXCEPTION: Steps 13a1 to 13b7 describe behaviour that depends on UE configuration; the "lower case letter" identifies a step sequence that takes place if such configuration was conducted.	-	-	-	-
13a1-13a7	IF the UE is configured to use preconditions THEN steps 6-12 of Annex A.5.1 of TS 34.229-5 [47] take place.	-	-	-	-
13b1-13b5	ELSE steps 6-10 of Annex A.5.2 of TS 34.229-5 [47] take place.	-	-	-	-

4.9.16.3 Specific message contents

**Table 4.9.16.3-1: RRCSetupRequest (step 2, Table 4.9.16.2.2-1)**

Derivation Path: Table 4.6.1-23			
Information Element	Value/remark	Comment	Condition
RRCSetupRequest ::= SEQUENCE {			
rrcSetupRequest SEQUENCE {			
establishmentCause	mt-Access		
}			
}			

**Table 4.9.16.3-2: SERVICE REQUEST (step 4, Table 4.9.16.2.2-1)**

Derivation Path: Table 4.7.1-16
---------------------------------

Information Element	Value/remark	Comment	Condition
Service type			
Service type value	'0010'B	Mobile Terminated Services	

**Table 4.9.16.3-3: PDU SESSION MODIFICATION COMMAND (step 10, Table 4.9.16.2.2-1)**

Derivation Path: Table 4.7.2-2			
Information Element	Value/remark	Comment	Condition
PDU session ID	Same value as sent in PDU SESSION ESTABLISHMENT REQUEST message.		
Authorized QoS rules	Reference QoS rule #7 as defined in Table 4.8.2.1-7 using condition IMS_VOICE.		
Authorized QoS flow descriptions	Reference QoS flow #5 as defined in Table 4.8.2.3-5.		

**Table 4.9.16.3-4: RRCReconfiguration (step 10, Table 4.9.16.2.2-1)**

Derivation Path: Table 4.8.1-1C
---------------------------------

## 4.9.17 Test procedure for IMS MO call release in 5GC

### 4.9.17.1 Scope

The purpose of this procedure is to make a UE initiated release of an ongoing IMS call.

### 4.9.17.2 Procedure description

#### 4.9.17.2.1 Initial conditions

System Simulator:

- 1 NR Cell connected to 5GC, default parameters.

User Equipment:

- The UE is in state 3N-A on the NR Cell with an active IMS call.

#### 4.9.17.2.2 Procedure sequence

**Table 4.9.17.2.2-1: IMS MO call release in 5GC**

St	Procedure	Message Sequence		TP	Verdict
		U – S	Message		
1-2	Generic test procedure for MO release of speech call, steps 1-2, as defined in annex A.7 of TS 34.229-5 [47] are performed.	-	-	-	-
3	The SS transmits an <i>RRCReconfiguration</i> message and an PDU SESSION MODIFICATION COMMAND	<--	NR RRC: <i>RRCReconfiguration</i> 5GMM: DL NAS TRANSPORT 5GSM: PDU SESSION MODIFICATION COMMAND	-	-
-	EXCEPTION: Steps 4 and 5 can occur in any order.	-	-	-	-

4	The UE transmits an <i>RRCReconfigurationComplete</i> message	-->	NR RRC: <i>RRCReconfigurationComplete</i>	-	-
5	Check: Does the UE transmit a <i>ULInformationTransfer</i> message, an UL NAS TRANSPORT message and an PDU SESSION MODIFICATION COMPLETE message?	-->	NR RRC: <i>ULInformationTransfer</i> 5GMM: UL NAS TRANSPORT 5GSM: PDU SESSION MODIFICATION COMPLETE	-	P

4.9.17.2.3 Specific message contents

**Table 4.9.17.2.3-1: RRCReconfiguration (step 3, Table 4.9.17.2.2-1)**

Derivation Path: Table 4.6.1-13.				
Information Element	Value/remark	Comment	Condition	
RRCReconfiguration ::= SEQUENCE {				
criticalExtensions CHOICE {				
rrcReconfiguration SEQUENCE {				
radioBearerConfig SEQUENCE {				
drb-ToReleaseList SEQUENCE (SIZE (1..maxDRB)) OF DRB-Identity {	1 entry		IMS_VOICE	
DRB-Identity[1]	DRB-Identity linked to the IMS speech bearer	entry 1		
}				
drb-ToReleaseList SEQUENCE (SIZE (1..maxDRB)) OF DRB-Identity {	2 entries		IMS_VIDEO	
DRB-Identity[1]	DRB-Identity linked to the IMS video bearer	entry 1		
DRB-Identity[2]	DRB-Identity linked to the IMS video bearer	entry 2		
}				
}				
nonCriticalExtension SEQUENCE {				
masterCellGroup SEQUENCE {				
rlc-BearerToReleaseList SEQUENCE (SIZE (1..maxLC-ID)) OF LogicalChannelIdentity {	1 entry		IMS_VOICE	
LogicalChannelIdentity[1]	Same value as drb-Identity[1] above	entry 1		
}				
rlc-BearerToReleaseList SEQUENCE (SIZE (1..maxLC-ID)) OF LogicalChannelIdentity {	2 entries		IMS_VIDEO	
LogicalChannelIdentity[1]	Same value as drb-Identity[1] above	entry 1		
LogicalChannelIdentity[2]	Same value as drb-Identity[2] above	entry 2		
}				
}				
}				
}				
}				
}				

Condition	Explanation
IMS_VOICE	If this QoS rule is used to setup an IMS voice session
IMS_VIDEO	If this QoS rule is used to setup an IMS video session

**Table 4.9.17.2.3-2: PDU SESSION MODIFICATION COMMAND (step 3, Table 4.9.17.2.2-1)**

Derivation Path: Table 4.7.2-9.			
Information Element	Value/remark	Comment	Condition
PDU session ID	Same value as sent in PDU SESSION ESTABLISHMENT REQUEST message.		

Authorized QoS rules			
QoS rule[1]			IMS_VOICE, IMS_VIDEO
QoS rule identifier	'0000011'B	QoS rule 3	
Rule operation code	'010'B	Delete existing QoS rule	
QoS rule[2]			IMS_VIDEO
QoS rule identifier	'0000100'B	QoS rule 4	
Rule operation code	'010'B	Delete existing QoS rule	
Authorized QoS flow descriptions			
QoS flow descriptions[1]			IMS_VOICE, IMS_VIDEO
QFI	'0000111'B	QFI 7	
Operation code	'010'B	Delete existing QoS flow	
QoS flow descriptions[2]			IMS_VIDEO
QFI	'0000100'B	QFI 8	
Operation code	'010'B	Delete existing QoS flow	

Condition	Explanation
IMS_VOICE	If this QoS rule is used to setup an IMS voice session
IMS_VIDEO	If this QoS rule is used to setup an IMS video session

## 4.9.18 Test procedure for IMS MT call release in 5GC

### 4.9.18.1 Scope

The purpose of this procedure is to make the network release an ongoing IMS call.

### 4.9.18.2 Procedure description

#### 4.9.18.2.1 Initial conditions

System Simulator:

- 1 NR Cell connected to 5GC, default parameters.

User Equipment:

- The UE is in state 3N-A on the NR Cell with an active IMS call.

#### 4.9.18.2.2 Procedure sequence

**Table 4.9.18.2.2-1: IMS MT call release in 5GC**

St	Procedure	Message Sequence		TP	Verdict
		U – S	Message		
1-2	Generic test procedure for MT release of speech call, steps 1-2, as defined in annex A.8 of TS 34.229-5 [47] are performed.	-	-	-	-
3	The SS transmits an <i>RRCReconfiguration</i> message and an PDU SESSION MODIFICATION COMMAND	<--	NR RRC: <i>RRCReconfiguration</i> 5GMM: DL NAS TRANSPORT 5GSM: PDU SESSION MODIFICATION COMMAND	-	-
-	EXCEPTION: Steps 4 and 5 can occur in any order.	-	-	-	-
4	The UE transmits an <i>RRCReconfigurationComplete</i> message	-->	NR RRC: <i>RRCReconfigurationComplete</i>	-	-

5	Check: Does the UE transmit a <i>ULInformationTransfer</i> message, an UL NAS TRANSPORT message and an PDU SESSION MODIFICATION COMPLETE message?	-->	NR RRC: <i>ULInformationTransfer</i> 5GMM: UL NAS TRANSPORT 5GSM: PDU SESSION MODIFICATION COMPLETE	-	P
---	---	-----	---	---	---

4.9.18.2.3 Specific message contents

**Table 4.9.18.2.3-1: RRCReconfiguration (step 3, Table 4.9.18.2.2-1)**

Derivation Path: Table 4.6.1-13.			
Information Element	Value/remark	Comment	Condition
RRCReconfiguration ::= SEQUENCE {			
criticalExtensions CHOICE {			
rrcReconfiguration SEQUENCE {			
radioBearerConfig SEQUENCE {			
drb-ToReleaseList SEQUENCE (SIZE (1..maxDRB)) OF DRB-Identity {	1 entry		IMS_VOICE
DRB-Identity[1]	DRB-Identity linked to the IMS speech bearer	entry 1	
}			
drb-ToReleaseList SEQUENCE (SIZE (1..maxDRB)) OF DRB-Identity {	2 entries		IMS_VIDEO
DRB-Identity[1]	DRB-Identity linked to the IMS video bearer	entry 1	
DRB-Identity[2]	DRB-Identity linked to the IMS video bearer	entry 2	
}			
}			
nonCriticalExtension SEQUENCE {			
masterCellGroup SEQUENCE {			
rlc-BearerToReleaseList SEQUENCE (SIZE (1..maxLC-ID)) OF LogicalChannelIdentity {	1 entry	entry 1	IMS_VOICE
LogicalChannelIdentity[1]	Same value as drb-Identity[1] above		
}			
rlc-BearerToReleaseList SEQUENCE (SIZE (1..maxLC-ID)) OF LogicalChannelIdentity {	2 entries		IMS_VIDEO
LogicalChannelIdentity[1]	Same value as drb-Identity[1] above	entry 1	
LogicalChannelIdentity[2]	Same value as drb-Identity[2] above	entry 2	
}			
}			
}			
}			
}			

Condition	Explanation
IMS_VOICE	If this QoS rule is used to setup an IMS voice session
IMS_VIDEO	If this QoS rule is used to setup an IMS video session

**Table 4.9.18.2.3-2: PDU SESSION MODIFICATION COMMAND (step 3, Table 4.9.18.2.2-1)**

Derivation Path: Table 4.7.2-9			
Information Element	Value/remark	Comment	Condition
PDU session ID	Same value as sent in PDU SESSION ESTABLISHMENT REQUEST message.		
Authorized QoS rules			
QoS rule			

QoS rule identifier	'00000011'B	QoS rule 3	IMS_VOICE, IMS_VIDEO
Rule operation code	'010'B	Delete existing QoS rule	
QoS rule[2]			IMS_VIDEO
QoS rule identifier	'00000100'B	QoS rule 4	
Rule operation code	'010'B	Delete existing QoS rule	
Authorized QoS flow descriptions			
QoS flow descriptions			
QFI	'00000111'B	QFI 7	IMS_VOICE, IMS_VIDEO
Operation code	'010'B	Delete existing QoS flow	
QoS flow descriptions[2]			IMS_VIDEO
QFI	'00001000'B	QFI 8	
Operation code	'010'B	Delete existing QoS flow	

Condition	Explanation
IMS_VOICE	If this QoS rule is used to setup an IMS voice session
IMS_VIDEO	If this QoS rule is used to setup an IMS video session

## 4.9.19 Test procedure for IMS MO SMS in 5GC

### 4.9.19.1 Scope

The purpose of this procedure is to transmit an IMS MO SMS.

### 4.9.19.2 Procedure description

#### 4.9.19.2.1 Initial conditions

System Simulator:

- 1 NR Cell connected to 5GC, default parameters.

User Equipment:

- The UE is in state 1N-A and registered to the IMS.

#### 4.9.19.2.2 Procedure sequence

**Table 4.9.19.2.2-1: IMS MO SMS in 5GS**

St	Procedure	Message Sequence		TP	Verdict
		U – S	Message		
1	Make the UE attempt an IMS MO SMS	-	-	-	-
2	The UE transmits an <i>RRCSetupRequest</i> message with 'establishmentCause' set to 'mo-SMS'.	-->	NR RRC: <i>RRCSetupRequest</i>	-	P
3	The SS transmits an <i>RRCSetup</i> message.	<--	NR RRC: <i>RRCSetup</i>	-	-
4	The UE transmits an <i>RRCSetupComplete</i> message to confirm the successful completion of the connection establishment and to initiate the session management procedure by including the SERVICE REQUEST message.	-->	NR RRC: <i>RRCSetupComplete</i> 5GMM: SERVICE REQUEST	-	P
5	The SS transmits a <i>SecurityModeCommand</i> message to activate AS security.	<--	NR RRC: <i>SecurityModeCommand</i>	-	-



6	The UE transmits a <i>SecurityModeComplete</i> message and establish the initial security configuration.	-->	NR RRC: <i>SecurityModeComplete</i>	-	P
7	The SS transmits an <i>RRCReconfiguration</i> message and a SERVICE ACCEPT message to establish SRB2 and DRB(s).	<--	NR RRC: <i>RRCReconfiguration</i> 5GMM: SERVICE ACCEPT	-	-
8	The UE transmits an <i>RRCReconfigurationComplete</i> message.	-->	NR RRC: <i>RRCReconfigurationComplete</i>	-	P
9-16	The steps 1-8 from the expected sequence defined in Annex A.13 of TS 34.229-5 [47] of IMS MO SMS / 5GS take place.	-	-	-	-

#### 4.9.19.3 Specific message contents

**Table 4.9.19.3-1: *RRCSetupRequest* (step 2, Table 4.9.19.2.2-1)**

Derivation Path: 38.508-1 [4], Table 4.6.1-23			
Information Element	Value/remark	Comment	Condition
<i>RRCSetupRequest</i> ::= SEQUENCE {			
<i>rrcSetupRequest</i> SEQUENCE {			
<i>establishmentCause</i>	mo-SMS		
}			
}			

**Table 4.9.19.3-2: SERVICE REQUEST (step 4, Table 4.9.19.2.2-1)**

Derivation Path: 38.508-1 [4], Table 4.7.1-16			
Information Element	Value/remark	Comment	Condition
Service type			
Service type value	'0001'B	data	

## 4.9.20 Test procedure for IMS MT SMS in 5GC

### 4.9.20.1 Scope

The purpose of this procedure is to receive an IMS MT SMS.

### 4.9.20.2 Procedure description

#### 4.9.20.2.1 Initial conditions

System Simulator:

- 1 NR Cell connected to 5GC, default parameters.

User Equipment:

- The UE is in state 1N-A and registered to the IMS.

#### 4.9.20.2.2 Procedure sequence

**Table 4.9.20.2.2-1: IMS MT SMS in 5GS**

St	Procedure	Message Sequence		TP	Verdict
		U – S	Message		
1	The SS transmits a <i>Paging</i> message.	<--	NR RRC: <i>Paging</i>	-	-
2	The UE transmits an <i>RRCSetupRequest</i> message with ' <i>establishmentCause</i> ' set to ' <i>mt-Access</i> '.	-->	NR RRC: <i>RRCSetupRequest</i>	-	P

3	The SS transmits an <i>RRCSetup</i> message.	<--	NR RRC: <i>RRCSetup</i>	-	-
4	The UE transmits an <i>RRCSetupComplete</i> message and a SERVICE REQUEST message.	-->	NR RRC: <i>RRCSetupComplete</i> 5GMM: SERVICE REQUEST	-	P
5	The SS transmits a <i>SecurityModeCommand</i> message.	<--	NR RRC: <i>SecurityModeCommand</i>	-	-
6	The UE transmits a <i>SecurityModeComplete</i> message.	-->	NR RRC: <i>SecurityModeComplete</i>	-	-
7	The SS transmits an <i>RRCReconfiguration</i> message and a SERVICE ACCEPT message to establish SRB2 and DRB(s). The <i>RRCReconfiguration</i> message is configured using <i>RRCReconfiguration-SRB2-DRB(n, m)</i> where n and m are the number of DRB(s) configured with RLC-AM and RLC-UM respectively.	<--	NR RRC: <i>RRCReconfiguration</i> 5GMM: SERVICE ACCEPT	-	-
8	The UE transmits an <i>RRCReconfigurationComplete</i> message.	-->	NR RRC: <i>RRCReconfigurationComplete</i>	-	P
9-12	The steps 1-4 from the expected sequence defined in Annex A.14 of TS 34.229-5 [47] IMS MT SMS / 5GS take place.	-	-	-	-

#### 4.9.20.3 Specific message contents

**Table 4.9.20.3-1: *RRCSetupRequest* (step 2, Table 4.9.20.2.2-1)**

Derivation Path: 38.508-1 [4], Table 4.6.1-23			
Information Element	Value/remark	Comment	Condition
<i>RRCSetupRequest</i> ::= SEQUENCE {			
<i>rrcSetupRequest</i> SEQUENCE {			
<i>establishmentCause</i>	mt-Access		
}			
}			

**Table 4.9.20.3-2: SERVICE REQUEST (step 4, Table 4.9.20.2.2-1)**

Derivation Path: 38.508-1 [4], Table 4.7.1-16			
Information Element	Value/remark	Comment	Condition
Service type			
Service type value	'0010'B	Mobile Terminated Services	

## 4.9.21 Test procedure for PDU Session Release

### 4.9.21.1 Scope

The purpose of this procedure is to release both the PDU session and the user plane resources.

### 4.9.21.2 Procedure description

#### 4.9.21.2.1 Initial conditions

The UE is in state 3N-A with PDU SESSION ACTIVE as per Table 4.4A.2-3. If this is a UE triggered PDU Session Release, this will be specified in the test case together with the sending of a PDU SESSION RELEASE REQUEST by the UE.

4.9.21.2.2 Procedure sequence

**Table 4.9.21.2-1: Procedure for PDU Session Release**

St	Procedure	Message Sequence	
		U – S	Message
1	The SS transmits an <i>RRCReconfiguration</i> message and a PDU SESSION RELEASE COMMAND	<--	NR RRC: <i>RRCReconfiguration</i> 5GMM: DL NAS TRANSPORT 5GSM: PDU SESSION RELEASE COMMAND
-	EXCEPTION: Depending upon UE implementation, step 1A and 2 can occur in any order	-	-
1A	The UE transmits a <i>RRCReconfigurationComplete</i>	-	NR RRC: <i>RRCReconfigurationComplete</i>
2	The UE transmits a PDU SESSION RELEASE COMPLETE message	-->	NR RRC: <i>ULInformationTransfer</i> 5GMM: UL NAS TRANSPORT 5GSM: PDU SESSION RELEASE COMPLETE

4.9.21.3 Specific message contents

The NAS message contents will be as specified in the test case.

**Table 4.9.21.3-1: *RRCReconfiguration* (step 1, Table 4.9.21.2-1)**

Derivation Path: Table 4.6.1-13.			
Information Element	Value/remark	Comment	Condition
<i>RRCReconfiguration</i> ::= SEQUENCE {			
criticalExtensions CHOICE {			
rrcReconfiguration SEQUENCE {			
radioBearerConfig SEQUENCE {			
drb-ToReleaseList SEQUENCE (SIZE (1..maxDRB)) OF DRB-Identity {	1 entry		
DRB-Identity[1]	DRB-Identity linked to the PDU Session to be released		
}			
}			
nonCriticalExtension SEQUENCE {			
masterCellGroup SEQUENCE {			
rlc-BearerToReleaseList SEQUENCE (SIZE (1..maxLC-ID)) OF LogicalChannelIdentity {	1 entry		
logicalChannelIdentity[1]	Same value as drb-Identity[1] above		
}			
}			
}			
}			
}			

4.9.22 Test procedure for establishing unicast mode NR sidelink communication / Initiating UE side

4.9.22.1 Scope

The purpose of this procedure is to establish unicast mode sidelink communication.

## 4.9.22.2 Procedure description

## 4.9.22.2.1 Initial conditions

The UE is in state 1N-B, 3N-B or 4-A.

## 4.9.22.2.2 Procedure sequence

**Table 4.9.22.2.2-1: Procedure for establishing unicast mode sidelink communication (Initiating UE side)**

St	Procedure	Message Sequence	
		U – S	Message
1	Void	-	-
-	EXCEPTION: Steps 1a1 to 1b2 describe behaviour which depends on procedure parameters; the "lower case letter" identifies a step sequence that takes place if a procedure parameter has a particular value.	-	-
1a1	IF the UE is in state 1N-B or 4-A, the UE is configured by upper layer to establish unicast mode link. NOTE: This can be done by sending AT COMMAND +CCUTLE to close test loop function.	-	-
1b1	ELSE IF the UE is in state 3N-B, the SS transmits a CLOSE UE TEST LOOP message.	<--	TC: CLOSE UE TEST LOOP
1b2	The UE transmits a CLOSE UE TEST LOOP COMPLETE message.	-->	TC: CLOSE UE TEST LOOP COMPLETE
2	The UE sends a DIRECT LINK ESTABLISHMENT REQUEST message.	-->	PC5-S: DIRECT LINK ESTABLISHMENT REQUEST
3	The NR-SS-UE sends a DIRECT LINK SECURITY MODE COMMAND message.	<--	PC5-S: DIRECT LINK SECURITY MODE COMMAND
4	The UE sends a DIRECT LINK SECURITY MODE COMPLETE message.	-->	PC5-S: DIRECT LINK SECURITY MODE COMPLETE
5	The NR-SS-UE sends a DIRECT LINK ESTABLISHMENT ACCEPT message.	<--	PC5-S: DIRECT LINK ESTABLISHMENT ACCEPT
6	The UE sends an RRCReconfigurationSidelink message to establish a unicast mode SL-DRB. NOTE: Unless specifically specified in the test case prose, the UE shall select the DRB parameters as specified in the pre-configured parameters.	-->	PC5-RRC: RRCReconfigurationSidelink
7	The NR-SS-UE sends an RRCReconfigurationCompleteSidelink message.	<--	PC5-RRC: RRCReconfigurationCompleteSidelink
8	Void	-	-
-	EXCEPTION: Steps 8a1 to 8b2 describe behaviour which depends on procedure parameters; the "lower case letter" identifies a step sequence that takes place if a procedure parameter has a particular value.	-	-
8a1	IF the UE is in state 1N-B or 4-A, the SS sends AT COMMAND +CCUTLE to open test loop function	-	-
8b1	ELSE IF the UE is in state 3N-B, the SS transmits an OPEN UE TEST LOOP message.	<--	TC: OPEN UE TEST LOOP
8b2	The UE transmits an OPEN UE TEST LOOP COMPLETE message.	-->	TC: OPEN UE TEST LOOP COMPLETE

## 4.9.22.3 Specific message contents

All specific message contents shall be according subclause 4.6 and 4.7B with the exceptions below.

**Table 4.9.22.3-1: +CCUTLE (Table 4.9.22.2.2-1, Step 1)**

Derivation Path: Table 4.7B-1 with condition Close and Transmit
---

**Table 4.9.22.3-2: CLOSE UE TEST LOOP (Table 4.9.22.2.2-1, Step 1b1)**

Derivation Path: 36.508 [2] Table 4.7A-3 with condition UE TEST LOOP MODE E(V2X Transmission)			
Information Element	Value/remark	Comment	Condition
UE test loop mode E LB setup			
Communication Transmit or Receive	0 0 0 0 0 0 1	'01' indicates V2X UE triggered to transmit NR sidelink communication with single spatial layer.	

**Table 4.9.22.3-3: DIRECT LINK ESTABLISHMENT REQUEST (Table 4.9.22.2.2-1, Step 2)**

Derivation Path: Table 4.7.4-7 with condition Tx
--

**Table 4.9.22.3-4: DIRECT LINK SECURITY MODE COMMAND (Table 4.9.22.2.2-1, Step 3)**

Derivation Path: Table 4.7.4-18 with condition Rx
---

**Table 4.9.22.3-5: DIRECT LINK SECURITY MODE COMPLETE (Table 4.9.22.2.2-1, Step 4)**

Derivation Path: Table 4.7.4-19 with condition Tx
---

**Table 4.9.22.3-6: DIRECT LINK ESTABLISHMENT ACCEPT (Table 4.9.22.2.2-1, Step 5)**

Derivation Path: Table 4.7.4-8 with condition Rx
--

**Table 4.9.22.3-7: RRCReconfigurationSidelink (Table 4.9.22.2.2-1, Step 6)**

Derivation Path: Table 4.6.1A-3 with condition TX and SL_DRB			
Information Element	Value/remark	Comment	Condition
RRCReconfigurationSidelink ::= SEQUENCE {			
criticalExtensions CHOICE {			
rrcReconfigurationSidelink-r16 SEQUENCE {			
slrb-ConfigToAddModList-r16 SEQUENCE (SIZE (1..maxNrofSLRB-r16)) OF SLRB-Config-r16 {	1 entry		
SLRB-Config-r16[1] SEQUENCE {		entry 1	
sl-SDAP-ConfigPC5-r16 SEQUENCE {			
sl-MappedQoS-FlowsToAddList-r16 SEQUENCE (SIZE (1.. maxNrofSL-QFIsPerDest-r16)) OF SL-PQFI-r16 {	1 entry		
SL-PQFI-r16[1]	(1..63)	entry 1	
}			
sl-MappedQoS-FlowsToReleaseList-r16	Not present		
sl-SDAP-Header-r16	present		
}			
sl-PDCP-ConfigPC5-r16 SEQUENCE {			
sl-PDCP-SN-Size-r16	len12bits		
sl-OutOfOrderDelivery-r16	Not present		
}			
sl-RLC-ConfigPC5-r16 CHOICE {			
sl-AM-RLC-r16 SEQUENCE {			
sl-SN-FieldLengthAM-r16	size12		
}			
}			
sl-MAC-LogicalChannelConfigPC5-r16 SEQUENCE {			
sl-LogicalChannelIdentity-r16	(4..32)		
}			
}			
}			

}			
}			
}			

**Table 4.9.22.3-8: RRCReconfigurationCompleteSidelink (Table 4.9.22.2-1, Step 7)**

Derivation Path: Table 4.6.1A-4 with condition RX

**Table 4.9.22.3-9: +CCUTLE (Table 4.9.22.2-1, Step 8a1)**

Derivation Path: Table 4.7B-1 with condition Open

### 4.9.23 Test procedure for establishing unicast mode NR sidelink communication / Peer UE side

#### 4.9.23.1 Scope

The purpose of this procedure is to establish unicast mode sidelink communication.

#### 4.9.23.2 Procedure description

##### 4.9.23.2.1 Initial conditions

The UE is in state 1N-B, 3N-B or 4-A.

##### 4.9.23.2.2 Procedure sequence

**Table 4.9.23.2.2-1: Procedure for establishing unicast mode sidelink communication (Peer UE side)**

St	Procedure	Message Sequence	
		U – S	Message
1	The NR-SS-UE sends a DIRECT LINK ESTABLISHMENT REQUEST message.	<--	PC5-S: DIRECT LINK ESTABLISHMENT REQUEST
2	The UE sends a DIRECT LINK SECURITY MODE COMMAND message.	-->	PC5-S: DIRECT LINK SECURITY MODE COMMAND
3	The NR-SS-UE sends a DIRECT LINK SECURITY MODE COMPLETE message.	<--	PC5-S: DIRECT LINK SECURITY MODE COMPLETE
4	The UE sends a DIRECT LINK ESTABLISHMENT ACCEPT message.	-->	PC5-S: DIRECT LINK ESTABLISHMENT ACCEPT
5	The NR-SS-UE sends an RRCReconfigurationSidelink message to establish a unicast mode SL-DRB.	<--	PC5-RRC: RRCReconfigurationSidelink
6	The UE sends an RRCReconfigurationCompleteSidelink message.	-->	PC5-RRC: RRCReconfigurationCompleteSidelink

#### 4.9.23.3 Specific message contents

All specific message contents shall be according subclause 4.6 and 4.7B.

**Table 4.9.23.3-1: DIRECT LINK ESTABLISHMENT REQUEST (Table 4.9.23.2.2-1, Step 1)**

Derivation Path: Table 4.7.4-7 with condition Rx

**Table 4.9.23.3-2: DIRECT LINK SECURITY MODE COMMAND (Table 4.9.23.2.2-1, Step 2)**

Derivation Path: Table 4.7.4-18 with condition Tx

**Table 4.9.23.3-3: DIRECT LINK SECURITY MODE COMPLETE (Table 4.9.23.2.2-1, Step 3)**

Derivation Path: Table 4.7.4-19 with condition Rx

**Table 4.9.23.3-4: DIRECT LINK ESTABLISHMENT ACCEPT (Table 4.9.23.2.2-1, Step 4)**

Derivation Path: Table 4.7.4-8 with condition Tx

**Table 4.9.23.3-5: RRCReconfigurationSidelink (Table 4.9.23.2.2-1, Step 5)**

Derivation Path: Table 4.6.1A-3 with condition RX and SL\_DRB

**Table 4.9.23.3-5: RRCReconfigurationCompleteSidelink (Table 4.9.23.2.2-1, Step 6)**

Derivation Path: Table 4.6.1A-4 with condition TX

## 4.9.24 Test procedure for IMS MO Video call establishment in 5GC

### 4.9.24.1 Scope

The purpose of this procedure is to establish an IMS MO Video call.

### 4.9.24.2 Procedure description

#### 4.9.24.2.1 Initial conditions

System Simulator:

- 1 NR Cell connected to 5GC, default parameters.

User Equipment:

- The UE is in state 1N-A and registered to the IMS.

#### 4.9.24.2.2 Procedure sequence

**Table 4.9.24.2.2-1: IMS MO video call establishment in 5GC**

St	Procedure	Message Sequence		TP	Verdict
		U – S	Message		
1	Make the UE attempt an IMS Video call	-	-	-	-
2	Check: Does the UE transmit an <i>RRCSetupRequest</i> message with 'establishmentCause' set to 'mo-VideoCall'?	-->	NR RRC: <i>RRCSetupRequest</i>	-	P
3	SS transmit an <i>RRCSetup</i> message.	<--	NR RRC: <i>RRCSetup</i>	-	-
4	Check: Does the UE transmit an <i>RRCSetupComplete</i> message to confirm the successful completion of the connection establishment and to initiate the session management procedure by including the SERVICE REQUEST message?	-->	NR RRC: <i>RRCSetupComplete</i> 5GMM: SERVICE REQUEST	-	P
5	The SS transmits a <i>SecurityModeCommand</i> message to activate AS security.	<--	NR RRC: <i>SecurityModeCommand</i>	-	-
6	Check: Does the UE transmit a <i>SecurityModeComplete</i> message and establish the initial security configuration?	-->	NR RRC: <i>SecurityModeComplete</i>	-	P

7	The SS transmits a <i>RRCReconfiguration</i> message and a SERVICE ACCEPT message to establish SRB2 and DRB(s).	<--	NR RRC: <i>RRCReconfiguration</i> 5GMM: SERVICE ACCEPT	-	-
-	EXCEPTION: In parallel to step 8 below, the steps specified in Table 4.9.24.2.2-2 take place.	-	-	-	-
8	The UE transmits an <i>RRCReconfigurationComplete</i> message.	-->	NR RRC: <i>RRCReconfigurationComplete</i>	-	-
-	EXCEPTION: Steps 9a1 to 9b4 describe behaviour that depends on UE configuration; the "lower case letter" identifies a step sequence that takes place if such configuration was conducted.	-	-	-	-
9a1-9a4	IF the UE is configured to use preconditions, THEN steps 2-5 of Annex A.15.1 of TS 34.229-5 [47] take place.	-	-	-	-
9b1-9b4	ELSE steps 2-5 of Annex A.15.2 of TS 34.229-5 [47] take place.	-	-	-	-
10	The SS transmits a <i>RRCReconfiguration</i> message and a PDU SESSION MODIFICATION COMMAND.	<--	NR RRC: <i>RRCReconfiguration</i> 5GMM: DL NAS TRANSPORT 5GSM: PDU SESSION MODIFICATION COMMAND	-	-
-	EXCEPTION: Depending upon UE implementation, steps 11 and 12 can occur in any order	-	-	-	-
11	The UE transmits an <i>RRCReconfigurationComplete</i> message	-->	NR RRC: <i>RRCReconfigurationComplete</i>	-	-
12	Check: Does the UE transmit a <i>ULInformationTransfer</i> message, an UL NAS TRANSPORT message and an PDU SESSION MODIFICATION COMPLETE message?	-->	NR RRC: <i>ULInformationTransfer</i> 5GMM: UL NAS TRANSPORT 5GSM: PDU SESSION MODIFICATION COMPLETE	-	P
-	EXCEPTION: Steps 13a1 to 13b8 describe behaviour that depends on UE configuration; the "lower case letter" identifies a step sequence that takes place if such configuration was conducted.	-	-	-	-
13a1-13a7	IF the UE is configured to use preconditions, THEN steps 6-12 of Annex A.15.1 of TS 34.229-5 [47] take place.	-	-	-	-
13b1-13b3	ELSE steps 6-10 of Annex A.15.2 of TS 34.229-5 [47] take place.	-	-	-	-

Table 4.9.24.2.2-2: Parallel Behaviour

St	Procedure	Message Sequence		TP	Verdict
		U - S	Message		
-	EXCEPTION: Steps 1a1 to 1b1 describe behaviour that depends on UE configuration; the "lower case letter" identifies a step sequence that takes place if such configuration was conducted.	-	-	-	-
1a1	IF the UE is configured to use preconditions, THEN step 1 of Annex A.15.1 of TS 34.229-5 [47] takes place.	-	-	-	-
1b1	ELSE step 1 of Annex A.15.2 of TS 34.229-5 [47] takes place	-	-	-	-

## 4.9.24.3 Specific message contents

Table 4.9.24.3-1: *RRCSetupRequest* (step 2, Table 4.9.24.2.2-1)

Derivation Path: TS 38.508-1 [21], Table 4.6.1-23.
--



Information Element	Value/remark	Comment	Condition
RRCSetupRequest ::= SEQUENCE {			
rrcSetupRequest SEQUENCE {			
establishmentCause	mo-VideoCall		
}			
}			

Table 4.9.24.3-2: SERVICE REQUEST (step 4, Table 4.9.24.2.2-1)

Derivation Path: TS 38.508-1 [21], Table 4.7.1-16			
Information Element	Value/remark	Comment	Condition
Service type			
Service type value	'0001'B	data	

Table 4.9.24.3-3: PDU SESSION MODIFICATION COMMAND (step 10, Table 4.9.24.2.2-1)

Derivation Path: TS 38.508-1 [21], Table 4.7.2-9.			
Information Element	Value/remark	Comment	Condition
PDU session ID	Same value as sent in PDU SESSION ESTABLISHMENT REQUEST message.		
Authorized QoS rules	Reference QoS rule #7 as defined in TS 38.508-1, Table 4.8.2.1-7 using conditions IMS_VOICE and IMS_VIDEO.		
Authorized QoS flow descriptions	Reference QoS flow #5 and QoS flow #6 as defined in TS 38.508-1, Table 4.8.2.3-5 & Table 4.8.2.3-6 respectively.		
Mapped EPS bearer contexts	Not Present		
Mapped EPS bearer contexts			Interworking _with_EPS
Mapped EPS bearer context EPS bearer identity	The same value as the one specified in the Reference QoS flow referred to from the Reference QoS rule indicated in the IE Authorized QoS rules		
Operation code	'001'B	Create new EPS bearer	
E bit	'1'B	Parameters list is included	
Number of EPS parameters	'0010'B	2 parameters	
Mapped EPS QoS parameters	See reference dedicated EPS bearer context #3 and #4 in TS 36.508 table 6.6.2-1		
Traffic Flow Template	See reference dedicated EPS bearer context #3 and #4 in TS 36.508 table 6.6.2-1		

Condition	Explanation
Interworking_with_EPS	If the UE has indicated support of S1, then the SS shall include this IE to provide details for the interworking with EPS being supported for a PDU session. This requirement is set up for the purpose of facilitating the test description. It is not mandatory for the Network to support Mapped EPS bearer contexts.

**Table 4.9.24.3-4: RRCReconfiguration (step 10, Table 4.9.24.2.2-1)**

Derivation Path: TS 38.508-1 [21], Table 4.8.1-1D
---

## 4.9.25 Test procedure for UE Configuration Update for transparent UE Policy delivery

### 4.9.25.1 Scope

The purpose of this procedure is to transfer UE policy data to the UE.

### 4.9.25.2 Procedure description

#### 4.9.25.2.1 Initial conditions

N/A

#### 4.9.25.2.2 Procedure sequence

**Table 4.9.25.2.2-1: Test procedure for UE Configuration Update for transparent UE Policy delivery**

St	Procedure	Message Sequence	
		U – S	Message
1	The SS transmits a DL NAS TRANSPORT message.	<--	5GMM: DL NAS TRANSPORT
2	The UE transmits a UL NAS TRANSPORT message.	-->	5GMM: UL NAS TRANSPORT

### 4.9.25.3 Specific message contents

**Table 4.9.25.3-1: DL NAS TRANSPORT (step 1, Table 4.9.25.2.2-1)**

Derivation Path: 38.508-1 [4], Table 4.7.1-11			
Information Element	Value/remark	Comment	Condition
Payload container type	'0101'B	UE policy container	
Payload container	Set according toTable 4.7.6-1 using condition URSP		

**Table 4.9.25.3-2: UL NAS TRANSPORT (step 2, Table 4.9.25.2.2-1)**

Derivation Path: 38.508-1 [4], Table 4.7.1-12			
Information Element	Value/remark	Comment	Condition
Payload container type	'0101'B	UE policy container	
Payload container	Set according toTable 4.7.6-2		

## 4.9.26 Test procedure for IMS MT video call establishment in 5GC

### 4.9.26.1 Scope

The purpose of this procedure is to establish an IMS MT video call.

### 4.9.26.2 Procedure description

#### 4.9.26.2.1 Initial conditions

System Simulator:

- 1 NR Cell connected to 5GC, default parameters.

User Equipment:

- The UE is in state 1N-A and registered to the IMS.

#### 4.9.26.2.2 Procedure sequence

**Table 4.9.26.2.2-1: IMS MT video call establishment in 5GC**

St	Procedure	Message Sequence		TP	Verdict
		U – S	Message		
1	The SS transmits a <i>Paging</i> message.	<--	NR RRC: <i>Paging</i>	-	-
2	Check: Does the UE transmit an <i>RRCSetupRequest</i> message with 'establishmentCause' set to 'mt-Access'?	-->	NR RRC: <i>RRCSetupRequest</i>	-	P
3	The SS transmits an <i>RRCSetup</i> message.	<--	NR RRC: <i>RRCSetup</i>	-	-
4	Check: Does the UE transmit an <i>RRCSetupComplete</i> message and a SERVICE REQUEST message?	-->	NR RRC: <i>RRCSetupComplete</i> 5GMM: SERVICE REQUEST	-	P
5	The SS transmits a <i>SecurityModeCommand</i> message.	<--	NR RRC: <i>SecurityModeCommand</i>	-	-
6	The UE transmits a <i>SecurityModeComplete</i> message.	-->	NR RRC: <i>SecurityModeComplete</i>	-	-
7	The SS transmits an <i>RRCReconfiguration</i> message and a SERVICE ACCEPT message to establish SRB2 and DRB(s). The RRCReconfiguration message is configured using RRCReconfiguration-SRB2-DRB(n, m) where n and m are the number of DRB(s) configured with RLC-AM and RLC-UM respectively.	<--	NR RRC: <i>RRCReconfiguration</i> 5GMM: SERVICE ACCEPT	-	-
8	Check: Does the UE transmit an <i>RRCReconfigurationComplete</i> message?	-->	NR RRC: <i>RRCReconfigurationComplete</i>	-	P
-	EXCEPTION: Steps 9a1 to 9b5 describe behaviour that depends on UE configuration; the "lower case letter" identifies a step sequence that takes place if such configuration was conducted.	-	-	-	-
9a1-9a5	IF the UE is configured to use preconditions THEN steps 1-5 of Annex A.16.1 of TS 34.229-5 [47] take place.	-	-	-	-
9b1-9b5	ELSE steps 1-5 of Annex A.16.2 of TS 34.229-5 [47] take place.	-	-	-	-
10	The SS transmits an <i>RRCReconfiguration</i> message and a PDU SESSION MODIFICATION COMMAND message.	<--	NR RRC: <i>RRCReconfiguration</i> 5GMM: DL NAS TRANSPORT 5GSM: PDU SESSION MODIFICATION COMMAND	-	-
-	EXCEPTION: Depending upon UE implementation, steps 11 and 12 can occur in any order	-	-	-	-
11	The UE transmits an <i>RRCReconfigurationComplete</i> message	-->	NR RRC: <i>RRCReconfigurationComplete</i>	-	-
12	Check: Does the UE transmit a <i>ULInformationTransfer</i> message, an UL NAS TRANSPORT message and an PDU SESSION MODIFICATION COMPLETE message?	-->	NR RRC: <i>ULInformationTransfer</i> 5GMM: UL NAS TRANSPORT 5GSM: PDU SESSION MODIFICATION COMPLETE	-	P
-	EXCEPTION: Steps 13a1 to 13b7 describe behaviour that depends on UE configuration; the "lower case letter" identifies a step sequence that takes place if such configuration was conducted.	-	-	-	-
13a1-	IF the UE is configured to use preconditions THEN steps 6-12 of Annex A.16.1 of TS	-	-	-	-

13a7	34.229-5 [47] take place.				
13b1 - 13b5	ELSE steps 6-10 of Annex A.16.2 of TS 34.229-5 [47] take place.	-	-	-	-

## 4.9.26.3 Specific message contents

**Table 4.9.26.3-1: RRCSetupRequest (step 2, Table 4.9.26.2.2-1)**

Derivation Path: Table 4.6.1-23			
Information Element	Value/remark	Comment	Condition
RRCSetupRequest ::= SEQUENCE {			
rrcSetupRequest SEQUENCE {			
establishmentCause	mt-Access		
}			
}			

**Table 4.9.26.3-2: SERVICE REQUEST (step 4, Table 4.9.26.2.2-1)**

Derivation Path: Table 4.7.1-26			
Information Element	Value/remark	Comment	Condition
Service type			
Service type value	'0010'B	Mobile Terminated Services	

**Table 4.9.26.3-3: PDU SESSION MODIFICATION COMMAND (step 10, Table 4.9.26.2.2-1)**

Derivation Path: TS 38.508-1 [21], Table 4.7.2-9.			
Information Element	Value/remark	Comment	Condition
PDU session ID	Same value as sent in PDU SESSION ESTABLISHMENT REQUEST message.		
Authorized QoS rules	Reference QoS rule #7 as defined in TS 38.508-1, Table 4.8.2.1-7 using conditions IMS_VOICE and IMS_VIDEO.		
Authorized QoS flow descriptions	Reference QoS flow #5 and QoS flow #6 as defined in TS 38.508-1, Table 4.8.2.3-5 & Table 4.8.2.3-6 respectively.		
Mapped EPS bearer contexts	Not Present		
Mapped EPS bearer contexts			Interworking _with_EPS
Mapped EPS bearer context			
EPS bearer identity	The same value as the one specified in the Reference QoS flow referred to from the Reference QoS rule indicated in the IE Authorized QoS rules		
Operation code	'001'B	Create new EPS bearer	
E bit	'1'B	Parameters list is included	
Number of EPS parameters	'0001'B	1 parameter	
Mapped EPS QoS parameters	See reference dedicated EPS bearer context #3 and EPS bearer context		

	#4 in TS 36.508 table 6.6.2-1		
Traffic flow Template	See reference dedicated EPS bearer context #3 and EPS bearer context #4 in TS 36.508 table 6.6.2-1		

Condition	Explanation
Interworking_with_EPS	If the UE has indicated support of S1, then the SS shall include this IE to provide details for the interworking with EPS being supported for a PDU session. This requirement is set up for the purpose of facilitating the test description. It is not mandatory for the Network to support Mapped EPS bearer contexts.

**Table 4.9.26.3-4: RRCReconfiguration (step 10, Table 4.9.26.2.2-1)**

Derivation Path: TS 38.508-1 [21], Table 4.8.1-1D

## 4.9.27 Test procedure for adding video to a speech call in 5GC

### 4.9.27.1 Scope

The purpose of this procedure is to add video to an established speech call.

### 4.9.27.2 Procedure description

#### 4.9.27.2.1 Initial conditions

System Simulator:

- 1 NR Cell connected to 5GC, default parameters.

User Equipment:

- The UE is in state 3N-A and registered to the IMS.

#### 4.9.27.2.2 Procedure sequence

**Table 4.9.27.2.2-1: IMS video call addition in 5GC**

St	Procedure	Message Sequence		TP	Verdict
		U – S	Message		
1	The SS transmits an <i>RRCReconfiguration</i> message and a PDU SESSION MODIFICATION COMMAND message.	<--	NR RRC: <i>RRCReconfiguration</i> 5GMM: DL NAS TRANSPORT 5GSM: PDU SESSION MODIFICATION COMMAND	-	-
-	EXCEPTION: Steps 2 and 3 can occur in any order.	-	-	-	-
2	The UE transmits an <i>RRCReconfigurationComplete</i> message	-->	NR RRC: <i>RRCReconfigurationComplete</i>	-	-
3	Check: Does the UE transmit a <i>ULInformationTransfer</i> message, an UL NAS TRANSPORT message and an PDU SESSION MODIFICATION COMPLETE message?	-->	NR RRC: <i>ULInformationTransfer</i> 5GMM: UL NAS TRANSPORT 5GSM: PDU SESSION MODIFICATION COMPLETE	-	-

## 4.9.27.3 Specific message contents

**Table 4.9.27.3-1: PDU SESSION MODIFICATION COMMAND (step 1, Table 4.9.27.2.2-1)**

Derivation Path: TS 38.508-1 [21], Table 4.7.2-9.			
Information Element	Value/remark	Comment	Condition
PDU session ID	Same value as sent in PDU SESSION ESTABLISHMENT REQUEST message.		
Authorized QoS rules	Reference QoS rule #7 as defined in Table 4.8.2.1-7 using condition IMS_VIDEO and Rule operation code 011.		
Authorized QoS flow descriptions	Reference QoS flow #6 as defined in Table 4.8.2.3-6 respectively.		
Mapped EPS bearer contexts	Not Present		
Mapped EPS bearer contexts			Interworking _with_EPS
Mapped EPS bearer context EPS bearer identity	The same value as the one specified in the Reference QoS flow referred to from the Reference QoS rule indicated in the IE Authorized QoS rules		
Operation code	'001'B	Create new EPS bearer	
E bit	'1'B	Parameters list is included	
Number of EPS parameters	'0001'B	1 parameter	
Mapped EPS QoS parameters	See reference dedicated EPS bearer context #3 in TS 36.508 table 6.6.2-1		
Traffic flow Template	See reference dedicated EPS bearer context#3 in TS 36.508 table 6.6.2-1		

Condition	Explanation
Interworking_with_EPS	If the UE has indicated support of S1, then the SS shall include this IE to provide details for the interworking with EPS being supported for a PDU session. This requirement is set up for the purpose of facilitating the test description. It is not mandatory for the Network to support Mapped EPS bearer contexts.

**Table 4.9.27.3-2: RRCReconfiguration (step 1, Table 4.9.27.2.2-1)**

Derivation Path: Table 4.6.1-13 with condition NR.			
Information Element	Value/remark	Comment	Condition
RRCReconfiguration ::= SEQUENCE {			
criticalExtensions CHOICE {			
c1 CHOICE {			
rrcReconfiguration SEQUENCE {			
radioBearerConfig	RadioBearerConfig-AddVideo		
}			
nonCriticalExtension SEQUENCE {			
masterCellGroup	CellGroupConfig-DRB(0,1)	OCTET STRING (CONTAINING CellGroupConfig)	
}			
}			

}			
}			

**Table 4.9.27.3-3 : RadioBearerConfig-AddVideo (Table 4.9.27.3-2)**

Derivation Path: Table 4.6.3-132 and condition SRB2.			
Information Element	Value/remark	Comment	Condition
RadioBearerConfig ::= SEQUENCE {			
drb-ToAddModList SEQUENCE (SIZE (1..maxDRB))	1 entry		
OF DRB-ToAddMod {			
DRB-ToAddMod [1] SEQUENCE {		entry 1	
cnAssociation CHOICE {			
sdap-Config SEQUENCE {	SDAP-Config		
defaultDRB	false		
}			
}			
}			
drb-Identity	j	j is allocated according to internal TTCN mapping	
reestablishPDCP	Not present		
recoverPDCP	Not present		
pdcp-Config	PDCP-Config with condition UM		
}			

## 4.9.28 Test procedure for removing video from an ongoing call in 5GC

### 4.9.28.1 Scope

The purpose of this procedure is to remove video from an established speech call.

### 4.9.28.2 Procedure description

#### 4.9.28.2.1 Initial conditions

System Simulator:

- 1 NR Cell connected to 5GC, default parameters.

User Equipment:

- The UE is in state 3N-A and registered to the IMS.

#### 4.9.28.2.2 Procedure sequence

**Table 4.9.28.2.2-1: IMS video removal from established call in 5GC**

St	Procedure	Message Sequence		TP	Verdict
		U – S	Message		
1	The SS transmits an <i>RRCReconfiguration</i> message and a PDU SESSION MODIFICATION COMMAND message.	<--	NR RRC: <i>RRCReconfiguration</i> 5GMM: DL NAS TRANSPORT MODIFICATION COMMAND	-	-
-	EXCEPTION: Steps 2 and 3 can occur in any order.	-	-	-	-
2	The UE transmits an <i>RRCReconfigurationComplete</i> message	-->	NR RRC: <i>RRCReconfigurationComplete</i>	-	-
3	Check: Does the UE transmit a <i>ULInformationTransfer</i> message, an UL NAS	-->	NR RRC: <i>ULInformationTransfer</i> 5GMM: UL NAS TRANSPORT	-	-

	TRANSPORT message and an PDU SESSION MODIFICATION COMPLETE message?		5GSM: PDU SESSION MODIFICATION COMPLETE		
--	---	--	---	--	--

4.9.28.3 Specific message contents

**Table 4.9.28.2.3-1: RRCReconfiguration (step 1, Table 4.9.28.2.2-1)**

Derivation Path: Table 4.6.1-13.			
Information Element	Value/remark	Comment	Condition
RRCReconfiguration ::= SEQUENCE {			
criticalExtensions CHOICE {			
rrcReconfiguration SEQUENCE {			
radioBearerConfig SEQUENCE {			
drb-ToReleaseList SEQUENCE (SIZE (1..maxDRB)) OF DRB-Identity {	1 entry		
DRB-Identity[1]	DRB-Identity linked to the IMS video bearer	entry 1	
}			
}			
nonCriticalExtension SEQUENCE {			
masterCellGroup SEQUENCE {			
rlc-BearerToReleaseList SEQUENCE (SIZE (1..maxLC-ID)) OF LogicalChannelIdentity {	1 entry		
LogicalChannelIdentity[1]	Same value as drb-Identity[1] above	entry 1	
}			
}			
}			
}			
}			

**Table 4.9.28.2.3-2: PDU SESSION MODIFICATION COMMAND (step 1, Table 4.9.28.2.2-1)**

Derivation Path: Table 4.7.2-9.			
Information Element	Value/remark	Comment	Condition
PDU session ID	Same value as sent in PDU SESSION ESTABLISHMENT REQUEST message.		
Authorized QoS rules			
QoS rule[1]			
QoS rule identifier	'0000100'B	QoS rule 7	
Rule operation code	'010'B	Delete existing QoS rule	
Authorized QoS flow descriptions			
QoS flow descriptions[1]			
QFI	'00001000'B	QFI 8	
Operation code	'010'B	Delete existing QoS flow	

4.9.29 Test Procedure for eCall over IMS establishment in 5GS: eCall Only Support

4.9.29.1 Scope

The purpose of this test procedure is to allow successful completion of eCall over IMS in 5GS when UE is in 5GMM-DEREGISTERED.eCALL-INACTIVE.

The test procedure is applicable for UEs with eCall over IMS support.



Note: The trigger to initiate MO call will be part of test case from where the generic procedure is called.

4.9.29.2 Procedure description

4.9.29.2.1 Initial conditions

System Simulator:

- 1 NR Cell connected to 5GC, default parameters.

User Equipment:

- The Test UICC shall be inserted. It shall provide Emergency Numbers.

The test procedure assumes that the UE is in test state 0-A, subclause 4.4A.2 on the NR Cell. All necessary details required shall be explicitly specified in the TC which calls the procedure in its entirety or refers to parts of it.

4.9.29.2.2 Procedure sequence

The establishment of eCall over IMS in 5GS is assumed to always be mobile originated.

**Table 4.9.29.2.2-1: Test procedure sequence for eCall over IMS Emergency establishment in 5GS (eCall Only Support)**

St	Procedure	Message Sequence		TP	Verdict
		U - S	Message/PDU/SDU		
-	EXCEPTION: Unless otherwise stated all the messages below are transmitted on the cell specified in the test case.	-	-	-	-
1	The UE is switched on and SS waits 15 sec to allow the UE to camp on the serving cell and enter and remain in substate 5GMM-DEREGISTERED.eCALL-INACTIVE	-	-	-	-
2	Make the UE attempt an eCall (Note)	-	-	-	-
3-20	Steps 2 to 19 of generic procedure 4.5.2.2-2 takes place.	-	-	-	-
21-26	Steps 8 to 13 of test procedure 4.9.11 takes place with condition 'eCall'.	-	-	-	-

Note: The request to originate a manual or Automatic eCall may be performed by MMI or AT command

4.9.29.2.3 Specific Message content

All specific message contents shall be according to subclause 4.6 and 4.7 with the exceptions below.

**Table 4.9.29.2.3-1: SIB1 (at any time prior and during the procedure, Table 4.9.29.2.2-1)**

Derivation Path: Table 4.6.1-28.			
Information Element	Value/remark	Comment	Condition
SIB1 ::= SEQUENCE {			
ims-EmergencySupport	Present	true	
}			

4.9.30 Test procedure for releasing unicast mode NR sidelink communication

4.9.30.1 Scope

The purpose of this procedure is to release unicast mode sidelink communication.

4.9.30.2 Procedure description

4.9.30.2.1 Initial conditions

The UE is in state 1N-B, 3N-B or 4-A with a PC5 unicast mode sidelink communication established.

4.9.30.2.2 Procedure sequence

**Table 4.9.30.2.2-1: Procedure for releasing unicast mode NR sidelink communication**

St	Procedure	Message Sequence	
		U – S	Message
1	The NR-SS-UE sends a DIRECT LINK RELEASE REQUEST message.	<--	PC5-S: DIRECT LINK RELEASE REQUEST
2	The UE sends a DIRECT LINK RELEASE ACCEPT message.	-->	PC5-S: DIRECT LINK RELEASE ACCEPT

4.9.30.3 Specific message contents

**Table 4.9.30.3-1: DIRECT LINK RELEASE REQUEST (Step 1, Table 4.9.30.2.2-1)**

Derivation Path: Table 4.7.4-11 with condition Rx
---

**Table 4.9.30.3-2: DIRECT LINK RELEASE ACCEPT (Step 2, Table 4.9.30.2.2-1)**

Derivation Path: Table 4.7.4-12 with condition Tx
---

## 4.9.31 Test procedure to check user plane connectivity on PC5 unicast link

4.9.31.1 Scope

The purpose of this procedure is to check user plane connectivity on established PC5 unicast link.

4.9.31.2 Procedure description

4.9.31.2.1 Initial conditions

The UE is in state 1N-B, 3N-B or 4-A. The PC5 unicast link between the UE and the NR-SS-UE and corresponding AS layer connection (PC5-RRC, sidelink DRB) have been established.

4.9.31.2.2 Procedure sequence

**Table 4.9.31.2.2-1: Procedure to check user plane connectivity on PC5 unicast link**

St	Procedure	Message Sequence		TP	Verdict
		U – S	Message		
1	Void	-	-	-	-
-	EXCEPTION: Steps 1a1 to 1b2 describe behaviour which depends on procedure parameters; the "lower case letter" identifies a step sequence that takes place if a procedure parameter has a particular value.	-	-	-	-
1a1	IF the UE is in state 1N-B or 4-A, the SS triggers UE to close UE test loop mode E (Receive Mode).  NOTE: Closing of UE test loop mode E may be performed by MMI or AT command (+CCUTLE).	-	-	-	-

1b1	ELSE IF the UE is in state 3N-B, the SS transmits a CLOSE UE TEST LOOP message to close UE test loop mode E (Receive Mode).	<--	TC: CLOSE UE TEST LOOP		
1b2	The UE transmits a CLOSE UE TEST LOOP COMPLETE message.	-->	TC: CLOSE UE TEST LOOP COMPLETE		
2	The NR-SS-UE transmits one SDAP SDU on SL DRB#n  NOTE: SL DRB#n is the SL DRB associated with the PC5 unicast link to be verified.	-	-	-	-
3	Void				
-	EXCEPTION: Steps 3a1 to 3b2 describe behaviour which depends on procedure parameters; the "lower case letter" identifies a step sequence that takes place if a procedure parameter has a particular value.	-	-	-	-
3a1	IF the UE is in state 1N-B or 4-A, the SS requests the UE to report the counter of successful reception of SDAP SDU packets.  NOTE: Requesting the UE to report the counter of successful reception of SDAP packets may be performed by MMI or AT command (+CUSPCREQ).	-	-	-	-
3a2	Check: Does the reported counters of successful reception of SDAP SDU/PSSCH/PSCCH packets satisfy following conditions? - Counter of SDAP SDU packets equals to 1; - Counter of PSSCH packets is greater than 0; - Counter of PSCCH packets is greater than 0;  NOTE: The UE reporting the counter of successful reception of SDAP SDU/PSSCH/PSCCH packets may be performed by MMI or AT command (+CUSPCREQ).	-	-	-	P
3b1	ELSE IF the UE is in state 3N-B, the SS transmits a UE TEST LOOP NR SIDELINK COUNTER REQUEST message to request the UE to report the counter of successful reception of SDAP SDU packets.	<--	TC: UE TEST LOOP NR SIDELINK COUNTER REQUEST	-	-
3b2	Check: Does the reported counters of successful reception of SDAP SDU/PSSCH/PSCCH packets in UE TEST LOOP NR SIDELINK COUNTER RESPONSE message transmitted by the UE satisfy following conditions? - Counter of SDAP SDU packets equals to 1; - Counter of PSSCH packets is greater than 0; - Counter of PSCCH packets is greater than 0;.	-->	TC: UE TEST LOOP NR SIDELINK COUNTER RESPONSE	-	P
4-5	Void	-	-	-	-
-	EXCEPTION: Steps 5a1 to 5b2 describe behaviour which depends on procedure parameters; the "lower case letter" identifies a step sequence that takes place if a procedure parameter has a particular value.	-	-	-	-
5a1	IF the UE is in state 1N-B or 4-A, the SS triggers UE to open UE test loop mode E.  NOTE: Opening of UE test loop mode E may be performed by MMI or AT command (+CCUTLE).	-	-	-	-
5b1	ELSE IF the UE is in state 3N-B, the SS transmits an OPEN UE TEST LOOP message to open UE test loop mode E.	<--	TC: OPEN UE TEST LOOP		
5b2	The UE transmits an OPEN UE TEST LOOP COMPLETE message.	-->	TC: OPEN UE TEST LOOP COMPLETE		

6	Void	-	-	-	-
-	EXCEPTION: Steps 6a1 to 6b2 describe behaviour which depends on procedure parameters; the "lower case letter" identifies a step sequence that takes place if a procedure parameter has a particular value.	-	-	-	-
6a1	IF the UE is in state 1N-B or 4-A, the SS triggers UE to close UE test loop mode E (Transmit Mode).  NOTE: Closing of UE test loop mode E may be performed by MMI or AT command (+CCUTLE).	-	-	-	-
6b1	ELSE IF the UE is in state 3N-B, the SS transmits a CLOSE UE TEST LOOP message to close UE test loop mode E (Transmit Mode).	<--	TC: CLOSE UE TEST LOOP		
6b2	The UE transmits a CLOSE UE TEST LOOP COMPLETE message.	-->	TC: CLOSE UE TEST LOOP COMPLETE		
7	Check: Does UE continuously send SDAP SDUs on SL DRB#n in the next 5 seconds?  NOTE: The UE sends multiple packets. The reception of one of them is sufficient for achieving the Pass verdict.	-	-	-	P
8	Void	-	-	-	-
-	EXCEPTION: Steps 8a1 to 8b2 describe behaviour which depends on procedure parameters; the "lower case letter" identifies a step sequence that takes place if a procedure parameter has a particular value.	-	-	-	-
8a1	The SS triggers UE to open UE test loop mode E.  NOTE: Opening of UE test loop mode E may be performed by MMI or AT command (+CCUTLE).	-	-	-	-
8b1	ELSE IF the UE is in state 3N-B, the SS transmits an OPEN UE TEST LOOP message to open UE test loop mode E.	<--	TC: OPEN UE TEST LOOP		
8b2	The UE transmits an OPEN UE TEST LOOP COMPLETE message.	-->	TC: OPEN UE TEST LOOP COMPLETE		

4.9.31.3 Specific message contents

All specific message contents shall be according subclause 4.6 and 4.7B with the exceptions below.

**Table 4.9.31.3-1: +CCUTLE (Table 4.9.31.2.2-1, Step 1a1)**

Derivation Path: Table 4.7B-1 with condition Close and Receive

**Table 4.9.31.3-2: CLOSE UE TEST LOOP (Table 4.9.31.2.2-1, Step 1b1)**

Derivation Path: 36.508 [2] Table 4.7A-3 with condition UE TEST LOOP MODE E (V2X Reception)

**Table 4.9.31.3-3: +CUSPCREQ (Table 4.9.31.2.2-1, Step 3a2)**

Derivation Path: 36.508[2] Table 4.7I-4			
Field	Value/remark	Comment	Condition
+CUSPCREQ =			
< type1 >	2	NR PSCCH transport blocks	
< format >	1		
<length1>	Not Checked		

<counter1>	Checked	Any value greater than 0	
< type2>	2	NR STCH SDAP SDU packets	
< format >	1		
<length2>	Not Checked		
<counter2>	1		
< type3>	2	NR PSSCH transport blocks	
< format >	1		
<length3>	Not Checked		
<counter3>	Checked	Any value greater than 0	

**Table 4.9.31.3-4: UE TEST LOOP NR SIDELINK PACKET COUNTER REQUEST (Table 4.9.31.2.2-1, Step 3b1)**

Derivation Path: 38.509 clause 6.9.1			
Information Element	Value/remark	Comment	Condition
Protocol discriminator	'1111'B		
Skip indicator	'0000'B		
Message type	'10101010'B		

**Table 4.9.31.3-5: UE TEST LOOP NR SIDELINK PACKET COUNTER RESPONSE (Table 4.9.31.2.2-1, Step 3b2)**

Derivation Path: 38.509 clause 6.9.2			
Information Element	Value/remark	Comment	Condition
Protocol discriminator	'1111'B		
Skip indicator	'0000'B		
Message type	'10101011'B		
NR Sidelink PSCCH Packet Counter(s) Value			
NR Sidelink PSCCH Packet Counter(s) Value type	'00000001'B		
Length of NR Sidelink PSCCH Packet Counter(s) Value contents in bytes	'00000100'B	4 bytes	
NR Sidelink PSCCH Packet Counter IE #0	Checked	Any value greater than 0	
NR Sidelink STCH Packet Counter(s) Value			
NR Sidelink STCH Packet Counter(s) Value type	'00000010'B		
Length of NR Sidelink STCH Packet Counter(s) Value in bytes	'00000100'B	4 bytes	
NR Sidelink STCH Packet Counter IE #0	'00000000 00000000 00000000 00000001'B		
NR Sidelink PSSCH Packet Counter(s) Value			
NR Sidelink PSSCH Packet Counter(s) Value type	'00000011'B		
Length of NR Sidelink PSSCH Packet Counter(s) Value contents in bytes	'00000100'B	4 bytes	
NR Sidelink PSSCH Packet Counter IE #0	Checked	Any value greater than 0	

**Table 4.9.31.3-6: +CCUTLE (Table 4.9.31.2.2-1, Step 5a1 and 8a1)**

Derivation Path: Table 4.7B-1 with condition Open
---

**Table 4.9.31.3-7: +CCUTLE (Table 4.9.31.2.2-1, Step 6a1)**

Derivation Path: Table 4.7B-1 with condition Close and Transmit
---

**Table 4.9.31.3-8: CLOSE UE TEST LOOP (Table 4.9.31.2.2-1, Step 6b1)**

Derivation Path: 36.508 [2] Table 4.7A-3 with condition UE TEST LOOP MODE E(V2X Transmission)			
Information Element	Value/remark	Comment	Condition
UE test loop mode E LB setup			
Communication Transmit or Receive	0 0 0 0 0 0 1	'01' indicates V2X UE triggered to transmit NR sidelink communication with single spatial layer.	

## 4.9.32 Test procedure to activate UE Power Limit Function (UPLF)

### 4.9.32.1 Initiation

UE is operating in FR2 in RRC\_CONNECTED state with UE power limit test function activated.

### 4.9.32.2 Procedure

**Table 4.9.32.2-1: Test procedure Sequence**

St	Procedure	Message Sequence		TP	Verdict
		U - S	Message/PDU/SDU		
1	SS request UE to activate UE Power Limit Function	<--	ACTIVATE POWER LIMIT REQUEST	-	-
2	UE confirms that UE Power Limit Function is activated	-->	ACTIVATE POWER LIMIT RESPONSE	-	-

### 4.9.32.3 Specific Message contents

**Table 4.9.32.3-1: ACTIVATE POWER LIMIT REQUEST**

Derivation Path: 38.509 clause 6.11.1			
Information Element	Value/remark	Comment	Condition
Protocol discriminator	1 1 1 1		
Skip indicator	0 0 0 0		
Message type	1 0 1 0 1 1 1 0		
TOTAL NR AGGREGATED BANDWIDTH	0 0 0 0 0 0 1 0		TOT NR AGG BW 100
TOTAL NR AGGREGATED BANDWIDTH	0 0 0 0 0 1 1		TOT NR AGG BW 150
TOTAL NR AGGREGATED BANDWIDTH	0 0 0 0 0 1 0 0		TOT NR AGG BW 200
TOTAL NR AGGREGATED BANDWIDTH	0 0 0 0 0 1 0 1		TOT NR AGG BW 250
TOTAL NR AGGREGATED BANDWIDTH	0 0 0 0 0 1 1 0		TOT NR AGG BW 300
TOTAL NR AGGREGATED BANDWIDTH	0 0 0 0 0 1 1 1		TOT NR AGG BW 350
TOTAL NR AGGREGATED BANDWIDTH	0 0 0 0 1 0 0 0		TOT NR AGG BW 400
TOTAL NR AGGREGATED BANDWIDTH	0 0 0 0 1 0 0 1		TOT NR AGG BW 450
TOTAL NR AGGREGATED BANDWIDTH	0 0 0 0 1 0 1 0		TOT NR AGG BW 500
TOTAL NR AGGREGATED BANDWIDTH	0 0 0 0 1 0 1 1		TOT NR AGG BW 550
TOTAL NR AGGREGATED BANDWIDTH	0 0 0 0 1 1 0 0		TOT NR AGG BW 600
TOTAL NR AGGREGATED BANDWIDTH	0 0 0 0 1 1 0 1		TOT NR AGG BW 650

TOTAL NR AGGREGATED BANDWIDTH	0 0 0 0 1 1 1 0		TOT NR AGG BW 700
TOTAL NR AGGREGATED BANDWIDTH	0 0 0 0 1 1 1 1		TOT NR AGG BW 750
TOTAL NR AGGREGATED BANDWIDTH	0 0 0 1 0 0 0 0		TOT NR AGG BW 800
TOTAL NR AGGREGATED BANDWIDTH	0 0 0 1 0 0 0 1		TOT NR AGG BW 850
TOTAL NR AGGREGATED BANDWIDTH	0 0 0 1 0 0 1 0		TOT NR AGG BW 900
TOTAL NR AGGREGATED BANDWIDTH	0 0 0 1 0 0 1 1		TOT NR AGG BW 950
TOTAL NR AGGREGATED BANDWIDTH	0 0 0 1 0 1 0 0		TOT NR AGG BW 1000
TOTAL NR AGGREGATED BANDWIDTH	0 0 0 1 0 1 0 1		TOT NR AGG BW 1050
TOTAL NR AGGREGATED BANDWIDTH	0 0 0 1 0 1 1 0		TOT NR AGG BW 1100
TOTAL NR AGGREGATED BANDWIDTH	0 0 0 1 0 1 1 1		TOT NR AGG BW 1150
TOTAL NR AGGREGATED BANDWIDTH	0 0 0 1 1 0 0 0		TOT NR AGG BW 1200
TOTAL NR AGGREGATED BANDWIDTH	0 0 0 1 1 0 0 1		TOT NR AGG BW 1250
TOTAL NR AGGREGATED BANDWIDTH	0 0 0 1 1 0 1 0		TOT NR AGG BW 1300
TOTAL NR AGGREGATED BANDWIDTH	0 0 0 1 1 0 1 1		TOT NR AGG BW 1350
TOTAL NR AGGREGATED BANDWIDTH	0 0 0 1 1 1 0 0		TOT NR AGG BW 1400
TOTAL NR AGGREGATED BANDWIDTH	0 0 0 1 1 1 0 1		TOT NR AGG BW 1450
TOTAL NR AGGREGATED BANDWIDTH	0 0 0 1 1 1 1 0		TOT NR AGG BW 1500
TOTAL NR AGGREGATED BANDWIDTH	0 0 0 1 1 1 1 1		TOT NR AGG BW 1550
TOTAL NR AGGREGATED BANDWIDTH	0 0 1 0 0 0 0 0		TOT NR AGG BW 1600
PCELL NR BANDWIDTH	0 0 0 0 0 0 0 1		PCELL NR BW 50
PCELL NR BANDWIDTH	0 0 0 0 0 0 1 0		PCELL NR BW 100
PCELL NR BANDWIDTH	0 0 0 0 0 1 0 0		PCELL NR BW 200
PCELL NR BANDWIDTH	0 0 0 0 1 0 0 0		PCELL NR BW 400

Condition	Explanation
TOT NR AGG BW 100	Total NR aggregated Bandwidth equal to 100 MHz
TOT NR AGG BW 150	Total NR aggregated Bandwidth equal to 150 MHz
TOT NR AGG BW 200	Total NR aggregated Bandwidth equal to 200 MHz
TOT NR AGG BW 250	Total NR aggregated Bandwidth equal to 250 MHz
TOT NR AGG BW 300	Total NR aggregated Bandwidth equal to 300 MHz
TOT NR AGG BW 350	Total NR aggregated Bandwidth equal to 350 MHz
TOT NR AGG BW 400	Total NR aggregated Bandwidth equal to 400 MHz
TOT NR AGG BW 450	Total NR aggregated Bandwidth equal to 450 MHz
TOT NR AGG BW 500	Total NR aggregated Bandwidth equal to 500 MHz
TOT NR AGG BW 550	Total NR aggregated Bandwidth equal to 550 MHz
TOT NR AGG BW 600	Total NR aggregated Bandwidth equal to 600 MHz
TOT NR AGG BW 650	Total NR aggregated Bandwidth equal to 650 MHz
TOT NR AGG BW 700	Total NR aggregated Bandwidth equal to 700 MHz
TOT NR AGG BW 750	Total NR aggregated Bandwidth equal to 750 MHz
TOT NR AGG BW 800	Total NR aggregated Bandwidth equal to 800 MHz
TOT NR AGG BW 850	Total NR aggregated Bandwidth equal to 850 MHz
TOT NR AGG BW 900	Total NR aggregated Bandwidth equal to 900 MHz

TOT NR AGG BW 950	Total NR aggregated Bandwidth equal to 950 MHz
TOT NR AGG BW 1000	Total NR aggregated Bandwidth equal to 1000 MHz
TOT NR AGG BW 1050	Total NR aggregated Bandwidth equal to 1050 MHz
TOT NR AGG BW 1100	Total NR aggregated Bandwidth equal to 1100 MHz
TOT NR AGG BW 1150	Total NR aggregated Bandwidth equal to 1150 MHz
TOT NR AGG BW 1200	Total NR aggregated Bandwidth equal to 1200 MHz
TOT NR AGG BW 1250	Total NR aggregated Bandwidth equal to 1250 MHz
TOT NR AGG BW 1300	Total NR aggregated Bandwidth equal to 1300 MHz
TOT NR AGG BW 1350	Total NR aggregated Bandwidth equal to 1350 MHz
TOT NR AGG BW 1400	Total NR aggregated Bandwidth equal to 1400 MHz
TOT NR AGG BW 1450	Total NR aggregated Bandwidth equal to 1450 MHz
TOT NR AGG BW 1500	Total NR aggregated Bandwidth equal to 1500 MHz
TOT NR AGG BW 1550	Total NR aggregated Bandwidth equal to 1550 MHz
TOT NR AGG BW 1600	Total NR aggregated Bandwidth equal to 1600 MHz
PCELL NR BW 50	PCC NR Bandwidth equal to 50 MHz
PCELL NR BW 100	PCC NR Bandwidth equal to 100 MHz
PCELL NR BW 200	PCC NR Bandwidth equal to 200 MHz
PCELL NR BW 400	PCC NR Bandwidth equal to 400 MHz

**Table 4.9.32.3-2: ACTIVATE POWER LIMIT RESPONSE**

Derivation Path: 38.509 clause 6.11.2			
Information Element	Value/remark	Comment	Condition
Protocol discriminator	1 1 1 1		
Skip indicator	0 0 0 0		
Message type	1 0 1 0 1 1 1 1		

### 4.9.33 Test procedure to deactivate UE Power Limit Function (UPLF)

*Editor’s note: The power limit request message values set by the UPLF test mode is currently applicable to equal PSD (equal channel bandwidths on all component carriers) only. Message values are pending for unequal channel bandwidths*

#### 4.9.33.1 Initiation

UE is operating in FR2 in RRC\_CONNECTED state.

#### 4.9.33.2 Procedure

**Table 4.9.33.2-1: Test procedure Sequence**

St	Procedure	Message Sequence		TP	Verdict
		U - S	Message/PDU/SDU		
1	SS request UE to deactivate UE Power Limit Function	<--	DEACTIVATE POWER LIMIT REQUEST	-	-
2	UE confirms that UE Power Limit Function is deactivated	-->	DEACTIVATE POWER LIMIT RESPONSE	-	-

#### 4.9.33.3 Specific Message contents

**Table 4.9.33.3-1: DEACTIVATE POWER LIMIT REQUEST**

Derivation Path: 38.509 clause 6.11.3			
Information Element	Value/remark	Comment	Condition
Protocol discriminator	1 1 1 1		
Skip indicator	0 0 0 0		
Message type	1 0 1 0 1 1 1 0		



Table 4.9.33.3-2: DEACTIVATE POWER LIMIT RESPONSE

Derivation Path: 38.509 clause 6.11.4			
Information Element	Value/remark	Comment	Condition
Protocol discriminator	1 1 1 1		
Skip indicator	0 0 0 0		
Message type	1 0 1 0 1 1 1 1		

## 4.9.34 Test procedure for MBS Multicast session join and session establishment

### 4.9.34.1 Scope

The purpose of this procedure is to establish a multicast MBS session.

### 4.9.34.2 Procedure description

#### 4.9.34.2.1 Initial conditions

System Simulator:

- 1 NR Cell connected to 5GC, default parameters.

User Equipment:

- The UE is in state 1N-A.

#### 4.9.34.2.2 Procedure sequence

Table 4.9.34.2.2-1: Procedure for MBS Multicast session join and session establishment

St	Procedure	Message Sequence		TP	Verdict
		U - S	Message/PDU/SDU		
-	EXCEPTION: Step 1a1 to 1b12a1 describe behaviour that depends on the UE capability the "lower case letter" identifies a step sequence that take place.	-	-	-	-
1a1	IF pc_Join_MBS_by_PDU_Modification THEN cause the UE to request establishment of associated PDU Session to the MBS DNN.(Note 1)	-	-	-	-
1a2-1a7	Steps 2-7 of expected sequence from Table 4.5.4.2-3 are performed.	-	-	-	-
-	EXCEPTION: Depending upon UE implementation, steps 1a8 and 1a9 can occur in any order	-	-	-	-
1a8	The UE transmits an <i>RRCReconfigurationComplete</i> message.	-->	NR RRC: <i>RRCReconfigurationComplete</i>	-	-
1a9	The UE transmits an UL NAS TRANSPORT message and a PDU SESSION ESTABLISHMENT REQUEST without MBS session ID and join request.	-->	NR RRC: <i>ULInformationTransfer</i> 5GMM: UL NAS TRANSPORT 5GSM: PDU SESSION ESTABLISHMENT REQUEST	-	-
1a10	The SS transmits an <i>RRCReconfiguration</i> message and an PDU SESSION ESTABLISHMENT ACCEPT	<--	NR RRC: <i>RRCReconfiguration</i> 5GMM: DL NAS TRANSPORT 5GSM: PDU SESSION ESTABLISHMENT ACCEPT	-	-
1a11	The UE transmits an <i>RRCReconfigurationComplete</i> message.	-->	NR RRC: <i>RRCReconfigurationComplete</i>	-	-
-	EXCEPTION: Step 1a12a1 describes behaviour depending UE implementation; the "lower case letter" identifies a step sequence	-	-	-	-

	that take place if the UE performs a specific action.				
1a12 a1	IF the 'IP address allocation' for the DNN for which the PDU session is established is set to "Yes" in Table 4.8.4-1 THEN, the generic procedure for IP address allocation in the user plane, specified in subclause 4.5A.3, takes place performing IP address allocation in the user plane.	-	-	-	-
1a13	Trigger UE to join MBS Multicast session.	-	-	-	-
1a14	Check: Does UE transmit an ULInformationTransfer message and a PDU SESSION MODIFICATION REQUEST message including MBS session ID and join request?	-->	NR RRC: ULInformationTransfer 5GMM: UL NAS TRANSPORT 5GSM: PDU SESSION MODIFICATION REQUEST	-	P
1a15	The SS transmits an RRCReconfiguration message and a PDU SESSION MODIFICATION COMMAND.	<--	NR RRC: RRCReconfiguration 5GMM: DL NAS TRANSPORT 5GSM: PDU SESSION MODIFICATION COMMAND	-	-
-	EXCEPTION: Depending upon UE implementation, steps 1a16 and 1a17 can occur in any order.	-	-	-	-
1a16	The UE transmits an RRCReconfigurationComplete message.	-->	NR RRC: RRCReconfigurationComplete	-	-
1a17	The UE transmits an ULInformationTransfer message and a PDU SESSION MODIFICATION COMPLETE message.	-->	NR RRC: ULInformationTransfer 5GMM: UL NAS TRANSPORT 5GSM: PDU SESSION MODIFICATION COMPLETE	-	-
1b1	ELSE trigger UE to join MBS Multicast session.	-	-	-	-
1b2- 1b7	Steps 2-7 of expected sequence from Table 4.5.4.2-3 are performed.	-	-	-	-
-	EXCEPTION: Depending upon UE implementation, steps 1b8 and 1b9 can occur in any order	-	-	-	-
1b8	The UE transmits an <i>RRCReconfigurationComplete</i> message.	-->	NR RRC: <i>RRCReconfigurationComplete</i>	-	-
1b9	Check: Does UE transmit an UL NAS TRANSPORT message and a PDU SESSION ESTABLISHMENT REQUEST including MBS session ID and join request?	-->	NR RRC: <i>ULInformationTransfer</i> 5GMM: UL NAS TRANSPORT 5GSM: PDU SESSION ESTABLISHMENT REQUEST	-	P
1b10	The SS transmits an <i>RRCReconfiguration</i> message and a PDU SESSION ESTABLISHMENT ACCEPT	<--	NR RRC: <i>RRCReconfiguration</i> 5GMM: DL NAS TRANSPORT 5GSM: PDU SESSION ESTABLISHMENT ACCEPT	-	-
1b11	The UE transmits an <i>RRCReconfigurationComplete</i> message.	-->	NR RRC: <i>RRCReconfigurationComplete</i>	-	-
-	EXCEPTION: Step 1b12a1 describes behaviour depending UE implementation; the "lower case letter" identifies a step sequence that take place if the UE performs a specific action.	-	-	-	-
1b12 a1	IF the 'IP address allocation' for the DNN for which the PDU session is established is set to "Yes" in Table 4.8.4-1 THEN, the generic procedure for IP address allocation in the user plane, specified in subclause 4.5A.3, takes place performing IP address allocation in the user plane.	-	-	-	-
Note 1: This could be done by e.g. MMI or AT command.					

## 4.9.34.3 Specific message contents

**Table 4.9.34.3-1: PDU SESSION ESTABLISHMENT REQUEST (step 1a9, Table 4.9.34.2.2-1)**

Derivation Path: Table 4.7.2-1.

Information Element	Value/remark	Comment	Condition
Requested MBS container	Not present		

**Table 4.9.34.3-1A: RRCReconfiguration (step 1a10, Table 4.9.34.2.2-1)**

Derivation Path: Table 4.6.1-13 and condition NR			
Information Element	Value/remark	Comment	Condition
RRCReconfiguration ::= SEQUENCE {			
criticalExtensions CHOICE {			
rrcReconfiguration ::= SEQUENCE {			
radioBearerConfig	RadioBearerConfig with condition DRBn	n is chosen as the next available number higher or equal to 2	
nonCriticalExtension SEQUENCE {			
masterCellGroup	CellGroupConfig with condition DRBn	n is set to the same value as for the radioBearerConfig IE above	
dedicatedNAS-MessageList SEQUENCE (SIZE(1..maxDRB)) OF DedicatedNAS-Message {	DedicatedNAS-Message		
}			
}			
}			
}			

**Table 4.9.34.3-2: PDU SESSION MODIFICATION REQUEST (step 1a14, Table 4.9.34.2.2-1)**

Derivation Path: Table 4.7.2-7.			
Information Element	Value/remark	Comment	Condition
Requested MBS container			
MBS session information			
MBS operation	'01'B	Join MBS session	
Type of MBS session ID	Not checked		
MBS session ID	Present but value not checked, the value is set according to the parameter given in the test case		

**Table 4.9.34.3-3: PDU SESSION MODIFICATION COMMAND (step 1a15, Table 4.9.34.2.2-1)**

Derivation Path: Table 4.7.2-9.			
Information Element	Value/remark	Comment	Condition
Received MBS container			
Received MBS information			
Rejection cause	'000'B	No additional information provided	
MSAI	'00'B	MBS service area not included	
MD	'010'B	MBS join is accepted	
MSCI	'0'B	MBS security container not included	
MTI	'00'B	No MBS timers included	
IPAE	'0'B	Source and destination IP address	

		information not included	
TMGI			
MBMS Service ID	'000101'H		
MCC	See table 4.4.2-3		
MNC	See table 4.4.2-3		
Source IP address information	Not present		
Destination IP address information	Not present		
MBS service area	Not present		
MBS timers	Not present		
MBS security container	Not present		

**Table 4.9.34.3-3A: RRCReconfiguration (step 1a15, Table 4.9.34.2.2-1)**

Derivation Path: Table 4.6.1-13 and condition NR			
Information Element	Value/remark	Comment	Condition
RRCReconfiguration ::= SEQUENCE {			
criticalExtensions CHOICE {			
rrcReconfiguration ::= SEQUENCE {			
radioBearerConfig	RadioBearerConfig with condition MRBm and UM_PTM	m=1	
nonCriticalExtension SEQUENCE {			
masterCellGroup	CellGroupConfig with condition MRBm and UM_PTM	m=1	
dedicatedNAS-MessageList SEQUENCE (SIZE(1..maxDRB)) OF DedicatedNAS-Message {}	DedicatedNAS-Message		
}			
}			
}			
}			

**Table 4.9.34.3-4: PDU SESSION ESTABLISHMENT REQUEST (step 1b9, Table 4.9.34.2.2-1)**

Derivation Path: Table 4.7.2-1.			
Information Element	Value/remark	Comment	Condition
Requested MBS container			
MBS session information			
MBS operation	'01'B	Join MBS session	
Type of MBS session ID	Not checked		
MBS session ID	Present but value not checked, the value is set according to the parameter given in the test case.		

**Table 4.9.34.3-5: PDU SESSION ESTABLISHMENT ACCEPT (step 1b10, Table 4.9.34.2.2-1)**

Derivation Path: Table 4.7.2-2.			
Information Element	Value/remark	Comment	Condition
Received MBS container			
Received MBS information			
Rejection cause	'000'B	No additional information provided	
MSAI	'00'B	MBS service area not included	
MD	'010'B	MBS join is accepted	
MSCI	'0'B	MBS security container not included	

MTI	'00'B	No MBS timers included	
IPAE	'0'B	Source and destination IP address information not included	
TMGI			
MBMS Service ID	'000101'H		
MCC	See table 4.4.2-3		
MNC	See table 4.4.2-3		
Source IP address information	Not present		
Destination IP address information	Not present		
MBS service area	Not present		
MBS timers	Not present		
MBS security container	Not present		

**Table 4.9.34.3-6: RRCReconfiguration (step 1b10, Table 4.9.34.2.2-1)**

Derivation Path: Table 4.6.1-13 and condition NR			
Information Element	Value/remark	Comment	Condition
RRCReconfiguration ::= SEQUENCE {			
criticalExtensions CHOICE {			
rrcReconfiguration ::= SEQUENCE {			
radioBearerConfig	RadioBearerConfig with condition DRBn and MRBm and UM_PTM	n is chosen as the next available number higher or equal to 2 m=1	
nonCriticalExtension SEQUENCE {			
masterCellGroup	CellGroupConfig with condition MRBm_DRBn and UM_PTM	n is set to the same value as for the radioBearerConfig IE above m=1	
dedicatedNAS-MessageList SEQUENCE (SIZE(1..maxDRB)) OF DedicatedNAS-Message {	DedicatedNAS-Message		
}			
}			
}			
}			

## 4.9.35 Test procedure for deleting configured S-NSSAI, default configured S-NSSAI and allowed S-NSSAI

### 4.9.35.1 Scope

The purpose of this procedure is to delete configured S-NSSAI, default configured S-NSSAI and allowed S-NSSAI from the UE.

### 4.9.35.2 Procedure description

#### 4.9.35.2.1 Initial conditions

System Simulator:

- 1 NR Cell connected to 5GC, default parameters.

User Equipment:

- The UE is in state 3N-A.

## 4.9.35.2.2 Procedure sequence

**Table 4.9.35.2.2-1: Procedure for configured S-NSSAI, default configured S-NSSAI and allowed S-NSSAI deletion**

St	Procedure	Message Sequence		TP	Verdict
		U – S	Message		
1	The SS transmits NSSAI DELETE REQUEST message to delete the Default Configured NSSAI list.	<--	NSSAI DELETE REQUEST	-	-
2	UE transmits NSSAI DELETE RESPONSE message.	-->	NSSAI DELETE RESPONSE	-	-
3	The SS transmits NSSAI DELETE REQUEST message to delete the Configured NSSAI list.	<--	NSSAI DELETE REQUEST	-	-
4	UE transmits NSSAI DELETE RESPONSE message.	-->	NSSAI DELETE RESPONSE	-	-
5	The SS transmits NSSAI DELETE REQUEST message to delete the Allowed NSSAI list.	<--	NSSAI DELETE REQUEST	-	-
6	UE transmits NSSAI DELETE RESPONSE message.	-->	NSSAI DELETE RESPONSE	-	-

## 4.9.35.3 Specific message contents

**Table 4.9.35.3-1: NSSAI DELETE REQUEST (step 1, Table 4.9.35.2.2-1)**

Derivation path: TS 38.509 Table 6.7.1			
Information Element	Value/remark	Comment	Condition
Protocol discriminator	1111		
Skip indicator	0000		
Message type	'10100110'B		
Delete NSSAI type	'00000000'B	Delete Default Configured NSSAI	

**Table 4.9.35.3-2: NSSAI DELETE REQUEST (step 3, Table 4.9.35.2.2-1)**

Derivation path: TS 38.509 Table 6.7.1			
Information Element	Value/remark	Comment	Condition
Protocol discriminator	1111		
Skip indicator	0000		
Message type	'10100110'B		
Delete NSSAI type	'00000001'B	Delete Configured NSSAI	
Configured NSSAI	00000000		

**Table 4.9.35.3-3: NSSAI DELETE REQUEST (step 5, Table 4.9.35.2.2-1)**

Derivation path: TS 38.509 Table 6.7.1			
Information Element	Value/remark	Comment	Condition
Protocol discriminator	1111		
Skip indicator	0000		
Message type	'10100110'B		
Delete NSSAI type	'00000010'B	Delete Allowed NSSAI	
Allowed NSSAI	00000000		

**Table 4.9.35.3-4: NSSAI DELETE RESPONSE (steps 2, 4 and 6, Table 4.9.35.2.2-1)**

Derivation path: TS 38.509 Table 6.7.2			
--	--	--	--

Information Element	Value/remark	Comment	Condition
Protocol discriminator	1111		
Skip indicator	0000		
Message type	'10100111'B		

## 4.9.36 Test procedure for registration of a MUSIM UE

### 4.9.36.1 Scope

The purpose of this procedure is to perform initial registration of a MUSIM UE.

### 4.9.36.2 Procedure description

#### 4.9.36.2.1 Initial conditions

System Simulator:

- NGC Cell A (home PLMN1) and cell G (home PLMN2) are configured according to tables 6.3.2.2-1, 6.3.2.2-3 and with default system information combination as defined in sub-clause 4.4.3.1.2. Any change in the cells and their configurations shall be explicitly specified in the TC which calls the procedure in its entirety or refers to parts of it.

User Equipment:

- The UE is a MUSIM UE.
- The UE is equipped with two USIMs with configuration as defined in Tables 6.4.1-27 and 6.4.1-28.

#### 4.9.36.2.2 Procedure sequence

**Table 4.9.36.2.2-1: Test procedure sequence for registration of a MUSIM UE**

St	Procedure	Message Sequence		TP	Verdict
		U - S	Message		
1	The SS configures: - NGC Cell A as the "Serving cell". - NGC Cell G as a "Non-Suitable Off cell".	-	-	-	-
2	UE is switched on.	-	-	-	-
-	The following messages are to be observed on NGC Cell A unless explicitly stated otherwise.	-	-	-	-
3	Check: Does UE with USIM configuration 6.4.1-27 transmit REGISTRATION REQUEST message including UE network capability with at least one MUSIM feature is set to "support"?	-->	REGISTRATION REQUEST	-	P
4-19	Steps 5 to 20a1 of the generic procedure for NR RRC_IDLE specified in TS 38.508-1 subclause 4.5.2 are performed.	-	-	-	-
20	The SS configures: - NGC Cell G as a "Serving cell".	-	-	-	-
-	The following messages are to be observed on NGC Cell G unless explicitly stated otherwise.	-	-	-	-
21	Check: Does UE with USIM configuration 6.4.1-28 transmit REGISTRATION REQUEST message including UE network capability with at least one MUSIM feature is set to "support"?	-->	REGISTRATION REQUEST	-	P
22-37	Steps 5 to 20a1 of the generic procedure for NR RRC_IDLE specified in TS 38.508-1 subclause 4.5.2 are performed.	-	-	-	-

## 4.9.36.3 Specific message contents

**Table 4.9.36.3-1: Message REGISTRATION REQUEST (steps 3 and 21, Table 4.9.36.2.2-1)**

Derivation path: Table 4.7.1-6			
Information Element	Value/Remark	Comment	Condition
5GMM capability			
All octets with the exception of octet 6, bit 5 to bit 8	Any allowed value		
N1 NAS signalling connection release (NCR) (octet 6, bit 5)	'1'B	N1 NAS signalling connection release supported	pc_5GC_M USIM_NCR
Paging indication for voice services (PIV) (octet 6, bit 6)	'1'B	paging indication for voice services is supported	pc_5GC_M USIM_PIV
Reject paging request (RPR) (octet 6, bit 7)	'1'B	reject paging request supported	pc_5GC_M USIM_RPR
Paging restriction (PR) (octet 6, bit 8)	'1'B	paging restriction is supported	pc_5GC_M USIM_PR

**Table 4.9.36.3-2: Message REGISTRATION ACCEPT (steps 13 and 31, Table 4.9.36.2.2-1)**

Derivation path: Table 4.7.1-7			
Information Element	Value/Remark	Comment	Condition
5GS network feature support	'0000 0101 0000 0000 0111 1000'B		

## 4.9.37 Test procedure for MBS Multicast session release

## 4.9.37.1 Scope

The purpose of this procedure is to release a multicast MBS session from NW.

## 4.9.37.2 Procedure description

## 4.9.37.2.1 Initial conditions

System Simulator:

- 1 NR Cell connected to 5GC, default parameters.

User Equipment:

- The UE is in state 3N-A.

## 4.9.37.2.2 Procedure sequence

**Table 4.9.37.2.2-1: Procedure for MBS Multicast session release**

St	Procedure	Message Sequence		TP	Verdict
		U - S	Message/PDU/SDU		
1	The SS transmits an RRCReconfiguration message and a PDU SESSION MODIFICATION COMMAND.	<--	NR RRC: RRCReconfiguration 5GMM: DL NAS TRANSPORT 5GSM: PDU SESSION MODIFICATION COMMAND	-	-
-	EXCEPTION: Depending upon UE implementation, steps 2 and 3 can occur in any order.	-	-	-	-
2	The UE transmits an RRCReconfigurationComplete message.	-->	NR RRC: RRCReconfigurationComplete	-	-



3	The UE transmits an ULInformationTransfer message and a PDU SESSION MODIFICATION COMPLETE message.	-->	NR RRC: ULInformationTransfer 5GMM: UL NAS TRANSPORT 5GSM: PDU SESSION MODIFICATION COMPLETE	-	-
---	--	-----	--	---	---

## 4.9.37.3 Specific message contents

**Table 4.9.37.3-1: RRCReconfiguration (step 1, Table 4.9.37.2.2-1)**

Derivation Path: Table 4.6.1-13.			
Information Element	Value/remark	Comment	Condition
RRCReconfiguration ::= SEQUENCE {			
criticalExtensions CHOICE {			
rrcReconfiguration SEQUENCE {			
radioBearerConfig SEQUENCE {			
mrb-ToReleaseList-r17 SEQUENCE (SIZE (1..maxMRB-r17)) OF MRB-Identity-r17	1 entry		
MRB-Identity[1]	MRB-Identity linked to the MBS Session to be released		
}			
}			
nonCriticalExtension SEQUENCE {			
masterCellGroup SEQUENCE {			
rlc-BearerToReleaseList SEQUENCE (SIZE (1..maxLC-ID)) OF LogicalChannelIdentity {	1 entry or 2 entries		
logicalChannelIdentity[1]	logicalChannelIdentity for PTP linked to MRB-Identity [1], if configured	entry 1	
logicalChannelIdentity[2]	logicalChannelIdentity for PTM linked to MRB-Identity [1], if configured	entry 2	
}			
}			
dedicatedNAS-MessageList SEQUENCE (SIZE(1..maxDRB)) OF DedicatedNAS-Message {	DedicatedNAS-Message		
}			
}			
}			
}			

**Table 4.9.37.3-2: PDU SESSION MODIFICATION COMMAND (step 1, Table 4.9.37.2.2-1)**

Derivation Path: Table 4.7.2-9.			
Information Element	Value/remark	Comment	Condition
Received MBS container			
Received MBS information			
Rejection cause	'110'B	MBS session is released	
MSAI	'00'B	MBS service area not included	
MD	'100'B	Remove UE from MBS session	
MSCI	'0'B	MBS security container not included	
MTI	'00'B	No MBS timers included	
IPAE	'0'B	Source and destination IP address information not included	
TMGI			

MBMS Service ID	'000101'B		
MCC	See table 4.4.2-3		
MNC	See table 4.4.2-3		
Source IP address information	Not present		
Destination IP address information	Not present		
MBS service area	Not present		
MBS timers	Not present		
MBS security container	Not present		

## 4.9.38 Test procedure to check TMGI and associated MRB reception in a multicast MBS session

### 4.9.38.1 Scope

The purpose of this procedure is to check that a TMGI for a multicast MBS session is valid and the MRB associated with the TMGI could be successfully received by UE in the multicast MBS session.

### 4.9.38.2 Procedure description

#### 4.9.38.2.1 Initial conditions

System Simulator:

- 1 NR Cell connected to 5GC, default parameters.

User Equipment:

- The UE is in state 1N-A.

#### 4.9.38.2.2 Procedure sequence

**Table 4.9.38.2.2-1: Procedure to check TMGI and associated MRB reception in a multicast MBS session**

St	Procedure	Message Sequence		TP	Verdict
		U - S	Message/PDU/SDU		
1	The SS transmits a <i>Paging</i> message including TMGI.	<--	NR RRC: <i>Paging</i>	-	-
2-8	Steps 2 to 8 of the NR RRC_CONNECTED procedure in Table 4.5.4.2-3 to complete service procedure.	-	-	-	-
9	The SS transmits an <i>RRCReconfiguration</i> message to establish MRB.	<--	NR RRC: <i>RRCReconfiguration</i>	-	-
10	The UE transmit an <i>RRCReconfigurationComplete</i> message	-->	NR RRC: <i>RRCReconfigurationComplete</i>	-	-
11a1 - 11a2	Steps 9a1 to 9a2 of the NR RRC_CONNECTED procedure in Table 4.5.4.2-3 are executed with condition UE TEST LOOP MODE C and Multicast MRB.	-	-	-	-
12	The SS transmits a MBS Packet on Multicast MRB associated with TMGI in the step 1.	<--	MBS Packet.	-	-
13	The SS transmits an UE TEST LOOP MODE C MBMS PACKET COUNTER REQUEST message.	<--	NR RRC: <i>DLInformationTransfer</i> TC: UE TEST LOOP MODE C MBMS PACKET COUNTER REQUEST	-	-
14	UE responds with UE TEST LOOP MODE C MBMS PACKET COUNTER RESPONSE.	-->	NR RRC: <i>ULInformationTransfer</i> TC: UE TEST LOOP MODE C MBMS PACKET COUNTER RESPONSE	-	-

15	Check: Is the number of reported MBS Packets received on the MRB in step 14 equal to 1?	-	-	-	P
----	---	---	---	---	---

4.9.38.3 Specific message contents

**Table 4.9.38.3-1: Paging (step 1, Table 4.9.38.2.2-1)**

Derivation Path: TS 38.508-1 [4], Table 4.6.1-9, condition TMGI			
Information Element	Value/remark	Comment	Condition
Paging ::= SEQUENCE {			
pagingRecordList	Not present		
nonCriticalExtension SEQUENCE {			
pagingGroupList-r17 SEQUENCE (SIZE(1..maxNrofPageGroup-r17)) OF TMGI-r17 {	1 entry		
TMGI-r17[1]	TMGI	entry 1	
}			
}			
}			

**Table 4.9.38.3-2: RRCReconfiguration (step 9, Table 4.9.38.2.2-1)**

Derivation Path: TS 38.508-1 [4], Table 4.6.1-13 and condition NR			
Information Element	Value/remark	Comment	Condition
RRCReconfiguration ::= SEQUENCE {			
criticalExtensions CHOICE {			
rrcReconfiguration ::= SEQUENCE {			
radioBearerConfig	RadioBearerConfig with condition MRBm and UM_PTM	m=1	
nonCriticalExtension SEQUENCE {			
masterCellGroup	CellGroupConfig with condition MRBm and UM_PTM	m=1	
}			
}			
}			
}			

**Table 4.9.38.3-3: CLOSE UE TEST LOOP (step 11a1, Table 4.9.38.2.2-1)**

Derivation Path: TS 38.508-1 [4], Table 4.7A-3, condition UE TEST LOOP MODE C and Multicast MRB
---

**Table 4.9.38.3-4: UE TEST LOOP MODE C MBMS PACKET COUNTER REQUEST (step 13, Table 4.9.38.2.2-1)**

Derivation Path: 36.508 [6], Table 4.7A-9
---

## 4.10 Reference configuration for V2X

### 4.10.1 Pre-configuration for V2X

– SL-PreconfigurationNR

**Table 4.10.1-1: SL-PreconfigurationNR**

Derivation Path: TS 38.331 [6], clause 9.3			
Information Element	Value/remark	Comment	Condition
SL-PreconfigurationNR-r16 ::= SEQUENCE {			
sidelinkPreconfigNR-r16 SEQUENCE {			
sl-PreconfigFreqInfoList-r16 SEQUENCE (SIZE (1..maxNrofFreqSL-r16)) OF SL-FreqConfigCommon-r16 {	1 entry		
SL-FreqConfigCommon-r16[1]	SL-FreqConfigCommon	entry 1	
}			
sl-PreconfigNR-AnchorCarrierFreqList-r16	Not present		
sl-PreconfigEUTRA-AnchorCarrierFreqList-r16	Not present		
sl-RadioBearerPreConfigList-r16 SEQUENCE (SIZE (1..maxNrofSLRB-r16)) OF SL-RadioBearerConfig-r16 {	1 entry		
SL-RadioBearerConfig-r16[1]	SL-RadioBearerConfig	entry 1	
}			
sl-RLC-BearerPreConfigList-r16 SEQUENCE (SIZE (1..maxSL-LCID-r16)) OF SL-RLC-BearerConfig-r16 {	1 entry		
SL-RLC-BearerConfig-r16[1]	SL-RLC-BearerConfig	entry 1	
}			
sl-MeasPreConfig-r16	Not present		
sl-OffsetDFN-r16	Not present		
t400-r16	ms1000		
sl-MaxNumConsecutiveDTX-r16	n32		
sl-SSB-PriorityNR-r16	1		
sl-PreconfigGeneral-r16 SEQUENCE {			
sl-TDD-Configuration-r16	Not present		
reservedBits-r16	00		
}			
sl-UE-SelectedPreConfig-r16 SEQUENCE {			
sl-PSSCH-TxConfigList-r16	SL-PSSCH-TxConfigList for Preconfiguration		
sl-ProbResourceKeep-r16	v0		
sl-ReselectAfter-r16	n9		
sl-CBR-CommonTxConfigList-r16	Not present		
ul-PrioritizationThres-r16	Not present		
sl-PrioritizationThres-r16	Not present		
}			
sl-CSI-Acquisition-r16	Not present		
sl-RoHC-Profiles-r16	Not present		
sl-MaxCID-r16	Not present	default value 15 is used	
}			
}			

**Table 4.10.1-2: SL-PSSCH-TxConfigList for Preconfiguration (Table 4.10.1-1)**

Derivation Path: TS 38.331 [6], clause 6.3.5			
Information Element	Value/remark	Comment	Condition
SL-PSSCH-TxConfigList-r16 ::= SEQUENCE (SIZE (1..maxPSSCH-TxConfig-r16)) OF SL-PSSCH-TxConfig-r16 {	1 entry		

sl-TypeTxSync-r16	Not present	Applicable for all synchronization reference types	
sl-ThresUE-Speed-r16	kmph60		
sl-ParametersAboveThres-r16 SEQUENCE {			
sl-MinMCS-PSSCH-r16	0		
sl-MaxMCS-PSSCH-r16	26		
sl-MinSubChannelNumPSSCH-r16	1		
sl-MaxSubchannelNumPSSCH-r16	27		
sl-MaxTxTransNumPSSCH-r16	4		
sl-MaxTxPower-r16	Not present		
}			
sl-ParametersBelowThres-r16 SEQUENCE {			
sl-MinMCS-PSSCH-r16	0		
sl-MaxMCS-PSSCH-r16	26		
sl-MinSubChannelNumPSSCH-r16	1		
sl-MaxSubchannelNumPSSCH-r16	27		
sl-MaxTxTransNumPSSCH-r16	4		
sl-MaxTxPower-r16	Not present		
}			
}			

## 4.11 GNSS Requirements for NR sidelink

### 4.11.1 General

This clause defines the GNSS scenarios and requirements which apply for all NR sidelink test cases that require simulated GNSS signals, unless otherwise specified.

The term SV ID used in this clause is defined as the satellite PRN for GPS and Modernized GPS, as Code Number for Galileo, as the satellite Slot Number for GLONASS and as the Ranging Code Number for BDS.

### 4.11.2 GNSS Scenarios

The following GNSS scenarios shall be used.

- Rinex navigation data: the required navigation data file(s) available in the GNSS orbital data sig zip file specified in TS 37.571-5 [49] Annex B are given in Table 4.11.2-1.

**Table 4.11.2-1: Rinex navigation data files for NR sidelink testing**

GNSS supported by UE	Rinex navigation file(s) <sup>(1)</sup>
GPS	Sig GNSS GPS 2020_9_17 Rinex.txt
GLONASS	Sig GNSS GLONASS 2020_9_17 Rinex.txt
Galileo	Sig GNSS Galileo 2020_9_17 Rinex.txt
BDS	Sig GNSS BDS 2020_9_17 Rinex.txt
Note 1: Where the UE supports more than one GNSS then all the relevant Rinex navigation data files are used	

- UE location(s) and motion:

Latitude: the simulated latitude(s) are given in Table 4.11.2-3

Longitude: the simulated longitude(s) are given in Table 4.11.2-3

Height: the simulated height is 30m

Motion: the simulated motion(s) are given in Table 4.11.2-2

**Table 4.11.2-2: UE location(s) and motion(s) for NR sidelink testing**

Scenario number and description	Step #	Action (Location details given in Table 4.11.2-3)	Notes
Scenario #1: static in Geographical area #1 Note 1	1	Static at location #1	
Scenario #2: move from inside Geographical area #1 to outside Geographical area #1 Note 1	1	Static at location #1	
	2	Trigger from test case to move in a straight line at 15m/s from current location to next location	Simulation leaves Geographical area #1 after 905 m, 60s after the trigger. An additional 1s is added to allow for UE position accuracy of +/- 15m. An additional 10s is added to allow for UE position update. Total time 71s
	3	Static at location #2	
Note 1: Geographical area #1 is defined in clause 4.7.5.5-9 and is defined by three points with the following coordinates: Point 1: latitude: 35.753056, longitude: 139.689167 Point 2: latitude: 35.735278, longitude: 139.689167 Point 3: latitude: 35.744167, longitude: 139.709167			

**Table 4.11.2-3: Location descriptions for NR sidelink testing**

Location number	Description for information only	Latitude (degrees)	Longitude (degrees)
#1	Approximate centre of Geographical area #1	35.74428	139.69916
#2	Approximately 1720m due west of location #1, outside Geographical area #1	35.74428	139.68017

**Table 4.11.2-4: Zone id calculations for NR sidelink testing**

Description	Latitude (degrees)	Longitude (degrees)	Long distance from 0,0 in m (x) Note 1	Lat distance from 0,0 in m (y) Note 1	Values for zone_id calculation (Note 2, Note 3)
Centre of zone	35.74478	139.70333	11061850	3957225	Zone_id = 2613 x <sub>1</sub> = 53, y <sub>1</sub> = 40
Note 1: all distances are +/- 1m Note 2: <i>s-ZoneLength</i> is set to 50m in accordance with Table 4.6.6-36, this allows for the accuracy with which a UE can define its position which is assumed to be +/- 15m. Note 3: zone id is calculated according to TS 38.331 [6] clause 5.8.11.					

- Nominal start time:  
17<sup>th</sup> September 2020 23:40:00 (GPS time) (UTC time: 17<sup>th</sup> September 2020 23:39:42).
- Visible satellites to be simulated are given in Table 4.11.2-5 and are above 15 degrees elevation with respect to the UE. These satellites have been selected to give a reasonable HDOP for the duration of the test.

**Table 4.11.2-5: Satellites to be simulated for NR sidelink testing**

GNSS supported by UE	SV IDs of Satellites to be simulated <sup>(1)</sup>
GPS	3, 4, 6, 17, 19, 28
GLONASS	3, 4, 5, 10, 18, 19
Galileo	3, 5, 13, 15, 21, 27
BDS	38, 40, 42, 43, 59, 60 <sup>(2)</sup>
Note 1: Where the UE supports more than one GNSS then all the relevant satellites are simulated. Note 2: For BDS, the satellite types are as follows: GEO: 59, 60, IGSO: 38, 40, MEO: 42, 43.	

- The levels of the simulated satellites are given in Table 4.11.2-6 and shall be generated with an accuracy of +/- 3dB. These conditions are defined for when there is no GNSS assistance data available at the UE and are specified in TS 38.133 [13] clause B.4.

**Table 4.11.2-6: GNSS Reference Signal Power Requirements**

System	Parameters	Unit	Value
	Number of generated satellites per system	-	6
GPS <sup>(1)</sup>	Reference signal power level for all satellites	dBm	-128.5
Galileo	Reference signal power level for all satellites	dBm	-127
GLONASS	Reference signal power level for all satellites	dBm	-131
BDS	Reference signal power level for all satellites	dBm	-133

NOTE 1: "GPS" here means GPS L1 C/A, Modernized GPS, or both, dependent on UE capabilities.  
NOTE 2: The DUT UE does not need to support all systems. The DUT UE shall support at least one system and will be tested for the supported system(s).

- Ionospheric model: simulated values are given in Tables 4.11.2-7 and 4.11.2-8.

**Table 4.11.2-7: Klobuchar ionospheric model for GPS or GLONASS or BDS if supported by the UE**

Model element	Units	Value/remark
alfa0	seconds	4.6566129 10E-9
alfa1	sec/semi-circle	1.4901161 10E-8
alfa2	sec/(semi-circle) <sup>2</sup>	-5.96046 10E-8
alfa3	sec/(semi-circle) <sup>3</sup>	-5.96046 10E-8
beta0	seconds	79872
beta1	sec/semi-circle	65536
beta2	sec/(semi-circle) <sup>2</sup>	-65536
beta3	sec/(semi-circle) <sup>3</sup>	-393216

**Table 4.11.2-8: neQuick ionospheric model for Galileo if supported by the UE**

Model Element	Units	Value/remark
ai0	solar flux unit	64.4
ai1	solar flux unit/degree	0
ai2	solar flux unit/degree <sup>2</sup>	0

- Tropospheric model: STANAG with SRI equal to 324.8, as defined in STANAG 4294 [50].

## 5 Test environments for RF test

### 5.0 General

#### 5.0.1 Single PDU configuration for RF testing

For RF and performance test case execution on 5G SA UE's defined in TS 38.521-1 [14], TS 38.521-2 [15], TS 38.521-4 [17], IMS shall not be considered and UE's shall be able use RRC (IDLE, CONNECTED) preambles defined in TS 38.508-1 clause 4.5. Before entering RRC\_CONNECTED or RRC\_IDLE state during initial conditions or test procedure, it is recommended that UE is pre-configured with 0 or 1 PDU (non-IMS).

For EN-DC settings the corresponding requirement holds that IMS shall not be considered and it is recommended that UE is pre-configured with 0PDU/0PDN or 1PDU/1 PDN.

### 5.1 Requirements of test equipment

#### 5.1.1 Requirements for transmission and reception tests

##### 5.1.1.1 Requirements common for conducted and OTA tests

No common RF test environment requirements are specified in addition to the common requirements described in clause 4.2.

##### 5.1.1.2 Requirements for conducted tests

No common RF test environment requirements are specified in addition to the common requirements described in clause 4.2.

##### 5.1.1.3 Requirements for OTA tests

###### Editor's Note:

- The UE pre-configuration mentioned below to disable UL Tx diversity schemes shall be voided once a test methodology solution to minimize spectral flatness artefacts between TE and UE over all test points is defined.
- The permitted test methods for transmission and reception test are DFF, DFF with simplification for centre of beam measurements, IFF and NFTF and are described in TR 38.810[24]. The minimum requirements for each test setup are described in the following clauses.
- For conformance testing using the OTA test environment, the UE under test shall be pre-configured with UL Tx diversity schemes disabled to account for single polarization System Simulator (SS) in the test environment. The UE under test may transmit with dual polarization.

##### 5.1.1.3.1 DFF and DFF with simplification for centre of beam measurements

- Far-field measurement system in an anechoic chamber.
- The minimum far-field distance R for a traditional far field anechoic chamber can be calculated based on the following equation:  $R > \frac{2D^2}{\lambda}$ , where D is the diameter of the smallest sphere that encloses the radiating parts of the DUT.
- A positioning system such that the angle between the dual-polarized measurement antenna and the DUT has at least two axes of freedom and maintains a polarization reference.



- For DFF(without simplification), a positioning system such that the angle between the link antenna and the DUT has at least two axes of freedom and maintains a polarization reference; this positioning system for the link antenna is in addition to the positioning system for the measurement antenna and provides for an angular relationship independently controllable from the measurement antenna.
- For setups intended for measurements of UE RF characteristics in non-standalone (NSA) mode with 1 UL configuration, an LTE link antenna is used to provide the LTE link to the DUT. The LTE link antenna provides a stable LTE signal without precise path loss or polarization control.
- For setups intended for measurements in NR CA mode with FR1 and FR2 inter-band NR CA, test setup provides NR FR1 link to the DUT. The NR FR1 link has a stable and noise-free signal without precise path loss or polarization control.
- Maximum permitted test system uncertainty is specified in Annex F in 38.521-2[15].

#### 5.1.1.3.2 IFF

- Indirect Far field of Compact Antenna Test Range(CATR) with quiet zone diameter at least D.
- The CATR system does not require a measurement distance of  $R > \frac{2D^2}{\lambda}$  to achieve a plane wave as in a standard far field range.
- A positioning system such that the angle between the dual-polarized measurement antenna and the DUT has at least two axes of freedom and maintains a polarization reference.
- For setups intended for measurements of UE RF characteristics in non-standalone (NSA) mode with 1UL configuration, an LTE link antenna is used to provide the LTE link to the DUT. The LTE link antenna provides a stable LTE signal without precise path loss or polarization control.
- For setups intended for measurements in NR CA mode with FR1 and FR2 inter-band NR CA, test setup provides NR FR1 link to the DUT. The NR FR1 link has a stable and noise-free signal without precise path loss or polarization control.
- Maximum permitted test system uncertainty is specified in Annex F in 38.521-2[15].

#### 5.1.1.3.3 NFTF

- Radiated Near Field UE beam pattern are measured and based on the NFTF mathematical transform, the final metric such as EIRP is the same as the metric for the DFF setup
- A positioning system such as the angle between the dual-polarized measurement/link antenna and the DUT has at least two axes of freedom and maintains a polarization reference
- For setups intended for measurements of UE RF characteristics in non-standalone (NSA) mode with 1UL configuration, an LTE link antenna is used to provide the LTE link to the DUT. The LTE link antenna provides a stable LTE signal without precise path loss or polarization control.
- For setups intended for measurements in NR CA mode with FR1 and FR2 inter-band NR CA, test setup provides NR FR1 link to the DUT. The NR FR1 link has a stable and noise-free signal without precise path loss or polarization control.
- Maximum permitted test system uncertainty is specified in Annex F in 38.521-2[15].

## 5.1.2 Requirements for performance tests

### 5.1.2.1 Void

### 5.1.2.2 Void

### 5.1.2.3 Requirements for OTA test method

**Editor's Note:** This subclause is intended to describe the test equipment requirements which are specific to OTA test environment for performance tests.

- The UE pre-configuration mentioned below to disable UL Tx diversity schemes shall be voided once a test methodology solution to minimize spectral flatness artefacts between TE and UE over all test points is defined.
- For conformance testing using the OTA test environment, the UE under test shall be pre-configured with UL Tx diversity schemes disabled to account for single polarization System Simulator (SS) in the test environment. The UE under test may transmit with dual polarization.

## 5.2 Reference test conditions

### 5.2.1 Signal levels

#### 5.2.1.1 Signal Levels for conducted testing

For NR FR1 cell, the downlink power settings are specified in TS 38.521-1[14] and TS 38.521-3[16].

The uncertainty value is specified in TS 38.521-1 [14] Annex F or in TS 38.521-3 [16] Annex F.

#### 5.2.1.2 Signal Levels for OTA testing

##### 5.2.1.2.1 Downlink Signal Levels

For E-UTRA cell in EN-DC with FR2 NR, the downlink power settings are specified in clause 4.7 of TS 38.521-3[16].

For FR2 NR cell, the downlink power settings are specified in Annex C.0 of TS 38.521-2[15] and Annex C.0 of TS 38.521-3[16].

The uncertainty value is specified in TS 38.521-2 [15] Annex F or in TS 38.521-3 [16] Annex F.

### 5.2.2 Test Frequencies

As defined in clause 4.3.1.1 with the following exceptions for Demodulation test cases

#### 5.2.2.1 NR operating bands in FR1

##### 5.2.2.1.1 Reference test frequencies for NR operating band n1

**Table 5.2.2.1-1: Void**

**Table 5.2.2.1.1-1: Test frequencies for NR operating band n1 and SCS 15 kHz**

CBW [MHz]	carrier Bandwidth	Range	Carrier centre [MHz]	Carrier centre [ARFC]	point A [MHz]	absolute Frequency Point	offset To Carrier	SS block SCS	GS CN	absolute Frequency	$k_{SSB}$	Offset Carrier	CORE SET#0 Index	offset Point A

	<i>dth</i> [PRBs]				N]		<i>tA</i> [ARFCN]	[Carrier PRBs]	[kHz]		SSB [ARFCN]		er COR ESET #0 [RBs] Note 2	(Offset [RBs]) Note 1	(SIB1) [PRBs] Note 1
10	52	Downlink	Mid	2140	428000	2135.32	427064	0	15	5344	427490	10	1	0 (0)	1
		Uplink	Mid	1950	390000	1945.32	389064	0	-	-	-	-	-	-	-

Note 1: The CORESET#0 Index and the associated CORESET#0 Offset refers to Table 13-1 in TS 38.213 [22]. The value of CORESET#0 Index is signalled in controlResourceSetZero (pdcch-ConfigSIB1) in the MIB. The offsetToPointA IE is expressed in units of resource blocks assuming 15 kHz subcarrier spacing for FR1 and 60 kHz subcarrier spacing for FR2.

Note 2: The parameter Offset Carrier CORESET#0 specifies the offset from the lowest subcarrier of the carrier and the lowest subcarrier of CORESET#0. It corresponds to the parameter  $\Delta F_{\text{OffsetCORESET-0-Carrier}}$  in Annex C expressed in number of common RBs.

5.2.2.1.2 Reference test frequencies for NR operating band n2

Table 5.2.2.1.2-1: Test frequencies for NR operating band n2 and SCS 15 kHz

CB W [MHz]	carrierBandwidth [PRBs]	Range		Carrier centre [MHz]	Carrier centre [ARFCN]	point A [MHz]	absoluteFrequencyPointA [ARFCN]	offsetToCarrier [Carrier PRBs]	SS block SCS [kHz]	GSC N	absoluteFrequencySB [ARFCN]	$k_{SSB}$	Offset Carrier CORESET#0 [RBs] Note 2	CORESET#0 Index (Offset [RBs]) Note 1	offsetToPointA (SIB1) [PRBs] Note 1
10	52	Downlink	Mid	1960	392000	1955.32	391064	0	15	4894	391490	10	1	0 (0)	1
		Uplink	Mid	1880	376000	1875.32	375064	0	-	-	-	-	-	-	-

Note 1: The CORESET#0 Index and the associated CORESET#0 Offset refers to Table 13-1 in TS 38.213 [22]. The value of CORESET#0 Index is signalled in controlResourceSetZero (pdcch-ConfigSIB1) in the MIB. The offsetToPointA IE is expressed in units of resource blocks assuming 15 kHz subcarrier spacing for FR1 and 60 kHz subcarrier spacing for FR2.

Note 2: The parameter Offset Carrier CORESET#0 specifies the offset from the lowest subcarrier of the carrier and the lowest subcarrier of CORESET#0. It corresponds to the parameter  $\Delta F_{\text{OffsetCORESET-0-Carrier}}$  in Annex C expressed in number of common RBs.

5.2.2.1.3 Reference test frequencies for NR operating band n3

Table 5.2.2.1.3-1: Test frequencies for NR operating band n3 and SCS 15 kHz

CB W [MHz]	carrierBandwidth [PRBs]	Range		Carrier centre [MHz]	Carrier centre [ARFCN]	point A [MHz]	absoluteFrequencyPointA [ARFCN]	offsetToCarrier [Carrier PRBs]	SS block SCS [kHz]	GSC N	absoluteFrequencySB [ARFCN]	$k_{SSB}$	Offset Carrier CORESET#0 [RBs] Note 2	CORESET#0 Index (Offset [RBs]) Note 1	offsetToPointA (SIB1) [PRBs] Note 1
10	52	Downlink	Mid	1842.5	368500	1837.82	367564	0	15	4598	367930	2	0	0 (0)	0

		Uplink	Mid	1747.5	349500	1742.82	348564	0	-	-	-	-	-	-	
Note 1:	The CORESET#0 Index and the associated CORESET#0 Offset refers to Table 13-1 in TS 38.213 [22]. The value of CORESET#0 Index is signalled in controlResourceSetZero (pdccch-ConfigSIB1) in the MIB. The offsetToPointA IE is expressed in units of resource blocks assuming 15 kHz subcarrier spacing for FR1 and 60 kHz subcarrier spacing for FR2.														
Note 2:	The parameter Offset Carrier CORESET#0 specifies the offset from the lowest subcarrier of the carrier and the lowest subcarrier of CORESET#0. It corresponds to the parameter $\Delta F_{\text{OffsetCORESET-0-Carrier}}$ in Annex C expressed in number of common RBs.														

5.2.2.1.4 FFS

5.2.2.1.5 Reference test frequencies for NR operating band n5

Table 5.2.2.1.5-1: Test frequencies for NR operating band n5 and SCS 15 kHz

CBW [MHz]	carrierBandwidth [PRBs]	Range		Carrier centre [MHz]	Carrier centre [ARFCN]	point A [MHz]	absoluteFrequencyPointA [ARFCN]	offsetToCarrier [Carrier PRBs]	SS block SCS [kHz]	GSCN	absoluteFrequencySB [ARFCN]	$k_{SSB}$	Offset Carrier CORESET#0 [RBs]	CORESET#0 Index (Offset [RBs])	offsetToPointA (SIB1) [PRBs]
10	52	Downlink	Mid	881.5	176300	876.82	175364	0	15	2197	175730	2	0	0 (0)	0
		Uplink	Mid	836.5	167300	831.82	166364	0	-	-	-	-	-	-	-
Note 1:	The CORESET#0 Index and the associated CORESET#0 Offset refers to Table 13-1 in TS 38.213 [22]. The value of CORESET#0 Index is signalled in controlResourceSetZero (pdccch-ConfigSIB1) in the MIB. The offsetToPointA IE is expressed in units of resource blocks assuming 15 kHz subcarrier spacing for FR1 and 60 kHz subcarrier spacing for FR2.														
Note 2:	The parameter Offset Carrier CORESET#0 specifies the offset from the lowest subcarrier of the carrier and the lowest subcarrier of CORESET#0. It corresponds to the parameter $\Delta F_{\text{OffsetCORESET-0-Carrier}}$ in Annex C expressed in number of common RBs.														
Note 3:	This UE channel bandwidth is applicable only to downlink.														

5.2.2.1.6 FFS

5.2.2.1.7 Reference test frequencies for NR operating band n7

Table 5.2.2.1.7-1: Test frequencies for NR operating band n7 and SCS 15 kHz

CBW [MHz]	carrierBandwidth [PRBs]	Range		Carrier centre [MHz]	Carrier centre [ARFCN]	point A [MHz]	absoluteFrequencyPointA [ARFCN]	offsetToCarrier [Carrier PRBs]	SS block SCS [kHz]	GSCN	absoluteFrequencySB [ARFCN]	$k_{SSB}$	Offset Carrier CORESET#0 [RBs]	CORESET#0 Index (Offset [RBs])	offsetToPointA (SIB1) [PRBs]
10	52	Downlink	Mid	2655	531000	2650.32	530064	0	15	6630	530430	2	0	0 (0)	0
		Uplink	Mid	2535	507000	2530.32	506064	0	-	-	-	-	-	-	-
Note 1:	The CORESET#0 Index and the associated CORESET#0 Offset refers to Table 13-1 in TS 38.213 [22]. The value of CORESET#0 Index is controlResourceSetZero (pdccch-ConfigSIB1) in the MIB. The offsetToPointA														

IE is expressed in units of resource blocks assuming 15 kHz subcarrier spacing for FR1 and 60 kHz subcarrier spacing for FR2.  
 Note 2: The parameter Offset Carrier CORESET#0 specifies the offset from the lowest subcarrier of the carrier and the lowest subcarrier of CORESET#0. It corresponds to the parameter  $\Delta F_{\text{OffsetCORESET-0-Carrier}}$  in Annex C expressed in number of common RBs.

5.2.2.1.8 Reference test frequencies for NR operating band n8

**Table 5.2.2.1.8-1: Test frequencies for NR operating band n8 and SCS 15 kHz**

CBW [MHz]	carrierBandwidth [PRBs]	Range		Carrier centre [MHz]	Carrier centre [ARF CN]	point A [MHz]	absoluteFrequencyPointA [ARF CN]	offsetToCarrier [Carrier PRBs]	SS block SCS [kHz]	GSC N	absoluteFrequencySB [ARF CN]	$k_{SSB}$	Offset Carrier CORESET#0 [RBs] Note 2	CORESET#0 Index (Offset [RBs]) Note 1	offsetToPointA (SIB1) [PRBs] Note 1
		Downlink	Uplink												
10	52	Downlink	Mid	942.5	18850	937.8	18756	0	15	2348	18793	2	0	0 (0)	0
		Uplink	Mid	897.5	17950	892.8	17856	0	-	-	-	-	-	-	-

Note 1: The CORESET#0 Index and the associated CORESET#0 Offset refers to Table 13-1 in TS 38.213 [22]. The value of CORESET#0 Index is signalled in controlResourceSetZero (pdccch-ConfigSIB1) in the MIB. The offsetToPointA IE is expressed in units of resource blocks assuming 15 kHz subcarrier spacing for FR1 and 60 kHz subcarrier spacing for FR2.  
 Note 2: The parameter Offset Carrier CORESET#0 specifies the offset from the lowest subcarrier of the carrier and the lowest subcarrier of CORESET#0. It corresponds to the parameter  $\Delta F_{\text{OffsetCORESET-0-Carrier}}$  in Annex C expressed in number of common RBs.

5.2.2.1.9 – 5.2.2.1.11 FFS

5.2.2.1.12 Reference test frequencies for NR operating band n12

**Table 5.2.2.1.12-1: Test frequencies for NR operating band n12 and SCS 15 kHz**

CBW [MHz]	carrierBandwidth [PRBs]	Range		Carrier centre [MHz]	Carrier centre [ARF CN]	point A [MHz]	absoluteFrequencyPointA [ARF CN]	offsetToCarrier [Carrier PRBs]	SS block SCS [kHz]	GSC N	absoluteFrequencySB [ARF CN]	$k_{SSB}$	Offset Carrier CORESET#0 [RBs] Note 2	CORESET#0 Index (Offset [RBs]) Note 1	offsetToPointA (SIB1) [PRBs] Note 1
		Downlink	Uplink												
10	52	Downlink	Mid	737.5	14750	732.8	14656	0	15	1837	14693	2	0	0 (0)	0
		Uplink	Mid	707.5	14150	702.8	14056	0	-	-	-	-	-	-	-

Note 1: The CORESET#0 Index and the associated CORESET#0 Offset refers to Table 13-1 in TS 38.213 [22]. The value of CORESET#0 Index is signalled in controlResourceSetZero (pdccch-ConfigSIB1) in the MIB. The offsetToPointA IE is expressed in units of resource blocks assuming 15 kHz subcarrier spacing for FR1 and 60 kHz subcarrier spacing for FR2.  
 Note 2: The parameter Offset Carrier CORESET#0 specifies the offset from the lowest subcarrier of the carrier and the lowest subcarrier of CORESET#0. It corresponds to the parameter  $\Delta F_{\text{OffsetCORESET-0-Carrier}}$  in Annex C expressed in number of common RBs.

5.2.2.1.13 FFS

5.2.2.1.14 Reference test frequencies for NR operating band n14

**Table 5.2.2.1.14-1: Test frequencies for NR operating band n14 and SCS 15 kHz**

CBW [MHz]	carrierBandwidth [PRBs]	Range		Carrier centre [MHz]	Carrier centre [ARFCN]	point A [MHz]	absoluteFrequencyPointA [ARFCN]	offsetToCarrier [Carrier PRBs]	SS block SCS [kHz]	GSCN	absoluteFrequencySB [ARFCN]	$k_{SSB}$	Offset Carrier CORESET#0 [RBs] Note 2	CORESET#0 Index (Offset [RBs]) Note 1	offsetToPointA (SIB1) [PRBs] Note 1
		Downlink	Uplink												
10	52	Downlink	Mid	763	15260	758.3	15166	0	15	1903	15221	2	1	2 (4)	5
		Uplink	Mid	793	15860	788.3	15766	0	-	-	-	-	-	-	-

Note 1: The CORESET#0 Index and the associated CORESET#0 Offset refers to Table 13-1 in TS 38.213 [22]. The value of CORESET#0 Index is signalled in controlResourceSetZero (pdccchConfigSIB1) in the MIB. The offsetToPointA IE is expressed in units of resource blocks assuming 15 kHz subcarrier spacing for FR1 and 60 kHz subcarrier spacing for FR2.

Note 2: The parameter Offset Carrier CORESET#0 specifies the offset from the lowest subcarrier of the carrier and the lowest subcarrier of CORESET#0. It corresponds to the parameter  $\Delta F_{OffsetCORESET0Carrier}$  in Annex C expressed in number of common RBs.

Note 3: 10 MHz test channel bandwidth is tested with Low range test frequency only. Low range test frequency shall be used instead of Mid range and High range test frequencies.

5.2.2.1.15 – 5.2.2.1.19 FFS

5.2.2.1.20 Reference test frequencies for NR operating band n20

**Table 5.2.2.1.20-1: Test frequencies for NR operating band n20 and SCS 15 kHz**

CBW [MHz]	carrierBandwidth [PRBs]	Range		Carrier centre [MHz]	Carrier centre [ARFCN]	point A [MHz]	absoluteFrequencyPointA [ARFCN]	offsetToCarrier [Carrier PRBs]	SS block SCS [kHz]	GSCN	absoluteFrequencySB [ARFCN]	$k_{SSB}$	Offset Carrier CORESET#0 [RBs] Note 2	CORESET#0 Index (Offset [RBs]) Note 1	offsetToPointA (SIB1) [PRBs] Note 1
		Downlink	Uplink												
10	52	Downlink	Mid	806	16120	801.3	16026	0	15	2009	16081	2	1	2 (4)	5
		Uplink	Mid	847	16940	842.3	16846	0	-	-	-	-	-	-	-

Note 1: The CORESET#0 Index and the associated CORESET#0 Offset refers to Table 13-1 in TS 38.213 [22]. The value of CORESET#0 Index is signalled in controlResourceSetZero (pdccch-ConfigSIB1) in the MIB. The offsetToPointA IE is expressed in units of resource blocks assuming 15 kHz subcarrier spacing for FR1 and 60 kHz subcarrier spacing for FR2.

Note 2: The parameter Offset Carrier CORESET#0 specifies the offset from the lowest subcarrier of the carrier and the lowest subcarrier of CORESET#0. It corresponds to the parameter  $\Delta F_{OffsetCORESET0Carrier}$  in Annex C expressed in number of common RBs.

5.2.2.1.21 – 5.2.2.1.23 FFS

5.2.2.1.24 Reference test frequencies for NR operating band n24

**Table 5.2.2.1.24-1: Test frequencies for NR operating band n24 and SCS 15 kHz**

UL/DL CBW [MHz]	carrier Bandwidth [PRBs]	Range		Carrier centre [MHz] Note 3	Carrier centre [ARF CN]	point A [MHz]	absolute Frequency Point A [ARF CN]	offset To Carrier [Carrier PRBs]	SS block SCS [kHz]	GSC N	absolute Frequency SB [ARF CN]	$k_{SSB}$	Offset Carrier CORESET#0 [RBs] Note 2	CORESET#0 Index (Offset [RBs]) Note 1	offsetToPointA (SIB1) [PRBs] Note 1
		Downlink	Mid												
10/10	52	Downlink	Mid	1531.0	30620	1526.32	305264	0	15	3823	305810	2	1	2 (4)	5
		Uplink	Mid	1632.5	32650	1627.82	325564	0	-	-	-	-	-	-	-

Note 1: The CORESET#0 Index and the associated CORESET#0 Offset refers to Table 13-1 in TS 38.213 [22]. The value of CORESET#0 Index is signalled in controlResourceSetZero (pdccch-ConfigSIB1) in the MIB. The offsetToPointA IE is expressed in units of resource blocks assuming 15 kHz subcarrier spacing for FR1 and 60 kHz subcarrier spacing for FR2.

Note 2: The parameter Offset Carrier CORESET#0 specifies the offset from the lowest subcarrier of the carrier and the lowest subcarrier of CORESET#0. It corresponds to the parameter  $\Delta F_{OffsetCORESET-0-Carrier}$  in Annex C expressed in number of common RBs.

Note 3: For symmetric CBW combinations, Low and Mid test frequencies are specified using Tx-Rx spacing of -101.5 MHz and High test frequency is specified using Tx-Rx spacing of -120.5 MHz

Note 4: For asymmetric CBW combination UL=10MHz and DL=5MHz, Low and Mid test frequencies are specified using Tx-Rx spacing of -104 MHz and High test frequency is specified using Tx-Rx spacing of -118 MHz.

5.2.2.1.25 Reference test frequencies for NR operating band n25

**Table 5.2.2.1.25-1: Test frequencies for NR operating band n25 and SCS 15 kHz**

CBW [MHz]	carrier Bandwidth [PRBs]	Range		Carrier centre [MHz]	Carrier centre [ARF CN]	point A [MHz]	absolute Frequency Point A [ARF CN]	offset To Carrier [Carrier PRBs]	SS block SCS [kHz]	GSC N	absolute Frequency SB [ARF CN]	$k_{SSB}$	Offset Carrier CORESET#0 [RBs] Note 2	CORESET#0 Index (Offset [RBs]) Note 1	offsetToPointA (SIB1) [PRBs] Note 1
		Downlink	Mid												
10	52	Downlink	Mid	1962.5	39250	1957.82	391564	0	15	4898	391930	2	0	0 (0)	0
		Uplink	Mid	1882.5	37650	1877.82	375564	0	-	-	-	-	-	-	-

Note 1: The CORESET#0 Index and the associated CORESET#0 Offset refers to Table 13-1 in TS 38.213 [22]. The value of CORESET#0 Index is signalled in controlResourceSetZero (pdccch-ConfigSIB1) in the MIB. The offsetToPointA IE is expressed in units of resource blocks assuming 15 kHz subcarrier spacing for FR1 and 60 kHz subcarrier spacing for FR2.

Note 2: The parameter Offset Carrier CORESET#0 specifies the offset from the lowest subcarrier of the carrier and the lowest subcarrier of CORESET#0. It corresponds to the parameter  $\Delta F_{OffsetCORESET-0-Carrier}$  in Annex C expressed in number of common RBs.

5.2.2.1.26 Reference test frequencies for NR operating band n26

**Table 5.2.2.1.26-1: Test frequencies for NR operating band n26 and SCS 15 kHz**

CBW [MHz]	carrierBandwidth [PRBs]	Range		Carrier centre [MHz]	Carrier centre [ARFCN]	point A [MHz]	absoluteFrequencyPointA [ARFCN]	offsetToCarrier [Carrier PRBs]	SS block SCS [kHz]	GSCN	absoluteFrequencySB [ARFCN]	$k_{SSB}$	Offset carrier CORESET#0 [RBs] Note 2	CORESET#0 Index (Offset [RBs] Note 1)	offsetToPointA (SIB1) [PRBs] Note 1
		Downlink	Uplink												
10	52	Downlink	Mid	876.5	175300	871.82	174364	0	15	2183	174730	2	0	0 (0)	0
		Uplink	Mid	831.5	166300	826.82	165364	0	-	-	-	-	-	-	-

Note 1: The CORESET#0 Index and the associated CORESET#0 Offset refers to Table 13-1 in TS 38.213 [22]. The value of CORESET#0 Index is signalled in controlResourceSetZero (pdccch-ConfigSIB1) in the MIB. The offsetToPointA IE is expressed in units of resource blocks assuming 15 kHz subcarrier spacing for FR1 and 60 kHz subcarrier spacing for FR2.

Note 2: The parameter Offset Carrier CORESET#0 specifies the offset from the lowest subcarrier of the carrier and the lowest subcarrier of CORESET#0. It corresponds to the parameter  $\Delta F_{OffsetCORESET-0-Carrier}$  in Annex C expressed in number of common RBs.

5.2.2.1.27 FFS

5.2.2.1.28 Reference test frequencies for NR operating band n28

**Table 5.2.2.1.28-1: Test frequencies for NR operating band n28 and SCS 15 kHz**

CBW [MHz]	carrierBandwidth [PRBs]	Range		Carrier centre [MHz]	Carrier centre [ARFCN]	point A [MHz]	absoluteFrequencyPointA [ARFCN]	offsetToCarrier [Carrier PRBs]	SS block SCS [kHz]	GSCN	absoluteFrequencySB [ARFCN]	$k_{SSB}$	Offset Carrier CORESET#0 [RBs] Note 3	CORESET#0 Index (Offset [RBs] Note 1)	offsetToPointA (SIB1) [PRBs] Note 1
		Downlink	Uplink												
10	52	Downlink	Mid	780.5	156100	775.82	155164	0	15	1943	155530	2	0	0 (0)	0
		Uplink	Mid	725.5	145100	720.82	144164	0	-	-	-	-	-	-	-

Note 1: The CORESET#0 Index and the associated CORESET#0 Offset refers to Table 13-1 in TS 38.213 [22]. The value of CORESET#0 Index is signalled in controlResourceSetZero (pdccch-ConfigSIB1) in the MIB. The offsetToPointA IE is expressed in units of resource blocks assuming 15 kHz subcarrier spacing for FR1 and 60 kHz subcarrier spacing for FR2.

Note 2: Carrier centre frequency moved for Mid Range and CBW=20 MHz due to Note 7 in TS 38.101-1 [7], Table 5.3.5-1.

Note 3: The parameter Offset Carrier CORESET#0 specifies the offset from the lowest subcarrier of the carrier and the lowest subcarrier of CORESET#0. It corresponds to the parameter  $\Delta F_{OffsetCORESET-0-Carrier}$  in Annex C expressed in number of common RBs.

Note 4: No carrier centre frequency specified for Mid Range and CBW=30 MHz due to Note 7 in TS 38.101-1 [7], Table 5.3.5-1. For test cases specifying Mid range and CBW=30 MHz to be tested, use Low range and CBW=30 MHz instead.



5.2.2.1.29 FFS

5.2.2.1.30 Reference test frequencies for NR operating band n30

**Table 5.2.2.1.30-1: Test frequencies for NR operating band n30 and SCS 15 kHz**

CBW [MHz]	carrierBandwidth [PRBs]	Range		Carrier centre [MHz]	Carrier centre [ARFCN]	point A [MHz]	absoluteFrequencyPointA [ARFCN]	offsetToCarrier [Carrier PRBs]	SS block SCS [kHz]	GSCN	absoluteFrequencySB [ARFCN]	$k_{SSB}$	Offset Carrier CORESET#0 [RBs] Note 2	CORESET#0 Index (Offset [RBs]) Note 1	offsetToPointA (SIB1) [PRBs] Note 1
		Downlink	Uplink												
10	52	Downlink	Mid	2355	47100	2350.32	470064	0	15	5880	470430	2	0	0 (0)	0
		Uplink	Mid	2310	46200	2396.04	479208	0	-	-	-	-	-	-	-

Note 1: The CORESET#0 Index and the associated CORESET#0 Offset refers to Table 13-1 in TS 38.213 [22]. The value of CORESET#0 Index is signalled in controlResourceSetZero (pdccch-ConfigSIB1) in the MIB. The offsetToPointA IE is expressed in units of resource blocks assuming 15 kHz subcarrier spacing for FR1 and 60 kHz subcarrier spacing for FR2.

Note 2: The parameter Offset Carrier CORESET#0 specifies the offset from the lowest subcarrier of the carrier and the lowest subcarrier of CORESET#0. It corresponds to the parameter  $\Delta F_{OffsetCORESET-0-Carrier}$  in Annex C expressed in number of common RBs.

5.2.2.1.31 – 5.2.2.1.37 FFS

5.2.2.1.38 Reference test frequencies for NR operating band n38

**Table 5.2.2.1.38-1: Test frequencies for NR operating band n38 and SCS 15 kHz**

FFS

**Table 5.2.2.1.38-2: Test frequencies for NR operating band n38 and SCS 30 kHz**

CBW [MHz]	carrierBandwidth [PRBs]	Range		Carrier centre [MHz]	Carrier centre [ARFCN]	point A [MHz]	absoluteFrequencyPointA [ARFCN]	offsetToCarrier [Carrier PRBs]	SS block SCS [kHz]	GSCN	absoluteFrequencySB [ARFCN]	$k_{SSB}$	Offset Carrier CORESET#0 [RBs] Note 2	CORESET#0 Index (Offset [RBs]) Note 1	offsetToPointA (SIB1) [PRBs] Note 1
		Downlink & Uplink	Mid												
40	106	Downlink & Uplink	Mid	2595	51900	2575.92	515184	0	30	6450	516030	18	0	1 (1)	2

Note 1: The CORESET#0 Index and the associated CORESET#0 Offset refers to Table 13-4 in TS 38.213 [22]. The value of CORESET#0 Index is signalled in controlResourceSetZero (pdccch-ConfigSIB1) in the MIB. The offsetToPointA IE is expressed in units of resource blocks assuming 15 kHz subcarrier spacing for FR1 and 60 kHz subcarrier spacing for FR2.

Note 2: The parameter Offset Carrier CORESET#0 specifies the offset from the lowest subcarrier of the carrier and the lowest subcarrier of CORESET#0. It corresponds to the parameter  $\Delta F_{OffsetCORESET-0-Carrier}$  in Annex C expressed in number of common RBs.

5.2.2.1.39 Reference test frequencies for NR operating band n39

**Table 5.2.2.1.39-1: Test frequencies for NR operating band n39 and SCS 15 kHz**

FFS

**Table 5.2.2.1.39-2: Test frequencies for NR operating band n39 and SCS 30 kHz**

CBW [MHz]	carrierBandwidth [PRBs]	Range		Carrier centre [MHz]	Carrier centre [ARFCN]	point A [MHz]	absoluteFrequencyPointA [ARFCN]	offsetToCarrier [Carrier PRBs]	SS block SCS [kHz]	GSCN	absoluteFrequencySB [ARFCN]	$k_{SSB}$	Offset Carrier CORESET#0 [RBs]	CORESET#0 Index (Offset [RBs])	offsetToPointA (SIB1) [PRBs]
40	106	Downlink & Uplink	Mid	1900	38000	1880.92	376184	0	30	4714	377090	14	0	2 (2)	4

Note 1: The CORESET#0 Index and the associated CORESET#0 Offset refers to Table 13-2 in TS 38.213 [22]. The value of CORESET#0 Index is signalled in controlResourceSetZero (pdcch-ConfigSIB1) in the MIB. The offsetToPointA IE is expressed in units of resource blocks assuming 15 kHz subcarrier spacing for FR1 and 60 kHz subcarrier spacing for FR2.

Note 2: The parameter Offset Carrier CORESET#0 specifies the offset from the lowest subcarrier of the carrier and the lowest subcarrier of CORESET#0. It corresponds to the parameter  $\Delta F_{OffsetCORESET-0-Carrier}$  in Annex C expressed in number of common RBs.

5.2.2.1.40 Reference test frequencies for NR operating band n40

**Table 5.2.2.1.40-1: Test frequencies for NR operating band n40 and SCS 15 kHz**

FFS

**Table 5.2.2.1.40-2: Test frequencies for NR operating band n40 and SCS 30 kHz**

CBW [MHz]	carrierBandwidth [PRBs]	Range		Carrier centre [MHz]	Carrier centre [ARFCN]	point A [MHz]	absoluteFrequencyPointA [ARFCN]	offsetToCarrier [Carrier PRBs]	SS block SCS [kHz]	GSCN	absoluteFrequencySB [ARFCN]	$k_{SSB}$	Offset Carrier CORESET#0 [RBs]	CORESET#0 Index (Offset [RBs])	offsetToPointA (SIB1) [PRBs]
40	106	Downlink & Uplink	Mid	2350	47000	2330.92	466184	0	30	5839	467090	14	0	2 (2)	4

Note 1: The CORESET#0 Index and the associated CORESET#0 Offset refers to Table 13-2 in TS 38.213 [22]. The value of CORESET#0 Index is signalled in controlResourceSetZero (pdcch-ConfigSIB1) in the MIB. The

offsetToPointA IE is expressed in units of resource blocks assuming 15 kHz subcarrier spacing for FR1 and 60 kHz subcarrier spacing for FR2.  
 Note 2: The parameter Offset Carrier CORESET#0 specifies the offset from the lowest subcarrier of the carrier and the lowest subcarrier of CORESET#0. It corresponds to the parameter  $\Delta F_{\text{OffsetCORESET-0-Carrier}}$  in Annex C expressed in number of common RBs.

5.2.2.1.41 Reference test frequencies for NR operating band n41

**Table 5.2.2.1.41-1: Test frequencies for NR operating band n41, SCS 15 kHz and  $\Delta F_{\text{Raster}}$  15 kHz**

FFS

**Table 5.2.2.1.41-2: Test frequencies for NR operating band n41, SCS 30 kHz and  $\Delta F_{\text{Raster}}$  30 kHz**

CBW [MHz]	carrierBandwidth [PRBs]	Range		Carrier centre [MHz]	Carrier centre [ARFCN]	point A [MHz]	absoluteFrequencyPointA [ARFCN]	offsetToCarrier [Carrier PRBs]	SS block SCS [kHz]	GSCN	absoluteFrequencySB [ARFCN]	$k_{\text{SSB}}$	Offset Carrier CORESET#0 [RBs]	CORESET#0 Index (Offset [RBs])	offsetToPointA (SIB1) [RBs]
40	106	Downlink & Uplink	Mid	2592.99	518598	2573.91	514782	0	30	6444	515550	16	0	0 (0)	0

Note 1: The CORESET#0 Index and the associated CORESET#0 Offset refers to Table 13-4 in TS 38.213 [22]. The value of CORESET#0 Index is signalled in controlResourceSetZero (pdcch-ConfigSIB1) in the MIB. The offsetToPointA IE is expressed in units of resource blocks assuming 15 kHz subcarrier spacing for FR1 and 60 kHz subcarrier spacing for FR2.  
 Note 2: The parameter Offset Carrier CORESET#0 specifies the offset from the lowest subcarrier of the carrier and the lowest subcarrier of CORESET#0. It corresponds to the parameter  $\Delta F_{\text{OffsetCORESET-0-Carrier}}$  in Annex C expressed in number of common RBs.

5.2.2.1.42 – 5.2.2.1.47 FFS

5.2.2.1.48 Reference test frequencies for NR operating band n48

**Table 5.2.2.1.48-1: Test frequencies for NR operating band n48 and SCS 15 kHz**

FFS

**Table 5.2.2.1.48-2: Test frequencies for NR operating band n48 and SCS 30 kHz**

CBW [MHz]	carrierBandwidth [PRBs]	Range		Carrier centre [MHz]	Carrier centre [ARFCN]	point A [MHz]	absoluteFrequencyPointA [ARFCN]	offsetToCarrier [Carrier PRBs]	SS block SCS [kHz]	GSCN	absoluteFrequencySB [ARFCN]	$k_{\text{SSB}}$	Offset Carrier CORESET#0 [RBs]	CORESET#0 Index (Offset [RBs])	offsetToPointA (SIB1) [RBs]
-----------	-------------------------	-------	--	----------------------	------------------------	---------------	---------------------------------	--------------------------------	--------------------	------	-----------------------------	------------------	--------------------------------	--------------------------------	-----------------------------

													Note 2	Note 1	
40	106	Downlink & Uplink	Mid	3624.99	641666	3605.91	640394	0	30	7923	640704	22	0	2 (2)	4
<p>Note 1: The CORESET#0 Index and the associated CORESET#0 Offset refers to Table 13-4 in TS 38.213 [22]. The value of CORESET#0 Index is signalled in controlResourceSetZero (pdcc-ConfigSIB1) in the MIB. The offsetToPointA IE is expressed in units of resource blocks assuming 15 kHz subcarrier spacing for FR1 and 60 kHz subcarrier spacing for FR2.</p> <p>Note 2: The parameter Offset Carrier CORESET#0 specifies the offset from the lowest subcarrier of the carrier and the lowest subcarrier of CORESET#0. It corresponds to the parameter <math>\Delta F_{\text{OffsetCORESET-0-Carrier}}</math> in Annex C expressed in number of common RBs.</p> <p>Note 3: For this bandwidth, the minimum requirements are restricted to operation when carrier is configured as a downlink only SCell part of a CA configuration. As the bandwidth is limited to SCell then absence of CORESET#0 is indicated in the MIB by setting <math>k_{\text{SSB}}=31</math>, <i>controlResourceSetZero=0</i> and <i>searchSpaceZero = 0</i> (TS 38.213 [22], clause 13).</p>															

5.2.2.1.49 FFS

5.2.2.1.50 Reference test frequencies for NR operating band n50

**Table 5.2.2.1.50-1: Test frequencies for NR operating band n50 and SCS 15 kHz**

FFS

**Table 5.2.2.1.50-2: Test frequencies for NR operating band n50 and SCS 30 kHz**

CBW [MHz]	carrierBandwidth [PRBs]	Range		Carrier centre [MHz]	Carrier centre [ARFCN]	point A [MHz]	absoluteFrequencyPointA [ARFCN]	offsetToCarrier [Carrier PRBs]	SS block SCS [kHz]	GSCN	absoluteFrequencySB [ARFCN]	$k_{\text{SSE}}$	Offset Carrier CORESET#0 [RBs]	CORESET#0 Index (Offset [RBs])	offsetToPointA (SIB1) [PRBs]
40	106	Downlink & Uplink	Mid	1474.5	294900	1455.42	291084	0	30	3648	291870	22	0	0 (0)	0
<p>Note 1: The CORESET#0 Index and the associated CORESET#0 Offset refers to Table 13-2 in TS 38.213 [22]. The value of CORESET#0 Index is signalled in controlResourceSetZero (pdcc-ConfigSIB1) in the MIB. The offsetToPointA IE is expressed in units of resource blocks assuming 15 kHz subcarrier spacing for FR1 and 60 kHz subcarrier spacing for FR2.</p> <p>Note 2: The parameter Offset Carrier CORESET#0 specifies the offset from the lowest subcarrier of the carrier and the lowest subcarrier of CORESET#0. It corresponds to the parameter <math>\Delta F_{\text{OffsetCORESET-0-Carrier}}</math> in Annex C expressed in number of common RBs.</p> <p>Note 3: This UE channel bandwidth is applicable only to downlink (TS 38.101-1 table 5.3.5-1).</p>															

5.2.2.1.51 – 5.2.2.1.64 FFS

5.2.2.1.65 Reference test frequencies for NR operating band n65

**Table 5.2.2.1.65-1: Test frequencies for NR operating band n65 and SCS 15 kHz**

CBW [MHz]	carrierBandwidth [PRBs]	Range		Carrier centre [MHz]	Carrier centre [ARFCN]	point A [MHz]	absoluteFrequencyPointA [ARFCN]	offsetToCarrier [Carrier PRBs]	SS block SCS [kHz]	GSCN	absoluteFrequencySB [ARFCN]	$k_{SSB}$	Offset Carrier CORESET#0 [RBs] Note 2	CORESET#0 Index (Offset [RBs]) Note 1	offsetToPointA (SIB1) [PRBs] Note 1
10	52	Downlink	Mid	2155	43100	2150.32	430064	0	15	5383	430610	2	1	2 (4)	5
		Uplink	Mid	1965	39300	1960.32	392064	0	-	-	-	-	-	-	-

Note 1: The CORESET#0 Index and the associated CORESET#0 Offset refers to Table 13-1 in TS 38.213 [22]. The value of CORESET#0 Index is signalled in controlResourceSetZero (pdcc-ConfigSIB1) in the MIB. The offsetToPointA IE is expressed in units of resource blocks assuming 15 kHz subcarrier spacing for FR1 and 60 kHz subcarrier spacing for FR2.

Note 2: The parameter Offset Carrier CORESET#0 specifies the offset from the lowest subcarrier of the carrier and the lowest subcarrier of CORESET#0. It corresponds to the parameter  $\Delta F_{OffsetCORESET-0-Carrier}$  in Annex C expressed in number of common RBs.

5.2.2.1.66 Reference test frequencies for NR operating band n66

**Table 5.2.2.1.66-1: Test frequencies for NR operating band n66, uplink and downlink channel bandwidth combinations and SCS 15 kHz**

UL/DL CBW Combination (Asymmetric BC S) Note 3	CBW [MHz]	carrierBandwidth [PRBs]	Range		Carrier centre [MHz]	Carrier centre [ARFCN]	point A [MHz]	absoluteFrequencyPointA [ARFCN]	offsetToCarrier [Carrier PRBs]	SS block SCS [kHz]	GSCN	absoluteFrequencySB [ARFCN]	$k_{SSB}$	Offset Carrier CORESET#0 [RBs] Note 2	CORESET#0 Index (Offset [RBs]) Note 1	offsetToPointA (SIB1) [PRBs] Note 1
10/10	10	52	Downlink	Mid	2145	42900	2140.32	428064	0	15	5355	428430	2	0	0 (0)	0
	10	52	Uplink	Mid	1745	34900	1740.32	348064	0	-	-	-	-	-	-	-

Note 1: The CORESET#0 Index and the associated CORESET#0 Offset refers to Table 13-1 in TS 38.213 [22]. The value of CORESET#0 Index is signalled in controlResourceSetZero (pdcc-ConfigSIB1) in the MIB. The offsetToPointA IE is expressed in units of resource blocks assuming 15 kHz subcarrier spacing for FR1 and 60 kHz subcarrier spacing for FR2.

Note 2: The parameter Offset Carrier CORESET#0 specifies the offset from the lowest subcarrier of the carrier and the lowest subcarrier of CORESET#0. It corresponds to the parameter  $\Delta F_{OffsetCORESET-0-Carrier}$  in Annex C expressed in number of common RBs.

Note 3 Asymmetric CBW BCS refers to applicable asymmetric UL and DL channel bandwidth combination set as specified in TS 38.101-1 [7], Table 5.3.6-1 for NR band n66.

5.2.2.1.67 – 5.2.2.1.69 FFS

5.2.2.1.70 Reference test frequencies for NR operating band n70

**Table 5.2.2.1.70-1: Test frequencies for NR operating band n70, default Tx-RX frequency separation 300MHz, uplink and downlink channel bandwidth combinations and SCS 15 kHz**

UL/DL Bandwidth combination	CBW [MHz]	carrier Bandwidth [PRBs]	Range		Carrier centre [MHz]	Carrier centre [ARFCN]	point A [MHz]	absoluteFrequencyPointA [ARFCN]	offsetToCarrier [Carrier PRBs]	SS block SCS [kHz]	GSCN	absoluteFrequencySB [ARFCN]	$k_{SSB}$	Offset Carrier CORESET#0 [RBs] Note 2	CORESET#0 Index (Offset [RBs]) Note 1	offsetToPointA (SIB1) [PRBs] Note 1
			Downlink	Uplink												
10/10	10	52	Downlink	Mid	2002.5	400500	1997.82	399564	0	15	5001	400110	2	1	2 (4)	5
	10	52	Uplink	Mid	1702.5	340500	1697.82	339564	0	-	-	-	-	-	-	-

Note 1: The CORESET#0 Index and the associated CORESET#0 Offset refers to Table 13-1 in TS 38.213 [22]. The value of CORESET#0 Index is signalled in controlResourceSetZero (pdccch-ConfigSIB1) in the MIB. The offsetToPointA IE is expressed in units of resource blocks assuming 15 kHz subcarrier spacing for FR1 and 60 kHz subcarrier spacing for FR2.

Note 2: The parameter Offset Carrier CORESET#0 specifies the offset from the lowest subcarrier of the carrier and the lowest subcarrier of CORESET#0. It corresponds to the parameter  $\Delta F_{OffsetCORESET-0-Carrier}$  in Annex C expressed in number of common RBs.

5.2.2.1.71 Reference test frequencies for NR operating band n71

**Table 5.2.2.1.71-1: Test frequencies for NR operating band n71 and SCS 15 kHz**

CBW [MHz]	carrier Bandwidth [PRBs]	Range		Carrier centre [MHz]	Carrier centre [ARFCN]	point A [MHz]	absoluteFrequencyPointA [ARFCN]	offsetToCarrier [Carrier PRBs]	SS block SCS [kHz]	GSCN	absoluteFrequencySB [ARFCN]	$k_{SSB}$	Offset Carrier CORESET#0 [RBs] Note 2	CORESET#0 Index (Offset [RBs]) Note 1	offsetToPointA (SIB1) [PRBs] Note 1
		Downlink	Uplink												
10	52	Downlink	Mid	634.5	12690	629.82	125964	0	15	1581	126510	2	1	2 (4)	5
		Uplink	Mid	680.5	13610	675.82	135164	0	-	-	-	-	-	-	-

Note 1: The CORESET#0 Index and the associated CORESET#0 Offset refers to Table 13-1 in TS 38.213 [22]. The value of CORESET#0 Index is signalled in controlResourceSetZero (pdccch-ConfigSIB1) in the MIB. The offsetToPointA IE is expressed in units of resource blocks assuming 15 kHz subcarrier spacing for FR1 and 60 kHz subcarrier spacing for FR2.

Note 2: The parameter Offset Carrier CORESET#0 specifies the offset from the lowest subcarrier of the carrier and the lowest subcarrier of CORESET#0. It corresponds to the parameter  $\Delta F_{OffsetCORESET-0-Carrier}$  in Annex C expressed in number of common RBs.

5.2.2.1.72 – 5.2.2.1.73 FFS

5.2.2.1.74 Reference test frequencies for NR operating band n74

**Table 5.2.2.1.74-1: Test frequencies for NR operating band n74 and SCS 15 kHz**

CBW [MHz]	carrierBandwidth [PRBs]	Range		Carrier centre [MHz]	Carrier centre [ARFCN]	point A [MHz]	absoluteFrequencyPointA [ARFCN]	offsetToCarrier [Carrier PRBs]	SS block SCS [kHz]	GSCN	absoluteFrequencySB [ARFCN]	$k_{SSE}$	Offset Carrier CORESET#0 [RBs]	CORESET#0 Index (Offset [RBs])	offsetToPointA (SIB1) [PRBs]
		Downlink	Uplink												
10	52	Downlink	Mid	1496.5	29930	1491.82	298364	0	15	3736	298850	6	1	1 (2)	3
		Uplink	Mid	1448.5	28970	1443.82	288764	0	-	-	-	-	-	-	-

Note 1: The CORESET#0 Index and the associated CORESET#0 Offset refers to Table 13-1 in TS 38.213 [22]. The value of CORESET#0 Index is signalled in controlResourceSetZero (pdcch-ConfigSIB1) in the MIB. The offsetToPointA IE is expressed in units of resource blocks assuming 15 kHz subcarrier spacing for FR1 and 60 kHz subcarrier spacing for FR2.

Note 2: The parameter Offset Carrier CORESET#0 specifies the offset from the lowest subcarrier of the carrier and the lowest subcarrier of CORESET#0. It corresponds to the parameter  $\Delta F_{OffsetCORESET-0-Carrier}$  in Annex C expressed in number of common RBs.

5.2.2.1.75 – 5.2.2.1.76 FFS

5.2.2.1.77 Reference test frequencies for NR operating band n77

**Table 5.2.2.1.77-1: Test frequencies for NR operating band n77, SCS 15 kHz and  $\Delta FRaster$  15 kHz**

FFS

**Table 5.2.2.1.77-2: Test frequencies for NR operating band n77, SCS 30 kHz and  $\Delta FRaster$  30 kHz**

CBW [MHz]	carrierBandwidth [PRBs]	Range		Carrier centre [MHz]	Carrier centre [ARFCN]	point A [MHz]	absoluteFrequencyPointA [ARFCN]	offsetToCarrier [Carrier PRBs]	SS block SCS [kHz]	GSCN	absoluteFrequencySB [ARFCN]	$k_{SSB}$	Offset Carrier CORESET#0 [RBs]	CORESET#0 Index (Offset [RBs])	offsetToPointA (SIB1) [PRBs]
		Downlink & Uplink	Mid												
40	106	Downlink & Uplink	Mid	3750	65000	3730.92	648728	0	30	8010	649056	16	0	3 (3)	6

Note 1: The CORESET#0 Index and the associated CORESET#0 Offset refers to Table 13-4 in TS 38.213 [22]. The value of CORESET#0 Index is signalled in controlResourceSetZero (pdcch-ConfigSIB1) in the MIB. The offsetToPointA IE is expressed in units of resource blocks assuming 15 kHz subcarrier spacing for FR1 and 60 kHz subcarrier spacing for FR2.

Note 2: The parameter Offset Carrier CORESET#0 specifies the offset from the lowest subcarrier of the carrier and the lowest subcarrier of CORESET#0. It corresponds to the parameter  $\Delta F_{\text{OffsetCORESET-0-Carrier}}$  in Annex C expressed in number of common RBs.

5.2.2.1.78 Reference test frequencies for NR operating band n78

Table 5.2.2.1.78-1: Test frequencies for NR operating band n78, SCS 15 kHz and  $\Delta F_{\text{Raster}}$  15 kHz

FFS

Table 5.2.2.1.78-2: Test frequencies for NR operating band n78, SCS 30 kHz and  $\Delta F_{\text{Raster}}$  30 kHz

CBW [MHz]	carrierBandwidth [PRBs]	Range		Carrier centre [MHz]	Carrier centre [ARFCN]	point A [MHz]	absoluteFrequencyPointA [ARFCN]	offsetToCarrier [Carrier PRBs]	SS block SCS [kHz]	GSCN	absoluteFrequencySB [ARFCN]	$k_{\text{SSB}}$	Offset Carrier CORESET#0 [RBs] Note 2	CORESET#0 Index (Offset [RBs]) Note 1	offsetToPointA (SIB1) [PRBs] Note 1
40	106	Downlink & Uplink	Mid	3549.99	636666	3530.91	635394	0	30	7871	635712	6	0	3 (3)	6

Note 1: The CORESET#0 Index and the associated CORESET#0 Offset refers to Table 13-4 in TS 38.213 [22]. The value of CORESET#0 Index is signalled in controlResourceSetZero (pdcch-ConfigSIB1) in the MIB. The offsetToPointA IE is expressed in units of resource blocks assuming 15 kHz subcarrier spacing for FR1 and 60 kHz subcarrier spacing for FR2.

Note 2: The parameter Offset Carrier CORESET#0 specifies the offset from the lowest subcarrier of the carrier and the lowest subcarrier of CORESET#0. It corresponds to the parameter  $\Delta F_{\text{OffsetCORESET-0-Carrier}}$  in Annex C expressed in number of common RBs.

5.2.2.1.79 Reference test frequencies for NR operating band n79

Table 5.2.2.1.79-1: Test frequencies for NR operating band n79, SCS 15 kHz and  $\Delta F_{\text{Raster}}$  15 kHz

FFS

Table 5.2.2.1.79-2: Test frequencies for NR operating band n79, SCS 30 kHz and  $\Delta F_{\text{Raster}}$  30 kHz

CBW [MHz]	carrierBandwidth [PRBs]	Range		Carrier centre [MHz]	Carrier centre [ARFCN]	point A [MHz]	absoluteFrequencyPointA [ARFCN]	offsetToCarrier [Carrier PRBs]	SS block SCS [kHz]	GSCN	absoluteFrequencySB [ARFCN]	$k_{\text{SSB}}$	Offset Carrier CORESET#0 [RBs] Note 2	CORESET#0 Index (Offset [RBs]) Note 1	offsetToPointA (SIB1) [PRBs] Note 1
40	106	Downlink & Uplink	Mid	4700.01	713334	4680.93	712062	0	30	8672	712608	18	8	1 (4)	24



Note 1: The CORESET#0 Index and the associated CORESET#0 Offset refers to Table 13-6 in TS 38.213 [22]. The value of CORESET#0 Index is signalled in controlResourceSetZero (pdcch-ConfigSIB1) in the MIB. The offsetToPointA IE is expressed in units of resource blocks assuming 15 kHz subcarrier spacing for FR1 and 60 kHz subcarrier spacing for FR2.

Note 2: The parameter Offset Carrier CORESET#0 specifies the offset from the lowest subcarrier of the carrier and the lowest subcarrier of CORESET#0. It corresponds to the parameter  $\Delta F_{\text{OffsetCORESET-0-Carrier}}$  in Annex C expressed in number of common RBs.

5.2.2.2 NR operating bands in FR2

5.2.2.2.1 Reference test frequencies for NR operating band n257

Table 5.2.2.2.1-1: Test frequencies for NR operating band n257, SCS 60 kHz and  $\Delta F_{\text{Raster}}$  60 kHz

FFS

Table 5.2.2.2.1-2: Test frequencies for NR operating band n257, SCS 120 kHz and  $\Delta F_{\text{Raster}}$  120 kHz

CB W [MHz]	carrierBandwidth [PRBs]	Range		Carrier centre [MHz]	Carrier centre [ARFCN]	point A [MHz]	absoluteFrequencyPointA [ARFCN]	offsetToCarrier [Carrier PRBs]	SS block SCS [kHz]	GSC N	absoluteFrequencySB [ARFCN]	$k_{\text{SSB}}$	Offset Carrier CORESET#0 [RBs]	CORESET#0 Index (Offset [RBs])	offsetToPointA (SIB1) [PRBs]
100	66	Downlink & Uplink	Mid	27999.96	2079165	27952.44	2078373	0	120	22472	2078875	11	6	1 (4)	20

Note 1: The CORESET#0 Index and the associated CORESET#0 Offset refers to Table 13-8 in TS 38.213 [22]. The value of CORESET#0 Index is signalled in controlResourceSetZero (pdcch-ConfigSIB1) in the MIB. The offsetToPointA IE is expressed in units of resource blocks assuming 15 kHz subcarrier spacing for FR1 and 60 kHz subcarrier spacing for FR2.

Note 2: The parameter Offset Carrier CORESET#0 specifies the offset from the lowest subcarrier of the carrier and the lowest subcarrier of CORESET#0. It corresponds to the parameter  $\Delta F_{\text{OffsetCORESET-0-Carrier}}$  in Annex C expressed in number of common RBs.

5.2.2.2.2 Reference test frequencies for NR operating band n258

Table 5.2.2.2.2-1: Test frequencies for NR operating band n258, SCS 60 kHz and  $\Delta F_{\text{Raster}}$  60 kHz

FFS

Table 5.2.2.2.2-2: Test frequencies for NR operating band n258, SCS 120 kHz and  $\Delta F_{\text{Raster}}$  120 kHz

CB W [MHz]	carrierBandwidth [PRBs]	Range		Carrier centre [MHz]	Carrier centre [ARFCN]	point A [MHz]	absoluteFrequencyPointA [ARFCN]	offsetToCarrier [Carrier PRBs]	SS block SCS [kHz]	GSC N	absoluteFrequencySB [ARFCN]	$k_{\text{SSB}}$	Offset Carrier CORESET#0 [RBs]	CORESET#0 Index (Offset [RBs])	offsetToPointA (SIB1) [PRBs]
------------	-------------------------	-------	--	----------------------	------------------------	---------------	---------------------------------	--------------------------------	--------------------	-------	-----------------------------	------------------	--------------------------------	--------------------------------	------------------------------

													Note 2	Note 1	
100	66	Downlink & Uplink	Mid	25875	20437 49	25827 .48	20429 57	0	120	2234 9	20434 51	7	6	1 (4)	20
<p>Note 1: The CORESET#0 Index and the associated CORESET#0 Offset refers to Table 13-8 in TS 38.213 [22]. The value of CORESET#0 Index is signalled in controlResourceSetZero (pdcch-ConfigSIB1) in the MIB. The offsetToPointA IE is expressed in units of resource blocks assuming 15 kHz subcarrier spacing for FR1 and 60 kHz subcarrier spacing for FR2.</p> <p>Note 2: The parameter Offset Carrier CORESET#0 specifies the offset from the lowest subcarrier of the carrier and the lowest subcarrier of CORESET#0. It corresponds to the parameter <math>\Delta F_{\text{OffsetCORESET-0-Carrier}}</math> in Annex C expressed in number of common RBs.</p>															

5.2.2.2.3 Reference test frequencies for NR operating band n259

Table 5.2.2.2.3-1: Test frequencies for NR operating band n260, SCS 60 kHz and  $\Delta F_{\text{Raster}}$  60 kHz

FFS

Table 5.2.2.2.3-2: Test frequencies for NR operating band n260, SCS 120 kHz and  $\Delta F_{\text{Raster}}$  120 kHz

CBW [MHz]	carrierBandwidth [PRBs]	Range		Carrier centre [MHz]	Carrier centre [ARFCN]	point A [MHz]	absoluteFrequencyPointA [ARFCN]	offsetToCarrier [Carrier PRBs]	SS block SCS [kHz]	GSC N	absoluteFrequencySB [ARFCN]	$k_{\text{SSB}}$	Offset Carrier CORESET#0 [RBs]	CORESET#0 Index (Offset [RBs])	offsetToPointA (SIB1) [PRBs]
100	66	Downlink & Uplink	Mid	41499 .96	23041 65	41452 .44	23033 73	102	120	2325 3	23038 03	11	3	1 (4)	14
<p>Note 1: The CORESET#0 Index and the associated CORESET#0 Offset refers to Table 13-8 in TS 38.213 [22]. The value of CORESET#0 Index is signalled in controlResourceSetZero (pdcch-ConfigSIB1) in the MIB. The offsetToPointA IE is expressed in units of resource blocks assuming 15 kHz subcarrier spacing for FR1 and 60 kHz subcarrier spacing for FR2.</p> <p>Note 2: The parameter Offset Carrier CORESET#0 specifies the offset from the lowest subcarrier of the carrier and the lowest subcarrier of CORESET#0. It corresponds to the parameter <math>\Delta F_{\text{OffsetCORESET-0-Carrier}}</math> in Annex C expressed in number of common RBs.</p>															

5.2.2.2.4 Reference test frequencies for NR operating band n260

Table 5.2.2.2.4-1: Test frequencies for NR operating band n260, SCS 60 kHz and  $\Delta F_{\text{Raster}}$  60 kHz

FFS

Table 5.2.2.2.4-2: Test frequencies for NR operating band n260, SCS 120 kHz and  $\Delta F_{\text{Raster}}$  120 kHz

CBW [MHz]	carrierBandwidth [PRBs]	Range		Carrier centre [MHz]	Carrier centre [ARFCN]	point A [MHz]	absoluteFrequencyPointA [ARFCN]	offsetToCarrier [Carrier PRBs]	SS block SCS [kHz]	GSC N	absoluteFrequencySB [ARFCN]	$k_{\text{SSB}}$	Offset Carrier CORESET#0 [RBs]	CORESET#0 Index (Offset)	offsetToPointA (SIB1) [PRBs]
-----------	-------------------------	-------	--	----------------------	------------------------	---------------	---------------------------------	--------------------------------	--------------------	-------	-----------------------------	------------------	--------------------------------	--------------------------	------------------------------

													[RBs ] Note 2	[RBs ] Note 1	Note 1
100	66	Downlink & Uplink	Mid	38499.96	2254165	38452.44	2253373	0	120	23079	2253691	3	3	0 (0)	6
<p>Note 1: The CORESET#0 Index and the associated CORESET#0 Offset refers to Table 13-8 in TS 38.213 [22]. The value of CORESET#0 Index is signalled in controlResourceSetZero (pdccch-ConfigSIB1) in the MIB. The offsetToPointA IE is expressed in units of resource blocks assuming 15 kHz subcarrier spacing for FR1 and 60 kHz subcarrier spacing for FR2.</p> <p>Note 2: The parameter Offset Carrier CORESET#0 specifies the offset from the lowest subcarrier of the carrier and the lowest subcarrier of CORESET#0. It corresponds to the parameter <math>\Delta F_{\text{OffsetCORESET-0-Carrier}}</math> in Annex C expressed in number of common RBs.</p>															

5.2.2.2.5 Reference test frequencies for NR operating band n261

Table 5.2.2.2.5-1: Test frequencies for NR operating band n261, SCS 60 kHz and  $\Delta F_{\text{Raster}}$  60 kHz

FFS

Table 5.2.2.2.5-2: Test frequencies for NR operating band n261, SCS 120 kHz and  $\Delta F_{\text{Raster}}$  120 kHz

CBW [MHz]	carrierBandwidth [PRBs]	Range		Carrier centre [MHz]	Carrier centre [ARFCN]	point A [MHz]	absoluteFrequencyPointA [ARFCN]	offsetToCarrier [Carrier PRBs]	SS block SCS [kHz]	GSCN	absoluteFrequencySB [ARFCN]	$k_{\text{SSB}}$	Offset Carrier CORESET#0 [RBs ] Note 2	CORESET#0 Index (Offset [RBs ]) Note 1	offsetToPointA (SIB1) [PRBs] Note 1
100	66	Downlink & Uplink	Mid	27924.96	2077915	27877.44	2077123	0	120	22467	2077435	0	3	0 (0)	6
<p>Note 1: The CORESET#0 Index and the associated CORESET#0 Offset refers to Table 13-8 in TS 38.213 [22]. The value of CORESET#0 Index is signalled in controlResourceSetZero (pdccch-ConfigSIB1) in the MIB. The offsetToPointA IE is expressed in units of resource blocks assuming 15 kHz subcarrier spacing for FR1 and 60 kHz subcarrier spacing for FR2.</p> <p>Note 2: The parameter Offset Carrier CORESET#0 specifies the offset from the lowest subcarrier of the carrier and the lowest subcarrier of CORESET#0. It corresponds to the parameter <math>\Delta F_{\text{OffsetCORESET-0-Carrier}}</math> in Annex C expressed in number of common RBs.</p>															

5.3 Void

Editor's Note: Reserved for future use.

5.4 Default NG-RAN RRC message and information elements contents

5.4.1 Radio resource control information elements

As defined in clause 4.6.3 with the following exceptions:

For Tx test cases in which Power Class 3 UEs verifying Power Class 3 requirements, refer to Table 5.4.1-1; For Tx test cases in which Power Class 2 UEs verifying Power Class 2 requirements, refer to Table 5.4.1-2; For Tx test cases in which Power Class 1.5 UEs verifying Power Class 1.5 requirements, refer to Table 5.4.1-2A.

**Table 5.4.1-1: P-Max-PC3**

Derivation Path: Table 4.6.3-89			
Information Element	Value/remark	Comment	Condition
P-Max	Not present		SA
	23		EN-DC

**Table 5.4.1-2: P-Max-PC2**

Derivation Path: Table 4.6.3-89			
Information Element	Value/remark	Comment	Condition
P-Max	Not present		SA
	26		EN-DC

Condition	Explanation
SA	NR standalone RF tests cases
EN-DC	EN-DC RF tests cases specified in 38.521-3

**Table 5.4.1-2A: P-Max-PC1.5**

Derivation Path: Table 4.6.3-89			
Information Element	Value/remark	Comment	Condition
P-Max	Not present		SA

**Table 5.4.1-3: Void****Table 5.4.1-4: PUSCH-Config**

Derivation Path: Clause 4.6.3 Table 4.6.3-118			
Information Element	Value/remark	Comment	Condition
PUSCH-Config ::= SEQUENCE {			
maxRank	2		2TX_UL_MIMO
	1		ULFPTx_Mode1 or ULFPTx_Mode2 or ULFPTx_ModeFull
ul-FullPowerTransmission-r16	Not present		2TX_UL_MIMO
	fullpowerMode1		ULFPTx_Mode1
	fullpowerMode2		ULFPTx_Mode2
	fullpower		ULFPTx_ModeFull
}			

Condition	Explanation
2TX_UL_MIMO	UL-MIMO test cases with 2 Tx antenna ports
ULFPTx_Mode1	UL-MIMO test cases with UEs supporting UL full power transmission Mode-1
ULFPTx_Mode2	UL-MIMO test cases with UEs supporting UL full power transmission Mode-2
ULFPTx_ModeFull	UL-MIMO test cases with UEs supporting UL full power transmission Mode-full power

CSI-RS for Tracking

**Table 5.4.1-5: CSI-RS-ResourceMapping for TRS**

Derivation Path: Table 4.6.3-45			
Information Element	Value/remark	Comment	Condition
CSI-RS-ResourceMapping ::= SEQUENCE { frequencyDomainAllocation CHOICE {			
row1	0001		TRS
}			
firstOFDMSymbolInTimeDomain	6	l <sub>0</sub> = 6 for CSI-RS resource 1 and 3	TRS AND FR1
	10	l <sub>0</sub> = 10 for CSI-RS resource 2 and 4	TRS AND FR1
	8	l <sub>0</sub> = 8 for CSI-RS resource 1	TRS AND FR2
	12	l <sub>0</sub> = 12 for CSI-RS resource 2	TRS AND FR2
nrofPorts	p1		TRS
Cdm-Type	noCDM		TRS
Density CHOICE{			
three	Null		TRS
}			
freqBand	CSI-FrequencyOccupation for TRS		TRS
}			

Condition	Explanation
TRS	Tracking-Reference Signal

**Table 5.4.1-6: CSI-ResourcePeriodicityAndOffset for TRS**

Derivation Path: Table 4.6.3-43			
Information Element	Value/remark	Comment	Condition
CSI-ResourcePeriodicityAndOffset ::= CHOICE {			
slots20	0	SCS 15kHz, CSI-RS resource 1 and 2	TRS AND FR1_15kHz
	1	SCS 15kHz, CSI-RS resource 3 and 4	TRS AND FR1_15kHz
Slots40	1	SCS 30kHz, CSI-RS resource 1 and 2	TRS AND FR1_30kHz
	2	SCS 30kHz, CSI-RS resource 3 and 4	TRS AND FR1_30kHz
Slots80	2	SCS 60kHz, FR1, CSI-RS resource 1 and 2	TRS AND FR1_60kHz
	3	SCS 60kHz, FR1, CSI-RS resource 3 and 4	TRS AND FR1_60kHz
	40	SCS 60kHz, FR2, CSI-RS resource 1 and 2	TRS AND FR2_60kHz
Slots160	80	SCS 120kHz, CSI-RS resource 1 and 2	TRS AND FR2_120kHz
}			

Condition	Explanation
FR1_15kHz	FR1 is used under the test. SCS is set to 15kHz.
FR1_30kHz	FR1 is used under the test. SCS is set to 30kHz.
FR1_60kHz	FR1 is used under the test. SCS is set to 60kHz.
FR2_60kHz	FR2 is used under the test. SCS is set to 60kHz.
FR2_120kHz	FR2 is used under the test. SCS is set to 120kHz.
TRS	Tracking-Reference Signal

Table 5.4.1-7: CSI-MeasConfig for TRS

Derivation Path: TS 38.508-1 Table 4.6.3-38			
Information Element	Value/remark	Comment	Condition
CSI-MeasConfig ::= SEQUENCE {			
nzp-CSI-RS-ResourceToAddModList SEQUENCE (SIZE (1..maxNrofNZP-CSI-RS-Resources)) OF NZP-CSI-RS-Resource {	2 entries in case of FR2 4 entries in case of FR1	2 entries in case of FR2 4 entries in case of FR1	
NZP-CSI-RS-Resource[1]	NZP-CSI-RS-Resource for TRS (1)	entry 1 CSI-RS resource 1	
NZP-CSI-RS-Resource[2]	NZP-CSI-RS-Resource for TRS (2)	entry 2 CSI-RS resource 2	
NZP-CSI-RS-Resource[3]	NZP-CSI-RS-Resource for TRS (3)	entry 3 CSI-RS resource 3	FR1
NZP-CSI-RS-Resource[4]	NZP-CSI-RS-Resource for TRS (4)	entry 4 CSI-RS resource 4	FR1
}			
nzp-CSI-RS-ResourceSetToAddModList SEQUENCE (SIZE (1..maxNrofNZP-CSI-RS-ResourceSets)) OF NZP-CSI-RS-ResourceSet {	1 entry		
NZP-CSI-RS-ResourceSet[1]	NZP-CSI-RS-ResourceSet for TRS	entry 1	
}			
csi-IM-ResourceToAddModList	Not present		
csi-IM-ResourceSetToAddModList	Not present		
csi-SSB-ResourceSetToAddModList	Not present		
csi-ResourceConfigToAddModList SEQUENCE (SIZE (1..maxNrofCSI-ResourceConfigurations)) OF CSI-ResourceConfig {	1 entry		
CSI-ResourceConfig[1]	CSI-ResourceConfig for TRS	entry 1	
}			
reportTriggerSize	Not present		
aperiodicTriggerStateList SetupRelease	Not present		
}			

Table 5.4.1-8: NZP-CSI-RS-Resource for TRS

Derivation Path: 38.508-1 Table 4.6.3-85			
Information Element	Value/remark	Comment	Condition
NZP-CSI-RS-Resource ::= SEQUENCE {			
NZP-CSI-RS-ResourceId	0 1 2 3	CSI-RS resource 1 CSI-RS resource 2 CSI-RS resource 3 CSI-RS resource 4	
CSI-RS-ResourceMapping	CSI-RS-ResourceMapping for TRS		Content conditioned by the CSI-RS resource #
powerControlOffset	0		
powerControlOffsetSS	db0		
scramblingID	ScramblingId		
periodicityAndOffset	CSI-ResourcePeriodicityAndOffset for TRS		Content conditioned by the CSI-RS resource #
qcl-InfoPeriodicCSI-RS	TCI-StateId		
}			

Table 5.4.1-9: NZP-CSI-RS-ResourceSet for TRS

Derivation Path: Table 4.6.3-87			
Information Element	Value/remark	Comment	Condition
NZP-CSI-RS-ResourceSet ::= SEQUENCE {			
nzp_CSI_ResourceSetId	0		
nzp-CSI-RS-Resources SEQUENCE (SIZE (1..maxNrofNZP-CSI-RS-ResourcesPerSet)) OF NZP-CSI-RS-ResourceId {	2 entries in case of FR2 4 entries in case of FR1		
NZP-CSI-RS-ResourceId[1]	0	entry 1 CSI-RS resource 1	
NZP-CSI-RS-ResourceId[2]	1	entry 2 CSI-RS resource 2	
NZP-CSI-RS-ResourceId[3]	2	entry 3 CSI-RS resource 3	FR1
NZP-CSI-RS-ResourceId[4]	3	entry 4 CSI-RS resource 4	FR1
}			
repetition	off		
aperiodicTriggeringOffset	Not present		
trs_Info	true		
}			

Table 5.4.1-10: CSI-ResourceConfig for TRS

Derivation Path: TS 38.508-1 Table 4.6.3-41			
Information Element	Value/remark	Comment	Condition
CSI-ResourceConfig ::= SEQUENCE {			
csi-ResourceConfigId	CSI-ResourceConfigId		
csi-RS-ResourceSetList CHOICE {			
nzp-CSI-RS-SSB SEQUENCE {			
nzp-CSI-RS-ResourceSetList SEQUENCE (SIZE (1..maxNrofNZP-CSI-RS-ResourceSetsPerConfig)) OF NZP-CSI-RS-ResourceSetId {	1 entry		
NZP-CSI-RS-ResourceSetId[1]	0	entry 1	
}			
csi-SSB-ResourceSetList	Not present		
}			
}			
bwp-Id	BWP-Id		
resourceType	periodic		
}			

Table 5.4.1-11: CSI-FrequencyOccupation for TRS

Derivation Path: TS 38.508-1 Table 4.6.3-33			
Information Element	Value/remark	Comment	Condition
CSI-FrequencyOccupation ::= SEQUENCE {			
startingRB	0		
nrofRBs	$\max(4 \cdot \text{ceil}(m/4), 24)$	m is the bandwidth of active BWP	
}			

Table 5.4.1-12: ServingCellConfig

Derivation Path: Table 4.6.3-167			
Information Element	Value/remark	Comment	Condition
ServingCellConfig ::= SEQUENCE {			
csi-MeasConfig CHOICE {			
setup	csi-MeasConfig for TRS		TRS
}			

## PDCCH Configuration

## PDCCH-config

Table 5.4.1-16: PDCCH ControlResourceSet

Derivation Path: Table 4.6.3-28			
Information Element	Value/remark	Comment	Condition
frequencyDomainResources	11111111 00000000 00000000 00000000 00000000 000000	CORESET to use the least significant 48 RBs of the BWP	RFACS AND AL8
	11111111 11111111 00000000 00000000 00000000 000000	CORESET to use the least significant 96 RBs of the BWP	RFACS AND AL16

Condition	Explanation
RFACS	Used in RF Adjacent Channel Selectivity testing
AL8	PDCCH aggregationLevel 8 is configured
AL16	PDCCH aggregationLevel 16 is configured

Table 5.4.1-17: PDCCH Search Space

Derivation Path: Table 4.6.3-162			
Information Element	Value/remark	Comment	Condition
nrofCandidates SEQUENCE {			
aggregationLevel1	n2		RFACS
aggregationLevel8	n2		RFACS
aggregationLevel16	n2		RFACS
}			
}			

Condition	Explanation
RFACS	Used in RF Adjacent Channel Selectivity testing

## PDSCH-ServingCellConfig

Table 5.4.1-18: PDSCH-ServingCellConfig

Derivation Path: Table 4.6.3-102			
Information Element	Value/remark	Comment	Condition
PDSCH-ServingCellConfig ::= SEQUENCE {			
nrofHARQ-ProcessesForPDSCH	Set according to definition in 38.521-1 [14], Table A.3.1-3		FR1 AND CA
}			

## PUCCH-Config

Table 5.4.1-19: PUCCH-Config

Derivation Path: Table 4.6.3-112			
Information Element	Value/remark	Comment	Condition
PUCCH-Config ::= SEQUENCE {			
di-DataToUL-ACK SEQUENCE (SIZE (1..8)) OF INTEGER {	8 entries		FR1 AND CA
INTEGER[1]	2	entry 1	
INTEGER[2]	3	entry 2	



INTEGER[3]	4	entry 3	
INTEGER[4]	5	entry 4	
INTEGER[5]	6	entry 5	
INTEGER[6]	7	entry 6	
INTEGER[7]	8	entry 7	
INTEGER[8]	10	entry 8	
}			
}			

### 5.4.2 Radio resource control information elements for Demodulation Performance and CSI reporting tests

As defined in clause 4.6.3 with the following exceptions: -

**Table 5.4.2-1 to 5.4.2.20: Void**

#### 5.4.2.0 Parameters common to all Demod and CSI tests

Physical layer parameters

**Table 5.4.2.0-1: Physical layer parameters for DCI format 1\_1 and DCI format 1\_0**

Derivation Path: Table 4.3.6.1.2.2-1			
Parameter	Value	Value in binary	Condition
PUCCH resource indicator	<i>PUCCH-ResourceId</i> [1] = 0 in <i>pucch-ResourceSetID</i> [1] or <i>PUCCH-ResourceId</i> [1] = 8 in <i>pucch-ResourceSetID</i> [2] as defined in Table 4.6.3-112 (Mapping as per Table 9.2.3-2 in TS 38.213)	'000'B	FR1
	<i>PUCCH-ResourceId</i> [5] = 12 in <i>pucch-ResourceSetID</i> [2] as defined in Table 4.6.3-112 (Mapping as per Table 9.2.3-2 in TS 38.213)	'100'B	FR2_SCS60kHz
	<i>PUCCH-ResourceId</i> [7] = 14 in <i>pucch-ResourceSetID</i> [2] as defined in Table 4.6.3-112 (Mapping as per Table 9.2.3-2 in TS 38.213)	'110'B	FR2_SCS120kHz
PDSCH-to-HARQ feedback timing indicator	$K_1$ slots as defined in 9.2.3 in TS 38.213. $K_1$ value used for the test is specified in the test description of each test case in TS 38.521-4.		

Common Serving Parameters

ServingCellConfigCommon

**Table 5.4.2.0-2: ServingCellConfigCommon**

Derivation Path: Table 4.6.3-168			
Information Element	Value/remark	Comment	Condition
ServingCellConfigCommon ::= SEQUENCE {			
physCellId	PhysCellId		
downlinkConfigCommon	DownlinkConfigCommon		
ssb-PositionsInBurst CHOICE {			
shortBitmap	1000		FR1 AND SSB#0 AND (2.4GHz<FREQ<=3GHz AND

			(FDD OR (TDD AND SCS15)) OR FREQ<=2.4GHz)
mediumBitmap	10000000		FR1 AND SSB#0 AND (2.4GHz<FREQ<=3GHz AND (TDD AND SCS30) OR FREQ>3GHz)
}			
ssb-periodicityServingCell	ms20		
dmrs-TypeA-Position	pos2		
subcarrierSpacing	SubcarrierSpacing according to test case id		
tdd-UL-DL-ConfigurationCommon	TDD-UL-DL-ConfigCommon Not present		FR1.30-1A FR2.120-1A FR1.FDD
ss-PBCH-BlockPower	0		
}			

Condition	Explanation
FREQ<=2.4GHz	Frequency range <= 2.4GHz
2.4GHz<FREQ<=3GHz	Frequency range > 2.4GHz and <= 3GHz
FREQ>3GHz	Frequency range > 3GHz
FR1.30-1A	TDD UL-DL pattern FR1.30-1A is used. Ref Annex A.1.2 of TS 38.521-4
FR2.120-1A	TDD UL-DL pattern FR2.120-1A is used. Ref Annex A.1.3 of TS 38.521-4
SSB#N	Cell configured with SSB-Index set to N as defined in Table 4.4.2-2

TDD-UL-DL-Config

Table 5.4.2.0-3: TDD-UL-DL-Config

Derivation Path: Table 4.6.3-192			
Information Element	Value/remark	Comment	Condition
TDD-UL-DL-ConfigCommon ::= SEQUENCE {			
referenceSubcarrierSpacing	SubcarrierSpacing		
pattern1 SEQUENCE {			
dl-UL-TransmissionPeriodicity	ms5		FR1.15-1, FR1.30-1
	ms2p5		FR1.30-2, FR1.30-3
	ms3		FR1.30-4
	ms2		FR1.30-5
	ms1		FR1.30-6
			FR2.60-1
	ms0p625		FR2.120.1
	ms0p5		FR2.120.2
nrofDownlinkSlots	7		FR1.30-1
	3		FR1.15-1 FR1.30-2 FR1.30-3 FR1.30-4 FR2.120.1
	1		FR1.30-5

			FR1.30-6
	2		FR2.60-1 FR2.120.2
nrofDownlinkSymbols	6		FR1.30-1 FR1.30-4
	10		FR1.15-1 FR1.30-2 FR1.30-3 FR1.30-6 FR2.120.1
	12		FR1.30-5
	11		FR2.60-1 FR2.120.2
nrofUplinkSlots	2		FR1.30-1  FR1.30-4 FR1.30-5
	1		FR1.15-1 FR1.30-2 FR1.30-3 FR2.60-1 FR2.120.1 FR2.120.2
	0		FR1.30-6
nrofUplinkSymbols	4		FR1.30-1  FR1.30-4 FR1.30-5
	0		FR1.30-6 FR2.60-1 FR2.120.2
	2		FR1.15-1 FR1.30-2 FR1.30-3 FR2.60-1 FR2.120.1 FR2.120.2
}			
pattern2	Not present		FR1.15-1, FR1.30-1 FR1.30-2 FR1.30-5 FR2.60-1 FR2.120.1 FR2.120.2
pattern2 SEQUENCE {			
dl-UL-TransmissionPeriodicity	ms2p5		FR1.30-3
	ms2		FR1.30-4
	ms1		FR1.30-6
nrofDownlinkSlots	2		FR1.30-3
	4		FR1.30-4
	0		FR1.30-6
nrofDownlinkSymbols	10		FR1.30-3
	0		FR1.30-4
	12		FR1.30-6
nrofUplinkSlots	2		FR1.30-3
	0		FR1.30-4
	1		FR1.30-6
nrofUplinkSymbols	2		FR1.30-3
	0		FR1.30-4 FR1.30-6
}			
}			

Condition	Explanation
FR1.15-1	TDD UL-DL pattern FR1.15-1 is used. Ref Annex A.1.2 of TS 38.521-4
FR1.30-1	TDD UL-DL pattern FR1.30-1 is used. Ref Annex A.1.2 of TS 38.521-4
FR1.30-2	TDD UL-DL pattern FR1.30-2 is used. Ref Annex A.1.2 of TS 38.521-4
FR1.30-3	TDD UL-DL pattern FR1.30-3 is used. Ref Annex A.1.2 of TS 38.521-4
FR1.30-4	TDD UL-DL pattern FR1.30-4 is used. Ref Annex A.1.2 of TS 38.521-4
FR1.30-5	TDD UL-DL pattern FR1.30-5 is used. Ref Annex A.1.2 of TS 38.521-4
FR1.30-6	TDD UL-DL pattern FR1.30-6 is used. Ref Annex A.1.2 of TS 38.521-4
FR2.60-1	TDD UL-DL pattern FR2.60-1 is used. Ref Annex A.1.3 of TS 38.521-4
FR2.120-1	TDD UL-DL pattern FR2.120-1 is used. Ref Annex A.1.3 of TS 38.521-4
FR2.120-2	TDD UL-DL pattern FR2.120-2 is used. Ref Annex A.1.3 of TS 38.521-4

PDCCH Configuration

PDCCH-ConfigCommon

**Table 5.4.2.0-4: PDCCH-ConfigCommon**

Derivation Path: Table 4.6.3-96

Information Element	Value/remark	Comment	Condition
PDCCH-ConfigCommon ::= SEQUENCE {			
searchSpaceZero	4		FDD FR1.30-1 FR1.30-2 FR1.30-3 FR1.30-4
	2		FR1.30-5 FR1.30-6
commonSearchSpaceList SEQUENCE (SIZE (1..4))	1 entry	1 search space for both SA and NSA	
OF SearchSpace {			
SearchSpace [1]	SearchSpace with condition CSS	entry 1	
}			
searchSpaceOtherSystemInformation	Not present		
}			

Condition	Explanation
CSS	Common SearchSpace

ServingCellConfig

**Table 5.4.2.0-5: ServingCellConfig**

Derivation Path: Table 4.6.3-167

Information Element	Value/remark	Comment	Condition
ServingCellConfig ::= SEQUENCE {			
csi-MeasConfig CHOICE {			
setup	csi-MeasConfig		
}			

PDCCH-config

**Table 5.4.2.0-6: PDCCH-ControlResourceSet**

Derivation Path: Table 4.6.3-28

Information Element	Value/remark	Comment	Condition
---------------------	--------------	---------	-----------

ControlResourceSet ::= SEQUENCE {			
controlResourceSetId	ControlResourceSetId		
frequencyDomainResources	Table 5.2-2 for tested channel bandwidth and subcarrier spacing		FR1
frequencyDomainResources	Table 7.2-2 for tested channel bandwidth and subcarrier spacing		FR2
Duration	2	SearchSpace duration of 2 symbols	DEMOD_FR 1, CSI_FR1, CSI_FR2
	1	SearchSpace duration of 1 symbols	DEMOD_FR 2, PDCCH_FR1, PDCCH_FR2
cce-REG-MappingType CHOICE {			
nonInterleaved	Null		
}			
precoderGranularity	sameAsREG-bundle		
tcI-StatesPDCCH-ToAddList SEQUENCE(SIZE (1..maxNrofTCI-StatesPDCCH)) OF TCI-StateId {	1 entry		
TCI-StateId[1]	0	entry 1 TCI State #0	
	1	TCI State #1	
}			
}			

Condition	Explanation
DEMOD_FR1	DEMOD testing in FR1.
DEMOD_FR2	DEMOD testing in FR2.
PDCCH_FR1	PDCCH testing in FR1
PDCCH_FR2	PDCCH testing in FR2
CSI_FR1	CSI testing in FR1
CSI_FR2	CSI testing in FR2

**Table 5.4.2.0-7: PDCCH Search Space**

Derivation Path: Table 4.6.3-162			
Information Element	Value/remark	Comment	Condition
SearchSpace ::= SEQUENCE {			
monitoringSlotPeriodicityAndOffset CHOICE {			
sl1	NULL		
}			
monitoringSymbolsWithinSlot	10000000000000	Starting symbol 0	
nrofCandidates SEQUENCE {			
aggregationLevel1	n0		
aggregationLevel2	n0		
aggregationLevel4	n0		
aggregationLevel8	n1	AL8	
aggregationLevel16	n0		
}			
searchSpaceType CHOICE {			
common SEQUENCE {			
ue-Specific SEQUENCE {			
dci-Formats	formats0-1-And-1-1	DCI Format 1_1	
}			
}			
}			

**Table 5.4.2.0-7a: PDCCH Search Space Ext**

Derivation Path: TS 38.331 [6], clause 6.3.2
--

Information Element	Value/remark	Comment	Condition
SearchSpaceExt-r16 ::= SEQUENCE {			
controlResourceSetId-r16	ControlResourceSetId		
searchSpaceType-r16	Not present		
searchSpaceGroupIdList-r16	Not present		
freqMonitorLocations-r16	Not present		
}			

NZP-CSI-RS for Tracking

NZP-CSI-RS-Resource

**Table 5.4.2.0-8: NZP-CSI-RS-Resource for TRS**

Derivation Path: Table 4.6.3-85

Information Element	Value/remark	Comment	Condition
NZP-CSI-RS-Resource ::= SEQUENCE {			
nzp-CSI-RS-ResourceId	0	CSI-RS resource 1	
	1	CSI-RS resource 2	
	2	CSI-RS resource 3	
	3	CSI-RS resource 4	
resourceMapping	CSI-RS-ResourceMapping for TRS		
powerControlOffset	0		
periodicityAndOffset	CSI-ResourcePeriodicityAndOffset for TRS		
qcl-InfoPeriodicCSI-RS	TCI-StateId 0		
}			

CSI-RS-ResourceMapping

**Table 5.4.2.0-9: CSI-RS-ResourceMapping for TRS**

Derivation Path: Table 4.6.3-45

Information Element	Value/remark	Comment	Condition
CSI-RS-ResourceMapping ::= SEQUENCE {			
frequencyDomainAllocation CHOICE {			
row1	0001	$k_0=0$ for CSI-RS resource 1,2,3,4	TRS
}			
firstOFDMSymbolInTimeDomain	6	$l_0 = 6$ for CSI-RS resource 1 and 3	TRS
	10	$l_0 = 10$ for CSI-RS resource 2 and 4	TRS
nrofPorts	p1	1 for CSI-RS resource 1,2,3,4	TRS
Cdm-Type	noCDM		TRS
Density CHOICE{			
three	Null		TRS
}			
freqBand	CSI-FrequencyOccupation		TRS
}			

CSI-ResourcePeriodicityAndOffset

**Table 5.4.2.0-10: CSI-ResourcePeriodicityAndOffset for TRS**

Derivation Path: Table 4.6.3-43

Information Element	Value/remark	Comment	Condition

CSI-ResourcePeriodicityAndOffset ::= CHOICE {			
slots20	10	Periodicity 20 slots and offset 10 for CSI-RS resource 1 and 2	SCS 15KHz
slots20	11	Periodicity 20 slots and offset 11 for CSI-RS resource 3 and 4	SCS 15 kHz
Slots40	20	Periodicity 40 slots and offset 20 for CSI-RS resource 1 and 2	SCS 30 kHz
Slots40	21	Periodicity 40 slots and offset 21 for CSI-RS resource 3 and 4	SCS 30 kHz
Slots80	40	Periodicity 80 slots and offset 40 for CSI-RS resource 1 and 2	SCS 60 kHz
Slots80	41	Periodicity 80 slots and offset 41 for CSI-RS resource 3 and 4	SCS 60 kHz
Slots160	80	Periodicity 160 slots and offset 80 for CSI-RS resource 1 and 2	SCS 120 kHz
Slots160	81	Periodicity 160 slots and offset 81 for CSI-RS resource 3 and 4	SCS 120 kHz
}			

## CSI-FrequencyOccupation

Table 5.4.2.0-11: CSI-FrequencyOccupation for TRS

Derivation Path: Table 4.6.3-33			
Information Element	Value/remark	Comment	Condition
CSI-FrequencyOccupation ::= SEQUENCE {			
nrofRBs	52	BW 10 MHz SCS 15kHz	TRS
	52	BW 20 MHz SCS 30kHz	TRS
	108	BW 40 MHz SCS 30kHz	TRS
	68	BW 100 MHz SCS 120 kHz	TRS
	132	BW 200 MHz SCS 120 kHz	TRS
}			

## Nzp-CSI-RS-ResourceSet

Table 5.4.2.0-12: Nzp-CSI-RS-ResourceSet for TRS

Derivation Path: Table 4.6.3-87			
Information Element	Value/remark	Comment	Condition
Nzp-CSI-RS-ResourceSet ::= SEQUENCE {			
nzp_CSI_ResourceSetId	0		
nzp-CSI-RS-Resources SEQUENCE (SIZE (1..maxNrofNzp-CSI-RS-ResourcesPerSet)) OF Nzp-CSI-RS-ResourceId {	4 entries		FR1, FR2
Nzp-CSI-RS-ResourceId[1]	0	entry 1 CSI-RS resource 1	

NZP-CSI-RS-ResourceId[2]	1	entry 2 CSI-RS resource 2	
NZP-CSI-RS-ResourceId[3]	2	entry 3 CSI-RS resource 3	
NZP-CSI-RS-ResourceId[4]	3	entry 4 CSI-RS resource 4	
}			
repetition	off		
aperiodicTriggeringOffset	Not present		
trs_Info	true		
}			

CSI-ResourceConfig

**Table 5.4.2.0-13: CSI-ResourceConfig for TRS**

Derivation Path: Table 4.6.3-41			
Information Element	Value/remark	Comment	Condition
CSI-ResourceConfig ::= SEQUENCE {			
csi-ResourceConfigId	CSI-ResourceConfigId		
csi-RS-ResourceSetList CHOICE {			
nzp-CSI-RS-SSB SEQUENCE {			
nzp-CSI-RS-ResourceSetList SEQUENCE (SIZE (1..maxNrofNZP-CSI-RS-ResourceSetsPerConfig)) OF NZP-CSI-RS-ResourceSetId {	1 entry		
NZP-CSI-RS-ResourceSetId[1]	0	entry 1	
}			
csi-SSB-ResourceSetList	Not present		
}			
}			
bwp-Id	BWP-Id		
resourceType	periodic		
}			

NZP CSI-RS for CSI Acquisition

NZP-CSI-RS-Resource

**Table 5.4.2.0-14: NZP-CSI-RS-Resource**

Derivation Path: Table 4.6.3-85			
Information Element	Value/remark	Comment	Condition
NZP-CSI-RS-Resource ::= SEQUENCE {			DEMOD_FR 1 DEMOD_FR 2
nzp-CSI-RS-ResourceId	4	CSI-RS resource 5	
resourceMapping	CSI-RS-ResourceMapping		
powerControlOffset	0		
periodicityAndOffset	CSI-ResourcePeriodicityAndOf fset		
qcl-InfoPeriodicCSI-RS	TCI-State #1		
}			

CSI-RS-ResourceMapping

**Table 5.4.2.0-15: CSI-RS-ResourceMapping**

Derivation Path: Table 4.6.3-45			
Information Element	Value/remark	Comment	Condition



CSI-RS-ResourceMapping ::= SEQUENCE {			
frequencyDomainAllocation CHOICE {			
row2	000000000001	K0 = 0, 1Tx test cases	
other	000001	K0 = 0, row3, 2Tx test cases	
row4	001	K0 = 0, 4Tx test cases	
}			
nrofPorts	P2	2Tx test cases	
	P4	4Tx test cases	
	P1	1Tx test cases	
firstOFDMSymbolInTimeDomain	12	l0 = 12	
cdm-Type	fd-CDM2	2Tx and 4Tx test cases	
	noCDM	1Tx test cases	
density CHOICE {			
one	NULL		
}			
freqBand	CSI-FrequencyOccupation		
}			

CSI-ResourcePeriodicityAndOffset

**Table 5.4.2.0-16: CSI-ResourcePeriodicityAndOffset**

Derivation Path: Table 4.6.3-43			
Information Element	Value/remark	Comment	Condition
CSI-ResourcePeriodicityAndOffset ::= CHOICE {			
Slots20	0		SCS 15kHz
Slots40	0		SCS 30kHz
Slots80	0		SCS 60kHz
Slots160	0		SCS 120kHz
}			

CSI-FrequencyOccupation

**Table 5.4.2.0-17: CSI-FrequencyOccupation for CSI Acquisition**

Derivation Path: Table 4.6.3-33			
Information Element	Value/remark	Comment	Condition
CSI-FrequencyOccupation ::= SEQUENCE {			
nrofRBs	52		BW 10 MHz SCS 15kHz
	52		BW 20 MHz SCS 30kHz
	108		BW 40 MHz SCS 30kHz
	68		BW 100MHz SCS 120kHz
	132		BW 200 MHz SCS 120 kHz
}			

NZP-CSI-RS-ResourceSet

**Table 5.4.2.0-18: NZP-CSI-RS-ResourceSet for CSI Acquisition**

Derivation Path: Table 4.6.3-87			
Information Element	Value/remark	Comment	Condition
NZP-CSI-RS-ResourceSet ::= SEQUENCE {			
nzp_CSI_ResourceSetId	1		

nzp-CSI-RS-Resources SEQUENCE (SIZE (1..maxNrofNZP-CSI-RS-ResourcesPerSet)) OF NZP-CSI-RS-ResourceId {	1 entry		FR1, FR2
NZP-CSI-RS-ResourceId[1]	4	entry 1 CSI-RS resource 5	
}			
repetition	off		
aperiodicTriggeringOffset	Not present		
trs_Info	Not present		
}			

CSI-ResourceConfig

**Table 5.4.2.0-19: CSI-ResourceConfig for CSI Acquisition**

Derivation Path: Table 4.6.3-41			
Information Element	Value/remark	Comment	Condition
CSI-ResourceConfig ::= SEQUENCE {			
csi-ResourceConfigId	1		
csi-RS-ResourceSetList CHOICE {			
nzp-CSI-RS-SSB SEQUENCE {			
nzp-CSI-RS-ResourceSetList SEQUENCE (SIZE (1..maxNrofNZP-CSI-RS-ResourceSetsPerConfig)) OF NZP-CSI-RS-ResourceSetId {	1 entry		
NZP-CSI-RS-ResourceSetId[1]	1	entry 1	
}			
csi-SSB-ResourceSetList	Not present		
}			
bwp-Id	BWP-Id		
resourceType	periodic		
}			

ZP CSI-RS for CSI Acquisition

ZP-CSI-RS-Resource

**Table 5.4.2.0-20: ZP-CSI-RS-Resource**

Derivation Path: Table 4.6.3-204			
Information Element	Value/remark	Comment	Condition
ZP-CSI-RS-Resource ::= SEQUENCE {			DEMOD_FR 1 DEMOD_FR 2
zp-CSI-RS-ResourceId	ZP-CSI-RS-ResourceId		
resourceMapping	ZP CSI-RS-ResourceMapping		
periodicityAndOffset	ZP CSI-ResourcePeriodicityAndOffset		
qcl-InfoPeriodicCSI-RS	TCI-State #1		
}			

CSI-RS-ResourceMapping

**Table 5.4.2.0-21: ZP CSI-RS-ResourceMapping**

Derivation Path: Table 4.6.3-45			
Information Element	Value/remark	Comment	Condition
CSI-RS-ResourceMapping ::= SEQUENCE {			

frequencyDomainAllocation CHOICE {			
other	000100	K0 = 4	
}			
nrofPorts	p4		
firstOFDMSymbolInTimeDomain	12	I0 = 12	
cdm-Type	fd-CDM2		
density CHOICE {			
one	NULL		
}			
freqBand	ZP CSI-FrequencyOccupation		
}			

CSI-ResourcePeriodicityAndOffset

**Table 5.4.2.0-22: ZP CSI-ResourcePeriodicityAndOffset**

Derivation Path: Table 4.6.3-43			
Information Element	Value/remark	Comment	Condition
CSI-ResourcePeriodicityAndOffset ::= CHOICE {			
Slots20	0		SCS 15kHz
Slots40	0		SCS 30kHz
Slots80	0		SCS 60kHz
Slots160	0		SCS 120kHz
}			

CSI-FrequencyOccupation

**Table 5.4.2.0-23: ZP CSI-FrequencyOccupation**

Derivation Path: Table 4.6.3-33			
Information Element	Value/remark	Comment	Condition
CSI-FrequencyOccupation ::= SEQUENCE {			
nrofRBs	52		BW 10 MHz SCS 15kHz
	52		BW 20 MHz SCS 30kHz
	108		BW 40 MHz SCS 30kHz
	68		BW 100 MHz SCS 120kHz
	132		BW 200 MHz SCS 120kHz
}			

PDSCH DMRS Configuration

DMRS-DownlinkConfig

**Table 5.4.2.0-24: DMRS-DownlinkConfig**

Derivation Path: Table 4.6.3-50			
Information Element	Value/remark	Comment	Condition
DMRS-DownlinkConfig ::= SEQUENCE {			
dmrs-AdditionalPosition	pos1		
phaseTrackingRS	Not present		DEMOD_FR 1
phaseTrackingRS SEQUENCE {			DEMOD_FR 2
epr-Ratio	0		
resourceElementOffset	Offset10		
}			
}			

## PDSCH Configuration

## PDSCH-ServingCellConfig

Table 5.4.2.0-25: PDSCH-ServingCellConfig

Derivation Path: Table 4.6.3-102			
Information Element	Value/remark	Comment	Condition
PDSCH-ServingCellConfig ::= SEQUENCE {			
codeBlockGroupTransmission	Not present		
xOverhead	Not present		
xOverhead	xOh6		DEMOD_FR 2
nrofHARQ-ProcessesForPDSCH	Set according to the test id	Typically n4 for FDD, n8 for TDD	
pucch-Cell	Not present		
}			

## PDSCH-Config

Table 5.4.2.0-26: PDSCH-Config

Derivation Path: Table 4.6.3-100			
Information Element	Value/remark	Comment	Condition
PDSCH-Config ::= SEQUENCE {			
dataScramblingIdentityPDSCH	0		
dmrs-DownlinkForPDSCH-MappingTypeA CHOICE {			
Setup	DMRS-DownlinkConfig		
}			
tci-StatesToAddModList SEQUENCE(SIZE (1.. maxNrofTCI-States)) OF TCI-State {	2 entries		
TCI-State[1] SEQUENCE {		entry 1	
tci-StateId	TCI-StateId 0		
qcl-type1 SEQUENCE {	QCL Type is Type1		
Cell	not present		
Bwp-id	Not present	BWP ID	
referenceSignal	Ssb : 0	SSB # 0	
Qcl-Type	Type C		
}			
qcl-type2 SEQUENCE {	QCL Type is Type2		DEMOD_FR 2
Cell	not present		
Bwp-id	Not present	BWP ID	
referenceSignal	Ssb : 0	SSB # 0	
Qcl-Type	Type D		
}			
}			
TCI-State[2] SEQUENCE {		entry 2	
tci-StateId	TCI-StateId 1		
qcl-type1 {	QCL Type is Type1		
Cell	Not present		
Bwp-id	0	BWP ID	
referenceSignal	csi-rs : 0	CSI-RS # 0	
Qcl-Type	Type A		
}			
qcl-type2 SEQUENCE {	QCL Type is Type2		DEMOD_FR 2
Cell	Not present		
Bwp-id	0	BWP ID	
referenceSignal	csi-rs : 0	CSI-RS # 0	
Qcl-Type	Type D		

}			
}			
}			
vrb-ToPRB-Interleaver	Not present		
resourceAllocation	resourceAllocationType0		
pdsch-AggregationFactor	Not present		
rbg-Size	config2	The UE ignores this field if <i>resourceAllocation</i> is set to <i>resourceAllocationType1</i> (see TS 38.214 [21], clause 5.1.2.2.1).	
prb-BundlingType CHOICE {			
staticBundling SEQUENCE {			
bundleSize	Not present	PRB Bundling size of 2	
}			
}			
ZP-CSI-RS-ResourceToAddModList SEQUENCE (SIZE (1..maxNrofNRP-CSI-RS-Resources)) OF NRP-CSI-RS-Resource {	1 entry		
ZP-CSI-RS-Resource[1]	ZP-CSI-RS-Resource	entry 1	
}			
p-ZP-CSI-RS-ResourceSet	p-ZP-CSI-RS-ResourceSet		
}			

PDSCH-TimeDomainResourceAllocationList

**Table 5.4.2.0-27: PDSCH-TimeDomainResourceAllocationList**

Derivation Path: Table 4.6.3-103			
Information Element	Value/remark	Comment	Condition
PDSCH-TimeDomainResourceAllocationList ::= SEQUENCE(SIZE(1..maxNrofDL-Allocations)) OF PDSCH-TimeDomainResourceAllocation {	2 entries		FR1
PDSCH-TimeDomainResourceAllocation[1] SEQUENCE {		entry 1	
K0	Not present		
mappingType	typeA		
startSymbolAndLength	44	Start symbol(S)=2, Length(L)=4	For Slot i, if mod(i, 10) = 7 for i from {0,...,39}
}			
PDSCH-TimeDomainResourceAllocation[2] SEQUENCE {		entry 2	
K0	Not present		
mappingType	typeA		
startSymbolAndLength	53	Start symbol(S)=2, Length(L)=12	For Slot i, if mod(i, 10) = {0,1,2,3,4,5,} for i from {1,...,39}
}			
}			
PDSCH-TimeDomainResourceAllocationList ::= SEQUENCE(SIZE(1..maxNrofDL-Allocations)) OF PDSCH-TimeDomainResourceAllocation {	3 entries		FR2
PDSCH-TimeDomainResourceAllocation[1] SEQUENCE {		entry 1	
K0	Not present		
mappingType	typeA		

startSymbolAndLength	53	Start symbol(S)=2, Length(L)=12	
}			
PDSCH-TimeDomainResourceAllocation[2] SEQUENCE {		entry 2	
K0	Not present		
mappingType	typeA		
startSymbolAndLength	96	Start symbol(S)=1, Length(L)=9	
}			
PDSCH-TimeDomainResourceAllocation[3] SEQUENCE {		entry 3	
K0	Not present		
mappingType	typeA		
startSymbolAndLength	40	Start symbol(S)=1, Length(L)=13	
}			
}			

CRS for Rate Matching

RateMatchPatternLTE-CRS

**Table 5.4.2.0-28: RateMatchPatternLTE-CRS**

Derivation Path: Table 4.6.3-138			
Information Element	Value/remark	Comment	Condition
RateMatchPatternLTE-CRS ::= SEQUENCE {			TC 5.2.2.1.4-2 and TC 5.2.3.1.4-2 of TS 38.521-4
carrierFreqDL	LTE EARFCN		
carrierBandwidthDL	n50	10MHz	
nrofCRS-Ports	n4		
v-Shift	n0		
}			

CSI-RS for beam refinement

NZP-CSI-RS-Resource

**Table 5.4.2.0-29: NZP-CSI-RS-Resource**

Derivation Path: Table 4.6.3-85			
Information Element	Value/remark	Comment	Condition
NZP-CSI-RS-Resource ::= SEQUENCE {			DEMOD_FR 2
nzp-CSI-RS-ResourceId	5	CSI-RS resource 6	Beam refinement
	6	CSI-RS resource 7	Beam refinement
resourceMapping	CSI-RS-ResourceMapping		
powerControlOffset	0		
periodicityAndOffset	CSI- ResourcePeriodicityAndOf fset		
qcl-InfoPeriodicCSI-RS	TCI-State #1		
}			

## CSI-RS-ResourceMapping

Table 5.4.2.0-30: CSI-RS-ResourceMapping

Derivation Path: Table 4.6.3-45			
Information Element	Value/remark	Comment	Condition
CSI-RS-ResourceMapping ::= SEQUENCE {			DEMOD_FR2
frequencyDomainAllocation CHOICE {			
row1	0001	K0 = 0, row1 for resource 1 and 2	
}			
nrofPorts	p1		
firstOFDMSymbolInTimeDomain	8	I0 = 8 for resource 1	
	9	I0 = 9 for resource 2	
cdm-Type	noCDM		
density CHOICE {			
three	NULL		
}			
freqBand	CSI-FrequencyOccupation		
}			

## CSI-ResourcePeriodicityAndOffset

Table 5.4.2.0-31: CSI-ResourcePeriodicityAndOffset

Derivation Path: Table 4.6.3-43			
Information Element	Value/remark	Comment	Condition
CSI-ResourcePeriodicityAndOffset ::= CHOICE {			DEMOD_FR2
Slots80	0		SCS 60kHz
Slots160	0		SCS 120kHz
}			

## CSI-FrequencyOccupation

Table 5.4.2.0-32: CSI-FrequencyOccupation for beam refinement

Derivation Path: Table 4.6.3-33			
Information Element	Value/remark	Comment	Condition
CSI-FrequencyOccupation ::= SEQUENCE {			DEMOD_FR2
nrofRBs	68		BW 100MHz SCS 120kHz
	132		BW 200MHz SCS 120kHz
}			

## NZIP-CSI-RS-ResourceSet

Table 5.4.2.0-33: NZP-CSI-RS-ResourceSet for beam refinement

Derivation Path: Table 4.6.3-87			
Information Element	Value/remark	Comment	Condition
NZIP-CSI-RS-ResourceSet ::= SEQUENCE {			DEMOD_FR2
nzip_CSI_ResourceSetId	2		
nzip-CSI-RS-Resources SEQUENCE (SIZE (1..maxNrofNZP-CSI-RS-ResourcesPerSet)) OF NZP-CSI-RS-ResourceId {	2 entries		
NZP-CSI-RS-ResourceId[1]	5	entry 1 CSI-RS resource 6	

NZP-CSI-RS-ResourceId[2]	6	entry 1 CSI-RS resource 7	
}			
repetition	off		
aperiodicTriggeringOffset	Not present		
trs_Info	Not present		
}			

CSI-ResourceConfig

**Table 5.4.2.0-34: CSI-ResourceConfig for beam refinement**

Derivation Path: Table 4.6.3-41			
Information Element	Value/remark	Comment	Condition
CSI-ResourceConfig ::= SEQUENCE {			
csi-ResourceConfigId	2		
csi-RS-ResourceSetList CHOICE {			
nzp-CSI-RS-SSB SEQUENCE {			
nzp-CSI-RS-ResourceSetList SEQUENCE (SIZE (1..maxNrofNZP-CSI-RS-ResourceSetsPerConfig)) OF NZP-CSI-RS-ResourceSetId {	1 entry		
NZP-CSI-RS-ResourceSetId[1]	2	entry 1	
}			
csi-SSB-ResourceSetList	Not present		
}			
}			
bwp-Id	BWP-Id		
resourceType	periodic		
}			

CSI-RS for beam management

NZP-CSI-RS-Resource

**Table 5.4.2.0-35: NZP-CSI-RS-Resource for beam management**

Derivation Path: Table 4.6.3-85			
Information Element	Value/remark	Comment	Condition
NZP-CSI-RS-Resource ::= SEQUENCE {			PDCCH_FR2
nzp-CSI-RS-ResourceId	4	CSI-RS resource 5	
	5	CSI-RS resource 6	
resourceMapping	CSI-RS-ResourceMapping for beam management		
powerControlOffset	0		
periodicityAndOffset	CSI-ResourcePeriodicityAndOffset for beam management		
qcl-InfoPeriodicCSI-RS	TCI-State #1		
}			

CSI-RS-ResourceMapping

**Table 5.4.2.0-36: CSI-RS-ResourceMapping for beam management**

Derivation Path: Table 4.6.3-45			
Information Element	Value/remark	Comment	Condition
CSI-RS-ResourceMapping ::= SEQUENCE {			PDCCH_FR2
frequencyDomainAllocation CHOICE {			



row1	0001	K0 = 0, row1 for resource 1 and 2	
}			
nrofPorts	p1		
firstOFDMsymbolInTimeDomain	8	l0 = 8 for resource 1	
	9	l0 = 9 for resource 2	
cdm-Type	noCDM		
density CHOICE {			
three	NULL		
}			
freqBand	CSI-FrequencyOccupation for beam management		
}			

CSI-ResourcePeriodicityAndOffset

**Table 5.4.2.0-37: CSI-ResourcePeriodicityAndOffset for beam management**

Derivation Path: Table 4.6.3-43			
Information Element	Value/remark	Comment	Condition
CSI-ResourcePeriodicityAndOffset ::= CHOICE {			PDCCH_FR2
Slots80	0		SCS 60kHz
Slots160	0		SCS 120kHz
}			

CSI-FrequencyOccupation

**Table 5.4.2.0-38: CSI-FrequencyOccupation for beam management**

Derivation Path: Table 4.6.3-33			
Information Element	Value/remark	Comment	Condition
CSI-FrequencyOccupation ::= SEQUENCE {			PDCCH_FR2
nrofRBs	68		BW 100MHz SCS 120kHz
	132		BW 200MHz SCS 120kHz
}			

NZP-CSI-RS-ResourceSet

**Table 5.4.2.0-39: NZP-CSI-RS-ResourceSet for beam management**

Derivation Path: Table 4.6.3-87			
Information Element	Value/remark	Comment	Condition
NZP-CSI-RS-ResourceSet ::= SEQUENCE {			PDCCH_FR2
nzp_CSI_ResourceSetId	1		
nzp-CSI-RS-Resources SEQUENCE (SIZE (1..maxNrofNZP-CSI-RS-ResourcesPerSet)) OF NZP-CSI-RS-ResourceId {	2 entries		
NZP-CSI-RS-ResourceId[1]	4	entry 1 CSI-RS resource 5	
NZP-CSI-RS-ResourceId[2]	5	entry 1 CSI-RS resource 6	
}			
repetition	off		
aperiodicTriggeringOffset	Not present		
trs_Info	Not present		
}			

CSI-ResourceConfig

**Table 5.4.2.0-40: CSI-ResourceConfig for beam management**

Derivation Path: Table 4.6.3-41			
Information Element	Value/remark	Comment	Condition
CSI-ResourceConfig ::= SEQUENCE {			
csi-ResourceConfigId	1		
csi-RS-ResourceSetList CHOICE {			
nzp-CSI-RS-SSB SEQUENCE {			
nzp-CSI-RS-ResourceSetList SEQUENCE (SIZE (1..maxNrofNZP-CSI-RS-ResourceSetsPerConfig)) OF NZP-CSI-RS-ResourceSetId {	1 entry		
NZP-CSI-RS-ResourceSetId[1]	1	entry 1	
}			
csi-SSB-ResourceSetList	Not present		
}			
bwp-Id	BWP-Id		
resourceType	periodic		
}			

PUCCH-Config

**Table 5.4.2.0-41: PUCCH-Config**

Derivation Path: Table 4.6.3-112			
Information Element	Value/remark	Comment	Condition
PUCCH-Config ::= SEQUENCE {			
dl-DataToUL-ACK SEQUENCE (SIZE (1..8)) OF INTEGER {	4 entries		FR1.15-1 FR1.30-2 FR2.120-1 FR2.120-1A
INTEGER[1]	2	entry 1	
INTEGER[2]	3	entry 2	
INTEGER[3]	4	entry 3	
INTEGER[4]	6	entry 4	
}			
dl-DataToUL-ACK SEQUENCE (SIZE (1..8)) OF INTEGER {	7 entries		FR1.30-1 FR1.30-1A FR1.30-4
INTEGER[1]	2	entry 1	
INTEGER[2]	3	entry 2	
INTEGER[3]	4	entry 3	
INTEGER[4]	5	entry 4	
INTEGER[5]	6	entry 5	
INTEGER[6]	7	entry 6	
INTEGER[7]	8	entry 7	
}			
dl-DataToUL-ACK SEQUENCE (SIZE (1..8)) OF INTEGER {	4 entries		FR1.30-3
INTEGER[1]	2	entry 1	
INTEGER[2]	3	entry 2	
INTEGER[3]	4	entry 3	
INTEGER[4]	5	entry 4	
}			
dl-DataToUL-ACK SEQUENCE (SIZE (1..8)) OF INTEGER {	2 entries		FR1.30-5 FR1.30-6
INTEGER[1]	2	entry 1	
INTEGER[2]	3	entry 2	
}			

} dl-DataToUL-ACK SEQUENCE (SIZE (1..8)) OF INTEGER {	3 entries		FR2.60-1 FR2.120-2
INTEGER[1]	2	entry 1	
INTEGER[2]	3	entry 2	
INTEGER[3]	5	entry 3	
}			
} dl-DataToUL-ACK SEQUENCE (SIZE (1..8)) OF INTEGER {	2 entries		FR2.120-1_CSI
INTEGER[1]	3	entry 1	
INTEGER[2]	6	entry 2	
}			
} dl-DataToUL-ACK SEQUENCE (SIZE (1..8)) OF INTEGER {	3 entries		FR2.120-2_CSI
INTEGER[1]	6	entry 1	
INTEGER[2]	7	entry 2	
INTEGER[3]	11	entry 3	
}			
}			

Condition	Explanation
FR1.15-1	TDD UL-DL pattern FR1.15-1 is used. Ref Annex A.1.2 of TS 38.521-4
FR1.30-1	TDD UL-DL pattern FR1.30-1 is used. Ref Annex A.1.2 of TS 38.521-4
FR1.30-2	TDD UL-DL pattern FR1.30-2 is used. Ref Annex A.1.2 of TS 38.521-4
FR1.30-3	TDD UL-DL pattern FR1.30-3 is used. Ref Annex A.1.2 of TS 38.521-4
FR1.30-4	TDD UL-DL pattern FR1.30-4 is used. Ref Annex A.1.2 of TS 38.521-4
FR1.30-5	TDD UL-DL pattern FR1.30-5 is used. Ref Annex A.1.2 of TS 38.521-4
FR1.30-6	TDD UL-DL pattern FR1.30-6 is used. Ref Annex A.1.2 of TS 38.521-4
FR2.60-1	TDD UL-DL pattern FR2.60-1 is used. Ref Annex A.1.3 of TS 38.521-4
FR2.120-1	TDD UL-DL pattern FR2.120-1 is used. Ref Annex A.1.3 of TS 38.521-4
FR2.120-2	TDD UL-DL pattern FR2.120-2 is used. Ref Annex A.1.3 of TS 38.521-4
FR2.120-1_CSI	TDD UL-DL pattern FR2.120-1 is used for CSI reporting test cases. Ref Table 8.1.2-1 of TS 38.521-4
FR2.120-2_CSI	TDD UL-DL pattern FR2.120-2 is used for CSI reporting test cases. Ref Table 8.1.2-1 of TS 38.521-4

5.4.2.1 Message contents for PDSCH Demodulation requirements

ZP CSI-RS for CSI Acquisition

p-ZP-CSI-RS-ResourceSet

Table 5.4.2.1-0: p-ZP-CSI-RS-ResourceSet

Derivation Path: TS 38.331 [6], clause 6.3.2.			
Information Element	Value/remark	Comment	Condition
p-ZP-CSI-RS-ResourceSet CHOICE {			
setup	ZP-CSI-RS-ResourceSet		
}			

Table 5.4.2.1-1: ZP-CSI-RS-ResourceSet

Derivation Path: Table 4.6.3-87			
Information Element	Value/remark	Comment	Condition
p-ZP-CSI-RS-ResourceSet ::= SEQUENCE {			
zp_CSI-RS_ResourceSetId	0		
zp_CSI-RS_ResourceIdList SEQUENCE (SIZE (1..maxNrofZP-CSI-RS-ResourcesPerSet)) OF ZP-CSI-RS-ResourceId {		1 entry	

ZP-CSI-RS-ResourceId[1]	0	entry 1 ZP CSI-RS resource 1	
}			
}			

CSI-MeasConfig

**Table 5.4.2.1-2: CSI-MeasConfig**

Derivation Path: Table 4.6.3-38

Information Element	Value/remark	Comment	Condition
CSI-MeasConfig ::= SEQUENCE {			
nzp-CSI-RS-ResourceToAddModList SEQUENCE (SIZE (1..maxNrofNZP-CSI-RS-Resources)) OF NZP-CSI-RS-Resource {	n entries	dependent on test condition	
NZP-CSI-RS-Resource[1]	NZP-CSI-RS-Resource for TRS (1)	entry 1 CSI-RS resource 1	
NZP-CSI-RS-Resource[2]	NZP-CSI-RS-Resource for TRS (2)	entry 2 CSI-RS resource 2	
NZP-CSI-RS-Resource[3]	NZP-CSI-RS-Resource for TRS (3)	entry 3 CSI-RS resource 3	
NZP-CSI-RS-Resource[4]	NZP-CSI-RS-Resource for TRS (4)	entry 4 CSI-RS resource 4	
NZP-CSI-RS-Resource[5]	NZP-CSI-RS-Resource for CSI Acquisition	entry 5 CSI-RS resource 5	
NZP-CSI-RS-Resource[6]	CSI-RS-Resource for beam refinement	entry 5 CSI-RS resource 6	DEMOD_FR 2
NZP-CSI-RS-Resource[7]	CSI-RS-Resource for beam refinement	entry 5 CSI-RS resource 7	DEMOD_FR 2
}			
nzp-CSI-RS-ResourceSetToAddModList SEQUENCE (SIZE (1..maxNrofNZP-CSI-RS-ResourceSets)) OF NZP-CSI-RS-ResourceSetId {	n entries	dependent on test condition	
NZP-CSI-RS-ResourceSet[1]	NZP-CSI-RS-ResourceSet for TRS	entry 1	
NZP-CSI-RS-ResourceSet[2]	NZP-CSI-RS-ResourceSet for CSI Acquisition	entry 2	
NZP-CSI-RS-ResourceSet[3]	CSI-RS-ResourceSet for beam refinement	entry 3	DEMOD_FR 2
}			
csi-IM-ResourceToAddModList	Not present		
csi-IM-ResourceSetToAddModList	Not present		
csi-SSB-ResourceSetToAddModList	Not present		
csi-ResourceConfigToAddModList SEQUENCE (SIZE (1..maxNrofCSI-ResourceConfigurations)) OF CSI-ResourceConfig {	n entries	dependent on test condition	
CSI-ResourceConfig[1]	CSI-ResourceConfig for TRS	entry 1	
CSI-ResourceConfig[2]	CSI-ResourceConfig for CSI Acquisition	entry 2	
CSI-ResourceConfig[2]	CSI-ResourceConfig for beam refinement	entry 3	DEMOD_FR 2
}			
}			

## 5.4.2.2 Message contents for PDCCH Demodulation requirements

NZIP-CSI-RS for Tracking

CSI-RS-ResourceMapping

Table 5.4.2.2-1: CSI-RS-ResourceMapping for TRS

Derivation Path: Table 4.6.3-45			
Information Element	Value/remark	Comment	Condition
CSI-RS-ResourceMapping ::= SEQUENCE { frequencyDomainAllocation CHOICE { row1	0001	$k_0=0$ for CSI-RS resource 1,2,3,4	TRS
}			
firstOFDMsymbolInTimeDomain	4	$l_0 = 4$ for CSI-RS resource 1 and 3	TRS
	8	$l_0 = 8$ for CSI-RS resource 2 and 4	TRS
nrofPorts	p1	1 for CSI-RS resource 1,2,3,4	TRS
Cdm-Type	noCDM		TRS
Density CHOICE{ three	Null		TRS
}			
freqBand	CSI-FrequencyOccupation		TRS
}			

CSI-MeasConfig

Table 5.4.2.2-2: CSI-MeasConfig

Derivation Path: Table 4.6.3-38			
Information Element	Value/remark	Comment	Condition
CSI-MeasConfig ::= SEQUENCE { nzip-CSI-RS-ResourceToAddModList SEQUENCE (SIZE (1..maxNrofNZIP-CSI-RS-Resources)) OF NZIP- CSI-RS-Resource {	n entries	Dependent on test condition	
NZIP-CSI-RS-Resource[1]	NZIP-CSI-RS-Resource for TRS (1)	entry 1 CSI-RS resource 1	
NZIP-CSI-RS-Resource[2]	NZIP-CSI-RS-Resource for TRS (2)	entry 2 CSI-RS resource 2	
NZIP-CSI-RS-Resource[3]	NZIP-CSI-RS-Resource for TRS (3)	entry 3 CSI-RS resource 3	
NZIP-CSI-RS-Resource[4]	NZIP-CSI-RS-Resource for TRS (4)	entry 4 CSI-RS resource 4	
NZIP-CSI-RS-Resource[5]	NZIP-CSI-RS-Resource for beam management (5)	entry 4 CSI-RS resource 5	PDCCH_FR2
NZIP-CSI-RS-Resource[6]	NZIP-CSI-RS-Resource for beam management (6)	entry 4 CSI-RS resource 6	PDCCH_FR2
}			
nzip-CSI-RS-ResourceSetToAddModList SEQUENCE (SIZE (1..maxNrofNZIP-CSI-RS-ResourceSets)) OF NZIP-CSI-RS-ResourceSetId {	1 entry		
NZIP-CSI-RS-ResourceSet[1]	NZIP-CSI-RS-ResourceSet for TRS	entry 1	
NZIP-CSI-RS-ResourceSet[2]	NZIP-CSI-RS-ResourceSet for beam management	entry 1	PDCCH_FR2
}			
csi-IM-ResourceToAddModList	Not present		
csi-IM-ResourceSetToAddModList	Not present		
csi-SSB-ResourceSetToAddModList	Not present		

csi-ResourceConfigToAddModList SEQUENCE (SIZE (1..maxNrofCSI-ResourceConfigurations)) OF CSI-ResourceConfig {	1 entry		
CSI-ResourceConfig[1]	CSI-ResourceConfig	entry 1	
CSI-ResourceConfig[2]	CSI-ResourceConfig for beam management	entry 1	PDCCH_FR2
}			
}			

PDSCH Configuration

PDSCH-Config

Table 5.4.2.2-3: PDSCH-Config

Derivation Path: Table 4.6.3-100			
Information Element	Value/remark	Comment	Condition
PDSCH-Config ::= SEQUENCE {			
dataScramblingIdentityPDSCH	0		
dmrs-DownlinkForPDSCH-MappingTypeA CHOICE {			
Setup	DMRS-DownlinkConfig		
}			
tci-StatesToAddModList SEQUENCE(SIZE (1..maxNrofTCI-States)) OF TCI-State {	2 entries		
TCI-State[1] SEQUENCE {		entry 1	
tci-StateId	TCI-StateId 0		
qcl-type1 SEQUENCE {	QCL Type is Type1		
Cell	Not Present		
Bwp-id	Not present	BWP ID	
referenceSignal	Ssb : 0	SSB # 0	
Qcl-Type	Type C		
}			
qcl-type2 SEQUENCE {	QCL Type is Type2		
Cell	Not Present		
Bwp-id	Not present	BWP ID	
referenceSignal	Ssb : 0	SSB # 0	
Qcl-Type	Type D		
}			
}			
TCI-State[2] SEQUENCE {		entry 2	
tci-StateId	TCI-StateId 1		
qcl-type1 SEQUENCE {	QCL Type is Type1		
Cell	Not Present		
Bwp-id	0	BWP ID	
referenceSignal	csi-rs : 0	CSI-RS # 0	
Qcl-Type	Type A		
}			
qcl-type2 SEQUENCE {	QCL Type is Type2		
Cell	Not Present		
Bwp-id	0	BWP ID	
referenceSignal	csi-rs : 0	CSI-RS # 0	
Qcl-Type	Type D		
}			
}			
vrb-ToPRB-Interleaver	Not present		
resourceAllocation	resourceAllocationType0		
pdsch-AggregationFactor	Not present		
prb-BundlingType CHOICE {			
staticBundling SEQUENCE {			
bundleSize	Not present	PRB Bundling size of 2	
}			
}			
}			

--	--	--

### 5.4.2.3 Message contents for Sustained downlink data rate requirements

Physical layer parameters

**Table 5.4.2.3-1: Physical layer parameters for DCI format 1\_1**

Derivation Path: Table 5.4.2.0-1
----------------------------------

Common Serving Parameters

ServingCellConfigCommon

**Table 5.4.2.3-2: ServingCellConfigCommon**

Derivation Path: Table 5.4.2.0-2
----------------------------------

TDD-UL-DL-Config

**Table 5.4.2.3-3: TDD-UL-DL-Config**

Derivation Path: Table 5.4.2.0-3
----------------------------------

PDCCH Configuration

PDCCH-ConfigCommon

**Table 5.4.2.3-4: PDCCH-ConfigCommon**

Derivation Path: Table 5.4.2.0-4
----------------------------------

ServingCellConfig

**Table 5.4.2.3-5: ServingCellConfig**

Derivation Path: Table 5.4.2.0-5
----------------------------------

PDCCH-config

**Table 5.4.2.3-6: PDCCH-ControlResourceSet**

Derivation Path: Table 5.4.2.0-6			
Information Element	Value/remark	Comment	Condition
ControlResourceSet ::= SEQUENCE {			
controlResourceSetId	ControlResourceSetId		
frequencyDomainResources	xxxxxxx xxxxxxxx xxxxxxx xxxxxxxx xxxxxxx xxxxx	TS 38.521-4 Table 5.2-2 for tested channel bandwidth and subcarrier spacing	SDR_FR1
frequencyDomainResources	xxxxxxx xxxxxxxx xxxxxxx xxxxxxxx xxxxxxx xxxxx	TS 38.521-4 Table 7.2-2 for tested channel bandwidth	SDR_FR2

		and subcarrier spacing	
duration	1	SearchSpace duration of 1 symbol	SDR_FR1, SDR_FR2
cce-REG-MappingType CHOICE { nonInterleaved	NULL		
}			
precoderGranularity	sameAsREG-bundle		
tci-StatesPDCCH-ToAddList	Not present	SearchSpace seen from all TCI states	
tci-StatesPDCCH-ToAddList SEQUENCE(SIZE (1..maxNrofTCI-StatesPDCCH)) OF TCI-StateId { TCI-StateId[1]	1 entry		MBWP
	0	QCL ssb 0	
	1	QCL csi-rs 0	
}			
}			

Condition	Explanation
SDR_FR1	SDR testing in FR1.
SDR_FR2	SDR testing in FR2.

Table 5.4.2.3-7: PDCCH Search Space

Derivation Path: Table 5.4.2.0-7

Information Element	Value/remark	Comment	Condition
SearchSpace ::= SEQUENCE { monitoringSlotPeriodicityAndOffset CHOICE { s1	NULL		
}			
duration	Not present	1 slot per default	
monitoringSymbolsWithinSlot	1000000000000000	Starting symbol 0	
nrofCandidates SEQUENCE { aggregationLevel1	n0		
aggregationLevel2	n2	1 for UL, 1 for DL	CORESET_ge_24_RBs
	n0		
aggregationLevel4	n2	1 for UL, 1 for DL	CORESET_ge_48_RBs
	n0		
aggregationLevel8	n2	1 for UL, 1 for DL	CORESET_ge_96_RBs
	n0		
aggregationLevel16	n0		
}			
searchSpaceType CHOICE { ue-Specific SEQUENCE { dci-Formats	formats0-1-And-1-1	DCI Format 1_1	USS
}			
}			
}			

Condition	Explanation
CORESET_ge_24_RBs	5MHz in scs15; 10MHz, 15MHz in scs30.
CORESET_ge_48_RBs	10MHz in scs15; 20MHz in scs30.
CORESET_ge_96_RBs	15MHz and above in scs15; 25MHz and above in scs30.



NZP-CSI-RS for Tracking

NZP-CSI-RS-Resource

**Table 5.4.2.3-8: NZP-CSI-RS-Resource for TRS**

Derivation Path: Table 5.4.2.0-8			
Information Element	Value/remark	Comment	Condition
NZP-CSI-RS-Resource ::= SEQUENCE {			
nzp-CSI-RS-ResourceId	0	CSI-RS resource 1	
	1	CSI-RS resource 2	
	2	CSI-RS resource 3	
	3	CSI-RS resource 4	
resourceMapping	CSI-RS-ResourceMapping for TRS		
powerControlOffset	0		
periodicityAndOffset	CSI-ResourcePeriodicityAndOffset		
qcl-InfoPeriodicCSI-RS	TCI-StateId 0	QCL ssb 0	
}			

CSI-RS-ResourceMapping

**Table 5.4.2.3-9: CSI-RS-ResourceMapping for TRS**

Derivation Path: Table 5.4.2.0-9			
Information Element	Value/remark	Comment	Condition
CSI-RS-ResourceMapping ::= SEQUENCE {			
frequencyDomainAllocation CHOICE {			
row1	1000	k <sub>0</sub> =3, row1	2TX, 4TX
}			
firstOFDMSymbolInTimeDomain	6	l <sub>0</sub> =6 for CSI-RS resource 1 and 3	
	10	l <sub>0</sub> =10 for CSI-RS resource 2 and 4	
nrofPorts	p1	1 for CSI-RS resource 1,2,3,4	2TX, 4TX
cdm-Type	noCDM		
density CHOICE{			
three	Null		
}			
freqBand	CSI-FrequencyOccupation for TRS		
}			

CSI-ResourcePeriodicityAndOffset

**Table 5.4.2.3-10: CSI-ResourcePeriodicityAndOffset for TRS**

Derivation Path: Table 5.4.2.0-10
-----------------------------------

CSI-FrequencyOccupation

**Table 5.4.2.3-11: CSI-FrequencyOccupation for TRS**

Derivation Path: Table 5.4.2.0-11			
Information Element	Value/remark	Comment	Condition
CSI-FrequencyOccupation ::= SEQUENCE {			
nrofRBs	52	BW 10MHz SCS 15kHz, BW 20MHz SCS 30kHz	

	108	BW 20MHz SCS 15kHz	
	276	BW 100MHz SCS 30kHz	
}			

NZP-CSI-RS-ResourceSet

**Table 5.4.2.3-12: NZP-CSI-RS-ResourceSet for TRS**

Derivation Path: Table 5.4.2.0-12

CSI-ResourceConfig

**Table 5.4.2.3-13: CSI-ResourceConfig for TRS**

Derivation Path: Table 5.4.2.0-13

NZP CSI-RS for CSI Acquisition

NZP-CSI-RS-Resource

**Table 5.4.2.3-14: NZP-CSI-RS-Resource for CSI Acquisition**

Derivation Path: Table 5.4.2.0-14

Information Element	Value/remark	Comment	Condition
NZP-CSI-RS-Resource ::= SEQUENCE {			
nzp-CSI-RS-ResourceId	4	CSI-RS resource 5	
resourceMapping	CSI-RS-ResourceMapping		
powerControlOffset	0		
periodicityAndOffset	CSI-ResourcePeriodicityAndOffset		
qcl-InfoPeriodicCSI-RS	TCI-StateId 1	QCL csi-rs 0	
}			

CSI-RS-ResourceMapping

**Table 5.4.2.3-15: CSI-RS-ResourceMapping for CSI Acquisition**

Derivation Path: Table 5.4.2.0-15

Information Element	Value/remark	Comment	Condition
CSI-RS-ResourceMapping ::= SEQUENCE {			
frequencyDomainAllocation CHOICE {			
other	000100	k <sub>0</sub> =4, row3	2TX
row4	010	k <sub>0</sub> =4, row4	4TX
}			
nrofPorts	p2		2TX
	p4		4TX
firstOFDMSymbolInTimeDomain	12	l <sub>0</sub> =12	
cdm-Type	fd-CDM2		
density CHOICE {			
one	NULL		
}			
freqBand	CSI-FrequencyOccupation for CSI Acquisition		
}			

CSI-ResourcePeriodicityAndOffset

**Table 5.4.2.3-16: CSI-ResourcePeriodicityAndOffset**

Derivation Path: Table 5.4.2.0-16

CSI-FrequencyOccupation

**Table 5.4.2.3-17: CSI-FrequencyOccupation for CSI Acquisition**

Derivation Path: Table 5.4.2.0-17			
Information Element	Value/remark	Comment	Condition
CSI-FrequencyOccupation ::= SEQUENCE {			
nrofRBs	52		BW 10MHz SCS 15kHz, BW 20MHz SCS 30kHz
	108		BW 20MHz SCS 15kHz
	276		BW 100MHz SCS 30kHz
}			

NZP-CSI-RS-ResourceSet

**Table 5.4.2.3-18: NZP-CSI-RS-ResourceSet for CSI Acquisition**

Derivation Path: Table 5.4.2.0-18

CSI-ResourceConfig

**Table 5.4.2.3-19: CSI-ResourceConfig for CSI Acquisition**

Derivation Path: Table 5.4.2.0-19

ZP CSI-RS for CSI Acquisition

ZP-CSI-RS-Resource

**Table 5.4.2.3-20: ZP-CSI-RS-Resource**

Derivation Path: Table 5.4.2.0-20			
Information Element	Value/remark	Comment	Condition
ZP-CSI-RS-Resource ::= SEQUENCE {			
zp-CSI-RS-ResourceId	ZP-CSI-RS-ResourceId		
resourceMapping	ZP CSI-RS-ResourceMapping		
periodicityAndOffset	ZP CSI-ResourcePeriodicityAndOffset		
qcl-InfoPeriodicCSI-RS	TCI-StateId 1	QCL csi-rs 0	
}			

CSI-RS-ResourceMapping

**Table 5.4.2.3-21: ZP CSI-RS-ResourceMapping**

Derivation Path: Table 5.4.2.0-21			
Information Element	Value/remark	Comment	Condition
CSI-RS-ResourceMapping ::= SEQUENCE {			
frequencyDomainAllocation CHOICE {			

row4	001	k <sub>0</sub> =0, row4	2TX, 4TX
}			
nrofPorts	p4		2TX, 4TX
firstOFDMSymbolInTimeDomain	12	l <sub>0</sub> =12	
cdm-Type	fd-CDM2		
density CHOICE {			
one	NULL		
}			
freqBand	ZP CSI-FrequencyOccupation		
}			

CSI-ResourcePeriodicityAndOffset

**Table 5.4.2.3-22: ZP CSI-ResourcePeriodicityAndOffset**

Derivation Path: Table 5.4.2.0-22

CSI-FrequencyOccupation

**Table 5.4.2.3-23: ZP CSI-FrequencyOccupation**

Derivation Path: Table 5.4.2.0-23			
Information Element	Value/remark	Comment	Condition
CSI-FrequencyOccupation ::= SEQUENCE {			
nrofRBs	52		BW 10MHz SCS 15kHz, BW 20MHz SCS 30kHz
	108		BW 20MHz SCS 15kHz
	276		BW 100MHz SCS 30kHz
}			

PDSCH DMRS Configuration

DMRS-DownlinkConfig

**Table 5.4.2.3-24: DMRS-DownlinkConfig**

Derivation Path: Table 5.4.2.0-24

PDSCH Configuration

PDSCH-ServingCellConfig

**Table 5.4.2.3-25: PDSCH-ServingCellConfig**

Derivation Path: Table 5.4.2.0-25

PDSCH-Config

**Table 5.4.2.3-26: PDSCH-Config**

Derivation Path: Table 5.4.2.0-26			
Information Element	Value/remark	Comment	Condition
PDSCH-Config ::= SEQUENCE {			
dataScramblingIdentityPDSCH	0		
dmrs-DownlinkForPDSCH-MappingTypeA CHOICE {			
setup	DMRS-DownlinkConfig		

}			
tci-StatesToAddModList SEQUENCE(SIZE (1..maxNrofTCI-States)) OF TCI-State {	2 entries		
TCI-State[1] SEQUENCE {		entry 1	
tci-StateId	0	TCI-StateId 0	
qcl-type1 SEQUENCE {			
cell	0		
bwp-id	Not present	BWP_ID	
referenceSignal	ssb		
ssb	0		
qcl-Type	typeC		
}			
qcl-type2 SEQUENCE {			SDR_FR2
cell	0		
bwp-id	Not present	BWP_ID	
referenceSignal	ssb		
ssb	0		
qcl-Type	typeD		
}			
}			
TCI-State[2] SEQUENCE {		entry 2	
tci-StateId	1	TCI-StateId 1	
qcl-type1 {			
cell	0		
bwp-id	0	BWP ID	
referenceSignal	csi-rs		
csi-rs	0		
qcl-Type	typeA		
}			
qcl-type2 SEQUENCE {			SDR_FR2
cell	0		
bwp-id	0	BWP ID	
referenceSignal	csi-rs		
csi-rs	0		
qcl-Type	typeD		
}			
}			
}			
vrb-ToPRB-Interleaver	Not present		
resourceAllocation	resourceAllocationType0		
pdsch-AggregationFactor	Not present		
rbg-Size	config1	The UE ignores this field if <i>resourceAllocation</i> is set to <i>resourceAllocationType1</i> (see TS 38.214 [21], clause 5.1.2.2.1).	
prb-BundlingType CHOICE {			
staticBundling SEQUENCE {			
bundleSize	wideband		SDR_FR1, SDR_FR2
}			
}			
ZP-CSI-RS-ResourceToAddModList SEQUENCE (SIZE (1..maxNrofNQP-CSI-RS-Resources)) OF NQP-CSI-RS-Resource {	1 entry		
ZP-CSI-RS-Resource[1]	ZP-CSI-RS-Resource	entry 1	
}			
p-ZP-CSI-RS-ResourceSet	p-ZP-CSI-RS-ResourceSet		
}			

## PDSCH-TimeDomainResourceAllocationList

**Table 5.4.2.3-27: PDSCH-TimeDomainResourceAllocationList**

Derivation Path: Table 5.4.2.0-27			
Information Element	Value/remark	Comment	Condition
PDSCH-TimeDomainResourceAllocationList ::= SEQUENCE(SIZE(1..maxNrofDL-Allocations)) OF PDSCH-TimeDomainResourceAllocation {	2 entries		
PDSCH-TimeDomainResourceAllocation[1]		entry 1	
SEQUENCE {			
k0	Not present		
mappingType	typeA		
startSymbolAndLength	44	Start symbol(S)=2, Length(L)=4	SDR_FR1
	96	Start symbol(S)=1, Length(L)=9	SDR_FR2
}			
PDSCH-TimeDomainResourceAllocation[2]		entry 2	
SEQUENCE {			
k0	Not present		
mappingType	typeA		
	40	Start symbol(S)=1, Length(L)=13	SDR_FR1, SDR_FR2
}			
}			

## – SecurityAlgorithmConfig

**Table 5.4.2.3-A1: SecurityAlgorithmConfig**

Derivation Path: Table 4.6.3-165			
Information Element	Value/remark	Comment	Condition
SecurityAlgorithmConfig ::= SEQUENCE {			
cipheringAlgorithm	nea0		SDR_FR1, SDR_FR2
integrityProtAlgorithm	nia2		
}			

## – Security mode command

**Table 5.4.2.3-A2: SECURITY MODE COMMAND**

Derivation Path: Table 4.7.1-25			
Information Element	Value/remark	Comment	Condition
Selected NAS security algorithms			
Type of ciphering algorithm	'0000'B	5G encryption algorithm 5G EA0 (null ciphering algorithm)	SDR_FR1, SDR_FR2
Type of integrity protection algorithm	Set according to PIXIT px_NAS_5GC_IntegrityProtAlgorithm for default integrity protection algorithm	This value should not be equal to the null integrity algorithm.	
Selected EPS NAS security algorithms	Not Present		
Selected EPS NAS security algorithms			UE_S1_SU PPORTED
Type of ciphering algorithm	'0000'B	EPS encryption algorithm EEA0 (null ciphering algorithm)	SDR_FR1, SDR_FR2

Type of integrity protection algorithm	Set according to PIXIT px_NAS_IntegrityProtAlgorithm for default integrity protection algorithm		
--	---	--	--

5.4.2.4 Message contents for CQI reporting requirements

NZP-CSI-RS for Tracking

CSI-RS-ResourceMapping

Table 5.4.2.4-1: CSI-RS-ResourceMapping for TRS

Derivation Path: Table 4.6.3-45			
Information Element	Value/remark	Comment	Condition
CSI-RS-ResourceMapping ::= SEQUENCE {			
frequencyDomainAllocation CHOICE {			
row1	0001	k <sub>0</sub> =0 for CSI-RS resource 1,2,3,4	TRS
}			
firstOFDMSymbolInTimeDomain	4	l <sub>0</sub> = 4 for CSI-RS resource 1 and 3	TRS
	8	l <sub>0</sub> = 8 for CSI-RS resource 2 and 4	TRS
nrofPorts	p1	1 for CSI-RS resource 1,2,3,4	TRS
Cdm-Type	noCDM		TRS
Density CHOICE{			
three	Null		TRS
}			
freqBand	CSI-FrequencyOccupation		TRS
}			

NZP CSI-RS for CSI Acquisition

CSI-RS-ResourceMapping

Table 5.4.2.4-2: CSI-RS-ResourceMapping

Derivation Path: Table 4.6.3-45			
Information Element	Value/remark	Comment	Condition
CSI-RS-ResourceMapping ::= SEQUENCE {			
frequencyDomainAllocation CHOICE {			
other	001000	K <sub>0</sub> = 6, row3,	NOT 1Tx test cases
row1	0001	K <sub>0</sub> = 0, row1	1Tx test cases
}			
nrofPorts	P2		NOT 1Tx test cases
	P1		1Tx test cases
firstOFDMSymbolInTimeDomain	13	l <sub>0</sub> = 13	
cdm-Type	fd-CDM2		NOT 1Tx test cases
	noCDM		1Tx test cases
density CHOICE {			
one	NULL		NOT 1Tx test cases
three	NULL		1Tx test cases
}			

freqBand	CSI-FrequencyOccupation		
}			

CSI-ResourcePeriodicityAndOffset

**Table 5.4.2.4-2a: NZP CSI-ResourcePeriodicityAndOffset**

Derivation Path: Table 4.6.3-43			
Information Element	Value/remark	Comment	Condition
CSI-ResourcePeriodicityAndOffset ::= CHOICE {			
slots5	1		FR1_FDD
slot10	1		FR1_TDD
slot8	1		FR2
}			

ZP CSI-RS for CSI Acquisition

CSI-RS-ResourceMapping

**Table 5.4.2.4-3: ZP CSI-RS-ResourceMapping**

Derivation Path: Table 4.6.3-45			
Information Element	Value/remark	Comment	Condition
CSI-RS-ResourceMapping ::= SEQUENCE {			
frequencyDomainAllocation CHOICE {			
other	000100	K0 = 4	FR1
row4	100	K0=8	FR2
}			
nrofPorts	P4		
firstOFDMSymbolInTimeDomain	9	I0 = 9	FR1
	13	I0 = 13	FR2
cdm-Type	fd-CDM2		
density CHOICE {			
one	NULL		
}			
freqBand	ZP CSI-FrequencyOccupation		
}			

CSI-ResourcePeriodicityAndOffset

**Table 5.4.2.4-4: ZP CSI-ResourcePeriodicityAndOffset**

Derivation Path: Table 4.6.3-43			
Information Element	Value/remark	Comment	Condition
CSI-ResourcePeriodicityAndOffset ::= CHOICE {			
slots5	1		FR1_FDD
slot10	1		FR1_TDD
slot8	1		FR2
}			

p-ZP-CSI-RS-ResourceSet

**Table 5.4.2.4-5: p-ZP-CSI-RS-ResourceSet**

Derivation Path: Table 4.6.3-87			
Information Element	Value/remark	Comment	Condition
p-ZP-CSI-RS-ResourceSet ::= SEQUENCE {			



zp_CSI-RS_ResourceSetId	0		
zp-CSI-RS-ResourceIdList SEQUENCE (SIZE (1..maxNrofZP-CSI-RS-ResourcesPerSet)) OF ZP-CSI-RS-ResourceId{	1 entry		
ZP-CSI-RS-ResourceId[1]	0	entry 1 ZP CSI-RS resource 1	
}			
}			

CSI-IM Configuration

CSI-IM-Resource

**Table 5.4.2.4-6: CSI-IM-Resource**

Derivation Path: TS 38.331 [6], clause 6.3.2			
Information Element	Value/remark	Comment	Condition
CSI-IM-Resource ::= SEQUENCE {			
csi-IM-ResourceId	CSI-IM-ResourceId		
csi-IM-ResourceElementPattern CHOICE {			
pattern0 SEQUENCE {			FR1
subcarrierLocation-p0	s4		
symbolLocation-p0	9		
}			
pattern1 SEQUENCE {			FR2
subcarrierLocation-p1	s8		
symbolLocation-p1	13		
}			
}			
freqBand	CSI-FrequencyOccupation		
periodicityAndOffset	CSI-ResourcePeriodicityAndOffset		
}			

CSI-IM-ResourceId

**Table 5.4.2.4-7: CSI-IM-ResourceId**

Derivation Path: TS 38.331 [6], clause 6.3.2			
Information Element	Value/remark	Comment	Condition
CSI-IM-ResourceId	0		

CSI-IM-ResourceSet

**Table 5.4.2.4-8: CSI-IM-ResourceSet**

Derivation Path: TS 38.331 [6], clause 6.3.2			
Information Element	Value/remark	Comment	Condition
CSI-IM-ResourceSet ::= SEQUENCE {			
csi-IM-ResourceSetId	CSI-IM-ResourceSetId		
csi-IM-Resources SEQUENCE (SIZE(1..maxNrofCSI-IM-ResourcesPerSet)) {	1 entry		
CSI-IM-ResourceId[1]	CSI-IM-ResourceId	entry 1	
}			
}			

CSI-IM-ResourceSetId

Table 5.4.2.4-9: CSI-IM-ResourceSetId

Derivation Path: TS 38.331 [6], clause 6.3.2			
Information Element	Value/remark	Comment	Condition
CSI-IM-ResourceSetId	0		

CSI-IM-ResourceConfig

Table 5.4.2.4-10: CSI-IM-ResourceConfig

Derivation Path: TS 38.331 [6], clause 6.3.2			
Information Element	Value/remark	Comment	Condition
CSI-ResourceConfig ::= SEQUENCE {			
csi-ResourceConfigId	2		
csi-RS-ResourceSetList CHOICE {			
csi-IM-ResourceSetList SEQUENCE (SIZE (1..maxNrofCSI-IM-ResourceSetsPerConfig)) OF CSI-IM-ResourceSetId {	1 entry		
csi-IM-ResourceSetId[0]	0	entry 1	
}			
}			
bwp-Id	BWP-Id		
resourceType	periodic		
}			

CSI-MeasConfig

Table 5.4.2.4-11: CSI-MeasConfig

Derivation Path: Table 4.6.3-38			
Information Element	Value/remark	Comment	Condition
CSI-MeasConfig ::= SEQUENCE {			
nzp-CSI-RS-ResourceToAddModList SEQUENCE (SIZE (1..maxNrofNZP-CSI-RS-Resources)) OF NZP-CSI-RS-Resource {	n entries	n=5 for FR1 n=7 for FR2	
NZP-CSI-RS-Resource[1]	NZP-CSI-RS-Resource for TRS (1)	entry 1 CSI-RS resource 1	
NZP-CSI-RS-Resource[2]	NZP-CSI-RS-Resource for TRS (2)	entry 2 CSI-RS resource 2	
NZP-CSI-RS-Resource[3]	NZP-CSI-RS-Resource for TRS (3)	entry 3 CSI-RS resource 3	
NZP-CSI-RS-Resource[4]	NZP-CSI-RS-Resource for TRS (4)	entry 4 CSI-RS resource 4	
NZP-CSI-RS-Resource[5]	NZP-CSI-RS-Resource for CSI Acquisition	entry 5 CSI-RS resource 5	
NZP-CSI-RS-Resource[6]	CSI-RS-Resource for beam refinement	entry 6 CSI-RS resource 6	FR2
NZP-CSI-RS-Resource[7]	CSI-RS-Resource for beam refinement	entry 7 CSI-RS resource 7	FR2
}			
nzp-CSI-RS-ResourceSetToAddModList SEQUENCE (SIZE (1..maxNrofNZP-CSI-RS-ResourceSets)) OF NZP-CSI-RS-ResourceSet {	n entries	n=2 for FR1 n=3 for FR2	
NZP-CSI-RS-ResourceSet[1]	NZP-CSI-RS-ResourceSet for TRS	entry 1	
NZP-CSI-RS-ResourceSet[2]	NZP-CSI-RS-ResourceSet for CSI Acquisition	entry 2	
NZP-CSI-RS-ResourceSet[3]	NZP-CSI-RS-ResourceSet for beam refinement	entry 3	FR2
}			

csi-IM-ResourceToAddModList SEQUENCE (SIZE (1..maxNrofCSI-IM-Resources)) OF CSI-IM-Resource {	1 entry		
CSI-IM-Resource[1]	CSI-IM-Resource		
}			
csi-IM-ResourceSetToAddModList SEQUENCE (SIZE (1..maxNrofCSI-IM-ResourceSets)) OF CSI-IM-ResourceSet {	1 entry		
CSI-IM-ResourceSet[1]	CSI-IM-ResourceSet	entry 1	
}			
csi-SSB-ResourceSetToAddModList	Not present		
csi-ResourceConfigToAddModList SEQUENCE (SIZE (1..maxNrofCSI-ResourceConfigurations)) OF CSI-ResourceConfig {	n entries	n=3 for FR1 n=4 for FR2	
CSI-ResourceConfig[1]	CSI-ResourceConfig for TRS	entry 1	
CSI-ResourceConfig[2]	CSI-ResourceConfig for CSI Acquisition	entry 2	
CSI-ResourceConfig[3]	CSI-IM-ResourceConfig	entry 3	
CSI-ResourceConfig[4]	CSI-ResourceConfig for beam refinement	entry 4	FR2
}			
}			

## CSI-ReportConfig

Table 5.4.2.4-12: CSI-ReportConfig

Derivation Path: TS 38.331 [6], clause 6.3.2			
Information Element	Value/remark	Comment	Condition
CSI-ReportConfig ::= SEQUENCE {			
reportConfigId	CSI-ReportConfigId		
carrier	ServCellIndex		
resourcesForChannelMeasurement	CSI-ResourceConfigId for CSI Acquisition		
csi-IM-ResourcesForInterference	CSI-ResourceConfigId for CSI-IM		
nzp-CSI-RS-ResourcesForInterference	not present		
reportConfigType CHOICE {			
periodic SEQUENCE {			
reportSlotConfig	CSI-ReportPeriodicityAndOffset		
pucch-CSI-ResourceList SEQUENCE (SIZE (1..maxNrofBWPs)) OF PUCCH-CSI-Resource {	2 entry		
PUCCH-CSI-Resource [1]	PUCCH-CSI-Resource	entry 1	
}			
}			
reportQuantity CHOICE {			
cri-RI-PMI-CQI	NULL		FR1, FR2
}			
reportFreqConfiguration SEQUENCE {			
cqi-FormatIndicator	widebandCQI		
pmi-FormatIndicator	widebandPMI		
csi-ReportingBand CHOICE {			
subbands7	'1111111'B		FR1
subbands9	'111111111'B		FR2
}			
}			
timeRestrictionForChannelMeasurements	notConfigured		
timeRestrictionForInterferenceMeasurements	notConfigured		
codebookConfig	CodebookConfig		
dummy	Not present		
groupBasedBeamReporting CHOICE {			
disabled SEQUENCE {			

nrofReportedRS	not present		
}			
}			
cqi-Table	table2		FR1
	table1		FR2
subbandSize	value2		
non-PMI-PortIndication	Not present		
}			

## CSI-ReportPeriodicityAndOffset

Table 5.4.2.4-13: CSI-ReportPeriodicityAndOffset

Derivation Path: TS 38.331 [6], clause 6.3.2			
Information Element	Value/remark	Comment	Condition
CSI-ReportPeriodicityAndOffset ::= CHOICE {			
slots10	9		FR1_TDD
slots5	0		FR1_FDD
slot8	3		FR2
}			

## PUCCH-CSI-Resource

Table 5.4.2.4-14: PUCCH-CSI-Resource

Derivation Path: TS 38.331 [6], clause 6.3.2			
Information Element	Value/remark	Comment	Condition
PUCCH-CSI-Resource ::= SEQUENCE {			
uplinkBandwidthPartId	BWP-id		FR1, FR2
pucch-Resource	8		FR1
	14		FR2
}			

## CodebookConfig

Table 5.4.2.4-15: CodebookConfig

Derivation Path: Table 4.6.3-25			
Information Element	Value/remark	Comment	Condition
CodebookConfig ::= SEQUENCE {			
codebookType CHOICE {			
type1 SEQUENCE {			
subType CHOICE {			
type1-SinglePanel SEQUENCE {			
nrOfAntennaPorts CHOICE {			
two SEQUENCE {			
twoTX-CodebookSubsetRestriction	'010000'B		
}			
}			
type1-SinglePanel-ri-Restriction	'11111111'B		
}			
}			
codebookMode	1		
}			
}			
}			

Physical layer parameters

**Table 5.4.2.4-16: Physical layer parameters for DCI format 1\_1**

Derivation Path: Table 4.3.6.1.2.2-1			
Parameter	Value	Value in binary	Condition
PUCCH resource indicator	<i>PUCCH-ResourceId</i> [1] = 8 in <i>pucch-ResourceSetID</i> [2] as defined in Table 4.6.3-112 (Mapping as per Table 9.2.3-2 in TS 38.213)	'110'B	SUBBAND_CQI

PUSCH-TimeDomainResourceAllocationList

**Table 5.4.2.4-17: PUSCH-TimeDomainResourceAllocationList**

Derivation Path: Table 5.4.2.0-27			
Information Element	Value/remark	Comment	Condition
PUSCH-TimeDomainResourceAllocationList ::= SEQUENCE (SIZE(1..maxNrofUL-Allocations)) OF PUSCH-TimeDomainResourceAllocation {	2 entries		SUBBAND_CQI
PUSCH-TimeDomainResourceAllocation[1]		entry 1	
SEQUENCE {			
startSymbolAndLength	55	Start symbol(S)=0, Length(L)=12	
}			
PUSCH-TimeDomainResourceAllocation[2]		entry 2	
SEQUENCE {			
startSymbolAndLength	55	Start symbol(S)=0, Length(L)=12	
}			
}			

Condition	Explanation
SUBBAND_CQI	For aperiodic subband CQI reporting under fading condition test cases

CSI-ResourceConfig

**Table 5.4.2.4-18: CSI-ResourceConfig for CSI Acquisition**

Derivation Path: Table 5.4.2.0-19			
Information Element	Value/remark	Comment	Condition
CSI-ResourceConfig ::= SEQUENCE {			
csi-ResourceConfigId	1		
csi-RS-ResourceSetList CHOICE {			
nzp-CSI-RS-SSB SEQUENCE {			
nzp-CSI-RS-ResourceSetList SEQUENCE (SIZE (1..maxNrofNZP-CSI-RS-ResourceSetsPerConfig)) OF NZP-CSI-RS-ResourceSetId {	1 entry		
NZP-CSI-RS-ResourceSetId[1]	1	entry 1	
}			
csi-SSB-ResourceSetList	Not present		
}			
}			
bwp-Id	BWP-Id		
resourceType	periodic		
}			

5.4.2.5 Message contents for PMI reporting requirements

NZP-CSI-RS for Tracking

CSI-RS-ResourceMapping

**Table 5.4.2.5-1: CSI-RS-ResourceMapping for TRS**

Derivation Path: Table 4.6.3-45			
Information Element	Value/remark	Comment	Condition
CSI-RS-ResourceMapping ::= SEQUENCE {			
frequencyDomainAllocation CHOICE {			
row1	0001	k <sub>0</sub> =0 for CSI-RS resource 1,2,3,4	TRS
}			
firstOFDMSymbolInTimeDomain	4	l <sub>0</sub> = 4 for CSI-RS resource 1 and 3	TRS
	8	l <sub>0</sub> = 8 for CSI-RS resource 2 and 4	TRS
nrofPorts	p1	1 for CSI-RS resource 1,2,3,4	TRS
cdm-Type	noCDM		TRS
density CHOICE{			
three	Null		TRS
}			
freqBand	CSI-FrequencyOccupation		TRS
}			

NZP CSI-RS for CSI Acquisition

CSI-RS-ResourceMapping

**Table 5.4.2.5-2: CSI-RS-ResourceMapping**

Derivation Path: Table 4.6.3-45			
Information Element	Value/remark	Comment	Condition
CSI-RS-ResourceMapping ::= SEQUENCE {			
frequencyDomainAllocation CHOICE {			
row3	001000	K <sub>0</sub> = 6, row3	2Tx
row4	001	K <sub>0</sub> = 0, row4	4Tx
other	001100	K <sub>0</sub> = 4, K <sub>1</sub> = 6, row8	8Tx
	011110	K <sub>0</sub> =2, row 12	16Tx
}			
nrofPorts	p2		2Tx
	p4		4Tx
	p8		8Tx
	p16		16Tx
firstOFDMSymbolInTimeDomain	13	l <sub>0</sub> = 13	2Tx, 4Tx
	5	l <sub>0</sub> = 5	8Tx, 16Tx
cdm-Type	fd-CDM2		2Tx, 4Tx
	cdm4-FD2-TD2		8Tx, 16Tx
density CHOICE {			
one	NULL		
}			
freqBand	CSI-FrequencyOccupation		
}			

Condition	Explanation
-----------	-------------

2Tx	For test cases using 2 CSI-RS ports for NZP-CSI-RS for CSI acquisition.
4Tx	For test cases using 4 CSI-RS ports for NZP-CSI-RS for CSI acquisition.
8Tx	For test cases using 8 CSI-RS ports for NZP-CSI-RS for CSI acquisition.
16Tx	For test cases using 16 CSI-RS ports for NZP-CSI-RS for CSI acquisition.

ZP CSI-RS for CSI Acquisition

CSI-RS-ResourceMapping

**Table 5.4.2.5-3: ZP CSI-RS-ResourceMapping**

Derivation Path: Table 4.6.3-45			
Information Element	Value/remark	Comment	Condition
CSI-RS-ResourceMapping ::= SEQUENCE {			
frequencyDomainAllocation CHOICE {			
other	000100	K0 = 4	FR1
row4	100	K0 = 8	FR2
}			
nrofPorts	p4		
firstOFDMSymbolInTimeDomain	9	l0 = 9	FR1
	13	l0 = 13	FR2
cdm-Type	fd-CDM2		
density CHOICE {			
one	NULL		
}			
freqBand	ZP CSI-FrequencyOccupation		
}			

**Table 5.4.2.5-4: Void**

CSI-ResourcePeriodicityAndOffset

**Table 5.4.2.5-4A: ZP CSI-ResourcePeriodicityAndOffset**

Derivation Path: Table 4.6.3-43			
Information Element	Value/remark	Comment	Condition
CSI-ResourcePeriodicityAndOffset ::= CHOICE {			
slots5	1		FR1_FDD
slot10	1		FR1_TDD
slot8	1		FR2
}			

**Table 5.4.2.5-5: Void**

p-ZP-CSI-RS-ResourceSet

**Table 5.4.2.5-5A: p-ZP-CSI-RS-ResourceSet**

Derivation Path: Table 4.6.3-87			
Information Element	Value/remark	Comment	Condition
p-ZP-CSI-RS-ResourceSet ::= SEQUENCE {			

zp_CSI-RS_ResourceSetId	0		
zp-CSI-RS-ResourceSetList SEQUENCE (SIZE (1..maxNrofZP-CSI-RS-ResourcesPerSet)) OF ZP-CSI-RS-ResourceSetId{	1 entry		
ZP-CSI-RS-ResourceSetId[1]	0	entry 1 ZP CSI-RS resource 1	
}			
}			

CSI-ResourceConfig

**Table 5.4.2.5-6: CSI-ResourceConfig for CSI Acquisition**

Derivation Path: Table 4.6.3-41			
Information Element	Value/remark	Comment	Condition
CSI-ResourceConfig ::= SEQUENCE {			
csi-ResourceConfigId	1		
csi-RS-ResourceSetList CHOICE {			
nzp-CSI-RS-SSB SEQUENCE {			
nzp-CSI-RS-ResourceSetList SEQUENCE (SIZE (1..maxNrofNzp-CSI-RS-ResourceSetsPerConfig)) OF NZP-CSI-RS-ResourceSetId {	1 entry		
NZP-CSI-RS-ResourceSetId[1]	1	entry 1	
}			
csi-SSB-ResourceSetList	Not present		
}			
bwp-Id	BWP-Id		
resourceType	aperiodic		
}			

CSI-IM Configuration

CSI-IM-Resource

**Table 5.4.2.5-7: CSI-IM-Resource**

Derivation Path: TS 38.331 [6], clause 6.3.2			
Information Element	Value/remark	Comment	Condition
CSI-IM-Resource ::= SEQUENCE {			
csi-IM-ResourceId	CSI-IM-ResourceId		
csi-IM-ResourceElementPattern CHOICE {			
pattern0 SEQUENCE {			FR1
subcarrierLocation-p0	s4		
symbolLocation-p0	9		
}			
pattern1 SEQUENCE {			FR2
subcarrierLocation-p1	s8		
symbolLocation-p1	13		
}			
}			
freqBand	CSI-FrequencyOccupation		
periodicityAndOffset	Not present		
}			

CSI-IM-ResourceId

**Table 5.4.2.5-8: CSI-IM-ResourceId**

Derivation Path: TS 38.331 [6], clause 6.3.2
--



Information Element	Value/remark	Comment	Condition
CSI-IM-ResourceId	0		

CSI-IM-ResourceSet

**Table 5.4.2.5-9: CSI-IM-ResourceSet**

Derivation Path: TS 38.331 [6], clause 6.3.2			
Information Element	Value/remark	Comment	Condition
CSI-IM-ResourceSet ::= SEQUENCE {			
csi-IM-ResourceSetId	CSI-IM-ResourceSetId		
csi-IM-Resources SEQUENCE (SIZE(1..maxNrofCSI-IM-ResourcesPerSet)) {	1 entry		
CSI-IM-ResourceId[1]	CSI-IM-ResourceId	entry 1	
}			
}			

CSI-IM-ResourceSetId

**Table 5.4.2.5-10: CSI-IM-ResourceSetId**

Derivation Path: TS 38.331 [6], clause 6.3.2			
Information Element	Value/remark	Comment	Condition
CSI-IM-ResourceSetId	0		

CSI-IM-ResourceConfig

**Table 5.4.2.5-11: CSI-IM-ResourceConfig**

Derivation Path: TS 38.331 [6], clause 6.3.2			
Information Element	Value/remark	Comment	Condition
CSI-ResourceConfig ::= SEQUENCE {			
csi-ResourceConfigId	2		
csi-RS-ResourceSetList CHOICE {			
csi-IM-ResourceSetList SEQUENCE (SIZE (1..maxNrofCSI-IM-ResourceSetsPerConfig)) OF CSI-IM-ResourceSetId {	1 entry		
csi-IM-ResourceSetId[0]	0	entry 1	
}			
}			
bwp-Id	BWP-Id		
resourceType	aperiodic		
}			

CSI-MeasConfig

**Table 5.4.2.5-12: CSI-MeasConfig**

Derivation Path: Table 4.6.3-38			
Information Element	Value/remark	Comment	Condition
CSI-MeasConfig ::= SEQUENCE {			
nzp-CSI-RS-ResourceToAddModList SEQUENCE (SIZE (1..maxNrofNZP-CSI-RS-Resources)) OF NZP-CSI-RS-Resource {	n entries	n=5 for FR1 n=7 for FR2	
NZP-CSI-RS-Resource[1]	NZP-CSI-RS-Resource for TRS (1)	entry 1 CSI-RS resource 1	
NZP-CSI-RS-Resource[2]	NZP-CSI-RS-Resource for TRS (2)	entry 2 CSI-RS resource 2	
NZP-CSI-RS-Resource[3]	NZP-CSI-RS-Resource for TRS (3)	entry 3 CSI-RS resource 3	

NZP-CSI-RS-Resource[4]	NZP-CSI-RS-Resource for TRS (4)	entry 4 CSI-RS resource 4	
NZP-CSI-RS-Resource[5]	NZP-CSI-RS-Resource for CSI Acquisition	entry 5 CSI-RS resource 5	
NZP-CSI-RS-Resource[6]	CSI-RS-Resource for beam refinement	entry 6 CSI-RS resource 6	FR2
NZP-CSI-RS-Resource[7]	CSI-RS-Resource for beam refinement	entry 7 CSI-RS resource 7	FR2
}			
nzp-CSI-RS-ResourceSetToAddModList SEQUENCE (SIZE (1..maxNrofNZP-CSI-RS-ResourceSets)) OF NZP-CSI-RS-ResourceSet {	n entries	n=2 for FR1 n=3 for FR2	
NZP-CSI-RS-ResourceSet[1]	NZP-CSI-RS-ResourceSet for TRS	entry 1	
NZP-CSI-RS-ResourceSet[2]	NZP-CSI-RS-ResourceSet for CSI Acquisition	entry 2	
NZP-CSI-RS-ResourceSet[3]	NZP-CSI-RS-ResourceSet for beam refinement	entry 3	FR2
}			
csi-IM-ResourceToAddModList SEQUENCE (SIZE (1..maxNrofCSI-IM-Resources)) OF CSI-IM-Resource {	1 entry		
CSI-IM-Resource[1]	CSI-IM-Resource		
}			
csi-IM-ResourceSetToAddModList SEQUENCE (SIZE (1..maxNrofCSI-IM-ResourceSets)) OF CSI-IM-ResourceSet {	1 entry		
CSI-IM-ResourceSet[1]	CSI-IM-ResourceSet		
}			
csi-SSB-ResourceSetToAddModList	Not present		
csi-ResourceConfigToAddModList SEQUENCE (SIZE (1..maxNrofCSI-ResourceConfigurations)) OF CSI-ResourceConfig {	n entries	n=3 for FR1 n=4 for FR2	
CSI-ResourceConfig[1]	CSI-ResourceConfig for TRS	entry 1	
CSI-ResourceConfig[2]	CSI-ResourceConfig for CSI Acquisition	entry 2	
CSI-ResourceConfig[3]	CSI-IM-ResourceConfig	entry 3	
CSI-ResourceConfig[4]	CSI-ResourceConfig for beam refinement	entry 4	FR2
}			
}			

CSI-ReportConfig

Table 5.4.2.5-13: CSI-ReportConfig

Derivation Path: TS 38.331 [6], clause 6.3.2			
Information Element	Value/remark	Comment	Condition
CSI-ReportConfig ::= SEQUENCE {			
reportConfigId	CSI-ReportConfigId		
carrier	ServCellIndex		
resourcesForChannelMeasurement	CSI-ResourceConfigId for CSI Acquisition		
csi-IM-ResourcesForInterference	CSI-ResourceConfigId for CSI-IM		
nzp-CSI-RS-ResourcesForInterference	not present		
reportConfigType CHOICE {			
aperiodic SEQUENCE {			
reportSlotOffsetList SEQUENCE {	2 entries		
reportSlotOffsetList[1]	4	entry 1	FR1_FDD_4 Tx, FR1_FDD_1 6Tx
	5		FR1_FDD_8 Tx

	8		FR1_TDD
	6		FR2
reportSlotOffsetList[2]	4	entry 2	FR1_FDD_4 Tx, FR1_FDD_1 6Tx
	5		FR1_FDD_8 Tx
	8		FR1_TDD
	6		FR2
}			
}			
reportQuantity CHOICE {			
cri-RI-PMI-CQI	NULL		
}			
reportFreqConfiguration SEQUENCE {			
cqi-FormatIndicator	widebandCQI		
pmi-FormatIndicator	widebandPMI		
csi-ReportingBand CHOICE {			FR1
subbands7	'1111111'B		
}			
csi-ReportingBand CHOICE {			FR2
subbands9	'111111111'B		
}			
timeRestrictionForChannelMeasurements	notConfigured		
timeRestrictionForInterferenceMeasurements	notConfigured		
codebookConfig	CodebookConfig		
dummy	Not present		
groupBasedBeamReporting CHOICE {			
disabled SEQUENCE {			
nrofReportedRS	not present		
}			
}			
cqi-Table	table1		
subbandSize	value2		
non-PMI-PortIndication	Not present		
}			

CodebookConfig

**Table 5.4.2.5-14: CodebookConfig**

Derivation Path: Table 4.6.3-25			
Information Element	Value/remark	Comment	Condition
CodebookConfig ::= SEQUENCE {			
codebookType CHOICE {			
type1 SEQUENCE {			
subType CHOICE {			
type1-SinglePanel SEQUENCE {			
nrOfAntennaPorts CHOICE {			
two SEQUENCE {			2Tx
twoTX-CodebookSubsetRestriction	'001111'B		
}			
moreThanTwo SEQUENCE {			4Tx, 8Tx
n1-n2 CHOICE {			
two-one-Type1-SinglePanel-Restriction	'11111111'B		
}			
type1-SinglePanel- codebookSubsetRestriction-i2	Not present		
}			
}			
}			
type1-SinglePanel-ri-Restriction	'11111111'B		2Tx

	'00000001'B		4Tx
	'00000010'B		8Tx
}			
codebookMode	1		
}			
}			
}			

CSI-AperiodicTriggerStateList

**Table 5.4.2.5-15: CSI-AperiodicTriggerStateList**

Derivation Path: Table 4.6.3-32			
Information Element	Value/remark	Comment	Condition
CSI-AperiodicTriggerStateList ::= SEQUENCE (SIZE (1..maxNrOfCSI-AperiodicTriggers)) OF CSI-AperiodicTriggerState {	1 entry		
CSI-AperiodicTriggerState[1] SEQUENCE {		entry 1	
associatedReportConfigInfoList SEQUENCE (SIZE(1..maxNrofReportConfigPerAperiodicTrigger)) OF CSI-AssociatedReportConfigInfo {	1 entry		
CSI-AssociatedReportConfigInfo[1] SEQUENCE {		entry 1	
reportConfigId	0		
resourcesForChannel CHOICE {			
nzp-CSI-RS SEQUENCE {			
resourceSet	1		
qcl-info SEQUENCE (SIZE(1..maxNrofAP-CSI-RS-ResourcesPerSet)) OF TCI-StateId {	1 entry		
TCI-StateId[1]	1	entry 1	
}			
}			
}			
csi-IM-ResourcesforInterference	1		
nzp-CSI-RS-ResourcesforInterference	Not present		
}			
}			
}			
}			

Physical layer parameters

**Table 5.4.2.5-16: Physical layer parameters for DCI format 1\_1**

Derivation Path: Table 5.4.2.0-1			
Parameter	Value	Value in binary	Condition
PUCCH resource indicator	PUCCH-ResourceId[7] = 6 in pucch-ResourceSetID[1] or PUCCH-ResourceId[7] = 14 in pucch-ResourceSetID[2] as defined in Table 4.6.3-112 (Mapping as per Table 9.2.3-2 in TS 38.213)	'110'B	

PUSCH-TimeDomainResourceAllocationList

**Table 5.4.2.5-17: PUSCH-TimeDomainResourceAllocationList**

Derivation Path: Table 5.4.2.0-27			
Information Element	Value/remark	Comment	Condition
PUSCH-TimeDomainResourceAllocationList ::= SEQUENCE (SIZE(1..maxNrofUL-Allocations)) OF PUSCH-TimeDomainResourceAllocation {	2 entries		

PUSCH-TimeDomainResourceAllocation[1] SEQUENCE {		entry 1	
startSymbolAndLength	55	Start symbol(S)=0, Length(L)=12	
}			
PUSCH-TimeDomainResourceAllocation[2] SEQUENCE {		entry 2	
startSymbolAndLength	55	Start symbol(S)=0, Length(L)=12	
}			
}			

5.4.2.6 Message contents for RI reporting requirements

NZP-CSI-RS for Tracking

CSI-RS-ResourceMapping

**Table 5.4.2.6-1: CSI-RS-ResourceMapping for TRS**

Derivation Path: Table 4.6.3-45			
Information Element	Value/remark	Comment	Condition
CSI-RS-ResourceMapping ::= SEQUENCE {			
frequencyDomainAllocation CHOICE {			
row1	0001	k <sub>0</sub> =0 for CSI-RS resource 1,2,3,4	TRS
}			
firstOFDMSymbolInTimeDomain	4	l <sub>0</sub> = 4 for CSI-RS resource 1 and 3	TRS
	8	l <sub>0</sub> = 8 for CSI-RS resource 2 and 4	TRS
nrofPorts	p1	1 for CSI-RS resource 1,2,3,4	TRS
cdm-Type	noCDM		TRS
density CHOICE{			
three	Null		TRS
}			
freqBand	CSI-FrequencyOccupation		TRS
}			

NZP CSI-RS for CSI Acquisition

CSI-RS-ResourceMapping

**Table 5.4.2.6-2: CSI-RS-ResourceMapping**

Derivation Path: Table 4.6.3-45			
Information Element	Value/remark	Comment	Condition
CSI-RS-ResourceMapping ::= SEQUENCE {			
frequencyDomainAllocation CHOICE {			
row4	001	K <sub>0</sub> = 0, row4	4Tx
other	001000	K <sub>0</sub> = 6, row3	2Tx
}			
nrofPorts	p4		4Tx
	p2		2Tx
firstOFDMSymbolInTimeDomain	13	l <sub>0</sub> = 13	2Tx, 4Tx
cdm-Type	fd-CDM2		2Tx, 4Tx
density CHOICE {			
one	NULL		
}			

freqBand	CSI-FrequencyOccupation		
}			

Condition	Explanation
2Tx	For test cases using 2 CSI-RS ports for NZP-CSI-RS for CSI acquisition.
4Tx	For test cases using 4 CSI-RS ports for NZP-CSI-RS for CSI acquisition.

**Table 5.4.2.6-3: CSI-ResourcePeriodicityAndOffset for CSI Acquisition**

Derivation Path: Table 4.6.3-43

Information Element	Value/remark	Comment	Condition
CSI-ResourcePeriodicityAndOffset ::= CHOICE {			
Slots5	1		FR1_FDD
Slots10	1		FR1_TDD
}			

ZP CSI-RS for CSI Acquisition

CSI-RS-ResourceMapping

**Table 5.4.2.6-4: ZP CSI-RS-ResourceMapping**

Derivation Path: Table 4.6.3-45

Information Element	Value/remark	Comment	Condition
CSI-RS-ResourceMapping ::= SEQUENCE {			
frequencyDomainAllocation CHOICE {			
other	000100	K0 = 4, row5	FR1
row4	100	K0 = 8, row4	FR2
}			
nrofPorts	p4		
firstOFDMSymbolInTimeDomain	9	I0 = 9	FR1
	13	I0 = 13	FR2
cdm-Type	fd-CDM2		
density CHOICE {			
one	NULL		
}			
freqBand	ZP CSI-FrequencyOccupation		
}			

CSI-ResourcePeriodicityAndOffset

**Table 5.4.2.6-5: ZP CSI-ResourcePeriodicityAndOffset**

Derivation Path: Table 4.6.3-43

Information Element	Value/remark	Comment	Condition
CSI-ResourcePeriodicityAndOffset ::= CHOICE {			
Slots5	1		FR1 FDD
Slots10	1		FR1 TDD
Slots8	1		FR2
}			

PDSCH-Config

Table 5.4.2.6-6: PDSCH-Config

Derivation Path: Table 4.6.3-100			
Information Element	Value/remark	Comment	Condition
PDSCH-Config ::= SEQUENCE {			
p-ZP-CSI-RS-ResourceSetsToAddModList	p-ZP-CSI-RS-ResourceSet		
}			

p-ZP-CSI-RS-ResourceSet

Table 5.4.2.6-7: p-ZP-CSI-RS-ResourceSet

Derivation Path: Table 4.6.3-87			
Information Element	Value/remark	Comment	Condition
p-ZP-CSI-RS-ResourceSetsToAddModList ::= SEQUENCE {			
zp_CSI-RS_ResourceSetId	0		
zp-CSI-RS-ResourceIdList SEQUENCE (SIZE (1..maxNrofZP-CSI-RS-ResourcesPerSet)) OF ZP-CSI-RS-ResourceId{	1 entry		
ZP-CSI-RS-ResourceId[1]	0	entry 1 ZP CSI-RS resource 1	
}			
}			

CSI-ResourceConfig

Table 5.4.2.6-8: CSI-ResourceConfig for CSI Acquisition

Derivation Path: Table 4.6.3-41			
Information Element	Value/remark	Comment	Condition
CSI-ResourceConfig ::= SEQUENCE {			
csi-ResourceConfigId	1		
csi-RS-ResourceSetList CHOICE {			
nzp-CSI-RS-SSB SEQUENCE {			
nzp-CSI-RS-ResourceSetList SEQUENCE (SIZE (1..maxNrofNzp-CSI-RS-ResourceSetsPerConfig)) OF Nzp-CSI-RS-ResourceSetId {	1 entry		
Nzp-CSI-RS-ResourceSetId[1]	1	entry 1	
}			
csi-SSB-ResourceSetList	Not present		
}			
bwp-Id	BWP-Id		
resourceType	periodic		FR1
	aperiodic		FR2
}			

Table 5.4.2.6-8A: CSI-ResourceConfig for beam refinement

Derivation Path: Table 4.6.3-41			
Information Element	Value/remark	Comment	Condition
CSI-ResourceConfig ::= SEQUENCE {			FR2
csi-ResourceConfigId	3		
csi-RS-ResourceSetList CHOICE {			
nzp-CSI-RS-SSB SEQUENCE {			

nzp-CSI-RS-ResourceSetList SEQUENCE (SIZE (1..maxNrofNZP-CSI-RS-ResourceSetsPerConfig)) OF NZP-CSI-RS-ResourceSetId {	1 entry		
NZP-CSI-RS-ResourceSetId[1]	2	entry 1	
}			
csi-SSB-ResourceSetList	Not present		
}			
}			
bwp-Id	BWP-Id		
resourceType	periodic		
}			

CSI-IM Configuration

CSI-IM-Resource

**Table 5.4.2.6-9: CSI-IM-Resource**

Derivation Path: Table 4.6.3-34			
Information Element	Value/remark	Comment	Condition
CSI-IM-Resource ::= SEQUENCE {			
csi-IM-ResourceId	CSI-IM-ResourceId		
csi-IM-ResourceElementPattern CHOICE {			
Pattern0 SEQUENCE {			
subcarrierLocation-p0	s4		FR1
	s8		FR2
symbolLocation-p0	9		FR1
	13		FR2
}			
}			
freqBand	CSI-FrequencyOccupation		
periodicityAndOffset	CSI-ResourcePeriodicityAndOffset		FR1
	Not present		FR2
}			

**Table 5.4.2.6-10: CSI-ResourcePeriodicityAndOffset**

Derivation Path: Table 4.6.3-43			
Information Element	Value/remark	Comment	Condition
CSI-ResourcePeriodicityAndOffset ::= CHOICE {			
Slots5	1		FR1_FDD
Slots10	1		FR1_TDD
}			

CSI-IM-ResourceId

**Table 5.4.2.6-11: CSI-IM-ResourceId**

Derivation Path: Table 4.6.3-35			
Information Element	Value/remark	Comment	Condition
CSI-IM-ResourceId	0		

CSI-IM-ResourceSet

**Table 5.4.2.6-12: CSI-IM-ResourceSet**

Derivation Path: Table 4.6.3-36			
---------------------------------	--	--	--



Information Element	Value/remark	Comment	Condition
CSI-IM-ResourceSet ::= SEQUENCE {			
csi-IM-ResourceSetId	CSI-IM-ResourceSetId		
csi-IM-Resources SEQUENCE (SIZE(1..maxNrofCSI-IM-ResourcesPerSet)) {	1 entry		
CSI-IM-ResourceId[1]	CSI-IM-ResourceId	entry 1	
}			
}			

CSI-IM-ResourceSetId

**Table 5.4.2.6-13: CSI-IM-ResourceSetId**

Derivation Path: Table 4.6.3-37			
Information Element	Value/remark	Comment	Condition
CSI-IM-ResourceSetId	0		

CSI-IM-ResourceConfig

**Table 5.4.2.6-14: CSI-IM-ResourceConfig**

Derivation Path: Table 4.6.3-41			
Information Element	Value/remark	Comment	Condition
CSI-ResourceConfig ::= SEQUENCE {			
csi-ResourceConfigId	2		
csi-RS-ResourceSetList CHOICE {			
csi-IM-ResourceSetList SEQUENCE (SIZE (1..maxNrofCSI-IM-ResourceSetsPerConfig)) OF CSI-IM-ResourceSetId {	1 entry		
csi-IM-ResourceSetId[0]	0		
}			
}			
bwp-Id	BWP-Id		
resourceType	periodic		FR1
	aperiodic		FR2
}			

CSI-MeasConfig

**Table 5.4.2.6-15: CSI-MeasConfig**

Derivation Path: Table 4.6.3-38			
Information Element	Value/remark	Comment	Condition
CSI-MeasConfig ::= SEQUENCE {			
nzp-CSI-RS-ResourceToAddModList SEQUENCE (SIZE (1..maxNrofNZP-CSI-RS-Resources)) OF NZP-CSI-RS-Resource {	n entries	n=5 for FR1 n=7 for FR2	
NZP-CSI-RS-Resource[1]	NZP-CSI-RS-Resource for TRS (1)	entry 1 CSI-RS resource 1	
NZP-CSI-RS-Resource[2]	NZP-CSI-RS-Resource for TRS (2)	entry 2 CSI-RS resource 2	
NZP-CSI-RS-Resource[3]	NZP-CSI-RS-Resource for TRS (3)	entry 3 CSI-RS resource 3	
NZP-CSI-RS-Resource[4]	NZP-CSI-RS-Resource for TRS (4)	entry 4 CSI-RS resource 4	
NZP-CSI-RS-Resource[5]	NZP-CSI-RS-Resource for CSI Acquisition	entry 5 CSI-RS resource 5	
NZP-CSI-RS-Resource[6]	NZP-CSI-RS-Resource for beam refinement	entry 6 CSI-RS resource 6	FR2
NZP-CSI-RS-Resource[7]	NZP-CSI-RS-Resource for beam refinement	entry 7 CSI-RS resource 7	FR2

}			
nzp-CSI-RS-ResourceSetToAddModList SEQUENCE (SIZE (1..maxNrofNZP-CSI-RS-ResourceSets)) OF NZP-CSI-RS-ResourceSet {	n entries	n=2 for FR1 n=3 for FR2	
NZP-CSI-RS-ResourceSet[1]	NZP-CSI-RS-ResourceSet for TRS	entry 1	
NZP-CSI-RS-ResourceSet[2]	NZP-CSI-RS-ResourceSet for CSI Acquisition	entry 2	
NZP-CSI-RS-ResourceSet[3]	NZP-CSI-RS-ResourceSet for beam refinement	entry 3	FR2
}			
csi-IM-ResourceToAddModList SEQUENCE (SIZE (1..maxNrofCSI-IM-Resources)) OF CSI-IM-Resource {	1 entry		
CSI-IM-Resource[1]	CSI-IM-Resource		
}			
csi-IM-ResourceSetToAddModList SEQUENCE (SIZE (1..maxNrofCSI-IM-ResourceSets)) OF CSI-IM-ResourceSet {	1 entry		
CSI-IM-ResourceSet[1]	CSI-IM-ResourceSet		
}			
csi-SSB-ResourceSetToAddModList	Not present		
csi-ResourceConfigToAddModList SEQUENCE (SIZE (1..maxNrofCSI-ResourceConfigurations)) OF CSI-ResourceConfig {	n entries	n=3 for FR1 n=4 for FR2	
CSI-ResourceConfig[1]	CSI-ResourceConfig for TRS	entry 1	
CSI-ResourceConfig[2]	CSI-ResourceConfig for CSI Acquisition	entry 2	
CSI-ResourceConfig[3]	CSI-IM-ResourceConfig	entry 3	
CSI-ResourceConfig[4]	CSI-ResourceConfig for beam refinement	entry 4	FR2
}			
}			

CSI-ReportConfig

Table 5.4.2.6-16: CSI-ReportConfig

Derivation Path: Table 4.6.3-39			
Information Element	Value/remark	Comment	Condition
CSI-ReportConfig ::= SEQUENCE {			
reportConfigId	CSI-ReportConfigId		
carrier	ServCellIndex		
resourcesForChannelMeasurement	CSI-ResourceConfigId for CSI Acquisition		
csi-IM-ResourcesForInterference	CSI-ResourceConfigId for CSI-IM		
nzp-CSI-RS-ResourcesForInterference	not present		
reportConfigType CHOICE {			
periodic SEQUENCE {			FR1
reportSlotConfig	CSI-ReportPeriodicityAndOffset		
pucch-CSI-ResourceList SEQUENCE (SIZE (1..maxNrofBWPs)) OF PUCCH-CSI-Resource {			
PUCCH-CSI-Resource [1]	PUCCH-CSI-Resource		
}			
aperiodic SEQUENCE {			FR2
reportSlotOffsetList SEQUENCE {			
reportSlotOffsetList[1]	6		
reportSlotOffsetList[2]	6		
}			
}			
}			
reportQuantity CHOICE {			

cri-RI-PMI-CQI	NULL,		
}			
reportFreqConfiguration SEQUENCE {			
cqi-FormatIndicator	widebandCQI		
pmi-FormatIndicator	widebandPMI		
csi-ReportingBand CHOICE {			FR1
subbands7	'1111111'B		
}			
csi-ReportingBand CHOICE {			FR2
subbands9	'111111111'B		
}			
}			
timeRestrictionForChannelMeasurements	notConfigured		
timeRestrictionForInterferenceMeasurements	notConfigured		
codebookConfig	CodebookConfig		
dummy	Not present		
groupBasedBeamReporting CHOICE {			
disabled SEQUENCE {			
nrofReportedRS	not present		
}			
}			
cqi-Table	table2		FR1
	table1		FR2
subbandSize	value2		
non-PMI-PortIndication	Not present		
}			

CodebookConfig

Table 5.4.2.6-17: CodebookConfig

Derivation Path: Table 4.6.3-25			
Information Element	Value/remark	Comment	Condition
CodebookConfig ::= SEQUENCE {			
codebookType CHOICE {			
type1 SEQUENCE {			
subType CHOICE {			
type1-SinglePanel SEQUENCE {			
nrOfAntennaPorts CHOICE {			
two SEQUENCE {			2Tx
twoTX-CodebookSubsetRestriction	'010000'B		Fixed rank2, 2x2, 2x4
	'010011'B		Follow rank, 2x2, 2x4
	'000011'B		Fixed rank1, 2x2, 2x4
}			
moreThanTwo SEQUENCE {			4Tx
n1-n2 CHOICE {			
two-one-Type1-SinglePanel-Restriction	'11111111'B		4x4
}			
}			
type1-SinglePanel-ri-Restriction	'11111111'B		2x2, 2x4
	'00000010'B		Fixed rank2, 4x4
	'00001111'B		Follow RI, 4x4
}			
}			
}			
}			
}			
}			
codebookMode	1		
}			
}			
}			

CSI-ReportPeriodicityAndOffset

**Table 5.4.2.4-18: CSI-ReportPeriodicityAndOffset**

Derivation Path: TS 38.331 [6], clause 6.3.2			
Information Element	Value/remark	Comment	Condition
CSI-ReportPeriodicityAndOffset ::= CHOICE {			
slots10	9		FR1_TDD
slots5	0		FR1_FDD
}			

PUCCH-CSI-Resource

**Table 5.4.2.4-19: PUCCH-CSI-Resource**

Derivation Path: TS 38.331 [6], clause 6.3.2			
Information Element	Value/remark	Comment	Condition
PUCCH-CSI-Resource ::= SEQUENCE {			
uplinkBandwidthPartId	BWP-id		FR1
pucch-Resource	8		FR1
}			

### 5.4.3 Sidelink information elements for Demodulation Performance tests

As defined in clause 4.6.3 with the following exceptions:

SL-ResourcePool

**Table 5.4.3-1: SL-ResourcePool**

Derivation Path: Table 4.6.6-25 with condition SL_HARQ			
Information Element	Value/remark	Comment	Condition
SL-ResourcePool-r16 ::= SEQUENCE {			
sl-PSFCH-Config-r16 CHOICE {			
setup SEQUENCE {			
sl-PSFCH-RB-Set-r16	ones(1,50)	All "1" sequence with a length of 50 bits	BW = 20MHz
	ones(1,100)	All "1" sequence with a length of 100 bits	BW = 40MHz
sl-NumMuxCS-Pair-r16	n1		
sl-MinTimeGapPSFCH-r16	sl3		
sl-PSFCH-CandidateResourceType-r16	allocSubCH		
}			
}			
sl-NumSubchannel-r16	5		BW = 20MHz
	10		BW = 40MHz
sl-RB-Number-r16	50		BW = 20MHz
	100		BW = 40MHz
sl-TimeResource-r16	one(1,160)	All "1" sequence with a length of 160 bits	
}			

SL-Thres-RSRP-List

**Table 5.4.3-2: SL-Thres-RSRP-List**

Derivation Path: Table 4.6.6-32			
Information Element	Value/remark	Comment	Condition
SL-Thres-RSRP-List-r16 ::= SEQUENCE (SIZE (64)) OF INTEGER {	64 entries		
INTEGER[k, k=1..64]	66	entry k corresponds to infinity dBm	
}			

## 5.5 Common procedures for RF testing

### 5.5.1 Procedure to configure SCC for NR RF CA testing

#### 5.5.1.1 Scope

The purpose of this procedure is to establish one or more SCC for NR CA testing.

#### 5.5.1.2 Procedure description

##### 5.5.1.2.1 Initial conditions

UE is operating in NR RRC\_CONNECTED state on NR Cell 1 without any SCell configured.

System Simulator:

- SS configures the number of SCells used by the test case using NR parameters for NR Cell 2 for SCC1, NR Cell 3 for SCC2, NR Cell 4 for SCC3 etc. as specified in Table 4.4.2-2.
- System information combination NR-2 as defined in clause 4.4.3.1.2 is used in all NR cells.

##### 5.5.1.2.2 Procedure sequence

**Table 5.5.1.2.2-1: Procedure to configure SCC**

St	Procedure	Message Sequence		TP	Verdict
		U - S	Message		
1	The SS transmits an RRCReconfiguration message including sCellToAddModList with SCell addition for the SCC under test.	<--	NR RRC: RRCReconfiguration	-	-
2	The UE transmits an RRCReconfigurationComplete message.	-->	NR RRC: RRCReconfigurationComplete	-	-

##### 5.5.1.2.3 Specific message contents

**Table 5.5.1.2.3-1: RRCReconfiguration-SCell(n)**

Derivation Path: Table 4.6.1-13 with condition SCell_add			
Information Element	Value/remark	Comment	Condition
RRCReconfiguration ::= SEQUENCE {			
criticalExtensions CHOICE {			
rrcReconfiguration ::= SEQUENCE {			
nonCriticalExtension SEQUENCE {			
masterCellGroup	CellGroupConfig-SCell(n)	n is number of SCC to be added.	
}			

}			
}			
}			

**Table 5.5.1.2.3-2: CellGroupConfig-SCell(n) (Table 5.5.1.2.3-1)**

Derivation Path: Table 4.6.3-19 with condition SCell_add			
Information Element	Value/remark	Comment	Condition
CellGroupConfig ::= SEQUENCE {			
sCellToAddModList SEQUENCE (SIZE (1..maxNrofSCells)) OF SCellConfig {	n entries	n the number of SCC to be added	
SCellConfig[k, k=1..n] SEQUENCE {		entry (1..n)	
sCellIndex			
sCellConfigCommon	ServingCellConfigCommon with condition SCell_add		
}			
}			
}			

## 5.5.2 Procedure to configure SCC for EN-DC RF CA testing

### 5.5.2.1 Scope

The purpose of this procedure is to establish one or more SCC for EN-DC CA testing.

### 5.5.2.2 Procedure description

#### 5.5.2.2.1 Initial conditions

The UE is in RRC\_CONNECTED state.

#### 5.5.2.2.2 Procedure sequence

**Table 5.5.2.2.2-1: Procedure to configure SCC**

St	Procedure	Message Sequence		TP	Verdict
		U - S	Message		
1	The SS transmits an <i>RRCConnectionReconfiguration</i> message using n.	<--	RRC: <i>RRCConnectionReconfiguration</i>	-	-
2	The UE transmits an <i>RRCConnectionReconfigurationComplete</i> message.	-->	RRC: <i>RRCConnectionReconfigurationComplete</i>	-	-
-	EXCEPTION: Steps 3a1 to 3a3 describe the SS sequence depending on procedure parameters; the "lower case letter" identifies a step sequence that take place if a procedure parameter has a particular value	-	-	-	-
3a1-3a3	IF E-UTRA SCC > 0, same as TS 36.508 [2] table 5.2A.4-1, steps 1-3.	-	-	-	-

Note 1: n > 0 in step 1.

#### 5.5.2.2.3 Specific message contents

**Table 5.5.2.2.3-1: RRCReconfiguration (step 1, Table 5.5.2.2.2-1)**

Derivation Path: Table 4.6.1-13 with condition EN-DC_SCell_add			
Information Element	Value/remark	Comment	Condition
RRCReconfiguration ::= SEQUENCE {			
criticalExtensions CHOICE {			
rrcReconfiguration ::= SEQUENCE {			

secondaryCellGroup	CellGroupConfig (n)	n is number of SCC to be added.	
}			
}			
}			

Table 5.5.2.2.3-2: CellGroupConfig (n) (Table 5.5.2.2.3-1)

Derivation Path: Table 4.6.1-13 with condition SCell_add			
Information Element	Value/remark	Comment	Condition
CellGroupConfig ::= SEQUENCE {			
sCellToAddModList SEQUENCE (SIZE (1..maxNrofSCells)) OF SCellConfig {	n entries	n is equal to the number of SCCs to be added	
SCellConfig[ k, k=1..n]		entry (1..n)	
sCellIndex			
sCellConfigCommon	ServingCellConfigCommon with condition SCell_add		
sCellConfigDedicated	ServingCellConfig		
}			
}			
}			

## 6 Test environments for Signalling test

### 6.1 Requirements of test equipment

#### 6.1.1 Requirements common for conducted and OTA tests

The requirements of test equipment specified in this subclause apply to Signalling test cases defined in TS 38.523-1 [12], in addition to the common requirements of test equipment specified in clause 4.2 of this specification.

Test equipment shall be able to simulate cells of Radio Access Technologies NR, E-UTRA, and UTRA. The number of cells to be simulated simultaneously by the test equipment shall not exceed the resources specified in Table 6.1-1

**Table 6.1-1: Maximum resources in terms of number / configuration of cells to be simulated simultaneously in a test setup**

Simulation of	Max. number of cells (NR)			Max. number of cells (E-UTRA)		Max. number of cells (UTRA)	
	Conducted	OTA(FR1+FR2)	OTA (FR2)	Conducted	OTA	Conducted	OTA
NR single-mode networks (FDD or TDD)	4 cells	4 cells	4 cells	n/a	n/a	n/a	n/a
NR dual-mode networks (FDD and TDD)	4 cells	4 cells	4 cells	n/a	n/a	n/a	n/a
NR networks involving Carrier Aggregation	4 cells	4 cells	4 cells	n/a	n/a	n/a	n/a
NR dual connectivity (NR-DC)	4 cells	4 cells	4 cells	n/a	n/a	n/a	n/a
NR dual connectivity (EN-DC)	4 cells	4 cells	4 cells	2 cells	2 cells	n/a	n/a
NR dual connectivity (EN-DC) involving Carrier Aggregation	4 cells	4 cells	4 cells	2 cells	2 cells	n/a	n/a
Mixed E-UTRA / NR networks	4 cells	4 cells	4 cells	2 cells	2 cells	n/a	n/a

Mixed UTRA / NR networks	4 cells	4 cells	4 cells	n/a	n/a	2 cells	2 cells
Note 1:	No differentiation between cell configuration types (as defined in clause 6.3.1) here, because these types are only relevant to specific test cases and their TTCN-3 implementation.						
Note 2:	Only network scenarios specified in clauses 4.4.1 and 6.3.2.1 have been covered.						
Note 3:	In case of Carrier Aggregation, each cell can act as a SpCell, an SCell, or a standalone cell (not used as a CA component carrier).						
Note 4:	In order to support test case requirements for conducted and OTA test methods, the number of active cells at any given time should be minimised in order to ensure maximum re use of SS Tx/Rx resources.						

Exceptions to the requirements outlined above are possible but need special evidence to be provided explicitly in the test case prose and should be allowed only if the test case purpose cannot be met otherwise.

Due to limited power level range for FR2 OTA test methods, when defining test cases requirements, care shall be taken to ensure that the number of active cells is minimised as this has an impact to have distinguishable power level difference. Cells that are used in initial parts of test cases and are no longer required for the rest of the procedure shall be clearly defined as Non-suitable "Off" cell to facilitate re use of SS Tx/Rx resources.

NR FR2 signal levels are defined along with a calibration procedure as well as uncertainty. Therefore, maximum 4 FR2 OTA Cells can be configured and activated including the test cases involving idle or connected mode measurements.

NR FR1+FR2 OTA calibration procedure is undefined which does not restrict to configure maximum 4 FR1+FR2 OTA cells. However, caution must be taken as specified in clause 6.2.2.2.3.

E-UTRA OTA calibration procedure is undefined which does not restrict to configure maximum 2 E-UTRA OTA cells. However, caution must be taken as specified in clause 6.2.2.2.4.

UTRA OTA calibration procedure is undefined which does not restrict to configure maximum 2 UTRA OTA cells. However, caution must be taken as specified in clause 6.2.2.2.5.

## 6.1.2 Requirements for conducted test method

No requirements are specified in addition to the common requirements described in clause 4.2 and clause 6.1.1.

## 6.1.3 Requirements for OTA test method

### 6.1.3.1 General

**Editor's Note:** The UE pre-configuration mentioned below to disable UL Tx diversity schemes shall be voided once a test methodology solution to minimize spectral flatness artefacts between TE and UE over all test points is defined.

The DFF or IFF based OTA test methodologies, defined in Annex B.1 should be used for Signalling test.

NOTE: For single cell test cases, usage of NF test methodology is not precluded.

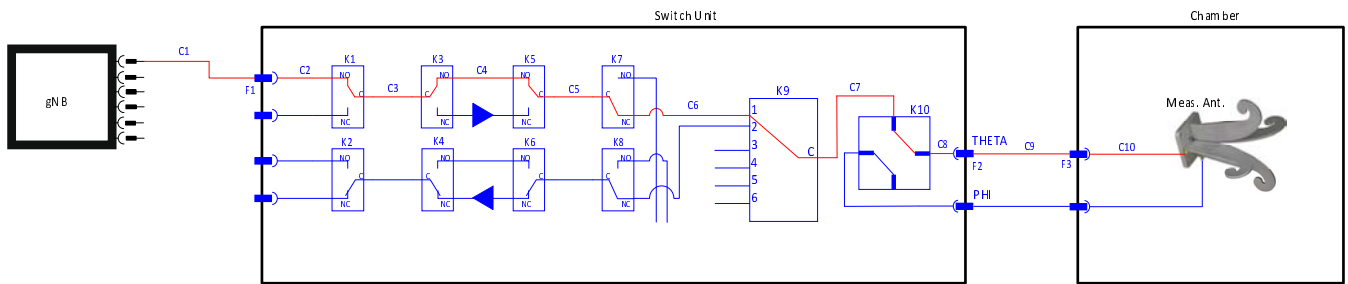
Clause 6.1.3.2 describes a sample OTA measurement test setup and clause 6.1.3.3 describes approaches to select a UE orientation.

For conformance testing using the OTA test environment, the UE under test shall be pre-configured with UL Tx diversity schemes disabled to account for single polarization System Simulator (SS) in the test environment. The UE under test may transmit with dual polarization. This approach also applies to calibration stage..

### 6.1.3.2 Sample OTA Measurement Test Setup

Please refer to Figure 6.1.3.2-1 for a sample OTA measurement test setup.





**Figure 6.1.3.2-1: Sample OTA measurement setup**

NOTE: Figure 6.1.3.2-1 is for illustrative purposes only.

For 5G NR signalling test cases, depending on the dynamic range of measurements the system complexity can be reduced. In the switch unit, as shown in Figure 6.1.3.2-1, the switches K7, K8, K9, K10 can be removed. The amplifier (PA/LNA) is optional. For the "single cell" and "multiple cell" test cases, the gNB emulator can be directly connected to the feed horn.

### 6.1.3.3 Procedure for selecting UE Orientation and for calibration

Set calibrated power level at the centre of the quiet zone for each polarization individually [FFS].

Before starting the test, the UE orientation with which the test system can provide a wide enough dynamic range to perform the test scenarios needs to be identified in order to obtain sufficient link budget.

The UE orientation can be determined by either of the approaches below:

- Approach 1: UE vendor declares the direction in which the measurement has to be made. In this case, the declaration confirms that the Rx Beam peak conditions in FR2 specified in TS 38.133 [13] Annex B are met
- Approach 2: Perform an Rx-beam peak search

For Approach 2 an Rx beam peak search needs to be performed as per the procedure in TS 38.521-2 [15] Annex K, which finds the direction in which Rx Beam peak conditions in FR2 specified in TS 38.133 [13] Annex B are met.

RSRP measurements can be configured by SS in X2NR meas configurations using FFS preambles in NSA (Ex - RRC\_Connected with connectivity parameter E-UTRA with MCG Only bearer established and meas config enabled for event B1 (Ex-per TC 8.2.3.1.1 of TS 38.523-1)) and FFS preambles in SA modes.

When signal level calibrated with a reference antenna (only applicable to single-cell test cases without thresholds):

- The RSRP reported from the DUT is within  $[\pm\text{FFSdB}]$  of expected RSRP mentioned in Table 6.2.2.2-1.

When signal level calibrated with the RSRP-based calibration:

- Before starting the tests, Rx-beam peak directions need to be determined using Approach 1 or Approach 2 above. Rx beam peak direction may depend on the operating band under test. If Rx-beam peak directions for all the operating bands required for test scenarios are identical, three different levels in Table 6.2.2.2-2 can be used in the test scenarios.
- Rx-beam peak directions are decided to be 'identical', if the detected beam peak positions are direct neighbours on the measurement grid.

If Rx-beam peak directions are identical:

1. Position the UE so that the Rx beam peak direction is aligned towards the measurement antenna.
2. Make the UE report SS-RSRP at each frequency used in the test scenarios, while setting the downlink SS power at the centre of the quiet zone to  $-82\text{dBm/SCS}$ . Here, the SS-RSRP reported levels are denoted as  $P_{\text{RSRP}}(f)$ .

3. Calculate 'Delta(NRf)' for each carrier frequency used in the test case, using the equation:  $\Delta(NRf) = P_{RSRP}(f) + 82$ .

### 6.1.3.4 Handling of Thresholds

Where a threshold value is specified in the test case (value identified as  $TH_{test\ case}$ ) it is signalled to the UE with a value  $TH_{sig}$  according to table 6.1.3.4-1.

**Table 6.1.3.4-1: Handling of signalled threshold values**

Type of Threshold	Signalled value	Comment
Absolute	$TH_{sig}(f) = TH_{test\ case} + \Delta(NRf)$	$\Delta(NRf)$ value according to the frequency of the cell being compared to the threshold
Relative, intra-frequency	$TH_{sig}(f) = TH_{test\ case}$	
Relative, inter-frequency	$a3-Offset_{sig} = a3-Offset_{test\ case} + \Delta(NRf_n) - \Delta(NRf_p)$	$\Delta(NRf_p)$ is the Delta value for the SpCell frequency $\Delta(NRf_n)$ is the Delta value for the neighbour cell frequency
Relative, inter-frequency, Event A6	$a6-Offset_{sig} = a6-Offset_{test\ case} + \Delta(NRf_n) - \Delta(NRf_s)$	$\Delta(NRf_s)$ is the Delta value for the SCell frequency $\Delta(NRf_n)$ is the Delta value for the neighbour cell frequency

### 6.1.4 Requirements for timer tolerances

The timer tolerances specified for the test environment in this subclause apply to all Signalling test cases defined in TS 38.523-1 [12] unless otherwise specified.

All the timers used during testing are within a tolerance margin given by the equation below. If for a specific test a different tolerance value is required, then this should be specified in the relevant test document (i.e. the document where the test is described).

Timer tolerance = 10%.

## 6.2 Reference test conditions

### 6.2.1 Physical Channel Allocations

#### 6.2.1.1 Antennas

If the UE has two or more Rx antennas, the same downlink signal is applied to each one, except if MIMO is tested. All UE Rx antennas shall be connected.

If the UE has one Rx antenna, the downlink signal is applied to it.

#### 6.2.1.2 Downlink physical channels and physical signals

In general for signalling test cases the power allocation for downlink physical channels and signals is specified in relation to a reference cell power.

Unless specifically specified otherwise in a signalling test case prose, all cells use only one beam.

In case of only one beam per cell this reference cell power is the EPRE of the secondary synchronization signal (SSS) and referred to as "SS/PBCH SSS EPRE".

In case of more than one beam per cell the power levels of the different SS/PBCH blocks may be different what makes it difficult to specify the EPREs of other physical channels and signals relative to the EPRE of any SSS. Therefore for multiple beams test cases the power levels are specified relative to the reference cell power.

For single beam per cell test cases the power allocation of downlink physical channels for signalling test cases is specified in table 6.2.1.2-1, for multiple beams per cell test cases the power allocation is specified in table 6.2.1.2-2.

**Table 6.2.1.2-1: Power allocation for OFDM symbols and reference signals for signalling test cases (single beam)**

Parameter	Unit	Value	Comment
SSS transmit power	dBm/SCS	Test specific (Note 1)	referred to as "SS/PBCH SSS EPRE"
EPRE ratio of PSS to SSS	dB	0	
EPRE ratio of PBCH DMRS to SSS	dB	0	
EPRE ratio of PBCH to PBCH DMRS	dB	0	
EPRE ratio of PDCCH DMRS to SSS	dB	0	
EPRE ratio of PDCCH to PDCCH DMRS	dB	0	
EPRE ratio of PDSCH DMRS to SSS	dB	0	
EPRE ratio of PDSCH to PDSCH DMRS	dB	-3	To reduce interference from PDSCH of intra-frequency neighbour cells.
EPRE ratio of PTRS to PDSCH	dB	3	i.e. the EPRE ratio of PTRS to SSS is 0dB

Note 1: Power level chosen to align with cell power level as specified in clause 6.2.2.

**Table 6.2.1.2-2: Power allocation for OFDM symbols and reference signals for signalling test cases (multiple beam)**

Parameter	Unit	Value	Comment
Reference cell power $EPRE_{CellRef}$	dBm/SCS	Test specific (Note 1)	
EPRE ratio of $SSS_{SSB\#N}$ to $EPRE_{CellRef}$	dB	Test specific (Note 2)	power of SSS within SSB with index N
EPRE ratio of $PSS_{SSB\#N}$ to $SSS_{SSB\#N}$	dB	0	power of PSS within SSB with index N
EPRE ratio of $PBCH\ DMRS_{SSB\#N}$ to $SSS_{SSB\#N}$	dB	0	power of PBCH DMRS within SSB with index N
EPRE ratio of $PBCH_{SSB\#N}$ to $PBCH\ DMRS_{SSB\#N}$	dB	0	power of PBCH within SSB with index N
EPRE ratio of PDCCH DMRS to $EPRE_{CellRef}$	dB	0	(Note 3)
EPRE ratio of PDCCH to PDCCH DMRS	dB	0	
EPRE ratio of PDSCH DMRS to $EPRE_{CellRef}$	dB	0	(Note 3)
EPRE ratio of PDSCH to PDSCH DMRS	dB	-3	To reduce interference from PDSCH of intra-frequency neighbour cells.
EPRE ratio of PTRS to PDSCH	dB	3	i.e. the EPRE ratio of PTRS to $EPRE_{CellRef}$ is 0dB
EPRE ratio of $CSI-RS_N$ to $EPRE_{CellRef}$	dB	Test specific (Note 2)	power of CSI-RS with index N; CSI-RS configured if required by a test case in TS 38.523-1 [12]

Note 1: Power level chosen to align with cell power level as specified in clause 6.2.2.  
Note 2: Test cases may specify "OFF" in which case the attenuation shall result in an absolute EPRE value being equal or less than the power level specified for a non-suitable "Off" cell in clause 6.2.2.  
Note 3: In general the UE cannot distinguish from which beam DL data is sent  $\Rightarrow$  PDCCH and PDSCH are considered as cell specific rather than beam specific.

### 6.2.1.3 Sidelink physical channels and physical signals

In general for signalling test cases the power allocation for sidelink physical channels and signals is specified in relation to a reference NR-SS-UE power.

The power allocation of sidelink physical channels for signalling test cases is specified in table 6.2.1.3-1.

**Table 6.2.1.3-1: Power allocation for OFDM symbols and reference signals for signalling test cases**

Parameter	Unit	Value	Comment
-----------	------	-------	---------

Reference NR-SS-UE power $EPRE_{NRSSUERef}$	dBm/SCS	Test specific (Note 1)	
EPRE ratio of S-SSS to $EPRE_{NRSSUERef}$	dB	Test specific (Note 2)	Power of S-SSS within S-SSB S-SSB configured if required by a test case in TS 38.523-1 [12]
EPRE ratio of S-PSS to S-SSS	dB	0	Power of S-PSS within S-SSB S-SSB configured if required by a test case in TS 38.523-1 [12]
EPRE ratio of PSBCH DMRS to S-SSS	dB	0	Power of PSBCH DMRS within S-SSB S-SSB configured if required by a test case in TS 38.523-1 [12]
EPRE ratio of PSBCH to PSBCH DMRS	dB	0	Power of PSBCH within S-SSB S-SSB configured if required by a test case in TS 38.523-1 [12]
EPRE ratio of PSCCH DMRS to $EPRE_{NRSSUERef}$	dB	0	
EPRE ratio of PSCCH to PSCCH DMRS	dB	0	
EPRE ratio of PSSCH DMRS to $EPRE_{NRSSUERef}$	dB	0	
EPRE ratio of PSSCH to PSSCH DMRS	dB	0	
EPRE ratio of PSFCH to PSSCH	dB	0	
EPRE ratio of SL CSI-RS to $EPRE_{NRSSUERef}$	dB	Test specific (Note 2)	Power of SL CSI-RS; SL CSI-RS configured if required by a test case in TS 38.523-1 [12]
EPRE ratio of SL PT-RS to PSSCH	dB	0	
Note 1: Power level chosen to align with NR-SS-UE power level as specified in clause 6.2.2.			
Note 2: Test cases may specify "OFF" in which case the attenuation shall result in an absolute EPRE value being equal or less than the power level specified for a "Off" NR-SS-UE in clause 6.2.2.			

## 6.2.2 Signal levels

### 6.2.2.1 Signal Levels for conducted testing

This section applies to the test cases, which use conducted testing for each configured cell or each configured NR-SS-UE.

For NR FR1 cell, the downlink power settings in Table 6.2.2.1-1 and 6.2.2.1-2 are used unless otherwise specified in a test case.

**Table 6.2.2.1-1: Default Downlink power levels for FR1 NR cell (5MHz – 25MHz)**

	SCS(kHz)	Unit	Channel bandwidth				
			5MHz	10MHz	15MHz	20MHz	25MHz
Channel BW Power	15	dBm	-63	-60	-58	-57	-56
	30	dBm	-67	-63	-61	-60	-59
	60	dBm	N/A	-67	-65	-63	-62
SS/PBCH SSS EPRE	All	dBm/SCS (Note 3)	-88	-88	-88	-88	-88
Note 1: The channel bandwidth powers are informative, based on -88 dBm/ SCS(SubCarrier Spacing) SS/PBCH SSS EPRE, then scaled according to the number of RBs and rounded to the nearest integer dBm value. Full RE allocation with no boost or deboost is assumed.							
Note 2: The power level is specified at each UE Rx antenna.							
Note 3: DL level is applied for any of the Subcarrier Spacing configuration ( $\mu$ ) with the same power spectrum density of -88 dBm/SCS(SubCarrier Spacing).							

**Table 6.2.2.1-2: Default Downlink power levels for FR1 NR cell (30MHz – 100MHz)**

	SCS(kHz)	Unit	Channel bandwidth						
			30MHz	40MHz	50MHz	60MHz	80MHz	90MHz	100MHz
Channel BW Power	15	dBm	-55	-54	-53	N/A	N/A	N/A	N/A
	30	dBm	-58	-57	-56	-55	-54	-53	-53
	60	dBm	-61	-60	-59	-58	-57	-56	-56

SS/PBCH SSS EPRE	All	dBm/SCS (Note 3)	-88	-88	-88	-88	-88	-88	-88
<p>Note 1: The channel bandwidth powers are informative, based on -88dBm/SCS(SubCarrier Spacing) SS/PBCH SSS EPRE, then scaled according to the number of RBs and rounded to the nearest integer dBm value. Full RE allocation with no boost or deboost is assumed.</p> <p>Note 2: The power level is specified at each UE Rx antenna.</p> <p>Note 3: DL level is applied for any of the Subcarrier Spacing configuration (<math>\mu</math>) with a power spectrum density of -88dBm/SCS(SubCarrier Spacing).</p>									

With simultaneous transmission of 24 RBs, a maximum of -78dBm/SCS SS/PBCH SSS EPRE can be allocated as cell power level.

The default settings of suitable cells and non-suitable cells for NR are specified in table 6.2.2.1-3.

Cells which are expected to be undetectable for UE under test shall fulfil the condition of non-suitable "Off" cell in table 6.2.2.1-3.

**Table 6.2.2.1-3: Default settings of suitable / non-suitable cells**

Power level type	NR (Note 1-3)		E-UTRAN	UTRAN
	Unit	Power level		
Serving cell	dBm/SCS	-88	Table 6.2.2.1-1 [2]	Table 6.1.1 (FDD) [52]
Suitable neighbour intra-frequency cell	dBm/SCS	-94	Table 6.2.2.1-1 [2]	Table 6.1.2 (FDD) [52]
Suitable neighbour inter-frequency cell	dBm/SCS	-99	Table 6.2.2.1-1 [2]	Table 6.1.2 (FDD) [52]
Non-suitable cell	dBm/SCS	-115	Table 6.2.2.1-1 [2]	Table 6.1.3 (FDD) [52]
Non-suitable "Off" cell	dBm/SCS	$\leq -145$	Table 6.2.2.1-1 [2]	Table 6.1.4 (FDD) [52]
<p>Note 1: The power level is specified in terms of SS/PBCH SSS EPRE instead of RSRP as RSRP is a measured value and cannot be directly controlled by the Full RE allocation with no boost or deboost is assumed. SS.</p> <p>Note 2: The power level is specified at each UE Rx antenna.</p> <p>Note 3: DL level is applied for any of the Subcarrier Spacing configuration (<math>\mu</math>) with the same power spectrum density of -88dBm/SCS.</p> <p>Note 4: The default settings assume that the UE is making relative measurements of neighbour cells compared to the serving cell.</p>				

The default signal level uncertainty is specified in table 6.2.2.1-4 for any level specified, unless a tighter uncertainty is specified by a test case in TS 38.523-1 [12].

**Table 6.2.2.1-4: SS signal level uncertainty**

	Absolute signal level uncertainty for each cell	Relative signal level uncertainty between multiple cells
Intra-frequency	+/-3 dB at each test port	+/-3 dB
Inter-frequency	+/-3 dB at each test port	See Note 1
<p>Note 1: For inter-frequency cells the relative signal level uncertainty between multiple cells is determined by the absolute uncertainty of each cell, and does not have any additional constraint.</p>		

SS/PBCH SSS EPRE setting should be equal to or higher than -115 dBm except for Non-suitable "Off" cell. The figure is chosen to ensure that for all bands the DL signal is within the RSRP measurement range specified in TS 38.133 [13], taking into account the SS default absolute signal level uncertainty.

NOTE: (The power spectral density of a white noise source; specified in TS 38.133 [13]) can be assumed to be -Infinity [dBm/SCS] for all intra and inter frequency test cases. It is applicable to both idle mode and connected mode in TS 38.523-1 [12], unless otherwise specified in specific test cases.

For NR-SS-UE, the sidelink power settings in Table 6.2.2.1-5 is used unless otherwise specified in a test case.

**Table 6.2.2.1-5: Default settings of NR-SS-UE power and signal level uncertainty**

Power level type	NR-SS-UE (Note 1)		Absolute signal level uncertainty for each NR-SS-UE
	Unit	Power level	
NR-SS-UE (default value)	dBm/15kHz	-85	+/-3 dB
NR-SS-UE ("Off")	dBm/15kHz	≤ -145	+/-3 dB
Note 1: The power level is specified at each Rx antenna of the UE under test.			

### 6.2.2.1.1 Measurement accuracy and side conditions

RSRP measurement accuracy in RRC\_CONNECTED state is specified in table 6.2.2.1.1-1, derived from TS 38.133 [13] clauses 10.1.2 and 10.1.4 selecting Normal condition with maximum  $I_o$  less than  $-50$  dBm/BW<sub>Channel</sub>. The ranges and side conditions in TS 38.133 [13] clauses 10.1.2 and 10.1.4 apply. This measurement accuracy is applicable to connected mode test cases specified in TS 38.523-1 [12]. For the serving cell and suitable neighbour cells, the following side conditions shall be satisfied including the effect of signal level uncertainty.

- RSRP ≥ -124 dBm
- RSRP  $\hat{E}_s/I_{ot} > -6$  dB
- $I_o$ : 117.5 dBm/SCS for 15kHz SCS and -114.5 dBm/SCS for 15kHz SCS dBm/SCS ... -50 dBm/BWChannel (for absolute and relative RSRP measurement accuracy).

RSRP measurement accuracy in RRC\_CONNECTED state is specified in table 6.2.2.1.1-1, derived from TS 38.133 [13] clauses 10.1.2 and 10.1.4 selecting Normal condition.

**Table 6.2.2.1.1-1: RSRP measurement accuracy in RRC\_CONNECTED state**

	Absolute RSRP measurement accuracy	Relative RSRP measurement accuracy
Intra-frequency	+/-8 dB	+/-3 dB
Inter-frequency	+/-8 dB	+/-4.5 dB

### 6.2.2.2 Signal Levels for OTA testing

#### 6.2.2.2.1 General

This section applies to the test cases, which require at least one of the configured cells to be a FR2 NR cell.

The following assumption is made for OTA testing:

- AWGN is not configured in the test case

#### 6.2.2.2.2 Signal Levels for FR2 OTA NR cells

For NR FR2 cell, the downlink power settings in Table 6.2.2.2.2-1 are used unless otherwise specified in a test case.

**Table 6.2.2.2.2-1: Default Downlink power levels for FR2 NR cell (50MHz - 400MHz)**

	SCS(kHz)	Unit	Channel bandwidth			
			50MHz	100MHz	200MHz	400MHz
Channel BW Power	60	dBm	FFS	FFS	FFS	FFS
	120	dBm	-57	-57	-57	-57
SS/PBCH SSS EPRE	All	dBm/SCS	-82	-82	-82	-82
Note 1: The channel bandwidth powers are informative, based on -82 dBm/SCS SS/PBCH SSS EPRE, then scaled according to the number of RBs and rounded to the nearest integer dBm value. A maximum RE allocation of 24 simultaneously transmitted RBs with no boost or deboost is assumed.						
Note 2: The power level is specified at the centre of quiet zone.						

The default settings of suitable cells and non-suitable cells for NR FR2 are specified in table 6.2.2.2.2-2.

NR FR2 cells which are expected to be undetectable for UE under test shall fulfil the condition of non-suitable "Off" cell in table 6.2.2.2.2-2.

**Table 6.2.2.2.2-2: Default settings of suitable / non-suitable FR2 NR cells**

Power level type	NR (Note 1-3)	
	Unit	Power level
Serving cell	dBm/SCS	-82
Suitable neighbour intra-frequency cell	dBm/SCS	-91
Suitable neighbour inter-frequency cell	dBm/SCS	-91
Non-suitable cell	dBm/SCS	-100
Non-suitable "Off" cell	dBm/SCS	$\leq -139$
Note 1: The power level is specified in terms of SS/PBCH SSS EPRE instead of RSRP as RSRP is a measured value and cannot be directly controlled by the SS.		
Note 2: The power level is specified at the centre of quiet zone.		
Note 3: DL level is applied for any of the Subcarrier Spacing configuration ( $\mu$ ) with the same power spectrum density in dBm/SCS (SubCarrier Spacing).		

The test system default signal level uncertainty is specified in tables 6.2.2.2.2-3 and 6.2.2.2.2-4 for any level specified, unless a tighter uncertainty is specified by a test case in TS 38.523-1 [12].

**Table 6.2.2.2.2-3: SS Absolute FR2 NR signal level uncertainty**

	Absolute signal level uncertainty
At each frequency	+/-6 dB at centre of the quiet zone

**Table 6.2.2.2.2-4: SS Relative FR2 NR signal level uncertainty**

	Relative signal level uncertainty between any two SS EPRE levels at the same frequency
At each frequency	+/-2.0 dB

### 6.2.2.2.3 Signal Levels for FR1 OTA NR cell(s) with FR2 OTA NR cell(s)

For NR cell in FR1 with FR2 NR, since the NR FR1 OTA link is uncalibrated in the signalling test setup, -88dBm/SCS should be applied as defined in the table 6.2.2.1-1 and table 6.2.2.1-2. -88dBm/SCS is suggested value and it is left to the TE vendor to ensure that NR cell power level fulfils the cell selection criteria.

The default settings of suitable cells and non-suitable cells for NR in FR1 with FR2 NR are specified in table 6.2.2.2-7.

NR Cells in FR1 with FR2 NR which are expected to be undetectable for UE under test shall fulfil the condition of non-suitable "Off" cell in table 6.2.2.2.3-1.

**Table 6.2.2.2.3-1: Default settings of suitable / non-suitable NR cells in FR1 with NR FR2**

Power level type	NR (Note 1-2)	
	Unit	Power level
Serving cell	dBm/SCS	-88
Non-suitable "Off" cell	dBm/SCS	$\leq -156$

Note 1: The power level is specified in terms of SS/PBCH SSS EPRE instead of RSRP as RSRP is a measured value and cannot be directly controlled by the SS.  
 Note 2: The power level is specified at the centre of quiet zone.

The following assumptions are considered for the test cases configuring at least one FR1 OTA NR cell:

- Multiple inter-frequency FR1 OTA NR cells can be configured.
- Only two power levels are allowed: Serving cell power level or Non-suitable "Off" cell power level (as defined in Table 6.2.2.2.3-1)
- If FR1 OTA NR cell does not require:
  - Cell Reselection measurements and
  - Connected Mode measurements and
  - Cell Selection between two active cells and
  - Multiple Signal Levels
    - Multiple FR1 OTA NR cells can be activated.
- Else
  - No more than one FR1 OTA NR cell is activated.

**6.2.2.2.4 Signal Levels for OTA E-UTRA cell(s) with FR2 OTA NR cell(s)**

For E-UTRA cell with FR2 NR, since the LTE OTA link is uncalibrated in the signalling test setup, the table 6.2.2.2.4-1 provides only suggestive value. It is left to the TE vendor to ensure that LTE cell power level fulfils the cell selection criteria.

**Table 6.2.2.2.4-1: Default Downlink power levels for E-UTRA cells with NR FR2**

	Unit	Channel bandwidth					
		1.4 MHz	3 MHz	5 MHz	10 MHz	15 MHz	20 MHz
Number of RBs		6	15	25	50	75	100
Channel BW Power	dBm	-77	-73	-71	-68	-66	-65
RS EPRE	dBm/15kHz	-96	-96	-96	-96	-96	-96
Note 1: The channel bandwidth powers are informative, based on -96 dBm/15kHz RS_EPRES, then scaled according to the number of RBs and rounded to the nearest integer dBm value. Full RE allocation with no boost or deboost is assumed.							
Note 2: The power level is specified at the centre of quiet zone.							

The default setting of suitable cells for E-UTRA with FR2 NR are specified in table 6.2.2.2.4-2.

E-UTRA Cells with FR2 NR which are expected to be undetectable for UE under test shall fulfil the condition of non-suitable "Off" cell in table 6.2.2.2.4-2.

**Table 6.2.2.2.4-2: Default settings of suitable / non-suitable E-UTRA cells with NR FR2**

Power level type	E-UTRAN (Note 1-2)	
	Unit	Power level
Serving cell	dBm/15KHz	-96
Non-suitable "Off" cell	dBm/15KHz	≤-156
Note 1: The power level is specified in terms of cell-specific RS EPRES instead of RSRP as RSRP is a measured value and cannot be directly controlled by the SS.		
Note 2: The power level is specified at the centre of quiet zone.		

The following assumptions are considered for the test cases configuring at least one OTA E-UTRA cell:



- Multiple inter-frequency OTA E-UTRA cells can be configured.
- Only two power levels are allowed: Serving cell power level or Non-suitable "Off" cell power level (as defined in Table 6.2.2.2.4-2)
- If OTA E-UTRA cell does not require:
  - Cell Reselection measurements and
  - Connected Mode measurements and
  - Cell Selection between two active cells and
  - Multiple Signal Levels,
    - Multiple OTA E-UTRA cells can be activated.
- Else
  - No more than one OTA E-UTRA cell is activated.

**6.2.2.2.5 Signal Levels for OTA UTRA cell(s) with FR2 OTA NR cell(s)**

For UTRA OTA cell with FR2 NR, the UTRA OTA link is uncalibrated in the signalling test setup.

UTRA Cells with FR2 NR which are expected to be undetectable for UE under test shall fulfil the condition of non-suitable "Off" cell in table 6.2.2.2.5-1.

**Table 6.2.2.2.5-1: Default settings of suitable / non-suitable UTRA cells with NR FR2**

Power level type	UTRAN (Note 1-2)	
	Unit	Power level
Serving cell	dBm/3.84 MHz	-60
Non-suitable "Off" cell	dBm/3.84 MHz	≤-132
Note 1: The power level is specified in terms of CPICH_Ec instead of CPICH_RSCP as RSCP is a receiver measurement and only CPICH_Ec can be directly controlled by the SS. Note 2: The power level is specified at the centre of quiet zone.		

The following assumptions are considered for the test cases configuring at least one OTA UTRA cell:

- Multiple inter-frequency OTA UTRA cells can be configured.
- Only two power levels are allowed: Serving cell power level or Non-suitable "Off" cell power level (as defined in Table 6.2.2.2.5-1)
- If OTA UTRA cell does not require:
  - Cell Reselection measurements and
  - Connected Mode measurements and
  - Cell Selection between two active cells and
  - Multiple Signal Levels,
    - Multiple OTA UTRA cells can be activated.
- Else
  - No more than one OTA UTRA cell is activated.

## 6.2.3 Default test frequencies

**Editor's note:** For FR2 test frequencies using 100 MHz default channel bandwidth it is FFS if 100MHz channel bandwidth can be used for FR2 multicell protocol testing.

### 6.2.3.1 Test frequencies for NR standalone signalling testing

The default channel bandwidth for signalling test is specified per NR band. The test frequencies are defined so that no frequency overlapping takes place, in order to avoid unnecessary inter-frequency interference.

For signalling test cases, the mapping of frequency ranges to NR test frequencies are as follows:

- for band with only one test frequency (e.g. n51): Low Range (NRf1);
- for band with up to two test frequencies: Low Range (NRf1) and High Range (NRf2);
- for band with up to three test frequencies: Low Range (NRf1), Mid Range (NRf2) and High Range (NRf3);
- for band with up to four test frequencies: Low Range (NRf1), Mid Low Range (NRf2), Mid High Range (NRf3) and High Range (NRf4);

The signalling test frequencies NRf5, NRf6, NRf7 are mapped respectively as NRf1, NRf2, NRf3 on the operating band for inter-band.

The test frequencies, subcarrier spacing, default channel bandwidth, SS/PBCH block and CORESET#0 parameters for signalling is specified in Table 6.2.3.1-1 (FDD FR1 BW 5MHz), Table 6.2.3.1-2 (FDD FR1 BW 10MHz), Table 6.2.3.1-3 (TDD FR1 BW 5MHz), Table 6.2.3.1-4 (TDD FR1 BW 10MHz), Table 6.2.3.1-4A (TDD FR1 BW 60MHz), Table 6.2.3.1-4B (TDD FR1 BW 20MHz for RedCap UE), Table 6.2.3.1-5 (TDD FR1 BW 100MHz), Table 6.2.3.1-5A (TDD FR1 BW 20MHz for RedCap UE), Table 6.2.3.1-6 (TDD FR2 BW 100MHz) and Table 6.2.3.1-7 (NR FDD FR1 SUL bands).

Table 6.2.3.1-1: Test frequencies for NR FDD FR1 bands using 5 MHz channel bandwidth

NR Band	SCS [kHz]	CBW [MHz]	carrier Band width [PRBs]	Range	Carrier centre [MHz]	Carrier centre [ARFCN]	point A [MHz]	absoluteFrequencyPointA [ARFCN]	offsetToCarrier [Carrier PRBs]	SS block SCS [kHz]	GSCN	absoluteFrequencySSB [ARFCN]	$k_{SSB}$	Offset Carrier CORES ET#0 [RBs]	CORES ET#0 Index (Offset [RBs]) Note 1	offsetToPointA (SIB1) [PRBs] Note 1	
n5	15	5	25	Downlink	Low, High	Same values as for Low and High range in clause 4.3.1.1.15 for bandwidth=5 MHz and SCS=15 kHz.											
					Mid-Low	878.2	175640	873.79	174758	12	15	2197	175730	0	1	2 (4)	17
					Mid-High	884.8	176960	878.23	175646	24		2212	176930	8	1	0 (0)	25
				Uplink	Low, High	Same values as for Low and High range in clause 4.3.1.1.5 for bandwidth=5 MHz and SCS=15 kHz.											
					Mid-Low	833.2	166640	824.47	164894	36	-	-	-	-	-	-	-
					Mid-High	839.8	167960	817.03	163406	114	-	-	-	-	-	-	-
n8	15	5	25	Downlink	Low, High	Same values as for Low and High range in clause 4.3.1.1.8 for bandwidth=5 MHz and SCS=15 kHz.											
					Mid-Low	937.5	187500	933.09	186618	12	15	2343	187470	8	1	0 (0)	13
					Mid-High	947.5	189500	940.93	188186	24		2368	189410	0	0	0 (0)	24
				Uplink	Low, High	Same values as for Low and High range in clause 4.3.1.8 for bandwidth=5 MHz and SCS=15 kHz.											
					Mid-Low	892.5	178500	883.77	176754	36	-	-	-	-	-	-	-
					Mid-High	902.5	180500	879.73	175946	114	-	-	-	-	-	-	-
n12	15	5	25	Downlink	Low, Mid, High	Same values as for Low, Mid and High range in clause 4.3.1.1.12 for bandwidth=5 MHz and SCS=15 kHz.											
				Uplink	Low, Mid, High	Same values as for Low, Mid and High range in clause 4.3.1.1.12 for bandwidth=5 MHz and SCS=15 kHz.											
n13	15	5	25	Downlink	Low, High	Same values as for Low and High range in clause 4.3.1.1.13 for bandwidth=5 MHz and SCS=15 kHz.											
				Uplink	Low, High	Same values as for Low and High range in clause 4.3.1.1.13 for bandwidth=5 MHz and SCS=15 kHz.											
n14	15	5	25	Downlink	Low, High	Same values as for Low and High range in clause 4.3.1.1.14 for bandwidth=5 MHz and SCS=15 kHz.											
				Uplink	Low, High	Same values as for Low and High range in clause 4.3.1.1.14 for bandwidth=5 MHz and SCS=15 kHz.											
n20	15	5	25	Downlink	Low, High	Same values as for Low and High range in clause 4.3.1.1.20 for bandwidth=5 MHz and SCS=15 kHz.											
					Mid-Low	801.8	160360	797.39	159478	12	15	2003	160330	8	1	0 (0)	13
					Mid-High	810.2	162040	803.63	160726	24		2024	162010	8	1	0 (0)	25
				Uplink	Low, High	Same values as for Low and High range in clause 4.3.1.1.20 for bandwidth=5 MHz and SCS=15 kHz.											
					Mid-Low	842.8	168560	834.07	166814	36	-	-	-	-	-	-	-
					Mid-High	851.2	170240	828.43	165686	114	-	-	-	-	-	-	-
n24	15	5	25	Downlink	Low, High	Same values as for Low and High range in clause 4.3.1.1.24 for DL bandwidth=5 MHz, UL bandwidth=5 MHz and SCS=15 kHz											
				Uplink	Low, High	Same values as for Low and High range in clause 4.3.1.1.24 for DL bandwidth=5 MHz, UL bandwidth=5 MHz and SCS=15 kHz											
n26	15	5	25	Downlink	Low, High	Same values as for Low and High range in clause 4.3.1.1.26 for bandwidth=5 MHz and SCS=15 kHz.											
					Mid-Low	871.5	174300	867.09	173418	12	15	2178	174270	8	1	0 (0)	13
					Mid-High	881.5	176300	874.93	174986	24		2203	176210	0	0	0 (0)	24
				Uplink	Low, High	Same values as for Low and High range in clause 4.3.1.1.26 for bandwidth=5 MHz and SCS=15 kHz.											
					Mid-Low	826.5	165300	817.77	163554	36	-	-	-	-	-	-	-
					Mid-High	836.5	167300	813.73	162746	114	-	-	-	-	-	-	-

n29	15	5	25	Downlink (SDL)	Low, High	Same values as for Low and High range in clause 4.3.1.1.1.29 for bandwidth=5 MHz and SCS=15 kHz.											
n30	15	5	25	Downlink Uplink	Low, High	Same values as for Low and High range in clause 4.3.1.1.1.30 for bandwidth=5 MHz and SCS=15 kHz.											
					Low, High	Same values as for Low and High range in clause 4.3.1.1.1.30 for bandwidth=5 MHz and SCS=15 kHz.											
n70	15	5	25	Downlink Uplink	Low, Mid, High	Same values as for Low, Mid and High range in clause 4.3.1.1.1.70 for DL bandwidth=5 MHz, UL bandwidth=5 MHz and SCS=15 kHz.											
					Low, Mid, High	Same values as for Low, Mid and High range in clause 4.3.1.1.1.70 for DL bandwidth=5 MHz, UL bandwidth=5 MHz and SCS=15 kHz.											
n71	15	5	25	Downlink	Low, High	Same values as for Low and High range in clause 4.3.1.1.1.71 for bandwidth=5 MHz and SCS=15 kHz.											
					Mid-Low	629.5	125900	625.09	125018	12	15	1573	125810	0	0	0 (0)	12
					Mid-High	639.5	127900	632.93	126586	24		1598	127930	4	1	1 (2)	27
				Uplink	Low, High	Same values as for Low and High range in clause 4.3.1.1.1.71 for bandwidth=5 MHz and SCS=15 kHz.											
					Mid-Low	675.5	135100	666.77	133354	36	-	-	-	-	-	-	-
					Mid-High	685.5	137100	662.73	132546	114	-	-	-	-	-	-	-
n76	15	5	25	Downlink (SDL)	Low	Same values as for Low range in clause 4.3.1.1.1.76 for bandwidth=5 MHz and SCS=15 kHz.											
n91	15	5	25	Downlink	Low	Same values as for Low range in clause 4.3.1.1.1.91 for bandwidth=5 MHz and SCS=15 kHz.											
				Uplink	Low	Same values as for Low range in clause 4.3.1.1.1.91 for bandwidth=5 MHz and SCS=15 kHz.											
n92	15	5	25	Downlink	Low, Mid, High	Same values as for Low, Mid and High range in clause 4.3.1.1.1.92 for bandwidth=5 MHz and SCS=15 kHz.											
				Uplink	Low, Mid, High	Same values as for Low, Mid and High range in clause 4.3.1.1.1.92 for bandwidth=5 MHz and SCS=15 kHz.											
n93	15	5	25	Downlink	Low	Same values as for Low range in clause 4.3.1.1.1.93 for bandwidth=5 MHz and SCS=15 kHz.											
				Uplink	Low	Same values as for Low range in clause 4.3.1.1.1.93 for bandwidth=5 MHz and SCS=15 kHz.											
n100	15	5	25	Downlink	Low, Mid, High	Same values as for Low, Mid and High range in clause 4.3.1.1.1.100 for bandwidth=5 MHz and SCS=15 kHz.											
				Uplink	Low, Mid, High	Same values as for Low, Mid and High range in clause 4.3.1.1.1.100 for bandwidth=5 MHz and SCS=15 kHz.											
Note 1: The CORESET#0 Index and the associated CORESET#0 Offset refers to Table 13-1 in TS 38.213 [22]. The value of CORESET#0 Index is signalled in controlResourceSetZero (pdcch-ConfigSIB1) in the MIB. The offsetToPointA IE is expressed in units of resource blocks assuming 15 kHz subcarrier spacing for FR1 and 60 kHz subcarrier spacing for FR2.																	

Table 6.2.3.1-2: Test frequencies for NR FDD FR1 bands using 10 MHz channel bandwidth

NR Band	SCS [kHz]	CBW [MHz]	carrier Band width [PRBs]	Range	Carrier centre [MHz]	Carrier centre [ARFCN]	point A [MHz]	absoluteFrequencyPointA [ARFCN]	offsetToCarrier [Carrier PRBs]	SS block SCS [kHz]	GSCN	absoluteFrequencySSB [ARFCN]	$k_{SSB}$	Offset Carrier CORESET#0 [RBs]	CORESET#0 Index (Offset [RBs]) Note 1	offsetToPointA (SIB1) [PRBs] Note 1	
n1	15	10	52	Downlink	Low, High	Same values as for Low and High range in clause 4.3.1.1.1.1 for bandwidth=10 MHz and SCS=15 kHz.											
					Mid-Low	2131.7	426340	2124.86	424972	12	15	5321	425770	2	0	0 (0)	12
					Mid-High	2148.3	429660	2139.3	427860	24		5364	429150	10	1	0 (0)	25
				Uplink	Low, High	Same values as for Low and High range in clause 4.3.1.1.1.1 for bandwidth=10 MHz and SCS=15 kHz.											

					Mid-Low	1941.7	388340	1930.54	386108	36	-	-	-	-	-	-	-	-	-
					Mid-High	1958.3	391660	1933.1	386620	114	-	-	-	-	-	-	-	-	-
n2	15	10	52	Downlink	Low, High	Same values as for Low and High range in clause 4.3.1.1.1.2 for bandwidth=10 MHz and SCS=15 kHz.													
						Mid-Low	1951.7	390340	1944.86	388972	12	15	4871	389770	2	0	0 (0)	12	
						Mid-High	1968.3	393660	1959.3	391860	24		4914	393150	10	1	0 (0)	25	
				Uplink	Low, High	Same values as for Low and High range in clause 4.3.1.1.1.2 for bandwidth=10 MHz and SCS=15 kHz.													
						Mid-Low	1871.7	374340	1860.54	372108	36	-	-	-	-	-	-	-	-
						Mid-High	1888.3	377660	1863.1	372620	114	-	-	-	-	-	-	-	-
n3	15	10	52	Downlink	Low, High	Same values as for Low and High range in clause 4.3.1.1.1.3 for bandwidth=10 MHz and SCS=15 kHz.													
						Mid-Low	1831.7	366340	1824.86	364972	12	15	4571	365770	2	0	0 (0)	12	
						Mid-High	1853.3	370660	1844.3	368860	24		4625	370090	2	0	0 (0)	24	
				Uplink	Low, High	Same values as for Low and High range in clause 4.3.1.1.1.3 for bandwidth=10 MHz and SCS=15 kHz.													
						Mid-Low	1736.7	347340	1725.54	345108	36	-	-	-	-	-	-	-	-
						Mid-High	1758.3	351660	1733.1	346620	114	-	-	-	-	-	-	-	-
n7	15	10	52	Downlink	Low, High	Same values as for Low and High range in clause 4.3.1.1.1.7 for bandwidth=10 MHz and SCS=15 kHz.													
						Mid-Low	2645	529000	2638.16	527632	12	15	6605	528490	10	1	0 (0)	13	
						Mid-High	2665	533000	2656	531200	24		6658	532610	2	1	2 (4)	29	
				Uplink	Low, High	Same values as for Low and High range in clause 4.3.1.1.1.7 for bandwidth=10 MHz and SCS=15 kHz.													
						Mid-Low	2525	505000	2513.84	502768	36	-	-	-	-	-	-	-	-
						Mid-High	2545	509000	2519.8	503960	114	-	-	-	-	-	-	-	-
n25	15	10	52	Downlink	Low, High	Same values as for Low and High range in clause 4.3.1.1.25 for bandwidth=10 MHz and SCS=15 kHz.													
						Mid-Low	1953.3	390660	1946.46	389292	12	15	4878	390270	2	1	2 (4)	17	
						Mid-High	1971.7	394340	1962.7	392540	24		4924	393890	6	1	1 (2)	27	
				Uplink	Low, High	Same values as for Low and High range in clause 4.3.1.1.1.25 for bandwidth=10 MHz and SCS=15 kHz.													
						Mid-Low	1873.3	374660	1862.14	372428	36	-	-	-	-	-	-	-	-
						Mid-High	1891.7	378340	1866.5	373300	114	-	-	-	-	-	-	-	-
n28 (Note 3)	15	10	52	Downlink	Low, High	Same values as for Low and High range in clause 4.3.1.1.1.28 for bandwidth=10 MHz and SCS=15 kHz.													
						Mid-Low	774.7	154940	767.86	153572	12	15	1930	154370	2	0	0 (0)	12	
						Mid-High	786.3	157260	777.3	155460	24		1959	156750	10	1	0 (0)	25	
				Uplink	Low, High	Same values as for Low and High range in clause 4.3.1.1.1.28 for bandwidth=10 MHz and SCS=15 kHz.													
						Mid-Low	719.7	143940	708.54	141708	36	-	-	-	-	-	-	-	-
						Mid-High	731.3	146260	706.1	141220	114	-	-	-	-	-	-	-	-
n65	15	10	52	Downlink	Low, High	Same values as for Low and High range in clause 4.3.1.1.65 for bandwidth=10 MHz and SCS=15 kHz.													
						Mid-Low	2141.7	428340	2134.86	426972	12	15	5349	427950	2	1	2 (4)	17	
						Mid-High	2168.3	433660	2159.3	431860	24		5414	433210	6	1	1 (2)	27	
				Uplink	Low, High	Same values as for Low and High range in clause 4.3.1.1.65 for bandwidth=10 MHz and SCS=15 kHz.													
						Mid-Low	1951.7	390340	1940.54	388108	36	-	-	-	-	-	-	-	-
						Mid-High	1978.3	395660	1953.1	390620	114	-	-	-	-	-	-	-	-
n66	15	10	52	Downlink	Low, High	Same values as for Low and High range in clause 4.3.1.1.1.66 for DL bandwidth=10 MHz, UL bandwidth=10 MHz and SCS=15 kHz.													
						Mid-Low	2141.7	428340	2134.86	426972	12	15	5349	427950	2	1	2 (4)	17	

					Mid-High	2168.3	433660	2159.3	431860	24		5414	433210	6	1	1 (2)	27
				Uplink	Low, High	Same values as for Low and High range in clause 4.3.1.1.1.66 for DL bandwidth=10 MHz, UL bandwidth=10 MHz and SCS=15 kHz.											
					Mid-Low	1741.7	348340	1730.54	346108	36	-	-	-	-	-	-	-
					Mid-High	1768.3	353660	1743.1	348620	114	-	-	-	-	-	-	-
n74	15	10	52	Downlink	Low, High	Same values as for Low and High range in clause 4.3.1.1.1.74 for bandwidth=5 MHz and SCS=15 kHz.											
					Mid-Low	1491	298200	1484.16	296832	12	15	3720	297630	2	0	0 (0)	12
					Mid-High	1502	300400	1493	298600	24		3749	300010	2	1	2 (4)	29
				Uplink	Low, High	Same values as for Low and High range in clause 4.3.1.1.1.74 for bandwidth=5 MHz and SCS=15 kHz.											
					Mid-Low	1443	288600	1431.84	286368	36	-	-	-	-	-	-	-
					Mid-High	1454	290800	1428.8	285760	114	-	-	-	-	-	-	-
n75	15	10	52	Downlink (SDL) Note 2	Low, High	Same values as for Low and High range in clause 4.3.1.1.1.75 for bandwidth=10 MHz and SCS=15 kHz.											
					Mid-Low	1462	292400	1455.16	291032	12	15	-	291824	31	-	0	-
					Mid-High	1487	297400	1478	295600	24		-	296824	31	-	0	-
n94	15	10	52	Downlink	Low, Mid, High	Same values as for Low, Mid and High range in clause 4.3.1.1.1.94 for bandwidth=10 MHz and SCS=15 kHz.											
				Uplink	Low, Mid, High	Same values as for Low, Mid and High range in clause 4.3.1.1.1.94 for bandwidth=10 MHz and SCS=15 kHz.											
<p>Note 1: The CORESET#0 Index and the associated CORESET#0 Offset refers to Table 13-1 in TS 38.213 [22]. The value of CORESET#0 Index is signalled in controlResourceSetZero (pdcch-ConfigSIB1) in the MIB. The offsetToPointA IE is expressed in units of resource blocks assuming 15 kHz subcarrier spacing for FR1 and 60 kHz subcarrier spacing for FR2.</p> <p>Note 2: FR1 carrier without any coreset is indicated in the MIB by setting <math>k_{SSB} = 31</math>, <i>controlResourceSetZero</i>=0 and <i>searchSpaceZero</i> = 0 (TS 38.213 [22], clause 13).</p> <p>Note 3: For the case of EN-DC configuration DC_21A_n28A the test frequencies in band n28 is restricted to 728 - 738 MHz for the UL and 783 - 793 MHz for the DL (Reference: TS 38.101-3 [9], Table 5.5B.4.1-1 for DC_21A_n28 and Note 17). Thus is only Low range as specified in Table 4.3.1.1.1.28-1A applicable for n28 when used with DC_21A_n28A.</p>																	

Table 6.2.3.1-3: Test frequencies for NR TDD FR1 bands using 5 MHz channel bandwidth

NR Band	SCS [kHz]	CBW [MHz]	carrier Band width [PRBs]	Range	Carrier centre [MHz]	Carrier centre [ARFCN]	point A [MHz]	absolut eFreque ncyPoin tA[ARF CN]	offsetToC arrier [Carrier PRBs]	SS block SCS [kHz]	GSCN	absoluteF requency SSB [ARFCN]	$k_{SSB}$	Offset Carrier CORES ET#0 [RBs]	CORES ET#0 Index (Offset [RBs]) Note 1	offsetToP ointA (SIB1) [PRBs] Note 1
n34	15	5	25	Downlink & Uplink	Low, Mid, High	Same values as for Low, Mid and High range in clause 4.3.1.1.1.34 for bandwidth=5 MHz and SCS=15 kHz.										
n51	15	5	25	Downlink & Uplink	Low	Same values as for Low range in clause 4.3.1.1.1.51 for bandwidth=5 MHz and SCS=15 kHz.										
n53	15	5	25	Downlink & Uplink	Low, High	Same values as for Low and High range in clause 4.3.1.1.1.53 for bandwidth=5 MHz and SCS=15 kHz.										
n101	15	5	25	Downlink & Uplink	Low, Mid, High	Same values as for Low, Mid and High range in clause 4.3.1.1.1.101 for bandwidth=5 MHz and SCS=15 kHz.										
<p>Note 1: For TDD FR1 bands typically the default SCS=30kHz is chosen. For n34 and n53 where SCS=30kHz would limit test coverage to one cell scenarios, SCS=15kHz and 5MHz CBW have been chosen to enable testing of scenarios with up to two cells.</p>																

Table 6.2.3.1-4: Test frequencies for NR TDD FR1 bands using 10 MHz channel bandwidth

NR Band	SCS [kHz]	CBW [MHz]	carrier Band width [PRBs]	Range	Carrier centre [MHz]	Carrier centre [ARFCN]	point A [MHz]	absoluteFrequencyPointA [ARFCN]	offsetToCarrier [Carrier PRBs]	SS block SCS [kHz]	GSCN	absoluteFrequencySSB [ARFCN]	$k_{SSB}$	Offset Carrier CORESET#0 [RBs]	CORESET#0 Index (Offset [RBs]) Note 1	offsetToPointA (SIB1) [PRBs] Note 1	
n38	30	10	24	Downlink & Uplink	Low, High	Same values as for Low and High range in clause 4.3.1.1.1.38 for bandwidth=10 MHz and SCS=30 kHz.											
					Mid-Low	2588.3	517660	2579.66	515932	12	30	6470	517690	10	0	2 (2)	28
					Mid-High	2601.7	520340	2588.74	517748	24		6505	520370	10	0	2 (2)	52
n39	30	10	24	Downlink & Uplink	Low, High	Same values as for Low and High range in clause 4.3.1.1.1.39 for bandwidth=10 MHz and SCS=30 kHz.											
					Mid-Low	1895	379000	1886.36	377272	12	30	4736	378970	14	0	1 (1)	26
					Mid-High	1905	381000	1892.04	378408	24		4761	380910	18	0	0 (0)	48
n40	30	10	24	Downlink & Uplink	Low, High	Same values as for Low and High range in clause 4.3.1.1.1.40 for bandwidth=10 MHz and SCS=30 kHz.											
					Mid-Low	2335	467000	2326.36	465272	12	30	5839	467090	6	0	3 (3)	30
					Mid-High	2365	473000	2352.04	470408	24		5914	473090	6	0	3 (3)	54
n48	30	10	24	Downlink & Uplink	Low, High	Same values as for Low and High range in clause 4.3.1.48 for bandwidth=10 MHz and SCS=30 kHz.											
					Mid-Low	3601.65	640110	3593.01	639534	12	30	7917	640128	18	0	2 (2)	28
					Mid-High	3648.33	643222	3635.37	642358	24		7949	643200	2	0	1 (1)	50
n50	30	10	24	Downlink & Uplink	Low, High	Same values as for Low and High range in clause 4.3.1.1.1.50 for bandwidth=10 MHz and SCS=30 kHz.											
					Mid-Low	1462	292400	1453.36	290672	12	30	3655	292370	14	0	1 (1)	26
					Mid-High	1487	297400	1474.04	294808	24		3716	297370	14	0	1 (1)	50

Note 1: The CORESET#0 Index and the associated CORESET#0 Offset refers to Table 13-4 in TS 38.213 [22] for all bands in the table. The value of CORESET#0 Index is signalled in controlResourceSetZero (pdcch-ConfigSIB1) in the MIB. The offsetToPointA IE is expressed in units of resource blocks assuming 15 kHz subcarrier spacing for FR1 and 60 kHz subcarrier spacing for FR2.

Table 6.2.3.1-4A: Test frequencies for NR TDD FR1 bands using 60 MHz channel bandwidth for non-RedCap UE

NR Band	SCS [kHz]	CBW [MHz]	carrier Band width [PRBs]	Range	Carrier centre [MHz]	Carrier centre [ARFCN]	point A [MHz]	absoluteFrequencyPointA [ARFCN]	offsetToCarrier [Carrier PRBs]	SS block SCS [kHz]	GSCN	absoluteFrequencySSB [ARFCN]	$k_{SSB}$	Offset Carrier CORESET#0 [RBs]	CORESET#0 Index (Offset [RBs]) Note 1	offsetToPointA (SIB1) [PRBs] Note 1
n41	30	60	162	Downlink & Uplink	Low, Mid, High	Same values as for Low, Mid and High range in clause 4.3.1.1.1.41 for bandwidth=60 MHz and SCS=30 kHz.										

Table 6.2.3.1-4B: Test frequencies for NR TDD FR1 bands using 20 MHz channel bandwidth for RedCap UE

NR Band	SCS [kHz]	CBW [MHz]	carrier Band width [PRBs]	Range		Carrier centre [MHz]	Carrier centre [ARFCN]	point A [MHz]	absoluteFrequencyPointA [ARFCN]	offsetToCarrier [Carrier PRBs]	SS block SCS [kHz]	GSCN	absoluteFrequencySSB [ARFCN]	$k_{SSB}$	Offset Carrier CORES ET#0 [RBs]	CORES ET#0 Index (Offset [RBs]) Note 1	offsetToPointA (SIB1) [PRBs] Note 1
n41	30	20	51	Downlink & Uplink	Low, Mid, High	Same values as for Low, Mid and High range in clause 4.3.1.1.1.41 for bandwidth=20 MHz and SCS=30 kHz.											

Table 6.2.3.1-4C: Test frequencies for NR TDD FR1 bands using 20 MHz channel bandwidth for non-RedCap UE

NR Band	SCS [kHz]	CBW [MHz]	carrier Band width [PRBs]	Range		Carrier centre [MHz]	Carrier centre [ARFCN]	point A [MHz]	absoluteFrequencyPointA [ARFCN]	offsetToCarrier [Carrier PRBs]	SS block SCS [kHz]	GSCN	absoluteFrequencySSB [ARFCN]	$k_{SSB}$	Offset Carrier CORES ET#0 [RBs]	CORES ET#0 Index (Offset [RBs]) Note 1	offsetToPointA (SIB1) [PRBs] Note 1
n46	30	20	51	Downlink & Uplink	Low, High	Same values as for Low and High range in clause 4.3.1.1.1.46 for bandwidth=20 MHz and SCS=30 kHz.											
					Mid-Low	5340	756000	5326.5	755100	12	30	9121	755712	12	0	3 (3)	30
					Mid-High	5659.98	777332	5642.16	776144	24		9343	777024	16	0	2 (2)	52
n96	30	20	51	Downlink & Uplink	Low, High	Same values as for Low and High range in clause 4.3.1.1.1.96 for bandwidth=20 MHz and SCS=30 kHz.											
					Mid-Low	5340	756000	5326.5	755100	12	30	9121	755712	22	0	0 (0)	24
					Mid-High	5659.98	777332	5642.16	776144	24		9343	777024	22	0	0 (0)	48

Table 6.2.3.1-5: Test frequencies for NR TDD FR1 bands using 100 MHz channel bandwidth for non-RedCap UE

NR Band	SCS [kHz]	CBW [MHz]	carrier Band width [PRBs]	Range		Carrier centre [MHz]	Carrier centre [ARFCN]	point A [MHz]	absoluteFrequencyPointA [ARFCN]	offsetToCarrier [Carrier PRBs]	SS block SCS [kHz]	GSCN	absoluteFrequencySSB [ARFCN]	$k_{SSB}$	Offset Carrier CORES ET#0 [RBs]	CORES ET#0 Index (Offset [RBs]) Note 1	offsetToPointA (SIB1) [PRBs] Note 1
n77	30	100	273	Downlink & Uplink	Low, High	Same values as for Low and High range in clause 4.3.1.1.1.77 for bandwidth=100 MHz and SCS=30 kHz.											
					Mid-Low	3616.68	641112	3563.22	637548	12	30	7896	638112	12	0	1 (1)	26
					Mid-High	3883.32	658888	3825.54	655036	24		8081	655872	20	0	0 (0)	48
n78	30	100	273	Downlink & Uplink	Low, High	Same values as for Low and High range in clause 4.3.1.1.1.78 for bandwidth=100 MHz and SCS=30 kHz.											
					Mid-Low	3483.33	632222	3429.87	628658	12	30	7804	629280	22	0	3 (3)	30
					Mid-High	3616.68	641112	3558.9	637260	24		7896	638112	12	0	1 (1)	50



n79	30	100	273	Downlink & Uplink	Low, High	Same values as for Low and High range in clause 4.3.1.1.1.79 for bandwidth=100 MHz and SCS=30 kHz.											
					Mid-Low	4616.67	707778	4563.21	704214	12	30	8592	704928	18	6	1 (4)	38
					Mid-High	4783.35	718890	4725.57	715038	24		8720	717216	18	54	1 (4)	160

Note 1: The CORESET#0 Index and the associated CORESET#0 Offset refers to Table 13-4 in TS 38.213 [22] for all bands in the table except for band n79 where Table 13-6 apply. The value of CORESET#0 Index is signalled in controlResourceSetZero (pdcc-ConfigSIB1) in the MIB. The offsetToPointA IE is expressed in units of resource blocks assuming 15 kHz subcarrier spacing for FR1 and 60 kHz subcarrier spacing for FR2.

**Table 6.2.3.1-5A: Test frequencies for NR TDD FR1 bands using 20 MHz channel bandwidth for RedCap UE**

NR Band	SCS [kHz]	CBW [MHz]	carrier Band width [PRBs]	Range	Carrier centre [MHz]	Carrier centre [ARFCN]	point A [MHz]	absoluteFrequencyPointA [ARFCN]	offsetToCarrier [Carrier PRBs]	SS block SCS [kHz]	GSCN	absoluteFrequencySSB [ARFCN]	$k_{SSB}$	Offset Carrier CORESET#0 [RBs]	CORESET#0 Index (Offset [RBs]) Note 1	offsetToPointA (SIB1) [PRBs] Note 1	
n77	30	20	51	Downlink & Uplink	Low, High	Same values as for Low and High range in clause 4.3.1.1.1.77 for bandwidth=20 MHz and SCS=30 kHz.											
					Mid-Low	3603.33	640222	3589.83	639322	12	30	7915	639936	14	0	3 (3)	30
					Mid-High	3896.67	659778	3878.85	658590	24		8118	659424	18	0	0 (0)	48
n78	30	20	51	Downlink & Uplink	Low, High	Same values as for Low and High range in clause 4.3.1.1.1.78 for bandwidth=20 MHz and SCS=30 kHz.											
					Mid-Low	3470.01	631334	3456.51	630434	12	30	7822	631008	22	0	1 (1)	26
					Mid-High	3630	642000	3612.18	640812	24		7933	641664	12	0	1 (1)	50
n79	30	20	51	Downlink & Uplink	Low, High	Same values as for Low and High range in clause 4.3.1.1.1.79 for bandwidth=20 MHz and SCS=30 kHz.											
					Mid-Low	4603.35	706890	4589.85	705990	12	30	8609	706560	18	1	0 (0)	26
					Mid-High	4796.67	719778	4778.85	718590	24		8743	719424	18	0	0 (0)	48

Note 1: The CORESET#0 Index and the associated CORESET#0 Offset refers to Table 13-4 in TS 38.213 [22] for all bands in the table except for band n79 where Table 13-6 apply. The value of CORESET#0 Index is signalled in controlResourceSetZero (pdcc-ConfigSIB1) in the MIB. The offsetToPointA IE is expressed in units of resource blocks assuming 15 kHz subcarrier spacing for FR1 and 60 kHz subcarrier spacing for FR2.

**Table 6.2.3.1-6: Test frequencies for NR TDD FR2 bands using 100 MHz channel bandwidth**

NR Band	SCS [kHz]	CBW [MHz]	carrier Band width [PRBs]	Range	Carrier centre [MHz]	Carrier centre [ARFCN]	point A [MHz]	absoluteFrequencyPointA [ARFCN]	offsetToCarrier [Carrier PRBs]	SS block SCS [kHz]	GSCN	absoluteFrequencySSB [ARFCN]	$k_{SSB}$	Offset Carrier CORESET#0 [RBs]	CORESET#0 Index (Offset [RBs]) Note 1	offsetToPointA (SIB1) [PRBs] Note 1	
n257	120	100	66	Downlink & Uplink	Low, High	Same values as for Low and High range in clause 4.3.1.2.1.1 for bandwidth=100 MHz and SCS=120 kHz.											
					Mid-Low	27516.6	2071109	27451.8	2070029	12	120	22444	2070811	7	6	1 (4)	44
					Mid-High	28483.32	2087221	28401.24	2085853	24		22500	2086939	3	7	1 (4)	70

n258	120	100	66	Downlink & Uplink	Low, High	Same values as for Low and High range in clause 4.3.1.2.1.2 for bandwidth=100 MHz and SCS=120 kHz.											
					Mid-Low	25350	2034999	25285.2	2033919	12	120	22318	2034523	2	3	0 (0)	30
					Mid-High	26400	2052499	26317.92	2051131	24		22379	2052091	0	2	1 (4)	60
n259	120	100	66	Downlink & Uplink	Low, High	Same values as for Low and High range in clause 4.3.1.2.1.3 for bandwidth=100 MHz and SCS=120 kHz.											
					Mid-Low	40850.04	2293333	40785.24	2292253	12	120	23215	2292859	3	3	0 (0)	30
					Mid-High	42150	2314999	42067.92	2313631	24		23290	2314459	6	0	0 (0)	48
n260	120	100	66	Downlink & Uplink	Low, High	Same values as for Low and High range in clause 4.3.1.2.1.4 for bandwidth=100 MHz and SCS=120 kHz.											
					Mid-Low	38016.6	2246109	37951.8	2245029	12	120	23051	2245627	11	2	0 (0)	28
					Mid-High	38983.32	2262221	38901.24	2260853	24		23107	2261755	7	3	0 (0)	54
n261	120	100	66	Downlink & Uplink	Low, High	Same values as for Low and High range in clause 4.3.1.2.1.5 for bandwidth=100 MHz and SCS=120 kHz.											
					Mid-Low	27800.04	2075833	27735.24	2074753	12	120	22460	2075419	9	1	1 (4)	34
					Mid-High	28050	2079999	27967.92	2078631	24		22474	2079451	2	0	0 (0)	48

Note 1: The CORESET#0 Index and the associated CORESET#0 Offset refers to Table 13-8 in TS 38.213 [22]. The value of CORESET#0 Index is signalled in controlResourceSetZero (pdcch-ConfigSIB1) in the MIB. The offsetToPointA IE is expressed in units of resource blocks assuming 15 kHz subcarrier spacing for FR1 and 60 kHz subcarrier spacing for FR2.

Table 6.2.3.1-7: Test frequencies for NR FDD FR1 SUL bands

NR Band	SCS [kHz]	CBW [MHz]	carrier Band width [PRBs]	Range		Carrier centre [MHz]	Carrier centre [ARFCN]	point A [MHz]	AbsoluteFrequencyPointA [ARFCN]	offsetToCarrier [Carrier PRBs]
n80	15	10	52	Uplink	Low, Mid, High	Same values as for Low, Mid and High range in table 4.3.1.1.1.80-1 for bandwidth=10 MHz and SCS=15 kHz.				
n81	15	10	52	Uplink	Low, Mid, High	Same values as for Low, Mid and High range in table 4.3.1.1.1.81-1 for bandwidth=10 MHz and SCS=15 kHz.				
n82	15	10	52	Uplink	Low, Mid, High	Same values as for Low, Mid and High range in table 4.3.1.1.1.82-1 for bandwidth=10 MHz and SCS=15 kHz.				
n83	15	10	52	Uplink	Low, Mid, High	Same values as for Low, Mid and High range in table 4.3.1.1.1.83-1 for bandwidth=10 MHz and SCS=15 kHz.				

n84	15	10	52	Uplink	Low, Mid, High	Same values as for Low, Mid and High range in table 4.3.1.1.1.84-1 for bandwidth=10 MHz and SCS=15 kHz.
n86	15	10	52	Uplink	Low, Mid, High	Same values as for Low, Mid and High range in table 4.3.1.1.1.86-1 for bandwidth=10 MHz and SCS=15 kHz.
n97	15	10	52	Uplink	Low, Mid, High	Same values as for Low, Mid and High range in table 4.3.1.1.1.97-1 for bandwidth=10 MHz and SCS=15 kHz.
n99	15	10	52	Uplink	Low, High	Same values as for Low and High range in clause 4.3.1.1.1.99-1 for bandwidth=10 MHz and SCS=15 kHz.

## 6.2.3.2 Test frequencies for EN-DC band combinations for signalling testing

### 6.2.3.2.1 General

The default channel bandwidths for EN-DC signalling test are specified per NR and E-UTRA band. The test frequencies are defined so that no frequency overlapping takes place, in order to avoid unnecessary inter-frequency interference.

### 6.2.3.2.2 E-UTRA 1CC and NR 1CC

For EN-DC Inter-band case with E-UTRA 1CC and NR 1CC (one E-UTRA band and one NR band) the EN-DC configurations are specified in clause 4.3.1.4.1.2 for EN-DC with NR FR1 and 4.3.1.5.1.2 for EN-DC with NR FR2.

The E-UTRA and NR test frequencies are specified in TS 36.508 [2], clause 6.2.3.1 for the E-UTRA band (E-UTRA f1, f2, f3 and f4); and in clause 6.2.3.1 for the NR band (NRf1, NRf2, NRf3, NRf4) and for the secondary NR band (NRf5, NRf6, NRf7) of the secondary EN-DC inter-band configuration.

For EN-DC Intra-band Contiguous case with E-UTRA 1CC and NR 1CC the EN-DC configurations and the test frequencies are specified in Table 6.2.3.2-1.

For EN-DC Intra-band Non-Contiguous with E-UTRA 1CC and NR 1CC case the EN-DC configurations and test frequencies are specified in Table 6.2.3.2-2.

For EN-DC Intra-Band Contiguous and EN-DC Intra-Band Non-Contiguous cases with E-UTRA 1CC and NR 1CC the mapping of frequency ranges to NR test frequencies NRf1, NRf2, NRf3, and NRf4 to PSCell; and to E-UTRA test frequencies f1, f2, f3, and f4 for PCell are as follows:

- for band combinations with only one test frequency: Low Range (NRf1, f1);
- for band combinations with up to two frequencies: Low Range (NRf1, f1), High Range (NRf2, f2);
- for band combinations with up to three frequencies: Mid Range (NRf3, f3), Low Range (NRf1, f1) and High Range (NRf2, f2);
- for band combinations with up to four frequencies: Mid-Low Range (NRf3, f3), High Range (NRf2, f2), Low Range (NRf1, f1) and Mid-High Range (NRf4, f4).

**Table 6.2.3.2.2-1: Test frequencies for EN-DC Intra-band Contiguous configurations with E-UTRA 1CC and NR 1CC**

EN-DC channel bandwidth combination	CC	Bandwidth [MHz]	carrierBandwidth [PRBs]	Range		Carrier centre [MHz] Note 2	Carrier centre [ARFCN]	point A [MHz]	absoluteFrequencyPoint A [ARFCN]	offsetToCarrier [Carrier PRBs]	SS block SCS [kHz]	GSC N	absoluteFrequencySSB [ARFCN]	$k_{SSB}$	Offset Carrier CORE SET#0 [RBs]	CORE SET#0 Index (Offset [RBs])	offsetToPointA (SIB1) [PRBs]
DC_(n)41A A	E-UTRA CC1	20	100	Downlink & Uplink	Low, High	Same values as for Low and High range values in Table 4.3.1.4.2.41.1-2 (SCS 30 kHz, 30 kHz NR raster and NR CC at the band edges) and EN-DC channel bandwidth combination "E-UTRA: 20MHz + NR: 60MHz".											
	NR CC1	60	162	Downlink & Uplink	Low, High												
DC_(n)71A A	E-UTRA CC1	5	25	Downlink	Low, Mid, High	Same values as for Low, Mid and High range values in Table 4.3.1.4.2.71.1-1 (SCS 15 kHz, 100 kHz NR raster and NR CC at the band edges) and EN-DC channel bandwidth combination "E-UTRA: 5MHz + NR: 5MHz".											
				Uplink	Low, Mid, High												
	NR CC1	5	25	Downlink	Low, Mid, High												
				Uplink	Low, Mid, High												

**Table 6.2.3.2.2-2: Test frequencies for EN-DC Intra-Band Non-Contiguous configurations with E-UTRA 1CC and NR 1CC**

EN-DC channel bandwidth combination	CC	Bandwidth [MHz]	carrierBandwidth [PRBs]	Range		Carrier centre [MHz] Note 2	Carrier centre [ARFCN]	point A [MHz]	absoluteFrequencyPoint A [ARFCN]	offsetToCarrier [Carrier PRBs]	SS block SCS [kHz]	GSC N	absoluteFrequencySSB [ARFCN]	$k_{SSB}$	Offset Carrier CORE SET#0 [RBs]	CORE SET#0 Index (Offset [RBs])	offsetToPointA (SIB1) [PRBs]
DC_41A_n4 1A	E-UTRA CC1	20	100	Downlink & Uplink	Low	Same values as for Test Frequency ID = "Low with maxWgap (NR – E-UTRA)" in Table 4.3.1.4.41.1-1 with NR SCS=30 kHz and CBW=60MHz; and E-UTRA CBW=20 MHz.											
	NR CC1	60	162	Downlink & Uplink	Low												

### 6.2.3.2.3 E-UTRA 1CC and NR CA 2CC

For EN-DC Inter-band case with E-UTRA 1CC and NR CA 2CC the EN-DC configurations are specified in clauses 4.3.1.4.1.2 (two bands) and 4.3.1.4.1.3 (three bands) for EN-DC and NR CA 2CC with FR1 bands, 4.3.1.5.1.2 (two bands) and 4.3.1.5.1.3 (three bands) for EN-DC with NR CA 2CC with FR2 bands and 4.3.1.6.1.2 for EN-DC and NR CA 2CC with FR1 and FR2 bands.

For EN-DC Inter-band case (3 bands), the E-UTRA test frequencies are specified in TS 36.508 [2], clause 6.2.3.1 for the E-UTRA band (E-UTRA f1) and the NR test frequencies are specified in clause 6.2.3.1 for the NR band used as PSCell (NRf1, NRf2, NRf3, NRf4) and for the NR band used as SCell (NRf5, NRf6, NRf7).

For EN-DC Inter-band case (2 bands) with NR Intra-band contiguous CA 2CC and NR Intra-band non-contiguous CA 2CC, the E-UTRA test frequencies are specified in TS 36.508 [2], clause 6.2.3.1 for the E-UTRA band (E-UTRA f1) and the NR test frequencies are specified in clause 6.2.3.4 for the NR CA CC1 used as PSCell (NRf1, NRf3) and for the NR CA CC2 used as SCell (NRf2, NRf4).

For EN-DC Intra-band Contiguous case with E-UTRA 1CC and NR CA 2CC the EN-DC configurations and the test frequencies are specified in Table 6.2.3.2.3-1.

For EN-DC Intra-band Non-Contiguous case with E-UTRA 1CC and NR 2CC the EN-DC configurations and test frequencies are specified in Table 6.2.3.2.3-2.

For EN-DC Intra-Band Contiguous and EN-DC Intra-Band Non-Contiguous cases with E-UTRA 1CC and NR CA 2CC the mapping of frequency ranges to NR test frequencies NRf1 for PSCell (CC1) and NRf2 for SCell (CC2); and to E-UTRA test frequency f1 for PCell is:

- for band combinations with only one test frequency: Low Range (NRf1=CC1, NRf2=CC2, f1); and
- for band combinations with up to two frequencies: Low Range (NRf1=CC1, NRf2=CC2, f1), High Range (NRf3=CC1, NRf4=CC2, f2).

Editor's note: No EN-DC Intra-band Contiguous configurations with NR CA 2CC have yet been introduced in TS 38.101-3.

**Table 6.2.3.2.3-1: Test frequencies for EN-DC Intra-band Contiguous configurations with E-UTRA 1CC and NR CA 2CC**

FFS

Editor's note: No EN-DC Intra-band Non-Contiguous configurations with NR CA 2CC have yet been introduced in TS 38.101-3.

**Table 6.2.3.2.3-2: Test frequencies for EN-DC Intra-Band Non-Contiguous configurations with E-UTRA 1CC and NR CA 2CC**

FFS

**6.2.3.2a Test frequencies for NE-DC band combinations for signalling testing**

**6.2.3.2a.1 General**

The default channel bandwidths for NE-DC signalling test are specified per NR and E-UTRA band. The test frequencies are defined so that no frequency overlapping takes place, in order to avoid unnecessary inter-frequency interference.

**6.2.3.2a.2 NR 1CC and E-UTRA 1CC**

For NE-DC Inter-band case with NR 1CC and E-UTRA 1CC (one NR band and one E-UTRA band) the NE-DC configurations are specified in clause 4.3.1.4a.1.2 for NE-DC with NR FR1.

The NR and E-UTRA test frequencies are specified in clause 6.2.3.1 for the NR band (NRf1, NRf2, NRf3, NRf4) and for the secondary NR band (NRf5, NRf6, NRf7) of the secondary NE-DC inter-band configuration; and in TS 36.508 [2], clause 6.2.3.1 for the E-UTRA band (E-UTRA f1, f2, f3 and f4).

### 6.2.3.3 Test frequencies for NR and E-UTRA Inter-RAT signalling testing

For NR and E-UTRA Inter-RAT testing, it is assumed that the NR and E-UTRA bands under test are different in order to avoid unnecessary interferences:

- for NR bands, the frequencies NRf1, NRf2, NRf3 and NRf4 are mapped as per clause 6.2.3.1
- for E-UTRA bands, the signalling test frequencies E-UTRA f1, E-UTRA f2, E-UTRA f3 and E-UTRA f4 are mapped respectively on f1, f2, f3 and f4 as per TS 36.508 [2] clause 6.2.3.1.

### 6.2.3.4 Test frequencies for NR CA configurations for signalling testing

The default channel bandwidths for NR CA signalling test are specified per NR band. The test frequencies are defined so that no frequency overlapping takes place, in order to avoid unnecessary inter-frequency interference.

For NR CA Inter-band case (2 bands) the NR CA configurations are specified in clause 4.3.1.1.2 for NR CA within FR1, in clause 4.3.1.2.2 for NR CA within FR2 and in clause 4.3.1.3.1 for NR CA between FR1 and FR2. NR test frequencies are specified in clause 6.2.3.1 for the NR band used as PCell (NRf1, NRf2, NRf3, NRf4) and for the NR band used as SCell (NRf5, NRf6, NRf7).

For NR CA Intra-band Contiguous case (2 CCs) the NR CA configurations and the test frequencies are specified in Table 6.2.3.4-1 for FR1 and in Table 6.2.3.4-2 for FR2. For NR CA Intra-band Non-Contiguous (2 CCs) case the NR CA configurations and test frequencies are specified in Table 6.2.3.4-3 for FR1 and in Table 6.2.3.4-4 for FR2.

For NR CA Intra-Band Contiguous case (2 CCs) and NR CA Intra-Band Non-Contiguous case (2 CCs) the mapping of frequency ranges to NR test frequencies NRf1, NRf2, NRf3, and NRf4 and PCell (CC1) and SCell (CC2) are as follows:

- for Intra-band configurations with only one test frequency: Low Range (NRf1=CC1 and NRf2=CC2); and
- for Intra-band configurations with up to two frequencies: Low Range (NRf1=CC1 and NRf2=CC2), High Range (NRf3=CC1 and NRf4=CC2)

For NR CA Intra-band Contiguous case (3 CCs) the NR CA configurations and the test frequencies are specified in Table 6.2.3.4-2a for FR2.

For NR CA Intra-Band Contiguous case (3CCs) the mapping of frequency ranges to NR test frequencies NRf1, NRf2, and NRf3 and PCell (CC1) and SCell (CC2, CC3) are as follows:

- For Intra-band configurations with up to three frequencies: Low Range (NRf1=CC1, NRf2=CC2, NRf3=CC3)



Table 6.2.3.4-1: Test frequencies for NR CA Intra-band Contiguous configurations with FR1

NR CA configuration	CC	CBW [MHz]	carrier Bandwidth [PRBs]	Range		Carrier centre [MHz] Note 2	Carrier centre [ARFCN]	point A [MHz]	absolute FrequencyPoint A [ARFCN]	offset ToCarrier [Carrier PRBs]	SS block SCS [kHz]	GSC N	absolute FrequencySSB [ARFCN]	$k_{SSB}$	Offset Carrier CORE SET#0 [RBs]	CORE SET#0 Index (Offset [RBs])	offsetTo PointA (SIB1) [PRBs]
CA_n41C	CC1	60	162+162	Downlink	Low	Same values as for Low range in Table 4.3.1.1.3.41.1-1 for CBW combination 60+60 and SCS=30 kHz.											
	CC2	60	162	& Uplink													
CA_n48B	CC1	10	24	Downlink	Low	Same values as for Low and High ranges in Table 4.3.1.1.3.48.1-2 for CBW combination 10+10 and SCS=30 kHz.											
	CC2	10	24	& Uplink	High												
CA_n66B	CC1	10	52	Downlink	Low	Same values as for Low and High ranges in Table 4.3.1.1.3.66.1-1 for CBW combination 10+15 and SCS=15 kHz.											
	CC2	15	79	& Uplink	High												
CA_n77C	CC1	60	162	Downlink	Low	Same values as for Low and High ranges in Table 4.3.1.1.3.77.1-1 for CBW combination 60+60 and SCS=30 kHz.											
	CC2	60	162	& Uplink	High												
CA_n78C	CC1	60	162	Downlink	Low	Same values as for Low and High ranges in Table 4.3.1.1.3.78.1-1 for CBW combination 60+60 and SCS=30 kHz.											
	CC2	60	162	& Uplink	High												

Table 6.2.3.4-2: Test frequencies for NR CA Intra-band Contiguous configurations with FR2

NR CA configuration	CC	CBW [MHz]	carrier Bandwidth [PRBs]	Range		Carrier centre [MHz] Note 2	Carrier centre [ARFCN]	point A [MHz]	absolute FrequencyPoint A [ARFCN]	offset ToCarrier [Carrier PRBs]	SS block SCS [kHz]	GSC N	absolute FrequencySSB [ARFCN]	$k_{SSB}$	Offset Carrier CORE SET#0 [RBs]	CORE SET#0 Index (Offset [RBs])	offsetTo PointA (SIB1) [PRBs]
CA_n257G	CC1,	100+100	66+66	Downlink	Low	Same values as for Low and High ranges in Table 4.3.1.2.3.1.6-4 for CBW combination 100+100 and SCS=120 kHz.											
	CC2			& Uplink	High												
CA_n258G	CC1,	100+100	66+66	Downlink	Low	Same values as for Low and High ranges in Table 4.3.1.2.3.2.6-2 for CBW combination 100+100 and SCS=120 kHz.											
	CC2			& Uplink	High												
CA_n260G	CC1,	100+100	66+66	Downlink	Low	Same values as for Low and High ranges in Table 4.3.1.2.3.4.6-2 for CBW combination 100+100 and SCS=120 kHz.											
	CC2			& Uplink	High												
CA_n261G	CC1,	100+100	66+66	Downlink	Low	Same values as for Low and High ranges in Table 4.3.1.2.3.5.6-2 for CBW combination 100+100 and SCS=120 kHz.											
	CC2			& Uplink	High												

Table 6.2.3.4-2a: Test frequencies for NR CA Intra-band Contiguous configurations with FR2 (3CC)

NR CA configuration	CC	CBW [MHz]	carrier Bandwidth [PRBs]	Range		Carrier centre [MHz] Note 2	Carrier centre [ARFCN]	point A [MHz]	absolute FrequencyPoint A [ARFCN]	offset ToCarrier [Carrier PRBs]	SS block SCS [kHz]	GSC N	absolute FrequencySSB [ARFCN]	$k_{SSB}$	Offset Carrier CORE SET#0 [RBs]	CORE SET#0 Index (Offset [RBs])	offsetTo PointA (SIB1) [PRBs]
CA_n257H	CC1, CC2, CC3	100+100+100	66+66+66	Downlink & Uplink	Low	Same values as for Low range in Table 4.3.1.2.3.1.7-4 for CBW combination 100+100+100 and SCS=120 kHz.											
CA_n258H	CC1, CC2, CC3	100+100+100	66+66+66	Downlink & Uplink	Low	Same values as for Low range in Table 4.3.1.2.3.2.7-2 for CBW combination 100+100+100 and SCS=120 kHz.											
CA_n260H	CC1, CC2, CC3	100+100+100	66+66+66	Downlink & Uplink	Low	Same values as for Low range in Table 4.3.1.2.3.4.7-1 for CBW combination 100+100+100 and SCS=120 kHz.											
CA_n261H	CC1, CC2, CC3	100+100+100	66+66+66	Downlink & Uplink	Low	Same values as for Low range in Table 4.3.1.2.3.5.7-2 for CBW combination 100+100+100 and SCS=120 kHz.											

**Table 6.2.3.4-3: Test frequencies for NR CA Intra-Band Non-Contiguous configurations with FR1**

NR CA configuration	SB	CBW [MHz]	carrier Bandwidth [PRBs]	Range	Carrier centre [MHz] Note 2	Carrier centre [ARFCN]	point A [MHz]	absolute FrequencyPoint A [ARFCN]	offset ToCarrier [Carrier PRBs]	SS block SCS [kHz]	GSC N	absolute FrequencySSB [ARFCN]	$k_{SSB}$	Offset Carrier CORE SET#0 [RBs]	CORE SET#0 Index (Offset [RBs])	offsetTo PointA (SIB1) [PRBs]
CA_n48(2A)	SB1 SB2	10+10	24+24	Downlink & Uplink	Low	Same values as for Low and High ranges in Table 4.3.1.1.5.48-2 for CBW combination 10+10 and SCS=30 kHz.										
					High											
CA_n66(2A)	SB1 SB2	10+10	52+52	Downlink & Uplink	Low	Same values as for Low and High ranges in Table 4.3.1.1.5.66-1 for CBW combination 10+10 and SCS=15 kHz.										
					High											
CA_n71(2A)	SB1, SB2	10+10	52+52	Downlink & Uplink	Low	Same values as for Low and High ranges in Table 4.3.1.1.5.71-1 for CBW combination 10+10 and SCS=15 kHz.										
					High											
CA_n78(2A)	SB1 SB2	50+50	133+ 133	Downlink & Uplink	Low	Same values as for Low and High ranges in Table 4.3.1.1.5.78-2 for CBW combination 50+50 and SCS=30 kHz.										
					High											

**Table 6.2.3.4-4: Test frequencies for NR CA Intra-Band Non-Contiguous configurations with FR2**

NR CA configuration	CC	CBW [MHz]	carrier Bandwidth [PRBs]	Range	Carrier centre [MHz] Note 2	Carrier centre [ARFCN]	point A [MHz]	absolute FrequencyPoint A [ARFCN]	offset ToCarrier [Carrier PRBs]	SS block SCS [kHz]	GSC N	absolute FrequencySSB [ARFCN]	$k_{SSB}$	Offset Carrier CORE SET#0 [RBs]	CORE SET#0 Index (Offset [RBs])	offsetTo PointA (SIB1) [PRBs]
CA_n261(2A)	CC1	100	66	Downlink	Low	Same values as for Low and High ranges in Table 4.3.1.2.4.5.1-1 for CBW combination 100+100 and SCS=120 kHz.										
	CC2	100	66	& Uplink	High											

## 6.2.3.5 Test frequencies for MFBI signalling testing

For signalling test cases, the mapping of MFBI frequency ranges to NR test frequencies are as follows: Low Range (NRf1), Mid Range (NRf2) and High Range (NRf3).

The test frequencies, subcarrier spacing, default channel bandwidth, SS/PBCH block and CORESET#0 parameters for signalling are specified in Table 6.2.3.5-1 and Table 6.2.3.5-1A(for RedCap UE).

Table 6.2.3.5-1: Test frequencies for MFBI NR bands in FR1 for non-RedCap UE

NR Band	MFBI overlapping NR Band	SCS [kHz]	Band width [MHz]	carrier Band width [PRBs]	Range	Carrier centre [MHz]	Carrier centre [ARFCN]	point A [MHz]	absoluteFrequencyPointA [ARFCN]	offsetToCarrier [Carrier PRBs]	SS block SCS [kHz]	GSC N	absoluteFrequencySSB [ARFCN]	$k_{SSB}$	Offset Carrier CORESET#0 [RBs]	CORESET#0 Index (Offset [RBs])	offsetToPointA (SIB1) [PRBs]
n2	n25	15	10	52	Downlink	Low, Mid, High	Same values as for Low, Mid and High range in clause 4.3.1.1.1.2 for bandwidth=10 MHz and SCS=15 kHz.										
					Uplink	Low, Mid, High	Same values as for Low, Mid and High range in clause 4.3.1.1.1.2 for bandwidth=10 MHz and SCS=15 kHz.										
n25	n2	15	10	52	Downlink	Low, Mid, High	Same values as for Low, Mid and High range in clause 4.3.1.1.1.2 for bandwidth=10 MHz and SCS=15 kHz.										
					Uplink	Low, Mid, High	Same values as for Low, Mid and High range in clause 4.3.1.1.1.2 for bandwidth=10 MHz and SCS=15 kHz.										
n38	n41	15	10	52	Downlink & Uplink	Low, Mid, High	Same values as for Low, Mid and High range in clause 4.3.1.1.1.38 for bandwidth=10 MHz and SCS=15 kHz.										
n41	n38	15	10	52	Downlink & Uplink	Low, Mid, High	Same values as for Low, Mid and High range in clause 4.3.1.1.1.38 for bandwidth=10 MHz and SCS=15 kHz.										
n77	n78	30	100	273	Downlink & Uplink	Low, Mid, High	Same values as for Low, Mid and High range in clause 4.3.1.1.1.78 for bandwidth=100 MHz and SCS=30 kHz.										
n78	n77	30	100	273	Downlink & Uplink	Low, Mid, High	Same values as for Low, Mid and High range in clause 4.3.1.1.1.78 for bandwidth=100 MHz and SCS=30 kHz.										

Table 6.2.3.5-1A: Test frequencies for MFBI NR bands in FR1 for RedCap UE

NR Band	MFBI overlapping NR Band	SCS [kHz]	Band width [MHz]	carrier Band width [PRBs]	Range	Carrier centre [MHz]	Carrier centre [ARFCN]	point A [MHz]	absoluteFrequencyPointA [ARFCN]	offsetToCarrier [Carrier PRBs]	SS block SCS [kHz]	GSCN	absoluteFrequencySSB [ARFCN]	$k_{SSB}$	Offset Carrier CORESET#0 [RBs]	CORE SET#0 Index (Offset [RBs])	offsetToPointA (SIB1) [PRBs]
n2	n25	Same values as in Table 6.2.3.5-1															
n25	n2	Same values as in Table 6.2.3.5-1															
n38	n41	Same values as in Table 6.2.3.5-1															
n41	n38	Same values as in Table 6.2.3.5-1															
n77	n78	30	20	51	Downlink & Uplink	Low, Mid, High	Same values as for Low, Mid and High range in clause 4.3.1.1.1.78 for bandwidth=20 MHz and SCS=30 kHz.										
n78	n77	30	20	51	Downlink & Uplink	Low, Mid, High	Same values as for Low, Mid and High range in clause 4.3.1.1.1.78 for bandwidth=20 MHz and SCS=30 kHz.										

Table 6.2.3.5-2: Test frequencies for MFBI NR bands in FR2

NR Band	MFBI overlapping NR Band	SCS [kHz]	Band width [MHz]	carrier Band width [PRBs]	Range	Carrier centre [MHz]	Carrier centre [ARFCN]	point A [MHz]	absoluteFrequencyPointA [ARFCN]	offsetToCarrier [Carrier PRBs]	SS block SCS [kHz]	GSCN	absoluteFrequencySSB [ARFCN]	$k_{SSB}$	Offset Carrier CORESET#0 [RBs] Note 2	CORE SET#0 Index (Offset [RBs]) Note 1	offsetToPointA (SIB1) [PRBs] Note 1	
n257	n258	120	100	66	Downlink & Uplink	Low	26557.08	2055117	26509.56	2054325	0	120	22388	2054683	0	1 (4)	1	8
						Mid	27006.36	2062605	26811.96	2059365	102		22414	2062171	0	1 (4)	1	212
						High	27438.36	2069805	26665.08	2056917	504		22439	2069371	0	1 (4)	1	1016
n257	n261	120	100	66	Downlink & Uplink	Low, Mid, High	Same values as for Low, Mid and High range in clause 4.3.1.2.1.5 for bandwidth=100 MHz and SCS=120 kHz.											
n258	n257	120	100	66	Downlink & Uplink	Low	26557.08	2055117	26509.56	2054325	0	120	22388	2054683	11	0	1 (4)	8
						Mid	27006.36	2062605	26811.96	2059365	102		22414	2062171	11	0	1 (4)	212
						High	27438.36	2069805	26665.08	2056917	504		22439	2069371	11	0	1 (4)	1016
n261	n257	120	100	66	Downlink & Uplink	Low, Mid, High	Same values as for Low, Mid and High range in clause 4.3.1.2.1.5 for bandwidth=100 MHz and SCS=120 kHz.											

					Uplink		
Note 1:	The CORESET#0 Index and the associated CORESET#0 Offset refers to Table 13-1 in TS 38.213 [22]. The value of CORESET#0 Index is signalled in controlResourceSetZero (pdccch-ConfigSIB1) in the MIB. The offsetToPointA IE is expressed in units of resource blocks assuming 15 kHz subcarrier spacing for FR1 and 60 kHz subcarrier spacing for FR2.						
Note 2:	The parameter Offset Carrier CORESET#0 specifies the offset from the lowest subcarrier of the carrier and the lowest subcarrier of CORESET#0. It corresponds to the parameter $\Delta F_{\text{OffsetCORESET-0-Carrier}}$ in Annex C expressed in number of common RBs.						

### 6.2.3.6 Test frequencies for NR DC configurations for signalling testing

The default channel bandwidths for NR DC signalling test are specified per NR band. The test frequencies are defined so that no frequency overlapping takes place, in order to avoid unnecessary inter-frequency interference.

For NR DC in FR1 (2 bands, 2CC) the NR DC configurations are specified in clause 4.3.1.1.7.1 for 1CC FR1 and 1CC FR1. NR test frequencies are specified in clause 6.2.3.1 for the NR band used as PCell (NRf1, NRf2, NRf3, NRf4) and for the NR band used as PSCell (NRf5, NRf6, NRf7).

For NR DC between FR1 and FR2 (2 bands, 2CC) the NR DC configurations are specified in clause 4.3.1.3.2.1 for 1CC FR1 and 1CC FR2. NR test frequencies are specified in clause 6.2.3.1 for the NR band used as PCell (NRf1, NRf2, NRf3, NRf4) and for the NR band used as PSCell (NRf5, NRf6, NRf7).

For NR DC between FR1 and FR2 with NR intra-band contiguous CA (2 bands, 3CC) the NR DC configurations are specified in clause 4.3.1.3.2.1 for 1CC FR1 and 2CC FR2. NR test frequencies are specified in clause 6.2.3.1 for the NR FR1 band used as PCell (NRf1) and in Table 6.2.3.4-2 for NR intra-band contiguous CA as PSCell (CC1, NRf5) and SCell (CC2, NRf6).

### 6.2.3.7 Test frequencies for NR sidelink configurations for signalling testing

The default channel bandwidths for NR sidelink signalling test are specified per NR sidelink operation band. The test frequencies are defined so that no frequency overlapping takes place, in order to avoid unnecessary inter-frequency interference.

For signalling test cases, the mapping of frequency ranges to NR sidelink test frequencies are as follows:

- for band with only one test frequency: Low Range (NRf1);
- for band with up to two test frequencies: Low Range (NRf1) and High Range (NRf2);
- for band with up to three test frequencies: Low Range (NRf1), Mid Range (NRf2) and High Range (NRf3);

The test frequencies, subcarrier spacing, default channel bandwidth and S-SSB parameters for signalling is specified in Table 6.2.3.7-1 for PC5-only operations.

For concurrent operation case the operation configurations are specified in clause 4.3.1.8.2.1 for inter-band concurrent cases. The test frequencies for signalling are specified in Table 6.2.3.7-1 for PC5 carrier and in clause 6.2.3.1 for Uu carrier.

For tests which need NR PC5 carrier and NR Uu carrier but not concurrent operation case, the test frequencies for signalling are specified in Table 6.2.3.7-1 for PC5 carrier in clause 6.2.3.1 for Uu carrier.

**Table 6.2.3.7-1: Test frequencies for NR Sidelink operating bands using 10 MHz channel bandwidth**

NR Band	SCS [kHz]	CBW [MHz]	carrierBandwidth [PRBs]	Range	Carrier centre [MHz]	Carrier centre [ARFCN]	point A [MHz]	sl-absoluteFrequencyPointA [ARFCN]	offsetToCarrier [Carrier PRBs]	sl-absoluteFrequencySSB [ARFCN]
n47	30	10	24	Low, Mid, High	Same values as for Low, Mid and High range in clause 4.3.1.8.1.2 for bandwidth=10 MHz and SCS=30 kHz. For <i>sl-absoluteFrequencySSB</i> , same value as for S-SSB Low in clause 4.3.1.8.1.2 for bandwidth=10 MHz and SCS=30 kHz is used.					

### 6.2.3.8 Test frequencies for NR NTN configurations for signalling testing

The default channel bandwidths for NR NTN signalling test are specified per NR NTN operation band.

For signalling test cases, the mapping of frequency ranges to NR NTN test frequencies are as follows:

- for band with only one test frequency: Low Range (NRf1);
- for band with up to two test frequencies: Low Range (NRf1) and High Range (NRf2);

- for band with up to three test frequencies: Low Range (NRf1), Mid Range (NRf2) and High Range (NRf3);

The test frequencies, subcarrier spacing, default channel bandwidth and S-SSB parameters for signalling is specified in Table 6.2.3.8-1 for NR NTN operations.



Table 6.2.3.8-1: Test frequencies for NR NTN operating band using 5 MHz channel bandwidth

NR Band	SCS [kHz]	CBW [MHz]	carrier Bandwidth [PRBs]	Range		Carrier centre [MHz]	Carrier centre [ARFCN]	point A [MHz]	absoluteFrequencyPointA [ARFCN]	offsetToCarrier [Carrier PRBs]	SS block SCS [kHz]	GSCN	absoluteFrequencySB [ARFCN]	$k_{SSB}$	Offset Carrier CORESET#0 [RBs]	CORESET#0 Index (Offset [RBs]) Note 1	offsetToPointA (SIB1) [PRBs] Note 1
n256	15	5	25	Downlink	Low, Mid, High	Same values as for Low, Mid and High range in clause 4.3.1.9.1.1-1 for bandwidth=5 MHz and SCS=15 kHz.											
				Uplink	Low, Mid, High	Same values as for Low, Mid and High range in clause 4.3.1.9.1.1-1 for bandwidth=5 MHz and SCS=15 kHz.											
<p>Note 1: The CORESET#0 Index and the associated CORESET#0 Offset refers to Table 13-1 in TS 38.213 [22]. The value of CORESET#0 Index is signalled in controlResourceSetZero (pdccch-ConfigSIB1) in the MIB. The offsetToPointA IE is expressed in units of resource blocks assuming 15 kHz subcarrier spacing for FR1 and 60 kHz subcarrier spacing for FR2.</p> <p>Note 2: The parameter Offset Carrier CORESET#0 specifies the offset from the lowest subcarrier of the carrier and the lowest subcarrier of CORESET#0. It corresponds to the parameter <math>\Delta F_{OffsetCORESET-0-Carrier}</math> in Annex C expressed in number of common RBs.</p>																	

## 6.3 Reference system configurations

### 6.3.1 Default System Information configurations

#### 6.3.1.1 Intra-frequency neighbouring cell list in SIB3 for NR cells

Intra-frequency neighbouring cell list for signalling test cases is defined in table 6.3.1.1-1. This table is referred to in the default contents of IE *intraFreqNeighCellList* in *SIB3* defined in table 4.6.2-2.

**Table 6.3.1.1-1: Intra-frequency neighbouring cell lists for NR cells**

cell ID	Test Frequency	intra-frequency neighbouring cell list			
		number of entries	physCellId[n]		
			1	1	3
NR Cell 1	NRf1	3	NR Cell 2	NR Cell 4	NR Cell 11
NR Cell 2	NRf1	3	NR Cell 1	NR Cell 4	NR Cell 11
NR Cell 4	NRf1	3	NR Cell 1	NR Cell 2	NR Cell 11
NR Cell 11	NRf1	3	NR Cell 1	NR Cell 2	NR Cell 4
NR Cell 3	NRf2	1	NR Cell 23	-	-
NR Cell 23	NRf2	1	NR Cell 3	-	-

**Editor's Note:** The intra-frequency NR neighbouring cell list for signalling NAS test cases when cells are on same PLMN is FFS.

#### 6.3.1.2 Inter-frequency carrier frequency list in SIB4 for NR cells

Inter-frequency NR carrier frequency list for signalling test cases is defined in table 6.3.1.2-1. This table is referred to in the default contents of IE *interFreqCarrierFreqList* in *SIB4* defined in table 4.6.2-3.

**Table 6.3.1.2-1: Inter-frequency carrier frequency lists for NR cells**

cell ID	Test Frequency	interFreqCarrierFreqList			
		number of entries	dl-CarrierFreq[n]		
			1	2	3
NR Cell 1 NR Cell 2 NR Cell 4 NR Cell 11	NRf1 (Note 2)	3	NRf2	NRf3	NRf5
NR Cell 3 NR Cell 23	NRf2 (Note 2)	3	NRf1	NRf3	NRf5
NR Cell 6	NRf3 (Note 2)	3	NRf1	NRf2	NRf5
NR Cell 10	NRf5 (Note 3)	3	NRf1	NRf2	NRf3
Note 1: Depending on the Band under test, NRf3 may not be applicable. Note 2: In case of Test frequency NRf1, NRf2 and NRf3, dl-CarrierFreq NRf5 as part of inter-frequency list is applicable only in case of multi-band scenarios. Note 3: Test frequency NRf5 is applicable only in case of multi-band scenarios.					

**Editor's Note:** The inter-frequency NR carrier frequency list for signalling NAS test cases when cells are on same PLMN is FFS.

#### 6.3.1.3 E-UTRA carrier frequency list in SIB5 for NR cells

The frequency mapping of E-UTRA cells are defined as per TS 36.508 [2] clause 4.4.2 and TS 36.508 [2] clause 6.3.2 for NGC NAS test cases, E-UTRA frequency mapping is according to clause 6.2.3.3. E-UTRA carrier frequency list for

signalling test cases is defined in table 6.3.1.3-1. This table is referred to in the default contents of IE *carrierFreqListEUTRA* in *SIB5* defined in table 4.6.2-4.

**Table 6.3.1.3-1: E-UTRA carrier frequency lists for NR cells**

interFreqCarrierFreqList	
number of entries	carrierFreq[n]
	1
1	E-UTRA f1
2	E-UTRA f2
3	E-UTRA f3
4	E-UTRA f4
Note 1: E-UTRAf1, E-UTRAf2, E-UTRAf3, E-UTRAf4 are according to clause 6.2.3.3	
Note 2: Depending on the Band under test, E-UTRA f2 or E-UTRA f3 or E-UTRA f4 may not be applicable.	

**Table 6.3.1.3-2: Void**

## 6.3.2 Default configurations for NAS test cases

The default configurations specified in this subclause apply only to NAS test cases. They apply to all NAS test cases unless otherwise specified.

### 6.3.2.1 Simulated network scenarios for NAS test cases

Simulated network scenarios for NAS test cases to be tested are specified in the pre-test conditions of each individual test case.

Any combination is allowed with the following restrictions:

- a maximum 3 cells on the same frequency can be used, i.e. only 3 cells out of NGC Cell A, NGC Cell B, NGC Cell C and NGC Cell D may be used simultaneously in each individual test case when cells in the test case are in different PLMNs (refer to Table 6.3.2.2-3).

### 6.3.2.2 Simulated NAS cells

Simulated NAS cells and default NAS parameters are specified in Table 6.3.2.2-1. Unless otherwise specified in a test case, default radio parameters of the NAS cells are specified as per Table 6.3.2.2-2.

Unless otherwise specified, the default parameters specified in clause 4.4.2 will also apply to all NAS cells.

**Table 6.3.2.2-1: Default NAS parameters for simulated NAS cells**

NAS cell ID	Tracking Area			TA# list (Note 1)	5G-GUTI (Note 2)			5G-TMSI	
	TA#	PLMN			TAC	AMF Identifier			
		MCC	MNC			AMF Region ID	AMF Set ID		AMF Pointer
NGC Cell A	TAI-1	(Note 3)		1	TAI-1	254	1	1	Arbitrarily selected according to TS 23.003 subclause 2.10.1 [26].
NGC Cell B	TAI-2	(Note 3)		2	TAI-2	254	1	1	
NGC Cell C	TAI-3	(Note 3)		3	TAI-3	252	1	1	
NGC Cell D	TAI-4	(Note 3)		4	TAI-4	252	1	1	
NGC Cell E	TAI-12	002	101	3	TAI-12	244	1	1	
NGC Cell F	TAI-11	003	101	2	TAI-11	239	1	1	
NGC Cell G	TAI-7	(Note 4)	02	1	TAI-7	238	1	1	
NGC Cell H	TAI-8	(Note 4)	02	2	TAI-8	237	1	1	
NGC Cell I	TAI-9	002	101	1	TAI-9	244	1	1	
NGC Cell J	TAI-10	003	101	1	TAI-10	236	1	1	

Note 1:	The value(s) in the column TA# list indicates TAI(s) included in the response messages of the registration procedure for initial access or mobility (REGISTRATION ACCEPT) when the UE performs the registration procedure on a corresponding cell.
Note 2:	The value in the column 5G-GUTI indicates GUTI included in the response messages of the registration procedure (REGISTRATION ACCEPT) when the UE performs the registration procedure on a corresponding cell.
Note 3:	Set to the same Mobile Country Code and Mobile Network Code stored in EF <sub>IMSI</sub> on the test USIM card (subclause 4.8.3).
Note 4:	Set to the same Mobile Country Code stored in EF <sub>IMSI</sub> on the test USIM card (subclause 4.8.3).

**Table 6.3.2.2-2: Default radio parameters for simulated NAS cells when cells are in same PLMN and access stratum is NR**

NAS cell ID	Frequency	NR cell ID (Note 1)
NGC Cell A	NRf1	NR Cell 1
NGC Cell B	NRf1	NR Cell 2
NGC Cell C	NRf1	NR Cell 4
NGC Cell D	NRf1	NR Cell 11
NGC Cell E	NA	NA
NGC Cell F	NRf2	NR Cell 3
NGC Cell G	NA	NA
NGC Cell H	NA	NA
NGC Cell I	NA	NA
NGC Cell J	NRf2	NR Cell 12
Note 1:	Default NR parameters for simulated NR cells are as specified in Table 4.4.2-2.	
Note 2:	Simultaneous co-existence of active NGC cells defined on the same frequency and same SSB-Index is not recommended (in line with Table 4.4.2-2 Note 3).	

**Table 6.3.2.2-3: Default PLMN and radio parameters for simulated NAS cells when cells are in different PLMNs and access stratum is NR**

NAS cell ID	PLMN	Frequency	NR cell ID (Note 1)
NGC Cell A	MCC/MNC=MCC/MNC in USIM	NRf1	NR Cell 1
NGC Cell B	MCC/MNC=MCC/MNC in USIM	NRf1	NR Cell 2
NGC Cell C	MCC/MNC=MCC/MNC in USIM	NRf1	NR Cell 4
NGC Cell D	MCC/MNC=MCC/MNC in USIM	NRf1	NR Cell 11
NGC Cell E	MCC=002 MNC=101	NRf2	NR Cell 3
NGC Cell F	MCC=003 MNC=101	NRf4	NR Cell 14
NGC Cell G	MCC = MCC in USIM MNC=02	NRf2	NR Cell 12
NGC Cell H	MCC = MCC in USIM MNC=02	NRf2	NR Cell 23
NGC Cell I	MCC=002 MNC=101	NRf3	NR Cell 6
NGC Cell J	MCC=002 MNC=101	NRf3	NR Cell 13
Note 1:	Default NR parameters for simulated NR cells are as specified in Table 4.4.2-2		
Note 2:	Simultaneous co-existence of active NGC cells defined on the same frequency and same SSB-Index is not recommended (in line with Table 4.4.2-2 Note 3).		

## 6.3.3 Cell configuration types

### 6.3.3.1 Introduction

For the purpose of test equipment resource management, different types of cell configurations are defined with different capabilities.

For E-UTRA cells, please refer to TS 36.508 [2] clauses 6.3.3 and 6.3.4.

The default NR cell configuration type is Full Cell: this NR cell configuration has, in minimum, all DL and UL physical channels and physical signals configured, as defined in subclause 4.2.2.

When not mentioned explicitly in a test case prose, an NR cell is of type Full Cell. The following subclauses define different NR cell types with lower capabilities than the Full Cell.

### 6.3.3.2 SCell types

When testing NR CA, the following NR SCell types may be specifically mentioned in the test case prose:

- Active SCell: An NR cell that may become an SCell at any point of time during the test case and which, while being an SCell, may be activated.
- Inactive SCell: An NR cell that may become an SCell at any point of time during the test case but is never activated while being an SCell.

SCell activation is defined as SS sending an SCell Activation/Deactivation MAC CE to the UE to activate the SCell.

Note that an Active SCell will not become an Inactive SCell if the SCell is deactivated via an SCell Activation/Deactivation MAC CE or after the *sCellDeactivationTimer* timer expires.

## 6.4 Signalling Test Case specific USIM Configurations

### 6.4.1 General

The default USIM fields are specified in section 4.8.3. Specific USIM fields are set according to the USIM configuration specified in the tables below. PLMN settings are defined in TS 36.523-1 [42] Table 6.0.1-1.

Note: Changes to any existing USIM configuration can be done only if the change WILL NOT HAVE IMPACT on any of the tests which are referring to the configuration! To establish whether this might be the case, the test case author needs to review all tests in all RAN5 test specifications, which refer to the particular USIM configuration e.g. all test cases in TS 38.523-1 [12].

**Table 6.4.1-1: USIM Configuration 1**

USIM field	Priority	Value	Access Technology Identifier
EF <sub>IMSI</sub>		The HPLMN (MCC+MNC) of the IMSI is set to PLMN1.	
EF <sub>PLMNwACT</sub>	1 2 3	Default PLMN17 PLMN16 Remaining mandatory entries use default values	Default All specified NG-RAN
EF <sub>OPLMNwACT</sub>	1	PLMN15 Remaining defined entries use default values	All specified
EF <sub>HPLMNwACT</sub>	1	PLMN1	NG-RAN
EF <sub>UST</sub>		Services 20, 42, 43 and 74 are supported. Service 71 is not supported (there is no EHPLMN list).	
EF <sub>HPPLMN</sub>		1 (6 minutes)	

Table 6.4.1-2: USIM Configuration 2

USIM field	Priority	Value	Access Technology Identifier
EF <sub>5GS3GPPLOCI</sub>		PLMN4	
EF <sub>PLMNwAcT</sub>		Empty	
EF <sub>IMSI</sub>		The HPLMN (MCC+MNC) of the IMSI is set to PLMN1.	
EF <sub>UST</sub>		Service n°71 and n°74 are "available"	
EF <sub>EHPLMN</sub>	1 2	PLMN15 PLMN1	
EF <sub>LRPLMNSI</sub>		01	

Table 6.4.1-3: USIM Configuration 3

USIM field	Priority	Value	Access Technology Identifier
EF <sub>5GS3GPPLOCI</sub>		PLMN4	
EF <sub>PLMNwAcT</sub>		Empty	
EF <sub>IMSI</sub>		The HPLMN (MCC+MNC) of the IMSI is set to PLMN1.	
EF <sub>UST</sub>		Service n°74 is "available"	
EF <sub>EHPLMN</sub>		Empty	
EF <sub>LRPLMNSI</sub>		01	

Table 6.4.1-4: USIM configuration 4

USIM field	Priority	Value	Access Technology Identifier
EF <sub>EHPLMN</sub>	1	PLMN1 Remaining mandatory entries use default values	
EF <sub>PLMNwAcT</sub>	1	PLMN2 Remaining mandatory entries use default values	NG-RAN
EF <sub>OPLMNwAcT</sub>	1	PLMN3 Remaining mandatory entries use default values	NG-RAN
EF <sub>UST</sub>		Services 20, 42 and 71 are supported.	
EF <sub>5GS3GPPLOCI</sub>		FF FF...FF FE 01 (20 Bytes)	
EF <sub>EPSLOCI</sub>		FF FF...FF FE 01 (18 Bytes)	
EF <sub>PSLOCI</sub>		FF FF...FE FF 01 (14 Bytes)	
EF <sub>LOCI</sub>		FF FF...FE FF 01 (11 Bytes)	
Note:	LOCI fields of this USIM configuration may get overwritten upon execution of test cases using a UICC loaded with this USIM configuration. The test operator shall ensure that USIM contents are as per this table before each execution of a test case that requires this USIM configuration.		

Table 6.4.1-5: USIM configuration 5

USIM field	Priority	Value	Access Technology Identifier
EF <sub>5GS3GPPLOCI</sub>		PLMN4 (See preamble)	
EF <sub>PLMNwAcT</sub>		Empty	
EF <sub>IMSI</sub>		The HPLMN (MCC+MNC) of the IMSI is set to PLMN1.	
EF <sub>UST</sub>		Service 71 is not supported Service 74 is supported.	
EF <sub>LRPLMNSI</sub>		00	
EF <sub>EHPLMN</sub>		0xFF..FF	

Table 6.4.1-6: USIM configuration 6

USIM field	Priority	Value	Access Technology Identifier
EF <sub>5GS3GPPLOCI</sub>		PLMN1 (See preamble)	

EF <sub>IMSI</sub>		The HPLMN (MCC+MNC) of the IMSI is set to PLMN3.	
EF <sub>PLMNwAcT</sub>	1	PLMN1 Remaining mandatory entries use default values	NG-RAN
EF <sub>OPLMNwAcT</sub>	1 2	PLMN2 PLMN4 Remaining defined entries use default values	NG-RAN NG-RAN
EF <sub>UST</sub>		Service 71 is not supported	

Table 6.4.1-7: USIM configuration 7

USIM field	Priority	Value	Access technology	Comment
E.F <sub>PLMNwAcT</sub>	1	PLMN13	NG-RAN	
	2	PLMN13	E-UTRAN	
EF <sub>OPLMNwAcT</sub>	1	PLMN2	All	
	2	PLMN14	E-UTRAN	
	3	PLMN13	NG-RAN	
EF <sub>5GS3GPPLOCi</sub>		FF FF...FF FE 01 (20 Bytes)		
EF <sub>EPSLOCi</sub>		FF FF...FF FE 01 (18 Bytes)		
EF <sub>PSLOCi</sub>		FF FF...FE FF 01 (14 Bytes)		
EF <sub>LOCi</sub>		FF FF...FE FF 01 (11 Bytes)		
Note:	LOCi fields of this USIM configuration may get overwritten upon execution of test cases using a UICC loaded with this USIM configuration. The test operator shall ensure that USIM contents are as per this table before each execution of a test case that requires this USIM configuration.			

Table 6.4.1-8: USIM configuration 8

USIM field	Priority	Value	Access technology	Comment
EF <sub>OPLMNwAcT</sub>	1	PLMN15	NG-RAN	
	2	PLMN15	E-UTRAN	
	3	PLMN17	E-UTRAN	
	4	PLMN16	NG-RAN	
EF <sub>5GS3GPPLOCi</sub>		FF FF...FF FE 01 (20 Bytes)		
EF <sub>EPSLOCi</sub>		FF FF...FF FE 01 (18 Bytes)		
EF <sub>PSLOCi</sub>		FF FF...FE FF 01 (14 Bytes)		
EF <sub>LOCi</sub>		FF FF...FE FF 01 (11 Bytes)		
EF <sub>UST</sub>		Service n°127 is not available"		
Note:	LOCi fields of this USIM configuration may get overwritten upon execution of test cases using a UICC loaded with this USIM configuration. The test operator shall ensure that USIM contents are as per this table before each execution of a test case that requires this USIM configuration.			

Table 6.4.1-9: USIM configuration 9

USIM field	Priority	Value	Access technology	Comment
EF <sub>PLMNwAcT</sub>	1	PLMN1	NG-RAN	
	2	PLMN15	E-UTRAN	
EF <sub>HPPLMN</sub>		1(=6 min)		The HPLMN Search Period on the USIM shall be set to 6 minutes.

Table 6.4.1-10: USIM configuration 10

USIM field	Priority	Value	Access Technology Identifier
EF <sub>OPLMNwACT</sub>	1	PLMN14	NG-RAN
	2	PLMN13	NG-RAN
	3	PLMN2	NG-RAN
		Remaining defined entries use default values	
EF <sub>UST</sub>		Service n°127 is "available"	
EF <sub>HPPLMN</sub>		1(=6 min)	
EF <sub>5GS3GPPLOCI</sub>		FF FF...FF FE 01 (20 Bytes)	
EF <sub>EPSLOCI</sub>		FF FF...FF FE 01 (18 Bytes)	
EF <sub>PSLOCI</sub>		FF FF...FE FF 01 (14 Bytes)	
EF <sub>LOCI</sub>		FF FF...FE FF 01 (11 Bytes)	
Note:	LOCI fields of this USIM configuration may get overwritten upon execution of test cases using a UICC loaded with this USIM configuration. The test operator shall ensure that USIM contents are as per this table before each execution of a test case that requires this USIM configuration.		

Table 6.4.1-11: USIM configuration 11

USIM field	Priority	Value	Access Technology Identifier
EF <sub>5GS3GPPLOCI</sub>		PLMN15 (See preamble)	
EF <sub>IMSI</sub>		The HPLMN (MCC+MNC) of the IMSI is set to PLMN1	
EF <sub>PLMNwACT</sub>	1	Default	Default
	2	PLMN16	NG-RAN
		Remaining defined entries use default values	Default
EF <sub>OPLMNwACT</sub>	1	PLMN15	NG-RAN
		Remaining defined entries use default values	Default
EF <sub>HPLMNwACT</sub>	1	PLMN1	NG-RAN
EF <sub>UST</sub>		Services 20, 42, 43, 74 and 96 are supported. Service 71 is not supported (there is no EHPLMN list)	
EF <sub>HPPLMN</sub>		1 (6 minutes)	
EF <sub>NASCONFIG</sub>		MinimumPeriodicSearchTimer set to 7 minutes	

Table 6.4.1-12: USIM configuration 12

USIM field	Priority	Value	Access technology	Comment
EF <sub>PLMNwACT</sub>		3GPP TS 31.102, Annex E		The EF is empty.
EF <sub>OPLMNwACT</sub>	1	PLMN2	NG-RAN	
	2	PLMN13	E-UTRAN	
	3	PLMN13	NG-RAN	
EF <sub>UST</sub>		Service n°127 is not "available"		
EF <sub>5GS3GPPLOCI</sub>		FF FF...FF FE 01 (20 Bytes)		
EF <sub>EPSLOCI</sub>		FF FF...FF FE 01 (18 Bytes)		
EF <sub>PSLOCI</sub>		FF FF...FE FF 01 (14 Bytes)		
EF <sub>LOCI</sub>		FF FF...FE FF 01 (11 Bytes)		
Note:	LOCI fields of this USIM configuration may get overwritten upon execution of test cases using a UICC loaded with this USIM configuration. The test operator shall ensure that USIM contents are as per this table before each execution of a test case that requires this USIM configuration.			



Table 6.4.1-13: USIM configuration 13

USIM field	Priority	Value	Access technology	Comment
EF <sub>OPLMNwAcT</sub>	1	PLMN2	NG-RAN	
	2	PLMN2	E-UTRAN	
	3	PLMN13	NG-RAN	

Table 6.4.1-14: Void

Table 6.4.1-15: USIM Configuration 15

USIM field	Priority	Value	Access Technology Identifier
EF <sub>IMSI</sub>		The HPLMN (MCC+MNC) of the IMSI is set to PLMN1.	
EF <sub>FPLMN</sub>		PLMN2	

Table 6.4.1-16: Void

Table 6.4.1-17: USIM Configuration 17

USIM field	Priority	Value	Access Technology Identifier
EF <sub>IMSI</sub>		The HPLMN (MCC+MNC) of the IMSI is set to PLMN1.	
EF <sub>PLMNwAcT</sub>	1	PLMN1	NG-RAN
EF <sub>UST</sub>		Service n°126 is "available".	
EF <sub>EHPLMN</sub>		PLMN1	
EF <sub>UAC_AIC</sub> and EF <sub>ACC</sub>		For Bits b4 and b8 in byte 1 of EF <sub>ACC</sub> (defined in TS 31.102 clause 4.2.15), only single bit is set to 1. Bits b1 and b2 in byte 1 of EF <sub>UAC_AIC</sub> (defined in TS 31.102 clause 4.4.11.7), and all remaining bits of EF <sub>ACC</sub> and EF <sub>UAC_AIC</sub> are set to 0.	

Table 6.4.1-18: USIM Configuration 18

USIM field	Priority	Value	Access Technology Identifier
EF <sub>IMSI</sub>		The HPLMN (MCC+MNC) of the IMSI is set to PLMN1.	
EF <sub>PLMNwAcT</sub>	1	PLMN2	NG-RAN
EF <sub>HPLMNwAcT</sub>	1	PLMN1	NG-RAN
EF <sub>UST</sub>		Service n°126 (for UAC Access Identities Configuration) defined in TS 31.102 clause 4.2.8 is declared "available"	
EF <sub>UAC_AIC</sub>		Bit b1 in byte 1 defined in TS 31.102 clause 4.4.11.7 is set to 1 and bit b2 in byte 1 is set to 0.	

Table 6.4.1-19: USIM Configuration 19

USIM field	Priority	Value	Access Technology Identifier
EF <sub>IMSI</sub>		The HPLMN (MCC+MNC) of the IMSI is set to PLMN1.	
EF <sub>PLMNwAcT</sub>	1	PLMN2	NG-RAN
EF <sub>HPLMNwAcT</sub>	1	PLMN1	NG-RAN

EF <sub>UST</sub>		Service n°126 (for UAC Access Identities Configuration) defined in TS 31.102 clause 4.2.8 is declared "available"	
EF <sub>UAC_AIC</sub>		Bit b2 in byte 1 defined in TS 31.102 clause 4.4.11.7 is set to 1 and bit b1 in byte 1 is set to 0.	

**Table 6.4.1-20: USIM Configuration 20**

USIM field	Priority	Value	Access Technology Identifier
EF <sub>ECC</sub>		144, 117	

**Table 6.4.1-21: USIM configuration 21**

USIM field	Priority	Value	Access Technology Identifier
EF <sub>OPLMNwACT</sub>	1 2 3	PLMN14 PLMN13 PLMN2 Remaining defined entries use default values	NG-RAN NG-RAN NG-RAN
EF <sub>UST</sub>		Service n°127 is not "available"	
EF <sub>HPPLMN</sub>		1(=6 min)	
EF <sub>5GS3GPPLOCI</sub>		FF FF...FF FE 01 (20 Bytes)	
EF <sub>EPSLOCI</sub>		FF FF...FF FE 01 (18 Bytes)	
EF <sub>PSLOCI</sub>		FF FF...FE FF 01 (14 Bytes)	
EF <sub>LOCI</sub>		FF FF...FE FF 01 (11 Bytes)	
Note: LOCI fields of this USIM configuration may get overwritten upon execution of test cases using a UICC loaded with this USIM configuration. The test operator shall ensure that USIM contents are as per this table before each execution of a test case that requires this USIM configuration.			

**Table 6.4.1-22: USIM Configuration 22**

USIM field	Priority	Value	Access Technology Identifier
EF <sub>UST</sub>		Service n°19 and n°51 defined in TS 31.102 clause 4.2.8 is declared "service not available"	

**Table 6.4.1-23: USIM Configuration 23**

USIM field	Priority	Value	Access Technology Identifier
EF <sub>UST</sub>		Service n°4 Service Dialling Numbers (SDN), Service n°99 URI support by UICC, Service n°89 eCall Data and Service n°112 eCall Data over IMS are available	
EF <sub>EST</sub>		Services n°1 Fixed Dialling Numbers (FDN) is disabled	
EF <sub>SDN</sub>		Two entries of SDNs, eCall Test Number (123456) and eCall reconfiguration number (345678)	
EF <sub>SDNURI</sub>		Two entries of SDNs, eCall Test Number (tel:123456) and eCall reconfiguration number (tel:345678)	

**Table 6.4.1-24: USIM Configuration 24**

USIM field	Priority	Value	Access Technology Identifier
EF <sub>UST</sub>		Service n°2 Fixed Dialling Numbers (FDN), Service n°99 URI support by UICC, Service n°89 eCall Data and Service n°112 eCall Data over IMS are available	
EF <sub>EST</sub>		Service n°1 Fixed Dialling Numbers (FDN) is enabled	

EF <sub>FDN</sub>		Two entries of FDNs, eCall Test Number (123456) and eCall reconfiguration number (345678)	
EF <sub>FDNURI</sub>		Two entries of FDNs, eCall Test Number (tel:123456) and eCall reconfiguration number (tel:345678)	

**Table 6.4.1-25: USIM Configuration 25**

USIM field	Priority	Value	Access Technology Identifier
EF <sub>IMSI</sub>		The HPLMN (MCC+MNC) of the IMSI is set to PLMN15.	

**Table 6.4.1-26: USIM Configuration 26**

USIM field	Priority	Value	Access Technology Identifier
EF <sub>UST</sub>		Service n°2 Fixed Dialling Numbers (FDN), Service n°99 URI support by UICC, Service n°89 eCall Data and Service n°112 eCall Data over IMS are available	
EF <sub>EST</sub>		Service n°1 Fixed Dialling Numbers (FDN) is enabled	
EF <sub>FDN</sub>		Two entries of FDNs, eCall Test Number (123456) and eCall reconfiguration number (345678)	
EF <sub>FDNURI</sub>		Two entries of FDNs, eCall Test Number (tel:123456) and eCall reconfiguration number (tel:345678)	
EF <sub>FPLMN</sub>		The HPLMN (MCC+MNC) of the IMSI is set to PLMN4.	

**Table 6.4.1-27: USIM Configuration 27**

USIM field	Priority	Value	Access Technology Identifier
EF <sub>IMSI</sub>		The HPLMN (MCC+MNC) of the IMSI is set to 001-01.	
EF <sub>FPLMN</sub>		001-02	

**Table 6.4.1-28: USIM Configuration 28**

USIM field	Priority	Value	Access Technology Identifier
EF <sub>IMSI</sub>		The HPLMN (MCC+MNC) of the IMSI is set to 001-02.	
EF <sub>FPLMN</sub>		001-01	

---

## 7 Test environments for RRM tests

### 7.0 General

#### 7.0.1 Single PDU configuration for RRM testing

For RRM test case execution on 5G SA UEs defined in TS 38.533 [18] 7.1 Requirements, IMS shall not be considered and UE's shall be able use RRC (IDLE, CONNECTED) preambles defined in TS 38.508-1 Section 4.5. Before entering RRC\_CONNECTED or RRC\_IDLE state during initial conditions or test procedure, it is recommended that UE is pre-configured with 0 or 1 PDU (non-IMS).

For EN-DC settings the corresponding requirement holds that IMS shall not be considered and it is recommended that UE is pre-configured with 0PDU/0PDN or 1PDU/1 PDN.

### 7.1 Test equipment requirements

#### 7.1.1 Void

#### 7.1.2 Void

#### 7.1.3 Requirements for OTA test method

##### 7.1.3.1 General

**Editor's Note:**

- The UE pre-configuration mentioned below to disable UL Tx diversity schemes shall be voided once a test methodology solution to minimize spectral flatness artefacts between TE and UE over all test points is defined.

For conformance testing using the OTA test environment, the UE under test shall be pre-configured with UL Tx diversity schemes disabled to account for single polarization System Simulator (SS) in the test environment. The UE under test may transmit with dual polarization.

##### 7.1.3.2 RRM baseline setup

The RRM baseline setup shall fulfil the capabilities detailed in this section.

The following permitted test setups are considered for OTA RRM testing:

- DFF test setup as described in Clause B.2.2.
- Simplified DFF test setup as described in Clause B.2.3.
- IFF test setup as described in Clause B.2.4.
- Enhanced IFF test setup based in the IFF test setup described in Clause B.2.6, with the enhancements described in this clause.
- IFF+DFF Hybrid test setup as described in Clause B.7.2, with the enhancements described in this clause.

##### 7.1.3.2.1 General description

TRxPs and Cells:

- Up to 2 NR transmission reception points TRxPs are emulated.

Support of interworking scenarios

- For test scenarios involving both, LTE and NR FR2 carriers, the test setup shall be capable to provide LTE link to the DUT. The emulated LTE cell provides a stable LTE signal without precise propagation modelling or path loss control between it and the DUT. No performance verification for and relative to LTE carriers is supported.
- For test scenarios involving both, NR FR1 and NR FR2 carriers, the test setup shall be capable to provide NR FR1 link to the DUT. The NR FR1 link has a stable and noise-free signal without precise path loss or polarization control. No performance verification for and relative to NR FR1 carriers is supported.

Antennas, polarization, simultaneously active AoAs:

- $N$  dual-polarized antennas transmitting the signals from the emulated gNB sources to the DUT.
- The antennas transmit into the test zone in such a way that signal polarization does not prevent the DUT receiving a consistent, predictable power level.
- $N \geq N_{\text{MAX\_AoAs}}$ , where  $N_{\text{MAX\_AoAs}}$  is the maximum number of simultaneously active (emulating signal) angles of arrival AoAs. The  $N_{\text{MAX\_AoAs}}$  for the different permitted test methods is:
  - For UE RRM baseline measurement setup based on DFF, the supported  $N_{\text{MAX\_AoAs}} = 2$ .
  - For UE RRM baseline measurement setup based on simplified DFF, the supported  $N_{\text{MAX\_AoAs}} = 1$ .
  - For UE RRM baseline measurement setup based on IFF, the supported  $N_{\text{MAX\_AoAs}} = 1$ .
  - For UE RRM baseline measurement setup based on enhanced IFF, the supported  $N_{\text{MAX\_AoAs}} = 2$ .
  - For UE RRM baseline measurement setup based on IFF+DFF, the supported  $N_{\text{MAX\_AoAs}} = 2$ .

Angular Relationship:

- A positioning system such that an angular relationship with two axes of freedom is provided between the DUT and the test system antennas (or the setup should provide equivalent functionality).
- For  $N_{\text{MAX\_AoAs}} = 2$  the setup shall enable following relative angular relationships between the  $N_{\text{MAX\_AoAs}}$  simultaneously active AoAs: 30°, 60°, 90°, 120° and 150°.
- For single active probe scenarios, in case that step change of AoA is required, the setup shall enable following relative angular change between initial and target AoA: 30°, 60°, 90°, 120° and 150°.

Wanted and noise (AWGN) signals can be transmitted from one or both active probes. Test description will define the exact signal/noise/SNR/SINR level per TRxP at the reference point.

Multiple DL transmission antenna ports:

- In case of multiple DL transmission antenna ports are required for RRM testing, the different antenna ports are mapped to different polarizations.

Measurement Uncertainty:

- The threshold MU for the equivalence framework for RRM will be based on direct far field (DFF) test method for  $D \leq 5$  cm and on indirect far field (IFF) test method for  $D > 5$  cm. If the MTSU for the IFF test method for  $D \leq 5$  cm is finalized before DFF, the IFF MTSU shall be used as provisional threshold MU until DFF is completed.

#### 7.1.3.2.2 Applicability criteria

The applicability criteria for the RRM measurement setup based on DFF is described in B.2.2.1.

The applicability criteria for the RRM measurement setup based on simplified DFF is described in B.2.3.1.

The applicability criteria for the RRM measurement setup based on IFF is described in B.2.4.1.

The applicability criteria for the RRM measurement setup based on enhanced IFF is described in B.2.6.1:

The applicability criteria for the RRM measurement setup based on IFF+DFF follows DFF as described in B.2.7.1:

### 7.1.3.2.3 Measurement distance and quiet zone

For RRM baseline measurement setup based on DFF:

- The measurement distance defined for the DFF UE RF test method described in B.2.2.4 applies.
- A DFF measurement setup has the centre of the Quiet Zone (QZ) located at the centre of the rotational axes (of DUT and measurement antenna). For the RRM measurement baseline setup based on DFF, the vertices of the N probes have to be aligned to the resulting centre of the QZ. The centre of the QZ is taken as the reference point for MU definition for each probe. The same QZ size as for DFF UE RF test method described in B.2.2.2 applies.

For RRM baseline measurement setup based on simplified DFF:

- The measurement distance defined for the simplified DFF UE RF test method described in B.2.3.4 applies.
- The same QZ size and definition as for simplified DFF UE RF test method described in B.2.3.2 applies.

For RRM baseline measurement setup based on IFF:

- The measurement distance defined for the IFF UE RF test method described in B.2.4.4 applies.
- The Quiet Zone definition for the IFF UE RF test method described in B.2.4.2 applies.

For RRM baseline measurement setup based on enhanced IFF:

- The measurement distance defined for the IFF UE RF test method described in B.2.6.4 applies.
- An IFF measurement setup has the centre of the Quiet Zone (QZ) located at the centre of the rotational axes (of DUT). For the RRM measurement baseline setup based on IFF, the reflectors have to be aligned to transmit a plane wave to the resulting centre of the QZ. The centre of the QZ is taken as the reference point for MU definition for each reflector. The QZ is a sphere of radius R. The size of the QZ defined in B.2.6.2 applies.

For RRM baseline measurement setup based on IFF+DFF:

- For IFF TRxPs, the measurement distance defined for the IFF UE RF test method described in B.2.4.4 applies.
- For DFF TRxPs, the measurement distance defined for the DFF UE RF test method described in B.2.2.4 applies.
- An IFF+DFF measurement setup has the centre of the Quiet Zone (QZ) located at the centre of the rotational axes (of DUT). For the RRM measurement baseline setup based on IFF+DFF, IFF reflectors have to be aligned to transmit a plane wave to the resulting centre of the QZ, and the vertices of the DFF probes have to be aligned to the resulting centre of the QZ. The centre of the QZ is taken as the reference point for MU definition for each reflector or probe. The QZ is a sphere of radius R. The size of the QZ is defined in B.2.7.2.

### 7.1.3.2.4 Quality of the quiet zone

For RRM, the quality of the quiet zone validation defined in Annex O of TS 38.521-2 [15] needs to assess only the single-directional EIRP and EIS metrics. For measurement setups with multiple probes, the QoQZ procedure needs to be performed with all probes present and in the conditions used for RRM testing.

The quality of the quiet zone for the RRM measurement setup based on DFF is described in B.2.2.3. The QoQZ validation needs to be performed only with the reference probe P0.

The quality of the quiet zone for the RRM measurement setup based on simplified DFF is described in B.2.3.3.

The quality of the quiet zone for the RRM measurement setup based on IFF is described in B.2.4.3.

The quality of the quiet zone for the RRM measurement setup based on enhanced IFF is described in B.2.6.3. The QoQZ validation needs to be performed only with the reference reflector, P0, if same sized IFF reflectors are used..

The quality of the quiet zone for the RRM measurement setup based on IFF+DFF is described in B.2.7.3. The QoQZ validation needs to be performed only with the one probe among all DFF probes and one probe among all IFF probes.

## 7.2 Reference test conditions

### 7.2.1 Signal levels

7.2.1.1 Void

7.2.1.2 Void

### 7.2.2 Physical layer parameters

#### 7.2.2.1 Downlink physical layer parameters

As defined in clause 4.3.6 with the following exceptions:

**Table 7.2.2.1-1: Physical layer parameters for DCI format 1\_1**

Derivation Path: Table 4.3.6.1.2.2-1			
Parameter	Value	Value in binary	Condition
PUCCH resource indicator	$PUCCH-ResourceID[1] = 0$ in $pucch-ResourceSetID[1]$ as defined in Table 4.6.3-112 (Mapping as per Table 9.2.3-2 in TS 38.213 [22])	"000"	
PDSCH-to-HARQ_feedback timing indicator	corresponding to K1 slots as per Table 9.2.3-1 in TS 38.213 [22] and dl-DataToUL-ACK in Table 4.6.3-112  For 120KHz SCS K1 = 4 if $\text{mod}(i,5) = 0$ K1 = 3 if $\text{mod}(i,5) = 1$ K1 = 7 if $\text{mod}(i,5) = 2$ where i is slot index per frame; $i = \{0, \dots, 79\}$	-	FR2
PDSCH-to-HARQ_feedback timing indicator	corresponding to K1 slots as per Table 9.2.3-1 in TS 38.213 [22] and dl-DataToUL-ACK in Table 4.6.3-112 K1 = 6 if $\text{mod}(i,10) = 8$ K1 = 5 if $\text{mod}(i,10) = 0$ K1 = 5 if $\text{mod}(i,10) = 1$ K1 = 5 if $\text{mod}(i,10) = 2$ K1 = 5 if $\text{mod}(i,10) = 9$ where i is slot index per frame; $i = \{0, \dots, 19\}$		TDDConf.2.1
PDSCH-to-HARQ_feedback timing indicator	corresponding to K1 slots as per Table 9.2.3-1 in TS 38.213 [22] and dl-DataToUL-ACK in Table 4.6.3-112 For FDD K1 = 2		FDD

Condition	Explanation
TDDConf.2.1	TDD UL/DL configuration for SCS=30kHz

**Table 7.2.2.1-2: Physical layer parameters for DCI format 1\_0**

Parameter	Value	Value in binary
PDSCH-to-HARQ_feedback timing indicator	corresponding to K1 slots as per Table 9.2.3-1 in TS 38.213 [22] and dl-DataToUL-ACK in Table 4.6.3-112 For FDD K1 = 2	

## 7.2.3 Default test frequencies

### 7.2.3.1 Default test frequencies FR1 NR operating bands

For FR1 NR operating bands the test frequencies for RRM testing are specified in clause 4.3.1.1.

### 7.2.3.2 Default test frequencies FR2 operating bands



7.2.3.2.1 Reference test frequencies for NR operating band n257

**Table 7.2.3.2.1-1: Test frequencies for NR operating band n257 (SCS 120 kHz,  $\Delta F_{\text{Raster}}$  120 kHz, SSB SCS=120kHz,  $k_{\text{SSB}}=0$  and Offset(RBs)=0)**

CB W [MHz]	carrier Bandwidth [PRBs]	Range		Carrier centre [MHz]	Carrier centre [ARFCN]	point A [MHz]	absoluteFrequencyPointA [ARFCN]	offsetToCarrier [Carrier PRBs]	SS block SCS [kHz]	GSC N	absoluteFrequencySB [ARFCN]	$k_{\text{SSB}}$	Offset Carrier CORESET#0 [RBs] Note 2	CORESET#0 Index (Offset [RBs]) Note 1	offsetToPointA (SIB1) [PRBs] Note 1
100	66	Downlink & Uplink	Mid	28015.68	20794.27	27968.16	20786.35	0	120	2247.2	20788.75	0	0	0 (0)	0
100	66	Downlink & Uplink	Adjacent inter-frequency cell	28119.36	20811.55	28071.84	20803.63	0	120	2247.8	20806.03	0	0	0 (0)	0

Note 1: The CORESET#0 Index and the associated CORESET#0 Offset refers to Table 13-8 in TS 38.213 [22]. The value of CORESET#0 Index is signalled controlResourceSetZero (pdcch-ConfigSIB1) in the MIB. The offsetToPointA IE is expressed in units of resource blocks assuming 15 kHz subcarrier spacing for FR1 and 60 kHz subcarrier spacing for FR2.

Note 2: The parameter Offset Carrier CORESET#0 specifies the offset from the lowest subcarrier of the carrier and the lowest subcarrier of CORESET#0. It corresponds to the parameter  $\Delta F_{\text{OffsetCORESET-0-Carrier}}$  in Annex C expressed in number of common RBs.

**Table 7.2.3.2.1-2: Test frequencies for NR operating band n257 (SCS 240 kHz,  $\Delta F_{\text{Raster}}$  120 kHz, SSB SCS=240kHz,  $k_{\text{SSB}}=0$  and Offset(RBs)=0)**

CB W [MHz]	carrier Bandwidth [PRBs]	Range		Carrier centre [MHz]	Carrier centre [ARFCN]	point A [MHz]	absoluteFrequencyPointA [ARFCN]	offsetToCarrier [Carrier PRBs]	SS block SCS [kHz]	GSC N	absoluteFrequencySB [ARFCN]	$k_{\text{SSB}}$	Offset Carrier CORESET#0 [RBs] Note 2	CORESET#0 Index (Offset [RBs]) Note 1	offsetToPointA (SIB1) [PRBs] Note 1
100	66	Downlink & Uplink	Mid	28001.28	20791.87	27953.76	20783.95	0	240	2247.2	20788.75	0	0	2 (0)	0
100	66	Downlink & Uplink	Adjacent inter-frequency cell	28104.96	20809.15	28057.44	20801.23	0	240	2247.8	20806.03	0	0	0 (0)	0

Note 1: The CORESET#0 Index and the associated CORESET#0 Offset refers to Table 13-10 in TS 38.213 [22]. The value of CORESET#0 Index is signalled controlResourceSetZero (pdcch-ConfigSIB1) in the MIB. The

offsetToPointA IE is expressed in units of resource blocks assuming 15 kHz subcarrier spacing for FR1 and 60 kHz subcarrier spacing for FR2.

Note 2: The parameter Offset Carrier CORESET#0 specifies the offset from the lowest subcarrier of the carrier and the lowest subcarrier of CORESET#0. It corresponds to the parameter  $\Delta F_{\text{OffsetCORESET-0-Carrier}}$  in Annex C expressed in number of common RBs.

7.2.3.2.2 Reference test frequencies for NR operating band n258

**Table 7.2.3.2.2-1: Test frequencies for NR operating band n258 (SCS 120 kHz,  $\Delta F_{\text{Raster}}$  120 kHz SSB SCS=120kHz,  $k_{\text{SSB}}=0$  and Offset(RBs)=0)**

CB W [MHz]	carrier Bandwidth [PRBs]	Range		Carrier centre [MHz]	Carrier centre [ARFCN]	point A [MHz]	absolute Frequency Point A [ARFCN]	offset To Carrier [Carrier PRBs]	SS block SCS [kHz]	GSC N	absolute Frequency SSB [ARFCN]	$k_{\text{SSB}}$	Offset Carrier CORESET#0 [RBs] Note 2	CORESET#0 Index (Offset [RBs]) Note 1	offset To Point A (SIB1) [PRBs] Note 1
100	66	Downlink & Uplink	Mid	25890.24	2044003	25842.72	2043211	0	120	22349	2043451	0	0	0 (0)	0
100	66	Downlink & Uplink	Adjacent inter-frequency cell	25993.92	2045731	25946.4	2044939	0	120	22355	2045179	0	0	0 (0)	0

Note 1: The CORESET#0 Index and the associated CORESET#0 Offset refers to Table 13-8 in TS 38.213 [22]. The value of CORESET#0 Index is signalled controlResourceSetZero (pdcch-ConfigSIB1) in the MIB. The offsetToPointA IE is expressed in units of resource blocks assuming 15 kHz subcarrier spacing for FR1 and 60 kHz subcarrier spacing for FR2.

Note 2: The parameter Offset Carrier CORESET#0 specifies the offset from the lowest subcarrier of the carrier and the lowest subcarrier of CORESET#0. It corresponds to the parameter  $\Delta F_{\text{OffsetCORESET-0-Carrier}}$  in Annex C expressed in number of common RBs.

**Table 7.2.3.2.2-2: Test frequencies for NR operating band n258 (SCS 120 kHz,  $\Delta F_{\text{Raster}}$  120 kHz, SSB SCS=240kHz,  $k_{\text{SSB}}=0$  and Offset(RBs)=0)**

CB W [MHz]	carrier Bandwidth [PRBs]	Range		Carrier centre [MHz]	Carrier centre [ARFCN]	point A [MHz]	absolute Frequency Point A [ARFCN]	offset To Carrier [Carrier PRBs]	SS block SCS [kHz]	GSC N	absolute Frequency SSB [ARFCN]	$k_{\text{SSB}}$	Offset Carrier CORESET#0 [RBs] Note 2	CORESET#0 Index (Offset [RBs]) Note 1	offset To Point A (SIB1) [PRBs] Note 1
100	66	Downlink & Uplink	Mid	25893.12	2044051	25845.6	2043259	0	240	22350	2043739	0	0	2 (0)	0
100	66	Downlink & Uplink	Adjacent inter-frequency cell	25996.8	2045779	25949.28	2044987	0	240	22356	2045467	0	0	0 (0)	0

Note 1: The CORESET#0 Index and the associated CORESET#0 Offset refers to Table 13-10 in TS 38.213 [22]. The value of CORESET#0 Index is signalled controlResourceSetZero (pdcch-ConfigSIB1) in the MIB. The

offsetToPointA IE is expressed in units of resource blocks assuming 15 kHz subcarrier spacing for FR1 and 60 kHz subcarrier spacing for FR2.  
 Note 2: The parameter Offset Carrier CORESET#0 specifies the offset from the lowest subcarrier of the carrier and the lowest subcarrier of CORESET#0. It corresponds to the parameter  $\Delta F_{\text{OffsetCORESET-0-Carrier}}$  in Annex C expressed in number of common RBs.

7.2.3.2.3 Reference test frequencies for NR operating band n259

**Table 7.2.3.2.3-1: Test frequencies for NR operating band n259 (SCS 120 kHz,  $\Delta F_{\text{Raster}}$  120 kHz SSB SCS=120kHz, kSSB=0 and Offset(RBs)=0)**

CB W [MHz]	carrierBandwidth [PRBs]	Range		Carrier centre [MHz]	Carrier centre [ARFCN]	point A [MHz]	absoluteFrequencyPointA [ARFCN]	offsetToCarrier [Carrier PRBs]	SS block SCS [kHz]	GSC N	absoluteFrequencySSB [ARFCN]	$k_{\text{SSB}}$	Offset Carrier CORESET#0 [RBs] Note 2	CORESET#0 Index (Offset [RBs]) Note 1	offsetToPointA (SIB1) [PRBs] Note 1
100	66	Downlink & Uplink	Mid	41511.36	2304355	41463.84	2303563	0	120	23253	2303803	0	0	0 (0)	0
100	66	Downlink & Uplink	Adjacent interference cell	41615.04	2306083	41567.52	2305291	0	120	23259	2305531	0	0	0 (0)	0

Note 1: The CORESET#0 Index and the associated CORESET#0 Offset refers to Table 13-8 in TS 38.213 [22]. The value of CORESET#0 Index is signalled controlResourceSetZero (pdcch-ConfigSIB1) in the MIB. The offsetToPointA IE is expressed in units of resource blocks assuming 15 kHz subcarrier spacing for FR1 and 60 kHz subcarrier spacing for FR2.  
 Note 2: The parameter Offset Carrier CORESET#0 specifies the offset from the lowest subcarrier of the carrier and the lowest subcarrier of CORESET#0. It corresponds to the parameter  $\Delta F_{\text{OffsetCORESET-0-Carrier}}$  in Annex C expressed in number of common RBs.

**Table 7.2.3.2.3-2: Test frequencies for NR operating band n259 (SCS 120 kHz,  $\Delta F_{\text{Raster}}$  120 kHz, SSB SCS=240kHz, kSSB=0 and Offset(RBs)=0)**

CB W [MHz]	carrierBandwidth [PRBs]	Range		Carrier centre [MHz]	Carrier centre [ARFCN]	point A [MHz]	absoluteFrequencyPointA [ARFCN]	offsetToCarrier [Carrier PRBs]	SS block SCS [kHz]	GSC N	absoluteFrequencySSB [ARFCN]	$k_{\text{SSB}}$	Offset Carrier CORESET#0 [RBs] Note 2	CORESET#0 Index (Offset [RBs]) Note 1	offsetToPointA (SIB1) [PRBs] Note 1
100	66	Downlink & Uplink	Mid	41514.24	2304403	41466.72	2303611	0	240	23254	2304091	0	0	2 (0)	0
100	66	Downlink & Uplink	Adjacent	41617.92	2306131	41570.4	2305339	0	240	23260	2305819	0	0	0 (0)	0

		Uplink	inter-frequency cell											
<p>Note 1: The CORESET#0 Index and the associated CORESET#0 Offset refers to Table 13-10 in TS 38.213 [22]. The value of CORESET#0 Index is signalled controlResourceSetZero (pdcch-ConfigSIB1) in the MIB. The offsetToPointA IE is expressed in units of resource blocks assuming 15 kHz subcarrier spacing for FR1 and 60 kHz subcarrier spacing for FR2.</p> <p>Note 2: The parameter Offset Carrier CORESET#0 specifies the offset from the lowest subcarrier of the carrier and the lowest subcarrier of CORESET#0. It corresponds to the parameter <math>\Delta F_{\text{OffsetCORESET-0-Carrier}}</math> in Annex C expressed in number of common RBs.</p>														

7.2.3.2.4 Reference test frequencies for NR operating band n260

**Table 7.2.3.2.4-1: Test frequencies for NR operating band n260 (SCS 120 kHz,  $\Delta F_{\text{Raster}}$  120 kHz SSB SCS=120kHz, kSSB=0 and Offset(RBs)=0)**

CBW [MHz]	carrierBandwidth [PRBs]	Range		Carrier centre [MHz]	Carrier centre [ARFCN]	point A [MHz]	absoluteFrequencyPointA [ARFCN]	offsetToCarrier [Carrier PRBs]	SS block SCS [kHz]	GSCN	absoluteFrequencySB [ARFCN]	$k_{\text{SSB}}$	Offset Carrier CORESET#0 [RBs]	CORESET#0 Index (Offset [RBs])	offsetToPointA (SIB1) [PRBs]
100	66	Downlink & Uplink	Mid	38504.64	2254243	38457.12	2253451	0	120	23079	2253691	0	0	0 (0)	0
100	66	Downlink & Uplink	Adjacent inter-frequency cell	38608.32	2255971	38560.8	2255179	0	120	23085	2255419	0	0	0 (0)	0
<p>Note 1: The CORESET#0 Index and the associated CORESET#0 Offset refers to Table 13-8 in TS 38.213 [22]. The value of CORESET#0 Index is signalled controlResourceSetZero (pdcch-ConfigSIB1) in the MIB. The offsetToPointA IE is expressed in units of resource blocks assuming 15 kHz subcarrier spacing for FR1 and 60 kHz subcarrier spacing for FR2.</p> <p>Note 2: The parameter Offset Carrier CORESET#0 specifies the offset from the lowest subcarrier of the carrier and the lowest subcarrier of CORESET#0. It corresponds to the parameter <math>\Delta F_{\text{OffsetCORESET-0-Carrier}}</math> in Annex C expressed in number of common RBs.</p>															

**Table 7.2.3.2.4-2: Test frequencies for NR operating band n260 (SCS 120 kHz,  $\Delta F_{\text{Raster}}$  120 kHz, SSB SCS=240kHz, kSSB=0 and Offset(RBs)=0)**

CBW [MHz]	carrierBandwidth [PRBs]	Range		Carrier centre [MHz]	Carrier centre [ARFCN]	point A [MHz]	absoluteFrequencyPointA [ARFCN]	offsetToCarrier [Carrier PRBs]	SS block SCS [kHz]	GSCN	absoluteFrequencySB [ARFCN]	$k_{\text{SSB}}$	Offset Carrier CORESET#0 [RBs]	CORESET#0 Index (Offset [RBs])	offsetToPointA (SIB1) [PRBs]

100	66	Downlink & Uplink	Mid	38507.52	2254291	38460	2253499	0	240	23080	2253979	0	0	2 (0)	0
100	66	Downlink & Uplink	Adjacent inter-frequency cell	38611.2	2256019	38563.68	2255227	0	240	23086	2255707	0	0	0 (0)	0

Note 1: The CORESET#0 Index and the associated CORESET#0 Offset refers to Table 13-10 in TS 38.213 [22]. The value of CORESET#0 Index is signalled controlResourceSetZero (pdcch-ConfigSIB1) in the MIB. The offsetToPointA IE is expressed in units of resource blocks assuming 15 kHz subcarrier spacing for FR1 and 60 kHz subcarrier spacing for FR2.

Note 2: The parameter Offset Carrier CORESET#0 specifies the offset from the lowest subcarrier of the carrier and the lowest subcarrier of CORESET#0. It corresponds to the parameter  $\Delta F_{\text{OffsetCORESET-0-Carrier}}$  in Annex C expressed in number of common RBs.

7.2.3.2.5 Reference test frequencies for NR operating band n261

**Table 7.2.3.2.5-1: Test frequencies for NR operating band n261 (SCS 120 kHz,  $\Delta F_{\text{Raster}}$  120 kHz SSB SCS=120kHz,  $k_{\text{SSB}}=0$  and Offset(RBs)=0)**

CB W [MHz]	carrierBandwidth [PRBs]	Range		Carrier centre [MHz]	Carrier centre [ARFCN]	point A [MHz]	absoluteFrequencyPointA [ARFCN]	offsetToCarrier [Carrier PRBs]	SS block SCS [kHz]	GSC N	absoluteFrequencySB [ARFCN]	$k_{\text{SSB}}$	Offset Carrier CORESET#0 [RBs] Note 2	CORESET#0 Index (Offset [RBs]) Note 1	offsetToPointA (SIB1) [PRBs] Note 1
100	66	Downlink & Uplink	Mid	27929.28	20779.87	27881.76	20771.95	0	120	22467	20774.35	0	0	0 (0)	0
100	66	Downlink & Uplink	Adjacent inter-frequency cell	28032.96	20797.15	27985.44	20789.23	0	120	22473	20791.63	0	0	0 (0)	0

Note 1: The CORESET#0 Index and the associated CORESET#0 Offset refers to Table 13-8 in TS 38.213 [22]. The value of CORESET#0 Index is signalled controlResourceSetZero (pdcch-ConfigSIB1) in the MIB. The offsetToPointA IE is expressed in units of resource blocks assuming 15 kHz subcarrier spacing for FR1 and 60 kHz subcarrier spacing for FR2.

Note 2: The parameter Offset Carrier CORESET#0 specifies the offset from the lowest subcarrier of the carrier and the lowest subcarrier of CORESET#0. It corresponds to the parameter  $\Delta F_{\text{OffsetCORESET-0-Carrier}}$  in Annex C expressed in number of common RBs.

**Table 7.2.3.2.5-2: Test frequencies for NR operating band n261 (SCS 120 kHz,  $\Delta F_{\text{Raster}}$  120 kHz, SSB SCS=240kHz,  $k_{\text{SSB}}=0$  and Offset(RBs)=0)**

CB W [MHz]	carrierBandwidth [PRBs]	Range		Carrier centre [MHz]	Carrier centre [ARFCN]	point A [MHz]	absoluteFrequencyPointA [ARFCN]	offsetToCarrier [Carrier PRBs]	SS block SCS [kHz]	GSC N	absoluteFrequencySB [ARFCN]	$k_{\text{SSB}}$	Offset Carrier CORESET#0 [RBs] Note 2	CORESET#0 Index (Offset [RBs]) Note 1	offsetToPointA (SIB1) [PRBs] Note 1
100	66	Downlink & Uplink	Mid	27932.16	20780.35	27884.64	20772.43	0	240	22468	20777.23	0	0	2 (0)	0
100	66	Downlink & Uplink	Adjacent inter-frequency cell	28035.84	20797.63	27988.32	20789.71	0	240	22474	20794.51	0	0	0 (0)	0

Note 1: The CORESET#0 Index and the associated CORESET#0 Offset refers to Table 13-10 in TS 38.213 [22]. The value of CORESET#0 Index is signalled controlResourceSetZero (pdcch-ConfigSIB1) in the MIB. The

offsetToPointA IE is expressed in units of resource blocks assuming 15 kHz subcarrier spacing for FR1 and 60 kHz subcarrier spacing for FR2.

Note 2: The parameter Offset Carrier CORESET#0 specifies the offset from the lowest subcarrier of the carrier and the lowest subcarrier of CORESET#0. It corresponds to the parameter  $\Delta F_{\text{OffsetCORESET-0-Carrier}}$  in Annex C expressed in number of common RBs.

## 7.3 Default NG-RAN RRC message and information elements contents for RRM

### 7.3.0 General definitions

This section defines general concepts and conditions used in the RRM message contents in clause 7.3:

- CSI-RS for Tracking, CSI reporting and beam management

**Table 7.3.0-1: Definitions of CSI-RS for Tracking, CSI reporting and beam management**

Type	Short version	Explanation
CSI-RS for tracking	TRS	Corresponds to TRS.X.Y FDD/TDD RMCs in TS 38.533 [18]
CSI-RS for BM	BM	Corresponds to CSI-RS.X.2 FDD/TDD RMCs in TS 38.533 [18]
CSI-RS for CSI reporting	CSI	Corresponds to CSI-RS.X.1 FDD/TDD RMCs in TS 38.533 [18]
CSI-RS for IM	CSI-IM	CSI-IM resources for CSI reporting. Needed when CSI-RS.X.1 FDD/TDD RMCs are configured.

**Editor's Note:** The message contents for CSI-RS.X.3/4 FDD/TDD RMCs in TS 38.533 [18] are not yet defined.

### 7.3.1 Radio resource control information elements for RRM

As defined in clause 4.6.3 with the following exceptions:

- *TDD-UL-DL-ConfigCommon*

**Table 7.3.1-1: TDD-UL-DL-ConfigCommon**

Information Element	Value/remark	Comment	Condition
Derivation Path: Table 4.6.3-192			
TDD-UL-DL-ConfigCommon ::= SEQUENCE {			
referenceSubcarrierSpacing	SubcarrierSpacing		
pattern1 SEQUENCE {			
dl-UL-TransmissionPeriodicity	ms0p625		TDDConf.3.1
nrofDownlinkSlots	3		TDDConf.2.1, TDDConf.3.1
	1		TDDConf.1.1
nrofDownlinkSymbols	10		TDDConf.1.1, TDDConf.3.1
	6		TDDConf.2.1
nrofUplinkSlots	2		TDDConf.1.1
	1		TDDConf.3.1
	4		TDDConf.2.1
nrofUplinkSymbols	4		TDDConf.2.1
	2		TDDConf.1.1, TDDConf.3.1
dl-UL-TransmissionPeriodicity-v1530	Not present ms4		TDDConf.1.1, TDDConf.2.1
}			
pattern2	Not present		
pattern2 SEQUENCE {			TDDConf.1.1,



			TDDConf.2.1
dl-UL-TransmissionPeriodicity	ms1		TDDConf.1.1, TDDConf.2.1
nrofDownlinkSlots	1		TDDConf.1.1
	2		TDDConf.2.1
nrofDownlinkSymbols	0		TDDConf.1.1, TDDConf.2.1
nrofUplinkSlots	0		TDDConf.1.1, TDDConf.2.1
nrofUplinkSymbols	0		TDDConf.1.1, TDDConf.2.1
}			
}			

Condition	Explanation
TDDConf.1.1	TDD UL/DL configuration for SCS=15kHz
TDDConf.2.1	TDD UL/DL configuration for SCS=30kHz
TDDConf.3.1	TDD UL/DL configuration for SCS=120kHz

– *FilterCoefficient*

**Table 7.3.1-2: FilterCoefficient**

Derivation Path: Table 4.6.3-57			
Information Element	Value/remark	Comment	Condition
FilterCoefficient	fc0	L3 filtering is not used	

– *SSB-MTC*

**Table 7.3.1-3: SSB-MTC**

Derivation Path: Table 4.6.3-185			
Information Element	Value/remark	Comment	Condition
SSB-MTC ::= SEQUENCE {			
periodicityAndOffset CHOICE {			
sf20	0		SMTC.1, SMTC.2
	10		SMTC.4, SMTC.5
	17		SMTC.6
sf40	0		SMTC.1 RedCap
	20		SMTC.3 RedCap
sf80	5		SMTC.2 RedCap SMTC.4 RedCap
sf160	0		SMTC.3
}			
duration	sf1		SMTC.1, SMTC.3, SMTC.4 SMTC.1 RedCap SMTC.2 RedCap SMTC.3 RedCap
	sf5		SMTC.2, SMTC.5 SMTC.6 SMTC.4 RedCap
}			

Condition	Explanation
SMTC.n	SMTC pattern n as defined in 38.533 Annex A.4
SMTC.n RedCap	RedCap-specific SMTC pattern n as defined in 38.533 Annex A.4A

– *SubcarrierSpacing*

**Table 7.3.1-3a: SubcarrierSpacing**

Derivation Path: Table 4.6.3-188			
Information Element	Value/remark	Comment	Condition
ssbSubcarrierSpacing	kHz15		SSB.1 FR1 SSB.3 FR1 SSB.5 FR1 SSB.4 RedCap FR1 SSB.6 RedCap FR1
	kHz30		SSB.2 FR1 SSB.4 FR1 SSB.6 FR1 SSB.1 RedCap FR1 SSB.2 RedCap FR1 SSB.3 RedCap FR1 SSB.5 RedCap FR1 SSB.7 RedCap FR1
	kHz120		SSB.1 FR2 SSB.3 FR2 SSB.5 FR2 SSB.7 FR2 SSB.1 RedCap FR2 SSB.2 RedCap FR2 SSB.3 RedCap FR2
	kHz240		SSB.2 FR2 SSB.4 FR2 SSB.6 FR2 SSB.8 FR2 SSB.4 RedCap FR2 SSB.5 RedCap FR2

Condition	Explanation
SSB.n FR1	SSB RMC n for FR1 as defined in 38.533 Annex A.3.1
SSB.n FR2	SSB RMC n for FR2 as defined in 38.533 Annex A.3.2
SSB.n RedCap FR1	RedCap specific SSB RMC n for FR1 as defined in 38.533 Annex A.3A.1
SSB.n RedCap FR2	RedCap specific SSB RMC n for FR2 as defined in 38.533 Annex A.3A.2

– *ServingCellConfigCommon*

**Table 7.3.1-4: ServingCellConfigCommon**

Derivation Path: Table 4.6.3-168			
Information Element	Value/remark	Comment	Condition
ServingCellConfigCommon ::= SEQUENCE {			
ssb-PositionsInBurst CHOICE {			
shortBitmap	1100	2 SS Blocks in low FR1 frequencies	2SSB AND ((SCS15 AND 1.88GHz<FR EQ<=3GHz) OR



		<p><math>n_2=0</math> if CSI-RS for BM is not configured in the test case. If CSI-RS for BM is configured in the test case, <math>n_2 = 2</math> if 2SSB, <math>n_2 = 1</math> otherwise</p> <p><math>n_3=4</math> if TRS is configured in test case, <math>n_3=0</math> otherwise;</p> <p><math>n_4=4</math> if second resource set of TRS is configured in test case, <math>n_4=0</math> otherwise;</p> <p><math>n_5=2</math> if aperiodic CSI-RS for BM is configured in test case, <math>n_5=0</math> otherwise;</p>	
NZP-CSI-RS-Resource[k, k=1.. $n_1$ ]	NZP-CSI-RS-Resource for CSI	entry 1	$n_1>0$
NZP-CSI-RS-Resource[k, k= $n_1+1.. n_1+n_2$ ]	NZP-CSI-RS-Resource for BM (k- $n_1-1$ )	entry ...	$n_2>0$
NZP-CSI-RS-Resource[k, k= $n_1+n_2+1.. n_1+n_2+n_3$ ]	NZP-CSI-RS-Resource for TRS (k- $n_1-n_2$ )	entry ...	$n_3>0$
NZP-CSI-RS-Resource[k, k= $n_1+n_2+n_3+1.. n_1+n_2+n_3+n_4$ ]	NZP-CSI-RS-Resource for TRS (k- $n_1-n_2-n_3$ ) with condition SECOND_SET	entry ...	$n_4>0$
NZP-CSI-RS-Resource[k, k= $n_1+n_2+n_3+n_4+1.. n_1+n_2+n_3+n_4+n_5$ ]	NZP-CSI-RS-Resource for BM (k- $n_1-n_2-n_3-n_4$ ) with condition APERIODIC	entry ...	$n_5>0$
}			
nzp-CSI-RS-ResourceSetToAddModList SEQUENCE (SIZE (1..maxNrofNZP-CSI-RS-ResourceSets)) OF NZP-CSI-RS-ResourceSet {	$m_1+m_2+m_3+m_4+m_5$ entries	$m_i=1$ if $n_i>0$ , $m_i=0$ otherwise	
NZP-CSI-RS-ResourceSet[k, k=1.. $m_1$ ]	NZP-CSI-RS-ResourceSet for CSI	entry 1	$n_1>0$
NZP-CSI-RS-ResourceSet[k, k= $m_1+1.. m_1+m_2$ ]	NZP-CSI-RS-ResourceSet for BM	entry ...	$n_2>0$
NZP-CSI-RS-ResourceSet[k, k= $m_1+m_2+1.. m_1+m_2+m_3$ ]	NZP-CSI-RS-ResourceSet for TRS	entry ...	$n_3>0$
NZP-CSI-RS-ResourceSet[k, k= $m_1+m_2+m_3+1.. m_1+m_2+m_3+m_4$ ]	NZP-CSI-RS-ResourceSet for TRS with condition SECOND_SET	entry ...	$n_4>0$
NZP-CSI-RS-ResourceSet[k, k= $m_1+m_2+m_3+m_4+1.. m_1+m_2+m_3+m_4+m_5$ ]	NZP-CSI-RS-ResourceSet for BM with condition APERIODIC	entry ...	$n_5>0$
}			
csi-IM-ResourceToAddModList SEQUENCE (SIZE (1..maxNrofCSI-IM-Resources)) OF CSI-IM-Resource {	1 entry		$n_1>0$
CSI-IM-Resource[1]	CSI-IM-Resource-RRM	entry 1	
}			
csi-IM-ResourceToAddModList	Not present		$n_1=0$
csi-IM-ResourceSetToAddModList SEQUENCE (SIZE (1..maxNrofCSI-IM-ResourceSets)) OF CSI-IM-ResourceSet {	1 entry		$n_1>0$
CSI-IM-ResourceSet[1]	CSI-IM-ResourceSet-RRM	entry 1	
}			
csi-IM-ResourceSetToAddModList	Not present		$n_1=0$

csi-SSB-ResourceSetToAddModList SEQUENCE (SIZE (1..maxNrofCSI-SSB-ResourceSets)) OF CSI-SSB-ResourceSet {			
CSI-SSB-ResourceSet[1]	CSI-SSB-ResourceSet-RRM	entry 1	
}			
csi-ResourceConfigToAddModList SEQUENCE (SIZE (1..maxNrofCSI-ResourceConfigurations)) OF CSI-ResourceConfig {	$p_1+m_2+m_3+m_4+m_5$ entries	$p_1=m_1+1$ if $n_1>0$ , $p_1=0$ otherwise.	
CSI-ResourceConfig[k, k=1..m <sub>1</sub> ]	CSI-ResourceConfig for CSI	entry 1	$n_1>0$
CSI-ResourceConfig[k, k=p <sub>1</sub> ]	CSI-ResourceConfig for CSI-IM	entry ...	$n_1>0$
CSI-ResourceConfig[k, k=p <sub>1</sub> +1.. p <sub>1</sub> +m <sub>2</sub> ]	CSI-ResourceConfig for BM	entry ...	$n_2>0$
CSI-ResourceConfig[k, k= p <sub>1</sub> +m <sub>2</sub> +1.. p <sub>1</sub> +m <sub>2</sub> +m <sub>3</sub> ]	CSI-ResourceConfig for TRS	entry ...	$n_3>0$
CSI-ResourceConfig[k, k= p <sub>1</sub> +m <sub>2</sub> +m <sub>3</sub> +1.. p <sub>1</sub> +m <sub>2</sub> +m <sub>3</sub> +m <sub>4</sub> ]	CSI-ResourceConfig for TRS with condition SECOND_SET	entry ...	$n_4>0$
CSI-ResourceConfig[k, k= p <sub>1</sub> +m <sub>2</sub> +m <sub>3</sub> +m <sub>4</sub> +1.. p <sub>1</sub> +m <sub>2</sub> +m <sub>3</sub> +m <sub>4</sub> +m <sub>5</sub> ]	CSI-ResourceConfig for BM with condition APERIODIC	entry ...	$n_5>0$
}			
csi-ReportConfigToAddModList SEQUENCE (SIZE (1..maxNrofCSI-ReportConfigurations)) OF CSI-ReportConfig {	$r_1+r_2+r_5+s_1$ entries	$r_1 = 1$ if CSI Reporting for CSI is configured in test case, $r_1 = 0$ otherwise;  $r_2 = 1$ if CSI Reporting for BM is configured in test case, $r_2 = 0$ otherwise;  $r_5 = 1$ if aperiodic CSI Reporting for BM is configured in test case, $r_5 = 0$ otherwise;  $s_1 = 1$ if: - this CSI-MeasConfig is configured on NR SpCell, and, - CSI-RS for CSI is configured on SCell in TC, and, - SCell is not a PUCCH-SCell  Otherwise $s_1 = 0$ .	
CSI-ReportConfig[k, k=1..r <sub>1</sub> ]	CSI-ReportConfig for CSI	entry 1	$r_1>0$
CSI-ReportConfig[k, k=r <sub>1</sub> +1.. r <sub>1</sub> +r <sub>2</sub> ]	CSI-ReportConfig for BM	entry ...	$r_2>0$
CSI-ReportConfig[k, k=r <sub>1</sub> +r <sub>2</sub> +1.. r <sub>1</sub> +r <sub>2</sub> +r <sub>5</sub> ]	CSI-ReportConfig for BM with condition APERIODIC	entry ...	$r_5>0$
CSI-ReportConfig[k, k=r <sub>1</sub> +r <sub>2</sub> +r <sub>5</sub> +1.. r <sub>1</sub> +r <sub>2</sub> +r <sub>5</sub> +s <sub>1</sub> +1]	CSI-ReportConfig for CSI with condition SCELL_CSI_ON_SPCELL	entry ...	$s_1>0$
}			
reportTriggerSize	Not present		
	1		$n_5>0$
aperiodicTriggerStateList CHOICE {	Not present		

setup	CSI-AperiodicTriggerStateList		n <sub>s</sub> >0
}			
}			

Condition	Explanation
2SSB	For configuration with 2 SS Blocks

– NZP-CSI-RS-Resource for TRS

**Table 7.3.1-7: NZP-CSI-RS-Resource for TRS(Id)**

Derivation Path: Table 4.6.3-45

Information Element	Value/remark	Comment	Condition
NZP-CSI-RS-Resource ::= SEQUENCE {			
NZP-CSI-RS-ResourceId	NZP-CSI-RS-ResourceId for TRS(Id)		
	NZP-CSI-RS-ResourceId for TRS(Id) with Condition SECOND_SET		SECOND_SET
CSI-RS-ResourceMapping	CSI-RS-ResourceMapping for TRS(Id)		
	CSI-RS-ResourceMapping for TRS(Id) with condition SECOND_SET		SECOND_SET
powerControlOffset	0		
powerControlOffsetSS	db0		
scramblingID	PhysCellId	PCI of the cell sending the TRS	
periodicityAndOffset	CSI-ResourcePeriodicityAndOffset for TRS(Id)		
qcl-InfoPeriodicCSI-RS	TCI-StateId-RRM(0)		
	TCI-StateId-RRM(1)		SECOND_SET
}			

Condition	Explanation
SECOND_SET	For resource belong to the second resource set for TRS, only applies to FR2 test

– NZP-CSI-RS-Resource for CSI

**Table 7.3.1-7A: NZP-CSI-RS-Resource for CSI**

Derivation Path: Table 4.6.3-45

Information Element	Value/remark	Comment	Condition
NZP-CSI-RS-Resource ::= SEQUENCE {			
nzp-CSI-RS-ResourceId	NZP-CSI-RS-ResourceId for CSI		
resourceMapping	CSI-RS-ResourceMapping for CSI		
powerControlOffset	0		
powerControlOffsetSS	db0		
scramblingID	0		
periodicityAndOffset	CSI-ResourcePeriodicityAndOffset for CSI		
qcl-InfoPeriodicCSI-RS	TCI-StateId-RRM(0)		

--	--	--

– *NZP-CSI-RS-Resource for BM*

**Table 7.3.1-7B: NZP-CSI-RS-Resource for BM(l<sub>d</sub>)**

Derivation Path: Table 4.6.3-45			
Information Element	Value/remark	Comment	Condition
NZP-CSI-RS-Resource ::= SEQUENCE {			
nzp-CSI-RS-ResourceId	NZP-CSI-RS-ResourceId for BM (l <sub>d</sub> )		
	NZP-CSI-RS-ResourceId for BM (l <sub>d</sub> ) with condition APERIODIC		APERIODIC
resourceMapping	CSI-RS-ResourceMapping for BM (l <sub>d</sub> )		
powerControlOffset	0		
powerControlOffsetSS	db0		
scramblingID	0		
periodicityAndOffset	CSI-ResourcePeriodicityAndOffset for BM		
	Not present		APERIODIC
qcl-InfoPeriodicCSI-RS	TCI-StateId-RRM(l <sub>d</sub> )		
	Not present		APERIODIC
}			

Condition	Explanation
APERIODIC	For aperiodic CSI-RS resources

– *NZP-CSI-RS-Resource for TRS*

**Table 7.3.1-7C: NZP-CSI-RS-ResourceId for TRS(l<sub>d</sub>)**

Derivation Path: Table 4.6.3-86			
Information Element	Value/remark	Comment	Condition
NZP-CSI-RS-ResourceId	n+l <sub>d</sub> -1	n is the first NZP-CSI-RS-ResourceId allocated for TRS resource set.  Value of n is left to internal implementation  l <sub>d</sub> = 1,2,3,4	
	n+l <sub>d</sub> +3		SECOND_SET

Condition	Explanation
SECOND_SET	For the second TRS resource set configured in test, only applies to FR2 test

– *NZP-CSI-RS-ResourceId for CSI*

**Table 7.3.1-7D: NZP-CSI-RS-ResourceId for CSI**

Derivation Path: Table 4.6.3-86			
Information Element	Value/remark	Comment	Condition

NZP-CSI-RS-ResourceId	n	n is the NZP-CSI-RS-ResourceId allocated for CSI-RS for CSI report.  Value of n is left to internal implementation	
-----------------------	---	--	--

– NZP-CSI-RS-ResourceId for BM

**Table 7.3.1-7E: NZP-CSI-RS-ResourceId for BM(Id)**

Derivation Path: Table 4.6.3-86			
Information Element	Value/remark	Comment	Condition
NZP-CSI-RS-ResourceId	n+Id	n is the first NZP-CSI-RS-ResourceId allocated for CSI-RS for BM.  Value of n is left to internal implementation  Id = 0,1	
	m+Id	m is the first NZP-CSI-RS-ResourceId allocated for aperiodic CSI-RS for BM.  Value of m is left to internal implementation  Id = 0,1	APERIODIC

Condition	Explanation
APERIODIC	For aperiodic CSI-RS resources

– CSI-RS-ResourceMapping for TRS

**Table 7.3.1-8: CSI-RS-ResourceMapping for TRS(Id)**

Derivation Path: Table 4.6.3-45 with condition TRS			
Information Element	Value/remark	Comment	Condition
CSI-RS-ResourceMapping ::= SEQUENCE { frequencyDomainAllocation CHOICE { row1	0001	k <sub>0</sub> =0 for CSI-RS resource 1,2,3,4	
}			
firstOFDMSymbolInTimeDomain	5	l <sub>0</sub> = 5 for CSI-RS resource 1 and 3	(Id = 1 or 3) AND FR1
	9	l <sub>0</sub> = 9 for CSI-RS resource 2 and 4	(Id = 2 or 4) AND FR1
	1		(Id = 1 or 3) AND FR2
	2		(Id = 1 or 3) AND FR2 AND



			SECOND_S ET
	5		(Id = 2 or 4) AND FR2
	6		(Id = 1 or 3) AND FR2 AND SECOND_S ET
nrofPorts	p1	1 for CSI-RS resource 1,2,3,4	
freqBand	CSI- FrequencyOccupation- RRM		
}			

Condition	Explanation
SECOND_SET	For the second resource set for TRS configured in test, only applies to FR2 test

– *CSI-RS-ResourceMapping for CSI*

**Table 7.3.1-8A: CSI-RS-ResourceMapping for CSI**

Derivation Path: Table 4.6.3-45			
Information Element	Value/remark	Comment	Condition
CSI-RS-ResourceMapping ::= SEQUENCE {			
frequencyDomainAllocation CHOICE {			
other	000001		
}			
nrofPorts	p2		
firstOFDMSymbolInTimeDomain	5		NOT SCS15
	4		SCS15
freqBand	CSI- FrequencyOccupation- RRM		
}			

– *CSI-RS-ResourceMapping for BM*

**Table 7.3.1-8B: CSI-RS-ResourceMapping for BM (Id)**

Derivation Path: Table 4.6.3-45			
Information Element	Value/remark	Comment	Condition
CSI-RS-ResourceMapping ::= SEQUENCE {			
frequencyDomainAllocation CHOICE {			
row1	0001		
}			
nrofPorts	p1		
firstOFDMSymbolInTimeDomain	6		Id = 0
	10		Id = 1
cdm-Type	noCDM		
density CHOICE {			
three	NULL		
}			
freqBand	CSI- FrequencyOccupation- RRM		
}			

– *CSI-RS-ResourceMapping for ZP-CSI-RS*

**Table 7.3.1-8C: CSI-RS-ResourceMapping-ZP-CSI-RS**

Derivation Path: Table 4.6.3-45			
Information Element	Value/remark	Comment	Condition
CSI-RS-ResourceMapping ::= SEQUENCE {			
frequencyDomainAllocation CHOICE {			
row4	100	k <sub>0</sub> = 8	
}			
nrofPorts	p4		
firstOFDMSymbolInTimeDomain	4		
cdm-Type	fd-CDM2		
density CHOICE {			
one	NULL		
}			
freqBand	CSI-FrequencyOccupation-RRM		
}			

– *CSI-ResourcePeriodicityAndOffset for TRS*

**Table 7.3.1-9: CSI-ResourcePeriodicityAndOffset for TRS(Id)**

Derivation Path: Table 4.6.3-43			
Information Element	Value/remark	Comment	Condition
CSI-ResourcePeriodicityAndOffset ::= CHOICE {			
slots80	40		(Id = 1 or 2) AND SCS120
	41		(Id = 3 or 4) AND SCS120
slots40	20	Periodicity 40 slots and offset 20 for CSI-RS resource 1 and 2	(Id = 1 or 2) AND SCS30
	21	Periodicity 40 slots and offset 21 for CSI-RS resource 3 and 4	(Id = 3 or 4) AND SCS30
slots20	10	Periodicity 20 slots and offset 10 for CSI-RS resource 1 and 2	(Id = 1 or 2) AND SCS15
	11	Periodicity 20 slots and offset 11 for CSI-RS resource 3 and 4	(Id = 3 or 4) AND SCS15
}			

– *CSI-ResourcePeriodicityAndOffset for CSI*

**Table 7.3.1-9A: CSI-ResourcePeriodicityAndOffset for CSI**

Derivation Path: Table 4.6.3-43			
Information Element	Value/remark	Comment	Condition
CSI-ResourcePeriodicityAndOffset ::= CHOICE {			
slots5	1		SCS15
slots10	2		SCS30
slots40	8		SCS120
}			

– *CSI-ResourcePeriodicityAndOffset for BM*

**Table 7.3.1-9B: CSI-ResourcePeriodicityAndOffset for BM**

Derivation Path: Table 4.6.3-43			
Information Element	Value/remark	Comment	Condition
CSI-ResourcePeriodicityAndOffset ::= CHOICE {			
slots10	1		SCS15
slots20	2		SCS30
slots80	16		SCS120
}			

– *CSI-FrequencyOccupation*

**Table 7.3.1-10: CSI-FrequencyOccupation-RRM**

Derivation Path: Table 4.6.3-33			
Information Element	Value/remark	Comment	Condition
CSI-FrequencyOccupation ::= SEQUENCE {			
startingRB	$4 \cdot \text{floor}(n/4)$	n is the start RB of active BWP  floor() means rounding down to the nearest integer  startingRB can only be multiple of 4	
nrofRBs	$\max(4 \cdot \text{ceil}(n/4 - \text{floor}(n/4) + m/4), 24)$	m is the bandwidth of active BWP  ceil() means rounding up to the nearest integer  Bandwidth of CSI-RS used in RRM test is required to be same as active BWP according to 38.133.  nrofRBs shall be no less than 24 and shall be multiple of 4	
}			

– *NZP-CSI-RS-ResourceSet for TRS*

**Table 7.3.1-11: NZP-CSI-RS-ResourceSet for TRS**

Derivation Path: Table 4.6.3-87 with Condition TRS
--

Information Element	Value/remark	Comment	Condition
NZP-CSI-RS-Resource ::= SEQUENCE {			
nzp_CSI_ResourceSetId	NZP-CSI-RS-ResourceSetId-TRS		
	NZP-CSI-RS-ResourceSetId-TRS with condition SECOND_SET		SECOND_SET
nzp-CSI-RS-Resources SEQUENCE (SIZE (1..maxNrofNZP-CSI-RS-ResourcesPerSet)) OF NZP-CSI-RS-ResourceId {	4 entries		
NZP-CSI-RS-ResourceId[1]	NZP-CSI-RS-ResourceId for TRS(1)	entry 1	
NZP-CSI-RS-ResourceId[2]	NZP-CSI-RS-ResourceId for TRS(2)	entry 2	
NZP-CSI-RS-ResourceId[3]	NZP-CSI-RS-ResourceId for TRS(3)	entry 3	
NZP-CSI-RS-ResourceId[4]	NZP-CSI-RS-ResourceId for TRS(4)	entry 4	
}			
nzp-CSI-RS-Resources SEQUENCE (SIZE (1..maxNrofNZP-CSI-RS-ResourcesPerSet)) OF NZP-CSI-RS-ResourceId {	4 entries		SECOND_SET
NZP-CSI-RS-ResourceId[1]	NZP-CSI-RS-ResourceId for TRS(1) with condition SECOND_SET	entry 1	
NZP-CSI-RS-ResourceId[2]	NZP-CSI-RS-ResourceId for TRS(2) with condition SECOND_SET	entry 2	
NZP-CSI-RS-ResourceId[3]	NZP-CSI-RS-ResourceId for TRS(3) with condition SECOND_SET	entry 3	
NZP-CSI-RS-ResourceId[4]	NZP-CSI-RS-ResourceId for TRS(4) with condition SECOND_SET	entry 4	
}			
}			

Condition	Explanation
SECOND_SET	For the second TRS resource set configured in test, only applies to FR2 test

– *NZP-CSI-RS-ResourceSet for CSI*

**Table 7.3.1-11A: NZP-CSI-RS-ResourceSet for CSI**

Derivation Path: Table 4.6.3-87

Information Element	Value/remark	Comment	Condition
NZP-CSI-RS-Resource ::= SEQUENCE {			
nzp_CSI_ResourceSetId	NZP-CSI-RS-ResourceSetId-CSI		
nzp-CSI-RS-Resources SEQUENCE (SIZE (1..maxNrofNZP-CSI-RS-ResourcesPerSet)) OF NZP-CSI-RS-ResourceId {	1 entry		
NZP-CSI-RS-ResourceId[1]	NZP-CSI-RS-ResourceId for CSI	entry 1	
}			
repetition	Not present		
}			

– *NZP-CSI-RS-ResourceSet for BM*

**Table 7.3.1-11B: NZP-CSI-RS-ResourceSet for BM**

Derivation Path: Table 4.6.3-87			
Information Element	Value/remark	Comment	Condition
NZP-CSI-RS-ResourceSet ::= SEQUENCE {			
nzp-CSI-ResourceSetId	NZP-CSI-RS-ResourceSetId-BM		
	NZP-CSI-RS-ResourceSetId-BM with condition APERIODIC		APERIODIC
nzp-CSI-RS-Resources SEQUENCE (SIZE (1..maxNrofNZP-CSI-RS-ResourcesPerSet)) OF NZP-CSI-RS-ResourceId {	2 entries		
NZP-CSI-RS-ResourceId[1]	NZP-CSI-RS-ResourceId for BM (0)	entry 1	
	NZP-CSI-RS-ResourceId for BM (0) with condition APERIODIC		APERIODIC
NZP-CSI-RS-ResourceId[2]	NZP-CSI-RS-ResourceId for BM (1)	entry 2	
	NZP-CSI-RS-ResourceId for BM (1) with condition APERIODIC		APERIODIC
}			
aperiodicTriggeringOffset	4		APERIODIC
	0		APERIODIC AND FR1
}			

Condition	Explanation
APERIODIC	For aperiodic CSI-RS resources

– *NZP-CSI-RS-ResourceSetId for TRS*

**Table 7.3.1-11C: NZP-CSI-RS-ResourceSetId-TRS**

Derivation Path: Table 4.6.3-88			
Information Element	Value/remark	Comment	Condition
NZP-CSI-RS-ResourceSetId	n	n is the first NZP-CSI-RS-ResourceSetId allocated for TRS resource set.  Value of n is left to internal implementation	
	n+1		SECOND_SET

Condition	Explanation
SECOND_SET	For the second TRS resource set configured in test, only applies to FR2 test

– *NZP-CSI-RS-ResourceSetId for CSI*

**Table 7.3.1-11D: NZP-CSI-RS-ResourceSetId-CSI**

Derivation Path: Table 4.6.3-88			
Information Element	Value/remark	Comment	Condition

NZP-CSI-RS-ResourceSetId	n	n is the NZP-CSI-RS-ResourceSetId allocated for resource set of CSI-RS for CSI reporting.  Value of n is left to internal implementation	
--------------------------	---	--	--

– NZP-CSI-RS-ResourceSetId for BM

**Table 7.3.1-11E: NZP-CSI-RS-ResourceSetId-BM**

Derivation Path: Table 4.6.3-88

Information Element	Value/remark	Comment	Condition
NZP-CSI-RS-ResourceSetId	n	n is the NZP-CSI-RS-ResourceSetId allocated for resource set of CSI-RS for BM.  Value of n is left to internal implementation	
	m	m is the NZP-CSI-RS-ResourceSetId allocated for resource set of aperiodic CSI-RS for BM.  Value of m is left to internal implementation	APERIODIC

Condition	Explanation
APERIODIC	For aperiodic CSI-RS resources

– CSI-ResourceConfig for TRS

**Table 7.3.1-12: CSI-ResourceConfig for TRS**

Derivation Path: TS 38.508-1 Table 4.6.3-41

Information Element	Value/remark	Comment	Condition
CSI-ResourceConfig ::= SEQUENCE {			
csi-ResourceConfigId	CSI-ResourceConfigId-TRS		
csi-RS-ResourceSetList CHOICE {			
nzp-CSI-RS-SSB SEQUENCE {			
nzp-CSI-RS-ResourceSetList SEQUENCE (SIZE (1..maxNrofNZP-CSI-RS-ResourceSetsPerConfig)) OF NZP-CSI-RS-ResourceSetId {	1 entry		
NZP-CSI-RS-ResourceSetId[1]	NZP-CSI-RS-ResourceSetId-TRS NZP-CSI-RS-ResourceSetId-TRS with condition SECOND_SET		SECOND_SET
}			
}			
bwp-Id	BWP-Id of active BWP		
}			

--	--	--

Condition	Explanation
SECOND_SET	For the second resource set for TRS configured in test, only applies to FR2 test

– *CSI-ResourceConfig for CSI*

**Table 7.3.1-12A: CSI-ResourceConfig for CSI**

Derivation Path: TS 38.508-1 Table 4.6.3-41

Information Element	Value/remark	Comment	Condition
CSI-ResourceConfig ::= SEQUENCE {			
csi-ResourceConfigId	CSI-ResourceConfigId-CSI		
csi-RS-ResourceSetList CHOICE {			
nzp-CSI-RS-SSB SEQUENCE {			
nzp-CSI-RS-ResourceSetList SEQUENCE (SIZE (1..maxNrofNZP-CSI-RS-ResourceSetsPerConfig)) OF NZP-CSI-RS-ResourceSetId {	1 entry		
NZP-CSI-RS-ResourceSetId[1]	NZP-CSI-RS-ResourceSetId-CSI	entry 1	
}			
}			
}			
bwp-Id	BWP-Id of active BWP		
}			

– *CSI-ResourceConfig for BM*

**Table 7.3.1-12B: CSI-ResourceConfig for BM**

Derivation Path: Table 4.6.3-41

Information Element	Value/remark	Comment	Condition
CSI-ResourceConfig ::= SEQUENCE {			
csi-ResourceConfigId	CSI-ResourceConfigId-BM		
	CSI-ResourceConfigId-BM with condition APERIODIC		APERIODIC
csi-RS-ResourceSetList CHOICE {			
nzp-CSI-RS-SSB SEQUENCE {			
nzp-CSI-RS-ResourceSetList SEQUENCE (SIZE (1..maxNrofNZP-CSI-RS-ResourceSetsPerConfig)) OF NZP-CSI-RS-ResourceSetId {	1 entry		
NZP-CSI-RS-ResourceSetId[1]	NZP-CSI-RS-ResourceSetId-BM		
	NZP-CSI-RS-ResourceSetId-BM with condition APERIODIC		APERIODIC
}			
}			
}			
bwp-Id	BWP-Id of active BWP		
resourceType	aperiodic		APERIODIC
	periodic		PERIODIC
}			

Condition	Explanation
APERIODIC	For aperiodic CSI-RS resources
PERIODIC	For periodic CSI-RS resources

– *CSI-ResourceConfig for CSI-IM*

**Table 7.3.1-12BA: CSI-ResourceConfig for CSI-IM**

Derivation Path: Table 4.6.3-41			
Information Element	Value/remark	Comment	Condition
CSI-ResourceConfig ::= SEQUENCE {			
csi-ResourceConfigId	CSI-ResourceConfigId-CSI-IM		
csi-RS-ResourceSetList CHOICE {			
csi-IM-ResourceSetList SEQUENCE (SIZE (1..maxNrofCSI-IM-ResourceSetsPerConfig)) OF CSI-IM-ResourceSetId {	1 entry		
CSI-IM-ResourceSetId[1]	CSI-IM-ResourceSetId-RRM	entry 1	
}			
}			
bwp-Id	BWP-Id		
resourceType	periodic		
}			

– *CSI-ResourceConfigId for TRS*

**Table 7.3.1-12C: CSI-ResourceConfigId-TRS**

Derivation Path: Table 4.6.3-42			
Information Element	Value/remark	Comment	Condition
CSI-ResourceConfigId	n	n is the CSI-ResourceConfigId allocated for resource config of TRS.  Value of n is left to internal implementation	

– *CSI-ResourceConfigId for CSI*

**Table 7.3.1-12D: CSI-ResourceConfigId-CSI**

Derivation Path: Table 4.6.3-42			
Information Element	Value/remark	Comment	Condition
CSI-ResourceConfigId	n	n is the CSI-ResourceConfigId allocated for resource config of CSI-RS for CSI reporting.  Value of n is left to internal implementation	

– *CSI-ResourceConfigId for BM*

**Table 7.3.1-12E: CSI-ResourceConfigId-BM**

Derivation Path: Table 4.6.3-42			
Information Element	Value/remark	Comment	Condition
CSI-ResourceConfigId	n	n is the CSI-ResourceConfigId	



		allocated for resource config of CSI-RS for BM.  Value of n is left to internal implementation	
	m	m is the CSI-ResourceConfigId allocated for resource config of aperiodic CSI-RS for BM.  Value of m is left to internal implementation	APERIODIC

Condition	Explanation
APERIODIC	For aperiodic CSI-RS resources

– *CSI-ResourceConfigId-CSI-IM*

**Table 7.3.1-12EA: CSI-ResourceConfigId-CSI-IM**

Derivation Path: Table 4.6.3-42			
Information Element	Value/remark	Comment	Condition
CSI-ResourceConfigId	n	n is the first CSI-ResourceConfigId allocated for CSI-IM resource configuration  Value of n is left to internal implementation	

– *CSI-ReportConfig for CSI*

**Table 7.3.1-12F: CSI-ReportConfig for CSI**

Derivation Path: Table 4.6.3-39			
Information Element	Value/remark	Comment	Condition
CSI-ReportConfig ::= SEQUENCE {			
reportConfigId	CSI-ReportConfigId-CSI CSI-ReportConfigId-CSI with condition SCELL_CSI_ON_SPCELL		SCELL_CSI_ON_SPCELL
carrier	Not present  ServCellIndex of the SCell	indicates the same serving cell as this report configuration	SCELL_CSI_ON_SPCELL
resourcesForChannelMeasurement	CSI-ResourceConfigId-CSI		
csi-IM-ResourcesForInterference	CSI-ResourceConfigId-CSI-IM		
nzp-CSI-RS-ResourcesForInterference	Not present		
reportConfigType CHOICE {			
periodic SEQUENCE {			
reportSlotConfig CHOICE {			
slots5	2		SCS15

slots10	4		SCS30
slots40	4		SCS120
}			
pucch-CSI-ResourceList SEQUENCE (SIZE (1..maxNrofBWPs)) OF PUCCH-CSI-Resource {	1 entry		
PUCCH-CSI-Resource [1] SEQUENCE {		entry 1	
uplinkBandwidthPartId	BWP-Id of active UL BWP		
pucch-Resource	8	The first format 2 PUCCH resource configured in Table 4.6.3-112 is used	
	8	The first format 2 PUCCH resource configured in Table 4.6.3-112 is used	SCELL_CSI_ON_SPCELL
}			
}			
}			
reportQuantity CHOICE {			
cri-RI-PMI-CQI	null		
}			
reportFreqConfiguration SEQUENCE {			
csi-ReportingBand CHOICE {			
subbands7	'1111111'B		FR1 AND MORE_THAN_24_PRBS
subbands9	'111111111'B		FR2 AND MORE_THAN_24_PRBS
}			
}			
codebookConfig	CodebookConfig-CSI		
}			

Condition	Explanation
SCELL_CSI_ON_SPCELL	For SCell CSI reporting on NR SpCell
MORE_THAN_24_PRBS	Total number of PRBs in the active BWP higher than 24

– CSI-ReportConfig for BM

**Table 7.3.1-12G: CSI-ReportConfig for BM**

Derivation Path: Table 4.6.3-39			
Information Element	Value/remark	Comment	Condition
CSI-ReportConfig ::= SEQUENCE {			
reportConfigId	CSI-ReportConfigId-BM		
	CSI-ReportConfigId-BM with condition APERIODIC		APERIODIC
carrier	Not present		
resourcesForChannelMeasurement	CSI-ResourceConfigId-BM		
	CSI-ResourceConfigId-BM with condition APERIODIC		APERIODIC
csi-IM-ResourcesForInterference	Not present		
nzp-CSI-RS-ResourcesForInterference	Not present		
reportConfigType CHOICE {			
periodic			
reportSlotConfig ::= CHOICE {			
slots80	2		SCS15
slots80	4		SCS30 OR SCS120
}			
pucch-CSI-ResourceList SEQUENCE (SIZE (1..maxNrofBWPs)) OF{			

PUCCH_CSI_Resource[0] SEQUENCE {			
uplinkBandwidthPartId	BWP-Id		
pucch_Resource	9		
}			
}			
}			
aperiodic SEQUENCE {			APERIODIC
reportSlotOffsetList SEQUENCE (SIZE (1..maxNrofUL-Allocations)) OF {	1 entry		
INTEGER[1]	8		
}			
}			
reportQuantity CHOICE {			
cri-RSRP	NULL		
}			
reportFreqConfiguration SEQUENCE {			
csi-ReportingBand CHOICE {			
subbands7	'1111111'B		FR1 AND MORE_THAN_24_PRBS
subbands9	'11111111'B		FR2 AND MORE_THAN_24_PRBS
}			
}			
codebookConfig	Not present		
}			

Condition	Explanation
APERIODIC	For aperiodic CSI-RS resources
MORE_THAN_24_PRBS	Total number of PRBs in the active BWP higher than 24

– CSI-ReportConfigId for CSI

Table 7.3.1-12H: CSI-ReportConfigId-CSI

Derivation Path: Table 4.6.3-40

Information Element	Value/remark	Comment	Condition
CSI-ReportConfigId	n	n is the CSI-ReportConfigId allocated for report config of CSI-RS for CSI.  Value of n is left to internal implementation	
	m	m is the CSI-ReportConfigId allocated for report config of SCell CSI on SpCell.  Value of m is left to internal implementation	SCELL_CSI_ON_SPCELL

Condition	Explanation
SCELL_CSI_ON_SPCELL	For SCell CSI reporting on NR SpCell

– *CSI-ReportConfigId for BM*

**Table 7.3.1-12I: CSI-ReportConfigId-BM**

Derivation Path: Table 4.6.3-40			
Information Element	Value/remark	Comment	Condition
CSI-ReportConfigId	n	n is the CSI-ReportConfigId allocated for report config of CSI-RS for BM.  Value of n is left to internal implementation	
	m	m is the CSI-ReportConfigId allocated for report config of aperiodic CSI-RS for BM.  Value of m is left to internal implementation	APERIODIC

Condition	Explanation
APERIODIC	For aperiodic CSI-RS resources

– *CSI-AperiodicTriggerStateList*

**Table 7.3.1-12J: CSI-AperiodicTriggerStateList**

Derivation Path: Table 4.6.3-32			
Information Element	Value/remark	Comment	Condition
CSI-AperiodicTriggerStateList ::= SEQUENCE (SIZE (1..maxNrOfCSI-AperiodicTriggers)) OF SEQUENCE {	1 entry		
associatedReportConfigInfoList[1] SEQUENCE (SIZE(1..maxNrOfReportConfigPerAperiodicTrigger)) OF SEQUENCE {	1 entry		
reportConfigId[1]	CSI-ReportConfigId-BM with condition APERIODIC		
resourcesForChannel[1] CHOICE {			
nzp-CSI-RS SEQUENCE {			
resourceSet	NZP-CSI-RS-ResourceSetId-BM with condition APERIODIC		
qcl-info SEQUENCE (SIZE(1..maxNrOfAP-CSI-RS-ResourcesPerSet)) OF {	2 entries		
TCI-StateId[1]	TCI-StateId-RRM(0)	QCL Type C+D to SSB #0	
TCI-StateId[2]	TCI-StateId-RRM(1)	QCL Type C+D to SSB #1	
}			
}			
}			
csi-IM-ResourcesForInterference[1]	Not present		
nzp-CSI-RS-ResourcesForInterference[1]	Not present		
}			
}			

– RACH-ConfigCommon

**Table 7.3.1-13: RACH-ConfigCommon**

Derivation Path: TS 38.508-1 Table 4.6.3-128			
Information Element	Value/remark	Comment	Condition
RACH-ConfigCommon ::= SEQUENCE {			
rach-ConfigGeneric	RACH-ConfigGeneric		
totalNumberOfRA-Preambles	48		
ssb-perRACH-OccasionAndCB-PreamblesPerSSB CHOICE {			
oneFourth	n48		
}			
ra-ContentionResolutionTimer	sf48		
rsrp-ThresholdSSB	51		
prach-RootSequenceIndex CHOICE {			
l139	0		
}			
}			

– RACH-ConfigGeneric

**Table 7.3.1-14: RACH-ConfigGeneric**

Derivation Path: TS 38.508-1 Table 4.6.3-130			
Information Element	Value/remark	Comment	Condition
RACH-ConfigGeneric ::= SEQUENCE {			
prach-ConfigurationIndex	102		FR1
	190		FR2
msg1-FDM	one		
msg1-FrequencyStart	0		
zeroCorrelationZoneConfig	11		
preambleReceivedTargetPower	-120		
preambleTransMax	n6		PRACH.4
	n200		FR1 or PRACH.4 FR2
powerRampingStep	dB2		
ra-ResponseWindow	sl10		
	sl1		PRACH.4 FR1 or
	sl40		PRACH.4 FR2
}			

Condition	Explanation
PRACH.4 FR1	When PRACH reference configuration PRACH.4 FR1 is used in test case
PRACH.4 FR2	When PRACH reference configuration PRACH.4 FR2 is used in test case

– ControlResourceSet

**Table 7.3.1-15: ControlResourceSet**

Derivation Path: Table 4.6.3-28			
Information Element	Value/remark	Comment	Condition
ControlResourceSet ::= SEQUENCE {			
controlResourceSetId	ControlResourceSetId		
frequencyDomainResources	11111111 00000000 00000000 00000000 00000000 000000		CCR.3.7 OR SCS240
duration	1		CCR.3.x

cce-REG-MappingType CHOICE {			
interleaved ::= SEQUENCE {			CCR.X.Y
reg-BundleSize	n6		
interleaverSize	n2		
shiftIndex	0		
}			
tci-StatesPDCCH-ToAddList	Not present		
tci-StatesPDCCH-ToAddList SEQUENCE(SIZE (1..maxNrofTCI-StatesPDCCH)) OF TCI-StateId {	1 entry		
TCI-StateId[1]	TCI-StateId-RRM(2)	TCI State #2, QCLed to TRS resource #4 in the first resource set entry 1	TRS
TCI-StateId[1]	TCI-StateId-RRM(3)	TCI State #3, QCLed to TRS resource #4 in the second resource set entry 1	SECOND_SET
}			
}			

Condition	Explanation
CCR.x.y	Refers to CCR.x.y as defined in A.1.3 of TS 38.533 [18]
TRS	When at least one TRS resource set is configured.
SECOND_SET	Two resource sets for TRS are configured in test, only applies to FR2.

- *SchedulingRequestResourceConfig*

**Table 7.3.1-16: SchedulingRequestResourceConfig**

Derivation Path: Table 4.6.3-157

Information Element	Value/remark	Comment	Condition
SchedulingRequestResourceConfig ::= SEQUENCE {			
periodicityAndOffset CHOICE {			
sl10	7	With SCS = kHz15 results in repetition every 10 ms	SCS_15kHz
sl20	7	With SCS = kHz30 results in repetition every 10 ms	SCS_30kHz
}			
}			

Condition	Explanation
SCS_15kHz	SCS=15kHz for frequency of the cell according to clause 6.2.3 for signalling test cases and clause 4.3.1 otherwise
SCS_30kHz	SCS=30kHz for frequency of the cell according to clause 6.2.3 for signalling test cases and clause 4.3.1 otherwise

- *SearchSpace*

**Table 7.3.1-17: SearchSpace**

Derivation Path: Table 4.6.3-162

Information Element	Value/remark	Comment	Condition
SearchSpace ::= SEQUENCE {			
monitoringSlotPeriodicityAndOffset CHOICE {			
sl10	1		SISS

sl160	0		(CCR.3.1 OR CCR.3.2 OR CCR.3.4 OR CCR.3.5 OR CCR.3.7) AND NOT_CONT_PDCCH
	80		(CCR.3.3 OR CCR.3.6) AND NOT_CONT_PDCCH
}			
monitoringSymbolsWithinSlot	11000000000000		(CCR.3.1 OR CCR.3.3 OR CCR.3.4 OR CCR.3.6 OR CCR.3.7) AND NOT_CONT_PDCCH
	00110000000000		(CCR.3.2 OR CCR.3.5) AND NOT_CONT_PDCCH
}			

Condition	Explanation
SISS	SearchSpace for SI
CCR.x.y	Refers to CCR.x.y as defined in A.1.3 of TS 38.533 [18]
NOT_CONT_PDCCH	The cell shall be configured with the default CCR.3.x settings and not transmit PDCCH continuously

– PDSCH-Config

Table 7.3.1-18: PDSCH-Config

Derivation Path: Table 4.6.3-100			
Information Element	Value/remark	Comment	Condition
PDSCH-Config ::= SEQUENCE { tci-StatesToAddModList SEQUENCE(SIZE (1.. maxNrofTCI-States)) OF TCI-State {	1+n <sub>1</sub> +n <sub>2</sub> +n <sub>3</sub> entries	n <sub>1</sub> = 1 if SSB configuration used in test case contains two SSBs in a burst, n <sub>1</sub> = 0 otherwise  n <sub>2</sub> = 1 if TRS is configured in test case, n <sub>1</sub> = 0 otherwise  n <sub>3</sub> = 1 if two resource sets of TRS are configured in test case, n <sub>3</sub> = 0 otherwise	
TCI-State[1]	TCI-State(0)	entry 1 QLed to SSB index #0	
TCI-State[k, k=2..1+n <sub>1</sub> ]	TCI-State(1)	entry ... QLed to SSB index #1	SECOND_S SB

TCI-State[k, k=2+n <sub>1</sub> ..1+n <sub>1</sub> +n <sub>2</sub> ]	TCI-State(2)	entry ... QCLed to TRS resource #4 in the first resource set	TRS
TCI-State[k, k=2+n <sub>1</sub> +n <sub>2</sub> ..1+n <sub>1</sub> +n <sub>2</sub> +n <sub>3</sub> ]	TCI-State(3)	entry ... QCLed to TRS resource #4 in the second resource set	SECOND_SET
}			
zp-CSI-RS-ResourceToAddModList SEQUENCE (SIZE (1..maxNrofZP-CSI-RS-Resources)) OF ZP-CSI-RS-Resource {	1 entry		
ZP-CSI-RS-Resource[1]	ZP-CSI-RS-Resource-RRM	entry 1	
}			
p-ZP-CSI-RS-ResourceSet CHOICE {			CSI
setup	ZP-CSI-RS-ResourceSet-RRM		
}			
}			

Condition	Explanation
SECOND_SSB	SSB configuration used in test case contain two SSBs in a burst
TRS	One resource set for TRS is configured in test case
SECOND_SET	Two resource sets for TRS are configured in test case, only applies to FR2.
CSI	CSI-RS for CSI reporting are configured in test case

- TCI-State

Table 7.3.1-19: TCI-State(lid)

Derivation Path: Table 4.6.3-190			
Information Element	Value/remark	Comment	Condition
TCI-State ::= SEQUENCE {			
tci-StateId	TCI-StateId-RRM(lid)		
qcl-Type1 SEQUENCE {			
bwp-Id	BWP-Id of the active BWP		Id = 2 or 3
referenceSignal CHOICE {			
ssb	SSB-Index of SSB #0		Id = 0
	SSB-Index of SSB #1		Id = 1
csi-rs	NZP-CSI-RS-ResourceId for TRS (4)		Id = 2
	NZP-CSI-RS-ResourceId for TRS (4) with condition SECOND SET		Id = 3
}			
qcl-Type	typeC		Id = 0 or 1
	typeA		Id = 2 or 3
}			
qcl-Type2	Not present		
qcl-Type2 SEQUENCE {			FR2
cell	Not present		
bwp-Id	Not present		Id = 0 or 1
	BWP-Id of the active BWP		Id = 2 or 3
referenceSignal CHOICE {			
ssb	SSB-Index of SSB #0		Id = 0
	SSB-Index of SSB #1		Id = 1
csi-rs	NZP-CSI-RS-ResourceId for TRS (4)		Id = 2
	NZP-CSI-RS-ResourceId for TRS (4) with condition SECOND SET		Id = 3
}			
}			



qcl-Type	typeD		
}			
}			

– *TCI-StateId*

**Table 7.3.1-20: TCI-StateId(Id)**

Derivation Path: Table 4.6.3-191			
Information Element	Value/remark	Comment	Condition
TCI-StateId	n+Id	n is the first TCI-StateId allocated for TCI-State configured in RRM test. Value of n is left to internal implementation Id = 0,1,2,3	

– *PUSCH-Config*

**Table 7.3.1-21: PUSCH-Config**

Derivation Path: Table 4.6.3-118			
Information Element	Value/remark	Comment	Condition
PUSCH-Config ::= SEQUENCE {			
pusch-TimeDomainAllocationList CHOICE {			APERIODIC
setup	PUSCH-TimeDomainResourceAllocationList-BM		
}			
}			
}			

Condition	Explanation
APERIODIC	For aperiodic CSI-RS resources

– *PUSCH-TimeDomainResourceAllocationList*

**Table 7.3.1-22: PUSCH-TimeDomainResourceAllocationList-BM**

Derivation Path: Table 4.6.3-122			
Information Element	Value/remark	Comment	Condition
PUSCH-TimeDomainResourceAllocationList ::= SEQUENCE (SIZE(1..maxNrofUL-Allocations)) OF PUSCH-TimeDomainResourceAllocation {	1 entry	same number of entries as reportSlotOffsetList in Table 7.3.1-12G	
PUSCH-TimeDomainResourceAllocation[1]		entry 1	
SEQUENCE {			
k2	4	Same with k2 configured in reportSlotOffsetList in Table 7.3.1-12G	FR1
}			
}			

– ServingCellConfig

**Table 7.3.1-23: ServingCellConfig**

Derivation Path: Table 4.6.3-167			
Information Element	Value/remark	Comment	Condition
ServingCellConfig ::= SEQUENCE {			
csi-MeasConfig CHOICE {			
setup	csi-MeasConfig		
}			

– CSI-IM-Resource-RRM

**Table 7.3.1-24: CSI-IM-Resource-RRM**

Derivation Path: Table 4.6.3-34			
Information Element	Value/remark	Comment	Condition
CSI-IM-Resource ::= SEQUENCE {			
csi-IM-ResourceId	CSI-IM-ResourceId-RRM		
csi-IM-ResourceElementPattern CHOICE {			
pattern1 SEQUENCE {			
subcarrierLocation-p1	s8		
symbolLocation-p1	4		
}			
}			
freqBand	CSI-FrequencyOccupation-RRM		
periodicityAndOffset	CSI-ResourcePeriodicityAndOffset for CSI		
}			

– CSI-IM-ResourceId-RRM

**Table 7.3.1-25: CSI-IM-ResourceId-RRM**

Derivation Path: Table 4.6.3-35			
Information Element	Value/remark	Comment	Condition
CSI-IM-ResourceId	n	n is the first CSI-IM-ResourceId allocated for CSI-IM resource.  Value of n is left to internal implementation	

– CSI-IM-ResourceSet-RRM

**Table 7.3.1-26: CSI-IM-ResourceSet-RRM**

Derivation Path: Table 4.6.3-36			
Information Element	Value/remark	Comment	Condition
CSI-IM-ResourceSet ::= SEQUENCE {			
csi-IM-ResourceSetId	CSI-IM-ResourceSetId-RRM		
csi-IM-Resources SEQUENCE (SIZE (1..maxNrofCSI-IM-ResourcesPerSet)) OF CSI-IM-ResourceId {	1 entry		
CSI-IM-ResourceId[1]	CSI-IM-ResourceId-RRM	entry 1	

--	--	--

– *CSI-IM-ResourceSetId-RRM*

**Table 7.3.1-27: CSI-IM-ResourceSetId-RRM**

Derivation Path: Table 4.6.3-37			
Information Element	Value/remark	Comment	Condition
CSI-IM-ResourceSetId	n	n is the first CSI-IM-ResourceSetId allocated for CSI-IM resource set.  Value of n is left to internal implementation	

– *SSB-Index*

**Table 7.3.1-28: SSB-Index**

Derivation Path: TS 38.331 [6], clause 6.3.2			
Information Element	Value/remark	Comment	Condition
SSB-Index	0		
	1		SECOND_SSB

Condition	Explanation
SECOND_SSB	SSB configuration used in test case contain two SSBs in a burst

– *CSI-SSB-ResourceSet*

**Table 7.3.1-29: CSI-SSB-ResourceSet**

Derivation Path: Table 4.6.3-47			
Information Element	Value/remark	Comment	Condition
CSI-SSB-ResourceSet ::= SEQUENCE {			
csi-SSB-ResourceSetId	CSI-SSB-ResourceSetId		
csi-SSB-Resource SEQUENCE (SIZE (1..maxNrofCSI-SSB-ResourcePerSet)) OF SSB-Index	1 entry		
SSB-Index[1]	SSB-Index	entry 1	
}			
csi-SSB-Resource SEQUENCE (SIZE (1..maxNrofCSI-SSB-ResourcePerSet)) OF SSB-Index	2 entries		SECOND_SSB
SSB-Index[1]	SSB-Index	entry 1	
SSB-Index[2]	SSB-Index with condition SECOND_SSB	entry 2	
}			
}			

Condition	Explanation
SECOND_SSB	SSB configuration used in test case contain two SSBs in a burst

– SCS-SpecificCarrier

**Table 7.3.1-30: SCS-SpecificCarrier**

Derivation Path: Table 4.6.3-160			
Information Element	Value/remark	Comment	Condition
SCS-SpecificCarrier ::= SEQUENCE {			
offsetToCarrier	offsetToCarrier as defined for the DL frequency of the cell	See 7.2.3.2	FR2 and DL_PointA
	offsetToCarrier as defined for the UL frequency of the cell	See 7.2.3.2	FR2 and UL_PointA
	offsetToCarrier as defined for the SL frequency	See 7.2.3.2	FR2 and SL_PointA
subcarrierSpacing	SubcarrierSpacing		
carrierBandwidth	carrierBandwidth as defined for the frequency of the cell	See 7.2.3.2	FR2
	24		Reduced_BW and SCS120 (for SSB)
	48		Reduced_BW and SCS240 (for SSB)
}			

Condition	Explanation
DL_PointA	IE absoluteFrequencyPointA for downlink
UL_PointA	IE absoluteFrequencyPointA for uplink
SL_PointA	IE absoluteFrequencyPointA for sidelink
Reduced_BW	Reduced RB allocation

– SSB-ToMeasure

**Table 7.3.1-31: SSB-ToMeasure**

Derivation Path: Table 4.6.3-187			
Information Element	Value/remark	Comment	Condition
SSB-ToMeasure ::= CHOICE {			
shortBitmap	1000		((1.88GHz<FREQ<=3GHz AND SCS15) OR FREQ<=1.88GHZ) AND NOT SECOND_S SB
	10000000		(1.88GHz<FREQ<=3GHz AND (TDD AND SCS30) OR FREQ>3GHz) AND NOT SECOND_S SB
longBitmap	10000000 00000000 00000000 00000000 00000000 00000000 00000000 00000000		FR2 AND NOT SECOND_S SB
	01000000 00000000 00000000 00000000 00000000 00000000 00000000 00000000		SSB.7 FR2 OR SSB.8 FR2

}		
---	--	--

Condition	Explanation
FREQ<=1.88GHz	Frequency range <= 1.88GHz
1.88GHz<FREQ<=3GHz	Frequency range > 1.88GHz and <= 3GHz
FREQ>3GHz	Frequency range > 3GHz
SECOND_SSB	SSB configuration used in test case contain two SSBs in a burst

– CodebookConfig-CSI

**Table 7.3.1-32: CodebookConfig-CSI**

Derivation Path: Table 4.6.3-25			
Information Element	Value/remark	Comment	Condition
CodebookConfig ::= SEQUENCE {			
codebookType CHOICE {			
type1 SEQUENCE {			
subType CHOICE {			
type1-SinglePanel SEQUENCE {			
nrOfAntennaPorts CHOICE {			
two SEQUENCE {			
twoTX-CodebookSubsetRestriction	111111		
}			
}			
}			
}			
}			
}			
}			

– PRB-Id

**Table 7.3.1-33: Void**

– ZP-CSI-RS-Resource-RRM

**Table 7.3.1-34: ZP-CSI-RS-Resource-RRM**

Derivation Path: Table 4.6.3-204			
Information Element	Value/remark	Comment	Condition
ZP-CSI-RS-Resource ::= SEQUENCE {			
zp-CSI-RS-ResourceId	ZP-CSI-RS-ResourceId-RRM		
resourceMapping	CSI-RS-ResourceMapping-ZP-CSI-RS		
periodicityAndOffset	CSI-ResourcePeriodicityAndOffset for CSI		
}			

**Table 7.3.1-35: ZP-CSI-RS-ResourceId-RRM**

Derivation Path: Table 4.6.3-204A			
Information Element	Value/remark	Comment	Condition
ZP-CSI-RS-ResourceId	n	n is the first ZP-CSI-RS-ResourceId	

		allocated for ZP CSI-RS resource.  Value of n is left to internal implementation	
--	--	--	--

– *ZP-CSI-RS-ResourceSet-RRM*

**Table 7.3.1-36: ZP-CSI-RS-ResourceSet-RRM**

Derivation Path: Table 4.6.3-205			
Information Element	Value/remark	Comment	Condition
ZP-CSI-RS-ResourceSet ::= SEQUENCE { zp-CSI-RS-ResourceSetId	ZP-CSI-RS-ResourceSetId-RRM		
zp-CSI-RS-ResourceSetIdList SEQUENCE (SIZE(1..maxNrofZP-CSI-RS-ResourcesPerSet)) OF ZP-CSI-RS-ResourceSetId { ZP-CSI-RS-ResourceSetId[1]	1 entry  ZP-CSI-RS-ResourceSetId-RRM	entry 1	
}			
}			

– *ZP-CSI-RS-ResourceSetId-RRM*

**Table 7.3.1-37: ZP-CSI-RS-ResourceSetId-RRM**

Derivation Path: Table 4.6.3-206			
Information Element	Value/remark	Comment	Condition
ZP-CSI-RS-ResourceSetId	n	n is the first ZP-CSI-RS-ResourceSetId allocated for ZP-CSI-RS resource set.  Value of n is left to internal implementation	

### 7.3.2 Sidelink information elements for RRM

As defined in clause 4.6.6 with the following exceptions:

– *SL-BWP-ConfigCommon*

**Table 7.3.2-1: SL-BWP-ConfigCommon**

Derivation Path: Table 4.6.6-2			
Information Element	Value/remark	Comment	Condition
SL-BWP-ConfigCommon-r16 ::= SEQUENCE { sl-BWP-PoolConfigCommon-r16	SL-BWP-PoolConfigCommon-r16	Table 7.3.2-2	
}			

– *SL-BWP-PoolConfigCommon*

**Table 7.3.2-2: SL-BWP-PoolConfigCommon**

Derivation Path: Table 4.6.6-4 with condition RXPOOL and SELECTED			
Information Element	Value/remark	Comment	Condition
SL-BWP-PoolConfigCommon-r16 ::= SEQUENCE {			
sl-RxPool-r16 SEQUENCE (SIZE (1..maxNrofRXPool-r16)) OF SL-ResourcePool-r16 {	1 entry		
SL-ResourcePool-r16[1]	SL-ResourcePool-r16	entry 1 Table 7.3.2-3	
}			
sl-TxPoolSelectedNormal-r16 SEQUENCE (SIZE (1..maxNrofTXPool-r16)) OF SL-ResourcePoolConfig-r16 {	1 entry		
SL-ResourcePoolConfig-r16[1] SEQUENCE {		entry 1	
sl-ResourcePool-r16	SL-ResourcePool-r16	Table 7.3.2-3	
}			
}			
}			

– *SL-ResourcePool*

**Table 7.3.2-3: SL-ResourcePool**

Derivation Path: Table 4.6.6-25			
Information Element	Value/remark	Comment	Condition
SL-ResourcePool-r16 ::= SEQUENCE {			
sl-NumSubchannel-r16	1		
sl-UE-SelectedConfigRP-r16 SEQUENCE {			
sl-ThresPSSCH-RSRP-List-r16	Set according to the configuration in specific test cases		
sl-SelectionWindowList-r16 SEQUENCE (SIZE (8)) OF SL-SelectionWindowConfig-r16 {	8 entries		
SL-SelectionWindowConfig-r16[k, k=1..8]		entry k	
SEQUENCE {			
sl-Priority-r16	k		
sl-SelectionWindow-r16	n20		
}			
}			
sl-PreemptionEnable-r16	enabled		
sl-MinMaxMCS-List-r16 SEQUENCE (SIZE (1..3)) OF SL-MinMaxMCS-Config-r16 {	1 entry		
SL-MinMaxMCS-Config-r16[1] SEQUENCE {		entry 1	
sl-MCS-Table-r16	qam64		
sl-MinMCS-PSSCH-r16	0		
sl-MaxMCS-PSSCH-r16	28		
}			
sl-TimeResource-r16	11111111111111111111		
}			

– *SL-PSSCH-TxConfigList*

**Table 7.3.2-4: SL-PSSCH-TxConfigList**

Derivation Path: Table 4.6.6-19			
Information Element	Value/remark	Comment	Condition
SL-PSSCH-TxConfigList-r16 ::= SEQUENCE (SIZE (1..maxPSSCH-TxConfig-r16)) OF SL-PSSCH-TxConfig-r16 {	1 entry		

sl-ThresUE-Speed-r16	kmph200		
sl-ParametersAboveThres-r16 SEQUENCE {			
sl-MaxSubchannelNumPSSCH-r16	1		
sl-MaxTxTransNumPSSCH-r16	1		
}			
sl-ParametersBelowThres-r16 SEQUENCE {			
sl-MinMCS-PSSCH-r16	4		
sl-MaxMCS-PSSCH-r16	25		
sl-MaxSubchannelNumPSSCH-r16	1		
sl-MaxTxTransNumPSSCH-r16	1		
}			
}			

– *SL-UE-SelectedConfig*

**Table 7.3.2-5: SL-UE-SelectedConfig**

Derivation Path: Table 4.6.6-35			
Information Element	Value/remark	Comment	Condition
SL-UE-SelectedConfig-r16 ::= SEQUENCE {			
sl-PSSCH-TxConfigList-r16	SL-PSSCH-TxConfigList-r16	Table 7.3.2-4	
sl-ProbResourceKeep-r16	v0dot8		
sl-ReselectAfter-r16	n1		
}			

## 7.4 FFS

Void.

## 7.5 Common procedures for RRM testing

### 7.5.1 Procedure to configure SCC(s) for NR RRM CA testing

Same procedure as described in clause 5.5.1.

### 7.5.2 Procedure to configure SCC(s) for EN-DC RRM CA testing

Same procedure as described in clause 5.5.1.



---

# Annex A (informative): Connection Diagrams

## A.1 Definition of Terms

**System Simulator or SS** – A device or system, that is capable of generating simulated Node B signalling and analysing UE signalling responses on one or more RF channels, in order to create the required test environment for the UE under test. It will also include the following capabilities:

1. Measurement and control of the UE Tx output power through TPC commands
2. Measurement of Throughput
3. Measurement of signalling timing and delays
4. Ability to simulate UTRAN and/or E-UTRAN and/or GERAN signalling

**Test System** – A combination of devices brought together into a system for the purpose of making one or more measurements on a UE in accordance with the test case requirements. A test system may include one or more System Simulators if additional signalling is required for the test case. The following diagrams are all examples of Test Systems.

NOTE 1: The above terms are logical definitions to be used to describe the test methods used in the documents TS 38.521-1, TS 38.521-2, TS 38.521-3, TS 38.523-1 and TS 38.533 in practice, real devices called 'System Simulators' may also include additional measurement capabilities or may only support those features required for the test cases they are designed to perform.

NOTE 2: Components in the connection diagrams:

The components in the connection diagrams represent ideal components. They are intended to display the wanted signal flow. They don't mandate real implementations.

**Connection:** Each connection is displayed as a one or two sided arrow, showing the intended signal flow. In some cases, for some tests, some connections shown may not be necessary (for example UL RX connection for a second cell).

**Circulator:** The signal, entering one port, is conducted to the adjacent port, indicated by the arrow. The attenuation among the above mentioned ports is ideally 0 and the isolation among the other ports is ideally  $\infty$ .

**Splitter:** a splitter has one input and 2 or more outputs. The signal at the input is equally divided to the outputs. The attenuation from input to the outputs is ideally 0 and the isolation between the outputs is ideally  $\infty$ .

**Combiner:** a combiner has one output and 2 or more inputs. The signals at the inputs are conducted to the output, all with the same, ideally 0 attenuation. The isolation between the inputs is ideally  $\infty$ .

**Switch:** contacts a sink (or source) alternatively to two or more sources (or sinks).

**Fader:** The fader has one input and one output. The MIMO fading channel is represented by several single faders (e.g. 8 in case of a MIMO antenna configuration 4x2) The correlation among the faders is described in TS 36.521-1 clause B.2.2. In some cases, for some tests, diagrams with fader(s) are referenced when no fading is required; in this case the fader(s) is omitted.

Attenuator: TBD

**Test Equipment Part (TE):** is the section of the connection diagram focused including a combination of devices to perform one or several measurements on a UE depending on the test requirements specified in 3GPP TS 38.101-1 [7], 3GPP TS 38.101-2 [8] and 3GPP TS 38.101-3 [9]. The basic TE is the system simulator to enable the connection between the gNB (and the eNB, if NSA mode) and the DUT. The number of cells, the number of streams per cell and how to combine them, channel and propagations conditions, etc. are also part of the TE. Other instruments as external spectrum analyser, interferer generators, external faders or external AWGN generators can be also considered part of the TE, as these instruments allow to measure a test requirement or to set the UE under certain conditions.

**DUT Part (UE):** for conducted measurement this section is focused on the number of physical antenna connectors and how to combine in the DUT. For radiated measurement this section shows the connections needed to translate the UL/DL streams to the radiated part.

**GNSS System Simulator or GSS:** A device or system, that is capable of generating simulated GNSS satellite transmissions in order to create the required test environment for the UE under test. It will also include the following capabilities:

1. Control of the output power of individual satellites and the simulation of atmospheric delays.
2. Ability to synchronize with NR timing in the SS.

---

## A.2 General Considerations on Connections Diagram

In order to improve the maintainability and the readability of this section and to make easy to identify the whole connection diagram to use per each test case, several considerations have been used for this section:

- The whole connection diagram to use for a specific test has been split in Test Equipment (TE) and User Equipment (UE) parts.
- The same connection diagram will be used for SA and NSA, where the LTE link is specified in each connection diagram (TE and UE) with a dashed line (and this part will be only used for NSA).
- To obtain the whole connection diagram required per each test case is necessary to specify the TE part required for each measurement and the UE part will depend on the UE antenna implementation.

## A.3 Setup Diagrams

### A.3.1 Test Equipment Parts for Conducted Measurements

#### A.3.1.1 Basic Transmitter/Receiver tests

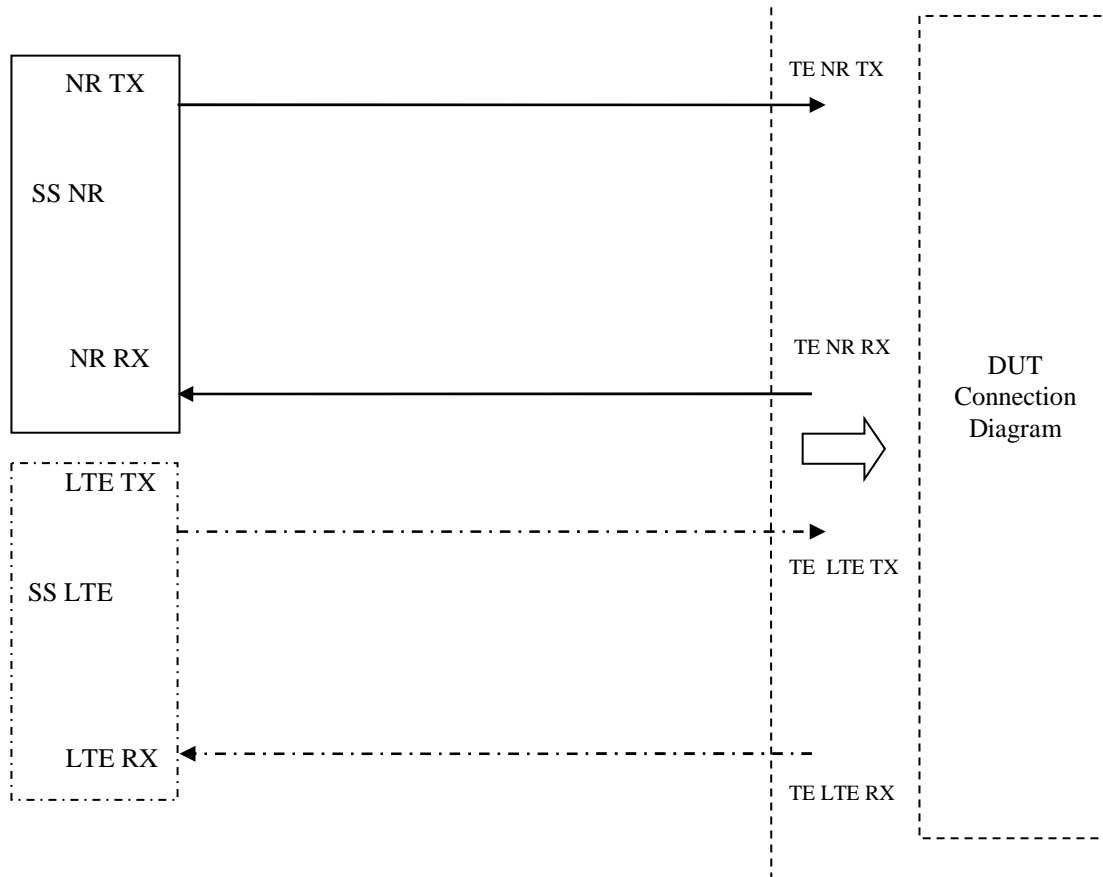


Figure A.3.1.1.1: Test Equipment connection for basic single cell, RX and TX tests

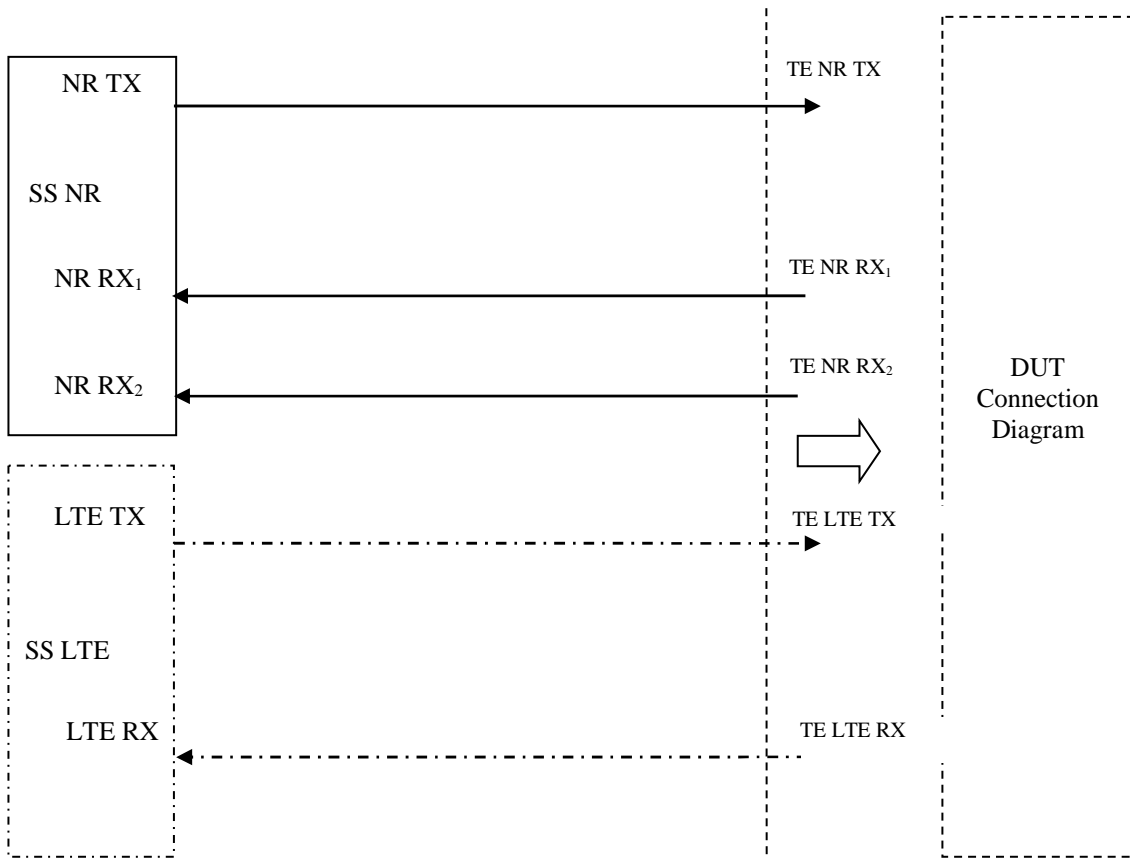


Figure A.3.1.1.2: Test Equipment connection for single cell, RX and TX tests for NR UL MIMO or NR Tx diversity

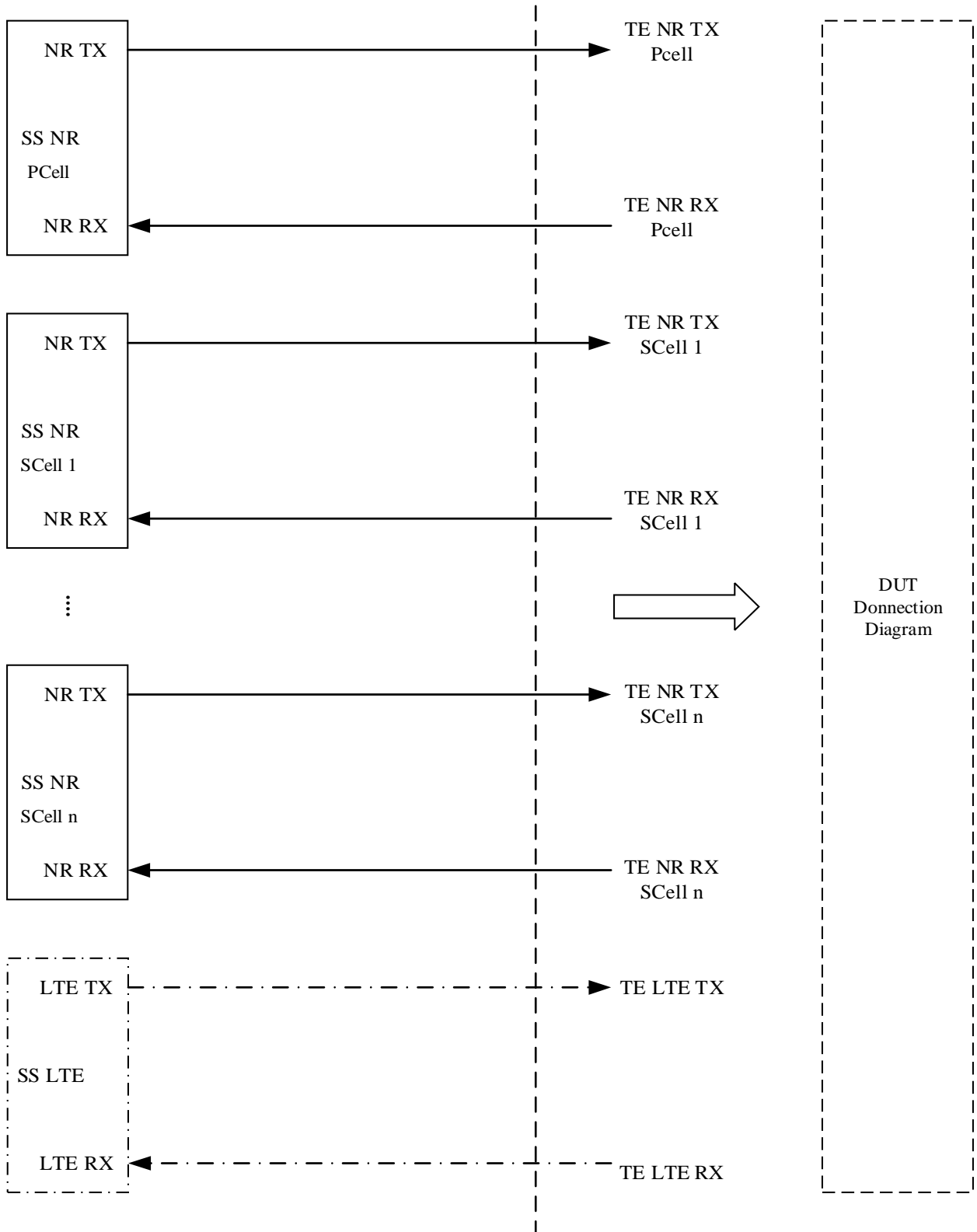


Figure A.3.1.1.3: Test Equipment connection for NR CA and NR-DC, basic RX and TX tests

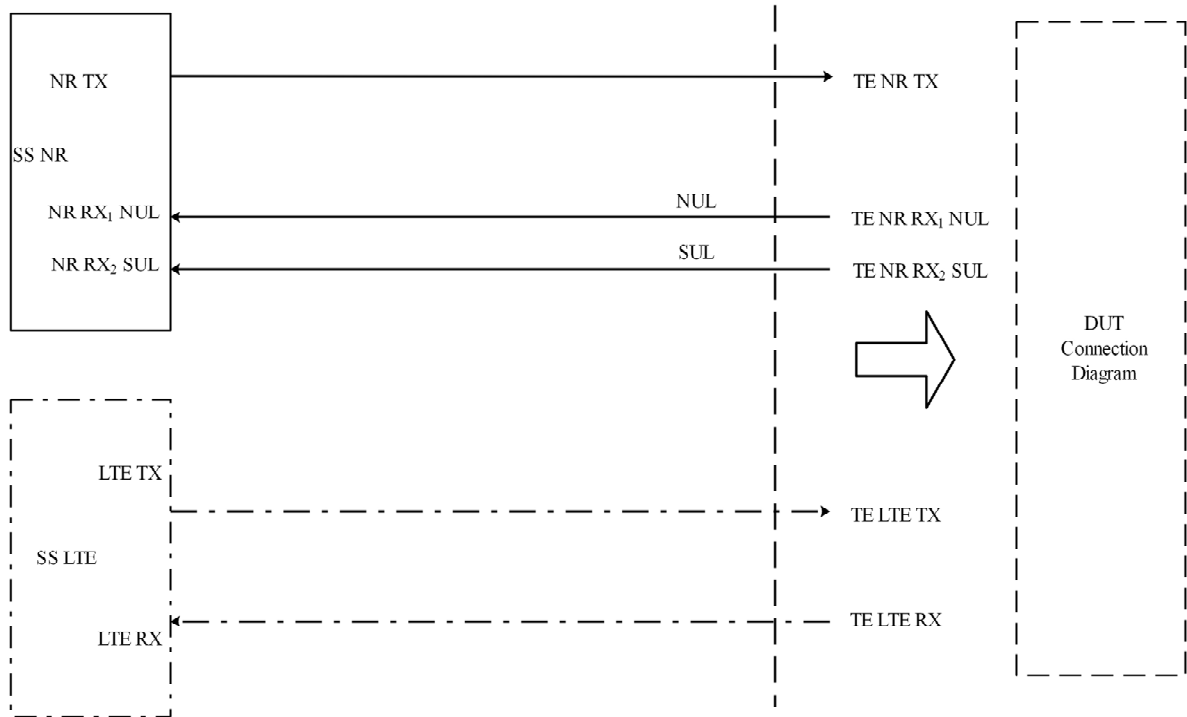


Figure A.3.1.1.4: Test Equipment connection for NR SUL, basic RX and TX tests

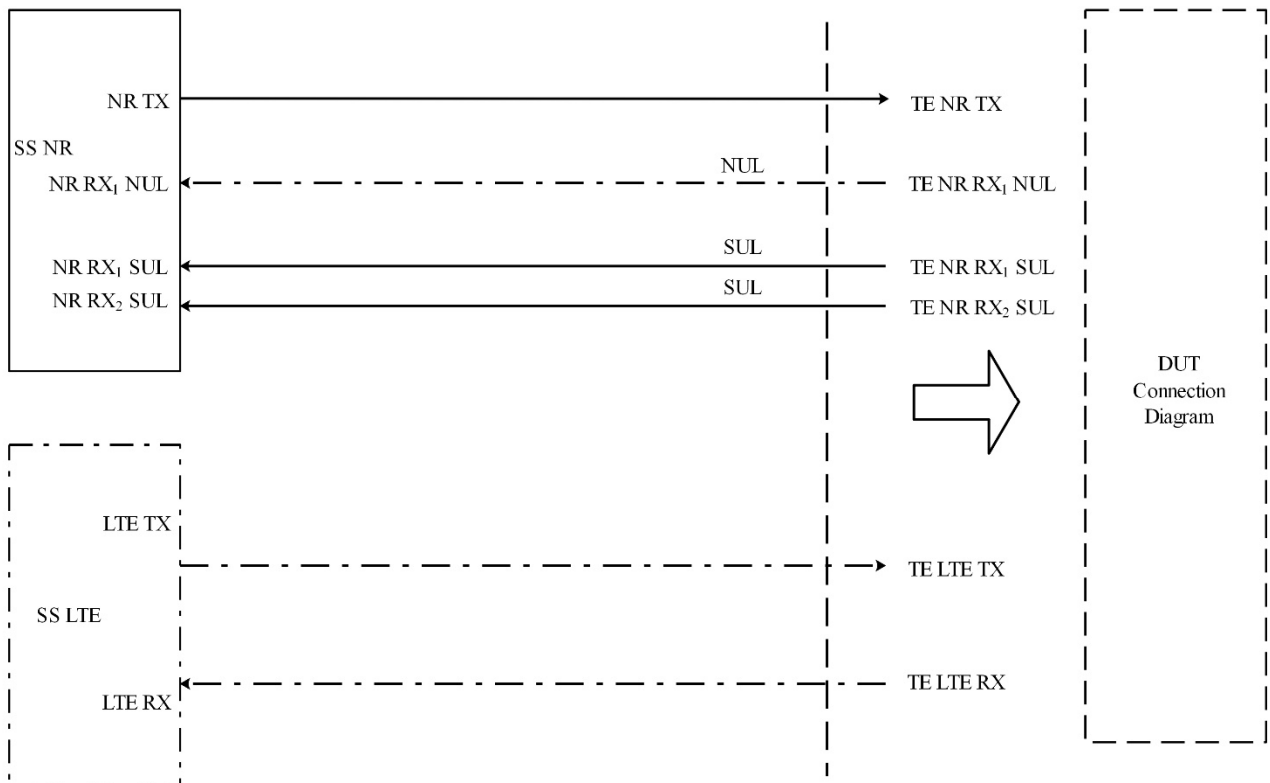


Figure A.3.1.1.5: Test Equipment connection for UL MIMO on SUL band, basic RX and TX tests

### A.3.1.2 Transmitter tests using Spectrum Analyser

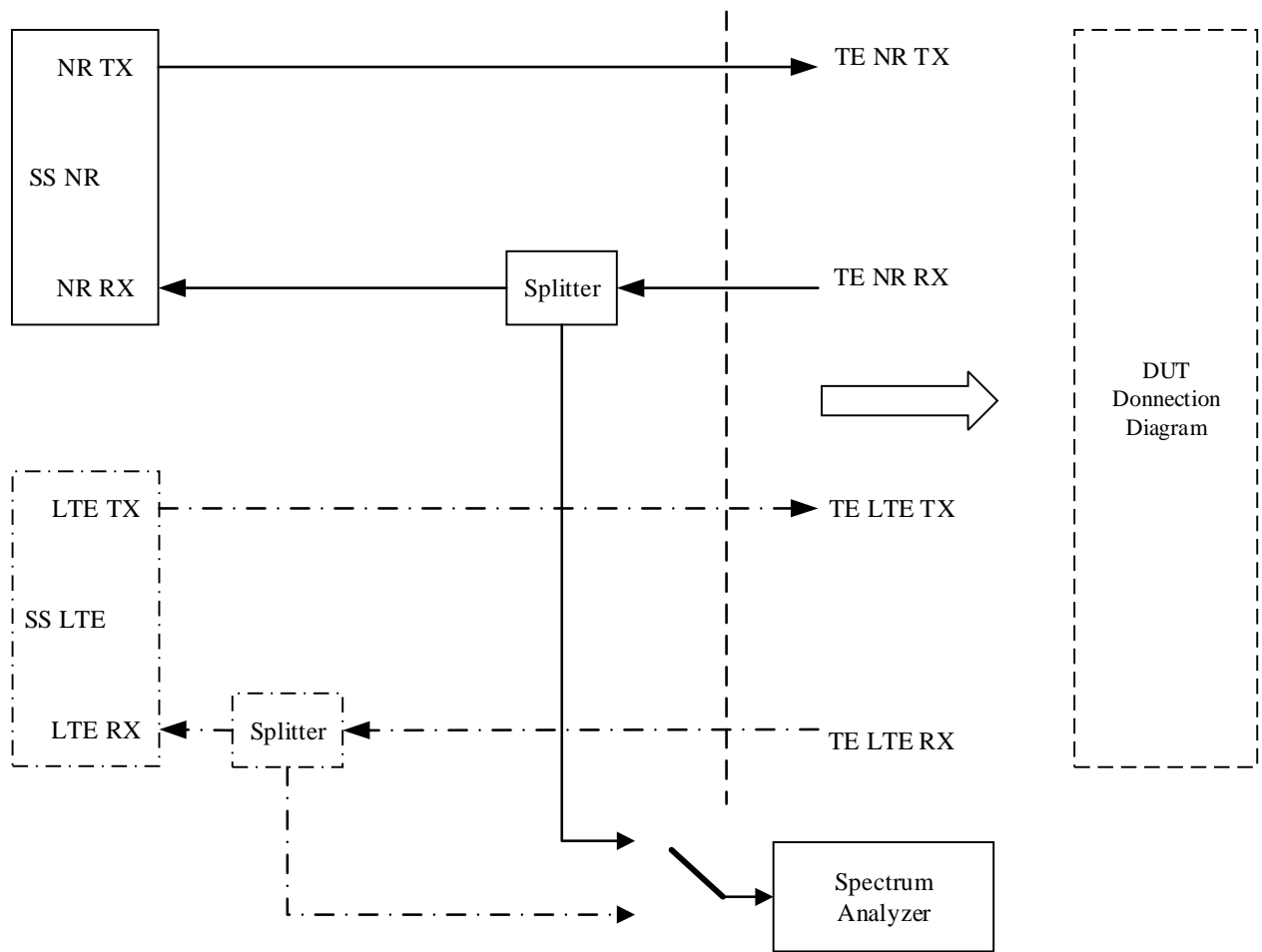


Figure A.3.1.2.1: Test Equipment connection for TX-tests with additional Spectrum Analyzer

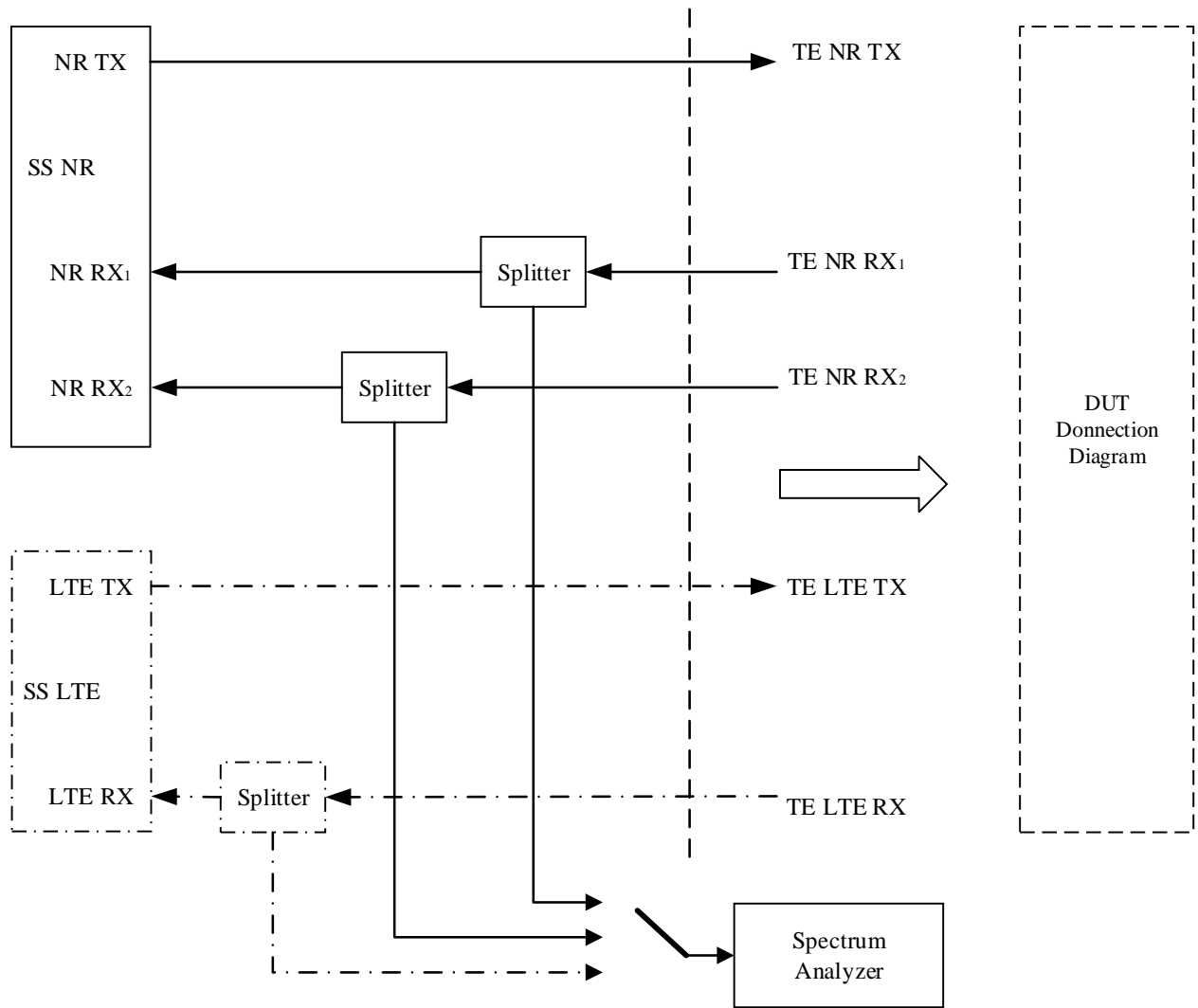


Figure A.3.1.2.2: Test Equipment connection for TX-tests for UL MIMO with additional Spectrum Analyser



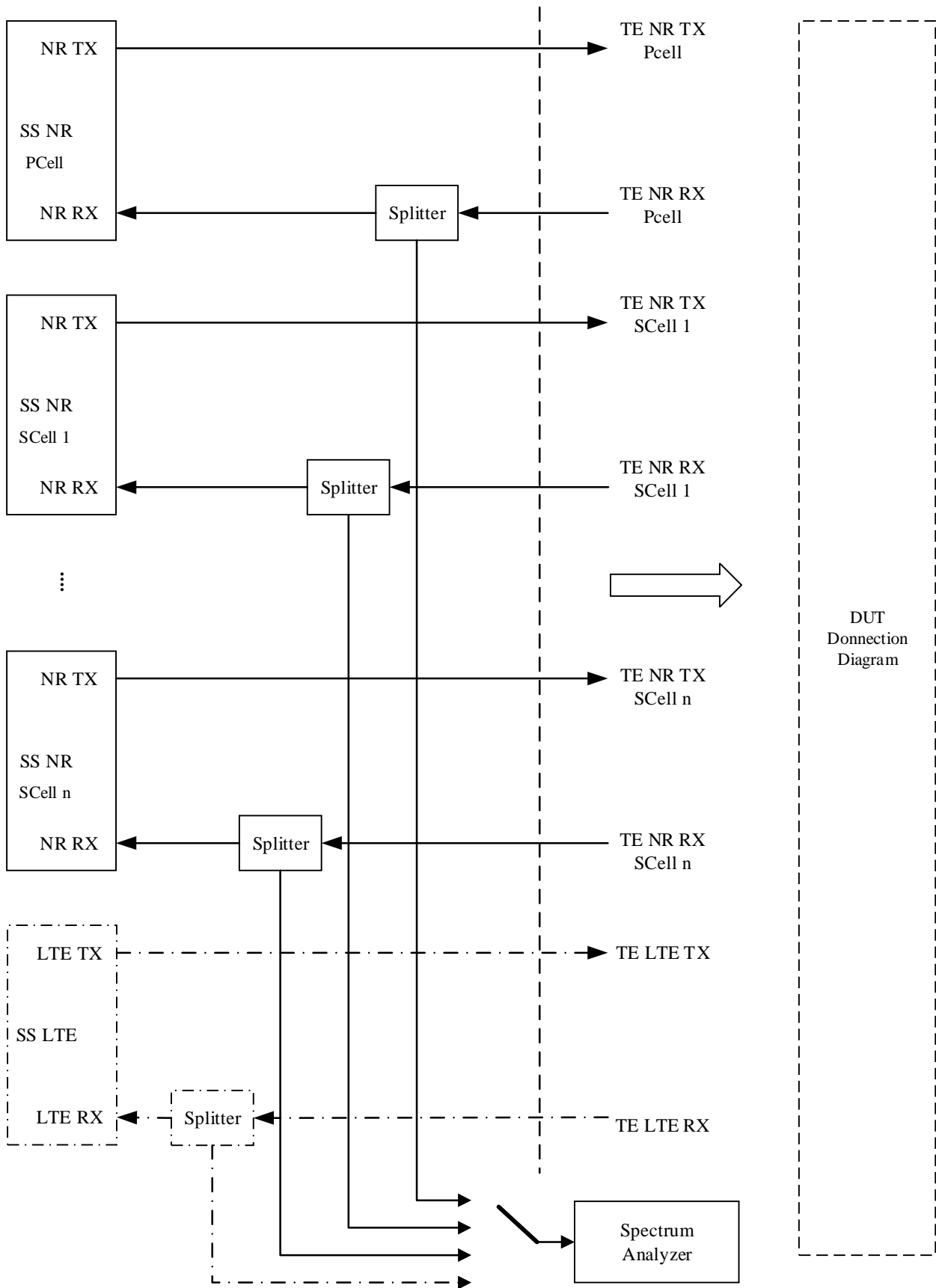


Figure A.3.1.2.3: Test Equipment connection for NR CA TX-tests with additional Spectrum Analyser

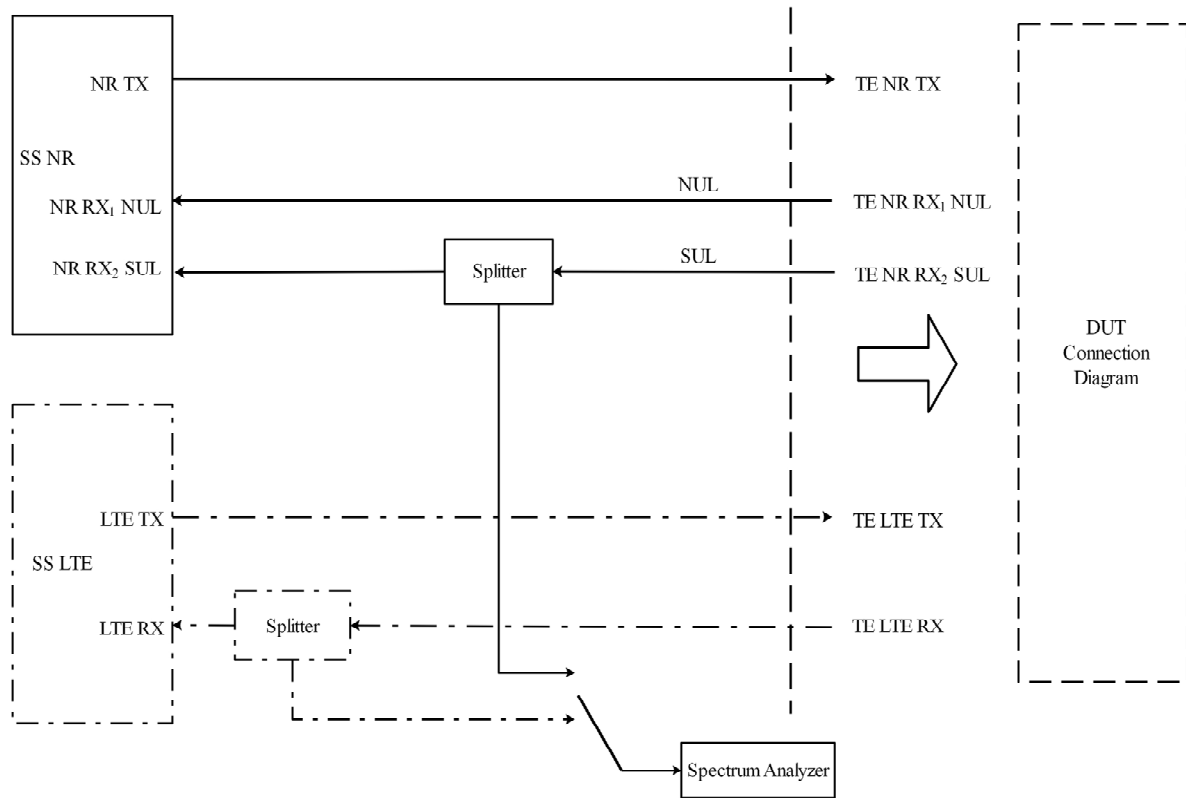


Figure A.3.1.2.4: Test Equipment connection for NR SUL TX-tests with additional Spectrum Analyzer

### A.3.1.3 Transmitter tests using Spectrum Analyser and Signal Generator

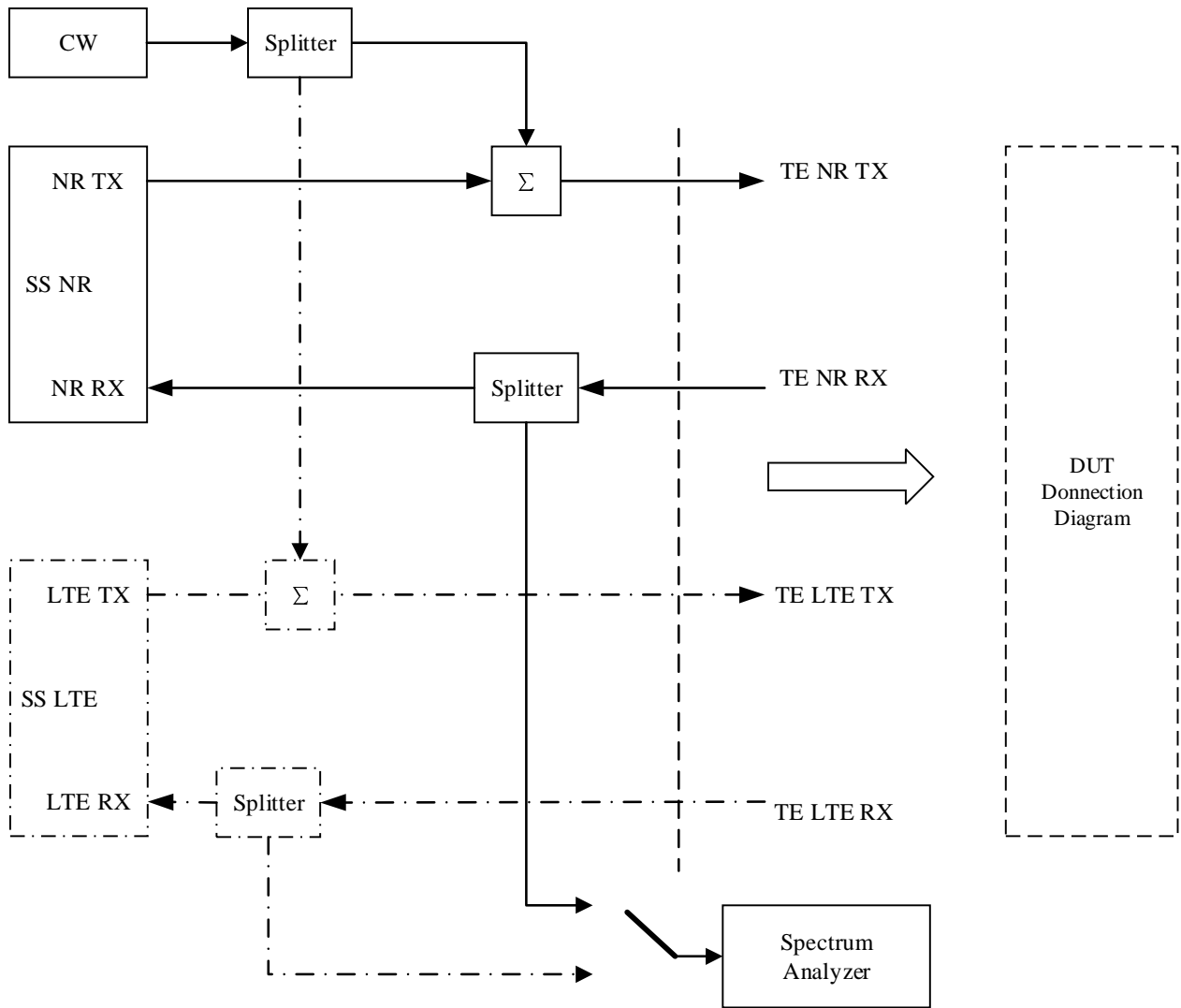


Figure A.3.1.3.1: Test Equipment connection for Transmitter tests with CW Interference and spectrum analyser

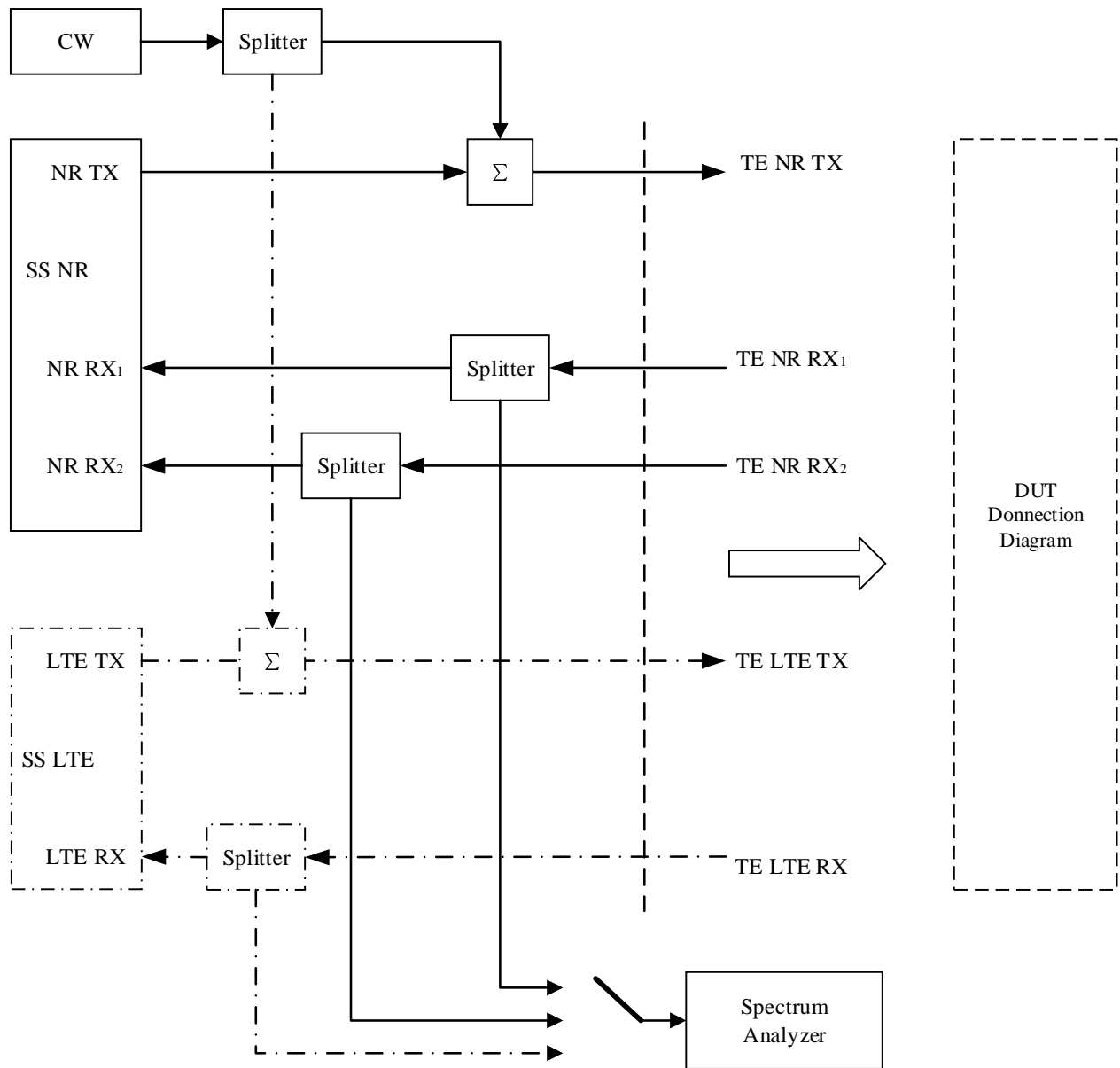


Figure A.3.1.3.2: Test Equipment connection for Transmitter tests for UL MIMO with CW Interference and spectrum analyser

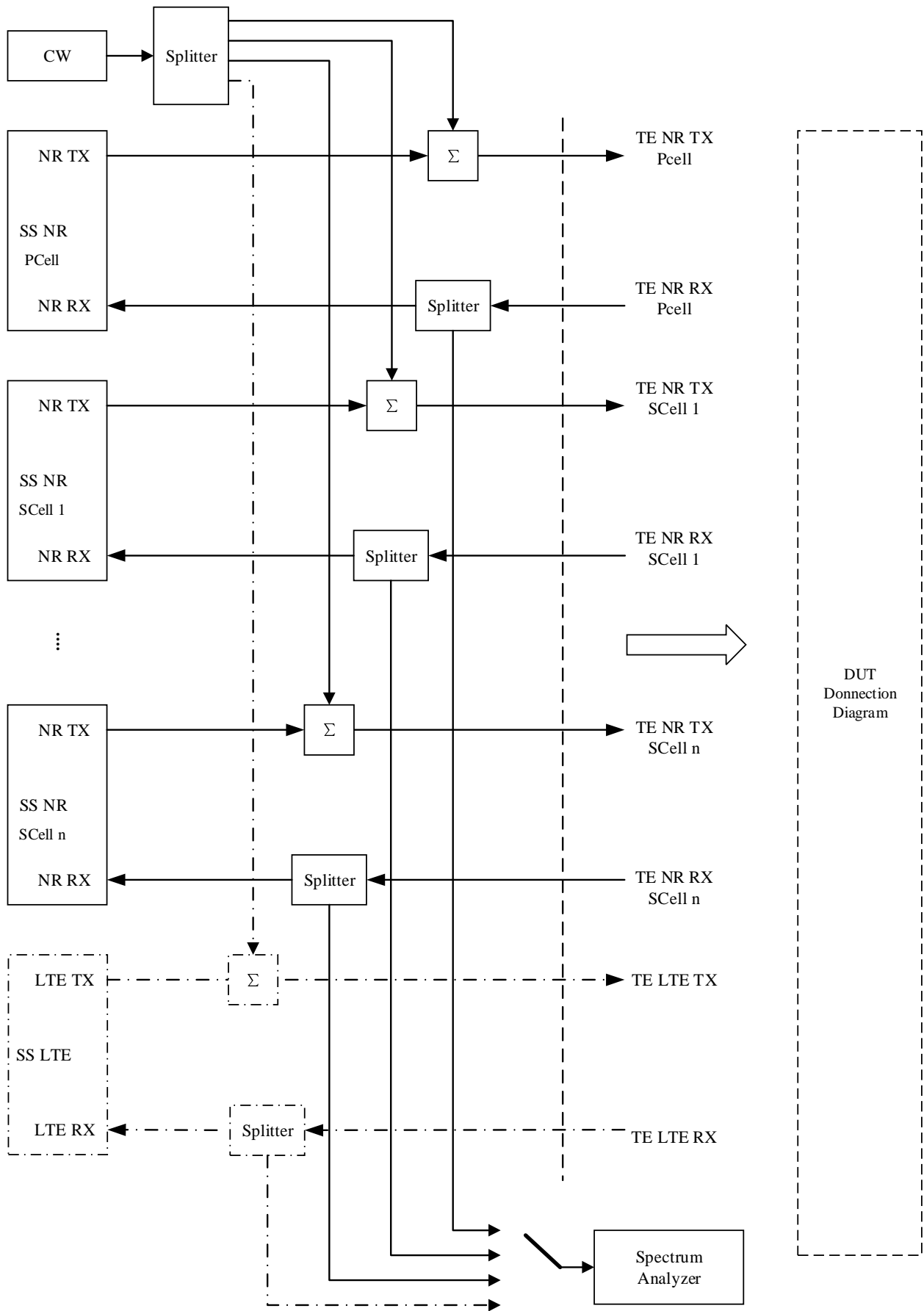


Figure A.3.1.3.3: Test Equipment connection for NR CA Transmitter tests with CW Interference and spectrum analyser

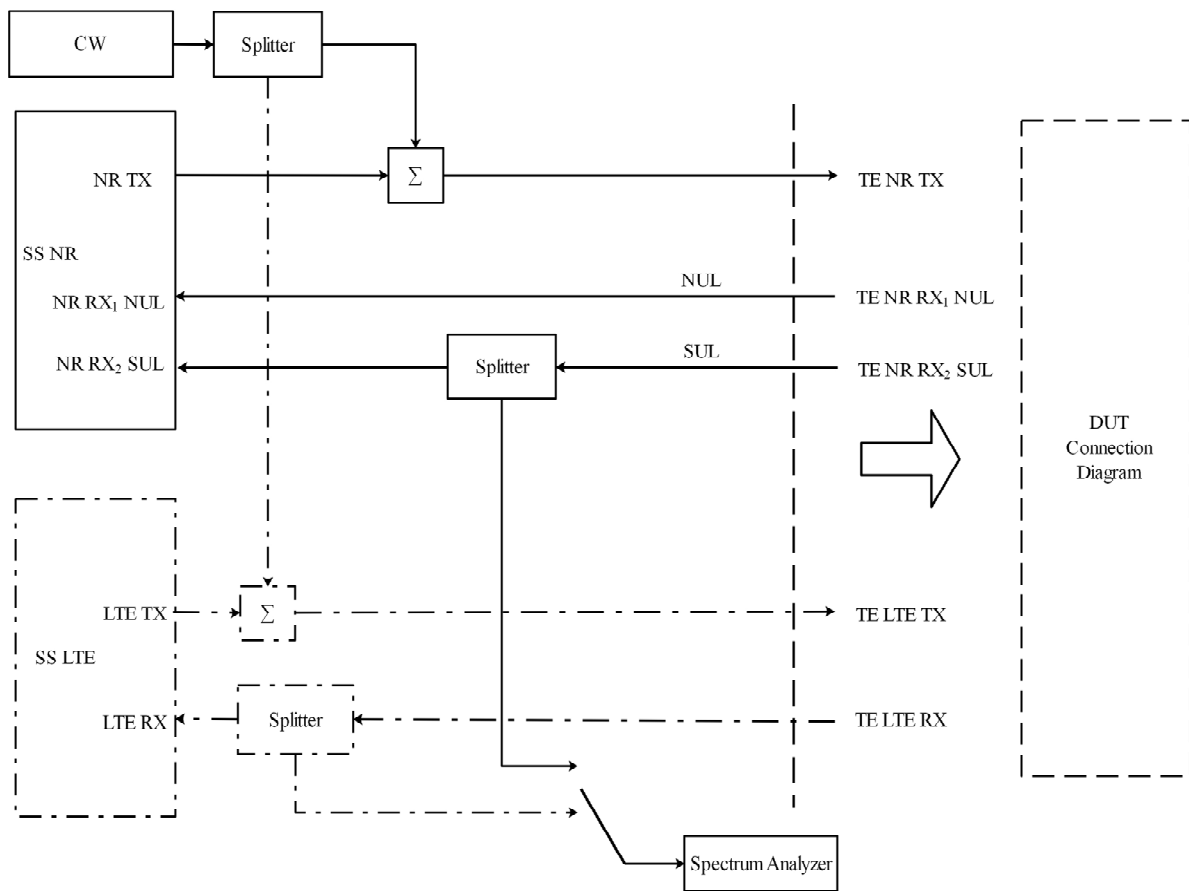


Figure A.3.1.3.4: Test Equipment connection for Transmitter tests for SUL with CW Interference and spectrum analyzer

### A.3.1.4 Receiver tests using Signal Generator

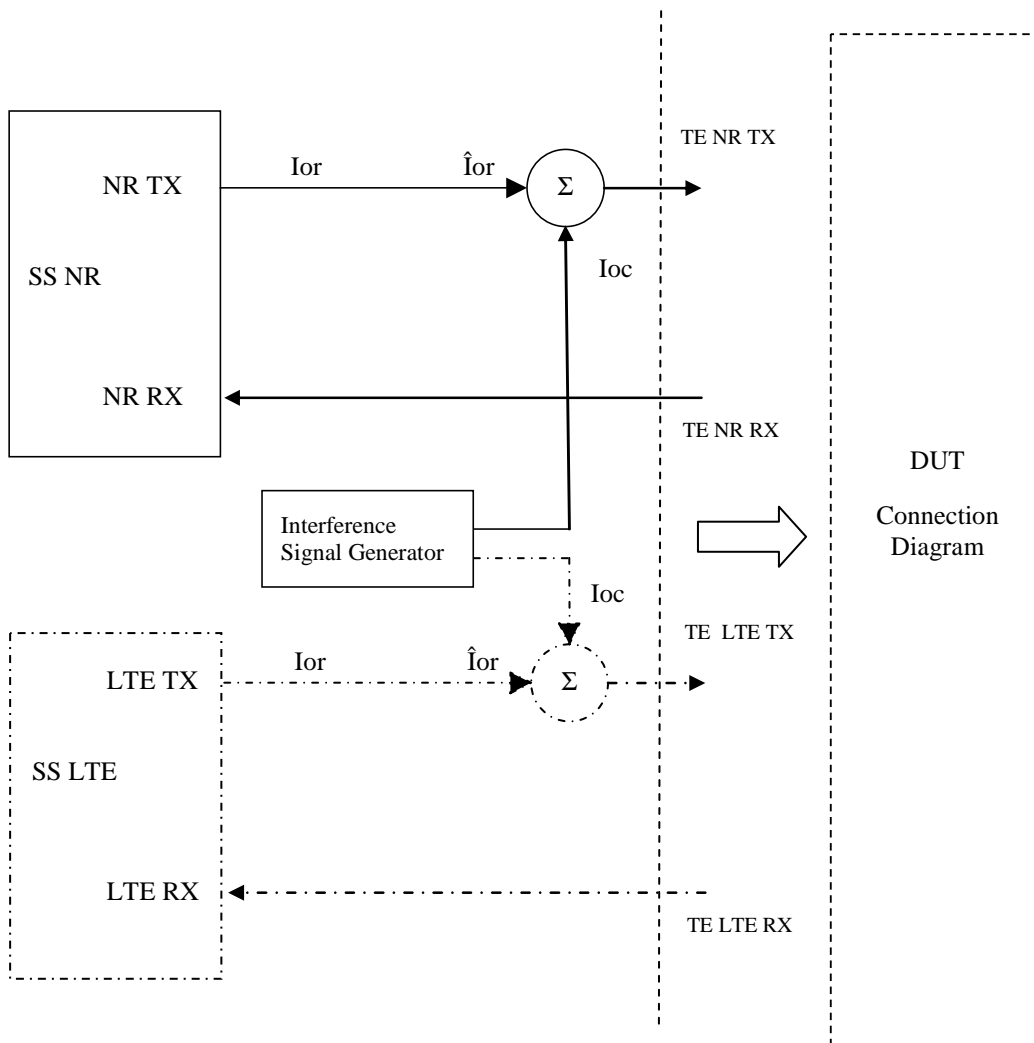


Figure A.3.1.4.1: Test Equipment connection for Receiver tests with Modulated Interference

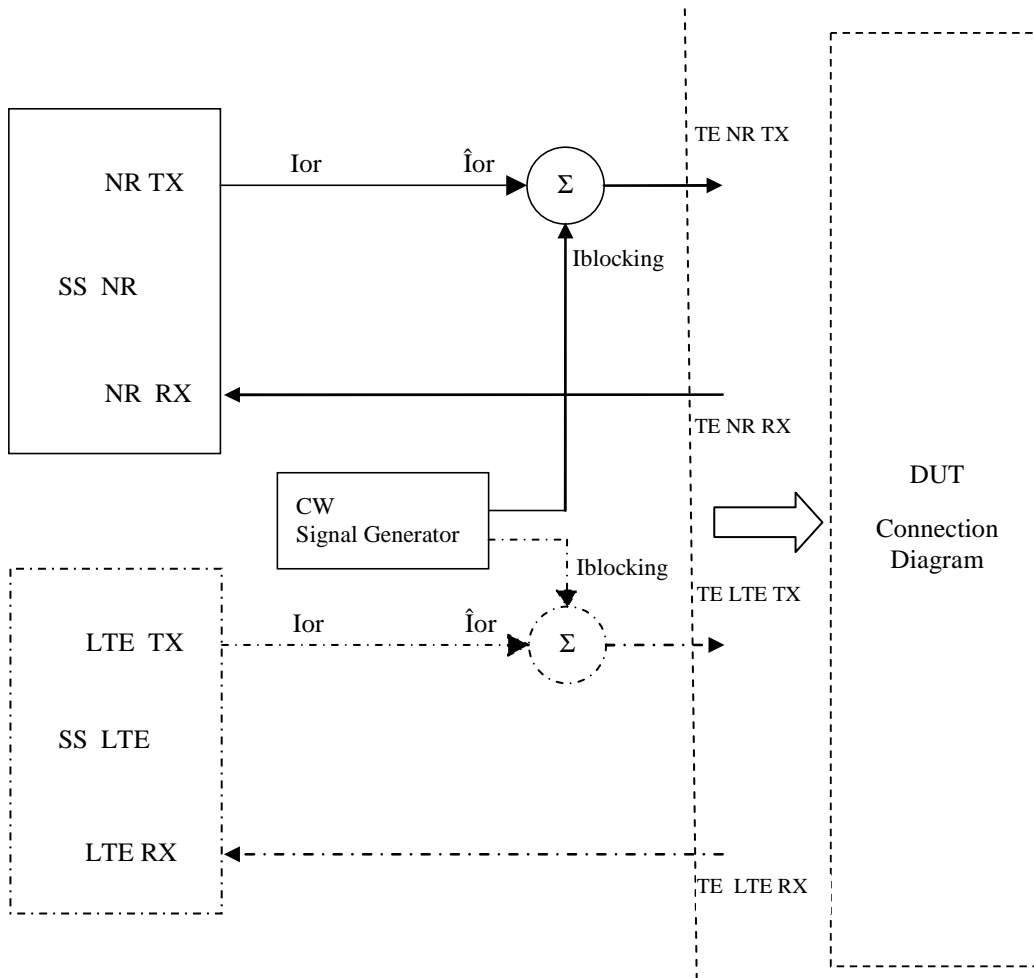
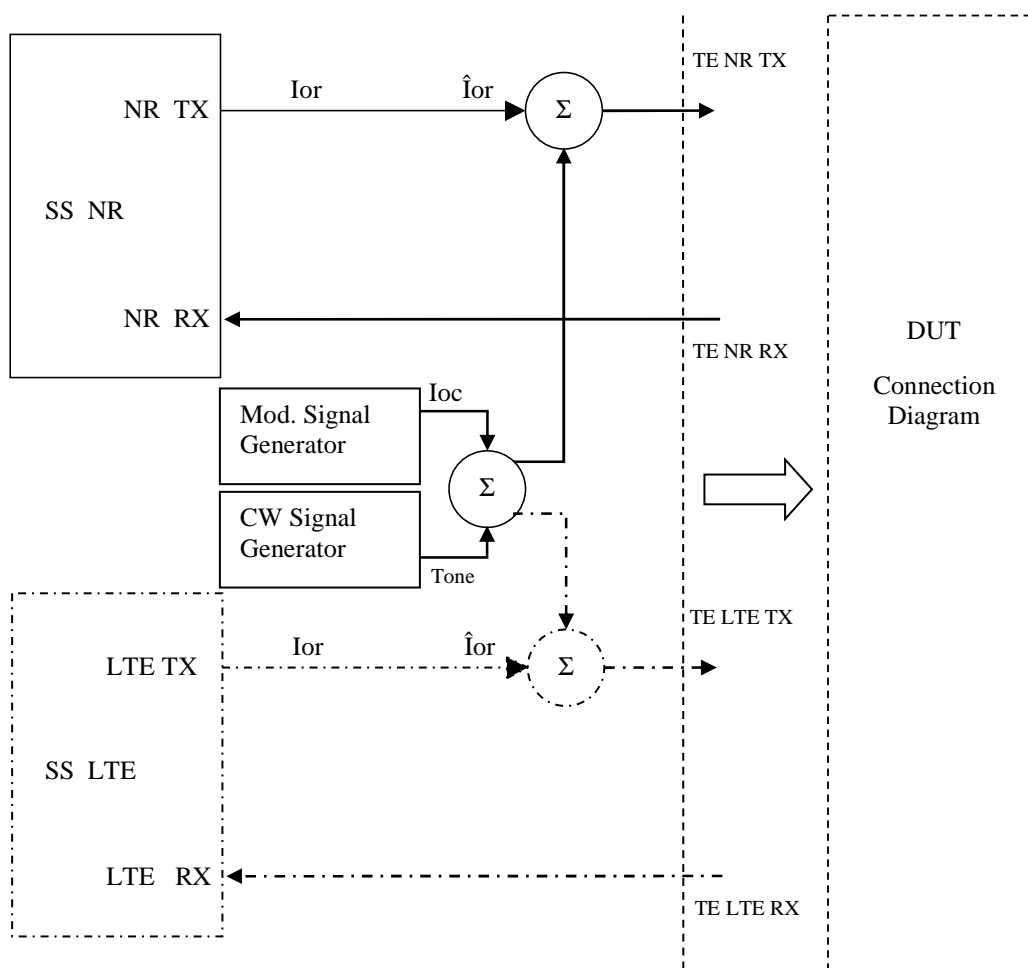
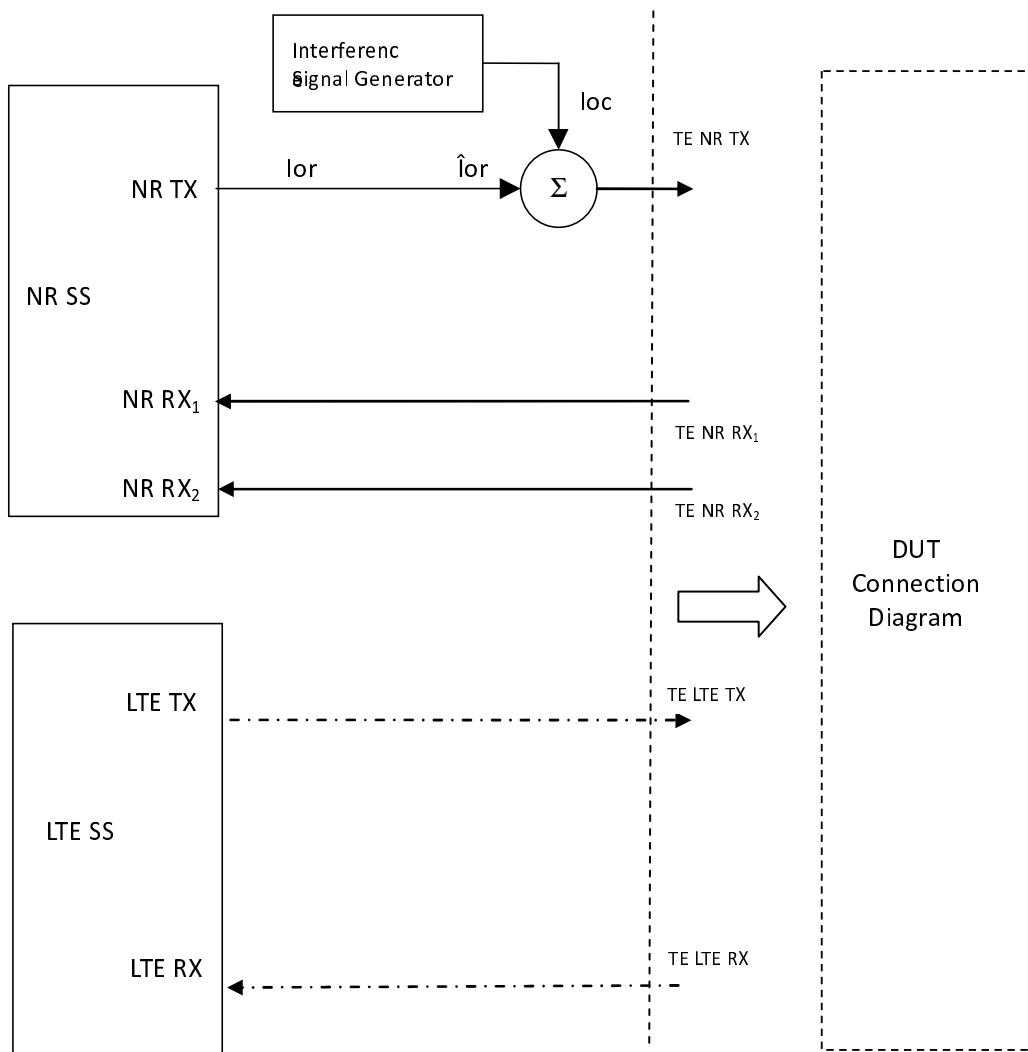


Figure A.3.1.4.2: Test Equipment connection for Receiver tests with CW Interference





**Figure A.3.1.4.3: Test Equipment connection for Receiver tests both Modulated and additional CW Interference signal**



**Figure A.3.1.4.4: Test Equipment connection for Receiver tests for UL MIMO with Modulated Interference**

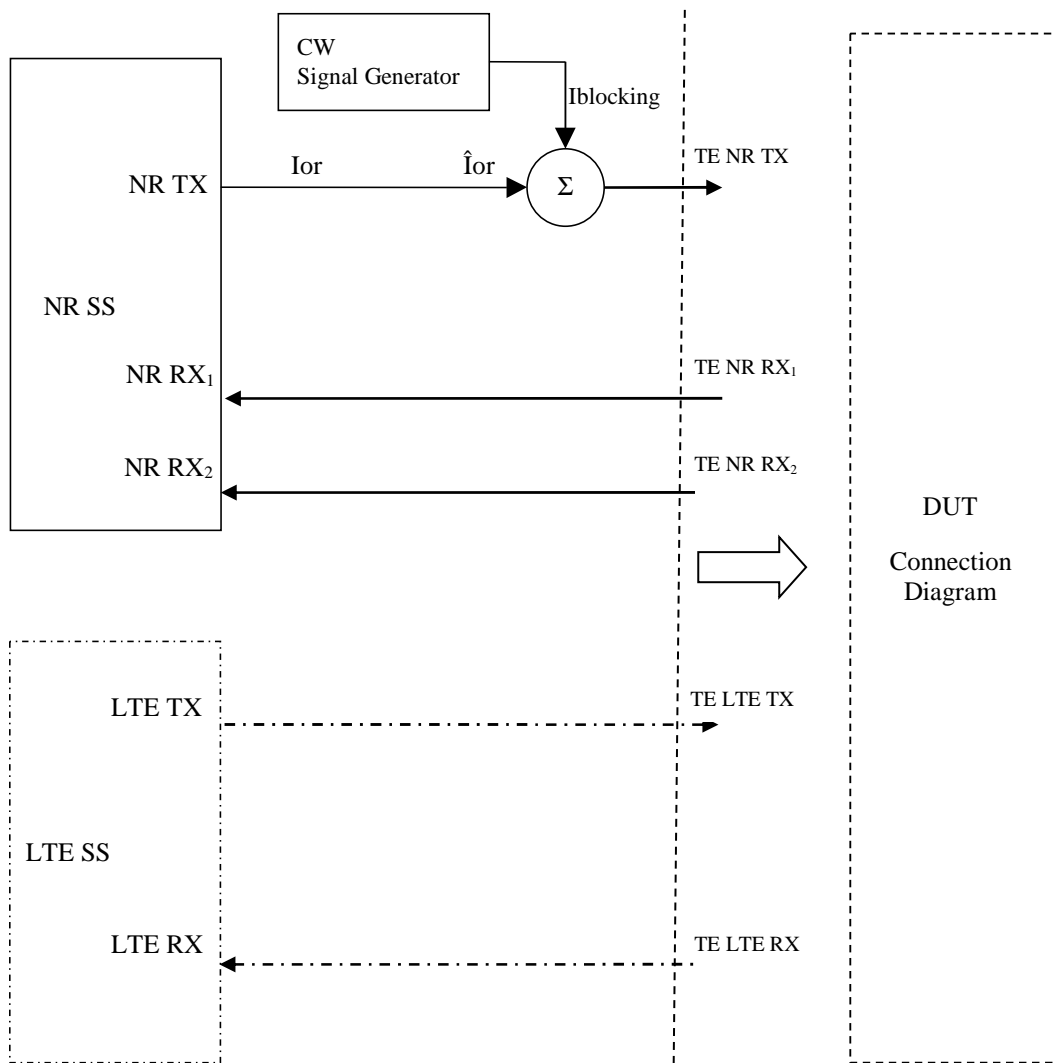


Figure A.3.1.4.5: Test Equipment connection for Receiver tests for UL MIMO with CW Interference

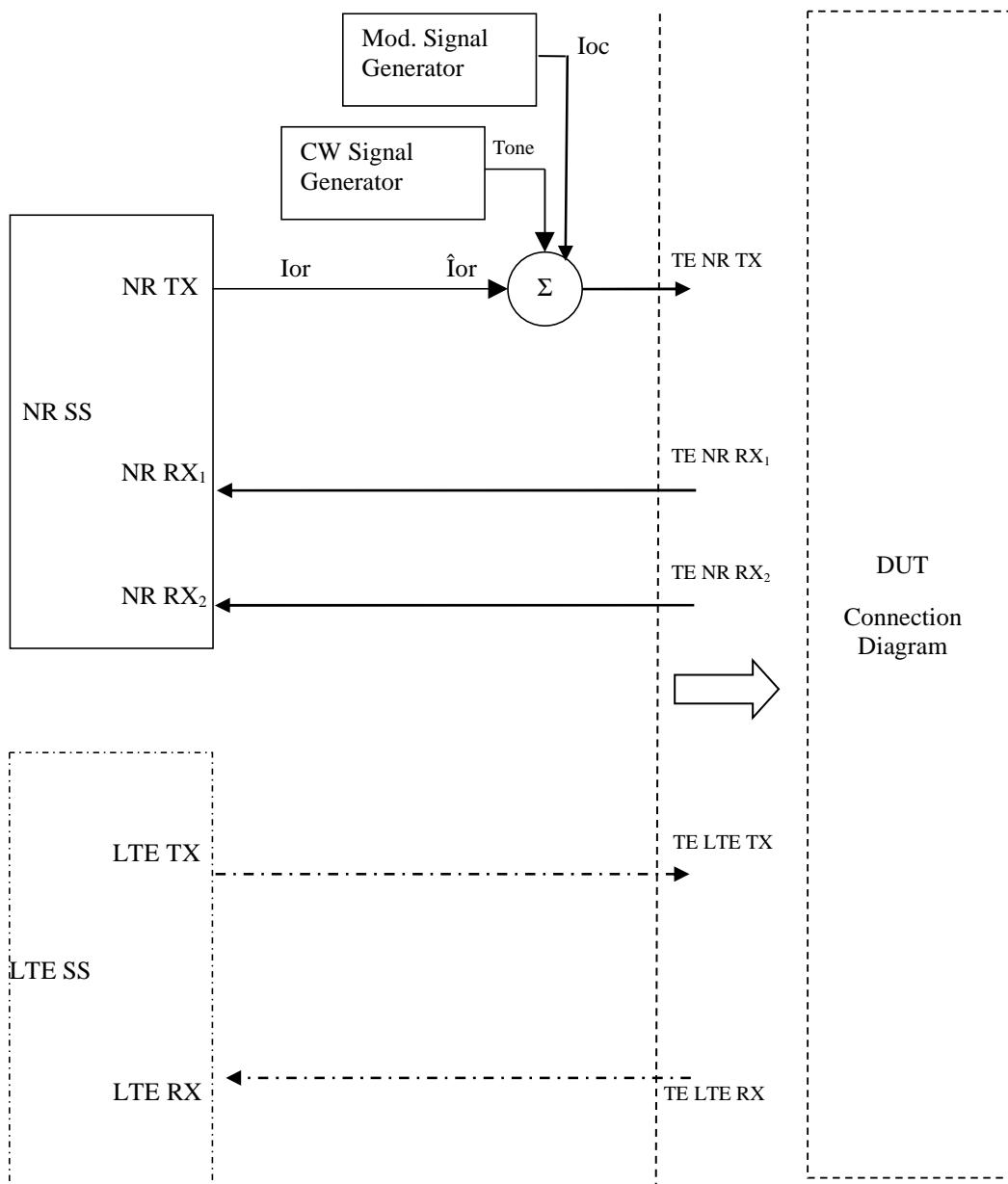
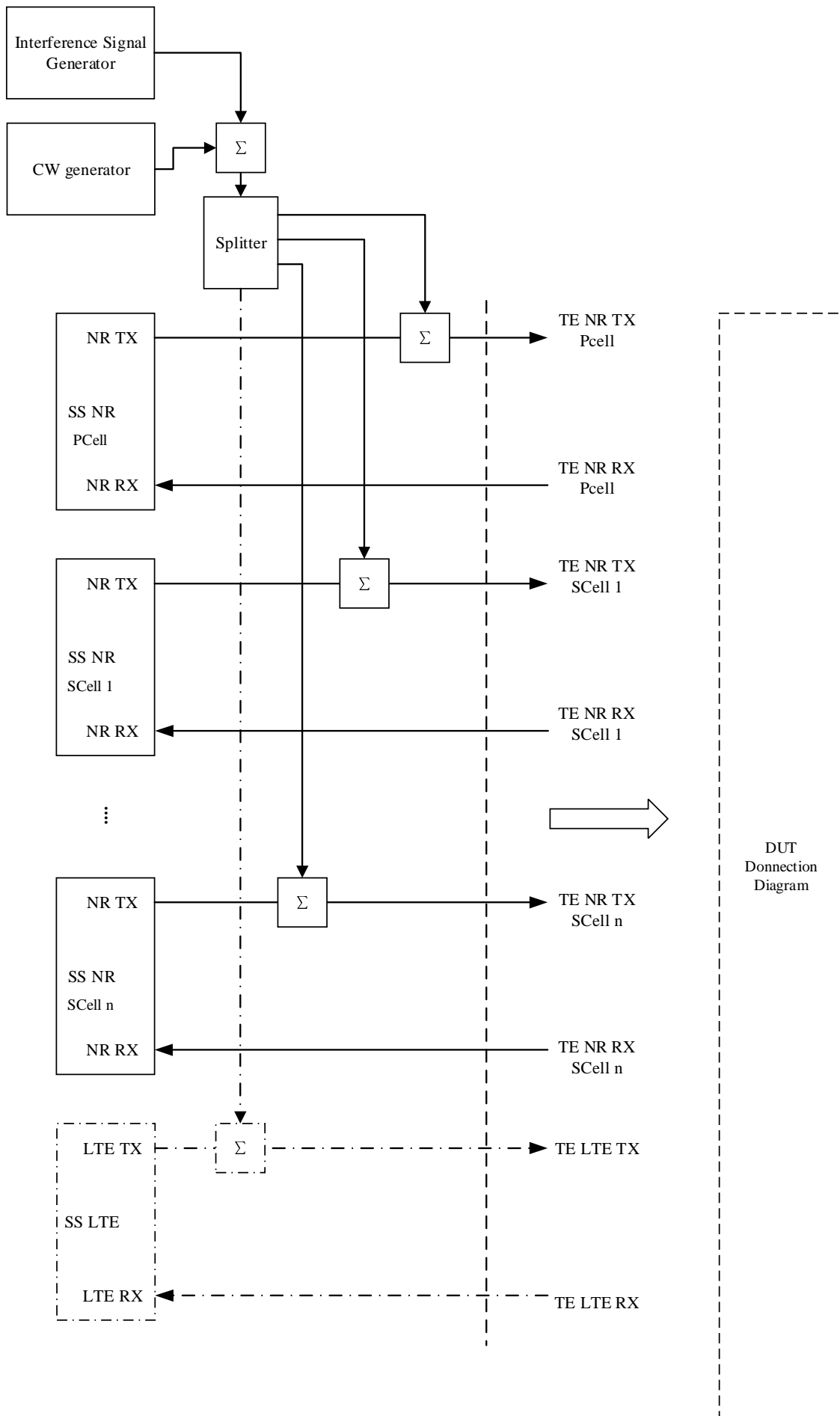
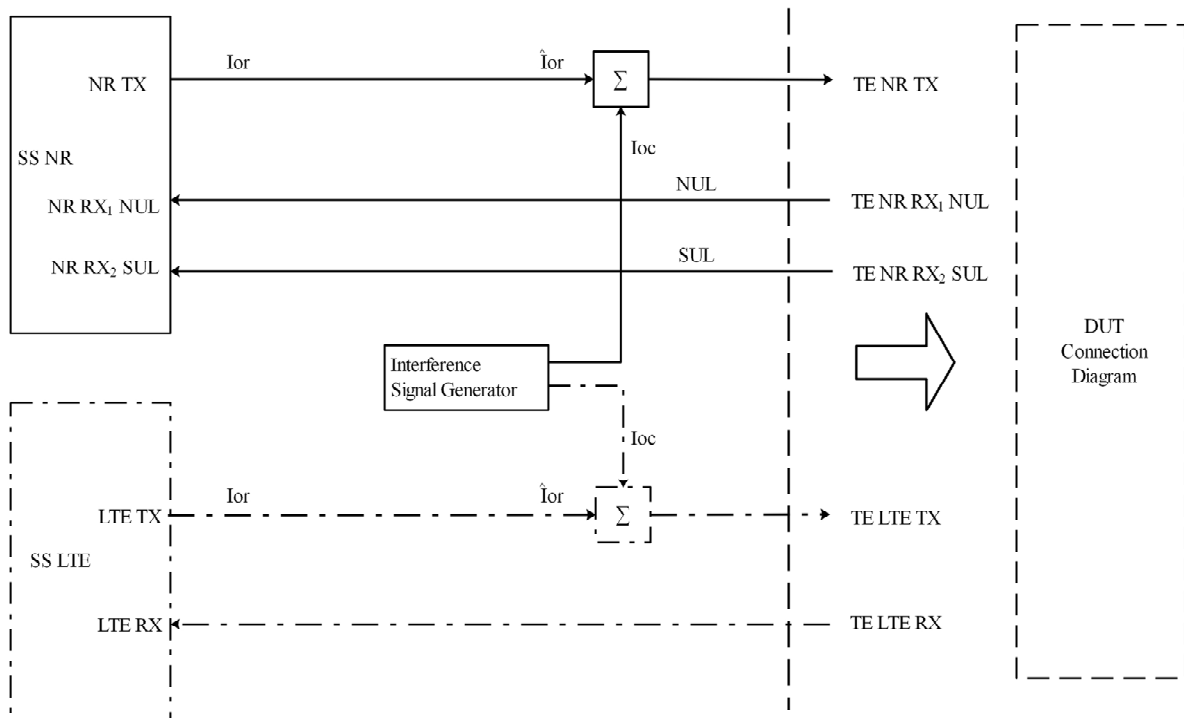


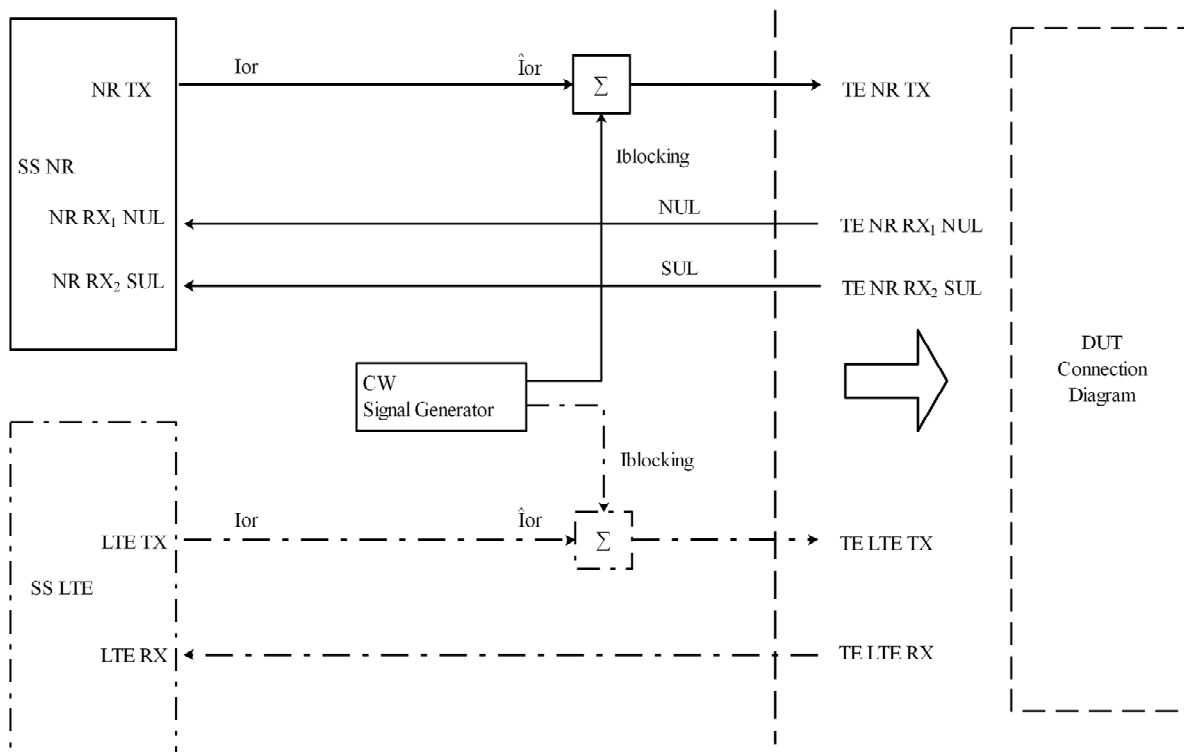
Figure A.3.1.4.6: Test Equipment connection for Receiver tests for UL MIMO with both Modulated and additional CW Interference signal



**Figure A.3.1.4.7: Test Equipment connection for NR CA Receiver tests with additional Modulated Interference signal and/or CW Interference signal**



**Figure A.3.1.4.8: Test Equipment connection for NR SUL Receiver tests with Modulated Interference**



**Figure A.3.1.4.9: Test Equipment connection for NR SUL Receiver tests with CW Interference**

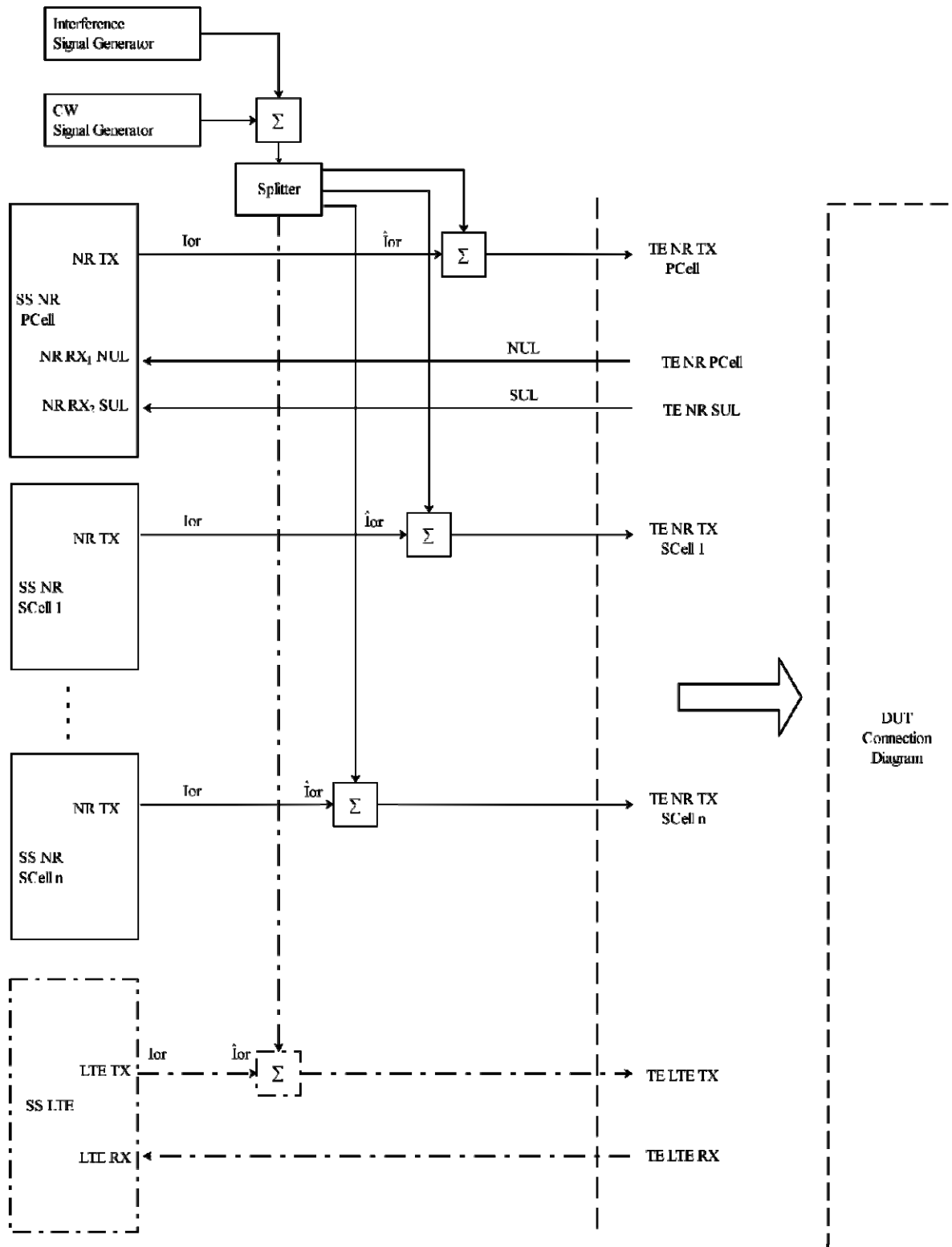


Figure A.3.1.4.10: Test Equipment connection for NR SUL with DL CA Receiver tests with additional Modulated Interference and/or CW Interference signal

### A.3.1.5 Receiver tests using Spectrum Analyser

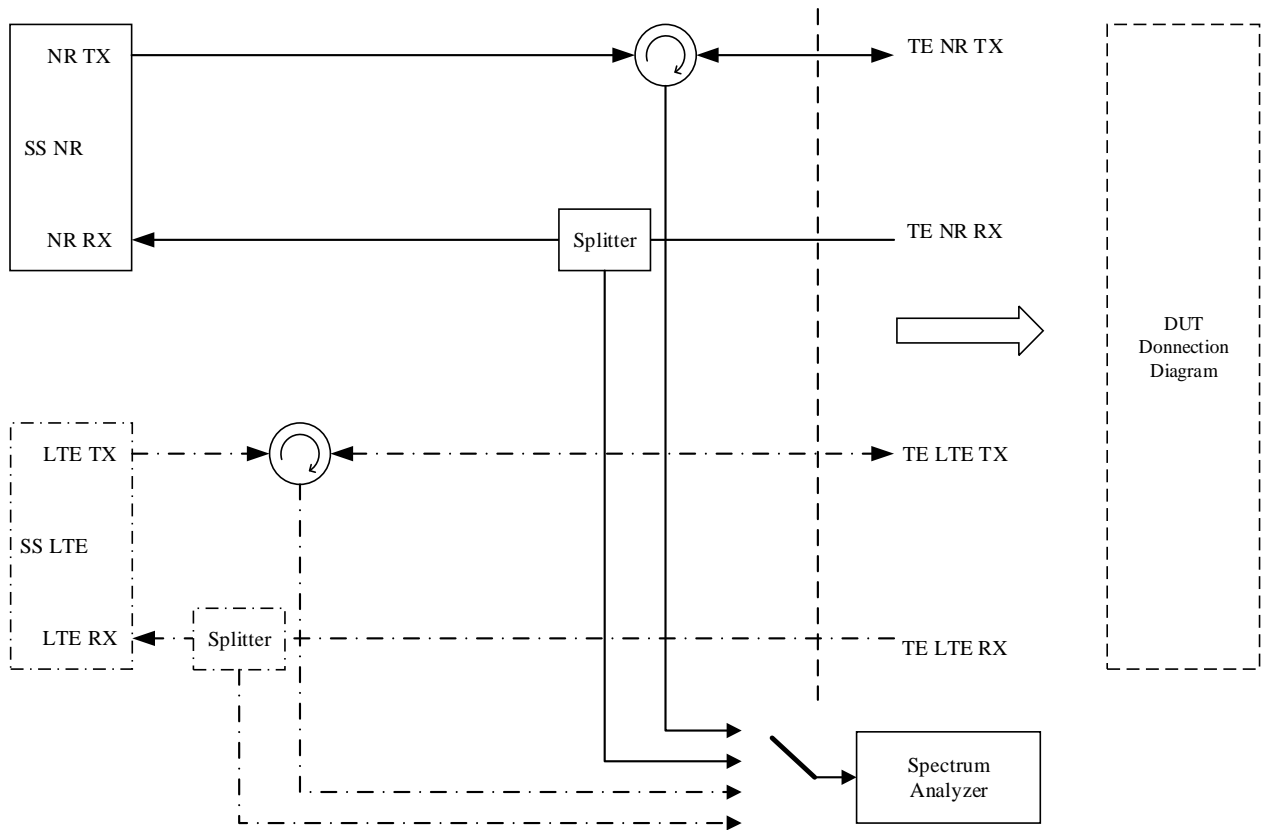


Figure A.3.1.5.1: Test Equipment connection for RX-tests with additional Spectrum Analyzer



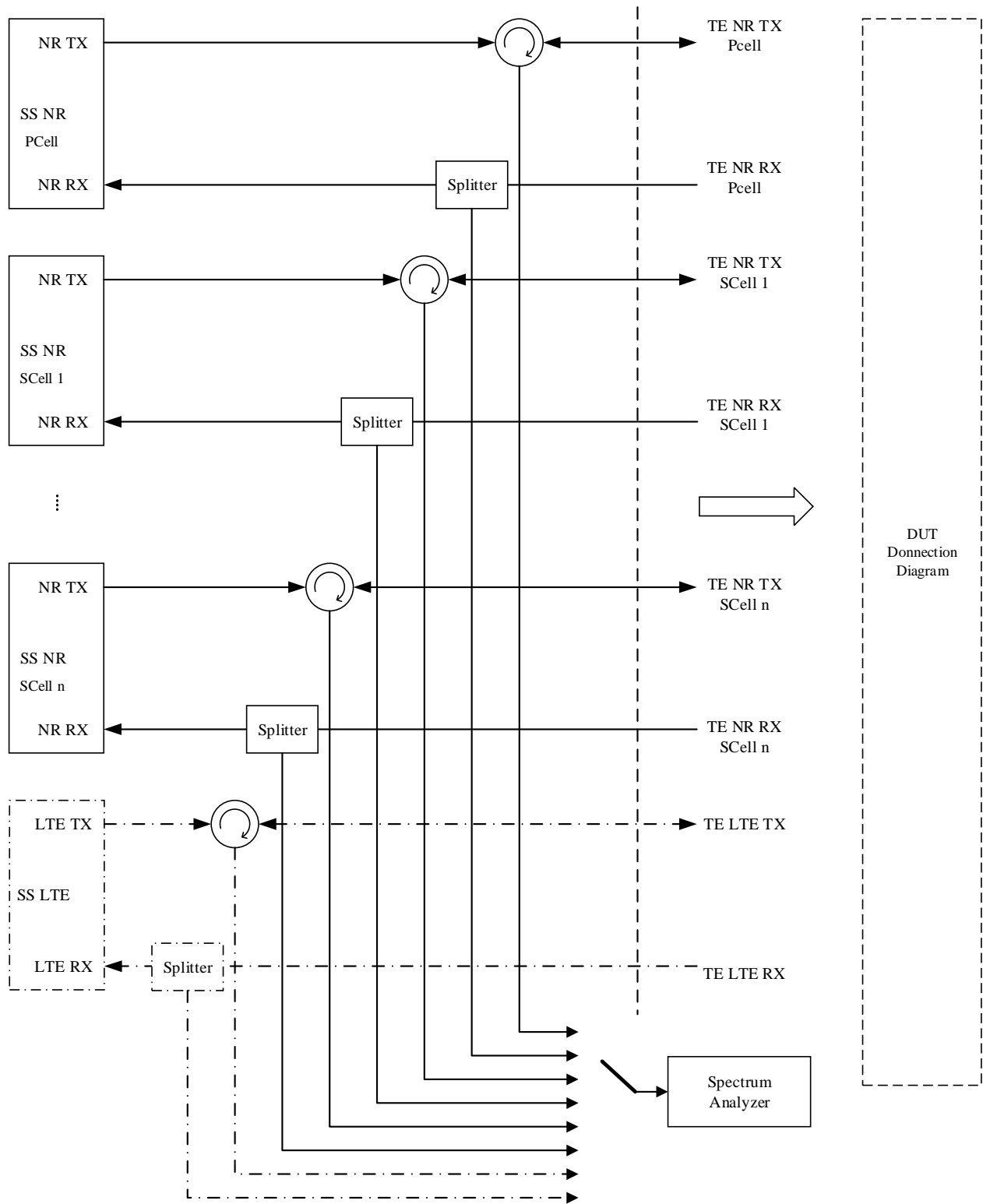


Figure A.3.1.5.2: Test Equipment connection for NR CA RX-tests with additional Spectrum Analyzer

### A.3.1.6 Receiver Performance tests

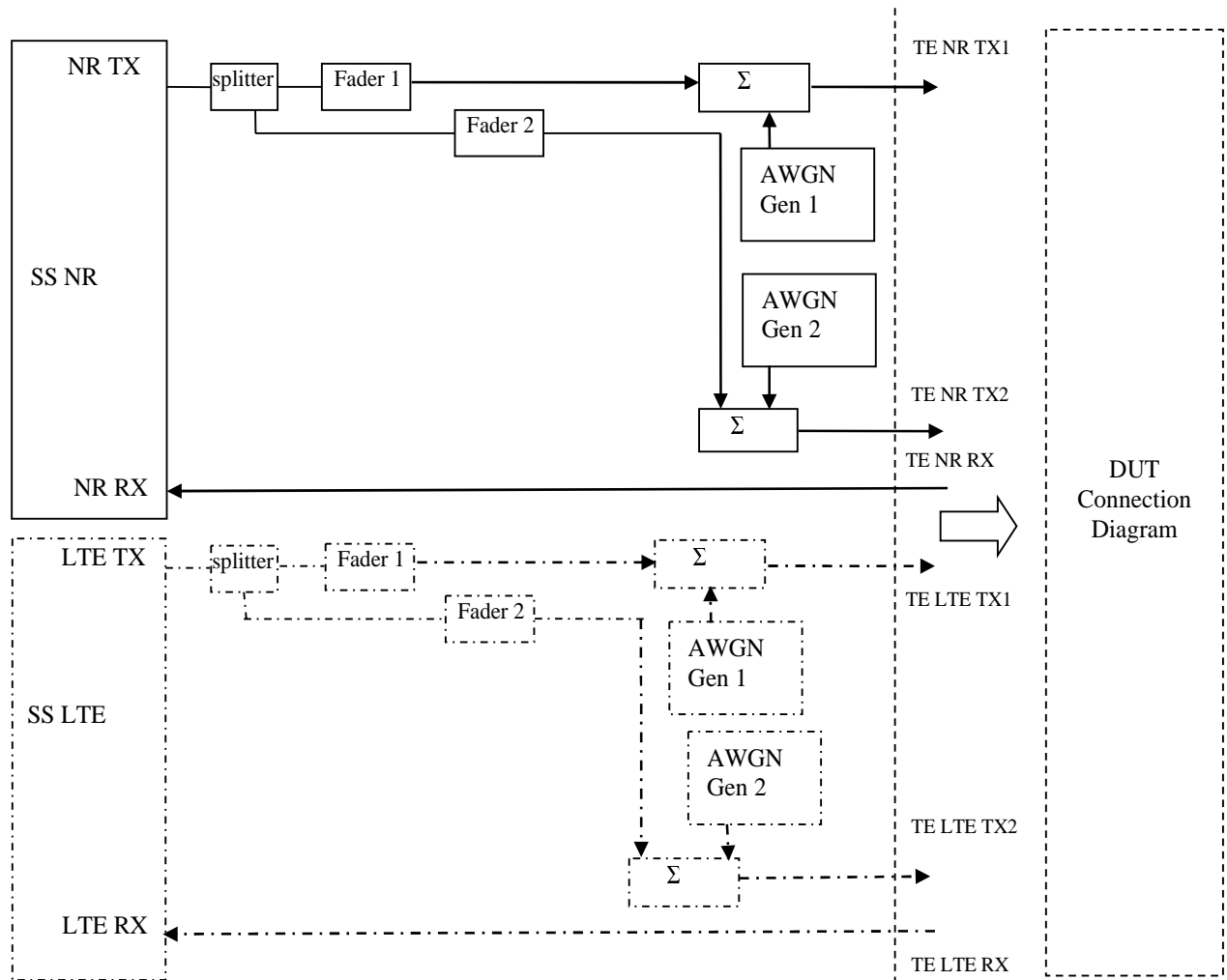
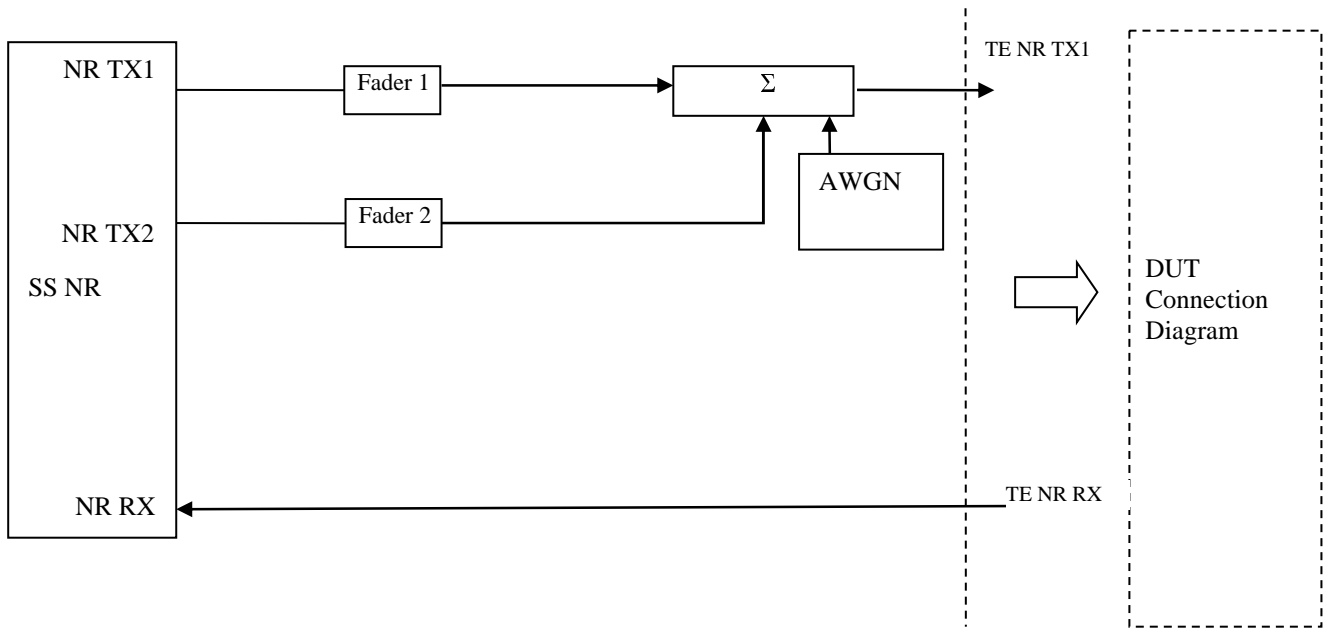


Figure A.3.1.6.1: Test Equipment connection for Receiver Performance tests with antenna configuration 1x2

### A.3.1.7 Demodulation Performance and CSI reporting tests



**Figure A.3.1.7.0: Test Equipment connection for Demodulation Performance and CSI reporting tests with antenna configuration 2x1**

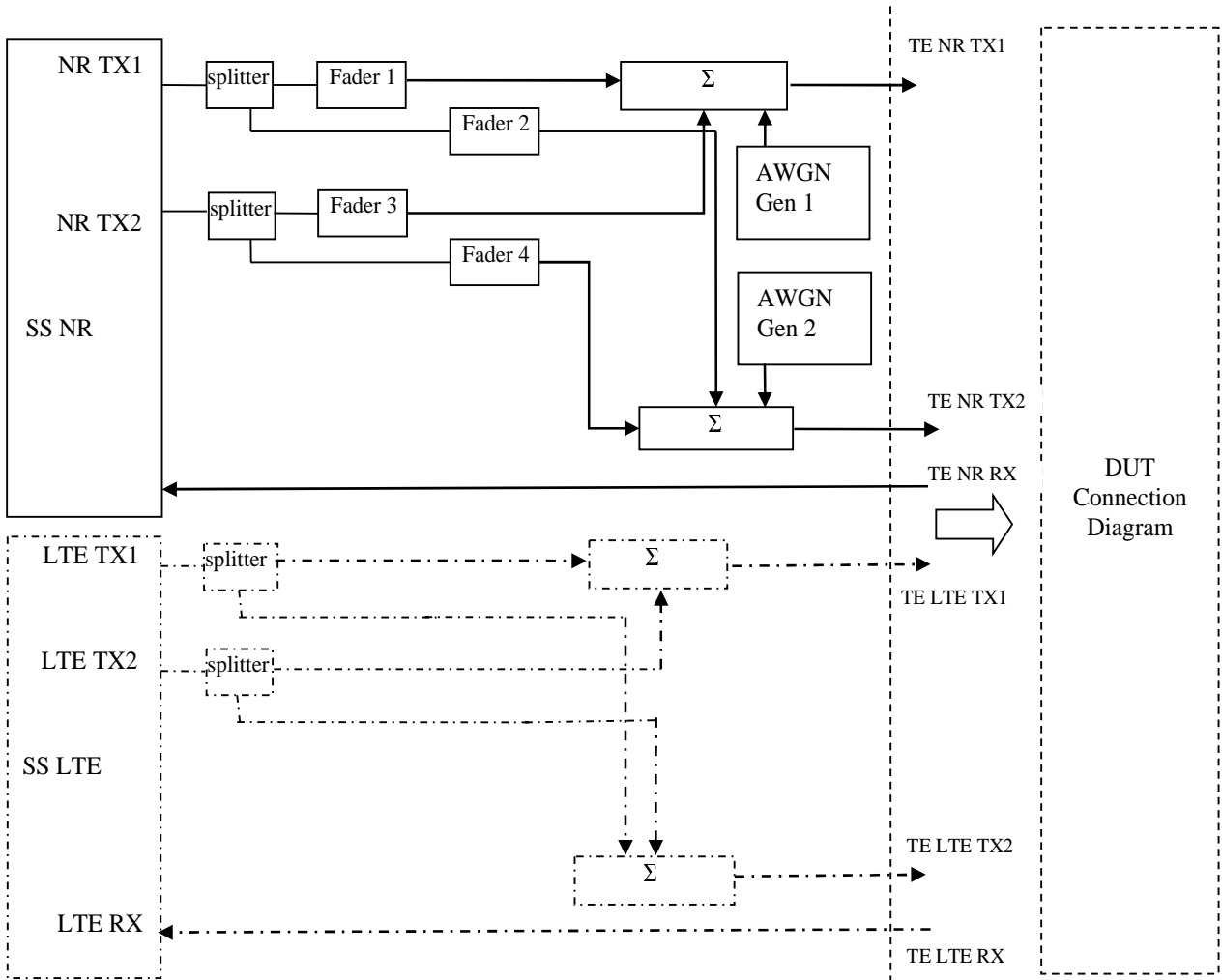


Figure A.3.1.7.1: Test Equipment connection for Demodulation Performance and CSI reporting tests with antenna configuration 2x2

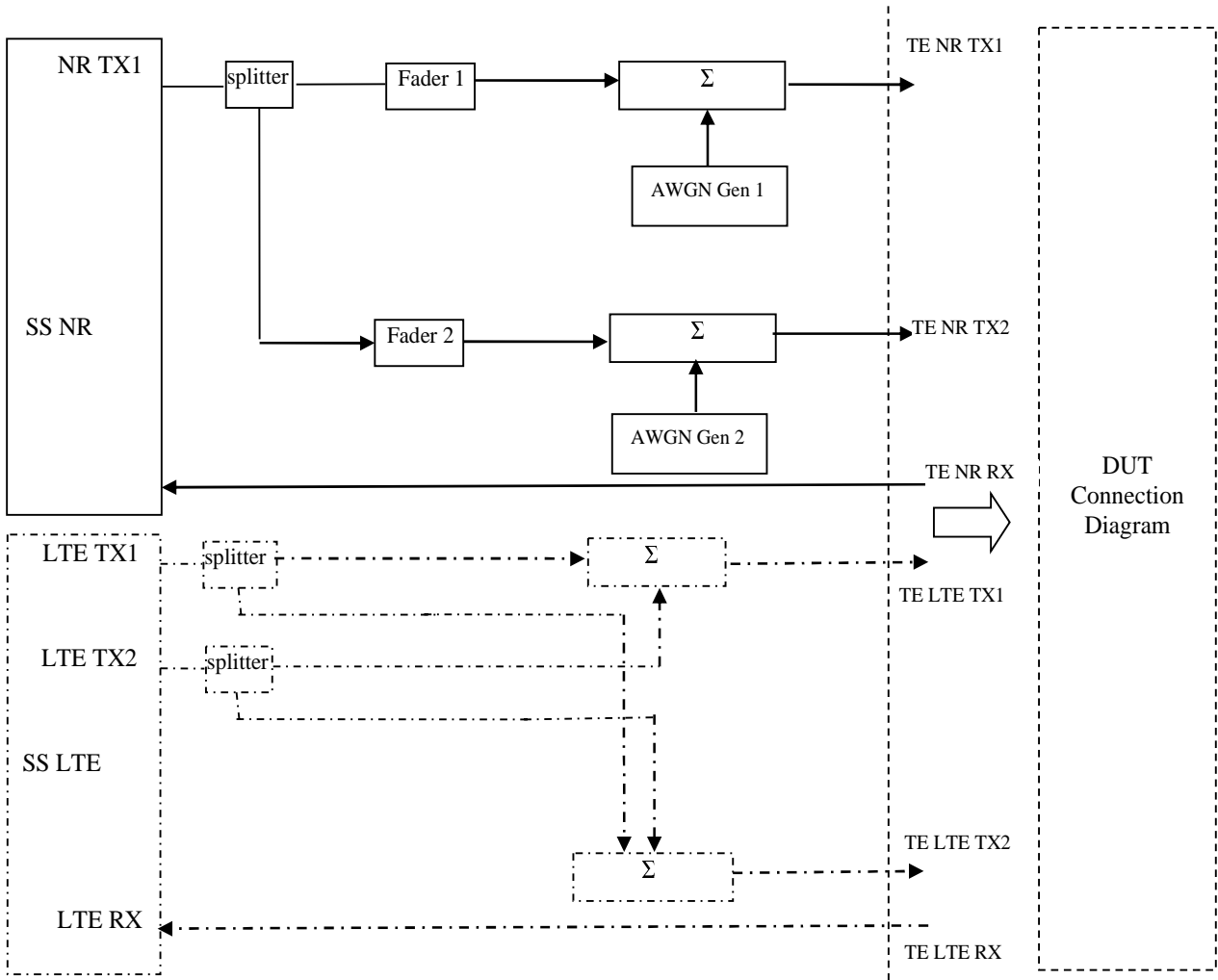
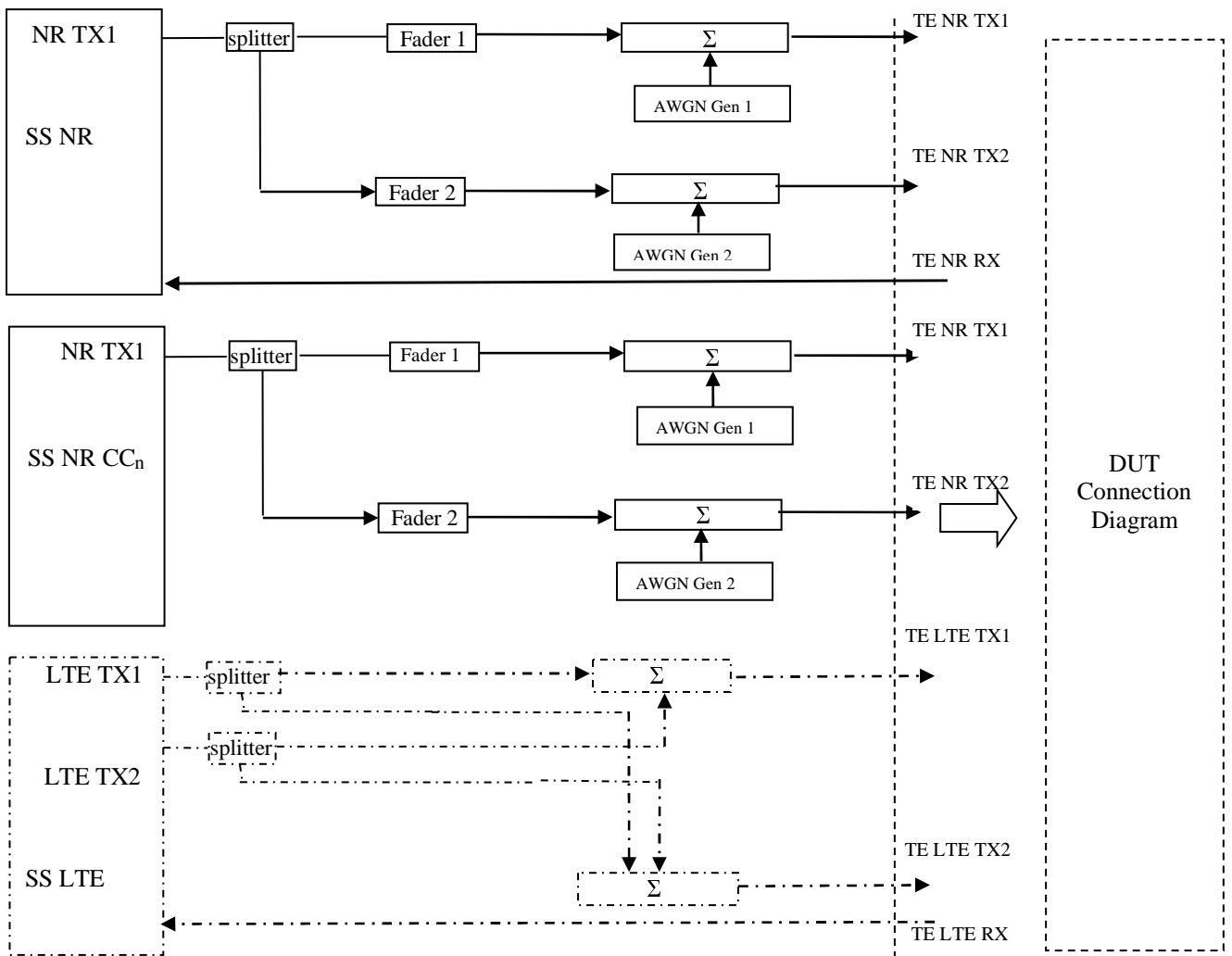
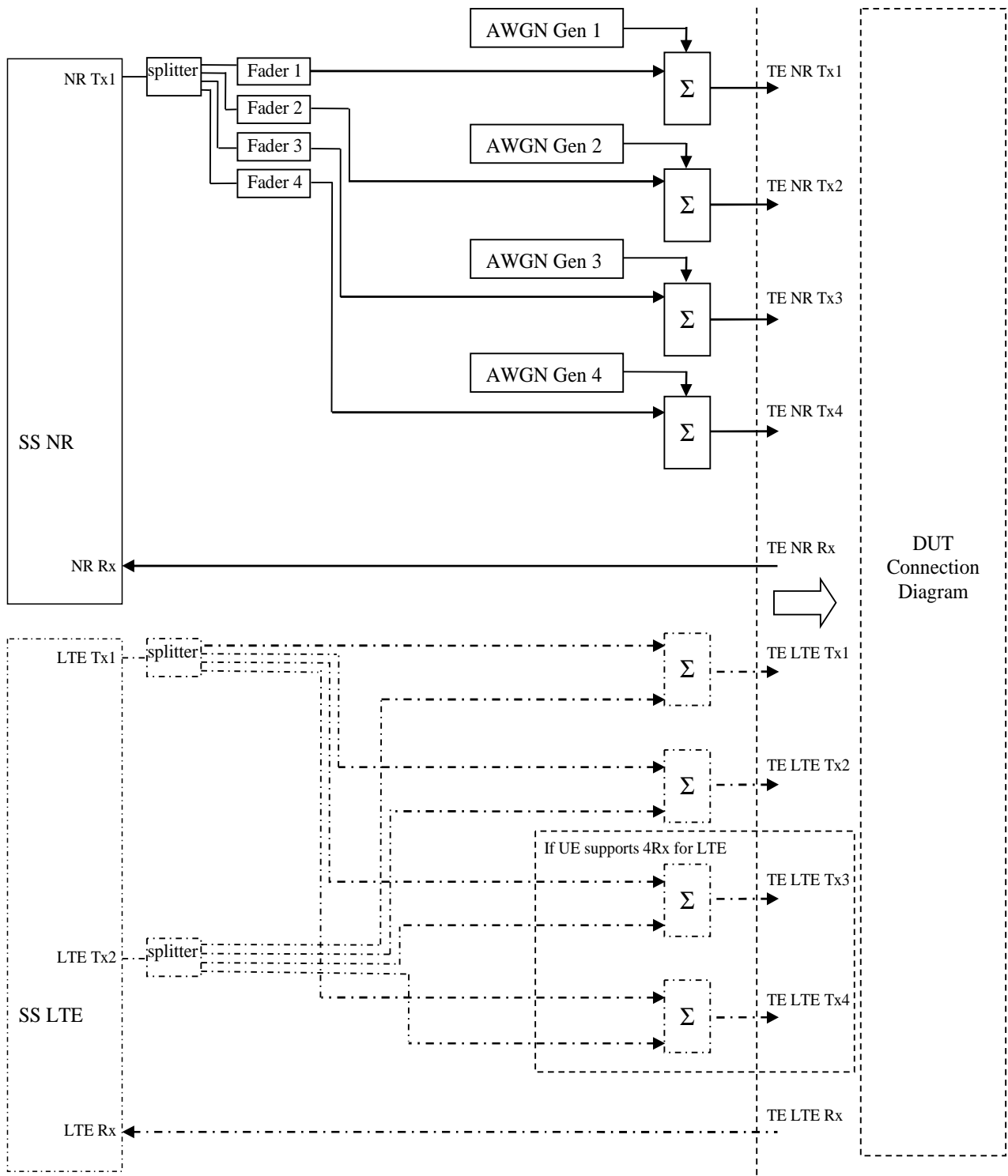


Figure A.3.1.7.2: Test Equipment connection for Demodulation Performance and CSI reporting tests with antenna configuration 1x2

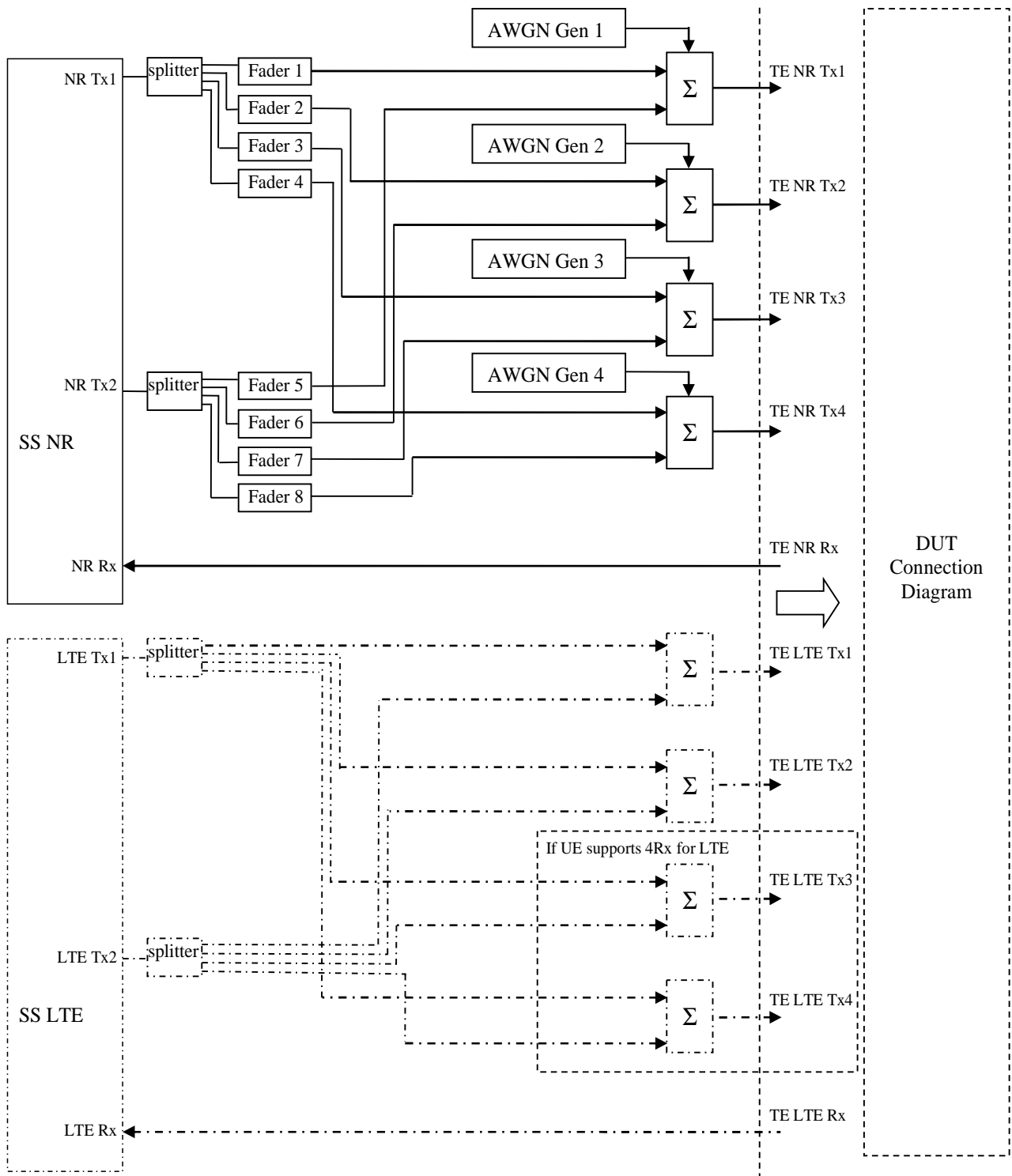


**Figure A.3.1.7.2A: Test Equipment connection for Demodulation Performance and CSI reporting tests with antenna configuration 1x2 for nDLCA**



**Figure A.3.1.7.3: Test Equipment connection for Demodulation Performance and CSI reporting tests with antenna configuration 1x4**

Note: LTE can be 2Rx or 4Rx and not dependent on NR #Rx

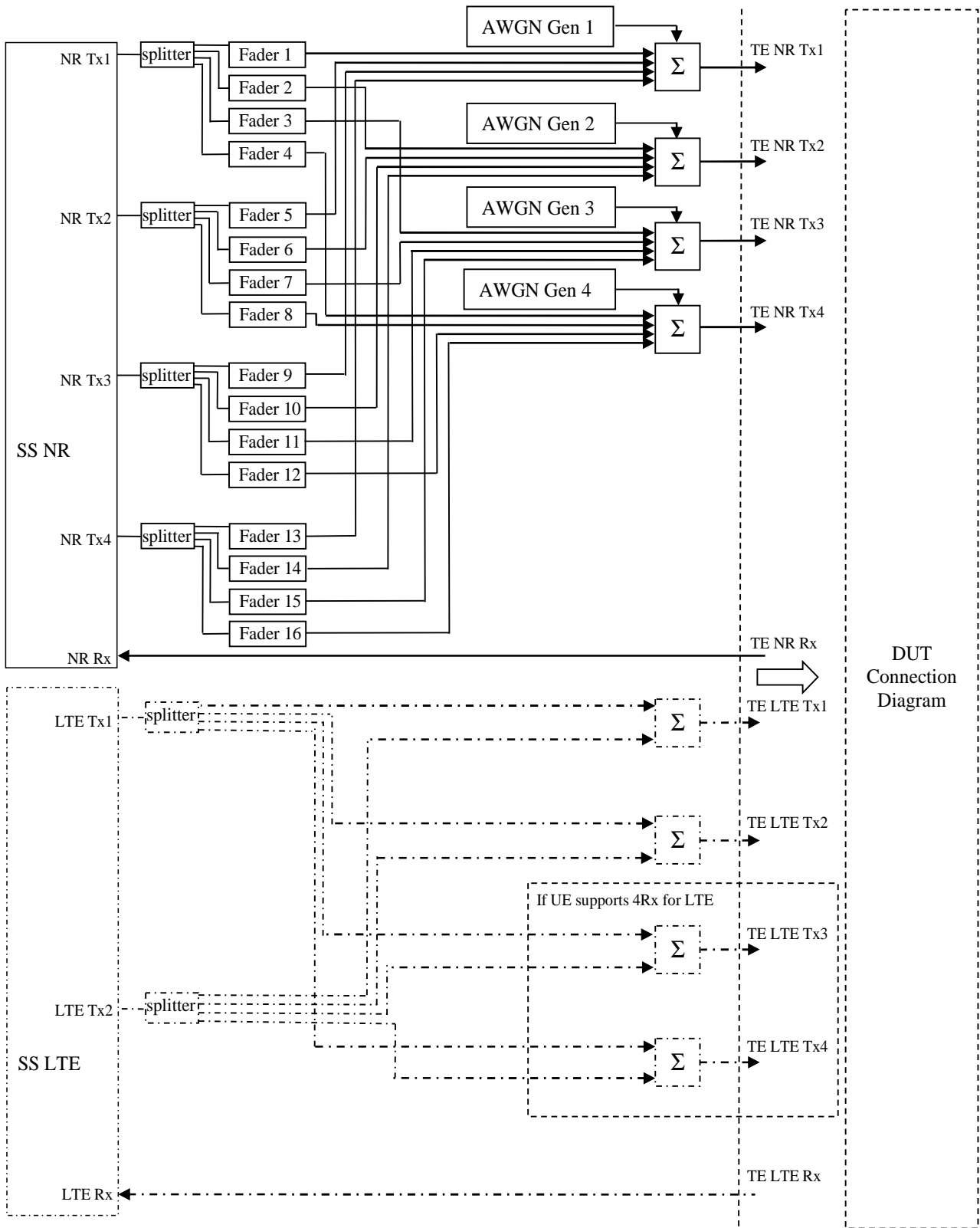


**Figure A.3.1.7.4: Test Equipment connection for Demodulation Performance and CSI reporting tests with antenna configuration 2x4**

Note 1: LTE can be 2Rx or 4Rx and not dependent on NR #Rx

Note 2: NR may be 2Rx on some of the CCs, in that case TE NR TX3 and TE NR TRX4 are not used

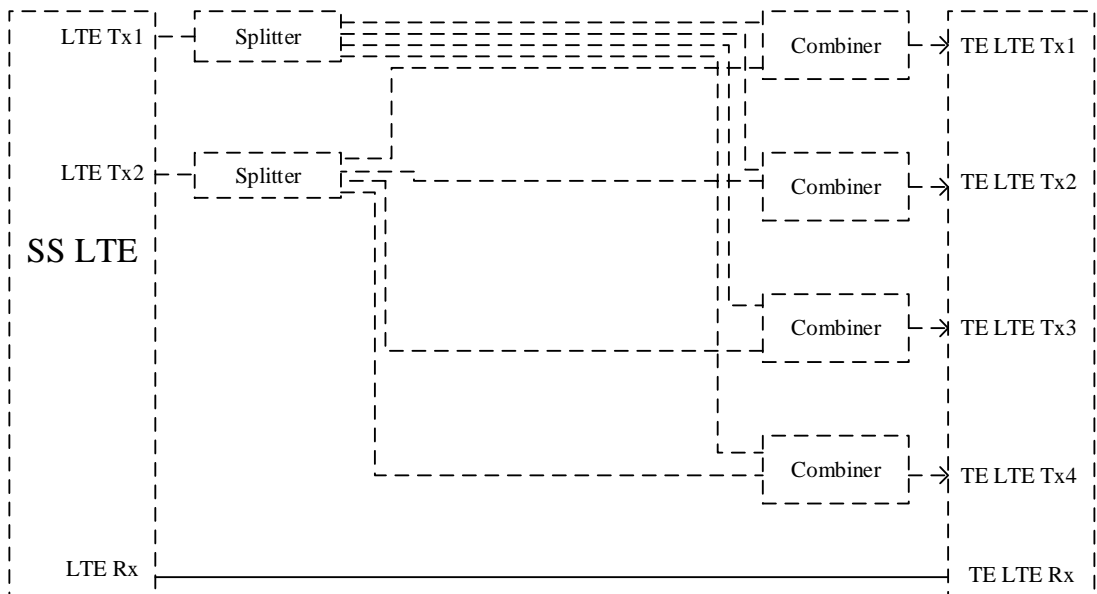
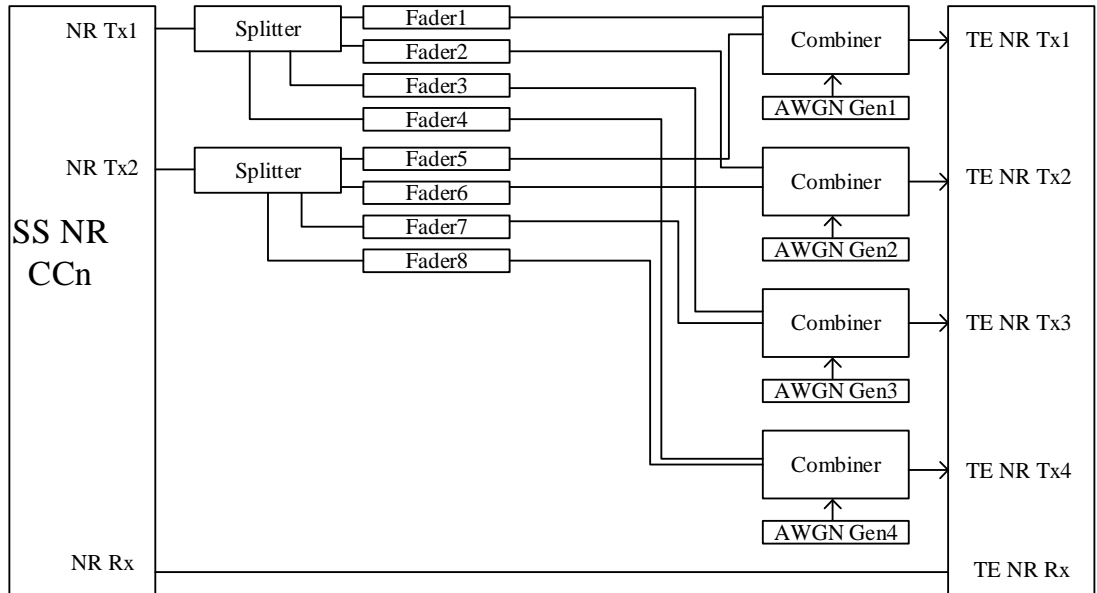
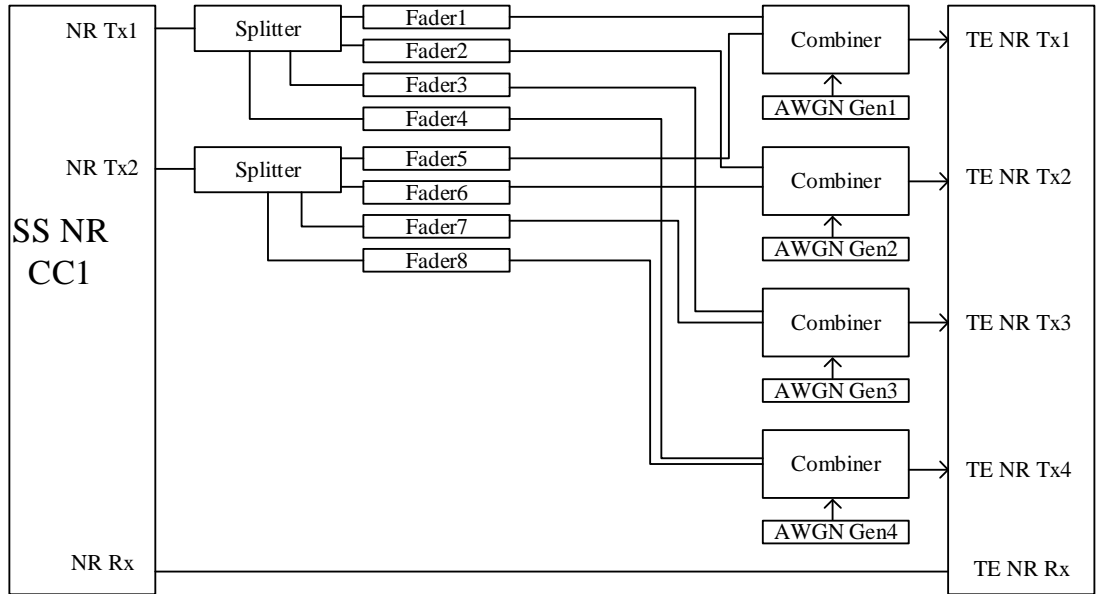




**Figure A.3.1.7.5: Test Equipment connection for Demodulation Performance and CSI reporting tests with antenna configuration 4x4**

Note 1: LTE can be 2Rx or 4Rx and not dependent on NR #Rx

Note: 2 NR may be 2Rx on some of the CCs, in that case TE NR TX3 and TE NR TX4 are not used

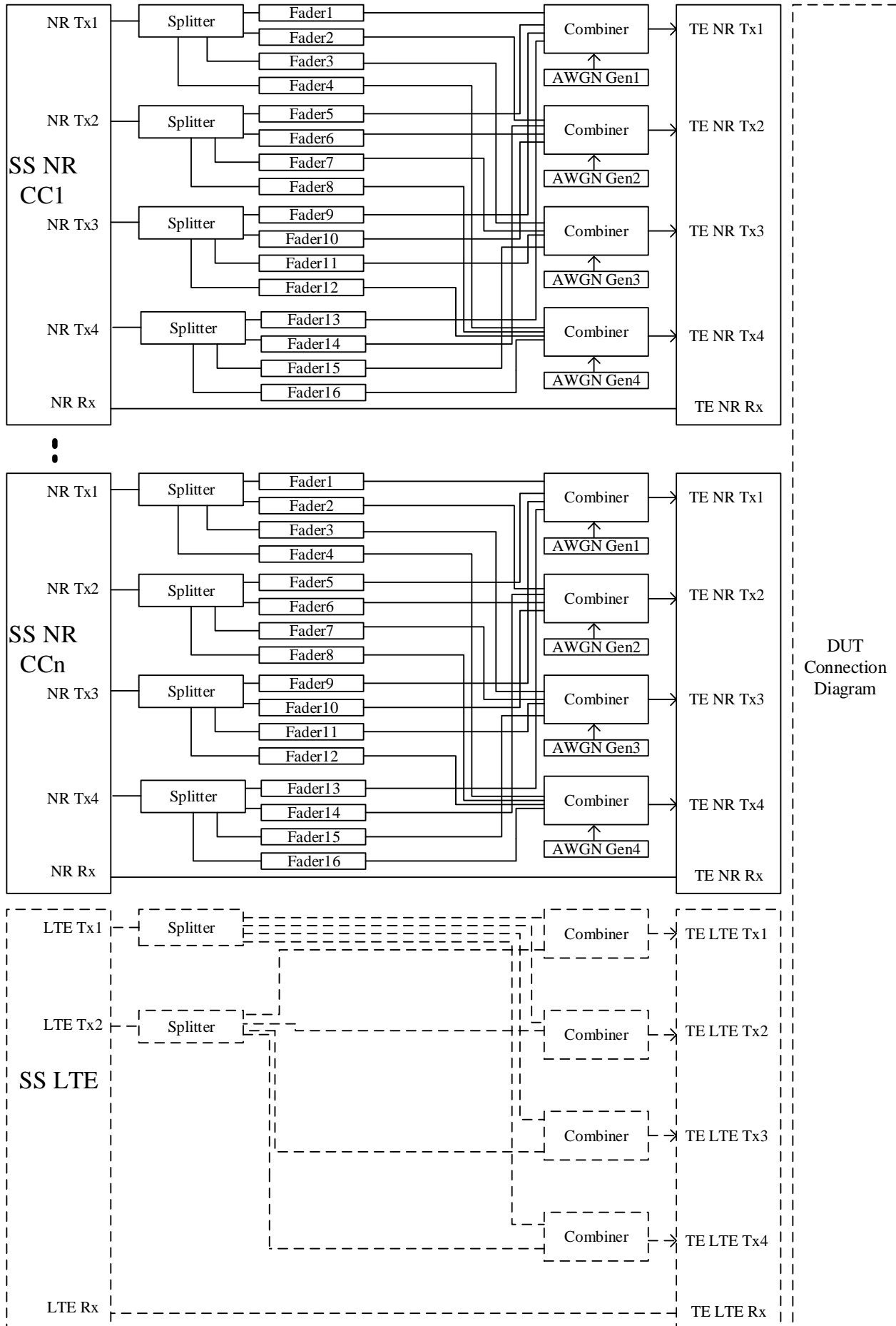


DUT Connection Diagram

**Figure A.3.1.7.6: Test Equipment connection for Demodulation Performance and CSI reporting tests with antenna configuration 2x4 for nDL CA**

Note 1: LTE can be 2Rx or 4Rx and not dependent on NR #Rx

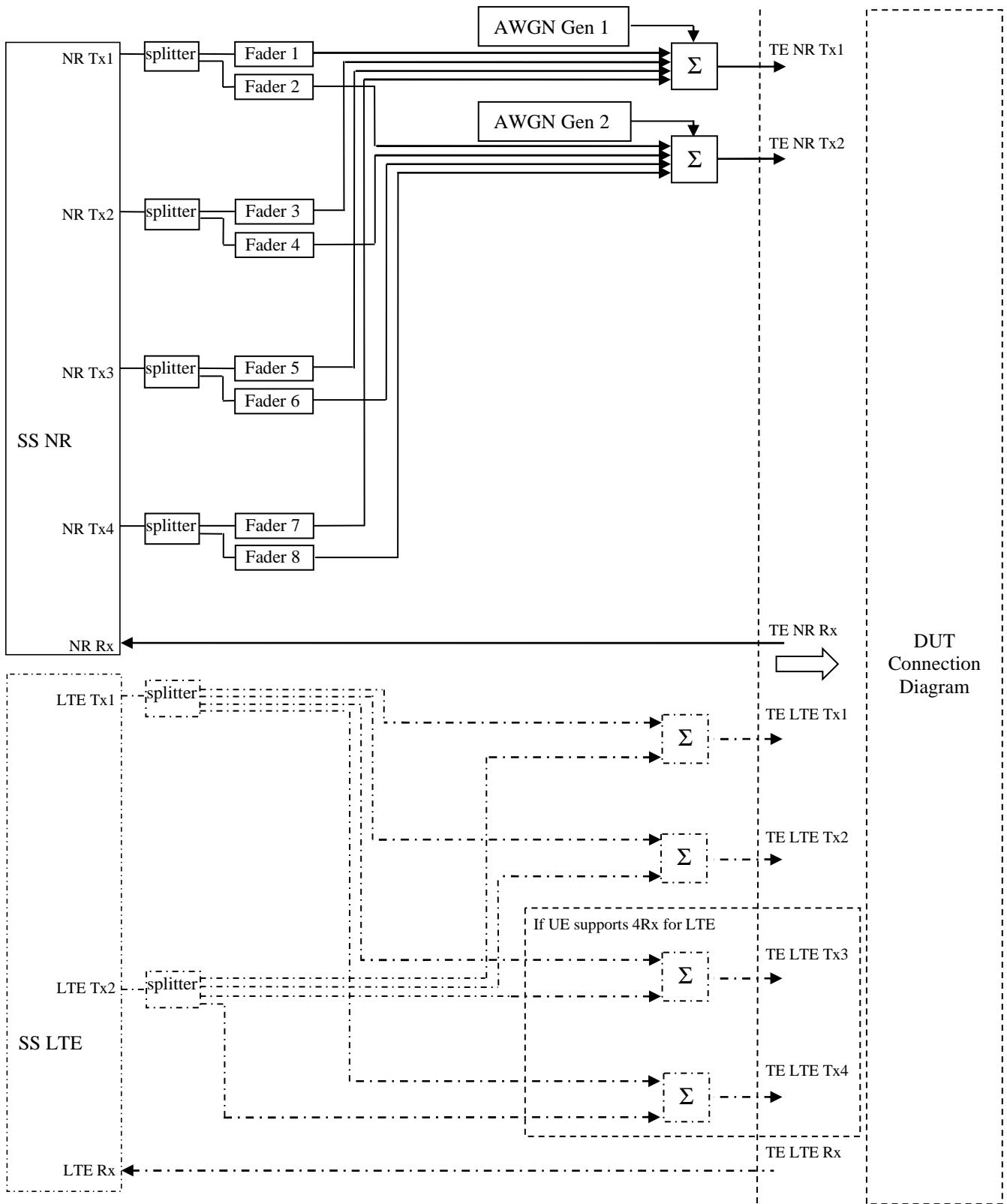
Note 2: NR may be 2Rx on some of the CCs, in that case TE NR TX3 and TE NR TX4 are not used



**Figure A.3.1.7.7: Test Equipment connection for Demodulation Performance and CSI reporting tests with antenna configuration 4x4 for nDL CA**

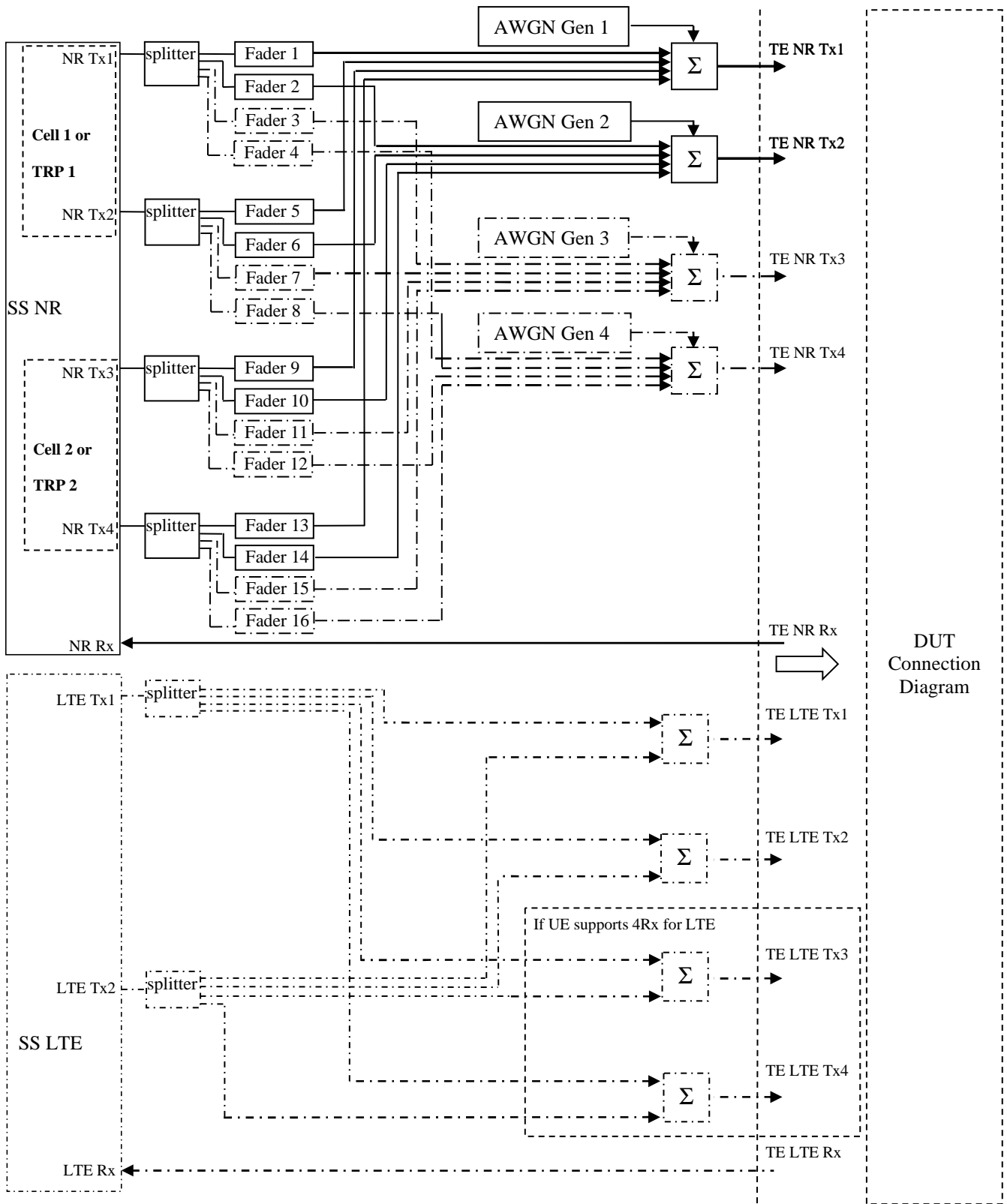
Note 1: LTE can be 2Rx or 4Rx and not dependent on NR #Rx

Note 2: NR may be 2Rx on some of the CCs, in that case TE NR TX3 and TE NR TX4 are not used



**Figure A.3.1.7.8: Test Equipment connection for Demodulation Performance and CSI reporting tests with antenna configuration 4x2**

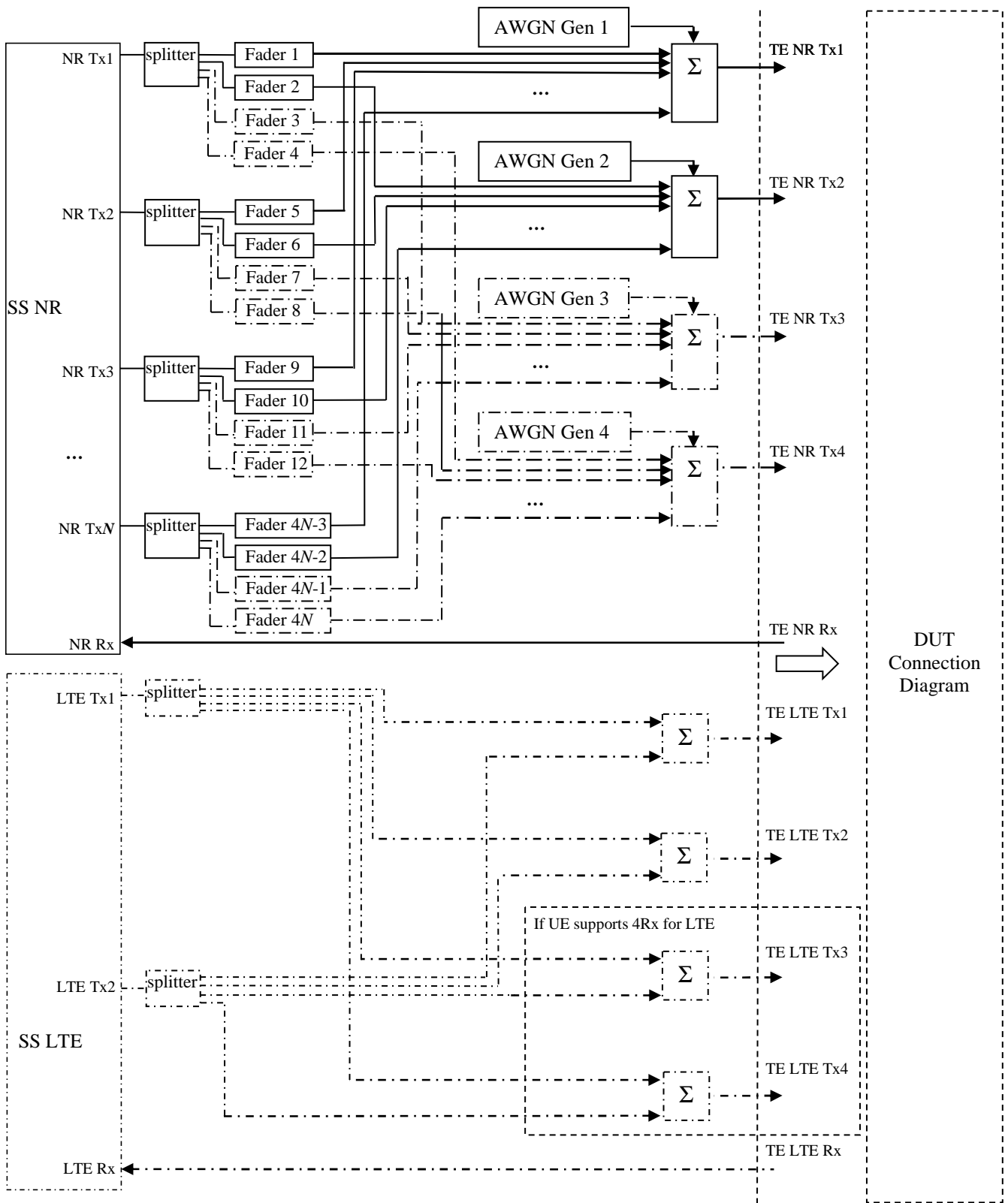
Note: LTE can be 2Rx or 4Rx and not dependent on NR #Rx



**Figure A.3.1.7.9: Test Equipment connection for Demodulation Performance and CSI reporting tests with 2 carriers or 2 TRPs (2x2 or 2x4)**

Note 1: LTE can be 2Rx or 4Rx and not dependent on NR #Rx

Note 2: NR may be 2Rx on some of the CCs, in that case TE NR TX3 and TE NR TX4 are not used



**Figure A.3.1.7.10: Test Equipment connection for Demodulation Performance and CSI reporting tests with antenna configuration Nx2 and Nx4, N=16 or N=32**

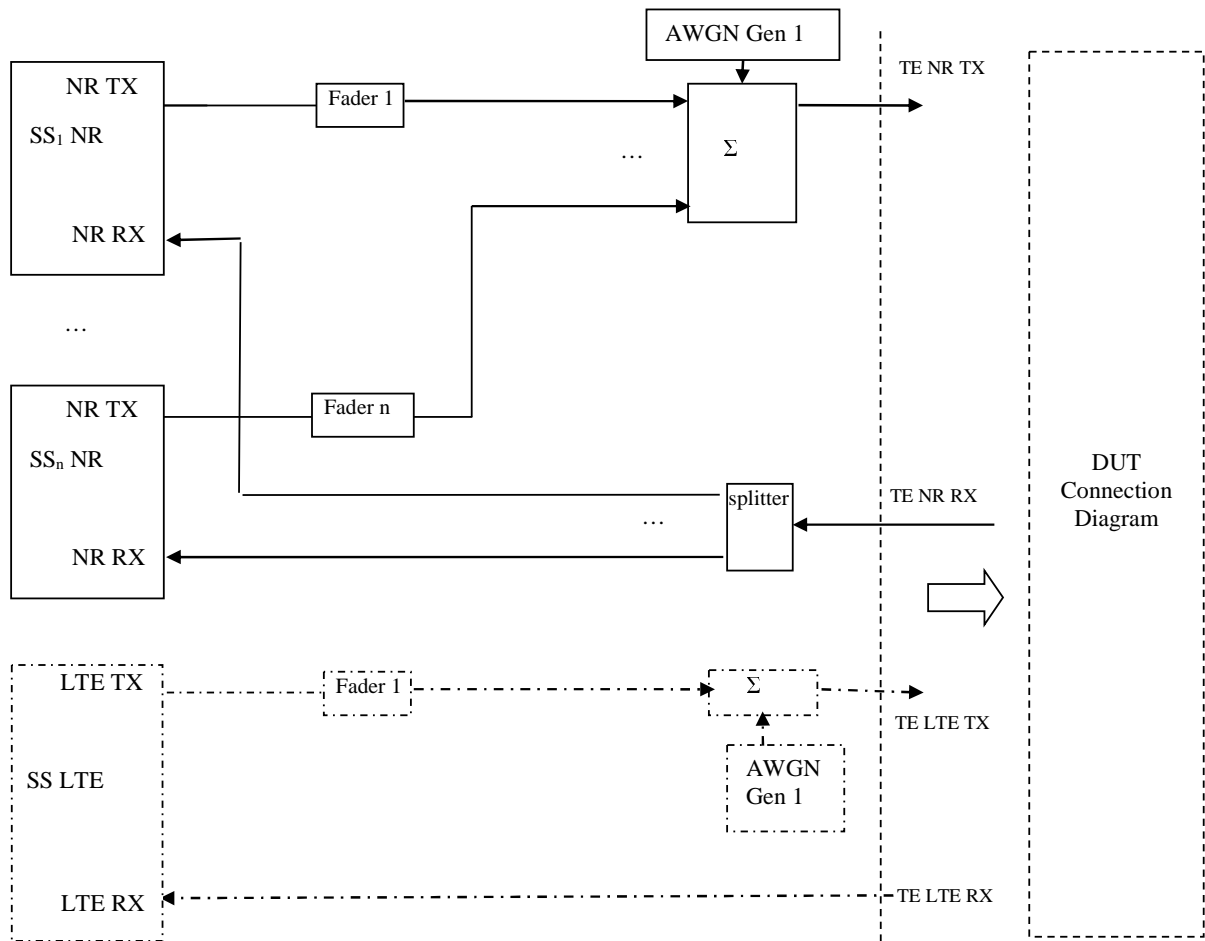
Note 1: LTE can be 2Rx or 4Rx and not dependent on NR #Rx

Note 2: NR may be 2Rx on some of the CCs, in that case TE NR TX3 and TE NR TX4 are not used

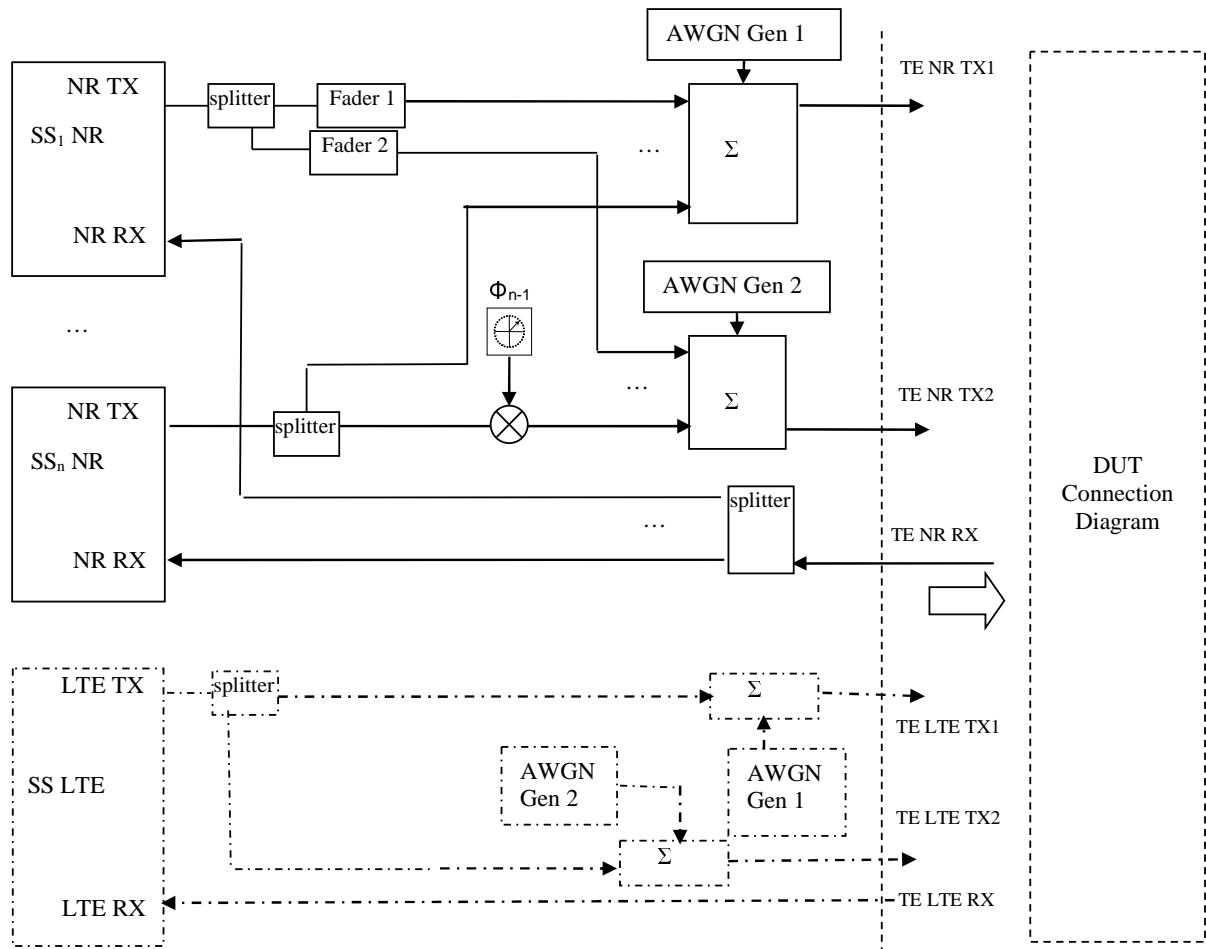


### A.3.1.8 RRM tests with more than one NR cell

The figures in this section represent connection diagrams for test cases with more than one NR cell. The parameters in the connection diagram, e.g. the number of cells  $n$  or the value of the phase rotator  $\varphi_i$  shall be defined by the test cases.



**Figure A.3.1.8.1: Test Equipment connection for tests with more than one NR cell and antenna configuration 1x1**



**Figure A.3.1.8.2: Test Equipment connection for tests with more than one NR cell and antenna configuration 1x2**

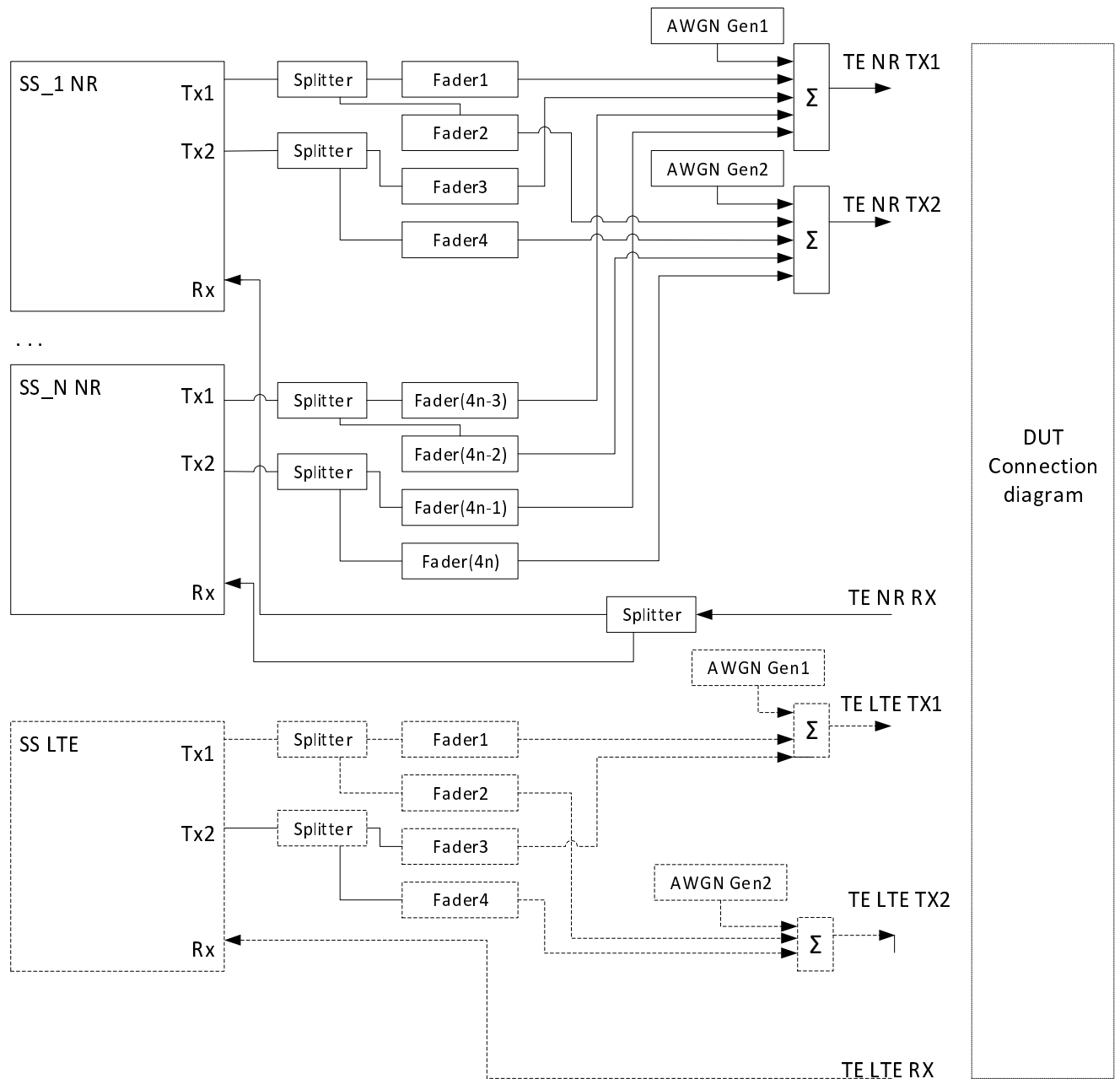
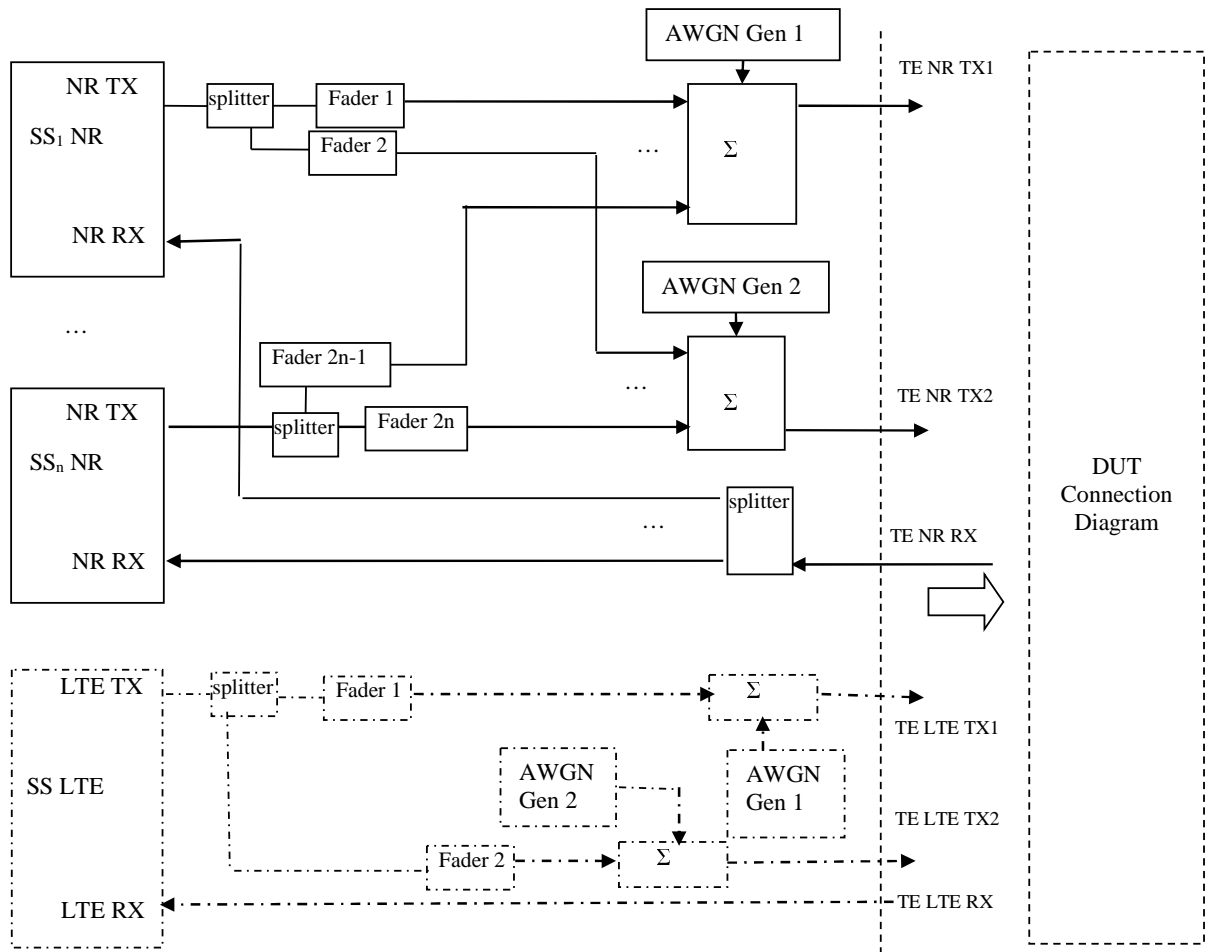


Figure A.3.1.8.2a: Test Equipment connection for tests with more than one NR cell and antenna configuration 2x2



**Figure A.3.1.8.3: Test Equipment connection for tests with more than one NR cell and antenna configuration 1x2 and fading**

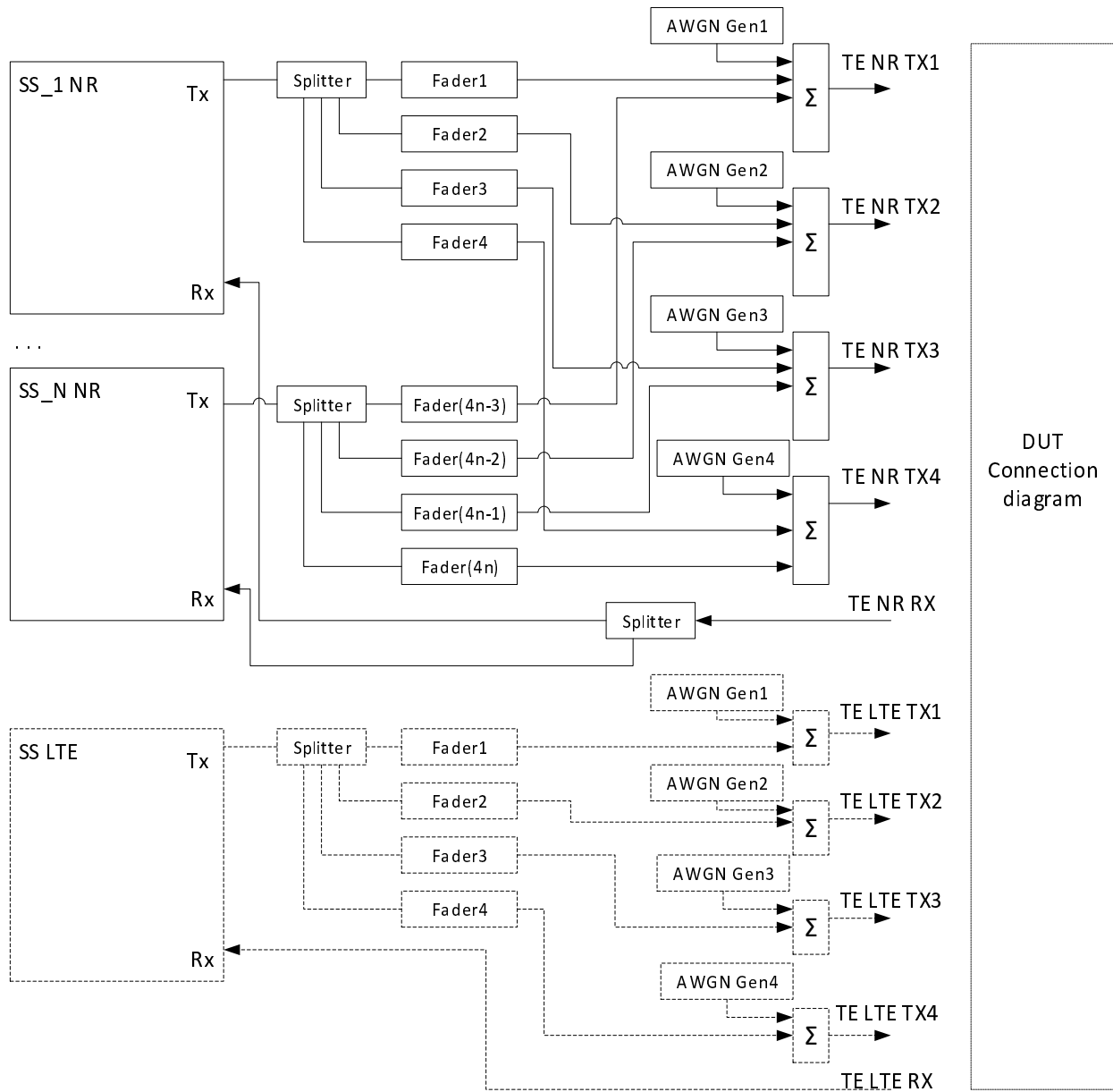


Figure A.3.1.8.4: Test Equipment connection for tests with more than one NR cell for 4Rx capable UEs with fading

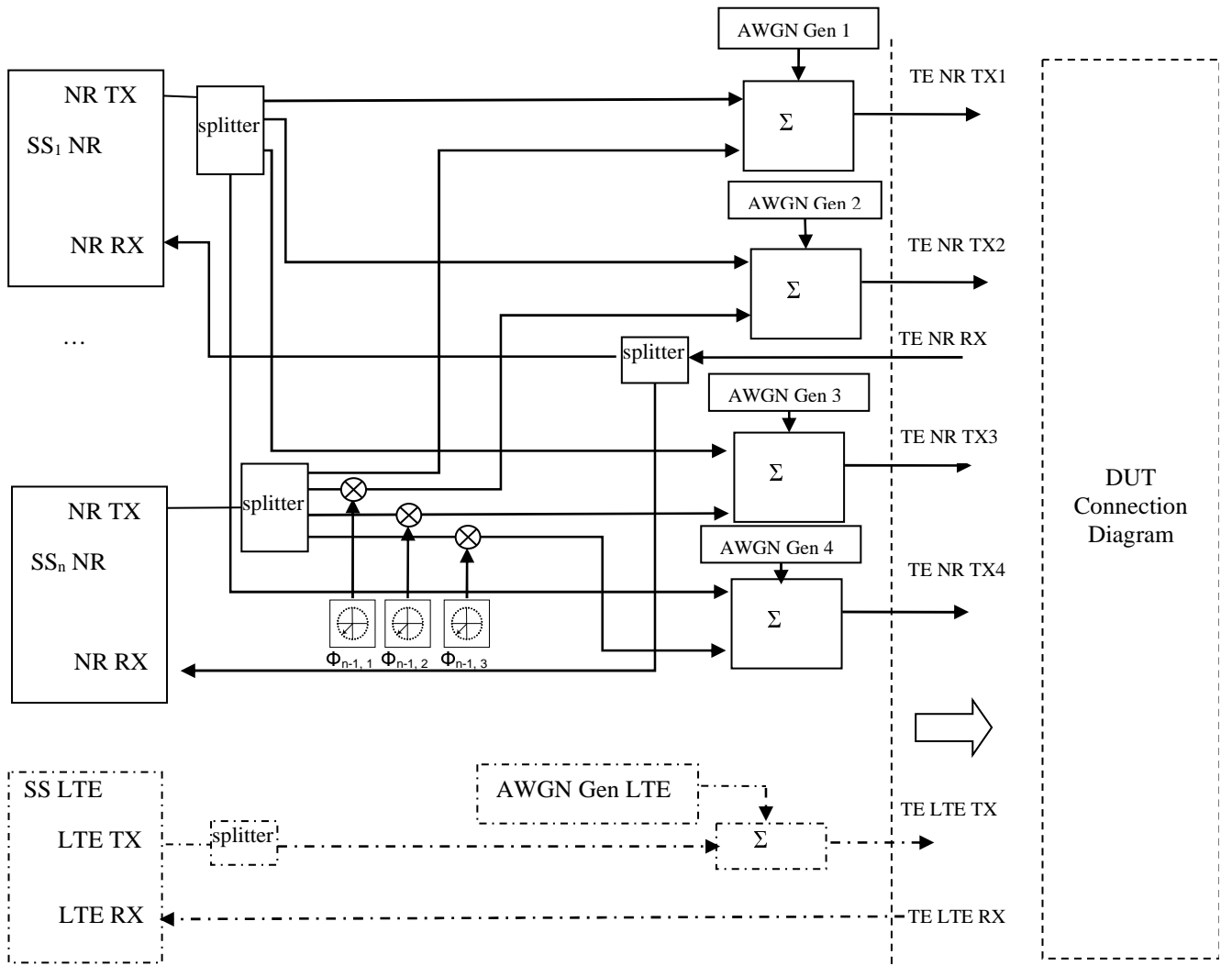
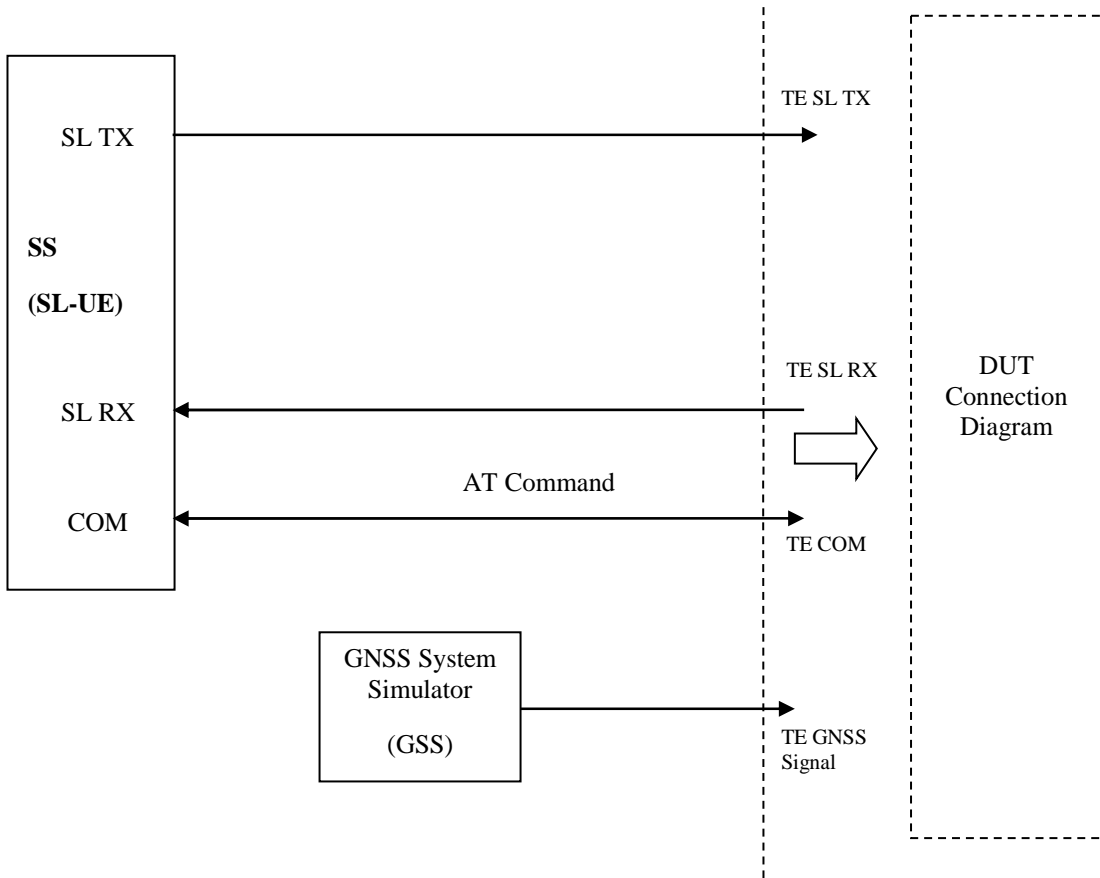


Figure A.3.1.8.5: Test Equipment connection for tests with more than one NR cell and antenna configuration 1x4

### A.3.1.9 Test Equipment supporting NR Sidelink



**Figure A.3.1.9.1: Test Equipment connection for NR sidelink operation non-concurrent with NR UL/DL transmission**

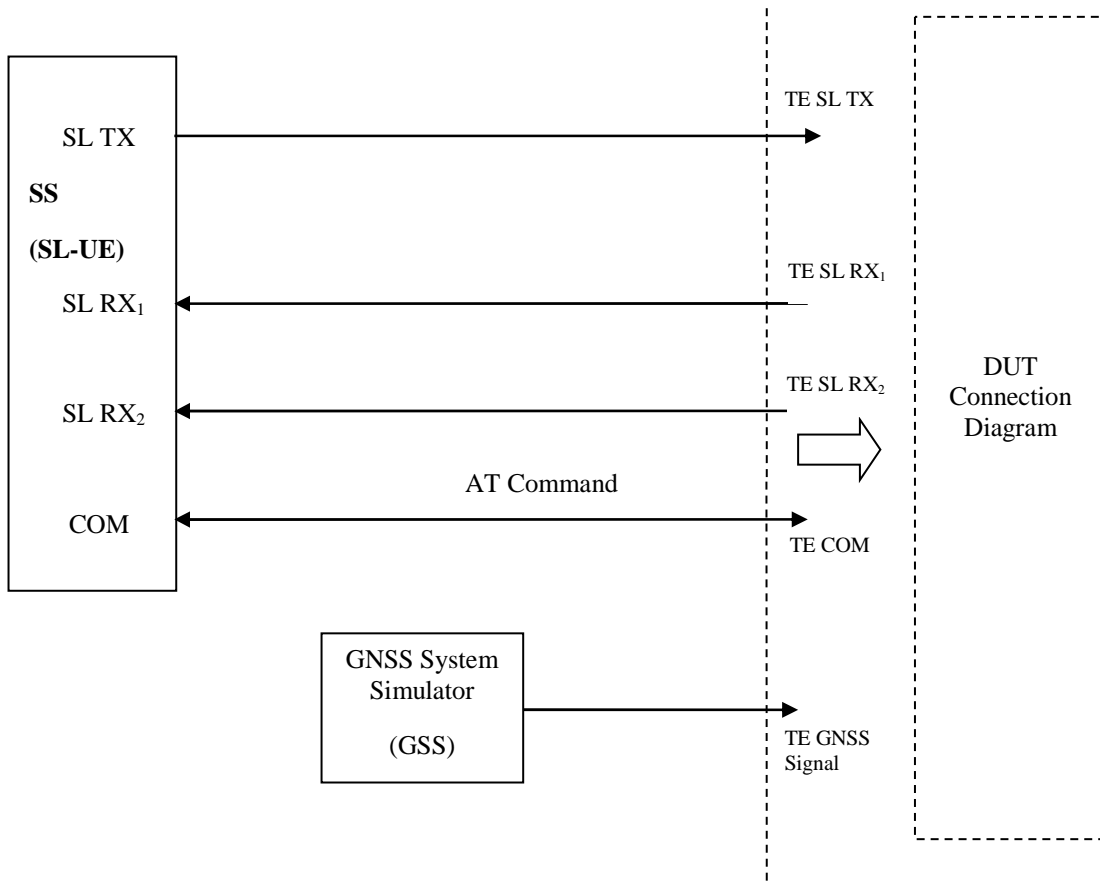


Figure A.3.1.9.2: Test Equipment connection for NR sidelink operation non-concurrent with NR UL/DL transmission SL-MIMO



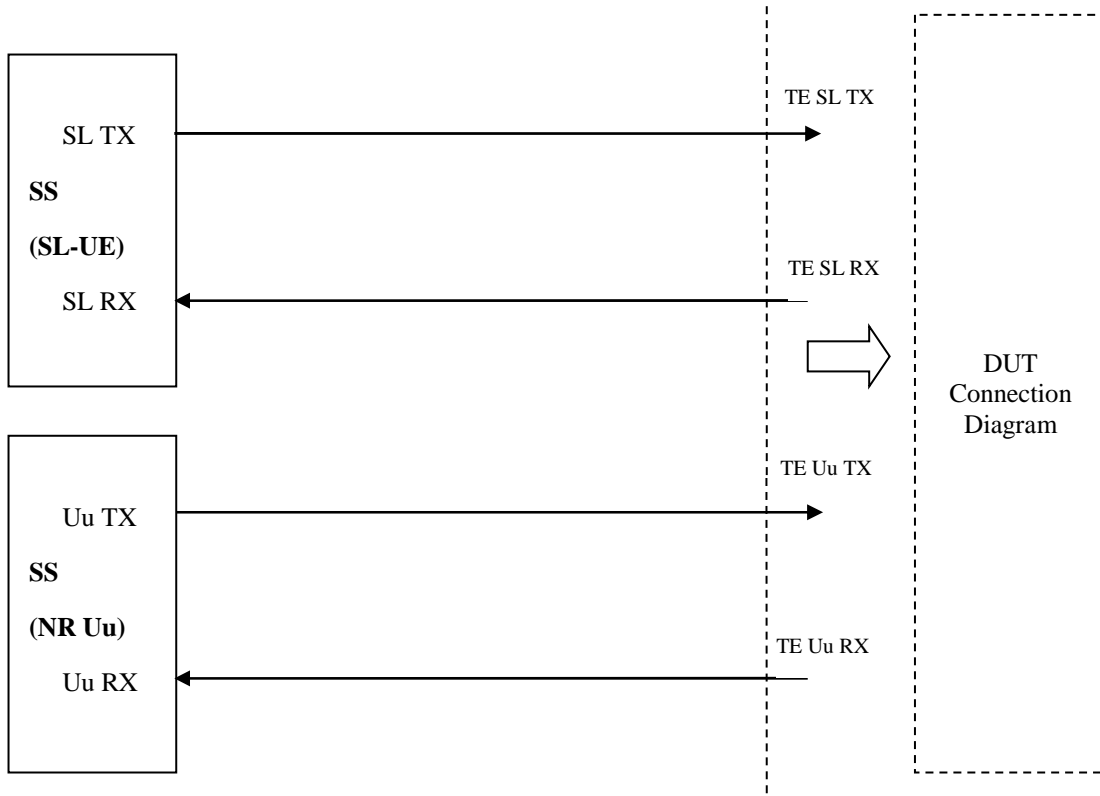


Figure A.3.1.9.3: Test Equipment connection for inter-band concurrent NR V2X operation

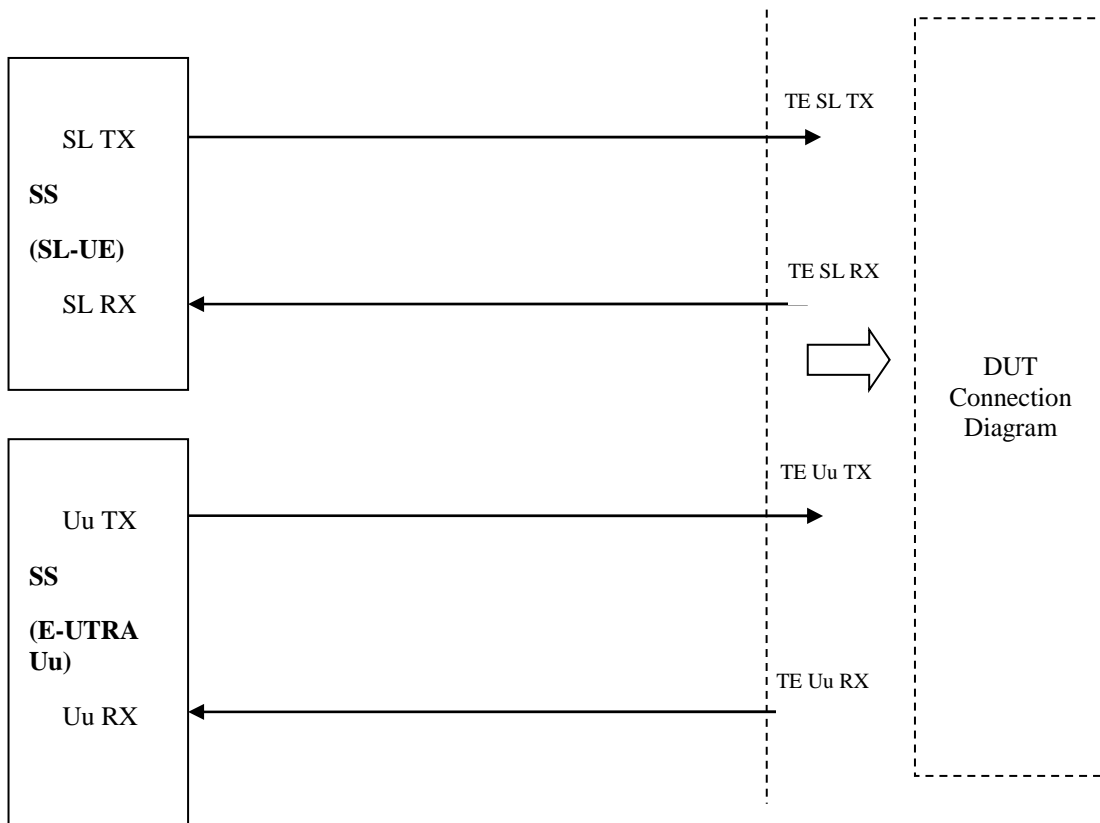
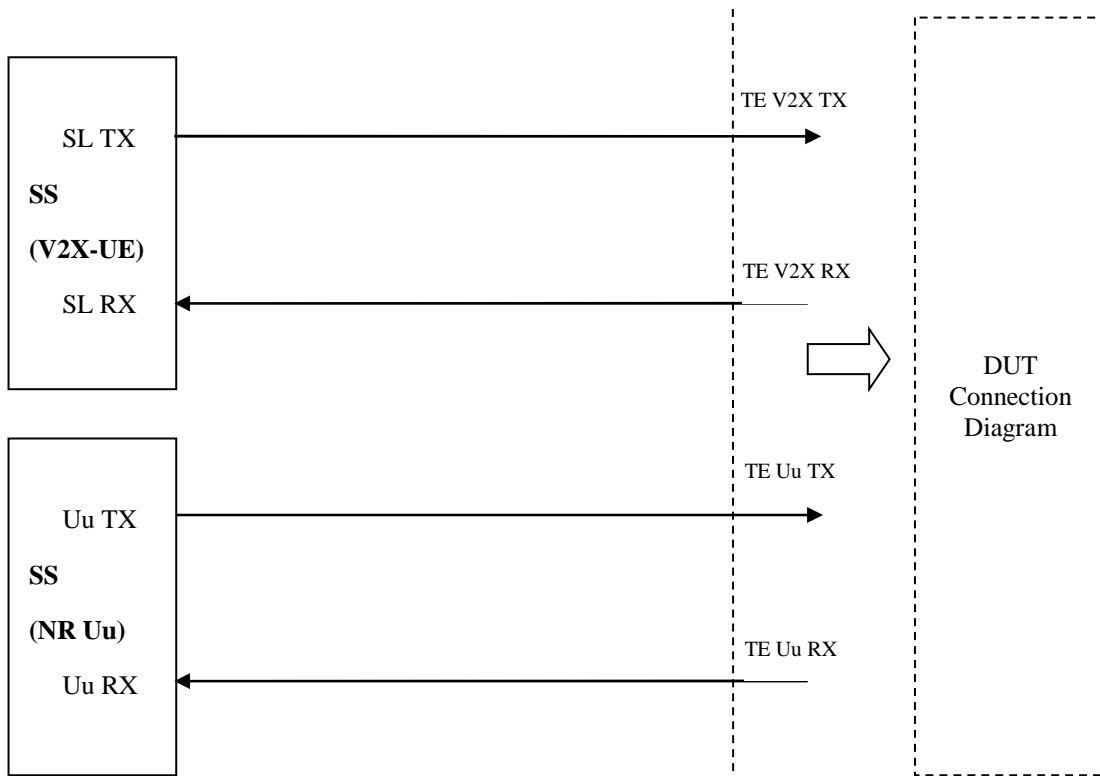


Figure A.3.1.9.4: Test Equipment connection for concurrent E-UTRA Uu and NR Sidelink operation



**Figure A.3.1.9.5: Test Equipment connection for con-current E-UTRA V2X sidelink and NR Uu operation**

## A.3.2 User Equipment Parts for Conducted Measurements

### A.3.2.1 General

The User Equipment part is focused on the number of physical antenna connectors and how to combine in the DUT. Depending on the DUT implementation only one of the following connection diagrams applies. These connection diagrams are examples of User equipment parts.

### A.3.2.2 One Antenna Connector

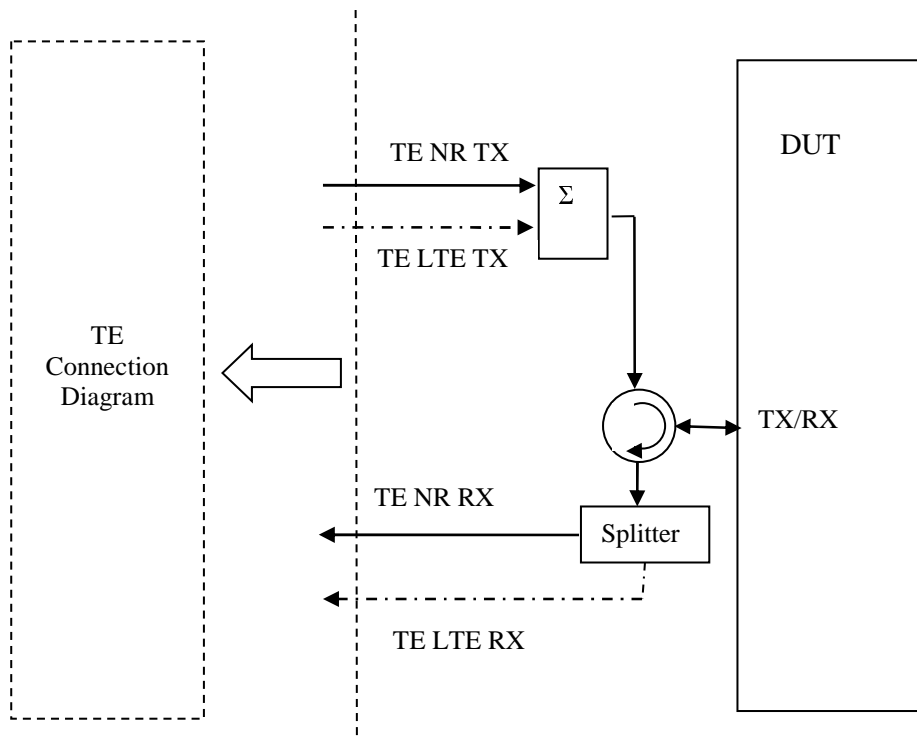


Figure A.3.2.2.1: User Equipment connection for single basic cell

### A.3.2.3 Two Antenna Connectors

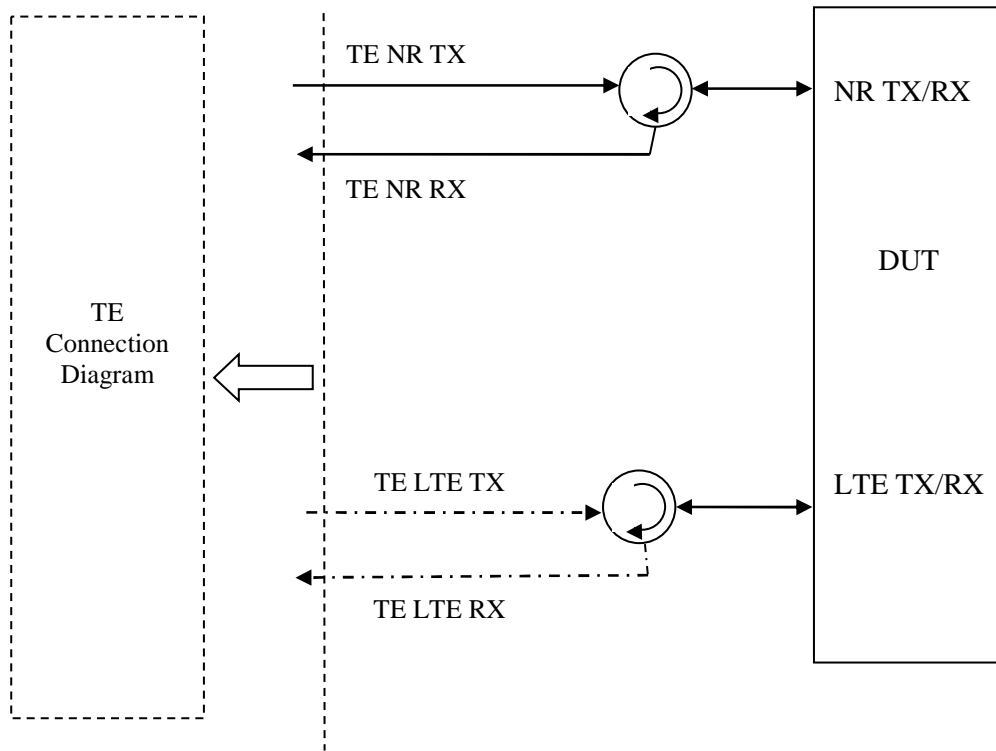
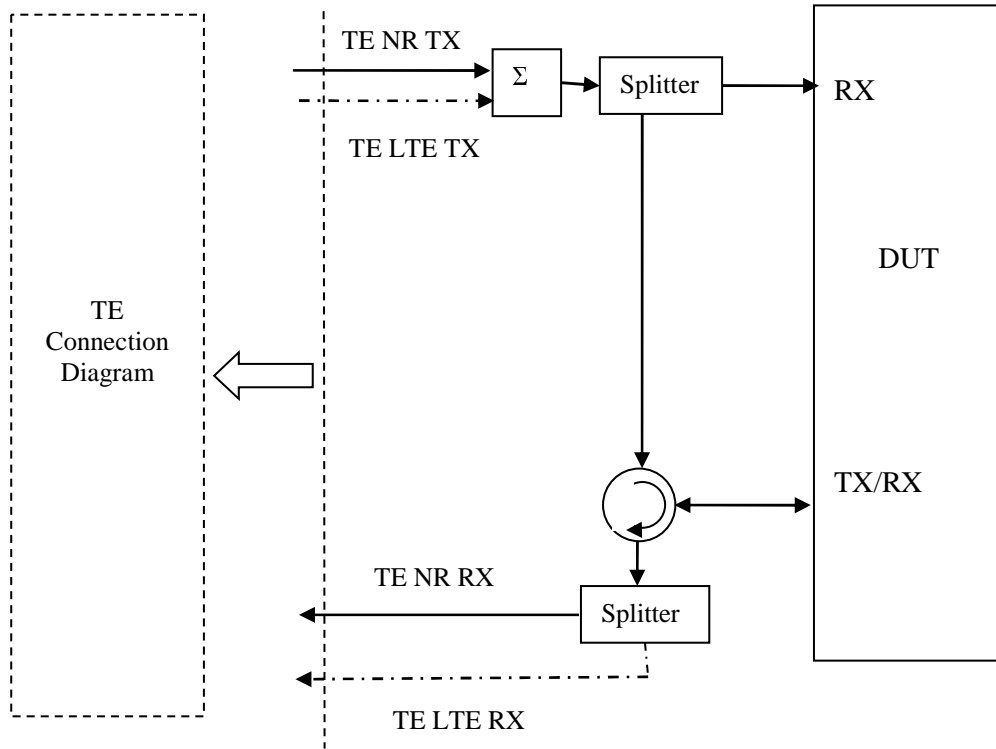
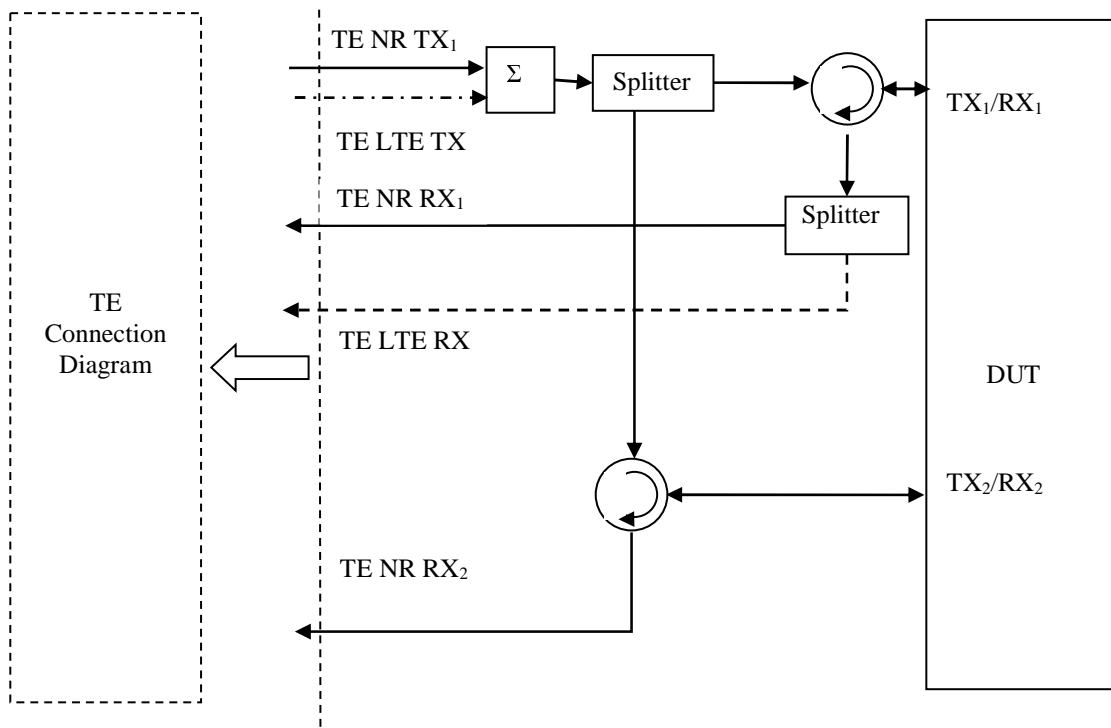


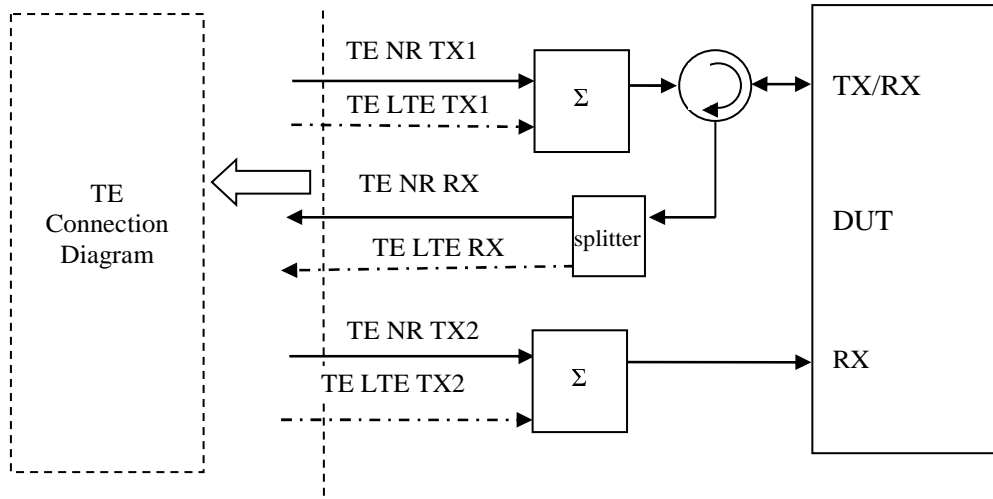
Figure A.3.2.3.1: User Equipment connection for single basic cell with NR and LTE cells at different separated connectors



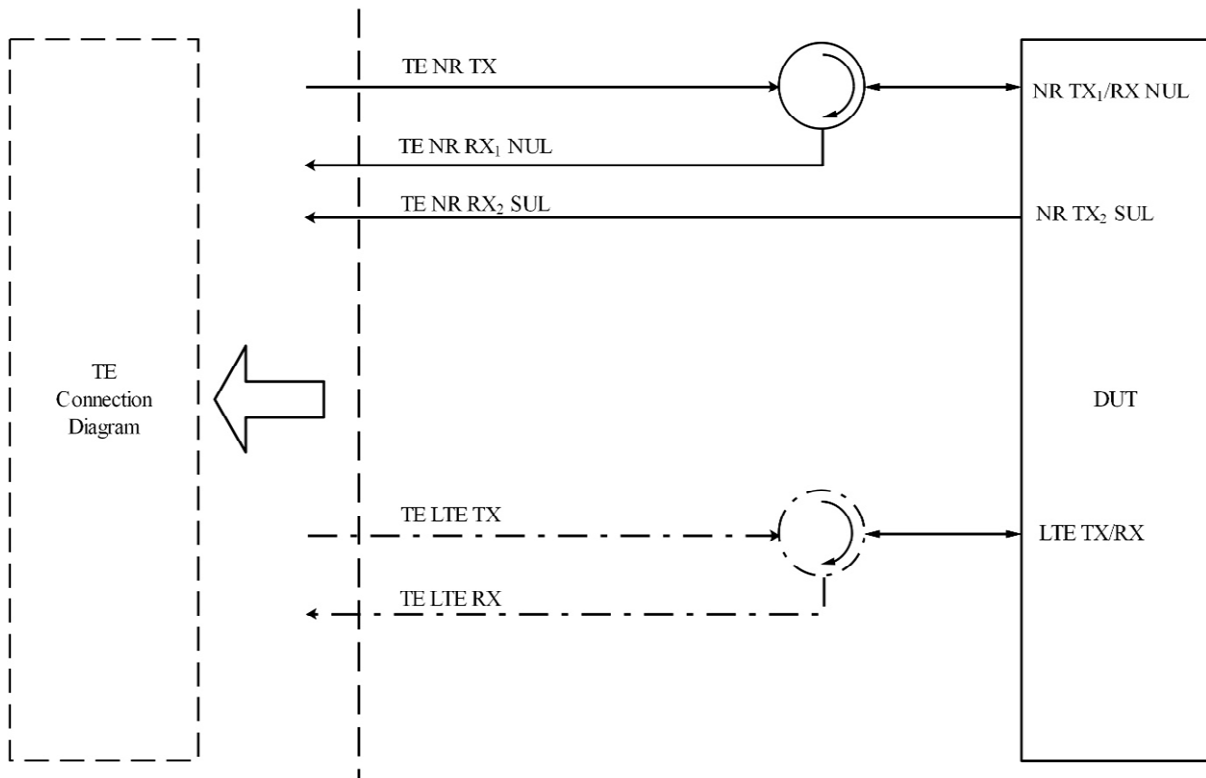
**Figure A.3.2.3.2: User Equipment connection for single basic cell with NR and LTE cells at the same connectors for both cells**



**Figure A.3.2.3.3: 2 Tx User Equipment connection for single basic cell with NR and LTE cells at the same connectors for both cells and 2TX UL MIMO or Tx diversity supported**



**Figure A.3.2.3.4: User Equipment connection for UEs with NR and LTE RxTx and Rx antenna at same connectors**



**Figure A.3.2.3.5: User Equipment connection for single basic cell with NR and LTE cells at different separated connectors with NR SUL and NR NUL transmitted on separate antenna connectors**

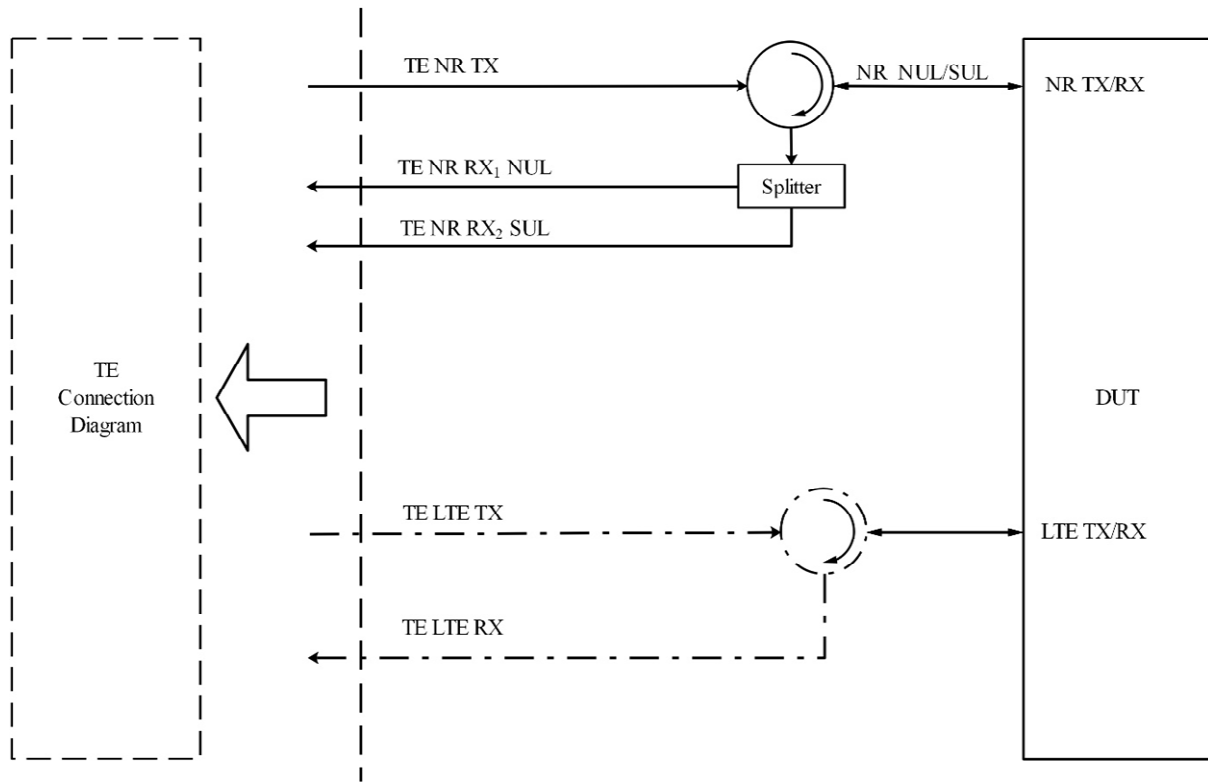


Figure A.3.2.3.6: User Equipment connection for single basic cell with NR and LTE cells at different separated connectors with NR SUL and NR NUL transmitted on the same antenna connector

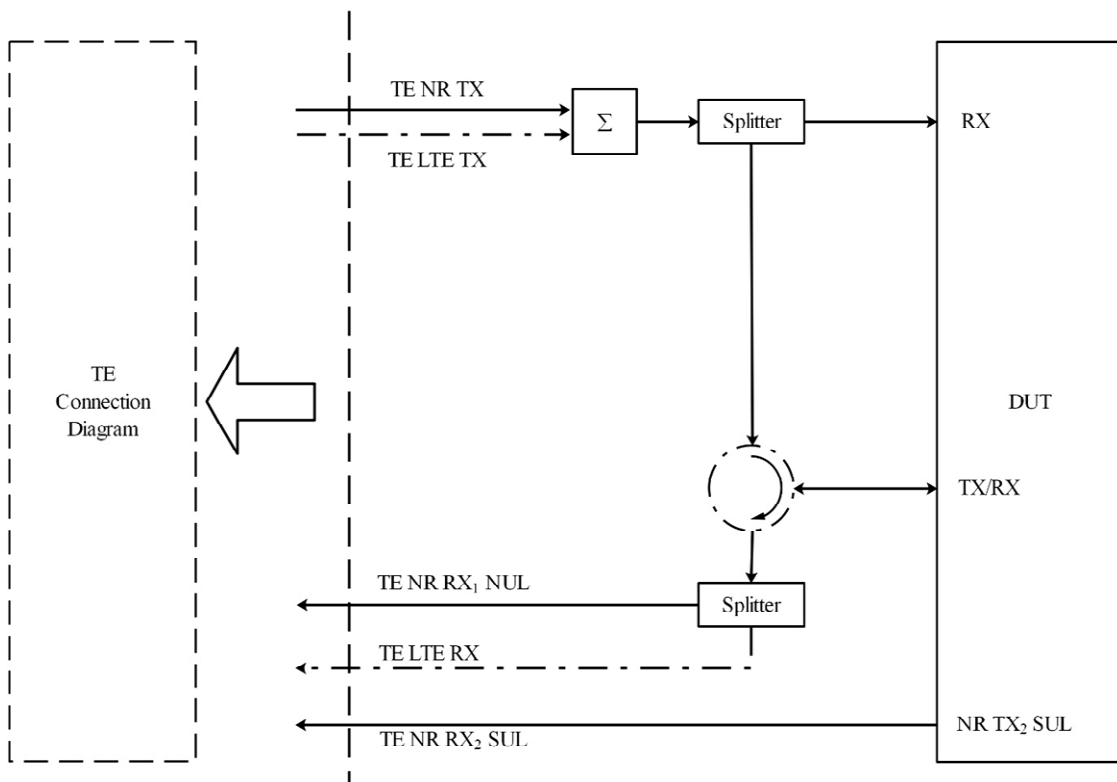
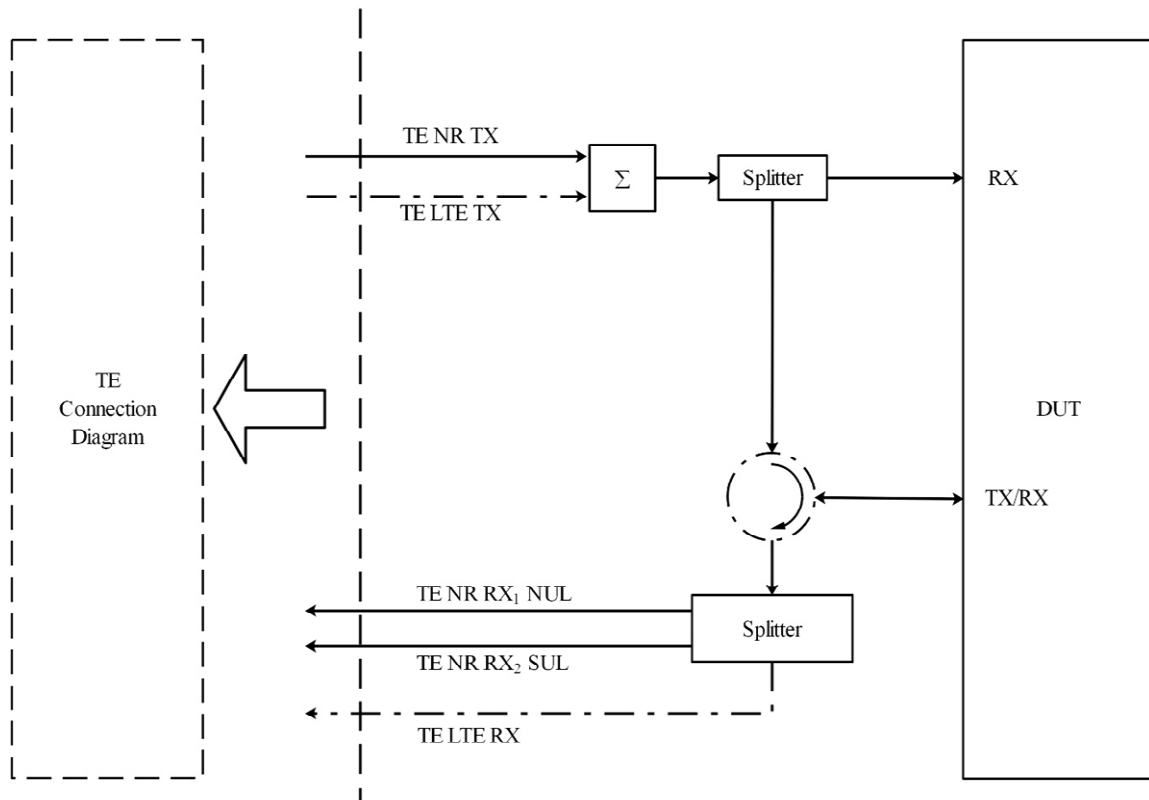


Figure A.3.2.3.7: User Equipment connection for single basic cell with NR and LTE cells at the same connectors for both cells with NR SUL and NR NUL transmitted on separate antenna connectors



**Figure A.3.2.3.8: User Equipment connection for single basic cell with NR and LTE cells at the same connectors for both cells with NR SUL and NR NUL transmitted on the same antenna connector**



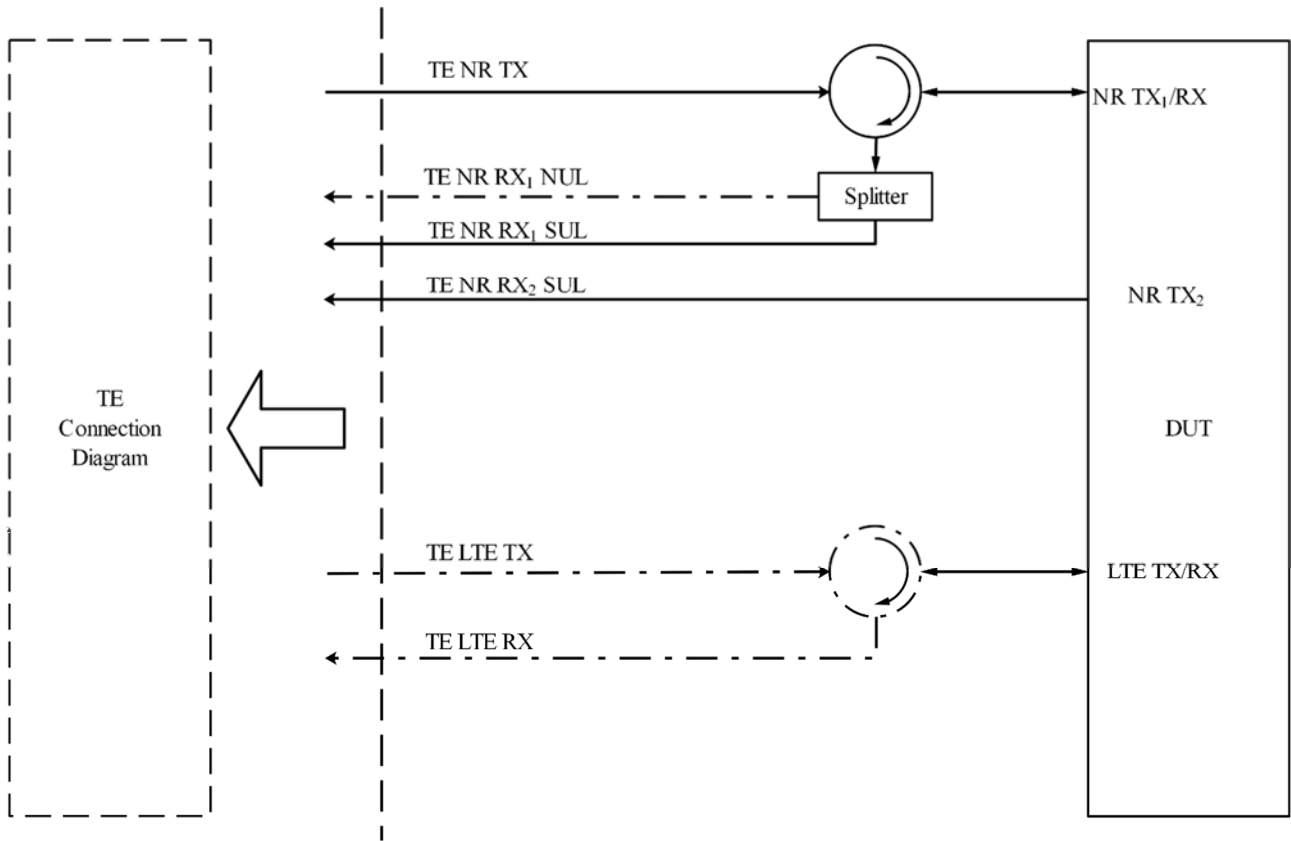


Figure A.3.2.3.9: User Equipment connection for single basic cell with NR and LTE cells at different separated connectors with UE supporting UL MIMO on SUL band

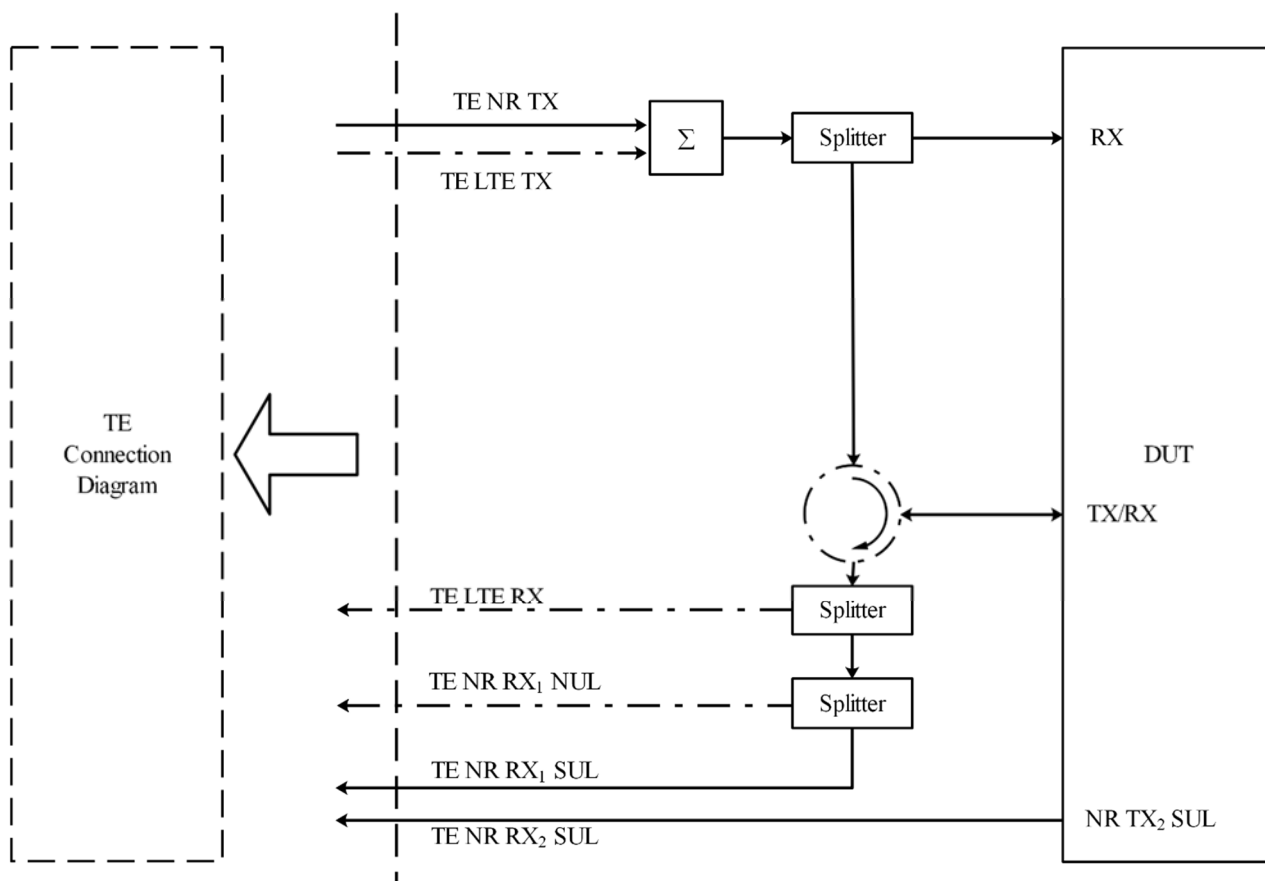
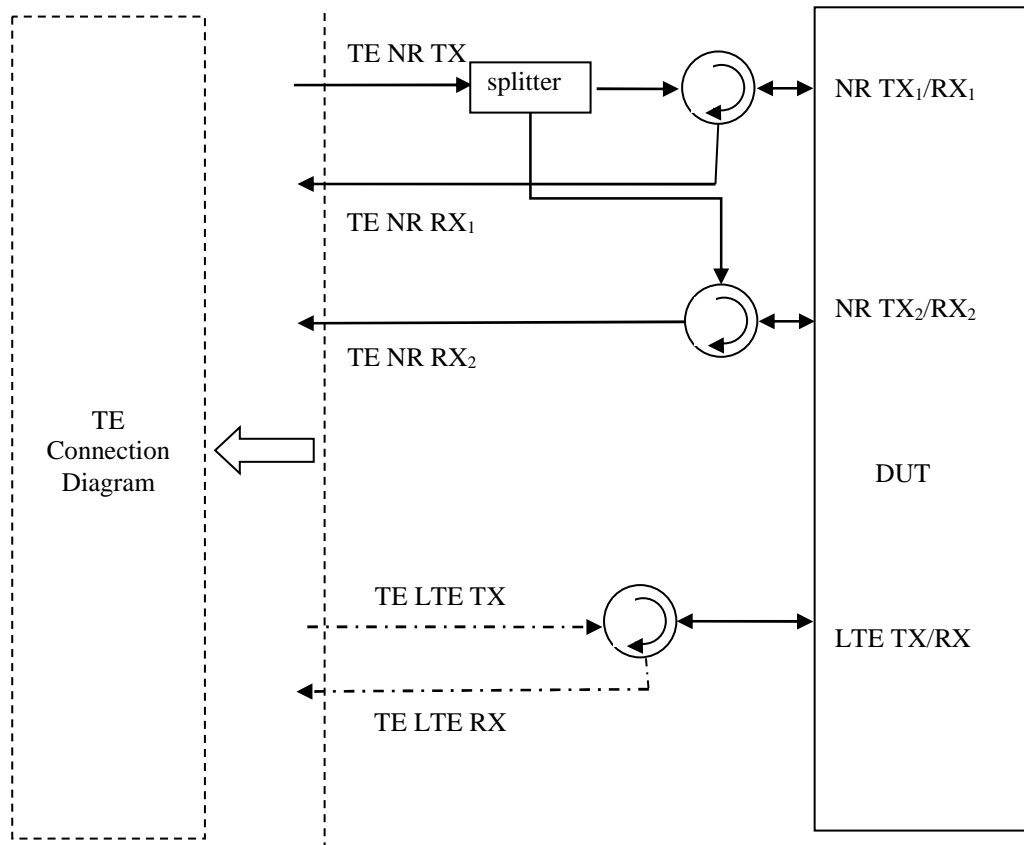


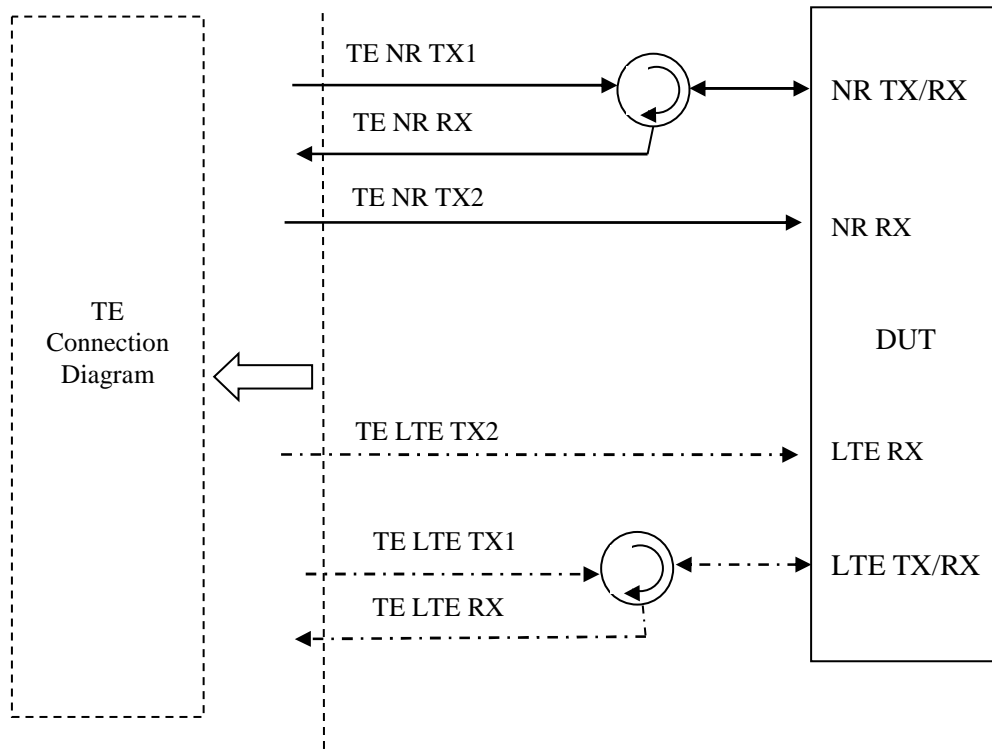
Figure A.3.2.3.10: User Equipment connection for single basic cell with NR and LTE cells at the same connectors for both cells with UE supporting UL MIMO on SUL band

### A.3.2.4 Three Antenna Connectors

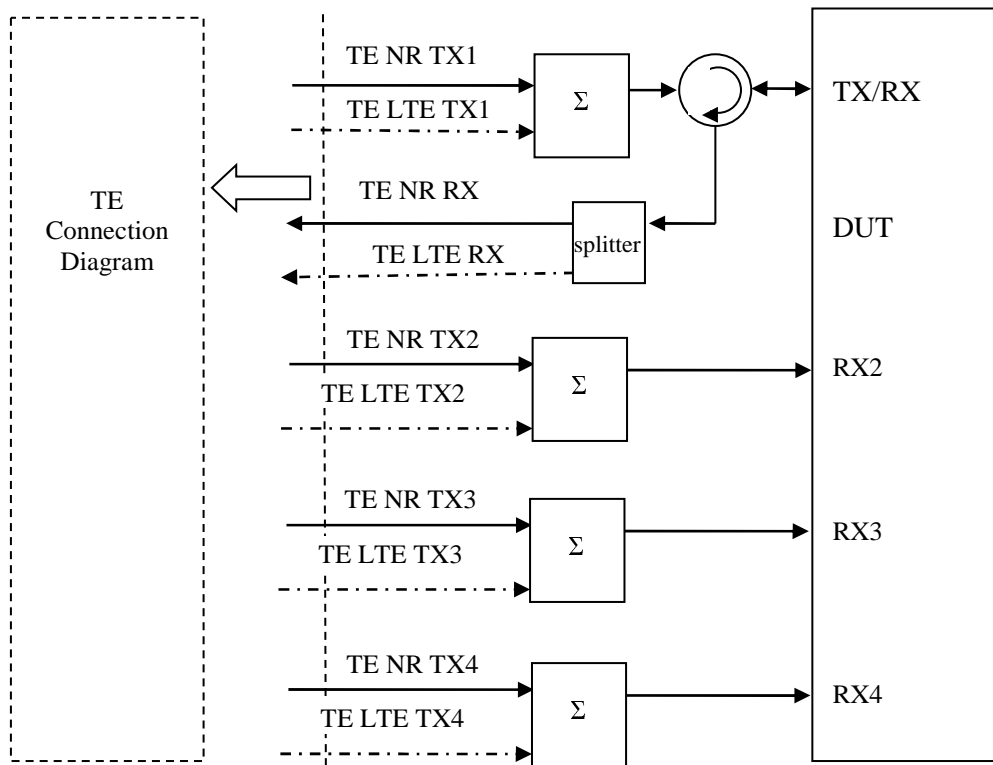


**Figure A.3.2.4.1: 2Tx User Equipment connection for single basic cell with NR and LTE cells at different separated connectors and 2TX UL MIMO supported**

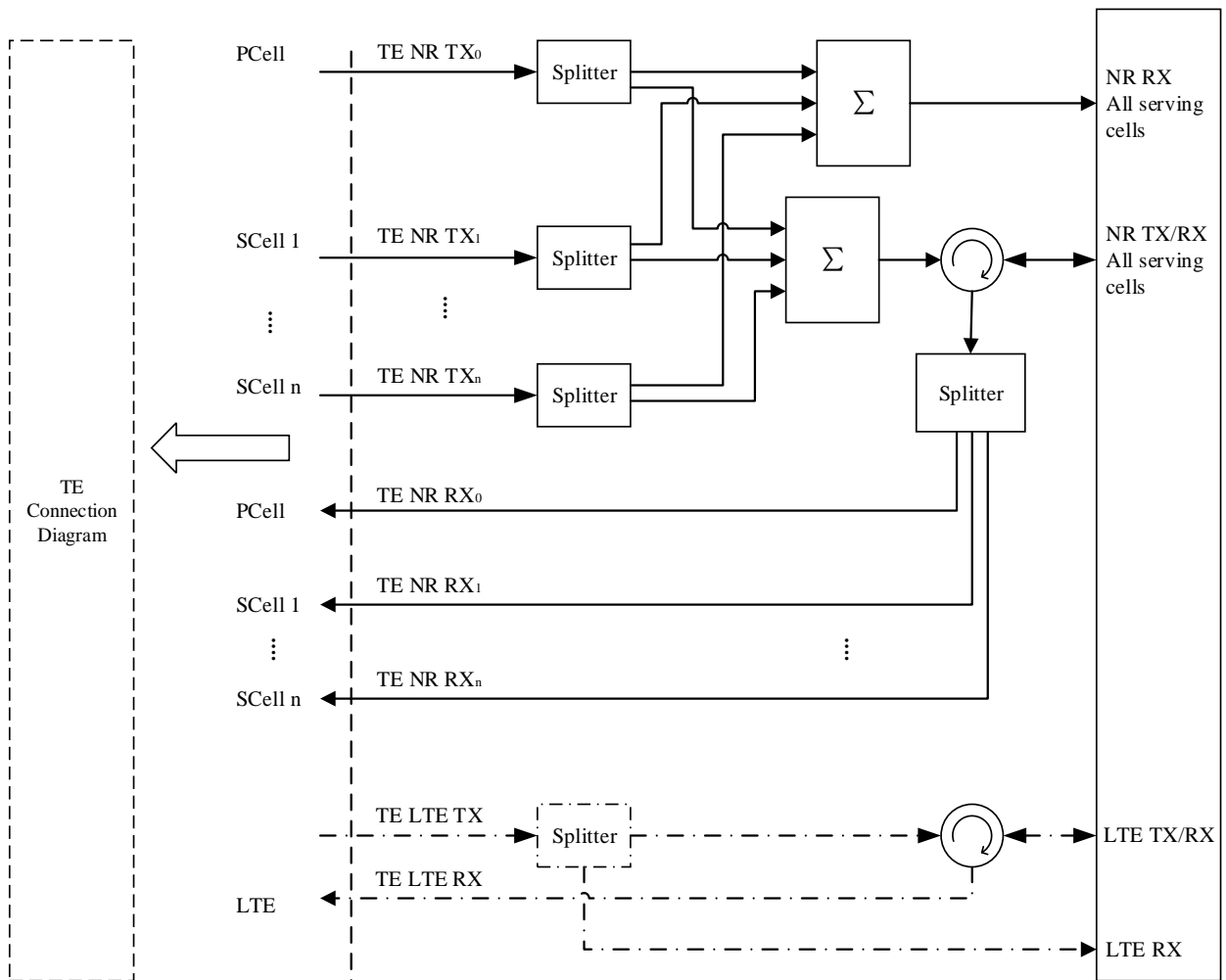
### A.3.2.5 Four Antenna Connectors



**Figure A.3.2.5.1: User Equipment connection for UEs with NR and LTE RxTx and Rx antenna at different separated connectors**



**Figure A.3.2.5.2: User Equipment connection for 4Rx capable UEs without any 2Rx RF bands (NR and LTE at same connectors)**



**Figure A.3.2.5.3: User Equipment connection for UEs with NR CA (component carriers on common connector) and LTE**

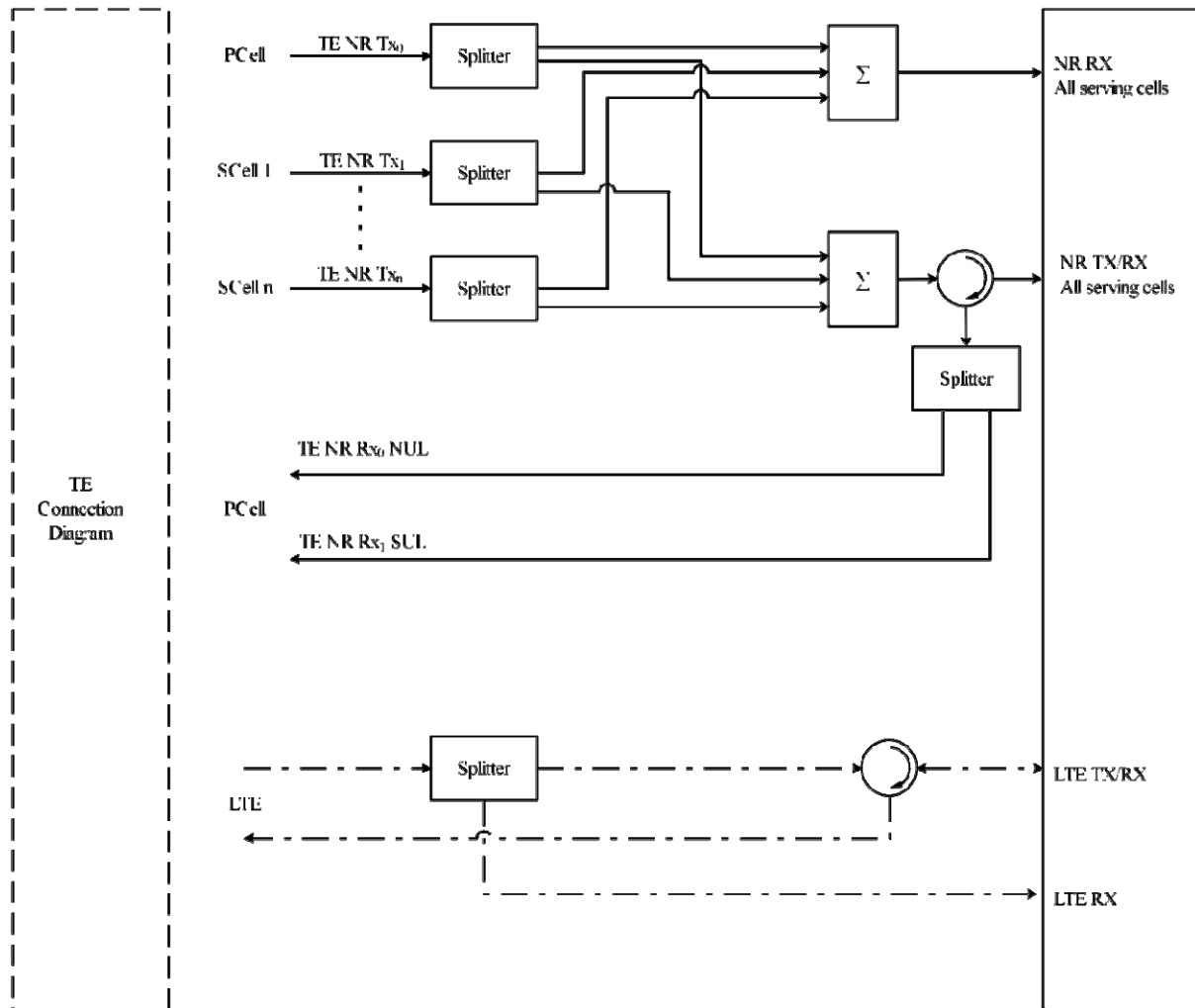


Figure A.3.2.5.4: User Equipment connection for UEs with NR SUL and DL CA (component carriers on common connector) and LTE

### A.3.2.6 Over Four Antenna Connectors

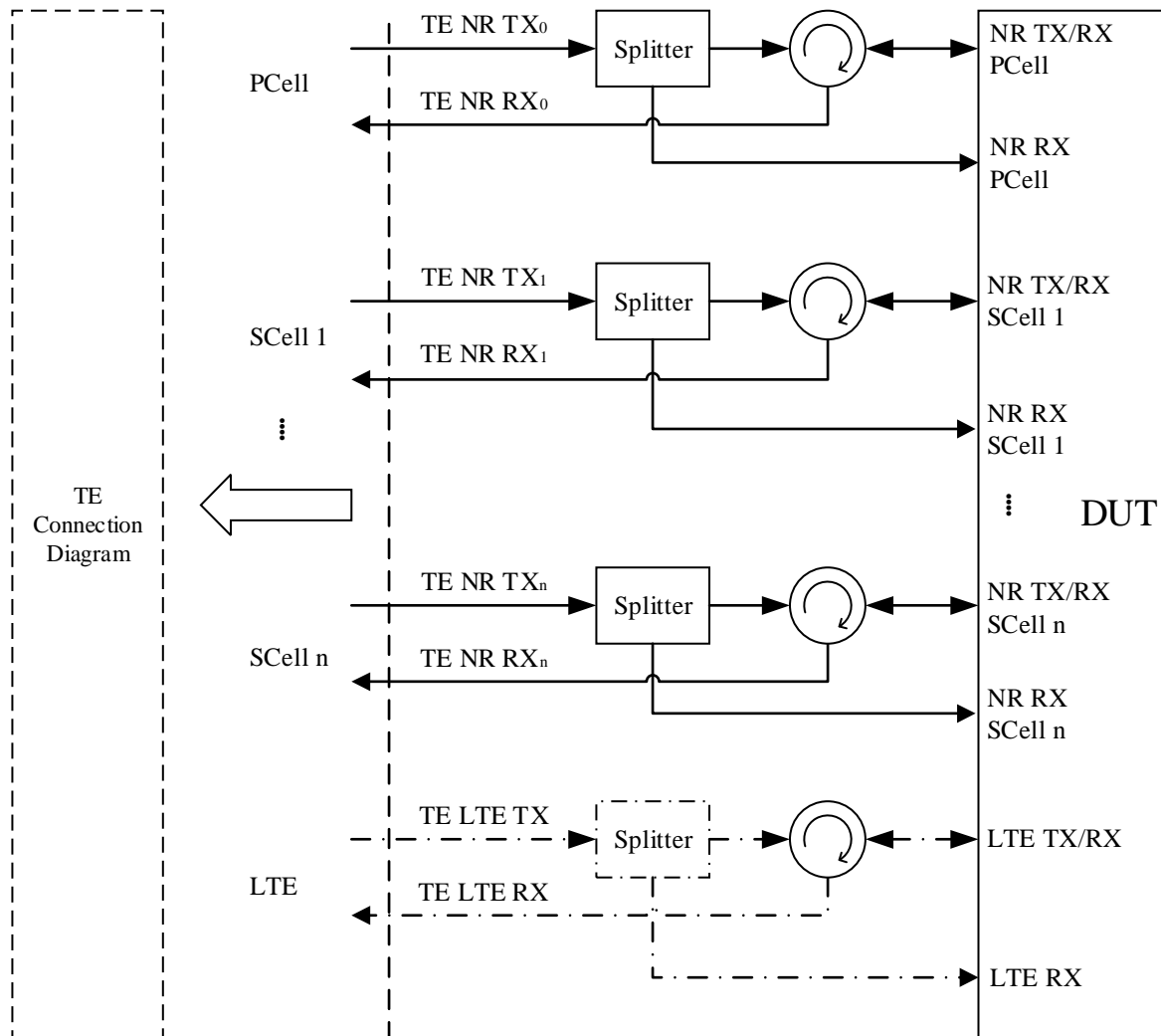
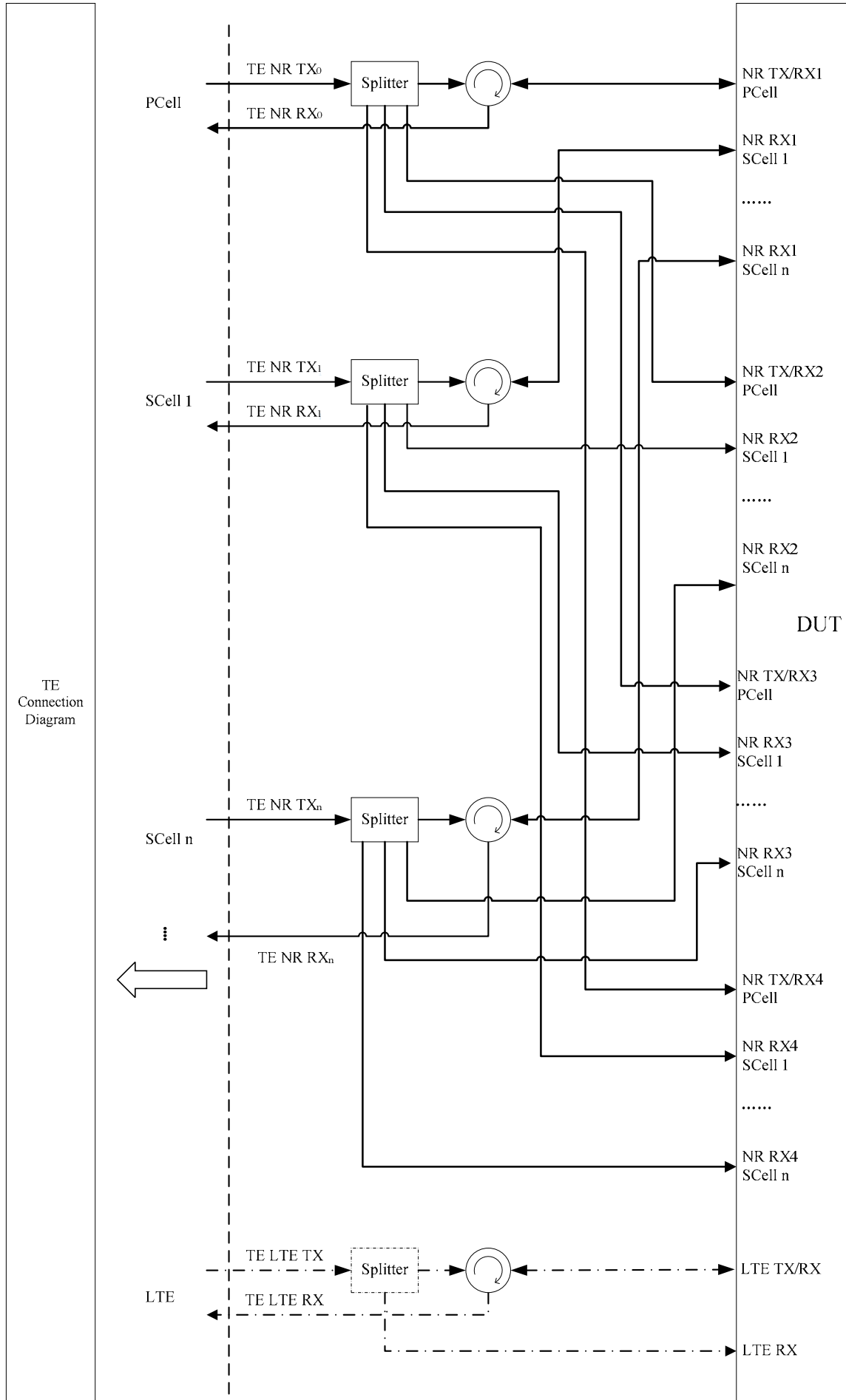


Figure A.3.2.6.1: User Equipment connection for UEs with NR CA (component carriers on separated connectors) and LTE

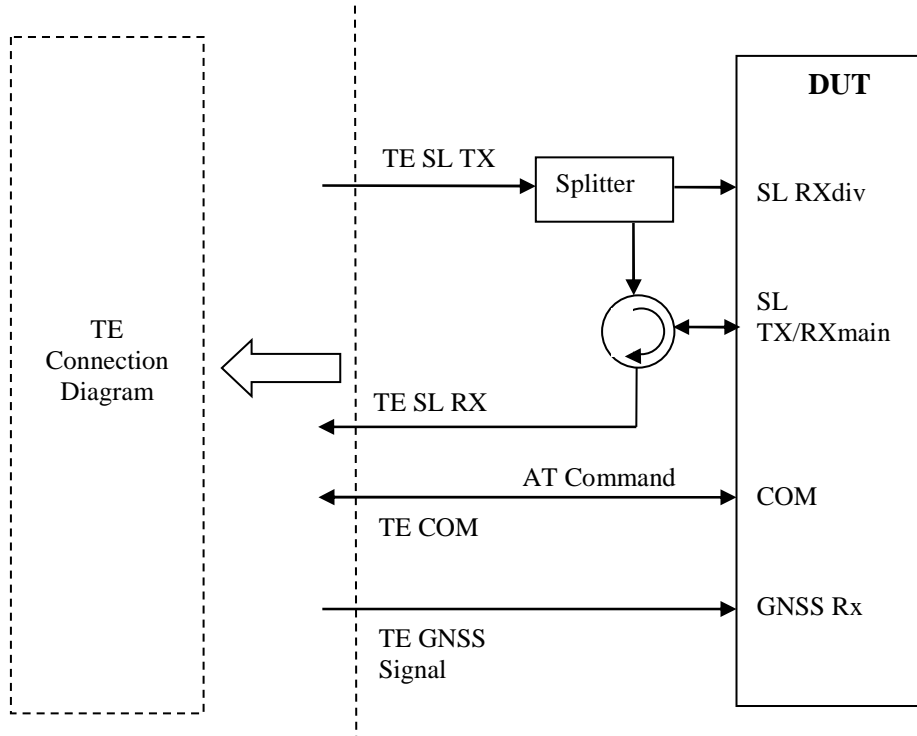




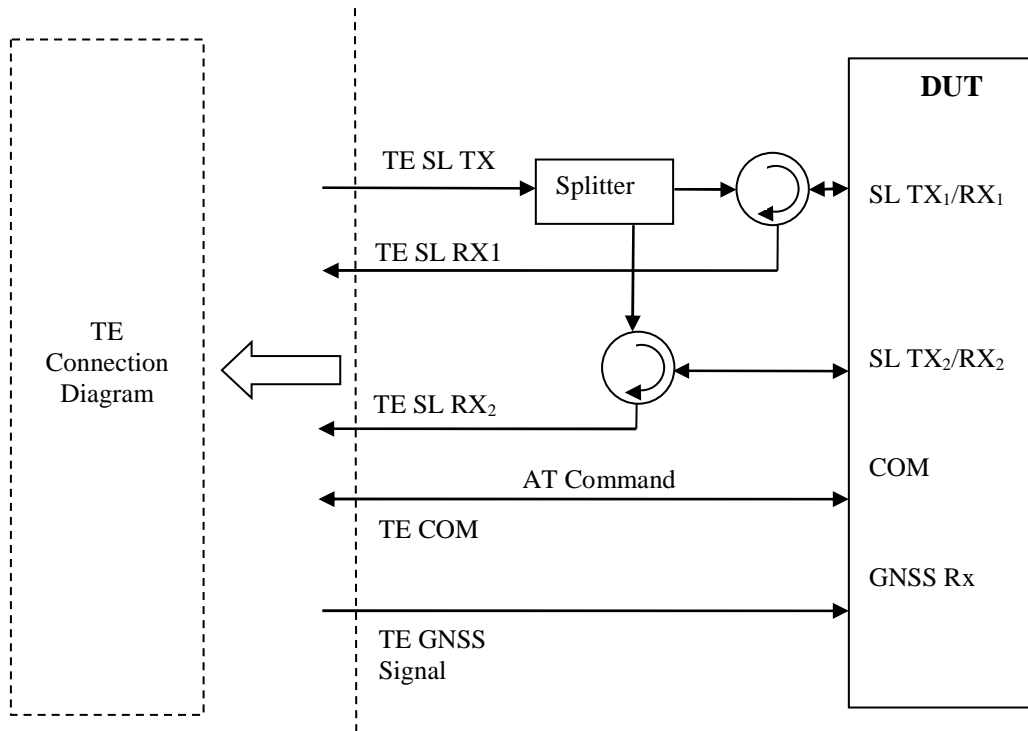
**Figure A.3.2.6.2: User Equipment connection for UEs with NR CA and NR 4Rx (component carriers on separated connectors) and LTE**

Note: NR may be 2Rx on some of the CCs, in that case RX3 and RX4 are not used

### A.3.2.7 User Equipment supporting NR Sidelink



**Figure A.3.2.7.1: User Equipment connection for NR sidelink operation non-concurrent with NR UL/DL transmission**



**Figure A.3.2.7.2: User Equipment connection for NR sidelink operation non-concurrent with NR UL/DL transmission with SL-MIMO**

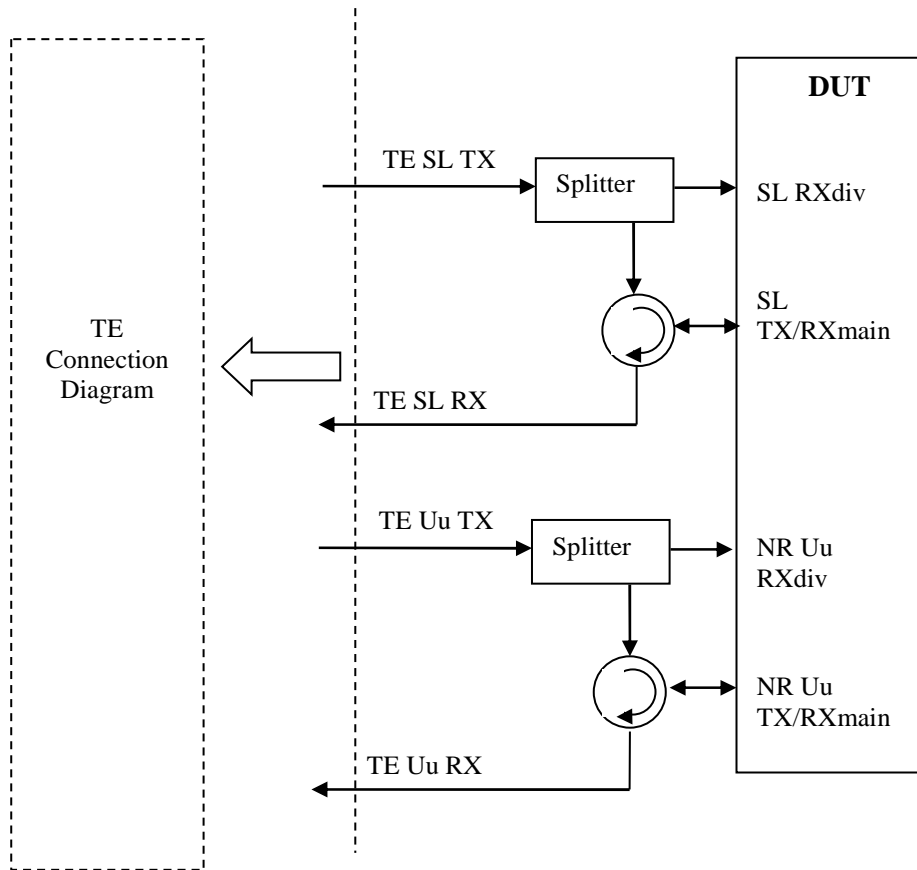


Figure A.3.2.7.3: User Equipment connection for inter-band concurrent NR V2X operation

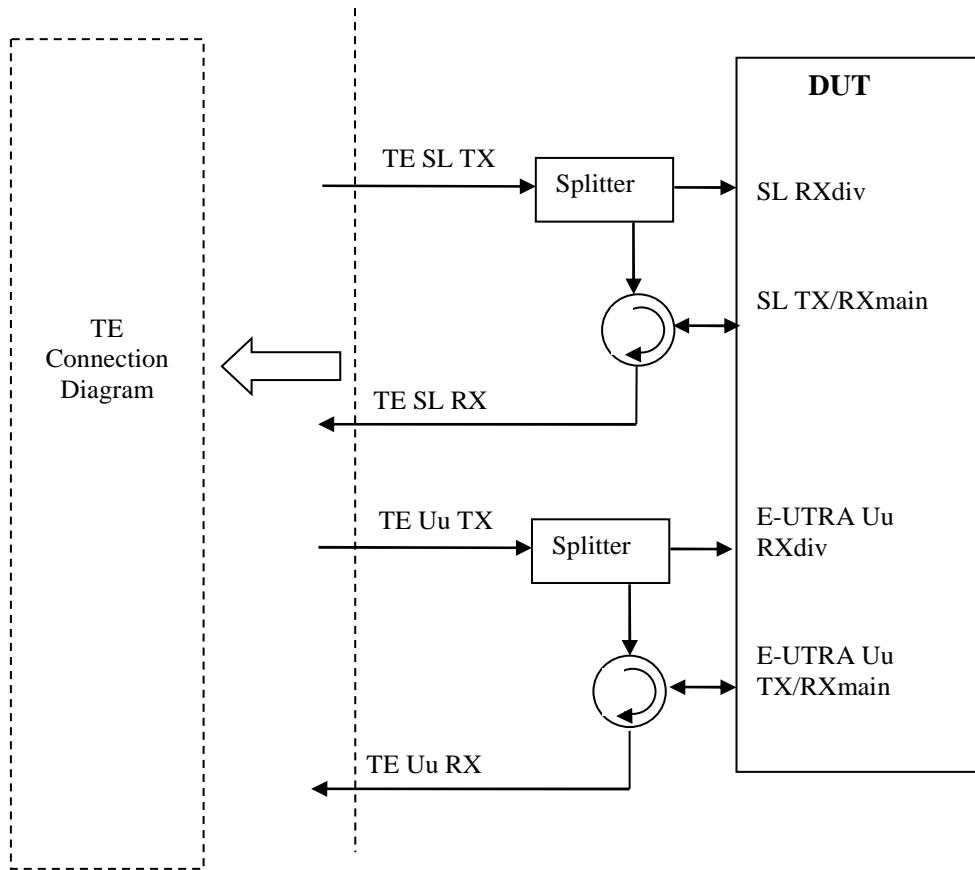


Figure A.3.2.7.4: User Equipment connection for con-current E-UTRA Uu and NR Sidelink operation

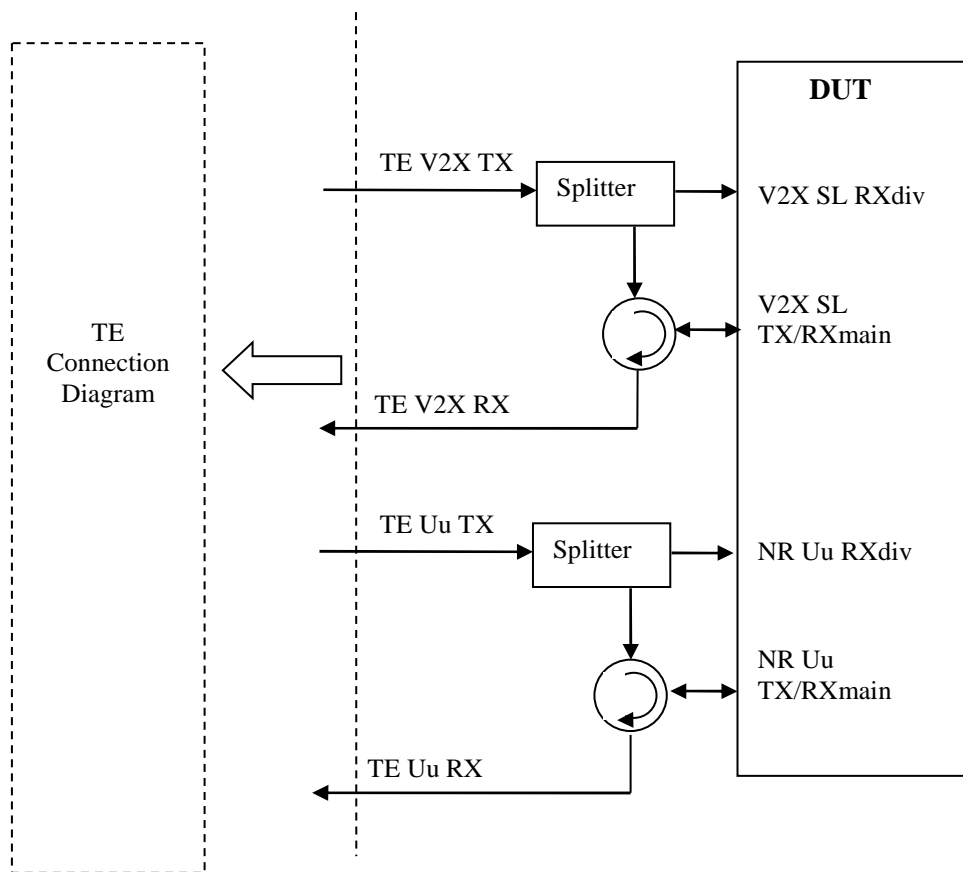
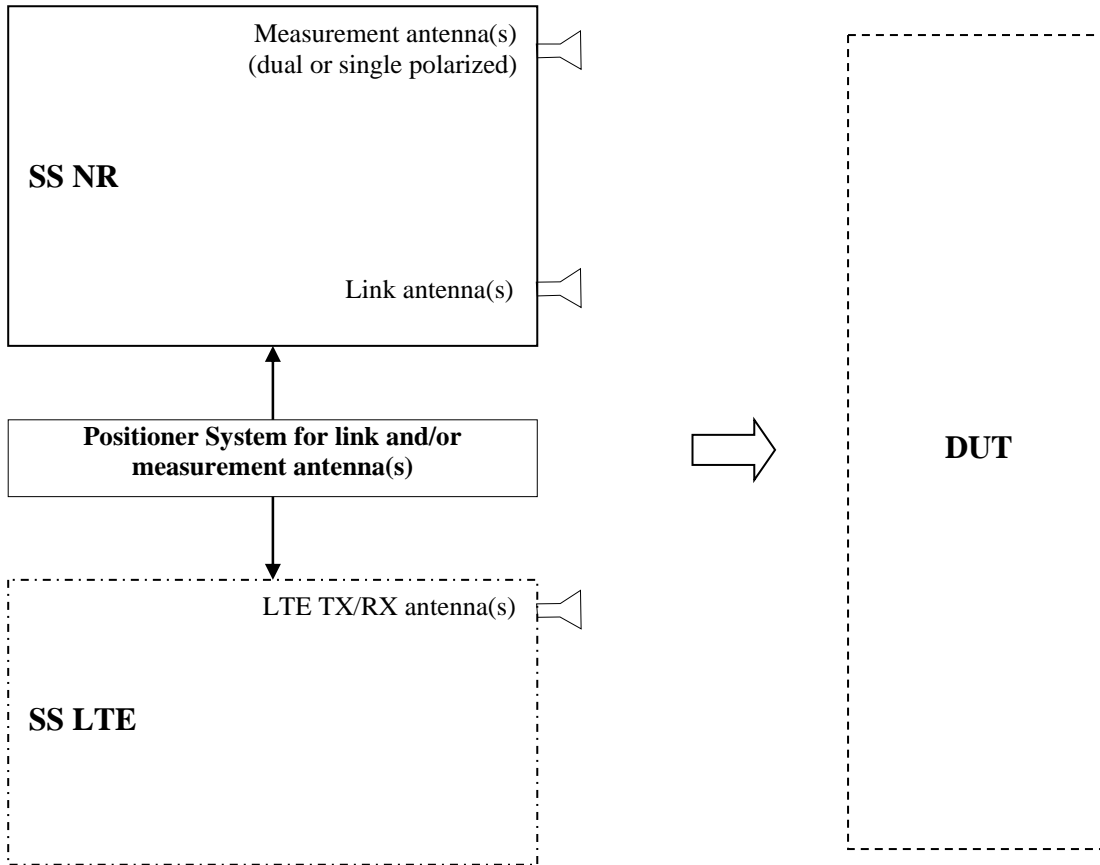


Figure A.3.2.7.5: User Equipment connection for con-current E-UTRA V2X sidelink and NR Uu operation

### A.3.3 Test Equipment Parts for Radiated Measurements

#### A.3.3.1 Transmitter/Receiver tests

The Test Equipment part is focused on logical representation of TE measurement and link antenna(s) and positioner controller. The Test Equipment connection diagram below is applicable for NR radiated RX and TX tests, including CA and UL MIMO tests.



**Figure A.3.3.1.1: Basic TE diagram for radiated RX and TX tests**

For NR radiated RX tests requiring to simulate a modulated interference, connection diagram defined in figure A.3.3.1.2 will apply.

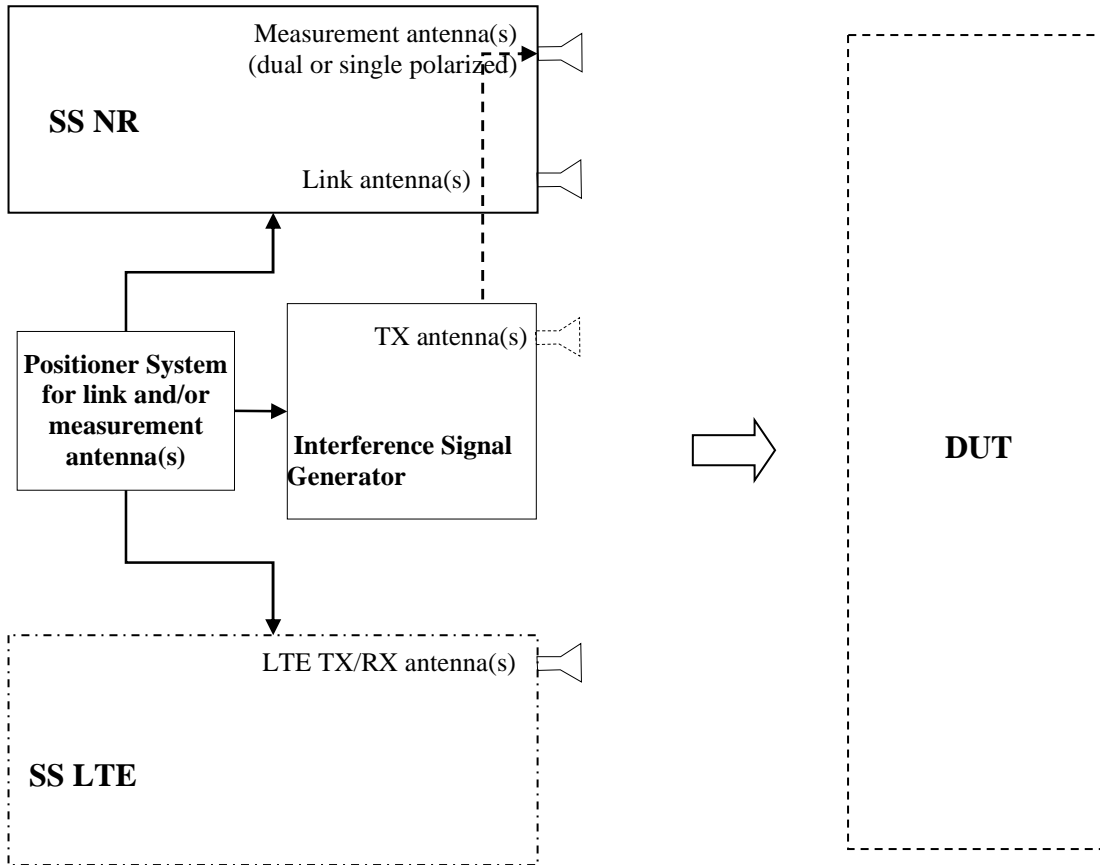


Figure A.3.3.1.2: TE diagram for radiated RX tests with Modulated Interference



A.3.3.2 Demodulation and CSI tests

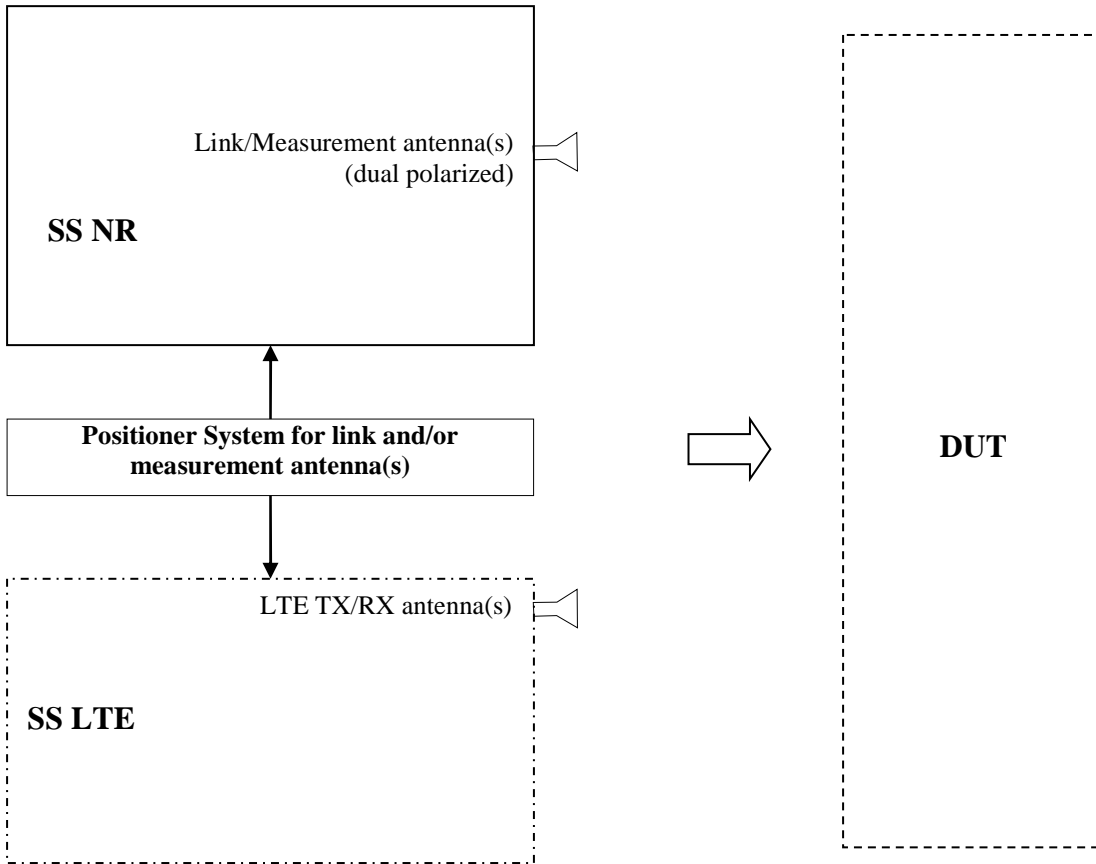


Figure A.3.3.2.1: Demodulation and CSI tests

Figures A.3.3.2.1-1 and A.3.3.2.1-1 show the connection diagram inside SS NR of Figure A.3.3.2.1 for downlink signal path.

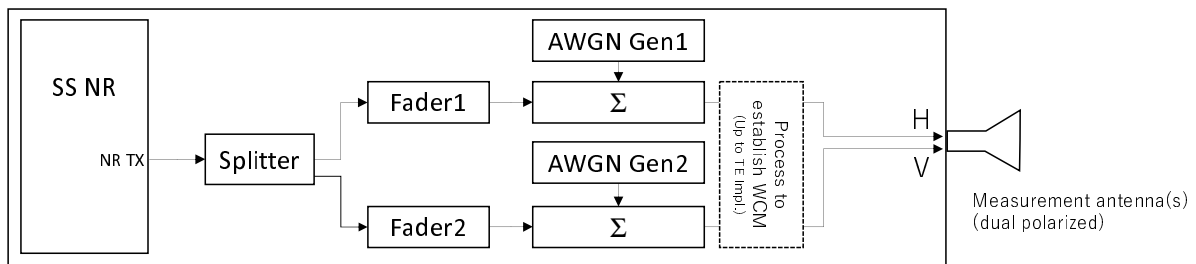


Figure A.3.3.2.1-1: TE diagram for Demodulation and CSI tests (1x2)

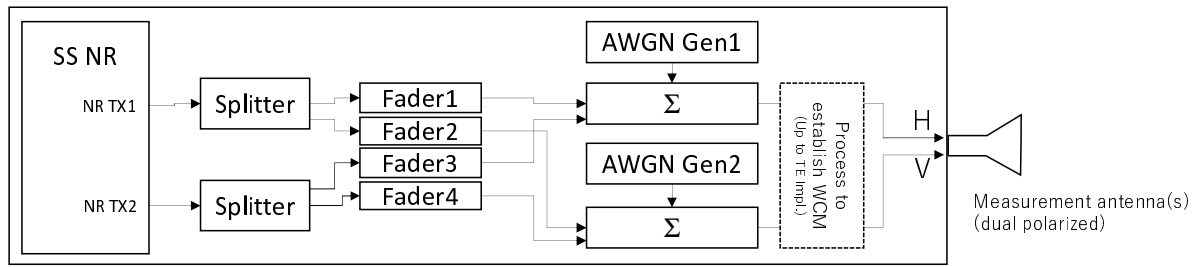


Figure A.3.3.2.1-2: TE diagram for Demodulation and CSI tests (2x2)

### A.3.3.3 RRM tests

The Test Equipment part is focused on logical representation of TE antenna(s) and positioner. The Test Equipment connection diagram below is applicable for NR radiated RRM tests. SS NR uses several antennas to cover all required AoA offsets. The actual number of antennas is not determined and depends on the TE implementation. Positioner in the TE part is optional.

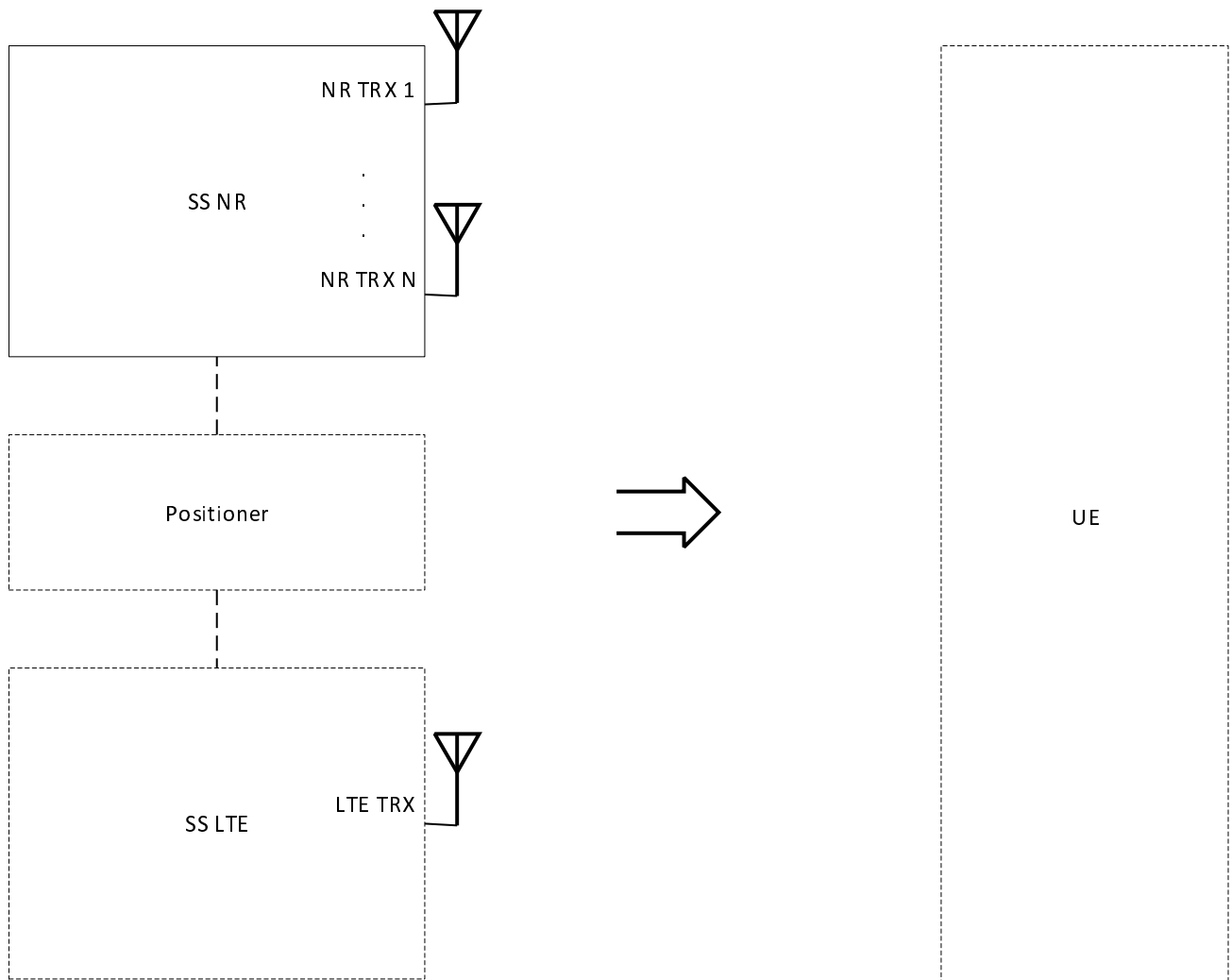


Figure A.3.3.3.1: TE diagram for radiated RRM tests

Figure A.3.3.3.1-1 shows the connection diagram inside the SS NR of Figure A.3.3.3.1 for downlink signal path (for single probe). 1x2 without fading in FR2 RRM test case represents the scenario with single antenna transmission from

TE side and 2 antenna receptions at UE side, which is equivalent to 1x1 in conducted test case from test equipment perspective.

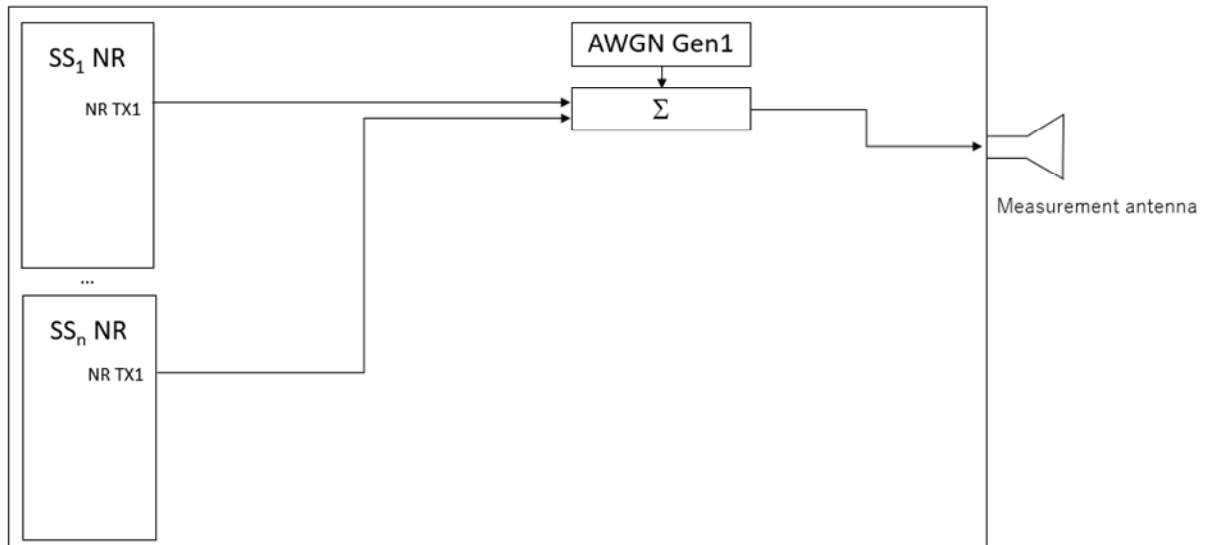


Figure A.3.3.3.1-1: TE diagram for radiated 1AoA RRM tests (1x2 without fading)

## A.3.4 User Equipment Parts for Radiated Measurements

### A.3.4.1 Basic Transmitter/Receiver tests

The User Equipment part is focused on logical representation of UE antenna(s), DUT positioner and positioner controller. The UE connection diagram below is applicable for NR radiated RX and TX tests, including CA and UL MIMO tests.

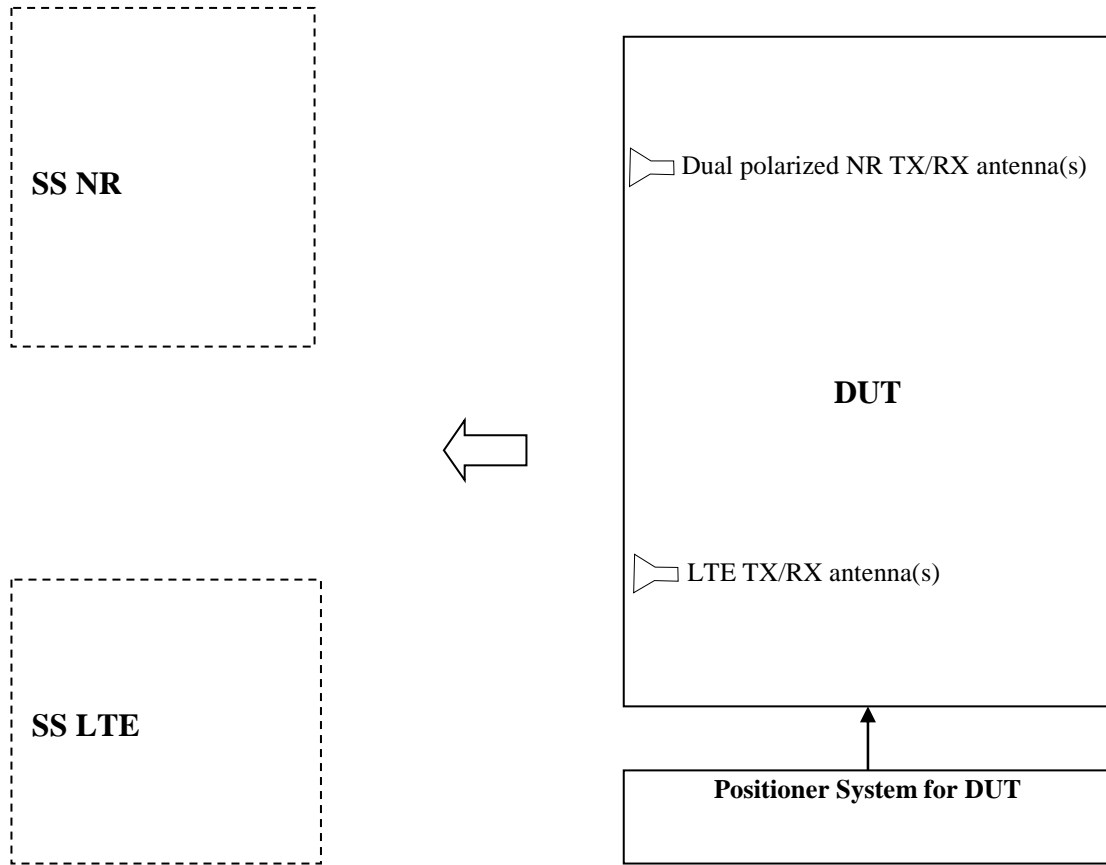


Figure A.3.4.1.1: UE diagram for radiated RX and TX tests

### A.3.4.2 Demodulation and CSI tests

Same as Figure A.3.4.1.1.

### A.3.4.3 RRM tests

Same as Figure A.3.4.1.1.

## Annex B (normative): Permitted test methods For OTA Testing

### B.1 General

**Editor's Note:** The working assumption is that the DFF or IFF: CATR based OTA test methodologies defined in Annexes B.2.2 and B.2.4 respectively should be used for Signalling test.

The applicability of the permitted test methods herein is defined by the appropriate references within clauses 5, 6, and 7. A summary of the applicability is shown in Table B.1-1.

**Table B.1-1: Permitted Test Methods Applicability Summary**

Permitted Test Methods	UE RF	Demodulation	RRM	
			1 AoA	2 AoA
DFF	yes	yes	yes	yes
DFF Simplification	yes	yes	yes	N/A
IFF	yes	yes	yes	N/A
NFTF	yes (Note 1)	N/A	N/A	N/A
Enhanced IFF	yes	yes	yes	yes
IFF+DFF	yes	yes	yes	yes
Note 1: Not applicable for EIS, Frequency Error, EVM, Carrier Leakage, In-Band Emission, EVM SF, OBW as defined in Table J-1 of TS38.521-2 [15]				

## B.2 Permitted Test Methods

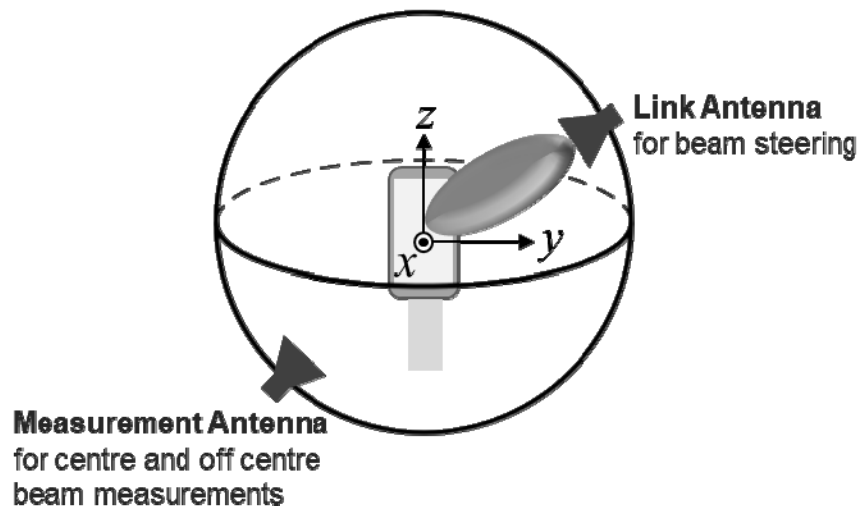
### B.2.1 General

The main objective of this annex is to specify basic parameters of permitted OTA test methods suitable for RF Tx and Rx, Performance, and RRM measurements and Signalling Conformance tests performed at high frequency in the FR2 operating bands defined in clause 4.3.1.2. The applicability of each OTA test method is summarized in Table B.1-1.

### B.2.2 Direct far field (DFF)

#### B.2.2.1 Description

The DFF measurement setup for FR2 is capable of centre and off-centre of beam measurements and is shown in Figure B.2.2.1-1 below.



**Figure B.2.2.1-1: DFF measurement setup**

The key aspects of the DFF setup are:

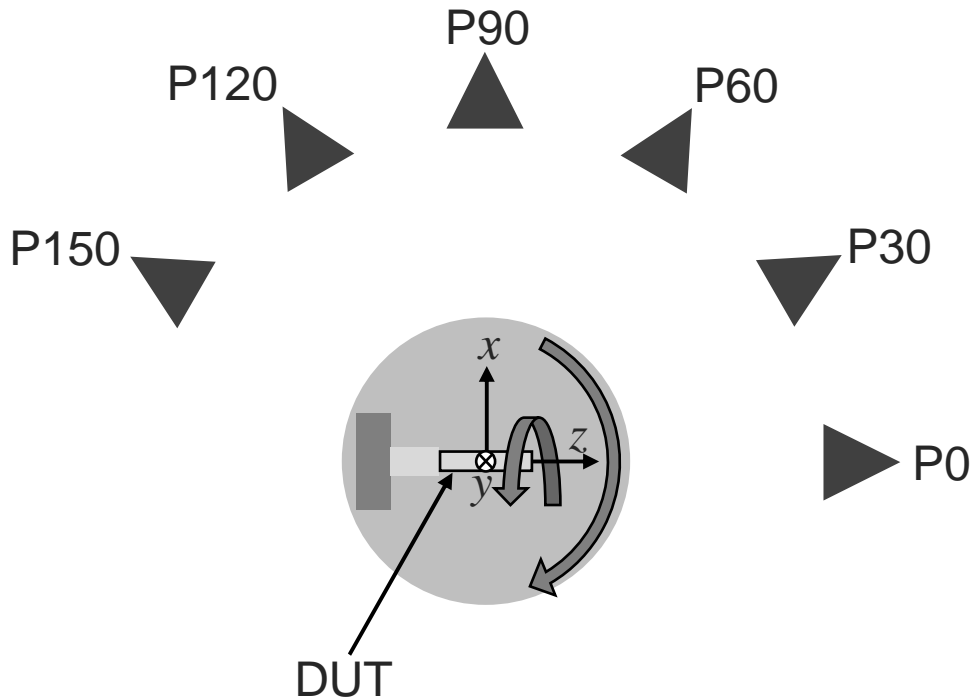
- Far-field measurement system in an anechoic chamber
  - The criterion for determining the far-field distance is described in B.2.2.4.
- A positioning system such that the angle between the dual-polarized measurement antenna and the DUT has at least two axes of freedom and maintains a polarization reference.
- A positioning system such that the angle between the link antenna and the DUT has at least two axes of freedom and maintains a polarization reference; this positioning system for the link antenna is in addition to the positioning system for the measurement antenna and provides for an angular relationship independently controllable from the measurement antenna.
- For setups intended for measurements of UE RF characteristics in non-standalone (NSA) mode with 1 UL configuration, an LTE link antenna is used to provide the LTE link to the DUT. The LTE link antenna provides a stable LTE signal without precise path loss or polarization control.
- For setups intended for measurements in NR CA mode with FR1 and FR2 inter-band NR CA, test setup provides NR FR1 link to the DUT. The NR FR1 link has a stable and noise-free signal without precise path loss or polarization control.

The applicability criteria of the DFF setup are:

- The DUT radiating aperture is  $D \leq 5$  cm
  - Either a single radiating aperture, multiple non-coherent apertures, or multiple coherent apertures DUTs can be tested
  - If multiple antenna panels that are phase coherent are defined as a single array, the criterion on DUT radiating aperture applies to this single array
  - $D$  is based on the MU assessment in Annex B.1.1.3 of TR 38.810 [24]
  - A measurement distance larger than the far-field criteria defined in B.2.2.4 is not precluded
  - If the uncertainties can be further optimized, the MU may be reduced or  $D$  may be increased
- A manufacturer declaration on the following elements is needed unless the entire DUT size is contained in a sphere of diameter of  $\leq 5$  cm:

- Manufacturer declares antenna array size

For RRM testing, an example baseline system with two simultaneously active AoA ( $N_{MAX\_AoAs} = 2$ ) as defined in Clause 7.1.3 using a DFF setup is illustrated in Figure 2.2.1-2. Implementations of the RRM baseline system with only a subset of the probes are possible as long as the system can satisfy the relative angular relationships outlined in Clause 7.1.3.2.1.

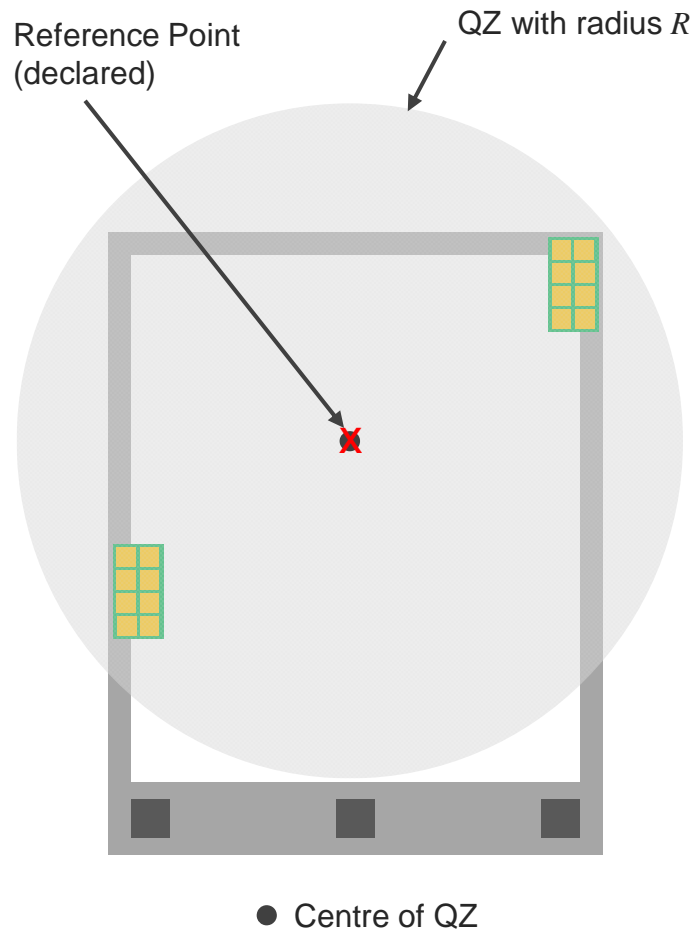


**Figure B.2.2.1-2: Example RRM baseline system with two simultaneously active AoA using a DFF setup.**

### B.2.2.2 Quiet zone dimension

In order to allow testing of DUTs of different sizes and to allow for flexibility in test chamber implementations, there will be various defined quiet zone dimensions. The smallest quiet zone shall have a radius of 100mm to accommodate DUTs such as smartphones. The next larger quiet zone shall have a radius of 150mm to accommodate larger DUTs such as tablets. To test even larger devices, e.g., larger tablets and laptops, quiet zones with 200mm and 275mm are defined. The device types are listed as examples and other device types are not precluded.

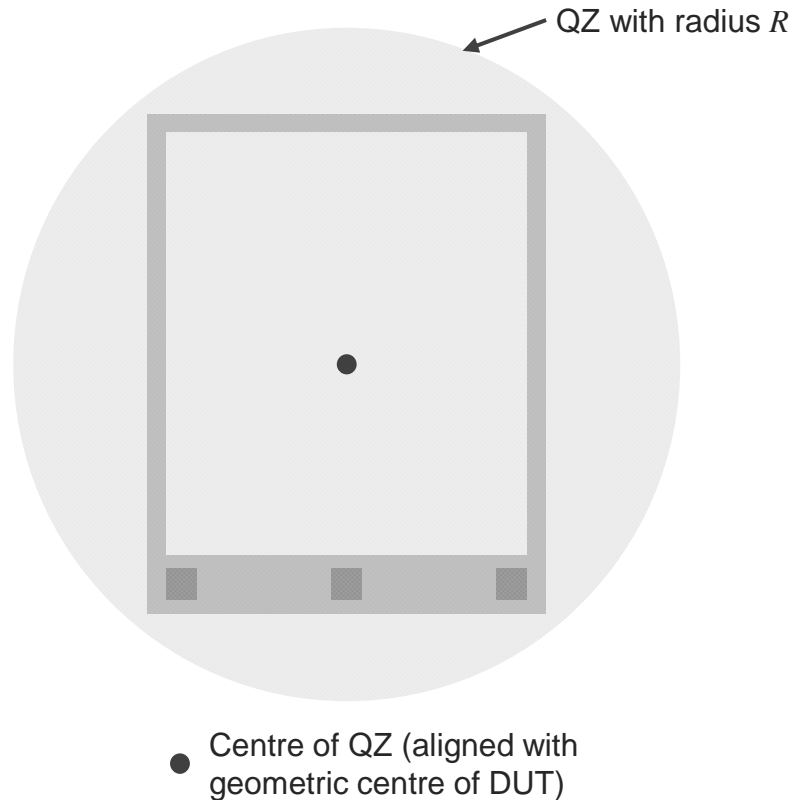
The radiating portions of the device have to be fully enclosed within the quiet zone, but the non-radiating portions of the device can be located/placed outside the quiet zone if a vendor declaration with positioning reference points and the minimum QZ required to contain all active antennas within the quiet zone (per band) is provided. This grey-box testing approach where the declared reference point is aligned with the centre of the QZ is further illustrated in Figure B.2.2.2-1.



**Figure B.2.2.2-1: Grey-box test approach**

In the absence of a vendor declaration, the geometric centre of the DUT shall be aligned with the centre of the QZ and the DUT shall be fully contained within the QZ. This black-box testing approach is further illustrated in Figure B.2.2.2-2.





**Figure B.2.2.2-2: Black-box test approach**

### B.2.2.3 Quality of the quiet zone

The quality of the quiet zone shall be measured for the frequencies defined in FFS. The measured quality of the quiet zone performance is used in uncertainty calculations for the appropriate quality of the quiet zone dimension utilized for the DUT.

### B.2.2.4 Measurement Distance

For far-field measurements, the distance  $R$  between the DUT and the measurement antenna shall be calculated by the following equation.

$$R > \frac{2D^2}{\lambda}$$

where  $\lambda$  is the largest wavelength within the frequency band of interest and  $D$  is the diameter of the smallest sphere that encloses the radiating parts of the DUT.

For DFF, free space path loss is calculated by applying the Free Space Loss formula with  $R$  equal to the far field

distance:  $\left(\frac{4\pi R}{\lambda}\right)^2$ .

The minimum range length of a DFF system, i.e., the minimum distance between the centre of the quiet zone and the measurement antenna, needs to take into account the unknown offset of the antenna aperture from the centre of quiet zone in order to guarantee far-field conditions for any antenna array integrated inside the DUT. The distance between the centre of the quiet zone to the measurement antenna is referenced as  $R_{\text{DFF}}$ , while the radius of the quiet zone is  $R_{\text{QZ}}$  as illustrated in Figure B.2.2.4-1. The minimum distance between the antenna array integrated anywhere within the DUT and the measurement antenna needs to meet the far-field distance,  $R_{\text{FF}} = 2D^2/\lambda$ .

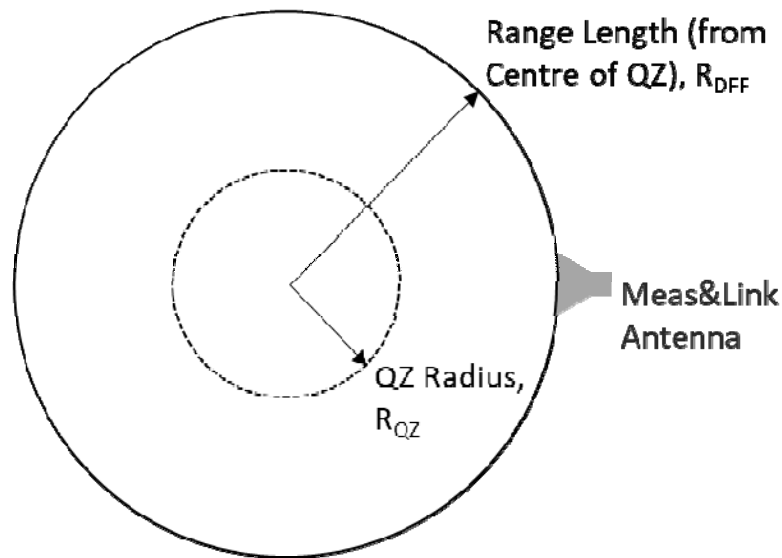


Figure B.2.2.4-1: Illustration of DFF System for range length definition

The setup in Figure B.2.2.4-2 is used to derive the minimum range length for NR FR2 DFF systems where the sphere enclosing the DUT matches the QZ and the DUT antenna with radiating aperture diameter  $D$  located in the corner of the DUT. With this setup, the minimum range length,  $R_{DFF}$ , can be determined as

$$R_{DFF} = R_{QZ} - D/2 + R_{FF} = R_{QZ} - D/2 + 2D^2/\lambda$$

which is tabulated in Table B.2.2.4-1 for two different QZ sizes assuming  $D=5\text{cm}$ .

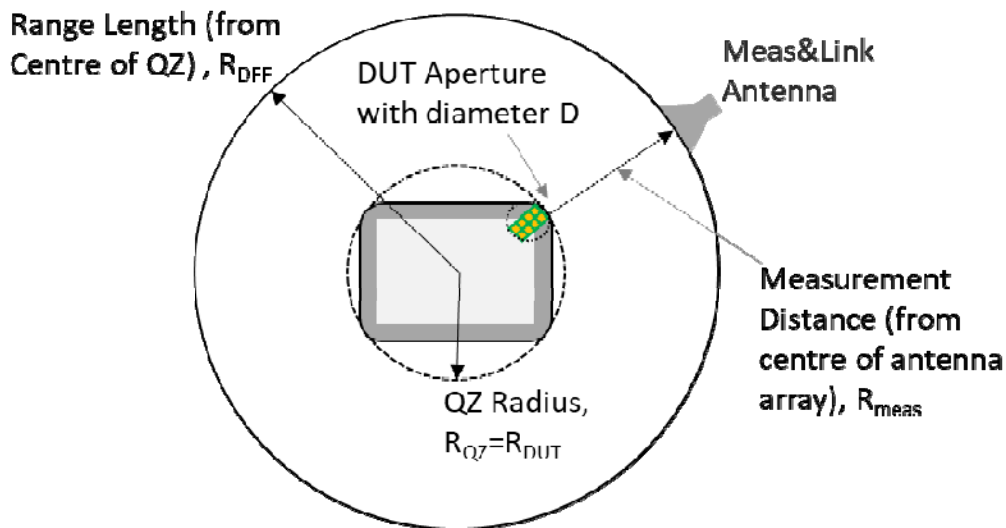


Figure B.2.2.4-2: Illustration of DFF System for minimum range length definition

Table B.2.2.4-1: Minimum Range Length of DFF System for  $D = 5\text{cm}$

$f$ [GHz] QZ [cm]	24.25	30	40	50	52.6
20	0.48	0.58	0.74	0.91	0.95

30	0.53	0.63	0.79	0.96	1.00
----	------	------	------	------	------

The influence of measurement distance on measurement uncertainty is discussed in Annex B.2.1 of TR 38.903 [XX].

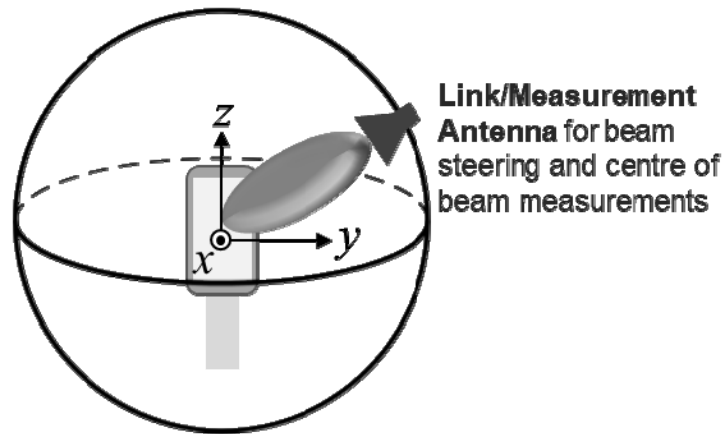
## B.2.3 Direct far field (DFF) setup simplification for centre of beam measurements

### B.2.3.1 Description

The DFF setup in Annex B.2.2 can be simplified in the following way to perform centre of the beam measurements:

- The measurement and the link antenna can be combined so that the single antenna is used to steer the beam and to perform UE measurements.

The measurement setup for FR2 capable of centre of beam measurements is shown in Figure B.2.3.1-1 below.



**Figure B.2.3.1-1: DFF simplification for centre of beam measurement setup**

The applicability criteria of the simplified DFF setup for centre of beam measurements are defined in B.2.2.1.

### B.2.3.2 Quiet zone dimension

Same as Annex B.2.2.2.

### B.2.3.3 Quality of the quiet zone

Same as Annex B.2.2.3.

### B.2.3.4 Measurement Distance

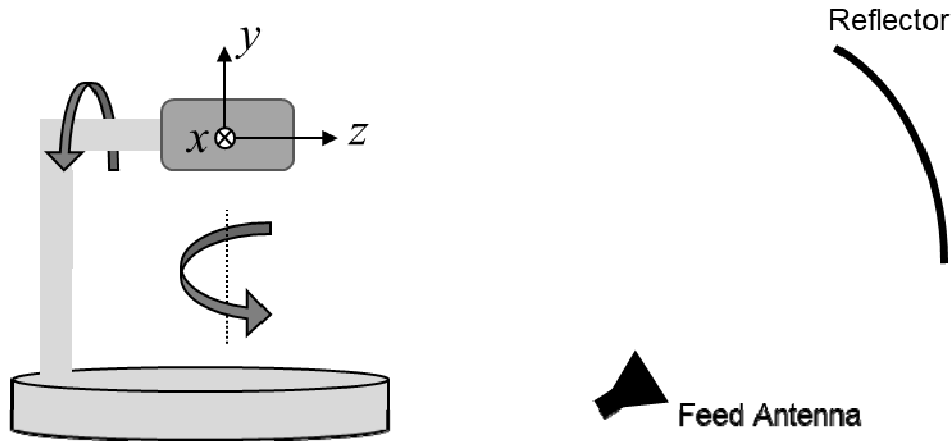
Same as Annex B.2.2.4.

## B.2.4 Indirect far field (IFF): Compact Antenna Test Range (CATR)

### B.2.4.1 Description

The IFF method utilizing a compact antenna test range (CATR) creates the far field environment using a transformation with a parabolic reflector.

The IFF CATR measurement setup for FR2 is capable of centre and off-centre of beam measurements and an example setup is shown in Figure B.2.4.1-1 below. The relative orientation of the coordinate system with respect to the reflector and the axes of rotation apply to any CATR measurement setup.



**Figure B.2.4.1-1: Example of IFF: CATR measurement setup**

The key aspects of this test method setup are:

- Indirect Far Field using Compact Antenna Test Range as described in TR 38.810 [24] with quiet zone diameter that meets the requirements of B.2.4.2.
- A positioning system such that the angle between the dual-polarized measurement antenna and the DUT has at least two axes of freedom and maintains a polarization reference.
- Before performing the UE Beamlock Test Function as defined in clause 4.9.2, the measurement probe acts as a link antenna maintaining polarization reference with respect to the DUT. Once the beam is locked then the link is to be passed to the link antenna which maintains reliable signal level with respect to the DUT.
- For setups intended for measurements of UE RF characteristics in non-standalone (NSA) mode with 1UL configuration, an LTE link antenna is used to provide the LTE link to the DUT. The LTE link antenna provides a stable LTE signal without precise path loss or polarization control.
- For setups intended for measurements in NR CA mode with FR1 and FR2 inter-band NR CA, test setup provides NR FR1 link to the DUT. The NR FR1 link has a stable and noise-free signal without precise path loss or polarization control.

The applicability criteria of this test method are:

- The total test volume, i.e., the quiet zone is defined as a sphere with radius R.
- DUT must fit within the quiet zone for the entire duration of the test.
- Either a single radiating aperture, multiple non-coherent apertures or multiple coherent apertures DUTs can be tested.
- No manufacturer declaration of the antenna array size is needed.

## B.2.4.2 Quiet zone dimension

Same as Annex B.2.2.2.

### B.2.4.3 Quality of the quiet zone

Same as Annex B.2.2.3.

### B.2.4.4 Measurement Distance

The CATR system does not require a measurement distance of  $R > \frac{2D^2}{\lambda}$  to achieve a plane wave as in a standard far field range.

For the CATR system, the far-field distance is seen as the focal length. The focal length is the distance between the feed and the reflector of the CATR. Further information on the focal length of a CATR system can be found in clause 5.2.3.2 of TR 38.810 [24].

The measurement distance for any CATR system implementation shall be adequate to meet the quiet zone dimensions defined in B.2.4.2.

In a CATR, from the reflector to the quiet zone, there is a plane wave with no free space path loss.

For CATR, free space path loss is calculated by applying the Free Space Loss formula with  $R$  equal to the far field

distance based on the focal length:  $\left(\frac{4\pi R}{\lambda}\right)^2$ .

A summary of the comparison of path losses which can be expected for the CATR compared to a Fraunhofer limit

distance ( $R > \frac{2D^2}{\lambda}$ ) for different antenna sizes and frequencies can be found in clause 5.2.3.2 of TR 38.810 [24].

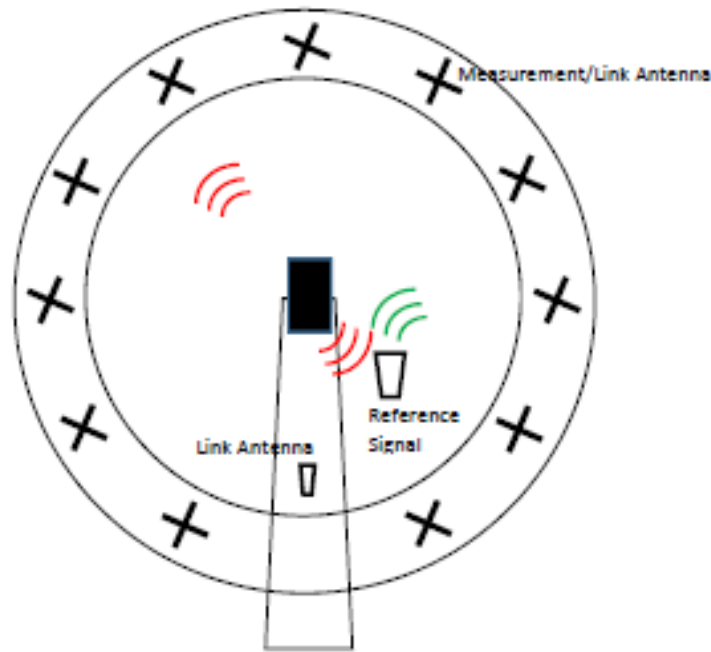
The influence of measurement distance on measurement uncertainty can be considered as zero as defined in Annex B.2.2 of TR 38.903 [XX].

## B.2.5 Near field to far field transform (NFTF)

### B.2.5.1 Description

The NFTF method computes the metrics defined in Far Field by using the Near Field to Far Field transformation.

The NFTF measurement setup of UE RF characteristics for FR2 is capable of centre and off centre of beam measurements and an example setup is shown in Figure B.2.5.1-1:



**Figure B.2.5.1-1: Example of NFTF measurement setup**

The key aspects of the Near Field test range are:

- Radiated Near Field UE beam pattern is measured and based on the NFTF mathematical transform, the final metric such as EIRP is the same as the metric for the baseline setup
- A positioning system such as the angle between the dual-polarized measurement/link antenna and the DUT has at least two axes of freedom and maintains a polarization reference
- For setups intended for measurements of UE RF characteristics in non-standalone (NSA) mode with 1UL configuration, an LTE link antenna is used to provide the LTE link to the DUT. The LTE link antenna provides a stable LTE signal without precise path loss or polarization control.
- For setups intended for measurements in NR CA mode with FR1 and FR2 inter-band NR CA, test setup provides NR FR1 link to the DUT. The NR FR1 link has a stable and noise-free signal without precise path loss or polarization control.

The applicability criteria of the NFTF setup are:

- The DUT radiating aperture is  $D \leq 5$  cm
  - Either a single radiating aperture, multiple non-coherent apertures or multiple coherent apertures DUTs can be tested
  - If multiple antenna panels that are phase coherent are defined as a single array, the criterion on DUT radiating aperture applies to this single array
  - D is based on the MU assessment in Annex B.1.4.3 of TR 38.810 [24]
  - If the uncertainties can be further optimized, the MU may be reduced or D may be increased
- A manufacturer declaration on the following elements is needed unless the entire DUT size is contained in a sphere of diameter of  $\leq 5$  cm:
  - Manufacturer declares antenna array size
- EIRP, TRP, and spurious emissions metrics can be tested.

## B.2.5.2 Quiet zone dimension

Same as Annex B.2.2.2.

## B.2.5.3 Quality of the quiet zone

Same as Annex B.2.2.3.

## B.2.5.4 Measurement Distance

The NFTF system does not require a measurement distance of  $R > \frac{2D^2}{\lambda}$  as in a standard far field range due to the use of the Near Field to Far Field transformation.

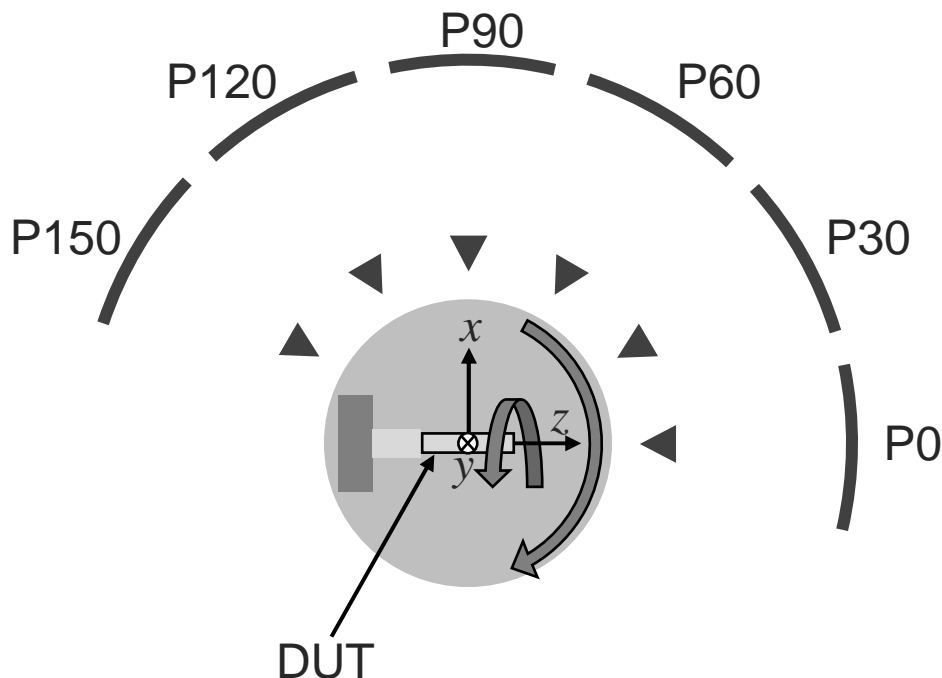
The measurement distance for any NFTF system implementation shall ensure that the DUT is not measured in the reactive near-field region and is adequate to meet the quiet zone dimensions defined in B.2.5.2.

## B.2.6 Enhanced IFF

### B.2.6.1 Description

The Enhanced IFF method utilizing multiple compact antenna test ranges (CATRs) creates the far field environment using a transformation with 2 or more parabolic reflectors for RRM testing with two simultaneously active AoA ( $N_{MAX\_AoAs} = 2$ ) as defined in Clause 7.1.3.

An example RRM baseline system using an Enhanced IFF setup are shown in Figure B.2.6.1-1. Implementations of the RRM baseline system with only a subset of the reflectors/probes are possible as long as the system can satisfy the relative angular relationships outlined in Clause 7.1.3.2.1.



**Figure B.2.6.1-1: Example RRM baseline system with two simultaneously active AoA using an Enhanced IFF setup**

The key aspects of this test method setup are the same as the IFF setup, outlined in Clause B.2.4.1.

### B.2.6.2 Quiet zone dimension

Same as Clause B.2.2.2.

### B.2.6.3 Quality of the quiet zone

Same as Clause B.2.2.3.

### B.2.6.4 Measurement Distance

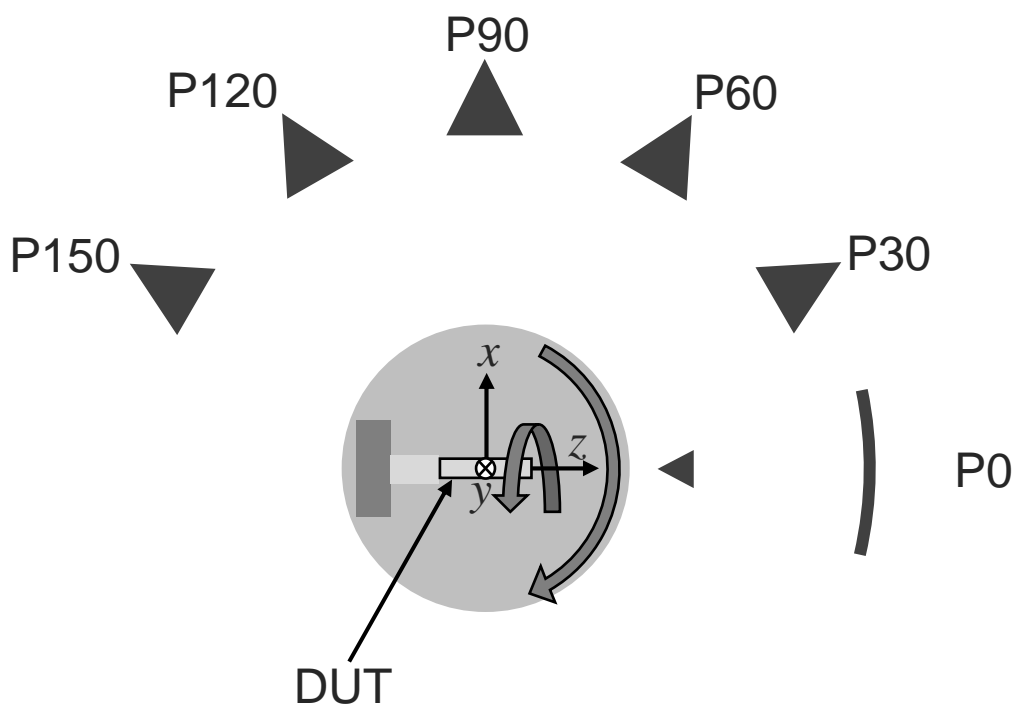
Same as Clause B.2.4.4.

## B.2.7 IFF+DFF

### B.2.7.1 Description

The IFF+DFF method is utilizing a combination of compact antenna test ranges (CATRs) and DFF probes for RRM testing with two simultaneously active AoA ( $N_{MAX\_AoAs} = 2$ ) as defined in Clause 7.1.3.

An example RRM baseline system using the IFF+DFF setup is shown in Figure B.2.7.1-1. Implementations of the RRM baseline system with only a subset of the probes are possible as long as the system can satisfy the relative angular relationships outlined in Clause 7.1.3.2.1.



**Figure B.2.7.1-1: Example RRM baseline system with two simultaneously active AoA using an IFF+DFF setup**

The key aspects of this test method setup are the same as the IFF setup for the probes based on the IFF method, outlined in B.2.4.1 and the DFF setup for the probes based on the DFF method, outlined in Clause B.2.2.1.

### B.2.7.2 Quiet zone dimension

Same as Clause B.2.2.2.



### B.2.7.3 Quality of the quiet zone

Same as Clause B.2.2.3.

### B.2.7.4 Measurement Distance

Same as Clause B.2.4.4 for the IFF setup for the probes based on the IFF method and Clause B.2.2.4 for the DFF setup for the probes based on the DFF method.

---

## Annex C (informative): Calculation of test frequencies

### C.0 General

Test frequencies are defined in clause 4.3.1 with extensions for signalling test cases in clause 6.2.3. This annex gives a guideline to determine these test frequencies and the associated signalling parameters for a given NR band, NR CA or NR DC band combination.

Clause C.1 describes definitions and parameters used by the procedures to determine test frequencies, SS/PBCH Block (SSB) and CORESET#0 configuration parameters.

Clause C.2 describes how to calculate test frequencies for symmetric NR bands, asymmetric NR bands, NR CA and NR DC configurations.

Clause C.3.2 describes how to determine the SSB, CORESET#0 and signalling parameters for FR1 carriers with SCS=15 kHz or SCS=30 kHz, and for FR2 carriers with SCS=60 kHz or SCS=120 kHz. CORESET#0 is required for a carrier to be used as a Pcell.

Clause C.3.3 describes how to determine the SSB and signalling parameters for a carriers without CORESET#0.

Clause C.5 describes how to calculate test frequencies for NR V2X bands.

---

### C.1 Definitions and Parameters

Figure C.1-1 shows SSB and CORESET#0 and related parameters. CORESET#0 is required for a carrier to be used as a PCell.

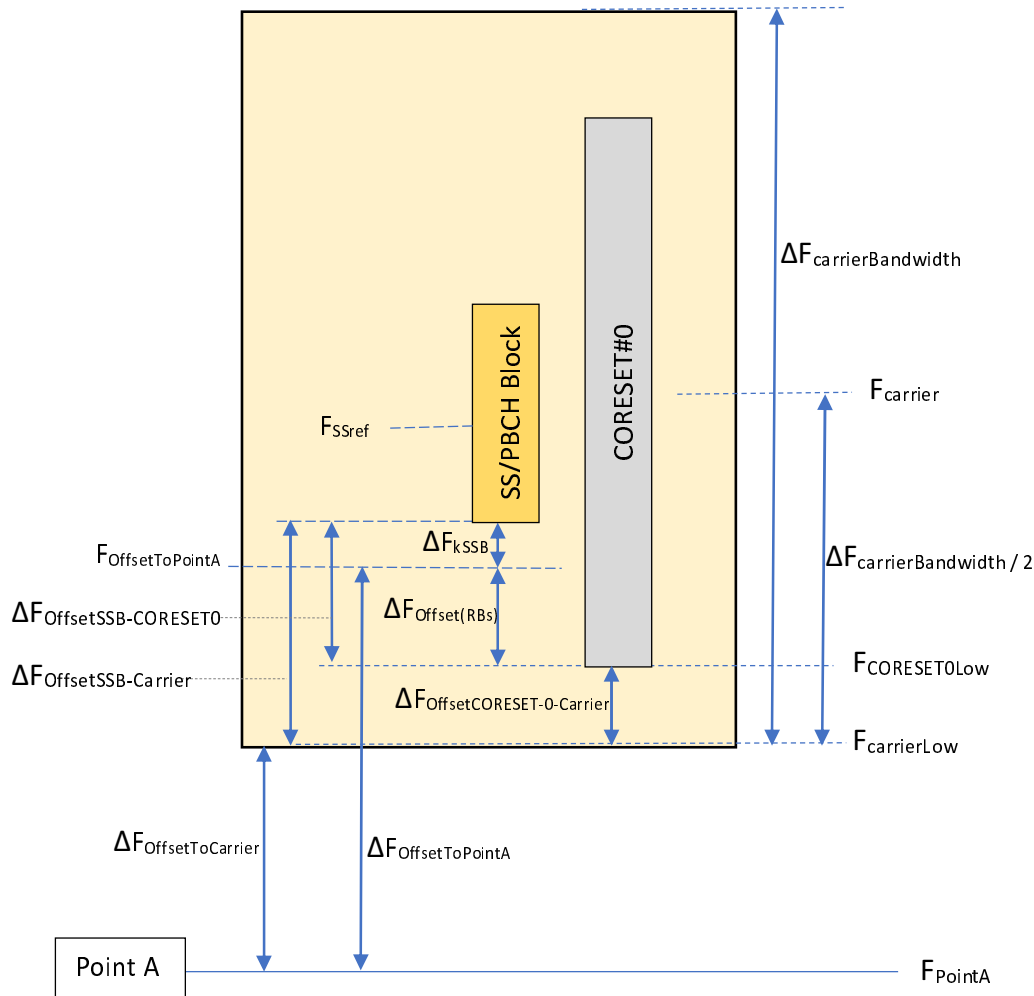


Figure C.1-1: location of SSB and CORESET#0 within a channel

The parameters referenced in figure C.1-1 are defined in Table C.1-1.

Table C.1-1: Definition of parameters in Figure C.1-1 used in Annex C

Parameter	Description
$F_{PointA}$	Reference Point A frequency.
$F_{carrier}$	$F_{carrier}$ is the centre frequency of a carrier corresponding to its NR-ARFCN value.
$F_{carrierLow}$	$F_{carrierLow}$ is the centre frequency of lowest subcarrier of the carrier. $F_{carrierLow} = F_{carrier} - 12 * SCS_{carrier} * (N_{RB} / 2)$ with $N_{RB}$ according to Table 5.3.2-1 of TS 38.101-1 [7] and TS 38.101-2 [8] for the channel bandwidth of the carrier.
$\Delta F_{carrierBandwidth}$	$\Delta F_{carrierBandwidth}$ is the carrier's channel bandwidth as provided in <i>carrierBandwidth</i> to the UE ( <i>SCS-SpecificCarrier</i> ).
$\Delta F_{offsetToCarrier}$	$\Delta F_{offsetToCarrier}$ is the frequency offset between Point A and the lower edge of the carrier. $F_{offsetToCarrier} = offsetToCarrier * PRB\ size$ , where PRB size according to the subcarrier spacing of the carrier. <i>offsetToCarrier</i> is signalled to the UE ( <i>SCS-SpecificCarrier</i> ).
$F_{SSref}$	Centre frequency of SSB. For a cell selectable as PCell the $F_{SSref}$ corresponds to a valid GSCN value according to clause 5.4.3.1 of TS 38.101-1 [7] and TS 38.101-2 [8].
$\Delta F_{Offset(RBs)}$	$\Delta F_{Offset(RBs)} = 12 * Offset(RBs) * subCarrierSpacingCommon$ , where <i>Offset(RBs)</i> is given in tables 13-1 to 13-10 of TS 38.213 [22].

$\Delta F_{kSSB}$	$\Delta F_{kSSB} = k_{SSB} * \{15 \text{ kHz for FR1, } subCarrierSpacingCommon \text{ (MIB) for FR2}\}$ (TS 38.211 [3], clause 7.4.3.1)
$\Delta F_{OffsetSSB-CORESET0}$	Frequency offset between the lowest subcarrier of the SSB and the lowest subcarrier of CORESET#0. $\Delta F_{OffsetSSB-CORESET0} = \Delta F_{Offset(RBs)} + \Delta F_{kSSB}$ .
$\Delta F_{OffsetCORESET0-Carrier}$	Frequency offset, $F_{OffsetCORESET\#0-Carrier}$ , between the lowest subcarrier of CORESET#0 and the lowest subcarrier of the carrier.
$\Delta F_{OffsetSSB-Carrier}$	Frequency offset between the lowest subcarrier of the SSB and the lowest subcarrier of the carrier.
$F_{CORESET0Low}$	Centre frequency of subcarrier 0 of CORESET#0.
$F_{OffsetToPointA}$	Frequency of the lowest subcarrier of the lowest resource block, which has the subcarrier spacing provided by the higher-layer parameter $subCarrierSpacingCommon$ and overlaps with the SS/PBCH block used by the UE for initial cell selection, expressed in units of resource blocks assuming 15 kHz subcarrier spacing for FR1 and 60 kHz subcarrier spacing for FR2 (TS 38.211 [29] clause 4.4.4.2).
$\Delta F_{OffsetToPointA}$	Frequency offset between $F_{OffsetToPointA}$ and point A. $\Delta F_{OffsetToPointA} = offsetToPointA * \{15 \text{ kHz for FR1; } 60 \text{ kHz for FR2}\}$ (TS 38.211 [29] clause 4.4.4.2).

Additional parameters used in this annex are defined in Table C.1-2.

**Table C.1-2: Definition of additional parameters used in Annex C.**

$k_{SSB}$	as defined in TS 38.211 [29] clause 7.4.3.1
$SCS_{Carrier}$	subcarrier spacing for the carrier ( <i>SCS-SpecificCarrier</i> ): FR1: 15kHz, 30kHz or 60kHz according to TS 38.101-1 [7] Table 5.3.5-1 FR2: 60kHz or 120kHz according to TS 38.101-2 [8] Table 5.3.5-1
$SCS_{SSB}$	SS/PBCH block subcarrier spacing FR1: 15kHz or 30kHz according to TS 38.101-1 [7] Table 5.4.3.3-1 FR2: 120kHz or 240kHz according to TS 38.101-2 [8] Table 5.4.3.3-1 NOTE: According to the tables in clause 13 of TS 38.213 [22] not all combinations of $SCS_{SSB}$ and $SCS_{Carrier}$ are applicable.
$SCS_{common}$	Subcarrier spacing for SIB1, Msg.2/4 for initial access, paging and broadcast SI-messages. Provided to the UE in the MIB in IE <i>subCarrierSpacingCommon</i> .
$PRB_{size}$	Physical Resource Block size of the carrier = $12 * SCS_{Carrier}$ .
$CRB_{size}$	Common Resource Block size = $12 * SCS_{common}$ .
$F_{DL\_Low}, F_{UL\_Low}$	Lowest frequency of the downlink and uplink frequency range of the band as defined in clause 5.2 of TS 38.101-1 [7] and TS 38.101-2 [8].
$F_{DL\_High}, F_{UL\_High}$	Highest frequency of the downlink and uplink frequency range of the band as defined in clause 5.2 of TS 38.101-1 [7] and TS 38.101-2 [8].
$\Delta F_{Raster}$	Frequency raster of the band as defined in clause 5.4.2.3 of TS 38.101-1 [7] and TS 38.101-2 [8].
$BW_{DL}$	Bandwidth of downlink frequency range of the band.
$BW_{UL}$	Bandwidth of uplink frequency range of the band.
$CBW_{DL}$	Downlink channel bandwidth (MHz) of the carrier according to Table 5.3.2-1 of TS 38.101-1 [7] and TS 38.101-2 [8].
$CBW_{UL}$	Uplink channel bandwidth (MHz) of the carrier according to Table 5.3.2-1 of TS 38.101-1 [7] and TS 38.101-2 [8].
$F_{Tx-Rx\_separation}$	Default Tx – Rx carrier centre frequency separation of the band as defined in clause 5.4.4 of TS 38.101-1 [7]. For TDD bands $F_{Tx-Rx\_separation} = 0$ .
$\Delta F_{Tx-Rx\_separation}$	$\Delta F_{Tx-Rx} =  (BW_{DL} - BW_{UL})/2 $ is the deviation to the default Tx-Rx carrier centre frequency separation ( $F_{Tx-Rx\_separation}$ ) for FDD FR1 bands supporting asymmetric channel bandwidths as defined in clause 5.3.6 of TS 38.101-1 [7].
$BW_{SSB}$	Bandwidth of the SSB. $BW_{SSB} = 12 * SCS_{SSB} * 20$
$\Delta GSCN, GSCN_{MIN}, GSCN_{MAX}$	GSCN step size, GSCN minimum and GSCN maximum values for the NR band according to table 5.4.3.3-1 of TS 38.101-1 [7] and TS 38.101-2 [8]
$Offset_{RBs}$	Offset (RBs) according to the applicable table 13-1 to 13-10 in TS 38.213 [22] for the given band and $\{SCS_{SSB}, SCS_{Carrier}\}$ combination of the carrier.
$Offset_{RBs,max}$	Maximum value for Offset (RBs) according to the applicable table 13-1 to 13-10 in TS 38.213 [22] for the given band and $\{SCS_{SSB}, SCS_{Carrier}\}$ combination of the carrier limited to the table indexes with number of RBs $N_{RB}^{CORESET}$ equal to the minimum value of $N_{RB}^{CORESET}$ in the table.
$Offset_{RBs,min}$	Minimum value for Offset (RBs) according to the applicable table 13-1 to 13-10 in TS 38.213 [22] for the given band and $\{SCS_{SSB}, SCS_{Carrier}\}$ combination of the carrier limited to the table indexes with number of RBs $N_{RB}^{CORESET}$ equal to the minimum value of $N_{RB}^{CORESET}$ in the table.

## C.2 Determination of test frequencies

### C.2.0 General

Test frequencies are determined as:

For symmetric NR bands (supporting same bandwidth in UL and DL):

- test frequencies for the supported symmetric channel bandwidth combinations are determined as described in clause C.2.1; and
- the test frequencies for the supported asymmetric channel bandwidth combinations are determined as described in clause C.2.3.

For asymmetric NR bands (supporting different bandwidth in UL and DL):

- the test frequencies for the supported symmetric channel bandwidth combinations are determined as described in clause C.2.2; and
- the test frequencies for the supported asymmetric channel bandwidth combinations are determined as described in clause C.2.3.

For NR CA and NR DC:

- the test frequencies are determined as described in the relevant subclause in C.2.4 depending to the type of configuration.

The carrier test frequencies are determined considering the channel raster according to clause 5.4.2.3 in TS 38.101-1 [7] for FR1 and in TS 38.101-2 [8] for FR2.

### C.2.1 Determination of test frequencies for symmetric NR bands and symmetric uplink and downlink channel bandwidth combinations

#### C.2.1.1 Determination of test frequencies for Low-, Mid- and High-Range

Downlink:

$F_{DL\_LowRange} = \text{Ceil}((F_{DL\_Low} + CBW_{DL}/2) / \Delta F_{Raster}) * \Delta F_{Raster}$	C.2.1.1-Eq1
$F_{DL\_MidRange} = \text{Round}((F_{DL\_Low} + BW_{DL}/2) / \Delta F_{Raster}) * \Delta F_{Raster}$	C.2.1.1-Eq2
$F_{DL\_HighRange} = \text{Floor}((F_{DL\_High} - CBW_{DL}/2) / \Delta F_{Raster}) * \Delta F_{Raster}$	C.2.1.1-Eq3

$F_{DL\_LowRange}$  is rounded up and  $F_{DL\_HighRange}$  is rounded down to obey to the minimum guard band according to clause 5.3.3 of TS 38.101-1 [7] and TS 38.101-2 [8].

Uplink:

$F_{UL\_LowRange} = F_{DL\_LowRange} - F_{Tx-Rx\_separation}$	C.2.1.1-Eq4
$F_{UL\_MidRange} = F_{DL\_MidRange} - F_{Tx-Rx\_separation}$	C.2.1.1-Eq5
$F_{UL\_HighRange} = F_{DL\_HighRange} - F_{Tx-Rx\_separation}$	C.2.1.1-Eq6

#### C.2.1.2 Determination test frequencies for of Mid-Low and Mid-High-Range for signalling tests

$F_{Mid-LowRange} = \text{Round}((F_{LowRange} + (F_{HighRange} - F_{LowRange})/3) / \Delta F_{Raster}) * \Delta F_{Raster}$	C.2.1.2-Eq1
$F_{Mid-HighRange} = \text{Round}((F_{LowRange} + 2*(F_{HighRange} - F_{LowRange})/3) / \Delta F_{Raster}) * \Delta F_{Raster}$	C.2.1.2-Eq2

## C.2.2 Determination of test frequencies for asymmetric NR bands and symmetric uplink and downlink channel bandwidth combinations

Determination of test frequencies for asymmetric NR bands, and symmetric uplink and downlink channel bandwidth combinations are determined using the procedure in clause C.2.3 with  $\Delta F_{\text{Tx-Rx}} = 0$ .

## C.2.3 Determination of test frequencies for bands supporting asymmetric channel bandwidth combinations

### C.2.3.1 General

The following procedure is used to calculate test frequencies for NR bands supporting asymmetric UL and DL channel bandwidths as described below, where  $\text{CBW}_{\text{UL}}$  and  $\text{CBW}_{\text{DL}}$  refer to the carrier's UL and DL channel bandwidths; and  $\text{BW}_{\text{UL}}$  and  $\text{BW}_{\text{DL}}$  refer to the band's total UL and DL bandwidths.

The procedure is also used to calculate test frequencies for symmetric UL and DL bandwidth combinations for asymmetric NR bands.

For FDD bands supporting asymmetric uplink and downlink bandwidth combinations a deviation of  $\Delta F_{\text{Tx-Rx}}$  (C.2.3.1-Eq1) is to be added to the default Tx-Rx carrier centre frequency separation,  $F_{\text{Tx-Rx\_separation}}$  (TS 38.101-1 [7] clause 5.3.6).

$\Delta F_{\text{Tx-Rx}} =  (\text{CBW}_{\text{DL}} - \text{CBW}_{\text{UL}})/2 $	C.2.3.1-Eq1
---	-------------

For the case of asymmetric NR bands and symmetric UL and DL bandwidth combinations  $\Delta F_{\text{Tx-Rx}} = 0$ . To meet the Tx-Rx frequency separation requirement for asymmetric NR bands where the supported overall UL bandwidth is smaller than the supported overall DL bandwidth it may not be possible to cover the full DL frequency range for all UL and DL channel bandwidth combinations. For CA when such band is only used for DL CC the full range can be used for all DL channel bandwidths.

To maximize the tested frequency range for the non-CA case the UL frequency range, as being smaller than the DL frequency range, need to be used as the starting point to calculate the uplink and downlink test frequencies.

### C.2.3.2 Determination of Low-, Mid- and High-Range for bands supporting asymmetric uplink and downlink bandwidth combinations

The following procedure is used to determine the test frequencies for Low-, Mid- and High-Range for bands supporting asymmetric UL and DL bandwidth combinations.

1. Calculate uplink carrier centre frequencies:

$F_{\text{UL\_LowRange}} = \text{Ceil}((F_{\text{UL\_Low}} + \text{CBW}_{\text{UL}}/2) / \Delta F_{\text{Raster}}) * \Delta F_{\text{Raster}}$	C.2.3.2-Eq1
$F_{\text{UL\_MidRange}} = \text{Round}((F_{\text{UL\_Low}} + \text{BW}_{\text{UL\_Band}}/2) / \Delta F_{\text{Raster}}) * \Delta F_{\text{Raster}}$	C.2.3.2-Eq2
$F_{\text{UL\_HighRange}} = \text{Floor}((F_{\text{UL\_Low}} + \text{BW}_{\text{UL\_Band}} - \text{CBW}_{\text{UL}}/2) / \Delta F_{\text{Raster}}) * \Delta F_{\text{Raster}}$	C.2.3.2-Eq3

2. Calculate the downlink frequencies:

Calculate the DL carrier centre frequencies from the UL frequencies in step 1.

$F_{\text{DL\_LowRange}} = F_{\text{UL\_LowRange}} + F_{\text{Tx-Rx\_separation}} + \Delta F_{\text{Tx-Rx}}$	C.2.3.2-Eq4
$F_{\text{DL\_MidRange}} = F_{\text{UL\_MidRange}} + F_{\text{Tx-Rx\_separation}} + \Delta F_{\text{Tx-Rx}}$	C.2.3.2-Eq5
$F_{\text{DL\_HighRange}} = F_{\text{UL\_HighRange}} + F_{\text{Tx-Rx\_separation}} + \Delta F_{\text{Tx-Rx}}$	C.2.3.2-Eq6

3. Check that the calculated centre test frequencies in step 2 for the  $\text{BW}_{\text{DL}}$  fits within the bands DL frequency range:

If  $F_{\text{DL\_LowRange}}$  is smaller than the lowest frequency of the band then recalculate the minimum  $F_{\text{DL\_LowRange}}$  and modify the associated  $F_{\text{UL\_LowRange}}$ ,  $F_{\text{DL\_MidRange}}$  and  $F_{\text{UL\_MidRange}}$  as:

$F_{DL\_LowRange} = \text{Ceil}((F_{DL\_Low} + CBW_{DL}/2) / \Delta F_{Raster}) * \Delta F_{Raster}$	C.2.3.2-Eq7
$F_{UL\_LowRange} = F_{DL\_LowRange} - F_{Tx-Rx\_separation} - \Delta F_{Tx-Rx}$	C.2.3.2-Eq8
$F_{DL\_MidRange} = \text{Round}((F_{DL\_LowRange} + F_{DL\_HighRange})/2 / \Delta F_{Raster}) * \Delta F_{Raster}$	C.2.3.2-Eq8a
$F_{UL\_MidRange} = F_{DL\_MidRange} - F_{Tx-Rx\_separation} - \Delta F_{Tx-Rx}$	C.2.3.2-Eq8b

If  $F_{DL\_HighRange}$  is larger than the higher frequency of the band then recalculate the maximum  $F_{DL\_HighRange}$  and modify the associated  $F_{UL\_HighRange}$ ,  $F_{DL\_MidRange}$  and  $F_{UL\_MidRange}$  as:

$F_{DL\_HighRange} = \text{Floor}((F_{DL\_Low} + BW_{DL\_Band} - CBW_{DL}/2) / \Delta F_{Raster}) * \Delta F_{Raster}$	C.2.3.2-Eq9
$F_{UL\_HighRange} = F_{DL\_HighRange} - F_{Tx-Rx\_separation} - \Delta F_{Tx-Rx}$	C.2.3.2-Eq10
$F_{DL\_MidRange} = \text{Round}((F_{DL\_LowRange} + F_{DL\_HighRange})/2 / \Delta F_{Raster}) * \Delta F_{Raster}$	C.2.3.2-Eq11
$F_{UL\_MidRange} = F_{DL\_MidRange} - F_{Tx-Rx\_separation} - \Delta F_{Tx-Rx}$	C.2.3.2-Eq12

### C.2.3.3 Determination of test frequencies for a Mid range adjacent inter-frequency cell for FR2 RRM multicell testing

The following procedure is used to determine the test frequencies for Mid-Range adjacent inter-frequency cell used for RRM FR2 NR multi-cell in NR SA and EN-DC test cases. The reason for using an adjacent inter-frequency cell to the Mid-range cell for FR2 instead of using Low- or High- Range test frequencies as used for FR1 is to reduce test system complexity.

In addition to the definition of parameters in clause C.1 the following parameters are used to calculate the test frequencies for the Mid adjacent inter-frequency cell:

Parameter	Description
$F_{Mid}$	Carrier centre frequency (MHz) of the Mid-range cell
$CBW_{Mid}$	Channel bandwidth (MHz) of the Mid-range cell
$CBW_{Adjacent}$	Channel bandwidth (MHz) of the adjacent cell

1. Calculate the Mid-range adjacent cell carrier centre frequencies:

$F_{MidRangeAdjacentCell} = \text{Ceil}((F_{Mid} + (CBW_{Mid} + CBW_{Adjacent})/2) / \Delta F_{Raster}) * \Delta F_{Raster}$	C.2.3.3-Eq1
--	-------------

2. Calculate SSB and CORESET#0 parameters as described in clause C.4.

## C.2.4 Frequency determination for NR CA and NR DC configurations

### C.2.4.1 Determination of test frequencies for NR Inter-band CA and NR DC

Test frequencies for NR Inter-band CA configurations and NR DC use the single carrier test frequencies for each of the included NR bands in the configuration as specified in clause 4.3.1.1.1 for FR1 bands and in clause 4.3.1.2.1 for FR2 bands.

### C.2.4.2 Determination of test frequencies for NR Intra-band Contiguous CA

#### C.2.4.2.1 General

By default, test frequencies for NR Intra-band Contiguous CA in clause 4.3.1 are specified using the nominal channel spacing between the carrier components as specified in TS 38.101-1 [7] clause 5.4A.1 for FR1 and TS 38.101-2 [8] clause 5.4A.1 for FR2. In addition, some NR bands may have test frequencies specified based on an adjusted channel spacing as specified in in TS 38.101-1 [7] clause 5.4A.1 for FR1 and TS 38.101-2 [8] clause 5.4A.1 for FR2.

The test frequencies for NR Intra-band Contiguous CA with SCS=15kHz or SCS=30 kHz for FR1 and with SCS=60 kHz or SCS=120 kHz for FR2 is calculated for each CC such that the specific test cases can decide which CC is used as PCell. This means that all CC test frequencies is calculated with a CORESET#0 as specified in clause C.3.2.

The test frequencies for CCs with SCS=60 kHz for FR1 and with SCS=240 kHz for FR2 is calculated without CORESET#0 as specified in C.3.3. CCs with SCS=60 kHz for FR1 and with SCS=240 kHz for FR2 can only be used for NR Intra-band Contiguous CA configurations with mixed numerologies.

Note: For NR Intra-band Contiguous CA configurations for bands where Tx frequency range is lower than Rx frequency range the RAN4 requirements for reference sensitivity testing is specified having the PCC frequency lower than the SCC frequencies such that UL PRB maximise the Tx-Rx separation. This means that CC1 shall be used as PCell in the reference test case for bands where Tx frequency range is lower than Rx frequency range; and highest CC shall be used as PCell in the reference test case for bands where Tx frequency range is higher than Rx frequency range.

In addition to the definition of parameters in clause C.1 the following parameters are used to calculate carrier components (CC) test frequencies for NR Intra-band Contiguous and Non-contiguous CA configurations:

Parameter	Description
$N_{CC}$	Number of CCs in the for NR Intra-band configuration
$CCBW_{DL}(i)$	Channel bandwidth (MHz) of downlink CC(i), where $i = 1$ to $N_{CC}$
$F_{Channel\_Spacing}(i)$	Channel spacing between CC(i) and CC(i+1), where $i = 1$ to $(N_{CC}-1)$

### C.2.4.2.2 Determination of test frequencies for Low-, Mid- and High-Range

Downlink CC(1), lowest frequency CC:

$F_{DL\_LowRange\_CC}(1)$  is rounded up and  $F_{DL\_HighRange\_CC}(1)$  is rounded down to obey to the minimum guard band according to clause 5.3.3 of TS 38.101-1 [7] and TS 38.101-2 [8].

$F_{DL\_LowRange\_CC}(1) = \text{Ceil}((F_{DL\_Low} + CCBW_{DL}(1) / 2) / \Delta F_{Raster}) * \Delta F_{Raster}$	C.2.4.2.2-Eq1
$F_{DL\_MidRange\_CC}(1) = \text{Round}((F_{DL\_Low} + BW_{DL}/2 - \sum_{k=1 \text{ to } (N_{CC})} CCBW_{DL}(k)/2 + CCBW_{DL}(1)/2) / \Delta F_{Raster}) * \Delta F_{Raster}$	C.2.4.2.2-Eq2
$F_{DL\_HighRange\_CC}(1) = \text{Floor}((F_{DL\_High} - CCBW_{DL}(N_{CC})/2 - \sum_{k=1 \text{ to } (N_{CC}-1)} F_{Channel\_Spacing}(k)) / \Delta F_{Raster}) * \Delta F_{Raster}$	C.2.4.2.2-Eq3

Downlink CC(2) to CC( $N_{CC}$ ), in increasing frequency order:

$F_{DL\_LowRange\_CC}(i) = F_{DL\_LowRange\_CC}(i-1) + F_{Channel\_Spacing}(i)$ , $i=2$ to $N_{CC}$	C.2.4.2.2-Eq4
$F_{DL\_MidRange\_CC}(i) = F_{DL\_MidRange\_CC}(i-1) + F_{Channel\_Spacing}(i)$ , $i=2$ to $N_{CC}$	C.2.4.2.2-Eq5
$F_{DL\_HighRange\_CC}(i) = F_{DL\_HighRange\_CC}(i-1) + F_{Channel\_Spacing}(i)$ , $i=2$ to $N_{CC}$	C.2.4.2.2-Eq6

Uplink CC(i),  $i=1$  to  $N_{CC}$ :

$F_{UL\_LowRange\_cc}(i) = F_{DL\_LowRange\_CC}(i) - F_{Tx-Rx\_separation}$	C.2.4.2.2-Eq7
$F_{UL\_MidRange\_cc}(i) = F_{DL\_MidRange\_CC}(i) - F_{Tx-Rx\_separation}$	C.2.4.2.2-Eq8
$F_{UL\_HighRange\_cc}(i) = F_{DL\_HighRange\_CC}(i) - F_{Tx-Rx\_separation}$	C.2.4.2.2-Eq9

## C.2.4.2A Determination of test frequencies for FR1 NR Intra-band Contiguous CA without UL CA for bands with uplink bandwidth less than downlink bandwidth

### C.2.4.2A.1 General

By default, test frequencies for FR1 NR Intra-band Contiguous CA for bands with uplink bandwidth less than downlink bandwidth in clause 4.3.1 (e.g. n66 and n70) are specified with CC1 used as PCC and all additional CCs are specified as SCCs without UL to enable the SCCs for High range to extend into the upper DL BW beyond the UL BW. The nominal channel spacing between the carrier components is calculated as specified in TS 38.101-1 [7] clause 5.4A.1.

In addition to the definition of parameters in clause C.1 the definition of parameters  $N_{CC}$ ,  $CCBW_{DL}$  and  $F_{Channel\_Spacing}$  in clause C.2.4.2.1, and  $\Delta F_{TX-RX}$  in clause C.2.3.1 are used to calculate the test frequencies.

### C.2.4.2A.2 Determination of test frequencies for Low-, Mid- and High-Range

1. Calculate UL carrier centre frequencies for Low and High ranges:



$F_{UL\_LowRange} = \text{Ceil}((F_{UL\_Low} + CBW_{UL}/2) / \Delta F_{Raster}) * \Delta F_{Raster}$	C.2.4.2A.2-Eq1
$F_{UL\_HighRange} = \text{Floor}((F_{UL\_Low} + BW_{UL\_Band} - CBW_{UL}/2) / \Delta F_{Raster}) * \Delta F_{Raster}$	C.2.4.2A.2-Eq2

2. Calculate the DL CC(1) carrier centre frequencies from the UL frequencies in step 1 for Low and High ranges:

$\Delta F_{TX-RX} =  (CBW_{DL}(1) - CBW_{UL})/2 $	C.2.4.2A.2-Eq3
$s = +1$ if $F_{UL\_Low} \leq F_{DL\_Low}$ else $-1$	C.2.4.2A.2-Eq4
$F_{DL\_LowRange\_cc}(1) = F_{UL\_LowRange} + s * (F_{Tx-Rx\_separation} + \Delta F_{Tx-Rx})$	C.2.4.2A.2-Eq5
$F_{DL\_HighRange\_cc}(1) = F_{UL\_HighRange} + s * (F_{Tx-Rx\_separation} + \Delta F_{Tx-Rx})$	C.2.4.2A.2-Eq6

3. Check that DL aggregated CBW for the High range fits into the DL bandwidth.

$F_{DL\_HighRange\_max} = \text{Floor}((F_{DL\_HighRange\_CC}(1) + \sum_{k=1 \text{ to } N_{cc}-1} F_{Channel\_Spacing}(k) + CCBW_{DL}(N_{cc})/2)$	C.2.4.2A.2-Eq7
--	----------------

If  $F_{DL\_HighRange\_max}$  is less or equal to  $F_{DL\_High}$  then goto step 4 else modify  $F_{DL\_HighRange\_CC}(1)$  such that the full aggregated CBW is located at the DL bandwidth high edge and recalculate  $F_{UL\_HighRange}$ .

$F_{DL\_HighRange\_CC}(1) = F_{DL\_High} - CCBW_{DL}(N_{cc})/2 - \sum_{k=1 \text{ to } (N_{cc}-2)} F_{Channel\_Spacing}(k)$	C.2.4.2A.2-Eq8
$F_{UL\_HighRange} = F_{DL\_HighRange\_CC}(1) - s * (F_{Tx-Rx\_separation} + \Delta F_{Tx-Rx})$	C.2.4.2A.2-Eq9

4. Calculate the  $F_{UL\_MidRange}$  and  $F_{DL\_MidRange\_CC}(1)$ :

$F_{DL\_MidRange\_cc}(1) = \text{Round}((F_{DL\_LowRange\_CC}(1) + F_{DL\_HighRange\_CC}(1))/2) / \Delta F_{Raster} * \Delta F_{Raster}$	C.2.4.2A.2-Eq10
$F_{UL\_MidRange} = F_{DL\_MidRange\_CC}(1) - s * (F_{Tx-Rx\_separation} + \Delta F_{Tx-Rx})$	C.2.4.2A.2-Eq11

5. Calculate DL CC(2) to CC( $N_{cc}$ ), in increasing frequency order:

$F_{DL\_LowRange\_CC}(i) = F_{DL\_LowRange\_CC}(i-1) + F_{Channel\_Spacing}(i), i=2 \text{ to } N_{cc}$	C.2.4.2A.2-Eq12
$F_{DL\_MidRange\_CC}(i) = F_{DL\_MidRange\_CC}(i-1) + F_{Channel\_Spacing}(i), i=2 \text{ to } N_{cc}$	C.2.4.2A.2-Eq13
$F_{DL\_HighRange\_CC}(i) = F_{DL\_HighRange\_CC}(i-1) + F_{Channel\_Spacing}(i), i=2 \text{ to } N_{cc}$	C.2.4.2A.2-Eq14

## C.2.4.3 Determination of test frequencies for NR Intra-band Non-Contiguous CA

### C.2.4.3.1 General

The default test frequencies in clause 4.3.1 for NR Intra-band Non-Contiguous CA are based on maximum  $W_{gap}$  between the carrier components of the different bands taking the UE capability of maximum supported frequency separation between the lower edge of lowest component carrier and upper edge of highest component carrier for UL for FR1, and UL and DL for FR2.

Test frequencies with  $W_{gap}$  different from maximum  $W_{gap}$  are specified in the specific test cases using them.

In addition to the definition of parameters in clause C.1 the following parameters are used to calculate carrier components (CC) test frequencies for NR Intra-band Contiguous and Non-contiguous CA configurations:

Parameter	Description
$N_{SB}$	Number of sub-block in the for NR Intra-band non-contiguous configuration
$SBCBW_{DL}(i)$	Downlink channel bandwidth (MHz) of sub-block SB(i), where $i = 1$ to $N_{SB}$
$maxF_{sBW}$	Maximum frequency separation bandwidth between the lower edge of lowest component carrier and upper edge of highest component carrier.
$maxW_{gap}$	$maxW_{gap}$ is the maximum separation in MHz between each sub-block in the NR Intra-band non-contiguous configuration within $maxF_{sBW}$ for a given sub-block combination.

### C.2.4.3.1A Selection of maximum frequency separation for FR1

Select the maxFsBW dependent on the type of configuration and aggregated CBW for the sub-block combination in Table C.2.4.3.1A-1:

**Table C.2.4.3.1A-1: Selecting maxFsBW for FR1**

Type of configuration	Aggregated CBW	maxFsBW
Without UL CA	All	Full NR bandwidth
With UL CA	<100 MHz	Min(Full NR bandwidth,100 MHz)
	>=100 MHz and <200 MHz	Min(Full NR bandwidth,200 MHz)
	>=200 MHz and <600 MHz	Min(Full NR bandwidth,600 MHz)=
	=600 MHz	Full NR bandwidth

### C.2.4.3.1B Selection of maximum frequency separation for FR2

Select the maxFsBW dependent on the type of configuration and aggregated CBW for the sub-block combination in Table C.2.4.3.1B-1:

**Table C.2.4.3.1B-1: Selecting maxFsBW for FR2**

Type of configuration	Aggregated CBW	maxFsBW (Note 1)
With non-contiguous UL CA	<400 MHz	400 MHz
	>=400 MHz and <600 MHz	600 MHz
	>=600 MHz and <800 MHz	800 MHz
	>=800 MHz and <1000 MHz	1000 MHz
	>=1000 MHz and <1200 MHz	1200 MHz
	>=1200 MHz and <1400 MHz	1400 MHz
	>=1400 MHz	N/A
Without non-contiguous UL CA	<400 MHz	400 MHz
	>=400 MHz and <600 MHz	600 MHz
	>=600 MHz and <800 MHz	800 MHz
	>=800 MHz and <1000 MHz	1000 MHz
	>=1000 MHz and <1200 MHz	1200 MHz
	>=1200 MHz and <1400 MHz	1400 MHz
	>=1400 MHz and <1600 MHz	1600 MHz
	>=1600 MHz and <1800 MHz	1800 MHz
	>=1800 MHz and <2000 MHz	2000 MHz
	>=2000 MHz and <2200 MHz	2200 MHz
>=2200 MHz and <2400 MHz	2400 MHz	
Note 1: For FR2 intra-band non-contiguous CA configurations with non-contiguous UL CA the selected value of maxFsBW is based on applicable frequency separation classes for UL non-contiguous operation in TS 38.101-2 [8], Table 5.3A.4-2. For FR2 intra-band non-contiguous CA configurations without non-contiguous UL CA the selected value of maxFsBW is based on applicable frequency separation classes for DL non-contiguous operation in TS 38.101-2 [8], Table 5.3A.4-2.		

### C.2.4.3.2 Determination of test frequencies for a sub-block combination

**Editor's note:** The number of test points for FR2 intra-band non-contiguous CA configurations is under investigation, e.g. "Low" and "High", or "Mid".

1. Calculate the maxWgap value between sub-blocks for the sub-block combination:

$$\text{maxWgap} = (\text{maxFsBW} - \sum_{k=1 \text{ to } N_{SB}} \text{SBCBW}_{DL}(k)) / (N_{SB} - 1) \quad \text{C.2.4.3.3-Eq1}$$

2. Calculate test frequencies for all sub-blocks in the sub-block combination:

If the maxFsBW is smaller than the full bandwidth of the NR band then calculate test frequencies for both Low and High range. Else only for the Low range.

For Low range the test frequencies are calculated such that the lower edge of the lowest component carrier of the lowest frequency sub-block is located at the lower edge of the NR bandwidth. The sub-blocks are separated by the calculated maxWgap in step 1.

For High range the test frequencies are calculated such that the upper edge of the highest component carrier of the highest frequency sub-block is located at the upper edge frequency of the NR bandwidth. The sub-blocks are separated by the calculated maxWgap in step 1.

Within each sub-block the test frequencies and parameters of the sub-block are calculated based on the location of the sub-block and the relevant principles in clause C.2, C3 and C4 for the type of component carriers in the sub-block.

The test frequencies for CCs with SCS=60 kHz for FR1 and with SCS=240 kHz for FR2 is calculated without CORESET#0 as specified in C.3.3. CCs with SCS=60 kHz for FR1 and with SCS=240 kHz for FR2 can only be used for NR Intra-band Non-Contiguous CA configurations with mixed numerologies.

### C.2.4.3.3 Void

## C.2.5 Frequency determination for supplemental uplink

### C.2.5.1 General

The following procedure is used to calculate test frequencies for NR supplemental uplink as described below, where  $CBW_{UL}$  refers to the carrier's UL channel bandwidths and  $BW_{UL}$  refers to the band's total UL bandwidths.

### C.2.5.2 Determination of Low-, Mid- and High-Range for supplemental uplink bands

The following procedure is used to determine the uplink carrier centre frequencies for Low-, Mid- and High-Range for supplemental uplink bands.

$F_{UL\_LowRange} = \text{Ceil}((F_{UL\_Low} + CBW_{UL}/2) / \Delta F_{Raster}) * \Delta F_{Raster}$	C.2.5.2-Eq1
$F_{UL\_MidRange} = \text{Round}((F_{UL\_Low} + BW_{UL\_Band}/2) / \Delta F_{Raster}) * \Delta F_{Raster}$	C.2.5.2-Eq2
$F_{UL\_HighRange} = \text{Floor}((F_{UL\_Low} + BW_{UL\_Band} - CBW_{UL}/2) / \Delta F_{Raster}) * \Delta F_{Raster}$	C.2.5.2-Eq3

## C.2.6 Frequency determination for EN-DC configurations

### C.2.6.1 Determination of test frequencies for EN-DC Inter-band

Test frequencies for EN-DC Intra-band non-contiguous configurations use the Low and High ranges test frequencies for each of the included single carrier E-UTRA and NR bands, and E-UTRA and NR CA configurations in the configuration as specified E-UTRA in TS 36.508 [2], clause 4.3.1 and for NR in clause 4.3.1.1.1 for FR1 bands and in clause 4.3.1.2.1 for FR2 bands.

### C.2.6.2 Determination of test frequencies for EN\_DC Intra-band Contiguous CA

#### C.2.6.2.1 General

By default, test frequencies for EN-DC Intra-band Contiguous CA in clause 4.3.1 are specified using the nominal channel spacing between the E-UTRA and NR carrier components as specified in TS 38.101-3 [9], clause 5.4B.1.

The test frequencies for EN\_DC Intra-band Contiguous CA is calculated for Low and High ranges for the following two cases:

- with NR CC at the band edge; and
- with E-UTRA CC at the band edge.

In addition to the definition of parameters in clause C.1 the following parameters are used to calculate carrier components (CC) test frequencies for EN\_DC Intra-band Contiguous:

Parameter	Description
$N_{NR\_CC}$	Number of NR CCs in the EN-DC Intra-band configuration
$N_{EUTRA\_CC}$	Number of E-UTRA CCs in the EN-DC Intra-band configuration
$CCBW_{NR\_DL}(i)$	Channel bandwidth (MHz) of downlink NR CC(i), where $i = 1$ to $N_{NR\_CC}$
$CCBW_{EUTRA\_DL}(m)$	Channel bandwidth (MHz) of downlink E-UTRA CC(m), where $m = 1$ to $N_{EUTRA\_CC}$
$F_{NR\_EUTRA\_Channel\_Spacing}$	Nominal channel spacing between adjacent NR and E-UTRA CCs as defined in TS 38.101-3 [9], 5.4B.1.
$F_{EUTRA\_Channel\_Spacing}(m)$	Nominal channel spacing between E-UTRA adjacent contiguous CC(m) and CC(m+1), where $m = 1$ to $(N_{EUTRA\_CC}-1)$ as defined in TS 36.101 [48], 5.7.1A.
$F_{NR\_Channel\_Spacing}(i)$	Nominal channel spacing between NR adjacent contiguous CC(i) and CC(i+1), where $i = 1$ to $(N_{NR\_CC}-1)$ as defined in TS 38.101-1 [7] clause 5.4A.1 for FR1 and TS 38.101-2 [8] clause 5.4A.1 for FR2
$LCM\Delta F_{Raster}$	Least Common Multiple of NR $\Delta F_{Raster}$ and E-UTRA $\Delta F_{Raster}$ equals to 300 kHz for E-UTRA $\Delta F_{Raster} = 100$ kHz and NR $\Delta F_{Raster} = 15$ kHz, 30kHz and 60kHz.

### C.2.6.2.2 Determination of test frequencies for Low-, Mid- and High-Range with NR at band edges

Downlink NR CC(1), lowest frequency CC:

$F_{NR\_DL\_LowRange\_CC}(1)$  is rounded up and  $F_{NR\_DL\_HighRange\_CC}(1)$  is rounded down to obey to the minimum guard band according to clause 5.3.3 of TS 38.101-1 [7] and TS 38.101-2 [8].

The NR test frequencies are calculated such that both the NR CC and E-UTRA CC adjacent to each other are located at the NR and E-UTRA frequency raster respectively.

$F_{NR\_DL\_LowRange\_CC}(1) = \text{Ceil}((F_{DL\_Low} + CCBW_{NR\_DL}(1) / 2 + F_{NR\_EUTRA\_Channel\_Spacing}) / LCM\Delta F_{Raster}) * LCM\Delta F_{Raster} - F_{NR\_EUTRA\_Channel\_Spacing}$ , where $F_{NR\_EUTRA\_Channel\_Spacing} = \text{Round}((CCBW_{EUTRA\_DL}(1) + CCBW_{NR\_DL}(N_{NR\_CC})) / (2 * \Delta F_{Raster})) * \Delta F_{Raster}$	C.2.6.2.2-Eq1
$F_{NR\_DL\_MidRange\_CC}(1) = \text{Round}((F_{DL\_Low} + BW_{DL}/2 - (\sum_{i=1}^{N_{NR\_CC}} CCBW_{NR\_DL}(i) + \sum_{m=1}^{N_{EUTRA\_CC}} CCBW_{EUTRA\_DL}(m)) / 2 + CCBW_{NR\_DL}(1)) / 2) + F_{NR\_EUTRA\_Channel\_Spacing} / LCM\Delta F_{Raster}) * LCM\Delta F_{Raster} - F_{NR\_EUTRA\_Channel\_Spacing}$ , where $F_{NR\_EUTRA\_Channel\_Spacing} = \text{Round}((CCBW_{EUTRA\_DL}(1) + CCBW_{NR\_DL}(N_{NR\_CC})) / (2 * \Delta F_{Raster})) * \Delta F_{Raster}$	C.2.6.2.2-Eq2
$F_{NR\_DL\_HighRange\_CC}(1) = \text{Floor}((F_{DL\_High} - CCBW_{NR\_DL}(N_{NR\_CC}) / 2 - \sum_{i=1}^{(N_{NR\_CC}-1)} F_{NR\_Channel\_Spacing}(i) - F_{NR\_EUTRA\_Channel\_Spacing}) / LCM\Delta F_{Raster}) * LCM\Delta F_{Raster} + F_{NR\_EUTRA\_Channel\_Spacing}$ , where $F_{NR\_EUTRA\_Channel\_Spacing} = \text{Round}((CCBW_{EUTRA\_DL}(N_{EUTRA\_CC}) + CCBW_{NR\_DL}(1)) / (2 * \Delta F_{Raster})) * \Delta F_{Raster}$	C.2.6.2.2-Eq3

Downlink NR CC(2) to CC( $N_{NR\_CC}$ ), in increasing frequency order:

$F_{NR\_DL\_LowRange\_CC}(k) = F_{DL\_LowRange\_CC}(k-1) + \sum F_{NR\_Channel\_Spacing}(k)$ , $k=2$ to $N_{DL\_CC}$	C.2.6.2.2-Eq4
$F_{NR\_DL\_MidRange\_CC}(k) = F_{DL\_MidRange\_CC}(k-1) + \sum F_{NR\_Channel\_Spacing}(k)$ , $k=2$ to $N_{DL\_CC}$	C.2.6.2.2-Eq5
$F_{NR\_DL\_HighRange\_CC}(k) = F_{DL\_HighRange\_CC}(k-1) + \sum F_{NR\_Channel\_Spacing}(k)$ , $k=2$ to $N_{DL\_CC}$	C.2.6.2.2-Eq6

Uplink NR CC(k),  $k=1$  to  $N_{CC}$ :

$F_{NR\_UL\_LowRange\_CC}(k) = F_{NR\_DL\_LowRange\_CC}(k) - F_{Tx-Rx\_separation}$	C.2.6.2.2-Eq7
$F_{NR\_UL\_MidRange\_CC}(k) = F_{NR\_DL\_MidRange\_CC}(k) - F_{Tx-Rx\_separation}$	C.2.6.2.2-Eq8
$F_{NR\_UL\_HighRange\_CC}(k) = F_{NR\_DL\_HighRange\_CC}(k) - F_{Tx-Rx\_separation}$	C.2.6.2.2-Eq9

Downlink E-UTRA CC(1), lowest frequency CC:

$\Delta F_{NR\_EUTRA\_Channel\_Spacing}$  is selected in each formula C.2.6.2.2-Eq10, C.2.6.2.2-Eq11 and C.2.6.2.2-Eq12 selected such that  $F_{EUTRA\_DL\_LowRange\_CC}(1)$ ,  $F_{EUTRA\_DL\_MidRange\_CC}(1)$  and  $F_{EUTRA\_DL\_HighRange\_CC}(1)$  are located on the E-UTRA band frequency raster.

$F_{EUTRA\_DL\_LowRange\_CC}(1) = F_{NR\_DL\_LowRange\_CC}(N_{DL\_CC}) + F_{NR\_EUTRA\_Channel\_Spacing}$	C.2.6.2.2-Eq10
$F_{EUTRA\_DL\_MidRange\_CC}(1) = F_{NR\_DL\_MidRange\_CC}(N_{DL\_CC}) + F_{NR\_EUTRA\_Channel\_Spacing}$	C.2.6.2.2-Eq11
$F_{EUTRA\_DL\_HighRange\_CC}(1) = F_{NR\_DL\_HighRange\_CC}(N_{DL\_CC}) - \sum_{i=1}^{(N_{NR\_CC}-1)} F_{NR\_Channel\_Spacing}(i) - F_{NR\_EUTRA\_Channel\_Spacing} - \sum_{i=1}^{(N_{EUTRA\_CC}-1)} F_{EUTRA\_Channel\_Spacing}(i)$	C.2.6.2.2-Eq12

Downlink E-UTRA CC(2) to CC( $N_{\text{EUTRA\_CC}}$ ), in increasing frequency order:

$F_{\text{EUTRA\_DL\_LowRange\_CC}}(k) = F_{\text{EUTRA\_DL\_LowRange\_CC}}(k-1) + \sum F_{\text{EUTRA\_Channel\_Spacing}}(k)$ , $k=2$ to $N_{\text{EUTRA\_CC}}$	C.2.6.2.2-Eq13
$F_{\text{EUTRA\_DL\_MidRange\_CC}}(k) = F_{\text{EUTRA\_DL\_MidRange\_CC}}(k-1) + \sum F_{\text{EUTRA\_Channel\_Spacing}}(k)$ , $k=2$ to $N_{\text{EUTRA\_CC}}$	C.2.6.2.2-Eq14
$F_{\text{EUTRA\_DL\_HighRange\_CC}}(k) = F_{\text{EUTRA\_DL\_HighRange\_CC}}(k-1) + \sum F_{\text{EUTRA\_Channel\_Spacing}}(k)$ , $k=2$ to $N_{\text{EUTRA\_CC}}$	C.2.6.2.2-Eq15

Uplink E-UTRA CC(k),  $k=1$  to  $N_{\text{EUTRA\_CC}}$ :

$F_{\text{EUTRA\_UL\_LowRange\_CC}}(k) = F_{\text{EUTRA\_DL\_LowRange\_CC}}(k) - F_{\text{Tx-Rx\_separation}}$	C.2.6.2.2-Eq16
$F_{\text{EUTRA\_UL\_MidRange\_CC}}(k) = F_{\text{EUTRA\_DL\_MidRange\_CC}}(k) - F_{\text{Tx-Rx\_separation}}$	C.2.6.2.2-Eq17
$F_{\text{EUTRA\_UL\_HighRange\_CC}}(k) = F_{\text{EUTRA\_DL\_HighRange\_CC}}(k) - F_{\text{Tx-Rx\_separation}}$	C.2.6.2.2-Eq18

### C.2.6.2.3 Determination of test frequencies for Low-, Mid- and High-Range with E-UTRA at band edges

To get the NR carrier on the synchronisation raster the calculations of the E-UTRA carrier components needs to be based on the location of the NR carrier.

Downlink NR CC(1), lowest frequency CC:

$F_{\text{NR\_DL\_LowRange\_CC}}(1)$  is rounded up and  $F_{\text{NR\_DL\_HighRange\_CC}}(1)$  is rounded down to obey to the minimum guard band according to clause 5.3.3 of TS 38.101-1 [7] and TS 38.101-2 [8].

$F_{\text{NR\_DL\_LowRange\_CC}}(1) = \text{Ceil}((F_{\text{DL\_Low}} + \sum_{m=1}^{N_{\text{EUTRA\_CC}}} \text{CCBW}_{\text{EUTRA\_DL}}(m) + \text{CCBW}_{\text{NR\_DL}}(1) / 2 - F_{\text{NR\_EUTRA\_Channel\_Spacing}}) / \text{LCM}\Delta F_{\text{Raster}}) * \text{LCM}\Delta F_{\text{Raster}} + F_{\text{NR\_EUTRA\_Channel\_Spacing}}$ , where $F_{\text{NR\_EUTRA\_Channel\_Spacing}} = \text{Round}((\text{CCBW}_{\text{EUTRA\_DL}}(N_{\text{EUTRA\_CC}}) + \text{CCBW}_{\text{NR\_DL}}(1)) / (2 * \Delta F_{\text{Raster}})) * \Delta F_{\text{Raster}}$	C.2.6.2.3-Eq1
$F_{\text{NR\_DL\_MidRange\_CC}}(1) = \text{same formula as C.2.6.2.2-Eq2}$	C.2.6.2.3-Eq2
$F_{\text{NR\_DL\_HighRange\_CC}}(1) = \text{Floor}((F_{\text{DL\_High}} - (\sum_{m=1}^{N_{\text{EUTRA\_CC}}} \text{CCBW}_{\text{EUTRA\_DL}}(m) + \sum_{i=1}^{N_{\text{NR\_CC}}} \text{CCBW}_{\text{NR\_DL}}(i)) + \text{CCBW}_{\text{NR\_DL}}(1) / 2 + F_{\text{NR\_EUTRA\_Channel\_Spacing}}) / \text{LCM}\Delta F_{\text{Raster}}) * \text{LCM}\Delta F_{\text{Raster}} - F_{\text{NR\_EUTRA\_Channel\_Spacing}}$ , where $F_{\text{NR\_EUTRA\_Channel\_Spacing}} = \text{Round}((\text{CCBW}_{\text{EUTRA\_DL}}(1) + \text{CCBW}_{\text{NR\_DL}}(N_{\text{NR\_CC}})) / (2 * \Delta F_{\text{Raster}})) * \Delta F_{\text{Raster}}$	C.2.6.2.3-Eq3

Downlink NR CC(2) to CC( $N_{\text{NR\_CC}}$ ), in increasing frequency order:

$F_{\text{NR\_DL\_LowRange\_CC}}(k) = \text{same formula as C.2.6.2.2-Eq4}$	C.2.6.2.3-Eq4
$F_{\text{NR\_DL\_MidRange\_CC}}(k) = \text{same formula as C.2.6.2.2-Eq5}$	C.2.6.2.3-Eq5
$F_{\text{NR\_DL\_HighRange\_CC}}(k) = \text{same formula as C.2.6.2.2-Eq6}$	C.2.6.2.3-Eq6

Uplink NR CC(k),  $k=1$  to  $N_{\text{CC}}$ :

$F_{\text{NR\_UL\_LowRange\_CC}}(k) = \text{same formula as C.2.6.2.2-Eq7}$	C.2.6.2.3-Eq7
$F_{\text{NR\_UL\_MidRange\_CC}}(k) = \text{same formula as C.2.6.2.2-Eq8}$	C.2.6.2.3-Eq8
$F_{\text{NR\_UL\_HighRange\_CC}}(k) = \text{same formula as C.2.6.2.2-Eq9}$	C.2.6.2.3-Eq9

Downlink E-UTRA CC(1), lowest frequency CC:

$F_{\text{EUTRA\_DL\_LowRange\_CC}}(1) = F_{\text{NR\_DL\_LowRange\_CC}}(1) - F_{\text{NR\_EUTRA\_Channel\_Spacing}} - \sum_{m=1}^{(N_{\text{EUTRA\_CC}} - 1)} F_{\text{EUTRA\_Channel\_Spacing}}(m)$	C.2.6.2.3-Eq10
$F_{\text{EUTRA\_DL\_MidRange\_CC}}(1) = \text{same formula as C.2.6.2.2-Eq11}$	C.2.6.2.3-Eq11
$F_{\text{EUTRA\_DL\_HighRange\_CC}}(1) = F_{\text{NR\_DL\_HighRange\_CC}}(N_{\text{DL\_CC}}) + \sum_{i=1}^{(N_{\text{NR\_CC}} - 1)} F_{\text{NR\_Channel\_Spacing}}(i) + F_{\text{NR\_EUTRA\_Channel\_Spacing}} + \sum_{i=1}^{(N_{\text{EUTRA\_CC}} - 1)} F_{\text{EUTRA\_Channel\_Spacing}}(i)$	C.2.6.2.3-Eq12

Downlink E-UTRA CC(2) to CC( $N_{\text{EUTRA\_CC}}$ ), in increasing frequency order:

$F_{\text{EUTRA\_DL\_LowRange\_CC}}(k) = \text{same formula as C.2.6.2.2-Eq13}$	C.2.6.2.3-Eq13
$F_{\text{EUTRA\_DL\_MidRange\_CC}}(k) = \text{same formula as C.2.6.2.2-Eq14}$	C.2.6.2.3-Eq14
$F_{\text{EUTRA\_DL\_HighRange\_CC}}(k) = \text{same formula as C.2.6.2.2-Eq15}$	C.2.6.2.3-Eq15

Uplink E-UTRA CC(k),  $k=1$  to  $N_{\text{EUTRA\_CC}}$ :

$F_{\text{EUTRA\_UL\_LowRange\_cc}}(\mathbf{k})$ = same formula as C.2.6.2.2-Eq16	C.2.6.2.3-Eq16
$F_{\text{EUTRA\_UL\_MidRange\_cc}}(\mathbf{k})$ = same formula as C.2.6.2.2-Eq17	C.2.6.2.3-Eq17
$F_{\text{EUTRA\_UL\_HighRange\_cc}}(\mathbf{k})$ = same formula as C.2.6.2.2-Eq18	C.2.6.2.3-Eq18

### C.2.6.3 Determination of test frequencies for EN-DC Intra-band non-contiguous

Test frequencies for EN-DC Intra-band non-contiguous configurations use the Low and High ranges test frequencies for each of the included single carrier E-UTRA and NR bands, and E-UTRA and NR CA configurations in the configuration as specified E-UTRA in TS 36.508 [2], clause 4.3.1 and for NR in clause 4.3.1.1.1 for FR1 bands and in clause 4.3.1.2.1 for FR2 bands.

The following cases of test frequencies are specified for relevant E-UTRA and NR CBW combinations, and NR SCS:

- Low with maxWgap (NR - E-UTRA): NR Low range and E-UTRA High range
- High with maxWgap (E-UTRA - NR): NR High range and E-UTRA Low range

## C.3 Determination of SSB and CORESET#0

### C.3.1 General

The requirements to be met and the principles used for determining the SSB and CORESET#0 for a PCell are:

1. The complete SSB and CORESET#0 shall be within the carrier's channel bandwidth.
2. The SSB centre frequency ( $F_{\text{SSref}}$ ) shall be on the synchronisation raster.
3. The SSB shall be kept as close as possible to the carrier's lower edge centre frequency.
4. CORESET#0 configuration is selected using lowest number of RBs and symbols in applicable table in TS 38.213 [22], clause 13.
5. The first SSB subcarrier shall be aligned with the defined resource grid given by SCS indicated by *subCarrierSpacingCommon* in the MIB.

### C.3.2 Determination of SSB, CORESET#0 and signalling parameters for a PCell

Calculation of SSB and CORESET#0 parameters is limited to FR1 carriers with SCS=15 kHz or SCS=30 kHz, and to FR2 carriers with SCS=60 kHz or SCS=120 kHz. CORESET#0 is required for a carrier to be used as a PCell.

The following procedure is used to determine an SSB on the synchronisation raster (GSCN) and a CORESET#0 configuration ( $k_{\text{SSB}}$ ,  $\text{Offset}_{\text{RBs}}$  and  $\text{OffsetToPointA}$ ) as close as possible to the carrier's lower edge. See figure C1-1 and clause C.1 for definition of parameters referenced in the procedure.

1. Determine SSB and CORESET#0:
  - 1a. Calculate the lower of  $F_{\text{SSref}}$ ,  $F_{\text{SSref\_Min}}$ , correspondent to SSB lowest subcarrier being at the same frequency as the carrier's lowest subcarrier; and the higher limit of  $F_{\text{SSref}}$ ,  $F_{\text{SSref\_Max}}$ , correspondent to SSB highest subcarrier being at the same frequency as the carrier's highest subcarrier  $F_{\text{SSref\_Min}}$

$F_{\text{carrierLow}}$ = see formula for $F_{\text{carrierLow}}$ in Table C.1-1
$F_{\text{SSref\_Min}} = F_{\text{carrierLow}} + \text{CRB}_{\text{size}} * \text{Offset}_{\text{RBs\_min}} + \text{BW}_{\text{SSB}} / 2$
$F_{\text{SSref\_Max}} = F_{\text{carrierLow}} + \Delta F_{\text{carrierBandwidth}} - \text{BW}_{\text{SSB}} / 2$

- 1b. Calculate  $\text{GSCN}_{\text{MIN}}$  correspondent to  $F_{\text{SSref\_Min}}$  in accordance to TS 38.101-1 [7], clause 5.4.3.1 for FR1 and TS 38.101-2 [7], clause 5.4.3.1 for FR2 and select the closest valid GSCN value with  $\text{GSCN} \geq \text{GSCN}_{\text{MIN}}$  for the carrier in according to the carrier's synchronisation raster as specified in clause 5.4.3.3 in TS 38.101-1 [7] and TS 38.101-2 [8].

- 1c. Calculate the  $F_{SSref}$  for the selected GSCN value in step 1b in accordance to TS 38.101-1 [7], clause 5.4.3.1 for FR1 and TS 38.101-2 [7], clause 5.4.3.1 for FR2.
- 1d. Calculate the frequency  $F_{offsetToPointA}$ , which is the lowest subcarrier of the lowest resource block with the subcarrier spacing being a multiple of resource blocks expressed in terms of common PRB size and overlaps with the SS/PBCH block subcarrier 0 of the first resource block of the SS/PBCH block,  $F_{SSBlow}$  (TS 38.211 [3], clause 7.4.3.1):

$F_{SSBlow} = F_{SSref} - BW_{SSB} / 2$
$F_{offsetToPointA} = CRB_{size} * Floor((F_{SSBlow} - F_{carrierLow}) / CRB_{size}) + F_{carrierLow}$

- 1e. Calculate the maximum  $Offset_{RBs}$  value with  $F_{CORESET0Low} \geq F_{carrierLow}$ :

$Max\_Offset_{RBs} = (F_{offsetToPointA} - F_{carrierLow}) / CRB_{size}$
--

- 1f. Select the largest valid  $Offset_{RBs}$  value equal or smaller than the calculated max value,  $Max\_Offset_{RBs}$  in step 1e within the applicable values for the carrier in TS 38.213 [4], table 13-1 to 13-10 limited to the table indexes with number of RBs  $N_{RB}^{CORESET}$  and number of symbols  $N_{symb}^{CORESET}$  equal to the minimum value of  $N_{RB}^{CORESET}$  in the table and minimum value of  $N_{symb}^{CORESET}$  for the selected  $N_{RB}^{CORESET}$ . If a valid  $Offset_{RBs}$  value is found, then continue from step 1g.

If no valid  $Offset_{RBs}$  value is found, then select the next valid GSCN with  $F_{SSref} \leq F_{SSref\_Max}$  within the valid GSCN range for the carrier and repeat steps 1b to 1f.

If no valid  $Offset_{RBs}$  value found within the valid GSCN range then will the carrier not be possible to use as PCell and  $F_{SSref}$ ,  $k_{SSB}$ ,  $F_{PointA}$ ,  $OffsetToCarrier$  and  $OffsetToPointA$  are calculated as described in clause C.3.3 and the procedure is completed.

- 1g. Calculate  $k_{SSB}$

$k_{SSB} = (F_{SSBlow} - F_{offsetToPointA}) / \{15 \text{ kHz for FR1, } subCarrierSpacingCommon \text{ (MIB) for FR2}\}$ (TS 38.211 [3], clause 7.4.3.1).
$N = SCS_{SSB} / \{15 \text{ kHz for FR1; } subCarrierSpacingCommon \text{ (MIB) for FR2}\}$ .
$k_{SSB} \text{ MOD } N \neq 0$ indicates that the SSB subcarriers are not aligned with the resource grid given by the SCS indicated by $subCarrierSpacingCommon$ in the MIB.

If  $k_{SSB}$  is an integer and  $k_{SSB} \text{ MOD } N = 0$ , then continue from step 2.

If  $k_{SSB}$  is not an integer value or  $k_{SSB} \text{ MOD } N \neq 0$ , then select the next valid GSCN with  $F_{SSref} < F_{SSref\_Max}$  within the valid GSCN range for the carrier and repeat steps 1b to 1g.

If  $N > 1$  and no valid  $k_{SSB}$  value found within the valid GSCN range for the currently selected carrier frequency  $F_{carrier}$  then shift  $F_{carrier}$  up by  $\Delta F_{Raster}$  for Low range; or down by  $\Delta F_{Raster}$  for Mid, Mid-Low, Mid-High and High ranges and repeat steps 1a to 1g for a maximum shift of  $3 * \Delta F_{Raster}$  (see clause C.3.1, Note 1). Cases requiring more than  $3 * \Delta F_{Raster}$  shifts shall be analyzed individually and, if eventually agreed, marked in section 4.3 to have been obtained applying certain exceptions over this section C.3.2. In case of an exception, for Mid, Mid-Low and Mid-High, shifting frequency up can also be considered to achieve the frequency closer to the ideal case.

If no valid  $k_{SSB}$  value found within the valid GSCN range then will the carrier not be possible to use as PCell and  $F_{SSref}$ ,  $k_{SSB}$ ,  $F_{PointA}$ ,  $OffsetToCarrier$  and  $OffsetToPointA$  are calculated as described in clause C.3.2 and the procedure is completed.

- 2. Determine  $OffsetToCarrier$

Select  $offsetToCarrier$  value for the carrier in accordance to Table C.3.2-1.

**Table C.3.2-1: Downlink and uplink  $offsetToCarrier$  default values for different frequency ranges**

Frequency range	Downlink $offsetToCarrier$	Uplink $offsetToCarrier$
-----------------	-------------------------------	-----------------------------

Low range	0	0
Mid range	102	504
High range	504	6
Mid-Low range	12	36
Mid-High range	24	114
Note:	Different values of <i>offsetToCarrier</i> have been selected for Low, Mid-Low, Mid, Mid-High and High ranges to achieve enhanced test coverage of the <i>offsetToCarrier</i> range of values.	

In case low, mid and high range are exactly the same frequency, use *offsetToCarrier* associated to low range.

2b. Determine  $F_{\text{pointA}}$ :

$$F_{\text{PointA}} = F_{\text{carrierLow}} - \text{offsetToCarrier} * \text{PRB}_{\text{size}}$$

3. Calculate  $\Delta F_{\text{OffsetCORESET-0-Carrier}}$ :

The  $\Delta F_{\text{OffsetCORESET-0-Carrier}}$  value is used to calculate the Offset Carrier CORESET#0 parameter included in the test frequency tables in sub-clauses 4.3.1 and 6.2.3.

$$\Delta F_{\text{OffsetCORESET-0-Carrier}} = F_{\text{offsetToPointA}} - \text{Offset}_{\text{RB}} * \text{CRB}_{\text{size}} - F_{\text{carrierLow}}$$

4. Calculate signalling parameters:

IE field	Value
ssb-SubcarrierOffset	Set to the 4 least significant bits of $k_{\text{SSB}}$ . For the case $k_{\text{SSB}} > 15$ the extended by an additional most significant bit encoded within PBCH as specified in TS 38.213 [22]. The IE field <i>ssb-SubcarrierOffset</i> is signalled in the MIB.
controlResourceSetZero	Set to the index associated with the selected $\text{Offset}_{\text{RBs}}$ value in the applicable table, 13-1 to 13-10, in TS 38.213 [22]. The IE field <i>controlResourceSetZero</i> is signalled in the IE <i>pdccch-ConfigSIB1</i> in the MIB.
absoluteFrequencySSB	Set to $F_{\text{SSref}}$ expressed in ARFCN as defined in TS 38.101-1 [15] and TS 38.101-2 [39], clause 5.4.2.
absoluteFrequencyPointA	Set to $F_{\text{PointA}}$ expressed in ARFCN as defined in TS 38.101-1 [15] and TS 38.101-2 [39], clause 5.4.2.
offsetToPointA	$(F_{\text{offsetToPointA}} - F_{\text{PointA}}) / (12 * \{15 \text{ kHz for FR1}; 60 \text{ kHz for FR2}\})$ . The IE field <i>offsetToPointA</i> is signalled in IE <i>FrequencyInfoDL-SIB</i> .
offsetToCarrier	Set to value calculated in step 2a. The IE field <i>offsetToCarrier</i> is signalled in IE <i>SCS-SpecificCarrier</i> .

### C.3.3 Determination of SSB and signalling parameters for a carrier without CORESET#0

The following procedure is used for calculation of SSB and signalling parameters for a carrier without a CORESET#0.

1. Calculate  $F_{\text{SSref}}$ ,  $k_{\text{SSB}}$  and  $F_{\text{PointA}}$  with the SSB lowest subcarrier at the carrier's lowest subcarrier ( $\Delta F_{\text{OffsetSSB-Carrier}}$  in Figure C.1-1 = 0):

$F_{\text{SSref}} = F_{\text{carrierLow}} + \text{BW}_{\text{SSB}} / 2$
$k_{\text{SSB}} = \{31 \text{ for FR1}; 15 \text{ for FR2}\}$ indicating that no CORESET#0 is present for the carrier (TS 38.213 [4], clause 13).
<i>offsetToCarrier</i> = target value for <i>offsetToCarrier</i> dependent on frequency range as specified in Table C.3.1-1.
$F_{\text{PointA}} = F_{\text{carrierLow}} - \text{offsetToCarrier} * \text{PRB}_{\text{size}}$

2. Calculate signalling parameters:

IE field	Value
----------	-------



ssb-SubcarrierOffset	Set to the 4 least significant bits of $k_{SSB}$ . For the case $k_{SSB} > 15$ the extended by an additional most significant bit encoded within PBCH as specified in TS 38.213 [22]. The IE field <i>ssb-SubcarrierOffset</i> is signalled in the MIB.
controlResourceSetZero	Set to 0 indicating that no CORESET#0 exist (TS 38.213 [22], clause 13). The IE field <i>controlResourceSetZero</i> is signalled in the IE <i>pdccch-ConfigSIB1</i> in the MIB.
searchSpaceZero	Set to 0 indicating that no CORESET#0 exist (TS 38.213 [22], clause 13). The IE field <i>searchSpaceZero</i> is signalled in the IE <i>pdccch-ConfigSIB1</i> in the MIB.
absoluteFrequencySSB	Set to $F_{SSref}$ expressed in ARFCN as defined in TS 38.101-1 [15] and TS 38.101-2 [39], clause 5.4.2.
absoluteFrequencyPointA	Set to $F_{PointA}$ expressed in ARFCN as defined in TS 38.101-1 [15] and TS 38.101-2 [39], clause 5.4.2.
offsetToCarrier	Set to <i>offsetToCarrier</i> target value selected in step 1.

## C.4 Determination of SSB and CORESET#0 for RRM testing with SSB SCS 120 kHz and 240 kHz

### C.4.1 General

The requirements to be met and the principles used for determining the SSB and CORESET#0 for a PCell used in RRM test cases are:

1. The complete SSB and CORESET#0 shall be within the carrier's channel bandwidth.
2. The SSB centre frequency ( $F_{SSref}$ ) shall be on the synchronisation raster.
3. The SSB shall be kept as close as possible to the carrier's lower edge centre frequency.
4. The CORESET#0 configuration is selected using 24 RBs and  $Offset_{RBs} = 0$  according to Table 13-8 and Index 0 for  $SCS_{SSB} = 120$  KHz and Table 13-10 and Index 0 for  $SCS_{SSB} = 240$  kHz.
5. The first SSB subcarrier shall be aligned with the defined resource grid given by SCS indicated by *subCarrierSpacingCommon* in the MIB.

### C.4.2 Determination of SSB, CORESET#0 and signalling parameters

The following procedure is used to determine an SSB on the synchronisation raster (GSCN) and a CORESET#0 configuration ( $k_{SSB}$ ,  $Offset_{RBs} = 0$  and *OffsetToPointA*) as close as possible to the carrier's lower edge. See figure C1-1 and clause C.1 for definition of parameters referenced in the procedure.

1. The target test frequencies for Low, Mid and High ranges are calculated as described in clause C.2.1.1.

For each of Low, Mid and High ranges do:

2. Determine SSB and CORESET#0:
  - 2a. Calculate the lower of  $F_{SSref}$ ,  $F_{SSref\_Min}$ , correspondent to SSB lowest subcarrier being at the same frequency as the carrier's lowest subcarrier; and the higher limit of  $F_{SSref}$ ,  $F_{SSref\_Max}$ , correspondent to SSB highest subcarrier being at the same frequency as the carrier's highest subcarrier  $F_{SSref\_Min}$

$F_{carrierLow} = \text{see formula for } F_{carrierLow} \text{ in Table C.1-1}$
$F_{SSref\_Min} = F_{carrierLow} + CRB_{size} * Offset_{RBs,min} + BW_{SSB} / 2$
$F_{SSref\_Max} = F_{carrierLow} + \Delta F_{carrierBandwidth} - BW_{SSB} / 2$

- 2b. Calculate  $GSCN_{MIN}$  correspondent to  $F_{SSref\_Min}$  in accordance to TS 38.101-2 [7], clause 5.4.3.1 and select the closest valid GSCN value with  $GSCN \geq GSCN_{MIN}$  for the carrier in according to the carrier's synchronisation raster as specified in clause 5.4.3.3 in TS 38.101-2 [8].

- 2c. Calculate the  $F_{SSref}$  for the selected GSCN value in step 2b in accordance to TS 38.101-2 [7], clause 5.4.3.1 for FR2.
- 2d. Calculate the frequency  $F_{SSBlow}$  and shift the carrier frequency to achieve  $F_{carrierLow}$  equal or as close as possible  $F_{SSBlow}$  on the carrier's frequency raster.

$F_{SSBlow} = F_{SSref} - BW_{SSB} / 2$
$F_{carrier} =$ calculated using the formula in clause C.2.1.1 with $F_{DL\_Low} = F_{SSBlow}$
$F_{carrierLow} =$ see formula for $F_{carrierLow}$ in Table C.1-1 with new value of $F_{carrier}$

- 2e. Calculate  $k_{SSB}$

$k_{SSB} = (F_{SSBlow} - F_{carrierLow}) / subCarrierSpacingCommon$ (MIB, FR2) (TS 38.211 [3], clause 7.4.3.1).
$N = SCS_{SSB} / subCarrierSpacingCommon$ (MIB, FR2).
$k_{SSB} \text{ MOD } N \neq 0$ indicates that the SSB subcarriers are not aligned with the resource grid given by the SCS indicated by <i>subCarrierSpacingCommon</i> in the MIB.

If  $k_{SSB}$  is an integer and  $k_{SSB} \text{ MOD } N = 0$ , then continue from step 3 else modify the carrier frequency to get valid value of  $k_{SSB}$  and  $k_{SSB} \text{ MOD } N = 0$ .

3. Calculate Point A frequency,  $\Delta F_{offsetToCarrier}$  and  $\Delta F_{offsetToPointA}$ :  
The CORESET#0 configuration is selected using 24 RBs and  $Offset_{RBs} = 0$  according to Table 13-8 and Index 0 for  $SCS_{SSB} = 120$  KHz and Table 13-10 and Index 0 for  $SCS_{SSB} = 240$  kHz (see C.4.1). This means that  $F_{offsetToPointA} = F_{carrierLow}$ . By selecting Point A equal to  $F_{carrierLow}$  this gives:

$F_{PointA} = F_{carrierLow}$
$\Delta F_{offsetToCarrier} = 0$
$\Delta F_{offsetToPointA} = 0$

4. Calculate signalling parameters:

IE field	Value
ssb-SubcarrierOffset	Set to the 4 least significant bits of $k_{SSB}$ . The IE field <i>ssb-SubcarrierOffset</i> is signalled in the MIB.
controlResourceSetZero	0 (Index=0 in table 13-8 for $SCS_{SSB} = 120$ KHz and table 13-10 for $SCS_{SSB} = 240$ KHz in TS 38.213 [22]). The IE field <i>controlResourceSetZero</i> is signalled in the IE <i>pdcc-ConfigSIB1</i> in the MIB.
absoluteFrequencySSB	Set to $F_{SSref}$ expressed in ARFCN as defined in TS 38.101-1 [15] and TS 38.101-2 [39], clause 5.4.2.
absoluteFrequencyPointA	Set to $F_{PointA}$ expressed in ARFCN as defined in TS 38.101-1 [15] and TS 38.101-2 [39], clause 5.4.2.
offsetToPointA	0 The IE field <i>offsetToPointA</i> is signalled in IE <i>FrequencyInfoDL-SIB</i> .
offsetToCarrier	0 The IE field <i>offsetToCarrier</i> is signalled in IE <i>SCS-SpecificCarrier</i> .

## C.5 Determination of test frequencies and S-SSB for V2X bands

### C.5.1 General

Figure C.5.1-1 shows carrier and S-SSB on V2X bands and related parameters.

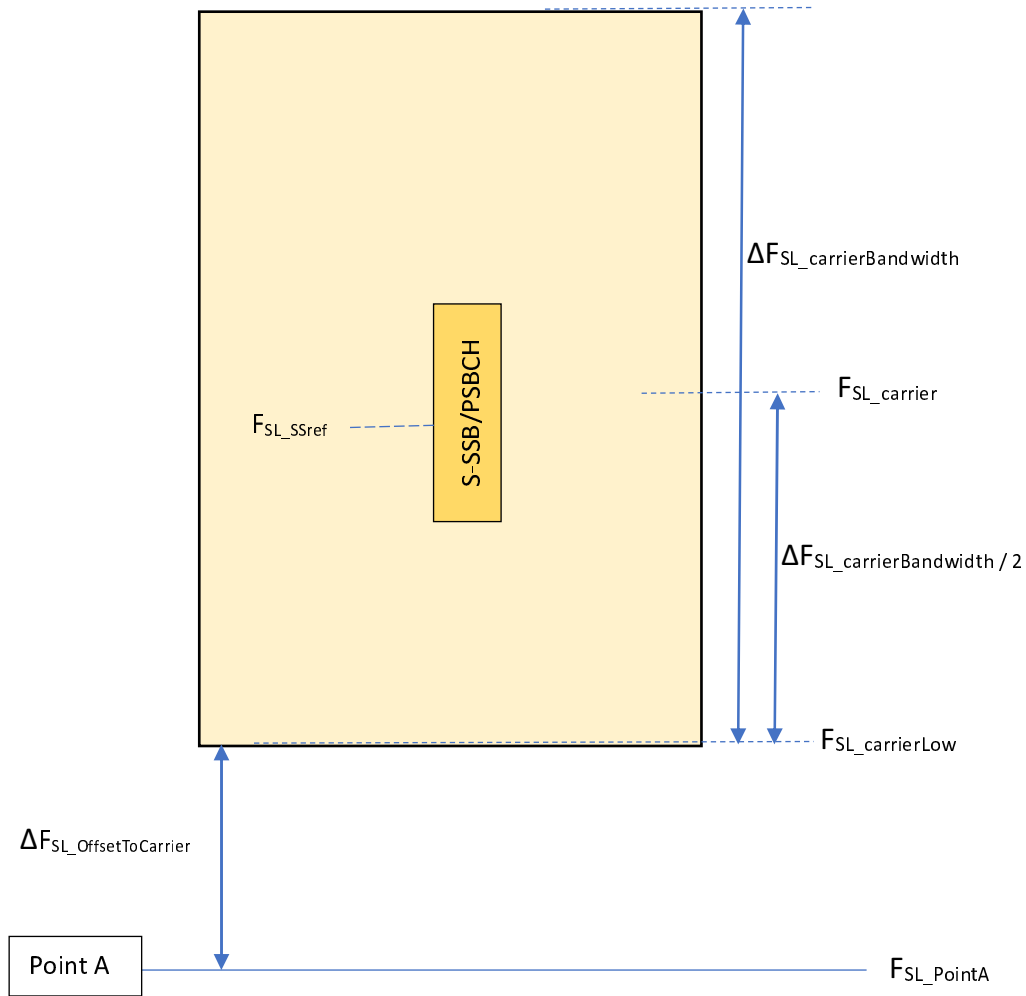


Figure C.5.1-1: location of S-SSB within a channel

The parameters referenced in Figure C.5.1-1 are defined in Table C.5.1-1.

Table C.5.1-1: Definition of parameters for V2X bands

Parameter	Description
$F_{SL\_PointA}$	Reference Point A frequency.
$F_{SL\_carrier}$	$F_{SL\_carrier}$ is the centre frequency of a carrier corresponding to its NR-ARFCN value.
$F_{SL\_carrierLow}$	$F_{SL\_carrierLow}$ is the centre frequency of lowest subcarrier of the carrier. $F_{SL\_carrierLow} = F_{SL\_carrier} - 12 * SCS_{SL\_Carrier} * (N_{RB} / 2)$ with $N_{RB}$ according to section 5.3E.1 of TS 38.101-1 for the channel bandwidth of the carrier.
$\Delta F_{SL\_carrierBandwidth}$	$\Delta F_{SL\_carrierBandwidth}$ is the carrier's channel bandwidth as provided in <i>carrierBandwidth</i> to the UE ( <i>sl-SCS-SpecificCarrierList-r16</i> ).
$\Delta F_{SL\_OffsetToCarrier}$	$\Delta F_{SL\_OffsetToCarrier}$ is the frequency offset between Point A and the lower edge of the carrier. $\Delta F_{SL\_OffsetToCarrier} = offsetToCarrier * CRB_{size}$ , where $CRB_{size}$ according to the subcarrier spacing of the carrier. <i>offsetToCarrier</i> is signalled to the UE ( <i>sl-SCS-SpecificCarrierList-r16</i> ).
$F_{SL\_SSref}$	Centre frequency of subcarrier with index 66 in the S-SS/PSBCH block, corresponding to NR-ARFCN value signalled to the UE by <i>sl-AbsoluteFrequencySSB-r16</i> .

Additional parameters used in this annex are defined in Table C.5.1-2.

**Table C.5.1-2: Definition of additional parameters used in section C.5.2**

SCS <sub>SL_Carrier</sub>	subcarrier spacing for the carrier ( <i>sl-SCS-SpecificCarrierList-r16</i> ): FR1: 15kHz, 30kHz or 60kHz according to TS 38.101-1 [7] Table 5.3.5-1
CRB <sub>size</sub>	Common Resource Block size = 12 * SCS <sub>SL_Carrier</sub> .
F <sub>SL_Low</sub>	Lowest frequency of the frequency range of the V2X band as defined in clause 5.2E.1 of TS 38.101-1 [7].
F <sub>SL_High</sub>	Highest frequency of the frequency range of the V2X band as defined in clause 5.2E.1 of TS 38.101-1 [7].
ΔF <sub>SL_Raster</sub>	Frequency raster of the band as defined in clause 5.4E.2.3 of TS 38.101-1 [7].
BW <sub>SL</sub>	Bandwidth of V2X operation frequency range of the band.
CBW <sub>SL</sub>	UE V2X operation channel bandwidth (MHz) of the carrier according to section 5.3E.1 of TS 38.101-1 [7].
BW <sub>SL_SSB</sub>	Bandwidth of the SSB. BW <sub>SL_SSB</sub> = 11 * SCS <sub>SL_Carrier</sub> * 20

## C.5.2 Determination of test frequencies and S-SSB for V2X bands

The carrier test frequencies are determined considering the channel raster according to clause 5.4.2.3 in TS 38.101-1 [7] for FR1.

The complete S-SSB shall be within a bandwidth of the SL BWP. The subcarrier with index 0 in the S-SSB shall be aligned with a subcarrier with index 0 in an RB of the SL BWP.

1. Determine sidelink carrier centre frequencies and the frequency of the carrier's lowest subcarrier:

$F_{SL\_LowRange} = \text{Ceil}((F_{SL\_Low} + CBW_{SL}/2) / \Delta F_{SL\_Raster}) * \Delta F_{SL\_Raster}$	C.5.2-Eq1
$F_{SL\_MidRange} = \text{Round}((F_{SL\_Low} + BW_{SL}/2) / \Delta F_{SL\_Raster}) * \Delta F_{SL\_Raster}$	C.5.2-Eq2
$F_{SL\_HighRange} = \text{Floor}((F_{SL\_High} - CBW_{SL}/2) / \Delta F_{SL\_Raster}) * \Delta F_{SL\_Raster}$	C.5.2-Eq3
$F_{SL\_carrierLow} = \text{see formula for } F_{SL\_carrierLow} \text{ in Table C.1-1}$	

2. Determine OffsetToCarrier

Select offsetToCarrier value for the carrier in accordance to Table C.5.2-1.

**Table C.5.2-1: Sidelink offsetToCarrier default values for different frequency ranges**

Frequency range	Sidelink offsetToCarrier
Low range	0
Mid range	504
High range	6
Mid-Low range	36
Mid-High range	114
Note:	Different values of <i>offsetToCarrier</i> have been selected for Low, Mid-Low, Mid, Mid-High and High ranges to achieve enhanced test coverage of the <i>offsetToCarrier</i> range of values.

3. Determine F<sub>SL\_PointA</sub>:

$$F_{SL\_PointA} = F_{SL\_carrierLow} - \text{offsetToCarrier} * CRB_{size}$$

4. Determine the centre frequencies of S-SSB for the lowest, mid and highest possible location of F<sub>SL\_SSBref</sub>:

$$F_{SL\_SSBref\_Low} = F_{carrierLow} + BW_{SL\_SSB} / 2$$

$$F_{SL\_SSBref\_Mid} = F_{carrierLow} + (\text{Floor}(N_{RB}/2) - 5) * CRB_{size} + BW_{SSB} / 2$$

$$F_{SL\_SSBref\_High} = F_{carrierLow} + (N_{RB} - 11) * CRB_{size} + BW_{SSB} / 2$$

5. Calculate signalling parameters:

IE field	Value
sl-AbsoluteFrequencySSB-r16	Set to $F_{SL\_SSref}$ expressed in ARFCN as defined in TS 38.101-1 [15] clause 5.4E.2.
sl-AbsoluteFrequencyPointA-r16	Set to $F_{SL\_PointA}$ expressed in ARFCN as defined in TS 38.101-1 [15] clause 5.4E.2.
offsetToCarrier	Set to value calculated in step 2. The IE field offsetToCarrier is signalled in IE sl-SCS-SpecificCarrierList-r16.

## Annex D (informative): Change history

Change history							
Date	Meeting	TDoc	CR	R ev t	Ca t	Subject/Comment	New version
2017-12	RAN5#77	R5-176995	-	-	-	TP on clauses of test equipment requirement in 38.508-1	0.1.0
2017-12	RAN5#77	R5-176779	-	-	-	Add references	0.1.0
2017-12	RAN5#77	R5-176917	-	-	-	Introduce general chapter for generic procedures	0.1.0
2017-12	RAN5#77	R5-176918	-	-	-	Add generic procedures RRC_IDLE and RRC_CONNECTED	0.1.0
2017-12	RAN5#77	R5-176920	-	-	-	Introduce RRC chapters	0.1.0
2018-01	RAN5#1- 5G-NR Adhoc	R5-180066	-	-	-	Definition of downlink physical layer parameters for NR	0.2.0
2018-03	RAN5#78	R5-181697	-	-	-	Addition of the environmental information into TS 38.508-1	0.3.0
2018-03	RAN5#78	R5-180265	-	-	-	Introduce chapter for reference configurations	0.3.0
2018-03	RAN5#78	R5-181311	-	-	-	Update the general chapter	0.3.0
2018-03	RAN5#78	R5-180382	-	-	-	Update RRCReconfiguration	0.3.0
2018-03	RAN5#78	R5-180383	-	-	-	Add draft RRC messages	0.3.0
2018-03	RAN5#78	R5-180577	-	-	-	Update chapter for test frequencies	0.3.0
2018-03	RAN5#78	R5-180709	-	-	-	Add CellGroupConfig	0.3.0
2018-03	RAN5#78	R5-180773	-	-	-	Add radioBearerConfig	0.3.0
2018-03	RAN5#78	R5-180775	-	-	-	Add draft Radio resource control information elements	0.3.0
2018-03	RAN5#78	R5-180966	-	-	-	Update RRC Connected state	0.3.0
2018-03	RAN5#78	R5-181035	-	-	-	Update RRC IDLE state	0.3.0
2018-03	RAN5#78	R5-180253	-	-	-	Revised WID on: UE Conformance Test Aspects - 5G system with NR and LTE	0.3.0
2018-04	RAN5#1- 5G-NR Adhoc	R5-181812	-	-	-	Update Radio resource control information elements	0.4.0
2018-04	RAN5#1- 5G-NR Adhoc	R5-182109	-	-	-	Update CellGroupConfig	0.4.0
2018-04	RAN5#1- 5G-NR Adhoc	R5-182064	-	-	-	Update radioBearerConfig	0.4.0
2018-04	RAN5#1- 5G-NR Adhoc	R5-182062	-	-	-	Update MIB	0.4.0
2018-04	RAN5#1- 5G-NR Adhoc	R5-182063	-	-	-	Introduce radio conditions	0.4.0
2018-04	RAN5#1- 5G-NR Adhoc	R5-181786	-	-	-	Update RRCReconfiguration	0.4.0
2018-04	RAN5#1- 5G-NR Adhoc	R5-181971	-	-	-	Add Other information elements	0.4.0
2018-04	RAN5#1- 5G-NR Adhoc	R5-182065	-	-	-	Update chapter 4.5.1 General	0.4.0
2018-04	RAN5#1- 5G-NR Adhoc	R5-181813	-	-	-	Update RRC IDLE state	0.4.0
2018-04	RAN5#1- 5G-NR Adhoc	R5-182066	-	-	-	Update RRC CONNECTED state	0.4.0
2018-04	RAN5#1- 5G-NR Adhoc	R5-182110	-	-	-	Text proposal to add clause 4.4 reference system configurations to TS 38.508-1	0.4.0
2018-04	RAN5#1- 5G-NR Adhoc	R5-182067	-	-	-	TP for definition of physical channel allocations in 38.508-1	0.4.0

2018-04	RAN5#1-5G-NR Adhoc	R5-182091	-	-	-	TP for clauses of signal level	0.4.0
2018-04	RAN5#1-5G-NR Adhoc	R5-181972	-	-	-	TP for updating of Downlink physical layer parameters	0.4.0
2018-04	RAN5#1-5G-NR Adhoc	R5-181893	-	-	-	Addition of UE capability information elements	0.4.0
2018-04	RAN5#1-5G-NR Adhoc	R5-181973	-	-	-	TP for adding Mid channel BW definition in TS 38.508-1	0.4.0
2018-04	RAN5#1-5G-NR Adhoc	R5-181974	-	-	-	Addition of SRB3	0.4.0
2018-04	RAN5#1-5G-NR Adhoc	R5-182068	-	-	-	Update MeasConfig information elements	0.4.0
2018-05	RAN5#79	R5-183082	-	-	-	Update radio resource control information elements	1.0.0
2018-05	RAN5#79	R5-182288	-	-	-	TP for updating of downlink physical layer parameters in 38.508-1	1.0.0
2018-05	RAN5#79	R5-182349	-	-	-	Corrections to clause 4.4 reference system configurations	1.0.0
2018-05	RAN5#79	R5-182792	-	-	-	TP for clauses of Supported Channels for a NR cell	1.0.0
2018-05	RAN5#79	R5-183218	-	-	-	pCR update chapter for test frequencies - EN-DC	1.0.0
2018-05	RAN5#79	R5-183234	-	-	-	TP for updating of physical channel allocation part in 38.508-1	1.0.0
2018-05	RAN5#79	R5-183256	-	-	-	pCR update chapter for test frequencies - FR1	1.0.0
2018-05	RAN5#79	R5-183916	-	-	-	TP for Annex A in TS 38.508-1 and adding a set of Connection Diagrams	1.0.0
2018-05	RAN5#79	R5-183920	-	-	-	Introduction of Environmental conditions for FR1	1.0.0
2018-05	RAN5#79	R5-182249	-	-	-	Add reference to NR cell table	1.0.0
2018-05	RAN5#79	R5-183210	-	-	-	Update PDCCH	1.0.0
2018-05	RAN5#79	R5-182312	-	-	-	Update chapter 4.5.1 General	1.0.0
2018-05	RAN5#79	R5-182313	-	-	-	Update RRC CONNECTED state	1.0.0
2018-05	RAN5#79	R5-183087	-	-	-	Addition of new RRCReconfiguration definition for AM/UM bearers	1.0.0
2018-05	RAN5#79	R5-183088	-	-	-	Updates to UE capability information elements	1.0.0
2018-05	RAN5#79	R5-183250	-	-	-	Updates to UE capability information elements	1.0.0
2018-05	RAN5#79	R5-183083	-	-	-	Update RACH	1.0.0
2018-05	RAN5#79	R5-183084	-	-	-	Update ARFCN	1.0.0
2018-05	RAN5#79	R5-183211	-	-	-	Update BWP-UplinkDedicated	1.0.0
2018-05	RAN5#79	R5-183212	-	-	-	Update serving cell	1.0.0
2018-05	RAN5#79	R5-183214	-	-	-	Update RadioBearerConfig	1.0.0
2018-05	RAN5#79	R5-183215	-	-	-	Update RRCReconfiguration	1.0.0
2018-05	RAN5#79	R5-182381	-	-	-	Update MIB	1.0.0
2018-05	RAN5#79	R5-183090	-	-	-	Update RRCReconfiguration for measurements	1.0.0
2018-05	RAN5#79	R5-183264	-	-	-	Corrections to clause 4.5	1.0.0
2018-05	RAN5#79	R5-183249	-	-	-	Correction to the Table CellGroupConfig	1.0.0
2018-05	RAN5#79	R5-183255	-	-	-	Update of FR1 signal levels	1.0.0
2018-05	RAN5#79	R5-183216	-	-	-	Update CellGroupConfig and some related information elements	1.0.0
2018-05	RAN5#79	R5-183086	-	-	-	Update CSI-MeasConfig	1.0.0
2018-05	RAN5#79	R5-183260	-	-	-	Update some information elements related to MeasConfig	1.0.0
2018-06	RAN#80	RP-181207	-	-	-	put under revision control as v15.0.0 with small editorial changes	15.0.0
2018-09	RAN#81	R5-184087	0004	-	F	Update chapter 3	15.1.0
2018-09	RAN#81	R5-184297	0012	-	F	Addition of Mid channel bandwidth definition for several missing bands	15.1.0
2018-09	RAN#81	R5-184327	0014	-	F	Adding condition for CP-OFDM waveform	15.1.0
2018-09	RAN#81	R5-184347	0019	-	F	Modified RRC_IDLE procedure to allow multi PDN configuration throughout the test case	15.1.0
2018-09	RAN#81	R5-184471	0044	-	F	Introduction of test frequencies for NR band n77	15.1.0
2018-09	RAN#81	R5-184472	0045	-	F	Introduction of test frequencies for NR band n78	15.1.0
2018-09	RAN#81	R5-184473	0046	-	F	Introduction of test frequencies for NR band n79	15.1.0
2018-09	RAN#81	R5-184474	0047	-	F	Introduction of test frequencies for NR band n257	15.1.0

2018-09	RAN#81	R5-184475	0048	-	F	Introduction of test frequencies for NR band n258	15.1.0
2018-09	RAN#81	R5-184476	0049	-	F	Introduction of test frequencies for NR band n260	15.1.0
2018-09	RAN#81	R5-184477	0050	-	F	Introduction of test frequencies for NR band n261	15.1.0
2018-09	RAN#81	R5-184599	0056	-	F	Add IE SS-RSSI-Measurement	15.1.0
2018-09	RAN#81	R5-184617	0059	-	F	Update MIB	15.1.0
2018-09	RAN#81	R5-184630	0072	-	F	Editorial Update in clause 4.6.3	15.1.0
2018-09	RAN#81	R5-184783	0079	-	F	Introduce 5GMM messages	15.1.0
2018-09	RAN#81	R5-184785	0080	-	F	Introduce 5GSM messages	15.1.0
2018-09	RAN#81	R5-184806	0081	-	F	Mid test CH BW for n71	15.1.0
2018-09	RAN#81	R5-185028	0002	1	F	Add SRB1 and SRB2 with NR PDCP	15.1.0
2018-09	RAN#81	R5-185029	0003	1	F	Update serving cell	15.1.0
2018-09	RAN#81	R5-185030	0005	1	F	Introduce SA RRC messages	15.1.0
2018-09	RAN#81	R5-185031	0006	1	F	Correct IE FrequencyInfoDL	15.1.0
2018-09	RAN#81	R5-185032	0007	1	F	Introduce SA system information blocks	15.1.0
2018-09	RAN#81	R5-185033	0008	1	F	Introduce SA other information elements	15.1.0
2018-09	RAN#81	R5-185035	0013	1	F	Correct IE GSCN-ValueNR	15.1.0
2018-09	RAN#81	R5-185036	0017	1	F	Update of FR1 signal levels	15.1.0
2018-09	RAN#81	R5-185037	0022	1	F	Addition of IP Connectivity check procedure	15.1.0
2018-09	RAN#81	R5-185038	0053	1	F	Introduce SA radio resource control information elements	15.1.0
2018-09	RAN#81	R5-185039	0054	1	F	Update IE PhysicalCellGroupConfig	15.1.0
2018-09	RAN#81	R5-185040	0055	1	F	Introduce cell configurations and timer tolerances chapter headers	15.1.0
2018-09	RAN#81	R5-185041	0057	1	F	Add IE SSB-MTC	15.1.0
2018-09	RAN#81	R5-185042	0058	1	F	Update BWP	15.1.0
2018-09	RAN#81	R5-185043	0060	1	F	Update PDSCH-Config	15.1.0
2018-09	RAN#81	R5-185044	0062	1	F	Update PUCCH and PUSCH configuration	15.1.0
2018-09	RAN#81	R5-185045	0063	1	F	Update RACH configuration	15.1.0
2018-09	RAN#81	R5-185046	0065	1	F	Update CellGroupConfig	15.1.0
2018-09	RAN#81	R5-185047	0066	1	F	Update CSI-MeasConfig	15.1.0
2018-09	RAN#81	R5-185048	0067	1	F	Update MeasConfig	15.1.0
2018-09	RAN#81	R5-185049	0068	1	F	Update other information elements	15.1.0
2018-09	RAN#81	R5-185050	0070	1	F	Update RadioBearerConfig	15.1.0
2018-09	RAN#81	R5-185051	0073	1	F	Specifying content for MeasResultSCG-Failure	15.1.0
2018-09	RAN#81	R5-185052	0075	1	F	Editorial correction to band representation of non-contiguous EN-DC band combination	15.1.0
2018-09	RAN#81	R5-185053	0076	1	F	Correction to RLC-Config IE	15.1.0
2018-09	RAN#81	R5-185054	0077	1	F	Correction to RadioBearerConfig-DRB	15.1.0
2018-09	RAN#81	R5-185055	0078	1	F	Corrections and updates to BandCombinationList and Feature Set IEs	15.1.0
2018-09	RAN#81	R5-185056	0084	1	F	Corrections and updates to UE Capability IEs	15.1.0
2018-09	RAN#81	R5-185085	0087	-	F	Addition of UM condition to RLC-Bearer-Config IE	15.1.0
2018-09	RAN#81	R5-185133	0086	1	F	Correction of clause 4.3.3.2.3	15.1.0
2018-09	RAN#81	R5-185163	0018	1	F	Modified RRC_Connected procedure for Multi PDN throughout the test case.	15.1.0
2018-09	RAN#81	R5-185165	0020	1	F	Update EN-DC Generic Procedure Parameter for Multi-PDN addition throughout Test Case	15.1.0
2018-09	RAN#81	R5-185168	0082	1	F	Introduction of OTA signalling test environment	15.1.0
2018-09	RAN#81	R5-185171	0009	2	F	Updates to PDCCH and SearchSpace configurations	15.1.0
2018-09	RAN#81	R5-185173	0016	1	F	Test Frequencies	15.1.0
2018-09	RAN#81	R5-185177	0051	1	F	Introduction of test frequencies for signalling testing in clause 6	15.1.0
2018-09	RAN#81	R5-185250	0023	1	F	Introduction of test frequencies for NR band n1	15.1.0
2018-09	RAN#81	R5-185251	0024	1	F	Introduction of test frequencies for NR band n2	15.1.0
2018-09	RAN#81	R5-185252	0025	1	F	Introduction of test frequencies for NR band n3	15.1.0
2018-09	RAN#81	R5-185253	0026	1	F	Introduction of test frequencies for NR band n5	15.1.0
2018-09	RAN#81	R5-185254	0027	1	F	Introduction of test frequencies for NR band n7	15.1.0
2018-09	RAN#81	R5-185255	0028	1	F	Introduction of test frequencies for NR band n8	15.1.0
2018-09	RAN#81	R5-185256	0029	1	F	Introduction of test frequencies for NR band n12	15.1.0
2018-09	RAN#81	R5-185257	0030	1	F	Introduction of test frequencies for NR band n20	15.1.0
2018-09	RAN#81	R5-185258	0031	1	F	Introduction of test frequencies for NR band n25	15.1.0
2018-09	RAN#81	R5-185259	0032	1	F	Introduction of test frequencies for NR band n28	15.1.0
2018-09	RAN#81	R5-185260	0033	1	F	Introduction of test frequencies for NR band n34	15.1.0
2018-09	RAN#81	R5-185261	0034	1	F	Introduction of test frequencies for NR band n38	15.1.0
2018-09	RAN#81	R5-185262	0035	1	F	Introduction of test frequencies for NR band n39	15.1.0



2018-09	RAN#81	R5-185263	0036	1	F	Introduction of test frequencies for NR band n40	15.1.0
2018-09	RAN#81	R5-185264	0037	1	F	Update of test frequencies for NR band n41	15.1.0
2018-09	RAN#81	R5-185265	0038	1	F	Introduction of test frequencies for NR band n51	15.1.0
2018-09	RAN#81	R5-185266	0039	1	F	Introduction of test frequencies for NR band n66	15.1.0
2018-09	RAN#81	R5-185267	0040	1	F	Introduction of test frequencies for NR band n70	15.1.0
2018-09	RAN#81	R5-185268	0041	1	F	Update of test frequencies for NR band n71	15.1.0
2018-09	RAN#81	R5-185269	0042	1	F	Introduction of test frequencies for NR band n75	15.1.0
2018-09	RAN#81	R5-185270	0043	1	F	Introduction of test frequencies for NR band n76	15.1.0
2018-09	RAN#81	R5-185443	0052	1	F	Correction to power level for FR1 RF tests	15.1.0
2018-09	RAN#81	R5-185557	0085	1	F	FR2_UE_BeamlockProcedure_38.508-1	15.1.0
2018-12	RAN#82	R5-186453	0239	-	F	Updates to clause 4.3.3, physical channel allocations	15.2.0
2018-12	RAN#82	R5-186457	0240	-	F	Correction to E-UTRA test frequency for intra-band contiguous configuration for band 41	15.2.0
2018-12	RAN#82	R5-186468	0241	-	F	E-UTRA test frequencies for EN-DC intra-band contiguous configurations for band 71	15.2.0
2018-12	RAN#82	R5-186491	0245	-	F	Update chapter 4.5 for RF connected procedure	15.2.0
2018-12	RAN#82	R5-186508	0249	-	F	FR2 UE and TE radiated connection diagram	15.2.0
2018-12	RAN#82	R5-186575	0251	-	F	Update IE ServingCellConfig	15.2.0
2018-12	RAN#82	R5-186612	0252	-	F	Add CounterCheck	15.2.0
2018-12	RAN#82	R5-186613	0253	-	F	Update DLInformationTransfer	15.2.0
2018-12	RAN#82	R5-186641	0255	-	F	Update IE SchedulingRequestResourceConfig	15.2.0
2018-12	RAN#82	R5-186665	0258	-	F	Update LocationMeasurementIndication	15.2.0
2018-12	RAN#82	R5-186666	0259	-	F	Update MeasurementReport	15.2.0
2018-12	RAN#82	R5-186677	0261	-	F	Resubmission of update to 38.508 for mid channel bandwidth	15.2.0
2018-12	RAN#82	R5-186682	0262	-	F	Update MobilityFromNRCommand	15.2.0
2018-12	RAN#82	R5-186691	0264	-	F	Update Paging	15.2.0
2018-12	RAN#82	R5-186692	0265	-	F	Update RRCReestablishment	15.2.0
2018-12	RAN#82	R5-186714	0267	-	F	Update RRCReject	15.2.0
2018-12	RAN#82	R5-186719	0268	-	F	Updates related to introduction of test frequencies	15.2.0
2018-12	RAN#82	R5-186722	0271	-	F	Update SecurityAlgorithmConfig	15.2.0
2018-12	RAN#82	R5-186723	0272	-	F	Updates to MeasResults	15.2.0
2018-12	RAN#82	R5-186734	0273	-	F	Update RRCRelease	15.2.0
2018-12	RAN#82	R5-186744	0274	-	F	Update RRCResume	15.2.0
2018-12	RAN#82	R5-186825	0279	-	F	Correction of test frequencies for NR band n1	15.2.0
2018-12	RAN#82	R5-186826	0280	-	F	Correction of test frequencies for NR band n2	15.2.0
2018-12	RAN#82	R5-186827	0281	-	F	Correction of test frequencies for NR band n3	15.2.0
2018-12	RAN#82	R5-186828	0282	-	F	Correction of test frequencies for NR band n5	15.2.0
2018-12	RAN#82	R5-186829	0283	-	F	Correction of test frequencies for NR band n7	15.2.0
2018-12	RAN#82	R5-186830	0284	-	F	Correction of test frequencies for NR band n8	15.2.0
2018-12	RAN#82	R5-186831	0285	-	F	Correction of test frequencies for NR band n12	15.2.0
2018-12	RAN#82	R5-186832	0286	-	F	Correction of test frequencies for NR band n20	15.2.0
2018-12	RAN#82	R5-186833	0287	-	F	Correction of test frequencies for NR band n25	15.2.0
2018-12	RAN#82	R5-186834	0288	-	F	Correction of test frequencies for NR band n28	15.2.0
2018-12	RAN#82	R5-186835	0289	-	F	Correction of test frequencies for NR band n34	15.2.0
2018-12	RAN#82	R5-186836	0290	-	F	Correction of test frequencies for NR band n38	15.2.0
2018-12	RAN#82	R5-186837	0291	-	F	Correction of test frequencies for NR band n39	15.2.0
2018-12	RAN#82	R5-186838	0292	-	F	Correction of test frequencies for NR band n40	15.2.0
2018-12	RAN#82	R5-186839	0293	-	F	Correction of test frequencies for NR band n41	15.2.0
2018-12	RAN#82	R5-186840	0294	-	F	Correction of test frequencies for NR band n51	15.2.0
2018-12	RAN#82	R5-186841	0295	-	F	Introduction of test frequencies for NR band n66	15.2.0
2018-12	RAN#82	R5-186842	0296	-	F	Introduction of test frequencies for NR band n70	15.2.0
2018-12	RAN#82	R5-186844	0298	-	F	Correction of test frequencies for NR band n75	15.2.0
2018-12	RAN#82	R5-186845	0299	-	F	Correction of test frequencies for NR band n76	15.2.0
2018-12	RAN#82	R5-186846	0300	-	F	Correction of test frequencies for NR band n77	15.2.0
2018-12	RAN#82	R5-186847	0301	-	F	Correction of test frequencies for NR band n78	15.2.0
2018-12	RAN#82	R5-186848	0302	-	F	Correction of test frequencies for NR band n79	15.2.0
2018-12	RAN#82	R5-186850	0304	-	F	Correction of test frequencies for NR band n258	15.2.0
2018-12	RAN#82	R5-186851	0305	-	F	Correction of test frequencies for NR band n260	15.2.0
2018-12	RAN#82	R5-186852	0306	-	F	Correction of test frequencies for NR band n261	15.2.0
2018-12	RAN#82	R5-186855	0309	-	F	Introduction of preamble test states	15.2.0
2018-12	RAN#82	R5-186857	0311	-	F	Introduction DCI format 1_0 for paging, SI and random access	15.2.0
2018-12	RAN#82	R5-186858	0312	-	F	Correction to DCI format 1_1	15.2.0

2018-12	RAN#82	R5-186859	0313	-	F	Update IE RateMatchPattern	15.2.0
2018-12	RAN#82	R5-186861	0315	-	F	Correction of generic procedure parameter naming for test loop function	15.2.0
2018-12	RAN#82	R5-186862	0316	-	F	Correction of test procedures to activate and deactivate UE Beamlock Function	15.2.0
2018-12	RAN#82	R5-186893	0318	-	F	Corrections to the notes in the OTA signal level tables	15.2.0
2018-12	RAN#82	R5-186911	0320	-	F	Add RRCSetupComplete	15.2.0
2018-12	RAN#82	R5-186912	0321	-	F	Add RRCSetupRequest	15.2.0
2018-12	RAN#82	R5-186913	0322	-	F	Add RRCSystemInfoRequest	15.2.0
2018-12	RAN#82	R5-186916	0323	-	F	Add SecurityModeCommand	15.2.0
2018-12	RAN#82	R5-186918	0324	-	F	Update SystemInformation	15.2.0
2018-12	RAN#82	R5-186920	0325	-	F	Add UEAssistanceInformation	15.2.0
2018-12	RAN#82	R5-186921	0326	-	F	Update UECapabilityEnquiry	15.2.0
2018-12	RAN#82	R5-186922	0327	-	F	Update ULInformationTransfer	15.2.0
2018-12	RAN#82	R5-186923	0328	-	F	Update IE PTRS-UplinkConfig	15.2.0
2018-12	RAN#82	R5-186925	0330	-	F	Update RRCResumeRequest	15.2.0
2018-12	RAN#82	R5-186929	0331	-	F	Update PTRS-DownlinkConfig	15.2.0
2018-12	RAN#82	R5-186936	0335	-	F	Update PUCCH-SpatialRelationInfo	15.2.0
2018-12	RAN#82	R5-186987	0342	-	F	Addition of SIB3 message_Resubmission of 185792	15.2.0
2018-12	RAN#82	R5-186988	0343	-	F	Addition of SIB5 message_Resubmission of 186054	15.2.0
2018-12	RAN#82	R5-186989	0344	-	F	Addition of SIB6 - SIB8 message_Resubmission of 186055	15.2.0
2018-12	RAN#82	R5-186990	0345	-	F	Addition of SIB9 message_Resubmission of 186056	15.2.0
2018-12	RAN#82	R5-187026	0348	-	F	Addition of P-Max in Test environment for RF test	15.2.0
2018-12	RAN#82	R5-187028	0350	-	F	Addition of test frequencies for SUL band n80	15.2.0
2018-12	RAN#82	R5-187030	0352	-	F	Addition of test frequencies for SUL band n82	15.2.0
2018-12	RAN#82	R5-187031	0353	-	F	Addition of test frequencies for SUL band n83	15.2.0
2018-12	RAN#82	R5-187032	0354	-	F	Addition of test frequencies for SUL band n84	15.2.0
2018-12	RAN#82	R5-187033	0355	-	F	Addition of test frequencies for SUL band n86	15.2.0
2018-12	RAN#82	R5-187110	0358	-	F	Correction to default message contents for SRB3 configuration	15.2.0
2018-12	RAN#82	R5-187159	0361	-	F	Updates to Configuration Update 5GMM messages	15.2.0
2018-12	RAN#82	R5-187160	0362	-	F	Updates to De-registration 5GMM messages	15.2.0
2018-12	RAN#82	R5-187161	0363	-	F	Updates to Identity 5GMM messages	15.2.0
2018-12	RAN#82	R5-187162	0364	-	F	Updates to NAS Transport 5GMM messages	15.2.0
2018-12	RAN#82	R5-187163	0365	-	F	Updates to Notification 5GMM messages	15.2.0
2018-12	RAN#82	R5-187164	0366	-	F	Updates to PDU session authentication 5GSM messages	15.2.0
2018-12	RAN#82	R5-187166	0368	-	F	Updates to PDU session modification 5GSM messages	15.2.0
2018-12	RAN#82	R5-187172	0374	-	F	Removal of Editor's Notes in section 4.6.3	15.2.0
2018-12	RAN#82	R5-187175	0377	-	F	Addition and updates to Information Elements in section 4.6.5	15.2.0
2018-12	RAN#82	R5-187270	0381	-	F	Updating 4.2.1 General functional requirements	15.2.0
2018-12	RAN#82	R5-187271	0382	-	F	Update the section for test equipment requirements for TRx	15.2.0
2018-12	RAN#82	R5-187272	0383	-	F	FR2 downlink signal level(38.508-1)	15.2.0
2018-12	RAN#82	R5-187413	0389	-	F	Uplink RNTI to valid value in TS 38.508-1	15.2.0
2018-12	RAN#82	R5-187415	0390	-	F	Update maxPayloadMinus1 in PUCCH config in TS 38.508-1	15.2.0
2018-12	RAN#82	R5-187420	0393	-	F	Addition of connection diagram for 2 TX UL MIMO	15.2.0
2018-12	RAN#82	R5-187557	0396	-	F	Addition of low and high test channel bandwidth in 38.508	15.2.0
2018-12	RAN#82	R5-188205	0397	1	F	Updates to Annex B to add Permitted OTA Test Methods	15.2.0
2018-12	RAN#82	R5-187610	0398	-	F	Corrections to IEs part of PDSCH-ServingCellConfig, ServingCellConfig and ServingCellConfigCommon	15.2.0
2018-12	RAN#82	R5-187659	0243	1	F	Wordings for Uplink NAS messages	15.2.0
2018-12	RAN#82	R5-187660	0247	1	F	Default cell configurations for NAS	15.2.0
2018-12	RAN#82	R5-187661	0248	1	F	Update IE SI-SchedulingInfo	15.2.0
2018-12	RAN#82	R5-187662	0349	1	F	Addition of Combinations of system information blocks in 4.4.3.1.2	15.2.0
2018-12	RAN#82	R5-187664	0263	1	F	Correction to various Radio resource control IEs	15.2.0
2018-12	RAN#82	R5-187665	0308	1	F	Correction to DCI formats 0_0 and 0_1	15.2.0
2018-12	RAN#82	R5-187666	0310	1	F	Introduction of SDL and SUL cells in simulated cells in clause 4.4.2	15.2.0
2018-12	RAN#82	R5-187667	0314	1	F	Correction to RRC_IDLE procedure	15.2.0
2018-12	RAN#82	R5-187668	0332	1	F	Update CSI related information elements	15.2.0
2018-12	RAN#82	R5-187669	0333	1	F	Update ServingCellConfigCommon and TDD-UL-DL-Config	15.2.0
2018-12	RAN#82	R5-187670	0334	1	F	Update SRS-Config	15.2.0
2018-12	RAN#82	R5-187671	0336	1	F	Update some information elements for measurements	15.2.0

2018-12	RAN#82	R5-187672	0337	1	F	Update CellGroupConfig and related information elements	15.2.0
2018-12	RAN#82	R5-187673	0338	1	F	CR of NR 508-1 clause 4.6.2_SIB2, SIB4	15.2.0
2018-12	RAN#82	R5-187674	0339	1	F	CR of NR 508-1 Table 4.4.2-2_Default NR Cells parameters	15.2.0
2018-12	RAN#82	R5-187675	0341	1	F	Update RLC-Config	15.2.0
2018-12	RAN#82	R5-187676	0357	1	F	Specifying Test procedure to check that UE is camped on a new NR cell belonging to a new TA	15.2.0
2018-12	RAN#82	R5-187677	0360	1	F	Updates to Authentication 5GMM messages	15.2.0
2018-12	RAN#82	R5-187678	0369	1	F	Updates to PDU session release 5GSM messages	15.2.0
2018-12	RAN#82	R5-187679	0371	1	F	Updates to Security mode 5GMM messages	15.2.0
2018-12	RAN#82	R5-187680	0375	1	F	Addition of new Information Elements in section 4.6.3	15.2.0
2018-12	RAN#82	R5-187681	0379	1	F	Updates to SIG OTA Calibration for FR2	15.2.0
2018-12	RAN#82	R5-187682	0394	1	F	Addition of default QoS configurations	15.2.0
2018-12	RAN#82	R5-187720	0319	2	F	Uplink PTRS disable for RF testing	15.2.0
2018-12	RAN#82	R5-188238	0242	2	F	Addition to E-UTRA test frequencies for intra-band contiguous configuration for band 41	15.2.0
2018-12	RAN#82	R5-187723	0303	1	F	Correction of test frequencies for NR band n257	15.2.0
2018-12	RAN#82	R5-187724	0269	1	F	New annex for NR test frequency calculations	15.2.0
2018-12	RAN#82	R5-187725	0297	1	F	Correction of test frequencies for NR band n71	15.2.0
2018-12	RAN#82	R5-187745	0238	1	F	Update SIB1	15.2.0
2018-12	RAN#82	R5-187747	0257	1	F	Correction to Signal levels for conducted testing	15.2.0
2018-12	RAN#82	R5-187748	0270	1	F	Updates to E-UTRA RRC_CONNECTED generic procedure	15.2.0
2018-12	RAN#82	R5-187750	0275	1	F	Add RRCResumeComplete	15.2.0
2018-12	RAN#82	R5-187751	0278	1	F	Update chapter 4.5.3 RRC_INACTIVE	15.2.0
2018-12	RAN#82	R5-187752	0307	1	F	Correction of test frequencies for signalling testing in clause 6	15.2.0
2018-12	RAN#82	R5-187753	0317	1	F	Specifying Test procedure to check that UE is in RRC_IDLE state on a certain NR cell	15.2.0
2018-12	RAN#82	R5-187754	0329	1	F	Update IE RLF-TimersAndConstants	15.2.0
2018-12	RAN#82	R5-187755	0346	1	F	Add RRCSetup	15.2.0
2018-12	RAN#82	R5-187756	0347	1	F	Update RRCReconfiguration	15.2.0
2018-12	RAN#82	R5-187757	0356	1	F	Update IE RadioBearerConfig	15.2.0
2018-12	RAN#82	R5-187759	0370	1	F	Updates to Registration 5GMM messages	15.2.0
2018-12	RAN#82	R5-187760	0372	1	F	Updates to Security protected 5GS NAS and 5GMM status messages	15.2.0
2018-12	RAN#82	R5-187761	0373	1	F	Updates to Service Request 5GMM messages	15.2.0
2018-12	RAN#82	R5-187762	0376	1	F	Addition and updates to Information Elements in section 4.6.4	15.2.0
2018-12	RAN#82	R5-187763	0388	1	F	Addition of 5GS related new EFs to Test UICC definition	15.2.0
2018-12	RAN#82	R5-187764	0395	1	F	Update IE CellGroupConfig	15.2.0
2018-12	RAN#82	R5-187802	0384	1	F	Updating power levels for LTE Anchor Link	15.2.0
2018-12	RAN#82	R5-187887	0351	1	F	Addition of test frequencies for SUL band n81	15.2.0
2018-12	RAN#82	R5-188031	0391	1	F	Addition of 2TX_UL_MIMO condition	15.2.0
2018-12	RAN#82	R5-188107	0367	2	F	Updates to PDU session establishment 5GSM messages	15.2.0
2018-12	RAN#82	R5-188122	0260	2	F	Update chapter 4.5.2 RRC_IDLE	15.2.0
2018-12	RAN#82	R5-188123	0250	1	F	Update chapter 4.5.4 RRC_CONNECTED	15.2.0
2019-03	RAN#83	R5-191047	0526	-	F	Update IE PDCCH-ConfigCommon	15.3.0
2019-03	RAN#83	R5-191048	0527	-	F	Update IE RadioBearerConfig	15.3.0
2019-03	RAN#83	R5-191094	0529	-	F	Updates of test channel bandwidth in TS 38.508-1	15.3.0
2019-03	RAN#83	R5-191129	0530	-	F	Update IE SDAP-Config	15.3.0
2019-03	RAN#83	R5-191145	0531	-	F	Update IE CellGroupId	15.3.0
2019-03	RAN#83	R5-191155	0532	-	F	Correction to temperature and voltage of Common test environments	15.3.0
2019-03	RAN#83	R5-191187	0534	-	F	Updates for Other SI support	15.3.0
2019-03	RAN#83	R5-191189	0536	-	F	Correction to RadioBearerConfig	15.3.0
2019-03	RAN#83	R5-191191	0538	-	F	Correction to SystemInformation	15.3.0
2019-03	RAN#83	R5-191192	0539	-	F	Correction to PUCCH-Config	15.3.0
2019-03	RAN#83	R5-191193	0540	-	F	Correction to SIB3 and SIB4	15.3.0
2019-03	RAN#83	R5-191194	0541	-	F	Correction of PUSCH-TimeDomainResourceAllocationList	15.3.0
2019-03	RAN#83	R5-191195	0542	-	F	Corrections and clarifications regarding DCI formats 0_1 and 1_1	15.3.0
2019-03	RAN#83	R5-191219	0545	-	F	Updates to Authentication 5GMM messages	15.3.0
2019-03	RAN#83	R5-191220	0546	-	F	Updates to Configuration Update 5GMM messages	15.3.0
2019-03	RAN#83	R5-191221	0547	-	F	Updates to De-registration 5GMM messages	15.3.0
2019-03	RAN#83	R5-191222	0548	-	F	Updates to NAS transport 5GMM messages	15.3.0

2019-03	RAN#83	R5-191223	0549	-	F	Updates to PDU session establishment 5GSM messages	15.3.0
2019-03	RAN#83	R5-191224	0550	-	F	Updates to PDU session modification 5GSM messages	15.3.0
2019-03	RAN#83	R5-191225	0551	-	F	Updates to PDU session release 5GSM messages	15.3.0
2019-03	RAN#83	R5-191226	0552	-	F	Updates to Registration 5GMM messages	15.3.0
2019-03	RAN#83	R5-191227	0553	-	F	Updates to Security Mode 5GMM messages	15.3.0
2019-03	RAN#83	R5-191228	0554	-	F	Updates to Security Protected 5GS NAS message	15.3.0
2019-03	RAN#83	R5-191229	0555	-	F	Updates to Service Request 5GMM messages	15.3.0
2019-03	RAN#83	R5-191233	0556	-	F	Update IE BWP-Id	15.3.0
2019-03	RAN#83	R5-191234	0557	-	F	Add IE RejectWaitTime	15.3.0
2019-03	RAN#83	R5-191235	0558	-	F	Update IE ShortMAC-I	15.3.0
2019-03	RAN#83	R5-191236	0559	-	F	Update IE UE-TimersAndConstants	15.3.0
2019-03	RAN#83	R5-191237	0560	-	F	Update IE PUCCH-ConfigCommon	15.3.0
2019-03	RAN#83	R5-191242	0561	-	F	Addition of Positioning specifications	15.3.0
2019-03	RAN#83	R5-191243	0562	-	F	Update AS security Algorithm for RF testing	15.3.0
2019-03	RAN#83	R5-191274	0563	-	F	Update of structure of test frequency clauses	15.3.0
2019-03	RAN#83	R5-191280	0564	-	F	Correction to UL configuration	15.3.0
2019-03	RAN#83	R5-191281	0565	-	F	Correction to default value of IE's in PDSCH-Config in Table 4.6.3-75	15.3.0
2019-03	RAN#83	R5-191301	0568	-	F	Correction of test frequencies for signalling testing in clause 6	15.3.0
2019-03	RAN#83	R5-191302	0569	-	F	Correction of test frequencies for EN-DC configuration DC_(n)41	15.3.0
2019-03	RAN#83	R5-191304	0571	-	F	Correction of test frequencies for NR band n1	15.3.0
2019-03	RAN#83	R5-191305	0572	-	F	Correction of test frequencies for NR band n2	15.3.0
2019-03	RAN#83	R5-191306	0573	-	F	Correction of test frequencies for NR band n3	15.3.0
2019-03	RAN#83	R5-191307	0574	-	F	Correction of test frequencies for NR band n5	15.3.0
2019-03	RAN#83	R5-191308	0575	-	F	Correction of test frequencies for NR band n7	15.3.0
2019-03	RAN#83	R5-191309	0576	-	F	Correction of test frequencies for NR band n8	15.3.0
2019-03	RAN#83	R5-191310	0577	-	F	Correction of test frequencies for NR band n12	15.3.0
2019-03	RAN#83	R5-191311	0578	-	F	Correction of test frequencies for NR band n20	15.3.0
2019-03	RAN#83	R5-191312	0579	-	F	Correction of test frequencies for NR band n25	15.3.0
2019-03	RAN#83	R5-191313	0580	-	F	Correction of test frequencies for NR band n28	15.3.0
2019-03	RAN#83	R5-191314	0581	-	F	Correction of test frequencies for NR band n34	15.3.0
2019-03	RAN#83	R5-191315	0582	-	F	Correction of test frequencies for NR band n38	15.3.0
2019-03	RAN#83	R5-191316	0583	-	F	Correction of test frequencies for NR band n39	15.3.0
2019-03	RAN#83	R5-191317	0584	-	F	Correction of test frequencies for NR band n40	15.3.0
2019-03	RAN#83	R5-191318	0585	-	F	Correction of test frequencies for NR band n41	15.3.0
2019-03	RAN#83	R5-191319	0586	-	F	Introduction of test frequencies for NR band n50	15.3.0
2019-03	RAN#83	R5-191320	0587	-	F	Correction of test frequencies for NR band n51	15.3.0
2019-03	RAN#83	R5-191321	0588	-	F	Correction of test frequencies for NR band n66	15.3.0
2019-03	RAN#83	R5-191322	0589	-	F	Correction of test frequencies for NR band n70	15.3.0
2019-03	RAN#83	R5-191323	0590	-	F	Correction of test frequencies for NR band n71	15.3.0
2019-03	RAN#83	R5-191324	0591	-	F	Introduction of test frequencies for NR band n74	15.3.0
2019-03	RAN#83	R5-191325	0592	-	F	Correction of test frequencies for NR band n75	15.3.0
2019-03	RAN#83	R5-191326	0593	-	F	Correction of test frequencies for NR band n76	15.3.0
2019-03	RAN#83	R5-191327	0594	-	F	Correction of test frequencies for NR band n77	15.3.0
2019-03	RAN#83	R5-191328	0595	-	F	Correction of test frequencies for NR band n78	15.3.0
2019-03	RAN#83	R5-191329	0596	-	F	Correction of test frequencies for NR band n79	15.3.0
2019-03	RAN#83	R5-191330	0597	-	F	Correction of test frequencies for NR band n257	15.3.0
2019-03	RAN#83	R5-191331	0598	-	F	Correction of test frequencies for NR band n258	15.3.0
2019-03	RAN#83	R5-191332	0599	-	F	Correction of test frequencies for NR band n260	15.3.0
2019-03	RAN#83	R5-191333	0600	-	F	Correction of test frequencies for NR band n261	15.3.0
2019-03	RAN#83	R5-191334	0601	-	F	Correction of DCI format 1_0	15.3.0
2019-03	RAN#83	R5-191352	0603	-	F	Update CounterCheckResponse	15.3.0
2019-03	RAN#83	R5-191354	0604	-	F	Add FailureInformation	15.3.0
2019-03	RAN#83	R5-191355	0605	-	F	Update LocationMeasurementIndication	15.3.0
2019-03	RAN#83	R5-191356	0606	-	F	Updates to section 4.8.3 (test USIM parameters)	15.3.0
2019-03	RAN#83	R5-191360	0607	-	F	Update MeasurementReport	15.3.0
2019-03	RAN#83	R5-191361	0608	-	F	Update MobilityFromNRCommand	15.3.0
2019-03	RAN#83	R5-191364	0609	-	F	Update Paging	15.3.0
2019-03	RAN#83	R5-191366	0610	-	F	Update RRCSetupComplete	15.3.0
2019-03	RAN#83	R5-191368	0611	-	F	Update SecurityModeComplete	15.3.0
2019-03	RAN#83	R5-191370	0612	-	F	Update SecurityModeFailure	15.3.0
2019-03	RAN#83	R5-191371	0613	-	F	Update UEAssistanceInformation	15.3.0

2019-03	RAN#83	R5-191372	0614	-	F	Update UECapabilityInformation	15.3.0
2019-03	RAN#83	R5-191384	0616	-	F	Correction to SecurityConfig of RadioBearerConfig	15.3.0
2019-03	RAN#83	R5-191385	0617	-	F	Correction to SIB9	15.3.0
2019-03	RAN#83	R5-191386	0618	-	F	Correction to SRS-Config of BWP-UplinkDedicated	15.3.0
2019-03	RAN#83	R5-191446	0620	-	F	Correction of default configuration of RRC IEs in 38.508-1	15.3.0
2019-03	RAN#83	R5-191450	0621	-	F	Addition of NR system information combination SIB6, SIB7	15.3.0
2019-03	RAN#83	R5-191538	0624	-	F	Update ULInformationTransfer	15.3.0
2019-03	RAN#83	R5-191539	0625	-	F	Update IE QuantityConfig and CSI-ReportConfig	15.3.0
2019-03	RAN#83	R5-191620	0629	-	F	Clarification for NR inter-band measurement test case configuration	15.3.0
2019-03	RAN#83	R5-191762	0637	-	F	Editorial update in MeasObjectNR and ReportConfigNR	15.3.0
2019-03	RAN#83	R5-191763	0638	-	F	Update ReportConfigNR and TimeToTrigger	15.3.0
2019-03	RAN#83	R5-192271	0570	1	F	Correction of test frequencies for EN-DC configuration DC_(n)71	15.3.0
2019-03	RAN#83	R5-192272	0602	1	F	Update chapter 4.5 RRC Connected initiation	15.3.0
2019-03	RAN#83	R5-192273	0626	1	F	Update RRCRelease	15.3.0
2019-03	RAN#83	R5-192274	0615	1	F	Correction to NR SchedulingRequestResourceConfig	15.3.0
2019-03	RAN#83	R5-192275	0627	1	F	Update IE I-RNTI-Value	15.3.0
2019-03	RAN#83	R5-192276	0628	1	F	Update IE ShortI-RNTI-Value	15.3.0
2019-03	RAN#83	R5-192277	0630	1	F	Updates to test environments for Signalling test	15.3.0
2019-03	RAN#83	R5-192278	0633	1	F	Addition of USIM Profiles for Signaling TC	15.3.0
2019-03	RAN#83	R5-192279	0636	1	F	Update QoS Configuration	15.3.0
2019-03	RAN#83	R5-192280	0643	1	F	Update to of Generic procedure E-UTRA RRC_IDLE	15.3.0
2019-03	RAN#83	R5-192281	0644	1	F	Introduction of EAP AKA	15.3.0
2019-03	RAN#83	R5-192290	0655	-	F	Update chapter 4.5 RRC_INACTIVE	15.3.0
2019-03	RAN#83	R5-192363	0631	1	F	Updating P-Max IE	15.3.0
2019-03	RAN#83	R5-192364	0632	2	F	Updating IEs part of SearchSpace	15.3.0
2019-03	RAN#83	R5-192400	0528	1	F	Setup diagram for receiver test using spectrum analyzer	15.3.0
2019-03	RAN#83	R5-192541	0622	1	F	Connection diagrams for RRM tests	15.3.0
2019-03	RAN#83	R5-192542	0646	1	F	Antenna Connection diagram for UE part for RRM	15.3.0
2019-03	RAN#83	R5-192543	0649	1	F	Connection diagram for FR1 demod test cases	15.3.0
2019-03	RAN#83	R5-192705	0645	1	F	Introduction of Non 3GPP Access over WLAN	15.3.0
2019-03	RAN#83	R5-192735	0533	1	F	Correction to PUSCH-Config	15.3.0
2019-03	RAN#83	R5-192736	0535	1	F	Addition of details on Test State 0	15.3.0
2019-03	RAN#83	R5-192737	0537	1	F	Correction of CellGroupConfig tables and logical channel identities	15.3.0
2019-03	RAN#83	R5-192738	0543	1	F	Additions and updates to UE capability Information Elements	15.3.0
2019-03	RAN#83	R5-192739	0544	1	F	Updates and additions of default QoS configurations	15.3.0
2019-03	RAN#83	R5-192740	0566	1	F	Update chapter 4.5 General for PDUs	15.3.0
2019-03	RAN#83	R5-192741	0567	1	F	Update of Annex C on calculation of test frequencies	15.3.0
2019-03	RAN#83	R5-192742	0619	1	F	Correction to schedulingRequestID Configuration	15.3.0
2019-03	RAN#83	R5-192743	0639	1	F	Addition of Switch/Power UE procedures	15.3.0
2019-03	RAN#83	R5-192744	0640	1	F	Update to Test procedure to check that UE is camped on a new cell belonging to a new TA	15.3.0
2019-03	RAN#83	R5-192745	0641	1	F	Update to Test procedure to check that UE is in state 5GC RRC_IDLE on a certain cell	15.3.0
2019-03	RAN#83	R5-192846	0648	1	F	Updates to Annex B to add Permitted OTA Test Methods	15.3.0
2019-03	RAN#83	-	-	-	-	Editorial updates of table numbering	15.3.0
2019-06	RAN#84	R5-193537	0680	-	F	Remove unused DCI formats from 38.508-1	15.4.0
2019-06	RAN#84	R5-193540	0681	-	F	Adding setup diagram for Receiver performance tests 2x2	15.4.0
2019-06	RAN#84	R5-193542	0682	-	F	Remove brackets from parameters for DCI formats for scheduling	15.4.0
2019-06	RAN#84	R5-193613	0691	-	F	Update default configuration of QuantityConfig	15.4.0
2019-06	RAN#84	R5-193681	0693	-	F	Update chapter 4.5.3 RRC_INACTIVE procedures	15.4.0
2019-06	RAN#84	R5-193682	0694	-	F	Update chapter 4.5.4 RRC_CONNECTED procedures	15.4.0
2019-06	RAN#84	R5-193683	0695	-	F	Update chapter 4.5.5 SWITCHED_OFF procedures	15.4.0
2019-06	RAN#84	R5-193690	0696	-	F	Resubmission: Connection diagram for 1x2 Demod test cases	15.4.0
2019-06	RAN#84	R5-193734	0701	-	F	Update IE I-RNTI-Value	15.4.0
2019-06	RAN#84	R5-193735	0702	-	F	Update IE ShortI-RNTI-Value	15.4.0
2019-06	RAN#84	R5-193746	0710	-	F	Update IE SubcarrierSpacing	15.4.0
2019-06	RAN#84	R5-193813	0711	-	F	Update of USIM EF5GS3GPPLOCI & EF5GSN3GPPLOCI	15.4.0
2019-06	RAN#84	R5-193828	0713	-	F	Add IE MultiFrequencyBandListNR-SIB	15.4.0
2019-06	RAN#84	R5-193829	0714	-	F	Add IE NR-NS-PmaxList	15.4.0

2019-06	RAN#84	R5-193843	0716	-	F	Update IE ServingCellConfig	15.4.0
2019-06	RAN#84	R5-193862	0717	-	F	Corrections to References	15.4.0
2019-06	RAN#84	R5-193980	0725	-	F	New test procedure for Registration Reject	15.4.0
2019-06	RAN#84	R5-193981	0726	-	F	Updates to test procedure 4.9.1	15.4.0
2019-06	RAN#84	R5-194038	0728	-	F	Editorial Correction - USIM Profiles for Signaling TC	15.4.0
2019-06	RAN#84	R5-194040	0729	-	F	Correction to QoS Configuration	15.4.0
2019-06	RAN#84	R5-194086	0733	-	F	Update K2 value to align with RF DL RMC	15.4.0
2019-06	RAN#84	R5-194087	0734	-	F	Update aggregationlevel2 in SearchSpace IE	15.4.0
2019-06	RAN#84	R5-194303	0740	-	F	TDD-UL-DL-Config for FR1 SCS 60kHz	15.4.0
2019-06	RAN#84	R5-194359	0742	-	F	Removal of column for Number of PDU sessions established from tables for Test States	15.4.0
2019-06	RAN#84	R5-194362	0743	-	F	Editorial correction to test frequency clauses	15.4.0
2019-06	RAN#84	R5-194364	0744	-	F	Update of test frequencies for EN-DC combination DC_41A_n41A	15.4.0
2019-06	RAN#84	R5-194367	0745	-	F	Common procedure to configure SCC for CA RF testing	15.4.0
2019-06	RAN#84	R5-194369	0746	-	F	Introduction of test frequencies for inter-band Rel-15 EN-DC two bands configurations	15.4.0
2019-06	RAN#84	R5-194420	0751	-	F	Update IE BWP-Downlink	15.4.0
2019-06	RAN#84	R5-194435	0752	-	F	Update IE BWP-Id	15.4.0
2019-06	RAN#84	R5-194438	0755	-	F	Updates to UE 4.6.5 Other Information Elements	15.4.0
2019-06	RAN#84	R5-194441	0757	-	F	Update IE BWP-Uplink	15.4.0
2019-06	RAN#84	R5-194479	0758	-	F	Editorial updates to 4.7.1 Contents of 5GMM messages	15.4.0
2019-06	RAN#84	R5-194480	0759	-	F	Editorial updates to 4.7.2 Contents of 5GSM messages	15.4.0
2019-06	RAN#84	R5-194510	0762	-	F	Update of Switch off - Power off procedure in RRC_CONNECTED	15.4.0
2019-06	RAN#84	R5-194539	0767	-	F	Introduction of test frequencies for EN-DC CA configuration DC_30A_n260(A-I)	15.4.0
2019-06	RAN#84	R5-194541	0768	-	F	Antenna Connection diagram for TE part for RRM	15.4.0
2019-06	RAN#84	R5-194709	0785	-	F	Update 38.508 RF and RRM clauses with agreed recommendation to configure UE as non-IMS	15.4.0
2019-06	RAN#84	R5-194783	0774	-	F	Introduction of test frequencies for NR band n50 and signalling testing	15.4.0
2019-06	RAN#84	R5-194784	0775	-	F	Introduction of test frequencies for NR band n74 and signalling testing	15.4.0
2019-06	RAN#84	R5-194790	0778	-	F	Updates to power allocations	15.4.0
2019-06	RAN#84	R5-194791	0779	-	F	Update of DownlinkConfigCommonSIB	15.4.0
2019-06	RAN#84	R5-194794	0684	1	F	Update IE PDSCH-Config	15.4.0
2019-06	RAN#84	R5-194795	0687	1	F	Update NR MeasObjectNR	15.4.0
2019-06	RAN#84	R5-194796	0690	1	F	Update default configuration of ReportConfigNR	15.4.0
2019-06	RAN#84	R5-194797	0692	1	F	Update chapter 4.5.2 RRC_IDLE procedures	15.4.0
2019-06	RAN#84	R5-194798	0704	1	F	Correction to the note associated to the Table 4.7.1-2	15.4.0
2019-06	RAN#84	R5-194800	0708	1	F	Update IE MIB	15.4.0
2019-06	RAN#84	R5-194801	0709	1	F	Update IE SchedulingRequestResourceConfig	15.4.0
2019-06	RAN#84	R5-194802	0712	1	F	Correct clause numbers in 4.5A	15.4.0
2019-06	RAN#84	R5-194803	0718	1	F	Update IE ServingCellConfigCommon	15.4.0
2019-06	RAN#84	R5-194804	0721	1	F	Update IE FrequencyInfoUL	15.4.0
2019-06	RAN#84	R5-194805	0722	1	F	Update IE FrequencyInfoUL-SIB	15.4.0
2019-06	RAN#84	R5-194806	0723	1	F	Update generic procedures chapter general	15.4.0
2019-06	RAN#84	R5-194807	0724	1	F	Update chapter 4.5.2 RRC_IDLE Initiation	15.4.0
2019-06	RAN#84	R5-194808	0730	1	F	Updates to RadioBearerConfig	15.4.0
2019-06	RAN#84	R5-194809	0732	1	F	Updates to PhysicalCellGroupConfig	15.4.0
2019-06	RAN#84	R5-194810	0739	1	F	New test procedure for RRC_CONNECTED	15.4.0
2019-06	RAN#84	R5-194811	0741	1	F	Updated IE MeasObjectEUTRA and ReportConfigInterRAT	15.4.0
2019-06	RAN#84	R5-194812	0753	1	F	Updates to Registration 5GMM messages	15.4.0
2019-06	RAN#84	R5-194813	0754	1	F	Updates to UE 4.6.4 UE Capability Information Elements	15.4.0
2019-06	RAN#84	R5-194814	0760	1	F	New Test procedure for UE for Tracking area updating / inter-system change from N1 mode to S1 mode in 5GMM/EMM-IDLE mode	15.4.0
2019-06	RAN#84	R5-194817	0777	1	F	New Test procedure for UE for Tracking area updating / inter-system change from S1 mode to N1 mode in 5GMM/EMM-IDLE mode	15.4.0

2019-06	RAN#84	R5-194821	0780	-	F	Introducing conditions for Handover in RRCReconfiguration and RadioBearerConfig	15.4.0
2019-06	RAN#84	R5-194824	0781	-	F	Updates to Service Request 5GMM message	15.4.0
2019-06	RAN#84	R5-194879	0735	1	F	Updates to Multi-Cell SIG OTA testing for FR2	15.4.0
2019-06	RAN#84	R5-194881	0763	1	F	Introduction of test frequencies for NR CA configuration CA_n257B	15.4.0
2019-06	RAN#84	R5-194882	0764	1	F	Introduction of test frequencies for NR CA configuration CA_n260B	15.4.0
2019-06	RAN#84	R5-194883	0765	1	F	Introduction of test frequencies for NR CA configuration CA_n260I	15.4.0
2019-06	RAN#84	R5-194884	0766	1	F	Introduction of test frequencies for NR CA configuration CA_n261B	15.4.0
2019-06	RAN#84	R5-194885	0782	1	F	Introduction of test frequencies for NR CA configuration CA_n260(A-I)	15.4.0
2019-06	RAN#84	R5-194889	0737	1	F	corrections to Non 3GPP Access over WLAN procedures	15.4.0
2019-06	RAN#84	R5-194894	0783	-	F	Update FFS in ResumeCause	15.4.0
2019-06	RAN#84	R5-194896	0784	-	F	Updates to reference QoS configurations for EPS interworking	15.4.0
2019-06	RAN#84	R5-194902	0685	1	F	Correction of Setup Diagrams for Receiver tests using Signal Generator in 38.508-1	15.4.0
2019-06	RAN#84	R5-195095	0750	1	F	Introduction of Connection diagram for 2x4 and 4x4 Demod test cases	15.4.0
2019-06	RAN#84	R5-195322	0686	1	F	Update NR SIB1	15.4.0
2019-06	RAN#84	R5-195323	0703	1	F	Update IE CommonCellGroupConfig	15.4.0
2019-06	RAN#84	R5-195324	0715	1	F	Update default configuration of MeasGapConfig	15.4.0
2019-06	RAN#84	R5-195325	0719	1	F	Addition of Switch off / Power off procedure in RRC_INACTIVE	15.4.0
2019-06	RAN#84	R5-195326	0720	1	F	Update of SIB5	15.4.0
2019-06	RAN#84	R5-195327	0731	1	F	Updates to RLC-BearerConfig	15.4.0
2019-06	RAN#84	R5-195328	0756	1	F	Updates to PDU session establishment 5GSM messages	15.4.0
2019-06	RAN#84	R5-195329	0773	1	F	Introduction of test frequencies for inter-RAT signalling testing	15.4.0
2019-06	RAN#84	R5-195330	0776	1	F	Correction to PUSCH-Config	15.4.0
2019-06	RAN#84	R5-195426	0727	2	F	38.508-1 implementation of FR2 UL demod OTA tests using single pol Rx TE	15.4.0
2019-06	RAN#84	R5-195427	0772	2	F	Addition of message contents needed for DEMOD test cases	15.4.0
2019-06	RAN#84	R5-194370	0747	-	F	Introduction of test frequencies for inter-band Rel-16 EN-DC two bands configurations	16.0.0
2019-06	RAN#84	R5-194371	0748	-	F	Introduction of test frequencies for inter-band Rel-16 EN-DC five bands configurations	16.0.0
2019-06	RAN#84	R5-194373	0749	-	F	Introduction of test frequencies for NR CA configuration CA_n41C	16.0.0
2019-09	RAN#85	R5-195696	0795	-	F	Update IE PDCP-Config	16.1.0
2019-09	RAN#85	R5-195711	0797	-	F	Add IE CGI-InfoEUTRA	16.1.0
2019-09	RAN#85	R5-195729	0798	-	F	Update IE CGI-Info	16.1.0
2019-09	RAN#85	R5-195730	0799	-	F	Update IE MeasResults	16.1.0
2019-09	RAN#85	R5-195731	0800	-	F	Update of 4.3.1.0A mid test CBW in 38.508-1	16.1.0
2019-09	RAN#85	R5-195747	0803	-	F	Update IE MeasResultCellListSFTD	16.1.0
2019-09	RAN#85	R5-195748	0804	-	F	Add IE MeasResultCellListSFTD-EUTRA	16.1.0
2019-09	RAN#85	R5-195749	0805	-	F	Add IE MeasResult2EUTRA	16.1.0
2019-09	RAN#85	R5-195750	0806	-	F	Add IE MeasResult2NR	16.1.0
2019-09	RAN#85	R5-195751	0807	-	F	Add IE SK-Counter	16.1.0
2019-09	RAN#85	R5-195752	0808	-	F	Update IE SS-RSSI-Measurement	16.1.0
2019-09	RAN#85	R5-195792	0811	-	F	Update MeasurementReport	16.1.0
2019-09	RAN#85	R5-195885	0814	-	F	Update RRCResume	16.1.0
2019-09	RAN#85	R5-195886	0815	-	F	Editorial update RRCReconfigurationComplete	16.1.0
2019-09	RAN#85	R5-195887	0816	-	F	Editorial update RRCReject	16.1.0
2019-09	RAN#85	R5-195888	0817	-	F	Editorial update RRCRelease	16.1.0
2019-09	RAN#85	R5-195889	0818	-	F	Add SCGFailureInformation	16.1.0
2019-09	RAN#85	R5-195890	0819	-	F	Add SCGFailureInformationEUTRA	16.1.0
2019-09	RAN#85	R5-195895	0820	-	F	Update UECapabilityEnquiry	16.1.0
2019-09	RAN#85	R5-195909	0821	-	F	Editorial update UECapabilityInformation	16.1.0
2019-09	RAN#85	R5-195910	0822	-	F	Add ULInformationTransferMRDC	16.1.0
2019-09	RAN#85	R5-195926	0823	-	F	Editorial update RRC IEs	16.1.0
2019-09	RAN#85	R5-195927	0824	-	F	Editorial update S-NSSAI	16.1.0

2019-09	RAN#85	R5-195944	0826	-	F	Correction to ReportConfigNR	16.1.0
2019-09	RAN#85	R5-195945	0827	-	F	Updates to default configurations for 5GC NAS test cases	16.1.0
2019-09	RAN#85	R5-196030	0829	-	F	Handling of thresholds in FR2 when Events A3 and A6 are inter-frequency	16.1.0
2019-09	RAN#85	R5-196031	0830	-	F	Adding references to TS 38.508-1	16.1.0
2019-09	RAN#85	R5-196136	0836	-	F	Addition new NR cell for SS-RSRP RRM tests	16.1.0
2019-09	RAN#85	R5-196148	0837	-	F	Update of Annex C for selecting SSB location for cells not selectable as PCell	16.1.0
2019-09	RAN#85	R5-196158	0838	-	F	Correction of references to test frequency tables	16.1.0
2019-09	RAN#85	R5-196159	0839	-	F	Correction of clause numbers for test frequencies for Non-3GPP Access	16.1.0
2019-09	RAN#85	R5-196168	0840	-	F	Correction of test frequency parameters for SSB location for NR band n1 and SCS 60kHz	16.1.0
2019-09	RAN#85	R5-196169	0841	-	F	Correction of test frequency parameters for SSB location for NR band n2 and SCS 60kHz	16.1.0
2019-09	RAN#85	R5-196170	0842	-	F	Correction of test frequency parameters for SSB location for NR band n3 and SCS 60kHz	16.1.0
2019-09	RAN#85	R5-196171	0843	-	F	Correction of test frequency parameters for SSB location for NR band n7 and SCS 60kHz	16.1.0
2019-09	RAN#85	R5-196172	0844	-	F	Correction of test frequency parameters for SSB location for NR band n25 and SCS 60kHz	16.1.0
2019-09	RAN#85	R5-196174	0846	-	F	Correction of test frequency parameters for SSB location for NR band n38 and SCS 60kHz	16.1.0
2019-09	RAN#85	R5-196175	0847	-	F	Correction of test frequency parameters for SSB location for NR band n39 and SCS 60kHz	16.1.0
2019-09	RAN#85	R5-196176	0848	-	F	Correction of test frequency parameters for SSB location for NR band n40 and SCS 60kHz	16.1.0
2019-09	RAN#85	R5-196177	0849	-	F	Correction of test frequency parameters for SSB location for NR band n41 and SCS 60kHz	16.1.0
2019-09	RAN#85	R5-196178	0850	-	F	Correction of test frequency parameters for SSB location for NR band n50 and SCS 60kHz	16.1.0
2019-09	RAN#85	R5-196179	0851	-	F	Correction of test frequency parameters for SSB location for NR band n66 and SCS 60kHz	16.1.0
2019-09	RAN#85	R5-196180	0852	-	F	Correction of test frequency parameters for SSB location for NR band n70 and SCS 60kHz	16.1.0
2019-09	RAN#85	R5-196181	0853	-	F	Correction of test frequency parameters for SSB location for NR band n74 and SCS 60kHz	16.1.0
2019-09	RAN#85	R5-196182	0854	-	F	Correction of test frequency parameters for SSB location for NR band n75 and SCS 15kHz and SCS 60kHz	16.1.0
2019-09	RAN#85	R5-196183	0855	-	F	Correction of test frequency parameters for SSB location for NR band n77 and SCS 60kHz	16.1.0
2019-09	RAN#85	R5-196184	0856	-	F	Correction of test frequency parameters for SSB location for NR band n78 and SCS 60kHz	16.1.0
2019-09	RAN#85	R5-196185	0857	-	F	Correction of test frequency parameters for SSB location for NR band n79 and SCS 60kHz	16.1.0
2019-09	RAN#85	R5-196197	0860	-	F	Update IE ServingCellConfigCommon	16.1.0
2019-09	RAN#85	R5-196198	0861	-	F	Update IE SubcarrierSpacing	16.1.0
2019-09	RAN#85	R5-196262	0863	-	F	Editorial update IE RLC-BearerConfig	16.1.0
2019-09	RAN#85	R5-196289	0864	-	F	Update chapter 4.5A.2 UE-requested PDU session establishment procedure	16.1.0
2019-09	RAN#85	R5-196310	0867	-	F	Addition of SUL bands for protocol testing in clause 6.2.3.1	16.1.0
2019-09	RAN#85	R5-196311	0868	-	F	Update of test frequency parameters for NR CA configuration CA_n41C	16.1.0
2019-09	RAN#85	R5-196315	0872	-	F	Update of test frequency parameters for NR CA configuration CA_n260(A-I)	16.1.0
2019-09	RAN#85	R5-196316	0873	-	F	Introduction of test frequencies for NR CA configuration CA_n261B and CA_n261C	16.1.0
2019-09	RAN#85	R5-196317	0874	-	F	Update of test frequency table for EN-DC configuration DC_41A_n41A for BCS1	16.1.0
2019-09	RAN#85	R5-196318	0875	-	F	Correction of test frequency parameters for EN-DC configuration DC_(n)41AA	16.1.0
2019-09	RAN#85	R5-196319	0876	-	F	Correction of test frequency parameters for EN-DC configuration DC_(n)71AA	16.1.0
2019-09	RAN#85	R5-196468	0885	-	F	Introduction of test frequencies for NR CA configuration CA_n258B and CA_n258C	16.1.0



2019-09	RAN#85	R5-196469	0886	-	F	Introduction of test frequencies for NR CA configuration CA_n258G to CA_n258M	16.1.0
2019-09	RAN#85	R5-196470	0887	-	F	Introduction of test frequencies for NR CA configuration CA_n260G to CA_n260I	16.1.0
2019-09	RAN#85	R5-196472	0889	-	F	Introduction of test frequencies for NR CA configuration CA_n261G to CA_n261I	16.1.0
2019-09	RAN#85	R5-196473	0890	-	F	Introduction of test frequencies for NR CA configuration CA_n261O to CA_n261Q	16.1.0
2019-09	RAN#85	R5-196490	0894	-	F	Introduction of test frequencies for NR CA configuration CA_n78C	16.1.0
2019-09	RAN#85	R5-196539	0895	-	F	Update to 38.508-1 for Demod specific message contents	16.1.0
2019-09	RAN#85	R5-196581	0897	-	F	Removing brackets from values for DCI formats	16.1.0
2019-09	RAN#85	R5-196597	0899	-	F	Cleanup of editor note of EFOPL5G	16.1.0
2019-09	RAN#85	R5-196637	0900	-	F	Update of default messages for EMERGENCY services test scenarios	16.1.0
2019-09	RAN#85	R5-196641	0904	-	F	Update of Test procedure for UE for Tracking area updating / Inter-system change from S1 mode to N1 mode in 5GMM/EMM-IDLE mode	16.1.0
2019-09	RAN#85	R5-196654	0905	-	F	Editorial correction of reference test conditions	16.1.0
2019-09	RAN#85	R5-196751	0911	-	F	AP#82.01: Update default DCI format to 0_1 / 1_1 in TS 38.508-1 for SIG test cases	16.1.0
2019-09	RAN#85	R5-196824	0917	-	F	Updates to UE 4.6.4 UE Capability Information Elements	16.1.0
2019-09	RAN#85	R5-196825	0918	-	F	Addition of default test control messages	16.1.0
2019-09	RAN#85	R5-196873	0922	-	F	Introduction of test frequencies for NR CA configuration CA_n258D to CA_n258F	16.1.0
2019-09	RAN#85	R5-196874	0923	-	F	Introduction of test frequencies for NR CA configuration CA_n260D to CA_n260F	16.1.0
2019-09	RAN#85	R5-196875	0924	-	F	Introduction of test frequencies for NR CA configuration CA_n260O to CA_n260Q	16.1.0
2019-09	RAN#85	R5-196942	0927	-	F	Correction of clause 2 and 4.3 in 38.508-1	16.1.0
2019-09	RAN#85	R5-196980	0786	1	F	Using generic procedure for IMS registration to 5GS	16.1.0
2019-09	RAN#85	R5-196981	0788	1	F	Update of SIB2	16.1.0
2019-09	RAN#85	R5-196982	0790	1	F	Update of SIB5	16.1.0
2019-09	RAN#85	R5-196984	0792	1	F	Update of frequency definition for Inter-RAT test cases	16.1.0
2019-09	RAN#85	R5-196985	0793	1	F	Update IE CellGroupConfig	16.1.0
2019-09	RAN#85	R5-196986	0858	1	F	Update MIB	16.1.0
2019-09	RAN#85	R5-196987	0865	1	F	Update chapter 4.5.4 RRC_CONNECTED procedures	16.1.0
2019-09	RAN#85	R5-196988	0831	1	F	Addition of IE MasterKeyUpdate	16.1.0
2019-09	RAN#85	R5-196990	0833	1	F	USIM Configuration for Signalling Test Cases	16.1.0
2019-09	RAN#85	R5-196991	0835	1	F	Correction to SIG OTA UE Orientation procedure	16.1.0
2019-09	RAN#85	R5-196992	0878	1	F	Addition of New Test Procedure - Response\No response to Paging for 5GC NAS testing	16.1.0
2019-09	RAN#85	R5-196994	0913	1	F	Update IE ServingCellConfig	16.1.0
2019-09	RAN#85	R5-196995	0910	1	F	Corrections to DCI_1_0 configuration	16.1.0
2019-09	RAN#85	R5-196996	0919	1	F	Updates to generic procedure using SERVICE REQUEST procedure	16.1.0
2019-09	RAN#85	R5-196997	0901	1	F	Introduction of Test Procedure for IMS Emergency call establishment in 5GC NORMAL-SERVICE	16.1.0
2019-09	RAN#85	R5-196998	0903	1	F	Update of Test procedure for UE for Tracking area updating / Inter-system change from N1 mode to S1 mode in 5GMM/EMM-IDLE mode	16.1.0
2019-09	RAN#85	R5-197014	0928	-	F	Addition of NR CA test frequencies for protocol testing in clause 6.2.3	16.1.0
2019-09	RAN#85	R5-197099	0929	-	F	Correction to Switch off-Power off procedure in RRC_CONNECTED	16.1.0
2019-09	RAN#85	R5-197104	0884	1	F	Introduction of test frequencies for NR CA configuration CA_n257G to CA_n257M	16.1.0
2019-09	RAN#85	R5-197106	0892	1	F	Update of EN-DC inter-band configurations in clause 4.3.1	16.1.0
2019-09	RAN#85	R5-197139	0891	2	F	Update of NR CA inter-band configurations in clause 4.3.1	16.1.0
2019-09	RAN#85	R5-197226	0915	1	F	changes for Non 3GPP Access over WLAN	16.1.0
2019-09	RAN#85	R5-197230	0883	1	F	Introduction of test frequencies for NR CA configuration CA_n257D to CA_n257F	16.1.0
2019-09	RAN#85	R5-197231	0869	1	F	Update of test frequency parameters for NR CA configuration CA_n257B and CA_n257C	16.1.0

2019-09	RAN#85	R5-197232	0870	1	F	Introduction of test frequencies for NR CA configuration CA_n260B and CA_n260C	16.1.0
2019-09	RAN#85	R5-197233	0888	1	F	Introduction of test frequencies for NR CA configuration CA_n260J to CA_n260M	16.1.0
2019-09	RAN#85	R5-197234	0813	1	F	Update RRCReconfiguration	16.1.0
2019-09	RAN#85	R5-197235	0796	1	F	Update RadioBearerConfig-DRB	16.1.0
2019-09	RAN#85	R5-197236	0825	1	F	Update RRCReconfiguration-HO	16.1.0
2019-09	RAN#85	R5-197241	0791	1	F	Update of EUTRA-AllowedMeasBandwidth	16.1.0
2019-09	RAN#85	R5-197243	0809	1	F	Addition of Delta to signalling threshold in System Information in FR2	16.1.0
2019-09	RAN#85	R5-197244	0866	1	F	Correction to REGISTRATION REJECT message	16.1.0
2019-09	RAN#85	R5-197246	0902	1	F	Introduction of Test Procedure for IMS Emergency call establishment in 5GC LIMITED-SERVICE or NO-SUPI	16.1.0
2019-09	RAN#85	R5-197296	0898	2	F	Update of PHR-Config	16.1.0
2019-09	RAN#85	R5-197300	0787	1	F	4x2 Connection Diagram for demodulation tests	16.1.0
2019-09	RAN#85	R5-197301	0862	1	F	Correction to Section 5.4.2 Message definition for Performance Test	16.1.0
2019-09	RAN#85	R5-197302	0882	1	F	Addition of FR2 CA connection diagram	16.1.0
2019-09	RAN#85	R5-197303	0920	1	F	Corrections to test frequencies and formulas	16.1.0
2019-09	RAN#85	R5-197304	0896	1	F	Removing IOT bit information from test channel bandwidth tables	16.1.0
2019-09	RAN#85	R5-197305	0908	1	F	Addition of SMTC Configuration for RRM test cases	16.1.0
2019-09	RAN#85	R5-197507	0906	1	F	Addition of TDD UL DL Config for RRM test cases	16.1.0
2019-09	RAN#85	R5-197508	0907	1	F	Addition of FilterCoefficient configuration for RRM test cases	16.1.0
2019-09	RAN#85	R5-197638	0881	2	F	Addition of FR1 CA connection diagram	16.1.0
2019-10	RAN#85	-	-	-	-	Implementation fixes	16.1.1
2019-12	RAN#86	R5-197727	0932	-	F	Editorial update IE BWP-Id	16.2.0
2019-12	RAN#86	R5-197751	0933	-	F	Editorial update IE PDSCH-TimeDomainResourceAllocationList	16.2.0
2019-12	RAN#86	R5-197835	0937	-	F	Correction to IE ReportConfigNR	16.2.0
2019-12	RAN#86	R5-197897	0940	-	F	Editorial update IE CodebookConfig	16.2.0
2019-12	RAN#86	R5-197932	0946	-	F	Editorial update IE PDSCH-Config	16.2.0
2019-12	RAN#86	R5-197967	0948	-	F	Update of Annex C on calculation of test frequencies and parameters	16.2.0
2019-12	RAN#86	R5-197968	0949	-	F	Correction of test frequency parameters for NR band n1	16.2.0
2019-12	RAN#86	R5-197969	0950	-	F	Correction of test frequency parameters for NR band n2	16.2.0
2019-12	RAN#86	R5-197970	0951	-	F	Correction of test frequency parameters for NR band n3	16.2.0
2019-12	RAN#86	R5-197971	0952	-	F	Correction of test frequency parameters for NR band n5	16.2.0
2019-12	RAN#86	R5-197972	0953	-	F	Correction of test frequency parameters for NR band n7	16.2.0
2019-12	RAN#86	R5-197973	0954	-	F	Correction of test frequency parameters for NR band n8	16.2.0
2019-12	RAN#86	R5-197974	0955	-	F	Correction of test frequency parameters for NR band n12	16.2.0
2019-12	RAN#86	R5-197975	0956	-	F	Correction of test frequency parameters for NR band n20	16.2.0
2019-12	RAN#86	R5-197976	0957	-	F	Correction of test frequency parameters for NR band n25	16.2.0
2019-12	RAN#86	R5-197977	0958	-	F	Correction of test frequency parameters for NR band n28	16.2.0
2019-12	RAN#86	R5-197978	0959	-	F	Correction of test frequency parameters for NR band n34	16.2.0
2019-12	RAN#86	R5-197979	0960	-	F	Correction of test frequency parameters for NR band n38	16.2.0
2019-12	RAN#86	R5-197980	0961	-	F	Correction of test frequency parameters for NR band n39	16.2.0
2019-12	RAN#86	R5-197981	0962	-	F	Correction of test frequency parameters for NR band n40	16.2.0
2019-12	RAN#86	R5-197982	0963	-	F	Correction of test frequency parameters for NR band n41	16.2.0
2019-12	RAN#86	R5-197983	0964	-	F	Correction of test frequency parameters for NR band n50	16.2.0
2019-12	RAN#86	R5-197984	0965	-	F	Correction of test frequency parameters for NR band n51	16.2.0
2019-12	RAN#86	R5-197985	0966	-	F	Correction of test frequency parameters for NR band n66	16.2.0
2019-12	RAN#86	R5-197986	0967	-	F	Correction of test frequency parameters for NR band n70	16.2.0
2019-12	RAN#86	R5-197987	0968	-	F	Correction of test frequency parameters for NR band n71	16.2.0
2019-12	RAN#86	R5-197988	0969	-	F	Correction of test frequency parameters for NR band n74	16.2.0
2019-12	RAN#86	R5-197989	0970	-	F	Correction of test frequency parameters for NR band n75 (SDL)	16.2.0
2019-12	RAN#86	R5-197990	0971	-	F	Correction of test frequency parameters for NR band n76 (SDL)	16.2.0
2019-12	RAN#86	R5-197991	0972	-	F	Correction of test frequency parameters for NR band n77	16.2.0
2019-12	RAN#86	R5-197992	0973	-	F	Correction of test frequency parameters for NR band n78	16.2.0
2019-12	RAN#86	R5-197993	0974	-	F	Correction of test frequency parameters for NR band n79	16.2.0
2019-12	RAN#86	R5-197994	0975	-	F	Editorial correction to note 1 in frequency tables for NR bands n257, n258, n260 and n261	16.2.0

2019-12	RAN#86	R5-197997	0978	-	F	Introduction of test frequencies for NR CA configuration CA_n261D to CA_n261F	16.2.0
2019-12	RAN#86	R5-197998	0979	-	F	Introduction of test frequencies for NR CA configuration CA_n261J to CA_n261M	16.2.0
2019-12	RAN#86	R5-198016	0983	-	F	Introduction of test frequencies parameters for Rel-16 NR CA configuration CA_n66B	16.2.0
2019-12	RAN#86	R5-198017	0984	-	F	Introduction of test frequencies parameters for Rel-16 NR CA configuration CA_n66(2A)	16.2.0
2019-12	RAN#86	R5-198018	0985	-	F	Introduction of test frequencies and parameters for NR band n29	16.2.0
2019-12	RAN#86	R5-198019	0986	-	F	Introduction of test frequencies and parameters for NR band n65	16.2.0
2019-12	RAN#86	R5-198028	0988	-	F	Add 4Rx connection diagram for RRM measurement tests	16.2.0
2019-12	RAN#86	R5-198057	0993	-	F	Editorial update IE RateMatchPattern	16.2.0
2019-12	RAN#86	R5-198058	0994	-	F	Editorial update IE SchedulingRequestResourceConfig	16.2.0
2019-12	RAN#86	R5-198082	0999	-	F	Introduce general chapter in 4.6	16.2.0
2019-12	RAN#86	R5-198120	1004	-	F	Correction of test frequencies parameters for Rel-15 EN-DC configuration DC_(n)41AA	16.2.0
2019-12	RAN#86	R5-198121	1005	-	F	Correction of test frequencies parameters for Rel-15 EN-DC configuration DC_(n)71AA	16.2.0
2019-12	RAN#86	R5-198125	1009	-	F	Introduction of test frequencies and parameters for NR band n48	16.2.0
2019-12	RAN#86	R5-198126	1010	-	F	Introduction of test frequencies for NR band b41 and CBW 30MHz	16.2.0
2019-12	RAN#86	R5-198131	1012	-	F	Update of USIM Configuration 15 for forbidden PLMN	16.2.0
2019-12	RAN#86	R5-198133	1014	-	F	Update IE ServingCellConfigCommonSIB	16.2.0
2019-12	RAN#86	R5-198141	1015	-	F	Clarification on default radio configuration of NAS cells	16.2.0
2019-12	RAN#86	R5-198217	1019	-	F	Correction of test frequency parameters for protocol testing and NR bands with scs=15kHz	16.2.0
2019-12	RAN#86	R5-198223	1021	-	F	Add IE BetaOffsets	16.2.0
2019-12	RAN#86	R5-198224	1022	-	F	Update IE PUSCH-Config	16.2.0
2019-12	RAN#86	R5-198250	1023	-	F	Update IE CSI-FrequencyOccupation	16.2.0
2019-12	RAN#86	R5-198251	1024	-	F	Update IE PHR-Config	16.2.0
2019-12	RAN#86	R5-198258	1026	-	F	Editorial update IE DRX-Config	16.2.0
2019-12	RAN#86	R5-198282	1027	-	F	Update to Connection diagram for 2x4 and 4x4 Demod test cases	16.2.0
2019-12	RAN#86	R5-198286	1028	-	F	Correction of mapping of frequency ranges to NR test frequencies for NR SA	16.2.0
2019-12	RAN#86	R5-198304	1029	-	F	Editorial update IE LogicalChannelConfig	16.2.0
2019-12	RAN#86	R5-198370	1035	-	F	Connection diagram for FR2 Demod and CSI test cases	16.2.0
2019-12	RAN#86	R5-198480	1039	-	F	Editorial update IE PDCCH-ConfigCommon	16.2.0
2019-12	RAN#86	R5-198485	1041	-	F	Editorial update IE PDCP-Config	16.2.0
2019-12	RAN#86	R5-198506	1044	-	F	Addition of RRCReconfiguration for Speech call setup	16.2.0
2019-12	RAN#86	R5-198507	1045	-	F	Editorial updates to section 4.7.0	16.2.0
2019-12	RAN#86	R5-198508	1046	-	F	New reference QoS configurations for IMS voice and video	16.2.0
2019-12	RAN#86	R5-198509	1047	-	F	Updates to REGISTRATION ACCEPT 5GMM message	16.2.0
2019-12	RAN#86	R5-198510	1048	-	F	Updates to test control messages	16.2.0
2019-12	RAN#86	R5-198540	1051	-	F	Update of REGISTRATION ACCEPT for IMS emergency support	16.2.0
2019-12	RAN#86	R5-198544	1053	-	F	Update of Table 4.6.3-162 SearchSpace in 38.508-1	16.2.0
2019-12	RAN#86	R5-198638	1058	-	F	Corrections on test frequencies for NR CA band n260 in 38.508-1	16.2.0
2019-12	RAN#86	R5-198649	1059	-	F	Corrections on test frequencies for NR CA band n261 in 38.508-1	16.2.0
2019-12	RAN#86	R5-198659	1062	-	F	Update TCI State Cell parameter in Demod section	16.2.0
2019-12	RAN#86	R5-198718	1067	-	F	Updates to RSRP-Range, RSRQ-Range and SINR-Range	16.2.0
2019-12	RAN#86	R5-198847	0941	1	F	Corrections to DCI_1_1 configuration	16.2.0
2019-12	RAN#86	R5-198848	0931	1	F	Update IE PUSCH-TimeDomainResourceAllocationList	16.2.0
2019-12	RAN#86	R5-198850	0934	1	F	Correction to IE MasterKeyUpdate	16.2.0
2019-12	RAN#86	R5-198851	0935	1	F	Update of NR SIBs	16.2.0
2019-12	RAN#86	R5-198852	0936	1	F	Correction to USIM configuration	16.2.0
2019-12	RAN#86	R5-198853	0938	1	F	Correction to IE ReportConfigInterRAT	16.2.0
2019-12	RAN#86	R5-198854	0942	1	F	Correction to Table 4.9.9.2.3-1 for Inter-system change from S1 mode to N1 mode in 5GMM-IDLE mode	16.2.0
2019-12	RAN#86	R5-198856	0982	1	F	Addition of frequency configurations for NR MFBI testing	16.2.0

2019-12	RAN#86	R5-198857	0992	1	F	Editorial update IE CSI-AperiodicTriggerStateList	16.2.0
2019-12	RAN#86	R5-198858	0998	1	F	Editorial update IE ServingCellConfig	16.2.0
2019-12	RAN#86	R5-198859	1000	1	F	Editorial update IE SecurityAlgorithmConfig	16.2.0
2019-12	RAN#86	R5-198860	1002	1	F	Update IE SRS-Config	16.2.0
2019-12	RAN#86	R5-198861	1001	1	F	Update of Generic Test Procedures for IMS Emergency call establishment 4.9.11 and 4.9.12 to reflect the fact that they can be used in multiple states and scenarios	16.2.0
2019-12	RAN#86	R5-198862	1013	1	F	Update IE ServingCellConfigCommon	16.2.0
2019-12	RAN#86	R5-198863	1016	1	F	Update IE CSI-RS-ResourceMapping	16.2.0
2019-12	RAN#86	R5-198865	1032	1	F	Update RRCReconfiguration	16.2.0
2019-12	RAN#86	R5-198866	1033	1	F	Update chapter 4.5.1 General	16.2.0
2019-12	RAN#86	R5-198867	1034	1	F	Update to PDU SESSION ESTABLISHMENT ACCEPT and Reference QoS flow descriptions to align EPS bearer id format	16.2.0
2019-12	RAN#86	R5-198869	1061	1	F	New Test Procedures for IMS Emergency call release	16.2.0
2019-12	RAN#86	R5-198870	1063	1	F	Update chapter 4.5.2 RRC_IDLE	16.2.0
2019-12	RAN#86	R5-198871	1072	1	F	Update of RRCReconfiguration for measurement configuration	16.2.0
2019-12	RAN#86	R5-198955	0995	1	F	Update procedure for NR RF CA testing	16.2.0
2019-12	RAN#86	R5-198956	0996	1	F	Update procedure for EN-DC RF CA testing	16.2.0
2019-12	RAN#86	R5-198957	1036	1	F	Update to 38.508-1 for DEMOD message contents	16.2.0
2019-12	RAN#86	R5-198958	0991	1	F	Update IE PUCCH-Config	16.2.0
2019-12	RAN#86	R5-198959	0976	1	F	Introduction of test frequencies for Rel-15 EN-DC inter-band configurations	16.2.0
2019-12	RAN#86	R5-198960	0980	1	F	Introduction of test frequencies for Rel-16 NR inter-band CA configurations	16.2.0
2019-12	RAN#86	R5-198961	0987	1	F	Introduction of test frequencies for NR configuration CA_n29A-n66A	16.2.0
2019-12	RAN#86	R5-198962	1003	1	F	Introduction of test frequencies for Rel-15 NR DC configurations	16.2.0
2019-12	RAN#86	R5-198997	1068	1	F	Introduction of test frequencies and parameters for NR bands n29, n48 and n65 for protocol testing	16.2.0
2019-12	RAN#86	R5-199008	0997	1	F	Editorial update WLAN table 4.5.2.2-3	16.2.0
2019-12	RAN#86	R5-199013	0943	1	F	Correction to SMTC and GAP for inter frequency cell	16.2.0
2019-12	RAN#86	R5-199015	0981	1	F	Correction of test frequencies for NR CA and EN-DC protocol testing	16.2.0
2019-12	RAN#86	R5-199016	1049	1	F	Updates to Test Procedure 4.9.11	16.2.0
2019-12	RAN#86	R5-199017	1050	1	F	Updates to Test Procedure 4.9.12	16.2.0
2019-12	RAN#86	R5-199020	1079	-	F	Update default setting of deriveSSB-IndexFromCell	16.2.0
2019-12	RAN#86	R5-199021	1011	1	F	Update IE TDD-UL-DL-Config	16.2.0
2019-12	RAN#86	R5-199022	1070	1	F	Updates to Signalling Reference test conditions	16.2.0
2019-12	RAN#86	R5-199026	1025	2	F	Update IE CellGroupConfig	16.2.0
2019-12	RAN#86	R5-199071	0944	2	F	Update of SUL related messages	16.2.0
2019-12	RAN#86	R5-199075	1080	1	F	Correction to NR RRC_IDLE mode procedure	16.2.0
2019-12	RAN#86	R5-199093	1065	2	F	Update chapter 4.5.4 RRC_CONNECTED	16.2.0
2019-12	RAN#86	R5-199094	1069	1	F	Updates for handling of Multiple PDU sessions / Multiple DRBs	16.2.0
2019-12	RAN#86	R5-199103	1076	2	F	Adding new generic procedure for UE-requested PDU session modification after the first S1 to N1 mode change	16.2.0
2019-12	RAN#86	R5-199300	1042	1	F	Corrections on category of EN-DC configurations for test frequencies in 38.508-1	16.2.0
2019-12	RAN#86	R5-199301	1054	1	F	Addition of ServingCellConfigCommon for RRM tests	16.2.0
2019-12	RAN#86	R5-199302	1057	1	F	Corrections on test frequencies for NR CA band n257 in 38.508-1	16.2.0
2019-12	RAN#86	R5-199303	1060	1	F	Corrections on test frequencies for NR CA band n258 in 38.508-1	16.2.0
2019-12	RAN#86	R5-199304	1066	1	F	Update Radio resource control information elements for RRM to add CSI-RS for Tracking	16.2.0
2019-12	RAN#86	R5-199423	1077	-	F	Update ra-responseWindow in TS 38.508-1	16.2.0
2019-12	RAN#86	R5-199481	0989	1	F	Addition of FR1 NR CA and NR 4Rx connection diagrams	16.2.0
2019-12	RAN#86	R5-199511	1078	-	F	Update of quiet zone size	16.2.0
2019-12	RAN#86	R5-199545	1020	1	F	Addition of multi-AoA capabilities for IFF	16.2.0
2020-03	RAN#87	R5-200135	1120		F	Removal of Correction to SIG OTA UE Orientation procedure	16.3.0
2020-03	RAN#87	R5-200147	1130		F	Update to USIM config 6.4.1-11	16.3.0
2020-03	RAN#87	R5-200244	1133		F	Correction to nAndPagingFrameOffset	16.3.0

2020-03	RAN#87	R5-200296	1136		F	Addition of generic procedure for IMS MO speech setup	16.3.0
2020-03	RAN#87	R5-200297	1137		F	Addition of generic procedure for IMS MT speech setup	16.3.0
2020-03	RAN#87	R5-200298	1138		F	Addition of generic procedure for IMS MO call release	16.3.0
2020-03	RAN#87	R5-200299	1139		F	Addition of generic procedure for IMS MT call release	16.3.0
2020-03	RAN#87	R5-200349	1142		F	Correction to frequencyBandList in SIB4	16.3.0
2020-03	RAN#87	R5-200431	1146		F	Correction to CSI-FrequencyOccupation	16.3.0
2020-03	RAN#87	R5-200432	1147		F	Correction to default setting of additionalPmax	16.3.0
2020-03	RAN#87	R5-200433	1148		F	Correction to powerControlOffset for performance tests	16.3.0
2020-03	RAN#87	R5-200434	1149		F	Correction to RACH configuration for RRM tests	16.3.0
2020-03	RAN#87	R5-200435	1150		F	Correction to TDD UL-DL Config for performance test cases	16.3.0
2020-03	RAN#87	R5-200477	1154		F	Update to Registration REQ and Authentication Response message	16.3.0
2020-03	RAN#87	R5-200499	1157		F	Correction of test frequency tables for NR band n1	16.3.0
2020-03	RAN#87	R5-200500	1158		F	Correction of test frequency tables for NR band n2	16.3.0
2020-03	RAN#87	R5-200501	1159		F	Correction of test frequency tables for NR band n3	16.3.0
2020-03	RAN#87	R5-200502	1160		F	Correction of test frequency tables for NR band n7	16.3.0
2020-03	RAN#87	R5-200503	1161		F	Correction of test frequency tables for NR band n25	16.3.0
2020-03	RAN#87	R5-200504	1162		F	Correction of test frequency tables for NR band n28	16.3.0
2020-03	RAN#87	R5-200505	1163		F	Correction of test frequency tables for NR band n34	16.3.0
2020-03	RAN#87	R5-200506	1164		F	Correction of test frequency tables for NR band n38	16.3.0
2020-03	RAN#87	R5-200507	1165		F	Correction of test frequency tables for NR band n39	16.3.0
2020-03	RAN#87	R5-200508	1166		F	Correction of test frequency tables for NR band n40	16.3.0
2020-03	RAN#87	R5-200510	1168		F	Correction of test frequency tables for NR band n50	16.3.0
2020-03	RAN#87	R5-200511	1169		F	Correction of test frequency tables for NR band n66	16.3.0
2020-03	RAN#87	R5-200512	1170		F	Correction of test frequency tables for NR band n70	16.3.0
2020-03	RAN#87	R5-200513	1171		F	Correction of test frequency tables for NR band n71	16.3.0
2020-03	RAN#87	R5-200514	1172		F	Correction of test frequency tables for NR band n74	16.3.0
2020-03	RAN#87	R5-200515	1173		F	Correction of test frequency tables for NR band n75	16.3.0
2020-03	RAN#87	R5-200531	1189		F	Correction of test frequency tables for NR band n29	16.3.0
2020-03	RAN#87	R5-200532	1190		F	Correction of test frequency tables for NR band n48	16.3.0
2020-03	RAN#87	R5-200533	1191		F	Correction of test frequency tables for NR band n65	16.3.0
2020-03	RAN#87	R5-200597	1200		F	Introduction of test frequencies for inter-band Rel-16 EN-DC configurations in 38.508-1	16.3.0
2020-03	RAN#87	R5-200605	1202		F	Addition of test frequencies for n95 SUL band	16.3.0
2020-03	RAN#87	R5-200645	1206		F	Updates to 4.6.4 UE Capability Information Elements	16.3.0
2020-03	RAN#87	R5-200646	1207		F	Correction to QoS rule number 7	16.3.0
2020-03	RAN#87	R5-200647	1208		F	Correction to IMS emergency call release procedures	16.3.0
2020-03	RAN#87	R5-201246	1209	1	F	TRS configuration messages definition for RF in 38.508-1	16.3.0
2020-03	RAN#87	R5-200678	1210		F	Update of IE ControlResourceSet to introduce band and channel bandwidth specific values for frequencyDomainResources	16.3.0
2020-03	RAN#87	R5-200703	1213		F	Correction to IE BeamFailureRecoveryConfig	16.3.0
2020-03	RAN#87	R5-200774	1215		F	Editorial update IE MeasConfig	16.3.0
2020-03	RAN#87	R5-200775	1216		F	Editorial update IE radioLinkMonitoringRS-Id	16.3.0
2020-03	RAN#87	R5-200804	1218		F	Correction of test frequency tables for NR band n5	16.3.0
2020-03	RAN#87	R5-200805	1219		F	Correction of test frequency tables for NR band n8	16.3.0
2020-03	RAN#87	R5-200806	1220		F	Correction of test frequency tables for NR band n12	16.3.0
2020-03	RAN#87	R5-200807	1221		F	Correction of test frequency tables for NR band n20	16.3.0
2020-03	RAN#87	R5-200808	1222		F	Correction of test frequency tables for NR band n51	16.3.0
2020-03	RAN#87	R5-200900	1197	1	F	Corrections on test frequencies for EN-DC band combinations including FR1 and FR2 in 38.508-1	16.3.0
2020-03	RAN#87	R5-200901	1198	1	F	Corrections on test frequencies for EN-DC band combinations including FR2 in 38.508-1	16.3.0
2020-03	RAN#87	R5-200902	1199	1	F	Corrections on uplink EN-DC configurations for test frequencies in 38.508-1	16.3.0
2020-03	RAN#87	R5-200921	1132	1	F	Addition of Rel-16 inter-band CA and EN-DC FR1 two bands test configurations	16.3.0
2020-03	RAN#87	R5-200930	1081	1	F	Update SIB1	16.3.0
2020-03	RAN#87	R5-200931	1082	1	F	Update CounterCheck	16.3.0
2020-03	RAN#87	R5-200932	1083	1	F	Editorial update DLInformationTransfer	16.3.0
2020-03	RAN#87	R5-200933	1084	1	F	Editorial update FailureInformation	16.3.0
2020-03	RAN#87	R5-200934	1085	1	F	Editorial update MeasurementReport	16.3.0
2020-03	RAN#87	R5-200935	1086	1	F	Editorial update MobilityFromNRCommand	16.3.0
2020-03	RAN#87	R5-200936	1087	1	F	Editorial update Paging	16.3.0

2020-03	RAN#87	R5-200937	1088	1	F	Editorial update RRCReestablishment	16.3.0
2020-03	RAN#87	R5-200938	1090	1	F	Editorial update RRCReconfigurationComplete	16.3.0
2020-03	RAN#87	R5-200939	1091	1	F	Editorial update RRCReject	16.3.0
2020-03	RAN#87	R5-200940	1092	1	F	Editorial update RRCRelease	16.3.0
2020-03	RAN#87	R5-200941	1093	1	F	Editorial update RRCResumeComplete	16.3.0
2020-03	RAN#87	R5-200942	1094	1	F	Editorial update RRCSetup	16.3.0
2020-03	RAN#87	R5-200943	1096	1	F	Editorial update SCGFailureInformation	16.3.0
2020-03	RAN#87	R5-200944	1097	1	F	Editorial update SecurityMode	16.3.0
2020-03	RAN#87	R5-200945	1098	1	F	Update SystemInformation	16.3.0
2020-03	RAN#87	R5-200946	1099	1	F	Editorial update UEAssistanceInformation	16.3.0
2020-03	RAN#87	R5-200947	1100	1	F	Editorial update UECapability	16.3.0
2020-03	RAN#87	R5-200948	1101	1	F	Editorial update ULInformation	16.3.0
2020-03	RAN#87	R5-200949	1103	1	F	Editorial update IE RLC-BearerConfig	16.3.0
2020-03	RAN#87	R5-200951	1108	1	F	Add IE TDD-UL-DL-ConfigDedicated	16.3.0
2020-03	RAN#87	R5-200952	1111	1	F	Update IE ServingCellConfig	16.3.0
2020-03	RAN#87	R5-200953	1112	1	F	Update IE ServingCellConfigCommonSIB	16.3.0
2020-03	RAN#87	R5-200954	1113	1	F	Update IE DMRS-DownlinkConfig	16.3.0
2020-03	RAN#87	R5-200955	1114	1	F	Update IE FrequencyInfoUL	16.3.0
2020-03	RAN#87	R5-200956	1118	1	F	Update chapter 4.5.1 General	16.3.0
2020-03	RAN#87	R5-200957	1122	1	F	Update chapter 4.5.4 RRC_CONNECTED	16.3.0
2020-03	RAN#87	R5-200958	1125	1	F	Update IE CellGroupld	16.3.0
2020-03	RAN#87	R5-200959	1126	1	F	Update IE ServCellIndex	16.3.0
2020-03	RAN#87	R5-200960	1127	1	F	Update IE SK-Counter	16.3.0
2020-03	RAN#87	R5-200961	1128	1	F	Update IE SDAP-Config	16.3.0
2020-03	RAN#87	R5-200965	1145	1	F	Correction to CORESET and search space configuration	16.3.0
2020-03	RAN#87	R5-200966	1193	1	F	Addition of NR SUL connection diagrams	16.3.0
2020-03	RAN#87	R5-200967	1201	1	F	Clarification to high test channel bandwidth table	16.3.0
2020-03	RAN#87	R5-200968	1203	1	F	Addition of missing EN-DC test frequencies	16.3.0
2020-03	RAN#87	R5-200996	1124	1	F	Correction to PUCCH-Config for Format1 and Format2	16.3.0
2020-03	RAN#87	R5-201005	1131	1	F	Update of Annex C on calculation of test frequencies to achieve full bandwidth testing of NR bands	16.3.0
2020-03	RAN#87	R5-201020	1155	1	F	Update SIG test frequencies in clause 6.2.3.x	16.3.0
2020-03	RAN#87	R5-201021	1167	1	F	Correction of test frequency tables for NR band n41	16.3.0
2020-03	RAN#87	R5-201022	1174	1	F	Correction of test frequency tables for NR band n77	16.3.0
2020-03	RAN#87	R5-201023	1175	1	F	Correction of test frequency tables for NR band n78	16.3.0
2020-03	RAN#87	R5-201024	1176	1	F	Correction of test frequency tables for NR band n79	16.3.0
2020-03	RAN#87	R5-201025	1177	1	F	Correction of test frequency tables for NR band n257	16.3.0
2020-03	RAN#87	R5-201026	1178	1	F	Correction of test frequency tables for NR band n258	16.3.0
2020-03	RAN#87	R5-201027	1179	1	F	Correction of test frequency tables for NR band n260	16.3.0
2020-03	RAN#87	R5-201028	1180	1	F	Correction of test frequency tables for NR band n261	16.3.0
2020-03	RAN#87	R5-201029	1192	1	F	Update of clause 4.4.2 on simulated cells	16.3.0
2020-03	RAN#87	R5-201061	1153	1	F	Addition of a few R16s inter-band EN-DC FR1 test configurations	16.3.0
2020-03	RAN#87	R5-201065	1194	1	F	Addition of test channel bandwidth for NR bands in 38.508-1	16.3.0
2020-03	RAN#87	R5-201092	1123	1	F	Updates to NR FR1 and LTE Power levels in OTA	16.3.0
2020-03	RAN#87	R5-201093	1224	1	F	Message content Updates for Carrier Aggregation	16.3.0
2020-03	RAN#87	R5-201108	1143	1	F	Correction to EUTRA-AllowedMeasBandwidth	16.3.0
2020-03	RAN#87	R5-201116	1204	1	F	Updates to 4.7.3 Contents of EAP-AKA messages in 38.508-1	16.3.0
2020-03	RAN#87	R5-201148	1134	1	F	Updates to default SSB index of intra-frequency NR cells	16.3.0
2020-03	RAN#87	R5-201159	1151	1	F	Correction to test frequencies for n257 intra-band contiguous CA	16.3.0
2020-03	RAN#87	R5-201173	1117	1	F	Update IE TDD-UL-DL-Config	16.3.0
2020-03	RAN#87	R5-201174	1095	1	F	Update RRCSysInfoRequest	16.3.0
2020-03	RAN#87	R5-201175	1106	1	F	Update IE RLF-TimersAndConstants	16.3.0
2020-03	RAN#87	R5-201176	1107	1	F	Update IE SCS-SpecificCarrier	16.3.0
2020-03	RAN#87	R5-201177	1109	1	F	Update chapter 4.6.0	16.3.0
2020-03	RAN#87	R5-201179	1116	1	F	Update IE MeasObjectNR	16.3.0
2020-03	RAN#87	R5-201189	1214	1	F	Addition of IFF DFF Hybrid Setup for FR2 2AoA RRM test	16.3.0
2020-03	RAN#87	R5-201194	1141	1	F	Update to Common Coreset RB IE and section 5-6 Demod message contents	16.3.0
2020-03	RAN#87	R5-201195	1144	1	F	Update of DCI 1_0 and DCI 1_1 configuration	16.3.0
2020-03	RAN#87	R5-201197	1152	1	F	Correction to TRS configuration for RRM tests	16.3.0

2020-03	RAN#87	R5-201202	1205	1	F	Update to Switch Off/ Power off procedure in RRC_CONNECTED mode	16.3.0
2020-03	RAN#87	R5-201203	1129	1	F	Update to PDCP-Config	16.3.0
2020-03	RAN#87	R5-201217	1217	1	F	Updates to PsDU session modification procedures	16.3.0
2020-03	RAN#87	R5-201221	1089	1	F	Update RRCReconfiguration	16.3.0
2020-03	RAN#87	R5-201222	1121	1	F	Update IE CellGroupConfig	16.3.0
2020-03	RAN#87	R5-201232	1140	2	F	CR to 38.508-1 to introduce DFF Range Length	16.3.0
2020-03	RAN#87	R5-201234	1110	2	F	Update IE ServingCellConfigCommon	16.3.0
2020-03	RAN#87	R5-201148	1134	1	F	Add new missing column of Table 4.4.2-2	16.3.1
2020-06	RAN#88	R5-201320	1225	-	F	Update IE CellGroupConfig	16.4.0
2020-06	RAN#88	R5-201322	1227	-	F	Update of default value of frequencyDomainResources in ControlResourceSet IE	16.4.0
2020-06	RAN#88	R5-201331	1228	-	F	Correction to Table 4.9.6.1-1-Switch off in Idle	16.4.0
2020-06	RAN#88	R5-201333	1230	-	F	Addition of 4.9.6.3A Switch off Power off procedure in RRC_CONNECTED with T3540 started	16.4.0
2020-06	RAN#88	R5-201335	1232	-	F	Update to USIM config 6.4.1-1	16.4.0
2020-06	RAN#88	R5-201336	1233	-	F	Update to USIM Table 6.4.1-10	16.4.0
2020-06	RAN#88	R5-201337	1234	-	F	Correction to Table 7.3.1-7 NZP-CSI-RS-Resource for TRS	16.4.0
2020-06	RAN#88	R5-201446	1235	-	F	Fixing wrong reference for RRC_CONNECTED state on WLAN access	16.4.0
2020-06	RAN#88	R5-201572	1253	-	F	Corrections to default content of DCI messages	16.4.0
2020-06	RAN#88	RP-201138	1258	1	F	Correction to IE SearchSpace	16.4.0
2020-06	RAN#88	R5-201731	1265	-	F	Addition of NR SUL connection diagram in A.3.1.4	16.4.0
2020-06	RAN#88	R5-201800	1267	-	F	Addition of USIM configuration for TC 6.3.1.8 and TC 6.3.1.9	16.4.0
2020-06	RAN#88	R5-201837	1268	-	F	Update of test channel bandwidths for band n48	16.4.0
2020-06	RAN#88	R5-201932	1271	-	F	Removing brackets from mid test channel BWs for FR2	16.4.0
2020-06	RAN#88	R5-201956	1273	-	F	Correction of clause 4.4.2 on simulated cells	16.4.0
2020-06	RAN#88	R5-201958	1275	-	F	Correction to Annex C on calculation of kSSB to align SSB and RMSI subcarriers	16.4.0
2020-06	RAN#88	R5-201959	1276	-	F	Removal of definition of frequencyDomainResources value dependent on CORESET#0 configuration in Annex C.	16.4.0
2020-06	RAN#88	R5-201961	1278	-	F	Correction of test frequency tables for NR band n1	16.4.0
2020-06	RAN#88	R5-201962	1279	-	F	Correction of test frequency tables for NR band n2	16.4.0
2020-06	RAN#88	R5-201963	1280	-	F	Correction of test frequency tables for NR band n3	16.4.0
2020-06	RAN#88	R5-201964	1281	-	F	Correction of test frequency tables for NR band n5	16.4.0
2020-06	RAN#88	R5-201965	1282	-	F	Correction of test frequency tables for NR band n7	16.4.0
2020-06	RAN#88	R5-201966	1283	-	F	Correction of test frequency tables for NR band n8	16.4.0
2020-06	RAN#88	R5-201967	1284	-	F	Correction of test frequency tables for NR band n12	16.4.0
2020-06	RAN#88	R5-201968	1285	-	F	Correction of test frequency tables for NR band n20	16.4.0
2020-06	RAN#88	R5-201969	1286	-	F	Correction of test frequency tables for NR band n25	16.4.0
2020-06	RAN#88	R5-201970	1287	-	F	Correction of test frequency tables for NR band n28	16.4.0
2020-06	RAN#88	R5-201971	1288	-	F	Correction of test frequency tables for NR band n34	16.4.0
2020-06	RAN#88	R5-201972	1289	-	F	Correction of test frequency tables for NR band n38	16.4.0
2020-06	RAN#88	R5-201973	1290	-	F	Correction of test frequency tables for NR band n39	16.4.0
2020-06	RAN#88	R5-201974	1291	-	F	Correction of test frequency tables for NR band n40	16.4.0
2020-06	RAN#88	R5-201975	1292	-	F	Correction of test frequency tables for NR band n41	16.4.0
2020-06	RAN#88	R5-201976	1293	-	F	Correction of test frequency tables for NR band n50	16.4.0
2020-06	RAN#88	R5-201977	1294	-	F	Correction of test frequency tables for NR band n51	16.4.0
2020-06	RAN#88	R5-201978	1295	-	F	Correction of test frequency tables for NR band n66	16.4.0
2020-06	RAN#88	R5-201979	1296	-	F	Correction of test frequency tables for NR band n70	16.4.0
2020-06	RAN#88	R5-201980	1297	-	F	Correction of test frequency tables for NR band n71	16.4.0
2020-06	RAN#88	R5-201981	1298	-	F	Correction of test frequency tables for NR band n74	16.4.0
2020-06	RAN#88	R5-201982	1299	-	F	Correction of test frequency tables for NR band n77	16.4.0
2020-06	RAN#88	R5-201983	1300	-	F	Correction of test frequency tables for NR band n78	16.4.0
2020-06	RAN#88	R5-201984	1301	-	F	Correction of test frequency tables for NR band n79	16.4.0
2020-06	RAN#88	R5-201989	1306	-	F	Corrections of test frequency tables for CA_n41C	16.4.0
2020-06	RAN#88	R5-201990	1307	-	F	Corrections of test frequency tables for CA_n78C	16.4.0
2020-06	RAN#88	R5-201991	1308	-	F	Editorial correction to test frequency clause numbering	16.4.0
2020-06	RAN#88	R5-201995	1312	-	F	Correction of test frequency tables for CA_n66B	16.4.0
2020-06	RAN#88	R5-201997	1314	-	F	Introduction of test frequencies for NR band n26	16.4.0
2020-06	RAN#88	R5-201998	1315	-	F	Introduction of test frequencies for NR band 26 for protocol testing	16.4.0
2020-06	RAN#88	R5-201999	1316	-	F	Correction of test frequency tables for NR band n29	16.4.0
2020-06	RAN#88	R5-202000	1317	-	F	Correction of test frequency tables for NR band n48	16.4.0

2020-06	RAN#88	R5-202001	1318	-	F	Correction of test frequency tables for NR band n65	16.4.0
2020-06	RAN#88	R5-202024	1327	-	F	Update IE PDCP-Config	16.4.0
2020-06	RAN#88	R5-202123	1330	-	F	CR to 38.508-1 to clarify the test zone/quiet zone	16.4.0
2020-06	RAN#88	R5-202186	1333	-	F	Addition of locationAndBandwidth in BWP for FR1 in 38.508-1	16.4.0
2020-06	RAN#88	R5-202210	1335	-	F	Corrections on test frequencies for inter-band EN-DC configurations within FR1 for five bands in 38.508-1	16.4.0
2020-06	RAN#88	R5-202212	1336	-	F	Corrections of test frequency tables for CA_n257x	16.4.0
2020-06	RAN#88	R5-202213	1337	-	F	Corrections of test frequency tables for CA_n258x	16.4.0
2020-06	RAN#88	R5-202214	1338	-	F	Corrections of test frequency tables for CA_n260x	16.4.0
2020-06	RAN#88	R5-202215	1339	-	F	Corrections of test frequency tables for CA_n261x	16.4.0
2020-06	RAN#88	R5-202244	1343	-	F	Correction to nrofRBs under TRS CSI-FrequencyOccupation for Demod test cases with 10 MHz CBW	16.4.0
2020-06	RAN#88	R5-202284	1351	-	F	Correction to configuration bwp-id parameter in TCI-State IE	16.4.0
2020-06	RAN#88	R5-202409	1354	-	F	Update PDCCH-ControlResourceSet for RRM testing	16.4.0
2020-06	RAN#88	R5-202410	1355	-	F	Addition Physical Layer Parameter section for RRM testing	16.4.0
2020-06	RAN#88	R5-202449	1356	-	F	Correction of test frequencies for DC n71AA	16.4.0
2020-06	RAN#88	R5-202486	1358	-	F	Correction to content of EF5GSN3GPPLOCI	16.4.0
2020-06	RAN#88	R5-202525	1360	-	F	Correction to System Information Combination for PWS	16.4.0
2020-06	RAN#88	R5-202531	1353	1	F	Addition of R16 new channel bandwidths for n1 in 38.508-1	16.4.0
2020-06	RAN#88	R5-202534	1266	1	F	Removal of USIM configuration 14	16.4.0
2020-06	RAN#88	R5-202549	1350	1	F	Aligning the tabular representation of ASN.1 with PRD13 sections 4.8 and 5	16.4.0
2020-06	RAN#88	R5-202554	1252	1	F	Updates to PDCCH-ConfigCommon	16.4.0
2020-06	RAN#88	R5-202561	1226	1	F	Update IE default content for control resource set establishment and common search space mapping	16.4.0
2020-06	RAN#88	R5-202562	1229	1	F	Update to 4.9.6.3 Switch off Power off procedure in RRC_CONNECTED	16.4.0
2020-06	RAN#88	R5-202563	1231	1	F	Correction to Table 4.9.7.2.3-1-Tracking Area Update Request	16.4.0
2020-06	RAN#88	R5-202564	1236	1	F	Correction to Table 4.5.2.2-2-Adding second SMC procedure for Selected EPS NAS security algorithms IE	16.4.0
2020-06	RAN#88	R5-202565	1237	1	F	Clarification to ROUND for negative Threshold values in SIB1 and SIB4	16.4.0
2020-06	RAN#88	R5-202573	1251	1	F	Updates to test frequency definitions for SDL NR bands	16.4.0
2020-06	RAN#88	R5-202574	1257	1	F	Correction to condition SRB_NR_PDCP in RadioBearerConfig	16.4.0
2020-06	RAN#88	R5-202575	1260	1	F	Correction to UECapabilityEnquiry in case of EN-DC interband CA	16.4.0
2020-06	RAN#88	R5-202576	1262	1	F	Updates to PDCP-Config	16.4.0
2020-06	RAN#88	R5-202577	1274	1	F	Clarifications of Annex C on calculation of test frequencies	16.4.0
2020-06	RAN#88	R5-202578	1277	1	F	Update SIG test frequencies in clause 6.2.3.x	16.4.0
2020-06	RAN#88	R5-202579	1302	1	F	Correction of test frequency tables for NR band n257	16.4.0
2020-06	RAN#88	R5-202580	1303	1	F	Correction of test frequency tables for NR band n258	16.4.0
2020-06	RAN#88	R5-202581	1304	1	F	Correction of test frequency tables for NR band n260	16.4.0
2020-06	RAN#88	R5-202582	1305	1	F	Correction of test frequency tables for NR band n261	16.4.0
2020-06	RAN#88	R5-202583	1322	1	F	Introduction of protocol testing applicability for EN-DC inter-band, NR-CA inter-band and NR DC test frequency tables	16.4.0
2020-06	RAN#88	R5-202585	1331	1	F	Correction to Reference QoS rules	16.4.0
2020-06	RAN#88	R5-202586	1346	1	F	Updates to Generic Test Procedure for IMS MT speech call establishment	16.4.0
2020-06	RAN#88	R5-202587	1347	1	F	Updates to Generic Test Procedure for IMS MO call release	16.4.0
2020-06	RAN#88	R5-202588	1349	1	F	Aligning the tabular representation of ASN.1 with PRD13 section 4.6	16.4.0
2020-06	RAN#88	R5-202589	1359	1	F	Update the default USIM configurations	16.4.0
2020-06	RAN#88	R5-202590	1361	1	F	Addition of Generic procedure to check user plane connectivity for CA tests	16.4.0
2020-06	RAN#88	R5-202703	1255	1	F	Clarifications on the QoQZ validation procedure for RRM	16.4.0
2020-06	RAN#88	R5-202708	1254	1	F	TRS - PowerControlOffset correction for UE RF testing	16.4.0
2020-06	RAN#88	R5-202820	1352	1	F	Correction to PRB-Id for secondHopPRB	16.4.0
2020-06	RAN#88	R5-202859	1329	1	F	Updates on FR2 inter-band EN-DC configurations for test frequencies in 38.508-1	16.4.0
2020-06	RAN#88	R5-202879	1332	1	F	Addition of BW to Table 4.6.3-33	16.4.0
2020-06	RAN#88	R5-202880	1334	1	F	Clarification of disabling Tx diversity for FR2 UE	16.4.0



2020-06	RAN#88	R5-202881	1341	1	F	Restructuring 38.508-1 message contents for Demod and CSI reporting test cases	16.4.0
2020-06	RAN#88	R5-202882	1342	1	F	Update of PUCCH-ResourceId for Demod test cases	16.4.0
2020-06	RAN#88	R5-202883	1348	1	F	Configuration of p-ZP-CSI-RS-ResourceSet for PDSCH Demod test cases	16.4.0
2020-06	RAN#88	R5-202956	1270	1	F	Update of default test channel BW	16.4.0
2020-06	RAN#88	R5-202962	1269	2	F	Updating DCI related messages	16.4.0
2020-06	RAN#88	R5-202967	1344	1	F	Update to default value of PDSCH-to-HARQ_feedback timing indicator (k1)	16.4.0
2020-06	RAN#88	R5-203056	1313	1	F	Introduction of test frequencies for Rel-16 NR CA configuration CA_n66B and CA_n66(2A) in cl 6.2.3.4	16.4.0
2020-06	RAN#88	R5-203057	1319	1	F	Addition of test frequencies for additional channel bandwidths for NR band n66	16.4.0
2020-06	RAN#88	R5-203078	1325	1	F	Updates to Generic Test Procedure for IMS MO speech call establishment	16.4.0
2020-06	RAN#88	R5-203079	1326	2	F	Update NR-DC in chapter 4	16.4.0
2020-09	RAN#89	R5-203275	1364	-	F	Editorial update IE ARFCN-ValueNR	16.5.0
2020-09	RAN#89	R5-203277	1366	-	F	Add IEs ARFCN-ValueUTRA-FDD, AvailabilityCombinationsPerCell, AvailabilityIndicator and BAP-Routing-ID	16.5.0
2020-09	RAN#89	R5-203278	1367	-	F	n26 Default CH BW in 38.508-1	16.5.0
2020-09	RAN#89	R5-203287	1368	-	F	Correction PRB-Id for PUCCH secondHopPRB	16.5.0
2020-09	RAN#89	R5-203320	1369	-	F	Add IE BeamFailureRecoverySCellConfig	16.5.0
2020-09	RAN#89	R5-203339	1372	-	F	Add IE CGI-InfoEUTRALogging	16.5.0
2020-09	RAN#89	R5-203340	1373	-	F	Add IEs CGI-Info-Logging and CLI-RSSI-Range	16.5.0
2020-09	RAN#89	R5-203341	1374	-	F	Add IEs CommonLocationInfo, CondReconfigId, CondReconfigToAddModList and ConditionalReconfiguration	16.5.0
2020-09	RAN#89	R5-203342	1375	-	F	Add IEs ConfiguredGrantConfigIndex and ConfiguredGrantConfigIndexMAC	16.5.0
2020-09	RAN#89	R5-203343	1376	-	F	Add IE DRX-ConfigSecondaryGroup	16.5.0
2020-09	RAN#89	R5-203344	1377	-	F	Add IE HighSpeedConfig	16.5.0
2020-09	RAN#89	R5-203345	1378	-	F	Add IE InvalidSymbolPattern	16.5.0
2020-09	RAN#89	R5-203346	1379	-	F	Add IEs LBT-FailureRecoveryConfig and LocationInfo	16.5.0
2020-09	RAN#89	R5-203347	1380	-	F	Add IE MeasIdleConfig	16.5.0
2020-09	RAN#89	R5-203348	1381	-	F	Add IE MeasObjectCLI	16.5.0
2020-09	RAN#89	R5-203349	1382	-	F	Add IE MeasObjectNR-SL	16.5.0
2020-09	RAN#89	R5-203350	1383	-	F	Add IE MeasObjectUTRA-FDD	16.5.0
2020-09	RAN#89	R5-203351	1384	-	F	Add IEs MeasResultIdleEUTRA and MeasResultIdleNR	16.5.0
2020-09	RAN#89	R5-203355	1387	-	F	Add IEs MsgA-ConfigCommon and MsgA-PUSCH-Config	16.5.0
2020-09	RAN#89	R5-203356	1388	-	F	Add IEs NeedForGapsConfigNR and NeedForGapsInfoNR	16.5.0
2020-09	RAN#89	R5-203357	1389	-	F	Correction to Table 4.5.2.2-2-second SMC procedure for Selected EPS NAS security algorithms IE	16.5.0
2020-09	RAN#89	R5-203359	1391	-	F	Correction to Table 4.6.3-141 ReportConfigInterRAT	16.5.0
2020-09	RAN#89	R5-203446	1395	-	F	Add IEs NPN-Identity and NPN-IdentityInfoList	16.5.0
2020-09	RAN#89	R5-203449	1396	-	F	Add IE PLMN-IdentityList2	16.5.0
2020-09	RAN#89	R5-203450	1397	-	F	Add IE PUCCH-ConfigurationList	16.5.0
2020-09	RAN#89	R5-203451	1398	-	F	Add IE PUCCH-SpatialRelationInfo-Id	16.5.0
2020-09	RAN#89	R5-203455	1399	-	F	Corrections to 4.5.1	16.5.0
2020-09	RAN#89	R5-203456	1400	-	F	Updating usages of TS 34.229-1 to TS 34.229-5	16.5.0
2020-09	RAN#89	R5-203467	1401	-	F	Add IE RACH-ConfigCommonTwoStepRA	16.5.0
2020-09	RAN#89	R5-203470	1402	-	F	Add IE RACH-ConfigGenericTwoStepRA	16.5.0
2020-09	RAN#89	R5-203471	1403	-	F	Add IE ReferenceTimeInfo	16.5.0
2020-09	RAN#89	R5-203472	1404	-	F	Add IE RepetitionSchemeConfig	16.5.0
2020-09	RAN#89	R5-203476	1405	-	F	Add IE ReportConfigNR-SL	16.5.0
2020-09	RAN#89	R5-203500	1410	-	F	Update to Table 4.6.3-74: MeasObjectEUTRA	16.5.0
2020-09	RAN#89	R5-203506	1411	-	F	Add IE RSSI-Range	16.5.0
2020-09	RAN#89	R5-203507	1412	-	F	Add IEs SemiStaticChannelAccessConfig and Sensor-LocationInfo	16.5.0
2020-09	RAN#89	R5-203508	1413	-	F	Add IE SI-RequestConfig	16.5.0
2020-09	RAN#89	R5-203509	1414	-	F	Add IEs SPS-ConfigIndex, SPS-PUCCH-AN and SPS-PUCCH-AN-List	16.5.0
2020-09	RAN#89	R5-203510	1415	-	F	Add IE SRS-RSRP-Range	16.5.0
2020-09	RAN#89	R5-203533	1417	-	F	Update to PDSCH-ServingCellConfig	16.5.0
2020-09	RAN#89	R5-203534	1418	-	F	Updates to CellGroupConfig and RNTI-Value for NR-DC	16.5.0
2020-09	RAN#89	R5-203557	1420	-	F	Add IEs UL-DelayValueConfig and UplinkCancellation	16.5.0

2020-09	RAN#89	R5-203575	1422	-	F	Add chapter Positioning System information blocks	16.5.0
2020-09	RAN#89	R5-203577	1423	-	F	Add IEs SIB10, SIB11, SIB12, SIB13 and SIB14	16.5.0
2020-09	RAN#89	R5-203582	1424	-	F	Add messages DedicatedSIBRequest, DL DedicatedMessageSegment, DLInformationTransferMRDC and IABOtherInformation	16.5.0
2020-09	RAN#89	R5-203634	1429	-	F	Introduction of test frequencies for additional Rel-16 EN-DC inter-band configurations	16.5.0
2020-09	RAN#89	R5-203662	1432	-	F	Removal of USIM profile #16	16.5.0
2020-09	RAN#89	R5-203671	1433	-	F	Update of PDSCH-to-HARQ_feedback timing indicator (k1) value	16.5.0
2020-09	RAN#89	R5-203681	1436	-	F	Editorial correction typos in annex C.2.3.2	16.5.0
2020-09	RAN#89	R5-203704	1438	-	F	Correction to Table 4.6.3-87 NZP-CSI-RS-ResourceSet	16.5.0
2020-09	RAN#89	R5-203719	1441	-	F	Add messages LoggedMeasurementConfiguration, MCGFailureInformation and SidelinkUEInformationNR	16.5.0
2020-09	RAN#89	R5-203725	1442	-	F	Add messages UEInformationRequest, UEInformationResponse, UL DedicatedMessageSegment and ULInformationTransferIRAT	16.5.0
2020-09	RAN#89	R5-203729	1443	-	F	Update IE RACH-ConfigGeneric	16.5.0
2020-09	RAN#89	R5-203730	1444	-	F	Scheduling Request Resource config for RRM test cases	16.5.0
2020-09	RAN#89	R5-203731	1445	-	F	OSI scheduling config for RRM test cases	16.5.0
2020-09	RAN#89	R5-203755	1447	-	F	Update IE SchedulingRequestResourceConfig	16.5.0
2020-09	RAN#89	R5-203767	1449	-	F	Addition of test frequencies for new Rel-16 CBW for NR band n77	16.5.0
2020-09	RAN#89	R5-203768	1450	-	F	Addition of test frequencies for new Rel-16 CBW for NR band n78	16.5.0
2020-09	RAN#89	R5-203769	1451	-	F	Introduction of test frequencies for Rel-16 NR band n30	16.5.0
2020-09	RAN#89	R5-203793	1454	-	F	Correction of n29 test frequencies for protocol testing	16.5.0
2020-09	RAN#89	R5-203794	1455	-	F	Introduction of n30 test frequencies for protocol testing	16.5.0
2020-09	RAN#89	R5-203796	1456	-	F	Correction of EN-DC test frequency information for protocol testing	16.5.0
2020-09	RAN#89	R5-203813	1457	-	F	Correction to PUCCH-Config	16.5.0
2020-09	RAN#89	R5-203815	1458	-	F	FR2 PUSCH K2 values alignment to TS 38.214	16.5.0
2020-09	RAN#89	R5-203908	1463	-	F	Corrections on test frequencies for NR FR2 CA band n261	16.5.0
2020-09	RAN#89	R5-203998	1467	-	F	Addition of test frequencies for new Rel-16 CBW 25 and 50 MHz for NR band n1	16.5.0
2020-09	RAN#89	R5-204021	1469	-	F	Correction of n51 and n76 test frequencies for protocol testing	16.5.0
2020-09	RAN#89	R5-204032	1470	-	F	Introduction of n259 test frequencies for protocol testing	16.5.0
2020-09	RAN#89	R5-204038	1471	-	F	Corrections of test frequency tables for EN-DC configuration DC_(n)41AA	16.5.0
2020-09	RAN#89	R5-204039	1472	-	F	Corrections of test frequency tables for EN-DC configuration DC_(n)71AA	16.5.0
2020-09	RAN#89	R5-204041	1473	-	F	Addition of test channel bandwidths for n1 new CBW in 38.508-1 R16	16.5.0
2020-09	RAN#89	R5-204049	1475	-	F	Correction to the procedure for determination of SSB and CORESET0	16.5.0
2020-09	RAN#89	R5-204052	1478	-	F	PUCCH Resource ID for CSI TCs	16.5.0
2020-09	RAN#89	R5-204053	1479	-	F	Correction to PDCCH-ConfigCommon for performance tests	16.5.0
2020-09	RAN#89	R5-204150	1484	-	F	Update Table 5.4.2.0-2: ServingCellConfigCommon	16.5.0
2020-09	RAN#89	R5-204167	1488	-	F	Corrections of test frequency tables for CA_n260(A-I)	16.5.0
2020-09	RAN#89	R5-204168	1489	-	F	Update Table 7.3.1-4: ServingCellConfigCommon	16.5.0
2020-09	RAN#89	R5-204223	1491	-	F	Update missing SMTC configurations in RRM message contents	16.5.0
2020-09	RAN#89	R5-204238	1493	-	F	Correction to default contents of RRCReestablishmentRequest message	16.5.0
2020-09	RAN#89	R5-204325	1495	-	F	Adding procedure for establishment of multiple additional PDN connections in EPS (S1 mode)	16.5.0
2020-09	RAN#89	R5-204327	1497	-	F	Updates to Test procedure for UE for Tracking area updating / Inter-system change from N1 mode to S1 mode in 5GMM/EMM-IDLE mode	16.5.0
2020-09	RAN#89	R5-204329	1499	-	F	Update of 4.5A.2 UE-requested PDU session establishment procedure	16.5.0
2020-09	RAN#89	R5-204330	1500	-	F	Updates Procedure to UE-requested PDU session modification after the first S1 to N1 mode change	16.5.0

2020-09	RAN#89	R5-204331	1501	-	F	Void 4.9.14 Procedure for UE-requested PDU session modification after the first S1 to N1 mode change	16.5.0
2020-09	RAN#89	R5-204346	1502	-	F	Introduction of test frequencies for Rel-16 NR band n259	16.5.0
2020-09	RAN#89	R5-204378	1427	1	F	Correction to NR inter-band CA configurations in FR1	16.5.0
2020-09	RAN#89	R5-204384	1409	1	F	Correction to test procedure for UE for Tracking area updating / Inter-system change from S1 mode to N1 mode in 5GMM/EMM-IDLE mode	16.5.0
2020-09	RAN#89	R5-204386	1390	1	F	Correction to Table 4.6.1-17 RRCResume	16.5.0
2020-09	RAN#89	R5-204387	1406	1	F	Corrections to generic procedures for MO and MT speech call establishment	16.5.0
2020-09	RAN#89	R5-204388	1407	1	F	Correction to USIM configurations 7 and 13	16.5.0
2020-09	RAN#89	R5-204389	1408	1	F	Correction to switch off / power off procedures for IMS	16.5.0
2020-09	RAN#89	R5-204390	1421	1	F	Correction of description of NGEN-DC in table 4.5.1-1	16.5.0
2020-09	RAN#89	R5-204391	1425	1	F	Correction to UE-CapabilityRAT-RequestList and UE-CapabilityRequestFilterNR	16.5.0
2020-09	RAN#89	R5-204392	1439	1	F	Addition of Generic Test Procedure for IMS MO SMS in 5GC	16.5.0
2020-09	RAN#89	R5-204393	1440	1	F	Addition of Generic Test Procedure for IMS MT SMS in 5GC	16.5.0
2020-09	RAN#89	R5-204394	1446	1	F	Update IE RLC-BearerConfig	16.5.0
2020-09	RAN#89	R5-204395	1481	1	F	Update IE SIB2	16.5.0
2020-09	RAN#89	R5-204396	1482	1	F	New procedure for PDU Session Release	16.5.0
2020-09	RAN#89	R5-204397	1483	1	F	Update to FreqBandList	16.5.0
2020-09	RAN#89	R5-204398	1490	1	F	Update IE ServingCellConfigCommon	16.5.0
2020-09	RAN#89	R5-204399	1494	1	F	Adding generic procedure E-UTRA RRC_IDLE with unrestricted number of PDN connections	16.5.0
2020-09	RAN#89	R5-204400	1496	1	F	Update of PDU SESSION ESTABLISHMENT ACCEPT for multi PDU-PDN handling	16.5.0
2020-09	RAN#89	R5-204401	1498	1	F	Updates of Test procedure for UE for Tracking area updating / Inter-system change from S1 mode to N1 mode in 5GMM/EMM-IDLE mode	16.5.0
2020-09	RAN#89	R5-204507	1371	1	F	Add IEs BH-RLC-ChannelConfig, BH-LogicalChannelIdentity, BH-LogicalChannelIdentity-Ext and BH-RLC-ChannelID	16.5.0
2020-09	RAN#89	R5-204508	1386	1	F	Add IEs MeasResultsSL and MeasTriggerQuantityEUTRA	16.5.0
2020-09	RAN#89	R5-204509	1416	1	F	Modification to InterRAT-Parameters to add the UE capability nr-HO-ToEN-DC-r16	16.5.0
2020-09	RAN#89	R5-204510	1419	1	F	Add IE SSB-PositionQCL-Relation	16.5.0
2020-09	RAN#89	R5-204704	1503	-	F	Adding the test frequency for DC_3A-7A_n78A	16.5.0
2020-09	RAN#89	R5-204706	1504	-	F	Adding the test frequency for DC_28A_n3A	16.5.0
2020-09	RAN#89	R5-204708	1435	1	F	Updating indicator for SUL FR1 test cases	16.5.0
2020-09	RAN#89	R5-204709	1437	1	F	Update frequencyDomainResources and nrofCandidates	16.5.0
2020-09	RAN#89	R5-204751	1428	1	F	Introduction of test frequencies for additional Rel-15 band EN-DC inter-band configurations	16.5.0
2020-09	RAN#89	R5-204752	1460	1	F	Correction to TCI-state related configurations	16.5.0
2020-09	RAN#89	R5-204753	1461	1	F	Correction to CSI-RS related configurations	16.5.0
2020-09	RAN#89	R5-204754	1468	1	F	Update on test frequencies for EN-DC configurations including FR2	16.5.0
2020-09	RAN#89	R5-204755	1485	1	F	Corrections of test frequency tables for CA_n258x	16.5.0
2020-09	RAN#89	R5-204756	1486	1	F	Corrections of test frequency tables for CA_n260x	16.5.0
2020-09	RAN#89	R5-204757	1487	1	F	Corrections of test frequency tables for CA_n261x	16.5.0
2020-09	RAN#89	R5-204758	1492	1	F	Add SSB subcarrier spacing configurations in RRM message contents	16.5.0
2020-09	RAN#89	R5-204800	1362	1	F	Introduction of test frequencies for Rel-16 inter-band EN-DC combinations within FR1	16.5.0
2020-09	RAN#89	R5-204852	1434	1	F	Jumbo CR for update to Demod message contents	16.5.0
2020-09	RAN#89	R5-204896	1370	1	F	Addition of test frequencies for n28 with CBW of 30MHz	16.5.0
2020-09	RAN#89	R5-204899	1448	1	F	Adding default value for IE rbg-Size for demodulation and CSI reporting tests	16.5.0
2020-09	RAN#89	R5-204900	1462	1	F	Introduction of definition of Mid, Low, High test channel bandwidth and removal of NOTES that incorrectly permit UE not to support mandatory BWs	16.5.0
2020-09	RAN#89	R5-204901	1476	1	F	Correction to message configuration for performance tests	16.5.0
2020-10	RAN#89	R5-204325	1495	-	F	Addition of missing Table 4.5A.2B.2.2-2 and specific message contents of R5-204325	16.5.1
2020-12	RAN#90	R5-205093	1507	-	F	Add IE BandCombinationListSidelink	16.6.0
2020-12	RAN#90	R5-205096	1508	-	F	Add IE CarrierAggregationVariant	16.6.0

2020-12	RAN#90	R5-205104	1509	-	F	Add IEs FreqSeparationClassDL-Only and HighSpeedParameters	16.6.0
2020-12	RAN#90	R5-205130	1514	-	F	Add IE PowSav-Parameters	16.6.0
2020-12	RAN#90	R5-205167	1519	-	F	Add IE OLPC-SRS-Pos	16.6.0
2020-12	RAN#90	R5-205172	1521	-	F	Add IEs SidelinkParameters, SON-Parameters and SpatialRelationsSRS-Pos	16.6.0
2020-12	RAN#90	R5-205178	1522	-	F	Add IE UE-BasedPerfMeas-Parameters	16.6.0
2020-12	RAN#90	R5-205181	1523	-	F	Add IE SharedSpectrumChAccessParamsPerBand	16.6.0
2020-12	RAN#90	R5-205186	1524	-	F	Add IEs AbsoluteTimeInfo, AreaConfiguration and BT-NameList	16.6.0
2020-12	RAN#90	R5-205187	1525	-	F	Add IEs IAB-IP-Address, IAB-IP-AddressIndex and IAB-IP-Usage	16.6.0
2020-12	RAN#90	R5-205188	1526	-	F	Add IEs LoggingDuration, LoggingInterval, LogMeasResultListBT and LogMeasResultListWLAN	16.6.0
2020-12	RAN#90	R5-205189	1527	-	F	Add IE PhysCellIdUTRA-FDD	16.6.0
2020-12	RAN#90	R5-205190	1528	-	F	Add IEs Sensor-NameList, TraceReference and UE-MeasurementsAvailable-r16	16.6.0
2020-12	RAN#90	R5-205191	1529	-	F	Add IEs UTRA-FDD-Q-OffsetRange, VisitedCellInfoList and WLAN-NameList	16.6.0
2020-12	RAN#90	R5-205215	1533	-	F	Update chapter 4.5.1 General	16.6.0
2020-12	RAN#90	R5-205249	1537	-	F	Introduction of test frequencies for NR Band n53 signalling testing	16.6.0
2020-12	RAN#90	R5-205250	1538	-	F	Introduction of test channel BWs for NR Band n53	16.6.0
2020-12	RAN#90	R5-205288	1539	-	F	Addition of IE DCP-Config-r16	16.6.0
2020-12	RAN#90	R5-205332	1542	-	F	Updates to generic procedure NR-DC RRC_CONNECTED	16.6.0
2020-12	RAN#90	R5-205334	1544	-	F	Updates to RadioBearerConfig in Table 4.6.3-132	16.6.0
2020-12	RAN#90	R5-205336	1546	-	F	Updates to RRCReconfiguration in Table 4.6.1-13	16.6.0
2020-12	RAN#90	R5-205339	1549	-	F	Updates to RRCReconfiguration-NR-DC in Table 4.8.1-1CA	16.6.0
2020-12	RAN#90	R5-205403	1554	-	F	Addition of PC5 RRC messages for sidelink communication	16.6.0
2020-12	RAN#90	R5-205404	1555	-	F	Addition of sidelink IEs for Uu RRC and PC5 RRC	16.6.0
2020-12	RAN#90	R5-205532	1573	-	F	Clarifications to Annex C and CORESET1	16.6.0
2020-12	RAN#90	R5-205661	1580	-	F	Update of Annex C on calculating test frequencies for RRM testing	16.6.0
2020-12	RAN#90	R5-205701	1588	-	F	Update RF test channel bandwidths for n14 and n30	16.6.0
2020-12	RAN#90	R5-205725	1594	-	F	Correction to test channel bandwidth for NR band n40 and n50	16.6.0
2020-12	RAN#90	R5-205728	1597	-	F	Adding test frequencies for CA_n78B	16.6.0
2020-12	RAN#90	R5-205771	1602	-	F	Addition of test frequencies for a few Rel-16 EN-DC configurations	16.6.0
2020-12	RAN#90	R5-205832	1603	-	F	Connection diagrams for radiated RRM Tests	16.6.0
2020-12	RAN#90	R5-205874	1607	-	F	Correction of test frequency of CA_n41C	16.6.0
2020-12	RAN#90	R5-205875	1608	-	F	Correction of test frequency of CA_n66B	16.6.0
2020-12	RAN#90	R5-205881	1610	-	F	Addition of test frequency for 40MHz of band n38	16.6.0
2020-12	RAN#90	R5-205926	1612	-	F	Correction to nrofRBs IE for CSI-FrequencyOccupation	16.6.0
2020-12	RAN#90	R5-205932	1614	-	F	Addition of IE configuration for ULFPtx to clause 5	16.6.0
2020-12	RAN#90	R5-205937	1615	-	F	Update of 4.9.12 Generic Test Procedure for IMS Emergency call establishment in 5GC without IMS emergency registration and editorials	16.6.0
2020-12	RAN#90	R5-205939	1617	-	F	Update for Flexible PDU-PDN - Default messages	16.6.0
2020-12	RAN#90	R5-205940	1618	-	F	Update for Flexible PDU-PDN - DNN Configurations	16.6.0
2020-12	RAN#90	R5-205997	1621	-	F	Correction of test frequencies for NR band n1	16.6.0
2020-12	RAN#90	R5-205998	1622	-	F	Editorial correction to NR-DC test frequency clause 4.3.1	16.6.0
2020-12	RAN#90	R5-206002	1626	-	F	Correction of FR1 NR band test frequency tables for protocol testing	16.6.0
2020-12	RAN#90	R5-206003	1627	-	F	Correction of FR2 NR band test frequency tables for protocol testing	16.6.0
2020-12	RAN#90	R5-206004	1628	-	F	Change of default SCS for NR CA test frequencies for FR2 protocol testing	16.6.0
2020-12	RAN#90	R5-206008	1632	-	F	Editorial correction to NR CA test frequencies for FR1 protocol testing	16.6.0
2020-12	RAN#90	R5-206019	1637	-	F	Correction of test frequencies for CA_n260 of intra-band non-contiguous A-I	16.6.0
2020-12	RAN#90	R5-206046	1642	-	F	Clarify usage of SSB-Ids for RRM test cases	16.6.0
2020-12	RAN#90	R5-206048	1644	-	F	Clarification on the conditions in DCI format 1_1 table for RRM	16.6.0

2020-12	RAN#90	R5-206060	1645	-	F	Correction to 4.9.17 IMS MO release	16.6.0
2020-12	RAN#90	R5-206061	1646	-	F	Correction to 4.9.18 IMS MT release	16.6.0
2020-12	RAN#90	R5-206065	1650	-	F	Alignment of Rel-16 5GSM messages	16.6.0
2020-12	RAN#90	R5-206066	1651	-	F	Addition of new SSTs	16.6.0
2020-12	RAN#90	R5-206067	1652	-	F	Update IE SIB2	16.6.0
2020-12	RAN#90	R5-206078	1654	-	F	Update IE SIB4	16.6.0
2020-12	RAN#90	R5-206086	1655	-	F	Addition of common message contents for sustained downlink data rate tests	16.6.0
2020-12	RAN#90	R5-206087	1656	-	F	Correction to Default RRM TRS qcl-info and PDCCH TCI State	16.6.0
2020-12	RAN#90	R5-206112	1657	-	F	Update requirements of test equipment for RF test	16.6.0
2020-12	RAN#90	R5-206113	1658	-	F	Update requirements of test equipment for RRM tests	16.6.0
2020-12	RAN#90	R5-206115	1659	-	F	Update requirements of reference test conditions for RRM tests	16.6.0
2020-12	RAN#90	R5-206157	1663	-	F	CSI-measConfig applicable for RRM testing	16.6.0
2020-12	RAN#90	R5-206158	1664	-	F	Editorial update IE CellAccessRelatedInfo-EUTRA-5GC	16.6.0
2020-12	RAN#90	R5-206164	1666	-	F	Editorial update IE CellAccessRelatedInfo-EUTRA-EPC	16.6.0
2020-12	RAN#90	R5-206266	1671	-	F	Corrections to test procedures in subclause 4.9	16.6.0
2020-12	RAN#90	R5-206288	1510	1	F	Corrections to UE-requested PDU session establishment procedure	16.6.0
2020-12	RAN#90	R5-206289	1515	1	F	Update of 4.9.7 Test procedure for UE for Tracking area updating / Inter-system change from N1 mode to S1 mode in 5GMM/EMM-IDLE mode	16.6.0
2020-12	RAN#90	R5-206290	1516	1	F	Update of 4.9.9 Test procedure for UE for Tracking area updating / Inter-system change from S1 mode to N1 mode in 5GMM/EMM-IDLE mode	16.6.0
2020-12	RAN#90	R5-206291	1517	1	F	Update of 4.5.2 RRC_IDLE	16.6.0
2020-12	RAN#90	R5-206292	1532	1	F	Correction to Test procedure 4.9.5	16.6.0
2020-12	RAN#90	R5-206293	1534	1	F	Corrections to generic procedures regarding IMS usage	16.6.0
2020-12	RAN#90	R5-206294	1540	1	F	Update Generic Test Procedures for IMS MO, MT speech call	16.6.0
2020-12	RAN#90	R5-206295	1543	1	F	Updates to generic procedure parameters in Table 4.5.1-1	16.6.0
2020-12	RAN#90	R5-206296	1616	1	F	Update for Flexible PDU-PDN - Session-Connection establishment	16.6.0
2020-12	RAN#90	R5-206297	1541	1	F	Updates to CellGroupConfig in Table 4.6.3-19	16.6.0
2020-12	RAN#90	R5-206298	1545	1	F	Updates to RadioBearerConfig in Table 4.6.3-132 for NR-DC	16.6.0
2020-12	RAN#90	R5-206299	1547	1	F	Updates to RRCReconfiguration in Table 4.6.1-13 for NR-DC	16.6.0
2020-12	RAN#90	R5-206300	1548	1	F	Updates to RRCReconfigurationComplete	16.6.0
2020-12	RAN#90	R5-206301	1586	1	F	Update IE SSB-ToMeasure	16.6.0
2020-12	RAN#90	R5-206302	1620	1	F	Correction to PDCCH-ConfigCommon	16.6.0
2020-12	RAN#90	R5-206303	1665	1	F	Messages Exceptions corrections for SUL cases	16.6.0
2020-12	RAN#90	R5-206304	1670	1	F	Update to ims-EmergencySupport indication of SIB1	16.6.0
2020-12	RAN#90	R5-206305	1595	1	F	Correction to test frequencies for signalling testing	16.6.0
2020-12	RAN#90	R5-206306	1625	1	F	Introducing test frequencies for CA_n261(2A) for protocol testing	16.6.0
2020-12	RAN#90	R5-206307	1629	1	F	Introduction of NR-DC test frequencies for protocol testing	16.6.0
2020-12	RAN#90	R5-206308	1661	1	F	Update requirements of test equipment for Signalling test	16.6.0
2020-12	RAN#90	R5-206309	1531	1	F	Correction to Table 4.8.1-1A RRCReconfiguration-HO	16.6.0
2020-12	RAN#90	R5-206388	1631	1	F	Introduction of n14 test frequencies for protocol testing	16.6.0
2020-12	RAN#90	R5-206394	1552	1	F	Adding ReferenceTimeInfo IE config for IIoT test	16.6.0
2020-12	RAN#90	R5-206403	1559	1	F	Update to RRC messages and IEs for R16 Mobility Enhancement	16.6.0
2020-12	RAN#90	R5-206407	1553	1	F	Correction to Uu RRC messages and SIBs for sidelink communication	16.6.0
2020-12	RAN#90	R5-206408	1556	1	F	Addition of V2X default configuration_USIM	16.6.0
2020-12	RAN#90	R5-206409	1557	1	F	Addition of V2X default configuration_NAS Messages	16.6.0
2020-12	RAN#90	R5-206419	1575	1	F	Updates to default contents of NAS messages for Rel-16 RACS	16.6.0
2020-12	RAN#90	R5-206420	1576	1	F	Updates to default contents of RRC messages for Rel-16 RACS	16.6.0
2020-12	RAN#90	R5-206426	1649	1	F	Alignment of Rel-16 5GMM messages	16.6.0
2020-12	RAN#90	R5-206427	1668	1	F	Updates to DLDedicatedMessageSegment message	16.6.0
2020-12	RAN#90	R5-206621	1589	1	F	Correction to test frequencies for NR band n34	16.6.0
2020-12	RAN#90	R5-206622	1590	1	F	Correction to test frequencies for NR band n38	16.6.0
2020-12	RAN#90	R5-206623	1591	1	F	Correction to test frequencies for NR band n39	16.6.0

2020-12	RAN#90	R5-206624	1592	1	F	Correction to test frequencies for NR band n40	16.6.0
2020-12	RAN#90	R5-206625	1593	1	F	Correction to test frequencies for NR band n50	16.6.0
2020-12	RAN#90	R5-206626	1609	1	F	Correction of test frequency of CA_n78C	16.6.0
2020-12	RAN#90	R5-206628	1611	1	F	Update to DEMOD message contents	16.6.0
2020-12	RAN#90	R5-206629	1669	1	F	Single PDN and PDU configuration for EN-DC RF testing	16.6.0
2020-12	RAN#90	R5-206630	1619	1	F	Addition of aperiodic CSI-RS reference configuration for RRM test	16.6.0
2020-12	RAN#90	R5-206631	1623	1	F	Introduction of test frequencies for SCS=60 kHz and EN-DC configurations DC_41X_n41A	16.6.0
2020-12	RAN#90	R5-206632	1505	1	F	Message contents for iRAT periodical measurements	16.6.0
2020-12	RAN#90	R5-206633	1638	1	F	Minor corrections of 4.1 for test environment conditions	16.6.0
2020-12	RAN#90	R5-206712	1579	1	F	Addition of UL and DL inter-band CA configurations for several FR1 bands	16.6.0
2020-12	RAN#90	R5-206713	1587	1	F	Update to reference test conditions for R16 EN-DC configuration	16.6.0
2020-12	RAN#90	R5-206714	1639	1	F	Introduction of test frequencies for additional Rel-16 EN-DC inter-band configurations	16.6.0
2020-12	RAN#90	R5-206715	1660	1	F	Introduction of test frequencies for additional Rel-16 EN-DC inter-band configurations	16.6.0
2020-12	RAN#90	R5-206736	1536	1	F	Introduction of test frequencies for NR Band n53	16.6.0
2020-12	RAN#90	R5-206737	1572	1	F	Addition of R16 new channel bandwidths for n3 in 38.508-1	16.6.0
2020-12	RAN#90	R5-206738	1630	1	F	Introduction of test frequencies for n14	16.6.0
2020-12	RAN#90	R5-206739	1636	1	F	Correction of 4.3.1 for test channel bandwidth of NR bands	16.6.0
2020-12	RAN#90	R5-206757	1596	1	F	Adding test frequencies for CA_n40B	16.6.0
2020-12	RAN#90	R5-206758	1598	1	F	Adding test frequencies for CA_n77A-n77A	16.6.0
2020-12	RAN#90	R5-206759	1599	1	F	Adding test frequencies for CA_n78A-n78A	16.6.0
2020-12	RAN#90	R5-206760	1633	1	F	Updating message contents for Uplink carrier switching	16.6.0
2020-12	RAN#90	R5-206790	1581	1	F	Introduction of test frequencies for RRM and NR band n257	16.6.0
2020-12	RAN#90	R5-206791	1582	1	F	Introduction of test frequencies for RRM and NR band n258	16.6.0
2020-12	RAN#90	R5-206792	1583	1	F	Introduction of test frequencies for RRM and NR band n260	16.6.0
2020-12	RAN#90	R5-206793	1584	1	F	Introduction of test frequencies for RRM and NR band n261	16.6.0
2020-12	RAN#90	R5-206794	1585	1	F	Introduction of test frequencies for RRM and NR band n259	16.6.0
2020-12	RAN#90	R5-206820	1667	1	F	Update to quality of quiet zone validation rule for IFF DFF hybrid setup	16.6.0
2020-12	RAN#90	R5-206860	1506	1	F	SSB bitmap correction for RRM test cases	16.6.0
2020-12	RAN#90	R5-206861	1624	1	F	Introducing test frequencies for CA_n261(2A)	16.6.0
2020-12	RAN#90	R5-206862	1643	1	F	Clarify the RF / RRM conditions for default messages	16.6.0
2021-03	RAN#91	R5-210186	1678	-	F	Update global conditions	16.7.0
2021-03	RAN#91	R5-210327	1688	-	F	Update FailureInformation message	16.7.0
2021-03	RAN#91	R5-210328	1689	-	F	Editorial update RRCReconfiguration message	16.7.0
2021-03	RAN#91	R5-210359	1692	-	F	Editorial update SidelinkUEInformationNR message	16.7.0
2021-03	RAN#91	R5-210394	1697	-	F	Editorial update UEAssistanceInformation message	16.7.0
2021-03	RAN#91	R5-210414	1699	-	F	Update UECapabilityEnquiry message	16.7.0
2021-03	RAN#91	R5-210468	1704	-	F	Add new SIB combination for RRM tests with single cell	16.7.0
2021-03	RAN#91	R5-210599	1711	-	F	Editorial correction on numbering of several Tables in 38.508-1	16.7.0
2021-03	RAN#91	R5-210616	1713	-	F	Editorial update DL DedicatedMessageSegment message	16.7.0
2021-03	RAN#91	R5-210623	1714	-	F	Correction to Table 4.6.1-13 RRCReconfiguration	16.7.0
2021-03	RAN#91	R5-210626	1717	-	F	Correction to Table 6.4.1-11 USIM Configuration 11	16.7.0
2021-03	RAN#91	R5-210627	1718	-	F	Correction to Table 4.8.2.1-7 Reference QoS rule 7	16.7.0
2021-03	RAN#91	R5-210687	1719	-	F	Correction to Table 4.6.3-25B CondReconfigId	16.7.0
2021-03	RAN#91	R5-210688	1720	-	F	Correction to Table 4.6.3-25C CondReconfigToAddModList	16.7.0
2021-03	RAN#91	R5-210689	1721	-	F	Correction to Table 4.6.3-25D ConditionalReconfiguration	16.7.0
2021-03	RAN#91	R5-210698	1723	-	F	Addition of IE SL-PreconfigurationNR	16.7.0
2021-03	RAN#91	R5-210699	1724	-	F	Addition of V2X NAS IEs	16.7.0
2021-03	RAN#91	R5-210701	1726	-	F	Correction of NR SL IE SL-BWP-ConfigCommon	16.7.0
2021-03	RAN#91	R5-210703	1728	-	F	Correction of NR SL IE SL-ConfigDedicatedNR	16.7.0
2021-03	RAN#91	R5-210704	1729	-	F	Correction of NR SL IE SL-FreqConfigCommon	16.7.0
2021-03	RAN#91	R5-210705	1730	-	F	Correction of NR SL IE SL-LogicalChannelConfig	16.7.0
2021-03	RAN#91	R5-210706	1731	-	F	Correction of NR SL IE SL-MeasConfigInfo	16.7.0
2021-03	RAN#91	R5-210707	1732	-	F	Correction of NR SL IE SL-PDCP-Config	16.7.0
2021-03	RAN#91	R5-210708	1733	-	F	Correction of NR SL IE SL-RadioBearerConfig	16.7.0
2021-03	RAN#91	R5-210709	1734	-	F	Correction of NR SL IE SL-ResourcePool	16.7.0
2021-03	RAN#91	R5-210710	1735	-	F	Correction of NR SL IE SL-RLC-BearerConfig	16.7.0

2021-03	RAN#91	R5-210711	1736	-	F	Correction of NR SL IE SL-RLC-Config	16.7.0
2021-03	RAN#91	R5-210713	1738	-	F	Correction to NR Uu IE ARFCN-ValueNR	16.7.0
2021-03	RAN#91	R5-210714	1739	-	F	Correction to NR Uu IE SCS-SpecificCarrier	16.7.0
2021-03	RAN#91	R5-210771	1744	-	F	Correction in CodebookConfig for 4Tx RI Demod test cases	16.7.0
2021-03	RAN#91	R5-210772	1745	-	F	Alignment xOverhead setting with PDSCH RMCs for Demod FR2 testing	16.7.0
2021-03	RAN#91	R5-210805	1746	-	F	Update IE SemiStaticChannelAccessConfig	16.7.0
2021-03	RAN#91	R5-210812	1747	-	F	Update IE ServingCellConfig	16.7.0
2021-03	RAN#91	R5-210824	1748	-	F	Number of control symbols for RRM tests with 240kHz SSB SCS	16.7.0
2021-03	RAN#91	R5-210826	1750	-	F	Editorial update IE ServingCellConfigCommon	16.7.0
2021-03	RAN#91	R5-210873	1752	-	F	Correction of aperiodic CSI-RS reference configuration for RRM tests	16.7.0
2021-03	RAN#91	R5-210897	1753	-	F	Correction to test frequency parameters for band n83	16.7.0
2021-03	RAN#91	R5-210898	1754	-	F	Correction to test frequency parameters for band n84	16.7.0
2021-03	RAN#91	R5-211032	1759	-	F	Correction test frequencies for CA_n261(2A)	16.7.0
2021-03	RAN#91	R5-211033	1760	-	F	Correction test frequencies for CA_n261(2A) for protocol testing	16.7.0
2021-03	RAN#91	R5-211034	1761	-	F	Correction of protocol applicability for test frequencies for DC_xA_n261(2A) configurations	16.7.0
2021-03	RAN#91	R5-211107	1770	-	F	Corrections to subclauses in 38.508-1 with appropriate subclause level and heading styles	16.7.0
2021-03	RAN#91	R5-211116	1772	-	F	Update of 4.3.1.1.3.41.1 for test frequency of NR intra-band contiguous CA_n41C	16.7.0
2021-03	RAN#91	R5-211117	1773	-	F	Update of 4.3.1.1.3.66.1 for test frequency of NR intra-band contiguous CA_n66B	16.7.0
2021-03	RAN#91	R5-211118	1774	-	F	Update of 4.3.1.1.3.78.1 for test frequency of NR intra-band contiguous CA_n78C	16.7.0
2021-03	RAN#91	R5-211121	1777	-	F	Update of 4.3.1.3.2.1 for test frequencies for NR-DC configurations between FR1 and FR2	16.7.0
2021-03	RAN#91	R5-211124	1780	-	F	Update of 4.3.1.6.1.3 for test frequencies for EN-DC band combinations including FR1 and FR2	16.7.0
2021-03	RAN#91	R5-211168	1784	-	F	Updates to PDU SESSION ESTABLISHMENT ACCEPT message	16.7.0
2021-03	RAN#91	R5-211170	1786	-	F	Editorial update to BandCombinationListSidelink IE	16.7.0
2021-03	RAN#91	R5-211171	1787	-	F	Update to RRCReconfiguration-Speech IE	16.7.0
2021-03	RAN#91	R5-211204	1791	-	F	Editorial update IE BWP	16.7.0
2021-03	RAN#91	R5-211328	1796	-	F	Correction to frequency parameters for band n53	16.7.0
2021-03	RAN#91	R5-211335	1727	1	F	Correction of NR SL IE SL-BWP-PoolConfigCommon	16.7.0
2021-03	RAN#91	R5-211336	1737	1	F	Correction of NR SL IE SL-SDAP-Config	16.7.0
2021-03	RAN#91	R5-211337	1740	1	F	Correction to PC5-RRC message RRCReconfigurationSidelink	16.7.0
2021-03	RAN#91	R5-211338	1741	1	F	Correction to PC5-RRC message UECapabilityEnquirySidelink	16.7.0
2021-03	RAN#91	R5-211339	1742	1	F	Correction to PC5-RRC message UECapabilityInformationSidelink	16.7.0
2021-03	RAN#91	R5-211369	1673	1	F	Corrections to generic test procedures for IMS	16.7.0
2021-03	RAN#91	R5-211370	1676	1	F	Correction to generic procedure for UE-requested PDU session modification after S1 to N1 change	16.7.0
2021-03	RAN#91	R5-211371	1680	1	F	Correction to test procedure 4.9.7	16.7.0
2021-03	RAN#91	R5-211372	1698	1	F	Correction to RRC IDLE procedures	16.7.0
2021-03	RAN#91	R5-211374	1712	1	F	Update IE PDCCH-ConfigCommon	16.7.0
2021-03	RAN#91	R5-211375	1715	1	F	Correction to Table 4.6.3-185 SSB-MTC	16.7.0
2021-03	RAN#91	R5-211456	1722	1	F	Correction to Table 4.6.3-142 ReportConfigNR	16.7.0
2021-03	RAN#91	R5-211462	1725	1	F	Addition of SI combination for NR SL	16.7.0
2021-03	RAN#91	R5-211465	1693	1	F	Updates to SIB1 and SIB10 for Rel-16 NPN	16.7.0
2021-03	RAN#91	R5-211466	1694	1	F	Addition of System information combination for Rel-16 NPN	16.7.0
2021-03	RAN#91	R5-211467	1684	1	F	Introduction of definition of common environment for R16 NR Immediate MDT	16.7.0
2021-03	RAN#91	R5-211468	1685	1	F	Updating Contents of RRC messages for Logged MDT test cases	16.7.0
2021-03	RAN#91	R5-211491	1700	1	F	Addition of Cell configurations for 5G-SRVCC from NG-RAN to UTRAN	16.7.0
2021-03	RAN#91	R5-211497	1682	1	F	Editorial update IE PhysicalCellGroupConfig	16.7.0
2021-03	RAN#91	R5-211498	1781	1	F	Introduction of support for URLLC	16.7.0

2021-03	RAN#91	R5-211499	1782	1	F	Addition of QoS for URLLC	16.7.0
2021-03	RAN#91	R5-211548	1695	1	F	Addition of NID information for Rel-16 NPN	16.7.0
2021-03	RAN#91	R5-211604	1794	-	F	Introduction of test frequencies for CBW 70 MHz for n77	16.7.0
2021-03	RAN#91	R5-211605	1795	-	F	Introduction of test frequencies for CBW 70 MHz for n78	16.7.0
2021-03	RAN#91	R5-211660	1677	1	F	Update of EN-DC inter-band configurations in clause 4.3.1	16.7.0
2021-03	RAN#91	R5-211661	1690	1	F	Addition of 3 band EN-DC Test Frequency (DC_1A-8A_n78A, DC_3A-8A_n78A)	16.7.0
2021-03	RAN#91	R5-211662	1691	1	F	Addition of 4 band EN-DC Test Frequency (DC_1A-3A-8A_n78A)	16.7.0
2021-03	RAN#91	R5-211663	1743	1	F	Update PDSCH-TimeDomainResourceAllocationList to consider coreset0 for Demod FR2 test cases	16.7.0
2021-03	RAN#91	R5-211664	1763	1	F	Update message content for PMI reporting test cases	16.7.0
2021-03	RAN#91	R5-211665	1705	1	F	Changes to RRM default message contents	16.7.0
2021-03	RAN#91	R5-211666	1706	1	F	Add SSB Index table for RRM with SECOND_SSB condition	16.7.0
2021-03	RAN#91	R5-211667	1751	1	F	Addition of default configuration of CSI-IM for RRM tests	16.7.0
2021-03	RAN#91	R5-211668	1790	1	F	Specify CSI-SSB-ResourceSet for RRM	16.7.0
2021-03	RAN#91	R5-211669	1702	1	F	Editorial rework of the conditions for CSI-FrequencyOccupation	16.7.0
2021-03	RAN#91	R5-211670	1703	1	F	Align TDD UL DL Common for RRM with TS 38.533	16.7.0
2021-03	RAN#91	R5-211671	1707	1	F	Correct reportOffsetList in CSI-ReportConfig	16.7.0
2021-03	RAN#91	R5-211672	1708	1	F	Specify CSI-SSB-ResourceSet	16.7.0
2021-03	RAN#91	R5-211673	1764	1	F	Clarification on the connection diagram for FR2 demod and RRM test cases	16.7.0
2021-03	RAN#91	R5-211762	1778	1	F	Update of 4.3.1.4.1 for test frequencies for EN-DC band combinations within FR1	16.7.0
2021-03	RAN#91	R5-211763	1779	1	F	Update of 4.3.1.5.1 for test frequencies for EN-DC band combinations including FR2	16.7.0
2021-03	RAN#91	R5-211784	1776	1	F	Update of 4.3.1.0A for mid test channel bandwidth	16.7.0
2021-03	RAN#91	R5-211785	1792	1	F	Correction of test frequencies for NR band n48	16.7.0
2021-03	RAN#91	R5-211855	1758	1	F	Updating the value of P-Max for EN-DC and NR SA test cases	16.7.0
2021-03	RAN#91	R5-211856	1768	1	F	Correction to the message contents for CQI reporting tests in 5.4.2.4	16.7.0
2021-03	RAN#91	R5-211857	1769	1	F	Correction to the message contents for PMI reporting tests in 5.4.2.5	16.7.0
2021-03	RAN#91	R5-210927	1755	-	F	Updating Rel-17 mid and highest channel bandwidth for n83 and n84	17.0.0
2021-03	RAN#91	R5-210928	1756	-	F	Adding Rel-17 CBW 30MHz test frequencies for n83	17.0.0
2021-03	RAN#91	R5-210929	1757	-	F	Updating test frequencies for Rel-17 new CBWs for band n84	17.0.0
2021-03	RAN#91	R5-211836	1766	1	F	Introduction of test frequencies for n48 adding CBW 70 MHz - DL only	17.0.0
2021-06	RAN#92	R5-212203	1804	-	F	Resubmission of Addition of SI combination for NR SL	17.1.0
2021-06	RAN#92	R5-212213	1807	-	F	Add IE Phy-ParametersSharedSpectrumChAccess	17.1.0
2021-06	RAN#92	R5-212248	1811	-	F	Correction to TCI stated of CSI-RS for TRS	17.1.0
2021-06	RAN#92	R5-212249	1812	-	F	Correction to physical layer parameters for demodulation tests	17.1.0
2021-06	RAN#92	R5-212250	1813	-	F	Update of TE diagram for FR2 RRM tests with multiple NR cells	17.1.0
2021-06	RAN#92	R5-212409	1817	-	F	Correction to IE BWP-DownlinkDedicated	17.1.0
2021-06	RAN#92	R5-212455	1822	-	F	Correction of NR SL IE SL-BWP-Config	17.1.0
2021-06	RAN#92	R5-212456	1823	-	F	Correction of NR SL IE SL-BWP-PoolConfig	17.1.0
2021-06	RAN#92	R5-212457	1824	-	F	Correction of NR SL IE SL-CBR-CommonTxConfigList	17.1.0
2021-06	RAN#92	R5-212458	1825	-	F	Correction of NR SL IE SL-CBR-PriorityTxConfigList	17.1.0
2021-06	RAN#92	R5-212459	1826	-	F	Correction of NR SL IE SL-ConfiguredGrantConfig	17.1.0
2021-06	RAN#92	R5-212460	1827	-	F	Correction of NR SL IE SL-DestinationIdentity	17.1.0
2021-06	RAN#92	R5-212461	1828	-	F	Correction of NR SL IE SL-FreqConfig	17.1.0
2021-06	RAN#92	R5-212462	1829	-	F	Correction of NR SL IE SL-MeasConfigCommon	17.1.0
2021-06	RAN#92	R5-212463	1830	-	F	Correction of NR SL IE SL-MeasIdList	17.1.0
2021-06	RAN#92	R5-212464	1831	-	F	Correction of NR SL IE SL-MeasObjectList	17.1.0
2021-06	RAN#92	R5-212465	1832	-	F	Correction of NR SL IE SL-PSBCH-Config	17.1.0
2021-06	RAN#92	R5-212468	1835	-	F	Correction of NR SL IE SL-QoS-Profile	17.1.0
2021-06	RAN#92	R5-212469	1836	-	F	Correction of NR SL IE SL-QuantityConfig	17.1.0
2021-06	RAN#92	R5-212473	1840	-	F	Correction of NR SL IE SL-ScheduledConfig	17.1.0
2021-06	RAN#92	R5-212476	1843	-	F	Correction of NR SL IE SL-TxPower	17.1.0



2021-06	RAN#92	R5-212478	1845	-	F	Correction of NR SL IE SL-UE-SelectedConfig	17.1.0
2021-06	RAN#92	R5-212479	1846	-	F	Correction of NR SL IE SL-ZoneConfig	17.1.0
2021-06	RAN#92	R5-212616	1859	-	F	Correction to PUCCH resource indicator value for PMI reporting requirements	17.1.0
2021-06	RAN#92	R5-212642	1861	-	F	Editorial correction of header level in clause 5.4.2.0 in 38.508-1	17.1.0
2021-06	RAN#92	R5-212688	1865	-	F	Correction of nominal channel spacing in test frequencies for CA_n257x	17.1.0
2021-06	RAN#92	R5-212689	1866	-	F	Correction of nominal channel spacing in test frequencies for CA_n258x	17.1.0
2021-06	RAN#92	R5-212690	1867	-	F	Correction of nominal channel spacing in test frequencies for CA_n260x	17.1.0
2021-06	RAN#92	R5-212691	1868	-	F	Correction of nominal channel spacing in test frequencies for CA_n261x	17.1.0
2021-06	RAN#92	R5-212692	1869	-	F	Correction of test frequencies for CA_n41C	17.1.0
2021-06	RAN#92	R5-212693	1870	-	F	Correction of test frequencies for CA_n78C	17.1.0
2021-06	RAN#92	R5-212694	1871	-	F	Correction of test frequencies for DC_(n)41AA	17.1.0
2021-06	RAN#92	R5-212695	1872	-	F	Editorial correction of test frequencies for protocol testing	17.1.0
2021-06	RAN#92	R5-212698	1875	-	F	Introduction of test frequencies for n41 adding CBW 70 MHz	17.1.0
2021-06	RAN#92	R5-212699	1876	-	F	Introduction of test frequencies for n48 adding CBW 30 MHz	17.1.0
2021-06	RAN#92	R5-212702	1879	-	F	Introduction of principles for calculating test frequencies for NR Intra-band Contiguous CA for asymmetric bands in Annex C	17.1.0
2021-06	RAN#92	R5-212703	1880	-	F	Correction of test frequencies for CA_n66B	17.1.0
2021-06	RAN#92	R5-212705	1881	-	F	Add message contents for RRM FR2 tests with reduced RB allocation	17.1.0
2021-06	RAN#92	R5-212724	1885	-	F	Correct number of HARQ processes for PDSCH	17.1.0
2021-06	RAN#92	R5-212819	1892	-	F	Correction of 4.3.1.0D for bandwidth part	17.1.0
2021-06	RAN#92	R5-212820	1893	-	F	Correction of 4.3.1.1.2 for test frequencies for NR FR1 inter-band CA configurations	17.1.0
2021-06	RAN#92	R5-212886	1897	-	F	Update of default SCS for n48 for protocol testing	17.1.0
2021-06	RAN#92	R5-212890	1898	-	F	Test frequencies definition for EN-DC band 41CA	17.1.0
2021-06	RAN#92	R5-212892	1900	-	F	Correction to NZP CSI-RS default configuration for RRM test	17.1.0
2021-06	RAN#92	R5-212921	1901	-	F	Addition of GNSS requirements for NR sidelink	17.1.0
2021-06	RAN#92	R5-212924	1904	-	F	Addition of connection diagram of NR sidelink testing	17.1.0
2021-06	RAN#92	R5-212946	1905	-	F	Updating IEs for URLLC	17.1.0
2021-06	RAN#92	R5-212986	1906	-	F	Introducing Rel-16 CA configuration CA_n28A-n41A to clause 4.3.1	17.1.0
2021-06	RAN#92	R5-213003	1907	-	F	Adding test frequency description for SUL configuration	17.1.0
2021-06	RAN#92	R5-213004	1908	-	F	Adding connection diagrams for SUL configuration with DL CA	17.1.0
2021-06	RAN#92	R5-213054	1910	-	F	Correction to PDU Session Authentication Command, PDU Session Authentication Complete and PDU Session Authentication Result messages.	17.1.0
2021-06	RAN#92	R5-213057	1912	-	F	Introduction of test frequencies for CA_n48(2A)	17.1.0
2021-06	RAN#92	R5-213150	1917	-	F	Updates to global conditions	17.1.0
2021-06	RAN#92	R5-213153	1920	-	F	Updates to PDU SESSION ESTABLISHMENT REJECT message	17.1.0
2021-06	RAN#92	R5-213154	1921	-	F	Updates to PDU SESSION MODIFICATION REJECT message	17.1.0
2021-06	RAN#92	R5-213155	1922	-	F	Updates to QoS flows	17.1.0
2021-06	RAN#92	R5-213180	1939	-	F	Update chapter 4.5.2 RRC_IDLE	17.1.0
2021-06	RAN#92	R5-213192	1940	-	F	Update chapter 4.5.4 RRC_CONNECTED	17.1.0
2021-06	RAN#92	R5-213304	1953	-	F	Correction of test frequencies for NR band n66	17.1.0
2021-06	RAN#92	R5-213307	1954	-	F	Correction of common default messages for demod FR2	17.1.0
2021-06	RAN#92	R5-213339	1956	-	F	Update PUCCH-ConfigCommon for Demod testing	17.1.0
2021-06	RAN#92	R5-213340	1957	-	F	Update message content for subband CQI reporting test cases	17.1.0
2021-06	RAN#92	R5-213400	1961	-	F	Inclusion of additional P-CSCF IP address in PDU session establishment	17.1.0
2021-06	RAN#92	R5-213409	1955	1	F	Editorial updates to test procedure titles	17.1.0
2021-06	RAN#92	R5-213416	1838	1	F	Correction of NR SL IE SL-ReportConfigList	17.1.0
2021-06	RAN#92	R5-213417	1841	1	F	Correction of NR SL IE SL-SyncConfig	17.1.0
2021-06	RAN#92	R5-213418	1848	1	F	Correction to PC5-RRC message MeasurementReportSidelink	17.1.0

2021-06	RAN#92	R5-213419	1850	1	F	Correction to PC5-RRC message RRCReconfigurationFailureSidelink	17.1.0
2021-06	RAN#92	R5-213423	1857	1	F	Updates to NETWORK SLICE-SPECIFIC AUTHENTICATION COMMAND and NETWORK SLICE- SPECIFIC AUTHENTICATION COMPLETE messages	17.1.0
2021-06	RAN#92	R5-213424	1858	1	F	Updates to NETWORK SLICE-SPECIFIC AUTHENTICATION RESULT message	17.1.0
2021-06	RAN#92	R5-213425	1924	1	F	Introduction of Always-On indication for URLLC	17.1.0
2021-06	RAN#92	R5-213439	1816	1	F	Correction to IMS call release sequences	17.1.0
2021-06	RAN#92	R5-213440	1886	1	F	Addition of Generic Test procedure for IMS MO Video call establishment in 5GC	17.1.0
2021-06	RAN#92	R5-213441	1913	1	F	Correction to Table 4.9.12.2.2-1 for IMS Emergency call establishment in 5GC without IMS emergency registration	17.1.0
2021-06	RAN#92	R5-213442	1914	1	F	Correction to Procedure for UE-requested PDU session modification after the first S1 to N1 mode change / Single- registration mode with N26	17.1.0
2021-06	RAN#92	R5-213443	1941	1	F	Update chapter 4.5.1 General	17.1.0
2021-06	RAN#92	R5-213444	1887	1	F	Addition of default contents for RRCReconfiguration-Video	17.1.0
2021-06	RAN#92	R5-213445	1888	1	F	Corrections to PDCP config	17.1.0
2021-06	RAN#92	R5-213446	1798	1	F	Update of USIM Configurations 4, 7, 8, 10, 12 and 21	17.1.0
2021-06	RAN#92	R5-213447	1854	1	F	Correction to Table 6.4.1-12 USIM Configuration 12	17.1.0
2021-06	RAN#92	R5-213448	1873	1	F	Update of default SCS for n38, n39, n40 and n50 for protocol testing	17.1.0
2021-06	RAN#92	R5-213449	1942	1	F	Update maximum number of simultaneous configured cells for FR1 and FR2 in OTA	17.1.0
2021-06	RAN#92	R5-213450	1951	1	F	Updates to FR1 and E-UTRA OTA signal level testing	17.1.0
2021-06	RAN#92	R5-213451	1802	1	F	Correction and editorials to default message content specification	17.1.0
2021-06	RAN#92	R5-213452	1915	1	F	Correction to Combinations of system information blocks	17.1.0
2021-06	RAN#92	R5-213557	1819	1	F	Addition of general procedures for NR sidelink	17.1.0
2021-06	RAN#92	R5-213558	1820	1	F	Addition of test procedure to establish sidelink unicast mode	17.1.0
2021-06	RAN#92	R5-213559	1821	1	F	Addition of test state for NR sidelink	17.1.0
2021-06	RAN#92	R5-213560	1833	1	F	Correction of NR SL IE SL-PSSCH-TxConfigList	17.1.0
2021-06	RAN#92	R5-213561	1834	1	F	Correction of NR SL IE SL-QoS-FlowIdentity	17.1.0
2021-06	RAN#92	R5-213562	1837	1	F	Correction of NR SL IE SLRB-Uu-ConfigIndex	17.1.0
2021-06	RAN#92	R5-213563	1839	1	F	Correction of NR SL IE SL-RLC-BearerConfigIndex	17.1.0
2021-06	RAN#92	R5-213564	1844	1	F	Correction of NR SL IE SL-TypeTxSync	17.1.0
2021-06	RAN#92	R5-213565	1847	1	F	Correction to PC5-RRC message MasterInformationBlockSidelink	17.1.0
2021-06	RAN#92	R5-213566	1849	1	F	Correction to PC5-RRC message RRCReconfigurationCompleteSidelink	17.1.0
2021-06	RAN#92	R5-213567	1856	1	F	Update IE SL-Thres-RSRP-List	17.1.0
2021-06	RAN#92	R5-213573	1890	1	F	Updates to NPN-Identity for Rel-16 NPN	17.1.0
2021-06	RAN#92	R5-213574	1891	1	F	Addition of System information combination for Rel-16 NPN	17.1.0
2021-06	RAN#92	R5-213580	1889	1	F	Updates to default contents of UECapabilityEnquiry message	17.1.0
2021-06	RAN#92	R5-213601	1855	1	F	Introduction of definition of common environment for R16 NR SON and MDT	17.1.0
2021-06	RAN#92	R5-213643	1918	1	F	Addition of DNN configurations for new SSTs	17.1.0
2021-06	RAN#92	R5-213644	1919	1	F	Updates to UE Policy Delivery messages	17.1.0
2021-06	RAN#92	R5-213645	1923	1	F	Updates to REGISTRATION ACCEPT message	17.1.0
2021-06	RAN#92	R5-213675	1960	1	F	Correction to procedure 4.9.9 Tracking area updating / Inter- system change from S1 mode to N1 mode in 5GMM/EMM- IDLE mode	17.1.0
2021-06	RAN#92	R5-213833	1926	1	F	Testing frequencies update for band n3	17.1.0
2021-06	RAN#92	R5-213834	1950	1	F	CR to 38.508-1 on larger quiet zone with grey-box approach	17.1.0
2021-06	RAN#92	R5-213853	1864	1	F	Correction of test frequencies for CA_n260(A-I)	17.1.0
2021-06	RAN#92	R5-213854	1862	1	F	Introduction of principles for calculating test frequencies for NR Intra-band Non-Contiguous CA in Annex C	17.1.0
2021-06	RAN#92	R5-213858	1896	1	F	Update Note about n28 Test frequency Mid range and CBW 30 MHz	17.1.0
2021-06	RAN#92	R5-213859	1925	1	F	Mid range test frequencies update in case asymmetric bandwidths	17.1.0
2021-06	RAN#92	R5-213860	1927	1	F	Testing frequencies update for band n34	17.1.0
2021-06	RAN#92	R5-213861	1928	1	F	Testing frequencies update for band n39	17.1.0
2021-06	RAN#92	R5-213862	1929	1	F	Testing frequencies update for band n53	17.1.0

2021-06	RAN#92	R5-213863	1930	1	F	Testing frequencies update for band n66	17.1.0
2021-06	RAN#92	R5-213864	1931	1	F	Testing frequencies update for band n70	17.1.0
2021-06	RAN#92	R5-213865	1932	1	F	Testing frequencies update for band n80	17.1.0
2021-06	RAN#92	R5-213866	1933	1	F	Testing frequencies update for band n81	17.1.0
2021-06	RAN#92	R5-213867	1934	1	F	Testing frequencies update for band n82	17.1.0
2021-06	RAN#92	R5-213868	1935	1	F	Testing frequencies update for band n86	17.1.0
2021-06	RAN#92	R5-213869	1937	1	F	OffsetToCarrier alignment for cases with equal low, mid and high frequency range (n30, n39, n51, n70) and editorial corrections in annex C.3.	17.1.0
2021-06	RAN#92	R5-213870	1884	1	F	Align Chapter 7 of TS 38.508-1 with Annex H of TS 38.533	17.1.0
2021-06	RAN#92	R5-213871	1944	1	F	Introduction of test frequencies for n257 for RRM Inter-freq adjacent cell	17.1.0
2021-06	RAN#92	R5-213872	1945	1	F	Introduction of test frequencies for n258 for RRM Inter-freq adjacent cell	17.1.0
2021-06	RAN#92	R5-213873	1947	1	F	Introduction of test frequencies for n260 for RRM Inter-freq adjacent cell	17.1.0
2021-06	RAN#92	R5-213874	1948	1	F	Introduction of test frequencies for n261 for RRM Inter-freq adjacent cell	17.1.0
2021-06	RAN#92	R5-213875	1863	1	F	Introduction of principles for calculating test frequencies for EN-DC configurations in Annex C	17.1.0
2021-06	RAN#92	R5-213876	1882	1	F	Add locationAndBandwidth for RRM FR2 tests with reduced RB allocation	17.1.0
2021-06	RAN#92	R5-213877	1936	1	F	Annex C: Clarifications to maximum and minimum offsetRBs	17.1.0
2021-06	RAN#92	R5-213878	1938	1	F	Annex C update to add SUL test frequencies calculation	17.1.0
2021-06	RAN#92	R5-213879	1949	1	F	Determination of test frequencies for a Mid range adjacent inter-frequency cell for FR2 RRM multicell testing in Annex C	17.1.0
2021-06	RAN#92	R5-213964	1877	1	F	Correction of test frequencies for CA_n66(2A)	17.1.0
2021-06	RAN#92	R5-213977	1946	1	F	Introduction of test frequencies for n259 for RRM Inter-freq adjacent cell	17.1.0
2021-06	RAN#92	R5-213996	1902	1	F	Addition of calculation method of NR sidelink test frequencies	17.1.0
2021-06	RAN#92	R5-213997	1903	1	F	Addition of V2X test frequencies of band n47	17.1.0
2021-06	RAN#92	R5-214017	1799	1	F	Updating test frequencies for Rel-17 EN-DC band combinations within FR1	17.1.0
2021-06	RAN#92	R5-214018	1801	1	F	Add test frequencies for R17 NR inter-band CA configurations in FR1	17.1.0
2021-06	RAN#92	R5-214019	1909	1	F	Introducing Rel-17 CA configuration CA_n28A-n79A to clause 4.3.1	17.1.0
2021-06	RAN#92	R5-214026	1809	1	F	RRC signalling for UL power boosting via suspended IBE requirements	17.1.0
2021-06	RAN#92	R5-214047	1959	1	F	Clarification on PDU configuration for RF, Demod and RRM tests	17.1.0
2021-06	RAN#92	R5-214076	1860	1	F	Update IE PDCCH-ConfigCommon for additional BWP	17.1.0
2021-06	RAN#92	R5-214107	1883	1	F	Align RRM CSI-ResourcePeriodicityAndOffset to TS 38.133	17.1.0
2021-09	RAN#93	R5-214381	1963	-	F	Correct dl_DataToUL_ACK for short DCI test cases	17.2.0
2021-09	RAN#93	R5-214436	1967	-	F	Correction to 38.508 Table 4.8.2.3-2: Reference QoS flow #2	17.2.0
2021-09	RAN#93	R5-214554	1968	-	F	Correction of default test frequencies for bands n38, n39, n40 and n50 and protocol testing	17.2.0
2021-09	RAN#93	R5-214611	1970	-	F	Correction of default test frequencies for band n48 and protocol testing	17.2.0
2021-09	RAN#93	R5-214622	1971	-	F	Editorial updates to test procedure titles	17.2.0
2021-09	RAN#93	R5-214678	1972	-	F	Correction to k1 setting for FR2 RRM	17.2.0
2021-09	RAN#93	R5-214727	1974	-	F	Introduction of test frequencies for CA_n48B	17.2.0
2021-09	RAN#93	R5-214728	1975	-	F	Corrections to UEInformationRequest and UEInformationResponse	17.2.0
2021-09	RAN#93	R5-214755	1976	-	F	Updates to System information combination for NR-DC	17.2.0
2021-09	RAN#93	R5-214800	1979	-	F	Correction to IEs for UE policy part	17.2.0
2021-09	RAN#93	R5-214808	1987	-	F	Correction to NR V2X USIM configuration	17.2.0
2021-09	RAN#93	R5-214853	1989	-	F	Introduction of test frequencies for CA_n48B and protocol testing	17.2.0
2021-09	RAN#93	R5-214900	1992	-	F	Editorial Updates to Clause. 4.4.3.1.2 for System information combination	17.2.0
2021-09	RAN#93	R5-214929	1994	-	F	Introduction of test frequencies for CA_n71(2A) for protocol testing	17.2.0
2021-09	RAN#93	R5-214947	1997	-	F	Correction to Table 6.4.1-8 USIM Configuration 8	17.2.0

2021-09	RAN#93	R5-214959	1998	-	F	Correction of test frequencies for CA_n66(2A) for protocol testing	17.2.0
2021-09	RAN#93	R5-214962	1999	-	F	Alignment of test frequency tables for CA_n48(2A), CA_n66(2A), CA_n77(2A) and CA_n78(2A)	17.2.0
2021-09	RAN#93	R5-214977	2003	-	F	Correction to default configuration-ControlResourceSet	17.2.0
2021-09	RAN#93	R5-214978	2004	-	F	Correction to default configuration-SCell CSI on PCell	17.2.0
2021-09	RAN#93	R5-215071	2006	-	F	Update to Out of Coverage procedure to trigger SL-MIMO transmission	17.2.0
2021-09	RAN#93	R5-215308	2012	-	F	Adding test frequencies for SUL band n97	17.2.0
2021-09	RAN#93	R5-215341	2015	-	F	Correction to TRS configuration for RF test cases	17.2.0
2021-09	RAN#93	R5-215456	2019	-	F	Update of 4.3.1.4.1 for test frequencies for EN-DC configurations within FR1	17.2.0
2021-09	RAN#93	R5-215462	2021	-	F	Correction of 4.3.1.0D for locationAndBandwidth in BWP	17.2.0
2021-09	RAN#93	R5-215499	2023	-	F	Introduction of V2X SST	17.2.0
2021-09	RAN#93	R5-215504	2028	-	F	Updates to Table 4.4A.5-2	17.2.0
2021-09	RAN#93	R5-215518	2029	-	F	Editorial correction: channel bandwidth and RB allocation revision in Test frequencies for CA_n260(A-l)	17.2.0
2021-09	RAN#93	R5-215530	2030	-	F	Correction on Test frequencies for DC_(n)41CA	17.2.0
2021-09	RAN#93	R5-215541	2031	-	F	Test frequencies update for CA_n257G, CA_n257H and CA_n257I	17.2.0
2021-09	RAN#93	R5-215612	2032	-	F	Correction RF E-UTRA CONNECTED state	17.2.0
2021-09	RAN#93	R5-215678	2034	-	F	RRC and NAS message handling in uplink in case of simultaneous RRC and NAS procedures	17.2.0
2021-09	RAN#93	R5-215679	2035	-	F	Enquiry of Capability and checking of UeCapabilityInformation contents for NR-DC	17.2.0
2021-09	RAN#93	R5-215689	2039	-	F	Correction to USIM Configuration 18 and 19	17.2.0
2021-09	RAN#93	R5-215691	2040	-	F	Update chapter 4.5.4 RRC_CONNECTED	17.2.0
2021-09	RAN#93	R5-215835	1964	1	F	Correct CSI-MeasConfig for test cases with 1SSB	17.2.0
2021-09	RAN#93	R5-215836	1965	1	F	Complete CSI-ReportConfig for RRM	17.2.0
2021-09	RAN#93	R5-215837	2014	1	F	Correction to CSI report configurations	17.2.0
2021-09	RAN#93	R5-215936	2005	1	F	Update of SIB2 to add messages for relaxed RRM measurement	17.2.0
2021-09	RAN#93	R5-215969	1962	1	F	Updating Test Frequencies for Rel-17 CA,DC band combinations within FR1 into TS 38.508-1	17.2.0
2021-09	RAN#93	R5-215970	1993	1	F	Introduction of test frequencies for CA_n71(2A)	17.2.0
2021-09	RAN#93	R5-215971	2008	1	F	Addition of R17 CADC configuration into 38.508-1	17.2.0
2021-09	RAN#93	R5-215972	2020	1	F	Update of 4.3.1.1.2 for NR inter-band CA configurations in FR1	17.2.0
2021-09	RAN#93	R5-216027	2016	1	F	Addition of Perf RI FR2 message contents	17.2.0
2021-09	RAN#93	R5-216070	2007	1	F	Adding connection diagram for eMIMO multi-TRP demod test cases	17.2.0
2021-09	RAN#93	R5-216079	1973	1	F	Updating test frequencies for Rel-17 inter-band EN-DC configurations	17.2.0
2021-09	RAN#93	R5-216116	2009	1	F	Updates to Test Equipment connection for Demodulation Performance and CSI reporting tests	17.2.0
2021-09	RAN#93	R5-216122	2010	1	B	Introduction of test frequencies for n24 and n99	17.2.0
2021-09	RAN#93	R5-216150	1977	1	F	Correction to Test Procedure for IMS MO and MT call release in 5GC	17.2.0
2021-09	RAN#93	R5-216151	2017	1	F	Correction to introduce Handling of PDU Session Release during switch off/Power off procedures	17.2.0
2021-09	RAN#93	R5-216152	2026	1	F	Addition of UE Configuration Update procedure	17.2.0
2021-09	RAN#93	R5-216153	2037	1	F	Corrections for IMS video call signalling	17.2.0
2021-09	RAN#93	R5-216154	2041	1	F	Correction to Table 4.6.3-142 and Table 4.6.3-79 for SFTD measurement reporting	17.2.0
2021-09	RAN#93	R5-216155	2024	1	F	Introduction of PS Data Off	17.2.0
2021-09	RAN#93	R5-216156	2025	1	F	Introduction of URSP	17.2.0
2021-09	RAN#93	R5-216157	2027	1	F	Updates to REGISTRATION messages	17.2.0
2021-09	RAN#93	R5-216158	2036	1	F	Correction to Table 4.8.2.2-1 for default Packet filter ID	17.2.0
2021-09	RAN#93	R5-216159	1969	1	F	Correction for USIM configurations	17.2.0
2021-09	RAN#93	R5-216160	2018	1	F	Updates to NR cell configurations for SIG	17.2.0
2021-09	RAN#93	R5-216161	2038	1	F	Correction to reference configurations for IMS video call signalling	17.2.0
2021-09	RAN#93	R5-216243	1991	1	F	Correction of test frequencies for CA_n66B for protocol testing	17.2.0
2021-09	RAN#93	R5-216256	2022	1	F	Introduction of MlIoT SST	17.2.0

2021-09	RAN#93	R5-216263	1980	1	F	Correction to IEs for V2XP info	17.2.0
2021-09	RAN#93	R5-216264	1981	1	F	Correction to IEs for Served by E-UTRA or served by NR	17.2.0
2021-09	RAN#93	R5-216265	1982	1	F	Correction to IEs for Not served by E-UTRA and not served by NR	17.2.0
2021-09	RAN#93	R5-216266	1983	1	F	Correction to IEs for V2X service identifier to PC5 RAT and Tx profiles mapping rules	17.2.0
2021-09	RAN#93	R5-216267	1984	1	F	Correction to IEs for Privacy config	17.2.0
2021-09	RAN#93	R5-216268	1985	1	F	Correction to IEs for V2X communication over PC5 in E-UTRA-PC5	17.2.0
2021-09	RAN#93	R5-216269	1986	1	F	Correction to IEs for V2X communication over PC5 in NR-PC5	17.2.0
2021-09	RAN#93	R5-216270	1988	1	F	Correction to UE Policy Delivery msg	17.2.0
2021-09	RAN#93	R5-216284	1990	1	F	Update default message contents of LoggedMeasurementConfiguration	17.2.0
2021-09	RAN#93	R5-216320	2011	1	B	Introduction of signalling test frequencies for n24 and n99	17.2.0
2021-09	RAN#93	R5-216321	2013	1	F	Adding signalling test frequencies for SUL band n97	17.2.0
2021-09	RAN#93	R5-216327	2000	1	F	Default message content update for NR EIEI	17.2.0
2021-09	RAN#93	R5-216328	2001	1	F	Generic procedure for eCall over IMS establishment in 5GS Normal Service	17.2.0
2021-09	RAN#93	R5-216329	2002	1	F	USIM configuration for NR EIEI	17.2.0
2021-12	RAN#94	R5-216510	2047	-	F	Updating Test Frequencies for Rel-16 CA,DC band combinations within FR1 into TS 38.508-1	17.3.0
2021-12	RAN#94	R5-216530	2048	-	F	Addition of test frequencies for asymmetric channel bandwidths for n24	17.3.0
2021-12	RAN#94	R5-216603	2051	-	F	Addition of NR band n95	17.3.0
2021-12	RAN#94	R5-216636	2052	-	F	Updates on simultaneous co-existence of NR cells	17.3.0
2021-12	RAN#94	R5-216761	2053	-	F	Addition of PDCCCH Search Space Ext configuration in 38.508-1	17.3.0
2021-12	RAN#94	R5-216767	2054	-	F	Updates to NETWORK SLICE-SPECIFIC AUTHENTICATION COMMAND message	17.3.0
2021-12	RAN#94	R5-216768	2055	-	F	Updates to NETWORK SLICE-SPECIFIC AUTHENTICATION COMPLETE message	17.3.0
2021-12	RAN#94	R5-216773	2059	-	F	Update IE SSB-PositionQCL-Relation	17.3.0
2021-12	RAN#94	R5-216829	2061	-	F	Correction to IMS MO emergency call release procedure	17.3.0
2021-12	RAN#94	R5-216851	2062	-	F	Correction to IE Table 7.3.1-3 - SSB-MTC	17.3.0
2021-12	RAN#94	R5-216895	2063	-	F	Correction to IE Table 4.6.3-77A - MeasObjectUTRA-FDD	17.3.0
2021-12	RAN#94	R5-216896	2064	-	F	Correction to IE Table 4.6.3-79 - MeasResults	17.3.0
2021-12	RAN#94	R5-216898	2066	-	F	Correction to IE Table 4.6.5-16 - UTRA-FDD-Q-OffsetRange	17.3.0
2021-12	RAN#94	R5-216899	2067	-	F	Correction to RRC message Table 4.6.1-8 - MobilityFromNRCommand	17.3.0
2021-12	RAN#94	R5-216905	2068	-	F	Correction to IE Table 4.6.3-62A - HighSpeedConfig	17.3.0
2021-12	RAN#94	R5-216922	2097	-	F	Update of Table 4.7.1-7-Registration Accept	17.3.0
2021-12	RAN#94	R5-217024	2101	-	F	Add Reference file	17.3.0
2021-12	RAN#94	R5-217025	2102	-	F	Correction to DIRECT LINK ESTABLISHMENT REQUEST msg	17.3.0
2021-12	RAN#94	R5-217026	2103	-	F	Correction to DIRECT LINK ESTABLISHMENT ACCEPT msg	17.3.0
2021-12	RAN#94	R5-217027	2104	-	F	Correction to DIRECT LINK MODIFICATION REQUEST msg	17.3.0
2021-12	RAN#94	R5-217028	2105	-	F	Correction to DIRECT LINK MODIFICATION ACCEPT msg	17.3.0
2021-12	RAN#94	R5-217029	2106	-	F	Correction to DIRECT LINK RELEASE REQUEST msg	17.3.0
2021-12	RAN#94	R5-217030	2107	-	F	Correction to DIRECT LINK RELEASE ACCEPT msg	17.3.0
2021-12	RAN#94	R5-217032	2109	-	F	Correction to DIRECT LINK KEEPALIVE RESPONSE msg	17.3.0
2021-12	RAN#94	R5-217035	2112	-	F	Correction to DIRECT LINK AUTHENTICATION REJECT msg	17.3.0
2021-12	RAN#94	R5-217038	2115	-	F	Correction to DIRECT LINK SECURITY MODE REJECT msg	17.3.0
2021-12	RAN#94	R5-217039	2116	-	F	Correction to DIRECT LINK REKEYING REQUEST msg	17.3.0
2021-12	RAN#94	R5-217040	2117	-	F	Correction to DIRECT LINK REKEYING RESPONSE msg	17.3.0
2021-12	RAN#94	R5-217044	2121	-	F	Correction to DIRECT LINK IDENTIFIER UPDATE REJECT msg	17.3.0
2021-12	RAN#94	R5-217045	2122	-	F	Correction to DIRECT LINK MODIFICATION REJECT msg	17.3.0
2021-12	RAN#94	R5-217095	2125	-	F	Update chapter 4.8.1 for NE-DC	17.3.0
2021-12	RAN#94	R5-217118	2128	-	F	Meas exception for TRS config in RF test cases	17.3.0
2021-12	RAN#94	R5-217243	2133	-	F	Correction to IE Table 4.6.3-127 QuantityConfig	17.3.0

2021-12	RAN#94	R5-217246	2134	-	F	Correction of spec number and addition of uncertainty value for OTA testing in section 5.2.1	17.3.0
2021-12	RAN#94	R5-217259	2135	-	F	Addition of 13 NR CA combinations to FR1 inter-band configurations table	17.3.0
2021-12	RAN#94	R5-217286	2137	-	F	Correction to IMS Emergency call establishment test procedure with IMS emergency registration	17.3.0
2021-12	RAN#94	R5-217298	2138	-	F	Addition of test frequencies for Rel-15 EN-DC configurations	17.3.0
2021-12	RAN#94	R5-217340	2139	-	F	Correction of 4.3.1.2.4.4.2 for test frequency for intra-band non-contiguous CA_n260	17.3.0
2021-12	RAN#94	R5-217366	2140	-	F	Addition of default message for 16Tx PMI reporting test cases in 5.4.2.5	17.3.0
2021-12	RAN#94	R5-217379	2141	-	F	Addition of default DCI_0_2 for URLLC	17.3.0
2021-12	RAN#94	R5-217390	2143	-	F	Update to SIG test frequencies for V2X	17.3.0
2021-12	RAN#94	R5-217430	2144	-	F	Correction to the periodicity of CSI-RS for tracking	17.3.0
2021-12	RAN#94	R5-217453	2146	-	F	Updates to 4.8.4	17.3.0
2021-12	RAN#94	R5-217527	2148	-	F	message content update for HST single tap 1Tx PDSCH test cases	17.3.0
2021-12	RAN#94	R5-217555	2153	-	F	Editorial correction in channel bandwidth clause	17.3.0
2021-12	RAN#94	R5-217587	2155	-	F	Addition of CA_n1A-n3A into TS 38.508-1	17.3.0
2021-12	RAN#94	R5-217588	2156	-	F	Introduction of test frequencies for CA_n48(2A) for protocol testing	17.3.0
2021-12	RAN#94	R5-217589	2157	-	F	Introduction of test frequencies for n38 and CBWs 25 MHz and 30 MHz	17.3.0
2021-12	RAN#94	R5-217682	2160	-	F	Editorial update to clause 4.5A.2	17.3.0
2021-12	RAN#94	R5-217735	2163	-	F	Introduction of test frequencies for CA_n260K, CA_n260L and CA_n260M	17.3.0
2021-12	RAN#94	R5-217766	2165	-	F	Correction to NR V2X default configuration	17.3.0
2021-12	RAN#94	R5-217792	2043	1	F	Update chapter 4.5.4 RRC_CONNECTED	17.3.0
2021-12	RAN#94	R5-217793	2044	1	F	Update chapter 4.5.1 General	17.3.0
2021-12	RAN#94	R5-217794	2045	1	F	Update chapter 4.5.2 RRC_IDLE	17.3.0
2021-12	RAN#94	R5-217795	2060	1	F	Addition of new generic procedure for IMS MT video call establishment	17.3.0
2021-12	RAN#94	R5-217796	2130	1	F	Adding test procedure for adding video to a speech call	17.3.0
2021-12	RAN#94	R5-217797	2136	1	F	Correction to IMS MO Video call establishment test procedure	17.3.0
2021-12	RAN#94	R5-217798	2147	1	F	Adding test procedure for removing video from an ongoing call	17.3.0
2021-12	RAN#94	R5-217799	2042	1	F	Update RRCReconfiguration	17.3.0
2021-12	RAN#94	R5-217800	2046	1	F	Update IE CellAccessRelatedInfo	17.3.0
2021-12	RAN#94	R5-217801	2127	1	F	Update RRCReconfigurationComplete	17.3.0
2021-12	RAN#94	R5-217877	2098	1	F	Correction to default configuration of SIB12	17.3.0
2021-12	RAN#94	R5-217878	2099	1	F	Addition of default configuration of DCI and SCI for NR SL test	17.3.0
2021-12	RAN#94	R5-217879	2100	1	F	Addition of power level setting for NR SL test	17.3.0
2021-12	RAN#94	R5-217880	2108	1	F	Correction to DIRECT LINK KEEPALIVE REQUEST msg	17.3.0
2021-12	RAN#94	R5-217881	2110	1	F	Correction to DIRECT LINK AUTHENTICATION REQUEST msg	17.3.0
2021-12	RAN#94	R5-217882	2111	1	F	Correction to DIRECT LINK AUTHENTICATION RESPONSE msg	17.3.0
2021-12	RAN#94	R5-217883	2113	1	F	Correction to DIRECT LINK SECURITY MODE COMMAND msg	17.3.0
2021-12	RAN#94	R5-217884	2114	1	F	Correction to DIRECT LINK SECURITY MODE COMPLETE msg	17.3.0
2021-12	RAN#94	R5-217885	2118	1	F	Correction to DIRECT LINK IDENTIFIER UPDATE REQUEST msg	17.3.0
2021-12	RAN#94	R5-217886	2119	1	F	Correction to DIRECT LINK IDENTIFIER UPDATE ACCEPT msg	17.3.0
2021-12	RAN#94	R5-217887	2120	1	F	Correction to DIRECT LINK IDENTIFIER UPDATE ACK msg	17.3.0
2021-12	RAN#94	R5-217888	2123	1	F	Correction to DIRECT LINK ESTABLISHMENT REJECT	17.3.0
2021-12	RAN#94	R5-217933	2050	1	F	Updates to UTRA signal levels in FR1 and OTA environment	17.3.0
2021-12	RAN#94	R5-217943	2124	1	F	Update Radio resource control information elements for NR 2-step RACH test cases	17.3.0
2021-12	RAN#94	R5-217944	2161	1	F	Test Procedure for eCall over IMS establishment in 5GS eCall only Support	17.3.0
2021-12	RAN#94	R5-217949	2056	1	F	Update IE MeasObjectNR	17.3.0

2021-12	RAN#94	R5-217950	2057	1	F	Update IE ServingCellConfigCommon	17.3.0
2021-12	RAN#94	R5-217951	2058	1	F	Update IE ServingCellConfigCommonSIB	17.3.0
2021-12	RAN#94	R5-218220	2158	1	F	Correction of test frequencies for CA_n257x	17.3.0
2021-12	RAN#94	R5-218221	2129	1	F	Add meas objects and report config for inter-RAT	17.3.0
2021-12	RAN#94	R5-218267	2049	1	F	Addition of NR inter-band CA configurations for CA_n260-n261 in FR2	17.3.0
2021-12	RAN#94	R5-218268	2151	1	F	Addition of R16 FR1+FR2 CADC configuration into 38.508-1	17.3.0
2021-12	RAN#94	R5-218269	2159	1	F	Addition of test frequencies for R16 EN-DC FR2 configurations with n260	17.3.0
2021-12	RAN#94	R5-218335	2065	1	F	Correction to IE Table 4.6.3-141 - ReportConfigInterRAT	17.3.0
2021-12	RAN#94	R5-218361	2152	1	F	Addition of test frequencies for n3 CBW 50MHz	17.3.0
2021-12	RAN#94	R5-218414	2166	1	F	Update to demod parameter CSI-RS-ResourceMapping to add 1Tx condition	17.3.0
2021-12	RAN#94	R5-218415	2164	1	F	Update to n71 test frequencies for LTE-NR coex test cases	17.3.0
2021-12	RAN#94	R5-218451	2132	1	F	Introduction_of_test_frequencies_for_new_EN-DC_comb_within_FR1	17.3.0
2021-12	RAN#94	R5-218452	2149	1	F	Introduction of test frequencies for CA_n48B BCS1	17.3.0
2021-12	RAN#94	R5-218470	2150	1	F	Introduction of test frequencies for CA_n48B BCS2	17.3.0
2022-03	RAN#95	R5-220090	2171	-	F	Correction of clause title typos of 4.3.1.1.1.x	17.4.0
2022-03	RAN#95	R5-220094	2172	-	F	Correction of test channel bandwidth for n38	17.4.0
2022-03	RAN#95	R5-220186	2186	-	F	Editorial update of test procedure 4.9.15	17.4.0
2022-03	RAN#95	R5-220206	2188	-	F	Addition of test frequencies for CA_n3A-n41A with and without UL configuration	17.4.0
2022-03	RAN#95	R5-220240	2189	-	F	Corrections to 4.9.17 on IMS MO call release	17.4.0
2022-03	RAN#95	R5-220248	2191	-	F	Correct TDD pattern for FR2 RF 60kHz SCS	17.4.0
2022-03	RAN#95	R5-220271	2192	-	F	Addition of test frequencies for CA_n41A-n79A with UL configuration	17.4.0
2022-03	RAN#95	R5-220308	2195	-	F	Introduction of test frequencies for CA_n261M	17.4.0
2022-03	RAN#95	R5-220309	2196	-	F	Correction of NR inter-band CA configurations for CA_n260-n261 in FR2	17.4.0
2022-03	RAN#95	R5-220311	2197	-	F	Introduction of test frequencies for Rel-16 inter-band EN-DC two band combinations within FR1	17.4.0
2022-03	RAN#95	R5-220374	2198	-	F	Introduction of test frequencies for additional Rel-17 EN-DC inter-band configurations	17.4.0
2022-03	RAN#95	R5-220449	2199	-	F	Update of test frequencies for protocol testing and NR inter-band CA	17.4.0
2022-03	RAN#95	R5-220452	2200	-	F	Correction to RF E-UTRA RRC_CONNECTED procedure	17.4.0
2022-03	RAN#95	R5-220541	2204	-	F	Introduction of test frequencies for n25 adding CBWs 25MHz, 30MHz, 40MHz	17.4.0
2022-03	RAN#95	R5-220567	2206	-	F	Addition of default AT command and information element for NR SL test	17.4.0
2022-03	RAN#95	R5-220569	2208	-	F	Correction to test procedures for establishing unicast link	17.4.0
2022-03	RAN#95	R5-220579	2218	-	F	Correction to SIB12	17.4.0
2022-03	RAN#95	R5-220580	2219	-	F	Correction to IE SL-BWP-Config and SL-BWP-ConfigCommon	17.4.0
2022-03	RAN#95	R5-220582	2221	-	F	Correction to IE SL-ResourcePool	17.4.0
2022-03	RAN#95	R5-220590	2229	-	F	Correction to V2X service identifier to PC5 RAT and Tx profiles mapping rule	17.4.0
2022-03	RAN#95	R5-220591	2230	-	F	Correction to V2X frequencies	17.4.0
2022-03	RAN#95	R5-220632	2231	-	F	Introduction_of_test_frequencies_for_new_EN-DC_comb_within_FR1	17.4.0
2022-03	RAN#95	R5-220643	2232	-	F	Introduction of test frequencies for n2 adding CBWs 25MHz, 30MHz, 40MHz	17.4.0
2022-03	RAN#95	R5-220653	2234	-	F	Addition of test frequencies for CA_n41C-n79A with and without UL configuration	17.4.0
2022-03	RAN#95	R5-220725	2237	-	F	Addition of default configuration for NR SL RRM test	17.4.0
2022-03	RAN#95	R5-220760	2238	-	F	Introduction of test frequencies for n5 adding CBW 25MHz	17.4.0
2022-03	RAN#95	R5-220761	2239	-	F	Editorial corrections for NR CA configuration CA_n48B	17.4.0
2022-03	RAN#95	R5-220771	2242	-	F	Introduction of test frequencies for CA_n66(2A) BCS1 and BCS2	17.4.0
2022-03	RAN#95	R5-220774	2243	-	F	Corrections to test procedures 4.9.26 and 4.9.27	17.4.0
2022-03	RAN#95	R5-220779	2245	-	F	Update of test frequencies for n66 and asymmetric channel bandwidth combination set 1	17.4.0
2022-03	RAN#95	R5-220788	2246	-	F	Addition of V2X connection diagram	17.4.0
2022-03	RAN#95	R5-220797	2249	-	F	Addition of connection diagram for 16Tx	17.4.0

2022-03	RAN#95	R5-220808	2250	-	F	Update to MAC-CellGroupConfig	17.4.0
2022-03	RAN#95	R5-220847	2253	-	F	Addition of test frequency n53 in Table 6.2.3.1-4	17.4.0
2022-03	RAN#95	R5-220860	2254	-	F	Introducing Rel-17 2 band CA configurations for n24 and n41 to clause 4.3.1	17.4.0
2022-03	RAN#95	R5-220861	2255	-	F	Introducing Rel-17 2 band CA configurations for n24 and n48 to clause 4.3.1	17.4.0
2022-03	RAN#95	R5-220862	2256	-	F	Introducing Rel-17 2 band CA configurations for n24 and n77 to clause 4.3.1	17.4.0
2022-03	RAN#95	R5-220916	2259	-	F	Addition of PRB-Id setting for RRM test cases	17.4.0
2022-03	RAN#95	R5-220955	2262	-	F	Updates to IE UE Route Selection Policy Rules	17.4.0
2022-03	RAN#95	R5-220960	2264	-	F	Addition of test frequency for DC_7C_n78A	17.4.0
2022-03	RAN#95	R5-220972	2265	-	F	Addition of test frequencies for Rel-16 EN-DC configurations	17.4.0
2022-03	RAN#95	R5-220974	2266	-	F	Correction to applicability for protocol testing for inter-band EN-DC configurations	17.4.0
2022-03	RAN#95	R5-221070	2269	-	F	USIM configurations for NR EIEI test cases	17.4.0
2022-03	RAN#95	R5-221104	2270	-	F	Addition of new USIM configuration for RACS test case	17.4.0
2022-03	RAN#95	R5-221132	2271	-	F	Updating channel bandwidths for NR band n97	17.4.0
2022-03	RAN#95	R5-221133	2272	-	F	Updating test frequencies for NR band n97	17.4.0
2022-03	RAN#95	R5-221167	2275	-	F	Update to Ciphering algo IE for FR1 NSA SDR	17.4.0
2022-03	RAN#95	R5-221176	2276	-	F	Introduction of test frequencies for NR CA configurations CA_n5A-n7A, CA_n5A-n78A and CA_n7A-n78A	17.4.0
2022-03	RAN#95	R5-221186	2278	-	F	Introduction of test frequencies for DC_1A_n5A, DC_1A_n7A, DC_3A_n5A, DC_7A_n5A, DC_28A_n7A	17.4.0
2022-03	RAN#95	R5-221255	2282	-	F	Update K1 value for RRM TDD FR1 30kHz RMC	17.4.0
2022-03	RAN#95	R5-221264	2284	-	F	Correction of csi-ResourceConfigId	17.4.0
2022-03	RAN#95	R5-221265	2285	-	F	Correction of DMRS-DownlinkConfig	17.4.0
2022-03	RAN#95	R5-221292	2287	-	F	Addition of Setup Diagram for RRM multicell 2x2 test cases	17.4.0
2022-03	RAN#95	R5-221369	2289	-	F	Update to PUCCH resource configuration for Scell CSI	17.4.0
2022-03	RAN#95	R5-221377	2290	-	F	Addition of Test frequencies for NE-DC band configurations for signalling testing	17.4.0
2022-03	RAN#95	R5-221389	2291	-	F	Correction to SIG test frequencies for intra-band non-contiguous CA	17.4.0
2022-03	RAN#95	R5-221413	2293	-	F	Update IE SDAP-Config	17.4.0
2022-03	RAN#95	R5-221419	2173	1	F	Update chapter 4.5.1 General	17.4.0
2022-03	RAN#95	R5-221420	2233	1	F	Correction to RRCReconfiguration message with condition REEST	17.4.0
2022-03	RAN#95	R5-221421	2277	1	F	Correction to the BWP-DownlinkDedicated	17.4.0
2022-03	RAN#95	R5-221422	2280	1	F	NE-DC support for UECapabilityEnquiry and UECapabilityInformation messages	17.4.0
2022-03	RAN#95	R5-221423	2194	1	F	Correction to IMS MO speech call establishment generic procedure	17.4.0
2022-03	RAN#95	R5-221424	2176	1	F	Correction to test procedure 4.9.11 IMS Emergency call or eCall over IMS establishment in 5GC with IMS emergency registration	17.4.0
2022-03	RAN#95	R5-221425	2177	1	F	Correction to test procedure 4.9.12 IMS Emergency call or eCall over IMS establishment in 5GC without IMS emergency registration	17.4.0
2022-03	RAN#95	R5-221426	2263	1	F	Updates to IE Route Selection Descriptors	17.4.0
2022-03	RAN#95	R5-221491	2168	1	F	Update of NR CA configurations for Protocol testing with NR CA 3CC	17.4.0
2022-03	RAN#95	R5-221492	2169	1	F	Update of inter-band cell environment for Protocol testing with NR CA 3CC	17.4.0
2022-03	RAN#95	R5-221493	2286	1	F	Modification of common test environment for EHC testing	17.4.0
2022-03	RAN#95	R5-221499	2207	1	F	Correction to generic test procedures for NR SL MIMO tests	17.4.0
2022-03	RAN#95	R5-221500	2209	1	F	Addition of test procedures for releasing unicast link	17.4.0
2022-03	RAN#95	R5-221501	2210	1	F	Addition of test procedures for data exchanging on unicast link	17.4.0
2022-03	RAN#95	R5-221502	2211	1	F	Correction to PC5 RRC message MasterInformationBlockSidelink	17.4.0
2022-03	RAN#95	R5-221503	2212	1	F	Correction to PC5 RRC message MeasurementReportSidelink	17.4.0
2022-03	RAN#95	R5-221504	2213	1	F	Correction to PC5 RRC message RRCReconfigurationSidelink	17.4.0
2022-03	RAN#95	R5-221505	2214	1	F	Correction to PC5 RRC message RRCReconfigurationCompleteSidelink	17.4.0



2022-03	RAN#95	R5-221506	2215	1	F	Correction to PC5 RRC message RRCReconfigurationFailureSidelink	17.4.0
2022-03	RAN#95	R5-221507	2216	1	F	Correction to PC5 RRC message UECapabilityEnquirySidelink	17.4.0
2022-03	RAN#95	R5-221508	2217	1	F	Correction to PC5 RRC message UECapabilityInformationSidelink	17.4.0
2022-03	RAN#95	R5-221509	2222	1	F	Correction to V2X message DIRECT LINK ESTABLISHMENT REQUEST	17.4.0
2022-03	RAN#95	R5-221510	2223	1	F	Correction to V2X message DIRECT LINK ESTABLISHMENT ACCEPT	17.4.0
2022-03	RAN#95	R5-221511	2224	1	F	Correction to V2X message DIRECT LINK RELEASE REQUEST	17.4.0
2022-03	RAN#95	R5-221512	2225	1	F	Correction to V2X message DIRECT LINK RELEASE ACCEPT	17.4.0
2022-03	RAN#95	R5-221513	2226	1	F	Correction to V2X message DIRECT LINK KEEPALIVE REQUEST	17.4.0
2022-03	RAN#95	R5-221514	2227	1	F	Correction to V2X message DIRECT LINK SECURITY MODE COMMAND	17.4.0
2022-03	RAN#95	R5-221515	2228	1	F	Correction to V2X message DIRECT LINK SECURITY MODE COMPLETE	17.4.0
2022-03	RAN#95	R5-221584	2251	1	F	Addition of default DCI_1_2 for URLLC	17.4.0
2022-03	RAN#95	R5-221591	2203	1	F	Addition of positioning system information blocks associated parameters	17.4.0
2022-03	RAN#95	R5-221667	2258	1	F	Correction to test frequency range for n14	17.4.0
2022-03	RAN#95	R5-221668	2268	1	F	Correction of 4.3.1.2.4.4.2 for test frequencies for CA_n260_A-I	17.4.0
2022-03	RAN#95	R5-221669	2236	1	F	Correction to default RRC IEs for RRM	17.4.0
2022-03	RAN#95	R5-221670	2167	1	F	Updated the related RRC information for DSS	17.4.0
2022-03	RAN#95	R5-221671	2190	1	F	Added FR2 connection diagram using modulated interferer	17.4.0
2022-03	RAN#95	R5-221672	2244	1	F	Correction of 4.1.1 on removal of lower humidity limit in NR test environment	17.4.0
2022-03	RAN#95	R5-221757	2267	1	F	Correction of 4.3.1.1.5.48 for test frequencies of CA_n48_2A	17.4.0
2022-03	RAN#95	R5-221787	2283	1	F	Update of mid test channel bandwidth for band n25	17.4.0
2022-03	RAN#95	R5-221815	2247	1	F	Update to NR sidelink preconfiguration	17.4.0
2022-03	RAN#95	R5-221816	2248	1	F	Update to GNSS configuration for NR sidelink	17.4.0
2022-03	RAN#95	R5-221869	2273	1	F	Updating test frequencies for NR band n1	17.4.0
2022-03	RAN#95	R5-221871	2185	1	F	Add test frequencies for R17 NR inter-band CA configurations in FR1	17.4.0
2022-03	RAN#95	R5-221872	2187	1	F	Addition of test frequencies for NE-DC configurations DC_n28A_3A, DC_n28A_3C, DC_n28A_39A, DC_n28A_39C	17.4.0
2022-03	RAN#95	R5-221873	2202	1	F	Update of protocol testing applicability for 3CC inter-band NR DC configurations	17.4.0
2022-03	RAN#95	R5-221874	2261	1	F	Addition of several NR CA combinations to FR1 inter-band configurations table	17.4.0
2022-03	RAN#95	R5-222039	2205	1	F	Correction to cl 4.5.3 RRC_INACTIVE generic procedure	17.4.0
2022-06	RAN#96	R5-222122	2294	-	F	Correction for Procedure for UE-requested PDU session modification after the first S1 to N1 mode change	17.5.0
2022-06	RAN#96	R5-222173	2296	-	F	Introduction of test frequencies for CA_n77C BCS0 and BCS1	17.5.0
2022-06	RAN#96	R5-222175	2297	-	F	Introduction of test frequencies for CA_n77C for protocol testing	17.5.0
2022-06	RAN#96	R5-222283	2300	-	F	Introduction of test frequencies for Rel-16 inter-band EN-DC three band combinations within FR1	17.5.0
2022-06	RAN#96	R5-222308	2302	-	F	Introduction of NR-DC in FR1 for test setup diagrams	17.5.0
2022-06	RAN#96	R5-222329	2303	-	F	Correction of test frequencies for CA_n66(2A) BCS1 and BCS2	17.5.0
2022-06	RAN#96	R5-222380	2308	-	F	Updating RRCReconfiguration and RadioBearerConfig for NR-DC and NE-DC	17.5.0
2022-06	RAN#96	R5-222431	2310	-	F	Correction to message contents for CQI reporting	17.5.0
2022-06	RAN#96	R5-222460	2312	-	F	Updates to REGISTRATION ACCEPT message	17.5.0
2022-06	RAN#96	R5-222461	2313	-	F	Updates to Configuration Update Command message	17.5.0
2022-06	RAN#96	R5-222462	2314	-	F	Updates to Registration Reject message	17.5.0
2022-06	RAN#96	R5-222463	2315	-	F	Updates to De-registration Request message	17.5.0

2022-06	RAN#96	R5-222464	2316	-	F	Update of Combinations of system information blocks for NE-DC	17.5.0
2022-06	RAN#96	R5-222502	2317	-	F	Addition of test frequency for performance test cases	17.5.0
2022-06	RAN#96	R5-222503	2318	-	F	Addition of locationAndBandwidth for BW 45 MHz	17.5.0
2022-06	RAN#96	R5-222512	2319	-	F	Correction to generic procedure 4.9.28	17.5.0
2022-06	RAN#96	R5-222513	2320	-	F	Editorial update RRCReconfiguration	17.5.0
2022-06	RAN#96	R5-222537	2321	-	F	Corrections to Table 7.3.1-12G	17.5.0
2022-06	RAN#96	R5-222565	2324	-	F	Update IE P-Max	17.5.0
2022-06	RAN#96	R5-222566	2325	-	F	Editorial update IE FreqBandList	17.5.0
2022-06	RAN#96	R5-222567	2326	-	F	Editorial update IE CellGroupConfig	17.5.0
2022-06	RAN#96	R5-222568	2327	-	F	Editorial update IE CellGroupId	17.5.0
2022-06	RAN#96	R5-222570	2328	-	F	Editorial update IE PDCCH-ConfigCommon	17.5.0
2022-06	RAN#96	R5-222572	2329	-	F	Addition of CA configuration for CA_n29A-n71A	17.5.0
2022-06	RAN#96	R5-222617	2331	-	F	Addition of default message contents for NR SL Demod	17.5.0
2022-06	RAN#96	R5-222647	2338	-	F	Correction to sidelink IE SL-ReportConfigList	17.5.0
2022-06	RAN#96	R5-222650	2341	-	F	Correction to general functional requirements for RedCap test	17.5.0
2022-06	RAN#96	R5-222657	2344	-	F	Editorial update IE SCellIndex	17.5.0
2022-06	RAN#96	R5-222818	2346	-	F	Correction to V2X message	17.5.0
2022-06	RAN#96	R5-222836	2354	-	F	Clarification of Annex C for calculation of SSB and CORESET#0 for PCells	17.5.0
2022-06	RAN#96	R5-222876	2370	-	F	Removing redundant ciphering algorithm for SDR testing	17.5.0
2022-06	RAN#96	R5-222917	2372	-	F	Connection diagram for 1x2 nDLCA Demodulation and CSI cases	17.5.0
2022-06	RAN#96	R5-222924	2373	-	F	Addition of connection diagram for Tx Diversity support	17.5.0
2022-06	RAN#96	R5-222933	2374	-	F	Update of auxiliary procedure 4.5A.2B	17.5.0
2022-06	RAN#96	R5-223025	2376	-	F	Update of NR inter-band CA configurations in FR1	17.5.0
2022-06	RAN#96	R5-223067	2378	-	F	Addition of test frequency for NR inter-band CA configurations including n1	17.5.0
2022-06	RAN#96	R5-223072	2379	-	F	Introduction of test frequencies for CA_n258G for protocol testing	17.5.0
2022-06	RAN#96	R5-223084	2382	-	F	Corrections to usages of Annex A.6 of TS 34.229-5	17.5.0
2022-06	RAN#96	R5-223126	2397	-	F	Introducing band configuration DC_20A_n257A	17.5.0
2022-06	RAN#96	R5-223158	2399	-	F	Editorial update IE ServCellIndex	17.5.0
2022-06	RAN#96	R5-223197	2401	-	F	Introduction of test frequencies for additional Rel-17 NR CA and EN-DC inter-band configurations	17.5.0
2022-06	RAN#96	R5-223222	2403	-	F	Correction to 4.3.1.1.2.1 on test frequencies for NR inter-band CA configurations in FR1 with two bands	17.5.0
2022-06	RAN#96	R5-223223	2404	-	F	Correction to 4.3.1.1.2.2 on test frequencies for NR inter-band CA configurations in FR1 with three bands	17.5.0
2022-06	RAN#96	R5-223224	2405	-	F	Correction to 4.3.1.1.5.66 on test frequencies for NR intra-band non-contiguous CA configurations of CA_n66 with class 2A	17.5.0
2022-06	RAN#96	R5-223225	2406	-	F	Correction to 4.3.1.1.5.71 on test frequencies for NR intra-band non-contiguous CA configurations of CA_n71 with class 2A	17.5.0
2022-06	RAN#96	R5-223229	2410	-	F	Correction to 4.3.1.4.1.3 on test frequencies for inter-band EN-DC R17 configurations with three bands	17.5.0
2022-06	RAN#96	R5-223234	2411	-	F	Editorial correction to 4.3.1.2.2 on test frequencies for NR inter-band CA configurations in FR2 for CA_n260-n261	17.5.0
2022-06	RAN#96	R5-223250	2412	-	F	Hardcoding USIM configurations	17.5.0
2022-06	RAN#96	R5-223341	2375	1	F	Update of Test procedure for IMS MO Emergency call release	17.5.0
2022-06	RAN#96	R5-223359	2332	1	F	Addition of test frequency for NR SL concurrent	17.5.0
2022-06	RAN#96	R5-223360	2333	1	F	Correction to default configuration of SCI	17.5.0
2022-06	RAN#96	R5-223361	2334	1	F	Correction to sidelink IE SL-BWP-PoolConfig	17.5.0
2022-06	RAN#96	R5-223362	2335	1	F	Correction to sidelink IE SL-BWP-PoolConfigCommon	17.5.0
2022-06	RAN#96	R5-223363	2336	1	F	Correction to sidelink IE SL-FreqConfig	17.5.0
2022-06	RAN#96	R5-223364	2337	1	F	Correction to sidelink IE SL-FreqConfigCommon	17.5.0
2022-06	RAN#96	R5-223365	2339	1	F	Correction to test procedures for unicast link establishment	17.5.0
2022-06	RAN#96	R5-223387	2330	1	F	Addition of scheduling information for positioning system information blocks	17.5.0
2022-06	RAN#96	R5-223399	2295	1	F	Addition of SIB11 to common environment for early measurements	17.5.0

2022-06	RAN#96	R5-223400	2414	1	F	Modification of SIB1 in common environment for idle/inactive measurements	17.5.0
2022-06	RAN#96	R5-223410	2340	1	F	Addition of abbreviations for RedCap test	17.5.0
2022-06	RAN#96	R5-223413	2380	1	F	Updates to Test procedure 4.9.15	17.5.0
2022-06	RAN#96	R5-223414	2307	1	F	Editorial updates to SIBs	17.5.0
2022-06	RAN#96	R5-223415	2381	1	F	Updates to Data-off condition for PDU SESSION ESTABLISHMENT REQUEST message	17.5.0
2022-06	RAN#96	R5-223416	2299	1	F	Resolving test frequency for n53 10 Mhz CBW	17.5.0
2022-06	RAN#96	R5-223417	2353	1	F	Correction to Combinations of system information blocks	17.5.0
2022-06	RAN#96	R5-223480	2402	1	F	Corrections on mandatory channel bandwidths after Rel-15	17.5.0
2022-06	RAN#96	R5-223602	2415	-	F	Correction to 4.3.1.4.1.3 on test frequencies for DC_1A-28A_n78C	17.5.0
2022-06	RAN#96	R5-223649	2398	1	F	Introduction of test frequencies for 3 band EN-DC configurations	17.5.0
2022-06	RAN#96	R5-223650	2400	1	F	Introduction of test frequencies for additional Rel-16 NR CA DC and EN-DC inter-band configurations	17.5.0
2022-06	RAN#96	R5-223651	2407	1	F	Correction to 4.3.1.1.5.77 on test frequencies for NR intra-band non-contiguous CA configurations of CA_n77 with class 2A	17.5.0
2022-06	RAN#96	R5-223652	2408	1	F	Correction to 4.3.1.1.5.78 on test frequencies for NR intra-band non-contiguous CA configurations of CA_n78 with class 2A	17.5.0
2022-06	RAN#96	R5-223653	2409	1	F	Correction to 4.3.1.4.1.3 on test frequencies for inter-band EN-DC R16 configurations	17.5.0
2022-06	RAN#96	R5-223755	2301	1	F	Introduction of test frequencies for NR-DC in FR1	17.5.0
2022-06	RAN#96	R5-223784	2371	1	F	Addition of RedCap default test channel bandwidth	17.5.0
2022-06	RAN#96	R5-223792	2322	1	F	Correction to test frequency for n53	17.5.0
2022-06	RAN#96	R5-223793	2369	1	F	Clarification of PCC and SCC configuration for CA test cases	17.5.0
2022-06	RAN#96	R5-223795	2323	1	F	CR on Permitted Methodologies and Applicability	17.5.0
2022-06	RAN#96	R5-223796	2377	1	F	Add new messages and procedure for test function to limit Pcell Power	17.5.0
2022-09	RAN#97	R5-223987	2416	-	F	Correction to test procedure 4.9.11 IMS Emergency call or eCall over IMS establishment in 5GC with IMS emergency registration	17.6.0
2022-09	RAN#97	R5-224033	2417	-	F	Introduction of test frequencies for NR-U band n46	17.6.0
2022-09	RAN#97	R5-224034	2418	-	F	Introduction of test frequencies for NR-U band n96	17.6.0
2022-09	RAN#97	R5-224094	2429	-	F	Update of MDT default RRC messages and IEs	17.6.0
2022-09	RAN#97	R5-224139	2434	-	F	Add IE BeamFailureRecoveryServingCellConfig	17.6.0
2022-09	RAN#97	R5-224140	2435	-	F	Add IE BetaOffsetsCrossPri	17.6.0
2022-09	RAN#97	R5-224149	2436	-	F	Introduction of test frequencies for Rel-16 inter-band DC_3A-7A-20A_n8A within FR1	17.6.0
2022-09	RAN#97	R5-224166	2437	-	F	Correction to Table 4.7.2-2 PDU Session Establishment Accept	17.6.0
2022-09	RAN#97	R5-224179	2438	-	F	Test frequencies for NR DC configurations in FR1 for signalling testing	17.6.0
2022-09	RAN#97	R5-224235	2443	-	F	Correction of the styles of the subclauses in 4.3.1.1 and 4.3.1.2	17.6.0
2022-09	RAN#97	R5-224276	2445	-	F	Add IE CandidateBeamRS	17.6.0
2022-09	RAN#97	R5-224284	2446	-	F	Add IE CFR-ConfigMulticast	17.6.0
2022-09	RAN#97	R5-224290	2447	-	F	Add IEs DL-PRS-ProcessingWindowPreConfig, DMRS-BundlingPUCCH-Config and DMRS-BundlingPUSCH-Config	17.6.0
2022-09	RAN#97	R5-224380	2459	-	F	Add IE FreqPriorityListNRSlicing	17.6.0
2022-09	RAN#97	R5-224458	2465	-	F	Alignment CSI-ResourcePeriodicityAndOffset to CSI-RS.3.2 TDD	17.6.0
2022-09	RAN#97	R5-224459	2466	-	F	Correction derivation path Table 7.3.1-35	17.6.0
2022-09	RAN#97	R5-224460	2467	-	F	Correction to 7.3.1-12G	17.6.0
2022-09	RAN#97	R5-224462	2469	-	F	Definition of ZP-CSI-RS-ResourceSetId	17.6.0
2022-09	RAN#97	R5-224638	2478	-	F	Clarification to Antenna ports of DCI format 1_1 for RF TCs	17.6.0
2022-09	RAN#97	R5-224639	2479	-	F	Correction to CSI-MeasConfig for RRM	17.6.0
2022-09	RAN#97	R5-224658	2482	-	F	Add IE GapPriority	17.6.0
2022-09	RAN#97	R5-224662	2484	-	F	Add IE HysteresisLocation	17.6.0
2022-09	RAN#97	R5-224685	2485	-	F	Correction to IMS MO Video call establishment test procedure in 5GC	17.6.0
2022-09	RAN#97	R5-224686	2486	-	F	Correction to IMS MT Video call establishment test procedure in 5GC	17.6.0

2022-09	RAN#97	R5-224689	2489	-	F	Correction to IMS MT speech call establishment test procedure in 5GC	17.6.0
2022-09	RAN#97	R5-224725	2491	-	F	Update the SN-FieldLength of PDCP-Config and RLC-Config for RedCap test	17.6.0
2022-09	RAN#97	R5-224740	2495	-	F	Add Default configuration for DCI format 4_1 scheduling MBS Multicast test	17.6.0
2022-09	RAN#97	R5-224741	2496	-	F	Add Default configuration for DCI format 4_2 scheduling MBS Multicast test	17.6.0
2022-09	RAN#97	R5-224762	2508	-	F	Add IE MeasGapId	17.6.0
2022-09	RAN#97	R5-224763	2509	-	F	Add IE MeasObjectRxTxDiff	17.6.0
2022-09	RAN#97	R5-224816	2511	-	F	Add IE MeasResultRxTxTimeDiff	17.6.0
2022-09	RAN#97	R5-224817	2512	-	F	Add IE MRB-Identity	17.6.0
2022-09	RAN#97	R5-224818	2513	-	F	Add IEs MUSIM-GapConfig, MUSIM-GapID and MUSIM-GapInfo	17.6.0
2022-09	RAN#97	R5-224819	2514	-	F	Add IEs NeedForGapNCSG-ConfigEUTRA, NeedForGapNCSG-ConfigNR, NeedForGapNCSG-InfoEUTRA and NeedForGapNCSG-InfoNR	17.6.0
2022-09	RAN#97	R5-224820	2515	-	F	Add IE NonCellDefiningSSB	17.6.0
2022-09	RAN#97	R5-224821	2516	-	F	Add IE NR-DL-PRS-PDC-Info	17.6.0
2022-09	RAN#97	R5-224822	2517	-	F	Add IEs NSAG-IdentityInfo and NTN-Config	17.6.0
2022-09	RAN#97	R5-224824	2519	-	F	Add IEs RxTxTimeDiff, SCellActivationRS-Config and SCellActivationRS-ConfigId	17.6.0
2022-09	RAN#97	R5-224825	2520	-	F	Add IE SemiStaticChannelAccessConfigUE	17.6.0
2022-09	RAN#97	R5-224859	2521	-	F	Add IE TCI-Info	17.6.0
2022-09	RAN#97	R5-224860	2522	-	F	Add IE UE-TimersAndConstantsRemoteUE	17.6.0
2022-09	RAN#97	R5-224861	2523	-	F	Add IEs UL-ExcessDelayConfig and UE UL-GapFR2-Config	17.6.0
2022-09	RAN#97	R5-224862	2524	-	F	Add IEs Uplink-PowerControl, Uu-RelayRLC-ChannelConfig and Uu-RelayRLC-ChannelID	17.6.0
2022-09	RAN#97	R5-224863	2525	-	F	Add IE AppLayerMeasParameters	17.6.0
2022-09	RAN#97	R5-224864	2526	-	F	Add IE FR2-2-AccessParamsPerBand	17.6.0
2022-09	RAN#97	R5-224877	2528	-	F	Add IE NTN-Parameters	17.6.0
2022-09	RAN#97	R5-224878	2529	-	F	Add IE PosSRS-RRC-Inactive-OutsidelInitialUL-BWP-r17	17.6.0
2022-09	RAN#97	R5-224880	2531	-	F	Add IE RedCapParameters	17.6.0
2022-09	RAN#97	R5-224881	2532	-	F	Add IE SRS-AllPosResourcesRRC-Inactive	17.6.0
2022-09	RAN#97	R5-224882	2533	-	F	Add IE UE-RadioPagingInfo	17.6.0
2022-09	RAN#97	R5-224883	2534	-	F	Add IE AppLayerMeasConfig	17.6.0
2022-09	RAN#97	R5-224909	2535	-	F	Update IE DownlinkConfigCommonSIB	17.6.0
2022-09	RAN#97	R5-224912	2537	-	F	Update IE MeasObjectNR	17.6.0
2022-09	RAN#97	R5-224913	2538	-	F	Add IE MeasResultForRSSI	17.6.0
2022-09	RAN#97	R5-224914	2539	-	F	Update IE MeasResults	17.6.0
2022-09	RAN#97	R5-224915	2540	-	F	Add IE MeasRSSI-ReportConfig	17.6.0
2022-09	RAN#97	R5-224916	2541	-	F	Update IE ReportConfigNR	17.6.0
2022-09	RAN#97	R5-224917	2542	-	F	Add IE RMTC Config	17.6.0
2022-09	RAN#97	R5-224992	2545	-	F	Add IE DedicatedInfoF1c	17.6.0
2022-09	RAN#97	R5-225007	2546	-	F	Add IE MeasConfigAppLayerId	17.6.0
2022-09	RAN#97	R5-225092	2550	-	F	Adding new connection diagram for SUL with UL MIMO test case	17.6.0
2022-09	RAN#97	R5-225177	2553	-	F	Introduction of new default 5GMM messages	17.6.0
2022-09	RAN#97	R5-225178	2554	-	F	Introduction of new default 5GSM messages	17.6.0
2022-09	RAN#97	R5-225180	2556	-	F	Updates to default 5GSM messages	17.6.0
2022-09	RAN#97	R5-225188	2557	-	F	CR to Correct Permitted Methodologies and Applicability	17.6.0
2022-09	RAN#97	R5-225212	2558	-	F	Update nrofRB for 200 MHz ChBw 120 kHz SCS	17.6.0
2022-09	RAN#97	R5-225215	2559	-	F	Update number of HARQ processes for RRM test cases	17.6.0
2022-09	RAN#97	R5-225271	2555	1	F	Updates to default 5GMM messages	17.6.0
2022-09	RAN#97	R5-225280	2494	1	F	Add Default configuration for DCI format 4_0 scheduling MBS Broadcast test	17.6.0
2022-09	RAN#97	R5-225290	2471	1	F	Correction of NR SL message contents	17.6.0
2022-09	RAN#97	R5-225291	2472	1	F	Correction of test procedure 4.9.31 - Connectivity check	17.6.0
2022-09	RAN#97	R5-225299	2448	1	F	Updates to Table 4.6.3-16: CellAccessRelatedInfo for NPN	17.6.0
2022-09	RAN#97	R5-225300	2456	1	F	Addition of Test Environment for legacy test cases applicable to SNPN Only UE	17.6.0
2022-09	RAN#97	R5-225310	2544	1	F	Update of protocol applicability for DC_19A_n77(2A), DC_19A_n78(2A), DC_21A_n77(2A) and DC_21A_n78(2A)	17.6.0
2022-09	RAN#97	R5-225311	2462	1	F	Correction of the scheduling information for combination NR-15	17.6.0

2022-09	RAN#97	R5-225312	2463	1	F	Addition of message contents for DedicatedSIBRequest	17.6.0
2022-09	RAN#97	R5-225316	2425	1	F	Update default message contents of RACH-ConfigDedicated	17.6.0
2022-09	RAN#97	R5-225321	2536	1	F	Update IE LBT FailureRecoveryConfig	17.6.0
2022-09	RAN#97	R5-225325	2497	1	F	Add test procedures for MBS Multicast test	17.6.0
2022-09	RAN#97	R5-225326	2502	1	F	Add SIB20 for MBS Broadcast test	17.6.0
2022-09	RAN#97	R5-225327	2503	1	F	Add SIB21 for MBS Broadcast test	17.6.0
2022-09	RAN#97	R5-225328	2504	1	F	Add MBSBroadcastConfiguration for MBS Broadcast test	17.6.0
2022-09	RAN#97	R5-225329	2505	1	F	Add MBSInterestIndication for MBS Broadcast test	17.6.0
2022-09	RAN#97	R5-225330	2506	1	F	Add MBS information elements for MBS test	17.6.0
2022-09	RAN#97	R5-225333	2475	1	F	Update of MDT message and information element	17.6.0
2022-09	RAN#97	R5-225342	2492	1	F	Addition of RedCap default test channel bandwidth for signaling MFBI test	17.6.0
2022-09	RAN#97	R5-225343	2493	1	F	Addition of RedCap default test channel bandwidth for signaling test	17.6.0
2022-09	RAN#97	R5-225352	2449	1	F	Update of Table 4.6.1-30 to add message contents values for SDT in UEAssistanceInformation	17.6.0
2022-09	RAN#97	R5-225353	2450	1	F	Update of Table 4.6.1-28 to add message contents values for SDT in SIB1	17.6.0
2022-09	RAN#97	R5-225354	2451	1	F	Update of Table 4.6.1-16 to add message contents values for SDT in RRCRelease	17.6.0
2022-09	RAN#97	R5-225355	2453	1	F	Update of Table 4.6.3-96 to add message contents values for SDT in PDCCH-ConfigCommon	17.6.0
2022-09	RAN#97	R5-225356	2473	1	F	Addition of SIB16 for slice based cell reselection	17.6.0
2022-09	RAN#97	R5-225357	2474	1	F	Updates to message contents for slice specific RACH configuration	17.6.0
2022-09	RAN#97	R5-225358	2464	1	F	Add UplinkDataCompression into PDCP-Config for NR UDC test	17.6.0
2022-09	RAN#97	R5-225362	2483	1	F	Updates to test procedures 4.9.12A and 4.9.12B	17.6.0
2022-09	RAN#97	R5-225363	2458	1	F	Add IEs DRX-ConfigSL, EphemerisInfo, FeatureCombination and FeatureCombinationPreambles	17.6.0
2022-09	RAN#97	R5-225364	2530	1	F	Editorial update IE RAT-Type	17.6.0
2022-09	RAN#97	R5-225365	2549	1	F	Updating the values for IE P-Max	17.6.0
2022-09	RAN#97	R5-225366	2428	1	F	Updates on UE Power Limit Messages: Option 2	17.6.0
2022-09	RAN#97	R5-225367	2548	1	F	Introducing FR2 signal test frequencies for intra-band contiguous 3CA	17.6.0
2022-09	RAN#97	R5-225681	2441	1	F	Correction of test channel bandwidth for R16	17.6.0
2022-09	RAN#97	R5-225682	2442	1	F	Correction of test channel bandwidth for n79	17.6.0
2022-09	RAN#97	R5-225684	2440	1	F	Correction of test channel bandwidth for R15	17.6.0
2022-09	RAN#97	R5-225686	2439	1	F	Update UE capability information elements for PC1.5 duty cycle	17.6.0
2022-09	RAN#97	R5-225730	2476	1	F	Addition of test frequencies for DC_21A_n28A	17.6.0
2022-09	RAN#97	R5-225731	2527	1	F	Addition of configurations for many 4CA NR combinations	17.6.0
2022-09	RAN#97	R5-225766	2543	1	F	Corrections on Mid test channel bandwidth for band n66 for Redcap	17.6.0
2022-09	RAN#97	R5-225780	2468	1	F	Correction quantity config for inter-RAT to UTRA	17.6.0
2022-09	RAN#97	R5-225781	2477	1	F	Correction to connection diagram for DL CA Demodulation and CSI test cases	17.6.0
2022-09	RAN#97	R5-225782	2481	1	F	Correction to RRC message for uplink CA	17.6.0
2022-12	RAN#98	R5-225952	2563		F	Introduction of test channel bandwidths for new NR bands n91, n92, n93 and n94	17.7.0
2022-12	RAN#98	R5-225953	2564		F	Introduction of test frequencies for new NR bands n91, n92, n93 and n94	17.7.0
2022-12	RAN#98	R5-225970	2566		F	Inclusive Language Review and update of IE SIB3	17.7.0
2022-12	RAN#98	R5-225971	2567		F	Inclusive Language Review and update of IE SIB4	17.7.0
2022-12	RAN#98	R5-225972	2568		F	Inclusive Language Review and update of IE SIB5	17.7.0
2022-12	RAN#98	R5-225973	2569		F	Inclusive Language Review and update of IE MeasObjectEUTRA	17.7.0
2022-12	RAN#98	R5-225974	2570		F	Inclusive Language Review and update of IE MeasObjectNR	17.7.0
2022-12	RAN#98	R5-225975	2571		F	Inclusive Language Review and update of IE ReportConfigNR	17.7.0
2022-12	RAN#98	R5-226020	2572		F	Update of test procedures 4.9.12A and 4.9.12B	17.7.0
2022-12	RAN#98	R5-226040	2573		F	Correction to test procedure 4.9.7	17.7.0
2022-12	RAN#98	R5-226041	2574		F	Updates to SysInfo for SCells operating on NR CA bands with no UL frequency	17.7.0
2022-12	RAN#98	R5-226110	2575		F	Correction to default configurations for RedCap RRM TCs	17.7.0

2022-12	RAN#98	R5-226247	2577	F	Add IE SIB17	17.7.0
2022-12	RAN#98	R5-226248	2578	F	Add IE SIB18	17.7.0
2022-12	RAN#98	R5-226249	2579	F	Add IE SIB19	17.7.0
2022-12	RAN#98	R5-226250	2580	F	Update IE BeamFailureRecoveryRSConfig	17.7.0
2022-12	RAN#98	R5-226251	2581	F	Update IE BeamFailureRecoveryServingCellConfig	17.7.0
2022-12	RAN#98	R5-226253	2583	F	Update IE DRX-ConfigSecondaryGroup	17.7.0
2022-12	RAN#98	R5-226254	2584	F	Update IE FreqPriorityListSlicing	17.7.0
2022-12	RAN#98	R5-226255	2585	F	Add IE FreqPriorityListDedicatedSlicing	17.7.0
2022-12	RAN#98	R5-226257	2587	F	Update IE MUSIM-GapId	17.7.0
2022-12	RAN#98	R5-226259	2589	F	Add IEs PCI-ARFCN-EUTRA and PCI-ARFCN-NR	17.7.0
2022-12	RAN#98	R5-226260	2590	F	Add IE ReferenceLocation	17.7.0
2022-12	RAN#98	R5-226261	2591	F	Update IE RMTC-Config	17.7.0
2022-12	RAN#98	R5-226262	2592	F	Add IE ServingCellAndBWP-Id	17.7.0
2022-12	RAN#98	R5-226263	2593	F	Update IE TCI-ActivatedConfig	17.7.0
2022-12	RAN#98	R5-226264	2594	F	Add IE TAR-Config	17.7.0
2022-12	RAN#98	R5-226265	2595	F	Add IEs TCI-UL-State and TCI-UL-StateId	17.7.0
2022-12	RAN#98	R5-226266	2596	F	Add IE TimeAlignmentTimer	17.7.0
2022-12	RAN#98	R5-226268	2598	F	Update IE PosSRS-RRC-Inactive-OutsideInitialUL-BWP	17.7.0
2022-12	RAN#98	R5-226269	2599	F	Add IE PRS-ProcessingCapabilityOutsideMGINPPWperType	17.7.0
2022-12	RAN#98	R5-226270	2600	F	Add IE SimultaneousRxTxPerBandPair	17.7.0
2022-12	RAN#98	R5-226271	2601	F	Update IE UE-MeasurementsAvailable	17.7.0
2022-12	RAN#98	R5-226352	2605	F	Addition of CGI specific information elements for R15 SON_MDT	17.7.0
2022-12	RAN#98	R5-226366	2607	F	Removal of Test freqs for R16 pending CADC configs from cl 4.3.1	17.7.0
2022-12	RAN#98	R5-226367	2608	F	Removal of Test freqs for R17 pending CADC configs from cl 4.3.1	17.7.0
2022-12	RAN#98	R5-226390	2613	F	Editorial correction for test procedure sequence in 4.7.2-2 on 38.508-1 in rel17	17.7.0
2022-12	RAN#98	R5-226400	2615	F	Updates for NR CA_n5A-n77A, CA_n66A-n77A	17.7.0
2022-12	RAN#98	R5-226494	2616	F	Correct typo in Table 4.6.3-68	17.7.0
2022-12	RAN#98	R5-226495	2617	F	Corrections to Table 7.3.1-22	17.7.0
2022-12	RAN#98	R5-226496	2618	F	Corrections to Table 7.3.1-31	17.7.0
2022-12	RAN#98	R5-226669	2625	F	Update to K1 value for FDD RRM test cases	17.7.0
2022-12	RAN#98	R5-226684	2626	F	Addition of 2x1 antenna connection for RedCap	17.7.0
2022-12	RAN#98	R5-226691	2627	F	n66_2A frequency correction	17.7.0
2022-12	RAN#98	R5-226693	2628	F	Corrections to ssbPositionInBurst for 7.3.1-x	17.7.0
2022-12	RAN#98	R5-226694	2629	F	Corrections to RACHConfigCommon for RRM	17.7.0
2022-12	RAN#98	R5-226695	2630	F	Removal of Table 7.3.1-33	17.7.0
2022-12	RAN#98	R5-226718	2638	F	Add low-mid-high ch BWs for NR-U	17.7.0
2022-12	RAN#98	R5-226727	2639	F	Update of test frequency for n3 R17 CBW	17.7.0
2022-12	RAN#98	R5-226731	2641	F	Update IE Phy-ParametersSharedSpectrumChAccess	17.7.0
2022-12	RAN#98	R5-226863	2644	F	Updating signalling test frequencies for n79 20MHz CBW	17.7.0
2022-12	RAN#98	R5-226864	2645	F	Updating test channel bandwidths for n79	17.7.0
2022-12	RAN#98	R5-226894	2646	F	Update of n28 test frequencies for DC_21A_n28A in clause 6.2.3.1	17.7.0
2022-12	RAN#98	R5-226934	2647	F	Updates to default 5GMM messages	17.7.0
2022-12	RAN#98	R5-226935	2648	F	Updates to default 5GSM messages	17.7.0
2022-12	RAN#98	R5-227084	2650	F	Update to offsetToCarrier for DC_21A_n28A	17.7.0
2022-12	RAN#98	R5-227087	2651	F	Addition of locationAndBandwidth for BW 35 MHz	17.7.0
2022-12	RAN#98	R5-227101	2653	F	Correction to definition of SRB_NR_PDCP	17.7.0
2022-12	RAN#98	R5-227108	2655	F	Test frequencies updates for band n7	17.7.0
2022-12	RAN#98	R5-227110	2657	F	Test frequencies updates for band n25	17.7.0
2022-12	RAN#98	R5-227111	2658	F	Test frequencies updates for band n66	17.7.0
2022-12	RAN#98	R5-227138	2660	F	Update of configuration of system information blocks for MBS Broadcast TC	17.7.0
2022-12	RAN#98	R5-227139	2661	F	Update of MBS IE CFR-ConfigMCCH-MTCH	17.7.0
2022-12	RAN#98	R5-227142	2664	F	Editorial correction of physical layer parameters for scheduling of MBS	17.7.0
2022-12	RAN#98	R5-227174	2671	F	Update PC5 message for LINK IDENTIFIER UPDATE procedure	17.7.0
2022-12	RAN#98	R5-227251	2674	F	Correction of test frequencies	17.7.0
2022-12	RAN#98	R5-227275	2677	F	Introduction of CA_n48A-n77A and CA_n71A-n77A configurations	17.7.0

2022-12	RAN#98	R5-227406	2614	1	F	Addition of Test procedure for deleting configured S-NSSAI, default configured S-NSSAI and allowed S-NSSAI	17.7.0
2022-12	RAN#98	R5-227407	2582	1	F	Update IE DL-PPW-PreConfig	17.7.0
2022-12	RAN#98	R5-227408	2586	1	F	Add IE LTE-NeighCellsCRS-AssistInfoList	17.7.0
2022-12	RAN#98	R5-227409	2597	1	F	Add IEs UplinkTxDirectCurrentMoreCarrierList and UplinkTxDirectCurrentTwoCarrierList	17.7.0
2022-12	RAN#98	R5-227410	2676	1	F	Updates to connectivity options	17.7.0
2022-12	RAN#98	R5-227449	2619	1	F	Update to cl 4.5B.1 for SNPN-only UEs	17.7.0
2022-12	RAN#98	R5-227473	2649	1	F	Correction to EHC parametrization in 38.508-1	17.7.0
2022-12	RAN#98	R5-227476	2678	1	F	Addition of USIM configuration for MUSIM test cases	17.7.0
2022-12	RAN#98	R5-227477	2679	1	F	Addition of test procedure for registration of a MUSIM UE	17.7.0
2022-12	RAN#98	R5-227480	2620	1	F	Update of Table 4.6.1-28 to add message contents values for NTN in SIB1	17.7.0
2022-12	RAN#98	R5-227499	2672	1	F	Updating SIB1 content with Paging Early Indication configuration	17.7.0
2022-12	RAN#98	R5-227507	2659	1	F	Update of CLOSE UE TEST LOOP message	17.7.0
2022-12	RAN#98	R5-227508	2662	1	F	Update of MBS IE TMGI	17.7.0
2022-12	RAN#98	R5-227509	2663	1	F	Update of Radio resource control information elements for Broadcast MBS TC	17.7.0
2022-12	RAN#98	R5-227510	2665	1	F	Update of DNN configuration for PDU session associated with MBS Multicast session	17.7.0
2022-12	RAN#98	R5-227511	2666	1	F	Update of Procedure for MBS Multicast session join and session establishment	17.7.0
2022-12	RAN#98	R5-227512	2667	1	F	Update of Radio resource control information elements for Multicast MBS TC	17.7.0
2022-12	RAN#98	R5-227518	2670	1	F	Update common configurations for RedCap UE	17.7.0
2022-12	RAN#98	R5-227542	2609	1	F	Update of information elements for slice specific RACH configuration	17.7.0
2022-12	RAN#98	R5-227544	2610	1	F	Update of MDT information element for SON_MDT	17.7.0
2022-12	RAN#98	R5-227587	2654	1	F	Update TS 38.508-1 clause 4.5B for RedCap UE	17.7.0
2022-12	RAN#98	R5-227593	2611	1	F	Addition of parameter related to SOR-CMCI for DL NAS transport and UL NAS transport message in 38.508-1	17.7.0
2022-12	RAN#98	R5-227700	2606	1	F	Removal of Test freqs for R15 pending CADC configs from cl 4.3.1	17.7.0
2022-12	RAN#98	R5-227701	2640	1	F	Update of test frequency for n8 R17 CBW 35MHz	17.7.0
2022-12	RAN#98	R5-227702	2643	1	F	Adding test frequencies for n79 new CBW 10MHz and 20MHz	17.7.0
2022-12	RAN#98	R5-227703	2602	1	F	Update to IE Table 4.6.3-62A - HighSpeedConfig	17.7.0
2022-12	RAN#98	R5-227639	2603	2	F	Update IE ServingCellConfigCommon	17.7.0
2022-12	RAN#98	R5-227705	2604	1	F	Update IE ServingCellConfigCommonSIB	17.7.0
2022-12	RAN#98	R5-227706	2673	1	F	Disabling of PUCCH intra-slot frequency hopping for RF	17.7.0
2022-12	RAN#98	R5-227840	2565	1	F	Introduction of test frequencies for signalling testing for new NR bands n91, n92, n93 and n94	17.7.0
2022-12	RAN#98	R5-227892	2675	1	F	Updates to determination of test frequencies for NR Intra-band Non-Contiguous CA	17.7.0
2023-03	RAN#99	R5-230065	2680	-	F	Introduction of test channel bandwidths for new NR bands n100, n101	17.8.0
2023-03	RAN#99	R5-230066	2681	-	F	Introduction of test frequencies for new NR bands n100, n101	17.8.0
2023-03	RAN#99	R5-230067	2682	-	F	Introduction of test frequencies for signalling testing for new NR bands n100, n101	17.8.0
2023-03	RAN#99	R5-230093	2683	-	F	Addition of test frequencies for new EN-DC comb within FR1	17.8.0
2023-03	RAN#99	R5-230103	2684	-	F	Updates to clause 4.5B.2 for RedCap test environment	17.8.0
2023-03	RAN#99	R5-230231	2692	-	F	Update IEs SIB16, CellReselectionPriority, FreqPriorityListSlicing, NSAG-ID and NSAG-IdentityInfo	17.8.0
2023-03	RAN#99	R5-230279	2696	-	F	Corrections to Clause 6.2.3.7 Test frequencies for NR sidelink configurations for signalling testing	17.8.0
2023-03	RAN#99	R5-230287	2697	-	F	Update inter-band NR CA configurations of three bands CA_n2A-n5A-n77A, CA_n2A-n66A-n77A, and CA_n5A-n66A-n77A	17.8.0
2023-03	RAN#99	R5-230457	2700	-	F	Correction to default configuration of RRC IEs for RedCap	17.8.0
2023-03	RAN#99	R5-230587	2703	-	F	Update IE BWP-UplinkDedicated	17.8.0
2023-03	RAN#99	R5-230588	2704	-	F	Update IE LBT-FailureRecoveryConfig	17.8.0
2023-03	RAN#99	R5-230601	2705	-	F	update default message contents of ReportConfigInterRAT	17.8.0
2023-03	RAN#99	R5-230675	2713	-	F	Correction to Test Procedures for Switch off/Power off	17.8.0

2023-03	RAN#99	R5-230753	2719	-	F	Introduction or test frequencies for n46 and n96 in clause 6.2.3.1	17.8.0
2023-03	RAN#99	R5-230754	2720	-	F	Corrections to Annex C for test frequency calculations	17.8.0
2023-03	RAN#99	R5-230755	2721	-	F	Update IE DownlinkConfigCommonSIB	17.8.0
2023-03	RAN#99	R5-230882	2723	-	F	NTN test channel bandwidths for n256 and n255	17.8.0
2023-03	RAN#99	R5-230884	2724	-	F	NR NTN test frequencies for n256	17.8.0
2023-03	RAN#99	R5-230897	2726	-	F	Addition of test frequency for DC_71A_n2A	17.8.0
2023-03	RAN#99	R5-230966	2728	-	F	Correction to PUCCH secondHopPRB for RF condition	17.8.0
2023-03	RAN#99	R5-230999	2729	-	F	Update IE BWP-UplinkCommon	17.8.0
2023-03	RAN#99	R5-231002	2731	-	F	Corrections to RRC Reconfiguration for SCell addition	17.8.0
2023-03	RAN#99	R5-231023	2733	-	F	Addition of default RRC message configuration for measurement gap enhancements	17.8.0
2023-03	RAN#99	R5-231079	2735	-	F	Updating test frequencies for n79	17.8.0
2023-03	RAN#99	R5-231185	2736	-	F	Correction to PDU SESSION ESTABLISHMENT ACCEPT message	17.8.0
2023-03	RAN#99	R5-231218	2737	-	F	Add condition to activate dedicated BWP to ServingCellConfig	17.8.0
2023-03	RAN#99	R5-231219	2738	-	F	Addition of scheduling information for high accuracy GNSS posSibTypes	17.8.0
2023-03	RAN#99	R5-231227	2739	-	F	Introduction of CA_n41A-n71A configuration.	17.8.0
2023-03	RAN#99	R5-231236	2744	-	F	Update IE NPN-IdentityInfoList	17.8.0
2023-03	RAN#99	R5-231243	2747	-	F	Test frequencies update for bands n8 and n25	17.8.0
2023-03	RAN#99	R5-231399	2722	1	F	Add IEs PathlossReferenceRS and PathlossReferenceRS-Id	17.8.0
2023-03	RAN#99	R5-231423	2701	1	F	Correction to PHY parameters for SL mode 1 transmission	17.8.0
2023-03	RAN#99	R5-231424	2702	1	F	Correction to RRC IEs for SL mode 1 transmission	17.8.0
2023-03	RAN#99	R5-231447	2695	1	F	Addition of CG SDT Configuration message contents for 3GPP SDT	17.8.0
2023-03	RAN#99	R5-231448	2727	1	F	Update of the contents of RRC messages for L2 U2N relay related operation	17.8.0
2023-03	RAN#99	R5-231453	2750	1	F	Adding default contents for SIB17	17.8.0
2023-03	RAN#99	R5-231461	2716	1	F	Addition of System information combination for Rel-17 eNPN	17.8.0
2023-03	RAN#99	R5-231467	2707	1	F	Addition of Procedure for MBS Multicast session release	17.8.0
2023-03	RAN#99	R5-231468	2708	1	F	Update of Contents of Paging for Multicast MBS TC	17.8.0
2023-03	RAN#99	R5-231469	2709	1	F	Correction of CLOSE UE TEST LOOP message for Loop Mode C	17.8.0
2023-03	RAN#99	R5-231470	2710	1	F	Correction of PDCP-Config for MBS TC	17.8.0
2023-03	RAN#99	R5-231471	2711	1	F	Correction of RadioBearerConfig for MBS TC	17.8.0
2023-03	RAN#99	R5-231472	2712	1	F	Correction of CellGroupConfig for MBS TC	17.8.0
2023-03	RAN#99	R5-231560	2715	1	F	Updates to SIB1 and SIB18 for Rel-17 Enpn	17.8.0
2023-03	RAN#99	R5-231570	2690	1	F	Update IE SIB2	17.8.0
2023-03	RAN#99	R5-231571	2706	1	F	update default message contents of MeasResults	17.8.0
2023-03	RAN#99	R5-231577	2691	1	F	Update IEs SIB11, ARFCN-ValueEUTRA, MeasIdleConfig and EUTRA-PhysCellIdRange	17.8.0
2023-03	RAN#99	R5-231603	2717	1	F	Correction of test frequencies for n46	17.8.0
2023-03	RAN#99	R5-231604	2718	1	F	Correction of test frequencies for n96	17.8.0
2023-03	RAN#99	R5-231634	2694	1	F	Introduction of CA_n41A-n66A configuration.	17.8.0
2023-03	RAN#99	R5-231792	2686	1	F	Update of Propagation Delay Compensation tables for UE Rx-Tx measurements	17.8.0
2023-03	RAN#99	R5-231793	2725	1	F	Addition of test frequencies for R16 combos	17.8.0
2023-03	RAN#99	R5-231867	2693	1	F	Correction to high range reference test frequency for n66 DL CA	17.8.0
2023-03	RAN#99	R5-231874	2698	1	F	Addition of test frequencies for new 3CC EN-DC comb within FR1	17.8.0
2023-03	RAN#99	R5-231902	2751	1	F	Correction to introduce search space configuration changes for DCI_2-6 transmission	17.8.0
2023-06	RAN#100	R5-232056	2752	-	F	Correction to test procedure 4.9.9	17.9.0
2023-06	RAN#100	R5-232337	2756	-	F	Addition of test frequencies for new 3CC EN-DC comb within FR2	17.9.0
2023-06	RAN#100	R5-232338	2757	-	F	Addition of test frequencies for new EN-DC comb within FR2	17.9.0
2023-06	RAN#100	R5-232350	2758	-	F	RF message exceptions for K1 and number of HARQ processes in CA	17.9.0
2023-06	RAN#100	R5-232441	2762	-	F	Introduction of test channel bandwidths for new NR band n13	17.9.0
2023-06	RAN#100	R5-232442	2763	-	F	Introduction of test frequencies for new NR band n13	17.9.0
2023-06	RAN#100	R5-232443	2764	-	F	Introduction of test frequencies for signalling testing for new NR band n13	17.9.0



2023-06	RAN#100	R5-232497	2765	-	F	Correction to default configuration of RRC IEs for NR cov enh test	17.9.0
2023-06	RAN#100	R5-232520	2766	-	F	NR NTN test frequencies for n255	17.9.0
2023-06	RAN#100	R5-232576	2767	-	F	Correction to RRC IEs for NR sidelink test	17.9.0
2023-06	RAN#100	R5-232654	2770	-	F	Update of NR inter-band CA configurations in FR1 for CA_n3A-n8A	17.9.0
2023-06	RAN#100	R5-232693	2774	-	F	Addition of NTN freq bands to clause 6.2.3 for Default test frequencies	17.9.0
2023-06	RAN#100	R5-232712	2776	-	F	Correction NZP-CSI-RS-ResourceSet for FR1	17.9.0
2023-06	RAN#100	R5-232723	2781	-	F	Correction to default P-Max value for Power Class 1.5 UEs	17.9.0
2023-06	RAN#100	R5-232743	2782	-	F	Update of the contents of RRC messages for L2 U2N relay related operation	17.9.0
2023-06	RAN#100	R5-232746	2783	-	F	Update of the contents of Sidelink information elements	17.9.0
2023-06	RAN#100	R5-232790	2786	-	F	Addition of test frequencies of CA_n39A-n41A config TC 4.3.1.1.2.1	17.9.0
2023-06	RAN#100	R5-232877	2787	-	F	Addition of new CA configuration CA-n41A-n66A-n71A	17.9.0
2023-06	RAN#100	R5-232934	2789	-	F	Update CSI-ReportConfig IE content for RRM testing	17.9.0
2023-06	RAN#100	R5-232946	2793	-	F	Delete NR-19 for MBS in the Common configurations of system information blocks	17.9.0
2023-06	RAN#100	R5-232970	2794	-	F	Update Service accept NAS message	17.9.0
2023-06	RAN#100	R5-232971	2795	-	F	Update RadioBearerConfig-SRB2-DRB message	17.9.0
2023-06	RAN#100	R5-232991	2797	-	F	Correction to RRM PDCCH TCI-State	17.9.0
2023-06	RAN#100	R5-232992	2798	-	F	Correction to RRM TRS CSI-ResourceConfig	17.9.0
2023-06	RAN#100	R5-233091	2799	-	F	Adding uplink CA test frequencies for CA_n77(2A)	17.9.0
2023-06	RAN#100	R5-233135	2804	-	F	Correction to RF or RRM condition for default messages	17.9.0
2023-06	RAN#100	R5-233142	2805	-	F	Update to test procedure for registration of a MUSIM UE	17.9.0
2023-06	RAN#100	R5-233195	2806	-	F	Corrections to Test frequencies for NR CA configurations for signalling testing	17.9.0
2023-06	RAN#100	R5-233317	2769	1	F	Correction to introduce search space configuration changes for DCI_2-6 transmission	17.9.0
2023-06	RAN#100	R5-233369	2775	1	F	Addition of new clause for UE Position Requirements for NR NTN testing	17.9.0
2023-06	RAN#100	R5-233379	2785	1	F	Addition of a new combination of system information block for SIB16	17.9.0
2023-06	RAN#100	R5-233382	2791	1	F	Addition of Procedure to check TMGI and associated MRB reception in a multicast MBS session	17.9.0
2023-06	RAN#100	R5-233383	2792	1	F	Update PDCCH-Config for MSS condition	17.9.0
2023-06	RAN#100	R5-233406	2790	1	F	Update general configuration parameter for HD-FDD UE	17.9.0
2023-06	RAN#100	R5-233423	2777	1	F	Addition of PC5 RRC message uuMessageTransferSidelink	17.9.0
2023-06	RAN#100	R5-233424	2778	1	F	Addition of PC5 RRC RemoteUEInformationSidelink message	17.9.0
2023-06	RAN#100	R5-233425	2780	1	F	Update of PC5 RRC message Uu-RelayRLC-ChannelConfig	17.9.0
2023-06	RAN#100	R5-233426	2779	1	F	Update of PC5 RRC message SL-L2RelayUE-Config	17.9.0
2023-06	RAN#100	R5-233429	2755	1	F	Add generic procedure for Switch off / Power off procedure in MA PDU session Established on NR and WLAN	17.9.0
2023-06	RAN#100	R5-233434	2771	1	F	Updates to SIB19 for NR NTN	17.9.0
2023-06	RAN#100	R5-233435	2772	1	F	Update IE ServingCellConfigCommon for NR NTN	17.9.0
2023-06	RAN#100	R5-233436	2773	1	F	Update to clause 4.4.3 Common parameters for NR NTN	17.9.0
2023-06	RAN#100	R5-233474	2768	1	F	Correction to switch off test procedure	17.9.0
2023-06	RAN#100	R5-233500	2808	1	F	Correction of 38.508-1 4.1.1 on lower humidity limit in temperature test environment	17.9.0
2023-06	RAN#100	R5-233674	2754	1	F	Addition and update of tables for HST FR2 scenario	17.9.0
2023-06	RAN#100	R5-233675	2807	1	F	Update to TS 38.508-1 clause 4.6.3-200BB for FR2 UL Gaps IE	17.9.0
2023-06	RAN#100	R5-233676	2809	-	F	Correction to frequency range for ssb-PositionsInBurst and SSB-ToMeasure	17.9.0
2023-06	RAN#100	R5-233699	2759	1	F	Correction of test frequency parameters for n79	17.9.0
2023-06	RAN#100	R5-233700	2802	1	F	Updating frequency calculation in Annex C.3.2	17.9.0
2023-06	RAN#100	R5-233734	2788	2	F	Addition of test frequency for new 3/4 band EN-DC comb	17.9.0

---

# History

<b>Document history</b>		
V17.4.0	May 2022	Publication
V17.5.0	September 2022	Publication
V17.6.0	October 2022	Publication
V17.7.0	February 2023	Publication
V17.8.0	June 2023	Publication
V17.9.0	July 2023	Publication