

ETSI TS 138 508-1 V15.1.0 (2018-10)



**5G;
5GS;
User Equipment (UE) conformance specification;
Part 1: Common test environment
(3GPP TS 38.508-1 version 15.1.0 Release 15)**



Reference

RTS/TSGR-0538508-1v10

Keywords

5G

ETSI

650 Route des Lucioles
F-06921 Sophia Antipolis Cedex - FRANCE

Tel.: +33 4 92 94 42 00 Fax: +33 4 93 65 47 16

Siret N° 348 623 562 00017 - NAF 742 C
Association à but non lucratif enregistrée à la
Sous-Préfecture de Grasse (06) N° 7803/88

Important notice

The present document can be downloaded from:

<http://www.etsi.org/standards-search>

The present document may be made available in electronic versions and/or in print. The content of any electronic and/or print versions of the present document shall not be modified without the prior written authorization of ETSI. In case of any existing or perceived difference in contents between such versions and/or in print, the only prevailing document is the print of the Portable Document Format (PDF) version kept on a specific network drive within ETSI Secretariat.

Users of the present document should be aware that the document may be subject to revision or change of status.

Information on the current status of this and other ETSI documents is available at

<https://portal.etsi.org/TB/ETSIDeliverableStatus.aspx>

If you find errors in the present document, please send your comment to one of the following services:

<https://portal.etsi.org/People/CommiteeSupportStaff.aspx>

Copyright Notification

No part may be reproduced or utilized in any form or by any means, electronic or mechanical, including photocopying and microfilm except as authorized by written permission of ETSI.

The content of the PDF version shall not be modified without the written authorization of ETSI.

The copyright and the foregoing restriction extend to reproduction in all media.

© ETSI 2018.

All rights reserved.

DECT™, **PLUGTESTS™**, **UMTS™** and the ETSI logo are trademarks of ETSI registered for the benefit of its Members.

3GPP™ and **LTE™** are trademarks of ETSI registered for the benefit of its Members and of the 3GPP Organizational Partners.

oneM2M logo is protected for the benefit of its Members.

GSM® and the GSM logo are trademarks registered and owned by the GSM Association.

Intellectual Property Rights

Essential patents

IPRs essential or potentially essential to normative deliverables may have been declared to ETSI. The information pertaining to these essential IPRs, if any, is publicly available for **ETSI members and non-members**, and can be found in ETSI SR 000 314: *"Intellectual Property Rights (IPRs); Essential, or potentially Essential, IPRs notified to ETSI in respect of ETSI standards"*, which is available from the ETSI Secretariat. Latest updates are available on the ETSI Web server (<https://ipr.etsi.org/>).

Pursuant to the ETSI IPR Policy, no investigation, including IPR searches, has been carried out by ETSI. No guarantee can be given as to the existence of other IPRs not referenced in ETSI SR 000 314 (or the updates on the ETSI Web server) which are, or may be, or may become, essential to the present document.

Trademarks

The present document may include trademarks and/or tradenames which are asserted and/or registered by their owners. ETSI claims no ownership of these except for any which are indicated as being the property of ETSI, and conveys no right to use or reproduce any trademark and/or tradename. Mention of those trademarks in the present document does not constitute an endorsement by ETSI of products, services or organizations associated with those trademarks.

Foreword

This Technical Specification (TS) has been produced by ETSI 3rd Generation Partnership Project (3GPP).

The present document may refer to technical specifications or reports using their 3GPP identities, UMTS identities or GSM identities. These should be interpreted as being references to the corresponding ETSI deliverables.

The cross reference between GSM, UMTS, 3GPP and ETSI identities can be found under <http://webapp.etsi.org/key/queryform.asp>.

Modal verbs terminology

In the present document "**shall**", "**shall not**", "**should**", "**should not**", "**may**", "**need not**", "**will**", "**will not**", "**can**" and "**cannot**" are to be interpreted as described in clause 3.2 of the [ETSI Drafting Rules](#) (Verbal forms for the expression of provisions).

"**must**" and "**must not**" are **NOT** allowed in ETSI deliverables except when used in direct citation.

Contents

Intellectual Property Rights	2
Foreword.....	2
Modal verbs terminology.....	2
Foreword.....	12
1 Scope	13
2 References	13
3 Definitions, symbols and abbreviations	14
3.1 Definitions	14
3.2 Symbols.....	14
3.3 Abbreviations	14
4 Common test environments.....	15
4.1 Environmental conditions.....	15
4.1.1 Temperature.....	15
4.1.2 Voltage.....	15
4.2 Common requirements of test equipment.....	16
4.2.1 General functional requirements.....	16
4.2.2 Minimum functional requirements	17
4.2.2.1 Supported Cell Configuration	17
4.2.2.1.1 Supported Channels for an E-UTRA cell (NSA mode only).....	17
4.2.2.1.2 Supported Channels for a NR cell	17
4.2.2.1.1.1 Logical channels	17
4.2.2.1.1.2 Transport channels	17
4.2.2.1.1.3 Physical channels	18
4.3 Reference test conditions.....	18
4.3.1 Test frequencies	18
4.3.1.0 General.....	18
4.3.1.0A Mid test channel bandwidth	18
4.3.1.0B Bandwidth part.....	19
4.3.1.1 Test frequencies for NR operating bands in FR1	21
4.3.1.1.1 Operating bands in FR1	21
4.3.1.1.2 Intra-band CA in FR1	85
4.3.1.1.3 Inter-band CA in FR1	85
4.3.1.1.4 Operating bands for DC in FR1.....	85
4.3.1.1.5 Operating band combination for SUL in FR1	85
4.3.1.2 Test frequencies for NR operating bands in FR2	85
4.3.1.2.1 Operating bands in FR2.....	85
4.3.1.2.2 Intra-band CA in FR2.....	85
4.3.1.2.3 Inter-band CA in FR2.....	85
4.3.1.3 Test frequencies for NR operation with other radios	85
4.3.1.3.1 Inter-band CA.....	85
4.3.1.3.2 EN-DC (two bands).....	85
4.3.1.3.2.0 Default reference test frequencies for EN-DC combinations (two bands).....	85
4.3.1.3.2.1 Reference test frequencies for EN-DC combinations beginning with B1	87
4.3.1.3.2.2 to 4.3.1.3.2.24 FFS	88
4.3.1.3.2.25 Reference test frequencies for EN-DC combinations beginning with B25.....	88
4.3.1.3.2.25.1 to 4.3.1.3.2.25.40 FFS	88
4.3.1.3.2.25.41 Reference test frequencies for EN-DC combination DC_25A_n41A / DC_25A_n41A	88
4.3.1.3.2.26 – 4.3.1.3.2.40 FFS	88
4.3.1.3.2.41 Reference test frequencies for EN-DC combinations beginning with B41.....	88
4.3.1.3.2.41.1	88
4.3.1.3.2.41.2 to 4.3.1.3.2.41.40 FFS	90
4.3.1.3.2.41.41 Reference test frequencies for EN-DC combination DC_(n)41AA / DC_(n)41AA	90
4.3.1.3.2.41.41A Reference test frequencies for EN-DC combination DC_41A_n41A / DC_41A_n41A.....	91
4.3.1.3.3 EN-DC (three bands).....	92

4.3.1.3.4	EN-DC (four bands)	92
4.3.1.3.5	EN-DC (five bands).....	92
4.3.2	Radio conditions	92
4.3.2.1	FR1, normal propagation condition for connected.....	92
4.3.2.2	FR2, condition for OTA.....	92
4.3.3	Physical channel allocations	92
4.3.3.1	E-UTRA.....	92
4.3.3.2	NR.....	92
4.3.3.2.1	Antennas.....	92
4.3.3.2.2	Downlink physical channels and physical signals.....	93
4.3.3.2.3	Mapping of downlink physical channels and signals to physical resources	93
4.3.3.2.4	Uplink physical channels and physical signals.....	93
4.3.3.2.5	Mapping of uplink physical channels and signals to physical resources	93
4.3.4	Signal levels.....	93
4.3.4.1	Signal levels for conducted testing.....	93
4.3.4.1.1	Downlink signal levels	93
4.3.4.2	Signal levels for OTA testing.....	93
4.3.5	Standard test signals.....	93
4.3.6	Physical layer parameters	93
4.3.6.1	Downlink physical layer parameters.....	93
4.3.6.1.1	Physical layer parameters for scheduling of PUSCH	93
4.3.6.1.1.1	Physical layer parameters for DCI format 0_0.....	93
4.3.6.1.1.2	Physical layer parameters for DCI format 0_1.....	94
4.3.6.1.2	Physical layer parameters for scheduling of PDSCH	95
4.3.6.1.2.1	Physical layer parameters for DCI format 1_0.....	95
4.3.6.1.2.2	Physical layer parameters for DCI format 1_1.....	96
4.3.6.1.3	Physical layer parameters for other purposes	97
4.3.6.1.3.1	Physical layer parameters for DCI format 2_0.....	97
4.3.6.1.3.2	Physical layer parameters for DCI format 2_1.....	98
4.3.6.1.3.3	Physical layer parameters for DCI format 2_2.....	98
4.3.6.1.3.4	Physical layer parameters for DCI format 2_3.....	98
4.4	Reference system configurations.....	99
4.4.1	Simulated network scenarios	99
4.4.1.1	Standalone cell network scenarios	99
4.4.1.1.1	Standalone E-UTRA single cell and multi cell network scenarios.....	99
4.4.1.1.2	Standalone NR single cell network scenarios.....	99
4.4.1.1.3	Standalone NR single mode multi cell network scenarios.....	99
4.4.1.1.4	Standalone NR dual mode multi cell network scenarios	100
4.4.1.1.5	Standalone NR 3GPP Inter-RAT network scenarios.....	100
4.4.1.2	Non-standalone cell network scenarios.....	100
4.4.1.2.1	Non-standalone E-UTRA single cell and NR single cell network scenarios.....	100
4.4.1.2.2	Non-standalone E-UTRA single cell and NR single mode multi cell network scenarios.....	100
4.4.1.2.3	Non-standalone E-UTRA single mode multi cell and NR single mode multi cell network scenarios	100
4.4.1.2.4	Non-standalone E-UTRA single cell and NR dual mode multi cell network scenarios	101
4.4.2	Simulated cells.....	101
4.4.3	Common parameters for simulated NR cells	103
4.4.3.1	Common configurations of system information blocks	104
4.4.3.1.1	Combinations of system information blocks for E-UTRA standalone, EN-DC and NGEN-DC ..	104
4.4.3.1.2	Combinations of system information blocks for NR standalone and NE-DC	104
4.5	Generic procedures.....	104
4.5.1	General.....	104
4.5.2	RRC_IDLE	105
4.5.2.1	Initiation.....	105
4.5.2.2	Procedures.....	105
4.5.2.3	Specific message contents.....	105
4.5.3	RRC_INACTIVE	105
4.5.3.1	Initiation.....	105
4.5.4	RRC_CONNECTED	105
4.5.4.1	Initiation.....	105
4.5.4.2	Procedures.....	106
4.5.4.3	Specific message contents.....	106

4.5.5	UE Beamlock Test Function (UBF)	107
4.5.5.1	Specific Message contents	107
4.5.5.1.1	ACTIVATE BEAMLOCK for Tx Only	107
4.5.5.1.2	ACTIVATE BEAMLOCK for Rx Only	108
4.5.5.1.3	ACTIVATE BEAMLOCK for TxRx	108
4.5.5.1.4	DEACTIVATE BEAMLOCK	108
4.6	Default NG-RAN RRC message and information elements contents	109
4.6.1	Contents of RRC messages	109
–	<i>DLInformationTransfer</i>	109
–	<i>LocationMeasurementIndication</i>	109
–	<i>MIB</i>	110
–	<i>MeasurementReport</i>	110
–	<i>MobilityFromNRCommand</i>	110
–	<i>Paging</i>	111
–	<i>RRCReestablishment</i>	111
–	<i>RRCReestablishmentComplete</i>	111
–	<i>RRCReestablishmentRequest</i>	112
–	<i>RRCReconfiguration</i>	112
–	<i>RRCReconfigurationComplete</i>	113
–	<i>RRCReject</i>	113
–	<i>RRCRelease</i>	113
–	<i>RRCResume</i>	114
–	<i>RRCResumeRequest</i>	114
–	<i>RRCResumeRequest1</i>	114
–	<i>SIB1</i>	115
–	<i>SystemInformation</i>	115
–	<i>UECapabilityEnquiry</i>	115
–	<i>UECapabilityInformation</i>	116
–	<i>ULInformationTransfer</i>	116
4.6.2	System information blocks	117
–	<i>SIB2</i>	117
–	<i>SIB3</i>	117
–	<i>SIB4</i>	117
–	<i>SIB5</i>	117
–	<i>SIB6</i>	118
–	<i>SIB7</i>	118
–	<i>SIB8</i>	118
–	<i>SIB9</i>	119
4.6.3	Radio resource control information elements	119
–	<i>AdditionalSpectrumEmission</i>	119
–	<i>Alpha</i>	119
–	<i>AMF-Identifier</i>	119
–	<i>ARFCN-ValueEUTRA</i>	119
–	<i>ARFCN-ValueNR</i>	120
–	<i>BWP</i>	120
–	<i>BWP-Downlink</i>	120
–	<i>BWP-DownlinkCommon</i>	121
–	<i>BWP-DownlinkDedicated</i>	121
–	<i>BWP-Uplink</i>	121
–	<i>BWP-UplinkCommon</i>	122
–	<i>BWP-UplinkDedicated</i>	122
–	<i>BWP-Id</i>	123
–	<i>BeamFailureRecoveryConfig</i>	123
–	<i>CellAccessRelatedInfo</i>	123
–	<i>CellGlobalIdNR</i>	123
–	<i>CellGroupConfig</i>	124
–	<i>CellGroupId</i>	124
–	<i>CellIdentity</i>	124
–	<i>CellReselectionPriority</i>	125
–	<i>CodebookConfig</i>	125
–	<i>ConfiguredGrantConfig</i>	125
–	<i>ConnEstFailureControl</i>	125

-	<i>ControlResourceSet</i>	126
-	<i>ControlResourceSetId</i>	126
-	<i>ControlResourceSetZero</i>	126
-	<i>CrossCarrierSchedulingConfig</i>	126
-	<i>CSI-AperiodicTriggerStateList</i>	127
-	<i>CSI-FrequencyOccupation</i>	127
-	<i>CSI-IM-Resource</i>	128
-	<i>CSI-IM-ResourceId</i>	128
-	<i>CSI-IM-ResourceSet</i>	128
-	<i>CSI-IM-ResourceSetId</i>	128
-	<i>CSI-MeasConfig</i>	129
-	<i>CSI-ReportConfig</i>	130
-	<i>CSI-ReportConfigId</i>	130
-	<i>CSI-ResourceConfig</i>	131
-	<i>CSI-ResourceConfigId</i>	131
-	<i>CSI-ResourcePeriodicityAndOffset</i>	131
-	<i>CSI-RS-ResourceConfigMobility</i>	132
-	<i>CSI-RS-ResourceMapping</i>	132
-	<i>CSI-SemiPersistentOnPUSCH-TriggerStateList</i>	132
-	<i>CSI-SSB-ResourceSetId</i>	132
-	<i>CSI-SSB-ResourceSet</i>	133
-	<i>DedicatedInfoNAS</i>	133
-	<i>DMRS-DownlinkConfig</i>	133
-	<i>DMRS-UplinkConfig</i>	134
-	<i>DownlinkConfigCommon</i>	134
-	<i>DownlinkConfigCommonSIB</i>	134
-	<i>DownlinkPreemption</i>	134
-	<i>DRB-Identity</i>	135
-	<i>EUTRA-MBSFN-SubframeConfigList</i>	135
-	<i>EUTRA-Q-OffsetRange</i>	135
-	<i>FilterCoefficient</i>	135
-	<i>FreqBandIndicatorNR</i>	135
-	<i>FrequencyInfoDL</i>	136
-	<i>FrequencyInfoDL-SIB</i>	136
-	<i>FrequencyInfoUL</i>	136
-	<i>Hysteresis</i>	136
-	<i>I-RNTI-Value</i>	137
-	<i>LocationMeasurementInfo</i>	137
-	<i>LogicalChannelConfig</i>	137
-	<i>LogicalChannelIdentity</i>	137
-	<i>MAC-CellGroupConfig</i>	138
-	<i>MeasConfig</i>	139
-	<i>MeasGapConfig</i>	139
-	<i>MeasGapSharingConfig</i>	139
-	<i>MeasId</i>	139
-	<i>MeasIdToAddModList</i>	140
-	<i>MeasObjectEUTRA</i>	140
-	<i>MeasObjectId</i>	140
-	<i>MeasObjectNR</i>	141
-	<i>MeasObjectToAddModList</i>	142
-	<i>MeasResults</i>	142
-	<i>MeasResultSCG-Failure</i>	143
-	<i>MeasResultCellListSFTD</i>	146
-	<i>MobilityStateParameters</i>	147
-	<i>MultiFrequencyBandListNR</i>	147
-	<i>NextHopChainingCount</i>	147
-	<i>NG-5G-S-TMSI</i>	147
-	<i>NZP-CSI-RS-Resource</i>	148
-	<i>NZP-CSI-RS-ResourceId</i>	148
-	<i>NZP-CSI-RS-ResourceSet</i>	148
-	<i>NZP-CSI-ResourceSetId</i>	148
-	<i>P-Max</i>	149

-	<i>PCI-List</i>	149
-	<i>PCI-Range</i>	149
-	<i>PCI-RangeElement</i>	149
-	<i>PCI-RangeIndex</i>	149
-	<i>PCI-RangeIndexList</i>	149
-	<i>PDCCH-Config</i>	150
-	<i>PDCCH-ConfigCommon</i>	150
-	<i>PDCCH-ConfigSIB1</i>	150
-	<i>PDCCH-ServingCellConfig</i>	151
-	<i>PDCP-Config</i>	151
-	<i>PDSCH-Config</i>	152
-	<i>PDSCH-ConfigCommon</i>	152
-	<i>PDSCH-ServingCellConfig</i>	153
-	<i>PDSCH-TimeDomainResourceAllocationList</i>	153
-	<i>PhysCellId</i>	153
-	<i>PhysicalCellGroupConfig</i>	154
-	<i>PLMN-Identity</i>	154
-	<i>PLMN-IdentityInfoList</i>	154
-	<i>PRB-Id</i>	154
-	<i>PTRS-DownlinkConfig</i>	155
-	<i>PTRS-UplinkConfig</i>	155
-	<i>PUCCH-Config</i>	156
-	<i>PUCCH-ConfigCommon</i>	162
-	<i>PUCCH-PathlossReferenceRS-Id</i>	162
-	<i>PUCCH-PowerControl</i>	163
-	<i>PUCCH-SpatialRelationInfo</i>	163
-	<i>PUCCH-TPC-CommandConfig</i>	163
-	<i>PUSCH-Config</i>	164
-	<i>PUSCH-ConfigCommon</i>	165
-	<i>PUSCH-PowerControl</i>	165
-	<i>PUSCH-ServingCellConfig</i>	166
-	<i>PUSCH-TimeDomainResourceAllocationList</i>	166
-	<i>PUSCH-TPC-CommandConfig</i>	166
-	<i>Q-OffsetRange</i>	166
-	<i>Q-QualMin</i>	166
-	<i>Q-RxLevMin</i>	167
-	<i>QuantityConfig</i>	168
-	<i>RACH-ConfigCommon</i>	169
-	<i>RACH-ConfigGeneric</i>	169
-	<i>RACH-ConfigDedicated</i>	170
-	<i>RadioBearerConfig</i>	171
-	<i>RadioLinkMonitoringConfig</i>	172
-	<i>RadioLinkMonitoringRSId</i>	172
-	<i>RAN-AreaCode</i>	172
-	<i>RateMatchPattern</i>	172
-	<i>RateMatchPatternId</i>	173
-	<i>RateMatchPatternLTE-CRS</i>	173
-	<i>ReportConfigId</i>	173
-	<i>ReportConfigInterRAT</i>	173
-	<i>ReportConfigNR</i>	174
-	<i>ReportConfigToAddModList</i>	177
-	<i>ReportInterval</i>	177
-	<i>ReselectionThreshold</i>	177
-	<i>ReselectionThresholdQ</i>	177
-	<i>ResumeCause</i>	177
-	<i>RLC-Bearer-Config</i>	178
-	<i>RLC-Config</i>	179
-	<i>RLF-TimersAndConstants</i>	180
-	<i>RNTI-Value</i>	180
-	<i>RSRP-Range</i>	180
-	<i>RSRQ-Range</i>	180
-	<i>SCellIndex</i>	180

-	<i>SchedulingRequestConfig</i>	181
-	<i>SchedulingRequestId</i>	181
-	<i>SchedulingRequestResourceConfig</i>	181
-	<i>SchedulingRequestResourceId</i>	181
-	<i>ScramblingId</i>	181
-	<i>SCS-SpecificCarrier</i>	182
-	<i>SDAP-Config</i>	182
-	<i>SearchSpace</i>	183
-	<i>SearchSpaceId</i>	184
-	<i>SearchSpaceZero</i>	184
-	<i>SecurityAlgorithmConfig</i>	184
-	<i>ServCellIndex</i>	184
-	<i>ServingCellConfig</i>	185
-	<i>ServingCellConfigCommon</i>	186
-	<i>ServingCellConfigCommonSIB</i>	186
-	<i>ShortI-RNTI-Value</i>	186
-	<i>SINR-Range</i>	187
-	<i>SI-SchedulingInfo</i>	187
-	<i>SlotFormatCombinationsPerCell</i>	187
-	<i>SlotFormatIndicator</i>	187
-	<i>S-NSSAI</i>	187
-	<i>SpeedStateScaleFactors</i>	187
-	<i>SS-RSSI-Measurement</i>	188
-	<i>SPS-Config</i>	188
-	<i>SRB-Identity</i>	188
-	<i>SRS-Config</i>	189
-	<i>SRS-CarrierSwitching</i>	191
-	<i>SRS-TPC-CommandConfig</i>	191
-	<i>SSB-Index</i>	191
-	<i>SSB-MTC</i>	191
-	<i>SSB-ToMeasure</i>	192
-	<i>SubcarrierSpacing</i>	192
-	<i>TCI-State</i>	192
-	<i>TCI-StateId</i>	192
-	<i>TDD-UL-DL-Config</i>	193
-	<i>TrackingAreaCode</i>	193
-	<i>T-Reselection</i>	193
-	<i>TimeToTrigger</i>	193
-	<i>UplinkConfigCommon</i>	194
-	<i>UplinkTxDirectCurrentList</i>	194
-	<i>UE-TimersAndConstants</i>	194
-	<i>ZP-CSI-RS-Resource</i>	194
-	<i>ZP-CSI-RS-ResourceSet</i>	195
-	<i>ZP-CSI-RS-ResourceSetId</i>	195
4.6.4	UE capability information elements	195
-	<i>AccessStratumRelease</i>	195
-	<i>BandCombinationList</i>	196
-	<i>CA-BandwidthClassNR</i>	196
-	<i>CA-BandwidthClassEUTRA</i>	196
-	<i>CA-ParametersNR</i>	197
-	<i>CA-ParametersEUTRA</i>	197
-	<i>FeatureSetCombination</i>	197
-	<i>FeatureSetCombinationId</i>	197
-	<i>FeatureSetDownlink</i>	198
-	<i>FeatureSetDownlinkId</i>	200
-	<i>FeatureSetEUTRA-DownlinkId</i>	200
-	<i>FeatureSetDownlinkPerCC</i>	200
-	<i>FeatureSetDownlinkPerCC-Id</i>	200
-	<i>FeatureSetUplink</i>	201
-	<i>FeatureSetUplinkId</i>	201
-	<i>FeatureSetEUTRA-UplinkId</i>	201
-	<i>FeatureSetUplinkPerCC</i>	202

–	<i>FeatureSetUplinkPerCC-Id</i>	202
–	<i>FeatureSets</i>	202
–	<i>FreqBandIndicatorEUTRA</i>	202
–	<i>FreqBandList</i>	203
–	<i>FreqSeparationClass</i>	203
–	<i>MIMO-Layers</i>	203
–	<i>ModulationOrder</i>	203
–	<i>MRDC-Parameters</i>	204
–	<i>RAT-Type</i>	204
–	<i>SupportedBandwidth</i>	204
–	<i>UE-CapabilityRAT-ContainerList</i>	204
–	<i>UE-MRDC-Capability</i>	205
–	<i>RF-ParametersMRDC</i>	206
–	<i>MeasParametersMRDC</i>	206
–	<i>UE-NR-Capability</i>	207
–	<i>Phy-Parameters</i>	211
–	<i>RF-Parameters</i>	214
–	<i>MIMO-ParametersPerBand</i>	217
–	<i>PDCP-Parameters</i>	220
–	<i>RLC-Parameters</i>	220
–	<i>MAC-Parameters</i>	221
–	<i>MeasParameters</i>	221
4.6.5	Other information elements	221
–	<i>EUTRA-AllowedMeasBandwidth</i>	221
–	<i>EUTRA-MultiBandInfoList</i>	221
–	<i>EUTRA-NS-PmaxList</i>	222
–	<i>EUTRA-PhysCellId</i>	222
–	<i>EUTRA-PhysCellIdRange</i>	222
–	<i>EUTRA-PresenceAntennaPort1</i>	222
–	<i>RRC-TransactionIdentifier</i>	223
4.7	Default 5GC NAS message and information elements contents	223
4.7.1	Contents of 5GMM messages	223
–	<i>Authentication request</i>	223
–	<i>Authentication response</i>	223
–	<i>Authentication result</i>	223
–	<i>Authentication failure</i>	224
–	<i>Authentication reject</i>	224
–	<i>Registration request</i>	224
–	<i>Registration accept</i>	224
–	<i>Registration complete</i>	225
–	<i>Registration reject</i>	225
–	<i>UL NAS transport</i>	225
–	<i>DL NAS transport</i>	226
–	<i>De-registration request (UE originating de-registration)</i>	226
–	<i>De-registration accept (UE originating de-registration)</i>	226
–	<i>De-registration request (UE terminated de-registration)</i>	226
–	<i>De-registration accept (UE terminated de-registration)</i>	227
–	<i>Service request</i>	227
–	<i>Service accept</i>	227
–	<i>Service reject</i>	228
–	<i>Configuration update command</i>	228
–	<i>Configuration update complete</i>	228
–	<i>Identity request</i>	228
–	<i>Identity response</i>	229
–	<i>Notification</i>	229
–	<i>Notification response</i>	229
–	<i>Security mode command</i>	230
–	<i>Security mode complete</i>	230
–	<i>Security mode reject</i>	230
–	<i>Security protected 5GS NAS message</i>	230
–	<i>5GMM status</i>	231
4.7.2	Contents of 5GSM messages	231

–	<i>PDU session establishment request</i>	231
–	<i>PDU session establishment accept</i>	231
–	<i>PDU session establishment reject</i>	232
–	<i>PDU session authentication command</i>	232
–	<i>PDU session authentication complete</i>	232
–	<i>PDU session authentication result</i>	232
–	<i>PDU session modification request</i>	233
–	<i>PDU session modification reject</i>	233
–	<i>PDU session modification command</i>	233
–	<i>PDU session modification complete</i>	234
–	<i>PDU session modification command reject</i>	234
–	<i>PDU session release request</i>	234
–	<i>PDU session release reject</i>	234
–	<i>PDU session release command</i>	235
–	<i>PDU session release complete</i>	235
–	<i>5GSM status</i>	235
4.8	Reference configurations.....	236
4.8.1	Radio configurations.....	236
–	<i>RRCReconfiguration-DRB(n, m)</i>	236
–	<i>CellGroupConfig-DRB(n, m)</i>	236
–	<i>RadioBearerConfig-DRB (n, m)</i>	237
4.9	Test procedures	237
4.9.1	Test procedure to check user plane connectivity on DRB#n	237
5	Test environments for RF test	238
5.1	Requirements of test equipment	238
5.1.1	Requirements for transmission and reception tests.....	238
5.1.1.1	Requirements common for conducted and OTA tests.....	238
5.1.1.2	Requirements for conducted tests	238
5.1.1.3	Requirements for OTA tests.....	238
5.1.2	Requirements for performance tests	238
5.1.2.1	Requirements common for conducted and OTA tests.....	238
5.1.2.2	Requirements for conducted test method	238
5.1.2.3	Requirements for OTA test method	238
5.2	Reference test conditions.....	238
5.2.1	Signal levels.....	238
5.2.1.1	Signal Levels for conducted testing	238
5.2.1.2	Signal Levels for OTA testing	238
5.2.1.2.1	Downlink Signal Levels.....	238
6	Test environments for Signalling test.....	239
6.1	Requirements of test equipment	239
6.1.1	Requirements common for conducted and OTA tests	239
6.1.2	Requirements for conducted test method.....	239
6.1.3	Requirements for OTA test method.....	239
6.1.3.1	General	239
6.1.3.2	Sample OTA Measurement Test Setup	239
6.1.3.3	RSRP Based Procedure for finding the optimum UE Orientation	239
6.1.4	Requirements for timer tolerances	240
6.2	Reference test conditions.....	240
6.2.1	Physical Channel Allocations	240
6.2.1.1	Antennas	240
6.2.1.2	Downlink physical channels and physical signals.....	240
6.2.2	Signal levels.....	241
6.2.2.1	Signal Levels for conducted testing	241
6.2.2.1.1	Measurement accuracy and side conditions.....	243
6.2.2.2	Signal Levels for OTA testing	244
6.2.3	Default test frequencies	245
6.2.3.1	Test frequencies for NR standalone signalling testing	245
6.2.3.2	Test frequencies for EN-DC band combinations for signalling testing.....	251
6.3	Reference system configurations.....	251
6.3.1	Cell configurations.....	251

7	Test environments for RRM tests.....	251
7.1	Requirements of test equipment	251
7.1.1	Requirements common for conducted and OTA tests	251
7.1.2	Requirements for conducted test method.....	251
7.1.3	Requirements for OTA test method.....	251
7.2	Reference test conditions.....	251
7.2.1	Signal levels.....	251
7.2.1.1	Signal Levels for conducted testing	251
7.2.1.2	Signal Levels for OTA testing	251
Annex A (informative): Connection Diagrams		252
A.1	Definition of Terms	252
A.2	General considerations on Connections Diagram	253
A.3	Connections Diagram.....	253
A.3.1	Test Equipment Parts.....	253
A.3.1.1	Basic Transmitter/Receiver tests.....	253
A.3.1.2	Transmitter tests using Spectrum Analyser	254
A.3.1.3	Transmitter tests using Spectrum Analyser and Signal Generator.....	254
A.3.1.4	Receiver tests using Signal Generator	254
A.3.1.5	Receiver tests using Spectrum Analyser.....	255
A.3.1.6	Receiver Performance tests.....	256
A.3.2	User Equipment Parts.....	256
A.3.2.1	Conducted Measurements.....	256
A.3.2.1.1	General	256
A.3.2.1.2	One Antenna Connector.....	257
A.3.2.1.3	Two Antenna Connectors.....	257
A.3.2.1.4	Three Antenna Connectors.....	258
A.3.2.1.5	Four Antenna Connectors	258
Annex B (normative): Permitted test methods For OTA Testing		259
B.1	General	259
Annex C (informative): Change history		260
History		265

Foreword

This Technical Specification has been produced by the 3rd Generation Partnership Project (3GPP).

The contents of the present document are subject to continuing work within the TSG and may change following formal TSG approval. Should the TSG modify the contents of the present document, it will be re-released by the TSG with an identifying change of release date and an increase in version number as follows:

Version x.y.z

where:

- x the first digit:
 - 1 presented to TSG for information;
 - 2 presented to TSG for approval;
 - 3 or greater indicates TSG approved document under change control.
- y the second digit is incremented for all changes of substance, i.e. technical enhancements, corrections, updates, etc.
- z the third digit is incremented when editorial only changes have been incorporated in the document.

The present document is part 1 of a multi-part deliverable covering the 5G System (5GS) User Equipment (UE) conformance specification, as identified below:

- **3GPP TS 38.508-1: "5GS; User Equipment (UE) conformance specification; Part 1: Common test environment"** (the present document).
- 3GPP TS 38.508-2 [10]: "5GS; User Equipment (UE) conformance specification; Part 2: Common Implementation Conformance Statement (ICS) proforma".

1 Scope

The present document defines the test environment for the 5G System.

This specification covers all aspects, including NG-RAN, 5GC and interworking between 5GS and EPS used for conformance tests of User Equipment (UE).

2 References

The following documents contain provisions which, through reference in this text, constitute provisions of the present document.

- References are either specific (identified by date of publication, edition number, version number, etc.) or non-specific.
- For a specific reference, subsequent revisions do not apply.
- For a non-specific reference, the latest version applies. In the case of a reference to a 3GPP document (including a GSM document), a non-specific reference implicitly refers to the latest version of that document *in the same Release as the present document*.

- [1] 3GPP TR 21.905: "Vocabulary for 3GPP Specifications".
- [2] 3GPP TS 36.508: "Evolved Universal Terrestrial Radio Access (E-UTRA) and Evolved Packet Core (EPC); User Equipment (UE) conformance specification".
- [3] 3GPP TS 36.300: "Evolved Universal Terrestrial Radio Access (E-UTRA) and Evolved Universal Terrestrial Radio Access (E-UTRAN); Overall description; Stage 2".
- [4] 3GPP TS 36.331: "Evolved Universal Terrestrial Radio Access (E-UTRA); Radio Resource Control (RRC) protocol specification".
- [5] 3GPP TS 38.300: "NR; Overall description; Stage 2".
- [6] 3GPP TS 38.331: "NR; Radio Resource Control (RRC); Protocol specification".
- [7] 3GPP TS 38.101-1: "NR; User Equipment (UE) radio transmission and reception; Part 1: Range 1 Standalone".
- [8] 3GPP TS 38.101-2: "NR; User Equipment (UE) radio transmission and reception; Part 1: Range 1 Standalone".
- [9] 3GPP TS 38.101-3: "NR; User Equipment (UE) radio transmission and reception; Part 3: Range 1 and Range 2 Interworking operation with other radios".
- [10] 3GPP TS 38.508-2: "5GS; User Equipment (UE) conformance specification; Part 2: Common Implementation Conformance Statement (ICS) proforma".
- [11] 3GPP TS 38.509: "5GS; Special conformance testing functions for User Equipment (UE)".
- [12] 3GPP TS 38.523-1: "5GS; User Equipment (UE) conformance specification; Part 1: Protocol".
- [13] 3GPP TS 38.133: "NR; Requirements for support of radio resource management".
- [14] 3GPP TS 38.521-1: "NR; User Equipment (UE) conformance specification; Radio transmission and reception; Part 1: Range 1 Standalone".
- [15] 3GPP TS 38.521-2: "NR; User Equipment (UE) conformance specification; Radio transmission and reception; Part 1: Range 1 Standalone".
- [16] 3GPP TS 38.521-3: "NR; User Equipment (UE) conformance specification; Radio transmission and reception; Part 3: Range 1 and Range 2 Interworking operation with other radios".

- [17] 3GPP TS 38.521-4: “NR; User Equipment (UE) conformance specification; Radio transmission and reception; Part 4: Performance”.
- [18] 3GPP TS 38.533: “NR; User Equipment (UE) conformance specification; Radio resource management”.
- [19] 3GPP TS 38.523-2: “5GS; User Equipment (UE) conformance specification; Part 2: Applicability of protocol test cases”.
- [20] 3GPP TS 38.321: “NR; Medium Access Control (MAC) protocol specification”.
- [21] 3GPP TS 36.214: “Evolved Universal Terrestrial Radio Access (E-UTRA); Physical layer; Measurements”.
- [22] 3GPP TS 38.213: “NR; Physical layer procedures for control”.
- [23] 3GPP TS 38.523-3: “5GS; UE conformance specification; Part 3: Test Suites”.
- [24] 3GPP TR 38.810: “Study on test methods for New Radio”

3 Definitions, symbols and abbreviations

3.1 Definitions

For the purposes of the present document, the terms and definitions given in 3GPP TR 21.905 [1] and the following apply. A term defined in the present document takes precedence over the definition of the same term, if any, in 3GPP TR 21.905 [1].

B: a value followed by "B" is a binary value.

H: a value followed by "H" is a hexadecimal value.

3.2 Symbols

For the purposes of the present document, the following symbols apply:

3.3 Abbreviations

For the purposes of the present document, the abbreviations given in 3GPP TR 21.905 [1] and the following apply. An abbreviation defined in the present document takes precedence over the definition of the same abbreviation, if any, in 3GPP TR 21.905 [1].

5GC	5G Core Network
5GMM	5GS Mobility Management
5GS	5G System
5GSM	5GS Session Management
EN-DC	E-UTRA-NR Dual Connectivity
MCG	Master Cell Group
MR-DC	Multi-RAT Dual Connectivity
NE-DC	NR-E-UTRA Dual Connectivity
NGEN-DC	NG-RAN E-UTRA-NR Dual Connectivity
NG-RAN	NG Radio Access Network
NR	NR Radio Access
RRC	Radio Resource Control
SCG	Secondary Cell Group
SS	System Simulator

4 Common test environments

4.1 Environmental conditions

The requirements in this clause apply to all types of UE(s).

4.1.1 Temperature

Regarding FR1 the UE shall fulfil all the requirements in the full temperature range of:

Table 4.1.1-1: Temperature conditions for FR1

+15°C to +35°C	For normal conditions (with relative humidity of 25 % to 75 %)
-10°C to +55°C	For extreme conditions (see IEC publications 68-2-1 and 68-2-2)

Outside this temperature range the UE, if powered on, shall not make ineffective use of the radio frequency spectrum. In no case shall the UE exceed the transmitted levels as defined in clause 6.2 for extreme operation.

The normative reference for this requirement is TS 38.101-1 [7] Annex E.2.

All RF requirements for UEs operating in FR2 are defined over the air and can only be tested in an OTA chamber.

Regarding FR2 the UE shall fulfil all requirements in the temperature range defined in Table 4.1.1-2.

Table 4.1.1-2: Temperature conditions

+ 25 °C ± [10] °C	For normal (room temperature) conditions with relative humidity of 25% to 75%
-10°C to +55°C	For extreme conditions

Outside this temperature range the UE, if powered on, shall not make ineffective use of the radio frequency spectrum. In no case shall the UE exceed the transmitted levels as defined in TS 38.101-2[8] for extreme operation.

The normative reference for this requirement is TS 38.101-2 [8] Annex E.1.

Some tests are performed also in extreme temperature conditions. These test conditions are denoted as TL (temperature low, -10°C) and TH (temperature high, +55°C).

4.1.2 Voltage

Editor's Note: This clause is incomplete. The following items are missing or are incomplete:

- Methodology to control the voltage in a case which a power cable is not connected to DUT is FFS since it is not agreed whether we can connect the power cable to DUT at the OTA measurement situation yet.

Regarding both FR1 and FR2 the UE shall fulfil all the requirements in the full voltage range, i.e. the voltage range between the extreme voltages.

The manufacturer shall declare the lower and higher extreme voltages and the approximate shutdown voltage. For the equipment that can be operated from one or more of the power sources listed below, the lower extreme voltage shall not be higher, and the higher extreme voltage shall not be lower than that specified below.

Table 4.1.2-1: Voltage conditions

Power source	Lower extreme voltage	Higher extreme voltage	Normal conditions voltage
AC mains	0,9 * nominal	1,1 * nominal	nominal
Regulated lead acid battery	0,9 * nominal	1,3 * nominal	1,1 * nominal
Non regulated batteries:			
Leclanché	0,85 * nominal	Nominal	Nominal
Lithium	0,95 * nominal	1,1 * Nominal	1,1 * Nominal
Mercury/nickel & cadmium	0,90 * nominal		Nominal

Outside this voltage range the UE if powered on, shall not make ineffective use of the radio frequency spectrum. In no case shall the UE exceed the transmitted levels as defined in TS 38.101-2[8] for extreme operation. In particular, the UE shall inhibit all RF transmissions when the power supply voltage is below the manufacturer declared shutdown voltage.

The normative reference for this requirement is TS 38.101-1 [7] Annex E.2 and TS 38.101-2 [8] Annex E.2.

Some tests are performed also in extreme voltage conditions. These test conditions are denoted as VL (lower extreme voltage) and VH (higher extreme voltage).

4.2 Common requirements of test equipment

Mobile conformance testing can be categorized into 3 distinct areas:

- RF Conformance Testing consisting of:
 - Transmission and Reception Conformance Testing.
 - Performance Conformance Testing.
- RRM Conformance Testing.
- Signalling Conformance Testing.

The test equipment required for each category of testing may or not be different, depending on the supplier of the test equipment. However, there will be some generic requirements of the test equipment that are essential for all three categories of test, and these are specified in this clause.

In addition, there will be requirements to test operation in multi-system configurations other than E-UTRA and NR dual connectivity (EN-DC). However, these would not form a common test equipment requirement for the three test areas and are not considered in the present document.

4.2.1 General functional requirements

NOTE: This clause has been written such that it does not constrain the implementation of different architectures and designs of test equipment.

All test equipment used to perform conformance testing for frequency range 1 on a UE shall provide the following minimum functionality:

- Conducted test method

All test equipment used to perform conformance testing for frequency range 2 on a UE shall provide the following minimum functionality:

- OTA test method

All test equipment used to perform conformance testing on a UE shall provide a platform suitable for testing UE's that are either:

- non-standalone(NSA) mode; or
- standalone(SA) mode.

All test equipment used to perform conformance testing on a UE shall provide a platform suitable for testing UE's that are either of following duplex mode for NR and E-UTRA (NSA only) respectively.

- a) FDD Mode; or
- b) TDD Mode; or
- c) both FDD/TDD Modes.

All test equipment shall provide the following minimum functionality.

- The capability of emulating a single NR cell and a single E-UTRA (for NSA mode only) cell with the appropriate channels to allow the UE to register on the cell.
- The capability to allow the UE to set up an RRC connection with the system simulator, and to maintain the connection for the duration of the test.
- The capability (for the specific test):
 - to select and support an appropriate radio bearer for the downlink;
 - to set up and support the appropriate radio bearer for the uplink;

4.2.2 Minimum functional requirements

4.2.2.1 Supported Cell Configuration

The System Simulator shall provide the capability to simulate a minimum number of cells whose number and capabilities are governed by the test cases that need to be performed (test cases are defined in 3GPP TS 38.523-1 [12] (Signalling), 3GPP TS 38.521-1 [14], 38.521-2 [15], 38.521-3 [16] (TRx) and 38.521-4 [17] (Performance) and 3GPP TS 38.533 [18] (RRM).

To perform test cases requiring multiple cell(s), the system simulator shall provide multiple cells offering the capabilities as required by the test case.

The type and number of channels (especially physical channels) constitute an important set of capabilities for a cell. The following clauses list possible channels that may be supported by the SS. Each channel type, however, and the minimum number of channels needed are only mandatory if specific test cases require them.

The mapping between Logical and Transport channels is as described in 3GPP TS 38.321 [20]. Similarly, the mapping between Transport channels and Physical channels is as described in 3GPP TS 38.211, TS 38.302 and TS 38.212. The reference measurement channels (mapping between Transport channels and Physical channels for PDSCH/PDCCH) are defined in 3GPP TS 38.521-1 [14] annex A

4.2.2.1.1 Supported Channels for an E-UTRA cell (NSA mode only)

Requirement for supported channels for E-UTRA cell is described in TS 36.508[2].

4.2.2.1.2 Supported Channels for a NR cell

4.2.2.1.1.1 Logical channels

Logical channel	Minimum number	Comments
BCCH	0 for EN-DC, TBD for SA	
CCCH	0 for EN-DC, TBD for SA	
DCCH	0 for EN-DC, TBD for SA	Split SRB or SRB3 is optional in EN-DC
PCCH	0 for EN-DC, TBD for SA	
DTCH	n	Depending on SS's support for RB service testing

4.2.2.1.1.2 Transport channels

Transport channel	Minimum number	Comments
BCH	1	
PCH	N/A for EN-DC, TBD for SA	
RACH	1	

DL-SCH	1	
UL-SCH	1	

4.2.2.1.1.3 Physical channels

Physical channel	Minimum number	Comments
PBCH	1	Physical Broadcast Channel
PDCCH	1	The physical downlink control channel carries scheduling assignments and other control information.
PDSCH	1	Physical Downlink Shared Channel
PUCCH	1	The physical uplink control channel carries uplink control information
PUSCH	1	Physical Uplink Shared Channel
PRACH	1	Physical Random Access Channel

4.2.2.1.1.4 Physical signals

Physical signal	Minimum number	Comments
Demodulation reference signal	NA	UL
Sounding Reference signal	NA	UL, if applicable
Phase Tracking Reference Signal	NA	UL, if applicable
Demodulation reference signal(PDSCH)	NA	DL
Demodulation reference signal(PDCCH)	NA	DL
Demodulation reference signal(PBCH)	NA	DL
Phase Tracking Reference Signal	NA	DL, if applicable
CSI reference signal	NA	DL
Primary synchronisation signal	NA	DL
Secondary synchronisation signal	NA	DL

4.3 Reference test conditions

4.3.1 Test frequencies

4.3.1.0 General

The test frequencies are based on operating bands defined in TS 38.101-1 [7], TS 38.101-2 [8] and TS 38.101-3 [9].

4.3.1.0A Mid test channel bandwidth

The Mid test channel bandwidth definition for RF is given in Table 4.3.1-1 and Table 4.3.1-2 for FR1 and FR2 respectively.

Table 4.3.1-1: Mid Test Channel bandwidths for each NR band, FR1

NR band / UE Mid Test Channel bandwidth	
NR Band	Mid [MHz]
n1	15
n2	15
n3	15
n5	15
n7	15
n8	15
n12	10
n20	15
n25	15
n28	15
n34	10
n38	15
n39	20
n40	30
n41	50
n51	5
n66	20
n70	15
n71	10
n75	15
n76	5
n77	50
n78	50
n79	60
n80	20
n81	15
n82	15
n83	15
n84	15
n86	20

Table 4.3.1-2: Mid Test Channel bandwidths for each NR band, FR2

NR band / UE Mid Test Channel bandwidth	
NR Band	Mid [MHz]
n257	[200]
n258	[200]
n260	[200]
NOTE 1: If Mid channel bandwidth is not supported by the UE in UL and/or DL, select the closest lower channel BW supported by the UE in both UL and DL.	

4.3.1.0B Bandwidth part

The value of *locationAndBandwidth* in *BWP* for FR1 is given in Table 4.3.1.0B-1. The value of *locationAndBandwidth* in *BWP* for FR2 is given in Table 4.3.1.0B-2.

Table 4.3.1.0B-1: locationAndBandwidth in BWP for FR1

BW [MHz]	SCS [kHz]	L_RBs (MAX N _{RB})	locationAndBandwidth (Note 1)
5	15	25	6600
5	30	11	2750
5	60	N/A	N/A
10	15	52	14025
10	30	24	6325
10	60	11	2750
15	15	79	21450
15	30	38	10175
15	60	18	4675
20	15	106	28875
20	30	51	13750
20	60	24	6325
25	15	133	36300
25	30	65	17600
25	60	31	8250
30	15	160	32174
30	30	78	21175
30	60	38	10175
40	15	216	16774
40	30	106	28875
40	60	51	13750
50	15	270	1924
50	30	133	36300
50	60	65	17600
60	15	N/A	N/A
60	30	162	31624
60	60	79	21450
80	15	N/A	N/A
80	30	217	16499
80	60	107	29150
90	15	N/A	N/A
90	30	245	8799
90	60	121	33000
100	15	N/A	N/A
100	30	273	1099
100	60	135	36850

Note 1: The value for *locationAndBandwidth* parameter is calculated as the RIV value in accordance to [21] TS 38.214 with $N_{\text{BWP}}^{\text{size}} = 275$, $RB_{\text{start}} = 0$ and $L_{\text{RBs}} = \text{Max } N_{\text{RB}}$ for each bandwidth and subcarrier spacing.

Table 4.3.1.0B-2: locationAndBandwidth in BWP for FR2

BW [MHz]	SCS [kHz]	L_RBs (MAX N _{RB})	locationAndBandwidth (Note 1)
50	60	66	17875
50	120	32	8525
100	60	132	36025
100	120	66	17875
200	60	264	3574
200	120	132	36025
400	60	N/A	N/A
400	120	264	3574

Note 1: The value for *locationAndBandwidth* parameter is calculated as the RIV value in accordance to [21] TS 38.214 with $N_{\text{BWP}}^{\text{size}} = 275$, $RB_{\text{start}} = 0$ and $L_{\text{RBs}} = \text{Max } N_{\text{RB}}$ for each bandwidth and subcarrier spacing.

4.3.1.1 Test frequencies for NR operating bands in FR1

4.3.1.1.1 Operating bands in FR1

4.3.1.1.1.1 Reference test frequencies for NR operating band n1

Table 4.3.1.1.1-1: Test frequencies for NR operating band n1 and SCS 15 kHz

Bandwidth [MHz]	carrierBand width [PRBs]	Range		Carrier centre [MHz]	Carrier centre [ARFCN]	point A [MHz]	absolute FrequencyPoint A [ARFCN]	offsetTo Carrier [PRBs]	SS block SCS [kHz]	GSCN	absoluteFrequencySSB [ARFCN]	k_{SSB}	CORE SET#0 Offset [RBs] Note 1	CORE SET#0 Index Note 1
5	25	Downlink	Low	2112.5	422500	2110.25	422050	0	15	5279	422410	0	0	0
			Mid	2140	428000	2119.57	423914	101		5350	427970	20	0	0
			High	2167.5	433500	1769.61	353922	2198		5418	433470	20	0	0
		Uplink	Low	1922.5	384500	1920.25	384050	0	-	-	-	-	-	-
			Mid	1950	390000	1552.11	310422	2198		-	-	-	-	-
			High	1977.5	395500	1975.07	395014	1		-	-	-	-	-
10	52	Downlink	Low	2115	423000	2110.32	422064	0	15	5280	422430	2	0	0
			Mid	2140	428000	2117.14	423428	101		5344	427490	22	0	0
			High	2165	433000	1764.68	352936	2198		5405	432490	22	0	0
		Uplink	Low	1925	385000	1920.32	384064	0	-	-	-	-	-	-
			Mid	1950	390000	1549.68	309936	2198		-	-	-	-	-
			High	1975	395000	1970.14	394028	1		-	-	-	-	-
15	79	Downlink	Low	2117.5	423500	2110.39	422078	0	15	5281	422450	4	0	0
			Mid	2140	428000	2114.71	422942	101		5338	427010	0	2	1
			High	2162.5	432500	1759.75	351950	2198		5395	431570	20	2	1
		Uplink	Low	1927.5	385500	1920.39	384078	0	-	-	-	-	-	-
			Mid	1950	390000	1547.25	309450	2198		-	-	-	-	-
			High	1972.5	394500	1965.21	393042	1		-	-	-	-	-
20	106	Downlink	Low	2120	424000	2110.46	422092	0	15	5282	422650	18	4	2
			Mid	2140	428000	2112.28	422456	101		5332	426530	2	2	1
			High	2160	432000	1754.82	350964	2198		5382	430590	22	2	1
		Uplink	Low	1930	386000	1920.46	384092	0	-	-	-	-	-	-
			Mid	1950	390000	1544.82	308964	2198		-	-	-	-	-
			High	1970	394000	1960.28	392056	1		-	-	-	-	-

Note 1: The CORESET#0 Index and the associated CORESET#0 Offset refers to Table 13-1 in TS 38.213 [22]. The value of CORESET#0 Index is signalled in the four most significant bits of the IE pdccch-ConfigSIB1 in the MIB

Table 4.3.1.1.1-2: Test frequencies for NR operating band n1 and SCS 30 kHz

Bandwidth [MHz]	carrierBand width [PRBs]	Range		Carrier centre [MHz]	Carrier centre [ARFCN]	point A [MHz]	absolute FrequencyPoint A [ARFCN]	offsetTo Carrier [PRBs]	SS block SCS [kHz]	GSCN	absoluteFrequencySSB [ARFCN]	k_{SSB}	CORE SET#0 Offset [RBs] Note 1	CORE SET#0 Index Note 1
10	24	Downlink	Low	2115	423000	2110.68	422136	0	15	5286	422910	18	5	0
			Mid	2140	428000	2099.32	419864	101		5350	427970	14	6	1
			High	2165	433000	1369.4	273880	2198		5411	432970	14	6	1
		Uplink	Low	1925	385000	1920.68	384136	0	-	-	-	-	-	-
			Mid	1950	390000	1154.4	230880	2198		-	-	-	-	-
			High	1975	395000	1970.32	394064	1		-	-	-	-	-
15	38	Downlink	Low	2117.5	423500	2110.66	422132	0	15	5287	422930	2	6	1
			Mid	2140	428000	2096.8	419360	101		5344	427490	22	6	1
			High	2162.5	432500	1364.38	272876	2198		5401	432050	18	7	2
		Uplink	Low	1927.5	385500	1920.66	384132	0	-	-	-	-	-	-
			Mid	1950	390000	1151.88	230376	2198		-	-	-	-	-
			High	1972.5	394500	1965.3	393060	1		-	-	-	-	-
20	51	Downlink	Low	2120	424000	2110.82	422164	0	15	5285	422890	2	5	0
			Mid	2140	428000	2094.46	418892	101		5338	427010	18	6	1
			High	2160	432000	1359.54	271908	2198		5388	431070	14	7	2
		Uplink	Low	1930	386000	1920.82	384164	0	-	-	-	-	-	-
			Mid	1950	390000	1149.54	229908	2198		-	-	-	-	-
			High	1970	394000	1960.46	392092	1		-	-	-	-	-

Note 1: The CORESET#0 Index and the associated CORESET#0 Offset refers to Table 13-2 in TS 38.213 [22]. The value of CORESET#0 Index is signalled in the four most significant bits of the IE pdcch-ConfigSIB1 in the MIB

Table 4.3.1.1.1-3: Test frequencies for NR operating band n1 and SCS 60 kHz

Bandwidth [MHz]	carrierBand width [PRBs]	Range	Carrier centre [MHz]	Carrier centre [ARFCN]	point A [MHz]	absolute FrequencyPoint A [ARFCN]	offsetTo Carrier [PRBs]	
10	11	Downlink	Low	2115	423000	2111.04	422208	0
			Mid	2140	428000	2063.32	412664	101
			High	2165	433000	578.48	115696	2198
		Uplink	Low	1925	385000	1921.04	384208	0
			Mid	1950	390000	363.48	72696	2198
			High	1975	395000	1970.32	394064	1
15	18	Downlink	Low	2117.5	423500	2111.02	422204	0
			Mid	2140	428000	2060.8	412160	101
			High	2162.5	432500	573.46	114692	2198
		Uplink	Low	1927.5	385500	1921.02	384204	0
			Mid	1950	390000	360.96	72192	2198
			High	1972.5	394500	1965.3	393060	1
20	24	Downlink	Low	2120	424000	2111.36	422272	0
			Mid	2140	428000	2058.64	411728	101
			High	2160	432000	568.8	113760	2198
		Uplink	Low	1930	386000	1921.36	384272	0
			Mid	1950	390000	358.8	71760	2198
			High	1970	394000	1960.64	392128	1

4.3.1.1.1.2 Reference test frequencies for NR operating band n2

Table 4.3.1.1.1.2-1: Test frequencies for NR operating band n2 and SCS 15 kHz

Bandwidth [MHz]	carrierBand width [PRBs]	Range		Carrier centre [MHz]	Carrier centre [ARFCN]	point A [MHz]	absolute FrequencyPoint A [ARFCN]	offsetTo Carrier [PRBs]	SS block SCS [kHz]	GSCN	absoluteFrequencySSB [ARFCN]	k_{SSB}	CORE SET#0 Offset [RBs] Note 1	CORE SET#0 Index Note 1
5	25	Downlink	Low	1932.5	386500	1930.25	386050	0	15	4829	386410	0	0	0
			Mid	1960	392000	1939.57	387914	101		4900	391970	20	0	0
			High	1987.5	397500	1589.61	317922	2198		4968	397470	20	0	0
		Uplink	Low	1852.5	370500	1850.25	370050	0	-	-	-	-	-	-
			Mid	1880	376000	1482.11	296422	2198		-	-	-	-	-
			High	1907.5	381500	1905.07	381014	1		-	-	-	-	-
10	52	Downlink	Low	1935	387000	1930.32	386064	0	15	4830	386430	2	0	0
			Mid	1960	392000	1937.14	387428	101		4894	391490	22	0	0
			High	1985	397000	1584.68	316936	2198		4955	396490	22	0	0
		Uplink	Low	1855	371000	1850.32	370064	0	-	-	-	-	-	-
			Mid	1880	376000	1479.68	295936	2198		-	-	-	-	-
			High	1905	381000	1900.14	380028	1		-	-	-	-	-
15	79	Downlink	Low	1937.5	387500	1930.39	386078	0	15	4831	386450	4	0	0
			Mid	1960	392000	1934.71	386942	101		4888	391010	0	2	1
			High	1982.5	396500	1579.75	315950	2198		4945	395570	20	2	1
		Uplink	Low	1857.5	371500	1850.39	370078	0	-	-	-	-	-	-
			Mid	1880	376000	1477.25	295450	2198		-	-	-	-	-
			High	1902.5	380500	1895.21	379042	1		-	-	-	-	-
20	106	Downlink	Low	1940	388000	1930.46	386092	0	15	4832	386650	18	4	2
			Mid	1960	392000	1932.28	386456	101		4882	390530	2	2	1
			High	1980	396000	1574.82	314964	2198		4932	394590	22	2	1
		Uplink	Low	1860	372000	1850.46	370092	0	-	-	-	-	-	-
			Mid	1880	376000	1474.82	294964	2198		-	-	-	-	-
			High	1900	380000	1890.28	378056	1		-	-	-	-	-

Note 1: The CORESET#0 Index and the associated CORESET#0 Offset refers to Table 13-1 in TS 38.213 [22]. The value of CORESET#0 Index is signalled in the four most significant bits of the IE pdcch-ConfigSIB1 in the MIB

Table 4.3.1.1.1.2-2: Test frequencies for NR operating band n2 and SCS 30 kHz

Bandwidth [MHz]	carrierBand width [PRBs]	Range		Carrier centre [MHz]	Carrier centre [ARFCN]	point A [MHz]	absolute FrequencyPoint A [ARFCN]	offsetTo Carrier [PRBs]	SS block SCS [kHz]	GSCN	absoluteFrequencySSB [ARFCN]	k_{SSB}	CORE SET#0 Offset [RBs] Note 1	CORE SET#0 Index Note 1
10	24	Downlink	Low	1935	387000	1930.68	386136	0	15	4836	386910	18	5	0
			Mid	1960	392000	1919.32	383864	101		4900	391970	14	6	1
			High	1985	397000	1189.4	237880	2198		4961	396970	14	6	1
		Uplink	Low	1855	371000	1850.68	370136	0	-	-	-	-	-	-
			Mid	1880	376000	1084.4	216880	2198		-	-	-	-	-
			High	1905	381000	1900.32	380064	1		-	-	-	-	-
15	38	Downlink	Low	1937.5	387500	1930.66	386132	0	15	4837	386930	2	6	1
			Mid	1960	392000	1916.8	383360	101		4894	391490	22	6	1
			High	1982.5	396500	1184.38	236876	2198		4951	396050	18	7	2
		Uplink	Low	1857.5	371500	1850.66	370132	0	-	-	-	-	-	-
			Mid	1880	376000	1081.88	216376	2198		-	-	-	-	-
			High	1902.5	380500	1895.3	379060	1		-	-	-	-	-
20	51	Downlink	Low	1940	388000	1930.82	386164	0	15	4835	386890	2	5	0
			Mid	1960	392000	1914.46	382892	101		4888	391010	18	6	1
			High	1980	396000	1179.54	235908	2198		4938	395070	14	7	2
		Uplink	Low	1860	372000	1850.82	370164	0	-	-	-	-	-	-
			Mid	1880	376000	1079.54	215908	2198		-	-	-	-	-
			High	1900	380000	1890.46	378092	1		-	-	-	-	-

Note 1: The CORESET#0 Index and the associated CORESET#0 Offset refers to Table 13-2 in TS 38.213 [22]. The value of CORESET#0 Index is signalled in the four most significant bits of the IE pdccch-ConfigSIB1 in the MIB

Table 4.3.1.1.1.2-3: Test frequencies for NR operating band n2 and SCS 60 kHz

Bandwidth [MHz]	carrierBand width [PRBs]	Range	Carrier centre [MHz]	Carrier centre [ARFCN]	point A [MHz]	absolute FrequencyPoint A [ARFCN]	offsetTo Carrier [PRBs]	
10	11	Downlink	Low	1935	387000	1931.04	386208	0
			Mid	1960	392000	1883.32	376664	101
			High	1985	397000	398.48	79696	2198
		Uplink	Low	1855	371000	1851.04	370208	0
			Mid	1880	376000	293.48	58696	2198
			High	1905	381000	1900.32	380064	1
15	18	Downlink	Low	1937.5	387500	1931.02	386204	0
			Mid	1960	392000	1880.8	376160	101
			High	1982.5	396500	393.46	78692	2198
		Uplink	Low	1857.5	371500	1851.02	370204	0
			Mid	1880	376000	290.96	58192	2198
			High	1902.5	380500	1895.3	379060	1
20	24	Downlink	Low	1940	388000	1931.36	386272	0
			Mid	1960	392000	1878.64	375728	101
			High	1980	396000	388.8	77760	2198
		Uplink	Low	1860	372000	1851.36	370272	0
			Mid	1880	376000	288.8	57760	2198
			High	1900	380000	1890.64	378128	1

4.3.1.1.1.3 Reference test frequencies for NR operating band n3

Table 4.3.1.1.1.3-1: Test frequencies for NR operating band n3 and SCS 15 kHz

Bandwidth [MHz]	carrierBand width [PRBs]	Range		Carrier centre [MHz]	Carrier centre [ARFCN]	point A [MHz]	absolute Frequency A [ARFCN]	offsetTo Carrier [PRBs]	SS block SCS [kHz]	GSCN	absoluteFrequencySSB [ARFCN]	k_{SSB}	CORE SET#0 Offset [RBs] Note 1	CORE SET#0 Index Note 1
5	25	Downlink	Low	1807.5	361500	1805.25	361050	0	15	4518	361470	20	0	0
			Mid	1842.5	368500	1822.07	364414	101		4604	368410	0	0	0
			High	1877.5	375500	1479.61	295922	2198		4693	375410	0	0	0
		Uplink	Low	1712.5	342500	1710.25	342050	0	-	-	-	-	-	-
			Mid	1747.5	349500	1349.61	269922	2198		-	-	-	-	-
			High	1782.5	356500	1780.07	356014	1		-	-	-	-	-
10	52	Downlink	Low	1810	362000	1805.32	361064	0	15	4519	361490	22	0	0
			Mid	1842.5	368500	1819.64	363928	101		4598	367930	2	0	0
			High	1875	375000	1474.68	294936	2198		4680	374430	2	0	0
		Uplink	Low	1715	343000	1710.32	342064	0	-	-	-	-	-	-
			Mid	1747.5	349500	1347.18	269436	2198		-	-	-	-	-
			High	1780	356000	1775.14	355028	1		-	-	-	-	-
15	79	Downlink	Low	1812.5	362500	1805.39	361078	0	15	4517	361450	4	0	0
			Mid	1842.5	368500	1817.21	363442	101		4592	367450	4	0	0
			High	1872.5	374500	1469.75	293950	2198		4667	373450	4	0	0
		Uplink	Low	1717.5	343500	1710.39	342078	0	-	-	-	-	-	-
			Mid	1747.5	349500	1344.75	268950	2198		-	-	-	-	-
			High	1777.5	355500	1770.21	354042	1		-	-	-	-	-
20	106	Downlink	Low	1815	363000	1805.46	361092	0	15	4518	361470	6	0	0
			Mid	1842.5	368500	1814.78	362956	101		4586	366970	6	0	0
			High	1870	374000	1464.82	292964	2198		4657	372530	2	2	1
		Uplink	Low	1720	344000	1710.46	342092	0	-	-	-	-	-	-
			Mid	1747.5	349500	1342.32	268464	2198		-	-	-	-	-
			High	1775	355000	1765.28	353056	1		-	-	-	-	-
25	133	Downlink	Low	1817.5	363500	1805.53	361106	0	15	4519	361490	8	0	0
			Mid	1842.5	368500	1812.35	362470	101		4580	366490	8	0	0
			High	1867.5	373500	1459.89	291978	2198		4644	371550	4	2	1
		Uplink	Low	1722.5	344500	1710.53	342106	0	-	-	-	-	-	-
			Mid	1747.5	349500	1339.89	267978	2198		-	-	-	-	-
			High	1772.5	354500	1760.35	352070	1		-	-	-	-	-
30	160	Downlink	Low	1820	364000	1805.6	361120	0	15	4520	361690	22	4	2
			Mid	1842.5	368500	1809.92	361984	101		4574	366010	10	0	0
			High	1865	373000	1454.96	290992	2198		4631	370570	6	2	1
		Uplink	Low	1725	345000	1710.6	342120	0	-	-	-	-	-	-
			Mid	1747.5	349500	1337.46	267492	2198		-	-	-	-	-
			High	1770	354000	1755.42	351084	1		-	-	-	-	-

Note 1: The CORESET#0 Index and the associated CORESET#0 Offset refers to Table 13-1 in TS 38.213 [22]. The value of CORESET#0 Index is signalled in the four most significant bits of the IE *pdccch-ConfigSIB1* in the MIB

Table 4.3.1.1.3-2: Test frequencies for NR operating band n3 and SCS 30 kHz

Bandwidth [MHz]	carrierBand width [PRBs]	Range		Carrier centre [MHz]	Carrier centre [ARFCN]	point A [MHz]	absolute FrequencyPoint A [ARFCN]	offsetTo Carrier [PRBs]	SS block SCS [kHz]	GSCN	absoluteFrequencySSB [ARFCN]	k_{SSB}	CORE SET#0 Offset [RBs] Note 1	CORE SET#0 Index Note 1
10	24	Downlink	Low	1810	362000	1805.68	361136	0	15	4525	361970	14	6	1
			Mid	1842.5	368500	1801.82	360364	101		4604	368410	18	5	0
			High	1875	375000	1079.4	215880	2198		4686	374910	18	5	0
		Uplink	Low	1715	343000	1710.68	342136	0	-	-	-	-	-	-
			Mid	1747.5	349500	951.9	190380	2198		-	-	-	-	-
			High	1780	356000	1775.32	355064	1		-	-	-	-	-
15	38	Downlink	Low	1812.5	362500	1805.66	361132	0	15	4523	361930	2	6	1
			Mid	1842.5	368500	1799.3	359860	101		4598	367930	2	6	1
			High	1872.5	374500	1074.38	214876	2198		4673	373930	2	6	1
		Uplink	Low	1717.5	343500	1710.66	342132	0	-	-	-	-	-	-
			Mid	1747.5	349500	949.38	189876	2198		-	-	-	-	-
			High	1777.5	355500	1770.3	354060	1		-	-	-	-	-
20	51	Downlink	Low	1815	363000	1805.82	361164	0	15	4524	361950	22	5	0
			Mid	1842.5	368500	1796.96	359392	101		4592	367450	22	5	0
			High	1870	374000	1069.54	213908	2198		4663	373010	18	6	1
		Uplink	Low	1720	344000	1710.82	342164	0	-	-	-	-	-	-
			Mid	1747.5	349500	947.04	189408	2198		-	-	-	-	-
			High	1775	355000	1765.46	353092	1		-	-	-	-	-
25	65	Downlink	Low	1817.5	363500	1805.8	361160	0	15	4525	361970	6	6	1
			Mid	1842.5	368500	1794.44	358888	101		4586	366970	6	6	1
			High	1867.5	373500	1064.52	212904	2198		4650	372030	2	7	2
		Uplink	Low	1722.5	344500	1710.8	342160	0	-	-	-	-	-	-
			Mid	1747.5	349500	944.52	188904	2198		-	-	-	-	-
			High	1772.5	354500	1760.44	352088	1		-	-	-	-	-
30	78	Downlink	Low	1820	364000	1805.96	361192	0	15	4523	361930	6	5	0
			Mid	1842.5	368500	1792.1	358420	101		4580	366490	2	6	1
			High	1865	373000	1059.68	211936	2198		4637	371050	22	6	1
		Uplink	Low	1725	345000	1710.96	342192	0	-	-	-	-	-	-
			Mid	1747.5	349500	942.18	188436	2198		-	-	-	-	-
			High	1770	354000	1755.6	351120	1		-	-	-	-	-

Note 1: The CORESET#0 Index and the associated CORESET#0 Offset refers to Table 13-2 in TS 38.213 [22]. The value of CORESET#0 Index is signalled in the four most significant bits of the IE pdccch-ConfigSIB1 in the MIB

Table 4.3.1.1.1.3-3: Test frequencies for NR operating band n3 and SCS 60 kHz

Bandwidth [MHz]	carrierBand width [PRBs]	Range	Carrier centre [MHz]	Carrier centre [ARFCN]	point A [MHz]	absolute FrequencyPoint A [ARFCN]	offsetTo Carrier [PRBs]	
10	11	Downlink	Low	1810	362000	1806.04	361208	0
			Mid	1842.5	368500	1765.82	353164	101
			High	1875	375000	288.48	57696	2198
		Uplink	Low	1715	343000	1711.04	342208	0
			Mid	1747.5	349500	160.98	32196	2198
			High	1780	356000	1775.32	355064	1
15	18	Downlink	Low	1812.5	362500	1806.02	361204	0
			Mid	1842.5	368500	1763.3	352660	101
			High	1872.5	374500	283.46	56692	2198
		Uplink	Low	1717.5	343500	1711.02	342204	0
			Mid	1747.5	349500	158.46	31692	2198
			High	1777.5	355500	1770.3	354060	1
20	24	Downlink	Low	1815	363000	1806.36	361272	0
			Mid	1842.5	368500	1761.14	352228	101
			High	1870	374000	278.8	55760	2198
		Uplink	Low	1720	344000	1711.36	342272	0
			Mid	1747.5	349500	156.3	31260	2198
			High	1775	355000	1765.64	353128	1
25	31	Downlink	Low	1817.5	363500	1806.34	361268	0
			Mid	1842.5	368500	1758.62	351724	101
			High	1867.5	373500	273.78	54756	2198
		Uplink	Low	1722.5	344500	1711.34	342268	0
			Mid	1747.5	349500	153.78	30756	2198
			High	1772.5	354500	1760.62	352124	1
30	38	Downlink	Low	1820	364000	1806.32	361264	0
			Mid	1842.5	368500	1756.1	351220	101
			High	1865	373000	268.76	53752	2198
		Uplink	Low	1725	345000	1711.32	342264	0
			Mid	1747.5	349500	151.26	30252	2198
			High	1770	354000	1755.6	351120	1
10	11	Downlink	Low	1810	362000	1806.04	361208	0
			Mid	1842.5	368500	1765.82	353164	101
			High	1875	375000	288.48	57696	2198
		Uplink	Low	1715	343000	1711.04	342208	0
			Mid	1747.5	349500	160.98	32196	2198
			High	1780	356000	1775.32	355064	1

4.3.1.1.1.4 FFS

4.3.1.1.1.5 Reference test frequencies for NR operating band n5

Table 4.3.1.1.1.5-1: Test frequencies for NR operating band n5 and SCS 15 kHz

Bandwidth [MHz]	carrierBand width [PRBs]	Range		Carrier centre [MHz]	Carrier centre [ARFCN]	point A [MHz]	absolute FrequencyPoint A [ARFCN]	offsetTo Carrier [PRBs]	SS block SCS [kHz]	GSCN	absoluteFrequencySSB [ARFCN]	k_{SSB}	CORE SET#0 Offset [RBs] Note 1	CORE SET#0 Index Note 1
5	25	Downlink	Low	871.5	174300	869.25	173850	0	15	2178	174270	20	0	0
			Mid	881.5	176300	861.07	172214	101		2203	176210	0	0	0
			High	891.5	178300	493.61	98722	2198		2228	178330	16	2	1
		Uplink	Low	826.5	165300	824.25	164850	0	-	-	-	-	-	-
			Mid	836.5	167300	438.61	87722	2198		-	-	-	-	-
			High	846.5	169300	844.07	168814	1		-	-	-	-	-
10	52	Downlink	Low	874	174800	869.32	173864	0	15	2179	174290	22	0	0
			Mid	881.5	176300	858.64	171728	101		2197	175730	2	0	0
			High	889	177800	488.68	97736	2198		2218	177410	14	4	2
		Uplink	Low	829	165800	824.32	164864	0	-	-	-	-	-	-
			Mid	836.5	167300	436.18	87236	2198		-	-	-	-	-
			High	844	168800	839.14	167828	1		-	-	-	-	-
15	79	Downlink	Low	876.5	175300	869.39	173878	0	15	2177	174250	4	0	0
			Mid	881.5	176300	856.21	171242	101		2191	175250	4	0	0
			High	886.5	177300	483.75	96750	2198		2205	176430	16	4	2
		Uplink	Low	831.5	166300	824.39	164878	0	-	-	-	-	-	-
			Mid	836.5	167300	433.75	86750	2198		-	-	-	-	-
			High	841.5	168300	834.21	166842	1		-	-	-	-	-
20	106	Downlink	Low	879	175800	869.46	173892	0	15	2178	174270	6	0	0
			Mid	881.5	176300	853.78	170756	101		2185	174770	6	0	0
			High	884	176800	478.82	95764	2198		2192	175450	18	4	2
		Uplink	Low	834	166800	824.46	164892	0	-	-	-	-	-	-
			Mid	836.5	167300	431.32	86264	2198		-	-	-	-	-
			High	839	167800	829.28	165856	1		-	-	-	-	-

Note 1: The CORESET#0 Index and the associated CORESET#0 Offset refers to Table 13-1 in TS 38.213 [22]. The value of CORESET#0 Index is signalled in the four most significant bits of the IE pdccch-ConfigSIB1 in the MIB

Table 4.3.1.1.1.5-2: Test frequencies for NR operating band n5 and SCS 30 kHz

Bandwidth [MHz]	carrierBand width [PRBs]	Range		Carrier centre [MHz]	Carrier centre [ARFCN]	point A [MHz]	absolute FrequencyPoint A [ARFCN]	offsetTo Carrier [PRBs]	SS block SCS [kHz]	GSCN	absoluteFrequencySSB [ARFCN]	k_{SSB}	CORE SET#0 Offset [RBs] Note 1	CORE SET#0 Index Note 1
10	24	Downlink	Low	874	174800	869.68	173936	0	15	2185	174770	14	6	1
			Mid	881.5	176300	840.82	168164	101		2203	176210	18	5	0
			High	889	177800	93.4	18680	2198		2224	177890	6	8	3
		Uplink	Low	829	165800	824.68	164936	0	-	-	-	-	-	-
			Mid	836.5	167300	40.9	8180	2198		-	-	-	-	-
			High	844	168800	839.32	167864	1		-	-	-	-	-
15	38	Downlink	Low	876.5	175300	869.66	173932	0	15	2183	174730	2	6	1
			Mid	881.5	176300	838.3	167660	101		2197	175730	2	6	1
			High	886.5	177300	88.38	17676	2198		2208	176670	6	5	0
		Uplink	Low	831.5	166300	824.66	164932	0	-	-	-	-	-	-
			Mid	836.5	167300	38.38	7676	2198		-	-	-	-	-
			High	841.5	168300	834.3	166860	1		-	-	-	-	-
20	51	Downlink	Low	879	175800	869.82	173964	0	15	2184	174750	22	5	0
			Mid	881.5	176300	835.96	167192	101		2191	175250	22	5	0
			High	884	176800	83.54	16708	2198		2195	175690	2	5	0
		Uplink	Low	834	166800	824.82	164964	0	-	-	-	-	-	-
			Mid	836.5	167300	36.04	7208	2198		-	-	-	-	-
			High	839	167800	829.46	165892	1		-	-	-	-	-

Note 1: The CORESET#0 Index and the associated CORESET#0 Offset refers to Table 13-2 in TS 38.213 [22]. The value of CORESET#0 Index is signalled in the four most significant bits of the IE pdccch-ConfigSIB1 in the MIB

4.3.1.1.1.6 FFS

4.3.1.1.1.7 Reference test frequencies for NR operating band n7

Table 4.3.1.1.1.7-1: Test frequencies for NR operating band n7 and SCS 15 kHz

Bandwidth [MHz]	carrierBand width [PRBs]	Range		Carrier centre [MHz]	Carrier centre [ARFCN]	point A [MHz]	absolute FrequencyPoint A [ARFCN]	offsetTo Carrier [PRBs]	SS block SCS [kHz]	GSCN	absoluteFrequencySSB [ARFCN]	k_{SSB}	CORE SET#0 Offset [RBs] Note 1	CORE SET#0 Index Note 1
5	25	Downlink	Low	2622.5	524500	2620.25	524050	0	15	6554	524410	0	0	0
			Mid	2655	531000	2634.57	526914	101		6636	530910	0	0	0
			High	2687.5	537500	2289.61	457922	2198		6718	537410	0	0	0
		Uplink	Low	2502.5	500500	2500.25	500050	0	-	-	-	-	-	-
			Mid	2535	507000	2137.11	427422	2198		-	-	-	-	-
			High	2567.5	513500	2565.07	513014	1		-	-	-	-	-
10	52	Downlink	Low	2625	525000	2620.32	524064	0	15	6555	524430	2	0	0
			Mid	2655	531000	2632.14	526428	101		6630	530430	2	0	0
			High	2685	537000	2284.68	456936	2198		6705	536430	2	0	0
		Uplink	Low	2505	501000	2500.32	500064	0	-	-	-	-	-	-
			Mid	2535	507000	2134.68	426936	2198		-	-	-	-	-
			High	2565	513000	2560.14	512028	1		-	-	-	-	-
15	79	Downlink	Low	2627.5	525500	2620.39	524078	0	15	6556	524450	4	0	0
			Mid	2655	531000	2629.71	525942	101		6624	529950	4	0	0
			High	2682.5	536500	2279.75	455950	2198		6692	535450	4	0	0
		Uplink	Low	2507.5	501500	2500.39	500078	0	-	-	-	-	-	-
			Mid	2535	507000	2132.25	426450	2198		-	-	-	-	-
			High	2562.5	512500	2555.21	511042	1		-	-	-	-	-
20	106	Downlink	Low	2630	526000	2620.46	524092	0	15	6557	524650	18	4	2
			Mid	2655	531000	2627.28	525456	101		6618	529470	6	0	0
			High	2680	536000	2274.82	454964	2198		6682	534530	2	2	1
		Uplink	Low	2510	502000	2500.46	500092	0	-	-	-	-	-	-
			Mid	2535	507000	2129.82	425964	2198		-	-	-	-	-
			High	2560	512000	2550.28	510056	1		-	-	-	-	-

Note 1: The CORESET#0 Index and the associated CORESET#0 Offset refers to Table 13-1 in TS 38.213 [22]. The value of CORESET#0 Index is signalled in the four most significant bits of the IE *pdccch-ConfigSIB1* in the MIB

Table 4.3.1.1.1.7-2: Test frequencies for NR operating band n7 and SCS 30 kHz

Bandwidth [MHz]	carrierBand width [PRBs]	Range		Carrier centre [MHz]	Carrier centre [ARFCN]	point A [MHz]	absolute FrequencyPoint A [ARFCN]	offsetTo Carrier [PRBs]	SS block SCS [kHz]	GSCN	absoluteFrequencySSB [ARFCN]	k_{SSB}	CORE SET#0 Offset [RBs] Note 1	CORE SET#0 Index Note 1
10	24	Downlink	Low	2625	525000	2620.68	524136	0	15	6561	524910	18	5	0
			Mid	2655	531000	2614.32	522864	101		6636	530910	18	5	0
			High	2685	537000	1889.4	377880	2198		6711	536910	18	5	0
		Uplink	Low	2505	501000	2500.68	500136	0	-	-	-	-	-	-
			Mid	2535	507000	1739.4	347880	2198		-	-	-	-	-
			High	2565	513000	2560.32	512064	1		-	-	-	-	-
15	38	Downlink	Low	2627.5	525500	2620.66	524132	0	15	6562	524930	2	6	1
			Mid	2655	531000	2611.8	522360	101		6630	530430	2	6	1
			High	2682.5	536500	1884.38	376876	2198		6698	535930	2	6	1
		Uplink	Low	2507.5	501500	2500.66	500132	0	-	-	-	-	-	-
			Mid	2535	507000	1736.88	347376	2198		-	-	-	-	-
			High	2562.5	512500	2555.3	511060	1		-	-	-	-	-
20	51	Downlink	Low	2630	526000	2620.82	524164	0	15	6560	524890	2	5	0
			Mid	2655	531000	2609.46	521892	101		6624	529950	22	5	0
			High	2680	536000	1879.54	375908	2198		6688	535010	18	6	1
		Uplink	Low	2510	502000	2500.82	500164	0	-	-	-	-	-	-
			Mid	2535	507000	1734.54	346908	2198		-	-	-	-	-
			High	2560	512000	2550.46	510092	1		-	-	-	-	-

Note 1: The CORESET#0 Index and the associated CORESET#0 Offset refers to Table 13-2 in TS 38.213 [22]. The value of CORESET#0 Index is signalled in the four most significant bits of the IE pdccch-ConfigSIB1 in the MIB

Table 4.3.1.1.1.7-3: Test frequencies for NR operating band n7 and SCS 60 kHz

Bandwidth [MHz]	carrierBand width [PRBs]	Range	Carrier centre [MHz]	Carrier centre [ARFCN]	point A [MHz]	absolute FrequencyPoint A [ARFCN]	offsetTo Carrier [PRBs]	
10	11	Downlink	Low	2625	525000	2621.04	524208	0
			Mid	2655	531000	2578.32	515664	101
			High	2685	537000	1098.48	219696	2198
		Uplink	Low	2505	501000	2501.04	500208	0
			Mid	2535	507000	948.48	189696	2198
			High	2565	513000	2560.32	512064	1
15	18	Downlink	Low	2627.5	525500	2621.02	524204	0
			Mid	2655	531000	2575.8	515160	101
			High	2682.5	536500	1093.46	218692	2198
		Uplink	Low	2507.5	501500	2501.02	500204	0
			Mid	2535	507000	945.96	189192	2198
			High	2562.5	512500	2555.3	511060	1
20	24	Downlink	Low	2630	526000	2621.36	524272	0
			Mid	2655	531000	2573.64	514728	101
			High	2680	536000	1088.8	217760	2198
		Uplink	Low	2510	502000	2501.36	500272	0
			Mid	2535	507000	943.8	188760	2198
			High	2560	512000	2550.64	510128	1

4.3.1.1.1.8 Reference test frequencies for NR operating band n8

Table 4.3.1.1.1.8-1: Test frequencies for NR operating band n8 and SCS 15 kHz

Bandwidth [MHz]	carrierBand width [PRBs]	Range		Carrier centre [MHz]	Carrier centre [ARFCN]	point A [MHz]	absolute FrequencyPoint A [ARFCN]	offsetTo Carrier [PRBs]	SS block SCS [kHz]	GSCN	absoluteFrequencySSB [ARFCN]	k_{SSB}	CORE SET#0 Offset [RBs] Note 1	CORE SET#0 Index Note 1
10	52	Downlink	Low	930	186000	925.32	185064	0	15	2319	185550	18	2	1
			Mid	942.5	188500	919.64	183928	101		2348	187930	2	0	0
			High	955	191000	554.68	110936	2198		2383	190610	14	4	2
		Uplink	Low	885	177000	880.32	176064	0	-	-	-	-	-	-
			Mid	897.5	179500	497.18	99436	2198		-	-	-	-	-
			High	910	182000	905.14	181028	1		-	-	-	-	-
15	79	Downlink	Low	932.5	186500	925.39	185078	0	15	2320	185570	20	2	1
			Mid	942.5	188500	917.21	183442	101		2342	187450	4	0	0
			High	952.5	190500	549.75	109950	2198		2370	189630	16	4	2
		Uplink	Low	887.5	177500	880.39	176078	0	-	-	-	-	-	-
			Mid	897.5	179500	494.75	98950	2198		-	-	-	-	-
			High	907.5	181500	900.21	180042	1		-	-	-	-	-
20	106	Downlink	Low	935	187000	925.46	185092	0	15	2318	185530	2	2	1
			Mid	942.5	188500	914.78	182956	101		2336	186970	6	0	0
			High	950	190000	544.82	108964	2198		2357	188650	18	4	2
		Uplink	Low	890	178000	880.46	176092	0	-	-	-	-	-	-
			Mid	897.5	179500	492.32	98464	2198		-	-	-	-	-
			High	905	181000	895.28	179056	1		-	-	-	-	-

Note 1: The CORESET#0 Index and the associated CORESET#0 Offset refers to Table 13-1 in TS 38.213 [22]. The value of CORESET#0 Index is signalled in the four most significant bits of the IE pdccch-ConfigSIB1 in the MIB

Table 4.3.1.1.1.8-2: Test frequencies for NR operating band n8 and SCS 30 kHz

Bandwidth [MHz]	carrierBand width [PRBs]	Range	Carrier centre [MHz]	Carrier centre [ARFCN]	point A [MHz]	absolute FrequencyPoint A [ARFCN]	offsetTo Carrier [PRBs]	SS block SCS [kHz]	GSCN	absoluteFrequencySSB [ARFCN]	k_{SSB}	CORE SET#0 Offset [RBs] Note 1	CORE SET#0 Index Note 1	
10	24	Downlink	Low	930	186000	925.68	185136	0	15	2325	186030	10	7	2
			Mid	942.5	188500	901.82	180364	101		2354	188410	18	5	0
			High	955	191000	159.4	31880	2198		2389	191090	6	8	3
		Uplink	Low	885	177000	880.68	176136	0	-	-	-	-	-	-
			Mid	897.5	179500	101.9	20380	2198		-	-	-	-	-
			High	910	182000	905.32	181064	1		-	-	-	-	-
15	38	Downlink	Low	932.5	186500	925.66	185132	0	15	2326	186050	18	7	2
			Mid	942.5	188500	899.3	179860	101		2348	187930	2	6	1
			High	952.5	190500	154.38	30876	2198		2373	189870	6	5	0
		Uplink	Low	887.5	177500	880.66	176132	0	-	-	-	-	-	-
			Mid	897.5	179500	99.38	19876	2198		-	-	-	-	-
			High	907.5	181500	900.3	180060	1		-	-	-	-	-
20	51	Downlink	Low	935	187000	925.82	185164	0	15	2324	186010	18	6	1
			Mid	942.5	188500	896.96	179392	101		2342	187450	22	5	0
			High	950	190000	149.54	29908	2198		2360	188890	2	5	0
		Uplink	Low	890	178000	880.82	176164	0	-	-	-	-	-	-
			Mid	897.5	179500	97.04	19408	2198		-	-	-	-	-
			High	905	181000	895.46	179092	1		-	-	-	-	-

Note 1: The CORESET#0 Index and the associated CORESET#0 Offset refers to Table 13-2 in TS 38.213 [22]. The value of CORESET#0 Index is signalled in the four most significant bits of the IE pdccch-ConfigSIB1 in the MIB

4.3.1.1.1.9 to 4.3.1.1.1.11 FFS

4.3.1.1.1.12 Reference test frequencies for NR operating band n12

Table 4.3.1.1.12-1: Test frequencies for NR operating band n12 and SCS 15 kHz

Bandwidth [MHz]	carrierBand width [PRBs]	Range		Carrier centre [MHz]	Carrier centre [ARFCN]	point A [MHz]	absolute FrequencyPoint A [ARFCN]	offsetTo Carrier [PRBs]	SS block SCS [kHz]	GSCN	absoluteFrequencySSB [ARFCN]	k_{SSB}	CORE SET#0 Offset [RBs] Note 1	CORE SET#0 Index Note 1
5	25	Downlink	Low	731.5	146300	729.25	145850	0	15	1828	146210	0	0	0
			Mid	737.5	147500	717.07	143414	101		1843	147410	0	0	0
			High	743.5	148700	345.61	69122	2198		1858	148610	0	0	0
		Uplink	Low	701.5	140300	699.25	139850	0	-	-	-	-	-	-
			Mid	707.5	141500	309.61	61922	2198		-	-	-	-	-
			High	713.5	142700	711.07	142214	1		-	-	-	-	-
10	52	Downlink	Low	734	146800	729.32	145864	0	15	1829	146410	14	4	2
			Mid	737.5	147500	714.64	142928	101		1837	146930	2	0	0
			High	741	148200	340.68	68136	2198		1845	147630	2	0	0
		Uplink	Low	704	140800	699.32	139864	0	-	-	-	-	-	-
			Mid	707.5	141500	307.18	61436	2198		-	-	-	-	-
			High	711	142200	706.14	141228	1		-	-	-	-	-
15	79	Downlink	Low	736.5	147300	729.39	145878	0	15	1830	146430	16	4	2
			Mid	737.5	147500	712.21	142442	101		1831	146450	4	0	0
			High	738.5	147700	335.75	67150	2198		1832	146650	4	0	0
		Uplink	Low	706.5	141300	699.39	139878	0	-	-	-	-	-	-
			Mid	707.5	141500	304.75	60950	2198		-	-	-	-	-
			High	708.5	141700	701.21	140242	1		-	-	-	-	-

Note 1: The CORESET#0 Index and the associated CORESET#0 Offset refers to Table 13-1 in TS 38.213 [22]. The value of CORESET#0 Index is signalled in the four most significant bits of the IE pdcch-ConfigSIB1 in the MIB

Table 4.3.1.1.12-2: Test frequencies for NR operating band n12 and SCS 30 kHz

Bandwidth [MHz]	carrierBand width [PRBs]	Range		Carrier centre [MHz]	Carrier centre [ARFCN]	point A [MHz]	absolute FrequencyPoint A [ARFCN]	offsetTo Carrier [PRBs]	SS block SCS [kHz]	GSCN	absoluteFrequencySSB [ARFCN]	k_{SSB}	CORE SET#0 Offset [RBs] Note 1	CORE SET#0 Index Note 1
10	24	Downlink	Low	734	146800	729.68	145936	0	15	1835	146890	6	8	3
			Mid	737.5	147500	696.82	139364	101		1843	147410	18	5	0
			High	741	148200	-54.6	-10920	2198		1851	148110	18	5	0
		Uplink	Low	704	140800	699.68	139936	0	-	-	-	-	-	-
			Mid	707.5	141500	-88.1	-17620	2198		-	-	-	-	-
			High	711	142200	706.32	141264	1		-	-	-	-	-
15	38	Downlink	Low	736.5	147300	729.66	145932	0	15	1833	146670	6	5	0
			Mid	737.5	147500	694.3	138860	101		1837	146930	2	6	1
			High	738.5	147700	-59.62	-11924	2198		1838	147130	2	6	1
		Uplink	Low	706.5	141300	699.66	139932	0	-	-	-	-	-	-
			Mid	707.5	141500	-90.62	-18124	2198		-	-	-	-	-
			High	708.5	141700	701.3	140260	1		-	-	-	-	-

Note 1: The CORESET#0 Index and the associated CORESET#0 Offset refers to Table 13-2 in TS 38.213 [22]. The value of CORESET#0 Index is signalled in the four most significant bits of the IE pdcch-ConfigSIB1 in the MIB

4.3.1.1.1.13 to 4.3.1.1.1.19 FFS

4.3.1.1.1.20 Reference test frequencies for NR operating band n20

Table 4.3.1.1.1.20-1: Test frequencies for NR operating band n20 and SCS 15 kHz

Bandwidth [MHz]	carrierBand width [PRBs]	Range		Carrier centre [MHz]	Carrier centre [ARFCN]	point A [MHz]	absolute FrequencyPoint A [ARFCN]	offsetTo Carrier [PRBs]	SS block SCS [kHz]	GSCN	absoluteFrequencySSB [ARFCN]	k_{SSB}	CORE SET#0 Offset [RBs] Note 1	CORE SET#0 Index Note 1
5	25	Downlink	Low	793.5	158700	791.25	158250	0	15	1983	158670	20	0	0
			Mid	806	161200	785.57	157114	101		2015	161290	12	4	2
			High	818.5	163700	420.61	84122	2198		2047	163730	16	2	1
		Uplink	Low	834.5	166900	832.25	166450	0	-	-	-	-	-	-
			Mid	847	169400	449.11	89822	2198		-	-	-	-	-
			High	859.5	171900	857.07	171414	1		-	-	-	-	-
10	52	Downlink	Low	796	159200	791.32	158264	0	15	1984	158690	22	0	0
			Mid	806	161200	783.14	156628	101		2009	160810	14	4	2
			High	816	163200	415.68	83136	2198		2034	162750	18	2	1
		Uplink	Low	837	167400	832.32	166464	0	-	-	-	-	-	-
			Mid	847	169400	446.68	89336	2198		-	-	-	-	-
			High	857	171400	852.14	170428	1		-	-	-	-	-
15	79	Downlink	Low	798.5	159700	791.39	158278	0	15	1982	158650	4	0	0
			Mid	806	161200	780.71	156142	101		2003	160330	16	4	2
			High	813.5	162700	410.75	82150	2198		2021	161770	20	2	1
		Uplink	Low	839.5	167900	832.39	166478	0	-	-	-	-	-	-
			Mid	847	169400	444.25	88850	2198		-	-	-	-	-
			High	854.5	170900	847.21	169442	1		-	-	-	-	-
20	106	Downlink	Low	801	160200	791.46	158292	0	15	1983	158670	6	0	0
			Mid	806	161200	778.28	155656	101		1997	159850	18	4	2
			High	811	162200	405.82	81164	2198		2011	160850	18	4	2
		Uplink	Low	842	168400	832.46	166492	0	-	-	-	-	-	-
			Mid	847	169400	441.82	88364	2198		-	-	-	-	-
			High	852	170400	842.28	168456	1		-	-	-	-	-

Note 1: The CORESET#0 Index and the associated CORESET#0 Offset refers to Table 13-1 in TS 38.213 [22]. The value of CORESET#0 Index is signalled in the four most significant bits of the IE pdccch-ConfigSIB1 in the MIB

Table 4.3.1.1.1.20-2: Test frequencies for NR operating band n20 and SCS 30 kHz

Bandwidth [MHz]	carrierBand width [PRBs]	Range		Carrier centre [MHz]	Carrier centre [ARFCN]	point A [MHz]	absolute FrequencyPoint A [ARFCN]	offsetTo Carrier [PRBs]	SS block SCS [kHz]	GSCN	absoluteFrequencySSB [ARFCN]	k_{SSB}	CORE SET#0 Offset [RBs] Note 1	CORE SET#0 Index Note 1
10	24	Downlink	Low	796	159200	791.68	158336	0	15	1990	159170	14	6	1
			Mid	806	161200	765.32	153064	101		2015	161290	6	8	3
			High	816	163200	20.4	4080	2198		2040	163230	10	7	2
		Uplink	Low	837	167400	832.68	166536	0	-	-	-	-	-	-
			Mid	847	169400	51.4	10280	2198		-	-	-	-	-
			High	857	171400	852.32	170464	1		-	-	-	-	-
15	38	Downlink	Low	798.5	159700	791.66	158332	0	15	1988	159130	2	6	1
			Mid	806	161200	762.8	152560	101		2006	160570	6	5	0
			High	813.5	162700	15.38	3076	2198		2027	162250	18	7	2
		Uplink	Low	839.5	167900	832.66	166532	0	-	-	-	-	-	-
			Mid	847	169400	48.88	9776	2198		-	-	-	-	-
			High	854.5	170900	847.3	169460	1		-	-	-	-	-
20	51	Downlink	Low	801	160200	791.82	158364	0	15	1989	159150	22	5	0
			Mid	806	161200	760.46	152092	101		2000	160090	2	5	0
			High	811	162200	10.54	2108	2198		2014	161090	2	5	0
		Uplink	Low	842	168400	832.82	166564	0	-	-	-	-	-	-
			Mid	847	169400	46.54	9308	2198		-	-	-	-	-
			High	852	170400	842.46	168492	1		-	-	-	-	-
Note 1: The CORESET#0 Index and the associated CORESET#0 Offset refers to Table 13-2 in TS 38.213 [22]. The value of CORESET#0 Index is signalled in the four most significant bits of the IE pdcch-ConfigSIB1 in the MIB														

4.3.1.1.1.21 to 4.3.1.1.1.24 FFS

4.3.1.1.1.25 Reference test frequencies for NR operating band n25

Table 4.3.1.1.1.25-1: Test frequencies for NR operating band n25 and SCS 15 kHz

Bandwidth [MHz]	carrierBand width [PRBs]	Range		Carrier centre [MHz]	Carrier centre [ARFCN]	point A [MHz]	absolute FrequencyPoint A [ARFCN]	offsetTo Carrier [PRBs]	SS block SCS [kHz]	GSCN	absoluteFrequencySSB [ARFCN]	k_{SSB}	CORE SET#0 Offset [RBs] Note 1	CORE SET#0 Index Note 1
5	25	Downlink	Low	1932.5	386500	1930.25	386050	0	15	4829	386410	0	0	0
			Mid	1962.5	392500	1942.07	388414	101		4904	392410	0	0	0
			High	1992.5	398500	1594.61	318922	2198		4979	398410	0	0	0
		Uplink	Low	1852.5	370500	1850.25	370050	0	-	-	-	-	-	-
			Mid	1882.5	376500	1484.61	296922	2198		-	-	-	-	-
			High	1912.5	382500	1910.07	382014	1		-	-	-	-	-
10	52	Downlink	Low	1935	387000	1930.32	386064	0	15	4830	386430	2	0	0
			Mid	1962.5	392500	1939.64	387928	101		4898	391930	2	0	0
			High	1990	398000	1589.68	317936	2198		4969	397490	22	0	0
		Uplink	Low	1855	371000	1850.32	370064	0	-	-	-	-	-	-
			Mid	1882.5	376500	1482.18	296436	2198		-	-	-	-	-
			High	1910	382000	1905.14	381028	1		-	-	-	-	-
15	79	Downlink	Low	1937.5	387500	1930.39	386078	0	15	4831	386450	4	0	0
			Mid	1962.5	392500	1937.21	387442	101		4892	391450	4	0	0
			High	1987.5	397500	1584.75	316950	2198		4956	396510	0	2	1
		Uplink	Low	1857.5	371500	1850.39	370078	0	-	-	-	-	-	-
			Mid	1882.5	376500	1479.75	295950	2198		-	-	-	-	-
			High	1907.5	381500	1900.21	380042	1		-	-	-	-	-
20	106	Downlink	Low	1940	388000	1930.46	386092	0	15	4832	386650	18	4	2
			Mid	1962.5	392500	1934.78	386956	101		4886	390970	6	0	0
			High	1985	397000	1579.82	315964	2198		4943	395530	2	2	1
		Uplink	Low	1860	372000	1850.46	370092	0	-	-	-	-	-	-
			Mid	1882.5	376500	1477.32	295464	2198		-	-	-	-	-
			High	1905	381000	1895.28	379056	1		-	-	-	-	-

Note 1: The CORESET#0 Index and the associated CORESET#0 Offset refers to Table 13-1 in TS 38.213 [22]. The value of CORESET#0 Index is signalled in the four most significant bits of the IE pdccch-ConfigSIB1 in the MIB

Table 4.3.1.1.1.25-2: Test frequencies for NR operating band n25 and SCS 30 kHz

Bandwidth [MHz]	carrierBand width [PRBs]	Range	Carrier centre [MHz]	Carrier centre [ARFCN]	point A [MHz]	absolute FrequencyPoint A [ARFCN]	offsetTo Carrier [PRBs]	SS block SCS [kHz]	GSCN	absoluteFrequencySSB [ARFCN]	k_{SSB}	CORE SET#0 Offset [RBs] Note 1	CORE SET#0 Index Note 1	
10	24	Downlink	Low	1935	387000	1930.68	386136	0	15	4836	386910	18	5	0
			Mid	1962.5	392500	1921.82	384364	101		4904	392410	18	5	0
			High	1990	398000	1194.4	238880	2198		4975	397970	14	6	1
		Uplink	Low	1855	371000	1850.68	370136	0	-	-	-	-	-	-
			Mid	1882.5	376500	1086.9	217380	2198		-	-	-	-	-
			High	1910	382000	1905.32	381064	1		-	-	-	-	-
15	38	Downlink	Low	1937.5	387500	1930.66	386132	0	15	4837	386930	2	6	1
			Mid	1962.5	392500	1919.3	383860	101		4898	391930	2	6	1
			High	1987.5	397500	1189.38	237876	2198		4962	396990	22	6	1
		Uplink	Low	1857.5	371500	1850.66	370132	0	-	-	-	-	-	-
			Mid	1882.5	376500	1084.38	216876	2198		-	-	-	-	-
			High	1907.5	381500	1900.3	380060	1		-	-	-	-	-
20	51	Downlink	Low	1940	388000	1930.82	386164	0	15	4835	386890	2	5	0
			Mid	1962.5	392500	1916.96	383392	101		4892	391450	22	5	0
			High	1985	397000	1184.54	236908	2198		4949	396010	18	6	1
		Uplink	Low	1860	372000	1850.82	370164	0	-	-	-	-	-	-
			Mid	1882.5	376500	1082.04	216408	2198		-	-	-	-	-
			High	1905	381000	1895.46	379092	1		-	-	-	-	-

Note 1: The CORESET#0 Index and the associated CORESET#0 Offset refers to Table 13-2 in TS 38.213 [22]. The value of CORESET#0 Index is signalled in the four most significant bits of the IE pdccch-ConfigSIB1 in the MIB

Table 4.3.1.1.1.25-3: Test frequencies for NR operating band n25 and SCS 60 kHz

Bandwidth [MHz]	carrierBand width [PRBs]	Range	Carrier centre [MHz]	Carrier centre [ARFCN]	point A [MHz]	absolute FrequencyPoint A [ARFCN]	offsetTo Carrier [PRBs]	
10	11	Downlink	Low	1935	387000	1931.04	386208	0
			Mid	1962.5	392500	1885.82	377164	101
			High	1990	398000	403.48	80696	2198
		Uplink	Low	1855	371000	1851.04	370208	0
			Mid	1882.5	376500	295.98	59196	2198
			High	1910	382000	1905.32	381064	1
15	18	Downlink	Low	1937.5	387500	1931.02	386204	0
			Mid	1962.5	392500	1883.3	376660	101
			High	1987.5	397500	398.46	79692	2198
		Uplink	Low	1857.5	371500	1851.02	370204	0
			Mid	1882.5	376500	293.46	58692	2198
			High	1907.5	381500	1900.3	380060	1
20	24	Downlink	Low	1940	388000	1931.36	386272	0
			Mid	1962.5	392500	1881.14	376228	101
			High	1985	397000	393.8	78760	2198
		Uplink	Low	1860	372000	1851.36	370272	0
			Mid	1882.5	376500	291.3	58260	2198
			High	1905	381000	1895.64	379128	1

4.3.1.1.1.26 to 4.3.1.1.1.27 FFS

4.3.1.1.1.28 Reference test frequencies for NR operating band n28

Table 4.3.1.1.1.28-1: Test frequencies for NR operating band n28 and SCS 15 kHz

Bandwidth [MHz]	carrierBand width [PRBs]	Range		Carrier centre [MHz]	Carrier centre [ARFCN]	point A [MHz]	absolute FrequencyPoint A [ARFCN]	offsetTo Carrier [PRBs]	SS block SCS [kHz]	GSCN	absoluteFrequencySSB [ARFCN]	k_{SSB}	CORE SET#0 Offset [RBs] Note 1	CORE SET#0 Index Note 1
5	25	Downlink	Low	760.5	152100	758.25	151650	0	15	1902	152190	12	4	2
			Mid	780.5	156100	760.07	152014	101		1949	156010	0	0	0
			High	800.5	160100	402.61	80522	2198		2002	160130	16	2	1
		Uplink	Low	705.5	141100	703.25	140650	0	-	-	-	-	-	-
			Mid	725.5	145100	327.61	65522	2198		-	-	-	-	-
			High	745.5	149100	743.07	148614	1		-	-	-	-	-
10	52	Downlink	Low	763	152600	758.32	151664	0	15	1903	152210	14	4	2
			Mid	780.5	156100	757.64	151528	101		1943	155530	2	0	0
			High	798	159600	397.68	79536	2198		1989	159150	18	2	1
		Uplink	Low	708	141600	703.32	140664	0	-	-	-	-	-	-
			Mid	725.5	145100	325.18	65036	2198		-	-	-	-	-
			High	743	148600	738.14	147628	1		-	-	-	-	-
15	79	Downlink	Low	765.5	153100	758.39	151678	0	15	1901	152170	20	2	1
			Mid	780.5	156100	755.21	151042	101		1937	155050	4	0	0
			High	795.5	159100	392.75	78550	2198		1976	158170	20	2	1
		Uplink	Low	710.5	142100	703.39	140678	0	-	-	-	-	-	-
			Mid	725.5	145100	322.75	64550	2198		-	-	-	-	-
			High	740.5	148100	733.21	146642	1		-	-	-	-	-
20	106	Downlink	Low	768	153600	758.46	151692	0	15	1902	152190	22	2	1
			Mid	780.5	156100	752.78	150556	101		1931	154570	6	0	0
			High	793	158600	387.82	77564	2198		1966	157250	18	4	2
		Uplink	Low	713	142600	703.46	140692	0	-	-	-	-	-	-
			Mid	725.5	145100	320.32	64064	2198		-	-	-	-	-
			High	738	147600	728.28	145656	1		-	-	-	-	-

Note 1: The CORESET#0 Index and the associated CORESET#0 Offset refers to Table 13-1 in TS 38.213 [22]. The value of CORESET#0 Index is signalled in the four most significant bits of the IE pdccch-ConfigSIB1 in the MIB

Table 4.3.1.1.1.28-2: Test frequencies for NR operating band n28 and SCS 30 kHz

Bandwidth [MHz]	carrierBand width [PRBs]	Range	Carrier centre [MHz]	Carrier centre [ARFCN]	point A [MHz]	absolute FrequencyPoint A [ARFCN]	offsetTo Carrier [PRBs]	SS block SCS [kHz]	GSCN	absoluteFrequencySSB [ARFCN]	k_{SSB}	CORE SET#0 Offset [RBs] Note 1	CORE SET#0 Index Note 1	
10	24	Downlink	Low	763	152600	758.68	151736	0	15	1909	152690	6	8	3
			Mid	780.5	156100	739.82	147964	101		1949	156010	18	5	0
			High	798	159600	2.4	480	2198		1995	159630	10	7	2
		Uplink	Low	708	141600	703.68	140736	0	-	-	-	-	-	-
			Mid	725.5	145100	-70.1	-14020	2198		-	-	-	-	-
			High	743	148600	738.32	147664	1		-	-	-	-	-
15	38	Downlink	Low	765.5	153100	758.66	151732	0	15	1907	152650	18	7	2
			Mid	780.5	156100	737.3	147460	101		1943	155530	2	6	1
			High	795.5	159100	-2.62	-524	2198		1982	158650	18	7	2
		Uplink	Low	710.5	142100	703.66	140732	0	-	-	-	-	-	-
			Mid	725.5	145100	-72.62	-14524	2198		-	-	-	-	-
			High	740.5	148100	733.3	146660	1		-	-	-	-	-
20	51	Downlink	Low	768	153600	758.82	151764	0	15	1908	152670	14	7	2
			Mid	780.5	156100	734.96	146992	101		1937	155050	22	5	0
			High	793	158600	-7.46	-1492	2198		1969	157490	2	5	0
		Uplink	Low	713	142600	703.82	140764	0	-	-	-	-	-	-
			Mid	725.5	145100	-74.96	-14992	2198		-	-	-	-	-
			High	738	147600	728.46	145692	1		-	-	-	-	-
Note 1: The CORESET#0 Index and the associated CORESET#0 Offset refers to Table 13-2 in TS 38.213 [22]. The value of CORESET#0 Index is signalled in the four most significant bits of the IE pdccch-ConfigSIB1 in the MIB														

4.3.1.1.1.29 to 4.3.1.1.1.33 FFS

4.3.1.1.1.34 Reference test frequencies for NR operating band n34

Table 4.3.1.1.1.34-1: Test frequencies for NR operating band n34 and SCS 15 kHz

Bandwidth [MHz]	carrierBand width [PRBs]	Range		Carrier centre [MHz]	Carrier centre [ARFCN]	point A [MHz]	absolute FrequencyPoint A [ARFCN]	offsetTo Carrier [PRBs]	SS block SCS [kHz]	GSCN	absoluteFrequencySSB [ARFCN]	k_{SSB}	CORE SET#0 Offset [RBs] Note 1	CORE SET#0 Index Note 1
5	25	Downlink & Uplink	Low	2012.5	402500	2010.25	402050	0	15	5032	402530	16	2	1
			Mid	2017.5	403500	1997.07	399414	101		5043	403470	20	0	0
			High	2022.5	404500	1624.61	324922	2198		5054	404410	0	0	0
10	52	Downlink & Uplink	Low	2015	403000	2010.32	402064	0	15	5030	402490	22	0	0
			Mid	2017.5	403500	1994.64	398928	101		5037	402990	22	0	0
			High	2020	404000	1619.68	323936	2198		5044	403490	22	0	0
15	79	Downlink & Uplink	Low	2017.5	403500	2010.39	402078	0	15	5031	402510	0	2	1
			Mid	2017.5	403500	1992.21	398442	101		5031	402510	0	2	1
			High	2017.5	403500	1614.75	322950	2198		5031	402510	0	2	1

Note 1: The CORESET#0 Index and the associated CORESET#0 Offset refers to Table 13-1 in TS 38.213 [22]. The value of CORESET#0 Index is signalled in the four most significant bits of the IE pdccch-ConfigSIB1 in the MIB

Table 4.3.1.1.1.34-2: Test frequencies for NR operating band n34 and SCS 30 kHz

Bandwidth [MHz]	carrierBand width [PRBs]	Range		Carrier centre [MHz]	Carrier centre [ARFCN]	point A [MHz]	absolute FrequencyPoint A [ARFCN]	offsetTo Carrier [PRBs]	SS block SCS [kHz]	GSCN	absoluteFrequencySSB [ARFCN]	k_{SSB}	CORE SET#0 Offset [RBs] Note 1	CORE SET#0 Index Note 1
10	24	Downlink & Uplink	Low	2015	403000	2010.68	402136	0	15	5036	402970	14	6	1
			Mid	2017.5	403500	1976.82	395364	101		5043	403470	14	6	1
			High	2020	404000	1224.4	244880	2198		5050	403970	14	6	1
15	38	Downlink & Uplink	Low	2017.5	403500	2010.66	402132	0	15	5037	402990	22	6	1
			Mid	2017.5	403500	1974.3	394860	101		5037	402990	22	6	1
			High	2017.5	403500	1219.38	243876	2198		5037	402990	22	6	1

Note 1: The CORESET#0 Index and the associated CORESET#0 Offset refers to Table 13-2 in TS 38.213 [22]. The value of CORESET#0 Index is signalled in the four most significant bits of the IE pdccch-ConfigSIB1 in the MIB

Table 4.3.1.1.1.34-3: Test frequencies for NR operating band n34 and SCS 60 kHz

Bandwidth [MHz]	carrierBand width [PRBs]	Range		Carrier centre [MHz]	Carrier centre [ARFCN]	point A [MHz]	absolute FrequencyPoint A [ARFCN]	offsetTo Carrier [PRBs]
10	11	Downlink & Uplink	Low	2015	403000	2011.04	402208	0
			Mid	2017.5	403500	1940.82	388164	101
			High	2020	404000	433.48	86696	2198
15	18	Downlink & Uplink	Low	2017.5	403500	2011.02	402204	0
			Mid	2017.5	403500	1938.3	387660	101
			High	2017.5	403500	428.46	85692	2198

4.3.1.1.1.35 to 4.3.1.1.1.37 FFS

4.3.1.1.1.38 Reference test frequencies for NR operating band n38

Table 4.3.1.1.1.38-1: Test frequencies for NR operating band n38 and SCS 15 kHz

Bandwidth [MHz]	carrierBand width [PRBs]	Range		Carrier centre [MHz]	Carrier centre [ARFCN]	point A [MHz]	absolute FrequencyPoint A [ARFCN]	offsetTo Carrier [PRBs]	SS block SCS [kHz]	GSCN	absoluteFrequencySSB [ARFCN]	k_{SSB}	CORE SET#0 Offset [RBs] Note 1	CORE SET#0 Index Note 1
5	25	Downlink & Uplink	Low	2572.5	514500	2570.25	514050	0	15	6432	514590	12	4	2
			Mid	2595	519000	2574.57	514914	101		6486	518910	0	0	0
			High	2617.5	523500	2219.61	443922	2198		6543	523470	20	0	0
10	52	Downlink & Uplink	Low	2575	515000	2570.32	514064	0	15	6433	514610	14	4	2
			Mid	2595	519000	2572.14	514428	101		6480	518430	2	0	0
			High	2615	523000	2214.68	442936	2198		6530	522490	22	0	0
15	79	Downlink & Uplink	Low	2577.5	515500	2570.39	514078	0	15	6431	514570	20	2	1
			Mid	2595	519000	2569.71	513942	101		6474	517950	4	0	0
			High	2612.5	522500	2209.75	441950	2198		6520	521570	20	2	1
20	106	Downlink & Uplink	Low	2580	516000	2570.46	514092	0	15	6432	514590	22	2	1
			Mid	2595	519000	2567.28	513456	101		6468	517470	6	0	0
			High	2610	522000	2204.82	440964	2198		6507	520590	22	2	1

Note 1: The CORESET#0 Index and the associated CORESET#0 Offset refers to Table 13-1 in TS 38.213 [22]. The value of CORESET#0 Index is signalled in the four most significant bits of the IE pdccch-ConfigSIB1 in the MIB

Table 4.3.1.1.1.38-2: Test frequencies for NR operating band n38 and SCS 30 kHz

Bandwidth [MHz]	carrierBand width [PRBs]	Range		Carrier centre [MHz]	Carrier centre [ARFCN]	point A [MHz]	absolute FrequencyPoint A [ARFCN]	offsetTo Carrier [PRBs]	SS block SCS [kHz]	GSCN	absoluteFrequencySSB [ARFCN]	k_{SSB}	CORE SET#0 Offset [RBs] Note 1	CORE SET#0 Index Note 1
10	24	Downlink & Uplink	Low	2575	515000	2570.68	514136	0	15	6439	515090	6	8	3
			Mid	2595	519000	2554.32	510864	101		6486	518910	18	5	0
			High	2615	523000	1819.4	363880	2198		6536	522970	14	6	1
15	38	Downlink & Uplink	Low	2577.5	515500	2570.66	514132	0	15	6437	515050	18	7	2
			Mid	2595	519000	2551.8	510360	101		6480	518430	2	6	1
			High	2612.5	522500	1814.38	362876	2198		6526	522050	18	7	2
20	51	Downlink & Uplink	Low	2580	516000	2570.82	514164	0	15	6438	515070	14	7	2
			Mid	2595	519000	2549.46	509892	101		6474	517950	22	5	0
			High	2610	522000	1809.54	361908	2198		6513	521070	14	7	2
Note 1: The CORESET#0 Index and the associated CORESET#0 Offset refers to Table 13-2 in TS 38.213 [22]. The value of CORESET#0 Index is signalled in the four most significant bits of the IE pdccch-ConfigSIB1 in the MIB														

Table 4.3.1.1.1.38-3: Test frequencies for NR operating band n38 and SCS 60 kHz

Bandwidth [MHz]	carrierBand width [PRBs]	Range		Carrier centre [MHz]	Carrier centre [ARFCN]	point A [MHz]	absolute FrequencyPoint A [ARFCN]	offsetTo Carrier [PRBs]
10	11	Downlink	Low	2575	515000	2571.04	514208	0
			Mid	2595	519000	2518.32	503664	101
			High	2615	523000	1028.48	205696	2198
15	18	Downlink	Low	2577.5	515500	2571.02	514204	0
			Mid	2595	519000	2515.8	503160	101
			High	2612.5	522500	1023.46	204692	2198
20	24	Downlink	Low	2580	516000	2571.36	514272	0
			Mid	2595	519000	2513.64	502728	101
			High	2610	522000	1018.8	203760	2198

4.3.1.1.1.39 Reference test frequencies for NR operating band n39

Table 4.3.1.1.1.39-1: Test frequencies for NR operating band n39 and SCS 15 kHz

Bandwidth [MHz]	carrierBand width [PRBs]	Range	Carrier centre [MHz]	Carrier centre [ARFCN]	point A [MHz]	absolute FrequencyPoint A [ARFCN]	offsetTo Carrier [PRBs]	SS block SCS [kHz]	GSCN	absoluteFrequencySSB [ARFCN]	k_{SSB}	CORE SET#0 Offset [RBs] Note 1	CORE SET#0 Index Note 1	
5	25	Downlink & Uplink	Low	1882.5	376500	1880.25	376050	0	15	4707	376590	12	4	2
			Mid	1900	380000	1879.57	375914	101		4750	379970	20	0	0
			High	1917.5	383500	1519.61	303922	2198		4793	383530	16	2	1
10	52	Downlink & Uplink	Low	1885	377000	1880.32	376064	0	15	4708	376610	14	4	2
			Mid	1900	380000	1877.14	375428	101		4744	379490	22	0	0
			High	1915	383000	1514.68	302936	2198		4783	382610	14	4	2
15	79	Downlink & Uplink	Low	1887.5	377500	1880.39	376078	0	15	4706	376570	20	2	1
			Mid	1900	380000	1874.71	374942	101		4738	379010	0	2	1
			High	1912.5	382500	1509.75	301950	2198		4770	381630	16	4	2
20	106	Downlink & Uplink	Low	1890	378000	1880.46	376092	0	15	4707	376590	22	2	1
			Mid	1900	380000	1872.28	374456	101		4732	378530	2	2	1
			High	1910	382000	1504.82	300964	2198		4757	380650	18	4	2
25	133	Downlink & Uplink	Low	1892.5	378500	1880.53	376106	0	15	4708	376610	0	4	2
			Mid	1900	380000	1869.85	373970	101		4726	378050	4	2	1
			High	1907.5	381500	1499.89	299978	2198		4744	379490	8	0	0
30	160	Downlink & Uplink	Low	1895	379000	1880.6	376120	0	15	4706	376570	6	2	1
			Mid	1900	380000	1867.42	373484	101		4720	377570	6	2	1
			High	1905	381000	1494.96	298992	2198		4731	378510	10	0	0
40	216	Downlink & Uplink	Low	1900	380000	1880.56	376112	0	15	4708	376610	22	2	1
			Mid	1900	380000	1862.38	372476	101		4708	376610	22	2	1
			High	1900	380000	1484.92	296984	2198		4708	376610	22	2	1

Note 1: The CORESET#0 Index and the associated CORESET#0 Offset refers to Table 13-1 in TS 38.213 [22]. The value of CORESET#0 Index is signalled in the four most significant bits of the IE pdccch-ConfigSIB1 in the MIB

Table 4.3.1.1.1.39-2: Test frequencies for NR operating band n39 and SCS 30 kHz

Bandwidth [MHz]	carrierBand width [PRBs]	Range	Carrier centre [MHz]	Carrier centre [ARFCN]	point A [MHz]	absolute FrequencyPoint A [ARFCN]	offsetTo Carrier [PRBs]	SS block SCS [kHz]	GSCN	absoluteFrequencySSB [ARFCN]	k_{SSB}	CORE SET#0 Offset [RBs] Note 1	CORE SET#0 Index Note 1	
10	24	Downlink & Uplink	Low	1885	377000	1880.68	376136	0	15	4714	377090	6	8	3
			Mid	1900	380000	1859.32	371864	101		4750	379970	14	6	1
			High	1915	383000	1119.4	223880	2198		4789	383090	6	8	3
15	38	Downlink & Uplink	Low	1887.5	377500	1880.66	376132	0	15	4712	377050	18	7	2
			Mid	1900	380000	1856.8	371360	101		4744	379490	22	6	1
			High	1912.5	382500	1114.38	222876	2198		4773	381870	6	5	0
20	51	Downlink & Uplink	Low	1890	378000	1880.82	376164	0	15	4713	377070	14	7	2
			Mid	1900	380000	1854.46	370892	101		4738	379010	18	6	1
			High	1910	382000	1109.54	221908	2198		4760	380890	2	5	0
25	65	Downlink & Uplink	Low	1892.5	378500	1880.8	376160	0	15	4714	377090	22	7	2
			Mid	1900	380000	1851.94	370388	101		4732	378530	2	7	2
			High	1907.5	381500	1104.52	220904	2198		4750	379970	6	6	1
30	78	Downlink & Uplink	Low	1895	379000	1880.96	376192	0	15	4712	377050	22	6	1
			Mid	1900	380000	1849.6	369920	101		4726	378050	22	6	1
			High	1905	381000	1099.68	219936	2198		4737	378990	2	6	1
40	106	Downlink & Uplink	Low	1900	380000	1880.92	376184	0	15	4714	377090	14	7	2
			Mid	1900	380000	1844.56	368912	101		4714	377090	14	7	2
			High	1900	380000	1089.64	217928	2198		4714	377090	14	7	2

Note 1: The CORESET#0 Index and the associated CORESET#0 Offset refers to Table 13-2 in TS 38.213 [22]. The value of CORESET#0 Index is signalled in the four most significant bits of the IE pdccch-ConfigSIB1 in the MIB

Table 4.3.1.1.1.39-3: Test frequencies for NR operating band n39 and SCS 60 kHz

Bandwidth [MHz]	carrierBand width [PRBs]	Range	Carrier centre [MHz]	Carrier centre [ARFCN]	point A [MHz]	absolute FrequencyPoint A [ARFCN]	offsetTo Carrier [PRBs]	
10	11	Downlink & Uplink	Low	1885	377000	1881.04	376208	0
			Mid	1900	380000	1823.32	364664	101
			High	1915	383000	328.48	65696	2198
15	18	Downlink & Uplink	Low	1887.5	377500	1881.02	376204	0
			Mid	1900	380000	1820.8	364160	101
			High	1912.5	382500	323.46	64692	2198
20	24	Downlink & Uplink	Low	1890	378000	1881.36	376272	0
			Mid	1900	380000	1818.64	363728	101
			High	1910	382000	318.8	63760	2198
25	31	Downlink & Uplink	Low	1892.5	378500	1881.34	376268	0
			Mid	1900	380000	1816.12	363224	101
			High	1907.5	381500	313.78	62756	2198
30	38	Downlink & Uplink	Low	1895	379000	1881.32	376264	0
			Mid	1900	380000	1813.6	362720	101
			High	1905	381000	308.76	61752	2198
40	51	Downlink & Uplink	Low	1900	380000	1881.64	376328	0
			Mid	1900	380000	1808.92	361784	101
			High	1900	380000	299.08	59816	2198

4.3.1.1.1.40 Reference test frequencies for NR operating band n40

Table 4.3.1.1.1.40-1: Test frequencies for NR operating band n40 and SCS 15 kHz

Bandwidth [MHz]	carrierBand width [PRBs]	Range	Carrier centre [MHz]	Carrier centre [ARFCN]	point A [MHz]	absolute FrequencyPoint A [ARFCN]	offsetTo Carrier [PRBs]	SS block SCS [kHz]	GSCN	absoluteFrequencySSB [ARFCN]	k_{SSB}	CORE SET#0 Offset [RBs] Note 1	CORE SET#0 Index Note 1	
5	25	Downlink & Uplink	Low	2302.5	460500	2300.25	460050	0	15	5757	460590	12	4	2
			Mid	2350	470000	2329.57	465914	101		5875	469970	20	0	0
			High	2397.5	479500	1999.61	399922	2198		5993	479530	16	2	1
10	52	Downlink & Uplink	Low	2305	461000	2300.32	460064	0	15	5758	460610	14	4	2
			Mid	2350	470000	2327.14	465428	101		5869	469490	22	0	0
			High	2395	479000	1994.68	398936	2198		5983	478610	14	4	2
15	79	Downlink & Uplink	Low	2307.5	461500	2300.39	460078	0	15	5756	460570	20	2	1
			Mid	2350	470000	2324.71	464942	101		5863	469010	0	2	1
			High	2392.5	478500	1989.75	397950	2198		5970	477630	16	4	2
20	106	Downlink & Uplink	Low	2310	462000	2300.46	460092	0	15	5757	460590	22	2	1
			Mid	2350	470000	2322.28	464456	101		5857	468530	2	2	1
			High	2390	478000	1984.82	396964	2198		5957	476650	18	4	2
25	133	Downlink & Uplink	Low	2312.5	462500	2300.53	460106	0	15	5758	460610	0	4	2
			Mid	2350	470000	2319.85	463970	101		5851	468050	4	2	1
			High	2387.5	477500	1979.89	395978	2198		5944	475490	8	0	0
30	160	Downlink & Uplink	Low	2315	463000	2300.6	460120	0	15	5756	460570	6	2	1
			Mid	2350	470000	2317.42	463484	101		5845	467570	6	2	1
			High	2385	477000	1974.96	394992	2198		5931	474510	10	0	0
40	216	Downlink & Uplink	Low	2320	464000	2300.56	460112	0	15	5758	460610	22	2	1
			Mid	2350	470000	2312.38	462476	101		5833	466610	22	2	1
			High	2380	476000	1964.92	392984	2198		5908	472610	22	2	1
50	270	Downlink & Uplink	Low	2325	465000	2300.7	460140	0	15	5757	460590	6	2	1
			Mid	2350	470000	2307.52	461504	101		5821	465650	2	4	2
			High	2375	475000	1955.06	391012	2198		5882	470650	2	4	2

Note 1: The CORESET#0 Index and the associated CORESET#0 Offset refers to Table 13-1 in TS 38.213 [22]. The value of CORESET#0 Index is signalled in the four most significant bits of the IE pdcch-ConfigSIB1 in the MIB

Table 4.3.1.1.40-2: Test frequencies for NR operating band n40 and SCS 30 kHz

Bandwidth [MHz]	carrierBand width [PRBs]	Range	Carrier centre [MHz]	Carrier centre [ARFCN]	point A [MHz]	absolute FrequencyPoint A [ARFCN]	offsetTo Carrier [PRBs]	SS block SCS [kHz]	GSCN	absoluteFrequencySSB [ARFCN]	k_{SSB}	CORE SET#0 Offset [RBs] Note 1	CORE SET#0 Index Note 1	
10	24	Downlink & Uplink	Low	2305	461000	2300.68	460136	0	15	5764	461090	6	8	3
			Mid	2350	470000	2309.32	461864	101		5875	469970	14	6	1
			High	2395	479000	1599.4	319880	2198		5989	479090	6	8	3
15	38	Downlink & Uplink	Low	2307.5	461500	2300.66	460132	0	15	5762	461050	18	7	2
			Mid	2350	470000	2306.8	461360	101		5869	469490	22	6	1
			High	2392.5	478500	1594.38	318876	2198		5973	477870	6	5	0
20	51	Downlink & Uplink	Low	2310	462000	2300.82	460164	0	15	5763	461070	14	7	2
			Mid	2350	470000	2304.46	460892	101		5863	469010	18	6	1
			High	2390	478000	1589.54	317908	2198		5960	476890	2	5	0
25	65	Downlink & Uplink	Low	2312.5	462500	2300.8	460160	0	15	5764	461090	22	7	2
			Mid	2350	470000	2301.94	460388	101		5857	468530	2	7	2
			High	2387.5	477500	1584.52	316904	2198		5950	475970	6	6	1
30	78	Downlink & Uplink	Low	2315	463000	2300.96	460192	0	15	5762	461050	22	6	1
			Mid	2350	470000	2299.6	459920	101		5851	468050	22	6	1
			High	2385	477000	1579.68	315936	2198		5937	474990	2	6	1
40	106	Downlink & Uplink	Low	2320	464000	2300.92	460184	0	15	5764	461090	14	7	2
			Mid	2350	470000	2294.56	458912	101		5839	467090	14	7	2
			High	2380	476000	1569.64	313928	2198		5914	473090	14	7	2
50	133	Downlink & Uplink	Low	2325	465000	2301.06	460212	0	15	5763	461070	22	6	1
			Mid	2350	470000	2289.7	457940	101		5827	466130	18	7	2
			High	2375	475000	1559.78	311956	2198		5888	471130	18	7	2
60	162	Downlink & Uplink	Low	2330	466000	2300.84	460168	0	15	5762	461050	6	7	2
			Mid	2350	470000	2284.48	456896	101		5812	464930	14	5	0
			High	2370	474000	1549.56	309912	2198		5862	468990	10	6	1
80	217	Downlink & Uplink	Low	2340	468000	2300.94	460188	0	15	5763	461070	6	7	2
			Mid	2350	470000	2274.58	454916	101		5788	463010	10	6	1
			High	2360	472000	1529.66	305932	2198		5813	465130	2	8	3

Note 1: The CORESET#0 Index and the associated CORESET#0 Offset refers to Table 13-2 in TS 38.213 [22]. The value of CORESET#0 Index is signalled in the four most significant bits of the IE pdcch-ConfigSIB1 in the MIB

Table 4.3.1.1.1.40-3: Test frequencies for NR operating band n40 and SCS 60 kHz

Bandwidth [MHz]	carrierBand width [PRBs]	Range	Carrier centre [MHz]	Carrier centre [ARFCN]	point A [MHz]	absolute FrequencyPoint A [ARFCN]	offsetTo Carrier [PRBs]	
10	11	Downlink & Uplink	Low	2305	461000	2301.04	460208	0
			Mid	2350	470000	2273.32	454664	101
			High	2395	479000	808.48	161696	2198
15	18	Downlink & Uplink	Low	2307.5	461500	2301.02	460204	0
			Mid	2350	470000	2270.8	454160	101
			High	2392.5	478500	803.46	160692	2198
20	24	Downlink & Uplink	Low	2310	462000	2301.36	460272	0
			Mid	2350	470000	2268.64	453728	101
			High	2390	478000	798.8	159760	2198
25	31	Downlink & Uplink	Low	2312.5	462500	2301.34	460268	0
			Mid	2350	470000	2266.12	453224	101
			High	2387.5	477500	793.78	158756	2198
30	38	Downlink & Uplink	Low	2315	463000	2301.32	460264	0
			Mid	2350	470000	2263.6	452720	101
			High	2385	477000	788.76	157752	2198
40	51	Downlink & Uplink	Low	2320	464000	2301.64	460328	0
			Mid	2350	470000	2258.92	451784	101
			High	2380	476000	779.08	155816	2198
50	65	Downlink & Uplink	Low	2325	465000	2301.6	460320	0
			Mid	2350	470000	2253.88	450776	101
			High	2375	475000	769.04	153808	2198
60	79	Downlink & Uplink	Low	2330	466000	2301.56	460312	0
			Mid	2350	470000	2248.84	449768	101
			High	2370	474000	759	151800	2198
80	107	Downlink & Uplink	Low	2340	468000	2301.48	460296	0
			Mid	2350	470000	2238.76	447752	101
			High	2360	472000	738.92	147784	2198

4.3.1.1.1.41 Reference test frequencies for NR operating band n41

Table 4.3.1.1.1.41-1: Test frequencies for NR operating band n41 and SCS 15 kHz

Bandwidth [MHz]	carrierBandwidth [PRBs]	Range	Carrier centre [MHz]	Carrier centre [ARFCN]	point A [MHz]	absolute FrequencyPoint A [ARFCN]	offsetTo Carrier [PRBs]	SS block SCS [kHz]	GSCN	absoluteFrequencySSB [ARFCN]	k_{SSB}	CORE SET#0 Offset [RBs] Note 1	CORE SET#0 Index Note 1	
10	52	Downlink & Uplink	Low	2501.01	500202	2496.33	499266	0	15	6246	499710	4	2	1
			Mid	2593.005	518601	2570.145	514029	101		6477	518190	7	4	2
			High	2685	537000	2284.68	456936	2198		6705	536430	2	0	0
15	79	Downlink & Uplink	Low	2503.5	500700	2496.39	499278	0	15	6246	499710	0	2	1
			Mid	2593.005	518601	2567.715	513543	101		6471	517710	9	4	2
			High	2682.495	536499	2279.745	455949	2198		6693	535470	11	0	0
20	106	Downlink & Uplink	Low	2506.005	501201	2496.465	499293	0	15	6246	499710	19	0	0
			Mid	2593.005	518601	2565.285	513057	101		6465	517230	11	4	2
			High	2679.99	535998	2274.81	454962	2198		6681	534510	20	0	0
40	216	Downlink & Uplink	Low	2516.01	503202	2496.57	499314	0	15	6246	499710	12	0	0
			Mid	2593.125	518625	2555.505	511101	101		6441	515310	23	4	2
			High	2670	534000	2254.92	450984	2198		6633	530670	18	4	2
50	270	Downlink & Uplink	Low	2521.005	504201	2496.705	499341	0	15	6246	499710	3	0	0
			Mid	2593.005	518601	2550.525	510105	101		6426	514110	3	0	0
			High	2664.99	532998	2245.05	449010	2198		6606	528510	4	0	0

Note 1: The CORESET#0 Index and the associated CORESET#0 Offset refers to Table 13-1 in TS 38.213 [22]. The value of CORESET#0 Index is signalled in the four most significant bits of the IE pdcch-ConfigSIB1 in the MIB

Table 4.3.1.1.1. 41-2: Test frequencies for NR operating band n41 and SCS 30 kHz

Bandwidth [MHz]	carrierBandwidth [PRBs]	Range	Carrier centre [MHz]	Carrier centre [ARFCN]	point A [MHz]	absolute FrequencyPoint A [ARFCN]	offsetTo Carrier [PRBs]	SS block SCS [kHz]	GSCN	absoluteFrequencySSB [ARFCN]	k_{SSB}	CORE SET#0 Offset [RBs] Note 1	CORE SET#0 Index Note 1	
10	24	Downlink & Uplink	Low	2501.01	500202	2496.69	499338	0	30	6252	500190	20	1	1
			Mid	2592.99	518598	2552.31	510462	101		6483	518670	0	3	3
			High	2685	537000	1889.4	377880	2198		6711	536910	18	0	0
15	38	Downlink & Uplink	Low	2503.5	500700	2496.66	499332	0	30	6252	500190	22	1	1
			Mid	2592.99	518598	2549.79	509958	101		6474	517950	0	0	0
			High	2682.48	536496	1884.36	376872	2198		6699	535950	10	1	1
20	51	Downlink & Uplink	Low	2506.02	501204	2496.84	499368	0	30	6252	500190	10	1	1
			Mid	2592.99	518598	2547.45	509490	101		6471	517710	4	3	3
			High	2679.99	535998	1879.53	375906	2198		6687	534990	12	1	1
40	106	Downlink & Uplink	Low	2516.01	503202	2496.93	499386	0	30	6252	500190	4	1	1
			Mid	2592.99	518598	2537.55	507510	101		6444	515550	16	0	0
			High	2670	534000	1859.64	371928	2198		6636	530910	2	0	0
50	133	Downlink & Uplink	Low	2521.02	504204	2497.08	499416	0	30	6252	500190	18	0	0
			Mid	2592.99	518598	2532.69	506538	101		6432	514590	20	0	0
			High	2664.99	532998	1849.77	369954	2198		6612	528990	20	0	0
60	162	Downlink & Uplink	Low	2526	505200	2496.84	499368	0	30	6252	500190	10	1	1
			Mid	2592.99	518598	2527.47	505494	101		6420	513630	0	2	2
			High	2659.98	531996	1839.54	367908	2198		6588	527070	14	2	2
80	217	Downlink & Uplink	Low	2536.02	507204	2496.96	499392	0	30	6252	500190	2	1	1
			Mid	2592.99	518598	2517.57	503514	101		6396	511710	20	2	2
			High	2649.99	529998	1819.65	363930	2198		6537	522990	4	1	1
90	245	Downlink & Uplink	Low	2541	508200	2496.9	499380	0	30	6252	500190	6	1	1
			Mid	2592.99	518598	2512.53	502506	101		6381	510510	4	0	0
			High	2644.98	528996	1809.6	361920	2198		6513	521070	10	2	2
100	273	Downlink & Uplink	Low	2546.01	509202	2496.87	499374	0	30	6252	500190	8	1	1
			Mid	2592.99	518598	2507.49	501498	101		6369	509550	20	0	0
			High	2640	528000	1799.58	359916	2198		6486	518910	6	0	0

Note 1: The CORESET#0 Index and the associated CORESET#0 Offset refers to Table 13-4 in TS 38.213 [22]. The value of CORESET#0 Index is signalled in the four most significant bits of the IE pdccch-ConfigSIB1 in the MIB

Table 4.3.1.1.1.41-3: Test frequencies for NR operating band n41 and SCS 60 kHz

Bandwidth [MHz]	carrierBand width [PRBs]	Range		Carrier centre [MHz]	Carrier centre [ARFCN]	point A [MHz]	absoluteFrequencyPointA [ARFCN]	offsetToCarrier [PRBs]
10	11	Downlink & Uplink	Low	2501.01	500202	2497.05	499410	0
			Mid	2593.005	518601	2516.325	503265	101
			High	2685	537000	1098.48	219696	2198
15	18	Downlink & Uplink	Low	2503.5	500700	2497.02	499404	0
			Mid	2593.005	518601	2513.805	502761	101
			High	2682.495	536499	1093.455	218691	2198
20	24	Downlink & Uplink	Low	2506.005	501201	2497.365	499473	0
			Mid	2593.005	518601	2511.645	502329	101
			High	2679.99	535998	1088.79	217758	2198
40	51	Downlink & Uplink	Low	2516.01	503202	2497.65	499530	0
			Mid	2593.005	518601	2501.925	500385	101
			High	2670	534000	1069.08	213816	2198
50	65	Downlink & Uplink	Low	2521.005	504201	2497.605	499521	0
			Mid	2593.005	518601	2496.885	499377	101
			High	2664.99	532998	1059.03	211806	2198
60	79	Downlink & Uplink	Low	2526	505200	2497.56	499512	0
			Mid	2593.005	518601	2491.845	498369	101
			High	2659.995	531999	1048.995	209799	2198
80	107	Downlink & Uplink	Low	2536.005	507201	2497.485	499497	0
			Mid	2593.005	518601	2481.765	496353	101
			High	2649.99	529998	1028.91	205782	2198
90	121	Downlink & Uplink	Low	2541	508200	2497.44	499488	0
			Mid	2593.005	518601	2476.725	495345	101
			High	2644.995	528999	1018.875	203775	2198
100	135	Downlink & Uplink	Low	2546.01	509202	2497.41	499482	0
			Mid	2593.005	518601	2471.685	494337	101
			High	2640	528000	1008.84	201768	2198

4.3.1.1.1.42 to 4.3.1.1.1.50 FFS

4.3.1.1.1.51 Reference test frequencies for NR operating band n51

Table 4.3.1.1.1.51-1: Test frequencies for NR operating band n51 and SCS 15 kHz

Bandwidth [MHz]	carrierBand width [PRBs]	Range		Carrier centre [MHz]	Carrier centre [ARFCN]	point A [MHz]	absolute FrequencyPoint A [ARFCN]	offsetTo Carrier [PRBs]	SS block SCS [kHz]	GSCN	absoluteFrequencySSB [ARFCN]	k_{SSB}	CORE SET#0 Offset [RBs] Note 1	CORE SET#0 Index Note 1
5	25	Downlink & Uplink	Low	1429.5	285900	1427.25	285450	0	15	3573	285870	20	0	0
			Mid	1429.5	285900	1409.07	281814	101		3573	285870	20	0	0
			High	1429.5	285900	1031.61	206322	2198		3573	285870	20	0	0
Note 1: The CORESET#0 Index and the associated CORESET#0 Offset refers to Table 13-1 in TS 38.213 [22]. The value of CORESET#0 Index is signalled in the four most significant bits of the IE pdccch-ConfigSIB1 in the MIB														

4.3.1.1.1.52 to 4.3.1.1.1.65 FFS

4.3.1.1.1.66 Reference test frequencies for NR operating band n66

Table 4.3.1.1.1.66-1: Test frequencies for NR operating band n66 and SCS 15 kHz
FFS

Table 4.3.1.1.1.66-2: Test frequencies for NR operating band n66 and SCS 30 kHz
FFS

Table 4.3.1.1.1.66-3: Test frequencies for NR operating band n66 and SCS 60 kHz
FFS

4.3.1.1.1.67 – 4.3.1.1.1.69 FFS

4.3.1.1.1.70 Reference test frequencies for NR operating band n70

Table 4.3.1.1.1.70-1: Test frequencies for NR operating band n70 and SCS 15 kHz
FFS

Table 4.3.1.1.1.70-2: Test frequencies for NR operating band n70 and SCS 30 kHz
FFS

Table 4.3.1.1.1.70-3: Test frequencies for NR operating band n70 and SCS 60 kHz
FFS

4.3.1.1.1.71 Reference test frequencies for NR operating band n71

Table 4.3.1.1.1.71-1: Test frequencies for NR operating band n71 and SCS 15 kHz

Bandwidth [MHz]	carrierBand width [PRBs]	Range		Carrier centre [MHz]	Carrier centre [ARFCN]	point A [MHz]	absolute Frequency Point A [ARFCN]	offsetTo Carrier [PRBs]	SS block SCS [kHz]	GSCN	absoluteFrequencySSB [ARFCN]	k_{SSB}	CORE SET#0 Offset [RBs] Note 1	CORE SET#0 Index Note 1
5	25	Downlink	Low	619.5	123900	617.25	123450	0	15	1548	123870	20	0	0
			Mid	634.5	126900	614.07	122814	101		1587	126990	12	4	2
			High	649.5	129900	251.61	50322	2198		1623	129870	20	0	0
		Uplink	Low	665.5	133100	663.25	132650	0	-	-	-	-	-	-
			Mid	680.5	136100	282.61	56522	2198		-	-	-	-	-
			High	695.5	139100	693.07	138614	1		-	-	-	-	-
10	52	Downlink	Low	622	124400	617.32	123464	0	15	1549	123890	22	0	0
			Mid	634.5	126900	611.64	122328	101		1581	126510	14	4	2
			High	647	129400	246.68	49336	2198		1610	128890	22	0	0
		Uplink	Low	668	133600	663.32	132664	0	-	-	-	-	-	-
			Mid	680.5	136100	280.18	56036	2198		-	-	-	-	-
			High	693	138600	688.14	137628	1		-	-	-	-	-
15	79	Downlink	Low	624.5	124900	617.39	123478	0	15	1547	123850	4	0	0
			Mid	634.5	126900	609.21	121842	101		1575	126030	16	4	2
			High	644.5	128900	241.75	48350	2198		1600	127970	20	2	1
		Uplink	Low	670.5	134100	663.39	132678	0	-	-	-	-	-	-
			Mid	680.5	136100	277.75	55550	2198		-	-	-	-	-
			High	690.5	138100	683.21	136642	1		-	-	-	-	-
20	106	Downlink	Low	627	125400	617.46	123492	0	15	1548	123870	6	0	0
			Mid	634.5	126900	606.78	121356	101		1569	125550	18	4	2
			High	642	128400	236.82	47364	2198		1587	126990	22	2	1
		Uplink	Low	673	134600	663.46	132692	0	-	-	-	-	-	-
			Mid	680.5	136100	275.32	55064	2198		-	-	-	-	-
			High	688	137600	678.28	135656	1		-	-	-	-	-

Note 1: The CORESET#0 Index and the associated CORESET#0 Offset refers to Table 13-1 in TS 38.213 [22]. The value of CORESET#0 Index is signalled in the four most significant bits of the IE pdccch-ConfigSIB1 in the MIB

Table 4.3.1.1.1.71-2: Test frequencies for NR operating band n71 and SCS 30 kHz

Bandwidth [MHz]	carrierBand width [PRBs]	Range		Carrier centre [MHz]	Carrier centre [ARFCN]	point A [MHz]	absolute FrequencyPoint A [ARFCN]	offsetTo Carrier [PRBs]	SS block SCS [kHz]	GSCN	absoluteFrequencySSB [ARFCN]	k_{SSB}	CORE SET#0 Offset [RBs] Note 1	CORE SET#0 Index Note 1
10	24	Downlink	Low	622	124400	617.68	123536	0	15	1555	124370	14	6	1
			Mid	634.5	126900	593.82	118764	101		1587	126990	6	8	3
			High	647	129400	563.84	112768	219		1616	129370	14	6	1
		Uplink	Low	668	133600	663.68	132736	0	-	-	-	-	-	-
			Mid	680.5	136100	597.34	119468	219		-	-	-	-	-
			High	693	138600	688.32	137664	1		-	-	-	-	-
15	38	Downlink	Low	624.5	124900	617.66	123532	0	15	1553	124330	2	6	1
			Mid	634.5	126900	591.3	118260	101		1578	126270	6	5	0
			High	644.5	128900	558.82	111764	219		1606	128450	18	7	2
		Uplink	Low	670.5	134100	663.66	132732	0	-	-	-	-	-	-
			Mid	680.5	136100	594.82	118964	219		-	-	-	-	-
			High	690.5	138100	683.3	136660	1		-	-	-	-	-
20	51	Downlink	Low	627	125400	617.82	123564	0	15	1554	124350	22	5	0
			Mid	634.5	126900	588.96	117792	101		1572	125790	2	5	0
			High	642	128400	553.98	110796	219		1593	127470	14	7	2
		Uplink	Low	673	134600	663.82	132764	0	-	-	-	-	-	-
			Mid	680.5	136100	592.48	118496	219		-	-	-	-	-
			High	688	137600	678.46	135692	1		-	-	-	-	-
Note 1: The CORESET#0 Index and the associated CORESET#0 Offset refers to Table 13-2 in TS 38.213 [22]. The value of CORESET#0 Index is signalled in the four most significant bits of the IE pdccch-ConfigSIB1 in the MIB														

4.3.1.1.1.72 – 4.3.1.1.1.74 FFS

4.3.1.1.1.75 Reference test frequencies for NR operating band n75 (SDL)

Table 4.3.1.1.1.75-1: Test frequencies for NR operating band n75 and SCS 15 kHz

Bandwidth [MHz]	carrierBand width [PRBs]	Range		Carrier centre [MHz]	Carrier centre [ARFCN]	point A [MHz]	absolute FrequencyPoint A [ARFCN]	offsetTo Carrier [PRBs]
5	25	Downlink	Low	1434.5	286900	1432.25	286450	0
			Mid	1474.5	294900	1454.07	290814	101
			High	1514.5	302900	1116.61	223322	2198
10	52	Downlink	Low	1437	287400	1432.32	286464	0
			Mid	1474.5	294900	1451.64	290328	101
			High	1512	302400	1111.68	222336	2198
15	79	Downlink	Low	1439.5	287900	1432.39	286478	0
			Mid	1474.5	294900	1449.21	289842	101
			High	1509.5	301900	1106.75	221350	2198
20	106	Downlink	Low	1442	288400	1432.46	286492	0
			Mid	1474.5	294900	1446.78	289356	101
			High	1507	301400	1101.82	220364	2198

Table 4.3.1.1.1.75-2: Test frequencies for NR operating band n75 and SCS 30 kHz

Bandwidth [MHz]	carrierBand width [PRBs]	Range		Carrier centre [MHz]	Carrier centre [ARFCN]	point A [MHz]	absolute FrequencyPoint A [ARFCN]	offsetTo Carrier [PRBs]
10	24	Downlink	Low	1437	287400	1432.68	286536	0
			Mid	1474.5	294900	1433.82	286764	101
			High	1512	302400	716.4	143280	2198
15	38	Downlink	Low	1439.5	287900	1432.66	286532	0
			Mid	1474.5	294900	1431.3	286260	101
			High	1509.5	301900	711.38	142276	2198
20	51	Downlink	Low	1442	288400	1432.82	286564	0
			Mid	1474.5	294900	1428.96	285792	101
			High	1507	301400	706.54	141308	2198

Table 4.3.1.1.1.75-3: Test frequencies for NR operating band n75 and SCS 60 kHz

Bandwidth [MHz]	carrierBand width [PRBs]	Range		Carrier centre [MHz]	Carrier centre [ARFCN]	point A [MHz]	absolute FrequencyPoint A [ARFCN]	offsetTo Carrier [PRBs]
10	11	Downlink	Low	1437	287400	1433.04	286608	0
			Mid	1474.5	294900	1397.82	279564	101
			High	1512	302400	1350.36	270072	219
15	18	Downlink	Low	1439.5	287900	1433.02	286604	0
			Mid	1474.5	294900	1395.3	279060	101
			High	1509.5	301900	1345.34	269068	219
20	24	Downlink	Low	1442	288400	1433.36	286672	0
			Mid	1474.5	294900	1393.14	278628	101
			High	1507	301400	1340.68	268136	219

4.3.1.1.1.76

Reference test frequencies for NR operating band n76 (SDL)

Table 4.3.1.1.1.76-1: Test frequencies for NR operating band n76 and SCS 15 kHz

Bandwidth [MHz]	carrierBand width [PRBs]	Range		Carrier centre [MHz]	Carrier centre [ARFCN]	point A [MHz]	absolute FrequencyPoint A [ARFCN]	offsetTo Carrier [PRBs]	SS block SCS [kHz]	GSCN	absoluteFrequencySSB [ARFCN]	k_{SSB}	CORE SET#0 Offset [RBs] Note 1	CORE SET#0 Index Note 1
5	25	Downlink	Low	1429.5	285900	1427.25	285450	0	15	3573	285870	20	0	0
			Mid	1429.5	285900	1409.07	281814	101		3573	285870	20	0	0
			High	1429.5	285900	1031.61	206322	2198		3573	285870	20	0	0

4.3.1.1.1.77 Reference test frequencies for NR operating band n77

Table 4.3.1.1.1.77-1: Test frequencies for NR operating band n77 and SCS 15 kHz

Bandwidth [MHz]	carrierBand width [PRBs]	Range	Carrier centre [MHz]	Carrier centre [ARFCN]	point A [MHz]	absoluteFrequencyPointA [ARFCN]	offsetToCarrier [PRBs]	SS block SCS [kHz]	GSCN	absoluteFrequencySSB [ARFCN]	k_{SSB}	CORE SET#0 Offset [RBs] Note 1	CORE SET#0 Index Note 1	
10	52	Downlink & Uplink	Low	3305.01	620334	3300.33	620022	0	30	7711	620352	18	6	1
			Mid	3750	650000	3727.14	648476	101		8020	650016	16	6	1
			High	4194.99	679666	3794.67	652978	2198		8329	679680	14	6	1
15	79	Downlink & Uplink	Low	3307.5	620500	3300.39	620026	0	30	7711	620352	14	6	1
			Mid	3750.165	650011	3724.875	648325	101		8018	649824	23	2	0
			High	4192.5	679500	3789.75	652650	2198		8325	679296	6	2	0
20	106	Downlink & Uplink	Low	3310.005	620667	3300.465	620031	0	30	7711	620352	9	6	1
			Mid	3750	650000	3722.28	648152	101		8016	649632	4	2	0
			High	4189.98	679332	3784.8	652320	2198		8322	679008	0	6	1
40	216	Downlink & Uplink	Low	3320.01	621334	3300.57	620038	0	30	7711	620352	2	6	1
			Mid	3750.255	650017	3712.635	647509	101		8010	649056	23	6	1
			High	4179.72	678648	3764.64	650976	2198		8308	677664	0	6	1
50	270	Downlink & Uplink	Low	3325.275	621685	3300.975	620065	0	30	7711	620352	23	2	0
			Mid	3750.075	650005	3707.595	647173	101		8006	648672	23	2	0
			High	4174.995	678333	3755.055	650337	2198		8301	676992	15	2	0

Note 1: The CORESET#0 Index and the associated CORESET#0 Offset refers to Table 13-3 in TS 38.213 [22]. The value of CORESET#0 Index is signalled in the four most significant bits of the IE pdccch-ConfigSIB1 in the MIB

Table 4.3.1.1.1.77-2: Test frequencies for NR operating band n77 and SCS 30 kHz

Bandwidth [MHz]	carrierBand width [PRBs]	Range		Carrier centre [MHz]	Carrier centre [ARFCN]	point A [MHz]	absolute FrequencyPoint A [ARFCN]	offsetTo Carrier [PRBs]	SS block SCS [kHz]	GSCN	absoluteFrequencySSB [ARFCN]	k_{SSB}	CORE SET#0 Offset [RBs] Note 1	CORE SET#0 Index Note 1
10	24	Downlink & Uplink	Low	3305.01	620334	3300.69	620046	0	30	7711	620352	18	2	2
			Mid	3750	650000	3709.32	647288	101		8020	650016	16	2	2
			High	4194.99	679666	3399.39	626626	2198		8329	679680	14	2	2
15	38	Downlink & Uplink	Low	3307.5	620500	3300.66	620044	0	30	7711	620352	20	2	2
			Mid	3750	650000	3706.8	647120	101		8018	649824	16	1	1
			High	4192.5	679500	3394.38	626292	2198		8325	679296	12	0	0
20	51	Downlink & Uplink	Low	3310.02	620668	3300.84	620056	0	30	7711	620352	8	2	2
			Mid	3750	650000	3704.46	646964	101		8016	649632	4	0	0
			High	4189.98	679332	3389.52	625968	2198		8322	679008	0	2	2
40	106	Downlink & Uplink	Low	3320.01	621334	3300.93	620062	0	30	7711	620352	2	2	2
			Mid	3750	650000	3694.56	646304	101		8010	649056	16	3	3
			High	4179.99	678666	3369.63	624642	2198		8308	677664	6	1	1
50	133	Downlink & Uplink	Low	3325.02	621668	3301.08	620072	0	30	7711	620352	16	1	1
			Mid	3750	650000	3689.7	645980	101		8006	648672	4	1	1
			High	4174.98	678332	3359.76	623984	2198		8301	676992	16	0	0
60	162	Downlink & Uplink	Low	3330	622000	3300.84	620056	0	30	7711	620352	8	2	2
			Mid	3750	650000	3684.48	645632	101		8003	648384	16	3	3
			High	4170	678000	3349.56	623304	2198		8294	676320	0	1	1
80	217	Downlink & Uplink	Low	3340.02	622668	3300.96	620064	0	30	7711	620352	0	2	2
			Mid	3750	650000	3674.58	644972	101		7996	647712	4	3	3
			High	4159.98	677332	3329.64	621976	2198		8280	674976	8	0	0
90	245	Downlink & Uplink	Low	3345	623000	3300.9	620060	0	30	7711	620352	4	2	2
			Mid	3750	650000	3669.54	644636	101		7992	647328	4	1	1
			High	4155	677000	3319.62	621308	2198		8273	674304	4	0	0
100	273	Downlink & Uplink	Low	3350.01	623334	3300.87	620058	0	30	7711	620352	6	2	2
			Mid	3750	650000	3664.5	644300	101		7989	647040	4	3	3
			High	4149.99	676666	3309.57	620638	2198		8266	673632	2	0	0

Note 1: The CORESET#0 Index and the associated CORESET#0 Offset refers to Table 13-4 in TS 38.213 [22]. The value of CORESET#0 Index is signalled in the four most significant bits of the IE pdcch-ConfigSIB1 in the MIB

Table 4.3.1.1.1.77-3: Test frequencies for NR operating band n77 and SCS 60 kHz

Bandwidth [MHz]	carrierBand width [PRBs]	Range	Carrier centre [MHz]	Carrier centre [ARFCN]	point A [MHz]	absolute FrequencyPoint A [ARFCN]	offsetTo Carrier [PRBs]	
10	11	Downlink & Uplink	Low	3305.01	620334	3301.05	620070	0
			Mid	3750	650000	3673.32	644888	101
			High	4194.99	679666	2608.47	521694	2198
15	18	Downlink & Uplink	Low	3307.5	620500	3301.02	620068	0
			Mid	3750	650000	3670.8	644720	101
			High	4192.5	679500	2603.46	520692	2198
20	24	Downlink & Uplink	Low	3310.005	620667	3301.365	620091	0
			Mid	3750	650000	3668.64	644576	101
			High	4189.995	679333	2598.795	519759	2198
40	51	Downlink & Uplink	Low	3320.01	621334	3301.65	620110	0
			Mid	3750	650000	3658.92	643928	101
			High	4179.99	678666	2579.07	515814	2198
50	65	Downlink & Uplink	Low	3325.005	621667	3301.605	620107	0
			Mid	3750	650000	3653.88	643592	101
			High	4174.995	678333	2569.035	513807	2198
60	79	Downlink & Uplink	Low	3330	622000	3301.56	620104	0
			Mid	3750	650000	3648.84	643256	101
			High	4170	678000	2559	511800	2198
80	107	Downlink & Uplink	Low	3340.005	622667	3301.485	620099	0
			Mid	3750	650000	3638.76	642584	101
			High	4159.995	677333	2538.915	507783	2198
90	121	Downlink & Uplink	Low	3345	623000	3301.44	620096	0
			Mid	3750	650000	3633.72	642248	101
			High	4155	677000	2528.88	505776	2198
100	135	Downlink & Uplink	Low	3350.01	623334	3301.41	620094	0
			Mid	3750	650000	3628.68	641912	101
			High	4149.99	676666	2518.83	503766	2198

4.3.1.1.1.78 Reference test frequencies for NR operating band n77

Table 4.3.1.1.1.78-1: Test frequencies for NR operating band n78 and SCS 15 kHz

Bandwidth [MHz]	carrierBand width [PRBs]	Range		Carrier centre [MHz]	Carrier centre [ARFCN]	point A [MHz]	absoluteFrequencyPointA [ARFCN]	offsetToCarrier [PRBs]	SS block SCS [kHz]	GSCN	absoluteFrequencySSB [ARFCN]	k_{SSB}	CORE SET#0 Offset [RBs] Note 1	CORE SET#0 Index Note 1
10	52	Downlink	Low	3305.01	620334	3300.33	620022	0	30	7711	620352	18	6	1
			Mid	3550.005	636667	3527.145	635143	101		7881	636672	5	6	1
			High	3794.88	652992	3394.56	626304	2198		8051	652992	0	6	1
		Uplink	Low	3305.01	620334	3300.33	620022	0	-	-	-	-	-	-
			Mid	3549.99	636666	3505.89	633726	219		-	-	-	-	-
			High	3795	653000	3790.14	652676	1		-	-	-	-	-
15	79	Downlink	Low	3307.5	620500	3300.39	620026	0	30	7711	620352	14	6	1
			Mid	3550.005	636667	3524.715	634981	101		7879	636480	23	2	0
			High	3792.27	652818	3389.52	625968	2198		8047	652608	0	2	0
		Uplink	Low	3307.5	620500	3300.39	620026	0	-	-	-	-	-	-
			Mid	3549.99	636666	3503.46	633564	219		-	-	-	-	-
			High	3792.495	652833	3785.205	652347	1		-	-	-	-	-
20	106	Downlink	Low	3310.005	620667	3300.465	620031	0	30	7711	620352	9	6	1
			Mid	3550.275	636685	3522.555	634837	101		7878	636384	23	6	1
			High	3789.66	652644	3384.48	625632	2198		8044	652320	0	6	1
		Uplink	Low	3310.005	620667	3300.465	620031	0	-	-	-	-	-	-
			Mid	3549.99	636666	3501.03	633402	219		-	-	-	-	-
			High	3789.99	652666	3780.27	652018	1		-	-	-	-	-
40	216	Downlink	Low	3320.01	621334	3300.57	620038	0	30	7711	620352	2	6	1
			Mid	3550.095	636673	3512.475	634165	101		7871	635712	23	6	1
			High	3780	652000	3364.92	624328	2198		8030	650976	8	2	0
		Uplink	Low	3320.01	621334	3300.57	620038	0	-	-	-	-	-	-
			Mid	3549.99	636666	3134.91	608994	2198		-	-	-	-	-
			High	3780	652000	3760.38	650692	1		-	-	-	-	-
50	270	Downlink	Low	3325.275	621685	3300.975	620065	0	30	7711	620352	23	2	0
			Mid	3550.005	636667	3507.525	633835	101		7867	635328	17	2	0
			High	3774.9	651660	3354.96	623664	2198		8023	650304	0	2	0
		Uplink	Low	3325.005	621667	3300.705	620047	0	-	-	-	-	-	-
			Mid	3549.99	636666	3130.05	608670	2198		-	-	-	-	-
			High	3774.99	651666	3750.51	650034	1		-	-	-	-	-

Note 1: The CORESET#0 Index and the associated CORESET#0 Offset refers to Table 13-3 in TS 38.213 [22]. The value of CORESET#0 Index is signalled in the four most significant bits of the IE pdccch-ConfigSIB1 in the MIB

Table 4.3.1.1.1.78-2: Test frequencies for NR operating band n78 and SCS 30 kHz

Bandwidth [MHz]	carrierBand width [PRBs]	Range		Carrier centre [MHz]	Carrier centre [ARFCN]	point A [MHz]	absolute Frequency A [ARFCN]	offsetTo Carrier [PRBs]	SS block SCS [kHz]	GSCN	absoluteFrequencySSB [ARFCN]	k_{SSB}	CORE SET#0 Offset [RBs] Note 1	CORE SET#0 Index Note 1
10	24	Downlink	Low	3305.01	620334	3300.69	620046	0	30	7711	620352	18	2	2
			Mid	3549.99	636666	3509.31	633954	101		7881	636672	6	2	2
			High	3795	653000	2999.4	599880	2198		8051	652992	16	1	1
		Uplink	Low	3305.01	620334	3300.69	620046	0	-	-	-	-	-	-
			Mid	3549.99	636666	3466.83	631122	219		-	-	-	-	-
			High	3795	653000	3790.32	652688	1		-	-	-	-	-
15	38	Downlink	Low	3307.5	620500	3300.66	620044	0	30	7711	620352	20	2	2
			Mid	3549.99	636666	3506.79	633786	101		7879	636480	6	1	1
			High	3792.48	652832	2994.36	598872	2198		8048	652704	16	3	3
		Uplink	Low	3307.5	620500	3300.66	620044	0	-	-	-	-	-	-
			Mid	3549.99	636666	3464.31	630954	219		-	-	-	-	-
			High	3792.48	652832	3785.28	652352	1		-	-	-	-	-
20	51	Downlink	Low	3310.02	620668	3300.84	620056	0	30	7711	620352	8	2	2
			Mid	3549.99	636666	3504.45	633630	101		7878	636384	18	3	3
			High	3789.99	652666	2989.53	597906	2198		8044	652320	2	1	1
		Uplink	Low	3310.02	620668	3300.84	620056	0	-	-	-	-	-	-
			Mid	3549.99	636666	3461.97	630798	219		-	-	-	-	-
			High	3789.99	652666	3780.45	652030	1		-	-	-	-	-
40	106	Downlink	Low	3320.01	621334	3300.93	620062	0	30	7711	620352	2	2	2
			Mid	3549.99	636666	3494.55	632970	101		7871	635712	6	3	3
			High	3780	652000	2969.64	593928	2198		8030	650976	8	0	0
		Uplink	Low	3320.01	621334	3300.93	620062	0	-	-	-	-	-	-
			Mid	3549.99	636666	2739.63	547926	2198		-	-	-	-	-
			High	3780	652000	3760.56	650704	1		-	-	-	-	-
50	133	Downlink	Low	3325.02	621668	3301.08	620072	0	30	7711	620352	16	1	1
			Mid	3549.99	636666	3489.69	632646	101		7867	635328	18	0	0
			High	3774.99	651666	2959.77	591954	2198		8024	650400	18	3	3
		Uplink	Low	3325.02	621668	3301.08	620072	0	-	-	-	-	-	-
			Mid	3549.99	636666	2734.77	546954	2198		-	-	-	-	-
			High	3774.99	651666	3750.69	650046	1		-	-	-	-	-
60	162	Downlink	Low	3330	622000	3300.84	620056	0	30	7711	620352	8	2	2
			Mid	3549.99	636666	3484.47	632298	101		7864	635040	6	3	3
			High	3769.98	651332	2949.54	589908	2198		8016	649632	4	0	0
		Uplink	Low	3330	622000	3300.84	620056	0	-	-	-	-	-	-
			Mid	3549.99	636666	2729.55	545910	2198		-	-	-	-	-
			High	3769.98	651332	3740.46	649364	1		-	-	-	-	-
80	217	Downlink	Low	3340.02	622668	3300.96	620064	0	30	7711	620352	0	2	2
			Mid	3549.99	636666	3474.57	631638	101		7857	634368	18	2	2
			High	3759.99	650666	2929.65	585930	2198		8003	648384	10	3	3
		Uplink	Low	3340.02	622668	3300.96	620064	0	-	-	-	-	-	-

90	245	Downlink	Mid	3549.99	636666	2719.65	543930	2198	30	-	-	-	-	-
			High	3759.99	650666	3720.57	648038	1		-	-	-	-	-
			Low	3345	623000	3300.9	620060	0		7711	620352	4	2	2
		Uplink	Mid	3549.99	636666	3469.53	631302	101		7853	633984	18	0	0
			High	3754.98	650332	2919.6	583920	2198		7996	647712	8	3	3
			Low	3345	623000	3300.9	620060	0		-	-	-	-	-
			Mid	3549.99	636666	2714.61	542922	2198		-	-	-	-	-
			High	3754.98	650332	3710.52	647368	1		-	-	-	-	-
			Low	3350.01	623334	3300.87	620058	0		-	-	-	-	-
100	273	Downlink	Mid	3549.99	636666	3464.49	630966	101	30	7711	620352	6	2	2
			High	3750	650000	2909.58	581916	2198		7850	633696	18	2	2
			Low	3350.01	623334	3300.87	620058	0		7989	647040	4	3	3
		Uplink	Mid	3549.99	636666	2709.57	541914	2198		-	-	-	-	-
			High	3750	650000	3700.5	646700	1		-	-	-	-	-
			Low	3350.01	623334	3300.87	620058	0		-	-	-	-	-
			Mid	3549.99	636666	2709.57	541914	2198		-	-	-	-	-
			High	3750	650000	3700.5	646700	1		-	-	-	-	-
			Low	3350.01	623334	3300.87	620058	0		-	-	-	-	-
Note 1: The CORESET#0 Index and the associated CORESET#0 Offset refers to Table 13-4 in TS 38.213 [22]. The value of CORESET#0 Index is signalled in the four most significant bits of the IE pdccch-ConfigSIB1 in the MIB														

Table 4.3.1.1.1.78-3: Test frequencies for NR operating band n78 and SCS 60 kHz

Bandwidth [MHz]	carrierBand width [PRBs]	Range		Carrier centre [MHz]	Carrier centre [ARFCN]	point A [MHz]	absoluteFr equencyPoi ntA [ARFCN]	offsetTo Carrier [PRBs]
10	11	Downlink	Low	3305.01	620334	3301.05	620070	0
			Mid	3550.005	636667	3473.325	631555	101
			High	3795	653000	2208.48	441696	2198
		Uplink	Low	3305.01	620334	3301.05	620070	0
			Mid	3549.99	636666	3388.35	625890	219
			High	3795	653000	3790.32	652688	1
15	18	Downlink	Low	3307.5	620500	3301.02	620068	0
			Mid	3550.005	636667	3470.805	631387	101
			High	3792.495	652833	2203.455	440691	2198
		Uplink	Low	3307.5	620500	3301.02	620068	0
			Mid	3549.99	636666	3385.83	625722	219
			High	3792.495	652833	3785.295	652353	1
20	24	Downlink	Low	3310.005	620667	3301.365	620091	0
			Mid	3550.005	636667	3468.645	631243	101
			High	3789.99	652666	2198.79	439758	2198
		Uplink	Low	3310.005	620667	3301.365	620091	0
			Mid	3549.99	636666	3383.67	625578	219
			High	3789.99	652666	3780.63	652042	1
40	51	Downlink	Low	3320.01	621334	3301.65	620110	0
			Mid	3550.005	636667	3458.925	630595	101
			High	3780	652000	2179.08	435816	2198
		Uplink	Low	3320.01	621334	3301.65	620110	0
			Mid	3549.99	636666	1949.07	389814	2198
			High	3780	652000	3760.92	650728	1
50	65	Downlink	Low	3325.005	621667	3301.605	620107	0
			Mid	3550.005	636667	3453.885	630259	101
			High	3774.99	651666	2169.03	433806	2198
		Uplink	Low	3325.005	621667	3301.605	620107	0
			Mid	3549.99	636666	1944.03	388806	2198
			High	3774.99	651666	3750.87	650058	1
60	79	Downlink	Low	3330	622000	3301.56	620104	0
			Mid	3550.005	636667	3448.845	629923	101
			High	3769.995	651333	2158.995	431799	2198
		Uplink	Low	3330	622000	3301.56	620104	0
			Mid	3549.99	636666	1938.99	387798	2198
			High	3769.995	651333	3740.835	649389	1
80	107	Downlink	Low	3340.005	622667	3301.485	620099	0
			Mid	3550.005	636667	3438.765	629251	101
			High	3759.99	650666	2138.91	427782	2198
		Uplink	Low	3340.005	622667	3301.485	620099	0
			Mid	3549.99	636666	1928.91	385782	2198
			High	3759.99	650666	2138.91	427782	2198

90	121	Downlink	High	3759.99	650666	3720.75	648050	1
			Low	3345	623000	3301.44	620096	0
			Mid	3550.005	636667	3433.725	628915	101
		Uplink	High	3754.995	650333	2128.875	425775	2198
			Low	3345	623000	3301.44	620096	0
			Mid	3549.99	636666	1923.87	384774	2198
100	135	Downlink	High	3754.995	650333	3710.715	647381	1
			Low	3350.01	623334	3301.41	620094	0
			Mid	3550.005	636667	3428.685	628579	101
		Uplink	High	3750	650000	2118.84	423768	2198
			Low	3350.01	623334	3301.41	620094	0
			Mid	3549.99	636666	1918.83	383766	2198
			High	3750	650000	3700.68	646712	1

4.3.1.1.1.79

Reference test frequencies for NR operating band n79

Table 4.3.1.1.1.79-1: Test frequencies for NR operating band n79 and SCS 15 kHz

Bandwidth [MHz]	carrierBand width [PRBs]	Range		Carrier centre [MHz]	Carrier centre [ARFCN]	point A [MHz]	absoluteFrequencyPointA [ARFCN]	offsetToCarrier [PRBs]	SS block SCS [kHz]	GSCN	absoluteFrequencySSB [ARFCN]	k_{SSB}	CORESET#0 Offset [RBs] Note 1	CORESET#0 Index Note 1
40	216	Downlink & Uplink	Low	4427.415	695161	4407.975	693865	0	30	8480	694176	23	4	0
			Mid	4703.895	713593	4666.275	711085	101		8672	712608	23	4	0
			High	4957.68	730512	4542.6	702840	2198		8848	729504	0	4	0
50	270	Downlink & Uplink	Low	4432.275	695485	4407.975	693865	0	30	8480	694176	23	4	0
			Mid	4708.755	713917	4666.275	711085	101		8672	712608	23	4	0
			High	4962.54	730836	4542.6	702840	2198		8848	729504	0	4	0
Note 1: The CORESET#0 Index and the associated CORESET#0 Offset refers to Table 13-5 in TS 38.213 [22]. The value of CORESET#0 Index is signalled in the four most significant bits of the IE pdccch-ConfigSIB1 in the MIB														

Table 4.3.1.1.1.79-2: Test frequencies for NR operating band n79 and SCS 30 kHz

Bandwidth [MHz]	carrierBand width [PRBs]	Range		Carrier centre [MHz]	Carrier centre [ARFCN]	point A [MHz]	absolute FrequencyPoint A [ARFCN]	offsetTo Carrier [PRBs]	SS block SCS [kHz]	GSCN	absoluteFrequencySSB [ARFCN]	k_{SSB}	CORESET#0 Offset [RBs] Note 1	CORESET#0 Index Note 1
40	106	Downlink & Uplink	Low	4426.35	695090	4407.27	693818	0	30	8480	694176	22	4	1
			Mid	4702.83	713522	4647.39	709826	101		8672	712608	22	4	1
			High	4979.64	731976	4169.28	677952	2198		8864	731040	0	4	1
50	133	Downlink & Uplink	Low	4431.21	695414	4407.27	693818	0	30	8480	694176	22	4	1
			Mid	4707.69	713846	4647.39	709826	101		8672	712608	22	4	1
			High	4962.9	730860	4147.68	676512	2198		8848	729504	0	0	0
60	162	Downlink & Uplink	Low	4436.43	695762	4407.27	693818	0	30	8480	694176	22	4	1
			Mid	4712.91	714194	4647.39	709826	101		8672	712608	22	4	1
			High	4968.12	731208	4147.68	676512	2198		8848	729504	0	0	0
80	217	Downlink & Uplink	Low	4446.33	696422	4407.27	693818	0	30	8480	694176	22	4	1
			Mid	4700.01	713334	4624.59	708306	101		8656	711072	6	4	1
			High	4954.98	730332	4124.64	674976	2198		8832	727968	0	0	0
100	273	Downlink & Uplink	Low	4456.41	697094	4407.27	693818	0	30	8480	694176	22	4	1
			Mid	4709.85	713990	4624.35	708290	101		8656	711072	22	4	1
			High	4942.02	729468	4101.6	673440	2198		8816	726432	0	0	0
Note 1: The CORESET#0 Index and the associated CORESET#0 Offset refers to Table 13-6 in TS 38.213 [22]. The value of CORESET#0 Index is signalled in the four most significant bits of the IE pdccch-ConfigSIB1 in the MIB														

Table 4.3.1.1.1.79-3: Test frequencies for NR operating band n79 and SCS 60 kHz

Bandwidth [MHz]	carrierBand width [PRBs]	Range	Carrier centre [MHz]	Carrier centre [ARFCN]	point A [MHz]	absoluteFrequency PointA [ARFCN]	offsetTo Carrier [PRBs]	
40	51	Downlink	Low	4420.005	694667	4401.645	693443	0
			Mid	4699.995	713333	4608.915	707261	101
			High	4980	732000	3379.08	625272	2198
50	65	Downlink	Low	4425	695000	4401.6	693440	0
			Mid	4699.995	713333	4603.875	706925	101
			High	4974.99	731666	3369.03	624602	2198
60	79	Downlink	Low	4430.01	695334	4401.57	693438	0
			Mid	4699.995	713333	4598.835	706589	101
			High	4969.995	731333	3358.995	623933	2198
80	107	Downlink	Low	4440	696000	4401.48	693432	0
			Mid	4699.995	713333	4588.755	705917	101
			High	4959.99	730666	3338.91	622594	2198
100	135	Downlink	Low	4450.005	696667	4401.405	693427	0
			Mid	4699.995	713333	4578.675	705245	101
			High	4950	730000	3318.84	621256	2198

4.3.1.1.1.80 – 4.3.1.1.1.256 FFS

4.3.1.1.1.257 Reference test frequencies for NR operating band n257

Table 4.3.1.1.1.257-1: Test frequencies for NR operating band n257 and SCS 60 kHz

Bandwidth [MHz]	carrierBand width [PRBs]	Range		Carrier centre [MHz]	Carrier centre [ARFCN]	point A [MHz]	absolute FrequencyPoint A [ARFCN]	offsetToCarrier [PRBs]
50	66	Downlink	Low	26525.04	2054583	26501.28	2054187	0
			Mid	28000.02	2079166	27903.54	2077558	101
			High	29475	2103749	27868.68	2076977	2198
		Uplink	Low	26525.04	2054583	26501.28	2054187	0
			Mid	27999.96	2079165	26393.64	2052393	2198
			High	29475	2103749	29450.52	2103341	1
100	132	Downlink	Low	26550	2054999	26502.48	2054207	0
			Mid	28000.02	2079166	27879.78	2077162	101
			High	29449.98	2103332	27819.9	2076164	2198
		Uplink	Low	26550	2054999	26502.48	2054207	0
			Mid	27999.96	2079165	26369.88	2051997	2198
			High	29449.98	2103332	29401.74	2102528	1
200	264	Downlink	Low	26600.04	2055833	26505	2054249	0
			Mid	28000.02	2079166	27832.26	2076370	101
			High	29400	2102499	27722.4	2074539	2198
		Uplink	Low	26600.04	2055833	26505	2054249	0
			Mid	27999.96	2079165	26322.36	2051205	2198
			High	29400	2102499	29304.24	2100903	1

Table 4.3.1.1.1.257-2: Test frequencies for NR operating band n257 and SCS 120kHz

Bandwidth [MHz]	carrierBand width [PRBs]	Range		Carrier centre [MHz]	Carrier centre [ARFCN]	point A [MHz]	absolute FrequencyPoint A [ARFCN]	offsetToCarrier [PRBs]	SS block SCS [kHz]	GSCN	absoluteFrequencySSB [ARFCN]	k_{SSB}	CORE SET#0 Offset [RBs] Note 1	CORE SET#0 Index Note 1
50	32	Downlink	Low	26532.6	2054709	26509.56	2054325	0	120	22388	2054683	22	4	1
			Mid	28001.4	2079189	27832.92	2076381	101		22473	2079163	22	4	1
			High	29471.52	2103691	26283.36	2050555	2198		22558	2103643	0	4	1
		Uplink	Low	26525.04	2054583	26502	2054199	0	-	-	-	-	-	-
			Mid	27999.96	2079165	24811.8	2026029	2198		-	-	-	-	-
			High	29475	2103749	29450.52	2103341	1		-	-	-	-	-
100	66	Downlink	Low	26557.08	2055117	26509.56	2054325	0	120	22388	2054683	22	4	1
			Mid	28008.6	2079309	27815.64	2076093	101		22472	2078875	22	4	1
			High	29449.92	2103331	26237.28	2049787	2198		22555	2102779	0	0	0
		Uplink	Low	26550	2054999	26502.48	2054207	0	-	-	-	-	-	-
			Mid	27999.96	2079165	24787.32	2025621	2198		-	-	-	-	-
			High	29449.92	2103331	29400.96	2102515	1		-	-	-	-	-
200	132	Downlink	Low	26604.6	2055909	26509.56	2054325	0	120	22388	2054683	22	4	1
			Mid	28004.28	2079237	27763.8	2075229	101		22469	2078011	22	4	1
			High	29393.76	2102395	26133.6	2048059	2198		22549	2101051	0	0	0
		Uplink	Low	26600.04	2055833	26505	2054249	0	-	-	-	-	-	-
			Mid	27999.96	2079165	24739.8	2024829	2198		-	-	-	-	-
			High	29400	2102499	29303.52	2100891	1		-	-	-	-	-
400	264	Downlink	Low	26700	2057499	26509.92	2054331	0	120	22388	2054683	16	4	1
			Mid	28001.4	2079189	27665.88	2073597	101		22463	2076283	22	0	0
			High	29298.72	2100811	25943.52	2044891	2198		22538	2097883	0	0	0
		Uplink	Low	26700	2057499	26509.92	2054331	0	-	-	-	-	-	-
			Mid	27999.96	2079165	24644.76	2023245	2198		-	-	-	-	-
			High	29299.92	2100831	29108.4	2097639	1		-	-	-	-	-

Note 1: The CORESET#0 Index and the associated CORESET#0 Offset refers to Table 13-8 in TS 38.213 [22]. The value of CORESET#0 Index is signalled in the four most significant bits of the IE pdcch-ConfigSIB1 in the MIB

4.3.1.1.1.258

Reference test frequencies for NR operating band n258

Table 4.3.1.1.1.258-1: Test frequencies for NR operating band n258 and SCS 60 kHz

Bandwidth [MHz]	carrierBand width [PRBs]	Range	Carrier centre [MHz]	Carrier centre [ARFCN]	point A [MHz]	absolute FrequencyPoint A [ARFCN]	offsetToCarrier [PRBs]	
50	66	Downlink	Low	24275.04	2017083	24251.28	2016687	0
			Mid	25875	2043749	25778.52	2042141	101
			High	27474.96	2070415	25868.64	2043643	2198
		Uplink	Low	24275.04	2017083	24251.28	2016687	0
			Mid	25875	2043749	24268.68	2016977	2198
			High	27474.96	2070415	27450.48	2070007	1
100	132	Downlink	Low	24300	2017499	24252.48	2016707	0
			Mid	25875	2043749	25754.76	2041745	101
			High	27450	2069999	25819.92	2042831	2198
		Uplink	Low	24300	2017499	24252.48	2016707	0
			Mid	25875	2043749	24244.92	2016328	2198
			High	27450	2069999	27401.76	2069195	1
200	264	Downlink	Low	24350.04	2018333	24255	2016749	0
			Mid	25875	2043749	25707.24	2040953	101
			High	27399.96	2069165	25722.36	2041205	2198
		Uplink	Low	24350.04	2018333	24255	2016749	0
			Mid	25875	2043749	24197.4	2013160	2198
			High	27399.96	2069165	27304.2	2067569	1

Table 4.3.1.1.1.258-2: Test frequencies for NR operating band n258 and SCS 120kHz

Bandwidth [MHz]	carrierBand width [PRBs]	Range		Carrier centre [MHz]	Carrier centre [ARFCN]	point A [MHz]	absolute FrequencyPoint A [ARFCN]	offsetT oCarrier [PRBs]	SS block SCS [kHz]	GSCN	absoluteFrequencySSB [ARFCN]	k_{SSB}	CORE SET#0 Offset [RBs] Note 1	CORE SET#0 Index Note 1
50	32	Downlink	Low	24275.04	2017083	24252	2016699	0	120	22257	2016955	16	0	0
			Mid	25875.96	2043765	25707.48	2040957	101		22350	2043739	22	4	1
			High	27472.8	2070379	24284.64	2017243	2198		22442	2070235	0	0	0
		Uplink	Low	24275.04	2017083	24252	2016699	0	-	-	-	-	-	-
			Mid	25875	2043749	22686.84	1912456	2198		-	-	-	-	-
			High	27474.96	2070415	27450.48	2070007	1		-	-	-	-	-
100	66	Downlink	Low	24300	2017499	24252.48	2016707	0	120	22257	2016955	8	0	0
			Mid	25883.16	2043885	25690.2	2040669	101		22349	2043451	22	4	1
			High	27445.44	2069923	24232.8	2015520	2198		22439	2069371	0	0	0
		Uplink	Low	24300	2017499	24252.48	2016707	0	-	-	-	-	-	-
			Mid	25875	2043749	22662.36	1910824	2198		-	-	-	-	-
			High	27450	2069999	27401.04	2069183	1		-	-	-	-	-
200	132	Downlink	Low	24358.2	2018469	24263.16	2016885	0	120	22258	2017243	22	4	1
			Mid	25878.84	2043813	25638.36	2039805	101		22346	2042587	22	4	1
			High	27399.96	2069165	24139.8	2009320	2198		22434	2067931	14	4	1
		Uplink	Low	24350.04	2018333	24255	2016749	0	-	-	-	-	-	-
			Mid	25875	2043749	22614.84	1907656	2198		-	-	-	-	-
			High	27399.96	2069165	27303.48	2067557	1		-	-	-	-	-
400	264	Downlink	Low	24453.24	2020053	24263.16	2016885	0	120	22258	2017243	22	4	1
			Mid	25875.96	2043765	25540.44	2038173	101		22340	2040859	22	0	0
			High	27294.24	2067403	23939.04	1995936	2198		22422	2064475	0	0	0
		Uplink	Low	24450	2019999	24259.92	2016831	0	-	-	-	-	-	-
			Mid	25875	2043749	22519.8	1901320	2198		-	-	-	-	-
			High	27300	2067499	27108.48	2064307	1		-	-	-	-	-

Note 1: The CORESET#0 Index and the associated CORESET#0 Offset refers to Table 13-8 in TS 38.213 [22]. The value of CORESET#0 Index is signalled in the four most significant bits of the IE pdccch-ConfigSIB1 in the MIB

4.3.1.1.1.259 FFS

4.3.1.1.1.260 Reference test frequencies for NR operating band n260

Table 4.3.1.1.1.260-1: Test frequencies for NR operating band n260 and SCS 60 kHz

Bandwidth [MHz]	carrierBand width [PRBs]	Range		Carrier centre [MHz]	Carrier centre [ARFCN]	point A [MHz]	absolute FrequencyPoint A [ARFCN]	offsetTo Carrier [PRBs]
50	66	Downlink	Low	37025.04	2229583	37001.28	2229187	0
			Mid	38500.02	2254166	38403.54	2252558	101
			High	39975	2278749	38368.68	2251977	2198
		Uplink	Low	37025.04	2229583	37001.28	2229187	0
			Mid	38499.96	2254165	36893.64	2227393	2198
			High	39975	2278749	39950.52	2278341	1
100	132	Downlink	Low	37050	2229999	37002.48	2229207	0
			Mid	38500.02	2254166	38379.78	2252162	101
			High	39949.98	2278332	38319.9	2251164	2198
		Uplink	Low	37050	2229999	37002.48	2229207	0
			Mid	38499.96	2254165	36869.88	2226997	2198
			High	39949.98	2278332	39901.74	2277528	1
200	264	Downlink	Low	37100.04	2230833	37005	2229249	0
			Mid	38500.02	2254166	38332.26	2251370	101
			High	39900	2277499	38222.4	2249539	2198
		Uplink	Low	37100.04	2230833	37005	2229249	0
			Mid	38499.96	2254165	36822.36	2226205	2198
			High	39900	2277499	39804.24	2275903	1
100	132	Downlink	Low	37050	2229999	37002.48	2229207	0
			Mid	38500.02	2254166	38379.78	2252162	101
			High	39949.98	2278332	38319.9	2251164	2198
		Uplink	Low	37050	2229999	37002.48	2229207	0
			Mid	38499.96	2254165	36869.88	2226997	2198
			High	39949.98	2278332	39901.74	2277528	1

Table 4.3.1.1.1.260-2: Test frequencies for NR operating band n260 and SCS 120kHz

Bandwidth [MHz]	carrierBand width [PRBs]	Range		Carrier centre [MHz]	Carrier centre [ARFCN]	point A [MHz]	absolute FrequencyPoint A [ARFCN]	offsetT oCarrier [PRBs]	SS block SCS [kHz]	GSCN	absoluteFrequencySSB [ARFCN]	k_{SSB}	CORE SET#0 Offset [RBs] Note 1	CORE SET#0 Index Note 1
50	32	Downlink	Low	37027.32	2229621	37004.28	2229237	0	120	22995	2229499	22	0	0
			Mid	38507.64	2254293	38339.16	2251485	101		23081	2254267	22	4	1
			High	39966.24	2278603	36778.08	2225467	2198		23165	2278459	0	0	0
		Uplink	Low	37025.04	2229583	37002	2229199	0	-	-	-	-	-	-
			Mid	38499.96	2254165	35311.8	2201029	2198		-	-	-	-	-
			High	39975	2278749	39950.52	2278341	1		-	-	-	-	-
100	66	Downlink	Low	37051.8	2230029	37004.28	2229237	0	120	22995	2229499	22	0	0
			Mid	38503.32	2254221	38310.36	2251005	101		23079	2253691	22	0	0
			High	39949.92	2278331	36737.28	2224787	2198		23163	2277883	8	4	1
		Uplink	Low	37050	2229999	37002.48	2229207	0	-	-	-	-	-	-
			Mid	38499.96	2254165	35287.32	2200621	2198		-	-	-	-	-
			High	39949.92	2278331	39900.96	2277515	1		-	-	-	-	-
200	132	Downlink	Low	37100.04	2230833	37005	2229249	0	120	22995	2229499	10	0	0
			Mid	38499.96	2254165	38259.48	2250157	101		23076	2252827	6	0	0
			High	39900	2277499	36639.84	2223163	2198		23157	2276155	0	0	0
		Uplink	Low	37100.04	2230833	37005	2229249	0	-	-	-	-	-	-
			Mid	38499.96	2254165	35239.8	2199829	2198		-	-	-	-	-
			High	39900	2277499	39803.52	2275891	1		-	-	-	-	-
400	264	Downlink	Low	37205.88	2232597	37015.8	2229429	0	120	22996	2229787	22	4	1
			Mid	38501.88	2254197	38166.36	2248605	101		23071	2251387	22	4	1
			High	39799.2	2275819	36444	2219899	2198		23146	2272987	0	4	1
		Uplink	Low	37200	2232499	37009.92	2229331	0	-	-	-	-	-	-
			Mid	38499.96	2254165	35144.76	2198245	2198		-	-	-	-	-
			High	39799.92	2275831	39608.4	2272639	1		-	-	-	-	-

Note 1: The CORESET#0 Index and the associated CORESET#0 Offset refers to Table 13-8 in TS 38.213 [22]. The value of CORESET#0 Index is signalled in the four most significant bits of the IE pdccch-ConfigSIB1 in the MIB

4.3.1.1.1.261

Reference test frequencies for NR operating band n261

Table 4.3.1.1.1.261-1: Test frequencies for NR operating band n261 and SCS 60 kHz

Bandwidth [MHz]	carrierBand width [PRBs]	Range	Carrier centre [MHz]	Carrier centre [ARFCN]	point A [MHz]	absolute FrequencyPoint A [ARFCN]	offsetToCarrier [PRBs]	
50	66	Downlink	Low	27525	2071249	27501.24	2070853	0
			Mid	27925.02	2077916	27828.54	2076308	101
			High	28324.98	2084582	26718.66	2057810	2198
		Uplink	Low	27525	2071249	27501.24	2070853	0
			Mid	27924.96	2077915	26318.64	2051143	2198
			High	28324.98	2084582	28300.5	2084174	1
100	132	Downlink	Low	27550.02	2071666	27502.5	2070874	0
			Mid	27925.02	2077916	27804.78	2075912	101
			High	28299.96	2084165	26669.88	2056997	2198
		Uplink	Low	27550.02	2071666	27502.5	2070874	0
			Mid	27924.96	2077915	26294.88	2050747	2198
			High	28299.96	2084165	28251.72	2083361	1
200	264	Downlink	Low	27600	2072499	27504.96	2070915	0
			Mid	27925.02	2077916	27757.26	2075120	101
			High	28249.98	2083332	26572.38	2055372	2198
		Uplink	Low	27600	2072499	27504.96	2070915	0
			Mid	27924.96	2077915	26247.36	2049955	2198
			High	28249.98	2083332	28154.22	2081736	1

Table 4.3.1.1.1.261-2: Test frequencies for NR operating band n261 and SCS 120kHz

Bandwidth [MHz]	carrierBand width [PRBs]	Range		Carrier centre [MHz]	Carrier centre [ARFCN]	point A [MHz]	absolute FrequencyPoint A [ARFCN]	offsetToCarrier [PRBs]	SS block SCS [kHz]	GSCN	absoluteFrequencySSB [ARFCN]	k_{SSB}	CORE SET#0 Offset [RBs] Note 1	CORE SET#0 Index Note 1	
50	32	Downlink	Low	27534.84	2071413	27511.8	2071029	0	120	22446	2071387	22	4	1	
			Mid	27932.28	2078037	27763.8	2075229	101		22469	2078011	22	4	1	
			High	28319.52	2084491	25131.36	2031355	2198		22491	2084347	0	0	0	
		Uplink	Low	27525	2071249	27501.96	2070865	0	-	-	-	-	-	-	-
			Mid	27924.96	2077915	24736.8	2024779	2198		-	-	-	-	-	-
			High	28324.92	2084581	28300.44	2084173	1		-	-	-	-	-	-
100	66	Downlink	Low	27559.32	2071821	27511.8	2071029	0	120	22446	2071387	22	4	1	
			Mid	27927.96	2077965	27735	2074749	101		22467	2077435	22	0	0	
			High	28292.16	2084035	25079.52	2030491	2198		22488	2083483	0	0	0	
		Uplink	Low	27550.08	2071667	27502.56	2070875	0	-	-	-	-	-	-	-
			Mid	27924.96	2077915	24712.32	2024371	2198		-	-	-	-	-	-
			High	28299.96	2084165	28251	2083349	1		-	-	-	-	-	-
200	132	Downlink	Low	27606.84	2072613	27511.8	2071029	0	120	22446	2071387	22	4	1	
			Mid	27924.96	2077915	27684.48	2073907	101		22464	2076571	0	0	0	
			High	28247.52	2083291	24987.36	2028955	2198		22483	2082043	0	4	1	
		Uplink	Low	27600	2072499	27504.96	2070915	0	-	-	-	-	-	-	-
			Mid	27924.96	2077915	24664.8	2023579	2198		-	-	-	-	-	-
			High	28249.92	2083331	28153.44	2081723	1		-	-	-	-	-	-
400	264	Downlink	Low	27701.88	2074197	27511.8	2071029	0	120	22446	2071387	22	4	1	
			Mid	27926.52	2077941	27591	2072349	101		22459	2075131	22	4	1	
			High	28140.96	2081515	24785.76	2025595	2198		22471	2078587	0	0	0	
		Uplink	Low	27700.08	2074167	27510	2070999	0	-	-	-	-	-	-	-
			Mid	27924.96	2077915	24569.76	2021995	2198		-	-	-	-	-	-
			High	28149.96	2081665	27958.44	2078473	1		-	-	-	-	-	-

Note 1: The CORESET#0 Index and the associated CORESET#0 Offset refers to Table 13-8 in TS 38.213 [22]. The value of CORESET#0 Index is signalled in the four most significant bits of the IE pdcch-ConfigSIB1 in the MIB

- 4.3.1.1.2 Intra-band CA in FR1
- 4.3.1.1.3 Inter-band CA in FR1
- 4.3.1.1.4 Operating bands for DC in FR1
- 4.3.1.1.5 Operating band combination for SUL in FR1
- 4.3.1.2 Test frequencies for NR operating bands in FR2
- 4.3.1.2.1 Operating bands in FR2

Table 4.3.1.2.1-1: NR operating band n257

Range	Bandwidth [MHz]	FFS	Frequency of Uplink [MHz]	FFS	Frequency of Downlink [MHz]
Low Range	FFS				
	FFS				
Mid Range	FFS				
High Range	FFS				
	FFS				

Table 4.3.1.2.1-2: NR operating band n258

Range	Bandwidth [MHz]	FFS	Frequency of Uplink [MHz]	FFS	Frequency of Downlink [MHz]
Low Range	FFS				
	FFS				
Mid Range	FFS				
High Range	FFS				
	FFS				

- 4.3.1.2.2 Intra-band CA in FR2
- 4.3.1.2.3 Inter-band CA in FR2
- 4.3.1.3 Test frequencies for NR operation with other radios
- 4.3.1.3.1 Inter-band CA

Table 4.3.1.3.1-1: Inter-band CA combination CA_n71A_n257A

Range	FFS	NR FR1					NR FR2				
		BW [RB]	FFS	f _{UL} [MHz]	FFS	f _{DL} [MHz]	BW [RB]	FFS	f _{UL} [MHz]	FFS	f _{DL} [MHz]
Low	FFS										
	FFS										
Mid	FFS										
	FFS										
High	FFS										
	FFS										

- 4.3.1.3.2 EN-DC (two bands)
- 4.3.1.3.2.0 Default reference test frequencies for EN-DC combinations (two bands)

For inter-band EN-DC configurations as listed in Table 4.3.1.3.2.0-1, the following apply:

For the E-UTRA band, test frequencies as specified in TS 36.508 [2] Table 4.3.1.1.1-1 are used.

For the NR band, test frequencies as specified in clause 4.3.1 are used.

Table 4.3.1.3.2.0-1: Inter-band EN-DC configurations (FR1, two bands)

EN-DC configuration	Uplink EN-DC configuration	E-UTRA configuration	NR configuration
DC_1A_n28A	DC_1A_n28A	1	n28A
DC_1A_n77A	DC_1A_n77A	1A	n77A
DC_1A_n78A	DC_1A_n78A	1A	n78A
DC_1A_n79A	DC_1A_n79A	1A	n79A
DC_3A_n77A	DC_3A_n77A	3A	n77A
DC_3A_n78A	DC_3A_n78A	3A	n78A
DC_3A_n79A	DC_3A_n79A	3A	n79A
DC_19A_n77A	DC_19A_n77A	19A	n77A
DC_19A_n78A	DC_19A_n78A	19A	n78A
DC_19A_n79A	DC_19A_n79A	19A	n79A
DC_20A_n78A	DC_20A_n78A	20A	n78A
DC_21A_n77A	DC_21A_n77A	21A	n77A
DC_21A_n78A	DC_21A_n78A	21A	n78A
DC_21A_n79A	DC_21A_n79A	21A	n79A
DC_25A_n41A	DC_25A_n41A	25	n41A
DC_28A_n77A	DC_28A_n77A	28A	n77A
DC_28A_n78A	DC_28A_n78A	28A	n78A
DC_28A_n79A	DC_28A_n79A	28A	n79A

Table 4.3.1.3.2.0-2: Inter-band EN-DC configurations (FR1, three bands)

EN-DC configuration	Uplink EN-DC configuration	E-UTRA configuration	NR configuration
FFS	FFS	FFS	FFS

Table 4.3.1.3.2.0-3: Inter-band EN-DC configurations (FR1, four bands)

EN-DC configuration	Uplink EN-DC configuration	E-UTRA configuration	NR configuration
FFS	FFS	FFS	FFS

Table 4.3.1.3.2.0-4: FFS**Table 4.3.1.3.2.0-5: Inter-band EN-DC configurations (FR1, five bands)**

EN-DC configuration	Uplink EN-DC configuration	E-UTRA configuration	NR configuration
FFS	FFS	FFS	FFS

Table 4.3.1.3.2.0-6: Inter-band EN-DC configurations (FR1, six bands)

EN-DC configuration	Uplink EN-DC configuration	E-UTRA configuration	NR configuration
FFS	FFS	FFS	FFS

Table 4.3.1.3.2.0-7: Inter-band EN-DC configurations (FR2, two bands)

EN-DC configuration	Uplink EN-DC configuration	E-UTRA configuration	NR configuration
DC_1A_n257A	DC_1A_n257A	1A	n257A
DC_3A_n257A	DC_3A_n257A	3A	n257A
DC_5A-n260A	DC_5A_n260A	5	n260A
DC_5A_n261A	DC_5A_n261A	5	n261A
DC_13A_n257A	DC_13A_n257A	13	n257A
DC_19A_n257A	DC_19A_n257A	19A	n257A
DC_21A_n257A	DC_21A_n257A	21A	n257A
DC_66A_n260A	DC_66A_n260A	66	n260A
DC_66A-n261A	DC_66A_n261A	66	n261A

Table 4.3.1.3.2.0-8: Inter-band EN-DC configurations (FR2, three bands)

EN-DC configuration	Uplink EN-DC configuration	E-UTRA configuration	NR configuration
FFS	FFS	FFS	FFS

Table 4.3.1.3.2.0-9: Inter-band EN-DC configurations (FR2, four bands)

EN-DC configuration	Uplink EN-DC configuration	E-UTRA configuration	NR configuration
FFS	FFS	FFS	FFS

Table 4.3.1.3.2.0-10: Inter-band EN-DC configurations (FR2, five bands)

EN-DC configuration	Uplink EN-DC configuration	E-UTRA configuration	NR configuration
FFS	FFS	FFS	FFS

Table 4.3.1.3.2.0-11: Inter-band EN-DC configurations (FR2, six bands)

EN-DC configuration	Uplink EN-DC configuration	E-UTRA configuration	NR configuration
FFS	FFS	FFS	FFS

4.3.1.3.2.1

Reference test frequencies for EN-DC combinations beginning with B1

Table 4.3.1.3.2.1-28: EN-DC combination DC_1_n28

Range	FFS	E-UTRA					NR				
		BW [RB]	N _{UL}	f _{UL} [MHz]	N _{DL}	f _{DL} [MHz]	BW [RB]	FFS	f _{UL} [MHz]	FFS	f _{DL} [MHz]
Low	FFS										
	FFS										
Mid	FFS										
	FFS										
High	FFS										
	FFS										

4.3.1.3.2.2 to 4.3.1.3.2.24 FFS

4.3.1.3.2.25 Reference test frequencies for EN-DC combinations beginning with B25

4.3.1.3.2.25.1 to 4.3.1.3.2.25.40 FFS

4.3.1.3.2.25.41 Reference test frequencies for EN-DC combination DC_25A_n41A / DC_25A_n41A

The test frequencies for B25A are found in TS 36.508 [2] Table 4.3.1.1.25-1.

The test frequencies for n41A are found in sub clause 4.3.1.1.1.41:

4.3.1.3.2.26 – 4.3.1.3.2.40 FFS

4.3.1.3.2.41 Reference test frequencies for EN-DC combinations beginning with B41

4.3.1.3.2.41.1

Table 4.3.1.3.2.41-1: EN-DC combination DC_(n)41, intra-band contiguous, SCS 15 kHz

Range	E-UTRA					NR		
	BW [MHz]	N _{UL}	f _{UL} [MHz]	N _{DL}	f _{DL} [MHz]	BW [MHz]	f _{UL} [MHz]	f _{DL} [MHz]
Low	5	39776	2508.6	39776	2508.6	10	2501.01	2501.01
Mid	5	40696	2600.6	40696	2600.6	10	2593.005	2593.005
High	5	41465	2677.5	41465	2677.5	10	2685	2685
Low	5	39825	2513.5	39825	2513.5	15	2503.5	2503.5
Mid	5	40721	2603.1	40721	2603.1	15	2593.005	2593.005
High	5	41414	2672.4	41414	2672.4	15	2682.495	2682.495
Low	5	39876	2518.6	39876	2518.6	20	2506.005	2506.005
Mid	5	40746	2605.6	40746	2605.6	20	2593.005	2593.005
High	5	41364	2667.4	41364	2667.4	20	2679.99	2679.99
Low	5	40076	2538.6	40076	2538.6	40	2516.01	2516.01
Mid	5	40847	2615.7	40847	2615.7	40	2593.125	2593.125
High	5	41165	2647.5	41165	2647.5	40	2670	2670
Low	5	40176	2548.6	40176	2548.6	50	2521.005	2521.005
Mid	5	40896	2620.6	40896	2620.6	50	2593.005	2593.005
High	5	41064	2637.4	41064	2637.4	50	2664.99	2664.99

NOTE 1: NR test frequencies are defined in sub-clause 4.3.1.1.1.41

Table 4.3.1.3.2.41-2: EN-DC combination DC_(n)41, intra-band contiguous, SCS 30 kHz

Range	E-UTRA					NR		
	BW [MHz]	N _{UL}	f _{UL} [MHz]	N _{DL}	f _{DL} [MHz]	BW [MHz]	f _{UL} [MHz]	f _{DL} [MHz]
Low	5	39776	2508.6	39776	2508.6	10	2501.01	2501.01
Mid	5	40695	2600.5	40695	2600.5	10	2592.99	2592.99
High	5	41465	2677.5	41465	2677.5	10	2685	2685
Low	5	39825	2513.5	39825	2513.5	15	2503.5	2503.5
Mid	5	40720	2603	40720	2603	15	2592.99	2592.99
High	5	41414	2672.4	41414	2672.4	15	2682.48	2682.48
Low	5	39876	2518.6	39876	2518.6	20	2506.02	2506.02
Mid	5	40745	2605.5	40745	2605.5	20	2592.99	2592.99
High	5	41364	2667.4	41364	2667.4	20	2679.99	2679.99
Low	5	40076	2538.6	40076	2538.6	40	2516.01	2516.01
Mid	5	40845	2615.5	40845	2615.5	40	2592.99	2592.99
High	5	41165	2647.5	41165	2647.5	40	2670	2670
Low	5	40176	2548.6	40176	2548.6	50	2521.02	2521.02
Mid	5	40895	2620.5	40895	2620.5	50	2592.99	2592.99
High	5	41064	2637.4	41064	2637.4	50	2664.99	2664.99
Low	5	40275	2558.5	40275	2558.5	60	2526	2526
Mid	5	40945	2625.5	40945	2625.5	60	2592.99	2592.99
High	5	40964	2627.4	40964	2627.4	60	2659.98	2659.98
Low	5	40476	2578.6	40476	2578.6	80	2536.02	2536.02
Mid	5	41045	2635.5	41045	2635.5	80	2592.99	2592.99
High	5	40764	2607.4	40764	2607.4	80	2649.99	2649.99
Low	5	40575	2588.5	40575	2588.5	90	2541	2541
Mid	5	41095	2640.5	41095	2640.5	90	2592.99	2592.99
High	5	40664	2597.4	40664	2597.4	90	2644.98	2644.98
Low	5	40676	2598.6	40676	2598.6	100	2546.01	2546.01
Mid	5	41145	2645.5	41145	2645.5	100	2592.99	2592.99
High	5	40565	2587.5	40565	2587.5	100	2640	2640

NOTE 1: NR test frequencies are defined in sub-clause 4.3.1.1.1.41

Table 4.3.1.3.2.41-3: EN-DC combination DC_(n)41, intra-band contiguous, SCS 60 kHz

Range	E-UTRA					NR		
	BW [MHz]	N _{UL}	f _{UL} [MHz]	N _{DL}	f _{DL} [MHz]	BW [MHz]	f _{UL} [MHz]	f _{DL} [MHz]
Low	5	39776	2508.6	39776	2508.6	10	2501.01	2501.01
Mid	5	40696	2600.6	40696	2600.6	10	2593.005	2593.005
High	5	41465	2677.5	41465	2677.5	10	2685	2685
Low	5	39825	2513.5	39825	2513.5	15	2503.5	2503.5
Mid	5	40721	2603.1	40721	2603.1	15	2593.005	2593.005
High	5	41414	2672.4	41414	2672.4	15	2682.495	2682.495
Low	5	39876	2518.6	39876	2518.6	20	2506.005	2506.005
Mid	5	40746	2605.6	40746	2605.6	20	2593.005	2593.005
High	5	41364	2667.4	41364	2667.4	20	2679.99	2679.99
Low	5	40076	2538.6	40076	2538.6	40	2516.01	2516.01
Mid	5	40846	2615.6	40846	2615.6	40	2593.005	2593.005
High	5	41165	2647.5	41165	2647.5	40	2670	2670
Low	5	40176	2548.6	40176	2548.6	50	2521.005	2521.005
Mid	5	40896	2620.6	40896	2620.6	50	2593.005	2593.005
High	5	41064	2637.4	41064	2637.4	50	2664.99	2664.99
Low	5	40275	2558.5	40275	2558.5	60	2526	2526
Mid	5	40946	2625.6	40946	2625.6	60	2593.005	2593.005
High	5	40964	2627.4	40964	2627.4	60	2659.995	2659.995
Low	5	40476	2578.6	40476	2578.6	80	2536.005	2536.005
Mid	5	41046	2635.6	41046	2635.6	80	2593.005	2593.005
High	5	40764	2607.4	40764	2607.4	80	2649.99	2649.99
Low	5	40575	2588.5	40575	2588.5	90	2541	2541
Mid	5	41096	2640.6	41096	2640.6	90	2593.005	2593.005
High	5	40664	2597.4	40664	2597.4	90	2644.995	2644.995
Low	5	40676	2598.6	40676	2598.6	100	2546.01	2546.01
Mid	5	41146	2645.6	41146	2645.6	100	2593.005	2593.005
High	5	40565	2587.5	40565	2587.5	100	2640	2640

NOTE 1: NR test frequencies are defined in sub-clause 4.3.1.1.1.41

4.3.1.3.2.41.2 to 4.3.1.3.2.41.40FFS

4.3.1.3.2.41.41 Reference test frequencies for EN-DC combination DC_(n)41AA / DC_(n)41AA

Table 4.3.1.3.2.41.41-1 identifies the EARFCN and frequency of the LTE CC for each NR CC. Test frequencies for NR operating band n41, SCS 30 kHz, are defined in 4.3.1.1.1.41.2.

Table 4.3.1.3.2.41.41-1: Test frequencies for EN-DC combination DC_(n)41AA / DC_(n)41AA (two bands)

Test Frequency ID	NR Bandwidth [MHz]	LTE Bandwidth [MHz]	LTE EARFCN	LTE Freq [MHz]
Low Range (LTE-NR) (NR-LTE)	40	20	FFS	FFS
	60	20	FFS	FFS
	80	20	FFS	FFS
	100	20	FFS	FFS
	40	20	FFS	FFS
	60	20	FFS	FFS
	80	20	FFS	FFS
	100	20	FFS	FFS
Mid Range (LTE-NR) (NR-LTE)	40	20	40324	2563.43
	60	20	40224	2553.35
	80	20	40126	2543.63
	100	20	40026	2533.55
	40	20	40906	2621.59
	60	20	41007	2631.67
	80	20	41108	2641.75
	100	20	41208	2651.83
High Range (LTE-NR) (NR-LTE)	40	20	FFS	FFS
	60	20	FFS	FFS
	80	20	FFS	FFS
	100	20	FFS	FFS
	40	20	FFS	FFS
	60	20	FFS	FFS
	80	20	FFS	FFS
	100	20	FFS	FFS

4.3.1.3.2.41.41A Reference test frequencies for EN-DC combination DC_41A_n41A / DC_41A_n41A

Table 4.3.1.3.2.41.41A-1 identifies the EARFCN and frequency of the LTE CC for each NR CC. Test frequencies for NR operating band n41, SCS 30 kHz, are defined in 4.3.1.1.1.41.2.

Table 4.3.1.3.2.41.41A-1: Test frequencies for EN-DC combination DC_41A_n41A / DC_41A_n41A (two bands)

Test Frequency ID	NR Bandwidth [MHz]	LTE Bandwidth [MHz]	LTE EARFCN	LTE Freq [kHz]
Low Range (LTE-NR) (NR-LTE)	40	20	FFS	FFS
	60	20	FFS	FFS
	80	20	FFS	FFS
	100	20	FFS	FFS
	40	20	FFS	FFS
	60	20	FFS	FFS
	80	20	FFS	FFS
	100	20	FFS	FFS
Mid Range (LTE-NR) (NR-LTE)	40	20	40224	2553.43
	60	20	40124	2543.35
	80	20	40026	2533.63
	100	20	39926	2523.55
	40	20	41006	2631.59
	60	20	41107	2641.67
	80	20	41208	2651.75
	100	20	41308	2661.83
High Range (LTE-NR) (NR-LTE)	40	20	FFS	FFS
	60	20	FFS	FFS
	80	20	FFS	FFS
	100	20	FFS	FFS
	40	20	FFS	FFS
	60	20	FFS	FFS
	80	20	FFS	FFS
	100	20	FFS	FFS

4.3.1.3.3 EN-DC (three bands)

4.3.1.3.4 EN-DC (four bands)

4.3.1.3.5 EN-DC (five bands)

4.3.2 Radio conditions

4.3.2.1 FR1, normal propagation condition for connected

The downlink connection between the System Simulator and the UE is without Additive White Gaussian Noise, and has no fading or multipath effects.

The uplink connection between the UE and System Simulator is without Additive White Gaussian Noise, and has no fading or multipath effects.

4.3.2.2 FR2, condition for OTA

FFS

4.3.3 Physical channel allocations

4.3.3.1 E-UTRA

The same physical channel allocations as in TS 36.508 [2] clause 4.3.3 applies.

4.3.3.2 NR

4.3.3.2.1 Antennas

For FR1 testing, if the UE has two or four Rx antennas, the same downlink signal is applied to each antenna. All UE Rx antennas shall be connected unless otherwise stated in the test case.

4.3.3.2.2 Downlink physical channels and physical signals

FFS

4.3.3.2.3 Mapping of downlink physical channels and signals to physical resources

Parameters for mapping of downlink physical channels and signals are specified as follows.

Normal Cyclic Prefix

N_{ID}^{cell} , Physical layer cell identity = [100] is used as the default physical layer cell identity

SCS, Subcarrier spacing = 15 kHz for FR1 FDD (the same SCS is used for synch and data)

SCS, Subcarrier spacing = 30 kHz for FR1 TDD (with SCS for synch 30 kHz for TDD bands supporting it otherwise using SCS for synch 15 kHz), except for band n34 and n51, where SCS = 15 kHz (the same SCS is used for synch and data)

SCS, Subcarrier spacing = 120 kHz for FR2 TDD (the same SCS is used for synch and data)

For Signalling testing, the default channel bandwidth is specified in clause 6.2.3.1 for each NR band.

For Signalling testing, single SS Tx antenna is used, in FR1, unless specified otherwise in the test case.

For RF testing, the mapping of DL physical channels to resource element is defined in Annex C of TS 38.101-1 [7] and TS 38.101-2 [8] and TS 38.101-3 [9].

4.3.3.2.4 Uplink physical channels and physical signals

[FFS].

4.3.3.2.5 Mapping of uplink physical channels and signals to physical resources

[FFS].

4.3.4 Signal levels

4.3.4.1 Signal levels for conducted testing

4.3.4.1.1 Downlink signal levels

For E-UTRA cell in EN-DC with FR1 NR, the downlink power setting specified in Table 4.3.4.1-1 of TS 36.508[2] are used unless otherwise specified in a test case.

4.3.4.2 Signal levels for OTA testing

As defined in clause 5.2.1.2 for RF tests.

As defined in clause 6.2.1.2 for Signalling tests.

As defined in clause 7.2.1.2 for RRM tests.

4.3.5 Standard test signals

4.3.6 Physical layer parameters

4.3.6.1 Downlink physical layer parameters

4.3.6.1.1 Physical layer parameters for scheduling of PUSCH

4.3.6.1.1.1 Physical layer parameters for DCI format 0_0

DCI format 0_0 is used for the scheduling of PUSCH in one cell.

Default physical layer parameters for DCI format 0_0 are specified in table 4.3.6.1.1.1-1.

Table 4.3.6.1.1.1-1: Physical layer parameters for DCI format 0_0

Parameter	Value	Value in binary
Identifier for DCI formats	Indicating an UL DCI format	["0"]
Frequency domain resource assignment	Dependent on test parameters	-
Time domain resource assignment	Dependent on test parameters	-
Frequency hopping flag	[w/o hopping]	["0"]
Modulation and coding scheme	Dependent on test parameters	
New data indicator	Set for every data transmission/retransmission according to the rules specified in TS 38.321	-
Redundancy version	Dependent on test parameters	-
HARQ process number	Depending on test parameters	-
TPC command for scheduled PUSCH	[0 dB (accumulated TPC) as per Table 7.1.1-1 in TS 38.213]	["01"]
UL/SUL indicator	[Not present (0 bit for UEs not configured with SUL in the cell)]	-

4.3.6.1.1.2 Physical layer parameters for DCI format 0_1

DCI format 0_1 is used for the scheduling of PUSCH in one cell.

Default physical layer parameters for DCI format 0_1 are specified in table 4.3.6.1.1.2-1.

Table 4.3.6.1.1.2-1: Physical layer parameters for DCI format 0_1

Parameter	Value	Value in binary
Carrier indicator	[Not present]	-
UL/SUL indicator	[Not present (0 bit for UEs not configured with SUL in the cell)]	-
Identifier for DCI formats	Indicating an UL DCI format	["0"]
Bandwidth part indicator	[Not present (indicating active BWP, not present in case of only one <i>BWP-Id</i> as per Table 4.6.3-4)]	-
Frequency domain resource assignment	Dependent on test parameters	-
Time domain resource assignment	Dependent on test parameters	-
Frequency hopping flag	[Not present]	-
Modulation and coding scheme	Dependent on test parameters	-
New data indicator	Set for every data transmission/retransmission according to the rules specified in TS 38.321	-
Redundancy version	Dependent on test parameters	-
HARQ process number	Depending on test parameters	-
1 st downlink assignment index	[$V_{T-DAI}^{UL} = 1$ as per Table 9.1.3-2 in TS 38.213]	["00"]
2 nd downlink assignment index	[Not present (0 bit if one HARQ-ACK sub-codebook)]	-
TPC command for scheduled PUSCH	[0 dB (accumulated TPC) as per Table 7.1.1-1 in TS 38.213]	["01"]
SRS resource indicator	[Not present]	-
Precoding information and number of layers	[Not present (0 bits for 1 antenna port and $TxConfig = \text{Codebook}$ as per Table 4.6.3-15)]	-
Antenna ports	[0 DMRS ports (PUSCH-tp=Disabled, UL-DMRS-config-type=1, UL-DMRS-max-len=1, rank = 1)]	["000"]
SRS request	No aperiodic SRS resource set triggered as per Table 7.3.1.1.2-24 in TS 38.212 (no SUL configured)	["00"]
CSI request	[Not present]	-
CBG transmission information	[Not present]	-
PTRS-DMRS association	[DMRS port 0]	["00"]
beta_offset indicator	[Not present (0 bit if the higher layer parameter dynamic in uci-on-PUSCH is not configured)]	-
DMRS sequence initialization	[$n_{SCID} = 0$ (ScramblingID0 is not present as per Table 4.6.3-36)]	["0"]

4.3.6.1.2 Physical layer parameters for scheduling of PDSCH

4.3.6.1.2.1 Physical layer parameters for DCI format 1_0

DCI format 1_0 is used for the scheduling of PDSCH in one cell.

Default physical layer parameters for DCI format 1_0 are specified in table 4.3.6.1.2.1-1.

Table 4.3.6.1.2.1-1: Physical layer parameters for DCI format 1_0

Parameter	Value	Value in binary
Identifier for DCI formats	Indicating a DL DCI format	["01"]
Frequency domain resource assignment	Dependent on test parameters	-
Time domain resource assignment	Dependent on test parameters	-
VRB-to-PRB mapping	[Non-interleaved]	["0"]
Modulation and coding scheme	Dependent on test parameters	-
New data indicator	Set for every data transmission/retransmission according to the rules specified in TS 38.321	-
Redundancy version	Dependent on test parameters	-
HARQ process number	Depending on test parameters	-
Downlink assignment index	$[V_{C-DAI}^{DL} / V_{T-DAI}^{DL} = 1$ as per Table 9.1.3-1 in TS 38.213]	["00"]
TPC command for scheduled PUCCH	[0 dB (accumulated TPC) as per Table 7.2.1-1 in TS 38.213]	["01"]
PUCCH resource indicator	[<i>PUCCH-ResourceId</i> [1] = [0] as defined in Table 4.6.3-84 (Mapping as per Table 9.2.3-2 in TS 38.213)]	["000"]
PDSCH-to-HARQ_feedback timing indicator	[2 slots as specified in 9.2.3 in TS 38.213]	["001"]

4.3.6.1.2.2 Physical layer parameters for DCI format 1_1

DCI format 1_1 is used for the scheduling of PDSCH in one cell.

Default physical layer parameters for DCI format 1_1 are specified in table 4.3.6.1.2.2-1.

Table 4.3.6.1.2.2-1: Physical layer parameters for DCI format 1_1

Parameter	Value	Value in binary
Carrier indicator	[Not present]	-
Identifier for DCI formats	Indicating a DL DCI format	["1"]
Bandwidth part indicator	[Not present]	-
Frequency domain resource assignment	Dependent on test parameters	-
Time domain resource assignment	Dependent on test parameters	-
VRB-to-PRB mapping	[Non-interleaved]	["0"]
PRB bundling size indicator	[Not present (semi-static PRB_bundling)]	-
Rate matching indicator	[Not present]	-
ZP CSI-RS trigger	[Not present]	-
Modulation and coding scheme (TB1)	Dependent on test parameters	-
New data indicator (TB1)	Set for every data transmission/retransmission according to the rules specified in TS 38.321	-
Redundancy version (TB1)	Dependent on test parameters	-
Modulation and coding scheme (TB2)	Dependent on test parameters	-
New data indicator (TB2)	Set for every data transmission/retransmission according to the rules specified in TS 38.321	-
Redundancy version (TB2)	Dependent on test parameters	-
HARQ process number	Depending on test parameters	-
Downlink assignment index	$[V_{C-DAI}^{DL} / V_{T-DAI}^{DL} = 1$ as per Table 9.1.3-1 in TS 38.213]	["00"]
TPC command for scheduled PUCCH	[0 dB (accumulated TPC) as per Table 7.2.1-1 in TS 38.213]	["01"]
PUCCH resource indicator	$[PUCCH-ResourceId[1] = 0]$ as defined in Table 4.6.3-84 (Mapping as per Table 9.2.3-2 in TS 38.213)]	["000"]
PDSCH-to-HARQ_feedback timing indicator	[2 slots] as per Table 9.2.3-1 in TS 38.213 and <i>dl-DataToUL-ACK</i> in Table [4.6.3-84]	["010"]
Antenna port(s)	[DMRS port 0 as per Table 7.3.1.2.2-1 in TS 38.212 (<i>dmrs-Type</i> = [Not present] and <i>maxLength</i> = [Not present] as per Table 4.6.3-29)]	["0000"]
Transmission configuration indication	[Not present (0 bits, <i>tci-PresentInDCI</i> = [Not present] as per Table 4.6.3-17)]	-
SRS request	No aperiodic SRS resource set triggered as per Table 7.3.1.1.2-24 in TS 38.212 (no SUL configured)	["00"]
CBG transmission information	[Not present]	-
CBG flushing out information	[Not present]	-
DMRS sequence initialization	$[n_{SCID} = 0$ (scramblingID0 is not present as per Table 4.6.3-29)]	["0"]

4.3.6.1.3 Physical layer parameters for other purposes

4.3.6.1.3.1 Physical layer parameters for DCI format 2_0

DCI format 2_0 is used for notifying the slot format.

Default physical layer parameters for DCI format 2_0 are specified in table 4.3.6.1.3.1-1.

Table 4.3.6.1.3.1-1: Physical layer parameters for DCI format 2_0

Parameter	Value	Value in binary
Identifier for DCI formats	TBD	TBD
Slot format indicator 1	TBD	TBD
Slot format indicator 2	TBD	TBD
Slot format indicator <i>N</i>	TBD	TBD

4.3.6.1.3.2 Physical layer parameters for DCI format 2_1

DCI format 2_1 is used for notifying the PRB(s) and OFDM symbol(s) where UE may assume no transmission is intended for the UE.

Default physical layer parameters for DCI format 2_1 are specified in table 4.3.6.1.3.2-1.

Table 4.3.6.1.3.2-1: Physical layer parameters for DCI format 2_1

Parameter	Value	Value in binary
Identifier for DCI formats	TBD	TBD
Pre-emption indication 1	TBD	TBD
Pre-emption indication 2	TBD	TBD
Pre-emption indication <i>N</i>	TBD	TBD

4.3.6.1.3.3 Physical layer parameters for DCI format 2_2

DCI format 2_2 is used for the transmission of TPC commands for PUCCH and PUSCH.

Default physical layer parameters for DCI format 2_2 are specified in table 4.3.6.1.3.3-1.

Table 4.3.6.1.3.3-1: Physical layer parameters for DCI format 2_2

Parameter	Value	Value in binary
Identifier for DCI formats	TBD	TBD
TPC command number 1	[0 dB (accumulated TPC) as per Table 7.1.1-1 and Table 7.2.1-1 in TS 38.213]	["01"]
TPC command number 2	[0 dB (accumulated TPC) as per Table 7.1.1-1 and Table 7.2.1-1 in TS 38.213]	["01"]
TPC command number <i>N</i>	[0 dB (accumulated TPC) as per Table 7.1.1-1 and Table 7.2.1-1 in TS 38.213]	["01"]

4.3.6.1.3.4 Physical layer parameters for DCI format 2_3

DCI format 2_3 is used for the transmission of a group of TPC commands for SRS transmissions by one or more UEs. Along with a TPC command, a SRS request may also be transmitted.

Default physical layer parameters for DCI format 2_3 are specified in table 4.3.6.1.3.4-1.

Table 4.3.6.1.3.4-1: Physical layer parameters for DCI format 2_3

Parameter	Value	Value in binary
Identifier for DCI formats	TBD	TBD
block number 1	TBD	TBD
SRS request (block number 1)	TBD	TBD
TPC command number (block number 1)	[0 dB (accumulated TPC) as per Table 7.1.1-1 in TS 38.213]	["01"]
block number 2	TBD	TBD
SRS request (block number 2)	TBD	TBD
TPC command number (block number 2)	[0 dB (accumulated TPC) as per Table 7.1.1-1 in TS 38.213]	["01"]
block number B	TBD	TBD
SRS request (block number B)	TBD	TBD
TPC command number (block number B)	[0 dB (accumulated TPC) as per Table 7.1.1-1 in TS 38.213]	["01"]

4.4 Reference system configurations

The reference system configurations specified in this sub clause apply to all test cases unless otherwise specified.

4.4.1 Simulated network scenarios

The simulated network scenarios will simulate UE operation in either standalone NR, standalone E-UTRA or in non-standalone NR and E-UTRA networks. For non-standalone case either the NR or the E-UTRA radio access acts as the master anchor node. For both standalone and non-standalone cases, the simulated networks may be single mode networks (FDD or TDD) or dual mode networks (FDD+TDD). For the standalone NR case the simulated networks may also be inter-RAT networks ((FDD or TDD) + (E-UTRA FDD or E-UTRA TDD)).

Simulated network scenarios to be tested are listed in this sub clause.

NOTE 1: The number of cells specified does not necessarily correspond to the maximum number of resources to be configured simultaneously in test equipment. Please refer to sub-clause 6.1 for such information.

NOTE 2: For NAS test cases see sub clause 6.3.2.

4.4.1.1 Standalone cell network scenarios

4.4.1.1.1 Standalone E-UTRA single cell and multi cell network scenarios

For standalone E-UTRA FDD or TDD single cell environment see TS 36.508 [2], clause 4.4.1.1.

For standalone E-UTRA FDD or TDD multi cell network scenarios see TS 36.508 [2], clause 4.4.1.2.

4.4.1.1.2 Standalone NR single cell network scenarios

For standalone NR FDD or TDD single cell environment, NR Cell 1 is used.

4.4.1.1.3 Standalone NR single mode multi cell network scenarios

For standalone NR FDD or TDD intra-frequency multi cell environment, NR Cell 1, NR Cell 2 and NR Cell 4 are used.

For standalone NR FDD or TDD inter-frequency multi cell environment, NR Cell 1, NR Cell 3 and NR Cell 6 are used.

For standalone NR FDD or TDD inter-band cell environment, NR Cell 1 and NR Cell 10 are used.

For standalone NR FDD or TDD multi tracking area intra-frequency multi cell environment, NR Cell 1 and NR Cell 11 are used.

For standalone NR FDD or TDD multi tracking area inter-frequency multi cell environment, NR Cell 1 and NR Cell 23 are used.

For standalone NR FDD or TDD multi PLMN inter-frequency multi cell environment, NR Cell 1, NR Cell 12, NR Cell 13 and NR Cell 14 are used.

4.4.1.1.4 Standalone NR dual mode multi cell network scenarios

For standalone NR FDD and TDD multi cell environment, NR Cell 1, NR Cell 10 and NR Cell 31 are used.

For standalone NR FDD and TDD multi PLMN multi cell environment, NR Cell 1, NR Cell 28, NR Cell 29 and NR Cell 30 are used.

In addition, standalone NR single mode multi cell network scenarios defined in clause 4.4.1.1.3 are combined with the dual mode scenarios defined in this clause when additional intra or inter-frequency cells are used.

4.4.1.1.5 Standalone NR 3GPP Inter-RAT network scenarios

For standalone NR FDD or TDD single cell with E-UTRA FDD or E-UTRA TDD single cell inter-RAT environment:

- NR Cell 1 is used for the NR cell; and
- Cell 1, as specified in TS 36.508 [2] clause 4.4.1.1, is used for the E-UTRA cell.

For standalone NR FDD or TDD single cell with E-UTRA FDD or E-UTRA TDD multi cell inter-RAT environment:

- NR Cell 1 is used for the NR cell; and
- Cell 1, Cell 2 and Cell 4, as specified in TS 36.508 [2] clause 4.4.1.2, is used for the E-UTRA cell; and

4.4.1.2 Non-standalone cell network scenarios

4.4.1.2.1 Non-standalone E-UTRA single cell and NR single cell network scenarios

For non-standalone NR FDD or TDD single cell and E-UTRA FDD or TDD single cell environment:

- Cell 1, as specified in TS 36.508 [2] clause 4.4.1.1, is used for the E-UTRA cell; and
- NR Cell 1 is used for the NR cell.

4.4.1.2.2 Non-standalone E-UTRA single cell and NR single mode multi cell network scenarios

For non-standalone E-UTRA single cell and FDD or TDD NR intra-frequency single mode multi cell environment:

- Cell 1, as specified in TS 36.508 [2] clause 4.4.1.1, is used for the E-UTRA cell; and
- NR Cell 1, NR Cell 2 and NR Cell 4 are used for NR cells.

For non-standalone E-UTRA single cell and FDD or TDD NR inter-frequency single mode multi cell environment:

- Cell 1, as specified in TS 36.508 [2] clause 4.4.1.1, is used for the E-UTRA cell; and
- NR Cell 1, NR Cell 3 and NR Cell 6 are used for the NR cells.

For non-standalone E-UTRA single cell and FDD or TDD NR inter-band single mode multi cell environment:

- Cell 1, as specified in TS 36.508 [2] clause 4.4.1.1, is used for the E-UTRA cell; and
- NR Cell 1 and NR Cell 10 are used for the NR cells.

4.4.1.2.3 Non-standalone E-UTRA single mode multi cell and NR single mode multi cell network scenarios

For non-standalone E-UTRA intra-frequency single mode multi cell and FDD or TDD NR intra-frequency single mode multi cell environment:

- E-UTRA Cell 1, Cell 2 and Cell 4, as specified in TS 36.508 [2] clause 4.4.1.2, is used for the E-UTRA cell; and
- NR Cell 1, NR Cell 2 and NR Cell 4 are used for NR cells.

For non-standalone FDD or TDD E-UTRA intra-frequency single mode multi cell and FDD or TDD NR inter-frequency single mode multi cell environment:

- E-UTRA Cell 1, Cell 2 and Cell 4, as specified in TS 36.508 [2] clause 4.4.1.2, is used for the E-UTRA cell; and
- NR Cell 1, NR Cell 3 and NR Cell 6 are used for the NR cells.

For non-standalone FDD or TDD E-UTRA inter-frequency single mode multi cell and FDD or TDD NR inter-frequency single mode multi cell environment:

- E-UTRA Cell 1, Cell 3 and Cell 6, as specified in TS 36.508 [2] clause 4.4.1.2, is used for the E-UTRA cell; and
- NR Cell 1, NR Cell 3 and NR Cell 6 are used for the NR cells.

For non-standalone single E-UTRA cell and FDD or TDD NR inter-band single mode multi cell environment:

- E-UTRA Cell 1, Cell 2 and Cell 4, as specified in TS 36.508 [2] clause 4.4.1.2, is used for the E-UTRA cell; and
- NR Cell 1 and NR Cell 10 are used for the NR cells.

4.4.1.2.4 Non-standalone E-UTRA single cell and NR dual mode multi cell network scenarios

Editor's note: It is FFS if the NR dual mode multi cell environment needs to include multiple E-UTRA cells in addition to the multiple NR cells.

For non-standalone single E-UTRA cell and FDD and TDD NR dual mode multi cell environment:

- Cell 1, as specified in TS 36.508 [2] clause 4.4.1.1, is used for the E-UTRA cell; and
- NR Cell 1, NR Cell 10 and NR Cell 31 are used for the NR cells.

In addition, standalone NR single mode multi cell network scenarios defined in clause 4.4.1.2.2 are combined with the dual mode scenarios defined in this clause when additional intra or inter-frequency NR cells are used.

4.4.2 Simulated cells

NOTE 1: For NAS test cases see subclause [FFS].

NOTE 2: Test frequency and range defined in table 4.4.2-1 do not apply to TS 38.521-1, TS 38.521-2 and TS 38.521-3 test cases.

Test frequencies and simulated NR cells are defined in table 4.4.2-1. Test frequencies and simulated E-UTRA cells are defined in TS 36.508 [2] table 4.4.2-1.

For NR cells, NRf1 is the default test frequency. For E-UTRA cells, f1 as specified in TS 36.508 [2] table 4.2.2-1 is the default test frequency.

Default parameters for simulated NR cells are specified in table 4.4.2-1A and table 4.4.2-2.

Default parameters for simulated E-UTRA cells are specified in TS 36.508 [2] table 4.4.2-1A and table 4.4.2-2.

Common parameters for NR simulated cells are specified in clauses 4.4.3 to 4.4.6A.

Common parameters for E-UTRA simulated cells are specified in TS 36.508 [2] clauses 4.4.3 to 4.4.6A.

Other cell specific parameters are specified in clause 4.4.7.

Editor's note: Notes 2 to 6 in Table 4.4.2-1 for NR cells have been inherited from TS 36.508 [2] Table 4.4.2-1 for E-UTRA cells assuming that similar notes will be needed for NR cells. The notes and the references in the table to the notes are marked by []-brackets pending the confirmation if the notes are needed or not.

Table 4.4.2-1: Definition of test frequencies and simulated NR cells

Test frequency	RAT	Operating band	Range	Simulated NR cells
NRf1	NR	Operating band under test	Mid ([Note 1], [Note 3], [Note 6])	NR Cell 1, NR Cell 2, NR Cell 4, NR Cell 11 ([Note 2])
NRf2	NR	Operating band under test	High ([Note 1], [Note 4], [Note 6])	NR Cell 3, NR Cell 12, NR Cell 23
NRf3	NR	Operating band under test	Low ([Note 1], [Note 5], [Note 6])	NR Cell 6, NR Cell 13
NRf4	NR	Operating band under test	([Note 1])	NR Cell 14
NRf5	NR	Operating band for inter-band cells	Mid ([Note 1])	NR Cell 10, NR Cell 30, NR Cell 31
NRf6	NR	Operating band for inter-band cells	High ([Note 1])	NR Cell 28, NR Cell 29
NRf7	NR	Operating band for inter-band cells	Low ([Note 1])	
<p>[Note 1: For signalling test, see clause [6.2.3].]</p> <p>[Note 2: For signalling test, simultaneous co-existence of NR Cell 2 with NR Cell 11 is not allowed.]</p> <p>[Note 3: For RRM test with intra-band contiguous CA, the set of contiguous component carriers are "Mid", with the test frequencies specified in clauses [4.3.1.1.xA] for FDD and [4.3.1.2.xA] for TDD]</p> <p>[Note 4: For RRM test with intra-band contiguous CA, the set of contiguous component carriers are "High", with the test frequencies specified in clauses [4.3.1.1.xA] for FDD and [4.3.1.2.xA] for TDD]</p> <p>[Note 5: For RRM test with intra-band contiguous CA, the set of contiguous component carriers are "Low", with the test frequencies specified in clauses [4.3.1.1.xA] for FDD and [4.3.1.2.xA] for TDD.]</p> <p>[Note 6: For RRM test with intra-band non-contiguous CA, the test frequencies for the set of non-contiguous component carriers are specified in clauses [4.3.1.1.xA] for FDD and [4.3.1.2.xA] for TDD without any regard to range. Thus "Low", "Mid" and "High" information in this table does not apply. Unless otherwise stated, test point with maximum Wgap is chosen.]</p>				

Table 4.4.2-2: Default NR parameters for simulated NR cells

cell ID	NR Cell Identifier		Physical layer cell identity	PRACH-rootSequenceIndex FDD	PRACH-rootSequenceIndex TDD
	gNB Identifier	Cell Identity		$L_{RA} = 139$ Note 1	$L_{RA} = 139$ Note 1
NR Cell 1	'0000 0000 0000 0000 0001'B	'0000 0000'B	0	0	0
NR Cell 2	'0000 0000 0000 0000 0001'B	'0000 0010'B	2	32	32
NR Cell 3	'0000 0000 0000 0000 0010'B	'0000 0011'B	3	0	0
NR Cell 4	'0000 0000 0000 0000 0011'B	'0000 0100'B	4	64	64
NR Cell 6	'0000 0000 0000 0000 0100'B	'0000 0110'B	6	0	0
NR Cell 10	'0000 0000 0000 0000 0101'B	'0000 1010'B	10	0	0
NR Cell 11	'0000 0000 0000 0000 0110'B	'0000 1011'B	11	96	96
NR Cell 12	'0000 0000 0000 0000 0010'B	'0000 1100'B	12	32	32
NR Cell 13	'0000 0000 0000 0000 0100'B	'0000 1101'B	13	32	32
NR Cell 14	'0000 0000 0000 0000 0111'B	'0000 1110'B	14	0	0
NR Cell 23	'0000 0000 0000 0000 0110'B	'0001 0111'B	23	64	64
NR Cell 28	'0000 0000 0000 0000 0010'B	'0001 1100'B	28	0	0
NR Cell 29	'0000 0000 0000 0000 0100'B	'0001 1101'B	29	32	32
NR Cell 30	'0000 0000 0000 0000 0111'B	'0001 1110'B	30	32	32
NR Cell 31	'0000 0000 0000 0000 0110'B	'0001 1111'B	31	64	64

Note 1: To avoid collision of the preambles between intra-frequency cells, with the default *zeroCorrelationZoneConfig* value set to 15, the *PRACH-rootSequenceIndex* values have been separated by 32 root sequences per intra-frequency cell.

Table 4.4.2-3: Default NAS parameters for simulated NR cells for 5GC testing

FFS

4.4.3 Common parameters for simulated NR cells

The parameters specified in this sub clause apply to the simulated NR cells in standalone NR and non-standalone network scenarios unless otherwise specified.

The common parameters for the simulated E-UTRA cells for standalone E-UTRA and non-standalone network scenarios are specified in TS 36.508 [2] clause 4.4.3 unless otherwise specified.

4.4.3.1 Common configurations of system information blocks

4.4.3.1.1 Combinations of system information blocks for E-UTRA standalone, EN-DC and NGEN-DC

The combination of system information blocks for standalone E-UTRA, EN-DC and NGEN-DC network scenarios are specified in TS 36.508 [2] clause 4.4.3.1.

For EN-DC and NGEN-DC network scenarios the SS shall in addition to broadcasting the E-UTRA system information blocks also broadcast the NR MIB on the NR cell(s).

4.4.3.1.2 Combinations of system information blocks for NR standalone and NE-DC

FFS

4.5 Generic procedures

4.5.1 General

The generic procedures are used by test cases to get UE under test into RRC_IDLE, RRC_INACTIVE or RRC_CONNECTED state.

A test case controls the SS by specifying the required RRC state and a set of generic procedure parameters applicable for the intended testing.

The connectivity *EN-DC* is MR-DC via E-UTRA-NR Dual Connectivity. This is a UE connected to the EPC. The connectivity *E-UTRA*, *NR*, *NGEN-DC*, *NE-DC* are all a UE connected to the 5GC.

MULTI_PDN configuration is defined in TS 36.508 [2], clause 4.5.2.

Table 4.5.1-1: Generic procedure parameters

Parameter	Values	Description	Parameter condition
Connectivity	<i>E-UTRA</i>	NG-RAN E-UTRA Radio Access	Mandatory
	<i>NR</i>	NG-RAN NR Radio Access	
	<i>EN-DC</i>	E-UTRA-NR Dual Connectivity	
	<i>NGEN-DC</i>	NG-RAN E-UTRA-NR Dual Connectivity	
	<i>NE-DC</i>	NR-E-UTRA Dual Connectivity	
Bearers	<i>MCG(s) and SCG</i>	MCG and SCG	Mandatory when Connectivity is set to <i>EN-DC</i> , <i>NGEN-DC</i> or <i>NE-DC</i> and when the generic procedures are used by test cases to get UE under test into RRC_CONNECTED state. s=1 if MULTI_PDN= FALSE and s=2 if MULTI_PDN=TRUE.
	<i>MCG(s) and split</i>	MCG and split	
	<i>MCG(s) only</i>	MCG only	
			Optional otherwise.
Test Mode	<i>On</i>	UE test mode active as specified in TS 38.509 [11], clause 5.2.2.	Optional
Test Function	<i>On</i>	UE test mode active with one of the UE test loop modes activated as specified in TS 38.509 [11], clauses 5.2.2 and 5.3.2.	Optional

Editor's Note: The following values are not available to use in the current version of this specification because details are still FFS: Connectivity (E-UTRA, NR, NGEN-DC, NE-DC).

4.5.2 RRC_IDLE

4.5.2.1 Initiation

The SS shall:

- 1> if connectivity is *EN-DC*
- 2> use 1 E-UTRA cell and 1 NR cell, default parameters;
- 2> perform according to the table 4.5.2.2-1: E-UTRA RRC_IDLE;

4.5.2.2 Procedures

Table 4.5.2.2-1: E-UTRA RRC_IDLE

St	Procedure	Message Sequence	
		U - S	Message
1-9	Same as TS 36.508 [2] table 4.5.2.3-1, steps 1-9a2.	-	-
-	EXCEPTION: Steps 10a1 to 10a2 describe behaviour which depends on procedure parameters; the "lower case letter" identifies a step sequence that take place if a procedure parameter has a particular value.	-	-
10a1 - 10a2	IF Test Mode = <i>On</i> OR Test Loop Function = <i>On</i> THEN same as TS 36.508 [2] table 4.5.2A.3-1, steps 10-11. The ACTIVATE TEST MODE is using the associated condition for the test loop.	-	-
-	EXCEPTION: Steps 11a1 to 11b9b1 describe the SS sequence depending on procedure parameters; the "lower case letter" identifies a step sequence that take place if a procedure parameter has a particular value.	-	-
11a1 - 11a9 b1	IF Test Loop Function = <i>On</i> THEN same as TS 36.508 [2] table 4.5.2A.3-1, steps 12-19.	-	-
11b1 - 11b9 b1	ELSE, same as TS 36.508 [2] table 4.5.2.3-1, steps 10-17.	-	-

4.5.2.3 Specific message contents

All specific message contents shall be according TS 36.508 [2] clause 4.6 and 4.7.

4.5.3 RRC_INACTIVE

4.5.3.1 Initiation

FFS

4.5.4 RRC_CONNECTED

4.5.4.1 Initiation

The SS shall:

- 1> perform according to clause 4.5.2 RRC_IDLE;
- 1> if connectivity is *EN-DC*:
 - 2> use 1 E-UTRA cell and 1 NR cell, default parameters;

2> perform according to the table 4.5.4.2-1: E-UTRA RRC_CONNECTED;

4.5.4.2 Procedures

Table 4.5.4.2-1: E-UTRA RRC_CONNECTED

St	Procedure	Message Sequence	
		U - S	Message
1-6	Same as TS 36.508 [2] table 4.5.3.3-1, steps 2-7.	-	-
7	Same as TS 36.508 [2] table 4.5.3.3-1, step 8. The <i>RRCConnectionReconfiguration</i> is using condition EN-DC_SRB2-DRB for bearers <i>MCG and SCG</i> or <i>MCG only</i> . The <i>RRCConnectionReconfiguration</i> is using an associated condition <i>MCG_and_SCG</i> for bearers <i>MCG(s) and SCG</i> or condition <i>MCG_and_split</i> for bearers <i>MCG(s) and split</i> . For bearers <i>MCG(s) only</i> there's no associated condition.	<--	<i>RRC: RRCConnectionReconfiguration</i> NAS: ACTIVATE DEDICATED EPS BEARER CONTEXT REQUEST
8-9	Same as TS 36.508 [2] table 4.5.3.3-1, steps 9-10a1	-	-
-	EXCEPTION: Steps 10a1 to 10a2 describe behaviour which depends on the SS sequence depending on procedure parameters; the "lower case letter" identifies a step sequence that take place if a procedure parameter has a particular value.	-	-
10a1 - 10a2	IF Test Loop Function= <i>On</i> , same as TS 36.508 [2] table 4.5.4.3-1, steps 1-2. The CLOSE UE TEST LOOP is using the associated condition for the test loop.	-	-

4.5.4.3 Specific message contents

All specific message contents shall be according clause 4.6 and TS 36.508 [2] clause 4.6 and 4.7 with the exceptions below.

Table 4.5.4.3-1: Message ACTIVATE DEDICATED EPS BEARER CONTEXT REQUEST (step 7, Table 4.5.4.2-1)

Derivation path: TS 36.508 [2] Table 4.7.3-3			
Information Element	Value/Remark	Comment	Condition
Linked EPS bearer identity	12		
EPS QoS	According to reference dedicated EPS bearer context #6 - in TS 36.508 [2] table 6.6.2-1A		
TFT	According to reference dedicated EPS bearer context #6 - in TS 36.508 [2] table 6.6.2-1A		
Negotiated QoS	According to reference dedicated EPS bearer context #6 - in TS 36.508 [2] table 6.6.2-1A		
Negotiated LLC SAPI	According to reference dedicated EPS bearer context #6 - in TS 36.508 [2] table 6.6.2-1A		
Radio priority	According to reference dedicated EPS bearer context #6 - in TS 36.508 [2] table 6.6.2-1A		
Protocol configuration options	According to reference dedicated EPS bearer context #6 - in TS 36.508 [2] table 6.6.2-1A		
Extended protocol configuration options	According to reference dedicated EPS bearer context #6 - in TS 36.508 [2] table 6.6.2-1A		

4.5.5 UE Beamlock Test Function (UBF)

Follow the procedures as per section 5.4 of 38.509 [12]. All specific message contents shall be according to clause 4.5.5.1.

4.5.5.1 Specific Message contents

4.5.5.1.1 ACTIVATE BEAMLOCK for Tx Only

Information Element	Reference	Presence	Format	Length
Protocol discriminator	TS 24.007 [5], sub clause 11.2.3.1.1	M	V	½
Skip indicator		M	V	½
Message type		M	V	1
UE Beamlock test Function		M	V	1

where message type is:

8	7	6	5	4	3	2	1	bit no.
1	0	1	0	0	0	0	0	octet 1

where UE Beamlock test Function is:

8	7	6	5	4	3	2	1	bit no.
						0	1	octet 1

4.5.5.1.2 ACTIVATE BEAMLOCK for Rx Only

Information Element	Reference	Presence	Format	Length
Protocol discriminator	TS 24.007 [5], sub clause 11.2.3.1.1	M	V	$\frac{1}{2}$
Skip indicator		M	V	$\frac{1}{2}$
Message type		M	V	1
UE Beamlock test Function		M	V	1

where message type is:

8	7	6	5	4	3	2	1	bit no.
1	0	1	0	0	0	0	0	octet 1

where UE Beamlock test Function is:

8	7	6	5	4	3	2	1	bit no.
						1	0	octet 1

4.5.5.1.3 ACTIVATE BEAMLOCK for TxRx

Information Element	Reference	Presence	Format	Length
Protocol discriminator	TS 24.007 [5], sub clause 11.2.3.1.1	M	V	$\frac{1}{2}$
Skip indicator		M	V	$\frac{1}{2}$
Message type		M	V	1
UE Beamlock test Function		M	V	1

where message type is:

8	7	6	5	4	3	2	1	bit no.
1	0	1	0	0	0	0	0	octet 1

where UE Beamlock test Function is:

8	7	6	5	4	3	2	1	bit no.
						1	1	octet 1

4.5.5.1.4 DEACTIVATE BEAMLOCK

Information Element	Reference	Presence	Format	Length
Protocol discriminator	TS 24.007 [5], sub clause 11.2.3.1.1	M	V	$\frac{1}{2}$
Skip indicator		M	V	$\frac{1}{2}$
Message type		M	V	1
UE Beamlock test Function		M	V	1

where message type is:

8	7	6	5	4	3	2	1	bit no.
1	0	1	0	0	0	0	0	octet 1

4.6 Default NG-RAN RRC message and information elements contents

4.6.1 Contents of RRC messages

– *DLInformationTransfer*

Editor’s Note: Based on ongoing RAN2 work on CR 100 for TS 38.331, R2-1812411 (CR 100r3).

Table 4.6.1-0A: DLInformationTransfer

Derivation Path: TS 38.331 [6], clause 6.2.2			
Information Element	Value/remark	Comment	Condition
DLInformationTransfer ::= SEQUENCE {			
rrc-TransactionIdentifier	RRC-TransactionIdentifier		
criticalExtensions CHOICE {			
c1 CHOICE {			
dlInformationTransfer ::= SEQUENCE {			
FFS			
}			
}			
}			
}			

Condition	Explanation
FFS	

– *LocationMeasurementIndication*

Editor’s Note: Based on ongoing RAN2 work on CR 100 for TS 38.331, R2-1812411 (CR 100r3).

Table 4.6.1-0B: LocationMeasurementIndication

Derivation Path: TS 38.331 [6], clause 6.2.2			
Information Element	Value/remark	Comment	Condition
LocationMeasurementIndication ::= SEQUENCE {			
criticalExtensions CHOICE {			
locationMeasurementIndication ::= SEQUENCE {			
measurementIndication CHOICE {			
FFS			
}			
lateNonCriticalExtension	Not present		
nonCriticalExtension	Not present		
}			
}			

Condition	Explanation
FFS	

MIB

Table 4.6.1-1: MIB

Derivation Path: TS 38.331 [6], clause 6.2.2			
Information Element	Value/remark	Comment	Condition
MIB ::= SEQUENCE {			
systemFrameNumber	A valid value as defined in TS 38.331 [6]		
subCarrierSpacingCommon	scs15or60		FR1_FDD
	scs30or120		FR1_TDD
	scs30or120		FR2_TDD
ssb-subcarrierOffset	Set to the integer value of the 4 LSB of kSSB defined for the frequency of the cell	For signalling test cases see subclause 6.2.3. Otherwise, see subclause 4.3.1.	
dmrs-TypeA-Position	pos2		
pdcch-ConfigSIB1	0		
cellBarred	notBarred		
intraFreqReselection	allowed		
spare	0		
}			

Condition	Explanation
FR1_FDD	FDD frequency range < 6GHz
FR1_TDD	TDD frequency range < 6GHz
FR2_TDD	TDD frequency range > 6GHz

MeasurementReport

Table 4.6.1-2: MeasurementReport

Derivation Path: TS 38.331 [6], clause 6.2.2			
Information Element	Value/remark	Comment	Condition
MeasurementReport ::= SEQUENCE {			
criticalExtensions CHOICE {			
c1 CHOICE {			
measurementReport ::= SEQUENCE {			
measResults	FFS		
}			
}			
}			
}			

Condition	Explanation
FFS	

MobilityFromNRCommand

Editor’s Note: Based on ongoing RAN2 work on CR 100 for TS 38.331, R2-1812411 (CR 100r3).

Table 4.6.1-2A: *MobilityFromNRCommand*

Derivation Path: TS 38.331 [6], clause 6.2.2			
Information Element	Value/remark	Comment	Condition
MobilityFromNRCommand ::= SEQUENCE {			
rrc-TransactionIdentifier	RRC-TransactionIdentifier		
criticalExtensions CHOICE {			
c1 CHOICE {			
mobilityFromNRCommand ::= SEQUENCE {			
FFS			
}			
}			
}			
}			

– *Paging*

Editor’s Note: Based on ongoing RAN2 work on CR 100 for TS 38.331, R2-1812411 (CR 100r3).

Table 4.6.1-2B: *Paging*

Derivation Path: TS 38.331 [6], clause 6.2.2			
Information Element	Value/remark	Comment	Condition
Paging ::= SEQUENCE {			
FFS			
}			

Condition	Explanation
FFS	

– *RRCReestablishment*

Editor’s Note: Based on ongoing RAN2 work on CR 100 for TS 38.331, R2-1812411 (CR 100r3).

Table 4.6.1-2C: *RRCReestablishment*

Derivation Path: TS 38.331 [6], clause 6.2.2			
Information Element	Value/remark	Comment	Condition
RRCReestablishment ::= SEQUENCE {			
rrc-TransactionIdentifier	RRC-TransactionIdentifier		
criticalExtensions CHOICE {			
c1 CHOICE {			
rrcReestablishment ::= SEQUENCE {			
FFS			
}			
}			
}			
}			

Condition	Explanation
FFS	

– *RRCReestablishmentComplete*

Editor’s Note: Based on ongoing RAN2 work on CR 100 for TS 38.331, R2-1812411 (CR 100r3).

Table 4.6.1-2D: RRCReestablishmentComplete

Derivation Path: TS 38.331 [6], clause 6.2.2			
Information Element	Value/remark	Comment	Condition
RRCReestablishmentComplete ::= SEQUENCE {			
rrc-TransactionIdentifier	RRC-TransactionIdentifier		
criticalExtensions CHOICE {			
rrcReestablishmentComplete ::= SEQUENCE {			
FFS			
}			
}			
}			

Condition	Explanation
FFS	

RRCReestablishmentRequest

Editor’s Note: Based on ongoing RAN2 work on CR 100 for TS 38.331, R2-1812411 (CR 100r3).

Table 4.6.1-2E: RRCReestablishmentRequest

Derivation Path: TS 38.331 [6], clause 6.2.2			
Information Element	Value/remark	Comment	Condition
RRCReestablishmentRequest ::= SEQUENCE {			
FFS			
}			

Condition	Explanation
FFS	

RRCReconfiguration

Table 4.6.1-3: RRCReconfiguration

Derivation Path: TS 38.331 [6], clause 6.2.2			
Information Element	Value/remark	Comment	Condition
RRCReconfiguration ::= SEQUENCE {			
rrc-TransactionIdentifier	RRC-TransactionIdentifier	Table 4.6.5-1.	
criticalExtensions CHOICE {			
c1 CHOICE {			
rrcReconfiguration ::= SEQUENCE {			
radioBearerConfig	Not present		
secondaryCellGroup	CellGroupConfig	OCTET STRING (CONTAINING CellGroupConfig)	EN-DC
measConfig	Not present		
	MeasConfig	Measurements configuration	MEAS
lateNonCriticalExtension	Not present		
nonCriticalExtension	Not present		
}			
}			
}			
}			

Condition	Explanation
EN-DC	E-UTRA-NR Dual Connectivity
MEAS	A NR measurement is configured

– *RRCReconfigurationComplete*

Table 4.6.1-4: RRCReconfigurationComplete

Derivation Path: TS 38.331 [6], clause 6.2.2			
Information Element	Value/remark	Comment	Condition
RRCReconfigurationComplete ::= SEQUENCE {			
rrc-TransactionIdentifier	Not checked		
criticalExtensions CHOICE {			
rrcReconfigurationComplete ::= SEQUENCE {			
lateNonCriticalExtension	Not checked		
nonCriticalExtension	Not checked		
}			
}			
}			

– *RRCReject*

Editor’s Note: Based on ongoing RAN2 work on CR 100 for TS 38.331, R2-1812411 (CR 100r3).

Table 4.6.1-4A: RRCReject

Derivation Path: TS 38.331 [6], clause 6.2.2			
Information Element	Value/remark	Comment	Condition
RRCReject ::= SEQUENCE {			
criticalExtensions CHOICE {			
c1 CHOICE {			
rrcReject ::= SEQUENCE {			
FFS			
}			
}			
}			
}			

Condition	Explanation
FFS	

– *RRCRelease*

Editor’s Note: Based on ongoing RAN2 work on CR 100 for TS 38.331, R2-1812411 (CR 100r3).

Table 4.6.1-4B: RRCRelease

Derivation Path: TS 38.331 [6], clause 6.2.2			
Information Element	Value/remark	Comment	Condition
RRCRelease ::= SEQUENCE {			
rrc-TransactionIdentifier	RRC-TransactionIdentifier		
criticalExtensions CHOICE {			
c1 CHOICE {			
rrcRelease ::= SEQUENCE {			
FFS			
}			
}			
}			
}			

Condition	Explanation
FFS	

– *RRCResume*

Editor’s Note: Based on ongoing RAN2 work on CR 100 for TS 38.331, R2-1812411 (CR 100r3).

Table 4.6.1-4C: RRCResume

Derivation Path: TS 38.331 [6], clause 6.2.2			
Information Element	Value/remark	Comment	Condition
RRCResume ::= SEQUENCE {			
rrc-TransactionIdentifier	RRC-TransactionIdentifier		
criticalExtensions CHOICE {			
c1 CHOICE {			
rrcResume ::= SEQUENCE {			
FFS			
}			
}			
}			
}			

Condition	Explanation
FFS	

– *RRCResumeRequest*

Editor’s Note: Based on ongoing RAN2 work on CR 100 for TS 38.331, R2-1812411 (CR 100r3).

Table 4.6.1-4D: RRCResumeRequest

Derivation Path: TS 38.331 [6], clause 6.2.2			
Information Element	Value/remark	Comment	Condition
RRCResumeRequest ::= SEQUENCE {			
rrcResumeRequest	FFS		
}			

Condition	Explanation
FFS	

– *RRCResumeRequest1*

Editor’s Note: Based on ongoing RAN2 work on CR 100 for TS 38.331, R2-1812411 (CR 100r3).

Table 4.6.1-4E: RRCResumeRequest1

Derivation Path: TS 38.331 [6], clause 6.2.2			
Information Element	Value/remark	Comment	Condition
RRCResumeRequest1 ::= SEQUENCE {			
rrcResumeRequest1	FFS		
}			

Condition	Explanation
FFS	

– *SIB1*Table 4.6.1-5: *SIB1*

Derivation Path: TS 38.331 [6], clause 6.2.2			
Information Element	Value/remark	Comment	Condition
SIB1 ::= SEQUENCE {			
ssb-PositionsInBurst ::= SEQUENCE {			
inOneGroup	FFS		
groupPresence	FFS		
}			
ssb-periodicityServingCell	FFS		
ss-PBCH-BlockPower	FFS		
frequencyInfoUL	FFS		
supplementaryUplink ::= SEQUENCE {			
frequencyInfoUL	FFS		
}			
tdd-UL-DL-configuration	FFS		
pucch-Format0-BaseSequenceHopping	FFS		
PUCCH-Format1-BaseSequenceHopping	FFS		
}			

Condition	Explanation
FFS	

– *SystemInformation*

Editor's Note: Based on ongoing RAN2 work on CR 100 for TS 38.331, R2-1812411 (CR 100r3).

Table 4.6.1-6: *SystemInformation*

Derivation Path: TS 38.331 [6], clause 6.2.2			
Information Element	Value/remark	Comment	Condition
SystemInformation ::= SEQUENCE {			
criticalExtensions CHOICE {			
systemInformation-r15 SEQUENCE {			
sib-TypeAndInfo SEQUENCE (SIZE (1..maxSIB))			
OF CHOICE {			
FFS			
}			
nonCriticalExtension	Not checked		
}			
}			

Condition	Explanation
FFS	

– *UECapabilityEnquiry*

Editor's Note: Based on ongoing RAN2 work on CR 100 for TS 38.331, R2-1812411 (CR 100r3).

Table 4.6.1-7: UECapabilityEnquiry

Derivation Path: TS 38.331 [6], clause 6.2.2			
Information Element	Value/remark	Comment	Condition
UECapabilityEnquiry ::= SEQUENCE {			
rrc-TransactionIdentifier	RRC-TransactionIdentifier		
criticalExtensions CHOICE {			
c1 CHOICE {			
UECapabilityEnquiry ::= SEQUENCE {			
FFS			
}			
}			
}			
}			

Condition	Explanation
FFS	

UECapabilityInformation

Editor’s Note: Based on ongoing RAN2 work on CR 100 for TS 38.331, R2-1812411 (CR 100r3).

Table 4.6.1-8: UECapabilityInformation

Derivation Path: TS 38.331 [6], clause 6.2.2			
Information Element	Value/remark	Comment	Condition
UECapabilityInformation ::= SEQUENCE {			
rrc-TransactionIdentifier	RRC-TransactionIdentifier		
criticalExtensions CHOICE {			
c1 CHOICE {			
UECapabilityInformation ::= SEQUENCE {			
FFS			
}			
}			
}			
}			

Condition	Explanation
FFS	

ULInformationTransfer

Editor’s Note: Based on ongoing RAN2 work on CR 100 for TS 38.331, R2-1812411 (CR 100r3).

Table 4.6.1-9: ULInformationTransfer

Derivation Path: TS 38.331 [6], clause 6.2.2			
Information Element	Value/remark	Comment	Condition
ULInformationTransfer ::= SEQUENCE {			
criticalExtensions CHOICE {			
c1 CHOICE {			
ulInformationTransfer ::= SEQUENCE {			
dedicatedInfoNAS	FFS		
lateNonCriticalExtension	Not checked		
nonCriticalExtension	Not checked		
}			
}			
}			
}			

Condition	Explanation
FFS	

4.6.2 System information blocks

– SIB2

Editor's Note: Based on ongoing RAN2 work on CR 100 for TS 38.331, R2-1812411 (CR 100r3).

Table 4.6.2-1: SIB2

Derivation Path: TS 38.331 [6], clause 6.3.1			
Information Element	Value/remark	Comment	Condition
SIB2 ::= SEQUENCE {			
FFS			
}			

Condition	Explanation
FFS	

– SIB3

Editor's Note: Based on ongoing RAN2 work on CR 100 for TS 38.331, R2-1812411 (CR 100r3).

Table 4.6.2-2: SIB3

Derivation Path: TS 38.331 [6], clause 6.3.1			
Information Element	Value/remark	Comment	Condition
SIB3 ::= SEQUENCE {			
FFS			
}			

Condition	Explanation
FFS	

– SIB4

Editor's Note: Based on ongoing RAN2 work on CR 100 for TS 38.331, R2-1812411 (CR 100r3).

Table 4.6.2-3: SIB4

Derivation Path: TS 38.331 [6], clause 6.3.1			
Information Element	Value/remark	Comment	Condition
SIB4 ::= SEQUENCE {			
FFS			
}			

Condition	Explanation
FFS	

– SIB5

Editor's Note: Based on ongoing RAN2 work on CR 100 for TS 38.331, R2-1812411 (CR 100r3).

Table 4.6.2-4: *SIB5*

Derivation Path: TS 38.331 [6], clause 6.3.1			
Information Element	Value/remark	Comment	Condition
SIB5 ::= SEQUENCE {			
FFS			
}			

Condition	Explanation
FFS	

– *SIB6*

Editor's Note: Based on ongoing RAN2 work on CR 100 for TS 38.331, R2-1812411 (CR 100r3).

Table 4.6.2-5: *SIB6*

Derivation Path: TS 38.331 [6], clause 6.3.1			
Information Element	Value/remark	Comment	Condition
SIB6 ::= SEQUENCE {			
FFS			
}			

Condition	Explanation
FFS	

– *SIB7*

Editor's Note: Based on ongoing RAN2 work on CR 100 for TS 38.331, R2-1812411 (CR 100r3).

Table 4.6.2-6: *SIB7*

Derivation Path: TS 38.331 [6], clause 6.3.1			
Information Element	Value/remark	Comment	Condition
SIB7 ::= SEQUENCE {			
FFS			
}			

Condition	Explanation
FFS	

– *SIB8*

Editor's Note: Based on ongoing RAN2 work on CR 100 for TS 38.331, R2-1812411 (CR 100r3).

Table 4.6.2-7: *SIB8*

Derivation Path: TS 38.331 [6], clause 6.3.1			
Information Element	Value/remark	Comment	Condition
SIB8 ::= SEQUENCE {			
FFS			
}			

Condition	Explanation
FFS	

– *SIB9*

Editor's Note: Based on ongoing RAN2 work on CR 100 for TS 38.331, R2-1812411 (CR 100r3).

Table 4.6.2-8: SIB9

Derivation Path: TS 38.331 [6], clause 6.3.1			
Information Element	Value/remark	Comment	Condition
SIB9 ::= SEQUENCE {			
FFS			
}			

Condition	Explanation
FFS	

4.6.3 Radio resource control information elements

– *AdditionalSpectrumEmission***Table 4.6.3-1: AdditionalSpectrumEmission**

Derivation Path: TS 38.331 [6], clause 6.3.2			
Information Element	Value/remark	Comment	Condition
AdditionalSpectrumEmission	0		

– *Alpha***Table 4.6.3-2: Alpha**

Derivation Path: TS 38.331 [6], clause 6.3.2			
Information Element	Value/remark	Comment	Condition
Alpha	alpha0		

– *AMF-Identifier*

Editor's Note: Based on ongoing RAN2 work on CR 100 for TS 38.331, R2-1812411 (CR 100r3).

Table 4.6.3-2A: AMF-Identifier

Derivation Path: TS 38.331 [6], clause 6.3.2			
Information Element	Value/remark	Comment	Condition
AMF-Identifier	FFS		

– *ARFCN-ValueEUTRA*

Editor's Note: Based on ongoing RAN2 work on CR 100 for TS 38.331, R2-1812411 (CR 100r3).

Table 4.6.3-2B: ARFCN-ValueEUTRA

Derivation Path: TS 38.331 [6], clause 6.3.2			
Information Element	Value/remark	Comment	Condition
ARFCN-ValueEUTRA	FFS		

– *ARFCN-ValueNR***Table 4.6.3-3: ARFCN-ValueNR**

Derivation Path: TS 38.331 [6], clause 6.3.2			
Information Element	Value/remark	Comment	Condition
ARFCN-ValueNR	ARFCN-ValueNR		
	Downlink ARFCN of the SSB under test. See table 4.3.1.n-n.		DL_SSB
	Downlink ARFCN of the point A under test. See table 4.3.1.n-n.		DL_PointA
	Uplink ARFCN of the point A under test. See table 4.3.1.n-n		UL_PointA

Condition	Explanation
DL_SSB	IE absoluteFrequencySSB for downlink
DL_PointA	IE absoluteFrequencyPointA for downlink
UL_PointA	IE absoluteFrequencyPointA for uplink

– *BWP***Table 4.6.3-4: BWP**

Derivation Path: TS 38.331 [6], clause 6.3.2			
Information Element	Value/remark	Comment	Condition
BWP ::= SEQUENCE {			
locationAndBandwidth	Set to value of locationAndBandwidth in Table 4.3.1.0b-1 for the bandwidth and subcarrier spacing under test.		FR1
	Set to value of locationAndBandwidth in Table 4.3.1.0b-2 for the bandwidth and subcarrier spacing under test.		FR2
subcarrierSpacing	SubcarrierSpacing		
cyclicPrefix	Not present		
}			

– *BWP-Downlink***Table 4.6.3-5: BWP-Downlink**

Derivation Path: TS 38.331 [6], clause 6.3.2			
Information Element	Value/remark	Comment	Condition
BWP-Downlink ::= SEQUENCE {			
bwp-Id	BWP-Id		
bwp-Common	BWP-DownlinkCommon		
bwp-Dedicated	BWP-DownlinkDedicated		
}			

– *BWP-DownlinkCommon***Table 4.6.3-6: BWP-DownlinkCommon**

Derivation Path: TS 38.331 [6], clause 6.3.2			
Information Element	Value/remark	Comment	Condition
BWP-DownlinkCommon ::= SEQUENCE {			
genericParameters	BWP		
pdccch-ConfigCommon CHOICE {			
setup	PDCCH-ConfigCommon		
}			
pdsch-ConfigCommon CHOICE {			
setup	PDSCH-ConfigCommon		
}			
}			

– *BWP-DownlinkDedicated***Table 4.6.3-7: BWP-DownlinkDedicated**

Derivation Path: TS 38.331 [6], clause 6.3.2			
Information Element	Value/remark	Comment	Condition
BWP-DownlinkDedicated ::= SEQUENCE {			
pdccch-Config CHOICE {			
setup	PDCCH-Config		
}			
pdsch-Config CHOICE {			
setup	PDSCH-Config		
}			
sps-Config	Not present		
radioLinkMonitoringConfig	Not present		
}			

– *BWP-Uplink***Table 4.6.3-7A: BWP-Uplink**

Derivation Path: TS 38.331 [6], clause 6.3.2			
Information Element	Value/remark	Comment	Condition
BWP-Uplink ::= SEQUENCE {			
bwp-Id	BWP-Id		
bwp-Common	BWP-UplinkCommon		
bwp-Dedicated	BWP-UplinkDedicated		
}			

– *BWP-UplinkCommon*

Table 4.6.3-7B: *BWP-UplinkCommon*

Derivation Path: TS 38.331 [6], clause 6.3.2			
Information Element	Value/remark	Comment	Condition
BWP-UplinkCommon ::= SEQUENCE {			
genericParameters	BWP		
rach-ConfigCommon CHOICE {			
setup	RACH-ConfigCommon		
}			
pusch-ConfigCommon CHOICE {			
setup	PUSCH-ConfigCommon		
}			
pucch-ConfigCommon CHOICE {			
setup	PUCCH-ConfigCommon		
}			
}			

– *BWP-UplinkDedicated*

Table 4.6.3-7C: *BWP-UplinkDedicated*

Derivation Path: TS 38.331 [6], clause 6.3.2			
Information Element	Value/remark	Comment	Condition
BWP-UplinkDedicated ::= SEQUENCE {			
pucch-Config CHOICE {			
setup	PUCCH-Config		
}			
pusch-Config CHOICE {			
setup	PUSCH-Config		
}			
configuredGrantConfig	Not present		
srs-Config	Not present		
beamFailureRecoveryConfig	Not present		
}			

Table 4.6.3-8: Void

Table 4.6.3-9: Void

Table 4.6.3-10: *BWP-DownlinkDedicated*

Derivation Path: TS 38.331 [6], clause 6.3.2			
Information Element	Value/remark	Comment	Condition
BWP-DownlinkDedicated ::= SEQUENCE {			
pdcch-Config CHOICE {			
setup	PDCCH-Config		
}			
pdsch-Config CHOICE {			
setup	PDSCH-Config		
}			
sps-Config	Not present		
radioLinkMonitoringConfig	Not present		
}			

– *BWP-Id***Table 4.6.3-11: BWP-Id**

Derivation Path: TS 38.331 [6], clause 6.3.2			
Information Element	Value/remark	Comment	Condition
BWP-Id	0		

– *BeamFailureRecoveryConfig***Table 4.6.3-12: BeamFailureRecoveryConfig**

Derivation Path: TS 38.331 [6], clause 6.3.2			
Information Element	Value/remark	Comment	Condition
BeamFailureRecoveryConfig ::= SEQUENCE {			
FFS			
}			

– *CellAccessRelatedInfo*

Editor's Note: Based on ongoing RAN2 work on CR 100 for TS 38.331, R2-1812411 (CR 100r3).

Table 4.6.3-12A: CellAccessRelatedInfo

Derivation Path: TS 38.331 [6], clause 6.3.2			
Information Element	Value/remark	Comment	Condition
CellAccessRelatedInfo ::= SEQUENCE {			
FFS			
}			

– *CellGlobaldNR*

Editor's Note: Based on ongoing RAN2 work on CR 100 for TS 38.331, R2-1812411 (CR 100r3).

Table 4.6.3-12B: CellGlobaldNR

Derivation Path: TS 38.331 [6], clause 6.3.2			
Information Element	Value/remark	Comment	Condition
CellGlobaldNR ::= SEQUENCE {			
FFS			
}			

CellGroupConfig

Table 4.6.3-13: CellGroupConfig

Derivation Path: TS 38.331 [6], clause 6.3.2			
Information Element	Value/remark	Comment	Condition
CellGroupConfig ::= SEQUENCE {			
cellGroupId	CellGroupId		
rlc-BearerToAddModList SEQUENCE (SIZE(1..maxLCH)) OF SEQUENCE {	1 entry		EN-DC
RLC-Bearer-Config[1]	RLC-Bearer-Config		
}			
rlc-BearerToReleaseList	Not present		
mac-CellGroupConfig	MAC-CellGroupConfig		
physicalCellGroupConfig	PhysicalCellGroupConfig		
spCellConfig SEQUENCE {			
servCellIndex	Not present		
	ServCellIndex		EN-DC
reconfigurationWithSync	Not present		
reconfigurationWithSync SEQUENCE {			EN-DC
spCellConfigCommon	ServingCellConfigCommon		
newUE-Identity	RNTI-Value		
t304	ms1000		
rach-ConfigDedicated CHOICE {			
uplink	RACH-ConfigDedicated		
}			
}			
rlf-TimersAndConstants CHOICE {			
setup	RLF-TimersAndConstants		
}			
rlmInSyncOutOfSyncThreshold	Not present		
spCellConfigDedicated	ServingCellConfig		
}			
sCellToAddModList	Not present		
sCellToReleaseList	Not present		
}			

Condition	Explanation
EN-DC	E-UTRA-NR Dual Connectivity

CellGroupId

Table 4.6.3-14: CellGroupId

Derivation Path: TS 38.331 [6], clause 6.3.2			
Information Element	Value/remark	Comment	Condition
CellGroupId	1		

CellIdentity

Editor's Note: Based on ongoing RAN2 work on CR 100 for TS 38.331, R2-1812411 (CR 100r3).

Table 4.6.3-14A: CellIdentity

Derivation Path: TS 38.331 [6], clause 6.3.2			
Information Element	Value/remark	Comment	Condition
CellIdentity	FFS		

– *CellReselectionPriority*

Editor's Note: Based on ongoing RAN2 work on CR 100 for TS 38.331, R2-1812411 (CR 100r3).

Table 4.6.3-14C: CellReselectionPriority

Derivation Path: TS 38.331 [6], clause 6.3.2			
Information Element	Value/remark	Comment	Condition
CellReselectionPriority	FFS		

– *CodebookConfig***Table 4.6.3-15: CodebookConfig**

Derivation Path: TS 38.331 [6], clause 6.3.2			
Information Element	Value/remark	Comment	Condition
CodebookConfig ::= SEQUENCE {			
codebookType CHOICE {			
type1 SEQUENCE {			
subType CHOICE {			
type1-SinglePanel SEQUENCE {			
nrOfAntennaPorts CHOICE {			
moreThanTwo SEQUENCE {			
n1-n2 CHOICE {			
two-one-Type1-SinglePanel-Restriction	11111111		FR2
four-one-Type1-SinglePanel-Restriction	11111111 11111111		FR1
},			
type1-SinglePanel-			
codebookSubsetRestriction-i2	Not present		
},			
type1-SinglePanel-ri-Restriction	11111111		
},			
},			
codebookMode	1		
},			
}			
}			

– *ConfiguredGrantConfig***Table 4.6.3-16: ConfiguredGrantConfig**

Derivation Path: TS 38.331 [6], clause 6.3.2			
Information Element	Value/remark	Comment	Condition
ConfiguredGrantConfig ::= SEQUENCE {			
FFS			
}			

– *ConnEstFailureControl*

Editor's Note: Based on ongoing RAN2 work on CR 100 for TS 38.331, R2-1812411 (CR 100r3).

Table 4.6.3-16A: ConnEstFailureControl

Derivation Path: TS 38.331 [6], clause 6.3.2			
Information Element	Value/remark	Comment	Condition
ConnEstFailureControl ::= SEQUENCE {			
FFS			
}			

– *ControlResourceSet***Table 4.6.3-17: ControlResourceSet**

Derivation Path: TS 38.331 [6], clause 6.3.2			
Information Element	Value/remark	Comment	Condition
ControlResourceSet ::= SEQUENCE {			
controlResourceSetId	ControlResourceSetId		
frequencyDomainResources	11110000 00000000 00000000 00000000 00000000 000000	CORESET to use the least significant 24 RBs of the BWP	
duration	2	SearchSpace duration of 2 symbols	
cce-REG-MappingType CHOICE {			
nonInterleaved	null		
}			
precoderGranularity	sameAsREG-bundle		
tci-StatesPDCCH-ToAddList	Not present		
tci-StatesPDCCH-ToReleaseList	Not present		
tci-PresentInDCI	Not present		
pdcch-DMRS-ScramblingID	Not present		
}			

– *ControlResourceSetId***Table 4.6.3-18: ControlResourceSetId**

Derivation Path: TS 38.331 [6], clause 6.3.2			
Information Element	Value/remark	Comment	Condition
ControlResourceSetId	1		

– *ControlResourceSetZero*

Editor's Note: Based on ongoing RAN2 work on CR 100 for TS 38.331, R2-1812411 (CR 100r3).

Table 4.6.3-18A: ControlResourceSetZero

Derivation Path: TS 38.331 [6], clause 6.3.2			
Information Element	Value/remark	Comment	Condition
ControlResourceSetZero	FFS		

– *CrossCarrierSchedulingConfig***Table 4.6.3-19: CrossCarrierSchedulingConfig**

Derivation Path: TS 38.331 [6], clause 6.3.2			
Information Element	Value/remark	Comment	Condition
CrossCarrierSchedulingConfig ::= SEQUENCE {			
FFS			
}			

– *CSI-AperiodicTriggerStateList*

Table 4.6.3-20: CSI-AperiodicTriggerStateList

Derivation Path: TS 38.331 [6], clause 6.3.2			
Information Element	Value/remark	Comment	Condition
CSI-AperiodicTriggerStateList ::= SEQUENCE (SIZE (1..maxNrOfCSI-AperiodicTriggers)) OF {	1 entry		
CSI-AperiodicTriggerState[1] SEQUENCE (SIZE(1..maxNrofReportConfigPerAperiodicTrigger)) OF {	[1 entry]		
reportConfigId[1]	CSI-ReportConfigId		
resourcesForChannel[1] CHOICE {			
nzp-CSI-RS SEQUENCE {			
resourceSet	8		FR1
	16		FR2
qcl-info SEQUENCE (SIZE(1..maxNrofAP-CSI-RS-ResourcesPerSet)) OF {	1 entry		
TCI-StateId[1]	TCI-StateId		
}			
}			
}			
csi-IM-ResourcesforInterference[1]	8		FR1
	16		FR2
nzp-CSI-RS-ResourcesforInterference[1]	8		FR1
	16		FR2
}			
}			

– *CSI-FrequencyOccupation*

Table 4.6.3-21: CSI-FrequencyOccupation

Derivation Path: TS 38.331 [6], clause 6.3.2			
Information Element	Value/remark	Comment	Condition
CSI-FrequencyOccupation ::= SEQUENCE {			
startingRB	0		
nrofRBs	160		FR1_60MHz
	216		FR1_80MHz
	272		FR1_100MHz
	64		FR2_100MHz
	52		TRS
}			

Condition	Explanation
FR1_60MHz	FR1 is used under the test. CBW is set to 60MHz.
FR1_80MHz	FR1 is used under the test. CBW is set to 80MHz.
FR1_100MHz	FR1 is used under the test. CBW is set to 100MHz.
FR2_100MHz	FR2 is used under the test. CBW is set to 100MHz.
TRS	Tracking-Reference Signal

– *CSI-IM-Resource*

Table 4.6.3-22: CSI-IM-Resource

Derivation Path: TS 38.331 [6], clause 6.3.2			
Information Element	Value/remark	Comment	Condition
CSI-IM-Resource ::= SEQUENCE {			
csi-IM-ResourceId	CSI-IM-ResourceId		
csi-IM-ResourceElementPattern CHOICE {			
pattern1 SEQUENCE {			
subcarrierLocation-p1	s4		
symbolLocation-p1	3		FR1
	4		FR2
}			
}			
freqBand	CSI-FrequencyOccupation		
periodicityAndOffset	Not present		
}			

– *CSI-IM-ResourceId*

Table 4.6.3-23: CSI-IM-ResourceId

Derivation Path: TS 38.331 [6], clause 6.3.2			
Information Element	Value/remark	Comment	Condition
CSI-IM-ResourceId	7		FR1
	31		FR2

– *CSI-IM-ResourceSet*

Table 4.6.3-24: CSI-IM-ResourceSet

Derivation Path: TS 38.331 [6], clause 6.3.2			
Information Element	Value/remark	Comment	Condition
CSI-IM-ResourceSet ::= SEQUENCE {			
csi-IM-ResourceSetId	CSI-IM-ResourceSetId		
csi-IM-Resources SEQUENCE (SIZE(1..maxNrofCSI-IM-ResourcesPerSet)) {	1 entry		
CSI-IM-ResourceId[1]	CSI-IM-ResourceId		
}			
}			

– *CSI-IM-ResourceSetId*

Table 4.6.3-25: CSI-IM-ResourceSetId

Derivation Path: TS 38.331 [6], clause 6.3.2			
Information Element	Value/remark	Comment	Condition
CSI-IM-ResourceSetId	0		

– *CSI-MeasConfig*Table 4.6.3-26: *CSI-MeasConfig*

Derivation Path: TS 38.331 [6], clause 6.3.2			
Information Element	Value/remark	Comment	Condition
CSI-MeasConfig ::= SEQUENCE {			
nzp-CSI-RS-ResourceToAddModList SEQUENCE {	1 entry		
Nzp-CSI-RS-Resource[1]	Nzp-CSI-RS-Resource		
}			
nzp-CSI-RS-ResourceToReleaseList	Not present		
nzp-CSI-RS-ResourceSetToAddModList SEQUENCE {	1 entry		
Nzp-CSI-RS-ResourceSet[1]	Nzp-CSI-RS-ResourceSet		
}			
nzp-CSI-RS-ResourceSetToReleaseList	Not present		
csi-IM-ResourceToAddModList SEQUENCE {	1 entry		
CSI-IM-Resource[1]	CSI-IM-Resource		
}			
csi-IM-ResourceToReleaseList	Not present		
csi-IM-ResourceSetToAddModList SEQUENCE {	1 entry		
CSI-IM-ResourceSet[1]	CSI-IM-ResourceSet		
}			
csi-IM-ResourceSetToReleaseList	Not present		
csi-SSB-ResourceSetToAddModList SEQUENCE {	1 entry		
CSI-SSB-ResourceSet[1]	CSI-SSB-ResourceSet		
}			
csi-SSB-ResourceSetToAddReleaseList	Not present		
csi-ResourceConfigToAddModList SEQUENCE {	1 entry		
CSI-ResourceConfig[1]	CSI-ResourceConfig		
}			
csi-ResourceConfigToReleaseList	Not present		
csi-ReportConfigToAddModList	1 entry		
CSI-ReportConfig[1]	CSI-ReportConfig		
}			
csi-ReportConfigToReleaseList	Not present		
reportTriggerSize	0		
aperiodicTriggerStateList SetupRelease {			
setup	CSI-AperiodicTriggerStateList		
}			
semiPersistentOnPUSCH-TriggerStateList	Not present		
}			

– *CSI-ReportConfig*

Table 4.6.3-27: CSI-ReportConfig

Derivation Path: TS 38.331 [6], clause 6.3.2			
Information Element	Value/remark	Comment	Condition
CSI-ReportConfig ::= SEQUENCE {			
reportConfigId	CSI-ReportConfigId		
carrier	ServCellIndex		
resourcesForChannelMeasurement	CSI-ResourceConfigId		
csi-IM-ResourcesForInterference	CSI-ResourceConfigId		
nzp-CSI-RS-ResourcesForInterference	CSI-ResourceConfigId		
reportConfigType CHOICE {			
aperiodic SEQUENCE {			
reportSlotOffsetList	14		
}			
}			
reportQuantity CHOICE {			
cri-RI-PMI-CQI	NULL,		FR1
cri-RI-LI-PMI-CQI	NULL		FR2
}			
reportFreqConfiguration SEQUENCE {			
cqi-FormatIndicator	widebandCQI		
pmi-FormatIndicator	widebandPMI		
csi-ReportingBand	Not present		
}			
timeRestrictionForChannelMeasurements	notConfigured		
timeRestrictionForInterferenceMeasurements	notConfigured		
codebookConfig	CodebookConfig		
nrofCQIsPerReport	n2		
groupBasedBeamReporting CHOICE {			
disabled SEQUENCE {			
nrofReportedRS	n1		
}			
}			
cqi-Table	table2		FR1
	table1		FR2
subbandSize	value2		
non-PMI-PortIndication	Not present		
}			

– *CSI-ReportConfigId*

Table 4.6.3-28: CCSI-ReportConfigId

Derivation Path: TS 38.331 [6], clause 6.3.2			
Information Element	Value/remark	Comment	Condition
CSI-ReportConfigID	0		

CSI-ResourceConfig

Table 4.6.3-29: CSI-ResourceConfig

Derivation Path: TS 38.331 [6], clause 6.3.2			
Information Element	Value/remark	Comment	Condition
CSI-ResourceConfig ::= SEQUENCE {			
csi-ResourceConfigId	CSI-ResourceConfigId		
csi-RS-ResourceSetList CHOICE {			
nzp-CSI-RS-SSB SEQUENCE {			
nzp-CSI-RS-ResourceSetList SEQUENCE (SIZE (1..maxNrofNZP-CSI-RS-ResourceSetsPerConfig))	2 entries		
OF {			
Nzp-CSI-RS-ResourceSetId[0]	0		
Nzp-CSI-RS-ResourceSetId[1]	1		
}			
csi-SSB-ResourceSetList	Not present		
}			
bwp-Id	BWP-Id		
resourceType	periodic		
}			

CSI-ResourceConfigId

Table 4.6.3-30: CSI-ResourceConfigId

Derivation Path: TS 38.331 [6], clause 6.3.2			
Information Element	Value/remark	Comment	Condition
CSI-ResourceConfigId	0		

CSI-ResourcePeriodicityAndOffset

Table 4.6.3-31: CSI-ResourcePeriodicityAndOffset

Derivation Path: TS 38.331 [6], clause 6.3.2			
Information Element	Value/remark	Comment	Condition
CSI-ResourcePeriodicityAndOffset ::= SEQUENCE {		Waiting for RAN4 decision.	
slots4	FFS		
slots5	FFS		
slots8	FFS		
slots10	FFS		
slots16	FFS		
slots20	FFS		
slots32	FFS		
slots40	FFS		
slots64	FFS		
slots80	10		FR1
slots160	FFS		
slots320	40		FR2
slots640	FFS		
}			

– *CSI-RS-ResourceConfigMobility***Table 4.6.3-31A: CSI-RS-ResourceConfigMobility**

Derivation Path: TS 38.331 [6], clause 6.3.2			
Information Element	Value/remark	Comment	Condition
CSI-RS-ResourceConfigMobility ::= SEQUENCE {			
subcarrierSpacing	SubcarrierSpacing		
csi-RS-CellList-Mobility	FFS		
}			

– *CSI-RS-ResourceMapping***Table 4.6.3-32: CSI-RS-ResourceMapping**

Derivation Path: TS 38.331 [6], clause 6.3.2			
Information Element	Value/remark	Comment	Condition
CSI-RS-ResourceMapping ::= SEQUENCE {			
frequencyDomainAllocation CHOICE {			
row1	1000		TRS
row4	010		FR2
other	011110		FR1
}			
nrofPorts	p8		FR1
	p4		FR2
	p1		TRS
firstOFDMSymbolInTimeDomain	3		FR1
	13		FR2
	4		TRS
firstOFDMSymbolInTimeDomain2	Not present		
cdm-Type	fd-CDM2		
	noCDM		TRS
density CHOICE {			
one	NULL		
three	NULL		TRS
}			
freqBand	CSI-FrequencyOccupation		
}			

Condition	Explanation
TRS	Tracking-Reference Signal

– *CSI-SemiPersistentOnPUSCH-TriggerStateList***Table 4.6.3-33: CSI-SemiPersistentOnPUSCH-TriggerStateList**

Derivation Path: TS 38.331 [6], clause 6.3.2			
Information Element	Value/remark	Comment	Condition
CSI-SemiPersistentOnPUSCH-TriggerStateList ::= SEQUENCE {			
FFS			
}			

– *CSI-SSB-ResourceSetId***Table 4.6.3-34: CSI-SSB-ResourceSetId**

Derivation Path: TS 38.331 [6], clause 6.3.2			
Information Element	Value/remark	Comment	Condition
CSI-SSB-ResourceSetId	FFS		

– *CSI-SSB-ResourceSet*

Table 4.6.3-35: CSI-SSB-ResourceSet

Derivation Path: TS 38.331 [6], clause 6.3.2			
Information Element	Value/remark	Comment	Condition
CSI-SSB-ResourceSet ::= SEQUENCE {			
FFS			
}			

– *DedicatedInfoNAS*

Editor’s Note: Based on ongoing RAN2 work on CR 100 for TS 38.331, R2-1812411 (CR 100r3).

Table 4.6.3-35A: DedicatedInfoNAS

Derivation Path: TS 38.331 [6], clause 6.3.2			
Information Element	Value/remark	Comment	Condition
DedicatedInfoNAS	FFS		

– *DMRS-DownlinkConfig*

Table 4.6.3-36: DMRS-DownlinkConfig

Derivation Path: TS 38.331 [6], clause 6.3.2			
Information Element	Value/remark	Comment	Condition
DMRS-DownlinkConfig ::= SEQUENCE {			
dmrs-Type	Not present		
dmrs-AdditionalPosition	pos1		FR1_FDD, FR1_TDD
	pos0		FR2_TDD
maxLength	Not present		
scramblingID0	Not present		
scramblingID1	Not present		
phaseTrackingRS	Not present		FR1
phaseTrackingRS CHOICE {			FR2
setup	PTRS-DownlinkConfig		
}			
}			

Condition	Explanation
FR1_FDD	FDD frequency range < 6GHz
FR1_TDD	TDD frequency range < 6GHz
FR2_TDD	TDD frequency range > 6GHz

– *DMRS-UplinkConfig***Table 4.6.3-37: DMRS-UplinkConfig**

Derivation Path: TS 38.331 [6], clause 6.3.2			
Information Element	Value/remark	Comment	Condition
DMRS-UplinkConfig ::= SEQUENCE {			
dmrs-Type	Not present		
dmrs-AdditionalPosition	pos1		FR1_FDD, FR1_TDD
	pos0		FR2_TDD
phaseTrackingRS CHOICE {			
setup	PTRS-UplinkConfig		
}			
maxLength	Not present		
transformPrecodingDisabled SEQUENCE {			
scramblingID0	Not present		
scramblingID1	Not present		
}			
transformPrecodingEnabled	Not present		
}			

Condition	Explanation
FR1_FDD	FDD frequency range < 6GHz
FR1_TDD	TDD frequency range < 6GHz
FR2_TDD	TDD frequency range > 6GHz

– *DownlinkConfigCommon***Table 4.6.3-37A: DownlinkConfigCommon**

Derivation Path: TS 38.331 [6], clause 6.3.2			
Information Element	Value/remark	Comment	Condition
DownlinkConfigCommon ::= SEQUENCE {			
frequencyInfoDL	FrequencyInfoDL		
initialDownlinkBWP	BWP-DownlinkCommon		
}			

– *DownlinkConfigCommonSIB*

Editor's Note: Based on ongoing RAN2 work on CR 100 for TS 38.331, R2-1812411 (CR 100r3).

Table 4.6.3-37B: DownlinkConfigCommonSIB

Derivation Path: TS 38.331 [6], clause 6.3.2			
Information Element	Value/remark	Comment	Condition
DownlinkConfigCommonSIB ::= SEQUENCE {			
FFS			
}			

– *DownlinkPreemption***Table 4.6.3-38: DownlinkPreemption**

Derivation Path: TS 38.331 [6], clause 6.3.2			
Information Element	Value/remark	Comment	Condition
DownlinkPreemption ::= SEQUENCE {			
FFS			
}			

– *DRB-Identity***Table 4.6.3-39: DRB-Identity**

Derivation Path: TS 38.331 [6], clause 6.3.2			
Information Element	Value/remark	Comment	Condition
DRB-Identity	2		
	1		DRB1

Condition	Explanation
DRB1	DRB-Identity 1

– *EUTRA-MBSFN-SubframeConfigList***Table 4.6.3-40: EUTRA-MBSFN-SubframeConfigList**

Derivation Path: TS 38.331 [6], clause 6.3.2			
Information Element	Value/remark	Comment	Condition
EUTRA-MBSFN-SubframeConfigList ::= SEQUENCE {			
FFS			
}			

– *EUTRA-Q-OffsetRange*

Editor's Note: Based on ongoing RAN2 work on CR 100 for TS 38.331, R2-1812411 (CR 100r3).

Table 4.6.3-40A: EUTRA-Q-OffsetRange

Derivation Path: TS 38.331 [6], clause 6.3.2			
Information Element	Value/remark	Comment	Condition
EUTRA-Q-OffsetRange	FFS		

– *FilterCoefficient***Table 4.6.3-41: FilterCoefficient**

Derivation Path: TS 38.331 [6], clause 6.3.2			
Information Element	Value/remark	Comment	Condition
FilterCoefficient	fc4		

– *FreqBandIndicatorNR***Table 4.6.3-42: FreqBandIndicatorNR**

Derivation Path: TS 38.331 [6], clause 6.3.2			
Information Element	Value/remark	Comment	Condition
FreqBandIndicatorNR	Operating band under test		

– *FrequencyInfoDL***Table 4.6.3-43: FrequencyInfoDL**

Derivation Path: TS 38.331 [6], clause 6.3.2			
Information Element	Value/remark	Comment	Condition
FrequencyInfoDL ::= SEQUENCE {			
absoluteFrequencySSB	ARFCN-ValueNR with condition DL_SSB		
frequencyBandList	MultiFrequencyBandList NR		
absoluteFrequencyPointA	ARFCN-ValueNR with condition DL_PointA		
scs-SpecificCarrierList SEQUENCE (SIZE (1..maxSCSs)) OF	1 entry		
SCS-SpecificCarrier[1]	SCS-SpecificCarrier		
}			
}			

– *FrequencyInfoDL-SIB*

Editor's Note: Based on ongoing RAN2 work on CR 100 for TS 38.331, R2-1812411 (CR 100r3).

Table 4.6.3-43A: FrequencyInfoDL-SIB

Derivation Path: TS 38.331 [6], clause 6.3.2			
Information Element	Value/remark	Comment	Condition
FrequencyInfoDL-SIB ::= SEQUENCE {			
FFS			
}			

– *FrequencyInfoUL***Table 4.6.3-44: FrequencyInfoUL**

Derivation Path: TS 38.331 [6], clause 6.3.2			
Information Element	Value/remark	Comment	Condition
FrequencyInfoUL ::= SEQUENCE {			
frequencyBandList	MultiFrequencyBandList NR		
absoluteFrequencyPointA	ARFCN-ValueNR with condition UL_PointA		
scs-SpecificCarriers SEQUENCE (SIZE (1..maxSCSs)) OF {	1 entry		
SCS-SpecificCarrier1	SCS-SpecificCarrier		
}			
additionalSpectrumEmission	AdditionalSpectrumEmission		
p-Max	P-Max		
frequencyShift7p5khz	Not present		
}			

Table 4.6.3-45: Void– *Hysteresis***Table 4.6.3-46: Hysteresis**

Derivation Path: TS 38.331 [6], clause 6.3.2			
Information Element	Value/remark	Comment	Condition
Hysteresis	4		

– *I-RNTI-Value*

Editor's Note: Based on ongoing RAN2 work on CR 100 for TS 38.331, R2-1812411 (CR 100r3).

Table 4.6.3-46A: *I-RNTI-Value*

Derivation Path: TS 38.331 [6], clause 6.3.2			
Information Element	Value/remark	Comment	Condition
I-RNTI-Value	FFS		

– *LocationMeasurementInfo*

Editor's Note: Based on ongoing RAN2 work on CR 100 for TS 38.331, R2-1812411 (CR 100r3).

Table 4.6.3-46B: *LocationMeasurementInfo*

Derivation Path: TS 38.331 [6], clause 6.3.2			
Information Element	Value/remark	Comment	Condition
LocationMeasurementInfo ::= CHOICE {			
eutra-RSTD	FFS		
}			

– *LogicalChannelConfig*Table 4.6.3-47: *LogicalChannelConfig*

Derivation Path: TS 38.331 [6], clause 6.3.2			
Information Element	Value/remark	Comment	Condition
LogicalChannelConfig ::= SEQUENCE {			
ul-SpecificParameters SEQUENCE {			
priority	1		
prioritisedBitRate	infinity		
bucketSizeDuration	ms50		
allowedServingCells	Not present		
allowedSCS-List	Not present		
maxPUSCH-Duration	Not present		
configuredGrantType1Allowed	Not present		
logicalChannelGroup	1		HI
	2		LO
schedulingRequestID	Not present		
logicalChannelSR-Mask	false		
logicalChannelSR-DelayTimerApplied	false		
}			
}			

Condition	Explanation
HI	Used for DRBs with high logical channel priority
LO	Used for DRBs with low logical channel priority

– *LogicalChannelIdentity*Table 4.6.3-48: *LogicalChannelIdentity*

Derivation Path: TS 38.331 [6], clause 6.3.2			
Information Element	Value/remark	Comment	Condition
LogicalChannelIdentity	1		

– *MAC-CellGroupConfig*

Table 4.6.3-49: MAC-CellGroupConfig

Derivation Path: TS 38.331 [6], clause 6.3.2			
Information Element	Value/remark	Comment	Condition
MAC-CellGroupConfig ::= SEQUENCE {			
drx-Config CHOICE {			
setup SEQUENCE {			
drx-onDurationTimer CHOICE {			
milliseconds	ms6		
}			
drx-InactivityTimer	ms1280		
drx-HARQ-RTT-TimerDL	56		
drx-HARQ-RTT-TimerUL	56		
drx-RetransmissionTimerDL	sl16		FR1
	sl64		FR2
drx-RetransmissionTimerUL	sl16		FR1
	sl64		FR2
drx-LongCycleStartOffset CHOICE {			
ms10240	0		
}			
shortDRX	not present		
drx-SlotOffset	0		
}			
}			
schedulingRequestConfig	SchedulingRequest-Config		
bsr-Config SEQUENCE {			
periodicBSR-Timer	sf1		
retxBSR-Timer	sf80		
logicalChannelSR-DelayTimer	Not present		
}			
tag-Config SEQUENCE {			
tag-ToReleaseList	Not present		
tag-ToAddModList SEQUENCE (SIZE (1..maxNrofTAGs)) OF SEQUENCE {	1 entry		
tag-Id	0		
timeAlignmentTimer	infinity		
}			
}			
phr-Config CHOICE {			
setup SEQUENCE {			
phr-PeriodicTimer	sf10		
phr-ProhibitTimer	sf0		
phr-Tx-PowerFactorChange	dB1		
multiplePHR	true		
phr-Type2SpCell	false		
phr-Type2OtherCell	false		
phr-ModeOtherCG	real		
}			
}			
skipUplinkTxDynamic	false		
}			

– *MeasConfig***Table 4.6.3-50: MeasConfig**

Derivation Path: TS 38.331 [6], clause 6.3.2			
Information Element	Value/remark	Comment	Condition
MeasConfig ::= SEQUENCE {			
measObjectToRemoveList	Not present		
measObjectToAddModList	MeasObjectToAddModList		
reportConfigToRemoveList	Not present		
reportConfigToAddModList	ReportConfigToAddModList		
measIdToRemoveList	Not present		
measIdToAddModList	MeasIdToAddModList		
s-MeasureConfig	Not present		
quantityConfig	QuantityConfig		
measGapConfig	Not present		
measGapSharingConfig	Not present		
}			

– *MeasGapConfig***Table 4.6.3-51: MeasGapConfig**

Derivation Path: TS 38.331 [6], clause 6.3.2			
Information Element	Value/remark	Comment	Condition
MeasGapConfig ::= SEQUENCE {			
gapFR2 CHOICE {			
setup SEQUENCE {			
gapOffset	159		
mgl	ms3dot5		
mgrp	ms160		
mgta	ms0		
}			
}			

– *MeasGapSharingConfig***Table 4.6.3-51A: MeasGapSharingConfig**

Derivation Path: TS 38.331 [6], clause 6.3.2			
Information Element	Value/remark	Comment	Condition
MeasGapSharingConfig ::= SEQUENCE {			
gapSharingFR2 CHOICE {			
setup SEQUENCE {			
MeasGapSharingScheme	FFS		
}			
}			

– *MeasId***Table 4.6.3-52: MeasId**

Derivation Path: TS 38.331 [6], clause 6.3.2			
Information Element	Value/remark	Comment	Condition
MeasId	1		

– *MeasIdToAddModList*

Table 4.6.3-53: MeasIdToAddModList

Derivation Path: TS 38.331 [6], clause 6.3.2			
Information Element	Value/remark	Comment	Condition
MeasIdToAddModList ::= SEQUENCE (SIZE (1..maxNrofMeasId)) OF SEQUENCE {	1 entry		
measId[1]	MeasId		
measObjectId[1]	MeasObjectId		
reportConfigId[1]	ReportConfigId		
}			

– *MeasObjectEUTRA*

Table 4.6.3-54: MeasObjectEUTRA

Derivation Path: TS 38.331 [6], clause 6.3.2			
Information Element	Value/remark	Comment	Condition
FFS			

– *MeasObjectId*

Table 4.6.3-55: MeasObjectId

Derivation Path: TS 38.331 [6], clause 6.3.2			
Information Element	Value/remark	Comment	Condition
MeasObjectId	1		

– *MeasObjectNR*Table 4.6.3-56: *MeasObjectNR*

Derivation Path: TS 38.331 [6], clause 6.3.2			
Information Element	Value/remark	Comment	Condition
MeasObjectNR ::= SEQUENCE {			
ssbFrequency	ARFCN-ValueNR with condition DL_SSB		
ssbSubcarrierSpacing	SubcarrierSpacing		
smtc1	SSB-MTC		
smtc2	Not present		
refFreqCSI-RS	Not present		
referenceSignalConfig SEQUENCE {			
ssb-ConfigMobility SEQUENCE {			
ssb-ToMeasure CHOICE {			
setup SEQUENCE {			
shortBitmap	0100		f<3GHz
mediumBitmap	01000000		3GHz<f<6G Hz
longBitmap	[01000000 00000000 00000000 00000000 00000000 00000000 00000000 00000000]		f>6GHz
}			
}			
}			
useServingCellTimingForSync	true		
ss-RSSI-Measurement	[Not present]	This value is temporarily set in RAN5#79.	
csi-rs-ResourceConfigMobility	Not present		
}			
absThreshSS-BlocksConsolidation SEQUENCE {			
thresholdRSRP	RSRP-Range		
thresholdRSRQ	Not present		
thresholdSINR	Not present		
}			
absThreshCSI-RS-Consolidation SEQUENCE {			
thresholdRSRP	RSRP-Range		
thresholdRSRQ	Not present		
thresholdSINR	Not present		
}			
nrofSS-BlocksToAverage	[2]	This value is temporarily set in RAN5#79.	
nrofCSI-RS-ResourcesToAverage	Not present		
quantityConfigIndex	[1]	This value is temporarily set in RAN5#79.	
offsetMO SEQUENCE {			
rsrpOffsetSSB	dB0		
rsrqOffsetSSB	dB0		
sinrOffsetSSB	dB0		
rsrpOffsetCSI-RS	dB0		
rsrqOffsetCSI-RS	dB0		
sinrOffsetCSI-RS	dB0		
}			
cellsToRemoveList	Not present		
cellsToAddModList	Not present		
blackCellsToRemoveList	Not present		
blackCellsToAddModList	Not present		
whiteCellsToRemoveList	Not present		
whiteCellsToAddModList	Not present		
}			

– *MeasObjectToAddModList***Table 4.6.3-57: MeasObjectToAddModList**

Derivation Path: TS 38.331 [6], clause 6.3.2			
Information Element	Value/remark	Comment	Condition
MeasObjectToAddModList ::= SEQUENCE (SIZE (1..maxNrofMeasId)) OF SEQUENCE {	1 entry		
measObjectId[1]	MeasObjectId		
measObject CHOICE {			
measObjectNR	MeasObjectNR		
}			
}			

– *MeasResults***Table 4.6.3-58: MeasResults**

Derivation Path: TS 38.331 [6], clause 6.3.2			
Information Element	Value/remark	Comment	Condition
MeasResults ::= SEQUENCE {			
FFS			
}			

– *MeasResultSCG-Failure*

Table 4.6.3-59: MeasResultSCG-Failure

Derivation Path: TS 38.331 [6], clause 6.3.2			
Information Element	Value/remark	Comment	Condition
MeasResultSCG-Failure ::= SEQUENCE {		<i>measResultPerMOList</i> for each <i>MeasObjectNR</i> for which a <i>measId</i> is configured (by the NR <i>RRCCongfiguration message</i>) and measurement results are available include an entry	
<i>measResultPerMOList</i> SEQUENCE (SIZE (1..maxFreq)) OF SEQUENCE {	<i>n</i> entries of <i>MeasResult2NR</i>	<i>MOList</i> [1] <i>n</i> denotes the number of non-serving frequencies being measured	
<i>MeasResult2NR</i> SEQUENCE {	entry [1]		
<i>ssbFrequency</i>	ARFCN-ValueNR with condition DL_SSB	the ARFCN if there is a <i>measId</i> configured with the <i>MeasObjectNR</i> and a <i>reportConfig</i> which has <i>rsType</i> set to <i>ssb</i>	
<i>refFreqCSI-RS</i>	INTEGER (0..3279165)	the ARFCN if there is a <i>measId</i> configured with the <i>MeasObjectNR</i> and a <i>reportConfig</i> which has <i>rsType</i> set to <i>csi-rs</i>	
<i>measResultServingCell</i> SEQUENCE {		if a serving cell is associated with the <i>MeasObjectNR</i>	
<i>physCellId</i>	INTEGER (0..1007)	the <i>physCellId</i> configured for this serving cell	
		--FFS: Details of cgi info	
<i>measResult</i> SEQUENCE {			
<i>cellResults</i> SEQUENCE {			
<i>resultsSSB-Cell</i> SEQUENCE {			
<i>rsrp</i>	as specified in Table 4.6.3-114	Integer value for RSRP measurements	
<i>rsrq</i>	as specified in Table 4.6.3-115	Integer value for RSRQ measurements	
<i>sinr</i>	as specified in Table 4.6.3-130	Integer value for SINR measurements	
}			
<i>resultsCSI-RS-Cell</i> SEQUENCE {			
<i>rsrp</i>	as specified in Table 4.6.3-114	Integer value for RSRP measurements	

rsrq	as specified in Table 4.6.3-115	Integer value for RSRQ measurements	
sinr	as specified in Table 4.6.3-130	Integer value for SINR measurements	
}			
}			
rsIndexResults SEQUENCE {			
resultsSSB-Indexes SEQUENCE (SIZE (1..maxNrofSSBs)) OF SEQUENCE {	<i>n</i> entries of ResultsPerSSB-Index	<i>ResultsPerSSB-IndexList</i>	
ResultsPerSSB-Index SEQUENCE {	entry [1]		
ssb-Index	SSB-Index)	an SS-Block within an SS-Burst	
ssb-Results SEQUENCE {		<i>MeasQuantityResults</i>	
rsrp	as specified in Table 4.6.3-114	Integer value for RSRP measurements	
rsrq	as specified in Table 4.6.3-115	Integer value for RSRQ measurements	
sinr	as specified in Table 4.6.3-130	Integer value for SINR measurements	
}			
}			
...		<i>ResultsPerSSB-Index</i> entry [x] if any	
}			
resultsCSI-RS-Indexes SEQUENCE (SIZE (1..maxNrofCSI-RS)) OF SEQUENCE {	<i>n</i> entries of ResultsPerCSI-RS-Index	<i>ResultsPerCSI-RS-IndexList</i>	
ResultsPerCSI-RS-Index SEQUENCE {	entry [1]		
csi-RS-Index	INTEGER (0..maxNrofCSI-RS-ResourcesRRM-1)	CSI-RS resource index associated to the measurement information to be reported	
csi-RS-Results SEQUENCE {		<i>MeasQuantityResults</i>	
rsrp	as specified in Table 4.6.3-114	Integer value for RSRP measurements	
rsrq	as specified in Table 4.6.3-115	Integer value for RSRQ measurements	
sinr	as specified in Table 4.6.3-130	Integer value for SINR measurements	
}			
}			
...		<i>ResultsPerCSI-RS-Index</i> entry [x] if any	
}			
}			
}			
}			
}			

measResultNeighCellListNR SEQUENCE (SIZE (1..maxCellReport)) OF SEQUENCE {	<i>n</i> entries of MeasResultNR	include the best measured cells, ordered such that the best cell is listed first, and based on measurements collected up to the moment the UE detected the failure	
MeasResultNR SEQUENCE {	entry [1]		
physCellId	INTEGER (0..1007)	the <i>physCellId</i> configured for the measured cell	
		--FFS: Details of cgi info	
measResult SEQUENCE {			
cellResults SEQUENCE {			
resultsSSB-Cell SEQUENCE {			
rsrp	as specified in Table 4.6.3-114	Integer value for RSRP measurements	
rsrq	as specified in Table 4.6.3-115	Integer value for RSRQ measurements	
sinr	as specified in Table 4.6.3-130	Integer value for SINR measurements	
}			
resultsCSI-RS-Cell SEQUENCE {			
rsrp	as specified in Table 4.6.3-114	Integer value for RSRP measurements	
rsrq	as specified in Table 4.6.3-115	Integer value for RSRQ measurements	
sinr	as specified in Table 4.6.3-130	Integer value for SINR measurements	
}			
}			
}			
...		<i>MeasResultNR</i> entry [x] if any	
}			
...		<i>MeasResult2NR</i> entry [x] if any	
}			
..		MOList [x] if any	
}			
}			

– *MeasResultCellListSFTD*

Table 4.6.3-60: MeasResultCellListSFTD

Derivation Path: TS 38.331 [6], clause 6.3.2			
Information Element	Value/remark	Comment	Condition
MeasResultCellListSFTD ::= SEQUENCE {			
FFS			
}			

– *MobilityStateParameters*

Editor's Note: Based on ongoing RAN2 work on CR 100 for TS 38.331, R2-1812411 (CR 100r3).

Table 4.6.3-60A: *MobilityStateParameters*

Derivation Path: TS 38.331 [6], clause 6.3.2			
Information Element	Value/remark	Comment	Condition
MobilityStateParameters ::= SEQUENCE {			
FFS			
}			

– *MultiFrequencyBandListNR*

Table 4.6.3-61: *MultiFrequencyBandListNR*

Derivation Path: TS 38.331 [6], clause 6.3.2			
Information Element	Value/remark	Comment	Condition
MultiFrequencyBandListNR ::= SEQUENCE (SIZE (1..maxNrofMultiBands)) OF {	1 entry		
FreqBandIndicatorNR[1]	FreqBandIndicatorNR		
}			

– *NextHopChainingCount*

Editor's Note: Based on ongoing RAN2 work on CR 100 for TS 38.331, R2-1812411 (CR 100r3).

Table 4.6.3-61A: *NextHopChainingCount*

Derivation Path: TS 38.331 [6], clause 6.3.2			
Information Element	Value/remark	Comment	Condition
NextHopChainingCount	FFS		

– *NG-5G-S-TMSI*

Editor's Note: Based on ongoing RAN2 work on CR 100 for TS 38.331, R2-1812411 (CR 100r3).

Table 4.6.3-61B: *NG-5G-S-TMSI*

Derivation Path: TS 38.331 [6], clause 6.3.2			
Information Element	Value/remark	Comment	Condition
NG-5G-S-TMSI ::= SEQUENCE {			
FFS			
}			

– *NZP-CSI-RS-Resource*

Table 4.6.3-62: NZP-CSI-RS-Resource

Derivation Path: TS 38.331 [6], clause 6.3.2			
Information Element	Value/remark	Comment	Condition
NZP-CSI-RS-Resource ::= SEQUENCE {			
nzp-CSI-RS-ResourceId	NZP-CSI-RS-ResourceId		
resourceMapping	CSI-RS-ResourceMapping		
powerControlOffset	-3		
powerControlOffsetSS	Not present		
scramblingID	ScramblingId		
periodicityAndOffset	CSI-ResourcePeriodicityAndOffset		
qcl-InfoPeriodicCSI-RS	TCI-StateId		
}			

– *NZP-CSI-RS-ResourceId*

Table 4.6.3-63: NZP-CSI-RS-ResourceId

Derivation Path: TS 38.331 [6], clause 6.3.2			
Information Element	Value/remark	Comment	Condition
NZP-CSI-RS-ResourceId	0		

– *NZP-CSI-RS-ResourceSet*

Table 4.6.3-64: NZP-CSI-RS-ResourceSet

Derivation Path: TS 38.331 [6], clause 6.3.2			
Information Element	Value/remark	Comment	Condition
NZP-CSI-RS-ResourceSet ::= SEQUENCE {			
nzp-CSI-ResourceSetId	NZP-CSI-RS-ResourceSetId		
nzp-CSI-RS-Resources SEQUENCE (SIZE (1..maxNrofNZP-CSI-RS-ResourcesPerSet)) OF {	[1 entry]		
NZP-CSI-RS-ResourceId[1]	NZP-CSI-RS-ResourceId		
}			
repetition	off		
aperiodicTriggeringOffset	Not present		
trs-Info	Not present		
	true		TRS
}			

Condition	Explanation
TRS	Tracking-Reference Signal

– *NZP-CSI-ResourceSetId*

Table 4.6.3-65: NZP-CSI-ResourceSetId

Derivation Path: TS 38.331 [6], clause 6.3.2			
Information Element	Value/remark	Comment	Condition
NZP-CSI-ResourceSetId	0		

– *P-Max*Table 4.6.3-66: *P-Max*

Derivation Path: TS 38.331 [6], clause 6.3.2			
Information Element	Value/remark	Comment	Condition
P-Max	23		FR1
	26		FR2

– *PCI-List*Table 4.6.3-67: *PCI-List*

Derivation Path: TS 38.331 [6], clause 6.3.2			
Information Element	Value/remark	Comment	Condition
PCI-List ::= SEQUENCE {			
FFS			
}			

– *PCI-Range*Table 4.6.3-68: *PCI-Range*

Derivation Path: TS 38.331 [6], clause 6.3.2			
Information Element	Value/remark	Comment	Condition
PCI-Range ::= SEQUENCE {			
start	PhysCellId		
range	FFS		
}			

– *PCI-RangeElement*Table 4.6.3-69: *PCI-RangeElement*

Derivation Path: TS 38.331 [6], clause 6.3.2			
Information Element	Value/remark	Comment	Condition
PCI-RangeElement ::= SEQUENCE {			
FFS			
}			

– *PCI-RangeIndex*Table 4.6.3-70: *PCI-RangeIndex*

Derivation Path: TS 38.331 [6], clause 6.3.2			
Information Element	Value/remark	Comment	Condition
PCI-RangeIndex	0		

– *PCI-RangeIndexList*Table 4.6.3-71: *PCI-RangeIndexList*

Derivation Path: TS 38.331 [6], clause 6.3.2			
Information Element	Value/remark	Comment	Condition
PCI-RangeIndexList ::= SEQUENCE {			
FFS			
}			

– *PDCCH-Config*Table 4.6.3-72: *PDCCH-Config*

Derivation Path: TS 38.331 [6], clause 6.3.2			
Information Element	Value/remark	Comment	Condition
PDCCH-Config ::= SEQUENCE {			
controlResourceSetToAddModList	Not present		
controlResourceSetToReleaseList	Not present		
searchSpacesToAddModList SEQUENCE(SIZE (1..10)) OF SEQUENCE {	1 entry		
SearchSpace[1]	SearchSpace with condition USS		
}			
searchSpacesToReleaseList	Not present		
downlinkPreemption	Not present		
tpc-PUSCH	Not present		
tpc-PUCCH	Not present		
tpc-SRS	Not present		
}			

– *PDCCH-ConfigCommon*Table 4.6.3-73: *PDCCH-ConfigCommon*

Derivation Path: TS 38.331 [6], clause 6.3.2			
Information Element	Value/remark	Comment	Condition
PDCCH-ConfigCommon ::= SEQUENCE {			
controlResourceSetZero	"CORESET#0 Index" as provided for the test frequency under test according to clause 6.2.3.1	TS 38.213 [22] Table 13-1 or Table 13-4: 24 RBs, 2 symbols, offset depending on the test frequency	FR1
	"CORESET#0 Index" as provided for the test frequency under test according to clause 6.2.3.1	TS 38.213 [22] Table 13-8: 24 RBs, 2 symbols, offset depending on the test frequency	FR2
commonControlResourceSet	ControlResourceSet		
searchSpaceZero	0	TS 38.213 [22] Table 13-11	FR1
	0	TS 38.213 [22] Table 13-12	FR2
commonSearchSpaces SEQUENCE(SIZE (1..4)) OF {	1 entry		
SearchSpace[1]	SearchSpace with condition CSS		
}			
searchSpaceSIB1	Not present		
searchSpaceOtherSystemInformation	Not present		
pagingSearchSpace	Not present		
ra-SearchSpace	SearchSpaceId with condition CSS		
}			

– *PDCCH-ConfigSIB1*

Editor's Note: Based on ongoing RAN2 work on CR 100 for TS 38.331, R2-1812411 (CR 100r3).

Table 4.6.3-73A: PDCCH-ConfigSIB1

Derivation Path: TS 38.331 [6], clause 6.3.2			
Information Element	Value/remark	Comment	Condition
PDCCH-ConfigSIB1 ::= SEQUENCE {			
FFS			
}			

– *PDCCH-ServingCellConfig*

Table 4.6.3-73B: PDCCH-ServingCellConfig

Derivation Path: TS 38.331 [6], clause 6.3.2			
Information Element	Value/remark	Comment	Condition
PDCCH-ServingCellConfig ::= SEQUENCE {			
slotFormatIndicator	Not present		
}			

– *PDCP-Config*

Table 4.6.3-74: PDCP-Config

Derivation Path: TS 38.331 [6], clause 6.3.2			
Information Element	Value/remark	Comment	Condition
PDCP-Config ::= SEQUENCE {			
drb SEQUENCE {			
discardTimer	infinity		
pdcp-SN-Size-UL	len18bits		
pdcp-SN-Size-DL	len18bits		
headerCompression CHOICE {			
notUsed	Null		
}			
integrityProtection	Not present		
statusReportRequired	true		
outOfOrderDelivery	Not present		
}			
moreThanOneRLC	Not present		
moreThanOneRLC SEQUENCE {			Split
primaryPath SEQUENCE {			
cellGroup	CellGroupId		
logicalChannel	LogicalChannelIdentity		
}			
ul-DataSplitThreshold	infinity		
pdcp-Duplication	false		
}			
t-Reordering	Not present		
}			

Condition	Explanation
Split	More than one RLC.

PDSCH-Config

Table 4.6.3-75: PDSCH-Config

Derivation Path: TS 38.331 [6], clause 6.3.2			
Information Element	Value/remark	Comment	Condition
PDSCH-Config ::= SEQUENCE {			
dataScramblingIdentityPDSCH	0		
dmrs-DownlinkForPDSCH-MappingTypeA CHOICE {			
setup	DMRS-DownlinkConfig		
}			
dmrs-DownlinkForPDSCH-MappingTypeB	Not present		
tci-StatesToAddModList SEQUENCE(SIZE (1.. maxNrofTCI-States)) OF {			
TCI-State[1]	TCI-State		
}			
tci-StatesToReleaseList	Not present		
vrb-ToPRB-Interleaver	n2		
resourceAllocation	resourceAllocationType0		
pdsch-TimeDomainAllocationList	Not present		
pdsch-AggregationFactor	Not present		
rateMatchPatternToAddModList SEQUENCE(SIZE (1.. maxNrofRateMatchPatterns)) OF {	1 entry		
RateMatchPattern[1]	RateMatchPattern		
}			
rateMatchPatternToReleaseList	Not present		
rateMatchPatternGroup1	Not present		
rateMatchPatternGroup2	Not present		
rbg-Size	config1		
mcs-Table	qam256		FR1
	Not present	qam64 per default	FR2
maxNrofCodeWordsScheduledByDCI	Not present		
prb-BundlingType CHOICE {			
staticBundling SEQUENCE {			
bundleSize	wideband		
}			
}			
zp-CSI-RS-ResourceToAddModList	Not present		
zp-CSI-RS-ResourceToReleaseList	Not present		
aperiodic-ZP-CSI-RS-ResourceSetsToAddModList	Not present		
aperiodic-ZP-CSI-RS-ResourceSetsToReleaseList	Not present		
sp-ZP-CSI-RS-ResourceSetsToAddModList	Not present		
sp-ZP-CSI-RS-ResourceSetsToReleaseList	Not present		
p-ZP-CSI-RS-ResourceSet	Not present		
}			

PDSCH-ConfigCommon

Table 4.6.3-76: PDSCH-ConfigCommon

Derivation Path: TS 38.331 [6], clause 6.3.2			
Information Element	Value/remark	Comment	Condition
PDSCH-ConfigCommon ::= SEQUENCE {			
pdsch-TimeDomainAllocationList	PDSCH-TimeDomainResourceAllocationList		
}			

– *PDSCH-ServingCellConfig*

Table 4.6.3-77: PDSCH-ServingCellConfig

Derivation Path: TS 38.331 [6], clause 6.3.2			
Information Element	Value/remark	Comment	Condition
PDSCH-ServingCellConfig ::= SEQUENCE {			
codeBlockGroupTransmission	Not present		
xOverhead	Not present		
nrofHARQ-ProcessesForPDSCH	n16		
pucch-Cell	[ServCellIndex]		
}			

– *PDSCH-TimeDomainResourceAllocationList*

Table 4.6.3-78: PDSCH-TimeDomainResourceAllocationList

Derivation Path: TS 38.331 [6], clause 6.3.2			
Information Element	Value/remark	Comment	Condition
PDSCH-TimeDomainResourceAllocationList ::= SEQUENCE(SIZE(1..maxNrofDL-Allocations)) OF {	2 entries		FR1
PDSCH-TimeDomainResourceAllocation[1]			
SEQUENCE {			
k0	Not present		
mappingType	typeA		
startSymbolAndLength	53	Start symbol(S)=2, Length(L)=12	
}			
PDSCH-TimeDomainResourceAllocation2			
SEQUENCE {			
k0	Not present		
mappingType	typeA		
startSymbolAndLength	72	S=2, L=6	
}			
}			
PDSCH-TimeDomainResourceAllocationList ::= SEQUENCE(SIZE(1..maxNrofDL-Allocations)) OF {	1 entry		FR2
PDSCH-TimeDomainResourceAllocation1			
SEQUENCE {			
k0	Not present		
mappingType	typeA		
startSymbolAndLength	53	S=2, L=12	
}			
}			

Table 4.6.3-79: Void

– *PhysCellId*

Table 4.6.3-80: PhysCellId

Derivation Path: TS 38.331 [6], clause 6.3.2			
Information Element	Value/remark	Comment	Condition
PhysCellId	Set according to table 4.4.2-2 for the NR Cell.		

– *PhysicalCellGroupConfig*

Table 4.6.3-80A: PhysicalCellGroupConfig

Derivation Path: TS 38.331 [6], clause 6.3.2			
Information Element	Value/remark	Comment	Condition
PhysicalCellGroupConfig ::= SEQUENCE {			
harq-ACK-SpatialBundlingPUCCH	true		
harq-ACK-SpatialBundlingPUSCH	true		
p-NR	P-Max		
pdsch-HARQ-ACK-Codebook	dynamic		
tpc-SRS-RNTI	Not present		
tpc-PUCCH-RNTI	Not present		
tpc-PUSCH-RNTI	Not present		
sp-CSI-RNTI	Not present		
cs-RNTI	Not present		
}			

– *PLMN-Identity*

Editor’s Note: Based on ongoing RAN2 work on CR 100 for TS 38.331, R2-1812411 (CR 100r3).

Table 4.6.3-80B: PLMN-Identity

Derivation Path: TS 38.331 [6], clause 6.3.2			
Information Element	Value/remark	Comment	Condition
PLMN-Identity ::= SEQUENCE {			
FFS			
}			

– *PLMN-IdentityInfoList*

Editor’s Note: Based on ongoing RAN2 work on CR 100 for TS 38.331, R2-1812411 (CR 100r3).

Table 4.6.3-80C: PLMN-IdentityInfoList

Derivation Path: TS 38.331 [6], clause 6.3.2			
Information Element	Value/remark	Comment	Condition
PLMN-IdentityInfoList ::= SEQUENCE {			
FFS			
}			

– *PRB-Id*

Table 4.6.3-81: PRB-Id

Derivation Path: TS 38.331 [6], clause 6.3.2			
Information Element	Value/remark	Comment	Condition
PRB-Id	0		
	Set to value of the number of RBs - 1 corresponding to 10 MHz channel bandwidth in clause 4.3.1 for the carrier and subcarrier under test.		secondHopPRB

Condition	Explanation
secondHopPRB	The IE secondHopPRB in PUCCH-Resource is now set.

– *PTRS-DownlinkConfig***Table 4.6.3-82: PTRS-DownlinkConfig**

Derivation Path: TS 38.331 [6], clause 6.3.2			
Information Element	Value/remark	Comment	Condition
PTRS-DownlinkConfig ::= SEQUENCE {			
frequencyDensity	FFS	Waiting for RAN4 decision.	
timeDensity	FFS	Waiting for RAN4 decision.	
epre-Ratio	0		
resourceElementOffset	Not present		
}			

– *PTRS-UplinkConfig***Table 4.6.3-83: PTRS-UplinkConfig**

Derivation Path: TS 38.331 [6], clause 6.3.2			
Information Element	Value/remark	Comment	Condition
PTRS-UplinkConfig ::= SEQUENCE {			
modeSpecificParameters CHOICE {			
cp-OFDM SEQUENCE {			
frequencyDensity	Not present		
timeDensity	Not present		
maxNrofPorts	n1		
resourceElementOffset	Not present		
ptrs-Power	p00		
}			
}			
}			

– *PUCCH-Config*

Table 4.6.3-84: *PUCCH-Config*

Derivation Path: TS 38.331 [6], clause 6.3.2			
Information Element	Value/remark	Comment	Condition
PUCCH-Config ::= SEQUENCE {			
resourceSetToAddModList SEQUENCE (SIZE (1..maxNrofPUCCH-ResourceSets)) OF SEQUENCE {	4 entries		
{			
pucch-ResourceSetId[1]	0		
resourceList[[1] SEQUENCE (SIZE (0..maxNrofPUCCH-ResourcesPerSet)) OF {	8 entries		
PUCCH-ResourceId[1]	0		
PUCCH-ResourceId[2]	1		
PUCCH-ResourceId[3]	2		
PUCCH-ResourceId[4]	3		
PUCCH-ResourceId[5]	4		
PUCCH-ResourceId[6]	5		
PUCCH-ResourceId[7]	6		
PUCCH-ResourceId[8]	7		
}			
maxPayloadMinus1[1]	256		
}			
{			
pucch-ResourceSetId[2]	1		
resourceList[2] SEQUENCE (SIZE (8..maxNrofPUCCH-ResourcesPerSet)) OF {	8 entries		
PUCCH-ResourceId[1]	8		
PUCCH-ResourceId[2]	9		
PUCCH-ResourceId[3]	10		
PUCCH-ResourceId[4]	11		
PUCCH-ResourceId[5]	12		
PUCCH-ResourceId[6]	13		
PUCCH-ResourceId[7]	14		
PUCCH-ResourceId[8]	15		
}			
}			
{			
maxPayloadMinus1[2]	256		
pucch-ResourceSetId[3]	2		
resourceList[3] SEQUENCE (SIZE (8..maxNrofPUCCH-ResourcesPerSet)) OF {	8 entries		
PUCCH-ResourceId[1]	8		
PUCCH-ResourceId[2]	9		
PUCCH-ResourceId[3]	10		
PUCCH-ResourceId[4]	11		
PUCCH-ResourceId[5]	12		
PUCCH-ResourceId[6]	13		
PUCCH-ResourceId[7]	14		
PUCCH-ResourceId[8]	15		
}			
}			
{			
maxPayloadMinus1[3]	256		
pucch-ResourceSetId[4]	3		
resourceList[4] SEQUENCE (SIZE (8..maxNrofPUCCH-ResourcesPerSet)) OF {	8 entries		
PUCCH-ResourceId[1]	8		
PUCCH-ResourceId[2]	9		
PUCCH-ResourceId[3]	10		
PUCCH-ResourceId[4]	11		
PUCCH-ResourceId[5]	12		
PUCCH-ResourceId[6]	13		
PUCCH-ResourceId[7]	14		
PUCCH-ResourceId[8]	15		
}			
}			
{			
maxPayloadMinus1[4]	256		
}			

}			
resourceSetToReleaseList	Not present		
resourceToAddModList SEQUENCE (SIZE (1..maxNrofPUCCH-Resources)) OF SEQUENCE {	[16 entries]		
{			
pucch-ResourceId[1]	0		
startingPRB[1]	PRB-Id		
intraSlotFrequencyHopping[[1]	enabled		
secondHopPRB[1]	PRB-Id with condition secondHopPRB		
format[1] CHOICE {			
format0 SEQUENCE {			
initialCyclicShift	0		
nrofSymbols	2		
startingSymbolIndex	[0		
}			
}			
}			
{			
pucch-ResourceId[2]	1		
startingPRB[2]	PRB-Id		
intraSlotFrequencyHopping[[2]	enabled		
secondHopPRB[2]	PRB-Id with condition secondHopPRB		
format[2] CHOICE {			
format0 SEQUENCE {			
initialCyclicShift	0		
nrofSymbols	2		
startingSymbolIndex	2		
}			
}			
}			
{			
pucch-ResourceId[3]	2		
startingPRB[3]	PRB-Id		
intraSlotFrequencyHopping[[3]	enabled		
secondHopPRB[3]	PRB-Id with condition secondHopPRB		
format[3] CHOICE {			
format0 SEQUENCE {			
initialCyclicShift	0		
nrofSymbols	2		
startingSymbolIndex	4		
}			
}			
}			
{			
pucch-ResourceId[4]	3		
startingPRB[4]	PRB-Id		
intraSlotFrequencyHopping[[4]	enabled		
secondHopPRB[4]	PRB-Id with condition secondHopPRB		
format[4] CHOICE {			
format0 SEQUENCE {			
initialCyclicShift	0		
nrofSymbols	2		
startingSymbolIndex	6		
}			
}			
}			
{			
pucch-ResourceId[5]	4		
startingPRB[5]	PRB-Id		
intraSlotFrequencyHopping[[5]	enabled		
secondHopPRB[5]	PRB-Id with condition secondHopPRB		

format[5] CHOICE {			
format0 SEQUENCE {			
initialCyclicShift	0		
nrofSymbols	2		
startingSymbolIndex	8		
}			
}			
}			
{			
pucch-ResourceId[6]	5		
startingPRB[6]	PRB-Id		
intraSlotFrequencyHopping[[6]	enabled		
secondHopPRB[6]	PRB-Id with condition secondHopPRB		
format[6] CHOICE {			
format0 SEQUENCE {			
initialCyclicShift	0		
nrofSymbols	2		
startingSymbolIndex	10		
}			
}			
}			
{			
pucch-ResourceId[7]	6		
startingPRB[7]	PRB-Id		
intraSlotFrequencyHopping[[7]	enabled		
secondHopPRB[7]	PRB-Id with condition secondHopPRB		
format[7] CHOICE {			
format0 SEQUENCE {			
initialCyclicShift	0		
nrofSymbols	2		
startingSymbolIndex	12		
}			
}			
}			
{			
pucch-ResourceId[8]	7		
startingPRB[8]	PRB-Id		
intraSlotFrequencyHopping[[8]	enabled		
secondHopPRB[8]	PRB-Id with condition secondHopPRB		
format[8] CHOICE {			
format1 SEQUENCE {			
initialCyclicShift	0		
nrofSymbols	14		
startingSymbolIndex	0		
timeDomainOCC	0		
}			
}			
}			
{			
pucch-ResourceId[9]	8		
startingPRB[9]	PRB-Id		
intraSlotFrequencyHopping[[9]	enabled		
secondHopPRB[9]	PRB-Id with condition secondHopPRB		
format[9] CHOICE {			
format2 SEQUENCE {			
nrofPRBs	6		
nrofSymbols	2		
startingSymbolIndex	0		
}			
}			
}			
}			

{			
pucch-ResourceId[10]	9		
startingPRB[10]	PRB-Id		
intraSlotFrequencyHopping[[10]	enabled		
secondHopPRB[10]	PRB-Id with condition secondHopPRB		
format[10] CHOICE {			
format2 SEQUENCE {			
nrofPRBs	6		
nrofSymbols	2		
startingSymbolIndex	2		
}			
}			
{			
pucch-ResourceId[11]	10		
startingPRB[11]	PRB-Id		
intraSlotFrequencyHopping[[11]	enabled		
secondHopPRB[11]	PRB-Id with condition secondHopPRB		
format[11] CHOICE {			
format2 SEQUENCE {			
nrofPRBs	6		
nrofSymbols	2		
startingSymbolIndex	4		
}			
}			
{			
pucch-ResourceId[12]	11		
startingPRB[12]	PRB-Id		
intraSlotFrequencyHopping[[12]	enabled		
secondHopPRB[12]	PRB-Id with condition secondHopPRB		
format[12] CHOICE {			
format2 SEQUENCE {			
nrofPRBs	6		
nrofSymbols	2		
startingSymbolIndex	6		
}			
}			
{			
pucch-ResourceId[13]	12		
startingPRB[13]	PRB-Id		
intraSlotFrequencyHopping[[13]	enabled		
secondHopPRB[13]	PRB-Id with condition secondHopPRB		
format[13] CHOICE {			
format2 SEQUENCE {			
nrofPRB	6		
nrofSymbols	2		
startingSymbolIndex	8		
}			
}			
{			
pucch-ResourceId[14]	13		
startingPRB[14]	PRB-Id		
intraSlotFrequencyHopping[[14]	enabled		
secondHopPRB[14]	PRB-Id with condition secondHopPRB		
format[14] CHOICE {			
format2 SEQUENCE {			
nrofPRBsinitial	6		
nrofSymbols	2		

startingSymbolIndex	10		
}			
}			
{			
pucch-ResourceId[15]	14		
startingPRB[15]	PRB-Id		
intraSlotFrequencyHopping[[15]	enabled		
secondHopPRB[15]	PRB-Id with condition secondHopPRB		
format[15] CHOICE {			
format2 SEQUENCE {			
nrofPRB	6		
nrofSymbols	2		
startingSymbolIndex	12		
}			
}			
}			
{			
pucch-ResourceId[16]	15		
startingPRB[16]	PRB-Id		
intraSlotFrequencyHopping[[16]	enabled		
secondHopPRB[16]	PRB-Id with condition secondHopPRB		
format[16] CHOICE {			
format3 SEQUENCE {			
nrofPRBs	1		
nrofSymbols	14		
startingSymbolIndex	0		
}			
}			
}			
}			
resourceToReleaseList	Not present		
format1 CHOICE {			
setup SEQUENCE {			
interslotFrequencyHopping	enabled		
additionalDMRS	true		
maxCodeRate	zeroDot25		
nrofSlots	Not present		
pi2BPSK	Not present		
simultaneousHARQ-ACK-CSI	true		
}			
}			
format2 CHOICE {			
setup SEQUENCE {			
interslotFrequencyHopping	enabled		
additionalDMRS	true		
maxCodeRate	zeroDot25		
nrofSlots	Not present		
pi2BPSK	Not present		
simultaneousHARQ-ACK-CSI	true		
}			
}			
format3 CHOICE {			
setup SEQUENCE {			
interslotFrequencyHopping	enabled		
additionalDMRS	True		
maxCodeRate	zeroDot25		
nrofSlots	Not present		
pi2BPSK	Not present		
simultaneousHARQ-ACK-CSI	true		
}			
}			
format4	Not present		

schedulingRequestResourceToAddModList SEQUENCE (SIZE (1..maxNrofSR-Resources)) OF SEQUENCE {	1 entry		
SchedulingRequestResourceConfig[1]	SchedulingRequestResourceConfig		
}			
schedulingRequestResourceToReleaseList	Not present		
multi-CSI-PUCCH-ResourceList	Not present		
dl-DataToUL-ACK SEQUENCE (SIZE (1..8)) OF {			
INTEGER[1]	2		
INTEGER[2]	3		
INTEGER[3]	4		
INTEGER[4]	5		
INTEGER[5]	6		
INTEGER[6]	7		
INTEGER[7]	8		
INTEGER[8]	9		
}			
spatialRelationInfoToAddModList	Not present		
spatialRelationInfoToReleaseList	Not present		
pucch-PowerControl	PUCCH-PowerControl		
}			

– *PUCCH-ConfigCommon*

Table 4.6.3-85: PUCCH-ConfigCommon

Derivation Path: TS 38.331 [6], clause 6.3.2			
Information Element	Value/remark	Comment	Condition
PUCCH-ConfigCommon ::= SEQUENCE {			
pucch-ResourceCommon	Not present		
pucch-GroupHopping	enable		
hoppingId	Not present		
p0-nominal	-90		
}			

– *PUCCH-PathlossReferenceRS-Id*

Table 4.6.3-86: PUCCH-PathlossReferenceRS-Id

Derivation Path: TS 38.331 [6], clause 6.3.2			
Information Element	Value/remark	Comment	Condition
PUCCH-PathlossReferenceRS-Id	0		

– *PUCCH-PowerControl***Table 4.6.3-87: PUCCH-PowerControl**

Derivation Path: TS 38.331 [6], clause 6.3.2			
Information Element	Value/remark	Comment	Condition
PUCCH-PowerControl ::= SEQUENCE {			
deltaF-PUCCH-f0	0		
deltaF-PUCCH-f1	0		
deltaF-PUCCH-f2	0		
deltaF-PUCCH-f3	0		
deltaF-PUCCH-f4	0		
p0-Set	Not present		
pathlossReferenceRSs SEQUENCE (SIZE (1..maxNrofPUCCH-PathlossReferenceRSs)) OF SEQUENCE {	1 entry		
pucch-PathlossReferenceRS-Id[1]	PUCCH-PathlossReferenceRS-Id		
referenceSignal CHOICE {			
ssb-Index	SSB-Index		
}			
twoPUCCH-PC-AdjustmentStates	Not present		
}			

– *PUCCH-SpatialRelationInfo*

Editor's Note: Based on ongoing RAN2 work on CR 100 for TS 38.331, R2-1812411 (CR 100r3).

Table 4.6.3-87A: PUCCH-SpatialRelationInfo

Derivation Path: TS 38.331 [6], clause 6.3.2			
Information Element	Value/remark	Comment	Condition
PUCCH-SpatialRelationInfo ::= SEQUENCE {			
FFS			
}			

– *PUCCH-TPC-CommandConfig***Table 4.6.3-88: PUCCH-TPC-CommandConfig**

Derivation Path: TS 38.331 [6], clause 6.3.2			
Information Element	Value/remark	Comment	Condition
PUCCH-TPC-CommandConfig ::= SEQUENCE {			
FFS			
}			

PUSCH-Config

Table 4.6.3-89: PUSCH-Config

Derivation Path: TS 38.331 [6], clause 6.3.2			
Information Element	Value/remark	Comment	Condition
PUSCH-Config ::= SEQUENCE {			
dataScramblingIdentityPUSCH	0		
txConfig	codebook		
dmrs-UplinkForPUSCH-MappingTypeA	Not present		
dmrs-UplinkForPUSCH-MappingTypeB CHOICE {			
setup	DMRS-UplinkConfig		
}			
pusch-PowerControl	PUSCH-PowerControl		
frequencyHopping	Not present		
frequencyHoppingOffsetLists	Not present		
resourceAllocation	resourceAllocationType1		
pusch-TimeDomainAllocationList	Not present		
pusch-AggregationFactor	Not present		
mcs-Table	gam256		FR1
	Not present		FR2
mcs-TableTransformPrecoder	gam256		FR1
	Not present		FR2
transformPrecoder	enabled	DFT-s-OFDM	
	Not present		CP-OFDM
codebookSubset	nonCoherent		
maxRank	2		
rbg-Size	Not present		
uci-OnPUSCH CHOICE {			
setup SEQUENCE {			
betaOffsets CHOICE {			
semiStatic SEQUENCE {			
betaOffsetACK-Index1	9		
betaOffsetACK-Index2	9		
betaOffsetACK-Index3	9		
betaOffsetCSI-Part1-Index1	6		
betaOffsetCSI-Part1-Index2	6		
betaOffsetCSI-Part2-Index1	6		
betaOffsetCSI-Part2-Index2	6		
}			
}			
}			
scaling	f1		
}			
}			
tp-pi2BPSK	Not present		
}			

Condition	Explanation
CP-OFDM	CP-OFDM waveform is configured

– *PUSCH-ConfigCommon*

Table 4.6.3-90: PUSCH-ConfigCommon

Derivation Path: TS 38.331 [6], clause 6.3.2			
Information Element	Value/remark	Comment	Condition
PUSCH-ConfigCommon ::= SEQUENCE {			
groupHoppingEnabledTransformPrecoding	enabled		
pusch-TimeDomainAllocationList	PUSCH-TimeDomainResourceAllocationList		
msg3-DeltaPreamble	1		
p0-NominalWithGrant	-90		
}			

– *PUSCH-PowerControl*

Table 4.6.3-91: PUSCH-PowerControl

Derivation Path: TS 38.331 [6], clause 6.3.2			
Information Element	Value/remark	Comment	Condition
PUSCH-PowerControl ::= SEQUENCE {			
tpc-Accumulation	Not present		
msg3-Alpha	alpha08		
p0-NominalWithoutGrant	-90		
p0-AlphaSets SEQUENCE (SIZE (1..maxNrofP0-PUSCH-AlphaSets)) OF SEQUENCE {	1 entry		
p0-PUSCH-AlphaSetId	0		
p0	0		
alpha	alpha08		
}			
pathlossReferenceRSToAddModList SEQUENCE (SIZE (1..maxNrofPUSCH-PathlossReferenceRSs)) OF SEQUENCE {	1 entry		
pusch-PathlossReferenceRS-Id	0		
referenceSignal CHOICE{			
ssb-Index	SSB-Index		
}			
}			
pathlossReferenceRSToReleaseList	Not present		
twoPUSCH-PC-AdjustmentStates	Not present		
deltaMCS	Not present		
sri-PUSCH-MappingToAddModList SEQUENCE (SIZE (1..maxNrofSRI-PUSCH-Mappings)) OF SEQUENCE {	1 entry		
sri-PUSCH-PowerControlId	0		
sri-PUSCH-PathlossReferenceRS-Id	0		
sri-P0-PUSCH-AlphaSetId	0		
sri-PUSCH-ClosedLoopIndex	i0		
}			
sri-PUSCH-MappingToReleaseList	Not present		
}			

– *PUSCH-ServingCellConfig***Table 4.6.3-92: PUSCH-ServingCellConfig**

Derivation Path: TS 38.331 [6], clause 6.3.2			
Information Element	Value/remark	Comment	Condition
PUSCH-ServingCellConfig ::= SEQUENCE {			
codeBlockGroupTransmission	Not present		
rateMatching	limitedBufferRM		
xOverhead	Not present		
}			

– *PUSCH-TimeDomainResourceAllocationList***Table 4.6.3-93: PUSCH-TimeDomainResourceAllocationList**

Derivation Path: TS 38.331 [6], clause 6.3.2			
Information Element	Value/remark	Comment	Condition
PUSCH-TimeDomainResourceAllocationList ::= SEQUENCE (SIZE(1..maxNrofUL-Allocations)) OF SEQUENCE {	1 entry		
k2	7		FR1
	4		FR2
mappingType	typeB		
startSymbolAndLength	27	Start symbol(S)=0, Length(L)=14	FR1
	14	S=0, L=2	FR2
}			

– *PUSCH-TPC-CommandConfig***Table 4.6.3-94: PUSCH-TPC-CommandConfig**

Derivation Path: TS 38.331 [6], clause 6.3.2			
Information Element	Value/remark	Comment	Condition
PUSCH-TPC-CommandConfig ::= SEQUENCE {			
tpc-Index	Not present		
tpc-IndexSUL	Not present		
targetCell	Not present		
}			

– *Q-OffsetRange***Table 4.6.3-95: Q-OffsetRange**

Derivation Path: TS 38.331 [6], clause 6.3.2			
Information Element	Value/remark	Comment	Condition
Q-OffsetRange	dB0		

– *Q-QualMin*

Editor's Note: Based on ongoing RAN2 work on CR 100 for TS 38.331, R2-1812411 (CR 100r3).

Table 4.6.3-95A: Q-QualMin

Derivation Path: TS 38.331 [6], clause 6.3.2			
Information Element	Value/remark	Comment	Condition
Q-QualMin	FFS		

– *Q-RxLevMin*

Editor's Note: Based on ongoing RAN2 work on CR 100 for TS 38.331, R2-1812411 (CR 100r3).

Table 4.6.3-95B: *Q-RxLevMin*

Derivation Path: TS 38.331 [6], clause 6.3.2			
Information Element	Value/remark	Comment	Condition
Q-RxLevMin	FFS		

QuantityConfig

Table 4.6.3-96: QuantityConfig

Derivation Path: TS 38.331 [6], clause 6.3.2			
Information Element	Value/remark	Comment	Condition
QuantityConfig ::= SEQUENCE {			
quantityConfigNR-List SEQUENCE (SIZE (1..maxNrofQuantityConfig)) OF SEQUENCE {	2 entries		
quantityConfigCell[1] SEQUENCE {			
ssb-FilterConfig SEQUENCE {			
filterCoefficientRSRP	FilterCoefficient		
filterCoefficientRSRQ	FilterCoefficient		
filterCoefficientRS-SINR	FilterCoefficient		
}			
cs-RS-FilterConfig SEQUENCE {			
filterCoefficientRSRP	FilterCoefficient		
filterCoefficientRSRQ	FilterCoefficient		
filterCoefficientRS-SINR	FilterCoefficient		
}			
}			
quantityConfigRS-Index[1] SEQUENCE {			
ssb-FilterConfig SEQUENCE {			
filterCoefficientRSRP	FilterCoefficient		
filterCoefficientRSRQ	FilterCoefficient		
filterCoefficientRS-SINR	FilterCoefficient		
}			
cs-RS-FilterConfig SEQUENCE {			
filterCoefficientRSRP	FilterCoefficient		
filterCoefficientRSRQ	FilterCoefficient		
filterCoefficientRS-SINR	FilterCoefficient		
}			
}			
quantityConfigCell[2] SEQUENCE {			
ssb-FilterConfig SEQUENCE {			
filterCoefficientRSRP	FilterCoefficient		
filterCoefficientRSRQ	FilterCoefficient		
filterCoefficientRS-SINR	FilterCoefficient		
}			
cs-RS-FilterConfig SEQUENCE {			
filterCoefficientRSRP	FilterCoefficient		
filterCoefficientRSRQ	FilterCoefficient		
filterCoefficientRS-SINR	FilterCoefficient		
}			
}			
quantityConfigRS-Index[2] SEQUENCE {			
ssb-FilterConfig SEQUENCE {			
filterCoefficientRSRP	FilterCoefficient		
filterCoefficientRSRQ	FilterCoefficient		
filterCoefficientRS-SINR	FilterCoefficient		
}			
cs-RS-FilterConfig SEQUENCE {			
filterCoefficientRSRP	FilterCoefficient		
filterCoefficientRSRQ	FilterCoefficient		
filterCoefficientRS-SINR	FilterCoefficient		
}			
}			
}			
}			

– *RACH-ConfigCommon***Table 4.6.3-97: RACH-ConfigCommon**

Derivation Path: TS 38.331 [6], clause 6.3.2			
Information Element	Value/remark	Comment	Condition
RACH-ConfigCommon ::= SEQUENCE {			
rach-ConfigGeneric	RACH-ConfigGeneric		
totalNumberOfRA-Preambles	Not present		
ssb-perRACH-OccasionAndCB-PreamblesPerSSB CHOICE {			
one	n8		
	n4		FR2
}			
groupBconfigured	Not present		
ra-ContentionResolutionTimer	sf64		
rsrp-ThresholdSSB	RSRP-Range		
rsrp-ThresholdSSB-SUL	RSRP-Range		
prach-RootSequenceIndex CHOICE {			
l139	Set according to table 4.4.2-2 for the NR Cell.		
}			
msg1-SubcarrierSpacing	SubcarrierSpacing		
restrictedSetConfig	unrestrictedSet		
msg3-transformPrecoding	Not present		
}			

– *RACH-ConfigGeneric***Table 4.6.3-98: RACH-ConfigGeneric**

Derivation Path: TS 38.331 [6], clause 6.3.2			
Information Element	Value/remark	Comment	Condition
RACH-ConfigGeneric ::= SEQUENCE {			
prach-ConfigurationIndex	160		
	149		FR2
msg1-FDM	four		
	one		FR2
msg1-FrequencyStart	0		
zeroCorrelationZoneConfig	15		
preambleReceivedTargetPower	-118		
preambleTransMax	n7		
powerRampingStep	dB4		
ra-ResponseWindow	sl20		
}			

– *RACH-ConfigDedicated*

Table 4.6.3-99: RACH-ConfigDedicated

Derivation Path: TS 38.331 [6], clause 6.3.2			
Information Element	Value/remark	Comment	Condition
RACH-ConfigDedicated ::= SEQUENCE {			
cfra SEQUENCE {			
occasions SEQUENCE {			
rach-ConfigGeneric	RACH-ConfigGeneric		
ssb-perRACH-Occasion	one		
}			
resources CHOICE {			
ssb SEQUENCE {			
ssb-ResourceList SEQUENCE (SIZE(1..maxRA-SSB-Resources)) OF {			
ssb	SSB-Index		
ra-PreambleIndex	8		
}			
ra-ssb-OccasionMaskIndex	0		
}			
}			
ra-Prioritization	Not present		
}			

RadioBearerConfig

Table 4.6.3-100: RadioBearerConfig

Derivation Path: TS 38.331 [6], clause 6.3.2			
Information Element	Value/remark	Comment	Condition
RadioBearerConfig ::= SEQUENCE {			
srb-ToAddModList	Not present		
srb-ToAddModList SEQUENCE {			SRB3
srb-Identity	SRB-Identity with condition SRB3		
reestablishPDCP	Not present		
discardOnPDCP	Not present		
pdcpc-Config	PDCP-Config		
}			
srb-ToAddModList SEQUENCE (SIZE (1..2)) OF SEQUENCE {	2 entries		SRB_NR_P DCP
SRB-Identity[1]	SRB-Identity with condition SRB1		
reestablishPDCP[1]	Not present		
discardOnPDCP[1]	Not present		
pdcpc-Config[1]	PDCP-Config		
SRB-Identity[2]	SRB-Identity with condition SRB2		
reestablishPDCP[2]	Not present		
discardOnPDCP[2]	Not present		
pdcpc-Config[2]	PDCP-Config		
}			
srb3-ToRelease	Not present		
drb-ToAddModList	Not present		
drb-ToAddModList SEQUENCE (SIZE (1..maxDRB)) OF SEQUENCE {	1 entry		EN-DC
cnAssociation CHOICE {			
eps-BearerIdentity	6		
sdap-Config	Not present		
}			
drb-Identity	DRB-Identity		
reestablishPDCP	Not present		
recoverPDCP	Not present		
pdcpc-Config	PDCP-Config		
}			
drb-ToAddModList SEQUENCE (SIZE (1..maxDRB)) OF SEQUENCE {	1 entry		MCG_NR_P DCP
cnAssociation CHOICE {			
eps-BearerIdentity	5		
sdap-Config	Not present		
}			
drb-Identity	DRB-Identity using condition DRB1		
reestablishPDCP	Not present		
recoverPDCP	Not present		
pdcpc-Config	PDCP-Config		
}			
drb-ToReleaseList	Not present		
securityConfig SEQUENCE {			
securityAlgorithmConfig	SecurityAlgorithmConfig		
keyToUse	s-KgNB keNB		SRB_NR_P DCP
}			
}			

Condition	Explanation
EN-DC	E-UTRA-NR Dual Connectivity
SRB3	Establishment of SRB3
MCG_NR_PDCP	EN-DC MCG DRB configured with NR PDCP
SRB_NR_PDCP	EN-DC SRB1 and SRB2 configured with NR PDCP

– *RadioLinkMonitoringConfig*

Table 4.6.3-101: RadioLinkMonitoringConfig

Derivation Path: TS 38.331 [6], clause 6.3.2			
Information Element	Value/remark	Comment	Condition
RadioLinkMonitoringConfig ::= SEQUENCE {			
failureDetectionResourcesToAddModList	1 entry		
SEQUENCE			
(SIZE(1..maxNrofFailureDetectionResources)) OF			
SEQUENCE {			
radioLinkMonitoringRS-Id	RadioLinkMonitoringRS-Id		
purpose	rlf		
detectionResource CHOICE {			
ssb-Index	SSB-Index		
}			
}			
failureDetectionResourcesToReleaseList	Not present		
beamFailureInstanceMaxCount	Not present		
beamFailureDetectionTimer	Not present		
}			

– *RadioLinkMonitoringRSId*

Table 4.6.3-102: RadioLinkMonitoringRSId

Derivation Path: TS 38.331 [6], clause 6.3.2			
Information Element	Value/remark	Comment	Condition
RadioLinkMonitoringRSId	0		

– *RAN-AreaCode*

Editor's Note: Based on ongoing RAN2 work on CR 100 for TS 38.331, R2-1812411 (CR 100r3).

Table 4.6.3-102A: RAN-AreaCode

Derivation Path: TS 38.331 [6], clause 6.3.2			
Information Element	Value/remark	Comment	Condition
RAN-AreaCode	FFS		

– *RateMatchPattern*

Table 4.6.3-103: RateMatchPattern

Derivation Path: TS 38.331 [6], clause 6.3.2			
Information Element	Value/remark	Comment	Condition
RateMatchPattern ::= SEQUENCE {			
rateMatchPatternId	RateMatchPatternId		
patternType CHOICE {			
controlResourceSet	ControlResourceSetId		
},			
subcarrierSpacing	SubcarrierSpacing		
mode	semiStatic		
}			

– *RateMatchPatternId***Table 4.6.3-104: RateMatchPatternId**

Derivation Path: TS 38.331 [6], clause 6.3.2			
Information Element	Value/remark	Comment	Condition
RateMatchPatternId	0		

– *RateMatchPatternLTE-CRS***Table 4.6.3-105: RateMatchPatternLTE-CRS**

Derivation Path: TS 38.331 [6], clause 6.3.2			
Information Element	Value/remark	Comment	Condition
RateMatchPatternLTE-CRS ::= SEQUENCE {			
FFS			
}			

– *ReportConfigId***Table 4.6.3-106: ReportConfigId**

Derivation Path: TS 38.331 [6], clause 6.3.2			
Information Element	Value/remark	Comment	Condition
ReportConfigId	1		

– *ReportConfigInterRAT*

Editor's Note: Based on ongoing RAN2 work on CR 100 for TS 38.331, R2-1812411 (CR 100r3).

Table 4.6.3-106A: ReportConfigInterRAT

Derivation Path: TS 38.331 [6], clause 6.3.2			
Information Element	Value/remark	Comment	Condition
ReportConfigInterRAT ::= SEQUENCE {			
FFS			
}			

– *ReportConfigNR*

Table 4.6.3-107: *ReportConfigNR*

Derivation Path: TS 38.331 [6], clause 6.3.2			
Information Element	Value/remark	Comment	Condition
ReportConfigNR ::= SEQUENCE {			
reportType CHOICE {			
eventTriggered SEQUENCE {			
eventId CHOICE {			
eventA1 SEQUENCE {			EVENT_A1
a1-Threshold SEQUENCE {			
rsrp	RSRP-Range		
rsrq	RSRQ-Range		
sinr	SINR-Range		
}			
reportOnLeave	[false]	This value is temporarily set in RAN5#79.	
hysteresis	Hysteresis		
timeToTrigger	TimeToTrigger with condition EVENT_A1		
}			
eventA2 SEQUENCE {			EVENT_A2
a2-Threshold SEQUENCE {			
rsrp	RSRP-Range		
rsrq	RSRQ-Range		
sinr	SINR-Range		
}			
reportOnLeave	[false]	This value is temporarily set in RAN5#79.	
hysteresis	Hysteresis		
timeToTrigger	TimeToTrigger		
}			
eventA3 SEQUENCE {			EVENT_A3
a3-Offset SEQUENCE {			
rsrp	4		
}			
reportOnLeave	false		
hysteresis	Hysteresis		
timeToTrigger	TimeToTrigger with condition EVENT_A3		
useWhiteCellList	false		
}			
eventA4 SEQUENCE {			EVENT_A4
a4-Threshold SEQUENCE {			
rsrp	RSRP-Range		
rsrq	RSRQ-Range		
sinr	SINR-Range		
}			
reportOnLeave	[false]	This value is temporarily set in RAN5#79.	
hysteresis	Hysteresis		
timeToTrigger	TimeToTrigger		
useWhiteCellList	[false]	This value is temporarily set in RAN5#79.	
}			
eventA5 SEQUENCE {			EVENT_A5
a5-Threshold1 SEQUENCE {			
rsrp	RSRP-Range		
rsrq	RSRQ-Range		
sinr	SINR-Range		
}			
a5-Threshold2 SEQUENCE {			
rsrp	RSRP-Range		
rsrq	RSRQ-Range		
sinr	SINR-Range		

}			
reportOnLeave	[false]	This value is temporarily set in RAN5#79.	
hysteresis	Hysteresis		
timeToTrigger	TimeToTrigger		
useWhiteCellList	[false]	This value is temporarily set in RAN5#79.	
}			
eventA6 SEQUENCE {			EVENT_A6
a6-Offset SEQUENCE {			
rsrp	[0]	This value is temporarily set in RAN5#79.	
}			
reportOnLeave	[false]	This value is temporarily set in RAN5#79.	
hysteresis	Hysteresis		
timeToTrigger	TimeToTrigger		
useWhiteCellList	[false]	This value is temporarily set in RAN5#79.	
}			
}			
rsType	ssb		
reportInterval	ReportInterval		
reportAmount	r2		
reportQuantityCell SEQUENCE {			
rsrp	true		
rsrq	true		
sinr	true		
}			
maxReportCells	8		
reportQuantityRsIndexes	Not present		
maxNrofRSIndexesToReport	Not present		
includeBeamMeasurements	false		
reportAddNeighMeas	Not present		
}			
}			
}			

Condition	Explanation
EVENT_A1	Configuration of Event A1
EVENT_A2	Configuration of Event A2
EVENT_A3	Configuration of Event A3
EVENT_A4	Configuration of Event A4
EVENT_A5	Configuration of Event A5
EVENT_A6	Configuration of Event A6

– *ReportConfigToAddModList***Table 4.6.3-108: ReportConfigToAddModList**

Derivation Path: TS 38.331 [6], clause 6.3.2			
Information Element	Value/remark	Comment	Condition
ReportConfigToAddModList ::= SEQUENCE(SIZE (1..maxReportConfigId)) OF SEQUENCE {	1 entry		
reportConfigId[1]	ReportConfigId		
reportConfig[1] CHOICE {			
reportConfigNR	ReportConfigNR		
}			
}			

– *ReportInterval***Table 4.6.3-109: ReportInterval**

Derivation Path: TS 38.331 [6], clause 6.3.2			
Information Element	Value/remark	Comment	Condition
ReportInterval	ms480		

– *ReselectionThreshold*

Editor's Note: Based on ongoing RAN2 work on CR 100 for TS 38.331, R2-1812411 (CR 100r3).

Table 4.6.3-109A: ReselectionThreshold

Derivation Path: TS 38.331 [6], clause 6.3.2			
Information Element	Value/remark	Comment	Condition
ReselectionThreshold	FFS		

– *ReselectionThresholdQ*

Editor's Note: Based on ongoing RAN2 work on CR 100 for TS 38.331, R2-1812411 (CR 100r3).

Table 4.6.3-109B: ReselectionThresholdQ

Derivation Path: TS 38.331 [6], clause 6.3.2			
Information Element	Value/remark	Comment	Condition
ReselectionThresholdQ	FFS		

– *ResumeCause*

Editor's Note: Based on ongoing RAN2 work on CR 100 for TS 38.331, R2-1812411 (CR 100r3).

Table 4.6.3-109C: ReselectionThresholdQ

Derivation Path: TS 38.331 [6], clause 6.3.2			
Information Element	Value/remark	Comment	Condition
ResumeCause	FFS		

– *RLC-Bearer-Config***Table 4.6.3-110: RLC-Bearer-Config**

Derivation Path: TS 38.331 [6], clause 6.3.2			
Information Element	Value/remark	Comment	Condition
RLC-Bearer-Config ::= SEQUENCE {			
logicalChannelIdentity[1]	LogicalChannelIdentity		
servedRadioBearer[1] CHOICE {			
drb-Identity	DRB-Identity		
}			
reestablishRLC[1]	Not present		
RLC-Config[1]	RLC-Config using condition AM		AM
	RLC-Config using condition UM.		UM
mac-LogicalChannelConfig[1]	LogicalChannelConfig using condition HI		AM
	LogicalChannelConfig using condition LO		UM
}			

Condition	Explanation
AM	RLC AM
UM	RLC UM

RLC-Config

Table 4.6.3-111: RLC-Config

Derivation Path: TS 38.331 [6], clause 6.3.2			
Information Element	Value/remark	Comment	Condition
RLC-Config ::= CHOICE {			
am SEQUENCE {			AM
ul-AM-RLC SEQUENCE {			
sn-FieldLength	size18		
t-PollRetransmit	ms30		FR1
	ms80		FR2
pollPDU	p32768		
pollByte	mB18		
maxRetxThreshold	t8		
}			
dl-AM-RLC SEQUENCE {			
sn-FieldLength	size18		
t-Reassembly	ms30		FR1
	ms80		FR2
t-StatusProhibit	ms30		
}			
}			
am SEQUENCE {		9.2.1.3 /TS 36.331	SRB3
ul-AM-RLC SEQUENCE {			
sn-FieldLength	size18		
t-PollRetransmit	ms30		FR1
	ms80		FR2
pollPDU	p32768		
pollByte	mB18		
maxRetxThreshold	t8		
}			
dl-AM-RLC SEQUENCE {			
sn-FieldLength	size18		
t-Reassembly	ms30		FR1
	ms80		FR2
t-StatusProhibit	ms30		
}			
}			
um-Bi-Directional SEQUENCE {			UM
ul-UM-RLC SEQUENCE {			
sn-FieldLength	size12		pc_um_With LongSN
	size6		NOT pc_um_With LongSN AND pc_um_With ShortSN
}			
dl-UM-RLC SEQUENCE {			
sn-FieldLength	size12		pc_um_With LongSN
	size6		NOT pc_um_With LongSN AND pc_um_With ShortSN
t-Reassembly	[ms30]		FR1
	[ms80]		FR2
}			
}			
}			

Condition	Explanation
AM	RLC AM
UM	RLC UM
SRB3	Establishment of SRB3

– *RLF-TimersAndConstants*

Table 4.6.3-112: RLF-TimersAndConstants

Derivation Path: TS 38.331 [6], clause 6.3.2			
Information Element	Value/remark	Comment	Condition
RLF-TimersAndConstants ::= SEQUENCE {			
t310	ms1000		
n310	n1		
n311	n1		
}			

– *RNTI-Value*

Table 4.6.3-113: RNTI-Value

Derivation Path: TS 38.331 [6], clause 6.3.2			
Information Element	Value/remark	Comment	Condition
RNTI-Value	0		

– *RSRP-Range*

Table 4.6.3-114: RSRP-Range

Derivation Path: TS 38.331 [6], clause 6.3.2			
Information Element	Value/remark	Comment	Condition
RSRP-Range	[0]	Mapping table is not yet specified in 38.133. This value is temporarily set in RAN5#79.	

– *RSRQ-Range*

Table 4.6.3-115: RSRQ-Range

Derivation Path: TS 38.331 [6], clause 6.3.2			
Information Element	Value/remark	Comment	Condition
RSRQ-Range	[0]	Mapping table is not yet specified in 38.133. This value is temporarily set in RAN5#79.	

– *SCellIndex*

Table 4.6.3-116: SCellIndex

Derivation Path: TS 38.331 [6], clause 6.3.2			
Information Element	Value/remark	Comment	Condition
SCellIndex	1		

– *SchedulingRequestConfig***Table 4.6.3-117: SchedulingRequestConfig**

Derivation Path: TS 38.331 [6], clause 6.3.2			
Information Element	Value/remark	Comment	Condition
SchedulingRequestConfig ::= SEQUENCE { schedulingRequestToAddModList (SIZE(1..maxNrofSR-ConfigPerCellGroup)) OF SEQUENCE {	1 entry		
schedulingRequestId	SchedulingRequestId		
sr-ProhibitTimer	Not present		
sr-TransMax	n16		
}			
schedulingRequestToReleaseList	Not present		
}			

– *SchedulingRequestId***Table 4.6.3-117A: SchedulingRequestId**

Derivation Path: TS 38.331 [6], clause 6.3.2			
Information Element	Value/remark	Comment	Condition
SchedulingRequestId	0		

– *SchedulingRequestResourceConfig***Table 4.6.3-118: SchedulingRequestResourceConfig**

Derivation Path: TS 38.331 [6], clause 6.3.2			
Information Element	Value/remark	Comment	Condition
SchedulingRequestResourceConfig ::= SEQUENCE {			
schedulingRequestResourceCellId	SchedulingRequestResourceCellId		
schedulingRequestID	0		
periodicityAndOffset CHOICE {			
sym2	NULL		
}			
resource	0		
}			

– *SchedulingRequestResourceCellId***Table 4.6.3-119: SchedulingRequestResourceCellId**

Derivation Path: TS 38.331 [6], clause 6.3.2			
Information Element	Value/remark	Comment	Condition
SchedulingRequestResourceCellId	1		

– *ScramblingId***Table 4.6.3-120: ScramblingId**

Derivation Path: TS 38.331 [6], clause 6.3.2			
Information Element	Value/remark	Comment	Condition
ScramblingId	0		

– *SCS-SpecificCarrier***Table 4.6.3-121: SCS-SpecificCarrier**

Derivation Path: TS 38.331 [6], clause 6.3.2			
Information Element	Value/remark	Comment	Condition
SCS-SpecificCarrier ::= SEQUENCE {			
offsetToCarrier	Set to value of offset point to carrier in clause 4.3.1 for the carrier and subcarrier spacing under test.		
subcarrierSpacing	SubcarrierSpacing		
carrierBandwidth	Set to value of the number of RBs correspondent to 10 MHz channel bandwidth in clause 4.3.1 for the carrier and subcarrier under test.		
}			

– *SDAP-Config***Table 4.6.3-122: SDAP-Config**

Derivation Path: TS 38.331 [6], clause 6.3.2			
Information Element	Value/remark	Comment	Condition
SDAP-Config ::= SEQUENCE {			
FFS			
}			

SearchSpace

Table 4.6.3-123: SearchSpace

Derivation Path: TS 38.331 [6], clause 6.3.2			
Information Element	Value/remark	Comment	Condition
SearchSpace ::= SEQUENCE {			
searchSpaceId	SearchSpaceId with condition CSS		CSS
	SearchSpaceId with condition USS		USS
controlResourceSetId	ControlResourceSetId		
monitoringSlotPeriodicityAndOffset CHOICE {			
sl1	NULL		
}			
duration	Not present	1 slot per default	
monitoringSymbolsWithinSlot	10000000000000		
nrofCandidates SEQUENCE {			
aggregationLevel1	n0		
aggregationLevel2	n8		
	n2		FR1_5MHz OR FR1_10MHz
aggregationLevel4	n8		
	[n1]		FR1_5MHz OR FR1_10MHz
	[n2]		FR2_100MHz
aggregationLevel8	[n8]		
	[n6]		FR1_60MHz
	[n0]		FR1_5MHz OR FR1_10MHz
	[n1]		FR2_100MHz
aggregationLevel16	n0		
}			
searchSpaceType CHOICE {			
common SEQUENCE {			CSS
dci-Format0-0-AndFormat1-0 SEQUENCE {			
}			
dci-Format2-0	Not present		
dci-Format2-1	Not present		
dci-Format2-2	Not present		
dci-Format2-3	Not present		
}			
ue-Specific SEQUENCE {			USS
dci-Formats	formats0-0-And-1-0		
}			
}			
}			

Condition	Explanation
FR1_5MHz	FR1 is used under the test. CBW is set to 5MHz.
FR1_10MHz	FR1 is used under the test. CBW is set to 10MHz.
FR1_60MHz	FR1 is used under the test. CBW is set to 60MHz.
FR1_80MHz	FR1 is used under the test. CBW is set to 80MHz.
FR1_100MHz	FR1 is used under the test. CBW is set to 100MHz.
FR2_100MHz	FR2 is used under the test. CBW is set to 100MHz.
CSS	Common SearchSpace
USS	UE-Specific SearchSpace

Table 4.6.3-124: Void

– *SearchSpaceId*Table 4.6.3-125: *SearchSpaceId*

Derivation Path: TS 38.331 [6], clause 6.3.2			
Information Element	Value/remark	Comment	Condition
SearchSpaceId	1		CSS
	2		USS

Condition	Explanation
CSS	Common SearchSpace
USS	UE-Specific SearchSpace

– *SearchSpaceZero*

Editor's Note: Based on ongoing RAN2 work on CR 100 for TS 38.331, R2-1812411 (CR 100r3).

Table 4.6.3-125A: *SearchSpaceZero*

Derivation Path: TS 38.331 [6], clause 6.3.2			
Information Element	Value/remark	Comment	Condition
SearchSpaceZero	FFS		

– *SecurityAlgorithmConfig*Table 4.6.3-126: *SecurityAlgorithmConfig*

Derivation Path: TS 38.331 [6], clause 6.3.2			
Information Element	Value/remark	Comment	Condition
SecurityAlgorithmConfig ::= SEQUENCE {			
cipherringAlgorithm	nea2		
integrityProtAlgorithm	nia2		
}			

– *ServCellIndex*Table 4.6.3-127: *ServCellIndex*

Derivation Path: TS 38.331 [6], clause 6.3.2			
Information Element	Value/remark	Comment	Condition
ServCellIndex	0		

ServingCellConfig

Table 4.6.3-128: ServingCellConfig

Derivation Path: TS 38.331 [6], clause 6.3.2			
Information Element	Value/remark	Comment	Condition
ServingCellConfig ::= SEQUENCE {			
tdd-UL-DL-ConfigurationDedicated	Not present		
initialDownlinkBWP	BWP-DownlinkDedicated		
downlinkBWP-ToReleaseList	Not present		
downlinkBWP-ToAddModList	Not present		
firstActiveDownlinkBWP-Id	BWP-Id		
bwp-InactivityTimer	Not present		
defaultDownlinkBWP-Id	BWP-Id		
uplinkConfig SEQUENCE {			
initialUplinkBWP	BWP-UplinkDedicated		
uplinkBWP-ToReleaseList	Not present		
uplinkBWP-ToAddModList	Not present		
firstActiveUplinkBWP-Id	BWP-Id		
pusch-ServingCellConfig CHOICE {			
setup	PUSCH-ServingCellConfig		
}			
carrierSwitching	Not present		
}			
supplementaryUplink	Not present		
pdcch-ServingCellConfig CHOICE {			
setup	PDCCH-ServingCellConfig		
}			
pdsch-ServingCellConfig CHOICE {			
setup	PDSCH-ServingCellConfig		
}			
csi-MeasConfig	Not present		
sCellDeactivationTimer	Not present		
crossCarrierSchedulingConfig	Not present		
tag-Id	0		
ue-BeamLockFunction	Not present		
pathlossReferenceLinking	pCell		
servingCellMO	MeasObjectId		
}			

– *ServingCellConfigCommon*

Table 4.6.3-129: ServingCellConfigCommon

Derivation Path: TS 38.331 [6], clause 6.3.2			
Information Element	Value/remark	Comment	Condition
ServingCellConfigCommon ::= SEQUENCE {			
physCellId	PhysCellId		
downlinkConfigCommon	DownlinkConfigCommon		
uplinkConfigCommon	UplinkConfigCommon		
supplementaryUplinkConfig	Not present		
n-TimingAdvanceOffset	Not present		
ssb-PositionsInBurst CHOICE {			
shortBitmap	0100		FREQ<=3G Hz
mediumBitmap	01000000		FR1 and FREQ>3GHz
}			
ssb-periodicityServingCell	ms20		
dmrs-TypeA-Position	pos2		
lte-CRS-ToMatchAround	Not present		
rateMatchPatternToAddModList	Not present		
rateMatchPatternToReleaseList	Not present		
subcarrierSpacing	Not present		
tdd-UL-DL-ConfigurationCommon	TDD-UL-DL-ConfigCommon		FR1_TDD, FR2_TDD
ss-PBCH-BlockPower	[0]		
}			

Condition	Explanation
FREQ<=3GHz	Frequency range <= 3GHz
FREQ>3GHz	Frequency range > 3GHz
FR1_TDD	TDD frequency range < 6GHz
FR2_TDD	TDD frequency range > 6GHz

– *ServingCellConfigCommonSIB*

Editor's Note: Based on ongoing RAN2 work on CR 100 for TS 38.331, R2-1812411 (CR 100r3).

Table 4.6.3-129A: ServingCellConfigCommonSIB

Derivation Path: TS 38.331 [6], clause 6.3.2			
Information Element	Value/remark	Comment	Condition
ServingCellConfigCommonSIB ::= SEQUENCE {			
FFS			
}			

– *ShortI-RNTI-Value*

Editor's Note: Based on ongoing RAN2 work on CR 100 for TS 38.331, R2-1812411 (CR 100r3).

Table 4.6.3-129B: ShortI-RNTI-Value

Derivation Path: TS 38.331 [6], clause 6.3.2			
Information Element	Value/remark	Comment	Condition
ShortI-RNTI-Value	FFS		

– *SINR-Range***Table 4.6.3-130: SINR-Range**

Derivation Path: TS 38.331 [6], clause 6.3.2			
Information Element	Value/remark	Comment	Condition
SINR-Range	[0]	Mapping table is not yet specified in 38.133. This value is temporarily set in RAN5#79.	

– *SI-SchedulingInfo*

Editor's Note: Based on ongoing RAN2 work on CR 100 for TS 38.331, R2-1812411 (CR 100r3).

Table 4.6.3-130A: SI-SchedulingInfo

Derivation Path: TS 38.331 [6], clause 6.3.2			
Information Element	Value/remark	Comment	Condition
SI-SchedulingInfo ::= SEQUENCE {			
FFS			
}			

– *SlotFormatCombinationsPerCell***Table 4.6.3-131: SlotFormatCombinationsPerCell**

Derivation Path: TS 38.331 [6], clause 6.3.2			
Information Element	Value/remark	Comment	Condition
SlotFormatCombinationsPerCell ::= SEQUENCE {			
FFS			
}			

– *SlotFormatIndicator***Table 4.6.3-132: SlotFormatIndicator**

Derivation Path: TS 38.331 [6], clause 6.3.2			
Information Element	Value/remark	Comment	Condition
SlotFormatIndicator ::= SEQUENCE {			
FFS			
}			

– *S-NSSAI*

Editor's Note: Based on ongoing RAN2 work on CR 100 for TS 38.331, R2-1812411 (CR 100r3).

Table 4.6.3-132A: S-NSSAI

Derivation Path: TS 38.331 [6], clause 6.3.2			
Information Element	Value/remark	Comment	Condition
S-NSSAI ::= CHOICE {			
FFS			
}			

– *SpeedStateScaleFactors*

Editor's Note: Based on ongoing RAN2 work on CR 100 for TS 38.331, R2-1812411 (CR 100r3).

Table 4.6.3-132B: SpeedStateScaleFactors

Derivation Path: TS 38.331 [6], clause 6.3.2			
Information Element	Value/remark	Comment	Condition
SpeedStateScaleFactors ::= SEQUENCE {			
FFS			
}			

– *SS-RSSI-Measurement***Table 4.6.3-132C: SS-RSSI-Measurement**

Derivation Path: TS 38.331 [6], clause 6.3.2			
Information Element	Value/remark	Comment	Condition
SS-RSSI-Measurement ::= SEQUENCE {			
FFS			
}			

– *SPS-Config***Table 4.6.3-133: SPS-Config**

Derivation Path: TS 38.331 [6], clause 6.3.2			
Information Element	Value/remark	Comment	Condition
SPS-Config ::= SEQUENCE {			
FFS			
}			

– *SRB-Identity***Table 4.6.3-134: SRB-Identity**

Derivation Path: TS 38.331 [6], clause 6.3.2			
Information Element	Value/remark	Comment	Condition
SRB-Identity	1		SRB1
	2		SRB2
	3		SRB3

Condition	Explanation
SRB1	SRB1
SRB2	SRB2
SRB3	SRB3

– *SRS-Config*

Table 4.6.3-135: *SRS-Config*

Derivation Path: TS 38.331 [6], clause 6.3.2			
Information Element	Value/remark	Comment	Condition
SRS-Config ::= SEQUENCE {			
srs-ResourceSetToReleaseList	Not present		
srs-ResourceSetToAddModList SEQUENCE (SIZE(0..maxNrofSRS-ResourceSets)) OF SEQUENCE {	[1 entry]		
srs-ResourceSetId	0		
srs-ResourceIdList SEQUENCE (SIZE(1..maxNrofSRS-ResourcesPerSet)) OF {	1 entry		
SRS-ResourceId[1]	0		
}			
resourceType CHOICE {			
aperiodic SEQUENCE {			
aperiodicSRS-ResourceTrigger	1		
csi-RS	Not present		
slotOffset	7		FR1
	4		FR2
}			
}			
usage	codebook		
alpha	Alpha		
p0	0		
pathlossReferenceRS CHOICE {			
ssb-Index	SSB-Index		
}			
srs-PowerControlAdjustmentStates	Not present		
}			
srs-ResourceToReleaseList	Not present		
srs-ResourceToAddModList SEQUENCE (SIZE(1..maxNrofSRS-Resources)) OF SEQUENCE {	1 entry		
srs-ResourceId	0		
nrofSRS-Ports	ports4		FR1
	ports2		FR2
ptrs-PortIndex	Not present		
transmissionComb CHOICE {			
n2 SEQUENCE {			
combOffset-n2	0		
cyclicShift-n2	0		
}			
}			
resourceMapping SEQUENCE {			
startPosition	0		
nrofSymbols	n1		
repetitionFactor	n1		
}			
freqDomainPosition	0		
freqDomainShift	0		
freqHopping SEQUENCE {			
c-SRS	63		FR1_100MH z
	17		FR2_100MH z
b-SRS	0		
b-hop	0		
}			
groupOrSequenceHopping	groupHopping		
resourceType CHOICE {			
aperiodic SEQUENCE {		In the TS 38.331 ver 15.2.1, there is no IE in aperiodic.	
}			
}			
sequenceld	0000000000		
spatialRelationInfo SEQUENCE {	SRS-SpatialRelationInfo		

servingCellId	Not present		
referenceSignal CHOICE {			
ssb-Index	SSB-Index		
}			
}			
tpc-Accumulation	Not present		
}			

– *SRS-CarrierSwitching*

Table 4.6.3-136: SRS-CarrierSwitching

Derivation Path: TS 38.331 [6], clause 6.3.2			
Information Element	Value/remark	Comment	Condition
SRS-CarrierSwitching ::= SEQUENCE {			
FFS			
}			

– *SRS-TPC-CommandConfig*

Table 4.6.3-137: SRS-TPC-CommandConfig

Derivation Path: TS 38.331 [6], clause 6.3.2			
Information Element	Value/remark	Comment	Condition
SRS-TPC-CommandConfig ::= SEQUENCE {			
FFS			
}			

– *SSB-Index*

Table 4.6.3-138: SSB-Index

Derivation Path: TS 38.331 [6], clause 6.3.2			
Information Element	Value/remark	Comment	Condition
SSB-Index	0		

– *SSB-MTC*

Table 4.6.3-138A: SSB-MTC

Derivation Path: TS 38.331 [6], clause 6.3.2			
Information Element	Value/remark	Comment	Condition
SSB-MTC ::= SEQUENCE {			
periodicityAndOffset CHOICE {			
sf20	0		FR1
sf160	0		FR2
}			
duration	sf2		FR1
	sf3		FR2
}			

Table 4.6.3-138B: SSB-MTC2

Derivation Path: TS 38.331 [6], clause 6.3.2			
Information Element	Value/remark	Comment	Condition
SSB-MTC2 ::= SEQUENCE {			
FFS			
}			

– *SSB-ToMeasure*

Editor's Note: Based on ongoing RAN2 work on CR 100 for TS 38.331, R2-1812411 (CR 100r3).

Table 4.6.3-138C: *SSB-ToMeasure*

Derivation Path: TS 38.331 [6], clause 6.3.2			
Information Element	Value/remark	Comment	Condition
SSB-ToMeasure ::= CHOICE {			
FFS			
}			

– *SubcarrierSpacing*Table 4.6.3-139: *SubcarrierSpacing*

Derivation Path: TS 38.331 [6], clause 6.3.2			
Information Element	Value/remark	Comment	Condition
SubcarrierSpacing	kHz15		FR1_FDD
	kHz30		FR1_TDD
	[kHz120]		FR2_TDD

Condition	Explanation
FR1_FDD	FDD frequency range < 6GHz
FR1_TDD	TDD frequency range < 6GHz
FR2_TDD	TDD frequency range > 6GHz

– *TCI-State*Table 4.6.3-140: *TCI-State*

Derivation Path: TS 38.331 [6], clause 6.3.2			
Information Element	Value/remark	Comment	Condition
TCI-State ::= SEQUENCE {			
tci-StateId	TCI-StateId		
qcl-Type1 SEQUENCE {			
cell	Not present		
bwp-Id	Not present		
referenceSignal CHOICE {			
ssb	SSB-Index		
}			
qcl-Type	typeD		
}			
qcl-Type2	Not present		
}			

– *TCI-StateId*Table 4.6.3-141: *TCI-StateId*

Derivation Path: TS 38.331 [6], clause 6.3.2			
Information Element	Value/remark	Comment	Condition
TCI-StateId	0		

– *TDD-UL-DL-Config***Table 4.6.3-142: TDD-UL-DL-Config**

Derivation Path: TS 38.331 [6], clause 6.3.2			
Information Element	Value/remark	Comment	Condition
TDD-UL-DL-ConfigCommon ::= SEQUENCE {			
referenceSubcarrierSpacing	SubcarrierSpacing		
pattern1 SEQUENCE {			
dl-UL-TransmissionPeriodicity	ms5		FR1
	ms0p625		FR2
nrofDownlinkSlots	7		FR1
	4		FR2
nrofDownlinkSymbols	6		FR1
	12		FR2
nrofUplinkSlots	2		FR1
	1		FR2
nrofUplinkSymbols	4		FR1
	0		FR2
}			
pattern2	Not present		
}			

– *TrackingAreaCode*

Editor's Note: Based on ongoing RAN2 work on CR 100 for TS 38.331, R2-1812411 (CR 100r3).

Table 4.6.3-142A: TrackingAreaCode

Derivation Path: TS 38.331 [6], clause 6.3.2			
Information Element	Value/remark	Comment	Condition
TrackingAreaCode	FFS		

– *T-Reselection*

Editor's Note: Based on ongoing RAN2 work on CR 100 for TS 38.331, R2-1812411 (CR 100r3).

Table 4.6.3-142B: T-Reselection

Derivation Path: TS 38.331 [6], clause 6.3.2			
Information Element	Value/remark	Comment	Condition
T-Reselection	FFS		

– *TimeToTrigger***Table 4.6.3-143: TimeToTrigger**

Derivation Path: TS 38.331 [6], clause 6.3.2			
Information Element	Value/remark	Comment	Condition
TimeToTrigger	[ms0]		EVENT_A1
	ms320		EVENT_A3

Condition	Explanation
EVENT_A1	Configuration of Event A1
EVENT_A3	Configuration of Event A3

– *UplinkConfigCommon***Table 4.6.3-143A: UplinkConfigCommon**

Derivation Path: TS 38.331 [6], clause 6.3.2			
Information Element	Value/remark	Comment	Condition
UplinkConfigCommon ::= SEQUENCE {			
frequencyInfoUL	FrequencyInfoUL		
initialUplinkBWP	BWP-UplinkCommon		
timeAlignmentTimerCommon	infinity		
}			

– *UplinkTxDirectCurrentList*

Editor's Note: Based on ongoing RAN2 work on CR 100 for TS 38.331, R2-1812411 (CR 100r3).

Table 4.6.3-143B: UplinkTxDirectCurrentList

Derivation Path: TS 38.331 [6], clause 6.3.2			
Information Element	Value/remark	Comment	Condition
UplinkTxDirectCurrentList ::= SEQUENCE (SIZE (1..maxNrofServingCells)) OF SEQUENCE {			
FFS			
}			

– *UE-TimersAndConstants*

Editor's Note: Based on ongoing RAN2 work on CR 100 for TS 38.331, R2-1812411 (CR 100r3).

Table 4.6.3-143C: UE-TimersAndConstants

Derivation Path: TS 38.331 [6], clause 6.3.2			
Information Element	Value/remark	Comment	Condition
UE-TimersAndConstants ::= SEQUENCE {			
FFS			
}			

– *ZP-CSI-RS-Resource***Table 4.6.3-144: ZP-CSI-RS-Resource**

Derivation Path: TS 38.331 [6], clause 6.3.2			
Information Element	Value/remark	Comment	Condition
ZP-CSI-RS-Resource ::= SEQUENCE {			
zp-CSI-RS-ResourceId	ZP-CSI-RS-ResourceId		
resourceMapping	CSI-RS-ResourceMapping		
periodicityAndOffset	CSI-ResourcePeriodicityAndOffset		
}			

– *ZP-CSI-RS-ResourceSet***Table 4.6.3-145: ZP-CSI-RS-ResourceSet**

Derivation Path: TS 38.331 [6], clause 6.3.2			
Information Element	Value/remark	Comment	Condition
ZP-CSI-RS-ResourceSet ::= SEQUENCE {			
zp-CSI-RS-ResourceSetId	ZP-CSI-RS-ResourceSetId		
zp-CSI-RS-ResourceSetIdList SEQUENCE (SIZE(1..maxNrofZP-CSI-RS-ResourcesPerSet)) OF {	1 entry		
ZP-CSI-RS-ResourceSetId [1]	FFS		
}			
}			

– *ZP-CSI-RS-ResourceSetId***Table 4.6.3-146: ZP-CSI-RS-ResourceSetId**

Derivation Path: TS 38.331 [6], clause 6.3.2			
Information Element	Value/remark	Comment	Condition
ZP-CSI-RS-ResourceSetId	FFS		

4.6.4 UE capability information elements

Editor's Note: Updated based on R2-1806391 Merged CR to 38331.

– *AccessStratumRelease***Table 4.6.4-1: AccessStratumRelease**

Derivation Path: TS 38.331 [6], clause 6.3.3			
Information Element	Value/remark	Comment	Condition
AccessStratumRelease	Same as indicated in TC applicability in TS 38.523-2 [19]		

– *BandCombinationList***Table 4.6.4-2: BandCombinationList**

Derivation Path: TS 38.331 [6], clause 6.3.3			
Information Element	Value/remark	Comment	Condition
BandCombinationList ::= SEQUENCE (SIZE (1..maxBandComb)) OF SEQUENCE {	1 entry		
bandList[1] SEQUENCE (SIZE (1..maxSimultaneousBands)) OF CHOICE {			
eutra SEQUENCE {			
bandEUTRA	FreqBandIndicatorEUTRA		
ca-BandwidthClassDL-EUTRA	CA-BandwidthClassEUTRA		
ca-BandwidthClassUL-EUTRA	CA-BandwidthClassEUTRA		
}			
nr SEQUENCE {			
bandNR	FreqBandIndicatorNR		
ca-BandwidthClassDL-NR	CA-BandwidthClassNR		
ca-BandwidthClassUL-NR	CA-BandwidthClassNR		
}			
featureSetCombination	FeatureSetCombinationId		
ca-ParametersEUTRA	CA-ParametersEUTRA		
ca-ParametersNR	CA-ParametersNR		
mrdc-Parameters	MRDC-Parameters		
supportedBandwidthCombinationSet	BIT STRING (SIZE (1..32))		

Table 4.6.4-3: Void**Table 4.6.4-4: Void****Table 4.6.4-5: Void**– *CA-BandwidthClassNR***Table 4.6.4-6: CA-BandwidthClassNR**

Derivation Path: TS 38.331 [6], clause 6.3.3			
Information Element	Value/remark	Comment	Condition
CA-BandwidthClassNR	[Not checked]		

– *CA-BandwidthClassEUTRA***Table 4.6.4-7: CA-BandwidthClassEUTRA**

Derivation Path: TS 38.331 [6], clause 6.3.3			
Information Element	Value/remark	Comment	Condition
CA-BandwidthClassEUTRA	[Not checked]		

– CA-ParametersNR

Table 4.6.4-7a: CA- ParametersNR

Derivation Path: TS 38.331 [6], clause 6.3.3			
Information Element	Value/remark	Comment	Condition
CA-ParametersNR ::= SEQUENCE {			
multipleTimingAdvances	[Not checked]		
parallelTxSRS-PUCCH-PUSCH	[Not checked]		
parallelTxPRACH-SRS-PUCCH-PUSCH	[Not checked]		
simultaneousRxTxInterBandCA	[Not checked]		
simultaneousRxTxSUL	[Not checked]		
diffNumerologyAcrossPUCCH-Group	[Not checked]		
diffNumerologyWithinPUCCH-Group	[Not checked]		
supportedNumberTAG	[Not checked]		
}			

– CA-ParametersEUTRA

Table 4.6.4-7b: CA- ParametersEUTRA

Derivation Path: TS 38.331 [6], clause 6.3.3			
Information Element	Value/remark	Comment	Condition
CA-ParametersEUTRA ::= SEQUENCE {			
multipleTimingAdvance	[Not checked]		
simultaneousRx-Tx	[Not checked]		
supportedNAICS-2CRS-AP	[Not checked]		
additionalRx-Tx-PerformanceReq	[Not checked]		
ue-CA-PowerClass-N	[Not checked]		
}			

– FeatureSetCombination

Table 4.6.4-7c: FeatureSetCombination

Derivation Path: TS 38.331 [6], clause 6.3.3			
Information Element	Value/remark	Comment	Condition
FeatureSetCombination ::= SEQUENCE (SIZE (1..maxSimultaneousBands)) OF SEQUENCE (SIZE (1..maxFeatureSetsPerBand) CHOICE {			
eutra SEQUENCE {			
downlinkSetEUTRA	[Not checked]		
uplinkSetEUTRA	[Not checked]		
}			
nr SEQUENCE {			
downlinkSetNR	[Not checked]		
uplinkSetNR	[Not checked]		
}			
}			

– FeatureSetCombinationId

Table 4.6.4-7d: FeatureSetCombinationId

Derivation Path: TS 38.331 [6], clause 6.3.3			
Information Element	Value/remark	Comment	Condition
FeatureSetCombinationId	[Not checked]		

– *FeatureSetDownlink*

Table 4.6.4-7e: FeatureSetDownlink

Derivation Path: TS 38.331 [6], clause 6.3.3			
Information Element	Value/remark	Comment	Condition
FeatureSetDownlink ::= SEQUENCE {			
featureSetListPerDownlinkCC SEQUENCE (SIZE (1..maxNrofServingCells)) OF			
FeatureSetDownlinkPerCC-Id[1]	[Not checked]		
intraBandFreqSeparationDL	FreqSeparationClass		
scalingFactor	[Not checked]		
crossCarrierSchedulingDL-OtherSCS	[Not checked]		
scellWithoutSSB	[Not checked]		
csi-RS-MeasSCellWithoutSSB	[Not checked]		
srs-AssocCSI-RS	[Not checked]		
type1-3-CSS	[Not checked]		
pdcchMonitoringAnyOccasions	[Not checked]		
pdcchMonitoringAnyOccasionsWithSpanGap	[Not checked]		
ue-SpecificUL-DL-Assignment	[Not checked]		
searchSpaceSharingCA-DL	[Not checked]		
timeDurationForQCL SEQUENCE {			
scs-60kHz	[Not checked]		
sch-120kHz	[Not checked]		
}			
pdsch-DifferentTB-PerSlot SEQUENCE {			
scs-15kHz	[Not checked]		
scs-30kHz	[Not checked]		
scs-60kHz	[Not checked]		
scs-120kHz	[Not checked]		
}			
csi-RS-IM-ReceptionForFeedback SEQUENCE {			
maxNumberNZP-CSI-RS-PerCC	[Not checked]		
maxNumberPortsAcrossNZP-CSI-RS-PerCC	[Not checked]		
maxNumberCS-IM-PerCC	[Not checked]		
maxNumberSimultaneousCSI-RS-ActBWP-AIICC	[Not checked]		
totalNumberPortsSimultaneousCSI-RS-ActBWP-AIICC	[Not checked]		
}			
typeI-SinglePanelCodebookList SEQUENCE (SIZE (1.. maxNrofCodebooks)) OF SEQUENCE {			
maxNumberTxPortsPerResource[1]	[Not checked]		
maxNumberResources[1]	[Not checked]		
totalNumberTxPorts[1]	[Not checked]		
supportedCodebookMode[1]	[Not checked]		
maxNumberCSI-RS-PerResourceSet[1]	[Not checked]		
}			
typeI-MultiPanelCodebookList SEQUENCE (SIZE (1.. maxNrofCodebooks)) OF SEQUENCE {			
maxNumberTxPortsPerResource[1]	[Not checked]		
maxNumberResources[1]	[Not checked]		
totalNumberTxPorts[1]	[Not checked]		
supportedCodebookMode[1]	[Not checked]		
supportedNumberPanels[1]	[Not checked]		
maxNumberCSI-RS-PerResourceSet[1]	[Not checked]		
}			
typeII-CodebookList SEQUENCE (SIZE (1.. maxNrofCodebooks)) OF SEQUENCE {			
maxNumberTxPortsPerResource[1]	[Not checked]		
maxNumberResources[1]	[Not checked]		
totalNumberTxPorts[1]	[Not checked]		
parameterLx[1]	[Not checked]		
amplitudeScalingType[1]	[Not checked]		
amplitudeSubsetRestriction[1]	[Not checked]		
maxNumberCSI-RS-PerResourceSet[1]	[Not checked]		
}			
typeII-CodebookPortSelectionList SEQUENCE (SIZE (1.. maxNrofCodebooks)) OF SEQUENCE {			
maxNumberTxPortsPerResource[1]	[Not checked]		
maxNumberResources[1]	[Not checked]		

totalNumberTxPorts[1]	[Not checked]		
parameterLx[1]	[Not checked]		
amplitudeScalingType[1]	[Not checked]		
maxNumberCSI-RS-PerResourceSet[1]	[Not checked]		
}			
}			

– *FeatureSetDownlinkId*

Table 4.6.4-7e: FeatureSetDownlinkId

Derivation Path: TS 38.331 [6], clause 6.3.3			
Information Element	Value/remark	Comment	Condition
FeatureSetDownlinkId	[Not checked]		

– *FeatureSetEUTRA-DownlinkId*

Table 4.6.4-7f: FeatureSetEUTRA-DownlinkId

Derivation Path: TS 38.331 [6], clause 6.3.3			
Information Element	Value/remark	Comment	Condition
FeatureSetEUTRA-DownlinkId	[Not checked]		

– *FeatureSetDownlinkPerCC*

Table 4.6.4-7g: FeatureSetDownlinkPerCC

Derivation Path: TS 38.331 [6], clause 6.3.3			
Information Element	Value/remark	Comment	Condition
FeatureSetDownlinkPerCC ::= SEQUENCE {			
supportedSubcarrierSpacingDL	SubcarrierSpacing		
supportedBandwidthDL	SupportedBandwidth		
channelBW-90mhz	[Not checked]		
maxNumberMIMO-LayersPDSCH	MIMO-LayersDL		
supportedModulationOrderDL	ModulationOrder		
}			

– *FeatureSetDownlinkPerCC-Id*

Table 4.6.4-7h: FeatureSetDownlinkPerCC-Id

Derivation Path: TS 38.331 [6], clause 6.3.3			
Information Element	Value/remark	Comment	Condition
FeatureSetDownlinkPerCC-Id	[Not checked]		

– *FeatureSetUplink*

Table 4.6.4-7i: FeatureSetUplink

Derivation Path: TS 38.331 [6], clause 6.3.3			
Information Element	Value/remark	Comment	Condition
FeatureSetUplink ::= SEQUENCE {			
featureSetListPerUplinkCC SEQUENCE (SIZE (1.. maxNrofServingCells)) OF FeatureSetUplinkPerCC-Id			
FeatureSetUplinkPerCC-Id[1]	[Not checked]		
scalingFactor	[Not checked]		
crossCarrierSchedulingUL-OtherSCS	[Not checked]		
intraBandFreqSeparationUL	FreqSeparationClass		
searchSpaceSharingCA-UL	[Not checked]		
srs-TxSwitch SEQUENCE {			
supportedSRS-TxPortSwitch	[Not checked]		
txSwitchImpactToRx	[Not checked]		
}			
supportedSRS-Resources SEQUENCE {			
maxNumberAperiodicSRS-PerBWP	[Not Checked]		
maxNumberAperiodicSRS-PerBWP-PerSlot	[Not Checked]		
maxNumberPeriodicSRS-PerBWP	[Not Checked]		
maxNumberPeriodicSRS-PerBWP-PerSlot	[Not Checked]		
maxNumberSemiPersistentSRS-PerBWP	[Not Checked]		
maxNumberSP-SRS-PerBWP-PerSlot	[Not Checked]		
maxNumberSRS-Ports-PerResource	[Not Checked]		
}			
twoPUCCH-Group	[Not checked]		
dynamicSwitchSUL	[Not checked]		
pusch-DifferentTB-PerSlot SEQUENCE {			
scs-15kHz	[Not checked]		
scs-30kHz	[Not checked]		
scs-60kHz	[Not checked]		
scs-120kHz	[Not checked]		
}			
csi-ReportFramework SEQUENCE {			
maxNumberPeriodicCSI-ReportPerBWP	[Not checked]		
maxNumberAperiodicCSI-ReportPerBWP	[Not checked]		
maxNumberSemiPersistentCSI-ReportPerBWP	[Not checked]		
simultaneousCSI-ReportsAllCC	[Not checked]		
}			
}			

– *FeatureSetUplinkId*

Table 4.6.4-7j: FeatureSetUplinkId

Derivation Path: TS 38.331 [6], clause 6.3.3			
Information Element	Value/remark	Comment	Condition
FeatureSetUplinkId	[Not checked]		

– *FeatureSetEUTRA-UplinkId*

Table 4.6.4-7k: FeatureSetEUTRA-UplinkId

Derivation Path: TS 38.331 [6], clause 6.3.3			
Information Element	Value/remark	Comment	Condition
FeatureSetEUTRA-UplinkId	[Not checked]		

– *FeatureSetUplinkPerCC*

Table 4.6.4-7l: FeatureSetUplinkPerCC

Derivation Path: TS 38.331 [6], clause 6.3.3			
Information Element	Value/remark	Comment	Condition
FeatureSetUplinkPerCC ::= SEQUENCE {			
supportedSubcarrierSpacingUL	SubcarrierSpacing		
supportedBandwidthUL	SupportedBandwidth		
channelBW-90mhz	[Not checked]		
mimo-CB-PUSCH SEQUENCE {			
maxNumberMIMO-LayersCB-PUSCH	MIMO-LayersUL		
maxNumberSRS-ResourcePerSet	[Not checked]		
}			
maxNumberMIMO-LayersNonCB-PUSCH	MIMO-LayersUL		
supportedModulationOrderUL	ModulationOrder		
simultaneousTxSUL-NonSUL	[Not checked]		
}			

– *FeatureSetUplinkPerCC-Id*

Table 4.6.4-7m: FeatureSetUplinkPerCC-Id

Derivation Path: TS 38.331 [6], clause 6.3.3			
Information Element	Value/remark	Comment	Condition
FeatureSetUplinkPerCC-Id	[Not checked]		

– *FeatureSets*

Table 4.6.4-7n: FeatureSets

Derivation Path: TS 38.331 [6], clause 6.3.3			
Information Element	Value/remark	Comment	Condition
FeatureSets ::= SEQUENCE {			
featureSetsDownlink SEQUENCE (SIZE (1..maxDownlinkFeatureSets)) OF FeatureSetDownlink			
FeatureSetDownlink[1]	FeatureSetDownlink		
featureSetsDownlinkPerCC SEQUENCE (SIZE (1..maxPerCC-FeatureSets)) OF FeatureSetDownlinkPerCC			
FeatureSetDownlinkPerCC[1]	FeatureSetDownlinkPerCC		
featureSetsUplink SEQUENCE (SIZE (1..maxUplinkFeatureSets)) OF FeatureSetUplink			
FeatureSetUplink[1]	FeatureSetUplink		
featureSetsUplinkPerCC SEQUENCE (SIZE (1..maxPerCC-FeatureSets)) OF FeatureSetUplinkPerCC			
FeatureSetUplinkPerCC[1]	FeatureSetUplinkPerCC		
}			

– *FreqBandIndicatorEUTRA*

Table 4.6.4-8: FreqBandIndicatorEUTRA

Derivation Path: TS 38.331 [6], clause 6.3.3			
Information Element	Value/remark	Comment	Condition
FreqBandIndicatorEUTRA	EUTRA Operating band under test		

– *FreqBandList***Table 4.6.4-9: FreqBandList**

Derivation Path: TS 38.331 [6], clause 6.3.3			
Information Element	Value/remark	Comment	Condition
FreqBandList ::= SEQUENCE (SIZE (1..maxBandsMRDC)) OF CHOICE {			
bandInformationEUTRA SEQUENCE {			
bandEUTRA	FreqBandIndicatorEUTRA		
ca-BandwidthClassDL-EUTRA	CA-BandwidthClassEUTRA		
ca-BandwidthClassUL-EUTRA	CA-BandwidthClassEUTRA		
}			
bandInformationNR SEQUENCE {			
bandNR	FreqBandIndicatorNR		
maxBandwidthRequestedDL	[Not checked]		
maxBandwidthRequestedUL	[Not checked]		
maxCarriersRequestedDL	[Not checked]		
maxCarriersRequestedUL	[Not checked]		
}			
}			

– *FreqSeparationClass***Table 4.6.4-10: FreqSeparationClass**

Derivation Path: TS 38.331 [6], clause 6.3.3			
Information Element	Value/remark	Comment	Condition
FreqSeparationClass	[Not checked]		

– *MIMO-Layers***Table 4.6.4-11: MIMO-Layers**

Derivation Path: TS 38.331 [6], clause 6.3.3			
Information Element	Value/remark	Comment	Condition
MIMO-LayersDL	[Not checked]		
MIMO-LayersUL	[Not checked]		

– *ModulationOrder***Table 4.6.4-12: ModulationOrder**

Derivation Path: TS 38.331 [6], clause 6.3.3			
Information Element	Value/remark	Comment	Condition
ModulationOrder	[Not checked]		

– *MRDC-Parameters***Table 4.6.4-12a: MRDC-Parameters**

Derivation Path: TS 38.331 [6], clause 6.3.3			
Information Element	Value/remark	Comment	Condition
MRDC-Parameters ::= SEQUENCE {			
singleUL-Transmission	[Not checked]		
dynamicPowerSharing	[Not checked]		
tdm-Pattern	[Not checked]		
ul-SharingEUTRA-NR	[Not checked]		
ul-SwitchingTimeEUTRA-NR	[Not checked]		
simultaneousRxTxInterBandENDC	[Not checked]		
asynclntraBandENDC	[Not checked]		
}			

– *RAT-Type***Table 4.6.4-13: RAT-Type**

Derivation Path: TS 38.331 [6], clause 6.3.3			
Information Element	Value/remark	Comment	Condition
RAT-Type	eutra-nr		

Table 4.6.4-14: Void– *SupportedBandwidth***Table 4.6.4-13a: SupportedBandwidth**

Derivation Path: TS 38.331 [6], clause 6.3.3			
Information Element	Value/remark	Comment	Condition
SupportedBandwidth ::= CHOICE {			
fr1	[Not checked]		
fr2	[Not checked]		
}			

– *UE-CapabilityRAT-ContainerList***Table 4.6.4-15: UE-CapabilityRAT-ContainerList**

Derivation Path: TS 38.331 [6], clause 6.3.3			
Information Element	Value/remark	Comment	Condition
UE-CapabilityRAT-ContainerList ::= SEQUENCE (SIZE (0.. maxRAT-CapabilityContainers)) OF SEQUENCE {	1 entry		
rat-Type[1]	RAT-Type		
ue-CapabilityRAT-Container[1]	UE-MRDC-Capability		EN-DC
}			
}			

– *UE-MRDC-Capability*

Table 4.6.4-16: UE-MRDC-Capability

Derivation Path: TS 38.331 [6], clause 6.3.3			
Information Element	Value/remark	Comment	Condition
UE-MRDC-Capability ::= SEQUENCE {			
measParametersMRDC	MeasParametersMRDC		
rf-ParametersMRDC	RF-ParametersMRDC		
generalParametersMRDC SEQUENCE {			
splitSRB-WithOneUL-Path	[Not checked]		
splitDRB-withUL-Both-MCG-SCG	[Not checked]		
srb3	[Not checked]		
}			
fdd-Add-UE-MRDC-Capabilities SEQUENCE {			
measParametersMRDC-XDD-Diff SEQUENCE {			
sftd-MeasPSCell	[Not checked]		
sftd-MeasNR-Cell	[Not checked]		
}			
generalParametersMRDC SEQUENCE {			
splitSRB-WithOneUL-Path	[Not checked]		
splitDRB-withUL-Both-MCG-SCG	[Not checked]		
srb3	[Not checked]		
}			
}			
tdd-Add-UE-MRDC-Capabilities SEQUENCE {			
measParametersMRDC-XDD-Diff SEQUENCE {			
sftd-MeasPSCell	[Not checked]		
sftd-MeasNR-Cell	[Not checked]		
}			
generalParametersMRDC SEQUENCE {			
splitSRB-WithOneUL-Path	[Not checked]		
splitDRB-withUL-Both-MCG-SCG	[Not checked]		
srb3	[Not checked]		
}			
}			
fr1-Add-UE-MRDC-Capabilities SEQUENCE {			
measParametersMRDC-FRX-Diff SEQUENCE {			
simultaneousRxDataSSB-DiffNumerology	[Not checked]		
}			
}			
fr2-Add-UE-MRDC-Capabilities			
measParametersMRDC-FRX-Diff SEQUENCE {			
simultaneousRxDataSSB-DiffNumerology	[Not checked]		
}			
}			
featureSetCombinations SEQUENCE (SIZE (1..maxFeatureSetCombinations)) OF FeatureSetCombination	FeatureSetCombination		
lateNonCriticalExtension	[Not checked]		
nonCriticalExtension SEQUENCE {	[Not checked]		
}			
}			

– *RF-ParametersMRDC***Table 4.6.4-16a: RF-ParametersMRDC**

Derivation Path: TS 38.331 [6], clause 6.3.3			
Information Element	Value/remark	Comment	Condition
RF-ParametersMRDC ::= SEQUENCE {			
supportedBandCombinationList	BandCombinationList		
appliedFreqBandListFilter	FreqBandList		
}			

– *MeasParametersMRDC***Table 4.6.4-16b: MeasParametersMRDC**

Derivation Path: TS 38.331 [6], clause 6.3.3			
Information Element	Value/remark	Comment	Condition
MeasParametersMRDC ::= SEQUENCE {			
measParametersMRDC-Common SEQUENCE {			
independentGapConfig	[Not checked]		
}			
measParametersMRDC-XDD-Diff SEQUENCE {			
sftd-MeasPSCell	[Not checked]		
sftd-MeasNR-Cell	[Not checked]		
}			
measParametersMRDC-FRX-Diff SEQUENCE {			
simultaneousRxDataSSB-DiffNumerology	[Not checked]		
}			
}			

– *UE-NR-Capability*

Table 4.6.4-17: UE-NR-Capability

Derivation Path: TS 38.331 [6], clause 6.3.3			
Information Element	Value/remark	Comment	Condition
UE-NR-Capability::= SEQUENCE {			
accessStratumRelease	AccessStratumRelease		
pdcp-Parameters	PDCCP-Parameters		
rlc-Parameters	RLC- Parameters		
mac-Parameters	MAC- Parameters		
phy-Parameters	Phy. Parameters		
rf-Parameters	RF- Parameters		
measParameters	Meas Parameters		
fdd-Add-UE-NR-Capabilities SEQUENCE {			
phy-ParametersXDD-Diff SEQUENCE {			
dynamicSFI	[Not checked]		
twoPUCCH-F0-2-ConsecSymbols	[Not checked]		
twoDifferentTPC-Loop-PUSCH	[Not checked]		
twoDifferentTPC-Loop-PUCCH	[Not checked]		
}			
mac-ParametersXDD-Diff SEQUENCE {			
skipUplinkTxDynamic	[Not checked]		
logicalChannelSR-DelayTimer	[Not checked]		
longDRX-Cycle	[Not checked]		
shortDRX-Cycle	[Not checked]		
multipleSR-Configurations	[Not checked]		
multipleConfiguredGrants	[Not checked]		
}			
measParametersXDD-Diff SEQUENCE {			
intraAndInterF-MeasAndReport	[Not checked]		
eventA-MeasAndReport	[Not checked]		
}			
}			
tdd-Add-UE-NR-Capabilities SEQUENCE {			
phy-ParametersXDD-Diff SEQUENCE {			
dynamicSFI	[Not checked]		
twoPUCCH-F0-2-ConsecSymbols	[Not checked]		
twoDifferentTPC-Loop-PUSCH	[Not checked]		
twoDifferentTPC-Loop-PUCCH	[Not checked]		
}			
mac-ParametersXDD-Diff SEQUENCE {			
skipUplinkTxDynamic	[Not checked]		
logicalChannelSR-DelayTimer	[Not checked]		
longDRX-Cycle	[Not checked]		
shortDRX-Cycle	[Not checked]		
multipleSR-Configurations	[Not checked]		
multipleConfiguredGrants	[Not checked]		
}			
measParametersXDD-Diff SEQUENCE {			
intraAndInterF-MeasAndReport	[Not checked]		
eventA-MeasAndReport	[Not checked]		
}			
}			
fr1-Add-UE-NR-Capabilities SEQUENCE {			
phy-ParametersFRX-Diff SEQUENCE {			
dynamicSFI	[Not checked]		
oneFL-DMRS-TwoAdditionalDMRS	[Not checked]		
twoFL-DMRS	[Not checked]		
twoFL-DMRS-TwoAdditionalDMRS	[Not checked]		
oneFL-DMRS-ThreeAdditionalDMRS	[Not checked]		
supportedDMRS-TypeDL	[Not checked]		
supportedDMRS-TypeUL	[Not checked]		
semiOpenLoopCSI	[Not checked]		
csi-ReportWithoutPMI	[Not checked]		
csi-ReportWithoutCQI	[Not checked]		
onePortsPTRS	[Not checked]		
twoPUCCH-F0-2-ConsecSymbols	[Not checked]		
pucch-F2-WithFH	[Not checked]		
}			
}			

pucch-F3-WithFH	[Not checked]		
pucch-F4-WithFH	[Not checked]		
freqHoppingPUCCH-F0-2	[Not checked]		
freqHoppingPUCCH-F1-3-4	[Not checked]		
mux-SR-HARQ-ACK-CSI-PUCCH	[Not checked]		
uci-CodeBlockSegmentation	[Not checked]		
onePUCCH-LongAndShortFormat	[Not checked]		
twoPUCCH-AnyOthersInSlot	[Not checked]		
intraSlotFreqHopping-PUSCH	[Not checked]		
pusch-LBRM	[Not checked]		
pdccch-BlindDetectionCA	[Not checked]		
tpc-PUSCH-RNTI	[Not checked]		
tpc-PUCCH-RNTI	[Not checked]		
tpc-SRS-RNTI	[Not checked]		
absoluteTPC-Command	[Not checked]		
twoDifferentTPC-Loop-PUSCH	[Not checked]		
twoDifferentTPC-Loop-PUCCH	[Not checked]		
pusch-HalfPi-BPSK	[Not checked]		
pucch-F3-4-HalfPi-BPSK	[Not checked]		
almostContiguousCP-OFDM-UL	[Not checked]		
sp-CSI-RS	[Not checked]		
sp-CSI-IM	[Not checked]		
tdd-MultiDL-UL-SwitchPerSlot	[Not checked]		
multipleCORESET	[Not checked]		
}			
measParametersFRX-Diff SEQUENCE {			
ss-SINR-Meas	[Not checked]		
csi-RSRP-AndRSRQ-MeasWithSSB	[Not checked]		
csi-RSRP-AndRSRQ-MeasWithoutSSB	[Not checked]		
csi-SINR-Meas	[Not checked]		
csi-RS-RLM	[Not checked]		
}			
}			
fr2-Add-UE-NR-Capabilities SEQUENCE {			
phy-ParametersFRX-Diff SEQUENCE {	[Not checked]		
dynamicSFI	[Not checked]		
oneFL-DMRS-TwoAdditionalDMRS	[Not checked]		
twoFL-DMRS	[Not checked]		
twoFL-DMRS-TwoAdditionalDMRS	[Not checked]		
oneFL-DMRS-ThreeAdditionalDMRS	[Not checked]		
supportedDMRS-TypeDL	[Not checked]		
supportedDMRS-TypeUL	[Not checked]		
semiOpenLoopCSI	[Not checked]		
csi-ReportWithoutPMI	[Not checked]		
csi-ReportWithoutCQI	[Not checked]		
onePortsPTRS	[Not checked]		
twoPUCCH-F0-2-ConsecSymbols	[Not checked]		
pucch-F2-WithFH	[Not checked]		
pucch-F3-WithFH	[Not checked]		
pucch-F4-WithFH	[Not checked]		
freqHoppingPUCCH-F0-2	[Not checked]		
freqHoppingPUCCH-F1-3-4	[Not checked]		
mux-SR-HARQ-ACK-CSI-PUCCH	[Not checked]		
uci-CodeBlockSegmentation	[Not checked]		
onePUCCH-LongAndShortFormat	[Not checked]		
twoPUCCH-AnyOthersInSlot	[Not checked]		
intraSlotFreqHopping-PUSCH	[Not checked]		
pusch-LBRM	[Not checked]		
pdccch-BlindDetectionCA	[Not checked]		
tpc-PUSCH-RNTI	[Not checked]		
tpc-PUCCH-RNTI	[Not checked]		
tpc-SRS-RNTI	[Not checked]		
absoluteTPC-Command	[Not checked]		
twoDifferentTPC-Loop-PUSCH	[Not checked]		
twoDifferentTPC-Loop-PUCCH	[Not checked]		

pusch-HalfPi-BPSK	[Not checked]		
pucch-F3-4-HalfPi-BPSK	[Not checked]		
almostContiguousCP-OFDM-UL	[Not checked]		
sp-CSI-RS	[Not checked]		
sp-CSI-IM	[Not checked]		
tdd-MultiDL-UL-SwitchPerSlot	[Not checked]		
multipleCORESET	[Not checked]		
}			
measParametersFRX-Diff SEQUENCE {			
ss-SINR-Meas	[Not checked]		
csi-RSRP-AndRSRQ-MeasWithSSB	[Not checked]		
csi-RSRP-AndRSRQ-MeasWithoutSSB	[Not checked]		
csi-SINR-Meas	[Not checked]		
csi-RS-RLM	[Not checked]		
}			
}			
featureSets	FeatureSets		
featureSetCombinations SEQUENCE (SIZE (1..maxFeatureSetCombinations)) OF FeatureSetCombination	FeatureSetCombination		
lateNonCriticalExtension	[Not checked]		
nonCriticalExtension SEQUENCE {			
}			
}			

– *Phy-Parameters*

Table 4.6.4-18: *Phy-Parameters*

Derivation Path: TS 38.331 [6], clause 6.3.3			
Information Element	Value/remark	Comment	Condition
Phy-Parameters ::= SEQUENCE {			
phy-ParametersCommon SEQUENCE {			
csi-RS-CFRA-ForHO	[Not checked]		
dynamicPRB-BundlingDL	[Not checked]		
sp-CSI-ReportPUCCH	[Not checked]		
sp-CSI-ReportPUSCH	[Not checked]		
nzp-CSI-RS-IntefMgmt	[Not checked]		
type2-SP-CSI-Feedback-LongPUCCH	[Not checked]		
precoderGranularityCORESET	[Not checked]		
dynamicHARQ-ACK-Codebook	[Not checked]		
semiStaticHARQ-ACK-Codebook	[Not checked]		
spatialBundlingHARQ-ACK	[Not checked]		
dynamicBetaOffsetInd-HARQ-ACK-CSI	[Not checked]		
pucch-Repetition-F1-3-4	[Not checked]		
ra-Type0-PUSCH	[Not checked]		
dynamicSwitchRA-Type0-1-PDSCH	[Not checked]		
dynamicSwitchRA-Type0-1-PUSCH	[Not checked]		
pdsch-MappingTypeA	[Not checked]		
pdsch-MappingTypeB	[Not checked]		
interleavingVRB-ToPRB-PDSCH	[Not checked]		
interSlotFreqHopping-PUSCH	[Not checked]		
type1-PUSCH-RepetitionMultiSlots	[Not checked]		
type2-PUSCH-RepetitionMultiSlots	[Not checked]		
pusch-RepetitionMultiSlots	[Not checked]		
pdsch-RepetitionMultiSlots	[Not checked]		
downlinkSPS	[Not checked]		
configuredUL-GrantType1	[Not checked]		
configuredUL-GrantType2	[Not checked]		
pre-EmptIndication-DL	[Not checked]		
cbg-TransIndication	[Not checked]		
cbg-TransIndication-UL	[Not checked]		
cbg-FlushIndication-DL	[Not checked]		
dynamicHARQ-ACK-CodeB-CBG-Retx-DL	[Not checked]		
rateMatchingResrcSetSemi-Static	[Not checked]		
rateMatchingResrcSetDynamic	[Not checked]		
rateMatchingLTE-CRS	[Not checked]		
bwp-SwitchingDelay	[Not checked]		
}			
phy-ParametersXDD-Diff SEQUENCE {			
dynamicSFI	[Not checked]		
twoPUCCH-F0-2-ConsecSymbols	[Not checked]		
twoDifferentTPC-Loop-PUSCH	[Not checked]		
twoDifferentTPC-Loop-PUCCH	[Not checked]		
}			
phy-ParametersFRX-Diff SEQUENCE {			
dynamicSFI	[Not checked]		
oneFL-DMRS-TwoAdditionalDMRS	[Not checked]		
twoFL-DMRS	[Not checked]		
twoFL-DMRS-TwoAdditionalDMRS	[Not checked]		
oneFL-DMRS-ThreeAdditionalDMRS	[Not checked]		
supportedDMRS-TypeDL	[Not checked]		
supportedDMRS-TypeUL	[Not checked]		
semiOpenLoopCSI	[Not checked]		
csi-ReportWithoutPMI	[Not checked]		
csi-ReportWithoutCQI	[Not checked]		
onePortsPTRS	[Not checked]		
twoPUCCH-F0-2-ConsecSymbols	[Not checked]		
pucch-F2-WithFH	[Not checked]		
pucch-F3-WithFH	[Not checked]		
pucch-F4-WithFH	[Not checked]		
freqHoppingPUCCH-F0-2	[Not checked]		
freqHoppingPUCCH-F1-3-4	[Not checked]		
mux-SR-HARQ-ACK-CSI-PUCCH	[Not checked]		

uci-CodeBlockSegmentation	[Not checked]		
onePUCCH-LongAndShortFormat	[Not checked]		
twoPUCCH-AnyOthersInSlot	[Not checked]		
intraSlotFreqHopping-PUSCH	[Not checked]		
pusch-LBRM	[Not checked]		
pdccch-BlindDetectionCA	[Not checked]		
tpc-PUSCH-RNTI	[Not checked]		
tpc-PUCCH-RNTI	[Not checked]		
tpc-SRS-RNTI	[Not checked]		
absoluteTPC-Command	[Not checked]		
twoDifferentTPC-Loop-PUSCH	[Not checked]		
twoDifferentTPC-Loop-PUCCH	[Not checked]		
pusch-HalfPi-BPSK	[Not checked]		
pucch-F3-4-HalfPi-BPSK	[Not checked]		
almostContiguousCP-OFDM-UL	[Not checked]		
sp-CSI-RS	[Not checked]		
sp-CSI-IM	[Not checked]		
tdd-MultiDL-UL-SwitchPerSlot	[Not checked]		
multipleCORESET	[Not checked]		
}			
phy-ParametersFR1 SEQUENCE {			
pdccchMonitoringSingleOccasion	[Not checked]		
scs-60kHz	[Not checked]		
pdsch-256QAM-FR1	[Not checked]		
pdsch-RE-MappingFR1	[Not checked]		
}			
phy-ParametersFR2 SEQUENCE {			
calibrationGapPA	[Not checked]		
pdsch-RE-MappingFR2	[Not checked]		
}			
}			

– *RF-Parameters*

Table 4.6.4-19: *RF-Parameters*

Derivation Path: TS 38.331 [6], clause 6.3.3			
Information Element	Value/remark	Comment	Condition
RF-Parameters ::= SEQUENCE {			
supportedBandListNR SEQUENCE (SIZE (1..maxBands)) OF SEQUENCE {	1 Entry		
bandNR[1]	FreqBandIndicatorNR		
modifiedMPR-Behaviour[1]	[Not checked]		
mimo-ParametersPerBand[1] SEQUENCE {			
timeDurationForQCL SEQUENCE {			
scs-60kHz	[Not checked]		
sch-120kHz	[Not checked]		
}			
maxNumberMIMO-LayersPDSCH	MIMO-LayersDL		
maxNumberMIMO-LayersCB-PUSCH	MIMO-LayersUL		
maxNumberMIMO-LayersNonCB-PUSCH	MIMO-LayersUL		
maxNumberConfiguredTCIstates	[Not checked]		
maxNumberActiveTCI-PerCC	[Not checked]		
pusch-TransCoherence	[Not checked]		
beamCorrespondence	[Not checked]		
periodicBeamReport	[Not checked]		
aperiodicBeamReport	[Not checked]		
sp-BeamReportPUCCH	[Not checked]		
sp-BeamReportPUSCH	[Not checked]		
beamManagementSSB-CSI-RS SEQUENCE {			
maxNumberSSB-CSI-RS-ResourceOneTx	[Not checked]		
maxNumberSSB-CSI-RS-ResourceTwoTx	[Not checked]		
supportedCSI-RS-Density	[Not checked]		
}			
maxNumberRxBeam	[Not checked]		
maxNumberRxTxBeamSwitchDL SEQUENCE {			
scs-15kHz	[Not checked]		
scs-30kHz	[Not checked]		
scs-60kHz	[Not checked]		
scs-120kHz	[Not checked]		
scs-240kHz	[Not checked]		
}			
maxNumberNonGroupBeamReporting	[Not checked]		
groupBeamReporting	[Not checked]		
uplinkBeamManagement SEQUENCE {			
maxNumberSRS-ResourcePerSet	[Not checked]		
maxNumberSRS-ResourceSet	[Not checked]		
}			
maxNumberCSI-RS-BFR	[Not checked]		
maxNumberSSB-BFR	[Not checked]		
maxNumberCSI-RS-SSB-BFR	[Not checked]		
twoPortsPTRS	[Not checked]		
supportedSRS-Resources SEQUENCE {			
maxNumberAperiodicSRS-PerBWP	[Not checked]		
maxNumberAperiodicSRS-PerBWP-PerSlot	[Not checked]		
maxNumberPeriodicSRS-PerBWP	[Not checked]		
maxNumberPeriodicSRS-PerBWP-PerSlot	[Not checked]		
maxNumberSemiPersistentSRS-PerBWP	[Not checked]		
maxNumberSP-SRS-PerBWP-PerSlot	[Not checked]		
maxNumberSRS-Ports-PerResource	[Not checked]		
}			
srs-TxSwitch SEQUENCE {			
supportedSRS-TxPortSwitch	[Not checked]		
txSwitchImpactToRx	[Not checked]		
}			
maxNumberSimultaneousSRS-PerCC	[Not checked]		
lowLatencyCSI-Feedback	[Not checked]		
}			
extendedCP[1]	[Not checked]		
multipleTCI[1]	[Not checked]		
bwp-WithoutRestriction [1]	[Not checked]		

bwp-SameNumerology[1]	[Not checked]		
bwp-DiffNumerology[1]	[Not checked]		
crossCarrierSchedulingDL-SameSCS [1]	[Not checked]		
crossCarrierSchedulingUL-SameSCS[1]	[Not checked]		
pdsch-256QAM-FR2[1]	[Not checked]		
pusch-256QAM[1]	[Not checked]		
ue-PowerClass[1]	[Not checked]		
rateMatchingLTE-CRS[1]	[Not checked]		
}			
supportedBandCombinationList	BandCombinationList		
appliedFreqBandListFilter	FreqBandList		
}			

– *MIMO-ParametersPerBand*

Table 4.6.4-20: MIMO-ParametersPerBand

Derivation Path: TS 38.331 [6], clause 6.3.3			
Information Element	Value/remark	Comment	Condition
MIMO-ParametersPerBand ::= SEQUENCE {			
tci-StatePDSCH SEQUENCE {			
maxNumberConfiguredTCIstatesPerCC	[Not checked]		
maxNumberActiveTCI-PerBWP	[Not checked]		
}			
additionalActiveTCI-StatePDCCH	[Not checked]		
pusch-TransCoherence	[Not checked]		
beamCorrespondence	[Not checked]		
periodicBeamReport	[Not checked]		
aperiodicBeamReport	[Not checked]		
sp-BeamReportPUCCH	[Not checked]		
sp-BeamReportPUSCH	[Not checked]		
beamManagementSSB-CSI-RS SEQUENCE {			
maxNumberSSB-CSI-RS-ResourceOneTx	[Not checked]		
maxNumberSSB-CSI-RS-ResourceTwoTx	[Not checked]		
supportedCSI-RS-Density	[Not checked]		
}			
maxNumberRxBeam	[Not checked]		
maxNumberRxTxBeamSwitchDL SEQUENCE {			
scs-15kHz	[Not checked]		
scs-30kHz	[Not checked]		
scs-60kHz	[Not checked]		
scs-120kHz	[Not checked]		
scs-240kHz	[Not checked]		
}			
maxNumberNonGroupBeamReporting	[Not checked]		
groupBeamReporting	[Not checked]		
uplinkBeamManagement SEQUENCE {			
maxNumberSRS-ResourcePerSet	[Not checked]		
maxNumberSRS-ResourceSet	[Not checked]		
}			
maxNumberCSI-RS-BFR	[Not checked]		
maxNumberSSB-BFR	[Not checked]		
maxNumberCSI-RS-SSB-BFR	[Not checked]		
twoPortsPTRS-DL	[Not checked]		
twoPortsPTRS-UL	[Not checked]		
supportedSRS-Resources SEQUENCE {			
maxNumberAperiodicSRS-PerBWP	[Not checked]		
maxNumberAperiodicSRS-PerBWP-PerSlot	[Not checked]		
maxNumberPeriodicSRS-PerBWP	[Not checked]		
maxNumberPeriodicSRS-PerBWP-PerSlot	[Not checked]		
maxNumberSemiPersistentSRS-PerBWP	[Not checked]		
maxNumberSP-SRS-PerBWP-PerSlot	[Not checked]		
maxNumberSRS-Ports-PerResource	[Not checked]		
}			
srs-TxSwitch SEQUENCE {			
supportedSRS-TxPortSwitch	[Not checked]		
txSwitchImpactToRx	[Not checked]		
}			
maxNumberSimultaneousSRS-PerCC	[Not checked]		
beamReportTiming SEQUENCE {			
scs-15kHz	[Not checked]		
scs-30kHz	[Not checked]		
scs-60kHz	[Not checked]		
scs-120kHz	[Not checked]		
}			
ptrs-DensityRecommendationSetDL SEQUENCE {			
scs-15kHz			
frequencyDensity1	[Not checked]		
frequencyDensity2	[Not checked]		
timeDensity1	[Not checked]		
timeDensity2	[Not checked]		
timeDensity3	[Not checked]		

}			
scs-30kHz			
frequencyDensity1	[Not checked]		
frequencyDensity2	[Not checked]		
timeDensity1	[Not checked]		
timeDensity2	[Not checked]		
timeDensity3	[Not checked]		
}			
scs-60kHz			
frequencyDensity1	[Not checked]		
frequencyDensity2	[Not checked]		
timeDensity1	[Not checked]		
timeDensity2	[Not checked]		
timeDensity3	[Not checked]		
}			
scs-120kHz			
frequencyDensity1	[Not checked]		
frequencyDensity2	[Not checked]		
timeDensity1	[Not checked]		
timeDensity2	[Not checked]		
timeDensity3	[Not checked]		
}			
}			
ptrs-DensityRecommendationSetUL SEQUENCE {			
scs-15kHz SEQUENCE {			
frequencyDensity1	[Not checked]		
frequencyDensity2	[Not checked]		
timeDensity1	[Not checked]		
timeDensity2	[Not checked]		
timeDensity3	[Not checked]		
sampleDensity1	[Not checked]		
sampleDensity2	[Not checked]		
sampleDensity3	[Not checked]		
sampleDensity4	[Not checked]		
sampleDensity5	[Not checked]		
}			
scs-30kHz SEQUENCE {			
frequencyDensity1	[Not checked]		
frequencyDensity2	[Not checked]		
timeDensity1	[Not checked]		
timeDensity2	[Not checked]		
timeDensity3	[Not checked]		
sampleDensity1	[Not checked]		
sampleDensity2	[Not checked]		
sampleDensity3	[Not checked]		
sampleDensity4	[Not checked]		
sampleDensity5	[Not checked]		
scs-60kHz SEQUENCE {			
frequencyDensity1	[Not checked]		
frequencyDensity2	[Not checked]		
timeDensity1	[Not checked]		
timeDensity2	[Not checked]		
timeDensity3	[Not checked]		
sampleDensity1	[Not checked]		
sampleDensity2	[Not checked]		
sampleDensity3	[Not checked]		
sampleDensity4	[Not checked]		
sampleDensity5	[Not checked]		
scs-120kHz SEQUENCE {			
frequencyDensity1	[Not checked]		
frequencyDensity2	[Not checked]		
timeDensity1	[Not checked]		
timeDensity2	[Not checked]		
timeDensity3	[Not checked]		
sampleDensity1	[Not checked]		

sampleDensity2	[Not checked]		
sampleDensity3	[Not checked]		
sampleDensity4	[Not checked]		
sampleDensity5	[Not checked]		
}			
csi-RS-ForTracking SEQUENCE {			
burstLength	[Not checked]		
maxSimultaneousResourceSetsPerCC	[Not checked]		
maxConfiguredResourceSetsPerCC	[Not checked]		
maxConfiguredResourceSetsAllCC	[Not checked]		
}			
aperiodicTRS	[Not checked]		
}			

– *PDCP-Parameters*

Table 4.6.4-21: PDCP-Parameters

Derivation Path: TS 38.331 [6], clause 6.3.3			
Information Element	Value/remark	Comment	Condition
PDCP-Parameters ::= SEQUENCE {			
supportedROHC-Profiles SEQUENCE {			
profile0x0000	[Not checked]		
profile0x0001	[Not checked]		
profile0x0002	[Not checked]		
profile0x0003	[Not checked]		
profile0x0004	[Not checked]		
profile0x0006	[Not checked]		
profile0x0101	[Not checked]		
profile0x0102	[Not checked]		
profile0x0103	[Not checked]		
profile0x0104	[Not checked]		
}			
maxNumberROHC-ContextSessions	[Not checked]		
uplinkOnlyROHC-Profiles	[Not checked]		
continueROHC-Context	[Not checked]		
outOfOrderDelivery	[Not checked]		
shortSN	[Not checked]		
}			

– *RLC-Parameters*

Table 4.6.4-22: RLC-Parameters

Derivation Path: TS 38.331 [6], clause 6.3.3			
Information Element	Value/remark	Comment	Condition
RLC-Parameters ::= SEQUENCE {			
am-WithShortSN	[Not checked]		
um-WithShortSN	[Not checked]		
um-WithLongSN	[Not checked]		
}			

– *MAC-Parameters*

Table 4.6.4-23: MAC-Parameters

Derivation Path: TS 38.331 [6], clause 6.3.3			
Information Element	Value/remark	Comment	Condition
MAC-Parameters ::= SEQUENCE {			
mac-ParametersCommon SEQUENCE {			
lcp-Restriction	[Not checked]		
pucch-SpatialRelInfoMAC-CE	[Not checked]		
}			
mac-ParametersXDD-Diff SEQUENCE {			
skipUplinkTxDynamic	[Not checked]		
logicalChannelSR-DelayTimer	[Not checked]		
longDRX-Cycle	[Not checked]		
shortDRX-Cycle	[Not checked]		
multipleSR-Configurations	[Not checked]		
multipleConfiguredGrants	[Not checked]		
}			
}			

– *MeasParameters*

Table 4.6.4-24: MeasParameters

Derivation Path: TS 38.331 [6], clause 6.3.3			
Information Element	Value/remark	Comment	Condition
MeasParameters ::= SEQUENCE {			
measParametersCommon SEQUENCE {			
supportedGapPattern	[Not checked]		
}			
measParametersXDD-Diff SEQUENCE {			
intraAndInterF-MeasAndReport	[Not checked]		
eventA-MeasAndReport	[Not checked]		
}			
measParametersFRX-Diff SEQUENCE {			
ss-SINR-Meas	[Not checked]		
csi-RSRP-AndRSRQ-MeasWithSSB	[Not checked]		
csi-RSRP-AndRSRQ-MeasWithoutSSB	[Not checked]		
csi-SINR-Meas	[Not checked]		
csi-RS-RLM	[Not checked]		
}			
}			

4.6.5 Other information elements

– *EUTRA-AllowedMeasBandwidth*

Editor's Note: Based on ongoing RAN2 work on CR 100 for TS 38.331, R2-1812411 (CR 100r3).

Table 4.6.5-0A: EUTRA-AllowedMeasBandwidth

Derivation Path: TS 38.331 [6], clause 6.3.4			
Information Element	Value/remark	Comment	Condition
EUTRA-AllowedMeasBandwidth	FFS		

– *EUTRA-MultiBandInfoList*

Editor's Note: Based on ongoing RAN2 work on CR 100 for TS 38.331, R2-1812411 (CR 100r3).

Table 4.6.5-0B: EUTRA-MultiBandInfoList

Derivation Path: TS 38.331 [6], clause 6.3.4			
Information Element	Value/remark	Comment	Condition
EUTRA-MultiBandInfoList ::= SEQUENCE (SIZE (1..maxMultiBands)) OF SEQUENCE {			
FFS			
}			

– *EUTRA-NS-PmaxList*

Editor's Note: Based on ongoing RAN2 work on CR 100 for TS 38.331, R2-1812411 (CR 100r3).

Table 4.6.5-0C: EUTRA-NS-PmaxList

Derivation Path: TS 38.331 [6], clause 6.3.4			
Information Element	Value/remark	Comment	Condition
EUTRA-NS-PmaxList ::= SEQUENCE (SIZE (1..maxEUTRA-NS-Pmax)) OF SEQUENCE {			
FFS			
}			

– *EUTRA-PhysCellId*

Editor's Note: Based on ongoing RAN2 work on CR 100 for TS 38.331, R2-1812411 (CR 100r3).

Table 4.6.5-0D: EUTRA-PhysCellId

Derivation Path: TS 38.331 [6], clause 6.3.4			
Information Element	Value/remark	Comment	Condition
EUTRA-PhysCellId	FFS		

– *EUTRA-PhysCellIdRange*

Editor's Note: Based on ongoing RAN2 work on CR 100 for TS 38.331, R2-1812411 (CR 100r3).

Table 4.6.5-0E: EUTRA-PhysCellIdRange

Derivation Path: TS 38.331 [6], clause 6.3.4			
Information Element	Value/remark	Comment	Condition
EUTRA-PhysCellIdRange ::= SEQUENCE {			
FFS			
}			

– *EUTRA-PresenceAntennaPort1*

Editor's Note: Based on ongoing RAN2 work on CR 100 for TS 38.331, R2-1812411 (CR 100r3).

Table 4.6.5-0F: EUTRA-PresenceAntennaPort1

Derivation Path: TS 38.331 [6], clause 6.3.4			
Information Element	Value/remark	Comment	Condition
EUTRA-PresenceAntennaPort1	FFS		

– *RRC-TransactionIdentifier***Table 4.6.5-1: RRC-TransactionIdentifier**

Derivation Path: TS 38.331 [6], clause 6.3.4			
Information Element	Value/remark	Comment	Condition
RRC-TransactionIdentifier	0		

4.7 Default 5GC NAS message and information elements contents

4.7.1 Contents of 5GMM messages

– *Authentication request***Table 4.7.1-1: AUTHENTICATION REQUEST**

Derivation Path: 24.501 clause 8.2.1			
Information Element	Value/remark	Comment	Condition
Extended protocol discriminator	5GMM		
Security header type	FFS		
Spare half octet	'0000'B		
FFS			

Condition	Explanation

– *Authentication response***Table 4.7.1-2: AUTHENTICATION RESPONSE**

Derivation Path: 24.501 clause 8.2.2			
Information Element	Value/remark	Comment	Condition
Extended protocol discriminator	5GMM		
Security header type	FFS		
Spare half octet	'0000'B		
FFS			

Condition	Explanation

– *Authentication result***Table 4.7.1-3: AUTHENTICATION RESULT**

Derivation Path: 24.501 clause 8.2.3			
Information Element	Value/remark	Comment	Condition
Extended protocol discriminator	5GMM		
Security header type	FFS		
Spare half octet	'0000'B		
FFS			

Condition	Explanation

– *Authentication failure***Table 4.7.1-4: AUTHENTICATION FAILURE**

Derivation Path: 24.501 clause 8.2.4			
Information Element	Value/remark	Comment	Condition
Extended protocol discriminator	5GMM		
Security header type	FFS		
Spare half octet	'0000'B		
FFS			

Condition	Explanation

– *Authentication reject***Table 4.7.1-5: AUTHENTICATION REJECT**

Derivation Path: 24.501 clause 8.2.5			
Information Element	Value/remark	Comment	Condition
Extended protocol discriminator	5GMM		
Security header type	FFS		
Spare half octet	'0000'B		
FFS			

Condition	Explanation

– *Registration request***Table 4.7.1-6: REGISTRATION REQUEST**

Derivation Path: 24.501 clause 8.2.6			
Information Element	Value/remark	Comment	Condition
Extended protocol discriminator	5GMM		
Security header type	FFS		
Spare half octet	'0000'B		
FFS			

Condition	Explanation

– *Registration accept***Table 4.7.1-7: REGISTRATION ACCEPT**

Derivation Path: 24.501 clause 8.2.7			
Information Element	Value/remark	Comment	Condition
Extended protocol discriminator	5GMM		
Security header type	FFS		
Spare half octet	'0000'B		
FFS			

Condition	Explanation

– *Registration complete*

Table 4.7.1-8: REGISTRATION COMPLETE

Derivation Path: 24.501 clause 8.2.8			
Information Element	Value/remark	Comment	Condition
Extended protocol discriminator	5GMM		
Security header type	FFS		
Spare half octet	'0000'B		
FFS			

Condition	Explanation

– *Registration reject*

Table 4.7.1-9: REGISTRATION REJECT

Derivation Path: 24.501 clause 8.2.9			
Information Element	Value/remark	Comment	Condition
Extended protocol discriminator	5GMM		
Security header type	FFS		
Spare half octet	'0000'B		
FFS			

Condition	Explanation

– *UL NAS transport*

Table 4.7.1-10: UL NAS TRANSPORT

Derivation Path: 24.501 clause 8.2.10			
Information Element	Value/remark	Comment	Condition
Extended protocol discriminator	5GMM		
Security header type	FFS		
Spare half octet	'0000'B		
FFS			

Condition	Explanation

– *DL NAS transport***Table 4.7.1-11: DL NAS TRANSPORT**

Derivation Path: 24.501 clause 8.2.11			
Information Element	Value/remark	Comment	Condition
Extended protocol discriminator	5GMM		
Security header type	FFS		
Spare half octet	'0000'B		
FFS			

Condition	Explanation

– *De-registration request (UE originating de-registration)***Table 4.7.1-12: DEREGISTRATION REQUEST_1**

Derivation Path: 24.501 clause 8.2.12			
Information Element	Value/remark	Comment	Condition
Extended protocol discriminator	5GMM		
Security header type	FFS		
Spare half octet	'0000'B		
FFS			

Condition	Explanation

– *De-registration accept (UE originating de-registration)***Table 4.7.1-13: DEREGISTRATION ACCEPT_1**

Derivation Path: 24.501 clause 8.2.13			
Information Element	Value/remark	Comment	Condition
Extended protocol discriminator	5GMM		
Security header type	FFS		
Spare half octet	'0000'B		
FFS			

Condition	Explanation

– *De-registration request (UE terminated de-registration)***Table 4.7.1-14: DEREGISTRATION REQUEST_2**

Derivation Path: 24.501 clause 8.2.14			
Information Element	Value/remark	Comment	Condition
Extended protocol discriminator	5GMM		
Security header type	FFS		
Spare half octet	'0000'B		
FFS			

Condition	Explanation

– *De-registration accept (UE terminated de-registration)*

Table 4.7.1-15: DEREGISTRATION ACCEPT_2

Derivation Path: 24.501 clause 8.2.15			
Information Element	Value/remark	Comment	Condition
Extended protocol discriminator	5GMM		
Security header type	FFS		
Spare half octet	'0000'B		
FFS			

Condition	Explanation

– *Service request*

Table 4.7.1-16: SERVICE REQUEST

Derivation Path: 24.501 clause 8.2.16			
Information Element	Value/remark	Comment	Condition
Extended protocol discriminator	5GMM		
Security header type	FFS		
Spare half octet	'0000'B		
FFS			

Condition	Explanation

– *Service accept*

Table 4.7.1-17: SERVICE ACCEPT

Derivation Path: 24.501 clause 8.2.17			
Information Element	Value/remark	Comment	Condition
Extended protocol discriminator	5GMM		
Security header type	FFS		
Spare half octet	'0000'B		
FFS			

Condition	Explanation

– *Service reject***Table 4.7.1-18: SERVICE REJECT**

Derivation Path: 24.501 clause 8.2.18			
Information Element	Value/remark	Comment	Condition
Extended protocol discriminator	5GMM		
Security header type	FFS		
Spare half octet	'0000'B		
FFS			

Condition	Explanation

– *Configuration update command***Table 4.7.1-19: CONFIGURATION UPDATE COMMAND**

Derivation Path: 24.501 clause 8.2.19			
Information Element	Value/remark	Comment	Condition
Extended protocol discriminator	5GMM		
Security header type	FFS		
Spare half octet	'0000'B		
FFS			

Condition	Explanation

– *Configuration update complete***Table 4.7.1-20: CONFIGURATION UPDATE COMPLETE**

Derivation Path: 24.501 clause 8.2.20			
Information Element	Value/remark	Comment	Condition
Extended protocol discriminator	5GMM		
Security header type	FFS		
Spare half octet	'0000'B		
FFS			

Condition	Explanation

– *Identity request***Table 4.7.1-21: IDENTITY REQUEST**

Derivation Path: 24.501 clause 8.2.21			
Information Element	Value/remark	Comment	Condition
Extended protocol discriminator	5GMM		
Security header type	FFS		
Spare half octet	'0000'B		
FFS			

Condition	Explanation

– *Identity response*

Table 4.7.1-22: IDENTITY RESPONSE

Derivation Path: 24.501 clause 8.2.22			
Information Element	Value/remark	Comment	Condition
Extended protocol discriminator	5GMM		
Security header type	FFS		
Spare half octet	'0000'B		
FFS			

Condition	Explanation

– *Notification*

Table 4.7.1-23: NOTIFICATION

Derivation Path: 24.501 clause 8.2.23			
Information Element	Value/remark	Comment	Condition
Extended protocol discriminator	5GMM		
Security header type	FFS		
Spare half octet	'0000'B		
FFS			

Condition	Explanation

– *Notification response*

Table 4.7.1-24: NOTIFICATION RESPONSE

Derivation Path: 24.501 clause 8.2.24			
Information Element	Value/remark	Comment	Condition
Extended protocol discriminator	5GMM		
Security header type	FFS		
Spare half octet	'0000'B		
FFS			

Condition	Explanation

– *Security mode command***Table 4.7.1-25: SECURITY MODE COMMAND**

Derivation Path: 24.501 clause 8.2.25			
Information Element	Value/remark	Comment	Condition
Extended protocol discriminator	5GMM		
Security header type	FFS		
Spare half octet	'0000'B		
FFS			

Condition	Explanation

– *Security mode complete***Table 4.7.1-26: SECURITY MODE COMPLETE**

Derivation Path: 24.501 clause 8.2.26			
Information Element	Value/remark	Comment	Condition
Extended protocol discriminator	5GMM		
Security header type	FFS		
Spare half octet	'0000'B		
FFS			

Condition	Explanation

– *Security mode reject***Table 4.7.1-27: SECURITY MODE REJECT**

Derivation Path: 24.501 clause 8.2.27			
Information Element	Value/remark	Comment	Condition
Extended protocol discriminator	5GMM		
Security header type	FFS		
Spare half octet	'0000'B		
FFS			

Condition	Explanation

– *Security protected 5GS NAS message***Table 4.7.1-28: SECURITY PROTECTED 5GS NAS MESSAGE**

Derivation Path: 24.501 clause 8.2.28			
Information Element	Value/remark	Comment	Condition
Extended protocol discriminator	5GMM		
Security header type	FFS		
Spare half octet	'0000'B		
FFS			

Condition	Explanation

– *5GMM status*

Table 4.7.1-29: 5GMM STATUS

Derivation Path: 24.501 clause 8.2.29			
Information Element	Value/remark	Comment	Condition
Extended protocol discriminator	5GMM		
Security header type	FFS		
Spare half octet	'0000'B		
FFS			

Condition	Explanation

4.7.2 Contents of 5GSM messages

– *PDU session establishment request*

Table 4.7.2-1: PDU SESSION ESTABLISHMENT REQUEST

Derivation Path: 24.501 clause 8.3.1			
Information Element	Value/remark	Comment	Condition
Extended protocol discriminator	5GSM		
PDU session ID	FFS		
PTI	FFS		
FFS			

Condition	Explanation

– *PDU session establishment accept*

Table 4.7.2-2: PDU SESSION ESTABLISHMENT ACCEPT

Derivation Path: 24.501 clause 8.3.2			
Information Element	Value/remark	Comment	Condition
Extended protocol discriminator	5GSM		
PDU session ID	FFS		
PTI	FFS		
FFS			

Condition	Explanation

– *PDU session establishment reject***Table 4.7.2-3: PDU SESSION ESTABLISHMENT REJECT**

Derivation Path: 24.501 clause 8.3.3			
Information Element	Value/remark	Comment	Condition
Extended protocol discriminator	5GSM		
PDU session ID	FFS		
PTI	FFS		
FFS			

Condition	Explanation

– *PDU session authentication command***Table 4.7.2-4: PDU SESSION AUTHENTICATION COMMAND**

Derivation Path: 24.501 clause 8.3.4			
Information Element	Value/remark	Comment	Condition
Extended protocol discriminator	5GSM		
PDU session ID	FFS		
PTI	FFS		
FFS			

Condition	Explanation

– *PDU session authentication complete***Table 4.7.2-5: PDU SESSION AUTHENTICATION COMPLETE**

Derivation Path: 24.501 clause 8.3.5			
Information Element	Value/remark	Comment	Condition
Extended protocol discriminator	5GSM		
PDU session ID	FFS		
PTI	FFS		
FFS			

Condition	Explanation

– *PDU session authentication result***Table 4.7.2-6: PDU SESSION AUTHENTICATION RESULT**

Derivation Path: 24.501 clause 8.3.6			
Information Element	Value/remark	Comment	Condition
Extended protocol discriminator	5GSM		
PDU session ID	FFS		
PTI	FFS		
FFS			

Condition	Explanation

– *PDU session modification request*

Table 4.7.2-7: PDU SESSION MODIFICATION REQUEST

Derivation Path: 24.501 clause 8.3.7			
Information Element	Value/remark	Comment	Condition
Extended protocol discriminator	5GSM		
PDU session ID	FFS		
PTI	FFS		
FFS			

Condition	Explanation

– *PDU session modification reject*

Table 4.7.2-8: PDU SESSION MODIFICATION REJECT

Derivation Path: 24.501 clause 8.3.8			
Information Element	Value/remark	Comment	Condition
Extended protocol discriminator	5GSM		
PDU session ID	FFS		
PTI	FFS		
FFS			

Condition	Explanation

– *PDU session modification command*

Table 4.7.2-9: PDU SESSION MODIFICATION COMMAND

Derivation Path: 24.501 clause 8.3.9			
Information Element	Value/remark	Comment	Condition
Extended protocol discriminator	5GSM		
PDU session ID	FFS		
PTI	FFS		
FFS			

Condition	Explanation

– *PDU session modification complete***Table 4.7.2-10: PDU SESSION MODIFICATION COMPLETE**

Derivation Path: 24.501 clause 8.3.10			
Information Element	Value/remark	Comment	Condition
Extended protocol discriminator	5GSM		
PDU session ID	FFS		
PTI	FFS		
FFS			

Condition	Explanation

– *PDU session modification command reject***Table 4.7.2-11: PDU SESSION MODIFICATION COMMAND REJECT**

Derivation Path: 24.501 clause 8.3.11			
Information Element	Value/remark	Comment	Condition
Extended protocol discriminator	5GSM		
PDU session ID	FFS		
PTI	FFS		
FFS			

Condition	Explanation

– *PDU session release request***Table 4.7.2-12: PDU SESSION RELEASE REQUEST**

Derivation Path: 24.501 clause 8.3.12			
Information Element	Value/remark	Comment	Condition
Extended protocol discriminator	5GSM		
PDU session ID	FFS		
PTI	FFS		
FFS			

Condition	Explanation

– *PDU session release reject***Table 4.7.2-13: PDU SESSION RELEASE REJECT**

Derivation Path: 24.501 clause 8.3.13			
Information Element	Value/remark	Comment	Condition
Extended protocol discriminator	5GSM		
PDU session ID	FFS		
PTI	FFS		
FFS			

Condition	Explanation

– *PDU session release command*

Table 4.7.2-14: PDU SESSION RELEASE COMMAND

Derivation Path: 24.501 clause 8.3.14			
Information Element	Value/remark	Comment	Condition
Extended protocol discriminator	5GSM		
PDU session ID	FFS		
PTI	FFS		
FFS			

Condition	Explanation

– *PDU session release complete*

Table 4.7.2-15: PDU SESSION RELEASE COMPLETE

Derivation Path: 24.501 clause 8.3.15			
Information Element	Value/remark	Comment	Condition
Extended protocol discriminator	5GSM		
PDU session ID	FFS		
PTI	FFS		
FFS			

Condition	Explanation

– *5GSM status*

Table 4.7.2-16: 5GSM STATUS

Derivation Path: 24.501 clause 8.3.16			
Information Element	Value/remark	Comment	Condition
Extended protocol discriminator	5GSM		
PDU session ID	FFS		
PTI	FFS		
FFS			

Condition	Explanation

4.8 Reference configurations

4.8.1 Radio configurations

– *RRCReconfiguration-DRB(n, m)*

Table 4.8.1-1: RRCReconfiguration-DRB (n, m)

Derivation Path: TS 38.508-1, table 4.6.1-3			
Information Element	Value/remark	Comment	Condition
RRCReconfiguration ::= SEQUENCE {			
criticalExtensions CHOICE {			
c1 CHOICE {			
rrcReconfiguration ::= SEQUENCE {			
radioBearerConfig	RadioBearerConfig-DRB(n,m)		
secondaryCellGroup	CellGroupConfig-DRB(n,m)		
}			
}			
}			

– *CellGroupConfig-DRB(n, m)*

Table 4.8.1-2: CellGroupConfig-DRB(n, m)

Derivation Path: TS 38.508-1, table 4.6.3-13: CellGroupConfig			
Information Element	Value/remark	Comment	Condition
CellGroupConfig ::= SEQUENCE {			
cellGroupId	1		
rlc-BearerToAddModList SEQUENCE (SIZE(1..maxLCH)) OF SEQUENCE {	n+m entries	BID is the total number of established DRBs in the UE, before applying the contents of this IE	
logicalChannelIdentity[k, k=1..n+m]	k, k=1..n+m		
servedRadioBearer[k, k=BID+n..BID+n+m] CHOICE {			
drb-Identity	k, k=BID+n..BID+n+m		
}			
reestablishRLC[k, k=1..n+m]	[Not present]		
RLC-Config[k, k=BID+1..BID+n]	RLC-Config using condition AM.	n AM RLC DRBs	n>0
RLC-Config[k, k=BID+n..BID+n+m]	RLC-Config using condition UM.	m UM RLC DRBs	m>0
mac-LogicalChannelConfig[k, k=1..n+m]	k, k=1..n+m		
}			
}			

Condition	Explanation
n>0	n is greater than zero
m>0	m is greater than zero

– *RadioBearerConfig-DRB (n, m)***Table 4.8.1-3: RadioBearerConfig-DRB (n, m)**

Derivation Path: TS 38.508-1, table 4.6.3-100 and condition EN-DC			
Information Element	Value/remark	Comment	Condition
RadioBearerConfig ::= SEQUENCE {			
drb-ToAddModList SEQUENCE (SIZE (1..maxDRB))	n+m entries	BID is the total number of established DRBs in the UE, before applying the contents of this IE	
OF SEQUENCE {			
cnAssociation[k] CHOICE {			
eps-BearerIdentity	k, k=BID+5..BID+4+n+m		
sdap-Config	Not present		
}			
drb-Identity[k]	k, k=BID+1..BID+n+m		
reestablishPDCP[k]	Not present		
recoverPDCP[k]	Not present		
pdcpc-Config[k]	PDCP-Config		
}			
}			

4.9 Test procedures

4.9.1 Test procedure to check user plane connectivity on DRB#n

This procedure aims at checking whether the UE User Plane Access Stratum is capable of exchanging data on DRB#n (#n is the DRB Id specified in the test case when the present procedure is called). In case the UE supports IP, it is also checked that the UE IP stack is connected to the UE User Plane Access Stratum.

Table 4.9.1-1: Test procedure sequence

St	Procedure	Message Sequence		TP	Verdict
		U - S	Message/PDU/SDU		
-	EXCEPTION: Steps 1a1 to 1c2 describe behaviour that depends on the UE implementation; the "lower case letter" identifies a step sequence that take place depending on the UE implementation.	-	-	-	-
1a1	IF (pc_IP_Ping = TRUE AND pc_IPv4 = TRUE) THEN, the SS sends an ICMP Echo request to the IPv4 address assigned to the UE on DRB#n.	<--	ICMP ECHO REQUEST	-	-
1a2	Check: Does the UE send an ICMP Echo reply on DRB#n?	-->	ICMP ECHO REPLY	-	P
1b1	ELSE IF (pc_IP_Ping = TRUE AND (pc_IPv4 = FALSE AND pc_IPv6 = TRUE)) THEN, the SS sends an ICMPv6 Echo request to the IPv6 address assigned to the UE on DRB#n.	<--	ICMPv6 ECHO REQUEST	-	-
1b2	Check: Does the UE send an ICMPv6 Echo reply on DRB#n?	-->	ICMPv6 ECHO REPLY	-	P
1c1	ELSE, the SS transmits one IP Packet to verify data path on DRB#n. See NOTE 1.	-	-	-	-
1c2	Check: Does UE send the IP Packet on DRB#n in the uplink?	-	-	-	P

NOTE 1: A Test Loop is assumed to already have been closed

5 Test environments for RF test

5.1 Requirements of test equipment

5.1.1 Requirements for transmission and reception tests

5.1.1.1 Requirements common for conducted and OTA tests

Editor's Note: This subclause is intended to describe the test equipment requirements which are specific to transmission and reception tests and common for conducted and OTA tests.

5.1.1.2 Requirements for conducted tests

Editor's Note: This subclause is intended to describe the test equipment requirements which are specific to conducted test environment for transmission and reception tests.

5.1.1.3 Requirements for OTA tests

Editor's Note: This subclause is intended to describe the test equipment requirements which are specific to OTA test environment for transmission and reception tests.

5.1.2 Requirements for performance tests

5.1.2.1 Requirements common for conducted and OTA tests

Editor's Note: This subclause is intended to describe the test equipment requirements which are specific to performance tests and common for conducted and OTA tests.

5.1.2.2 Requirements for conducted test method

Editor's Note: This subclause is intended to describe the test equipment requirements which are specific to conducted test environment for performance tests.

5.1.2.3 Requirements for OTA test method

Editor's Note: This subclause is intended to describe the test equipment requirements which are specific to OTA test environment for performance tests.

5.2 Reference test conditions

5.2.1 Signal levels

5.2.1.1 Signal Levels for conducted testing

For NR FR1 cell, the downlink power settings are specified in TS 38.521-1[14] and TS 38.521-3[16].

The uncertainty value is specified in TS 38.521-1 [14] Annex F or in TS 38.521-2 [15] Annex F.

5.2.1.2 Signal Levels for OTA testing

5.2.1.2.1 Downlink Signal Levels

For E-UTRA cell in EN-DC with FR2 NR, the downlink power settings in table 5.2.1.2.1-1 are used unless otherwise specified in a test case.

Table 5.2.1.2.1-1: Default Downlink power levels for E-UTRA cell in EN-DC with FR2 NR

	Unit	Channel bandwidth					
		1.4 MHz	3 MHz	5 MHz	10 MHz	15 MHz	20 MHz
RS EPRE	dBm/15kHz	N/A	N/A	[-114.5] to -78.2	N/A	N/A	N/A

Note 1: The power level is specified at RSRP reference point as defined in TS 36.214 [21]

For FR2 NR cell, the downlink power settings in table 5.2.1.2.1-2 are used unless otherwise specified in a test case.

Table 5.2.1.2.1-2: Default Downlink power levels for FR2 NR in EN-DC with FR2 NR

TBD

6 Test environments for Signalling test

6.1 Requirements of test equipment

6.1.1 Requirements common for conducted and OTA tests

Editor's Note: This subclause is intended to describe the test equipment requirements which are specific to signalling tests and common for conducted and OTA tests.

6.1.2 Requirements for conducted test method

Editor's Note: This subclause is intended to describe the test equipment requirements which are specific to conducted test environment for signalling tests.

6.1.3 Requirements for OTA test method

6.1.3.1 General

The DFF or IFF based OTA test methodologies, defined in Annex B.1, should be used for Signalling test.

Note: For single cell test cases, which is the current scope for FR2 testing, usage of NF test methodology is not precluded

The section 6.1.3.2 describes a sample OTA measurement test setup and section 6.1.3.3 describes an optional procedure to find the optimum UE orientation.

6.1.3.2 Sample OTA Measurement Test Setup

Please refer to Figure 6.1.3.2-1 for a sample OTA measurement test setup.

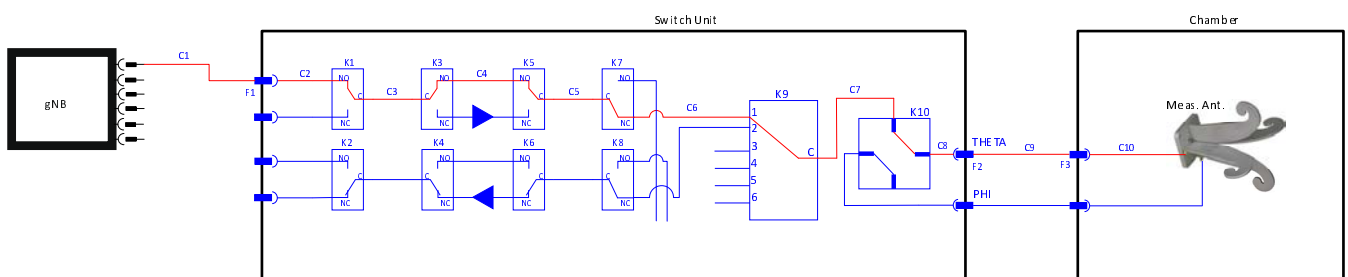

Figure 6.1.3.2-1: Sample OTA measurement setup

Note: Figure 6.1.3.2-1 is for illustrative purposes only.

For 5G NR signalling test cases, depending on the dynamic range of measurements the system complexity can be reduced. In the switch unit, as shown in Figure 6.1.3.2-1, the switches K7, K8, K9, K10 can be removed. The amplifier (PA/LNA) is optional. For the "single cell" test cases, the gNB emulator can be directly connected to the feed horn.

6.1.3.3 RSRP Based Procedure for finding the optimum UE Orientation

Before starting the test, optimum UE orientation needs to be identified in order to obtain reasonable link budget. The RSRP based feedback mechanism is described below for that purpose :

- Set calibrated power level at the centre of the QZ for each polarization individually.
- Set the UE in the test fixture in the chamber. Rotate the UE with step size of [5] degrees to search for a suitable direction for test which maximises reported RSRP.

Once this direction is identified using the above procedure, move UE to that direction to start the tests.

6.1.4 Requirements for timer tolerances

The timer tolerances specified for the test environment in this subclause apply to all Signalling test cases defined in TS 38.523-1 [12] unless otherwise specified

All the timers used during testing are within a tolerance margin given by the equation below. If for a specific test a different tolerance value is required, then this should be specified in the relevant test document (i.e. the document where the test is described).

Timer tolerance = 10%.

6.2 Reference test conditions

6.2.1 Physical Channel Allocations

6.2.1.1 Antennas

If the UE has two or more Rx antennas, the same downlink signal is applied to each one, except if MIMO is tested. All UE Rx antennas shall be connected.

If the UE has one Rx antenna, the downlink signal is applied to it.

6.2.1.2 Downlink physical channels and physical signals

Power allocation of downlink physical channels for Signalling test cases is specified in table 6.2.1.2-1.

Table 6.2.1.2-1: Power allocation for OFDM symbols and reference signals for Signalling test cases

Physical Channel	EPRE Ratio	Comment
PBCH	PBCH = 0 dB	Absolute EPRE conveyed to DUT by <i>SS-PBCH-BlockPower</i> (38.214 4.1)
PSS	PSS = 0 dB	Absolute EPRE conveyed to DUT by <i>SS-PBCH-BlockPower</i> (38.214 4.1)
SSS	SSS = 0 dB	Absolute EPRE conveyed to DUT by <i>SS-PBCH-BlockPower</i> (38.214 4.1)
PDCCH	PDCCH = 0 dB	0dB EPRE ratio to SSS
PDCCH DM-RS	PDCCH DM-RS = 0dB	0dB EPRE ratio to SSS
PDSCH	PDSCH = -3 dB	To reduce interference from PDSCH of intra-frequency neighbour cells. Conveyed to DUT by <i>Pc</i> as EPRE ratio to CSI-RS (38.214 5.2.2.3.1)
PDSCH DM-RS	PDSCH DM-RS = 0dB	0dB EPRE ratio to SSS
PDSCH PT-RS	PDSCH PT-RS=0dB	0dB EPRE ratio to SSS (38.214 4.1) (Note 1)
PBCH DM-RS	PBCH DM-RS = 0dB	0dB EPRE ratio to SSS (38.214 4.1)
CSI-RS	CSI-RS = 0dB	Conveyed to DUT by <i>Pc_SS</i> as EPRE ratio to SS/PBCH block (38.215 5.2.2.3.1) (Note 1)
Note 1: CSI-RS configured if the test cases defined in 38.523-1 [12] requires		

6.2.2 Signal levels

6.2.2.1 Signal Levels for conducted testing

Editor's note: Once RAN4 has defined the UE RSRP measurement accuracy, the power levels defined in this section need to be adapted.

For NR FR1 cell, the downlink power settings in Table 6.2.2.1-1 and 6.2.2.1-2 are used unless otherwise specified in a test case.

Table 6.2.2.1-1: Default Downlink power levels for FR1 NR cell (5MHz – 25MHz)

	SCS(kHz)	Unit	Channel bandwidth				
			5MHz	10MHz	15MHz	20MHz	25MHz
Channel BW Power	15	dBm	-63	-60	-58	-57	-56
	30	dBm	-67	-63	-61	-60	-59
	60	dBm	N/A	-67	-65	-63	-62
SS/PBCH SSS EPRE	All	dBm/SCS (Note 3)	-88	-88	-88	-88	-88
Note 1: The channel bandwidth powers are informative, based on -85 dBm/ SCS(SubCarrier Spacing) SS/PBCH SSS EPRE, then scaled according to the number of RBs and rounded to the nearest integer dBm value. Full RE allocation with no boost or deboost is assumed. Note 2: The power level is specified at each UE Rx antenna. Note 3: DL level is applied for any of the Subcarrier Spacing configuration (μ) with the same power spectrum density of -85 dBm/SCS(SubCarrier Spacing).							

Table 6.2.2.1-2: Default Downlink power levels for FR1 NR cell (30MHz – 100MHz)

	SCS(kHz)	Unit	Channel bandwidth						
			30MHz	40MHz	50MHz	60MHz	80MHz	90MHz	100MHz
Channel BW Power	15	dBm	-55	-54	-53	N/A	N/A	N/A	N/A
	30	dBm	-58	-57	-56	-55	-54	-53	-53
	60	dBm	-61	-60	-59	-58	-57	-56	-56
SS/PBCH SSS EPRE	All	dBm/SCS (Note 3)	-88	-88	-88	-88	-88	-88	-88
Note 1: The channel bandwidth powers are informative, based on -88dBm/SCS(SubCarrier Spacing) SS/PBCH SSS EPRE, then scaled according to the number of RBs and rounded to the nearest integer dBm value. Full RE allocation with no boost or deboost is assumed. Note 2: The power level is specified at each UE Rx antenna. Note 3: DL level is applied for any of the Subcarrier Spacing configuration (μ) with a power spectrum density of -88dBm/SCS(SubCarrier Spacing).									

The default settings of suitable cells and non-suitable cells for NR are specified in table 6.2.2.1-3.

Cells which are expected to be undetectable for UE under test shall fulfil the condition of non-suitable "Off" cell in table 6.2.2.1-3.

Table 6.2.2.1-3: Default settings of suitable / non-suitable cells

Power level type	NR (Note 1-3)		E-UTRAN
	Unit	Power level	
Serving cell	dBm/15kHz	-88	Table 6.2.2.1-1 [2]
Suitable neighbour intra-frequency cell	dBm/15kHz	[4-9]	Table 6.2.2.1-1 [2]
Suitable neighbour inter-frequency cell	dBm/15kHz	99[-]	Table 6.2.2.1-1 [2]
Non-suitable cell	dBm/15kHz	[-115]	Table 6.2.2.1-1 [2]
Non-suitable "Off" cell	dBm/15kHz	[\leq -145]	Table 6.2.2.1-1 [2]
Note 1:	The power level is specified in terms of SS/PBCH SSS EPRE instead of RSRP as RSRP is a measured value and cannot be directly controlled by the Full RE allocation with no boost or deboost is assumed. SS.		
Note 2:	The power level is specified at each UE Rx antenna.		
Note 3:	DL level is applied for any of the Subcarrier Spacing configuration (μ) with the same power spectrum density of [-85]dBm/15kHz.		
Note 4:	The default settings assume that the UE is making relative measurements of neighbour cells compared to the serving cell.		

The default signal level uncertainty is specified in table 6.2.2.1-4 for any level specified, unless a tighter uncertainty is specified by a test case in TS 38.523-1 [12].

Table 6.2.2.1-4: SS signal level uncertainty

	Absolute signal level uncertainty for each cell	Relative signal level uncertainty between multiple cells
Intra-frequency	+/-3 dB at each test port	+/-3 dB
Inter-frequency	+/-3 dB at each test port	See Note 1
Note 1:	For Inter-frequency cells the relative signal level uncertainty between multiple cells is determined by the absolute uncertainty of each cell, and does not have any additional constraint.	

SS/PBCH SSS EPRE setting should be equal to or higher than [FFS] dBm except for Non-suitable "Off" cell. The figure is chosen to ensure that for all bands the DL signal is within the RSRP measurement range specified in TS 38.133 [13], taking into account the SS default absolute signal level uncertainty.

NOTE: (The power spectral density of a white noise source; specified in TS 38.133 [13]) can be assumed to be -Infinity [dBm/15kHz] for all intra and inter frequency test cases. It is applicable to both idle mode and connected mode in TS 38.523-1 [12], unless otherwise specified in specific test cases.

6.2.2.1.1 Measurement accuracy and side conditions

RSRP measurement accuracy in RRC_CONNECTED state is specified in table 6.2.2.1.1-1, derived from TS 38.133 [13] clauses 10.1.2 and 10.1.4 selecting Normal condition with maximum I_o less than -50 dBm/BW_{Channel}. The ranges and side conditions in TS 38.133 [13] clauses 10.1.2 and 10.1.4 apply. This measurement accuracy is applicable to connected mode test cases specified in TS 38.523-1 [12]. For the serving cell and suitable neighbour cells, the following side conditions shall be satisfied including the effect of signal level uncertainty.

- RSRP \geq [-124] dBm
- RSRP $\hat{E}_s/I_{ot} > [-6]$ dB
- I_o : [TBD] dBm/SCS ... -50 dBm/BW_{Channel} (for absolute RSRP measurement accuracy)
- I_o : [TBD] dBm/SCS ... -50 dBm/BW_{Channel} (for relative RSRP measurement accuracy)

RSRP measurement accuracy in RRC_CONNECTED state is specified in table 6.2.2.1.1-1, derived from TS 38.133 [13] clauses 10.1.2 and 10.1.4 selecting Normal condition.

Table 6.2.2.1.1-1: RSRP measurement accuracy in RRC_CONNECTED state

	Absolute RSRP measurement accuracy	Relative RSRP measurement accuracy
Intra-frequency	+/-[8] dB	+/-[3] dB
Inter-frequency	+/-[8] dB	+/-[4.5] dB

6.2.2.2 Signal Levels for OTA testing

The power levels defined in this section are based on the following assumptions:

- For EN-DC, no more than one E-UTRA and one NR cell is configured in the test case
- For SA option 2, no more than one NR cell is configured in the test case
- AWGN is not configured in the test case

For NR FR2 cell, the downlink power settings in Table 6.2.2.2-1 are used unless otherwise specified in a test case.

Table 6.2.2.2-1: Default Downlink power levels for FR2 NR cell (50MHz - 400MHz)

	SCS(kHz)	Unit	Channel bandwidth			
			50MHz	100MHz	200MHz	400MHz
Channel BW Power	60	dBm	-66	-63	[-60]	NA
	120	dBm	-69	-66	[-63]	[-60]
SS/PBCH SSS EPRE	All	dBm/SCS	-95	-95	[-95]	[-95]
Note 1: The channel bandwidth powers are informative, based on -95 dBm/SCS SS/PBCH SSS EPRE, then scaled according to the number of RBs and rounded to the nearest integer dBm value. Full RE allocation with no boost or deboost is assumed.						
Note 2: The power level is specified at each UE Rx antenna.						

The default settings of suitable cells and non-suitable cells for NR are specified in table 6.2.2.2-2.

Cells which are expected to be undetectable for UE under test shall fulfil the condition of non-suitable "Off" cell in table 6.2.2.2-2.

Table 6.2.2.2-2: Default settings of suitable / non-suitable FR2 NR cells

Power level type	NR (Note 1-2)	
	Unit	Power level
Serving cell	dBm/SCS	-95
Suitable neighbour intra-frequency cell	dBm/SCS	TBD
Suitable neighbour inter-frequency cell	dBm/SCS	TBD
Non-suitable cell	dBm/SCS	TBD
Non-suitable "Off" cell	dBm/SCS	TBD
Note 1: The power level is specified in terms of SS/PBCH SSS EPRE instead of RSRP as RSRP is a measured value and cannot be directly controlled by the SS.		
Note 2: The power level is specified at each UE Rx antenna.		

For E-UTRA cell in EN-DC with FR2 NR, since the LTE OTA link is uncalibrated in the signalling test setup, the table 6.2.2.2-3 provides only suggestive value. It is left to the TE vendor to ensure that LTE cell power level fulfils the cell selection criteria.

Table 6.2.2.2-3: Default Downlink power levels

	Unit	Channel bandwidth					
		1.4 MHz	3 MHz	5 MHz	10 MHz	15 MHz	20 MHz
Number of RBs		6	15	25	50	75	100
Channel BW Power	dBm	-77	-73	-71	-68	-66	-65
RS EPRE	dBm/15kHz	-96	-96	-96	-96	-96	-96
Note 1:	The channel bandwidth powers are informative, based on -96 dBm/15kHz RS_EPRES, then scaled according to the number of RBs and rounded to the nearest integer dBm value. Full RE allocation with no boost or deboost is assumed.						
Note 2:	The power level is specified at each UE Rx antenna.						

The default settings of suitable cells and non-suitable cells for E-UTRA in EN-DC with FR2 NR are specified in table 6.2.2.2-4.

E-UTRA Cells in EN-DC with FR2 NR which are expected to be undetectable for UE under test shall fulfil the condition of non-suitable "Off" cell in table 6.2.2.2-4.

Table 6.2.2.2-4: Default settings of suitable / non-suitable E-UTRA cells in EN-DC with NR FR2

Power level type	NR (Note 1-2)	
	Unit	Power level
Serving cell	dBm/15KHz	-96
Suitable neighbour intra-frequency cell	dBm/15KHz	TBD
Suitable neighbour inter-frequency cell	dBm/15KHz	TBD
Non-suitable cell	dBm/15KHz	TBD
Non-suitable "Off" cell	dBm/15KHz	TBD
Note 1:	The power level is specified in terms of SS/PBCH SSS EPRES instead of RSRP as RSRP is a measured value and cannot be directly controlled by the SS.	
Note 2:	The power level is specified at each UE Rx antenna.	

6.2.3 Default test frequencies

Editor's note: For FR2 test frequencies using 100 MHz default channel bandwidth it is FFS if 100MHz channel bandwidth can be used for FR2 multicell protocol testing.

6.2.3.1 Test frequencies for NR standalone signalling testing

The default channel bandwidth for signalling test is specified per NR band. The test frequencies are defined so that no frequency overlapping takes place, in order to avoid unnecessary inter-frequency interference.

For some NR bands (e.g. n51 or n76), only one test frequency NRf1 is defined. All other operating bands can accommodate at least three test frequencies NRf1, NRf2 and NRf3 (NRf3<NRf1<NRf2). The fourth test frequency NRf4 (NRf3<NRf1<NRf4<NRf2) is applicable to the operating bands which have at least quadruple of the default bandwidth.

The signalling test frequencies NRf1, NRf2, NRf3, and NRf4 and associated signalling parameters for bands with up to three frequencies are mapped as follows: Low Range (NRf3), Mid Range (NRf1) and High Range (NRf2). For bands with up to four frequencies, the frequencies are mapped as follows: Low Range (NRf3), High Range (NRf2), Mid-Low Range (NRf1) and Mid-High Range (NRf4). For bands with only one test frequency, the frequency is mapped as follows: Mid Range (NRf1).

The test frequencies, subcarrier spacing, default channel bandwidth, SS/PBCH block and CORESET#0 parameters for signalling is specified in Table 6.2.3.1-1 (FDD FR1 BW 5MHz), Table 6.2.3.1-2 (FDD FR1 BW 10MHz), Table 6.2.3.1-3 (TDD FR1 BW 5MHz), Table 6.2.3.1-4 (TDD FR1 BW 10MHz), Table 6.2.3.1-5 (TDD FR1 BW 100MHz) and Table 6.2.3.1-6 (TDD FR2 BW 100MHz).

Table 6.2.3.1-1: Test frequencies for NR FDD FR1 bands using 5 MHz channel bandwidth

NR Band	SCS [kHz]	Band width [MHz]	carrier Bandwidth [PRBs]	Range	Carrier centre [MHz]	Carrier centre [ARFCN]	point A [MHz]	absolute Frequency Point A [ARFCN]	offsetTo Carrier [PRBs]	SS block SCS [kHz]	GSC N	absolute FrequencySSB [ARFCN]	k_{SSB}	CORE SET#0 Offset [RBs] Note 1	CORE SET#0 Index Note 1	
n5	15	5	25	Downlink	Low, High	Same values as for Low and High range in clause 4.3.1.5 for bandwidth=5 MHz and SCS=15 kHz.										
					Mid-Low	878.2	175640	874.15	174830	10	15	2197	175730	12	4	2
					Mid-High	884.8	176960	878.59	175718	22	2212	176930	20	0	0	
				Uplink	Low, High	Same values as for Low and High range in clause 4.3.1.5 for bandwidth=5 MHz and SCS=15 kHz.										
					Mid-Low	833.1	166620	825.09	165018	32	-	-	-	-	-	-
					Mid-High	839.8	167960	817.21	163442	113	-	-	-	-	-	-
n8	15	5	25	Downlink	Low, High	Same values as for Low and High range in clause 4.3.1.8 for bandwidth=5 MHz and SCS=15 kHz.										
					Mid-Low	937.5	187500	933.45	186690	10	15	2343	187470	20	0	0
					Mid-High	947.5	189500	941.29	188258	22	2368	189410	0	0	0	
				Uplink	Low, High	Same values as for Low and High range in clause 4.3.1.8 for bandwidth=5 MHz and SCS=15 kHz.										
					Mid-Low	892.5	178500	884.49	176898	32	-	-	-	-	-	-
					Mid-High	902.5	180500	879.91	175982	113	-	-	-	-	-	-
n12	15	5	25	Downlink	Low, High	Same values as for Low, Mid and High range in clause 4.3.1.12 for bandwidth=5 MHz and SCS=15 kHz.										
				Uplink	Low, High	Same values as for Low, Mid and High range in clause 4.3.1.12 for bandwidth=5 MHz and SCS=15 kHz.										
n20	15	5	25	Downlink	Low, High	Same values as for Low and High range in clause 4.3.1.20 for bandwidth=5 MHz and SCS=15 kHz.										
					Mid-Low	801.8	160360	797.75	159550	10	15	2003	160330	20	0	0
					Mid-High	810.2	162040	803.99	160798	22	2024	162010	20	0	0	
				Uplink	Low, High	Same values as for Low and High range in clause 4.3.1.20 for bandwidth=5 MHz and SCS=15 kHz.										
					Mid-Low	842.8	168560	834.79	166958	32	-	-	-	-	-	-
					Mid-High	851.1	170220	828.51	165702	113	-	-	-	-	-	-
n70	15	5	25	Downlink	Low, High	FFS										
				Uplink	Low, High	FFS										
n71	15	5	25	Downlink	Low, High	Same values as for Low and High range in clause 4.3.1.71 for bandwidth=5 MHz and SCS=15 kHz.										
					Mid-Low	629.5	125900	625.45	125090	10	15	1573	125810	0	0	0
					Mid-High	639.5	127900	633.29	126658	22	1598	127930	16	2	1	
				Uplink	Low, High	Same values as for Low and High range in clause 4.3.1.71 for bandwidth=5 MHz and SCS=15 kHz.										
					Mid-Low	675.5	135100	667.49	133498	32	-	-	-	-	-	-
					Mid-High	685.5	137100	662.91	132582	113	-	-	-	-	-	-
n76	15	5	25	Downlink (SDL)	Mid	Same values as for Mid range in clause 4.3.1.76 for bandwidth=5 MHz and SCS=15 kHz.										
Note 1: The CORESET#0 Index and the associated CORESET#0 Offset refers to Table 13-1 in TS 38.213 [22]. The value of CORESET#0 Index is signalled in the four most significant bits of the IE pdcch-ConfigSIB1 in the MIB																

Table 6.2.3.1-2: Test frequencies for NR FDD FR1 bands using 10 MHz channel bandwidth

NR Band	SCS [kHz]	Band width [MHz]	carrier Bandwidth [PRBs]	Range	Carrier centre [MHz]	Carrier centre [ARFCN]	point A [MHz]	absolute Frequency Point A [ARFCN]	offsetTo Carrier [PRBs]	SS block SCS [kHz]	GSC N	absolute FrequencySSB [ARFCN]	k_{SSB}	CORE SET#0 Offset [RBs] Note 1	CORE SET#0 Index Note 1	
n1	15	10	52	Downlink	Low, High	Same values as for Low and High range in clause 4.3.1.1 for bandwidth=10 MHz and SCS=15 kHz.										
					Mid-Low	2131.7	426340	2125.22	425044	10	15	5321	425770	2	0	0
					Mid-High	2148.3	429660	2139.66	427932	22		5364	429150	22	0	0
				Uplink	Low, High	Same values as for Low and High range in clause 4.3.1.1 for bandwidth=10 MHz and SCS=15 kHz.										
					Mid-Low	1941.6	388320	1931.16	386232	32	-	-	-	-	-	-
					Mid-High	1958.3	391660	1933.28	386656	113	-	-	-	-	-	-
n2	15	10	52	Downlink	Low, High	Same values as for Low and High range in clause 4.3.1.2 for bandwidth=10 MHz and SCS=15 kHz.										
					Mid-Low	1951.7	390340	1945.22	389044	10	15	4871	389770	2	0	0
					Mid-High	1968.3	393660	1959.66	391932	22		4914	393150	22	0	0
				Uplink	Low, High	Same values as for Low and High range in clause 4.3.1.2 for bandwidth=10 MHz and SCS=15 kHz.										
					Mid-Low	1871.6	374320	1861.16	372232	32	-	-	-	-	-	-
					Mid-High	1888.3	377660	1863.28	372656	113	-	-	-	-	-	-
n3	15	10	52	Downlink	Low, High	Same values as for Low and High range in clause 4.3.1.3 for bandwidth=10 MHz and SCS=15 kHz.										
					Mid-Low	1831.7	366340	1825.22	365044	10	15	4571	365770	2	0	0
					Mid-High	1853.3	370660	1844.66	368932	22		4625	370090	2	0	0
				Uplink	Low, High	Same values as for Low and High range in clause 4.3.1.3 for bandwidth=10 MHz and SCS=15 kHz.										
					Mid-Low	1736.6	347320	1726.16	345232	32	-	-	-	-	-	-
					Mid-High	1758.3	351660	1733.28	346656	113	-	-	-	-	-	-
n7	15	10	52	Downlink	Low, High	Same values as for Low and High range in clause 4.3.1.7 for bandwidth=10 MHz and SCS=15 kHz.										
					Mid-Low	2645	529000	2638.52	527704	10	15	6605	528490	22	0	0
					Mid-High	2665	533000	2656.36	531272	22		6658	532610	14	4	2
				Uplink	Low, High	Same values as for Low and High range in clause 4.3.1.7 for bandwidth=10 MHz and SCS=15 kHz.										
					Mid-Low	2525	505000	2514.56	502912	32	-	-	-	-	-	-
					Mid-High	2545	509000	2519.98	503996	113	-	-	-	-	-	-
n25	15	10	52	Downlink	Low, High	Same values as for Low and High range in clause 4.3.1.25 for bandwidth=10 MHz and SCS=15 kHz.										
					Mid-Low	1953.3	390660	1946.82	389364	10	15	4878	390270	14	4	2
					Mid-High	1971.7	394340	1963.06	392612	22		4924	393890	18	2	1
				Uplink	Low, High	Same values as for Low and High range in clause 4.3.1.25 for bandwidth=10 MHz and SCS=15 kHz.										
					Mid-Low	1873.3	374660	1862.86	372572	32	-	-	-	-	-	-
					Mid-High	1891.6	378320	1866.58	373316	113	-	-	-	-	-	-
n28	15	10	52	Downlink	Low, High	Same values as for Low and High range in clause 4.3.1.28 for bandwidth=10 MHz and SCS=15 kHz.										
					Mid-Low	774.7	154940	768.22	153644	10	15	1930	154370	2	0	0
					Mid-High	786.3	157260	777.66	155532	22		1959	156750	22	0	0
				Uplink	Low, High	Same values as for Low and High range in clause 4.3.1.28 for bandwidth=10 MHz and SCS=15 kHz.										
					Mid-Low	719.6	143920	709.16	141832	32	-	-	-	-	-	-
					Mid-High	731.3	146260	706.28	141256	113	-	-	-	-	-	-
n66	15	10	52	Downlink	Low, High	FFS										
					Mid-Low	FFS	FFS	FFS	FFS	FFS	15	FFS	FFS	FFS	FFS	FFS
					Mid-High	FFS	FFS	FFS	FFS	FFS		FFS	FFS	FFS	FFS	FFS

				Uplink	Low, High	FFS									
					Mid-Low	FFS	FFS	FFS	FFS	FFS	-	-	-	-	-
					Mid-High	FFS	FFS	FFS	FFS	FFS	-	-	-	-	-
n75	15	10	52	Downlink (SDL)	Low, High	Same values as for Low, Mid and High range in clause 4.3.1.75 for bandwidth=10 MHz and SCS=15 kHz.									

Note 1: The CORESET#0 Index and the associated CORESET#0 Offset refers to Table 13-1 in TS 38.213 [22]. The value of CORESET#0 Index is signalled in the four most significant bits of the IE pdccch-ConfigSIB1 in the MIB

Table 6.2.3.1-3: Test frequencies for NR TDD FR1 bands using 5 MHz channel bandwidth

NR Band	SCS [kHz]	Band width [MHz]	carrierBandwidth [PRBs]	Range	Carrier centre [MHz]	Carrier centre [ARFCN]	point A [MHz]	absolute FrequencyPoint A [ARFCN]	offsetTo Carrier [PRBs]	SS block SCS [kHz]	GSC N	absolute FrequencySSB [ARFCN]	k_{SSB}	CORE SET#0 Offset [RBs]	CORE SET#0 Index
n34	15	5	25	Downlink & Uplink	Low, Mid, High	Same values as for Low, Mid and High range in clause 4.3.1.12 for bandwidth=5 MHz and SCS=15 kHz.									
n51	15	5	25	Downlink & Uplink	Mid	Same values as for Mid range in clause 4.3.1.51 for bandwidth=5 MHz and SCS=15 kHz.									

Table 6.2.3.1-4: Test frequencies for NR TDD FR1 bands using 10 MHz channel bandwidth

NR Band	SCS [kHz]	Band width [MHz]	carrierBandwidth [PRBs]	Range	Carrier centre [MHz]	Carrier centre [ARFCN]	point A [MHz]	absolute FrequencyPoint A [ARFCN]	offsetTo Carrier [PRBs]	SS block SCS [kHz]	GSC N	absolute FrequencySSB [ARFCN]	k_{SSB}	CORE SET#0 Offset [RBs] Note 1	CORE SET#0 Index Note 1	
n38	15	10	52	Downlink & Uplink	Low, High	Same values as for Low and High range in clause 4.3.1.38 for bandwidth=10 MHz and SCS=15 kHz.										
					Mid-Low	2588.3	517660	2581.82	516364	10	15	6464	517210	18	2	1
					Mid-High	2601.7	520340	2593.06	518612	22		6499	519890	18	2	1
n39	15	10	52	Downlink & Uplink	Low High	Same values as for Low and High range in clause 4.3.1.39 for bandwidth=10 MHz and SCS=15 kHz.										
					Mid-Low	1895	379000	1888.52	377704	10	15	4730	378490	22	0	0
					Mid-High	1905	381000	1896.36	379272	22		4755	380430	2	0	0
n40	15	10	52	Downlink & Uplink	Low, High	Same values as for Low and High range in clause 4.3.1.40 for bandwidth=10 MHz and SCS=15 kHz.										
					Mid-Low	2335	467000	2328.52	465704	10	15	5833	466610	14	4	2
					Mid-High	2365	473000	2356.36	471272	22		5908	472610	14	4	2
n41	30	10	24	Downlink & Uplink	Low, High	Same values as for Low and High range in clause 4.3.1.41 for bandwidth=10 MHz and SCS=30 kHz.										
					Mid-Low	2562.33	512466	2554.41	510882	10	30	6405	512430	12	1	1
					Mid-High	2623.68	524736	2611.44	522288	22		6558	524670	2	1	1

Note 1: The CORESET#0 Index and the associated CORESET#0 Offset refers to Table 13-1 in TS 38.213 [22] for all bands in the table except for band n41 where Table 13-4 apply. The value of CORESET#0 Index is signalled in the four most significant bits of the IE pdccch-ConfigSIB1 in the MIB

Table 6.2.3.1-5: Test frequencies for NR TDD FR1 bands using 100 MHz channel bandwidth

NR Band	SCS [kHz]	Band width [MHz]	carrier Bandwidth [PRBs]	Range	Carrier centre [MHz]	Carrier centre [ARFCN]	point A [MHz]	absolute Frequency Point A [ARFCN]	offsetTo Carrier [PRBs]	SS block SCS [kHz]	GSC N	absolute Frequency SSB [ARFCN]	k_{SSB}	CORE SET#0 Offset [RBs] Note 1	CORE SET#0 Index Note 1	
n77	30	100	273	Downlink & Uplink	Low, High	Same values as for Low and High range in clause 4.3.1.77 for bandwidth=100 MHz and SCS=30 kHz.										
					Mid-Low	3616.68	641112	3563.94	637596	10	30	7896	638112	12	1	1
					Mid-High	3883.32	658888	3826.26	655084	22	8081	655872	20	0	0	
n78	30	100	273	Downlink & Uplink	Low, High	Same values as for Low and High range in clause 4.3.1.78 for bandwidth=100 MHz and SCS=30 kHz.										
					Mid-Low	3483.33	632222	3430.59	628706	10	30	7804	629280	22	3	3
					Mid-High	3616.68	641112	3559.62	637308	22	7896	638112	12	1	1	
n79	30	100	273	Downlink & Uplink	Low, High	Same values as for Low and High range in clause 4.3.1.79 for bandwidth=100 MHz and SCS=30 kHz.										
					Mid-Low	4617.69	707846	4564.95	704330	10	30	8592	704928	22	4	0
					Mid-High	4780.74	718716	4723.68	714912	22	8704	715680	0	0	0	
Note 1: The CORESET#0 Index and the associated CORESET#0 Offset refers to Table 13-4 in TS 38.213 [22] for all bands in the table except for band n79 where Table 13-6 apply. The value of CORESET#0 Index is signalled in the four most significant bits of the IE pdccch-ConfigSIB1 in the MIB																

Table 6.2.3.1-6: Test frequencies for NR TDD FR2 bands using 100 MHz channel bandwidth

NR Band	SCS [kHz]	Band width [MHz]	carrier Bandwidth [PRBs]	Range	Carrier centre [MHz]	Carrier centre [ARFCN]	point A [MHz]	absolute Frequency Point A [ARFCN]	offsetTo Carrier [PRBs]	SS block SCS [kHz]	GSCN	absolute Frequency SSB [ARFCN]	k_{SSE}	CORE SET#0 Offset [RBs] Note 1	CORE SET#0 Index Note 1	
n257	120	100	66	Downlink & Uplink	Low, High	Same values as for Low and High range in clause 4.3.1.257 for bandwidth=100 MHz and SCS=120 kHz.										
					Mid-Low	27524.76	2071245	27462.84	2070213	10	120	22444	2070811	22	4	1
					Mid-High	28492.44	2087373	28413.24	2086053	22	22500	2086939	22	4	1	
n258	120	100	66	Downlink & Uplink	Low, High	Same values as for Low and High range in clause 4.3.1.258 for bandwidth=100 MHz and SCS=120 kHz.										
					Mid-Low	25348.44	2034973	25286.52	2033941	10	120	22318	2034523	6	4	1
					Mid-High	26401.56	2052525	26322.36	2051205	22	22379	2052091	22	4	1	
n260	120	100	66	Downlink & Uplink	Low, High	Same values as for Low and High range in clause 4.3.1.260 for bandwidth=100 MHz and SCS=120 kHz.										
					Mid-Low	38019.48	2246157	37957.56	2245125	10	120	23051	2245627	22	0	0
					Mid-High	38987.16	2262285	38907.96	2260965	22	23107	2261755	22	0	0	
n261	120	100	66	Downlink & Uplink	Low, High	Same values as for Low and High range in clause 4.3.1.261 for bandwidth=100 MHz and SCS=120 kHz.										
					Mid-Low	27807	2075949	27745.08	2074917	10	120	22460	2075419	22	0	0
					Mid-High	28048.92	2079981	27969.72	2078661	22	22474	2079451	22	0	0	
Note 1: The CORESET#0 Index and the associated CORESET#0 Offset refers to Table 13-8 in TS 38.213 [22]. The value of CORESET#0 Index is signalled in the four most significant bits of the IE pdccch-ConfigSIB1 in the MIB																

6.2.3.2 Test frequencies for EN-DC band combinations for signalling testing

For EN-DC Inter-band case (2 bands) the EN-DC configurations are specified in clause 4.3.1.3.2.0 and the E-UTRA and NR test frequencies are specified in TS 36.508 [2], clause 6.2.3.1 for the E-UTRA band (E-UTRA f1, f2, f3 and f4); and in clause 6.2.3.1 for the NR band (NRf1, NRf2, NRf3, NRf4). For EN-DC Intra-Band Contiguous case (2 bands) and EN-DC Intra-Band Non-Contiguous case (2 bands) for NR bands with up to 3 frequencies use the test frequencies as specified for Low (NRf2), Mid (NRf1) and High (NRf3) in clause [4.3.1.3.2] for the EN-DC configuration using default bandwidth for the E-UTRA cell as specified in TS 36.508 [2], clause 6.2.3.1 and the default bandwidth of the NR cell as specified in clause 6.2.3.1.

For EN-DC Intra-Band Contiguous case (2 bands) and up to 4 frequencies use the test frequencies as specified in clause [4.3.FFS].

6.3 Reference system configurations

6.3.1 Cell configurations

Editor's Note: To define different types of SS cell configurations. It may be similar as defined in 3GPP TS 36.508 [2], clause 6.3.3 and 6.3.4 i.e. full, minimum uplink, broadcast only and virtual cell configuration. But details are FFS and depending on different connectivity options (MR-DC and SA).

7 Test environments for RRM tests

7.1 Requirements of test equipment

7.1.1 Requirements common for conducted and OTA tests

Editor's Note: This subclause is intended to describe the test equipment requirements which are specific to RRM tests and common for conducted and OTA tests.

7.1.2 Requirements for conducted test method

Editor's Note: This subclause is intended to describe the test equipment requirements which are specific to conducted test environment for RRM tests.

7.1.3 Requirements for OTA test method

Editor's Note: This subclause is intended to describe the test equipment requirements which are specific to OTA test environment for RRM tests.

7.2 Reference test conditions

7.2.1 Signal levels

7.2.1.1 Signal Levels for conducted testing

TBD

7.2.1.2 Signal Levels for OTA testing

TBD

Annex A (informative): Connection Diagrams

A.1 Definition of Terms

System Simulator or SS – A device or system, that is capable of generating simulated Node B signalling and analysing UE signalling responses on one or more RF channels, in order to create the required test environment for the UE under test. It will also include the following capabilities:

1. Measurement and control of the UE Tx output power through TPC commands
2. Measurement of Throughput
3. Measurement of signalling timing and delays
4. Ability to simulate UTRAN and/or E-UTRAN and/or GERAN signalling

Test System – A combination of devices brought together into a system for the purpose of making one or more measurements on a UE in accordance with the test case requirements. A test system may include one or more System Simulators if additional signalling is required for the test case. The following diagrams are all examples of Test Systems.

NOTE 1: The above terms are logical definitions to be used to describe the test methods used in the documents TS38.521-1, TS38.521-2, TS38.521-3, TS 38.523-1 and TS38.533 in practice, real devices called 'System Simulators' may also include additional measurement capabilities or may only support those features required for the test cases they are designed to perform.

NOTE 2: Components in the connection diagrams:

The components in the connection diagrams represent ideal components. They are intended to display the wanted signal flow. They don't mandate real implementations.

Connection: Each connection is displayed as a one or two sided arrow, showing the intended signal flow. In some cases, for some tests, some connections shown may not be necessary (for example UL RX connection for a second cell).

Circulator: The signal, entering one port, is conducted to the adjacent port, indicated by the arrow. The attenuation among the above mentioned ports is ideally 0 and the isolation among the other ports is ideally ∞ .

Splitter: a splitter has one input and 2 or more outputs. The signal at the input is equally divided to the outputs. The attenuation from input to the outputs is ideally 0 and the isolation between the outputs is ideally ∞ .

Combiner: a combiner has one output and 2 or more inputs. The signals at the inputs are conducted to the output, all with the same, ideally 0 attenuation. The isolation between the inputs is ideally ∞ .

Switch: contacts a sink (or source) alternatively to two or more sources (or sinks).

Fader: The fader has one input and one output. The MIMO fading channel is represented by several single faders (e.g. 8 in case of a MIMO antenna configuration 4x2) The correlation among the faders is described in TS 36.521-1 clause B.2.2. In some cases, for some tests, diagrams with fader(s) are referenced when no fading is required; in this case the fader(s) is omitted.

Attenuator: TBD

Test Equipment Part (TE): is the section of the connection diagram focused including a combination of devices to perform one or several measurements on a UE depending on the test requirements specified in 3GPP TS 38.101-1 [7], 3GPP TS 38.101-2 [8] and 3GPP TS 38.101-3 [9]. The basic TE is the system simulator to enable the connection between the gNB (and the eNB, if NSA mode) and the DUT. The number of cells, the number of streams per cell and how to combine them, channel and propagations conditions, etc. are also part of the TE. Other instruments as external spectrum analyser, interferer generators, external faders or external AWGN generators can be also considered part of the TE, as these instruments allow to measure a test requirement or to set the UE under certain conditions.

DUT Part (UE): for conducted measurement this section is focused on the number of physical antenna connectors and how to combine in the DUT. For radiated measurement this section shows the connections needed to translate the UL/DL streams to the radiated part.

A.2 General considerations on Connections Diagram

In order to improve the maintainability and the readability of this section and to make easy to identify the whole connection diagram to use per each test case, several considerations have been used for this section:

- The whole connection diagram to use for a specific test has been split in Test Equipment (TE) and User Equipment (UE) parts.
- The same connection diagram will be used for SA and NSA, where the LTE link is specified in each connection diagram (TE and UE) with a dashed line (and this part will be only used for NSA).
- To obtain the whole connection diagram required per each test case is necessary to specify the TE part required for each measurement and the UE part will depend on the UE antenna implementation.

A.3 Connections Diagram

A.3.1 Test Equipment Parts

Editor's note: RAN4 has not defined yet any interferer requirement for NSA in TS 38.101-3 then Receiver tests using Signal Generator connection diagrams do not include LTE part.

A.3.1.1 Basic Transmitter/Receiver tests

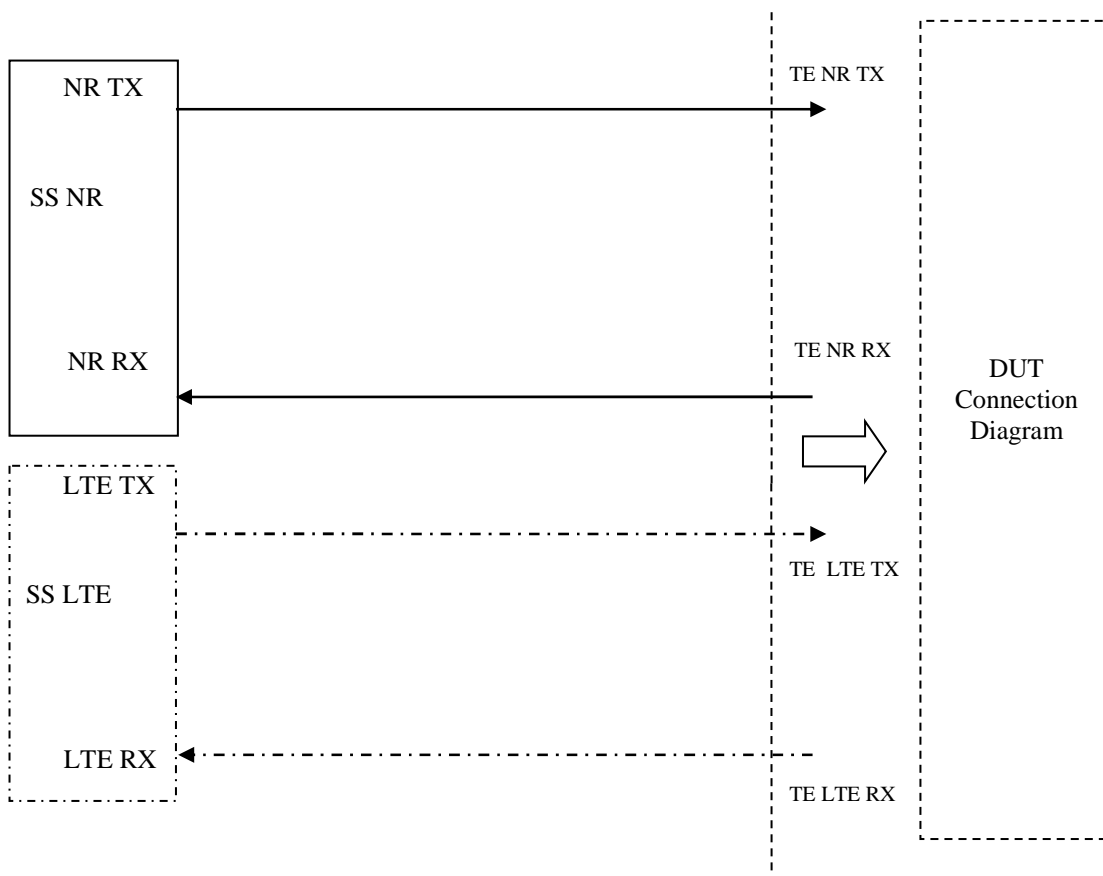

Figure A.3.1.1.1: Test Equipment connection for basic single cell, RX and TX tests

A.3.1.2 Transmitter tests using Spectrum Analyser

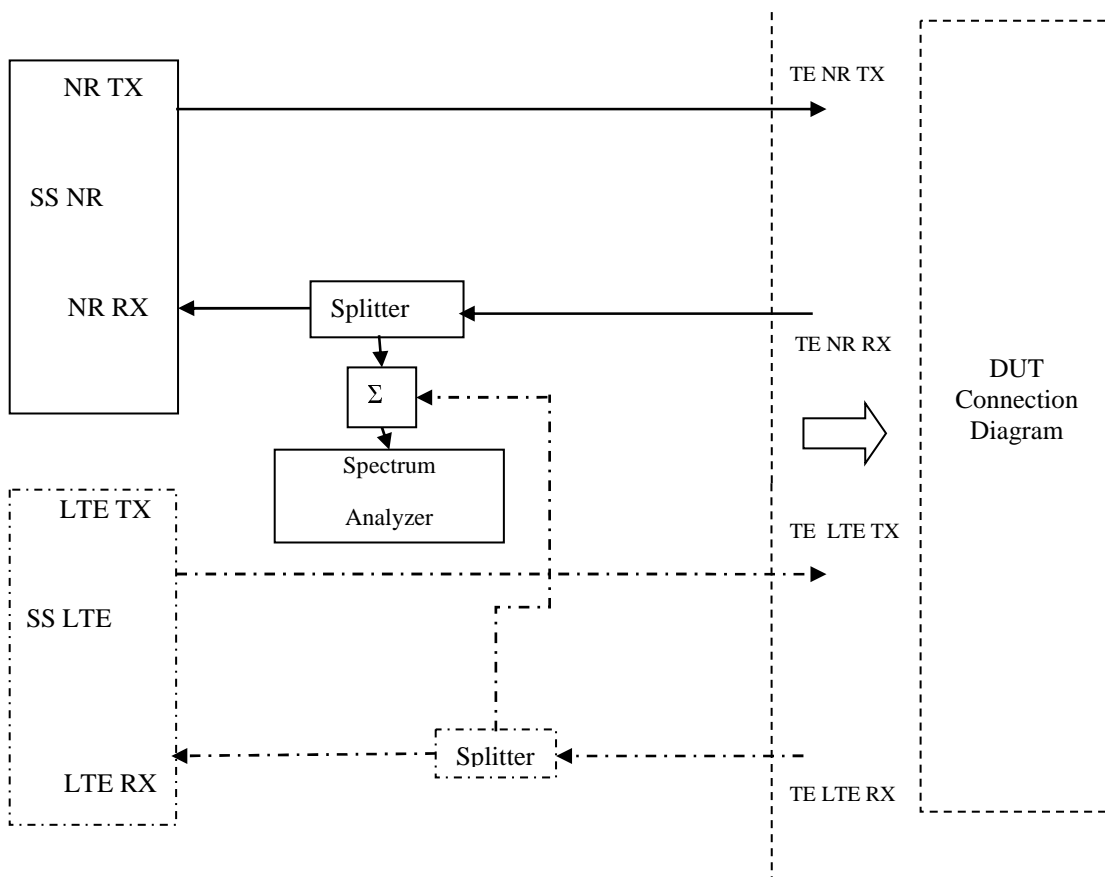

Figure A.3.1.2.1: Test Equipment connection for TX-tests with additional Spectrum Analyser

A.3.1.3 Transmitter tests using Spectrum Analyser and Signal Generator

A.3.1.4 Receiver tests using Signal Generator

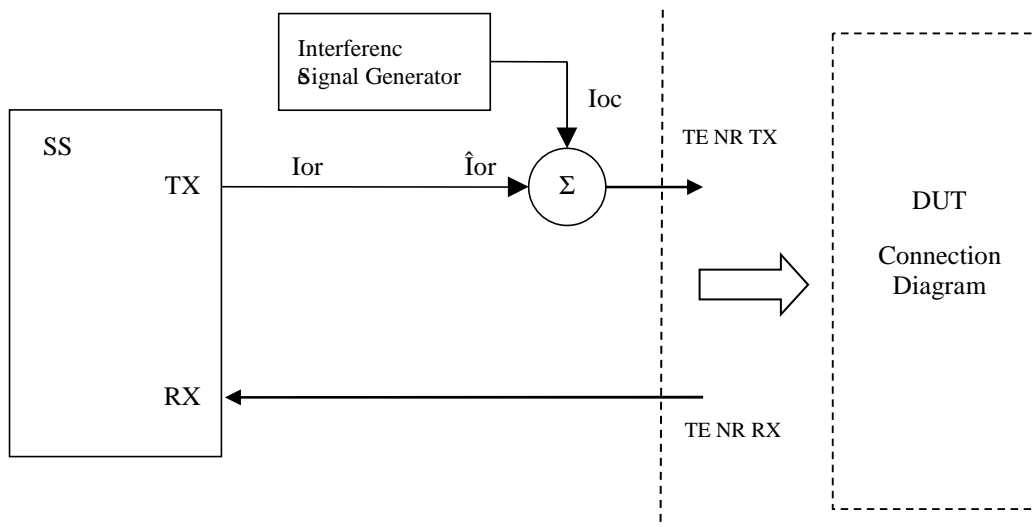

Figure A.3.1.4.1: Test Equipment connection for Receiver tests with Modulated Interference

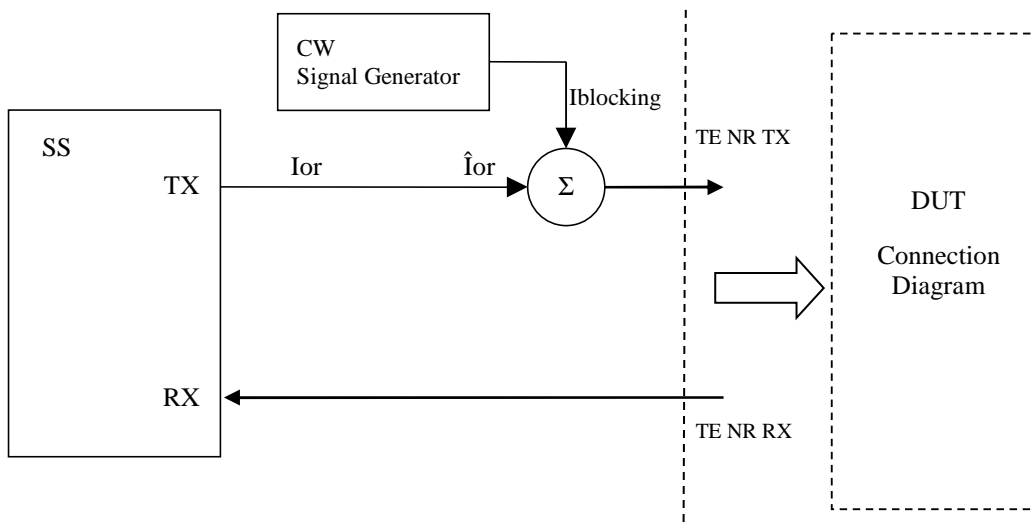

Figure A.3.1.4.2: Test Equipment connection for Receiver tests with CW Interference

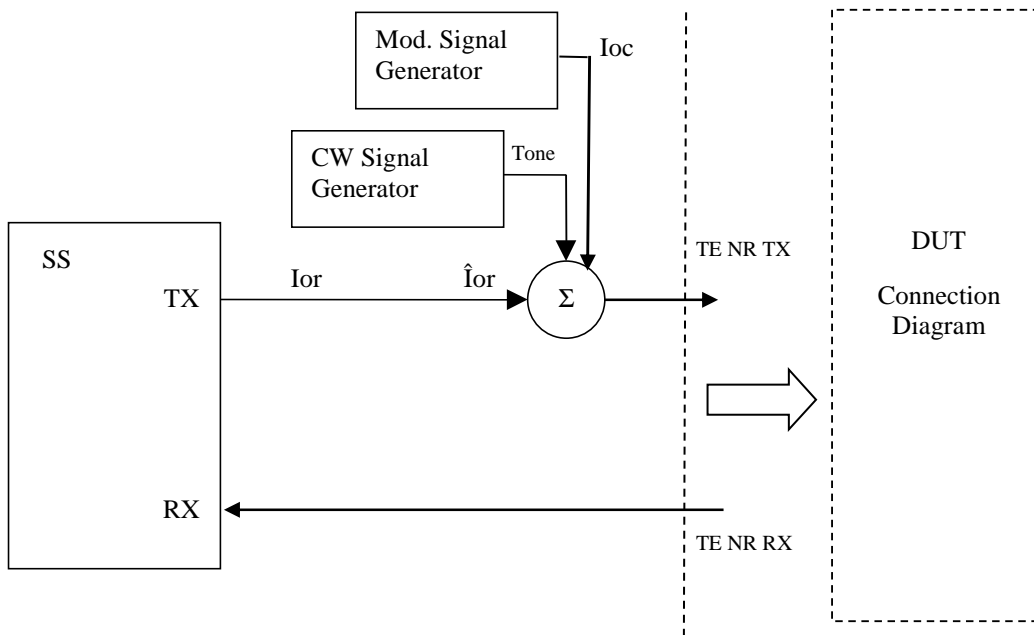

Figure A.3.1.4.3: Test Equipment connection for Receiver tests both Modulated and additional CW Interference signal

A.3.1.5 Receiver tests using Spectrum Analyser

FFS

A.3.1.6 Receiver Performance tests

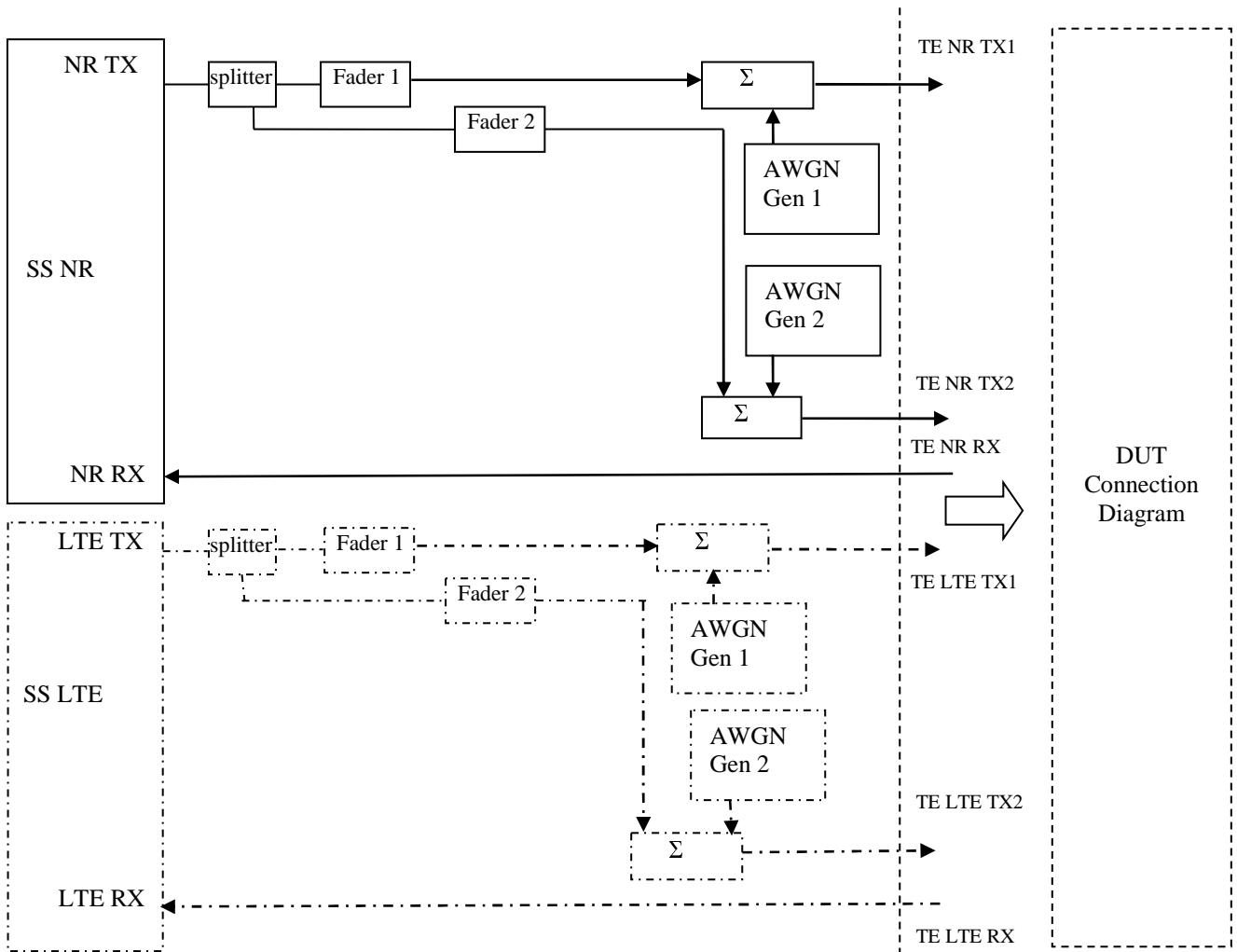

Figure A.3.1.6.1: Test Equipment connection for Receiver Performance tests with antenna configuration 1x2

A.3.2 User Equipment Parts

A.3.2.1 Conducted Measurements

A.3.2.1.1 General

The User Equipment part is focused on the number of physical antenna connectors and how to combine in the DUT. Depending on the DUT implementation only one of the following connection diagrams applies. These connection diagrams are examples of User equipment parts.

A.3.2.1.2 One Antenna Connector

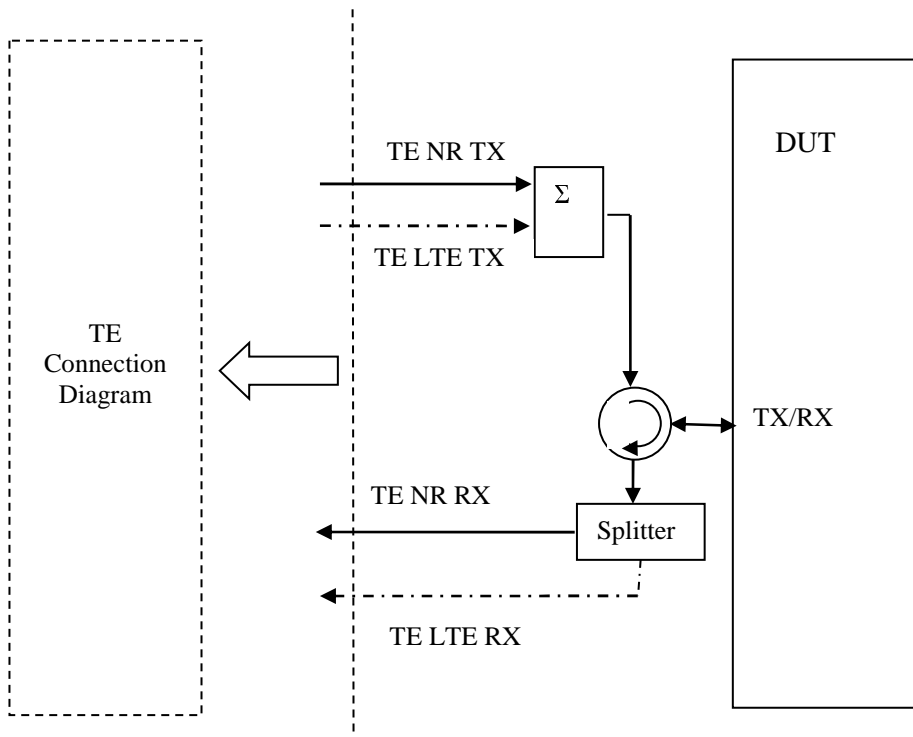

Figure A.3.2.1.2.1: User Equipment connection for single basic cell

A.3.2.1.3 Two Antenna Connectors

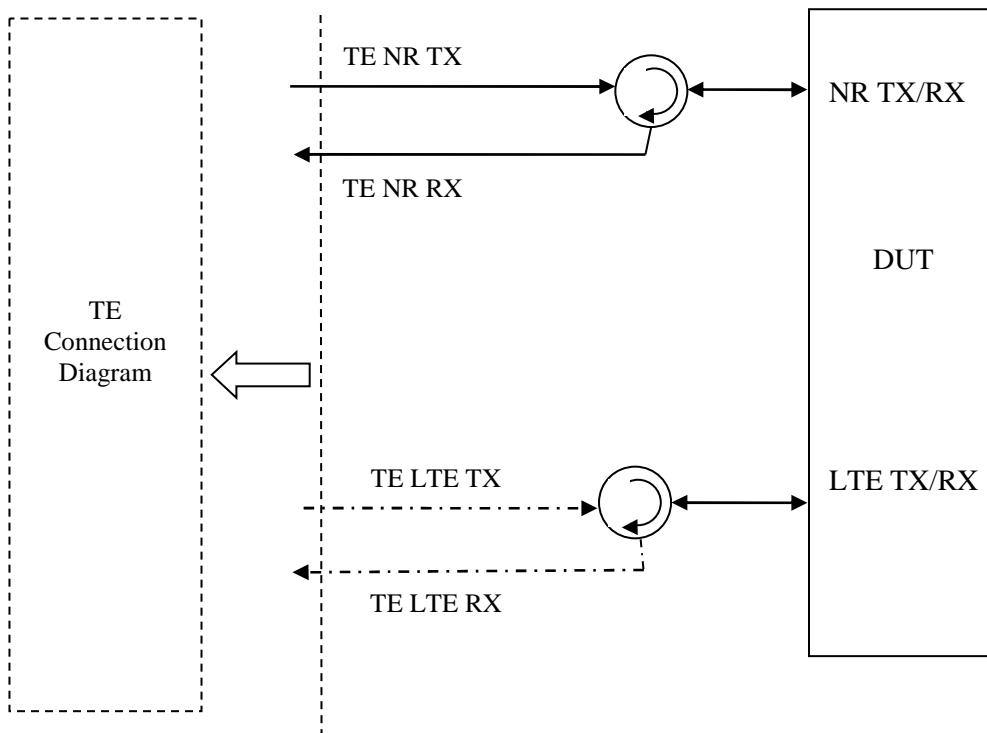

Figure A.3.2.1.3.1: User Equipment connection for single basic cell with NR and LTE cells at different separated connectors

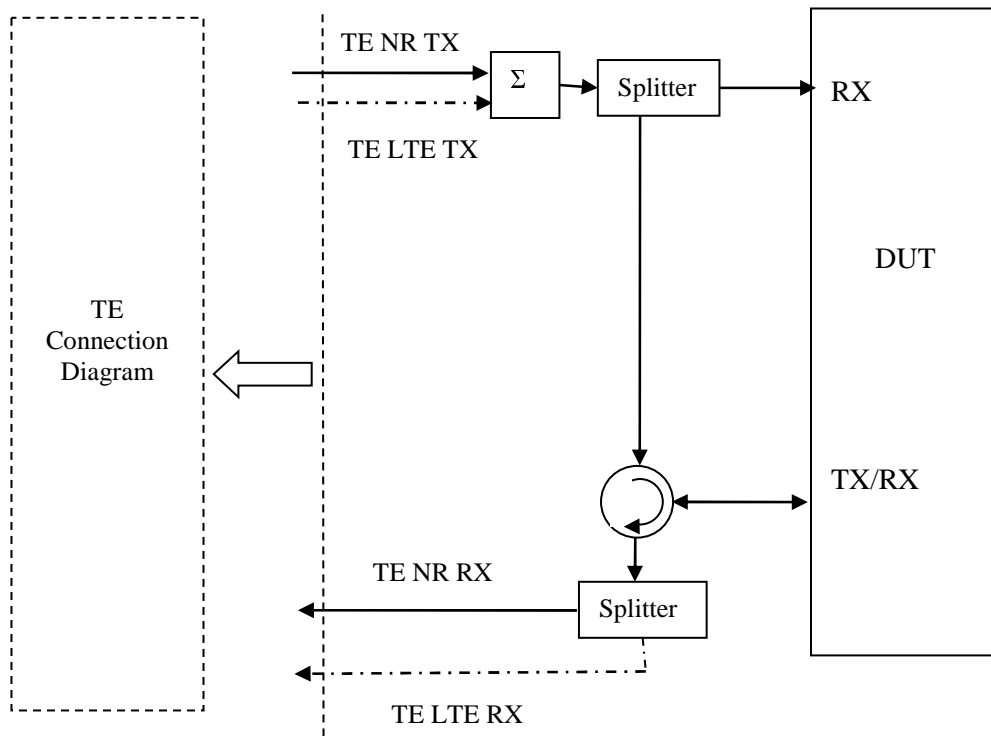

Figure A.3.2.1.3.2: User Equipment connection for single basic cell with NR and LTE cells at the same connectors for both cells

A.3.2.1.4 Three Antenna Connectors

FFS

A.3.2.1.5 Four Antenna Connectors

FFS

Annex B (normative): Permitted test methods For OTA Testing

B.1 General

Editor's Note: The working assumption is that the DFF or IFF based OTA test methodologies defined in clause 5.2.1 and 5.2.3 respectively of TR 38.810 [22] should be used for Signalling test. The exact text of Annex B is TBD.

Annex C (informative): Change history

Change history							
Date	Meeting	TDoc	CR	Rev	Cat	Subject/Comment	New version
2017-12	RAN5#77	R5-176995	-	-	-	TP on clauses of test equipment requirement in 38.508-1	0.1.0
2017-12	RAN5#77	R5-176779	-	-	-	Add references	0.1.0
2017-12	RAN5#77	R5-176917	-	-	-	Introduce general chapter for generic procedures	0.1.0
2017-12	RAN5#77	R5-176918	-	-	-	Add generic procedures RRC_IDLE and RRC_CONNECTED	0.1.0
2017-12	RAN5#77	R5-176920	-	-	-	Introduce RRC chapters	0.1.0
2018-01	RAN5#1-5G-NR Adhoc	R5-180066	-	-	-	Definition of downlink physical layer parameters for NR	0.2.0
2018-03	RAN5#78	R5-181697	-	-	-	Addition of the environmental information into TS 38.508-1	0.3.0
2018-03	RAN5#78	R5-180265	-	-	-	Introduce chapter for reference configurations	0.3.0
2018-03	RAN5#78	R5-181311	-	-	-	Update the general chapter	0.3.0
2018-03	RAN5#78	R5-180382	-	-	-	Update RRCReconfiguration	0.3.0
2018-03	RAN5#78	R5-180383	-	-	-	Add draft RRC messages	0.3.0
2018-03	RAN5#78	R5-180577	-	-	-	Update chapter for test frequencies	0.3.0
2018-03	RAN5#78	R5-180709	-	-	-	Add CellGroupConfig	0.3.0
2018-03	RAN5#78	R5-180773	-	-	-	Add radioBearerConfig	0.3.0
2018-03	RAN5#78	R5-180775	-	-	-	Add draft Radio resource control information elements	0.3.0
2018-03	RAN5#78	R5-180966	-	-	-	Update RRC Connected state	0.3.0
2018-03	RAN5#78	R5-181035	-	-	-	Update RRC IDLE state	0.3.0
2018-03	RAN5#78	R5-180253	-	-	-	Revised WID on: UE Conformance Test Aspects - 5G system with NR and LTE	0.3.0
2018-04	RAN5#1-5G-NR Adhoc	R5-181812	-	-	-	Update Radio resource control information elements	0.4.0
2018-04	RAN5#1-5G-NR Adhoc	R5-182109	-	-	-	Update CellGroupConfig	0.4.0
2018-04	RAN5#1-5G-NR Adhoc	R5-182064	-	-	-	Update radioBearerConfig	0.4.0
2018-04	RAN5#1-5G-NR Adhoc	R5-182062	-	-	-	Update MIB	0.4.0
2018-04	RAN5#1-5G-NR Adhoc	R5-182063	-	-	-	Introduce radio conditions	0.4.0
2018-04	RAN5#1-5G-NR Adhoc	R5-181786	-	-	-	Update RRCReconfiguration	0.4.0
2018-04	RAN5#1-5G-NR Adhoc	R5-181971	-	-	-	Add Other information elements	0.4.0
2018-04	RAN5#1-5G-NR Adhoc	R5-182065	-	-	-	Update chapter 4.5.1 General	0.4.0
2018-04	RAN5#1-5G-NR Adhoc	R5-181813	-	-	-	Update RRC IDLE state	0.4.0
2018-04	RAN5#1-5G-NR Adhoc	R5-182066	-	-	-	Update RRC CONNECTED state	0.4.0
2018-04	RAN5#1-5G-NR Adhoc	R5-182110	-	-	-	Text proposal to add clause 4.4 reference system configurations to TS 38.508-1	0.4.0
2018-04	RAN5#1-5G-NR Adhoc	R5-182067	-	-	-	TP for definition of physical channel allocations in 38.508-1	0.4.0
2018-04	RAN5#1-5G-NR Adhoc	R5-182091	-	-	-	TP for clauses of signal level	0.4.0
2018-04	RAN5#1-5G-NR Adhoc	R5-181972	-	-	-	TP for updating of Downlink physical layer parameters	0.4.0
2018-04	RAN5#1-5G-NR Adhoc	R5-181893	-	-	-	Addition of UE capability information elements	0.4.0
2018-04	RAN5#1-5G-NR Adhoc	R5-181973	-	-	-	TP for adding Mid channel BW definition in TS 38.508-1	0.4.0

2018-04	RAN5#1-5G-NR Adhoc	R5-181974	-	-	-	Addition of SRB3	0.4.0
2018-04	RAN5#1-5G-NR Adhoc	R5-182068	-	-	-	Update MeasConfig information elements	0.4.0
2018-05	RAN5#79	R5-183082	-	-	-	Update radio resource control information elements	1.0.0
2018-05	RAN5#79	R5-182288	-	-	-	TP for updating of downlink physical layer parameters in 38.508-1	1.0.0
2018-05	RAN5#79	R5-182349	-	-	-	Corrections to clause 4.4 reference system configurations	1.0.0
2018-05	RAN5#79	R5-182792	-	-	-	TP for clauses of Supported Channels for a NR cell	1.0.0
2018-05	RAN5#79	R5-183218	-	-	-	pCR update chapter for test frequencies - EN-DC	1.0.0
2018-05	RAN5#79	R5-183234	-	-	-	TP for updating of physical channel allocation part in 38.508-1	1.0.0
2018-05	RAN5#79	R5-183256	-	-	-	pCR update chapter for test frequencies - FR1	1.0.0
2018-05	RAN5#79	R5-183916	-	-	-	TP for Annex A in TS 38.508-1 and adding a set of Connection Diagrams	1.0.0
2018-05	RAN5#79	R5-183920	-	-	-	Introduction of Environmental conditions for FR1	1.0.0
2018-05	RAN5#79	R5-182249	-	-	-	Add reference to NR cell table	1.0.0
2018-05	RAN5#79	R5-183210	-	-	-	Update PDCCH	1.0.0
2018-05	RAN5#79	R5-182312	-	-	-	Update chapter 4.5.1 General	1.0.0
2018-05	RAN5#79	R5-182313	-	-	-	Update RRC CONNECTED state	1.0.0
2018-05	RAN5#79	R5-183087	-	-	-	Addition of new RRCReconfiguration definition for AM/UM bearers	1.0.0
2018-05	RAN5#79	R5-183088	-	-	-	Updates to UE capability information elements	1.0.0
2018-05	RAN5#79	R5-183250	-	-	-	Updates to UE capability information elements	1.0.0
2018-05	RAN5#79	R5-183083	-	-	-	Update RACH	1.0.0
2018-05	RAN5#79	R5-183084	-	-	-	Update ARFCN	1.0.0
2018-05	RAN5#79	R5-183211	-	-	-	Update BWP-UplinkDedicated	1.0.0
2018-05	RAN5#79	R5-183212	-	-	-	Update serving cell	1.0.0
2018-05	RAN5#79	R5-183214	-	-	-	Update RadioBearerConfig	1.0.0
2018-05	RAN5#79	R5-183215	-	-	-	Update RRCReconfiguration	1.0.0
2018-05	RAN5#79	R5-182381	-	-	-	Update MIB	1.0.0
2018-05	RAN5#79	R5-183090	-	-	-	Update RRCReconfiguration for measurements	1.0.0
2018-05	RAN5#79	R5-183264	-	-	-	Corrections to clause 4.5	1.0.0
2018-05	RAN5#79	R5-183249	-	-	-	Correction to the Table CellGroupConfig	1.0.0
2018-05	RAN5#79	R5-183255	-	-	-	Update of FR1 signal levels	1.0.0
2018-05	RAN5#79	R5-183216	-	-	-	Update CellGroupConfig and some related information elements	1.0.0
2018-05	RAN5#79	R5-183086	-	-	-	Update CSI-MeasConfig	1.0.0
2018-05	RAN5#79	R5-183260	-	-	-	Update some information elements related to MeasConfig	1.0.0
2018-06	RAN#80	RP-181207	-	-	-	put under revision control as v15.0.0 with small editorial changes	15.0.0
2018-09	RAN#81	R5-184087	000 4	-	F	Update chapter 3	15.1.0
2018-09	RAN#81	R5-184297	001 2	-	F	Addition of Mid channel bandwidth definition for several missing bands	15.1.0
2018-09	RAN#81	R5-184327	001 4	-	F	Adding condition for CP-OFDM waveform	15.1.0
2018-09	RAN#81	R5-184347	001 9	-	F	Modified RRC_IDLE procedure to allow multi PDN configuration throughout the test case	15.1.0
2018-09	RAN#81	R5-184471	004 4	-	F	Introduction of test frequencies for NR band n77	15.1.0
2018-09	RAN#81	R5-184472	004 5	-	F	Introduction of test frequencies for NR band n78	15.1.0
2018-09	RAN#81	R5-184473	004 6	-	F	Introduction of test frequencies for NR band n79	15.1.0
2018-09	RAN#81	R5-184474	004 7	-	F	Introduction of test frequencies for NR band n257	15.1.0
2018-09	RAN#81	R5-184475	004 8	-	F	Introduction of test frequencies for NR band n258	15.1.0
2018-09	RAN#81	R5-184476	004 9	-	F	Introduction of test frequencies for NR band n260	15.1.0
2018-09	RAN#81	R5-184477	005 0	-	F	Introduction of test frequencies for NR band n261	15.1.0
2018-09	RAN#81	R5-184599	005 6	-	F	Add IE SS-RSSI-Measurement	15.1.0
2018-09	RAN#81	R5-184617	005 9	-	F	Update MIB	15.1.0
2018-09	RAN#81	R5-184630	007 2	-	F	Editorial Update in clause 4.6.3	15.1.0
2018-09	RAN#81	R5-184783	007 9	-	F	Introduce 5GMM messages	15.1.0
2018-09	RAN#81	R5-184785	008 0	-	F	Introduce 5GSM messages	15.1.0
2018-09	RAN#81	R5-184806	008 1	-	F	Mid test CH BW for n71	15.1.0

2018-09	RAN#81	R5-185028	000 2	1	F	Add SRB1 and SRB2 with NR PDCP	15.1.0
2018-09	RAN#81	R5-185029	000 3	1	F	Update serving cell	15.1.0
2018-09	RAN#81	R5-185030	000 5	1	F	Introduce SA RRC messages	15.1.0
2018-09	RAN#81	R5-185031	000 6	1	F	Correct IE FrequencyInfoDL	15.1.0
2018-09	RAN#81	R5-185032	000 7	1	F	Introduce SA system information blocks	15.1.0
2018-09	RAN#81	R5-185033	000 8	1	F	Introduce SA other information elements	15.1.0
2018-09	RAN#81	R5-185035	001 3	1	F	Correct IE GSCN-ValueNR	15.1.0
2018-09	RAN#81	R5-185036	001 7	1	F	Update of FR1 signal levels	15.1.0
2018-09	RAN#81	R5-185037	002 2	1	F	Addition of IP Connectivity check procedure	15.1.0
2018-09	RAN#81	R5-185038	005 3	1	F	Introduce SA radio resource control information elements	15.1.0
2018-09	RAN#81	R5-185039	005 4	1	F	Update IE PhysicalCellGroupConfig	15.1.0
2018-09	RAN#81	R5-185040	005 5	1	F	Introduce cell configurations and timer tolerances chapter headers	15.1.0
2018-09	RAN#81	R5-185041	005 7	1	F	Add IE SSB-MTC	15.1.0
2018-09	RAN#81	R5-185042	005 8	1	F	Update BWP	15.1.0
2018-09	RAN#81	R5-185043	006 0	1	F	Update PDSCH-Config	15.1.0
2018-09	RAN#81	R5-185044	006 2	1	F	Update PUCCH and PUSCH configuration	15.1.0
2018-09	RAN#81	R5-185045	006 3	1	F	Update RACH configuration	15.1.0
2018-09	RAN#81	R5-185046	006 5	1	F	Update CellGroupConfig	15.1.0
2018-09	RAN#81	R5-185047	006 6	1	F	Update CSI-MeasConfig	15.1.0
2018-09	RAN#81	R5-185048	006 7	1	F	Update MeasConfig	15.1.0
2018-09	RAN#81	R5-185049	006 8	1	F	Update other information elements	15.1.0
2018-09	RAN#81	R5-185050	007 0	1	F	Update RadioBearerConfig	15.1.0
2018-09	RAN#81	R5-185051	007 3	1	F	Specifying content for MeasResultSCG-Failure	15.1.0
2018-09	RAN#81	R5-185052	007 5	1	F	Editorial correction to band representation of non-contiguous EN-DC band combination	15.1.0
2018-09	RAN#81	R5-185053	007 6	1	F	Correction to RLC-Config IE	15.1.0
2018-09	RAN#81	R5-185054	007 7	1	F	Correction to RadioBearerConfig-DRB	15.1.0
2018-09	RAN#81	R5-185055	007 8	1	F	Corrections and updates to BandCombinationList and Feature Set IEs	15.1.0
2018-09	RAN#81	R5-185056	008 4	1	F	Corrections and updates to UE Capability IEs	15.1.0
2018-09	RAN#81	R5-185085	008 7	-	F	Addition of UM condition to RLC-Bearer-Config IE	15.1.0
2018-09	RAN#81	R5-185133	008 6	1	F	Correction of clause 4.3.3.2.3	15.1.0
2018-09	RAN#81	R5-185163	001 8	1	F	Modified RRC_Connected procedure for Multi PDN throughout the test case.	15.1.0
2018-09	RAN#81	R5-185165	002 0	1	F	Update EN-DC Generic Procedure Parameter for Multi-PDN addition throughout Test Case	15.1.0
2018-09	RAN#81	R5-185168	008 2	1	F	Introduction of OTA signalling test environment	15.1.0
2018-09	RAN#81	R5-185171	000 9	2	F	Updates to PDCCH and SearchSpace configurations	15.1.0
2018-09	RAN#81	R5-185173	001 6	1	F	Test Frequencies	15.1.0
2018-09	RAN#81	R5-185177	005 1	1	F	Introduction of test frequencies for signalling testing in clause 6	15.1.0
2018-09	RAN#81	R5-185250	002 3	1	F	Introduction of test frequencies for NR band n1	15.1.0

2018-09	RAN#81	R5-185251	002 4	1	F	Introduction of test frequencies for NR band n2	15.1.0
2018-09	RAN#81	R5-185252	002 5	1	F	Introduction of test frequencies for NR band n3	15.1.0
2018-09	RAN#81	R5-185253	002 6	1	F	Introduction of test frequencies for NR band n5	15.1.0
2018-09	RAN#81	R5-185254	002 7	1	F	Introduction of test frequencies for NR band n7	15.1.0
2018-09	RAN#81	R5-185255	002 8	1	F	Introduction of test frequencies for NR band n8	15.1.0
2018-09	RAN#81	R5-185256	002 9	1	F	Introduction of test frequencies for NR band n12	15.1.0
2018-09	RAN#81	R5-185257	003 0	1	F	Introduction of test frequencies for NR band n20	15.1.0
2018-09	RAN#81	R5-185258	003 1	1	F	Introduction of test frequencies for NR band n25	15.1.0
2018-09	RAN#81	R5-185259	003 2	1	F	Introduction of test frequencies for NR band n28	15.1.0
2018-09	RAN#81	R5-185260	003 3	1	F	Introduction of test frequencies for NR band n34	15.1.0
2018-09	RAN#81	R5-185261	003 4	1	F	Introduction of test frequencies for NR band n38	15.1.0
2018-09	RAN#81	R5-185262	003 5	1	F	Introduction of test frequencies for NR band n39	15.1.0
2018-09	RAN#81	R5-185263	003 6	1	F	Introduction of test frequencies for NR band n40	15.1.0
2018-09	RAN#81	R5-185264	003 7	1	F	Update of test frequencies for NR band n41	15.1.0
2018-09	RAN#81	R5-185265	003 8	1	F	Introduction of test frequencies for NR band n51	15.1.0
2018-09	RAN#81	R5-185266	003 9	1	F	Introduction of test frequencies for NR band n66	15.1.0
2018-09	RAN#81	R5-185267	004 0	1	F	Introduction of test frequencies for NR band n70	15.1.0
2018-09	RAN#81	R5-185268	004 1	1	F	Update of test frequencies for NR band n71	15.1.0
2018-09	RAN#81	R5-185269	004 2	1	F	Introduction of test frequencies for NR band n75	15.1.0
2018-09	RAN#81	R5-185270	004 3	1	F	Introduction of test frequencies for NR band n76	15.1.0
2018-09	RAN#81	R5-185443	005 2	1	F	Correction to power level for FR1 RF tests	15.1.0
2018-09	RAN#81	R5-185557	008 5	1	F	FR2_UE_BeamlockProcedure_38.508-1	15.1.0

History

Document history		
V15.0.0	July 2018	Publication
V15.1.0	October 2018	Publication