

ETSI TS 138 351 V17.4.0 (2023-04)



**5G;
NR;
Sidelink Relay Adaptation Protocol (SRAP) Specification
(3GPP TS 38.351 version 17.4.0 Release 17)**



Reference

RTS/TSGR-0238351vh40

Keywords

5G

ETSI

650 Route des Lucioles
F-06921 Sophia Antipolis Cedex - FRANCE

Tel.: +33 4 92 94 42 00 Fax: +33 4 93 65 47 16

Siret N° 348 623 562 00017 - APE 7112B
Association à but non lucratif enregistrée à la
Sous-Préfecture de Grasse (06) N° w061004871

Important notice

The present document can be downloaded from:

<https://www.etsi.org/standards-search>

The present document may be made available in electronic versions and/or in print. The content of any electronic and/or print versions of the present document shall not be modified without the prior written authorization of ETSI. In case of any existing or perceived difference in contents between such versions and/or in print, the prevailing version of an ETSI deliverable is the one made publicly available in PDF format at www.etsi.org/deliver.

Users of the present document should be aware that the document may be subject to revision or change of status.

Information on the current status of this and other ETSI documents is available at

<https://portal.etsi.org/TB/ETSIDeliverableStatus.aspx>

If you find errors in the present document, please send your comment to one of the following services:

<https://portal.etsi.org/People/CommitteeSupportStaff.aspx>

If you find a security vulnerability in the present document, please report it through our
Coordinated Vulnerability Disclosure Program:

<https://www.etsi.org/standards/coordinated-vulnerability-disclosure>

Notice of disclaimer & limitation of liability

The information provided in the present deliverable is directed solely to professionals who have the appropriate degree of experience to understand and interpret its content in accordance with generally accepted engineering or other professional standard and applicable regulations.

No recommendation as to products and services or vendors is made or should be implied.

No representation or warranty is made that this deliverable is technically accurate or sufficient or conforms to any law and/or governmental rule and/or regulation and further, no representation or warranty is made of merchantability or fitness for any particular purpose or against infringement of intellectual property rights.

In no event shall ETSI be held liable for loss of profits or any other incidental or consequential damages.

Any software contained in this deliverable is provided "AS IS" with no warranties, express or implied, including but not limited to, the warranties of merchantability, fitness for a particular purpose and non-infringement of intellectual property rights and ETSI shall not be held liable in any event for any damages whatsoever (including, without limitation, damages for loss of profits, business interruption, loss of information, or any other pecuniary loss) arising out of or related to the use of or inability to use the software.

Copyright Notification

No part may be reproduced or utilized in any form or by any means, electronic or mechanical, including photocopying and microfilm except as authorized by written permission of ETSI.

The content of the PDF version shall not be modified without the written authorization of ETSI.

The copyright and the foregoing restriction extend to reproduction in all media.

© ETSI 2023.
All rights reserved.

Intellectual Property Rights

Essential patents

IPRs essential or potentially essential to normative deliverables may have been declared to ETSI. The declarations pertaining to these essential IPRs, if any, are publicly available for **ETSI members and non-members**, and can be found in ETSI SR 000 314: "*Intellectual Property Rights (IPRs); Essential, or potentially Essential, IPRs notified to ETSI in respect of ETSI standards*", which is available from the ETSI Secretariat. Latest updates are available on the ETSI Web server (<https://ipr.etsi.org/>).

Pursuant to the ETSI Directives including the ETSI IPR Policy, no investigation regarding the essentiality of IPRs, including IPR searches, has been carried out by ETSI. No guarantee can be given as to the existence of other IPRs not referenced in ETSI SR 000 314 (or the updates on the ETSI Web server) which are, or may be, or may become, essential to the present document.

Trademarks

The present document may include trademarks and/or tradenames which are asserted and/or registered by their owners. ETSI claims no ownership of these except for any which are indicated as being the property of ETSI, and conveys no right to use or reproduce any trademark and/or tradename. Mention of those trademarks in the present document does not constitute an endorsement by ETSI of products, services or organizations associated with those trademarks.

DECT™, **PLUGTESTS™**, **UMTS™** and the ETSI logo are trademarks of ETSI registered for the benefit of its Members. **3GPP™** and **LTE™** are trademarks of ETSI registered for the benefit of its Members and of the 3GPP Organizational Partners. **oneM2M™** logo is a trademark of ETSI registered for the benefit of its Members and of the oneM2M Partners. **GSM®** and the GSM logo are trademarks registered and owned by the GSM Association.

Legal Notice

This Technical Specification (TS) has been produced by ETSI 3rd Generation Partnership Project (3GPP).

The present document may refer to technical specifications or reports using their 3GPP identities. These shall be interpreted as being references to the corresponding ETSI deliverables.

The cross reference between 3GPP and ETSI identities can be found under <https://webapp.etsi.org/key/queryform.asp>.

Modal verbs terminology

In the present document "**shall**", "**shall not**", "**should**", "**should not**", "**may**", "**need not**", "**will**", "**will not**", "**can**" and "**cannot**" are to be interpreted as described in clause 3.2 of the [ETSI Drafting Rules](#) (Verbal forms for the expression of provisions).

"**must**" and "**must not**" are **NOT** allowed in ETSI deliverables except when used in direct citation.

Contents

Intellectual Property Rights	2
Legal Notice	2
Modal verbs terminology.....	2
Foreword.....	5
1 Scope	7
2 References	7
3 Definitions of terms, symbols and abbreviations	7
3.1 Terms.....	7
3.2 Abbreviations	7
4 General	8
4.1 Introduction	8
4.2 SRAP architecture	8
4.2.1 General.....	8
4.2.2 SRAP entities.....	8
4.3 Services	11
4.3.1 Services provided to upper layers	11
4.3.2 Services expected from lower layers	11
4.4 Functions	11
4.5 Configurations	11
5 Procedures	11
5.1 SRAP entity handling.....	11
5.1.1 SRAP entity establishment	11
5.1.2 SRAP entity release	12
5.2 DL Data transfer.....	12
5.2.1 Receiving operation of U2N Relay UE.....	12
5.2.2 Transmitting operation of U2N Relay UE	12
5.2.2.1 Egress link determination.....	12
5.2.2.2 Egress RLC channel determination.....	12
5.2.3 Receiving operation of U2N Remote UE	13
5.3 UL Data transfer.....	13
5.3.1 Transmitting operation of U2N Remote UE	13
5.3.1.1 UE ID field and BEARER ID field determination	13
5.3.1.2 Egress RLC channel determination.....	14
5.3.2 Receiving operation of U2N Relay UE.....	14
5.3.3 Transmitting operation of U2N Relay UE	14
5.3.3.1 UE ID field and BEARER ID field determination	14
5.3.3.2 Egress RLC channel determination.....	14
5.4 Handling of unknown, unforeseen, and erroneous protocol data	15
6 Protocol data units, formats, and parameters.....	15
6.1 Protocol data units	15
6.1.1 Data PDU.....	15
6.2 Formats.....	15
6.2.1 General.....	15
6.2.2 Data PDU.....	15
6.3 Parameters	16
6.3.1 General.....	16
6.3.2 UE ID.....	16
6.3.3 BEARER ID	16
6.3.4 Data.....	16
6.3.5 R	17
6.3.6 D/C.....	17
Annex A (informative): Change history	18

History19

Foreword

This Technical Specification has been produced by the 3rd Generation Partnership Project (3GPP).

The contents of the present document are subject to continuing work within the TSG and may change following formal TSG approval. Should the TSG modify the contents of the present document, it will be re-released by the TSG with an identifying change of release date and an increase in version number as follows:

Version x.y.z

where:

- x the first digit:
 - 1 presented to TSG for information;
 - 2 presented to TSG for approval;
 - 3 or greater indicates TSG approved document under change control.
- y the second digit is incremented for all changes of substance, i.e. technical enhancements, corrections, updates, etc.
- z the third digit is incremented when editorial only changes have been incorporated in the document.

In the present document, modal verbs have the following meanings:

- shall** indicates a mandatory requirement to do something
- shall not** indicates an interdiction (prohibition) to do something

The constructions "shall" and "shall not" are confined to the context of normative provisions, and do not appear in Technical Reports.

The constructions "must" and "must not" are not used as substitutes for "shall" and "shall not". Their use is avoided insofar as possible, and they are not used in a normative context except in a direct citation from an external, referenced, non-3GPP document, or so as to maintain continuity of style when extending or modifying the provisions of such a referenced document.

- should** indicates a recommendation to do something
- should not** indicates a recommendation not to do something
- may** indicates permission to do something
- need not** indicates permission not to do something

The construction "may not" is ambiguous and is not used in normative elements. The unambiguous constructions "might not" or "shall not" are used instead, depending upon the meaning intended.

- can** indicates that something is possible
- cannot** indicates that something is impossible

The constructions "can" and "cannot" are not substitutes for "may" and "need not".

- will** indicates that something is certain or expected to happen as a result of action taken by an agency the behaviour of which is outside the scope of the present document
- will not** indicates that something is certain or expected not to happen as a result of action taken by an agency the behaviour of which is outside the scope of the present document
- might** indicates a likelihood that something will happen as a result of action taken by some agency the behaviour of which is outside the scope of the present document

might not indicates a likelihood that something will not happen as a result of action taken by some agency the behaviour of which is outside the scope of the present document

In addition:

is (or any other verb in the indicative mood) indicates a statement of fact

is not (or any other negative verb in the indicative mood) indicates a statement of fact

The constructions "is" and "is not" do not indicate requirements.

1 Scope

The present document provides description of the Sidelink Relay Adaptation Protocol (SRAP).

2 References

The following documents contain provisions which, through reference in this text, constitute provisions of the present document.

- References are either specific (identified by date of publication, edition number, version number, etc.) or non-specific.
- For a specific reference, subsequent revisions do not apply.
- For a non-specific reference, the latest version applies. In the case of a reference to a 3GPP document (including a GSM document), a non-specific reference implicitly refers to the latest version of that document *in the same Release as the present document*.

- [1] 3GPP TR 21.905: "Vocabulary for 3GPP Specifications".
 - [2] 3GPP TS 38.300: "NG Radio Access Network; Overall description".
 - [3] 3GPP TS 38.331: "NR Radio Resource Control (RRC); Protocol Specification".
 - [4] 3GPP TS 38.322: "NR Radio Link Control (RLC) protocol specification".
 - [5] 3GPP TS 38.323: "NR; Packet Data Convergence Protocol (PDCP) specification".
-

3 Definitions of terms, symbols and abbreviations

3.1 Terms

For the purposes of the present document, the terms given in TR 21.905 [1] and the following apply. A term defined in the present document takes precedence over the definition of the same term, if any, in TR 21.905 [1].

Egress RLC channel: a RLC channel on which a packet is transmitted by a U2N Relay UE, a U2N Remote UE or a network node.

Egress link: a radio link on which a packet is transmitted by a U2N Relay UE, a U2N Remote UE or a network node.

Ingress RLC channel: a RLC channel on which a packet is received from a U2N Relay UE, a U2N Remote UE or a network node.

Ingress link: a radio link on which a packet is received from a U2N Relay UE, a U2N Remote UE or a network node.

U2N Relay UE: a UE that provides functionality to support connectivity to the network for U2N Remote UE(s).

U2N Remote UE: a UE that communicates with the network via a U2N Relay UE.

3.2 Abbreviations

For the purposes of the present document, the abbreviations given in TR 21.905 [1] and the following apply. An abbreviation defined in the present document takes precedence over the definition of the same abbreviation, if any, in TR 21.905 [1].

SRAP	Sidelink Relay Adaptation Protocol
U2N	UE-to-Network

4 General

4.1 Introduction

The objective is to describe the SRAP architecture and the SRAP entities from a functional point of view.

4.2 SRAP architecture

4.2.1 General

This clause describes a model of the SRAP, i.e., it does not specify or restrict implementations.

4.2.2 SRAP entities

Figure 4.2.2-1 represents one possible structure for the SRAP sublayer. The figure is based on the radio interface protocol architecture defined in TS 38.300 [2].

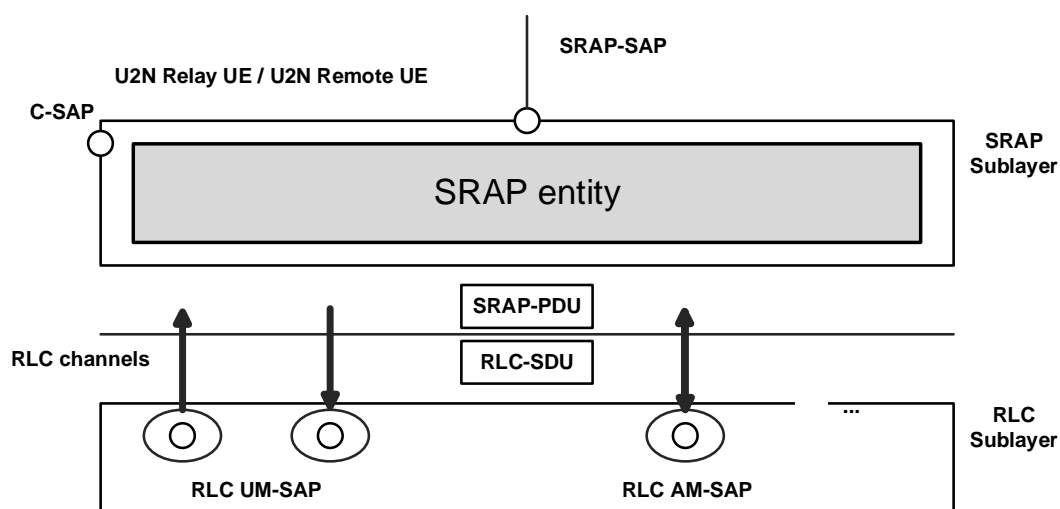

Figure 4.2.2-1: SRAP structure overview

On the U2N Relay UE, the SRAP sublayer contains one SRAP entity at Uu interface and a separate collocated SRAP entity at the PC5 interface. On the U2N Remote UE, the SRAP sublayer contains only one SRAP entity at the PC5 interface.

Each SRAP entity has a transmitting part and a receiving part. Across the PC5 interface, the transmitting part of the SRAP entity at the U2N Remote UE has a corresponding receiving part of an SRAP entity at the U2N Relay UE, and vice versa. Across the Uu interface, the transmitting part of the SRAP entity at the U2N Relay UE has a corresponding receiving part of an SRAP entity at the gNB, and vice versa.

Figure 4.2.2-2 and Figure 4.2.2-3 represents the functional view of the SRAP entity for the SRAP sublayer at PC5 interface and at Uu interface respectively.

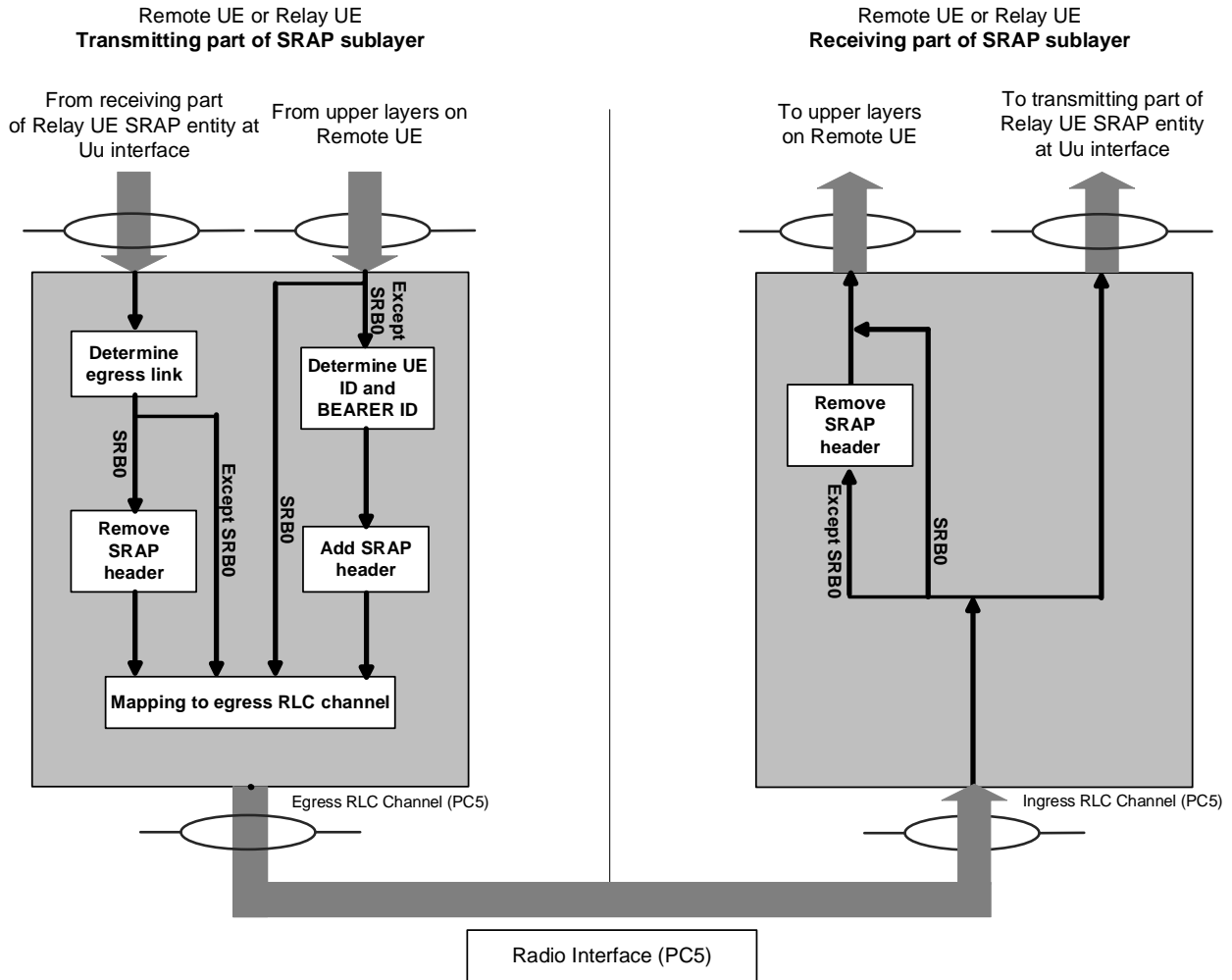

Figure 4.2.2-2: Example of functional view of SRAP sublayer at PC5 interface

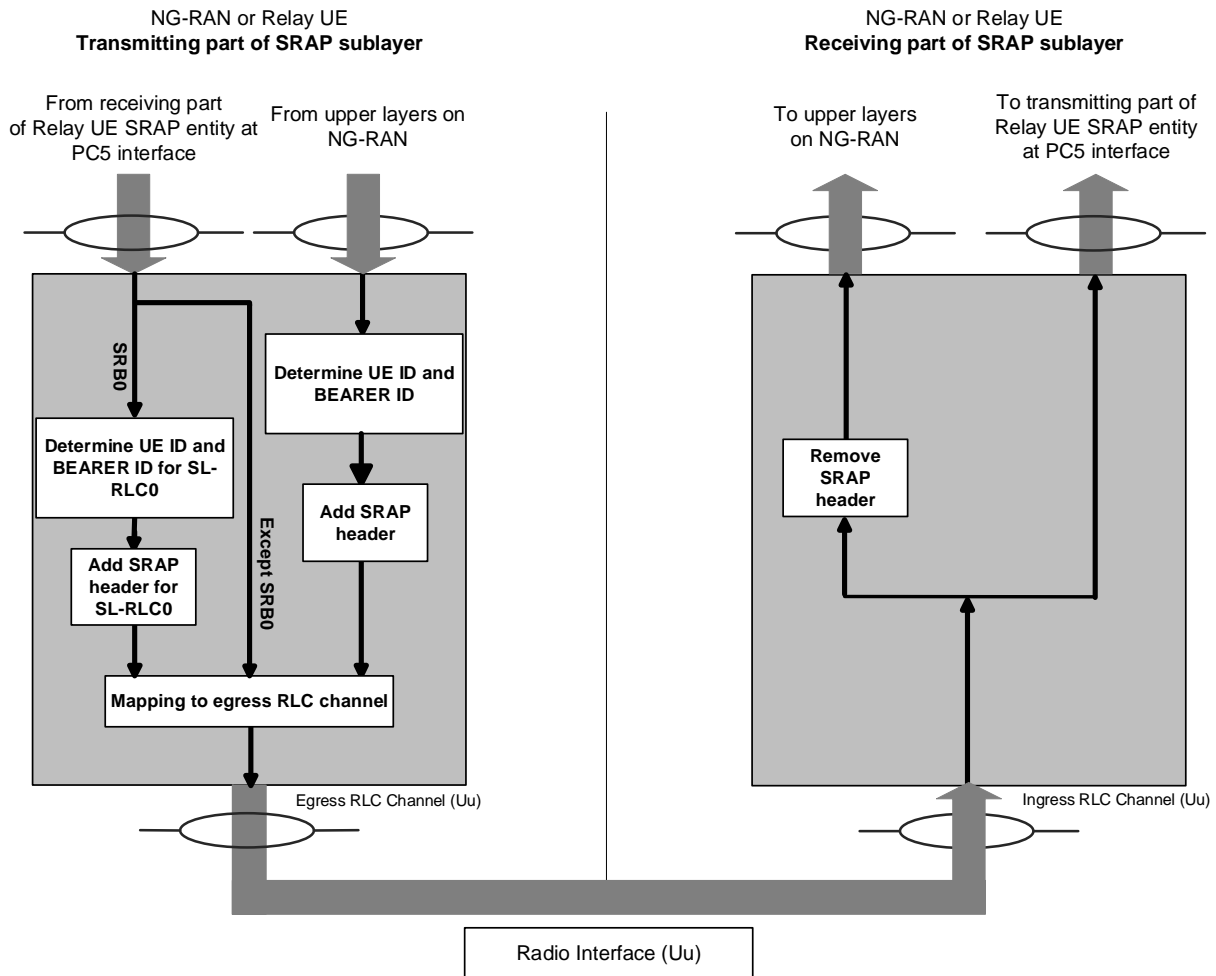

Figure 4.2.2-3: Example of functional view of SRAP sublayer at Uu interface

In the example of Figure 4.2.2-2 and Figure 4.2.2-3, at relay UE:

- For data packet not corresponding to SRB0, the receiving part on the SRAP entity of Uu interface delivers SRAP Data PDUs to the transmitting part on the collocated SRAP entity of PC5 interface, and the receiving part on the SRAP entity of PC5 interface delivers SRAP Data PDUs to the transmitting part on the collocated SRAP entity of Uu interface. As an alternative, the receiving part may deliver SRAP SDUs to the transmitting part on the collocated SRAP entity. When passing SRAP SDUs, the receiving part removes the SRAP header and the transmitting part of the relay UE adds the SRAP header with the same SRAP header content as carried on the SRAP Data PDU header prior to removal. Passing SRAP SDUs in this manner is therefore functionally equivalent to passing SRAP Data PDUs, in implementation. The following specification therefore refers to the passing of SRAP data packets.
- For UL data packet corresponding to SRB0, the receiving part on the SRAP entity of PC5 interface delivers SRAP SDUs to the transmitting part on the collocated SRAP entity of Uu interface, and the transmitting part on the SRAP entity of Uu interface adds the SRAP header in accordance with clause 5.3.3.
- For DL data packet corresponding to SRB0, the receiving part on the SRAP entity of Uu interface delivers SRAP Data PDUs to the transmitting part on the collocated SRAP entity of PC5 interface, and the transmitting part on the SRAP entity of PC5 interface removes the SRAP header in accordance with clause 5.2.2. As an alternative for handling DL data packet corresponding to SRB0 not shown in Figure 4.2.2-2 or Figure 4.2.2-3, the receiving part on the SRAP entity of Uu interface removes the SRAP header and delivers SRAP SDUs to the transmitting part on the collocated SRAP entity of PC5 interface.

4.3 Services

4.3.1 Services provided to upper layers

The following services are provided by the SRAP sublayer to upper layers:

- Data transfer.

4.3.2 Services expected from lower layers

An SRAP sublayer expects the following services from lower layers per RLC entity (for a detailed description see TS 38.322 [4]):

- Acknowledged data transfer service;
- Unacknowledged data transfer service.

4.4 Functions

The SRAP sublayer supports the following functions:

- Data transfer;
- Determination of UE ID field and BEARER ID field for data packets;
- Determination of egress link;
- Determination of egress RLC channel.

4.5 Configurations

The configuration of the SRAP entity for U2N Remote UE includes:

- Mapping from a radio bearer identified by BEARER ID field to egress PC5 Relay RLC channel via RRC;
- The local identity via RRC.

The configuration of the SRAP entity for U2N Relay UE includes:

- The local identity for each U2N Remote UE via RRC;
- Mapping from a radio bearer identified by UE ID field and BEARER ID field to egress Uu Relay RLC channel for each U2N Remote UE via RRC;
- Mapping from a radio bearer identified by UE ID field and BEARER ID field to egress PC5 Relay RLC channel for each U2N Remote UE via RRC.

5 Procedures

5.1 SRAP entity handling

5.1.1 SRAP entity establishment

When upper layers request establishment of an SRAP entity, UE shall:

- establish an SRAP entity;
- follow the procedures in clause 5.

5.1.2 SRAP entity release

When upper layers request release of an SRAP entity, UE shall:

- release the SRAP entity and the related SRAP configurations.

5.2 DL Data transfer

5.2.1 Receiving operation of U2N Relay UE

Upon receiving an SRAP Data PDU from lower layer, the receiving part of the SRAP entity on the Uu interface of U2N Relay UE shall:

- deliver the SRAP data packet to the transmitting part of the collocated SRAP entity on the PC5 interface.

5.2.2 Transmitting operation of U2N Relay UE

The transmitting part of the SRAP entity on the PC5 interface of U2N Relay UE receives SRAP data packets from the receiving part of the SRAP entity on the Uu interface of the same U2N Relay UE, and construct SRAP Data PDUs as needed (see clause 4.2.2).

When the transmitting part of the SRAP entity on the PC5 interface has an SRAP Data PDU to transmit, the transmitting part of the SRAP entity on the PC5 interface shall:

- Determine the egress link in accordance with clause 5.2.2.1;
- Determine the egress RLC channel in accordance with clause 5.2.2.2;
- if the SRAP Data PDU is for SRB0 (the BEARER ID field is 0, and the bearer is identified as SRB based on *sl-RemoteUE-RB-Identity* associated with the entry containing the *sl-EgressRLC-ChannelUu* which matches the LCID of the Uu Relay RLC Channel from which the SRAP Data PDU is received):
 - Remove the SRAP header from the SRAP Data PDU;
 - Submit this SRAP Data PDU to the determined egress RLC channel of the determined egress link.

5.2.2.1 Egress link determination

For a SRAP Data PDU to be transmitted, SRAP entity shall:

- if there is an entry in *sl-SRAP-ConfigRelay*, whose *sl-LocalIdentity* matches the UE ID field in SRAP Data PDU:
 - Determine the egress link on PC5 interface corresponding to *sl-L2IdentityRemote* configured for the concerned *sl-LocalIdentity* as specified in TS 38.331 [3].

5.2.2.2 Egress RLC channel determination

For a SRAP Data PDU to be transmitted, the SRAP entity shall:

- if the SRAP Data PDU is for SRB0 (the BEARER ID field is 0 and the bearer is identified as SRB based on *sl-RemoteUE-RB-Identity* associated with the entry containing the *sl-EgressRLC-ChannelUu* which matches the LCID of the Uu Relay RLC Channel from which the SRAP Data PDU is received):
 - Determine the egress PC5 Relay RLC channel in the determined egress link corresponding to *logicalChannelIdentity* for SL-RLC0 as specified in TS 38.331 [3];
- else if there is an entry in *sl-SRAP-ConfigRelay*, whose *sl-LocalIdentity* matches the UE ID field in SRAP Data PDU, which includes an *sl-RemoteUE-RB-Identity* that matches the SRB identity or DRB identity of the SRAP Data PDU determined by the BEARER ID field (For the BEARER ID shared by both SRB and DRB, SRB and DRB are differentiated based on *sl-RemoteUE-RB-Identity* associated with the entry containing the *sl-EgressRLC-ChannelUu* which matches the LCID of the Uu Relay RLC Channel from which the SRAP Data PDU is received):

- Determine the egress PC5 Relay RLC channel in the determined egress link corresponding to *sl-EgressRLC-ChannelPC5* configured for the concerned *sl-LocalIdentity* and concerned *sl-RemoteUE-RB-Identity* as specified in TS 38.331 [3].

5.2.3 Receiving operation of U2N Remote UE

Upon receiving an SRAP Data PDU from lower layer, the receiving part of the SRAP entity shall:

- if the SRAP Data PDU is not for SRB0 (not received from SL-RLC0 as specified in TS 38.331 [3]):
 - if *sl-RemoteUE-RB-Identity* is configured:
 - remove the SRAP header of this SRAP Data PDU and deliver the SRAP SDU to upper layer entity corresponding to the BEARER ID field of this SRAP Data PDU (For the BEARER ID shared by both SRB and DRB, SRB and DRB are differentiated based on *sl-RemoteUE-RB-Identity* associated with the entry containing the *sl-EgressRLC-ChannelPC5* which matches LCID of the PC5 Relay RLC Channel from which the SRAP Data PDU is received, and for DRB, the upper layer entity for BEARER ID plus 1);
 - else
 - remove the SRAP header of this SRAP Data PDU and deliver the SRAP SDU to PDCP entity of SRB1 by ignoring the UE ID field and BEARER ID field of this SRAP Data PDU;
- else:
 - deliver the SRAP SDU (i.e., same as SRAP PDU for SRB0) to upper layer, i.e., RRC layer entity (TS 38.331 [3]).

5.3 UL Data transfer

5.3.1 Transmitting operation of U2N Remote UE

The transmitting part of the SRAP entity on the PC5 interface of U2N Remote UE can receive SRAP SDU from upper layer and constructs SRAP Data PDU.

Upon receiving an SRAP SDU from upper layer, the transmitting part of the SRAP entity on the PC5 interface shall:

- if the SRAP SDU is not for SRB0:
 - Determine the UE ID field and BEARER ID field in accordance with clause 5.3.1.1;
 - Construct an SRAP Data PDU with SRAP header, where the UE ID field and BEARER ID field are set to the determined values, in accordance with clause 6.2.2;
- else:
 - Construct an SRAP Data PDU without SRAP header in accordance with clause 6.2.2.
- Determine the egress RLC channel in accordance with clause 5.3.1.2;
- Submit this SRAP Data PDU to the determined egress RLC channel.

5.3.1.1 UE ID field and BEARER ID field determination

For an SRAP SDU received from upper layer, the SRAP entity shall:

- Determine the UE ID field corresponding to *sl-LocalIdentity*, configured as specified in TS 38.331 [3];
- Determine the BEARER ID field corresponding to SRB identity for SRB (i.e., set the BEARER ID field to *srb-Identity*), or corresponding to DRB identity minus 1 for DRB (i.e., set the BEARER ID field to *drb-Identity* minus 1), from which the SRAP SDU is received, configured as specified in TS 38.331 [3].

5.3.1.2 Egress RLC channel determination

For a SRAP Data PDU to be transmitted, the SRAP entity shall:

- if the SRAP Data PDU is for SRB0:
 - Determine the egress PC5 Relay RLC channel in the link with U2N Relay UE corresponding to *logicalChannelIdentity* for SL-RLC0 as specified in TS 38.331 [3];
- else if there is an entry in *sl-SRAP-ConfigRemote*, whose *sl-RemoteUE-RB-Identity* matches the SRB identity or DRB identity of the SRAP Data PDU:
 - Determine the egress PC5 Relay RLC channel of the link with U2N Relay UE corresponding to *sl-EgressRLC-ChannelPC5* configured for the concerned *sl-RemoteUE-RB-Identity* as specified in TS 38.331 [3].

5.3.2 Receiving operation of U2N Relay UE

Upon receiving an SRAP Data PDU from lower layer, the receiving part of the SRAP entity on the PC5 interface shall:

- deliver the SRAP data packet to the transmitting part of the collocated SRAP entity on the Uu interface.

5.3.3 Transmitting operation of U2N Relay UE

The transmitting part of the SRAP entity on the Uu interface of U2N Relay UE can receive SRAP data packets from the receiving part of the SRAP entity on the PC5 interface of the same U2N Relay UE, and construct SRAP Data PDUs as needed (see clause 4.2.2).

When the transmitting part of the SRAP entity on the Uu interface has an SRAP Data PDU to transmit, the transmitting part of the SRAP entity on the Uu interface shall:

- if the SRAP Data PDU is received from SL-RLC0 as specified in TS 38.331 [3]:
 - Determine the UE ID field and BEARER ID field in accordance with clause 5.3.3.1;
 - Construct an SRAP Data PDU with SRAP header, where the UE ID field and BEARER ID field are set to the determined values, in accordance with clause 6.2.2;
- Determine the egress RLC channel in accordance with clause 5.3.3.2;
- Submit this SRAP Data PDU to the determined egress RLC channel.

5.3.3.1 UE ID field and BEARER ID field determination

For an SRAP Data PDU received from SL-RLC0 as specified in TS 38.331 [3], the SRAP entity shall:

- if there is an entry in *sl-RemoteUE-ToAddModList*, whose *sl-L2IdentityRemote* matches the Layer-2 ID of the remote UE from which the SRAP Data PDU is received:
 - Determine the UE ID field corresponding to *sl-LocalIdentity* configured for the concerned *sl-L2IdentityRemote* as specified in TS 38.331 [3];
 - Determine the BEARER ID field as 0 (i.e., set BEARER ID field as 0).

5.3.3.2 Egress RLC channel determination

For a SRAP Data PDU to be transmitted, the SRAP entity shall:

- if there is an entry in *sl-SRAP-ConfigRelay*, whose *sl-LocalIdentity* matches the UE ID field in SRAP Data PDU, and which includes an *sl-RemoteUE-RB-Identity* matches SRB identity or DRB identity of the SRAP Data PDU determined by the BEARER ID field (For the BEARER ID shared by both SRB and DRB, SRB and DRB are differentiated based on *sl-RemoteUE-RB-Identity* associated with the entry containing the *sl-EgressRLC-*

ChannelPC5 which matches LCID of the PC5 Relay RLC Channel from which the SRAP Data PDU is received, and for DRB, the DRB identity is BEARER ID plus 1):

- Determine the egress Uu Relay RLC channel corresponding to *sl-EgressRLC-ChannelUu* configured for the concerned *sl-LocalIdentity* and concerned *sl-RemoteUE-RB-Identity* as specified in TS 38.331 [3].

5.4 Handling of unknown, unforeseen, and erroneous protocol data

For U2N Remote UE, if *sl-LocalIdentity* and *sl-RemoteUE-RB-Identity* are both configured, when a SRAP Data PDU with SRAP header that contains a UE ID field or BEARER ID field which does not match *sl-LocalIdentity* or *sl-RemoteUE-RB-Identity* included in *sl-SRAP-ConfigRemote* is received, the SRAP entity shall:

- discard the received SRAP Data PDU.

For U2N Relay UE, when a SRAP Data PDU with SRAP header that contains a UE ID field or BEARER ID field which does not match *sl-LocalIdentity* or *sl-RemoteUE-RB-Identity* included in *sl-SRAP-ConfigRelay* is received except in the case where the SRAP Data PDU from SL-RLC1 as specified in TS 38.331 [3] is the first SRAP Data PDU received from a U2N Remote UE, or when a SRAP Data PDU that contains a UE ID which does not match the concerned *sl-LocalIdentity* corresponding to *sl-L2IdentityRemote* of the ingress link is received by U2N Relay UE, the SRAP entity shall:

- discard the received SRAP Data PDU.

When the U2N Remote UE or the U2N Relay UE receives a SRAP PDU with invalid or reserved values, the SRAP entity shall:

- discard the received SRAP PDU.

6 Protocol data units, formats, and parameters

6.1 Protocol data units

6.1.1 Data PDU

The SRAP Data PDU is used to convey the following with or without the PDU header:

- upper layer data.

6.2 Formats

6.2.1 General

An SRAP Data PDU is a bit string that is byte aligned (i.e. multiple of 8 bits) in length. The formats of SRAP Data PDUs are described in clause 6.2.2 and their parameters are described in clause 6.3.

6.2.2 Data PDU

Figure 6.2.2-1 shows the format of the SRAP Data PDU with SRAP header being configured. This SRAP Data PDU format is applicable to SRAP SDU except those for SRB0 delivered over PC5 interface.

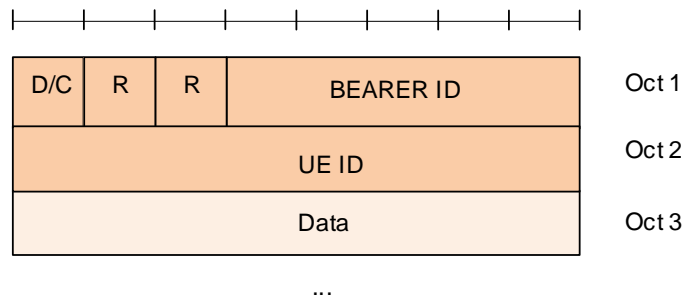

Figure 6.2.2-1: SRAP Data PDU format with SRAP header

Figure 6.2.2-2 shows the format of the SRAP Data PDU consisting only of a data field without any SRAP header. This SRAP Data PDU format is applicable to SRAP SDU for SRB0 delivered over PC5 interface.

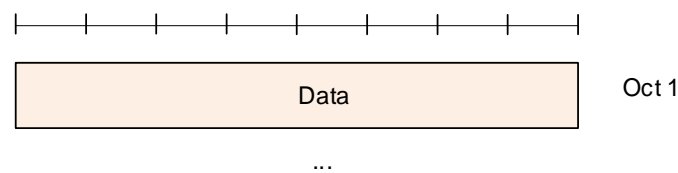

Figure 6.2.2-2: SRAP Data PDU format without SRAP header

6.3 Parameters

6.3.1 General

If not otherwise mentioned in the definition of each field the bits in the parameters shall be interpreted as follows: the left most bit is the first and most significant and the right most bit is the last and least significant bit.

Unless otherwise mentioned, integers are encoded in standard binary encoding for unsigned integers. In all cases the bits appear ordered from MSB to LSB when read in the PDU.

6.3.2 UE ID

Length: 8 bits.

This field carries local identity of U2N Remote UE.

6.3.3 BEARER ID

Length: 5 bits.

This field carries Uu radio bearer identity for U2N Remote UE.

6.3.4 Data

Length: Variable

This field carries the SRAP SDU (i.e. PDCP PDU or RRC PDU).

6.3.5 R

Length: 1 bit

Reserved. In this release, reserved bits shall be set to 0. Reserved bits shall be ignored by the receiver.

6.3.6 D/C

Length: 1 bit

This field indicates whether the corresponding SRAP PDU is an SRAP Data PDU or an SRAP Control PDU (not used in this release).

Table 6.3.6-1: D/C field

Bit	Description
0	SRAP Data PDU
1	SRAP Control PDU (not used in this release)

Annex A (informative): Change history

Change history							
Date	Meeting	TDoc	CR	Rev	Cat	Subject/Comment	New version
11/2021	RAN2#1 16	R2-2109400				Skeleton	0.0.0
11/2021	RAN2#1 16	R2-2111485				Skeleton update	0.0.1
11/2021	RAN2#1 16	R2-2111489				Capture the agreement till R2#116	0.1.0
01/2022	RAN2#1 16bis	R2-2200364				Capture the agreement till R2#116 that related to the 38.331 running CR	0.2.0
01/2022	RAN2#1 16bis	R2-2201996				Capture the agreement during R2#116bis	0.3.0
02/2022	RAN2#1 17	R2-2202276				Capture the agreement till R2#116bis that related to the 38.331 running CR	0.4.0
02/2022	RAN2#1 17	R2-2203594				Capture the agreement during R2#117	0.5.0
03/2022	RAN#95	RP-220794				Submit to RAN for approval	1.0.0
03/2022	RP-95					Upgraded to Rel-17 by MCC	17.0.0
06/2022	RP-96	RP-221732	0001	1	F	Correction on SRAP for L2 UE-to-Network Relay	17.1.0
09/2022	RP-97	RP-222524	0009	2	F	Correction on SRAP for L2 U2N Relay	17.2.0
12/2022	RP-98	RP-223412	0012	2	F	Corrections for L2 U2N Relay	17.3.0
03/2023	RP-99	RP-230692	0015	1	F	Corrections on SRAP for SL relay	17.4.0
	RP-99	RP-230692	0016	1	F	Correction to error handling in SRAP	17.4.0
	RP-99	RP-230692	0017	2	F	Correction on SRAP for L2 U2N Relay	17.4.0
	RP-99	RP-230692	0018	-	F	38.351 SRAP corrections	17.4.0

History

Document history		
V17.0.0	May 2022	Publication
V17.1.0	August 2022	Publication
V17.2.0	October 2022	Publication
V17.3.0	January 2023	Publication
V17.4.0	April 2023	Publication