

ETSI TS 138 176-2 V17.4.0 (2023-05)



TECHNICAL SPECIFICATION

**5G;
NR;**

**Integrated Access and Backhaul (IAB) conformance testing;
Part 2: Radiated conformance testing
(3GPP TS 38.176-2 version 17.4.0 Release 17)**



Reference

RTS/TSGR-0438176-2vh40

Keywords

5G

ETSI

650 Route des Lucioles
F-06921 Sophia Antipolis Cedex - FRANCE

Tel.: +33 4 92 94 42 00 Fax: +33 4 93 65 47 16

Siret N° 348 623 562 00017 - APE 7112B
Association à but non lucratif enregistrée à la
Sous-Préfecture de Grasse (06) N° w061004871

Important notice

The present document can be downloaded from:

<https://www.etsi.org/standards-search>

The present document may be made available in electronic versions and/or in print. The content of any electronic and/or print versions of the present document shall not be modified without the prior written authorization of ETSI. In case of any existing or perceived difference in contents between such versions and/or in print, the prevailing version of an ETSI deliverable is the one made publicly available in PDF format at www.etsi.org/deliver.

Users of the present document should be aware that the document may be subject to revision or change of status.

Information on the current status of this and other ETSI documents is available at

<https://portal.etsi.org/TB/ETSIDeliverableStatus.aspx>

If you find errors in the present document, please send your comment to one of the following services:

<https://portal.etsi.org/People/CommitteeSupportStaff.aspx>

If you find a security vulnerability in the present document, please report it through our
Coordinated Vulnerability Disclosure Program:

<https://www.etsi.org/standards/coordinated-vulnerability-disclosure>

Notice of disclaimer & limitation of liability

The information provided in the present deliverable is directed solely to professionals who have the appropriate degree of experience to understand and interpret its content in accordance with generally accepted engineering or other professional standard and applicable regulations.

No recommendation as to products and services or vendors is made or should be implied.

No representation or warranty is made that this deliverable is technically accurate or sufficient or conforms to any law and/or governmental rule and/or regulation and further, no representation or warranty is made of merchantability or fitness for any particular purpose or against infringement of intellectual property rights.

In no event shall ETSI be held liable for loss of profits or any other incidental or consequential damages.

Any software contained in this deliverable is provided "AS IS" with no warranties, express or implied, including but not limited to, the warranties of merchantability, fitness for a particular purpose and non-infringement of intellectual property rights and ETSI shall not be held liable in any event for any damages whatsoever (including, without limitation, damages for loss of profits, business interruption, loss of information, or any other pecuniary loss) arising out of or related to the use of or inability to use the software.

Copyright Notification

No part may be reproduced or utilized in any form or by any means, electronic or mechanical, including photocopying and microfilm except as authorized by written permission of ETSI.

The content of the PDF version shall not be modified without the written authorization of ETSI.

The copyright and the foregoing restriction extend to reproduction in all media.

© ETSI 2023.
All rights reserved.

Intellectual Property Rights

Essential patents

IPRs essential or potentially essential to normative deliverables may have been declared to ETSI. The declarations pertaining to these essential IPRs, if any, are publicly available for **ETSI members and non-members**, and can be found in ETSI SR 000 314: "*Intellectual Property Rights (IPRs); Essential, or potentially Essential, IPRs notified to ETSI in respect of ETSI standards*", which is available from the ETSI Secretariat. Latest updates are available on the ETSI Web server (<https://ipr.etsi.org/>).

Pursuant to the ETSI Directives including the ETSI IPR Policy, no investigation regarding the essentiality of IPRs, including IPR searches, has been carried out by ETSI. No guarantee can be given as to the existence of other IPRs not referenced in ETSI SR 000 314 (or the updates on the ETSI Web server) which are, or may be, or may become, essential to the present document.

Trademarks

The present document may include trademarks and/or tradenames which are asserted and/or registered by their owners. ETSI claims no ownership of these except for any which are indicated as being the property of ETSI, and conveys no right to use or reproduce any trademark and/or tradename. Mention of those trademarks in the present document does not constitute an endorsement by ETSI of products, services or organizations associated with those trademarks.

DECT™, **PLUGTESTS™**, **UMTS™** and the ETSI logo are trademarks of ETSI registered for the benefit of its Members. **3GPP™** and **LTE™** are trademarks of ETSI registered for the benefit of its Members and of the 3GPP Organizational Partners. **oneM2M™** logo is a trademark of ETSI registered for the benefit of its Members and of the oneM2M Partners. **GSM®** and the GSM logo are trademarks registered and owned by the GSM Association.

Legal Notice

This Technical Specification (TS) has been produced by ETSI 3rd Generation Partnership Project (3GPP).

The present document may refer to technical specifications or reports using their 3GPP identities. These shall be interpreted as being references to the corresponding ETSI deliverables.

The cross reference between 3GPP and ETSI identities can be found under <https://webapp.etsi.org/key/queryform.asp>.

Modal verbs terminology

In the present document "**shall**", "**shall not**", "**should**", "**should not**", "**may**", "**need not**", "**will**", "**will not**", "**can**" and "**cannot**" are to be interpreted as described in clause 3.2 of the [ETSI Drafting Rules](#) (Verbal forms for the expression of provisions).

"**must**" and "**must not**" are **NOT** allowed in ETSI deliverables except when used in direct citation.

Contents

Intellectual Property Rights	2
Legal Notice	2
Modal verbs terminology.....	2
Foreword.....	14
1 Scope	16
2 References	16
3 Definitions of terms, symbols and abbreviations	17
3.1 Terms.....	17
3.2 Symbols.....	21
3.3 Abbreviations	23
4 General radiated test conditions and declarations	25
4.1 Measurement uncertainties and test requirements	25
4.1.1 General.....	25
4.1.2 Acceptable uncertainty of OTA Test System	27
4.1.2.1 General	27
4.1.2.2 Measurement of transmitter	28
4.1.2.3 Measurement of receiver.....	30
4.1.2.4 Measurement of performance requirement	32
4.1.3 Interpretation of measurement results.....	32
4.2 Radiated requirement reference points	32
4.3 IAB classes.....	33
4.3.1 <i>IAB-DU class</i>	33
4.3.2 <i>IAB-MT class</i>	34
4.4 Regional requirements.....	34
4.5 IAB configurations	35
4.5.1 Transmit configurations	35
4.5.2 Receive configurations	36
4.5.3 Power supply options.....	37
4.5.4 IAB with integrated Iuant BS modem.....	37
4.6 Manufacturer's declarations.....	37
4.7 Test configurations	46
4.7.1 General.....	46
4.7.2 Test signal configurations.....	46
4.7.2.1 Test signal used to build Test Configurations	46
4.7.2.2 IABTC1: Contiguous spectrum operation.....	47
4.7.2.2.1 IABTC1 generation	47
4.7.2.2.2 IABTC1 power allocation	48
4.7.2.3 IABTC2: Contiguous CA occupied bandwidth.....	48
4.7.2.3.1 IABTC2 generation	48
4.7.2.3.2 IABTC2 power allocation	48
4.7.2.4 IABTC3: Non-contiguous spectrum operation	48
4.7.2.4.1 IABTC3 generation	49
4.7.2.4.2 IABTC3 power allocation	49
4.7.2.5 IABTC4: Multi-band test configuration for full carrier allocation.....	49
4.7.2.5.1 IABTC4 generation	49
4.7.2.5.2 IABTC4 power allocation	50
4.7.2.6 IABTC5: Multi-band test configuration with high PSD per carrier.....	50
4.7.2.6.1 IABTC5 generation	50
4.7.2.6.2 IABTC5 power allocation	51
4.8 Applicability of requirements.....	51
4.8.1 Requirement set applicability	51
4.8.2 Applicability of test configurations for single-band RIB.....	51
4.8.3 Applicability of test configurations for multi-band RIB.....	53
4.9 RF channels and test models	55

4.9.1	RF channels	55
4.9.2	Test models	56
4.9.2.1	General	56
4.9.2.2	FR2 test models for IAB-DU	56
4.9.2.3	FR2 test models for IAB-MT	56
4.9.2.3.1	FR2 test model 1.1 (IAB-MT-FR2-TM1.1).....	57
4.9.2.3.2	FR2 test model 2 (IAB-MT-FR2-TM2)	57
4.9.2.3.2a	FR2 test model 2a (IAB-MT-FR2-TM2a).....	58
4.9.2.3.3	FR2 test model 3.1 (IAB-MT-FR2-TM3.1).....	58
4.9.2.3.4	FR2 test model 3.1a (IAB-MT-FR2-TM3.1a).....	58
4.9.2.3	Data content of physical channels and signals for IAB-MT-FR2-TM	59
4.9.2.3.1	PUSCH	59
4.10	Requirements for contiguous and non-contiguous spectrum.....	59
4.11	Requirements for IAB capable of multi-band operation.....	60
4.12	Co-location requirements	60
4.12.1	General.....	60
4.12.2	Co-location test antenna.....	61
4.12.2.1	General	61
4.12.2.2	Co-location test antenna characteristics	61
4.12.2.3	Co-location test antenna alignment	61
4.13	Test efficiency optimization	62
4.14	Format and interpretation of tests	64
4.15	Reference coordinate system	65
4.16	Requirements for IAB-DU and IAB-MT capable of simultaneous operation	65
5	Operating bands and channel arrangement.....	66
6	Radiated transmitter characteristics.....	66
6.1	General	66
6.2	Radiated transmit power.....	66
6.2.1	Definition and applicability	66
6.2.2	Minimum requirement	67
6.2.3	Test purpose.....	67
6.2.4	Method of test	67
6.2.4.1	Initial conditions	67
6.2.4.2	Procedure	68
6.2.5	Test requirement	68
6.2.5.1	IAB-DU.....	68
6.2.5.2	IAB-MT	68
6.3	IAB output power.....	69
6.3.1	Definition and applicability	69
6.3.2	Minimum requirement	69
6.3.3	Test purpose.....	69
6.3.4	Method of test	70
6.3.4.1	Initial conditions	70
6.3.4.2	Procedure	70
6.3.5	Test requirement	70
6.3.5.1	IAB type 1-O.....	70
6.3.5.2	IAB type 2-O.....	71
6.4	OTA output power dynamics	71
6.4.1	IAB-DU OTA Output Power Dynamics.....	71
6.4.1.1	General	71
6.4.1.2	OTA RE power control dynamic range.....	71
6.4.1.2.1	Definition and applicability	71
6.4.1.2.2	Minimum requirement.....	71
6.4.1.2.3	Test purpose	71
6.4.1.3	OTA total power dynamic range.....	71
6.4.1.3.1	Definition and applicability	71
6.4.1.3.2	Minimum requirement.....	72
6.4.1.3.3	Test purpose	72
6.4.1.3.4	Method of test.....	72
6.4.1.3.5	Test requirements	73

6.4.2	IAB-MT OTA Output Power Dynamics.....	74
6.4.2.1	OTA total power dynamic range.....	74
6.4.2.1.1	Definition and applicability.....	74
6.4.2.1.2	Minimum requirement.....	74
6.4.2.1.3	Test purpose.....	74
6.4.2.1.4	Method of test.....	74
6.4.2.1.5	Test requirements.....	75
6.4.2.2	Relative power tolerance for local area IAB-MT.....	76
6.4.2.2.1	Definition and applicability.....	76
6.4.2.2.2	Minimum requirement.....	76
6.4.2.2.3	Test purpose.....	76
6.4.2.3	Aggregate power tolerance for local area IAB-MT.....	76
6.4.2.3.1	Definition and applicability.....	76
6.4.2.3.2	Minimum requirement.....	76
6.4.2.3.3	Test purpose.....	76
6.5	OTA transmit ON/OFF power.....	76
6.5.1	OTA transmitter OFF power.....	76
6.5.1.1	Definition and applicability.....	76
6.5.1.2	Minimum requirement.....	77
6.5.1.3	Test purpose.....	77
6.5.1.4	Method of test.....	77
6.5.1.5	Test requirements.....	77
6.5.2	OTA transmitter transient period.....	77
6.5.2.1	Definition and applicability.....	77
6.5.2.2	Minimum requirement.....	78
6.5.2.3	Test purpose.....	78
6.5.2.4	Method of test.....	78
6.5.2.4.1	Initial conditions.....	78
6.5.2.4.2	Procedure.....	78
6.5.2.5	Test requirements.....	79
6.5.2.5.1	IAB type 1-O.....	79
6.5.2.5.2	IAB type 2-O.....	80
6.6	OTA transmitted signal quality.....	80
6.6.1	General.....	80
6.6.2	OTA frequency error.....	80
6.6.2.1	IAB-DU OTA frequency error.....	80
6.6.2.1.1	Definition and applicability.....	80
6.6.2.1.2	Minimum Requirement.....	80
6.6.2.1.3	Test purpose.....	80
6.6.2.1.4	Method of test.....	80
6.6.2.1.5	Test Requirements.....	81
6.6.2.2	IAB-MT OTA frequency error.....	81
6.6.2.2.1	Definition and applicability.....	81
6.6.2.2.2	Minimum Requirement.....	81
6.6.2.2.3	Test purpose.....	81
6.6.2.2.4	Method of test.....	81
6.6.2.2.5	Test Requirements.....	81
6.6.3	OTA modulation quality.....	81
6.6.3.1	Definition and applicability.....	81
6.6.3.2	Minimum Requirement.....	82
6.6.3.3	Test purpose.....	82
6.6.3.4	Method of test.....	82
6.6.3.4.1	Initial conditions.....	82
6.6.3.4.2	Procedure for IAB-DU.....	82
6.6.3.4.3	Procedure for IAB-MT.....	84
6.6.3.5	Test requirements.....	85
6.6.3.5.1	IAB-DU type 1-O and IAB-MT type 1-O.....	85
6.6.3.5.2	IAB-DU type 2-O and IAB-MT type 2-O.....	86
6.6.4	OTA time alignment error.....	87
6.6.4.1	Definition and applicability.....	87
6.6.4.2	Minimum requirement.....	87
6.6.4.3	Test purpose.....	87

6.6.4.4	Method of test	87
6.6.4.4.1	Initial conditions	87
6.6.4.4.2	Procedure for IAB-DU	88
6.6.4.5	Test Requirement	88
6.6.4.5.1	<i>IAB-DU type 1-O</i>	88
6.6.4.5.2	<i>IAB-DU type 2-O</i>	89
6.6.5	Timing error between IAB-DU and IAB-MT	89
6.6.5.1	Definition and applicability	89
6.6.5.2	Minimum requirement	89
6.6.5.3	Test purpose	89
6.6.5.4	Method of test	89
6.6.5.4.1	Initial conditions	89
6.6.5.4.2	Procedure	89
6.6.5.5	Test Requirement	90
6.6.5.5.1	IAB type 1-O	90
6.6.5.5.2	IAB type 2-O	90
6.7	OTA unwanted emissions	90
6.7.1	General	90
6.7.2	OTA occupied bandwidth	91
6.7.2.1	Definition and applicability	91
6.7.2.2	Minimum requirement	91
6.7.2.3	Test purpose	91
6.7.2.4	Method of test	91
6.7.2.4.1	Initial conditions	91
6.7.2.4.2	Procedure	92
6.7.2.5	Test requirement	93
6.7.2.5.1	<i>IAB-DU type 1-O and IAB-DU type 2-O</i>	93
6.7.2.5.2	<i>IAB-MT type 1-O and IAB-MT type 2-O</i>	93
6.7.3	OTA Adjacent Channel Leakage Power Ratio (ACLR)	93
6.7.3.1	Definition and applicability	93
6.7.3.2	Minimum requirement	93
6.7.3.3	Test purpose	94
6.7.3.4	Method of test	94
6.7.3.4.1	Initial conditions	94
6.7.3.4.2	Procedure	94
6.7.3.5	Test requirements	95
6.7.3.5.1	<i>IAB-DU type 1-O and IAB-MT type 1-O</i>	95
6.7.3.5.2	<i>IAB-DU type 2-O and Wide Area IAB-MT type 2-O</i>	98
6.7.3.5.3	<i>Local Area IAB-MT type 2-O</i>	101
6.7.4	OTA operating band unwanted emissions	104
6.7.4.1	Definition and applicability	104
6.7.4.1.1	<i>IAB-DU type 1-O</i>	104
6.7.4.1.2	<i>IAB-MT type 1-O</i>	104
6.7.4.1.3	<i>IAB-DU type 2-O and IAB-MT type 2-O</i>	104
6.7.4.2	Minimum requirement	104
6.7.4.3	Test purpose	104
6.7.4.4	Method of test	104
6.7.4.4.1	Initial conditions	104
6.7.4.4.2	Procedure	105
6.7.4.5	Test requirements	105
6.7.4.5.1	<i>IAB type 1-O</i>	105
6.7.4.6.1	Medium Range IAB-DU (Category A and B)	110
6.7.4.6.2	Local Area IAB-DU and Local Area IAB-MT (Category A and B)	112
6.7.4.6.3	Additional requirements	114
6.7.4.6.4	<i>IAB type 2-O</i>	114
6.7.5	OTA transmitter spurious emissions	117
6.7.5.1	General	117
6.7.5.2	General OTA transmitter spurious emissions requirements	118
6.7.5.2.1	Definition and applicability	118
6.7.5.2.2	Minimum requirement	118
6.7.5.2.3	Test purpose	118
6.7.5.2.4	Method of test	118

6.7.5.2.5	Test requirement	119
6.7.5.3	Void.....	121
6.7.5.4	Additional spurious emissions requirements	121
6.7.5.4.1	Definition and applicability	121
6.7.5.4.2	Minimum Requirement	122
6.7.5.4.3	Test purpose	122
6.7.5.4.4	Method of test.....	122
6.7.5.4.5	Test requirement	124
6.7.5.5	Co-location requirements	131
6.7.5.5.1	Definition and applicability	131
6.7.5.5.2	Minimum requirements	131
6.7.5.5.3	Test purpose	131
6.7.5.5.4	Method of test.....	131
6.7.5.5.5	Test requirements	132
6.8	OTA transmitter intermodulation	136
6.8.1	Definition and applicability	136
6.8.2	Minimum requirement	137
6.8.3	Test purpose.....	137
6.8.4	Method of test	137
6.8.4.1	Initial conditions	137
6.8.4.2	Procedure	137
6.8.5	Test requirements.....	139
6.8.5.1	Requirement for <i>IAB type 1-O</i>	139
7	Radiated receiver characteristics	140
7.1	General	140
7.2	OTA sensitivity	141
7.2.1	Definition and applicability	141
7.2.2	Minimum requirement	141
7.2.3	Test purpose.....	141
7.2.4	Method of test	142
7.2.4.1	Initial conditions	142
7.2.4.2	Procedure	142
7.2.5	Test requirements.....	142
7.2.5.1	General	142
7.2.5.2	Test requirements for <i>IAB-DU type 1-H</i> and <i>IAB-DU type 1-O</i>	142
7.2.5.3	Test requirements for <i>IAB-MT type 1-H</i> and <i>IAB-MT type 1-O</i>	143
7.3	OTA reference sensitivity level.....	143
7.3.1	Definition and applicability	143
7.3.2	Minimum requirement	143
7.3.3	Test Purpose.....	144
7.3.4	Method of test	144
7.3.4.1	Initial conditions	144
7.3.4.2	Procedure	144
7.3.5	Test requirements.....	144
7.3.5.1	General	144
7.3.5.2	IAB-DU OTA reference sensitivity level.....	145
7.3.5.2.1	Test requirements for <i>IAB-DU type 1-O</i>	145
7.3.5.2.2	Test requirements for <i>IAB-DU type 2-O</i>	146
7.3.5.3	IAB-MT OTA reference sensitivity level	147
7.3.5.3.1	Test requirement for <i>IAB-MT type 1-O</i>	147
7.3.5.3.2	Minimum requirement for <i>IAB-MT type 2-O</i>	147
7.4	OTA dynamic range	148
7.4.1	Definition and applicability	148
7.4.2	Minimum requirement	148
7.4.3	Test purpose.....	148
7.4.4	Method of test	148
7.4.4.1	Initial conditions	148
7.4.4.2	Procedure	149
7.4.5	Test requirement	149
7.4.5.1	General	149
7.4.5.2	Test requirements for <i>IAB-DU type 1-O</i>	149

7.5	OTA in-band selectivity and blocking.....	153
7.5.1	OTA adjacent channel selectivity	153
7.5.1.1	Definition and applicability.....	153
7.5.1.2	Minimum requirement	153
7.5.1.3	Test purpose	153
7.5.1.4	Method of test	153
7.5.1.4.1	Initial conditions	153
7.5.1.4.2	Procedure.....	153
7.5.1.5	Test requirement	154
7.5.1.5.1	General	154
7.5.1.5.2	Test requirements for <i>IAB-DU type 1-O</i>	154
7.5.1.5.3	Test requirements for <i>IAB-DU type 2-O</i>	155
7.5.1.5.4	Test requirements for <i>IAB-MT type 1-O</i>	156
7.5.1.5.5	Test requirements for <i>IAB-MT type 2-O</i>	157
7.5.2	OTA in-band blocking.....	158
7.5.2.1	Definition and applicability.....	158
7.5.2.2	Minimum requirement	158
7.5.2.3	Test purpose	158
7.5.2.4	Method of test	158
7.5.2.4.1	Initial conditions	158
7.5.2.4.2	Procedure.....	159
7.5.2.5	Test requirement	161
7.5.2.5.1	General	161
7.5.2.5.2	Test requirements for <i>IAB-DU type 1-O</i>	161
7.5.2.5.3	Test requirements for <i>IAB-DU type 2-O</i>	165
7.5.2.5.4	Test requirements for <i>IAB-MT type 1-O</i>	166
7.5.2.5.5	Test requirements for <i>IAB-MT type 2-O</i>	168
7.6	OTA out-of-band blocking	169
7.6.1	Definition and applicability	169
7.6.2	Minimum requirement	169
7.6.3	Test purpose.....	169
7.6.4	Method of test.....	169
7.6.4.1	Initial conditions	169
7.6.4.2	Procedure	170
7.6.4.2.1	<i>IAB type 1-O</i> procedure for out-of-band blocking.....	170
7.6.4.2.2	<i>IAB type 1-O</i> procedure for co-location blocking.....	170
7.6.4.2.3	<i>IAB type 2-O</i> procedure for out-of-band blocking.....	171
7.6.5	Test requirements.....	172
7.6.5.1	Requirement for <i>IAB Type 1-O</i>	172
7.6.5.1.1	General	172
7.6.5.1.2	Co-location requirement	172
7.6.5.2	Requirement for <i>IAB type 2-O</i>	173
7.6.5.2.1	General requirement	173
7.7	OTA receiver spurious emissions.....	173
7.7.1	Definition and applicability	173
7.7.2	Minimum requirement	174
7.7.3	Test purpose.....	174
7.7.4	Method of test	174
7.7.4.1	Initial conditions	174
7.7.4.2	Procedure	175
7.7.5	Test requirement	175
7.7.5.1	Test requirement for <i>IAB type 1-O</i>	175
7.7.5.2	Test requirement for <i>IAB type 2-O</i>	176
7.8	OTA receiver intermodulation	177
7.8.1	Definition and applicability	177
7.8.2	Minimum requirement	177
7.8.3	Test purpose.....	177
7.8.4	Method of test.....	177
7.8.4.1	Initial conditions	177
7.8.4.2	Procedure	178
7.8.5	Test requirement	178
7.8.5.1	IAB-DU type 1-O.....	178

7.8.5.2	IAB-DU type 2-O.....	183
7.8.5.3	IAB-MT type 1-O	183
7.9	OTA in-channel selectivity.....	187
7.9.1	Definition and applicability	187
7.9.2	Minimum requirement	187
7.9.3	Test purpose.....	187
7.9.4	Method of test	187
7.9.4.1	Initial conditions	187
7.9.4.2	Procedure	187
7.9.5	Test requirement	188
7.9.5.1	<i>IAB-DU type 1-O</i>	188
7.9.5.2	<i>IAB-DU type 2-O</i>	190
8	Radiated performance requirements.....	191
8.1	IAB-DU performance requirements	191
8.1.1	General.....	191
8.1.1.1	Scope and definitions	191
8.1.1.2	OTA demodulation branches	192
8.1.1.3	Applicability rule	192
8.1.1.3.1	General	192
8.1.1.3.2	Applicability of PUSCH performance requirements	192
8.1.1.3.3	Applicability of PUCCH performance requirements.....	193
8.1.1.3.4	Applicability of PRACH performance requirements.....	194
8.1.2	Performance requirements for PUSCH.....	194
8.1.2.1	Performance requirements for PUSCH with transform precoding disabled.....	194
8.1.2.1.1	Definition and applicability	194
8.1.2.1.2	Minimum Requirement	194
8.1.2.1.3	Test purpose	194
8.1.2.1.4	Method of test.....	194
8.1.2.1.5	Test Requirement.....	196
8.1.2.2	Performance requirements for PUSCH with transform precoding enabled	202
8.1.2.2.1	Definition and applicability	202
8.1.2.2.2	Minimum Requirement	202
8.1.2.2.3	Test Purpose	202
8.1.2.2.4	Method of test.....	202
8.1.2.2.5	Test Requirement.....	204
8.1.2.3	Performance requirements for UCI multiplexed on PUSCH	205
8.1.2.3.1	Definition and applicability	205
8.1.2.3.2	Minimum Requirement	205
8.1.2.3.3	Test Purpose	206
8.1.2.3.4	Method of test.....	206
8.1.2.3.5	Test Requirement.....	208
8.1.3	Performance requirements for PUCCH	209
8.1.3.1	Performance requirements for PUCCH format 0	209
8.1.3.1.1	Definition and applicability	209
8.1.3.1.2	Minimum Requirement	210
8.1.3.1.3	Test Purpose	210
8.1.3.1.4	Method of test.....	210
8.1.3.1.5	Test Requirement.....	212
8.1.3.2	Performance requirements for PUCCH format 1	212
8.1.3.2.1	NACK to ACK detection.....	212
8.1.3.2.2	ACK missed detection	215
8.1.3.3	Performance requirements for PUCCH format 2	218
8.1.3.3.1	ACK missed detection performance requirements	218
8.1.3.3.2	UCI BLER performance requirements	221
8.1.3.4	Performance requirements for PUCCH format 3	223
8.1.3.4.1	Definition and applicability	223
8.1.3.4.2	Minimum Requirement	224
8.1.3.4.3	Test Purpose	224
8.1.3.4.4	Method of test.....	224
8.1.3.4.5	Test Requirement.....	225
8.1.3.5	Performance requirements for PUCCH format 4	226

8.1.3.5.1	Definition and applicability	226
8.1.3.5.2	Minimum Requirement	227
8.1.3.5.3	Test Purpose	227
8.1.3.5.4	Method of test.....	227
8.1.3.5.5	Test Requirement.....	228
8.1.3.6	Performance requirements for multi-slot PUCCH	229
8.1.3.6.1	Performance requirements for multi-slot PUCCH format 1	229
8.1.4	Performance requirements for PRACH	233
8.1.4.1	PRACH false alarm probability and missed detection	233
8.1.4.1.1	Definition and applicability	233
8.1.4.1.2	Minimum requirement.....	233
8.1.4.1.3	Test purpose	233
8.1.4.1.4	Method of test.....	233
8.1.4.1.5	Test requirement for Normal Mode.....	235
8.2	IAB-MT performance requirements	236
8.2.1	General.....	236
8.2.1.1	Scope and definitions	236
8.2.2	Demodulation performance requirements.....	237
8.2.2.1	General	237
8.2.2.1.1	Applicability rule for IAB-MT	237
8.2.2.2	Performance requirements for PDSCH	238
8.2.2.2.1	Definition and applicability	238
8.2.2.2.2	Minimum requirements	238
8.2.2.2.3	Test purpose	238
8.2.2.2.4	Method of test.....	238
8.2.2.2.5	Test requirements	240
8.2.2.3	Demodulation performance requirements for PDCCCH	241
8.2.2.3.1	Definition and applicability	241
8.2.2.3.2	Minimum requirement.....	241
8.2.2.3.3	Test purpose	241
8.2.2.3.4	Method of test.....	241
8.2.2.3.5	Test requirements	242
8.2.3	CSI reporting requirements.....	243
8.2.3.1	General	243
8.2.3.1.1	Applicability of requirements	243
8.2.3.1.2	Common test parameters	244
8.2.3.2	Reporting of Channel Quality Indicator (CQI)	245
8.2.3.2.1	Definition and applicability	245
8.2.3.2.2	Minimum requirement.....	245
8.2.3.2.3	Test purpose	246
8.2.3.2.4	Method of test.....	246
8.2.3.2.5	Test requirement	249
8.2.3.3	Reporting of Precoding Matrix Information (PMI).....	249
8.2.3.3.1	Definition and applicability	249
8.2.3.3.2	Minimum requirement.....	250
8.2.3.3.3	Test purpose	250
8.2.3.3.4	Method of test.....	250
8.2.3.3.5	Test requirement	253
8.2.3.4	Reporting of Rank Information (RI)	254
8.2.3.4.1	Definition and applicability	254
8.2.3.4.2	Minimum requirement.....	254
8.2.3.4.3	Test purpose	254
8.2.3.4.4	Method of test.....	254
8.2.3.4.5	Test requirement	256
Annex A (normative):	Reference measurement channels	257
A.1	IAB-DU and IAB-MT Reference measurement channels.....	257
A.1.1	IAB-DU Reference measurement channels.....	257
A.1.2	IAB-MT Reference measurement channels.....	257
A.1.2.1	Fixed Reference Channels for reference sensitivity level, ACS, in-band blocking, out-of-band blocking and receiver intermodulation (QPSK, R=1/3).....	257

A.2	IAB-DU Fixed Reference Channels.....	258
A.2.1	Fixed Reference Channels for PUSCH performance requirements (QPSK, R=193/1024).....	258
A.2.2	Fixed Reference Channels for PUSCH performance requirements (16QAM, R=434/1024).....	263
A.2.3	Fixed Reference Channels for PUSCH performance requirements (16QAM, R=658/1024).....	264
A.2.4	Fixed Reference Channels for PUSCH performance requirements (64QAM, R=567/1024).....	267
A.2.5	PRACH Test preambles	269
A.3	IAB-MT Fixed Reference Channels.....	269
A.3.1	Fixed Reference Channels for PDSCH performance requirements (16QAM).....	269
A.3.2	Fixed Reference Channels for PDSCH performance requirements (64QAM).....	270
A.3.3	Fixed Reference Channels for PDSCH performance requirements (256QAM).....	271
A.3.4	Fixed Reference Channels for PDCCH performance requirements	272
A.3.5	Fixed Reference Channels for CSI reporting requirements.....	272
Annex B (normative): Environmental requirements for the BS equipment		275
B.1	General	275
B.2	Normal test environment	275
B.3	Extreme test environment.....	275
B.3.1	General	275
B.3.2	Extreme temperature	275
B.4	Vibration.....	276
B.5	Power supply	276
B.6	Measurement of test environments.....	276
B.7	OTA extreme test methods.....	277
B.7.1	Direct far field method	277
B.7.2	Relative method.....	277
Annex C (informative): Test tolerances and derivation of test requirements.....		279
C.1	Measurement of transmitter.....	280
C.2	Measurement of receiver	286
C.3	Measurement of performance requirements	288
C.3.1	IAB-DU Test Tolerances.....	288
C.3.2	IAB-MT Test Tolerances	289
C.3.2.1	Demodulation Performance	289
C.3.2.2	Channel State Information Reporting	289
Annex D (normative): Calibration.....		290
D.1	General	290
Annex E (informative): OTA measurement system set-up.....		291
E.1	Transmitter	291
E.1.1	Radiated transmit power, OTA output power dynamics, OTA transmitted signal quality, OTA occupied bandwidth, and OTA transmit ON/OFF power (<i>IAB type 2-O</i>)	291
E.1.2	OTA IAB output power, OTA ACLR, OTA operating band unwanted emissions	292
E.1.3	OTA spurious emissions	292
E.1.4	OTA co-location emissions, OTA transmit ON/OFF power (<i>IAB type 1-O</i>)	293
E.1.5	OTA transmitter intermodulation	294
E.2	Receiver.....	294
E.2.1	OTA sensitivity and OTA reference sensitivity level.....	294
E.2.2	OTA dynamic range	295
E.2.3	OTA adjacent channel selectivity, general OTA blocking, and OTA narrowband blocking	295
E.2.4	OTA blocking.....	296
E.2.4.1	General OTA out-of-band blocking.....	296
E.2.4.2	OTA co-location blocking	297

E.2.5	OTA receiver spurious emissions.....	297
E.2.6	OTA receiver intermodulation	298
E.2.7	OTA in-channel selectivity.....	298
E.3	Measurement set-up IAB-MT and IAB-DU performance requirements.....	299
E.3.1	PUSCH and PUCCH single antenna port in multipath fading	299
E.3.2	2 antenna port PUSCH, PDCCH, PDSCH in multi-path fading.....	299
E.3.3	PUSCH, PRACH, CSI in static AWGN.....	300
Annex F (normative):	Void	302
Annex G (informative):	Transmitter spatial emissions declaration.....	303
G.1	General	303
G.2	Declarations.....	304
Annex H (normative):	Characteristics of the interfering signals.....	305
H.1	Characteristics of the interfering signals for IAB-DU	305
H.2	Characteristics of the interfering signals for IAB-MT.....	305
Annex I (normative):	TRP measurement procedures	306
Annex J (normative):	Propagation conditions.....	307
J.1	Static propagation condition.....	307
J.1.1	IAB-MT Receiver with 2 Rx.....	307
J.2	Multi-path fading propagation conditions	307
J.2.1	Delay profiles	307
J.2.1.1	Delay profiles for FR1	309
J.2.1.2	Delay profiles for FR2	310
J.2.2	Combinations of channel model parameters	310
J.2.3	MIMO channel correlation matrices.....	310
J.2.3.1	MIMO correlation matrices using Uniform Linear Array (ULA).....	311
J.2.3.1.1	Definition of MIMO correlation matrices	311
J.2.3.1.2	MIMO correlation matrices at high, medium and low level	312
J.2.3.2	Multi-antenna channel models using cross polarized antennas.....	314
J.2.3.2.1	Definition of MIMO correlation matrices using cross polarized antennas.....	314
J.2.3.2.2	Spatial correlation matrices at IAB-MT and IAB-DU sides	315
J.2.3.2.2.1	Spatial correlation matrices at IAB-MT side.....	315
J.2.3.2.2.2	Spatial correlation matrices at IAB-DU side	315
J.2.3.2.3	MIMO correlation matrices using cross polarized antennas	315
J.3	Physical signals, channels mapping and precoding.....	316
J.3.1	General	316
Annex K (informative):	Measuring noise close to noise-floor.....	318
Annex L (normative):	In-channel TX tests for IAB-DU.....	319
Annex M (normative):	In-channel TX tests for IAB-MT.....	320
M.0	Applicability.....	320
M.1	General	320
M.2	Basic principles	320
M.2.1	Output signal of the TX under test	320
M.2.2	Ideal signal	320
M.2.3	Measurement results.....	321
M.2.4	Measurement points	321
M.3	Pre-FFT minimization process	323

M.4	Timing of the FFT window	323
M.5	Resource element TX power	324
M.6	Post-FFT equalisation.....	325
M.7	EVM.....	327
M.7.0	General	327
M.7.1	Averaged EVM (TDD).....	327
Annex N (normative):	General rules for statistical testing.....	329
Annex O (informative):	Change history	330
History		333

Foreword

This Technical Specification has been produced by the 3rd Generation Partnership Project (3GPP).

The contents of the present document are subject to continuing work within the TSG and may change following formal TSG approval. Should the TSG modify the contents of the present document, it will be re-released by the TSG with an identifying change of release date and an increase in version number as follows:

Version x.y.z

where:

- x the first digit:
 - 1 presented to TSG for information;
 - 2 presented to TSG for approval;
 - 3 or greater indicates TSG approved document under change control.
- y the second digit is incremented for all changes of substance, i.e. technical enhancements, corrections, updates, etc.
- z the third digit is incremented when editorial only changes have been incorporated in the document.

In the present document, modal verbs have the following meanings:

- shall** indicates a mandatory requirement to do something
- shall not** indicates an interdiction (prohibition) to do something

The constructions "shall" and "shall not" are confined to the context of normative provisions, and do not appear in Technical Reports.

The constructions "must" and "must not" are not used as substitutes for "shall" and "shall not". Their use is avoided insofar as possible, and they are not used in a normative context except in a direct citation from an external, referenced, non-3GPP document, or so as to maintain continuity of style when extending or modifying the provisions of such a referenced document.

- should** indicates a recommendation to do something
- should not** indicates a recommendation not to do something
- may** indicates permission to do something
- need not** indicates permission not to do something

The construction "may not" is ambiguous and is not used in normative elements. The unambiguous constructions "might not" or "shall not" are used instead, depending upon the meaning intended.

- can** indicates that something is possible
- cannot** indicates that something is impossible

The constructions "can" and "cannot" are not substitutes for "may" and "need not".

- will** indicates that something is certain or expected to happen as a result of action taken by an agency the behaviour of which is outside the scope of the present document
- will not** indicates that something is certain or expected not to happen as a result of action taken by an agency the behaviour of which is outside the scope of the present document
- might** indicates a likelihood that something will happen as a result of action taken by some agency the behaviour of which is outside the scope of the present document

might not indicates a likelihood that something will not happen as a result of action taken by some agency the behaviour of which is outside the scope of the present document

In addition:

is (or any other verb in the indicative mood) indicates a statement of fact

is not (or any other negative verb in the indicative mood) indicates a statement of fact

The constructions "is" and "is not" do not indicate requirements.

1 Scope

The present specifies document the Radio Frequency (RF) test methods and conformance requirements for NR Integrated access and backhaul: *IAB type 1-H*, *IAB type 1-O* and *IAB type 2-O*. These have been derived from, and are consistent with the radiated requirements for *IAB type 1-H*, *IAB type 1-O* and *IAB type 2-O* in BS specification defined in TS 38.174 [2].

A *IAB type 1-H* has both conducted and radiated requirements, so it requires compliance to the applicable requirements of the present document and TS 38.176-1 [3].

IAB type 1-O and *IAB type 2-O* have only radiated requirements, so they require compliance to the present document only.

2 References

The following documents contain provisions which, through reference in this text, constitute provisions of the present document.

- References are either specific (identified by date of publication, edition number, version number, etc.) or non-specific.
- For a specific reference, subsequent revisions do not apply.
- For a non-specific reference, the latest version applies. In the case of a reference to a 3GPP document (including a GSM document), a non-specific reference implicitly refers to the latest version of that document *in the same Release as the present document*.

- [1] 3GPP TR 21.905: "Vocabulary for 3GPP Specifications".
- [2] 3GPP TS 38.174: "NR; Integrated access and backhaul radio transmission and reception".
- [3] 3GPP TS 38.176-1: " NR; Integrated Access and Backhaul (IAB) conformance testing; Part 1: Conducted conformance testing".
- [4] 3GPP TS 38.104: "NR; Base Station (BS) radio transmission and reception".
- [5] 3GPP TS 38.141-1: "NR, Base Station (BS) conformance testing, Part 1: Conducted conformance testing".
- [6] 3GPP TS 38.141-2: "NR, Base Station (BS) conformance testing, Part 2: Radiated conformance testing".
- [7] 3GPP TS 38.211: "NR; Physical channels and modulation".
- [8] 3GPP TS 38.212: "NR; Multiplexing and channel coding".
- [9] 3GPP TS 38.213: "NR; Physical layer procedures for control".
- [10] Recommendation ITU-R SM.329: "Unwanted emissions in the spurious domain".
- [11] ERC Recommendation 74-01: "Unwanted emissions in the spurious domain".
- [12] Recommendation ITU-R M.1545, "Measurement uncertainty as it applies to test limits for the terrestrial component of International Mobile Telecommunications-2000".
- [13] Recommendation ITU-R SM.328: "Spectra and bandwidth of emissions".
- [14] "Title 47 of the Code of Federal Regulations (CFR)", Federal Communications Commission.
- [15] 3GPP TR 25.942: "RF system scenarios".
- [16] 3GPP TS 38.101-1: "NR; User Equipment (UE) radio transmission and reception; Part 1: Range 1 Standalone".

- [17] 3GPP TS 38.101-2: "NR; User Equipment (UE) radio transmission and reception; Part 2: Range 2 Standalone".
- [18] 3GPP TS 38.101-4: "NR; User Equipment (UE) radio transmission and reception; Part 4: Performance requirements".
- [19] IEC 60 721-3-3: "Classification of environmental conditions - Part 3-3: Classification of groups of environmental parameters and their severities - Stationary use at weather protected locations".
- [20] IEC 60 721-3-4: "Classification of environmental conditions - Part 3: Classification of groups of environmental parameters and their severities - Clause 4: Stationary use at non-weather protected locations".
- [21] IEC 60 721: "Classification of environmental conditions".
- [22] IEC 60 068-2-1 (2007): "Environmental testing - Part 2: Tests. Tests A: Cold".
- [23] IEC 60 068-2-2: (2007): "Environmental testing - Part 2: Tests. Tests B: Dry heat".
- [24] IEC 60 068-2-6: (2007): "Environmental testing - Part 2: Tests - Test Fc: Vibration (sinusoidal)".
- [25] 3GPP TR 37.941: "Radio Frequency (RF) conformance testing background for radiated Base Station (BS) requirements".
- [26] 3GPP TR 38.901: "Study on channel model for frequencies from 0.5 to 100 GHz".
- [27] 3GPP TS 38.214: "NR; Physical layer procedures for data".
- [28] 3GPP TS 38.521-1: "NR; User Equipment (UE) conformance specification; Radio transmission and reception; Part 1: Range 1 standalone".
- [29] 3GPP TS 38.521-2: "NR; User Equipment (UE) conformance specification; Radio transmission and reception; Part 2: Range 2 standalone".

3 Definitions of terms, symbols and abbreviations

3.1 Terms

For the purposes of the present document, the terms given in 3GPP TR 21.905 [1] and the following apply. A term defined in the present document takes precedence over the definition of the same term, if any, in 3GPP TR 21.905 [1].

active transmitter unit: transmitter unit which is ON, and has the ability to send modulated data streams that are parallel and distinct to those sent from other transmitter units to one or more *IAB type 1-H TAB connectors* at the *transceiver array boundary*

Aggregated IAB-DU channel bandwidth: The RF bandwidth in which an IAB-DU transmits and receives multiple contiguously aggregated carriers. The aggregated IAB-DU channel bandwidth is measured in MHz.

Aggregated IAB-MT channel bandwidth: The RF bandwidth in which an IAB-MT transmits and receives multiple contiguously aggregated carriers. The aggregated IAB-MT channel bandwidth is measured in MHz.

Aggregated IAB channel bandwidth: The RF bandwidth in which IAB-DU and IAB-MT transmit or receives multiple contiguously aggregated carriers simultaneously. The aggregated IAB channel bandwidth is measured in MHz.

basic limit: emissions limit relating to the power supplied by a single transmitter to a single antenna transmission line in ITU-R SM.329 [16] used for the formulation of unwanted emission requirements for FR1

beam: beam (of the antenna) is the main lobe of the radiation pattern of an *antenna array*

NOTE: For certain *antenna array*, there may be more than one beam.

beam centre direction: direction equal to the geometric centre of the half-power contour of the beam

beam direction pair: data set consisting of the *beam centre direction* and the related *beam peak direction*

beam peak direction: direction where the maximum EIRP is found

beamwidth: beam which has a half-power contour that is essentially elliptical, the half-power beamwidths in the two pattern cuts that respectively contain the major and minor axis of the ellipse

Carrier aggregation: aggregation of two or more component carriers in order to support wider *transmission bandwidths*

Carrier aggregation configuration: a set of one or more *operating bands* across which the IAB-DU or IAB-MT aggregates carriers with a specific set of technical requirements

Channel edge: lowest or highest frequency of the NR carrier, separated by the *IAB-MT channel bandwidth* or *IAB-DU channel bandwidth*.

co-location reference antenna: a passive antenna used as reference for co-location requirements

Contiguous spectrum: spectrum consisting of a contiguous block of spectrum with no *sub-block gap(s)*.

directional requirement: requirement which is applied in a specific direction within the *OTA coverage range* for the Tx and when the AoA of the incident wave of a received signal is within the *OTA REFSENS RoAoA* or the *minSENS RoAoA* as appropriate for the receiver

equivalent isotropic radiated power: equivalent power radiated from an isotropic directivity device producing the same field intensity at a point of observation as the field intensity radiated in the direction of the same point of observation by the discussed device

NOTE: Isotropic directivity is equal in all directions (i.e. 0 dBi).

equivalent isotropic sensitivity: sensitivity for an isotropic directivity device equivalent to the sensitivity of the discussed device exposed to an incoming wave from a defined AoA

NOTE 1: The sensitivity is the minimum received power level at which specific requirement is met.

NOTE 2: Isotropic directivity is equal in all directions (i.e. 0 dBi).

fractional bandwidth: *fractional bandwidth* FBW is defined as $FBW = 200 \cdot \frac{F_{FBW\ high} - F_{FBW\ low}}{F_{FBW\ high} + F_{FBW\ low}} \%$

highest carrier: The carrier with the highest carrier frequency transmitted/received in a specified frequency band.

IAB-DU channel bandwidth: RF bandwidth supporting a single IAB-DU RF carrier with the *transmission bandwidth* configured in the uplink or downlink

NOTE 1: The *IAB-DU channel bandwidth* is measured in MHz and is used as a reference for transmitter and receiver RF requirements.

NOTE 2: It is possible for the IAB to transmit to and/or receive from one or more IAB-MT bandwidth parts that are smaller than or equal to the *IAB transmission bandwidth configuration*, in any part of the *IAB transmission bandwidth configuration*.

IAB-donor: gNB that provides network access to UEs via a network of backhaul and access links.

IAB-DU RF Bandwidth: RF bandwidth in which an IAB-DU transmits and/or receives single or multiple carrier(s) within a supported *operating band*

IAB-DU RF Bandwidth edge: frequency of one of the edges of the *IAB-DU RF Bandwidth*.

IAB-MT channel bandwidth: RF bandwidth supporting a single IAB-MT RF carrier with the *transmission bandwidth* configured in the uplink or downlink

NOTE 1: The *IAB-MT channel bandwidth* is measured in MHz and is used as a reference for transmitter and receiver RF requirements.

IAB-MT RF Bandwidth: RF bandwidth in which an IAB-MT transmits and/or receives single or multiple carrier(s) within a supported *operating band*

NOTE: In single carrier operation, the *IAB-MT RF Bandwidth* is equal to the *IAB-MT channel bandwidth*.

IAB-MT RF Bandwidth edge: frequency of one of the edges of the *IAB-MT RF Bandwidth*.

IAB RF Bandwidth: RF bandwidth in which an IAB-DU and/or IAB-MT transmits and/or receives single or multiple carrier(s) within a supported *operating band*

IAB RF Bandwidth edge: frequency of one of the edges of the *IAB RF Bandwidth*.

IAB Simultaneous Operation: IAB-DU and IAB-MT operating with simultaneous transmission, or simultaneous reception.

IAB type 1-H: IAB-DU or IAB-MT operating at FR1 with a *requirement set* consisting of conducted requirements defined at individual *TAB connectors* and OTA requirements defined at RIB

IAB type 1-O: IAB-DU or IAB-MT operating at FR1 with a *requirement set* consisting only of OTA requirements defined at the RIB

IAB type 2-O: IAB-DU or IAB-MT operating at FR2 with a *requirement set* consisting only of OTA requirements defined at the RIB

inter-band gap: The frequency gap between two supported consecutive *operating bands*.

Inter RF Bandwidth gap: frequency gap between two consecutive *IAB-DU and/or IAB-MT RF Bandwidths* that are placed within two supported *operating bands*

lowest Carrier: The carrier with the lowest carrier frequency transmitted/received in a specified frequency band.

maximum carrier output power: mean power level measured per carrier at the indicated interface, during the *transmitter ON period* in a specified reference condition

maximum carrier TRP output power: mean power level measured per RIB during the *transmitter ON period* for a specific carrier in a specified reference condition and corresponding to the declared *rated carrier TRP output power* ($P_{\text{rated,c,TRP}}$)

measurement bandwidth: RF bandwidth in which an emission level is specified

minSENS: the lowest declared EIS value for the OSDD's declared for OTA sensitivity requirement.

minSENS RoAoA: The *reference RoAoA* associated with the OSDD with the lowest declared EIS

multi-band connector: *TAB connector* of *IAB type 1-H* associated with a transmitter or receiver that is characterized by the ability to process two or more carriers in common active RF components simultaneously, where at least one carrier is configured at a different *operating band* than the other carrier(s) and where this different *operating band* is not a *sub-band* or *superseding-band* of another supported *operating band*

multi-band RIB: *operating band* specific RIB associated with a transmitter or receiver that is characterized by the ability to process two or more carriers in common active RF components simultaneously, where at least one carrier is configured at a different *operating band* than the other carrier(s) and where this different *operating band* is not a *sub-band* or *superseding-band* of another supported *operating band*

Non-contiguous spectrum: spectrum consisting of two or more *sub-blocks* separated by *sub-block gap(s)*.

operating band: frequency range in which NR operates (paired or unpaired), that is defined with a specific set of technical requirements

NOTE: The *operating band(s)* for an IAB-DU and IAB-MT are declared by the manufacturer

OTA coverage range: a common range of directions within which TX OTA requirements that are neither specified in the *OTA peak directions sets* nor as *TRP requirement* are intended to be met

OTA peak directions set: set(s) of *beam peak directions* within which certain TX OTA requirements are intended to be met, where all *OTA peak directions set(s)* are subsets of the *OTA coverage range*

NOTE: The *beam peak directions* are related to a corresponding contiguous range or discrete list of *beam centre directions* by the *beam direction pairs* included in the set.

OTA REFSENS RoAoA: the RoAoA determined by the contour defined by the points at which the achieved EIS is 3dB higher than the achieved EIS in the reference direction assuming that for any AoA, the receiver gain is optimized for that AoA

NOTE: This contour will be related to the average element/sub-array radiation pattern 3dB beamwidth.

OTA sensitivity directions declaration: set of manufacturer declarations comprising at least one set of declared minimum EIS values (with *IAB-DU* or *IAB-MT channel bandwidth*), and related directions over which the EIS applies

NOTE: All the directions apply to all the EIS values in an OSDD.

Parent node: IAB-MT's next hop neighbour node; the parent node can be IAB-node or IAB-donor.

polarization match: condition that exists when a plane wave, incident upon an antenna from a given direction, has a polarization that is the same as the receiving polarization of the antenna in that direction

radiated interface boundary: *operating band* specific radiated requirements reference where the radiated requirements apply

NOTE: For requirements based on EIRP/EIS, the *radiated interface boundary* is associated to the far-field region

Radio Bandwidth: frequency difference between the upper edge of the highest used carrier and the lower edge of the lowest used carrier

rated beam EIRP: For a declared beam and *beam direction pair*, the *rated beam EIRP* level is the maximum power that the IAB-DU or IAB-MT is declared to radiate at the associated *beam peak direction* during the *transmitter ON period*

rated carrier output power: mean power level associated with a particular carrier the manufacturer has declared to be available at the indicated interface, during the *transmitter ON period* in a specified reference condition

rated carrier TRP output power: mean power level declared by the manufacturer per carrier, for IAB-DU or IAB-MT operating in single carrier, multi-carrier, carrier aggregation configurations, or *IAB Simultaneous Operation* that the manufacturer has declared to be available at the RIB during the *transmitter ON period*

rated total output power: mean power level associated with a particular *operating band* the manufacturer has declared to be available at the indicated interface, during the *transmitter ON period* in a specified reference condition

rated total TRP output power: mean power level declared by the manufacturer, that the manufacturer has declared to be available at the RIB during the *transmitter ON period*

reference beam direction pair: declared *beam direction pair*, including reference *beam centre direction* and reference *beam peak direction* where the reference *beam peak direction* is the direction for the intended maximum EIRP within the *OTA peak directions set*

receiver target: AoA in which reception is performed by *IAB type 1-H* or *IAB type 1-O*

receiver target redirection range: union of all the *sensitivity RoAoA* achievable through redirecting the *receiver target* related to particular OSDD

receiver target reference direction: direction inside the *OTA sensitivity directions declaration* declared by the manufacturer for conformance testing. For an OSDD without *receiver target redirection range*, this is a direction inside the *sensitivity RoAoA*

reference RoAoA: the *sensitivity RoAoA* associated with the *receiver target reference direction* for each OSDD.

requirement set: one of the NR requirement sets as defined for *IAB type 1-H*, *IAB type 1-O*, and *IAB type 2-O*

sensitivity RoAoA: RoAoA within the *OTA sensitivity directions declaration*, within which the declared EIS(s) of an OSDD is intended to be achieved at any instance of time for a specific IAB-DU or IAB-MT direction setting

single-band connector: *IAB type 1-H TAB connector* supporting operation either in a single *operating band* only, or in multiple *operating bands* but does not meet the conditions for a *multi-band connector*.

sub-band: A *sub-band* of an operating band contains a part of the uplink and downlink frequency range of the operating band.

sub-block: one contiguous allocated block of spectrum for transmission and reception by the same IAB-DU and/or IAB-MT

NOTE: There may be multiple instances of *sub-blocks* within a *IAB RF Bandwidth*.

sub-block gap: frequency gap between two consecutive sub-blocks within a *IAB RF Bandwidth*, where the RF requirements in the gap are based on co-existence for un-coordinated operation

superseding-band: A *superseding-band* of an operating band includes the whole of the uplink and downlink frequency range of the operating band.

TAB connector: *transceiver array boundary* connector

TAB connector RX min cell group: *operating band* specific declared group of *TAB connectors* to which *IAB type 1-H* conducted RX requirements are applied

NOTE: Within this definition, the group corresponds to the group of *TAB connectors* which are responsible for receiving a cell when the *IAB type 1-H* setting corresponding to the declared minimum number of cells with reception on all *TAB connectors* supporting an *operating band*, but its existence is not limited to that condition

TAB connector TX min cell group: *operating band* specific declared group of *TAB connectors* to which *IAB type 1-H* conducted TX requirements are applied.

NOTE: Within this definition, the group corresponds to the group of *TAB connectors* which are responsible for transmitting a cell when the *IAB type 1-H* setting corresponding to the declared minimum number of cells with transmission on all *TAB connectors* supporting an *operating band*, but its existence is not limited to that condition

total radiated power: is the total power radiated by the antenna

NOTE: The *total radiated power* is the power radiating in all direction for two orthogonal polarizations. *Total radiated power* is defined in both the near-field region and the far-field region

transceiver array boundary: conducted interface between the transceiver unit array and the composite antenna

transmission bandwidth: RF Bandwidth of an instantaneous transmission from an IAB-DU or IAB-MT, measured in resource block units

transmitter OFF period: time period during which the IAB-DU or IAB-MT transmitter is not allowed to transmit

transmitter ON period: time period during which the IAB-DU or IAB-MT transmitter is transmitting data and/or reference symbols

transmitter transient period: time period during which the transmitter is changing from the OFF period to the ON period or vice versa

3.2 Symbols

For the purposes of the present document, the following symbols apply:

β	Percentage of the mean transmitted power emitted outside the occupied bandwidth on the assigned channel
$BeW_{\theta,REFSENS}$	Beamwidth equivalent to the <i>OTA REFSENS RoAoA</i> in the θ -axis in degrees. Applicable for FR1 only.
$BeW_{\phi,REFSENS}$	Beamwidth equivalent to the <i>OTA REFSENS RoAoA</i> in the ϕ -axis in degrees. Applicable for FR1 only.
$BW_{Channel}$	<i>IAB channel bandwidth</i>
$BW_{Channel_CA}$	<i>Aggregated IAB Channel Bandwidth</i> , expressed in MHz. $BW_{Channel_CA} = F_{edge,high} - F_{edge,low}$.
BW_{Config}	<i>Transmission bandwidth configuration</i> , where $BW_{Config} = N_{RB} \times SCS \times 12$

$BW_{\text{Contiguous}}$	Contiguous <i>transmission bandwidth</i> , i.e. <i>IAB channel bandwidth</i> for single carrier or <i>Aggregated IAB channel bandwidth</i> for contiguously aggregated carriers. For non-contiguous operation within a band the term is applied per <i>sub-block</i> .
Δf	Separation between the <i>channel edge</i> frequency and the nominal -3 dB point of the measuring filter closest to the carrier frequency
Δf_{max}	$f_{\text{offset}_{\text{max}}}$ minus half of the bandwidth of the measuring filter
Δf_{OBUE}	Maximum offset of the <i>operating band</i> unwanted emissions mask from the downlink <i>operating band</i> edge
Δf_{OOB}	Maximum offset of the out-of-band boundary from the uplink <i>operating band</i> edge
$\Delta_{\text{FR2_REFSENS}}$	Offset applied to the FR2 OTA REFSSENS depending on the AoA
Δ_{minSENS}	Difference between conducted reference sensitivity and minSENS
$\Delta_{\text{OTAREFSSENS}}$	Difference between conducted reference sensitivity and OTA REFSSENS
EIS_{minSENS}	The EIS declared for the <i>minSENS RoAoA</i>
EIS_{REFSENS}	OTA REFSSENS EIS value
$EIS_{\text{REFSENS_50M}}$	Declared OTA reference sensitivity basis level for FR2 based on a reference measurement channel with 50MHz <i>IAB channel bandwidth</i>
\hat{E}_s	Received energy per RE (power normalized to the subcarrier spacing) during the useful part of the symbol, i.e. excluding the cyclic prefix, at the IAB-MT antenna connector
F_{FBWhigh}	Highest supported frequency within supported <i>operating band</i> , for which <i>fractional bandwidth</i> support was declared
F_{FBWlow}	Lowest supported frequency within supported <i>operating band</i> , for which <i>fractional bandwidth</i> support was declared
$F_{\text{C,low}}$	The F_c of the <i>lowest carrier</i> , expressed in MHz.
$F_{\text{C,high}}$	The F_c of the <i>highest carrier</i> , expressed in MHz.
$F_{\text{DL,low}}$	The lowest frequency of the downlink <i>operating band</i>
$F_{\text{DL,high}}$	The highest frequency of the downlink <i>operating band</i>
$F_{\text{edge,low}}$	The lower edge of <i>Aggregated IAB Channel Bandwidth</i> , expressed in MHz. $F_{\text{edge,low}} = F_{\text{C,low}} - F_{\text{offset,low}}$.
$F_{\text{edge,high}}$	The upper edge of <i>Aggregated IAB Channel Bandwidth</i> , expressed in MHz. $F_{\text{edge,high}} = F_{\text{C,high}} + F_{\text{offset,high}}$.
f_{offset}	Separation between the <i>channel edge</i> frequency and the centre of the measuring
$f_{\text{offset}_{\text{max}}}$	The offset to the frequency Δf_{OBUE} outside the downlink <i>operating band</i>
$F_{\text{step,X}}$	Frequency steps for the OTA transmitter spurious emissions (Category B)
$F_{\text{UL,low}}$	The lowest frequency of the uplink <i>operating band</i>
$F_{\text{UL,high}}$	The highest frequency of the uplink <i>operating band</i>
I_o	The total received power density, including signal and interference, as measured at the IAB-MT antenna connector.
I_{oc}	The power spectral density (integrated in a noise bandwidth equal to the chip rate and normalized to the chip rate) of a band limited noise source (simulating interference from cells, which are not defined in a test procedure) as measured at the IAB-MT antenna connector.
I_{ot}	The received power spectral density of the total noise and interference for a certain IAB-MT (power integrated over the RE and normalized to the subcarrier spacing) as measured at the IAB-MT antenna connector
N_{oc}	The power spectral density of a white noise source (average power per RE normalised to the subcarrier spacing), simulating interference from cells that are not defined in a test procedure, as measured at the IAB-MT antenna connector
N_{cells}	The declared number corresponding to the minimum number of cells that can be transmitted by an <i>IAB type 1-H</i> in a particular <i>operating band</i>
$N_{\text{RXU,active}}$	The number of active receiver units. The same as the number of <i>demodulation branches</i> to which compliance is declared for clause 8 performance requirements
$N_{\text{RXU,counted}}$	The number of active receiver units that are taken into account for conducted Rx spurious emission scaling, as calculated in clause 7.6.1
$N_{\text{RXU,countedpercell}}$	The number of active receiver units that are taken into account for conducted RX spurious emissions scaling per cell, as calculated in clause 7.6.1
N_{TA}	Timing offset between uplink and downlink radio frames at the UE, as defined in clause 4.2.3 in TS 38.213 [9]
$N_{\text{TXU,counted}}$	The number of <i>active transmitter units</i> as calculated in clause 6.1, that are taken into account for conducted TX output power limit in clause 6.2.1, and for unwanted TX emissions scaling
$N_{\text{TXU,countedpercell}}$	The number of <i>active transmitter units</i> that are taken into account for conducted TX emissions scaling per cell, as calculated in clause 6.1
$P_{\text{CMAX},f,c}$	The configured maximum output power for carrier f of serving cell c in each slot

$P_{\max,c,TABC}$	The maximum carrier output power per TAB connector
$P_{\max,c,TRP}$	Maximum carrier TRP output power measured at the RIB(s), and corresponding to the declared rated carrier TRP output power ($P_{\text{rated},c,TRP}$)
$P_{\max,c,EIRP}$	The maximum carrier EIRP when the IAB is configured at the maximum rated carrier output TRP ($P_{\text{rated},c,TRP}$)
$P_{\text{rated},c,cell}$	The rated carrier output power per TAB connector TX min cell group
$P_{\text{rated},c,EIRP}$	The rated carrier EIRP output power declared per RIB
$P_{\text{rated},c,FBW\text{high}}$	The rated carrier EIRP for the higher supported frequency range within supported <i>operating band</i> , for which <i>fractional bandwidth</i> support was declared
$P_{\text{rated},c,FBW\text{low}}$	The rated carrier EIRP for the lower supported frequency range within supported <i>operating band</i> , for which <i>fractional bandwidth</i> support was declared
$P_{\text{rated},c,sys}$	The sum of $P_{\text{rated},c,TABC}$ for all TAB connectors for a single carrier
$P_{\text{rated},c,TABC}$	The rated carrier output power per TAB connector
$P_{\text{rated},c,TRP}$	Rated carrier TRP output power declared per RIB
$P_{\text{rated},t,TABC}$	The rated total output power declared at TAB connector
$P_{\text{rated},t,TRP}$	Rated total TRP output power declared per RIB
P_{REFSENS}	Conducted Reference Sensitivity power level
SSB_RP	Received (linear) average power of the resource elements that carry SSB signals and channels, measured at the IAB-MT antenna connector
T_c	Basic time unit, defined in clause 4.1 of TS 38.211 [7]
W_{gap}	Sub-block gap or Inter RF Bandwidth gap size

3.3 Abbreviations

For the purposes of the present document, the abbreviations given in 3GPP TR 21.905 [1] and the following apply. An abbreviation defined in the present document takes precedence over the definition of the same abbreviation, if any, in 3GPP TR 21.905 [1].

AA	Antenna Array
ACLR	Adjacent Channel Leakage Ratio
ACS	Adjacent Channel Selectivity
AoA	Angle of Arrival
AWGN	Additive White Gaussian Noise
BFD	Beam Failure Detection
BFD-RS	BFD Reference Signal
BLER	Block Error Rate
BM-RS	Beam Management Reference Signal
BS	Base Station
BW	Bandwidth
BWP	Bandwidth Part
CA	Carrier Aggregation
CACLR	Cumulative ACLR
CBD	Candidate Beam Detection
CCE	Control Channel Element
CORESET	Control Resource Set
CP	Cyclic Prefix
CP-OFDM	Cyclic Prefix-OFDM
CSI	Channel-State Information
CSI-RS	CSI Reference Signal
CW	Continuous Wave
DCI	Downlink Control Information
DL	Downlink
DMRS	Demodulation Reference Signal
DM-RS	Demodulation Reference Signal
DRX	Discontinuous Reception
EIS	Equivalent Isotropic Sensitivity
EIRP	Equivalent Isotropic Radiated Power
E-UTRA	Evolved UTRA
EVM	Error Vector Magnitude
FBW	Fractional Bandwidth
FR	Frequency Range

FRC	Fixed Reference Channel
GSM	Global System for Mobile communications
IAB	Integrated Access and Backhaul
IAB-DU	IAB Distribution Unit
IAB-MT	IAB Mobile Termination
ITU-R	Radiocommunication Sector of the International Telecommunication Union
ICS	In-Channel Selectivity
L1-RSRP	Layer 1 RSRP
LA	Local Area
MCS	Modulation and Coding Scheme
MGRP	Measurement Gap Repetition Period
MR	Medium Range
NB-IoT	Narrowband – Internet of Things
NR	New Radio
NR-ARFCN	NR Absolute Radio Frequency Channel Number
OBUE	Operating Band Unwanted Emissions
OOB	Out-of-band
OSDD	OTA Sensitivity Directions Declaration
OTA	Over-The-Air
PCell	Primary Cell
PDCCH	Physical Downlink Control Channel
PDSCH	Physical Downlink Shared Channel
PCell	Primary Cell
PRACH	Physical RACH
PDCCH	Physical Downlink Control Channel
PDSCH	Physical Downlink Shared Channel
PRACH	Physical RACH
PRB	Physical Resource Block
PSCell	Primary SCell
PSS	Primary Synchronization Signal
pTAG	Primary Timing Advance Group
PUCCH	Physical Uplink Control Channel
PUSCH	Physical Uplink Shared Channel
QAM	Quadrature Amplitude Modulation
QCL	Quasi Co-Location
RB	Resource Block
RDN	Radio Distribution Network
RE	Resource Element
REFSENS	Reference Sensitivity
REG	Resource Element Group
RF	Radio Frequency
RIB	Radiated Interface Boundary
RLM	Radio Link Monitoring
RLM-RS	Reference Signal for RLM
RMS	Root Mean Square (value)
RoAoA	Range of Angles of Arrival
RRC	Radio Resource Control
RRM	Radio Resource Management
RX	Receiver
SCell	Secondary Cell
SCS	Sub-Carrier Spacing
SMTC	SSB-based Measurement Timing configuration
SpCell	Special Cell
SRS	Sounding Reference Signal
SS-RSRP	Synchronization Signal based Reference Signal Received Power
SSB	Synchronization Signal Block
SSB_RP	Received (linear) average power of the resource elements that carry NR SSB signals and channels, measured at the UE antenna connector.
SSS	Secondary Synchronization Signal
TA	Timing Advance
TAB	Transceiver Array Boundary
TCI	Transmission Configuration Indicator

TX	Transmitter
TRP	Total Radiated Power
UTRA	Universal Terrestrial Radio Access
WA	Wide Area

4 General radiated test conditions and declarations

4.1 Measurement uncertainties and test requirements

4.1.1 General

The requirements of this clause apply to all applicable tests in TS 38.176-2 (the present document), i.e. to all radiated tests defined in FR1 for *IAB type 1-H*, *IAB type 1-O* and radiated tests defined in FR2 for *IAB type 2-O*. The frequency ranges FR1 and FR2 are defined in clause 5.1 of TS 38.174 [2].

The minimum requirements are given in TS 38.174 [2]. Test Tolerances for the radiated test requirements (TT_{OTA}) explicitly stated in the present document are given in annex C.

Test Tolerances are individually calculated for each test. Test Tolerances are used to relax the minimum requirements to create test requirements.

When a test requirement differs from the corresponding minimum requirement, then the Test Tolerance applied for the test is non-zero. The Test Tolerance for the test and the explanation of how the minimum requirement has been relaxed by the Test Tolerance are given in annex C.

The requirements are classified according to spatial characteristics as shown in table 4.1.1-1 and table 4.1.1-2.

Table 4.1.1-1: Overview of radiated Tx requirements

Tx requirement		Classification	Coverage range		Number of conformance directions
			FR1	FR2	
Radiated transmit power		Directional	OTA peak directions set	OTA peak directions set	5
OTA IAB output power		TRP	See annex I		
OTA output power dynamics		Directional	OTA peak directions set	OTA peak directions set	1
OTA transmitter OFF power		Co-location	See clause 4.12	N/A	See clause 4.12
		Directional	N/A	OTA peak directions set (Note 2)	1
OTA transient period		Co-location	See clause 4.12	N/A	See clause 4.12
		Directional	N/A	OTA peak directions set (Note 2)	1
OTA modulation quality		Directional	OTA coverage range	OTA coverage range	5
OTA frequency error		Directional	OTA coverage range	OTA coverage range	1
OTA time alignment error		Directional	OTA coverage range	OTA coverage range	1
OTA occupied bandwidth		Directional	OTA coverage range	OTA coverage range	1
OTA ACLR		TRP	N/A	N/A	See annex I
OTA operating band unwanted emission		TRP	N/A	N/A	See annex I
OTA transmitter spurious emission	General requirement	TRP	N/A	N/A	See annex I
	Additional spurious emissions	TRP	N/A	N/A	See annex I
	Co-location with other base stations	Co-location	See clause 4.12	N/A	See clause 4.12
OTA transmitter intermodulation		Co-location	See clause 4.12	N/A	See clause 4.12
NOTE 1: Directional requirement does not imply one compliance direction only. The directional requirement applies to a single direction at a time.					
NOTE 2: For FR2, RF Core requirements are defined on TRP levels. Conformance requirements are verified by EIRP measurements in the reference direction.					

Table 4.1.1-2: Overview of radiated Rx requirements

Rx requirement		Classification	Applicability levels		Coverage range		Number of conformance directions
			FR1	FR2	FR1	FR2	
OTA sensitivity		Directional	Minimum EIS	N/A	OSDD	N/A	5
OTA reference sensitivity		Directional	OTA REFSSENS	OTA REFSSENS	OTA REFSSENS RoAoA		5
OTA Dynamic range		Directional	OTA REFSSENS	N/A	OTA REFSSENS RoAoA	N/A	1
OTA adjacent channel selectivity		Directional	minSENS	OTA REFSSENS	minSENS RoAoA	OTA REFSSENS RoAoA	1
OTA in-band blocking		Directional	OTA REFSSENS and minSENS	OTA REFSSENS	OTA REFSSENS RoAoA and minSENS RoAoA	OTA REFSSENS RoAoA	5
OTA out-of-band blocking	General requirement	Directional	minSENS	OTA REFSSENS	minSENS RoAoA	OTA REFSSENS RoAoA	1
	Co-location with other base stations	Co-location (Note 2)	minSENS	N/A	minSENS RoAoA	N/A	1
OTA receiver spurious emissions		TRP	See clause 7.7	See clause 7.7	N/A	N/A	See annex I
OTA receiver intermodulation		Directional	OTA REFSSENS and minSENS	OTA REFSSENS	OTA REFSSENS RoAoA and minSENS RoAoA	OTA REFSSENS RoAoA	1
OTA in-channel selectivity		Directional	minSENS	OTA REFSSENS	minSENS RoAoA	OTA REFSSENS RoAoA	1
NOTE 1: Directional requirement does not imply one compliance direction only. The directional requirement applies to a single direction at a time.							
NOTE 2: The compliance direction for co-location blocking is applicable for the wanted signal only but not the interfering signal.							

4.1.2 Acceptable uncertainty of OTA Test System

4.1.2.1 General

The maximum acceptable uncertainty of the OTA Test System is specified below for each radiated test defined explicitly in the present specification, where appropriate.

The OTA Test System shall enable the stimulus signals in the test case to be adjusted to within the specified tolerance and the EUT to be measured with an uncertainty not exceeding the specified values. All tolerances and uncertainties are absolute values, and are valid for a confidence level of 95 %, unless otherwise stated.

A confidence level of 95% is the measurement uncertainty tolerance interval for a specific measurement that contains 95% of the performance of a population of test equipment.

For details on measurement uncertainty budget calculation, OTA measurement methodology description (including calibration and measurement stage for each test range), MU budget format and its contributions, refer to TR 37.941 [25].

4.1.2.2 Measurement of transmitter

The maximum OTA Test System uncertainty for OTA transmitter tests minimum requirements are given in tables 4.1.2.2-1 and 4.1.2.2-2. Details for derivation of OTA Test System uncertainty are given in corresponding clauses in TR 37.941 [25].

Table 4.1.2.2-1: Maximum OTA Test System uncertainty for FR1 OTA transmitter tests

Clause	Maximum OTA Test System uncertainty
6.2 Radiated transmit power	Normal condition: ± 1.1 dB, $f \leq 3$ GHz ± 1.3 dB, 3 GHz $< f \leq 6$ GHz Extreme condition: ± 2.5 dB, $f \leq 3$ GHz ± 2.6 dB, 3 GHz $< f \leq 6$ GHz
6.3 OTA IAB output power	± 1.4 dB, $f \leq 3.0$ GHz ± 1.5 dB, 3.0 GHz $< f \leq 4.2$ GHz ± 1.5 dB, 4.2 GHz $< f \leq 6.0$ GHz
6.4.1 IAB-DU OTA Output Power Dynamics	± 0.4 dB
6.4.2 IAB-MT OTA Output Power Dynamics	± 0.7 dB, $BW \leq 40$ MHz ± 1.0 dB, 40 MHz $< f \leq 100$ MHz
6.5.1 OTA transmitter OFF power	± 3.4 dB, $f \leq 3.0$ GHz ± 3.6 dB, 3.0 GHz $< f \leq 6$ GHz (Note 1)
6.5.2 OTA transmitter transient period	N/A
6.6.2.1 IAB-DU OTA Frequency error	± 12 Hz
6.6.2.2 OTA IAB-MT Frequency error	± 15 Hz, $f \leq 3.0$ GHz ± 36 Hz, $f > 3.0$ GHz
6.6.3 OTA modulation quality	± 1 %
6.6.4 OTA time alignment error	± 25 ns
6.6.5 OTA timing error between IAB-DU and IAB-MT	± 25 ns
6.7.2 OTA occupied bandwidth	± 100 kHz, $BW_{\text{Channel}} 5$ MHz, 10 MHz ± 300 kHz, $BW_{\text{Channel}} 15$ MHz, 20 MHz, 25 MHz, 30 MHz, 40 MHz, 50 MHz ± 600 kHz, $BW_{\text{Channel}} 60$ MHz, 70 MHz, 80 MHz, 90 MHz, 100 MHz
6.7.3 OTA ACLR/CACLR	$f \leq 3.0$ GHz ± 1 dB, $BW \leq 20$ MHz ± 1 dB, $BW > 20$ MHz 3.0 GHz $< f \leq 6.0$ GHz ± 1.2 dB, $BW \leq 20$ MHz ± 1.2 dB, $BW > 20$ MHz Absolute power ± 2.2 dB, $f \leq 3.0$ GHz Absolute power ± 2.7 dB, 3.0 GHz $< f \leq 4.2$ GHz Absolute power ± 2.7 dB, 4.2 GHz $< f \leq 6.0$ GHz
6.7.4 OTA operating band unwanted emissions	Absolute power ± 1.8 dB, $f \leq 3.0$ GHz Absolute power ± 2 dB, 3.0 GHz $< f \leq 4.2$ GHz Absolute power ± 2 dB, 4.2 GHz $< f \leq 6.0$ GHz
6.7.5.2 OTA transmitter spurious emissions, mandatory requirements	± 2.3 dB, 30 MHz $< f \leq 6$ GHz ± 4.2 dB, 6 GHz $< f \leq 26$ GHz
6.7.5.4 OTA transmitter spurious emissions, additional spurious emissions requirements	± 2.6 dB, $f \leq 3$ GHz ± 3.0 , 3 GHz $< f \leq 4.2$ GHz ± 3.5 , 4.2 GHz $< f \leq 6$ GHz
6.7.5.5 OTA transmitter spurious emissions, co-location	± 3.1 dB, $f \leq 3$ GHz ± 3.3 dB, 3 GHz $< f \leq 4.2$ GHz ± 3.4 , 4.2 GHz $< f \leq 6$ GHz (Note 1)
6.8 OTA transmitter intermodulation	The value below applies only to the interfering signal and is unrelated to the measurement uncertainty of the tests in 6.7.3 (ACLR), 6.7.4 (OBU) and 6.7.5 (spurious emissions) which have to be carried out in the presence of the interferer. ± 3.2 dB, $f \leq 3.0$ GHz ± 3.4 dB, 3.0 GHz $< f \leq 4.2$ GHz ± 3.5 dB, 4.2 GHz $< f \leq 6$ GHz (Note 1)

NOTE 1: Fulfilling the criteria for CLTA selection and placement in clause 4.12 is deemed sufficient for the test purposes. When these criteria are met, the measurement uncertainty related to the selection of the co-location test antenna and its alignment as specified in the appropriate measurement uncertainty budget in TR 37.941 [25] shall be used for evaluating the test system uncertainty.

NOTE 2: Test system uncertainty values are applicable for normal condition unless otherwise stated.

Table 4.1.2.2-2: Maximum OTA Test System uncertainty for FR2 OTA transmitter tests

Clause	Maximum OTA Test System uncertainty	
	IAB-DU	IAB-MT
6.2 Radiated transmit power	Normal condition: ±1.7 dB (24.25 – 29.5 GHz) ±2.0 dB (37 – 43.5 GHz)	Normal condition: ±2.6 dB (24.25 – 29.5 GHz) ±2.6 dB (37 – 43.5 GHz)
	Extreme condition: ±3.1 dB (24.25 – 29.5 GHz) ±3.3 dB (37 – 43.5 GHz)	Extreme condition: ±3.7 dB (24.25 – 29.5 GHz) ±3.7 dB (37 – 43.5 GHz)
6.3 OTA base station output power	±2.1 dB (24.25 – 29.5 GHz) ±2.4 dB (37 – 43.5 GHz)	±2.8 dB (24.25 – 29.5 GHz) ±2.9 dB (37 – 43.5 GHz)
6.4.1 IAB-DU OTA Output Power Dynamics	±0.4 dB	N/A
6.4.2 IAB-MT OTA Output Power Dynamics	N/A	±0.7 dB, BW ≤ 40MHz ±1.0 dB, 40MHz < f ≤ 100MHz
6.5.1 OTA transmitter OFF power	±2.9 dB (24.25 – 29.5 GHz) ±3.3 dB (37 – 43.5 GHz)	
6.5.2 OTA transmitter transient period	N/A	
6.6.2 OTA frequency error	±12 Hz	± 0.01 ppm
6.6.3 OTA modulation quality	1%	
6.6.4 OTA time alignment error	±25 ns	
6.6.5 OTA timing error between IAB-DU and IAB-MT	± 25 ns	
6.7.2 OTA occupied bandwidth	600 kHz	
6.7.3 OTA ACLR	Relative ACLR: ±2.3 dB (24.25 – 29.5 GHz) ±2.6 dB (37 – 43.5 GHz)	Relative ACLR: ±2.8 dB (24.25 – 29.5 GHz) ±2.9 dB (37 – 43.5 GHz)
	Absolute ACLR: ±2.7 dB (24.25 – 29.5 GHz) ±2.7 dB (37 – 43.5 GHz)	Absolute ACLR: ±2.9 dB (24.25 – 29.5 GHz) ±3.0 dB (37 – 43.5 GHz)
6.7.4 OTA operating band unwanted emissions	±2.7 dB (24.25 – 29.5 GHz) ±2.7 dB (37 – 43.5 GHz)	±2.9 dB (24.25 – 29.5 GHz) ±3.0 dB (37 – 43.5 GHz)
6.7.5.2 OTA transmitter spurious emissions, mandatory requirements	±2.3 dB, 30 MHz ≤ f ≤ 6 GHz ±2.7 dB, 6 GHz < f ≤ 40 GHz ±5.0 dB, 40 GHz < f ≤ 60 GHz	±2.3 dB, 30 MHz ≤ f ≤ 6 GHz ±2.9 dB, 6 GHz < f ≤ 40 GHz ±5.2 dB, 40 GHz < f ≤ 60 GHz
6.7.5.4 OTA transmitter spurious emissions, additional requirements	±2.3 dB, 30 MHz ≤ f ≤ 6 GHz ±2.7 dB, 6 GHz < f ≤ 40 GHz ±5.0 dB, 40 GHz < f ≤ 60 GHz	±2.3 dB, 30 MHz ≤ f ≤ 6 GHz ±2.9 dB, 6 GHz < f ≤ 40 GHz ±5.2 dB, 40 GHz < f ≤ 60 GHz

Note: Test system uncertainty values are applicable for normal condition unless otherwise stated.

4.1.2.3 Measurement of receiver

The maximum OTA Test System uncertainty for OTA receiver tests minimum requirements are given in tables 4.1.2.3-1 and 4.1.2.3-2. Details for derivation of OTA Test System uncertainty are given in corresponding clauses in TR 37.941 [25].

Table 4.1.2.3-1: Maximum OTA Test System uncertainty for FR1 OTA receiver tests

Clause	Maximum OTA Test System uncertainty
7.2 OTA sensitivity	±1.3 dB, $f \leq 3.0$ GHz ±1.4 dB, $3.0 \text{ GHz} < f \leq 4.2$ GHz ±1.6 dB, $4.2 \text{ GHz} < f \leq 6.0$ GHz
7.3 OTA reference sensitivity level	±1.3 dB, $f \leq 3.0$ GHz ±1.4 dB, $3.0 \text{ GHz} < f \leq 4.2$ GHz ±1.6 dB, $4.2 \text{ GHz} < f \leq 6.0$ GHz
7.4 OTA dynamic range	±0.3 dB
7.5.1 OTA adjacent channel selectivity	±1.7 dB, $f \leq 3.0$ GHz ±2.1 dB, $3.0 \text{ GHz} < f \leq 4.2$ GHz ±2.4 dB, $4.2 \text{ GHz} < f \leq 6.0$ GHz
7.5.2 In-band blocking (General)	±1.9 dB, $f \leq 3.0$ GHz ±2.2 dB, $3.0 \text{ GHz} < f \leq 4.2$ GHz ±2.5 dB, $4.2 \text{ GHz} < f \leq 6.0$ GHz
7.5.2 In-band blocking (Narrowband)	±1.7 dB, $f \leq 3.0$ GHz ±2.1 dB, $3.0 \text{ GHz} < f \leq 4.2$ GHz ±2.4 dB, $4.2 \text{ GHz} < f \leq 6.0$ GHz
7.6 OTA out-of-band blocking (General)	$f_{\text{wanted}} \leq 3.0$ GHz: ±2.0 dB, $f_{\text{interferer}} \leq 3.0$ GHz ±2.1 dB, $3.0 \text{ GHz} < f_{\text{interferer}} \leq 6.0$ GHz ±3.5 dB, $6.0 \text{ GHz} < f_{\text{interferer}} \leq 12.75$ GHz 3 GHz < $f_{\text{wanted}} \leq 4.2$ GHz: ±2.0 dB, $f_{\text{interferer}} \leq 3.0$ GHz ±2.1 dB, $3.0 \text{ GHz} < f_{\text{interferer}} \leq 6.0$ GHz ±3.6 dB, $6.0 \text{ GHz} < f_{\text{interferer}} \leq 12.75$ GHz 4.2 GHz < $f_{\text{wanted}} \leq 6.0$ GHz: ±2.2 dB, $f_{\text{interferer}} \leq 3.0$ GHz ±2.3 dB, $3.0 \text{ GHz} < f_{\text{interferer}} \leq 6.0$ GHz ±3.6 dB, $6.0 \text{ GHz} < f_{\text{interferer}} \leq 12.75$ GHz
7.6 OTA out-of-band blocking (Co-location) (Note 1)	$f_{\text{wanted}} \leq 3.0$ GHz: ±3.4 dB, $f_{\text{interferer}} \leq 3.0$ GHz ±3.5 dB, $3.0 \text{ GHz} < f_{\text{interferer}} \leq 4.2$ GHz ±3.7 dB, $4.2 \text{ GHz} < f_{\text{interferer}} \leq 6.0$ GHz 3 GHz < $f_{\text{wanted}} \leq 4.2$ GHz: ±3.5 dB, $f_{\text{interferer}} \leq 3.0$ GHz ±3.6 dB, $3.0 \text{ GHz} < f_{\text{interferer}} \leq 4.2$ GHz ±3.7 dB, $4.2 \text{ GHz} < f_{\text{interferer}} \leq 6.0$ GHz 4.2 GHz < $f_{\text{wanted}} \leq 6.0$ GHz: ±3.6 dB, $f_{\text{interferer}} \leq 3.0$ GHz ±3.7 dB, $3.0 \text{ GHz} < f_{\text{interferer}} \leq 4.2$ GHz ±3.8 dB, $4.2 \text{ GHz} < f_{\text{interferer}} \leq 6.0$ GHz
7.7 OTA receiver spurious emissions	±2.5 dB, $30 \text{ MHz} \leq f \leq 6.0$ GHz ±4.2 dB, $6.0 \text{ GHz} < f \leq 26$ GHz
7.8 OTA receiver intermodulation	±2.0 dB, $f \leq 3.0$ GHz ±2.6 dB, $3.0 \text{ GHz} < f \leq 4.2$ GHz ±3.2 dB, $4.2 \text{ GHz} < f \leq 6.0$ GHz
7.9 OTA in-channel selectivity	±1.7 dB, $f \leq 3.0$ GHz ±2.1 dB, $3.0 \text{ GHz} < f \leq 4.2$ GHz ±2.4 dB, $4.2 \text{ GHz} < f \leq 6.0$ GHz
NOTE 1: Fulfilling the criteria for CLTA selection and placement in clause 4.12 is deemed sufficient for the test purposes. When these criteria are met, the measurement uncertainty related to the selection of the co-location test antenna and its alignment as specified in the appropriate measurement uncertainty budget in TR 37.941 [25], shall be used for evaluating the test system uncertainty.	
NOTE 2: Test system uncertainty values are applicable for normal condition unless otherwise stated.	

Table 4.1.2.3-2: Maximum OTA Test System uncertainty for FR2 OTA receiver tests

Clause	Maximum OTA Test System uncertainty	
	IAB-DU	IAB-MT
7.3 OTA reference sensitivity level	± 2.4 dB, 24.25 GHz < f \leq 29.5 GHz ± 2.4 dB, 37 GHz < f \leq 43.5 GHz	± 3.3 dB, 24.25 GHz < f \leq 29.5 GHz ± 3.3 dB, 37 GHz < f \leq 43.5 GHz
7.5.1 OTA adjacent channel selectivity	± 3.4 dB, 24.25 GHz < f \leq 29.5 GHz ± 3.4 dB, 37 GHz < f \leq 43.5 GHz	± 4.2 dB, 24.25 GHz < f \leq 29.5 GHz ± 4.2 dB, 37 GHz < f \leq 43.5 GHz
7.5.2 In-band blocking (General)	± 3.4 dB, 24.25 GHz < f \leq 29.5 GHz ± 3.4 dB, 37 GHz < f \leq 43.5 GHz	± 4.2 dB, 24.25 GHz < f \leq 29.5 GHz ± 4.2 dB, 37 GHz < f \leq 43.5 GHz
7.6 OTA out-of-band blocking	± 3.6 dB, 24.25 GHz < f \leq 29.5 GHz ± 3.6 dB, 37 GHz < f \leq 43.5 GHz	± 4.4 dB, 24.25 GHz < f \leq 29.5 GHz ± 4.4 dB, 37 GHz < f \leq 43.5 GHz
7.7 OTA receiver spurious emissions	± 2.5 dB, 30 MHz \leq f \leq 6 GHz ± 2.7 dB, 6 GHz < f \leq 40 GHz ± 5.0 dB, 40 GHz < f \leq 60 GHz	± 2.5 dB, 30 MHz \leq f \leq 6 GHz ± 2.9 dB, 6 GHz < f \leq 40 GHz ± 5.2 dB, 40 GHz < f \leq 60 GHz
7.8 OTA receiver intermodulation	± 3.9 dB, 24.25 GHz < f \leq 29.5 GHz ± 3.9 dB, 37 GHz < f \leq 43.5 GHz	N/A
7.9 OTA in-channel selectivity	± 3.4 dB, 24.25 GHz < f \leq 29.5 GHz ± 3.4 dB, 37 GHz < f \leq 43.5 GHz	N/A

NOTE: Test system uncertainty values are applicable for normal condition unless otherwise stated.

4.1.2.4 Measurement of performance requirement

Texts will be added.

4.1.3 Interpretation of measurement results

The measurement results returned by the OTA Test System are compared - without any modification - against the test requirements as defined by the Shared Risk principle in Recommendation ITU-R M.1545 [12].

The actual measurement uncertainty of the OTA Test System for the measurement of each parameter shall be included in the test report.

The recorded value for the OTA Test System uncertainty shall be, for each OTA measurement, equal to or lower than the appropriate figure in clause 4.1.2 of the present document.

If the OTA Test System for an OTA test is known to have a measurement uncertainty greater than that specified in clause 4.1.2, it is still permitted to use this apparatus provided that an adjustment is made as follows:

Any additional uncertainty in the OTA Test System over and above that specified in clause 4.1.2 shall be used to tighten the OTA test requirement, making the test harder to pass. For some tests e.g. receiver tests, this may require modification of stimulus signals. This procedure will ensure that an OTA Test System not compliant with clause 4.1.2 does not increase the chance of passing a EUT where that device would otherwise have failed the test if an OTA Test System compliant with clause 4.1.2 had been used.

4.2 Radiated requirement reference points

Radiated characteristics for *IAB type 1-H*, *IAB type 1-O* and *IAB type 2-O* are defined over the air (OTA) where the operating band specific radiated interface is referred to as the *Radiated Interface Boundary* (RIB). Radiated requirements are also referred to as OTA requirements. The (spatial) characteristics in which the OTA requirements apply are detailed for each requirement. For *IAB type 1-H* the requirements are defined for two points of reference, signified by radiated requirements at the RIB and the conducted requirements at *transceiver array boundary* (TAB). The OTA requirements of *IAB type 1-H* are tested in the far field (Fraunhofer) region.

General architecture and reference points of *IAB type 1-H*, *IAB type 1-O* and *IAB type 2-O* are presented on the following figures 4.2-1 and 4.2-2.

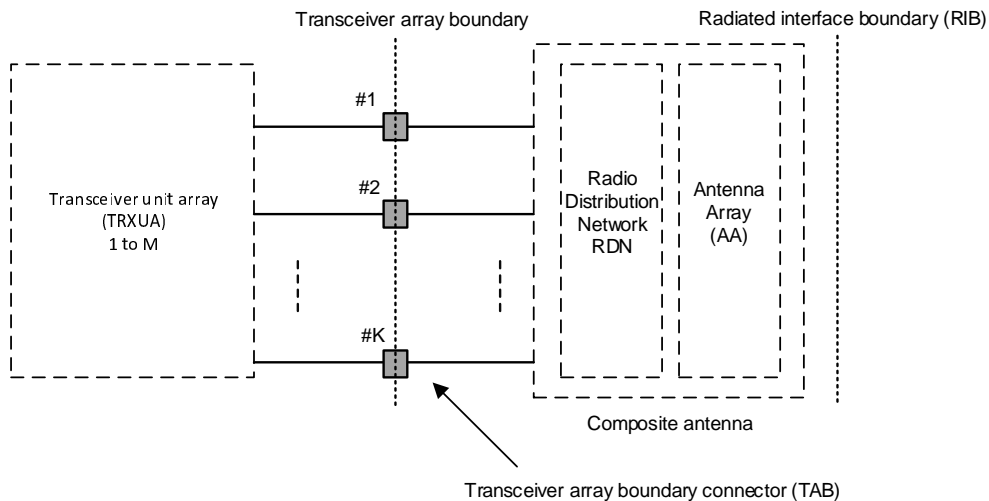

Figure 4.2-1: General architecture of IAB type 1-H

The present document details only radiated test requirements and hence only requires the radiated reference points.

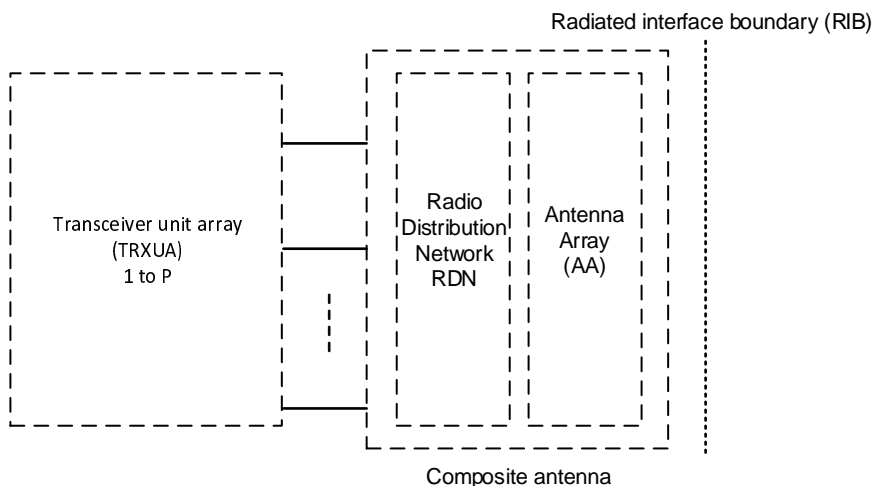

Figure 4.2-2: General architecture of IAB type 1-O and IAB type 2-O

The transceiver unit array is part of the composite transceiver functionality generating modulated transmit signal structures and performing receiver combining and demodulation.

The transceiver unit array contains an implementation specific number of transmitter units and an implementation specific number of receiver units. Transmitter units and receiver units may be combined into transceiver units. The transmitter/receiver units have the ability to receive/send parallel independent modulated symbol streams.

The composite antenna contains a *radio distribution network* (RDN) and an antenna array. The RDN is a linear passive network that distributes the RF power between the *transceiver array boundary* and the antenna array, in an implementation specific way.

4.3 IAB classes

4.3.1 IAB-DU class

The requirements in the present document apply to Wide Area IAB-DU, Medium Range IAB-DU and Local Area IAB-DU unless otherwise stated. The associated deployment scenarios for each class are exactly the same for IAB-DU with and without connectors.

For *IAB type 1-O* and *2-O*, IAB-DU classes are defined as indicated below:

- Wide Area IAB-DU are characterised by requirements derived from Macro Cell scenarios with a BS to UE minimum distance along the ground equal to 35 m.
- Medium Range IAB-DU are characterised by requirements derived from Micro Cell scenarios with a BS to UE minimum distance along the ground equal to 5 m.
- Local Area IAB-DU are characterised by requirements derived from Pico Cell scenarios with a BS to UE minimum distance along the ground equal to 2 m.

The manufacturer shall declare the intended class of the IAB under test.

4.3.2 IAB-MT class

The requirements in the present document apply to Wide Area IAB-MT and Local Area IAB-MT classes unless otherwise stated.

For *IAB type 1-O*, and *IAB type 2-O*, IAB-MT classes are defined as indicated below:

- Wide Area IAB-MT are characterised by requirements derived from Macro Cell and/or Micro Cell scenarios.
- Local Area IAB-MT are characterised by requirements derived from Pico Cell and /or Micro Cell scenarios.

4.4 Regional requirements

Some requirements in the present document may only apply in certain regions either as optional requirements, or set by local and regional regulation as mandatory requirements. It is normally not stated in the 3GPP specifications under what exact circumstances that the requirements apply, since this is defined by local or regional regulation.

Table 4.4-1 lists all requirements in the present specification that may be applied differently in different regions.

Table 4.4-1: List of regional requirements

Clause	Requirement	Comments
5.2	<i>Operating bands</i>	Some NR <i>operating bands</i> may be applied regionally.
6.2.3	IAB output power: Additional requirements	These requirements may be applied regionally as additional IAB output power requirements.
9.7.2	OTA occupied bandwidth	The requirement may be applied regionally. There may also be regional requirements to declare the occupied bandwidth according to the definition in present specification.
9.7.4.2 9.7.4.3	OTA operating band unwanted emissions	Category A or Category B operating band unwanted emissions limits may be applied regionally.
9.7.4.4.1	OTA operating band unwanted emissions: Limits in FCC Title 47 [14]	The IAB may have to comply with the additional requirements, when deployed in regions where those limits are applied, and under the conditions declared by the manufacturer.
9.7.5.2.2 9.7.5.3.2	OTA Tx spurious emissions	Category A or Category B spurious emission limits, as defined in Recommendation ITU-R SM.329 [2], may apply regionally. The emission limits for <i>IAB type 1-O</i> specified as the <i>basic limit</i> + X (dB) are applicable, unless stated differently in regional regulation.
9.7.5.2.3 9.7.5.3.3	OTA Tx spurious emissions: additional requirements	These requirements may be applied for the protection of system operating in frequency ranges other than the <i>IAB operating band</i> .
9.8.2	OTA transmitter intermodulation	Interfering signal positions that are partially or completely outside of any downlink <i>operating band</i> of the IAB are not excluded from the requirement in Japan in Band n77, n78, n79.
10.7.2 10.7.3	OTA Rx spurious emissions	The emission limits for <i>IAB type 1-O</i> specified as the <i>basic limit</i> + X (dB) are applicable, unless stated differently in regional regulation.

4.5 IAB configurations

4.5.1 Transmit configurations

Unless otherwise stated, the radiated transmitter characteristics in clause 6 are specified at RIB, with a full complement of transceiver units for the configuration in normal operating conditions.

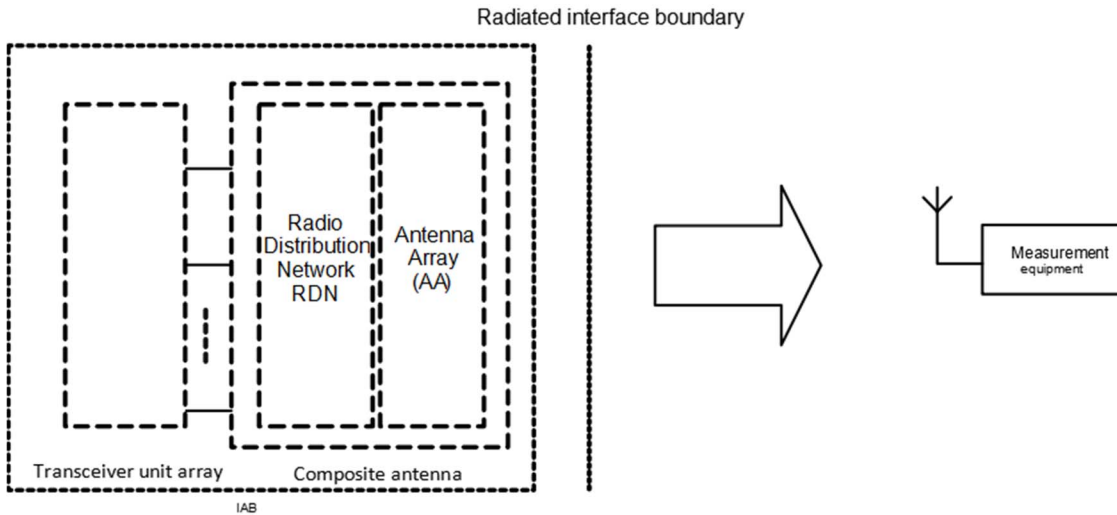

Figure 4.5.1-1: Transmitter test interfaces

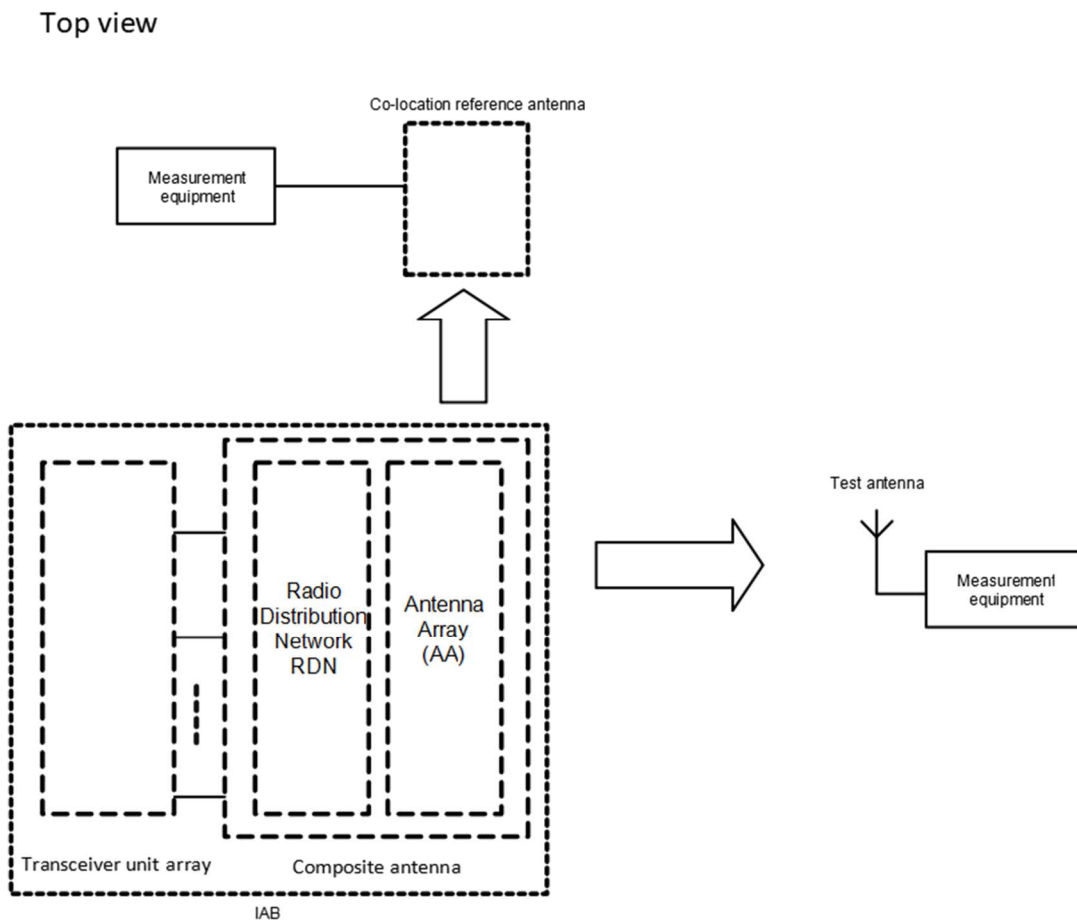

Figure 4.5.1-2: Transmitter test interfaces for co-location concept

4.5.2 Receive configurations

Unless otherwise stated, the radiated receiver characteristics in clause 7 are specified at RIB, with a full complement of transceiver units for the configuration in normal operating conditions.

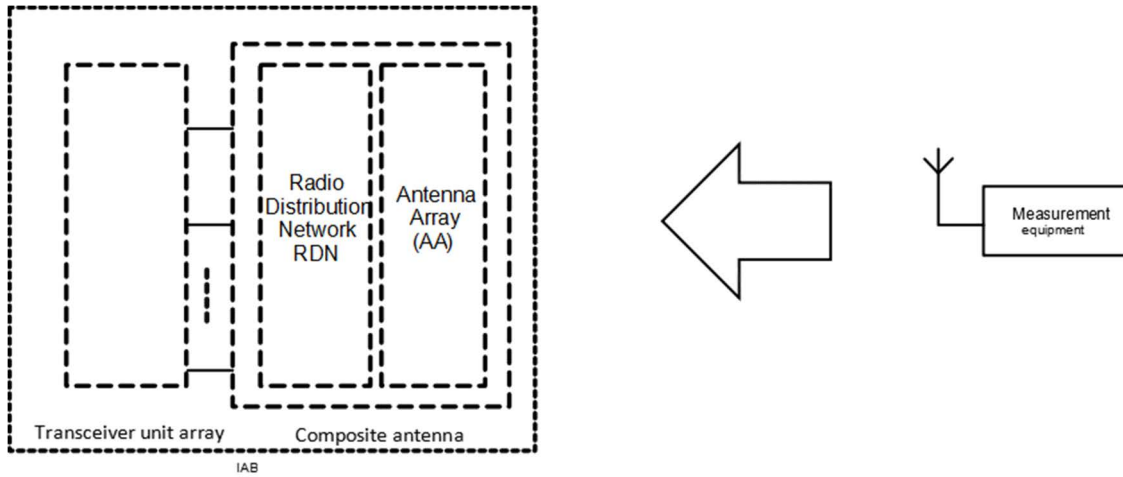

Figure 4.5.2-1: Receiver test interface

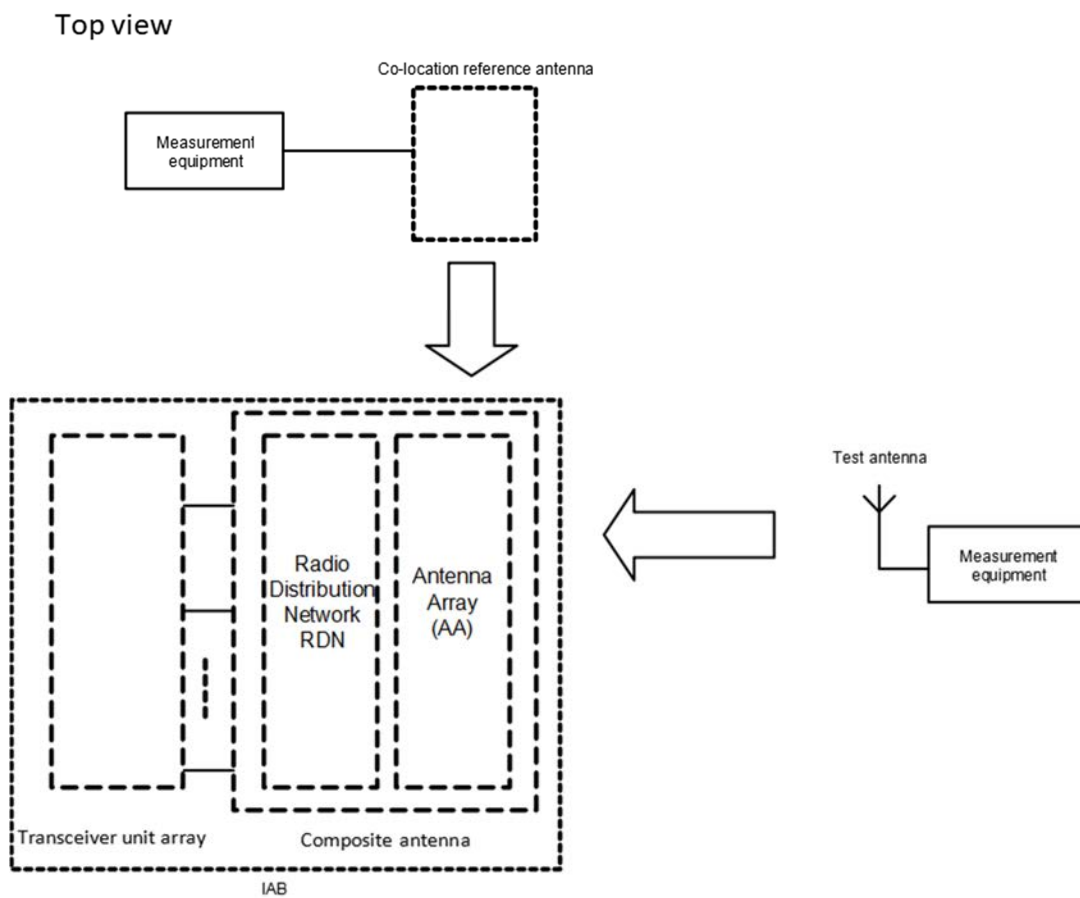

Figure 4.5.2-2: Receiver test interfaces for co-location concept

4.5.3 Power supply options

If the IAB is supplied with a number of different power supply configurations, it may not be necessary to test RF parameters for each of the power supply options, provided that it can be demonstrated that the range of conditions over which the equipment is tested is at least as great as the range of conditions due to any of the power supply configurations.

4.5.4 IAB with integrated Iuant BS modem

Unless otherwise stated, for the tests in the present document, the integrated Iuant BS modem shall be switched OFF.

4.6 Manufacturer's declarations

The following IAB manufacturer's declarations listed in table 4.6-1, when applicable to the IAB under test, are required to be provided by the manufacturer for radiated requirements testing for *IAB type 1-H*, *IAB type 1-O* and *IAB type 2-O*. Declarations may be provided independently for IAB-MT and IAB-DU. The applicability columns for different IAB-types in table 4.6-1 designate applicability for both IAB-DU and IAB-MT, unless otherwise stated.

For the *IAB type 1-H* declarations required for the conducted requirements testing, refer to TS 38.176-1 [3], clause 4.6.

Table 4.6-1: Manufacturers declarations for *IAB type 1-H*, *IAB type 1-O* and *IAB type 2-O* radiated test requirements

Declaration identifier	Declaration	Description	Applicability (Note 1)		
			<i>IAB type 1-H</i> (Note 2)	<i>IAB type 1-O</i>	<i>IAB type 2-O</i>
D.1	Coordinate system reference point	Location of coordinated system reference point in reference to an identifiable physical feature of the IAB-MT or IAB-DU enclosure.	x	x	x
D.2	Coordinate system orientation	Orientation of the coordinate system in reference to an identifiable physical feature of the IAB enclosure.	x	x	x
D.3	Beam identifier	<p>A unique title to identify a beam, e.g. a, b, c or 1, 2, 3. The vendor may declare any number of beams with unique identifiers. The minimum set to declare for conformance, corresponds to the beams at the reference beam direction with the highest intended EIRP, and covering the properties listed below:</p> <ol style="list-style-type: none"> 1) A beam with the narrowest intended BeW_{θ} and narrowest intended BeW_{ϕ} possible when narrowest intended BeW_{θ} is used. 2) A beam with the narrowest intended BeW_{ϕ} and narrowest intended BeW_{θ} possible when narrowest intended BeW_{ϕ} is used. 3) A beam with the widest intended BeW_{θ} and widest intended BeW_{ϕ} possible when widest intended BeW_{θ} is used. 4) A beam with the widest intended BeW_{ϕ} and widest intended BeW_{θ} possible when widest intended BeW_{ϕ} is used. 5) A beam which provides the highest intended EIRP of all possible beams. <p>When selecting the above five beam widths for declaration, all beams that the IAB is intended to produce shall be considered, including beams that during operation may be identified by any kind of cell or UE specific reference signals, with the exception of any type of beam that is created from a group of transmitters that are not all phase synchronised.</p> <p>(Note 3)</p>	x	x	x

Declaration identifier	Declaration	Description	Applicability (Note 1)		
D.4	Operating bands and frequency ranges	List of NR <i>operating band(s)</i> supported by the IAB-DU or IAB-MT and if applicable, frequency range(s) within the <i>operating band(s)</i> that the IAB can operate in supported bands declared for every beam (D.3). (Note 4)	c	x	x
D.5	IAB requirements set	Declaration of one of the IAB <i>requirements set</i> as defined for <i>IAB type 1-H</i> , <i>IAB type 1-O</i> , or <i>IAB type 2-O</i> .	c	x	x
D.6	IAB class	Declared as Wide Area IAB-DU, Medium Range IAB-DU, or Local Area IAB-DU. Declared as Wide Area IAB-MT, or Local Area IAB-MT.	c	x	x
D.7	IAB channel band width and SCS support	IAB-DU or IAB-MT supported SCS and channel bandwidth per supported SCS. Declared for each beam (D.3) and each <i>operating band</i> (D.4).	c	x	x
D.8	OTA peak directions set reference beam direction pair	The beam direction pair, describing the reference beam peak direction and the reference beam centre direction. Declared for every beam (D.3).	x	x	x
D.9	OTA peak directions set	The OTA peak directions set for each beam. Declared for every beam (D.3).	x	x	x
D.10	OTA peak directions set maximum steering direction(s)	The <i>beam direction pair(s)</i> corresponding to the following points: 1) The beam peak direction corresponding to the maximum steering from the reference beam centre direction in the positive Φ direction, while the θ value being the closest possible to the reference beam centre direction. 2) The beam peak direction corresponding to the maximum steering from the reference beam centre direction in the negative Φ direction, while the θ value being the closest possible to the reference beam centre direction. 3) The beam peak direction corresponding to the maximum steering from the reference beam centre direction in the positive θ direction, while the Φ value being the closest possible to the reference beam centre direction. 4) The beam peak direction corresponding to the maximum steering from the reference beam centre direction in the negative θ direction, while the Φ value being the closest possible to the reference beam centre direction. The maximum steering direction(s) may coincide with the reference beam centre direction. Declared for every beam (D.3).	x	x	x
D.11	Rated beam EIRP	The rated EIRP level per carrier ($P_{\text{rated,c,EIRP}}$) at the <i>beam peak direction</i> associated with a particular <i>beam direction pair</i> for each of the declared maximum steering directions (D.10), as well as the reference <i>beam direction pair</i> (D.8). Declared for every beam (D.3). (Note 12, 14, 18)	x	x	x
D.12	Beamwidth	The <i>beamwidth</i> for the reference <i>beam direction pair</i> and the four maximum steering directions. Declared for every beam (D.3).	x	x	x

Declaration identifier	Declaration	Description	Applicability (Note 1)		
D.13	Equivalent beams	List of beams which are declared to be equivalent. Equivalent beams imply that the beams are expected to have identical <i>OTA peak directions sets</i> and intended to have identical spatial properties at all steering directions within the <i>OTA peak directions set</i> when presented with identical signals. All declarations (D.4 – D.12) made for the beams are identical and the transmitter unit, RDN and antenna array responsible for generating the beam are of identical design.	x	x	x
D.14	Parallel beams	List of beams which have been declared equivalent (D.13) and can be generated in parallel using independent RF power resources. Independent power resources mean that the beams are transmitted from mutually exclusive transmitter units.	x	x	x
D.15	Number of carriers at maximum TRP	The number of carriers per operating band the IAB is capable of generating at maximum TRP declared for every beam (D.3).	n/a	x	x
D.16	Operating bands with multi-band dependencies	List of <i>operating bands</i> which are generated using transceiver units supporting operation in multiple <i>operating bands</i> through common active RF components. Declared for each <i>operating band</i> for which multi-band transceiver is used.	c	x	n/a
D.17	Maximum radiated IAB RF Bandwidth	Maximum <i>Base Station RF Bandwidth</i> in the <i>operating band</i> , declared for each supported operating band (D.4). (Note 15)	c	x	x
D.18	Maximum <i>Radio Bandwidth</i> of the <i>operating band</i> with multi-band dependencies	Largest <i>Radio Bandwidth</i> that can be supported by the <i>operating bands</i> with multi-band dependencies. Declared for each supported <i>operating band</i> which has multi-band dependencies (D.16).	c	x	n/a
D.19	Total RF bandwidth (BW_{tot})	Total RF bandwidth BW_{tot} of transmitter and receiver, declared per the band combinations (D.52).	c	x	x
D.20	CA-only operation	Declared of CA-only (with equal power spectral density among carriers) but not multiple carriers operation, declared per <i>operating band</i> (D.4) and per beam (D.3).	c	x	x
D.21	Maximum number of supported carriers per <i>operating band</i> in multi-band operations	Maximum number of supported carriers per supported <i>operating band</i> declared to have multi-band dependencies (D.16).	c	x	n/a
D.22	Contiguous or non-contiguous spectrum operation support	Ability of IAB-DU or IAB-MT to support contiguous or non-contiguous (or both) frequency distribution of carriers when operating multi-carrier in an operating band.	c	x	x
D.23	OSDD identifier	A unique identifier for the OSDD.	x	x	n/a
D.24	OSDD operating band support	Operating band supported by the OSDD, declared for every OSDD (D.23). (Note 5)	x	x	n/a
D.25	OTA sensitivity supported IAB channel bandwidth and SCS	The IAB-DU or IAB-MT supported SCS and channel bandwidth per supported SCS by each OSDD.	x	x	n/a
D.26	Redirection of receiver target support	Ability to redirect the receiver target related to the OSDD.	x	x	n/a

Declaration identifier	Declaration	Description	Applicability (Note 1)		
D.27	Minimum EIS for FR1 (EIS _{minSENS})	The minimum EIS _{minSENS} requirement (i.e. maximum allowable EIS value) applicable to all sensitivity RoAoA per OSDD. Declared per NR supported channel BW for the OSDD (D.30). The lowest EIS value for all the declared OSDD's is called minSENS, while its related range of angles of arrival is called <i>minSENS RoAoA</i> . (Note 6)	x	x	n/a
D.28	EIS REFSENS for FR2 (EIS _{REFSENS_50M})	The EIS _{REFSENS_50M} level applicable in the OTA REFSENS RoAoA, (used as a basis for the derivation of the FR2 EIS _{REFSENS} for other channel bandwidths supported by IAB). (Note 7)	n/a	n/a	x
D.29	Receiver target reference direction Sensitivity Range of Angle of Arrival	The sensitivity RoAoA associated with the receiver target reference direction (D.31) for each OSDD.	x	x	n/a
D.30	Receiver target redirection range	For each OSDD the associated union of all the sensitivity RoAoA achievable through redirecting the receiver target related to the OSDD. (Note 8)	x	x	n/a
D.31	Receiver target reference direction	For each OSDD an associated direction inside the receiver target redirection range (D.30). (Note 9)	x	x	n/a
D.32	Conformance test directions sensitivity RoAoA	For each OSDD that includes a receiver target redirection range, four sensitivity RoAoA comprising the conformance test directions (D.33).	x	x	n/a

Declaration identifier	Declaration	Description	Applicability (Note 1)		
D.33	Conformance test directions	<p>For each OSDD four conformance test directions. If the OSDD includes a receiver target redirection range the following four directions shall be declared:</p> <ol style="list-style-type: none"> 1) The direction determined by the maximum φ value achievable inside the receiver target redirection range, while θ value being the closest possible to the receiver target reference direction. 2) The direction determined by the minimum φ value achievable inside the receiver target redirection range, while θ value being the closest possible to the receiver target reference direction. 3) The direction determined by the maximum θ value achievable inside the receiver target redirection range, while φ value being the closest possible to the receiver target reference direction. 4) The direction determined by the minimum θ value achievable inside the receiver target redirection range, while φ value being the closest possible to the receiver target reference direction. <p>If an OSDD does not include a receiver target redirection range the following 4 directions shall be declared:</p> <ol style="list-style-type: none"> 1) The direction determined by the maximum φ value achievable inside the sensitivity RoAoA, while θ value being the closest possible to the receiver target reference direction. 2) The direction determined by the minimum φ value achievable inside the sensitivity RoAoA, while θ value being the closest possible to the receiver target reference direction. 3) The direction determined by the maximum θ value achievable inside the sensitivity RoAoA, while φ value being the closest possible to the receiver target reference direction. 4) The direction determined by the minimum θ value achievable inside the sensitivity RoAoA, while φ value being the closest possible to the receiver target reference direction. 	x	x	n/a

Declaration identifier	Declaration	Description	Applicability (Note 1)		
D.34	OTA coverage range	Declared as a single range of directions within which selected TX OTA requirements are intended to be met. (Note 10)	x	x	x
D.35	OTA coverage range reference direction	The direction describing the reference direction of the <i>OTA coverage range</i> (D.34). (Note 11)	x	x	x
D.36	OTA coverage range maximum directions	The directions corresponding to the following points: 1) The direction determined by the maximum φ value achievable inside the <i>OTA coverage range</i> , while θ value being the closest possible to the <i>OTA coverage range</i> reference direction. 2) The direction determined by the minimum φ value achievable inside the <i>OTA coverage range</i> , while θ value being the closest possible to the <i>OTA coverage range</i> reference direction. 3) The direction determined by the maximum θ value achievable inside the <i>OTA coverage range</i> , while φ value being the closest possible to the <i>OTA coverage range</i> reference direction. 4) The direction determined by the minimum θ value achievable inside the <i>OTA coverage range</i> , while φ value being the closest possible to the <i>OTA coverage range</i> reference direction.	x	x	x
D.37	The rated carrier OTA IAB power, $P_{\text{rated,c,TRP}}$	$P_{\text{rated,c,TRP}}$ is declared as TRP OTA power per carrier, declared per supported operating band. (Notes 12, 14, 18)	n/a	x	x
D.38	Rated transmitter TRP, $P_{\text{rated,t,TRP}}$	Rated total radiated output power. Declared per supported <i>operating band</i> . (Notes 12,14, 18)	n/a	x	x
D.39	CLTA placement for co-location test	The manufacturer shall declare the side of EUT where radiating elements are placed closest to the edge of EUT when applicable. The CLTA shall be placed at the EUT side where radiating elements are placed closest.	n/a	x	n/a
D.40	Spurious emission category	Declare the IAB-DU or IAB-MT spurious emission category as either category A or B with respect to the limits for spurious emissions, as defined in Recommendation ITU-R SM.329 [5].	c	x	x
D.41	Additional operating band unwanted emissions	The manufacturer shall declare whether the IAB under test is intended to operate in geographic areas where the additional operating band unwanted emission limits defined in clause 6.7.4 apply.	c	x	x
D.42	Co-existence with other systems	The manufacturer shall declare whether the IAB under test is intended to operate in geographic areas where one or more of the systems GSM850, GSM900, DCS1800, PCS1900, UTRA FDD, UTRA TDD, E-UTRA and/or PHS operating in another operating band are deployed.	c	x	x
D.43	Co-location with other base stations	The manufacturer shall declare whether the IAB under test is intended to operate co-located with Base Stations of one or more of the systems GSM850, GSM900, DCS1800, PCS1900, UTRA FDD, UTRA TDD and/or E-UTRA operating in another operating band.	c	x	n/a
D.44	Single-band RIB or multi-band RIB	List of single-band RIB and/or multi-band RIB for the supported operating bands (D.4).	c	x	n/a
D.45	Single or multiple carrier	IAB capability to operate with a single carrier (only) or multiple carriers. Declared per supported operating band, per RIB. (Note 17)	c	x	x

Declaration identifier	Declaration	Description	Applicability (Note 1)		
D.46	Maximum number of supported carriers per <i>operating band</i>	Maximum number of supported carriers. Declared per supported operating band, per RIB. (Note 15)	c	x	x
D.47	Total maximum number of supported carriers	Maximum number of supported carriers for all supported operating bands. Declared per RIB.	c	x	x
D.48	Other band combination multi-band restrictions	Declare any other limitation under simultaneous operation in the declared band combinations (D.16), which have any impact on the test configuration generation.	c	x	n/a
D.49	N_{cells}	Number corresponding to the minimum number of cells that can be transmitted by an IAB-DU or IAB-MT in a particular <i>operating band</i> . Declared per <i>operating band</i> (D.4).	c	n/a	n/a
D.50	Maximum supported power difference between carriers	Maximum supported power difference between carriers in each supported <i>operating band</i> . Declared per <i>operating band</i> (D.4).	c	x	x
D.51	Maximum supported power difference between carriers in different <i>operating bands</i>	Maximum supported power difference between any two carriers in any two different supported <i>operating bands</i> . Declared per operating bands combination (D.52). (Note 19)	c	x	n/a
D.52	Operating band combination support	List of <i>operating bands</i> combinations supported by <i>single-band RIB(s)</i> and/or <i>multi-band RIB(s)</i> of the IAB-DU or IAB-MT.	c	x	n/a
D.53	OTA REFSENS RoAoA	Range of angles of arrival associated with the OTA REFSENS.	n/a	x	x
D.54	OTA REFSENS receiver target reference direction	Reference direction inside the OTA REFSENS RoAoA (D.53).	n/a	x	x
D.55	OTA REFSENS conformance test directions	The following four OTA REFSENS conformance test directions shall be declared: 1) The direction determined by the maximum φ value achievable inside the OTA REFSENS RoAoA, while θ value being the closest possible to the OTA REFSENS receiver target reference direction. 2) The direction determined by the minimum φ value achievable inside the OTA REFSENS RoAoA, while θ value being the closest possible to the OTA REFSENS receiver target reference direction. 3) The direction determined by the maximum θ value achievable inside the OTA REFSENS RoAoA, while φ value being the closest possible to the OTA REFSENS receiver target reference direction. 4) The direction determined by the minimum θ value achievable inside the OTA REFSENS RoAoA, while φ value being the closest possible to the OTA REFSENS receiver target reference direction.	n/a	x	x
D.56	Supported frequency range of the NR <i>operating band</i>	List of supported frequency ranges representing <i>fractional bandwidths</i> (FBW) of <i>operating bands</i> with FBW larger than 6%.	x	x	x
D.57	Rated beam EIRP at lower end of the <i>fractional bandwidth</i> ($P_{\text{rated,c,FBWlow}}$)	The rated EIRP level per carrier at lower frequency range of the <i>fractional bandwidth</i> ($P_{\text{rated,c,FBWlow}}$), at the <i>beam peak direction</i> associated with a particular <i>beam direction pair</i> for each of the declared maximum steering directions (D.10), as well as the reference <i>beam direction pair</i> (D.8). Declared per beam for all supported frequency ranges (D.56). (Notes 12, 13, 14, 15, 18)	x	x	x

Declaration identifier	Declaration	Description	Applicability (Note 1)		
D.58	Rated beam EIRP at higher frequency range of the <i>fractional bandwidth</i> ($P_{\text{rated,c,FBWhigh}}$)	The rated EIRP level per carrier at higher frequency range of the <i>fractional bandwidth</i> ($P_{\text{rated,c,FBWhigh}}$), at the <i>beam peak direction</i> associated with a particular <i>beam direction pair</i> for each of the declared maximum steering directions (D.10), as well as the reference <i>beam direction pair</i> (D.8). Declared per beam for all supported frequency ranges in (D.56). (Notes 12, 13, 14, 15, 18)	x	x	x
D.59	Relation between supported maximum RF bandwidth, number of carriers and Rated maximum TRP	If the rated transmitter TRP and total number of supported carriers are not simultaneously supported, the manufacturer shall declare the following additional parameters: - The reduced number of supported carriers at the rated transmitter TRP; - The reduced total output power at the maximum number of supported carriers.	n/a	x	x
D.60	Inter-band CA	Declaration of operating band(s) combinations supporting inter-band CA. Declared per operating band combination (D.52).	c	x	x
D.61	Intra-band contiguous CA	Declaration of operating band(s) supporting intra-band contiguous CA. Declared per <i>operating band</i> with CA support.	c	x	x
D.62	Intra-band non-contiguous CA	Declaration of operating band(s) supporting intra-band non-contiguous CA. Declared per operating band with CA support.	c	x	x
D.63	Total maximum number of supported carriers in multi-band operation	Maximum number of supported carriers for all supported <i>operating bands</i> declared to have multi-band dependencies (D.16).	c	x	n/a
D.IAB-1	Same RF implementation	Declaration whether IAB-MT and IAB-DU have the same RF implementation.	c	x	x
D.IAB-2	IAB-MT test model PT-RS configuration	Declaration of PT-RS configuration in IAB-MT test model: without PT-RS, with PT-RS or both.	n/a	n/a	x
D.IAB-3	IAB simultaneous operation	Declare support of IAB simultaneous operation, simultaneous transmission, or simultaneous reception or both.	c	x	x
D.IAB-4	Maximum power imbalance for IAB simultaneous transmission	Declare the maximum PSD offset in dB of IAB-MT carrier and IAB-DU carrier for IAB simultaneous transmission	c	x	x
D.100	PUSCH mapping type	IAB-DU only: Declaration of the supported PUSCH mapping type for FR1 as specified in TS 38.211 [7], i.e., type A, type B or both.	c	x	n/a
D.101	PUSCH additional DM-RS positions	IAB-DU only: Declaration of the supported additional DM-RS position(s) for FR2, i.e., pos0, pos1, or both.	n/a	n/a	x
D.102	PUCCH format	IAB-DU only: Declaration of the supported PUCCH format(s) as specified in TS 38.211 [7], i.e., format 0, format 1, format 2, format 3, format 4.	c	x	x
D.103	PRACH format and SCS	IAB-DU only: Declaration of the supported PRACH format(s) as specified in [x], i.e., format: 0, A1, A2, A3, B4, C0, C2. Declaration of the supported SCS(s) per supported PRACH format with short sequence, as specified in TS 38.211 [7], i.e.: - For <i>IAB type 1-O</i> : 15 kHz, 30 kHz or both. - For <i>IAB type 2-O</i> : 60 kHz, 120 kHz or both.	c	x	x
D.104	Additional DM-RS for PUCCH format 3	IAB-DU only: Declaration of the supported additional DM-RS for PUCCH format 3: without additional DM-RS, with additional DM-RS or both.	c	x	x

Declaration identifier	Declaration	Description	Applicability (Note 1)		
D.105	Additional DM-RS for PUCCH format 4	IAB-DU only: Declaration of the supported additional DM-RS for PUCCH format 4: without additional DM-RS, with additional DM-RS or both.	c	x	x
D.106	PUSCH PT-RS	IAB-DU only: Declaration of PT-RS in PUSCH support: without PT-RS, with PT-RS or both.	n/a	n/a	x
D.107	PUCCH multi-slot	Declaration of multi-slot PUCCH support.	c	x	n/a
D.108	UL CA	IAB-DU only: For the highest supported SCS, declaration of the carrier combination with the largest aggregated bandwidth. If there is more than one combination, the carrier combination with the largest number of carriers shall be declared.	c	x	x
D.109	Modulation order	IAB-DU only: Declaration of the supported modulation orders: QPSK, 16QAM, 64QAM	c	x	x
D.110	Transform precoding	IAB-DU only: Declaration on the supporting of transform precoding	c	x	x
D.200	256QAM for PDSCH for FR1	Declaration of the supported of 256QAM modulation scheme for PDSCH for FR1, i.e. supported or not supported.	c	x	n/a
D.201	Maximum number of ports across all configured NZP-CSI-RS resources per CC	Declaration of the maximum number of ports across all configured NZP-CSI-RS resources per CC, i.e. 2, 4, 8, 12, 16, 24, 32, 40, 48 ... ,256 or not supported.	c	x	n/a
D.202	Maximum number of PDSCH MIMO layers	Declaration of the the maximum number of spatial multiplexing layer(s) supported by the UE for DL reception, i.e. 2, 4, 8 or not supported.	c	x	x
D.203	1 port of DL PTRS	Declaration of the supported of PT-RS with 1 antenna port in DL reception, i.e. supported or not supported.	n/a	n/a	x

Declaration identifier	Declaration	Description	Applicability (Note 1)
NOTE 1:	Manufacturer declarations applicable per IAB <i>requirement set</i> were marked as "x". Manufacturer declarations not applicable per IAB <i>requirement set</i> were marked as "n/a".		
NOTE 2:	For IAB <i>type 1-H</i> , the only radiated declarations are related to EIRP and EIS requirements. For IAB <i>type 1-H</i> declarations required for the conducted requirements testing, refer to TS 38.176-1 [3]. For declarations marked as 'c', related conducted declarations in TS 38.176-1 [3] apply. When separately declared, they shall still use the same declaration identifier.		
NOTE 3:	Depending on the capability of the system some of these beams may be the same. For those same beams, testing is not repeated.		
NOTE 4:	These <i>operating bands</i> are related to their respective single-band RIBs.		
NOTE 5:	As each identified OSDD has a declared minimum EIS value (D.27), multiple operating band can only be declared if they have the same minimum EIS declaration.		
NOTE 6:	If the IAB <i>type 1-H</i> or IAB <i>type 1-O</i> is not capable of redirecting the receiver target related to the OSDD then there is only one RoAoA applicable to the OSDD.		
NOTE 7:	Although EIS _{REFSENS_50M} level is based on a reference measurement channel with BW _{Channel} = 50 MHz, it does not imply that IAB-DU or IAB-MT has to support 50 MHz channel bandwidth.		
NOTE 8:	Not applicable for IAB <i>type 2-O</i> .		
NOTE 9:	For an OSDD without receiver target redirection range, this is a direction inside the sensitivity RoAoA.		
NOTE 10:	OTA <i>coverage range</i> is used for conformance testing of such TX OTA requirements as occupied bandwidth, frequency error, TAE or EVM.		
NOTE 11:	The OTA <i>coverage reference</i> direction may be the same as the Reference beam direction pair (D.8) but does not have to be.		
NOTE 12:	If an IAB <i>type 2-O</i> is capable of 64QAM DL operation but not capable of 256QAM DL operation, then up to two rated output power declarations may be made. One declaration is applicable when configured for 64QAM transmissions and the other declaration is applicable when not configured for 64QAM transmissions.		
NOTE 13:	If D.57 and D.58 are declared for certain frequency range (D.56), there shall be no "Rated beam EIRP" declaration (D.11) for the <i>operating band</i> containing that particular frequency range.		
NOTE 14:	If an IAB <i>type 1-H</i> or IAB <i>type 1-O</i> is capable of 256QAM DL operation then two rated output power declarations may be made. One declaration is applicable when configured for 256QAM transmissions and the other declaration is applicable when not configured for 256QAM transmissions.		
NOTE 15:	Parameters for contiguous or non-contiguous spectrum operation in the operating band are assumed to be the same unless they are separately declared.		
NOTE 16:	void		
NOTE 17:	In case of IAB <i>type 1-H</i> , this declaration applies per TAB <i>connector</i> .		
NOTE 18:	If a IAB <i>type 2-O</i> is capable of 256QAM DL operation, then up to three rated output power declarations may be made. One declaration is applicable when configured for 256QAM transmissions, a different declaration is applicable when configured for 64QAM transmissions and the other declaration is applicable when not configured neither for 256QAM nor 64QAM transmissions.		
NOTE 19:	The power difference is declared at highest rated output power (D.38).		
NOTE 20:	For declaration applied both IAB-MT and IAB-DU, it can be applied to IAB simultaneous operation where applicable.		

4.7 Test configurations

4.7.1 General

The test configurations shall be constructed using the methods defined below subject to the parameters declared by the manufacturer as listed in clause 4.6.

The applicable test models for generation of the carrier transmit test signal are defined in clause 4.9.2.

NOTE: If required, carriers are shifted to align with the channel raster.

4.7.2 Test signal configurations

4.7.2.1 Test signal used to build Test Configurations

The signal's IAB-DU and IAB-MT *channel bandwidth* and subcarrier spacing used to build IAB-DU and IAB-MT Test Configurations shall be selected according to tables 4.7.2.1-1 and 4.7.2.1-2.

Table 4.7.2.1-1: Signal to be used to build IAB TCs for IAB type 1-H and IAB type 1-O

Operating band characteristics		$F_{DL_high} - F_{DL_low} < 100$ MHz	$F_{DL_high} - F_{DL_low} \geq 100$ MHz
TC signal	$BW_{channel}$	10 MHz (Note)	20 MHz (Note)
characteristics	Subcarrier spacing	Smallest supported subcarrier spacing declared per operating band (D.7)	
NOTE: If this <i>IAB channel bandwidth</i> is not supported, the narrowest supported <i>IAB channel bandwidth</i> declared per <i>operating band</i> (D.7) shall be used.			

Table 4.7.2.1-2: Signal to be used to build IAB TCs for IAB type 2-O

Operating band characteristics		$F_{DL_high} - F_{DL_low} \leq 3250$ MHz
TC signal	$BW_{channel}$	100 MHz (Note 1, Note 2)
characteristics	Subcarrier spacing	Smallest supported subcarrier spacing declared per operating band (D.7)
NOTE 1: <i>IAB</i> vendor can decide to test with 50 MHz <i>IAB channel bandwidth</i> and smallest supported SCS declared per <i>operating band</i> (D.7) instead of 100 MHz <i>IAB channel bandwidth</i> in certain regions, where spectrum allocation and regulation require testing with 50 MHz.		
NOTE 2: If this <i>IAB channel bandwidth</i> is not supported, the narrowest supported <i>IAB channel bandwidth</i> declared per <i>operating band</i> (D.7) shall be used.		

4.7.2.2 IABTC1: Contiguous spectrum operation

The purpose of test configuration IABTC1 is to test all IAB-DU and IAB-MT requirements excluding CA occupied bandwidth.

For IABTC1 used in receiver tests only the two outermost UL carriers and two outermost DL carriers within each supported operating band need to be generated by the test equipment.

4.7.2.2.1 IABTC1 generation

IABTC1 shall be constructed on a per band basis using the following method:

- The *IAB RF Bandwidth* of each supported operating band shall be the declared maximum radiated *IAB RF Bandwidth* for contiguous operation (D.17).
- For IAB not supporting simultaneous transmission between IAB-DU and IAB-MT, select the IAB-DU and IAB-MT carrier to be tested according to 4.7.2.1 and place them adjacent to the lower *IAB-DU and IAB-MT RF Bandwidth edge*. Place same signals adjacent to the upper IAB-DU and IAB-MT RF Bandwidth edge.
- For IAB supporting simultaneous transmission between IAB-DU and IAB-MT, select the IAB UL carrier to be tested according to 4.7.2 and place it adjacent to the lower IAB RF Bandwidth edge. Place the same IAB UL carrier adjacent to the upper IAB RF Bandwidth edge. Select the IAB DL carrier to be tested according to 4.7.2.1 and place it adjacent to the already placed IAB UL carrier at the lower IAB RF Bandwidth edge. Place the same IAB DL carrier adjacent to the already placed IAB UL carrier at the upper.
- For transmitter tests, select as many IAB-DU and IAB-MT carriers (according to 4.7.2.1) that the beam supports within a band and that fit in the rest of the declared maximum *IAB RF Bandwidth*. Place the carriers adjacent to each other starting from the upper *IAB RF Bandwidth edge*. The nominal carrier spacing defined in TS 38.174 [2] clause 5.4.1 shall apply;

The test configuration should be constructed on a per band basis for all component carriers of the inter-band CA bands declared to be supported by the beam (D.60). All configured component carriers are transmitted simultaneously in the tests where the transmitter should be on.

4.7.2.2.2 IABTC1 power allocation

Set the number of carriers to the number of carriers at maximum TRP (D.15).

For EIRP accuracy requirements set each beam to rated beam EIRP (D.11) for the tested *beam direction pair*.

For all other requirements set the power of each carrier to the same level so that the sum of the carrier powers equals the rated transmitter TRP $P_{\text{rated,t,TRP}}$ (D.38).

For a beam declared to support CA-only operation (D.20), set the power spectral density of each carrier to the same level so that the sum of the carrier power equals the same value as above.

4.7.2.3 IABTC2: Contiguous CA occupied bandwidth

IABTC2 in this clause is used to test CA occupied bandwidth.

4.7.2.3.1 IABTC2 generation

IABTC2 shall be constructed on a per band basis using the following method:

- All component carrier combinations supported by the beam, which have different sum of channel bandwidths of component carrier, shall be tested. For all component carrier combinations which have the same sum of channel bandwidths of component carriers, only one of the component carrier combinations shall be tested.
- Of all component carrier combinations which have same sum of channel bandwidths of component carrier, select those with the narrowest carrier with the smallest supported subcarrier spacing declared per *operating band* (D.7) at the lower *IAB RF Bandwidth edge*.
- Of the combinations selected in the previous step, select one with the narrowest carrier with the smallest supported subcarrier spacing declared per *operating band* (D.7) at the upper *IAB RF Bandwidth edge*.
- If there are multiple combinations fulfilling previous steps, select the one with the smallest number of component carrier.
- If there are multiple combinations fulfilling previous steps, select the one with the widest carrier with the smallest supported subcarrier spacing declared per *operating band* (D.7) being adjacent to the lowest carrier.
- If there are multiple combinations fulfilling previous steps, select the one with the widest carrier with the smallest supported subcarrier spacing declared per *operating band* (D.7) being adjacent to the highest carrier.
- If there are multiple combinations fulfilling previous steps, select the one with the widest carrier with the smallest supported subcarrier spacing declared per *operating band* (D.7) being adjacent to the carrier which has been selected in the previous step.
- If there are multiple combinations fulfilling previous steps, repeat the previous step until there is only one combination left.
- The nominal channel spacing defined in TS 38.174 [2] clause 5.4.1 shall apply.

4.7.2.3.2 IABTC2 power allocation

Set the number of carriers to the number of carriers at maximum TRP (D.15).

For EIRP accuracy requirements set each beam to rated beam EIRP (D.11) for the tested *beam direction pair*.

Set the power spectral density of each carrier to the same level so that the sum of the carrier powers equals the rated transmitter TRP $P_{\text{rated,t,TRP}}$ (D.38).

4.7.2.4 IABTC3: Non-contiguous spectrum operation

The purpose of IABTC3 is to test NR multicarrier non-contiguous aspects.

For IABTC3 used in receiver tests, outermost DL and UL carriers for each sub-block need to be generated by the test equipment; other supported carriers are optional to be generated.

4.7.2.4.1 IABTC3 generation

IABTC3 is constructed on a per band basis using the following method:

- The *IAB RF Bandwidth* of each supported operating band shall be the declared maximum radiated *IAB RF Bandwidth* for non-contiguous operation (D.17). The *IAB RF Bandwidth* consists of one sub-block gap and two sub-blocks located at the edges of the declared maximum radiated *IAB RF Bandwidth* for non-contiguous operation (D.17).
- For IAB not supporting simultaneous transmission between IAB-DU and IAB-MT, select the IAB-DU carrier and IAB-MT carrier to be tested according to 4.7.2.1. Place them adjacent to the upper *IAB RF Bandwidth edge* and place the same signals adjacent to the lower *IAB RF Bandwidth edge*.
- For IAB supporting simultaneous transmission between IAB-DU and IAB-MT, select the IAB UL carrier to be tested according to 4.7.2 and place it adjacent to the lower IAB RF Bandwidth edge. Place the same IAB UL carrier adjacent to the upper IAB RF Bandwidth edge. Select the IAB DL carrier to be tested according to 4.7.2.1 and place it adjacent to the already placed IAB UL carrier at the lower IAB RF Bandwidth edge. Place the same IAB DL carrier adjacent to the already placed IAB UL carrier at the upper.
- For single-band operation receiver tests, if the remaining gap is at least 15 MHz (or 60 MHz if channel bandwidth of the carrier to be tested is 20 MHz) for FR1 or 150 MHz for FR2 plus two times the *channel bandwidth* used in the previous step and the beam supports at least 4 carriers, place a IAB-DU carrier and IAB-MT carrier of this *channel bandwidth* adjacent to each already placed carrier for each sub-block. The nominal channel spacing defined in TS 38.174 [2] clause 5.4.1 shall apply.
- The sub-block edges adjacent to the sub-block gap shall be determined using the specified $F_{\text{offset_high}}$ and $F_{\text{offset_low}}$ for the carriers adjacent to the sub-block gap.

4.7.2.4.2 IABTC3 power allocation

Set the number of carriers to the number of carriers at maximum TRP (D.15).

For EIRP accuracy requirements set each beam to rated beam EIRP (D.11) for the tested *beam direction pair*.

For all other requirements set the power of each carrier to the same level so that the sum of the carrier powers equals the rated transmitter TRP $P_{\text{rated, t,TRP}}$ (D.38).

4.7.2.5 IABTC4: Multi-band test configuration for full carrier allocation

The purpose of IABTC4 is to test beams which have been generated using transceiver units supporting operation in multiple operating bands through common active RF components, considering maximum supported number of carriers.

4.7.2.5.1 IABTC4 generation

IABTC4 is based on re-using the existing test configuration applicable per band on beams generated using Multi-band transceiver units and hence have declared multi-band dependencies (D.16). It is constructed using the following method:

- The *IAB RF Bandwidth* of each supported operating band shall be the declared maximum radiated *IAB RF Bandwidth* (D.17).
- The number of carriers of each supported operating band shall be the declared maximum number of supported carriers per *operating band* in multi-band operation (D.21). Carriers shall be selected according to 4.7.2.1 and shall first be placed at the outermost edges of the declared maximum radiated *Radio Bandwidth* (D.18). Additional carriers shall next be placed at the edges of *IAB RF Bandwidth*, if possible.
- The allocated *IAB RF Bandwidth* of the outermost bands shall be located at the outermost edges of the declared maximum radiated *Radio Bandwidth* (D.18).
- Each concerned band shall be considered as an independent band and the corresponding test configuration shall be generated in each band. The mirror image of the single band test configuration shall be used in the highest band being tested for the beam.

- If an operating band with multi-band dependencies supports three carriers only, two carriers shall be placed in one band according to the relevant test configuration while the remaining carrier shall be placed at the edge of the maximum *Radio Bandwidth* in the other band.
- If the sum of the maximum *IAB RF bandwidths* of each of the supported operating bands is greater than the declared *total RF bandwidth* BW_{tot} (D.19) of transmitter and receiver for the declared band combinations of the IAB, then repeat the steps above for test configurations where the *IAB RF Bandwidth* of one of the operating band shall be reduced so that the declared *total RF bandwidth* is not exceeded and vice versa.
- If the sum of the maximum number of supported carriers per *operating band* in multi-band operation (D.21) is larger than the declared total maximum number of supported carriers in multi-band operation (D.63), repeat the steps above for test configurations where in each test configuration the number of carriers of one of the operating band shall be reduced so that the total number of supported carriers is not be exceeded and vice versa.

4.7.2.5.2 IABTC4 power allocation

Set the number of carriers to the total maximum number of supported carriers in multi-band operation (D.63).

For EIRP accuracy requirements set each beam to rated beam EIRP (D.11) for the tested *beam direction pair*.

For all other requirements set the power of each carrier to the same level so that the sum of the carrier powers equals the rated transmitter TRP $P_{rated, t, TRP}$ (D.38).

If the allocated number of carriers in an operating band exceeds the declared number of carriers at maximum TRP in an operating band (D.15) the carriers should if possible be allocated to a different operating band.

4.7.2.6 IABTC5: Multi-band test configuration with high PSD per carrier

The purpose of IABTC5 is to test multi-band operation aspects considering higher PSD cases with reduced number of carriers and non-contiguous operation (if supported) in multi-band mode.

4.7.2.6.1 IABTC5 generation

IABTC5 is based on re-using the existing test configuration applicable for operating bands using multi-band transceiver units and hence have declared multi-band dependencies (D.16). It is constructed using the following method:

- The *IAB RF Bandwidth* of each supported operating band shall be the declared maximum radiated *IAB RF Bandwidth* (D.17).
- The allocated *Radio Bandwidth* of the outermost bands shall be located at the outermost edges of the declared maximum *Radio Bandwidth* of the operating band with multi-band dependencies (D.18).
- The maximum number of carriers is limited to two per band. Carriers shall be selected according to 4.7.2.1 and shall be placed at the outermost edges of the declared maximum *Radio Bandwidth* of the operating band with multi-band dependencies (D.18).
- Each concerned band shall be considered as an independent band and the carrier placement in each band shall be according to IABTC3, where the declared parameters for multi-band operation shall apply. Narrowest supported *IAB channel bandwidth* with the smallest subcarrier spacing declared per *operating band* (D.7) shall be used in the test configuration.
- If an *operating band* with multi-band dependencies supports three carriers only, two carriers shall be placed in one band according to the relevant test configuration while the remaining carrier shall be placed at the edge of the maximum *Radio Bandwidth* in the other band.
- If the sum of the maximum *IAB RF bandwidths* of each of the supported *operating bands* is greater than the declared *total RF bandwidth* BW_{tot} (D.19) of transmitter and receiver for the declared band combinations of the IAB, then repeat the steps above for test configurations where the *IAB RF Bandwidth* of one of the *operating band* shall be reduced so that the declared *total RF bandwidth* BW_{tot} of the *operating band* with multi-band dependencies (D.18) is not exceeded and vice versa.

4.7.2.6.2 IABTC5 power allocation

Set the number of carriers to the total maximum number of supported carriers in multi-band operation (D.63).

For EIRP accuracy requirements set each beam to rated beam EIRP (D.11) for the tested *beam direction pair*.

For all other requirements set the power of each carrier to the same level so that the sum of the carrier powers equals the rated transmitter TRP $P_{\text{rated},t,\text{TRP}}$ (D.38).

If the sum of the TRP for all carriers in an operating band(s) exceeds the sum of the rated carrier TRP output power $P_{\text{rated},c,\text{TRP}}$ (D.37) for the number of carriers at maximum TRP (D.15) in multi-band operation, the exceeded part shall, if possible, be reallocated into the other band(s). If the TRP allocated for a carrier exceeds the declared rated carrier OTA IAB power, $P_{\text{rated},c,\text{TRP}}$, the exceeded power shall, if possible, be reallocated into the other carriers.

4.8 Applicability of requirements

4.8.1 Requirement set applicability

In table 4.8.1-1, the requirement applicability for each requirement set is defined. For each requirement, the applicable requirement clause in the specification is identified. Requirements not included in a requirement set is marked not applicable (NA).

Table 4.8.1-1: Requirement set applicability for IAB-DU and IAB-MT

Requirement	Requirement set					
	IAB-DU type 1-H	IAB-DU type 1-O	IAB-DU type 2-O	IAB-MT type 1-H	IAB-MT type 1-O	IAB-MT type 2-O
Radiated transmit power	6.2	6.2	6.2	6.2	6.2	6.2
OTA IAB-DU output power	NA	6.3	6.3	NA	6.3	6.3
OTA output power dynamics		6.4	6.4		6.4	6.4
OTA transmit ON/OFF power		6.5	6.5		6.5	6.5
OTA transmitted signal quality		6.6	6.6		6.6	6.6
OTA occupied bandwidth		6.7.2	6.7.2		6.7.2	6.7.2
OTA ACLR		6.7.3	6.7.3		6.7.3	6.7.3
OTA out-of-band emission		6.7.4	6.7.4		6.7.4	6.7.4
OTA transmitter spurious emission		6.7.5	6.7.5		6.7.5	6.7.5
OTA transmitter intermodulation		6.8	NA		6.8	NA
OTA sensitivity		7.2	7.2		NA	7.2
OTA reference sensitivity level	NA	7.3	7.3	NA	7.3	7.3
OTA dynamic range		7.4	NA		NA	NA
OTA in-band selectivity and blocking		7.5	7.5		7.5	7.5
OTA out-of-band blocking		7.6	7.6		7.6	7.6
OTA receiver spurious emission		7.7	7.7		7.7	7.7
OTA receiver intermodulation		7.8	7.8		7.8	7.8
OTA in-channel selectivity		7.9	7.9		NA	NA
Radiated performance requirements		8	8		8	8

4.8.2 Applicability of test configurations for single-band RIB

The applicable test configurations are specified in the tables below for each the supported RF configuration, which shall be declared according to clause 4.6. The generation and power allocation for each test configuration is defined in clause 4.7. This clause contains the test configurations for *single-band RIB*.

For an IAB node declared to be capable of single carrier operation only, a single carrier (SC) shall be used for testing.

For a *single-band RIB* declared to support multi-carrier and/or CA operation in contiguous spectrum operation, the test configurations in the second column of table 4.8.2-1 shall be used for testing.

For a *single-band RIB* declared to support multi-carrier and/or CA operation in contiguous and non-contiguous spectrum and where the parameters in the manufacturer's declaration according to clause 4.6 are identical for contiguous

(C) and non-contiguous (NC) spectrum operation, the test configurations in the third column of table 4.8.2-1 shall be used for testing.

For a *single-band RIB* declared to support multi-carrier and/or CA in contiguous and non-contiguous spectrum and where the parameters in the manufacture's declaration according to clause 4.6 are not identical for contiguous and non-contiguous spectrum operation, the test configurations in the fourth column of table 4.8.2-1 shall be used for testing.

For a *single-band RIB* declared to support multi-carrier and/or CA and IAB simultaneous operation (D.x) in contiguous and non-contiguous spectrum and where the parameters in the manufacture's declaration according to clause 4.6 are identical for contiguous and non-contiguous spectrum operation, the test configurations in the third column of table 4.8.2-2 shall be used for testing.

For a *single-band RIB* declared to support multi-carrier and/or CA and IAB simultaneous operation (D.x) in contiguous and non-contiguous spectrum and where the parameters in the manufacture's declaration according to clause 4.6 are not identical for contiguous and non-contiguous spectrum operation, the test configurations in the fourth column of table 4.8.2-2 shall be used for testing.

Unless otherwise stated, single carrier configuration (SC) tests shall be performed using signal with narrowest supported *IAB-DU* or *IAB-MT channel bandwidth* with the smallest supported subcarrier spacing declared per *operating band* (D.7).

Table 4.8.2-1: Test configurations for a *single-band RIB* of IAB

IAB test case	Contiguous spectrum capable IAB	C and NC capable IAB with identical parameters	C and NC capable IAB with different parameters
Radiated transmit power	IABTC1	IABTC1	IABTC1, IABTC3
OTA IAB maximum output power	IABTC1	IABTC1	IABTC1, IABTC3
OTA RE Power control dynamic range (only applied to IAB-DU)	Tested with Error Vector Magnitude	Tested with Error Vector Magnitude	Tested with Error Vector Magnitude
OTA total power dynamic range	SC	SC	SC
OTA transmit ON/OFF power (only applied to NR TDD IAB)	IABTC1	IABTC1	IABTC1, IABTC3
OTA frequency error	Tested with Error Vector Magnitude	Tested with Error Vector Magnitude	Tested with Error Vector Magnitude
OTA error Vector Magnitude	IABTC1	IABTC1	IABTC1, IABTC3
OTA time alignment error	IABTC1	IABTC1	IABTC1, IABTC3
OTA Occupied bandwidth	SC, IABTC2 (Note 1)	SC, IABTC2 (Note 1)	SC, IABTC2 (Note 1)
OTA ACLR	IABTC1	IABTC1, IABTC3	IABTC1, IABTC3
OTA CACLR	-	IABTC3	IABTC3
OTA operating band unwanted emissions	IABTC1, SC (Note 2)	IABTC1, IABTC3, SC (Note 2)	IABTC1, IABTC3, SC (Note 2)
OTA transmitter spurious emissions	IABTC1	IABTC3	IABTC1, IABTC3
OTA transmitter intermodulation	IABTC1	IABTC1, IABTC3	IABTC1, IABTC3
OTA sensitivity	SC	SC	SC
OTA reference sensitivity level	SC	SC	SC
OTA dynamic range (only applied to IAB-DU)	SC	SC	SC
OTA adjacent channel selectivity	IABTC1	IABTC3	IABTC1, IABTC3
In-band blocking	IABTC1	IABTC3	IABTC1, IABTC3
OTA out-of-band blocking	IABTC1	IABTC3	IABTC1, IABTC3
OTA receiver spurious emissions	IABTC1	IABTC3	IABTC1, IABTC3
OTA receiver intermodulation	IABTC1	IABTC3	IABTC1, IABTC3
OTA in-channel selectivity (only applied to IAB-DU)	SC	SC	SC

NOTE 1: IABTC2 is only applicable when contiguous CA is supported.
NOTE 2: OBUE SC shall be tested using the widest supported channel bandwidth and the highest supported subcarrier spacing.

Table 4.8.2-2: Test configurations for a *single-band RIB* of IAB capable of simultaneous operation

IAB test case	Contiguous spectrum capable IAB	C and NC capable IAB with identical parameters	C and NC capable IAB with different parameters
Radiated transmit power	IABTC1	IABTC1	IABTC1, IABTC3
OTA IAB maximum output power	IABTC1	IABTC1	IABTC1, IABTC3
OTA RE Power control dynamic range (only applied to IAB-DU)	Tested with Error Vector Magnitude	Tested with Error Vector Magnitude	Tested with Error Vector Magnitude
OTA transmit ON/OFF power (only applied to NR TDD IAB)	IABTC1	IABTC1	IABTC1, IABTC3
OTA frequency error	Tested with Error Vector Magnitude	Tested with Error Vector Magnitude	Tested with Error Vector Magnitude
OTA error Vector Magnitude	IABTC1	IABTC1	IABTC1, IABTC3
OTA time alignment error between IAB-DU and IAB-MT	IABTC1	IABTC1	IABTC1, IABTC3
OTA ACLR	IABTC1	IABTC1, IABTC3	IABTC1, IABTC3
OTA CA CLR	-	IABTC3	IABTC3
OTA operating band unwanted emissions	IABTC1	IABTC1, IABTC3	IABTC1, IABTC3
OTA transmitter spurious emissions	IABTC1	IABTC3	IABTC1, IABTC3
OTA transmitter intermodulation (NOTE 1)	IABTC1	IABTC1, IABTC3	IABTC1, IABTC3
OTA adjacent channel selectivity	IABTC1	IABTC3	IABTC1, IABTC3
In-band blocking	IABTC1	IABTC3	IABTC1, IABTC3
OTA out-of-band blocking	IABTC1	IABTC3	IABTC1, IABTC3
OTA receiver spurious emissions	IABTC1	IABTC3	IABTC1, IABTC3
OTA receiver intermodulation (NOTE 1)	IABTC1	IABTC3	IABTC1, IABTC3

NOTE 1: Test case does not apply to IAB type 2-O.

4.8.3 Applicability of test configurations for multi-band RIB

For a *multi-band RIB*, the test configuration in table 4.8.3-1 shall be used for testing.

For a *multi-band RIB* and IAB capable of simultaneous operation, the test configuration in table 4.8.3-2 shall be used for testing.

Unless otherwise stated, single carrier configuration (SC) tests shall be performed using signal with narrowest supported *IAB-DU* or *IAB-MT channel bandwidth* with the smallest supported subcarrier spacing declared per *operating band* (D.7).

NOTE: The applicability of test configurations in table 4.8.3-1 are not applicable to *IAB type 2-O*.

Table 4.8.3-1: Test configuration for a *multi-band RIB* of IAB

IAB test case	Test configuration
Radiated transmit power	IABTC1/3 (Note 1), IABTC4
OTA IAB-DU maximum output power	IABTC1/3 (Note 1), IABTC4
OTA RE power control dynamic range (only applied to IAB-DU)	Tested with Error Vector Magnitude
OTA total power dynamic range	SC
OTA transmit ON/OFF power (only applied to NR TDD IAB)	IABTC4
OTA frequency error	Tested with Error Vector Magnitude
OTA Error Vector Magnitude	IABTC1/3 (Note 1), IABTC4
OTA time alignment error	IABTC1/3 (Note 1), IABTC5 (Note 2)
OTA occupied bandwidth	SC, IABTC2 (Note 3)
OTA ACLR	IABTC1/3 (Note 1), IABTC5 (Note 4)
OTA CA CLR	IABTC3 (Note 1), IABTC5 (Note 4)
OTA operating band unwanted emissions	IABTC1/3 (Note 1), IABTC5, SC (Note 5)
OTA transmitter spurious emissions	IABTC1/3 (Note 1), IABTC5
OTA transmitter intermodulation	IABTC1/3 (Note 1)
OTA sensitivity	SC
OTA reference sensitivity level	SC
OTA dynamic range (only applied to IAB-DU)	SC
OTA adjacent channel selectivity	IABTC5
In-band blocking	IABTC5
OTA out-of-band blocking	IABTC5
OTA receiver spurious emissions	IABTC1/3 (Note 1), IABTC5
OTA receiver intermodulation	IABTC5
OTA in-channel selectivity (only applied to IAB-DU)	SC
NOTE 1: IABTC1 and/or IABTC3 shall be applied in each supported operating band.	
NOTE 2: IABTC5 is only applicable when inter-band CA is supported.	
NOTE 3: IABTC2 is only applicable when contiguous CA is supported.	
NOTE 4: IABTC5 may be applied for Inter RF Bandwidth gap only.	
NOTE 5: OBUE SC shall be tested using the widest supported channel bandwidth and the highest supported sub-carrier spacing.	

Table 4.8.3-2: Test configuration for a *multi-band RIB* of IAB capable of simultaneous operation

IAB test case	Test configuration
Radiated transmit power	IABTC1/3 (Note 1), IABTC4
OTA IAB-DU maximum output power	IABTC1/3 (Note 1), IABTC4
OTA transmit ON/OFF power (only applied to NR TDD IAB)	IABTC4
OTA frequency error	Tested with Error Vector Magnitude
OTA Error Vector Magnitude	IABTC1/3 (Note 1), IABTC4
OTA time alignment error between IAB-DU and IAB-MT	IABTC1/3 (Note 1), IABTC5
OTA ACLR	IABTC1/3 (Note 1), IABTC5 (Note 4)
OTA CA CLR	IABTC3 (Note 1), IABTC5 (Note 4)
OTA operating band unwanted emissions	IABTC1/3 (Note 1), IABTC5, SC (Note 5)
OTA transmitter spurious emissions	IABTC1/3 (Note 1), IABTC5
OTA transmitter intermodulation	IABTC1/3 (Note 1)
OTA adjacent channel selectivity	IABTC5
In-band blocking	IABTC5
OTA out-of-band blocking	IABTC5
OTA receiver spurious emissions	IABTC1/3 (Note 1), IABTC5
OTA receiver intermodulation	IABTC5
NOTE 1: IABTC1 and/or IABTC3 shall be applied in each supported operating band.	
NOTE 2: Void	
NOTE 3: Void	
NOTE 4: IABTC5 may be applied for Inter RF Bandwidth gap only.	

4.9 RF channels and test models

4.9.1 RF channels

For the single carrier testing many tests in the present document are performed with appropriate frequencies in the bottom, middle and top channels of the supported frequency range of the IAB. These are denoted as RF channels B (bottom), M (middle) and T (top).

Unless otherwise stated, the test shall be performed with a single carrier at each of the RF channels B, M and T.

Many tests in the present document are performed with the maximum *IAB RF Bandwidth* located at the bottom, middle and top of the supported frequency range in the operating band. These are denoted as B_{RFBW} (bottom), M_{RFBW} (middle) and T_{RFBW} (top).

Unless otherwise stated, the test shall be performed at B_{RFBW} , M_{RFBW} and T_{RFBW} defined as following:

- B_{RFBW} : maximum *IAB RF Bandwidth* located at the bottom of the supported frequency range in the operating band.
- M_{RFBW} : maximum *IAB RF Bandwidth* located in the middle of the supported frequency range in the operating band.
- T_{RFBW} : maximum *IAB RF Bandwidth* located at the top of the supported frequency range in the operating band.

For a IAB capable of multi-band operation and capable of dual-band operation, unless otherwise stated, the test shall be performed at $B_{\text{RFBW_T'RFBW}}$ and $B'\text{RFBW_T'RFBW}$ defined as following:

- $B_{\text{RFBW_T'RFBW}}$: the *IAB RF Bandwidths* located at the bottom of the supported frequency range in the lower operating band and at the highest possible simultaneous frequency position, within the maximum *Radio Bandwidth*, in the upper operating band.
- $B'\text{RFBW_T'RFBW}$: the *IAB RF Bandwidths* located at the top of the supported frequency range in the upper operating band and at the lowest possible simultaneous frequency position, within the maximum *Radio Bandwidth*, in the lower operating band.

NOTE: $B_{\text{RFBW_T'RFBW}} = B'\text{RFBW_T'RFBW} = B_{\text{RFBW_T'RFBW}}$ when the declared maximum *Radio Bandwidth* (see clause 4.6) spans both operating bands. $B_{\text{RFBW_T'RFBW}}$ means the *IAB RF Bandwidths* are located at the bottom of the supported frequency range in the lower operating band and at the top of the supported frequency range in the upper operating band.

Occupied bandwidth test in the present document are performed with the *aggregated IAB channel bandwidth* and sub-block bandwidths located at the bottom, middle and top of the supported frequency range in the operating band. These are denoted as $B_{\text{BW Channel CA}}$ (bottom), $M_{\text{BW Channel CA}}$ (middle) and $T_{\text{BW Channel CA}}$ (top) for contiguous spectrum operation.

Unless otherwise stated, the test for contiguous spectrum operation shall be performed at $B_{\text{BW Channel CA}}$, $M_{\text{BW Channel CA}}$ and $T_{\text{BW Channel CA}}$ defined as following:

- $B_{\text{BW Channel CA}}$: *aggregated IAB channel bandwidth* located at the bottom of the supported frequency range in each operating band;
- $M_{\text{BW Channel CA}}$: *aggregated IAB channel bandwidth* located close in the middle of the supported frequency range in each operating band;
- $T_{\text{BW Channel CA}}$: *aggregated IAB channel bandwidth* located at the top of the supported frequency range in each operating band.

When a test is performed by a test laboratory, the position of B, M and T for single carrier, B_{RFBW} , M_{RFBW} and T_{RFBW} for single band operation, $B_{\text{BW Channel CA}}$, $M_{\text{BW Channel CA}}$ and $T_{\text{BW Channel CA}}$ for contiguous spectrum operation in the operating band, the position of $B_{\text{RFBW_T'RFBW}}$ and $B'\text{RFBW_T'RFBW}$ in the supported operating band combinations shall be specified by the laboratory. The laboratory may consult with operators, the manufacturer or other bodies.

4.9.2 Test models

4.9.2.1 General

The following clauses will describe the test models needed for *IAB type 2-O*. Note the IAB FR1 test models described in TS 38.176-1 [3] are also applicable for *IAB type 1-O* conformance testing.

4.9.2.2 FR2 test models for IAB-DU

FR2 test model in clause 4.9.2.2 in TS 38.141-2 [6] applies to IAB-DU as below:

NR-FR2-TM1.1 applies to IAB-DU-FR2-TM1.1

NR-FR2-TM2 applies to IAB-DU-FR2-TM2

NR-FR2-TM2a applies to IAB-DU-FR2-TM2a

NR-FR2-TM3.1 applies to IAB-DU-FR2-TM3.1

NR-FR2-TM3.1a applies to IAB-DU-FR2-TM3.1a

4.9.2.3 FR2 test models for IAB-MT

The set-up of physical channels for transmitter tests shall be according to one of the test models (IAB-MT-FR2-TM) below. A reference to the applicable test model is made within each test.

The following general parameters are used by all NR test models:

- Duration is 2 radio frames for TDD (20 ms)
- The slots are numbered 0 to $10 \times 2^\mu - 1$ where μ is the numerology corresponding to the subcarrier spacing
- N_{RB} is the maximum transmission bandwidth configuration seen in table 5.3.2-2 in TS 38.174 [2].
- Normal CP
- Virtual resource blocks of localized type

For FR2 TDD, IAB-MT test models are derived based on the uplink/downlink configuration as shown in the table 4.9.2.3-1 using information element *TDD-UL-DL-ConfigCommon* as defined in TS 38.331 [z].

Table 4.9.2.3-1: Configurations of TDD for *IAB-MT type 2-O* test models

Field name	Value	
referenceSubcarrierSpacing (kHz)	60	120
Periodicity (ms) for dl-UL-TransmissionPeriodicity	1.25	1.25
nrofDownlinkSlots	3	7
nrofDownlinkSymbols	10	6
nrofUplinkSlots	1	2
nrofUplinkSymbols	2	4

Common physical channel parameters for all FR2 test models are specified in table 4.9.2.3-2 and table 4.9.2.3-3 for PUSCH. Specific physical channel parameters for FR2 test models are described in clauses 4.9.2.3.1 to 4.9.2.3.3.

Table 4.9.2.3-2: Common physical channel parameters for IAB-MT type 2-O PUSCH

Parameter	Value
mapping type	PUSCH mapping type A
<i>dmrs-TypeA-Position</i> for the first DM-RS symbol	'pos2'
<i>dmrs-AdditionalPosition</i> for additional DM-RS symbol(s)	'pos0'
<i>dmrs-Type</i> for comb pattern	Configuration type 1
maxLength	1
Ratio of PUSCH EPRE to DM-RS EPRE	0 dB
PTRS configuration and density	$L_{PT-RS} = 4$ $K_{PT-RS} = 2$ $k_{ref}^{RE} = 00$
Ratio of PT-RS EPRE to DM-RS EPRE	0 dB

Table 4.9.2.3-3: Common physical channel parameters for PUSCH by RNTI for IAB-MT type 2-O test models

Parameter	Value
PUSCH $n_{RNTI} = 0$	

4.9.2.3.1 FR2 test model 1.1 (IAB-MT-FR2-TM1.1)

This model shall be used for tests on:

- Radiated transmit power
- IAB output power
- Transmit ON/OFF power
- Unwanted emissions
 - Occupied bandwidth
 - ACLR
 - Operating band unwanted emissions
 - Transmitter spurious emissions
- Receiver spurious emissions

Common physical channel parameters are defined in clause 4.9.2.3. Specific physical channel parameters for IAB-MT-FR2-TM1.1 are defined in table 4.9.2.3.1-1.

Table 4.9.2.3.1-1: Specific physical channel parameters of IAB-MT-FR2-TM1.1

Parameter	Value
# of PRBs PUSCH $n_{RNTI} = 0$	N_{RB}
Modulation PUSCH $n_{RNTI} = 0$	QPSK

4.9.2.3.2 FR2 test model 2 (IAB-MT-FR2-TM2)

This model shall be used for tests on:

- Total power dynamic range (at lower PSD TX power limit at min power)
- EVM of single PRB allocation (at lower PSD TX power limit at min power)
- Frequency error (at lower PSD TX power limit at min power)

Common physical channel parameters are defined in clause 4.9.2.3. Specific physical channel parameters for IAB-MT-FR2-TM2 are defined in table 4.9.2.3.2-1 for 64QAM. For 16QAM and QPSK, specific physical channel parameters for IAB-MT-FR2-TM2 are defined in table 4.9.2.3.2-1 with 64QAM PUSCH PRB replaced with selected modulation order PUSCH PRB according to the corresponding test procedure.

Table 4.9.2.3.2-1: Specific physical channel parameters of IAB-MT-FR2-TM2

Parameter	Value		
# of 64QAM PUSCH PRBs	1		
Level of boosting (dB)	0		
Location of 64QAM PRB	Slot	RB	n
	3n	0	$n = 0, \dots, \left\lfloor \frac{10 \times 2^\mu}{3} \right\rfloor - 1$
	3n+1	$\left\lfloor \frac{N_{RB}}{2} \right\rfloor$	$n = 0, \dots, \left\lfloor \frac{10 \times 2^\mu - 1}{3} \right\rfloor - 1$
	3n+2	$N_{RB} - 1$	$n = 0, \dots, \left\lfloor \frac{10 \times 2^\mu - 2}{3} \right\rfloor - 1$
# of PUSCH PRBs which are not allocated	$N_{RB} - 1$		

4.9.2.3.2a FR2 test model 2a (IAB-MT-FR2-TM2a)

This model shall be used for tests on:

- Total power dynamic range (at lower PSD TX power limit at min power)
- EVM of single PRB allocation (at lower PSD TX power limit at min power)
- Frequency error (at lower PSD TX power limit at min power)

Common physical channel parameters are defined in clause 4.9.2.3. Specific physical channel parameters for IAB-MT-FR2-TM2a are defined in table 4.9.2.3.2-1 with all 64QAM PUSCH PRBs replaced by 256QAM PUSCH PRBs.

4.9.2.3.3 FR2 test model 3.1 (IAB-MT-FR2-TM3.1)

This model shall be used for tests on:

- Output power dynamics
 - Total power dynamic range (upper TX PSD power limit at max power with all 64QAM PRBs allocated)
- Transmitted signal quality
 - Frequency error (at max power)
 - EVM for modulation (at max power)

Common physical channel parameters are defined in clause 4.9.2.3. Specific physical channel parameters for IAB-MT-FR2-TM3.1 are defined in table 4.9.2.3.1-1 with all QPSK PUSCH PRBs replaced with selected modulation order PUSCH PRBs according to the corresponding test procedure.

4.9.2.3.4 FR2 test model 3.1a (IAB-MT-FR2-TM3.1a)

This model shall be used for tests on:

- Output power dynamics
 - Total power dynamic range (upper TX PSD power limit at max power with all 256QAM PRBs allocated)
- Transmitted signal quality
 - Frequency error (at max power)
 - EVM for 256QAM modulation (at max power)

Common physical channel parameters are defined in clause 4.9.2.3. Specific physical channel parameters for IAB-MT-FR2-TM3.1a shall be defined in table 4.9.2.3.1-1 with all QPSK PUSCH PRBs replaced by 256QAM.

4.9.2.3 Data content of physical channels and signals for IAB-MT-FR2-TM

Randomisation of the data content is obtained by utilizing a PN sequence generator and the length-31 Gold sequence scrambling of TS 38.211 [7], clause 5.2.1 which is invoked by all physical channels prior to modulation and mapping to the RE grid.

Initialization of the scrambler and RE-mappers as defined in TS 38.211 [7] use the following additional parameters:

- $N_{ID}^{cell} = 1$
- $q = 0$ (single code word)
- Rank 1, single layer

4.9.2.3.1 PUSCH

- Generate the required amount of bits from the output of the PN23 sequence generator [28]. The PN sequence generator is initialized with a starting seed of "all ones" in the first allocated slot of each frame. The PN sequence is continuous over the slot boundaries.
- Perform user specific scrambling according to TS 38.211 [7], clause 6.3.1.1.
- $n_{ID} = N_{ID}^{cell}$
- Perform modulation of the scrambled bits with the modulation scheme defined for each user according to TS 38.211 [7], clause 6.3.1.3.
- Perform mapping of the complex-valued symbols to layer according to TS 38.211 [7], clause 6.3.1.3.
- Perform PDSCH mapping type A according to TS 38.211 [7].
- DM-RS sequence generation according to TS 38.211 [7], clause 6.4.1.1.1 where l is the OFDM symbol number within the slot with symbols indicated by table 4.9.2.2-3.
- $N_{ID}^{n_{SCID}} = N_{ID}^{cell}$
- $n_{SCID} = 0$
- DM-RS mapping according to TS 38.211 [7], clause 6.4.1.1.3 with parameters listed in table 4.9.2.2-3.
- For NR-IAB-MT-FR2-TM PT-RS sequence generation according to TS 38.211 [7], clause 6.4.1.2.1, with parameters listed in table 4.9.2.2-3.
- For NR-IAB-MT-FR2-TM PT-RS mapping according to TS 38.211 [7], clause 6.4.1.2.2, with parameters listed in table 4.9.2.2-3.

4.10 Requirements for contiguous and non-contiguous spectrum

A spectrum allocation where an IAB operates can either be contiguous or non-contiguous. Unless otherwise stated, the requirements in the present specification apply for IAB configured for both *contiguous spectrum* operation and *non-contiguous spectrum* operation.

For IAB operation in *non-contiguous spectrum*, some requirements apply both at the *IAB-DU RF Bandwidth edges* or *IAB-MT RF bandwidth edges* and inside the *sub-block gaps*. For each such requirement, it is stated how the limits apply relative to the *IAB-DU RF Bandwidth edges* or *IAB-MT RF bandwidth edges* and the *sub-block edges* respectively.

4.11 Requirements for IAB capable of multi-band operation

For *multi-band RIB*, the RF requirements in clause 6 and 7 apply separately to each supported *operating band* unless otherwise stated. For some requirements, it is explicitly stated that specific additions or exclusions to the requirement apply at *multi-band RIB(s)* as detailed in the requirement clause.

IAB type 1-O may be capable of supporting operation in multiple *operating bands* with one of the following implementations at the *radiated interface boundary*:

- All RIBs are *single-band RIBs*.
- All RIBs are *multi-band RIBs*.
- A combination of *single-band RIBs* and *multi-band RIBs* provides support of the *IAB type 1-O* capability of operation in multiple *operating bands*.

For *multi-band RIBs* supporting the bands for TDD, the RF requirements in the present specification assume no simultaneous uplink and downlink occur between the bands.

4.12 Co-location requirements

4.12.1 General

Co-location requirements are requirements which are based on assuming the *IAB type 1-O* is co-located with another BS or IAB of the same base station class. They ensure that both co-located systems can operate with minimal degradation to each other.

The co-location requirements in table 4.12.1-1 rely on a *co-location reference antenna* used to mimic an IAB to base station or IAB co-location scenario.

Table 4.12.1-1: Co-location requirements

Clause number	Requirement	Co-location reference antenna operation	Type
6.5	OTA transmit ON/OFF power for FR1	Measure emission	Mandatory
6.7.5.3 6.7.5.5	OTA spurious emission: Protection of the IAB receiver of own or different BS and IAB OTA spurious emission: Co-location with other base stations and IAB-Nodes	Measure emission	Optional based on declaration
6.8	OTA transmitter intermodulation	Inject the interferer signal	Mandatory
7.6	OTA out-of-band blocking: Co-location with other base stations or IAB-Nodes	Inject the interferer signal	Optional based on declaration

The OTA transmit ON/OFF power requirement and OTA transmitter intermodulation requirement are mandatory requirements where the test requirement is derived using the *co-location reference antenna*, which represents the worst-case scenario.

The *co-location reference antenna* is defined in TS 38.174 [2].

4.12.2 Co-location test antenna

4.12.2.1 General

Co-location requirements are specified as power levels into or out of the conducted interface of the *co-location reference antenna*. For conformance testing the requirements are translated to the input or output of a *co-location test antenna* (CLTA).

A CLTA is a practical antenna which can be used to test conformance to the co-location requirements.

4.12.2.2 Co-location test antenna characteristics

A *co-location test antenna* is a practical passive antenna that is used for conformance testing of the co-location requirements and is based on the definition of the *co-location reference antenna*. A CLTA shall comply with the requirements specified in table 4.12.2.2-1.

Translation of the requirements to other test antennas are not precluded but suitable translations between the co-location reference antenna and test antenna must be provided to demonstrate that the method is within the specified MU.

NOTE: The currently defined CLTAs are suitable for testing *IAB type I-O* implemented with a planar antenna array. The method for testing IAB with other antenna array implementations is not covered by the present release of the present document.

Table 4.12.2.2-1: CLTA characteristics

Parameter	In-band CLTA	Out-of-band CLTAs
Vertical radiating dimension (h)	Test object vertical radiating length $\pm 30\%$	N/A
Horizontal beam width	$65^\circ \pm 10^\circ$	$65^\circ \pm 10^\circ$
Vertical beam width	N/A	The half-power vertical beam width of the CLTA equals the narrowest declared (D.3) vertical beamwidth $\pm 3^\circ$
Polarization	Match	Match to in-band
Conducted interface return loss	> 10 dB	> 10 dB
NOTE:	If a multi-column or multi-band antenna is used the column closest to the NR IAB shall be selected while other columns are terminated during testing.	

4.12.2.3 Co-location test antenna alignment

The alignment between the NR IAB under test and the *co-location test antenna* is described in table 4.12.2.3-1 and figure 4.12.2.3-1. The same physical alignment applies to in-band and out-of-band co-location requirements.

Table 4.12.2.3-1: CLTA alignment tolerances

Parameter	
Edge-to-edge separation between the NR IAB and the CLTA, d	0.1 m \pm 0.01 m
Vertical alignment	Centre \pm 0.01 m
Front alignment	Radome front \pm 0.01 m

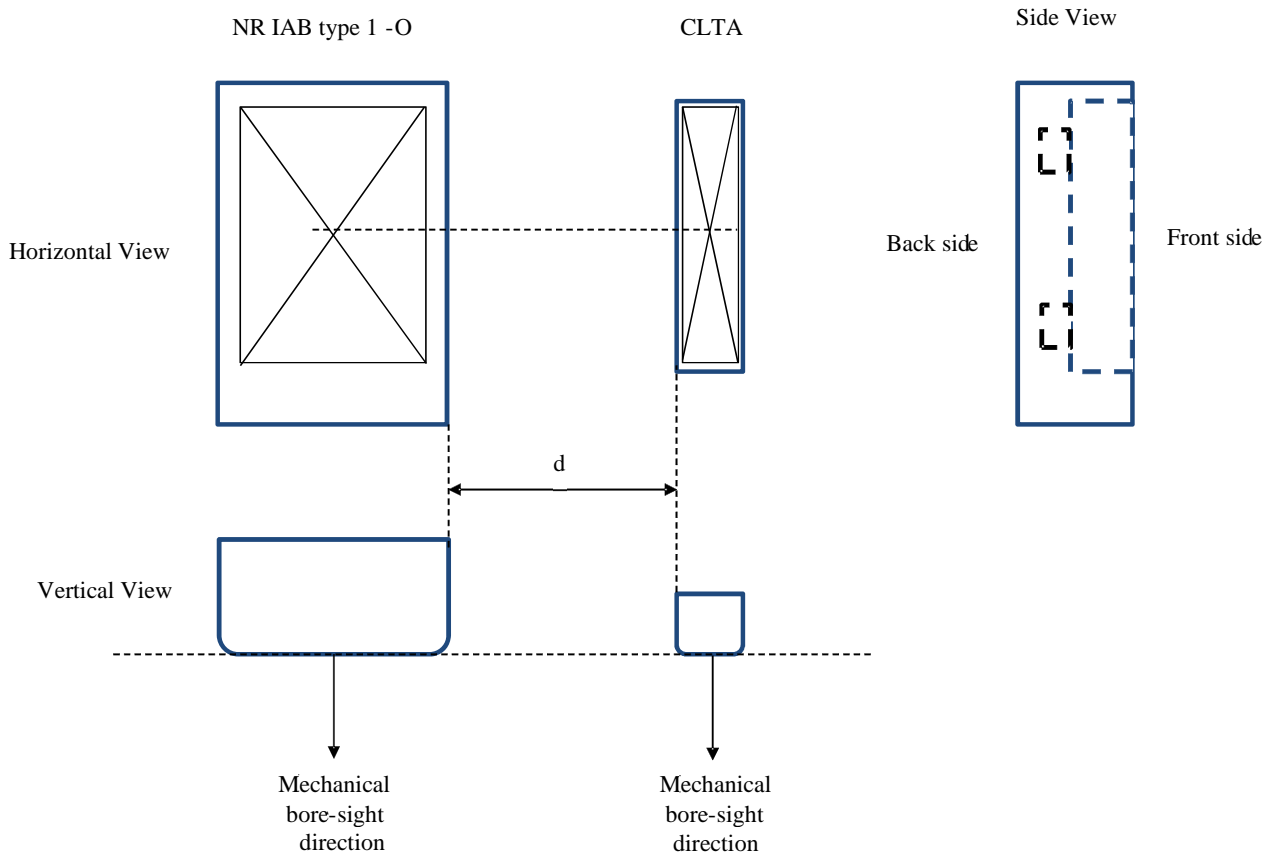

Figure 4.12.2.3-1: Alignment of NR IAB and CLTA

4.13 Test efficiency optimization

When manufacture declares the same RF implementation for IAB-MT and IAB-DU (D.IAB-1) and the declarations in table 4.13-1 are the same for IAB-DU and IAB-MT, it is sufficient to test only IAB-MT or IAB-DU with the test requirement applicability according to table 4.13-2 for Tx requirements and table 4.13-3 for Rx requirements.

For *IAB type 1-H* the test efficiency optimization for radiated requirements apply only for radiated transmit power and OTA sensitivity. Test efficiency optimization for conducted requirements is defined in TS 38.176-1 [3].

For *IAB type 1-O* and *IAB type 2-O* it is required that the DUT selection between requirements follows following rules:

- out of radiated transmit power, OTA modulation quality and OTA frequency error, IAB-DU and IAB-MT are required to be the DUT at least once,
- out of OTA ACLR, OTA operating band unwanted emissions and OTA transmitter general spurious emissions, are required to be the DUT at least once,
- out of OTA reference sensitivity, OTA ACS, OTA receiver intermodulation, IAB-DU and IAB-MT are required to be the DUT at least once.

In some cases, the test requirements are the same but the MU for the IAB-MT is larger than for the IAB-DU. When the test efficiency optimization is applicable for such cases, the lower MU value should be used.

Table 4.13-1: Declarations required to be the same for IAB-DU and IAB-MT for test efficiency optimization to apply

Declaration identifier	Declaration	Additional conditions	Applicability (Note 1)		
			IAB type 1-H	IAB type 1-O	IAB type 2-O
D.4	Operating bands and frequency ranges		c	x	x
D.6	IAB class	Medium range IAB-DU can apply test efficiency optimization with wide area IAB-MT other declarations in this table are the same.	c	x	x
D.11	Rated beam EIRP		x	x	x
D.17	Maximum radiated IAB RF Bandwidth		c	x	x
D.19	Total RF bandwidth (BW_{tot})		c	x	x
D.21	Maximum number of supported carriers per operating band in multi-band operations		c	x	n/a
D.27	Minimum EIS for FR1 ($EIS_{minSENS}$)		x	x	n/a
D.28	EIS REFSSENS for FR2 ($EIS_{REFSENS_50M}$)		n/a	n/a	x
D.33	Conformance test directions	Required only for IAB type 1-H	x	x	n/a
D.34	OTA coverage range		x	x	x
D.37	The rated carrier OTA IAB power, $P_{rated,c,TRP}$		n/a	x	x
D.44	Single-band RIB or multi-band RIB		c	x	n/a
D.46	Maximum number of supported carriers per operating band		c	x	x
D.48	Other band combination multi-band restrictions		c	x	n/a
D.53	OTA REFSSENS RoAoA		n/a	x	x
D.63	Total maximum number of supported carriers in multi-band operation		c	x	n/a

NOTE 1: Manufacturer declarations applicable per IAB requirement set were marked as "x". Manufacturer declarations not applicable per IAB requirement set were marked as "n/a". For declarations marked as 'c', related conducted declarations in TS 38.176-1 [3] apply.

Table 4.13-2: Test requirement applicability for TX requirements

Tx requirement	Test efficiency optimization applicable	Test requirement applicability (Note 1)
Radiated transmit power	Yes	FR2: IAB-DU
OTA output power	Yes	FR2: IAB-DU
OTA Output power dynamics (only for IAB-DU)	No	(Note 3)
OTA Output power dynamics (only for IAB-MT)	No	(Note 3)
OTA Transmitter OFF power	Yes	
OTA Transient period	Yes	
IAB-DU OTA Frequency Error	No	
IAB-MT OTA Frequency Error	No	
OTA Modulation quality	Yes	
OTA Time alignment error (only for IAB-DU)	No	(Note 3)
OTA Occupied bandwidth	Yes	
OTA ACLR	Yes	FR2: IAB-DU (Note 2)
OTA Operating band unwanted emission	Yes	FR2: IAB-DU
General requirement	Yes	FR2: IAB-DU

OTA Transmitter spurious emission	Additional spurious emissions	Yes	FR2: IAB-DU
	Co-location with other base stations		
OTA transmitter intermodulation		Yes	FR2: IAB-DU
NOTE 1: Test requirement applicability defines how to select whether IAB-DU or IAB-MT test requirement is applied. In case no applicability definition is provided or the applicability definition test requirement is the same for IAB-DU and IAB-MT, either can apply.			
NOTE 2: Local Area <i>IAB-MT type 2-O</i> is required to use IAB-DU test requirement.			
NOTE 3: Test efficiency optimization is not applicable and therefore original test requirement applies.			

Table 4.13-3: Test requirement applicability for Rx requirements

Rx requirement	Test efficiency optimization applicable	Test requirement applicability (Note 1)
OTA sensitivity	Yes	FR2: IAB-DU
OTA reference sensitivity	Yes	FR2: IAB-DU
OTA Dynamic range (only for IAB-DU)	No	(Note 2)
OTA Adjacent channel selectivity	Yes	IAB-MT
OTA In-band blocking	Yes	IAB-MT
OTA Out-of-band blocking	General requirement	Yes
	Co-location requirement	Yes
OTA Receiver spurious emissions	Yes	FR2: IAB-DU
OTA Receiver intermodulation	Yes	IAB-MT
OTA In-channel selectivity (only for IAB-DU)	No	(Note 2)
NOTE 1: Test requirement applicability defines how to select whether IAB-DU or IAB-MT test requirement is applied. In case no applicability definition is provided or the applicability definition test requirement is the same for IAB-DU and IAB-MT, either can apply.		
NOTE 2: Test efficiency optimization is not applicable and therefore original test requirement applies.		

4.14 Format and interpretation of tests

Each test has a standard format:

X Title

All tests are applicable to all equipment within the scope of the present document, unless otherwise stated.

X.1 Definition and applicability

This clause gives the general definition of the parameter under consideration and specifies whether the test is applicable to all equipment or only to a certain subset. Required manufacturer declarations may be included here.

X.2 Minimum requirement

This clause contains the reference to the clause to the 3GPP reference (or core) specification which defines the minimum requirement.

X.3 Test purpose

This clause defines the purpose of the test.

X.4 Method of test

X.4.1 General

In some cases there are alternative test procedures or initial conditions. In such cases, guidance for which initial conditions and test procedures can be applied are stated here. In the case only one test procedure is applicable, that is stated here.

X.4.2y First test method

X.4.2y.1 Initial conditions

This clause defines the initial conditions for each test, including the test environment, the RF channels to be tested and the basic measurement set-up.

X.4.2y.2 Procedure

This clause describes the steps necessary to perform the test and provides further details of the test definition like domain (e.g. frequency-span), range, weighting (e.g. bandwidth), and algorithms (e.g. averaging). The procedure may comprise data processing of the measurement result before comparison with the test requirement (e.g. average result from several measurement positions).

X.4.3y Alternative test method (if any)

If there are alternative test methods, each is described with its initial conditions and procedures.

X.5 Test requirement

This clause defines the pass/fail criteria for the equipment under test, see clause 4.1.3 (Interpretation of measurement results). Test requirements for every minimum requirement referred in clause X.2 are listed here. Cases where minimum requirements do not apply need not be mentioned.

4.15 Reference coordinate system

Radiated requirements are stated in terms of electromagnetic characteristics (e.g. EIRP and EIS) at certain angles with respect to the base station. To be able to declare radiated characteristics part of radiated requirements a reference coordinate system is required. The reference coordinate system is should be associated to an identifiable physical feature on the base station enclosure. The location of the origin and the orientation of the reference coordinate system are for the base station manufacturer to declare.

The reference coordinate system is created of a Cartesian coordinate system with rectangular axis (x, y, z) and spherical angles (θ , ϕ) as showed in figure 4.15-1.

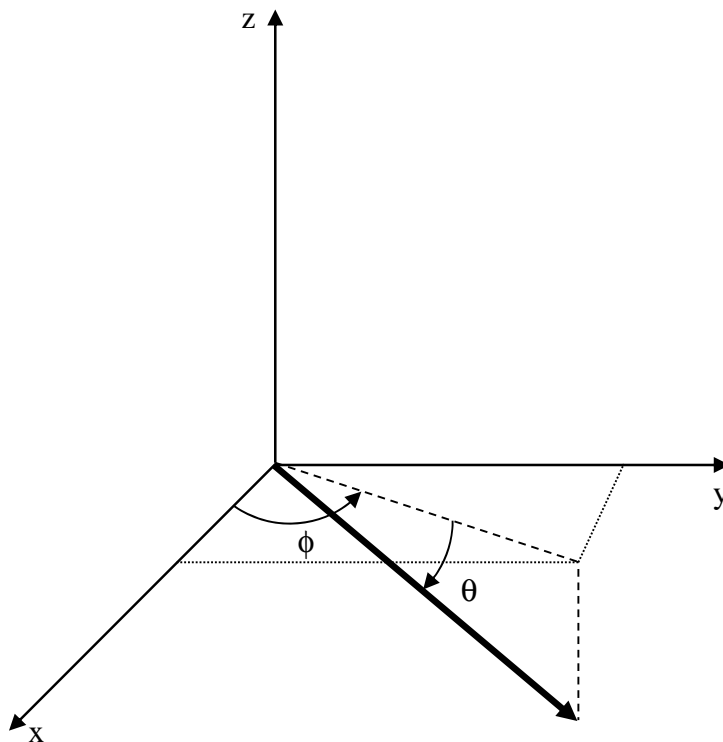

Figure 4.15-1: Reference coordinate system

ϕ is the angle in the x/y plane, between the x-axis and the projection of the radiating vector onto the x/y plane and is defined between -180° and $+180^\circ$, inclusive. θ is the angle between the projection of the vector in the x/y plane and the radiating vector and is defined between -90° and $+90^\circ$, inclusive. Note that θ is defined as positive along the down-tilt angle.

4.16 Requirements for IAB-DU and IAB-MT capable of simultaneous operation

IAB-DU and IAB-MT can be configured as *IAB Simultaneous Operation* based on declaration. Unless otherwise stated, for IAB-DU and IAB-MT simultaneous transmission, the requirements of IAB-DU apply and for IAB-DU and IAB-MT simultaneous reception, the requirements of IAB-MT apply.

For IAB-node in *IAB Simultaneous Operation*, as detailed in the requirement clause, transmitter requirements apply whatever the type of transmitter considered and for all transmission modes foreseen by the manufacturer's specification as detailed in the requirement clause.

NOTE: For IAB node operating as simultaneous transmission of IAB-DU and IAB-MT, the manufacturer can provide declaration on power imbalance between IAB-DU and IAB-MT (D.IAB-4) for verification on Modulation quality and ACLR according to the conformance specification requirements.

For IAB-node in *IAB Simultaneous Operation*, as detailed in the requirement clause, receiver requirements shall be met for any transmitter setting unless otherwise stated.

5 Operating bands and channel arrangement

For the IAB operation in NR operating bands specification, their channel bandwidth configurations, channel spacing and raster, as well as synchronization raster specification, refer to TS 38.174 [2], clause 5 and its relevant clauses.

For radiated testing purposes in the present document, FR1 and FR2 operating bands are considered.

6 Radiated transmitter characteristics

6.1 General

General test conditions for transmitter tests are given in clause 4, including interpretation of measurement results and configurations for testing. IAB configurations for the tests are defined in clause 4.5.

If beams have been declared equivalent and parallel (D.13, D.14), only a representative beam is necessary to be tested to demonstrate conformance.

6.2 Radiated transmit power

6.2.1 Definition and applicability

IAB-DU and *IAB-MT type 1-H*, *IAB-DU* and *IAB-MT type 1-O* and *IAB-DU* and *IAB-MT type 2-O* are declared to support one or more beams, as per manufacturer's declarations. Radiated transmit power is defined as the EIRP level for a declared beam at a specific *beam peak direction*. Declarations are done for *IAB-DU* and *IAB-MT* separately.

For each beam, the requirement is based on declaration of a beam identity, *reference beam direction pair*, beamwidth, *rated beam EIRP*, *OTA peak directions set*, the *beam direction pairs* at the maximum steering directions and their associated *rated beam EIRP* and beamwidth(s).

For a declared beam and *beam direction pair*, the *rated beam EIRP* level is the maximum power that the *IAB-DU* or *IAB-MT* is declared to radiate at the associated *beam peak direction* during the *transmitter ON period*.

For each *beam peak direction* associated with a *beam direction pair* within the *OTA peak directions set*, a specific *rated beam EIRP* level may be claimed. Any claimed value shall be met within the accuracy requirement as described below. *Rated beam EIRP* is only required to be declared for the *beam direction pairs* subject to conformance testing.

NOTE 1: *OTA peak directions set* is set of *beam peak directions* for which the EIRP accuracy requirement is intended to be met. The *beam peak directions* are related to a corresponding contiguous range or discrete list of *beam centre directions* by the *beam direction pairs* included in the set.

NOTE 2: A *beam direction pair* is data set consisting of the *beam centre direction* and the related *beam peak direction*.

NOTE 3: A declared EIRP value is a value provided by the manufacturer for verification according to the conformance specification declaration requirements, whereas a claimed EIRP value is provided by the manufacturer to the equipment user for normal operation of the equipment and is not subject to formal conformance testing.

For *operating bands* where the supported *fractional bandwidth* (FBW) is larger than 6%, two rated carrier EIRP may be declared by manufacturer:

- $P_{\text{rated,c,FBWlow}}$ for lower supported frequency range, and
- $P_{\text{rated,c,FBWhigh}}$ for higher supported frequency range.

For frequencies in between F_{FBWlow} and F_{FBWhigh} the rated carrier EIRP is:

- $P_{\text{rated,c,FBWlow}}$, for the carrier whose carrier frequency is within frequency range $F_{\text{FBWlow}} \leq f < (F_{\text{FBWlow}} + F_{\text{FBWhigh}}) / 2$,
- $P_{\text{rated,c,FBWhigh}}$, for the carrier whose carrier frequency is within frequency range $(F_{\text{FBWlow}} + F_{\text{FBWhigh}}) / 2 \leq f \leq F_{\text{FBWhigh}}$.

6.2.2 Minimum requirement

Radiated transmit power minimum requirement for *IAB-DU type 1-H*, *IAB-DU type 1-O*, *IAB-MT type 1-H* and *IAB-MT type 1-O* is defined in TS 38.174 [2], clause 9.2.2.

Radiated transmit power minimum requirement for *IAB-DU type 2-O* and *IAB-MT type 2-O* is defined in TS 38.174 [2], clause 9.2.3.

6.2.3 Test purpose

The test purpose is to verify the ability to accurately generate and direct radiated power per beam, across the frequency range and under normal conditions, for all declared beams of the *IAB-DU type 1-H*, *IAB-DU type 1-O*, *IAB-MT type 1-H*, *IAB-MT type 1-O*, *IAB-DU type 2-O* and *IAB-MT type 2-O*.

6.2.4 Method of test

6.2.4.1 Initial conditions

Test environments:

- Normal, see annex B.2.

RF channels to be tested for single carrier: B, M and T; see clause 4.9.1.

IAB RF bandwidth positions to be tested for multi-carrier and/or CA:

- B_{RFBW} , M_{RFBW} and T_{RFBW} in single-band operation, see clause 4.9.1,
- $B_{\text{RFBW}}T_{\text{RFBW}}$ and $B'_{\text{RFBW}}T_{\text{RFBW}}$ in multi-band operation, see clause 4.9.1.

Directions to be tested:

- OTA peak directions set reference beam direction pair (D.8), and
- OTA peak directions set maximum steering directions (D.10).

Beams to be tested: Declared beam with the highest intended EIRP for the narrowest intended beam corresponding to the smallest $BeW\theta$, or for the narrowest intended beam corresponding to the smallest $BeW\phi$ (D.3, D.11).

NOTE: Tests under extreme power supply conditions also test extreme temperatures.

6.2.4.2 Procedure

For normal test environment conditions in OTA domain, the test procedure is as follows:

- 1) Place the IAB at the positioner.
- 2) Align the manufacturer declared coordinate system orientation (D.2) of the IAB with the test system.
- 3) Orient the positioner (and IAB) in order that the direction to be tested aligns with the test antenna.
- 4) Configure the *beam peak direction* of the IAB according to the declared *beam direction pair*.
- 5) Set the IAB to transmit according to the applicable test configuration in clause 4.8 using the corresponding test model(s) in clause 4.9.2.

For a IAB declared to be capable of multi-carrier and/or CA operation use the applicable test signal configuration and corresponding power setting specified in clauses 4.7.2 and 4.8 using the corresponding test model(s) in clause 4.9.2 on all carriers configured.

For an IAB node declared to be capable of simultaneous transmission between IAB-DU and IAB-MT (D.IAB-3), use the applicable test signal configuration and corresponding power setting specified in clauses 4.7.2 and 4.8 using the corresponding test model(s) in clause 4.9.2 for IAB-MT and IAB-DU.

- 6) Measure EIRP for any two orthogonal polarizations (denoted p1 and p2) and calculate total radiated transmit power for particular *beam direction pair* as $EIRP = EIRP_{p1} + EIRP_{p2}$.
- 7) Test steps 3 to 6 are repeated for all declared beams (D.3) and their reference *beam direction pairs* and *maximum steering directions* (D.8 and D.10).

For multi-band capable IAB and single band tests, repeat the steps above per involved *operating band* where single band test configurations and test models shall apply with no carriers activated in the other band.

For extreme conditions tests the methods in annex B.7 may be used.

6.2.5 Test requirement

6.2.5.1 IAB-DU

For each declared conformance *beam direction pair*, the EIRP measurement results in clause 6.2.4.2 shall remain within the values provided in table 6.2.5.1-1, relative to the manufacturer's declared rated beam EIRP (D.11) value:

Table 6.2.5.1-1: Test requirement for radiated transmit power for IAB-DU

	Normal test environment
<i>IAB-DU type 1-H</i>	$f \leq 3$ GHz: ± 3.3 dB
	3 GHz $< f \leq 6$ GHz: ± 3.5 dB
<i>IAB-DU type 1-O</i>	$f \leq 3$ GHz: ± 3.3 dB
	3 GHz $< f \leq 6$ GHz: ± 3.5 dB
<i>IAB-DU type 2-O</i>	24.15 GHz $< f \leq 29.5$ GHz: ± 5.1 dB
	37 GHz $< f \leq 43.5$ GHz: ± 5.4 dB

6.2.5.2 IAB-MT

For each declared conformance *beam direction pair*, the EIRP measurement results in clause 6.2.4.2 shall remain within the values provided in table 6.2.5.2-1, relative to the manufacturer's declared rated beam EIRP (D.11) value:

Table 6.2.5.2-1: Test requirement for radiated transmit power for IAB-MT

	Normal test environment
<i>IAB-MT type 1-H</i>	$f \leq 3$ GHz: ± 3.3 dB
	3 GHz $< f \leq 6$ GHz: ± 3.5 dB
<i>IAB-MT type 1-O</i>	$f \leq 3$ GHz: ± 3.3 dB
	3 GHz $< f \leq 6$ GHz: ± 3.5 dB
<i>IAB-MT type 2-O</i>	24.15 GHz $< f \leq 29.5$ GHz: ± 6 dB
	37 GHz $< f \leq 43.5$ GHz: ± 6 dB

6.3 IAB output power

6.3.1 Definition and applicability

OTA IAB output power is declared as the TRP radiated requirement, with the output power accuracy requirement defined at the RIB during the *transmitter ON period*. TRP does not change with beamforming settings as long as the *beam peak direction* is within the *OTA peak directions set*. Thus the TRP accuracy requirement must be met for any beamforming setting for which the *beam peak direction* is within the *OTA peak directions set*. Declarations are made separately for IAB-DU and IAB-MT.

The IAB *rated carrier TRP output power* for IAB type 1-O shall be within limits as specified in table 6.3.1-1 for IAB-DU type 1-O and in table 6.3.1-2 for IAB-MT type 1-O.

Table 6.3.1-1: IAB-DU rated carrier TRP output power limits for IAB-DU type 1-O

IAB-DU class	$P_{\text{rated,c,TRP}}$
Wide Area IAB-DU	(Note)
Medium Range IAB-DU	$\leq + 47$ dBm
Local Area IAB-DU	$\leq + 33$ dBm
NOTE: There is no upper limit for the $P_{\text{rated,c,TRP}}$ of the Wide Area IAB-DU	

Table 6.3.1-2: IAB-MT rated carrier TRP output power limits for IAB-MT type 1-O

IAB-MT class	$P_{\text{rated,c,TRP}}$
Wide Area IAB-MT	(Note)
Local Area IAB-MT	≤ 24 dBm + $10\log(N_{\text{TXU,counted}})$
NOTE: There is no upper limit for the $P_{\text{rated,c,TRP}}$ of the Wide Area IAB-MT.	

There is no upper limit for the *rated carrier TRP output power* of IAB type 2-O.

Despite the general requirements for the IAB output power described in clauses 6.3.2 – 6.3.3, additional regional requirements might be applicable.

NOTE: In certain regions, power limits corresponding to IAB classes may apply for IAB type 2-O.

6.3.2 Minimum requirement

The minimum requirement for IAB-DU type 1-O and IAB-MT type 1-O is in TS 38.174 [2], clause 6.3.2.

The minimum requirement for IAB type 2-O is in TS 38.174 [2], clause 6.3.3.

6.3.3 Test purpose

The test purpose is to verify the accuracy of the *maximum carrier TRP* ($P_{\text{max,c,TRP}}$) across the frequency range for all RIBs.

6.3.4 Method of test

6.3.4.1 Initial conditions

Test environment: Normal, see annex B.2.

RF channels to be tested for single carrier: B, M, T; see clause 4.9.1.

IAB RF Bandwidth positions to be tested for multi-carrier and/or CA:

- B_{RFBW} , M_{RFBW} and T_{RFBW} in single band operation; see clause 4.9.1.
- B'_{RFBW} , T'_{RFBW} and B''_{RFBW} , T''_{RFBW} in multi-band operation, see clause 4.9.1.

Beams to be tested:

As the requirement is TRP the beam pattern(s) may be set up to optimise the TRP measurement procedure (see annex I) as long as the required TRP level is achieved.

6.3.4.2 Procedure

The following procedure for measuring TRP is based on the directional power measurements as described in annex I. An alternative method to measure TRP is to use a characterized and calibrated reverberation chamber if so follow steps 1, 3, 5, and 7.

- 1) Place the IAB at the positioner.
- 2) Align the manufacturer declared coordinate system orientation (D.2) of the IAB with the test system.
- 3) Configure the IAB such that the beam peak direction(s) applied during the power measurement step 6 are consistent with the grid and measurement approach for the TRP test.
- 4) Set the IAB to transmit according to the applicable test configuration in clause 4.8 using the corresponding test model(s) in clause 4.9.2.

For a IAB declared to be capable of multi-carrier and/or CA operation use the applicable test signal configuration and corresponding power setting specified in clauses 4.7.2 and 4.8 using the corresponding test model(s) in clause 4.9.2 on all carriers configured.

For an IAB node declared to be capable of Simultaneous transmission between IAB-DU and IAB-MT (D.IAB-3), use the applicable test signal configuration and corresponding power setting specified in clauses 4.7.2 and 4.8 using the corresponding test model(s) in clause 4.9.2 for IAB-MT and IAB-DU.

- 5) Orient the positioner (and IAB) in order that the direction to be tested aligns with the test antenna such that measurements to determine TRP can be performed (see annex I).
- 6) Measure the radiated power for any two orthogonal polarizations (denoted p1 and p2) and calculate total radiated transmit power for particular beam direction pair as $EIRP = EIRP_{p1} + EIRP_{p2}$.

If the test chamber is a reverberation chamber measure TRP directly.

- 7) Repeat step 6-7 for all directions in the appropriated TRP measurement grid needed for full TRP estimation (see annex I).
- 8) Calculate TRP using the EIRP measurements.

For *multi-band RIBs* and single band tests, repeat the steps above per involved band where single band test configurations and test models shall apply with no carriers activated in the other band.

6.3.5 Test requirement

6.3.5.1 *IAB type 1-0*

The final TRP measurement result in clause 6.3.4.2 shall remain:

- within +3.4 dB and -3.4 dB of the manufacturer's declared *rated carrier TRP* $P_{\text{rated,c,TRP}}$ carrier frequency $f \leq 3.0$ GHz;
- within +3.5 dB and -3.5 dB of the manufacturer's declared *rated carrier TRP* $P_{\text{rated,c,TRP}}$ for carrier frequency $3.0 \text{ GHz} < f \leq 4.2 \text{ GHz}$.
- within +3.5 dB and -3.5 dB of the manufacturer's declared *rated carrier TRP* $P_{\text{rated,c,TRP}}$ for carrier frequency $4.2 \text{ GHz} < f \leq 6.0 \text{ GHz}$.

6.3.5.2 IAB type 2-O

The final TRP measurement result in clause 6.3.4.2 shall remain:

- within +5.1 dB and -5.1 dB of the manufacturer's declared *rated carrier TRP* $P_{\text{rated,c,TRP}}$ carrier frequency $24.25 \text{ GHz} < f \leq 29.5 \text{ GHz}$.
- within +5.4 dB and -5.4 dB of the manufacturer's declared *rated carrier TRP* $P_{\text{rated,c,TRP}}$ for carrier frequency $37 \text{ GHz} < f \leq 43.5 \text{ GHz}$.

6.4 OTA output power dynamics

6.4.1 IAB-DU OTA Output Power Dynamics

6.4.1.1 General

The requirements in clause 6.4 apply during the *transmitter ON period*. Transmit signal quality (as specified in clause 6.6) shall be maintained for the output power dynamics requirements.

The OTA output power requirements are single direction requirements and apply to the beam peak directions over the OTA peak directions set.

6.4.1.2 OTA RE power control dynamic range

6.4.1.2.1 Definition and applicability

The OTA RE power control dynamic range is the difference between the power of an RE and the average RE power for a IAB-DU at maximum output power ($P_{\text{max,c,EIRP}}$) for a specified reference condition.

This requirement shall apply at each RIB supporting transmission in the *operating band*.

6.4.1.2.2 Minimum requirement

The minimum requirement for *IAB-DU type 1-O* is in TS 38.174 [2], clause 9.4.1.2.

6.4.1.2.3 Test purpose

No specific test or test requirements are defined for RE power control dynamic range. The Error Vector Magnitude (EVM) test, as described in clause 6.5.4 provides sufficient test coverage for this requirement.

6.4.1.3 OTA total power dynamic range

6.4.1.3.1 Definition and applicability

The OTA total power dynamic range is the difference between the maximum and the minimum transmit power of an OFDM symbol for a specified reference condition.

This requirement shall apply at each RIB supporting transmission in the *operating band*.

NOTE: The upper limit of the OTA total power dynamic range is the IAB-DU maximum carrier EIRP ($P_{\max,c,EIRP}$) when transmitting on all RBs. The lower limit of the OTA total power dynamic range is the average EIRP for single RB transmission in the same direction using the same beam. The OFDM symbols shall carry PDSCH and not contain PDCCH, RS or SSB.

6.4.1.3.2 Minimum requirement

The minimum requirement for *IAB type 1-O* is in TS 38.174 [2], clause 9.4.1.3.2.

The minimum requirement for *IAB type 2-O* is in TS 38.174 [2], clause 9.4.1.3.3.

6.4.1.3.3 Test purpose

The test purpose is to verify that the total power dynamic range is within the limits specified by the minimum requirement.

6.4.1.3.4 Method of test

6.4.1.3.4.1 Initial conditions

Test environment: Normal, see annex B.2.

RF channels to be tested for single carrier: M ; see clause 4.9.1.

Beams to be tested: Declared beam with the highest intended EIRP for the narrowest intended beam corresponding to the smallest BeW_{θ} , or for the narrowest intended beam corresponding to the smallest BeW_{ϕ} (D.3, D.11).

Directions to be tested: The OTA peak directions set reference beam direction pair (D.8).

6.4.1.3.4.2 Procedure

- 1) Place the IAB-DU at the positioner.
- 2) Align the manufacturer declared coordinate system orientation (D.2) of the IAB-DU with the test system.
- 3) Orient the positioner (and IAB-DU) in order that the direction to be tested aligns with the test antenna.
- 4) Configure the beam peak direction of the IAB-DU according to the declared beam direction pair.
- 5) For *IAB type 1-O*, set the IAB-DU to transmit a signal according to the applicable test configuration in clause 4.8 using the corresponding test models:

- IAB-DU-FR1-TM3.1a if 256QAM is supported by IAB-DU without power back off;
- IAB-DU-FR1-TM3.1 if 256QAM is not supported by IAB-DU;
- IAB-DU-FR1-TM3.1 if 256QAM is supported by IAB-DU with power back off;

For *IAB type 2-O*, set the BS to transmit a signal according to the applicable test configuration in clause 4.8 using the corresponding test model:

- IAB-DU-FR2-TM3.1a if 256QAM is supported by IAB-DU without power back off, or
- IAB-DU-FR2-TM3.1 if 256QAM is supported by BS with power back off, or 256QAM is not supported by IAB-DU; with 64QAM signals if 64QAM is supported by IAB-DU without power back off, or;
- IAB-DU-FR2-TM3.1 with highest modulation order supported without power back off if 64QAM is not supported by IAB-DU, or;
- IAB-DU-FR2-TM3.1 with highest modulation order supported without power back off if 64QAM is supported by IAB-DU with power back off;

6) Measure the OFDM symbol TX power as defined in annex L by measuring the EIRP for any two orthogonal polarizations (denoted p1 and p2) and calculate total radiated transmit power for particular *beam direction pair* as $EIRP = EIRP_{p1} + EIRP_{p2}$.

7) For *IAB type 1-O*, set the BS to transmit a signal according to the applicable test configuration in clause 4.8 using the corresponding test models:

- IAB-DU-FR1-TM2a if 256QAM is supported by IAB-DU;
- IAB-DU-FR1-TM2 if 256QAM is not supported by IAB-DU;

For *IAB type 2-O*, set the BS to transmit a signal according to the applicable test configuration in clause 4.8 using the corresponding test models:

- IAB-DU-FR2-TM2a if 256QAM is supported by IAB-DU, or;
- IAB-DU-FR2-TM2 with highest modulation order supported if 256QAM is not supported by IAB-DU;

8) Measure the OFDM symbol TX power (OSTP) as defined in annex L by measuring the EIRP for any two orthogonal polarizations (denoted p1 and p2) and calculate total radiated transmit power for particular *beam direction pair* as $EIRP = EIRP_{p1} + EIRP_{p2}$.

The measured OFDM symbols shall not contain RS or SSB.

In addition, for *multi-band RIB(s)*, the following steps shall apply:

9) For *multi-band RIBs* and single band tests, repeat the steps above per involved band where single band test configurations and test models shall apply with no carrier activated in the other band.

6.4.1.3.5 Test requirements

6.4.1.3.5.1 *IAB type 1-O*

The downlink (DL) total power dynamic range for each NR carrier shall be larger than or equal to the level in table 6.4.1.3.5.1-1.

Table 6.4.1.3.5.1-1: Total power dynamic range

IAB channel bandwidth (MHz)	Total power dynamic range (dB)		
	15 kHz SCS	30 kHz SCS	60 kHz SCS
10	16.7	13.4	10
15	18.5	15.3	12.1
20	19.8	16.6	13.4
25	20.8	17.7	14.5
30	21.6	18.5	15.3
40	22.9	19.8	16.6
50	23.9	20.8	17.7
60	N/A	21.6	18.5
70	N/A	22.3	19.2
80	N/A	22.9	19.8
90	N/A	23.4	20.4
100	N/A	23.9	20.9

NOTE: Additional test requirements for the Error Vector Magnitude (EVM) at the lower limit of the dynamic range are defined in clause 6.6.

6.4.1.3.5.2 *IAB type 2-O*

OTA total power dynamic range minimum requirement for IAB-DU *type 2-O* is specified such as for each NR carrier it shall be larger than or equal to the levels specified in table 6.3.1.3.5.2-1.

Table 6.4.1.3.5.2-1: Minimum requirement for IAB-DU type 2-O total power dynamic range

SCS (kHz)	50 MHz	100 MHz	200 MHz	400 MHz
	OTA total power dynamic range (dB)			
60	17.7	20.8	23.8	N.A
120	14.6	17.7	20.8	23.8

NOTE: Additional test requirements for the EVM at the lower limit of the dynamic range are defined in clause 6.6.

6.4.2 IAB-MT OTA Output Power Dynamics

6.4.2.1 OTA total power dynamic range

6.4.2.1.1 Definition and applicability

The OTA total power dynamic range is the difference between the maximum and the minimum controlled transmit power in the channel bandwidth for a specified reference condition. The maximum and minimum output powers are defined as the mean power in at least one sub-frame 1ms

NOTE: The specified reference condition(s) are specified in the conformance specification. Changes in the controlled transmit power in the channel bandwidth due to changes in the specified reference condition are not include as part of the dynamic range.

This requirement shall apply at each RIB supporting transmission in the *operating band*.

6.4.2.1.2 Minimum requirement

The IAB-MT total power dynamic range is defined in TS 38.174 [2], clause 9.4.2.1.

6.4.2.1.3 Test purpose

The test purpose is to verify that the IAB-MT OTA total power dynamic range is within the limits specified by the minimum requirement.

6.4.2.1.4 Method of test

6.4.2.1.4.1 Initial conditions

Test environment: Normal, see annex B.2.

RF channels to be tested for single carrier: M; see clause 4.9.1.

Beams to be tested: Declared beam with the highest intended EIRP for the narrowest intended beam corresponding to the smallest BeW_{θ} , or for the narrowest intended beam corresponding to the smallest BeW_{ϕ} (D.3, D.11).

Directions to be tested: The OTA peak directions set reference beam direction pair (D.8).

6.4.2.1.4.2 Procedure

- 1) Place the IAB-MT at the positioner.
- 2) Align the manufacturer declared coordinate system orientation (D.2) of the IAB-MT with the test system.
- 3) Orient the positioner (and IAB-MT) in order that the direction to be tested aligns with the test antenna.
- 4) Configure the beam peak direction of the IAB-MT according to the declared beam direction pair.
- 5) For IAB *type 1-O*, set the IAB-MT to transmit a signal according to the applicable test configuration in clause 4.8 using the corresponding test models:

- IAB-MT-FR1-TM3.1

For IAB type 2-O, set the IAB-MT to transmit a signal according to the applicable test configuration in clause 4.8 using the corresponding test model:

- IAB-MT-FR2-TM3.1;

6) Measure the power by measuring the EIRP for any two orthogonal polarizations (denoted p1 and p2) over 1ms and calculate total EIRP for particular *beam direction pair* as $EIRP = EIRP_{p1} + EIRP_{p2}$.

7) For IAB type 1-O, set the IAB-MT to transmit a signal according to the applicable test configuration in clause 4.8 using the corresponding test models:

- IAB-MT-FR1-TM2

For IAB type 2-O, set the IAB-MT to transmit a signal according to the applicable test configuration in clause 4.8 using the corresponding test models:

- IAB-MT-FR2-TM2;

8) Measure the power by measuring the EIRP for any two orthogonal polarizations (denoted p1 and p2) over 1ms and calculate total EIRP for particular *beam direction pair* as $EIRP = EIRP_{p1} + EIRP_{p2}$.

In addition, for *multi-band RIB(s)*, the following steps shall apply:

9) For *multi-band RIBs* and single band tests, repeat the steps above per involved band where single band test configurations and test models shall apply with no carrier activated in the other band.

6.4.2.1.5 Test requirements

6.4.2.1.5.1 IAB type 1-O

For IAB-MT the ΔP between the power measured in step 6 and step 8 of clause 6.4.2.1.4.2 shall be:

Table 6.4.2.1.5.1-1: IAB type 1-0 Output power dynamics test requirements.

IAB-MT Type	IAB-MT channel bandwidth	Requirement (Note 1)
Wide area	$\leq 40\text{MHz}$	$10 \log(\text{Maximum RB}) - 1.2 < \Delta P \leq 10 \log(\text{Maximum RB}) + 11.2$
	$40\text{MHz} < \text{BW} \leq 100\text{MHz}$	$10 \log(\text{Maximum RB}) - 1.5 < \Delta P \leq 10 \log(\text{Maximum RB}) + 11.5$
Local area	$\leq 40\text{MHz}$	$10 \log(\text{Maximum RB}) + 3.8 < \Delta P \leq 10 \log(\text{Maximum RB}) + 15.2$
	$40\text{MHz} < \text{BW} \leq 100\text{MHz}$	$10 \log(\text{Maximum RB}) + 3.5 < \Delta P \leq 10 \log(\text{Maximum RB}) + 16.5$

6.4.2.1.5.2 IAB type 2-O

For IAB-MT the ΔP between the power measured in step 6 and step 8 of clause 6.4.2.1.4.2 shall be:

Table 6.4.2.1.5.2-1: IAB type 2-0 Output power dynamics test requirements.

IAB-MT Type	IAB-MT channel bandwidth	Requirement
Wide area	$\leq 40\text{MHz}$	$10 \log(\text{Maximum RB}) - 1.2 < \Delta P \leq 10 \log(\text{Maximum RB}) + 11.2$
	$40\text{MHz} < \text{BW} \leq 100\text{MHz}$	$10 \log(\text{Maximum RB}) - 1.5 < \Delta P \leq 10 \log(\text{Maximum RB}) + 11.5$
Local area	$\leq 40\text{MHz}$	$10 \log(\text{Maximum RB}) + 3.8 < \Delta P \leq 10 \log(\text{Maximum RB}) + 15.2$
	$40\text{MHz} < \text{BW} \leq 100\text{MHz}$	$10 \log(\text{Maximum RB}) + 3.5 < \Delta P \leq 10 \log(\text{Maximum RB}) + 16.5$

6.4.2.2 Relative power tolerance for local area IAB-MT

6.4.2.2.1 Definition and applicability

The relative power tolerance is the ability of the transmitter to set its output power in a target sub-frame (1 ms) relatively to the power of the most recently transmitted reference sub-frame (1 ms) if the transmission gap between these sub-frames is less than or equal to 20 ms.

6.4.2.2.2 Minimum requirement

The Power control for local area *IAB-MT type 1-O* is defined in TS 38.174 [2], clause 9.4.3.1.1

The Power control for local area *IAB-MT type 2-O* is defined in TS 38.174 [2], clause 9.4.3.2.1

6.4.2.2.3 Test purpose

No specific test or test requirements are defined for Relative power tolerance. The Total power dynamic range test, as described in clause 6.4.2.1 provides sufficient test coverage for this requirement.

6.4.2.3 Aggregate power tolerance for local area IAB-MT

6.4.2.3.1 Definition and applicability

The aggregate power control tolerance is the ability of the transmitter to maintain its power in a sub-frame (1 ms) during non-contiguous transmissions within [21 ms] in response to 0 dB commands with respect to the first transmission and all other power control parameters as specified in 3GPP TS 38.213 [9] kept constant.

6.4.2.3.2 Minimum requirement

The IAB-MT Aggregate power tolerance for local area *IAB-MT type 1-O* is defined in TS 38.174 [2], clause 9.4.3.1.2.

The IAB-MT Aggregate power tolerance for local area *IAB-MT type 2-O* is defined in TS 38.174 [2], clause 9.4.3.2.2.

6.4.2.3.3 Test purpose

No specific test or test requirements are defined for IAB-MT Aggregate power tolerance.

6.5 OTA transmit ON/OFF power

6.5.1 OTA transmitter OFF power

6.5.1.1 Definition and applicability

OTA transmitter OFF power is defined as the mean power measured over $70/N$ μ s filtered with a square filter of bandwidth equal to the *transmission bandwidth configuration* of the IAB (BW_{config}) centred on the assigned channel frequency during the *transmitter OFF period*. $N = \text{SCS}/15$, where SCS is Sub Carrier Spacing in kHz.

For IAB node supporting intra-band contiguous CA, the OTA transmitter OFF power is defined as the mean power measured over $70/N$ μ s filtered with a square filter of bandwidth equal to the *aggregated IAB-DU channel bandwidth or IAB-MT channel bandwidth* $BW_{\text{Channel_CA}}$ centred on $(F_{\text{edge,high}} + F_{\text{edge,low}})/2$ during the *transmitter OFF period*. $N = \text{SCS}/15$, where SCS is the smallest supported Sub Carrier Spacing in kHz in the *aggregated IAB-DU channel bandwidth or aggregated IAB-MT channel bandwidth*.

For *IAB type 1-O*, the transmitter OFF power is defined as the output power at the *co-location reference antenna* conducted output(s). For *IAB type 2-O* the transmitter OFF power is defined as TRP.

For *multi-band RIBs* and *single band RIBs* supporting transmission in multiple bands, the requirement is only applicable during the *transmitter OFF period* in all supported *operating bands*.

6.5.1.2 Minimum requirement

The minimum requirement for *IAB-DU type 1-O* is in TS 38.174 [2], clause 9.5.2.2.

The minimum requirement for *IAB-DU type 2-O* is in TS 38.174 [2], clause 9.5.2.3.

The minimum requirement for *IAB-MT type 1-O* is in TS 38.174 [2], clause 9.5.2.4.

The minimum requirement for *IAB-MT type 2-O* is in TS 38.174 [2], clause 9.5.2.5.

6.5.1.3 Test purpose

The purpose of this test is to verify the OTA transmitter OFF power is within the limits of the minimum requirements.

6.5.1.4 Method of test

Requirement is tested together with transmitter transient period, as described in clause 6.5.2.4.

6.5.1.5 Test requirements

The conformance testing of transmit OFF power is included in the conformance testing of transmitter transient period; therefore, see clause 6.5.2.5 for test requirements.

6.5.2 OTA transmitter transient period

6.5.2.1 Definition and applicability

The OTA *transmitter transient period* is the time period during which the transmitter unit is changing from the OFF period to the ON period or vice versa. The OTA *transmitter transient period* is illustrated in figure 6.5.2.1-1.

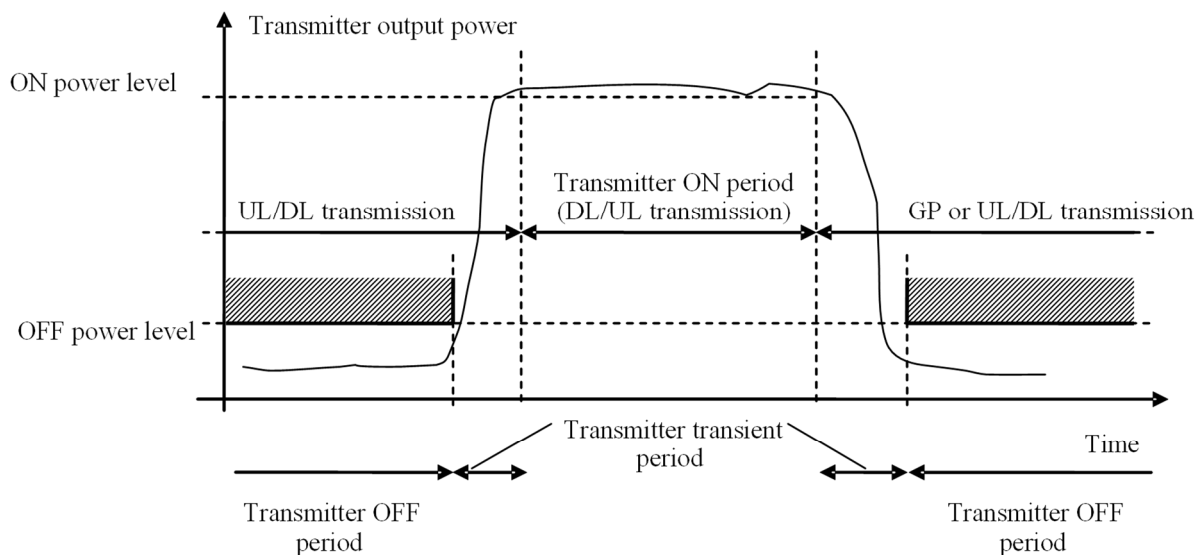

Figure 6.5.2.1-1: Illustration of the relations of transmitter ON period, transmitter OFF period and transmitter transient period for IAB

For *IAB type 1-O*, this requirement applies for RIB supporting transmission in the *operating band* and is measured at the *co-location test antenna* conducted outputs. For *IAB type 2-O*, the requirement applies at each RIB supporting transmission in the *operating band*.

6.5.2.2 Minimum requirement

The minimum requirement for *IAB-DU type 1-O* is in TS 38.174 [2], clause 9.5.3.2.

The minimum requirement for *IAB-DU type 2-O* is in TS 38.174 [2], clause 9.5.3.3.

The minimum requirement for *IAB-MT type 1-O* is in TS 38.174 [2], clause 9.5.3.4.

The minimum requirement for *IAB-MT type 2-O* is in TS 38.174 [2], clause 9.5.3.5.

6.5.2.3 Test purpose

The purpose of this test is to verify the OTA transmitter transient periods are within the limits of the minimum requirements.

6.5.2.4 Method of test

6.5.2.4.1 Initial conditions

Test environment: Normal; see annex B.2.

RF channels to be tested: M; see clause 4.9.1.

Base Station RF Bandwidth positions to be tested for multi-carrier and/or CA:

- M_{RFBW} in single band operation, see clause 4.9.1;
- $B'_{\text{RFBW}}T'_{\text{RFBW}}$ and $B'_{\text{RFBW}}T_{\text{RFBW}}$ in multi-band operation; see clause 4.9.1.

Directions to be tested:

- The requirement for *IAB type 1-O* is specified as co-location requirement. For general description of co-location requirements, refer to clause 4.12.
- The requirement for *IAB type 2-O* is verified by an EIRP measurement at a direction corresponding to the OTA peak directions set reference beam direction pair (D.8) for the beam identifier (D.3) which provides the highest intended EIRP.

6.5.2.4.2 Procedure

6.5.2.4.2.1 General procedure

- 1) Place the IAB node at the positioner.
- 2) Align the manufacturer declared coordinate system orientation (D.2) of the IAB node with the test system.

6.5.2.4.2.2 *IAB type 1-O*

- 3) Set the IAB node in the direction of the declared beam peak direction of the beam direction pair, for the beam to be tested.
- 4) Place the *co-location test antenna* as specified in clause 4.12.
- 5) Configure the beam peak direction of the IAB node according to the declared beam direction pair.
- 6) Set the IAB node to transmit according to the applicable test configuration in clause 4.8 using the corresponding test models or set of physical channels in clause 4.9.2.

For an IAB node declared to be capable of Simultaneous transmission between IAB-DU and IAB-MT (D. IAB-3), above steps will apply for IAB-MT or IAB-DU respectively according to test single configuration and test models specified in clauses 4.7.2 and 4.8 with both IAB-MT and IAB-DU configured.

For an IAB node declared to be capable of multi-carrier and/or CA operation, use the applicable test signal configuration and corresponding power setting specified in clauses 4.7.2 and 4.8 using the corresponding test models or set of physical channels in clause 4.9.2 on all carriers configured.

- 7) Measure the mean power spectral density at the output(s) of co-location test antenna as power sum over two orthogonal polarizations over $70/N$ μs filtered with a square filter of bandwidth equal to the RF bandwidth of the IAB node centred on the central frequency of the RF bandwidth. $70/N$ μs average window centre is set from $35/N$ μs after end of one transmitter ON period + 10 μs to $35/N$ μs before start of next transmitter ON period - 10 μs . $N = \text{SCS}/15$, where SCS is Sub Carrier Spacing in kHz.
- 8) For an IAB node supporting contiguous CA, measure the mean power spectral density at the output(s) of co-location test antenna as power sum over two orthogonal polarizations over $70/N$ μs filtered with a square filter of bandwidth equal to the *aggregated IAB-DU channel bandwidth* or *aggregated IAB-MT channel bandwidth* $\text{BW}_{\text{Channel_CA}}$ centred on $(F_{\text{edge_high}}+F_{\text{edge_low}})/2$. $70/N$ μs average window centre is set from $35/N$ μs after end of one transmitter ON period + 10 μs to $35/N$ μs before start of next transmitter ON period - 10 μs . $N = \text{SCS}/15$, where SCS is the smallest supported Sub Carrier Spacing in kHz in the *aggregated IAB-DU channel bandwidth* or *aggregated IAB-MT channel bandwidth*.

In addition, for a *multi-band RIB*, the following steps shall apply:

- 9) For a *multi-band RIB* and single band tests, repeat the steps above per involved band where single band test configurations and test models shall apply with no carrier activated in the other band.

6.5.2.4.2.3 IAB type 2-O

- 3) Set the IAB node in the direction of the declared beam peak direction of the *beam direction pair*, for the beam to be tested.
- 4) Set the IAB node to transmit according to the applicable test configuration in clause 4.8 using the corresponding test model IAB-DU-FR2-TM1.1 or IAB-MT-FR2-TM1.1 and set of physical channels in clause 4.9.2.

For a IAB node declared to be capable of multi-carrier and/or CA operation, use the applicable test signal configuration and corresponding power setting specified in clauses 4.7.2 and 4.8 using the corresponding test model IAB-DU-FR2-TM1.1 or IAB-MT-FR2-TM1.1 and set of physical channels in clause 4.9.2 on all carriers configured.

For an IAB node declared to be capable of Simultaneous transmission between IAB-DU and IAB-MT (D. IAB-3), above steps will apply for IAB-MT or IAB-DU respectively according to test signal configuration and test models specified in clauses 4.7.2 and 4.8 with both IAB-MT and IAB-DU configured.

- 5) Measure the mean EIRP spectral density as the power sum over two orthogonal polarizations over $70/N$ μs filtered with a square filter of bandwidth equal to the RF bandwidth of the IAB node centred on the central frequency of the RF bandwidth. $70/N$ μs average window centre is set from $35/N$ μs after end of one transmitter ON period + 3 μs to $35/N$ μs before start of next transmitter ON period - 3 μs . $N = \text{SCS}/15$, where SCS is Sub Carrier Spacing in kHz.

NOTE: Make sure that the measurement receiver is not overloaded.

- 6) For an IAB node supporting contiguous CA, measure the mean EIRP spectral density as the power sum over two orthogonal polarizations over $70/N$ μs filtered with a square filter of bandwidth equal to the *aggregated IAB-DU channel bandwidth* or *aggregated IAB-MT channel bandwidth* $\text{BW}_{\text{Channel_CA}}$ centred on $(F_{\text{edge_high}}+F_{\text{edge_low}})/2$. $70/N$ μs average window centre is set from $35/N$ μs after end of one transmitter ON period + 3 μs to $35/N$ μs before start of next transmitter ON period - 3 μs . $N = \text{SCS}/15$, where SCS is the smallest supported Sub Carrier Spacing in kHz in the *aggregated IAB-DU channel bandwidth* or *aggregated IAB-MT channel bandwidth*.

6.5.2.5 Test requirements

6.5.2.5.1 IAB type 1-O

The mean power spectral density measured according to clause 6.5.2.4.2 shall be less than -102.6 dBm/MHz for carrier frequency $f \leq 3.0$ GHz.

The mean power spectral density measured according to clause 6.5.2.4.2 shall be less than -102.4 dBm/MHz for carrier frequency $3.0 \text{ GHz} < f \leq 6.0 \text{ GHz}$.

For *multi-band RIB*, the requirement is only applicable during the transmitter OFF period in all supported operating bands.

For *IAB simultaneous transmission*, the requirement is only applicable during the transmitter OFF period for both IAB-DU and IAB-MT.

6.5.2.5.2 IAB type 2-O

The measured mean EIRP spectral density according to clause 6.5.2.4.2 shall be less than $-33.1 + P_{\text{rated,c,EIRP}} - P_{\text{rated,c,TRP}}$ dBm/MHz for carrier frequency $24.15 \text{ GHz} < f \leq 29.5 \text{ GHz}$, where $P_{\text{rated,c,EIRP}}$ is the value declared for the *reference beam direction pair* (D.8) for the beam identifier (D.3) which provides the highest intended EIRP.

The measured mean EIRP spectral density according to clause 6.5.2.4.2 shall be less than $-32.7 + P_{\text{rated,c,EIRP}} - P_{\text{rated,c,TRP}}$ dBm/MHz for carrier frequency $37 \text{ GHz} < f \leq 43.5 \text{ GHz}$, where $P_{\text{rated,c,EIRP}}$ is the value declared for the *reference beam direction pair* (D.8) for the beam identifier (D.3) which provides the highest intended EIRP.

For *IAB simultaneous transmission*, the requirement is only applicable during the transmitter OFF period for both IAB-DU and IAB-MT.

6.6 OTA transmitted signal quality

6.6.1 General

Unless otherwise stated, the requirements in clause 6.6 apply during the *transmitter ON period*.

6.6.2 OTA frequency error

6.6.2.1 IAB-DU OTA frequency error

6.6.2.1.1 Definition and applicability

For IAB-DU, OTA frequency error is the measure of the difference between the actual IAB-DU transmit frequency and the assigned frequency. The same source shall be used for RF frequency and data clock generation.

For IAB-DU, OTA frequency error requirement is defined as a directional requirement at the RIB and shall be met within the OTA coverage range.

6.6.2.1.2 Minimum Requirement

The minimum requirements for *IAB-DU type 1-O* and *IAB-DU type 2-O* are in TS 38.174 [2], clause 9.6.1.1.

6.6.2.1.3 Test purpose

The test purpose is to verify that OTA frequency error is within the limit specified by the minimum requirement.

6.6.2.1.4 Method of test

Requirement is tested together with OTA modulation quality test, as described in clause 6.6.3.

6.6.2.1.4.1 Initial conditions

Directions to be tested: OTA coverage range reference direction (D.35).

6.6.2.1.5 Test Requirements

For IAB-DU, the modulated carrier frequency of each NR carrier configured by the IAB-DU shall be accurate to within the accuracy range given in table 6.6.2.1.5-1 observed over 1 ms.

Table 6.6.2.1.5-1: OTA frequency error test requirement for IAB-DU type 1-O and IAB-DU type 2-O

IAB-DU class	Accuracy
Wide Area IAB-DU	$\pm(0.05 \text{ ppm} + 12 \text{ Hz})$
Medium Range IAB-DU	$\pm(0.1 \text{ ppm} + 12 \text{ Hz})$
Local Area IAB-DU	$\pm(0.1 \text{ ppm} + 12 \text{ Hz})$

6.6.2.2 IAB-MT OTA frequency error

6.6.2.2.1 Definition and applicability

For IAB-MT, OTA frequency error is the measure of the difference between actual IAB-MT transmit frequency and the carrier frequency received from the parent node.

For IAB-MT, OTA frequency error requirement is defined as a directional requirement at the RIB and shall be met within the OTA coverage range.

6.6.2.2.2 Minimum Requirement

The minimum requirement for *IAB-MT type 1-O* and *IAB-MT type 2-O* are in TS 38.174 [2], clause 9.6.1.2.

6.6.2.2.3 Test purpose

The test purpose is to verify that OTA frequency error is within the limit specified by the minimum requirement.

6.6.2.2.4 Method of test

Requirement is tested together with OTA modulation quality test, as described in clause 6.6.3.

6.6.2.2.4.1 Initial conditions

Directions to be tested: OTA coverage range reference direction (D.35).

6.6.2.2.5 Test Requirements

For *IAB-MT type 1-O* and *IAB-MT type 2-O*, the mean value of basic measurements of IAB-MT modulated carrier frequency shall be accurate to within the accuracy range given in table 6.6.2.2.5-1 observed over 1 ms cumulated measurement intervals compared to the carrier frequency received from the parent node.

Table 6.6.2.2.5-1: OTA frequency error test requirement for IAB-MT type 1-O

IAB-MT frequency range	Accuracy
$f \leq 3.0\text{GHz}$	$\pm(0.1 \text{ ppm} + 15 \text{ Hz})$
$3.0\text{GHz} < f \leq 7.125\text{GHz}$	$\pm(0.1 \text{ ppm} + 36 \text{ Hz})$
$24.25\text{GHz} < f \leq 52.6\text{GHz}$	$\pm(0.1 \text{ ppm} + 0.01\text{ppm})$

6.6.3 OTA modulation quality

6.6.3.1 Definition and applicability

OTA modulation quality is defined by the difference between the measured carrier signal and an ideal signal. Modulation quality can e.g. be expressed as Error Vector Magnitude (EVM). The Error Vector Magnitude is a measure

of the difference between the ideal symbols and the measured symbols after the equalization. This difference is called the error vector.

OTA modulation quality requirement is defined as a directional requirement at the RIB and shall be met within the *OTA coverage range*.

6.6.3.2 Minimum Requirement

The minimum requirement for *IAB-DU type 1-O*, is in TS 38.174 [2], clause 9.6.2.1.

The minimum requirement for *IAB-DU type 2-O*, is in TS 38.174 [2], clause 9.6.2.1.

The minimum requirement for *IAB-MT type 1-O*, is in TS 38.174 [2], clause 9.6.2.2.

The minimum requirement for *IAB-MT type 2-O*, is in TS 38.174 [2], clause 9.6.2.3.

6.6.3.3 Test purpose

The test purpose is to verify that OTA modulation quality is within the limit specified by the minimum requirement.

6.6.3.4 Method of test

6.6.3.4.1 Initial conditions

Test environment: Normal; see annex B.2.

RF channels to be tested for single carrier:

- B and T; see clause 4.9.1.

IAB RF bandwidth positions to be tested for multi-carrier and/or CA:

- B_{RFBW} and T_{RFBW} in single-band operation, see clause 4.9.1;
- $B'_{\text{RFBW}}T_{\text{RFBW}}$ and $B_{\text{RFBW}}T'_{\text{RFBW}}$ in multi-band operation, see clause 4.9.1.

Directions to be tested:

- The OTA coverage range reference direction (D.35).
- The OTA coverage range maximum directions (D.36).

Polarizations to be tested: For dual polarized systems the requirement shall be tested and met for both polarizations.

6.6.3.4.2 Procedure for IAB-DU

- 1) Place the IAB-DU at the positioner.
- 2) Align the manufacturer declared coordinate system orientation (D.2) of the IAB-DU with the test system.
- 3) Orient the positioner (and IAB-DU) in order that the direction to be tested aligns with the test antenna.
- 4) Configure the beamforming settings of the IAB-DU according to the direction to be tested.
- 5) Set the IAB-DU to output according to the applicable test configuration in clause 4.8 using the corresponding test models or set of physical channels in clause 4.9.2.

For *IAB-DU type 1-O* declared to be capable of single carrier operation only, set the IAB-DU to transmit a signal according to:

- IAB-DU-FR1-TM3.1a if 256QAM is supported by IAB-DU without power back off
- or IAB-DU-FR1-TM3.1a if 256QAM is supported by IAB-DU with power back off, at manufacturer's declared rated output power ($P_{\text{rated,c,EIRP}}$) and IAB-DU-FR1-TM3.1 at maximum power

- or IAB-DU-FR1-TM3.1 if highest modulation order supported by IAB-DU is 64QAM
- or IAB-DU-FR1-TM3.2 if highest modulation order supported by IAB-DU is 16QAM
- or IAB-DU-FR1-TM3.3 if highest modulation order supported by IAB-DU is QPSK.

For *IAB-DU type 1-O* declared to be capable of multi-carrier and/or CA operation, set the IAB-DU to transmit according to the applicable test signal configuration and corresponding power setting specified in clauses 4.7.2 and 4.8 using the corresponding test models on all carriers configured:

- IAB-DU-FR1-TM3.1a if 256QAM is supported by IAB-DU without power back off
- or IAB-DU-FR1-TM3.1a if 256QAM is supported by IAB-DU with power back off, at manufacturer's declared rated output power ($P_{\text{rated,c,EIRP}}$) and IAB-DU-FR1-TM3.1 at maximum power
- or IAB-DU-FR1-TM3.1 if highest modulation order supported by IAB-DU is 64QAM
- or IAB-DU-FR1-TM3.2 if highest modulation order supported by IAB-DU is 16QAM
- or IAB-DU-FR1-TM3.3 if highest modulation order supported by IAB-DU is QPSK.

For *IAB-DU type 2-O* declared to be capable of single carrier operation only, set the IAB-DU to transmit a signal according to the applicable test signal configuration and corresponding power setting specified in clause 4.7.2 and 4.8 using the corresponding test models on all carriers configured:

- IAB-DU-FR2-TM3.1a with 256QAM signal if 256QAM is supported by IAB-DU without power back off, or
- IAB-DU-FR2-TM3.1a at manufacturer's declared rated output power if 256QAM is supported by IAB-DU with power back off, and IAB-DU-FR2-TM3.1 with highest modulation order supported without power back off, or
- IAB-DU-FR2-TM3.1 with 64QAM signal if 64QAM is supported by IAB-DU without power back off, or
- IAB-DU-FR2-TM 3.1 with highest modulation order without power back off if 64QAM is not supported by IAB-DU, or
- if 64 QAM is supported by IAB-DU with power back off, IAB-DU-FR2-TM 3.1 with 64QAM at manufacturer's declared rated output power ($P_{\text{rated,c,EIRP}}$) and IAB-DU-FR2-TM3.1 with highest modulation order supported at maximum power.

For *IAB-DU type 2-O* declared to be capable of multi-carrier and/or CA operation, set the IAB-DU or IAB-MT to transmit according to:

- IAB-DU-FR2-TM3.1a with 256QAM signal if 256QAM is supported by IAB-DU without power back off, or
- IAB-DU-FR2-TM3.1a at manufacturer's declared rated output power if 256QAM is supported by IAB-DU with power back off, and IAB-DU-FR2-TM3.1 at maximum power, or
- IAB-DU-FR2-TM3.1 with 64QAM signal if 64QAM is supported by IAB-DU without power back off, or
- IAB-DU-FR2-TM3.1 with highest modulation order supported without power back off if 64QAM is not supported by IAB-DU, or
- if 64QAM is supported by IAB-DU with power back off, IAB-DU-FR2-TM3.1 with 64QAM signal at manufacturer's declared rated output power ($P_{\text{rated,c,EIRP}}$) and IAB-DU-FR2-TM3.1 with highest supported modulation order at maximum power

For IAB-DU-FR1-TM 3.1a and IAB-DU-FR2-TM 3.1, power back-off shall be applied if it is declared.

- 6) For each carrier, measure the EVM and frequency error as defined in annex L.
- 7) Repeat steps 5 and 6 for IAB-DU-FR1-TM2 if 256QAM is not supported by *IAB-DU type 1-O* or for IAB-DU-FR1-TM2a if 256QAM is supported by *IAB-DU type 1-O*. For IAB-DU-FR1-TM2 and IAB-DU-FR1-TM2a the OFDM symbol power (in the conformance direction) shall be at the lower limit of the dynamic range according to the test procedure in clause 6.4.3.4.2 and test requirements in clause 6.4.3.5.1.

Repeat steps 5 and 6 for IAB-DU-FR2-TM2 if 256QAM is not supported by *IAB-DU type 2-O* or for IAB-DU-FR2-TM2a if 256QAM is supported by *IAB-DU type 2-O*. For IAB-DU-FR2-TM2 and IAB-DU-FR1-TM2a the

OFDM symbol power (in the conformance direction) shall be at the lower limit of the dynamic range according to the test procedure in clause 6.4.3.4.2 and test requirements in clause 6.4.3.5.2.

In addition, for multi-band RIB, the following steps shall apply:

- 8) For multi-band RIB and single band tests, repeat the steps above per involved band where single band test configurations and test models shall apply with no carrier activated in the other band.

6.6.3.4.3 Procedure for IAB-MT

- 1) Place the IAB-MT at the positioner.
- 2) Align the manufacturer declared coordinate system orientation (D.2) of the IAB-MT with the test system.
- 3) Orient the positioner (and IAB-MT) in order that the direction to be tested aligns with the test antenna.
- 4) Configure the beamforming settings of the IAB-MT according to the direction to be tested.
- 5) Set the IAB-MT to output according to the applicable test configuration in clause 4.8 using the corresponding test models or set of physical channels in clause 4.9.2.

For *IAB-MT type 1-O* declared to be capable of single carrier operation only, set the IAB-MT to transmit a signal according to:

- IAB-MT-FR1-TM3.1a if 256QAM is supported by IAB-MT without power back off
- or IAB-MT-FR1-TM3.1a if 256QAM is supported by IAB-MT with power back off, at manufacturer's declared rated output power ($P_{\text{rated,c,EIRP}}$) and IAB-MT-FR1-TM3.1 at maximum power
- or IAB-MT-FR1-TM3.1 with highest modulation order supported by IAB-MT.

For *IAB-MT type 1-O* declared to be capable of multi-carrier and/or CA operation, set the IAB-MT to transmit according to the applicable test signal configuration and corresponding power setting specified in clauses 4.7.2 and 4.8 using the corresponding test models on all carriers configured:

- IAB-MT-FR1-TM3.1a if 256QAM is supported by IAB-MT without power back off
- or IAB-MT-FR1-TM3.1a if 256QAM is supported by IAB-MT with power back off, at manufacturer's declared rated output power ($P_{\text{rated,c,EIRP}}$) and IAB-MT-FR1-TM3.1 at maximum power
- or IAB-MT-FR1-TM3.1 with highest modulation order supported by IAB-MT.

For *IAB-MT type 2-O* declared to be capable of single carrier operation only, set the IAB-MT to transmit a signal according to the applicable test signal configuration and corresponding power setting specified in clause 4.7.2 and 4.8 using the corresponding test models on all carriers configured:

- IAB-MT-FR2-TM3.1 with 64QAM signal if 64QAM is supported by IAB-MT without power back off, or
- IAB-MT-FR2-TM 3.1 with highest modulation order without power back off if 64QAM is not supported by IAB-MT, or
- if 64 QAM is supported by IAB-MT with power back off, IAB-MT-FR2-TM 3.1 with 64QAM at manufacturer's declared rated output power ($P_{\text{rated,c,EIRP}}$) and IAB-MT-FR2-TM3.1 with highest modulation order supported at maximum power.

For *IAB-MT type 2-O* declared to be capable of multi-carrier and/or CA operation, set the IAB-MT to transmit according to:

- IAB-MT-FR2-TM3.1 with 64QAM signal if 64QAM is supported by IAB-MT without power back off, or
- IAB-MT-FR2-TM3.1 with highest modulation order supported without power back off if 64QAM is not supported by IAB-MT, or
- if 64QAM is supported by IAB-MT with power back off, IAB-MT-FR2-TM3.1 with 64QAM signal at manufacturer's declared rated output power ($P_{\text{rated,c,EIRP}}$) and IAB-MT-FR2-TM3.1 with highest supported modulation order at maximum power

For IAB-MT-FR1-TM 3.1a and IAB-MT-FR2-TM 3.1, power back-off shall be applied if it is declared.

- 6) For each carrier, measure the EVM and frequency error as defined in annex L.
- 7) Repeat steps 5 and 6 for IAB-MT-FR1-TM2 if 256QAM is not supported by *IAB-MT type 1-O* or for IAB-MT-FR1-TM2a if 256QAM is supported by *IAB-MT type 1-O*. For IAB-MT-FR1-TM2 and IAB-MT-FR1-TM2a the OFDM symbol power (in the conformance direction) shall be at the lower limit of the dynamic range according to the test procedure in clause 6.4.3.4.2 and test requirements in clause 6.4.3.5.1.

Repeat steps 5 and 6 for IAB-MT-FR2-TM2 if 256QAM is not supported by *IAB-MT type 2-O* or for IAB-MT-FR2-TM2a if 256QAM is supported by *IAB-MT type 2-O*. For IAB-DU-FR2-TM2 and IAB-DU-FR1-TM2a the OFDM symbol power (in the conformance direction) shall be at the lower limit of the dynamic range according to the test procedure in clause 6.4.3.4.2 and test requirements in clause 6.4.3.5.2.

In addition, for multi-band RIB, the following steps shall apply:

- 8) For multi-band RIB and single band tests, repeat the steps above per involved band where single band test configurations and test models shall apply with no carrier activated in the other band.

6.6.3.5 Test requirements

6.6.3.5.1 *IAB-DU type 1-O* and *IAB-MT type 1-O*

For *IAB-DU type 1-O* or *IAB-MT type 1-O*, the EVM of each NR carrier for different modulation schemes on PDSCH or PUSCH shall be less than the limits in table 6.6.3.5.1-1.

Table 6.6.3.5.1-1: EVM requirements for *IAB type 1-O*

Modulation scheme for PDSCH or PUSCH	Required EVM (%)
QPSK	18.5
16QAM	13.5
64QAM	9
256QAM	4.5

EVM shall be evaluated for each NR carrier over all allocated resource blocks and downlink slots for IAB-DU or uplink slots for IAB-MT. Different modulation schemes listed in table 6.6.3.5.1-1 shall be considered for rank 1.

For all bandwidths, the EVM measurement shall be performed for each NR carrier over all allocated resource blocks and downlink slots for IAB-DU or uplink slots for IAB-MT within 10 ms measurement periods. The boundaries of the EVM measurement periods need not be aligned with radio frame boundaries.

Tables 6.6.3.5.1-2, 6.6.3.5.1-3, 6.6.3.5.1-4 below specify the EVM window length (W) for normal CP for *IAB type 1-O*.

Table 6.6.3.5.1-2: EVM window length for normal CP, FR1, 15 kHz SCS

Channel bandwidth (MHz)	FFT size	Cyclic prefix length for symbols 1-6 and 8-13 in FFT samples	EVM window length W	Ratio of W to total CP length for symbols 1-6 and 8-13 (Note) (%)
10	1024	72	28	40
15	1536	108	44	40
20	2048	144	58	40
25	2048	144	72	50
30	3072	216	108	50
40	4096	288	144	50
50	4096	288	144	50

NOTE: These percentages are informative and apply to a slot's symbols 1 to 6 and 8 to 13. Symbols 0 and 7 have a longer CP and therefore a lower percentage.

Table 6.6.3.5.1-3: EVM window length for normal CP, FR1, 30 kHz SCS

Channel bandwidth (MHz)	FFT size	Cyclic prefix length for symbols 1-13 in FFT samples	EVM window length W	Ratio of W to total CP length for symbols 1-13 (Note) (%)
10	512	36	14	40
15	768	54	22	40
20	1024	72	28	40
25	1024	72	36	50
30	1536	108	54	50
40	2048	144	72	50
50	2048	144	72	50
60	3072	216	130	60
70	3072	216	130	60
80	4096	288	172	60
90	4096	288	172	60
100	4096	288	172	60

NOTE: These percentages are informative and apply to a slot's symbols 1 through 13. Symbol 0 has a longer CP and therefore a lower percentage.

Table 6.6.3.5.1-4: EVM window length for normal CP for NR, FR1, 60 kHz SCS

Channel bandwidth (MHz)	FFT size	Cyclic prefix length in FFT samples	EVM window length W	Ratio of W to total CP (Note) (%)
10	256	18	8	40
15	384	27	11	40
20	512	36	14	40
25	512	36	18	50
30	768	54	26	50
40	1024	72	36	50
50	1024	72	36	50
60	1536	108	64	60
70	1536	108	64	60
80	2048	144	86	60
90	2048	144	86	60
100	2048	144	86	60

NOTE: These percentages are informative and apply to all OFDM symbols within subframe except for symbol 0 of slot 0 and slot 2. Symbol 0 of slot 0 and slot 2 may have a longer CP and therefore a lower percentage.

6.6.3.5.2 IAB-DU type 2-O and IAB-MT type 2-O

For IAB-DU type 2-O and IAB-MT type 2-O, the EVM of each NR carrier for different modulation schemes on PDSCH or PUSCH shall be less than the limits in table 6.6.3.5.2-1.

Table 6.6.3.5.2-1: EVM requirements for IAB type 2-O

Modulation scheme for PDSCH or PUSCH	Required EVM (%)
QPSK	18.5
16QAM	13.5
64QAM	9
256QAM	4.5

NOTE: 256QAM is not supported by FR2 IAB-MT PUSCH

EVM requirements shall apply for each NR carrier over all allocated resource blocks and downlink slots for IAB-DU or uplink slots for IAB-MT. PT-RS should be configured for localized setting for every fourth symbol for every second RB for IAB-DU and IAB-MT. Different modulation schemes listed in table 6.6.3.5.2-1 shall be considered for rank 1.

For all bandwidths, the EVM measurement shall be performed for each NR carrier over all allocated resource blocks and downlink slots for IAB-DU or uplink slots for IAB-MT within 10 ms measurement periods. The boundaries of the EVM measurement periods need not be aligned with radio frame boundaries.

Tables 6.6.3.5.2-2 and 6.6.3.5.2-3 below specify the EVM window length (W) for normal CP for *IAB-DU type 2-O* and *IAB-MT type 2-O*.

Table 6.6.3.5.2-2: EVM window length for normal CP, FR2, 60 kHz SCS

Channel bandwidth (MHz)	FFT size	Cyclic prefix length in FFT samples	EVM window length W	Ratio of W to total CP length (Note) (%)
50	1024	72	36	50
100	2048	144	72	50
200	4096	288	144	50

NOTE: These percentages are informative and apply to all OFDM symbols within subframe except for symbol 0 of slot 0 and slot 2. Symbol 0 of slot 0 and slot 2 may have a longer CP and therefore a lower percentage.

Table 6.6.3.5.2-3: EVM window length for normal CP, FR2, 120 kHz SCS

Channel bandwidth (MHz)	FFT size	Cyclic prefix length in FFT samples	EVM window length W	Ratio of W to total CP length (Note) (%)
50	512	36	18	50
100	1024	72	36	50
200	2048	144	72	50
400	4096	288	144	50

NOTE: These percentages are informative and apply to all OFDM symbols within subframe except for symbol 0 of slot 0 and slot 4. Symbol 0 of slot 0 and slot 4 may have a longer CP and therefore a lower percentage.

6.6.4 OTA time alignment error

6.6.4.1 Definition and applicability

For *IAB-DU*, this requirement shall apply to frame timing in MIMO transmission, carrier aggregation and their combinations. There's no time alignment error requirement for *IAB-MT*.

Frames of the NR signals present in the radiated domain are not perfectly aligned in time. In relation to each other, the RF signals present in the radiated domain may experience certain timing differences.

For a specific set of signals/transmitter configuration/transmission mode, the OTA Time Alignment Error (OTA TAE) is defined as the largest timing difference between any two different NR signals. The OTA time alignment error requirement is defined as a *directional requirement* at the RIB and shall be met within the *OTA coverage range*.

6.6.4.2 Minimum requirement

The minimum requirement for *IAB-DU type 1-O* is in TS 38.174 [2], clause 9.6.3.1.

The minimum requirement for *IAB-DU type 2-O* is in TS 38.174 [2], clause 9.6.3.1.

6.6.4.3 Test purpose

To verify that the OTA time alignment error is within the limit specified by the minimum requirement.

6.6.4.4 Method of test

6.6.4.4.1 Initial conditions

Test environment: Normal; see annex B.2.

RF channels to be tested for single carrier: M; see clause 4.9.1.

IAB-DU RF Bandwidth positions to be tested for multi-carrier and/or CA:

- M_{RFBW} in single-band operation, see clause 4.9.1;
- B'_{RFBW_T} and B'_{RFBW_T} in multi-band operation, see clause 4.9.1.

Directions to be tested: OTA coverage range reference direction (D.35).

Polarizations to be tested: For dual polarized systems the requirement shall be tested and met considering both polarisations. If the measurement antenna does not support dual polarization, time alignment error shall be measured under the condition that measurement antenna is aligned between the IAB-DU polarisations such that it receives half the power from each polarisation.

6.6.4.4.2 Procedure for IAB-DU

- 1) Place the IAB-DU at the positioner.
- 2) Align the manufacturer declared coordinate system orientation (D.2) of the IAB-DU with the test system.
- 3) Orient the positioner (and IAB-DU) in order that the direction to be tested aligns with the test antenna.
- 4) Configure the beamforming settings of the IAB-DU according to the direction of the testing.
- 5) Set the *IAB-DU type 1-O* to transmit IAB-DU-FR1-TM1.1 or any DL signal using MIMO transmission or carrier aggregation, using the configuration with the minimum number of cells and reference signals.

Set the *IAB-DU type 2-O* to transmit IAB-DU-FR2-TM 1.1 or any DL signal using MIMO transmission or carrier aggregation, using the configuration with the minimum number of cells and reference signals.

NOTE: For MIMO transmission, different ports may be configured in IAB-DU-FR1-TM1.1 and IAB-DU-FR2-TM 1.1 (using DMRS ports $p = 1000$ and 1001 with CDM).

For an IAB-DU declared to be capable of single carrier operation only, set the IAB-DU to transmit according to the applicable test configuration in clause 4.8 using the corresponding test model at manufacturer's declared rated output power, $P_{\text{rated,c,TRP}}$.

If the IAB-DU supports intra band contiguous or non-contiguous Carrier Aggregation set the IAB-DU to transmit using the applicable test configuration and corresponding power setting specified in clauses 4.7.2 and 4.8.

If the IAB-DU supports inter band carrier aggregation set the IAB-DU to transmit, for each band, a single carrier or all carriers, using the applicable test configuration and corresponding power setting specified in clauses 4.7.2 and 4.8.

For *IAB-DU type 1-O* declared to be capable of multi-carrier operation, set the IAB-DU to transmit according to the applicable test signal configuration and corresponding power setting specified in clauses 4.7.2 and 4.8 using the corresponding test model on all carriers configured.

For *IAB-DU type 2-O* declared to be capable of multi-carrier operation, set the IAB-DU to transmit according to the applicable test signal configuration and corresponding power setting specified in clauses 4.7.2 and 4.8 using the corresponding test model on all carriers configured.

- 6) Measure the time alignment error between the different reference symbols on different beams on the carrier(s).

In addition, for a multi-band RIB, the following steps shall apply:

- 7) For a multi-band RIB and single band tests, repeat the steps above per involved band where single band test configurations and test models shall apply with no carrier activated in the other band.

6.6.4.5 Test Requirement

6.6.4.5.1 *IAB-DU type 1-O*

For MIMO transmission, at each carrier frequency, OTA TAE shall not exceed 90 ns.

For intra-band contiguous carrier aggregation, with or without MIMO, OTA TAE shall not exceed 285 ns.

For intra-band non-contiguous carrier aggregation, with or without MIMO, OTA TAE shall not exceed 3.025 μ s.

For inter-band carrier aggregation, with or without MIMO, OTA TAE shall not exceed 3.025 μ s.

6.6.4.5.2 IAB-DU type 2-O

For MIMO transmission, at each carrier frequency, OTA TAE shall not exceed 90 ns.

For intra-band contiguous carrier aggregation, with or without MIMO, OTA TAE shall not exceed 155 ns.

For intra-band non-contiguous carrier aggregation, with or without MIMO, OTA TAE shall not exceed 285 ns.

For inter-band carrier aggregation, with or without MIMO, OTA TAE shall not exceed 3.025 μ s.

6.6.5 Timing error between IAB-DU and IAB-MT

6.6.5.1 Definition and applicability

This requirement shall apply to IAB-DU DL and IAB-MT UL simultaneous transmission.

The timing error between IAB-DU and IAB-MT is specified for a specific set of simultaneous signals/transmitter configuration/transmission mode.

6.6.5.2 Minimum requirement

The minimum requirement for *IAB type 1-O* is in TS 38.174 [2], clause 6.5.4.

The minimum requirement for *IAB type 2-O* is in TS 38.174 [2], clause 9.6.4.

6.6.5.3 Test purpose

To verify that the OTA timing error between IAB-DU and IAB-MT simultaneous transmission is within the limit specified by the minimum requirement.

6.6.5.4 Method of test

6.6.5.4.1 Initial conditions

Test environment: Normal; see annex B.2.

RF channels to be tested for single carrier: M; see clause 4.9.1.

IAB-DU RF Bandwidth positions to be tested for multi-carrier and/or CA:

- M_{RFBW} in single-band operation, see clause 4.9.1;
- $B_{\text{RFBW_T}_{\text{RFBW}}}$ and $B'_{\text{RFBW_T}_{\text{RFBW}}}$ in multi-band operation, see clause 4.9.1.

Directions to be tested: OTA coverage range reference direction (D.35).

Polarizations to be tested: For dual polarized systems the requirement shall be tested and met considering both polarisations. If the measurement antenna does not support dual polarization, time alignment error shall be measured under the condition that measurement antenna is aligned between the IAB-DU polarisations such that it receives half the power from each polarisation.

6.6.5.4.2 Procedure

- 1) Place the IAB-DU and IAB-MT at the positioner.

- 2) Align the manufacturer declared coordinate system orientation (D.2) of the IAB-DU and IAB-MT with the test system.
- 3) Orient the positioner (and IAB-DU and IAB-MT) in order that the direction to be tested aligns with the test antenna.
- 4) Configure the beamforming settings of the IAB-DU and IAB-MT according to the direction of the testing.
- 5) Set the *IAB type 1-O* to transmit IAB-DU-FR1-TM1.1 or IAB-MT-FR1-TM1.1. using the configuration with the minimum number of cells and reference signals.
 - Set the *IAB type 2-O* to transmit IAB-DU-FR2-TM 1.1 or IAB-MT-FR1-TM1.1 using the configuration with the minimum number of cells and reference signals.
 - For an IAB-DU declared to be capable of single carrier operation only, set the IAB-DU to transmit according to the applicable test configuration in clause 4.8 using the corresponding test model at manufacturer's declared rated output power, $P_{\text{rated,c,TRP}}$.
 - For *IAB type 1-O* declared to be capable of multi-carrier operation, set the IAB-DU and IAB-MT to transmit according to the applicable test signal configuration and corresponding power setting specified in clauses 4.7.2 and 4.8 using the corresponding test model on all carriers configured.
 - For *IAB type 2-O* declared to be capable of multi-carrier operation, set the IAB-DU and IAB-MT to transmit according to the applicable test signal configuration and corresponding power setting specified in clauses 4.7.2 and 4.8 using the corresponding test model on all carriers configured.
- 6) Measure the timing error between the DM-RS symbols on the IAB-DU and IAB-MT beams. Note that the possible difference in DM-RS symbol position and slot number shall be compensated for in the measured timing error.

In addition, for a multi-band RIB, the following steps shall apply:

- 7) For a multi-band RIB and single band tests, repeat the steps above per involved band where single band test configurations and test models shall apply with no carrier activated in the other band.

6.6.5.5 Test Requirement

6.6.5.5.1 IAB type 1-O

The timing error between IAB-DU and IAB-MT shall not exceed minimum requirement plus measurement uncertainty defined in Table 4.1.2.2-1.

6.6.5.5.2 IAB type 2-O

The timing error between IAB-DU and IAB-MT shall not exceed minimum requirement plus measurement uncertainty defined in Table 4.1.2.2-2.

6.7 OTA unwanted emissions

6.7.1 General

Unwanted emissions consist of so-called out-of-band emissions and spurious emissions according to ITU definitions ITU-R SM.329 [10]. In ITU terminology, out of band emissions are unwanted emissions immediately outside the *channel bandwidth* resulting from the modulation process and non-linearity in the transmitter but excluding spurious emissions. Spurious emissions are emissions which are caused by unwanted transmitter effects such as harmonics emission, parasitic emission, intermodulation products and frequency conversion products, but exclude out of band emissions.

The OTA out-of-band emissions requirement for the *IAB-MT type 1-O*, *IAB-DU type 1-O*, *IAB-DU type 1-O* and *IAB-DU type 2-O* transmitter is specified both in terms of Adjacent Channel Leakage power Ratio (ACLR) and operating

band unwanted emissions (OBUE). OTA Unwanted emissions outside of this frequency range are limited by an OTA spurious emissions requirement.

The maximum offset of the operating band unwanted emissions mask from the *operating band* edge is Δf_{OBUE} . The value of Δf_{OBUE} is defined in table 6.7.1-1 *IAB-DU type 1-O* and *type 2-O* and in table 6.7.1-2 *IAB-MT type 1-O* and *type 2-O* for NR *operating bands*.

Table 6.7.1-1: Maximum offset Δf_{OBUE} outside the downlink *operating band* for IAB-DU

IAB-DU type	Operating band characteristics	Δf_{OBUE} (MHz)
<i>IAB-DU type 1-O</i>	$F_{\text{DL,high}} - F_{\text{DL,low}} < 100$ MHz	10
	$100 \text{ MHz} \leq F_{\text{DL,high}} - F_{\text{DL,low}} \leq 900$ MHz	40
<i>IAB-DU type 2-O</i>	$F_{\text{DL,high}} - F_{\text{DL,low}} \leq 4000$ MHz	1500

Table 6.7.1-2: Maximum offset Δf_{OBUE} outside the uplink *operating band* for IAB-MT

IAB-MT type	Operating band characteristics	Δf_{OBUE} (MHz)
<i>IAB-MT type 1-O</i>	$F_{\text{UL,high}} - F_{\text{UL,low}} < 100$ MHz	10
	$100 \text{ MHz} \leq F_{\text{UL,high}} - F_{\text{UL,low}} \leq 900$ MHz	40
<i>IAB-MT type 2-O</i>	$F_{\text{UL,high}} - F_{\text{UL,low}} \leq 4000$ MHz	1500

The unwanted emission requirements are applied per cell for all the configurations. Requirements for OTA unwanted emissions are captured using TRP, *directional requirements* or co-location requirements as described per requirement.

There is in addition a requirement for occupied bandwidth.

6.7.2 OTA occupied bandwidth

6.7.2.1 Definition and applicability

The OTA occupied bandwidth is the width of a frequency band such that, below the lower and above the upper frequency limits, the mean powers emitted are each equal to a specified percentage $\beta/2$ of the total mean transmitted power. See also recommendation ITU-R SM.328 [13].

The value of $\beta/2$ shall be taken as 0.5%.

The OTA occupied bandwidth requirement shall apply during the *transmitter ON period* for a single transmitted carrier. The minimum requirement below may be applied regionally. There may also be regional requirements to declare the OTA occupied bandwidth according to the definition in the present clause.

The OTA occupied bandwidth is defined as a *directional requirement* and shall be met in the manufacturer's declared *OTA coverage range* at the RIB.

6.7.2.2 Minimum requirement

The minimum requirement for *IAB-DU type 1-O* and *IAB-DU type 2-O* are in TS 38.174 [2], clause 9.7.2.2.

The minimum requirement for *IAB-MT type 1-O* and *IAB-MT type 2-O* are in TS 38.174 [2], clause 9.7.2.3.

6.7.2.3 Test purpose

The test purpose is to verify that the emission at the *RIB* does not occupy an excessive bandwidth for the service to be provided and is, therefore, not likely to create interference to other users of the spectrum beyond undue limits.

6.7.2.4 Method of test

6.7.2.4.1 Initial conditions

Test environment: Normal, see annex B.2.

RF channels to be tested for single carrier: M; see clause 4.9.1.

Directions to be tested: OTA coverage range reference direction (D.35).

Beams to be tested: Declared beam with the highest intended EIRP for the narrowest intended beam corresponding to the smallest $BeW\theta$, or for the narrowest intended beam corresponding to the smallest $BeW\phi$ (D.3, D.11).

Aggregated IAB channel bandwidth positions to be tested for contiguous carrier aggregation: $M_{BW_Channel_CA}$; see clause 4.9.1.

For a IAB declared to be capable of single carrier operation, start transmission according to the applicable test configuration in clause 4.8 using the corresponding test model IAB-DU-FR1-TM1.1 for *IAB-DU type 1-O*, IAB-MT-FR1-TM1.1 for *IAB-MT type 1-O*, IAB-DU-FR2-TM1.1 for *IAB-DU type 2-O* or IAB-MT-FR2-TM1.1 for *IAB-MT type 2-O* in clause 4.9.2 at manufacturers declared rated carrier EIRP ($P_{rated,c,EIRP}$, D.11).

For a IAB declared to be capable of contiguous carrier aggregation operation, set the IAB to transmit according to IABDU-FR1-TM1.1 for *IAB-DU type 1-O*, IAB-MT-FR1-TM1.1 for *IAB-MT type 1-O*, IAB-DU-FR2-TM1.1 for *IAB-DU type 2-O* or IAB-MT-FR2-TM1.1 for *IAB-MT type 2-O* in clause 4.9.2 on all carriers configured using the applicable test configuration and corresponding power setting specified in clauses 4.7.2.3.1 and 4.8.

For an IAB declared to be capable of Simultaneous transmission between IAB-DU and IAB-MT (D. IAB-3), set the IAB to transmit according to IABDU-FR1-TM1.1 for *IAB-DU type 1-O*, IAB-MT-FR1-TM1.1 for *IAB-MT type 1-O*, IAB-DU-FR2-TM1.1 for *IAB-DU type 2-O* or IAB-MT-FR2-TM1.1 for *IAB-MT type 2-O* in clause 4.9.2 using the applicable test configuration and corresponding power setting specified in clauses 4.7.2 and 4.8.

6.7.2.4.2 Procedure

- 1) Place the IAB at the positioner.
- 2) Align the manufacturer declared coordinate system orientation (D.2) of the IAB with the test system.
- 3) Orient the positioner (and IAB) in order that the direction to be tested aligns with the test antenna..
- 4) Configure the beam peak direction of the IAB according to the declared beam direction pair.
- 5) Set the IAB to transmit signal.
- 6) Measure the spectrum emission of the transmitted signal using at least the number of measurement points, and across a span, as listed in table 6.7.2.4.2-1 and table 6.7.2.4.2-2. The selected resolution bandwidth (RBW) filter of the analyser shall be 30 kHz or less.

NOTE: The detection mode of the spectrum analyser will not have any effect on the result if the statistical properties of the out-of-OBW power are the same as those of the inside-OBW power. Both are expected to have the Rayleigh distribution of the amplitude of Gaussian noise. In any case where the statistics are not the same, though, the detection mode is power responding. There are at least two ways to be power responding. The spectrum analyser can be set to "sample" detection, with its video bandwidth setting at least three times its RBW setting. Or the analyser may be set to respond to the average of the power (root-mean-square of the voltage) across the measurement cell.

Table 6.7.2.4.2-1: Span and number of measurement points for OBW measurements for FR1

Bandwidth	IAB channel bandwidth $BW_{Channel}$ (MHz)				Aggregated IAB channel bandwidth $BW_{Channel_CA}$ (MHz)
	10	15	20	> 20	> 20
Span (MHz)	20	30	40	$2 \times BW_{Channel}$	$2 \times BW_{Channel_CA}$
Minimum number of measurement points	400	400	400	$\left\lceil \frac{2 \times BW_{Channel}}{100kHz} \right\rceil$	$\left\lceil \frac{2 \times BW_{Channel_CA}}{100kHz} \right\rceil$

Table 6.7.2.4.2-2: Span and number of measurement points for OBW measurements for FR2

Bandwidth	IAB channel bandwidth BW_{Channel} (MHz)				Aggregated IAB channel bandwidth $BW_{\text{Channel_CA}}$ (MHz)
	50	100	200	400	> 50
Span (MHz)	$2 \times BW_{\text{Channel}}$				$2 \times BW_{\text{Channel_CA}}$
Minimum number of measurement points	$\left\lceil \frac{2 \times BW_{\text{Channel}}}{200\text{kHz}} \right\rceil$				$\left\lceil \frac{2 \times BW_{\text{Channel_CA}}}{200\text{kHz}} \right\rceil$

- 7) Compute the total of the EIRP, P₀, (in power units, not decibel units) of all the measurement cells in the measurement span. Compute P₁, the EIRP outside the occupied bandwidth on each side. P₁ is half of the total EIRP outside the bandwidth. P₁ is half of (100 % - (occupied percentage)) of P₀. Measure the EIRP for any two orthogonal polarizations (denoted p₁ and p₂) and calculate total radiated transmit power for particular *beam direction pair* as $EIRP = EIRP_{p1} + EIRP_{p2}$.
- 8) Determine the lowest frequency, f₁, for which the sum of all EIRP in the measurement cells from the beginning of the span to f₁ exceeds P₁.
- 9) Determine the highest frequency, f₂, for which the sum of all EIRP in the measurement cells from the end of the span to f₂ exceeds P₁.
- 10) Compute the OTA occupied bandwidth as f₂ - f₁.

In addition, for *multi-band RIB(s)*, the following steps shall apply:

- 11) For *multi-band RIBs* and single band tests, repeat the steps 6) - 10) above per involved band where single band test configurations and test models shall apply with no carriers activated in the other band.

6.7.2.5 Test requirement

6.7.2.5.1 IAB-DU type 1-O and IAB-DU type 2-O

The OTA occupied bandwidth for each NR carrier shall be less than the *IAB-DU channel bandwidth*. For intra-band contiguous CA, the OTA occupied bandwidth shall be less than or equal to the *Aggregated IAB-DU Channel Bandwidth*.

6.7.2.5.2 IAB-MT type 1-O and IAB-MT type 2-O

The OTA occupied bandwidth for each NR carrier shall be less than the *IAB-MT channel bandwidth*. For intra-band contiguous CA, the OTA occupied bandwidth shall be less than or equal to the *Aggregated IAB-MT Channel Bandwidth*.

6.7.3 OTA Adjacent Channel Leakage Power Ratio (ACLR)

6.7.3.1 Definition and applicability

OTA Adjacent Channel Leakage power Ratio (ACLR) is the ratio of the filtered mean power centred on the assigned channel frequency to the filtered mean power centred on an adjacent channel frequency. The measured power is TRP.

The requirement shall be applied per RIB during the *transmitter ON period*.

6.7.3.2 Minimum requirement

The minimum requirement for *IAB-DU type 1-O* and *IAB-MT type 1-O* is in TS 38.174 [2], clause 9.7.3.2.

The minimum requirement for *IAB-DU type 2-O* and *Wide Area IAB-MT type 2-O* is in TS 38.174 [2], clause 9.7.3.3.

6.7.3.3 Test purpose

To verify that the OTA adjacent channel leakage ratio requirement shall be met as specified by the minimum requirement.

6.7.3.4 Method of test

6.7.3.4.1 Initial conditions

Test environment: normal; see annex B.2.

RF channels to be tested for single carrier: B and T; see clause 4.9.1.

IAB RF Bandwidth positions to be tested for multi-carrier and/or CA:

- B_{RFBW} and T_{RFBW} in single-band operation, see clause 4.9.1;
- $B'_{\text{RFBW}}T'_{\text{RFBW}}$ and $B'_{\text{RFBW}}T_{\text{RFBW}}$ in multi-band operation, see clause 4.9.1.

Directions to be tested: As the requirement is TRP the beam pattern(s) may be set up to optimise the TRP measurement procedure (see annex I) as long as the required TRP level is achieved.

6.7.3.4.2 Procedure

The following procedure for measuring TRP is based on the directional power measurements as described in annex I. An alternative method to measure TRP is to use a characterized and calibrated reverberation chamber if so follow steps 1, 3, 4, 6, 8, 9, 10, 11, 12 and 13.

- 1) Place the IAB at the positioner.
- 2) Align the manufacturer declared coordinate system orientation (D.2) of the IAB with the test system.
- 3) The measurement devices characteristics shall be:
 - measurement filter bandwidth: defined in clause 6.7.3.5.
 - detection mode: true RMS voltage or true power averaging.
- 4) For single carrier operation, set the IAB to transmit according to the applicable test configuration in clause 4.8 using the corresponding test model(s) in clause 4.9.2 at manufacturers declared *rated carrier output power* ($P_{\text{rated,c,TRP}}$).
 - For a IAB declared to be capable of multi-carrier and/or CA operation use the applicable test signal configuration and corresponding power setting specified in clauses 4.7.2 and 4.8 using the corresponding test model(s) in clause 4.9.2 on all carriers configured.
 - For an IAB node declared to be capable of Simultaneous transmission between IAB-DU and IAB-MT (D. IAB-3), use the applicable test signal configuration and corresponding power setting in clauses 4.7.2 and 4.8 using the corresponding test model(s) in clause 4.9.2 for IAB-MT and IAB-DU.
- 5) Orient the positioner (and IAB) in order that the direction to be tested aligns with the test antenna such that measurements to determine TRP can be performed (see annex I).
- 6) Measure the absolute power of the assigned channel frequency and the (adjacent channel frequency).
- 7) Repeat step 5-6 for all directions in the appropriated TRP measurement grid needed for $\text{TRP}_{\text{Estimate}}$ (see annex I).
- 8) Calculate $\text{TRP}_{\text{Estimate}}$ for the absolute total radiated power of the wanted channel and the adjacent channel using the measurements made in Step 7.
- 9) Calculate relative ACLR estimate.

NOTE 1: ACLR is calculated by the ratio of the absolute TRP of the assigned channel frequency and the absolute TRP of the adjacent frequency channel.

NOTE 2: For FR1 the measurement uncertainty of the reverberation chamber for the relative ACLR is higher than the measurement uncertainty in clause 4.1.2 the test requirements in table 6.7.3.5.1-1 shall be tightened following the procedure in clause 4.1.3.

10) Measure OTA ACLR for the frequency offsets both side of channel frequency as specified in table 6.7.3.5.1-1 for *IAB type 1-O* or table 6.7.3.5.2-1 for *IAB type 2-O* respectively. In multiple carrier case only offset frequencies below the lowest and above the highest carrier frequency used shall be measured.

11) For the OTA ACLR requirement applied inside sub-block gap for non-contiguous spectrum operation or inside *Inter RF Bandwidth gap* for multi-band operation:

- a) Measure OTA ACLR inside sub-block gap or *Inter RF Bandwidth gap*, if applicable.
- b) Measure OTA CACLR inside sub-block gap or *Inter RF Bandwidth gap*, if applicable.

12) Repeat the test with the channel set-up using IAB- FR1-TM1.2 defined in clause 4.9.2 in TS 38.176-1 [3] for *IAB type 1-O*.

In addition, for *multi-band RIB*, the following steps shall apply:

13) For *IAB type 1-O* and *multi-band RIB* and single band tests, repeat the steps above per involved band where single band test configurations and test models shall apply with no carrier activated in the other band.

6.7.3.5 Test requirements

6.7.3.5.1 *IAB-DU type 1-O* and *IAB-MT type 1-O*

For the OTA ACLR requirement either the OTA ACLR limits in tables 6.7.3.5.1-1/3 or the OTA ACLR absolute limits in table 6.7.3.5.1-2 shall apply, whichever is less stringent. The OTA CACLR limits in table 6.7.3.5.1-4 or the OTA CACLR absolute limits in table 6.7.3.5.1-5 shall apply, whichever is less stringent.

The CACLR in a sub-block gap and *Inter RF Bandwidth gap* is the ratio of:

- a) the sum of the filtered mean power centred on the assigned channel frequencies for the two carriers adjacent to each side of the sub-block gap or the *Inter RF Bandwidth gap*, and
- b) the filtered mean power centred on a frequency channel adjacent to one of the respective sub-block edges or Base Station RF Bandwidth edges.

The assumed filter for the adjacent channel frequency is defined in table 6.7.3.5.1-4 and the filters on the assigned channels are defined in table 6.7.3.5.1-6.

For operation in paired and unpaired spectrum, the OTA ACLR measurement result shall not be less than the OTA ACLR limit specified in table 6.7.3.5.1-1.

Table 6.7.3.5.1-1: IAB-DU and IAB-MT type 1-O ACLR limit

IAB channel bandwidth of lowest/highest NR carrier transmitted BW_{Channel} (MHz)	IAB adjacent channel centre frequency offset below the lowest or above the highest carrier centre frequency transmitted	Assumed adjacent channel carrier (informative)	Filter on the adjacent channel frequency and corresponding filter bandwidth	OTA ACLR limit (0 – 3 GHz)	OTA ACLR limit (3 – 6 GHz)
10, 15, 20, 25, 30, 40, 50, 60, 70, 80, 90, 100	BW_{Channel}	NR of same BW (Note 2)	Square (BW_{Config})	44 dB	43.8 dB
	$2 \times BW_{\text{Channel}}$	NR of same BW (Note 2)	Square (BW_{Config})	44 dB	43.8 dB
	$BW_{\text{Channel}}/2 + 2.5$ MHz	5 MHz E-UTRA	Square (4.5 MHz)	44 dB (Note 3)	43.8 dB (Note 3)
	$BW_{\text{Channel}}/2 + 7.5$ MHz	5 MHz E-UTRA	Square (4.5 MHz)	44 dB (Note 3)	43.8 dB (Note 3)
NOTE 1: BW_{Channel} and BW_{Config} are the IAB channel bandwidth and transmission bandwidth configuration of the lowest/highest NR carrier transmitted on the assigned channel frequency.					
NOTE 2: With SCS that provides largest transmission bandwidth configuration (BW_{Config}).					
NOTE 3: The requirements are applicable when the band is also defined for E-UTRA or UTRA.					

The absolute total power measurement shall not exceed the OTA ACLR absolute limit specified in table 6.7.3.5.1-2.

Table 6.7.3.5.1-2: IAB-DU and IAB-MT type 1-O ACLR absolute limit

IAB category / IAB class	OTA ACLR absolute limit
Category A Wide Area IAB-DU and Category A Wide Area IAB-MT	-4 dBm/MHz
Category B Wide Area IAB-DU and Category B Wide Area IAB-MT	-6 dBm/MHz
Medium Range IAB-DU	-16 dBm/MHz
Local Area IAB-DU and Local Area IAB-MT	-23 dBm/MHz
NOTE 1: The test requirement is derived from the basic limit a scaling factor of 9 dB and any applicable TT.	

For operation in non-contiguous spectrum or multiple bands, the OTA ACLR measurement result shall not be less than the OTA ACLR limit specified in table 6.7.3.5.1-3.

Table 6.7.3.5.1-3: IAB-DU and IAB-MT type 1-O ACLR limit in non-contiguous spectrum or multiple bands

IAB-DU and IAB-MT channel bandwidth of lowest/highest NR carrier transmitted BW_{Channel} (MHz)	Sub-block or Inter RF Bandwidth gap size (W_{gap}) where the limit applies (MHz)	IAB-DU and IAB-MT adjacent channel centre frequency offset below or above the sub-block or Base Station RF Bandwidth edge (inside the gap)	Assumed adjacent channel carrier	Filter on the adjacent channel frequency and corresponding filter bandwidth	OTA ACLR limit (0-3GHz)	OTA ACLR limit (3-6GHz)
10, 15, 20	$W_{\text{gap}} \geq 15$ (Note 3) $W_{\text{gap}} \geq 45$ (Note 4)	2.5 MHz	5 MHz NR (Note 2)	Square (BW_{Config})	44 dB	43.8 dB
	$W_{\text{gap}} \geq 20$ (Note 3) $W_{\text{gap}} \geq 50$ (Note 4)	7.5 MHz	5 MHz NR (Note 2)	Square (BW_{Config})	44 dB	43.8 dB
25, 30, 40, 50, 60, 70, 80, 90, 100	$W_{\text{gap}} \geq 60$ (Note 4) $W_{\text{gap}} \geq 30$ (Note 3)	10 MHz	20 MHz NR (Note 2)	Square (BW_{Config})	44 dB	43.8 dB
	$W_{\text{gap}} \geq 80$ (Note 4) $W_{\text{gap}} \geq 50$ (Note 3)	30 MHz	20 MHz NR (Note 2)	Square (BW_{Config})	44 dB	43.8 dB
<p>NOTE 1: BW_{Config} is the transmission bandwidth configuration of the assumed adjacent channel carrier.</p> <p>NOTE 2: With SCS that provides largest transmission bandwidth configuration (BW_{Config}).</p> <p>NOTE 3: Applicable in case the <i>IAB channel bandwidth</i> of the NR carrier transmitted at the other edge of the gap is 10, 15, 20 MHz.</p> <p>NOTE 4: Applicable in case the <i>IAB channel bandwidth</i> of the NR carrier transmitted at the other edge of the gap is 25, 30, 40, 50, 60, 70, 80, 90, 100 MHz.</p>						

The OTA CACLR measurement result shall not less than the OTA CACLR limit specified in table 6.7.3.5.1-4.

Table 6.7.3.5.1-4: *IAB-DU* and *IAB-MT* type 1-O CACLR limit

<i>IAB-DU</i> and <i>IAB-MT</i> channel bandwidth of lowest/highest NR carrier transmitted BW_{Channel} (MHz)	Sub-block or Inter RF Bandwidth gap size (W_{gap}) where the limit applies (MHz)	<i>IAB-DU</i> and <i>IAB-MT</i> adjacent channel centre frequency offset below or above the sub-block or Base Station RF Bandwidth edge (inside the gap)	Assumed adjacent channel carrier	Filter on the adjacent channel frequency and corresponding filter bandwidth	OTA CACLR limit (0-3 GHz)	OTA CACLR limit (3-6 GHz)
10, 15, 20	$5 \leq W_{\text{gap}} < 15$ (Note 3) $5 \leq W_{\text{gap}} < 45$ (Note 4)	2.5 MHz	5 MHz NR (Note 2)	Square (BW_{Config})	44 dB	43.8 dB
	$10 < W_{\text{gap}} < 20$ (Note 3) $10 \leq W_{\text{gap}} < 50$ (Note 4)	7.5 MHz	5 MHz NR (Note 2)	Square (BW_{Config})	44 dB	43.8 dB
25, 30, 40, 50, 60, 70, 80, 90, 100	$20 \leq W_{\text{gap}} < 60$ (Note 4) $20 \leq W_{\text{gap}} < 30$ (Note 3)	10 MHz	20 MHz NR (Note 2)	Square (BW_{Config})	44 dB	43.8 dB
	$40 < W_{\text{gap}} < 80$ (Note 4) $40 \leq W_{\text{gap}} < 50$ (Note 3)	30 MHz	20 MHz NR (Note 2)	Square (BW_{Config})	44 dB	43.8 dB

NOTE 1: BW_{Config} is the transmission bandwidth configuration of the assumed adjacent channel carrier.
NOTE 2: With SCS that provides largest transmission bandwidth configuration (BW_{Config}).
NOTE 3: Applicable in case the *IAB channel bandwidth* of the NR carrier transmitted at the other edge of the gap is 10, 15, 20 MHz.
NOTE 4: Applicable in case the *IAB channel bandwidth* of the NR carrier transmitted at the other edge of the gap is 25, 30, 40, 50, 60, 70, 80, 90, 100 MHz.

The absolute total power measurement shall not exceed the OTA CACLR absolute limit specified in table 6.7.3.5.1-5.

Table 6.7.3.5.1-5: *IAB-DU* and *IAB-MT* type 1-O CACLR absolute limit

IAB category / IAB class	OTA CACLR absolute limit
Category A Wide Area IAB-DU and Category A Wide Area IAB-MT	-4 dBm/MHz
Category B Wide Area IAB-DU and Category B Wide Area IAB-MT	-6 dBm/MHz
Medium Range IAB-DU	-16 dBm/MHz
Local Area IAB-DU and Local Area IAB-MT	-23 dBm/MHz

NOTE 1: The test requirement is derived from the basic limit a scaling factor of 9 dB and any applicable TT.

Table 6.7.3.5.1-6: Filter parameters for the assigned channel

RAT of the carrier adjacent to the sub-block or Inter RF Bandwidth gap	Filter on the assigned channel frequency and corresponding filter bandwidth
NR	NR of same BW with SCS that provides largest transmission bandwidth configuration

6.7.3.5.2 *IAB-DU* type 2-O and Wide Area *IAB-MT* type 2-O

The OTA ACLR absolute limit in table 6.7.3.5.2-2 or the OTA ACLR limit in table 6.7.3.5.2-1/3, whichever is less stringent, shall apply. The OTA CACLR absolute limit in table 6.7.3.5.2-5 or the OTA CACLR limit in table 6.7.3.5.2-4, whichever is less stringent, shall apply.

For a *RIB* operating in multi-carrier or contiguous CA, the OTA ACLR requirements in table 6.7.3.5.2-1 shall apply to *IAB-DU* and *IAB-MT channel bandwidths* of the outermost carrier for the frequency ranges defined in the table. For a *RIB* operating in *non-contiguous spectrum*, the OTA ACLR requirement in table 6.7.3.5.2-3 shall apply in *sub-block gaps* for the frequency ranges defined in the table, while the OTA CACLR requirement in table 6.7.3.5.2-4 shall apply in *sub-block gaps* for the frequency ranges defined in the table.

The CACLR in a *sub-block gap* is the ratio of:

- a) the sum of the filtered mean power centred on the assigned channel frequencies for the two carriers adjacent to each side of the *sub-block gap*, and
- b) the filtered mean power centred on a frequency channel adjacent to one of the respective *sub-block* edges.

The assumed filter for the adjacent channel frequency is defined in table 6.7.3.5.2-4 and the filters on the assigned channels are defined in table 6.7.3.5.2-6.

For operation in *non-contiguous spectrum*, the CACLR for NR carriers located on either side of the *sub-block gap* shall be higher than the value specified in table 6.7.3.5.2-4.

Table 6.7.3.5.2-1: *IAB-DU* type 2-O and Wide area *IAB-MT* type 2-O ACLR limit

IAB-DU and IAB-MT channel bandwidth of lowest/highest carrier transmitted BW_{Channel} (MHz)	IAB-DU and IAB-MT adjacent channel centre frequency offset below the lowest or above the highest carrier centre frequency transmitted	Assumed adjacent channel carrier	Filter on the adjacent channel frequency and corresponding filter bandwidth	ACLR limit (dB)
50, 100, 200, 400	BW_{Channel}	NR of same BW (Note 2)	Square (BW_{Config})	25.7 for IAB-DU (Note 3) 23.4 for IAB-DU (Note 4) 25.2 for IAB-MT (Note 3) 23.1 for IAB-MT (Note 4)
NOTE 1: BW_{Channel} and BW_{Config} are the <i>IAB-DU</i> and <i>IAB-MT</i> channel bandwidth and transmission bandwidth configuration of the lowest/highest carrier transmitted on the assigned channel frequency.				
NOTE 2: With SCS that provides largest transmission bandwidth configuration (BW_{Config}).				
NOTE 3: Applicable to bands defined within the frequency spectrum range of 24.25 – 33.4 GHz				
NOTE 4: Applicable to bands defined within the frequency spectrum range of 37 – 52.6 GHz				

Table 6.7.3.5.2-2: *IAB-DU* type 2-O and Wide area *IAB-MT* type 2-O ACLR absolute limit

IAB-DU and IAB-MT class	ACLR absolute limit
Wide area IAB-DU	-10.3 dBm/MHz
Wide Area IAB-MT	-10.1 dBm/MHz (Note 1) -10.0 dBm/MHz (Note 2)
Medium range IAB-DU	-17.3 dBm/MHz
Local area IAB-DU	-17.3 dBm/MHz
NOTE 1: Applicable to bands defined within the frequency spectrum range of 24.25 – 33.4 GHz	
NOTE 2: Applicable to bands defined within the frequency spectrum range of 37 – 52.6 GHz	

Table 6.7.3.5.2-3: IAB DU type 2-O and Wide Area IAB-MT type 2-O ACLR limit in non-contiguous spectrum

IAB-DU and IAB-MT channel bandwidth of lowest/highest carrier transmitted (MHz)	Sub-block gap size (W_{gap}) where the limit applies (MHz)	IAB-DU and IAB-MT adjacent channel centre frequency offset below or above the sub-block edge (inside the gap)	Assumed adjacent channel carrier	Filter on the adjacent channel frequency and corresponding filter bandwidth	ACLR limit (dB)
50, 100	$W_{\text{gap}} \geq 100$ (Note 5) $W_{\text{gap}} \geq 250$ (Note 6)	25 MHz	50 MHz NR (Note 2)	Square (BW_{Config})	25.7 for IAB-DU (Note 3) 23.4 for IAB-DU (Note 4) 25.2 for IAB-MT (Note 3) 23.1 for IAB-MT (Note 4)
200, 400	$W_{\text{gap}} \geq 400$ (Note 6) $W_{\text{gap}} \geq 250$ (Note 5)	100 MHz	200 MHz NR (Note 2)	Square (BW_{Config})	25.7 for IAB-DU (Note 3) 23.4 for IAB-DU (Note 4) 25.2 for IAB-MT (Note 3) 23.1 for IAB-MT (Note 4)

NOTE 1: BW_{Config} is the *transmission bandwidth configuration* of the assumed adjacent channel carrier.
NOTE 2: With SCS that provides largest *transmission bandwidth configuration* (BW_{Config}).
NOTE 3: Applicable to bands defined within the frequency spectrum range of 24.25 – 33.4 GHz.
NOTE 4: Applicable to bands defined within the frequency spectrum range of 37 – 52.6 GHz.
NOTE 5: Applicable in case the *IAB-DU or IAB-MT channel bandwidth* of the NR carrier transmitted at the other edge of the gap is 50 or 100 MHz.
NOTE 6: Applicable in case the *IAB-DU or IAB-MT channel bandwidth* of the NR carrier transmitted at the other edge of the gap is 200 or 400 MHz.

Table 6.7.3.5.2-4: IAB DU type 2-O and Wide Area IAB-MT type 2-O CACLR limit in non-contiguous spectrum

IAB-DU and IAB-MT channel bandwidth of lowest/highest carrier transmitted (MHz)	Sub-block gap size (W_{gap}) where the limit applies (MHz)	IAB-DU and IAB-MT adjacent channel centre frequency offset below or above the sub-block edge (inside the gap)	Assumed adjacent channel carrier	Filter on the adjacent channel frequency and corresponding filter bandwidth	CACLR limit (dB)
50, 100	$50 \leq W_{\text{gap}} < 100$ (Note 5) $50 \leq W_{\text{gap}} < 250$ (Note 6)	25 MHz	50 MHz NR (Note 2)	Square (BW_{Config})	25.7 for IAB-DU (Note 3) 23.4 for IAB-DU (Note 4) 25.2 for IAB-MT (Note 3) 23.1 for IAB-MT (Note 4)
200, 400	$200 \leq W_{\text{gap}} < 400$ (Note 6) $200 \leq W_{\text{gap}} < 250$ (Note 5)	100 MHz	200 MHz NR (Note 2)	Square (BW_{Config})	25.7 for IAB-DU (Note 3) 23.4 for IAB-DU (Note 4) 25.2 for IAB-MT (Note 3) 23.1 for IAB-MT (Note 4)

NOTE 1: BW_{Config} is the transmission bandwidth configuration of the assumed adjacent channel carrier.
NOTE 2: With SCS that provides largest transmission bandwidth configuration (BW_{Config}).
NOTE 3: Applicable to bands defined within the frequency spectrum range of 24.25 – 33.4 GHz.
NOTE 4: Applicable to bands defined within the frequency spectrum range of 37 – 52.6 GHz.
NOTE 5: Applicable in case the IAB-DU or IAB-MT channel bandwidth of the NR carrier transmitted at the other edge of the gap is 50 or 100 MHz.
NOTE 6: Applicable in case the IAB-DU or IAB-MT channel bandwidth of the NR carrier transmitted at the other edge of the gap is 200 or 400 MHz.

Table 6.7.3.5.2-5: IAB-DU type 2-O and Wide area IAB-MT type 2-O CACLR absolute limit

IAB-DU and IAB-MT class	CACLR absolute limit
Wide area IAB-DU	-10.3 dBm/MHz
Wide area IAB-MT	-10.1 dBm/MHz (Note 1) -10.0 dBm/MHz (Note 2)
Medium range IAB-DU	-17.3 dBm/MHz
Local area IAB-DU	-17.3 dBm/MHz

NOTE 1: Applicable to bands defined within the frequency spectrum range of 24.25 – 33.4 GHz
NOTE 2: Applicable to bands defined within the frequency spectrum range of 37 – 52.6 GHz

Table 6.7.3.5.2-6: Filter parameters for the assigned channel

RAT of the carrier adjacent to the sub-block gap	Filter on the assigned channel frequency and corresponding filter bandwidth
NR	NR of same BW with SCS that provides largest transmission bandwidth configuration

6.7.3.5.3 Local Area IAB-MT type 2-O

The OTA ACLR absolute limit in table 6.7.3.5.3-2 or the ACLR limit in table 6.7.3.5.3-1/3, whichever is less stringent, shall apply. The OTA CACLR absolute limit in table 6.7.3.5.3-5 or the CACLR limit in table 6.7.3.5.3-4, whichever is less stringent, shall apply.

Requirements specified for Local Area IAB-DU type 2-O in clause 6.7.3.5.3 shall apply to Local Area IAB-MT type 2-O during transmission in DL timeslot.

For a RIB operating in multi-carrier or contiguous CA, the OTA ACLR requirements in table 6.7.3.5.3-1 shall apply to IAB-MT channel bandwidths of the outermost carrier for the frequency ranges defined in the table. For a RIB

operating in *non-contiguous spectrum*, the OTA ACLR requirement in table 6.7.3.5.3-3 shall apply in *sub-block gaps* for the frequency ranges defined in the table, while the OTA CACLR requirement in table 6.7.3.5.3-4 shall apply in *sub-block gaps* for the frequency ranges defined in the table.

The CACLR in a *sub-block gap* is the ratio of:

- a) the sum of the filtered mean power centred on the assigned channel frequencies for the two carriers adjacent to each side of the *sub-block gap*, and
- b) the filtered mean power centred on a frequency channel adjacent to one of the respective *sub-block* edges.

The assumed filter for the adjacent channel frequency is defined in table 6.7.3.5.3-4 and the filters on the assigned channels are defined in table 6.7.3.5.3-6.

For operation in *non-contiguous spectrum*, the CACLR for NR carriers located on either side of the *sub-block gap* shall be higher than the value specified in table 6.7.3.5.3-4.

Table 6.7.3.3.5-1: Local Area IAB-MT type 2-O ACLR limit

IAB-MT channel bandwidth of lowest/highest carrier transmitted BW_{Channel} (MHz)	IAB-MT adjacent channel centre frequency offset below the lowest or above the highest carrier centre frequency transmitted	Assumed adjacent channel carrier	Filter on the adjacent channel frequency and corresponding filter bandwidth	ACLR limit (dB)
50, 100, 200, 400	BW_{Channel}	NR of same BW (Note 2)	Square (BW_{Config})	21.2 (Note 3) 21.1 (Note 4)
NOTE 1: BW_{Channel} and BW_{Config} are the <i>IAB-MT channel bandwidth</i> and <i>transmission bandwidth configuration</i> of the <i>lowest/highest carrier</i> transmitted on the assigned channel frequency.				
NOTE 2: With SCS that provides largest <i>transmission bandwidth configuration</i> (BW_{Config}).				
NOTE 3: Applicable to bands defined within the frequency spectrum range of 24.25 – 33.4 GHz				
NOTE 4: Applicable to bands defined within the frequency spectrum range of 37 – 52.6 GHz				

Table 6.7.3.5.3-2: Local Area IAB-MT type 2-O ACLR absolute limit

IAB-MT class	ACLR absolute limit
Local area IAB-MT	-17.1 dBm/MHz (Note 1) -17.0 dBm/MHz (Note 2)
NOTE 1: Applicable to bands defined within the frequency spectrum range of 24.25 – 33.4 GHz	
NOTE 2: Applicable to bands defined within the frequency spectrum range of 37 – 52.6 GHz	

Table 6.7.3.5.3-3: Local Area IAB-MT type 2-O ACLR limit in non-contiguous spectrum

IAB-MT channel bandwidth of lowest/highest carrier transmitted (MHz)	Sub-block gap size (W_{gap}) where the limit applies (MHz)	IAB-MT adjacent channel centre frequency offset below or above the sub-block edge (inside the gap)	Assumed adjacent channel carrier	Filter on the adjacent channel frequency and corresponding filter bandwidth	ACLR limit
50, 100	$W_{\text{gap}} \geq 100$ (Note 4) $W_{\text{gap}} \geq 250$ (Note 5)	25 MHz	50 MHz NR (Note 2)	Square (BW_{Config})	21.2 (Note 3) 21.1 (Note 6)
200, 400	$W_{\text{gap}} \geq 400$ (Note 5) $W_{\text{gap}} \geq 250$ (Note 4)	100 MHz	200 MHz NR (Note 2)	Square (BW_{Config})	21.2 (Note 3) 21.1 (Note 6)

NOTE 1: BW_{Config} is the transmission bandwidth configuration of the assumed adjacent channel carrier.

NOTE 2: With SCS that provides largest transmission bandwidth configuration (BW_{Config}).

NOTE 3: Applicable to bands defined within the frequency spectrum range of 24.25 – 33.4 GHz.

NOTE 4: Applicable in case the IAB-MT channel bandwidth of the NR carrier transmitted at the other edge of the gap is 50 or 100 MHz.

NOTE 5: Applicable in case the IAB-MT channel bandwidth of the NR carrier transmitted at the other edge of the gap is 200 or 400 MHz.

NOTE 6: Applicable to bands defined within the frequency spectrum range of 37 – 52.6 GHz.

Table 6.7.3.5.3-4: Local Area IAB-MT type 2-O CACLR limit in non-contiguous spectrum

IAB-MT channel bandwidth of lowest/highest carrier transmitted (MHz)	Sub-block gap size (W_{gap}) where the limit applies (MHz)	IAB-MT adjacent channel centre frequency offset below or above the sub-block edge (inside the gap)	Assumed adjacent channel carrier	Filter on the adjacent channel frequency and corresponding filter bandwidth	CACLR limit
50, 100	$50 \leq W_{\text{gap}} < 100$ (Note 4) $50 \leq W_{\text{gap}} < 250$ (Note 5)	25 MHz	50 MHz NR (Note 2)	Square (BW_{Config})	21.2 (Note 3) 21.1 (Note 6)
200, 400	$200 \leq W_{\text{gap}} < 400$ (Note 5) $200 \leq W_{\text{gap}} < 250$ (Note 4)	100 MHz	200 MHz NR (Note 2)	Square (BW_{Config})	21.2 (Note 3) 21.1 (Note 6)

NOTE 1: BW_{Config} is the transmission bandwidth configuration of the assumed adjacent channel carrier.

NOTE 2: With SCS that provides largest transmission bandwidth configuration (BW_{Config}).

NOTE 3: Applicable to bands defined within the frequency spectrum range of 24.25 – 33.4 GHz.

NOTE 4: Applicable in case the IAB-MT channel bandwidth of the NR carrier transmitted at the other edge of the gap is 50 or 100 MHz.

NOTE 5: Applicable in case the IAB-MT channel bandwidth of the NR carrier transmitted at the other edge of the gap is 200 or 400 MHz.

Table 6.7.3.5.3-5: Local Area IAB-MT type 2-O CACLR absolute limit

IAB-MT class	CACLR absolute limit
Local area IAB-MT	-17.1 dBm/MHz (Note 1) -17.0 dBm/MHz (Note 2)

NOTE 1: Applicable to bands defined within the frequency spectrum range of 24.25 – 33.4 GHz

NOTE 2: Applicable to bands defined within the frequency spectrum range of 37 – 52.6 GHz

Table 6.7.3.5.3-6: Filter parameters for the assigned channel

RAT of the carrier adjacent to the sub-block gap	Filter on the assigned channel frequency and corresponding filter bandwidth
NR	NR of same BW with SCS that provides largest transmission bandwidth configuration

6.7.4 OTA operating band unwanted emissions

6.7.4.1 Definition and applicability

The OTA limits for operating band unwanted emissions are specified as TRP per RIB, unless otherwise stated.

6.7.4.1.1 *IAB-DU type 1-O*

For *IAB-DU type 1-O*, for a *RIB* operating in multi-carrier or contiguous CA, the requirements apply to *IAB-DU channel bandwidths* of the outermost carrier. In addition, for a *RIB* operating in non-contiguous spectrum, the requirements shall apply inside any sub-block gap. In addition, for a *multi-band RIB*, the requirements shall apply inside any Inter RF Bandwidth gap.

6.7.4.1.2 *IAB-MT type 1-O*

For *IAB-MT type 1-O*, for a *RIB* operating in multi-carrier or contiguous CA, the requirements apply to *IAB-MT channel bandwidths* of the outermost carrier. In addition, for a *RIB* operating in non-contiguous spectrum, the requirements shall apply inside any sub-block gap. In addition, for a *multi-band RIB*, the requirements shall apply inside any Inter RF Bandwidth gap.

6.7.4.1.3 *IAB-DU type 2-O and IAB-MT type 2-O*

For *IAB-DU type 2-O* and *IAB-MT type 2-O*, for a *RIB* operating in multi-carrier or contiguous CA, the requirements apply to the frequencies (Δf_{OBUE}) starting from the edge of the *contiguous transmission bandwidth*. In addition, for a *RIB* operating in non-contiguous spectrum, the requirements apply inside any sub-block gap.

6.7.4.2 Minimum requirement

The minimum requirement for *IAB-DU type 1-O* is defined in TS 38.174 [2], clause 9.7.4.2.

The minimum requirement for *IAB-MT type 1-O* is defined in TS 38.174 [2], clause 9.7.4.3.

The minimum requirement for *IAB-DU type 2-O* and *IAB-MT type 2-O* are defined in TS 38.174 [2], clause 9.7.4.5.

6.7.4.3 Test purpose

This test measures the emissions of the IAB-Node, close to the assigned channel bandwidth of the wanted signal, while the IAB-Node is in operation.

6.7.4.4 Method of test

6.7.4.4.1 Initial conditions

Test environment: normal; see annex B.2.

RF channels to be tested for single carrier: B, M and T; see clause 4.9.1.

IAB RF Bandwidth positions to be tested for multi-carrier and/or CA:

- B_{RFBW} , M_{RFBW} and T_{RFBW} in single-band operation, see clause 4.9.1;
- B'_{RFBW} , T'_{RFBW} and B'_{RFBW} , T'_{RFBW} in multi-band operation, see clause 4.9.1.

Directions to be tested: As the requirement is TRP the beam pattern(s) may be set up to optimise the TRP measurement procedure (see annex I) as long as the required TRP level is achieved.

6.7.4.4.2 Procedure

The following procedure for measuring TRP is based on the directional power measurements as described in annex I. An alternative method to measure TRP is to use a characterized and calibrated reverberation chamber if so follow steps 1, 3, 4, 6 and 9.

- 1) Place the IAB-Node at the positioner.
- 2) Align the manufacturer declared coordinate system orientation (D.2) of the IAB-Node with the test system.
- 3) The measurement devices characteristics shall be:
 - measurement filter bandwidth: defined in clause 6.7.4.5.
 - detection mode: true RMS voltage or true power averaging.
- 4) For single carrier operation, set the IAB-Node to transmit according to the applicable test configuration in clause 4.8 using the corresponding test model(s) in clause 4.9.2 at manufacturers declared *rated carrier output power* ($P_{\text{rated,c,TRP}}$).
 - For a IAB declared to be capable of multi-carrier and/or CA operation, use the applicable test signal configuration and corresponding power setting specified in clause 4.7.2 and 4.8 using the corresponding test model(s) in clause 4.9.2 on all carriers configured.
 - For an IAB node declared to be capable of Simultaneous transmission between IAB-DU and IAB-MT (D.IAB-3), use the applicable test signal configuration and corresponding power setting in clauses 4.7.2 and 4.8 using the corresponding test model(s) in clause 4.9.2 for IAB-DU and IAB-MT.
- 5) Orient the positioner (and IAB) in order that the direction to be tested aligns with the test antenna such that measurements to determine TRP can be performed (see annex I).
- 6) Sweep the centre frequency of the measurement filter in contiguous steps and measure emission power within the specified frequency ranges with the specified measurement bandwidth.
- 7) Repeat step 5-6 for all directions in the appropriated TRP measurement grid needed for $\text{TRP}_{\text{Estimate}}$ (see annex I).
- 8) Calculate $\text{TRP}_{\text{Estimate}}$ using the measurements made in step 6.
- 9) For *IAB type 1-O* and *multi-band RIB* and single band tests, repeat the steps above per involved band where single band test configurations and test models shall apply with no carrier activated in the other band.

6.7.4.5 Test requirements

6.7.4.5.1 *IAB type 1-O*

The emission measurement result shall not exceed the maximum levels specified in tables 6.7.4.5.1.1-1 to 6.7.4.5.1.5-3, where:

- Δf is the separation between the channel edge frequency and the nominal -3dB point of the measuring filter closest to the carrier frequency.
- f_{offset} is the separation between the channel edge frequency and the centre of the measuring filter.
- $f_{\text{offset,max}}$ is the offset to the frequency Δf_{OBUE} MHz outside the downlink operating band.
- Δf_{max} is equal to $f_{\text{offset,max}}$ minus half of the bandwidth of the measuring filter.

For a *multi-band RIB* inside any *Inter RF Bandwidth gaps* with $W_{\text{gap}} < 2 * \Delta f_{\text{OBUE}}$, emissions shall not exceed the cumulative sum of the test requirements specified at the *IAB RF Bandwidth edges* on each side of the *Inter RF Bandwidth gap*. The test requirement for *IAB RF Bandwidth edge* is specified in the tables 6.7.4.5.1.1-1 to 6.7.4.5.1.5-3 below, where in this case:

- Δf is the separation between the *IAB RF Bandwidth edge* frequency and the nominal -3 dB point of the measuring filter closest to the *IAB RF Bandwidth edge*.

- f_{offset} is the separation between the *IAB RF Bandwidth edge* frequency and the centre of the measuring filter.
- $f_{\text{offset}_{\text{max}}}$ is equal to the *Inter RF Bandwidth gap* minus half of the bandwidth of the measuring filter.
- Δf_{max} is equal to $f_{\text{offset}_{\text{max}}}$ minus half of the bandwidth of the measuring filter.

For a *multi-band RIB*, the operating band unwanted emission limits apply also in a supported operating band without any carrier transmitted, in the case where there are carrier(s) transmitted in another supported operating band. In this case, no cumulative limit is applied in the *inter-band gap* between a supported downlink operating band with carrier(s) transmitted and a supported downlink operating band without any carrier transmitted and

- In case the *inter-band gap* between a supported downlink operating band with carrier(s) transmitted and a supported downlink operating band without any carrier transmitted is less than $2 * \Delta f_{\text{OBUE}}$, $f_{\text{offset}_{\text{max}}}$ shall be the offset to the frequency Δf_{OBUE} MHz outside the outermost edges of the two supported downlink operating bands and the operating band unwanted emission limit of the band where there are carriers transmitted, as defined in the tables of the present clause, shall apply across both downlink bands.
- In other cases, the operating band unwanted emission limit of the band where there are carriers transmitted, as defined in the tables of the present clause for the largest frequency offset (Δf_{max}), shall apply from Δf_{OBUE} MHz below the lowest frequency, up to Δf_{OBUE} MHz above the highest frequency of the supported downlink operating band without any carrier transmitted.

For a multicarrier *single-band RIB* or a *single-band RIB* configured for intra-band contiguous or non-contiguous carrier aggregation the definitions above apply to the lower edge of the carrier transmitted at the lowest carrier frequency and the upper edge of the carrier transmitted at the highest carrier frequency within a specified frequency band.

In addition inside any sub-block gap for a *single-band RIB* operating in non-contiguous spectrum, emissions shall not exceed the cumulative sum of the test requirements specified for the adjacent sub blocks on each side of the sub block gap. The test requirement for each sub block is specified in the tables 6.7.4.5.1.1-1 to 6.7.4.5.1.5-3 below, where in this case:

- Δf is the separation between the sub block edge frequency and the nominal -3 dB point of the measuring filter closest to the sub block edge.
- f_{offset} is the separation between the sub block edge frequency and the centre of the measuring filter.
- $f_{\text{offset}_{\text{max}}}$ is equal to the sub block gap bandwidth minus half of the bandwidth of the measuring filter.
- Δf_{max} is equal to $f_{\text{offset}_{\text{max}}}$ minus half of the bandwidth of the measuring filter.

6.7.4.5.1.1 Wide Area IAB-DU and Wide Area IAB-MT (Category A)

For operating in Bands n41, n77, n78, n79, emissions shall not exceed the maximum levels specified in tables 6.7.4.5.1.1-1 to 6.7.4.5.1.1-3:

**Table 6.7.4.5.1.1-1: Wide Area IAB-DU and Wide Area IAB-MT *operating band* unwanted emission limits
(1 GHz < NR bands ≤ 3 GHz) for Category A**

Frequency offset of measurement filter -3dB point, Δf	Frequency offset of measurement filter centre frequency, f_{offset}	Test requirement (Note 1, 2, 4)	Measurement bandwidth
$0 \text{ MHz} \leq \Delta f < 5 \text{ MHz}$	$0.05 \text{ MHz} \leq f_{\text{offset}} < 5.05 \text{ MHz}$	$3.8 \text{ dBm} - 7/5(f_{\text{offset}}/\text{MHz} - 0.05) \text{ dB}$	100 kHz
$5 \text{ MHz} \leq \Delta f < \min(10 \text{ MHz}, \Delta f_{\text{max}})$	$5.05 \text{ MHz} \leq f_{\text{offset}} < \min(10.05 \text{ MHz}, f_{\text{offset}_{\text{max}}})$	-3.2 dBm	100 kHz
$10 \text{ MHz} \leq \Delta f \leq \Delta f_{\text{max}}$	$10.05 \text{ MHz} \leq f_{\text{offset}} < f_{\text{offset}_{\text{max}}}$	-4 dBm (Note 3)	100 kHz
NOTE 1: For a IAB supporting non-contiguous spectrum operation within any <i>operating band</i> , the emission limits within sub-block gaps is calculated as a cumulative sum of contributions from adjacent sub blocks on each side of the sub block gap. Exception is $\Delta f \geq 10\text{MHz}$ from both adjacent sub blocks on each side of the sub-block gap, where the emission limits within sub-block gaps shall be -4 dBm/100 kHz.			
NOTE 2: For a <i>multi-band RIB</i> with Inter RF Bandwidth gap < $2 \cdot \Delta f_{\text{OBUE}}$ the emission limits within the Inter RF Bandwidth gaps is calculated as a cumulative sum of contributions from adjacent sub-blocks or RF Bandwidth on each side of the Inter RF Bandwidth gap.			
NOTE 3: The requirement is not applicable when $\Delta f_{\text{max}} < 10 \text{ MHz}$.			
NOTE 4: The test requirement is derived from the basic limit a scaling factor of 9 dB and any applicable TT.			

**Table 6.7.4.5.1.1-2: Wide Area IAB-DU and Wide Area IAB-MT *operating band* unwanted emission limits
(3 GHz < NR bands ≤ 4.2 GHz) for Category A**

Frequency offset of measurement filter -3dB point, Δf	Frequency offset of measurement filter centre frequency, f_{offset}	Test requirement (Note 1, 2, 4)	Measurement bandwidth
$0 \text{ MHz} \leq \Delta f < 5 \text{ MHz}$	$0.05 \text{ MHz} \leq f_{\text{offset}} < 5.05 \text{ MHz}$	$4 \text{ dBm} - 7/5(f_{\text{offset}}/\text{MHz} - 0.05) \text{ dB}$	100 kHz
$5 \text{ MHz} \leq \Delta f < \min(10 \text{ MHz}, \Delta f_{\text{max}})$	$5.05 \text{ MHz} \leq f_{\text{offset}} < \min(10.05 \text{ MHz}, f_{\text{offset}_{\text{max}}})$	-3 dBm	100 kHz
$10 \text{ MHz} \leq \Delta f \leq \Delta f_{\text{max}}$	$10.5 \text{ MHz} \leq f_{\text{offset}} < f_{\text{offset}_{\text{max}}}$	-4 dBm (Note 3)	1MHz
NOTE 1: For a IAB supporting non-contiguous spectrum operation within any <i>operating band</i> , the emission limits within sub-block gaps is calculated as a cumulative sum of contributions from adjacent sub blocks on each side of the sub block gap, where the contribution from the far-end sub-block shall be scaled according to the measurement bandwidth of the near-end sub-block. Exception is $\Delta f \geq 10\text{MHz}$ from both adjacent sub blocks on each side of the sub-block gap, where the emission limits within sub-block gaps shall be -4 dBm/1 MHz.			
NOTE 2: For a <i>multi-band RIB</i> with Inter RF Bandwidth gap < $2 \cdot \Delta f_{\text{OBUE}}$ the emission limits within the Inter RF Bandwidth gaps is calculated as a cumulative sum of contributions from adjacent sub-blocks or RF Bandwidth on each side of the Inter RF Bandwidth gap, where the contribution from the far-end sub-block or RF Bandwidth shall be scaled according to the measurement bandwidth of the near-end sub-block or RF Bandwidth.			
NOTE 3: The requirement is not applicable when $\Delta f_{\text{max}} < 10 \text{ MHz}$.			
NOTE 4: The test requirement is derived from the basic limit a scaling factor of 9 dB and any applicable TT.			

**Table 6.7.4.5.1.1-3: Wide Area IAB-DU and Wide Area IAB-MT *operating band* unwanted emission limits
(4.2 GHz < NR bands ≤ 6 GHz) for Category A**

Frequency offset of measurement filter -3dB point, Δf	Frequency offset of measurement filter centre frequency, f_{offset}	Test requirement (Note 1, 2, 4)	Measurement bandwidth
$0 \text{ MHz} \leq \Delta f < 5 \text{ MHz}$	$0.05 \text{ MHz} \leq f_{\text{offset}} < 5.05 \text{ MHz}$	4 dBm-7/5(f_{offset} /MHz-0.05)dB	100 kHz
$5 \text{ MHz} \leq \Delta f < \min(10 \text{ MHz}, \Delta f_{\text{max}})$	$5.05 \text{ MHz} \leq f_{\text{offset}} < \min(10.05 \text{ MHz}, f_{\text{offset}_{\text{max}}})$	-3 dBm	100 kHz
$10 \text{ MHz} \leq \Delta f \leq \Delta f_{\text{max}}$	$10.5 \text{ MHz} \leq f_{\text{offset}} < f_{\text{offset}_{\text{max}}}$	-4 dBm (Note 3)	1MHz
<p>NOTE 1: For a IAB supporting non-contiguous spectrum operation within any <i>operating band</i>, the emission limits within sub-block gaps is calculated as a cumulative sum of contributions from adjacent sub blocks on each side of the sub block gap, where the contribution from the far-end sub-block shall be scaled according to the measurement bandwidth of the near-end sub-block. Exception is $\Delta f \geq 10\text{MHz}$ from both adjacent sub blocks on each side of the sub-block gap, where the emission limits within sub-block gaps shall be -4 dBm/1 MHz.</p> <p>NOTE 2: For a <i>multi-band RIB</i> with Inter RF Bandwidth gap < $2 \cdot \Delta f_{\text{OBUe}}$ the emission limits within the Inter RF Bandwidth gaps is calculated as a cumulative sum of contributions from adjacent sub-blocks or RF Bandwidth on each side of the Inter RF Bandwidth gap, where the contribution from the far-end sub-block or RF Bandwidth shall be scaled according to the measurement bandwidth of the near-end sub-block or RF Bandwidth.</p> <p>NOTE 3: The requirement is not applicable when $\Delta f_{\text{max}} < 10 \text{ MHz}$.</p> <p>NOTE 4: The test requirement is derived from the basic limit a scaling factor of 9 dB and any applicable TT.</p> <p>NOTE 5: Void</p>			

6.7.4.5.1.2 Wide Area IAB-DU and Wide Area IAB-MT (Category B)

For IAB-DU and IAB-MT operating in Bands n41, n77, n78, n79 for Category B emissions shall not exceed the maximum levels specified in tables 6.7.4.5.1.2-1 to 6.7.4.5.1.2-3:

**Table 6.7.4.5.1.2-1: Wide Area IAB-DU and IAB-MT *operating band* unwanted emission limits
(1 GHz < NR bands ≤ 3 GHz) for Category B**

Frequency offset of measurement filter -3dB point, Δf	Frequency offset of measurement filter centre frequency, f_{offset}	Test requirement (Note 1, 2, 4)	Measurement bandwidth
$0 \text{ MHz} \leq \Delta f < 5 \text{ MHz}$	$0.05 \text{ MHz} \leq f_{\text{offset}} < 5.05 \text{ MHz}$	3.8 dBm-7/5(f_{offset} /MHz-0.05)dB	100 kHz
$5 \text{ MHz} \leq \Delta f < \min(10 \text{ MHz}, \Delta f_{\text{max}})$	$5.05 \text{ MHz} \leq f_{\text{offset}} < \min(10.05 \text{ MHz}, f_{\text{offset}_{\text{max}}})$	-3.2 dBm	100 kHz
$10 \text{ MHz} \leq \Delta f \leq \Delta f_{\text{max}}$	$10.5 \text{ MHz} \leq f_{\text{offset}} < f_{\text{offset}_{\text{max}}}$	-6 dBm (3)	1MHz
<p>NOTE 1: For a IAB supporting non-contiguous spectrum operation within any <i>operating band</i>, the emission limits within sub-block gaps is calculated as a cumulative sum of contributions from adjacent sub blocks on each side of the sub block gap, where the contribution from the far-end sub-block shall be scaled according to the measurement bandwidth of the near-end sub-block. Exception is $\Delta f \geq 10\text{MHz}$ from both adjacent sub blocks on each side of the sub-block gap, where the emission limits within sub-block gaps shall be -6 dBm/1 MHz.</p> <p>NOTE 2: For a <i>multi-band RIB</i> with Inter RF Bandwidth gap < $2 \cdot \Delta f_{\text{OBUe}}$ the emission limits within the Inter RF Bandwidth gaps is calculated as a cumulative sum of contributions from adjacent sub-blocks or RF Bandwidth on each side of the Inter RF Bandwidth gap, where the contribution from the far-end sub-block or RF Bandwidth shall be scaled according to the measurement bandwidth of the near-end sub-block or RF Bandwidth.</p> <p>NOTE 3: The requirement is not applicable when $\Delta f_{\text{max}} < 10 \text{ MHz}$.</p> <p>NOTE 4: The test requirement is derived from the basic limit a scaling factor of 9 dB and any applicable TT.</p>			

**Table 6.7.4.5.1.2-2: Wide Area IAB-DU and IAB-MT operating band unwanted emission limits
(1 GHz < NR bands ≤ 3 GHz) for Category B**

Frequency offset of measurement filter -3dB point, Δf	Frequency offset of measurement filter centre frequency, f_{offset}	Test requirement (Note 1, 2, 4)	Measurement bandwidth
$0 \text{ MHz} \leq \Delta f < 5 \text{ MHz}$	$0.05 \text{ MHz} \leq f_{\text{offset}} < 5.05 \text{ MHz}$	4 dBm-7/5(f_{offset} /MHz-0.05)dB	100 kHz
$5 \text{ MHz} \leq \Delta f < \min(10 \text{ MHz}, \Delta f_{\text{max}})$	$5.05 \text{ MHz} \leq f_{\text{offset}} < \min(10.05 \text{ MHz}, f_{\text{offset}_{\text{max}}})$	-3 dBm	100 kHz
$10 \text{ MHz} \leq \Delta f \leq \Delta f_{\text{max}}$	$10.5 \text{ MHz} \leq f_{\text{offset}} < f_{\text{offset}_{\text{max}}}$	-6 dBm (Note 3)	1MHz
NOTE 1: For a IAB supporting non-contiguous spectrum operation within any <i>operating band</i> , the emission limits within sub-block gaps is calculated as a cumulative sum of contributions from adjacent sub blocks on each side of the sub block gap, where the contribution from the far-end sub-block shall be scaled according to the measurement bandwidth of the near-end sub-block. Exception is $\Delta f \geq 10\text{MHz}$ from both adjacent sub blocks on each side of the sub-block gap, where the emission limits within sub-block gaps shall be -6 dBm/1 MHz.			
NOTE 2: For a <i>multi-band RIB</i> with Inter RF Bandwidth gap < $2 \cdot \Delta f_{\text{OBUe}}$ the emission limits within the Inter RF Bandwidth gaps is calculated as a cumulative sum of contributions from adjacent sub-blocks or RF Bandwidth on each side of the Inter RF Bandwidth gap, where the contribution from the far-end sub-block or RF Bandwidth shall be scaled according to the measurement bandwidth of the near-end sub-block or RF Bandwidth.			
NOTE 3: The requirement is not applicable when $\Delta f_{\text{max}} < 10 \text{ MHz}$.			
NOTE 4: The test requirement is derived from the basic limit a scaling factor of 9 dB and any applicable TT.			

**Table 6.7.4.5.1.2-2: Wide Area IAB-DU and IAB-MT operating band unwanted emission limits
(4.2 GHz < NR bands ≤ 6 GHz) for Category B**

Frequency offset of measurement filter -3dB point, Δf	Frequency offset of measurement filter centre frequency, f_{offset}	Test requirement (Note 1, 2, 4)	Measurement bandwidth
$0 \text{ MHz} \leq \Delta f < 5 \text{ MHz}$	$0.05 \text{ MHz} \leq f_{\text{offset}} < 5.05 \text{ MHz}$	4 dBm-7/5(f_{offset} /MHz-0.05)dB	100 kHz
$5 \text{ MHz} \leq \Delta f < \min(10 \text{ MHz}, \Delta f_{\text{max}})$	$5.05 \text{ MHz} \leq f_{\text{offset}} < \min(10.05 \text{ MHz}, f_{\text{offset}_{\text{max}}})$	-3 dBm	100 kHz
$10 \text{ MHz} \leq \Delta f \leq \Delta f_{\text{max}}$	$10.5 \text{ MHz} \leq f_{\text{offset}} < f_{\text{offset}_{\text{max}}}$	-6 dBm (Note 3)	1MHz
NOTE 1: For a IAB supporting non-contiguous spectrum operation within any <i>operating band</i> , the emission limits within sub-block gaps is calculated as a cumulative sum of contributions from adjacent sub blocks on each side of the sub block gap, where the contribution from the far-end sub-block shall be scaled according to the measurement bandwidth of the near-end sub-block. Exception is $\Delta f \geq 10\text{MHz}$ from both adjacent sub blocks on each side of the sub-block gap, where the emission limits within sub-block gaps shall be -6 dBm/1 MHz.			
NOTE 2: For a <i>multi-band RIB</i> with Inter RF Bandwidth gap < $2 \cdot \Delta f_{\text{OBUe}}$ the emission limits within the Inter RF Bandwidth gaps is calculated as a cumulative sum of contributions from adjacent sub-blocks or RF Bandwidth on each side of the Inter RF Bandwidth gap, where the contribution from the far-end sub-block or RF Bandwidth shall be scaled according to the measurement bandwidth of the near-end sub-block or RF Bandwidth.			
NOTE 3: The requirement is not applicable when $\Delta f_{\text{max}} < 10 \text{ MHz}$.			
NOTE 4: The test requirement is derived from the basic limit a scaling factor of 9 dB and any applicable TT.			

6.7.4.6.1 Medium Range IAB-DU (Category A and B)

For Medium Range IAB-DU in NR bands ≤ 3 GHz, emissions shall not exceed the maximum levels specified in tables 6.7.4.6.1-1 and 6.7.4.6.1-4.

For Medium Range IAB-DU in 3GHz < NR bands ≤ 4.2 GHz, emissions shall not exceed the maximum levels specified in tables 6.7.4.6.1-2 and 6.7.4.6.1-5.

For Medium Range IAB-DU in 4.2GHz < NR bands ≤ 6 GHz, emissions shall not exceed the maximum levels specified in tables 6.7.4.6.1-3 and 6.7.4.6.1-6.

For the tables in this clause for IAB-DU type I-H and IAB-DU type I-O $P_{\text{rated},x} = P_{\text{rated},c,\text{cell}} - 10 \cdot \log_{10}(N_{\text{TXU, counted per cell}})$,

Table 6.7.4.6.1-1: Medium Range IAB-DU operating band unwanted emission limits, $31 < P_{\text{rated},x} \leq 38$ dBm (NR bands ≤ 3 GHz)

Frequency offset of measurement filter -3dB point, Δf	Frequency offset of measurement filter centre frequency, f_{offset}	Test requirement (Note 1, 2, 4)	Measurement bandwidth
$0 \text{ MHz} \leq \Delta f < 5 \text{ MHz}$	$0.05 \text{ MHz} \leq f_{\text{offset}} < 5.05 \text{ MHz}$	$P_{\text{rated},c,\text{TRP}} - 51.2 \text{ dB} - \frac{7}{5} \left(\frac{f_{\text{offset}}}{\text{MHz}} - 0.05 \right) \text{ dB}$	100 kHz
$5 \text{ MHz} \leq \Delta f < \min(10 \text{ MHz}, \Delta f_{\text{max}})$	$5.05 \text{ MHz} \leq f_{\text{offset}} < \min(10.05 \text{ MHz}, f_{\text{offset,max}})$	$P_{\text{rated},c,\text{TRP}} - 58.2 \text{ dB}$	100 kHz
$10 \text{ MHz} \leq \Delta f \leq \Delta f_{\text{max}}$	$10.05 \text{ MHz} \leq f_{\text{offset}} < f_{\text{offset,max}}$	$\text{Min}(P_{\text{rated},c,\text{TRP}} - 60 \text{ dB}, -16 \text{ dBm})$ (Note 3)	100 kHz

NOTE 1: For a IAB supporting non-contiguous spectrum operation within any *operating band* the emission limits within sub-block gaps is calculated as a cumulative sum of contributions from adjacent sub blocks on each side of the sub block gap. Exception is $\Delta f \geq 10$ MHz from both adjacent sub blocks on each side of the sub-block gap, where the emission limits within sub-block gaps shall be $\text{Min}(P_{\text{rated},c,\text{TRP}} - 60 \text{ dB}, -16 \text{ dBm})/100\text{kHz}$.

NOTE 2: For a *multi-band RIB* with Inter RF Bandwidth gap $< 2 \cdot \Delta f_{\text{OBUe}}$ the emission limits within the Inter RF Bandwidth gaps is calculated as a cumulative sum of contributions from adjacent sub-blocks or RF Bandwidth on each side of the Inter RF Bandwidth gap.

NOTE 3: The requirement is not applicable when $\Delta f_{\text{max}} < 10$ MHz.

NOTE 4: The test requirement is derived from the basic limit a scaling factor of 9 dB and any applicable TT.

Table 6.7.4.6.1-2: Medium Range IAB-DU operating band unwanted emission limits, $31 < P_{\text{rated},x} \leq 38$ dBm (3 GHz < NR bands ≤ 4.2 GHz)

Frequency offset of measurement filter -3dB point, Δf	Frequency offset of measurement filter centre frequency, f_{offset}	Test requirement (Note 1, 2, 4)	Measurement bandwidth
$0 \text{ MHz} \leq \Delta f < 5 \text{ MHz}$	$0.05 \text{ MHz} \leq f_{\text{offset}} < 5.05 \text{ MHz}$	$P_{\text{rated},c,\text{TRP}} - 51 \text{ dB} - \frac{7}{5} \left(\frac{f_{\text{offset}}}{\text{MHz}} - 0.05 \right) \text{ dB}$	100 kHz
$5 \text{ MHz} \leq \Delta f < \min(10 \text{ MHz}, \Delta f_{\text{max}})$	$5.05 \text{ MHz} \leq f_{\text{offset}} < \min(10.05 \text{ MHz}, f_{\text{offset,max}})$	$P_{\text{rated},c,\text{TRP}} - 58 \text{ dB}$	100 kHz
$10 \text{ MHz} \leq \Delta f \leq \Delta f_{\text{max}}$	$10.05 \text{ MHz} \leq f_{\text{offset}} < f_{\text{offset,max}}$	$\text{Min}(P_{\text{rated},c,\text{TRP}} - 60 \text{ dB}, -16 \text{ dBm})$ (Note 3)	100 kHz

NOTE 1: For a IAB supporting non-contiguous spectrum operation within any *operating band* the emission limits within sub-block gaps is calculated as a cumulative sum of contributions from adjacent sub blocks on each side of the sub block gap. Exception is $\Delta f \geq 10$ MHz from both adjacent sub blocks on each side of the sub-block gap, where the emission limits within sub-block gaps shall be $\text{Min}(P_{\text{rated},c,\text{TRP}} - 60 \text{ dB}, -16 \text{ dBm})/100\text{kHz}$.

NOTE 2: For a *multi-band RIB* with Inter RF Bandwidth gap $< 2 \cdot \Delta f_{\text{OBUe}}$ the emission limits within the Inter RF Bandwidth gaps is calculated as a cumulative sum of contributions from adjacent sub-blocks or RF Bandwidth on each side of the Inter RF Bandwidth gap.

NOTE 3: The requirement is not applicable when $\Delta f_{\text{max}} < 10$ MHz.

NOTE 4: The test requirement is derived from the basic limit a scaling factor of 9 dB and any applicable TT.

Table 6.7.4.6.1-3: Medium Range IAB-DU *operating band* unwanted emission limits, $31 < P_{\text{rated},x} \leq 38$ dBm (3 GHz < NR bands \leq 4.2 GHz)

Frequency offset of measurement filter -3dB point, Δf	Frequency offset of measurement filter centre frequency, f_{offset}	Test requirement (Note 1, 2, 4)	Measurement bandwidth
$0 \text{ MHz} \leq \Delta f < 5 \text{ MHz}$	$0.05 \text{ MHz} \leq f_{\text{offset}} < 5.05 \text{ MHz}$	$P_{\text{rated},c,\text{TRP}} - 51 \text{ dB} - \frac{7}{5} \left(\frac{f_{\text{offset}}}{\text{MHz}} - 0.05 \right) \text{ dB}$	100 kHz
$5 \text{ MHz} \leq \Delta f < \min(10 \text{ MHz}, \Delta f_{\text{max}})$	$5.05 \text{ MHz} \leq f_{\text{offset}} < \min(10.05 \text{ MHz}, f_{\text{offset}_{\text{max}}})$	$P_{\text{rated},c,\text{TRP}} - 58 \text{ dB}$	100 kHz
$10 \text{ MHz} \leq \Delta f \leq \Delta f_{\text{max}}$	$10.05 \text{ MHz} \leq f_{\text{offset}} < f_{\text{offset}_{\text{max}}}$	$\text{Min}(P_{\text{rated},c,\text{TRP}} - 60 \text{ dB}, -16 \text{ dBm})$ (Note 3)	100 kHz

NOTE 1: For a IAB supporting non-contiguous spectrum operation within any *operating band* the emission limits within sub-block gaps is calculated as a cumulative sum of contributions from adjacent sub blocks on each side of the sub block gap. Exception is $\Delta f \geq 10\text{MHz}$ from both adjacent sub blocks on each side of the sub-block gap, where the emission limits within sub-block gaps shall be $\text{Min}(P_{\text{rated},c,\text{TRP}} - 60 \text{ dB}, -16 \text{ dBm})/100\text{kHz}$.

NOTE 2: For a *multi-band RIB* with Inter RF Bandwidth gap $< 2 \cdot \Delta f_{\text{OBUE}}$ the emission limits within the Inter RF Bandwidth gaps is calculated as a cumulative sum of contributions from adjacent sub-blocks or RF Bandwidth on each side of the Inter RF Bandwidth gap.

NOTE 3: The requirement is not applicable when $\Delta f_{\text{max}} < 10 \text{ MHz}$.

NOTE 4: The test requirement is derived from the basic limit a scaling factor of 9 dB and any applicable TT.

Table 6.7.4.6.1-4: Medium Range IAB-DU *operating band* unwanted emission limits, $P_{\text{rated},x} \leq 31$ dBm (NR bands \leq 3 GHz)

Frequency offset of measurement filter -3dB point, Δf	Frequency offset of measurement filter centre frequency, f_{offset}	Test requirement (Note 1, 2, 4)	Measurement bandwidth
$0 \text{ MHz} \leq \Delta f < 5 \text{ MHz}$	$0.05 \text{ MHz} \leq f_{\text{offset}} < 5.05 \text{ MHz}$	$-11.2 \text{ dB} - \frac{7}{5} \left(\frac{f_{\text{offset}}}{\text{MHz}} - 0.05 \right) \text{ dB}$	100 kHz
$5 \text{ MHz} \leq \Delta f < \min(10 \text{ MHz}, \Delta f_{\text{max}})$	$5.05 \text{ MHz} \leq f_{\text{offset}} < \min(10.05 \text{ MHz}, f_{\text{offset}_{\text{max}}})$	-18.2 dBm	100 kHz
$10 \text{ MHz} \leq \Delta f \leq \Delta f_{\text{max}}$	$10.05 \text{ MHz} \leq f_{\text{offset}} < f_{\text{offset}_{\text{max}}}$	-20 dBm (Note 3)	100 kHz

NOTE 1: For a IAB supporting non-contiguous spectrum operation within any *operating band* the emission limits within sub-block gaps is calculated as a cumulative sum of contributions from adjacent sub blocks on each side of the sub block gap. Exception is $\Delta f \geq 10\text{MHz}$ from both adjacent sub blocks on each side of the sub-block gap, where the emission limits within sub-block gaps shall be -20 dBm/100kHz.

NOTE 2: For a *multi-band RIB* with Inter RF Bandwidth gap $< 2 \cdot \Delta f_{\text{OBUE}}$ the emission limits within the Inter RF Bandwidth gaps is calculated as a cumulative sum of contributions from adjacent sub-blocks or RF Bandwidth on each side of the Inter RF Bandwidth gap.

NOTE 3: The requirement is not applicable when $\Delta f_{\text{max}} < 10 \text{ MHz}$.

NOTE 4: The test requirement is derived from the basic limit a scaling factor of 9 dB and any applicable TT.

Table 6.7.4.6.1-5: Medium Range IAB-DU operating band unwanted emission limits, $P_{\text{rated},x} \leq 31$ dBm (3 GHz < NR bands \leq 4.2 GHz)

Frequency offset of measurement filter -3dB point, Δf	Frequency offset of measurement filter centre frequency, f_{offset}	Test requirement (Note 1, 2, 4)	Measurement bandwidth
$0 \text{ MHz} \leq \Delta f < 5 \text{ MHz}$	$0.05 \text{ MHz} \leq f_{\text{offset}} < 5.05 \text{ MHz}$	$-1 \text{ dB} - \frac{7}{5} \left(\frac{f_{\text{offset}}}{\text{MHz}} - 0.05 \right) \text{ dB}$	100 kHz
$5 \text{ MHz} \leq \Delta f < \min(10 \text{ MHz}, \Delta f_{\text{max}})$	$5.05 \text{ MHz} \leq f_{\text{offset}} < \min(10.05 \text{ MHz}, f_{\text{offset}_{\text{max}}})$	-18 dBm	100 kHz
$10 \text{ MHz} \leq \Delta f \leq \Delta f_{\text{max}}$	$10.05 \text{ MHz} \leq f_{\text{offset}} < f_{\text{offset}_{\text{max}}}$	-20 dBm (Note 3)	100 kHz
<p>NOTE 1: For a IAB supporting non-contiguous spectrum operation within any <i>operating band</i> the emission limits within sub-block gaps is calculated as a cumulative sum of contributions from adjacent sub blocks on each side of the sub block gap. Exception is $\Delta f \geq 10\text{MHz}$ from both adjacent sub blocks on each side of the sub-block gap, where the emission limits within sub-block gaps shall be -20 dBm/100kHz.</p> <p>NOTE 2: For a <i>multi-band RIB</i> with Inter RF Bandwidth gap < $2 \cdot \Delta f_{\text{OBUe}}$ the emission limits within the Inter RF Bandwidth gaps is calculated as a cumulative sum of contributions from adjacent sub-blocks or RF Bandwidth on each side of the Inter RF Bandwidth gap.</p> <p>NOTE 3: The requirement is not applicable when $\Delta f_{\text{max}} < 10$ MHz.</p> <p>NOTE 4: The test requirement is derived from the basic limit a scaling factor of 9 dB and any applicable TT.</p>			

Table 6.7.4.6.1-6: Medium Range IAB-DU operating band unwanted emission limits, $P_{\text{rated},x} \leq 31$ dBm (4.2 GHz < NR bands \leq 6 GHz)

Frequency offset of measurement filter -3dB point, Δf	Frequency offset of measurement filter centre frequency, f_{offset}	Test requirement (Note 1, 2, 4)	Measurement bandwidth
$0 \text{ MHz} \leq \Delta f < 5 \text{ MHz}$	$0.05 \text{ MHz} \leq f_{\text{offset}} < 5.05 \text{ MHz}$	$-1 \text{ dB} - \frac{7}{5} \left(\frac{f_{\text{offset}}}{\text{MHz}} - 0.05 \right) \text{ dB}$	100 kHz
$5 \text{ MHz} \leq \Delta f < \min(10 \text{ MHz}, \Delta f_{\text{max}})$	$5.05 \text{ MHz} \leq f_{\text{offset}} < \min(10.05 \text{ MHz}, f_{\text{offset}_{\text{max}}})$	-18 dBm	100 kHz
$10 \text{ MHz} \leq \Delta f \leq \Delta f_{\text{max}}$	$10.05 \text{ MHz} \leq f_{\text{offset}} < f_{\text{offset}_{\text{max}}}$	-20 dBm (Note 3)	100 kHz
<p>NOTE 1: For a IAB supporting non-contiguous spectrum operation within any <i>operating band</i> the emission limits within sub-block gaps is calculated as a cumulative sum of contributions from adjacent sub blocks on each side of the sub block gap. Exception is $\Delta f \geq 10\text{MHz}$ from both adjacent sub blocks on each side of the sub-block gap, where the emission limits within sub-block gaps shall be -20 dBm/100kHz.</p> <p>NOTE 2: For a <i>multi-band RIB</i> with Inter RF Bandwidth gap < $2 \cdot \Delta f_{\text{OBUe}}$ the emission limits within the Inter RF Bandwidth gaps is calculated as a cumulative sum of contributions from adjacent sub-blocks or RF Bandwidth on each side of the Inter RF Bandwidth gap.</p> <p>NOTE 3: The requirement is not applicable when $\Delta f_{\text{max}} < 10$ MHz.</p> <p>NOTE 4: The test requirement is derived from the basic limit a scaling factor of 9 dB and any applicable TT.</p>			

6.7.4.6.2 Local Area IAB-DU and Local Area IAB-MT (Category A and B)

For Local Area IAB-DU and Local Area IAB-MT in NR bands \leq 3 GHz, emissions shall not exceed the maximum levels specified in table 6.7.4.6.2-1.

For Local Area IAB-DU and Local Area IAB-MT in 3 GHz < NR bands \leq 4.2 GHz, emissions shall not exceed the maximum levels specified in table 6.7.4.6.2-2.

For Local Area IAB-DU and Local Area IAB-MT in 4.2 GHz < NR bands \leq 6 GHz, emissions shall not exceed the maximum levels specified in table 6.7.4.6.2-3.

Table 6.7.4.6.2-1: Local Area IAB-DU and Local Area IAB-MT operating band unwanted emission limits (NR bands ≤ 3 GHz)

Frequency offset of measurement filter -3dB point, Δf	Frequency offset of measurement filter centre frequency, f_{offset}	Test requirement (Note 1, 2, 4)	Measurement bandwidth
$0 \text{ MHz} \leq \Delta f < 5 \text{ MHz}$	$0.05 \text{ MHz} \leq f_{\text{offset}} < 5.05 \text{ MHz}$	$-19.2\text{dB} - \frac{7}{5} \left(\frac{f_{\text{offset}}}{\text{MHz}} - 0.05 \right) \text{dB}$	100 kHz
$5 \text{ MHz} \leq \Delta f < \min(10 \text{ MHz}, \Delta f_{\text{max}})$	$5.05 \text{ MHz} \leq f_{\text{offset}} < \min(10.05 \text{ MHz}, f_{\text{offset}_{\text{max}}})$	-26.2 dBm	100 kHz
$10 \text{ MHz} \leq \Delta f \leq \Delta f_{\text{max}}$	$10.05 \text{ MHz} \leq f_{\text{offset}} < f_{\text{offset}_{\text{max}}}$	-28 dBm (Note 3)	100 kHz
<p>NOTE 1: For a IAB supporting non-contiguous spectrum operation within any <i>operating band</i> the emission limits within sub-block gaps is calculated as a cumulative sum of contributions from adjacent sub blocks on each side of the sub block gap. Exception is $\Delta f \geq 10\text{MHz}$ from both adjacent sub blocks on each side of the sub-block gap, where the emission limits within sub-block gaps shall be -28 dBm/100kHz.</p> <p>NOTE 2: For a <i>multi-band RIB</i> with Inter RF Bandwidth gap $< 2 \cdot \Delta f_{\text{BUE}}$ the emission limits within the Inter RF Bandwidth gaps is calculated as a cumulative sum of contributions from adjacent sub-blocks or RF Bandwidth on each side of the Inter RF Bandwidth gap.</p> <p>NOTE 3: The requirement is not applicable when $\Delta f_{\text{max}} < 10 \text{ MHz}$.</p> <p>NOTE 4: The test requirement is derived from the basic limit a scaling factor of 9 dB and any applicable TT.</p> <p>NOTE 5: Void</p>			

Table 6.7.4.6.2-2: Local Area IAB-DU and Local Area IAB-MT operating band unwanted emission limits (3 GHz < NR bands ≤ 4.2 GHz)

Frequency offset of measurement filter -3dB point, Δf	Frequency offset of measurement filter centre frequency, f_{offset}	Test requirement (Note 1, 2, 4)	Measurement bandwidth
$0 \text{ MHz} \leq \Delta f < 5 \text{ MHz}$	$0.05 \text{ MHz} \leq f_{\text{offset}} < 5.05 \text{ MHz}$	$-19\text{dB} - \frac{7}{5} \left(\frac{f_{\text{offset}}}{\text{MHz}} - 0.05 \right) \text{dB}$	100 kHz
$5 \text{ MHz} \leq \Delta f < \min(10 \text{ MHz}, \Delta f_{\text{max}})$	$5.05 \text{ MHz} \leq f_{\text{offset}} < \min(10.05 \text{ MHz}, f_{\text{offset}_{\text{max}}})$	-26 dBm	100 kHz
$10 \text{ MHz} \leq \Delta f \leq \Delta f_{\text{max}}$	$10.05 \text{ MHz} \leq f_{\text{offset}} < f_{\text{offset}_{\text{max}}}$	-28 dBm (Note 3)	100 kHz
<p>NOTE 1: For a IAB supporting non-contiguous spectrum operation within any <i>operating band</i> the emission limits within sub-block gaps is calculated as a cumulative sum of contributions from adjacent sub blocks on each side of the sub block gap. Exception is $\Delta f \geq 10\text{MHz}$ from both adjacent sub blocks on each side of the sub-block gap, where the emission limits within sub-block gaps shall be -28 dBm/100kHz.</p> <p>NOTE 2: For a <i>multi-band RIB</i> with Inter RF Bandwidth gap $< 2 \cdot \Delta f_{\text{BUE}}$ the emission limits within the Inter RF Bandwidth gaps is calculated as a cumulative sum of contributions from adjacent sub-blocks or RF Bandwidth on each side of the Inter RF Bandwidth gap.</p> <p>NOTE 3: The requirement is not applicable when $\Delta f_{\text{max}} < 10 \text{ MHz}$.</p> <p>NOTE 4: The test requirement is derived from the basic limit a scaling factor of 9 dB and any applicable TT.</p>			

Table 6.7.4.6.2-3: Local Area IAB-DU and Local Area IAB-MT operating band unwanted emission limits (4.2 GHz < NR bands ≤ 6 GHz)

Frequency offset of measurement filter -3dB point, Δf	Frequency offset of measurement filter centre frequency, f_{offset}	Test requirement (Note 1, 2, 4)	Measurement bandwidth
$0 \text{ MHz} \leq \Delta f < 5 \text{ MHz}$	$0.05 \text{ MHz} \leq f_{\text{offset}} < 5.05 \text{ MHz}$	$-19\text{dB} - \frac{7}{5} \left(\frac{f_{\text{offset}}}{\text{MHz}} - 0.05 \right) \text{dB}$	100 kHz
$5 \text{ MHz} \leq \Delta f < \min(10 \text{ MHz}, \Delta f_{\text{max}})$	$5.05 \text{ MHz} \leq f_{\text{offset}} < \min(10.05 \text{ MHz}, f_{\text{offset}_{\text{max}}})$	-26 dBm	100 kHz
$10 \text{ MHz} \leq \Delta f \leq \Delta f_{\text{max}}$	$10.05 \text{ MHz} \leq f_{\text{offset}} < f_{\text{offset}_{\text{max}}}$	-28 dBm (Note 3)	100 kHz
<p>NOTE 1: For a IAB supporting non-contiguous spectrum operation within any <i>operating band</i> the emission limits within sub-block gaps is calculated as a cumulative sum of contributions from adjacent sub blocks on each side of the sub block gap. Exception is $\Delta f \geq 10\text{MHz}$ from both adjacent sub blocks on each side of the sub-block gap, where the emission limits within sub-block gaps shall be -28 dBm/100kHz.</p> <p>NOTE 2: For a <i>multi-band RIB</i> with Inter RF Bandwidth gap < $2 \cdot \Delta f_{\text{OBUE}}$ the emission limits within the Inter RF Bandwidth gaps is calculated as a cumulative sum of contributions from adjacent sub-blocks or RF Bandwidth on each side of the Inter RF Bandwidth gap.</p> <p>NOTE 3: The requirement is not applicable when $\Delta f_{\text{max}} < 10 \text{ MHz}$.</p> <p>NOTE 4: The test requirement is derived from the basic limit a scaling factor of 9 dB and any applicable TT.</p>			

6.7.4.6.3 Additional requirements

6.7.4.6.3.1 Limits in FCC Title 47

In addition to the requirements in clauses 6.6.4.2.1, 6.6.4.2.2, 6.6.4.2.3 and 6.6.4.2.4 in TS 38.174 [2], the IAB-DU and IAB-MT may have to comply with the applicable emission limits established by FCC Title 47 [14], when deployed in regions where those limits are applied, and under the conditions declared by the manufacturer.

6.7.4.6.4 IAB type 2-O

The requirements of either clause 6.7.4.6.4.1 (Category A limits) or clause 6.7.4.6.4.1 (Category B limits) shall apply. The application of either Category A or Category B limits shall be the same as for General OTA transmitter spurious emissions requirements (*IAB type 2-O*) in clause 6.7.5.2.5.2. In addition, the limits in clause 6.7.4.5.2.4 may also apply. The emission measurement result shall not exceed the maximum levels specified in the tables below, where:

- Δf is the separation between the *contiguous transmission bandwidth* edge frequency and the nominal -3dB point of the measuring filter closest to the *contiguous transmission bandwidth* edge.
- f_{offset} is the separation between the *contiguous transmission bandwidth* edge frequency and the centre of the measuring filter.
- $f_{\text{offset}_{\text{max}}}$ is the offset to the frequency Δf_{OBUE} outside the downlink *operating band*, where Δf_{OBUE} is defined in table 6.7.1-1.

In addition, inside any sub-block gap for a *RIB* operating in non-contiguous spectrum, emissions shall not exceed the cumulative sum of the test requirements specified for the adjacent sub blocks on each side of the sub block gap. The test requirement for each sub-block is specified in the clauses 6.7.4.5.2.2 and 6.7.4.5.2.3 below, where in this case:

- Δf is the separation between the sub block edge frequency and the nominal -3 dB point of the measuring filter closest to the sub block edge.
- f_{offset} is the separation between the sub block edge frequency and the centre of the measuring filter.
- $f_{\text{offset}_{\text{max}}}$ is equal to the sub block gap bandwidth minus half of the bandwidth of the measuring filter.
- Δf_{max} is equal to $f_{\text{offset}_{\text{max}}}$ minus half of the bandwidth of the measuring filter.

6.7.4.6.4.1 OTA operating band unwanted emission limits (Category A)

The power of unwanted emission of IAB-DU shall not exceed the limits in table 6.7.4.6.4.1-1 or 6.7.4.6.4.1-2. The power of unwanted emission of IAB-MT shall not exceed the limits in table 6.7.4.6.4.1-3 or 6.7.4.6.4.1-4.

Table 6.7.4.6.4.1-1: OBUE limits applicable for IAB-DU in the frequency range 24.25 – 33.4 GHz

Frequency offset of measurement filter -3 dB point, Δf	Frequency offset of measurement filter centre frequency, f_{offset}	Test limit	Measurement bandwidth
$0 \text{ MHz} \leq \Delta f < 0.1 * \text{BW}_{\text{contiguous}}$	$0.5 \text{ MHz} \leq f_{\text{offset}} < 0.1 * \text{BW}_{\text{contiguous}} + 0.5 \text{ MHz}$	Min(-2.3 dBm, Max($P_{\text{rated,t,TRP}} - 32.3 \text{ dB}$, -9.3 dBm))	1 MHz
$0.1 * \text{BW}_{\text{contiguous}} \leq \Delta f < \Delta f_{\text{max}}$	$0.1 * \text{BW}_{\text{contiguous}} + 0.5 \text{ MHz} \leq f_{\text{offset}} < f_{\text{offset}_{\text{max}}}$	Min(-13 dBm, Max($P_{\text{rated,t,TRP}} - 43 \text{ dB}$, -20 dBm))	1 MHz
NOTE: For non-contiguous spectrum operation within any operating band the limit within sub-block gaps is calculated as a cumulative sum of contributions from adjacent sub blocks on each side of the sub block gap.			

Table 6.7.4.6.4.1-2: OBUE limits applicable for IAB-DU in the frequency range 37 GHz – 52.6 GHz

Frequency offset of measurement filter -3 dB point, Δf	Frequency offset of measurement filter centre frequency, f_{offset}	Test limit	Measurement bandwidth
$0 \text{ MHz} \leq \Delta f < 0.1 * \text{BW}_{\text{contiguous}}$	$0.5 \text{ MHz} \leq f_{\text{offset}} < 0.1 * \text{BW}_{\text{contiguous}} + 0.5 \text{ MHz}$	Min(-2.3 dBm, Max($P_{\text{rated,t,TRP}} - 30.3 \text{ dB}$, -9.3 dBm))	1 MHz
$0.1 * \text{BW}_{\text{contiguous}} \leq \Delta f < \Delta f_{\text{max}}$	$0.1 * \text{BW}_{\text{contiguous}} + 0.5 \text{ MHz} \leq f_{\text{offset}} < f_{\text{offset}_{\text{max}}}$	Min(-13 dBm, Max($P_{\text{rated,t,TRP}} - 41 \text{ dB}$, -20 dBm))	1 MHz
NOTE: For non-contiguous spectrum operation within any operating band the limit within sub-block gaps is calculated as a cumulative sum of contributions from adjacent sub blocks on each side of the sub block gap.			

Table 6.7.4.6.4.1-3: OBUE limits applicable for IAB-MT in the frequency range 24.25 – 33.4 GHz

Frequency offset of measurement filter -3 dB point, Δf	Frequency offset of measurement filter centre frequency, f_{offset}	Test limit	Measurement bandwidth
$0 \text{ MHz} \leq \Delta f < 0.1 * \text{BW}_{\text{contiguous}}$	$0.5 \text{ MHz} \leq f_{\text{offset}} < 0.1 * \text{BW}_{\text{contiguous}} + 0.5 \text{ MHz}$	Min(-2.1 dBm, Max($P_{\text{rated,t,TRP}} - 32.1 \text{ dB}$, -9.1 dBm))	1 MHz
$0.1 * \text{BW}_{\text{contiguous}} \leq \Delta f < \Delta f_{\text{max}}$	$0.1 * \text{BW}_{\text{contiguous}} + 0.5 \text{ MHz} \leq f_{\text{offset}} < f_{\text{offset}_{\text{max}}}$	Min(-13 dBm, Max($P_{\text{rated,t,TRP}} - 43 \text{ dB}$, -20 dBm))	1 MHz
NOTE: For non-contiguous spectrum operation within any operating band the limit within sub-block gaps is calculated as a cumulative sum of contributions from adjacent sub blocks on each side of the sub block gap.			

Table 6.7.4.6.4.1-4: OBUE limits applicable for IAB-MT in the frequency range 37 GHz – 52.6 GHz

Frequency offset of measurement filter -3 dB point, Δf	Frequency offset of measurement filter centre frequency, f_{offset}	Test limit	Measurement bandwidth
$0 \text{ MHz} \leq \Delta f < 0.1 * \text{BW}_{\text{contiguous}}$	$0.5 \text{ MHz} \leq f_{\text{offset}} < 0.1 * \text{BW}_{\text{contiguous}} + 0.5 \text{ MHz}$	Min(-2.0 dBm, Max($P_{\text{rated,t,TRP}} - 30.0 \text{ dB}$, -9.0 dBm))	1 MHz
$0.1 * \text{BW}_{\text{contiguous}} \leq \Delta f < \Delta f_{\text{max}}$	$0.1 * \text{BW}_{\text{contiguous}} + 0.5 \text{ MHz} \leq f_{\text{offset}} < f_{\text{offset}_{\text{max}}}$	Min(-13 dBm, Max($P_{\text{rated,t,TRP}} - 41 \text{ dB}$, -20 dBm))	1 MHz
NOTE: For non-contiguous spectrum operation within any operating band the limit within sub-block gaps is calculated as a cumulative sum of contributions from adjacent sub blocks on each side of the sub block gap.			

6.7.4.6.4.2 OTA operating band unwanted emission limits (Category B)

The power of unwanted emission of IAB-DU shall not exceed the limits in table 6.7.4.6.4.2-1 or 6.7.4.6.4.2-2. The power of unwanted emission of IAB-MT shall not exceed the limits in table 6.7.4.6.4.2-3 or 6.7.4.6.4.2-4.

Table 6.7.4.6.4.2-1: OBUE limits applicable for IAB-DU in the frequency range 24.25 – 33.4 GHz

Frequency offset of measurement filter -3 dB point, Δf	Frequency offset of measurement filter centre frequency, f_{offset}	Test limit	Measurement bandwidth
$0 \text{ MHz} \leq \Delta f < 0.1 * BW_{\text{contiguous}}$	$0.5 \text{ MHz} \leq f_{\text{offset}} < 0.1 * BW_{\text{contiguous}} + 0.5 \text{ MHz}$	Min(-2.3 dBm, Max($P_{\text{rated,t,TRP}} - 32.3 \text{ dB}$, -9.3 dBm))	1 MHz
$0.1 * BW_{\text{contiguous}} \leq \Delta f < \Delta f_{\text{B}}$	$0.1 * BW_{\text{contiguous}} + 0.5 \text{ MHz} \leq f_{\text{offset}} < \Delta f_{\text{B}} + 0.5 \text{ MHz}$	Min(-13 dBm, Max($P_{\text{rated,t,TRP}} - 43 \text{ dB}$, -20 dBm))	1 MHz
$\Delta f_{\text{B}} \leq \Delta f < \Delta f_{\text{max}}$	$\Delta f_{\text{B}} + 5 \text{ MHz} \leq f_{\text{offset}} < f_{\text{offset}_{\text{max}}}$	Min(-5 dBm, Max($P_{\text{rated,t,TRP}} - 33 \text{ dB}$, -10 dBm))	10 MHz

NOTE 1: For non-contiguous spectrum operation within any *operating band* the limit within sub-block gaps is calculated as a cumulative sum of contributions from adjacent sub blocks on each side of the sub block gap.

NOTE 2: $\Delta f_{\text{B}} = 2 * BW_{\text{contiguous}}$ when $BW_{\text{contiguous}} \leq 500 \text{ MHz}$, otherwise $\Delta f_{\text{B}} = BW_{\text{contiguous}} + 500 \text{ MHz}$.

Table 6.7.4.6.4.2-2: OBUE limits applicable for IAB-DU in the frequency range 37 – 52.6 GHz

Frequency offset of measurement filter -3 dB point, Δf	Frequency offset of measurement filter centre frequency, f_{offset}	Test limit	Measurement bandwidth
$0 \text{ MHz} \leq \Delta f < 0.1 * BW_{\text{contiguous}}$	$0.5 \text{ MHz} \leq f_{\text{offset}} < 0.1 * BW_{\text{contiguous}} + 0.5 \text{ MHz}$	Min(-2.3 dBm, Max($P_{\text{rated,t,TRP}} - 30.3 \text{ dB}$, -9.3 dBm))	1 MHz
$0.1 * BW_{\text{contiguous}} \leq \Delta f < \Delta f_{\text{B}}$	$0.1 * BW_{\text{contiguous}} + 0.5 \text{ MHz} \leq f_{\text{offset}} < \Delta f_{\text{B}} + 0.5 \text{ MHz}$	Min(-13 dBm, Max($P_{\text{rated,t,TRP}} - 41 \text{ dB}$, -20 dBm))	1 MHz
$\Delta f_{\text{B}} \leq \Delta f < \Delta f_{\text{max}}$	$\Delta f_{\text{B}} + 5 \text{ MHz} \leq f_{\text{offset}} < f_{\text{offset}_{\text{max}}}$	Min(-5 dBm, Max($P_{\text{rated,t,TRP}} - 31 \text{ dB}$, -10 dBm))	10 MHz

NOTE 1: For non-contiguous spectrum operation within any *operating band* the limit within sub-block gaps is calculated as a cumulative sum of contributions from adjacent sub blocks on each side of the sub block gap.

NOTE 2: $\Delta f_{\text{B}} = 2 * BW_{\text{contiguous}}$ when $BW_{\text{contiguous}} \leq 500 \text{ MHz}$, otherwise $\Delta f_{\text{B}} = BW_{\text{contiguous}} + 500 \text{ MHz}$.

Table 6.7.4.6.4.2-3: OBUE limits applicable for IAB-MT in the frequency range 24.25 – 33.4 GHz

Frequency offset of measurement filter -3 dB point, Δf	Frequency offset of measurement filter centre frequency, f_{offset}	Test limit	Measurement bandwidth
$0 \text{ MHz} \leq \Delta f < 0.1 * BW_{\text{contiguous}}$	$0.5 \text{ MHz} \leq f_{\text{offset}} < 0.1 * BW_{\text{contiguous}} + 0.5 \text{ MHz}$	Min(-2.1 dBm, Max($P_{\text{rated,t,TRP}} - 32.1 \text{ dB}$, -9.1 dBm))	1 MHz
$0.1 * BW_{\text{contiguous}} \leq \Delta f < \Delta f_{\text{B}}$	$0.1 * BW_{\text{contiguous}} + 0.5 \text{ MHz} \leq f_{\text{offset}} < \Delta f_{\text{B}} + 0.5 \text{ MHz}$	Min(-13 dBm, Max($P_{\text{rated,t,TRP}} - 43 \text{ dB}$, -20 dBm))	1 MHz
$\Delta f_{\text{B}} \leq \Delta f < \Delta f_{\text{max}}$	$\Delta f_{\text{B}} + 5 \text{ MHz} \leq f_{\text{offset}} < f_{\text{offset}_{\text{max}}}$	Min(-5 dBm, Max($P_{\text{rated,t,TRP}} - 33 \text{ dB}$, -10 dBm))	10 MHz

NOTE 1: For non-contiguous spectrum operation within any *operating band* the limit within sub-block gaps is calculated as a cumulative sum of contributions from adjacent sub blocks on each side of the sub block gap.

NOTE 2: $\Delta f_{\text{B}} = 2 * BW_{\text{contiguous}}$ when $BW_{\text{contiguous}} \leq 500 \text{ MHz}$, otherwise $\Delta f_{\text{B}} = BW_{\text{contiguous}} + 500 \text{ MHz}$.

Table 6.7.4.6.4.2-4: OBUE limits applicable for IAB- MT in the frequency range 37 – 52.6 GHz

Frequency offset of measurement filter -3 dB point, Δf	Frequency offset of measurement filter centre frequency, f_{offset}	Test limit	Measurement bandwidth
$0 \text{ MHz} \leq \Delta f < 0.1 * \text{BW}_{\text{contiguous}}$	$0.5 \text{ MHz} \leq f_{\text{offset}} < 0.1 * \text{BW}_{\text{contiguous}} + 0.5 \text{ MHz}$	Min(-2.0 dBm, Max($P_{\text{rated,t,TRP}} - 30.0 \text{ dB}$, -9.0 dBm))	1 MHz
$0.1 * \text{BW}_{\text{contiguous}} \leq \Delta f < \Delta f_{\text{B}}$	$0.1 * \text{BW}_{\text{contiguous}} + 0.5 \text{ MHz} \leq f_{\text{offset}} < \Delta f_{\text{B}} + 0.5 \text{ MHz}$	Min(-13 dBm, Max($P_{\text{rated,t,TRP}} - 41 \text{ dB}$, -20 dBm))	1 MHz
$\Delta f_{\text{B}} \leq \Delta f < \Delta f_{\text{max}}$	$\Delta f_{\text{B}} + 5 \text{ MHz} \leq f_{\text{offset}} < f_{\text{offset}_{\text{max}}}$	Min(-5 dBm, Max($P_{\text{rated,t,TRP}} - 31 \text{ dB}$, -10 dBm))	10 MHz
NOTE 1: For non-contiguous spectrum operation within any <i>operating band</i> the limit within sub-block gaps is calculated as a cumulative sum of contributions from adjacent sub blocks on each side of the sub block gap.			
NOTE 2: $\Delta f_{\text{B}} = 2 * \text{BW}_{\text{contiguous}}$ when $\text{BW}_{\text{contiguous}} \leq 500 \text{ MHz}$, otherwise $\Delta f_{\text{B}} = \text{BW}_{\text{contiguous}} + 500 \text{ MHz}$.			

6.7.4.6.4.3 Additional OTA operating band unwanted emission limits

6.7.4.6.4.3.1 Protection of Earth Exploration Satellite Service

For IAB-Node operating in the frequency range 24.25 – 27.5 GHz, the power of unwanted emission shall not exceed the limits in table 6.7.4.6.4.3.1-1.

Table 6.7.4.6.4.3.1-1: OBUE limits for protection of Earth Exploration Satellite Service

Frequency range	Measurement filter centre frequency range	Limit	Measurement Bandwidth
23.6 – 24 GHz	23.7 – 23.9 GHz	-3 dBm (Note 1)	200 MHz
23.6 – 24 GHz	23.7 – 23.9 GHz	-9 dBm (Note 2)	200 MHz
NOTE 1: This limit applies to IAB-DU and IAB-MT brought into use on or before 1 September 2027.			
NOTE 2: This limit applies to IAB-DU and IAB-MT brought into use after 1 September 2027.			

6.7.5 OTA transmitter spurious emissions

6.7.5.1 General

For IAB-DU, the OTA transmitter spurious emission limits for FR1 shall apply from 30 MHz to 12.75 GHz, excluding the frequency range from Δf_{OBUE} below the lowest frequency of each supported downlink *operating band*, up to Δf_{OBUE} above the highest frequency of each supported downlink *operating band*, where the Δf_{OBUE} is defined in table 9.7.1-1. For some FR1 *operating bands*, the upper limit is higher than 12.75 GHz in order to comply with the 5th harmonic limit of the downlink *operating band*, as specified in Recommendation ITU-R SM.329 [10].

For IAB-MT, the OTA transmitter spurious emission limits for FR1 shall apply from 30 MHz to 12.75 GHz, excluding the frequency range from Δf_{OBUE} below the lowest frequency of each supported uplink *operating band*, up to Δf_{OBUE} above the highest frequency of each supported uplink *operating band*, where the Δf_{OBUE} is defined in table 9.7.1-2. For some FR1 *operating bands*, the upper limit is higher than 12.75 GHz in order to comply with the 5th harmonic limit of the uplink *operating band*, as specified in Recommendation ITU-R SM.329 [10].

For *multi-band RIB* each supported *operating band* and Δf_{OBUE} MHz around each band are excluded from the OTA transmitter spurious emissions requirements.

The requirements shall apply whatever the type of transmitter considered (single carrier or multi-carrier). It applies for all transmission modes foreseen by the manufacturer's specification.

IAB-DU type 1-O and *IAB-MT type 1-O* requirements consist of OTA transmitter spurious emission requirements based on TRP and co-location requirements not based on TRP.

6.7.5.2 General OTA transmitter spurious emissions requirements

6.7.5.2.1 Definition and applicability

The general OTA transmitter spurious emissions requirements are specified as TRP per RIB, per cell, unless otherwise specified.

6.7.5.2.2 Minimum requirement

The minimum requirement for *IAB type 1-O* is specified in TS 38.174 [2], clause 9.7.5.2.

The minimum requirement for *IAB type 2-O* is specified in TS 38.174 [2], clause 9.7.5.3.

6.7.5.2.3 Test purpose

The test purpose is to verify if the radiated spurious emissions from the IAB at the RIB are within the specified minimum requirements.

6.7.5.2.4 Method of test

6.7.5.2.4.1 Initial conditions

Test environment: Normal; see annex B.2.

RF channels to be tested for single carrier, see clause 4.9.1:

- For FR1:
 - B when testing from 30 MHz to $F_{DL_low} - \Delta f_{OBUE}$ for IAB-DU or $F_{UL_low} - \Delta f_{OBUE}$ for IAB-MT
 - T when testing from $F_{DL_high} + \Delta f_{OBUE}$ for IAB-DU or $F_{UL_high} + \Delta f_{OBUE}$ for IAB-MT to 12.75 GHz (or to 5th harmonic)
- For FR2:
 - B when testing from 30 MHz to $F_{DL_low} - \Delta f_{OBUE}$ for IAB-DU or $F_{UL_low} - \Delta f_{OBUE}$ for IAB-MT
 - T when testing from $F_{DL_high} + \Delta f_{OBUE}$ for IAB-DU or $F_{UL_high} + \Delta f_{OBUE}$ for IAB-MT to 2nd harmonic (or to 60 GHz)

RF bandwidth positions to be tested in single-band multi-carrier operation, see clause 4.9.1:

- For FR1:
 - B_{RFBW} when testing from 30 MHz to $F_{DL_low} - \Delta f_{OBUE}$ for IAB-DU or $F_{UL_low} - \Delta f_{OBUE}$ for IAB-MT
 - T_{RFBW} when testing from $F_{DL_high} + \Delta f_{OBUE}$ for IAB-DU or $F_{UL_high} + \Delta f_{OBUE}$ for IAB-MT to 12.75 GHz (or 5th harmonic)
- For FR2:
 - B_{RFBW} when testing from 30 MHz to $F_{DL_low} - \Delta f_{OBUE}$ for IAB-DU or $F_{UL_low} - \Delta f_{OBUE}$ for IAB-MT
 - T_{RFBW} when testing from $F_{DL_high} + \Delta f_{OBUE}$ for IAB-DU or $F_{UL_high} + \Delta f_{OBUE}$ for IAB-MT to 2nd harmonic (or to 60 GHz)

RF bandwidth positions to be tested in multi-band multi-carrier operation, see clause 4.9.1:

- For FR1:
 - $B'_{RFBW_T'_{RFBW}}$ when testing from 30 MHz to $F_{DL_Blow_low} - \Delta f_{OBUE}$ for IAB-DU or $F_{UL_Blow_low} - \Delta f_{OBUE}$ for IAB-M
 - $B'_{RFBW_T'_{RFBW}}$ when testing from $F_{DL_Bhigh_high} + \Delta f_{OBUE}$ for IAB-DU or $F_{UL_Bhigh_high} + \Delta f_{OBUE}$ for IAB-MT to 12.75 GHz (or to 5th harmonic)

- $B_{\text{RFBW}_T}^{\text{RFBW}}$ and $B_{\text{RFBW}_T}^{\text{RFBW}}$ when testing from $F_{\text{DL_Blow_high}} + \Delta f_{\text{OBUE}}$ to $F_{\text{DL_Bhigh_low}} - \Delta f_{\text{OBUE}}$ for IAB-DU or $F_{\text{UL_Blow_high}} + \Delta f_{\text{OBUE}}$ to $F_{\text{UL_Bhigh_low}} - \Delta f_{\text{OBUE}}$ for IAB-MT

Directions to be tested: As the requirement is TRP the beam pattern(s) may be set up to optimise the TRP measurement procedure (see annex I) as long as the required TRP level is achieved.

6.7.5.2.4.2 Procedure

The following procedure for measuring TRP is based on directional power measurements as described in annex I. An alternative method to measure TRP is to use a characterized and calibrated reverberation chamber if so follow steps 1, 3, 4, 5, 7 and 10.

- 1) Place the IAB-Node at the positioner.
- 2) Align the manufacturer declared coordinate system orientation (D.2) of the IAB with the test system.
- 3) Measurements shall use a measurement bandwidth in accordance to the conditions in clause 6.7.5.2.5.
- 4) The measurement device characteristics shall be:
 - Detection mode: True RMS.
- 5) Set the IAB to transmit:
 - For RIB declared to be capable of single carrier operation only, set the RIB to transmit a signal according to the applicable test configuration in clause 4.8 using the corresponding test model in clause 4.9.2 (i.e. IAB-DU-FR1-TM1.1 for *IAB-DU type 1-O*, IAB-MT-FR1-TM1.1 for *IAB-MT type 1-O*, IAB-DU-FR2-TM1.1 for *IAB-DU type 2-O* or IAB-MT-FR2-TM1.1 for *IAB-MT type 2-O*), at manufacturer's declared rated output power $P_{\text{rated,c,TRP}}$.
 - For a RIB declared to be capable of multi-carrier and/or CA operation, set the RIB to transmit according to the corresponding test model in clause 4.9.2 on all carriers configured using the applicable test configuration and corresponding power setting specified in clause 4.7.2 and 4.8.
 - For an IAB node declared to be capable of Simultaneous transmission between IAB-DU and IAB-MT (D.IAB-3), using the corresponding test model(s) in clause 4.9.2 for IAB-MT and IAB-DU using the applicable test configuration and corresponding power setting specified in clause 4.7.2 and 4.8.
- 6) Orient the positioner (and IAB) in order that the direction to be tested aligns with the test antenna such that measurements to determine TRP can be performed (see annex I).
- 7) Measure the emission at the specified frequencies with specified measurement bandwidth.
- 8) Repeat step 6-7 for all directions in the appropriated TRP measurement grid needed for full TRP estimation (see annex I).

NOTE 1: The TRP measurement grid may not be the same for all measurement frequencies.

NOTE 2: The frequency sweep or the TRP measurement grid sweep may be done in any order.

- 9) Calculate TRP at each specified frequency using the directional measurements.

In addition, for *multi-band RIB(s)*, the following steps shall apply:

- 10) For *IAB type 1-O* and *multi-band RIBs* and single band tests, repeat the steps above per involved band where single band test configurations and test models shall apply with no carrier activated in the other band.

6.7.5.2.5 Test requirement

6.7.5.2.5.1 Test requirement for *IAB type 1-O*

For a IAB meeting category A the TRP of any spurious emission shall not exceed the limits in table 6.7.5.2.5.1-1.

Table 6.7.5.2.5.1-1: General IAB-DU and IAB-MT transmitter spurious emission limits in FR1 (Category A)

Spurious frequency range	Test limit	Measurement bandwidth	Notes
30 MHz – 1 GHz	-13 + X dBm	100 kHz	Note 1, Note 6
1 GHz – 12.75 GHz		1 MHz	Note 1, Note 2, Note 6
12.75 GHz – 5 th harmonic of the upper frequency edge of the DL <i>operating band</i> in GHz		1 MHz	Note 1, Note 2, Note 3, Note 6
NOTE 1: Measurement bandwidths as in ITU-R SM.329 [10], s4.1.			
NOTE 2: Upper frequency as in ITU-R SM.329 [10], s2.5 table 1.			
NOTE 3: This spurious frequency range applies only for <i>operating bands</i> for which the 5 th harmonic of the upper frequency edge of the DL <i>operating band</i> is reaching beyond 12.75 GHz.			
NOTE 4: Void.			
NOTE 5: Void.			
NOTE 6: X = 9 dB, unless stated differently in regional regulation.			

For a IAB meeting category B the TRP of any spurious emission shall not exceed the limits in table 6.7.5.2.5.1-2.

Table 6.7.5.2.5.1-2: General IAB-DU and IAB-MT transmitter spurious emission limits in FR1 (Category B)

Spurious frequency range	Test limit	Measurement bandwidth	Notes
30 MHz – 1 GHz	-36 + X dBm	100 kHz	Note 1, Note 5
1 GHz – 12.75 GHz	-30 + X dBm	1 MHz	Note 1, Note 2, Note 5
12.75 GHz – 5 th harmonic of the upper frequency edge of the DL <i>operating band</i> in GHz		1 MHz	Note 1, Note 2, Note 3, Note 5
NOTE 1: Measurement bandwidths as in ITU-R SM.329 [10], s4.1.			
NOTE 2: Upper frequency as in ITU-R SM.329 [105], s2.5 table 1.			
NOTE 3: This spurious frequency range applies only for <i>operating bands</i> for which the 5 th harmonic of the upper frequency edge of the DL <i>operating band</i> is reaching beyond 12.75GHz.			
NOTE 4: Void.			
NOTE 5: X = 9 dB, unless stated differently in regional regulation.			

6.7.5.2.5.2 Test requirement for *IAB type 2-0*

6.7.5.2.5.2.1 General

The requirements of either clause 6.7.5.2.5.2.2 (Category A limits) or clause 6.7.5.2.5.2.3 (Category B limits) shall apply. The application of either Category A or Category B limits shall be the same as for Operating band unwanted emissions in clause 6.7.1.

6.7.5.2.5.2.2 OTA transmitter spurious emissions (Category A)

The power of any spurious emission shall not exceed the limits in table 6.7.5.2.5.2.2-1.

Table 6.7.5.2.5.2.2-1: General IAB-DU and IAB-MT transmitter spurious emission limits in FR2 (Category A)

Spurious frequency range	Test limit	Measurement bandwidth	Notes
30 MHz – 1 GHz	-13 dBm	100 kHz	Note 1
1 GHz – min(2 nd harmonic of the upper frequency edge of the DL operating band in GHz; 60 GHz)		1 MHz	Note 1, Note 2
NOTE 1: Measurement bandwidth as in ITU-R SM.329 [10], s4.1.			
NOTE 2: Upper frequency as in ITU-R SM.329 [10], s2.5 table 1.			

6.7.5.2.5.2.3 OTA transmitter spurious emissions (Category B)

The power of any spurious emission shall not exceed the limits in table 6.7.5.2.5.2.3-1.

Table 6.7.5.2.5.2.3-1: IAB-DU and IAB-MT radiated Tx spurious emission limits in FR2 (Category B)

Frequency range (Note 4)	Test limit	Measurement Bandwidth	Note
30 MHz ↔ 1 GHz	-36 dBm	100 kHz	Note 1
1 GHz ↔ 18 GHz	-30 dBm	1 MHz	Note 1
18 GHz ↔ $F_{\text{step},1}$	-20 dBm	10 MHz	Note 2
$F_{\text{step},1}$ ↔ $F_{\text{step},2}$	-15 dBm	10 MHz	Note 2
$F_{\text{step},2}$ ↔ $F_{\text{step},3}$	-10 dBm	10 MHz	Note 2
$F_{\text{step},4}$ ↔ $F_{\text{step},5}$	-10 dBm	10 MHz	Note 2
$F_{\text{step},5}$ ↔ $F_{\text{step},6}$	-15 dBm	10 MHz	Note 2
$F_{\text{step},6}$ ↔ min(2 nd harmonic of the upper frequency edge of the DL operating band in GHz; 60 GHz)	-20 dBm	10 MHz	Note 2, Note 3
NOTE 1: Bandwidth as in ITU-R SM.329 [10], s4.1			
NOTE 2: Limit and bandwidth as in ERC Recommendation 74-01 [11], annex 2.			
NOTE 3: Upper frequency as in ITU-R SM.329 [10], s2.5 table 1.			
NOTE 4: The step frequencies $F_{\text{step},x}$ are defined in table 6.7.5.2.5.2.3-2.			

Table 6.7.5.2.5.2.3-2: Step frequencies for defining the IAB-DU and IAB-MT radiated Tx spurious emission limits in FR2 (Category B)

Operating band	$F_{\text{step},1}$ (GHz)	$F_{\text{step},2}$ (GHz)	$F_{\text{step},3}$ (GHz) (Note 2)	$F_{\text{step},4}$ (GHz) (Note 2)	$F_{\text{step},5}$ (GHz)	$F_{\text{step},6}$ (GHz)
n257	18	23.5	25	31	32.5	41.5
n258	18	21	22.75	29	30.75	40.5
n259	23.5	35.5	38	45	47.5	59.5
NOTE 1: $F_{\text{step},x}$ are based on ERC Recommendation 74-01 [11], annex 2.						
NOTE 2: $F_{\text{step},3}$ and $F_{\text{step},4}$ are aligned with the values for Δf_{OBUe} in table 6.7.1-1.						

6.7.5.3 Void

6.7.5.4 Additional spurious emissions requirements

6.7.5.4.1 Definition and applicability

These requirements may be applied for the protection of systems operating in frequency ranges other than the IAB downlink operating band. The limits may apply as an optional protection of such systems that are deployed in the same geographical area as the IAB-Node, or they may be set by local or regional regulation as a mandatory requirement for an NR operating band. It is in some cases not stated in the present document whether a requirement is mandatory or

under what exact circumstances that a limit applies, since this is set by local or regional regulation. An overview of regional requirements in the present document is given in clause 4.4.

Some requirements may apply for the protection of specific equipment (UE, MS and/or BS) or equipment operating in specific systems (GSM, CDMA, UTRA, E-UTRA, NR, etc.).

The requirement shall apply at each RIB supporting transmission in the *operating band*.

All additional spurious requirements are TRP unless otherwise stated.

6.7.5.4.2 Minimum Requirement

The minimum requirement for *IAB type 1-O* is specified in TS 38.174 [2], clause 9.7.5.2.3.

The minimum requirement for *IAB type 2-O* is specified in TS 38.174 [2], clause 9.7.5.3.3.

6.7.5.4.3 Test purpose

The test purpose is to verify the radiated spurious emissions from the IAB at the RIB are within the specified additional spurious emissions requirements.

6.7.5.4.4 Method of test

6.7.5.4.4.1 Initial conditions

Test environment: Normal; see annex B.2.

RF channels to be tested for single carrier:

- For FR1:
 - B when testing from 30 MHz to $F_{DL_low} - \Delta f_{OBUE}$ for IAB-DU or $F_{UL_low} - \Delta f_{OBUE}$ for IAB-MT
 - T when testing from $F_{DL_high} + \Delta f_{OBUE}$ for IAB-DU or $F_{UL_high} + \Delta f_{OBUE}$ for IAB-MT to 12.75 GHz (or to 5th harmonic)
- For FR2:
 - B when testing from 30 MHz to $F_{DL_low} - \Delta f_{OBUE}$ for IAB-DU or $F_{UL_low} - \Delta f_{OBUE}$ for IAB-MT
 - T when testing from $F_{DL_high} + \Delta f_{OBUE}$ for IAB-DU or $F_{UL_high} + \Delta f_{OBUE}$ for IAB-MT to 60 GHz (or to 2nd harmonic)

RF bandwidth positions to be tested in single-band multi-carrier operation:

- For FR1:
 - B_{RFBW} when testing from 30 MHz to $F_{DL_low} - \Delta f_{OBUE}$ for IAB-DU or $F_{UL_low} - \Delta f_{OBUE}$ for IAB-MT
 - T_{RFBW} when testing from $F_{DL_high} + \Delta f_{OBUE}$ for IAB-DU or $F_{UL_high} + \Delta f_{OBUE}$ for IAB-MT to 12.75 GHz (or to 5th harmonic)
- For FR2:
 - B_{RFBW} when testing from 30 MHz to $F_{DL_low} - \Delta f_{OBUE}$ for IAB-DU or $F_{UL_low} - \Delta f_{OBUE}$ for IAB-MT
 - T_{RFBW} when testing from $F_{DL_high} + \Delta f_{OBUE}$ for IAB-DU or $F_{UL_high} + \Delta f_{OBUE}$ for IAB-MT to 60 GHz (or to 2nd harmonic)

RF bandwidth positions to be tested in multi-band multi-carrier operation:

- For FR1:
 - $B_{RFBW_T_{RFBW}}$ when testing from 30 MHz to $F_{DL_Blow_low} - \Delta f_{OBUE}$ for IAB-DU or $F_{UL_low} - \Delta f_{OBUE}$ for IAB-MT

- $B'_{\text{RFBW_TRFBW}}$ when testing from $F_{\text{DL_Bhigh_high}} + \Delta f_{\text{OBUE}}$ for IAB-DU or $F_{\text{UL_Bhigh_high}} + \Delta f_{\text{OBUE}}$ for IAB-MT to 12.75 GHz (or to 5th harmonic)
- $B'_{\text{RFBW_TRFBW}}$ and $B'_{\text{RFBW_TRFBW}}$ when testing from $F_{\text{DL_Blow_high}} + \Delta f_{\text{OBUE}}$ to $F_{\text{DL_Bhigh_low}} - \Delta f_{\text{OBUE}}$ for IAB-DU or $F_{\text{UL_Blow_high}} + \Delta f_{\text{OBUE}}$ to $F_{\text{UL_Bhigh_low}} - \Delta f_{\text{OBUE}}$ for IAB-MT

Directions to be tested: As the requirements are TRP the beam pattern(s) may be set up to optimise the TRP measurement procedure (see annex I) as long as the required TRP level is achieved.

6.7.5.4.4.2 Procedure

The following procedure for measuring TRP is based on the directional power measurements as described in annex I. An alternative method to measure TRP is to use a characterized and calibrated reverberation chamber if so follow steps 1, 3, 4, 5, 7 and 10.

- 1) Place the IAB-Node at the positioner.
- 2) Align the manufacturer declared coordinate system orientation (D.2) of the IAB with the test system.
- 3) Measurements shall use a measurement bandwidth in accordance to the conditions in clause 6.7.5.4.5.
- 4) The measurement device characteristics shall be:
 - Detection mode: True RMS.
- 5) Set the IAB-Node to transmit:
 - For RIB declared to be capable of single carrier operation only, set the RIB to transmit a signal according to the applicable test configuration in clause 4.8 using the corresponding test model in clause 4.9.2 (IAB-DU-FR1-TM1.1 for *IAB-DU type 1-O*, IAB-MT-FR1-TM1.1 for *IAB-MT type 1-O*, IAB-DU-FR2-TM1.1 for *IAB-DU type 2-O* or IAB-MT-FR2-TM1.1 for *IAB-MT type 2-O*), at manufacturer's declared rated output power $P_{\text{rated,c,TRP}}$.
 - For a RIB declared to be capable of multi-carrier and/or CA operation, set the RIB to transmit according to IAB-DU-FR1-TM1.1 for *IAB-DU type 1-O*, IAB-MT-FR1-TM1.1 for *IAB-MT type 1-O*, IAB-DU-FR2-TM1.1 for *IAB-DU type 2-O* or IAB-MT-FR2-TM1.1 for *IAB-MT type 2-O* in clause 4.9.2 on all carriers configured using the applicable test configuration and corresponding power setting specified in clause 4.7.2 and 4.8.
 - For an IAB node declared to be capable of Simultaneous transmission between IAB-DU and IAB-MT (D.IAB-3), set the RIB to transmit according to IAB-DU-FR1-TM1.1 for *IAB-DU type 1-O*, IAB-MT-FR1-TM1.1 for *IAB-MT type 1-O*, IAB-DU-FR2-TM1.1 for *IAB-DU type 2-O* or IAB-MT-FR2-TM1.1 for *IAB-MT type 2-O* in clause 4.9.2 using the applicable test configuration and corresponding power setting specified in clause 4.7.2 and 4.8.
- 6) Orient the positioner (and IAB) in order that the direction to be tested aligns with the test antenna such that measurements to determine TRP can be performed (see annex I).
- 7) Measure the emission at the specified frequencies with specified measurement bandwidth.
- 8) Repeat step 6-7 for all directions in the appropriated TRP measurement grid needed for full TRP estimation (see annex I).

NOTE 1: The TRP measurement grid may not be the same for all measurement frequencies.

NOTE 2: The frequency sweep or the TRP measurement grid sweep may be done in any order.

- 9) Calculate TRP at each specified frequency using the directional measurements.

In addition, for *multi-band RIB(s)*, the following steps shall apply:

- 10) For *multi-band RIBs* and single band tests, repeat the steps above per involved band where single band test configurations and test models shall apply with no carrier activated in the other band.

6.7.5.4.5 Test requirement

6.7.5.4.5.1 Test requirement for *IAB type 1-0*

The power of any spurious emission shall not exceed the test limits in table 6.7.5.4.5-1 for a IAB where requirements for co-existence with the system listed in the first column apply. For a *multi-band RIB*, the exclusions and conditions in the Note column of table 6.7.5.4.5-1 apply for each supported *operating band*.

Table 6.7.5.4.5.1-1: IAB-DU and IAB-MT spurious emissions basic limits for co-existence with systems operating in other frequency bands

System type to co-exist with	Frequency range for co-existence requirement	Test limits	Measurement bandwidth	Note
GSM900	921 – 960 MHz	-45.4 dBm	100 kHz	
	876 – 915 MHz	-49.4 dBm	100 kHz	
DCS1800	1805 – 1880 MHz	-35.4 dBm	100 kHz	
	1710 – 1785 MHz	-49.4 dBm	100 kHz	
PCS1900	1930 – 1990 MHz	-35.4 dBm	100 kHz	
	1850 – 1910 MHz	-49.4 dBm	100 kHz	
GSM850 or CDMA850	869 – 894 MHz	-45.4 dBm	100 kHz	
	824 – 849 MHz	-49.4 dBm	100 kHz	
UTRA FDD Band I or E-UTRA Band 1 or NR Band n1	2110 – 2170 MHz	-40.4 dBm	1 MHz	
	1920 – 1980 MHz	-37.4 dBm	1 MHz	
UTRA FDD Band II or E-UTRA Band 2 or NR Band n2	1930 – 1990 MHz	-40.4 dBm	1 MHz	
	1850 – 1910 MHz	-37.4 dBm	1 MHz	
UTRA FDD Band III or E-UTRA Band 3 or NR Band n3	1805 – 1880 MHz	-40.4 dBm	1 MHz	
	1710 – 1785 MHz	-37.4 dBm	1 MHz	
UTRA FDD Band IV or E-UTRA Band 4	2110 – 2155 MHz	-40.4 dBm	1 MHz	
	1710 – 1755 MHz	-37.4 dBm	1 MHz	
UTRA FDD Band V or E-UTRA Band 5 or NR Band n5	869 – 894 MHz	-40.4 dBm	1 MHz	
	824 – 849 MHz	-37.4 dBm	1 MHz	
UTRA FDD Band VI, XIX or E-UTRA Band 6, 18, 19 or NR Band n18	860 – 890 MHz	-40.4 dBm	1 MHz	
	815 – 830 MHz	-37.4 dBm	1 MHz	
	830 – 845 MHz	-37.4 dBm	1 MHz	
UTRA FDD Band VII or E-UTRA Band 7 or NR Band n7	2620 – 2690 MHz	-40.4 dBm	1 MHz	
	2500 – 2570 MHz	-37.4 dBm	1 MHz	

System type to co-exist with	Frequency range for co-existence requirement	Test limits	Measurement bandwidth	Note
UTRA FDD Band VIII or E-UTRA Band 8 or NR Band n8	925 – 960 MHz	-40.4 dBm	1 MHz	
	880 – 915 MHz	-37.4 dBm	1 MHz	
UTRA FDD Band IX or E-UTRA Band 9	1844.9 – 1879.9 MHz	-40.4 dBm	1 MHz	
	1749.9 – 1784.9 MHz	-37.4 dBm	1 MHz	
UTRA FDD Band X or E-UTRA Band 10	2110 – 2170 MHz	-40.4 dBm	1 MHz	
	1710 – 1770 MHz	-37.4 dBm	1 MHz	
UTRA FDD Band XI or XXI or E-UTRA Band 11 or 21	1475.9 – 1510.9 MHz	-40.4 dBm	1 MHz	
	1427.9 – 1447.9 MHz	-37.4 dBm	1 MHz	
	1447.9 – 1462.9 MHz	-37.4 dBm	1 MHz	
UTRA FDD Band XII or E-UTRA Band 12 or NR Band n12	729 – 746 MHz	-40.4 dBm	1 MHz	
	699 – 716 MHz	-37.4 dBm	1 MHz	
UTRA FDD Band XIII or E-UTRA Band 13	746 – 756 MHz	-40.4 dBm	1 MHz	
	777 – 787 MHz	-37.4 dBm	1 MHz	
UTRA FDD Band XIV or E-UTRA Band 14 or NR band n14	758 – 768 MHz	-40.4 dBm	1 MHz	
	788 – 798 MHz	-37.4 dBm	1 MHz	
E-UTRA Band 17	734 – 746 MHz	-40.4 dBm	1 MHz	
	704 – 716 MHz	-37.4 dBm	1 MHz	
UTRA FDD Band XX or E-UTRA Band 20 or NR Band n20	791 – 821 MHz	-40.4 dBm	1 MHz	
	832 – 862 MHz	-37.4 dBm	1 MHz	
UTRA FDD Band XXII or E-UTRA Band 22	3510 – 3590 MHz	-40 dBm	1 MHz	This requirement does not apply to IAB-DU and IAB-MT operating in band n77 or n78.
	3410 – 3490 MHz	-37 dBm	1 MHz	This requirement does not apply to IAB-DU and IAB-MT operating in band n77 or n78.

System type to co-exist with	Frequency range for co-existence requirement	Test limits	Measurement bandwidth	Note
E-UTRA Band 24	1525 – 1559 MHz	-40.4 dBm	1 MHz	
	1626.5 – 1660.5 MHz	-37.4 dBm	1 MHz	
UTRA FDD Band XXV or E-UTRA Band 25 or NR band n25	1930 – 1995 MHz	-40.4 dBm	1 MHz	
	1850 – 1915 MHz	-37.4 dBm	1 MHz	
UTRA FDD Band XXVI or E-UTRA Band 26 or NR Band n26	859 – 894 MHz	-40.4 dBm	1 MHz	
	814 – 849 MHz	-37.4 dBm	1 MHz	
E-UTRA Band 27	852 – 869 MHz	-40.4 dBm	1 MHz	
	807 – 824 MHz	-37.4 dBm	1 MHz	
E-UTRA Band 28 or NR Band n28	758 – 803 MHz	-40.4 dBm	1 MHz	
	703 – 748 MHz	-37.4 dBm	1 MHz	
E-UTRA Band 29 or NR Band n29	717 – 728 MHz	-40.4 dBm	1 MHz	
E-UTRA Band 30 or NR Band n30	2350 – 2360 MHz	-40.4 dBm	1 MHz	
	2305 – 2315 MHz	-37.4 dBm	1 MHz	
E-UTRA Band 31	462.5 – 467.5 MHz	-40.4 dBm	1 MHz	
	452.5 – 457.5 MHz	-37.4 dBm	1 MHz	
UTRA FDD band XXXII or E-UTRA band 32	1452 – 1496 MHz	-40.4 dBm	1 MHz	
UTRA TDD Band a) or E-UTRA Band 33	1900 – 1920 MHz	-40.4 dBm	1 MHz	
UTRA TDD Band a) or E-UTRA Band 34 or NR band n34	2010 – 2025 MHz	-40.4 dBm	1 MHz	
UTRA TDD Band b) or E-UTRA Band 35	1850 – 1910 MHz	-40.4 dBm	1 MHz	
UTRA TDD Band b) or E-UTRA Band 36	1930 – 1990 MHz	-40.4 dBm	1 MHz	
UTRA TDD Band c) or E-UTRA Band 37	1910 – 1930 MHz	-40.4 dBm	1 MHz	

System type to co-exist with	Frequency range for co-existence requirement	Test limits	Measurement bandwidth	Note
UTRA TDD Band d) or E-UTRA Band 38 or NR Band n38	2570 – 2620 MHz	-40.4 dBm	1 MHz	
UTRA TDD Band f) or E-UTRA Band 39 or NR band n39	1880 – 1920MHz	-40.4 dBm	1 MHz	
UTRA TDD Band e) or E-UTRA Band 40 or NR Band n40	2300 – 2400MHz	-40.4 dBm	1 MHz	
E-UTRA Band 41 or NR Band n41, n90	2496 – 2690 MHz	-40.4 dBm	1 MHz	This is not applicable IAB-DU and IAB-MT operating in Band n41.
E-UTRA Band 42	3400 – 3600 MHz	-40 dBm	1 MHz	This is not applicable to IAB-DU and IAB-MT operating in Band n77 or n78.
E-UTRA Band 43	3600 – 3800 MHz	-40 dBm	1 MHz	This is not applicable to IAB-DU and IAB-MT operating in Band n77 or n78.
E-UTRA Band 44	703 – 803 MHz	-40.4 dBm	1 MHz	
E-UTRA Band 45	1447 – 1467 MHz	-40.4 dBm	1 MHz	
E-UTRA Band 46 or NR Band n46	5150 – 5925 MHz	-39.5 dBm	1 MHz	
E-UTRA Band 47	5855 – 5925 MHz	-39.5 dBm	1 MHz	
E-UTRA Band 48 or NR Band n48	3550 – 3700 MHz	-40 dBm	1 MHz	This is not applicable to IAB-DU and IAB-MT operating in Band n77 or n78.
E-UTRA Band 50 or NR band n50	1432 – 1517 MHz	-40.4 dBm	1 MHz	
E-UTRA Band 51 or NR Band n51	1427 – 1432 MHz	-40.4 dBm	1 MHz	
E-UTRA Band 53 or NR Band n53	2483.5 - 2495 MHz	-40.4 dBm	1 MHz	This is not applicable to IAB-DU and IAB-MT operating in Band n41.
E-UTRA Band 65 or NR Band n65	2110 – 2200 MHz	-40.4 dBm	1 MHz	
	1920 – 2010 MHz	-37.4 dBm	1 MHz	
E-UTRA Band 66 or NR Band n66	2110 – 2200 MHz	-40.4 dBm	1 MHz	
	1710 – 1780 MHz	-37.4 dBm	1 MHz	
E-UTRA Band 67	738 – 758 MHz	-40.4 dBm	1 MHz	
E-UTRA Band 68	753 -783 MHz	-40.4 dBm	1 MHz	
	698-728 MHz	-37.4 dBm	1 MHz	
E-UTRA Band 69	2570 – 2620 MHz	-40.4 dBm	1 MHz	
E-UTRA Band 70 or NR Band n70	1995 – 2020 MHz	-40.4 dBm	1 MHz	

System type to co-exist with	Frequency range for co-existence requirement	Test limits	Measurement bandwidth	Note
	1695 – 1710 MHz	-37.4 dBm	1 MHz	
E-UTRA Band 71 or NR Band n71	617 – 652 MHz	-40.4 dBm	1 MHz	
	663 – 698 MHz	-37.4 dBm	1 MHz	
E-UTRA Band 72	461 – 466 MHz	-40.4 dBm	1 MHz	
	451 – 456 MHz	-37.4 dBm	1 MHz	
E-UTRA Band 74 or NR Band n74	1475 – 1518 MHz	-40.4 dBm	1 MHz	
	1427 – 1470 MHz	-37.4 dBm	1 MHz	
E-UTRA Band 75 or NR Band n75	1432 – 1517 MHz	-40.4 dBm	1 MHz	
E-UTRA Band 76 or NR Band n76	1427 – 1432 MHz	-40.4 dBm	1 MHz	
NR Band n77	3.3 – 4.2 GHz	-40 dBm	1 MHz	This requirement does not apply to IAB-DU and IAB-MT operating in Band n77 or n78
NR Band n78	3.3 – 3.8 GHz	-40 dBm	1 MHz	This requirement does not apply to IAB-DU and IAB-MT operating in Band n77 or n78
NR Band n79	4.4 – 5.0 GHz	-39.5 dBm	1 MHz	This requirement does not apply to IAB-DU and IAB-MT operating in Band n79
NR Band n80	1710 – 1785 MHz	-37.4 dBm	1 MHz	
NR Band n81	880 – 915 MHz	-40.4 dBm	1 MHz	
NR Band n82	832 – 862 MHz	-45.4 dBm	1 MHz	
NR Band n83	703 – 748 MHz	-49.4 dBm	1 MHz	
NR Band n84	1920 – 1980 MHz	-35.4 dBm	1 MHz	
E-UTRA Band 85 or NR Band n85	728 – 746 MHz	-49.4 dBm	1 MHz	
	698 – 716 MHz	-35.4 dBm	1 MHz	
NR Band n86	1710 – 1780 MHz	-49.4 dBm	1 MHz	
NR Band n89	824 – 849 MHz	-45.4 dBm	1 MHz	
NR Band n91	1427 – 1432 MHz	-49.4 dBm	1 MHz	
	832 – 862 MHz	-40.4 dBm	1 MHz	
NR Band n92	1432 – 1517 MHz	-37.4 dBm	1 MHz	
	832 – 862 MHz	-40.4 dBm	1 MHz	
NR Band n93	1427 – 1432 MHz	-37.4 dBm	1 MHz	
	880 – 915 MHz	-40.4 dBm	1 MHz	
NR Band n94	1432 – 1517 MHz	-37.4 dBm	1 MHz	
	880 – 915 MHz	-40.4 dBm	1 MHz	

System type to co-exist with	Frequency range for co-existence requirement	Test limits	Measurement bandwidth	Note
NR Band n95	2010 – 2025 MHz	-37.4 dBm	1 MHz	
NR Band n96	5925 – 7125 MHz	-39.5 dBm	1 MHz	
NR Band n97	2300 – 2400MHz	-40.4 dBm	1 MHz	
NR Band n98	1880 – 1920MHz	-40.4 dBm	1 MHz	
NR Band n99	1626.5 – 1660.5 MHz	-37.4 dBm	1 MHz	
NR Band n101	1900 - 1910 MHz	-40.4 dBm	1 MHz	
NR Band n102	6425 – 7125 MHz	-39.5 dBm	1 MHz	
E-UTRA Band 103	757 – 758 MHz	-40.4 dBm	1 MHz	
	787 – 788 MHz	-37.4 dBm	1 MHz	
NR Band n104	6425 – 7125 MHz	-39.5 dBm	1 MHz	

NOTE 1: As defined in the scope for spurious emissions in this clause the co-existence requirements in table 6.7.5.4.5.1-1 do not apply for the Δf_{OBUE} frequency range immediately outside the downlink *operating band* (see table 5.2-1). Emission limits for this excluded frequency range may be covered by local or regional requirements.

NOTE 2: Table 6.7.5.4.5.1-1 assumes that two *operating bands*, where the frequency ranges in table 5.2-1 would be overlapping, are not deployed in the same geographical area. For such a case of operation with overlapping frequency arrangements in the same geographical area, special co-existence requirements may apply that are not covered by the 3GPP specifications.

6.7.5.5 Co-location requirements

6.7.5.5.1 Definition and applicability

These requirements may be applied for the protection of other BS, IAB-DU or IAB-MT receivers when GSM900, DCS1800, PCS1900, GSM850, CDMA850, UTRA FDD, UTRA TDD, E-UTRA, NR BS, IAB-DU or IAB-MT are co-located with IAB-MT and/or IAB-DU.

The requirements assume a 30 dB coupling loss between transmitter and receiver and are based on co-location with same class.

6.7.5.5.2 Minimum requirements

The minimum requirement for *IAB type I-O* is defined in TS 38.174 [2], clause 9.7.5.2.

6.7.5.5.3 Test purpose

For OTA co-locate spurious emission, the test purpose is to verify that the emission is within the specified requirement limits at the CLTA conducted output(s).

6.7.5.5.4 Method of test

6.7.5.5.4.1 Initial conditions

Test environment: normal; see clause B.2.

RF channels to be tested for single carrier: M; see clause 4.9.1.

IAB RF Bandwidth positions to be tested for multi-carrier:

- M_{RFBW} in *single-band RIB*, see clause 4.9.1;
- $B'_{\text{RFBW_T'RFBW}}$ and $B_{\text{RFBW_T'RFBW}}$ in *multi-band RIB*, see clause 4.9.1.

In addition, for *multi-band RIB*:

- For $B_{\text{RFBW_T'RFBW}}$, emission testing above the highest operating band may be omitted.
- For $B'_{\text{RFBW_T'RFBW}}$, emission testing below the lowest operating band may be omitted.

Directions to be tested: The FR1 requirement is specified as co-location requirement. For general description of co-location requirements, refer to clause 4.12.

The co-location spurious emission is measured at the CLTA conducted output(s).

6.7.5.5.4.2 Procedure

- 1) Select and place the IAB-Node and CLTA as described in clause 4.12, with parameters as specified in table 4.12.2.2-1 and table 4.12.2.3-1.
- 2) Several CLTAs might be required to cover the whole co-location spurious emission frequency ranges.
- 3) Place test antenna in reference direction at far-field distance, aligned in all supported polarizations (single or dual) with the IAB-Node as depicted in annex E.1.3.
- 4) The test antenna shall be dual (or single) polarized with the same frequency range as the IAB-Node for co-location spurious emission test case.
- 5) Connect test antenna and CLTA to the measurement equipment as depicted in annex E.1.3.
- 6) OTA co-location spurious emission is measured as the power sum over all supported polarizations at the CLTA conducted output(s).
- 7) The measurement device (signal analyser) characteristics shall be:
 - Detection mode: True RMS.
- 8) Set the *IAB type 1-O* to transmit:
 - Set the IAB-Node to transmit maximum power according to the applicable test configuration in clause 4.8 using the corresponding test models or set of physical channels in clause 4.9.2.
 - For the IAB-Node declared to be capable of multi-carrier and/or CA operation, set the IAB-Node to transmit according to the applicable test configuration and corresponding power setting specified in clause 4.7.2 and 4.8 using the corresponding test models on all carriers configured.
 - For an IAB-Node declared to be capable of Simultaneous transmission between IAB-DU and IAB-MT (D.IAB-3), set the IAB-Node to transmit according to the applicable test configuration and corresponding power setting specified in clause 4.7.2 and 4.8 for IAB-DU and IAB-MT.
- 9) Measure the emission at the specified frequencies with specified measurement bandwidth.

In addition, for *multi-band RIB*, the following steps shall apply:

- 10) For *multi-band RIB* and single band tests, repeat the steps above per involved band where single band test configurations and test models shall apply with no carrier activated in the other band.

6.7.5.5.5 Test requirements

6.7.5.5.5.1 Test requirement for *IAB type 1-O*

These requirements may be applied for the protection of other IAB receivers when GSM900, DCS1800, PCS1900, GSM850, CDMA850, UTRA FDD, UTRA TDD, E-UTRA and/or NR BS are co-located with a IAB Node.

The requirements assume co-location with base stations of the same class.

NOTE: For co-location with UTRA, the requirements are based on co-location with UTRA FDD or TDD base stations.

This requirement is a co-location requirement as defined in clause 4.9, in TS 38.174 [2], the power levels are specified at the CLTA output.

The output of the CLTA of any spurious emission shall not exceed the test limit in table 6.7.5.5.1-1.

For a *multi-band RIB*, the exclusions and conditions in the notes column of table 6.7.5.5.1-1 apply for each supported operating band.

Table 6.7.5.5.1-1: IAB-DU and IAB-MT spurious emissions basic limits for co-location with BS or IAB-Node

Co-located system	Frequency range for co-location requirement	Test limits			Measurement bandwidth	Note
		WA IAB-DU and WA IAB-MT	MR IAB-DU	LA IAB-DU and LA IAB-MT		
GSM900	876 – 915 MHz	-115.9 dBm	-108.9 dBm	-87.9 dBm	100 kHz	
DCS1800	1710 – 1785 MHz	-115.9 dBm	-108.9 dBm	--97.9 dBm	100 kHz	
PCS1900	1850 – 1910 MHz	-115.9 dBm	-108.9 dBm	--97.9 dBm	100 kHz	
GSM850 or CDMA850	824 – 849 MHz	-115.9 dBm	-108.9 dBm	-87.9 dBm	100 kHz	
UTRA FDD Band I or E-UTRA Band 1 or NR Band n1	1920 – 1980 MHz	-113.9 dBm	-108.9 dBm	-105.9 dBm	100 kHz	
UTRA FDD Band II or E-UTRA Band 2 or NR Band n2	1850 – 1910 MHz	-113.9 dBm	-108.9 dBm	-105.9 dBm	100 kHz	
UTRA FDD Band III or E-UTRA Band 3 or NR Band n3	1710 – 1785 MHz	-113.9 dBm	-108.9 dBm	-105.9 dBm	100 kHz	
UTRA FDD Band IV or E-UTRA Band 4	1710 – 1755 MHz	-113.9 dBm	-108.9 dBm	-105.9 dBm	100 kHz	
UTRA FDD Band V or E-UTRA Band 5 or NR Band n5	824 – 849 MHz	-113.9 dBm	-108.9 dBm	-105.9 dBm	100 kHz	
UTRA FDD Band VI, XIX or E-UTRA Band 6, 19	830 – 845 MHz	-113.9 dBm	-108.9 dBm	-105.9 dBm	100 kHz	
UTRA FDD Band VII or E-UTRA Band 7 or NR Band n7	2500 – 2570 MHz	-113.9 dBm	-108.9 dBm	-105.9 dBm	100 kHz	
UTRA FDD Band VIII or E-UTRA Band 8 or NR Band n8	880 – 915 MHz	-113.9 dBm	-108.9 dBm	-105.9 dBm	100 kHz	
UTRA FDD Band IX or E-UTRA Band 9	1749.9 – 1784.9 MHz	-113.9 dBm	-108.9 dBm	-105.9 dBm	100 kHz	
UTRA FDD Band X or E-UTRA Band 10	1710 – 1770 MHz	-113.9 dBm	-108.9 dBm	-105.9 dBm	100 kHz	
UTRA FDD Band XI or E-UTRA Band 11	1427.9 – 1447.9 MHz	-113.9 dBm	-108.9 dBm	-105.9 dBm	100 kHz	
UTRA FDD Band XII or E-UTRA Band 12 or NR Band n12	699 – 716 MHz	-113.9 dBm	-108.9 dBm	-105.9 dBm	100 kHz	
UTRA FDD Band XIII or E-UTRA Band 13	777 – 787 MHz	-113.9 dBm	-108.9 dBm	-105.9 dBm	100 kHz	
UTRA FDD Band XIV or E-UTRA Band 14 or NR Band n14	788 – 798 MHz	-113.9 dBm	-108.9 dBm	-105.9 dBm	100 kHz	
E-UTRA Band 17	704 – 716 MHz	-113.9 dBm	-108.9 dBm	-105.9 dBm	100 kHz	

Co-located system	Frequency range for co-location requirement	Test limits			Measurement bandwidth	Note
		WA IAB-DU and WA IAB-MT	MR IAB-DU	LA IAB-DU and LA IAB-MT		
E-UTRA Band 18 or NR Band n18	815 – 830 MHz	-113.9 dBm	-108.9 dBm	-105.9 dBm	100 kHz	
UTRA FDD Band XX or E-UTRA Band 20 or NR Band n20	832 – 862 MHz	-113.9 dBm	-108.9 dBm	-105.9 dBm	100 kHz	
UTRA FDD Band XXI or E-UTRA Band 21	1447.9 – 1462.9 MHz	-113.9 dBm	-108.9 dBm	-105.9 dBm	100 kHz	
UTRA FDD Band XXII or E-UTRA Band 22	3410 – 3490 MHz	-113.7 dBm	-108.7 dBm	-105.7 dBm	100 kHz	This is not applicable to IAB-DU and IAB-MT operating in Band n77 or n78
E-UTRA Band 23	2000 – 2020 MHz	-113.9 dBm	-108.9 dBm	-105.9 dBm	100 kHz	
E-UTRA Band 24	1626.5 – 1660.5 MHz	-113.9 dBm	-108.9 dBm	-105.9 dBm	100 kHz	
UTRA FDD Band XXV or E-UTRA Band 25 or NR Band n25	1850 – 1915 MHz	-113.9 dBm	-108.9 dBm	-105.9 dBm	100 kHz	
UTRA FDD Band XXVI or E-UTRA Band 26 or NR Band n26	814 – 849 MHz	-113.9 dBm	-108.9 dBm	-105.9 dBm	100 kHz	
E-UTRA Band 27	807 – 824 MHz	-113.9 dBm	-108.9 dBm	-105.9 dBm	100 kHz	
E-UTRA Band 28 or NR Band n28	703 – 748 MHz	-113.9 dBm	-108.9 dBm	-105.9 dBm	100 kHz	
E-UTRA Band 30 or NR Band n30	2305 – 2315 MHz	-113.9 dBm	-108.9 dBm	-105.9 dBm	100 kHz	
E-UTRA Band 31	452.5 – 457.5 MHz	-113.9 dBm	-108.9 dBm	-105.9 dBm	100 kHz	
UTRA TDD Band a) or E-UTRA Band 33	1900 – 1920 MHz	-113.9 dBm	-108.9 dBm	-105.9 dBm	100 kHz	
UTRA TDD Band a) or E-UTRA Band 34 or NR band n34	2010 – 2025 MHz	-113.9 dBm	-108.9 dBm	-105.9 dBm	100 kHz	
UTRA TDD Band b) or E-UTRA Band 35	1850 – 1910 MHz	-113.9 dBm	-108.9 dBm	-105.9 dBm	100 kHz	
UTRA TDD Band b) or E-UTRA Band 36	1930 – 1990 MHz	-113.9 dBm	-108.9 dBm	-105.9 dBm	100 kHz	
UTRA TDD Band c) or E-UTRA Band 37	1910 – 1930 MHz	-113.9 dBm	-108.9 dBm	-105.9 dBm	100 kHz	
UTRA TDD Band d) or E-UTRA Band 38 or NR Band n38	2570 – 2620 MHz	-113.9 dBm	-108.9 dBm	-105.9 dBm	100 kHz	
UTRA TDD Band f) or E-UTRA Band 39 or NR band n39	1880 – 1920MHz	-113.9 dBm	-108.9 dBm	-105.9 dBm	100 kHz	
UTRA TDD Band e) or E-UTRA Band 40 or NR Band n40	2300 – 2400MHz	-113.9 dBm	-108.9 dBm	-105.9 dBm	100 kHz	
E-UTRA Band 41 or NR Band n41, n90	2496 – 2690 MHz	-113.9 dBm	-108.9 dBm	-105.9 dBm	100 kHz	This is not applicable to IAB-DU and IAB-MT operating in Band n41
E-UTRA Band 42	3400 – 3600 MHz	-113.7 dBm	-108.7 dBm	-105.7 dBm	100 kHz	This is not applicable to IAB-DU and IAB-MT operating in Band n77 or n78

Co-located system	Frequency range for co-location requirement	Test limits			Measurement bandwidth	Note
		WA IAB-DU and WA IAB-MT	MR IAB-DU	LA IAB-DU and LA IAB-MT		
E-UTRA Band 43	3600 – 3800 MHz	-113.7 dBm	-108.7 dBm	-105.7 dBm	100 kHz	This is not applicable to IAB-DU and IAB-MT operating in Band n77 or n78
E-UTRA Band 44	703 – 803 MHz	-113.9 dBm	-108.9 dBm	-105.9 dBm	100 kHz	
E-UTRA Band 45	1447 – 1467 MHz	-113.9 dBm	-108.9 dBm	-105.9 dBm	100 kHz	
E-UTRA Band 46 or NR Band n46	5150 – 5925 MHz	N/A	-108.6 dBm	-105.6 dBm	100 kHz	
E-UTRA Band 48 or NR Band n48	3550 – 3700 MHz	-113.7 dBm	-108.7 dBm	-105.7 dBm	100 kHz	This is not applicable to IAB-DU and IAB-MT operating in Band n77 or n78
E-UTRA Band 50 or NR Band n50	1432 – 1517 MHz	-113.9 dBm	-108.9 dBm	-105.9 dBm	100 kHz	
E-UTRA Band 51 or NR Band n51	1427 – 1432 MHz	N/A	N/A	-105.9 dBm	100 kHz	
E-UTRA Band 53 or NR Band n53	2483.5 – 2495 MHz	N/A	-108.9 dBm	-105.9 dBm	100 kHz	This is not applicable to IAB-DU and IAB-MT operating in Band n41
E-UTRA Band 65 or NR Band n65	1920 – 2010 MHz	-113.9 dBm	-108.9 dBm	-105.9 dBm	100 kHz	
E-UTRA Band 66 or NR Band n66	1710 – 1780 MHz	-113.9 dBm	-108.9 dBm	-105.9 dBm	100 kHz	
E-UTRA Band 68	698 – 728 MHz	-113.9 dBm	-108.9 dBm	-105.9 dBm	100 kHz	
E-UTRA Band 70 or NR Band n70	1695 – 1710 MHz	-113.9 dBm	-108.9 dBm	-105.9 dBm	100 kHz	
E-UTRA Band 71 or NR Band n71	663 – 698 MHz	-113.9 dBm	-108.9 dBm	-105.9 dBm	100 kHz	
E-UTRA Band 72	451 – 456 MHz	-113.9 dBm	-108.9 dBm	-105.9 dBm	100 kHz	
E-UTRA Band 74 or NR Band n74	1427 – 1470 MHz	-113.9 dBm	-108.9 dBm	-105.9 dBm	100 kHz	
NR Band n77	3.3 – 4.2 GHz	-113.7 dBm	-108.7 dBm	-105.7 dBm	100 kHz	This is not applicable to IAB-DU and IAB-MT operating in Band n77 or n78
NR Band n78	3.3 – 3.8 GHz	-113.7 dBm	-108.7 dBm	-105.7 dBm	100 kHz	This is not applicable to IAB-DU and IAB-MT operating in Band n77 or n78
NR Band n79	4.4 – 5.0 GHz	-113.6 dBm	-108.6 dBm	-105.6 dBm	100 kHz	This is not applicable to IAB-DU and IAB-MT operating in Band n79
NR Band n80	1710 – 1785 MHz	-113.9 dBm	-108.9 dBm	-105.9 dBm	100 kHz	
NR Band n81	880 – 915 MHz	-113.9 dBm	-108.9 dBm	-105.9 dBm	100 kHz	
NR Band n82	832 – 862 MHz	-113.9 dBm	-108.9 dBm	-105.9 dBm	100 kHz	
NR Band n83	703 – 748 MHz	-113.9 dBm	-108.9 dBm	-105.9 dBm	100 kHz	

Co-located system	Frequency range for co-location requirement	Test limits			Measurement bandwidth	Note
		WA IAB-DU and WA IAB-MT	MR IAB-DU	LA IAB-DU and LA IAB-MT		
NR Band n84	1920 – 1980 MHz	-113.9 dBm	-108.9 dBm	-105.9 dBm	100 kHz	
E-UTRA Band 85 or NR Band n85	698 – 716 MHz	-113.9 dBm	-108.9 dBm	-105.9 dBm	100 kHz	
NR Band n86	1710 – 1780 MHz	-113.9 dBm	-108.9 dBm	-105.9 dBm	100 kHz	
NR Band n89	824 – 849 MHz	-113.9 dBm	-108.9 dBm	-105.9 dBm	100 kHz	
NR Band n91	832 – 862 MHz	-113.9 dBm	-108.9 dBm	-105.9 dBm	100 kHz	
NR Band n92	832 – 862 MHz	-113.9 dBm	-108.9 dBm	-105.9 dBm	100 kHz	
NR Band n93	880 – 915 MHz	-113.9 dBm	-108.9 dBm	-105.9 dBm	100 kHz	
NR Band n94	880 – 915 MHz	-113.9 dBm	-108.9 dBm	-105.9 dBm	100 kHz	
NR Band n95	2010 – 2025 MHz	-113.9 dBm	-108.9 dBm	-105.9 dBm	100 kHz	
NR Band n96	5925 – 7125 MHz	N/A	-107.6 dBm	-104.6 dBm	100 kHz	
NR Band n97	2300 – 2400MHz	-113.9 dBm	-108.9 dBm	-105.9 dBm	100 kHz	
NR Band n98	1880 – 1920 MHz	-113.9 dBm	-108.9 dBm	-105.9 dBm	100 kHz	
NR Band n99	1626.5 – 1660.5 MHz	-113.9 dBm	-108.9 dBm	-105.9 dBm	100 kHz	
NR band n101	1900 - 1910 MHz	-113.9 dBm	NA	NA	100 kHz	
NR Band n102	6425 – 7125 MHz	N/A	-107.6 dBm	-104.6 dBm	100 kHz	
E-UTRA Band 103	787 – 788 MHz	-113.9 dBm	-108.9 dBm	-105.9 dBm	100 kHz	
NR Band n104	6425 – 7125 MHz	-112.6 dBm	-107.6 dBm	-104.6 dBm	100 kHz	

NOTE 1: As defined in the scope for spurious emissions in this clause, the co-location requirements in table 6.6.5.2.3-1 do not apply for the frequency range extending Δf_{OBUe} immediately outside the transmit frequency range of a IAB-MT and IAB-DU. The current state-of-the-art technology does not allow a single generic solution for co-location with other system on adjacent frequencies for 30dB antenna to antenna minimum coupling loss. However, there are certain site-engineering solutions that can be used. These techniques are addressed in TR 25.942 [15].

NOTE 2: Table 6.6.5.2.3-1 assumes that two operating bands, where the corresponding transmit and receive frequency ranges in table 5.2-1 would be overlapping, are not deployed in the same geographical area. For such a case of operation with overlapping frequency arrangements in the same geographical area, special co-location requirements may apply that are not covered by the 3GPP specifications.

6.8 OTA transmitter intermodulation

6.8.1 Definition and applicability

The OTA transmitter intermodulation requirement is a measure of the capability of the transmitter unit to inhibit the generation of signals in its non-linear elements caused by presence of the wanted signal and an interfering signal reaching the transmitter unit via the RDN and antenna array from a co-located base station. The requirement applies during the *transmitter ON period* and the *transmitter transient period*.

The requirement applies at each RIB supporting transmission in the operating band.

The transmitter intermodulation level is the total radiated power of the intermodulation products when an interfering signal is injected into the CLTA.

For *IAB type 1-O*, the transmitter intermodulation requirement is captured by the co-location transmitter intermodulation scenario case, in which the interfering signal is injected into the CLTA.

6.8.2 Minimum requirement

The minimum requirement for *IAB -DU type 1-O* and *IAB -MT type 1-O* is defined in TS 38.174 [2], clause 9.8.2.

The OTA transmitter intermodulation requirement is not applicable for *IAB type 2-O*.

6.8.3 Test purpose

The test purpose is to verify the ability of the transmitter units associated with the *RIB* under test to restrict the generation of intermodulation products in its nonlinear elements caused by presence of the wanted signal and an interfering signal reaching the transmitter unit via the RDN and antenna array from a co-located base station to below specified levels.

6.8.4 Method of test

6.8.4.1 Initial conditions

Test environment: normal; see annex B.2.

RF channels to be tested for single carrier: M ; see clause 4.9.1.

IAB RF Bandwidth positions to be tested for multi-carrier:

- M_{RFBW} in *single-band RIB*, see clause 4.9.1;
- $B_{\text{RFBW_T'RFBW}}$ and $B'_{\text{RFBW_T'RFBW}}$ in *multi-band RIB*, see clause 4.9.1.

In addition, for *multi-band RIB*:

- For $B_{\text{RFBW_T'RFBW}}$, emission testing above the highest operating band may be omitted.
- For $B'_{\text{RFBW_T'RFBW}}$, emission testing below the lowest operating band may be omitted.

Directions to be tested: The FR1 requirement is specified as co-location requirement. For general description of co-location requirements, refer to clause 4.12.

6.8.4.2 Procedure

- 1) Select a CLTA according to the description in clause 4.12 and parameters given in table 4.12.2.2-1.
- 2) Place the CLTA according to the description in clause 4.12 and parameters given in table 4.12.2.3-1.
- 3) The test antenna(s) shall be dual (or single) polarized covering the same frequency range as the IAB and the emission frequencies.
- 4) Several test antennas are required to cover both the IAB and the whole emission frequency range.
- 5) Connect test antenna and CLTA to the measurement equipment as shown in annex E.1.5.
- 6) During the OTA emission measurements at the test antenna conducted output(s), both IAB and CLTA are rotated around same axis.
- 7) The OTA emission measurement method shall be TRP, according to the procedure described in annex I.
- 8) The measurement device (signal analyser) characteristics shall be:

- Detection mode: True RMS.

9) Set the IAB node to transmit:

For IAB-DU:

- Set the IAB-DU to transmit maximum power according to the applicable test configuration in clause 4.8 using the corresponding test models or set of physical channels in clause 4.9.2.
- For the IAB-DU declared to be capable of multi-carrier and/or CA operation, set the IAB-DU to transmit according to the applicable test configuration and corresponding power setting specified in clause 4.7.2 and 4.8 using the corresponding test models on all carriers configured.

For IAB-MT:

- Set the IAB-MT to transmit maximum power according to the applicable test configuration in clause 4.8 using the corresponding test models or set of physical channels in clause 4.9.2.
- For the IAB-MT declared to be capable of multi-carrier and/or CA operation, set the IAB-MT to transmit according to the applicable test configuration and corresponding power setting specified in clause 4.7.2 and 4.8 using the corresponding test models on all carriers configured.

For IAB node declared to be capable of Simultaneous transmission between IAB-DU and IAB-MT(D.IAB-3), set IAB-DU and IAB-MT to transmit maximum power within maximum power imbalance declared by manufacturer according to the applicable test configuration and test models specified in clauses 4.7.2 and 4.8 with both IAB-MT and IAB-DU configured.

10) Generate the interfering signal for *IAB node* via the CLTA. The CLTA is fed with a power level equal to declared $P_{\text{rated,t,TRP}}$, divided over all the supported polarizations, from the same signal generator source:

For IAB-DU:

- using test model as defined in clause 4.9.2.2 for IAB-DU, at a centre frequency offset according to the conditions in table 9.8.2-1 in TS 38.174 [2], but exclude interfering frequencies that are outside of the allocated downlink operating band or interfering frequencies that are not completely within the sub-block gap or within the Inter RF Bandwidth gap.

For IAB-MT:

- using test model as defined in clause 4.9.2.3 for IAB-MT, at a centre frequency offset according to the conditions in table 9.8.2-1 in TS 38.174 [2], but exclude interfering frequencies that are outside of the allocated downlink operating band or interfering frequencies that are not completely within the sub-block gap or within the Inter RF Bandwidth gap.

11) Adjust the interfering signal level at the CLTA conducted input(s) as defined in:

- transmitter intermodulation table 9.8.2-1 in TS 38.174 [2].

12) If the interferer signal is applicable according to clause 4.7, perform the unwanted emission tests specified in clauses 6.7.3 (OTA ACLR) and 6.7.4 (OTA OBUE) for all third and fifth order intermodulation products which appear in the frequency ranges defined in clauses 6.7.3 and 6.7.4 (Note 2). The width of the intermodulation products shall be taken into account.

13) If the interferer signal is applicable according to clause 4.7, perform the Transmitter spurious emissions test as specified in clause 6.7.5 (OTA spurious emission), except OTA co-location spurious emission, for all third and fifth order intermodulation products which appear in the frequency ranges defined in clause 6.7.5 (Note 2). The width of the intermodulation products shall be taken into account.

14) Verify that the emission level does not exceed the required level in clause 6.8.5 (Test requirements) with the exception of interfering signal frequencies.

15) Repeat the test for the remaining interfering signal centre frequency offsets according to the conditions of:

- transmitter intermodulation table 9.8.2-1 in TS 38.174 [2].

16) Repeat the test for the remaining interfering signals defined in clause 4.7 for requirements 6.7.3 (OTA ACLR), 6.7.4 (OTA OBUE) and 6.7.5 (OTA spurious emission), except OTA co-location spurious emission.

In addition, for *multi-band RIB*, the following steps shall apply:

17) For *multi-band RIB* and single band tests, repeat the steps above per involved band where single band test configurations and test models shall apply with no carrier activated in the other band.

NOTE 1: The third order intermodulation products are centred at $2F1 \pm F2$ and $2F2 \pm F1$. The fifth order intermodulation products are centred at $3F1 \pm 2F2$, $3F2 \pm 2F1$, $4F1 \pm F2$, and $4F2 \pm F1$ where $F1$ represents the test signal centre frequency or centre frequency of each sub-block and $F2$ represents the interfering signal centre frequency. The widths of intermodulation products are:

- $(n \cdot BW_{F1} + m \cdot BW_{F2})$ for the $nF1 \pm mF2$ products;
- $(n \cdot BW_{F2} + m \cdot BW_{F1})$ for the $nF2 \pm mF1$ products;

where BW_{F1} represents the test wanted signal RF bandwidth or channel bandwidth in case of single carrier, or sub-block bandwidth and BW_{F2} represents the interfering signal channel bandwidth.

NOTE 2: During the conformance test the interferer signal can be applied on one side of the wanted signal, while the transmitter intermodulation emission is measured only on the opposite side of the wanted signal. This applies for intermodulation products which are within the operating band or OBUE region.

6.8.5 Test requirements

6.8.5.1 Requirement for *IAB type 1-O*

The transmitter intermodulation level shall not exceed the TRP unwanted emission limits specified for OTA transmitter spurious emission in clause 6.7.5 (except co-location with other base stations), OTA out-of-band emissions in clause 6.7.4 and OTA ACLR in clause 6.7.3 in the presence of a wanted signal and an interfering signal, defined in table 6.8.5.1-1.

The requirement is applicable outside the *IAB RF Bandwidth edges*. The interfering signal offset is defined relative to the *IAB RF Bandwidth edges* or *Radio Bandwidth edges*.

For RIBs supporting operation in *non-contiguous spectrum*, the requirement is also applicable inside a *sub-block gap* for interfering signal offsets where the interfering signal falls completely within the *sub-block gap*. The interfering signal offset is defined relative to the *sub-block edges*.

For RIBs supporting operation in multiple *operating bands*, the requirement shall apply relative to the *IAB RF Bandwidth edges* of each *operating band*. In case the inter RF Bandwidth gap is less than $3 \cdot BW_{\text{Channel}}$ MHz (where BW_{Channel} is the minimal *IAB channel bandwidth* of the band), the requirement in the gap shall apply only for interfering signal offsets where the interfering signal falls completely within the inter RF Bandwidth gap.

Table 6.8.5.1-1: Interfering and wanted signals for the OTA transmitter intermodulation requirement

Parameter	Value
Wanted signal	NR single or multi-carrier, or multiple intra-band contiguously or non-contiguously aggregated carriers
Interfering signal type	NR signal the minimum <i>IAB-DU channel bandwidth</i> (BW_{Channel}) or <i>IAB-MT channel bandwidth</i> (BW_{Channel}) with 15 kHz SCS of the band defined in clause 5.3.5
Interfering signal level	The interfering signal level is the same power level as the IAB ($P_{\text{rated,t,TRP}}$) fed into a <i>co-location reference antenna</i> ..
Interfering signal centre frequency offset from the lower (upper) edge of the wanted signal or edge of <i>sub-block</i> inside a gap	$f_{\text{offset}} = \pm BW_{\text{Channel}} \left(n - \frac{1}{2} \right)$, for $n=1, 2$ and 3
NOTE 1: Interfering signal positions that are partially or completely outside of any downlink <i>operating band</i> of the IAB are excluded from the requirement, unless the interfering signal positions fall within the frequency range of adjacent downlink <i>operating bands</i> in the same geographical area.	
NOTE 2: In Japan, note 1 is not applied in Band n77, n78, n79.	
NOTE 3: The $P_{\text{rated,t,TRP}}$ is split between supported polarizations at the CLTA input ports.	

7 Radiated receiver characteristics

7.1 General

General test conditions for receiver tests are given in clause 4, including interpretation of measurement results and configurations for testing. IAB configurations for the tests are defined in clause 4.5.

Unless otherwise stated, the following arrangements apply for radiated receiver characteristics requirements in clause 7:

- Requirements apply during the IAB receive period.
- Requirements shall be met for any transmitter setting.
- Throughput requirements defined for the radiated receiver characteristics do not assume HARQ retransmissions.
- When IAB is configured to receive multiple carriers, all the throughput requirements are applicable for each received carrier.
- For ACS, blocking and intermodulation characteristics, the negative offsets of the interfering signal apply relative to the lower *IAB RF Bandwidth* edge or *sub-block* edge inside a *sub-block gap*, and the positive offsets of the interfering signal apply relative to the upper *IAB RF Bandwidth* edge or *sub-block* edge inside a *sub-block gap*.

NOTE 1: In normal operating condition the IAB in TDD operation is configured to TX OFF power during *receive period*.

Each requirement, except OTA receiver spurious emissions, shall be met over the RoAoA specified.

For FR1 requirements which are to be met over the *OTA REFSENS RoAoA* absolute requirement values are offset by the following term:

$$\Delta_{\text{OTAREFSENS}} = 44.1 - 10 \cdot \log_{10}(\text{Be}W_{\theta, \text{REFSENS}} \cdot \text{Be}W_{\phi, \text{REFSENS}}) \text{ (dB) for the reference direction.}$$

And

$$\Delta_{\text{OTAREFSENS}} = 41.1 - 10 \cdot \log_{10}(\text{Be}W_{\theta, \text{REFSENS}} \cdot \text{Be}W_{\phi, \text{REFSENS}}) \text{ (dB) for all other directions.}$$

For requirements which are to be met over the *minSENS RoAoA* absolute requirement values are offset by the following term:

$$\Delta_{\text{minSENS}} = P_{\text{REFSENS}} - \text{EIS}_{\text{minSENS}} \text{ (dB)}$$

For FR2 requirements which are to be met over the *OTA REFSENS RoAoA* absolute requirement values are offset by the following term:

$$\Delta_{\text{FR2_REFSENS}} = -3 \text{ dB for the reference direction}$$

and

$$\Delta_{\text{FR2_REFSENS}} = 0 \text{ dB for all other directions}$$

7.2 OTA sensitivity

7.2.1 Definition and applicability

The OTA sensitivity requirement is based upon the declaration of one or more *OTA sensitivity direction declarations* (OSDD), related to a *IAB type 1-H* and *IAB type 1-O* receiver.

The *IAB type 1-H* and *IAB type 1-O* receiver may optionally be capable of redirecting/changing the *receiver target* by means of adjusting BS settings resulting in multiple *sensitivity RoAoA*. The *sensitivity RoAoA* resulting from the current BS settings is the active *sensitivity RoAoA*.

If the IAB is capable of redirecting the *receiver target* related to the OSDD then the OSDD shall include:

- *IAB channel bandwidth* and declared minimum EIS level applicable to any active *sensitivity RoAoA* inside the *receiver target redirection range* in the OSDD.
- A declared *receiver target redirection range*, describing all the angles of arrival that can be addressed for the OSDD through alternative settings in the BS.
- Five declared *sensitivity RoAoA* comprising the conformance testing directions as detailed in TR 37. 941 [29].
- The *receiver target reference direction*.

NOTE 1: Some of the declared *sensitivity RoAoA* may coincide depending on the redirection capability.

NOTE 2: In addition to the declared *sensitivity RoAoA*, several *sensitivity RoAoA* may be implicitly defined by the *receiver target redirection range* without being explicitly declared in the OSDD.

If the IAB is not capable of redirecting the *receiver target* related to the OSDD, then the OSDD includes only:

- *IAB channel bandwidth* and declared minimum EIS level applicable to the *sensitivity RoAoA* in the OSDD.
- One declared active *sensitivity RoAoA*.
- The receiver target reference direction.

NOTE 3: For BS without target redirection capability, the declared (fixed) *sensitivity RoAoA* is always the active *sensitivity RoAoA*.

The OTA sensitivity EIS level declaration shall apply to each supported polarization, under the assumption of *polarization match*.

7.2.2 Minimum requirement

The minimum requirement for *IAB-DU type 1-H* and *IAB-DU type 1-O* is in TS 38.174 [2], clause 10.2.1.

The minimum requirement for *IAB-MT type 1-H* and *IAB-MT type 1-O* is in TS 38.174 [2], clause 10.2.2.

7.2.3 Test purpose

The test purpose is to verify that the BS can meet the throughput requirement for a specified measurement channel at the EIS level and the range of angles of arrival declared in the OSDD.

7.2.4 Method of test

7.2.4.1 Initial conditions

Test environment: Normal, see annex B.2.

RF channels to be tested for single carrier: M; see clause 4.9.1.

Directions to be tested:

- receiver target reference direction (D.31),
- conformance test directions (D.33).

7.2.4.2 Procedure

- 1) Place the BS with its manufacturer declared coordinate system reference point in the same place as calibrated point in the test system, as shown in annex E.2.1.
- 2) Align the manufacturer declared coordinate system orientation of the BS with the test system.
- 3) Align the BS with the test antenna in the declared direction to be tested.
- 4) Ensure the polarization is accounted for such that all the power from the test antenna is captured by the BS under test.
- 5) Start the signal generator for the wanted signal to transmit:
 - The test signal as specified in clause 7.2.5.
- 6) Set the test signal mean power so the calibrated radiated power at the BS Antenna Array coordinate system reference point is as specified in clause 7.2.5.
- 7) Measure the throughput according to annex A.1 for each supported polarization.
- 8) Repeat steps 3 to 9 for all OSDD(s) declared for the BS (D.23), and supported polarizations.

For multi-band capable BS and single band tests, repeat the steps above per involved band where single band test configurations and test models shall apply with no carriers activated in the other band.

7.2.5 Test requirements

7.2.5.1 General

The minimum EIS level is a declared figure (D.27, D.28) for each OSDD (D.23). The test requirement is calculated from the declared value offset by the EIS Test Tolerance specified in clause 4.1.

7.2.5.2 Test requirements for *IAB-DU type 1-H* and *IAB-DU type 1-O*

For each measured carrier, the throughput measured in step 7 of clause 7.2.4.2 shall be ≥ 95 % of the maximum throughput of the reference measurement channel as specified in annex A.1 with parameters specified in table 7.2.5.2-1.

Table 7.2.5.2-1: EIS levels

IAB-DU channel bandwidth (MHz)	Sub-carrier spacing (kHz)	Reference measurement channel (annex A.1)	OTA sensitivity level, EIS (dBm)		
			$f \leq 3.0$ GHz	3.0 GHz $< f \leq 4.2$ GHz	4.2 GHz $< f \leq 6.0$ GHz
10, 15	15	G-FR1-A1-1	Declared minimum EIS + 1.3	Declared minimum EIS + 1.4	Declared minimum EIS + 1.6
10, 15	30	G-FR1-A1-2			
10, 15	60	G-FR1-A1-3			
20, 25, 30, 40, 50	15	G-FR1-A1-4			
20, 25, 30, 40, 50, 60, 70, 80, 90, 100	30	G-FR1-A1-5			
20, 25, 30, 40, 50, 60, 70, 80, 90, 100	60	G-FR1-A1-6			
NOTE: EIS is the power level of a single instance of the reference measurement channel. This requirement shall be met for each consecutive application of a single instance of the reference measurement channel mapped to disjoint frequency ranges with a width corresponding to the number of resource blocks of the reference measurement channel each, except for one instance that might overlap one other instance to cover the full IAB-DU channel bandwidth.					

7.2.5.3 Test requirements for IAB-MT type 1-H and IAB-MT type 1-O

For each measured carrier, the throughput measured in step 7 of clause 7.2.4.2 shall be ≥ 95 % of the maximum throughput of the reference measurement channel as specified in annex A.1 with parameters specified in table 7.2.5.2-1.

Table 7.2.5.3-1: EIS levels

IAB-MT channel bandwidth (MHz)	Sub-carrier spacing (kHz)	Reference measurement channel (annex A.1)	OTA sensitivity level, EIS (dBm)		
			$f \leq 3.0$ GHz	3.0 GHz $< f \leq 4.2$ GHz	4.2 GHz $< f \leq 6.0$ GHz
10, 15	30	G-FR1-A1-22 (Note 1)	Declared minimum EIS + 1.3	Declared minimum EIS + 1.4	Declared minimum EIS + 1.6
10, 15	60	G-FR1-A1-23 (Note 1)			
20, 25, 30, 40, 50, 60, 70, 80, 90, 100	30	G-FR1-A1-25 (Note 1)			
20, 25, 30, 40, 50, 60, 70, 80, 90, 100	60	G-FR1-A1-26 (Note 1)			
NOTE: EIS is the power level of a single instance of the reference measurement channel. This requirement shall be met for each consecutive application of a single instance of the reference measurement channel mapped to disjoint frequency ranges with a width corresponding to the number of resource blocks of the reference measurement channel each, except for one instance that might overlap one other instance to cover the full IAB-MT channel bandwidth.					

7.3 OTA reference sensitivity level

7.3.1 Definition and applicability

The OTA REFSSENS requirement is a directional requirement and is intended to ensure the minimum OTA reference sensitivity level for a declared *OTA REFSSENS RoAoA*. The OTA reference sensitivity power level $EIS_{REFSENS}$ is the minimum mean power received at the RIB at which a reference performance requirement shall be met for a specified reference measurement channel.

The OTA REFSSENS EIS level declaration shall apply to each supported polarization, under the assumption of *polarization match*.

7.3.2 Minimum requirement

For IAB-DU type 1-O the minimum requirement is in TS 38.174 [2], clause 10.3.2.1.

For IAB-DU type 2-O the minimum requirement is in TS 38.174 [2], clause 10.3.3.2.

For *IAB-MT type 1-O* the minimum requirement is in TS 38.174 [2], clause 10.3.3.2.

For *IAB-MT type 2-O* the minimum requirement is in TS 38.174 [2], clause 10.3.3.3.

7.3.3 Test Purpose

The test purpose is to verify that the IAB can meet the throughput requirement for a specified measurement channel at the $EIS_{REFSENS}$ level and the range of angles of arrival within the *OTA REFSENS RoAoA*.

7.3.4 Method of test

7.3.4.1 Initial conditions

Test environment: Normal, see annex B.2.

RF channels to be tested for single carrier:

- B, M and T; see clause 4.9.1.

Directions to be tested:

- OTA REFSENS receiver target reference direction (D.54),
- OTA REFSENS conformance test directions (D.55).

7.3.4.2 Procedure

- 1) Place the IAB with its manufacturer declared coordinate system reference point in the same place as calibrated point in the test system, as shown in annex E.2.1.
- 2) Align the manufacturer declared coordinate system orientation of the IAB with the test system.
- 3) Align the IAB with the test antenna in the declared direction to be tested.
- 4) Ensure the polarization is accounted for such that all the power from the test antenna is captured by the IAB under test.
- 5) Start the signal generator for the wanted signal to transmit:
 - The test signal as specified in clause 7.3.5.
- 6) Set the test signal mean power so the calibrated radiated power at the BS Antenna Array coordinate system reference point is as specified in clause 7.3.5.
- 7) Measure the throughput according to annex A.1 for each supported polarization.
- 9) Repeat steps 3 to 9 for all OTA REFSENS conformance test directions of the IAB (D.55), and supported polarizations.

For multi-band capable FR1 IAB and single band tests, repeat the steps above per involved band where single band test configurations and test models shall apply with no carriers activated in the other band.

7.3.5 Test requirements

7.3.5.1 General

The FR1 $EIS_{REFSENS}$ level is the conducted REFSENS requirement value offset by $\Delta_{OTAREFSNS}$. The test requirement is calculated from the $EIS_{REFSENS}$ level offset by the $EIS_{REFSENS}$ Test Tolerance specified in clause 4.1.

7.3.5.2 IAB-DU OTA reference sensitivity level

7.3.5.2.1 Test requirements for IAB-DU type 1-0

For each measured carrier, the throughput measured in step 7 of clause 7.3.4.2 shall be $\geq 95\%$ of the maximum throughput of the reference measurement channel as specified in annex A.1 with parameters specified in tables 7.3.5.2.1-1 to 7.3.5.2.1-3.

Table 7.3.5.2.1-1: Wide Area IAB-DU EIS_{REFSENS} levels

IAB-DU channel bandwidth (MHz)	Sub-carrier spacing (kHz)	Reference measurement channel (annex A.1)	OTA reference sensitivity level, EIS _{REFSENS} (dBm)		
			$f \leq 3.0$ GHz	3.0 GHz $< f \leq 4.2$ GHz	4.2 GHz $< f \leq 6.0$ GHz
10, 15	15	G-FR1-A1-1	-100.4 – $\Delta_{\text{OTAREFSNS}}$	-100.3 – $\Delta_{\text{OTAREFSNS}}$	-100.1 – $\Delta_{\text{OTAREFSNS}}$
10, 15	30	G-FR1-A1-2	-100.5 – $\Delta_{\text{OTAREFSNS}}$	-100.4 – $\Delta_{\text{OTAREFSNS}}$	-100.2 – $\Delta_{\text{OTAREFSNS}}$
10, 15	60	G-FR1-A1-3	-97.6 – $\Delta_{\text{OTAREFSNS}}$	-97.5 – $\Delta_{\text{OTAREFSNS}}$	-97.3 – $\Delta_{\text{OTAREFSNS}}$
20, 25, 30, 40, 50	15	G-FR1-A1-4	-94 – $\Delta_{\text{OTAREFSNS}}$	-93.9 – $\Delta_{\text{OTAREFSNS}}$	-93.7 – $\Delta_{\text{OTAREFSNS}}$
20, 25, 30, 40, 50, 60, 70, 80, 90, 100	30	G-FR1-A1-5	-94.3 – $\Delta_{\text{OTAREFSNS}}$	-94.2 – $\Delta_{\text{OTAREFSNS}}$	-94 – $\Delta_{\text{OTAREFSNS}}$
20, 25, 30, 40, 50, 60, 70, 80, 90, 100	60	G-FR1-A1-6	-94.4 – $\Delta_{\text{OTAREFSNS}}$	-94.3 – $\Delta_{\text{OTAREFSNS}}$	-94.1 – $\Delta_{\text{OTAREFSNS}}$

NOTE: EIS_{REFSENS} is the power level of a single instance of the reference measurement channel. This requirement shall be met for each consecutive application of a single instance of the reference measurement channel mapped to disjoint frequency ranges with a width corresponding to the number of resource blocks of the reference measurement channel each, except for one instance that might overlap one other instance to cover the full IAB-DU channel bandwidth.

Table 7.3.5.2-2: Medium Range IAB-DU EIS_{REFSENS} levels

IAB-DU channel bandwidth (MHz)	Sub-carrier spacing (kHz)	Reference measurement channel (annex A.1)	EIS _{REFSENS} (dBm)		
			$f \leq 3.0$ GHz	3.0 GHz $< f \leq 4.2$ GHz	4.2 GHz $< f \leq 6.0$ GHz
10, 15	15	G-FR1-A1-1	-95.4 – $\Delta_{\text{OTAREFSNS}}$	-95.3 – $\Delta_{\text{OTAREFSNS}}$	-95.1 – $\Delta_{\text{OTAREFSNS}}$
10, 15	30	G-FR1-A1-2	-95.5 – $\Delta_{\text{OTAREFSNS}}$	-95.4 – $\Delta_{\text{OTAREFSNS}}$	-95.2 – $\Delta_{\text{OTAREFSNS}}$
10, 15	60	G-FR1-A1-3	-92.6 – $\Delta_{\text{OTAREFSNS}}$	-92.5 – $\Delta_{\text{OTAREFSNS}}$	-92.3 – $\Delta_{\text{OTAREFSNS}}$
20, 25, 30, 40, 50	15	G-FR1-A1-4	-89 – $\Delta_{\text{OTAREFSNS}}$	-88.9 – $\Delta_{\text{OTAREFSNS}}$	-88.7 – $\Delta_{\text{OTAREFSNS}}$
20, 25, 30, 40, 50, 60, 70, 80, 90, 100	30	G-FR1-A1-5	-89.3 – $\Delta_{\text{OTAREFSNS}}$	-89.2 – $\Delta_{\text{OTAREFSNS}}$	-89 – $\Delta_{\text{OTAREFSNS}}$
20, 25, 30, 40, 50, 60, 70, 80, 90, 100	60	G-FR1-A1-6	-89.4 – $\Delta_{\text{OTAREFSNS}}$	-89.3 – $\Delta_{\text{OTAREFSNS}}$	-89.1 – $\Delta_{\text{OTAREFSNS}}$

NOTE: EIS_{REFSENS} is the power level of a single instance of the reference measurement channel. This requirement shall be met for each consecutive application of a single instance of the reference measurement channel mapped to disjoint frequency ranges with a width corresponding to the number of resource blocks of the reference measurement channel each, except for one instance that might overlap one other instance to cover the full IAB-DU channel bandwidth.

Table 7.3.5.2.1-3: Local Area IAB-DU EIS_{REFSENS} levels

IAB-DU channel bandwidth (MHz)	Sub-carrier spacing (kHz)	Reference measurement channel (annex A.1)	OTA reference sensitivity level, EIS _{REFSENS} (dBm)		
			f ≤ 3.0 GHz	3.0 GHz < f ≤ 4.2 GHz	4.2 GHz < f ≤ 6.0 GHz
10, 15	15	G-FR1-A1-1	-92.4 – Δ _{OTAREFS}	-92.3 – Δ _{OTAREFS}	-92.1 – Δ _{OTAREFS}
10, 15	30	G-FR1-A1-2	-92.5 – Δ _{OTAREFS}	-92.4 – Δ _{OTAREFS}	-92.2 – Δ _{OTAREFS}
10, 15	60	G-FR1-A1-3	-89.6 – Δ _{OTAREFS}	-89.5 – Δ _{OTAREFS}	-89.3 – Δ _{OTAREFS}
20, 25, 30, 40, 50	15	G-FR1-A1-4	-86 – Δ _{OTAREFS}	-85.9 – Δ _{OTAREFS}	-85.7 – Δ _{OTAREFS}
20, 25, 30, 40, 50, 60, 70, 80, 90, 100	30	G-FR1-A1-5	-86.3 – Δ _{OTAREFS}	-86.2 – Δ _{OTAREFS}	-86 – Δ _{OTAREFS}
20, 25, 30, 40, 50, 60, 70, 80, 90, 100	60	G-FR1-A1-6	-86.4 – Δ _{OTAREFS}	-86.3 – Δ _{OTAREFS}	-86.1 – Δ _{OTAREFS}

NOTE: EIS_{REFSENS} is the power level of a single instance of the reference measurement channel. This requirement shall be met for each consecutive application of a single instance of the reference measurement channel mapped to disjoint frequency ranges with a width corresponding to the number of resource blocks of the reference measurement channel each, except for one instance that might overlap one other instance to cover the full IAB-DU channel bandwidth.

7.3.5.2.2 Test requirements for IAB-DU type 2-O

The throughput shall be ≥ 95% of the maximum throughput of the reference measurement channel as specified in annex A.1 when the OTA test signal is at the corresponding EIS_{REFSENS} level and arrives from any direction within the OTA REFSENS RoAoA.

EIS_{REFSENS} levels are derived from a single declared basis level EIS_{REFSENS_50M}, which is based on a reference measurement channel with 50 MHz IAB-DU channel bandwidth. EIS_{REFSENS_50M} itself is not a requirement and although it is based on a reference measurement channel with 50 MHz IAB channel bandwidth it does not imply that IAB-DU has to support 50 MHz IAB-DU channel bandwidth.

For Wide Area IAB-DU, EIS_{REFSENS_50M} is an integer value in the range -96 to -119 dBm. The specific value is declared by the vendor.

For Medium Range IAB-DU, EIS_{REFSENS_50M} is an integer value in the range -91 to -114 dBm. The specific value is declared by the vendor.

For Local Area IAB-DU, EIS_{REFSENS_50M} is an integer value in the range -86 to -109 dBm. The specific value is declared by the vendor.

Table 7.3.5.2.2-1 FR2 OTA reference sensitivity requirement

IAB-DU channel bandwidth (MHz)	Sub-carrier spacing (kHz)	Reference measurement channel (annex A.1)	OTA reference sensitivity level, EIS _{REFSENS} (dBm)
50, 100, 200	60	G-FR2-A1-1	EIS _{REFSENS_50M} + 2.4 + Δ _{FR2_REFSENS}
50	120	G-FR2-A1-2	EIS _{REFSENS_50M} + 2.4 + Δ _{FR2_REFSENS}
100, 200, 400	120	G-FR2-A1-3	EIS _{REFSENS_50M} + 3 + 2.4 + Δ _{FR2_REFSENS}

NOTE 1: EIS_{REFSENS} is the power level of a single instance of the reference measurement channel. This requirement shall be met for each consecutive application of a single instance of the reference measurement channel mapped to disjoint frequency ranges with a width corresponding to the number of resource blocks of the reference measurement channel each, except for one instance that might overlap one other instance to cover the full IAB-DU channel bandwidth.

NOTE 2: The declared EIS_{REFSENS_50M} shall be within the range specified above.

7.3.5.3 IAB-MT OTA reference sensitivity level

7.3.5.3.1 Test requirement for *IAB-MT type 1-O*

For each measured carrier, the throughput measured in step 7 of clause 7.3.4.2 shall be $\geq 95\%$ of the maximum throughput of the reference measurement channel as specified in annex A.1 with parameters specified in tables 7.3.5.3.1-1 to 7.3.5.3.12.

Table 7.3.5.3.1-1: Wide Area *IAB-MT type 1-O* reference sensitivity levels

<i>IAB-MT channel bandwidth</i> (MHz)	Sub-carrier spacing (kHz)	Reference measurement channel	OTA reference sensitivity level, $EIS_{REFSENS}$ (dBm)		
			$f \leq 3.0$ GHz	3.0 GHz $< f \leq 4.2$ GHz	4.2 GHz $< f \leq 6.0$ GHz
10, 15	30	G-FR1-A1-22	-100.7 - $\Delta_{OTAREFSENS}$	-100.6 - $\Delta_{OTAREFSENS}$	-100.4 - $\Delta_{OTAREFSENS}$
10, 15	60	G-FR1-A1-23	-97.7 - $\Delta_{OTAREFSENS}$	-97.6 - $\Delta_{OTAREFSENS}$	-97.4 - $\Delta_{OTAREFSENS}$
20, 25, 30, 40, 50, 60, 70, 80, 90, 100	30	G-FR1-A1-25	-94.1 - $\Delta_{OTAREFSENS}$	-94.0 - $\Delta_{OTAREFSENS}$	-93.8 - $\Delta_{OTAREFSENS}$
20, 25, 30, 40, 50, 60, 70, 80, 90, 100	60	G-FR1-A1-26	-94.3 - $\Delta_{OTAREFSENS}$	-94.2 - $\Delta_{OTAREFSENS}$	-94.0 - $\Delta_{OTAREFSENS}$

NOTE: $EIS_{REFSENS}$ is the power level of a single instance of the reference measurement channel. This requirement shall be met for each consecutive application of a single instance of the reference measurement channel mapped to disjoint frequency ranges with a width corresponding to the number of resource blocks of the reference measurement channel each, except for one instance that might overlap one other instance to cover the full *IAB-MT channel bandwidth*.

Table 7.3.5.3.1-2: Local Area *IAB-MT type 1-O* reference sensitivity levels

<i>IAB-MT channel bandwidth</i> (MHz)	Sub-carrier spacing (kHz)	Reference measurement channel	OTA reference sensitivity level, $EIS_{REFSENS}$ (dBm)		
			$f \leq 3.0$ GHz	3.0 GHz $< f \leq 4.2$ GHz	4.2 GHz $< f \leq 6.0$ GHz
10, 15	30	G-FR1-A1-22	-92.7 - $\Delta_{OTAREFSENS}$	-92.6 - $\Delta_{OTAREFSENS}$	-92.4 - $\Delta_{OTAREFSENS}$
10, 15	60	G-FR1-A1-23	-89.7 - $\Delta_{OTAREFSENS}$	-89.6 - $\Delta_{OTAREFSENS}$	-89.4 - $\Delta_{OTAREFSENS}$
20, 25, 30, 40, 50, 60, 70, 80, 90, 100	30	G-FR1-A1-25	-86.1 - $\Delta_{OTAREFSENS}$	-86.0 - $\Delta_{OTAREFSENS}$	-85.8 - $\Delta_{OTAREFSENS}$
20, 25, 30, 40, 50, 60, 70, 80, 90, 100	60	G-FR1-A1-26	-86.3 - $\Delta_{OTAREFSENS}$	-86.2 - $\Delta_{OTAREFSENS}$	-86.0 - $\Delta_{OTAREFSENS}$

NOTE: $EIS_{REFSENS}$ is the power level of a single instance of the reference measurement channel. This requirement shall be met for each consecutive application of a single instance of the reference measurement channel mapped to disjoint frequency ranges with a width corresponding to the number of resource blocks of the reference measurement channel each, except for one instance that might overlap one other instance to cover the full *IAB-MT channel bandwidth*.

7.3.5.3.2 Minimum requirement for *IAB-MT type 2-O*

The throughput shall be $\geq 95\%$ of the maximum throughput of the reference measurement channel as specified in the corresponding table and annex A.1 when the OTA test signal is at the corresponding $EIS_{REFSENS}$ level and arrives from any direction within the *OTA REFSENS RoAoA*.

$EIS_{REFSENS}$ levels are derived from a single declared basis level $EIS_{REFSENS_50M}$, which is based on a reference measurement channel with 50 MHz *IAB-MT channel bandwidth*. $EIS_{REFSENS_50M}$ itself is not a requirement and although it is based on a reference measurement channel with 50 MHz *IAB-MT channel bandwidth* it does not imply that *IAB-MT* has to support 50 MHz *IAB-MT channel bandwidth*.

For Wide Area IAB-MT, $EIS_{REFSENS_50M}$ is an integer value in the range -96 to -119 dBm. The specific value is declared by the vendor.

For Local Area IAB-MT, $EIS_{REFSENS_50M}$ is an integer value in the range -86 to -114 dBm. The specific value is declared by the vendor.

Table 7.3.5.3.2-1: FR2 OTA reference sensitivity requirement

<i>IAB-MT channel Bandwidth (MHz)</i>	<i>Sub-carrier spacing (kHz)</i>	<i>Reference measurement channel</i>	<i>OTA reference sensitivity level, $EIS_{REFSENS}$ (dBm)</i>
50, 100, 200	60	G-FR2-A1-21	$EIS_{REFSENS_50M} + 3.3 + \Delta_{FR2_REFSENS}$
50	120	G-FR2-A1-22	$EIS_{REFSENS_50M} + 3.3 + \Delta_{FR2_REFSENS}$
100, 200, 400	120	G-FR2-A1-23	$EIS_{REFSENS_50M} + 3.3 + 3 + \Delta_{FR2_REFSENS}$
NOTE 1: $EIS_{REFSENS}$ is the power level of a single instance of the reference measurement channel. This requirement shall be met for each consecutive application of a single instance of the reference measurement channel mapped to disjoint frequency ranges with a width corresponding to the number of resource blocks of the reference measurement channel each, except for one instance that might overlap one other instance to cover the full <i>IAB-MT channel bandwidth</i> .			
NOTE 2: The declared $EIS_{REFSENS_50M}$ shall be within the range specified above.			

7.4 OTA dynamic range

7.4.1 Definition and applicability

The OTA dynamic range is a measure of the capability of the receiver unit to receive a wanted signal in the presence of an interfering signal inside the received *IAB-DU channel bandwidth*.

The requirement shall apply at the RIB when the AoA of the incident wave of a received signal and the interfering signal are from the same direction and are within the *OTA REFSENS RoAoA*.

The wanted and interfering signals apply to each supported polarization, under the assumption of *polarization match*.

7.4.2 Minimum requirement

For *IAB-DU type I-O*, the minimum requirement is in TS 38.174 [2], clause 10.4.1.

7.4.3 Test purpose

The test purpose is to verify that at the IAB-DU receiver dynamic range, the relative throughput shall fulfil the specified limit.

7.4.4 Method of test

7.4.4.1 Initial conditions

Test environment: Normal: see annex B.2.

RF channels to be tested for single carrier: M; see clause 4.9.1.

Directions to be tested: OTA REFSENS receiver target reference direction (D.54).

7.4.4.2 Procedure

- 1) Place the IAB-DU with its manufacturer declared coordinate system reference point in the same place as calibrated point in the test system, as shown in annex E.2.2.
- 2) Align the manufacturer declared coordinate system orientation of the IAN-DU with the test system.
- 3) Align the IAB-DU with the test antenna in the declared direction to be tested.
- 4) Ensure the polarization is accounted for such that all the power from the test antenna is captured by the IAB-DU under test.
- 5) Set the test signal mean power so that the calibrated radiated power at the IAB-DU Antenna Array coordinate system reference point is as follows:
 - a) Set the signal generator for the wanted signal to transmit as specified in table 7.4.5.2-1 to 7.4.5.2-3.
 - b) Set the signal generator for the AWGN interfering signal at the same frequency as the wanted signal to transmit as specified in table 7.4.5.2-1 to 7.4.5.2-3.
- 6) Measure the throughput according to annex A.2 for each supported polarization.

For *multi-band RIB(s)* and single band tests, repeat the steps above per involved band where single band test configurations and test models shall apply with no carriers activated in the other band.

7.4.5 Test requirement

7.4.5.1 General

The test requirement is calculated from the OTA wanted signal mean power level offset by the OTA dynamic range Test Tolerance specified in clause 4.1.

7.4.5.2 Test requirements for *IAB-DU type 1-0*

For each measured carrier, the throughput measured in step 6 of clause 7.4.4.2 shall be ≥ 95 % of the maximum throughput of the reference measurement channel as specified in annex A.2 with parameters specified in tables 7.4.5.2-1 to 7.4.5.2-3.

Table 7.4.5.2-1: Wide Area IAB-DU dynamic range

IAB-DU channel bandwidth (MHz)	Subcarrier spacing (kHz)	Reference measurement channel (annex A.2)	Wanted signal mean power (dBm)	Interfering signal mean power (dBm) / BW_{Config}	Type of interfering signal
10	15	G-FR1-A2-1	$-70.4 - \Delta_{OTAREFSNS}$	$-79.3 - \Delta_{OTAREFSNS}$	AWGN
	30	G-FR1-A2-2	$-71.1 - \Delta_{OTAREFSNS}$		
	60	G-FR1-A2-3	$-68.1 - \Delta_{OTAREFSNS}$		
15	15	G-FR1-A2-1	$-70.4 - \Delta_{OTAREFSNS}$	$-77.5 - \Delta_{OTAREFSNS}$	AWGN
	30	G-FR1-A2-2	$-71.1 - \Delta_{OTAREFSNS}$		
	60	G-FR1-A2-3	$-68.1 - \Delta_{OTAREFSNS}$		
20	15	G-FR1-A2-4	$-64.2 - \Delta_{OTAREFSNS}$	$-76.2 - \Delta_{OTAREFSNS}$	AWGN
	30	G-FR1-A2-5	$-64.2 - \Delta_{OTAREFSNS}$		
	60	G-FR1-A2-6	$-64.5 - \Delta_{OTAREFSNS}$		
25	15	G-FR1-A2-4	$-64.2 - \Delta_{OTAREFSNS}$	$-75.2 - \Delta_{OTAREFSNS}$	AWGN
	30	G-FR1-A2-5	$-64.2 - \Delta_{OTAREFSNS}$		
	60	G-FR1-A2-6	$-64.5 - \Delta_{OTAREFSNS}$		
30	15	G-FR1-A2-4	$-64.2 - \Delta_{OTAREFSNS}$	$-74.4 - \Delta_{OTAREFSNS}$	AWGN
	30	G-FR1-A2-5	$-64.2 - \Delta_{OTAREFSNS}$		
	60	G-FR1-A2-6	$-64.5 - \Delta_{OTAREFSNS}$		
40	15	G-FR1-A2-4	$-64.2 - \Delta_{OTAREFSNS}$	$-73.1 - \Delta_{OTAREFSNS}$	AWGN
	30	G-FR1-A2-5	$-64.2 - \Delta_{OTAREFSNS}$		
	60	G-FR1-A2-6	$-64.5 - \Delta_{OTAREFSNS}$		
50	15	G-FR1-A2-4	$-64.2 - \Delta_{OTAREFSNS}$	$-72.1 - \Delta_{OTAREFSNS}$	AWGN
	30	G-FR1-A2-5	$-64.2 - \Delta_{OTAREFSNS}$		
	60	G-FR1-A2-6	$-64.5 - \Delta_{OTAREFSNS}$		
60	30	G-FR1-A2-5	$-64.2 - \Delta_{OTAREFSNS}$	$-71.3 - \Delta_{OTAREFSNS}$	AWGN
	60	G-FR1-A2-6	$-64.5 - \Delta_{OTAREFSNS}$		
70	30	G-FR1-A2-5	$-64.2 - \Delta_{OTAREFSNS}$	$-70.7 - \Delta_{OTAREFSNS}$	AWGN
	60	G-FR1-A2-6	$-64.5 - \Delta_{OTAREFSNS}$		
80	30	G-FR1-A2-5	$-64.2 - \Delta_{OTAREFSNS}$	$-70.1 - \Delta_{OTAREFSNS}$	AWGN
	60	G-FR1-A2-6	$-64.5 - \Delta_{OTAREFSNS}$		
90	30	G-FR1-A2-5	$-64.2 - \Delta_{OTAREFSNS}$	$-69.5 - \Delta_{OTAREFSNS}$	AWGN
	60	G-FR1-A2-6	$-64.5 - \Delta_{OTAREFSNS}$		
100	30	G-FR1-A2-5	$-64.2 - \Delta_{OTAREFSNS}$	$-69.1 - \Delta_{OTAREFSNS}$	AWGN
	60	G-FR1-A2-6	$-64.5 - \Delta_{OTAREFSNS}$		

NOTE: The wanted signal mean power is the power level of a single instance of the corresponding reference measurement channel. This requirement shall be met for each consecutive application of a single instance of the reference measurement channel mapped to disjoint frequency ranges with a width corresponding to the number of resource blocks of the reference measurement channel each, except for one instance that might overlap one other instance to cover the full *IAB-DU channel bandwidth*.

Table 7.4.5.2-2: Medium Range IAB-DU dynamic range

IAB-DU channel bandwidth (MHz)	Subcarrier spacing (kHz)	Reference measurement channel (annex A.2)	Wanted signal mean power (dBm)	Interfering signal mean power (dBm) / BW_{Config}	Type of interfering signal
10	15	G-FR1-A2-1	$-65.4 - \Delta_{OTAREFSENS}$	$-74.3 - \Delta_{OTAREFSENS}$	AWGN
	30	G-FR1-A2-2	$-66.1 - \Delta_{OTAREFSENS}$		
	60	G-FR1-A2-3	$-63.1 - \Delta_{OTAREFSENS}$		
15	15	G-FR1-A2-1	$-65.4 - \Delta_{OTAREFSENS}$	$-72.5 - \Delta_{OTAREFSENS}$	AWGN
	30	G-FR1-A2-2	$-66.1 - \Delta_{OTAREFSENS}$		
	60	G-FR1-A2-3	$-63.1 - \Delta_{OTAREFSENS}$		
20	15	G-FR1-A2-4	$-59.2 - \Delta_{OTAREFSENS}$	$-71.2 - \Delta_{OTAREFSENS}$	AWGN
	30	G-FR1-A2-5	$-59.2 - \Delta_{OTAREFSENS}$		
	60	G-FR1-A2-6	$-59.5 - \Delta_{OTAREFSENS}$		
25	15	G-FR1-A2-4	$-59.2 - \Delta_{OTAREFSENS}$	$-70.2 - \Delta_{OTAREFSENS}$	AWGN
	30	G-FR1-A2-5	$-59.2 - \Delta_{OTAREFSENS}$		
	60	G-FR1-A2-6	$-59.5 - \Delta_{OTAREFSENS}$		
30	15	G-FR1-A2-4	$-59.2 - \Delta_{OTAREFSENS}$	$-69.4 - \Delta_{OTAREFSENS}$	AWGN
	30	G-FR1-A2-5	$-59.2 - \Delta_{OTAREFSENS}$		
	60	G-FR1-A2-6	$-59.5 - \Delta_{OTAREFSENS}$		
40	15	G-FR1-A2-4	$-59.2 - \Delta_{OTAREFSENS}$	$-68.1 - \Delta_{OTAREFSENS}$	AWGN
	30	G-FR1-A2-5	$-59.2 - \Delta_{OTAREFSENS}$		
	60	G-FR1-A2-6	$-59.5 - \Delta_{OTAREFSENS}$		
50	15	G-FR1-A2-4	$-59.2 - \Delta_{OTAREFSENS}$	$-67.1 - \Delta_{OTAREFSENS}$	AWGN
	30	G-FR1-A2-5	$-59.2 - \Delta_{OTAREFSENS}$		
	60	G-FR1-A2-6	$-59.5 - \Delta_{OTAREFSENS}$		
60	30	G-FR1-A2-5	$-59.2 - \Delta_{OTAREFSENS}$	$-66.3 - \Delta_{OTAREFSENS}$	AWGN
	60	G-FR1-A2-6	$-59.5 - \Delta_{OTAREFSENS}$		
70	30	G-FR1-A2-5	$-59.2 - \Delta_{OTAREFSENS}$	$-65.7 - \Delta_{OTAREFSENS}$	AWGN
	60	G-FR1-A2-6	$-59.5 - \Delta_{OTAREFSENS}$		
80	30	G-FR1-A2-5	$-59.2 - \Delta_{OTAREFSENS}$	$-65.1 - \Delta_{OTAREFSENS}$	AWGN
	60	G-FR1-A2-6	$-59.5 - \Delta_{OTAREFSENS}$		
90	30	G-FR1-A2-5	$-59.2 - \Delta_{OTAREFSENS}$	$-64.5 - \Delta_{OTAREFSENS}$	AWGN
	60	G-FR1-A2-6	$-59.5 - \Delta_{OTAREFSENS}$		
100	30	G-FR1-A2-5	$-59.2 - \Delta_{OTAREFSENS}$	$-64.1 - \Delta_{OTAREFSENS}$	AWGN
	60	G-FR1-A2-6	$-59.5 - \Delta_{OTAREFSENS}$		

NOTE: The wanted signal mean power is the power level of a single instance of the corresponding reference measurement channel. This requirement shall be met for each consecutive application of a single instance of the reference measurement channel mapped to disjoint frequency ranges with a width corresponding to the number of resource blocks of the reference measurement channel each, except for one instance that might overlap one other instance to cover the full IAB-DU channel bandwidth.

Table 7.4.5.2-3: Local Area IAB-DU dynamic range

IAB-DU channel bandwidth (MHz)	Subcarrier spacing (kHz)	Reference measurement channel (annex A.2)	Wanted signal mean power (dBm)	Interfering signal mean power (dBm) / BW_{Config}	Type of interfering signal
10	15	G-FR1-A2-1	$-62.4 - \Delta_{OTAREFSENS}$	$-71.3 - \Delta_{OTAREFSENS}$	AWGN
	30	G-FR1-A2-2	$-64.1 - \Delta_{OTAREFSENS}$		
	60	G-FR1-A2-3	$-60.1 - \Delta_{OTAREFSENS}$		
15	15	G-FR1-A2-1	$-62.4 - \Delta_{OTAREFSENS}$	$-69.5 - \Delta_{OTAREFSENS}$	AWGN
	30	G-FR1-A2-2	$-64.1 - \Delta_{OTAREFSENS}$		
	60	G-FR1-A2-3	$-60.1 - \Delta_{OTAREFSENS}$		
20	15	G-FR1-A2-4	$-56.2 - \Delta_{OTAREFSENS}$	$-68.2 - \Delta_{OTAREFSENS}$	AWGN
	30	G-FR1-A2-5	$-56.2 - \Delta_{OTAREFSENS}$		
	60	G-FR1-A2-6	$-56.5 - \Delta_{OTAREFSENS}$		
25	15	G-FR1-A2-4	$-56.2 - \Delta_{OTAREFSENS}$	$-67.2 - \Delta_{OTAREFSENS}$	AWGN
	30	G-FR1-A2-5	$-56.2 - \Delta_{OTAREFSENS}$		
	60	G-FR1-A2-6	$-56.5 - \Delta_{OTAREFSENS}$		
30	15	G-FR1-A2-4	$-56.2 - \Delta_{OTAREFSENS}$	$-66.4 - \Delta_{OTAREFSENS}$	AWGN
	30	G-FR1-A2-5	$-56.2 - \Delta_{OTAREFSENS}$		
	60	G-FR1-A2-6	$-56.5 - \Delta_{OTAREFSENS}$		
40	15	G-FR1-A2-4	$-56.2 - \Delta_{OTAREFSENS}$	$-65.1 - \Delta_{OTAREFSENS}$	AWGN
	30	G-FR1-A2-5	$-56.2 - \Delta_{OTAREFSENS}$		
	60	G-FR1-A2-6	$-56.5 - \Delta_{OTAREFSENS}$		
50	15	G-FR1-A2-4	$-56.2 - \Delta_{OTAREFSENS}$	$-64.1 - \Delta_{OTAREFSENS}$	AWGN
	30	G-FR1-A2-5	$-56.2 - \Delta_{OTAREFSENS}$		
	60	G-FR1-A2-6	$-56.5 - \Delta_{OTAREFSENS}$		
60	30	G-FR1-A2-5	$-56.2 - \Delta_{OTAREFSENS}$	$-63.3 - \Delta_{OTAREFSENS}$	AWGN
	60	G-FR1-A2-6	$-56.5 - \Delta_{OTAREFSENS}$		
70	30	G-FR1-A2-5	$-56.2 - \Delta_{OTAREFSENS}$	$-62.7 - \Delta_{OTAREFSENS}$	AWGN
	60	G-FR1-A2-6	$-56.5 - \Delta_{OTAREFSENS}$		
80	30	G-FR1-A2-5	$-56.2 - \Delta_{OTAREFSENS}$	$-62.1 - \Delta_{OTAREFSENS}$	AWGN
	60	G-FR1-A2-6	$-56.5 - \Delta_{OTAREFSENS}$		
90	30	G-FR1-A2-5	$-56.2 - \Delta_{OTAREFSENS}$	$-61.5 - \Delta_{OTAREFSENS}$	AWGN
	60	G-FR1-A2-6	$-56.5 - \Delta_{OTAREFSENS}$		
100	30	G-FR1-A2-5	$-56.2 - \Delta_{OTAREFSENS}$	$-61.1 - \Delta_{OTAREFSENS}$	AWGN
	60	G-FR1-A2-6	$-56.5 - \Delta_{OTAREFSENS}$		

NOTE: The wanted signal mean power is the power level of a single instance of the corresponding reference measurement channel. This requirement shall be met for each consecutive application of a single instance of the reference measurement channel mapped to disjoint frequency ranges with a width corresponding to the number of resource blocks of the reference measurement channel each, except for one instance that might overlap one other instance to cover the full *IAB-DU channel bandwidth*.

7.5 OTA in-band selectivity and blocking

7.5.1 OTA adjacent channel selectivity

7.5.1.1 Definition and applicability

OTA Adjacent channel selectivity (ACS) is a measure of the receiver's ability to receive an OTA wanted signal at its assigned channel frequency in the presence of an OTA adjacent channel signal with a specified centre frequency offset of the interfering signal to the band edge of a victim system. The wanted and interfering signals apply to each supported polarization, under the assumption of polarization match.

7.5.1.2 Minimum requirement

For *IAB-DU type 1-O*, the minimum requirements are in TS 38.174 [2], clause 10.5.1.2.

For *IAB-DU type 2-O*, The minimum requirements are in TS 38.174 [2], clause 10.5.1.3.

For *IAB-MT type 1-O*, The minimum requirements are in TS 38.174 [2], clause 10.5.1.5.

For *IAB-MT type 2-O*, The minimum requirements are in TS 38.174 [2], clause 10.5.1.4.

7.5.1.3 Test purpose

The test purpose is to verify the ability of the IAB receiver filter to suppress interfering signals in the channels adjacent to the wanted channel.

7.5.1.4 Method of test

7.5.1.4.1 Initial conditions

Test environment: Normal, see annex B.2.

RF channels to be tested for single carrier:

- M ; see clause 4.9.1.

IAB RF Bandwidth edge position to be tested for multi-carrier and/or CA:

- M_{RFBW} in single-band operation, see clause 4.9.1;
- $B'_{\text{RFBW}}T'_{\text{RFBW}}$ and $B'_{\text{RFBW}}T_{\text{RFBW}}$ in multi-band operation, see clause 4.9.1.

Directions to be tested:

- For *IAB type 1-O*, receiver target reference direction (D.31),
- For *IAB type 2-O*, OTA REFSSENS receiver target reference direction (D.54).

7.5.1.4.2 Procedure

- 1) Place the IAB with its manufacturer declared coordinate system reference point in the same place as calibrated point in the test system, as shown in annex E.2.3.
- 2) Align the manufacturer declared coordinate system orientation of the IAB with the test system.
- 3) Align the IAB with the test antenna in the declared direction to be tested.
- 4) Align the IAB so that the wanted signal and interferer signal is *polarization matched* with the test antenna(s).
- 5) Configure the beam peak direction for the transmitter according to the declared reference beam direction pair for the appropriate beam identifier.

- 6) Set the test signal mean power so that the calibrated radiated power at the IAB Antenna Array coordinate system reference point is as follows:
- a) For *IAB-DU type 1-O*, set the signal generator for the wanted signal to transmit as specified in table 7.5.1.5.2-1.
- For *IAB-DU type 2-O*, set the signal generator for the wanted signal to transmit as specified in Table 7.5.1.5.3-1.
- For *IAB-MT type 1-O*, set the signal generator for the wanted signal to transmit as specified in table 7.5.1.5.4-1.
- For *IAB-MT type 2-O*, set the signal generator for the wanted signal to transmit as specified in table 7.5.1.5.5-1.
- For simultaneous operation tests for IAB type 1-O, set the signal generator for the wanted signal of IAB-DU type 1-O to transmit as specified in table 7.5.1.5.2-1 and for the wanted signal of IAB-MT type 1-O to transmit in table 7.5.1.5.4-1. For simultaneous operation tests for IAB type 2-O, set the signal generator for the wanted signal of IAB-DU type 2-O to transmit as specified in table 7.5.1.5.3-1 and for the wanted signal of IAB-MT type 2-O to transmit in table 7.5.1.5.5-1.
- b) For IAB-DU type 1-O, set the signal generator for the interfering signal at the adjacent channel frequency of the wanted signal to transmit as specified in table 7.5.1.5.2-2.
- For IAB-DU type 2-O, set the signal generator for the interfering signal at the adjacent channel frequency of the wanted signal to transmit as specified in table 7.5.1.5.3-2.
- For *IAB-MT type 1-O*, set the signal generator for the interfering signal at the adjacent channel frequency of the wanted signal to transmit as specified in table 7.5.1.5.4-2.
- For *IAB-MT type 2-O*, set the signal generator for the interfering signal at the adjacent channel frequency of the wanted signal to transmit as specified in table 7.5.1.5.5-2.
- For simultaneous operation tests for IAB type 1-O, set the signal generator for the interfering signal at the adjacent channel frequency of the wanted signal to transmit as specified in table 7.5.1.5.4-2.
- For simultaneous operation tests for IAB type 2-O, set the signal generator for the interfering signal at the adjacent channel frequency of the wanted signal to transmit as specified in table 7.5.1.5.5-2.
- 7) Measure throughput according to annex A.1 for each supported polarization, for multi-carrier and/or CA operation the throughput shall be measured for relevant carriers specified by the test configuration specified in clauses 4.7.2 and 4.8.

For *multi-band RIB(s)* and single band tests, repeat the steps above per involved band where single band test configurations and test models shall apply with no carriers activated in the other band.

7.5.1.5 Test requirement

7.5.1.5.1 General

The test requirement is calculated from the OTA wanted signal mean power level offset by the OTA ACS Test Tolerance specified in annex C.

7.5.1.5.2 Test requirements for *IAB-DU type 1-O*

The requirement shall apply at the RIB when the AoA of the incident wave of a received signal and the interfering signal are from the same direction, and the AoA of the incident wave of a received signal and the interfering signal are within the *minSENS RoAoA*.

The wanted and interfering signals apply to each supported polarization, under the assumption of *polarization match*.

The throughput shall be $\geq 95\%$ of the maximum throughput of the reference measurement channel.

For FR1, the OTA wanted and the interfering signal are specified in table 7.5.1.5.2-1 and table 7.5.1.5.2-2 for ACS. The reference measurement channel for the OTA wanted signal is identified in clause 7.3.5.2 and is further specified in annex A.1. The characteristics of the interfering signal is further specified in annex H.

The OTA ACS requirement is applicable outside the IAB RF Bandwidth or Radio Bandwidth. The OTA interfering signal offset is defined relative to the IAB RF Bandwidth edges or Radio Bandwidth edges.

For RIBs supporting operation in *non-contiguous spectrum* within any operating band, the OTA ACS requirement shall apply in addition inside any sub-block gap, in case the sub-block gap size is at least as wide as the NR interfering signal in table 7.5.1.5.2-2. The OTA interfering signal offset is defined relative to the sub-block edges inside the sub-block gap.

For *multi-band RIBs*, the OTA ACS requirement shall apply in addition inside any Inter RF Bandwidth gap, in case the Inter RF Bandwidth gap size is at least as wide as the NR interfering signal in table 7.5.1.5.2-2. The interfering signal offset is defined relative to the IAB RF Bandwidth edges inside the Inter RF Bandwidth gap.

Table 7.5.1.5.2-1: OTA ACS requirement for IAB-DU type 1-0

IAB-DU channel bandwidth of the lowest/highest carrier received (MHz)	Wanted signal mean power (dBm) (Note 2)			Interfering signal mean power (dBm)
	$f \leq 3.0$ GHz	$3.0 \text{ GHz} < f \leq 4.2$ GHz	$4.2 \text{ GHz} < f \leq 6.0$ GHz	
10, 15, 20, 25, 30, 40, 50, 60, 70, 80, 90, 100 (Note 1)	EIS _{minSENS} + 6 dB			Wide Area IAB: -52 – Δ_{minSENS} Medium Range IAB: -47– Δ_{minSENS} Local Area IAB: -44– Δ_{minSENS}
NOTE 1: The SCS for the lowest/highest carrier received is the lowest SCS supported by the IAB-DU for that bandwidth. NOTE 2: EIS _{minSENS} depends on the IAB-DU channel bandwidth as specified in TS 38.104 [4], clause 10.2.1.				

Table 7.5.1.5.2-2: OTA ACS interferer frequency offset for IAB-DU type 1-0

IAB-DU channel bandwidth of the lowest/highest carrier received (MHz)	Interfering signal centre frequency offset from the lower/upper IABF Bandwidth edge or sub-block edge inside a sub-block gap (MHz)	Type of interfering signal
10	± 2.5075	5 MHz DFT-s-OFDM NR signal, 15 kHz SCS, 25 RBs
15	± 2.5125	
20	± 2.5025	
25	± 9.4675	20 MHz DFT-s-OFDM NR signal, 15 kHz SCS, 100 RBs
30	± 9.4725	
40	± 9.4675	
50	± 9.4625	
60	± 9.4725	
70	± 9.4675	
80	± 9.4625	
90	± 9.4725	
100	± 9.4675	

7.5.1.5.3 Test requirements for IAB-DU type 2-0

The requirement shall apply at the RIB when the AoA of the incident wave of a received signal and the interfering signal are from the same direction and are within the *OTA REFSENS RoAoA*.

The wanted and interfering signals apply to each supported polarization, under the assumption of *polarization match*.

The throughput shall be $\geq 95\%$ of the maximum throughput of the reference measurement channel.

For FR2, the OTA wanted and the interfering signal are specified in table 7.5.1.5.3-1 and table 7.5.1.5.3-2 for ACS. The reference measurement channel for the OTA wanted signal is identified in clause 7.3.5.3 and is further specified in annex A.1. The characteristics of the interfering signal is further specified in annex H.

The OTA ACS requirement is applicable outside the IAB RF Bandwidth. The OTA interfering signal offset is defined relative to the IAB RF Bandwidth edges.

For RIBs supporting operation in *non-contiguous spectrum* within any *operating band*, the OTA ACS requirement shall apply in addition inside any sub-block gap, in case the sub-block gap size is at least as wide as the NR interfering signal in table 7.5.1.5.3-2. The OTA interfering signal offset is defined relative to the sub-block edges inside the sub-block gap.

Table 7.5.1.5.3-1: OTA ACS requirement for IAB-DU type 2-O

IAB-DU channel bandwidth of the lowest/highest carrier received (MHz)	Wanted signal mean power (dBm)		Interfering signal mean power (dBm)
	24.24 GHz < f ≤ 33.4 GHz	37 GHz < f ≤ 52.6 GHz	
50, 100, 200, 400	EIS _{REFSENS} + 6 dB (Note 3)	EIS _{REFSENS} + 6 dB (Note 3)	EIS _{REFSENS_50M} + 27.7 + Δ _{FR2_REFSENS} (Note 1) EIS _{REFSENS_50M} + 26.7 + Δ _{FR2_REFSENS} (Note 2)
NOTE 1: Applicable to bands defined within the frequency spectrum range of 24.25 – 33.4 GHz.			
NOTE 2: Applicable to bands defined within the frequency spectrum range of 37 – 52.6 GHz.			
NOTE 3: EIS _{REFSENS} is specified in TS 38.174 [2], clause 10.3.3.			

Table 7.5.1.5.3-2: OTA ACS interferer frequency offset for IAB-DU type 2-O

IAB-DU channel bandwidth of the lowest/highest carrier received (MHz)	Interfering signal centre frequency offset from the lower/upper IAB Bandwidth edge or sub-block edge inside a sub-block gap (MHz)	Type of interfering signal
50	±24.29	50 MHz DFT-s-OFDM NR signal, 60 kHz SCS, 64 RBs
100	±24.31	
200	±24.29	
400	±24.31	

7.5.1.5.4 Test requirements for IAB-MT type 1-O

The requirement shall apply at the RIB when the AoA of the incident wave of a received signal and the interfering signal are from the same direction and are within the *minSENS RoAoA*.

The wanted and interfering signals apply to each supported polarization, under the assumption of *polarization match*.

The throughput shall be ≥ 95% of the maximum throughput of the reference measurement channel.

For FR1, the OTA wanted and the interfering signal are specified in table 7.5.1.5.4-1, table 7.5.1.5.4-2 for OTA ACS. The reference measurement channel for the OTA wanted signal is further specified in annex A.1. The characteristics of the interfering signal is further specified in annex H.

The OTA ACS requirement is applicable outside the *IAB-MT RF Bandwidth* or *Radio Bandwidth*. The OTA interfering signal offset is defined relative to the *IAB-MT RF Bandwidth edges* or *Radio Bandwidth edges*.

For RIBs supporting operation in *non-contiguous spectrum* within any *operating band*, the OTA ACS requirement shall apply in addition inside any *sub-block gap*, in case the *sub-block gap* size is at least as wide as the NR interfering signal in table 7.5.1.5.4-2. The OTA interfering signal offset is defined relative to the *sub-block* edges inside the *sub-block gap*.

For *multi-band RIBs*, the OTA ACS requirement shall apply in addition inside any *Inter RF Bandwidth gap*, in case the *Inter RF Bandwidth gap* size is at least as wide as the NR interfering signal in table 7.5.1.5.4-2. The interfering signal offset is defined relative to the *IAB-MT RF Bandwidth edges* inside the *Inter RF Bandwidth gap*.

Table 7.5.1.5.4-1: OTA ACS requirement for *IAB-MT*

<i>IAB-MT channel bandwidth of the lowest/highest carrier received (MHz)</i>	Wanted signal mean power (dBm) (Note 2)	Interfering signal mean power (dBm)
10, 15, 20, 25, 30, 40, 50, 60, 70, 80,90, 100 (Note 1)	$EIS_{\min\text{SENS}} + 6 \text{ dB}$	Wide Area IAB-MT: $-52 - \Delta_{\min\text{SENS}}$ Local Area IAB-MT: $-44 - \Delta_{\min\text{SENS}}$
NOTE 1: The SCS for the <i>lowest/highest carrier</i> received is the lowest SCS supported by the IAB-MT for that bandwidth		
NOTE 2: $EIS_{\min\text{SENS}}$ depends on the IAB-MT <i>channel bandwidth</i>		

Table 7.5.1.5.4-2: OTA ACS interferer frequency offset for *IAB-MT type 1-0*

<i>IAB-MT channel bandwidth of the lowest/highest carrier received (MHz)</i>	Interfering signal centre frequency offset from the lower/upper <i>IAB-MT RF Bandwidth edge</i> or <i>sub-block edge</i> inside a <i>sub-block gap</i> (MHz)	Type of interfering signal
10	± 2.5075	5 MHz CP-OFDM NR signal, 15 kHz SCS, 25 RBs
15	± 2.5125	
20	± 2.5025	
25	± 9.4675	20 MHz CP-OFDM NR signal, 15 kHz SCS, 100 RBs
30	± 9.4725	
40	± 9.4675	
50	± 9.4625	
60	± 9.4725	
70	± 9.4675	
80	± 9.4625	
90	± 9.4725	
100	± 9.4675	

7.5.1.5.5 Test requirements for *IAB-MT type 2-0*

The requirement shall apply at the RIB when the AoA of the incident wave of a received signal and the interfering signal are from the same direction and are within the *OTA REFSENS RoAoA*.

The wanted and interfering signals apply to all supported polarizations, under the assumption of *polarization match*.

The throughput shall be $\geq 95\%$ of the maximum throughput of the reference measurement channel.

For FR2, the OTA wanted and the interfering signal are specified in table 7.5.1.5.5-1 and table 7.5.1.5.5-2 for ACS. The reference measurement channel for the OTA wanted signal is further specified in annex A.1. The characteristics of the interfering signal is further specified in annex H.

The OTA ACS requirement is applicable outside the *IAB-MT RF Bandwidth*. The OTA interfering signal offset is defined relative to the *IAB-MT RF Bandwidth edges*.

For Wide Area IAB-MT, for RIBs supporting operation in *non-contiguous spectrum* within any *operating band*, the OTA ACS requirement shall apply in addition inside any sub-block gap, in case the sub-block gap size is at least as wide as the NR interfering signal in table 7.5.1.5.5-2. The OTA interfering signal offset is defined relative to the sub-block edges inside the sub-block gap.

Table 7.5.1.5.5-1: OTA ACS requirement for Wide Area and Local Area IAB MT

IAB-MT channel bandwidth of the lowest/highest carrier received (MHz)	Wanted signal mean power (dBm)	Interfering signal mean power (dBm)
50, 100, 200, 400	$EIS_{REFSENS} + 6$ dB (Note 3)	$EIS_{REFSENS_50M} + 27.7 + \Delta_{FR2_REFSENS}$ (Note 1) $EIS_{REFSENS_50M} + 26.7 + \Delta_{FR2_REFSENS}$ (Note 2)
NOTE 1: Applicable to bands defined within the frequency spectrum range of 24.25 – 33.4 GHz		
NOTE 2: Applicable to bands defined within the frequency spectrum range of 37 – 52.6 GHz		
NOTE 3: $EIS_{REFSENS}$ is given in subclause 7.3.5.3		

Table 7.5.1.5.5-2: OTA ACS interferer frequency offset for IAB-MT type 2-O

IAB-MT channel bandwidth of the lowest/highest carrier received (MHz)	Interfering signal centre frequency offset from the lower/upper IAB-MT RF Bandwidth edge or sub-block edge inside a sub-block gap (MHz)	Type of interfering signal
50	± 24.29	50 MHz CP-OFDM NR signal, 60 kHz SCS, 64 RBs
100	± 24.31	
200	± 24.29	
400	± 24.31	

7.5.2 OTA in-band blocking

7.5.2.1 Definition and applicability

The OTA in-band blocking characteristics is a measure of the receiver's ability to receive a OTA wanted signal at its assigned channel in the presence of an unwanted OTA interferer, which is an NR signal for general blocking or an NR signal with one RB for narrowband blocking.

7.5.2.2 Minimum requirement

For *IAB-DU type 1-O*, the minimum requirements are in TS 38.174 [2], clause 10.5.2.2.

For *IAB-DU type 2-O*, The minimum requirements are in TS 38.174 [2], clause 10.5.2.3.

For *IAB-MT type 1-O*, The minimum requirements are in TS 38.174 [2], clause 10.5.2.5.

For *IAB-MT type 2-O*, The minimum requirements are in TS 38.174 [2], clause 10.5.2.4

7.5.2.3 Test purpose

The test purpose is to verify the ability of the IAB receiver to withstand high-levels of in-band interference from unwanted signals at specified frequency offsets without undue degradation of its sensitivity.

7.5.2.4 Method of test

7.5.2.4.1 Initial conditions

Test environment: Normal, see annex B.2.

RF channels to be tested for single carrier: M; see clause 4.9.1.

IAB RF Bandwidth edge position to be tested for multi-carrier and/or CA:

- M_{RFBW} in single-band operation, see clause 4.9.1;
- $B'_{\text{RFBW}}T'_{\text{RFBW}}$ and $B''_{\text{RFBW}}T''_{\text{RFBW}}$ in multi-band operation, see clause 4.9.1.

Directions to be tested:

For *IAB type 1-O*:

- receiver target reference direction for the minSENS OSDD (D.31),
- OTA REFSSENS conformance test directions (D.55),

For *IAB type 2-O*:

- OTA REFSSENS receiver target reference direction (D.54),
- OTA REFSSENS conformance test directions (D.55).

7.5.2.4.2 Procedure

- 1) Place the IAB with its manufacturer declared coordinate system reference point in the same place as calibrated point in the test system, as shown in annex E.2.3.
- 2) Align the manufacturer declared coordinate system orientation of the IAB with the test system.
- 3) Align the IAB with the test antenna in the declared direction to be tested.
- 4) Align the IAB to that the wanted signal and interferer signal is *polarization matched* with the test antenna(s).
- 5) Configure the beam peak direction for the transmitter according to the declared reference beam direction pair for the appropriate beam identifier.
- 6) Set the test signal mean power so that the calibrated radiated power at the IAB Antenna Array coordinate system reference point is as follows:

For general OTA blocking:

- a) For *IAB-DU type 1-O*, set the signal generator for the wanted signal to transmit as specified in table 7.5.2.5.2-1.

For *IAB-DU type 2-O*, set the signal generator for the wanted signal to transmit as specified in table 7.5.2.5.3-1.

For *IAB-MT type 1-O*, set the signal generator for the wanted signal to transmit as specified in table 7.5.2.5.4-1.

For *IAB-MT type 2-O*, set the signal generator for the wanted signal to transmit as specified in table 7.5.2.5.5-1.

For simultaneous operation tests for IAB type 1-O, set the signal generator for the wanted signal of IAB-DU type 1-O to transmit as specified in table 7.5.2.5.2-1 and for the wanted signal of IAB-MT type 1-O to transmit in table 7.5.2.5.4-1.

For simultaneous operation tests for IAB type 2-O, set the signal generator for the wanted signal of IAB-DU type 2-O to transmit as specified in table 7.5.2.5.3-1 and for the wanted signal of IAB-MT type 2-O to transmit in table 7.5.2.5.5-1. b) For *IAB-DU type 1-O*, set the signal generator for the interfering signal at the specified frequency offset from the wanted signal to transmit as specified in table 7.5.2.5.2-1. The interfering signal shall be swept with a step size of 1 MHz starting from the minimum offset to the channel edges of the wanted signals.

For *IAB-DU type 2-O*, set the signal generator for the interfering signal at the specified frequency offset from the wanted signal to transmit as specified in table 7.5.2.5.3-1. The interfering signal shall be swept with a step size indicated in Table 7.5.2.4.2-1 starting from the minimum offset to the channel edges of the wanted signals.

For *IAB-MT type 1-O*, set the signal generator for the interfering signal at the specified frequency offset from the wanted signal to transmit as specified in table 7.5.2.5.4-1. The interfering signal shall be swept with a step size of 1 MHz starting from the minimum offset to the channel edges of the wanted signals.

For *IAB-MT type 2-O*, set the signal generator for the interfering signal at the specified frequency offset from the wanted signal to transmit as specified in table 7.5.2.5.5-1. The interfering signal shall be swept with a step size indicated in Table 7.5.2.4.2-1 starting from the minimum offset to the channel edges of the wanted signals.

For IAB simultaneous operation tests for IAB type 1-O, set the signal generator for the interfering signal at the specified frequency offset from the wanted signal to transmit as specified in table table 7.5.2.5.4-1. The interfering signal shall be swept with a step size of 1 MHz starting from the minimum offset to the channel edges of the wanted signals.

For IAB simultaneous operation tests for IAB type 2-O, set the signal generator for the interfering signal at the specified frequency offset from the wanted signal to transmit as specified in table table 7.5.2.5.5-1. The interfering signal shall be swept with a step size indicated in Table 7.5.2.4.2-1 starting from the minimum offset to the channel edges of the wanted signals.

Table 7.5.2.4.2-1: FR2 Interferer signal step size

Minimum supported <i>IAB channel bandwidth</i> (MHz)	Measurement step size (MHz)
50	15
100	30
200	60
400	60

For OTA narrowband blocking:

- a) For *IAB-DU type 1-O*, set the signal generator for the wanted signal to transmit as specified in table 7.5.2.5.2-2.

For *IAB-DU type 2-O*, set the signal generator for the wanted signal to transmit as specified in table 7.5.2.5.3-2.

For *IAB-MT type 1-O*, set the signal generator for the wanted signal to transmit as specified in table 7.5.2.5.4-2.

For *IAB-MT type 2-O*, set the signal generator for the wanted signal to transmit as specified in table 7.5.2.5.5-2.

For simultaneous operation tests for IAB type 1-O, set the signal generator for the wanted signal of IAB-DU type 1-O to transmit as specified in table 7.5.2.5.2-2 and for the wanted signal of IAB-MT type 1-O to transmit in table 7.5.2.5.4-2.

For simultaneous operation tests for IAB type 2-O, set the signal generator for the wanted signal of IAB-DU type 2-O to transmit as specified in table 7.5.2.5.3-2 and for the wanted signal of IAB-MT type 2-O to transmit in table 7.5.2.5.5-2.

- b) For *IAB-DU type 1-O*, set the signal generator for the interfering signal at the specified frequency offset from the wanted signal to transmit as specified in tables 7.5.2.5.2-2 and 7.5.2.5.2-3. Set-up and sweep the interfering RB centre frequency offset to the channel edge of the wanted signal according to table 7.5.2.5.2-3.

For *IAB-DU type 2-O*, set the signal generator for the interfering signal at the specified frequency offset from the wanted signal to transmit as specified in tables 7.5.2.5.3-2 and 7.5.2.5.3-3. Set-up and sweep the interfering RB centre frequency offset to the channel edge of the wanted signal according to table 7.5.2.5.3-3.

For *IAB-MT type 1-O*, set the signal generator for the interfering signal at the specified frequency offset from the wanted signal to transmit as specified in tables 7.5.2.5.4-2 and 7.5.2.5.4-3. Set-up and sweep the

interfering RB centre frequency offset to the channel edge of the wanted signal according to table 7.5.2.5.4-3.

For *IAB-MT type 2-O*, set the signal generator for the interfering signal at the specified frequency offset from the wanted signal to transmit as specified in tables 7.5.2.5.5-2 and 7.5.2.5.5-3. Set-up and sweep the interfering RB centre frequency offset to the channel edge of the wanted signal according to table 7.5.2.5.5-3.

For IAB simultaneous operation tests for IAB type 1-O, set the signal generator for the interfering signal at the specified frequency offset from the wanted signal to transmit as specified in tables 7.5.2.5.4-2 and 7.5.2.5.4-3. Set-up and sweep the interfering RB centre frequency offset to the channel edge of the wanted signal according to table 7.5.2.5.2-3.

For IAB simultaneous operation tests for IAB type 2-O, set the signal generator for the interfering signal at the specified frequency offset from the wanted signal to transmit as specified in tables 7.5.2.5.5-2 and 7.5.2.5.5-3. Set-up and sweep the interfering RB centre frequency offset to the channel edge of the wanted signal according to table 7.5.2.5.3-3.

- 7) Measure throughput according to annex A.1 for each supported polarization, for multi-carrier and/or CA operation the throughput shall be measured for relevant carriers specified by the test configuration specified in clauses 4.7.2 and 4.8.
- 8) Repeat steps 3 to 8 for all the specified measurement directions.

For *multi-band RIB(s)* and single band tests, repeat the steps above per involved band where single band test configurations and test models shall apply with no carriers activated in the other band.

7.5.2.5 Test requirement

7.5.2.5.1 General

The test requirement is calculated from the OTA wanted signal mean power level offset by the OTA in-band blocking Test Tolerance specified in annex C.

7.5.2.5.2 Test requirements for *IAB-DU type 1-O*

The requirement shall apply at the RIB when the AoA of the incident wave of a received signal and the interfering signal are from the same direction, and:

- when the wanted signal is based on $EIS_{REFSENS}$: the AoA of the incident wave of a received signal and the interfering signal are within the *OTA REFSENS RoAoA*.
- when the wanted signal is based on $EIS_{minSENS}$: the AoA of the incident wave of a received signal and the interfering signal are within the *minSENS RoAoA*.

The wanted and interfering signals apply to each supported polarization, under the assumption of *polarization match*.

The throughput shall be $\geq 95\%$ of the maximum throughput of the reference measurement channel, with OTA wanted and OTA interfering signal specified in tables 7.5.2.5.2-1, table 7.5.2.5.2-2 and table 7.5.2.5.2-3 for general OTA and narrowband OTA blocking requirements. The reference measurement channel for the OTA wanted signal is identified in clause 7.3.5.2 and is further specified in annex A.1. The characteristics of the interfering signal is further specified in annex H.

The OTA in-band blocking requirements apply outside the *IAB RF Bandwidth* or *Radio Bandwidth*. The interfering signal offset is defined relative to the *IAB RF Bandwidth edges* or *Radio Bandwidth edges*.

For *IAB-DU type 1-O* the OTA in-band blocking requirement shall apply in the in-band blocking frequency range, which is defined within frequency range from $F_{UL_low} - \Delta f_{OOB}$ to $F_{UL_high} + \Delta f_{OOB}$, where the Δf_{OOB} for *IAB type 1-O* is defined in table 7.5.2.5.2-0.

Table 7.5.2.5.2-0: Δf_{OOB} offset for NR *operating bands* in FR1

IAB-DU type	Operating band characteristics	Δf_{OOB} (MHz)
IAB-DU type 1-O	$F_{\text{UL_high}} - F_{\text{UL_low}} < 100$ MHz	20
	$100 \text{ MHz} \leq F_{\text{UL_high}} - F_{\text{UL_low}} \leq 900$ MHz	60

For RIBs supporting operation in *non-contiguous spectrum* within any *operating band*, the OTA in-band blocking requirements apply in addition inside any sub-block gap, in case the sub-block gap size is at least as wide as twice the interfering signal minimum offset in table 7.5.2.5.2-1. The interfering signal offset is defined relative to the sub-block edges inside the sub-block gap.

For *multi-band RIBs*, the OTA in-band blocking requirements apply in the in-band blocking frequency ranges for each supported *operating band*. The requirement shall apply in addition inside any *Inter RF Bandwidth gap*, in case the *Inter RF Bandwidth gap* size is at least as wide as twice the interfering signal minimum offset in tables 7.5.2.5.2-1 and 7.5.2.5.2-3.

For a RIBs supporting operation in *non-contiguous spectrum* within any operating band, the OTA narrowband blocking requirements apply in addition inside any sub-block gap, in case the sub-block gap size is at least as wide as the interfering signal minimum offset in table 7.5.2.5.2-3. The interfering signal offset is defined relative to the sub-block edges inside the sub-block gap.

For a *multi-band RIBs*, the OTA narrowband blocking requirements apply in the narrowband blocking frequency ranges for each supported *operating band*. The requirement shall apply in addition inside any *Inter RF Bandwidth gap*, in case the *Inter RF Bandwidth gap* size is at least as wide as the interfering signal minimum offset in table 7.5.2.5.2-3.

Table 7.5.2.5-1: General OTA blocking requirement for IAB-DU type 1-O

IAB-DU channel bandwidth of the lowest/highest carrier received (MHz)	Wanted signal mean power (dBm)			Interfering signal mean power (dBm)	Interfering signal centre frequency minimum offset from the lower/upper IAB RF Bandwidth edge or sub-block edge inside a sub-block gap (MHz)	Type of interfering signal
	$f \leq 3.0$ GHz	3.0 GHz < $f \leq 4.2$ GHz	4.2 GHz < $f \leq 6.0$ GHz			
10, 15, 20	EIS _{REFSENS} + 6 dB (NOTE 2)			Wide Area IAB: -43 - $\Delta_{OTAREFSENS}$ Medium Range IAB: -38 - $\Delta_{OTAREFSENS}$ Local Area IAB: -35 - $\Delta_{OTAREFSENS}$ (NOTE 2)	±7.5	5 MHz DFT-s-OFDM NR signal, 15 kHz SCS, 25 RBs
	EIS _{minSENS} + 6 dB (NOTE 3)			Wide Area IAB: -43 - $\Delta_{minSENS}$ Medium Range IAB: -38 - $\Delta_{minSENS}$ Local Area IAB: -35 - $\Delta_{minSENS}$ (NOTE 3)		
25, 30, 40, 50, 60, 70, 80, 90, 100	EIS _{REFSENS} + 6 dB (NOTE 2)			Wide Area IAB: -43 - $\Delta_{OTAREFSENS}$ Medium Range IAB: -38 - $\Delta_{OTAREFSENS}$ Local Area IAB: -35 - $\Delta_{OTAREFSENS}$ (NOTE 2)	±30	20 MHz DFT-s-OFDM NR signal, 15 kHz SCS, 100 RBs
	EIS _{minSENS} + 6 dB (NOTE 3)			Wide Area IAB: -43 - $\Delta_{minSENS}$ Medium Range IAB: -38 - $\Delta_{minSENS}$ Local Area IAB: -35 - $\Delta_{minSENS}$ (NOTE 3)		
NOTE 1: EIS _{REFSENS} and EIS _{minSENS} depends on the IAB-DU channel bandwidth as specified in TS 38.174 [2], clause 10.3.2 and 10.2.1.						
NOTE 2: This test requirement is only applied in the OTA REFSENS conformance test directions.						
NOTE 3: This test requirement is only applied in the OTA minSENS receiver target reference direction.						

Table 7.5.2.5.2-2: OTA narrowband blocking requirement for IAB-DU type 1-O

IAB-DU channel bandwidth of the lowest/highest carrier received (MHz)	OTA Wanted signal mean power (dBm)			OTA Interfering signal mean power (dBm)
	$f \leq 3.0$ GHz	$3.0 \text{ GHz} < f \leq 4.2 \text{ GHz}$	$4.2 \text{ GHz} < f \leq 6.0 \text{ GHz}$	
10, 15, 20	EIS _{REFSENS} + 6 dB (NOTE 3)			Wide Area IAB: -49 - $\Delta_{\text{OTAREFSENS}}$ Medium Range IAB: -44 - $\Delta_{\text{OTAREFSENS}}$ Local Area IAB: -41 - $\Delta_{\text{OTAREFSENS}}$
	EIS _{minSENS} + 6 dB (NOTE 4)			Wide Area IAB: -49 - Δ_{minSENS} Medium Range IAB: -44 - Δ_{minSENS} Local Area IAB: -41 - Δ_{minSENS}
25, 30, 40, 50, 60, 70, 80, 90, 100	EIS _{REFSENS} + 6 dB (NOTE 3)			Wide Area IAB: -49 - $\Delta_{\text{OTAREFSENS}}$ Medium Range IAB: -44 - $\Delta_{\text{OTAREFSENS}}$ Local Area IAB: -41 - $\Delta_{\text{OTAREFSENS}}$
	EIS _{minSENS} + 6 dB (NOTE 4)			Wide Area IAB: -49 - Δ_{minSENS} Medium Range IAB: -44 - Δ_{minSENS} Local Area IAB: -41 - Δ_{minSENS}

NOTE 1: The SCS for the lowest/highest carrier received is the lowest SCS supported by the IAB-DU for that bandwidth.

NOTE 2: EIS_{REFSENS} and EIS_{minSENS} depends on the IAB-DU channel bandwidth as specified in TS 38.174 [2], clause 10.3.2 and 10.2.1.

NOTE 3: This test requirement is only applied in the OTA REFSENS conformance test directions.

NOTE 4: This test requirement is only applied in the OTA minSENS receiver target reference direction.

NOTE 5: 7.5 kHz shift is not applied to the wanted signal.

Table 7.5.2.5.2-3: OTA narrowband blocking interferer frequency offsets for *IAB-DU type 1-O*

<i>IAB-DU channel bandwidth of the lowest/highest carrier received (MHz)</i>	<i>Interfering RB centre frequency offset to the lower/upper IAB RF Bandwidth edge or sub-block edge inside a sub-block gap (kHz)</i> (Note 2)	<i>Type of interfering signal</i>
10	$\pm(355 + m \cdot 180)$, m=0, 1, 2, 3, 4, 9, 14, 19, 24	5 MHz DFT-s-OFDM NR signal, 15 kHz SCS, 1 RB
15	$\pm(360 + m \cdot 180)$, m=0, 1, 2, 3, 4, 9, 14, 19, 24	
20	$\pm(350 + m \cdot 180)$, m=0, 1, 2, 3, 4, 9, 14, 19, 24	
25	$\pm(565 + m \cdot 180)$, m=0, 1, 2, 3, 4, 29, 54, 79, 99	20 MHz DFT-s-OFDM NR signal, 15 kHz SCS, 1 RB
30	$\pm(570 + m \cdot 180)$, m=0, 1, 2, 3, 4, 29, 54, 79, 99	
40	$\pm(565 + m \cdot 180)$, m=0, 1, 2, 3, 4, 29, 54, 79, 99	
50	$\pm(560 + m \cdot 180)$, m=0, 1, 2, 3, 4, 29, 54, 79, 99	
60	$\pm(570 + m \cdot 180)$, m=0, 1, 2, 3, 4, 29, 54, 79, 99	
70	$\pm(565 + m \cdot 180)$, m=0, 1, 2, 3, 4, 29, 54, 79, 99	
80	$\pm(560 + m \cdot 180)$, m=0, 1, 2, 3, 4, 29, 54, 79, 99	
90	$\pm(570 + m \cdot 180)$, m=0, 1, 2, 3, 4, 29, 54, 79, 99	
100	$\pm(565 + m \cdot 180)$, m=0, 1, 2, 3, 4, 29, 54, 79, 99	

NOTE 1: Interfering signal consisting of one resource block is positioned at the stated offset, the channel bandwidth of the interfering signal is located adjacently to the lower/upper IAB RF Bandwidth edge.

NOTE 2: The centre of the interfering RB refers to the frequency location between the two central subcarriers.

7.5.2.5.3 Test requirements for *IAB-DU type 2-O*

The requirement shall apply at the RIB when the AoA of the incident wave of a received signal and the interfering signal are from the same direction and are within the *OTA REFSENS RoAoA*.

The wanted and interfering signals apply to each supported polarization, under the assumption of *polarization match*.

The throughput shall be $\geq 95\%$ of the maximum throughput of the reference measurement channel.

For *IAB-DU type 2-O*, the OTA wanted and OTA interfering signals are provided at RIB using the parameters in table 7.5.2.5.3-1 for general OTA blocking requirements. The reference measurement channel for the OTA wanted signal is identified in clause 7.3.5.3 and is further specified in annex A.1. The characteristics of the interfering signal is further specified in annex H.

The OTA blocking requirements are applicable outside the *IAB RF Bandwidth*. The interfering signal offset is defined relative to the *IAB RF Bandwidth edges*.

For *IAB-DU type 2-O* the OTA blocking requirement shall apply in the in-band blocking frequency range, which is defined within frequency range from $F_{UL_low} - \Delta f_{OOB}$ to $F_{UL_high} + \Delta f_{OOB}$, where the Δf_{OOB} for *IAB-DU type 2-O* is defined in table 7.5.2.5.3-0.

Table 7.5.2.5.3-0: Δf_{OOB} offset for NR operating bands in FR2

<i>IAB-DU type</i>	<i>Operating band characteristics</i>	<i>Δf_{OOB} (MHz)</i>
IAB-DU type 2-O	$F_{UL_high} - F_{UL_low} \leq 4000$ MHz	1500

For a RIBs supporting operation in *non-contiguous spectrum* within any *operating band*, the OTA blocking requirements apply in addition inside any sub-block gap, in case the sub-block gap size is at least as wide as twice the interfering signal minimum offset in table 7.5.2.5.3-1. The interfering signal offset is defined relative to the sub-block edges inside the sub-block gap.

Table 7.5.2.5.3-1: General OTA blocking requirement for IAB-DU type 2-O

IAB-DU channel bandwidth of the lowest/highest carrier received (MHz)	OTA wanted signal mean power (dBm)		OTA interfering signal mean power (dBm)	OTA interfering signal centre frequency offset from the lower/upper IAB RF Bandwidth edge or sub-block edge inside a sub-block gap (MHz)	Type of OTA interfering signal
	24.24 GHz < f ≤ 33.4 GHz	37 GHz < f ≤ 52.6 GHz			
50, 100, 200, 400	EIS _{REFSENS} + 6 dB	EIS _{REFSENS} + 6 dB	EIS _{REFSENS_50M} + 33 + Δ _{FR2_REFSENS} dB	±75	50 MHz DFT-s-OFDM NR signal, 60 kHz SCS, 64 RBs

NOTE: EIS_{REFSENS} and EIS_{REFSENS_50M} are given in TS 38.104 [2], clause 10.3.3.

7.5.2.5.4 Test requirements for IAB-MT type 1-O

The requirement shall apply at the RIB when the AoA of the incident wave of a received signal and the interfering signal are from the same direction, and:

- when the wanted signal is based on EIS_{REFSENS}: the AoA of the incident wave of a received signal and the interfering signal are within the *OTA REFSENS RoAoA*.
- when the wanted signal is based on EIS_{minSENS}: the AoA of the incident wave of a received signal and the interfering signal are within the *minSENS RoAoA*.

The wanted and interfering signals apply to each supported polarization, under the assumption of *polarization match*.

The throughput shall be ≥ 95% of the maximum throughput of the reference measurement channel, with OTA wanted and OTA interfering signal specified in tables 10.5.2.5-1, table 10.5.2.5-2 and table 10.5.2.5-3 for general OTA and narrowband OTA blocking requirements. The reference measurement channel for the OTA wanted signal is identified in clause 10.3.3 and are further specified in annex A.1. The characteristics of the interfering signal is further specified in annex H.

The OTA in-band blocking requirements apply outside the *IAB-MT RF Bandwidth* or *Radio Bandwidth*. The interfering signal offset is defined relative to the *IAB-MT RF Bandwidth edges* or *Radio Bandwidth edges*.

For *IAB-MT type 1-O* the OTA in-band blocking requirement shall apply in the in-band blocking frequency range, which is from $F_{DL,low} - \Delta f_{OoB}$ to $F_{DL,high} + \Delta f_{OoB}$. The Δf_{OoB} for *wide area IAB-MT type 1-O* is defined in table 10.5.2.5-0.

Table 7.5.2.5.4-0: Δf_{OoB} offset for NR operating bands in FR1

IAB-MT type	Operating band characteristics	Δf _{OoB} (MHz)
IAB-MT type 1-O	$F_{DL,high} - F_{DL,low} < 100$ MHz	20
	$100 \text{ MHz} \leq F_{DL,high} - F_{DL,low} \leq 900$ MHz	60

For RIBs supporting operation in *non-contiguous spectrum* within any *operating band*, the OTA in-band blocking requirements apply in addition inside any *sub-block gap*, in case the *sub-block gap* size is at least as wide as twice the interfering signal minimum offset in table 10.5.2.2-1. The interfering signal offset is defined relative to the *sub-block edges* inside the *sub-block gap*.

For *multi-band RIBs*, the OTA in-band blocking requirements apply in the in-band blocking frequency ranges for each supported *operating band*. The requirement shall apply in addition inside any *Inter RF Bandwidth gap*, in case the *Inter RF Bandwidth gap* size is at least as wide as twice the interfering signal minimum offset in tables 10.5.2.5-1 and 10.5.2.5-3.

For a RIBs supporting operation in *non-contiguous spectrum* within any *operating band*, the OTA narrowband blocking requirements apply in addition inside any *sub-block gap*, in case the *sub-block gap* size is at least as wide as the interfering signal minimum offset in table 10.5.2.5-3. The interfering signal offset is defined relative to the *sub-block* edges inside the *sub-block gap*.

For a *multi-band RIBs*, the OTA narrowband blocking requirements apply in the narrowband blocking frequency ranges for each supported *operating band*. The requirement shall apply in addition inside any *Inter RF Bandwidth gap*, in case the *Inter RF Bandwidth gap* size is at least as wide as the interfering signal minimum offset in table 10.5.2.5-3.

Table 7.5.2.5.4-1: General OTA blocking requirement for IAB-MT type 1-0

IAB-MT channel bandwidth of the lowest/highest carrier received (MHz)	Wanted signal mean power (dBm)	Interfering signal mean power (dBm)	Interfering signal centre frequency minimum offset from the lower/upper IAB-MT RF Bandwidth edge or sub-block edge inside a sub-block gap (MHz)	Type of interfering signal
10, 15, 20	EIS _{REFSENS} + 6 dB	Wide Area IAB-MT: -43 - $\Delta_{OTAREFSENS}$ Local Area IAB-MT: -35 - $\Delta_{OTAREFSENS}$	±7.5	5 MHz CP-OFDM NR signal, 15 kHz SCS, 25 RBs
	EIS _{minSENS} + 6 dB	Wide Area IAB-MT: -43 - $\Delta_{minSENS}$ Local Area IAB-MT: -35 - $\Delta_{minSENS}$	±7.5	
25, 30, 40, 50, 60, 70, 80, 90, 100	EIS _{REFSENS} + 6 dB	Wide Area IAB-MT: -43 - $\Delta_{OTAREFSENS}$ Local Area IAB-MT: -35 - $\Delta_{OTAREFSENS}$	±30	20 MHz CP-OFDM NR signal, 15 kHz SCS, 100 RBs
	EIS _{minSENS} + 6 dB	Wide Area IAB-MT: -43 - $\Delta_{minSENS}$ Local Area IAB-MT: -35 - $\Delta_{minSENS}$	±30	

Table 7.5.2.5.4-2: OTA narrowband blocking requirement for IAB-MT type 1-0

IAB-MT channel bandwidth of the lowest/highest carrier received (MHz)	OTA Wanted signal mean power (dBm)	OTA Interfering signal mean power (dBm)
10, 15, 20	EIS _{REFSENS} + 6 dB	Wide Area IAB-MT: -49 - $\Delta_{OTAREFSENS}$ Local Area IAB-MT: -41 - $\Delta_{OTAREFSENS}$
	EIS _{minSENS} + 6 dB	Wide Area IAB-MT: -49 - $\Delta_{minSENS}$ Local Area IAB-MT: -41 - $\Delta_{OTAREFSENS}$
25, 30, 40, 50, 60, 70, 80, 90, 100	EIS _{REFSENS} + 6 dB	Wide Area IAB-MT: -49 - $\Delta_{OTAREFSENS}$ Local Area IAB-MT: -41 - $\Delta_{OTAREFSENS}$
	EIS _{minSENS} + 6 dB	Wide Area IAB-MT: -49 - $\Delta_{minSENS}$ Local Area IAB-MT: -41 - $\Delta_{OTAREFSENS}$
NOTE 1: The SCS for the <i>lowest/highest carrier</i> received is the lowest SCS supported by the IAB-MT for that bandwidth.		
NOTE 2: 7.5 kHz shift is not applied to the wanted signal.		

Table 7.5.2.5.4-3: OTA narrowband blocking interferer frequency offsets for *IAB-MT type 1-O*

IAB-MT channel bandwidth of the lowest/highest carrier received (MHz)	Interfering RB centre frequency offset to the lower/upper IAB-MT RF Bandwidth edge or sub-block edge inside a sub-block gap (kHz) (Note 2)	Type of interfering signal
10	$\pm(355 + m \cdot 180)$, $m=0, 1, 2, 3, 4, 9, 14, 19, 24$	5 MHz CP-OFDM NR signal, 15 kHz SCS, 1 RB
15	$\pm(360 + m \cdot 180)$, $m=0, 1, 2, 3, 4, 9, 14, 19, 24$	
20	$\pm(350 + m \cdot 180)$, $m=0, 1, 2, 3, 4, 9, 14, 19, 24$	
25	$\pm(565 + m \cdot 180)$, $m=0, 1, 2, 3, 4, 29, 54, 79, 99$	20 MHz CP-OFDM NR signal, 15 kHz SCS, 1 RB
30	$\pm(570 + m \cdot 180)$, $m=0, 1, 2, 3, 4, 29, 54, 79, 99$	
40	$\pm(565 + m \cdot 180)$, $m=0, 1, 2, 3, 4, 29, 54, 79, 99$	
50	$\pm(560 + m \cdot 180)$, $m=0, 1, 2, 3, 4, 29, 54, 79, 99$	
60	$\pm(570 + m \cdot 180)$, $m=0, 1, 2, 3, 4, 29, 54, 79, 99$	
70	$\pm(565 + m \cdot 180)$, $m=0, 1, 2, 3, 4, 29, 54, 79, 99$	
80	$\pm(560 + m \cdot 180)$, $m=0, 1, 2, 3, 4, 29, 54, 79, 99$	
90	$\pm(570 + m \cdot 180)$, $m=0, 1, 2, 3, 4, 29, 54, 79, 99$	
100	$\pm(565 + m \cdot 180)$, $m=0, 1, 2, 3, 4, 29, 54, 79, 99$	
NOTE 1: Interfering signal consisting of one resource block is positioned at the stated offset, the channel bandwidth of the interfering signal is located adjacently to the lower/upper IAB-MT RF Bandwidth edge or sub-block edge inside a sub-block gap.		
NOTE 2: The centre of the interfering RB refers to the frequency location between the two central subcarriers.		

7.5.2.5.5 Test requirements for *IAB-MT type 2-O*

The requirement shall apply at the RIB when the AoA of the incident wave of a received signal and the interfering signal are from the same direction and are within the *OTA REFSENS RoAoA*.

The wanted and interfering signals apply to each supported polarization, under the assumption of *polarization match*.

The throughput shall be $\geq 95\%$ of the maximum throughput of the reference measurement channel.

For Wide Area *IAB-MT type 2-O*, the OTA wanted and OTA interfering signals are provided at RIB using the parameters in table 7.5.2.5.5-1 for general OTA blocking requirements. The reference measurement channel for the wanted signal is further specified in annex A.1. The characteristics of the interfering signal is further specified in annex H.

The OTA blocking requirements are applicable outside the IAB-MT RF Bandwidth. The interfering signal offset is defined relative to the *IAB-MT RF Bandwidth edges*.

For Wide Area *IAB-MT type 2-O* the OTA in-band blocking requirement shall apply from $F_{DL_low} - \Delta f_{OOB}$ to $F_{DL_high} + \Delta f_{OOB}$. The Δf_{OOB} for *IAB-MT type 2-O* is defined in table 7.5.2.5.5-0.

Table 7.5.2.5.5-0: Δf_{OOB} offset for NR operating bands for Wide Area IAB-MT in FR2

IAB-MT type	Operating band characteristics	Δf_{OOB} (MHz)
<i>IAB-MT type 2-O</i>	$F_{DL_high} - F_{DL_low} \leq 3250$ MHz	1500

For Wide Area IAB-MT and for a RIBs supporting operation in *non-contiguous spectrum* within any *operating band*, the OTA blocking requirements apply in addition inside any sub-block gap, in case the sub-block gap size is at least as wide as twice the interfering signal minimum offset in table 7.5.2.5.5-1. The interfering signal offset is defined relative to the sub-block edges inside the sub-block gap.

Table 7.5.2.5.5-1: General OTA blocking requirement for *Wide Area IAB-MT*

<i>IAB MT channel bandwidth of the lowest/highest carrier received (MHz)</i>	OTA wanted signal mean power (dBm)	OTA interfering signal mean power (dBm)	OTA interfering signal centre frequency offset from the lower/upper IAB MT [RF Bandwidth] edge or sub-block edge inside a sub-block gap (MHz)	Type of OTA interfering signal
50, 100, 200, 400	$EIS_{REFSENS} + 6$ dB	$EIS_{REFSENS_50M} + 33 + \Delta_{FR2_REFSENS}$	± 75	50 MHz CP-OFDM NR signal, 60 kHz SCS, 64 RBs
NOTE: $EIS_{REFSENS}$ and $EIS_{REFSENS_50M}$ are given in subclause 10.3.3.				

7.6 OTA out-of-band blocking

7.6.1 Definition and applicability

The OTA out-of-band blocking characteristics are a measure of the receiver unit ability to receive a wanted signal at the *RIB* at its assigned channel in the presence of an unwanted interferer.

For the general OTA out-of-band blocking the requirement applies to the wanted signal for each supported polarization, under the assumption of *polarization match*. The interferer shall be polarization matched for in-band frequencies and the polarization maintained for out-of-band frequencies.

7.6.2 Minimum requirement

For *IAB type 1-O*, the minimum requirements are defined in TS 38.174 [2], clause 10.6.2. Co-location minimum requirements are defined in TS 38.174[2], clause 10.6.4.

For *IAB type 2-O*, the minimum requirements are defined in TS 38.174 [2], clause 10.6.3.

7.6.3 Test purpose

The test stresses the ability of the receiver unit associated with the *RIB* under test to withstand high-level interference from unwanted signals at specified frequency bands, without undue degradation of its sensitivity.

7.6.4 Method of test

7.6.4.1 Initial conditions

Test environment: Normal; see annex B.2.

RF channels to be tested for single carrier (SC): M; see clause 4.9.1.

IAB RF Bandwidth positions to be tested for multi-carrier (MC):

- M_{RFBW} in *single-band RIB*, see clause 4.9.1; $B_{RFBW_T'RFBW}$ and $B'_{RFBW_T'RFBW}$ in *multi-band RIB*, see clause 4.9.1.

In addition, for *multi-band RIB*:

- For $B_{\text{RFBW}}T_{\text{RFBW}}$, blocking testing above the highest operating band may be omitted.
- For $B'_{\text{RFBW}}T_{\text{RFBW}}$, blocking testing below the lowest operating band may be omitted.

Directions to be tested:

- For *IAB type 1-O*, receiver target reference direction (D.31).
- For *IAB type 2-O*, OTA REFSENS receiver target reference direction (D.54).

7.6.4.2 Procedure

7.6.4.2.1 *IAB type 1-O* procedure for out-of-band blocking

- 1) Place IAB and the test antenna(s) according to annex E.2.4.1.
- 2) Align the IAB and test antenna(s) according to the directions to be tested.
- 3) Connect test antenna(s) to the measurement equipment as shown in annex E.2.4.1.
- 4) The test antenna(s) shall be dual (or single) polarized covering the same frequency ranges as the *IAB* and the blocking frequencies. If the test antenna does not cover both the wanted and interfering signal frequencies, separate test antennas for the wanted and interfering signal are required.
- 5) The OTA blocking interferer is injected into the test antenna, with the blocking interferer producing specified interferer field strength level for each supported polarization. The interferer shall be *polarization matched* in-band and the polarization maintained for out-of-band frequencies.
- 6) Generate the wanted signal in receiver target reference direction, according to the applicable test configuration (see clause 4.8) using applicable reference measurement channel to the RIB, according to annex A.1.

For simultaneous operation tests for *IAB type 1-O*, set the signal generator for the wanted signal of *IAB-DU type 1-O* to transmit as specified in table 7.6.5.1.1-1 and for the wanted signal of *IAB-MT type 1-O* to transmit in table 7.6.5.1.1-1.7) Adjust the signal generators to the type of interfering signals, levels and the frequency offsets as specified for general test requirements in table 7.6.5.1.1-1. The distance between the test object and test antenna injecting the interferer signal is adjusted when necessary to ensure specified interferer signal level to be received.

- 8) The CW interfering signal shall be swept with a step size of 1 MHz within the frequency range specified in clause 7.6.5.1.1.
- 9) Measure the performance of the wanted signal at the receiver unit associated with the RIB, as defined in the clause 7.6.5, for the relevant carriers specified by the test configuration in clause 4.7 and 4.8.
- 10) Repeat for all supported polarizations.

In addition, for *multi-band RIB*, the following steps shall apply:

- 11) For *multi-band RIB* and single band tests, repeat the steps above per involved band where single band test configurations and test models shall apply with no carrier activated in the other band.

7.6.4.2.2 *IAB type 1-O* procedure for co-location blocking

- 1) Place NR IAB and CLTA as specified in clause 4.12.2.3.
- 2) Several CLTA are required to cover the whole co-location blocking frequency ranges. The CLTA shall be selected according to clause 4.12.2.2.
- 3) Align the NR IAB and test antenna(s) according to the directions to be tested.
- 4) Connect test antenna and CLTA to the measurement equipment as depicted in annex E.2.4.2.
- 5) The NR IAB receives the wanted signal in all supported polarizations, in the receiver target reference direction from the test antenna.

- 6) The OTA co-location blocking interferer is injected via the CLTA. The CLTA is fed with the specified co-location blocking interferer power per supported polarization.
- 7) Generate the wanted signal in receiver target reference direction, all supported polarizations, from the test antenna, according to the applicable test configuration (see clause 4.8) using applicable reference measurement channel to the RIB, according to annex A.1.

For simultaneous operation tests for IAB type 1-O, set the signal generator for the wanted signal of IAB-DU type 1-O to transmit as specified in Table 7.6.5.1.2-1 and for the wanted signal of IAB-MT type 1-O to transmit in Table 7.6.5.1.2-1.

- 8) Adjust the signal generators to the type of interfering signals, levels and the frequency offsets as specified for general test requirements in table 7.6.5.1.1-1 and, when applicable, for co-location test requirements in table 7.6.5.1.2-1.
- 9) The CW interfering signal shall be swept with a step size of 1 MHz within the frequency range corresponding to downlink operating bands related to co-located systems (according to declaration D.43).
- 10) Measure the performance of the wanted signal at the receiver unit associated with the RIB, as defined in the clause 7.6.5, for the relevant carriers specified by the test configuration in clause 4.7 and 4.8.

In addition, for *multi-band RIB*, the following steps shall apply:

- 11) For *multi-band RIB* and single band tests, repeat the steps above per involved band where single band test configurations and test models shall apply with no carrier activated in the other band.

7.6.4.2.3 IAB type 2-O procedure for out-of-band blocking

- 1) Place IAB and the test antenna(s) according to annex E.2.4.1.
- 2) Align the IAB and test antenna(s) according to the directions to be tested.
- 3) Connect test antenna(s) to the measurement equipment as shown in annex E.2.4.1.
- 4) The test antenna(s) shall be dual (or single) polarized covering the same frequency ranges as the *IAB* and the blocking frequencies. If the test antenna does not cover both the wanted and interfering signal frequencies, separate test antennas for the wanted and interfering signal are required.
- 5) The OTA blocking interferer is injected into the test antenna, with the blocking interferer producing specified interferer field strength level for each supported polarization. The interferer shall be *polarization matched* in-band and the polarization maintained for out-of-band frequencies.
- 6) Generate the wanted signal, according to the applicable test configuration (see clause 4.7 and 4.8) using applicable reference measurement channel to the RIB, according to annex A.1.

For simultaneous operation tests for IAB type 1-O, set the signal generator for the wanted signal of IAB-DU type 1-O to transmit as specified in Table 7.6.5.2.1-1 and for the wanted signal of IAB-MT type 1-O to transmit in Table 7.6.5.2.1-1.

- 7) Adjust the signal generators to the type of interfering signals, levels and the frequency offsets as specified for general test requirements in table 7.6.5.2.1-1. The distance between the test object and test antenna injecting the interferer signal is adjusted when necessary to ensure specified interferer signal level to be received.
- 8) The interfering signal shall be swept within the frequency range specified in table 7.6.5.2.1-1 with the step size specified in table 7.6.4.2.3-1.
- 9) Measure the performance of the wanted signal at the receiver unit associated with the RIB, as defined in the clause 7.6.5, for the relevant carriers specified by the test configuration in clause 4.7 and 4.8.

Table 7.6.4.2.3-1: Interferer signal step size

Frequency range (MHz)	Minimum supported IAB channel bandwidth (MHz)	Measurement step size (MHz)
30 to 6000	50, 100, 200, 400	1
6000 to 60000	50	15
	100	30
	200	60
	400	60

10) Repeat for all supported polarizations.

7.6.5 Test requirements

7.6.5.1 Requirement for IAB Type 1-O

The test requirement consists of general and co-location requirements.

7.6.5.1.1 General

For OTA wanted and OTA interfering signals provided at the RIB using the parameters in table 7.6.5.1.1-1, the following requirements shall be met:

- The throughput shall be $\geq 95\%$ of the maximum throughput of the reference measurement channel. The reference measurement channel for the OTA wanted signal is identified in clause 10.3.2 in TS 38.104 [4] for each IAB channel bandwidth and further specified in annex A.1.

For a multi-band RIB, the OTA out-of-band requirement shall apply for each supported operating band, with the exception that the in-band blocking frequency ranges of all supported operating bands according to clause 7.4.2.2 in TS 38.104 [4] shall be excluded from the OTA out-of-band blocking requirement.

For IAB type 1-O the OTA out-of-band blocking requirement apply from 30 MHz to $F_{UL_low} - \Delta f_{OOB}$ and from $F_{UL_high} + \Delta f_{OOB}$ up to 12750 MHz. The Δf_{OOB} for IAB type 1-O is defined in table 7.5.2.5.2-0.

Table 7.6.5.1.1-1: OTA out-of-band blocking performance requirement

Wanted signal mean power (dBm)	Interfering signal RMS field-strength (V/m)	Type of interfering signal
EIS _{minSENS} + 6 dB (Note 1)	0.36 V/m	CW carrier
NOTE 1: EIS _{minSENS} depends on the channel bandwidth as specified in TS 38.104 [4], clause 10.2.1. NOTE 2: The RMS field-strength level in V/m is related to the interferer EIRP level at a distance described as $E = \frac{\sqrt{30EIRP}}{r}$, where EIRP is in W and r is in m; for example, 0.36 V/m is equivalent to 36 dBm at fixed distance of 30 m.		

7.6.5.1.2 Co-location requirement

This additional OTA out-of-band blocking requirement may be applied for the protection of IAB receivers when NR, E-UTRA BS, UTRA BS, CDMA BS, GSM/EDGE BS or IAB-DU and/or IAB-MT operating in a different frequency band are co-located with an IAB-Node.

The requirement is a co-location requirement. The interferer power levels are specified at the co-location reference antenna conducted input. The interfering signal power is specified per supported polarization.

The requirement is valid over the minSENS RoAoA.

For OTA wanted and OTA interfering signal provided at the RIB using the parameters in table 7.6.5.1.2-1, the following requirements shall be met:

- The throughput shall be $\geq 95\%$ of the maximum throughput of the reference measurement channel. The reference measurement channel for the OTA wanted signal is identified in TS 38.174 [2] clause 10.3 for each *IAB channel bandwidth* and further specified in annex A.1. The characteristics of the interfering signal is further specified in annex H.

For *IAB type 1-O* the OTA blocking requirement for co-location with BS or IAB-Node in other frequency bands is applied for all *operating bands* for which co-location protection is provided.

Table 7.6.5.1.2-1: OTA blocking requirement for co-location with BS or IAB-Node in other frequency bands

Frequency range of interfering signal	Wanted signal mean power (dBm)	Interfering signal mean power for WA IAB-Node (dBm)	Interfering signal mean power for MR IAB-Node (dBm)	Interfering signal mean power for LA IAB-Node (dBm)	Type of interfering signal
Frequency range of co-located downlink <i>operating band</i>	$EIS_{\min\text{SENS}} + 6$ dB (Note 1)	+46	+38	+24	CW carrier
NOTE 1: $EIS_{\min\text{SENS}}$ depends on the IAB class and on the <i>IAB channel bandwidth</i> , see TS 38.174 [2] clause 10.3.					
NOTE 2: The requirement does not apply when the interfering signal falls within any of the supported downlink <i>operating band(s)</i> or in Δf_{OOB} immediately outside any of the supported downlink <i>operating band(s)</i> .					

7.6.5.2 Requirement for *IAB type 2-O*

The test requirement consists of general requirements.

7.6.5.2.1 General requirement

For OTA wanted and OTA interfering signals provided at the RIB using the parameters in table 7.6.5.2.1-1, the following requirements shall be met:

- The throughput shall be $\geq 95\%$ of the maximum throughput of the reference measurement channel. The reference measurement channel for the OTA wanted signal is identified in clause 10.3.3 in TS 38.174 [2] for each *IAB channel bandwidth* and further specified in annex A.1.

For *IAB type 2-O* the OTA out-of-band blocking requirement apply from 30 MHz to $F_{\text{UL_low}} - \Delta f_{\text{OOB}}$ and from $F_{\text{UL_high}} + \Delta f_{\text{OOB}}$ up to $\min(2^{\text{nd}}$ harmonic of the upper frequency edge of the *operating band*, 60 GHz). The Δf_{OOB} for *IAB type 2-O* is defined in table 7.5.2.5.3-0.

Table 7.6.5.2.1-1: OTA out-of-band blocking performance requirement

Frequency range of interfering signal (MHz)	Wanted signal mean power (dBm)	Interferer RMS field-strength (V/m)	Type of interfering signal
30 to 12750	$EIS_{\text{REFSENS}} + 6$ dB	0.36	CW carrier
12750 to $F_{\text{UL_low}} - \Delta f_{\text{OOB}}$		0.1	
$F_{\text{UL_high}} + \Delta f_{\text{OOB}}$ to $\min(2^{\text{nd}}$ harmonic of the upper frequency edge of the operating band, 60000)		0.1	
NOTE: EIS_{REFSENS} is given in TS 38.174 [2], clause 10.3.3.			

7.7 OTA receiver spurious emissions

7.7.1 Definition and applicability

The OTA RX spurious emission is the power of the emissions radiated from the antenna array from a receiver unit.

Unless otherwise stated, all requirements are measured as mean power.

The OTA receiver spurious emission limits for FR1 shall apply from 30 MHz to 12.75 GHz, excluding the frequency range from Δf_{OBUE} below the lowest frequency of each supported downlink *operating band*, up to Δf_{OBUE} above the highest frequency of each supported downlink *operating band*, where the Δf_{OBUE} is defined in clause [6.7.1]. For some *operating bands*, the upper limit of the spurious range might be higher than 12.75 GHz in order to comply with the 5th harmonic limit of the uplink *operating band*, as specified in Recommendation ITU-R SM.329 [10].

For *multi-band RIB* the above exclusion applies for each supported *operating band*.

The OTA receiver spurious emission limits for FR2 shall apply from 30 MHz to 2nd harmonic of the upper frequency edge of the uplink *operating band*, excluding the frequency range from Δf_{OBUE} below the lowest frequency of each supported downlink *operating band*, up to Δf_{OBUE} above the highest frequency of each supported downlink *operating band*, where the Δf_{OBUE} is defined in clause [6.7.1].

For a IAB operating in TDD, the OTA RX spurious emissions requirement shall apply during the *transmitter OFF period* only.

The metric used to capture OTA receiver spurious emissions for *IAB type 1-O* and *IAB type 2-O* is total radiated power (TRP), with the requirement defined at the RIB.

7.7.2 Minimum requirement

The minimum requirement for *IAB-DU type 1-O* is specified in TS 38.174 [2], clause 10.7.1.2.

The minimum requirement for *IAB-DU type 2-O* is specified in TS 38.174 [2], clause 10.7.2.2.

The minimum requirement for *IAB-MT type 1-O* is specified in TS 38.174 [2], clause 10.7.3.1.

The minimum requirement for *IAB-MT type 2-O* is specified in TS 38.174 [2], clause 10.7.3.2.

7.7.3 Test purpose

The test purpose is to verify if the receiver radiated spurious emissions from the IAB at the RIB are within the specified minimum requirements.

7.7.4 Method of test

7.7.4.1 Initial conditions

Test environment: Normal; see annex B.2.

RF channels to be tested for single carrier, see clause 4.9.1:

- For FR1:
 - B when testing from 30 MHz to $F_{\text{DL_low}} - \Delta f_{\text{OBUE}}$
 - T when testing from $F_{\text{DL_high}} + \Delta f_{\text{OBUE}}$ to 12.75 GHz (or to 5th harmonic)
- For FR2:
 - B when testing from 30 MHz to $F_{\text{DL_low}} - \Delta f_{\text{OBUE}}$
 - T when testing from $F_{\text{DL_high}} + \Delta f_{\text{OBUE}}$ to 2nd harmonic (or to 60 GHz)

RF bandwidth positions to be tested in single-band operation, see clause 4.9.1:

- For FR1:
 - B_{RFBW} when testing from 30 MHz to $F_{\text{DL_low}} - \Delta f_{\text{OBUE}}$
 - T_{RFBW} when testing from $F_{\text{DL_high}} + \Delta f_{\text{OBUE}}$ to 12.75 GHz (or to 5th harmonic)

- For FR2:
 - B_{RFBW} when testing from 30 MHz to $F_{\text{DL_low}} - \Delta f_{\text{OBUE}}$
 - T_{RFBW} when testing from $F_{\text{DL_high}} + \Delta f_{\text{OBUE}}$ to 2nd harmonic (or to 60 GHz)

RF bandwidth positions to be tested in multi-band operation, see clause 4.9.1:

- For FR1:
 - $B_{\text{RFBW_T'RFBW}}$ when testing from 30 MHz to $F_{\text{DL_Blow_low}} - \Delta f_{\text{OBUE}}$
 - $B'_{\text{RFBW_T'RFBW}}$ when testing from $F_{\text{DL_Bhigh_high}} + \Delta f_{\text{OBUE}}$ to 12.75 GHz (or to 5th harmonic)
 - $B_{\text{RFBW_T'RFBW}}$ and $B'_{\text{RFBW_T'RFBW}}$ when testing from $F_{\text{DL_Blow_high}} + \Delta f_{\text{OBUE}}$ to $F_{\text{DL_Bhigh_low}} - \Delta f_{\text{OBUE}}$

Directions to be tested: As the requirement is TRP the beam pattern(s) may be set up to optimise the TRP measurement procedure (see annex I) as long as the required TRP level is achieved.

7.7.4.2 Procedure

The following procedure for measuring TRP is based on the directional power measurements as described in annex I. An alternative method to measure TRP is to use a characterized and calibrated reverberation chamber if so follow steps 1, 3, 4, 5, 7 and 10.

- 1) Place the IAB at the positioner.
- 2) Align the manufacturer declared coordinate system orientation (D.2) of the IAB with the test system.
- 3) Measurements shall use a measurement bandwidth in accordance to the conditions in clause 7.7.5.
- 4) The measurement device characteristics shall be:
 - Detection mode: True RMS.
- 5) Set the TDD IAB to receive only. For *IAB type 1-O* and *IAB type 2-O* supporting simultaneous reception of IAB-DU and IAB-MT (D.IAB-3), both IAB-DU and IAB-MT shall be configured to simultaneously receive only during the test.
- 6) Orient the positioner (and IAB) in order that the direction to be tested aligns with the test antenna such that measurements to determine TRP can be performed (see annex I).
- 7) Measure the emission at the specified frequencies with specified measurement bandwidth
- 8) Repeat step 6-9 for all directions in the appropriated TRP measurement grid needed for full TRP estimation (see annex I).

NOTE 1: The TRP measurement grid may not be the same for all measurement frequencies.

NOTE 2: The frequency sweep or the TRP measurement grid sweep may be done in any order

- 9) Calculate TRP at each specified frequency using the directional measurements.

In addition, for *multi-band RIB(s)*, the following steps shall apply:

- 10) For *IAB type 1-O* and *multi-band RIB(s)* and single band tests, repeat the steps above per involved band where single band test configurations and test models shall apply with no carrier activated in the other band.

7.7.5 Test requirement

7.7.5.1 Test requirement for *IAB type 1-O*

For RX only *multi-band RIB*, the OTA receiver spurious emissions requirements are subject to exclusion zones in each supported *operating band*.

The power of any spurious emission shall not exceed the levels in table 7.7.5.1-1:

Table 7.7.5.1-1: General OTA receiver spurious emission limits for IAB type 1-O

Spurious frequency range	Test limits (Note 6, Note 8)	Measurement bandwidth	Notes
30 MHz – 1 GHz	-36 + X dBm	100 kHz	Note 1, Note 6
1 GHz – 6 GHz	-30 + X dBm	1 MHz	Note 1, Note 2, Note 6
12.75 GHz – 5 th harmonic of the upper frequency edge of the UL <i>operating band</i> in GHz	-30 + X dBm	1 MHz	Note 1, Note 2, Note 3, Note 6
NOTE 1: Measurement bandwidths as in ITU-R SM.329 [10], s4.1. NOTE 2: Upper frequency as in ITU-R SM.329 [10], s2.5 table 1. NOTE 3: This spurious frequency range applies only for <i>operating bands</i> for which the 5 th harmonic of the upper frequency edge of the UL <i>operating band</i> is reaching beyond 12.75 GHz. NOTE 4: The frequency range from Δf_{OBUE} below the lowest frequency of the IAB transmitter operating band to Δf_{OBUE} above the highest frequency of the IAB transmitter <i>operating band</i> may be excluded from the requirement. Δf_{OBUE} is defined in clause 6.7.1. For <i>multi-band RIBs</i> , the exclusion applies for all supported <i>operating bands</i> . NOTE 5: Void NOTE 6: X = 9 dB, unless stated differently in regional regulation. NOTE 7: Void NOTE 8: Additional limits may apply regionally.			

7.7.5.2 Test requirement for IAB type 2-O

The power of any receiver spurious emission shall not exceed the limits in table 7.7.5.2-1.

Table 7.7.5.2-1: Radiated Rx spurious emission limits for IAB type 2-O

Spurious frequency range (Note 4)	Limit (Note 5)	Measurement Bandwidth	Note
30 MHz ↔ 1 GHz	-36 dBm	100 kHz	Note 1
1 GHz ↔ 18 GHz	-30 dBm	1 MHz	Note 1
18 GHz ↔ $F_{\text{step},1}$	-20 dBm	10 MHz	Note 2
$F_{\text{step},1}$ ↔ $F_{\text{step},2}$	-15 dBm	10 MHz	Note 2
$F_{\text{step},2}$ ↔ $F_{\text{step},3}$	-10 dBm	10 MHz	Note 2
$F_{\text{step},4}$ ↔ $F_{\text{step},5}$	-10 dBm	10 MHz	Note 2
$F_{\text{step},5}$ ↔ $F_{\text{step},6}$	-15 dBm	10 MHz	Note 2
$F_{\text{step},6}$ ↔ min(2 nd harmonic of the upper frequency edge of the UL operating band in GHz; 60 GHz)	-20 dBm	10 MHz	Note 2, Note 3
NOTE 1: Bandwidth as in ITU-R SM.329 [10], s4.1. NOTE 2: Limit and bandwidth as in ERC Recommendation 74-01 [11], Annex 2. NOTE 3: Upper frequency as in ITU-R SM.329 [10], s2.5 table 1. NOTE 4: The step frequencies $F_{\text{step},x}$ are defined in table 7.7.5.2-2. NOTE 5: Additional limits may apply regionally.			

Table 7.7.5.2-2: Step frequencies for defining the radiated Rx spurious emission limits for IAB-DU type 2-0

Operating band	F _{step,1} (GHz)	F _{step,2} (GHz)	F _{step,3} (GHz)	F _{step,4} (GHz)	F _{step,5} (GHz)	F _{step,6} (GHz)
n257	18	23.5	25	31	32.5	41.5
n258	18	21	22.75	29	30.75	40.5
n259	23.5	35.5	38	45	47.5	59.5
n260	25	34	35.5	41.5	43	52
n261	18	25.5	26.0	29.85	30.35	38.35

In addition, the following requirement may be applied for protection of EESS for IAB operating in frequency range 24.25 – 27.5 GHz.

The power of any receiver spurious emission shall not exceed the limits in Table 7.7.5.2-3.

Table 7.7.5.2-3: Limits for protection of Earth Exploration Satellite Service

Frequency range	Limit	Measurement Bandwidth	Note
23.6 – 24 GHz	-3 dBm	200 MHz	Note 1
23.6 – 24 GHz	-9 dBm	200 MHz	Note 2
NOTE 1: This limit applies to IAB brought into use on or before 1 September 2027 and enters into force from [January 1], 2021.			
NOTE 2: This limit applies to IAB brought into use after 1 September 2027.			

7.8 OTA receiver intermodulation

7.8.1 Definition and applicability

Third and higher order mixing of the two interfering RF signals can produce an interfering signal in the band of the desired channel. Intermodulation response rejection is a measure of the capability of the receiver unit to receive a wanted signal on its assigned channel frequency in the presence of two interfering signals which have a specific frequency relationship to the wanted signal. The requirement is defined as a directional requirement at the *RIB*.

The wanted and interfering signals apply to each supported polarization, under the assumption of *polarization match*.

7.8.2 Minimum requirement

The minimum requirements for *IAB-DU type 1-0* are in TS 38.174 [2], clause 10.8.2.

The minimum requirements for *IAB-DU type 2-0* are in TS 38.174 [2], clause 10.8.3.

The minimum requirements for *IAB-MT type 1-0* are in TS 38.174 [2], clause 10.8.4.

7.8.3 Test purpose

The test purpose is to verify the ability of the IAB receiver to inhibit the generation of intermodulation products in its non-linear elements caused by the presence of two high-level interfering signals at frequencies with a specific relationship to the frequency of the wanted signal.

7.8.4 Method of test

7.8.4.1 Initial conditions

Test environment: Normal, annex B.2.

RF channels to be tested for single carrier: M; see clause 4.9.1.

IAB RF Bandwidth positions to be tested for multi-carrier and/or CA:

- M_{RFBW} for single-band operation, see clause 4.9.1.
- $B_{RFBW_T_{RFBW}}$ and $B'_{RFBW_T_{RFBW}}$ for multi-band operation, see clause 4.9.1.

Directions to be tested:

- OTA REFSSENS receiver target reference direction (D.54).
- In addition, for *IAB type 1-O*, receiver target reference direction (D.31).

7.8.4.2 Procedure

- 1) Place the IAB with its manufacturer declared coordinate system reference point in the same place as calibrated point in the test system, as shown in annex E.2.6.
- 2) Align the manufacturer declared coordinate system orientation of the IAB with the test system.
- 3) Align the IAB with the test antenna in the declared direction to be tested.
- 4) Align the IAB to that the wanted signal and interferer signal is *polarization matched* with the test antenna(s).
- 5) Configure the beam peak direction of the IAB according to declared reference beam direction pair for the appropriate beam identifier.
- 6) Set the test signal mean power so the calibrated radiated power at the IAB Antenna Array coordinate system reference point is as specified as follows:
 - a) Set the signal generator for the wanted signal to transmit as specified in sub-clause 7.8.5.1 for *IAB-DU type 1-O*, sub-clause 7.8.5.2 for *IAB-DU type 2-O* and sub-clause 7.8.5.3 for *IAB-MT type 1-O*.
 - b) Set the signal generator for the interfering signal at the same frequency as the wanted signal to transmit as specified in sub-clause 7.8.5.1 for *IAB-DU type 1-O*, sub-clause 7.8.5.2 for *IAB-DU type 2-O* and sub-clause 7.8.5.3 for *IAB-MT type 1-O*.
- 7) Set the signal generator for the interfering signal to transmit at the frequency offset and as specified in sub-clause 7.8.5.1 for *IAB-DU type 1-O*, sub-clause 7.8.5.2 for *IAB-DU type 2-O* and sub-clause 7.8.5.3 for *IAB-MT type 1-O*.
- 8) Measure the throughput according to annex A.1 for each supported polarization, for multi-carrier and/or CA operation the throughput shall be measured for relevant carriers specified by the test configuration specified in clause 4.7. For an *IAB type 1-O* node declared to be capable of Simultaneous reception between IAB-DU and IAB-MT (D.IAB-3) the throughput shall be measured for both IAB-MT and IAB-DU according to applicable test signal configuration and test models specified in clauses 4.7.2 and 4.8.
- 9) Repeat for all the specified measurement directions and supported polarizations.

In addition, for *multi-band RIB(s)*, the following steps shall apply:

- 10) For *multi-band RIBs* and single band tests, repeat the steps above per involved band where single band test configurations and test models shall apply with no carrier activated in the other band.

7.8.5 Test requirement

7.8.5.1 IAB-DU type 1-O

The requirement shall apply at the RIB when the AoA of the incident wave of a received signal and the interfering signal are from the same direction, and:

- when the wanted signal is based on $EIS_{REFSENS}$: the AoA of the incident wave of a received signal and the interfering signal are within the *FRI OTA REFSSENS RoAoA*.

- when the wanted signal is based on $EIS_{\min SENS}$: the AoA of the incident wave of a received signal and the interfering signal are within the $minSENS RoAoA$.

The throughput shall be $\geq 95\%$ of the maximum throughput of the reference measurement channel, with a wanted signal at the assigned channel frequency and two interfering signals at the RIB with the conditions specified in tables 7.8.5.1-1 and 7.8.5.1-2 for intermodulation performance and in tables 7.8.5.1-3 and 7.8.5.1-4 for narrowband intermodulation performance.

The reference measurement channel for the wanted signal is identified in table 7.3.5.2-1, table 7.3.5.2-2 and table 7.3.5.2-3 for each *IAB-DU channel bandwidth* and further specified in annex A.1.

The subcarrier spacing for the modulated interfering signal shall be the same as the subcarrier spacing for the wanted signal, except for the case of wanted signal subcarrier spacing 60 kHz and *IAB-DU channel bandwidth* ≤ 20 MHz, for which the subcarrier spacing of the interfering signal should be 30 kHz.

The receiver intermodulation requirement is applicable outside the IAB-DU RF Bandwidth or Radio Bandwidth edges. The interfering signal offset is defined relative to the IAB-DU RF Bandwidth edges or Radio Bandwidth edges.

For a RIBs supporting operation in non-contiguous spectrum within any *operating band*, the narrowband intermodulation requirement shall apply in addition inside any sub-block gap in case the sub-block gap is at least as wide as the *IAB-DU channel bandwidth* of the NR interfering signal in tables 7.8.5.1-2 and 7.8.5.1-4. The interfering signal offset is defined relative to the sub-block edges inside the sub-block gap.

For *multi-band RIBs*, the intermodulation requirement shall apply in addition inside any Inter RF Bandwidth gap, in case the gap size is at least twice as wide as the NR interfering signal centre frequency offset from the IAB-DU RF Bandwidth edge.

For *multi-band RIBs*, the narrowband intermodulation requirement shall apply in addition inside any Inter RF Bandwidth gap in case the gap size is at least as wide as the NR interfering signal in tables 7.8.5.1-2 and 7.8.5.1-4. The interfering signal offset is defined relative to the IAB-DU RF Bandwidth edges inside the Inter RF Bandwidth gap.

Table 7.8.5.1-1: General intermodulation requirement

IAB-DU class	Wanted Signal mean power (dBm)	Mean power of interfering signals (dBm)	Type of interfering signal
Wide Area	$EIS_{REFSENS} + 6$ dB	$-52 - \Delta_{OTAREFSENS}$	See table 7.8.5.1-2
	$EIS_{\min SENS} + 6$ dB	$-52 - \Delta_{\min SENS}$	
Medium Range	$EIS_{REFSENS} + 6$ dB	$-47 - \Delta_{OTAREFSENS}$	
	$EIS_{\min SENS} + 6$ dB	$-47 - \Delta_{\min SENS}$	
Local Area	$EIS_{REFSENS} + 6$ dB	$-44 - \Delta_{OTAREFSENS}$	
	$EIS_{\min SENS} + 6$ dB	$-44 - \Delta_{\min SENS}$	
NOTE: $EIS_{REFSENS}$ and $EIS_{\min SENS}$ depend on the IAB-DU class and on the IAB-DU <i>channel bandwidth</i> as specified in TS 38.174 [2], clause 10.2.1.1 and 10.3.2.1.			

Table 7.8.5.1-2: Interfering signals for intermodulation requirement

<i>IAB-DU channel bandwidth of the lowest/highest carrier received (MHz)</i>	<i>Interfering signal centre frequency offset from the lower/upper IAB-DU RF Bandwidth edge (MHz)</i>	<i>Type of interfering signal (Note 3)</i>
10	± 7.465	CW
	± 17.5	5MHz DFT-s-OFDM NR signal (Note 1)
15	± 7.43	CW
	± 17.5	5MHz DFT-s-OFDM NR signal (Note 1)
20	± 7.395	CW
	± 17.5	5MHz DFT-s-OFDM NR signal (Note 1)
25	± 7.465	CW
	± 25	20 MHz DFT-s-OFDM NR signal (Note 2)
30	± 7.43	CW
	± 25	20MHz DFT-s-OFDM NR signal (Note 2)
40	± 7.45	CW
	± 25	20MHz DFT-s-OFDM NR signal (Note 2)
50	± 7.35	CW
	± 25	20MHz DFT-s-OFDM NR signal (Note 2)
60	± 7.49	CW
	± 25	20MHz DFT-s-OFDM NR signal (Note 2)
70	± 7.42	CW
	± 25	20 MHz DFT-s-OFDM NR signal (Note 2)
80	± 7.44	CW
	± 25	20MHz DFT-s-OFDM NR signal (Note 2)
90	± 7.46	CW
	± 25	20 MHz DFT-s-OFDM NR signal (Note 2)
100	± 7.48	CW
	± 25	20MHz DFT-s-OFDM NR signal (Note 2)
NOTE 1: For the 15 kHz subcarrier spacing, the number of RB is 25. For the 30 kHz subcarrier spacing, the number of RB is 10.		
NOTE 2: For the 15 kHz subcarrier spacing, the number of RB is 100. For the 30 kHz subcarrier spacing, the number of RB is 50. For the 60 kHz subcarrier spacing, the number of RB is 24.		
NOTE 3: The RBs shall be placed adjacent to the transmission bandwidth configuration edge which is closer to the <i>IAB-DU RF Bandwidth edge</i> .		

Table 7.8.5.1-3: Narrowband intermodulation performance requirement in FR1

IAB-DU class	Wanted signal mean power (dBm)	Interfering signal mean power (dBm)	Type of interfering signal
Wide Area	$EIS_{REFSENS} + 6$ dB (Note 1)	$-52 - \Delta_{OTAREFSENS}$	See table 7.8.5.1-4
	$EIS_{minSENS} + 6$ dB (Note 1)	$-52 - \Delta_{minSENS}$	
Medium Range	$EIS_{REFSENS} + 6$ dB (Note 1)	$-47 - \Delta_{OTAREFSENS}$	
	$EIS_{minSENS} + 6$ dB (Note 1)	$-47 - \Delta_{minSENS}$	
Local Area	$EIS_{REFSENS} + 6$ dB (Note 1)	$-44 - \Delta_{OTAREFSENS}$	
	$EIS_{minSENS} + 6$ dB (Note 1)	$-44 - \Delta_{minSENS}$	
NOTE: $EIS_{REFSENS}$ and $EIS_{minSENS}$ depends on the IAB <i>channel bandwidth</i> as specified in TS 38.174 [2], clause 10.2.1.1 and 10.3.2.1.			

Table 7.8.5.1-4: Interfering signals for narrowband intermodulation requirement in FR1

<i>IAB-DU channel bandwidth of the lowest/highest carrier received (MHz)</i>	<i>Interfering RB centre frequency offset from the lower/upper IAB-DU RF Bandwidth edge or sub-block edge inside a sub-block gap (kHz) (Note 3)</i>	<i>Type of interfering signal</i>
10	±370	CW
	±1960	5MHz DFT-s-OFDM NR signal, 1 RB (NOTE 1)
15 (NOTE 2)	±380	CW
	±1960	5MHz DFT-s-OFDM NR signal, 1 RB (NOTE 1)
20 (NOTE 2)	±390	CW
	±2320	5MHz DFT-s-OFDM NR signal, 1 RB (NOTE 1)
25 (NOTE 2)	±325	CW
	±2350	20MHz DFT-s-OFDM NR signal, 1 RB (NOTE 1)
30 (NOTE 2)	±335	CW
	±2350	20MHz DFT-s-OFDM NR signal, 1 RB (NOTE 1)
40 (NOTE 2)	±355	CW
	±2710	20MHz DFT-s-OFDM NR signal, 1 RB (NOTE 1)
50 (NOTE 2)	±375	CW
	±2710	20MHz DFT-s-OFDM NR signal, 1 RB (NOTE 1)
60 (NOTE 2)	±395	CW
	±2710	20MHz DFT-s-OFDM NR signal, 1 RB (NOTE 1)
70 (NOTE 2)	±415	CW
	±2710	20MHz DFT-s-OFDM NR signal, 1 RB (NOTE 1)
80 (NOTE 2)	±435	CW
	±2710	20MHz DFT-s-OFDM NR signal, 1 RB (NOTE 1)
90 (NOTE 2)	±365	CW
	±2530	20MHz DFT-s-OFDM NR signal, 1 RB (NOTE 1)
100 (NOTE 2)	±385	CW
	±2530	20MHz DFT-s-OFDM NR signal, 1 RB (NOTE 1)

NOTE 1: Interfering signal consisting of one resource block positioned at the stated offset, the *IAB-DU channel bandwidth* of the interfering signal is located adjacently to the lower/upper IAB-DU RF Bandwidth edge.

NOTE 2: This requirement shall apply only for a G-FRC mapped to the frequency range at the channel edge adjacent to the interfering signals.

NOTE 3: The centre of the interfering RB refers to the frequency location between the two central subcarriers.

7.8.5.2 IAB-DU type 2-O

Throughput shall be $\geq 95\%$ of the maximum throughput of the reference measurement channel, with OTA wanted signal at the assigned channel frequency and two OTA interfering signals provided at the RIB using the parameters in tables 7.8.5.2-1 and 7.8.5.2-2. All of the OTA test signals arrive from the same direction, and the requirement is valid if the signals arrive from any direction within the *FR2 OTA REFSENS RoAoA*. The reference measurement channel for the wanted signal is identified in table 7.3.5.3-1 for each *IAB-DU channel bandwidth* and further specified in annex A.1.

The subcarrier spacing for the modulated interfering signal shall be the same as the subcarrier spacing for the wanted signal.

The receiver intermodulation requirement is applicable outside the IAB-DU RF Bandwidth. The interfering signal offset is defined relative to the IAB-DU RF Bandwidth edges.

Table 7.8.5.2-1: General intermodulation requirement

<i>IAB-DU channel bandwidth of the lowest/highest carrier received (MHz)</i>	<i>Mean power of interfering signals (dBm)</i>	<i>Wanted signal mean power (dBm)</i>	<i>Type of interfering signal</i>
50, 100, 200, 400	$EIS_{REFSENS_50M} + 25 + \Delta_{FR2_REFSENS}$ dB	$EIS_{REFSENS} + 6$ dB	See table 7.8.5.2-2
NOTE: $EIS_{REFSENS}$ and $EIS_{REFSENS_50M}$ are given in TS 38.174 [2], clause 10.3.2.2.			

Table 7.8.5.2-2: Interfering signals for intermodulation requirement

<i>IAB-DU channel bandwidth of the lowest/highest carrier received (MHz)</i>	<i>Interfering signal centre frequency offset from the IAB-DU RF Bandwidth edge (MHz)</i>	<i>Type of interfering signal</i>
50 MHz	± 7.5	CW
	± 40	50MHz DFT-s-OFDM NR signal (Note)
100 MHz	± 6.88	CW
	± 40	50MHz DFT-s-OFDM NR signal (Note)
200 MHz	± 5.64	CW
	± 40	50MHz DFT-s-OFDM NR signal (Note)
400 MHz	± 6.02	CW
	± 45	50MHz DFT-s-OFDM NR signal (Note)
NOTE: For the 60 kHz subcarrier spacing, the number of RB is 64. For the 120 kHz subcarrier spacing, the number of RB is 32.		

7.8.5.3 IAB-MT type 1-O

The requirement shall apply at the RIB when the AoA of the incident wave of a received signal and the interfering signal are from the same direction, and:

- when the wanted signal is based on $EIS_{REFSENS}$: the AoA of the incident wave of a received signal and the interfering signal are within the *FR1 OTA REFSENS RoAoA*.
- when the wanted signal is based on $EIS_{minSENS}$: the AoA of the incident wave of a received signal and the interfering signal are within the *minSENS RoAoA*.

The throughput shall be $\geq 95\%$ of the maximum throughput of the reference measurement channel, with a wanted signal at the assigned channel frequency and two interfering signals at the RIB with the conditions specified in tables 7.8.5.3-1

and 7.8.5.3-2 for intermodulation performance and in tables 7.8.5.3-3 and 7.8.5.3-4 for narrowband intermodulation performance.

The reference measurement channel for the wanted signal is identified in table 7.3.5.2-1, table 7.3.5.2-2 and table 7.3.5.2-3 for each *IAB-MT channel bandwidth* and further specified in annex A.1.

The subcarrier spacing for the modulated interfering signal shall be the same as the subcarrier spacing for the wanted signal, except for the case of wanted signal subcarrier spacing 60 kHz and *IAB-MT channel bandwidth* ≤ 20 MHz, for which the subcarrier spacing of the interfering signal should be 30 kHz.

The receiver intermodulation requirement is applicable outside the IAB-MT RF Bandwidth or Radio Bandwidth edges. The interfering signal offset is defined relative to the IAB-MT RF Bandwidth edges or Radio Bandwidth edges.

For a RIBs supporting operation in non-contiguous spectrum within any *operating band*, the narrowband intermodulation requirement shall apply in addition inside any sub-block gap in case the sub-block gap is at least as wide as the *IAB-MT channel bandwidth* of the NR interfering signal in tables 7.8.5.3-1 and 7.8.5.3-2. The interfering signal offset is defined relative to the sub-block edges inside the sub-block gap.

For *multi-band RIBs*, the intermodulation requirement shall apply in addition inside any Inter RF Bandwidth gap, in case the gap size is at least twice as wide as the NR interfering signal centre frequency offset from the IAB-MT RF Bandwidth edge.

For *multi-band RIBs*, the narrowband intermodulation requirement shall apply in addition inside any Inter RF Bandwidth gap in case the gap size is at least as wide as the NR interfering signal in tables 7.8.5.3-3 and 7.8.5.3-4. The interfering signal offset is defined relative to the IAB-MT RF Bandwidth edges inside the Inter RF Bandwidth gap.

Table 7.8.5.3-1: General intermodulation requirement

IAB-MT class	Wanted Signal mean power (dBm)	Mean power of interfering signals (dBm)	Type of interfering signal
Wide Area	$EIS_{REFSENS} + 6$ dB	$-52 - \Delta_{OTAREFSENS}$	See table 7.8.5.3-2
	$EIS_{minSENS} + 6$ dB	$-52 - \Delta_{minSENS}$	
Local Area	$EIS_{REFSENS} + 6$ dB	$-44 - \Delta_{OTAREFSENS}$	
	$EIS_{minSENS} + 6$ dB	$-44 - \Delta_{minSENS}$	
NOTE: $EIS_{REFSENS}$ and $EIS_{minSENS}$ depend on the IAB-MT class and on the <i>IAB-MT channel bandwidth</i> as specified in TS 38.174 [2], clause 10.2.2.1.2 and 10.3.3.2.			

Table 7.8.5.3-2: Interfering signals for intermodulation requirement

<i>IAB-DU channel bandwidth of the lowest/highest carrier received (MHz)</i>	<i>Interfering signal centre frequency offset from the lower/upper IAB-DU RF Bandwidth edge (MHz)</i>	<i>Type of interfering signal (Note 3)</i>
10	± 7.465	CW
	± 17.5	5MHz CP-OFDM NR signal (Note 1)
15	± 7.43	CW
	± 17.5	5MHz CP-OFDM NR signal (Note 1)
20	± 7.395	CW
	± 17.5	5MHz CP-OFDM NR signal (Note 1)
25	± 7.465	CW
	± 25	20 MHz CP-OFDM NR signal (Note 2)
30	± 7.43	CW
	± 25	20MHz CP-OFDM NR signal (Note 2)
40	± 7.45	CW
	± 25	20MHz CP-OFDM NR signal (Note 2)
50	± 7.35	CW
	± 25	20MHz CP-OFDM NR signal (Note 2)
60	± 7.49	CW
	± 25	20MHz CP-OFDM NR signal (Note 2)
70	± 7.42	CW
	± 25	20 MHz CP-OFDM NR signal (Note 2)
80	± 7.44	CW
	± 25	20MHz CP-OFDM NR signal (Note 2)
90	± 7.46	CW
	± 25	20 MHz CP-OFDM NR signal (Note 2)
100	± 7.48	CW
	± 25	20MHz CP-OFDM NR signal (Note 2)

NOTE 1: For the 15 kHz subcarrier spacing, the number of RB is 25. For the 30 kHz subcarrier spacing, the number of RB is 10.

NOTE 2: For the 15 kHz subcarrier spacing, the number of RB is 100. For the 30 kHz subcarrier spacing, the number of RB is 50. For the 60 kHz subcarrier spacing, the number of RB is 24.

NOTE 3: The RBs shall be placed adjacent to the transmission bandwidth configuration edge which is closer to the *IAB-MT RF Bandwidth edge*.

Table 7.8.5.3-3: Narrowband intermodulation performance requirement in FR1

IAB-MT class	Wanted signal mean power (dBm)	Interfering signal mean power (dBm)	Type of interfering signal
Wide Area	$EIS_{REFSENS} + 6$ dB (Note 1)	$-52 - \Delta_{OTAREFSENS}$	See table 7.8.5.3-4
	$EIS_{minSENS} + 6$ dB (Note 1)	$-52 - \Delta_{minSENS}$	
Local Area	$EIS_{REFSENS} + 6$ dB (Note 1)	$-44 - \Delta_{OTAREFSENS}$	
	$EIS_{minSENS} + 6$ dB (Note 1)	$-44 - \Delta_{minSENS}$	
NOTE: $EIS_{REFSENS}$ and $EIS_{minSENS}$ depends on the <i>IAB-MT channel bandwidth</i> as specified in TS 38.174 [2], clause 10.2.2.1.2 and 10.3.3.2.			

Table 7.8.5.3-4: Interfering signals for narrowband intermodulation requirement in FR1

<i>IAB-MT channel bandwidth of the lowest/highest carrier received (MHz)</i>	<i>Interfering RB centre frequency offset from the lower/upper IAB-MT RF Bandwidth edge or sub-block edge inside a sub-block gap (kHz) (Note 3)</i>	<i>Type of interfering signal</i>
10	± 370	CW
	± 1960	5MHz CP-OFDM NR signal, 1 RB (Note 1)
15 (NOTE 2)	± 380	CW
	± 1960	5MHz CP-OFDM NR signal, 1 RB (Note 1)
20 (NOTE 2)	± 390	CW
	± 2320	5MHz CP-OFDM NR signal, 1 RB (Note 1)
25 (NOTE 2)	± 325	CW
	± 2350	20MHz CP-OFDM NR signal, 1 RB (Note 1)
30 (NOTE 2)	± 335	CW
	± 2350	20MHz CP-OFDM NR signal, 1 RB (Note 1)
40 (NOTE 2)	± 355	CW
	± 2710	20MHz CP-OFDM NR signal, 1 RB (Note 1)
50 (NOTE 2)	± 375	CW
	± 2710	20MHz CP-OFDM NR signal, 1 RB (Note 1)
60 (NOTE 2)	± 395	CW
	± 2710	20MHz CP-OFDM NR signal, 1 RB (Note 1)
70 (NOTE 2)	± 415	CW
	± 2710	20MHz CP-OFDM NR signal, 1 RB (Note 1)
80 (NOTE 2)	± 435	CW
	± 2710	20MHz CP-OFDM NR signal, 1 RB (Note 1)
90 (NOTE 2)	± 365	CW
	± 2530	20MHz CP-OFDM NR signal, 1 RB (Note 1)
100 (NOTE 2)	± 385	CW
	± 2530	20MHz CP-OFDM NR signal, 1 RB (Note 1)
NOTE 1: Interfering signal consisting of one resource block positioned at the stated offset, the <i>IAB-MT channel bandwidth</i> of the interfering signal is located adjacently to the lower/upper IAB-MT RF Bandwidth edge.		
NOTE 2: This requirement shall apply only for a G-FRC mapped to the frequency range at the channel edge adjacent to the interfering signals.		
NOTE 3: The centre of the interfering RB refers to the frequency location between the two central subcarriers.		

7.9 OTA in-channel selectivity

7.9.1 Definition and applicability

In-channel selectivity (ICS) is a measure of the receiver ability to receive a wanted signal at its assigned resource block locations in the presence of an interfering signal received at a larger power spectral density. In this condition a throughput requirement shall be met for a specified reference measurement channel. The interfering signal shall be an NR signal as specified in annex E in TS 38.176-1 [3] and shall be time aligned with the wanted signal.

7.9.2 Minimum requirement

The minimum requirement for *IAB-DU type 1-O* is in TS 38.174 [2], clause 10.9.2.

The minimum requirement for *IAB-DU type 2-O* is in TS 38.174 [2], clause 10.9.3.

7.9.3 Test purpose

The purpose of this test is to verify the IAB receiver ability to suppress the IQ leakage.

7.9.4 Method of test

7.9.4.1 Initial conditions

Test environment: Normal, see annex B.2.

RF channels to be tested for single carrier:M; see clause 4.9.1.

Directions to be tested:

- For *IAB type 1-O*, receiver target reference direction (D.31),
- For *IAB type 2-O*, OTA REFSSENS receiver target reference direction (D.54).

7.9.4.2 Procedure

- 1) Place the IAB-DU with its manufacturer declared coordinate system reference point in the same place as calibrated point in the test system, as shown in annex E.2.7.
- 2) Align the manufacturer declared coordinate system orientation of the IAB node with the test system.
- 3) Align the IAB-DU with the test antenna in the declared direction to be tested.
- 4) Align the IAB-DU to that the wanted signal and interferer signal is *polarization matched* with the test antenna(s).
- 5) Configure the beam peak direction for the transmitter according to the declared reference beam direction pair for the appropriate beam identifier.
- 6) Set the test signal mean power so the calibrated radiated power at the IAB Antenna Array coordinate system reference point is as specified as follows:
 - a) Adjust the signal generator for the wanted signal as specified in subclause 7.9.5.1 for *IAB-DU type 1-O* and subclause 7.9.5.2 for *IAB-DU type 2-O*;
 - b) Adjust the signal generator for the interfering signal as specified in subclause 7.9.5.1 for *IAB-DU type 1-O* and subclause 7.9.5.2 for *IAB-DU type 2-O*;
- 7) Measure throughput according to annex A.1 for each supported polarization.

- 8) Repeat the measurement with the wanted signal on the other side of the F_C , and the interfering signal at opposite side of the F_C and adjacent to the wanted signal.
- 9) Repeat for all the specified measurement directions and supported polarizations.

In addition, for *multi-band RIB(s)*, the following steps shall apply:

- 10) For *multi-band RIBs* and single band tests, repeat the steps above per involved band where single band test configurations and test models shall apply with no carrier activated in the other band.

7.9.5 Test requirement

7.9.5.1 IAB-DU type 1-O

The requirement shall apply at the RIB when the AoA of the incident wave of the received signal and the interfering signal are the same direction and are within the *minSENS RoAoA*

The wanted and interfering signals applies to each supported polarization, under the assumption of *polarization match*.

For a wanted and an interfering signal coupled to the RIB, the following requirements shall be met:

- For *IAB-DU 1-O*, the throughput shall be $\geq 95\%$ of the maximum throughput of the reference measurement channel as specified in annex A.1 with parameters specified in table 7.9.5.1-1 for Wide Area IAB-DU, in table 7.9.5.1-2 for Medium Range IAB-DU and in table 7.9.5.1-3 for Local Area IAB-DU.

Table 7.9.5.1-1: Wide Area IAB-DU in-channel selectivity

NR channel bandwidth (MHz)	Subcarrier spacing (kHz)	Reference measurement channel (annex A.1)	Wanted signal mean power (dBm)			Interfering signal mean power (dBm)	Type of interfering signal
			$f \leq 3.0$ GHz	$3.0 \text{ GHz} < f \leq 4.2$ GHz	$4.2 \text{ GHz} < f \leq 6.0$ GHz		
10, 15, 20, 25, 30	15	G-FR1-A1-1	-97- Δ_{minSENS}	-96.6- Δ_{minSENS}	-96.3- Δ_{minSENS}	-77.4 - Δ_{minSENS}	DFT-s-OFDM NR signal, 15 kHz SCS, 25 RBs
40, 50	15	G-FR1-A1-4	-90.6- Δ_{minSENS}	-90.2- Δ_{minSENS}	-89.9- Δ_{minSENS}	-71.4 - Δ_{minSENS}	DFT-s-OFDM NR signal, 15 kHz SCS, 100 RBs
10, 15, 20, 25, 30	30	G-FR1-A1-2	-97.1- Δ_{minSENS}	-96.7- Δ_{minSENS}	-96.4- Δ_{minSENS}	-78.4 - Δ_{minSENS}	DFT-s-OFDM NR signal, 30 kHz SCS, 10 RBs
40, 50, 60, 70, 80, 90, 100	30	G-FR1-A1-5	-90.9- Δ_{minSENS}	-90.5- Δ_{minSENS}	-90.2- Δ_{minSENS}	-71.4 - Δ_{minSENS}	DFT-s-OFDM NR signal, 30 kHz SCS, 50 RBs
10, 15, 20, 25, 30	60	G-FR1-A1-9	-96.5- Δ_{minSENS}	-96.1- Δ_{minSENS}	-95.8- Δ_{minSENS}	-78.4 - Δ_{minSENS}	DFT-s-OFDM NR signal, 60 kHz SCS, 5 RBs
40, 50, 60, 70, 80, 90, 100	60	G-FR1-A1-6	-91- Δ_{minSENS}	-90.6- Δ_{minSENS}	-90.3- Δ_{minSENS}	-71.6 - Δ_{minSENS}	DFT-s-OFDM NR signal, 60 kHz SCS, 24 RBs

NOTE: Wanted and interfering signal are placed adjacently around F_C , where the F_C is defined for *IAB-DU channel bandwidth* of the wanted signal according to the table 5.4.2.2-1 in TS 38.104 [4]. The aggregated wanted and interferer signal shall be centred in the IAB-DU channel bandwidth of the wanted signal.

Table 7.9.5.1-2: Medium Range IAB-DU in-channel selectivity

NR channel bandwidth (MHz)	Subcarrier spacing (kHz)	Reference measurement channel (annex A.1)	Wanted signal mean power (dBm)			Interfering signal mean power (dBm)	Type of interfering signal
			$f \leq 3.0$ GHz	$3.0 \text{ GHz} < f \leq 4.2$ GHz	$4.2 \text{ GHz} < f \leq 6.0$ GHz		
10, 15, 20, 25, 30	15	G-FR1-A1-1	-92- Δ_{minSENS}	-91.6- Δ_{minSENS}	-91.3- Δ_{minSENS}	-72.4 - Δ_{minSENS}	DFT-s-OFDM NR signal, 15 kHz SCS, 25 RBs
40, 50	15	G-FR1-A1-4	-85.6- Δ_{minSENS}	-85.2- Δ_{minSENS}	-84.9- Δ_{minSENS}	-66.4 - Δ_{minSENS}	DFT-s-OFDM NR signal, 15 kHz SCS, 100 RBs
10, 15, 20, 25, 30	30	G-FR1-A1-2	-92.1- Δ_{minSENS}	-91.7- Δ_{minSENS}	-91.4- Δ_{minSENS}	-73.4 - Δ_{minSENS}	DFT-s-OFDM NR signal, 30 kHz SCS, 10 RBs
40, 50, 60, 70, 80, 90, 100	30	G-FR1-A1-5	-85.9- Δ_{minSENS}	-85.5- Δ_{minSENS}	-85.2- Δ_{minSENS}	-66.4 - Δ_{minSENS}	DFT-s-OFDM NR signal, 30 kHz SCS, 50 RBs
10, 15, 20, 25, 30	60	G-FR1-A1-9	-91.5- Δ_{minSENS}	-91.1- Δ_{minSENS}	-90.8- Δ_{minSENS}	-73.4 - Δ_{minSENS}	DFT-s-OFDM NR signal, 60 kHz SCS, 5 RBs
40, 50, 60, 70, 80, 90, 100	60	G-FR1-A1-6	-86- Δ_{minSENS}	-85.6- Δ_{minSENS}	-85.3- Δ_{minSENS}	-66.6 - Δ_{minSENS}	DFT-s-OFDM NR signal, 60 kHz SCS, 24 RBs
NOTE: Wanted and interfering signal are placed adjacently around F_c , where the F_c is defined for <i>IAB-DU channel bandwidth</i> of the wanted signal according to the table 5.4.2.2-1 in TS 38.104 [4]. The aggregated wanted and interferer signal shall be centred in the IAB-DU channel bandwidth of the wanted signal.							

Table 7.9.5.1-3: Local area IAB-DU in-channel selectivity

NR channel bandwidth (MHz)	Subcarrier spacing (kHz)	Reference measurement channel (annex A.1)	Wanted signal mean power (dBm)			Interfering signal mean power (dBm)	Type of interfering signal
			$f \leq 3.0$ GHz	$3.0 \text{ GHz} < f \leq 4.2$ GHz	$4.2 \text{ GHz} < f \leq 6.0$ GHz		
10, 15, 20, 25, 30	15	G-FR1-A1-1	-89- Δ_{minSENS}	-88.6- Δ_{minSENS}	-88.3- Δ_{minSENS}	-69.4 - Δ_{minSENS}	DFT-s-OFDM NR signal, 15 kHz SCS, 25 RBs
40, 50	15	G-FR1-A1-4	-82.6- Δ_{minSENS}	-82.2- Δ_{minSENS}	-81.9- Δ_{minSENS}	-63.4 - Δ_{minSENS}	DFT-s-OFDM NR signal, 15 kHz SCS, 100 RBs
10, 15, 20, 25, 30	30	G-FR1-A1-2	-89.1- Δ_{minSENS}	-88.7- Δ_{minSENS}	-88.4- Δ_{minSENS}	-70.4 - Δ_{minSENS}	DFT-s-OFDM NR signal, 30 kHz SCS, 10 RBs
40, 50, 60, 70, 80, 90, 100	30	G-FR1-A1-5	-82.9- Δ_{minSENS}	-82.5- Δ_{minSENS}	-82.2- Δ_{minSENS}	-63.4 - Δ_{minSENS}	DFT-s-OFDM NR signal, 30 kHz SCS, 50 RBs
10, 15, 20, 25, 30	60	G-FR1-A1-9	-88.5- Δ_{minSENS}	-88.1- Δ_{minSENS}	-87.8- Δ_{minSENS}	-70.4 - Δ_{minSENS}	DFT-s-OFDM NR signal, 60 kHz SCS, 5 RBs
40, 50, 60, 70, 80, 90, 100	60	G-FR1-A1-6	-83- Δ_{minSENS}	-82.6- Δ_{minSENS}	-82.3- Δ_{minSENS}	-63.6 - Δ_{minSENS}	DFT-s-OFDM NR signal, 60 kHz SCS, 24 RBs
NOTE: Wanted and interfering signal are placed adjacently around F_c , where the F_c is defined for <i>IAB-DU channel bandwidth</i> of the wanted signal according to the table 5.4.2.2-1 in TS 38.104 [4]. The aggregated wanted and interferer signal shall be centred in the IAB-DU channel bandwidth of the wanted signal.							

7.9.5.2 IAB-DU type 2-O

For *IAB-DU type 2-O*, the throughput shall be $\geq 95\%$ of the maximum throughput of the reference measurement channel as specified in annex A.1 with parameters specified in table 7.9.5.2-1.

The wanted and interfering signals applies to each supported polarization, under the assumption of *polarization match*.

Table 7.9.5.2-1: OTA in-channel selectivity requirement for *IAB-DU type 2-0*

NR channel bandwidth (MHz)	Subcarrier spacing (kHz)	Reference measurement channel (annex A.1)	Wanted signal mean power (dBm) (Note 2)	Interfering signal mean power (dBm) (Note 2)	Type of interfering signal
50	60	G-FR2-A1-4	$EIS_{REFSENS_50M} + 3.4 + \Delta_{FR2_REFSENS}$	$EIS_{REFSENS_50M} + 10 + \Delta_{FR2_REFSENS}$	DFT-s-OFDM NR signal, 60 kHz SCS, 32 RBs
100, 200	60	G-FR2-A1-1	$EIS_{REFSENS_50M} + 6.4 + \Delta_{FR2_REFSENS}$	$EIS_{REFSENS_50M} + 13 + \Delta_{FR2_REFSENS}$	DFT-s-OFDM NR signal, 60 kHz SCS, 64 RBs
50	120	G-FR2-A1-5	$EIS_{REFSENS_50M} + 3.4 + \Delta_{FR2_REFSENS}$	$EIS_{REFSENS_50M} + 10 + \Delta_{FR2_REFSENS}$	DFT-s-OFDM NR signal, 120 kHz SCS, 16 RBs
100, 200, 400	120	G-FR2-A1-2	$EIS_{REFSENS_50M} + 6.4 + \Delta_{FR2_REFSENS}$	$EIS_{REFSENS_50M} + 13 + \Delta_{FR2_REFSENS}$	DFT-s-OFDM NR signal, 120 kHz SCS, 32 RBs

NOTE 1: Wanted and interfering signal are placed adjacently around F_c , where the F_c is defined for *IAB-DU channel bandwidth* of the wanted signal according to the table 5.4.2.2-1 in TS 38.104 [4]. The aggregated wanted and interferer signal shall be centred in the IAB-DU channel bandwidth of the wanted signal.

NOTE 2: $EIS_{REFSENS_50M}$ is defined in TS 38.174 [2], clause 10.2.1.2.

8 Radiated performance requirements

8.1 IAB-DU performance requirements

8.1.1 General

8.1.1.1 Scope and definitions

Radiated performance requirements specify the ability of the *IAB type 1-0* or *IAB type 2-0* to correctly demodulate radiated signals in various conditions and configurations. Radiated performance requirements are specified at the RIB.

Radiated performance requirements for the BS are specified for the fixed reference channels and propagation conditions defined in TS 38.174 [2] annex A and annex G, respectively. The requirements only apply to those FRCs that are supported by the IAB-DU.

The radiated performance requirements for *IAB type 1-0* and for the *IAB type 2-0* are limited to two OTA *demodulations branches* as described in clause 8.1.1.2. Conformance requirements can only be tested for 1 or 2 *demodulation branches* depending on the number of polarizations supported by the IAB-DU, with the required SNR applied separately per polarization.

NOTE: IAB-DU can support more than 2 *demodulation branches*, however OTA conformance testing can only be performed for 1 or 2 *demodulation branches*.

Unless stated otherwise, radiated performance requirements apply for a single carrier only. Radiated performance requirements for a IAB-DU supporting CA are defined in terms of single carrier requirements.

The method of synchronization with the TE is left to implementation. Neither the use of downlink signal configuration nor the use of proprietary means is precluded. In tests performed with signal generators a synchronization signal may be provided between the IAB-DU and the signal generator, or a common (e.g., GNSS) source may be provided to both IAB node and the signal generator, to enable correct timing of the wanted signal.

The SNR used in this clause is specified based on a single carrier and defined as:

$$SNR = S / N$$

Where:

S is the total signal energy in a slot on a RIB.

N is the noise energy in a bandwidth corresponding to the transmission bandwidth over the duration of a slot.

8.1.1.2 OTA demodulation branches

Radiated performance requirements are only specified for up to 2 *demodulation branches*.

If the *IAB type 1-O*, or the *IAB type 2-O* uses polarization diversity and has the ability to maintain isolation between the signals for each of the *demodulation branches*, then radiated performance requirements can be tested for up to two *demodulation branches* (i.e. 1RX or 2RX test setups). When tested for two *demodulation branches*, each demodulation branch maps to one polarization.

If the *IAB type 1-O*, or the *IAB type 2-O* does not use polarization diversity then radiated performance requirements can only be tested for a single *demodulation branch* (i.e. 1RX test setup).

8.1.1.3 Applicability rule

8.1.1.3.1 General

Unless otherwise stated, for a IAB-DU declared to support more than 2 demodulation branches (for *IAB type 1-O* and *IAB type 2-O*), the performance requirement tests for 2 demodulation branches shall apply, and the mapping between connectors and demodulation branches is up to BS implementation.

The tests requiring more than [20] dB SNR level are set to N/A in the test requirements.

8.1.1.3.2 Applicability of PUSCH performance requirements

8.1.1.3.2.1 Applicability of requirements for different subcarrier spacings

Unless otherwise stated, PUSCH requirement tests shall apply only for each subcarrier spacing declared to be supported (see D.7 in table 4.6-1).

Unless otherwise stated, if IAB-DU supports more than one SCS then PUSCH requirement tests with highest modulation order (see D.109 in table 4.6-1) shall apply only with lowest supported SCS and PUSCH requirement tests with other modulation orders (see D.109 in table 4.6-1) shall apply only with highest supported SCS. Otherwise, all modulation orders are tested on supported SCS.

8.1.1.3.2.2 Applicability of requirements for different channel bandwidths

For each subcarrier spacing declared to be supported, the test requirements for a specific channel bandwidth shall apply only if the IAB-DU supports it (see D.7 in table 4.6-1).

Unless otherwise stated, for each subcarrier spacing declared to be supported, the tests shall be done only for the widest supported channel bandwidth. If performance requirement is not specified for this widest supported channel bandwidth, the tests shall be done by using performance requirement for the closest channel bandwidth lower than this widest supported bandwidth; the tested PRBs shall then be centered in this widest supported channel bandwidth.

8.1.1.3.2.3 Applicability of requirements for different configurations

Unless otherwise stated, for *IAB type 1-O*, PUSCH requirement tests shall apply only for the mapping type declared to be supported (see D.100 in table 4.6-1). If both mapping type A and type B are declared to be supported, the tests shall be done for either type A or type B; the same chosen mapping type shall then be used for all tests.

Unless otherwise stated, for *IAB type 2-O*, PUSCH requirement tests shall apply only for the additional DM-RS position declared to be supported (see D.101 in table 4.6-1). If both options (i.e., pos0 and pos1) are declared to be supported, the tests shall be done for pos1.

Unless otherwise stated, for *IAB type 2-O*, PUSCH requirement tests with transform precoding disabled shall apply for the PT-RS option declared to be supported (see D.106 in table 4.6-1). If both PT-RS options (without and with PT-RS)

are declared to be supported, the tests shall be done for either without or with PT-RS only; the same chosen option shall then be used for all tests.

Unless otherwise stated, for *IAB type 2-O*, PUSCH requirement tests with transform precoding enabled shall be done for without PT-RS.

8.1.1.3.2.4 Applicability of requirements for uplink carrier aggregation

The tests for uplink carrier aggregation shall be carried out according to the declaration (see D.108 in table 4.6-1).

Unless otherwise stated, the tests for uplink carrier aggregation shall apply only for PUSCH with transform precoding disabled, and shall be conducted on per component carrier basis.

8.1.1.3.2.5 Applicability of requirements for TDD with different UL-DL patterns

Unless otherwise stated, for each subcarrier spacing declared to be supported, if IAB-DU supports multiple TDD UL-DL patterns, only one of the supported TDD UL-DL patterns shall be used for all tests.

8.1.1.3.2.6 Applicability of requirements for transform precoding

Unless otherwise stated, the tests with transform precoding enabled shall apply only, if the IAB-DU supports it (see D.110 in table 4.6-1).

8.1.1.3.3 Applicability of PUCCH performance requirements

8.1.1.3.3.1 Applicability of requirements for different formats

Unless otherwise stated, PUCCH requirement tests shall apply only for each PUCCH format declared to be supported (see D.102 in table 4.6-1).

8.1.1.3.3.2 Applicability of requirements for different subcarrier spacings

Unless otherwise stated, PUCCH requirement tests shall apply only for each subcarrier spacing declared to be supported (see D.7 in table 4.6-1). If multiple subcarrier spacings are declared to be supported, each supported PUCCH format can be tested on one subcarrier spacing.

8.1.1.3.3.3 Applicability of requirements for different channel bandwidths

For each subcarrier spacing declared to be supported by the IAB-DU, the test requirements for a specific channel bandwidth shall apply only if the IAB-DU supports it (see D.7 in table 4.6-1).

Unless otherwise stated, for each subcarrier spacing declared to be supported, the tests shall be done only for the widest supported channel bandwidth. If performance requirement is not specified for this widest supported channel bandwidth, the tests shall be done by using performance requirement for the closest channel bandwidth lower than this widest supported bandwidth; the tested PRBs shall then be centered in this widest supported channel bandwidth.

8.1.1.3.3.4 Applicability of requirements for different configurations

Unless otherwise stated, PUCCH format 3 requirement tests shall apply only for the additional DM-RS configuration declared to be supported (see D.104 in table 4.6-1). If both options (without and with additional DM-RS) are declared to be supported, the tests shall be done for either without or with additional DM-RS; the same chosen option shall then be used for all tests.

Unless otherwise stated, PUCCH format 4 requirement tests shall apply only for the additional DM-RS configuration declared to be supported (see D.105 in table 4.6-1). If both options (without and with additional DM-RS) are declared to be supported, the tests shall be done for either without or with additional DM-RS; the same chosen option shall then be used for all tests.

8.1.1.3.3.5 Applicability of requirements for multi-slot PUCCH

Unless otherwise stated, multi-slot PUCCH requirement tests shall apply only if the IAB-DU supports it (see D.107 in table 4.6-1).

8.1.1.3.4 Applicability of PRACH performance requirements

8.1.1.3.4.1 Applicability of requirements for different formats

Unless otherwise stated, PRACH requirement tests shall apply only for PRACH formats declared to be supported (see D.103 in table 4.6-1).

For IAB-DU declares to support more than one PRACH formats, limit the number of tests to any two cases chosen by the manufacturer. If IAB-DU declares to support more than one PRACH formats where formats for both long and short PRACH sequences are presented, require choosing formats with different sequences (see D.103 in table 4.6-1).

8.1.1.3.4.2 Applicability of requirements for different subcarrier spacings

Unless otherwise stated, for each PRACH format with short sequence declared to be supported, for each FR, the tests shall apply only for the smallest supported subcarrier spacing in the FR (see D.103 in table 4.6-1).

8.1.1.3.4.3 Applicability of requirements for different channel bandwidths

Unless otherwise stated, for the subcarrier spacing to be tested, the test requirements shall apply only for anyone channel bandwidth declared to be supported (see D.7 in table 4.6-1).

8.1.2 Performance requirements for PUSCH

8.1.2.1 Performance requirements for PUSCH with transform precoding disabled

8.1.2.1.1 Definition and applicability

The performance requirement of PUSCH is determined by a minimum required throughput for a given SNR. The required throughput is expressed as a fraction of maximum throughput for the FRCs listed in annex A. The performance requirements assume HARQ re-transmissions.

Which specific test(s) are applicable to IAB-DU is based on the test applicability rules defined in clause 8.1.1.3.2.

8.1.2.1.2 Minimum Requirement

For *BS type 1-O*, the minimum requirement is in TS 38.174 [2], clause 11.1.2.1.1.

For *BS type 2-O*, the minimum requirement is in TS 38.174 [2], clause 11.1.2.2.1

8.1.2.1.3 Test purpose

The test shall verify the receiver's ability to achieve throughput under multipath fading propagation conditions for a given SNR.

8.1.2.1.4 Method of test

8.1.2.1.4.1 Initial conditions

Test environment: Normal, see annex B.2.

RF channels to be tested for single carrier: M, see clause 4.9.1.

RF channels to be tested for carrier aggregation: $M_{\text{BW Channel CA}}$; see clause 4.9.1.

Direction to be tested: OTA REFSSENS *receiver target reference direction* (see D.54 in table 4.6-1).

8.1.2.1.4.2 Procedure

- 1) Place the IAB-DU with its manufacturer declared coordinate system reference point in the same place as calibrated point in the test system, as shown in annex E.3.
- 2) Align the manufacturer declared coordinate system orientation of the IAB-DU with the test system.
- 3) Set the IAB-DU in the declared direction to be tested.
- 4) Connect the IAB-DU tester generating the wanted signal, multipath fading simulators and AWGN generators to a test antenna via a combining network in OTA test setup, as shown in annex E.3. Each of the demodulation branch signals should be transmitted on one polarization of the test antenna(s).
- 5) The characteristics of the wanted signal shall be configured according to the corresponding UL reference measurement channel defined in annex A, and according to additional test parameters listed in table 8.1.2.1.4.2-1.

Table 8.1.2.1.4.2-1: Test parameters for testing PUSCH

Parameter		IAB type 1-O	IAB type 2-O
Transform precoding		Disabled	
Cyclic prefix		Normal	
Default TDD UL-DL pattern (Note)		15 kHz SCS: 3D1S1U, S=10D:2G:2U 30 kHz SCS: 7D1S2U, S=6D:4G:4U	60 kHz and 120kHz SCS: 3D1S1U, S=10D:2G:2U
HARQ	Maximum number of HARQ transmissions	4	
	RV sequence	0, 2, 3, 1	
DM-RS	DM-RS configuration type	1	
	DM-RS duration	single-symbol DM-RS	
	Additional DM-RS position	pos1	{pos0, pos1}
	Number of DM-RS CDM group(s) without data	2	
	Ratio of PUSCH EPRE to DM-RS EPRE	-3 dB	
	DM-RS port(s)	{0}, {0,1}	
	DM-RS sequence generation	$N_{ID}^0=0, n_{SCID}=0$	
Time domain resource assignment	PUSCH mapping type	A, B	B
	Start symbol	0	0
	Allocation length	14	10
Frequency domain resource assignment	RB assignment	Full applicable test bandwidth	
	Frequency hopping	Disabled	
TPMI index for 2Tx two layer spatial multiplexing transmission		0	
Code block group based PUSCH transmission		Disabled	
PTRS configuration	Frequency density (K_{PT-RS})	N.A.	2, Disabled
	Time density (L_{PT-RS})	N.A.	1, Disabled
NOTE: The same requirements are applicable with different UL-DL patterns for IAB type 1-O and IAB type 2-O.			

- 6) The multipath fading emulators shall be configured according to the corresponding channel model defined in annex J.
- 7) Adjust the test signal mean power so the calibrated radiated SNR value at the IAB-DU receiver is as specified in clause 8.1.2.1.5.1 and 8.1.2.1.5.2 for IAB type 1-O and IAB type 2-O respectively, and that the SNR at the IAB-DU receiver is not impacted by the noise floor.

The power level for the transmission may be set such that the AWGN level at the RIB is equal to the AWGN level in table 8.1.2.1.4.2-2.

Table 8.1.2.1.4.2-2: AWGN power level at the IAB-DU input

IAB-DU type	Sub-carrier spacing (kHz)	Channel bandwidth (MHz)	AWGN power level
IAB type 1-O	15	10	-83.3 - $\Delta_{\text{OTAREFSSENS}}$ dBm / 9.36 MHz
		20	-80.2 - $\Delta_{\text{OTAREFSSENS}}$ dBm / 19.08 MHz
	30	10	-83.6 - $\Delta_{\text{OTAREFSSENS}}$ dBm / 8.64 MHz
		20	-80.4 - $\Delta_{\text{OTAREFSSENS}}$ dBm / 18.36 MHz
		40	-77.2 - $\Delta_{\text{OTAREFSSENS}}$ dBm / 38.16 MHz
		100	-73.1 - $\Delta_{\text{OTAREFSSENS}}$ dBm / 98.28 MHz
IAB type 2-O	60	50	$\text{EIS}_{\text{REFSENS_50M}} + \Delta_{\text{FR2_REFSENS}} + 15$ dBm / 47.52 MHz
		100	$\text{EIS}_{\text{REFSENS_50M}} + \Delta_{\text{FR2_REFSENS}} + 18$ dBm / 95.04 MHz
	120	50	$\text{EIS}_{\text{REFSENS_50M}} + \Delta_{\text{FR2_REFSENS}} + 15$ dBm / 46.08 MHz
		100	$\text{EIS}_{\text{REFSENS_50M}} + \Delta_{\text{FR2_REFSENS}} + 18$ dBm / 95.04 MHz
		200	$\text{EIS}_{\text{REFSENS_50M}} + \Delta_{\text{FR2_REFSENS}} + 21$ dBm / 190.08 MHz
		NOTE 1: $\Delta_{\text{OTAREFSSENS}}$ as declared in D.53 in table 4.6-1 and clause 7.1.	
NOTE 2: $\Delta_{\text{FR2_REFSENS}} = -3$ dB as described in clause 7.1, since the OTA REFSSENS reference direction (as declared in D.54 in table 4.6-1) is used for testing.			
NOTE 3: $\text{EIS}_{\text{REFSENS_50M}}$ as declared in D.28 in table 4.6-1.			

8) For reference channels applicable to the IAB-DU, measure the throughput.

8.1.2.1.5 Test Requirement

8.1.2.1.5.1 Test requirement for IAB type 1-O

The throughput measured according to clause 8.1.2.1.4.2 shall not be below the limits for the SNR levels specified in table 8.1.2.1.5.1-1 to table 8.1.2.1.5.1-14 for 1Tx and for 2Tx two layer spatial multiplexing transmission.

Table 8.1.2.1.5.1-1: Void**Table 8.1.2.1.5.1-2: Test requirements for PUSCH with 70% of maximum throughput, Type A, 10 MHz channel bandwidth, 15 kHz SCS**

Number of TX antennas	Number of demodulation branches	Propagation conditions and correlation matrix (annex J)	FRC (annex A)	Additional DM-RS position	SNR (dB)
1	2	TDLB100-400 Low	D-FR1-A.2.1-2	pos1	-1.9
		TDLC300-100 Low	D-FR1-A.2.3-2	pos1	10.8
		TDLA30-10 Low	D-FR1-A.2.4-2	pos1	12.8
2	2	TDLB100-400 Low	D-FR1-A.2.1-9	pos1	2.5
		TDLC300-100 Low	D-FR1-A.2.3-9	pos1	19.1

Table 8.1.2.1.5.1-3: Test requirements for PUSCH with 70% of maximum throughput, Type A, 20 MHz channel bandwidth, 15 kHz SCS

Number of TX antennas	Number of demodulation branches	Propagation conditions and correlation matrix (annex J)	FRC (annex A)	Additional DM-RS position	SNR (dB)
1	2	TDLB100-400 Low	D-FR1-A.2.1-3	pos1	-1.5
		TDLC300-100 Low	D-FR1-A.2.3-3	pos1	10.6
		TDLA30-10 Low	D-FR1-A.2.4-3	pos1	13.0
2	2	TDLB100-400 Low	D-FR1-A.2.1-10	pos1	2.9
		TDLC300-100 Low	D-FR1-A.2.3-10	pos1	19.1

Table 8.1.2.1.5.1-4: Test requirements for PUSCH with 70% of maximum throughput, Type A, 10 MHz channel bandwidth, 30 kHz SCS

Number of TX antennas	Number of demodulation branches	Propagation conditions and correlation matrix (annex J)	FRC (annex A)	Additional DM-RS position	SNR (dB)
1	2	TDLB100-400 Low	D-FR1-A.2.1-4	pos1	-1.7
		TDLC300-100 Low	D-FR1-A.2.3-4	pos1	10.8
		TDLA30-10 Low	D-FR1-A.2.4-4	pos1	13.4
2	2	TDLB100-400 Low	D-FR1-A.2.1-11	pos1	2.1
		TDLC300-100 Low	D-FR1-A.2.3-11	pos1	19.2

Table 8.1.2.1.5.1-5: Test requirements for PUSCH with 70% of maximum throughput, Type A, 20 MHz channel bandwidth, 30 kHz SCS

Number of TX antennas	Number of demodulation branches	Propagation conditions and correlation matrix (annex J)	FRC (annex A)	Additional DM-RS position	SNR (dB)
1	2	TDLB100-400 Low	D-FR1-A.2.1-5	pos1	-2.3
		TDLC300-100 Low	D-FR1-A.2.3-5	pos1	10.8
		TDLA30-10 Low	D-FR1-A.2.4-5	pos1	13.1
2	2	TDLB100-400 Low	D-FR1-A.2.1-12	pos1	2.1
		TDLC300-100 Low	D-FR1-A.2.3-12	pos1	18.9

Table 8.1.2.1.5.1-6: Test requirements for PUSCH with 70% of maximum throughput, Type A, 40 MHz channel bandwidth, 30 kHz SCS

Number of TX antennas	Number of demodulation branches	Propagation conditions and correlation matrix (annex J)	FRC (annex A)	Additional DM-RS position	SNR (dB)
1	2	TDLB100-400 Low	D-FR1-A.2.1-6	pos1	-1.9
		TDLC300-100 Low	D-FR1-A.2.3-6	pos1	10.6
		TDLA30-10 Low	D-FR1-A.2.4-6	pos1	13.0
2	2	TDLB100-400 Low	D-FR1-A.2.1-13	pos1	2.1
		TDLC300-100 Low	D-FR1-A.2.3-13	pos1	20.3

Table 8.1.2.1.5.1-7: Test requirements for PUSCH with 70% of maximum throughput, Type A, 100 MHz channel bandwidth, 30 kHz SCS

Number of TX antennas	Number of demodulation branches	Propagation conditions and correlation matrix (annex J)	FRC (annex A)	Additional DM-RS position	SNR (dB)
1	2	TDLB100-400 Low	D-FR1-A.2.1-7	pos1	-2.2
		TDLC300-100 Low	D-FR1-A.2.3-7	pos1	10.8
		TDLA30-10 Low	D-FR1-A.2.4-7	pos1	13.6
2	2	TDLB100-400 Low	D-FR1-A.2.1-14	pos1	2.2
		TDLC300-100 Low	D-FR1-A.2.3-14	pos1	20.0

Table 8.1.2.1.5.1-8: Void**Table 8.1.2.1.5.1-9: Test requirements for PUSCH with 70% of maximum throughput, Type B, 10 MHz channel bandwidth, 15 kHz SCS**

Number of TX antennas	Number of demodulation branches	Propagation conditions and correlation matrix (annex J)	FRC (annex A)	Additional DM-RS position	SNR (dB)
1	2	TDLB100-400 Low	D-FR1-A.2.1-2	pos1	-1.7
		TDLC300-100 Low	D-FR1-A.2.3-2	pos1	11.1
		TDLA30-10 Low	D-FR1-A.2.4-2	pos1	13.2
2	2	TDLB100-400 Low	D-FR1-A.2.1-9	pos1	2.8
		TDLC300-100 Low	D-FR1-A.2.3-9	pos1	19.5

Table 8.1.2.1.5.1-10: Test requirements for PUSCH with 70% of maximum throughput, Type B, 20 MHz channel bandwidth, 15 kHz SCS

Number of TX antennas	Number of demodulation branches	Propagation conditions and correlation matrix (annex J)	FRC (annex A)	Additional DM-RS position	SNR (dB)
1	2	TDLB100-400 Low	D-FR1-A.2.1-3	pos1	-1.5
		TDLC300-100 Low	D-FR1-A.2.3-3	pos1	11.0
		TDLA30-10 Low	D-FR1-A.2.4-3	pos1	12.9
2	2	TDLB100-400 Low	D-FR1-A.2.1-10	pos1	2.4
		TDLC300-100 Low	D-FR1-A.2.3-10	pos1	18.9

Table 8.1.2.1.5.1-11: Test requirements for PUSCH with 70% of maximum throughput, Type B, 10 MHz channel bandwidth, 30 kHz SCS

Number of TX antennas	Number of demodulation branches	Propagation conditions and correlation matrix (annex J)	FRC (annex A)	Additional DM-RS position	SNR (dB)
1	2	TDLB100-400 Low	D-FR1-A.2.1-4	pos1	-1.8
		TDLC300-100 Low	D-FR1-A.2.3-4	pos1	10.7
		TDLA30-10 Low	D-FR1-A.2.4-4	pos1	13.1
2	2	TDLB100-400 Low	D-FR1-A.2.1-11	pos1	1.9
		TDLC300-100 Low	D-FR1-A.2.3-11	pos1	19.3

Table 8.1.2.1.5.1-12: Test requirements for PUSCH with 70% of maximum throughput, Type B, 20 MHz channel bandwidth, 30 kHz SCS

Number of TX antennas	Number of demodulation branches	Propagation conditions and correlation matrix (annex J)	FRC (annex A)	Additional DM-RS position	SNR (dB)
1	2	TDLB100-400 Low	D-FR1-A.2.1-5	pos1	-2.3
		TDLC300-100 Low	D-FR1-A.2.3-5	pos1	10.7
		TDLA30-10 Low	D-FR1-A.2.4-5	pos1	13.1
2	2	TDLB100-400 Low	D-FR1-A.2.1-12	pos1	2.1
		TDLC300-100 Low	D-FR1-A.2.3-12	pos1	19.0

Table 8.1.2.1.5.1-13: Test requirements for PUSCH with 70% of maximum throughput, Type B, 40 MHz channel bandwidth, 30 kHz SCS

Number of TX antennas	Number of demodulation branches	Propagation conditions and correlation matrix (annex J)	FRC (annex A)	Additional DM-RS position	SNR (dB)
1	2	TDLB100-400 Low	D-FR1-A.2.1-6	pos1	-1.9
		TDLC300-100 Low	D-FR1-A.2.3-6	pos1	10.6
		TDLA30-10 Low	D-FR1-A.2.4-6	pos1	13.1
2	2	TDLB100-400 Low	D-FR1-A.2.1-13	pos1	2.5
		TDLC300-100 Low	D-FR1-A.2.3-13	pos1	19.5

Table 8.1.2.1.5.1-14: Test requirements for PUSCH with 70% of maximum throughput, Type B, 100 MHz channel bandwidth, 30 kHz SCS

Number of TX antennas	Number of demodulation branches	Propagation conditions and correlation matrix (annex J)	FRC (annex A)	Additional DM-RS position	SNR (dB)
1	2	TDLB100-400 Low	D-FR1-A.2.1-7	pos1	-1.9
		TDLC300-100 Low	D-FR1-A.2.3-7	pos1	10.7
		TDLA30-10 Low	D-FR1-A.2.4-7	pos1	13.7
2	2	TDLB100-400 Low	D-FR1-A.2.1-14	pos1	2.4
		TDLC300-100 Low	D-FR1-A.2.3-14	pos1	20.1

NOTE: If the above Test Requirement differs from the Minimum Requirement then the Test Tolerance applied for this test is non-zero. The Test Tolerance for this test and the explanation of how the Minimum Requirement has been relaxed by the Test Tolerance is given in annex C.

8.1.2.1.5.2 Test requirement for IAB type 2-O

The throughput measured according to clause 8.1.2.1.4.2 shall not be below the limits for the SNR levels specified in table 8.1.2.1.5.2-1 to 8.1.2.1.5.2-7.

Table 8.1.2.1.5.2-1: Test requirements for PUSCH with 70% of maximum throughput, 50 MHz Channel Bandwidth, 60 kHz SCS

Number of TX antennas	Number of demodulation branches	Propagation conditions and correlation matrix (annex J)	FRC (annex A)	Additional DM-RS position	PT-RS	SNR (dB)
1	2	TDLA30-300 Low	D-FR2-A.2.1-1	pos0	No	-1.4
			D-FR2-A.2.1-13	pos1	No	-1.6
		TDLA30-300 Low	D-FR2-A.2.3-1	pos0	Yes	12.6
				No	12.1	
			D-FR2-A.2.3-11	pos1	Yes	11.3
				No	11.3	
		TDLA30-75 Low	D-FR2-A.2.4-1	pos0	Yes	14.3
				No	13.7	
			D-FR2-A.2.4-6	pos1	Yes	14.0
		No	13.5			
2	2	TDLA30-300 Low	D-FR2-A.2.1-6	pos0	No	2.3
			D-FR2-A.2.1-18	pos1	No	2.0
		TDLA30-300 Low	D-FR2-A.2.2-1	pos0	Yes	16.0
				No	15.1	
			D-FR2-A.2.2-6	pos1	Yes	14.6
				No	13.8	

Table 8.1.2.1.5.2-2: Test requirements for PUSCH with 70% of maximum throughput, 100 MHz Channel Bandwidth, 60 kHz SCS

Number of TX antennas	Number of demodulation branches	Propagation conditions and correlation matrix (annex J)	FRC (annex A)	Additional DM-RS position	PT-RS	SNR (dB)
1	2	TDLA30-300 Low	D-FR2-A.2.1-2	pos0	No	-1.5
			D-FR2-A.2.1-14	pos1	No	-1.8
		TDLA30-300 Low	D-FR2-A.2.3-2	pos0	Yes	12.8
				No	11.8	
			D-FR2-A.2.3-12	pos1	Yes	11.8
				No	11.2	
		TDLA30-75 Low	D-FR2-A.2.4-2	pos0	Yes	14.8
				No	13.9	
			D-FR2-A.2.4-7	pos1	Yes	14.3
		No	13.7			
2	2	TDLA30-300 Low	D-FR2-A.2.1-7	pos0	No	2.3
			D-FR2-A.2.1-19	pos1	No	2.0
		TDLA30-300 Low	D-FR2-A.2.2-2	pos0	Yes	16.8
				No	15.7	
			D-FR2-A.2.2-7	pos1	Yes	14.6
				No	13.9	

Table 8.1.2.1.5.2-3: Test requirements for PUSCH with 70% of maximum throughput, 50 MHz Channel Bandwidth, 120 kHz SCS

Number of TX antennas	Number of demodulation branches	Propagation conditions and correlation matrix (annex J)	FRC (annex A)	Additional DM-RS position	PT-RS	SNR (dB)
1	2	TDLA30-300 Low	D-FR2-A.2.1-3	pos0	No	-1.2
			D-FR2-A.2.1-15	pos1	No	-1.5
		TDLA30-300 Low	D-FR2-A.2.3-3	pos0	Yes	12.2
				No	11.5	
			D-FR2-A.2.3-13	pos1	Yes	11.5
				No	11.1	
		TDLA30-75 Low	D-FR2-A.2.4-3	pos0	Yes	14.3
				No	13.7	
			D-FR2-A.2.4-8	pos1	Yes	13.8
		No	13.6			
2	2	TDLA30-300 Low	D-FR2-A.2.1-8	pos0	No	2.2
			D-FR2-A.2.1-20	pos1	No	2.1
		TDLA30-300 Low	D-FR2-A.2.2-3	pos0	Yes	15.0
				No	14.4	
			D-FR2-A.2.2-8	Pos1	Yes	14.7
				No	13.9	

Table 8.1.2.1.5.2-4: Test requirements for PUSCH with 70% of maximum throughput, 100 MHz Channel Bandwidth, 120 kHz SCS

Number of TX antennas	Number of demodulation branches	Propagation conditions and correlation matrix (annex J)	FRC (annex A)	Additional DM-RS position	PT-RS	SNR (dB)
1	2	TDLA30-300 Low	D-FR2-A.2.1-4	pos0	No	-1.8
			D-FR2-A.2.1-16	pos1	No	-1.9
		TDLA30-300 Low	D-FR2-A.2.3-4	pos0	Yes	12.5
				No	11.1	
			D-FR2-A.2.3-14	pos1	Yes	11.7
				No	11.1	
		TDLA30-75 Low	D-FR2-A.2.4-4	pos0	Yes	14.1
				No	13.5	
			D-FR2-A.2.4-9	pos1	Yes	14.0
		No	13.4			
2	2	TDLA30-300 Low	D-FR2-A.2.1-9	pos0	No	2.2
			D-FR2-A.2.1-21	pos1	No	2.0
		TDLA30-300 Low	D-FR2-A.2.2-4	pos0	Yes	14.7
				No	14.0	
			D-FR2-A.2.2-9	pos1	Yes	14.3
				No	13.7	

Table 8.1.2.1.5.2-5: Test requirements for PUSCH with 70% of maximum throughput, 200 MHz Channel Bandwidth, 120 kHz SCS

Number of TX antennas	Number of demodulation branches	Propagation conditions and correlation matrix (annex J)	FRC (annex A)	Additional DM-RS position	PT-RS	SNR (dB)
1	2	TDLA30-300 Low	D-FR2-A.2.1-5	pos0	No	-1.5
			D-FR2-A.2.1-17	pos1	No	-1.8
		TDLA30-300 Low	D-FR2-A.2.3-5	pos0	Yes	11.9
				No	No	11.5
			D-FR2-A.2.3-15	pos1	Yes	11.8
				No	No	11.3
		TDLA30-75 Low	D-FR2-A.2.4-5	pos0	Yes	14.7
				No	No	14.0
			D-FR2-A.2.4-10	pos1	Yes	14.3
		2	2	TDLA30-300 Low	D-FR2-A.2.1-10	pos0
D-FR2-A.2.1-22	pos1				No	1.9
TDLA30-300 Low	D-FR2-A.2.2-5			pos0	Yes	14.8
				No	No	14.1
	D-FR2-A.2.2-10			pos1	Yes	14.4
				No	No	13.8

NOTE: If the above Test Requirement differs from the Minimum Requirement then the Test Tolerance applied for this test is non-zero. The Test Tolerance for this test and the explanation of how the Minimum Requirement has been relaxed by the Test Tolerance is given in annex C.

8.1.2.2 Performance requirements for PUSCH with transform precoding enabled

8.1.2.2.1 Definition and applicability

The performance requirement of PUSCH is determined by a minimum required throughput for a given SNR. The required throughput is expressed as a fraction of maximum throughput for the FRCs listed in annex A. The performance requirements assume HARQ re-transmissions.

Which specific test(s) are applicable to IAB-DU is based on the test applicability rules defined in clause 8.1.1.3.2.

8.1.2.2.2 Minimum Requirement

For *IAB type 1-O*, the minimum requirement is in TS 38.174 [2], clause 11.1.2.1.2.

For *IAB type 2-O*, the minimum requirement is in TS 38.174 [2], clause 11.1.2.2.2.

8.1.2.2.3 Test Purpose

The test shall verify the receiver's ability to achieve throughput under multipath fading propagation conditions for a given SNR.

8.1.2.2.4 Method of test

8.1.2.2.4.1 Initial Conditions

Test environment: Normal, see clause B.2.

RF channels to be tested for single carrier: M, see clause 4.9.1.

Direction to be tested: OTA REFSSENS *receiver target reference direction* (see D.54 in table 4.6-1).

8.1.2.2.4.2 Procedure

- 1) Place the IAB-DU with its manufacturer declared coordinate system reference point in the same place as calibrated point in the test system, as shown in annex E.3.
- 2) Align the manufacturer declared coordinate system orientation of the IAB-DU with the test system.
- 3) Set the IAB-DU in the declared direction to be tested.
- 4) Connect the IAB-DU tester generating the wanted signal, multipath fading simulators and AWGN generators to a test antenna via a combining network in OTA test setup, as shown in annex E.3. Each of the demodulation branch signals should be transmitted on one polarization of the test antenna(s).
- 5) The characteristics of the wanted signal shall be configured according to the corresponding UL reference measurement channel defined in annex A, and according to additional test parameters listed in table 8.1.2.2.4.2-1.

Table 8.1.2.2.4.2-1: Test parameters for testing PUSCH

Parameter		IAB type 1-O	IAB type 2-O
Transform precoding		Enabled	
Cyclic prefix		Normal	
Default TDD UL-DL pattern (Note)		15 kHz SCS: 3D1S1U, S=10D:2G:2U 30 kHz SCS: 7D1S2U, S=6D:4G:4U	60 kHz and 120kHz SCS: 3D1S1U, S=10D:2G:2U
HARQ	Maximum number of HARQ transmissions	4	
	RV sequence	0, 2, 3, 1	
DM-RS	DM-RS configuration type	1	
	DM-RS duration	single-symbol DM-RS	
	Additional DM-RS position	pos1	pos0, pos1
	Number of DM-RS CDM group(s) without data	2	
	Ratio of PUSCH EPRE to DM-RS EPRE	-3 dB	
	DM-RS port(s)	0	
	DM-RS sequence generation	$N_{ID}^0=0$, group hopping and sequence hopping are disabled	
Time domain resource assignment	PUSCH mapping type	A, B	B
	Start symbol	0	0
	Allocation length	14	10
Frequency domain resource assignment	RB assignment	15 kHz SCS: 25 PRBs in the middle of the test bandwidth 30 kHz SCS: 24 PRBs in the middle of the test bandwidth	30 PRBs in the middle of the test bandwidth
	Frequency hopping	Disabled	
Code block group based PUSCH transmission		Disabled	
PT-RS		Not configured	
NOTE: The same requirements are applicable to TDD with different UL-DL patterns for IAB type 1-O, and IAB type 2-O.			

- 6) The multipath fading emulators shall be configured according to the corresponding channel model defined in annex J.
- 7) Adjust the test signal mean power so the calibrated radiated SNR value at the IAB-DU receiver is as specified in clause 8.1.2.2.5.1 and 8.1.2.2.5.2 for IAB type 1-O and IAB type 2-O respectively, and that the SNR at the IAB-DU receiver is not impacted by the noise floor.

The power level for the transmission may be set such that the AWGN level at the RIB is equal to the AWGN level in table 8.1.2.2.4.2-2.

Table 8.1.2.2.4-2: AWGN power level at the BS input

IAB-DU type	Sub-carrier spacing (kHz)	Channel bandwidth (MHz)	AWGN power level
IAB type 1-O	15	5	-86.5 - $\Delta_{\text{OTAREFSSENS}}$ dBm / 4.5 MHz
	30	10	-83.6 - $\Delta_{\text{OTAREFSSENS}}$ dBm / 8.64 MHz
IAB type 2-O	60	50	$EIS_{\text{REFSENS}_{50\text{M}}} + \Delta_{\text{FR2_REFSENS}} + 15$ dBm / 47.52MHz
	120	50	$EIS_{\text{REFSENS}_{50\text{M}}} + \Delta_{\text{FR2_REFSENS}} + 15$ dBm / 46.08 MHz
NOTE 1: $\Delta_{\text{OTAREFSSENS}}$ as declared in D.53 in table 4.6-1 and clause 7.1.			
NOTE 2: $\Delta_{\text{FR2_REFSENS}} = -3$ dB as described in clause 7.1, since the OTA REFSSENS reference direction (as declared in D.54 in table 4.6-1) is used for testing.			
NOTE 3: $EIS_{\text{REFSENS}_{50\text{M}}}$ as declared in D.28 in table 4.6-1.			

8) For reference channels applicable to the IAB-DU, measure the throughput.

8.1.2.2.5 Test Requirement

8.1.2.2.5.1 Test requirement for IAB type 1-O

The throughput measured according to clause 8.1.2.2.4.2 shall not be below the limits for the SNR levels specified in table 8.1.2.2.5.1-1 to table 8.1.2.2.5.1-4.

Table 8.1.2.2.5.1-1: Test requirements for PUSCH with 70% of maximum throughput, Type A, 5 MHz channel bandwidth, 15 kHz SCS

Number of TX antennas	Number of demodulation branches	Propagation conditions and correlation matrix (annex J)	FRC (annex A)	Additional DM-RS position	SNR (dB)
1	2	TDLB100-400 Low	D-FR1-A.2.1-15	pos1	-1.8

Table 8.1.2.2.5.1-2: Test requirements for PUSCH with 70% of maximum throughput, Type A, 10 MHz channel bandwidth, 30 kHz SCS

Number of TX antennas	Number of demodulation branches	Propagation conditions and correlation matrix (annex J)	FRC (annex A)	Additional DM-RS position	SNR (dB)
1	2	TDLB100-400 Low	D-FR1-A.2.1-16	pos1	-1.9

Table 8.1.2.2.5.1-3: Test requirements for PUSCH with 70% of maximum throughput, Type B, 5 MHz channel bandwidth, 15 kHz SCS

Number of TX antennas	Number of demodulation branches	Propagation conditions and correlation matrix (annex J)	FRC (annex A)	Additional DM-RS position	SNR (dB)
1	2	TDLB100-400 Low	D-FR1-A.2.1-15	pos1	-1.7

Table 8.1.2.2.5.1-4: Test requirements for PUSCH with 70% of maximum throughput, Type B, 10 MHz channel bandwidth, 30 kHz SCS

Number of TX antennas	Number of demodulation branches	Propagation conditions and correlation matrix (annex J)	FRC (annex A)	Additional DM-RS position	SNR (dB)
1	2	TDLB100-400 Low	D-FR1-A.2.1-16	pos1	-2.1

8.1.2.2.5.2 Test requirement for IAB type 2-O

The throughput measured according to clause 8.1.2.2.4.2 shall not be below the limits for the SNR levels specified in table 8.1.2.2.5.2-1 to table 8.1.2.2.5.2-2.

Table 8.1.2.2.5.2-1: Test requirements for PUSCH with 70% of maximum throughput, Type B, 50 MHz channel bandwidth, 60 kHz SCS

Number of TX antennas	Number of demodulation branches	Propagation conditions and correlation matrix (annex J)	FRC (annex A)	Additional DM-RS position	SNR (dB)
1	2	TDLA30-300 Low	D-FR2-A.2.1-11	Pos0	-1.2
			D-FR2-A.2.1-23	pos1	-1.3

Table 8.1.2.2.5.2-2: Test requirements for PUSCH with 70% of maximum throughput, Type B, 50 MHz channel bandwidth, 120 kHz SCS

Number of TX antennas	Number of demodulation branches	Propagation conditions and correlation matrix (annex J)	FRC (annex A)	Additional DM-RS position	SNR (dB)
1	2	TDLA30-300 Low	D-FR2-A.2.1-12	Pos0	-1.2
			D-FR2-A.2.1-24	pos1	-1.3

8.1.2.3 Performance requirements for UCI multiplexed on PUSCH

8.1.2.3.1 Definition and applicability

The performance requirement of UCI multiplexed on PUSCH is determined by two parameters: block error probability (BLER) of CSI part 1 and block error probability of CSI part 2. The performance is measured by the required SNR at block error probability of CSI part 1 not exceeding 0.1 %, and the required SNR at block error probability of CSI part 2 not exceeding 1 %.

The CSI part 1 BLER is defined as the probability of incorrectly decoding the CSI part 1 information when the CSI part 1 information is sent.

The CSI part 2 BLER is defined as the probability of incorrectly decoding the CSI part 2 information when the CSI part 2 information is sent.

In the test of UCI multiplexed on PUSCH, the UCI information only contains CSI part 1 and CSI part 2 information, there is no HACK/ACK information transmitted.

The number of UCI information bit payload per slot is defined for two cases as follows:

- 7 bits: 5 bits in CSI part 1, 2 bits in CSI part 2
- 40 bits: 20 bits in CSI part 1, 20 bits in CSI part 2

The 7 bits UCI information case is further defined with the bitmap [c0 c1 c2 c3 c4] = [0 1 0 1 0] for CSI part 1 information, where c0 is mapping to the RI information, and with the bitmap [c0 c1] = [1 0] for CSI part 2 information.

The 40 bits UCI information case is assumed random information bit selection.

In both tests, PUSCH data, CSI part 1 and CSI part 2 are transmitted simultaneously.

Which specific test(s) is applicable to IAB-DU is based on the test applicability rule defined in clause 8.1.1.3.2.

8.1.2.3.2 Minimum Requirement

For IAB type 1-O, the minimum requirement is in TS 38.174 [2] clause 11.1.2.1.3.

For IAB type 2-O, the minimum requirement is in TS 38.174 [2] clause 11.1.2.2.3.

8.1.2.3.3 Test Purpose

The test shall verify the receiver's ability to detect UCI with CSI part 1 and CSI part 2 bits multiplexed on PUSCH under multipath fading propagation conditions for a given SNR.

8.1.2.3.4 Method of test

8.1.2.3.4.1 Initial Conditions

Test environment: Normal; see annex B.2.

RF channels to be tested for single carrier: M; see clause 4.9.1

Direction to be tested: OTA REFSENS *receiver target reference direction* (see D.54 in table 4.6-1).

8.1.2.3.4.2 Procedure

- 1) Place the IAB-DU with its manufacturer declared coordinate system reference point in the same place as calibrated point in the test system, as shown in annex E.3.
- 2) Align the manufacturer declared coordinate system orientation of the IAB-DU with the test system.
- 3) Set the IAB-DU in the declared direction to be tested.
- 4) Connect the IAB-DU tester generating the wanted signal, multipath fading simulators and AWGN generators to a test antenna via a combining network in OTA test setup, as shown in annex E.3. Each of the demodulation branch signals should be transmitted on one polarization of the test antenna(s).
- 5) The characteristics of the wanted signal shall be configured to the corresponding UL reference measurement channel defined in annex A, and according to additional test parameters listed in table 8.1.2.3.4.2-1. The UCI information bit payload per slot is equal to 7bits with CSI part 1 5bits, CSI part 2 2bits, and the UCI information bit payload per slot is equal to 40 bits with CSI part 1 20bits, CSI part 2 20 bits.

Table: 8.1.2.3.4.2-1 Test parameters for testing UCI multiplexed on PUSCH

Parameter		IAB type 1-O	IAB type 2-O
Transform precoding		Disabled	
Cyclic prefix		Normal	
Default TDD UL-DL pattern (Note)		30 kHz SCS: 7D1S2U, S=6D:4G:4U	120 kHz SCS: 3D1S1U, S=10D:2G:2U
HARQ	Maximum number of HARQ transmissions	1	
	RV sequence	0	
DM-RS	DM-RS configuration type	1	
	DM-RS duration	Single-symbol DM-RS	
	Additional DM-RS position	pos1	pos0,pos1
	Number of DM-RS CDM group(s) without data	2	
	Ratio of PUSCH EPRE to DM-RS EPRE	-3 dB	
	DM-RS port(s)	{0}	{0}
	DM-RS sequence generation	$N_{ID}^0=0, n_{SCID}=0$	
Time domain resource assignment	PUSCH mapping type	A,B	B
	Start symbol	0	
	Allocation length	14	10
Frequency domain resource assignment	RB assignment	Full applicable test bandwidth	
	Frequency hopping	Disabled	
Code block group based PUSCH transmission		Disabled	
PT-RS configuration	PT-RS	Disabled	Enabled
	Frequency density (K_{PT-RS})	N.A.	2
	Time density (L_{PT-RS})	N.A.	1
UCI	Number of CSI part1 and CSI part2 information bit payload	{5, 2}, {20,20}	
	scaling	1	
	betaOffsetACK-Index1	11	
	betaOffsetCSI-Part1-Index1 and betaOffsetCSI-Part1-Index2	13	
	betaOffsetCSI-Part2-Index1 and betaOffsetCSI-Part2-Index2	13	
	UCI partition for frequency hopping	Disabled	
NOTE: The same requirements are applicable to TDD with different UL-DL patterns for IAB type 1-O and IAB type 2-O.			

- 6) The multipath fading emulators shall be configured according to the corresponding channel model defined in annex J.
- 7) Adjust the test signal mean power so the calibrated radiated SNR value at the IAB-DU receiver is as specified in clause 8.1.2.3.5.1 and 8.1.2.3.5.2 for IAB type 1-O and IAB type 2-O respectively, and that the SNR at the BS receiver is not impacted by the noise floor.

The power level for the transmission may be set such that the AWGN level at the RIB is equal to the AWGN level in table 8.1.2.3.4.2-2.

Table 8.1.2.3.4.2-2: AWGN power level at the BS input

IAB-DU type	Sub-carrier spacing (kHz)	Channel bandwidth (MHz)	AWGN power level
IAB type 1-O	30	10	-83.6 - $\Delta_{OTAREFSENS}$ dBm / 8.64 MHz
IAB type 2-O	120	50	$E_{ISREFSENS_50M} + \Delta_{FR2_REFSENS} + 15$ dBm / 46.08 MHz
NOTE 1: $\Delta_{OTAREFSENS}$ as declared in D.53 in table 4.6-1 and clause 7.1.			
NOTE 2: $\Delta_{FR2_REFSENS} = -3$ dB as declared in clause 7.1, since the OTA REFSSENS reference direction (as declared in D.54 in table 4.6-1) is used for testing.			
NOTE 3: $E_{ISREFSENS_50M}$ as declared in D.28 in table 4.6-1.			

- 8) The signal generator sends a test pattern where UCI with CSI part 1 and CSI part 2 information can be multiplexed on PUSCH. The following statistics are kept: the number of incorrectly decoded CSI part 1

information transmitted, the number of incorrectly decoded CSI part 2 information transmitted during UCI multiplexed on PUSCH transmission.

8.1.2.3.5 Test Requirement

8.1.2.3.5.1 Test requirement for IAB type 1-0

The fraction of incorrectly decoded UCI with CSI part 1 according to clause 8.1.2.3.4.2 shall be less than 0.1 % for the SNR listed in table 8.1.2.3.5.1-1 and table 8.1.2.3.5.1-2. The fraction of incorrectly decoded UCI with CSI part 2 according to clause 8.1.2.3.4.2 shall be less than 1 % for the SNR listed in table 8.1.2.3.5.1-3 and table 8.1.2.3.5.1-4.

Table 8.1.2.3.5.1-1: Test requirements for UCI multiplexed on PUSCH, Type A, CSI part 1, 10 MHz channel bandwidth, 30 kHz SCS

Number of TX antennas	Number of demodulation branches	Propagation conditions and correlation matrix (Annex J)	UCI bits (CSI part 1, CSI part 2)	Additional DM-RS position	FRC (Annex A)	SNR (dB)
1	2	TDLC300-100 Low	7 (5, 2)	pos1	D-FR1-A.2.3-4	6.0
	2	TDLC300-100 Low	40 (20,20)	pos1	D-FR1-A.2.3-4	4.9

Table 8.1.2.3.5.1-2: Test requirements for UCI multiplexed on PUSCH, Type B, CSI part 1, 10MHz channel bandwidth, 30 kHz SCS

Number of TX antennas	Number of demodulation branches	Propagation conditions and correlation matrix (Annex J)	UCI bits (CSI part 1, CSI part 2)	Additional DM-RS position	FRC (Annex A)	SNR (dB)
1	2	TDLC300-100 Low	7 (5, 2)	pos1	D-FR1-A.2.3-4	6.4
	2	TDLC300-100 Low	40 (20,20)	pos1	D-FR1-A.2.3-4	4.7

Table 8.1.2.3.5.1-3: Test requirements for UCI multiplexed on PUSCH, Type A, CSI part 2, 10MHz channel bandwidth, 30 kHz SCS

Number of TX antennas	Number of demodulation branches	Propagation conditions and correlation matrix (Annex J)	UCI bits (CSI part 1, CSI part 2)	Additional DM-RS position	FRC (Annex A)	SNR (dB)
1	2	TDLC300-100 Low	7 (5, 2)	pos1	D-FR1-A.2.3-4	0.4
	2	TDLC300-100 Low	40 (20,20)	pos1	D-FR1-A.2.3-4	3.0

Table 8.1.2.3.5.1-4: Test requirements for UCI multiplexed on PUSCH, Type B, CSI part 2, 10MHz channel bandwidth, 30 kHz SCS

Number of TX antennas	Number of demodulation branches	Propagation conditions and correlation matrix (Annex J)	UCI bits (CSI part 1, CSI part 2)	Additional DM-RS position	FRC (Annex A)	SNR (dB)
1	2	TDLC300-100 Low	7 (5, 2)	pos1	D-FR1-A.2.3-4	0.9
	2	TDLC300-100 Low	40 (20,20)	pos1	D-FR1-A.2.3-4	3.2

8.1.2.3.5.2 Test requirement for IAB type 2-0

The fraction of incorrectly decoded UCI with CSI part 1 measured according to clause 8.1.2.3.4.2 shall be less than 0.1 % for the SNR listed in table 8.1.2.3.5.2-1 and table 8.1.2.3.5.2-2. The fraction of incorrectly decoded UCI with CSI part 2 measured according to clause 8.1.2.3.4.2 shall be less than 1 % for the SNR listed in table 8.1.2.3.5.2-3 and table 8.1.2.3.5.2-4.

Table 8.1.2.3.5.2-1: Test requirements for UCI multiplexed on PUSCH, Type B, with PT-RS, CSI part 1, 50 MHz channel bandwidth, 120 kHz SCS

Number of TX antennas	Number of demodulation branches	Propagation conditions and correlation matrix (Annex J)	UCI bits (CSI part 1, CSI part 2)	Additional DM-RS position	FRC (Annex A)	SNR (dB)
1	2	TDLA30-300 Low	7 (5, 2)	pos0	D-FR2-A.2.3-3	7.8
	2	TDLA30-300 Low	40 (20,20)	pos0	D-FR2-A.2.3-3	6.4
	2	TDLA30-300 Low	7 (5, 2)	pos1	D-FR2-A.2.3-13	8.4
	2	TDLA30-300 Low	40 (20,20)	pos1	D-FR2-A.2.3-13	6.5

Table 8.1.2.3.5.2-2: Test requirements for UCI multiplexed on PUSCH, Type B, without PT-RS, CSI part 1, 50MHz channel bandwidth, 120 kHz SCS

Number of TX antennas	Number of demodulation branches	Propagation conditions and correlation matrix (Annex J)	UCI bits (CSI part 1, CSI part 2)	Additional DM-RS position	FRC (Annex A)	SNR (dB)
1	2	TDLA30-300 Low	7 (5, 2)	pos0	D-FR2-A.2.3-3	7.7
	2	TDLA30-300 Low	40 (20,20)	pos0	D-FR2-A.2.3-3	6.4
	2	TDLA30-300 Low	7 (5, 2)	pos1	D-FR2-A.2.3-13	7.9
	2	TDLA30-300 Low	40 (20,20)	pos1	D-FR2-A.2.3-13	6.1

Table 8.1.2.3.5.2-3: Test requirements for UCI multiplexed on PUSCH, Type B, with PT-RS, CSI part 2, 50 MHz channel bandwidth, 120 kHz SCS

Number of TX antennas	Number of demodulation branches	Propagation conditions and correlation matrix (Annex J)	UCI bits (CSI part 1, CSI part 2)	Additional DM-RS position	FRC (Annex A)	SNR (dB)
1	2	TDLA30-300 Low	7 (5, 2)	pos0	D-FR2-A.2.3-3	1.7
	2	TDLA30-300 Low	40 (20,20)	pos0	D-FR2-A.2.3-3	4.6
	2	TDLA30-300 Low	7 (5, 2)	pos1	D-FR2-A.2.3-13	1.9
	2	TDLA30-300 Low	40 (20,20)	pos1	D-FR2-A.2.3-13	4.6

Table 8.1.2.3.5.2-4: Test requirements for UCI multiplexed on PUSCH, Type B, Without PT-RS, CSI part 2, 50MHz channel bandwidth, 120 kHz SCS

Number of TX antennas	Number of demodulation branches	Propagation conditions and correlation matrix (Annex J)	UCI bits (CSI part 1, CSI part 2)	Additional DM-RS position	FRC (Annex A)	SNR (dB)
1	2	TDLA30-300 Low	7 (5, 2)	pos0	D-FR2-A.2.3-3	1.7
	2	TDLA30-300 Low	40 (20,20)	pos0	D-FR2-A.2.3-3	4.5
	2	TDLA30-300 Low	7 (5, 2)	pos1	D-FR2-A.2.3-13	1.8
	2	TDLA30-300 Low	40 (20,20)	pos1	D-FR2-A.2.3-13	4.3

8.1.3 Performance requirements for PUCCH

8.1.3.1 Performance requirements for PUCCH format 0

8.1.3.1.1 Definition and applicability

The performance requirement of single user PUCCH format 0 for ACK missed detection is determined by the two parameters: probability of false detection of the ACK and the probability of detection of ACK. The performance is measured by the required SNR at probability of detection equal to 0.99. The probability of false detection of the ACK shall be 0.01 or less.

The probability of false detection of the ACK is defined as a conditional probability of erroneous detection of the ACK when input is only noise.

The probability of detection of ACK is defined as conditional probability of detection of the ACK when the signal is present.

The transient period as specified in TS 38.101-1 [16] clause 6.3.3.1 and TS 38.101-2 [17] clause 6.3.3.1 is not taken into account for performance requirement testing, where the RB hopping is symmetric to the CC center, i.e. intra-slot frequency hopping is enabled.

Which specific test(s) are applicable to IAB-DU is based on the test applicability rules defined in clause 8.1.1.3.3.

8.1.3.1.2 Minimum Requirement

For *IAB type 1-O*, the minimum requirements are in TS 38.174 [2] clause 11.3.1.1 and 11.1.3.1.2.

For *IAB type 2-O*, the minimum requirements are in TS 38.174 [2] clause 11.3.2.1 and 11.1.3.2.2.

8.1.3.1.3 Test Purpose

The test shall verify the receiver's ability to detect ACK under multipath fading propagation conditions for a given SNR.

8.1.3.1.4 Method of test

8.1.3.1.4.1 Initial Conditions

Test environment: Normal, see annex B.2.

RF channels to be tested: single carrier M; see clause 4.9.1.

Direction to be tested: OTA REFSENS *receiver target reference direction* (see D.54 in table 4.6-1).

8.1.3.1.4.2 Procedure

- 1) Place the IAB-DU with its manufacturer declared coordinate system reference point in the same place as calibrated point in the test system, as shown in annex E.3.
- 2) Align the manufacturer declared coordinate system orientation of the IAB-DU with the test system.
- 3) Set the IAB-DU in the declared direction to be tested.
- 4) Connect the BS tester generating the wanted signal, multipath fading simulators and AWGN generators to a test antenna via a combining network in OTA test setup, as shown in annex E.3. Each of the demodulation branch signals should be transmitted on one polarization of the test antenna(s).
- 5) The characteristics of the wanted signal shall be configured according to TS 38.211 [7] and according to additional test parameters listed in table 8.1.3.1.4.2-1.

Table 8.1.3.1.4.2-1: Test parameters

Parameter	IAB type 1-O	IAB type 2-O
number of UCI information bits	1	1
Number of PRBs	1	1
First PRB prior to frequency hopping	0	0
Intra-slot frequency hopping	N/A for 1 symbol Enabled for 2 symbols	N/A for 1 symbol Enabled for 2 symbols
First PRB after frequency hopping	The largest PRB index – (number of PRBs – 1)	The largest PRB index – (number of PRBs – 1)
Group and sequence hopping	neither	neither
Hopping ID	0	0
Initial cyclic shift	0	0
First symbol	13 for 1 symbol 12 for 2 symbols	13 for 1 symbol 12 for 2 symbols
Cyclic prefix	normal	

- 6) The multipath fading emulators shall be configured according to the corresponding channel model defined in annex J.2.
- 7) Adjust the test signal mean power so the calibrated radiated SNR value at the IAB-DU receiver is as specified in clause 8.1.3.1.5.1 and 8.1.3.1.5.2 for *IAB type 1-O* and *IAB type 2-O* respectively, and that the SNR at the IAB-DU receiver is not impacted by the noise floor.

The power level for the transmission may be set such that the AWGN level at the RIB is equal to the AWGN level quoted in table 8.1.3.1.4.2-2.

Table 8.1.3.1.4.2-2: AWGN power level at the IAB-DU input

IAB-DU type	Sub-carrier spacing (kHz)	Channel bandwidth (MHz)	AWGN power level
<i>IAB type 1-O</i>	15	10	-80.3 - $\Delta_{OTAREFSENS}$ dBm / 9.36 MHz
		20	-77.2 - $\Delta_{OTAREFSENS}$ dBm / 19.08 MHz
	30	10	-80.6 - $\Delta_{OTAREFSENS}$ dBm / 8.64 MHz
		20	-77.4 - $\Delta_{OTAREFSENS}$ dBm / 18.36 MHz
		40	-74.2 - $\Delta_{OTAREFSENS}$ dBm / 38.16 MHz
		100	-70.1 - $\Delta_{OTAREFSENS}$ dBm / 98.28 MHz
<i>IAB type 2-O</i>	60	50	$EIS_{REFSENS_50M} + \Delta_{FR2_REFSENS} + 15$ dBm / 47.52 MHz
		100	$EIS_{REFSENS_50M} + \Delta_{FR2_REFSENS} + 18$ dBm / 95.04 MHz
	120	50	$EIS_{REFSENS_50M} + \Delta_{FR2_REFSENS} + 15$ dBm / 46.08 MHz
		100	$EIS_{REFSENS_50M} + \Delta_{FR2_REFSENS} + 18$ dBm / 95.04 MHz
		200	$EIS_{REFSENS_50M} + \Delta_{FR2_REFSENS} + 21$ dBm / 190.08 MHz

NOTE 1: $\Delta_{OTAREFSENS}$ as declared in D.53 in table 4.6-1 and clause 7.1.
 NOTE 2: $\Delta_{FR2_REFSENS} = -3$ dB as described in clause 7.1 since the OTA REFSENS reference direction (as declared in D.54 in table 4.6-1) is used for testing.
 NOTE 3: $EIS_{REFSENS_50M}$ as declared in D.28 in table 4.6-1.

- 8) The signal generator sends a test pattern with the pattern outlined in figure 8.1.3.1.4.2-1. The following statistics are kept: the number of ACKs detected in the idle periods and the number of missed ACKs.



Figure 8.1.3.1.4.2-1: Test signal pattern for single user PUCCH format 0 demodulation tests

8.1.3.1.5 Test Requirement

8.1.3.1.5.1 Test requirement for *IAB type 1-0*

The fraction of falsely detected ACKs shall be less than 1% and the fraction of correctly detected ACKs shall be larger than 99% for the SNR listed in table 8.1.3.1.5.1-1 and in table 8.1.3.1.5.1-2.

Table 8.1.3.1.5.1-1: Test requirements for PUCCH format 0 and 15 kHz SCS

Number of TX antennas	Number of demodulation branches	Propagation conditions and correlation matrix (annex J)	Number of OFDM symbols	Channel bandwidth / SNR (dB)	
				10 MHz	20 MHz
1	2	TDLC300-100 Low	1	9.4	9.9
			2	4.3	3.9

Table 8.1.3.1.5.1-2: Test requirements for PUCCH format 0 and 30 kHz SCS

Number of TX antennas	Number of demodulation branches	Propagation conditions and correlation matrix (annex J)	Number of OFDM symbols	Channel bandwidth / SNR (dB)			
				10 MHz	20 MHz	40 MHz	100 MHz
1	2	TDLC300-100 Low	1	10.4	10.4	10.1	9.8
			2	4.8	4.2	4.4	4.1

8.1.3.1.5.2 Test requirement for *IAB type 2-0*

The fraction of falsely detected ACKs shall be less than 1% and the fraction of correctly detected ACKs shall be larger than 99% for the SNR listed in table 8.1.3.1.5.2-1 and in table 8.1.3.1.5.2-2.

Table 8.1.3.1.5.2-1: Test requirements for PUCCH format 0 and 60 kHz SCS

Number of TX antennas	Number of demodulation branches	Propagation conditions and correlation matrix (annex J)	Number of OFDM symbols	Channel bandwidth / SNR (dB)	
				50 MHz	100 MHz
1	2	TDLA30-300 Low	1	9.9	9.6
			2	4.8	4.6

Table 8.1.3.1.5.2-2: Test requirements for PUCCH format 0 and 120 kHz SCS

Number of TX antennas	Number of demodulation branches	Propagation conditions and correlation matrix (annex J)	Number of OFDM symbols	Channel bandwidth / SNR (dB)		
				50 MHz	100 MHz	200 MHz
1	2	TDLA30-300 Low	1	10.1	9.8	10.3
			2	4.7	4.4	4.6

8.1.3.2 Performance requirements for PUCCH format 1

8.1.3.2.1 NACK to ACK detection

8.1.3.2.1.1 Definition and applicability

The performance requirement of PUCCH format 1 for NACK to ACK detection is determined by the two parameters: probability of false detection of the ACK and the NACK to ACK detection probability. The performance is measured by the required SNR at probability of the NACK to ACK detection equal to 0.1% or less. The probability of false detection of the ACK shall be 0.01 or less.

The probability of false detection of the ACK is defined as a conditional probability of erroneous detection of the ACK at particular bit position when input is only noise. Each false bit detection is counted as one error.

The NACK to ACK detection probability is the probability of detecting an ACK bit when an NACK bit was sent on particular bit position. Each NACK bit erroneously detected as ACK bit is counted as one error. Erroneously detected NACK bits in the definition do not contain the NACK bits which are mapped from DTX, i.e. NACK bits received when DTX is sent should not be considered.

The transient period as specified in TS 38.101-1 [16] and TS 38.101-2 [17] clause 6.3.3.1 is not taken into account for performance requirement testing, where the RB hopping is symmetric to the CC center, i.e. intra-slot frequency hopping is enabled.

Which specific test(s) are applicable to IAB-DU is based on the test applicability rules defined in clause 8.1.1.3.3.

8.1.3.2.1.2 Minimum Requirement

For BS type 1-O, the minimum requirement is in TS 38.174 [2], clause 11.1.3.1.3.

For BS type 2-O, the minimum requirement is in TS 38.174 [2], clause 11.1.3.2.3.

8.1.3.2.1.3 Test Purpose

The test shall verify the receiver's ability not to falsely detect NACK bits as ACK bits under multipath fading propagation conditions for a given SNR.

8.1.3.2.1.4 Method of test

8.1.3.2.1.4.1 Initial Conditions

Test environment: Normal; see annex B.2.

RF channels to be tested for single carrier: M; see clause 4.9.1

Direction to be tested: OTA REFSSENS receiver target reference direction (see D.54 in table 4.6-1).

8.1.3.2.1.4.2 Procedure

- 1) Place the IAB-DU with its manufacturer declared coordinate system reference point in the same place as calibrated point in the test system, as shown in annex E.3.
- 2) Align the manufacturer declared coordinate system orientation of the IAB-DU with the test system.
- 3) Set the IAB-DU in the declared direction to be tested.
- 4) Connect the IAB-DU tester generating the wanted signal, multipath fading simulators and AWGN generators to a test antenna via a combining network in OTA test setup, as shown in annex E.3. Each of the demodulation branch signals should be transmitted on one polarization of the test antenna(s).
- 5) The characteristics of the wanted signal shall be configured according to TS 38.211 [7], and according to additional test parameters listed in table 8.1.3.2.1.4.2-1.

Table 8.1.3.2.1.4.2-1: Test parameters

Parameter	Test
Number of information bits	2
Number of PRBs	1
Number of symbols	14
First PRB prior to frequency hopping	0
Intra-slot frequency hopping	enabled
First PRB after frequency hopping	The largest PRB index - (nrofPRBs - 1)
Group and sequence hopping	neither
Hopping ID	0
Initial cyclic shift	0
First symbol	0
Index of orthogonal cover code (<i>timeDomainOCC</i>)	0
Cyclic prefix	normal

- 6) The multipath fading emulators shall be configured according to the corresponding channel model defined in annex J.
- 7) Adjust the test signal mean power so the calibrated radiated SNR value at the IAB-DU receiver is as specified in clause 8.1.3.2.1.5.1 and 8.1.3.2.1.5.2 for *IAB type 1-O* and *IAB type 2-O* respectively, and that the SNR at the IAB-DU receiver is not impacted by the noise floor.

The power level for the transmission may be set such that the AWGN level at the RIB is equal to the AWGN level in table 8.1.3.2.1.4.2-2.

Table 8.1.3.2.1.4.2-2: AWGN power level at the BS input

IAB type	Subcarrier spacing (kHz)	Channel bandwidth (MHz)	AWGN power level
<i>IAB type 1-O</i>	15 kHz	10	$-80.3 - \Delta_{\text{OTAREFSENS}}$ dBm / 9.36 MHz
		20	$-77.2 - \Delta_{\text{OTAREFSENS}}$ dBm / 19.08 MHz
	30 kHz	10	$-80.6 - \Delta_{\text{OTAREFSENS}}$ dBm / 8.64 MHz
		20	$-77.4 - \Delta_{\text{OTAREFSENS}}$ dBm / 18.36 MHz
		40	$-74.2 - \Delta_{\text{OTAREFSENS}}$ dBm / 38.16 MHz
	100	$-70.1 - \Delta_{\text{OTAREFSENS}}$ dBm / 98.28 MHz	
<i>IAB type 2-O</i>	60 kHz	50	$\text{EIS}_{\text{REFSENS_50M}} + \Delta_{\text{FR2_REFSENS}} + 15$ dBm / 47.52 MHz
		100	$\text{EIS}_{\text{REFSENS_50M}} + \Delta_{\text{FR2_REFSENS}} + 18$ dBm / 95.04 MHz
		50	$\text{EIS}_{\text{REFSENS_50M}} + \Delta_{\text{FR2_REFSENS}} + 15$ dBm / 46.08 MHz
		100	$\text{EIS}_{\text{REFSENS_50M}} + \Delta_{\text{FR2_REFSENS}} + 18$ dBm / 95.04 MHz
		200	$\text{EIS}_{\text{REFSENS_50M}} + \Delta_{\text{FR2_REFSENS}} + 21$ dBm / 190.08 MHz
NOTE 1: $\Delta_{\text{OTAREFSENS}}$ as declared in D.53 in table 4.6-1 and clause 7.1.			
NOTE 2: $\Delta_{\text{FR2_REFSENS}} = -3$ dB as described in clause 7.1, since the OTA REFSSENS reference direction (as declared in D.54 in table 4.6-1) is used for testing.			
NOTE 3: $\text{EIS}_{\text{REFSENS_50M}}$ as declared in D.28 in table 4.6-1.			

- 8) The signal generator sends random codeword from applicable codebook, in regular time periods. The following statistics are kept: the number of ACK bits detected in the idle periods and the number of NACK bits detected as ACK.

8.1.3.2.1.5 Test Requirement

8.1.3.2.1.5.1 Test requirement for *IAB type 1-O*

The fraction of falsely detected ACK bits shall be less than 1 % and the fraction of NACK bits falsely detected as ACK shall be less than 0.1 % for the SNR listed in tables 8.1.3.2.1.5.1-1 and table 8.1.3.2.1.5.1-2.

Table 8.1.3.2.1.5.1-1: Required SNR for PUCCH format 1 with 15 kHz SCS

Number of TX antennas	Number of Demodulation Branches	Propagation conditions and correlation matrix (annex J)	Channel bandwidth / SNR (dB)	
			10 MHz	20 MHz
1	2	TDLC300-100 Low	-3.0	-3.0

Table 8.1.3.2.1.5.1-2: Required SNR for PUCCH format 1 with 30 kHz SCS

Number of TX antennas	Number of Demodulation Branches	Propagation conditions and correlation matrix (annex J)	Channel bandwidth / SNR (dB)			
			10 MHz	20 MHz	40 MHz	100 MHz
1	2	TDLC300-100 Low	-2.2	-2.7	-3.3	-2.9

8.1.3.2.1.5.2 Test requirement for IAB type 2-0

The fraction of falsely detected ACK bits shall be less than 1 % and the fraction of NACK bits falsely detected as ACK shall be less than 0.1 % for the SNR listed in tables 8.1.3.2.1.5.2-1 and table 8.1.3.2.1.5.2-2.

Table 8.1.3.2.1.5.2-1: Required SNR for PUCCH format 1 with 60 kHz SCS

Number of TX antennas	Number of Demodulation Branches	Propagation conditions and correlation matrix (annex J)	Channel bandwidth / SNR (dB)	
			50 MHz	100 MHz
1	2	TDLA30-300 Low	-0.6	-3.6

Table 8.1.3.2.1.5.2-2: Required SNR for PUCCH format 1 with 120 kHz SCS

Number of TX antennas	Number of Demodulation Branches	Propagation conditions and correlation matrix (annex J)	Channel bandwidth / SNR (dB)		
			50 MHz	100 MHz	200 MHz
1	2	TDLA30-300 Low	-3.3	-3.3	-2.4

8.1.3.2.2 ACK missed detection

8.1.3.2.2.1 Definition and applicability

The performance requirement of PUCCH format 1 for ACK missed detection is determined by the two parameters: probability of false detection of the ACK and the probability of detection of ACK. The performance is measured by the required SNR at probability of detection equal to 0.99. The probability of false detection of the ACK shall be 0.01 or less.

The probability of false detection of the ACK is defined as a conditional probability of erroneous detection of the ACK when input is only noise.

The probability of detection of ACK is defined as conditional probability of detection of the ACK when the signal is present.

The transient period as specified in TS 38.101-1 [16] and TS 38.101-2 [17] clause 6.3.3.1 is not taken into account for performance requirement testing, where the RB hopping is symmetric to the CC center, i.e. intra-slot frequency hopping is enabled.

Which specific test(s) are applicable to IAB DU is based on the test applicability rules defined in clause 8.1.1.3.3.

8.1.3.2.2.2 Minimum Requirement

For *IAB type 1-O*, the minimum requirement is in TS 38.174 [7], clause 11.1.3.1.3.

For *IAB type 2-O*, the minimum requirement is in TS 38.174 [7], clause 11.1.3.2.3.

8.1.3.2.2.3 Test Purpose

The test shall verify the receiver's ability to detect ACK bits under multipath fading propagation conditions for a given SNR.

8.1.3.2.2.4 Method of test

8.1.3.2.2.4.1 Initial Conditions

Test environment: Normal; see annex B.2.

RF channels to be tested for single carrier: M; see clause 4.9.1.

Direction to be tested: OTA REFSENS receiver target reference direction (see D.54 in table 4.6-1).

8.1.3.2.2.4.2 Procedure

- 1) Place the IAB DU with its manufacturer declared coordinate system reference point in the same place as calibrated point in the test system, as shown in annex E.3.
- 2) Align the manufacturer declared coordinate system orientation of the IAB DU with the test system.
- 3) Set the IAB DU in the declared direction to be tested.
- 4) Connect the IAB DU tester generating the wanted signal, multipath fading simulators and AWGN generators to a test antenna via a combining network in OTA test setup, as shown in annex E.3. Each of the demodulation branch signals should be transmitted on one polarization of the test antenna(s).
- 5) The characteristics of the wanted signal shall be configured according to TS 38.211 [7], and according to additional test parameters listed in table 8.1.3.2.2.4.2-1.

Table 8.1.3.2.2.4.2-1: Test Parameters

Parameter	Test
Number of information bits	2
Number of PRBs	1
Number of symbols	14
First PRB prior to frequency hopping	0
Intra-slot frequency hopping	enabled
First PRB after frequency hopping	The largest PRB index – (nrofPRBs – 1)
Group and sequence hopping	neither
Hopping ID	0
Initial cyclic shift	0
First symbol	0
Index of orthogonal cover code (<i>timeDomainOCC</i>)	0
Cyclic prefix	normal

- 6) The multipath fading emulators shall be configured according to the corresponding channel model defined in annex J.2.
- 7) Adjust the test signal mean power so the calibrated radiated SNR value at the IAB DU receiver is as specified in clause 8.1.3.2.2.5.1 and 8.1.3.2.2.5.2 for *IAB type 1-O* and *IAB type 2-O* respectively, and that the SNR at the IAB DU receiver is not impacted by the noise floor.

The power level for the transmission may be set such that the AWGN level at the RIB is equal to the AWGN level in table 8.1.3.2.2.4.2-2.

Table 8.1.3.2.4.2-2: AWGN power level at the BS input

IAB type	Subcarrier spacing (kHz)	Channel bandwidth (MHz)	AWGN power level
<i>IAB type 1-0</i>	15 kHz	10	$-80.3 - \Delta_{\text{OTAREFSSENS}}$ dBm / 9.36 MHz
		20	$-77.2 - \Delta_{\text{OTAREFSSENS}}$ dBm / 19.08 MHz
	30 kHz	10	$-80.6 - \Delta_{\text{OTAREFSSENS}}$ dBm / 8.64 MHz
		20	$-77.4 - \Delta_{\text{OTAREFSSENS}}$ dBm / 18.36 MHz
		40	$-74.2 - \Delta_{\text{OTAREFSSENS}}$ dBm / 38.16 MHz
		100	$-70.1 - \Delta_{\text{OTAREFSSENS}}$ dBm / 98.28 MHz
<i>IAB type 2-0</i>	60 kHz	50	$EIS_{\text{REFSENS_50M}} + \Delta_{\text{FR2_REFSENS}} + 15$ dBm / 47.52 MHz
		100	$EIS_{\text{REFSENS_50M}} + \Delta_{\text{FR2_REFSENS}} + 18$ dBm / 95.04 MHz
		50	$EIS_{\text{REFSENS_50M}} + \Delta_{\text{FR2_REFSENS}} + 15$ dBm / 46.08 MHz
		100	$EIS_{\text{REFSENS_50M}} + \Delta_{\text{FR2_REFSENS}} + 18$ dBm / 95.04 MHz
		200	$EIS_{\text{REFSENS_50M}} + \Delta_{\text{FR2_REFSENS}} + 21$ dBm / 47.52 MHz

NOTE 1: $\Delta_{\text{OTAREFSSENS}}$ as declared in D.53 in table 4.6-1 and clause 7.1.
NOTE 2: $\Delta_{\text{FR2_REFSENS}} = -3$ dB as described in clause 7.1, since the OTA REFSENS reference direction (as declared in D.54 in table 4.6-1) is used for testing.
NOTE 3: $EIS_{\text{REFSENS_50M}}$ as declared in D.28 in table 4.6-1.

- 8) The tester sends random codewords from applicable codebook, in regular time periods. The following statistics are kept: the number of ACK bits falsely detected in the idle periods and the number of missed ACK bits. Each falsely detected ACK bit in the idle periods is accounted as one error for the statistics of false ACK detection, and each missed ACK bit is accounted as one error for the statistics of missed ACK detection.

Note that the procedure described in this clause for ACK missed detection has the same condition as that described in clause 8.1.3.2.1.4.2 for NACK to ACK detection. Both statistics are measured in the same testing.

8.1.3.2.2.5 Test Requirement

8.1.3.2.2.5.1 Test requirement for *IAB type 1-0*

The fraction of falsely detected ACK bits shall be less than 1% and the fraction of correctly detected ACK bits shall be larger than 99% for the SNR listed in tables 8.1.3.2.2.5-1 and table 8.1.3.2.2.5-2.

Table 8.1.3.2.2.5.1-1: Required SNR for PUCCH format 1 with 15 kHz SCS

Number of TX antennas	Number of Demodulation Branches	Propagation conditions and correlation matrix (annex J)	Channel bandwidth / SNR (dB)	
			10 MHz	20 MHz
1	2	TDLC300-100 Low	-3.8	-4.4

Table 8.1.3.2.2.5.1-2: Required SNR for PUCCH format 1 with 30 kHz SCS

Number of TX antennas	Number of Demodulation Branches	Propagation conditions and correlation matrix (annex J)	Channel bandwidth / SNR (dB)			
			10 MHz	20 MHz	40 MHz	100 MHz
1	2	TDLC300-100 Low	-3.3	-3.8	-3.8	-3.6

8.1.3.2.2.5.2 Test requirement for *IAB type 2-0*

The fraction of falsely detected ACK bits shall be less than 1% and the fraction of correctly detected ACK bits shall be larger than 99% for the SNR listed in tables 8.1.3.2.2.5.2-1 and table 8.1.3.2.2.5.2-2.

Table 8.1.3.2.5.2-1: Required SNR for PUCCH format 1 with 60 kHz SCS

Number of TX antennas	Number of Demodulation Branches	Propagation conditions and correlation matrix (annex J)	Channel bandwidth / SNR (dB)	
			50 MHz	100 MHz
1	2	TDLA30-300 Low	-3.3	-3.6

Table 8.1.3.2.5.2-2: Required SNR for PUCCH format 1 with 120 kHz SCS

Number of TX antennas	Number of Demodulation Branches	Propagation conditions and correlation matrix (annex J)	Channel bandwidth / SNR (dB)		
			50 MHz	100 MHz	200 MHz
1	2	TDLA30-300 Low	-4.1	-4.0	-4.0

8.1.3.3 Performance requirements for PUCCH format 2

8.1.3.3.1 ACK missed detection performance requirements

8.1.3.3.1.1 Definition and applicability

The performance requirement of PUCCH format 2 for ACK missed detection is determined by the two parameters: probability of false detection of the ACK and the probability of detection of ACK on the wanted signal. The performance is measured by the required SNR at probability of detection equal to 0.99. The probability of false detection of the ACK shall be 0.01 or less.

The probability of false detection of the ACK is defined as a probability of erroneous detection of the ACK when input is only noise.

The probability of detection of ACK is defined as probability of detection of the ACK when the signal is present.

Which specific test(s) are applicable to IAB DU is based on the test applicability rules defined in clause 8.1.1.3.

The transient period as specified in TS 38.101-1 [16] and TS 38.101-2 [17] clause 6.3.3.1 is not taken into account for performance requirement testing, where the RB hopping is symmetric to the CC center, i.e. intra-slot frequency hopping is enabled.

8.1.3.3.1.2 Minimum Requirement

For *IAB type 1-O*, the minimum requirement is in TS 38.174 [2] clause 11.1.3.1.4.

For *IAB type 2-O*, the minimum requirement is in TS 38.174 [2] clause 11.1.3.2.4.

8.1.3.3.1.3 Test Purpose

The test shall verify the receiver's ability to detect ACK bits under multipath fading propagation conditions for a given SNR.

8.1.3.3.1.4 Method of test

8.1.3.3.1.4.1 Initial Conditions

Test environment: Normal, see clause B.2.

RF channels to be tested for single carrier;M; see clause 4.9.1.

Direction to be tested: OTA REFSENS *receiver target reference direction* (see D.54 in table.4.6-1).

8.1.3.3.1.4.2 Procedure

- 1) Place the IAB DU with its manufacturer declared coordinate system reference point in the same place as calibrated point in the test system, as shown in annex E.3.
- 2) Align the manufacturer declared coordinate system orientation of the IAB DU with the test system.
- 3) Set the IAB DU in the declared direction to be tested.
- 4) Connect the IAB DU tester generating the wanted signal, multipath fading simulators and AWGN generators to a test antenna via a combining network in OTA test setup, as shown in annex E.3. Each of the demodulation branch signals should be transmitted one polarization of the test antenna(s).
- 5) The characteristics of the wanted signal shall be configured according to TS 38.211 [7], and according to additional test parameters listed in table 8.1.3.3.1.4.2-1.

Table 8.1.3.3.1.4.2-1: Test parameters

Parameter	Value
Modulation order	QPSK
First PRB prior to frequency hopping	0
Intra-slot frequency hopping	N/A
First PRB after frequency hopping	The largest PRB index - (Number of PRBs-1)
Number of PRBs	4
Number of symbols	1
The number of UCI information bits	4
First symbol	13
DM-RS sequence generation	$N_{ID}^0=0$
Cyclic prefix	normal

- 6) The multipath fading emulators shall be configured according to the corresponding channel model defined in annex J.
- 7) Adjust the test signal mean power so the calibrated radiated SNR value at the IAB DU receiver is as specified in clause 8.1.3.3.1.5.1 and 8.1.3.3.1.5.2 for *IAB type 1-O* and *IAB type 2-O* respectively, and that the SNR at the IAB DU receiver is not impacted by the noise floor.

The power level for the transmission may be set such that the AWGN level at the RIB is equal to the AWGN level in table 8.1.3.3.1.4.2-2.

Table 8.1.3.3.1.4.2-2: AWGN power level at the BS input

IAB type	Sub-carrier spacing (kHz)	Channel bandwidth (MHz)	AWGN power level
IAB type 1-O	15 kHz	10	-80.3 - $\Delta_{OTAREFSENS}$ dBm / 9.36 MHz
		20	-77.2 - $\Delta_{OTAREFSENS}$ dBm / 19.08 MHz
	30 kHz	10	-80.6 - $\Delta_{OTAREFSENS}$ dBm / 8.64 MHz
		20	-77.4 - $\Delta_{OTAREFSENS}$ dBm / 18.36 MHz
		40	-74.2 - $\Delta_{OTAREFSENS}$ dBm / 38.16 MHz
		100	-70.1 - $\Delta_{OTAREFSENS}$ dBm / 98.28 MHz
IAB type 2-O	60 kHz	50	$EIS_{REFSENS_50M} + \Delta_{FR2_REFSENS} + 15$ dBm / 47.52MHz
		100	$EIS_{REFSENS_50M} + \Delta_{FR2_REFSENS} + 18$ dBm / 95.04 MHz
	120 kHz	50	$EIS_{REFSENS_50M} + \Delta_{FR2_REFSENS} + 15$ dBm / 46.08 MHz
		100	$EIS_{REFSENS_50M} + \Delta_{FR2_REFSENS} + 18$ dBm / 95.04 MHz
		200	$EIS_{REFSENS_50M} + \Delta_{FR2_REFSENS} + 21$ dBm / 190.08 MHz

NOTE 1: $\Delta_{OTAREFSENS}$ as declared in D.53 in table 4.6-1 and clause 7.1.
 NOTE 2: $\Delta_{FR2_REFSENS} = -3$ dB as declared in clause 7.1, since the OTA REFSENS receiver target reference direction (as declared in D.54 in table 4.6-1) is used for testing.
 NOTE 3: $EIS_{REFSENS_50M}$ as declared in D.28 in table 4.6-1.

8) The tester sends a test pattern with pattern outlined in figure 8.1.3.3.1.4.2-1. The following statistics are kept: the number of ACK bits detected in the idle periods and the number of missed ACKs.



Figure 8.1.3.3.1.4.2-1: Test signal pattern for PUCCH format 2 demodulation tests

8.1.3.3.1.5 Test Requirement

8.1.3.3.1.5.1 Test requirement for IAB type 1-O

The fraction of falsely detected ACKs shall be less than 1% and the fraction of correctly detected ACKs shall be larger than 99% for the SNR listed in table 8.1.3.3.1.5.1-1 and table 8.1.3.3.1.5.1-2.

Table 8.1.3.3.1.5.1-1: Required SNR for PUCCH format 2 with 15 kHz SCS

Number of TX antennas	Number of demodulation branches	Propagation conditions and correlation matrix (annex J)	Channel bandwidth / SNR (dB)	
			10 MHz	20 MHz
1	2	TDLC300-100 Low	6.2	6.5

Table 8.1.3.3.1.5.1-2: Required SNR for PUCCH format 2 with 30 kHz SCS

Number of TX antennas	Number of demodulation branches	Propagation conditions and correlation matrix (annex J)	Channel bandwidth/ SNR (dB)			
			10MHz	20MHz	40MHz	100MHz
1	2	TDLC300-100 Low	6.1	6.2	6.1	6.3

8.1.3.3.1.5.2 Test requirement for *IAB type 2-O*

The fraction of falsely detected ACKs shall be less than 1% and the fraction of correctly detected ACKs shall be larger than 99% for the SNR listed in table 8.1.3.3.1.5.2-1 and table 8.1.3.3.1.5.2.-2.

Table 8.1.3.3.1.5.2-1: Required SNR for PUCCH format 2 with 60 kHz SCS

Number of TX antennas	Number of demodulation branches	Propagation conditions and correlation matrix (annex J)	Channel bandwidth / SNR (dB)	
			50 MHz	100 MHz
1	2	TDLA30-300 Low	7.3	7.8

Table 8.1.3.3.1.5.2-2: Required SNR for PUCCH format 2 with 120 kHz SCS

Number of TX antennas	Number of demodulation branches	Propagation conditions and correlation matrix (annex J)	Channel bandwidth / SNR (dB)		
			50 MHz	100 MHz	200 MHz
1	2	TDLA30-300 Low	7.2	6.9	7.2

8.1.3.3.2 UCI BLER performance requirements

8.1.3.3.2.1 Definition and applicability

The UCI block error probability is defined as the probability of incorrectly decoding the UCI information when the UCI information is sent. The UCI information does not contain CSI part 2.

Which specific test(s) are applicable to IAB DU is based on the test applicability rules defined in clause 8.1.2.

The transient period as specified in TS 38.101-1 [16] and TS 38.101-2 [17] clause 6.3.3.1 is not taken into account for performance requirement testing, where the RB hopping is symmetric to the CC center, i.e. intra-slot frequency hopping is enabled.

8.1.3.3.2.2 Minimum Requirement

For *IAB type 1-O*, the minimum requirement is in TS 38.174 [2] clause 11.1.3.1.4.

For *IAB type 2-O*, the minimum requirement is in TS 38.174 [2] clause 11.1.3.2.4.

8.1.3.3.2.3 Test Purpose

The test shall verify the receiver's ability to detect UCI under multipath fading propagation conditions for a given SNR.

8.1.3.3.2.4 Method of test

8.1.3.3.2.4.1 Initial Conditions

Test environment: Normal, see clause B.2.

RF channels to be tested for single carrier: M ; see clause 4.9.1

Direction to be tested: OTA REFSENS *receiver target reference direction* (see D.54 in table 4.6-1).

8.1.3.3.2.4.2 Procedure

- 1) Place the IAB DU with its manufacturer declared coordinate system reference point in the same place as calibrated point in the test system, as shown in annex E.3.
- 2) Align the manufacturer declared coordinate system orientation of the IAB DU with the test system.

- 3) Set the IAB DU in the declared direction to be tested.
- 4) Connect the IAB DU tester generating the wanted signal, multipath fading simulators and AWGN generators to a test antenna via a combining network in OTA test setup, as shown in annex E.3. Each of the demodulation branches signals should be transmitted on each polarization of the test antenna(s).
- 5) The characteristics of the wanted signal shall be configured according to TS 38.211 [7], and according to additional test parameters listed in table 8.1.3.3.2.4.2-1.

Table 8.1.3.3.2.4.2-1: Test parameters

Parameter	Value
Modulation order	QPSK
First PRB prior to frequency hopping	0
Intra-slot frequency hopping	enabled
First PRB after frequency hopping	The largest PRB index - (Number of PRBs-1)
Number of PRBs	9
Number of symbols	2
The number of UCI information bits	22
First symbol	12
DM-RS sequence generation	$N_{ID}^0=0$
Cyclic prefix	normal

- 6) The multipath fading emulators shall be configured according to the corresponding channel model defined in annex J.
- 7) Adjust the test signal mean power so the calibrated radiated SNR value at the IAB DU receiver is as specified in clause 8.1.3.3.2.5.1 and 8.1.3.3.2.5.2 for *IAB type 1-O* and *IAB type 2-O* respectively, and that the SNR at the IAB DU receiver is not impacted by the noise floor.

The power level for the transmission may be set such that the AWGN level at the RIB is equal to the AWGN level in table 8.3.3.2.4.2-2.

Table 8.1.3.3.2.4.2-2: AWGN power level at the BS input

IAB type	Sub-carrier spacing (kHz)	Channel bandwidth (MHz)	AWGN power level
<i>IAB type 1-O</i>	15 kHz	10	$-80.3 - \Delta_{OTAREFSENS}$ dBm / 9.36 MHz
		20	$-77.2 - \Delta_{OTAREFSENS}$ dBm / 19.08 MHz
	30 kHz	10	$-80.6 - \Delta_{OTAREFSENS}$ dBm / 8.64 MHz
		20	$-77.4 - \Delta_{OTAREFSENS}$ dBm / 18.36 MHz
		40	$-74.2 - \Delta_{OTAREFSENS}$ dBm / 38.16 MHz
		100	$-70.1 - \Delta_{OTAREFSENS}$ dBm / 98.28 MHz
<i>IAB type 2-O</i>	60 kHz	50	$E_{ISREFSENS_50M} + \Delta_{FR2_REFSENS} + 15$ dBm / 47.52MHz
		100	$E_{ISREFSENS_50M} + \Delta_{FR2_REFSENS} + 18$ dBm / 95.04 MHz
	120 kHz	50	$E_{ISREFSENS_50M} + \Delta_{FR2_REFSENS} + 15$ dBm / 46.08 MHz
		100	$E_{ISREFSENS_50M} + \Delta_{FR2_REFSENS} + 18$ dBm / 95.04 MHz
		200	$E_{ISREFSENS_50M} + \Delta_{FR2_REFSENS} + 21$ dBm / 190.08 MHz
		NOTE 1: $\Delta_{OTAREFSENS}$ as declared in D.53 in table 4.6-1 and clause 7.1.	
NOTE 2: $\Delta_{FR2_REFSENS} = -3$ dB as declared in clause 7.1.			
NOTE 3: $E_{ISREFSENS_50M}$ as declared in D.28 in table 4.6-1.			

- 8) The tester sends a test pattern with the pattern outlined in figure 8.1.3.3.2.4.2-1. The following statistics are kept: the number of incorrectly decoded UCI.



Figure 8.1.3.3.2.4.2-1: Test signal pattern for PUCCH format 2 demodulation tests

8.1.3.3.2.5 Test Requirement

8.1.3.3.2.5.1 Test requirement for *IAB type 1-0*

The fraction of incorrectly decoded UCI is shall be less than 1% for the SNR listed in table 8.1.3.3.2.5.1-1 and table 8.1.3.3.2.5.1-2.

Table 8.1.3.3.2.5.1-1: Required SNR for PUCCH format 2 with 15 kHz SCS

Number of TX antennas	Number of demodulation branches	Propagation conditions and correlation matrix (annex J)	Channel bandwidth / SNR (dB)	
			10 MHz	20 MHz
1	2	TDLC300-100 Low	1.4	1.8

Table 8.1.3.3.2.5.1-2: Required SNR for PUCCH format 2 with 30 kHz SCS

Number of TX antennas	Number of demodulation branches	Propagation conditions and correlation matrix (annex J)	Channel bandwidth/ SNR (dB)			
			10MHz	20MHz	40MHz	100MHz
1	2	TDLC300-100 Low	1.1	1.7	1.0	0.9

8.1.3.3.2.5.2 Test requirement for *IAB type 2-0*

The fraction of incorrectly decoded UCI is shall be less than 1% for the SNR listed in table 8.1.3.3.2.5.2-1 and table 8.1.3.3.2.5.2-2.

Table 8.1.3.3.2.5.2-1: Required SNR for PUCCH format 2 with 60 kHz SCS

Number of TX antennas	Number of demodulation branches	Propagation conditions and correlation matrix (annex J)	Channel bandwidth / SNR (dB)	
			50 MHz	100 MHz
1	2	TDLA30-300 Low	3.2	1.7

Table 8.1.3.3.2.5.2-2: Required SNR for PUCCH format 2 with 120 kHz SCS

Number of TX antennas	Number of demodulation branches	Propagation conditions and correlation matrix (annex J)	Channel bandwidth / SNR (dB)		
			50 MHz	100 MHz	200 MHz
1	2	TDLA30-300 Low	1.8	1.8	1.7

8.1.3.4 Performance requirements for PUCCH format 3

8.1.3.4.1 Definition and applicability

The performance is measured by the required SNR at UCI block error probability not exceeding 1%.

The UCI block error probability is defined as the conditional probability of incorrectly decoding the UCI information when the UCI information is sent. The UCI information does not contain CSI part 2.

The transient period as specified in TS 38.101-1 [16] clause 6.3.3.1 and TS 38.101-2 [17] clause 6.3.3.1 is not taken into account for performance requirement testing, where the RB hopping is symmetric to the CC center, i.e. intra-slot frequency hopping is enabled.

Which specific test(s) are applicable to IAB DU is based on the test applicability rules defined in clause 8.1.1.3.

8.1.3.4.2 Minimum Requirement

For *IAB type 1-O*, the minimum requirement is in TS 38.174 [7], clause 11.1.3.1.5.

For *IAB type 2-O*, the minimum requirement is in TS 38.174 [7], clause 11.1.3.2.5.

8.1.3.4.3 Test Purpose

The test shall verify the receiver's ability to detect UCI under multipath fading propagation conditions for a given SNR.

8.1.3.4.4 Method of test

8.1.3.4.4.1 Initial Conditions

Test environment: Normal; see annex B.2.

RF channels to be tested for single carrier: M; see clause 4.9.1

Direction to be tested:

- OTA REFSENS *receiver target reference direction* (see D.54 in table 4.6-1).

8.1.3.4.4.2 Procedure

- 1) Place the IAB DU with its manufacturer declared coordinate system reference point in the same place as calibrated point in the test system, as shown in annex E.3.
- 2) Align the manufacturer declared coordinate system orientation of the IAB DU with the test system.
- 3) Set the IAB DU in the declared direction to be tested.
- 4) Connect the IAB DU tester generating the wanted signal, multipath fading simulators and AWGN generators to a test antenna via a combining network in OTA test setup, as shown in annex E.3. Each of the demodulation branch signals should be transmitted on one polarization of the test antenna(s).
- 5) The characteristics of the wanted signal shall be configured according to TS 38.211 [7], and according to additional test parameters listed in table 8.1.3.4.4.2-1.

Table 8.1.3.4.4.2-1: Test parameters

Parameter	Test 1	Test 2
Modulation order	QPSK	
Cyclic prefix	normal	
First PRB prior to frequency hopping	0	
Intra-slot frequency hopping	enabled	
First PRB after frequency hopping	The largest PRB index - (Number of PRBs - 1)	
Group and sequence hopping	neither	
Hopping ID	0	
Number of PRBs	1	3
Number of symbols	14	4
The number of UCI information bits	16	16
First symbol	0	0

- 6) The multipath fading emulators shall be configured according to the corresponding channel model defined in annex J.

- 7) Adjust the test signal mean power so the calibrated radiated SNR value at the IAB-DU receiver is as specified in clause 8.1.3.4.5.1 and 8.1.3.4.5.2 for *IAB type 1-O* and *IAB type 2-O* respectively, and the SNR at the IAB-DU receiver is not impacted by the noise floor.

The power level for the transmission may be set such that the AWGN level at the RIB is equal to the AWGN level in table 8.1.3.4.4.2-2.

Table 8.1.3.4.4.2-2: AWGN power level at the BS input

IAB type	Subcarrier spacing (kHz)	Channel bandwidth (MHz)	AWGN power level
<i>IAB type 1-O</i>	15	10	-80.3 - $\Delta_{OTAREFSENS}$ dBm / 9.36MHz
		20	-77.2 - $\Delta_{OTAREFSENS}$ dBm / 19.08MHz
	30	10	-80.6 - $\Delta_{OTAREFSENS}$ dBm / 8.64MHz
		20	-77.4 - $\Delta_{OTAREFSENS}$ dBm / 18.36MHz
		40	-74.2 - $\Delta_{OTAREFSENS}$ dBm / 38.16MHz
<i>IAB type 2-O</i>	60	50	$EIS_{REFSENS_50M} + \Delta_{FR2_REFSENS} + 15$ dBm/ 47.52MHz
		100	$EIS_{REFSENS_50M} + \Delta_{FR2_REFSENS} + 18$ dBm/ 95.04 MHz
	120	50	$EIS_{REFSENS_50M} + \Delta_{FR2_REFSENS} + 15$ dBm/ 46.08 MHz
		100	$EIS_{REFSENS_50M} + \Delta_{FR2_REFSENS} + 18$ dBm/ 95.04 MHz
		200	$EIS_{REFSENS_50M} + \Delta_{FR2_REFSENS} + 21$ dBm/ 190.08 MHz
NOTE 1: $\Delta_{OTAREFSENS}$ as declared in D.53 in table 4.6-1 and clause 7.1.			
NOTE 2: $\Delta_{FR2_REFSENS} = -3$ dB as described in clause 7.1, since the OTA REFSENS receiver target reference direction (as declared in D.54 in table 4.6-1) is used for testing.			
NOTE 3: $EIS_{REFSENS_50M}$ as declared in D.28 in table 4.6-1.			

8.1.3.4.5 Test Requirement

8.1.3.4.5.1 Test requirement for *IAB type 1-O*

The fraction of incorrectly decoded UCI is shall be less than 1% for the SNR listed in table 8.1.3.4.5.1-1 and table 8.1.3.4.5.1-2.

Table 8.1.3.4.5.1-1: Required SNR for PUCCH format 3 with 15 kHz SCS

Test Number	Number of TX antennas	Number of demodulation branches	Propagation conditions and correlation matrix (annex J)	Additional DM-RS configuration	Channel bandwidth / SNR (dB)	
					10 MHz	20 MHz
1	1	2	TDLC300-100 Low	No additional DM-RS	1.7	0.9
				Additional DM-RS	1.1	0.5
2	1	2	TDLC300-100 Low	No additional DM-RS	2.8	2.6

Table 8.1.3.4.5.1-2: Required SNR for PUCCH format 3 with 30 kHz SCS

Test Number	Number of TX antennas	Number of demodulation branches	Propagation conditions and correlation matrix (annex J)	Additional DM-RS configuration	Channel bandwidth / SNR (dB)			
					10 MHz	20 MHz	40 MHz	100 MHz
1	1	2	TDLC300-100 Low	No additional DM-RS	1.5	1.2	1.2	1.5
				Additional DM-RS	1.1	0.9	0.6	0.7
2	1	2	TDLC300-100 Low	No additional DM-RS	2.4	2.6	2.6	2.1

8.1.3.4.5.2 Test requirement for IAB type 2-O

The fraction of incorrectly decoded UCI is shall be less than 1% for the SNR listed in table 8.1.3.4.5.2-1 and table 8.1.3.4.5.2-2.

Table 8.1.3.4.5.2-1: Required SNR for PUCCH format 3 with 60 kHz SCS

Test Number	Number of TX antennas	Number of demodulation branches	Propagation conditions and correlation matrix (annex J)	Additional DM-RS configuration	Channel bandwidth / SNR (dB)	
					50 MHz	100 MHz
1	1	2	TDLA30-300 Low	No additional DM-RS	2.2	1.3
				Additional DM-RS	1.9	1.5
2	1	2	TDLA30-300 Low	No additional DM-RS	3.6	3.0

Table 8.1.3.4.5.2-2: Required SNR for PUCCH format 3 with 120 kHz SCS

Test Number	Number of TX antennas	Number of demodulation branches	Propagation conditions and correlation matrix (annex J)	Additional DM-RS configuration	Channel bandwidth / SNR (dB)		
					50 MHz	100 MHz	200 MHz
1	1	2	TDLA30-300 Low	No additional DM-RS	2.0	1.3	1.3
				Additional DM-RS	1.9	2.0	1.5
2	1	2	TDLA30-300 Low	No additional DM-RS	1.7	3.5	2.0

8.1.3.5 Performance requirements for PUCCH format 4

8.1.3.5.1 Definition and applicability

The performance is measured by the required SNR at UCI block error probability not exceeding 1%.

The UCI block error probability is defined as the conditional probability of incorrectly decoding the UCI information when the UCI information is sent. The UCI information does not contain CSI part 2.

The transient period as specified in TS 38.101-1 [16] and TS 38.101-2 [17] clause 6.3.3.1 is not taken into account for performance requirement testing, where the RB hopping is symmetric to the CC center, i.e. intra-slot frequency hopping is enabled.

Which specific test(s) are applicable to BS is based on the test applicability rules defined in clause 8.1.1.3.3.

8.1.3.5.2 Minimum Requirement

For *IAB type 1-O*, the minimum requirement is in TS 38.174 [2], clause 11.1.3.1.6.

For *IAB type 2-O*, the minimum requirement is in TS 38.174 [2], clause 11.1.3.2.6.

8.1.3.5.3 Test Purpose

The test shall verify the receiver's ability to detect UCI under multipath fading propagation conditions for a given SNR.

8.1.3.5.4 Method of test

8.1.3.5.4.1 Initial Conditions

Test environment: Normal; see annex B.2.

RF channels to be tested for single carrier: M; see clause 4.9.1

Direction to be tested:

- OTA REFSSENS *receiver target reference direction* (see D.54 in table 4.6-1).

8.1.3.5.4.2 Procedure

- 1) Place the IAB DU with its manufacturer declared coordinate system reference point in the same place as calibrated point in the test system, as shown in annex E.3.
- 2) Align the manufacturer declared coordinate system orientation of the IAB DU with the test system.
- 3) Set the IAB DU in the declared direction to be tested.
- 4) Connect the IAB DU tester generating the wanted signal, multipath fading simulators and AWGN generators to a test antenna via a combining network in OTA test setup, as shown in annex E.3. Each of the demodulation branch signals should be transmitted on one polarization of the test antenna(s).
- 5) The characteristics of the wanted signal shall be configured according to TS 38.211 [7], and according to additional test parameters listed in table 8.1.3.4.4.2-1.

Table 8.1.3.5.4.2-1: Test parameters

Parameter	Value
Modulation order	QPSK
Cyclic prefix	normal
First PRB prior to frequency hopping	0
Number of PRBs	1
Intra-slot frequency hopping	enabled
First PRB after frequency hopping	The largest PRB index - (Number of PRBs - 1)
Group and sequence hopping	neither
Hopping ID	0
Number of symbols	14
The number of UCI information bits	22
First symbol	0
Length of the orthogonal cover code	n2
Index of the orthogonal cover code	n0

- 6) The multipath fading emulators shall be configured according to the corresponding channel model defined in annex J.
- 7) Adjust the test signal mean power so the calibrated radiated SNR value at the IAB DU receiver is as specified in clause 8.1.3.5.5.1 and 8.1.3.5.5.2 for *IAB type 1-O* and *IAB type 2-O* respectively, and that the SNR at the IAB DU receiver is not impacted by the noise floor.

The power level for the transmission may be set such that the AWGN level at the RIB is equal to the AWGN level in table 8.1.3.5.4.2-2.

Table 8.1.3.5.4.2-2: AWGN power level at the BS input

IAB type	Subcarrier spacing (kHz)	Channel bandwidth (MHz)	AWGN power level
<i>IAB type 1-0</i>	15	10	-80.3 - $\Delta_{\text{OTAREFSSENS}}$ dBm / 9.36MHz
		20	-77.2 - $\Delta_{\text{OTAREFSSENS}}$ dBm / 19.08MHz
	30	10	-80.6 - $\Delta_{\text{OTAREFSSENS}}$ dBm / 8.64MHz
		20	-77.4 - $\Delta_{\text{OTAREFSSENS}}$ dBm / 18.36MHz
		40	-74.2 - $\Delta_{\text{OTAREFSSENS}}$ dBm / 38.16MHz
		100	-70.1 - $\Delta_{\text{OTAREFSSENS}}$ dBm / 98.28MHz
<i>IAB type 2-0</i>	60	50	$\text{EIS}_{\text{REFSENS_50M}} + \Delta_{\text{FR2_REFSENS}} + 15$ dBm/ 47.52 MHz
		100	$\text{EIS}_{\text{REFSENS_50M}} + \Delta_{\text{FR2_REFSENS}} + 18$ dBm/ 95.04 MHz
	120	50	$\text{EIS}_{\text{REFSENS_50M}} + \Delta_{\text{FR2_REFSENS}} + 15$ dBm/ 46.08 MHz
		100	$\text{EIS}_{\text{REFSENS_50M}} + \Delta_{\text{FR2_REFSENS}} + 18$ dBm/ 95.04 MHz
		200	$\text{EIS}_{\text{REFSENS_50M}} + \Delta_{\text{FR2_REFSENS}} + 21$ dBm/ 190.08 MHz
		NOTE 1: $\Delta_{\text{OTAREFSSENS}}$ as declared in D.53 in table 4.6-1 and clause 7.1.	
NOTE 2: $\Delta_{\text{FR2_REFSENS}} = -3$ dB as described in clause 7.1, since the OTA REFSSENS receiver target reference direction (as declared in D.54 in table 4.6-1) is used for testing.			
NOTE 3: $\text{EIS}_{\text{REFSENS_50M}}$ as declared in D.28 in table 4.6-1.			

8.1.3.5.5 Test Requirement

8.1.3.5.5.1 Test requirement for *IAB type 1-0*

The fraction of incorrectly decoded UCI is shall be less than 1% for the SNR listed in table 8.1.3.5.5.1-1 and table 8.1.3.5.5.1-2.

Table 8.1.3.5.5.1-1: Required SNR for PUCCH format 4 with 15 kHz SCS

Number of TX antennas	Number of demodulation branches	Propagation conditions and correlation matrix (annex J)	Additional DM-RS configuration	Channel bandwidth / SNR (dB)	
				10 MHz	20 MHz
1	2	TDLC300-100 Low	No additional DM-RS	3.2	2.8
			Additional DM-RS	3.0	2.4

Table 8.1.3.5.5.1-2: Required SNR for PUCCH format 4 with 30 kHz SCS

Number of TX antennas	Number of demodulation branches	Propagation conditions and correlation matrix (annex J)	Additional DM-RS configuration	Channel bandwidth / SNR (dB)			
				10 MHz	20 MHz	40 MHz	100 MHz
1	2	TDLC300-100 Low	No additional DM-RS	3.7	3.4	3.7	3.4
			Additional DM-RS	3.4	2.9	3.7	2.8

8.1.3.5.5.2 Test requirement for *IAB type 2-0*

The fraction of incorrectly decoded UCI is shall be less than 1% for the SNR listed in table 8.1.3.5.5.2-1 and table 8.1.3.5.5.2-2.

Table 8.1.3.5.5.2-1: Required SNR for PUCCH format 4 with 60 kHz SCS

Number of TX antennas	Number of demodulation branches	Propagation conditions and correlation matrix (annex J)	Additional DM-RS configuration	Channel bandwidth / SNR (dB)	
				50 MHz	100 MHz
1	2	TDLA30-300 Low	No additional DM-RS	3.6	3.3
			Additional DM-RS	3.7	4.1

Table 8.1.3.5.5.2-2: Required SNR for PUCCH format 4 with 120 kHz SCS

Number of TX antennas	Number of demodulation branches	Propagation conditions and correlation matrix (annex J)	Additional DM-RS configuration	Channel bandwidth / SNR (dB)		
				50 MHz	100 MHz	200MHz
1	2	TDLA30-300 Low	No additional DM-RS	3.4	3.4	4.1
			Additional DM-RS	4.2	4.4	3.8

8.1.3.6 Performance requirements for multi-slot PUCCH

8.1.3.6.1 Performance requirements for multi-slot PUCCH format 1

8.1.3.6.1.1 NACK to ACK detection

8.1.3.6.1.1.1 Definition and applicability

The performance requirement of PUCCH format 1 for NACK to ACK detection is determined by the two parameters: probability of false detection of the ACK and the NACK to ACK detection probability. The performance is measured by the required SNR at probability of the NACK to ACK detection equal to 0.1% or less. The probability of false detection of the ACK shall be 0.01 or less.

The probability of false detection of the ACK is defined as a conditional probability of erroneous detection of the ACK at particular bit position when input is only noise. Each false bit detection is counted as one error.

The NACK to ACK detection probability is the probability of detecting an ACK bit when an NACK bit was sent on particular bit position. Each NACK bit erroneously detected as ACK bit is counted as one error. Erroneously detected NACK bits in the definition do not contain the NACK bits which are mapped from DTX, i.e. NACK bits received when DTX is sent should not be considered.

Which specific test(s) are applicable to IAB DU is based on the test applicability rules defined in clause 8.1.1.3.3.

8.1.3.6.1.1.2 Minimum Requirement

For *IAB type 1-O*, the minimum requirement is in TS 38.174 [2], clause 11.1.3.1.7.

8.1.3.6.1.1.3 Test Purpose

8.1.3.6.1.1.4 Method of test

The test shall verify the receiver's ability not to falsely detect NACK bits as ACK bits under multipath fading propagation conditions for a given SNR.

8.1.3.6.1.1.4.1 Initial Conditions

Test environment: Normal; see annex B.2.

RF channels to be tested for single carrier: M; see clause 4.9.1

Direction to be tested: OTA REFSENS *receiver target reference direction* (D.54).

8.1.3.6.1.1.4.2 Procedure

- 1) Place the IAB DU with its manufacturer declared coordinate system reference point in the same place as calibrated point in the test system, as shown in annex E.3.
- 2) Align the manufacturer declared coordinate system orientation of the IAB DU with the test system.
- 3) Set the IAB DU in the declared direction to be tested.
- 4) Connect the IAB DU tester generating the wanted signal, multipath fading simulators and AWGN generators to a test antenna via a combining network in OTA test setup, as shown in annex E.3. Each of the demodulation branch signals should be transmitted on one polarization of the test antenna(s).
- 5) The characteristics of the wanted signal shall be configured according to TS 38.211 [7], and according to additional test parameters listed in table 8.1.3.6.1.1.4.2-1.

Table 8.1.3.6.1.1.4.2-1: Test Parameters for multi-slot PUCCH format 1

Parameter	Test
Number of information bits	2
Number of PRBs	1
Number of symbols	14
First PRB prior to frequency hopping	0
Intra-slot frequency hopping	disabled
Inter-slot frequency hopping	enabled
First PRB after frequency hopping	The largest PRB index - (nrOfPRBs - 1)
Group and sequence hopping	neither
Hopping ID	0
Initial cyclic shift	0
First symbol	0
Index of orthogonal cover code (<i>timeDomainOCC</i>)	0
Number of slots for PUCCH repetition	2
Cyclic prefix	normal

- 6) The multipath fading emulators shall be configured according to the corresponding channel model defined in annex J.
- 7) Adjust the test signal mean power so the calibrated radiated SNR value at the IAB DU receiver is as specified in clause 8.1.3.6.1.1.5.1 for *IAB type 1-O*, and that the SNR at the IAB DU receiver is not impacted by the noise floor.

The power level for the transmission may be set such that the AWGN level at the RIB is equal to the AWGN level in table 8.1.3.6.1.1.4.2-2.

Table 8.1.3.6.1.1.4.2-2: AWGN power level at the BS input

IAB type	Subcarrier spacing (kHz)	Channel bandwidth (MHz)	AWGN power level
<i>IAB type 1-O</i>	15 kHz	10	-80.3 - $\Delta_{\text{OTAREFSENS}}$ dBm / 9.36 MHz
		20	-77.2 - $\Delta_{\text{OTAREFSENS}}$ dBm / 19.08 MHz
	30 kHz	10	-80.6 - $\Delta_{\text{OTAREFSENS}}$ dBm / 8.64 MHz
		20	-77.4 - $\Delta_{\text{OTAREFSENS}}$ dBm / 18.36 MHz
		40	-74.2 - $\Delta_{\text{OTAREFSENS}}$ dBm / 38.16 MHz
		100	-70.1 - $\Delta_{\text{OTAREFSENS}}$ dBm / 98.28 MHz
NOTE: $\Delta_{\text{OTAREFSENS}}$ as declared in D.53 in table 4.6-1 and clause 7.1.			

- 8) The tester sends random codeword from applicable codebook, in regular time periods. The following statistics are kept: the number of ACK bits detected in the idle periods and the number of NACK bits detected as ACK.

8.1.3.6.1.1.5 Test Requirement

8.1.3.6.1.1.5.1 Test requirement for *IAB type 1-O*

The fraction of falsely detected ACK bits shall be less than 1% and the fraction of NACK bits falsely detected as ACK shall be less than 0.1% for the SNR listed in table 8.1.3.6.1.1.5.1-1.

Table 8.1.3.6.1.1.5.1-1: Required SNR for multi-slot PUCCH format 1 with 30 kHz SCS

Number of TX antennas	Number of RX antennas	Propagation conditions and correlation matrix (Annex J)	Channel bandwidth (MHz) / SNR (dB)
			40 MHz
1	2	TDLC-300-100 Low	-5.7

8.1.3.6.1.2 ACK missed detection

8.1.3.6.1.2.1 Definition and applicability

The performance requirement of PUCCH format 1 for ACK missed detection is determined by the two parameters: probability of false detection of the ACK and the probability of detection of ACK. The performance is measured by the required SNR at probability of detection equal to 0.99. The probability of false detection of the ACK shall be 0.01 or less.

The probability of false detection of the ACK is defined as a conditional probability of erroneous detection of the ACK when input is only noise.

The probability of detection of ACK is defined as conditional probability of detection of the ACK when the signal is present.

8.1.3.6.1.2.2 Minimum Requirement

For *IAB type 1-O*, the minimum requirement is in TS 38.174 [2], clause 11.1.3.1.7.

8.1.3.6.1.2.3 Test Purpose

The test shall verify the receiver's ability to detect ACK bits under multipath fading propagation conditions for a given SNR.

8.1.3.6.1.2.4 Method of test

8.1.3.6.1.2.4.1 Initial Conditions

Test environment: Normal; see annex B.2.

RF channels to be tested for single carrier (SC): M; see clause 4.9.1

Direction to be tested: OTA REFSSENS *receiver target reference direction* (D.54).

8.1.3.6.1.2.4.2 Procedure

- 1) Place the IAB DU with its manufacturer declared coordinate system reference point in the same place as calibrated point in the test system, as shown in annex E.3.
- 2) Align the manufacturer declared coordinate system orientation of the IAB DU with the test system.
- 3) Set the IAB DU in the declared direction to be tested.
- 4) Connect the IAB DU tester generating the wanted signal, multipath fading simulators and AWGN generators to a test antenna via a combining network in OTA test setup, as shown in annex E.3. Each of the demodulation branch signals should be transmitted on one polarization of the test antenna(s).

- 5) The characteristics of the wanted signal shall be configured according to TS 38.211 [7], and according to additional test parameters listed in table 8.1.3.6.1.2.4.2-1.

Table 8.1.3.6.1.2.4.2-1: Test Parameters for multi-slot PUCCH format 1

Parameter	Test
Number of information bits	2
Number of PRBs	1
Number of symbols	14
First PRB prior to frequency hopping	0
Intra-slot frequency hopping	disabled
Inter-slot frequency hopping	enabled
First PRB after frequency hopping	The largest PRB index - (nrofPRBs - 1)
Group and sequence hopping	neither
Hopping ID	0
Initial cyclic shift	0
First symbol	0
Index of orthogonal cover code (<i>timeDomainOCC</i>)	0
Number of slots for PUCCH repetition	2
Cyclic prefix	normal

- 6) The multipath fading emulators shall be configured according to the corresponding channel model defined in annex J.
- 7) Adjust the test signal mean power so the calibrated radiated SNR value at the IAB DU receiver is as specified in clause 8.1.3.6.1.2.5.1 for *IAB type 1-O*, and that the SNR at the IAB DU receiver is not impacted by the noise floor.

The power level for the transmission may be set such that the AWGN level at the RIB is equal to the AWGN level in table 8.1.3.6.1.2.4.2-2.

Table 8.1.3.6.1.2.4.2-2: AWGN power level at the BS input

IAB type	Subcarrier spacing (kHz)	Channel bandwidth (MHz)	AWGN power level
<i>IAB type 1-O</i>	15 kHz	10	-80.3 - $\Delta_{OTAREFSENS}$ dBm / 9.36 MHz
		20	-77.2 - $\Delta_{OTAREFSENS}$ dBm / 19.08 MHz
	30 kHz	10	-80.6 - $\Delta_{OTAREFSENS}$ dBm / 8.64 MHz
		20	-77.4 - $\Delta_{OTAREFSENS}$ dBm / 18.36 MHz
		40	-74.2 - $\Delta_{OTAREFSENS}$ dBm / 38.16 MHz
		100	-70.1 - $\Delta_{OTAREFSENS}$ dBm / 98.28 MHz

NOTE: $\Delta_{OTAREFSENS}$ as declared in D.53 in table 4.6-1 and clause 7.1.

- 8) The tester sends a test pattern with the pattern outlined in figure 8.1.3.6.1.2.4.2-1. The following statistics are kept: the number of ACKs detected in the idle periods and the number of missed ACKs.



Figure 8.1.3.6.1.2.4.2-1: Test signal pattern for PUCCH format 1 demodulation tests

8.1.3.6.1.2.5 Test Requirement

8.1.3.6.1.2.5.1 Test requirement for *IAB type 1-O*

The fraction of falsely detected ACK bits shall be less than 1% and the fraction of correctly detected ACK bits shall be larger than 99% for the SNR listed in table 8.1.3.6.1.2.5.1-1.

Table 8.1.3.6.1.2.5.1-1: Required SNR for multi-slot PUCCH format 1 with 30 kHz SCS

Number of TX antennas	Number of RX antennas	Propagation conditions and correlation matrix (Annex G)	Channel bandwidth (MHz) / SNR (dB)
			40 MHz
1	2	TDLC-300-100 Low	-7.0

8.1.4 Performance requirements for PRACH

8.1.4.1 PRACH false alarm probability and missed detection

8.1.4.1.1 Definition and applicability

The performance requirement of PRACH for preamble detection is determined by the two parameters: total probability of false detection of the preamble (P_{fa}) and the probability of detection of preamble (P_d). The performance is measured by the required SNR at probability of detection, P_d of 99%. P_{fa} shall be 0.1% or less.

P_{fa} is defined as a conditional total probability of erroneous detection of the preamble (i.e. erroneous detection from any detector) when input is only noise.

P_d is defined as conditional probability of detection of the preamble when the signal is present. The erroneous detection consists of several error cases – detecting only different preamble(s) than the one that was sent, not detecting any preamble at all, or detecting the correct preamble but with the out-of-bounds timing estimation value. For AWGN, TDLC300-100 and TDLA30-300, a timing estimation error occurs if the estimation error of the timing of the strongest path is larger than the time error tolerance values given in table 8.1.4.1.1-1.

Table 8.1.4.1.1-1: Time error tolerance for AWGN, TDLC300-100 and TDLA30-300

PRACH preamble	PRACH SCS (kHz)	Time error tolerance		
		AWGN	TDLC300-100	TDLA30-300
0	1.25	1.04 us	2.55 us	N/A
A1, A2, A3, B4, C0, C2	15	0.52 us	2.03 us	N/A
	30	0.26 us	1.77 us	N/A
	60 (FR2)	0.13 us	N/A	0.28 us
	120	0.07 us	N/A	0.22 us

The test preambles for normal mode are listed in table A.2.5-1 and A.2.5-2.

Which specific test(s) are applicable to BS is based on the test applicability rules defined in clause 8.1.1.3.4.

8.1.4.1.2 Minimum requirement

For *IAB type 1-O*, the minimum requirement is in TS 38.174 [2] clause 11.1.4.1.1 and 11.1.4.1.2.

For *IAB type 2-O*, the minimum requirement is in TS 38.174 [2] clause 11.1.4.2.1 and 11.1.4.2.2.

8.1.4.1.3 Test purpose

The test shall verify the receiver's ability to detect PRACH preamble under static conditions and multipath fading propagation conditions for a given SNR.

8.1.4.1.4 Method of test

8.1.4.1.4.1 Initial conditions

Test environment: Normal, see clause B.2.

RF channels to be tested: for single carrier: M; see clause 4.9.1.

Direction to be tested: OTA REFSENS receiver target reference direction (see D.54 in table 4.6-1).

8.1.4.1.4.2 Procedure

- 1) Place the IAB DU with its manufacturer declared coordinate system reference point in the same place as calibrated point in the test system, as shown in annex E.3.
- 2) Align the manufacturer declared coordinate system orientation of the IAB DU with the test system.
- 3) Set the IAB DU in the declared direction to be tested.
- 4) Connect the IAB DU tester generating the wanted signal, multipath fading simulators and AWGN generators to a test antenna via a combining network in OTA test setup, as shown in annex E.3. Each of the demodulation branch signals should be transmitted on one polarization of the test antenna(s).
- 5) The characteristics of the wanted signal shall be configured according to the corresponding UL reference measurement channel defined in annex A and the test parameter *msg1-FrequencyStart* is set to 0.
- 6) The multipath fading emulators shall be configured according to the corresponding channel model defined in annex J.
- 7) Adjust the AWGN generator, according to the SCS and channel bandwidth. The power level for the transmission may be set such that the AWGN level at the RIB is equal to the AWGN level in table 8.1.4.1.4.2-1.

Table 8.1.4.1.4.2-1: AWGN power level at the BS input

IAB type	Sub-carrier spacing (kHz)	Channel bandwidth (MHz)	AWGN power level
IAB type 1-O	15	10	-80.3 - $\Delta_{OTAREFSENS}$ dBm / 9.36MHz
		20	-77.2 - $\Delta_{OTAREFSENS}$ dBm / 19.08MHz
	30	10	-80.6 - $\Delta_{OTAREFSENS}$ dBm / 8.64MHz
		20	-77.4 - $\Delta_{OTAREFSENS}$ dBm / 18.36MHz
		40	-74.2 - $\Delta_{OTAREFSENS}$ dBm / 38.16MHz
		100	-70.1 - $\Delta_{OTAREFSENS}$ dBm / 98.28MHz
IAB type 2-O	60	50	$EIS_{REFSENS_50M} + \Delta_{FR2_REFSENS} + 15$ dBm / 47.52 MHz
		100	$EIS_{REFSENS_50M} + \Delta_{FR2_REFSENS} + 18$ dBm / 95.04 MHz
	120	50	$EIS_{REFSENS_50M} + \Delta_{FR2_REFSENS} + 15$ dBm / 46.08 MHz
		100	$EIS_{REFSENS_50M} + \Delta_{FR2_REFSENS} + 18$ dBm / 95.04 MHz
		200	$EIS_{REFSENS_50M} + \Delta_{FR2_REFSENS} + 21$ dBm / 190.08 MHz
		NOTE 1: $\Delta_{OTAREFSENS}$ as declared in D.53 in table 4.6-1 and clause 7.1.	
NOTE 2: $\Delta_{FR2_REFSENS} = -3$ dB as described in clause 7.1, since the OTA REFSENS receiver target reference direction (as declared in D.54 in table 4.6-1) is used for testing.			
NOTE 3: $EIS_{REFSENS_50M}$ as declared in D.28 in table 4.6-1.			

- 8) Adjust the frequency offset of the test signal according to table 8.1.4.1.5.1-1 or 8.1.4.1.5.1-2 or 8.1.4.1.5.1-3 or 8.1.4.1.6.1-1 or 8.1.4.1.6.1-2 or 8.1.4.1.6.1-3 or 8.1.4.1.6.1-4 or 8.1.4.1.5.2-1 or 8.1.4.1.5.2-2.
- 9) Adjust the equipment so that the SNR specified in table 8.1.4.1.5.1-1 or 8.1.4.1.5.1-2 or 8.1.4.1.5.1-3 or 8.1.4.1.6.1-1 or 8.1.4.1.6.1-2 or 8.1.4.1.6.1-3 or 8.1.4.1.6.1-4 or 8.1.4.1.5.2-1 or 8.1.4.1.5.2-2 is achieved at the BS input during the PRACH preambles.
- 10) The test signal generator sends a preamble and the receiver tries to detect the preamble. This pattern is repeated as illustrated in figure 8.1.4.1.4.2-1. The preambles are sent with certain timing offsets as described below. The following statistics are kept: the number of preambles detected in the idle period and the number of missed preambles.



Figure 8.1.4.1.4.2-1: PRACH preamble test pattern

The timing offset base value for PRACH preamble format 0 is set to 50% of Ncs. This offset is increased within the loop, by adding in each step a value of 0.1us, until the end of the tested range, which is 0.9us. Then the loop is being reset and the timing offset is set again to 50% of Ncs. The timing offset scheme for PRACH preamble format 0 is presented in Figure 8.1.4.1.4.2-2.

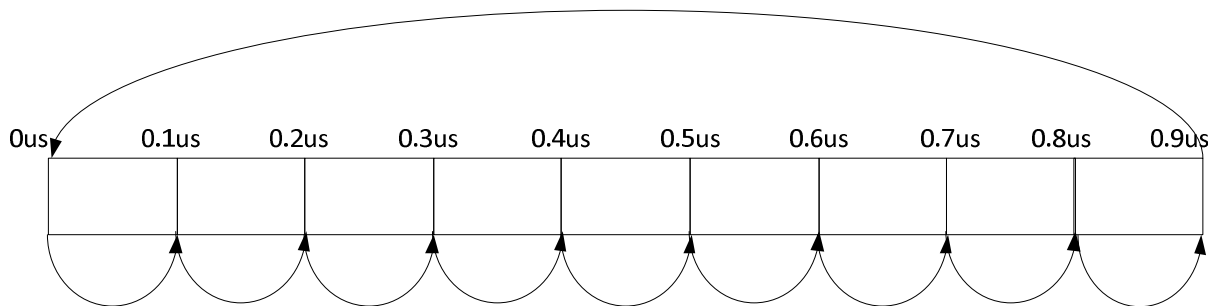

Figure 8.1.4.1.4.2-2: Timing offset scheme for PRACH preamble format 0

The timing offset base value for PRACH preamble format A1, A2, A3, B4, C0 and C2 is set to 0. This offset is increased within the loop, by adding in each step a value of 0.1us, until the end of the tested range, which is 0.8us. Then the loop is being reset and the timing offset is set again to 0. The timing offset scheme for PRACH preamble format A1, A2, A3, B4, C0 and C2 is presented in Figure 8.1.4.1.4.2-3.

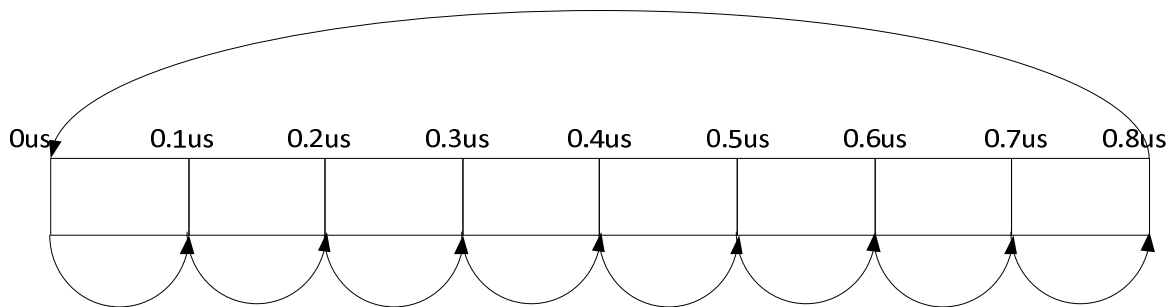

Figure 8.1.4.1.4.2-3: Timing offset scheme for PRACH preamble format A1, A2, A3, B4, C0 and C2

8.1.4.1.5 Test requirement for Normal Mode

8.1.4.1.5.1 Test requirement for IAB type 1-0

Pfa shall not exceed 0.1%. Pd shall not be below 99% for the SNRs in tables 8.1.4.1.5.1-1 to 8.1.4.1.5.1-3.

Table 8.1.4.1.5.1-1: PRACH missed detection test requirements for Normal Mode, 1.25 kHz SCS

Number of TX antennas	Number of demodulation branches	Propagation conditions and correlation matrix (annex J)	Frequency offset	SNR (dB)
				Burst format 0
1	2	AWGN	0	-14.2
		TDLC300-100 Low	400 Hz	-6.0

Table 8.1.4.1.5.1-2: PRACH missed detection test requirements for Normal Mode, 15 kHz SCS

Number of TX antennas	Number of demodulation branches	Propagation conditions and correlation matrix (annex J)	Frequency offset	SNR (dB)					
				Burst format A1	Burst format A2	Burst format A3	Burst format B4	Burst format C0	Burst format C2
1	2	AWGN	0	-9.0	-12.3	-13.9	-16.5	-6.0	-12.2
		TDL300-100 Low	400 Hz	-1.5	-4.2	-6.0	-8.2	1.4	-4.3

Table 8.1.4.1.5.1-3: PRACH missed detection test requirements for Normal Mode, 30 kHz SCS

Number of TX antennas	Number of demodulation branches	Propagation conditions and correlation matrix (annex J)	Frequency offset	SNR (dB)					
				Burst format A1	Burst format A2	Burst format A3	Burst format B4	Burst format C0	Burst format C2
1	2	AWGN	0	-8.8	-11.7	-13.5	-16.2	-5.8	-11.6
		TDL300-100 Low	400 Hz	-2.2	-5.1	-6.8	-9.3	0.7	-5.0

8.1.4.1.5.2 Test requirement for IAB type 2-0

P_{fa} shall not exceed 0.1%. P_d shall not be below 99% for the SNRs in tables 8.1.4.1.5.2-1 to 8.1.4.1.5.2-2.

Table 8.1.4.1.5.2-1: PRACH missed detection test requirements for Normal Mode, 60 kHz SCS

Number of TX antennas	Number of demodulation branches	Propagation conditions and correlation matrix (annex J)	Frequency offset	SNR (dB)					
				Burst format A1	Burst format A2	Burst format A3	Burst format B4	Burst format C0	Burst format C2
1	2	AWGN	0	-8.6	-11.6	-13.2	-15.5	-5.7	-11.5
		TDLA30-300 Low	4000 Hz	-1.0	-3.2	-4.2	-6.3	1.7	-3.3

Table 8.1.4.1.5.2-2: PRACH missed detection test requirements for Normal Mode, 120 kHz SCS

Number of TX antennas	Number of demodulation branches	Propagation conditions and correlation matrix (annex J)	Frequency offset	SNR (dB)					
				Burst format A1	Burst format A2	Burst format A3	Burst format B4	Burst format C0	Burst format C2
1	2	AWGN	0	-8.4	-11.2	-13.0	-15.5	-5.5	-11.1
		TDLA30-300 Low	4000 Hz	-1.1	-3.8	-5.2	-6.9	1.8	-3.6

8.2 IAB-MT performance requirements

8.2.1 General

8.2.1.1 Scope and definitions

Radiated performance requirements specify the ability of the *IAB-MT type 1-0* and *IAB-MT type 2-0* to correctly demodulate signals in various conditions and configurations. Radiated performance requirements are specified at the RIB.

Radiated performance requirements for the IAB-MT are specified for the fixed reference channels defined in annex A and the propagation conditions in annex J. The requirements only apply to those FRCs that are supported by the IAB-MT.

The radiated performance requirements for *IAB-MT type 1-O* and for *IAB-MT type 2-O* are limited to two OTA *demodulation branches* as described in clause 8.1.1.2. Conformance requirements can only be tested for 1 or 2 *demodulation branches* depending on the number of polarizations supported by the IAB-MT, with the required SNR applied separately per polarization.

NOTE: IAB-MT can support more than 2 *demodulation branches*, however OTA conformance testing can only be performed for 1 or 2 *demodulation branches*.

The SNR used in this clause is specified based on a single carrier and defined as:

$$\text{SNR} = S / N$$

Where:

S is the total signal energy in the slot on a single *TAB connector* (for *IAB-MT type 1-H*).

N is the noise energy in a bandwidth corresponding to the transmission bandwidth over the duration of a slot on a single *TAB connector* (for *IAB-MT type 1-H*).

8.2.2 Demodulation performance requirements

8.2.2.1 General

8.2.2.1.1 Applicability rule for IAB-MT

8.2.2.1.1.1 General

Unless otherwise stated, for an IAB-MT declared to support more than 2 demodulation branches (for *IAB-MT type 1-O* and *IAB-MT type 2-O*), the performance requirement tests for 2 demodulation branches shall apply, and the mapping between connectors and demodulation branches is up to IAB-MT implementation.

The tests requiring more than [20] dB SNR level are set to N/A in the test requirements.

8.2.2.1.1.2 Applicability of requirements for different subcarrier spacings

Unless otherwise stated, the tests shall apply only for each subcarrier spacing declared to be supported (see D.7 in table 4.6-1).

8.2.2.1.1.3 Applicability of requirements for TDD with different UL-DL patterns

Unless otherwise stated, for each subcarrier spacing declared to be supported, if IAB-MT supports multiple TDD UL-DL patterns, only one of the supported TDD UL-DL patterns shall be used for all tests.

8.2.2.1.1.4 Applicability of requirements for IAB-MT features

Unless otherwise stated, for *IAB type 1-O*, the PDSCH 256QAM tests (Test 1-1 of Clause 8.2.2.5.1) shall apply only for the 256QAM for PDSCH for FR1 declared to be supported (see D.200 in table 4.6-1, *pdsch-256QAM-FR1*).

Unless otherwise stated, for both *IAB type 1-O* and *IAB type 2-O*, the PDSCH tests shall apply only in case the PDSCH MIMO rank in the test case does not exceed the maximum number of PDSCH MIMO layers declared to be supported (see D.202 in table 4.6-1, *maxNumberMIMO-LayersPDSCH*).

Unless otherwise stated, for *IAB type 2-O*, the PDSCH tests shall apply only for the PT-RS option declared to be supported (see D.203 in table 4.6-1, *onePortsPTRS* (MSB)).

Note: Applicability information may be obtained based on vendor declaration (Section 4.6) or alternatively from reading capability signaling.

8.2.2.2 Performance requirements for PDSCH

8.2.2.2.1 Definition and applicability

The performance requirement of PDSCH is determined by a minimum required throughput for a given SNR. The required throughput is expressed as a fraction of maximum throughput for the FRCs listed in annex A. The performance requirements assume HARQ re-transmissions.

Which specific test(s) are applicable to IAB-MT is based on the test applicability rules defined in clause 8.2.2.1.1.

8.2.2.2.2 Minimum requirements

For *IAB type 1-O*, the minimum requirement is in TS 38.174 [2], clause 11.2.2.1.1.

For *IAB type 2-O*, the minimum requirement is in TS 38.174 [2], clause 11.2.2.2.1.

8.2.2.2.3 Test purpose

The test shall verify the receiver's ability to achieve throughput under multipath fading propagation conditions for a given SNR.

8.2.2.2.4 Method of test

8.2.2.2.4.1 Initial conditions

Test environment: Normal, see annex B.2.

RF channels to be tested for single carrier: M, see clause 4.9.1.

RF channels to be tested for carrier aggregation: $M_{\text{BW Channel CA}}$; see clause 4.9.1.

Direction to be tested: OTA REFSENS *receiver target reference direction* (see D.54 in table 4.6-1).

8.2.2.2.4.2 Test procedure

- 1) Place the IAB-MT with its manufacturer declared coordinate system reference point in the same place as calibrated point in the test system, as shown in annex E.3.
- 2) Align the manufacturer declared coordinate system orientation of the IAB-MT with the test system.
- 3) Set the IAB-MT in the declared direction to be tested.
- 4) Connect the IAB-MT tester generating the wanted signal, multipath fading simulators and AWGN generators to a test antenna via a combining network in OTA test setup, as shown in annex E.3. Each of the demodulation branch signals should be transmitted on one polarization of the test antenna(s).
- 5) The characteristics of the wanted signal shall be configured according to the corresponding DL reference measurement channel defined in annex A, and according to additional test parameters listed in table 8.2.2.2.4.2-1.

Table: 8.2.2.4.2-1 Test parameters for testing PDSCH

Parameter		IAB type 1-O	IAB type 2-O
Cyclic prefix		Normal	Normal
Default TDD UL-DL pattern (Note)		7D1S2U, S=6D:4G:4U	3D1S1U, S=10D:2G:2U
HARQ	Maximum number of HARQ transmissions	4	4
	RV sequence	0, 2, 3, 1	0, 2, 3, 1
DM-RS	DM-RS configuration type	1	1
	DM-RS duration	single-symbol DM-RS	single-symbol DM-RS
	DM-RS position (l_0)	2	2
	Additional DM-RS position	pos1	pos1
	Number of DM-RS CDM group(s) without data	1 for Rank 1 and Rank 2 tests 2 for Rank 3 and Rank 4 tests	1
	DM-RS port(s)	{1000} for Rank 1 tests {1000-1001} for Rank 2 tests {1000-1002} for Rank 3 tests {1000-1003} for Rank 4 tests	{1000} for Rank 1 tests {1000-1001} for Rank 2 tests
	DM-RS sequence generation	NID0=0	NID0=0
Time domain resource assignment	PDSCH mapping type	A	A
	Start symbol	2	1
	Allocation length	12	13
Frequency domain resource assignment	RB assignment	Full applicable test bandwidth	Full applicable test bandwidth
PT-RS configuration	Frequency density (K_{PT-RS})	Not configured	2
	Time density (L_{PT-RS})		1
PRB bundling size		2	2
VRB-to-PRB mapping type		Not interleaved	Not interleaved
PDSCH & PDSCH DMRS Precoding configuration		Single Panel Type I, Random precoder selection updated per slot, with equal probability of each applicable i_1, i_2 combination, and with PRB bundling granularity	Single Panel Type I, Random precoder selection updated per slot, with equal probability of each applicable i_1, i_2 combination, and with PRB bundling granularity
NOTE: The same requirements are applicable to TDD with different UL-DL patterns.			

- 6) The multipath fading emulators shall be configured according to the corresponding channel model defined in annex J.
- 7) Adjust the test signal mean power so the calibrated radiated SNR value at the IAB-MT receiver is as specified in clause 8.2.2.2.5.1 and 8.2.2.2.5.2 for *IAB type 1-O* and *IAB type 2-O* respectively, and that the SNR at the IAB receiver is not impacted by the noise floor.

The power level for the transmission may be set such that the AWGN level at the RIB is equal to the AWGN level in table 8.2.2.4.2-2.

Table 8.2.2.4.2-2: AWGN power level at the IAB-MT input

IAB type	Sub-carrier spacing (kHz)	Channel bandwidth (MHz)	AWGN power level
IAB type 1-O	30	40	-77.2 - $\Delta_{\text{OTAREFSENS}}$ dBm / 38.16 MHz
IAB type 2-O	60	50	$E_{\text{ISREFSENS}_{50\text{M}}} + \Delta_{\text{FR2_REFSENS}} + 15$ dBm / 47.52 MHz
	120	100	$E_{\text{ISREFSENS}_{50\text{M}}} + \Delta_{\text{FR2_REFSENS}} + 18$ dBm / 95.04 MHz

NOTE 1: $\Delta_{\text{OTAREFSENS}}$ as declared in D.53 in table 4.6-1 and clause 7.1.
NOTE 2: $\Delta_{\text{FR2_REFSENS}} = -3$ dB as described in clause 7.1, since the OTA REFSENS reference direction (as declared in D.54 in table 4.6-1) is used for testing.
NOTE 3: $E_{\text{ISREFSENS}_{50\text{M}}}$ as declared in D.28 in table 4.6-1.

8) For reference channels applicable to the IAB, measure the throughput.

8.2.2.2.5 Test requirements

8.2.2.2.5.1 Test requirement for IAB type 1-O

The throughput shall be equal to or larger than the fraction of maximum throughput for the FRCs stated in Tables 8.2.2.2.5.1-1 and 8.2.2.2.5.1-2 at the given SNR with the test parameters stated in Table 8.2.2.4.2-1.

Table 8.2.2.2.5.1-1: Minimum requirements for PDSCH Type A with Rank 1

Test number	FRC (Annex A)	Bandwidth (MHz) / Subcarrier spacing (kHz)	Propagation conditions (Annex J)	Antenna configuration	Fraction of maximum throughput (%)	SNR (dB)
1-1	M-FR1-A.3.3-1	40/30	TDLA30-10	2x2, ULA Low	70	26.3
1-2	M-FR1-A.3.1-1	40/30	TDLA30-10	2x2, ULA Low	30	3.2

Table 8.2.2.2.5.1-2: Minimum requirements for PDSCH Type A with Rank 2

Test number	FRC (Annex A)	Bandwidth (MHz) / Subcarrier spacing (kHz)	Propagation conditions (Annex J)	Antenna configuration	Fraction of maximum throughput (%)	SNR (dB)
2-1	M-FR1-A.3.2-1	40/30	TDLA30-10	2x2, ULA Low	70	20.8

8.2.2.2.5.2 Test requirement for IAB type 2-O

The throughput shall be equal to or larger than the fraction of maximum throughput for the FRCs stated in Tables 8.2.2.2.5.2-1 and 8.2.2.2.5.2-2 at the given SNR with the test parameters stated in Table 8.2.2.4.2-1.

Table 8.2.2.2.5.2-1: Minimum requirements for PDSCH Type A with Rank 1

Test number	FRC (Annex A)	Bandwidth (MHz) / Subcarrier spacing (kHz)	Propagation conditions (Annex J)	Antenna configuration	Fraction of maximum throughput (%)	SNR (dB)
1-1	M-FR2-A.3.1-1	100/120	TDLA30-75	2x2, ULA Low	30	4.1
1-2	M-FR2-A.3.2-1	100/120	TDLA30-75	2x2, ULA Low	70	13.5

Table 8.2.2.5.2-2: Minimum requirements for PDSCH Type A with Rank 2

Test number	FRC (Annex A)	Bandwidth (MHz) / Subcarrier spacing (kHz)	Propagation conditions (Annex J)	Antenna configuration	Fraction of maximum throughput (%)	SNR (dB)
2-1	M-FR2-A.3.1-2	100/120	TDLA30-75	2x2, ULA Low	70	15.9
2-2	M-FR2-A.3.1-3	50/60	TDLA30-75	2x2, ULA Low	70	16.0
2-3	M-FR2-A.3.2-2	100/120	TDLA30-75	2x2, ULA Low	70	20.3

8.2.2.3 Demodulation performance requirements for PDCCH

8.2.2.3.1 Definition and applicability

The receiver characteristics of the PDCCH are determined by the probability of miss-detection of the Downlink Scheduling Grant (Pm-dsg).

Which specific test(s) are applicable to IAB-MT is based on the test applicability rules defined in clause 8.2.2.1.1.

8.2.2.3.2 Minimum requirement

For *IAB type 1-O*, the minimum requirement is in TS 38.174 [2], clause 11.2.2.1.2.

For *IAB type 2-O*, the minimum requirement is in TS 38.174 [2], clause 11.2.2.2.2.

8.2.2.3.3 Test purpose

The test shall verify the receiver's ability to detect the Downlink Scheduling Grant (Pm-dsg) under multipath fading propagation conditions for a given SNR.

8.2.2.3.4 Method of test

8.2.2.3.4.1 Initial conditions

Test environment: Normal, see annex B.2.

RF channels to be tested for single carrier: M, see clause 4.9.1.

RF channels to be tested for carrier aggregation: $M_{\text{BW Channel CA}}$; see clause 4.9.1.

Direction to be tested: OTA REFSSENS *receiver target reference direction* (see D.54 in table 4.6-1).

8.2.2.3.4.2 Test procedure

- 1) Place the IAB-MT with its manufacturer declared coordinate system reference point in the same place as calibrated point in the test system, as shown in annex E.3.
- 2) Align the manufacturer declared coordinate system orientation of the IAB-MT with the test system.
- 3) Set the IAB-MT in the declared direction to be tested.
- 4) Connect the IAB-MT tester generating the wanted signal, multipath fading simulators and AWGN generators to a test antenna via a combining network in OTA test setup, as shown in annex E.3. Each of the demodulation branch signals should be transmitted on one polarization of the test antenna(s).
- 5) The characteristics of the wanted signal shall be configured according to the corresponding DL reference measurement channel defined in annex A, and according to additional test parameters listed in table 8.2.2.3.4.2-1.

Table: 8.2.2.3.4.2-1 Test parameters for testing PDSCH

Parameter	<i>IAB type 1-O</i>	<i>IAB-type 2-O</i>
Cyclic prefix	Normal	Normal
Default TDD UL-DL pattern (Note)	7D1S2U, S=6D:4G:4U	3D1S1U, S=10D:2G:2U
DM-RS sequence generation	NID=0	NID=0
Frequency domain resource allocation for CORESET	Start from RB = 0 with contiguous RB allocation	Start from RB = 0 with contiguous RB allocation
CCE to REG mapping type	Interleaved	Interleaved
Interleaver size	3	3 for test with aggregation level 2, 8 2 for test with aggregation level 4
REG bundle size	2 for test with aggregation level 2, 4 6 for test with aggregation level 8	2 for test with aggregation level 2, 8 6 for test with aggregation level 4
Shift Index	0	0
Slots for PDCCH monitoring	Each slot	Each slot
Number of PDCCH candidates for the tested aggregation level	1	1
PDCCH Precoding configuration	Single Panel Type I, Random precoder selection updated per slot, with equal probability of each applicable i_1, i_2 combination with REG bundling granularity for number of Tx larger than 1	Single Panel Type I, Random precoder selection updated per slot, with equal probability of each applicable i_1, i_2 combination with REG bundling granularity for number of Tx larger than 1
NOTE: The same requirements are applicable to TDD with different UL-DL patterns.		

- 6) The multipath fading emulators shall be configured according to the corresponding channel model defined in annex J.
- 7) Adjust the test signal mean power so the calibrated radiated SNR value at the IAB-MT receiver is as specified in clause 8.2.2.3.5.1 and 8.2.2.3.5.2 for *IAB type 1-O* and *IAB type 2-O* respectively, and that the SNR at the IAB receiver is not impacted by the noise floor.

The power level for the transmission may be set such that the AWGN level at the RIB is equal to the AWGN level in table 8.2.2.3.4.2-2.

Table 8.2.2.3.4.2-2: AWGN power level at the IAB-MT input

IAB type	Sub-carrier spacing (kHz)	Channel bandwidth (MHz)	AWGN power level
IAB type 1-O	30	40	$-77.2 - \Delta_{\text{OTAREFSENS}}$ dBm / 38.16 MHz
IAB type 2-O	60	50	$\text{EIS}_{\text{REFSENS}_{50\text{M}}} + \Delta_{\text{FR2_REFSENS}} + 15$ dBm / 47.52 MHz
	120	100	$\text{EIS}_{\text{REFSENS}_{50\text{M}}} + \Delta_{\text{FR2_REFSENS}} + 18$ dBm / 95.04 MHz
NOTE 1: $\Delta_{\text{OTAREFSENS}}$ as declared in D.53 in table 4.6-1 and clause 7.1.			
NOTE 2: $\Delta_{\text{FR2_REFSENS}} = -3$ dB as described in clause 7.1, since the OTA REFSENS reference direction (as declared in D.54 in table 4.6-1) is used for testing.			
NOTE 3: $\text{EIS}_{\text{REFSENS}_{50\text{M}}}$ as declared in D.28 in table 4.6-1.			

- 8) For reference channels applicable to the IAB, measure the miss-detection of the Downlink Scheduling Grant (Pm-dsg).

8.2.2.3.5 Test requirements

8.2.2.3.5.1 Test requirement for *IAB type 1-O*

The Pm-dsg shall be equal to or smaller than 1%, for the cases stated in Table 8.2.2.3.5.1-1 at the given SNR with the test parameters stated in Table 8.2.2.3.4.2-1.

Table 8.2.2.3.5.1-1: Minimum requirements for PDCCH

Test number	Bandwidth (MHz) / Subcarrier spacing (kHz)	CORESET RB	CORESET duration	Aggregation level	FRC (Annex A)	Propagation conditions (Annex J)	Antenna configuration	Pm-dsg (%)	SNR (dB)
1	40/30	102	1	2	M-FR1-A.3.4-1	TDLA30-10	1x2, ULA Low	1	7.9
2	40/30	102	1	4	M-FR1-A.3.4-1	TDLA30-10	1x2, ULA Low	1	5.8
3	40/30	90	1	8	M-FR1-A.3.4-1	TDLA30-10	2x2, ULA Low	1	0.3

8.2.2.3.5.2 Test requirement for IAB type 2-O

The Pm-dsg shall be equal to or smaller than 1%, for the cases stated in Table 8.2.2.3.5.2-1 at the given SNR with the test parameters stated in Table 8.2.2.3.4.2-1.

Table 8.2.2.3.5.2-1: Minimum requirements for PDCCH

Test number	Bandwidth (MHz) / Subcarrier spacing (kHz)	CORESET RB	CORESET duration	Aggregation level	FRC (Annex A)	Propagation conditions (Annex J)	Antenna configuration	Pm-dsg (%)	SNR (dB)
1	100/120	60	1	2	M-FR2-A.3.4-1	TDLA30-75	1x2, ULA Low	1	8.1
2	100/120	60	1	4	M-FR2-A.3.4-2	TDLA30-75	1x2, ULA Low	1	4.6
3	100/120	60	1	8	M-FR2-A.3.4-3	TDLA30-75	2x2, ULA Low	1	1.9

8.2.3 CSI reporting requirements

8.2.3.1 General

8.2.3.1.1 Applicability of requirements

8.2.3.1.1.1 General

Unless otherwise stated, for a IAB-MT declared to support more than 2 demodulation branches (for *IAB-MT type 1-O* and *IAB-MT type 2-O*), the performance requirement tests for 2 demodulation branches shall apply, and the mapping between connectors and demodulation branches is up to IAB-MT implementation.

The tests requiring more than [20] dB SNR level are set to N/A in the test requirements.

8.2.3.1.1.2 Applicability of requirements for different subcarrier spacings

Unless otherwise stated, the tests shall apply only for each subcarrier spacing declared to be supported (see D.7 in table 4.6-1).

8.2.3.1.1.3 Applicability of requirements for TDD with different UL-DL patterns

Unless otherwise stated, for each subcarrier spacing declared to be supported, if IAB-MT supports multiple TDD UL-DL patterns, only one of the supported TDD UL-DL patterns shall be used for all tests.

8.2.3.1.1.4 Applicability of PMI/RI requirements

Testing of performance requirements for RI and PMI reporting is optional.

8.2.3.1.1.5 Applicability of requirements for IAB-MT features

Unless otherwise stated, for *IAB type 1-O*, the CSI reporting tests (clauses 8.2.3.3, 8.2.3.4) shall apply only in case the number of NZP-CSI-RS ports in the test case satisfies maximum number of ports across all configured NZP-CSI-RS resources per CC declared to be supported (see D.201 in table 4.6-1, *maxConfigNumberPortsAcrossNZP-CSI-RS-PerCC*).

Unless otherwise stated, for *IAB type 1-O*, the CSI reporting tests (clauses 8.2.3.2, 8.2.3.3, 8.2.3.4) shall apply only in case the PDSCH MIMO rank in the test case does not exceed the maximum number of PDSCH MIMO layers declared to be supported (see D.202 in table 4.6-1, *maxNumberMIMO-LayersPDSCH*).

Unless otherwise stated, for *IAB type 2-O*, the CSI reporting tests (clauses 8.2.3.2, 8.2.3.3, 8.2.3.4) shall apply only for the PT-RS option declared to be supported (see D.203 in table 4.6-1, *onePortPTRS*).

NOTE: Applicability information may be obtained based on vendor declaration (Section 4.6) or alternatively from reading capability signaling.

8.2.3.1.2 Common test parameters

Parameters specified in Table 8.2.3.1.2-1 are applied for all test cases in this clause unless otherwise stated.

Table 8.2.3.1.2-1: Test parameters for CSI test cases

Parameter		Unit	Value FR1	Value FR2
PDSCH transmission scheme			Transmission scheme 1	Transmission scheme 1
Duplex mode			TDD	TDD
PTRS epre-Ratio			N/A	0
Actual carrier configuration	Offset between Point A and the lowest usable subcarrier on this carrier (Note 3)	RBs	0	0
	Subcarrier spacing	kHz	30	120
DL BWP configuration #1	Cyclic prefix		Normal	Normal
	RB offset	RBs	0	0
	Number of contiguous PRB	PRBs	106	66
Active DL BWP index			1	1
PDSCH configuration	Mapping type		Type A	Type A
	k0		0	0
	Starting symbol (S)		2	2
	Length (L)		12	12
	PDSCH aggregation factor		1	1
	PRB bundling type		Static	Static
	PRB bundling size		2	2
	Resource allocation type		Type 0	type 0
	RBG size			Config 2
PDSCH DMRS configuration	DMRS Type		Type 1	Type 1
	Number of additional DMRS		1	1
PTRS configuration	Maximum number of OFDM symbols for DL front loaded DMRS		1	1
	DMRS ports indexes		{1000}	{1000}
	Number of PDSCH DMRS CDM group(s) without data		2	2
N/ZP CSI-RS for CSI acquisition	Frequency density (K_{PT-RS})		N/A	2
	Time density (L_{PT-RS})		N/A	1
	Resource Element Offset		N/A	2
Redundancy version coding sequence			Start PRB 0 Number of PRB = BWP size	Start PRB 0 Number of PRB = BWP size
			{0,2,3,1}	{0,2,3,1}

NOTE 1: PDSCH is not scheduled on slots containing CSI-RS or slots which are not full DL.
NOTE 2: Point A coincides with minimum guard band as specified in Table 5.3.3-1 from TS 38.101-1 [16] or 38.101-2 [17] for tested channel bandwidth and subcarrier spacing.

8.2.3.2 Reporting of Channel Quality Indicator (CQI)

8.2.3.2.1 Definition and applicability

The performance requirement of CSI reporting is determined by the reporting variance and the BLER performance using the transport format indicated by the reported CQI. The purpose is to verify that the reported CQI values are in accordance with the CQI definition given in TS 38.214 [27]. To account for sensitivity of the input SNR the reporting definition is considered to be verified if the reporting accuracy is met for at least one of two SNR levels separated by an offset of 1 dB.

8.2.3.2.2 Minimum requirement

The minimum requirement for *IAB-MT type 1-O* is in TS 38.174 [2] clause 11.2.3.1.1

The minimum requirement for *IAB-MT type 2-O* is in TS 38.174 [2] clause 11.2.3.2.2.

8.2.3.2.3 Test purpose

The test shall verify the receiver's ability to report correct median CQI and expected BLER performance under AWGN conditions.

8.2.3.2.4 Method of test

8.2.3.2.4.1 Initial conditions

Test environment: Normal, see annex B.2.

RF channels to be tested for single carrier: M ; see clause 4.9.1.

RF channels to be tested for carrier aggregation: $M_{\text{BW Channel CA}}$; see clause 4.9.1.

Direction to be tested: OTA REFSSENS *receiver target reference direction* (see D.54 in table 4.6-1).

8.2.3.2.4.2 Procedure

- 1) Place the IAB-MT with its manufacturer declared coordinate system reference point in the same place as calibrated point in the test system, as shown in annex E.3.
- 2) Align the manufacturer declared coordinate system orientation of the IAB-MT with the test system.
- 3) Set the IAB-MT in the declared direction to be tested.
- 4) Connect the IAB-MT tester generating the wanted signal and AWGN generators to a test antenna via a combining network in OTA test setup, as shown in annex E.3. Each of the demodulation branch signals should be transmitted on one polarization of the test antenna(s).
- 5) The characteristics of the wanted signal shall be configured according to the corresponding DL reference measurement channel defined in annex A, and according to additional test parameters listed in table 8.2.3.2.4.2-2 or 8.2.3.2.4.2-2.

Table 8.2.3.2.4.2-1: Test parameters for testing CQI reporting requirements for FR1

Parameter		Unit	Test 1	Test 2
Bandwidth		MHz	40	
Subcarrier spacing		kHz	30	
Duplex Mode			TDD	
SNR		dB	8	9
Propagation channel			14	15
Antenna configuration			AWGN	
Beamforming Model			2x2 with static channel specified in Annex J.1	
NZIP CSI-RS for CSI acquisition	CSI-RS resource Type		As specified in Annex J.3.1	
	Number of CSI-RS ports (X)		Periodic	
	CDM Type		2	
	Density (ρ)		FD-CDM2	
	First subcarrier index in the PRB used for CSI-RS (k_0, k_1)		1	
	First OFDM symbol in the PRB used for CSI-RS (l_0)		Row 3,(6,-)	
	NZIP CSI-RS-timeConfig periodicity and offset	slot	13	
CSI-IM configuration	NZIP CSI-RS-timeConfig periodicity and offset	slot	10/1	
	CSI-IM resource Type		Periodic	
	CSI-IM RE pattern		0	
	CSI-IM Resource Mapping (k_{CSI-IM}, l_{CSI-IM})		(4, 9)	
CSI-IM timeConfig periodicity and offset	slot	10/1		
ReportConfigType		Periodic		
CQI-table		Table 2		
reportQuantity		cri-RI-PMI-CQI		
cqi-FormatIndicator		Wideband		
pmi-FormatIndicator		Wideband		
Sub-band Size	RB	16		
Csi-ReportingBand		1111111		
CSI-Report periodicity and offset	slot	10/9		
Codebook configuration	Codebook Type		type1-SinglePanel	
	Codebook Mode		1	
	(CodebookConfig-N1, CodebookConfig-N2)		Not configured	
	CodebookSubsetRestriction		010000	
RI Restriction		N/A		
CQI/RI/PMI delay	ms	9.5		
Maximum number of HARQ transmission		1		
Measurement channel		As specified in Table A.2.6-1, M-FR1-A.3.5-1		

Table 8.2.3.2.4.2-2: Test parameters for testing CQI reporting requirements for FR2

Parameter		Unit	Test 1	Test 2
Bandwidth		MHz	100	
Subcarrier spacing		kHz	120	
Duplex Mode			TDD	
SNR _{BB}		dB	8	9 14 15
Propagation channel			AWGN	
Antenna configuration			2x2 with static channel specified in Annex J.1	
Beamforming Model			As specified in Annex J.3.1	
NXP CSI-RS for CSI acquisition	CSI-RS resource Type		Periodic	
	Number of CSI-RS ports (X)		2	
	CDM Type		fd-CDM2	
	Density (ρ)		1	
	First subcarrier index in the PRB used for CSI-RS (k ₀ , k ₁)		6	
	First OFDM symbol in the PRB used for CSI-RS (l ₀ , l ₁)		13	
	NXP CSI-RS-timeConfig periodicity and offset	slot	8/1	
CSI-IM configuration	CSI-IM resource Type		Periodic	
	CSI-IM RE pattern		1	
	CSI-IM Resource Mapping (k _{CSI-IM} , l _{CSI-IM})		(8, 13)	
	CSI-IM timeConfig periodicity and offset	slot	8/1	
ReportConfigType		Periodic		
CQI-table		Table 1		
reportQuantity		cri-RI-PMI-CQI		
timeRestrictionForChannelMeasurements		Not configured		
timeRestrictionForInterferenceMeasurements		Not configured		
cqi-FormatIndicator		Wideband		
pmi-FormatIndicator		Wideband		
Sub-band Size	RB	8		
csi-ReportingBand		11111111		
CSI-Report periodicity and offset	slot	8/3		
Codebook configuration	Codebook Type		type1-SinglePanel	
	Codebook Mode		1	
	(CodebookConfig-N1, CodebookConfig-N2)		Not configured	
	CodebookSubsetRestriction		010000	
RI Restriction		N/A		
CQI/RI/PMI delay	ms	8.375		
Maximum number of HARQ transmission		1		
Measurement channel		As specified in Table A.2.6-3, M-FR2-A.3.5-2		

- 7) Adjust the test signal mean power so the calibrated radiated SNR value at the IAB-MT receiver is as specified in clause 8.2.3.2.5.1 and 8.2.3.2.5.2 for *IAB type 1-O* and *IAB type 2-O* respectively, and that the SNR at the IAB-MT receiver is not impacted by the noise floor.

The power level for the transmission may be set such that the AWGN level at the RIB is equal to the AWGN level in table 8.2.3.2.4.2-2.

Table 8.2.3.2.4.2-2: AWGN power level at the IAB-MT input

BS type	Sub-carrier spacing (kHz)	Channel bandwidth (MHz)	AWGN power level
IAB-MT type 1-O	30	40	-77.2 - $\Delta_{OTAREFSENS}$ dBm / 38.16 MHz
IAB-MT type 2-O	120	100	$EIS_{REFSENS_50M} + \Delta_{FR2_REFSENS} + 18$ dBm / 95.04 MHz
NOTE 1: $\Delta_{OTAREFSENS}$ as declared in D.53 in table 4.6-1 and clause 7.1.			
NOTE 2: $\Delta_{FR2_REFSENS} = -3$ dB as described in clause 7.1, since the OTA REFSSENS reference direction (as declared in D.54 in table 4.6-1) is used for testing.			
NOTE 3: $EIS_{REFSENS_50M}$ as declared in D.28 in table 4.6-1.			

- 8) For reference channels applicable to the IAB-MT, measure the median CQI and the BLER at (median CQI +1) and (median CQI -1).

8.2.3.2.5 Test requirement

8.2.3.2.5.1 Test requirement for IAB type 1-O

For the parameters specified in Table 8.2.3.2.4.2-1, the minimum requirements are specified by the following:

- The reported CQI value according to the reference channel shall be in the range of ± 1 of the reported median more than 90% of the time.
- If the PDSCH BLER using the transport format indicated by median CQI is less than or equal to 0.1, then the BLER using the transport format indicated by the (median CQI+1) shall be greater than 0.1. If the PDSCH BLER using the transport format indicated by the median CQI is greater than 0.1, then the BLER using transport format indicated by (median CQI-1) shall be less than or equal to 0.1.

8.2.3.2.5.2 Test requirement for IAB type 2-O

For the parameters specified in Table 8.2.3.2.4.2-2, the minimum requirements are specified by the following:

- the reported CQI value shall be in the range of ± 1 of the reported median more than 90% of the time;
- if the PDSCH BLER using the transport format indicated by median CQI is less than or equal to 0.1, the BLER using the transport format indicated by the (median CQI + 1) shall be greater than 0.1. If the PDSCH BLER using the transport format indicated by the median CQI is greater than 0.1, the BLER using transport format indicated by (median CQI - 1) shall be less than or equal to 0.1.

8.2.3.3 Reporting of Precoding Matrix Information (PMI)

8.2.3.3.1 Definition and applicability

The minimum performance requirements of PMI reporting are defined based on the precoding gain, expressed as the relative increase in throughput when the transmitter is configured according to the IAB-MT reported PMI compared to the case when the transmitter is using random precoding, respectively. When the transmitter uses random precoding, for each PDSCH allocation a precoder is randomly generated with equal probability of each applicable i_1 and i_2 combination and applied to the PDSCH. A fixed transport format (FRC) is configured for all requirements.

The requirements for transmission mode 1 with higher layer parameter *codebookType* set to 'typeI-SinglePanel' are specified in terms of the ratio:

$$\gamma = \frac{t_{ue, follow 1, follow 2}}{t_{rnd1, rnd2}}$$

In the definition of γ , for 4TX, 8TX PMI requirements, $t_{follow1, follow2}$ is 90 % of the maximum throughput obtained at $SNR_{follow1, follow2}$ using the precoders configured according to the IAB-MT reports, and $t_{md1, md2}$ is the throughput measured at $SNR_{follow1, follow2}$ with random precoding.

8.2.3.3.2 Minimum requirement

The minimum requirement for *IAB-MT type 1-O* is in TS 38.174 [2] clause 11.2.3.1.2.

The minimum requirement for *IAB-MT type 2-O* is in TS 38.174 [2] clause 11.2.3.2.3.

8.2.3.3.3 Test purpose

The test shall verify the receiver's ability to report correct PMI under the defined fading conditions.

8.2.3.3.4 Method of test

8.2.3.3.4.1 Initial conditions

Test environment: Normal, see annex B.2.

RF channels to be tested for single carrier: M; see clause 4.9.1.

RF channels to be tested for carrier aggregation: $M_{BW Channel CA}$; see clause 4.9.1.

Direction to be tested: OTA REFSENS *receiver target reference direction* (see D.54 in table 4.6-1).

8.2.3.3.4.2 Procedure

- 1) Place the IAB-MT with its manufacturer declared coordinate system reference point in the same place as calibrated point in the test system, as shown in annex E.3.
- 2) Align the manufacturer declared coordinate system orientation of the IAB-MT with the test system.
- 3) Set the IAB-MT in the declared direction to be tested.
- 4) Connect the IAB-MT tester generating the wanted signal and AWGN generators to a test antenna via a combining network in OTA test setup, as shown in annex E.3. Each of the demodulation branch signals should be transmitted on one polarization of the test antenna(s).
- 5) The characteristics of the wanted signal shall be configured according to the corresponding DL reference measurement channel defined in annex A, and according to additional test parameters listed in table 8.2.3.3.4.2-1.

Table 8.2.3.3.4.2-1: Test parameters for testing PMI reporting requirements

Parameter		Unit	FR1	FR2
Bandwidth		MHz	40	100
Subcarrier spacing		kHz	30	120
Duplex Mode			TDD	TDD
TDD DL-UL configuration			7D1S2U, S=6D:4G:4U	3D1S1U, S=10D:2G:2U
Propagation channel			TDLA30-5	TDLA30-35
Antenna configuration			High XP 4 x 2 (N1,N2) = (2,1) High XP 8 x 2 (N1,N2) = (4,1)	2 x 2 ULA Low
Beamforming Model			As specified in Annex J.3.1	As specified in Annex J.3.1
NXP CSI-RS for CSI acquisition	CSI-RS resource Type		Periodic	
	Number of CSI-RS ports (X)		Test for 4 TX ports: 4 Test for 8 TX ports: 8	2
	CDM Type		Test for 4 TX ports: FD- CDM2 Test for 8 TX ports: CDM4 (FD2, TD2)	FD-CDM2
	Density (ρ)		1	1
	First subcarrier index in the PRB used for CSI-RS (k_0, k_1)		Test for 4 TX ports: Row 4 (0,-) Test for 8 TX ports: Row 8, (4,6)	Row 3, (6,-)
	First OFDM symbol in the PRB used for CSI-RS (l_0, l_1)		Test for 4 TX ports, 2RX: (13,-) Test for 8 TX ports: (5,-)	(13,-)
	CSI-RS interval and offset	Slot	10/1	8/1
ReportConfigType			Periodic	Periodic
Sub-band Size		RB	16	8
csi-ReportingBand			1111111	111111111
CSI-Report periodicity and offset		slot	10/9	8/3
pmi-FormatIndicator			Wideband	Wideband
Codebook configuration	Codebook Type		type1-SinglePanel	type1-SinglePanel
	Codebook Mode		1	1
	(CodebookConfig-N1, CodebookConfig-N2)		Test for 4 TX ports: (2,1) Test for 8 TX ports: (4,1)	NA
	(CodebookConfig-O1, CodebookConfig-O2)		Test for 4 TX ports: (4,1) Test for 8 TX ports: (4,1)	NA
	CodebookSubsetRestriction		Test for 4 TX ports: 11111111 Test for 8 TX ports: 0x FFFF	001111
RI Restriction		Test for 4 TX ports: 00000001 Test for 8 TX ports: 00000010	NA	
Maximum number of HARQ transmission			4	4
CQI/RI/PMI delay		ms	5.5	1.375
Measurement channel			Test for 4 TX ports: M- FR1-A.3.5-1 Test for 8 TX ports: M- FR1-A.3.5-2	M-FR2-A.3.5-3

Parameter	Unit	FR1	FR2
NOTE 1: The same requirements are applicable for TDD with different UL-DL pattern.			
NOTE 2: When Throughput is measured using random precoder selection, the precoder shall be updated in each slot (0.5 ms FR1 / 0.125 ms FR2 granularity) with equal probability of each applicable i_1, i_2 combination.			
NOTE 3: If the IAB-MT reports in an available uplink reporting instance at slot #n based on PMI estimation at a downlink slot not later than slot#(n-4), this reported PMI cannot be applied at the gNB downlink before slot#(n+4).			
NOTE 4: Randomization of the principle beam direction shall be used as specified in Annex J.2.3.2.3.			
NOTE 5: SSB, TRS, CSI-RS and/or other unspecified test parameters with respect to TS 38.101-4 [18] are left up to test implementation, if transmitted or needed.			

- 7) Adjust the test signal mean power so the calibrated radiated SNR value at the IAB-MT receiver is as specified in clause 8.2.3.3.5.1 and 8.2.3.3.5.2 for *IAB type 1-O* and *IAB type 2-O* respectively, and that the SNR at the IAB-MT receiver is not impacted by the noise floor.

The power level for the transmission may be set such that the AWGN level at the RIB is equal to the AWGN level in table 8.2.3.3.4.2-2.

Table 8.2.3.3.4.2-2: AWGN power level at the IAB-MT input

BS type	Sub-carrier spacing (kHz)	Channel bandwidth (MHz)	AWGN power level
IAB-MT type 1-O	30	40	-77.2 - $\Delta_{\text{OTAREFSENS}}$ dBm / 38.16 MHz
IAB-MT type 2-O	120	100	$E_{\text{ISREFSENS}_{50\text{M}}} + \Delta_{\text{FR2_REFSENS}} + 18$ dBm / 95.04 MHz
NOTE 1: $\Delta_{\text{OTAREFSENS}}$ as declared in D.53 in table 4.6-1 and clause 7.1.			
NOTE 2: $\Delta_{\text{FR2_REFSENS}} = -3$ dB as described in clause 7.1, since the OTA REFSENS reference direction (as declared in D.54 in table 4.6-1) is used for testing.			
NOTE 3: $E_{\text{ISREFSENS}_{50\text{M}}}$ as declared in D.28 in table 4.6-1.			

- 8) For reference channels applicable to the IAB-MT, measure the ratio of the throughput obtained when following the PMI feedback to the throughput obtained when applying random PMI as described in subclause 8.2.3.3.1.

8.2.3.3.5 Test requirement

8.2.3.3.5.1 Test requirement for *IAB type 1-O*

γ as defined in subclause 8.2.3.3.1 shall be greater than the indicated requirement.

Table 8.2.3.3.5.1-1: PMI reporting requirements for FR1

Parameter	Test	Requirement
γ	4TX, 2RX	1.3
γ	8TX, 2RX	1.5

8.2.3.3.5.2 Test requirement for *IAB type 2-O*

γ as defined in subclause 8.2.3.3.1 shall be greater than the indicated requirement.

Table 8.2.3.3.5.1-2: PMI reporting requirements for FR2

Parameter	Requirement
γ	1.05

8.2.3.4 Reporting of Rank Information (RI)

8.2.3.4.1 Definition and applicability

The purpose of this test is to verify that the reported rank indicator accurately represents the channel rank. The accuracy of RI reporting is determined by the relative increase of the throughput obtained when transmitting based on the reported rank compared to the case for which a fixed rank is used for transmission.

8.2.3.4.2 Minimum requirement

The minimum requirement for *IAB-MT type 1-O* is in TS 38.174 [2] clause 11.2.3.1.3.

The minimum requirement for *IAB-MT type 2-O* is in TS 38.174 [2] clause 11.2.3.2.4.

8.2.3.4.3 Test purpose

The test shall verify the receiver's ability to report correct RI under the defined fading conditions.

8.2.3.4.4 Method of test

8.2.3.4.4.1 Initial conditions

Test environment: Normal, see annex B.2.

RF channels to be tested for single carrier: M ; see clause 4.9.1.

RF channels to be tested for carrier aggregation: $M_{\text{BW Channel CA}}$; see clause 4.9.1.

Direction to be tested: OTA REFSSENS *receiver target reference direction* (see D.54 in table 4.6-1).

8.2.3.4.4.2 Procedure

- 1) Place the IAB-MT with its manufacturer declared coordinate system reference point in the same place as calibrated point in the test system, as shown in annex E.3.
- 2) Align the manufacturer declared coordinate system orientation of the IAB-MT with the test system.
- 3) Set the IAB-MT in the declared direction to be tested.
- 4) Connect the IAB-MT tester generating the wanted signal and AWGN generators to a test antenna via a combining network in OTA test setup, as shown in annex E.3. Each of the demodulation branch signals should be transmitted on one polarization of the test antenna(s).
- 5) The characteristics of the wanted signal shall be configured according to the corresponding DL reference measurement channel defined in annex A, and according to additional test parameters listed in table 8.2.3.4.4.2-1.

Table 8.2.3.4.4.2-1: Test parameters for testing RI reporting requirements

Parameter		Unit	FR1	FR2
Bandwidth		MHz	40	100
Subcarrier spacing		kHz	30	120
Duplex Mode			TDD	TDD
TDD Slot Configuration			7D1S2U, S=6D:4G:4U	3D1S1U, S=10D:2G:2U
SNR		dB	Test 1: 0 Test 2: 20 Test 3: 20	Test 1: 0 Test 2: 16 Test 3: 16
Propagation channel			TDLA30-5	TDLA30-35
Antenna configuration			Test 1, 2: ULA Low 2x2 Test 3: ULA High 2x2	Test 1, 2: ULA Low 2x2 Test 3: XP High 2x2
Beamforming Model			As defined in Annex J.3.1	As defined in Annex J.3.1
NZIP CSI-RS for CSI acquisition	CSI-RS resource Type		Periodic	Periodic
	Number of CSI-RS ports (X)		2	2
	CDM Type		FD-CDM2	FD-CDM2
	Density (ρ)		1	1
	First subcarrier index in the PRB used for CSI-RS (k_0, k_1)		Row 3 (6,-)	Row 3 (6,-)
	First OFDM symbol in the PRB used for CSI-RS (l_0, l_1)		(13,-)	(13,-)
	NZIP CSI-RS-timeConfig periodicity and offset	slot	10/1	10/1
CSI-IM configuration	CSI-IM resource Type		Periodic	Periodic
	CSI-IM RE pattern		Pattern 0	Pattern 1
	CSI-IM Resource Mapping (k_{CSI-IM}, l_{CSI-IM})		(4,9)	(8,13)
	CSI-IM timeConfig periodicity and offset	slot	10/1	8/1
ReportConfigType			Periodic	Periodic
CQI-table			Table 2	Table 1
reportQuantity			cri-RI-PMI-CQI	cri-RI-PMI-CQI
cqi-FormatIndicator			Wideband	Wideband
pmi-FormatIndicator			Wideband	Wideband
Sub-band Size		RB	16	8
csi-ReportingBand			1111111	1111111
CSI-Report periodicity and offset		slot	10/9	8/3
Codebook configuration	Codebook Type		type1-SinglePanel	type1-SinglePanel
	Codebook Mode (CodebookConfig-N1, CodebookConfig-N2)		1	1
	CodebookSubsetRestriction		N/A	N/A
	RI Restriction		000011 for fixed rank 1, 010000 for fixed rank 2, 010011 for following rank	000011 for fixed rank 1, 010000 for fixed rank 2, 010011 for following rank
CQI/RI/PMI delay		ms	9.5	1.375
Maximum number of HARQ transmission			1	1
RI Configuration			Test 1: Fixed RI = 2 and follow RI Tests 2, 3: Fixed RI = 1 and follow RI	Test 1: Fixed RI = 2 and follow RI Tests 2, 3: Fixed RI = 1 and follow RI
NOTE 1: The same requirements are applicable to with different UL-DL patterns.				
NOTE 2: SSB, TRS, CSI-RS and/or other unspecified test parameters with respect to TS 38.101-4 [18] are left up to test implementation, if transmitted or needed.				

7) Adjust the test signal mean power so the calibrated radiated SNR value at the IAB-MT receiver is as specified in table 8.2.3.4.4.2-1 for *IAB type 1-O* and *IAB type 2-O* respectively, and that the SNR at the IAB-MT receiver is not impacted by the noise floor.

The power level for the transmission may be set such that the AWGN level at the RIB is equal to the AWGN level in table 8.2.3.4.4.2-2.

Table 8.2.3.4.4.2-2: AWGN power level at the IAB-MT input

BS type	Sub-carrier spacing (kHz)	Channel bandwidth (MHz)	AWGN power level
IAB-MT type 1-O	30	40	-77.2 - $\Delta_{\text{OTAREFSSENS}}$ dBm / 38.16 MHz
IAB-MT type 2-O	120	100	$\text{EIS}_{\text{REFSENS}_{50\text{M}}} + \Delta_{\text{FR2_REFSENS}} + 18$ dBm / 95.04 MHz
NOTE 1: $\Delta_{\text{OTAREFSSENS}}$ as declared in D.53 in table 4.6-1 and clause 7.1.			
NOTE 2: $\Delta_{\text{FR2_REFSENS}} = -3$ dB as described in clause 7.1, since the OTA REFSSENS reference direction (as declared in D.54 in table 4.6-1) is used for testing.			
NOTE 3: $\text{EIS}_{\text{REFSENS}_{50\text{M}}}$ as declared in D.28 in table 4.6-1.			

- 8) For reference channels applicable to the IAB-MT, measure the ratio of the throughput obtained when following the RI feedback to the throughput obtained when applying random RI as described in subclause 8.2.3.4.5.

8.2.3.4.5 Test requirement

8.2.3.4.5.1 Test requirement for IAB type 1-O

The test requirement for RI reporting is defined as

- The ratio of the throughput obtained when transmitting based on IAB-MT reported RI and that obtained when transmitting with fixed rank 1 shall be $\geq \gamma_1$;
- The ratio of the throughput obtained when transmitting based on IAB-MT reported RI and that obtained when transmitting with fixed rank 2 shall be $\geq \gamma_2$;

For the parameters specified in Table 8.2.3.4.4.2-1, the test requirements are specified in Table 8.2.3.4.5.1-1.

Table 8.2.3.4.5.1-1: Test requirements for RI reporting

	Test 1	Test 2	Test 3
γ_1	N/A	1.05	0.9
γ_2	1.0	N/A	N/A

8.2.3.4.5.2 Test requirement for IAB type 2-O

The test requirement for RI reporting is defined as

- The ratio of the throughput obtained when transmitting based on IAB-MT reported RI and that obtained when transmitting with fixed rank 1 shall be $\geq \gamma_1$;
- The ratio of the throughput obtained when transmitting based on IAB-MT reported RI and that obtained when transmitting with fixed rank 2 shall be $\geq \gamma_2$;

For the parameters specified in Table 8.2.3.4.4.2-1, the test requirements are specified in Table 8.2.3.4.5.2-1.

Table 8.2.3.4.5.2-1: Test requirements for RI reporting

	Test 1	Test 2	Test 3
γ_1	N/A	1.05	1.05
γ_2	1.0	N/A	N/A

Annex A (normative): Reference measurement channels

A.1 IAB-DU and IAB-MT Reference measurement channels

A.1.1 IAB-DU Reference measurement channels

The Annex A in TS 38.141-2 [6] applies to IAB-DU.

A.1.2 IAB-MT Reference measurement channels

A.1.2.1 Fixed Reference Channels for reference sensitivity level, ACS, in-band blocking, out-of-band blocking and receiver intermodulation (QPSK, R=1/3)

The parameters for the reference measurement channels are specified in tables A.1.2.1-1 for FR1 reference sensitivity level, ACS, in-band blocking, out-of-band blocking, receiver intermodulation, OTA sensitivity, OTA reference sensitivity level, OTA ACS, OTA in-band blocking, OTA out-of-band blocking, and OTA receiver intermodulation.

The parameters for the reference measurement channels are specified in tables A.1.2.1-2 for FR2 OTA reference sensitivity level, OTA ACS, OTA in-band blocking, and OTA out-of-band blocking.

Table A1.2.1-1: FRC parameters for FR1 reference sensitivity level for IAB-MT.

Reference channel	G-FR1-A1-22	G-FR1-A1-23	G-FR1-A1-25	G-FR1-A1-26
Subcarrier spacing (kHz)	30	60	30	60
Allocated resource blocks	11	11	51	24
CP-OFDM Symbols per slot (Note 1)	9	9	9	9
Modulation	QPSK	QPSK	QPSK	QPSK
Code rate (Note 2)	1/3	1/3	1/3	1/3
Payload size (bits)	736	736	3368	1608
Transport block CRC (bits)	16	16	16	16
Code block CRC size (bits)	-	-	-	-
Number of code blocks - C	1	1	1	1
Code block size including CRC (bits) (Note 3)	752	752	3384	1624
Total number of bits per slot	2376	2376	11016	5184
Total symbols per slot	1188	1188	5508	2592
NOTE 1 : $DL-DMRS-config-type = 1$ with $DL-DMRS-max-len = 1$, $DL-DMRS-add-pos = pos2$ with $\begin{matrix} 1 \\ \vdots \\ 2 \end{matrix} = 2$, $\begin{matrix} 1 \\ \vdots \\ 6 \end{matrix} = 6$ and 9 as per Table 7.4.1.1.2-3 of TS 38.211 [7]. NOTE 2 : MCS index 4 and target coding rate = 308/1024 are adopted to calculate payload size for receiver sensitivity NOTE 3 : Code block size including CRC (bits) equals to $\begin{matrix} 1 \\ \vdots \\ 2 \end{matrix}$ in sub-clause 5.2.2 of TS 38.212 [8].				

Table A1.2.1-2: FRC parameters for FR2 reference sensitivity level for IAB-MT.

Reference channel	G-FR2-A1-21	G-FR2-A1-22	G-FR2-A1-23
Subcarrier spacing (kHz)	60	120	120
Allocated resource blocks	66	32	66
CP-OFDM Symbols per slot (Note 1)	9	9	9
Modulation	QPSK	QPSK	QPSK
Code rate (Note 2)	1/3	1/3	1/3
Payload size (bits)	5632	2792	5632
Transport block CRC (bits)	24	16	24
Code block CRC size (bits)	-	-	-
Number of code blocks - C	1	1	1
Code block size including CRC (bits) (Note 3)	4248	2104	4248
Total number of bits per slot	14256	6912	14256
Total symbols per slot	7128	3456	7128
NOTE 1: DM-RS configuration type = 1 with DM-RS duration = single-symbol DM-RS, additional DM-RS position = pos2 with $l_0 = 2$, $l = 6$ and 9 as per Table 7.4.1.1.2-3 of TS 38.211 [7]. NOTE 2: MCS index 4 and target coding rate = 308/1024 are adopted to calculate payload size.			

A.2 IAB-DU Fixed Reference Channels

A.2.1 Fixed Reference Channels for PUSCH performance requirements (QPSK, R=193/1024)

The parameters for the reference measurement channels are specified in table A.2.1-1 and table A.2.1-2 for FR1 PUSCH performance requirements:

- FRC parameters are specified in table A.2.1-1 for FR1 PUSCH with transform precoding disabled, additional DM-RS position = pos1 and 1 transmission layer.
- FRC parameters are specified in table A.2.1-2 for FR1 PUSCH with transform precoding disabled, additional DM-RS position = pos1 and 2 transmission layers.
- FRC parameters are specified in table A.2.1-3 for FR1 PUSCH with transform precoding enabled, additional DM-RS position = pos1 and 1 transmission layer.

The parameters for the reference measurement channels are specified in table A.2.1-3 to table A.2.1-9 for FR2 PUSCH performance requirements:

- FRC parameters are specified in table A.2.1-4 for FR2 PUSCH with transform precoding disabled, additional DM-RS position = pos0 and 1 transmission layer.

- FRC parameters are specified in table A.2.1-5 for FR2 PUSCH with transform precoding disabled, additional DM-RS position = pos0 and 2 transmission layers.
- FRC parameters are specified in table A.2.1-6 for FR2 PUSCH with transform precoding enabled, additional DM-RS position = pos0 and 1 transmission layer.
- FRC parameters are specified in table A.2.1-7 for FR2 PUSCH with transform precoding disabled, additional DM-RS position = pos1 and 1 transmission layer.
- FRC parameters are specified in table A.2.1-8 for FR2 PUSCH with transform precoding disabled, additional DM-RS position = pos1 and 2 transmission layers.
- FRC parameters are specified in table A.2.1-9 for FR2 PUSCH with transform precoding enabled, additional DM-RS position = pos1 and 1 transmission layer.

Table A.2.1-1: FRC parameters for FR1 PUSCH performance requirements, transform precoding disabled, additional DM-RS position = pos1 and 1 transmission layer (QPSK, R=193/1024)

Reference channel	D-FR1-A.2.1-1	D-FR1-A.2.1-2	D-FR1-A.2.1-3	D-FR1-A.2.1-4	D-FR1-A.2.1-5	D-FR1-A.2.1-6	D-FR1-A.2.1-7
Subcarrier spacing (kHz)	15	15	15	30	30	30	30
Allocated resource blocks	25	52	106	24	51	106	273
CP-OFDM Symbols per slot (Note 1)	12	12	12	12	12	12	12
Modulation	QPSK	QPSK	QPSK	QPSK	QPSK	QPSK	QPSK
Code rate	193/1024	193/1024	193/1024	193/1024	193/1024	193/1024	193/1024
Payload size (bits)	1352	2856	5768	1320	2792	5768	14856
Transport block CRC (bits)	16	16	24	16	16	24	24
Code block CRC size (bits)	-	-	24	-	-	24	24
Number of code blocks - C	1	1	2	1	1	2	4
Code block size including CRC (bits) (Note 2)	1368	2872	2920	1336	2808	2920	3744
Total number of bits per slot	7200	14976	30528	6912	14688	30528	78624
Total symbols per slot	3600	7488	15264	3456	7344	15264	39312
NOTE 1: DM-RS configuration type = 1 with DM-RS duration = single-symbol DM-RS and the number of DM-RS CDM groups without data is 2, additional DM-RS position = pos1, $l_0 = 2$ and $l = 11$ for PUSCH mapping type A, $l_0 = 0$ and $l = 10$ for PUSCH mapping type B as per table 6.4.1.1.3-3 of TS 38.211 [7].							
NOTE 2: Code block size including CRC (bits) equals to K' in clause 5.2.2 of TS 38.212 [8].							

Table A.2.1-2: FRC parameters for FR1 PUSCH performance requirements, transform precoding disabled, additional DM-RS position = pos1 and 2 transmission layers (QPSK, R=193/1024)

Reference channel	D-FR1-A.2.1-8	D-FR1-A.2.1-9	D-FR1-A.2.1-10	D-FR1-A.2.1-11	D-FR1-A.2.1-12	D-FR1-A.2.1-13	D-FR1-A.2.1-14
Subcarrier spacing (kHz)	15	15	15	30	30	30	30
Allocated resource blocks	25	52	106	24	51	106	273
CP-OFDM Symbols per slot (Note 1)	12	12	12	12	12	12	12
Modulation	QPSK	QPSK	QPSK	QPSK	QPSK	QPSK	QPSK
Code rate	193/1024	193/1024	193/1024	193/1024	193/1024	193/1024	193/1024
Payload size (bits)	2728	5640	11528	2600	5512	11528	29736
Transport block CRC (bits)	16	24	24	16	24	24	24
Code block CRC size (bits)	-	24	24	-	24	24	24
Number of code blocks - C	1	2	4	1	2	4	8
Code block size including CRC (bits) (Note 2)	2744	2856	2912	2616	2792	2912	3744
Total number of bits per slot	14400	29952	61056	13824	29376	61056	157248
Total symbols per slot	7200	14976	30528	6912	14688	30528	78624
NOTE 1: DM-RS configuration type = 1 with DM-RS duration = single-symbol DM-RS and the number of DM-RS CDM groups without data is 2, additional DM-RS position = pos1, $l_0 = 2$ and $l = 11$ for PUSCH mapping type A, $l_0 = 0$ and $l = 10$ for PUSCH mapping type B as per table 6.4.1.1.3-3 of TS 38.211 [7].							
NOTE 2: Code block size including CRC (bits) equals to K' in clause 5.2.2 of TS 38.212 [8].							

Table A.2.1-3: FRC parameters for FR1 PUSCH performance requirements, transform precoding enabled, additional DM-RS position = pos1 and 1 transmission layer (QPSK, R=193/1024)

Reference channel	D-FR1-A.2.1-15	D-FR1-A.2.1-16
Subcarrier spacing (kHz)	15	30
Allocated resource blocks	25	24
DFT-s-OFDM Symbols per slot (Note 1)	12	12
Modulation	QPSK	QPSK
Code rate	193/1024	193/1024
Payload size (bits)	1352	1320
Transport block CRC (bits)	16	16
Code block CRC size (bits)	-	-
Number of code blocks - C	1	1
Code block size including CRC (bits) (Note 2)	1368	1336
Total number of bits per slot	7200	6912
Total symbols per slot	3600	3456

NOTE 1: DM-RS configuration type = 1 with DM-RS duration = single-symbol DM-RS and the number of DM-RS CDM groups without data is 2, additional DM-RS position = pos1, $l_0 = 2$ and $l = 11$ for PUSCH mapping type A, $l_0 = 0$ and $l = 10$ for PUSCH mapping type B as per table 6.4.1.1.3-3 of TS 38.211 [7].

NOTE 2: Code block size including CRC (bits) equals to K' in clause 5.2.2 of TS 38.212 [8].

Table A.2.1-4: FRC parameters for FR2 PUSCH performance requirements, transform precoding disabled, additional DM-RS position = pos0 and 1 transmission layer (QPSK, R=193/1024)

Reference channel	D-FR2-A.2.1-1	D-FR2-A.2.1-2	D-FR2-A.2.1-3	D-FR2-A.2.1-4	D-FR2-A.2.1-5
Subcarrier spacing (kHz)	60	60	120	120	120
Allocated resource blocks	66	132	32	66	132
CP-OFDM Symbols per slot (Note 1)	9	9	9	9	9
Modulation	QPSK	QPSK	QPSK	QPSK	QPSK
Code rate	193/1024	193/1024	193/1024	193/1024	193/1024
Payload size (bits)	2664	5384	1320	2664	5384
Transport block CRC (bits)	16	24	16	16	24
Code block CRC size (bits)	-	24	-	-	24
Number of code blocks - C	1	2	1	1	2
Code block size including CRC (bits) (Note 2)	2680	2728	1336	2680	2728
Total number of bits per slot	14256	28512	6912	14256	28512
Total symbols per slot	7128	14256	3456	7128	14256

NOTE 1: DM-RS configuration type = 1 with DM-RS duration = single-symbol DM-RS and the number of DM-RS CDM groups without data is 2, additional DM-RS position = pos0 with $l_0 = 0$ as per table 6.4.1.1.3-3 of TS 38.211 [7].

NOTE 2: Code block size including CRC (bits) equals to K' in clause 5.2.2 of TS 38.212 [8].

Table A.2.1-5: FRC parameters for FR2 PUSCH performance requirements, transform precoding disabled, additional DM-RS position = pos0 and 2 transmission layers (QPSK, R=193/1024)

Reference channel	D-FR2-A.2.1-6	D-FR2-A.2.1-7	D-FR2-A.2.1-8	D-FR2-A.2.1-9	D-FR2-A.2.1-10
Subcarrier spacing (kHz)	60	60	120	120	120
Allocated resource blocks	66	132	32	66	132
CP-OFDM Symbols per slot (Note 1)	9	9	9	9	9
Modulation	QPSK	QPSK	QPSK	QPSK	QPSK
Code rate	193/1024	193/1024	193/1024	193/1024	193/1024
Payload size (bits)	5384	10752	2600	5384	10752
Transport block CRC (bits)	24	24	16	24	24
Code block CRC size (bits)	24	24	-	24	24
Number of code blocks - C	2	3	1	2	3
Code block size including CRC (bits) (Note 2)	2728	3616	2616	2728	3616
Total number of bits per slot	28512	57024	13824	28512	57024
Total symbols per slot	14256	28512	6912	14256	28512

NOTE 1: DM-RS configuration type = 1 with DM-RS duration = single-symbol DM-RS and the number of DM-RS CDM groups without data is 2, additional DM-RS position = pos0 with $l_0=0$ as per table 6.4.1.1.3-3 of TS 38.211 [7].

NOTE 2: Code block size including CRC (bits) equals to K' in clause 5.2.2 of TS 38.212 [8].

Table A.2.1-6: FRC parameters for FR2 PUSCH performance requirements, transform precoding enabled, additional DM-RS position = pos0 and 1 transmission layer (QPSK, R=193/1024)

Reference channel	D-FR2-A.2.1-11	D-FR2-A.2.1-12
Subcarrier spacing (kHz)	60	120
Allocated resource blocks	30	30
DFT-s-OFDM Symbols per slot (Note 1)	9	9
Modulation	QPSK	QPSK
Code rate	193/1024	193/1024
Payload size (bits)	1224	1224
Transport block CRC (bits)	16	16
Code block CRC size (bits)	-	-
Number of code blocks - C	1	1
Code block size including CRC (bits) (Note 2)	1240	1240
Total number of bits per slot	6480	6480
Total symbols per slot	3240	3240

NOTE 1: DM-RS configuration type = 1 with DM-RS duration = single-symbol DM-RS and the number of DM-RS CDM groups without data is 2, additional DM-RS position = pos0 with $l_0=0$ as per table 6.4.1.1.3-3 of TS 38.211 [7].

NOTE 2: Code block size including CRC (bits) equals to K' in clause 5.2.2 of TS 38.212 [8].

Table A.2.1-7: FRC parameters for FR2 PUSCH performance requirements, transform precoding disabled, additional DM-RS position = pos1 and 1 transmission layer (QPSK, R=193/1024)

Reference channel	D-FR2-A.2.1-13	D-FR2-A.2.1-14	D-FR2-A.2.1-15	D-FR2-A.2.1-16	D-FR2-A.2.1-17
Subcarrier spacing (kHz)	60	60	120	120	120
Allocated resource blocks	66	132	32	66	132
CP-OFDM Symbols per slot (Note 1)	8	8	8	8	8
Modulation	QPSK	QPSK	QPSK	QPSK	QPSK
Code rate	193/1024	193/1024	193/1024	193/1024	193/1024
Payload size (bits)	2408	4744	1160	2408	4744
Transport block CRC (bits)	16	24	16	16	24
Code block CRC size (bits)	-	24	-	-	24
Number of code blocks - C	1	2	1	1	2
Code block size including CRC (bits) (Note 2)	2424	2408	1176	2424	2408
Total number of bits per slot	12672	25344	6144	12672	25344
Total symbols per slot	6336	12672	3072	6336	12672
NOTE 1: DM-RS configuration type = 1 with DM-RS duration = single-symbol DM-RS and the number of DM-RS CDM groups without data is 2, additional DM-RS position = pos1 with $l_0 = 0$ and $l = 8$ as per table 6.4.1.1.3-3 of TS 38.211 [7].					
NOTE 2: Code block size including CRC (bits) equals to K' in clause 5.2.2 of TS 38.212 [8].					

Table A.2.1-8: FRC parameters for FR2 PUSCH performance requirements, transform precoding disabled, additional DM-RS position = pos1 and 2 transmission layers (QPSK, R=193/1024)

Reference channel	D-FR2-A.2.1-18	D-FR2-A.2.1-19	D-FR2-A.2.1-20	D-FR2-A.2.1-21	D-FR2-A.2.1-22
Subcarrier spacing (kHz)	60	60	120	120	120
Allocated resource blocks	66	132	32	66	132
CP-OFDM Symbols per slot (Note 1)	8	8	8	8	8
Modulation	QPSK	QPSK	QPSK	QPSK	QPSK
Code rate	193/1024	193/1024	193/1024	193/1024	193/1024
Payload size (bits)	4744	9480	2408	4744	9480
Transport block CRC (bits)	24	24	16	24	24
Code block CRC size (bits)	24	24	-	24	24
Number of code blocks - C	2	3	1	2	3
Code block size including CRC (bits) (Note 2)	2408	3192	2424	2408	3192
Total number of bits per slot	25344	50688	12288	25344	50688
Total symbols per slot	12672	25344	6144	12672	25344
NOTE 1: DM-RS configuration type = 1 with DM-RS duration = single-symbol DM-RS and the number of DM-RS CDM groups without data is 2, additional DM-RS position = pos1 with $l_0 = 0$ and $l = 8$ as per table 6.4.1.1.3-3 of TS 38.211 [7].					
NOTE 2: Code block size including CRC (bits) equals to K' in clause 5.2.2 of TS 38.212 [8].					

Table A.2.1-9: FRC parameters for FR2 PUSCH performance requirements, transform precoding enabled, additional DM-RS position = pos1 and 1 transmission layer (QPSK, R=193/1024)

Reference channel	D-FR2-A.2.1-23	D-FR2-A.2.1-24
Subcarrier spacing (kHz)	60	120
Allocated resource blocks	30	30
DFT-s-OFDM Symbols per slot (Note 1)	8	8
Modulation	QPSK	QPSK
Code rate	193/1024	193/1024
Payload size (bits)	1128	1128
Transport block CRC (bits)	16	16
Code block CRC size (bits)	-	-
Number of code blocks - C	1	1
Code block size including CRC (bits) (Note 2)	1144	1144
Total number of bits per slot	5760	5760
Total symbols per slot	2880	2880

NOTE 1: DM-RS configuration type = 1 with DM-RS duration = single-symbol DM-RS and the number of DM-RS CDM groups without data is 2, additional DM-RS position = pos1 with $l_0 = 0$ and $l = 8$ as per table 6.4.1.1.3-3 of TS 38.211 [7].

NOTE 2: Code block size including CRC (bits) equals to K' in clause 5.2.2 of TS 38.212 [8].

A.2.2 Fixed Reference Channels for PUSCH performance requirements (16QAM, R=434/1024)

The parameters for the reference measurement channels are specified in table A.2.2-1 for FR2 PUSCH performance requirements with transform precoding disabled, additional DM-RS position = pos0 and 2 transmission layers.

The parameters for the reference measurement channels are specified in table A.2.2-2 for FR2 PUSCH performance requirements with transform precoding disabled, additional DM-RS position = pos1 and 2 transmission layers.

Table A.2.2-1: FRC parameters for FR2 PUSCH performance requirements, transform precoding disabled, Additional DM-RS position = pos0 and 2 transmission layers (16QAM, R=434/1024)

Reference channel	D-FR2-A.2.2-1	D-FR2-A.2.2-2	D-FR2-A.2.2-3	D-FR2-A.2.2-4	D-FR2-A.2.2-5
Subcarrier spacing (kHz)	60	60	120	120	120
Allocated resource blocks	66	132	32	66	132
CP-OFDM Symbols per slot (Note 1)	9	9	9	9	9
Modulation	16QAM	16QAM	16QAM	16QAM	16QAM
Code rate	434/1024	434/1024	434/1024	434/1024	434/1024
Payload size (bits)	24072	48168	11784	24072	48168
Transport block CRC (bits)	24	24	24	24	24
Code block CRC size (bits)	24	24	24	24	24
Number of code blocks - C	3	6	2	3	6
Code block size including CRC (bits) (Note 2)	8056	8056	5928	8056	8056
Total number of bits per slot	57024	114048	27648	57024	114048
Total symbols per slot	14256	28512	6912	14256	28512

NOTE 1: DM-RS configuration type = 1 with DM-RS duration = single-symbol DM-RS and the number of DM-RS CDM groups without data is 2, Additional DM-RS position = pos0 with $l_0 = 0$ as per Table 6.4.1.1.3-3 of TS 38.211 [7].

NOTE 2: Code block size including CRC (bits) equals to K' in sub-clause 5.2.2 of TS 38.212 [8].

Table A.2.2-2: FRC parameters for FR2 PUSCH performance requirements, transform precoding disabled, Additional DM-RS position = pos1 and 2 transmission layers (16QAM, R=434/1024)

Reference channel	D-FR2-A.2.2-6	D-FR2-A.2.2-7	D-FR2-A.2.2-8	D-FR2-A.2.2-9	D-FR2-A.2.2-10
Subcarrier spacing (kHz)	60	60	120	120	120
Allocated resource blocks	66	132	32	66	132
CP-OFDM Symbols per slot (Note 1)	8	8	8	8	8
Modulation	16QAM	16QAM	16QAM	16QAM	16QAM
Code rate	434/1024	434/1024	434/1024	434/1024	434/1024
Payload size (bits)	21504	43032	10504	21504	43032
Transport block CRC (bits)	24	24	24	24	24
Code block CRC size (bits)	24	24	24	24	24
Number of code blocks - C	3	6	2	3	6
Code block size including CRC (bits) (Note 2)	7200	7200	5288	7200	7200
Total number of bits per slot	50688	101376	24576	50688	101376
Total symbols per slot	12672	25344	6144	12672	25344
NOTE 1: <i>DM-RS configuration type = 1 with DM-RS duration = single-symbol DM-RS and the number of DM-RS CDM groups without data is 2, Additional DM-RS position = pos1 with $l_0 = 0$ and $l = 8$ as per Table 6.4.1.1.3-3 of TS 38.211 [7].</i>					
NOTE 2: Code block size including CRC (bits) equals to K' in sub-clause 5.2.2 of TS 38.212 [8].					

A.2.3 Fixed Reference Channels for PUSCH performance requirements (16QAM, R=658/1024)

The parameters for the reference measurement channels are specified in table A.2.3-1 and table A.2.3-2 for FR1 PUSCH performance requirements:

- FRC parameters are specified in table A.2.3-1 for FR1 PUSCH with transform precoding disabled, additional DM-RS position = pos1 and 1 transmission layer.
- FRC parameters are specified in table A.2.3-2 for FR1 PUSCH with transform precoding disabled, additional DM-RS position = pos1 and 2 transmission layers.

The parameters for the reference measurement channels are specified in table A.2.3-3 to table A.2.3-6 for FR2 PUSCH performance requirements:

- FRC parameters are specified in table A.2.3-3 for FR2 PUSCH with transform precoding disabled, additional DM-RS position = pos0 and 1 transmission layer.
- FRC parameters are specified in table A.2.3-4 for FR2 PUSCH with transform precoding disabled, additional DM-RS position = pos0 and 2 transmission layers.
- FRC parameters are specified in table A.1.3-5 for FR2 PUSCH with transform precoding disabled, additional DM-RS position = pos1 and 1 transmission layer.
- FRC parameters are specified in table A.2.3-6 for FR2 PUSCH with transform precoding disabled, additional DM-RS position = pos1 and 2 transmission layers.

Table A.2.3-1: FRC parameters for FR1 PUSCH performance requirements, transform precoding disabled, additional DM-RS position = pos1 and 1 transmission layer (16QAM, R=658/1024)

Reference channel	D-FR1-A.2.3-1	D-FR1-A.2.3-2	D-FR1-A.2.3-3	D-FR1-A.2.3-4	D-FR1-A.2.3-5	D-FR1-A.2.3-6	D-FR1-A.2.3-7
Subcarrier spacing (kHz)	15	15	15	30	30	30	30
Allocated resource blocks	25	52	106	24	51	106	273
CP-OFDM Symbols per slot (Note 1)	12	12	12	12	12	12	12
Modulation	16QAM	16QAM	16QAM	16QAM	16QAM	16QAM	16QAM
Code rate	658/1024	658/1024	658/1024	658/1024	658/1024	658/1024	658/1024
Payload size (bits)	9224	19464	38936	8968	18960	38936	100392
Transport block CRC (bits)	24	24	24	24	24	24	24
Code block CRC size (bits)	24	24	24	24	24	24	24
Number of code blocks - C	2	3	5	2	3	5	12
Code block size including CRC (bits) (Note 2)	4648	6520	7816	4520	6352	7816	8392
Total number of bits per slot	14400	29952	61056	13824	29376	61056	157248
Total symbols per slot	3600	7488	15264	3456	7344	15264	39312
NOTE 1: DM-RS configuration type = 1 with DM-RS duration = single-symbol DM-RS and the number of DM-RS CDM groups without data is 2, additional DM-RS position = pos1, $l_0 = 2$ and $l = 11$ for PUSCH mapping type A, $l_0 = 0$ and $l = 10$ for PUSCH mapping type B as per table 6.4.1.1.3-3 of TS 38.211 [7].							
NOTE 2: Code block size including CRC (bits) equals to K' in clause 5.2.2 of TS 38.212 [8].							

Table A.2.3-2: FRC parameters for FR1 PUSCH performance requirements, transform precoding disabled, additional DM-RS position = pos1 and 2 transmission layers (16QAM, R=658/1024)

Reference channel	D-FR1-A.2.3-8	D-FR1-A.2.3-9	D-FR1-A.2.3-10	D-FR1-A.2.3-11	D-FR1-A.2.3-12	D-FR1-A.2.3-13	D-FR1-A.2.3-14
Subcarrier spacing (kHz)	15	15	15	30	30	30	30
Allocated resource blocks	25	52	106	24	51	106	273
CP-OFDM Symbols per slot (Note 1)	12	12	12	12	12	12	12
Modulation	16QAM	16QAM	16QAM	16QAM	16QAM	16QAM	16QAM
Code rate	658/1024	658/1024	658/1024	658/1024	658/1024	658/1024	658/1024
Payload size (bits)	18432	38936	77896	17928	37896	77896	200808
Transport block CRC (bits)	24	24	24	24	24	24	24
Code block CRC size (bits)	24	24	24	24	24	24	24
Number of code blocks - C	3	5	10	3	5	10	24
Code block size including CRC (bits) (Note 2)	6176	7816	7816	6008	7608	7816	8392
Total number of bits per slot	28800	59904	122112	27648	58752	122112	314496
Total symbols per slot	7200	14976	30528	6912	14688	30528	78624
NOTE 1: DM-RS configuration type = 1 with DM-RS duration = single-symbol DM-RS and the number of DM-RS CDM groups without data is 2, additional DM-RS position = pos1, $l_0 = 2$ and $l = 11$ for PUSCH mapping type A, $l_0 = 0$ and $l = 10$ for PUSCH mapping type B as per table 6.4.1.1.3-3 of TS 38.211 [7].							
NOTE 2: Code block size including CRC (bits) equals to K' in clause 5.2.2 of TS 38.212 [8].							

Table A.2.3-3: FRC parameters for FR2 PUSCH performance requirements, transform precoding disabled, additional DM-RS position = pos0 and 1 transmission layer (16QAM, R=658/1024)

Reference channel	D-FR2-A.2.3-1	D-FR2-A.2.3-2	D-FR2-A.2.3-3	D-FR2-A.2.3-4	D-FR2-A.2.3-5
Subcarrier spacing (kHz)	60	60	120	120	120
Allocated resource blocks	66	132	32	66	132
CP-OFDM Symbols per slot (Note 1)	9	9	9	9	9
Modulation	16QAM	16QAM	16QAM	16QAM	16QAM
Code rate	658/1024	658/1024	658/1024	658/1024	658/1024
Payload size (bits)	18432	36896	8968	18432	36896
Transport block CRC (bits)	24	24	24	24	24
Code block CRC size (bits)	24	24	24	24	24
Number of code blocks - C	3	5	2	3	5
Code block size including CRC (bits) (Note 2)	6176	7408	4520	6176	7408
Total number of bits per slot	28512	57024	13824	28512	57024
Total symbols per slot	7128	14256	3456	7128	14256
NOTE 1: DM-RS configuration type = 1 with DM-RS duration = single-symbol DM-RS and the number of DM-RS CDM groups without data is 2, additional DM-RS position = pos0 with $l_0=0$ as per table 6.4.1.1.3-3 of TS 38.211 [7].					
NOTE 2: Code block size including CRC (bits) equals to K' in clause 5.2.2 of TS 38.212 [8].					

Table A.2.3-4: FRC parameters for FR2 PUSCH performance requirements, transform precoding disabled, additional DM-RS position = pos0 and 2 transmission layers (16QAM, R=658/1024)

Reference channel	D-FR2-A.2.3-6	D-FR2-A.2.3-7	D-FR2-A.2.3-8	D-FR2-A.2.3-9	D-FR2-A.2.3-10
Subcarrier spacing (kHz)	60	60	120	120	120
Allocated resource blocks	66	132	32	66	132
CP-OFDM Symbols per slot (Note 1)	9	9	9	9	9
Modulation	16QAM	16QAM	16QAM	16QAM	16QAM
Code rate	658/1024	658/1024	658/1024	658/1024	658/1024
Payload size (bits)	36896	73776	17928	36896	73776
Transport block CRC (bits)	24	24	24	24	24
Code block CRC size (bits)	24	24	24	24	24
Number of code blocks - C	5	9	3	5	9
Code block size including CRC (bits) (Note 2)	7408	8224	6008	7408	8224
Total number of bits per slot	57024	114048	27648	57024	114048
Total symbols per slot	14256	28512	6912	14256	28512
NOTE 1: DM-RS configuration type = 1 with DM-RS duration = single-symbol DM-RS and the number of DM-RS CDM groups without data is 2, additional DM-RS position = pos0 with $l_0=0$ as per table 6.4.1.1.3-3 of TS 38.211 [7].					
NOTE 2: Code block size including CRC (bits) equals to K' in clause 5.2.2 of TS 38.212 [8].					

Table A.2.3-5: FRC parameters for FR2 PUSCH performance requirements, transform precoding disabled, additional DM-RS position = pos1 and 1 transmission layer (16QAM, R=658/1024)

Reference channel	D-FR2-A.2.3-11	D-FR2-A.2.3-12	D-FR2-A.2.3-13	D-FR2-A.2.3-14	D-FR2-A.2.3-15
Subcarrier spacing (kHz)	60	60	120	120	120
Allocated resource blocks	66	132	32	66	132
CP-OFDM Symbols per slot (Note 1)	8	8	8	8	8
Modulation	16QAM	16QAM	16QAM	16QAM	16QAM
Code rate	658/1024	658/1024	658/1024	658/1024	658/1024
Payload size (bits)	16392	32776	7936	16392	32776
Transport block CRC (bits)	24	24	24	24	24
Code block CRC size (bits)	24	24	-	24	24
Number of code blocks - C	2	4	1	2	4
Code block size including CRC (bits) (Note 2)	8232	8224	7960	8232	8224
Total number of bits per slot	25344	50688	12288	25344	50688
Total symbols per slot	6336	12672	3072	6336	12672
NOTE 1: DM-RS configuration type = 1 with DM-RS duration = single-symbol DM-RS and the number of DM-RS CDM groups without data is 2, additional DM-RS position = pos1 with $l_0 = 0$ and $l = 8$ as per table 6.4.1.1.3-3 of TS 38.211 [7].					
NOTE 2: Code block size including CRC (bits) equals to K' in clause 5.2.2 of TS 38.212 [8].					

Table A.2.3-6: FRC parameters for FR2 PUSCH performance requirements, transform precoding disabled, additional DM-RS position = pos1 and 2 transmission layers (16QAM, R=658/1024)

Reference channel	D-FR2-A.2.3-16	D-FR2-A.2.3-17	D-FR2-A.2.3-18	D-FR2-A.2.3-19	D-FR2-A.2.3-20
Subcarrier spacing (kHz)	60	60	120	120	120
Allocated resource blocks	66	132	32	66	132
CP-OFDM Symbols per slot (Note 1)	8	8	8	8	8
Modulation	16QAM	16QAM	16QAM	16QAM	16QAM
Code rate	658/1024	658/1024	658/1024	658/1024	658/1024
Payload size (bits)	32776	65576	15880	32776	65576
Transport block CRC (bits)	24	24	24	24	24
Code block CRC size (bits)	24	24	24	24	24
Number of code blocks - C	4	8	2	4	8
Code block size including CRC (bits) (Note 2)	8224	8224	7976	8224	8224
Total number of bits per slot	50688	101376	24576	50688	101376
Total symbols per slot	12672	25344	6144	12672	25344
NOTE 1: DM-RS configuration type = 1 with DM-RS duration = single-symbol DM-RS and the number of DM-RS CDM groups without data is 2, additional DM-RS position = pos1 with $l_0 = 0$ and $l = 8$ as per table 6.4.1.1.3-3 of TS 38.211 [7].					
NOTE 2: Code block size including CRC (bits) equals to K' in clause 5.2.2 of TS 38.212 [8].					

A.2.4 Fixed Reference Channels for PUSCH performance requirements (64QAM, R=567/1024)

The parameters for the reference measurement channels are specified in table A.2.4-1 for FR1 PUSCH performance requirements:

- FRC parameters are specified in table A.2.4-1 for FR1 PUSCH with transform precoding disabled, Additional DM-RS position = pos1 and 1 transmission layer.

The parameters for the reference measurement channels are specified in table A.2.4-2 and table A.2.4-3 for FR2 PUSCH performance requirements:

- FRC parameters are specified in table A.2.4-2 for FR2 PUSCH with transform precoding disabled, additional DM-RS position = pos0 and 1 transmission layer.
- FRC parameters are specified in table A.2.4-3 for FR2 PUSCH with transform precoding disabled, additional DM-RS position = pos1 and 1 transmission layer.

Table A.2.4-1: FRC parameters for FR1 PUSCH performance requirements, transform precoding disabled, additional DM-RS position = pos1 and 1 transmission layer (64QAM, R=567/1024)

Reference channel	D-FR1-A.2.4-1	D-FR1-A.2.4-2	D-FR1-A.2.4-3	D-FR1-A.2.4-4	D-FR1-A.2.4-5	D-FR1-A.2.4-6	D-FR1-A.2.4-7
Subcarrier spacing (kHz)	15	15	15	30	30	30	30
Allocated resource blocks	25	52	106	24	51	106	273
CP-OFDM Symbols per slot (Note 1)	12	12	12	12	12	12	12
Modulation	64QAM	64QAM	64QAM	64QAM	64QAM	64QAM	64QAM
Code rate	567/1024	567/1024	567/1024	567/1024	567/1024	567/1024	567/1024
Payload size (bits)	12040	25104	50184	11528	24576	50184	131176
Transport block CRC (bits)	24	24	24	24	24	24	24
Code block CRC size (bits)	24	24	24	24	24	24	24
Number of code blocks - C	2	3	6	2	3	6	16
Code block size including CRC (bits) (Note 2)	6056	8400	8392	5800	8224	8392	8224
Total number of bits per slot	21600	44928	91584	20736	44064	91584	235872
Total symbols per slot	3600	7488	15264	3456	7344	15264	39312

NOTE 1: DM-RS configuration type = 1 with DM-RS duration = single-symbol DM-RS and the number of DM-RS CDM groups without data is 2, additional DM-RS position = pos1, $l_0 = 2$ and $l = 11$ for PUSCH mapping type A, $l_0 = 0$ and $l = 10$ for PUSCH mapping type B as per table 6.4.1.1.3-3 of TS 38.211 [7].

NOTE 2: Code block size including CRC (bits) equals to K' in clause 5.2.2 of TS 38.212 [8].

Table A.2.4-2: FRC parameters for FR2 PUSCH performance requirements, transform precoding disabled, additional DM-RS position = pos0 and 1 transmission layer (64QAM, R=567/1024)

Reference channel	D-FR2-A.2.4-1	D-FR2-A.2.4-2	D-FR2-A.2.4-3	D-FR2-A.2.4-4	D-FR2-A.2.4-5
Subcarrier spacing (kHz)	60	60	120	120	120
Allocated resource blocks	66	132	32	66	132
CP-OFDM Symbols per slot (Note 1)	9	9	9	9	9
Modulation	64QAM	64QAM	64QAM	64QAM	64QAM
Code rate	567/1024	567/1024	567/1024	567/1024	567/1024
Payload size (bits)	23568	47112	11528	23568	47112
Transport block CRC (bits)	24	24	24	24	24
Code block CRC size (bits)	24	24	24	24	24
Number of code blocks - C	3	6	2	3	6
Code block size including CRC (bits) (Note 2)	7888	7880	5800	7888	7880
Total number of bits per slot	42768	85536	20736	42768	85536
Total symbols per slot	7128	14256	3456	7128	14256

NOTE 1: DM-RS configuration type = 1 with DM-RS duration = single-symbol DM-RS and the number of DM-RS CDM groups without data is 2, additional DM-RS position = pos0 with $l_0 = 0$ as per table 6.4.1.1.3-3 of TS 38.211 [7].

NOTE 2: Code block size including CRC (bits) equals to K' in clause 5.2.2 of TS 38.212 [8].

Table A.2.4-3: FRC parameters for FR2 PUSCH performance requirements, transform precoding disabled, additional DM-RS position = pos1 and 1 transmission layer (64QAM, R=567/1024)

Reference channel	D-FR2-A.2.4-6	D-FR2-A.2.4-7	D-FR2-A.2.4-8	D-FR2-A.2.4-9	D-FR2-A.2.4-10
Subcarrier spacing (kHz)	60	60	120	120	120
Allocated resource blocks	66	132	32	66	132
CP-OFDM Symbols per slot (Note 1)	8	8	8	8	8
Modulation	64QAM	64QAM	64QAM	64QAM	64QAM
Code rate	567/1024	567/1024	567/1024	567/1024	567/1024
Payload size (bits)	21000	42016	10248	21000	42016
Transport block CRC (bits)	24	24	24	24	24
Code block CRC size (bits)	24	24	24	24	24
Number of code blocks - C	3	5	2	3	5
Code block size including CRC (bits) (Note 2)	7032	8432	5160	7032	8432
Total number of bits per slot	38016	76032	18432	38016	76032
Total symbols per slot	6336	12672	3072	6336	12672
NOTE 1: DM-RS configuration type = 1 with DM-RS duration = single-symbol DM-RS and the number of DM-RS CDM groups without data is 2, additional DM-RS position = pos1 with $l_0 = 0$ and $l = 8$ as per table 6.4.1.1.3-3 of TS 38.211 [7].					
NOTE 2: Code block size including CRC (bits) equals to K' in clause 5.2.2 of TS 38.212 [8].					

A.2.5 PRACH Test preambles

Table A.2.5-1 Test preambles for Normal Mode in FR1

Burst format	SCS (kHz)	Ncs	Logical sequence index	v
0	1.25	13	22	32
A1, A2, A3, B4, C0, C2	15	23	0	0
	30	46	0	0

Table A.2.5-2 Test preambles for Normal Mode in FR2

Burst format	SCS (kHz)	Ncs	Logical sequence index	v
A1, A2, A3, B4, C0, C2	60	69	0	0
	120	69	0	0

A.3 IAB-MT Fixed Reference Channels

A.3.1 Fixed Reference Channels for PDSCH performance requirements (16QAM)

The parameters for the reference measurement channels are specified in table A.3.1-1 for FR1 PDSCH performance requirements.

The parameters for the reference measurement channels are specified in table A.3.1-2 for FR2 PDSCH performance requirements.

Table A.3.1-1: Fixed Reference Channels for FR1 PDSCH (16QAM)

Reference channel	M-FR1-A.3.1-1	M-FR1-A.3.1-2	M-FR1-A.3.1-3
Channel bandwidth (MHz)	40	40	40
Subcarrier spacing (kHz)	30	30	30
Allocated resource blocks	106	106	106
Number of consecutive PDSCH symbols	12	12	12
MCS table	64QAM	64QAM	64QAM
MCS index	13	13	13
Modulation	16QAM	16QAM	16QAM
Target Coding Rate	490/1024	490/1024	490/1024
Number of MIMO layers	1	3	4
Number of DMRS REs	12	24	24
Overhead for TBS determination	0	0	0
Information Bit Payload per Slot (bits)	26632	73776	98376
Transport block CRC per Slot (bits)	24	24	24
Number of Code Blocks per Slot	4	9	12
Binary Channel Bits Per Slot (bits)	55968	152640	203520

Table A.3.1-2: Fixed Reference Channels for FR2 PDSCH (16QAM)

Reference channel	M-FR2-A.3.1-1	M-FR2-A.3.1-2	M-FR2-A.3.1-3
Channel bandwidth (MHz)	100	100	50
Subcarrier spacing (kHz)	120	120	60
Allocated resource blocks	66	66	66
Number of consecutive PDSCH symbols	13	13	13
MCS table	64QAM	64QAM	64QAM
MCS index	13	13	13
Modulation	16QAM	16QAM	16QAM
Target Coding Rate	490/1024	490/1024	490/1024
Number of MIMO layers	1	2	2
Number of DMRS REs	12	12	12
Overhead for TBS determination	6	6	6
Information Bit Payload per Slot (bits)	17424	34816	34816
Transport block CRC per Slot (bits)	24	24	24
Number of Code Blocks per Slot	3	5	5
Binary Channel Bits Per Slot (bits)	36564	73128	73128

A.3.2 Fixed Reference Channels for PDSCH performance requirements (64QAM)

The parameters for the reference measurement channels are specified in table A.3.2-1 for FR1 PDSCH performance requirements.

The parameters for the reference measurement channels are specified in table A.3.2-2 for FR2 PDSCH performance requirements.

Table A.3.2-1: Fixed Reference Channels for FR1 PDSCH (64QAM)

Reference channel	M-FR1-A.3.2-1
Channel bandwidth (MHz)	40
Subcarrier spacing (kHz)	30
Allocated resource blocks	106
Number of consecutive PDSCH symbols	12
MCS table	64QAM
MCS index	19
Modulation	64QAM
Target Coding Rate	517/1024
Number of MIMO layers	2
Number of DMRS REs	12
Overhead for TBS determination	0
Information Bit Payload per Slot (bits)	83976
Transport block CRC per Slot (bits)	24
Number of Code Blocks per Slot	10
Binary Channel Bits Per Slot (bits)	167904

Table A.3.2-2: Fixed Reference Channels for FR2 PDSCH (64QAM)

Reference channel	M-FR2-A.3.2-1	M-FR2-A.3.2-2
Channel bandwidth (MHz)	100	100
Subcarrier spacing (kHz)	120	120
Allocated resource blocks	66	66
Number of consecutive PDSCH symbols	13	13
MCS table	64QAM	64QAM
MCS index	18	17
Modulation	64QAM	64QAM
Target Coding Rate	466/1024	438/1024
Number of MIMO layers	1	2
Number of DMRS REs	12	12
Overhead for TBS determination	6	6
Information Bit Payload per Slot (bits)	25104	47112
Transport block CRC per Slot (bits)	24	24
Number of Code Blocks per Slot	3	6
Binary Channel Bits Per Slot (bits)	54846	109692

A.3.3 Fixed Reference Channels for PDSCH performance requirements (256QAM)

The parameters for the reference measurement channels are specified in table A.3.3-1 for FR1 PDSCH performance requirements.

Table A.3.3-1: Fixed Reference Channels for FR1 PDSCH (256QAM)

Reference channel	M-FR1-A.3.3-1
Channel bandwidth (MHz)	40
Subcarrier spacing (kHz)	30
Allocated resource blocks	106
Number of consecutive PDSCH symbols	12
MCS table	256QAM
MCS index	24
Modulation	256QAM
Target Coding Rate	0.82
Number of MIMO layers	1
Number of DMRS REs	12
Overhead for TBS determination	0
Information Bit Payload per Slot (bits)	92200
Transport block CRC per Slot (bits)	24
Number of Code Blocks per Slot	11
Binary Channel Bits Per Slot (bits)	111936

A.3.4 Fixed Reference Channels for PDCCH performance requirements

The parameters for the reference measurement channels are specified in table A.3.4-1 for FR1 PDCCH performance requirements.

The parameters for the reference measurement channels are specified in table A.3.4-2 for FR2 PDCCH performance requirements.

Table A.3.4-1: Fixed Reference Channels for FR1 PDCCH

Reference channel	M-FR1-A.3.4-1	M-FR1-A.3.4-2	M-FR1-A.3.4-3
Subcarrier spacing (kHz)	30	30	30
CORESET frequency domain allocation	102	102	90
CORESET time domain allocation	1	1	1
Aggregation level	2	4	8
DCI Format	1_0	1_1	1_1
Payload (without CRC) (bits)	41	53	53

Table A.3.4-2: Fixed Reference Channels for FR2 PDCCH

Reference channel	M-FR2-A.3.4-1	M-FR2-A.3.4-2	M-FR2-A.3.4-3
Subcarrier spacing (kHz)	120	120	120
CORESET frequency domain allocation	60	60	60
CORESET time domain allocation	1	1	1
Aggregation level	2	4	8
DCI Format	1_0	1_1	1_1
Payload (without CRC) (bits)	40	56	56

A.3.5 Fixed Reference Channels for CSI reporting requirements

The parameters for the reference measurement channels are specified in table A.3.5-1 for FR1 CQI and RI reporting requirements with CQI table 2 and MCS table 2.

The parameters for the reference measurement channels are specified in table A.3.5-2 for FR1 PMI reporting requirements.

The parameters for the reference measurement channels are specified in table A.3.5-3 for FR2 CQI and RI reporting requirements with CQI table 1 and MCS table 1.

The parameters for the reference measurement channels are specified in table A.3.5-4 for FR2 PMI reporting requirements.

Table A.3.5-1: FRC for FR1 CQI and RI reporting with CQI table 2 and MCS table 2

Reference channel				M-FR1-A.3.5-1	M-FR1-A.3.5-2	M-FR1-A.3.5-3	M-FR1-A.3.5-4
Number of allocated PDSCH resource blocks				106	106	106	106
Number of consecutive PDSCH symbols				12	12	12	12
Number of PDSCH MIMO layers				1	2	3	4
Number of DMRS REs (Note 1)				24	24	24	24
Overhead for TBS determination				0	0	0	0
Available RE-s for PDSCH				12720	12720	12720	12720
CQI index	Spectral efficiency	MCS index	Modulation	Information Bit Payload per Slot			
0	0	0	0	N/A	N/A	N/A	N/A
1	0.1523	0	QPSK	2976	5896	8976	11784
2	0.3770	1		4744	9480	14344	18976
3	0.8770	3		11016	22536	33816	45096
4	1.4766	5	16QAM	18960	37896	56368	75792
5	1.9141	7		24576	49176	73776	98376
6	2.4063	9		30728	61480	92200	122976
7	2.7305	11	64QAM	34816	69672	104496	139376
8	3.3223	13		42016	83976	127080	167976
9	3.9023	15		49176	98376	147576	196776
10	4.5234	17	256QAM	57376	114776	172176	229576
11	5.1152	19		65576	131176	196776	262376
12	5.5547	21		69672	139376	213176	278776
13	6.2266	23	256QAM	79896	159880	237776	319784
14	6.9141	25		88064	176208	262376	352440
15	7.4063	27		94248	188576	278776	376896

NOTE 1: Number of DMRS REs includes the overhead of the DM-RS CDM groups without data.
NOTE 2: PDSCH is only scheduled on slots which are full DL.

Table A.3.5-2: Fixed Reference Channels for FR1 PMI reporting (16QAM)

Reference channel	M-FR1-A.3.5-5	M-FR1-A.3.5-6
Channel bandwidth (MHz)	40	40
Subcarrier spacing (kHz)	30	30
Allocated resource blocks	106	106
Number of consecutive PDSCH symbols	12	12
MCS table	64QAM	64QAM
MCS index	13	13
Modulation	16QAM	16QAM
Target Coding Rate	490/1024	490/1024
Number of MIMO layers	1	2
Number of DMRS REs	24	24
Overhead for TBS determination	0	0
Information Bit Payload per Slot (bits)	24576	49176
Transport block CRC per Slot (bits)	24	24
Number of Code Blocks per Slot	3	6
Binary Channel Bits Per Slot (bits)	50880	101760

Table A.3.5-3: FRC for FR2 CQI and RI reporting with CQI table 1 and MCS table 1

Reference channel				M-FR2-A.3.5-1	M-FR2-A.3.5-2
Number of allocated PDSCH resource blocks				66	66
Number of consecutive PDSCH symbols				12	12
Number of PDSCH MIMO layers				1	2
Number of DMRS REs (Note 1)				24	24
Overhead for TBS determination				6	6
Available RE-s				7590	7590
CQI index	Spectral efficiency	MCS index	Modulation	Information Bit Payload per Slot	
0	OOOR	OOOR	OOOR	N/A	N/A
1	0.1523	0	QPSK	1800	3624
2	0.2344	0		1800	3624
3	0.3770	2		2856	5640
4	0.6016	4		4480	8968
5	0.8770	6		6528	13064
6	1.1758	8		8712	17928
7	1.4766	11	16QAM	11016	22032
8	1.9141	13		14343	28680
9	2.4063	15		17928	35856
10	2.7305	18	64QAM	20496	40976
11	3.3223	20		25104	50184
12	3.9023	22		29192	58384
13	4.5234	24		33816	67584
14	5.1152	26		38936	77896
15	5.5547	28		42016	83976

NOTE 1: Number of DMRS REs includes the overhead of the DM-RS CDM groups without data.
NOTE 2: PDSCH is only scheduled on slots which are full DL.

Table A.3.5-4: Fixed Reference Channels for FR2 PMI reporting (16QAM)

Reference channel	M-FR2-A.3.5-3
Channel bandwidth (MHz)	100
Subcarrier spacing (kHz)	120
Allocated resource blocks	66
Number of consecutive PDSCH symbols	12
MCS table	64QAM
MCS index	13
Modulation	16QAM
Target Coding Rate	490/1024
Number of MIMO layers	1
Number of DMRS REs	24
Overhead for TBS determination	6
Information Bit Payload per Slot (bits)	14344
Transport block CRC per Slot (bits)	24
Number of Code Blocks per Slot	2
Binary Channel Bits Per Slot (bits)	30360

Annex B (normative): Environmental requirements for the BS equipment

B.1 General

For each test in the present document, the environmental conditions under which the IAB is to be tested are defined.

For OTA requirements where it is not possible to environmentally control the entire calibrated OTA chamber either localised control of the IAB hardware or alternative OTA measurements which are then related to the original specification are acceptable, see annex B.7.

B.2 Normal test environment

When a normal test environment is specified for a test, the test should be performed within the minimum and maximum limits of the conditions stated in table B.1.

Table B.1: Limits of conditions for normal test environment

Condition	Minimum	Maximum
Barometric pressure	86 kPa	106 kPa
Temperature	15 °C	30 °C
Relative humidity	20 %	85 %
Power supply	Nominal, as declared by the manufacturer	
Vibration	Negligible	

The ranges of barometric pressure, temperature and humidity represent the maximum variation expected in the uncontrolled environment of a test laboratory. If it is not possible to maintain these parameters within the specified limits, the actual values shall be recorded in the test report.

NOTE: This may, for instance, be the case for measurements of radiated emissions performed on an open field test site.

B.3 Extreme test environment

B.3.1 General

The manufacturer shall declare one of the following:

- 1) The equipment class for the equipment under test, as defined in the IEC 60 721-3-3 [19];
- 2) The equipment class for the equipment under test, as defined in the IEC 60 721-3-4 [20];
- 3) The equipment that does not comply with the mentioned classes, the relevant classes from IEC 60 721 [21] documentation for temperature, humidity and vibration shall be declared.

NOTE: Reduced functionality for conditions that fall outside of the standard operational conditions is not tested in the present document. These may be stated and tested separately.

B.3.2 Extreme temperature

When an extreme temperature test environment is specified for a test, the test shall be performed at the standard minimum and maximum operating temperatures defined by the manufacturer's declaration for the equipment under test.

Minimum temperature:

The test shall be performed with the environment test equipment and methods including the required environmental phenomena into the equipment, conforming to the test procedure of IEC 60 068-2-1 [22].

Maximum temperature:

The test shall be performed with the environmental test equipment and methods including the required environmental phenomena into the equipment, conforming to the test procedure of IEC 60 068-2-2 [23].

NOTE: It is recommended that the equipment is made fully operational prior to the equipment being taken to its lower operating temperature.

B.4 Vibration

When vibration conditions are specified for a test, the test shall be performed while the equipment is subjected to a vibration sequence as defined by the manufacturer's declaration for the equipment under test. This shall use the environmental test equipment and methods of inducing the required environmental phenomena in to the equipment, conforming to the test procedure of IEC 60 068-2-6 [24]. Other environmental conditions shall be within the ranges specified in annex B.2.

NOTE: The higher levels of vibration may induce undue physical stress in to equipment after a prolonged series of tests. The testing body should only vibrate the equipment during the RF measurement process.

B.5 Power supply

When extreme power supply conditions are specified for a test, the test shall be performed at the standard upper and lower limits of operating voltage defined by manufacturer's declaration for the equipment under test.

Upper voltage limit:

The equipment shall be supplied with a voltage equal to the upper limit declared by the manufacturer (as measured at the input terminals to the equipment). The tests shall be carried out at the steady state minimum and maximum temperature limits declared by the manufacturer for the equipment, to the methods described in IEC 60 068-2-1 [10] Test Ab/Ad and IEC 60 068-2-2 [11] Test Bb/Bd: Dry heat.

Lower voltage limit:

The equipment shall be supplied with a voltage equal to the lower limit declared by the manufacturer (as measured at the input terminals to the equipment). The tests shall be carried out at the steady state minimum and maximum temperature limits declared by the manufacturer for the equipment, to the methods described in IEC 60 068-2-1 [10] Test Ab/Ad and IEC 60 068-2-2 [11] Test Bb/Bd: Dry heat.

B.6 Measurement of test environments

The measurement accuracy of the IAB test environments defined in annex B shall be:

Pressure: ± 5 kPa

Temperature: ± 2 degrees

Relative humidity: ± 5 %

DC voltage: ± 1.0 %

AC voltage: ± 1.5 %

Vibration: 10 %

Vibration frequency: 0.1 Hz

The above values shall apply unless the test environment is otherwise controlled and the specification for the control of the test environment specifies the uncertainty for the parameter.

B.7 OTA extreme test methods

B.7.1 Direct far field method

The IAB under test is placed inside a sealed RF transparent environmental enclosure, as showed in Figure B.7.1-1. This is connected to an environment control system which regulates the temperature inside the enclosure. The remaining equipment inside the OTA chamber (any suitable antenna test range chamber type is acceptable) is outside the environmental control and is at nominal temperature. Positioners, test antennas and all other OTA test equipment do not need to be specified over the extreme temperature range.

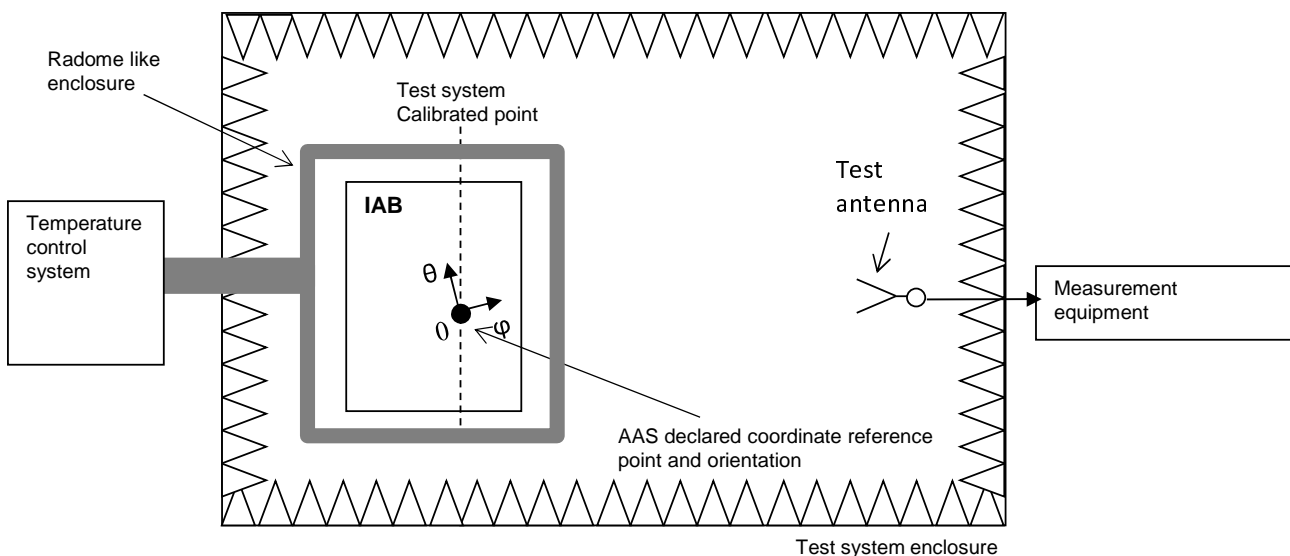

Figure B.7.1-1: Measurement set up for extreme conditions for EIRP accuracy using direct far field method

The presence of the environmental chamber inside the OTA chamber may affect the measurement accuracy due to additional reflections and refractions, also the loss through the environmental enclosure may not be consistent with direction as the path through the radome may vary with angle. Hence the system should be calibrated in all tested directions, frequencies and temperatures if necessary.

NOTE: Currently only a single direction is specified for extreme testing so a single calibration direction is sufficient.

Conformance may be demonstrated by measuring the difference between the nominal measurement and the extreme measurement (Δ_{sample}) or by measuring $P_{\text{max,c,EIRP, extreme}}$ directly.

Measure EIRP for any two orthogonal polarizations (denoted p_1 and p_2) and calculate total radiated transmit power for particular *beam direction pair* as $\text{EIRP} = \text{EIRP}_{p_1} + \text{EIRP}_{p_2}$.

B.7.2 Relative method

The IAB under test is placed inside a small (compared to a far field chamber) anechoic chamber which is both RF a screened and suitable for environmental conditioning. The RF conditions inside the chamber are absorptive and capable of dissipating the power of the IAB when radiating. A sample antenna or RF probe are placed in a location which gives a sample of the main beam EIRP but does not have to accurately measure the EIRP directly, instead the near-field response is measured. For this method test components are exposed to the full temperature range for example the test antenna/probe, cables, absorbers etc. may change as a function of temperature.

Using the relative method it is also necessary to measure the EIRP under nominal conditions using an appropriately calibrated far field (or near field) test range to obtain $P_{\max,c,EIRP}$.

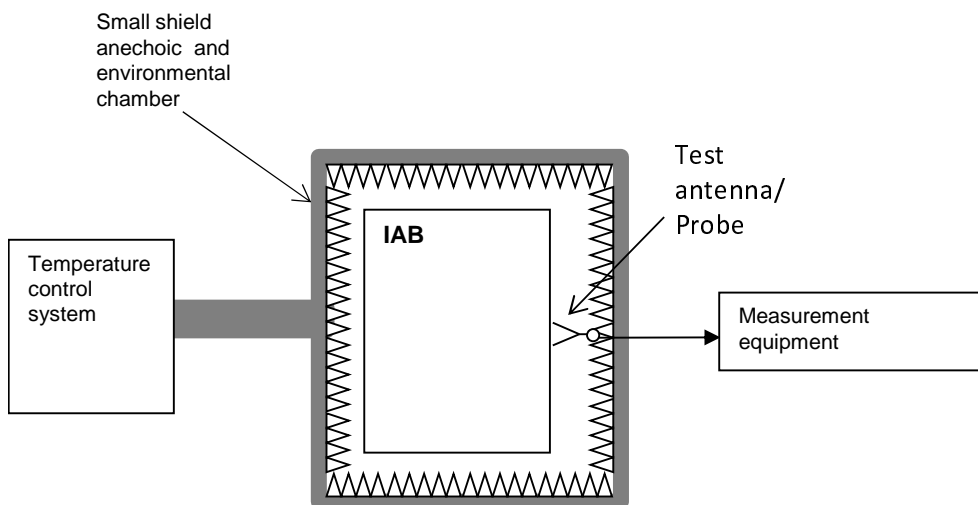

Figure B.7.2-1: Measurement set up for extreme conditions for EIRP accuracy using difference method

Measurements from the test antenna/probe are taken under nominal conditions and extreme conditions to calculate (Δ_{sample}). The difference between the nominal and extreme conditions (Δ_{sample}) is then used along with the nominal EIRP measurement ($P_{\max,c,EIRP}$) made in the appropriate far field or near field chamber and compared against the extreme requirement. As follows:

$$P_{\max,c,EIRP, \text{ extreme}} = P_{\max,c,EIRP} + \Delta_{\text{sample}}$$

Measure EIRP for any two orthogonal polarizations (denoted p1 and p2) and calculate total radiated transmit power for particular *beam direction pair* as $EIRP = EIRP_{p1} + EIRP_{p2}$.

Annex C (informative): Test tolerances and derivation of test requirements

The test requirements explicitly defined in the present document have been calculated by relaxing the minimum requirements of the core specification TS 38.174 [2] using the test tolerances (TT) defined here. When the TT value is zero, the test requirement will be the same as the minimum requirement. When the TT value is non-zero, the test requirements will differ from the minimum requirements, and the formula used for this relaxation is given in the following tables.

The TT_{OTA} values are derived from OTA Test System uncertainties, regulatory requirements and criticality to system performance. As a result, the TT_{OTA} values may sometimes be set to zero.

The TT_{OTA} values should not be modified for any reason e.g. to take account of commonly known OTA Test System errors (such as mismatch, cable loss, etc.).

Note that a formula for applying TT_{OTA} values is provided for all OTA tests, even those with a test tolerance of zero. This is necessary in the case where the OTA Test System uncertainty is greater than that allowed in clause 4.1.2. In this event, the excess error shall be subtracted from the defined TT_{OTA} value in order to generate the correct tightened test requirements as defined in this annex.

C.1 Measurement of transmitter

Table C.1-1: Derivation of test requirements (FR1 OTA transmitter tests)

Test	Minimum requirement in TS 38.174 [2]	Test Tolerance (TT _{OTA})	Test requirement in the present document
6.2 Radiated transmit power	See TS 38.174 [2], clause 9.2	Normal conditions: 1.1 dB, $f \leq 3.0$ GHz 1.3 dB, 3.0 GHz $< f \leq 4.2$ GHz 1.3 dB, 4.2 GHz $< f \leq 6.0$ GHz Extreme conditions: 2.5 dB, $f \leq 3.0$ GHz 2.6 dB, 3.0 GHz $< f \leq 4.2$ GHz 2.6 dB, 4.2 GHz $< f \leq 6.0$ GHz	Formula: Upper limit + TT, Lower limit – TT
6.3 IAB output power	See TS 38.174 [2], clause 9.3	1.4 dB, $f \leq 3.0$ GHz 1.5 dB, 3.0 GHz $< f \leq 4.2$ GHz 1.5 dB, 4.2 GHz $< f \leq 6.0$ GHz	Formula: Upper limit + TT, Lower limit – TT
[6.4.1.3] IAB-DU OTA output power dynamics	See TS 38.174 [2], clause 9.4.1	0.4 dB	Formula: Total power dynamic range – TT
[6.4.2] IAB-MT OTA output power dynamics	See TS 38.174 [2], clause 9.4.2	$f \leq 3.0$ GHz ± 0.7 dB, $BW \leq 40$ MHz ± 1.0 dB, 40 MHz $< BW \leq 100$ MHz 3.0 GHz $< f \leq 4.2$ GHz ± 1.0 dB, $BW \leq 40$ MHz ± 1.6 dB, 40 MHz $< BW \leq 100$ MHz 4.2 GHz $< f \leq 6.0$ GHz ± 1.3 dB, $BW \leq 20$ MHz ± 1.5 dB, 20 MHz $< BW \leq 40$ MHz ± 1.6 dB, 40 MHz $< BW \leq 100$ MHz	Formula: Total power dynamic range – TT
6.5.1 OTA transmitter OFF power	See TS 38.174 [2], clause 9.5.2	3.4 dB, $f \leq 3.0$ GHz 3.6 dB, 3.0 GHz $< f \leq 4.2$ GHz 3.6 dB, 4.2 GHz $< f \leq 6.0$ GHz	Formula: Minimum Requirement + TT
6.6.2.1 IAB-DU OTA frequency Error	See TS 38.174 [2], clause 9.6.1.1	12 Hz	Formula: Frequency Error limit + TT
6.6.2.2 IAB-MT OTA frequency error	See TS 38.174 [2], clause 9.6.1.2	± 15 Hz, $f \leq 3.0$ GHz ± 36 Hz, $f > 3.0$ GHz	Formula: Frequency Error limit + TT
6.6.3 OTA Modulation quality (EVM)	See TS 38.174 [2], clause 9.6.2	1%	Formula: EVM limit + TT
6.6.4 OTA time alignment error	See TS 38.174 [2], clause 9.6.3	25 ns	
6.7.2 OTA occupied bandwidth	See TS 38.174 [2], clause 9.7.2	0 Hz	Formula: Minimum Requirement + TT
6.7.3 OTA Adjacent Channel Leakage Power Ratio (ACLR)	See TS 38.174 [2], clause 9.7.3	Relative: 1.0 dB, $f \leq 3.0$ GHz 1.2 dB, 3.0 GHz $< f \leq 4.2$ GHz 1.2 dB, 4.2 GHz $< f \leq 6.0$ GHz Absolute: 0 dB	Formula: Relative limit - TT Absolute limit +TT
6.7.4 OTA operating band unwanted emissions	See TS 38.174 [2], clause 9.7.4	Offsets < 10 MHz 1.8 dB, $f \leq 3.0$ GHz 2 dB, 3.0 GHz $< f \leq 4.2$ GHz 2 dB, 4.2 GHz $< f \leq 6.0$ GHz Offsets ≥ 10 MHz 0 dB	Formula: Minimum Requirement + TT
6.7.5.2 General transmitter spurious emissions requirements Category A	See TS 38.174 [2], clause 9.7.5.2.2	0 dB	Formula: Minimum Requirement + TT

Test	Minimum requirement in TS 38.174 [2]	Test Tolerance (TT _{OTA})	Test requirement in the present document
6.7.5.2 General transmitter spurious emissions requirements Category B	See TS 38.174 [2], clause 9.7.5.2.2	0 dB	Formula: Minimum Requirement + TT
6.7.5.3 Additional spurious emissions requirements	See TS 38.174 [2], clause 9.7.5.2.3	2.6 dB, $f \leq 3$ GHz 3.0 dB, $3 \text{ GHz} < f \leq 4.2 \text{ GHz}$ 3.5 dB, $4.2 \text{ GHz} < f \leq 6 \text{ GHz}$ For co-existence with PHS 0 dB	Formula: Minimum Requirement + TT
6.7.5.4 Co-location with other base stations	See TS 38.174 [2], clause 9.7.5.2.4	3.1 dB, $f \leq 3.0\text{GHz}$ 3.3 dB, $3.0\text{GHz} < f \leq 4.2\text{GHz}$ 3.4 dB, $4.2\text{GHz} < f \leq 6.0\text{GHz}$	Formula: Minimum Requirement + TT
6.8 OTA transmitter intermodulation	See TS 38.174 [2], clause 9.8	0 dB	
NOTE: TT values are applicable for normal condition unless otherwise stated.			

Table C.1-2: Derivation of test requirements (FR2 OTA transmitter tests)

Test	Minimum requirement in TS 38.174 [2]	Test Tolerance (TT _{OTA})		Test requirement in the present document
		IAB-DU	IAB-MT	
6.2 Radiated transmit power	See TS 38.174 [2], clause 9.2	Normal conditions: 1.7 dB, 24.25GHz < f ≅ 29.5GHz 2.0 dB, 37GHz < f ≅ 43.5GHz Extreme conditions: 3.1 dB, 24.25GHz < f ≅ 29.5GHz 3.3 dB, 37GHz < f ≅ 43.5GHz	Normal condition: ±2.6 dB (24.25 – 29.5 GHz) ±2.6 dB (37 – 43.5 GHz) Extreme condition: ±3.7 dB (24.25 – 29.5 GHz) ±3.7 dB (37 – 43.5 GHz)	Formula: Upper limit + TT, Lower limit – TT
6.3 IAB output power	See TS 38.174 [2], clause 9.3	2.1 dB, 24.25GHz < f ≅ 29.5GHz 2.4 dB, 37GHz < f ≅ 43,5GHz	±2.8 dB (24.25 – 29.5 GHz) ±2.9 dB (37 – 43.5 GHz)	Formula: Upper limit + TT, Lower limit – TT
6.4.1.3 IAB-DU OTA output power dynamics	See TS 38.174 [2], clause 9.4.1.3	0.4 dB	N/A	Formula: Total power dynamic range – TT
6.4.2 IAB-MT OTA output power dynamics	See TS 38.174 [2], clause 9.4.2	N/A	±0.7 dB, BW ≤ 40MHz ±1.0 dB, 40MHz < f ≤ 100MHz	Formula: Total power dynamic range – TT
6.5.1 OTA transmitter OFF power	See TS 38.174 [2], clause 9.5.2	2.9 dB, 24.25GHz < f ≅ 29.5GHz 3.3 dB, 37GHz < f ≅ 43.5GHz		Formula: Minimum Requirement + TT
6.6.2 OTA frequency Error	See TS 38.174 [2], clause 9.6.1	12 Hz	[± 0.01 ppm]	Formula: Frequency Error limit + TT
6.6.3 OTA Modulation quality (EVM)	See TS 38.174 [2], clause 9.6.2	1 %		Formula: EVM limit + TT
6.6.4 OTA time alignment error	See TS 38.174 [2], clause 9.6.3	25 ns	N/A	
6.7.2 OTA occupied bandwidth	See TS 38.174 [2], clause 9.7.2	0 Hz		Formula: Minimum Requirement + TT
6.7.3 OTA Adjacent Channel Leakage Power Ratio (ACLR)	See TS 38.174 [2], clause 9.7.3	Relative: 2.3 dB, 24.25GHz < f ≅ 29.5GHz 2.6 dB, 37GHz < f ≅ 43.5GHz Absolute: 2.7 dB, 24.25GHz < f ≅ 29.5GHz 2.7 dB, 37GHz < f ≅ 43.5GHz	Relative ACLR: ±2.8 dB (24.25 – 29.5 GHz) ±2.9 dB (37 – 43.5 GHz) Absolute ACLR: ±2.9 dB (24.25 – 29.5 GHz) ±3.0 dB (37 – 43.5 GHz)	Formula: Relative limit - TT Absolute limit +TT

Test	Minimum requirement in TS 38.174 [2]	Test Tolerance (TT _{OTA})		Test requirement in the present document
		IAB-DU	IAB-MT	
6.7.4 OTA operating band unwanted emissions	See TS 38.174 [2], clause 9.7.4	0 MHz ≤ Δf < 0.1*BWcontiguous 2.7 dB, 24.25GHz < f ≅ 29.5GHz 2.7 dB, 37GHz < f ≅ 43.5GHz 0.1*BWcontiguous ≤ Δf < Δfmax 0 dB For co-existence with Earth Exploration Satellite Service 0 dB	0 MHz ≤ Δf < 0.1*BWcontiguous ±2.9 dB (24.25 – 29.5 GHz) ±3.0 dB (37 – 43.5 GHz) 0.1*BWcontiguous ≤ Δf < Δfmax 0 dB For co-existence with Earth Exploration Satellite Service 0 dB	Formula: Minimum Requirement + TT
6.7.5.2 General transmitter spurious emissions requirements Category A	See TS 38.174 [2], clause 9.7.5.2.2	0 dB		Formula: Minimum Requirement + TT
6.7.5.2 General transmitter spurious emissions requirements Category B	See TS 38.174 [2], clause 9.7.5.2.2	0 dB		Formula: Minimum Requirement + TT
6.7.5.4 OTA transmitter spurious emissions, additional requirements	See TS 38.174 [2], clause 9.7.5.3.3	For co-existence with Earth Exploration Satellite Service 0 dB		Formula: Minimum Requirement + TT

NOTE: TT values are applicable for normal condition unless otherwise stated.

C.2 Measurement of receiver

Table C.2-1: Derivation of test requirements (FR1 OTA receiver tests)

Test	Minimum requirement in TS 38.174 [2]	Test Tolerance (TT _{OTA})	Test requirement in the present document
7.2 OTA sensitivity	See TS 38.174 [2], clause 10.2	1.3 dB, $f \leq 3.0$ GHz 1.4 dB, $3.0 \text{ GHz} < f \leq 4.2 \text{ GHz}$ 1.6 dB, $4.2 \text{ GHz} < f \leq 6.0 \text{ GHz}$	Formula: Declared Minimum EIS + TT
7.3 OTA reference sensitivity level	See TS 38.174 [2], clause 10.3	1.3 dB, $f \leq 3.0$ GHz 1.4 dB, $3.0 \text{ GHz} < f \leq 4.2 \text{ GHz}$ 1.6 dB, $4.2 \text{ GHz} < f \leq 6.0 \text{ GHz}$	Formula: EIS _{REFSENS} + TT
7.4 OTA dynamic range	See TS 38.174 [2], clause 10.4	0.3 dB, $f \leq 6$ GHz	Formula: Wanted signal power + TT Interferer signal power unchanged.
7.5.1 OTA adjacent channel selectivity	See TS 38.174 [2], clause 10.5.1	0 dB	Formula: Wanted signal power + TT Interferer signal power unchanged.
7.5.2 In-band blocking (General)	See TS 38.174 [2], clause 10.5.2	0 dB	Formula: Wanted signal power + TT Interferer signal power unchanged.
7.5.2 In-band blocking (Narrowband)	See TS 38.174 [2], clause 10.5.2	0 dB	Formula: Wanted signal power + TT Interferer signal power unchanged.
7.6 OTA out-of-band blocking (General)	See TS 38.174 [2], clause 10.6	0 dB	Formula: Wanted signal power + TT Interferer signal power unchanged.
7.6 OTA out-of-band blocking (Co-location)	See TS 38.174 [2], clause 10.6	0 dB	Formula: Wanted signal power unchanged Interferer signal power - TT.
7.7 OTA receiver spurious emissions	See TS 38.174 [2], clause 10.7	0 dB	Formula: Minimum Requirement + TT
7.8 OTA receiver intermodulation	See TS 38.174 [2], clause 10.8	0 dB	Formula: Wanted signal power + TT Interferer signal power unchanged
7.9 OTA in-channel selectivity	See TS 38.174 [2], clause 10.9	1.7 dB, $f \leq 3.0$ GHz 2.1 dB, $3.0 \text{ GHz} < f \leq 4.2 \text{ GHz}$ 2.4 dB, $4.2 \text{ GHz} < f \leq 6.0 \text{ GHz}$	Formula: Wanted signal power + TT Interferer signal power unchanged

NOTE: TT values are applicable for normal condition unless otherwise stated.

Table C.2-2: Derivation of test requirements (FR2 OTA receiver tests)

Test	Minimum requirement in TS 38.174 [2]	Test Tolerance (TT _{OTA})		Test requirement in the present document
		IAB-DU	IAB-MT	
7.3 OTA reference sensitivity level	See TS 38.174 [2], clause 10.3	2.4 dB, 24.25 GHz < f ≤ 33.4 GHz 2.4 dB, 37 GHz < f ≤ 43.5 GHz	± 3.3 dB, 24.25 GHz < f ≤ 29.5 GHz ± 3.3 dB, 37 GHz < f ≤ 43.5 GHz	Formula: EISREFSENS+ TT
7.5.1 OTA adjacent channel selectivity	See TS 38.174 [2], clause 10.5.1	0 dB	0 dB	Formula: Wanted signal power + TT Interferer signal power unchanged.
7.5.2 In-band blocking	See TS 38.174 [2], clause 10.5.2	0 dB	0 dB	Formula: Wanted signal power + TT Interferer signal power unchanged.
7.6 OTA out-of-band blocking	See TS 38.174 [2], clause 10.6	0 dB	0 dB	Formula: Wanted signal power + TT Interferer signal power unchanged
7.7 OTA receiver spurious emissions	See TS 38.174 [2], clause 10.7	0 dB	0 dB	Formula: Minimum Requirement + TT
7.8 OTA receiver intermodulation	See TS 38.174 [2], clause 10.8	0 dB	N/A	Formula: Wanted signal power + TT Interferer signal power unchanged.
7.9 OTA in-channel selectivity	See TS 38.174 [2], clause 10.9	3.4 dB, 24.25 GHz < f ≤ 33.4 GHz 3.4 dB, 37 GHz < f ≤ 43.5 GHz	N/A	Formula: Wanted signal power + TT Interferer signal power unchanged.
NOTE: TT values are applicable for normal condition unless otherwise stated.				

C.3 Measurement of performance requirements

C.3.1 IAB-DU Test Tolerances

Table C.3.1-1: Derivation of test requirements (FR1 and FR2 performance tests)

Test	Minimum Requirement in TS 38.174 [2]	Test Tolerance (TT_{OTA})	Test requirement in the present document
Performance requirements for PUSCH with transform precoding disabled	SNRs as specified	0.6 dB	Formula: $SNR + TT_{OTA}$ T-put limit unchanged
Performance requirements for PUSCH with transform precoding enabled	SNRs as specified	0.6 dB	Formula: $SNR + TT_{OTA}$ T-put limit unchanged
Performance requirements for UCI multiplexed on PUSCH	SNRs as specified	0.6 dB	Formula: $SNR + TT_{OTA}$ BLER limit unchanged
Performance requirements for PUCCH format 0	SNRs as specified	0.6 dB	Formula: $SNR + TT_{OTA}$ False ACK limit unchanged Correct ACK limit unchanged
Performance requirements for PUCCH format 1	SNRs as specified	0.6 dB	Formula: $SNR + TT_{OTA}$ False ACK limit unchanged False NACK limit unchanged Correct ACK limit unchanged
Performance requirements for PUCCH format 2	SNRs as specified	0.6 dB	Formula: $SNR + TT_{OTA}$ False ACK limit unchanged Correct ACK limit unchanged UCI BLER limit unchanged
Performance requirements for PUCCH format 3	SNRs as specified	0.6 dB	Formula: $SNR + TT_{OTA}$ UCI BLER limit unchanged
Performance requirements for PUCCH format 4	SNRs as specified	0.6 dB	Formula: $SNR + TT_{OTA}$ UCI BLER limit unchanged
Performance requirements for multi-slot PUCCH	SNRs as specified	0.6 dB	Formula: $SNR + TT_{OTA}$ False ACK limit unchanged False NACK limit unchanged Correct ACK limit unchanged
PRACH false alarm probability and missed detection	SNRs as specified	0.3 dB	Formula: $SNR + TT_{OTA}$ PRACH False detection limit unchanged PRACH detection limit unchanged

NOTE: TT values are applicable for normal condition unless otherwise stated.

C.3.2 IAB-MT Test Tolerances

C.3.2.1 Demodulation Performance

Table C.3.2.1-1: Derivation of Test Requirements (FR1 demodulation performance tests)

Test	Minimum Requirement in TS 38.174 [2]	Test Tolerance (TT)	Test requirement in the present document
Performance requirements for PDSCH	SNRs as specified	0.9 dB for > 10 Hz doppler 1.0 dB for 10Hz doppler	Formula: SNR + TT T-put limit unchanged
Performance requirements for PDCCH with 1 Tx antenna performance	SNRs as specified	1.0 dB	Formula: SNR + TT T-put limit unchanged
Performance requirements for PDCCH with 2 Tx antenna performance	SNRs as specified	0.9 dB	Formula: SNR + TT T-put limit unchanged

Table C.3.2.1-2: Derivation of Test Requirements (FR2 demodulation performance tests)

Test	Minimum Requirement in TS 38.174 [2]	Test Tolerance (TT)	Test requirement in the present document
Performance requirements for PDSCH	SNRs as specified	2Tx, Rank 1: 1.8 dB 2Tx, Rank 2: 1.7 dB for doppler < 100Hz 1.6 dB otherwise	Formula: SNR + TT T-put limit unchanged
Performance requirements for PDCCH with 1 Tx antenna	SNRs as specified	1Tx, rank1: 1.7 dB	Formula: SNR + TT T-put limit unchanged
Performance requirements for PDCCH with 2 Tx antenna	SNRs as specified	2Tx, rank1: 1.8 dB	Formula: SNR + TT T-put limit unchanged

C.3.2.2 Channel State Information Reporting

Table C.3.2.2-1: Derivation of Test Requirements (FR1 and FR2 CSI reporting tests)

Test	Minimum Requirement in TS 38.174 [2]	Test Tolerance (TT)	Test requirement in the present document
CQI reporting	SNRs as specified Limits as in the Test Procedure	SNR 0 dB γ 0.01	SNR unchanged
PMI reporting	SNRs as specified γ as specified	SNR 0 dB γ_1 0.01 γ_2 0.01	SNR unchanged γ -TT
RI reporting	SNRs as specified γ_1 or γ_2 as specified	SNR 0 dB γ 0.01	SNR unchanged γ_1 -TT or γ_2 -TT

Annex D (normative): Calibration

D.1 General

OTA test requirements specific and OTA measurement chamber specific calibration (and measurement) procedures were captured in TR 37.941 [25] for the following requirements sets:

- TX and Rx directional requirements
- In-band and out-of-band TRP requirements
- Co-location requirements
- In-band and out-of-band blocking requirements

All the calibrations procedures in TR 37.941 [25] for the BS are assumed to be also applicable to *IAB type 1-H* and *IAB type 1-O* for the FR1 frequency range (i.e. up to 6 GHz), as well as for *IAB type 2-O* for the FR2 frequency range, unless stated otherwise.

Annex E (informative): OTA measurement system set-up

E.1 Transmitter

E.1.1 Radiated transmit power, OTA output power dynamics, OTA transmitted signal quality, OTA occupied bandwidth, and OTA transmit ON/OFF power (*IAB type 2-0*)

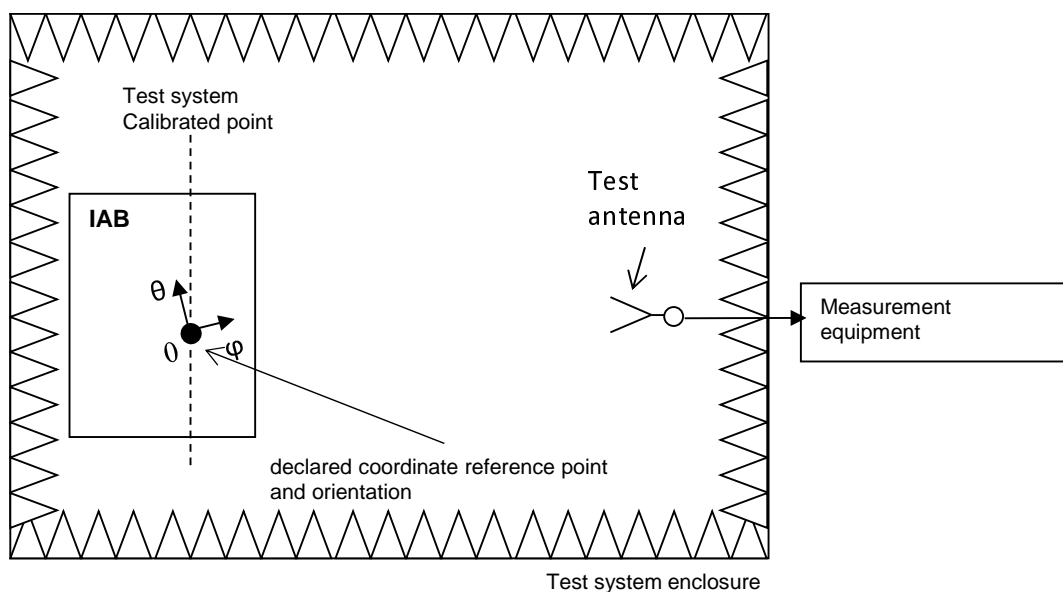

Figure E.1.1-1: Measurement set up for radiated transmit power, OTA output power dynamics, OTA transmitted signal quality, OTA occupied bandwidth, and OTA transmit ON/OFF power (*IAB type 2-0*)

The OTA chamber shown in figure E.1.1-1 is intended to be generic and can be replaced with any suitable OTA chamber (Far field anechoic chamber, CATR, Near field chamber, etc.)

E.1.2 OTA IAB output power, OTA ACLR, OTA operating band unwanted emissions

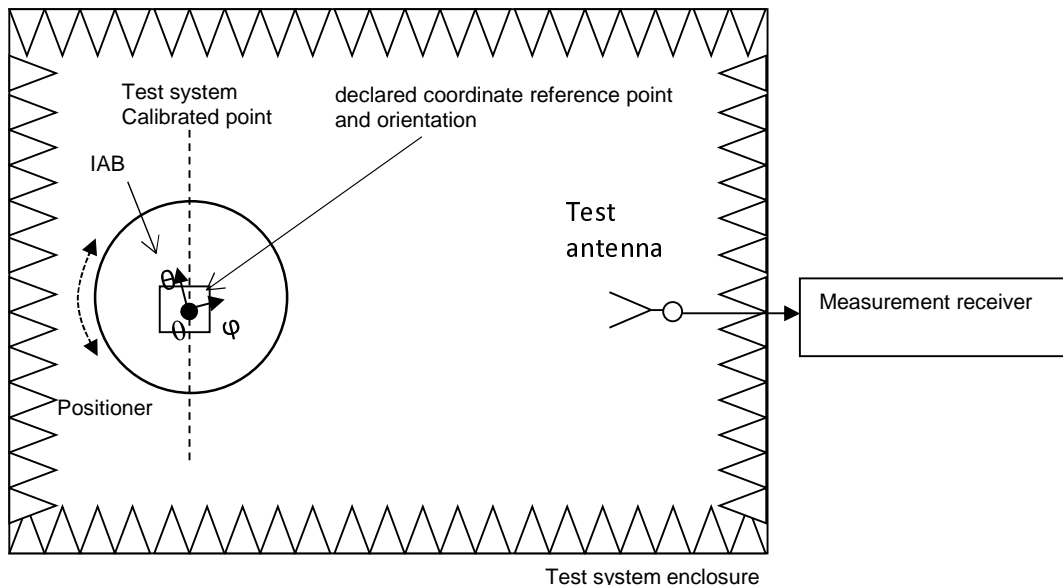

Figure E.1.2-1: Measurement set up for OTA IAB output power, OTA ACLR, OTA operating band unwanted emissions

The OTA chamber shown in figure E.1.2-1 is intended to be generic and can be replaced with any suitable OTA chamber (Far field anechoic chamber, CATR, Near field chamber, etc.)

E.1.3 OTA spurious emissions

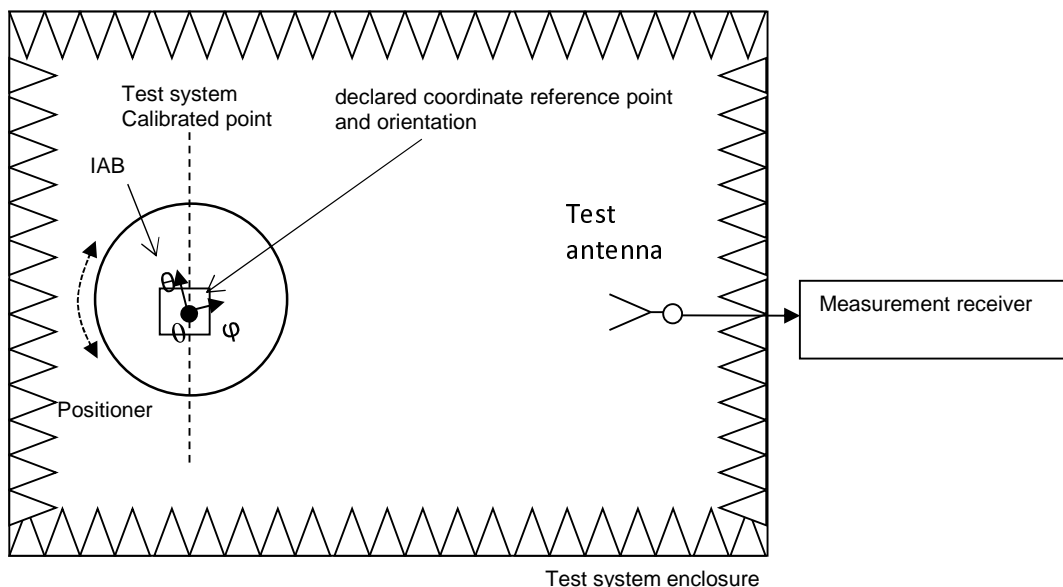

Figure E.1.3-1: Measurement set up for OTA spurious emissions

The OTA chamber shown in figure E.1.3-1 is intended to be generic and can be replaced with any suitable OTA chamber (Far field anechoic chamber, CATR, etc.).

E.1.4 OTA co-location emissions, OTA transmit ON/OFF power (IAB type 1-O)

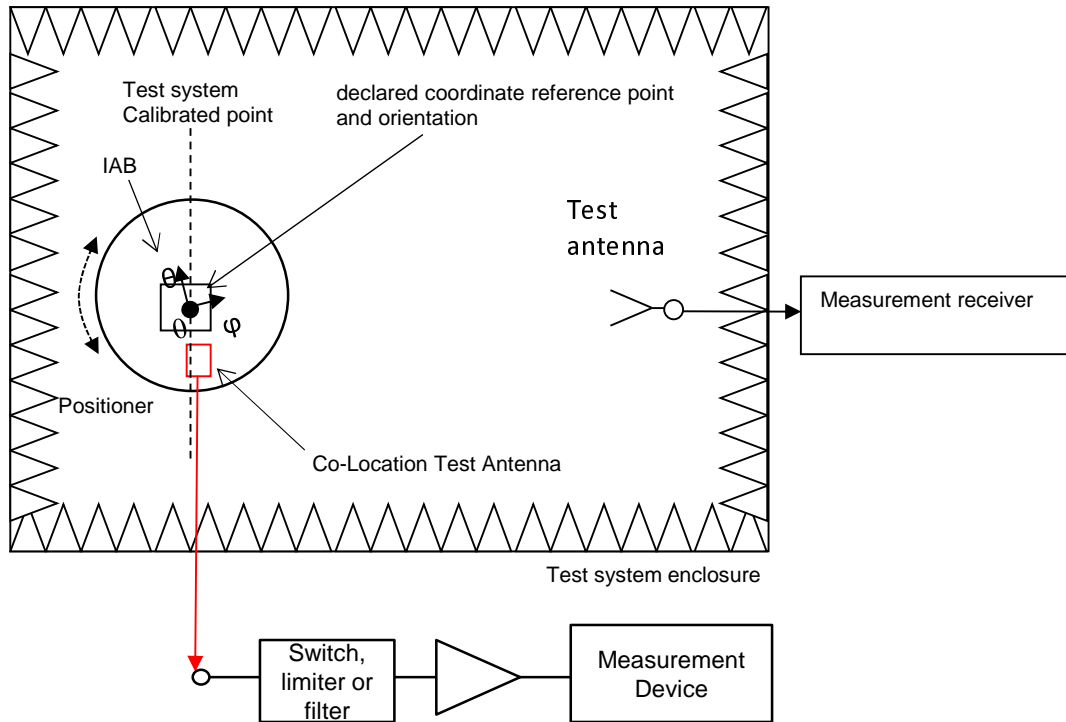

Figure E.1.4-1: Measurement set up for OTA co-location emissions, OTA transmit ON/OFF power (IAB type 1-O)

The OTA chamber shown in figure E.1.4-1 is intended to be generic and can be replaced with any suitable OTA chamber (Far field anechoic chamber, CATR, Near field chamber, etc.)

E.1.5 OTA transmitter intermodulation

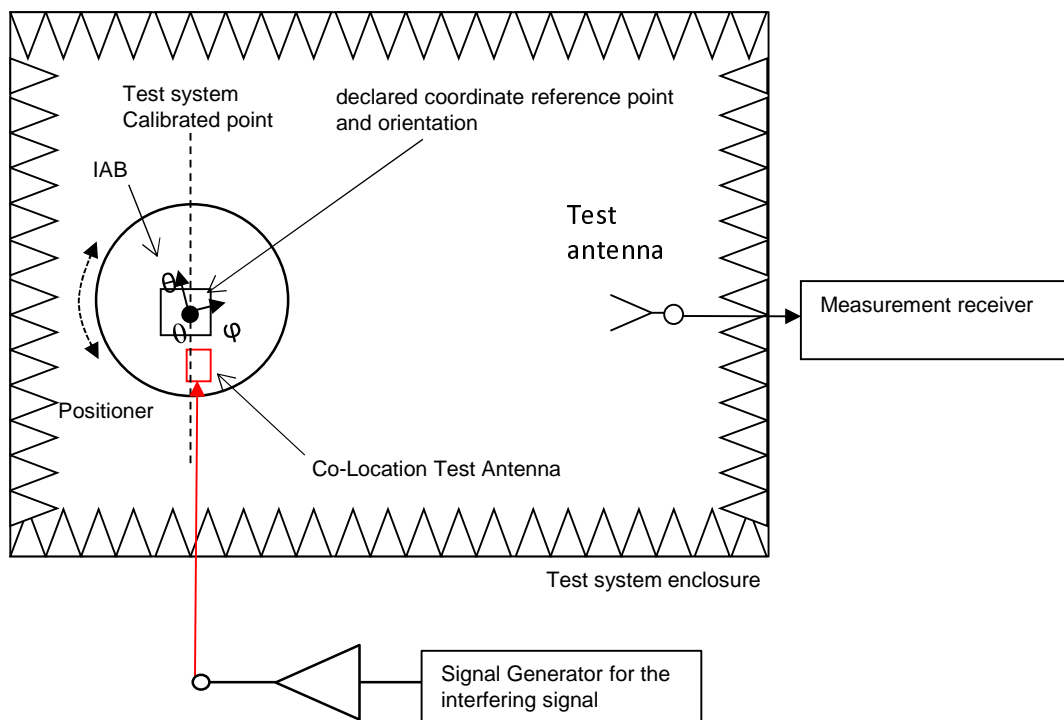

Figure E.1.5-1: Measurement set up for OTA transmitter intermodulation

The OTA chamber shown in figure E.1.5-1 is intended to be generic and can be replaced with any suitable OTA chamber (Far field anechoic chamber, CATR, etc.). When injecting the interferer signal into the CLTA ports, a splitter might be needed. For testing emission far out-of-band an additional test antenna might be needed.

E.2 Receiver

E.2.1 OTA sensitivity and OTA reference sensitivity level

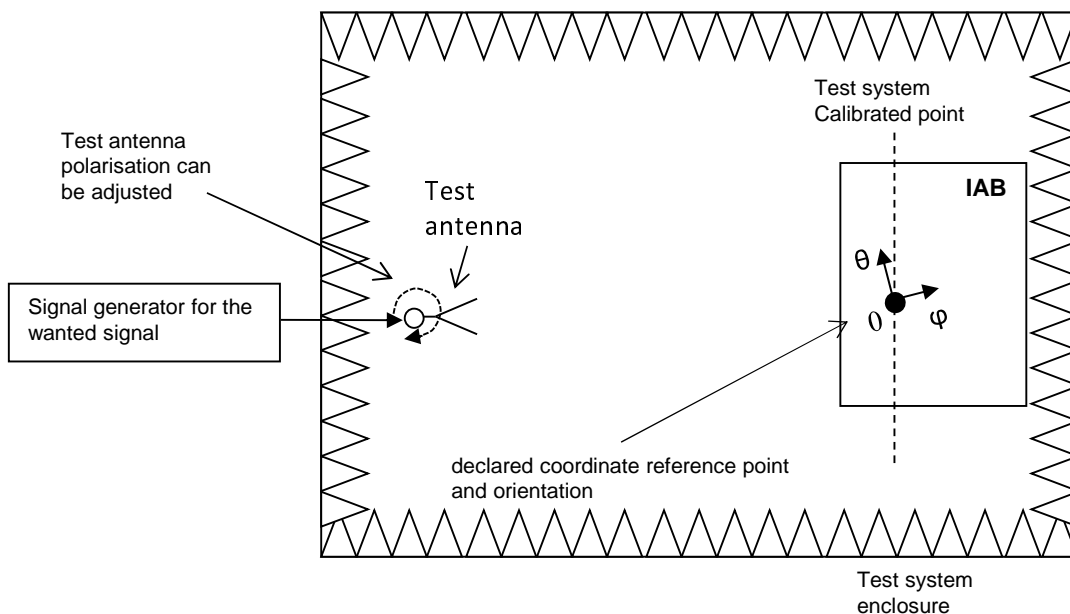

Figure E.2.1-1: Measurement set up for OTA sensitivity and OTA reference sensitivity level

The OTA chamber shown in figure E.2.1-1 is intended to be generic and can be replaced with any suitable OTA chamber (Far field anechoic chamber, CATR, etc.).

E.2.2 OTA dynamic range

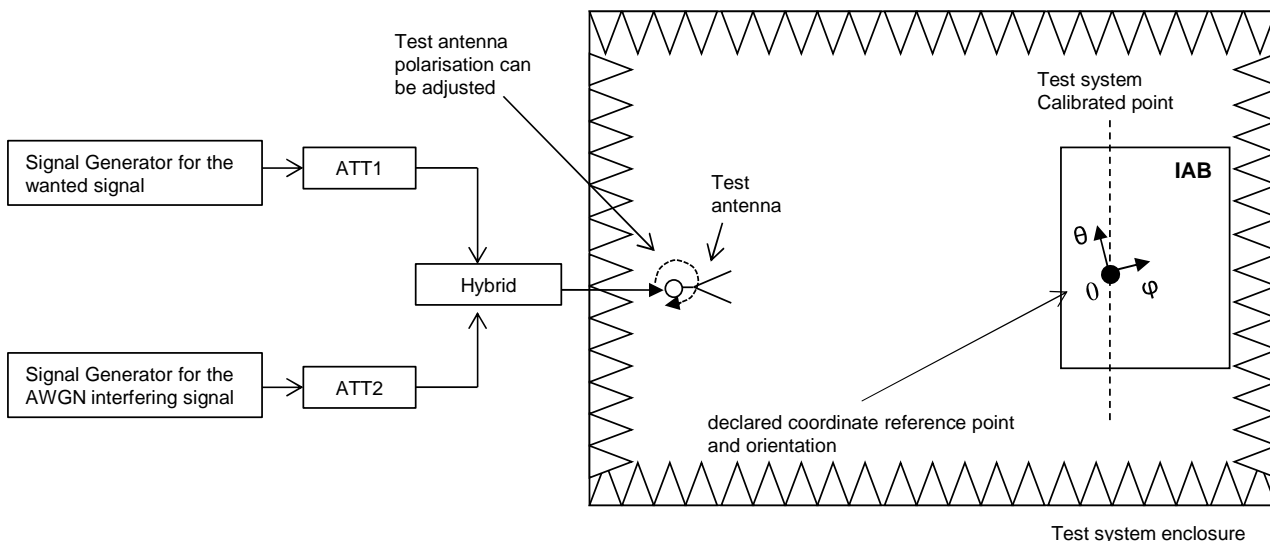

Figure E.2.2-1: Measurement set up for OTA dynamic range

The OTA chamber shown in figure E.2.2-1 is intended to be generic and can be replaced with any suitable OTA chamber (Far field anechoic chamber, CATR, etc.).

E.2.3 OTA adjacent channel selectivity, general OTA blocking, and OTA narrowband blocking

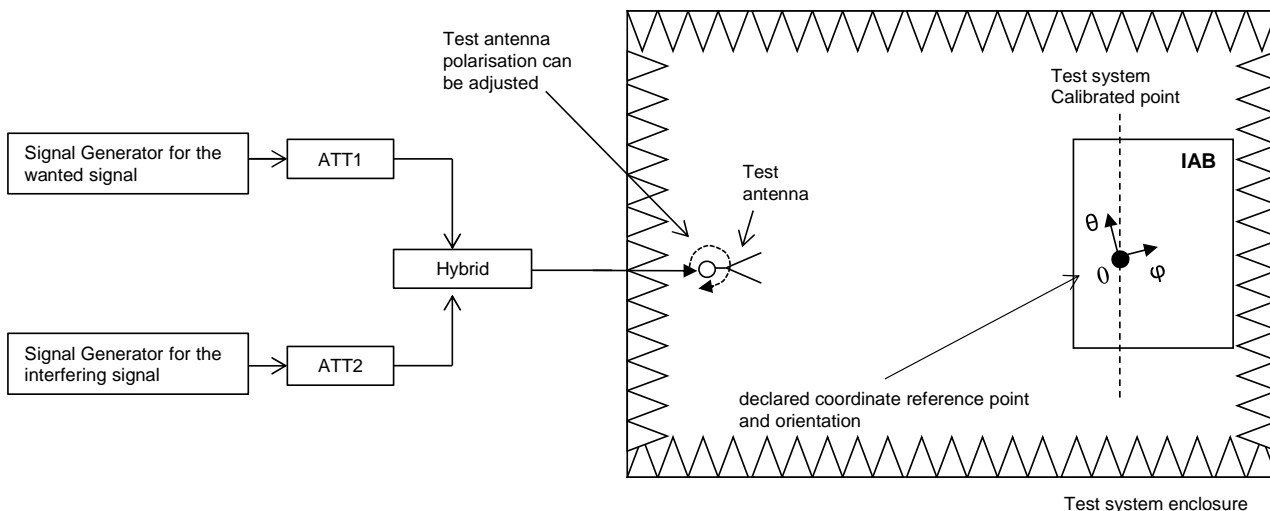

Figure E.2.3-1: Measurement set up for OTA ACS and OTA narrowband blocking

The OTA chamber shown in figure E.2.3-1 is intended to be generic and can be replaced with any suitable OTA chamber (Far field anechoic chamber, CATR, etc.).

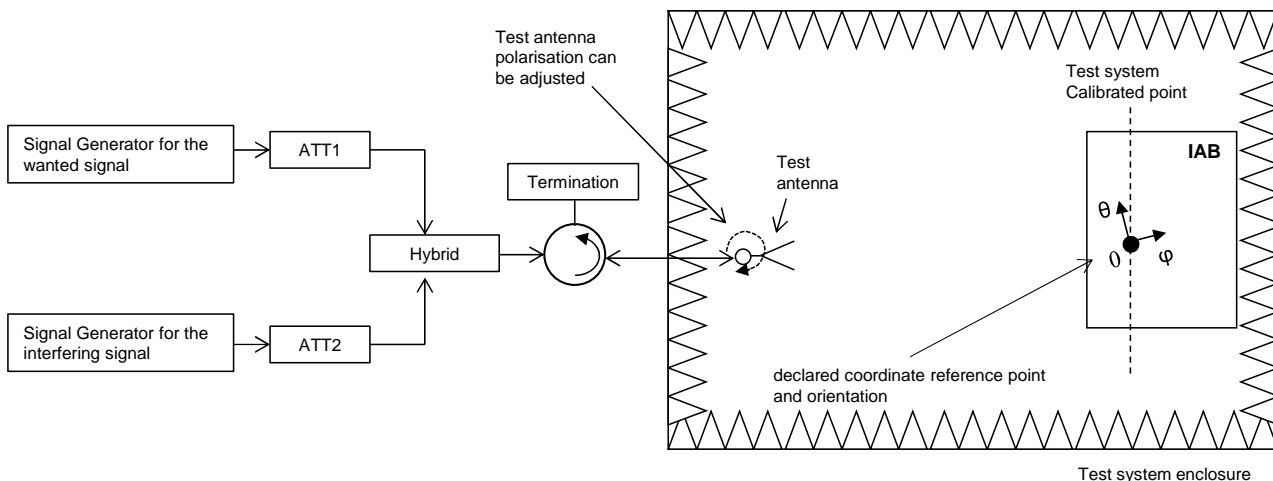

Figure E.2.3-2: Measurement set up for general OTA blocking

The OTA chamber shown in figure E.2.3-2 is intended to be generic and can be replaced with any suitable OTA chamber (Far field anechoic chamber, CATR, etc.).

E.2.4 OTA blocking

E.2.4.1 General OTA out-of-band blocking

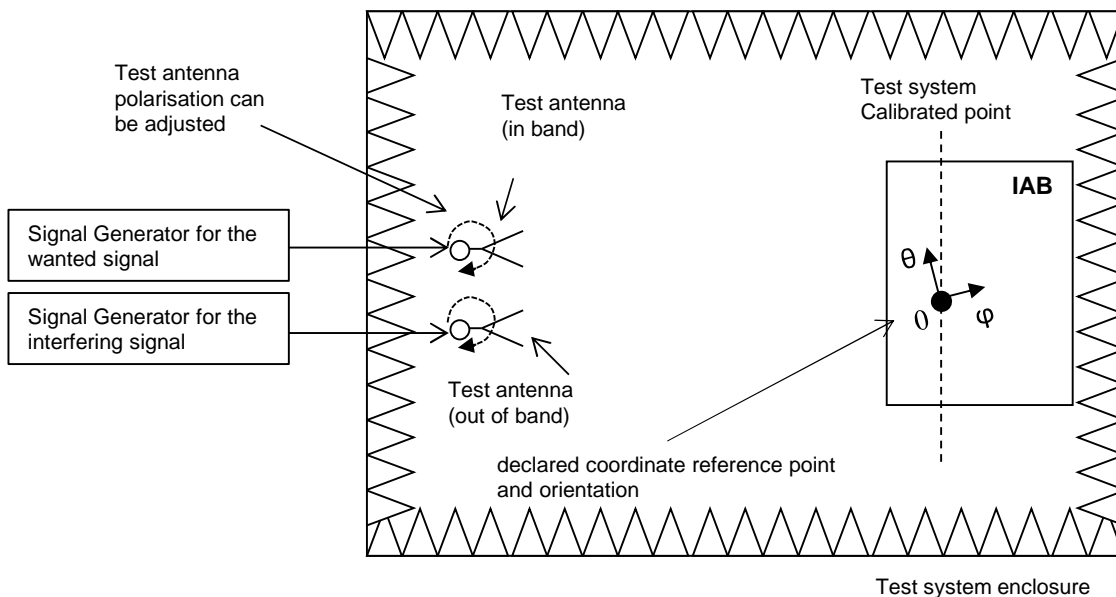

Figure E.2.4.1-1: Measurement set up for general OTA out-of-band blocking

The OTA chamber shown in figure E.2.4.1-1 is intended to be generic and can be replaced with any suitable OTA chamber (Far field anechoic chamber, CATR, etc.).

E.2.4.2 OTA co-location blocking

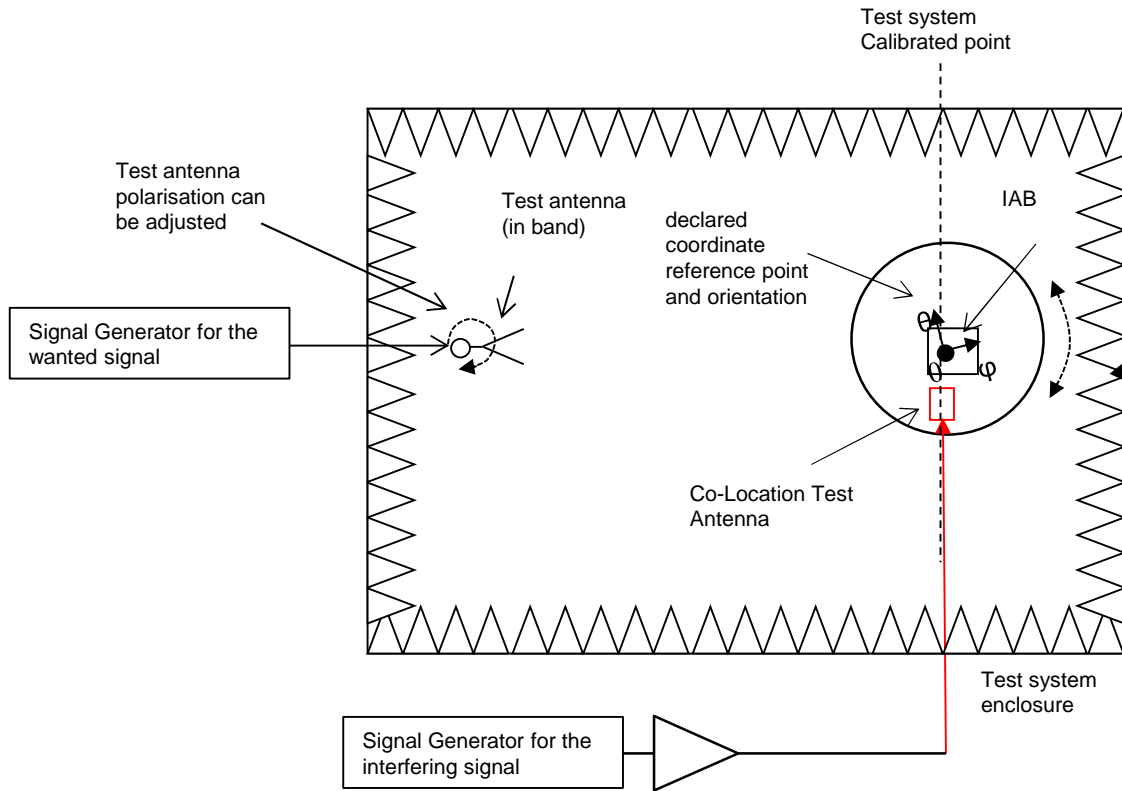

Figure E.2.4.2-1: Measurement set up for OTA co-location blocking

The OTA chamber shown in figure E.2.4.2-1 is intended to be generic and can be replaced with any suitable OTA chamber (Far field anechoic chamber, CATR, etc.). For testing blocking far out-of-band several CLTAs might be needed.

E.2.5 OTA receiver spurious emissions

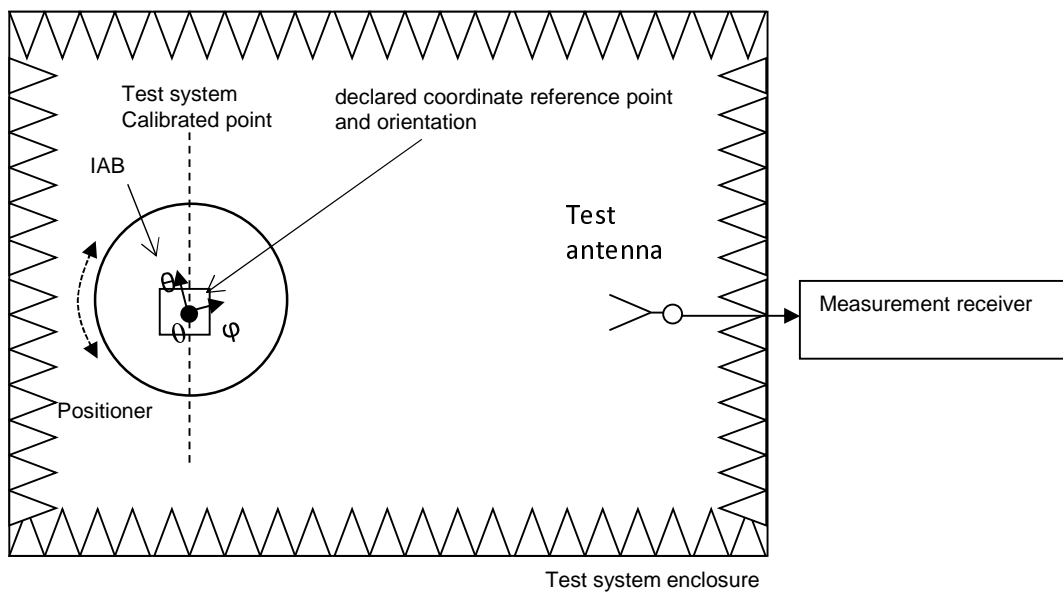

Figure E.2.5-1: Measurement set up for OTA receiver spurious emissions

The OTA chamber shown in figure E.2.5-1 is intended to be generic and can be replaced with any suitable OTA chamber (Far field anechoic chamber, CATR, etc.).

E.2.6 OTA receiver intermodulation

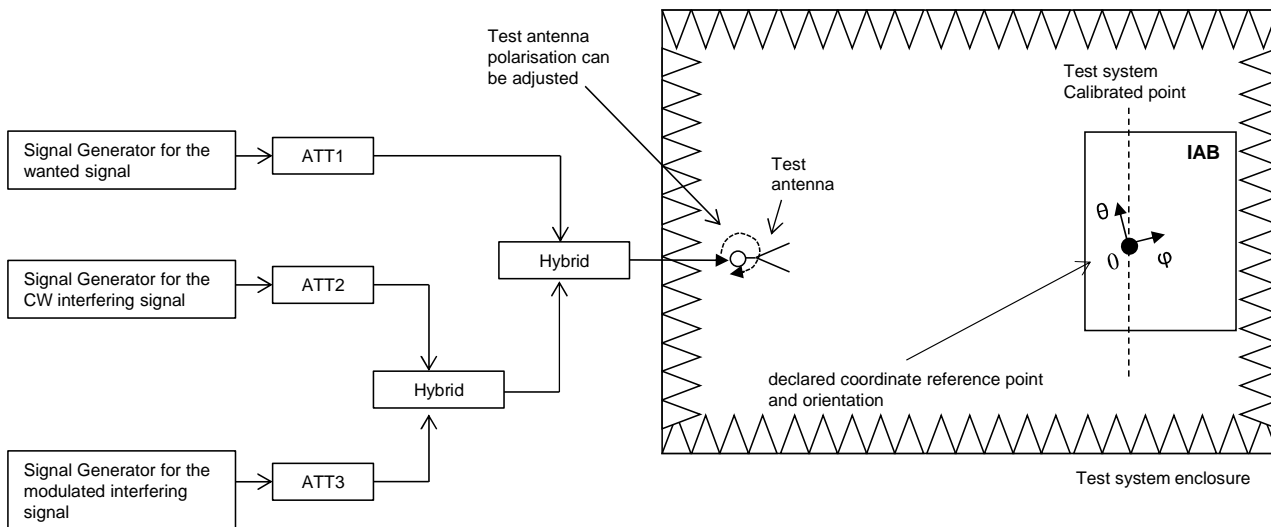

Figure E.2.6-1: Measurement set up for OTA receiver intermodulation

The OTA chamber shown in figure E.2.6-1 is intended to be generic and can be replaced with any suitable OTA chamber (Far field anechoic chamber, CATR, etc.).

E.2.7 OTA in-channel selectivity

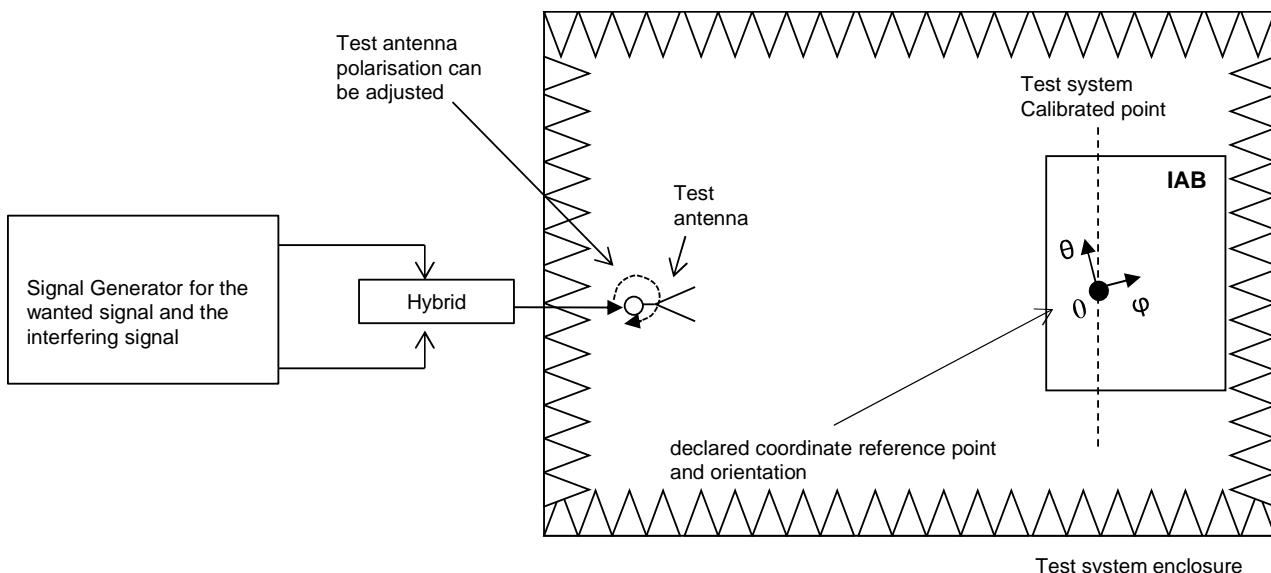

Figure E.2.7-1: Measurement set up for OTA in-channel selectivity

The OTA chamber shown in figure E.2.7-1 is intended to be generic and can be replaced with any suitable OTA chamber (Far field anechoic chamber, CATR, etc.).

E.3 Measurement set-up IAB-MT and IAB-DU performance requirements

E.3.1 PUSCH and PUCCH single antenna port in multipath fading

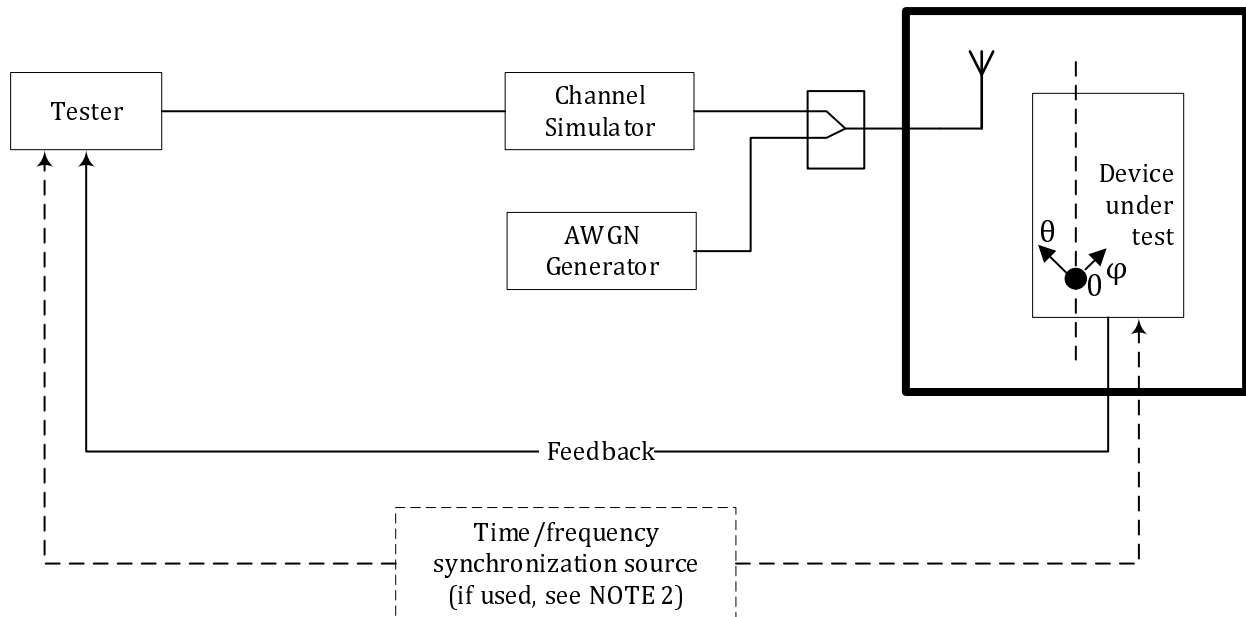

Figure E.3.1-1: Functional set-up for PUSCH and PUCCH single antenna port performance requirements in multipath fading

The OTA chamber shown in Figure E.3.1-1 is intended to be generic and can be replaced with any suitable OTA chamber (e.g. far field anechoic chamber, CATR, etc.).

NOTE 1: The feedback could be done as an RF feedback, either using NR channels or using other means, or as a digital feedback. The HARQ Feedback should be error free.

NOTE 2: In tests performed with signal generators, a synchronization signal may be provided between the IAB node and the signal generator, or a common (e.g., GNSS) source may be provided to both IAB node and the signal generator, to enable correct timing of the wanted signal. The method of synchronization with the TE is left to test implementation.

NOTE 3: It is left up to implementation how L1/L2 is configured for testing.

E.3.2 2 antenna port PUSCH, PDCCH, PDSCH in multi-path fading

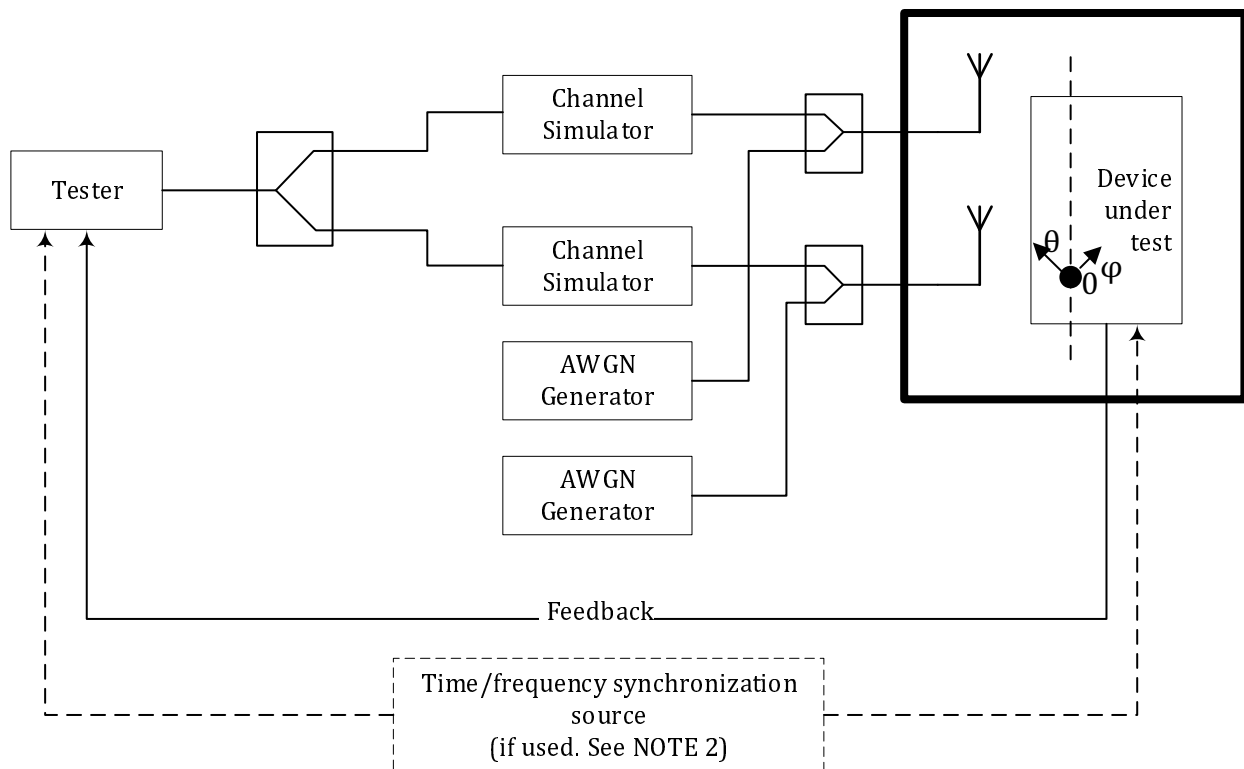

Figure E.3.2-1: Functional set-up for PUSCH, PDCCH, PDSCH performance requirements with Rx diversity (2 Rx case shown)

The OTA chamber shown in Figure E.3.2-1 is intended to be generic and can be replaced with any suitable OTA chamber (e.g. far field anechoic chamber, CATR, etc.).

NOTE 1: The feedback could be done as an RF feedback, either using NR channels or using other means, or as a digital feedback. The HARQ Feedback should be error free.

NOTE 2: In tests performed with signal generators, a synchronization signal may be provided between the IAB node and the signal generator, or a common (e.g., GNSS) source may be provided to both IAB node and the signal generator, to enable correct timing of the wanted signal. The method of synchronization with the TE is left to test implementation.

NOTE 3: It is left up to implementation how L1/L2 is configured for testing.

E.3.3 PUSCH, PRACH, CSI in static AWGN

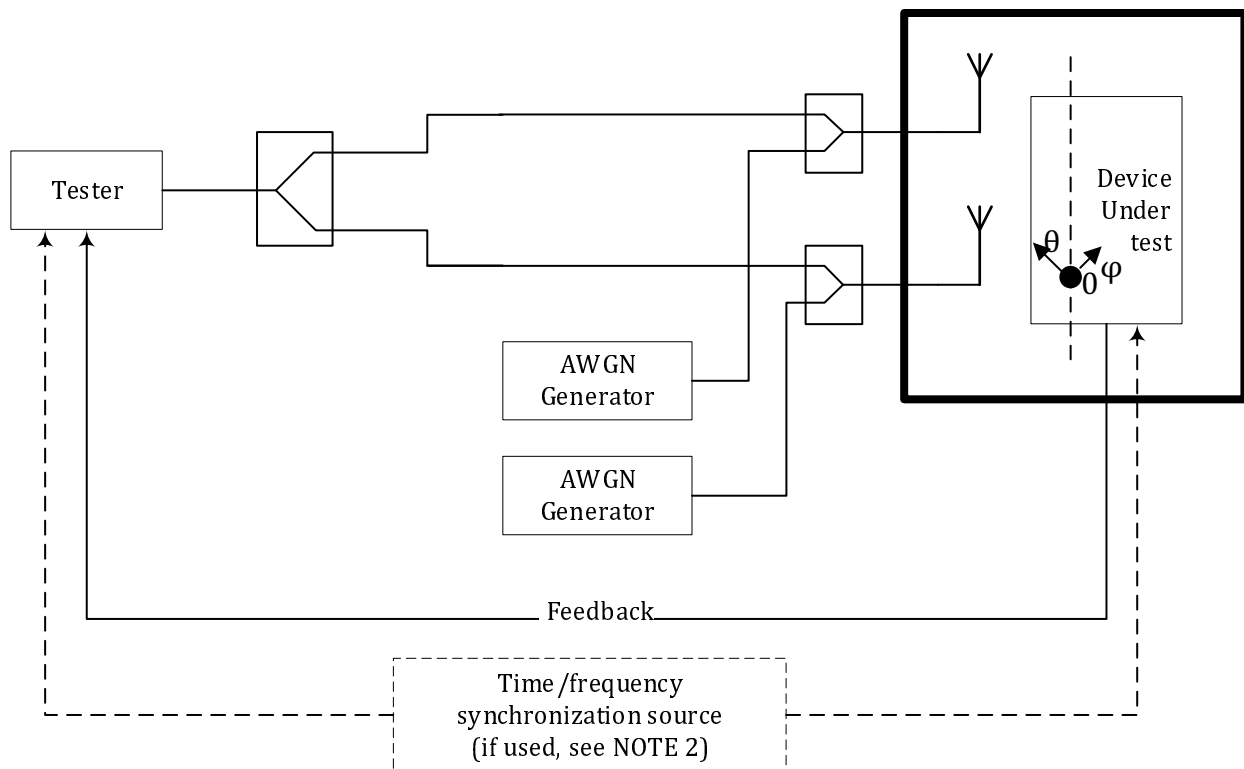

Figure E.3.3-1: Functional set-up for PUSCH, PRACH, CSI reporting performance requirements in static AWGN channel with Rx diversity (2 Rx case shown)

The OTA chamber shown in Figure E.3.3-1 is intended to be generic and can be replaced with any suitable OTA chamber (e.g. far field anechoic chamber, CATR, etc.).

NOTE 1: The feedback could be done as an RF feedback, either using NR channels or using other means, or as a digital feedback. The HARQ Feedback should be error free.

NOTE 2: In tests performed with signal generators, a synchronization signal may be provided between the IAB node and the signal generator, or a common (e.g., GNSS) source may be provided to both IAB node and the signal generator, to enable correct timing of the wanted signal. The method of synchronization with the TE is left to test implementation.

NOTE 3: It is left up to implementation how L1/L2 is configured for testing.

Annex F (normative):
Void

Annex G (informative): Transmitter spatial emissions declaration

G.1 General

The transmitter spatial emission declaration is an optional declaration which provides additional information on the power level of emission in the intended (in cell) spatial directions and the unintended (out of cell) spatial directions. The declarations are only valid when the beam is configured in one of the EIRP conformance directions.

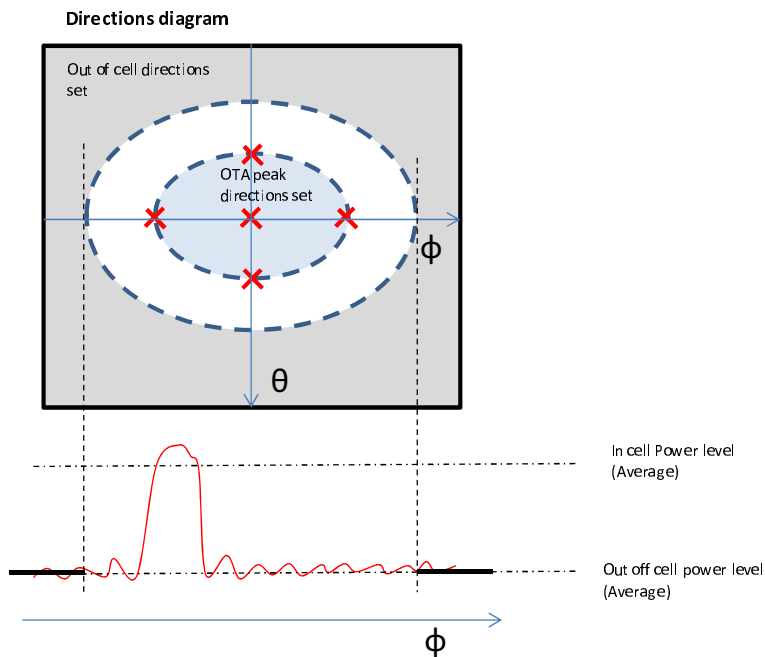

Figure G.1-1: Example of out of cell directions set and declared single beam at a single extreme steering direction

The declaration of unwanted spatial emission may in many circumstances not directly relate to system performance on its own. This is because it is often not possible to differentiate wanted and unwanted radiation, and furthermore because the benefits of optimizing beamforming performance may outweigh the impacts of "unwanted" radiation, leading to systems with apparently higher unwanted radiation also providing superior throughput performance. System performance should additionally be characterized taking all factors into account.

G.2 Declarations

Table G.2-1: Optional manufacturer declarations

Declaration identifier	Declaration	Description
Dxx.1	Out of cell directions set	The set of directions which are outside the intended directions of radiation or outside the wanted cell. Declared per operating band.
Dxx.2	Out of cell power level	Declared in band average power inside each of the out of cell directions set(s) (DE.1) declared for each of the 5 conformance directions (D9.x)
Dxx.3	In cell power level	Declared in band average power outside the out of cell directions set(s) (DE.1) declared for each of the 5 conformance directions (D9.x)
Dxx.4	Average out of cell power level	Declared in band average power inside each of the out of cell directions set(s) (DE.1) averaged over the 5 conformance directions (D9.x).
DE.5	Average in cell power level	Declared in band average power inside each of the out of cell directions set(s) (DE.1) averaged over the 5 conformance directions (D9.x)

NOTE 1: The declaration of unwanted spatial emission may in many circumstances not directly relate to system performance on its own. This is because it is often not possible to differentiate wanted and unwanted radiation, and furthermore because the benefits of optimizing beamforming performance may outweigh the impacts of "unwanted" radiation, leading to systems with apparently higher unwanted radiation also providing superior throughput performance. System performance should additionally be characterized taking all factors into account.

NOTE 2: The average out of cell power level reflects the impact of out of cell radiation on other cells more accurately than the out of cell power level for individual test beams.

Annex H (normative): Characteristics of the interfering signals

H.1 Characteristics of the interfering signals for IAB-DU

The Annex D in TS 38.104 [4] apply to FR2 IAB-DU.

H.2 Characteristics of the interfering signals for IAB-MT

The interfering signal shall be configured with PDSCH and PDCCH containing data and DM-RS symbols. Normal cyclic prefix is used. The data content shall be uncorrelated to the wanted signal and modulated according to clause 7 of TS 38.211 [7]. Mapping of PDSCH modulation to receiver requirement are specified in table E.2-1.

Table E.2-1: Modulation of the interfering signal

Receiver requirement	Modulation
Adjacent channel selectivity and narrow-band blocking	QPSK
General blocking	QPSK
Receiver intermodulation	QPSK

Annex I (normative): TRP measurement procedures

The Annex I in TS38.141-2[6] applies to IAB.

Annex J (normative): Propagation conditions

J.1 Static propagation condition

The propagation for the static performance measurement is an Additive White Gaussian Noise (AWGN) environment. No fading or multi-paths exist for this propagation model.

J.1.1 IAB-MT Receiver with 2 Rx

For 1 port transmission the channel matrix is defined in the frequency domain by:

$$\mathbf{H} = \begin{pmatrix} 1 \\ 1 \end{pmatrix}.$$

For 2 port transmission the channel matrix is defined in the frequency domain by:

$$\mathbf{H} = \begin{pmatrix} 1 & j \\ 1 & -j \end{pmatrix}.$$

For 4 port transmission the channel matrix is defined in the frequency domain by:

$$\mathbf{H} = \begin{bmatrix} 1 & 1 & j & j \\ 1 & 1 & -j & -j \end{bmatrix}$$

For 8 port transmission the channel matrix is defined in the frequency domain by:

$$\mathbf{H} = \begin{bmatrix} 1 & 1 & 1 & 1 & j & j & j & j \\ 1 & 1 & 1 & 1 & -j & -j & -j & -j \end{bmatrix}$$

J.2 Multi-path fading propagation conditions

The multipath propagation conditions consist of several parts:

- A delay profile in the form of a "tapped delay-line", characterized by a number of taps at fixed positions on a sampling grid. The profile can be further characterized by the r.m.s. delay spread and the maximum delay spanned by the taps.
- A combination of channel model parameters that include the Delay profile and the Doppler spectrum that is characterized by a classical spectrum shape and a maximum Doppler frequency.
- Different models are used for FR1 (410 MHz - 7.125GHz) and FR2 (24.25 GHz – 52.6 GHz).

J.2.1 Delay profiles

The delay profiles are simplified from the TR 38.901 [26] TDL models. The simplification steps are shown below for information. These steps are only used when new delay profiles are created. Otherwise, the delay profiles specified in annex J.2.1.1 and J.2.1.2 can be used as such.

Step 1: Use the original TDL model from TR 38.901 [26].

Step 2: Re-order the taps in ascending delays.

Step 3: Perform delay scaling according to the procedure described in clause 7.7.3 in TR 38.901 [26].

Step 4: Apply the quantization to the delay resolution 5 ns. This is done simply by rounding the tap delays to the nearest multiple of the delay resolution.

Step 5: If multiple taps are rounded to the same delay bin, merge them by calculating their linear power sum.

Step 6: If there are more than 12 taps in the quantized model, merge the taps as follows:

- Find the weakest tap from all taps (both merged and unmerged taps are considered)
- If there are two or more taps having the same value and are the weakest, select the tap with the smallest delay as the weakest tap.
- When the weakest tap is the first delay tap, merge taps as follows:
 - Update the power of the first delay tap as the linear power sum of the weakest tap and the second delay tap.
 - Remove the second delay tap.
- When the weakest tap is the last delay tap, merge taps as follows:
 - Update the power of the last delay tap as the linear power sum of the second-to-last tap and the last tap.
 - Remove the second-to-last tap.
- Otherwise:
 - For each side of the weakest tap, identify the neighbour tap that has the smaller delay difference to the weakest tap.
 - When the delay difference between the weakest tap and the identified neighbour tap on one side equals the delay difference between the weakest tap and the identified neighbour tap on the other side.
 - Select the neighbour tap that is weaker in power for merging.
 - Otherwise, select the neighbour tap that has smaller delay difference for merging.
 - To merge, the power of the merged tap is the linear sum of the power of the weakest tap and the selected tap.
 - When the selected tap is the first tap, the location of the merged tap is the location of the first tap. The weakest tap is removed.
 - When the selected tap is the last tap, the location of the merged tap is the location of the last tap. The weakest tap is removed.
 - Otherwise, the location of the merged tap is based on the average delay of the weakest tap and selected tap. If the average delay is on the sampling grid, the location of the merged tap is the average delay. Otherwise, the location of the merged tap is rounded towards the direction of the selected tap (e.g. 10 ns & 20 ns → 15 ns, 10 ns & 25 ns → 20 ns, if 25 ns had higher or equal power; 15 ns, if 10 ns had higher power). The weakest tap and the selected tap are removed.
- Repeat step 6 until the final number of taps is 12.

Step 7: Round the amplitudes of taps to one decimal (e.g. -8.78 dB → -8.8 dB)

Step 8: If the delay spread has slightly changed due to the tap merge, adjust the final delay spread by increasing or decreasing the power of the last tap so that the delay spread is corrected.

Step 9: Re-normalize the highest tap to 0 dB.

NOTE 1: Some values of the delay profile created by the simplification steps may differ from the values in tables J.2.1.1-2, J.2.1.1-3, J.2.1.1-4, and J.2.1.2-2 for the corresponding model.

NOTE 2: For Step 5 and Step 6, the power values are expressed in the linear domain using 6 digits of precision. The operations are in the linear domain.

J.2.1.1 Delay profiles for FR1

The delay profiles for FR1 are selected to be representative of low, medium and high delay spread environment. The resulting model parameters are specified in Table J.2.1.1-1 and the tapped delay line models are specified in tables J.2.1.1-2 to J.2.1.1-4.

Table J.2.1.1-1: Delay profiles for NR channel models

Model	Number of channel taps	Delay spread (r.m.s.)	Maximum excess tap delay (span)	Delay resolution
TDLA30	12	30 ns	290 ns	5 ns
TDLB100	12	100 ns	480 ns	5 ns
TDLC300	12	300 ns	2595 ns	5 ns

Table J.2.1.1-2: TDLA30 (DS = 30 ns)

Tap #	Delay (ns)	Power (dB)	Fading distribution
1	0	-15.5	Rayleigh
2	10	0	
3	15	-5.1	
4	20	-5.1	
5	25	-9.6	
6	50	-8.2	
7	65	-13.1	
8	75	-11.5	
9	105	-11.0	
10	135	-16.2	
11	150	-16.6	
12	290	-26.2	

Table J.2.1.1-3: TDLB100 (DS = 100ns)

Tap #	Delay (ns)	Power (dB)	Fading distribution
1	0	0	Rayleigh
2	10	-2.2	
3	20	-0.6	
4	30	-0.6	
5	35	-0.3	
6	45	-1.2	
7	55	-5.9	
8	120	-2.2	
9	170	-0.8	
10	245	-6.3	
11	330	-7.5	
12	480	-7.1	

Table J.2.1.1-4: TDLC300 (DS = 300 ns)

Tap #	Delay (ns)	Power (dB)	Fading distribution
1	0	-6.9	Rayleigh
2	65	0	
3	70	-7.7	
4	190	-2.5	
5	195	-2.4	
6	200	-9.9	
7	240	-8.0	
8	325	-6.6	
9	520	-7.1	
10	1045	-13.0	
11	1510	-14.2	
12	2595	-16.0	

J.2.1.2 Delay profiles for FR2

The delay profiles for FR2 are specified in J.2.1.2-1 and the tapped delay line models are specified in table J.2.1.2-2.

Table J.2.1.2-1: Delay profiles for NR channel models

Model	Number of channel taps	Delay spread (r.m.s.)	Maximum excess tap delay (span)	Delay resolution
TDLA30	12	30 ns	290 ns	5 ns

Table J.2.1.2-2: TDLA30 (DS = 30 ns)

Tap #	Delay (ns)	Power (dB)	Fading distribution
1	0	-15.5	Rayleigh
2	10	0	
3	15	-5.1	
4	20	-5.1	
5	25	-9.6	
6	50	-8.2	
7	65	-13.1	
8	75	-11.5	
9	105	-11.0	
10	135	-16.2	
11	150	-16.6	
12	290	-26.2	

J.2.2 Combinations of channel model parameters

The propagation conditions used for the performance measurements in multi-path fading environment are indicated as a combination of a channel model name and a maximum Doppler frequency, i.e., TDLA<DS>-<Doppler>, TDLB<DS>-<Doppler> or TDLC<DS>-<Doppler> where '<DS>' indicates the desired delay spread and '<Doppler>' indicates the maximum Doppler frequency (Hz).

Table J.2.2-1 and J.2.2-2 show the propagation conditions that are used for the performance measurements in multi-path fading environment for low, medium and high Doppler frequencies for FR1 and FR2, respectively.

Table J.2.2-1: Channel model parameters for FR1

Combination name	Model	Maximum Doppler frequency
TDLA30-5	TDLA30	5 Hz
TDLA30-10	TDLA30	10 Hz
TDLB100-400	TDLB100	400 Hz
TDLC300-100	TDLC300	100 Hz

Table J.2.2-2: Channel model parameters for FR2

Combination name	Model	Maximum Doppler frequency
TDLA30-75	TDLA30	75 Hz
TDLA30-300	TDLA30	300 Hz

J.2.3 MIMO channel correlation matrices

The MIMO channel correlation matrices defined in J.2.3 apply for the antenna configuration using uniform linear arrays at both IAB-DU and IAB-MT and for the antenna configuration using cross polarized antennas.

J.2.3.1 MIMO correlation matrices using Uniform Linear Array (ULA)

The MIMO channel correlation matrices defined in J.2.3.1 apply for the antenna configuration using uniform linear array (ULA) at both IAB-DU and IAB-MT.

J.2.3.1.1 Definition of MIMO correlation matrices

Table J.2.3.1.1-1 defines the correlation matrix for the IAB-DU.

Table J.2.3.1.1-1: IAB-DU correlation matrix

One antenna	IAB-DU correlation $R_{gNB} = 1$
Two antennas	$R_{gNB} = \begin{pmatrix} 1 & \alpha \\ \alpha^* & 1 \end{pmatrix}$
Four antennas	$R_{gNB} = \begin{pmatrix} 1 & \alpha^{1/9} & \alpha^{4/9} & \alpha \\ \alpha^{1/9*} & 1 & \alpha^{1/9} & \alpha^{4/9} \\ \alpha^{4/9*} & \alpha^{1/9*} & 1 & \alpha^{1/9} \\ \alpha^* & \alpha^{4/9*} & \alpha^{1/9*} & 1 \end{pmatrix}$
Eight antennas	$R_{gNB} = \begin{pmatrix} 1 & \alpha^{1/49} & \alpha^{4/49} & \alpha^{9/49} & \alpha^{16/49} & \alpha^{25/49} & \alpha^{36/49} & \alpha \\ \alpha^{1/49*} & 1 & \alpha^{1/49} & \alpha^{4/49} & \alpha^{9/49} & \alpha^{16/49} & \alpha^{25/49} & \alpha^{36/49} \\ \alpha^{4/49*} & \alpha^{1/49*} & 1 & \alpha^{1/49} & \alpha^{4/49} & \alpha^{9/49} & \alpha^{16/49} & \alpha^{25/49} \\ \alpha^{9/49*} & \alpha^{4/49*} & \alpha^{1/49*} & 1 & \alpha^{1/49} & \alpha^{4/49} & \alpha^{9/49} & \alpha^{16/49} \\ \alpha^{16/49*} & \alpha^{9/49*} & \alpha^{4/49*} & \alpha^{1/49*} & 1 & \alpha^{1/49} & \alpha^{4/49} & \alpha^{9/49} \\ \alpha^{25/49*} & \alpha^{16/49*} & \alpha^{9/49*} & \alpha^{4/49*} & \alpha^{1/49*} & 1 & \alpha^{1/49} & \alpha^{4/49} \\ \alpha^{36/49*} & \alpha^{25/49*} & \alpha^{16/49*} & \alpha^{9/49*} & \alpha^{4/49*} & \alpha^{1/49*} & 1 & \alpha^{1/49} \\ \alpha^* & \alpha^{36/49*} & \alpha^{25/49*} & \alpha^{16/49*} & \alpha^{9/49*} & \alpha^{4/49*} & \alpha^{1/49*} & 1 \end{pmatrix}$

Table J.2.3.1.1-2 defines the correlation matrix for the IAB-MT:

Table J.2.3.1.1-2: IAB-MT correlation matrix

	One antenna	Two antennas	Four antennas
IAB-MT correlation	$R_{UE} = 1$	$R_{UE} = \begin{pmatrix} 1 & \beta \\ \beta^* & 1 \end{pmatrix}$	$R_{UE} = \begin{pmatrix} 1 & \beta^{1/9} & \beta^{4/9} & \beta \\ \beta^{1/9*} & 1 & \beta^{1/9} & \beta^{4/9} \\ \beta^{4/9*} & \beta^{1/9*} & 1 & \beta^{1/9} \\ \beta^* & \beta^{4/9*} & \beta^{1/9*} & 1 \end{pmatrix}$

Table J.2.3.1.1-3 defines the channel spatial correlation matrix R_{spat} . The parameters, α and β in table J.2.3.1.1-3 defines the spatial correlation between the antennas at the IAB-DU and IAB-MT respectively.

Table J.2.3.1.1-3: R_{spat} correlation matrices

1x2 case	$R_{spat} = R_{gNB} = \begin{bmatrix} 1 & \alpha \\ \alpha^* & 1 \end{bmatrix}$
1x4 case	$R_{spat} = R_{gNB} = \begin{pmatrix} 1 & \alpha^{1/9} & \alpha^{4/9} & \alpha \\ \alpha^{1/9*} & 1 & \alpha^{1/9} & \alpha^{4/9} \\ \alpha^{4/9*} & \alpha^{1/9*} & 1 & \alpha^{1/9} \\ \alpha^* & \alpha^{4/9*} & \alpha^{1/9*} & 1 \end{pmatrix}$
2x2 case	$R_{spat} = R_{UE} \otimes R_{gNB} = \begin{pmatrix} 1 & \beta \\ \beta^* & 1 \end{pmatrix} \otimes \begin{pmatrix} 1 & \alpha \\ \alpha^* & 1 \end{pmatrix} = \begin{pmatrix} 1 & \alpha & \beta & \beta\alpha \\ \alpha^* & 1 & \beta\alpha^* & \beta \\ \beta^* & \beta^*\alpha & 1 & \alpha \\ \beta^*\alpha^* & \beta^* & \alpha^* & 1 \end{pmatrix}$
2x4 case	$R_{spat} = R_{UE} \otimes R_{gNB} = \begin{pmatrix} 1 & \beta \\ \beta^* & 1 \end{pmatrix} \otimes \begin{pmatrix} 1 & \alpha^{1/9} & \alpha^{4/9} & \alpha \\ \alpha^{1/9*} & 1 & \alpha^{1/9} & \alpha^{4/9} \\ \alpha^{4/9*} & \alpha^{1/9*} & 1 & \alpha^{1/9} \\ \alpha^* & \alpha^{4/9*} & \alpha^{1/9*} & 1 \end{pmatrix}$
4x4 case	$R_{spat} = R_{UE} \otimes R_{gNB} = \begin{pmatrix} 1 & \beta^{1/9} & \beta^{4/9} & \beta \\ \beta^{1/9*} & 1 & \beta^{1/9} & \beta^{4/9} \\ \beta^{4/9*} & \beta^{1/9*} & 1 & \beta^{1/9} \\ \beta^* & \beta^{4/9*} & \beta^{1/9*} & 1 \end{pmatrix} \otimes \begin{pmatrix} 1 & \alpha^{1/9} & \alpha^{4/9} & \alpha \\ \alpha^{1/9*} & 1 & \alpha^{1/9} & \alpha^{4/9} \\ \alpha^{4/9*} & \alpha^{1/9*} & 1 & \alpha^{1/9} \\ \alpha^* & \alpha^{4/9*} & \alpha^{1/9*} & 1 \end{pmatrix}$

For cases with more antennas at either IAB-DU or IAB-MT or both, the channel spatial correlation matrix can still be expressed as the Kronecker product of R_{UE} and R_{gNB} according to $R_{spat} = R_{UE} \otimes R_{gNB}$.

J.2.3.1.2 MIMO correlation matrices at high, medium and low level

The α and β for different correlation types are given in table J.2.3.1.2-1.

Table J.2.3.1.2-1: Correlation for high, medium and low level

Low correlation		Medium correlation		High correlation	
α	β	α	β	α	β
0	0	0.9	0.3	0.9	0.9

The correlation matrices for high, medium and low correlation are defined in tables J.2.3.1.2-2, J.2.3.1.2-3 and J.2.3.1.2-4 as below.

The values in table J.2.3.1.2-2 have been adjusted for the 2x4 and 4x4 high correlation cases to ensure the correlation matrix is positive semi-definite after round-off to 4 digit precision. This is done using the equation:

$$\mathbf{R}_{high} = [\mathbf{R}_{spatial} + a\mathbf{I}_n] / (1+a)$$

Where the value "a" is a scaling factor such that the smallest value is used to obtain a positive semi-definite result. For the 2x4 high correlation case, a=0.00010. For the 4x4 high correlation case, a=0.00012.

The same method is used to adjust the 4x4 medium correlation matrix in table J.2.3.1.2-3 to ensure the correlation matrix is positive semi-definite after round-off to 4 digit precision with a =0.00012.

Table J.2.3.1.2-4: MIMO correlation matrices for low correlation

1x2 case	$R_{low} = \mathbf{I}_2$
1x4 case	$R_{low} = \mathbf{I}_4$
1x8 case	$R_{low} = \mathbf{I}_8$
2x2 case	$R_{low} = \mathbf{I}_4$
2x4 case	$R_{low} = \mathbf{I}_8$
2x8 case	$R_{low} = \mathbf{I}_{16}$
4x4 case	$R_{low} = \mathbf{I}_{16}$

In table J.2.3.1.2-4, \mathbf{I}_d is a $d \times d$ identity matrix.

NOTE: For completeness, the correlation matrices were defined for high, medium and low correlation but performance requirements exist only for low correlation.

J.2.3.2 Multi-antenna channel models using cross polarized antennas

The MIMO channel correlation matrices defined in J.2.3.2 apply to two cases as presented below:

- One TX antenna and multiple RX antennas case, with cross polarized antennas used at gNB
- Multiple TX antennas and multiple RX antennas case, with cross polarized antennas used at both UE and gNB

The cross-polarized antenna elements with +/-45 degrees polarization slant angles are deployed at gNB. For one TX antenna case, antenna element with +90 degree polarization slant angle is deployed at UE. For multiple TX antennas case, cross-polarized antenna elements with +90/0 degrees polarization slant angles are deployed at UE.

For the cross-polarized antennas, the N antennas are labelled such that antennas for one polarization are listed from 1 to N/2 and antennas for the other polarization are listed from N/2+1 to N, where N is the number of TX or RX antennas.

J.2.3.2.1 Definition of MIMO correlation matrices using cross polarized antennas

For the channel spatial correlation matrix, the following is used:

$$R_{spat} = P_{UL} (R_{UE} \otimes \Gamma_{UL} \otimes R_{gNB}) P_{UL}^T$$

Where

- R_{UE} is the spatial correlation matrix at the UE with same polarization,
- R_{gNB} is the spatial correlation matrix at the gNB with same polarization,
- Γ_{UL} is a polarization correlation matrix,
- P_{UL} is a permutation matrix, and
- $(\bullet)^T$ denotes transpose.

Table J.2.3.2.1-1 defines the polarization correlation matrix.

Table J.2.3.2.1-1 : Polarization correlation matrix

	One TX antenna	Multiple TX antennas
Polarization correlation matrix	$\Gamma_{UL} = \begin{bmatrix} 1 & -\gamma \\ -\gamma & 1 \end{bmatrix}$	$\Gamma_{UL} = \begin{bmatrix} 1 & -\gamma & 0 & 0 \\ -\gamma & 1 & 0 & 0 \\ 0 & 0 & 1 & \gamma \\ 0 & 0 & \gamma & 1 \end{bmatrix}$

The matrix P_{UL} is defined as

$$\mathbf{P}_{UL}(a,b) = \begin{cases} 1 & \text{for } a = (j-1)Nr + i \text{ and } b = 2(j-1)Nr + i, & i = 1, \dots, Nr, j = 1, \dots, \lceil Nt/2 \rceil \\ 1 & \text{for } a = (j-1)Nr + i \text{ and } b = 2(j - Nt/2)Nr - Nr + i, & i = 1, \dots, Nr, j = \lceil Nt/2 \rceil + 1, \dots, Nt \\ 0 & \text{otherwise} \end{cases}$$

where Nt and Nr is the number of TX and RX antennas respectively, and $\lceil \bullet \rceil$ is the ceiling operator.

The matrix P_{UL} is used to map the spatial correlation coefficients in accordance with the antenna element labelling system described in J.2.3.2.

J.2.3.2.2 Spatial correlation matrices at IAB-MT and IAB-DU sides

J.2.3.2.2.1 Spatial correlation matrices at IAB-MT side

For 1-antenna transmitter, $R_{UE} = 1$.

For 2-antenna transmitter using one pair of cross-polarized antenna elements, $R_{UE} = 1$.

For 4-antenna transmitter using two pairs of cross-polarized antenna elements, $R_{UE} = \begin{pmatrix} 1 & \beta \\ \beta^* & 1 \end{pmatrix}$.

J.2.3.2.2.2 Spatial correlation matrices at IAB-DU side

For 2-antenna receiver using one pair of cross-polarized antenna elements, $R_{gNB} = 1$.

For 4-antenna receiver using two pairs of cross-polarized antenna elements, $R_{gNB} = \begin{bmatrix} 1 & \alpha \\ \alpha^* & 1 \end{bmatrix}$.

For 8-antenna receiver using four pairs of cross-polarized antenna elements, $R_{gNB} = \begin{pmatrix} 1 & \alpha^{1/9} & \alpha^{4/9} & \alpha \\ \alpha^{1/9*} & 1 & \alpha^{1/9} & \alpha^{4/9} \\ \alpha^{4/9*} & \alpha^{1/9*} & 1 & \alpha^{1/9} \\ \alpha^* & \alpha^{4/9*} & \alpha^{1/9*} & 1 \end{pmatrix}$.

J.2.3.2.3 MIMO correlation matrices using cross polarized antennas

The values for parameters α , β and γ for low spatial correlation are given in table J.2.3.2.3-1.

Table J.2.3.2.3-1: Values for parameters α , β and γ

Low spatial correlation		
α	β	γ
0	0	0

NOTE 1: Value of α applies when more than one pair of cross-polarized antenna elements at gNB side.
 NOTE 2: Value of β applies when more than one pair of cross-polarized antenna elements at UE side.

The correlation matrices for low spatial correlation are defined in table J.2.3.2.3-2 as below.

Table J.2.3.2.3-2: MIMO correlation matrices for low spatial correlation

1x8 case	$R_{low} = \mathbf{I}_8$
2x8 case	$R_{low} = \mathbf{I}_{16}$

In table J.2.3.2.3-2, \mathbf{I}_d is a $d \times d$ identity matrix.

J.3 Physical signals, channels mapping and precoding

J.3.1 General

Unless otherwise stated, the transmission on antenna port(s) $p = p_b, p_b + 1, \dots, p_b + N_p - 1$ is defined by using a precoder matrix $W(i)$ of size $N_{ANT} \times N_p$, where N_{ANT} is the number of physical transmit antenna elements configured per test, N_p is the number of ports for a reference signal or physical channel configured per test, and p_b is the first port for that reference signal or physical channel as defined in clauses 7.3 and 7.4 in TS 38.211 [9]. This precoder takes as an input a block of signals for antenna port(s) $p = p_b, p_b + 1, \dots, p_b + N_p - 1$,

$y^{(p)}(i) = [y^{(p_b)}(i) \ y^{(p_b+1)}(i) \ \dots \ y^{(p_b+N_p-1)}(i)]^T$, $i = 0, 1, \dots, M_{\text{symb}}^{\text{ap}} - 1$, with $M_{\text{symb}}^{\text{ap}}$ being the number of modulation symbols per antenna port including the reference signal symbols, and generates a block of signals

$y_{bf}^{(p)}(i) = [y_{bf}^{(p)}(i) \ y_{bf}^{(p+1)}(i) \ \dots \ y_{bf}^{(p+N_p-1)}(i)]^T$ the elements of which are to be mapped onto the frequency-time index pair (k, l) as per the test configuration but transmitted on different physical antenna elements:

$$y_{bf}^{(p)}(i) = W(i)y^{(p)}(i)$$

For Clause 6 and 8, the transmission of PDCCH and PDCCH DMRS on antenna port $p = p_b$ is defined by using a precoder matrix $W(i)$ of size 2×1 . This precoder takes as an input a block of signals for antenna port(s) $p = p_b$,

$y^{(p)}(i) = y^{(p_b)}(i)$ and generates a block of signals $y_{bf}^{(p)}(i) = [y_{bf}^{(p)}(i) \ y_{bf}^{(\frac{N_{ANT}}{2})}(i)]^T$ the elements of which are to be

mapped onto the frequency-time index pair (k, l) as per the test configuration but transmitted on different physical antenna elements:

$$y_{bf}^{(p)}(i) = W(i)y^{(p)}(i)$$

The precoder matrix $W(i)$ is specific to the test case configuration $W(i)$ is defined in Clause 5.2.2.2 of TS 38.214 [24].

The transmission on PT-RS antenna port is associated (using same precoder) with the lowest indexed DM-RS antenna port among the DM-RS antenna ports assigned for the PDSCH.

The physical antenna elements are identified by indices $j = 0, 1, \dots, N_{ANT} - 1$, where N_{ANT} is the number of physical antenna elements configured per test.

Modulation symbols $a_{k,l}^{(p)}$ with $p \in \{0, 1, \dots, 1000\}$ (i.e. PSS, SSS, PBCH and DM-RS for PBCH) are directly mapped to first physical antenna element.

Modulation symbols $a_{k,l}$ for CSI-RS resources which configured for tracking with one port are directly mapped to first physical antenna element.

Modulation symbols $a_{k,l}$ for CSI-RS resources which configured for beam refinement with one port are directly mapped to first physical antenna element.

Modulation symbols $a_{k,l}^{(p)}$ for NZP CSI-RS which configured for CSI acquisition with

$p \in \{p_0, p_0 + 1, \dots, p_0 + N_{CSI} - 1\}$ are mapped to the physical antenna index $j = p - p_0$ where N_{CSI} is the number of NZP CSI-RS ports configured per test.

Annex K (informative): Measuring noise close to noise-floor

As the emission level seen by the measurement receiver (P_{UEM}) for co-location requirements are very low, it is suggested to measure relative noise change instead of absolute noise level. For the situation where the noise level is stable, the noise level change can be identified by a relative noise measurement method. This method measures the relative noise change extracted from when the test object is operating and when the power is disconnected. From the two measured noise levels the relative noise change can be determined. The relations between measured noise change δ_1 , noise floor N_0 and the relation to P_{UEM} with respect to the noise floor denoted δ_2 is visualized in the left drawing in figure K-1.

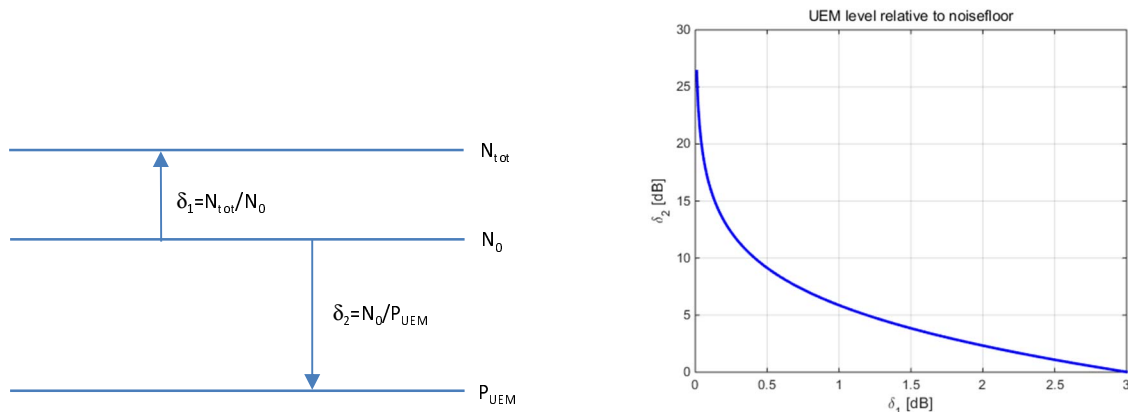

Figure K-1: Relative noise measurement

The absolute emission level in decibel scale is determined from a relative measurement of δ_1 as:

$$P_{UEM} = N_0 - \delta_2$$

where N_0 is the noise floor of the measurement receiver and δ_2 is plotted as function of δ_1 at the right in figure K-1. The absolute noise floor of the measurement receiver, including probe antenna, cables, filter and LNA is determined by a calibration procedure. The calibration will determine the absolute emission level (N_0) accuracy of measuring out-of-band unwanted emission close to the thermal noise floor.

Annex L (normative): In-channel TX tests for IAB-DU

The Annex H in TS 38.141-2 [6] applies to FR1 and FR2 IAB-DU.

Annex M (normative): In-channel TX tests for IAB-MT

M.0 Applicability

IAB-MT EVM can be determined by the process according to following alternatives:

- Alternative 1: Annex E in TS 38.521-1 [28] for FR1 IAB-MT and Annex E in TS 38.521-2 [29] for FR2 IAB-MT . Only CP-OFDM waveform of PUSCH is measured for IAB-MT; or
- Alternative 2: from Annex M.1 to Annex M.7.

M.1 General

The in-channel TX test enables the measurement of all relevant parameters that describe the In-channel quality of the output signal of the TX under test in a single measurement process.

The parameters describing the in-channel quality of a transmitter, however, are not necessarily independent. The algorithm chosen for description inside this annex places particular emphasis on the exclusion of all interdependencies among the parameters.

M.2 Basic principles

The process is based on the comparison of the actual output signal of the TX under test, received by an ideal receiver, with an ideal signal, that is generated by the measuring equipment and represents an ideal error free received signal. All signals are represented as equivalent (generally complex) baseband signals.

The description below uses numbers and illustrations as examples only. These numbers are taken from a TDD frame structure with normal CP length, 120 kHz SCS and a transmission bandwidth configuration of 400 MHz ($N_{RB} = 264$). The application of the text below, however, is not restricted to this parameter set.

M.2.1 Output signal of the TX under test

The output signal of the TX under test is acquired by the measuring equipment and stored for further processing. It is sampled at a sampling rate which is the product of the SCS and the *FFT size*, and it is named $z(v)$.

For FR1, *FFT size* is determined by the transmission bandwidth in TS 38.176-1 [3] table 6.5.3.5-2 for 15 kHz SCS, table 6.5.3.5-3 for 30 kHz SCS and table 6.5.3.5-4 for 60 kHz SCS.

For FR2, *FFT size* is determined by the transmission bandwidth in table 6.6.3.5.2-2 for 60 kHz SCS, and table 6.6.3.5.2-3 for 120 kHz SCS. In the time domain it comprises at least 10 ms. It is modelled as a signal with the following parameters:

- demodulated data content,
- carrier frequency,
- amplitude and phase for each subcarrier.

For the example in the annex, the *FFT size* is 4096 based on table 6.6.3.5.2-3. The sampling rate of 491.52 Msps is the product of the *FFT size* and SCS.

M.2.2 Ideal signal

Two types of ideal signals are defined:

The first ideal signal $i_1(v)$ is constructed by the measuring equipment according to the relevant TX specifications, using the following parameters:

- demodulated data content,
- nominal carrier frequency,
- nominal amplitude and phase for each subcarrier.

It is represented as a sequence of samples at the sampling rate determined from annex M.2.1 in the time domain. The structure of the signal is described in the test models.

The second ideal signal $i_2(v)$ is constructed by the measuring equipment according to the relevant TX specifications, using the following parameters for FR1 and FR2:

- nominal demodulation reference signal and nominal PT-RS if present (all other modulation symbols are set to 0 V),
- nominal carrier frequency,
- nominal amplitude and phase for each applicable subcarrier,
- nominal timing.

It is represented as a sequence of samples at the sampling rate determined from annex M.2.1 in the time domain.

M.2.3 Measurement results

The measurement results, achieved by the in-channel TX test are the following:

- Carrier frequency error.
- EVM.
- Resource element TX power.
- OFDM symbol TX power (OSTP).

Other side results are: residual amplitude- and phase response of the TX chain after equalisation.

M.2.4 Measurement points

The resource element TX power is measured after the FFT box as described in figure M.2.4-1 for FR1 and in figure M.2.4.2. The EVM shall be measured at the point after the FFT and a zero-forcing (ZF) equalizer in the receiver, as depicted in for FR1 in figure M.2.4-1 and for FR2 in figure M.2.4-2. The FFT window of $FFT\ size$ samples out of ($FFT\ size + cyclic\ prefix\ length$) samples in the time domain is selected in the "Remove CP" box.

For FR1, The $FFT\ size$ and the cyclic prefix length are obtained from TS 38.176-1 [3] table 6.5.3.5-2 for 15 kHz SCS, table 6.5.3.5-3 for 30 kHz SCS and table 6.5.3.5-4 for 60 kHz SCS.

For FR2, $FFT\ size$ and the cyclic prefix length is determined from table 6.6.3.5.2-2 for 60 kHz SCS, and table 6.6.3.5.2-3 for 120 kHz SCS.

In one subframe, there are two symbols with the length of the cyclic prefix larger than the values listed in TS 38.176-1 [3] tables 6.5.3.5-2, 6.5.3.5-3 and 6.5.3.5-4 for FR1 and table 6.6.3.5.2-2 and table 6.6.3.5.2-3 for FR2. Table M.2.4-1 lists the slot number and the symbol number and the formula how to compute the length of cyclic prefix for those two symbols according to the sampling rate.

Table M.2.4-1: Slot number and symbol number identifying the longer CP length for normal CP

SCS (kHz)	Frequency Range	# slots in subframe	Symbol # and slot # with longer CP	Longer CP length
15	FR1	1	(symbol 0, slot 0) (symbol 7, slot 0)	CP length + FFT size / 128
30		2	(symbol 0, slot 0) (symbol 0, slot 1)	CP length + FFT size / 64
60		4	(symbol 0, slot 0) (symbol 0, slot 2)	CP length + FFT size / 32
60	FR2	4	(symbol 0, slot 0) (symbol 0, slot 2)	CP length + FFT size / 32
120		8	(symbol 0, slot 0) (symbol 0, slot 4)	CP length + FFT size / 16

For the example used in the annex, the "Remove CP" box selects 4096 samples out of 4384 samples. Symbol 0 of slot 0 and slot 4 has 256 more samples in the cyclic prefix than the other symbols (the longer CP length = 544).

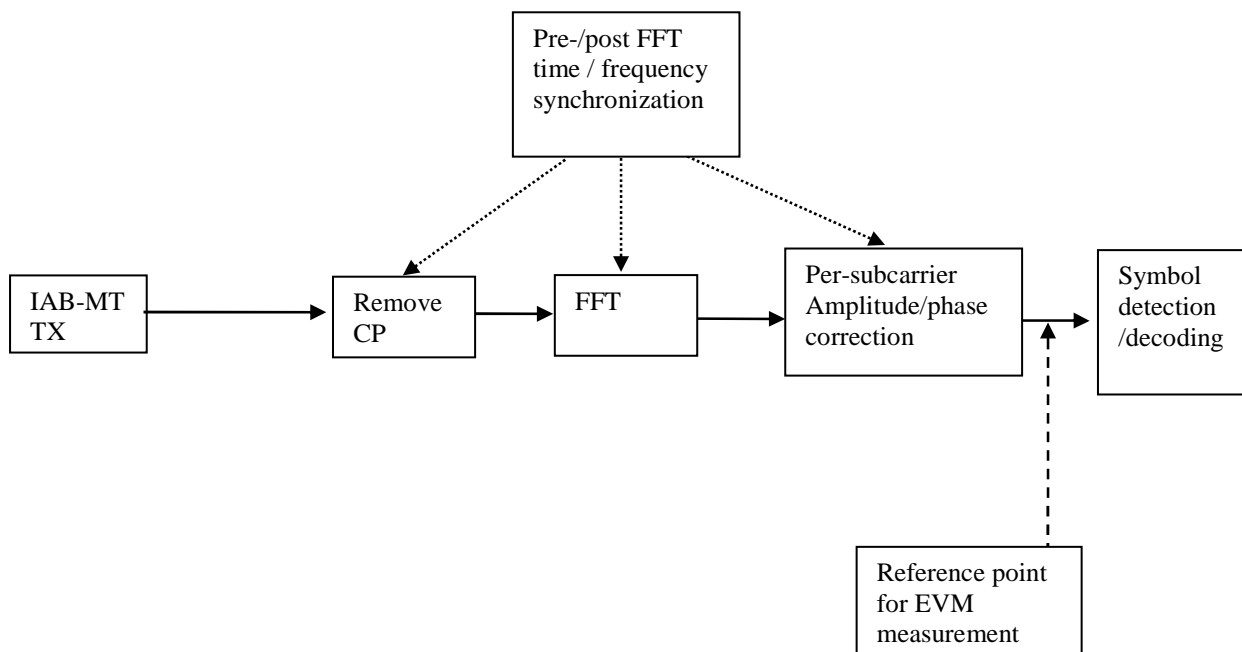

Figure M.2.4-1: Reference point for FR1 EVM measurements

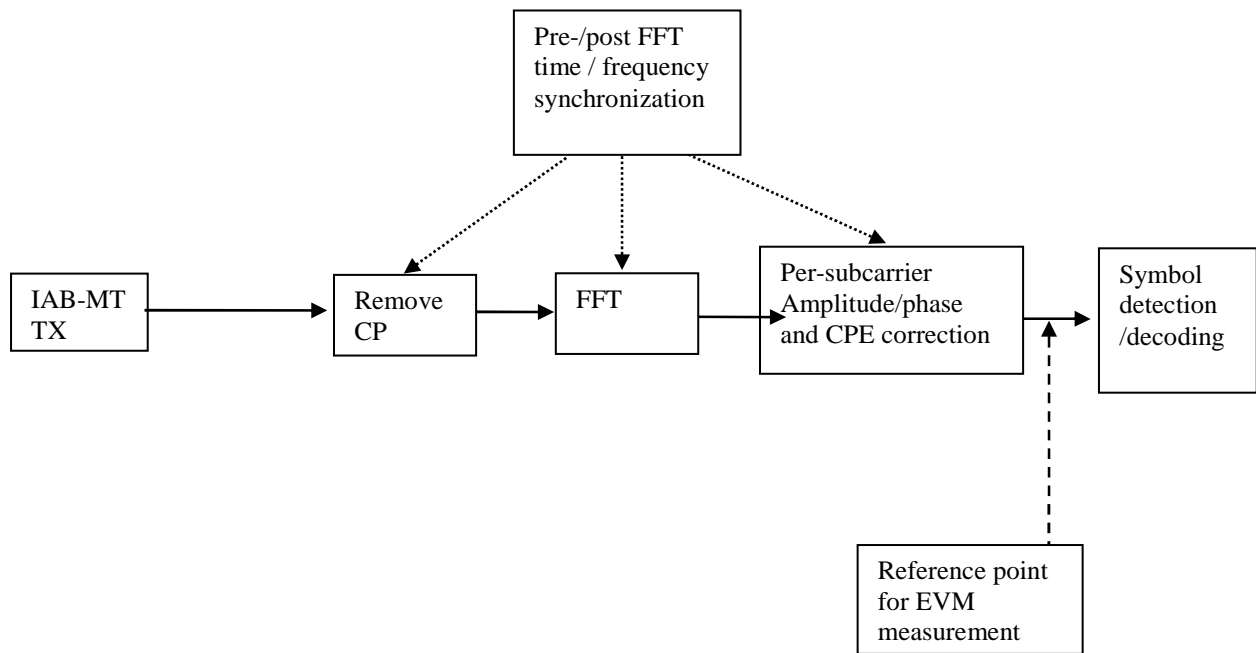

Figure M.2.4-2: Reference point for FR2 EVM measurements

M.3 Pre-FFT minimization process

Sample timing, carrier frequency in $z(v)$ are varied in order to minimise the difference between $z(v)$ and $i_1(v)$, after the amplitude ratio of $z(v)$ and $i_1(v)$ has been scaled. Best fit (minimum difference) is achieved when the RMS difference value between $z(v)$ and $i_1(v)$ is an absolute minimum.

The carrier frequency variation is the measurement result: carrier frequency error.

From the acquired samples, one value of carrier frequency error can be derived.

NOTE 1: The minimisation process, to derive the RF error can be supported by post-FFT operations. However the minimisation process defined in the pre-FFT domain comprises all acquired samples (i.e. it does not exclude the samples in-between the FFT widths and it does not exclude the bandwidth outside the transmission bandwidth configuration).

NOTE 2: The algorithm would allow to derive carrier frequency error and sample frequency error of the TX under test separately. However there are no requirements for sample frequency error. Hence the algorithm models the RF and the sample frequency commonly (not independently). It returns one error and does not distinguish between both.

After this process the samples $z(v)$ are called $z^0(v)$.

M.4 Timing of the FFT window

The FFT window length is *FFT size* samples per OFDM symbol. For TDD, the number of FFTs performed is the number of uplink symbols in the measurement interval.

The position in time for the FFT shall be determined.

In an ideal signal, the FFT may start at any instant within the cyclic prefix without causing an error. The TX filter, however, reduces the window. The EVM requirements shall be met within a window $W < CP$. There are three different instants for FFT:

- Centre of the reduced window, called $\Delta\tilde{c}$,

- $\Delta c - W/2$, and
- $\Delta c + W/2$.

The value of EVM window length W is obtained from the transmission bandwidth and TS 38.176-1 [3] table 6.5.3.5-2 for 15 kHz SCS, table 6.5.3.5-3 for 30 kHz SCS and table 6.5.3.5-4 for 60 kHz SCS for FR1, and table 6.6.3.5.2-2 for 60 kHz SCS, and table 6.6.3.5.2-3 for 120 kHz SCS for FR2.

The IAB-MT shall transmit a signal according to the test models intended for EVM. The demodulation reference signal of the second ideal signal shall be used to find the centre of the FFT window.

The timing of the measured signal is determined in the pre FFT domain as follows, using $z^0(v)$ and $i_2(v)$:

1. The measured signal is delay spread by the TX filter. Hence the distinct borders between the OFDM symbols and between data and CP are also spread and the timing is not obvious.
2. In the ideal signal $i_2(v)$, the timing is known.

Correlation between bullet (1) and (2) will result in a correlation peak. The meaning of the correlation peak is approximately the "impulse response" of the TX filter.

3. The meaning of "impulse response" assumes that the autocorrelation of the ideal signal $i_2(v)$ is a Dirac peak and that the correlation between the ideal signal $i_2(v)$ and the data in the measured signal is 0. The correlation peak, (the highest, or in case of more than one highest, the earliest) indicates the timing in the measured signal.

The number of samples, used for FFT is reduced compared to $z^0(v)$. This subset of samples is called $z'(v)$.

From the acquired samples one timing can be derived.

The timing of the centre $\Delta\tilde{c}$ is determined according to the cyclic prefix length of the OFDM symbols. For normal CP, there are two values for $\Delta\tilde{c}$ in a 1 ms period:

- $\Delta\tilde{c} = \text{length of cyclic prefix} / 2$,
- $\Delta\tilde{c} = \text{Longer CP length} - \text{length of cyclic prefix} / 2$,

Where the length of cyclic prefix is obtained from TS 38.176-1 [3] table 6.5.3.5-2 for 15 kHz SCS, table 6.5.3.5-3 for 30 kHz SCS and table 6.5.3.5-4 for 60 kHz SCS for FR1, and table 6.6.3.5.2-2 for 60 kHz SCS, and table 6.6.3.5.2-3 for 120 kHz SCS for FR2, and the longer CP length is obtained from table M.2.4-1.

As per the example values.

- $\Delta\tilde{c} = 144$ within the CP of length 288 for most OFDM symbols in 1 ms,
- $\Delta\tilde{c} = 400 (= 544 - 144)$ within the CP of length 544 for OFDM symbol 0 of slot 0 and slot 4.

M.5 Resource element TX power

Perform FFT on $z'(v)$ with the FFT window timing $\Delta\tilde{c}$.

The result is called $Z'(t, f)$. The RE TX (RETP) power is then defined as:

$$RETP = |Z'(t, f)|^2 \text{SCS}$$

where SCS is the subcarrier spacing in Hz.

From RETP, the OFDM symbol TX power (OSTP) is derived as follows:

$$OSTP = \frac{1}{N_{sym}} \sum RETP$$

Where the summation accumulates $N_{RB}N_{sc}^{RB}$ values of all N_{sym} OFDM symbols that carry PUSCH and not containing PUCCH, SRS or PRACH within a slot.

$$N_{sc}^{RB} = 12.$$

For TDD, N_{ul} is the number of slots with downlink symbols in a 10 ms measurement interval and is computed according to the values in table 4.9.2.2-1.

For the example used in the annex, $N_{ul} = 64$ and $N_{RB} = 264$.

M.6 Post-FFT equalisation

Perform $14N_{ul}$ FFTs on $z'(v)$, one for each OFDM symbol within 10 ms measurement interval with the FFT window timing to produce an array of samples, $14N_{ul}$ in the time axis t by *FFT size* in the frequency axis f .

For the example in the annex, 1120 FFTs are performed on $z'(v)$. The result is an array of samples, 1120 in the time axis by 4096 in the frequency axis.

The equalizer coefficients $\tilde{a}(f)$ and $\tilde{\varphi}(f)$ are determined as follows:

1. Calculate the complex ratios (amplitude and phase) of the post-FFT acquired signal $Z'(t, f)$ and the post-FFT ideal signal $I_2(t, f)$, for each demodulation reference signal, over 10 ms measurement interval. This process creates a set of complex ratios:

$$a(t, f)e^{j\varphi(t, f)} = \frac{Z'(t, f)}{I_2(t, f)}$$

2. Perform time averaging at each demodulation reference signal subcarrier of the complex ratios, the time-averaging length is 10 ms measurement interval. Prior to the averaging of the phases $\varphi(t_i, f)$ an unwrap operation must be performed according to the following definition:
 - The unwrap operation corrects the radian phase angles of $\varphi(t_i, f)$ by adding multiples of $2 * \pi$ when absolute phase jumps between consecutive time instances t_i are greater than or equal to the jump tolerance of π radians.
 - This process creates an average amplitude and phase for each demodulation reference signal subcarrier (i.e. every second subcarrier).

$$a(f) = \frac{\sum_{i=1}^N a(t_i, f)}{N}$$

$$\varphi(f) = \frac{\sum_{i=1}^N \varphi(t_i, f)}{N}$$

Where N is the number of demodulation reference signal time-domain locations t_i from $Z'(t, f)$ for each demodulation reference signal subcarrier f .

3. The equalizer coefficients for amplitude and phase $\hat{a}(f)$ and $\hat{\varphi}(f)$ at the demodulation reference signal subcarriers are obtained by computing the moving average in the frequency domain of the time-averaged demodulation reference signal subcarriers. The moving average window size is 19 and averaging is over the DM-RS subcarriers in the allocated RBs. For DM-RS subcarriers at or near the edge of the channel, or when the number of available DM-RS subcarriers within a set of contiguously allocated RBs is smaller than the moving average window size, the window size is reduced accordingly as per figure M.6-1.
4. Perform linear interpolation from the equalizer coefficients $\hat{a}(f)$ and $\hat{\varphi}(f)$ to compute coefficients $\tilde{a}(f)$, $\tilde{\varphi}(f)$ for each subcarrier.

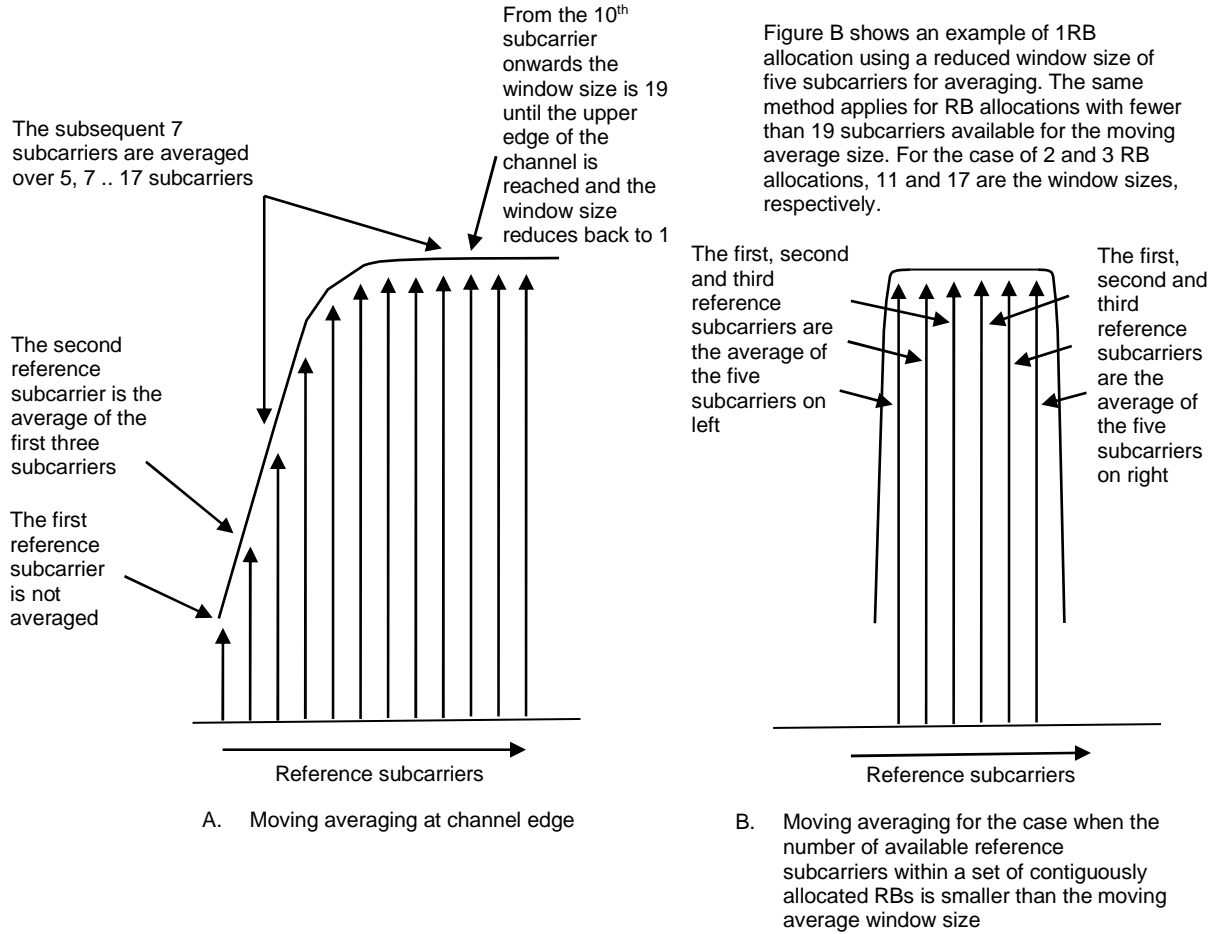

Figure M.6-1: Reference subcarrier smoothing in the frequency domain

- a) In case of FR2 EVM, to account for the common phase error (CPE) experienced in millimetre wave frequencies, $\bar{\varphi}(f)$, in the estimated coefficients contain phase rotation due to the CPE, θ , in addition to the phase of the equalizer coefficient $\tilde{\varphi}(f)$, that is:

$$\bar{\varphi}(f) = \tilde{\varphi}(f) + \theta(t)$$

For OFDM symbols where PT-RS does not exist, $\theta(t)$ can be estimated by performing linear interpolation from neighboring symbols where PT-RS is present.

In order to separate component of the CPE, θ , contained in, $\bar{\varphi}(f)$, estimation and compensation of the CPE needs to follow. $\theta(t)$ is the common phase error (CPE), that rotates all the subcarriers of the OFDM symbol at time t .

Estimate of the CPE, $\theta(t)$, at OFDM symbol time, t , can then be obtained from using the PT-RS employing the expression:

$$\tilde{\theta}(t) = \text{arg} \left\{ \sum_{f \in f^{ptrs}} \left(\frac{z'(t,f)}{I_{ptrs}(t,f)} \right) (\tilde{a}(f) e^{-j\tilde{\varphi}(f)}) \right\}$$

In the above equation, f^{ptrs} is the set of subcarriers where PT-RS are mapped, $t \in t^{ptrs}$ where t^{ptrs} is the set of OFDM symbols where PT-RS are mapped while $Z'(t, f)$ and $I_{ptrs}(t, f)$ are is the post-FFT acquired signal and the ideal PT-RS signal respectively. That is, estimate of the CPE at a given OFDM symbol is obtained from frequency correlation of the complex ratios at the PT-RS positions with the conjugate of the estimated equalizer complex coefficients. The estimated CPE can be subtracted from $\bar{\varphi}(f)$ to remove influence of the CPE, and obtain estimate of the complex coefficient's phase:

$$\tilde{\varphi}(f) = \bar{\varphi}(f) - \tilde{\theta}(t)$$

M.7 EVM

M.7.0 General

For EVM create two sets of $Z_{eq}'(t, f)$, according to the timing $(\Delta c - W/2)$ and $(\Delta c + W/2)$, using the equalizer coefficients from M.6.

The equivalent ideal samples are calculated from $i_1(v)$ (annex M.2.2) and are called $I(t, f)$.

The EVM is the difference between the ideal signal and the equalized measured signal.

$$EVM = \sqrt{\frac{\sum_{t \in T} \sum_{f \in F(i)} |Z_{eq}'(t, f) - I(t, f)|^2}{\sum_{t \in T} \sum_{f \in F(i)} |I(t, f)|^2}}$$

Where:

- T is the set of symbols with the considered modulation scheme being active within the slot,
- $F(t)$ is the set of subcarriers within the resource blocks with the considered modulation scheme being active in symbol t ,
- $I(t, f)$ is the ideal signal reconstructed by the measurement equipment in accordance with relevant test models,
- $Z_{eq}'(t, f)$ is the equalized signal under test.

NOTE: Although the basic unit of measurement is one slot, the equalizer is calculated over the entire 10 ms measurement interval to reduce the impact of noise in the reference signals.

M.7.1 Averaged EVM (TDD)

Let N_{ul}^{TDD} be the number of slots with uplink symbols within a 10 ms measurement interval. For TDD, the averaging in the time domain can be calculated from N_{ul}^{TDD} slots of different 10 ms measurement intervals and should have a minimum of N_{ul} slots averaging length where N_{ul} is the number of slots in a 10 ms measurement interval.

\overline{EVM}_{frame} is derived by: Square the EVM results in each 10 ms measurement interval. Sum the squares, divide the sum by the number of EVM relevant locations, square-root the quotient (RMS).

$$\overline{EVM}_{frame} = \sqrt{\frac{1}{\sum_{i=1}^{N_{ul}^{TDD}} N_i} \sum_{i=1}^{N_{ul}^{TDD}} \sum_{j=1}^{N_i} EVM_{i,j}^2}$$

Where N_i is the number of resource blocks with the considered modulation scheme in slot i .

The EVM_{frame} is calculated, using the maximum of \overline{EVM}_{frame} at the window W extremities. Thus $\overline{EVM}_{frame,l}$ is calculated using $\tilde{t} = \Delta \tilde{t}_l$ and $\overline{EVM}_{frame,h}$ is calculated using $\tilde{t} = \Delta \tilde{t}_h$ (l and h , low and high; where low is the timing $(\Delta c - W/2)$ and high is the timing $(\Delta c + W/2)$).

$$EVM_{frame} = \max(\overline{EVM}_{frame,l}, \overline{EVM}_{frame,h})$$

In order to unite at least N_{dl} slots, consider the minimum integer number of 10 ms measurement intervals, where N_{frame} is determined by

$$N_{frame} = \left\lceil \frac{10 \times N_{slot}}{N_{dl}^{TDD}} \right\rceil$$

And for FR1, $N_{slot} = 1$ for 15 kHz SCS, $N_{slot} = 2$ for 30 kHz SCS and $N_{slot} = 4$ for 60 kHz SCS normal CP. For FR2, $N_{slot} = 4$ for 60 kHz SCS and $N_{slot} = 8$ for 120 kHz SCS.

Unite by RMS.

$$\overline{EVM} = \sqrt{\frac{1}{N_{frame}} \sum_{k=1}^{N_{frame}} EVM_{frame,k}^2}$$

The resulting \overline{EVM} is compared against the limit.

Annex N (normative): General rules for statistical testing

Annex O (informative): Change history

Change history							
Date	Meeting	TDoc	CR	Rev	Cat	Subject/Comment	New version
2021-04	RAN4#98 bis-e	R4-2106313				TS skeleton	0.0.1
2021-05	RAN4#99-e	R4-2110944				TS 38.176-2 skeleton after RAN4#98bis-e Update of IAB conducted conformance TS with agreed TP in RAN4#98bis-e: 1. R4-2106057 TP to TS 38.xxx-2: Clause 4.2~4.5 2. R4-2106055 TP to TS38.176-2 on subclause 4.10 -5 3. R4-2106073 TP for TS 38.176-2: OTA transmit ON/OFF power 4. R4-2106076 TP to TS 38.xxx-2: TX IMD requirements 5. R4-2106077 TP to TS 38.176-2 Annex A for IAB OTA test specification 6. R4-2106078 TP to TS 38.xxx-2: RX IMD requirements 7. R4-2106080 TP to TS 38.176-2 - OTA Sensitivity, clause 7.2, 7.3 8. R4-2106081 TP to TS 38.176-2 - OTA Rx dynamic range, clause 7.3 9. R4-2106082 TP on IBB, OBB and RX spurious for OTA receiver characteristic test 10. R4-2106083 TP to TS 38.146-2 Clause 4.6 Declarations for IAB radiated test specification 11. R4-2106084 TP to TS 38.176-2 - Annex D&E 12. R4-2106051 TP for Annex G and H for OTA IAB test specification	0.1.0
2021-06	RAN4#99-e	R4-2108096				Big TP to 38.176-2 on RF part Update of IAB conducted conformance TS with endorsed TP in RAN4#99-e: 1. R4-2108566 TP to TS 38.176-2 on test efficiency clause 4.13 2. R4-2108570 TP for TS 38.176-2: Test configurations and applicability of requirements 3. R4-2108568 TP to TS 38.176-2:IAB Common test issue on test model-OTA 4. R4-2108572 TP for TS 38.176-2: Annex B and C 5. R4-2108574 TP to TS 38.176-2 -Clause 4.1 7. R4-2108578 TP to 38.176-2 Editor update – editorials 8. R4-2108579 TP for TS 38.176-2: OTA transmitted signal quality 9. R4-2108580 TP to TS 38.176-2: clauses 6.1, 6.2, 6.3 and 6.7 10. R4-2108088 TP to TS 38.176-2 - OTA Tx dynamic range, clause 6.4 11. R4-2110608 TP to TS 38.176-2: RX ICS requirements, ZTE 12. R4-2111178 TP on IBB, OBB and RX spurious for OTA receiver characteristic test 13. R4-2111406 TP to TS 38.176-2 - OTA Sensitivity, clause 7.2, 7.3 14. R4-2108583 TP to TS 38.176-2 Clause 4.6 Declarations for IAB radiated test specification 15. R4-2108584 TP to TS38.176-2 on Annex I and Annex K 16. R4-2108585 TP to TS 38.176-2: Annex L and M: In-channel TX test 17. R4-2108586 TP to TS 38.176-2 – Clause 3 18. R4-2108587 IAB-MT specific declaration FR2	0.2.0
2021-06	RAN#92-e	RP-211312				Presented to TSG RAN for approval. (Including RF and Demod parts: R4-2108096, Big TP to TS 38.176-2 on RF part R4-2111396, Big TP draft to TS 38.176-2 Demodulation performance)	1.0.0
2021-06	RAN#92					TS was approved by RAN plenary	16.0.0
2021-09	RAN#93	RP-211892	0002		F	Big CR for TS 38.176-2 Maintenance (Rel-16, CAT F)	16.1.0
2021-12	RAN#94	RP-212851	0003		F	Big CR for TS 38.176-2 Maintenance (Rel-16, CAT F)	16.2.0
2022-03	RAN#95	RP-220334	0005		F	Big CR for TS 38.176-2 Maintenance (Rel-16, CAT F)	16.3.0

Change history							
Date	Meeting	TDoc	CR	Rev	Cat	Subject/Comment	New version
2022-03	RAN#95					Approved by plenary – Rel-17 spec under change control	17.0.0
2022-06	RAN#96	RP-221673	0006		B	CR to TS 38.176-2 - Introduction of licensed 6GHz band n104	17.1.0
2022-06	RAN#96	RP-221665	0008		F	Big CR for TS 38.176-2 Maintenance (Rel-17, CAT F)	17.1.0
2022-09	RAN#97	RP-222049	0013		B	Big CR for TS 38.176-2 (Rel-17, CAT B)	17.2.0
2022-12	RAN#98-e	RP-223310	0014		F	CR on eIAB performance -general requirement -38.176-2	17.3.0
2023-03	RAN#99	RP-230515	0016		A	CR to TS 38.176-2 with updates to OTA modulation quality	17.4.0
2023-03	RAN#99	RP-230515	0017		F	CR to TS 38.176-2 with bracket removal for measurement uncertainties for OTA timing error between IAB-DU and IAB-MT	17.4.0

History

Document history		
V17.0.0	April 2022	Publication
V17.1.0	August 2022	Publication
V17.2.0	October 2022	Publication
V17.3.0	January 2023	Publication
V17.4.0	May 2023	Publication