

ETSI TS 138 176-1 V16.3.0 (2022-04)



**5G;
NR;
Integrated Access and Backhaul (IAB) conformance testing;
Part 1: Conducted conformance testing
(3GPP TS 38.176-1 version 16.3.0 Release 16)**



Reference

RTS/TSGR-0438176-1vg30

Keywords

5G

ETSI

650 Route des Lucioles
F-06921 Sophia Antipolis Cedex - FRANCE

Tel.: +33 4 92 94 42 00 Fax: +33 4 93 65 47 16

Siret N° 348 623 562 00017 - APE 7112B
Association à but non lucratif enregistrée à la
Sous-Préfecture de Grasse (06) N° w061004871

Important notice

The present document can be downloaded from:

<http://www.etsi.org/standards-search>

The present document may be made available in electronic versions and/or in print. The content of any electronic and/or print versions of the present document shall not be modified without the prior written authorization of ETSI. In case of any existing or perceived difference in contents between such versions and/or in print, the prevailing version of an ETSI deliverable is the one made publicly available in PDF format at www.etsi.org/deliver.

Users of the present document should be aware that the document may be subject to revision or change of status.

Information on the current status of this and other ETSI documents is available at

<https://portal.etsi.org/TB/ETSIDeliverableStatus.aspx>

If you find errors in the present document, please send your comment to one of the following services:

<https://portal.etsi.org/People/CommitteeSupportStaff.aspx>

If you find a security vulnerability in the present document, please report it through our

Coordinated Vulnerability Disclosure Program:

<https://www.etsi.org/standards/coordinated-vulnerability-disclosure>

Notice of disclaimer & limitation of liability

The information provided in the present deliverable is directed solely to professionals who have the appropriate degree of experience to understand and interpret its content in accordance with generally accepted engineering or other professional standard and applicable regulations.

No recommendation as to products and services or vendors is made or should be implied.

No representation or warranty is made that this deliverable is technically accurate or sufficient or conforms to any law and/or governmental rule and/or regulation and further, no representation or warranty is made of merchantability or fitness for any particular purpose or against infringement of intellectual property rights.

In no event shall ETSI be held liable for loss of profits or any other incidental or consequential damages.

Any software contained in this deliverable is provided "AS IS" with no warranties, express or implied, including but not limited to, the warranties of merchantability, fitness for a particular purpose and non-infringement of intellectual property rights and ETSI shall not be held liable in any event for any damages whatsoever (including, without limitation, damages for loss of profits, business interruption, loss of information, or any other pecuniary loss) arising out of or related to the use of or inability to use the software.

Copyright Notification

No part may be reproduced or utilized in any form or by any means, electronic or mechanical, including photocopying and microfilm except as authorized by written permission of ETSI.

The content of the PDF version shall not be modified without the written authorization of ETSI.

The copyright and the foregoing restriction extend to reproduction in all media.

© ETSI 2022.
All rights reserved.

Intellectual Property Rights

Essential patents

IPRs essential or potentially essential to normative deliverables may have been declared to ETSI. The declarations pertaining to these essential IPRs, if any, are publicly available for **ETSI members and non-members**, and can be found in ETSI SR 000 314: "*Intellectual Property Rights (IPRs); Essential, or potentially Essential, IPRs notified to ETSI in respect of ETSI standards*", which is available from the ETSI Secretariat. Latest updates are available on the ETSI Web server (<https://ipr.etsi.org/>).

Pursuant to the ETSI Directives including the ETSI IPR Policy, no investigation regarding the essentiality of IPRs, including IPR searches, has been carried out by ETSI. No guarantee can be given as to the existence of other IPRs not referenced in ETSI SR 000 314 (or the updates on the ETSI Web server) which are, or may be, or may become, essential to the present document.

Trademarks

The present document may include trademarks and/or tradenames which are asserted and/or registered by their owners. ETSI claims no ownership of these except for any which are indicated as being the property of ETSI, and conveys no right to use or reproduce any trademark and/or tradename. Mention of those trademarks in the present document does not constitute an endorsement by ETSI of products, services or organizations associated with those trademarks.

DECT™, **PLUGTESTS™**, **UMTS™** and the ETSI logo are trademarks of ETSI registered for the benefit of its Members. **3GPP™** and **LTE™** are trademarks of ETSI registered for the benefit of its Members and of the 3GPP Organizational Partners. **oneM2M™** logo is a trademark of ETSI registered for the benefit of its Members and of the oneM2M Partners. **GSM®** and the GSM logo are trademarks registered and owned by the GSM Association.

Legal Notice

This Technical Specification (TS) has been produced by ETSI 3rd Generation Partnership Project (3GPP).

The present document may refer to technical specifications or reports using their 3GPP identities. These shall be interpreted as being references to the corresponding ETSI deliverables.

The cross reference between 3GPP and ETSI identities can be found under <http://webapp.etsi.org/key/queryform.asp>.

Modal verbs terminology

In the present document "**shall**", "**shall not**", "**should**", "**should not**", "**may**", "**need not**", "**will**", "**will not**", "**can**" and "**cannot**" are to be interpreted as described in clause 3.2 of the [ETSI Drafting Rules](#) (Verbal forms for the expression of provisions).

"**must**" and "**must not**" are **NOT** allowed in ETSI deliverables except when used in direct citation.

Contents

Intellectual Property Rights	2
Legal Notice	2
Modal verbs terminology.....	2
Foreword.....	12
1 Scope	14
2 References	14
3 Definitions of terms, symbols and abbreviations	15
3.1 Terms.....	15
3.2 Symbols.....	18
3.3 Abbreviations	19
4 General conducted test conditions and declarations.....	20
4.1 Measurement uncertainties and test requirements	20
4.1.1 General.....	20
4.1.2 Acceptable uncertainty of Test System.....	20
4.1.2.1 General	20
4.1.2.2 Measurement of transmitter	21
4.1.2.3 Measurement of receiver	22
4.1.2.4 Measurement of performance requirements.....	24
4.1.3 Interpretation of measurement results.....	25
4.2 Conducted requirement reference points	25
4.2.1 IAB type 1-H	25
4.3 IAB classes.....	26
4.3.1 IAB-DU class	26
4.3.2 IAB-MT class	26
4.4 Regional requirements.....	26
4.5 IAB configurations	27
4.5.1 IAB type 1-H	27
4.5.1.1 Transmit configurations	27
4.5.1.2 Receive configurations.....	28
4.5.1.3 Power supply options	28
4.5.2 IAB with integrated Iuant BS modem.....	28
4.6 Manufacturer declarations	28
4.7 Test configurations	33
4.7.1 General.....	33
4.7.2 Test signal used to build Test Configurations.....	33
4.7.3 IABTC1: Contiguous spectrum operation	33
4.7.3.1 General	33
4.7.3.2 IABTC1 generation.....	33
4.7.3.3 IABTC1 power allocation	33
4.7.4 IABTC2: Contiguous CA occupied bandwidth	34
4.7.4.1 General	34
4.7.4.2 IABTC2 generation.....	34
4.7.4.3 IABTC2 power allocation	34
4.7.5 IABTC3: Non-contiguous spectrum operation	34
4.7.5.1 General	34
4.7.5.2 IABTC3 generation.....	34
4.7.5.3 IABTC3 power allocation	35
4.7.6 IABTC4: Multi-band test configuration for full carrier allocation	35
4.7.6.1 General.....	35
4.7.6.2 IABTC4 generation.....	35
4.7.6.3 IABTC4 power allocation	35
4.7.7 IABTC5: Multi-band test configuration with high PSD per carrier.....	36
4.7.7.1 General	36
4.7.7.2 IABTC5 generation.....	36

4.7.7.3	IABTC5 power allocation	36
4.8	Applicability of requirements	36
4.8.1	General	36
4.8.2	Requirement set applicability	36
4.8.3	Applicability of test configurations for single-band operation	37
4.8.4	Applicability of test configurations for multi-band operation	38
4.9	RF channels and test models	39
4.9.1	RF channels	39
4.9.2	Test models	40
4.9.2.1	General	40
4.9.2.2	FR1 test models for IAB-DU	40
4.9.2.3	FR1 test models for IAB-MT	41
4.9.2.3.1	General	41
4.9.2.3.2	FR1 test model 1.1 (IAB-MT-FR1-TM1.1)	42
4.9.2.3.3	FR1 test model 2 (IAB-MT-FR1-TM2)	42
4.9.2.3.3a	FR1 test model 2a (IAB-MT-FR1-TM2a)	42
4.9.2.3.4	FR1 test model 3.1 (IAB-MT-FR1-TM3.1)	43
4.9.2.3.5	FR1 test model 3.1a (IAB-MT-FR1-TM3.1a)	43
4.9.2.4	Data content of Physical channels and Signals for IAB-MT-FR1-TM	43
4.9.2.4.1	General	43
4.9.2.4.2	PUSCH	44
4.10	Requirements for contiguous and non-contiguous spectrum	44
4.11	Requirements for IAB capable of multi-band operation	44
4.12	Format and interpretation of tests	45
4.13	Test efficiency optimization	46
5	Operating bands and channel arrangement	48
6	Conducted transmitter characteristics (IAB-DU and IAB-MT)	49
6.1	General	49
6.2	IAB output power	49
6.2.1	General	49
6.2.2	Minimum requirement	50
6.2.3	Test purpose	50
6.2.4	Method of test	50
6.2.4.1	Initial conditions	50
6.2.4.2	Procedure	50
6.2.5	Test requirement	51
6.3	Output power dynamics	51
6.3.1	IAB-DU Output Power Dynamics	51
6.3.1.1	General	51
6.3.1.2	RE power control dynamic range	51
6.3.1.2.1	Definition and applicability	51
6.3.1.2.2	Minimum requirement	51
6.3.1.2.3	Test purpose	51
6.3.1.3	Total power dynamic range	51
6.3.1.3.1	Definition and applicability	51
6.3.1.3.2	Minimum requirement	51
6.3.1.3.3	Test purpose	52
6.3.1.3.4	Method of test	52
6.3.1.3.4.1	Initial conditions	52
6.3.1.3.4.2	Procedure	52
6.3.1.3.5	Test requirements	52
6.3.2	IAB-MT Output Power Dynamics	53
6.3.2.1	Total power dynamic range	53
6.3.2.1.1	Definition and applicability	53
6.3.2.1.2	Minimum requirement	53
6.3.2.1.3	Test purpose	53
6.3.2.1.4	Method of test	53
6.3.2.1.4.1	Initial conditions	53
6.3.2.1.4.2	Procedure	53
6.3.2.1.5	Test requirements	54

6.3.2.2	Relative power tolerance for local area IAB-MT	54
6.3.2.2.1	Definition and applicability	54
6.3.2.2.2	Minimum requirement	54
6.3.2.2.3	Test purpose	54
6.3.2.3	Aggregate power tolerance for local area IAB-MT	54
6.3.2.3.1	Definition and applicability	54
6.3.2.3.2	Minimum requirement	55
6.3.2.3.3	Test purpose	55
6.4	Transmit ON/OFF power	55
6.4.1	Transmitter OFF power	55
6.4.1.1	Definition and applicability	55
6.4.1.2	Minimum requirement	55
6.4.1.3	Test purpose	55
6.4.1.4	Method of test	55
6.4.1.5	Test requirements	55
6.4.2	Transmitter transient period	55
6.4.2.1	Definition and applicability	55
6.4.2.2	Minimum requirement	56
6.4.2.3	Test purpose	56
6.4.2.4	Method of test	56
6.4.2.4.1	Initial conditions	56
6.4.2.4.2	Procedure	57
6.4.2.5	Test requirements	57
6.5	Transmitted signal quality	57
6.5.1	General	57
6.5.2	Frequency error	58
6.5.2.1	IAB-DU frequency error	58
6.5.2.1.1	Definition and applicability	58
6.5.2.1.2	Minimum Requirement	58
6.5.2.1.3	Test purpose	58
6.5.2.1.4	Method of test	58
6.5.2.1.5	Test Requirements	58
6.5.2.2	IAB-MT frequency error	58
6.5.2.2.1	Definition and applicability	58
6.5.2.2.2	Minimum Requirement	58
6.5.2.2.3	Test purpose	58
6.5.2.2.4	Method of test	59
6.5.2.2.5	Test Requirements	59
6.5.3	Modulation quality	59
6.5.3.1	Definition and applicability	59
6.5.3.2	Minimum Requirement	59
6.5.3.3	Test purpose	59
6.5.3.4	Method of test	59
6.5.3.4.1	Initial conditions	59
6.5.3.4.2	Procedure for IAB-DU	59
6.5.3.4.3	Procedure for IAB-MT	60
6.5.3.5	Test requirements	61
6.5.4	Time alignment error	62
6.5.4.1	Definition and applicability	62
6.5.4.2	Minimum requirement	62
6.5.4.3	Test purpose	63
6.5.4.4	Method of test	63
6.5.4.4.1	Initial conditions	63
6.5.4.4.2	Procedure	63
6.5.4.5	Test requirement	64
6.6	Unwanted emissions	64
6.6.1	General	64
6.6.2	Occupied bandwidth	64
6.6.2.1	General	64
6.6.2.2	Minimum Requirements	65
6.6.2.3	Test purpose	65
6.6.2.4	Method of test	65

6.6.2.4.1	Initial conditions	65
6.6.2.4.2	Procedure	65
6.6.2.5	Test requirements	66
6.6.3	Adjacent Channel Leakage Power Ratio	66
6.6.3.1	General	66
6.6.3.2	Minimum requirement	66
6.6.3.3	Test purpose	66
6.6.3.4	Method of test	67
6.6.3.4.1	Initial conditions	67
6.6.3.4.2	Procedure	67
6.6.3.5	Test requirements	67
6.6.3.5.1	General requirements	67
6.6.3.5.2	Limits and <i>basic limits</i>	68
6.6.3.5.3	<i>IAB type 1-H</i>	70
6.6.4	Operating band unwanted emissions	71
6.6.4.1	Definition and applicability	71
6.6.4.2	Minimum requirement	73
6.6.4.3	Test purpose	73
6.6.4.4	Method of test	73
6.6.4.4.1	Initial conditions	73
6.6.4.4.2	Procedure	73
6.6.4.5	Test requirements	74
6.6.4.5.1	General requirements	74
6.6.4.5.2	Basic limits for Wide Area IAB-DU and IAB-MT (Category A)	74
6.6.4.5.3	Basic limits for Wide Area IAB-DU and Wide Area IAB-MT (Category B)	75
6.6.4.5.3.1	General	75
6.6.4.5.3.2	Category B requirements	75
6.6.4.5.4	<i>Basic limits</i> for Medium Range IAB-DU (Category A and B)	76
6.6.4.5.5	<i>Basic limits</i> for Local Area IAB-DU and Local Area IAB-MT (Category A and B)	78
6.6.4.5.5	<i>Basic limits</i> for additional requirements	79
6.6.4.5.5.1	Limits in FCC Title 47	79
6.6.4.5.6	<i>IAB type 1-H</i>	79
6.6.5	Transmitter spurious emissions	79
6.6.5.1	Definition and applicability	79
6.6.5.2	Minimum requirement	80
6.6.5.3	Test purpose	80
6.6.5.4	Method of test	80
6.6.5.4.1	Initial conditions	80
6.6.5.4.2	Procedure	80
6.6.5.5	Test requirements	81
6.6.5.5.1	Basic limits	81
6.6.5.5.1.1	Tx spurious emissions	81
6.6.5.5.2	Additional spurious emissions requirements	82
6.6.5.5.3	Co-location with base stations and IAB-nodes	87
6.6.5.6	<i>IAB type 1-H</i>	90
6.7	Transmitter intermodulation	90
6.7.1	Definition and applicability	90
6.7.2	Minimum requirement	90
6.7.3	Test purpose	91
6.7.4	Method of test	91
6.7.4.1	Initial conditions	91
6.7.4.2	Procedure	91
6.7.5	Test requirements	92
6.7.5.1	<i>IAB type 1-H</i>	92
6.7.5.1.1	Co-location minimum requirements	92
6.7.5.1.2	Intra-system minimum requirements	93
6.7.5.1.3	Additional requirements	93
7	Conducted receiver characteristics (IAB-DU and IAB-MT)	94
7.1	General	94
7.2	Reference sensitivity level	94
7.2.1	Definition and applicability	94

7.2.2	Minimum requirement	94
7.2.3	Test purpose.....	94
7.2.4	Method of test	94
7.2.4.1	Initial conditions	94
7.2.4.2	Procedure	94
7.2.5	Test requirements.....	95
7.2.5.1	Test requirements for <i>IAB-DU</i>	95
7.2.5.2	Test requirements for <i>IAB-MT</i>	96
7.3	Dynamic range	97
7.3.1	Definition and applicability	97
7.3.2	Minimum requirement	97
7.3.3	Test purpose.....	97
7.3.4	Method of test	97
7.3.4.1	Initial conditions	97
7.3.4.2	Procedure	97
7.3.5	Test requirements.....	98
7.4	In-band selectivity and blocking	100
7.4.1	Adjacent Channel Selectivity (ACS)	100
7.4.1.1	Definition and applicability.....	100
7.4.1.2	Minimum requirement	100
7.4.1.3	Test purpose	101
7.4.1.4	Method of test	101
7.4.1.4.1	Initial conditions	101
7.4.1.4.2	Procedure.....	101
7.4.1.5	Test requirements	101
7.4.1.5.1	Test requirements for <i>IAB-DU</i>	101
7.4.1.5.2	Test requirements for <i>IAB-MT</i>	102
7.4.2	In-band blocking	103
7.4.2.1	Definition and applicability.....	103
7.4.2.2	Minimum requirement	103
7.4.2.3	Test purpose	104
7.4.2.4	Method of test	104
7.4.2.4.1	Initial conditions	104
7.4.2.4.2	Procedure for general blocking.....	104
7.4.2.4.3	Procedure for narrowband blocking	104
7.4.2.5	Test requirements	105
7.4.2.5.1	Test requirements for <i>IAB-DU</i>	105
7.4.2.5.2	Test requirements for <i>IAB-MT</i>	107
7.5	Out-of-band blocking	109
7.5.1	Definition and applicability	109
7.5.2	Minimum requirement	109
7.5.3	Test purpose.....	110
7.5.4	Method of test	110
7.5.4.1	Initial conditions	110
7.5.4.2	Procedure	110
7.5.5	Test requirements.....	110
7.5.5.1	General requirements for <i>IAB-DU</i>	110
7.5.5.2	Co-location requirements for <i>IAB-DU</i>	111
7.5.5.3	General requirements for <i>IAB-MT</i>	111
7.5.5.4	Co-location requirements for <i>IAB-MT</i>	112
7.6	Receiver spurious emissions.....	113
7.6.1	Definition and applicability	113
7.6.2	Minimum requirement	113
7.6.3	Test purpose.....	113
7.6.4	Method of test	114
7.6.4.1	Initial conditions	114
7.6.4.2	Procedure	114
7.6.5	Test requirements.....	114
7.6.5.1	Basic limits for <i>IAB-DU</i>	114
7.6.5.2	Test requirement for <i>IAB-DU</i>	115
7.6.5.3	Basic limits for <i>IAB-MT</i>	115
7.6.5.4	Test requirement for <i>IAB-MT</i>	116

7.7	Receiver intermodulation	116
7.7.1	Definition and applicability	116
7.7.2	Minimum requirement	116
7.7.3	Test purpose.....	117
7.7.4	Method of test	117
7.7.4.1	Initial conditions	117
7.7.4.2	Procedure	117
7.7.5	Test requirements.....	117
7.7.5.1	IAB-DU	117
7.7.5.2	IAB-MT	120
7.8	In-channel selectivity	123
7.8.1	Definition and applicability	123
7.8.2	Minimum requirement	123
7.8.3	Test purpose.....	124
7.8.4	Method of test	124
7.8.4.1	Initial conditions	124
7.8.4.2	Procedure	124
7.8.5	Test requirements.....	124
7.8.5.1	IAB-DU	124
8	Conducted performance requirements.....	126
8.1	IAB-DU performance requirements	126
8.1.1	General.....	126
8.1.1.1	Scope and definitions	126
8.1.1.2	Applicability rule	127
8.1.1.2.1	General	127
8.1.1.2.2	Applicability of PUSCH performance requirements	127
8.1.1.2.3	Applicability of PUCCH performance requirements.....	128
8.1.1.2.4	Applicability of PRACH performance requirements.....	128
8.1.2	Performance requirements for PUSCH.....	129
8.1.2.1	Performance requirements for PUSCH with transform precoding disabled.....	129
8.1.2.1.1	Definition and applicability	129
8.1.2.1.2	Minimum requirement.....	129
8.1.2.1.3	Test purpose	129
8.1.2.1.4	Method of test.....	129
8.1.2.1.5	Test requirement	130
8.1.2.2	Performance requirements for PUSCH with transform precoding enabled	136
8.1.2.2.1	Definition and applicability	136
8.1.2.2.2	Minimum requirement.....	136
8.1.2.2.3	Test purpose	137
8.1.2.2.4	Method of test.....	137
8.1.2.2.5	Test requirement	138
8.1.2.3	Performance requirements for UCI multiplexed on PUSCH	139
8.1.2.3.1	Definition and applicability	139
8.1.2.3.2	Minimum requirement.....	139
8.1.2.3.3	Test purpose	139
8.1.2.3.4	Method of test.....	139
8.1.2.3.5	Test requirement	140
8.1.3	Performance requirements for PUCCH	141
8.1.3.1	Performance requirements for PUCCH format 0	141
8.1.3.1.1	Definition and applicability	141
8.1.3.1.2	Minimum requirement.....	142
8.1.3.1.3	Test purpose	142
8.1.3.1.4	Method of test.....	142
8.1.3.1.5	Test requirement	143
8.1.3.2	Performance requirements for PUCCH format 1	144
8.1.3.2.1	NACK to ACK detection.....	144
8.1.3.2.2	ACK missed detection.....	145
8.1.3.3	Performance requirements for PUCCH format 2	148
8.1.3.3.1	ACK missed detection.....	148
8.1.3.3.2	UCI BLER performance requirements	149
8.1.3.4	Performance requirements for PUCCH format 3	151

8.1.3.4.1	Definition and applicability	151
8.1.3.4.2	Minimum requirement	151
8.1.3.4.3	Test purpose	151
8.1.3.4.4	Method of test.....	152
8.1.3.4.5	Test requirement	153
8.1.3.5	Performance requirements for PUCCH format 4	153
8.1.3.5.1	Definition and applicability	153
8.1.3.5.2	Minimum requirement	154
8.1.3.5.3	Test purpose	154
8.1.3.5.4	Method of test.....	154
8.1.3.5.5	Test requirement	155
8.1.3.6	Performance requirements for multi-slot PUCCH	156
8.1.3.6.1	Performance requirements for multi-slot PUCCH format 1	156
8.1.4	Performance requirements for PRACH	159
8.1.4.1	PRACH false alarm probability and missed detection requirements	159
8.1.4.1.1	Definition and applicability	159
8.1.4.1.2	Minimum requirement.....	160
8.1.4.1.3	Test purpose	160
8.1.4.1.4	Method of test.....	160
8.1.4.1.5	Test requirement	161
8.2	IAB-MT Performance requirements.....	162
8.2.1	General.....	162
8.2.1.1	Scope and definitions	162
8.2.2	Demodulation performance requirements.....	163
8.2.2.1	General	163
8.2.2.1.1	Applicability of requirements	163
8.2.2.2	Performance requirements for PDSCH	164
8.2.2.2.1	Definition and applicability	164
8.2.2.2.2	Minimum requirement.....	164
8.2.2.2.3	Test purpose	164
8.2.2.2.4	Method of test.....	164
8.2.2.2.5	Test requirement	166
8.2.2.3	Performance requirements for PDCCH.....	166
8.2.2.3.1	Definition and applicability	166
8.2.2.3.2	Minimum requirement.....	166
8.2.2.3.3	Test purpose	167
8.2.2.3.4	Method of test.....	167
8.2.2.3.5	Test requirement	167
8.2.3	CSI reporting requirements.....	168
8.2.3.1	General	168
8.2.3.1.1	Applicability rule for IAB-MT	168
8.2.3.1.1.1	General.....	168
8.2.3.1.1.2	Applicability of requirements for different subcarrier spacings	168
8.2.3.1.1.3	Applicability of requirements for TDD with different UL-DL patterns	168
8.2.3.1.1.4	Applicability of requirements for IAB-MT features	168
8.2.3.2	Reporting Channel Quality Indicator (CQI).....	168
8.2.3.2.1	Definition and applicability	168
8.2.3.2.2	Minimum requirement.....	168
8.2.3.2.3	Test purpose	168
8.2.3.2.4	Method of test.....	169
8.2.3.2.5	Test requirement	170
8.2.3.3	Reporting of Precoding Matrix Indicator (PMI)	170
8.2.3.3.1	Definition and applicability	170
8.2.3.3.2	Minimum requirement.....	170
8.2.3.3.3	Test purpose	170
8.2.3.3.4	Method of test.....	170
8.2.3.3.5	Test requirement	172
8.2.3.4	Reporting of Rank Indicator (RI).....	172
8.2.3.4.1	General	172
8.2.3.4.2	Minimum requirements	172
8.2.3.4.3	Test purpose	172
8.2.3.4.4	Method of test.....	172

8.2.3.4.5	Test requirement	173
Annex A (normative): Reference measurement channels		175
A.1	IAB-DU and IAB-MT Reference measurement channels.....	175
A.1.1	IAB-DU Reference measurement channels.....	175
A.1.2	IAB-MT Reference measurement channels.....	175
A.1.2.1	Fixed Reference Channels for reference sensitivity level, ACS, in-band blocking, out-of-band blocking and receiver intermodulation (QPSK, R=1/3).....	175
A.2	IAB-DU Fixed Reference Channels.....	175
A.2.1	Fixed Reference Channels for PUSCH performance requirements (QPSK, R = 193/1024).....	175
A.2.2	Fixed Reference Channels for PUSCH performance requirements (16QAM, R=434/1024).....	177
A.2.3	Fixed Reference Channels for PUSCH performance requirements (16QAM, R = 658/1024).....	177
A.2.4	Fixed Reference Channels for PUSCH performance requirements (64QAM, R = 567/1024).....	178
A.2.5	PRACH test preambles.....	179
A.3	IAB-MT Fixed Reference Channels.....	179
A.3.1	Fixed Reference Channels for PDSCH performance requirements (16QAM).....	179
A.3.2	Fixed Reference Channels for PDSCH performance requirements (64QAM).....	180
A.3.3	Fixed Reference Channels for PDSCH performance requirements (256QAM).....	180
A.3.4	Fixed Reference Channels for PDCCH performance requirements	181
A.3.5	Fixed Reference Channels for CSI reporting performance requirements.....	181
Annex B (normative): Environmental requirements for the IAB equipment.....		183
B.1	General	183
B.2	Normal test environment.....	183
B.3	Extreme test environment.....	183
B.3.1	General	183
B.3.2	Extreme temperature	183
B.4	Vibration.....	184
B.5	Power supply	184
B.6	Measurement of test environments.....	184
Annex C (informative): Test tolerances and derivation of test requirements.....		186
C.1	Measurement of transmitter.....	186
C.2	Measurement of receiver.....	187
C.3	Measurement of performance requirements	189
C.3.1	List IAB-DU TTs.....	189
C.3.2	List IAB-MT TTs	189
Annex D (informative): Measurement system set-up.....		190
D.1	<i>IAB type 1-H</i> transmitter.....	190
D.1.1	IAB output power, output power dynamics, transmitter ON/OFF power, frequency error, EVM, unwanted emissions for IAB type 1-H	190
D.1.2	Transmitter intermodulation for IAB type 1-H	191
D.1.3	Transmitter spurious emissions for IAB type 1-H.....	191
D.1.4	Time alignment error for <i>IAB-DU</i>	193
D.2	IAB type 1-H receiver	193
D.2.1	Reference sensitivity level for IAB type 1-H	193
D.2.2	Receiver dynamic range for IAB type 1-H.....	194
D.2.3	Receiver adjacent channel selectivity and narrowband blocking for IAB type 1-H.....	194
D.2.4	Receiver spurious emissions.....	194
D.2.5	Receiver In-channel selectivity for IAB type 1-H.....	196
D.2.6	Receiver intermodulation for IAB type 1-H.....	196
D.3	IAB type 1-H performance requirements	197

D.3.1	Performance requirements for PUSCH and PUCCH on single antenna port in multipath fading conditions.....	197
D.3.2	Performance requirements for PUSCH, PDSCH, PDCCH transmission and PMI/RI reporting on two antenna ports in multipath fading conditions.....	198
D.3.3	Performance requirements for PUSCH, PRACH transmission and CQI reporting in static conditions ...	199
Annex E (normative): Characteristics of interfering signals.....		200
E.1	Characteristics of the interfering signals for IAB-DU.....	200
E.2	Characteristics of the interfering signals for IAB-MT	200
Annex F (normative): Propagation conditions.....		201
F.1	Static propagation condition.....	201
F1.1	IAB-MT receiver with 2RX	201
F.2	Multi-path fading propagation conditions	201
F.2.1	General	201
F.2.2	Delay profiles	201
F.2.2.1	General.....	201
F.2.2.2	Delay profiles for FR1	203
F.2.3	Combinations of channel model parameters	204
F.2.4	MIMO channel correlation matrices.....	204
F.2.4.1	General.....	204
F.2.4.2	MIMO correlation matrices using Uniform Linear Array	204
F.2.4.2.1	General	204
F.2.4.2.2	Definition of MIMO correlation matrices	204
F.2.4.2.3	MIMO correlation matrices at high, medium and low level	206
F.2.4.3	Multi-antenna channel models using cross polarized antennas.....	208
F.2.4.3.1	General	208
F.2.4.3.2	Definition of MIMO correlation matrices using cross polarized antennas.....	208
F.2.4.2.3	Spatial correlation matrices at UE/IAB-MT and IAB-DU/gNB sides	209
F.2.4.2.3.1	Spatial correlation matrices at IAB-MT/UE side	209
F.2.4.2.3.2	Spatial correlation matrices at IAB-DU/gNB side.....	209
F.2.4.2.4	MIMO correlation matrices using cross polarized antennas	209
Annex G (normative) : In-channel TX tests for IAB-DU		211
Annex H (normative) : In-channel TX tests for IAB-MT		212
H.0	Applicability.....	212
H.1	General	212
H.2	Basic principles	212
H.2.1	Output signal of the TX under test	212
H.2.2	Ideal signal	212
H.2.3	Measurement results.....	213
H.2.4	Measurement points	213
H.3	Pre-FFT minimization process	214
H.4	Timing of the FFT window	214
H.5	Resource element TX power	215
H.6	Post-FFT equalisation.....	216
H.7	EVM.....	217
H.7.0	General	217
H.7.1	Averaged EVM (TDD).....	218
Annex I (informative): Change history.....		219
History		220

Foreword

This clause is mandatory; do not alter the text in any way other than to choose between "Specification" and "Report".

This Technical Specification has been produced by the 3rd Generation Partnership Project (3GPP).

The contents of the present document are subject to continuing work within the TSG and may change following formal TSG approval. Should the TSG modify the contents of the present document, it will be re-released by the TSG with an identifying change of release date and an increase in version number as follows:

Version x.y.z

where:

- x the first digit:
 - 1 presented to TSG for information;
 - 2 presented to TSG for approval;
 - 3 or greater indicates TSG approved document under change control.
- y the second digit is incremented for all changes of substance, i.e. technical enhancements, corrections, updates, etc.
- z the third digit is incremented when editorial only changes have been incorporated in the document.

In the present document, modal verbs have the following meanings:

- shall** indicates a mandatory requirement to do something
- shall not** indicates an interdiction (prohibition) to do something

The constructions "shall" and "shall not" are confined to the context of normative provisions, and do not appear in Technical Reports.

The constructions "must" and "must not" are not used as substitutes for "shall" and "shall not". Their use is avoided insofar as possible, and they are not used in a normative context except in a direct citation from an external, referenced, non-3GPP document, or so as to maintain continuity of style when extending or modifying the provisions of such a referenced document.

- should** indicates a recommendation to do something
- should not** indicates a recommendation not to do something
- may** indicates permission to do something
- need not** indicates permission not to do something

The construction "may not" is ambiguous and is not used in normative elements. The unambiguous constructions "might not" or "shall not" are used instead, depending upon the meaning intended.

- can** indicates that something is possible
- cannot** indicates that something is impossible

The constructions "can" and "cannot" are not substitutes for "may" and "need not".

- will** indicates that something is certain or expected to happen as a result of action taken by an agency the behaviour of which is outside the scope of the present document
- will not** indicates that something is certain or expected not to happen as a result of action taken by an agency the behaviour of which is outside the scope of the present document
- might** indicates a likelihood that something will happen as a result of action taken by some agency the behaviour of which is outside the scope of the present document

might not indicates a likelihood that something will not happen as a result of action taken by some agency the behaviour of which is outside the scope of the present document

In addition:

is (or any other verb in the indicative mood) indicates a statement of fact

is not (or any other negative verb in the indicative mood) indicates a statement of fact

The constructions "is" and "is not" do not indicate requirements.

1 Scope

The present document establishes the minimum RF characteristics and minimum performance requirements of NR Integrated access and backhaul (IAB).

The present document specifies the Radio Frequency (RF) test methods and conformance requirements for NR Integrated access and backhaul (IAB) type 1-H. These have been derived from, and are consistent with the conducted requirements for NR Integrated access and backhaul (IAB) type 1-H in NR Integrated access and backhaul specification defined in TS 38.174 [2].

An *IAB type 1-H* has both conducted and radiated requirements so it requires compliance to the applicable requirements of the present document and TS 38.176-2 [3].

IAB type 1-O and *IAB type 2-O* have only radiated requirements so they require compliance to TS 38.176-2 [3] only.

2 References

The following documents contain provisions which, through reference in this text, constitute provisions of the present document.

- References are either specific (identified by date of publication, edition number, version number, etc.) or non-specific.
- For a specific reference, subsequent revisions do not apply.
- For a non-specific reference, the latest version applies. In the case of a reference to a 3GPP document (including a GSM document), a non-specific reference implicitly refers to the latest version of that document *in the same Release as the present document*.

- [1] 3GPP TR 21.905: "Vocabulary for 3GPP Specifications".
- [2] 3GPP TS 38.174: "NR Integrated access and backhaul radio transmission and reception".
- [3] 3GPP TS 38.176-2: "NR; Integrated Access and Backhaul (IAB) conformance testing; Part 2: Radiated conformance testing".
- [4] Recommendation ITU-R M.1545: "Measurement uncertainty as it applies to test limits for the terrestrial component of International Mobile Telecommunications-2000".
- [5] Recommendation ITU-R SM.329: "Unwanted emissions in the spurious domain".
- [6] Recommendation ITU-R SM.328: "Spectra and bandwidth of emissions".
- [7] "Title 47 of the Code of Federal Regulations (CFR)", Federal Communications Commission.
- [8] 3GPP TR 25.942: "RF system scenarios"
- [9] 3GPP TS 38.211: "NR; Physical channels and modulation"
- [10] 3GPP TS 38.212: "NR; Multiplexing and channel coding"
- [11] 3GPP TS 38.104: "NR Base Station (BS) radio transmission and reception"
- [12] 3GPP TS 38.213: "NR; Physical layer procedures for control".
- [13] 3GPP TS 38.141-1: "NR; Base Station (BS) conformance testing; Part 1: Conducted conformance testing".
- [14] 3GPP TS 38.331: "NR; Radio Resource Control (RRC); Protocol specification".
- [15] Recommendation ITU-T O.150, "Equipment for the measurement of digital and analogue/digital parameters"

- [16] 3GPP TS 38.521-1: "NR; User Equipment (UE) conformance specification; Radio transmission and reception; Part 1: Range 1 Standalone".
- [17] IEC 60 721-3-3: "Classification of environmental conditions - Part 3-3: Classification of groups of environmental parameters and their severities - Stationary use at weather protected locations"
- [18] IEC 60 721-3-4: "Classification of environmental conditions - Part 3: Classification of groups of environmental parameters and their severities - Clause 4: Stationary use at non-weather protected locations"
- [19] IEC 60 721: "Classification of environmental conditions"
- [20] IEC 60 068-2-1 (2007): "Environmental testing - Part 2: Tests. Tests A: Cold"
- [21] IEC 60 068-2-2: (2007): "Environmental testing - Part 2: Tests. Tests B: Dry heat"
- [22] IEC 60 068-2-6: (2007): "Environmental testing - Part 2: Tests - Test Fc: Vibration (sinusoidal)"
- [23] 3GPP TS 38.101-1: "NR; User Equipment (UE) radio transmission and reception; Part 1: Range 1 Standalone"
- [24] 3GPP TS 38.214: "NR; Physical layer procedures for data"
- [25] 3GPP TR 38.901: "Study on channel model for frequencies from 0.5 to 100 GHz"

3 Definitions of terms, symbols and abbreviations

3.1 Terms

For the purposes of the present document, the terms given in 3GPP TR 21.905 [1] and the following apply. A term defined in the present document takes precedence over the definition of the same term, if any, in 3GPP TR 21.905 [1].

aggregated IAB channel bandwidth: the RF bandwidth in which a IAB-DU or IAB-MT transmits and receives multiple contiguously aggregated carriers. The *aggregated IAB channel bandwidth* is measured in MHz

active transmitter unit: transmitter unit which is ON, and has the ability to send modulated data streams that are parallel and distinct to those sent from other transmitter units to one or more *IAB type 1-H TAB connectors* at the *transceiver array boundary*

basic limit: emissions limit relating to the power supplied by a single transmitter to a single antenna transmission line in ITU-R SM.329 [5] used for the formulation of unwanted emission requirements for FR1

beam: beam (of the antenna) is the main lobe of the radiation pattern of an *antenna array*

NOTE: For certain *antenna array*, there may be more than one beam.

Channel edge: lowest or highest frequency of the NR carrier, separated by the *IAB-MT channel bandwidth* or *IAB-DU channel bandwidth*.

Carrier aggregation: aggregation of two or more component carriers in order to support wider *transmission bandwidths*

Carrier aggregation configuration: a set of one or more *operating bands* across which the IAB-DU or IAB-MT aggregates carriers with a specific set of technical requirements

co-location reference antenna: a passive antenna used as reference for co-location requirements

Contiguous spectrum: spectrum consisting of a contiguous block of spectrum with no *sub-block gap(s)*.

fractional bandwidth: *fractional bandwidth* FBW is defined as $FBW = 200 \cdot \frac{F_{FBW_{high}} - F_{FBW_{low}}}{F_{FBW_{high}} + F_{FBW_{low}}} \%$

highest carrier: The carrier with the highest carrier frequency transmitted/received in a specified frequency band.

IAB-donor: gNB that provides network access to UEs via a network of backhaul and access links.

IAB-DU channel bandwidth: RF bandwidth supporting a single IAB-DU RF carrier with the *transmission bandwidth* configured in the uplink or downlink

NOTE 1: The *IAB-DU channel bandwidth* is measured in MHz and is used as a reference for transmitter and receiver RF requirements.

NOTE 2: It is possible for the IAB to transmit to and/or receive from one or more UE bandwidth parts that are smaller than or equal to the *IAB transmission bandwidth configuration*, in any part of the *IAB transmission bandwidth configuration*.

IAB-DU RF Bandwidth: RF bandwidth in which an IAB-DU transmits and/or receives single or multiple carrier(s) within a supported *operating band*

IAB-DU RF Bandwidth edge: frequency of one of the edges of the *IAB-DU RF Bandwidth*.

IAB-MT channel bandwidth: RF bandwidth supporting a single IAB-MT RF carrier with the *transmission bandwidth* configured in the uplink or downlink

NOTE 1: The *IAB-MT channel bandwidth* is measured in MHz and is used as a reference for transmitter and receiver RF requirements.

IAB-MT RF Bandwidth: RF bandwidth in which an IAB-MT transmits and/or receives single or multiple carrier(s) within a supported *operating band*

NOTE: In single carrier operation, the *IAB-MT RF Bandwidth* is equal to the *IAB-MT channel bandwidth*.

IAB-MT RF Bandwidth edge: frequency of one of the edges of the *IAB-MT RF Bandwidth*.

IAB RF Bandwidth: RF bandwidth in which an IAB-DU or IAB-MT transmits and/or receives single or multiple carrier(s) within a supported *operating band*

IAB RF Bandwidth edge: frequency of one of the edges of the *IAB RF Bandwidth*.

IAB type 1-H: IAB-DU or IAB-MT operating at FR1 with a *requirement set* consisting of conducted requirements defined at individual *TAB connectors* and OTA requirements defined at RIB

IAB type 1-O: IAB-DU or IAB-MT operating at FR1 with a *requirement set* consisting only of OTA requirements defined at the RIB

IAB type 2-O: IAB-DU or IAB-MT operating at FR2 with a *requirement set* consisting only of OTA requirements defined at the RIB

inter-band gap: The frequency gap between two supported consecutive *operating bands*.

Inter RF Bandwidth gap: frequency gap between two consecutive *IAB-DU* or *IAB-MT RF Bandwidths* that are placed within two supported *operating bands*

lowest Carrier: The carrier with the lowest carrier frequency transmitted/received in a specified frequency band.

maximum carrier output power: mean power level measured per carrier at the indicated interface, during the *transmitter ON period* in a specified reference condition

measurement bandwidth: RF bandwidth in which an emission level is specified

multi-band connector: *TAB connector* of *IAB type 1-H* associated with a transmitter or receiver that is characterized by the ability to process two or more carriers in common active RF components simultaneously, where at least one carrier is configured at a different *operating band* than the other carrier(s) and where this different *operating band* is not a *sub-band* or *superseding-band* of another supported *operating band*

multi-band RIB: *operating band* specific RIB associated with a transmitter or receiver that is characterized by the ability to process two or more carriers in common active RF components simultaneously, where at least one carrier is configured at a different *operating band* than the other carrier(s) and where this different *operating band* is not a *sub-band* or *superseding-band* of another supported *operating band*

Non-contiguous spectrum: spectrum consisting of two or more *sub-blocks* separated by *sub-block gap(s)*.

operating band: frequency range in which NR operates (paired or unpaired), that is defined with a specific set of technical requirements

NOTE: The *operating band(s)* for an IAB-DU and IAB-MT are declared by the manufacturer

Parent node: IAB-MT's next hop neighbour node; the parent node can be IAB-node or IAB-donor.

Radio Bandwidth: frequency difference between the upper edge of the highest used carrier and the lower edge of the lowest used carrier

rated carrier output power: mean power level associated with a particular carrier the manufacturer has declared to be available at the indicated interface, during the *transmitter ON period* in a specified reference condition

rated total output power: mean power level associated with a particular *operating band* the manufacturer has declared to be available at the indicated interface, during the *transmitter ON period* in a specified reference condition

requirement set: one of the NR requirement sets as defined for *IAB type 1-H*, *IAB type 1-O*, and *IAB type 2-O*

single-band connector: *IAB type 1-H TAB connector* supporting operation either in a single *operating band* only, or in multiple *operating bands* but does not meet the conditions for a *multi-band connector*.

sub-band: A *sub-band* of an operating band contains a part of the uplink and downlink frequency range of the operating band.

sub-block: one contiguous allocated block of spectrum for transmission and reception by the same IAB-DU or IAB-MT

NOTE: There may be multiple instances of *sub-blocks* within a *IAB RF Bandwidth*.

sub-block gap: frequency gap between two consecutive sub-blocks within a *IAB RF Bandwidth*, where the RF requirements in the gap are based on co-existence for un-coordinated operation

superseding-band: A *superseding-band* of an operating band includes the whole of the uplink and downlink frequency range of the operating band.

TAB connector: *transceiver array boundary* connector

TAB connector RX min cell group: *operating band* specific declared group of *TAB connectors* to which *IAB type 1-H* conducted RX requirements are applied

NOTE: Within this definition, the group corresponds to the group of *TAB connectors* which are responsible for receiving a cell when the *IAB type 1-H* setting corresponding to the declared minimum number of cells with reception on all *TAB connectors* supporting an *operating band*, but its existence is not limited to that condition

TAB connector TX min cell group: *operating band* specific declared group of *TAB connectors* to which *IAB type 1-H* conducted TX requirements are applied.

NOTE: Within this definition, the group corresponds to the group of *TAB connectors* which are responsible for transmitting a cell when the *IAB type 1-H* setting corresponding to the declared minimum number of cells with transmission on all *TAB connectors* supporting an *operating band*, but its existence is not limited to that condition

transceiver array boundary: conducted interface between the transceiver unit array and the composite antenna

transmission bandwidth: RF Bandwidth of an instantaneous transmission from an IAB-DU or IAB-MT, measured in resource block units

transmitter OFF period: time period during which the IAB-DU or IAB-MT transmitter is not allowed to transmit

transmitter ON period: time period during which the IAB-DU or IAB-MT transmitter is transmitting data and/or reference symbols

transmitter transient period: time period during which the transmitter is changing from the OFF period to the ON period or vice versa

3.2 Symbols

For the purposes of the present document, the following symbols apply:

β	Percentage of the mean transmitted power emitted outside the occupied bandwidth on the assigned channel
BW_{Channel}	<i>IAB-DU channel bandwidth</i> or <i>IAB-MT channel bandwidth</i>
$BW_{\text{Channel_CA}}$	<i>aggregated IAB channel bandwidth</i> , expressed in MHz. $BW_{\text{Channel_CA}} = F_{\text{edge_high}} - F_{\text{edge_low}}$.
BW_{Config}	Transmission bandwidth configuration, expressed in MHz, where $BW_{\text{Config}} = N_{\text{RB}} \times \text{SCS} \times 12 \text{ kHz}$
BW_{tot}	<i>Total RF bandwidth</i>
Δf	Separation between the channel edge frequency and the nominal -3 dB point of the measuring filter closest to the carrier frequency
Δf_{max}	$f_{\text{offset_max}}$ minus half of the bandwidth of the measuring filter
Δf_{OBUE}	Maximum offset of the <i>operating band</i> unwanted emissions mask from the downlink <i>operating band</i> edge
Δf_{OOB}	Maximum offset of the out-of-band boundary from the uplink <i>operating band</i> edge
F_{C}	<i>RF reference frequency</i> on the channel raster
$F_{\text{C,block, high}}$	Fc of the highest transmitted/received carrier in a sub-block
$F_{\text{C,block, low}}$	Fc of the lowest transmitted/received carrier in a sub-block
$F_{\text{C,low}}$	The Fc of the lowest carrier, expressed in MHz
$F_{\text{C,high}}$	The Fc of the highest carrier, expressed in MHz
$F_{\text{edge_low}}$	The lower edge of <i>aggregated IAB channel bandwidth</i> , expressed in MHz. $F_{\text{edge_low}} = F_{\text{C,low}} - F_{\text{offset_low}}$
$F_{\text{edge_high}}$	The upper edge of <i>aggregated IAB channel bandwidth</i> , expressed in MHz. $F_{\text{edge_high}} = F_{\text{C,high}} + F_{\text{offset_high}}$.
$F_{\text{offset_high}}$	Frequency offset from $F_{\text{C,high}}$ to the upper <i>Base Station RF Bandwidth edge</i> , or from $F_{\text{C,block, high}}$ to the upper sub-block edge
$F_{\text{offset_low}}$	Frequency offset from $F_{\text{C,low}}$ to the lower <i>Base Station RF Bandwidth edge</i> , or from $F_{\text{C,block, low}}$ to the lower sub-block edge
$F_{\text{DL,low}}$	The lowest frequency of the downlink <i>operating band</i>
$F_{\text{DL,high}}$	The highest frequency of the downlink <i>operating band</i>
f_{offset}	Separation between the channel edge frequency and the centre of the measuring filter
$f_{\text{offset_max}}$	The offset to the frequency Δf_{OBUE} outside the downlink <i>operating band</i>
$F_{\text{DL,low}}$	The lowest frequency of the downlink <i>operating band</i>
$F_{\text{DL,high}}$	The highest frequency of the downlink <i>operating band</i>
$F_{\text{UL,low}}$	The lowest frequency of the uplink <i>operating band</i>
$F_{\text{UL,high}}$	The highest frequency of the uplink <i>operating band</i>
I_{uant}	gNB internal logical interface between the implementation specific O&M function and the RET antennas and TMAs control unit function of the gNB
N_{cells}	The declared number corresponding to the minimum number of cells that can be transmitted by an <i>IAB type 1-H</i> in a particular <i>operating band</i>
N_{RB}	Transmission bandwidth configuration, expressed in resource blocks
$N_{\text{RXU,active}}$	The number of active receiver units. The same as the number of <i>demodulation branches</i> to which compliance is declared for clause 8 performance requirements
$N_{\text{RXU,counted}}$	The number of active receiver units that are taken into account for conducted Rx spurious emission scaling, as calculated in clause 7.6.1
$N_{\text{RXU,countedpercell}}$	The number of active receiver units that are taken into account for conducted RX spurious emissions scaling per cell, as calculated in clause 7.6.1
$N_{\text{TXU,counted}}$	The number of <i>active transmitter units</i> as calculated in clause 6.1, that are taken into account for conducted TX output power limit in clause 6.2.1, and for unwanted TX emissions scaling
$N_{\text{TXU,countedpercell}}$	The number of <i>active transmitter units</i> that are taken into account for conducted TX emissions scaling per cell, as calculated in clause 6.1
$P_{\text{max,c,TABC}}$	The <i>maximum carrier output power per TAB connector</i>
$P_{\text{rated,c,sys}}$	The sum of $P_{\text{rated,c,TABC}}$ for all <i>TAB connectors</i> for a single carrier
$P_{\text{rated,c,TABC}}$	The <i>rated carrier output power per TAB connector</i>
$P_{\text{rated,t,TABC}}$	The <i>rated total output power</i> declared at <i>TAB connector</i>
P_{REFSENS}	Conducted Reference Sensitivity power level
W_{gap}	Sub-block gap or Inter RF Bandwidth gap size

3.3 Abbreviations

For the purposes of the present document, the abbreviations given in 3GPP TR 21.905 [1] and the following apply. An abbreviation defined in the present document takes precedence over the definition of the same abbreviation, if any, in 3GPP TR 21.905 [1].

ACLR	Adjacent Channel Leakage Ratio
ACS	Adjacent Channel Selectivity
AWGN	Additive White Gaussian Noise
BS	Base Station
BW	Bandwidth
CA	Carrier Aggregation
CACLR	Cumulative ACLR
CP-OFDM	Cyclic Prefix-OFDM
CW	Continuous Wave
DFT-s-OFDM	Discrete Fourier Transform-spread-OFDM
DM-RS	Demodulation Reference Signal
E-UTRA	Evolved UTRA
EVM	Error Vector Magnitude
FDD	Frequency Division Duplex
FR	Frequency Range
GSM	Global System for Mobile communications
ITU-R	Radiocommunication Sector of the International Telecommunication Union
IAB	Integrated Access and Backhaul
IAB-DU	IAB Distribution Unit
IAB-MT	IAB Mobile Termination
ICS	In-Channel Selectivity
LA	Local Area
MR	Medium Range
NB-IoT	Narrowband – Internet of Things
NR	New Radio
NR-ARFCN	NR Absolute Radio Frequency Channel Number
OBUE	Operating Band Unwanted Emissions
OCC	Orthogonal Covering Code
OTA	Over The Air
RB	Resource Block
RDN	Radio Distribution Network
REFSENS	Reference Sensitivity
RF	Radio Frequency
RIB	Radiated Interface Boundary
RMS	Root Mean Square (value)
RS	Reference Signal
RX	Receiver
SCS	Sub-Carrier Spacing
SDL	Supplementary Downlink
SSB	Synchronization Signal Block
SUL	Supplementary Uplink
TAB	Transceiver Array Boundary
TAE	Time Alignment Error
TDD	Time division Duplex
TX	Transmitter
TT	Test Tolerance
UCI	Uplink Control Information
WA	Wide Area
ZF	Zero Forcing

4 General conducted test conditions and declarations

4.1 Measurement uncertainties and test requirements

4.1.1 General

The requirements of this clause apply to all applicable tests in part 1 of the present document, i.e. to all conducted tests defined for FR1. The frequency ranges FR1 and FR2 are defined in clause 5.1 of TS 38.174 [2].

The minimum requirements are given in TS 38.174 [2] and the references therein. Test Tolerances for the conducted test requirements explicitly stated in the present document are given in Annex C of the present document.

Test Tolerances are individually calculated for each test. The Test Tolerances are used to relax the minimum requirements to create test requirements.

When a test requirement differs from the corresponding minimum requirement, then the Test Tolerance applied for the test is non-zero. The Test Tolerance for the test and the explanation of how the minimum requirement has been relaxed by the Test Tolerance are given in Annex C.

4.1.2 Acceptable uncertainty of Test System

4.1.2.1 General

The maximum acceptable uncertainty of the Test System is specified below for each test defined explicitly in the present specification, where appropriate. The maximum acceptable uncertainty of the Test System for test requirements included by reference is defined in the respective referred test specification.

For *IAB type 1-H* when a requirement is applied per *TAB connector* then the test uncertainty is applied to the measured value. When a requirement is applied for a group of *TAB connectors* then the test uncertainty is applied to sum of the measured power on each *TAB connector* in the group.

The Test System shall enable the stimulus signals in the test case to be adjusted to within the specified tolerance and the equipment under test to be measured with an uncertainty not exceeding the specified values. All tolerances and uncertainties are absolute values, and are valid for a confidence level of 95 %, unless otherwise stated.

A confidence level of 95 % is the measurement uncertainty tolerance interval for a specific measurement that contains 95 % of the performance of a population of test equipment.

For RF tests, it should be noted that the uncertainties in clause 4.1.2 apply to the Test System operating into a nominal 50 ohm load and do not include system effects due to mismatch between the DUT and the Test System.

4.1.2.2 Measurement of transmitter

Table 4.1.2.2-1: Maximum Test System uncertainty for transmitter tests

Clause	Maximum Test System Uncertainty	Derivation of Test System Uncertainty
6.2 IAB output power	± 0.7 dB, $f \leq 3$ GHz ± 1.0 dB, 3 GHz $< f \leq 6$ GHz (Note)	
6.3.1 IAB-DU Output power dynamics	± 0.4 dB	
6.3.2 IAB-MT Output power dynamics	± 0.7 dB, $BW \leq 40$ MHz ± 1.0 dB, 40 MHz $< f \leq 100$ MHz	
6.4.1 Transmit OFF power	± 2.0 dB, $f \leq 3$ GHz ± 2.5 dB, 3 GHz $< f \leq 6$ GHz (Note)	
6.4.2 Transmitter transient period	N/A	
6.5.2.1 IAB-DU Frequency error	± 12 Hz	
6.5.2.2 IAB-MT Frequency error	± 15 Hz, $f \leq 3.0$ GHz ± 36 Hz, $f > 3.0$ GHz	
6.5.3 EVM	$\pm 1\%$	
6.5.4 Time alignment error	± 25 ns	
6.6.2 Occupied bandwidth	10 MHz IAB Channel BW: ± 100 kHz 15 MHz, 20 MHz, 25 MHz, 30 MHz, 40 MHz, 50 MHz IAB Channel BW: ± 300 kHz 60 MHz, 70 MHz, 80 MHz, 90 MHz, 100 MHz IAB Channel BW: ± 600 kHz	
6.6.3 Adjacent Channel Leakage power Ratio (ACLR)	ACLR/ CACLR BW ≤ 20 MHz: ± 0.8 dB BW > 20 MHz: ± 1.2 dB Absolute power ± 2.0 dB, $f \leq 3$ GHz Absolute power ± 2.5 dB, 3 GHz $< f \leq 6$ GHz (Note) CACLR BW ≤ 20 MHz: ± 0.8 dB BW > 20 MHz: ± 1.2 dB CACLR absolute power ± 2.0 dB, $f \leq 3$ GHz CACLR absolute power ± 2.5 dB, 3 GHz $< f \leq 6$ GHz (Note)	
6.6.4 Operating band unwanted emissions	± 1.5 dB, $f \leq 3$ GHz ± 1.8 dB, 3 GHz $< f \leq 6$ GHz (Note)	
6.6.5.5.1.1 Transmitter spurious emissions, Mandatory Requirements	9 kHz $< f \leq 4$ GHz: ± 2.0 dB 4 GHz $< f \leq 19$ GHz: ± 4.0 dB 19 GHz $< f \leq 26$ GHz: ± 4.5 dB	
6.6.5.5.1.2 Transmitter spurious emissions, Additional spurious emission requirements	± 2.0 dB for > -60 dBm, $f \leq 3$ GHz ± 2.5 dB, 3 GHz $< f \leq 4.2$ GHz ± 3.0 dB, 4.2 GHz $< f \leq 6$ GHz ± 3.0 dB for ≤ -60 dBm, $f \leq 3$ GHz ± 3.5 dB, 3 GHz $< f \leq 4.2$ GHz ± 4.0 dB, 4.2 GHz $< f \leq 6$ GHz	
6.6.5.2.3 Transmitter spurious emissions, Co-location	± 3.0 dB	
6.7 Transmitter intermodulation (interferer requirements) This tolerance applies to the stimulus and not the measurements defined in 6.6.3, 6.6.4 and 6.6.5	The value below applies only to the interfering signal and is unrelated to the measurement uncertainty of the tests in 6.6.3 (ACLR), 6.6.4 (OBUE) and 6.6.5 (spurious emissions) which have to be carried out in the presence of the interferer. ± 1.0 dB	The uncertainty of interferer has double the effect on the result due to the frequency offset
NOTE: Test system uncertainty values for 4.2 GHz $< f \leq 6$ GHz apply for IAB operates in licensed spectrum only.		

4.1.2.3 Measurement of receiver

Table 4.1.2.3-1: Maximum Test System uncertainty for receiver tests

Clause	Maximum Test System Uncertainty	Derivation of Test System Uncertainty
7.2 Reference sensitivity level	±0.7 dB, $f \leq 3$ GHz ±1.0 dB, $3 \text{ GHz} < f \leq 4.2 \text{ GHz}$ ±1.2 dB, $4.2 \text{ GHz} < f \leq 6 \text{ GHz}$	
7.3 Dynamic range	±0.3 dB	
7.4.1 Adjacent channel selectivity	±1.4 dB, $f \leq 3$ GHz ±1.8 dB, $3 \text{ GHz} < f \leq 4.2 \text{ GHz}$ ±2.1 dB, $4.2 \text{ GHz} < f \leq 6 \text{ GHz}$ (NOTE 2)	Overall system uncertainty comprises three quantities: 1. Wanted signal level error 2. Interferer signal level error 3. Additional impact of interferer leakage Items 1 and 2 are assumed to be uncorrelated so can be root sum squared to provide the ratio error of the two signals. The interferer leakage effect is systematic, and is added arithmetically. Test System uncertainty = SQRT (wanted_level_error ² + interferer_level_error ²) + leakage effect. $f \leq 3$ GHz Wanted signal level ±0.7 dB Interferer signal level ±0.7 dB $3 \text{ GHz} < f \leq 4.2 \text{ GHz}$ Wanted signal level ±1.0 dB Interferer signal level ±1.0 dB $4.2 \text{ GHz} < f \leq 6 \text{ GHz}$ Wanted signal level ±1.22 dB Interferer signal level ±1.22 dB $f \leq 6$ GHz Impact of interferer leakage 0.4 dB
7.4.2 In-band blocking (General blocking)	±1.6 dB, $f \leq 3$ GHz ±2.0 dB, $3 \text{ GHz} < f \leq 4.2 \text{ GHz}$ ±2.2 dB, $4.2 \text{ GHz} < f \leq 6 \text{ GHz}$ (NOTE 2)	
7.4.2 In-band blocking (Narrow band blocking)	±1.4 dB, $f \leq 3$ GHz ±1.8 dB, $3 \text{ GHz} < f \leq 4.2 \text{ GHz}$ ±2.1 dB, $4.2 \text{ GHz} < f \leq 6 \text{ GHz}$ (NOTE 2)	
7.5.5.1, 7.5.5.3 Out-of-band blocking (General requirements)	$f_{\text{wanted}} \leq 3 \text{ GHz}$ $1 \text{ MHz} < f_{\text{interferer}} \leq 3 \text{ GHz}$: ±1.3 dB $3.0 \text{ GHz} < f_{\text{interferer}} \leq 4.2 \text{ GHz}$: ±1.5 dB $4.2 \text{ GHz} < f_{\text{interferer}} \leq 12.75 \text{ GHz}$: ±3.2 dB $3 \text{ GHz} < f_{\text{wanted}} \leq 4.2 \text{ GHz}$: $1 \text{ MHz} < f_{\text{interferer}} \leq 3 \text{ GHz}$: ±1.5 dB $3.0 \text{ GHz} < f_{\text{interferer}} \leq 4.2 \text{ GHz}$: ±1.7 dB $4.2 \text{ GHz} < f_{\text{interferer}} \leq 12.75 \text{ GHz}$: ±3.3 dB $4.2 \text{ GHz} < f_{\text{wanted}} \leq 6.0 \text{ GHz}$: $1 \text{ MHz} < f_{\text{interferer}} \leq 3 \text{ GHz}$: ±1.7 dB $3.0 \text{ GHz} < f_{\text{interferer}} \leq 4.2 \text{ GHz}$: ±1.8 dB $4.2 \text{ GHz} < f_{\text{interferer}} \leq 12.75 \text{ GHz}$: ±3.3 dB	Overall system uncertainty comprises three quantities: 1. Wanted signal level error 2. Interferer signal level error 3. Interferer broadband noise Items 1 and 2 are assumed to be uncorrelated so can be root sum squared to provide the ratio error of the two signals. The Interferer Broadband noise effect is systematic, and is added arithmetically. Test System uncertainty = SQRT (wanted_level_error ² + interferer_level_error ²) + Broadband noise effect. Out of band blocking, using CW interferer: Wanted signal level: ±0.7 dB up to 3 GHz ±1.0 dB up to 4.2 GHz ±1.22 dB up to 6 GHz Interferer signal level: ±1.0 dB up to 3 GHz ±1.2 dB up to 4.2 GHz ±3.0 dB up to 12.75 GHz Impact of interferer Broadband noise 0.1 dB

7.5.5.2, 7.5.5.4 Out-of-band blocking (Co-location requirements)	Co-location blocking, using CW interferer: ±2.5 dB, $f \leq 3.0$ GHz ±2.6 dB, $3.0 \text{ GHz} < f \leq 4.2 \text{ GHz}$ ±2.7 dB, $4.2 \text{ GHz} < f \leq 6.0 \text{ GHz}$	Co-location blocking, using CW interferer: $f \leq 3.0$ GHz Wanted signal level ± 0.7 dB $3.0 \text{ GHz} < f \leq 4.2 \text{ GHz}$ Wanted signal level ± 1.0dB $4.2 \text{ GHz} < f \leq 6.0 \text{ GHz}$ Wanted signal level ± 1.22 dB $f \leq 6.0$ GHz Interferer signal level: ± 2.0 dB Interferer ACLR not applicable Impact of interferer Broadband noise 0.4 dB
7.6 Receiver spurious emissions	30 MHz ≤ f ≤ 4 GHz: ±2.0 dB 4 GHz < f ≤ 19 GHz: ±4.0 dB 19 GHz < f ≤ 26 GHz: ±4.5 dB	
7.7 Receiver intermodulation	±1.8 dB, $f \leq 3.0$ GHz ±2.4 dB, $3.0 \text{ GHz} < f \leq 4.2 \text{ GHz}$ ±3.0 dB, $4.2 \text{ GHz} < f \leq 6.0 \text{ GHz}$ (NOTE 2)	Overall system uncertainty comprises four quantities: 1. Wanted signal level error 2. CW Interferer level error 3. Modulated Interferer level error 4. Impact of interferer ACLR The effect of the closer CW signal has twice the effect. Items 1, 2 and 3 are assumed to be uncorrelated so can be root sum squared to provide the combined effect of the three signals. The interferer ACLR effect is systematic, and is added arithmetically. Test System uncertainty = SQRT [(2 x CW_level_error) ² +(mod interferer_level_error) ² +(wanted signal_level_error) ²] + ACLR effect. $f \leq 3.0$ GHz Wanted signal level ± 0.7dB CW interferer level ± 0.5 dB Mod interferer level ± 0.7 dB $3.0 \text{ GHz} < f \leq 4.2 \text{ GHz}$ Wanted signal level ± 1.0 dB CW Interferer level ± 0.7 dB Mod Interferer level ± 1.0 dB $4.2 \text{ GHz} < f \leq 6 \text{ GHz}$ Wanted signal level ± 1.22 dB CW Interferer level ± 0.98 dB Mod Interferer level ± 1.22 dB $f \leq 6$ GHz Impact of interferer ACLR 0.4 dB
7.8 In-channel selectivity	±1.4 dB, $f \leq 3$ GHz ±1.8 dB, $3 \text{ GHz} < f \leq 4.2 \text{ GHz}$ ±2.1 dB, $4.2 \text{ GHz} < f \leq 6 \text{ GHz}$ (NOTE 2)	
NOTE 1: Unless otherwise noted, only the Test System stimulus error is considered here. The effect of errors in the throughput measurements due to finite test duration is not considered. NOTE 2: Test system uncertainty values for $4.2 \text{ GHz} < f \leq 6 \text{ GHz}$ apply for IAB operates in licensed spectrum only.		

4.1.2.4 Measurement of performance requirements

{Editor note: table(s) to added}

4.1.3 Interpretation of measurement results

The measurement results returned by the Test System are compared - without any modification - against the test requirements as defined by the Shared Risk principle.

The Shared Risk principle is defined in Recommendation ITU-R M.1545 [4].

The actual measurement uncertainty of the Test System for the measurement of each parameter shall be included in the test report.

The recorded value for the Test System uncertainty shall be, for each measurement, equal to or lower than the appropriate figure in clause 4.1.2 of the present document.

If the Test System for a test is known to have a measurement uncertainty greater than that specified in clause 4.1.2, it is still permitted to use this apparatus provided that an adjustment is made as follows.

Any additional uncertainty in the Test System over and above that specified in clause 4.1.2 shall be used to tighten the test requirement, making the test harder to pass. For some tests e.g. receiver tests, this may require modification of stimulus signals. This procedure will ensure that a Test System not compliant with clause 4.1.2 does not increase the chance of passing a device under test where that device would otherwise have failed the test if a Test System compliant with clause 4.1.2 had been used.

4.2 Conducted requirement reference points

4.2.1 IAB type 1-H

IAB type 1-H requirements are defined for two points of reference, signified by radiated requirements and conducted requirements.

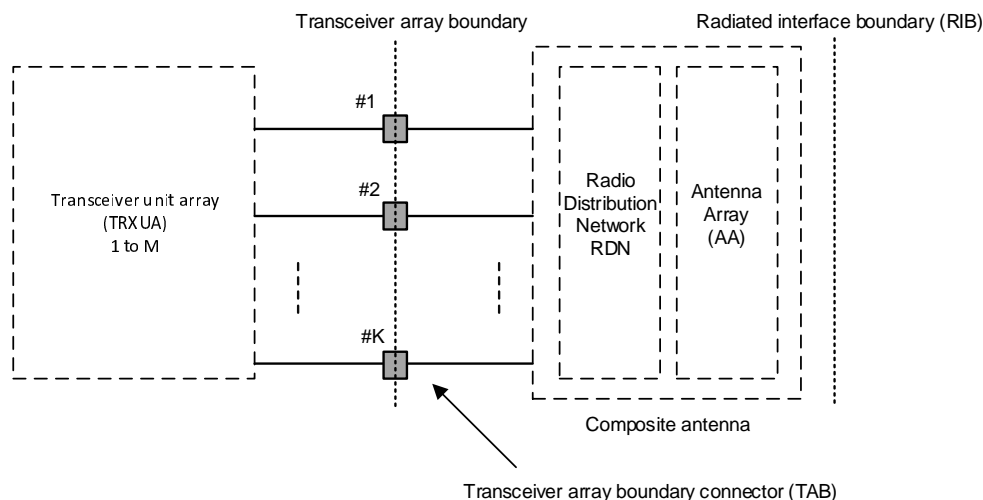

Figure 4.2.1-1: Radiated and conducted reference points for IAB type 1-H

Radiated characteristics are defined over the air (OTA), where the *operating band* specific radiated interface is referred to as the *Radiated Interface Boundary (RIB)*. Radiated requirements are also referred to as OTA requirements. The (spatial) characteristics in which the OTA requirements apply are detailed for each requirement.

NOTE: Radiated conformance requirements are captured in TS 38.176-2 [3] and are out of scope of the present document.

Conducted characteristics are defined at individual or groups of *TAB connectors* at the *transceiver array boundary*, which is the conducted interface between the transceiver unit array and the composite antenna.

The transceiver unit array is part of the composite transceiver functionality generating modulated transmit signal structures and performing receiver combining and demodulation.

The transceiver unit array contains an implementation specific number of transmitter units and an implementation specific number of receiver units. Transmitter units and receiver units may be combined into transceiver units. The transmitter/receiver units have the ability to transmit/receive parallel independent modulated symbol streams.

The composite antenna contains a radio distribution network (RDN) and an antenna array. The RDN is a linear passive network which distributes the RF power generated by the transceiver unit array to the antenna array, and/or distributes the radio signals collected by the antenna array to the transceiver unit array, in an implementation specific way.

How a conducted requirement is applied to the *transceiver array boundary* is detailed in the respective requirement clause.

4.3 IAB classes

4.3.1 IAB-DU class

The requirements in the present document apply to Wide Area IAB-DU, Medium Range IAB-DU and Local Area IAB-DU unless otherwise stated. For *IAB type 1-H*, IAB-DU classes are defined as indicated below:

- Wide Area IAB-DU are characterised by requirements derived from Macro Cell scenarios with a BS to UE minimum coupling loss equal to 70 dB.
- Medium Range IAB-DU are characterised by requirements derived from Micro Cell scenarios with a BS to UE minimum coupling loss equals to 53 dB.
- Local Area IAB-DU are characterised by requirements derived from Pico Cell scenarios with a BS to UE minimum coupling loss equal to 45 dB.

4.3.2 IAB-MT class

The requirements in the present document apply to Wide Area IAB-MT and Local Area IAB-MT classes unless otherwise stated.

For *IAB type 1-H*, IAB-MT classes are defined as indicated below:

- Wide Area IAB-MT are characterised by requirements derived from Macro Cell and/or Micro Cell scenarios.
- Local Area IAB-MT are characterised by requirements derived from Pico Cell and /or Micro Cell scenarios.

4.4 Regional requirements

Some requirements in the present document may only apply in certain regions either as optional requirements, or as mandatory requirements set by local and regional regulation. It is normally not stated in the 3GPP specifications under what exact circumstances the regional requirements apply, since this is defined by local or regional regulation.

Table 4.4-1 lists all requirements in the present specification that may be applied differently in different regions.

Table 4.4-1: List of regional requirements

Clause number	Requirement	Comments
5.2	<i>Operating bands</i>	Some NR <i>operating bands</i> may be applied regionally.
6.2.3	IAB output power: Additional requirements	These requirements may be applied regionally as additional IAB output power requirements.
6.6.2	Occupied bandwidth	The requirement may be applied regionally. There may also be regional requirements to declare the occupied bandwidth according to the definition in present specification.
6.6.4.2	Operating band unwanted emission	Category A or Category B operating band unwanted emissions limits may be applied regionally.
6.6.4.2.5.1	Operating band unwanted emission	The IAB may have to comply with the additional requirements, when deployed in regions where those limits are applied, and under the conditions declared by the manufacturer.
6.6.5.2.1,	Tx spurious emissions,	Category A or Category B spurious emission limits, as defined in Recommendation ITU-R SM.329 [5], may apply regionally. The emission limits for <i>IAB type 1-H</i> specified as the <i>basic limit + X</i> (dB) are applicable, unless stated differently in regional regulation.
6.6.5.2.2,	Tx spurious emissions: additional requirements, OTA Tx spurious emissions: additional requirements	These requirements may be applied for the protection of system operating in frequency ranges other than the <i>IAB operating band</i> .
6.7.2.1	Transmitter intermodulation,	Interfering signal positions that are partially or completely outside of any downlink <i>operating band</i> of the IAB are not excluded from the requirement in Japan in Band n77, n78, n79.
7.6.2, 7.6.3	Rx spurious emissions,	The emission limits for <i>IAB type 1-H</i> specified as the <i>basic limit + X</i> (dB) are applicable, unless stated differently in regional regulation.

4.5 IAB configurations

4.5.1 IAB type 1-H

4.5.1.1 Transmit configurations

Unless otherwise stated, the conducted transmitter characteristics in clause 6 are specified at the *transceiver array boundary* at the *TAB connector(s)* with a full complement of transceiver units for the configuration in normal operating conditions.

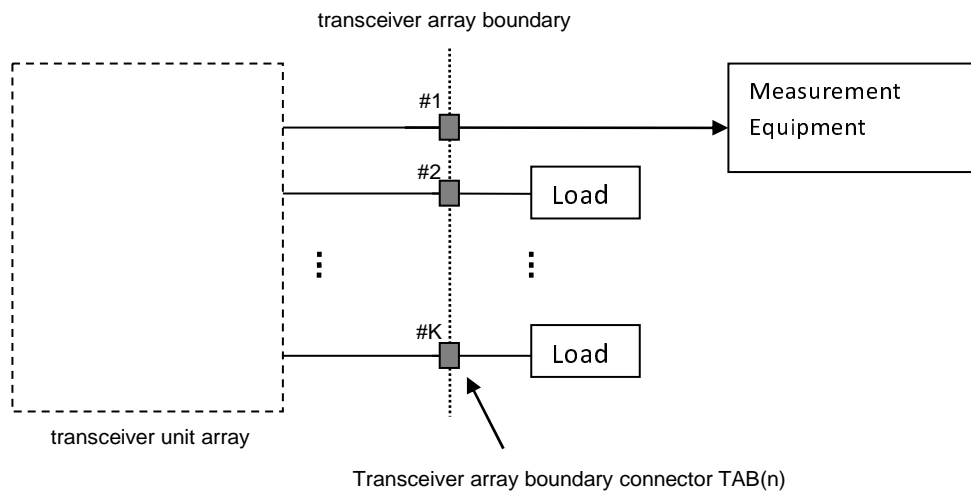

Figure 4.5.1.1-1: Transmitter test ports

Unless otherwise stated, for the tests in clause 6 of the present document, the requirement applies for each transmit *TAB connector*.

4.5.1.2 Receive configurations

Unless otherwise stated, the conducted receiver characteristics in clause 7 are specified at the *TAB connector* with a full complement of transceiver units for the configuration in normal operating conditions.

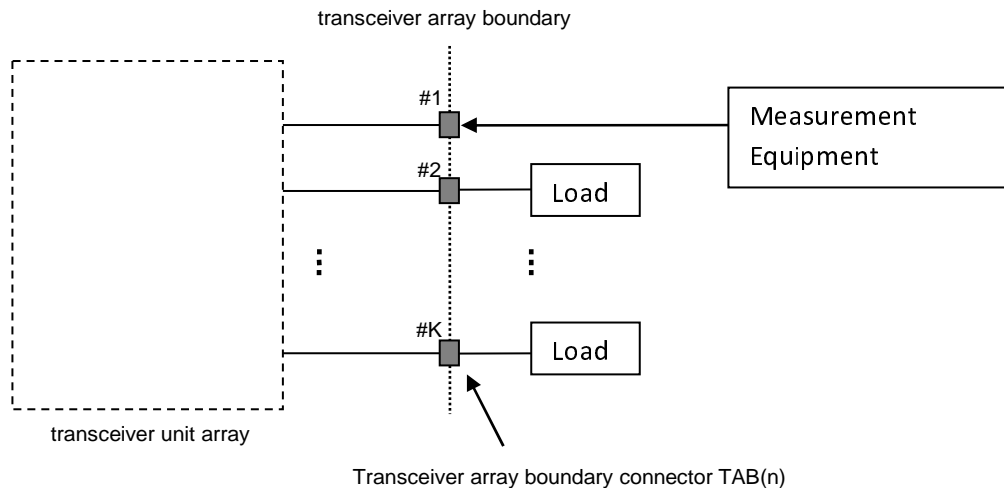

Figure 4.5.1.2-1: Receiver test ports

For the tests in clause 7 of the present document, the requirement applies at each receive *TAB connector*.

Conducted receive requirements are tested at the *TAB connector*, with the remaining receiver units(s) disabled or their *TAB connector(s)* being terminated.

4.5.1.3 Power supply options

If the *IAB type 1-H* is supplied with a number of different power supply configurations, it may not be necessary to test RF parameters for each of the power supply options, provided that it can be demonstrated that the range of conditions over which the equipment is tested is at least as great as the range of conditions due to any of the power supply configurations.

4.5.2 IAB with integrated Iuant BS modem

Unless otherwise stated, for the tests in the present document, the integrated Iuant BS modem shall be switched OFF. Spurious emissions according to clauses 6.6.5 and 7.6 shall be measured only for frequencies above 20 MHz with the integrated Iuant BS modem switched ON.

4.6 Manufacturer declarations

The following *IAB type 1-H* declarations listed in table 4.6-1, when applicable to the IAB-DU or IAB-MT under test, are required to be provided by the manufacturer for the conducted requirements testing of the *IAB type 1-H*. Declarations may be provided independently for IAB-MT and IAB-DU.

For the *IAB type 1-H* declarations required for the radiated requirements testing, refer to TS 38.176-2 [3].

Table 4.6-1 Manufacturer declarations for IAB-type 1-H conducted test requirements

Declaration identifier	Declaration	Description	Applicability	
			IAB-DU type 1-H	IAB-MT type 1-H
D.1	IAB requirements set	Declaration of one of the IAB requirement's set as defined for <i>IAB type 1-H</i> .	x	x
D.2	IAB class	IAB class of the IAB, declared as Wide Area IAB, Medium Range IAB, or Local Area IAB.	x	x
D.3	<i>Operating bands</i> and frequency ranges	List of NR <i>operating band(s)</i> supported by <i>single-band connector(s)</i> and/or <i>multi-band connector(s)</i> of the IAB-DU or IAB-MT and if applicable, frequency range(s) within the <i>operating band(s)</i> that the IAB can operate in. Declarations shall be made per <i>TAB connector</i> for <i>IAB type 1-H</i> .	x	x
D.4	Spurious emission category	Declare the IAB-DU or IAB-MT spurious emission category as either category A or B with respect to the limits for spurious emissions, as defined in Recommendation ITU-R SM.329 [5].	x	x
D.5	Additional operating band unwanted emissions	The manufacturer shall declare whether the IAB-DU or IAB-MT under test is intended to operate in geographic areas where the additional operating band unwanted emission limits defined in clause 6.6.4.5 apply.	x	x
D.6	Co-existence with other systems	The manufacturer shall declare whether the IAB-DU or IAB-MT under test is intended to operate in geographic areas where one or more of the systems GSM850, GSM900, DCS1800, PCS1900, UTRA FDD, UTRA TDD, E-UTRA, PHS and/or NR operating in another band are deployed.	x	x
D.7	Co-location with other IAB	The manufacturer shall declare whether the IAB-DU or IAB-MT under test is intended to operate co-located with IAB of one or more of the systems GSM850, GSM900, DCS1800, PCS1900, UTRA FDD, UTRA TDD, E-UTRA and/or NR operating in another band.	x	x
D.8	<i>Single band connector</i> or <i>multi-band connector</i>	Declaration of the single band or multi-band capability of <i>single band connector(s)</i> or <i>multi-band connector(s)</i> , declared for every connector.	x	x
D.9	Contiguous or non-contiguous spectrum operation support	Ability to support contiguous or non-contiguous (or both) frequency distribution of carriers when operating multi-carrier. Declared per <i>single band connector</i> or <i>multi-band connector</i> , per <i>operating band</i> .	x	x
D.10	void	void		
D.11	Maximum <i>IAB RF Bandwidth</i>	Maximum <i>IAB RF Bandwidth</i> in the <i>operating band</i> for single-band operation. Declared per supported <i>operating band</i> , per <i>TAB connector</i> for <i>IAB type 1-H</i> . (Note 2)	x	x
D.12	Maximum <i>IAB RF Bandwidth</i> for multi-band operation	Maximum <i>IAB RF Bandwidth</i> for multi-band operation. Declared per supported <i>operating band</i> , per <i>TAB connector</i> for <i>IAB type 1-H</i> .	x	x
D.13	Total RF bandwidth (BW_{tot})	Total RF bandwidth BW_{tot} of transmitter and receiver, declared per the band combinations (D.27).	x	x
D.14	NR supported channel bandwidths and SCS	NR supported SCS and channel bandwidths per supported SCS. Declared per supported <i>operating band</i> , per <i>TAB connector</i> for <i>IAB type 1-H</i> .	x	x
D.15	CA only operation	Declaration of CA-only operation (with equal power spectral density among carriers) but not multiple carriers, declared per <i>operating band</i> per <i>TAB connector</i> for <i>IAB type 1-H</i> .	x	x
D.16	Single or multiple carrier	Capable of operating with a single carrier (only) or multiple carriers. Declared per supported <i>operating band</i> , per <i>TAB connector</i> for <i>IAB type 1-H</i> .	x	x

Declaration identifier	Declaration	Description	Applicability	
			IAB-DU type 1-H	IAB-MT type 1-H
D.17	Maximum number of supported carriers per operating band in single band operation	Maximum number of supported carriers per supported <i>operation band</i> in single band operation. Declared per supported <i>operating band</i> , per <i>TAB connector</i> for <i>IAB type 1-H</i> . (Note 2)	x	x
D.18	Maximum number of supported carriers per operating band in multi-band operation	Maximum number of supported carriers per supported <i>operation band</i> in multi-band operation. (Note 2)	x	x
D.19	Total maximum number of supported carriers in multi-band operation	Maximum number of supported carriers for all supported <i>operating bands</i> in multi-band operation. Declared for all connectors (D.18).	x	x
D.20	Other band combination multi-band restrictions	Declare any other limitations under simultaneous operation in the declared band combinations (D.38) for each <i>multi-band connector</i> which have any impact on the test configuration generation. Declared for every <i>multi-band connector</i> .	x	x
D.21	Rated carrier output power ($P_{\text{rated,c,AC}}$, or $P_{\text{rated,c,TABC}}$)	Conducted rated carrier output power, per <i>single band connector</i> or <i>multi-band connector</i> . Declared per supported <i>operating band</i> , per <i>TAB connector</i> for <i>IAB type 1-H</i> . (Note 1, 2)	x	x
D.22	Rated total output power ($P_{\text{rated,t,AC}}$, or $P_{\text{rated,t,TABC}}$)	Conducted total rated output power. Declared per supported <i>operating band</i> , per <i>TAB connector</i> for <i>IAB type 1-H</i> . For <i>multi-band connectors</i> declared for each supported <i>operating band</i> in each supported band combination. (Note 1, 2)	x	x
D.23	Rated multi-band total output power, $P_{\text{rated,MB,TABC}}$	Conducted multi-band rated total output power. Declared per supported operating band combinations, per <i>multi-band connector</i> . (Note 1)	x	x
D.24	N_{cells}	Number corresponding to the minimum number of cells that can be transmitted by a IAB in a particular <i>operating band</i> with transmission on all <i>TAB connectors</i> supporting the <i>operating band</i> .	x	x
D.25	Maximum supported power difference between carriers	Maximum supported power difference between carriers. Declared per supported <i>operating band</i> , per <i>TAB connector</i> for <i>IAB type 1-H</i> . (Note 3).	x	x
D.26	Maximum supported power difference between carriers is different <i>operating bands</i>	Supported power difference between any two carriers in any two different supported <i>operating bands</i> . Declared per supported operating band combination, per <i>multi-band connector</i> .	x	x
D.27	Operating band combination support	List of operating bands combinations supported by <i>single-band connector(s)</i> and/or <i>multi-band connector(s)</i> of the IAB. Declared per <i>TAB connector</i> for <i>IAB type 1-H</i> .	x	x
D.28	void	void		
D.29	Intra-system interfering signal declaration list	List of <i>single band connector(s)</i> or <i>multi-band connector(s)</i> for which an intra-system interfering signal level is required to be declared. Declaration is required if the intra-system interfering signal level is larger than the co-location interfering signal level.	x	x
D.30	Intra-system interfering signal level	The interfering signal level in dBm. Declared per supported <i>operating band</i> , per <i>TAB connector</i> for <i>IAB type 1-H</i> covered by D.29.	x	x

Declaration identifier	Declaration	Description	Applicability	
			IAB-DU type 1-H	IAB-MT type 1-H
D.31	TAE groups	Set of declared <i>TAB connector beam forming groups</i> on which the TAE requirements apply. All <i>TAB connectors</i> belong to at least one <i>TAB connector beam forming group</i> (even if it's a <i>TAB connector beam forming group</i> consisting of one connector). The smallest possible number of <i>TAB connector beam forming groups</i> need to be declared such that there is no <i>TAB connector</i> not contained in at least one of the declared <i>TAB connector beam forming groups</i> . Declared per supported <i>operating band</i> .	x	
D.32	Equivalent connectors	List of <i>TAB connector</i> of <i>IAB type 1-H</i> , which have been declared equivalent. Equivalent connectors imply that the <i>TAB connector</i> of <i>IAB type 1-H</i> , are expected to behave in the same way when presented with identical signals under the same operating conditions. All declarations made for the <i>TAB connector</i> of <i>IAB type 1-H</i> are identical and the transmitter unit and/or receiver unit driving the <i>TAB connector</i> of <i>IAB type 1-H</i> are of identical design.	x	x
D.33	<i>TAB connector RX min cell group</i>	Declared as a group of <i>TAB connectors</i> to which RX requirements are applied. This declaration corresponds to group of <i>TAB connectors</i> which are responsible for receiving a cell when the <i>IAB type 1-H</i> setting corresponding to the declared minimum number of cells (N_{cells}) with transmission on all <i>TAB connectors</i> supporting an <i>operating band</i> .	X	x
D.34	<i>TAB connector TX min cell group</i>	Declared group of <i>TAB connectors</i> to which TX requirements are applied. This declaration corresponds to group of <i>TAB connectors</i> which are responsible for transmitting a cell when the <i>IAB type 1-H</i> setting corresponding to the declared minimum number of cells (N_{cells}) with transmission on all <i>TAB connectors</i> supporting an <i>operating band</i> .	x	x
D.35	void	void		
D.36	Relation between supported maximum RF bandwidth, number of carriers and Rated total output power	If the rated total output power and total number of supported carriers are not simultaneously supported, the manufacturer shall declare the following additional parameters: - The reduced number of supported carriers at the rated total output power; - The reduced total output power at the maximum number of supported carriers.	x	x
D.37	<i>TAB connectors</i> used for performance requirement testing	To reduce test complexity, declaration of a representative (sub)set of <i>TAB connectors</i> to be used for performance requirement test purposes. At least one <i>TAB connector</i> mapped to each <i>demodulation branch</i> is declared.	x	x
D.38	Inter-band CA	Band combinations declared to support inter-band CA (per CA capable <i>multi-band connector(s)</i> , as in D.15). Declared for every <i>multi-band connector</i> which support CA.	x	x
D.39	Intra-band contiguous CA	Bands declared to support intra-band contiguous CA (per CA capable <i>single band connector(s)</i> or <i>multi-band connector(s)</i> , as in D.15). Declared per <i>TAB connector</i> for <i>IAB type 1-H</i> .	x	x

Declaration identifier	Declaration	Description	Applicability	
			IAB-DU type 1-H	IAB-MT type 1-H
D.40	Intra-band non-contiguous CA	Bands declared to support intra-band non-contiguous CA (per CA capable <i>single band connector(s)</i> or <i>multi-band connector(s)</i> , as in D.15). Declared per or <i>TAB connector</i> for IAB type 1-H..	x	x
D.41	void	void		
D.42	void	void		
D.43	void	void		
D.IAB-1	Same RF implementation.	Declaration whether IAB-MT and IAB-DU have same RF implementation.	x	x
D.100	PUSCH mapping type	Declaration of the supported PUSCH mapping type as specified in TS 38.211 [9], i.e., type A, type B or both.	x	
D.101	PUSCH additional DM-RS positions	Declaration of the supported additional DM-RS position(s), i.e., pos0, pos1 or both.	x	
D.102	PUCCH format	Declaration of the supported PUCCH format(s) as specified in TS 38.211 [9], i.e., format 0, format 1, format 2, format 3, format 4.	x	
D.103	PRACH format and SCS	Declaration of the supported PRACH format(s) as specified in TS 38.211 [9], i.e., format: 0, A1, A2, A3, B4, C0, C2. Declaration of the supported SCS(s) per supported PRACH format with short sequence, as specified in TS 38.211 [9], i.e., 15 kHz, 30 kHz or both.	x	
D.104	Additional DM-RS for PUCCH format 3	Declaration of the supported additional DM-RS for PUCCH format 3: without additional DM-RS, with additional DM-RS or both.	x	
D.105	Additional DM-RS for PUCCH format 4	Declaration of the supported additional DM-RS for PUCCH format 4: without additional DM-RS, with additional DM-RS or both.	x	
D.106	PUCCH multi-slot	Declaration of multi-slot PUCCH support.	x	
D.107	UL CA	For the highest supported SCS, declaration of the carrier combination with the largest aggregated bandwidth. If there is more than one combination, the carrier combination with the largest number of carriers shall be declared.	x	
D.108	Modulation order	Declaration of the supported modulation order, i.e. QPSK, 16QAM, 64QAM	x	
D.109	DFT-s-OFDM	Declaration of the supported of DFT-s-OFDM, i.e. supported or not supported.	x	
D.200	256QAM for PDSCH for FR1	Declaration of the supported of 256QAM modulation scheme for PDSCH for FR1, i.e. supported or not supported.		x
D.201	Maximum number of ports across all configured NZP-CSI-RS resources per CC	Declaration of the maximum number of ports across all configured NZP-CSI-RS resources per CC, i.e. 2, 4, 8, 12, 16, 24, 32, 40, 48 ... ,256 or not supported.		x
D.202	Maximum number of PDSCH MIMO layers	Declaration of the the maximum number of spatial multiplexing layer(s) supported by the UE for DL reception, i.e. 2, 4, 8 or not supported.		x
NOTE 1: If an IAB-DU or IAB-MT is capable of 256QAM DL operation then two rated output power declarations may be made. One declaration is applicable when configured for 256QAM transmissions and the other declaration is applicable when not configured for 256QAM transmissions.				
NOTE 2: Parameters for contiguous or non-contiguous spectrum operation in the operating band are assumed to be the same unless they are separately declared. When separately declared, they shall still use the same declaration identifier.				
NOTE 3: The power difference is declared at highest rated output power.				

4.7 Test configurations

4.7.1 General

The test configurations shall be constructed using the methods defined below, subject to the parameters declared by the manufacturer for the supported RF configurations as listed in clause 4.6. The test configurations to use for conformance testing are defined for each supported RF configuration in clauses 4.8.3 and 4.8.4.

The applicable test models for generation of the carrier transmit test signal are defined in clause 4.9.

NOTE: If required, carriers are shifted to align with the channel raster.

4.7.2 Test signal used to build Test Configurations

The signal's channel bandwidth and subcarrier spacing used to build IAB Test Configurations shall be selected according to table 4.7.2-1.

Table 4.7.2-1: Signal to be used to build IAB TCs

Operating Band characteristics		$F_{DL_high} - F_{DL_low} < 100$ MHz	$F_{DL_high} - F_{DL_low} \geq 100$ MHz
TC signal characteristics	BW _{channel}	10 MHz (Note 1)	20 MHz (Note 1)
	Subcarrier spacing	Smallest supported subcarrier spacing	
NOTE 1: If this channel bandwidth is not supported, the narrowest supported channel bandwidth shall be used.			

4.7.3 IABTC1: Contiguous spectrum operation

4.7.3.1 General

The purpose of test configuration IABTC1 is to test all IAB requirements excluding CA occupied bandwidth.

For IABTC1 used in receiver tests only the two outermost UL carriers and two outermost DL carriers within each supported operating band need to be generated by the test equipment;

4.7.3.2 IABTC1 generation

IABTC1 shall be constructed on a per band basis using the following method:

- Declared maximum IAB RF Bandwidth supported for contiguous spectrum operation (D.11) shall be used;
- Select the IAB carrier to be tested according to 4.7.2 and place it adjacent to the lower IAB RF Bandwidth edge. Place same signals adjacent to the upper IAB RF Bandwidth edge.
- For transmitter tests, select as many IAB carriers (according to 4.7.2) that the IAB supports within an *operating band* and fit in the rest of the declared maximum IAB RF Bandwidth (D.11). Place the carriers adjacent to each other starting from the upper IAB RF Bandwidth edge. The nominal channel spacing defined in TS 38.174 [2], clause 5.4.1 shall apply.

The test configuration should be constructed sequentially on a per band basis for all component carriers of the inter-band CA bands declared to be supported by the IAB and are transmitted using the same *TAB connector*. All configured component carriers are transmitted simultaneously in the tests where the transmitter should be ON.

4.7.3.3 IABTC1 power allocation

Set the power spectral density of each carrier to the same level so that the sum of the carrier powers equals the rated total output power ($P_{rated,t,AC}$, or $P_{rated,t,TABC}$, D.22) for IAB according to the manufacturer's declaration in clause 4.6.

4.7.4 IABTC2: Contiguous CA occupied bandwidth

4.7.4.1 General

IABTC2 in this clause is used to test CA occupied bandwidth.

4.7.4.2 IABTC2 generation

The CA specific test configuration should be constructed on a per band basis using the following method:

- All component carrier combinations supported by the IAB, which have different sum of channel bandwidth of component carrier, shall be tested. For all component carrier combinations which have the same sum of channel bandwidth of component carriers, only one of the component carrier combinations shall be tested.
- Of all component carrier combinations which have same sum of channel bandwidth of component carrier, select those with the narrowest carrier with the smallest supported subcarrier spacing at the lower IAB RF Bandwidth edge.
- Of the combinations selected in the previous step, select one with the narrowest carrier with the smallest supported subcarrier spacing at the upper IAB RF Bandwidth edge.
- If there are multiple combinations fulfilling previous steps, select the one with the smallest number of component carrier.
- If there are multiple combinations fulfilling previous steps, select the one with the widest carrier with the smallest supported subcarrier spacing being adjacent to the lowest carrier.
- If there are multiple combinations fulfilling previous steps, select the one with the widest carrier with the smallest supported subcarrier spacing being adjacent to the highest carrier.
- If there are multiple combinations fulfilling previous steps, select the one with the widest carrier with the smallest supported subcarrier spacing being adjacent to the carrier which has been selected in the previous step.
- If there are multiple combinations fulfilling previous steps, repeat the previous step until there is only one combination left.
- The nominal channel spacing defined in TS 38.174 [2], clause 5.4.1 shall apply.

4.7.4.3 IABTC2 power allocation

Set the power spectral density of each carrier to be the same level so that the sum of the carrier powers equals the rated total output power ($P_{\text{rated,t,AC}}$, or $P_{\text{rated,t,TABC}}$, D.22) for IAB according to the manufacturer's declaration in clause 4.6.

4.7.5 IABTC3: Non-contiguous spectrum operation

4.7.5.1 General

The purpose of IABTC3 is to test all IAB requirements excluding CA occupied bandwidth.

For IABTC3 used in receiver tests, outermost DL and UL carriers for each sub-block need to be generated by the test equipment; other supported carriers are optional to be generated.

4.7.5.2 IABTC3 generation

IABTC3 is constructed on a per band basis using the following method:

- The IAB RF Bandwidth shall be the maximum IAB RF Bandwidth supported for non-contiguous spectrum operation (D.11). The IAB RF Bandwidth consists of one sub-block gap and two sub-blocks located at the edges of the declared maximum supported IAB RF Bandwidth (D.11).
- Select the IAB carrier to be tested according to clause 4.7.2. Place it adjacent to the upper IAB RF Bandwidth edge and another carrier (as described in clause 4.7.2) adjacent to the lower IAB RF Bandwidth edge.

- For single-band operation receiver tests, if the remaining gap is at least 15 MHz (or 60 MHz if channel bandwidth of the carrier to be tested is 20 MHz) plus two times the channel BW used in the previous step and the IAB supports at least 4 carriers, place a carrier of this BW adjacent to each already placed carrier for each sub-block. The nominal channel spacing defined in TS 38.174 [2], clause 5.4.1 shall apply.
- The sub-block edges adjacent to the sub-block gap shall be determined using the specified $F_{\text{offset_high}}$ and $F_{\text{offset_low}}$ for the carriers adjacent to the sub-block gap.

4.7.5.3 IABTC3 power allocation

Set the power of each carrier to the same level so that the sum of the carrier powers equals the rated total output power ($P_{\text{rated,t,AC}}$, or $P_{\text{rated,t,TABC}}$, D.22) for IAB according to the manufacturer's declaration in clause 4.6.

4.7.6 IABTC4: Multi-band test configuration for full carrier allocation

4.7.6.1 General

The purpose of IABTC4 is to test multi-band operation aspects considering maximum supported number of carriers.

4.7.6.2 IABTC4 generation

IABTC4 is based on re-using the previously specified test configurations (IABTC1, IABTC2 and IABTC3) applicable per band involved in multi-band operation. It is constructed using the following method:

- The IAB RF Bandwidth of each supported operating band shall be the declared maximum IAB RF Bandwidth in multi-band operation (D.12).
- The number of carriers of each supported *operating band* shall be the declared maximum number of supported carriers per operating band in multi-band operation (D. 18). Carriers shall be selected according to 4.7.2 and shall first be placed at the outermost edges of the declared maximum Radio Bandwidth. Additional carriers shall next be placed at the IAB RF Bandwidths edges, if possible.
- The allocated IAB RF Bandwidth of the outermost bands shall be located at the outermost edges of the declared maximum Radio Bandwidth.
- Each concerned band shall be considered as an independent band and the carrier placement in each band shall be according to IABTC1, where the declared parameters for multi-band operation shall apply. The mirror image of the single-band test configuration shall be used in each alternate band(s) and in the highest band being.
- If only three carriers are supported, two carriers shall be placed in one band according to the relevant test configuration while the remaining carrier shall be placed at the edge of the maximum *Radio Bandwidth* in the other band.
- If the sum of the maximum IAB RF Bandwidths of each supported *operating bands* is larger than the declared *Total RF Bandwidth* BW_{tot} (D.13) of transmitter and receiver for the declared band combinations of the IAB, repeat the steps above for test configurations where the IAB RF Bandwidth of one of the operating band shall be reduced so that the *Total RF Bandwidth* of transmitter and receiver is not exceeded and vice versa.
- If the sum of the maximum number of supported carriers per operating band in multi-band operation (D.18) is larger than the declared total maximum number of supported carriers in multi-band operation (D. 19), repeat the steps above for test configurations where in each test configuration the number of carriers of one of the operating band shall be reduced so that the total number of supported carriers is not exceeded and vice versa.

4.7.6.3 IABTC4 power allocation

Unless otherwise stated, set the power of each carrier in all supported *operating bands* to the same power so that the sum of the carrier powers equals the rated total output power ($P_{\text{rated,t,AC}}$ or $P_{\text{rated,t,TABC}}$, D.22) according to the manufacturer's declaration.

If the allocated power of a supported *operating band(s)* exceeds the declared rated total output power of the *operating band(s)* in multi-band operation, the exceeded part shall, if possible, be reallocated into the other band(s). If the power

allocated for a carrier exceeds the rated output power declared for that carrier, the exceeded power shall, if possible, be reallocated into the other carriers.

4.7.7 IABTC5: Multi-band test configuration with high PSD per carrier

4.7.7.1 General

The purpose of IABTC5 is to test multi-band operation aspects considering higher PSD cases with reduced number of carriers and non-contiguous operation (if supported) in multi-band mode.

4.7.7.2 IABTC5 generation

IABTC5 is based on re-using the existing test configuration applicable per band involved in multi-band operation. It is constructed using the following method:

- The IAB RF Bandwidth of each supported *operating band* shall be the declared maximum IAB RF Bandwidth in multi-band operation (D.12).
- The allocated IAB RF Bandwidth of the outermost bands shall be located at the outermost edges of the declared Maximum Radio Bandwidth.
- The maximum number of carriers is limited to two per band. Carriers shall be selected according to 4.7.2 and shall first be placed at the outermost edges of the declared Maximum Radio Bandwidth for outermost bands and at the IAB RF Bandwidths edges for middle band(s) if any. Additional carriers shall next be placed at the IAB RF Bandwidths edges, if possible.
- Each concerned band shall be considered as an independent band and the carrier placement in each band shall be according to IABTC3, where the declared parameters for multi-band operation shall apply. Narrowest supported NR channel bandwidth and smallest subcarrier spacing shall be used in the test configuration.
- If only one carrier can be placed for the concerned band(s), the carrier(s) shall be placed at the outermost edges of the declared maximum radio bandwidth for outermost band(s) and at one of the outermost edges of the supported frequency range within the IAB RF Bandwidths for middle band(s) if any.
- If the sum of the maximum IAB RF Bandwidth of each supported operating bands is larger than the declared *Total RF Bandwidth* BW_{tot} (D.13) of transmitter and receiver for the declared band combinations of the IAB, repeat the steps above for test configurations where the IAB RF Bandwidth of one of the operating band shall be reduced so that the *Total RF Bandwidth* BW_{tot} of transmitter and receiver is not exceeded and vice versa.

4.7.7.3 IABTC5 power allocation

Unless otherwise stated, set the power of each carrier in all supported *operating bands* to the same power so that the sum of the carrier powers equals the total rated output power ($P_{rated,t,AC}$ or $P_{rated,t,TABC}$, D.22) according to the manufacturer's declaration.

If the allocated power of a supported *operating band(s)* exceeds the declared rated total output power of the *operating band(s)* in multi-band operation, the exceeded part shall, if possible, be reallocated into the other band(s). If the power allocated for a carrier exceeds the rated output power declared for that carrier, the exceeded power shall, if possible, be reallocated into the other carriers.

4.8 Applicability of requirements

4.8.1 General

4.8.2 Requirement set applicability

In table 4.8.2-1, the requirement applicability for each requirement set of IAB-DU and IAB-MT is defined. For each requirement, the applicable requirement clause in the specification is identified. Requirements not included in a requirement set is marked not applicable (NA).

Table 4.8.2-1: Requirement set applicability for IAB-DUs and IAB-MTs

Requirement	IAB-DU Requirement set	IAB-MT Requirement set
Output power	6.2	6.2
Output power dynamics	6.3	6.3
Transmit ON/OFF power	6.4	6.4
Transmitted signal quality	6.5	6.5
Occupied bandwidth	6.6.2	6.6.2
ACLR	6.6.3	6.6.3
Operating band unwanted emissions	6.6.4	6.6.4
Transmitter spurious emissions	6.6.5	6.6.5
Transmitter intermodulation	6.7.5	6.7.5
Reference sensitivity level	7.2	7.2
Dynamic range	7.3	NA
In-band selectivity and blocking	7.4	7.4
Out-of-band blocking	7.5	7.5
Receiver spurious emissions	7.6	7.6
Receiver intermodulation	7.7	7.7
In-channel selectivity	7.8	NA
Performance requirements	8	8

4.8.3 Applicability of test configurations for single-band operation

The applicable test configurations are specified in the tables below for each the supported RF configuration, which shall be declared according to clause 4.6. The generation and power allocation for each test configuration is defined in clause 4.7. This clause contains the test configurations for an IAB node capable of single carrier, multi-carrier and/or CA operation in both contiguous and non-contiguous spectrum in single band.

For an IAB node declared to be capable of single carrier operation only (D.16), a single carrier (SC) shall be used for testing.

For an IAB node declared to support multi-carrier and/or CA operation in contiguous spectrum within a single band (D.15-D.16), the test configurations in the second column of table 4.8.3-1 shall be used for testing.

For an IAB node declared to support multi-carrier and/or CA operation in contiguous and non-contiguous spectrum within a single band (D.15-D.16) and where the parameters in the manufacture's declaration according to clause 4.6 are identical for contiguous (C) and non-contiguous (NC) spectrum operation (D.9), the test configurations in the third column of table 4.8.3-1 shall be used for testing.

For an IAB node declared to support multi-carrier and/or CA in operation contiguous and non-contiguous spectrum within a single band (D.15-D.16) and where the parameters in the manufacture's declaration according to clause 4.6 are not identical for contiguous (C) and non-contiguous (NC) spectrum operation (D.9), the test configurations in the fourth column of table 4.8.3-1 shall be used for testing.

Unless otherwise stated, single carrier configuration (SC) tests shall be performed using signal with narrowest supported channel bandwidth and the smallest supported sub-carrier spacing.

Table 4.8.3-1: Test configurations for a IAB capable of multi-carrier and/or CA in a single band

IAB test case	Contiguous spectrum capable IAB	C and NC capable IAB with identical parameters	C and NC capable IAB with different parameters
Output power	IABTC1	IABTC1	IABTC1, IABTC3
RE Power control dynamic range (only applied to IAB-DU)	Tested with Error Vector Magnitude	Tested with Error Vector Magnitude	Tested with Error Vector Magnitude
Total power dynamic range	SC	SC	SC
Transmit ON/OFF power (only applied to NR TDD IAB)	IABTC1	IABTC1	IABTC1, IABTC3
Frequency error	Tested with Error Vector Magnitude	Tested with Error Vector Magnitude	Tested with Error Vector Magnitude
Error Vector Magnitude	IABTC1	IABTC1	IABTC1, IABTC3
Time alignment error (only applied to IAB-DU)	IABTC1	IABTC1	IABTC1, IABTC3
Occupied bandwidth	SC, IABTC2 (Note 1)	SC, IABTC2 (Note 1)	SC, IABTC2 (Note 1)
Adjacent Channel Leakage power Ratio (ACLR)	IABTC1	IABTC3	IABTC1, IABTC3
Cumulative ACLR requirement in non-contiguous spectrum	-	IABTC3	IABTC3
Operating band unwanted emissions	IABTC1, SC (Note 2)	IABTC1, IABTC3, SC (Note 2)	IABTC1, IABTC3, SC (Note 2)
Transmitter spurious emissions	IABTC1	IABTC3	IABTC1, IABTC3
Transmitter intermodulation	IABTC1	IABTC1, IABTC3	IABTC1, IABTC3
Reference sensitivity level	SC	SC	SC
Dynamic range	SC	SC	SC
Adjacent Channel Selectivity (ACS)	IABTC1	IABTC3	IABTC1, IABTC3
In-band blocking	IABTC1	IABTC3	IABTC1, IABTC3
Out-of-band blocking	IABTC1	IABTC3	IABTC1, IABTC3
Receiver spurious emissions	IABTC1	IABTC3	IABTC1, IABTC3
Receiver intermodulation	IABTC1	IABTC3	IABTC1, IABTC3
In-channel selectivity (only applied to IAB-DU)	SC	SC	SC

NOTE 1: IABTC2 is only applicable when contiguous CA is supported.
NOTE 2: OBUE SC shall be tested using the widest supported channel bandwidth and the highest supported sub-carrier spacing.

4.8.4 Applicability of test configurations for multi-band operation

For an IAB node declared to be capable of multi-band operation, the test configuration in table 4.8.4-1 and/or table 4.8.3-1 shall be used for testing. In the case where multiple bands are mapped on common *multi-band connector*, the test configuration in the second column of table 4.8.4-1 shall be used. In the case where multiple bands are mapped on common *single-band connector*, the test configuration in table 4.8.3-1 shall be used. In the case where multiple bands are mapped on separate *single-band connector* or *multi-band connector*, the test configuration in the third column of table 4.8.4-1 shall be used.

Unless otherwise stated, single carrier configuration (SC) tests shall be performed using signal with narrowest supported channel bandwidth and the smallest supported sub-carrier spacing.

Table 4.8.4-1: Test configuration for a IAB capable of multi-band operation

IAB test case	Test configuration	
	Common connector	Separate connectors
Output power	IABTC1/3 (Note 1), IABTC4	IABTC1/3 (Note 1), IABTC4
RE Power control dynamic range (only applied to IAB-DU)	Tested with Error Vector Magnitude	Tested with Error Vector Magnitude
Total power dynamic range	SC	SC
Transmit ON/OFF power (only applied to NR TDD IAB)	IABTC4	IABTC4
Frequency error	Tested with Error Vector Magnitude	Tested with Error Vector Magnitude
Error Vector Magnitude	IABTC1/3 (Note 1), IABTC4	IABTC1/3 (Note 1), IABTC4
Time alignment error (only applied to IAB-DU)	IABTC1/3 (Note 1), IABTC5 (Note 2)	IABTC1/3 (Note 1), IABTC5 (Note 2)
Occupied bandwidth	SC, IABTC2 (Note 3)	SC, IABTC2 (Note 3)
Adjacent Channel Leakage power Ratio (ACLR)	IABTC1/3 (Note 1), IABTC5 (Note 4)	IABTC1/3 (Note 1, 5), IABTC5 (Note 4, 5)
Cumulative ACLR requirement in non-contiguous spectrum	IABTC3 (Note 1), IABTC5 (Note 4)	IABTC3 (Note 1, 5)
Operating band unwanted emissions	IABTC1/3 (Note 1), IABTC5, SC (Note 7)	IABTC1/3 (Note 1, 5), IABTC5 (Note 5), SC (Note 7)
Transmitter spurious emissions	IABTC1/3 (Note 1), IABTC5	IABTC1/3 (Note 1, 5), IABTC5 (Note 5)
Transmitter intermodulation	IABTC1/3 (Note 1)	IABTC1/3 (Note 1, 5)
Reference sensitivity level	SC	SC
Dynamic range	SC	SC
Adjacent Channel Selectivity (ACS)	IABTC5	IABTC1/3 (Note 1), IABTC5 (Note 6)
In-band blocking	IABTC5	IABTC1/3 (Note 1), IABTC5 (Note 6)
Out-of-band blocking	IABTC5	IABTC1/3 (Note 1), IABTC5 (Note 6)
Receiver spurious emissions	IABTC1/3 (Note 1), IABTC5	IABTC1/3 (Note 1, 5), IABTC5 (Note 5)
Receiver intermodulation	IABTC5	IABTC1/3 (Note 1), IABTC5 (Note 6)
In-channel selectivity (only applied to IAB-DU)	SC	SC
NOTE 1: IABTC1 and/or IABTC3 shall be applied in each supported operating band.		
NOTE 2: IABTC5 is only applicable when inter-band CA is supported.		
NOTE 3: IABTC2 is only applicable when contiguous CA is supported.		
NOTE 4: IABTC5 may be applied for Inter RF Bandwidth gap only.		
NOTE 5: For single-band operation test, other TAB connector(s) is (are) terminated.		
NOTE 6: IABTC5 is only applicable for multi-band receiver.		
NOTE 7: OBUE SC shall be tested using the widest supported channel bandwidth and the highest supported sub-carrier spacing.		

4.9 RF channels and test models

4.9.1 RF channels

For the single carrier testing many tests in this TS are performed with appropriate frequencies in the bottom, middle and top channels of the supported frequency range of the IAB. These are denoted as RF channels B (bottom), M (middle) and T (top).

Unless otherwise stated, the test shall be performed with a single carrier at each of the RF channels B, M and T.

Many tests in this TS are performed with the maximum IAB RF Bandwidth located at the bottom, middle and top of the supported frequency range in the operating band. These are denoted as B_{RFBW} (bottom), M_{RFBW} (middle) and T_{RFBW} (top).

Unless otherwise stated, the test shall be performed at B_{RFBW} , M_{RFBW} and T_{RFBW} defined as following:

- B_{RFBW} : maximum IAB RF Bandwidth located at the bottom of the supported frequency range in the operating band.
- M_{RFBW} : maximum IAB RF Bandwidth located in the middle of the supported frequency range in the operating band.
- T_{RFBW} : maximum IAB RF Bandwidth located at the top of the supported frequency range in the operating band.

Occupied bandwidth test in this TS is performed with the *aggregated IAB channel bandwidth* and sub-block bandwidths located at the bottom, middle and top of the supported frequency range in the operating band. These are denoted as $B_{\text{BW Channel CA}}$ (bottom), $M_{\text{BW Channel CA}}$ (middle) and $T_{\text{BW Channel CA}}$ (top) for contiguous spectrum operation.

Unless otherwise stated, the test for contiguous spectrum operation shall be performed at $B_{\text{BW Channel CA}}$, $M_{\text{BW Channel CA}}$ and $T_{\text{BW Channel CA}}$ defined as following:

- $B_{\text{BW Channel CA}}$: *aggregated IAB channel bandwidth* located at the bottom of the supported frequency range in each operating band;
- $M_{\text{BW Channel CA}}$: *aggregated IAB channel bandwidth* located close in the middle of the supported frequency range in each operating band;
- $T_{\text{BW Channel CA}}$: *aggregated IAB channel bandwidth* located at the top of the supported frequency range in each operating band.

For IAB capable of multi-band operation, unless otherwise stated, the test shall be performed at $B_{\text{RFBW}_T\text{RFBW}}$ and $B'_{\text{RFBW}_T\text{RFBW}}$ defined as following:

- $B_{\text{RFBW}_T\text{RFBW}}$: the *IAB RF Bandwidths* located at the bottom of the supported frequency range in the lowest operating band and at the highest possible simultaneous frequency position, within the Maximum Radio Bandwidth, in the highest operating band.
- $B'_{\text{RFBW}_T\text{RFBW}}$: the *IAB RF Bandwidths* located at the top of the supported frequency range in the highest operating band and at the lowest possible simultaneous frequency position, within the Maximum Radio Bandwidth, in the lowest operating band.

NOTE: $B_{\text{RFBW}_T\text{RFBW}} = B'_{\text{RFBW}_T\text{RFBW}} = B_{\text{RFBW}_T\text{RFBW}}$ when the declared Maximum Radio Bandwidth spans all operating bands. $B_{\text{RFBW}_T\text{RFBW}}$ means the *IAB RF Bandwidths* are located at the bottom of the supported frequency range in the lower operating band and at the top of the supported frequency range in the upper operating band.

When a test is performed by a test laboratory, the position of B, M and T for single carrier, B_{RFBW} , M_{RFBW} and T_{RFBW} for single band operation, $B_{\text{BW Channel CA}}$, $M_{\text{BW Channel CA}}$ and $T_{\text{BW Channel CA}}$ for contiguous spectrum operation in each supported operating band, the position of $B_{\text{RFBW}_T\text{RFBW}}$ and $B'_{\text{RFBW}_T\text{RFBW}}$ in the supported operating band combinations shall be specified by the laboratory. The laboratory may consult with operators, the manufacturer or other bodies.

4.9.2 Test models

4.9.2.1 General

The following clauses will describe the FR1 test models needed for *IAB type 1-H*. Note that the NR FR1 test models are also applicable to *IAB type 1-O* conformance testing in TS 38.176-2 [3].

4.9.2.2 FR1 test models for IAB-DU

FR1 test model in clause 4.9.2.2 in TS 38.141-1[13] applies to IAB-DU as below:

NR-FR1-TM1.1 applies to IAB-DU-FR1-TM1.1

NR-FR1-TM1.2 applies to IAB-DU-FR1-TM1.2

NR-FR1-TM2 applies to IAB-DU-FR1-TM2

NR-FR1-TM2a applies to IAB-DU-FR1-TM2a

NR-FR1-TM3.1 applies to IAB-DU-FR1-TM3.1

NR-FR1-TM3.1a applies to IAB-DU-FR1-TM3.1a

NR-FR1-TM3.2 applies to IAB-DU-FR1-TM3.2

NR-FR1-TM3.3 applies to IAB-DU-FR1-TM3.3

Testing models applying to NB-IoT operation in clause 4.9.2.2 in TS 38.141-1[13] are not applicable to IAB-DU.

4.9.2.3 FR1 test models for IAB-MT

4.9.2.3.1 General

The set-up of physical channels for transmitter tests shall be according to one of the FR1 test models (IAB-MT-FR1-TM) below. A reference to the applicable test model is made within each test.

The following general parameters are used by all IAB-MT test models:

- Duration is 2 radio frames for TDD (20 ms)
- The slots are numbered 0 to $10 \times 2^\mu - 1$ where μ is the numerology corresponding to the subcarrier spacing
- N_{RB} is the maximum transmission bandwidth configuration seen in clause 5.3.2 in TS 38.174[2].
- Normal CP
- Virtual resource blocks of localized type

IAB-MT test models are derived based on the uplink/downlink configuration as shown in the table 4.9.2.3.1-1 using information element *TDD-UL-DL-ConfigCommon* as defined in TS 38.331 [14].

Table 4.9.2.3.1-1: Configurations of TDD for IAB type 1-H test models

Field name	Value		
referenceSubcarrierSpacing (kHz)	15	30	60
Periodicity (ms) for dl-UL-TransmissionPeriodicity	5	5	5
nrofDownlinkSlots	3	7	14
nrofDownlinkSymbols	10	6	12
nrofUplinkSlots	1	2	4
nrofUplinkSymbols	2	4	8

Common physical channel parameters for all IAB-MT FR1 test models are specified in table 4.9.2.3.1-2 and table 4.9.2.3.1-3 for PUSCH. Specific physical channel parameters for IAB-MT FR1 test models are described in clauses 4.9.2.3.2 to 4.9.2.3.5.

Table 4.9.2.3.1-2: Common physical channel parameters for PUSCH for IAB type 1-H test models

Parameter	Value
Mapping type	PUSCH mapping type A
<i>dmrs-TypeA-Position</i> for the first DM-RS symbol	pos2
<i>dmrs-AdditionalPosition</i> for additional DM-RS symbol(s)	Pos1
<i>dmrs-Type</i> for comb pattern	Configuration type 1
<i>maxLength</i>	1
Ratio of PUSCH EPRE to DM-RS EPRE	0 dB

Table 4.9.2.3.1-3: Common physical channel parameters for PUSCH by RNTI for IAB type 1-H test models

Parameter	Value
PUSCH $n_{RNTI} = 0$	

4.9.2.3.2 FR1 test model 1.1 (IAB-MT-FR1-TM1.1)

This model shall be used for tests on:

- IAB output power
- Transmit ON/OFF power
- Unwanted emissions
 - Occupied bandwidth
 - ACLR
 - Operating band unwanted emissions
 - Transmitter spurious emissions
- Transmitter intermodulation
- Receiver spurious emissions

Common physical channel parameters are defined in clause 4.9.2.3.1. Specific physical channel parameters for IAB-MT-FR1-TM1.1 are defined in table 4.9.2.3.2-1.

Table 4.9.2.3.2-1: Specific physical channel parameters of IAB-MT-FR1-TM1.1

Parameter	Value
# of PRBs PUSCH	N_{RB}
Modulation PUSCH	QPSK

4.9.2.3.3 FR1 test model 2 (IAB-MT-FR1-TM2)

This model shall be used for tests on:

- Total power dynamic range (at lower PSD TX power limit at min power)
- Transmitted signal quality
 - EVM of single 64QAM PRB allocation (at lower PSD TX power limit at min power)
 - Frequency error (at min power)

Common physical channel parameters are defined in clause 4.9.2.3.1. Specific physical channel parameters for IAB-MT-FR1-TM2 are defined in table 4.9.2.3.3-1.

Table 4.9.2.3.3-1: Specific physical channel parameters of IAB-MT-FR1-TM2

Parameter	Value		
# of 64QAM PUSCH PRBs	1		
Level of boosting (dB)	0		
Location of 64QAM PRB	Slot	RB	n
	$3n$	0	$n = 0, \dots, \left\lfloor \frac{10 \times 2^\mu}{3} \right\rfloor - 1$
	$3n+1$	$\left\lfloor \frac{N_{RB}}{2} \right\rfloor$	$n = 0, \dots, \left\lfloor \frac{10 \times 2^\mu - 1}{3} \right\rfloor - 1$
	$3n+2$	$N_{RB} - 1$	$n = 0, \dots, \left\lfloor \frac{10 \times 2^\mu - 2}{3} \right\rfloor - 1$
# of PUSCH PRBs which are not allocated	$N_{RB} - 1$		

4.9.2.3.3a FR1 test model 2a (IAB-MT-FR1-TM2a)

This model shall be used for tests on:

- EVM of single 256QAM PRB allocation (at min power)
- Frequency error (at min power)

Common physical channel parameters are defined in clause 4.9.2.3.3. Physical channel parameters and numbers of the allocated PRB are defined in table 4.9.2.3.3-1 with all 64QAM PUSCH PRBs replaced by 256QAM PUSCH PRBs.

4.9.2.3.4 FR1 test model 3.1 (IAB-MT-FR1-TM3.1)

This model shall be used for tests on:

- Output power dynamics
 - Total power dynamic range (upper TX PSD power limit at max power with all 64QAM PRBs allocated)
- Transmitted signal quality
 - Frequency error (at max power)
 - EVM for modulation (at max power)

Common physical channel parameters are defined in clause 4.9.2.3.1. Physical channel parameters are defined in table 4.9.2.3.2-1 with all QPSK PUSCH PRBs replaced with selected modulation order PUSCH PRBs according to the corresponding test procedure.

4.9.2.3.5 FR1 test model 3.1a (IAB-MT-FR1-TM3.1a)

This model shall be used for tests on:

- Output power dynamics
 - Total power dynamic range (upper TX PSD power limit at max power with all 256QAM PRBs allocated)
- Transmitted signal quality
 - Frequency error (at max power)
 - EVM for 256QAM modulation (at max power)

Common physical channel parameters are defined in clause 4.9.2.3.1. Physical channel parameters are defined in table 4.9.2.3.2-1 with all QPSK PUSCH PRBs replaced by 256QAM PUSCH PRBs.

4.9.2.4 Data content of Physical channels and Signals for IAB-MT-FR1-TM

4.9.2.4.1 General

Randomisation of the data content is obtained by utilizing a PN sequence generator and the length-31 Gold sequence scrambling of TS 38.211 [9], clause 5.2.1 which is invoked by all physical channels prior to modulation and mapping to the RE grid.

Initialization of the scrambler and RE-mappers as defined in TS 38.211 [9] use the following additional parameters:

- N_{ID}^{cell} , Physical layer cell identity = 1 is used as the default physical layer cell identity
- $q = 0$ (single code word)
- Rank 1, single layer

4.9.2.4.2 PUSCH

- Generate the required amount of bits from the output of the PN23 sequence generator [15]. The PN sequence generator is initialized with a starting seed of "all ones" in the first allocated slot of each frame. The PN sequence is continuous over the slot boundaries.
- Perform user specific scrambling according to TS 38.211 [9], clause 6.3.1.1.
- Perform modulation of the scrambled bits with the modulation scheme defined for each user according to TS 38.211 [9], clause 6.3.1.2
- $n_{ID} = N_{ID}^{cell}$
- Perform mapping of the complex-valued symbols to layer according to TS 38.211 [9], clause 6.3.1.3.
- Perform PUSCH mapping according to TS 38.211 [9] using parameters listed in table 4.9.2.3-2.
- DM-RS sequence generation according to TS 38.211 [9], clause 6.4.1.1.1 where l is the OFDM symbol number within the slot with the symbols indicated by table 4.9.2.2-3.
- $N_{ID}^{n_{SCID}} = N_{ID}^{cell}$
- $n_{SCID} = 0$
- DM-RS mapping according to TS 38.211 [9], clause 6.4.1.1.3 using parameters listed in table 4.9.2.2-3.

4.10 Requirements for contiguous and non-contiguous spectrum

A spectrum allocation where an IAB-DU or IAB-MT operates can either be contiguous or non-contiguous. Unless otherwise stated, the requirements in the present specification apply for IAB-DU and IAB-MT configured for both *contiguous spectrum* operation and *non-contiguous spectrum* operation.

For IAB-DU or IAB-MT operation in *non-contiguous spectrum*, some requirements apply both at the *IAB RF Bandwidth edges* and inside the *sub-block gaps*. For each such requirement, it is stated how the limits apply relative to the *IAB RF Bandwidth edges* and the *sub-block edges* respectively.

4.11 Requirements for IAB capable of multi-band operation

For *multi-band connector* the conducted test requirements in clause 6 and 7 apply separately to each supported *operating band* unless otherwise stated. For some requirements, it is explicitly stated that specific additions or exclusions to the requirement apply at *multi-band connector(s)* as detailed in the requirement clause. For *IAB-DU* or *IAB-MT* capable of multi-band operation, various structures in terms of combinations of different transmitter and receiver implementations (multi-band or single band) with mapping of transceivers to one or more *TAB connectors* for *IAB type 1-H* in different ways are possible. For *multi-band connector(s)* the exclusions or provisions for multi-band apply. For *single-band connector(s)*, the following applies:

- Single-band transmitter spurious emissions, *operating band* unwanted emissions, ACLR, transmitter intermodulation and receiver spurious emissions requirements apply to this *connector* that is mapped to single-band.
- If the IAB-DU or IAB-MT is configured for single-band operation, single-band requirements shall apply to this *connector* configured for single-band operation and no exclusions or provisions for multi-band capable *IAB-DU* or *IAB-MT* are applicable. Single-band requirements are tested separately at the *connector* configured for single-band operation, with all other *TAB connectors* terminated.

An *IAB type 1-H* may be capable of supporting operation in multiple *operating bands* with one of the following implementations of *TAB connectors* in the *transceiver array boundary*:

- All *TAB connectors* are *single-band connectors*.
- Different sets of *single-band connectors* support different *operating bands*, but each *TAB connector* supports only operation in one single *operating band*.

- Sets of *single-band connectors* support operation in multiple *operating bands* with some *single-band connectors* supporting more than one *operating band*.
- All *TAB connectors* are multi-band *connectors*.
- A combination of single-band sets and multi-band sets of *TAB connectors* provides support of the type *IAB type I-H* capability of operation in multiple *operating bands*.

Unless otherwise stated all requirements specified for an *operating band* apply only to the set of *TAB connectors* supporting that *operating band*.

In the case of an *operating band* being supported only by *single-band connectors* in a *TAB connector TX min cell group* or a *TAB connector RX min cell group*, *single-band requirements* apply to that set of *TAB connectors*.

In the case of an *operating band* being supported only by *multi-band connectors* supporting the same *operating band* combination in a *TAB connector TX min cell group* or a *TAB connector RX min cell group*, *multi-band requirements* apply to that set of *TAB connectors*.

For multi-band connectors supporting the bands for TDD, the RF requirements in the present specification assume no simultaneous uplink and downlink occur between the bands.

NOTE 1: The case of an operating band being supported by both multi-band connectors and single-band connectors in a TAB connector TX min cell group or a TAB connector RX min cell group is not covered by the present release of the present document.

NOTE 2: The case of an operating band being supported by multi-band connectors which are not all supporting the same operating band combination in a TAB connector TX min cell group or a TAB connector RX min cell group is not covered by the present release of the present document.

4.12 Format and interpretation of tests

Each test has a standard format:

X Title

All tests are applicable to all equipment within the scope of the present document, unless otherwise stated.

X.1 Definition and applicability

This clause gives the general definition of the parameter under consideration and specifies whether the test is applicable to all equipment or only to a certain subset. Required manufacturer declarations may be included here.

X.2 Minimum requirement

This clause contains the reference to the clause to the 3GPP reference (or core) specification which defines the minimum requirement.

X.3 Test purpose

This clause defines the purpose of the test.

X.4 Method of test

X.4.1 General

In some cases there are alternative test procedures or initial conditions. In such cases, guidance for which initial conditions and test procedures can be applied are stated here. In the case only one test procedure is applicable, that is stated here.

X.4.2y First test method

X.4.2y.1 Initial conditions

This clause defines the initial conditions for each test, including the test environment, the RF channels to be tested and the basic measurement set-up.

X.4.2y.2 Procedure

This clause describes the steps necessary to perform the test and provides further details of the test definition like domain (e.g. frequency-span), range, weighting (e.g. bandwidth), and algorithms (e.g. averaging). The procedure may comprise data processing of the measurement result before comparison with the test requirement (e.g. average result from several measurement positions).

X.4.3y Alternative test method (if any)

If there are alternative test methods, each is described with its initial conditions and procedures.

X.5 Test requirement

This clause defines the pass/fail criteria for the equipment under test, see clause 4.1.3 (Interpretation of measurement results). Test requirements for every minimum requirement referred in clause X.2 are listed here. Cases where minimum requirements do not apply need not be mentioned.

4.13 Test efficiency optimization

When manufacture declares the same RF implementation for IAB-MT and IAB-DU (D.IAB-1) and the declarations in table 4.13-1 are the same for IAB-DU and IAB-MT, it is sufficient to test only IAB-MT or IAB-DU with the test requirement applicability according to Table 4.13-2 for Tx requirements and Table 4.13-3 for Rx requirements.

For *IAB type 1-H* it is required that the DUT selection between requirements follows following rules:

- Out of maximum output transmit power, modulation quality and ACLR, operating band unwanted emissions and transmitter general spurious emissions, IAB-DU and IAB-MT are required to be the DUT at least once,
- Out of reference sensitivity, receiver spurious emissions, receiver intermodulation, IAB-DU and IAB-MT are required to be the DUT at least once.

In some cases, the test requirements are the same but the MU for the IAB-MT may be larger than for the IAB-DU. In cases where the test efficiency optimization is applicable the lower MU value should be used.

Table 4.13-1: Declarations required to be the same for IAB-DU and IAB-MT for test efficiency optimization to apply

Declaration identifier	Declaration	Additional conditions	Applicability	
			IAB-DU type 1-H	IAB-MT type 1-H
D.2	IAB class	Medium range IAB-DU can apply test efficiency optimization with wide area IAB-MT in case other declarations in this table are the same.	x	x
D.3	<i>Operating bands and frequency ranges</i>		x	x
D.8	<i>Single band connector or multi-band connector</i>		x	x
D.11	<i>Maximum IAB RF Bandwidth</i>		x	x
D.13	Total RF bandwidth (BW_{tot})		x	x
D.14	NR supported channel bandwidths and SCS		x	x
D.17	Maximum number of supported carriers per operating band in single band operation		x	x
D.18	Maximum number of supported carriers per operating band in multi-band operation		x	x
D.19	Total maximum number of supported carriers in multi-band operation		x	x
D.20	Other band combination multi-band restrictions		x	x
D.21	Rated carrier output power ($P_{rated,c,AC}$, or $P_{rated,c,TABC}$)		x	x
D.22	Rated total output power ($P_{rated,t,AC}$, or $P_{rated,t,TABC}$)		x	x

Table 4.13-2: Test requirement applicability for TX requirements

Tx requirement		Test efficiency optimization applicable	Test requirement applicability (Note 1)
Maximum output power		Yes	
Output power dynamics (only for IAB-DU)		No	(Note 2)
Output power dynamics (only for IAB-MT)		No	(Note 2)
Transmitter OFF power		Yes	
Transient period		Yes	
IAB-DU Frequency Error		No	(Note 2)
IAB-MT Frequency Error		No	(Note 2)
Modulation quality		Yes	
Time alignment error (only for IAB-DU)		No	(Note 2)
Occupied bandwidth		Yes	
ACLR		Yes	
Operating band unwanted emission		Yes	
Transmitter spurious emission	General requirement		
	Additional spurious emissions		
	Co-location with other base stations		
OTA transmitter intermodulation		Yes	
NOTE 1: Test requirement applicability defines how to select whether IAB-DU or IAB-MT test requirement is applied. In case no applicability definition is provided or the applicability definition test requirement is the same for IAB-DU and IAB-MT, either can apply.			
NOTE 2: Test efficiency optimization is not applicable and therefore original test requirement applies.			

Table 4.13-3: Test requirement applicability for receiver requirements

Rx requirement		Test efficiency optimization applicable	Test requirement applicability (Note 1)
Reference sensitivity		Yes	
Dynamic range (only for IAB-DU)		No	(Note 2)
Adjacent channel selectivity		Yes	IAB-MT
In-band blocking		Yes	IAB-MT
Out-of-band blocking	General requirement		IAB-MT
	Co-location requirement		
Receiver spurious emissions		Yes	
Receiver intermodulation		Yes	IAB-MT
In-channel selectivity (only for IAB-DU)		No	(Note 2)
NOTE 1: Test requirement applicability defines how to select whether IAB-DU or IAB-MT test requirement is applied. In case no applicability definition is provided or the applicability definition test requirement is the same for IAB-DU and IAB-MT, either can apply.			
NOTE 2: Test efficiency optimization is not applicable and therefore original test requirement applies.			

5 Operating bands and channel arrangement

For the IAB operation in NR operating bands specification, their channel bandwidth configurations, channel spacing and raster, as well as synchronization raster specification, refer to TS 38.174 [2], clause 5 and its relevant clauses.

For conducted testing purposes in the present document, only FR1 operating bands are considered.

6 Conducted transmitter characteristics (IAB-DU and IAB-MT)

6.1 General

General test conditions for conducted transmitter tests are given in clause 4, including interpretation of measurement results and configurations for testing. IAB configurations for the tests are defined in clause 4.5.

If a number of *single-band connectors*, or *multi-band connectors* have been declared equivalent (D.32), only a representative one is necessary to be tested to demonstrate conformance.

In clause 6.6.3.5.3, if representative *TAB connectors* are used then per connector criteria (i.e. option 2) shall be applied.

For *IAB-DU* and *IAB-MT* the manufacturer shall declare the minimum number of supported geographical cells (i.e. geographical areas). The declaration is done separately for *IAB-DU* and *IAB-MT*. The minimum number of supported geographical cells (N_{cells} , D.24) relates to the setting with the minimum amount of cell splitting supported with transmission on all *TAB connectors* supporting the *operating band*.

For *IAB-DU* and *IAB-MT* manufacturer shall also declare *TAB connector TX min cell groups* (D.34). The declaration is done separately for *IAB-DU* and *IAB-MT*. Every *TAB connector* of the *IAB type 1-H* supporting transmission in an *operating band* shall map to one *TAB connector TX min cell group* supporting the same *operating band*, where mapping of *TAB connectors* to cells/beams is implementation dependent.

The number of *active transmitter units* that are considered when calculating the conducted TX emissions limits ($N_{\text{TXU,counted}}$) for *IAB-DU* and *IAB-MT* is calculated as follows:

$$N_{\text{TXU,counted}} = \min(N_{\text{TXU,active}}, 8 \times N_{\text{cells}})$$

$N_{\text{TXU,countedpercell}}$ is used for scaling of *basic limits* and is derived as $N_{\text{TXU,countedpercell}} = N_{\text{TXU,counted}} / N_{\text{cells}}$

NOTE: $N_{\text{TXU,active}}$ depends on the actual number of *active transmitter units* and is independent to the declaration of N_{cells} .

6.2 IAB output power

6.2.1 General

The *IAB type 1-H* conducted output power requirement is at *TAB connector* for *IAB type 1-H*.

The *rated carrier output power* of the *IAB type 1-H* shall be as specified in table 6.2.1-1 for *IAB-DU* and in table 6.2.1-2 for *IAB-MT*.

Table 6.2.1-1: IAB type 1-H rated output power limits for IAB-DU classes

IAB-DU class	$P_{\text{rated,c,sys}}$	$P_{\text{rated,c,TABC}}$
Wide Area IAB-DU	(Note)	(Note)
Medium Range IAB-DU	$\leq 38 \text{ dBm} + 10\log(N_{\text{TXU,counted}})$	$\leq 38 \text{ dBm}$
Local Area IAB-DU	$\leq 24 \text{ dBm} + 10\log(N_{\text{TXU,counted}})$	$\leq 24 \text{ dBm}$
NOTE: There is no upper limit for the $P_{\text{rated,c,sys}}$ or $P_{\text{rated,c,TABC}}$ of the Wide Area IAB-DU.		

Table 6.2.1-2: IAB type 1-H rated output power limits for IAB-MT classes

IAB-MT class	$P_{\text{rated,c,sys}}$	$P_{\text{rated,c,TABC}}$
Wide Area IAB-MT	(Note)	(Note)
Local Area IAB-MT	$\leq 24 \text{ dBm} + 10\log(N_{\text{TXU,counted}})$	$\leq 24 \text{ dBm}$
NOTE: There is no upper limit for the $P_{\text{rated,c,sys}}$ or $P_{\text{rated,c,TABC}}$ of the Wide area IAB-MT.		

6.2.2 Minimum requirement

The minimum requirement *IAB type 1-H* applies per *single-band connector*, or per *multi-band connector* supporting transmission in the *operating band*.

The minimum requirement for *IAB-DU* is defined in TS 38.174 [2], clause 6.2.2.

The minimum requirement for *IAB-MT* is defined in TS 38.174 [2], clause 6.2.2.

6.2.3 Test purpose

The test purpose is to verify the accuracy of the *maximum carrier output power* across the frequency range and under normal and extreme conditions.

6.2.4 Method of test

6.2.4.1 Initial conditions

Test environment:

- Normal, see annex B.2,
- Extreme, see annexes B.3 and B.5.

RF channels to be tested for single carrier: B, M and T; see clause 4.9.1

IAB RF Bandwidth positions to be tested for multi-carrier and/or CA:

- B_{RFBW} , M_{RFBW} and T_{RFBW} for *single-band connector(s)*, see clause 4.9.1.
- $B'_{\text{RFBW}}T'_{\text{RFBW}}$ and $B'_{\text{RFBW}}T'_{\text{RFBW}}$ for *multi-band connector(s)*, see clause 4.9.1.

Under extreme test environment, it is sufficient to test on one NR-ARFCN or one RF bandwidth position, and with one applicable test configuration defined in clauses 4.7 and 4.8. Testing shall be performed under extreme power supply conditions, as defined in Annex B.5.

NOTE: Tests under extreme power supply conditions also test extreme temperatures.

6.2.4.2 Procedure

For *IAB type 1-H* where there may be multiple *TAB connectors*, they may be tested one at a time or multiple *TAB connectors* may be tested in parallel as shown in annex D.1.1. Whichever method is used the procedure is repeated until all *TAB connectors* necessary to demonstrate conformance have been tested.

- 1) Connect the power measuring equipment to *single-band connector(s)* or to *multi-band connector(s)* under test as shown in annex D.1.1 for *IAB type 1-H*. All connectors not under test shall be terminated.
- 2) For single carrier set the connector under test to transmit according to the applicable test configuration in clause 4.8 using the corresponding test models or set of physical channels in clause 4.9.2 at *rated carrier output power* $P_{\text{rated,c,TABC}}$ for *IAB type 1-H* (D.21).

For a connector under test declared to be capable of multi-carrier and/or CA operation (D.15-D.16) set the connector under test to transmit on all carriers configured using the applicable test configuration and corresponding power setting specified in clauses 4.7 and 4.8 using the corresponding test models or set of physical channels in clause 4.9.2.

- 3) Measure the *maximum carrier output power* ($P_{\text{max,c,TABC}}$ for *IAB type 1-H*) for each carrier at each connector under test.

In addition, for *multi-band connectors*, the following steps shall apply:

- 4) For a *multi-band connectors* and single band tests, repeat the steps above per involved *operating band* where single band test configurations and test models shall apply with no carrier activated in the other *operating band*.

6.2.5 Test requirement

For each *single-band connector* or *multi-band connector* under test, the power measured in clause 6.2.4.2 in step 3 shall remain within the values provided in table 6.2.5-1 for normal and extreme test environments relative to the manufacturer's declared $P_{\text{rated,c,TABC}}$ for *IAB type 1-H* (D.21):

Table 6.2.5-1: Test requirement for conducted IAB-DU and IAB-MT output power

	Normal test environment	Extreme test environment
<i>IAB-DU</i> , <i>IAB-MT</i>	$f \leq 3.0$ GHz: ± 2.7 dB	$f \leq 3.0$ GHz: ± 3.2 dB
	3.0 GHz $< f \leq 6.0$ GHz: ± 3.0 dB	3.0 GHz $< f \leq 6.0$ GHz: ± 3.5 dB

6.3 Output power dynamics

6.3.1 IAB-DU Output Power Dynamics

6.3.1.1 General

The requirements in clause 6.3.1 apply during the *transmitter ON period*. Transmit signal quality requirements (as specified in clause 6.5) shall be maintained for the output power dynamics requirements of this clause.

6.3.1.2 RE power control dynamic range

6.3.1.2.1 Definition and applicability

The RE power control dynamic range is the difference between the power of an RE and the average RE power for an IAB-DU at *maximum carrier output power* ($P_{\text{max,c,TABC}}$, or $P_{\text{max,c,AC}}$) for a specified reference condition.

For *IAB type 1-H* this requirement shall apply at each *TAB connector* supporting transmission in the *operating band*.

6.3.1.2.2 Minimum requirement

The minimum requirement applies per *single-band connector*, or per *multi-band connector* supporting transmission in the *operating band*.

The minimum requirement for *IAB type 1-H* is defined in TS 38.174 [2], clause 6.3.1.2.

6.3.1.2.3 Test purpose

No specific test or test requirements are defined for conducted RE power control dynamic range. The Error Vector Magnitude (EVM) test, as described in clause 6.5.3 provides sufficient test coverage for this requirement.

6.3.1.3 Total power dynamic range

6.3.1.3.1 Definition and applicability

The IAB-DU total power dynamic range is the difference between the maximum and the minimum transmit power of an OFDM symbol for a specified reference condition.

For *IAB type 1-H* this requirement shall apply at each *TAB connector* supporting transmission in the *operating band*.

NOTE: The upper limit of the dynamic range is the OFDM symbol power for an IAB-DU when transmitting on all RBs at maximum output power. The lower limit of the total power dynamic range is the average power for single RB transmission. The OFDM symbol shall carry PDSCH and not contain PDCCH, RS or SSB.

6.3.1.3.2 Minimum requirement

The minimum requirement applies per *single-band connector*, or per *multi-band connector*.

The minimum requirement for *IAB-DU* is in TS 38.174 [2], clause 6.3.1.3.

6.3.1.3.3 Test purpose

The test purpose is to verify that the total power dynamic range is within the limits specified by the minimum requirement.

6.3.1.3.4 Method of test

6.3.1.3.4.1 Initial conditions

Test environment: Normal, see annex B.2.

RF channels to be tested: M; see clause 4.9.1.

Set the channel set-up of the connector under as shown in annex D.1 for *IAB type 1-H*.

6.3.1.3.4.2 Procedure

For *IAB type 1-H* where there may be multiple *TAB connectors*, they may be tested one at a time or multiple *TAB connectors* may be tested in parallel as shown in annex D.1.1. Whichever method is used the procedure is repeated until all *TAB connectors* necessary to demonstrate conformance have been tested.

- 1) Connect the *single-band connector(s)* under test as shown in annex D.1.1 for *IAB type 1-H*. All connectors not under test shall be terminated.
- 2) Set each connector under test to transmit according to the applicable test configuration in clause 4.8 using the corresponding test models in clause 4.9.2 at $P_{\text{rated,c,TABC}}$ for *IAB type 1-H* (D.21).
- 3) For *IAB-DU type 1-H*, set the IAB-DU to transmit a signal according to:
 - IAB-DU-FR1-TM3.1a if 256QAM is supported without power back off, or
 - IAB-DU-FR1-TM3.1 if 256QAM is supported with power back off, or
 - IAB-DU-FR1-TM3.1 if 256QAM is not supported by IAB-DU.
- 4) Measure the OFDM symbol TX power (OSTP) as defined in the annex H.
- 5) For *IAB-DU type 1-H*, set to transmit a signal according to:
 - IAB-DU-FR1-TM2a if 256QAM is supported, or
 - IAB-DU-FR1-TM2 if 256QAM is not supported;
- 6) Measure the OFDM symbol TX power (OSTP) as defined in the annex H.

In addition, for *multi-band connectors*, the following steps shall apply:

- 7) For a *multi-band connectors* and single band tests, repeat the steps above per involved *operating band* where single band test configurations and test models shall apply with no carrier activated in the other *operating band*.

6.3.1.3.5 Test requirements

The downlink (DL) total power dynamic range for each NR carrier shall be larger than or equal to the level in table 6.3.1.3.5-1.

Table 6.3.1.3.5-1: IAB-DU total power dynamic range

NR channel bandwidth (MHz)	Total power dynamic range (dB)		
	15 kHz SCS	30 kHz SCS	60 kHz SCS
10	16.7	13.4	10
15	18.5	15.3	12.1
20	19.8	16.6	13.4
25	20.8	17.7	14.5
30	21.6	18.5	15.3
40	22.9	19.8	16.6
50	23.9	20.8	17.7
60	N/A	21.6	18.5
70	N/A	22.3	19.2
80	N/A	22.9	19.8
90	N/A	23.4	20.4
100	N/A	23.9	20.9

NOTE: Additional test requirements for the EVM at the lower limit of the dynamic range are defined in clause 6.5.3.

6.3.2 IAB-MT Output Power Dynamics

6.3.2.1 Total power dynamic range

6.3.2.1.1 Definition and applicability

The IAB-MT total power dynamic range is the difference between the maximum and the minimum controlled transmit power in the channel bandwidth for a specified reference condition. The maximum and minimum output powers are defined as the mean power in at least one sub-frame 1ms.

NOTE: The specified reference condition(s) are specified in the conformance specification. Changes in the controlled transmit power in the channel bandwidth due to changes in the specified reference condition are not include as part of the dynamic range.

6.3.2.1.2 Minimum requirement

The IAB-MT total power dynamic range is defined in TS 38.174 [2], clause 6.3.2.1.2.

6.3.2.1.3 Test purpose

The test purpose is to verify that the IAB-MT total power dynamic range is within the limits specified by the minimum requirement.

6.3.2.1.4 Method of test

6.3.2.1.4.1 Initial conditions

Test environment: Normal, see annex B.2.

RF channels to be tested: M; see clause 4.9.1.

Set the channel set-up of the connector under as shown in annex D.1 for *IAB type I-H*.

6.3.2.1.4.2 Procedure

For *IAB type I-H* where there may be multiple *TAB connectors*, they may be tested one at a time or multiple *TAB connectors* may be tested in parallel as shown in annex D.1.1. Whichever method is used the procedure is repeated until all *TAB connectors* necessary to demonstrate conformance have been tested.

- 1) Connect the *single-band connector(s)* under test as shown in annex D.1.1 for *IAB type I-H*. All connectors not under test shall be terminated.
- 2) Set each connector under test to transmit according to the applicable test configuration in clause 4.8 using the corresponding test models in clause 4.9.2 at $P_{\text{rated,c,TABC}}$ for *IAB type I-H* (D.21).
- 3) Set the IAB-MT to transmit a signal according to IAB-MT-FR1-TM3.1
- 4) Measure the power over 1ms
- 5) Set to transmit a signal according to IAB-MT-FR1-TM2.
- 6) Measure the power over 1ms

In addition, for *multi-band connectors*, the following steps shall apply:

- 7) For a *multi-band connectors* and single band tests, repeat the steps above per involved *operating band* where single band test configurations and test models shall apply with no carrier activated in the other *operating band*.

6.3.2.1.5 Test requirements

The ΔP between the power measured in step 4 and step 6 of clause 6.3.2.1.4.2 shall be:

Table 6.3.2.1.5-1: IAB-MT Output power dynamics test requirements.

IAB-MT Type	IAB-MT channel bandwidth	Requirement
Wide area	$\leq 40\text{MHz}$	$10 \log(\text{Maximum RB}) - 1.2 < \Delta P \leq 10 \log(\text{Maximum RB}) + 11.2$
	$40\text{MHz} < \text{BW} \leq 100\text{MHz}$	$10 \log(\text{Maximum RB}) - 1.5 < \Delta P \leq 10 \log(\text{Maximum RB}) + 11.5$
Local area	$\leq 40\text{MHz}$	$10 \log(\text{Maximum RB}) + 3.8 < \Delta P \leq 10 \log(\text{Maximum RB}) + 15.2$
	$40\text{MHz} < \text{BW} \leq 100\text{MHz}$	$10 \log(\text{Maximum RB}) + 3.5 < \Delta P \leq 10 \log(\text{Maximum RB}) + 16.5$

6.3.2.2 Relative power tolerance for local area IAB-MT

6.3.2.2.1 Definition and applicability

The relative power tolerance is the ability of the transmitter to set its output power in a target sub-frame (1 ms) relatively to the power of the most recently transmitted reference sub-frame (1 ms) if the transmission gap between these sub-frames is less than or equal to 20 ms.

6.3.2.2.2 Minimum requirement

The IAB-MT total power dynamic range is defined in TS 38.174 [2], clause 6.3.3.1

6.3.2.2.3 Test purpose

No specific test or test requirements are defined for Relative power tolerance. The Total power dynamic range test, as described in clause 6.3.2.1 provides sufficient test coverage for this requirement.

6.3.2.3 Aggregate power tolerance for local area IAB-MT

6.3.2.3.1 Definition and applicability

The aggregate power control tolerance is the ability of the transmitter to maintain its power in a sub-frame (1 ms) during non-contiguous transmissions within [21 ms] in response to 0 dB commands with respect to the first transmission and all other power control parameters as specified in 3GPP TS 38.213 [12] kept constant.

6.3.2.3.2 Minimum requirement

The IAB-MT Aggregate power tolerance is defined in TS 38.174 [2], clause 6.3.3.2

6.3.2.3.3 Test purpose

No specific test or test requirements are defined for IAB-MT Aggregate power tolerance.

6.4 Transmit ON/OFF power

6.4.1 Transmitter OFF power

6.4.1.1 Definition and applicability

Transmit OFF power requirements apply to TDD operation of IAB-DU and TDD operation of IAB-MT.

Transmitter OFF power is defined as the mean power measured over $70/N$ us filtered with a square filter of bandwidth equal to the *transmission bandwidth configuration* of the IAB (BW_{Config}) centred on the assigned channel frequency during the *transmitter OFF period*. $N = \text{SCS}/15$, where SCS is Sub Carrier Spacing in kHz.

For *IAB type 1-H*, for *multi-band connectors* and for *single band connectors* supporting transmission in multiple *operating bands*, the requirement is only applicable during the *transmitter OFF period* in all supported *operating bands*.

For *IAB type 1-H* supporting intra-band contiguous CA, the transmitter OFF power is defined as the mean power measured over $70/N$ us filtered with a square filter of bandwidth equal to the *aggregated IAB channel bandwidth* $BW_{\text{Channel, CA}}$ centred on $(F_{\text{edge, high}} + F_{\text{edge, low}})/2$ during the *transmitter OFF period*. $N = \text{SCS}/15$, where SCS is the smallest supported Sub Carrier Spacing in kHz in the *aggregated IAB channel bandwidth*.

6.4.1.2 Minimum requirement

The minimum requirement for *IAB type 1-H*:

For *IAB-DU* is in TS 38.174 [2], clause 6.4.1.3.

For *IAB-MT* is in TS 38.174 [2], clause 6.4.1.4.

6.4.1.3 Test purpose

The purpose of this test is to verify the transmitter OFF power is within the limits of the minimum requirements.

6.4.1.4 Method of test

Requirement is tested together with transmitter transient period, as described in clause 6.4.2.4.

6.4.1.5 Test requirements

The conformance testing of transmit OFF power is included in the conformance testing of transmitter transient period; therefore, see clause 6.4.2.5 for test requirements.

6.4.2 Transmitter transient period

6.4.2.1 Definition and applicability

Transmitter transient period requirements apply to TDD operation of IAB-DU and TDD operation of IAB-MT.

The transmitter transient period is the time period during which the transmitter is changing from the transmitter OFF period to the transmitter ON period or vice versa. The transmitter transient period is illustrated in figure 6.4.2.1-1 for IAB-DU and IAB-MT.

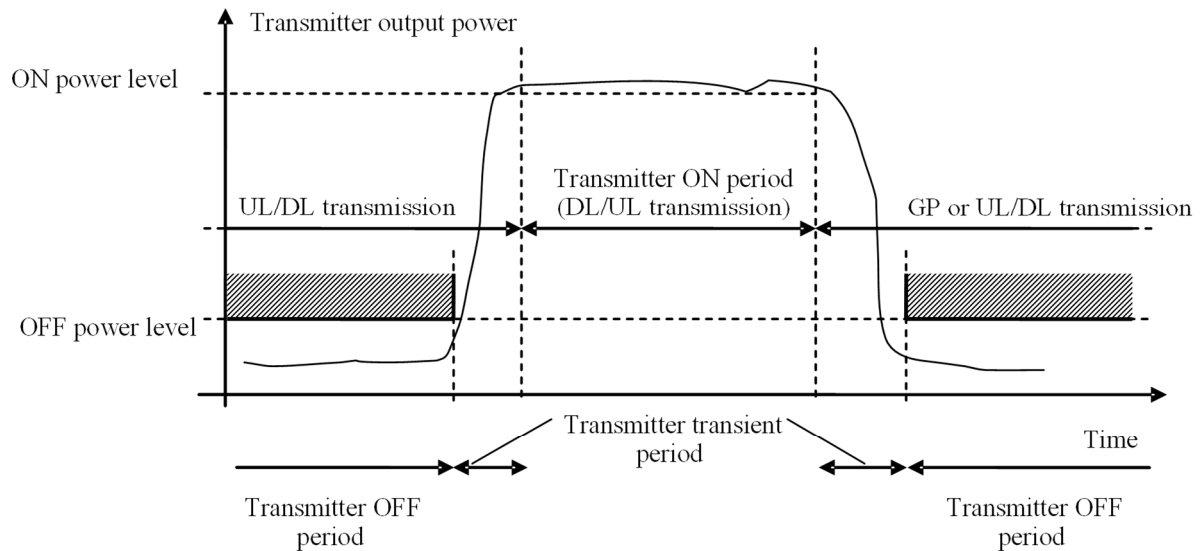

Figure 6.4.2.1-1: Example of relations between transmitter ON period, transmitter OFF period and transmitter transient period for IAB-DU and IAB-MT

For IAB type 1-H, this requirement shall be applied at each TAB connector supporting transmission in the operating band.

6.4.2.2 Minimum requirement

The minimum requirement for *IAB type 1-H*:

For *IAB-DU* is in TS 38.174 [2], clause 6.4.2.2.

For *IAB-MT* is in TS 38.174 [2], clause 6.4.2.3.

6.4.2.3 Test purpose

The purpose of this test is to verify the transmitter transient periods are within the limits of the minimum requirements.

6.4.2.4 Method of test

6.4.2.4.1 Initial conditions

Test environment:

- normal; see annex B.2.

RF channels to be tested for single carrier:

- M; see clause 4.9.1.

RF bandwidth positions to be tested for multi-carrier and/or CA:

- MRFBW in single-band operation, see clause 4.9.1;
- BRFBW_T'RFBW and B'RFBW_TRFBW in multi-band operation, see clause 4.9.1.

6.4.2.4.2 Procedure

The minimum requirement is applied to all *TAB connectors*, they may be tested one at a time or multiple *TAB connectors* may be tested in parallel as shown in annex D.1.1 for *IAB type 1-H*. Whichever method is used the procedure is repeated until all *TAB connectors* necessary to demonstrate conformance have been tested.

- 1) Connect *TAB connector* to measurement equipment as shown in annex D.1.1 for *IAB type 1-H*. All *TAB connectors* not under test shall be terminated.

As a general rule, the resolution bandwidth of the measuring equipment should be equal to the measurement bandwidth. However, to improve measurement accuracy, sensitivity, efficiency and avoiding e.g. carrier leakage, the resolution bandwidth may be smaller than the measurement bandwidth. When the resolution bandwidth is smaller than the measurement bandwidth, the result should be integrated over the measurement bandwidth in order to obtain the equivalent noise bandwidth of the measurement bandwidth.

- 2) For single carrier set the *TAB connector* under test to transmit according to the applicable test configuration in clause 4.8 using the corresponding test models or set of physical channels in clause 4.9.2 at manufacturers declared *rated carrier output power per TAB connector* ($P_{\text{rated,c,TABC}}$, D.21).

For a connector under test declared to be capable of multi-carrier and/or CA operation (D.15-D.16) set the connector under test to transmit on all carriers configured using the applicable test configuration and corresponding power setting specified in clauses 4.7 and 4.8 using the corresponding test models or set of physical channels in clause 4.9.2.

- 3) Measure the mean power spectral density over $70/N \mu\text{s}$ filtered with a square filter of bandwidth equal to the RF bandwidth of the *TAB connector* centred on the central frequency of the RF bandwidth. $70/N \mu\text{s}$ average window centre is set from $35/N \mu\text{s}$ after end of one transmitter ON period + $10 \mu\text{s}$ to $35/N \mu\text{s}$ before start of next transmitter ON period – $10 \mu\text{s}$. $N = \text{SCS}/15$, where SCS is Sub Carrier Spacing in kHz.
- 4) For a *TAB connector* supporting contiguous CA, measure the mean power spectral density over $70/N \mu\text{s}$ filtered with a square filter of bandwidth equal to the *aggregated IAB channel bandwidth* $\text{BW}_{\text{Channel_CA}}$ centred on $(F_{\text{edge_high}} + F_{\text{edge_low}})/2$. $70/N \mu\text{s}$ average window centre is set from $35/N \mu\text{s}$ after end of one transmitter ON period + $10 \mu\text{s}$ to $35/N \mu\text{s}$ before start of next transmitter ON period – $10 \mu\text{s}$. $N = \text{SCS}/15$, where SCS is the smallest supported Sub Carrier Spacing in kHz in the *aggregated IAB channel bandwidth*.

In addition, for *multi-band connector(s)*, the following steps shall apply:

- 5) For *multi-band connectors* and single band tests, repeat the steps above per involved band where single band test configurations and test models shall apply with no carrier activated in the other band.

6.4.2.5 Test requirements

The measured mean power spectral density according to clause 6.4.2.4.2 shall be less than -83 dBm/MHz for carrier frequency $f \leq 3.0 \text{ GHz}$.

The measured mean power spectral density according to clause 6.4.2.4.2 shall be less than -82.5 dBm/MHz for carrier frequency $3.0 \text{ GHz} < f \leq 6.0 \text{ GHz}$.

For *multi-band connector*, the requirement is only applicable during the transmitter OFF period in all supported operating bands.

6.5 Transmitted signal quality

6.5.1 General

Unless otherwise stated, the requirements in clause 6.5 apply during the *transmitter ON period*.

6.5.2 Frequency error

6.5.2.1 IAB-DU frequency error

6.5.2.1.1 Definition and applicability

For IAB-DU, frequency error is the measure of the difference between the actual IAB-DU transmit frequency and the assigned frequency. The same source shall be used for RF frequency and data clock generation.

It is not possible to verify by testing that the data clock is derived from the same frequency source as used for RF generation. This may be confirmed by the manufacturer's declaration.

For *IAB type 1-H* this requirement shall be applied at each *TAB connector* supporting transmission in the *operating band*.

6.5.2.1.2 Minimum Requirement

For IAB-DU, the minimum requirement is in TS 38.174 [2], clause 6.5.1.1.

6.5.2.1.3 Test purpose

The test purpose is to verify that frequency error is within the limit specified by the minimum requirement.

6.5.2.1.4 Method of test

Requirement is tested together with modulation quality test, as described in clause 6.5.3.

6.5.2.1.5 Test Requirements

For IAB-DU, the modulated carrier frequency of each NR carrier configured by the IAB-DU shall be accurate to within the accuracy range given in table 6.5.2.1.5-1 observed over 1 ms.

Table 6.5.2.1.5-1: Frequency error test requirement for IAB-DU

IAB-DU class	Accuracy
Wide Area IAB-DU	$\pm(0.05 \text{ ppm} + 12 \text{ Hz})$
Medium Range IAB-DU	$\pm(0.1 \text{ ppm} + 12 \text{ Hz})$
Local Area IAB-DU	$\pm(0.1 \text{ ppm} + 12 \text{ Hz})$

6.5.2.2 IAB-MT frequency error

6.5.2.2.1 Definition and applicability

For IAB-MT, frequency error is the measure of the difference between actual IAB-MT transmit frequency and the carrier frequency received from the parent node.

For *IAB type 1-H* this requirement shall be applied at each *TAB connector* supporting transmission in the *operating band*.

6.5.2.2.2 Minimum Requirement

For IAB-MT, the minimum requirement is in TS 38.174 [2], clause 6.5.1.2.

6.5.2.2.3 Test purpose

The test purpose is to verify that frequency error is within the limit specified by the minimum requirement.

6.5.2.2.4 Method of test

Requirement is tested together with modulation quality test, as described in clause 6.5.3.

6.5.2.2.5 Test Requirements

For IAB-MT, the mean value of basic measurements of IAB-MT modulated carrier frequency shall be accurate to within the accuracy range given in table 6.6.2.2.5-1 observed over 1 ms cumulated measurement intervals compared to the carrier frequency received from the parent node.

Table 6.5.2.2.5-1: Frequency error test requirement for IAB-MT

IAB-MT frequency range	Accuracy
$f \leq 3.0\text{GHz}$	$\pm(0.1 \text{ ppm} + 15 \text{ Hz})$
$f > 3.0\text{GHz}$	$\pm(0.1 \text{ ppm} + 36 \text{ Hz})$

6.5.3 Modulation quality

6.5.3.1 Definition and applicability

Modulation quality is defined by the difference between the measured carrier signal and an ideal signal. Modulation quality can e.g. be expressed as Error Vector Magnitude (EVM). The Error Vector Magnitude is a measure of the difference between the ideal symbols and the measured symbols after the equalization. This difference is called the error vector.

For *IAB type 1-H* this requirement shall be applied at each *TAB connector* supporting transmission in the *operating band*.

6.5.3.2 Minimum Requirement

For IAB-DU, the minimum requirement is in TS 38.174 [2], clause 6.5.2.1.

For IAB-MT, the minimum requirement is in TS 38.174 [2], clause 6.5.2.2.

6.5.3.3 Test purpose

The test purpose is to verify that modulation quality is within the limit specified by the minimum requirement.

6.5.3.4 Method of test

6.5.3.4.1 Initial conditions

Test environment: Normal; see annex B.2.

RF channels to be tested for single carrier: B, M and T; see clause 4.9.1.

RF bandwidth positions to be tested for multi-carrier and/or CA:

- B_{RFBW} , M_{RFBW} and T_{RFBW} in single-band operation, see clause 4.9.1;
- $B'_{\text{RFBW}}T'_{\text{RFBW}}$ and $B'_{\text{RFBW}}T_{\text{RFBW}}$ in multi-band operation, see clause 4.9.1.

6.5.3.4.2 Procedure for IAB-DU

For IAB-DU, the minimum requirement is applied to all *TAB connectors*, they may be tested one at a time or multiple *TAB connectors* may be tested in parallel as shown in annex D.1.1 for *IAB type 1-H*. Whichever method is used the procedure is repeated until all *TAB connectors* necessary to demonstrate conformance have been tested.

1) For a *TAB connector* declared to be capable of single carrier operation only (D.16), set the *TAB connector* under test to transmit a signal according to the applicable test configuration in clause 4.8 using the corresponding test models:

- IAB-DU-FR1-TM3.1a if 256QAM is supported by IAB-DU without power back off, or
- IAB-DU-FR1-TM3.1a at manufacturer's declared rated output power if 256QAM is supported by IAB-DU with power back off, and IAB-DU-FR1-TM3.1 at maximum power, or
- IAB-DU-FR1-TM3.1 if highest modulation order supported by IAB-DU is 64QAM, or
- IAB-DU-FR1-TM3.2 if highest modulation order supported by IAB-DU is 16QAM, or
- IAB-DU-FR1-TM3.3 if highest modulation order supported by IAB-DU is QPSK.

For a *TAB connector* declared to be capable of multi-carrier and/or CA operation (D.15-D.16), set the *TAB connector* under test to transmit according to the applicable test configuration and corresponding power setting specified in clauses 4.7 and 4.8 using the corresponding test models on all carriers configured:

- IAB-DU-FR1-TM 3.1a if 256QAM is supported by IAB-DU without power back off, or
- IAB-DU-FR1-TM3.1a at manufacturer's declared rated output power if 256QAM is supported by IAB node with power back off, and IAB-DU-FR1-TM3.1 at maximum power, or
- IAB-DU-FR1-TM3.1 if highest modulation order supported by IAB-DU is 64QAM, or
- IAB-DU-FR1-TM3.2 if highest modulation order supported by IAB-DU is 16QAM, or
- IAB-DU-FR1-TM3.3 if highest modulation order supported by IAB-DU is QPSK.

For IAB-DU-FR1-TM3.1a, power back-off shall be applied if it is declared.

2) Measure the EVM and frequency error as defined in annex H.

3) Repeat steps 1 and 2 for IAB-DU-FR1-TM2 if 256QAM is not supported by IAB-DU or for IAB-DU-FR1-TM2a if 256QAM is supported by IAB-DU. For IAB-DU-FR1-TM2 and IAB-DU-FR1-TM2a the OFDM symbol TX power (OSTP) shall be at the lower limit of the dynamic range according to the test procedure in clause 6.3.3.4 and test requirements in clause 6.3.3.5.

In addition, for *multi-band connector(s)*, the following steps shall apply:

4) For *multi-band connectors* and single band tests, repeat the steps above per involved band where single band test configurations and test models shall apply with no carrier activated in the other band.

6.5.3.4.3 Procedure for IAB-MT

For IAB-MT, the minimum requirement is applied to all *TAB connectors*, they may be tested one at a time or multiple *TAB connectors* may be tested in parallel as shown in annex D.1.1 for *IAB type 1-H*. Whichever method is used the procedure is repeated until all *TAB connectors* necessary to demonstrate conformance have been tested.

1) For a *TAB connector* declared to be capable of single carrier operation only (D.16), set the *TAB connector* under test to transmit a signal according to the applicable test configuration in clause 4.8 using the corresponding test models:

- IAB-MT-FR1-TM3.1a if 256QAM is supported by IAB-MT without power back off, or
- IAB-MT-FR1-TM3.1a at manufacturer's declared rated output power if 256QAM is supported by IAB-MT with power back off, and IAB-MT-FR1-TM3.1 at maximum power, or
- IAB-MT-FR1-TM3.1 with highest modulation order supported by IAB-MT.

For a *TAB connector* declared to be capable of multi-carrier and/or CA operation (D.15-D.16), set the *TAB connector* under test to transmit according to the applicable test configuration and corresponding power setting specified in clauses 4.7 and 4.8 using the corresponding test models on all carriers configured:

- IAB-MT-FR1-TM3.1a if 256QAM is supported by IAB-MT without power back off, or
- IAB-MT-FR1-TM3.1a at manufacturer's declared rated output power if 256QAM is supported by IAB-MT with power back off, and IAB-MT-FR1-TM3.1 at maximum power, or
- IAB-MT-FR1-TM3.1 with highest modulation order supported by IAB-MT..

For IAB-MT-FR1-TM3.1a, power back-off shall be applied if it is declared.

2) Measure the EVM and frequency error as defined in annex H.

3) Repeat steps 1 and 2 for IAB-MT-FR1-TM2 if 256QAM is not supported by IAB-MT or for IAB-MT-FR1-TM2a if 256QAM is supported by IAB-MT. For IAB-MT-FR1-TM2 and IAB-MT-FR1-TM2a the OFDM symbol TX power (OSTP) shall be at the lower limit of the dynamic range according to the test procedure in clause 6.3.3.4 and test requirements in clause 6.3.3.5.

In addition, for *multi-band connector(s)*, the following steps shall apply:

4) For *multi-band connectors* and single band tests, repeat the steps above per involved band where single band test configurations and test models shall apply with no carrier activated in the other band.

6.5.3.5 Test requirements

The EVM of each NR carrier for different modulation schemes on PDSCH or PUSCH shall be less than the limits in table 6.5.3.5-1a.

Table 6.5.3.5-1: EVM requirements for IAB type 1-H

Modulation scheme for PDSCH or PUSCH	Required EVM (%)
QPSK	18.5 %
16QAM	13.5 %
64QAM	9 %
256QAM	4.5 %

EVM shall be evaluated for each NR carrier over all allocated resource blocks and downlink slots for IAB-DU or uplink slots for IAB-MT. Different modulation schemes listed in table 6.5.3.5-1 shall be considered for rank 1.

For all bandwidths, the EVM measurement shall be performed for each NR carrier over all allocated resource blocks and downlink slots for IAB-DU or uplink slots for IAB-MT within 10 ms measurement periods. The boundaries of the EVM measurement periods need not be aligned with radio frame boundaries.

Table 6.5.3.5-2, 6.5.3.5-3, 6.5.3.5-4 below specify the EVM window length (W) for normal CP for IAB type 1-H.

Table 6.5.3.5-2: EVM window length for normal CP for NR, FR1, 15 kHz SCS

Channel bandwidth (MHz)	FFT size	Cyclic prefix length for symbols 1-6 and 8-13 in FFT samples	EVM window length W	Ratio of W to total CP length for symbols 1-6 and 8-13 (%) (Note)
10	1024	72	28	40
15	1536	108	44	40
20	2048	144	58	40
25	2048	144	72	50
30	3072	216	108	50
40	4096	288	144	50
50	4096	288	144	50

NOTE: These percentages are informative and apply to a slot's symbols 1 to 6 and 8 to 13. Symbols 0 and 7 have a longer CP and therefore a lower percentage.

Table 6.5.3.5-3: EVM window length for normal CP for NR, FR1, 30 kHz SCS

Channel bandwidth (MHz)	FFT size	Cyclic prefix length for symbols 1-13 in FFT samples	EVM window length W	Ratio of W to total CP length for symbols 1-13 (%) (Note)
10	512	36	14	40
15	768	54	22	40
20	1024	72	28	40
25	1024	72	36	50
30	1536	108	54	50
40	2048	144	72	50
50	2048	144	72	50
60	3072	216	130	60
70	3072	216	130	60
80	4096	288	172	60
90	4096	288	172	60
100	4096	288	172	60

NOTE: These percentages are informative and apply to a slot's symbols 1 through 13. Symbol 0 has a longer CP and therefore a lower percentage.

Table 6.5.3.5-4: EVM window length for normal CP for NR, FR1, 60 kHz SCS

Channel bandwidth (MHz)	FFT size	Cyclic prefix length in FFT samples	EVM window length W	Ratio of W to total CP length (%) (Note)
10	256	18	8	40
15	384	27	11	40
20	512	36	14	40
25	512	36	18	50
30	768	54	26	50
40	1024	72	36	50
50	1024	72	36	50
60	1536	108	64	60
70	1536	108	64	60
80	2048	144	86	60
90	2048	144	86	60
100	2048	144	86	60

NOTE: These percentages are informative and apply to all OFDM symbols within subframe except for symbol 0 of slot 0 and slot 2. Symbol 0 of slot 0 and slot 2 has a longer CP and therefore a lower percentage.

6.5.4 Time alignment error

6.5.4.1 Definition and applicability

For IAB-DU, this requirement applies to frame timing in MIMO transmission, carrier aggregation and their combinations. There's no time alignment error requirement for IAB-MT.

Frames of the NR signals present at the IAB-DU transmitter *TAB connectors* are not perfectly aligned in time and may experience certain timing differences in relation to each other.

For IAB type 1-H, the TAE is defined as the largest timing difference between any two signals belonging to *TAB connectors* belonging to different transmitter groups at the *transceiver array boundary*, where transmitter groups are associated with the *TAB connectors* in the transceiver unit array corresponding to MIMO transmission, *carrier aggregation* for a specific set of signals/transmitter configuration/transmission mode.

6.5.4.2 Minimum requirement

The minimum requirements for IAB-DU are in TS 38.174 [2], clause 6.5.3.1.

6.5.4.3 Test purpose

To verify that the time alignment error is within the limit specified by the minimum requirement.

6.5.4.4 Method of test

6.5.4.4.1 Initial conditions

Test environment: Normal, see annex B.2.

RF channels to be tested for single carrier: M; see clause 4.9.1.

RF bandwidth positions to be tested for multi-carrier and/or CA:

- M_{RFBW} in single-band operation, see clause 4.9.1.
- $B_{\text{RFBW}}T_{\text{RFBW}}$ and $B'_{\text{RFBW}}T_{\text{RFBW}}$ in multi-band operation, see clause 4.9.1.

6.5.4.4.2 Procedure

For *IAB type 1-H TAB connectors* to be tested are identified from the declared sets of *TAB connector beam forming groups* in the TAE groups declaration (D.31).

Compliance is to be demonstrated between all pairs of *single-band connectors and/or multi-band connectors*, however it is not required to exhaustively measure TAE between every combination of pairs of representative connectors. Compliance can be demonstrated by comparison of a reduced set of representative measurement results.

1) Conducted measurement setup:

- For *IAB type 1-H*: Connect two representative *TAB connectors* one from separate TAE group (D.31) to the measurement equipment according to annex D.1.4. Terminate any unused *TAB connector(s)*.

2) Set the connectors under test to transmit IAB-DU-FR1-TM 1.1 or any DL signal using MIMO transmission or carrier aggregation.

NOTE: For MIMO transmission, different ports may be configured in IAB-DU-FR1-TM 1.1 (using *PDSCH DMRS ports 1000 and 1001*).

3) For a connectors declared to be capable of single carrier operation only (D.16), set the representative connectors under test to transmit according to the applicable test configuration in clause 4.8 using the corresponding test models in clause 4.9.2 at *rated carrier output power* ($P_{\text{rated,c,AC}}$, or $P_{\text{rated,c,TABC}}$, D.21).

If the connector under test supports intra band contiguous or non-contiguous CA, set the representative connectors to transmit using the applicable test configuration and corresponding power setting specified in clauses 4.7 and 4.8.

If the IAB-DU supports inter band CA, set the representative connectors to transmit, for each band, a single carrier or all carriers, using the applicable test configuration and corresponding power setting specified in clauses 4.7 and 4.8.

For a connector declared to be capable of multi-carrier operation (D.15), set the IAB-DU to transmit according to the applicable test signal configuration and corresponding power setting specified in clauses 4.7 and 4.8 using the corresponding test model in clause 4.9.2 on all carriers configured.

4) Measure the time alignment error between the different PDSCH demodulation reference signals on different antenna ports belonging to different connectors on the carrier(s) from the representative connectors under test.

5) Repeat step 1 - 4 for any other configuration of connectors, which could be required to demonstrate compliance.

In addition, for *multi-band connectors*, the following steps shall apply:

6) For a *multi-band connectors* and single band tests, repeat the steps above per involved *operating band* where single band test configurations and test models shall apply with no carrier activated in the other *operating band*.

6.5.4.5 Test requirement

For MIMO transmission, at each carrier frequency, TAE shall not exceed 90 ns.

For intra-band contiguous CA, with or without MIMO, TAE shall not exceed 285 ns.

For intra-band non-contiguous CA, with or without MIMO, TAE shall not exceed 3.025 μ s.

For inter-band CA, with or without MIMO, TAE shall not exceed 3.025 μ s.

6.6 Unwanted emissions

6.6.1 General

Unwanted emissions consist of out-of-band emissions and spurious emissions according to ITU definitions in recommendation ITU-R SM.329 [5]. In ITU terminology, out of band emissions are unwanted emissions immediately outside the channel bandwidth resulting from the modulation process and non-linearity in the transmitter but excluding spurious emissions. Spurious emissions are emissions which are caused by unwanted transmitter effects such as harmonics emission, parasitic emission, intermodulation products and frequency conversion products, but exclude out of band emissions.

The out-of-band emissions requirement for the IAB-DU and IAB-MT transmitter is specified both in terms of Adjacent Channel Leakage power Ratio (ACLR) and *operating band* unwanted emissions (OBUE).

The maximum offset of the *operating band* unwanted emissions mask from the *operating band* edge is Δf_{OBUE} . The Operating band unwanted emissions define all unwanted emissions in each supported downlink *operating band* of IAB-DU and uplink *operating band* of IAB-MT, plus the frequency ranges Δf_{OBUE} above and Δf_{OBUE} below each band. Unwanted emissions outside of this frequency range are limited by a spurious emissions requirement.

The values of Δf_{OBUE} are defined in tables 6.6.1-1 and 6.6.1-2 for the NR *operating bands*.

Table 6.6.1-1: Maximum offset of OBUE outside the downlink *operating band* of IAB-DU

IAB-DU type	Operating band characteristics	Δf_{OBUE} (MHz)
IAB type 1-H	$F_{\text{DL,high}} - F_{\text{DL,low}} < 100$ MHz	10
	$100 \text{ MHz} \leq F_{\text{DL,high}} - F_{\text{DL,low}} \leq 900$ MHz	40

Table 6.6.1-2: Maximum offset of OBUE outside the uplink *operating band* of IAB-MT

IAB-MT type	Operating band characteristics	Δf_{OBUE} (MHz)
IAB type 1-H	$F_{\text{UL,high}} - F_{\text{UL,low}} < 100$ MHz	10
	$100 \text{ MHz} \leq F_{\text{UL,high}} - F_{\text{UL,low}} \leq 900$ MHz	40

For IAB type 1-H the unwanted emission requirements are applied per the TAB connector TX min cell groups for all the supported configurations. The *basic limits* and corresponding emissions scaling are defined in each relevant clause.

There is in addition a requirement for occupied bandwidth.

6.6.2 Occupied bandwidth

6.6.2.1 General

The occupied bandwidth is the width of a frequency band such that, below the lower and above the upper frequency limits, the mean powers emitted are each equal to a specified percentage $\beta/2$ of the total mean transmitted power. See also Recommendation ITU-R SM.328 [6].

The value of $\beta/2$ shall be taken as 0.5%.

The occupied bandwidth requirement shall apply during the *transmitter ON period* for a single transmitted carrier. The minimum requirement below may be applied regionally. There may also be regional requirements to declare the occupied bandwidth according to the definition in the present clause.

For *IAB type 1-H* this requirement shall be applied at each *TAB connector* supporting transmission in the *operating band*.

6.6.2.2 Minimum Requirements

The minimum requirement for *IAB type 1-H* is in TS 38.174 [2] clause 6.6.2.

6.6.2.3 Test purpose

The test purpose is to verify that the emission at the *TAB connector* does not occupy an excessive bandwidth for the service to be provided and is, therefore, not likely to create interference to other users of the spectrum beyond undue limits.

6.6.2.4 Method of test

6.6.2.4.1 Initial conditions

Test environment: Normal; see annex B.2.

RF channels to be tested for single carrier: M; see clause 4.9.1.

Aggregated IAB channel bandwidth positions to be tested for contiguous carrier aggregation: $M_{BW_{Channel\ CA}}$; see clause 4.9.1.

- 1) Connect the measurement device to *TAB connector* as shown in annex D.1.1 for *IAB type 1-H*.
- 2) For a IAB declared to be capable of single carrier operation (D.16), start transmission according to the applicable test configuration in clause 4.8 using the corresponding test model IAB-DU-FR1-TM1.1 for *IAB-DU type 1-H* or IAB-MT-FR1-TM1.1 for *IAB-MT type 1-H* at manufacturer's declared rated output power ($P_{rated,c,TABC}$, D.21).

For an IAB declared to be capable of contiguous CA operation, set the IAB to transmit according to IAB-DU-FR1-TM1.1 for *IAB-DU type 1-H* or IAB-MT-FR1-TM1.1 for *IAB-MT type 1-H* on all carriers configured using the applicable test configuration and corresponding power setting specified in clauses 4.7.4 and 4.8.

6.6.2.4.2 Procedure

- 1) Measure the spectrum emission of the transmitted signal using at least the number of measurement points, and across a span, as listed in table 6.6.2.4.2-1. The selected resolution bandwidth (RBW) filter of the analyser shall be 30 kHz or less.

Table 6.6.2.4.2-1: Span and number of measurement points for OBW measurements

Bandwidth	<i>IAB-DU channel bandwidth or IAB-MT channel bandwidth</i> $BW_{Channel}$ (MHz)				<i>Aggregated IAB channel bandwidth</i> $BW_{Channel_CA}$ (MHz)
	10	15	20	> 20	> 20
Span (MHz)	20	30	40	$2 \times BW_{Channel}$	$2 \times BW_{Channel_CA}$
Minimum number of measurement points	400	400	400	$\left\lceil \frac{2 \times BW_{Channel}}{100kHz} \right\rceil$	$\left\lceil \frac{2 \times BW_{Channel_CA}}{100kHz} \right\rceil$

NOTE: The detection mode of the spectrum analyser will not have any effect on the result if the statistical properties of the out-of-OBW power are the same as those of the inside-OBW power. Both are expected to have the Rayleigh distribution of the amplitude of Gaussian noise. In any case where the statistics are not the same, though, the detection mode must be power responding. The analyser may be set to respond to the average of the power (root-mean-square of the voltage) across the measurement cell.

- 2) Compute the total of the power, P_0 , (in power units, not decibel units) of all the measurement cells in the measurement span. Compute P_1 , the power outside the occupied bandwidth on each side. P_1 is half of the total power outside the bandwidth. P_1 is half of $(100\% - (\text{occupied percentage}))$ of P_0 . For the occupied percentage of 99 %, P_1 is 0.005 times P_0 .
- 3) Determine the lowest frequency, f_1 , for which the sum of all power in the measurement cells from the beginning of the span to f_1 exceeds P_1 .
- 4) Determine the highest frequency, f_2 , for which the sum of all power in the measurement cells from f_2 to the end of the span exceeds P_1 .
- 5) Compute the occupied bandwidth as $f_2 - f_1$.

In addition, for a multi-band capable IAB, the following step shall apply:

- 6) For multi-band capable IAB and single band tests, repeat the steps above per involved band where single carrier test models shall apply, with no carrier activated in the other band. In addition, when contiguous CA is supported, single band test configurations and test models shall apply with no carrier activated in the other band.

6.6.2.5 Test requirements

The occupied bandwidth for each carrier shall be less than the channel bandwidth as defined in TS 38.174 [2], table 5.3.5-1. For contiguous CA, the occupied bandwidth shall be less than or equal to the *aggregated IAB channel bandwidth* as defined in TS 38.174 [2], clause 5.3A.

6.6.3 Adjacent Channel Leakage Power Ratio

6.6.3.1 General

Adjacent Channel Leakage power Ratio (ACLR) is the ratio of the filtered mean power centred on the assigned channel frequency to the filtered mean power centred on an adjacent channel frequency.

The requirements shall apply outside the *IAB-DU RF Bandwidth*, *IAB-MT RF Bandwidth* or *Radio Bandwidth* whatever the type of transmitter considered (single carrier or multi-carrier) and for all transmission modes foreseen by the manufacturer's specification.

For an IAB- node operating in *non-contiguous spectrum*, the ACLR requirement in clause 6.6.3.2 shall apply in *sub-block gaps* for the frequency ranges defined in table 6.6.3.2-3, while the CACLR requirement in clause 6.6.3.2 shall apply in *sub-block gaps* for the frequency ranges defined in table 6.6.3.2-4.

For a *multi-band connector*, the ACLR requirement in clause 6.6.3.2 shall apply in *Inter RF Bandwidth gaps* for the frequency ranges defined in table 6.6.3.2-3, while the CACLR requirement in clause 6.6.3.2 shall apply in *Inter RF Bandwidth gaps* for the frequency ranges defined in table 6.6.3.2-4.

The requirement shall apply during the *transmitter ON period*.

6.6.3.2 Minimum requirement

The minimum requirement applies per *single-band connector*, or per *multi-band connector* supporting transmission in the *operating band*.

The minimum requirement for *IAB type 1-H* is defined in TS 38.174 [2], clause 6.6.3.

6.6.3.3 Test purpose

To verify that the adjacent channel leakage power ratio requirement shall be met as specified by the minimum requirement.

6.6.3.4 Method of test

6.6.3.4.1 Initial conditions

Test environment: Normal; see annex B.2.

RF channels to be tested for single carrier: B, M and T; see clause 4.9.1.

IAB RF Bandwidth positions to be tested for multi-carrier and/or CA:

- B_{RFBW} , M_{RFBW} and T_{RFBW} in single-band operation; see clause 4.9.1.
- B'_{RFBW} , T'_{RFBW} and $B'_{RFBW} \cup T'_{RFBW}$ in multi-band operation, see clause 4.9.1.

6.6.3.4.2 Procedure

For *IAB type 1-H* where there may be multiple *TAB connectors*, they may be tested one at a time or multiple *TAB connectors* may be tested in parallel as shown in annex D.1.1. Whichever method is used the procedure is repeated until all *TAB connectors* necessary to demonstrate conformance have been tested.

- 1) Connect the *single-band connector* or *multi-band connector* under test to measurement equipment as shown in annex D.1.1 for *IAB type 1-H*. All connectors not under test shall be terminated.

The measurement device characteristics shall be:

- Measurement filter bandwidth: defined in clause 6.6.3.5.
- Detection mode: true RMS voltage or true average power.

- 2) For a connectors declared to be capable of single carrier operation only (D.16), set the representative connectors under test to transmit according to the applicable test configuration in clause 4.8 using the corresponding test models IAB-DU-FR1-TM1.1 or IAB-MT-FR1-TM1.1 in clause 4.9.2 at *rated carrier output power* $P_{\text{rated,c,TABC}}$ for IAB type 1-H (D.21).

For a connector under test declared to be capable of multi-carrier and/or CA operation (D.15-D.16) set the connector under test to transmit on all carriers configured using the applicable test configuration and corresponding power setting specified in clauses 4.7 and 4.8 using the corresponding test models or set of physical channels in clause 4.9.2.

- 3) Measure ACLR for the frequency offsets both side of channel frequency as specified in table 6.6.3.5.2-1. In multiple carrier case only offset frequencies below the lowest and above the highest carrier frequency used shall be measured.
- 4) For the ACLR requirement applied inside sub-block gap for non-contiguous spectrum operation, or inside *Inter RF Bandwidth gap* for multi-band operation:
 - a) Measure ACLR inside sub-block gap or *Inter RF Bandwidth gap* as specified in clause 6.6.3.5.2, if applicable.
 - b) Measure CAACLR inside sub-block gap or *Inter RF Bandwidth gap* as specified in clause 6.6.3.5.2, if applicable.
- 5) Repeat the test with the channel set-up according to IAB-DU-FR1-TM1.2 in clause 4.9.2.

In addition, for *multi-band connectors*, the following steps shall apply:

- 6) For a *multi-band connectors* and single band tests, repeat the steps above per involved *operating band* where single band test configurations and test models shall apply with no carrier activated in the other *operating band*.

6.6.3.5 Test requirements

6.6.3.5.1 General requirements

The ACLR requirements in clause 6.6.3.5.2 shall apply as described in clauses 6.6.3.5.3 or 6.6.3.5.4.

6.6.3.5.2 Limits and *basic limits*

The ACLR is defined with a square filter of bandwidth equal to the transmission bandwidth configuration of the transmitted signal (BW_{Config}) centred on the assigned channel frequency and a filter centred on the adjacent channel frequency according to the tables below.

For operation in paired and unpaired spectrum, the ACLR shall be higher than the value specified in table 6.6.3.5.2-1.

Table 6.6.3.5.2-1: IAB type 1-H ACLR limit

<i>IAB-DU channel bandwidth and IAB-MT channel bandwidth of lowest/highest carrier transmitted BW_{Channel} (MHz)</i>	<i>IAB-DU and IAB-MT adjacent channel centre frequency offset below the lowest or above the highest carrier centre frequency transmitted</i>	<i>Assumed adjacent channel carrier (informative)</i>	<i>Filter on the adjacent channel frequency and corresponding filter bandwidth</i>	<i>ACLR limit</i>
10, 15, 20	BW_{Channel}	NR of same BW (Note 2)	Square (BW_{Config})	44.2
	$2 \times BW_{\text{Channel}}$	NR of same BW (Note 2)	Square (BW_{Config})	44.2
	$BW_{\text{Channel}}/2 + 2.5 \text{ MHz}$	5 MHz E-UTRA	Square (4.5 MHz)	44.2 (Note 3)
	$BW_{\text{Channel}}/2 + 7.5 \text{ MHz}$	5 MHz E-UTRA	Square (4.5 MHz)	44.2 (Note 3)
25, 30, 40, 50, 60, 70, 80, 90,100	BW_{Channel}	NR of same BW (Note 2)	Square (BW_{Config})	43.8 dB
	$2 \times BW_{\text{Channel}}$	NR of same BW (Note 2)	Square (BW_{Config})	43.8 dB
	$BW_{\text{Channel}}/2 + 2.5 \text{ MHz}$	5 MHz E-UTRA	Square (4.5 MHz)	43.8 dB (Note 3)
	$BW_{\text{Channel}}/2 + 7.5 \text{ MHz}$	5 MHz E-UTRA	Square (4.5 MHz)	43.8 dB (Note 3)
NOTE 1: BW_{Channel} and BW_{Config} are the <i>IAB-DU channel bandwidth and IAB-MT channel bandwidth and transmission bandwidth configuration of the lowest/highest carrier transmitted on the assigned channel frequency.</i>				
NOTE 2: With SCS that provides largest transmission bandwidth configuration (BW_{Config}).				
NOTE 3: The requirements are applicable when the band is also defined for E-UTRA or UTRA.				

The ACLR absolute *basic limit* is specified in table 6.6.3.5.2-2.

Table 6.6.3.5.2-2: IAB type 1-H ACLR absolute basic limit

<i>IAB-DU and IAB-MT category / class</i>	<i>ACLR absolute basic limit</i>
Category A Wide Area IAB-DU and Category A Wide Area IAB-MT	-13 dBm/MHz
Category B Wide Area IAB-DU and Category B Wide Area IAB-MT	-15 dBm/MHz
Medium Range IAB-DU	-25 dBm/MHz
Local Area IAB-DU and Local Area IAB-MT	-32 dBm/MHz

For operation in non-contiguous spectrum or multiple bands, the ACLR shall be higher than the value specified in Table 6.6.3.5.2-3.

Table 6.6.3.5.2-3: *IAB type 1-H ACLR limit in non-contiguous spectrum or multiple bands*

<i>IAB-DU channel bandwidth and IAB-MT channel bandwidth of lowest/highest carrier transmitted BW_{Channel} (MHz)</i>	<i>Sub-block or Inter RF Bandwidth gap size (W_{gap}) where the limit applies (MHz)</i>	<i>IAB-DU and IAB-MT adjacent channel centre frequency offset below or above the sub-block or IAB RF Bandwidth edge (inside the gap)</i>	<i>Assumed adjacent channel carrier</i>	<i>Filter on the adjacent channel frequency and corresponding filter bandwidth</i>	<i>ACLR limit</i>
10, 15, 20	$W_{\text{gap}} \geq 15$ (Note 3)	2.5 MHz	5 MHz NR (Note 2)	Square (BW_{Config})	44.2 dB
	$W_{\text{gap}} \geq 45$ (Note 4)				
	$W_{\text{gap}} \geq 20$ (Note 3) $W_{\text{gap}} \geq 50$ (Note 4)	7.5 MHz	5 MHz NR (Note 2)	Square (BW_{Config})	44.2 dB
25, 30, 40, 50, 60, 70, 80, 90, 100	$W_{\text{gap}} \geq 60$ (Note 4)	10 MHz	20 MHz NR (Note 2)	Square (BW_{Config})	43.8 dB
	$W_{\text{gap}} \geq 30$ (Note 3)				
	$W_{\text{gap}} \geq 80$ (Note 4) $W_{\text{gap}} \geq 50$ (Note 3)	30 MHz	20 MHz NR (Note 2)	Square (BW_{Config})	43.8 dB

NOTE 1: BW_{Config} is the transmission bandwidth configuration of the assumed adjacent channel carrier.
NOTE 2: With SCS that provides largest transmission bandwidth configuration (BW_{Config}).
NOTE 3: Applicable in case the *IAB-DU channel bandwidth* or *IAB-MT channel bandwidth* of the NR carrier transmitted at the other edge of the gap is 10, 15, 20 MHz.
NOTE 4: Applicable in case the *IAB-DU channel bandwidth* or *IAB-MT channel bandwidth* of the NR carrier transmitted at the other edge of the gap is 25, 30, 40, 50, 60, 70, 80, 90, 100 MHz.

The Cumulative Adjacent Channel Leakage power Ratio (CACLR) in a *sub-block gap* or the *Inter RF Bandwidth gap* is the ratio of:

- a) the sum of the filtered mean power centred on the assigned channel frequencies for the two carriers adjacent to each side of the *sub-block gap* or the *Inter RF Bandwidth gap*, and
- b) the filtered mean power centred on a frequency channel adjacent to one of the respective *sub-block edges* or *IAB RF Bandwidth edges*.

The assumed filter for the adjacent channel frequency is defined in table 6.6.3.2-4 and the filters on the assigned channels are defined in table 6.6.3.2-6.

For operation in *non-contiguous spectrum* or multiple bands, the CACLR for NR carriers located on either side of the *sub-block gap* or the *Inter RF Bandwidth gap* shall be higher than the value specified in table 6.6.3.2-4.

Table 6.6.3.5.2-4: IAB type 1-H CACLR limit

IAB-DU channel bandwidth and IAB-MT channel bandwidth of lowest/highest carrier transmitted BW_{Channel} (MHz)	Sub-block or Inter RF Bandwidth gap size (W_{gap}) where the limit applies (MHz)	IAB-DU and IAB-MT adjacent channel centre frequency offset below or above the sub-block or IAB RF Bandwidth edge (inside the gap)	Assumed adjacent channel carrier	Filter on the adjacent channel frequency and corresponding filter bandwidth	CACLR limit
10, 15, 20	$5 \leq W_{\text{gap}} < 15$ (Note 3) $5 \leq W_{\text{gap}} < 45$ (Note 4)	2.5 MHz	5 MHz NR (Note 2)	Square (BW_{Config})	44.2 dB
	$10 < W_{\text{gap}} < 20$ (Note 3) $10 \leq W_{\text{gap}} < 50$ (Note 4)	7.5 MHz	5 MHz NR (Note 2)	Square (BW_{Config})	44.2 dB
25, 30, 40, 50, 60, 70, 80, 90, 100	$20 \leq W_{\text{gap}} < 60$ (Note 4) $20 \leq W_{\text{gap}} < 30$ (Note 3)	10 MHz	20 MHz NR (Note 2)	Square (BW_{Config})	43.8 dB
	$40 < W_{\text{gap}} < 80$ (Note 4) $40 \leq W_{\text{gap}} < 50$ (Note 3)	30 MHz	20 MHz NR (Note 2)	Square (BW_{Config})	43.8 dB

NOTE 1: BW_{Config} is the transmission bandwidth configuration of the assumed adjacent channel carrier.
NOTE 2: With SCS that provides largest transmission bandwidth configuration (BW_{Config}).
NOTE 3: Applicable in case the IAB-DU channel bandwidth or IAB-MT channel bandwidth of the NR carrier transmitted at the other edge of the gap is 10, 15, 20 MHz.
NOTE 4: Applicable in case the IAB-DU channel bandwidth or IAB-MT channel bandwidth of the NR carrier transmitted at the other edge of the gap is 25, 30, 40, 50, 60, 70, 80, 90, 100 MHz.

The CACLR absolute *basic limit* is specified in table 6.6.3.2-5.

Table 6.6.3.2-5: IAB type 1-H CACLR absolute *basic limit*

IAB-DU and IAB-MT category / class	CACLR absolute <i>basic limit</i>
Category A Wide Area IAB-DU and Category A Wide Area IAB-MT	-13 dBm/MHz
Category B Wide Area IAB-DU and Category B Wide Area IAB-MT	-15 dBm/MHz
Medium Range IAB-DU	-25 dBm/MHz
Local Area IAB-DU and Local Area IAB-MT	-32 dBm/MHz

Table 6.6.3.5.2-6: Filter parameters for the assigned channel

RAT of the carrier adjacent to the <i>sub-block</i> or <i>Inter RF Bandwidth gap</i>	Filter on the assigned channel frequency and corresponding filter bandwidth
NR	NR of same BW with SCS that provides largest <i>transmission bandwidth configuration</i>

6.6.3.5.3 IAB type 1-H

The ACLR absolute *basic limits* in table 6.6.3.5.2-2+ X (where $X = 10\log_{10}(N_{\text{TXU, countedpercell}})$) or the ACLR *limits* in table 6.6.3.5.2-1, or 6.6.3.5.2-3, whichever is less stringent, shall apply for each *TAB connector TX min cell group*.

The CACLR absolute *basic limits* in table 6.6.3.5.2-5 + X, (where $X = 10\log_{10}(N_{\text{TXU, countedpercell}})$) or the CACLR *limits* in table 6.6.3.5.2-4, whichever is less stringent, shall apply for each *TAB connector TX min cell group*.

Conformance to the *IAB type 1-H ACLR (CACLR)* limit can be demonstrated by meeting at least one of the following criteria as determined by the manufacturer

- 1) The ratio of the sum of the filtered mean power measured on each *TAB connector* in the *TAB connector TX min cell group* at the assigned channel frequency to the sum of the filtered mean power measured on each *TAB connector* in the *TAB connector TX min cell group* at the adjacent channel frequency shall be greater than or equal to the ACLR (CACLR) limit of the IAB-MT or IAB-DU. This shall apply for each *TAB connector TX min cell group*.

Or

- 2) The ratio of the filtered mean power at the *TAB connector* centred on the assigned channel frequency to the filtered mean power at this *TAB connector* centred on the adjacent channel frequency shall be greater than or equal to the ACLR (CACLR) limit of the IAB-MT or IAB-DU for every *TAB connector* in the *TAB connector TX min cell group*, for each *TAB connector TX min cell group*.

In case the ACLR (CACLR) absolute *basic limit* of *IAB type 1-H* are applied, the conformance can be demonstrated by meeting at least one of the following criteria as determined by the manufacturer:

- 1) The sum of the filtered mean power measured on each *TAB connector* in the *TAB connector TX min cell group* at the adjacent channel frequency shall be less than or equal to the ACLR (CACLR) absolute *basic limit* + X (where $X = 10\log_{10}(N_{\text{TXU, counted per cell}})$) of the IAB-MT or IAB-DU. This shall apply to each *TAB connector TX min cell group*.

Or

- 2) The filtered mean power at each *TAB connector* centred on the adjacent channel frequency shall be less than or equal to the ACLR (CACLR) absolute *basic limit* of the IAB-MT or IAB-DU scaled by $X - 10\log_{10}(n)$ for every *TAB connector* in the *TAB connector TX min cell group*, for each *TAB connector TX min cell group*, where n is the number of *TAB connectors* in the *TAB connector TX min cell group*.

6.6.4 Operating band unwanted emissions

6.6.4.1 Definition and applicability

Unless otherwise stated, the operating band unwanted emission (OBUE) limits for IAB-DU in FR1 are defined from Δf_{OBUE} below the lowest frequency of each supported downlink *operating band* up to Δf_{OBUE} above the highest frequency of each supported downlink *operating band*. The values of Δf_{OBUE} are defined in table 6.6.1-1 for the NR *operating bands*.

Unless otherwise stated, the operating band unwanted emission (OBUE) limits for IAB-MT in FR1 are defined from Δf_{OBUE} below the lowest frequency of each supported uplink *operating band* up to Δf_{OBUE} above the highest frequency of each supported uplink *operating band*. The values of Δf_{OBUE} are defined in table 6.6.1-2 for the NR *operating bands*.

The requirements shall apply whatever the type of transmitter considered and for all transmission modes foreseen by the manufacturer's specification. In addition, for IAB-DU and IAB-MT operating in *non-contiguous spectrum*, the requirements apply inside any *sub-block gap*. In addition, for a IAB-MT or IAB-DU operating in multiple bands, the requirements apply inside any *Inter RF Bandwidth gap*.

Basic limits are specified in the tables below, where:

- Δf is the separation between the *channel edge* frequency and the nominal -3dB point of the measuring filter closest to the carrier frequency.
- f_{offset} is the separation between the *channel edge* frequency and the centre of the measuring filter.
- $f_{\text{offset,max}}$ is the offset to the frequency Δf_{OBUE} outside the downlink *operating band* of IAB-DU and uplink *operating band* of IAB-MT, where Δf_{OBUE} is defined in tables 6.6.1-1 and 6.6.1-2.
- Δf_{max} is equal to $f_{\text{offset,max}}$ minus half of the bandwidth of the measuring filter.

For a *multi-band connector* inside any *Inter RF Bandwidth gaps* with $W_{\text{gap}} < 2 * \Delta f_{\text{OBUE}}$, a combined *basic limit* shall be applied which is the cumulative sum of the *basic limits* specified at the *IAB RF Bandwidth edges* on each side of the

Inter RF Bandwidth gap. The *basic limit* for *IAB RF Bandwidth edge* is specified in clauses 6.6.4.2.1 to 6.6.4.2.4 below, where in this case:

- Δf is the separation between the *IAB RF Bandwidth edge* frequency and the nominal -3 dB point of the measuring filter closest to the *IAB RF Bandwidth edge*.
- f_{offset} is the separation from the *IAB RF Bandwidth edge* frequency to the centre of the measuring filter.
- $f_{\text{offset}_{\text{max}}}$ is equal to the *Inter RF Bandwidth gap* minus half of the bandwidth of the measuring filter.
- Δf_{max} is equal to $f_{\text{offset}_{\text{max}}}$ minus half of the bandwidth of the measuring filter.

For a *multi-band connector* of IAB-DU, the operating band unwanted emission limits apply also in a supported downlink *operating band* without any carrier transmitted, in the case where there are carrier(s) transmitted in another supported downlink *operating band*. In this case, no cumulative *basic limit* is applied in the *inter-band gap* between a supported downlink *operating band* with carrier(s) transmitted and a supported downlink *operating band* without any carrier transmitted and

- In case the *inter-band gap* between a supported downlink *operating band* with carrier(s) transmitted and a supported downlink *operating band* without any carrier transmitted is less than $2 * \Delta f_{\text{OBUE}}$, $f_{\text{offset}_{\text{max}}}$ shall be the offset to the frequency Δf_{OBUE} MHz outside the outermost edges of the two supported downlink *operating bands* and the operating band unwanted emission *basic limits* of the band where there are carriers transmitted, as defined in the tables of the present clause, shall apply across both downlink bands.
- In other cases, the operating band unwanted emission *basic limits* of the band where there are carriers transmitted, as defined in the tables of the present clause for the largest frequency offset (Δf_{max}), shall apply from Δf_{OBUE} MHz below the lowest frequency, up to Δf_{OBUE} MHz above the highest frequency of the supported downlink *operating band* without any carrier transmitted.

For a *multi-band connector* of IAB-MT, the operating band unwanted emission limits apply also in a supported uplink *operating band* without any carrier transmitted, in the case where there are carrier(s) transmitted in another supported uplink *operating band*. In this case, no cumulative *basic limit* is applied in the *inter-band gap* between a supported uplink *operating band* with carrier(s) transmitted and a supported uplink *operating band* without any carrier transmitted and

- In case the *inter-band gap* between a supported uplink *operating band* with carrier(s) transmitted and a supported uplink *operating band* without any carrier transmitted is less than $2 * \Delta f_{\text{OBUE}}$, $f_{\text{offset}_{\text{max}}}$ shall be the offset to the frequency Δf_{OBUE} MHz outside the outermost edges of the two supported uplink *operating bands* and the operating band unwanted emission *basic limits* of the band where there are carriers transmitted, as defined in the tables of the present clause, shall apply across both uplink bands.
- In other cases, the operating band unwanted emission *basic limits* of the band where there are carriers transmitted, as defined in the tables of the present clause for the largest frequency offset (Δf_{max}), shall apply from Δf_{OBUE} MHz below the lowest frequency, up to Δf_{OBUE} MHz above the highest frequency of the supported uplink *operating band* without any carrier transmitted.

For a multicarrier *single-band connector* or a *single-band connector* configured for intra-band contiguous or non-contiguous *carrier aggregation* the definitions above apply to the lower edge of the carrier transmitted at the *lowest carrier* frequency and the upper edge of the carrier transmitted at the *highest carrier* frequency within a specified frequency band.

In addition, inside any *sub-block gap* for a *single-band connector* operating in *non-contiguous spectrum*, a combined *basic limit* shall be applied which is the cumulative sum of the *basic limits* specified for the adjacent *sub-blocks* on each side of the *sub-block gap*. The *basic limit* for each *sub-block* is specified in clauses 6.6.4.2.1 to 6.6.4.2.4 below, where in this case:

- Δf is the separation between the *sub-block* edge frequency and the nominal -3 dB point of the measuring filter closest to the *sub-block* edge.
- f_{offset} is the separation between the *sub-block* edge frequency and the centre of the measuring filter.
- $f_{\text{offset}_{\text{max}}}$ is equal to the *sub-block gap* bandwidth minus half of the bandwidth of the measuring filter.
- Δf_{max} is equal to $f_{\text{offset}_{\text{max}}}$ minus half of the bandwidth of the measuring filter.

For Wide Area IAB-DU and Wide Area IAB-MT, the requirements of either clause 6.6.4.2.1 (Category A limits) or clause 6.6.4.2.2 (Category B limits) shall apply.

For Medium Range IAB-DU, the requirements in clause 6.6.4.2.3 shall apply (Category A and B).

For Local Area IAB-DU and Local Area IAB-MT, the requirements of clause 6.6.4.2.4 shall apply (Category A and B).

The application of either Category A or Category B *basic limits* shall be the same as for Transmitter spurious emissions in clause 6.6.5.

6.6.4.2 Minimum requirement

The minimum requirement applies per single-band connector, or per multi-band connector supporting transmission in the operating band.

The minimum requirement for *IAB type 1-H* are defined in TS 38.174 [2], clause 6.6.4.2.

6.6.4.3 Test purpose

This test measures the emissions close to the assigned channel bandwidth of the wanted signal, while the transmitter is in operation.

6.6.4.4 Method of test

6.6.4.4.1 Initial conditions

Test environment: Normal; see annex B.2.

RF channels to be tested for single carrier: B, M and T; see clause 4.9.1.

IAB RF Bandwidth positions to be tested for multi-carrier:

- B_{RFBW} , M_{RFBW} and T_{RFBW} in single-band operation; see clause 4.9.1.
- $B'_{\text{RFBW}}T'_{\text{RFBW}}$ and $B'_{\text{RFBW}}T_{\text{RFBW}}$ in multi-band operation, see clause 4.9.1.

6.6.4.4.2 Procedure

For *IAB type 1-H* where there may be multiple *TAB connectors*, they may be tested one at a time or multiple *TAB connectors* may be tested in parallel as shown in annex D.1.1. Whichever method is used the procedure is repeated until all *TAB connectors* necessary to demonstrate conformance have been tested.

- 1) Connect the *single-band connector* or *multi-band connector* under test to measurement equipment as shown in annex D.1.1 for *IAB type 1-H*. All connectors not under test shall be terminated.

As a general rule, the resolution bandwidth of the measuring equipment should be equal to the measurement bandwidth. However, to improve measurement accuracy, sensitivity, efficiency and avoiding e.g. carrier leakage, the resolution bandwidth may be smaller than the measurement bandwidth. When the resolution bandwidth is smaller than the measurement bandwidth, the result should be integrated over the measurement bandwidth in order to obtain the equivalent noise bandwidth of the measurement bandwidth.

The measurement device characteristics shall be:

- Detection mode: True RMS.
- 2) For a connectors declared to be capable of single carrier operation only, set the representative connectors under test to transmit according to the applicable test configuration in clause 4.8 at *rated carrier output power* $P_{\text{rated,c,TABC}}$ (D.21). Channel set-up shall be according to IAB-DU-FR1-TM1.1 or IAB-MT-FR1-TM1.1.

For a connector under test declared to be capable of multi-carrier and/or CA operation set the connector under test to transmit on all carriers configured using the applicable test configuration and corresponding power setting specified in clauses 4.7 and 4.8 using the corresponding test models or set of physical channels in clause 4.9.2.

- 3) Step the centre frequency of the measurement filter in contiguous steps and measure the emission within the specified frequency ranges with the specified measurement bandwidth. For connector under test declared to operate in multiple bands or non-contiguous spectrum, the emission within the *Inter RF Bandwidth* or *sub-block gap* shall be measured using the specified measurement bandwidth from the closest RF Bandwidth or sub block edge.
- 4) Repeat the test for the remaining test cases, with the channel set-up according to IAB-DU-FR1-TM1.2.

In addition, for *multi-band connectors*, the following steps shall apply:

- 5) For a *multi-band connectors* and single band tests, repeat the steps above per involved *operating band* where single band test configurations and test models shall apply with no carrier activated in the other *operating band*.

6.6.4.5 Test requirements

6.6.4.5.1 General requirements

6.6.4.5.2 Basic limits for Wide Area IAB-DU and IAB-MT (Category A)

For IAB-DU and IAB-MT operating in Bands n41 *basic limits* are specified in table 6.6.4.2.1-1:

Table 6.6.4.2.1-1: Wide Area IAB-DU and Wide Area IAB-MT *operating band* unwanted emission limits (1GHz < NR bands ≤ 3GHz) for Category A

Frequency offset of measurement filter -3dB point, Δf	Frequency offset of measurement filter centre frequency, f_{offset}	<i>Basic limits</i> (Note 1, 2)	<i>Measurement bandwidth</i>
$0 \text{ MHz} \leq \Delta f < 5 \text{ MHz}$	$0.05 \text{ MHz} \leq f_{\text{offset}} < 5.05 \text{ MHz}$	$-5.5 \text{ dBm} - \frac{7}{5} \left(\frac{f_{\text{offset}}}{\text{MHz}} - 0.05 \right) \text{ dB}$	100 kHz
$5 \text{ MHz} \leq \Delta f < \min(10 \text{ MHz}, \Delta f_{\text{max}})$	$5.05 \text{ MHz} \leq f_{\text{offset}} < \min(10.05 \text{ MHz}, f_{\text{offset}_{\text{max}}})$	-12.5 dBm	100 kHz
$10 \text{ MHz} \leq \Delta f \leq \Delta f_{\text{max}}$	$10.5 \text{ MHz} \leq f_{\text{offset}} < f_{\text{offset}_{\text{max}}}$	-13 dBm (Note 3)	1MHz
NOTE 1: For an IAB-DU and IAB-MT supporting <i>non-contiguous spectrum</i> operation within any <i>operating band</i> , the emission limits within <i>sub-block gaps</i> is calculated as a cumulative sum of contributions from adjacent <i>sub-blocks</i> on each side of the <i>sub-block gap</i> , where the contribution from the far-end <i>sub-block</i> shall be scaled according to the <i>measurement bandwidth</i> of the near-end <i>sub-block</i> . Exception is $\Delta f \geq 10 \text{ MHz}$ from both adjacent <i>sub-blocks</i> on each side of the <i>sub-block gap</i> , where the emission limits within <i>sub-block gaps</i> shall be -13 dBm/1 MHz.			
NOTE 2: For a <i>multi-band connector</i> with <i>Inter RF Bandwidth gap</i> < $2 * \Delta f_{\text{OBUe}}$ the emission limits within the <i>Inter RF Bandwidth gaps</i> is calculated as a cumulative sum of contributions from adjacent <i>sub-blocks</i> or RF Bandwidth on each side of the <i>Inter RF Bandwidth gap</i> , where the contribution from the far-end <i>sub-block</i> or RF Bandwidth shall be scaled according to the <i>measurement bandwidth</i> of the near-end <i>sub-block</i> or RF Bandwidth.			
NOTE 3: The requirement is not applicable when $\Delta f_{\text{max}} < 10 \text{ MHz}$.			

For IAB-DU and IAB-MT operating in Bands n77, n78 and n79 *basic limits* are specified in table 6.6.4.2.1-2:

Table 6.6.4.2.1-2: Wide Area IAB-DU and Wide Area IAB-MT operating band unwanted emission limits (NR bands >3GHz) for Category A

Frequency offset of measurement filter -3dB point, Δf	Frequency offset of measurement filter centre frequency, f_{offset}	Basic limit (Note 1, 2)	Measurement bandwidth
$0 \text{ MHz} \leq \Delta f < 5 \text{ MHz}$	$0.05 \text{ MHz} \leq f_{\text{offset}} < 5.05 \text{ MHz}$	$-5.2 \text{ dBm} - \frac{7}{5} \cdot \left(\frac{f_{\text{offset}}}{\text{MHz}} - 0.05 \right) \text{ dB}$	100 kHz
$5 \text{ MHz} \leq \Delta f < \min(10 \text{ MHz}, \Delta f_{\text{max}})$	$5.05 \text{ MHz} \leq f_{\text{offset}} < \min(10.05 \text{ MHz}, f_{\text{offset}_{\text{max}}})$	-12.2 dBm	100 kHz
$10 \text{ MHz} \leq \Delta f \leq \Delta f_{\text{max}}$	$10.5 \text{ MHz} \leq f_{\text{offset}} < f_{\text{offset}_{\text{max}}}$	-13 dBm (Note 3)	1 MHz
NOTE 1: For an IAB-DU and IAB-MT supporting <i>non-contiguous spectrum</i> operation within any <i>operating band</i> , the emission limits within <i>sub-block gaps</i> is calculated as a cumulative sum of contributions from adjacent <i>sub-blocks</i> on each side of the <i>sub-block gap</i> , where the contribution from the far-end <i>sub-block</i> shall be scaled according to the <i>measurement bandwidth</i> of the near-end <i>sub-block</i> . Exception is $\Delta f \geq 10 \text{ MHz}$ from both adjacent <i>sub-blocks</i> on each side of the <i>sub-block gap</i> , where the emission limits within <i>sub-block gaps</i> shall be -13 dBm/1 MHz.			
NOTE 2: For a <i>multi-band connector</i> with <i>Inter RF Bandwidth gap</i> $< 2 \cdot \Delta f_{\text{OBUe}}$ the emission limits within the <i>Inter RF Bandwidth gaps</i> is calculated as a cumulative sum of contributions from adjacent <i>sub-blocks</i> or RF Bandwidth on each side of the <i>Inter RF Bandwidth gap</i> , where the contribution from the far-end <i>sub-block</i> or RF Bandwidth shall be scaled according to the <i>measurement bandwidth</i> of the near-end <i>sub-block</i> or RF Bandwidth.			
NOTE 3: The requirement is not applicable when $\Delta f_{\text{max}} < 10 \text{ MHz}$.			

6.6.4.5.3 Basic limits for Wide Area IAB-DU and Wide Area IAB-MT (Category B)

6.6.4.5.3.1 General

For Category B Operating band unwanted emissions, the *basic limits* in clause 6.6.4.5.3.2 shall be applied.

6.6.4.5.3.2 Category B requirements

For IAB-DU and IAB-MT operating in Bands n41 *basic limits* are specified in table 6.6.4.5.3.2-1:

Table 6.6.4.5.3.2-1: Wide Area IAB-DU and IAB-MT operating band unwanted emission limits (1GHz < NR bands ≤ 3GHz) for Category B

Frequency offset of measurement filter -3dB point, Δf	Frequency offset of measurement filter centre frequency, f_{offset}	Basic limits (Note 1, 2)	Measurement bandwidth
$0 \text{ MHz} \leq \Delta f < 5 \text{ MHz}$	$0.05 \text{ MHz} \leq f_{\text{offset}} < 5.05 \text{ MHz}$	$-5.5 \text{ dBm} - \frac{7}{5} \cdot \left(\frac{f_{\text{offset}}}{\text{MHz}} - 0.05 \right) \text{ dB}$	100 kHz
$5 \text{ MHz} \leq \Delta f < \min(10 \text{ MHz}, \Delta f_{\text{max}})$	$5.05 \text{ MHz} \leq f_{\text{offset}} < \min(10.05 \text{ MHz}, f_{\text{offset}_{\text{max}}})$	-12.5 dBm	100 kHz
$10 \text{ MHz} \leq \Delta f \leq \Delta f_{\text{max}}$	$10.5 \text{ MHz} \leq f_{\text{offset}} < f_{\text{offset}_{\text{max}}}$	-15 dBm (Note 3)	1 MHz
NOTE 1: For an IAB-DU and IAB-MT supporting <i>non-contiguous spectrum</i> operation within any <i>operating band</i> , the emission limits within <i>sub-block gaps</i> is calculated as a cumulative sum of contributions from adjacent <i>sub-blocks</i> on each side of the <i>sub-block gap</i> , where the contribution from the far-end <i>sub-block</i> shall be scaled according to the <i>measurement bandwidth</i> of the near-end <i>sub-block</i> . Exception is $\Delta f \geq 10 \text{ MHz}$ from both adjacent <i>sub-blocks</i> on each side of the <i>sub-block gap</i> , where the emission limits within <i>sub-block gaps</i> shall be -15 dBm/1 MHz.			
NOTE 2: For a <i>multi-band connector</i> with <i>Inter RF Bandwidth gap</i> $< 2 \cdot \Delta f_{\text{OBUe}}$ the emission limits within the <i>Inter RF Bandwidth gaps</i> is calculated as a cumulative sum of contributions from adjacent <i>sub-blocks</i> or RF Bandwidth on each side of the <i>Inter RF Bandwidth gap</i> , where the contribution from the far-end <i>sub-block</i> or RF Bandwidth shall be scaled according to the <i>measurement bandwidth</i> of the near-end <i>sub-block</i> or RF Bandwidth.			
NOTE 3: The requirement is not applicable when $\Delta f_{\text{max}} < 10 \text{ MHz}$.			

For IAB-DU and IAB-MT operating in Bands n77, n78 and n79 *basic limits* are specified in table 6.6.4.5.3.2-2:

Table 6.6.4.5.3.2-2: Wide Area IAB-DU and Wide Area IAB-MT operating band unwanted emission limits (NR bands >3GHz) for Category B

Frequency offset of measurement filter -3dB point, Δf	Frequency offset of measurement filter centre frequency, f_{offset}	Basic limit (Note 1, 2)	Measurement bandwidth
$0 \text{ MHz} \leq \Delta f < 5 \text{ MHz}$	$0.05 \text{ MHz} \leq f_{\text{offset}} < 5.05 \text{ MHz}$	$-5.2 \text{ dBm} - \frac{7}{5} \cdot \left(\frac{f_{\text{offset}}}{\text{MHz}} - 0.05 \right) \text{ dB}$	100 kHz
$5 \text{ MHz} \leq \Delta f < \min(10 \text{ MHz}, \Delta f_{\text{max}})$	$5.05 \text{ MHz} \leq f_{\text{offset}} < \min(10.05 \text{ MHz}, f_{\text{offsetmax}})$	-12.2 dBm	100 kHz
$10 \text{ MHz} \leq \Delta f \leq \Delta f_{\text{max}}$	$10.5 \text{ MHz} \leq f_{\text{offset}} < f_{\text{offsetmax}}$	-15 dBm (Note 3)	1MHz
<p>NOTE 1: For an IAB-DU and IAB-MT supporting <i>non-contiguous spectrum</i> operation within any <i>operating band</i>, the emission limits within <i>sub-block gaps</i> is calculated as a cumulative sum of contributions from adjacent <i>sub-blocks</i> on each side of the <i>sub-block gap</i>, where the contribution from the far-end <i>sub-block</i> shall be scaled according to the <i>measurement bandwidth</i> of the near-end <i>sub-block</i>. Exception is $\Delta f \geq 10 \text{ MHz}$ from both adjacent <i>sub-blocks</i> on each side of the <i>sub-block gap</i>, where the emission limits within <i>sub-block gaps</i> shall be -15 dBm/1 MHz.</p> <p>NOTE 2: For a <i>multi-band connector</i> with <i>Inter RF Bandwidth gap</i> $< 2 \cdot \Delta f_{\text{OBUe}}$ the emission limits within the <i>Inter RF Bandwidth gaps</i> is calculated as a cumulative sum of contributions from adjacent <i>sub-blocks</i> or RF Bandwidth on each side of the <i>Inter RF Bandwidth gap</i>, where the contribution from the far-end <i>sub-block</i> or RF Bandwidth shall be scaled according to the <i>measurement bandwidth</i> of the near-end <i>sub-block</i> or RF Bandwidth.</p> <p>NOTE 3: The requirement is not applicable when $\Delta f_{\text{max}} < 10 \text{ MHz}$.</p>			

6.6.4.5.4 Basic limits for Medium Range IAB-DU (Category A and B)

For Medium Range IAB-DU, *basic limits* are specified in table 6.6.4.5.4-1 to table 6.6.4.5.4-4.

For the tables in this clause for *IAB type 1-H* $P_{\text{rated},x} = P_{\text{rated},c,\text{cell}} - 10 \cdot \log_{10}(N_{\text{TXU},\text{countedpercell}})$,

Table 6.6.4.5.4-1: Medium Range IAB-DU operating band unwanted emission limits, $31 < P_{\text{rated},x} \leq 38 \text{ dBm}$ (NR bands $\leq 3 \text{ GHz}$)

Frequency offset of measurement filter -3dB point, Δf	Frequency offset of measurement filter centre frequency, f_{offset}	Basic limits (Note 1, 2)	Measurement bandwidth
$0 \text{ MHz} \leq \Delta f < 5 \text{ MHz}$	$0.05 \text{ MHz} \leq f_{\text{offset}} < 5.05 \text{ MHz}$	$P_{\text{rated},x} - 51.5 \text{ dB} - \frac{7}{5} \cdot \left(\frac{f_{\text{offset}}}{\text{MHz}} - 0.05 \right) \text{ dB}$	100 kHz
$5 \text{ MHz} \leq \Delta f < \min(10 \text{ MHz}, \Delta f_{\text{max}})$	$5.05 \text{ MHz} \leq f_{\text{offset}} < \min(10.05 \text{ MHz}, f_{\text{offsetmax}})$	$P_{\text{rated},x} - 58.5 \text{ dB}$	100 kHz
$10 \text{ MHz} \leq \Delta f \leq \Delta f_{\text{max}}$	$10.05 \text{ MHz} \leq f_{\text{offset}} < f_{\text{offsetmax}}$	$\text{Min}(P_{\text{rated},x} - 60 \text{ dB}, -25 \text{ dBm})$ (Note 3)	100 kHz
<p>NOTE 1: For an IAB-DU supporting <i>non-contiguous spectrum</i> operation within any <i>operating band</i> the emission limits within <i>sub-block gaps</i> is calculated as a cumulative sum of contributions from adjacent <i>sub-blocks</i> on each side of the <i>sub-block gap</i>. Exception is $\Delta f \geq 10 \text{ MHz}$ from both adjacent <i>sub-blocks</i> on each side of the <i>sub-block gap</i>, where the emission limits within <i>sub-block gaps</i> shall be $\text{Min}(P_{\text{rated},x} - 60 \text{ dB}, -25 \text{ dBm})/100 \text{ kHz}$.</p> <p>NOTE 2: For a <i>multi-band connector</i> with <i>Inter RF Bandwidth gap</i> $< 2 \cdot \Delta f_{\text{OBUe}}$ the emission limits within the <i>Inter RF Bandwidth gaps</i> is calculated as a cumulative sum of contributions from adjacent <i>sub-blocks</i> or RF Bandwidth on each side of the <i>Inter RF Bandwidth gap</i>.</p> <p>NOTE 3: The requirement is not applicable when $\Delta f_{\text{max}} < 10 \text{ MHz}$.</p>			

Table 6.6.4.5.4-2: Medium Range IAB-DU operating band unwanted emission limits, $P_{\text{rated},x} \leq 31$ dBm (NR bands ≤ 3 GHz)

Frequency offset of measurement filter -3dB point, Δf	Frequency offset of measurement filter centre frequency, f_{offset}	Basic limits (Note 1, 2)	Measurement bandwidth
$0 \text{ MHz} \leq \Delta f < 5 \text{ MHz}$	$0.05 \text{ MHz} \leq f_{\text{offset}} < 5.05 \text{ MHz}$	$-20.5 \text{ dBm} - \frac{7}{5} \left(\frac{f_{\text{offset}}}{\text{MHz}} - 0.05 \right) \text{ dB}$	100 kHz
$5 \text{ MHz} \leq \Delta f < \min(10 \text{ MHz}, \Delta f_{\text{max}})$	$5.05 \text{ MHz} \leq f_{\text{offset}} < \min(10.05 \text{ MHz}, f_{\text{offset}_{\text{max}}})$	-27.5 dBm	100 kHz
$10 \text{ MHz} \leq \Delta f \leq \Delta f_{\text{max}}$	$10.05 \text{ MHz} \leq f_{\text{offset}} < f_{\text{offset}_{\text{max}}}$	-29 dBm (Note 3)	100 kHz

NOTE 1: For an IAB-DU supporting *non-contiguous spectrum* operation within any *operating band* the emission limits within *sub-block gaps* is calculated as a cumulative sum of contributions from adjacent *sub-blocks* on each side of the *sub-block gap*. Exception is $\Delta f \geq 10$ MHz from both adjacent *sub-blocks* on each side of the *sub-block gap*, where the emission limits within *sub-block gaps* shall be -29dBm/100kHz.

NOTE 2: For a *multi-band connector* with *Inter RF Bandwidth gap* $< 2 \cdot \Delta f_{\text{OBUE}}$ the emission limits within the *Inter RF Bandwidth gaps* is calculated as a cumulative sum of contributions from adjacent *sub-blocks* or RF Bandwidth on each side of the *Inter RF Bandwidth gap*.

NOTE 3: The requirement is not applicable when $\Delta f_{\text{max}} < 10$ MHz.

Table 6.6.4.5.4-3: Medium Range IAB-DU operating band unwanted emission limits, $31 < P_{\text{rated},x} \leq 38$ dBm (NR bands > 3 GHz)

Frequency offset of measurement filter -3dB point, Δf	Frequency offset of measurement filter centre frequency, f_{offset}	Basic limit (Note 1, 2)	Measurement bandwidth
$0 \text{ MHz} \leq \Delta f < 5 \text{ MHz}$	$0.05 \text{ MHz} \leq f_{\text{offset}} < 5.05 \text{ MHz}$	$P_{\text{rated},x} - 51.2 \text{ dB} - \frac{7}{5} \left(\frac{f_{\text{offset}}}{\text{MHz}} - 0.05 \right) \text{ dB}$	100 kHz
$5 \text{ MHz} \leq \Delta f < \min(10 \text{ MHz}, \Delta f_{\text{max}})$	$5.05 \text{ MHz} \leq f_{\text{offset}} < \min(10.05 \text{ MHz}, f_{\text{offset}_{\text{max}}})$	$P_{\text{rated},x} - 58.2 \text{ dB}$	100 kHz
$10 \text{ MHz} \leq \Delta f \leq \Delta f_{\text{max}}$	$10.05 \text{ MHz} \leq f_{\text{offset}} < f_{\text{offset}_{\text{max}}}$	$\text{Min}(P_{\text{rated},x} - 60 \text{ dB}, -25 \text{ dBm})$ (Note 3)	100 kHz

NOTE 1: For an IAB-DU supporting *non-contiguous spectrum* operation within any *operating band* the emission limits within *sub-block gaps* is calculated as a cumulative sum of contributions from adjacent *sub-blocks* on each side of the *sub-block gap*. Exception is $\Delta f \geq 10$ MHz from both adjacent *sub-blocks* on each side of the *sub-block gap*, where the emission limits within *sub-block gaps* shall be -29dBm/100kHz.

NOTE 2: For a *multi-band connector* with *Inter RF Bandwidth gap* $< 2 \cdot \Delta f_{\text{OBUE}}$ the emission limits within the *Inter RF Bandwidth gaps* is calculated as a cumulative sum of contributions from adjacent *sub-blocks* or RF Bandwidth on each side of the *Inter RF Bandwidth gap*.

NOTE 3: The requirement is not applicable when $\Delta f_{\text{max}} < 10$ MHz.

Table 6.6.4.5.4-4: Medium Range IAB-DU operating band unwanted emission limits, $P_{\text{rated},x} \leq 31$ dBm (NR bands >3GHz)

Frequency offset of measurement filter -3dB point, Δf	Frequency offset of measurement filter centre frequency, f_{offset}	Basic limit (Note 1, 2)	Measurement bandwidth
$0 \text{ MHz} \leq \Delta f < 5 \text{ MHz}$	$0.05 \text{ MHz} \leq f_{\text{offset}} < 5.05 \text{ MHz}$	$-20.2 \text{ dBm} - \frac{7}{5} \left(\frac{f_{\text{offset}}}{\text{MHz}} - 0.05 \right) \text{ dB}$	100 kHz
$5 \text{ MHz} \leq \Delta f < \min(10 \text{ MHz}, \Delta f_{\text{max}})$	$5.05 \text{ MHz} \leq f_{\text{offset}} < \min(10.05 \text{ MHz}, f_{\text{offset}_{\text{max}}})$	-27.2 dBm	100 kHz
$10 \text{ MHz} \leq \Delta f \leq \Delta f_{\text{max}}$	$10.05 \text{ MHz} \leq f_{\text{offset}} < f_{\text{offset}_{\text{max}}}$	-29 dBm (Note 3)	100 kHz
<p>NOTE 1: For an IAB-DU supporting <i>non-contiguous spectrum</i> operation within any <i>operating band</i> the emission limits within <i>sub-block gaps</i> is calculated as a cumulative sum of contributions from adjacent <i>sub-blocks</i> on each side of the <i>sub-block gap</i>. Exception is $\Delta f \geq 10$ MHz from both adjacent <i>sub-blocks</i> on each side of the <i>sub-block gap</i>, where the emission limits within <i>sub-block gaps</i> shall be -29dBm/100kHz.</p> <p>NOTE 2: For a <i>multi-band connector</i> with <i>Inter RF Bandwidth gap</i> $< 2 \cdot \Delta f_{\text{OBUe}}$ the emission limits within the <i>Inter RF Bandwidth gaps</i> is calculated as a cumulative sum of contributions from adjacent <i>sub-blocks</i> or RF Bandwidth on each side of the <i>Inter RF Bandwidth gap</i>.</p> <p>NOTE 3: The requirement is not applicable when $\Delta f_{\text{max}} < 10$ MHz.</p>			

6.6.4.5.5 Basic limits for Local Area IAB-DU and Local Area IAB-MT (Category A and B)

For Local Area IAB-DU and Local Area IAB-MT in NR bands ≤ 3 GHz, *basic limits* are specified in table 6.6.4.5.4-1.

For Local Area IAB-DU and Local Area IAB-MT in NR bands ≤ 3 GHz, *basic limits* are specified in table 6.6.4.5.4-2.

Table 6.6.4.5.4-1: Local Area IAB-DU and Local Area IAB-MT operating band unwanted emission limits (NR bands ≤ 3 GHz)

Frequency offset of measurement filter -3dB point, Δf	Frequency offset of measurement filter centre frequency, f_{offset}	Basic limits (Note 1, 2)	Measurement bandwidth
$0 \text{ MHz} \leq \Delta f < 5 \text{ MHz}$	$0.05 \text{ MHz} \leq f_{\text{offset}} < 5.05 \text{ MHz}$	$-28.5 \text{ dBm} - \frac{7}{5} \left(\frac{f_{\text{offset}}}{\text{MHz}} - 0.05 \right) \text{ dB}$	100 kHz
$5 \text{ MHz} \leq \Delta f < \min(10 \text{ MHz}, \Delta f_{\text{max}})$	$5.05 \text{ MHz} \leq f_{\text{offset}} < \min(10.05 \text{ MHz}, f_{\text{offset}_{\text{max}}})$	-35.5 dBm	100 kHz
$10 \text{ MHz} \leq \Delta f \leq \Delta f_{\text{max}}$	$10.05 \text{ MHz} \leq f_{\text{offset}} < f_{\text{offset}_{\text{max}}}$	-37 dBm (Note 10)	100 kHz
<p>NOTE 1: For an IAB-DU and IAB-MT supporting <i>non-contiguous spectrum</i> operation within any <i>operating band</i> the emission limits within <i>sub-block gaps</i> is calculated as a cumulative sum of contributions from adjacent <i>sub-blocks</i> on each side of the <i>sub-block gap</i>. Exception is $\Delta f \geq 10$ MHz from both adjacent <i>sub-blocks</i> on each side of the <i>sub-block gap</i>, where the emission limits within <i>sub-block gaps</i> shall be -37dBm/100kHz.</p> <p>NOTE 2: For a <i>multi-band connector</i> with <i>Inter RF Bandwidth gap</i> $< 2 \cdot \Delta f_{\text{OBUe}}$ the emission limits within the <i>Inter RF Bandwidth gaps</i> is calculated as a cumulative sum of contributions from adjacent <i>sub-blocks</i> or RF Bandwidth on each side of the <i>Inter RF Bandwidth gap</i>.</p> <p>NOTE 3: The requirement is not applicable when $\Delta f_{\text{max}} < 10$ MHz.</p>			

Table 6.6.4.5.4-2: Local Area IAB-DU and Local Area IAB-MT operating band unwanted emission limits (NR bands >3GHz)

Frequency offset of measurement filter -3dB point, Δf	Frequency offset of measurement filter centre frequency, f_{offset}	Basic limit (Note 1, 2)	Measurement bandwidth
$0 \text{ MHz} \leq \Delta f < 5 \text{ MHz}$	$0.05 \text{ MHz} \leq f_{\text{offset}} < 5.05 \text{ MHz}$	$-28.2 \text{ dBm} - \frac{7}{5} \left(\frac{f_{\text{offset}}}{\text{MHz}} - 0.05 \right) \text{ dB}$	100 kHz
$5 \text{ MHz} \leq \Delta f < \min(10 \text{ MHz}, \Delta f_{\text{max}})$	$5.05 \text{ MHz} \leq f_{\text{offset}} < \min(10.05 \text{ MHz}, f_{\text{offset}_{\text{max}}})$	-35.2 dBm	
$10 \text{ MHz} \leq \Delta f \leq \Delta f_{\text{max}}$	$10.05 \text{ MHz} \leq f_{\text{offset}} < f_{\text{offset}_{\text{max}}}$	-37 dBm (Note 3)	
<p>NOTE 1: For an IAB-DU and IAB-MT supporting <i>non-contiguous spectrum</i> operation within any <i>operating band</i> the emission limits within <i>sub-block gaps</i> is calculated as a cumulative sum of contributions from adjacent <i>sub-blocks</i> on each side of the <i>sub-block gap</i>. Exception is $\Delta f \geq 10 \text{ MHz}$ from both adjacent <i>sub-blocks</i> on each side of the <i>sub-block gap</i>, where the emission limits within <i>sub-block gaps</i> shall be -37dBm/100kHz.</p> <p>NOTE 2: For a <i>multi-band connector</i> with <i>Inter RF Bandwidth gap</i> $< 2 \cdot \Delta f_{\text{OBUE}}$ the emission limits within the <i>Inter RF Bandwidth gaps</i> is calculated as a cumulative sum of contributions from adjacent <i>sub-blocks</i> or RF Bandwidth on each side of the <i>Inter RF Bandwidth gap</i></p> <p>NOTE 3: The requirement is not applicable when $\Delta f_{\text{max}} < 10 \text{ MHz}$.</p>			

6.6.4.5.5 Basic limits for additional requirements

6.6.4.5.5.1 Limits in FCC Title 47

In addition to the requirements in clauses 6.6.4.2.1, 6.6.4.2.2, 6.6.4.2.3 and 6.6.4.2.4, the IAB-DU and IAB-MT may have to comply with the applicable emission limits established by FCC Title 47 [7], when deployed in regions where those limits are applied, and under the conditions declared by the manufacturer.

6.6.4.5.6 IAB type 1-H

The operating band unwanted emissions requirements for *IAB type 1-H* are that for each *TAB connector TX min cell group* and each applicable *basic limit* in clause 6.6.4.2, the power summation emissions at the *TAB connectors* of the *TAB connector TX min cell group* shall not exceed a limit specified as the *basic limit* + X, where $X = 10 \log_{10}(N_{\text{TXU, counted per cell}})$.

NOTE: Conformance to the *IAB type 1-H* operating band unwanted emission requirement can be demonstrated by meeting at least one of the following criteria as determined by the manufacturer:

- 1) The sum of the emissions power measured on each *TAB connector* in the *TAB connector TX min cell group* shall be less than or equal to the limit as defined in this clause for the respective frequency span.
- Or
- 2) The unwanted emissions power at each *TAB connector* shall be less than or equal to the *type 1-H* limit as defined in this clause for the respective frequency span, scaled by $-10 \log_{10}(n)$, where n is the number of *TAB connectors* in the *TAB connector TX min cell group*.

6.6.5 Transmitter spurious emissions

6.6.5.1 Definition and applicability

For IAB-DU, the transmitter spurious emission limits shall apply from 9 kHz to 12.75 GHz, excluding the frequency range from Δf_{OBUE} below the lowest frequency of each supported downlink *operating band*, up to Δf_{OBUE} above the highest frequency of each supported downlink *operating band*, where the Δf_{OBUE} is defined in table 6.6.1-1. For some *operating bands*, the upper limit is higher than 12.75 GHz in order to comply with the 5th harmonic limit of the downlink *operating band*, as specified in Recommendation ITU-R SM.329 [5].

For IAB-MT, the transmitter spurious emission limits shall apply from 9 kHz to 12.75 GHz, excluding the frequency range from Δf_{OBUE} below the lowest frequency of each supported uplink *operating band*, up to Δf_{OBUE} above the highest

frequency of each supported uplink *operating band*, where the Δf_{OBUE} is defined in table 6.6.1-2. For some *operating bands*, the upper limit is higher than 12.75 GHz in order to comply with the 5th harmonic limit of the uplink *operating band*, as specified in Recommendation ITU-R SM.329 [5].

For a *multi-band connector*, for each supported *operating band* together with Δf_{OBUE} around the band is excluded from the transmitter spurious emissions requirement.

The requirements shall apply whatever the type of transmitter considered (single carrier or multi-carrier). It applies for all transmission modes foreseen by the manufacturer's specification.

Unless otherwise stated, all requirements are measured as mean power (RMS).

6.6.5.2 Minimum requirement

The minimum requirement applies per *single-band connector*, or per *multi-band connector* supporting transmission in the *operating band*.

The minimum requirement for *IAB type 1-H* are defined in TS 38.174 [2], clause 6.6.5.

6.6.5.3 Test purpose

This test measures conducted spurious emissions while the transmitter is in operation.

6.6.5.4 Method of test

6.6.5.4.1 Initial conditions

Test environment: Normal; see annex B.2.

RF channels to be tested for single carrier:

- B when testing the spurious emissions below $F_{\text{DL_low}} - \Delta f_{\text{OBUE}}$ for IAB-DU or $F_{\text{UL_low}} - \Delta f_{\text{OBUE}}$ for IAB-MT,
- T when testing the spurious emissions above $F_{\text{DL_high}} + \Delta f_{\text{OBUE}}$ for IAB-DU or $F_{\text{UL_high}} + \Delta f_{\text{OBUE}}$ for IAB-MT; see clause 4.9.1.

IAB RF Bandwidth positions to be tested for multi-carrier and/or CA:

- B_{RFBW} when testing the spurious frequencies below $F_{\text{DL_low}} - \Delta f_{\text{OBUE}}$ for IAB-DU or $F_{\text{UL_low}} - \Delta f_{\text{OBUE}}$ for IAB-MT; T_{RFBW} when testing the spurious frequencies above $F_{\text{DL_high}} + \Delta f_{\text{OBUE}}$ for IAB-DU or $F_{\text{UL_high}} + \Delta f_{\text{OBUE}}$ for IAB-MT in single-band operation; see clause 4.9.1.
- $B_{\text{RFBW}}T_{\text{RFBW}}$ when testing the spurious frequencies below $F_{\text{DL_low}} - \Delta f_{\text{OBUE}}$ for IAB-DU or $F_{\text{UL_low}} - \Delta f_{\text{OBUE}}$ for IAB-MT of the lowest operating band; $B'_{\text{RFBW}}T'_{\text{RFBW}}$ when testing the spurious frequencies above $F_{\text{DL_high}} + \Delta f_{\text{OBUE}}$ for IAB-DU or $F_{\text{UL_high}} + \Delta f_{\text{OBUE}}$ for IAB-MT of the highest operating band in multi-band operation, see clause 4.9.1.

6.6.5.4.2 Procedure

For *IAB type 1-H* where there may be multiple *TAB connectors*, they may be tested one at a time or multiple *TAB connectors* may be tested in parallel as shown in annex D.13.1. Whichever method is used the procedure is repeated until all *TAB connectors* necessary to demonstrate conformance have been tested.

- 1) Connect the *single-band connector* or *multi-band connector* under test to measurement equipment as shown in annex D.1.1. All connectors not under test shall be terminated.
- 2) Measurements shall use a measurement bandwidth in accordance to the conditions in clause 6.6.5.5.

The measurement device characteristics shall be:

- Detection mode: True RMS.

- 3) For a connectors declared to be capable of single carrier operation only (D.16), set the representative connectors under test to transmit according to the applicable test configuration in clause 4.8 at *rated carrier output power* ($P_{\text{rated,c,AC}}$, or $P_{\text{rated,c,TABC}}$, D.21). Channel set-up shall be according to IAB-DU-FR1-TM1.1 or IAB-MT-FR1-TM1.1.

For a connector under test declared to be capable of multi-carrier and/or CA operation (D.15-D.16) set the connector under test to transmit on all carriers configured using the applicable test configuration and corresponding power setting specified in clauses 4.7 and 4.8 using the corresponding test models or set of physical channels in clause 4.9.2.

- 4) Measure the emission at the specified frequencies with specified measurement bandwidth.

In addition, for *multi-band connectors*, the following steps shall apply:

- 5) For a *multi-band connectors* and single band tests, repeat the steps above per involved *operating band* where single band test configurations and test models shall apply with no carrier activated in the other *operating band*.

6.6.5.5 Test requirements

6.6.5.5.1 Basic limits

6.6.5.5.1.1 Tx spurious emissions

The *basic limits* of either table 6.6.5.5.1.1-1 (Category A limits) or table 6.6.5.5.1.1-2 (Category B limits) shall apply. The application of either Category A or Category B limits shall be the same as for operating band unwanted emissions in clause 6.6.4.

Table 6.6.5.5.1.1-1: General IAB-DU and IAB-MT transmitter spurious emission limits in FR1, Category A

Spurious frequency range	Basic limit	Measurement bandwidth	Notes
9 kHz – 150 kHz	-13 dBm	1 kHz	Note 1, Note 4
150 kHz – 30 MHz		10 kHz	Note 1, Note 4
30 MHz – 1 GHz		100 kHz	Note 1
1 GHz 12.75 GHz		1 MHz	Note 1, Note 2
12.75 GHz – 5 th harmonic of the upper frequency edge of the DL <i>operating band</i> in GHz		1 MHz	Note 1, Note 2, Note 3
NOTE 1: <i>Measurement bandwidths</i> as in ITU-R SM.329 [5], s4.1.			
NOTE 2: Upper frequency as in ITU-R SM.329 [5], s2.5 table 1.			
NOTE 3: For IAB-DU, this spurious frequency range applies only for <i>operating bands</i> for which the 5 th harmonic of the upper frequency edge of the DL <i>operating band</i> is reaching beyond 12.75 GHz. For IAB-MT, this spurious frequency range applies only for <i>operating bands</i> for which the 5 th harmonic of the upper frequency edge of the UL <i>operating band</i> is reaching beyond 12.75 GHz.			
NOTE 4: This spurious frequency range applies only to <i>IAB type 1-H</i> .			

Table 6.6.5.5.1-2: General IAB-DU and IAB-MT transmitter spurious emission limits in FR1, Category B

Spurious frequency range	Basic limit	Measurement bandwidth	Notes
9 kHz – 150 kHz	-36 dBm	1 kHz	Note 1, Note 4
150 kHz – 30 MHz		10 kHz	Note 1, Note 4
30 MHz – 1 GHz		100 kHz	Note 1
1 GHz – 12.75 GHz	-30 dBm	1 MHz	Note 1, Note 2
12.75 GHz – 5 th harmonic of the upper frequency edge of the DL <i>operating band</i> in GHz		1 MHz	Note 1, Note 2, Note 3
NOTE 1: <i>Measurement bandwidths</i> as in ITU-R SM.329 [5], s4.1.			
NOTE 2: Upper frequency as in ITU-R SM.329 [5], s2.5 table 1.			
NOTE 3: For IAB-DU, this spurious frequency range applies only for <i>operating bands</i> for which the 5 th harmonic of the upper frequency edge of the DL <i>operating band</i> is reaching beyond 12.75 GHz. For IAB-MT, this spurious frequency range applies only for <i>operating bands</i> for which the 5 th harmonic of the upper frequency edge of the UL <i>operating band</i> is reaching beyond 12.75 GHz.			
NOTE 4: This spurious frequency range applies only to <i>IAB type 1-H</i> .			

6.6.5.5.2 Additional spurious emissions requirements

These requirements may be applied for the protection of system operating in other frequency ranges. The limits may apply as an optional protection of such systems that are deployed in the same geographical area as the IAB-node, or they may be set by local or regional regulation as a mandatory requirement for an NR *operating band*. It is in some cases not stated in the present document whether a requirement is mandatory or under what exact circumstances that a limit applies, since this is set by local or regional regulation. An overview of regional requirements in the present document is given in clause 4.5.

Some requirements may apply for the protection of specific equipment (UE, MS and/or BS) or equipment operating in specific systems (GSM, CDMA, UTRA, E-UTRA, NR, etc.) as listed below.

The spurious emission *basic limits* are provided in table 6.6.5.5.2-1 where requirements for co-existence with the system listed in the first column apply for IAB-MT and IAB-DU. For a *multi-band connector*, the exclusions and conditions in the Note column of table 6.6.5.5.2-1 apply for each supported *operating band*.

Table 6.6.5.5.2-1: IAB-DU and IAB-MT spurious emissions *basic limits* for co-existence with systems operating in other frequency bands

System type to co-exist with	Frequency range for co-existence requirement	Basic limits	Measurement bandwidth	Note
GSM900	921 – 960 MHz	-57 dBm	100 kHz	
	876 – 915 MHz	-61 dBm	100 kHz	
DCS1800	1805 – 1880 MHz	-47 dBm	100 kHz	
	1710 – 1785 MHz	-61 dBm	100 kHz	
PCS1900	1930 – 1990 MHz	-47 dBm	100 kHz	
	1850 – 1910 MHz	-61 dBm	100 kHz	
GSM850 or CDMA850	869 – 894 MHz	-57 dBm	100 kHz	
	824 – 849 MHz	-61 dBm	100 kHz	
UTRA FDD Band I or E-UTRA Band 1 or NR Band n1	2110 – 2170 MHz	-52 dBm	1 MHz	
	1920 – 1980 MHz	-49 dBm	1 MHz	
UTRA FDD Band II or E-UTRA Band 2 or NR Band n2	1930 – 1990 MHz	-52 dBm	1 MHz	
	1850 – 1910 MHz	-49 dBm	1 MHz	
UTRA FDD	1805 – 1880 MHz	-52 dBm	1 MHz	

System type to co-exist with	Frequency range for co-existence requirement	Basic limits	Measurement bandwidth	Note
Band III or E-UTRA Band 3 or NR Band n3	1710 – 1785 MHz	-49 dBm	1 MHz	
UTRA FDD Band IV or E-UTRA Band 4	2110 – 2155 MHz	-52 dBm	1 MHz	
	1710 – 1755 MHz	-49 dBm	1 MHz	
UTRA FDD Band V or E-UTRA Band 5 or NR Band n5	869 – 894 MHz	-52 dBm	1 MHz	
	824 – 849 MHz	-49 dBm	1 MHz	
UTRA FDD Band VI, XIX or E-UTRA Band 6, 18, 19 or NR Band n18	860 – 890 MHz	-52 dBm	1 MHz	
	815 – 830 MHz	-49 dBm	1 MHz	
	830 – 845 MHz	-49 dBm	1 MHz	
UTRA FDD Band VII or E-UTRA Band 7 or NR Band n7	2620 – 2690 MHz	-52 dBm	1 MHz	
	2500 – 2570 MHz	-49 dBm	1 MHz	
UTRA FDD Band VIII or E-UTRA Band 8 or NR Band n8	925 – 960 MHz	-52 dBm	1 MHz	
	880 – 915 MHz	-49 dBm	1 MHz	
UTRA FDD Band IX or E-UTRA Band 9	1844.9 – 1879.9 MHz	-52 dBm	1 MHz	
	1749.9 – 1784.9 MHz	-49 dBm	1 MHz	
UTRA FDD Band X or E-UTRA Band 10	2110 – 2170 MHz	-52 dBm	1 MHz	
	1710 – 1770 MHz	-49 dBm	1 MHz	
UTRA FDD Band XI or XXI or E-UTRA Band 11 or 21	1475.9 – 1510.9 MHz	-52 dBm	1 MHz	
	1427.9 – 1447.9 MHz	-49 dBm	1 MHz	
	1447.9 – 1462.9 MHz	-49 dBm	1 MHz	
UTRA FDD Band XII or E-UTRA Band 12 or NR Band n12	729 – 746 MHz	-52 dBm	1 MHz	
	699 – 716 MHz	-49 dBm	1 MHz	
UTRA FDD Band XIII or E-UTRA Band 13	746 – 756 MHz	-52 dBm	1 MHz	
	777 – 787 MHz	-49 dBm	1 MHz	

System type to co-exist with	Frequency range for co-existence requirement	Basic limits	Measurement bandwidth	Note
UTRA FDD Band XIV or E-UTRA Band 14 or NR band n14	758 – 768 MHz	-52 dBm	1 MHz	
	788 – 798 MHz	-49 dBm	1 MHz	
E-UTRA Band 17	734 – 746 MHz	-52 dBm	1 MHz	
	704 – 716 MHz	-49 dBm	1 MHz	
UTRA FDD Band XX or E-UTRA Band 20 or NR Band n20	791 – 821 MHz	-52 dBm	1 MHz	
	832 – 862 MHz	-49 dBm	1 MHz	
UTRA FDD Band XXII or E-UTRA Band 22	3510 – 3590 MHz	-52 dBm	1 MHz	This requirement does not apply to IAB-DU and IAB-MT operating in band n77 or n78.
	3410 – 3490 MHz	-49 dBm	1 MHz	This requirement does not apply to IAB-DU and IAB-MT operating in band n77 or n78.
E-UTRA Band 24	1525 – 1559 MHz	-52 dBm	1 MHz	
	1626.5 – 1660.5 MHz	-49 dBm	1 MHz	
UTRA FDD Band XXV or E-UTRA Band 25 or NR band n25	1930 – 1995 MHz	-52 dBm	1 MHz	
	1850 – 1915 MHz	-49 dBm	1 MHz	
UTRA FDD Band XXVI or E-UTRA Band 26 or NR Band n26	859 – 894 MHz	-52 dBm	1 MHz	
	814 – 849 MHz	-49 dBm	1 MHz	
E-UTRA Band 27	852 – 869 MHz	-52 dBm	1 MHz	
	807 – 824 MHz	-49 dBm	1 MHz	
E-UTRA Band 28 or NR Band n28	758 – 803 MHz	-52 dBm	1 MHz	
	703 – 748 MHz	-49 dBm	1 MHz	
E-UTRA Band 29 or NR Band n29	717 – 728 MHz	-52 dBm	1 MHz	
E-UTRA Band 30 or NR Band n30	2350 – 2360 MHz	-52 dBm	1 MHz	
	2305 – 2315 MHz	-49 dBm	1 MHz	
E-UTRA Band 31	462.5 – 467.5 MHz	-52 dBm	1 MHz	
	452.5 – 457.5 MHz	-49 dBm	1 MHz	
UTRA FDD band XXXII or E-UTRA band 32	1452 – 1496 MHz	-52 dBm	1 MHz	
UTRA TDD Band a) or E-UTRA Band 33	1900 – 1920 MHz	-52 dBm	1 MHz	

System type to co-exist with	Frequency range for co-existence requirement	Basic limits	Measurement bandwidth	Note
UTRA TDD Band a) or E-UTRA Band 34 or NR band n34	2010 – 2025 MHz	-52 dBm	1 MHz	
UTRA TDD Band b) or E-UTRA Band 35	1850 – 1910 MHz	-52 dBm	1 MHz	
UTRA TDD Band b) or E-UTRA Band 36	1930 – 1990 MHz	-52 dBm	1 MHz	
UTRA TDD Band c) or E-UTRA Band 37	1910 – 1930 MHz	-52 dBm	1 MHz	
UTRA TDD Band d) or E-UTRA Band 38 or NR Band n38	2570 – 2620 MHz	-52 dBm	1 MHz	
UTRA TDD Band f) or E-UTRA Band 39 or NR band n39	1880 – 1920 MHz	-52 dBm	1 MHz	
UTRA TDD Band e) or E-UTRA Band 40 or NR Band n40	2300 – 2400 MHz	-52 dBm	1 MHz	
E-UTRA Band 41 or NR Band n41, n90	2496 – 2690 MHz	-52 dBm	1 MHz	This is not applicable IAB-DU and IAB-MT operating in Band n41.
E-UTRA Band 42	3400 – 3600 MHz	-52 dBm	1 MHz	This is not applicable to IAB-DU and IAB-MT operating in Band n77 or n78.
E-UTRA Band 43	3600 – 3800 MHz	-52 dBm	1 MHz	This is not applicable to IAB-DU and IAB-MT operating in Band n77 or n78.
E-UTRA Band 44	703 – 803 MHz	-52 dBm	1 MHz	
E-UTRA Band 45	1447 – 1467 MHz	-52 dBm	1 MHz	
E-UTRA Band 46 or NR Band n46	5150 – 5925 MHz	-52 dBm	1 MHz	
E-UTRA Band 47	5855 – 5925 MHz	-52 dBm	1 MHz	
E-UTRA Band 48 or NR Band n48	3550 – 3700 MHz	-52 dBm	1 MHz	This is not applicable to IAB-DU and IAB-MT operating in Band n77 or n78.
E-UTRA Band 50 or NR band n50	1432 – 1517 MHz	-52 dBm	1 MHz	
E-UTRA Band 51 or NR Band n51	1427 – 1432 MHz	-52 dBm	1 MHz	
E-UTRA Band 53 or NR Band n53	2483.5 - 2495 MHz	-52 dBm	1 MHz	This is not applicable to IAB-DU and IAB-MT operating in Band n41.
E-UTRA Band 65 or NR Band n65	2110 – 2200 MHz	-52 dBm	1 MHz	
	1920 – 2010 MHz	-49 dBm	1 MHz	

System type to co-exist with	Frequency range for co-existence requirement	Basic limits	Measurement bandwidth	Note
E-UTRA Band 66 or NR Band n66	2110 – 2200 MHz	-52 dBm	1 MHz	
	1710 – 1780 MHz	-49 dBm	1 MHz	
E-UTRA Band 67	738 – 758 MHz	-52 dBm	1 MHz	
E-UTRA Band 68	753 -783 MHz	-52 dBm	1 MHz	
	698-728 MHz	-49 dBm	1 MHz	
E-UTRA Band 69	2570 – 2620 MHz	-52 dBm	1 MHz	
E-UTRA Band 70 or NR Band n70	1995 – 2020 MHz	-52 dBm	1 MHz	
	1695 – 1710 MHz	-49 dBm	1 MHz	
E-UTRA Band 71 or NR Band n71	617 – 652 MHz	-52 dBm	1 MHz	
	663 – 698 MHz	-49 dBm	1 MHz	
E-UTRA Band 72	461 – 466 MHz	-52 dBm	1 MHz	
	451 – 456 MHz	-49 dBm	1 MHz	
E-UTRA Band 74 or NR Band n74	1475 – 1518 MHz	-52 dBm	1 MHz	
	1427 – 1470 MHz	-49 dBm	1MHz	
E-UTRA Band 75 or NR Band n75	1432 – 1517 MHz	-52 dBm	1 MHz	
E-UTRA Band 76 or NR Band n76	1427 – 1432 MHz	-52 dBm	1 MHz	
NR Band n77	3.3 – 4.2 GHz	-52 dBm	1 MHz	This requirement does not apply to IAB-DU and IAB-MT operating in Band n77 or n78
NR Band n78	3.3 – 3.8 GHz	-52 dBm	1 MHz	This requirement does not apply to IAB-DU and IAB-MT operating in Band n77 or n78
NR Band n79	4.4 – 5.0 GHz	-52 dBm	1 MHz	This requirement does not apply to IAB-DU and IAB-MT operating in Band n79
NR Band n80	1710 – 1785 MHz	-49 dBm	1 MHz	
NR Band n81	880 – 915 MHz	-49 dBm	1 MHz	
NR Band n82	832 – 862 MHz	-49 dBm	1 MHz	
NR Band n83	703 – 748 MHz	-49 dBm	1 MHz	
NR Band n84	1920 – 1980 MHz	-49 dBm	1 MHz	
E-UTRA Band 85	728 – 746 MHz	-52 dBm	1 MHz	
	698 – 716 MHz	-49 dBm	1 MHz	
NR Band n86	1710 – 1780 MHz	-49 dBm	1 MHz	
NR Band n89	824 – 849 MHz	-49 dBm	1 MHz	
NR Band n91	1427 – 1432 MHz	-52 dBm	1 MHz	
	832 – 862 MHz	-49 dBm	1 MHz	
NR Band n92	1432 – 1517 MHz	-52 dBm	1 MHz	
	832 – 862 MHz	-49 dBm	1 MHz	
NR Band n93	1427 – 1432 MHz	-52 dBm	1 MHz	
	880 – 915 MHz	-49 dBm	1 MHz	
NR Band n94	1432 – 1517 MHz	-52 dBm	1 MHz	
	880 – 915 MHz	-49 dBm	1 MHz	
NR Band n95	2010 – 2025 MHz	-52 dBm	1 MHz	
NR Band n96	5925 – 7125 MHz	-52 dBm	1 MHz	

NOTE 1: As defined in the scope for spurious emissions in this clause the co-existence requirements in table 6.6.5.2.2-1 do not apply for the Δf_{OBU} frequency range immediately outside the downlink *operating band* (see table 5.2-1). Emission limits for this excluded frequency range may be covered by local or regional requirements.

NOTE 2: Table 6.6.5.2.2-1 assumes that two *operating bands*, where the frequency ranges in table 5.2-1 would be overlapping, are not deployed in the same geographical area. For such a case of operation with overlapping frequency arrangements in the same geographical area, special co-existence requirements may apply that are not covered by the 3GPP specifications.

6.6.5.5.3 Co-location with base stations and IAB-nodes

These requirements may be applied for the protection of other BS, IAB-DU or IAB-MT receivers when GSM900, DCS1800, PCS1900, GSM850, CDMA850, UTRA FDD, UTRA TDD, E-UTRA, NR BS, IAB-DU or IAB-MT are co-located with IAB-MT and/or IAB-DU.

The requirements assume a 30 dB coupling loss between transmitter and receiver and are based on co-location with same class.

The *basic limits* are in table 6.6.5.2.3-1 for an IAB-DU and IAB-MT. Requirements for co-location with a system listed in the first column apply, depending on the declared IAB-DU and IAB-MT class. For a *multi-band connector*, the exclusions and conditions in the Note column of table 6.6.5.2.3-1 shall apply for each supported *operating band*.

Table 6.6.5.3-1: IAB-DU and IAB-MT spurious emissions *basic limits* for co-location with BS or IAB-node

Co-located system	Frequency range for co-location requirement	Basic limits			Measurement bandwidth	Note
		WA IAB-DU and WA IAB-MT	MR IAB-DU	LA IAB-DU and LA IAB-MT		
GSM900	876 – 915 MHz	-98 dBm	-91 dBm	-70 dBm	100 kHz	
DCS1800	1710 – 1785 MHz	-98 dBm	-91 dBm	-80 dBm	100 kHz	
PCS1900	1850 – 1910 MHz	-98 dBm	-91 dBm	-80 dBm	100 kHz	
GSM850 or CDMA850	824 – 849 MHz	-98 dBm	-91 dBm	-70 dBm	100 kHz	
UTRA FDD Band I or E-UTRA Band 1 or NR Band n1	1920 – 1980 MHz	-96 dBm	-91 dBm	-88 dBm	100 kHz	
UTRA FDD Band II or E-UTRA Band 2 or NR Band n2	1850 – 1910 MHz	-96 dBm	-91 dBm	-88 dBm	100 kHz	
UTRA FDD Band III or E-UTRA Band 3 or NR Band n3	1710 – 1785 MHz	-96 dBm	-91 dBm	-88 dBm	100 kHz	
UTRA FDD Band IV or E-UTRA Band 4	1710 – 1755 MHz	-96 dBm	-91 dBm	-88 dBm	100 kHz	
UTRA FDD Band V or E-UTRA Band 5 or NR Band n5	824 – 849 MHz	-96 dBm	-91 dBm	-88 dBm	100 kHz	
UTRA FDD Band VI, XIX or E-UTRA Band 6, 19	830 – 845 MHz	-96 dBm	-91 dBm	-88 dBm	100 kHz	
UTRA FDD Band VII or E-UTRA Band 7 or NR Band n7	2500 – 2570 MHz	-96 dBm	-91 dBm	-88 dBm	100 kHz	
UTRA FDD Band VIII or E-UTRA Band 8 or NR Band n8	880 – 915 MHz	-96 dBm	-91 dBm	-88 dBm	100 kHz	
UTRA FDD Band IX or E-UTRA Band 9	1749.9 – 1784.9 MHz	-96 dBm	-91 dBm	-88 dBm	100 kHz	
UTRA FDD Band X or E-UTRA Band 10	1710 – 1770 MHz	-96 dBm	-91 dBm	-88 dBm	100 kHz	
UTRA FDD Band XI or E-UTRA Band 11	1427.9 – 1447.9 MHz	-96 dBm	-91 dBm	-88 dBm	100 kHz	
UTRA FDD Band XII or E-UTRA Band 12 or NR Band n12	699 – 716 MHz	-96 dBm	-91 dBm	-88 dBm	100 kHz	
UTRA FDD Band XIII or E-UTRA Band 13	777 – 787 MHz	-96 dBm	-91 dBm	-88 dBm	100 kHz	
UTRA FDD Band XIV or E-UTRA Band 14 or NR Band n14	788 – 798 MHz	-96 dBm	-91 dBm	-88 dBm	100 kHz	

Co-located system	Frequency range for co-location requirement	Basic limits			Measurement bandwidth	Note
		WA IAB-DU and WA IAB-MT	MR IAB-DU	LA IAB-DU and LA IAB-MT		
E-UTRA Band 17	704 – 716 MHz	-96 dBm	-91 dBm	-88 dBm	100 kHz	
E-UTRA Band 18 or NR Band n18	815 – 830 MHz	-96 dBm	-91 dBm	-88 dBm	100 kHz	
UTRA FDD Band XX or E-UTRA Band 20 or NR Band n20	832 – 862 MHz	-96 dBm	-91 dBm	-88 dBm	100 kHz	
UTRA FDD Band XXI or E-UTRA Band 21	1447.9 – 1462.9 MHz	-96 dBm	-91 dBm	-88 dBm	100 kHz	
UTRA FDD Band XXII or E-UTRA Band 22	3410 – 3490 MHz	-96 dBm	-91 dBm	-88 dBm	100 kHz	This is not applicable to IAB-DU and IAB-MT operating in Band n77 or n78
E-UTRA Band 23	2000 – 2020 MHz	-96 dBm	-91 dBm	-88 dBm	100 kHz	
E-UTRA Band 24	1626.5 – 1660.5 MHz	-96 dBm	-91 dBm	-88 dBm	100 kHz	
UTRA FDD Band XXV or E-UTRA Band 25 or NR Band n25	1850 – 1915 MHz	-96 dBm	-91 dBm	-88 dBm	100 kHz	
UTRA FDD Band XXVI or E-UTRA Band 26 or NR Band n26	814 – 849 MHz	-96 dBm	-91 dBm	-88 dBm	100 kHz	
E-UTRA Band 27	807 – 824 MHz	-96 dBm	-91 dBm	-88 dBm	100 kHz	
E-UTRA Band 28 or NR Band n28	703 – 748 MHz	-96 dBm	-91 dBm	-88 dBm	100 kHz	
E-UTRA Band 30 or NR Band n30	2305 – 2315 MHz	-96 dBm	-91 dBm	-88 dBm	100 kHz	
E-UTRA Band 31	452.5 – 457.5 MHz	-96 dBm	-91 dBm	-88 dBm	100 kHz	
UTRA TDD Band a) or E-UTRA Band 33	1900 – 1920 MHz	-96 dBm	-91 dBm	-88 dBm	100 kHz	
UTRA TDD Band a) or E-UTRA Band 34 or NR band n34	2010 – 2025 MHz	-96 dBm	-91 dBm	-88 dBm	100 kHz	
UTRA TDD Band b) or E-UTRA Band 35	1850 – 1910 MHz	-96 dBm	-91 dBm	-88 dBm	100 kHz	
UTRA TDD Band b) or E-UTRA Band 36	1930 – 1990 MHz	-96 dBm	-91 dBm	-88 dBm	100 kHz	
UTRA TDD Band c) or E-UTRA Band 37	1910 – 1930 MHz	-96 dBm	-91 dBm	-88 dBm	100 kHz	
UTRA TDD Band d) or E-UTRA Band 38 or NR Band n38	2570 – 2620 MHz	-96 dBm	-91 dBm	-88 dBm	100 kHz	
UTRA TDD Band f) or E-UTRA Band 39 or NR band n39	1880 – 1920MHz	-96 dBm	-91 dBm	-88 dBm	100 kHz	
UTRA TDD Band e) or E-UTRA Band 40 or NR Band n40	2300 – 2400MHz	-96 dBm	-91 dBm	-88 dBm	100 kHz	
E-UTRA Band 41 or NR Band n41, n90	2496 – 2690 MHz	-96 dBm	-91 dBm	-88 dBm	100 kHz	This is not applicable to IAB-DU and IAB-MT operating in Band n41
E-UTRA Band 42	3400 – 3600 MHz	-96 dBm	-91 dBm	-88 dBm	100 kHz	This is not applicable to IAB-DU and IAB-MT operating in Band n77 or n78
E-UTRA Band 43	3600 – 3800 MHz	-96 dBm	-91 dBm	-88 dBm	100 kHz	This is not applicable to IAB-DU and IAB-MT operating in Band n77 or n78

Co-located system	Frequency range for co-location requirement	Basic limits			Measurement bandwidth	Note
		WA IAB-DU and WA IAB-MT	MR IAB-DU	LA IAB-DU and LA IAB-MT		
E-UTRA Band 44	703 – 803 MHz	-96 dBm	-91 dBm	-88 dBm	100 kHz	
E-UTRA Band 45	1447 – 1467 MHz	-96 dBm	-91 dBm	-88 dBm	100 kHz	
E-UTRA Band 46 or NR Band n46	5150 – 5925 MHz	N/A	-91 dBm	-88 dBm	100 kHz	
E-UTRA Band 48 or NR Band n48	3550 – 3700 MHz	-96 dBm	-91 dBm	-88 dBm	100 kHz	This is not applicable to IAB-DU and IAB-MT operating in Band n77 or n78
E-UTRA Band 50 or NR Band n50	1432 – 1517 MHz	-96 dBm	-91 dBm	-88 dBm	100 kHz	
E-UTRA Band 51 or NR Band n51	1427 – 1432 MHz	N/A	N/A	-88 dBm	100 kHz	
E-UTRA Band 53 or NR Band n53	2483.5 – 2495 MHz	N/A	-91 dBm	-88 dBm	100 kHz	This is not applicable to IAB-DU and IAB-MT operating in Band n41
E-UTRA Band 65 or NR Band n65	1920 – 2010 MHz	-96 dBm	-91 dBm	-88 dBm	100 kHz	
E-UTRA Band 66 or NR Band n66	1710 – 1780 MHz	-96 dBm	-91 dBm	-88 dBm	100 kHz	
E-UTRA Band 68	698 – 728 MHz	-96 dBm	-91 dBm	-88 dBm	100 kHz	
E-UTRA Band 70 or NR Band n70	1695 – 1710 MHz	-96 dBm	-91 dBm	-88 dBm	100 kHz	
E-UTRA Band 71 or NR Band n71	663 – 698 MHz	-96 dBm	-91 dBm	-88 dBm	100 kHz	
E-UTRA Band 72	451 – 456 MHz	-96 dBm	-91 dBm	-88 dBm	100 kHz	
E-UTRA Band 74 or NR Band n74	1427 – 1470 MHz	-96 dBm	-91 dBm	-88 dBm	100 kHz	
NR Band n77	3.3 – 4.2 GHz	-96 dBm	-91 dBm	-88 dBm	100 kHz	This is not applicable to IAB-DU and IAB-MT operating in Band n77 or n78
NR Band n78	3.3 – 3.8 GHz	-96 dBm	-91 dBm	-88 dBm	100 kHz	This is not applicable to IAB-DU and IAB-MT operating in Band n77 or n78
NR Band n79	4.4 – 5.0 GHz	-96 dBm	-91 dBm	-88 dBm	100 kHz	This is not applicable to IAB-DU and IAB-MT operating in Band n79
NR Band n80	1710 – 1785 MHz	-96 dBm	-91 dBm	-88 dBm	100 kHz	
NR Band n81	880 – 915 MHz	-96 dBm	-91 dBm	-88 dBm	100 kHz	
NR Band n82	832 – 862 MHz	-96 dBm	-91 dBm	-88 dBm	100 kHz	
NR Band n83	703 – 748 MHz	-96 dBm	-91 dBm	-88 dBm	100 kHz	
NR Band n84	1920 – 1980 MHz	-96 dBm	-91 dBm	-88 dBm	100 kHz	
E-UTRA Band 85	698 – 716 MHz	-96 dBm	-91 dBm	-88 dBm	100 kHz	
NR Band n86	1710 – 1780 MHz	-96 dBm	-91 dBm	-88 dBm	100 kHz	
NR Band n89	824 – 849 MHz	-96 dBm	-91 dBm	-88 dBm	100 kHz	
NR Band n91	832 – 862 MHz	N/A	N/A	-88 dBm	100 kHz	
NR Band n92	832 – 862 MHz	-96 dBm	-91 dBm	-88 dBm	100 kHz	
NR Band n93	880 – 915 MHz	N/A	N/A	-88 dBm	100 kHz	
NR Band n94	880 – 915 MHz	-96 dBm	-91 dBm	-88 dBm	100 kHz	
NR Band n95	2010 – 2025 MHz	-96 dBm	-91 dBm	-88 dBm	100 kHz	
NR Band n96	5925 – 7125 MHz	N/A	-90 dBm	-87 dBm	100 kHz	

NOTE 1: As defined in the scope for spurious emissions in this clause, the co-location requirements in table 6.6.5.2.3-1 do not apply for the frequency range extending $\Delta f_{\text{OBU E}}$ immediately outside the transmit frequency range of a IAB-MT and IAB-DU. The current state-of-the-art technology does not allow a single generic solution for co-location with other system on adjacent frequencies for 30dB antenna to antenna minimum coupling loss. However, there are certain site-engineering solutions that can be used. These techniques are addressed in TR 25.942 [8].

NOTE 2: Table 6.6.5.2.3-1 assumes that two *operating bands*, where the corresponding transmit and receive frequency ranges in table 5.2-1 would be overlapping, are not deployed in the same geographical area. For such a case of operation with overlapping frequency arrangements in the same geographical area, special co-location requirements may apply that are not covered by the 3GPP specifications.

6.6.5.6 IAB type 1-H

The Tx spurious emissions requirements for *IAB type 1-H* are that for each *TAB connector TX min cell group* and each applicable *basic limit* in clause 6.6.5.2, the power summation of emissions at the *TAB connectors* of the *TAB connector TX min cell group* shall not exceed a limit specified as the *basic limit* + X, where $X = 10\log_{10}(N_{\text{TXU, counted per cell}})$, unless stated differently in regional regulation.

NOTE: Conformance to the *IAB type 1-H* spurious emission requirement can be demonstrated by meeting at least one of the following criteria as determined by the manufacturer:

- 1) The sum of the emissions power measured on each *TAB connector* in the *TAB connector TX min cell group* shall be less than or equal to the limit as defined in this clause for the respective frequency span.
- Or
- 2) The unwanted emissions power at each *TAB connector* shall be less than or equal to the *type 1-H* limit as defined in this clause for the respective frequency span, scaled by $-10\log_{10}(n)$, where n is the number of *TAB connectors* in the *TAB connector TX min cell group*.

6.7 Transmitter intermodulation

6.7.1 Definition and applicability

The transmitter intermodulation requirement is a measure of the capability of the transmitter unit to inhibit the generation of signals in its non-linear elements caused by presence of the wanted signal and an interfering signal reaching the transmitter unit via the antenna, RDN and antenna array. The requirement shall apply during the transmitter ON period and the *transmitter transient period*.

For *IAB type 1-H*, the transmitter intermodulation level is the power of the intermodulation products when an interfering signal is injected into the *TAB connector*.

For *IAB type 1-H*, there are two types of transmitter intermodulation cases captured by the transmitter intermodulation requirement:

- 1) Co-location transmitter intermodulation in which the interfering signal is from a co-located base station.
- 2) Intra-system transmitter intermodulation in which the interfering signal is from other transmitter units within the *IAB type 1-H*.

For *IAB type 1-H*, the co-location transmitter intermodulation requirement is considered sufficient if the interference signal for the co-location requirement is higher than the declared interference signal for intra-system transmitter (D.30) intermodulation requirement.

6.7.2 Minimum requirement

The minimum requirement applies per *single-band connector*, or per *multi-band connector* supporting transmission in the *operating band*.

The minimum requirement for *IAB type 1-H* is defined in TS 38.174 [2], clause 6.7.2.

6.7.3 Test purpose

The test purpose is to verify the ability of the transmitter units associated with the *single-band connectors* or *multi-band connector* under test to restrict the generation of intermodulation products in its nonlinear elements caused by presence of the wanted signal and an interfering signal reaching the transmitter via the antenna to below specified levels.

6.7.4 Method of test

6.7.4.1 Initial conditions

Test environment: Normal; see annex B.2.

RF channels to be tested for single carrier: M; see clause 4.9.1.

IAB RF Bandwidth positions to be tested for multi-carrier and/or CA:

- M_{RFBW} in single-band operation; see clause 4.9.1.
- $B_{\text{RFBW}}T_{\text{RFBW}}$ and $B'_{\text{RFBW}}T_{\text{RFBW}}$ in multi-band operation, see clause 4.9.1.

NOTE: When testing in M (or M_{RFBW}), if the interferer is fully or partially located outside the supported frequency range, then the test shall be done instead in B (or B_{RFBW}) and T (or T_{RFBW}), and only with the interferer located inside the supported frequency range.

6.7.4.2 Procedure

For *IAB type 1-H* where there may be multiple *TAB connectors*, they may be tested one at a time or multiple *TAB connectors* may be tested in parallel as shown in annex D.1.1. Whichever method is used the procedure is repeated until all *TAB connectors* necessary to demonstrate conformance have been tested.

- 1) Connect the *single-band connector* or *multi-band connector* under test to measurement equipment as shown in annex D.1.2 for *IAB type 1-H*. All connectors not under test shall be terminated.
- 2) The measurement device characteristics shall be:
 - Detection mode: True RMS.
- 3) For a connectors declared to be capable of single carrier operation only (D.16), set the representative connectors under test to transmit according to the applicable test configuration in clause 4.8 at *rated carrier output power* $P_{\text{rated,c,TABC}}$ for *IAB type 1-H* (D.21). Channel set-up shall be according to IAB-DU-FR1-TM 1.1 for IAB-DU and IAB-MT-FR1-TM 1.1 for IAB-MT.

For a connector under test declared to be capable of multi-carrier and/or CA operation (D.15-D.16) set the connector under test to transmit on all carriers configured using the applicable test configuration and corresponding power setting specified in clauses 4.7 and 4.8 using the corresponding test models or set of physical channels in clause 4.9.2 for IAB-DU and IAB-MT.

- 4) For IAB 1-H, generate the interfering signal according to IAB-DU-FR1-TM 1.1 for IAB-DU and IAB-MT-FR1-TM 1.1 for IAB-MT, as defined in clause 4.9.2, with the minimum channel bandwidth (BW_{Channel}) with 15 kHz SCS of the band defined in clause 5.3.5 and a centre frequency offset from the lower/upper edge of the wanted signal or edge of sub-block inside a sub-block gap $f_{\text{offset}} = \pm BW_{\text{Channel}} \left(n - \frac{1}{2} \right)$, for $n = 1, 2$ and 3 , but exclude interfering frequencies that are outside of the allocated downlink operating band or interfering frequencies that are not completely within the sub-block gap or within the Inter RF Bandwidth gap.
- 5) Adjust ATT attenuator (as in the test setup in annex D.1.2 for *IAB type 1-H*) so that level of the interfering signal is as defined in clause 6.7.5.
- 6) Perform the unwanted emission tests specified in clauses 6.6.3 and 6.6.4 for all third and fifth order intermodulation products which appear in the frequency ranges defined in clauses 6.6.3 and 6.6.4. The width of the intermodulation products shall be taken into account.

- 7) Perform the transmitter spurious emissions test as specified in clause 6.6.5, for all third and fifth order intermodulation products which appear in the frequency ranges defined in clause 6.6.5. The width of the intermodulation products shall be taken into account.
- 8) Verify that the emission level does not exceed the required level in clause 6.7.5 with the exception of interfering signal frequencies.
- 9) Repeat the test for the remaining interfering signal centre frequency offsets according to step 4.
- 10) Repeat the test for the remaining test signals defined in clause 6.7.5 for additional requirements and for *IAB type 1-H* intra-system requirements.

In addition, for *multi-band connectors*, the following steps shall apply:

- 11) For a *multi-band connectors* and single band tests, repeat the steps above per involved *operating band* where single band test configurations and test models shall apply with no carrier activated in the other *operating band*.

NOTE: The third order intermodulation products are centred at $2F1 \pm F2$ and $2F2 \pm F1$. The fifth order intermodulation products are centred at $3F1 \pm 2F2$, $3F2 \pm 2F1$, $4F1 \pm F2$, and $4F2 \pm F1$ where $F1$ represents the test signal centre frequency or centre frequency of each sub-block and $F2$ represents the interfering signal centre frequency. The widths of intermodulation products are:

- $(n \cdot BW_{F1} + m \cdot BW_{F2})$ for the $nF1 \pm mF2$ products;
- $(n \cdot BW_{F2} + m \cdot BW_{F1})$ for the $nF2 \pm mF1$ products;

where BW_{F1} represents the test wanted signal RF bandwidth or channel bandwidth in case of single carrier, or sub-block bandwidth and BW_{F2} represents the interfering signal channel bandwidth.

6.7.5 Test requirements

6.7.5.1 *IAB type 1-H*

6.7.5.1.1 Co-location minimum requirements

The transmitter intermodulation level shall not exceed the unwanted emission limits in clauses 6.6.3, 6.6.4 and 6.6.5 in the presence of an NR interfering signal according to table 6.7.5.1.1-1.

The requirement is applicable outside the *IAB RF Bandwidth edges*. The interfering signal offset is defined relative to the *IAB RF Bandwidth edges* or *Radio Bandwidth edges*.

For *TAB connectors* supporting operation in *non-contiguous spectrum*, the requirement is also applicable inside a *sub-block gap* for interfering signal offsets where the interfering signal falls completely within the *sub-block gap*. The interfering signal offset is defined relative to the *sub-block edges*.

For *multi-band connector*, the requirement shall apply relative to the *IAB RF Bandwidth edges* of each operating band. In case the inter RF Bandwidth gap is less than $3 \cdot BW_{\text{Channel}}$ MHz (where BW_{Channel} is the minimal *IAB-DU channel bandwidth* and *IAB-MT channel bandwidth* of the band), the requirement in the gap shall apply only for interfering signal offsets where the interfering signal falls completely within the inter RF Bandwidth gap.

Table 6.7.5.1.1-1: Interfering and wanted signals for the co-location transmitter intermodulation requirement

Parameter	Value
Wanted signal type	NR single carrier, or multi-carrier, or multiple intra-band contiguously or non-contiguously aggregated carriers
Interfering signal type	NR signal, the minimum <i>IAB-DU channel bandwidth</i> (BW_{Channel}) or <i>IAB-MT channel bandwidth</i> (BW_{Channel}) with 15 kHz SCS of the band defined in clause 5.3.5.
Interfering signal level	Rated total output power per <i>TAB connector</i> ($P_{\text{rated,t,TABC}}$) in the <i>operating band</i> – 30 dB
Interfering signal centre frequency offset from the lower/upper edge of the wanted signal or edge of <i>sub-block</i> inside a gap	$f_{\text{offset}} = \pm BW_{\text{Channel}} \left(n - \frac{1}{2} \right)$, for $n=1, 2$ and 3
NOTE 1: Interfering signal positions that are partially or completely outside of any downlink <i>operating band</i> of the TAB connector are excluded from the requirement, unless the interfering signal positions fall within the frequency range of adjacent downlink <i>operating bands</i> in the same geographical area.	
NOTE 2: In Japan, NOTE 1 is not applied in Band n77, n78, n79.	

6.7.5.1.2 Intra-system minimum requirements

The transmitter intermodulation level shall not exceed the unwanted emission limits in clauses 6.6.3 and 6.6.4 in the presence of an NR interfering signal according to table 6.7.5.1.2-1.

Table 6.7.5.1.2-1: Interfering and wanted signals for intra-system transmitter intermodulation requirement

Parameter	Value
Wanted signal type	NR signal
Interfering signal type	NR signal of the same <i>IAB-DU channel bandwidth</i> or <i>IAB-MT channel bandwidth</i> and SCS as the wanted signal (Note 1).
Interfering signal level	Power level declared by the IAB manufacturer (Note 2).
Frequency offset between interfering signal and wanted signal	0 MHz
NOTE 1: The interfering signal shall be incoherent with the wanted signal.	
NOTE 2: The declared interfering signal power level at each <i>TAB connector</i> is the sum of the co-channel leakage power coupled via the combined RDN and Antenna Array from all the other <i>TAB connectors</i> , but does not comprise power radiated from the Antenna Array and reflected back from the environment. The power at each of the interfering <i>TAB connectors</i> is $P_{\text{rated,c,TABC}}$.	

6.7.5.1.3 Additional requirements

For Band n41 operation in Japan, the transmitter intermodulation level shall not exceed the unwanted emission limits in clauses 6.6.3, 6.6.4 and 6.6.5 in the presence of an NR interfering signal according to table 6.7.5.1.3-1.

Table 6.7.5.1.3-1 Interfering and wanted signals for the additional transmitter intermodulation requirement for Band n41

Parameter	Value
Wanted signal	NR single carrier (NOTE)
Interfering signal type	NR signal of 10 MHz <i>channel bandwidth</i>
Interfering signal level	Rated total output power in the operating band – 30 dB
Interfering signal centre frequency offset from the lower/upper carrier centre frequency of the wanted signal	± 5 MHz ± 15 MHz ± 25 MHz
NOTE: This requirement applies for NR carriers allocated within 2545-2645 MHz.	

7 Conducted receiver characteristics (IAB-DU and IAB-MT)

7.1 General

7.2 Reference sensitivity level

7.2.1 Definition and applicability

The reference sensitivity power level P_{REFSENS} is the minimum mean power received at the *TAB connector* for *IAB type 1-H* at which a throughput requirement shall be met for a specified reference measurement channel.

7.2.2 Minimum requirement

The minimum requirement for *IAB type 1-H*:

For *IAB-DU* is in TS 38.174 [2], clause 7.2.1.

For *IAB-MT* is in TS 38.174 [2], clause 7.2.2.

7.2.3 Test purpose

To verify that for each *IAB type 1-H TAB connector* at the reference sensitivity level the throughput requirement shall be met for a specified reference measurement channel.

7.2.4 Method of test

7.2.4.1 Initial conditions

Test environment:

- Normal; see annex B.2.
- Extreme, see annexes B.3 and B.5.

RF channels to be tested for single carrier: B, M and T; see clause 4.9.1.

Under extreme test environment, the test shall be performed on each of B, M and T under extreme power supply conditions as defined in annex B.5.

NOTE: Tests under extreme power supply conditions also test extreme temperatures.

7.2.4.2 Procedure

The minimum requirement is applied to all connectors under test.

The procedure is repeated until all *TAB connectors* necessary to demonstrate conformance have been tested; see clause 7.1.

- 1) Connect the connector under test to measurement equipment as shown in annex D.2.1.
- 2) Start the signal generator for the wanted signal to transmit the Fixed Reference Channels for reference sensitivity in clause 7.2.5 and according to annex A.1.
- 3) Set the signal generator for the wanted signal power as specified in clause 7.2.5.
- 4) Measure the throughput according to annex A.1.

In addition, for a *multi-band connector*, the following steps shall apply:

- 5) For *multi-band connector* and single band tests, repeat the steps above per involved band where single band test configurations and test models shall apply with no carrier activated in the other band.

7.2.5 Test requirements

7.2.5.1 Test requirements for IAB-DU

The throughput shall be $\geq 95\%$ of the maximum throughput of the reference measurement channel as specified in annex A.1 with parameters specified in table 7.2.5.1-1 for Wide Area IAB-DU, in table 7.2.5.1-2 for Medium Range IAB-DU and in table 7.2.5.1-3 for Local Area OAB-DU.

Table 7.2.5.1-1: NR Wide Area IAB-DU reference sensitivity levels

IAB-DU channel bandwidth (MHz)	Sub-carrier spacing (kHz)	Reference measurement channel	Reference sensitivity power level, P_{REFSENS} (dBm)		
			$f \leq 3.0$ GHz	3.0 GHz $< f \leq 4.2$ GHz	4.2 GHz $< f \leq 6.0$ GHz
10, 15	15	G-FR1-A1-1 (Note 1)	-101	-100.7	-100.5
10, 15	30	G-FR1-A1-2 (Note 1)	-101.1	-100.8	-100.6
10, 15	60	G-FR1-A1-3 (Note 1)	-98.2	-97.9	-97.7
20, 25, 30, 40, 50	15	G-FR1-A1-4 (Note 1)	-94.6	-94.3	-94.1
20, 25, 30, 40, 50, 60, 70, 80, 90, 100	30	G-FR1-A1-5 (Note 1)	-94.9	-94.6	-94.4
20, 25, 30, 40, 50, 60, 70, 80, 90, 100	60	G-FR1-A1-6 (Note 1)	-95	-94.7	-94.5

NOTE 1: P_{REFSENS} is the power level of a single instance of the reference measurement channel. This requirement shall be met for each consecutive application of a single instance of the reference measurement channel mapped to disjoint frequency ranges with a width corresponding to the number of resource blocks of the reference measurement channel each, except for one instance that might overlap one other instance to cover the full IAB-DU channel bandwidth.

Table 7.2.5.1-2: NR Medium Range IAB-DU reference sensitivity levels

IAB-DU channel bandwidth (MHz)	Sub-carrier spacing (kHz)	Reference measurement channel	Reference sensitivity power level, P_{REFSENS} (dBm)		
			$f \leq 3.0$ GHz	3.0 GHz $< f \leq 4.2$ GHz	4.2 GHz $< f \leq 6.0$ GHz
10, 15	15	G-FR1-A1-1 (Note 1)	-96	-95.7	-95.5
10, 15	30	G-FR1-A1-2 (Note 1)	-96.1	-95.8	-95.6
10, 15	60	G-FR1-A1-3 (Note 1)	-93.2	-92.9	-92.7
20, 25, 30, 40, 50	15	G-FR1-A1-4 (Note 1)	-89.6	-89.3	-89.1
20, 25, 30, 40, 50, 60, 70, 80, 90, 100	30	G-FR1-A1-5 (Note 1)	-89.9	-89.6	-89.4
20, 25, 30, 40, 50, 60, 70, 80, 90, 100	60	G-FR1-A1-6 (Note 1)	-90	-89.7	-89.5

NOTE 1: P_{REFSENS} is the power level of a single instance of the reference measurement channel. This requirement shall be met for each consecutive application of a single instance of the reference measurement channel mapped to disjoint frequency ranges with a width corresponding to the number of resource blocks of the reference measurement channel each, except for one instance that might overlap one other instance to cover the full IAB-DU channel bandwidth.

Table 7.2.5.1-3: NR Local Area IAB-DU reference sensitivity levels

IAB-DU channel bandwidth (MHz)	Sub-carrier spacing (kHz)	Reference measurement channel	Reference sensitivity power level, P_{REFSENS} (dBm)		
			$f \leq 3.0$ GHz	3.0 GHz < $f \leq 4.2$ GHz	4.2 GHz < $f \leq 6.0$ GHz
10, 15	15	G-FR1-A1-1 (Note 1)	-93	-92.7	-92.5
10, 15	30	G-FR1-A1-2 (Note 1)	-93.1	-92.8	-92.6
10, 15	60	G-FR1-A1-3 (Note 1)	-90.2	-89.9	-89.7
20, 25, 30, 40, 50	15	G-FR1-A1-4 (Note 1)	-86.6	-86.3	-86.1
20, 25, 30, 40, 50, 60, 70, 80, 90, 100	30	G-FR1-A1-5 (Note 1)	-86.9	-86.6	-86.4
20, 25, 30, 40, 50, 60, 70, 80, 90, 100	60	G-FR1-A1-6 (Note 1)	-87	-86.7	-86.5

NOTE 1: P_{REFSENS} is the power level of a single instance of the reference measurement channel. This requirement shall be met for each consecutive application of a single instance of the reference measurement channel mapped to disjoint frequency ranges with a width corresponding to the number of resource blocks of the reference measurement channel each, except for one instance that might overlap one other instance to cover the full IAB-DU channel bandwidth.

7.2.5.2 Test requirements for IAB-MT

The throughput shall be $\geq 95\%$ of the maximum throughput of the reference measurement channel as specified in annex A.1 with parameters specified in table 7.2.5.2-1 for Wide Area IAB-MT and in table 7.2.5.2-2 for Local Area IAB-MT.

Table 7.2.5.2-1: Wide Area IAB-MT reference sensitivity levels

IAB-MT channel bandwidth (MHz)	Sub-carrier spacing (kHz)	Reference measurement channel	Reference sensitivity power level, P_{REFSENS} (dBm)		
			$f \leq 3.0$ GHz	3.0 GHz < $f \leq 4.2$ GHz	4.2 GHz < $f \leq 6.0$ GHz
10, 15	30	G-FR1-A1-22 (Note 1)	-101.3	-101	-100.8
10, 15	60	G-FR1-A1-23 (Note 1)	-98.3	-98	-97.8
20, 25, 30, 40, 50, 60, 70, 80, 90, 100	30	G-FR1-A1-25 (Note 1)	-94.7	-94.4	-94.2
20, 25, 30, 40, 50, 60, 70, 80, 90, 100	60	G-FR1-A1-26 (Note 1)	-94.9	-94.6	-94.4

NOTE 1: P_{REFSENS} is the power level of a single instance of the reference measurement channel. This requirement shall be met for each consecutive application of a single instance of the reference measurement channel mapped to disjoint frequency ranges with a width corresponding to the number of resource blocks of the reference measurement channel each, except for one instance that might overlap one other instance to cover the full IAB-MT channel bandwidth.

Table 7.2.5.2-2: Local Area IAB-MT reference sensitivity levels

IAB-MT channel bandwidth (MHz)	Sub-carrier spacing (kHz)	Reference measurement channel	Reference sensitivity power level, P_{REFSENS} (dBm)		
			$f \leq 3.0$ GHz	3.0 GHz < $f \leq 4.2$ GHz	4.2 GHz < $f \leq 6.0$ GHz
10, 15	30	G-FR1-A1-22 (Note 1)	-93.3	-93	-92.8
10, 15	60	G-FR1-A1-23 (Note 1)	-90.3	-90	-89.8
20, 25, 30, 40, 50, 60, 70, 80, 90, 100	30	G-FR1-A1-25 (Note 1)	-86.7	-86.4	-86.2
20, 25, 30, 40, 50, 60, 70, 80, 90, 100	60	G-FR1-A1-26 (Note 1)	-86.9	-86.6	-86.4

NOTE 1: P_{REFSENS} is the power level of a single instance of the reference measurement channel. This requirement shall be met for each consecutive application of a single instance of the reference measurement channel mapped to disjoint frequency ranges with a width corresponding to the number of resource blocks of the reference measurement channel each, except for one instance that might overlap one other instance to cover the full *IAB-MT channel bandwidth*.

7.3 Dynamic range

7.3.1 Definition and applicability

The dynamic range is specified as a measure of the capability of the receiver to receive a wanted signal in the presence of an interfering signal at the *TAB connector* for *IAB-DU* inside the received *IAB-DU channel bandwidth*. In this condition, a throughput requirement shall be met for a specified reference measurement channel. The interfering signal for the dynamic range requirement is an AWGN signal.

7.3.2 Minimum requirement

The minimum requirement for *IAB type 1-H* for *IAB-DU* is in TS 38.174 [2], clause 7.3.1.

7.3.3 Test purpose

To verify that the *IAB type 1-H TAB connector* receiver dynamic range, the relative throughput shall fulfil the specified limit.

7.3.4 Method of test

7.3.4.1 Initial conditions

Test environment: Normal; see annex B.2.

RF channels to be tested for single carrier: M; see clause 4.9.1.

7.3.4.2 Procedure

The minimum requirement is applied to all connectors under test.

The procedure is repeated until all *TAB connectors* necessary to demonstrate conformance have been tested; see clause 7.1.

- 1) Connect the connector under test to measurement equipment as shown in annex D.2.2 .
- 2) Set the signal generator for the wanted signal to transmit as specified in table 7.3.5-1 to table 7.3.5-3 according to the appropriate IAB class.

- 3) Set the Signal generator for the AWGN interfering signal at the same frequency as the wanted signal to transmit as specified in table 7.3.5-1 to table 7.3.5-3 according to the appropriate IAB class.
- 4) Measure the throughput according to annex A.2.

In addition, for a *multi-band connector*, the following steps shall apply:

- 5) For *multi-band connector* and single band tests, repeat the steps above per involved band where single band test configurations and test models shall apply with no carrier activated in the other band.

7.3.5 Test requirements

The throughput shall be $\geq 95\%$ of the maximum throughput of the reference measurement channel as specified in annex A.2 with parameters specified in table 7.3.2-1 for Wide Area IAB-DU, in table 7.3.2-2 for Medium Range IAB-DU and in table 7.3.2-3 for Local Area IAB-DU.

Table 7.3.5-1: Wide Area IAB-DU dynamic range

<i>IAB-DU channel bandwidth (MHz)</i>	<i>Subcarrier spacing (kHz)</i>	<i>Reference measurement channel</i>	<i>Wanted signal mean power (dBm)</i>	<i>Interfering signal mean power (dBm) / BW_{Config}</i>	<i>Type of interfering signal</i>
10	15	G-FR1-A2-1	-70.4	-79.3	AWGN
	30	G-FR1-A2-2	-71.1		
	60	G-FR1-A2-3	-68.1		
15	15	G-FR1-A2-1	-70.4	-77.5	AWGN
	30	G-FR1-A2-2	-71.1		
	60	G-FR1-A2-3	-68.1		
20	15	G-FR1-A2-4	-64.2	-76.2	AWGN
	30	G-FR1-A2-5	-64.2		
	60	G-FR1-A2-6	-64.5		
25	15	G-FR1-A2-4	-64.2	-75.2	AWGN
	30	G-FR1-A2-5	-64.2		
	60	G-FR1-A2-6	-64.5		
30	15	G-FR1-A2-4	-64.2	-74.4	AWGN
	30	G-FR1-A2-5	-64.2		
	60	G-FR1-A2-6	-64.5		
40	15	G-FR1-A2-4	-64.2	-73.1	AWGN
	30	G-FR1-A2-5	-64.2		
	60	G-FR1-A2-6	-64.5		
50	15	G-FR1-A2-4	-64.2	-72.1	AWGN
	30	G-FR1-A2-5	-64.2		
	60	G-FR1-A2-6	-64.5		
60	30	G-FR1-A2-5	-64.2	-71.3	AWGN
	60	G-FR1-A2-6	-64.5		
70	30	G-FR1-A2-5	-64.2	-70.7	AWGN
	60	G-FR1-A2-6	-64.5		
80	30	G-FR1-A2-5	-64.2	-70.1	AWGN
	60	G-FR1-A2-6	-64.5		
90	30	G-FR1-A2-5	-64.2	-69.5	AWGN
	60	G-FR1-A2-6	-64.5		
100	30	G-FR1-A2-5	-64.2	-69.1	AWGN
	60	G-FR1-A2-6	-64.5		

NOTE: The wanted signal mean power is the power level of a single instance of the corresponding reference measurement channel. This requirement shall be met for each consecutive application of a single instance of the reference measurement channel mapped to disjoint frequency ranges with a width corresponding to the number of resource blocks of the reference measurement channel each, except for one instance that might overlap one other instance to cover the full *IAB-DU channel bandwidth*.

Table 7.3.5-2: Medium Range IAB-DU dynamic range

<i>IAB-DU channel bandwidth (MHz)</i>	<i>Subcarrier spacing (kHz)</i>	<i>Reference measurement channel</i>	<i>Wanted signal mean power (dBm)</i>	<i>Interfering signal mean power (dBm) / BW_{Config}</i>	<i>Type of interfering signal</i>
10	15	G-FR1-A2-1	-65.4	-74.3	AWGN
	30	G-FR1-A2-2	-66.1		
	60	G-FR1-A2-3	-63.1		
15	15	G-FR1-A2-1	-65.4	-72.5	AWGN
	30	G-FR1-A2-2	-66.1		
	60	G-FR1-A2-3	-63.1		
20	15	G-FR1-A2-4	-59.2	-71.2	AWGN
	30	G-FR1-A2-5	-59.2		
	60	G-FR1-A2-6	-59.5		
25	15	G-FR1-A2-4	-59.2	-70.2	AWGN
	30	G-FR1-A2-5	-59.2		
	60	G-FR1-A2-6	-59.5		
30	15	G-FR1-A2-4	-59.2	-69.4	AWGN
	30	G-FR1-A2-5	-59.2		
	60	G-FR1-A2-6	-59.5		
40	15	G-FR1-A2-4	-59.2	-68.1	AWGN
	30	G-FR1-A2-5	-59.2		
	60	G-FR1-A2-6	-59.5		
50	15	G-FR1-A2-4	-59.2	-67.1	AWGN
	30	G-FR1-A2-5	59.8		
	60	G-FR1-A2-6	-59.5		
60	30	G-FR1-A2-5	-59.2	-66.3	AWGN
	60	G-FR1-A2-6	-59.5		
70	30	G-FR1-A2-5	-59.2	-65.7	AWGN
	60	G-FR1-A2-6	-59.5		
80	30	G-FR1-A2-5	-59.2	-65.1	AWGN
	60	G-FR1-A2-6	-59.5		
90	30	G-FR1-A2-5	-59.2	-64.5	AWGN
	60	G-FR1-A2-6	-59.5		
100	30	G-FR1-A2-5	-59.2	-64.1	AWGN
	60	G-FR1-A2-6	-59.5		

NOTE: The wanted signal mean power is the power level of a single instance of the corresponding reference measurement channel. This requirement shall be met for each consecutive application of a single instance of the reference measurement channel mapped to disjoint frequency ranges with a width corresponding to the number of resource blocks of the reference measurement channel each, except for one instance that might overlap one other instance to cover the full *IAB-DU channel bandwidth*.

Table 7.3.5-3: Local Area IAB-DU dynamic range

<i>IAB-DU channel bandwidth (MHz)</i>	<i>Subcarrier spacing (kHz)</i>	<i>Reference measurement channel</i>	<i>Wanted signal mean power (dBm)</i>	<i>Interfering signal mean power (dBm) / BW_{Config}</i>	<i>Type of interfering signal</i>
10	15	G-FR1-A2-1	-62.4	-71.3	AWGN
	30	G-FR1-A2-2	-63.1		
	60	G-FR1-A2-3	-60.1		
15	15	G-FR1-A2-1	-62.4	-69.5	AWGN
	30	G-FR1-A2-2	-63.1		
	60	G-FR1-A2-3	-60.1		
20	15	G-FR1-A2-4	-56.2	-68.2	AWGN
	30	G-FR1-A2-5	-56.2		
	60	G-FR1-A2-6	-56.5		
25	15	G-FR1-A2-4	-56.2	-67.2	AWGN
	30	G-FR1-A2-5	-56.2		
	60	G-FR1-A2-6	-56.5		
30	15	G-FR1-A2-4	-56.2	-66.4	AWGN
	30	G-FR1-A2-5	-56.2		
	60	G-FR1-A2-6	-56.5		
40	15	G-FR1-A2-4	-56.2	-65.1	AWGN
	30	G-FR1-A2-5	-56.2		
	60	G-FR1-A2-6	-56.5		
50	15	G-FR1-A2-4	-56.2	-64.1	AWGN
	30	G-FR1-A2-5	-56.2		
	60	G-FR1-A2-6	-56.5		
60	30	G-FR1-A2-5	-56.2	-63.3	AWGN
	60	G-FR1-A2-6	-56.5		
70	30	G-FR1-A2-5	-56.2	-62.7	AWGN
	60	G-FR1-A2-6	-56.5		
80	30	G-FR1-A2-5	-56.2	-62.1	AWGN
	60	G-FR1-A2-6	-56.5		
90	30	G-FR1-A2-5	-56.2	-61.5	AWGN
	60	G-FR1-A2-6	-56.5		
100	30	G-FR1-A2-5	-56.2	-61.1	AWGN
	60	G-FR1-A2-6	-56.5		

NOTE: The wanted signal mean power is the power level of a single instance of the corresponding reference measurement channel. This requirement shall be met for each consecutive application of a single instance of the reference measurement channel mapped to disjoint frequency ranges with a width corresponding to the number of resource blocks of the reference measurement channel each, except for one instance that might overlap one other instance to cover the full *IAB-DU channel bandwidth*.

7.4 In-band selectivity and blocking

7.4.1 Adjacent Channel Selectivity (ACS)

7.4.1.1 Definition and applicability

Adjacent channel selectivity (ACS) is a measure of the receiver's ability to receive a wanted signal at its assigned channel frequency at the *TAB connector* for *IAB type 1-H* in the presence of an adjacent channel signal with a specified centre frequency offset of the interfering signal to the band edge of a victim system.

7.4.1.2 Minimum requirement

The minimum requirement for *IAB type 1-H*:

For *IAB-DU* are in TS 38.174 [2], clause 7.4.1.2.

For *IAB-MT* are in TS 38.174 [2], clause 7.4.1.3.

7.4.1.3 Test purpose

The test purpose is to verify the ability of the IAB receiver filter to suppress interfering signals in the channels adjacent to the wanted channel.

7.4.1.4 Method of test

7.4.1.4.1 Initial conditions

Test environment: Normal; see annex B.2.

RF channels to be tested for single carrier (SC): M; see clause 4.9.1.

IAB RF Bandwidth positions to be tested for multi-carrier (MC):

- M_{RFBW} for *single-band connector(s)*, see clause 4.9.1,
- $B'_{\text{RFBW}}T'_{\text{RFBW}}$ and $B''_{\text{RFBW}}T''_{\text{RFBW}}$ for *multi-band connector(s)*, see clause 4.9.1.

7.4.1.4.2 Procedure

The minimum requirement is applied to all connectors under test.

For *IAB type 1-H* the procedure is repeated until all *TAB connectors* necessary to demonstrate conformance have been tested; see clause 7.1.

- 1) Connect the connector under test to measurement equipment as shown in annex D.2.3 for *IAB type 1-H*.
- 2) For IAB-DU, set the signal generator for the wanted signal to transmit as specified in table 7.4.1.5.1-1.
For IAB-MT, set the signal generator for the wanted signal to transmit as specified in table 7.4.1.5.2-1.
- 3) For IAB-DU, set the signal generator for the interfering signal to transmit at the frequency offset and as specified in table 7.4.1.5.1-1 and 7.4.1.5.1-2.
For IAB-MT, set the signal generator for the interfering signal to transmit at the frequency offset and as specified in table 7.4.1.5.2-1 and 7.4.1.5.2-2.
- 4) Measure the throughput according to annex A.1.

In addition, for a *multi-band connector*, the following steps shall apply:

- 5) For *multi-band connector* and single band tests, repeat the steps above per involved band where single band test configurations and test models shall apply with no carrier activated in the other band.

7.4.1.5 Test requirements

7.4.1.5.1 Test requirements for IAB-DU

The throughput shall be $\geq 95\%$ of the maximum throughput of the reference measurement channel.

For IAB, the wanted and the interfering signal coupled to the *IAB type 1-H TAB connector* are specified in table 7.4.1.5.1-1 and the frequency offset between the wanted and interfering signal in table 7.4.1.5.1-2 for ACS. The reference measurement channel for the wanted signal is identified in table 7.2.5.1-1, 7.2.5.1-2 and 7.2.5.1-3 for each channel bandwidth and further specified in annex A.1. The characteristics of the interfering signal is further specified in annex F.

The ACS requirement is applicable outside the IAB RF Bandwidth or Radio Bandwidth. The interfering signal offset is defined relative to the *IAB RF Bandwidth edges* or Radio Bandwidth edges.

For a IAB operating in non-contiguous spectrum within any *operating band*, the ACS requirement shall apply in addition inside any sub-block gap, in case the sub-block gap size is at least as wide as the NR interfering signal in table 7.4.1.5.1-2. The interfering signal offset is defined relative to the sub-block edges inside the sub-block gap.

For a *multi-band connector*, the ACS requirement shall apply in addition inside any Inter RF Bandwidth gap, in case the Inter RF Bandwidth gap size is at least as wide as the NR interfering signal in table 7.4.1.5.1-2. The interfering signal offset is defined relative to the *IAB RF Bandwidth edges* inside the Inter RF Bandwidth gap

Conducted requirement is defined at the *TAB connector* for *IAB type 1-H*.

Table 7.4.1.5.1-1: IAB ACS requirement

<i>IAB-DU channel bandwidth of the lowest/highest carrier received (MHz)</i>	<i>Wanted signal mean power (dBm)</i>	<i>Interfering signal mean power (dBm)</i>
10, 15, 20, 25, 30, 40, 50, 60, 70, 80, 90, 100 (Note 1)	$P_{\text{PRESENSE}} + 6 \text{ dB}$	Wide Area IAB-DU: -52 Medium Range IAB-DU: -47 Local Area IAB-DU: -44
NOTE 1: The SCS for the lowest/highest carrier received is the lowest SCS supported by the IAB for that bandwidth.		
NOTE 2: P_{PRESENSE} depends on the RAT. For NR, P_{PRESENSE} depends also on the <i>IAB-DU channel bandwidth</i> as specified in TS 38.174 [2], table 7.2.2-1, 7.2.2-2 and 7.2.2-3.		

Table 7.4.1.5.1-2: IAB ACS interferer frequency offset values

<i>IAB-DU channel bandwidth of the lowest/highest carrier received (MHz)</i>	<i>Interfering signal centre frequency offset from the lower/upper IAB RF Bandwidth edge or sub-block edge inside a sub-block gap (MHz)</i>	<i>Type of interfering signal</i>
10	± 2.5075	5 MHz DFT-s-OFDM NR signal, 15 kHz SCS, 25 RBs
15	± 2.5125	
20	± 2.5025	
25	± 9.4675	20 MHz DFT-s-OFDM NR signal, 15 kHz SCS, 100 RBs
30	± 9.4725	
40	± 9.4675	
50	± 9.4625	
60	± 9.4725	
70	± 9.4675	
80	± 9.4625	
90	± 9.4725	
100	± 9.4675	

7.4.1.5.2 Test requirements for IAB-MT

The throughput shall be $\geq 95\%$ of the maximum throughput of the reference measurement channel.

For IAB-MT, the wanted and the interfering signal coupled to the *IAB type 1-H TAB connector* are specified in table 7.4.1.5.1-1 and the frequency offset between the wanted and interfering signal in table 7.4.1.5.2-2 for ACS. The reference measurement channel for the wanted signal is identified in table 7.2.5.2-1 and 7.2.5.2-2 for each *IAB-MT channel bandwidth* and further specified in annex A.1. The characteristics of the interfering signal is further specified in annex F.

The ACS requirement is applicable outside the *IAB-MT RF Bandwidth* or *Radio Bandwidth*. The interfering signal offset is defined relative to the *IAB-MT RF Bandwidth edges* or *Radio Bandwidth edges*.

For IAB-MT operating in *non-contiguous spectrum* within any *operating band*, the ACS requirement shall apply in addition inside any *sub-block gap*, in case the *sub-block gap size* is at least as wide as the NR interfering signal in table 7.4.1.5.2-2. The interfering signal offset is defined relative to the *sub-block edges* inside the *sub-block gap*.

For a *multi-band connector*, the ACS requirement shall apply in addition inside any *Inter RF Bandwidth gap*, in case the *Inter RF Bandwidth gap size* is at least as wide as the NR interfering signal in table 7.4.1.5.2-2. The interfering signal offset is defined relative to the *IAB-MT RF Bandwidth edges* inside the *Inter RF Bandwidth gap*.

Minimum conducted requirement is defined at the *TAB connector* for *IAB type 1-H*.

Table 7.4.1.5.2-1: ACS requirement for IAB-MT

IAB-MT channel bandwidth of the lowest/highest carrier received (MHz)	Wanted signal mean power (dBm)	Interfering signal mean power (dBm)
10, 15, 20, 25, 30, 40, 50, 60, 70, 80, 90, 100 (Note 1)	$P_{\text{REFSENS}} + 6 \text{ dB}$	Wide Area IAB-MT: -52 Local Area IAB-MT: -44
NOTE 1: The SCS for the lowest/highest carrier received is the lowest SCS supported by the IAB-MT for that bandwidth.		

Table 7.4.1.5.2-2: IAB-MT ACS interferer frequency offset values

IAB-MT channel bandwidth of the lowest/highest carrier received (MHz)	Interfering signal centre frequency offset from the lower/upper IAB-MT RF Bandwidth edge or sub-block edge inside a sub-block gap (MHz)	Type of interfering signal
10	± 2.5075	5 MHz CP-OFDM NR signal 15 kHz SCS, 25 RBs
15	± 2.5125	
20	± 2.5025	
25	± 9.4675	
30	± 9.4725	20 MHz CP-OFDM NR signal 15 kHz SCS, 100 RBs
40	± 9.4675	
50	± 9.4625	
60	± 9.4725	
70	± 9.4675	
80	± 9.4625	
90	± 9.4725	
100	± 9.4675	

7.4.2 In-band blocking

7.4.2.1 Definition and applicability

The in-band blocking characteristics is a measure of the receiver's ability to receive a wanted signal at its assigned channel at the *TAB connector* for *IAB type 1-H* in the presence of an unwanted interferer, which is an NR signal for general blocking or an NR signal with one resource block for narrowband blocking.

7.4.2.2 Minimum requirement

The minimum requirement for *IAB type 1-H*:

For *IAB-DU* are in TS 38.174 [2], clause 7.4.2.2.

For *IAB-MT* are in TS 38.174 [2], clause 7.4.2.3.

7.4.2.3 Test purpose

The test purpose is to verify the ability of the IAB receiver to withstand high-levels of in-band interference from unwanted signals at specified frequency offsets without undue degradation of its sensitivity.

7.4.2.4 Method of test

7.4.2.4.1 Initial conditions

Test environment: Normal; see annex B.2.

RF channels to be tested for single carrier (SC): M; see clause 4.9.1

IAB RF Bandwidth positions to be tested for multi-carrier (MC) and/or CA:

- M_{RFBW} for *single-band connector(s)*, see clause 4.9.1,
- $B_{\text{RFBW}}T_{\text{RFBW}}$ and $B'_{\text{RFBW}}T_{\text{RFBW}}$ for *multi-band connector(s)*, see clause 4.9.1.

NOTE: When testing in M (or M_{RFBW}), if the interferer is fully or partially located outside the supported frequency range, then the test shall be done instead in B (or B_{RFBW}) and T (or T_{RFBW}), and only with the interferer located inside the supported frequency range.

7.4.2.4.2 Procedure for general blocking

The minimum requirement is applied to all connectors under test.

For *IAB type 1-H* the procedure is repeated until all *TAB connectors* necessary to demonstrate conformance have been tested; see clause 7.1.

- 1) Connect the connector under test to measurement equipment as shown in annex D.2.3 for *IAB type 1-H*.
- 2) For IAB-DU, set the signal generator for the wanted signal to transmit as specified in table 7.4.2.5.1-1.
For IAB-MT, set the signal generator for the wanted signal to transmit as specified in table 7.4.2.5.2-1.
- 3) For IAB-DU, set the signal generator for the interfering signal to transmit at the frequency offset and as specified in table 7.4.2.5.1-1. The interfering signal shall be swept with a step size of 1 MHz starting from the minimum offset to the channel edges of the wanted signals as specified in table 7.4.2.5.1-1.
For IAB-MT, set the signal generator for the interfering signal to transmit at the frequency offset and as specified in table 7.4.2.5.2-1. The interfering signal shall be swept with a step size of 1 MHz starting from the minimum offset to the channel edges of the wanted signals as specified in table 7.4.2.5.2-1.
- 4) Measure the throughput according to annex A.1.

In addition, for a *multi-band connector*, the following steps shall apply:

- 5) For *multi-band connector* and single band tests, repeat the steps above per involved band where single band test configurations and test models shall apply with no carrier activated in the other band.

7.4.2.4.3 Procedure for narrowband blocking

The minimum requirement is applied to all connectors under test.

For *IAB type 1-H* the procedure is repeated until all *TAB connectors* necessary to demonstrate conformance have been tested; see clause 7.1.

- 1) Connect the connector under test to measurement equipment as shown in annex D.2.3 for *IAB type 1-H*.
- 2) For IAB-DU, set the signal generator for the wanted signal to transmit as specified in table 7.4.2.5.1-2.
For IAB-MT, set the signal generator for the wanted signal to transmit as specified in table 7.4.2.5.2-2.

- 3) For IAB-DU, set the signal generator for the interfering signal to transmit at the frequency offset and as specified in table 7.4.2.5.1-2 and 7.4.2.5.1-3. Set-up and sweep the interfering RB centre frequency offset to the channel edge of the wanted signal according to table 7.4.2.5.1-3.

For IAB-MT, set the signal generator for the interfering signal to transmit at the frequency offset and as specified in table 7.4.2.5.2-2 and 7.4.2.5.2-3. Set-up and sweep the interfering RB centre frequency offset to the channel edge of the wanted signal according to table 7.4.2.5.2-3.

- 4) Measure the throughput according to annex A.1.

In addition, for a *multi-band connector*, the following steps shall apply:

- 5) For *multi-band connector* and single band tests, repeat the steps above per involved band where single band test configurations and test models shall apply with no carrier activated in the other band.

7.4.2.5 Test requirements

7.4.2.5.1 Test requirements for IAB-DU

The throughput shall be $\geq 95\%$ of the maximum throughput of the reference measurement channel, with a wanted and an interfering signal coupled to *IAB type 1-H TAB connector* using the parameters in tables 7.4.2.5.1-1, 7.4.2.5.1-2 and 7.4.2.5.1-3 for general blocking and narrowband blocking requirements. The reference measurement channel for the wanted signal is identified in clause 7.2.5.1 for each channel bandwidth and further specified in annex A.1. The characteristics of the interfering signal is further specified in annex E.

The in-band blocking requirements apply outside the IAB RF Bandwidth or Radio Bandwidth. The interfering signal offset is defined relative to the *IAB RF Bandwidth edges* or *Radio Bandwidth edges*.

For *IAB type 1-H*, the in-band blocking requirement applies from $F_{UL_low} - \Delta f_{OOB}$ to $F_{UL_high} + \Delta f_{OOB}$, excluding the downlink frequency range of the *operating band*. The Δf_{OOB} for *IAB type 1-H* is defined in table 7.4.2.5.1-0.

Minimum conducted requirement is defined at the *TAB connector* for *IAB type 1-H*.

Table 7.4.2.5.1-0: Δf_{OOB} offset for NR *operating bands*

IAB-DU type	Operating band characteristics	Δf_{OOB} (MHz)
<i>IAB type 1-H</i>	$F_{UL_high} - F_{UL_low} < 100$ MHz	20
	100 MHz $\leq F_{UL_high} - F_{UL_low} \leq 900$ MHz	60
	100 MHz $\leq F_{UL_high} - F_{UL_low} \leq 900$ MHz	60

For a IAB operating in non-contiguous spectrum within any *operating band*, the in-band blocking requirements apply in addition inside any sub-block gap, in case the sub-block gap size is at least as wide as twice the interfering signal minimum offset in table 7.4.2.5.1-1. The interfering signal offset is defined relative to the sub-block edges inside the sub-block gap.

For a *multi-band connector*, the blocking requirements apply in the in-band blocking frequency ranges for each supported *operating band*. The requirement applies in addition inside any Inter RF Bandwidth gap, in case the Inter RF Bandwidth gap size is at least as wide as twice the interfering signal minimum offset in table 7.4.2.5.1-1.

For a IAB operating in non-contiguous spectrum within any operating band, the narrowband blocking requirement applies in addition inside any sub-block gap, in case the sub-block gap size is at least as wide as the channel bandwidth of the NR interfering signal in table 7.4.2.5.1-3. The interfering signal offset is defined relative to the sub-block edges inside the sub-block gap.

For a *multi-band connector*, the narrowband blocking requirement applies in addition inside any Inter RF Bandwidth gap, in case the Inter RF Bandwidth gap size is at least as wide as the NR interfering signal in table 7.4.2.5.1-3. The interfering signal offset is defined relative to the *IAB RF Bandwidth edges* inside the *Inter RF Bandwidth gap*.

Table 7.4.2.5.1-1: IAB general blocking requirement

<i>IAB-DU channel bandwidth of the lowest/highest carrier received (MHz)</i>	Wanted signal mean power (dBm)	Interfering signal mean power (dBm)	Interfering signal centre frequency minimum offset from the lower/upper IAB-DU RF Bandwidth edge or sub-block edge inside a sub-block gap (MHz)	Type of interfering signal
10, 15, 20	$P_{\text{REFSENS}} + 6$ dB	Wide Area IAB-DU: -43 Medium Range IAB-DU: -38 Local Area IAB-DU: -35	± 7.5	5 MHz DFT-s-OFDM NR signal, 15 kHz SCS, 25 RBs
25, 30, 40, 50, 60, 70, 80, 90, 100	$P_{\text{REFSENS}} + 6$ dB	Wide Area IAB-DU: -43 Medium Range IAB-DU: -38 Local Area IAB-DU: -35	± 30	20 MHz DFT-s-OFDM NR signal, 15 kHz SCS, 100 RBs
NOTE: P_{REFSENS} depends on the RAT. For NR, P_{REFSENS} depends also on the <i>IAB-DU channel bandwidth</i> as specified in TS 38.174 [2], table 7.2.2-1, 7.2.2-2 and 7.2.2-3.				

Table 7.4.2.5.2-2: IAB-DU narrowband blocking requirement

<i>IAB-DU channel bandwidth of the lowest/highest carrier received (MHz)</i>	Wanted signal mean power (dBm)	Interfering signal mean power (dBm)
10, 15, 20, 25, 30, 40, 50, 60, 70, 80, 90, 100 (Note 1)	$P_{\text{REFSENS}} + 6$ dB	Wide Area IAB-DU: -49 Medium Range IAB-DU: -44 Local Area IAB-DU: -41
NOTE 1: The SCS for the lowest/highest carrier received is the lowest SCS supported by the IAB-DU for that <i>IAB-DU channel bandwidth</i>		
NOTE 2: P_{REFSENS} depends on the <i>IAB-DU channel bandwidth</i> as specified in TS 38.174 [2], table 7.2.2-1, 7.2.2-2 and 7.2.2-3.		
NOTE 3: 7.5 kHz shift is not applied to the wanted signal.		

Table 7.4.2.5.1-3: IAB-DU narrowband blocking interferer frequency offsets

<i>IAB-DU channel bandwidth of the lowest/highest carrier received (MHz)</i>	Interfering RB centre frequency offset to the lower/upper IAB-DU RF Bandwidth edge or sub-block edge inside a sub-block gap (kHz) (Note 2)	Type of interfering signal
10	$\pm(355+m*180)$, m=0, 1, 2, 3, 4, 9, 14, 19, 24	5 MHz DFT-s-OFDM NR signal, 15 kHz SCS, 1 RB
15	$\pm(360+m*180)$, m=0, 1, 2, 3, 4, 9, 14, 19, 24	
20	$\pm(350+m*180)$, m=0, 1, 2, 3, 4, 9, 14, 19, 24	
25	$\pm(565+m*180)$, m=0, 1, 2, 3, 4, 29, 54, 79, 99	20 MHz DFT-s-OFDM NR signal, 15 kHz SCS, 1 RB
30	$\pm(570+m*180)$, m=0, 1, 2, 3, 4, 29, 54, 79, 99	
40	$\pm(565+m*180)$, m=0, 1, 2, 3, 4, 29, 54, 79, 99	
50	$\pm(560+m*180)$, m=0, 1, 2, 3, 4, 29, 54, 79, 99	
60	$\pm(570+m*180)$, m=0, 1, 2, 3, 4, 29, 54, 79, 99	
70	$\pm(565+m*180)$, m=0, 1, 2, 3, 4, 29, 54, 79, 99	
80	$\pm(560+m*180)$, m=0, 1, 2, 3, 4, 29, 54, 79, 99	
90	$\pm(570+m*180)$, m=0, 1, 2, 3, 4, 29, 54, 79, 99	
100	$\pm(565+m*180)$, m=0, 1, 2, 3, 4, 29, 54, 79, 99	
NOTE 1: Interfering signal consisting of one resource block positioned at the stated offset, the <i>channel bandwidth</i> of the interfering signal is located adjacently to the lower/upper <i>IAB-DU RF Bandwidth edge</i> or <i>sub-block edge</i> inside a sub-block gap.		
NOTE 2: The centre of the interfering RB refers to the frequency location between the two central subcarriers.		

7.4.2.5.2 Test requirements for IAB-MT

The throughput shall be $\geq 95\%$ of the maximum throughput of the reference measurement channel, with a wanted and an interfering signal coupled to *IAB type 1-H TAB connector* using the parameters in tables 7.4.2.5.2-1, 7.4.2.5.2-2 and 7.4.2.5.2-3 for general blocking and narrowband blocking requirements. The reference measurement channel for the wanted signal is identified in clause 7.2.2 for each *IAB-MT channel bandwidth* and further specified in annex A.1. The characteristics of the interfering signal is further specified in annex E.

The in-band blocking requirements apply outside the *IAB-MT RF Bandwidth* or *Radio Bandwidth*. The interfering signal offset is defined relative to the *IAB-MT RF Bandwidth edges* or *Radio Bandwidth edges*.

The in-band blocking requirement shall apply from $F_{DL,low} - \Delta f_{OOB}$ to $F_{DL,high} + \Delta f_{OOB}$. The Δf_{OOB} for *wide area IAB-MT* is defined in table 7.4.2.5.2-0.

Minimum conducted requirement is defined at the *TAB connector* for *IAB-MT*.

Table 7.4.2.5.2-0: Δf_{OOB} offset for NR operating bands

IAB-MT type	Operating band characteristics	Δf_{OOB} (MHz)
<i>IAB type 1-H</i>	$F_{DL,high} - F_{DL,low} < 100$ MHz	20
	$100 \text{ MHz} \leq F_{DL,high} - F_{DL,low} \leq 900$ MHz	60

For an IAB-MT operating in *non-contiguous spectrum* within any *operating band*, the in-band blocking requirements apply in addition inside any *sub-block gap*, in case the *sub-block gap* size is at least as wide as twice the interfering signal minimum offset in Table 7.4.2.5.2-1. The interfering signal offset is defined relative to the *sub-block* edges inside the *sub-block gap*.

For a *multi-band connector*, the blocking requirements apply in the in-band blocking frequency ranges for each supported *operating band*. The requirement shall apply in addition inside any *Inter RF Bandwidth gap*, in case the *Inter RF Bandwidth gap* size is at least as wide as twice the interfering signal minimum offset in Table 7.4.2.5.2-1.

For an IAB-MT operating in *non-contiguous spectrum* within any *operating band*, the narrowband blocking requirement shall apply in addition inside any *sub-block gap*, in case the *sub-block gap* size is at least as wide as the channel bandwidth of the NR interfering signal in Table 7.4.2.5.2-3. The interfering signal offset is defined relative to the *sub-block* edges inside the *sub-block gap*.

For a *multi-band connector*, the narrowband blocking requirement shall apply in addition inside any *Inter RF Bandwidth gap*, in case the *Inter RF Bandwidth gap* size is at least as wide as the NR interfering signal in Table 7.4.2.5.2-3. The interfering signal offset is defined relative to the *IAB-MT RF Bandwidth* edges inside the *Inter RF Bandwidth gap*.

Table 7.4.2.5.2-1: IAB-MT general blocking requirement

<i>IAB-MT channel bandwidth of the lowest/highest carrier received (MHz)</i>	<i>Wanted signal mean power (dBm)</i>	<i>Interfering signal mean power (dBm)</i>	<i>Interfering signal centre frequency minimum offset from the lower/upper IAB-MT RF Bandwidth edge or sub-block edge inside a sub-block gap (MHz)</i>	<i>Type of interfering signal</i>
10, 15, 20	$P_{\text{REFSENS}} + 6$ dB	Wide Area IAB-MT: -43 Local Area IAB-MT: -35	± 7.5	5 MHz CP-OFDM NR signal 15 kHz SCS, 25 RBs
25, 30, 40, 50, 60, 70, 80, 90, 100	$P_{\text{REFSENS}} + 6$ dB	Wide Area IAB-MT: -43 Local Area IAB-MT: -35	± 30	20 MHz CP-OFDM NR signal 15 kHz SCS, 100 RBs

NOTE: P_{REFSENS} depends on the RAT. For NR, P_{REFSENS} depends also on the IAB-MT *channel bandwidth* as specified in tables 7.2.2-1, 7.2.2-2.

Table 7.4.2.5.2-2: IAB-MT narrowband blocking requirement

<i>IAB-MT channel bandwidth of the lowest/highest carrier received (MHz)</i>	<i>Wanted signal mean power (dBm)</i>	<i>Interfering signal mean power (dBm)</i>
10, 15, 20, 25, 30, 40, 50, 60, 70, 80, 90, 100 (Note 1)	$P_{\text{REFSENS}} + 6$ dB	Wide Area IAB-MT: -49 Local Area IAB-MT: -41

NOTE 1: The SCS for the *lowest/highest carrier* received is the lowest SCS supported by the IAB-MT for that IAB-MT *channel bandwidth*

NOTE 2: P_{REFSENS} depends on the IAB-MT *channel bandwidth* as specified in tables 7.2.2-1 and 7.2.2-2.

NOTE 3: 7.5 kHz shift is not applied to the wanted signal.

Table 7.4.2.5.2-3: IAB-MT narrowband blocking interferer frequency offsets

<i>IAB-MT channel bandwidth of the lowest/highest carrier received (MHz)</i>	<i>Interfering RB centre frequency offset to the lower/upper IAB-MT RF Bandwidth edge or sub-block edge inside a sub-block gap (kHz) (Note 2)</i>	<i>Type of interfering signal</i>	
10	$\pm(355+m*180)$, m=0, 1, 2, 3, 4, 9, 14, 19, 24	5 MHz CP-OFDM NR signal, 15 kHz SCS, 1 RB	
15	$\pm(360+m*180)$, m=0, 1, 2, 3, 4, 9, 14, 19, 24		
20	$\pm(350+m*180)$, m=0, 1, 2, 3, 4, 9, 14, 19, 24		
25	$\pm(565+m*180)$, m=0, 1, 2, 3, 4, 29, 54, 79, 99	20 MHz CP-OFDM NR signal, 15 kHz SCS, 1 RB	
30	$\pm(570+m*180)$, m=0, 1, 2, 3, 4, 29, 54, 79, 99		
40	$\pm(565+m*180)$, m=0, 1, 2, 3, 4, 29, 54, 79, 99		
50	$\pm(560+m*180)$, m=0, 1, 2, 3, 4, 29, 54, 79, 99		
60	$\pm(570+m*180)$, m=0, 1, 2, 3, 4, 29, 54, 79, 99		
70	$\pm(565+m*180)$, m=0, 1, 2, 3, 4, 29, 54, 79, 99		
80	$\pm(560+m*180)$, m=0, 1, 2, 3, 4, 29, 54, 79, 99		
90	$\pm(570+m*180)$, m=0, 1, 2, 3, 4, 29, 54, 79, 99		
100	$\pm(565+m*180)$, m=0, 1, 2, 3, 4, 29, 54, 79, 99		
NOTE 1: Interfering signal consisting of one resource block positioned at the stated offset, the channel bandwidth of the interfering signal is located adjacently to the lower/upper IAB-MT RF Bandwidth edge or sub-block edge inside a sub-block gap.			
NOTE 2: The centre of the interfering RB refers to the frequency location between the two central subcarriers.			

7.5 Out-of-band blocking

7.5.1 Definition and applicability

The out-of-band blocking characteristics is a measure of the receiver ability to receive a wanted signal at its assigned channel at the *TAB connector* for *IAB type I-H* in the presence of an unwanted interferer out of the *operating band*, which is a CW signal for out-of-band blocking.

7.5.2 Minimum requirement

The minimum requirement for *IAB type I-H*:

For *IAB-DU* are defined in TS 38.174 [2], clause 7.5.3.

For *IAB-MT* are defined in TS 38.174 [2], clause 7.5.5.

Co-location minimum requirements for *IAB type I-H*:

For *IAB-DU* are defined in TS 38.174 [2], clause 7.5.4.

For *IAB-MT* are defined in TS 38.174 [2], clause 7.5.6.

7.5.3 Test purpose

To verify the ability of the receiver to receive a wanted signal at its assigned channel at the *TAB connector* for *IAB type 1-H* in the presence of an unwanted interferer out of the *operating band*, which is a CW signal for out-of-band blocking.

7.5.4 Method of test

7.5.4.1 Initial conditions

Test environment: Normal; see annex B.2.

RF channels to be tested for single carrier (SC):

- M ; see clause 4.9.1

IAB RF Bandwidth positions to be tested for multi-carrier (MC):

- M_{RFBW} for *single-band connector(s)*, see clause 4.9.1,
- $B_{\text{RFBW_T_RFBW}}$ and $B'_{\text{RFBW_T_RFBW}}$ for *multi-band connector(s)*, see clause 4.9.1.

In addition, for a multi-band *connector*:

- For $B_{\text{RFBW_T_RFBW}}$, out-of-band blocking testing above the highest operating band may be omitted.
- For $B'_{\text{RFBW_T_RFBW}}$, out-of-band blocking testing below the lowest operating band may be omitted.

7.5.4.2 Procedure

The minimum requirement is applied to all connectors under test.

For *IAB type 1-H* the procedure is repeated until all *TAB connectors* necessary to demonstrate conformance have been tested; see clause 7.1.

- 1) Connect the connector under test to measurement equipment as shown in annex D.2.3 for *IAB type 1-H*.
- 2) For IAB-DU, set the signal generator for the wanted signal as defined in clause 7.5.5 to transmit as specified in table 7.5.5.1-1 and 7.5.5.2-1.

For IAB-MT, set the signal generator for the wanted signal as defined in clause 7.5.5 to transmit as specified in table 7.5.5.3-2 and 7.5.5.4-1.

- 3) For IAB-DU, set the Signal generator for the interfering signal to transmit at the frequency offset and as specified in table 7.5.5.1-1 and 7.5.5.2-1. The CW interfering signal shall be swept with a step size of 1 MHz over than range 1 MHz to $(F_{\text{UL_low}} - \Delta f_{\text{OOB}})$ MHz and $(F_{\text{UL_high}} + \Delta f_{\text{OOB}})$ MHz to 12750 MHz.

For IAB-MT, set the Signal generator for the interfering signal to transmit at the frequency offset and as specified in table 7.5.5.3-2 and 7.5.5.4-1. The CW interfering signal shall be swept with a step size of 1 MHz over than range 1 MHz to $(F_{\text{UL_low}} - \Delta f_{\text{OOB}})$ MHz and $(F_{\text{UL_high}} + \Delta f_{\text{OOB}})$ MHz to 12750 MHz.

- 4) Measure the throughput according to annex A.1.

In addition, for a *multi-band connector*, the following steps shall apply:

- 5) For *multi-band connector* and single band tests, repeat the steps above per involved band where single band test configurations and test models shall apply with no carrier activated in the other band.

7.5.5 Test requirements

7.5.5.1 General requirements for IAB-DU

The throughput shall be $\geq 95\%$ of the maximum throughput of the reference measurement channel, with a wanted and an interfering signal coupled to *IAB type 1-H TAB connector* using the parameters in table 7.5.5.1-1. The reference

measurement channel for the wanted signal is identified in clause 7.2.2 for each channel bandwidth and further specified in annex A.1.

For *IAB type 1-H* the out-of-band blocking requirement apply from 1 MHz to $F_{UL_low} - \Delta f_{OOB}$ and from $F_{UL_high} + \Delta f_{OOB}$ up to 12750 MHz. The Δf_{OOB} for *IAB type 1-H* is defined in table 7.4.2.5.1-0.

Minimum conducted requirement is defined at the *TAB connector* for *IAB type 1-H*.

For a IAB capable of multi-band operation, the requirement in the out-of-band blocking frequency ranges apply for each *operating band*, with the exception that the in-band blocking frequency ranges of all supported *operating bands* according to clause 7.4.2.5 shall be excluded from the out-of-band blocking requirement.

Table 7.5.5.1-1: Out-of-band blocking performance requirement

Wanted signal mean power (dBm)	Interfering signal mean power (dBm)	Type of interfering signal
$P_{\text{REFSENS}} + 6$ dB (Note 1)	-15	CW carrier
NOTE 1: P_{REFSENS} depends on the RAT. For NR, P_{REFSENS} depends also on the <i>IAB-DU channel bandwidth</i> as specified in TS 38.174 [2], tables 7.2.2-1, 7.2.2-2 and 7.2.2-3.		

7.5.5.2 Co-location requirements for IAB-DU

This additional blocking requirement may be applied for the protection of NR IAB receivers when GSM, CDMA, UTRA, E-UTRA BS or NR IAB operating in a different frequency band are co-located with a NR IAB. The requirement is applicable to all channel bandwidths supported by the NR IAB.

The requirements in this clause assume a 30 dB coupling loss between interfering transmitter and NR IAB receiver and are based on co-location with base stations or IAB of the same class.

The throughput shall be $\geq 95\%$ of the maximum throughput of the reference measurement channel, with a wanted and an interfering signal coupled to IAB antenna input using the parameters in table 7.5.5.2-1 for all the IAB classes. The reference measurement channel for the wanted signal is identified in tables 7.2.5-1, 7.2.5-2 and 7.2.5-3 for each channel bandwidth and further specified in annex A.1.

For *IAB type 1-H* blocking requirement for co-location with IAB in other bands is applied for all operating bands for which co-location protection is provided.

Minimum conducted requirement is defined at the *TAB connector* for *IAB type 1-H*.

Table 7.5.5.2-1: Blocking performance requirement for NR IAB when co-located with BS/IAB in other frequency bands.

Frequency range of interfering signal	Wanted signal mean power for WA IAB-DU (dBm)	Interfering signal mean power for WA IAB-DU (dBm)	Interfering signal mean power for MR IAB-DU (dBm)	Interfering signal mean power for LA IAB-DU (dBm)	Type of interfering signal
Frequency range of co-located downlink operating band	$P_{\text{REFSENS}} + 6$ dB (Note 1)	+16	+8	x (Note 2)	CW carrier
NOTE 1: P_{REFSENS} depends on the <i>IAB-DU channel bandwidth</i> as specified in TS 38.174 [2], tables 7.2.2-1, 7.2.2-2 and 7.2.2-3.					
NOTE 2: x = -7 dBm for NR IAB co-located with Pico GSM850 or Pico CDMA850 x = -4 dBm for NR IAB co-located with Pico DCS1800 or Pico PCS1900 x = -6 dBm for NR IAB co-located with UTRA bands or E-UTRA bands or NR bands					
NOTE 3: The requirement does not apply when the interfering signal falls within any of the supported uplink operating band(s) or in Δf_{OOB} immediately outside any of the supported uplink operating band(s).					

7.5.5.3 General requirements for IAB-MT

The throughput shall be $\geq 95\%$ of the maximum throughput of the reference measurement channel, with a wanted and an interfering signal coupled to *IAB type 1-H TAB connector* using the parameters in table 7.5.5.3-2. The reference

measurement channel for the wanted signal is identified in subclause 7.2.1 and subclause 7.2.2 for each *IAB-MT channel bandwidth* and further specified in annex A.1.

The out-of-band blocking requirement apply from 1 MHz to $F_{DL,low} - \Delta f_{OOB}$ and from $F_{DL,high} + \Delta f_{OOB}$ up to 12750 MHz. The Δf_{OOB} for *IAB-MT* is defined in table 7.5.5.3-1.

Table 7.5.5.3-1: Δf_{OOB} offset for NR operating bands

IAB-MT type	Operating band characteristics	Δf_{OOB} (MHz)
<i>IAB type 1-H</i>	$F_{DL,high} - F_{DL,low} < 100$ MHz	20
	$100 \text{ MHz} \leq F_{DL,high} - F_{DL,low} \leq 900$ MHz	60

Minimum conducted requirement is defined and at the *TAB connector* for *IAB-MT type 1-H*.

For a *multi-band connector*, the requirement in the out-of-band blocking frequency ranges apply for each *operating band*, with the exception that the in-band blocking frequency ranges of all supported *operating bands* according to clause 7.4.2.2 shall be excluded from the out-of-band blocking requirement.

Table 7.5.5.3-2: Out-of-band blocking performance requirement for NR

Wanted Signal mean power (dBm)	Interfering Signal mean power (dBm)	Type of Interfering Signal
$P_{\text{REFSENS}} + 6$ dB (Note)	-15	CW carrier
NOTE 1: For NR, P_{REFSENS} depends also on the <i>IAB-MT channel bandwidth</i> as specified in subclause 7.2.1 and subclause 7.2.2.		

7.5.5.4 Co-location requirements for IAB-MT

This additional blocking requirement may be applied for the protection of IAB-MT receivers when GSM, CDMA, UTRA, E-UTRA, NR BS or IAB-node operating in a different frequency band are co-located with an IAB-node. The requirement is applicable to all *IAB-MT channel bandwidths* supported by the IAB-node.

The requirements in this clause assume a 30 dB coupling loss between interfering transmitter and IAB-node receiver and are based on co-location with base stations of the same class.

The throughput shall be $\geq 95\%$ of the maximum throughput of the reference measurement channel, with a wanted and an interfering signal coupled to *IAB type 1-H TAB connector* input using the parameters in table 7.5.5.4-1 for all the IAB classes. The reference measurement channel for the wanted signal is identified in subclause 7.2.1 and subclause 7.2.2 for each *IAB-MT channel bandwidth* and further specified in annex A.1.

The blocking requirement for co-location with BS or IAB-node in other bands is applied for all *operating bands* for which co-location protection is provided.

Minimum conducted requirement is defined at the *TAB connector* for *IAB type 1-H*.

Table 7.5.5.4-1: Blocking performance requirement for the IAB node

Frequency range of interfering signal	Wanted signal mean power (dBm)	Interfering signal mean power for WA IAB node (dBm)	Interfering signal mean power for LA IAB node (dBm)	Type of interfering signal
Frequency range of co-located downlink <i>operating band</i>	$P_{\text{REFSENS}} + 6\text{dB}$ (Note 1)	+16	x (Note 2)	CW carrier
NOTE 1: P_{REFSENS} depends on the <i>IAB-MT channel bandwidth</i> as specified in subclause 7.2.1 and subclause 7.2.2. NOTE 2: x = -7 dBm for IAB-MT co-located with Pico GSM850 or Pico CDMA850 x = -4 dBm for IAB-MT co-located with Pico DCS1800 or Pico PCS1900 x = -6 dBm for IAB-MT co-located with UTRA bands or E-UTRA bands or NR bands NOTE 3: The requirement does not apply when the interfering signal falls within any of the supported downlink <i>operating band(s)</i> or in Δf_{OoB} immediately outside any of the supported downlink <i>operating band(s)</i> .				

7.6 Receiver spurious emissions

7.6.1 Definition and applicability

The receiver spurious emissions power is the power of emissions generated or amplified in a receiver unit that appear at the *TAB connector* (for *IAB type 1-H*). The requirements apply to all IAB-DU and IAB-MT with separate RX and TX *TAB connectors*.

For *TAB connectors* supporting both RX and TX in TDD, the requirements apply during the *transmitter OFF period*.

For RX-only *multi-band connectors*, the spurious emissions requirements are subject to exclusion zones in each supported *operating band*. For *multi-band connectors* that both transmit and receive in *operating band* supporting TDD, RX spurious emissions requirements are applicable during the *TX OFF period*, and are subject to exclusion zones in each supported *operating band*.

For *IAB type 1-H* manufacturer shall declare *TAB connector RX min cell groups*. The declaration is done separately for IAB-DU and IAB-MT. Every *TAB connector* of *IAB type 1-H* supporting reception in an *operating band* shall map to one *TAB connector RX min cell group*, where mapping of *TAB connectors* to cells/beams is implementation dependent.

The number of active receiver units that are considered when calculating the conducted RX spurious emission limits ($N_{\text{RXU,counted}}$) for IAB type 1-H is calculated as follows:

$$N_{\text{RXU,counted}} = \min(N_{\text{RXU,active}}, 8 \times N_{\text{cells}})$$

$N_{\text{RXU,countedpercell}}$ is used for scaling of *basic limits* and is derived as $N_{\text{RXU,countedpercell}} = N_{\text{RXU,counted}} / N_{\text{cells}}$, where N_{cells} is defined in clause 6.1.

NOTE: $N_{\text{RXU,active}}$ is the number of actually active receiver units and is independent to the declaration of N_{cells} .

7.6.2 Minimum requirement

The minimum requirement for *IAB type 1-H*:

For *IAB-DU* are in TS 38.174 [2], clause 7.6.2.

For *IAB-MT* are in TS 38.174 [2], clause 7.6.3.

7.6.3 Test purpose

The test purpose is to verify the ability of the IAB to limit the interference caused by receiver spurious emissions to other systems.

7.6.4 Method of test

7.6.4.1 Initial conditions

Test environment: Normal; see annex B.2.

RF channels to be tested for single carrier: M; see clause 4.9.1.

IAB RF Bandwidth positions to be tested for multi-carrier:

- M_{RFBW} in single-band operation, see clause 4.9.1,
- $B_{\text{RFBW}} \cdot T_{\text{RFBW}}$ and $B'_{\text{RFBW}} \cdot T_{\text{RFBW}}$ in multi-band operation, see clause 4.9.1.

7.6.4.2 Procedure

The minimum requirement is applied to all connectors under test,

For *IAB type 1-H* where there may be multiple *TAB connectors* they may be tested one at a time or multiple *TAB connectors* may be tested in parallel as shown in annex D.2.4. Whichever method is used the procedure is repeated until all *TAB connectors* necessary to demonstrate conformance have been tested.

- 1) Connect the connector under test to measurement equipment as shown in annex D.2.4 for *IAB type 1-H*.
- 2) For TDD connectors capable of transmit and receive ensure the transmitter is OFF.
- 3) For IAB-DU, set the measurement equipment parameters as specified in table 7.6.5.1-1.
For IAB-MT, set the measurement equipment parameters as specified in table 7.6.5.3-1.
- 4) For IAB-DU, measure the spurious emissions over each frequency range described in table 7.6.5.1-1.

For IAB-MT, measure the spurious emissions over each frequency range described in table 7.6.5.3-1.

In addition, for a *multi-band connector*, the following steps shall apply:

- 5) For *multi-band connector* and single band tests, repeat the steps above per involved band where single band test configurations and test models shall apply with no carrier activated in the other band.

7.6.5 Test requirements

7.6.5.1 Basic limits for IAB-DU

The receiver spurious emissions limits are provided in table 7.6.5.1-1.

Table 7.6.5.1-1: General receiver spurious emissions limits

Spurious frequency range	Basic limit	Measurement bandwidth	Notes
30 MHz – 1 GHz	-57 dBm	100 kHz	Note 1
1 GHz – 12.75 GHz	-47 dBm	1 MHz	Note 1, Note 2
12.75 GHz – 5 th harmonic of the upper frequency edge of the UL <i>operating band</i> in GHz	-47 dBm	1 MHz	Note 1, Note 2, Note 3
NOTE 1: Measurement bandwidths as in ITU-R SM.329 [5], s4.1.			
NOTE 2: Upper frequency as in ITU-R SM.329 [5], s2.5 table 1.			
NOTE 3: This spurious frequency range applies only for <i>operating bands</i> for which the 5 th harmonic of the upper frequency edge of the UL <i>operating band</i> is reaching beyond 12.75 GHz.			
NOTE 4: The frequency range from Δf_{OBUE} below the lowest frequency of the IAB transmitter operating band to Δf_{OBUE} above the highest frequency of the IAB transmitter <i>operating band</i> may be excluded from the requirement. Δf_{OBUE} is defined in clause 6.6.1. For <i>multi-band connectors</i> , the exclusion applies for all supported <i>operating bands</i> .			
NOTE 5: Void			

7.6.5.2 Test requirement for IAB-DU

The RX spurious emissions requirements for *IAB type 1-H* are that for each applicable *basic limit* specified in table 7.6.5.1-1 for each *TAB connector RX min cell group*, the power sum of emissions at respective *TAB connectors* shall not exceed the IAB limits specified as the *basic limits* + X, where $X = 10\log_{10}(N_{\text{RXU, counted per cell}})$, unless stated differently in regional regulation.

The RX spurious emission requirements are applied per the *TAB connector RX min cell group* for all the configurations supported by the IAB-DU.

NOTE: Conformance to the IAB-DU receiver spurious emissions requirement can be demonstrated by meeting at least one of the following criteria as determined by the manufacturer:

- 1) The sum of the spurious emissions power measured on each *TAB connector* in the *TAB connector RX min cell group* shall be less than or equal to the IAB-DU limit above for the respective frequency span.

Or

- 2) The spurious emissions power at each *TAB connector* shall be less than or equal to the IAB-DU limit as defined above for the respective frequency span, scaled by $-10\log_{10}(n)$, where n is the number of *TAB connectors* in the *TAB connector RX min cell group*.

7.6.5.3 Basic limits for IAB-MT

The IAB-MT receiver spurious emissions *basic limits* are provided in table 7.6.5.3-1.

Table 7.6.5.3-1: General IAB-MT receiver spurious emissions limits

Spurious frequency range	Basic limits	Measurement bandwidth	Note
30 MHz – 1 GHz	-57 dBm	100 kHz	Note 1
1 GHz – 12.75 GHz	-47 dBm	1 MHz	Note 1, Note 2
12.75 GHz – 5 th harmonic of the upper frequency edge of the DL <i>operating band</i> in GHz	-47 dBm	1 MHz	Note 1, Note 2, Note 3
NOTE 1: <i>Measurement bandwidths</i> as in ITU-R SM.329 [5], s4.1. NOTE 2: Upper frequency as in ITU-R SM.329 [5], s2.5 table 1. NOTE 3: This spurious frequency range applies only for <i>operating bands</i> for which the 5 th harmonic of the upper frequency edge of the DL <i>operating band</i> is reaching beyond 12.75 GHz. NOTE 4: The frequency range from Δf_{OBUE} below the lowest frequency of the IAB-MT transmitter <i>operating band</i> to Δf_{OBUE} above the highest frequency of the IAB-MT transmitter <i>operating band</i> may be excluded from the requirement. Δf_{OBUE} is defined in clause [6.6.1]. For <i>multi-band connectors</i> , the exclusion applies for all supported <i>operating bands</i> .			

7.6.5.4 Test requirement for IAB-MT

The RX spurious emissions requirements for *IAB type 1-H* are that for each applicable *basic limit* specified in table 7.6.5.3-1 for each *TAB connector RX min cell group*, the power sum of emissions at respective *TAB connectors* shall not exceed the IAB-MT limits specified as the *basic limits* + X, where $X = 10\log_{10}(N_{\text{RXU, counted per cell}})$, unless stated differently in regional regulation.

The RX spurious emission requirements are applied per the *TAB connector RX min cell group* for all the configurations supported by the IAB-MT.

NOTE: Conformance to the IAB-MT receiver spurious emissions requirement can be demonstrated by meeting at least one of the following criteria as determined by the manufacturer:

- 1) The sum of the spurious emissions power measured on each *TAB connector* in the *TAB connector RX min cell group* shall be less than or equal to the IAB-MT limit above for the respective frequency span.

Or

- 2) The spurious emissions power at each *TAB connector* shall be less than or equal to the IAB-MT limit as defined above for the respective frequency span, scaled by $-10\log_{10}(n)$, where n is the number of *TAB connectors* in the *TAB connector RX min cell group*.

7.7 Receiver intermodulation

7.7.1 Definition and applicability

Third and higher order mixing of the two interfering RF signals can produce an interfering signal in the band of the desired channel. Intermodulation response rejection is a measure of the capability of the receiver to receive a wanted signal on its assigned channel frequency at the *TAB connector* for *IAB type 1-H* in the presence of two interfering signals which have a specific frequency relationship to the wanted signal.

7.7.2 Minimum requirement

The minimum requirement for *IAB type 1-H*:

For *IAB-DU* are in TS 38.174 [2], clause 7.7.2.

For *IAB-MT* are in TS 38.174 [2], clause 7.7.3.

7.7.3 Test purpose

The test purpose is to verify the ability of the IAB node receiver to inhibit the generation of intermodulation products in its non-linear elements caused by the presence of two high-level interfering signals at frequencies with a specific relationship to the frequency of the wanted signal.

7.7.4 Method of test

7.7.4.1 Initial conditions

Test environment: Normal; see annex B.2.

RF channels to be tested for single carrier (SC): M; see clause 4.9.1

IAB RF Bandwidth positions to be tested for multi-carrier (MC) and/or CA:

- M_{RFBW} for *single-band connector(s)*, see clause 4.9.1,
- $B'_{\text{RFBW}}T'_{\text{RFBW}}$ and $B_{\text{RFBW}}T_{\text{RFBW}}$ for *multi-band connector(s)*, see clause 4.9.1.

NOTE: When testing in M (or M_{RFBW}), if the interferer is fully or partially located outside the supported frequency range, then the test shall be done instead in B (or B_{RFBW}) and T (or T_{RFBW}), and only with the interferer located inside the supported frequency range.

7.7.4.2 Procedure

The minimum requirement is applied to all connectors under test.

For *IAB type 1-H* the procedure is repeated until all *TAB connectors* necessary to demonstrate conformance have been tested; see clause 7.1.

- 1) Connect the connector under test to measurement equipment as shown in annex D.2.6 for *IAB type 1-H*.
- 2) Set the signal generator for the wanted signal to transmit as specified in table 7.7.5.1-1 and 7.7.5.1-3 for IAB-DU and table 7.7.5.2-1 and 7.7.5.2-3 for IAB-MT.
- 3) Set the signal generator for the interfering signal to transmit at the frequency offset and as specified in table 7.7.5.1-2 and 7.7.5.1-4 for IAB-DU and table 7.7.5.2-2 and 7.7.5.2-4 for IAB-MT.
- 4) Measure the throughput according to annex A.1.

In addition, for a *multi-band connector*, the following steps shall apply:

- 5) For *multi-band connector* and single band tests, repeat the steps above per involved band where single band test configurations and test models shall apply with no carrier activated in the other band.

7.7.5 Test requirements

7.7.5.1 IAB-DU

The throughput shall be $\geq 95\%$ of the maximum throughput of the reference measurement channel, with a wanted signal at the assigned channel frequency and two interfering signals coupled to the *IAB type 1-H TAB connector*, with the conditions specified in tables 7.7.5.1-1 and 7.7.5.1-2 for intermodulation performance and in tables 7.7.5.1-3, and 7.7.5.1-4 for narrowband intermodulation performance. The reference measurement channel for the wanted signal is identified in tables 7.2.5.1-1 to 7.2.5.1-3 for each channel bandwidth and further specified in annex A.1. The characteristics of the interfering signal is further specified in annex E.

The subcarrier spacing for the modulated interfering signal shall in general be the same as the subcarrier spacing for the wanted signal, except for the case of wanted signal subcarrier spacing 60 kHz and *IAB-DU channel bandwidth* $\leq 20\text{MHz}$, for which the subcarrier spacing of the interfering signal should be 30 kHz.

The receiver intermodulation requirement is applicable outside the *IAB-DU RF Bandwidth* or Radio Bandwidth edges. The interfering signal offset is defined relative to the *IAB-DU RF Bandwidth edges* or *Radio Bandwidth edges*.

For an IAB-DU operating in non-contiguous spectrum within any *operating band*, the narrowband intermodulation requirement applies in addition inside any sub-block gap in case the sub-block gap is at least as wide as the channel bandwidth of the NR interfering signal in table 7.7.5.1-2 or 7.7.5.1-4. The interfering signal offset is defined relative to the sub-block edges inside the sub-block gap.

For a *multi-band connectors*, the intermodulation requirement applies in addition inside any *Inter RF Bandwidth gap*, in case the gap size is at least twice as wide as the NR interfering signal centre frequency offset from the *IAB-DU RF Bandwidth edge*.

For a *multi-band connectors*, the narrowband intermodulation requirement applies in addition inside any *Inter RF Bandwidth gap* in case the gap size is at least as wide as the NR interfering signal in tables 7.7.5.1-2 and 7.7.5.1-4. The interfering signal offset is defined relative to the *IAB-DU RF Bandwidth edges* inside the *Inter RF Bandwidth gap*.

Table 7.7.5.1-1: General intermodulation requirement

IAB-DU type	Wanted Signal mean power (dBm)	Mean power of interfering signals (dBm)	Type of interfering signals
Wide Area	$P_{\text{REFSENS}} + 6 \text{ dB}$	-52	See table 7.7.5.1-2
Medium Range	$P_{\text{REFSENS}} + 6 \text{ dB}$	-47	
Local Area	$P_{\text{REFSENS}} + 6 \text{ dB}$	-44	
NOTE: P_{REFSENS} depends on the RAT and the IAB class. For NR, P_{REFSENS} depends also on the IAB-DU <i>channel bandwidth</i> as specified in TS 38.174 [2], clause 7.2.1.2.			

Table 7.7.5.1-2: Interfering signals for intermodulation requirement

<i>IAB-DU channel bandwidth of the lowest/highest carrier received (MHz)</i>	<i>Interfering signal centre frequency offset from the lower/upper IAB-DU RF Bandwidth edge (MHz)</i>	<i>Type of interfering signal (Note 3)</i>
10	±7.465	CW
	±17.5	5 MHz DFT-s-OFDM NR signal, (Note 1)
15	±7.43	CW
	±17.5	5 MHz DFT-s-OFDM NR signal, (Note 1)
20	±7.395	CW
	±17.5	5 MHz DFT-s-OFDM NR signal, (Note 1)
25	±7.465	CW
	±25	20MHz DFT-s-OFDM NR signal, (Note 2)
30	±7.43	CW
	±25	20 MHz DFT-s-OFDM NR signal, (Note 2)
40	±7.45	CW
	±25	20 MHz DFT-s-OFDM NR signal, (Note 2)
50	±7.35	CW
	±25	20 MHz DFT-s-OFDM NR signal, (Note 2)
60	±7.49	CW
	±25	20 MHz DFT-s-OFDM NR signal, (Note 2)
70	±7.42	CW
	±25	20 MHz DFT-s-OFDM NR signal, (Note 2)
80	±7.44	CW
	±25	20 MHz DFT-s-OFDM NR signal, (Note 2)
90	±7.46	CW
	±25	20 MHz DFT-s-OFDM NR signal, (Note 2)
100	±7.48	CW
	±25	20 MHz DFT-s-OFDM NR signal, (Note 2)

NOTE 1: For the 15 kHz subcarrier spacing, the number of RB is 25. For the 30 kHz subcarrier spacing, the number of RB is 10.

NOTE 2: For the 15 kHz subcarrier spacing, the number of RB is 100. For the 30 kHz subcarrier spacing, the number of RB is 50. For the 60 kHz subcarrier spacing, the number of RB is 24.

NOTE 3: The RBs shall be placed adjacent to the transmission bandwidth configuration edge which is closer to the *IAB-DU RF Bandwidth edge*.

Table 7.7.5.1-3: Narrowband intermodulation performance requirement in FR1

IAB-DU type	Wanted signal mean power (dBm) (Note 1)	Mean power of interfering signals (dBm)	Type of interfering signal
Wide Area	$P_{\text{REFSENS}} + 6 \text{ dB}$	-52	See table 7.7.5.1-4
Medium Range	$P_{\text{REFSENS}} + 6 \text{ dB}$	-47	
Local Area	$P_{\text{REFSENS}} + 6 \text{ dB}$	-44	

NOTE: P_{REFSENS} depends on the RAT. For NR, P_{REFSENS} depends also on the *IAB-DU channel bandwidth* as specified in TS 38.174 [2], clause 7.2.1.2.

Table 7.7.5.1-4: Interfering signals for narrowband intermodulation requirement in FR1

<i>IAB-DU channel bandwidth of the lowest/highest carrier received (MHz)</i>	<i>Interfering RB centre frequency offset from the lower/upper IAB-DU RF Bandwidth edge or sub-block edge inside a sub-block gap (kHz) (Note 3)</i>	<i>Type of interfering signals</i>
10	±370	CW
	±1960	5 MHz DFT-s-OFDM NR signal, 1 RB (Note 1)
15 (Note 2)	±380	CW
	±1960	5 MHz DFT-s-OFDM NR signal, 1 RB (Note 1)
20 (Note 2)	±390	CW
	±2320	5 MHz DFT-s-OFDM NR signal, 1 RB (Note 1)
25 (Note 2)	±325	CW
	±2350	20 MHz DFT-s-OFDM NR signal, 1 RB (Note 1)
30 (Note 2)	±335	CW
	±2350	20 MHz DFT-s-OFDM NR signal, 1 RB (Note 1)
40 (Note 2)	±355	CW
	±2710	20 MHz DFT-s-OFDM NR signal, 1 RB (Note 1)
50 (Note 2)	±375	CW
	±2710	20 MHz DFT-s-OFDM NR signal, 1 RB (Note 1)
60 (Note 2)	±395	CW
	±2710	20 MHz DFT-s-OFDM NR signal, 1 RB (Note 1)
70 (Note 2)	±415	CW
	±2710	20 MHz DFT-s-OFDM NR signal, 1 RB (Note 1)
80 (Note 2)	±435	CW
	±2710	20 MHz DFT-s-OFDM NR signal, 1 RB (Note 1)
90 (Note 2)	±365	CW
	±2530	20 MHz DFT-s-OFDM NR signal, 1 RB (Note 1)
100 (Note 2)	±385	CW
	±2530	20 MHz DFT-s-OFDM NR signal, 1 RB (Note 1)
NOTE 1: Interfering signal consisting of one resource block positioned at the stated offset, the <i>IAB-DU channel bandwidth</i> of the interfering signal is located adjacently to the lower/upper <i>IAB-DU RF Bandwidth edge</i> or sub-block edge inside a sub-block gap.		
NOTE 2: This requirement shall apply only for a G-FRC mapped to the frequency range at the channel edge adjacent to the interfering signals.		
NOTE 3: The centre of the interfering RB refers to the frequency location between the two central subcarriers.		

7.7.5.2 IAB-MT

The throughput shall be $\geq 95\%$ of the maximum throughput of the reference measurement channel, with a wanted signal at the assigned channel frequency and two interfering signals coupled to the *IAB type 1-H TAB connector*, with the conditions specified in tables 7.7.5.2-1 and 7.7.5.2-2 for intermodulation performance and in tables 7.7.5.2-3, and

7.7.5.2-4 for narrowband intermodulation performance. The reference measurement channel for the wanted signal is identified in tables 7.2.5.2-1 to 7.2.5.2-3 for each channel bandwidth and further specified in annex A.1. The characteristics of the interfering signal is further specified in annex E.

The subcarrier spacing for the modulated interfering signal shall in general be the same as the subcarrier spacing for the wanted signal, except for the case of wanted signal subcarrier spacing 60 kHz and *IAB-MT channel bandwidth* ≤ 20 MHz, for which the subcarrier spacing of the interfering signal should be 30 kHz.

The receiver intermodulation requirement is applicable outside the *IAB-MT RF Bandwidth* or *Radio Bandwidth* edges. The interfering signal offset is defined relative to the *IAB-MT RF Bandwidth edges* or *Radio Bandwidth edges*.

For an *IAB-MT* operating in non-contiguous spectrum within any *operating band*, the narrowband intermodulation requirement applies in addition inside any sub-block gap in case the sub-block gap is at least as wide as the channel bandwidth of the NR interfering signal in table 7.7.5.2-2 or 7.7.5.2-4. The interfering signal offset is defined relative to the sub-block edges inside the sub-block gap.

For a *multi-band connectors*, the intermodulation requirement applies in addition inside any *Inter RF Bandwidth gap*, in case the gap size is at least twice as wide as the NR interfering signal centre frequency offset from the *IAB-MT RF Bandwidth edge*.

For a *multi-band connectors*, the narrowband intermodulation requirement applies in addition inside any *Inter RF Bandwidth gap* in case the gap size is at least as wide as the NR interfering signal in tables 7.7.5.2-2 and 7.7.5.2-4. The interfering signal offset is defined relative to the *IAB-MT RF Bandwidth edges* inside the *Inter RF Bandwidth gap*.

Table 7.7.5.2-1: General intermodulation requirement

IAB-MT type	Wanted Signal mean power (dBm)	Mean power of interfering signals (dBm)	Type of interfering signals
Wide Area	$P_{\text{REFSENS}} + 6$ dB	-52	See table 7.7.5.2-2
Local Area	$P_{\text{REFSENS}} + 6$ dB	-44	
NOTE: P_{REFSENS} depends on the RAT and the IAB class. For NR, P_{REFSENS} depends also on the <i>IAB-MT channel bandwidth</i> as specified in TS 38.174 [2], clause 7.2.2.2.			

Table 7.7.5.2-2: Interfering signals for intermodulation requirement

<i>IAB-MT channel bandwidth of the lowest/highest carrier received (MHz)</i>	<i>Interfering signal centre frequency offset from the lower/upper IAB-MT RF Bandwidth edge (MHz)</i>	<i>Type of interfering signal (Note 3)</i>
10	±7.465	CW
	±17.5	5 MHz CP-OFDM NR signal, (Note 1)
15	±7.43	CW
	±17.5	5 MHz CP-OFDM NR signal, (Note 1)
20	±7.395	CW
	±17.5	5 MHz CP-OFDM NR signal, (Note 1)
25	±7.465	CW
	±25	20MHz CP-OFDM NR signal, (Note 2)
30	±7.43	CW
	±25	20 MHz CP-OFDM NR signal, (Note 2)
40	±7.45	CW
	±25	20 MHz CP-OFDM NR signal, (Note 2)
50	±7.35	CW
	±25	20 MHz CP-OFDM NR signal, (Note 2)
60	±7.49	CW
	±25	20 MHz CP-OFDM NR signal, (Note 2)
70	±7.42	CW
	±25	20 MHz CP-OFDM NR signal, (Note 2)
80	±7.44	CW
	±25	20 MHz CP-OFDM NR signal, (Note 2)
90	±7.46	CW
	±25	20 MHz CP-OFDM NR signal, (Note 2)
100	±7.48	CW
	±25	20 MHz CP-OFDM NR signal, (Note 2)

NOTE 1: For the 15 kHz subcarrier spacing, the number of RB is 25. For the 30 kHz subcarrier spacing, the number of RB is 10.

NOTE 2: For the 15 kHz subcarrier spacing, the number of RB is 100. For the 30 kHz subcarrier spacing, the number of RB is 50. For the 60 kHz subcarrier spacing, the number of RB is 24.

NOTE 3: The RBs shall be placed adjacent to the transmission bandwidth configuration edge which is closer to the *IAB-MT RF Bandwidth edge*.

Table 7.7.5.2-3: Narrowband intermodulation performance requirement in FR1

<i>IAB-MT type</i>	<i>Wanted signal mean power (dBm) (Note 1)</i>	<i>Mean power of interfering signals (dBm)</i>	<i>Type of interfering signal</i>
Wide Area	$P_{\text{REFSENS}} + 6$ dB	-52	See table 7.7.5.2-4
Local Area	$P_{\text{REFSENS}} + 6$ dB	-44	

NOTE: P_{REFSENS} depends on the RAT. For NR, P_{REFSENS} depends also on the *IAB-MT channel bandwidth* as specified in TS 38.174 [2], clause 7.2.2.2.

Table 7.7.5.2-4: Interfering signals for narrowband intermodulation requirement in FR1

<i>IAB-MT channel bandwidth of the lowest/highest carrier received (MHz)</i>	<i>Interfering RB centre frequency offset from the lower/upper IAB-MT RF Bandwidth edge or sub-block edge inside a sub-block gap (kHz) (Note 3)</i>	<i>Type of interfering signals</i>
10	± 370	CW
	± 1960	5 MHz CP-OFDM NR signal, 1 RB (Note 1)
15 (Note 2)	± 380	CW
	± 1960	5 MHz CP-OFDM NR signal, 1 RB (Note 1)
20 (Note 2)	± 390	CW
	± 2320	5 MHz CP-OFDM NR signal, 1 RB (Note 1)
25 (Note 2)	± 325	CW
	± 2350	20 MHz CP-OFDM NR signal, 1 RB (Note 1)
30 (Note 2)	± 335	CW
	± 2350	20 MHz CP-OFDM NR signal, 1 RB (Note 1)
40 (Note 2)	± 355	CW
	± 2710	20 MHz CP-OFDM NR signal, 1 RB (Note 1)
50 (Note 2)	± 375	CW
	± 2710	20 MHz CP-OFDM NR signal, 1 RB (Note 1)
60 (Note 2)	± 395	CW
	± 2710	20 MHz CP-OFDM NR signal, 1 RB (Note 1)
70 (Note 2)	± 415	CW
	± 2710	20 MHz CP-OFDM NR signal, 1 RB (Note 1)
80 (Note 2)	± 435	CW
	± 2710	20 MHz CP-OFDM NR signal, 1 RB (Note 1)
90 (Note 2)	± 365	CW
	± 2530	20 MHz CP-OFDM NR signal, 1 RB (Note 1)
100 (Note 2)	± 385	CW
	± 2530	20 MHz CP-OFDM NR signal, 1 RB (Note 1)
NOTE 1: Interfering signal consisting of one resource block positioned at the stated offset, the <i>IAB-MT channel bandwidth</i> of the interfering signal is located adjacently to the lower/upper <i>IAB-MT RF Bandwidth edge</i> or sub-block edge inside a sub-block gap.		
NOTE 2: This requirement shall apply only for a G-FRC mapped to the frequency range at the channel edge adjacent to the interfering signals.		
NOTE 3: The centre of the interfering RB refers to the frequency location between the two central subcarriers.		

7.8 In-channel selectivity

7.8.1 Definition and applicability

In-channel selectivity (ICS) is a measure of the receiver ability to receive a wanted signal at its assigned resource block locations at the *TAB connector* for *IAB-DU* in the presence of an interfering signal received at a larger power spectral density. In this condition a throughput requirement shall be met for a specified reference measurement channel. The interfering signal shall be an NR signal which is time aligned with the wanted signal.

7.8.2 Minimum requirement

The minimum requirements for *IAB type 1-H* for *IAB-DU* are in TS 38.174 [2], clause 7.8.2.

7.8.3 Test purpose

The purpose of this test is to verify the IAB-DU receiver ability to suppress the IQ leakage.

7.8.4 Method of test

7.8.4.1 Initial conditions

Test environment: Normal; see annex B.2.

RF channels to be tested for single carrier: M; see clause 4.9.1.

7.8.4.2 Procedure

The minimum requirement is applied to all connectors under test.

For *IAB type 1-H* the procedure is repeated until all *TAB connectors* necessary to demonstrate conformance have been tested; see clause 7.1.

- 1) Set the signal generator for the wanted signal to transmit as specified in sub-clause 7.8.5.
- 2) Set the signal generator for the interfering signal to transmit at the frequency offset and as specified in sub-clause 7.8.5.
- 3) Measure the throughput according to annex A.1.

In addition, for a *multi-band connector*, the following steps shall apply:

- 4) For *multi-band connector* and single band tests, repeat the steps above per involved band where single band test configurations and test models shall apply with no carrier activated in the other band.

7.8.5 Test requirements

7.8.5.1 *IAB-DU*

For *IAB-DU*, the throughput shall be $\geq 95\%$ of the maximum throughput of the reference measurement channel as specified in annex A.1 with parameters specified in table 7.8.5.1-1 for Wide Area IAB-DU, in table 7.8.5.1-2 for Medium Range IAB-DU and in table 7.8.5.1-3 for Local Area IAB-DU. The characteristics of the interfering signal is further specified in annex E.

Table 7.8.5.1-1: Wide Area IAB-DU in-channel selectivity

IAB-DU channel bandwidth (MHz)	Subcarrier spacing (kHz)	Reference measurement channel	Wanted signal mean power (dBm)			Interfering signal mean power (dBm)	Type of interfering signal
			$f \leq 3.0$ GHz	3.0 GHz < $f \leq 4.2$ GHz	4.2 GHz < $f \leq 6.0$ GHz		
10, 15, 20, 25, 30	15	G-FR1-A1-1	-97.3	-96.9	-96.6	-77.4	DFT-s-OFDM NR signal, 15 kHz SCS, 25 RBs
40, 50	15	G-FR1-A1-4	-90.9	-90.5	-90.2	-71.4	DFT-s-OFDM NR signal, 15 kHz SCS, 100 RBs
10, 15, 20, 25, 30	30	G-FR1-A1-2	-97.4	-97	-96.7	-78.4	DFT-s-OFDM NR signal, 30 kHz SCS, 10 RBs
40, 50, 60, 70, 80, 90, 100	30	G-FR1-A1-5	-91.2	-90.8	-90.5	-71.4	DFT-s-OFDM NR signal, 30 kHz SCS, 50 RBs
10, 15, 20, 25, 30	60	G-FR1-A1-9	-96.8	-96.4	-96.1	-78.4	DFT-s-OFDM NR signal, 60 kHz SCS, 5 RBs
40, 50, 60, 70, 80, 90, 100	60	G-FR1-A1-6	-91.3	-90.9	-90.6	-71.6	DFT-s-OFDM NR signal, 60 kHz SCS, 24 RBs

NOTE: Wanted and interfering signal are placed adjacently around F_c , where the F_c is defined for IAB-DU channel bandwidth of the wanted signal according to the clause 5.4.2.2 in TS 38.174 [2]. The aggregated wanted and interferer signal shall be centred in the IAB-DU channel bandwidth of the wanted signal.

Table 7.8.5.1-2: Medium Range IAB-DU in-channel selectivity

IAB-DU channel bandwidth (MHz)	Subcarrier spacing (kHz)	Reference measurement channel	Wanted signal mean power (dBm)			Interfering signal mean power (dBm)	Type of interfering signal
			$f \leq 3.0$ GHz	3.0 GHz < $f \leq 4.2$ GHz	4.2 GHz < $f \leq 6.0$ GHz		
10, 15, 20, 25, 30	15	G-FR1-A1-1	-92.3	-91.9	-91.6	-72.4	DFT-s-OFDM NR signal, 15 kHz SCS, 25 RBs
40, 50	15	G-FR1-A1-4	-85.9	-85.5	-85.2	-66.4	DFT-s-OFDM NR signal, 15 kHz SCS, 100 RBs
10, 15, 20, 25, 30	30	G-FR1-A1-2	-92.4	-92	-91.7	-73.4	DFT-s-OFDM NR signal, 30 kHz SCS, 10 RBs
40, 50, 60, 70, 80, 90, 100	30	G-FR1-A1-5	-86.2	-85.8	-85.5	-66.4	DFT-s-OFDM NR signal, 30 kHz SCS, 50 RBs
10, 15, 20, 25, 30	60	G-FR1-A1-9	-91.8	-91.4	-91.1	-73.4	DFT-s-OFDM NR signal, 60 kHz SCS, 5 RBs
40, 50, 60, 70, 80, 90, 100	60	G-FR1-A1-6	-86.3	-85.9	-85.6	-66.6	DFT-s-OFDM NR signal, 60 kHz SCS, 24 RBs

NOTE: Wanted and interfering signal are placed adjacently around F_c , where the F_c is defined for IAB-DU channel bandwidth of the wanted signal according to the clause 5.4.2.2 in TS 38.174 [2]. The aggregated wanted and interferer signal shall be centred in the IAB-DU channel bandwidth of the wanted signal.

Table 7.8.5.1-3: Local area IAB-DU in-channel selectivity

IAB-DU channel bandwidth (MHz)	Subcarrier spacing (kHz)	Reference measurement channel	Wanted signal mean power (dBm)			Interfering signal mean power (dBm)	Type of interfering signal
			$f \leq 3.0$ GHz	3.0 GHz < $f \leq 4.2$ GHz	4.2 GHz < $f \leq 6.0$ GHz		
10, 15, 20, 25, 30	15	G-FR1-A1-1	-89.3	-88.9	-88.6	-69.4	DFT-s-OFDM NR signal, 15 kHz SCS, 25 RB
40, 50	15	G-FR1-A1-4	-82.9	-82.5	-82.2	-63.4	DFT-s-OFDM NR signal, 15 kHz SCS, 100 RBs
10, 15, 20, 25, 30	30	G-FR1-A1-2	-89.4	-89	-88.7	-70.4	DFT-s-OFDM NR signal, 30 kHz SCS, 10 RBs
40, 50, 60, 70, 80, 90, 100	30	G-FR1-A1-5	-83.2	-82.8	-82.5	-63.4	DFT-s-OFDM NR signal, 30 kHz SCS, 50 RBs
10, 15, 20, 25, 30	60	G-FR1-A1-9	-88.8	-88.4	-88.1	-70.4	DFT-s-OFDM NR signal, 60 kHz SCS, 5 RBs
40, 50, 60, 70, 80, 90, 100	60	G-FR1-A1-6	-83.3	-82.9	-82.6	-63.6	DFT-s-OFDM NR signal, 60 kHz SCS, 24 RBs

NOTE: Wanted and interfering signal are placed adjacently around F_c , where the F_c is defined for IAB-DU channel bandwidth of the wanted signal according to the clause 5.4.2.2 in TS 38.174 [2]. The aggregated wanted and interferer signal shall be centred in the IAB-DU channel bandwidth of the wanted signal.

8 Conducted performance requirements

8.1 IAB-DU performance requirements

8.1.1 General

8.1.1.1 Scope and definitions

Conducted performance requirements specify the ability of the IAB type 1-H to correctly demodulate signals in various conditions and configurations. Conducted performance requirements are specified at the TAB connector(s).

Conducted performance requirements for the IAB-DU are specified for the fixed reference channels and the propagation conditions defined in TS 38.174 [2] annex A and annex F, respectively. The requirements only apply to those FRCs that are supported by the IAB-DU.

Unless stated otherwise, performance requirements apply for a single carrier only. Performance requirements for a IAB-DU supporting CA are defined in terms of single carrier requirements.

The method of synchronization with the TE is left to implementation. Neither the use of downlink signal configuration nor the use of proprietary means is precluded. In tests performed with signal generators a synchronization signal may be provided between the IAB-DU and the signal generator, or a common (e.g., GNSS) source may be provided to both IAB node and the signal generator, to enable correct timing of the wanted signal.

The SNR used in this clause is specified based on a single carrier and defined as:

$$\text{SNR} = S / N$$

Where:

S is the total signal energy in a slot on a single TAB connector.

N is the noise energy in a bandwidth corresponding to the transmission bandwidth over the duration of a slot.

8.1.1.2 Applicability rule

8.1.1.2.1 General

Unless otherwise stated, for a IAB-DU supporting more than 8 *TAB connectors* (see D.37 in table 4.6-1), the performance requirement tests for 8 RX antennas shall apply, and the specific connectors used for testing are based on manufacturer declaration.

Unless otherwise stated, for a IAB-DU supporting different numbers of *TAB connectors* (see D.37 in table 4.6-1), the tests with low MIMO correlation level shall apply only for the highest numbers of supported connectors, and the specific connectors used for testing are based on manufacturer declaration.

8.1.1.2.2 Applicability of PUSCH performance requirements

8.1.1.2.2.1 Applicability of requirements for different subcarrier spacings

Unless otherwise stated, PUSCH requirement tests shall apply only for each subcarrier spacing declared to be supported (see D.14 in table 4.6-1).

Unless otherwise stated, if IAB-DU supports more than one SCS then PUSCH requirement tests with highest modulation order (see D.109 in table 4.6-1) shall apply only with lowest supported SCS and PUSCH requirement tests with other modulation orders (see D.109 in table 4.6-1) shall apply only with highest supported SCS. Otherwise, all modulation orders are tested on supported SCS.

8.1.1.2.2.2 Applicability of requirements for different channel bandwidths

For each subcarrier spacing declared to be supported, the test requirements for a specific channel bandwidth shall apply only if the IAB-DU supports it (see D.14 in table 4.6-1).

Unless otherwise stated, for each subcarrier spacing declared to be supported, the tests shall be done only for the widest supported channel bandwidth. If performance requirement is not specified for this widest supported channel bandwidth, the tests shall be done by using performance requirement for the closest channel bandwidth lower than this widest supported bandwidth; the tested PRBs shall then be centred in this widest supported channel bandwidth.

8.1.1.2.2.3 Applicability of requirements for different configurations

Unless otherwise stated, PUSCH requirement tests shall apply only for the mapping type declared to be supported (see D.100 in table 4.6-1). If both mapping type A and type B are declared to be supported, the tests shall be done for either type A or type B; the same chosen mapping type shall then be used for all tests except the requirement for PUSCH mapping Type B with 2 symbol length allocated.

8.1.1.2.2.4 Applicability of requirements for uplink carrier aggregation

The tests for uplink carrier aggregation shall be carried out according to the declaration (see D.107 in table 4.6-1).

Unless otherwise stated, the tests for uplink carrier aggregation shall apply only for PUSCH with transform precoding disabled and shall be conducted on per component carrier basis.

8.1.1.2.2.5 Applicability of requirements for TDD with different UL-DL patterns

Unless otherwise stated, for each subcarrier spacing declared to be supported, if IAB-DU supports multiple TDD UL-DL patterns, only one of the supported TDD UL-DL patterns shall be used for all tests.

8.1.1.2.2.6 Applicability of requirements for transform precoding

Unless otherwise stated, the tests with transform precoding enabled shall apply only, if the IAB-DU supports it (see D.109 in table 4.6-1).

8.1.1.2.3 Applicability of PUCCH performance requirements

8.1.1.2.3.1 Applicability of requirements for different formats

Unless otherwise stated, PUCCH requirement tests shall apply only for each PUCCH format declared to be supported (see D.102 in table 4.6-1).

8.1.1.2.3.2 Applicability of requirements for different subcarrier spacings

Unless otherwise stated, PUCCH requirement tests shall apply only for each subcarrier spacing declared to be supported (see D.14 in table 4.6-1). If multiple subcarrier spacings are declared to be supported, each supported PUCCH format can be tested on one subcarrier spacing.

8.1.1.2.3.3 Applicability of requirements for different channel bandwidths

For each subcarrier spacing declared to be supported by the IAB-DU, the test requirements for a specific channel bandwidth shall apply only if the IAB-DU supports it (see D.14 in table 4.6-1).

Unless otherwise stated, for each subcarrier spacing declared to be supported, the tests shall be done only for the widest supported channel bandwidth. If performance requirement is not specified for this widest supported channel bandwidth, the tests shall be done by using performance requirement for the closest channel bandwidth lower than this widest supported bandwidth; the tested PRIAB-DU shall then be centred in this widest supported channel bandwidth.

8.1.1.2.3.4 Applicability of requirements for different configurations

Unless otherwise stated, PUCCH format 3 requirement tests shall apply only for the additional DM-RS configuration declared to be supported (see D.104 in table 4.6-1). If both options (without and with additional DM-RS) are declared to be supported, the tests shall be done for either without or with additional DM-RS; the same chosen option shall then be used for all tests.

Unless otherwise stated, PUCCH format 4 requirement tests shall apply only for the additional DM-RS configuration declared to be supported (see D.105 in table 4.6-1). If both options (without and with additional DM-RS) are declared to be supported, the tests shall be done for either without or with additional DM-RS; the same chosen option shall then be used for all tests.

8.1.1.2.3.5 Applicability of requirements for multi-slot PUCCH

Unless otherwise stated, multi-slot PUCCH requirement tests shall apply only if the IAB-DU supports it (see D.106 in table 4.6-1).

8.1.1.2.4 Applicability of PRACH performance requirements

8.1.1.2.4.1 Applicability of requirements for different formats

Unless otherwise stated, PRACH requirement tests shall apply only for PRACH formats declared to be supported (see D.103 in table 4.6-1).

For IAB-DU declares to support more than one PRACH formats, limit the number of tests to any two cases chosen by the manufacturer. If IAB-DU declares to support more than one PRACH formats where formats for both long and short PRACH sequences are presented, require choosing formats with different sequences (see D.103 in table 4.6-1).

8.1.1.2.4.2 Applicability of requirements for different subcarrier spacings

Unless otherwise stated, for each PRACH format with short sequence declared to be supported, for each FR, the tests shall apply only for the smallest supported subcarrier spacing in the FR (see D.103 in table 4.6-1).

8.1.1.2.4.3 Applicability of requirements for different channel bandwidths

Unless otherwise stated, for the subcarrier spacing to be tested, the test requirements shall apply only for anyone channel bandwidth declared to be supported (see D.14 in table 4.6-1).

8.1.2 Performance requirements for PUSCH

8.1.2.1 Performance requirements for PUSCH with transform precoding disabled

8.1.2.1.1 Definition and applicability

The performance requirement of PUSCH is determined by a minimum required throughput for a given SNR. The required throughput is expressed as a fraction of maximum throughput for the FRCs listed in annex A. The performance requirements assume HARQ re-transmissions.

Which specific test(s) are applicable to IAB-DU is based on the test applicability rules defined in clause 8.1.1.2.2.

8.1.2.1.2 Minimum requirement

The minimum requirement is in TS 38.174 [2] clause 8.1.2.1.

8.1.2.1.3 Test purpose

The test shall verify the receiver's ability to achieve throughput under multipath fading propagation conditions for a given SNR.

8.1.2.1.4 Method of test

8.1.2.1.4.1 Initial conditions

Test environment: Normal, see annex B.2.

RF channels to be tested for single carrier: M ; see clause 4.9.1.

RF channels to be tested for carrier aggregation: $M_{\text{BW Channel CA}}$; see clause 4.9.1.

8.1.2.1.4.2 Test procedure

- 1) Connect the IAB-DU tester generating the wanted signal, multipath fading simulators and AWGN generators to all IAB-DU *TAB connectors* for diversity reception via a combining network as shown in annex D. 3.
- 2) Adjust the AWGN generator, according to the channel bandwidth, defined in table 8.1.2.1.4.2-1.

Table 8.1.2.1.4.2-1: AWGN power level at the IAB-DU input

Sub-carrier spacing (kHz)	Channel bandwidth (MHz)	AWGN power level
15 kHz	10	-83.3 dBm / 9.36MHz
	20	-80.2 dBm / 19.08MHz
30 kHz	10	-83.6 dBm / 8.64MHz
	20	-80.4 dBm / 18.36MHz
	40	-77.2 dBm / 38.16MHz
	100	-73.1 dBm / 98.28MHz

- 3) The characteristics of the wanted signal shall be configured according to the corresponding UL reference measurement channel defined in annex A and the test parameters in table 8.2.1.4.2-2.

Table 8.2.1.4.2-2: Test parameters for testing PUSCH

Parameter		Value
Transform precoding		Disabled
Cyclic prefix		Normal
Default TDD UL-DL pattern (Note 1)		15 kHz SCS: 3D1S1U, S=10D:2G:2U 30 kHz SCS: 7D1S2U, S=6D:4G:4U
HARQ	Maximum number of HARQ transmissions	4
	RV sequence	0, 2, 3, 1
DM-RS	DM-RS configuration type	1
	DM-RS duration	single-symbol DM-RS
	Additional DM-RS position	pos1
	Number of DM-RS CDM group(s) without data	2
	Ratio of PUSCH EPRE to DM-RS EPRE	-3 dB
	DM-RS port(s)	{0}, {0, 1}
	DM-RS sequence generation	$N_{ID}^0=0$, $n_{SCID}=0$
Time domain resource assignment	PUSCH mapping type	A, B
	Start symbol	0
	Allocation length	14
Frequency domain resource assignment	RB assignment	Full applicable test bandwidth
	Frequency hopping	Disabled
TPMI index for 2Tx two layer spatial multiplexing transmission		0
Code block group based PUSCH transmission		Disabled
NOTE 1: The same requirements are applicable with different UL-DL patterns.		

- 4) The multipath fading emulators shall be configured according to the corresponding channel model defined in annex F.
- 5) Adjust the equipment so that required SNR specified in table 8.1.2.1.5-1 to 8.1.2.1.5-14 is achieved at the IAB-DU input.
- 6) For each of the reference channels in table 8.1.2.1.5-1 to 8.1.2.1.5-14 applicable for the base station, measure the throughput.

8.1.2.1.5 Test requirement

The throughput measured according to clause 8.1.2.1.4.2 shall not be below the limits for the SNR levels specified in table 8.1.2.1.5-1 to 8.1.2.1.5-14.

Table 8.1.2.1.5-1: Void

Table 8.1.2.1.5-2: Test requirements for PUSCH with 70% of maximum throughput, Type A, 10 MHz channel bandwidth, 15 kHz SCS

Number of TX antennas	Number of RX antennas	Propagation conditions and correlation matrix (annex F)	FRC (annex A)	Additional DM-RS position	SNR (dB)
1	2	TDLB100-400 Low	D-FR1-A.2.1-2	pos1	-1.9
		TDLC300-100 Low	D-FR1-A.2.3-2	pos1	10.8
		TDLA30-10 Low	D-FR1-A.2.4-2	pos1	12.8
	4	TDLB100-400 Low	D-FR1-A.2.1-2	pos1	-5.4
		TDLC300-100 Low	D-FR1-A.2.3-2	pos1	6.9
		TDLA30-10 Low	D-FR1-A.2.4-2	pos1	9.2
	8	TDLB100-400 Low	D-FR1-A.2.1-2	pos1	-8.1
		TDLC300-100 Low	D-FR1-A.2.3-2	pos1	3.7
		TDLA30-10 Low	D-FR1-A.2.4-2	pos1	6.1
2	2	TDLB100-400 Low	D-FR1-A.2.1-9	pos1	2.5
		TDLC300-100 Low	D-FR1-A.2.3-9	pos1	19.1
	4	TDLB100-400 Low	D-FR1-A.2.1-9	pos1	-1.2
		TDLC300-100 Low	D-FR1-A.2.3-9	pos1	12.0
	8	TDLB100-400 Low	D-FR1-A.2.1-9	pos1	-4.7
		TDLC300-100 Low	D-FR1-A.2.3-9	pos1	7.6

Table 8.1.2.1.5-3: Test requirements for PUSCH with 70% of maximum throughput, Type A, 20 MHz channel bandwidth, 15 kHz SCS

Number of TX antennas	Number of RX antennas	Propagation conditions and correlation matrix (annex F)	FRC (annex A)	Additional DM-RS position	SNR (dB)
1	2	TDLB100-400 Low	D-FR1-A.2.1-3	pos1	-1.5
		TDLC300-100 Low	D-FR1-A.2.3-3	pos1	10.6
		TDLA30-10 Low	D-FR1-A.2.4-3	pos1	13.0
	4	TDLB100-400 Low	D-FR1-A.2.1-3	pos1	-4.9
		TDLC300-100 Low	D-FR1-A.2.3-3	pos1	6.8
		TDLA30-10 Low	D-FR1-A.2.4-3	pos1	9.2
	8	TDLB100-400 Low	D-FR1-A.2.1-3	pos1	-7.9
		TDLC300-100 Low	D-FR1-A.2.3-3	pos1	3.6
		TDLA30-10 Low	D-FR1-A.2.4-3	pos1	6.1
2	2	TDLB100-400 Low	D-FR1-A.2.1-10	pos1	2.9
		TDLC300-100 Low	D-FR1-A.2.3-10	pos1	19.1
	4	TDLB100-400 Low	D-FR1-A.2.1-10	pos1	-1.0
		TDLC300-100 Low	D-FR1-A.2.3-10	pos1	11.9
	8	TDLB100-400 Low	D-FR1-A.2.1-10	pos1	-4.5
		TDLC300-100 Low	D-FR1-A.2.3-10	pos1	7.7

Table 8.1.2.1.5-4: Test requirements for PUSCH with 70% of maximum throughput, Type A, 10 MHz channel bandwidth, 30 kHz SCS

Number of TX antennas	Number of RX antennas	Propagation conditions and correlation matrix (annex F)	FRC (annex A)	Additional DM-RS position	SNR (dB)
1	2	TDLB100-400 Low	D-FR1-A.2.1-4	pos1	-1.7
		TDLC300-100 Low	D-FR1-A.2.3-4	pos1	10.8
		TDLA30-10 Low	D-FR1-A.2.4-4	pos1	13.4
	4	TDLB100-400 Low	D-FR1-A.2.1-4	pos1	-5.0
		TDLC300-100 Low	D-FR1-A.2.3-4	pos1	7.0
		TDLA30-10 Low	D-FR1-A.2.4-4	pos1	9.2
	8	TDLB100-400 Low	D-FR1-A.2.1-4	pos1	-8.0
		TDLC300-100 Low	D-FR1-A.2.3-4	pos1	3.9
		TDLA30-10 Low	D-FR1-A.2.4-4	pos1	6.1
2	2	TDLB100-400 Low	D-FR1-A.2.1-11	pos1	2.1
		TDLC300-100 Low	D-FR1-A.2.3-11	pos1	19.2
	4	TDLB100-400 Low	D-FR1-A.2.1-11	pos1	-1.4
		TDLC300-100 Low	D-FR1-A.2.3-11	pos1	12.0
	8	TDLB100-400 Low	D-FR1-A.2.1-11	pos1	-4.4
		TDLC300-100 Low	D-FR1-A.2.3-11	pos1	7.8

Table 8.1.2.1.5-5: Test requirements for PUSCH with 70% of maximum throughput, Type A, 20 MHz channel bandwidth, 30 kHz SCS

Number of TX antennas	Number of RX antennas	Propagation conditions and correlation matrix (annex F)	FRC (annex A)	Additional DM-RS position	SNR (dB)
1	2	TDLB100-400 Low	D-FR1-A.2.1-5	pos1	-2.3
		TDLC300-100 Low	D-FR1-A.2.3-5	pos1	10.8
		TDLA30-10 Low	D-FR1-A.2.4-5	pos1	13.1
	4	TDLB100-400 Low	D-FR1-A.2.1-5	pos1	-5.4
		TDLC300-100 Low	D-FR1-A.2.3-5	pos1	7.0
		TDLA30-10 Low	D-FR1-A.2.4-5	pos1	9.2
	8	TDLB100-400 Low	D-FR1-A.2.1-5	pos1	-8.2
		TDLC300-100 Low	D-FR1-A.2.3-5	pos1	3.8
		TDLA30-10 Low	D-FR1-A.2.4-5	pos1	6.1
2	2	TDLB100-400 Low	D-FR1-A.2.1-12	pos1	2.1
		TDLC300-100 Low	D-FR1-A.2.3-12	pos1	18.9
	4	TDLB100-400 Low	D-FR1-A.2.1-12	pos1	-1.4
		TDLC300-100 Low	D-FR1-A.2.3-12	pos1	12.1
	8	TDLB100-400 Low	D-FR1-A.2.1-12	pos1	-4.5
		TDLC300-100 Low	D-FR1-A.2.3-12	pos1	7.7

Table 8.1.2.1.5-6: Test requirements for PUSCH with 70% of maximum throughput, Type A, 40 MHz channel bandwidth, 30 kHz SCS

Number of TX antennas	Number of RX antennas	Propagation conditions and correlation matrix (annex F)	FRC (annex A)	Additional DM-RS position	SNR (dB)
1	2	TDLB100-400 Low	D-FR1-A.2.1-6	pos1	-1.9
		TDLC300-100 Low	D-FR1-A.2.3-6	pos1	10.6
		TDLA30-10 Low	D-FR1-A.2.4-6	pos1	13.0
	4	TDLB100-400 Low	D-FR1-A.2.1-6	pos1	-5.2
		TDLC300-100 Low	D-FR1-A.2.3-6	pos1	6.9
		TDLA30-10 Low	D-FR1-A.2.4-6	pos1	9.1
	8	TDLB100-400 Low	D-FR1-A.2.1-6	pos1	-8.1
		TDLC300-100 Low	D-FR1-A.2.3-6	pos1	3.7
		TDLA30-10 Low	D-FR1-A.2.4-6	pos1	6.0
2	2	TDLB100-400 Low	D-FR1-A.2.1-13	pos1	2.1
		TDLC300-100 Low	D-FR1-A.2.3-13	pos1	20.3
	4	TDLB100-400 Low	D-FR1-A.2.1-13	pos1	-1.5
		TDLC300-100 Low	D-FR1-A.2.3-13	pos1	12.1
	8	TDLB100-400 Low	D-FR1-A.2.1-13	pos1	-4.4
		TDLC300-100 Low	D-FR1-A.2.3-13	pos1	7.7

Table 8.1.2.1.5-7: Test requirements for PUSCH with 70% of maximum throughput, Type A, 100 MHz channel bandwidth, 30 kHz SCS

Number of TX antennas	Number of RX antennas	Propagation conditions and correlation matrix (annex F)	FRC (annex A)	Additional DM-RS position	SNR (dB)
1	2	TDLB100-400 Low	D-FR1-A.2.1-7	pos1	-2.2
		TDLC300-100 Low	D-FR1-A.2.3-7	pos1	10.8
		TDLA30-10 Low	D-FR1-A.2.4-7	pos1	13.6
	4	TDLB100-400 Low	D-FR1-A.2.1-7	pos1	-5.2
		TDLC300-100 Low	D-FR1-A.2.3-7	pos1	7.1
		TDLA30-10 Low	D-FR1-A.2.4-7	pos1	9.6
	8	TDLB100-400 Low	D-FR1-A.2.1-7	pos1	-8.1
		TDLC300-100 Low	D-FR1-A.2.3-7	pos1	3.8
		TDLA30-10 Low	D-FR1-A.2.4-7	pos1	6.4
2	2	TDLB100-400 Low	D-FR1-A.2.1-14	pos1	2.2
		TDLC300-100 Low	D-FR1-A.2.3-14	pos1	20.0
	4	TDLB100-400 Low	D-FR1-A.2.1-14	pos1	-1.4
		TDLC300-100 Low	D-FR1-A.2.3-14	pos1	12.4
	8	TDLB100-400 Low	D-FR1-A.2.1-14	pos1	-4.4
		TDLC300-100 Low	D-FR1-A.2.3-14	pos1	7.9

Table 8.1.2.1.5-8: Void

Table 8.1.2.1.5-9: Test requirements for PUSCH with 70% of maximum throughput, Type B, 10 MHz channel bandwidth, 15 kHz SCS

Number of TX antennas	Number of RX antennas	Propagation conditions and correlation matrix (annex F)	FRC (annex A)	Additional DM-RS position	SNR (dB)
1	2	TDLB100-400 Low	D-FR1-A.2.1-2	pos1	-1.7
		TDLC300-100 Low	D-FR1-A.2.3-2	pos1	11.1
		TDLA30-10 Low	D-FR1-A.2.4-2	pos1	13.2
	4	TDLB100-400 Low	D-FR1-A.2.1-2	pos1	-5.1
		TDLC300-100 Low	D-FR1-A.2.3-2	pos1	7.1
		TDLA30-10 Low	D-FR1-A.2.4-2	pos1	9.5
	8	TDLB100-400 Low	D-FR1-A.2.1-2	pos1	-8.4
		TDLC300-100 Low	D-FR1-A.2.3-2	pos1	3.8
		TDLA30-10 Low	D-FR1-A.2.4-2	pos1	6.4
2	2	TDLB100-400 Low	D-FR1-A.2.1-9	pos1	2.8
		TDLC300-100 Low	D-FR1-A.2.3-9	pos1	19.5
	4	TDLB100-400 Low	D-FR1-A.2.1-9	pos1	-1.5
		TDLC300-100 Low	D-FR1-A.2.3-9	pos1	12.1
	8	TDLB100-400 Low	D-FR1-A.2.1-9	pos1	-4.4
		TDLC300-100 Low	D-FR1-A.2.3-9	pos1	7.8

Table 8.1.2.1.5-10: Test requirements for PUSCH with 70% of maximum throughput, Type B, 20 MHz channel bandwidth, 15 kHz SCS

Number of TX antennas	Number of RX antennas	Propagation conditions and correlation matrix (annex F)	FRC (annex A)	Additional DM-RS position	SNR (dB)
1	2	TDLB100-400 Low	D-FR1-A.2.1-3	pos1	-1.5
		TDLC300-100 Low	D-FR1-A.2.3-3	pos1	11.0
		TDLA30-10 Low	D-FR1-A.2.4-3	pos1	12.9
	4	TDLB100-400 Low	D-FR1-A.2.1-3	pos1	-5.1
		TDLC300-100 Low	D-FR1-A.2.3-3	pos1	6.9
		TDLA30-10 Low	D-FR1-A.2.4-3	pos1	9.4
	8	TDLB100-400 Low	D-FR1-A.2.1-3	pos1	-7.9
		TDLC300-100 Low	D-FR1-A.2.3-3	pos1	3.7
		TDLA30-10 Low	D-FR1-A.2.4-3	pos1	6.3
2	2	TDLB100-400 Low	D-FR1-A.2.1-10	pos1	2.4
		TDLC300-100 Low	D-FR1-A.2.3-10	pos1	18.9
	4	TDLB100-400 Low	D-FR1-A.2.1-10	pos1	-1.2
		TDLC300-100 Low	D-FR1-A.2.3-10	pos1	12.0
	8	TDLB100-400 Low	D-FR1-A.2.1-10	pos1	-4.5
		TDLC300-100 Low	D-FR1-A.2.3-10	pos1	7.7

Table 8.1.2.1.5-11: Test requirements for PUSCH with 70% of maximum throughput, Type B, 10 MHz channel bandwidth, 30 kHz SCS

Number of TX antennas	Number of RX antennas	Propagation conditions and correlation matrix (annex F)	FRC (annex A)	Additional DM-RS position	SNR (dB)
1	2	TDLB100-400 Low	D-FR1-A.2.1-4	pos1	-1.8
		TDLC300-100 Low	D-FR1-A.2.3-4	pos1	10.7
		TDLA30-10 Low	D-FR1-A.2.4-4	pos1	13.1
	4	TDLB100-400 Low	D-FR1-A.2.1-4	pos1	-5.1
		TDLC300-100 Low	D-FR1-A.2.3-4	pos1	7.0
		TDLA30-10 Low	D-FR1-A.2.4-4	pos1	9.2
	8	TDLB100-400 Low	D-FR1-A.2.1-4	pos1	-8.2
		TDLC300-100 Low	D-FR1-A.2.3-4	pos1	3.8
		TDLA30-10 Low	D-FR1-A.2.4-4	pos1	6.2
2	2	TDLB100-400 Low	D-FR1-A.2.1-11	pos1	1.9
		TDLC300-100 Low	D-FR1-A.2.3-11	pos1	19.3
	4	TDLB100-400 Low	D-FR1-A.2.1-11	pos1	-1.7
		TDLC300-100 Low	D-FR1-A.2.3-11	pos1	12.1
	8	TDLB100-400 Low	D-FR1-A.2.1-11	pos1	-4.8
		TDLC300-100 Low	D-FR1-A.2.3-11	pos1	7.8

Table 8.1.2.1.5-12: Test requirements for PUSCH with 70% of maximum throughput, Type B, 20 MHz channel bandwidth, 30 kHz SCS

Number of TX antennas	Number of RX antennas	Propagation conditions and correlation matrix (annex F)	FRC (annex A)	Additional DM-RS position	SNR (dB)
1	2	TDLB100-400 Low	D-FR1-A.2.1-5	pos1	-2.3
		TDLC300-100 Low	D-FR1-A.2.3-5	pos1	10.7
		TDLA30-10 Low	D-FR1-A.2.4-5	pos1	13.1
	4	TDLB100-400 Low	D-FR1-A.2.1-5	pos1	-5.4
		TDLC300-100 Low	D-FR1-A.2.3-5	pos1	6.9
		TDLA30-10 Low	D-FR1-A.2.4-5	pos1	9.2
	8	TDLB100-400 Low	D-FR1-A.2.1-5	pos1	-8.4
		TDLC300-100 Low	D-FR1-A.2.3-5	pos1	3.7
		TDLA30-10 Low	D-FR1-A.2.4-5	pos1	6.2
2	2	TDLB100-400 Low	D-FR1-A.2.1-12	pos1	2.1
		TDLC300-100 Low	D-FR1-A.2.3-12	pos1	19.0
	4	TDLB100-400 Low	D-FR1-A.2.1-12	pos1	-1.5
		TDLC300-100 Low	D-FR1-A.2.3-12	pos1	12.0
	8	TDLB100-400 Low	D-FR1-A.2.1-12	pos1	-4.6
		TDLC300-100 Low	D-FR1-A.2.2-12	pos1	7.8

Table 8.1.2.1.5-13: Test requirements for PUSCH with 70% of maximum throughput, Type B, 40 MHz channel bandwidth, 30 kHz SCS

Number of TX antennas	Number of RX antennas	Propagation conditions and correlation matrix (annex F)	FRC (annex A)	Additional DM-RS position	SNR (dB)
1	2	TDLB100-400 Low	D-FR1-A.2.1-6	pos1	-1.9
		TDLC300-100 Low	D-FR1-A.2.3-6	pos1	10.6
		TDLA30-10 Low	D-FR1-A.2.4-6	pos1	13.1
	4	TDLB100-400 Low	D-FR1-A.2.1-6	pos1	-5.2
		TDLC300-100 Low	D-FR1-A.2.3-6	pos1	6.8
		TDLA30-10 Low	D-FR1-A.2.4-6	pos1	9.3
	8	TDLB100-400 Low	D-FR1-A.2.1-6	pos1	-8.2
		TDLC300-100 Low	D-FR1-A.2.3-6	pos1	3.6
		TDLA30-10 Low	D-FR1-A.2.4-6	pos1	6.1
2	2	TDLB100-400 Low	D-FR1-A.2.1-13	pos1	2.5
		TDLC300-100 Low	D-FR1-A.2.3-13	pos1	19.5
	4	TDLB100-400 Low	D-FR1-A.2.1-13	pos1	-1.3
		TDLC300-100 Low	D-FR1-A.2.3-13	pos1	12.0
	8	TDLB100-400 Low	D-FR1-A.2.1-13	pos1	-4.4
		TDLC300-100 Low	D-FR1-A.2.3-13	pos1	7.7

Table 8.1.2.1.5-14: Test requirements for PUSCH with 70% of maximum throughput, Type B, 100 MHz channel bandwidth, 30 kHz SCS

Number of TX antennas	Number of RX antennas	Propagation conditions and correlation matrix (annex F)	FRC (annex A)	Additional DM-RS position	SNR (dB)
1	2	TDLB100-400 Low	D-FR1-A.2.1-7	pos1	-1.9
		TDLC300-100 Low	D-FR1-A.2.3-7	pos1	10.7
		TDLA30-10 Low	D-FR1-A.2.4-7	pos1	13.7
	4	TDLB100-400 Low	D-FR1-A.2.1-7	pos1	-5.2
		TDLC300-100 Low	D-FR1-A.2.3-7	pos1	6.9
		TDLA30-10 Low	D-FR1-A.2.4-7	pos1	9.8
	8	TDLB100-400 Low	D-FR1-A.2.1-7	pos1	-8.1
		TDLC300-100 Low	D-FR1-A.2.3-7	pos1	3.7
		TDLA30-10 Low	D-FR1-A.2.4-7	pos1	6.5
2	2	TDLB100-400 Low	D-FR1-A.2.1-14	pos1	2.4
		TDLC300-100 Low	D-FR1-A.2.3-14	pos1	20.1
	4	TDLB100-400 Low	D-FR1-A.2.1-14	pos1	-1.4
		TDLC300-100 Low	D-FR1-A.2.3-14	pos1	12.4
	8	TDLB100-400 Low	D-FR1-A.2.1-14	pos1	-4.5
		TDLC300-100 Low	D-FR1-A.2.3-14	pos1	7.9

8.1.2.2 Performance requirements for PUSCH with transform precoding enabled

8.1.2.2.1 Definition and applicability

The performance requirement of PUSCH is determined by a minimum required throughput for a given SNR. The required throughput is expressed as a fraction of maximum throughput for the FRCs listed in annex A. The performance requirements assume HARQ re-transmissions.

Which specific test(s) are applicable to IAB-DU is based on the test applicability rules defined in clause 8.1.1.2.2.

8.1.2.2.2 Minimum requirement

The minimum requirement is in TS 38.174 [2], clause 8.1.2.2.

8.1.2.2.3 Test purpose

The test shall verify the receiver's ability to achieve throughput under multipath fading propagation conditions for a given SNR.

8.1.2.2.4 Method of test

8.1.2.2.4.1 Initial conditions

Test environment: Normal, see annex B.2.

RF channels to be tested for single carrier: M; see clause 4.9.1.

8.1.2.2.4.2 Test procedure

- 1) Connect the IAB-DU tester generating the wanted signal, multipath fading simulators and AWGN generators to all IAB-DU *TAB connectors* for diversity reception via a combining network as shown in annex D. 3.
- 2) Adjust the AWGN generator, according to the SCS and channel bandwidth, defined in table 8.1.2.2.4.2-1.

Table 8.1.2.2.4.2-1: AWGN power level at the IAB-DU input

Sub-carrier spacing (kHz)	Channel bandwidth (MHz)	AWGN power level
15	5	-86.5 dBm / 4.5MHz
30	10	-83.6 dBm / 8.64MHz

- 3) The characteristics of the wanted signal shall be configured according to the corresponding UL reference measurement channel defined in annex A and the test parameters in table 8.1.2.2.4.2-2.

Table 8.1.2.2.4.2-2: Test parameters for testing PUSCH

Parameter		Value
Transform precoding		Enabled
Cyclic prefix		Normal
Default TDD UL-DL pattern (Note 1)		15 kHz SCS: 3D1S1U, S=10D:2G:2U 30 kHz SCS: 7D1S2U, S=6D:4G:4U
HARQ	Maximum number of HARQ transmissions	4
	RV sequence	0, 2, 3, 1
DM-RS	DM-RS configuration type	1
	DM-RS duration	single-symbol DM-RS
	Additional DM-RS position	pos1
	Number of DM-RS CDM group(s) without data	2
	Ratio of PUSCH EPRE to DM-RS EPRE	-3 dB
	DM-RS port(s)	0
	DM-RS sequence generation	$N_{ID}^0=0$, group hopping and sequence hopping are disabled
Time domain resource assignment	PUSCH mapping type	A, B
	Start symbol	0
	Allocation length	14
Frequency domain resource assignment	RB assignment	15 kHz SCS: 25 PRBs in the middle of the test bandwidth 30 kHz SCS: 24 PRBs in the middle of the test bandwidth
	Frequency hopping	Disabled
Code block group based PUSCH transmission		Disabled
NOTE 1: The same requirements are applicable to different UL-DL patterns.		

- 4) The multipath fading emulators shall be configured according to the corresponding channel model defined in annex F.

- 5) Adjust the equipment so that required SNR specified in table 8.1.2.2.5-1 to 8.1.2.2.5-4 is achieved at the IAB-DU input.
- 6) For each of the reference channels in table 8.1.2.2.5-1 to 8.1.2.2.5-4 applicable for the base station, measure the throughput.

8.1.2.2.5 Test requirement

The throughput measured according to clause 8.1.2.2.4.2 shall not be below the limits for the SNR levels specified in table 8.1.2.2.5-1 to 8.1.2.2.5-4.

Table 8.1.2.2.5-1: Test requirements for PUSCH with 70% of maximum throughput, Type A, 5 MHz channel bandwidth, 15 kHz SCS

Number of TX antennas	Number of RX antennas	Propagation conditions and correlation matrix (annex F)	FRC (annex A)	Additional DM-RS position	SNR (dB)
1	2	TDLB100-400 Low	D-FR1-A.2.1-15	pos1	-1.8
	4	TDLB100-400 Low	D-FR1-A.2.1-15	pos1	-5.1
	8	TDLB100-400 Low	D-FR1-A.2.1-15	pos1	-7.9

Table 8.1.2.2.5-2: Test requirements for PUSCH with 70% of maximum throughput, Type A, 10 MHz channel bandwidth, 30 kHz SCS

Number of TX antennas	Number of RX antennas	Propagation conditions and correlation matrix (annex F)	FRC (annex A)	Additional DM-RS position	SNR (dB)
1	2	TDLB100-400 Low	D-FR1-A.2.1-16	pos1	-1.9
	4	TDLB100-400 Low	D-FR1-A.2.1-16	pos1	-5.1
	8	TDLB100-400 Low	D-FR1-A.2.1-16	pos1	-7.8

Table 8.1.2.2.5-3: Test requirements for PUSCH with 70% of maximum throughput, Type B, 5 MHz channel bandwidth, 15 kHz SCS

Number of TX antennas	Number of RX antennas	Propagation conditions and correlation matrix (annex F)	FRC (annex A)	Additional DM-RS position	SNR (dB)
1	2	TDLB100-400 Low	D-FR1-A.2.1-15	pos1	-1.7
	4	TDLB100-400 Low	D-FR1-A.2.1-15	pos1	-5.2
	8	TDLB100-400 Low	D-FR1-A.2.1-15	pos1	-8.0

Table 8.1.2.2.5-4: Test requirements for PUSCH with 70% of maximum throughput, Type B, 10 MHz channel bandwidth, 30 kHz SCS

Number of TX antennas	Number of RX antennas	Propagation conditions and correlation matrix (annex F)	FRC (annex A)	Additional DM-RS position	SNR (dB)
1	2	TDLB100-400 Low	D-FR1-A.2.1-16	pos1	-2.1
	4	TDLB100-400 Low	D-FR1-A.2.1-16	pos1	-5.4
	8	TDLB100-400 Low	D-FR1-A.2.1-16	pos1	-8.2

8.1.2.3 Performance requirements for UCI multiplexed on PUSCH

8.1.2.3.1 Definition and applicability

The performance requirement of UCI multiplexed on PUSCH is determined by two parameters: block error probability (BLER) of CSI part 1 and block error probability of CSI part 2. The performance is measured by the required SNR at block error probability of CSI part 1 not exceeding 0.1 %, and the required SNR at block error probability of CSI part 2 not exceeding 1 %.

The CSI part 1 BLER is defined as the probability of incorrectly decoding the CSI part 1 information when the CSI part 1 information is sent.

The CSI part 2 BLER is defined as the probability of incorrectly decoding the CSI part 2 information when the CSI part 2 information is sent.

In the test of UCI multiplexed on PUSCH, the UCI information only contains CSI part 1 and CSI part 2 information, there is no HACK/ACK information transmitted.

The number of UCI information bit payload per slot is defined for two cases as follows:

- 7 bits: 5 bits in CSI part 1, 2 bits in CSI part 2,
- 40 bits: 20 bits in CSI part 1, 20 bits in CSI part 2.

The 7 bits UCI information case is further defined with the bitmap [c0 c1 c2 c3 c4] = [0 1 0 1 0] for CSI part 1 information, where c0 is mapping to the RI information, and with the bitmap [c0 c1] = [1 0] for CSI part 2 information.

The 40 bits UCI information case is assumed random information bit selection.

In both tests, PUSCH data, CSI part 1 and CSI part 2 are transmitted simultaneously.

Which specific test(s) is applicable to IAB-DU is based on the test applicability rule defined in clause 8.1.1.2.2.

8.1.2.3.2 Minimum requirement

The minimum requirements are in TS 38.174 [2] clause 8.1.2.3.

8.1.2.3.3 Test purpose

The test shall verify the receiver's ability to detect UCI with CSI part 1 and CSI part 2 bits multiplexed on PUSCH under multipath fading propagation conditions for a given SNR.

8.1.2.3.4 Method of test

8.1.2.3.4.1 Initial conditions

Test environment: Normal, see annex B.2.

RF channels to be tested for single carrier: M; see clause 4.9.1.

8.1.2.3.4.2 Test procedure

- 1) Connect the IAB-DU tester generating the wanted signal, multipath fading simulators and AWGN generators to all IAB-DU *TAB connectors* for diversity reception via a combining network as shown in annex D. 3.
- 2) Adjust the AWGN generator, according to combination of SCS and channel bandwidth defined in table 8.1.2.3.4.2-1.

Table 8.2.3.4.2-1: AWGN power level at the IAB-DU input

Sub-carrier spacing (kHz)	Channel bandwidth (MHz)	AWGN power level
30	10	-80.6 dBm / 8.64 MHz

- 3) The characteristics of the wanted signal shall be configured according to the corresponding UL reference measurement channel defined in annex A and the specific test parameters are configured as below. The UCI information bit payload per slot is equal to 7 bits with CSI part 1 5bits, CSI part 2 2bit; and the UCI information bit payload per slot is equal to 40 bits with CSI part 1 20bits, CSI part 2 20bits.

Table: 8.1.2.3.4.2-2: Test parameters for testing UCI multiplexed on PUSCH

Parameter		Value
Transform precoding		Disabled
Cyclic prefix		Normal
Default TDD UL-DL pattern (Note 1)		30 kHz SCS: 7D1S2U, S=6D:4G:4U
HARQ	Maximum number of HARQ transmissions	1
	RV sequence	0
DM-RS	DM-RS configuration type	1
	DM-RS duration	Single-symbol DM-RS
	Additional DM-RS position	pos1
	Number of DM-RS CDM group(s) without data	2
	Ratio of PUSCH EPRE to DM-RS EPRE	-3 dB
	DM-RS port(s)	{0}
	DM-RS sequence generation	$N_{ID}^0 = 0, n_{SCID} = 0$
Time domain resource assignment	PUSCH mapping type	A, B
	Start symbol	0
	Allocation length	14
Frequency domain resource assignment	RB assignment	Full applicable test bandwidth
	Frequency hopping	Disabled
Code block group based PUSCH transmission		Disabled
UCI	Number of CSI part 1 and CSI part 2 information bit payload	{5,2}, {20, 20}
	<i>scaling</i>	1
	<i>betaOffsetACK-Index1</i>	11
	<i>betaOffsetCSI-Part1-Index1 and betaOffsetCSI-Part1-Index2</i>	13
	<i>betaOffsetCSI-Part2-Index1 and betaOffsetCSI-Part2-Index2</i>	13
	UCI partition for frequency hopping	Disabled

NOTE 1: The same requirements are applicable to different UL-DL patterns.

- 4) The multipath fading emulators shall be configured according to the corresponding channel model defined in annex F.
- 5) Adjust the equipment so that required SNR specified in table 8.1.2.3.5-1 to 8.1.2.3.5-4 is achieved at the IAB-DU input during the UCI multiplexed on PUSCH transmissions.
- 6) The tester sends a test pattern where UCI with CSI part 1 and CSI part 2 information can be multiplexed on PUSCH. The following statistics are kept: the number of incorrectly decoded CSI part 1 information transmission, the number of incorrectly decoded CSI part 2 information transmission during UCI multiplexed on PUSCH transmission.

8.1.2.3.5 Test requirement

The fractional of incorrectly decoded UCI with CSI part 1 according to clause 8.1.2.3.4.2 shall be less than 0.1 % for SNR listed in table 8.1.2.3.5-1 and table 8.1.2.3.5-2. The fractional of incorrectly decoded UCI with CSI part 2 according to clause 8.1.2.3.4.2 shall be less than 1 % for SNR listed in table 8.1.2.3.5-3 and table 8.1.2.3.5-4.

Table 8.1.2.3.5-1: Test requirements for UCI multiplexed on PUSCH, Type A, CSI part 1, 10 MHz channel bandwidth, 30 kHz SCS

Number of TX antennas	Number of RX antennas	Propagation conditions and correlation matrix (Annex F)	UCI bits (CSI part 1, CSI part 2)	Additional DM-RS position	FRC (Annex A)	SNR (dB)
1	2	TDLC300-100 Low	7 (5, 2)	pos1	D-FR1-A.2.3-4	6.0
	2	TDLC300-100 Low	40 (20,20)	pos1	D-FR1-A.2.3-4	4.9

Table 8.1.2.3.5-2: Test requirements for UCI multiplexed on PUSCH, Type B, CSI part 1, 10 MHz channel bandwidth, 30 kHz SCS

Number of TX antennas	Number of RX antennas	Propagation conditions and correlation matrix (Annex F)	UCI bits (CSI part 1, CSI part 2)	Additional DM-RS position	FRC (Annex A)	SNR (dB)
1	2	TDLC300-100 Low	7 (5, 2)	pos1	D-FR1-A.2.3-4	6.4
	2	TDLC300-100 Low	40 (20,20)	pos1	D-FR1-A.2.3-4	4.7

Table 8.1.2.3.5-3: Test requirements for UCI multiplexed on PUSCH, Type A, CSI part 2, 10 MHz channel bandwidth, 30 kHz SCS

Number of TX antennas	Number of RX antennas	Propagation conditions and correlation matrix (Annex F)	UCI bits (CSI part 1, CSI part 2)	Additional DM-RS position	FRC (Annex A)	SNR (dB)
1	2	TDLC300-100 Low	7 (5, 2)	pos1	D-FR1-A.2.3-4	0.4
	2	TDLC300-100 Low	40 (20,20)	pos1	D-FR1-A.2.3-4	3.0

Table 8.1.2.3.5-4: Test requirements for UCI multiplexed on PUSCH, Type B, CSI part 2, 10 MHz channel bandwidth, 30 kHz SCS

Number of TX antennas	Number of RX antennas	Propagation conditions and correlation matrix (Annex F)	UCI bits (CSI part 1, CSI part 2)	Additional DM-RS position	FRC (Annex A)	SNR (dB)
1	2	TDLC300-100 Low	7 (5, 2)	pos1	D-FR1-A.2.3-4	0.9
	2	TDLC300-100 Low	40 (20,20)	pos1	D-FR1-A.2.3-4	3.2

8.1.3 Performance requirements for PUCCH

8.1.3.1 Performance requirements for PUCCH format 0

8.1.3.1.1 Definition and applicability

The performance requirement of single user PUCCH format 0 for ACK missed detection is determined by the two parameters: probability of false detection of the ACK and the probability of detection of ACK. The performance is measured by the required SNR at probability of detection equal to 0.99. The probability of false detection of the ACK shall be 0.01 or less.

The probability of false detection of the ACK is defined as a conditional probability of erroneous detection of the ACK when input is only noise.

The probability of detection of ACK is defined as conditional probability of detection of the ACK when the signal is present.

The transient period as specified in TS 38.101-1 [23] clause 6.3.3.1 is not taken into account for performance requirement testing, where the RB hopping is symmetric to the CC centre, i.e. intra-slot frequency hopping is enabled.

Which specific test(s) are applicable to IAB-DU is based on the test applicability rules defined in clause 8.1.1.2.3.

8.1.3.1.2 Minimum requirement

The minimum requirements are in TS 38.174 [2] clause 8.1.3.2.

8.1.3.1.3 Test purpose

The test shall verify the receiver's ability to detect ACK under multipath fading propagation conditions for a given SNR.

8.1.3.1.4 Method of test

8.1.3.1.4.1 Initial conditions

Test environment: Normal, see annex B.2.

RF channels to be tested: single carrier M; see clause 4.9.1.

8.1.3.1.4.2 Test procedure

- 1) Connect the IAB-DU tester generating the wanted signal, multipath fading simulators and AWGN generators to all IAB-DU *TAB connectors* for diversity reception via a combining network as shown in annex D. 3.
- 2) Adjust the AWGN generator, according to the channel bandwidth and sub-carrier spacing defined in table 8.1.3.1.4.2-1.

Table 8.1.3.1.4.2-1: AWGN power level at the IAB-DU input

Subcarrier spacing (kHz)	Channel bandwidth (MHz)	AWGN power level
15	10	-80.3 dBm / 9.36 MHz
	20	-77.2 dBm / 19.08 MHz
30	10	-80.6 dBm / 8.64 MHz
	20	-77.4 dBm / 18.36 MHz
	40	-74.2 dBm / 38.16 MHz
	100	-70.1 dBm / 98.28 MHz

- 3) The characteristics of the wanted signal shall be configured according to TS 38.211 [9] and the specific test parameters are configured as mentioned in table 8.1.3.1.4.2-2:

Table 8.1.3.1.4.2-2: Test Parameters

Parameter	Test
number of UCI information bits	1
Number of PRBs	1
First PRB prior to frequency hopping	0
Intra-slot frequency hopping	N/A for 1 symbol Enabled for 2 symbols
First PRB after frequency hopping	The largest PRB index – (Number of PRBs – 1)
Group and sequence hopping	neither
Hopping ID	0
Initial cyclic shift	0
First symbol	13 for 1 symbol 12 for 2 symbols

- 4) The multipath fading emulators shall be configured according to the corresponding channel model defined in annex B.
- 5) Adjust the equipment so that the SNR specified in table 8.1.3.1.5-1 or table 8.1.3.1.5-2 is achieved at the IAB-DU input during the ACK transmissions.
- 6) The tester sends a test pattern with the pattern outlined in figure 8.1.3.1.4.2-1. The following statistics are kept: the number of ACKs detected in the idle periods and the number of missed ACKs.



Figure 8.1.3.1.4.2-1: Test signal pattern for single user PUCCH format 0 demodulation tests

8.1.3.1.5 Test requirement

The fraction of falsely detected ACKs shall be less than 1% and the fraction of correctly detected ACKs shall be larger than 99% for the SNR listed in table 8.1.3.1.5-1 and in table 8.1.3.1.5-2.

Table 8.1.3.1.5-1: Test requirements for PUCCH format 0 and 15 kHz SCS

Number of TX antennas	Number of RX antennas	Propagation conditions and correlation matrix (annex F)	Number of OFDM symbols	Channel bandwidth / SNR (dB)		
				5 MHz	10 MHz	20 MHz
1	2	TDLC-300-100 Low	1	10.0	9.4	9.9
			2	3.4	4.3	3.9
1	4	TDLC-300-100 Low	1	3.6	3.5	3.8
			2	-0.4	0.1	-0.2
1	8	TDLC-300-100 Low	1	-0.5	-0.5	-0.5
			2	-3.5	-3.3	-3.4

Number of TX antennas	Number of RX antennas	Propagation conditions and correlation matrix (annex F)	Number of OFDM symbols	Channel bandwidth / SNR (dB)	
				10 MHz	20 MHz
1	2	TDLC-300-100 Low	1	9.4	9.9
			2	4.3	3.9
1	4	TDLC-300-100 Low	1	3.5	3.8
			2	0.1	-0.2
1	8	TDLC-300-100 Low	1	-0.5	-0.5
			2	-3.3	-3.4

Table 8.1.3.1.5-2: Test requirements for PUCCH format 0 and 30 kHz SCS

Number of TX antennas	Number of RX antennas	Propagation conditions and correlation matrix (annex F)	Number of OFDM symbols	Channel bandwidth / SNR (dB)			
				10 MHz	20 MHz	40 MHz	100 MHz
1	2	TDLC-300-100 Low	1	10.4	10.4	10.1	9.8
			2	4.8	4.2	4.4	4.1
1	4	TDLC-300-100 Low	1	4.0	4.0	3.6	3.9
			2	0.3	0.2	0.1	-0.2
1	8	TDLC-300-100 Low	1	-0.4	-0.4	-0.5	-0.4
			2	-3.1	-3.2	-3.4	-3.3

8.1.3.2 Performance requirements for PUCCH format 1

8.1.3.2.1 NACK to ACK detection

8.1.3.2.1.1 Definition and applicability

The performance requirement of PUCCH format 1 for NACK to ACK detection is determined by the two parameters: probability of false detection of the ACK and the NACK to ACK detection probability. The performance is measured by the required SNR at probability of the NACK to ACK detection equal to 0.1% or less. The probability of false detection of the ACK shall be 0.01 or less.

The probability of false detection of the ACK is defined as a conditional probability of erroneous detection of the ACK at particular bit position when input is only noise. Each false bit detection is counted as one error.

The NACK to ACK detection probability is the probability of detecting an ACK bit when an NACK bit was sent on particular bit position. Each NACK bit erroneously detected as ACK bit is counted as one error. Erroneously detected NACK bits in the definition do not contain the NACK bits which are mapped from DTX, i.e. NACK bits received when DTX is sent should not be considered.

The transient period as specified in TS 38.101-1 [23] clause 6.3.3.1 is not taken into account for performance requirement testing, where the RB hopping is symmetric to the CC centre, i.e. intra-slot frequency hopping is enabled.

Which specific test(s) are applicable to IAB-DU is based on the test applicability rules defined in clause 8.1.1.2.3.

8.1.3.2.1.2 Minimum requirement

The minimum requirement is in TS 38.174 [2] clause 8.1.3.3.1

8.1.3.2.1.3 Test purpose

The test shall verify the receiver's ability not to falsely detect NACK bits as ACK bits under multipath fading propagation conditions for a given SNR.

8.1.3.2.1.4 Method of test

8.1.3.2.1.4.1 Initial conditions

Test environment: Normal; see annex B.2.

RF channels to be tested: for single carrier: M; see clause 4.9.1.

8.1.3.2.1.4.2 Test procedure

- 1) Connect the IAB-DU tester generating the wanted signal, multipath fading simulators and AWGN generators to all IAB-DU *TAB connectors* for diversity reception via a combining network as shown in annex D. 3.
- 2) Adjust the AWGN generator, according to the combinations of SCS and channel bandwidth defined in table 8.1.3.2.1.4.2-1.

Table 8.1.3.2.1.4.2-1: AWGN power level at the IAB-DU input

Sub-carrier spacing (kHz)	Channel bandwidth (MHz)	AWGN power level
15 kHz	10	-80.3 dBm / 9.36 MHz
	20	-77.2 dBm / 19.08 MHz
30 kHz	10	-80.6 dBm / 8.64 MHz
	20	-77.4 dBm / 18.36 MHz
	40	-74.2 dBm / 38.16 MHz
	100	-70.1 dBm / 98.28 MHz

- 3) The characteristics of the wanted signal shall be configured according to TS 38.211 [9], and the specific test parameters are configured as below:

Table 8.1.3.2.1.4.2-2: Test parameters

Parameter	Values
Cyclic prefix	Normal
Number of information bits	2
Number of PRBs	1
Number of symbols	14
First PRB prior to frequency hopping	0
Intra-slot frequency hopping	enabled
First PRB after frequency hopping	The largest PRB index - (nrofPRBs -1)
Group and sequence hopping	neither
Hopping ID	0
Initial cyclic shift	0
First symbol	0
Index of orthogonal cover code (<i>timeDomainOCC</i>)	0

- 4) The multipath fading emulators shall be configured according to the corresponding channel model defined in annex F.
- 5) Adjusting the equipment so that the SNR specified in table 8.1.3.2.1.5-1 and table 8.1.3.2.1.5-2 is achieved at the IAB-DU input during the transmissions.
- 6) The signal generator sends random codeword from applicable codebook, in regular time periods. The following statistics are kept: the number of ACK bits detected in the idle periods and the number of NACK bits detected as ACK.

8.1.3.2.1.5 Test requirement

The fraction of falsely detected ACK bits shall be less than 1% and the fraction of NACK bits falsely detected as ACK shall be less than 0.1% for the SNR listed in tables 8.1.3.2.1.5-1 and table 8.1.3.2.1.5-2.

Table 8.1.3.2.1.5-1: Required SNR for PUCCH format 1 with 15 kHz SCS

Number of TX antennas	Number of RX antennas	Propagation conditions and correlation matrix (annex F)	Channel bandwidth / SNR (dB)	
			10 MHz	20 MHz
1	2	TDLC-300-100 Low	-3.0	-3.0
	4	TDLC-300-100 Low	-7.0	-7.8
	8	TDLC-300-100 Low	-10.8	-10.8

Table 8.1.3.2.1.5-2: Required SNR for PUCCH format 1 with 30 kHz SCS

Number of TX antennas	Number of RX antennas	Propagation conditions and correlation matrix (annex F)	Channel bandwidth / SNR (dB)			
			10 MHz	20 MHz	40 MHz	100 MHz
1	2	TDLC-300-100 Low	-2.2	-2.7	-3.3	-2.9
	4	TDLC-300-100 Low	-7.5	-7.7	-6.9	-7.4
	8	TDLC-300-100 Low	-10.9	-10.6	-10.1	-10.7

8.1.3.2.2 ACK missed detection

8.1.3.2.2.1 Definition and applicability

The performance requirement of PUCCH format 1 for ACK missed detection is determined by the two parameters: probability of false detection of the ACK and the probability of detection of ACK. The performance is measured by the

required SNR at probability of detection equal to 0.99. The probability of false detection of the ACK shall be 0.01 or less.

The probability of false detection of the ACK is defined as a conditional probability of erroneous detection of the ACK when input is only noise.

The probability of detection of ACK is defined as conditional probability of detection of the ACK when the signal is present.

The transient period as specified in TS 38.101-1 [23] clause 6.3.3.1 is not taken into account for performance requirement testing, where the RB hopping is symmetric to the CC centre, i.e. intra-slot frequency hopping is enabled.

Which specific test(s) are applicable to IAB-DU is based on the test applicability rules defined in clause 8.1.1.2.3.

8.1.3.2.2.2 Minimum requirement

The minimum requirement is in TS 38.174 [2] clause 8.1.3.3.2

8.1.3.2.2.3 Test purpose

The test shall verify the receiver's ability to detect ACK bits under multipath fading propagation conditions for a given SNR.

8.1.3.2.2.4 Method of test

8.1.3.2.2.4.1 Initial conditions

Test environment: Normal; see annex B.2.

RF channels to be tested: for single carrier (SC): M; see clause 4.9.1.

8.1.3.2.2.4.2 Test procedure

- 1) Connect the IAB-DU tester generating the wanted signal, multipath fading simulators and AWGN generators to all IAB-DU *TAB connectors* for diversity reception via a combining network as shown in annex D. 3.
- 2) Adjust the AWGN generator, according to the combinations of SCS and channel bandwidth defined in table 8.1.3.2.2.4.2-1.

Table 8.1.3.2.2.4.2-1: AWGN power level at the IAB-DU input

Sub-carrier spacing (kHz)	Channel bandwidth (MHz)	AWGN power level
15 kHz	10	-80.3 dBm / 9.36 MHz
	20	-77.2 dBm / 19.08 MHz
30 kHz	10	-80.6 dBm / 8.64 MHz
	20	-77.4 dBm / 18.36 MHz
	40	-74.2 dBm / 38.16 MHz
	100	-70.1 dBm / 98.28 MHz

- 3) The characteristics of the wanted signal shall be configured according to TS 38.211 [9], and the specific test parameters are configured as below:

Table 8.3.2.2.4.2-2: Test parameters

Parameter	Values
Cyclic prefix	Normal
Number of information bits	2
Number of PRBs	1
Number of symbols	14
First PRB prior to frequency hopping	0
Intra-frequency hopping	enabled
First PRB after frequency hopping	The largest PRB index - (nrofPRBs - 1)
Group and sequence hopping	neither
Hopping ID	0
Initial cyclic shift	0
First symbol	0
Index of orthogonal cover code (<i>timeDomainOCC</i>)	0

- 4) The multipath fading emulators shall be configured according to the corresponding channel model defined in annex F.
- 5) Adjusting the equipment so that the SNR specified in table 8.3.2.2.5-1 and table 8.3.2.2.5-2 is achieved at the IAB-DU input during the transmissions.
- 6) The tester sends random codewords from applicable codebook, in regular time periods. The following statistics are kept: the number of ACK bits falsely detected in the idle periods and the number of missed ACK bits. Each falsely detected ACK bit in the idle periods is accounted as one error for the statistics of false ACK detection, and each missed ACK bit is accounted as one error for the statistics of missed ACK detection.

Note that the procedure described in this clause for ACK missed detection has the same condition as that described in clause 8.1.3.2.1.4.2 for NACK to ACK detection. Both statistics are measured in the same testing.

8.1.3.2.2.5 Test requirement

The fraction of falsely detected ACK bits shall be less than 1% and the fraction of correctly detected ACK bits shall be larger than 99% for the SNR listed in tables 8.1.3.2.2.5-1 and table 8.1.3.2.2.5-2.

Table 8.1.3.2.2.5-1 Required SNR for PUCCH format 1 with 15 kHz SCS

Number of TX antennas	Number of RX antennas	Propagation conditions and correlation matrix (annex F)	Channel bandwidth / SNR (dB)	
			10 MHz	20 MHz
1	2	TDLC300-100 Low	-3.8	-4.4
	4	TDLC300-100 Low	-7.6	-7.9
	8	TDLC300-100 Low	-10.9	-10.9

Table 8.1.3.2.2.5-2 Required SNR for PUCCH format 1 with 30 kHz SCS

Number of TX antennas	Number of RX antennas	Propagation conditions and correlation matrix (annex F)	Channel bandwidth / SNR (dB)			
			10 MHz	20 MHz	40 MHz	100 MHz
1	2	TDLC300-100 Low	-3.3	-3.8	-3.8	-3.6
	4	TDLC300-100 Low	-7.4	-7.5	-7.8	-7.7
	8	TDLC300-100 Low	-10.8	-10.8	-10.8	-10.8

8.1.3.3 Performance requirements for PUCCH format 2

8.1.3.3.1 ACK missed detection

8.1.3.3.1.1 Definition and applicability

The performance requirement of PUCCH format 2 for ACK missed detection is determined by the two parameters: probability of false detection of the ACK and the probability of detection of ACK. The performance is measured by the required SNR at probability of detection equal to 0.99. The probability of false detection of the ACK shall be 0.01 or less.

The probability of false detection of the ACK is defined as a probability of erroneous detection of the ACK when input is only noise.

The probability of detection of ACK is defined as probability of detection of the ACK when the signal is present.

Which specific test(s) are applicable to IAB-DU is based on the test applicability rules defined in clause 8.1.1.2.3.

The transient period as specified in TS 38.101-1 [23] clause 6.3.3.1 is not taken into account for performance requirement testing, where the RB hopping is symmetric to the CC centre, i.e. intra-slot frequency hopping is enabled.

8.1.3.3.1.2 Minimum requirement

The minimum requirements are in TS 38.174 [2] clause 8.1.3.4.1

8.1.3.3.1.3 Test purpose

The test shall verify the receiver's ability to detect ACK bits under multipath fading propagation conditions for a given SNR.

8.1.3.3.1.4 Method of test

8.1.3.3.1.4.1 Initial conditions

Test environment: Normal, see annex B.2.

RF channels to be tested for single carrier; M; see clause 4.9.1.

8.1.3.3.1.4.2 Test procedure

- 1) Connect the IAB-DU tester generating the wanted signal, multipath fading simulators and AWGN generators to all IAB-DU *TAB connectors* for diversity reception via a combining network as shown in annex D. 3.
- 2) Adjust the AWGN generator, according to the channel bandwidth defined in table 8.1.3.3.1.4.2-1.

Table 8.1.3.3.1.4.2-1: AWGN power level at the IAB-DU input

Sub-carrier spacing (kHz)	Channel bandwidth (MHz)	AWGN power level
15	10	-80.3 dBm / 9.36 MHz
	20	-77.2 dBm / 19.08MHz
30	10	-80.6 dBm / 8.64 MHz
	20	-77.4 dBm / 18.36 MHz
	40	-74.2 dBm / 38.16 MHz
	100	-70.1 dBm / 98.28 MHz

- 3) The characteristics of the wanted signal shall be configured according to TS 38.211 [9], and the specific test parameters are configured as blow:

Table 8.3.3.1.4.2-2: Test parameters

Parameter	Values
Cyclic prefix	Normal
Modulation order	QPSK
First PRB prior to frequency hopping	0
Intra-slot frequency hopping	N/A
First PRB after frequency hopping	The largest PRB index - (Number of PRBs - 1)
Number of PRBs	4
Number of symbols	1
The number of UCI information bits	4
First symbol	13
DM-RS sequence generation	$N_D^0=0$

- 4) The multipath fading emulators shall be configured according to the corresponding channel model defined in annex F.
- 5) Adjust the equipment so that the SNR specified in table 8.1.3.3.1.5-1 and table 8.1.3.3.1.5-2 is achieved at the IAB-DU input during the UCI transmissions.
- 6) The tester sends a test pattern with the pattern outlined in figure 8.1.3.3.1.4.2-1. The following statistics are kept: the number of ACKs detected in the idle periods and the number of missed ACKs.



Figure 8.1.3.3.1.4.2-1: Test signal pattern for PUCCH format 2 demodulation tests

8.1.3.3.1.5 Test requirement

The fraction of falsely detected ACKs shall be less than 1% and the fraction of correctly detected ACKs shall be larger than 99% for the SNR listed in table 8.1.3.3.1.5-1 and table 8.1.3.3.1.5-2.

Table 8.1.3.3.1.5-1: Required SNR for PUCCH format 2 with 15 kHz SCS

Number of TX antennas	Number of RX antennas	Propagation conditions and correlation matrix (annex F)	Channel bandwidth / SNR (dB)	
			10 MHz	20 MHz
1	2	TDLC300-100 Low	6.2	6.5
	4	TDLC300-100 Low	1.1	0.9
	8	TDLC300-100 Low	-2.9	-2.9

Table 8.1.3.3.1.5-2: Required SNR for PUCCH format 2 with 30 kHz SCS

Number of TX antennas	Number of RX antennas	Propagation conditions and correlation matrix (annex F)	Channel bandwidth / SNR (dB)			
			10MHz	20MHz	40MHz	100MHz
1	2	TDLC300-100 Low	6.1	6.2	6.1	6.3
	4	TDLC300-100 Low	0.9	0.8	0.9	1.0
	8	TDLC300-100 Low	-3.0	-3.0	-2.9	-2.7

8.1.3.3.2 UCI BLER performance requirements

8.1.3.3.2.1 Definition and applicability

The performance is measured by the required SNR at UCI block error probability not exceeding 1%.

The UCI block error probability is defined as the probability of incorrectly decoding the UCI information when the UCI information is sent. The UCI information does not contain CSI part 2.

Which specific test(s) are applicable to IAB-DU is based on the test applicability rules defined in clause 8.1.1.2.3.

The transient period as specified in TS 38.101-1 [23] clause 6.3.3.1 is not taken into account for performance requirement testing, where the RB hopping is symmetric to the CC centre, i.e. intra-slot frequency hopping is enabled.

8.1.3.3.2.2 Minimum requirement

The minimum requirement is TS 38.174 [2] clause 8.1.3.4.2

8.1.3.3.2.3 Test purpose

The test shall verify the receiver's ability to detect UCI under multipath fading propagation conditions for a given SNR.

8.1.3.3.2.4 Method of test

8.1.3.3.2.4.1 Initial conditions

Test environment: Normal, see annex B.2.

RF channels to be tested for single carrier; M; see clause 4.9.1

8.1.3.3.2.4.2 Test procedure

- 1) Connect the IAB-DU tester generating the wanted signal, multipath fading simulators and AWGN generators to all IAB-DU *TAB connectors* for diversity reception via a combining network as shown in annex D. 3.
- 2) Adjust the AWGN generator, according to the channel bandwidth defined in table 8.1.3.3.2.4.2-1.

Table 8.1.3.3.2.4.2-1: AWGN power level at the IAB-DU input

Sub-carrier spacing (kHz)	Channel bandwidth (MHz)	AWGN power level
15	10	-80.3 dBm / 9.36 MHz
	20	-77.2 dBm / 19.08 MHz
30	10	-80.6 dBm / 8.64 MHz
	20	-77.4 dBm / 18.36 MHz
	40	-74.2 dBm / 38.16 MHz
	100	-70.1 dBm / 98.28 MHz

- 3) The characteristics of the wanted signal shall be configured according to TS 38.211 [9], and the specific test parameters are configured as blow:

Table 8.1.3.3.2.4.2-2: Test parameters

Parameter	Values
Cyclic prefix	Normal
Modulation order	QPSK
First PRB prior to frequency hopping	0
Intra-slot frequency hopping	enabled
First PRB after frequency hopping	The largest PRB index – (Number of PRBs - 1)
Number of PRBs	9
Number of symbols	2
The number of UCI information bits	22
First symbol	12
DM-RS sequence generation	$N_{ID}^0=0$

- 4) The multipath fading emulators shall be configured according to the corresponding channel model defined in annex F.

- 5) Adjust the equipment so that the SNR specified in table 8.1.3.3.2.5-1 or table 8.1.3.3.2.5-2 is achieved at the IAB-DU input during the UCI transmissions.
- 6) The tester sends a test pattern with the pattern outlined in figure 8.1.3.3.2.4.2-1. The following statistics are kept: the number of incorrectly decoded UCI.



Figure 8.1.3.3.2.4.2-1: Test signal pattern for PUCCH format 2 demodulation tests

8.1.3.3.2.5 Test requirement

The fraction of incorrectly decoded UCI shall be less than 1% for the SNR listed in table 8.1.3.3.2.5-1 and table 8.1.3.3.2.5-2.

Table 8.1.3.3.2.5-1: Required SNR for PUCCH format 2 with 15 kHz SCS

Number of TX antennas	Number of RX antennas	Propagation conditions and correlation matrix (annex F)	Channel bandwidth / SNR (dB)	
			10 MHz	20 MHz
1	2	TDLC300-100 Low	1.4	1.8
	4	TDLC300-100 Low	-2.6	-2.6
	8	TDLC300-100 Low	-6.1	-6.2

Table 8.1.3.3.2.5-2: Required SNR for PUCCH format 2 with 30 kHz SCS

Number of TX antennas	Number of RX antennas	Propagation conditions and correlation matrix (annex F)	Channel bandwidth / SNR (dB)			
			10MHz	20MHz	40MHz	100MHz
1	2	TDLC300-100 Low	1.1	1.7	1.0	0.9
	4	TDLC300-100 Low	-2.7	-2.3	-2.7	-2.8
	8	TDLC300-100 Low	-5.2	-5.2	-6.1	-5.3

8.1.3.4 Performance requirements for PUCCH format 3

8.1.3.4.1 Definition and applicability

The performance is measured by the required SNR at UCI block error probability not exceeding 1%.

The UCI block error probability is defined as the conditional probability of incorrectly decoding the UCI information when the UCI information is sent. The UCI information does not contain CSI part 2.

The transient period as specified in TS 38.101-1 [23] clause 6.3.3.1 is not taken into account for performance requirement testing, where the RB hopping is symmetric to the CC centre, i.e. intra-slot frequency hopping is enabled.

Which specific test(s) are applicable to IAB-DU is based on the test applicability rules defined in clause 8.1.2.2.3.

8.1.3.4.2 Minimum requirement

The minimum requirement is in TS 38.174 [2] clause 8.1.3.5.

8.1.3.4.3 Test purpose

The test shall verify the receiver's ability to detect UCI under multipath fading propagation conditions for a given SNR.

8.1.3.4.4 Method of test

8.1.3.4.4.1 Initial conditions

Test environment: Normal; see annex B.2.

RF channels to be tested for single carrier: M; see clause 4.9.1

8.1.3.4.4.2 Test procedure

- 1) Connect the IAB-DU tester generating the wanted signal, multipath fading simulators and AWGN generators to all IAB-DU *TAB connectors* for diversity reception via a combining network as shown in annex D.6.
- 2) Adjust the AWGN generator, according to the subcarrier spacing and channel bandwidth defined in table 8.1.3.4.4.2-1.

Table 8.1.3.4.4.2-1: AWGN power level at the IAB-DU input

Sub-carrier spacing (kHz)	Channel bandwidth (MHz)	AWGN power level
15	10	-80.3 dBm / 9.36 MHz
	20	-77.2 dBm / 19.08 MHz
30	10	-80.6 dBm / 8.64 MHz
	20	-77.4 dBm / 18.36 MHz
	40	-74.2 dBm / 38.16 MHz
	100	70.1 dBm / 98.28 MHz

- 3) The characteristics of the wanted signal shall be configured according to TS 38.211 [9]. The specific test parameters are configured as below:

Table 8.1.3.4.4.2-2: Test parameters

Parameter	Test 1	Test 2
Cyclic prefix	Normal	
Modulation order	QPSK	
First PRB prior to frequency hopping	0	
Intra-slot frequency hopping	enabled	
First PRB after frequency hopping	The largest PRB index - (Number of PRBs - 1)	
Group and sequence hopping	neither	
Hopping ID	0	
Number of PRBs	1	3
Number of symbols	14	4
The number of UCI information bits	16	16
First symbol	0	0

- 4) The multipath fading emulators shall be configured according to the corresponding channel model defined in annex F.
- 5) Adjust the equipment so that the SNR specified in table 8.1.3.4.5-1 or table 8.1.3.4.5-2 is achieved at the IAB-DU input during the UCI transmissions.
- 6) The tester sends a test pattern with the pattern outlined in figure 8.1.3.4.4.2-1. The following statistics are kept: the number of incorrectly decoded UCI.



Figure 8.1.3.4.4.2-1: Test signal pattern for PUCCH format 3 demodulation tests

8.1.3.4.5 Test requirement

The fraction of incorrectly decoded UCI is shall be less than 1% for the SNR listed in table 8.1.3.4.5-1 and table 8.1.3.4.5-2.

Table 8.1.3.4.5-1: Required SNR for PUCCH format 3 with 15 kHz SCS

Test Number	Number of TX antennas	Number of RX antennas	Propagation conditions and correlation matrix (annex F)	Additional DM-RS configuration	Channel bandwidth / SNR (dB)	
					10 MHz	20 MHz
1	1	2	TDLC300-100 Low	No additional DM-RS	1.7	0.9
				Additional DM-RS	1.1	0.5
		4	TDLC300-100 Low	No additional DM-RS	-2.7	-3.2
				Additional DM-RS	-3.4	-3.4
		8	TDLC300-100 Low	No additional DM-RS	-6.1	-6.3
				Additional DM-RS	-6.9	-7.1
2	2	2	TDLC300-100 Low	No additional DM-RS	2.8	2.6
		4	TDLC300-100 Low	No additional DM-RS	-1.9	-1.9
		8	TDLC300-100 Low	No additional DM-RS	-5.4	-5.6

Table 8.1.3.4.5-2: Required SNR for PUCCH format 3 with 30 kHz SCS

Test Number	Number of TX antennas	Number of RX antennas	Propagation conditions and correlation matrix (annex F)	Additional DM-RS configuration	Channel bandwidth / SNR (dB)			
					10 MHz	20 MHz	40 MHz	100 MHz
1	1	2	TDLC300-100 Low	No additional DM-RS	1.5	1.2	1.2	1.5
				Additional DM-RS	1.1	0.9	0.6	0.7
		4	TDLC300-100 Low	No additional DM-RS	-2.5	-2.8	-2.6	-2.9
				Additional DM-RS	-3.1	-3.5	-3.4	-3.6
		8	TDLC300-100 Low	No additional DM-RS	-6.0	-6.1	-6.2	-6.2
				Additional DM-RS	-6.9	-7.0	-7.0	-7.1
2	1	2	TDLC300-100 Low	No additional DM-RS	2.4	2.6	2.6	2.1
		4	TDLC300-100 Low	No additional DM-RS	-2.3	-2.4	-1.8	-2.4
		8	TDLC300-100 Low	No additional DM-RS	-5.8	-5.4	-5.8	-5.6

8.1.3.5 Performance requirements for PUCCH format 4

8.1.3.5.1 Definition and applicability

The performance is measured by the required SNR at UCI block error probability not exceeding 1%.

The UCI block error probability is defined as the conditional probability of incorrectly decoding the UCI information when the UCI information is sent. The UCI information does not contain CSI part 2.

The transient period as specified in TS 38.101-1 [23] clause 6.3.3.1 is not taken into account for performance requirement testing, where the RB hopping is symmetric to the CC centre, i.e. intra-slot frequency hopping is enabled.

Which specific test(s) are applicable to IAB-DU is based on the test applicability rules defined in clause 8.1.1.2.3.

8.1.3.5.2 Minimum requirement

The minimum requirement is in TS 38.104 [11] clause 8.1.3.6.

8.1.3.5.3 Test purpose

The test shall verify the receiver's ability to detect UCI under multipath fading propagation conditions for a given SNR.

8.1.3.5.4 Method of test

8.1.3.5.4.1 Initial conditions

Test environment: Normal; see annex B.2.

RF channels to be tested for single carrier: M; see clause 4.9.1

8.1.3.5.4.2 Test procedure

- 1) Connect the IAB-DU tester generating the wanted signal, multipath fading simulators and AWGN generators to all IAB-DU *TAB connectors* for diversity reception via a combining network as shown in annex D. 3..
- 2) Adjust the AWGN generator, according to the subcarrier spacing and channel bandwidth defined in table 8.1.3.5.4.2-1.

Table 8.1.3.5.4.2-1: AWGN power level at the IAB-DU input

Sub-carrier spacing (kHz)	Channel bandwidth (MHz)	AWGN power level
15	10	-80.3 dBm / 9.36 MHz
	20	-77.2 dBm / 19.08 MHz
30	10	-80.6 dBm / 8.64 MHz
	20	-77.4 dBm / 18.36 MHz
	40	-74.2 dBm / 38.16 MHz
	100	-70.1 dBm / 98.28 MHz

- 3) The characteristics of the wanted signal shall be configured according to TS 38.211 [9]. The test parameters are configured as below:

Table 8.1.3.5.4.2-2: Test parameters

Parameter	Values
Cyclic prefix	Normal
Modulation order	QPSK
First PRB prior to frequency hopping	0
Number of PRBs	1
Intra-slot frequency hopping	enabled
First PRB after frequency hopping	The largest PRB index - (Number of PRBs - 1)
Group and sequence hopping	neither
Hopping ID	0
Number of symbols	14
The number of UCI information bits	22
First symbol	0
Length of the orthogonal cover code	n2
Index of the orthogonal cover code	n0

- 4) The multipath fading emulators shall be configured according to the corresponding channel model defined in annex F.
- 5) Adjust the equipment so that the SNR specified in table 8.1.3.5.5-1 or table 8.1.3.5.5-2 is achieved at the IAB-DU input during the UCI transmissions.
- 6) The tester sends a test pattern with the pattern outlined in figure 8.1.3.5.4.2-1. The following statistics are kept: the number of incorrectly decoded UCI.

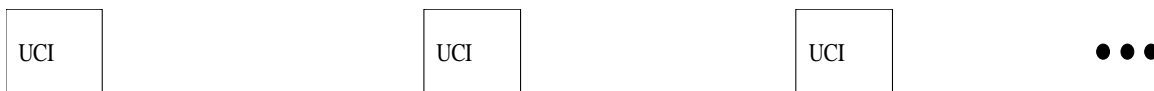

Figure 8.1.3.5.4.2-1: Test signal pattern for PUCCH format 4 demodulation tests

8.1.3.5.5 Test requirement

The fraction of incorrectly decoded UCI is shall be less than 1% for the SNR listed in table 8.1.3.5.5-1 and table 8.1.3.5.5-2.

Table 8.1.3.5.5-1: Required SNR for PUCCH format 4 with 15 kHz SCS

Number of TX antennas	Number of RX antennas	Propagation conditions and correlation matrix (annex F)	Additional DM-RS configuration	Channel bandwidth / SNR (dB)	
				10 MHz	20 MHz
1	2	TDLC300-100 Low	No additional DM-RS	3.2	2.8
			Additional DM-RS	3.0	2.4
	4	TDLC300-100 Low	No additional DM-RS	-1.3	-1.6
			Additional DM-RS	-2.0	-2.1
	8	TDLC300-100 Low	No additional DM-RS	-5.1	-5.2
			Additional DM-RS	-5.8	-5.7

Table 8.1.3.5.5-2: Required SNR for PUCCH format 4 with 30 kHz SCS

Number of TX antennas	Number of RX antennas	Propagation conditions and correlation matrix (annex F)	Additional DM-RS configuration	Channel bandwidth / SNR (dB)			
				10 MHz	20 MHz	40 MHz	100 MHz
1	2	TDLC300-100 Low	No additional DM-RS	3.7	3.4	3.7	3.4
			Additional DM-RS	3.4	2.9	3.7	2.8
	4	TDLC300-100 Low	No additional DM-RS	-1.1	-1.3	-1.1	-1.5
			Additional DM-RS	-1.4	-1.9	-1.9	-1.8
	8	TDLC300-100 Low	No additional DM-RS	-5.0	-4.9	-4.9	-4.9
			Additional DM-RS	-5.6	-5.5	-5.8	-5.6

8.1.3.6 Performance requirements for multi-slot PUCCH

8.1.3.6.1 Performance requirements for multi-slot PUCCH format 1

8.1.3.6.1.1 NACK to ACK detection

8.1.3.6.1.1.1 Definition and applicability

The performance requirement of multi-slot PUCCH format 1 for NACK to ACK detection is determined by the two parameters: probability of false detection of the ACK and the NACK to ACK detection probability. The performance is measured by the required SNR at probability of the NACK to ACK detection equal to 0.1 % or less. The probability of false detection of the ACK shall be 0.01 % or less.

The probability of false detection of the ACK is defined as a conditional probability of erroneous detection of the ACK at particular bit position when input is only noise. Each false bit detection is counted as one error.

The NACK to ACK detection probability is the probability of detecting an ACK bit when an NACK bit was sent on particular bit position. Each NACK bit erroneously detected as ACK bit is counted as one error. Erroneously detected NACK bits in the definition do not contain the NACK bits which are mapped from DTX, i.e. NACK bits received when DTX is sent should not be considered.

Which specific test(s) are applicable to IAB-DU is based on the test applicability rules defined in clause 8.1.1.2.3.

8.1.3.6.1.1.2 Minimum requirement

The minimum requirement is in TS 38.174 [2] clause 8.1.3.7.2.1.

8.1.3.6.1.1.3 Test purpose

The test shall verify the receiver's ability not to falsely detect NACK bits as ACK bits under multipath fading propagation conditions for a given SNR.

8.1.3.6.1.1.4 Method of test

8.1.3.6.1.1.4.1 Initial conditions

Test environment: Normal; see annex B.2.

RF channels to be tested: for single carrier: M; see clause 4.9.1.

8.1.3.6.1.1.4.2 Test procedure

- 1) Connect the IAB-DU tester generating the wanted signal, multipath fading simulators and AWGN generators to all IAB-DU *TAB connectors* for diversity reception via a combining network as shown in annex D. 3.
- 2) Adjust the AWGN generator, according to the combinations of SCS and channel bandwidth defined in Table 8.1.3.6.1.1.4.2-1.

Table 8.1.3.6.1.1.4.2-1: AWGN power level at the IAB-DU input

Sub-carrier spacing (kHz)	Channel bandwidth (MHz)	AWGN power level
15	10	-80.3 dBm / 9.36 MHz
	20	-77.2 dBm / 19.08 MHz
30	10	-80.6 dBm / 8.64 MHz
	20	-77.4 dBm / 18.36 MHz
	40	-74.2 dBm / 38.16 MHz
	100	-70.1 dBm / 98.28 MHz

- 3) The characteristics of the wanted signal shall be configured according to TS 38.211 [9], and the specific test parameters are configured as below:

Table 8.1.3.6.1.1.4.2-2: Test parameters for multi-slot PUCCH format 1

Parameter	Test
Cyclic prefix	Normal
Number of information bits	2
Number of PRBs	1
Number of symbols	14
First PRB prior to frequency hopping	0
Intra-slot frequency hopping	disabled
Inter-slot frequency hopping	enabled
First PRB after frequency hopping	The largest PRB index - (nrofPRBs - 1)
Group and sequence hopping	neither
Hopping ID	0
Initial cyclic shift	0
First symbol	0
Index of orthogonal cover code (<i>timeDomainOCC</i>)	0
Number of slots for PUCCH repetition	2

- 4) The multipath fading emulators shall be configured according to the corresponding channel model defined in annex F.
- 5) Adjusting the equipment so that the SNR specified in table 8.1.3.6.1.1.5-1 is achieved at the IAB-DU input during the transmissions.
- 6) The tester sends random codeword from applicable codebook, in regular time periods. The following statistics are kept: the number of ACK bits detected in the idle periods and the number of NACK bits detected as ACK.

8.1.3.6.1.1.5 Test requirement

The fraction of falsely detected ACK bits shall be less than 1 % and the fraction of NACK bits falsely detected as ACK shall be less than 0.1 % for the SNR listed in table 8.1.3.6.1.1.5-1.

Table 8.1.3.6.1.1.5-1: Minimum requirements for multi-slot PUCCH format 1 with 30 kHz SCS

Number of TX antennas	Number of RX antennas	Propagation conditions and correlation matrix (annex F)	Channel bandwidth / SNR (dB)
			40 MHz
1	2	TDLC-300-100 Low	-5.7

8.1.3.6.1.2 ACK missed detection

8.1.3.6.1.2.1 Definition and applicability

The performance requirement of PUCCH format 1 for ACK missed detection is determined by the two parameters: probability of false detection of the ACK and the probability of detection of ACK. The performance is measured by the

required SNR at probability of detection equal to 0.99. The probability of false detection of the ACK shall be 0.01 or less.

The probability of false detection of the ACK is defined as a conditional probability of erroneous detection of the ACK when input is only noise.

The probability of detection of ACK is defined as conditional probability of detection of the ACK when the signal is present.

8.1.3.6.1.2.2 Minimum requirement

The minimum requirement is in TS 38.174 [2] clause 8.1.3.7.2.2.

8.1.3.6.1.2.3 Test purpose

The test shall verify the receiver's ability to detect ACK bits under multipath fading propagation conditions for a given SNR.

8.1.3.6.1.2.4 Method of test

8.1.3.6.1.2.4.1 Initial conditions

Test environment: Normal; see annex B.2.

RF channels to be tested: for single carrier: M; see clause 4.9.1.

8.1.3.6.1.2.4.2 Test procedure

- 1) Connect the IAB-DU tester generating the wanted signal, multipath fading simulators and AWGN generators to all IAB-DU *TAB connectors* for diversity reception via a combining network as shown in annex D. 3.
- 2) Adjust the AWGN generator, according to the combinations of SCS and channel bandwidth defined in table 8.1.3.6.1.2.4.2-1.

Table 8.1.3.6.1.2.4.2-1: AWGN power level at the IAB-DU input

Sub-carrier spacing (kHz)	Channel bandwidth (MHz)	AWGN power level
15	10	-80.3 dBm / 9.36 MHz
	20	-77.2 dBm / 19.08 MHz
30	10	-80.6 dBm / 8.64 MHz
	20	-77.4 dBm / 18.36 MHz
	40	-74.2 dBm / 38.16 MHz
	100	-70.1 dBm / 98.28 MHz

- 3) The characteristics of the wanted signal shall be configured according to TS 38.211 [9], and the specific test parameters are configured as below:

Table 8.1.3.6.1.2.4.2-2: Test parameters for multi-slot PUCCH format 1

Parameter	Test
Cyclic prefix	Normal
Number of information bits	2
Number of PRBs	1
Number of symbols	14
First PRB prior to frequency hopping	0
Intra-slot frequency hopping	disabled
Inter-slot frequency hopping	enabled
First PRB after frequency hopping	The largest PRB index - (nrofPRBs - 1)
Group and sequence hopping	neither
Hopping ID	0
Initial cyclic shift	0
First symbol	0
Index of orthogonal cover code (<i>timeDomainOCC</i>)	0
Number of slots for PUCCH repetition	2

- 4) The multipath fading emulators shall be configured according to the corresponding channel model defined in annex F.
- 5) Adjusting the equipment so that the SNR specified in table 8.1.3.6.1.2.5-1 is achieved at the IAB-DU input during the transmissions.
- 6) The tester sends random codewords from applicable codebook, in regular time periods. The following statistics are kept: the number of ACK bits falsely detected in the idle periods and the number of missed ACK bits. Each falsely detected ACK bit in the idle periods is accounted as one error for the statistics of false ACK detection, and each missed ACK bit is accounted as one error for the statistics of missed ACK detection.

Note that the procedure described in this clause for ACK missed detection has the same condition as that described in clause 8.1.3.6.1.1.4.2 for NACK to ACK detection. Both statistics are measured in the same testing.

8.1.3.6.1.2.5 Test requirement

The fraction of falsely detected ACK bits shall be less than 1 % and the fraction of correctly detected ACK bits shall be larger than 99 % for the SNR listed in table 8.1.3.6.1.2.5-1.

Table 8.1.3.6.1.2.5-1: Minimum requirements for multi-slot PUCCH format 1 with 30 kHz SCS

Number of TX antennas	Number of RX antennas	Propagation conditions and correlation matrix (annex F)	Channel bandwidth / SNR (dB)
			40 MHz
1	2	TDLC-300-100 Low	-7.0

8.1.4 Performance requirements for PRACH

8.1.4.1 PRACH false alarm probability and missed detection requirements

8.1.4.1.1 Definition and applicability

The performance requirement of PRACH for preamble detection is determined by the two parameters: total probability of false detection of the preamble (Pfa) and the probability of detection of preamble (Pd). The performance is measured by the required SNR at probability of detection, Pd of 99%. Pfa shall be 0.1% or less.

Pfa is defined as a conditional total probability of erroneous detection of the preamble (i.e. erroneous detection from any detector) when input is only noise.

P_d is defined as conditional probability of detection of the preamble when the signal is present. The erroneous detection consists of several error cases – detecting only different preamble(s) than the one that was sent, not detecting any preamble at all, or detecting the correct preamble but with the out-of-bounds timing estimation value.

For AWGN and TDLC300-100, a timing estimation error occurs if the estimation error of the timing of the strongest path is larger than the time error tolerance values given in table 8.1.4.1.1-1.

Table 8.1.4.1.1-1: Time error tolerance for AWGN and TDLC300-100

PRACH preamble	PRACH SCS (kHz)	Time error tolerance	
		AWGN	TDLC300-100
0	1.25	1.04 us	2.55 us
A1, A2, A3, B4, C0, C2	15	0.52 us	2.03 us
	30	0.26 us	1.77 us

The test preambles for normal mode are listed in A.2.5-1.

Which specific test(s) are applicable to IAB-DU is based on the test applicability rules defined in clause 8.1.1.2.4.

8.1.4.1.2 Minimum requirement

The minimum requirement is in TS 38.174 [2] clause 8.1.4.1 and 8.1.4.2.

8.1.4.1.3 Test purpose

The test shall verify the receiver's ability to detect PRACH preamble under static conditions and multipath fading propagation conditions for a given SNR.

8.1.4.1.4 Method of test

8.1.4.1.4.1 Initial conditions

Test environment: Normal; see annex B.2.

RF channels to be tested: for single carrier: M; see clause 4.9.1.

8.1.4.1.4.2 Test procedure

- 1) Connect the IAB-DU tester generating the wanted signal, multipath fading simulators and AWGN generators to all IAB-DU *TAB connectors* for diversity reception via a combining network as shown in annex D. 3.
- 2) Adjust the AWGN generator, according to the SCS and channel bandwidth.

Table 8.1.4.1.4.2-1: AWGN power level at the IAB-DU input

Sub-carrier spacing (kHz)	Channel bandwidth (MHz)	AWGN power level
15	10	-80.3 dBm / 9.36MHz
	20	-77.2 dBm / 19.08MHz
30	10	-80.6 dBm / 8.64MHz
	20	-77.4 dBm / 18.36MHz
	40	-74.2 dBm / 38.16MHz
	100	-70.1 dBm / 98.28MHz

- 3) The characteristics of the wanted signal shall be configured according to the corresponding UL reference measurement channel defined in annex A and the test parameter *msg1-FrequencyStart* is set to 0.
- 4) The multipath fading emulators shall be configured according to the corresponding channel model defined in annex F.

- 5) Adjust the frequency offset of the test signal according to table 8.1.4.1.5-1 or 8.1.4.1.5-2 or 8.1.4.1.5-3 or 8.1.4.1.6-1 or 8.1.4.1.6-2 or 8.1.4.1.6-3 or 8.1.4.1.6-4.
- 6) Adjust the equipment so that the SNR specified in table 8.1.4.1.5-1 or 8.1.4.1.5-2 or 8.1.4.1.5-3 or 8.1.4.1.6-1 or 8.1.4.1.6-2 or 8.1.4.1.6-3 or 8.1.4.1.6-4 is achieved at the IAB-DU input during the PRACH preambles.
- 7) The test signal generator sends a preamble and the receiver tries to detect the preamble. This pattern is repeated as illustrated in figure 8.1.4.1.4.2-1. The preambles are sent with certain timing offsets as described below. The following statistics are kept: the number of preambles detected in the idle period and the number of missed preambles.



Figure 8.1.4.1.4.2-1: PRACH preamble test pattern

The timing offset base value for PRACH preamble format 0 is set to 50% of N_{cs} . This offset is increased within the loop, by adding in each step a value of 0.1 μ s, until the end of the tested range, which is 0.9 μ s. Then the loop is being reset and the timing offset is set again to 50% of N_{cs} . The timing offset scheme for PRACH preamble format 0 is presented in figure 8.1.4.1.4.2-2.

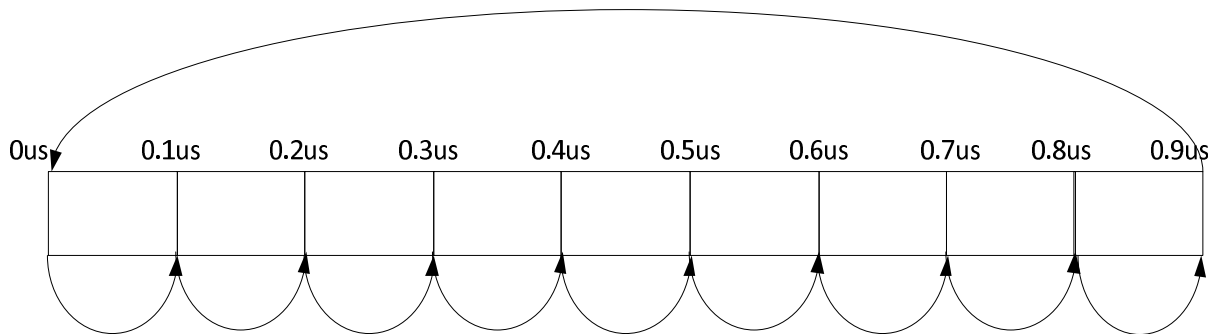

Figure 8.1.4.1.4.2-2: Timing offset scheme for PRACH preamble format 0

The timing offset base value for PRACH preamble format A1, A2, A3, B4, C0 and C2 is set to 0. This offset is increased within the loop, by adding in each step a value of 0.1 μ s, until the end of the tested range, which is 0.8 μ s. Then the loop is being reset and the timing offset is set again to 0. The timing offset scheme for PRACH preamble format A1, A2, A3, B4, C0 and C2 is presented in figure 8.1.4.1.4.2-3.

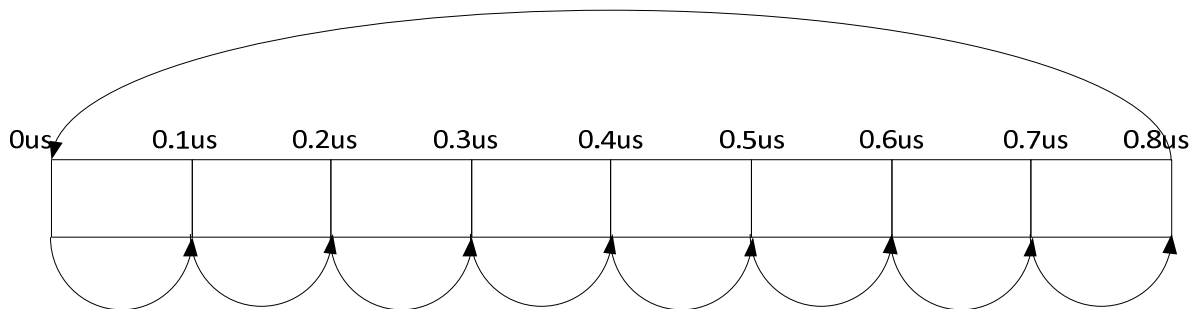

Figure 8.1.4.1.4.2-3: Timing offset scheme for PRACH preamble format A1 A2, A3, B4, C0 and C2

8.1.4.1.5 Test requirement

P_{fa} shall not exceed 0.1%. P_d shall not be below 99% for the SNRs in tables 8.1.4.1.5-1 to 8.1.4.1.5-3.

Table 8.1.4.1.5-1: PRACH missed detection test requirements for Normal Mode, 1.25 kHz SCS

Number of TX antennas	Number of RX antennas	Propagation conditions and correlation matrix (annex F)	Frequency offset	SNR (dB)
				Burst format 0
1	2	AWGN	0	-14.2
		TDLC300-100 Low	400 Hz	-6.0
	4	AWGN	0	-16.4
		TDLC300-100 Low	400 Hz	-11.3
	8	AWGN	0	-18.6
		TDLC300-100 Low	400 Hz	-15.2

Table 8.1.4.1.5-2: PRACH missed detection test requirements for Normal Mode, 15 kHz SCS

Number of TX antennas	Number of RX antennas	Propagation conditions and correlation matrix (annex F)	Frequency offset	SNR (dB)					
				Burst format A1	Burst format A2	Burst format A3	Burst format B4	Burst format C0	Burst format C2
1	2	AWGN	0	-9.0	-12.3	-13.9	-16.5	-6.0	-12.2
		TDLC300-100 Low	400 Hz	-1.5	-4.2	-6.0	-8.2	1.4	-4.3
	4	AWGN	0	-11.3	-14.0	-15.7	-18.7	-8.4	-13.8
		TDLC300-100 Low	400 Hz	-6.7	-9.7	-11.1	-13.2	-3.7	-9.6
	8	AWGN	0	-13.5	-16.4	-17.9	-20.9	-10.8	-16.3
		TDLC300-100 Low	400 Hz	-10.4	-13.3	-14.6	-16.7	-7.5	-13.3

Table 8.1.4.1.5-3: PRACH missed detection test requirements for Normal Mode, 30 kHz SCS

Number of TX antennas	Number of RX antennas	Propagation conditions and correlation matrix (annex F)	Frequency offset	SNR (dB)					
				Burst format A1	Burst format A2	Burst format A3	Burst format B4	Burst format C0	Burst format C2
1	2	AWGN	0	-8.8	-11.7	-13.5	-16.2	-5.8	-11.6
		TDLC300-100 Low	400 Hz	-2.2	-5.1	-6.8	-9.3	0.7	-5.0
	4	AWGN	0	-11.1	-13.9	-15.6	-18.7	-8.3	-13.8
		TDLC300-100 Low	400 Hz	-6.6	-9.8	-11.4	-13.9	-3.9	-9.8
	8	AWGN	0	-13.4	-16.3	-17.8	-20.8	-10.7	-16.2
		TDLC300-100 Low	400 Hz	-10.1	-13.1	-14.5	-17.0	-7.2	-13.1

8.2 IAB-MT Performance requirements

8.2.1 General

8.2.1.1 Scope and definitions

Conducted performance requirements specify the ability of the IAB-MT to correctly demodulate signals in various conditions and configurations. Conducted performance requirements are specified at the TAB connector(s).

Conducted performance requirements for the IAB-MT are specified for the fixed reference channels and the propagation conditions defined in TS 38.174 [2] annex A and annex F, respectively. The requirements only apply to those FRCs that are supported by the IAB-MT.

Unless stated otherwise, performance requirements apply for a single carrier only. Performance requirements for an IAB-MT supporting CA are defined in terms of single carrier requirements.

The SNR used in this clause is specified based on a single carrier and defined as:

$$\text{SNR} = S / N$$

Where:

S is the total signal energy in a slot on a single *TAB connector*.

N is the noise energy in a bandwidth corresponding to the transmission bandwidth over the duration of a slot.

8.2.2 Demodulation performance requirements

8.2.2.1 General

8.2.2.1.1 Applicability of requirements

8.2.2.1.1.1 General

Unless otherwise stated, for a IAB-MT declared to support more than 2 demodulation branches (for *IAB-MT type 1-O* and *IAB-MT type 2-O*), the performance requirement tests for 2 demodulation branches shall apply, and the mapping between connectors and demodulation branches is up to IAB-MT implementation.

The tests requiring more than [20] dB SNR level are set to N/A in the test requirements.

8.2.2.1.1.2 Applicability of requirements for different subcarrier spacings

Unless otherwise stated, the tests shall apply only for each subcarrier spacing declared to be supported (see D.7 in table 4.6-1).

8.2.2.1.1.3 Applicability of requirements for TDD with different UL-DL patterns

Unless otherwise stated, for each subcarrier spacing declared to be supported, if IAB-MT supports multiple TDD UL-DL patterns, only one of the supported TDD UL-DL patterns shall be used for all tests.

8.2.2.1.1.4 Applicability of requirements for IAB-MT features

Unless otherwise stated, the PDSCH 256QAM tests (Test 1-1 of Clause 8.2.2.2.5) shall apply only if 256QAM for PDSCH for FR1 is declared to be supported (see D.200 in table 4.6-1, *pdsch-256QAM-FRI*).

Unless otherwise stated, the PDSCH tests (Tests 4, 5 of clause 8.2.2.2.5) shall apply only in case the number of NZP-CSI-RS ports in the test case satisfies maximum number of ports across all configured NZP-CSI-RS resources per CC declared to be supported (see D.201 in table 4.6-1, *maxConfigNumberPortsAcrossNZP-CSI-RS-PerCC*).

Unless otherwise stated, the PDSCH tests (Tests 3, 4, 5 of clause 8.2.2.2.5) shall apply only in case the PDSCH MIMO rank in the test case does not exceed the maximum number of PDSCH MIMO layers declared to be supported (see D.202 in table 4.6-1, *maxConfigNumberPortsAcrossNZP-CSI-RS-PerCC*).

NOTE: Applicability information may be obtained based on vendor declaration (Section 4.6) or alternatively from reading capability signaling.

8.2.2.2 Performance requirements for PDSCH

8.2.2.2.1 Definition and applicability

The performance requirement of PDSCH is determined by a minimum required throughput for a given SNR. The required throughput is expressed as a fraction of maximum throughput for the FRCs listed in annex A. The performance requirements assume HARQ re-transmissions.

8.2.2.2.2 Minimum requirement

The minimum requirement is in TS 38.174 [2] clause 8.2.2.1.2.

8.2.2.2.3 Test purpose

The test shall verify the receiver's ability to achieve throughput under multipath fading propagation conditions for a given SNR.

8.2.2.2.4 Method of test

8.2.2.2.4.1 Initial conditions

Test environment: Normal, see annex B.2.

RF channels to be tested for single carrier: M ; see clause 4.9.1.

RF channels to be tested for carrier aggregation: $M_{\text{BW Channel CA}}$; see clause 4.9.1.

8.2.2.2.4.2 Procedure

- 1) Connect the IAB tester generating the wanted signal, multipath fading simulators and AWGN generators to all IAB-MT *TAB connectors* for diversity reception via a combining network as shown in annex D.6.
- 2) Adjust the AWGN generator and adjust the AWGN power level to -77.2 dBm / 38.16MHz.
- 3) The characteristics of the wanted signal shall be configured according to the corresponding DL reference measurement channel defined in annex A and the test parameters in table 8.2.2.2.4.2-1.

Table 8.2.2.4.2-1: Test parameters for testing PDSCH

Parameter		Unit	Value
Duplex mode			TDD
Active BWP index			1
Default TDD UL-DL pattern (Note 1)			7D1S2U, S=6D:4G:4U
PDSCH transmission scheme			Transmission scheme 1
Carrier configuration	Offset between Point A and the lowest usable subcarrier on this carrier (Note 1)	RBs	0
	Subcarrier spacing	kHz	30
DL BWP configuration #1	Cyclic prefix		Normal
	RB offset	RBs	0
	Number of contiguous PRB	PRBs	106
PDSCH DMRS configuration	Antenna ports indexes		{1000} for Rank 1 tests {1000, 1001} for Rank 2 tests {1000-1002} for Rank 3 tests {1000-1003} for Rank 4 tests
	Position of the first DMRS for PDSCH mapping type A		2
	Number of PDSCH DMRS CDM group(s) without data		1 for Rank 1 and Rank 2 tests 2 for Rank 3 and Rank 4 tests
	DMRS Type		Type 1
	Number of additional DMRS		1
	Maximum number of OFDM symbols for DL front loaded DMRS		1
PDSCH configuration	Mapping type		Type A
	k ₀		0
	Starting symbol (S)		2
	Length (L)		Specific to each Reference channel
	PDSCH aggregation factor		1
	PRB bundling type		Static
	PRB bundling size		2
	Resource allocation type		Type 0
	RBG size		Config2
	VRB-to-PRB mapping type		Non-interleaved
VRB-to-PRB mapping interleaver bundle size		N/A	
PT-RS configuration			PT-RS is not configured
Maximum number of code block groups for ACK/NACK feedback			1
Maximum number of HARQ transmission			4
HARQ ACK/NACK bundling			Multiplexed
Redundancy version coding sequence			{0,2,3,1}
PDSCH & PDSCH DMRS Precoding configuration			Single Panel Type I, Random precoder selection updated per slot, with equal probability of each applicable i ₁ , i ₂ combination, and with PRB bundling granularity
NOTE 1: The same requirements are applicable to TDD with different UL-DL patterns.			
NOTE 2: Point A coincides with minimum guard band as specified in TS 38.174 [2] for tested channel bandwidth and subcarrier spacing.			

- 4) The multipath fading emulators shall be configured according to the corresponding channel model defined in annex F.
- 5) Adjust the equipment so that required SNR specified in tables 8.2.2.2.5.1-1, 8.2.2.2.5.1-2, 8.2.2.2.5.1-3 or 8.2.2.2.5.2-1-4 (as applicable) is achieved at the IAB-MT input.
- 6) For each of the reference channels in tables 8.2.2.2.5.1-1, 8.2.2.2.5.1-2, 8.2.2.2.5.1-3 or 8.2.2.2.5.2-1-4 applicable for the IAB-MT, measure the throughput.

8.2.2.2.5 Test requirement

The throughput measured according to clause 8.2.2.2.4.2 shall not be below the limits for the SNR levels specified in table 8.2.2.2.5-1, 8.2.2.2.5-2, 8.2.2.2.5-3 and 8.2.2.2.5-4.

Table 8.2.2.2.5-1: Minimum performance for Rank 1

Test num.	Reference channel	Bandwidth (MHz) / Subcarrier spacing (kHz)	Modulation format and code rate	Propagation condition	Correlation matrix and antenna configuration	Reference value	
						Fraction of maximum throughput (%)	SNR (dB)
1	M-FR1-A.3.3-1	40 / 30	256QAM, 0.82	TDLA30-10	2x4, ULA Low	70	[22.5]
2	M-FR1-A.3.1-1	40 / 30	16QAM, 0.48	TDLA30-10	2x4, ULA Low	30	[-0.1]

Table 8.2.2.2.5-2: Minimum performance for Rank 2

Test num.	Reference channel	Bandwidth (MHz) / Subcarrier spacing (kHz)	Modulation format and code rate	Propagation condition	Correlation matrix and antenna configuration	Reference value	
						Fraction of maximum throughput (%)	SNR (dB)
3	M-FR1-A.3.2-1	40 / 30	64QAM, 0.50	TDLA30-10	2x4, ULA Low	70	[14.6]

Table 8.2.2.2.5-3: Minimum performance for Rank 3

Test num.	Reference channel	Bandwidth (MHz) / Subcarrier spacing (kHz)	Modulation format and code rate	Propagation condition	Correlation matrix and antenna configuration	Reference value	
						Fraction of maximum throughput (%)	SNR (dB)
4	M-FR1-A.3.1-3	40 / 30	16QAM, 0.48	TDLA30-10	4x4, ULA Low	70	[12.4]

Table 8.2.2.2.5-4: Minimum performance for Rank 4

Test num.	Reference channel	Bandwidth (MHz) / Subcarrier spacing (kHz)	Modulation format and code rate	Propagation condition	Correlation matrix and antenna configuration	Reference value	
						Fraction of maximum throughput (%)	SNR (dB)
5	M-FR1-A.3.1-4	40 / 30	16QAM, 0.48	TDLA30-10	4x4, ULA Low	70	[16.4]

8.2.2.3 Performance requirements for PDCCH

8.2.2.3.1 Definition and applicability

The performance requirement of PDCCH is determined by a maximum allowed missed detection rate for a given SNR. The required missed detection rate is expressed for the FRCs listed in annex A.

8.2.2.3.2 Minimum requirement

The minimum requirement is in TS 38.174 [2] clause 8.2.2.2.

8.2.2.3.3 Test purpose

The test shall verify the receiver's ability to achieve missed detection rate under multipath fading propagation conditions for a given SNR.

8.2.2.3.4 Method of test

8.2.2.3.4.1 Initial conditions

Test environment: Normal, see annex B.2.

RF channels to be tested for single carrier: M ; see clause 4.9.1.

RF channels to be tested for carrier aggregation: $M_{\text{BW Channel CA}}$; see clause 4.9.1.

8.2.2.3.4.2 Procedure

- 1) Connect the IAB tester generating the wanted signal, multipath fading simulators and AWGN generators to all IAB-MT *TAB connectors* for diversity reception via a combining network as shown in annex D.6.
- 2) Adjust the AWGN generator and adjust the AWGN power level to -77.2 dBm / 38.16MHz.
- 3) The characteristics of the wanted signal shall be configured according to the corresponding DL reference measurement channel defined in annex A and the test parameters in table 8.2.2.3.4.2-1.

Table 8.2.2.3.4.2-1: Test parameters for testing PDCCH

Parameter	Unit	1 Tx Antenna	2 Tx Antenna
CCE to REG mapping type		interleaved	interleaved
Interleaver size		3	
REG bundle size		2	6
Shift Index		0	

- 4) The multipath fading emulators shall be configured according to the corresponding channel model defined in annex F.
- 5) Adjust the equipment so that required SNR specified in tables 8.2.2.3.5.1-1, 8.2.2.3.5.2-2, 8.2.2.3.6.1-3, 8.2.2.3.6.2-4 (as applicable) is achieved at the IAB-MT input.
- 6) For each of the reference channels in table 8.2.2.3.5.1-1, 8.2.2.3.5.2-2, 8.2.2.3.6.1-3, 8.2.2.3.6.2-4 applicable for the IAB-MT, measure the missed detection.

8.2.2.3.5 Test requirement

For the parameters specified in Table 8.2.2.3.4.2.1-1, the average probability of a missed downlink scheduling grant ($P_{\text{m-dsg}}$) shall be below the specified value in Table 8.2.2.3.5-1.

Table 8.2.2.3.5-1: Minimum performance for PDCCH

Test number	Bandwidth (MHz)	CORESET RB	CORESET duration	Aggregation level	Reference Channel	Propagation Condition	Antenna configuration and correlation Matrix	Reference value	
								$P_{\text{m-dsg}}$ (%)	SNR (dB)
1	40	102	1	2	M-FR1-A.3.4-1	TDLA30-10	1x4 Low	1	[2.1]
2	40	102	1	4	M-FR1-A.3.4-2	TDLA30-10	1x4 Low	1	[-0.9]
3	40	90	1	8	M-FR1-A.3.4-3	TDLA30-10	2x4 Low	1	[-4.3]

8.2.3 CSI reporting requirements

8.2.3.1 General

8.2.3.1.1 Applicability rule for IAB-MT

8.2.3.1.1.1 General

Unless otherwise stated, for an IAB-MT declared to support more than 4 *TAB connectors* (for *IAB type 1-H*), the performance requirement tests for 4 RX antennas shall apply, and the specific connectors used for testing is up to IAB-MT implementation.

Testing of performance requirements for RI and PMI reporting is optional.

8.2.3.1.1.2 Applicability of requirements for different subcarrier spacings

Unless otherwise stated, the tests shall apply only for each subcarrier spacing declared to be supported (see D.14 in table 4.6-1).

8.2.3.1.1.3 Applicability of requirements for TDD with different UL-DL patterns

Unless otherwise stated, for each subcarrier spacing declared to be supported, if IAB-MT supports multiple TDD UL-DL patterns, only one of the supported TDD UL-DL patterns shall be used for all tests.

8.2.3.1.1.4 Applicability of requirements for IAB-MT features

Unless otherwise stated, for *IAB type 1-H*, the CSI reporting tests shall apply only in case the number of NZP-CSI-RS ports in the test case satisfies maximum number of ports across all configured NZP-CSI-RS resources per CC declared to be supported (see D.201 in table 4.6-1, *maxConfigNumberPortsAcrossNZP-CSI-RS-PerCC*).

Unless otherwise stated, for *IAB type 1-H*, the CSI reporting tests shall apply only in case the PDSCH MIMO rank in the test case does not exceed the maximum number of PDSCH MIMO layers declared to be supported (see D.202 in table 4.6-1, *maxNumberMIMO-LayersPDSCH*).

Note: Applicability information may be obtained based on vendor declaration (Section 4.6) or alternatively from reading capability signaling.

8.2.3.2 Reporting Channel Quality Indicator (CQI)

8.2.3.2.1 Definition and applicability

The reporting accuracy of the channel quality indicator (CQI) under frequency non-selective conditions is determined by the reporting variance and the BLER performance using the transport format indicated by the reported CQI median. The purpose is to verify that the reported CQI values are in accordance with the CQI definition given in TS 38.214 [24]. To account for sensitivity of the input SNR the reporting definition is considered to be verified if the reporting accuracy is met for at least one of two SNR levels separated by an offset of 1 dB.

Which specific test(s) are applicable to IAB-MT is based on the test applicability rules defined in clause 8.2.1.2.

8.2.3.2.2 Minimum requirement

The minimum requirement is in TS 38.174 [2] clause 8.2.3.1.

8.2.3.2.3 Test purpose

The test shall verify the receiver's ability to report CQI values accordance with the CQI definition given in TS 38.214 [24].

8.2.3.2.4 Method of test

8.2.3.2.4.1 Initial conditions

Test environment: Normal, see annex B.2.

RF channels to be tested for single carrier: M ; see clause 4.9.1.

8.2.3.2.4.2 Test procedure

- 1) Connect the IAB-MT tester generating the wanted signal and AWGN generators to all IAB-MT *TAB* connectors for diversity reception via a combining network as shown in annex D.5 and D.6.
- 2) Adjust the AWGN generator, according to the channel bandwidth, defined in table 8.2.3.2.4.2-1.

Table 8.2.3.2.4.2-1: AWGN power level at the IAB-MT input

Sub-carrier spacing (kHz)	Channel bandwidth (MHz)	AWGN power level
30 kHz	40	-77.2 dBm / 38.16MHz

- 3) The characteristics of the wanted signal shall be configured according to the corresponding DL reference measurement channel defined in annex A and the test parameters in table 8.2.3.2.4.2-2.

Table 8.2.3.2.4.2-2: Test parameters for testing CQI reporting

Parameter		Unit	Test 1	Test 2	
Bandwidth		MHz	40		
Subcarrier spacing		kHz	30		
Default TDD UL-DL pattern (Note 1)			7D1S2U, S=6D:4G:4U		
SNR		dB	5	6	11 12
Propagation channel			AWGN		
Antenna configuration			2x4		
Beamforming Model			As specified in Annex J.3		
NZP CSI-RS for CSI acquisition	CSI-RS resource Type		Periodic		
	Number of CSI-RS ports (X)		2		
	CDM Type		FD-CDM2		
	Density (ρ)		1		
	First subcarrier index in the PRB used for CSI-RS (k_0, k_1)		Row 3,(6,-)		
	First OFDM symbol in the PRB used for CSI-RS (l_0)		13		
	NZP CSI-RS-timeConfig periodicity and offset	slot	10/1		
ReportConfigType			Periodic		
CQI-table			Table 2		
reportQuantity			cri-RI-PMI-CQI		
cqi-FormatIndicator			Wideband		
pmi-FormatIndicator			Wideband		
Sub-band Size		RB	16		
Csi-ReportingBand			1111111		
CSI-Report periodicity and offset		slot	10/9		
Codebook configuration	Codebook Type		type1-SinglePanel		
	Codebook Mode		1		
	CodebookSubsetRestriction		010000		
	RI Restriction		N/A		
CQI/RI/PMI delay		ms	9.5		
Maximum number of HARQ transmission			1		
Measurement channel			M-FR1-A.3.5-2		

NOTE 1: The same requirements are applicable for TDD with different UL-DL pattern.

- 4) Adjust the equipment so that required SNR specified in table 8.2.3.2.4.2-2 is achieved at the IAB-MT input.
- 5) For each test specified in table 8.2.3.2.4.2-2 applicable for the IAB-MT, measure the median CQI and the BLER at median CQI and (median CQI+1 or median CQI-1) as per clause 8.2.3.2.5.

8.2.3.2.5 Test requirement

For the parameters specified in Table 8.2.3.2.4.2-2, and using the downlink physical channels specified in Annex A, the test requirements are specified by the following:

- a) The reported CQI value according to the reference channel shall be in the range of ± 1 of the reported median more than 90% of the time.
- b) If the PDSCH BLER using the transport format indicated by median CQI is less than or equal to 0.1, then the BLER using the transport format indicated by the (median CQI+1) shall be greater than 0.1. If the PDSCH BLER using the transport format indicated by the median CQI is greater than 0.1, then the BLER using transport format indicated by (median CQI-1) shall be less than or equal to 0.1.

8.2.3.3 Reporting of Precoding Matrix Indicator (PMI)

8.2.3.3.1 Definition and applicability

The minimum performance requirements of PMI reporting are defined based on the precoding gain, expressed as the relative increase in throughput when the transmitter is configured according to the UE reported PMI compared to the case when the transmitter is using random precoding, respectively. When the transmitter uses random precoding, for each PDSCH allocation a precoder is randomly generated with equal probability of each applicable i_1 and i_2 combination and applied to the PDSCH. A fixed transport format (FRC) is configured for all requirements.

The requirements for transmission mode 1 with higher layer parameter *codebookType* set to 'typeI-SinglePanel' are specified in terms of the ratio:

$$\gamma = \frac{t_{ue, follow 1, follow 2}}{t_{rnd1, rnd2}}$$

In the definition of γ for 4TX and 8TX PMI requirements, $t_{follow1, follow2}$ is 90 % of the maximum throughput obtained at $SNR_{follow1, follow2}$ using the precoders configured according to the UE reports, and $t_{rnd1, rnd2}$ is the throughput measured at $SNR_{follow1, follow2}$ with random precoding.

8.2.3.3.2 Minimum requirement

The minimum requirement is in TS 38.174 [2] clause 8.2.3.2.

8.2.3.3.3 Test purpose

The test shall verify the receiver's ability to achieve throughput gain under multipath fading propagation conditions using reporting PMI comparing to using random PMI.

8.2.3.3.4 Method of test

8.2.3.3.4.1 Initial conditions

Test environment: Normal, see annex B.2.

RF channels to be tested for single carrier: M; see clause 4.9.1.

8.2.3.3.4.2 Test procedure

- 1) Connect the IAB-MT tester generating the wanted signal and AWGN generators to all IAB-MT *TAB* connectors for diversity reception via a combining network as shown in annex D.5 and D.6.
- 2) Adjust the AWGN generator, according to the channel bandwidth, defined in table 8.2.3.3.4.2-1.

Table 8.2.3.3.4.2-1: AWGN power level at the IAB-MT input

Sub-carrier spacing (kHz)	Channel bandwidth (MHz)	AWGN power level
30 kHz	40	-77.2 dBm / 38.16MHz

- 3) The characteristics of the wanted signal shall be configured according to the corresponding DL reference measurement channel defined in annex A and the test parameters in table 8.2.3.3.4.2-2.

Table 8.2.3.3.4.2-2: Test parameters for testing PMI reporting

Parameter		Unit	Test 1	Test 2
Bandwidth		MHz	40	40
Subcarrier spacing		kHz	30	30
Default TDD UL-DL pattern (Note 1)			7D1S2U, S=6D:4G:4U	7D1S2U, S=6D:4G:4U
Propagation channel			TDLA30-5	TDLA30-5
Antenna configuration			High XP 4 x 4 (N1,N2) = (2,1)	High XP 8 x 4 (N1,N2) = (4,1)
Beamforming Model			As specified in Annex J.3	As specified in Annex J.3
NZP CSI-RS for CSI acquisition	CSI-RS resource Type		Periodic	Periodic
	Number of CSI-RS ports (X)		4	8
	CDM Type		FD-CDM2	CDM4 (FD2, TD2)
	Density (ρ)		1	1
	First subcarrier index in the PRB used for CSI-RS (k_0, k_1)		Row 4, (0,-)	Row 8, (4,6)
	First OFDM symbol in the PRB used for CSI-RS (l_0, l_1)		(13,-)	(5,-)
NZP CSI-RS-timeConfig periodicity and offset		slot	10/1	10/1
ReportConfigType			Periodic	Periodic
CQI-table			Table 1	Table 1
reportQuantity			cri-RI-PMI-CQI	cri-RI-PMI-CQI
cqi-FormatIndicator			Wideband	Wideband
pmi-FormatIndicator			Wideband	Wideband
Sub-band Size		RB	16	16
csi-ReportingBand			1111111	1111111
CSI-Report periodicity and offset		slot	10/9	10/9
Codebook configuration	Codebook Type		type1-SinglePanel	type1-SinglePanel
	Codebook Mode		1	1
	(CodebookConfig-N1,CodebookConfig- N2)		(2,1)	(4,1)
	(CodebookConfig-O1,CodebookConfig- O2)		(4,1)	(4,1)
	CodebookSubsetRestriction		11111111	0x FFFF
RI Restriction			00000001	00000010
CQI/RI/PMI delay		ms	5.5	6.5
Maximum number of HARQ transmission			4	4
Measurement channel			M-FR1-A.3.5-5	M-FR1-A.3.5-6
NOTE 1: The same requirements are applicable for TDD with different UL-DL pattern.				
NOTE 2: When Throughput is measured using random precoder selection, the precoder shall be updated in each slot (0.5 ms granularity) with equal probability of each applicable i_1, i_2 combination.				
NOTE 3: If the UE reports in an available uplink reporting instance at slot#n based on PMI estimation at a downlink slot not later than slot#(n-4) for Test 1 or slot#(n-6) for Test 2, this reported PMI cannot be applied at the gNB downlink before slot#(n+4) for Test 1 or slot#(n+6) for Test 2 respectively.				
NOTE 4: Randomization of the principle beam direction shall be used as specified in Annex F.2.4.2.4.				

- 4) The multipath fading emulators shall be configured according to the corresponding channel model defined in annex F.
- 5) Adjust the equipment so that required SNR specified in clause 8.2.3.3.1 is achieved at the IAB-MT input.
- 6) For each test specified in table 8.2.3.3.4.2-2 applicable for the IAB-MT, calculate γ .

8.2.3.3.5 Test requirement

For the parameters specified in Table 8.2.3.3.4.2-2, and using the downlink physical channels specified in Annex A, the test requirements are specified in Table 8.2.3.3.5-1.

Table 8.2.3.3.5-1 Test requirements for PMI reporting

Parameter	Test 1	Test 2
γ	1.29	1.49

8.2.3.4 Reporting of Rank Indicator (RI)

8.2.3.4.1 General

The purpose of this test is to verify that the reported rank indicator accurately represents the channel rank. The accuracy of RI reporting is determined by the relative increase of the throughput obtained when transmitting based on the reported rank compared to the case for which a fixed rank is used for transmission.

8.2.3.4.2 Minimum requirements

The minimum requirement is in TS 38.174 [2] clause 8.2.3.3.

8.2.3.4.3 Test purpose

The test shall verify the receiver's ability to report rank indicator accurately represents the channel rank.

8.2.3.4.4 Method of test

8.2.3.4.4.1 Initial conditions

Test environment: Normal, see annex B.2.

RF channels to be tested for single carrier:M; see clause 4.9.1.

8.2.3.4.4.2 Test procedure

- 1) Connect the IAB-MT tester generating the wanted signal and AWGN generators to all IAB-MT *TAB* connectors for diversity reception via a combining network as shown in annex D.5 and D.6.
- 2) Adjust the AWGN generator, according to the channel bandwidth, defined in table 8.2.3.4.4.2-1.

Table 8.2.3.4.4.2-1: AWGN power level at the IAB-MT input

Sub-carrier spacing (kHz)	Channel bandwidth (MHz)	AWGN power level
30 kHz	40	-77.2 dBm / 38.16MHz

- 3) The characteristics of the wanted signal shall be configured according to the corresponding DL reference measurement channel defined in annex A and the test parameters in table 8.2.3.4.4.2-2.

Table 8.2.3.4.4.2-2: Test parameters for testing RI reporting

Parameter		Unit	Test 1	Test 2	Test 3	Test 4
Bandwidth		MHz	40	40	40	40
Subcarrier spacing		kHz	30	30	30	30
Default TDD UL-DL pattern (Note 1)			7D1S2U, S=6D:4G:4U	7D1S2U, S=6D:4G:4U	7D1S2U, S=6D:4G:4U	7D1S2U, S=6D:4G:4U
SNR			-2	16	16	22
Propagation channel			TDLA30-5	TDLA30-5	TDLA30-5	TDLA30-5
Antenna configuration			ULA Low 2x4	ULA Low 2x4	ULA High 2x4	ULA Low 4x4
Beamforming Model			As specified in Annex J.3	As specified in Annex J.3	As specified in Annex J.3	As specified in Annex J.3
NZIP CSI-RS for CSI acquisition	CSI-RS resource Type		Periodic	Periodic	Periodic	Periodic
	Number of CSI-RS ports (X)		2	2	2	4
	CDM Type		FD-CDM2	FD-CDM2	FD-CDM2	FD-CDM2
	Density (ρ)		1	1	1	1
	First subcarrier index in the PRB used for CSI-RS (k_0, k_1)		Row 3 (6,-)	Row 3 (6,-)	Row 3 (6,-)	Row 4 (0,-)
	First OFDM symbol in the PRB used for CSI-RS (l_0, l_1)		(13,-)	(13,-)	(13,-)	(13,-)
	NZIP CSI-RS-timeConfig periodicity and offset	slot	10/1	10/1	10/1	10/1
ReportConfigType			Periodic	Periodic	Periodic	Periodic
CQI-table			Table 2	Table 2	Table 2	Table 2
reportQuantity			cri-RI-PMI-CQI	cri-RI-PMI-CQI	cri-RI-PMI-CQI	cri-RI-PMI-CQI
cqi-FormatIndicator			Wideband	Wideband	Wideband	Wideband
pmi-FormatIndicator			Wideband	Wideband	Wideband	Wideband
Sub-band Size		RB	16	16	16	16
csi-ReportingBand			1111111	1111111	1111111	1111111
CSI-Report periodicity and offset		slot	10/9	10/9	10/9	10/9
Codebook configuration	Codebook Type		type1- SinglePanel	type1- SinglePanel	type1- SinglePanel	type1- SinglePanel
	Codebook Mode		1	1	1	1
	(CodebookConfig-N1, CodebookConfig-N2)		N/A	N/A	N/A	(2,1)
	CodebookSubsetRestriction		010000 for fixed rank 2, 010011 for following rank	000011 for fixed rank 1, 010011 for following rank	000011 for fixed rank 1, 010011 for following rank	11111111
	RI Restriction		N/A	N/A	N/A	00000010 for fixed Rank 2 and 00001111 for follow RI
CQI/RI/PMI delay		ms	9.5	9.5	9.5	9.5
Maximum number of HARQ transmission			1	1	1	1
RI Configuration			Fixed RI = 2 and follow RI	Fixed RI = 1 and follow RI	Fixed RI = 1 and follow RI	Fixed RI = 2 and follow RI
NOTE 1: The same requirements are applicable for TDD with different UL-DL pattern.						
NOTE 2: Measurements channels are specified in Table A.3.5-1. M-FR1-A.3.5-1 is used for Rank 1 case. M-FR1-A.3.5-2 is used for Rank 2 case. M-FR1-A.3.5-3 is used for Rank 3 case. M-FR1-A.3.5-4 is used for Rank 4 case.						

- 4) The multipath fading emulators shall be configured according to the corresponding channel model defined in annex F.
- 5) Adjust the equipment so that required SNR specified in Table 8.2.3.4.4.2-2 is achieved at the IAB-MT input.
- 6) For each test specified in table 8.2.3.4.4.2-2 applicable for the IAB-MT, calculate γ .

8.2.3.4.5 Test requirement

The test requirement for RI reporting is defined as

- a) The ratio of the throughput obtained when transmitting based on IAB-MT reported RI and that obtained when transmitting with fixed rank 1 shall be $\geq \gamma_1$;
- b) The ratio of the throughput obtained when transmitting based on IAB-MT reported RI and that obtained when transmitting with fixed rank 2 shall be $\geq \gamma_2$;

For the parameters specified in Table 8.2.3.4.4.2-2 and using the downlink physical channels specified in Annex A, the test requirements are specified in Table 8.2.3.4.5-1.

Table 8.2.3.4.5-1 Test requirements for RI reporting

	Test 1	Test 2	Test 3	Test 4
γ_1	N/A	1.05	0.9	N/A
γ_2	0.9	N/A	N/A	0.9

Annex A (normative): Reference measurement channels

A.1 IAB-DU and IAB-MT Reference measurement channels

A.1.1 IAB-DU Reference measurement channels

A.1.2 IAB-MT Reference measurement channels

A.1.2.1 Fixed Reference Channels for reference sensitivity level, ACS, in-band blocking, out-of-band blocking and receiver intermodulation (QPSK, R=1/3)

The parameters for the reference measurement channels are specified in tables A.1.2.1-1 for FR1 reference sensitivity level, ACS, in-band blocking, out-of-band blocking, receiver intermodulation, OTA sensitivity, OTA reference sensitivity level, OTA ACS, OTA in-band blocking, OTA out-of-band blocking, and OTA receiver intermodulation.

Table A.1.2.1-1: FRC parameters for FR1 reference sensitivity level for IAB-MT.

Reference channel	G-FR1-A1-22	G-FR1-A1-23	G-FR1-A1-25	G-FR1-A1-26
Subcarrier spacing (kHz)	30	60	30	60
Allocated resource blocks	11	11	51	24
CP-OFDM Symbols per slot (Note 1)	9	9	9	9
Modulation	QPSK	QPSK	QPSK	QPSK
Code rate (Note 2)	1/3	1/3	1/3	1/3
Payload size (bits)	736	736	3368	1608
Transport block CRC (bits)	16	16	16	16
Code block CRC size (bits)	-	-	-	-
Number of code blocks - C	1	1	1	1
Code block size including CRC (bits) (Note 3)	752	752	3384	1624
Total number of bits per slot	2376	2376	11016	5184
Total symbols per slot	1188	1188	5508	2592
NOTE 1: $DL-DMRS-config-type = 1$ with $DL-DMRS-max-len = 1$, $DL-DMRS-add-pos = pos2$ with $\begin{matrix} \text{pos2} \\ \text{pos2} \end{matrix} = 2$, $\begin{matrix} \text{pos2} \\ \text{pos2} \end{matrix} = 6$ and 9 as per Table 7.4.1.1.2-3 of TS 38.211 [9].				
NOTE 2: MCS index 4 and target coding rate = 308/1024 are adopted to calculate payload size for receiver sensitivity				
NOTE 3: Code block size including CRC (bits) equals to K in sub-clause 5.2.2 of TS 38.212 [10].				

A.2 IAB-DU Fixed Reference Channels

A.2.1 Fixed Reference Channels for PUSCH performance requirements (QPSK, R = 193/1024)

The parameters for the reference measurement channels are specified in table A.2.1-1 and table A.2.1-2 for FR1 PUSCH performance requirements:

- FRC parameters are specified in table A.2.1-1 for FR1 PUSCH with transform precoding disabled, additional DM-RS position = pos1 and 1 transmission layer.
- FRC parameters are specified in table A.2.1-2 for FR1 PUSCH with transform precoding disabled, additional DM-RS position = pos1 and 2 transmission layers.
- FRC parameters are specified in table A.2.1-3 for FR1 PUSCH with transform precoding enabled, additional DM-RS position = pos1 and 1 transmission layer.

Table A.2.1-1: FRC parameters for FR1 PUSCH performance requirements, transform precoding disabled, additional DM-RS position = pos1 and 1 transmission layer (QPSK, R=193/1024)

Reference channel	D-FR1-A.2.1-1	D-FR1-A.2.1-2	D-FR1-A.2.1-3	D-FR1-A.2.1-4	D-FR1-A.2.1-5	D-FR1-A.2.1-6	D-FR1-A.2.1-7
Subcarrier spacing (kHz)	15	15	15	30	30	30	30
Allocated resource blocks	25	52	106	24	51	106	273
CP-OFDM Symbols per slot (Note 1)	12	12	12	12	12	12	12
Modulation	QPSK	QPSK	QPSK	QPSK	QPSK	QPSK	QPSK
Code rate	193/1024	193/1024	193/1024	193/1024	193/1024	193/1024	193/1024
Payload size (bits)	1352	2856	5768	1320	2792	5768	14856
Transport block CRC (bits)	16	16	24	16	16	24	24
Code block CRC size (bits)	-	-	24	-	-	24	24
Number of code blocks - C	1	1	2	1	1	2	4
Code block size including CRC (bits) (Note 2)	1368	2872	2920	1336	2808	2920	3744
Total number of bits per slot	7200	14976	30528	6912	14688	30528	78624
Total symbols per slot	3600	7488	15264	3456	7344	15264	39312
Note 1:	DM-RS configuration type = 1 with DM-RS duration = single-symbol DM-RS and the number of DM-RS CDM groups without data is 2, additional DM-RS position = pos1, $l_0 = 2$ and $l = 11$ for PUSCH mapping type A, $l_0 = 0$ and $l = 10$ for PUSCH mapping type B as per table 6.4.1.1.3-3 of TS 38.211 [9].						
Note 2:	Code block size including CRC (bits) equals to K' in clause 5.2.2 of TS 38.212 [10].						

Table A.2.1-2: FRC parameters for FR1 PUSCH performance requirements, transform precoding disabled, additional DM-RS position = pos1 and 2 transmission layers (QPSK, R=193/1024)

Reference channel	D-FR1-A.2.1-8	D-FR1-A.2.1-9	D-FR1-A.2.1-10	D-FR1-A.2.1-11	D-FR1-A.2.1-12	D-FR1-A.2.1-13	D-FR1-A.2.1-14
Subcarrier spacing (kHz)	15	15	15	30	30	30	30
Allocated resource blocks	25	52	106	24	51	106	273
CP-OFDM Symbols per slot (Note 1)	12	12	12	12	12	12	12
Modulation	QPSK	QPSK	QPSK	QPSK	QPSK	QPSK	QPSK
Code rate	193/1024	193/1024	193/1024	193/1024	193/1024	193/1024	193/1024
Payload size (bits)	2728	5640	11528	2600	5512	11528	29736
Transport block CRC (bits)	16	24	24	16	24	24	24
Code block CRC size (bits)	-	24	24	-	24	24	24
Number of code blocks - C	1	2	4	1	2	4	8
Code block size including CRC (bits) (Note 2)	2744	2856	2912	2616	2792	2912	3744
Total number of bits per slot	14400	29952	61056	13824	29376	61056	157248
Total symbols per slot	7200	14976	30528	6912	14688	30528	78624
Note 1:	DM-RS configuration type = 1 with DM-RS duration = single-symbol DM-RS and the number of DM-RS CDM groups without data is 2, additional DM-RS position = pos1, $l_0 = 2$ and $l = 11$ for PUSCH mapping type A, $l_0 = 0$ and $l = 10$ for PUSCH mapping type B as per table 6.4.1.1.3-3 of TS 38.211 [9].						
Note 2:	Code block size including CRC (bits) equals to K' in clause 5.2.2 of TS 38.212 [10].						

Table A.2.1-3: FRC parameters for FR1 PUSCH performance requirements, transform precoding enabled, additional DM-RS position = pos1 and 1 transmission layer (QPSK, R=193/1024)

Reference channel	D-FR1-A.2.1-15	D-FR1-A.2.1-16
Subcarrier spacing (kHz)	15	30
Allocated resource blocks	25	24
DFT-s-OFDM Symbols per slot (Note 1)	12	12
Modulation	QPSK	QPSK
Code rate	193/1024	193/1024
Payload size (bits)	1352	1320
Transport block CRC (bits)	16	16
Code block CRC size (bits)	-	-
Number of code blocks - C	1	1
Code block size including CRC (bits) (Note 2)	1368	1336
Total number of bits per slot	7200	6912
Total symbols per slot	3600	3456

NOTE 1: DM-RS configuration type = 1 with DM-RS duration = single-symbol DM-RS and the number of DM-RS CDM groups without data is 2, additional DM-RS position = pos1, $l_0 = 2$ and $l = 11$ for PUSCH mapping type A, $l_0 = 0$ and $l = 10$ for PUSCH mapping type B as per table 6.4.1.1.3-3 of TS 38.211 [9].

NOTE 2: Code block size including CRC (bits) equals to K' in clause 5.2.2 of TS 38.212 [10].

A.2.2 Fixed Reference Channels for PUSCH performance requirements (16QAM, R=434/1024)

A.2.3 Fixed Reference Channels for PUSCH performance requirements (16QAM, R = 658/1024)

The parameters for the reference measurement channels are specified in table A.2.3-1 and table A.2.3-2 for FR1 PUSCH performance requirements:

- FRC parameters are specified in table A.2.3-1 for FR1 PUSCH with transform precoding disabled, additional DM-RS position = pos1 and 1 transmission layer.
- FRC parameters are specified in table A.2.3-2 for FR1 PUSCH with transform precoding disabled, additional DM-RS position = pos1 and 2 transmission layers.

Table A.2.3-1: FRC parameters for FR1 PUSCH performance requirements, transform precoding disabled, additional DM-RS position = pos1 and 1 transmission layer (16QAM, R=658/1024)

Reference channel	D-FR1-A.2.3-1	D-FR1-A.2.3-2	D-FR1-A.2.3-3	D-FR1-A.2.3-4	D-FR1-A.2.3-5	D-FR1-A.2.3-6	D-FR1-A.2.3-7
Subcarrier spacing (kHz)	15	15	15	30	30	30	30
Allocated resource blocks	25	52	106	24	51	106	273
CP-OFDM Symbols per slot (Note 1)	12	12	12	12	12	12	12
Modulation	16QAM	16QAM	16QAM	16QAM	16QAM	16QAM	16QAM
Code rate	658/1024	658/1024	658/1024	658/1024	658/1024	658/1024	658/1024
Payload size (bits)	9224	19464	38936	8968	18960	38936	100392
Transport block CRC (bits)	24	24	24	24	24	24	24
Code block CRC size (bits)	24	24	24	24	24	24	24
Number of code blocks - C	2	3	5	2	3	5	12
Code block size including CRC (bits) (Note 2)	4648	6520	7816	4520	6352	7816	8392
Total number of bits per slot	14400	29952	61056	13824	29376	61056	157248
Total symbols per slot	3600	7488	15264	3456	7344	15264	39312

NOTE 1: DM-RS configuration type = 1 with DM-RS duration = single-symbol DM-RS and the number of DM-RS CDM groups without data is 2, additional DM-RS position = pos1, $l_0 = 2$ and $l = 11$ for PUSCH mapping type A, $l_0 = 0$ and $l = 10$ for PUSCH mapping type B as per table 6.4.1.1.3-3 of TS 38.211 [9].

NOTE 2: Code block size including CRC (bits) equals to K' in clause 5.2.2 of TS 38.212 [10].

Table A.2.3-2: FRC parameters for FR1 PUSCH performance requirements, transform precoding disabled, additional DM-RS position = pos1 and 2 transmission layers (16QAM, R=658/1024)

Reference channel	D-FR1-A.2.3-8	D-FR1-A.2.3-9	D-FR1-A.2.3-10	D-FR1-A.2.3-11	D-FR1-A.2.3-12	D-FR1-A.2.3-13	D-FR1-A.2.3-14
Subcarrier spacing (kHz)	15	15	15	30	30	30	30
Allocated resource blocks	25	52	106	24	51	106	273
CP-OFDM Symbols per slot (Note 1)	12	12	12	12	12	12	12
Modulation	16QAM	16QAM	16QAM	16QAM	16QAM	16QAM	16QAM
Code rate	658/1024	658/1024	658/1024	658/1024	658/1024	658/1024	658/1024
Payload size (bits)	18432	38936	77896	17928	37896	77896	200808
Transport block CRC (bits)	24	24	24	24	24	24	24
Code block CRC size (bits)	24	24	24	24	24	24	24
Number of code blocks - C	3	5	10	3	5	10	24
Code block size including CRC (bits) (Note 2)	6176	7816	7816	6008	7608	7816	8392
Total number of bits per slot	28800	59904	122112	27648	58752	122112	314496
Total symbols per slot	7200	14976	30528	6912	14688	30528	78624

NOTE 1: DM-RS configuration type = 1 with DM-RS duration = single-symbol DM-RS and the number of DM-RS CDM groups without data is 2, additional DM-RS position = pos1, $l_0 = 2$ and $l = 11$ for PUSCH mapping type A, $l_0 = 0$ and $l = 10$ for PUSCH mapping type B as per table 6.4.1.1.3-3 of TS 38.211 [9].

NOTE 2: Code block size including CRC (bits) equals to K' in clause 5.2.2 of TS 38.212 [10].

A.2.4 Fixed Reference Channels for PUSCH performance requirements (64QAM, R = 567/1024)

The parameters for the reference measurement channels are specified in table A.2.4-1 for FR1 PUSCH performance requirements:

- FRC parameters are specified in table A.2.4-1 for FR1 PUSCH with transform precoding disabled, Additional DM-RS position = pos1 and 1 transmission layer.

Table A.2.3-1: FRC parameters for FR1 PUSCH performance requirements, transform precoding disabled, additional DM-RS position = pos1 and 1 transmission layer (64QAM, R=567/1024)

Reference channel	D-FR1-A.2.4-1	D-FR1-A.2.4-2	D-FR1-A.2.4-3	D-FR1-A.2.4-4	D-FR1-A.2.4-5	D-FR1-A.2.4-6	D-FR1-A.2.4-7
Subcarrier spacing (kHz)	15	15	15	30	30	30	30
Allocated resource blocks	25	52	106	24	51	106	273
CP-OFDM Symbols per slot (Note 1)	12	12	12	12	12	12	12
Modulation	64QAM	64QAM	64QAM	64QAM	64QAM	64QAM	64QAM
Code rate	567/1024	567/1024	567/1024	567/1024	567/1024	567/1024	567/1024
Payload size (bits)	12040	25104	50184	11528	24576	50184	131176
Transport block CRC (bits)	24	24	24	24	24	24	24
Code block CRC size (bits)	24	24	24	24	24	24	24
Number of code blocks - C	2	3	6	2	3	6	16
Code block size including CRC (bits) (Note 2)	6056	8400	8392	5800	8224	8392	8224
Total number of bits per slot	21600	44928	91584	20736	44064	91584	235872
Total symbols per slot	3600	7488	15264	3456	7344	15264	39312

NOTE 1: DM-RS configuration type = 1 with DM-RS duration = single-symbol DM-RS and the number of DM-RS CDM groups without data is 2, additional DM-RS position = pos1, $l_0 = 2$ and $l = 11$ for PUSCH mapping type A, $l_0 = 0$ and $l = 10$ for PUSCH mapping type B as per table 6.4.1.1.3-3 of TS 38.211 [9].

NOTE 2: Code block size including CRC (bits) equals to K' in clause 5.2.2 of TS 38.212 [10].

A.2.5 PRACH test preambles

Table A.2.5-1 Test preambles for Normal Mode in FR1

Burst format	SCS (kHz)	Ncs	Logical sequence index	v
0	1.25	13	22	32
A1, A2, A3,	15	23	0	0
B4, C0, C2				

A.3 IAB-MT Fixed Reference Channels

A.3.1 Fixed Reference Channels for PDSCH performance requirements (16QAM)

The parameters for the reference measurement channels are specified in table A.3.1-1 for FR1 PDSCH performance requirements

Table A.3.1-1: Fixed Reference Channels for FR1 PDSCH (16QAM)

Reference channel	M-FR1-A.3.1-1	M-FR1-A.3.1-2	M-FR1-A.3.1-3	M-FR1-A.3.1-4	M-FR1-A.3.1-5
Channel bandwidth (MHz)	40	40	40	40	40
Subcarrier spacing (kHz)	30	30	30	30	30
Allocated resource blocks	106	106	106	106	106
Number of consecutive PDSCH symbols	12	12	12	12	12
MCS table	64QAM	64QAM	64QAM	64QAM	64QAM
MCS index	13	13	13	13	13
Modulation	16QAM	16QAM	16QAM	16QAM	16QAM
Target Coding Rate	490/1024	490/1024	490/1024	490/1024	490/1024
Number of MIMO layers	1	3	4	1	2
Number of DMRS REs	12	24	24	24	24
Overhead for TBS determination	0	0	0	0	0
Information Bit Payload per Slot (bits)	26632	73776	98376	24576	49176
Transport block CRC per Slot (bits)	24	24	24	24	24
Number of Code Blocks per Slot	4	9	12	3	6
Binary Channel Bits Per Slot (bits)	55968	152640	203520	50880	101760

A.3.2 Fixed Reference Channels for PDSCH performance requirements (64QAM)

The parameters for the reference measurement channels are specified in table A.3.2-1 for FR1 PDSCH performance requirements.

Table A.3.2-1: Fixed Reference Channels for FR1 PDSCH (64QAM)

Reference channel	M-FR1-A.3.2-1
Channel bandwidth (MHz)	40
Subcarrier spacing (kHz)	30
Allocated resource blocks	106
Number of consecutive PDSCH symbols	12
MCS table	64QAM
MCS index	19
Modulation	64QAM
Target Coding Rate	517/1024
Number of MIMO layers	2
Number of DMRS REs	12
Overhead for TBS determination	0
Information Bit Payload per Slot (bits)	83976
Transport block CRC per Slot (bits)	24
Number of Code Blocks per Slot	10
Binary Channel Bits Per Slot (bits)	167904

A.3.3 Fixed Reference Channels for PDSCH performance requirements (256QAM)

The parameters for the reference measurement channels are specified in table A.3.3-1 for FR1 PDSCH performance requirements.

Table A.3.3-1: Fixed Reference Channels for FR1 PDSCH (256QAM)

Reference channel	M-FR1-A.3.3-1
Channel bandwidth (MHz)	40
Subcarrier spacing (kHz)	30
Allocated resource blocks	106
Number of consecutive PDSCH symbols	12
MCS table	256QAM
MCS index	24
Modulation	256QAM
Target Coding Rate	0.82
Number of MIMO layers	1
Number of DMRS REs	12
Overhead for TBS determination	0
Information Bit Payload per Slot (bits)	92200
Transport block CRC per Slot (bits)	24
Number of Code Blocks per Slot	11
Binary Channel Bits Per Slot (bits)	111936

A.3.4 Fixed Reference Channels for PDCCH performance requirements

The parameters for the reference measurement channels are specified in table A.3.5-1 for FR1 PDCCH performance requirements.

Table A.3.4-1: Fixed Reference Channels for FR1 PDCCH

Reference channel	M-FR1-A.3.4-1	M-FR1-A.3.4-2	M-FR1-A.3.4-3
Subcarrier spacing (kHz)	30	30	30
CORESET frequency domain allocation	102	102	90
CORESET time domain allocation	1	1	1
Aggregation level	2	4	8
DCI Format	1_0	1_1	1_1
Payload (without CRC) (bits)	41	53	53

A.3.5 Fixed Reference Channels for CSI reporting performance requirements

This clause defines the DL signal applicable to the reporting of channel state information

Tables A.3.5-1 specifies the mapping of CQI index to Information Bit payload, which complies with the CQI definition specified in clause 5.2.2.1 of TS 38.214 [24] and with MCS definition specified in clause 5.1.3 of TS 38.214 [24].

The parameters for the reference measurement channels are specified in table A.3.5-2 for FR1 PMI reporting performance requirements

Table A.3.5-1: Fixed Reference Channels for CSI reporting

Reference channel				M-FR1-A.2.5-1	M-FR1-A.2.5-2	M-FR1-A.2.5-3	M-FR1-A.2.5-4
MCS table				256QAM			
Number of allocated PDSCH resource blocks				106	106	106	106
Number of consecutive PDSCH symbols				12	12	12	12
Number of PDSCH MIMO layers				1	2	3	4
Number of DMRS REs (Note 1)				24	24	24	24
Overhead for TBS determination				0	0	0	0
Available RE-s for PDSCH				12720	12720	12720	12720
CQI index	Spectral efficiency	MCS index	Modulation				
0	0.1523	0	QPSK	N/A	N/A	N/A	N/A
1	0.3770	1	QPSK	2976	5896	8976	11784
2	0.8770	3		4744	9480	14344	18976
3	1.4766	5		11016	22536	33816	45096
4	1.9141	7	16QAM	18960	37896	56368	75792
5	2.4063	9		24576	49176	73776	98376
6	2.7305	11		30728	61480	92200	122976
7	3.3223	13	64QAM	34816	69672	104496	139376
8	3.9023	15		42016	83976	127080	167976
9	4.5234	17		49176	98376	147576	196776
10	5.1152	19	256QAM	57376	114776	172176	229576
11	5.5547	21		65576	131176	196776	262376
12	6.2266	23		69672	139376	213176	278776
13	6.9141	25		79896	159880	237776	319784
14	7.4063	27		88064	176208	262376	352440
15				94248	188576	278776	376896

Note 1: Number of DMRS REs includes the overhead of the DM-RS CDM groups without data
Note 2: PDSCH is only scheduled on slots which are full DL

Table A.3.5-2: Fixed Reference Channels for FR1 PMI reporting

Reference channel	M-FR1-A.3.5-5	M-FR1-A.3.5-6
Channel bandwidth (MHz)	40	40
Subcarrier spacing (kHz)	30	30
Allocated resource blocks	106	106
Number of consecutive PDSCH symbols	12	12
MCS table	64QAM	64QAM
MCS index	13	13
Modulation	16QAM	16QAM
Target Coding Rate	490/1024	490/1024
Number of MIMO layers	1	2
Number of DMRS REs	24	24
Overhead for TBS determination	0	0
Information Bit Payload per Slot (bits)	24576	49176
Transport block CRC per Slot (bits)	24	24
Number of Code Blocks per Slot	3	6
Binary Channel Bits Per Slot (bits)	50880	101760

Annex B (normative): Environmental requirements for the IAB equipment

B.1 General

For each test in the present document, the environmental conditions under which the IAB is to be tested are defined.

B.2 Normal test environment

When a normal test environment is specified for a test, the test should be performed within the minimum and maximum limits of the conditions stated in table B.1.

Table B.1: Limits of conditions for normal test environment

Condition	Minimum	Maximum
Barometric pressure	86 kPa	106 kPa
Temperature	15 °C	30 °C
Relative humidity	20 %	85 %
Power supply	Nominal, as declared by the manufacturer	
Vibration	Negligible	

The ranges of barometric pressure, temperature and humidity represent the maximum variation expected in the uncontrolled environment of a test laboratory. If it is not possible to maintain these parameters within the specified limits, the actual values shall be recorded in the test report.

NOTE: This may, for instance, be the case for measurements of radiated emissions performed on an open field test site.

B.3 Extreme test environment

B.3.1 General

The manufacturer shall declare one of the following:

- 1) The equipment class for the equipment under test, as defined in the IEC 60 721-3-3 [17].
- 2) The equipment class for the equipment under test, as defined in the IEC 60 721-3-4 [18].
- 3) The equipment that does not comply with the mentioned classes, the relevant classes from IEC 60 721 [19] documentation for temperature, humidity and vibration shall be declared.

NOTE: Reduced functionality for conditions that fall outside of the standard operational conditions is not tested in the present document. These may be stated and tested separately.

B.3.2 Extreme temperature

When an extreme temperature test environment is specified for a test, the test shall be performed at the standard minimum and maximum operating temperatures defined by the manufacturer's declaration for the equipment under test.

Minimum temperature:

The test shall be performed with the environment test equipment and methods including the required environmental phenomena into the equipment, conforming to the test procedure of IEC 60 068-2-1 [20].

Maximum temperature:

The test shall be performed with the environmental test equipment and methods including the required environmental phenomena into the equipment, conforming to the test procedure of IEC 60 068-2-2 [21].

NOTE: It is recommended that the equipment is made fully operational prior to the equipment being taken to its lower operating temperature.

B.4 Vibration

When vibration conditions are specified for a test, the test shall be performed while the equipment is subjected to a vibration sequence as defined by the manufacturer's declaration for the equipment under test. This shall use the environmental test equipment and methods of inducing the required environmental phenomena in to the equipment, conforming to the test procedure of IEC 60 068-2-6 [22]. Other environmental conditions shall be within the ranges specified in annex B.2.

NOTE: The higher levels of vibration may induce undue physical stress in to equipment after a prolonged series of tests. The testing body should only vibrate the equipment during the RF measurement process.

B.5 Power supply

When extreme power supply conditions are specified for a test, the test shall be performed at the standard upper and lower limits of operating voltage defined by manufacturer's declaration for the equipment under test.

Upper voltage limit:

The equipment shall be supplied with a voltage equal to the upper limit declared by the manufacturer (as measured at the input terminals to the equipment). The tests shall be carried out at the steady state minimum and maximum temperature limits declared by the manufacturer for the equipment, to the methods described in IEC 60 068-2-1 [20] Test Ab/Ad and IEC 60 068-2-2 [21] Test Bb/Bd: Dry heat.

Lower voltage limit:

The equipment shall be supplied with a voltage equal to the lower limit declared by the manufacturer (as measured at the input terminals to the equipment). The tests shall be carried out at the steady state minimum and maximum temperature limits declared by the manufacturer for the equipment, to the methods described in IEC 60 068-2-1 [20] Test Ab/Ad and IEC 60 068-2-2 [21] Test Bb/Bd: Dry heat.

B.6 Measurement of test environments

The measurement accuracy of the IAB test environments defined in annex B shall be:

Pressure: ± 5 kPa

Temperature: ± 2 degrees

Relative humidity: ± 5 %

DC voltage: ± 1.0 %

AC voltage: ± 1.5 %

Vibration: 10 %

Vibration frequency: 0.1 Hz

The above values shall apply unless the test environment is otherwise controlled and the specification for the control of the test environment specifies the uncertainty for the parameter.

Annex C (informative): Test tolerances and derivation of test requirements

C.1 Measurement of transmitter

Table C.1-1: Derivation of test requirements (Transmitter tests)

Test	Minimum requirement in TS 38.174 [2]	Test Tolerance (TT)	Test requirement in the present document
6.2 IAB output power	See TS 38.174 [2], clause 6.2	Normal and extreme conditions: 0.7 dB, $f \leq 3.0$ GHz 1.0 dB, 3.0 GHz $< f \leq 6$ GHz (Note 1)	Formula: Upper limit + TT, Lower limit - TT
6.3.1 IAB-DU Output power dynamics	See TS 38.174 [2], clause 6.3.1	0.4 dB	Formula: Total power dynamic range – TT (dB)
6.3.2 IAB-MT Total power dynamic range	See TS 38.174 [2], clause 6.3.2	± 0.7 dB, $BW \leq 40$ MHz ± 1.0 dB, 40 MHz $< f \leq 100$ MHz	Formula: Total power dynamic range – TT (dB)
6.4.1 Transmitter OFF power	See TS 38.174 [2], clause 6.4.1	2.0 dB, $f \leq 3.0$ GHz 2.5 dB, 3.0 GHz $< f \leq 6$ GHz (Note 1)	Formula: Minimum Requirement + TT
6.4.2 Transient period	See TS 38.174 [2], clause 6.4.2	N/A	
6.5.2.1 IAB-DU Frequency error	See TS 38.174 [2], clause 6.5.1.1	12 Hz	Formula: Frequency Error limit + TT
6.5.2.2 IAB-MT Frequency error	See TS 38.174 [2], clause 6.5.1.2	± 15 Hz, $f \leq 3.0$ GHz ± 36 Hz, $f > 3.0$ GHz	Formula: Frequency Error limit + TT
6.5.4 Modulation quality (EVM)	See TS 38.174 [2], clause 6.5.2	1%	Formula: EVM limit + TT
6.5.4 Time alignment error	See TS 38.174 [2], clause 6.5.3.1	25ns	Formula: Time alignment error limit + TT+ TT
6.6.2 Occupied bandwidth	See TS 38.174 [2], clause 6.6.2	0 Hz	Formula: Minimum Requirement + TT
6.6.3 Adjacent Channel Leakage Power Ratio (ACLR)	See TS 38.174 [2], clause 6.6.3	ACLR/CACLR: $BW \leq 20$ MHz: 0.8dB $BW > 20$ MHz: 1.2 dB Absolute ACLR/CACLR: 0 dB	Formula: ACLR Minimum Requirement - TT Absolute limit +TT
6.6.4 Operating band unwanted emissions	See TS 38.174 [2], clause 6.6.4	Offsets < 10 MHz 1.5 dB, $f \leq 3.0$ GHz 1.8 dB, 3.0 GHz $< f \leq 6$ GHz (Note 1) Offsets ≥ 10 MHz 0dB	Formula: Minimum Requirement + TT
6.6.5.5.1 General transmitter spurious emissions requirements Category A	See TS 38.174 [2], clause 6.6.5.2.1	0dB	Formula: Minimum Requirement + TT
6.6.5.5.1 General transmitter spurious emissions requirements Category B	See TS 38.174 [2], clause 6.6.5.2.1	0dB	Formula: Minimum Requirement + TT
6.6.5.5.2 Additional spurious emissions requirements	See TS 38.174 [2], clause 6.6.5.2.2	0dB	Formula: Minimum Requirement + TT
6.6.5.5.3 Co-location with other base stations	See TS 38.174 [2], clause 6.6.5.2.3	0dB	Formula: Minimum Requirement + TT
6.7 Transmitter intermodulation	See TS 38.174 [2], clause 6.7	0dB	Formula: Ratio + TT
NOTE 1: TT values for 4.2 GHz $< f \leq 6.0$ GHz apply for IAB operates in licensed spectrum only.			
NOTE 2: TT values are applicable for normal condition unless otherwise stated.			

C.2 Measurement of receiver

Table C.2-1: Derivation of test requirements (Receiver tests)

Test	Minimum requirement in TS 38.174 [2]	Test Tolerance (TT)	Test requirement in the present document
7.2 Reference sensitivity level	See TS 38.174 [2], clause 7.2	Normal and extreme conditions: 0.7 dB, $f \leq 3.0$ GHz 1.0 dB, 3.0 GHz $< f \leq 4.2$ GHz 1.2 dB, 4.2 GHz $< f \leq 6.0$ GHz	Formula: Reference sensitivity power level + TT
7.3 Dynamic range	See TS 38.174 [2], clause 7.3	0.3 dB	Formula: Wanted signal power + TT
7.4 In-band selectivity and blocking	See TS 38.174 [2], clause 7.4	0dB	Formula: Wanted signal power + TT
7.5 Out-of-band blocking	See TS 38.174 [2], clause 7.5	0dB	Formula: Wanted signal power + TT
7.6 Receiver spurious emissions	See TS 38.174 [2], clause 7.6	0dB	Formula: Minimum Requirement + TT
7.7 Receiver intermodulation	See TS 38.174 [2], clause 7.7	0dB	Formula: Wanted signal power + TT
7.8 In-channel selectivity	See TS 38.174 [2], clause 7.8	1.4 dB, $f \leq 3.0$ GHz 1.8 dB, 3.0 GHz $< f \leq 4.2$ GHz 2.1 dB, 4.2 GHz $< f \leq 6.0$ GHz	Formula: Wanted signal power + TT
NOTE: TT values are applicable for normal condition unless otherwise stated.			

C.3 Measurement of performance requirements

C.3.1 List IAB-DU TTs

Table C.3-1: Derivation of Test Requirements (Performance tests)

Test	Minimum Requirement in TS 38.174 [2]	Test Tolerance (TT)	Test requirement in the present document
Performance requirements for PUSCH with transform precoding disabled	SNRs as specified	0.6 dB for 1Tx cases 0.8 dB for 2Tx cases	Formula: SNR + TT T-put limit unchanged
Performance requirements for PUSCH with transform precoding enabled	SNRs as specified	0.6 dB	Formula: SNR + TT T-put limit unchanged
Performance requirements for UCI multiplexed on PUSCH	SNRs as specified	0.6 dB	Formula: SNR + TT BLER limit unchanged
Performance requirements for PUCCH format 0	SNRs as specified	0.6 dB	Formula: SNR + TT False ACK limit unchanged Correct ACK limit unchanged
Performance requirements for PUCCH format 1	SNRs as specified	0.6 dB	Formula: SNR + TT False ACK limit unchanged False NACK limit unchanged Correct ACK limit unchanged
Performance requirements for PUCCH format 2	SNRs as specified	0.6 dB	Formula: SNR + TT False ACK limit unchanged Correct ACK limit unchanged UCI BLER limit unchanged
Performance requirements for PUCCH format 3	SNRs as specified	0.6 dB	Formula: SNR + TT UCI BLER limit unchanged
Performance requirements for PUCCH format 4	SNRs as specified	0.6 dB	Formula: SNR + TT UCI BLER limit unchanged
Performance requirements for multi-slot PUCCH	SNRs as specified	0.6 dB	Formula: SNR + TT False ACK limit unchanged False NACK limit unchanged Correct ACK limit unchanged
PRACH false alarm probability and missed detection	SNRs as specified	0.3 dB	Formula: SNR + TT PRACH false detection limit unchanged PRACH detection limit unchanged

C.3.2 List IAB-MT TTs

Table C.3-2: Derivation of Test Requirements (Performance tests)

Test	Minimum Requirement in TS 38.174 [2]	Test Tolerance (TT)	Test requirement in the present document
Performance requirements for PDSCH	SNRs as specified	[1dB]	Formula: SNR + TT T-put limit unchanged
Performance requirements for PDCCH	SNRs as specified	[0.9 dB] for 1TX [1dB] for 2TX	Formula: SNR + TT T-put limit unchanged
Performance requirements for CSI reporting	SNRs as specified	No test tolerances applied	SNR limit unchanged

Annex D (informative): Measurement system set-up

D.1 IAB type 1-H transmitter

D.1.1 IAB output power, output power dynamics, transmitter ON/OFF power, frequency error, EVM, unwanted emissions for IAB type 1-H

TAB connectors may be connected to the measurement equipment singularly and tested one at a time (figure D.1.1-1), or may be tested simultaneously in groups (figure D.1.1-2) where the group size may range from two to all the *TAB connectors* which are subject to particular transmitter test in this test setup.

In all cases the measurement is per *TAB connector* but the measurement may be done in parallel.

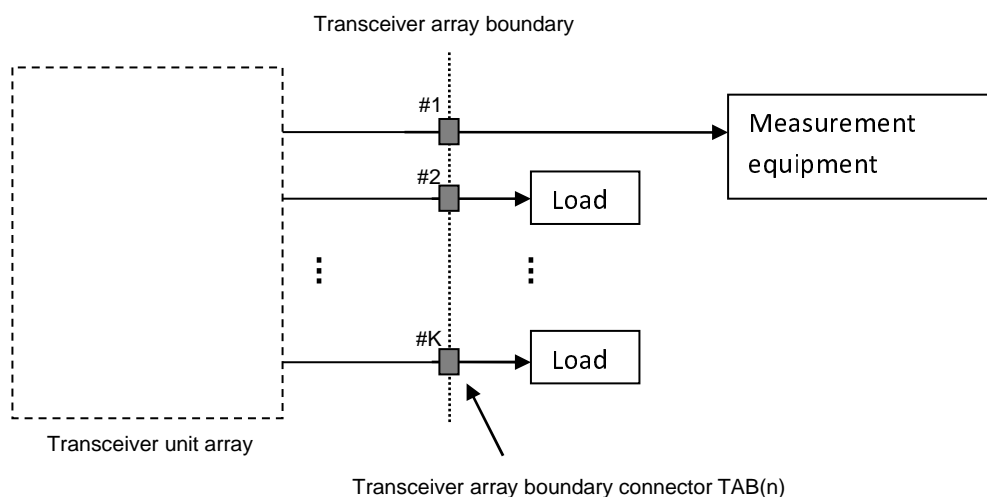

Figure D.1.1-1: Measuring system set-up for IAB type 1-H output power, output power dynamics, transmitter ON/OFF power, frequency error, EVM, unwanted emissions for a single TAB connector

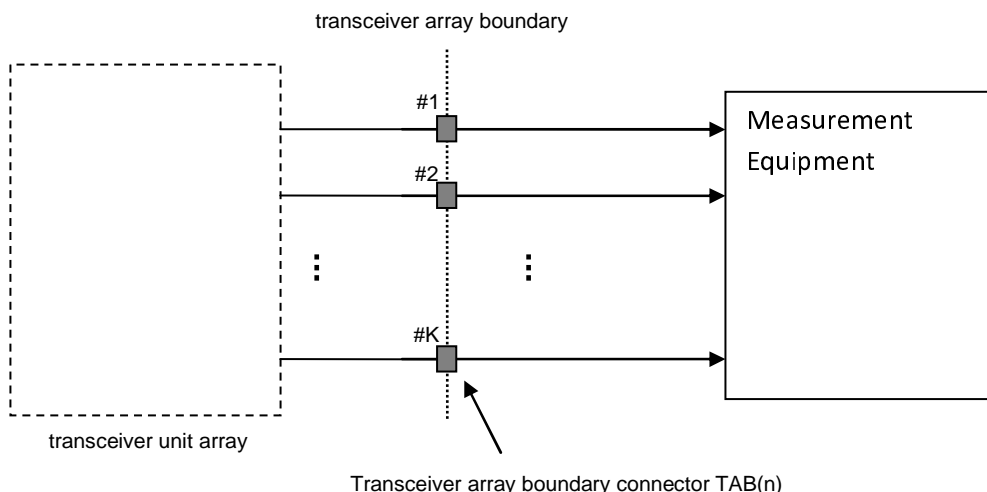

Figure D.1.1-2: Measuring system set-up for IAB type 1-H output power, output power dynamics, transmitter ON/OFF power, frequency error, EVM, unwanted emissions for multiple TAB connectors

D.1.2 Transmitter intermodulation for IAB type 1-H

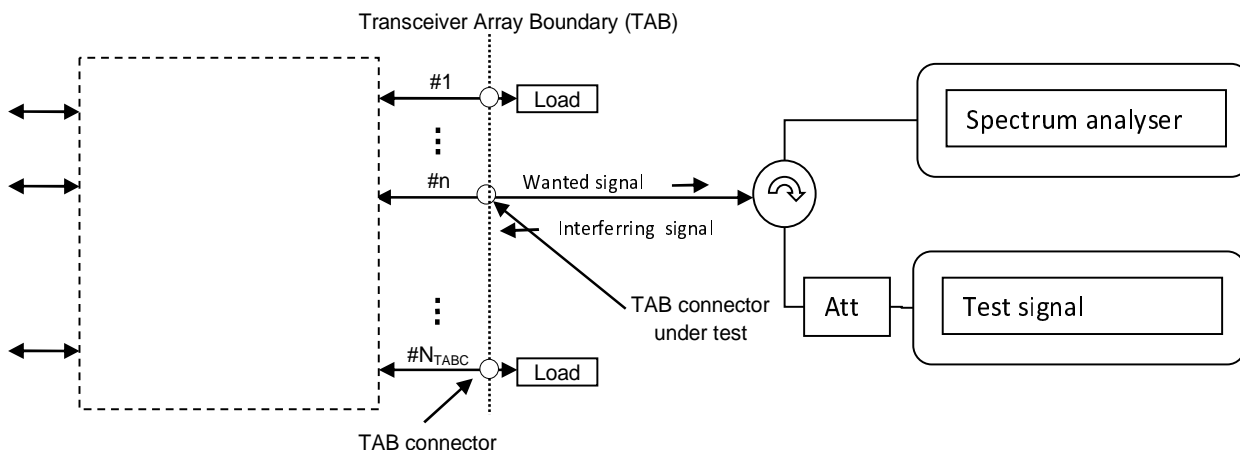

Figure D.3.2-1: Measuring system set-up for IAB type 1-H transmitter intermodulation

D.1.3 Transmitter spurious emissions for IAB type 1-H

TAB connectors may be connected to the measurement equipment singularly and tested one at a time (figure D.1.3-1), or may be tested simultaneously in groups (figure D.1.3-2) where the group size may range from two to all the TAB connectors which are subject to transmitter spurious emissions test.

In all cases the measurement is per TAB connector but the measurement may be done in parallel.

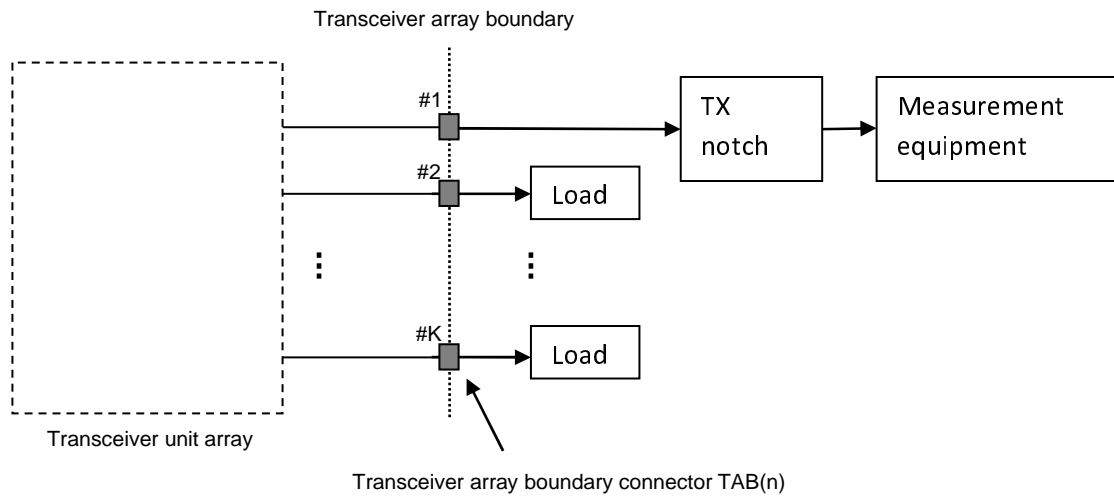

Figure D.1.3-1: Measuring system set-up for transmitter spurious emissions for a single *TAB* connector

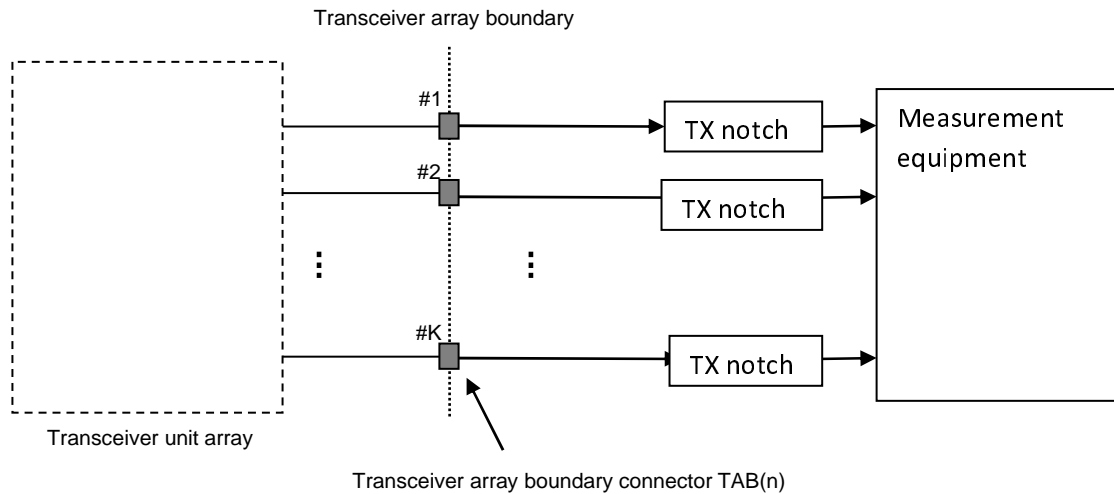

Figure D.1.3-2: Measuring system set-up for transmitter spurious emissions for multiple *TAB* connectors in parallel test

D.1.4 Time alignment error for IAB-DU

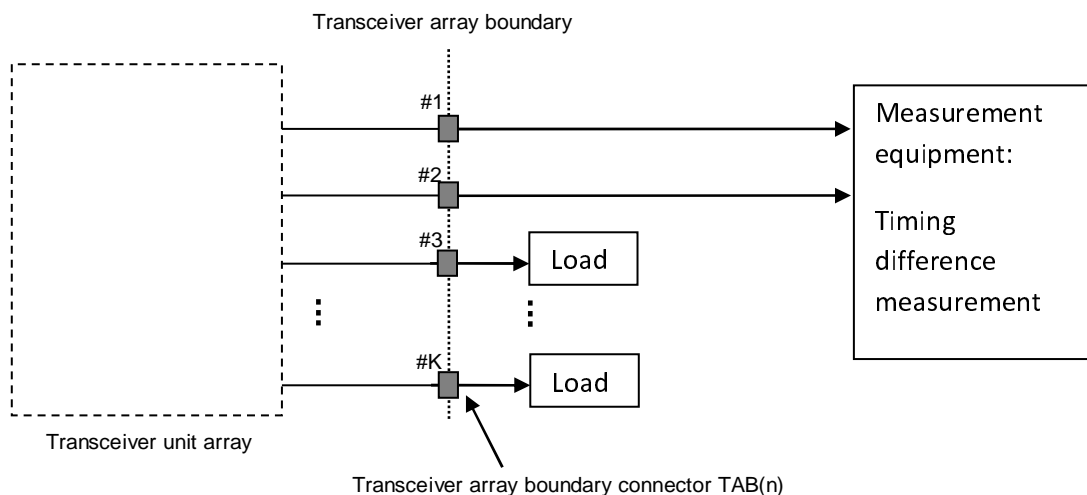

Figure D.1.4-1: Measuring system set-up for IAB-DU test of time alignment error

D.2 IAB type 1-H receiver

D.2.1 Reference sensitivity level for IAB type 1-H

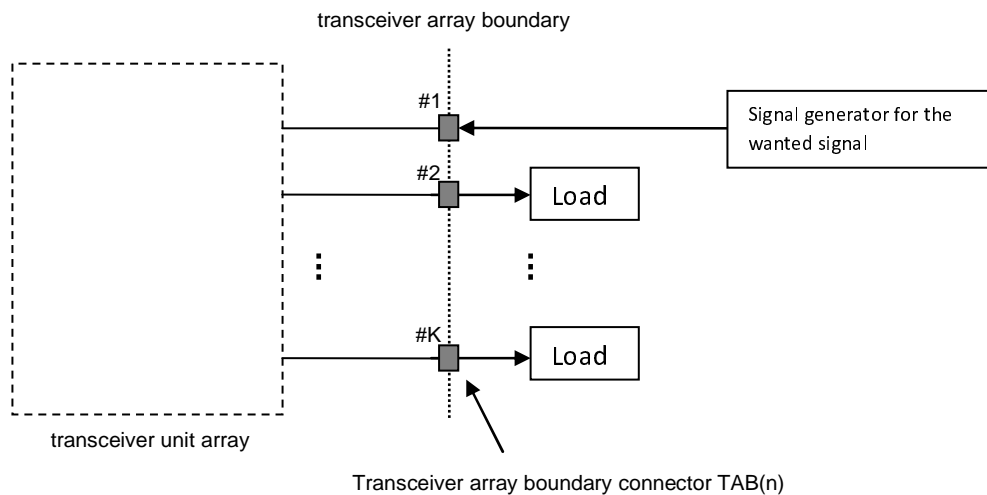

Figure D.2.1-1: Measuring system set-up for IAB type 1-H reference sensitivity level test

D.2.2 Receiver dynamic range for IAB type 1-H

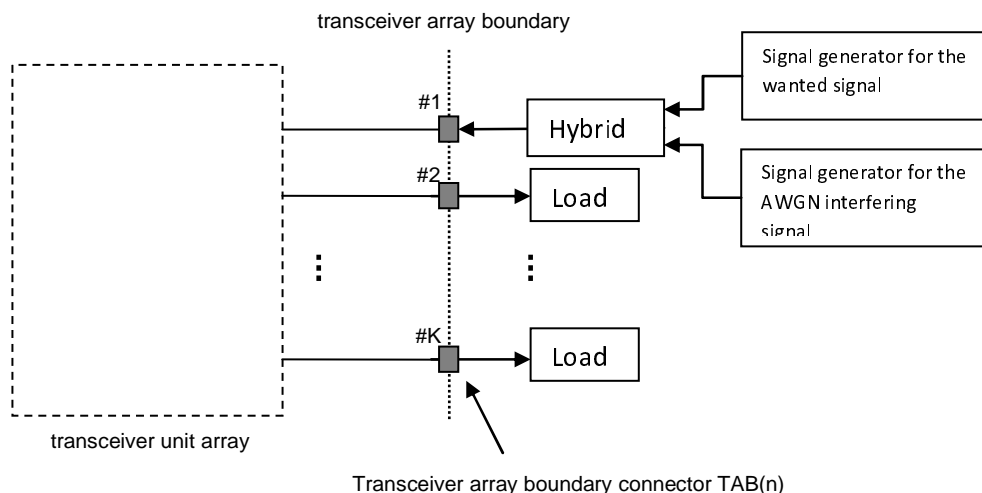

Figure D.2.2-1: Measuring system set-up for IAB type 1-H dynamic range test

D.2.3 Receiver adjacent channel selectivity and narrowband blocking for IAB type 1-H

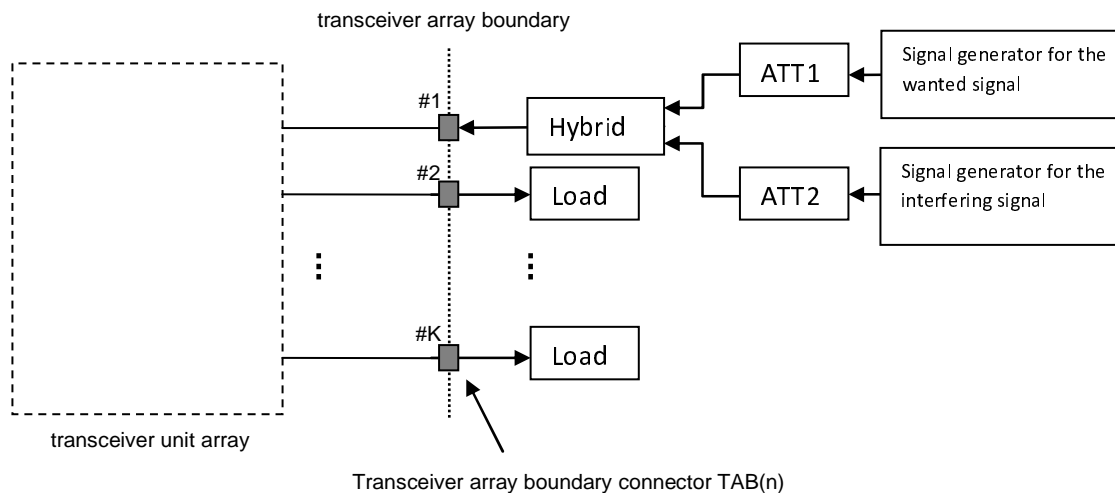

Figure D.2.3-1: Measuring system set-up for IAB type 1-H adjacent channel selectivity and narrowband blocking test

D.2.4 Receiver spurious emissions

TAB connector(s) may be connected to the measurement equipment singularly and tested one at a time (figure D.2.2-1), or may be tested simultaneously in groups (figure D.2.2-2) where the group size may range from 2 to all the TAB connectors.

In all cases the measurement is per TAB connector but the measurement may be done in parallel.

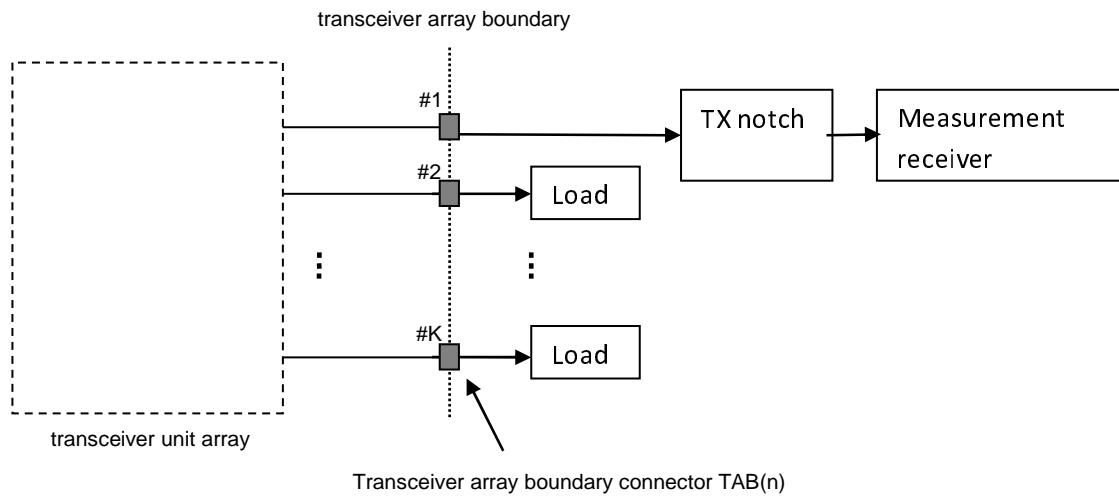

Figure D.2.4-1: Measuring system set-up for IAB type 1-H receiver spurious emissions for a single TAB connector

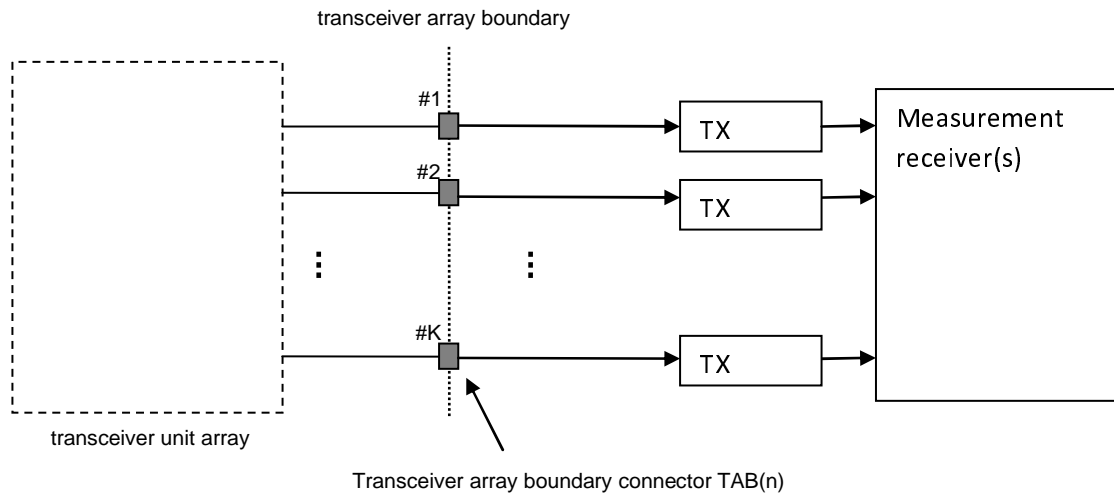

Figure D.2.4-2: Measuring system set-up for IAB type 1-H receiver spurious emissions for multiple TAB connectors

D.2.5 Receiver In-channel selectivity for IAB type 1-H

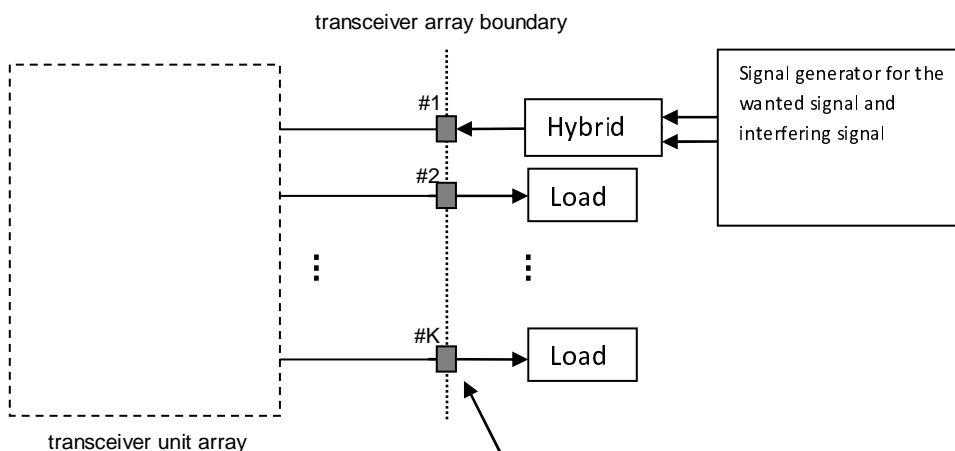

Figure D.2.5-1: Measuring system set-up for IAB type 1-H in-channel selectivity test

D.2.6 Receiver intermodulation for IAB type 1-H

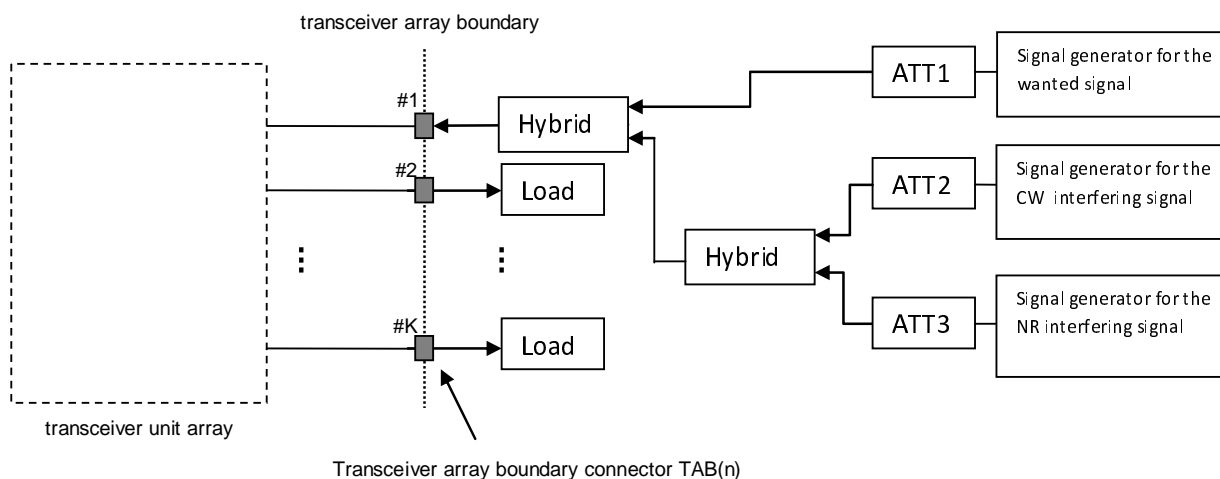

Figure D.2.6-1: Measuring system set-up for IAB type 1-H receiver intermodulation test

D.3 IAB type 1-H performance requirements

D.3.1 Performance requirements for PUSCH and PUCCH on single antenna port in multipath fading conditions

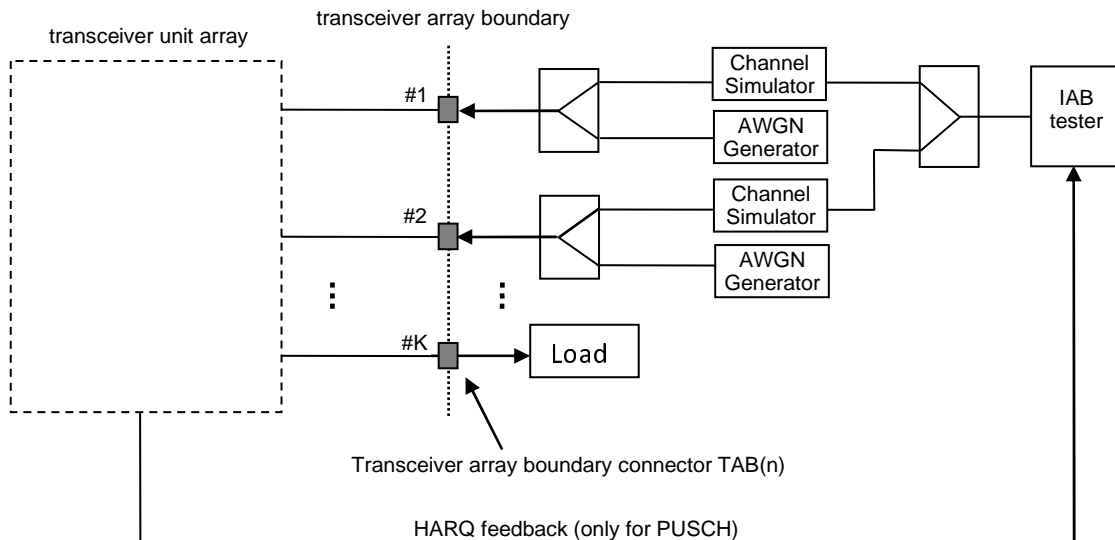

Figure D.3.1-1: Functional set-up for performance requirements for PUSCH and PUCCH for IAB with Rx diversity (2 Rx case shown)

NOTE 1: The feedback could be done as an RF feedback, either using NR channels or using other means, or as a digital feedback. The HARQ Feedback should be error free.

NOTE 2: In tests performed with signal generators, a synchronization signal may be provided between the IAB node and the signal generator, or a common (e.g., GNSS) source may be provided to both IAB node and the signal generator, to enable correct timing of the wanted signal. The method of synchronization with the TE is left to test implementation.

NOTE 3: It is left up to implementation how L1/L2 is configured for testing.

D.3.2 Performance requirements for PUSCH, PDSCH, PDCCH transmission and PMI/RI reporting on two antenna ports in multipath fading conditions

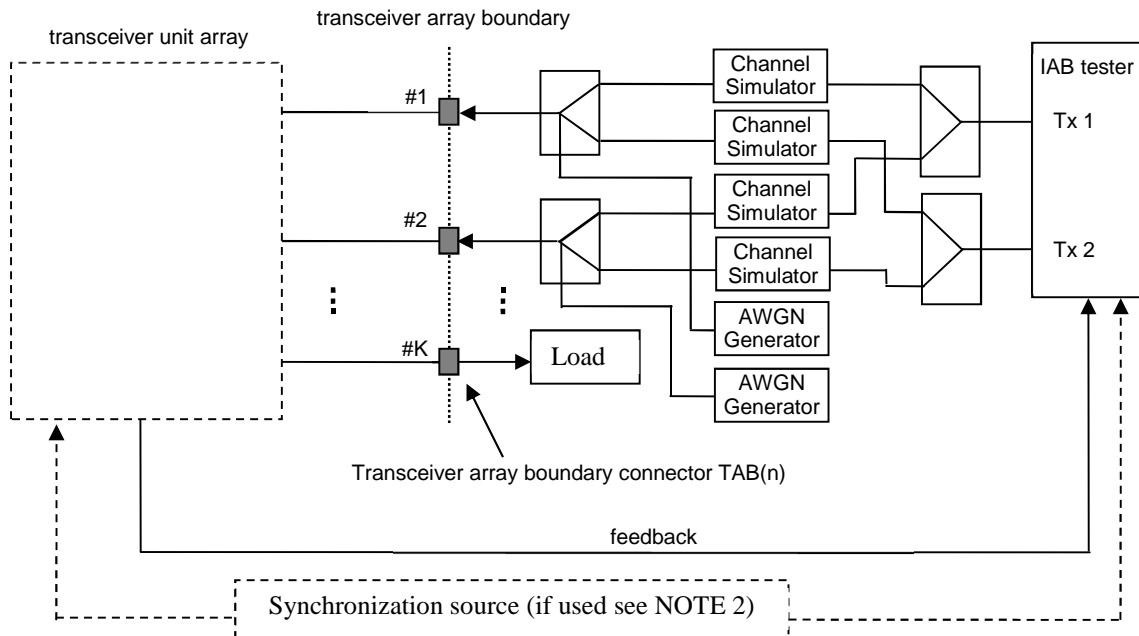

Figure D.3.2-1: Functional set-up for performance requirements for PUSCH, PDSCH and PDCCH transmission on two antenna ports in multipath fading conditions (2 Rx case shown)

NOTE 1: The feedback could be done as an RF feedback, either using NR channels or using other means, or as a digital feedback. The HARQ Feedback should be error free.

NOTE 2: In tests performed with signal generators, a synchronization signal may be provided between the IAB node and the signal generator, or a common (e.g., GNSS) source may be provided to both IAB node and the signal generator, to enable correct timing of the wanted signal. The method of synchronization with the TE is left to test implementation.

NOTE 3: It is left up to implementation how L1/L2 is configured for testing.

D.3.3 Performance requirements for PUSCH, PRACH transmission and CQI reporting in static conditions

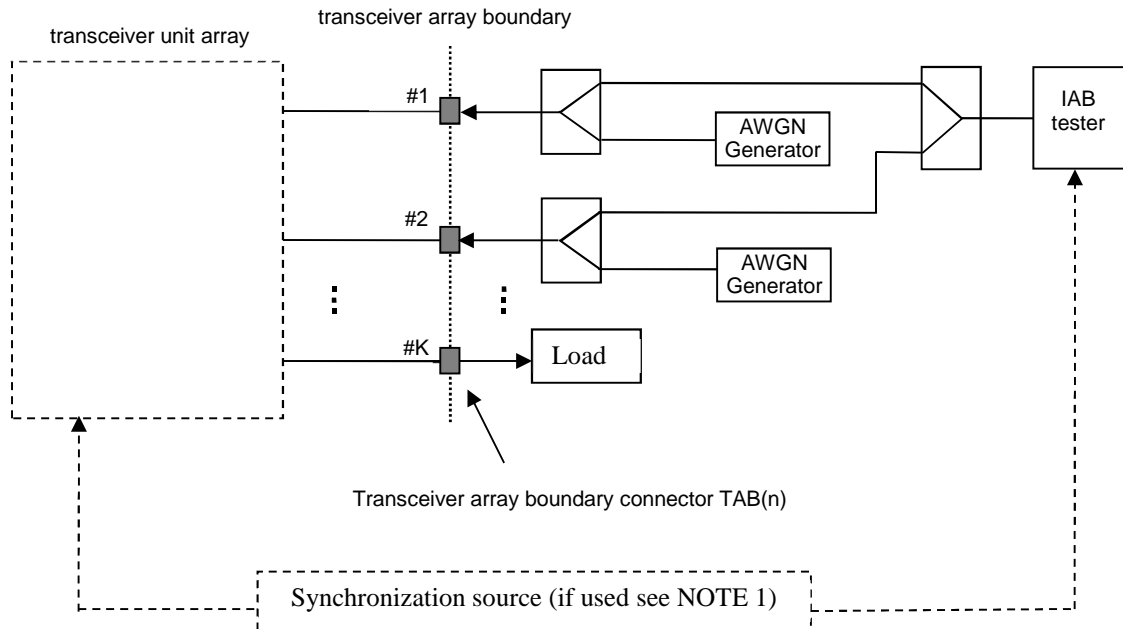

Figure D.3.3-1: Functional set-up for performance requirements for PUSCH and PRACH in static conditions for IAB-DU with Rx diversity (2 Rx case shown)

NOTE 1: In tests performed with signal generators, a synchronization signal may be provided between the IAB node and the signal generator, or a common (e.g., GNSS) source may be provided to both IAB node and the signal generator, to enable correct timing of the wanted signal. The method of synchronization with the TE is left to test implementation.

NOTE 2: It is left up to implementation how L1/L2 is configured for testing.

Annex E (normative): Characteristics of interfering signals

E.1 Characteristics of the interfering signals for IAB-DU

The Annex D in TS 38.104 [11] apply to FR1 IAB-DU.

E.2 Characteristics of the interfering signals for IAB-MT

The interfering signal shall be configured with PDSCH and PDCCH containing data and DM-RS symbols. Normal cyclic prefix is used. The data content shall be uncorrelated to the wanted signal and modulated according to clause 7 of TS38.211 [9]. Mapping of PDSCH modulation to receiver requirement are specified in table E.2-1.

Table E.2-1: Modulation of the interfering signal

Receiver requirement	Modulation
Adjacent channel selectivity and narrow-band blocking	QPSK
General blocking	QPSK
Receiver intermodulation	QPSK

Annex F (normative): Propagation conditions

F.1 Static propagation condition

The propagation for the static performance measurement is an Additive White Gaussian Noise (AWGN) environment. No fading or multi-paths exist for this propagation model.

F1.1 IAB-MT receiver with 2RX

For 1 port transmission the channel matrix is defined in the frequency domain by:

$$\mathbf{H} = \begin{pmatrix} 1 \\ 1 \end{pmatrix}.$$

For 2 port transmission the channel matrix is defined in the frequency domain by:

$$\mathbf{H} = \begin{pmatrix} 1 & j \\ 1 & -j \end{pmatrix}.$$

For 4 port transmission the channel matrix is defined in the frequency domain by:

$$\mathbf{H} = \begin{bmatrix} 1 & 1 & j & j \\ 1 & 1 & -j & -j \end{bmatrix}$$

For 8 port transmission the channel matrix is defined in the frequency domain by:

$$\mathbf{H} = \begin{bmatrix} 1 & 1 & 1 & 1 & j & j & j & j \\ 1 & 1 & 1 & 1 & -j & -j & -j & -j \end{bmatrix}$$

F.2 Multi-path fading propagation conditions

F.2.1 General

The multipath propagation conditions consist of several parts:

- A delay profile in the form of a "tapped delay-line", characterized by a number of taps at fixed positions on a sampling grid. The profile can be further characterized by the r.m.s. delay spread and the maximum delay spanned by the taps.
- A combination of channel model parameters that include the Delay profile and the Doppler spectrum that is characterized by a classical spectrum shape and a maximum Doppler frequency.
- Different models are used for FR1 (410 MHz - 7.125 GHz) and FR2 (24.25 GHz – 52.6 GHz).

F.2.2 Delay profiles

F.2.2.1 General

The delay profiles are simplified from the TR 38.901 [25] TDL models. The simplification steps are shown below for information. These steps are only used when new delay profiles are created. Otherwise, the delay profiles specified in F.2.2.1 can be used as such.

- Step 1: Use the original TDL model from TR 38.901 [25].
- Step 2: Re-order the taps in ascending delays.
- Step 3: Perform delay scaling according to the procedure described in clause 7.7.3 in TR 38.901 [25].
- Step 4: Apply the quantization to the delay resolution 5 ns. This is done simply by rounding the tap delays to the nearest multiple of the delay resolution.
- Step 5: If multiple taps are rounded to the same delay bin, merge them by calculating their linear power sum.
- Step 6: If there are more than 12 taps in the quantized model, merge the taps as follows:
 - Find the weakest tap from all taps (both merged and unmerged taps are considered):
 - If there are two or more taps having the same value and are the weakest, select the tap with the smallest delay as the weakest tap.
 - When the weakest tap is the first delay tap, merge taps as follows:
 - Update the power of the first delay tap as the linear power sum of the weakest tap and the second delay tap.
 - Remove the second delay tap.
 - When the weakest tap is the last delay tap, merge taps as follows:
 - Update the power of the last delay tap as the linear power sum of the second-to-last tap and the last tap.
 - Remove the second-to-last tap.
 - Otherwise:
 - For each side of the weakest tap, identify the neighbour tap that has the smaller delay difference to the weakest tap.
 - When the delay difference between the weakest tap and the identified neighbour tap on one side equals the delay difference between the weakest tap and the identified neighbour tap on the other side.
 - Select the neighbour tap that is weaker in power for merging.
 - Otherwise, select the neighbour tap that has smaller delay difference for merging.- To merge, the power of the merged tap is the linear sum of the power of the weakest tap and the selected tap:
 - When the selected tap is the first tap, the location of the merged tap is the location of the first tap. The weakest tap is removed.
 - When the selected tap is the last tap, the location of the merged tap is the location of the last tap. The weakest tap is removed.
 - Otherwise, the location of the merged tap is based on the average delay of the weakest tap and selected tap. If the average delay is on the sampling grid, the location of the merged tap is the average delay. Otherwise, the location of the merged tap is rounded towards the direction of the selected tap (e.g. 10 ns & 20 ns → 15 ns, 10 ns & 25 ns → 20 ns, if 25 ns had higher or equal power; 15 ns, if 10 ns had higher power). The weakest tap and the selected tap are removed.
 - Repeat step 6 until the final number of taps is 12.
- Step 7: Round the amplitudes of taps to one decimal (e.g. -8.78 dB → -8.8 dB)
- Step 8: If the delay spread has slightly changed due to the tap merge, adjust the final delay spread by increasing or decreasing the power of the last tap so that the delay spread is corrected.

- Step 9: Re-normalize the highest tap to 0 dB.

NOTE 1: Some values of the delay profile created by the simplification steps may differ from the values in tables F.2.2.2-2, F.2.2.2-3, and F.2.1.1-4 for the corresponding model.

NOTE 2: For Step 5 and Step 6, the power values are expressed in the linear domain using 6 digits of precision. The operations are in the linear domain.

F.2.2.2 Delay profiles for FR1

The delay profiles for FR1 are selected to be representative of low, medium and high delay spread environment. The resulting model parameters are specified in F.2.2.2-1 and the tapped delay line models are specified in tables F.2.2.2-2 ~ table F.2.2.2-4.

Table F.2.2.2-1: Delay profiles for NR channel models

Model	Number of channel taps	Delay spread (r.m.s.)	Maximum excess tap delay (span)	Delay resolution
TDLA30	12	30 ns	290 ns	5 ns
TDLB100	12	100 ns	480 ns	5 ns
TDLC300	12	300 ns	2595 ns	5 ns

Table F.2.2.2-2: TDLA30 (DS = 30 ns)

Tap #	Delay (ns)	Power (dB)	Fading distribution
1	0	-15.5	Rayleigh
2	10	0	
3	15	-5.1	
4	20	-5.1	
5	25	-9.6	
6	50	-8.2	
7	65	-13.1	
8	75	-11.5	
9	105	-11.0	
10	135	-16.2	
11	150	-16.6	
12	290	-26.2	

Table F.2.2.2-3: TDLB100 (DS = 100ns)

Tap #	Delay (ns)	Power (dB)	Fading distribution
1	0	0	Rayleigh
2	10	-2.2	
3	20	-0.6	
4	30	-0.6	
5	35	-0.3	
6	45	-1.2	
7	55	-5.9	
8	120	-2.2	
9	170	-0.8	
10	245	-6.3	
11	330	-7.5	
12	480	-7.1	

Table F.2.2.2-4: TDLC300 (DS = 300 ns)

Tap #	Delay (ns)	Power (dB)	Fading distribution
1	0	-6.9	Rayleigh
2	65	0	
3	70	-7.7	
4	190	-2.5	
5	195	-2.4	
6	200	-9.9	
7	240	-8.0	
8	325	-6.6	
9	520	-7.1	
10	1045	-13.0	
11	1510	-14.2	
12	2595	-16.0	

F.2.3 Combinations of channel model parameters

The propagation conditions used for the performance measurements in multi-path fading environment are indicated as a combination of a channel model name and a maximum Doppler frequency, i.e., TDLA<DS>-<Doppler>, TDLB<DS>-<Doppler> or TDLC<DS>-<Doppler> where '<DS>' indicates the desired delay spread and '<Doppler>' indicates the maximum Doppler frequency (Hz).

Table F.2.3-1 show the propagation conditions that are used for the performance measurements in multi-path fading environment for low, medium and high Doppler frequencies for FR1.

Table F.2.3-1: Channel model parameters for FR1

Combination name	Model	Maximum Doppler frequency
TDLA30-5	TDLA30	5 Hz
TDLA30-10	TDLA30	10 Hz
TDLB100-400	TDLB100	400 Hz
TDLC300-100	TDLC300	100 Hz

F.2.4 MIMO channel correlation matrices

F.2.4.1 General

The MIMO channel correlation matrices defined in annex F.2.4 apply for the antenna configuration using uniform linear arrays at both IAB and UE and for the antenna configuration using cross polarized antennas.

F.2.4.2 MIMO correlation matrices using Uniform Linear Array

F.2.4.2.1 General

The MIMO channel correlation matrices defined in annex F.2.4.2 apply for the antenna configuration using uniform linear array (ULA) at both IAB and UE.

F.2.4.2.2 Definition of MIMO correlation matrices

Table F.2.4.2.2-1 defines the correlation matrix for the IAB.

Table F.2.4.2.2-1: IAB-DU or gNB correlation matrix

IAB-DU or gNB correlation	
One antenna	$R_{gNB} = 1$
Two antennas	$R_{gNB} = \begin{pmatrix} 1 & \alpha \\ \alpha^* & 1 \end{pmatrix}$
Four antennas	$R_{gNB} = \begin{pmatrix} 1 & \alpha^{1/9} & \alpha^{4/9} & \alpha \\ \alpha^{1/9*} & 1 & \alpha^{1/9} & \alpha^{4/9} \\ \alpha^{4/9*} & \alpha^{1/9*} & 1 & \alpha^{1/9} \\ \alpha^* & \alpha^{4/9*} & \alpha^{1/9*} & 1 \end{pmatrix}$
Eight antennas	$R_{gNB} = \begin{pmatrix} 1 & \alpha^{1/49} & \alpha^{4/49} & \alpha^{9/49} & \alpha^{16/49} & \alpha^{25/49} & \alpha^{36/49} & \alpha \\ \alpha^{1/49*} & 1 & \alpha^{1/49} & \alpha^{4/49} & \alpha^{9/49} & \alpha^{16/49} & \alpha^{25/49} & \alpha^{36/49} \\ \alpha^{4/49*} & \alpha^{1/49*} & 1 & \alpha^{1/49} & \alpha^{4/49} & \alpha^{9/49} & \alpha^{16/49} & \alpha^{25/49} \\ \alpha^{9/49*} & \alpha^{4/49*} & \alpha^{1/49*} & 1 & \alpha^{1/49} & \alpha^{4/49} & \alpha^{9/49} & \alpha^{16/49} \\ \alpha^{16/49*} & \alpha^{9/49*} & \alpha^{4/49*} & \alpha^{1/49*} & 1 & \alpha^{1/49} & \alpha^{4/49} & \alpha^{9/49} \\ \alpha^{25/49*} & \alpha^{16/49*} & \alpha^{9/49*} & \alpha^{4/49*} & \alpha^{1/49*} & 1 & \alpha^{1/49} & \alpha^{4/49} \\ \alpha^{36/49*} & \alpha^{25/49*} & \alpha^{16/49*} & \alpha^{9/49*} & \alpha^{4/49*} & \alpha^{1/49*} & 1 & \alpha^{1/49} \\ \alpha^* & \alpha^{36/49*} & \alpha^{25/49*} & \alpha^{16/49*} & \alpha^{9/49*} & \alpha^{4/49*} & \alpha^{1/49*} & 1 \end{pmatrix}$
NOTE: The matrix applies to the IAB-DU for IAB-DU requirements and gNB for IAB-MT requirements.	

Table F.2.4.2.2-2 defines the correlation matrix for the UE:

Table F.2.4.2.2-2: IAB-MT or UE correlation matrix

	One antenna	Two antennas	Four antennas
IAB-MT / UE correlation	$R_{UE} = 1$	$R_{UE} = \begin{pmatrix} 1 & \beta \\ \beta^* & 1 \end{pmatrix}$	$R_{UE} = \begin{pmatrix} 1 & \beta^{1/9} & \beta^{4/9} & \beta \\ \beta^{1/9*} & 1 & \beta^{1/9} & \beta^{4/9} \\ \beta^{4/9*} & \beta^{1/9*} & 1 & \beta^{1/9} \\ \beta^* & \beta^{4/9*} & \beta^{1/9*} & 1 \end{pmatrix}$
NOTE: The matrix applies to the UE for IAB-DU requirements and IAB-MT for IAB-MT requirements.			

Table F.2.4.2.2-3 defines the channel spatial correlation matrix R_{spat} . The parameters, α and β in table F.2.4.2.2-3 defines the spatial correlation between the antennas at the IAB and UE respectively.

Table F.2.4.2.2-3: R_{spat} correlation matrices

1x2 case	$R_{spat} = R_{gNB} = \begin{bmatrix} 1 & \alpha \\ \alpha^* & 1 \end{bmatrix}$
1x4 case	$R_{spat} = R_{gNB} = \begin{pmatrix} 1 & \alpha^{1/9} & \alpha^{4/9} & \alpha \\ \alpha^{1/9*} & 1 & \alpha^{1/9} & \alpha^{4/9} \\ \alpha^{4/9*} & \alpha^{1/9*} & 1 & \alpha^{1/9} \\ \alpha^* & \alpha^{4/9*} & \alpha^{1/9*} & 1 \end{pmatrix}$
2x2 case	$R_{spat} = R_{UE} \otimes R_{gNB} = \begin{pmatrix} 1 & \beta \\ \beta^* & 1 \end{pmatrix} \otimes \begin{pmatrix} 1 & \alpha \\ \alpha^* & 1 \end{pmatrix} = \begin{pmatrix} 1 & \alpha & \beta & \beta\alpha \\ \alpha^* & 1 & \beta\alpha^* & \beta \\ \beta^* & \beta^*\alpha & 1 & \alpha \\ \beta^*\alpha^* & \beta^* & \alpha^* & 1 \end{pmatrix}$
2x4 case	$R_{spat} = R_{UE} \otimes R_{gNB} = \begin{pmatrix} 1 & \beta \\ \beta^* & 1 \end{pmatrix} \otimes \begin{pmatrix} 1 & \alpha^{1/9} & \alpha^{4/9} & \alpha \\ \alpha^{1/9*} & 1 & \alpha^{1/9} & \alpha^{4/9} \\ \alpha^{4/9*} & \alpha^{1/9*} & 1 & \alpha^{1/9} \\ \alpha^* & \alpha^{4/9*} & \alpha^{1/9*} & 1 \end{pmatrix}$
4x4 case	$R_{spat} = R_{UE} \otimes R_{gNB} = \begin{pmatrix} 1 & \beta^{1/9} & \beta^{4/9} & \beta \\ \beta^{1/9*} & 1 & \beta^{1/9} & \beta^{4/9} \\ \beta^{4/9*} & \beta^{1/9*} & 1 & \beta^{1/9} \\ \beta^* & \beta^{4/9*} & \beta^{1/9*} & 1 \end{pmatrix} \otimes \begin{pmatrix} 1 & \alpha^{1/9} & \alpha^{4/9} & \alpha \\ \alpha^{1/9*} & 1 & \alpha^{1/9} & \alpha^{4/9} \\ \alpha^{4/9*} & \alpha^{1/9*} & 1 & \alpha^{1/9} \\ \alpha^* & \alpha^{4/9*} & \alpha^{1/9*} & 1 \end{pmatrix}$
NOTE 1: R_{gNB} refers to an IAB-DU for IAB-DU requirements or a gNB for IAB-MT requirements. NOTE 2: R_{UE} refers to an UE for IAB-DU requirements or and IAB-MT for IAB-MT requirements	

For cases with more antennas at either IAB or gNB/UE or both, the channel spatial correlation matrix can still be expressed as the Kronecker product of R_{UE} and R_{gNB} according to $R_{spat} = R_{UE} \otimes R_{gNB}$.

F.2.4.2.3 MIMO correlation matrices at high, medium and low level

The α and β for different correlation types are given in table F.2.4.2.3-1.

Table F.2.4.2.3-1: Correlation for high, medium and low level

Low correlation		Medium correlation		High correlation	
α	β	α	β	α	β
0	0	0.9	0.3	0.9	0.9

The correlation matrices for high, medium and low correlation are defined in table F.2.4.2.3-2, F.2.4.2.3-3 and F.2.4.2.3-4 as below.

The values in table F.2.4.2.3-2 have been adjusted for the 2x4 and 4x4 high correlation cases to ensure the correlation matrix is positive semi-definite after round-off to 4 digit precision. This is done using the equation:

$$\mathbf{R}_{high} = [\mathbf{R}_{spatial} + a\mathbf{I}_n] / (1 + a)$$

Where the value "a" is a scaling factor such that the smallest value is used to obtain a positive semi-definite result. For the 2x4 high correlation case, a = 0.00010. For the 4x4 high correlation case, a = 0.00012.

The same method is used to adjust the 4x4 medium correlation matrix in table F.2.4.2.3-3 to insure the correlation matrix is positive semi-definite after round-off to 4 digit precision with a = 0.00012.

Table F.2.4.2.3-4: MIMO correlation matrices for low correlation

1x2 case	$R_{low} = \mathbf{I}_2$
1x4 case	$R_{low} = \mathbf{I}_4$
1x8 case	$R_{low} = \mathbf{I}_8$
2x2 case	$R_{low} = \mathbf{I}_4$
2x4 case	$R_{low} = \mathbf{I}_8$
2x4 case	$R_{low} = \mathbf{I}_{16}$
4x4 case	$R_{low} = \mathbf{I}_{16}$

In table F.2.4.12.3-4, \mathbf{I}_d is a $d \times d$ identity matrix.

NOTE: For completeness, the correlation matrices were defined for high, medium and low correlation but performance requirements exist only for low correlation.

F.2.4.3 Multi-antenna channel models using cross polarized antennas

F.2.4.3.1 General

The MIMO channel correlation matrices defined in annex F.2.4.3 apply to two cases as presented below:

- One TX antenna and multiple RX antennas case, with cross polarized antennas used at IAB
- Multiple TX antennas and multiple RX antennas case, with cross polarized antennas used at both UE and IAB

The cross-polarized antenna elements with +/-45 degrees polarization slant angles are deployed at IAB. For one TX antenna case, antenna element with +90 degree polarization slant angle is deployed at UE. For multiple TX antennas case, cross-polarized antenna elements with +90/0 degrees polarization slant angles are deployed at UE.

For the cross-polarized antennas, the N antennas are labelled such that antennas for one polarization are listed from 1 to N/2 and antennas for the other polarization are listed from N/2+1 to N, where N is the number of TX or RX antennas.

F.2.4.3.2 Definition of MIMO correlation matrices using cross polarized antennas

For the channel spatial correlation matrix, the following is used:

$$R_{spat} = P_{UL} (R_{UE} \otimes \Gamma_{UL} \otimes R_{gNB}) P_{UL}^T$$

Where

- R_{UE} is the spatial correlation matrix at the UE (IAB-DU requirements) or IAB-MT (IAB-MT requirements) with same polarization,
- R_{gNB} is the spatial correlation matrix at the IAB-DU (IAB-DU requirements) or gNB (IAB-MT requirements) with same polarization,
- Γ_{UL} is a polarization correlation matrix,
- P_{UL} is a permutation matrix, and
- $(\bullet)^T$ denotes transpose.

Table F.2.4.3.2-1 defines the polarization correlation matrix.

Table F.2.4.3.2-1: Polarization correlation matrix

	One TX antenna	Multiple TX antennas
Polarization correlation matrix	$\Gamma_{UL} = \begin{bmatrix} 1 & -\gamma \\ -\gamma & 1 \end{bmatrix}$	$\Gamma_{UL} = \begin{bmatrix} 1 & -\gamma & 0 & 0 \\ -\gamma & 1 & 0 & 0 \\ 0 & 0 & 1 & \gamma \\ 0 & 0 & \gamma & 1 \end{bmatrix}$

The matrix P_{UL} is defined as

$$\mathbf{P}_{UL}(a,b) = \begin{cases} 1 & \text{for } a = (j-1)Nr + i \text{ and } b = 2(j-1)Nr + i, \quad i = 1, \dots, Nr, j = 1, \dots, \lceil Nt/2 \rceil \\ 1 & \text{for } a = (j-1)Nr + i \text{ and } b = 2(j - Nt/2)Nr - Nr + i, \quad i = 1, \dots, Nr, j = \lceil Nt/2 \rceil + 1, \dots, Nt \\ 0 & \text{otherwise} \end{cases}$$

where Nt and Nr is the number of TX and RX antennas respectively, and $\lceil \bullet \rceil$ is the ceiling operator.

The matrix P_{UL} is used to map the spatial correlation coefficients in accordance with the antenna element labelling system described in F.2.4.3.

F.2.4.2.3 Spatial correlation matrices at UE/IAB-MT and IAB-DU/gNB sides

F.2.4.2.3.1 Spatial correlation matrices at IAB-MT/UE side

In this subclause, R_{UE} refers to a UE for IAB-DU requirements or an IAB-MT for IAB-MT requirements.

For 1-antenna transmitter, $R_{UE} = 1$.

For 2-antenna transmitter using one pair of cross-polarized antenna elements, $R_{UE} = 1$.

For 4-antenna transmitter using two pairs of cross-polarized antenna elements, $R_{UE} = \begin{pmatrix} 1 & \beta \\ \beta^* & 1 \end{pmatrix}$.

F.2.4.2.3.2 Spatial correlation matrices at IAB-DU/gNB side

In this subclause, R_{gNB} refers to an IAB-DU for IAB-DU requirements or a gNB for IAB-MT requirements.

For 2-antenna receiver using one pair of cross-polarized antenna elements, $R_{gNB} = 1$.

For 4-antenna receiver using two pairs of cross-polarized antenna elements, $R_{gNB} = \begin{bmatrix} 1 & \alpha \\ \alpha^* & 1 \end{bmatrix}$.

For 8-antenna receiver using four pairs of cross-polarized antenna elements, $R_{gNB} = \begin{pmatrix} 1 & \alpha^{1/9} & \alpha^{4/9} & \alpha \\ \alpha^{1/9*} & 1 & \alpha^{1/9} & \alpha^{4/9} \\ \alpha^{4/9*} & \alpha^{1/9*} & 1 & \alpha^{1/9} \\ \alpha^* & \alpha^{4/9*} & \alpha^{1/9*} & 1 \end{pmatrix}$.

F.2.4.2.4 MIMO correlation matrices using cross polarized antennas

The values for parameters α , β and γ for low spatial correlation are given in table F.2.4.2.4-1.

Table F.2.4.2.4-1: Values for parameters α , β and γ

Low spatial correlation		
α	\square	γ
0	0	0
NOTE 1: Value of α applies when more than one pair of cross-polarized antenna elements at gNB side.		
NOTE 2: Value of β applies when more than one pair of cross-polarized antenna elements at UE side.		

The correlation matrices for low spatial correlation are defined in table F.2.4.2.4-2 as below.

Table F.2.4.2.4-2: MIMO correlation matrices for low spatial correlation

1x8 case	$R_{low} = \mathbf{I}_8$
2x8 case	$R_{low} = \mathbf{I}_{16}$

In table F.2.4.2.4-2, \mathbf{I}_d is a $d \times d$ identity matrix.

Annex G (normative) : In-channel TX tests for IAB-DU

The Annex H in TS 38.141-1 [13] applies to FR1 IAB-DU.

Annex H (normative) :

In-channel TX tests for IAB-MT

H.0 Applicability

FR1 IAB-MT EVM can be determined by the process according to following alternatives:

Alternative 1: Annex E in TS 38.521-1 [16]. Only CP-OFDM waveform of PUSCH is measured for IAB-MT or

Alternative 2: from Annex H.1 to Annex H.7.

H.1 General

The in-channel TX test enables the measurement of all relevant parameters that describe the in-channel quality of the output signal of the TX under test in a single measurement process.

The parameters describing the in-channel quality of a transmitter, however, are not necessarily independent. The algorithm chosen for description inside this annex places particular emphasis on the exclusion of all interdependencies among the parameters.

H.2 Basic principles

The process is based on the comparison of the actual output signal of the TX under test, received by an ideal receiver, with an ideal signal, that is generated by the measuring equipment and represents an ideal error free received signal. All signals are represented as equivalent (generally complex) baseband signals.

The description below uses numbers and illustrations as examples only. These numbers are taken from a TDD frame structure with normal CP length, 30 kHz SCS and a transmission bandwidth configuration of 100 MHz ($N_{RB} = 273$). The application of the text below, however, is not restricted to this parameter set.

H.2.1 Output signal of the TX under test

The output signal of the TX under test is acquired by the measuring equipment and stored for further processing. It is sampled at a sampling rate which is the product of the SCS and the *FFT size*, and it is named $z(v)$. The *FFT size* is determined by the transmission bandwidth in table 6.5.3.5-2 for 15 kHz SCS, table 6.5.3.5-3 for 30 kHz SCS and table 6.5.3.5-4 for 60 kHz SCS. In the time domain, it comprises at least 10 ms. It is modelled as a signal with the following parameters:

- demodulated data content,
- carrier frequency,
- amplitude and phase for each subcarrier.

For the example in the annex, the *FFT size* is 4096 based on table 6.5.3.5-3. The sampling rate of 122.88 Msps is the product of the *FFT size* and SCS.

H.2.2 Ideal signal

Two types of ideal signals are defined:

The first ideal signal $i_1(v)$ is constructed by the measuring equipment according to the relevant TX specifications, using the following parameters:

- demodulated data content,

- nominal carrier frequency,
- nominal amplitude and phase for each subcarrier.

It is represented as a sequence of samples at the sampling rate determined from annex H.2.1 in the time domain. The structure of the signal is described in the test models.

The second ideal signal $i_2(v)$ is constructed by the measuring equipment according to the relevant TX specifications, using the following parameters:

- nominal demodulation reference signals (all other modulation symbols are set to 0 V),
- nominal carrier frequency,
- nominal amplitude and phase for each applicable subcarrier,
- nominal timing.

It is represented as a sequence of samples at the sampling rate determined from annex H.2.1 in the time domain.

H.2.3 Measurement results

The measurement results, achieved by the in-channel TX test are the following:

- Carrier frequency error
- EVM
- Resource element TX power
 - OFDM symbol TX power (OSTP)

Other side results are: residual amplitude- and phase response of the TX chain after equalisation.

H.2.4 Measurement points

The resource element TX power is measured after the FFT box as described in figure H.2.4-1. The EVM shall be measured at the point after the FFT and a zero-forcing (ZF) equalizer in the receiver, as depicted for FR1 in figure H.2.4-1. The FFT window of $FFT\ size$ samples out of ($FFT\ size +$ cyclic prefix length) samples in the time domain is selected in the "Remove CP" box. The $FFT\ size$ and the cyclic prefix length are obtained from table 6.5.3.5-2 for 15 kHz SCS, table 6.5.3.5-3 for 30 kHz SCS and table 6.5.3.5-4 for 60 kHz SCS.

In one subframe, there are two symbols with the length of the cyclic prefix larger than the values listed in tables 6.5.3.5-2, 6.5.3.5-3 and 6.5.3.5-4. Table H.2.4-1 lists the slot number and the symbol number and the formula how to compute the length of cyclic prefix for those two symbols according to the sampling rate.

Table H.2.4-1: Slot number and symbol number identifying the longer CP length for normal CP

SCS (kHz)	# slots in subframe	Symbol # and slot # with longer CP	Longer CP length
15	1	(symbol 0, slot 0) (symbol 7, slot 0)	CP length + $FFT\ size / 128$
30	2	(symbol 0, slot 0) (symbol 0, slot 1)	CP length + $FFT\ size / 64$
60	4	(symbol 0, slot 0) (symbol 0, slot 2)	CP length + $FFT\ size / 32$

For the example used in the annex, the "Remove CP" box selects 4096 samples out of 4384 samples. Symbol 0 has 64 more samples in the cyclic prefix than the other 13 symbols in the slot (the longer CP length = 352).

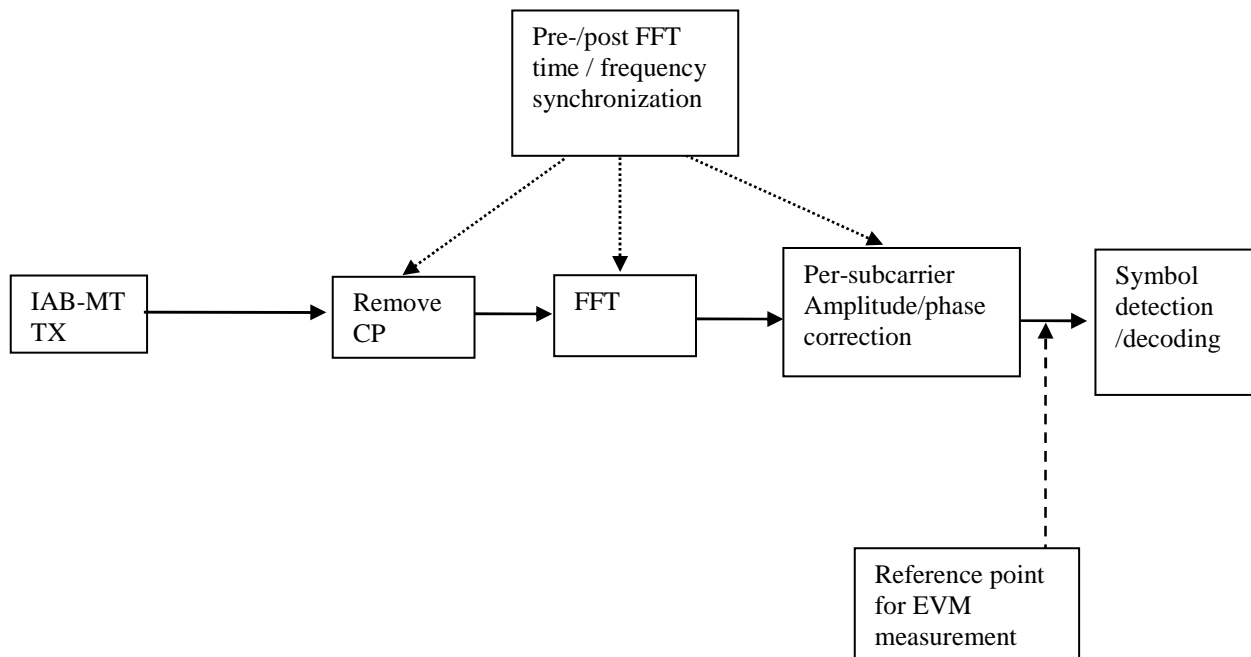

Figure H.2.4-1: Reference point for FR1 EVM measurements

H.3 Pre-FFT minimization process

Sample Timing, Carrier Frequency in $z(v)$ are varied in order to minimise the difference between $z(v)$ and $i_1(v)$, after the amplitude ratio of $z(v)$ and $i_1(v)$ has been scaled. Best fit (minimum difference) is achieved when the RMS difference value between $z(v)$ and $i_1(v)$ is an absolute minimum.

The carrier frequency variation is the measurement result: carrier frequency error.

From the acquired samples, one value of carrier frequency error can be derived.

NOTE 1: The minimisation process, to derive the RF error can be supported by post-FFT operations. However the minimisation process defined in the pre-FFT domain comprises all acquired samples (i.e. it does not exclude the samples in-between the FFT widths and it does not exclude the bandwidth outside the transmission bandwidth configuration).

NOTE 2: The algorithm would allow to derive carrier frequency error and sample frequency error of the TX under test separately. However there are no requirements for sample frequency error. Hence the algorithm models the RF and the sample frequency commonly (not independently). It returns one error and does not distinguish between both.

After this process, the samples $z(v)$ are called $z^0(v)$.

H.4 Timing of the FFT window

The FFT window length is *FFT size* samples per OFDM symbol.

The position in time for the FFT shall be determined.

In an ideal signal, the FFT may start at any instant within the cyclic prefix without causing an error. The TX filter, however, reduces the window. The EVM requirements shall be met within a window $W < CP$. There are three different instants for FFT:

- Centre of the reduced window, called $\Delta\tilde{c}$,
- $\Delta c - W/2$, and

- $\Delta c + W/2$.

The value of EVM window length W is obtained from tables 6.5.3.5-2 for 15 kHz SCS, 6.5.3.5-3 for 30 kHz SCS and 6.5.3.5-4 for 60 kHz SCS and the transmission bandwidth.

The IAB-MT shall transmit a signal according to the test models intended for EVM. The demodulation reference signal of the second ideal signal shall be used to find the centre of the FFT window.

The timing of the measured signal is determined in the pre-FFT domain as follows, using $z^0(v)$ and $i_2(v)$:

1. The measured signal is delay spread by the TX filter. Hence the distinct borders between the OFDM symbols and between data and CP are also spread and the timing is not obvious.
2. In the ideal signal $i_2(v)$, the timing is known.

Correlation between bullet (1) and (2) will result in a correlation peak. The meaning of the correlation peak is approximately the "impulse response" of the TX filter.

3. The meaning of "impulse response" assumes that the autocorrelation of the ideal signal $i_2(v)$ is a Dirac peak and that the correlation between the ideal signal $i_2(v)$ and the data in the measured signal is 0. The correlation peak, (the highest, or in case of more than one highest, the earliest) indicates the timing in the measured signal.

The number of samples used for FFT is reduced compared to $z^0(v)$. This subset of samples is called $z'(v)$.

From the acquired samples one timing can be derived.

The timing of the centre $\Delta\tilde{c}$ is determined according to the cyclic prefix length of the OFDM symbols. For normal CP, there are two values for $\Delta\tilde{c}$ in a 1 ms period:

- $\Delta\tilde{c} = \text{length of cyclic prefix} / 2$,
- $\Delta\tilde{c} = \text{Longer CP length} - \text{length of cyclic prefix} / 2$,

Where the length of cyclic prefix is obtained from table 6.5.3.5-2 for 15 kHz SCS, table 6.5.3.5-3 for 30 kHz SCS and table 6.5.3.5-4 for 60 kHz SCS, and the longer CP length is obtained from table H.2.4-1.

As per the example values:

- $\Delta\tilde{c} = 144$ within the CP of length 288 for OFDM symbols 1 to 13 of a slot,
- $\Delta\tilde{c} = 208 = 352 - 144$ within the CP of length 352 for OFDM symbol 0 of a slot.

H.5 Resource element TX power

Perform FFT on $z'(v)$ with the FFT window timing $\Delta\tilde{c}$. The result is called $Z'(t, f)$. The RE TX power (RETP) is then defined as:

$$RETP = |Z'(t, f)|^2 SCS$$

Where SCS is the subcarrier spacing in Hz.

From RETP the OFDM Symbol TX power (OSTP) is derived as follows:

$$OSTP = \frac{1}{N_{sym}} \sum RETP$$

Where the summation accumulates $N_{RB} N_{SC}^{RB}$ RETP values of all N_{sym} OFDM symbols that carry PUSCH and not containing PUCCH, SRS or PRACH within a slot.

From the acquired samples, N_{ul} values for each OSTP can be obtained and averaged where for TDD, N_{ul} is the number of slots with uplink symbols in a 10 ms measurement interval and is computed according to the values in table 4.9.2.2-1.

For the example used in the annex, $N_{ul} = 20$ and $N_{RB} = 273$.

H.6 Post-FFT equalisation

Perform $14N_{ul}$ FFTs on $z'(v)$, one for each OFDM symbol within 10 ms measurement interval with the FFT window timing to produce an array of samples, $14N_{ul}$ in the time axis t by *FFT size* in the frequency axis f .

For the example in the annex, 280 FFTs are performed on $z'(v)$. The result is an array of samples, 280 in the time axis by 4096 in the frequency axis.

The equalizer coefficients $\tilde{a}(f)$ and $\tilde{\varphi}(f)$ are determined as follows:

1. Calculate the complex ratios (amplitude and phase) of the post-FFT acquired signal $Z'(t, f)$ and the post-FFT ideal signal $I_2(t, f)$ for each demodulation reference signal, over 10 ms measurement interval. This process creates a set of complex ratios:

$$a(t, f)e^{j\varphi(t, f)} = \frac{Z'(t, f)}{I_2(t, f)}$$

2. Perform time averaging at each demodulation reference signal subcarrier of the complex ratios, the time-averaging length is 10 ms measurement interval. Prior to the averaging of the phases $\varphi(t_i, f)$ an unwrap operation must be performed according to the following definition:

- The unwrap operation corrects the radian phase angles of $\varphi(t_i, f)$ by adding multiples of $2 * \pi$ when absolute phase jumps between consecutive time instances t_i are greater than or equal to the jump tolerance of π radians.
- This process creates an average amplitude and phase for each demodulation reference signal subcarrier (i.e. every second subcarrier).

$$a(f) = \frac{\sum_{i=1}^N a(t_i, f)}{N}$$

and

$$\varphi(f) = \frac{\sum_{i=1}^N \varphi(t_i, f)}{N}$$

Where N is the number of demodulation reference signals time-domain locations t_i from $Z'(t, f)$ for each demodulation reference signal subcarrier f .

3. The equalizer coefficients for amplitude and phase $\hat{a}(f)$ and $\hat{\varphi}(f)$ at the demodulation reference signal subcarriers are obtained by computing the moving average in the frequency domain of the time-averaged demodulation reference signal subcarriers. The moving average window size is 19 and averaging is over the DM-RS subcarriers in the allocated RBs. For DM-RS subcarriers at or near the edge of the channel, or when the number of available DM-RS subcarriers within a set of contiguously allocated RBs is smaller than the moving average window size, the window size is reduced accordingly as per figure H.6-1.

4. Perform linear interpolation from the equalizer coefficients $\hat{a}(f)$ and $\hat{\varphi}(f)$ to compute coefficients $\tilde{a}(f)$, $\tilde{\varphi}(f)$ for each subcarrier.

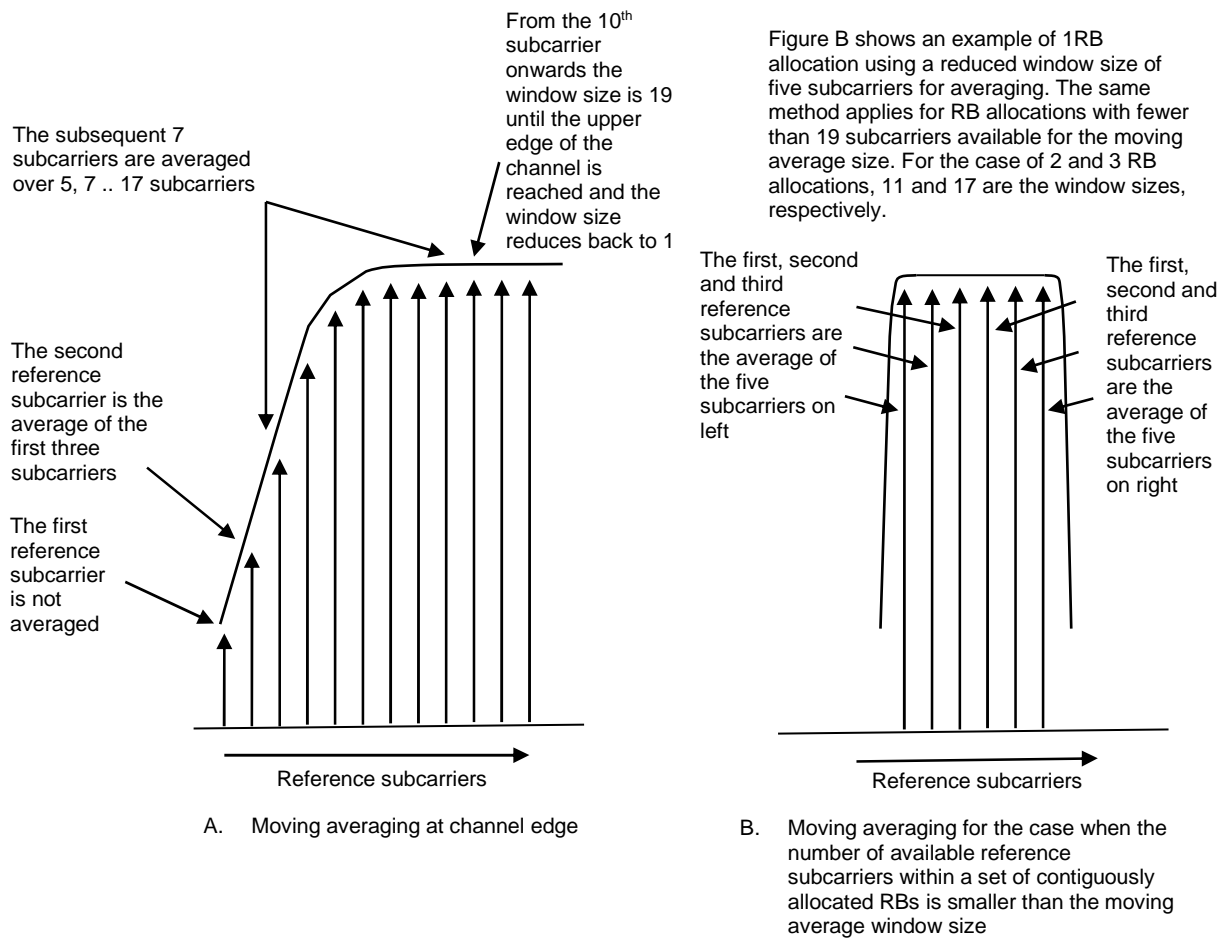

Figure H.6-1: Reference subcarrier smoothing in the frequency domain

H.7 EVM

H.7.0 General

For EVM create two sets of $Z_{eq}'(t, f)$, according to the timing $(\Delta c - W/2)$ and $(\Delta c + W/2)$, using the equalizer coefficients from H.6.

The equivalent ideal samples are calculated from $i_1(v)$ (annex H.2.2) and are called $I(t, f)$.

The EVM is the difference between the ideal signal and the equalized measured signal.

$$EVM = \sqrt{\frac{\sum_{t \in T} \sum_{f \in F(i)} |Z_{eq}'(t, f) - I(t, f)|^2}{\sum_{t \in T} \sum_{f \in F(i)} |I(t, f)|^2}}$$

Where:

- T is the set of symbols with the considered modulation scheme being active within the slot,
- $F(t)$ is the set of subcarriers within the resource blocks with the considered modulation scheme being active in symbol t ,
- $I(t, f)$ is the ideal signal reconstructed by the measurement equipment in accordance with relevant test models,
- $Z_{eq}'(t, f)$ is the equalized signal under test.

NOTE: Although the basic unit of measurement is one slot, the equalizer is calculated over the entire 10 ms measurement interval to reduce the impact of noise in the reference signals.

H.7.1 Averaged EVM (TDD)

EVM is averaged over all allocated uplink resource blocks with the considered modulation scheme in the frequency domain, and a minimum of N_{ul} slots where N_{ul} is the number of slots in a 10 ms measurement interval.

For TDD, let N_{ul}^{TDD} be the number of slots with uplink symbols within a 10 ms measurement interval, the averaging in the time domain can be calculated from N_{ul}^{TDD} slots of different 10 ms measurement intervals and should have a minimum of N_{ul} slots averaging length where N_{ul} is the number of slots in a 10 ms measurement interval.

- \overline{EVM}_{frame} is derived by: Square the EVM results in each 10 ms measurement interval. Sum the squares, divide the sum by the number of EVM relevant locations, square-root the quotient (RMS).

$$\overline{EVM}_{frame} = \sqrt{\frac{1}{\sum_{i=1}^{N_{ul}^{TDD}} N_i} \sum_{i=1}^{N_{ul}^{TDD}} \sum_{j=1}^{N_i} EVM_{i,j}^2}$$

- Where N_i is the number of resource blocks with the considered modulation scheme in slot i .
- The \overline{EVM}_{frame} is calculated, using the maximum of \overline{EVM}_{frame} at the window W extremities. Thus $\overline{EVM}_{frame,l}$ is calculated using $\tilde{t} = \Delta\tilde{t}_l$ and $\overline{EVM}_{frame,h}$ is calculated using $\tilde{t} = \Delta\tilde{t}_h$ (l and h , low and high; where low is the timing ($\Delta c - W/2$) and high is the timing ($\Delta c + W/2$)).

$$EVM_{frame} = \max(\overline{EVM}_{frame,l}, \overline{EVM}_{frame,h})$$

- In order to unite at least N_{ul} slots, consider the minimum integer number of 10 ms measurement intervals, where N_{frame} is determined by.

$$N_{frame} = \left\lceil \frac{10 \times N_{slot}}{N_{ul}^{TDD}} \right\rceil$$

and $N_{slot} = 1$ for 15 kHz SCS, $N_{slot} = 2$ for 30 kHz SCS and $N_{slot} = 4$ for 60 kHz SCS normal CP.

- Unite by RMS.

$$\overline{EVM} = \sqrt{\frac{1}{N_{frame}} \sum_{k=1}^{N_{frame}} EVM_{frame,k}^2}$$

Annex I (informative): Change history

Change history							
Date	Meeting	TDoc	CR	Rev	Cat	Subject/Comment	New version
04/2021	RAN4#9 8bis-e	R4-2106058				IAB conducted conformance specification skeleton	0.0.1
05/2021	RAN4#9 9-e	R4-2111397				Update of IAB conducted conformance TS with agreed TP in RAN4#98bis-e: R4-2106050 TP for Annex E for conducted IAB test specification R4-2106054 TP to TS38.176-1 on subclause 4.10 -5 R4-2106131 TP to TS 38.176-1 -Clause 4.1 R4-2106059 TP to TS 38.176-1 - Annex D R4-2106056 TP to TS 38.xxx-1: Section 4.2-4.5 R4-2106062 TP for TS 38.176-1: Transmit ON/OFF power R4-2106064 TP to TS 38.176-1: Output power and Unwanted emission R4-2106065 TP to TS 38.xxx-1: TX IMD requirements R4-2106066 TP to TS 38.176-1 Annex A for IAB conducted test specification R4-2106069 TP to TS 38.176-1 - Sensitivity, clause 7.2 R4-2106070 TP to TS 38.176-1 - Rx dynamic range, clause 7.3 R4-2106071 TP for IBB, OBB and RX spurious of conducted receiver test R4-2106067 TP to TS 38.xxx-1: RX IMD requirements R4-2106068 TP to TS 38.xxx-1: RX ICS requirements R4-2106072 TP to TS 38.176-1 Clause 4.6 Declarations for IAB conducted test specification	0.1.0
05/2021	RAN4#9 9-e	R4-2108095				Update of IAB conducted conformance TS with agreed TP in RAN4#99-e: R4-2111399 TP to TS 38.176-1 -Clean up R4-2108565 TP to TS 38.176-1 on test efficiency clause 4.13 R4-2108569 TP for TS 38.176-1: Test configurations and applicability of requirements R4-2108567 TP to TS 38.176-1: IAB Common test issue on test model-Conducted R4-2108571 TP for TS 38.176-1: Annex B and C R4-2108573 TP to TS 38.176-1 -Clause 4.1 R4-2111397 TS 38.176-1 -Updated TS 37.176-1 R4-2111399 TP to TS 38.176-1 -Clean up R4-2108710 TP for TS 38.176-1: Transmitted signal quality R4-2108087 TP to TS 38.176-1 - OTA Tx dynamic range, clause 6.3 R4-2111177 TP for IBB, OBB and RX spurious of conducted receiver test R4-2111405 TP to TS 38.176-1 - Sensitivity, clause 7.2 R4-2108576 TP to TS 38.176-1 Clause 4.6 Declarations for IAB conducted test specification R4-2108577 TP to TS 38.176-1: Annex G and H: In-channel TX test	0.2.0
06/2021	RAN#92- e	RP-211342				Presented to TSG RAN for approval. (Including RF and Demod parts: R4-2108095 Big TP to TS 38.176-1 on RF part R4-2109211 Big TP to TS 38.176-1: IAB demodulation performance requirement)	1.0.0
2021-06	RAN#92					TS was approved by RAN plenary	16.0.0
2021-09	RAN#93	RP-211892	0002		F	Big CR for TS 38.176-1 Maintenance (Rel-16, CAT F)	16.1.0
2021-12	RAN#94	RP-212851	0003		F	Big CR for TS 38.176-1 Maintenance (Rel-16, CAT F)	16.2.0
2022-03	RAN#95	RP-220334	0004		F	Big CR for TS 38.176-1 Maintenance (Rel-16, CAT F)	16.3.0

History

Document history		
V16.0.0	September 2021	Publication
V16.1.0	October 2021	Publication
V16.2.0	March 2022	Publication
V16.3.0	April 2022	Publication