

ETSI TS 138 161 V17.0.0 (2022-10)



**5G;
NR;
User Equipment (UE) TRP (Total Radiated Power)
and TRS (Total Radiated Sensitivity) requirements;
Range 1 Standalone and Range 1 Interworking operation with
other radios
(3GPP TS 38.161 version 17.0.0 Release 17)**



Reference

DTS/TSGR-0438161vh00

Keywords

5G

ETSI

650 Route des Lucioles
F-06921 Sophia Antipolis Cedex - FRANCE

Tel.: +33 4 92 94 42 00 Fax: +33 4 93 65 47 16

Siret N° 348 623 562 00017 - APE 7112B
Association à but non lucratif enregistrée à la
Sous-Préfecture de Grasse (06) N° w061004871

Important notice

The present document can be downloaded from:

<http://www.etsi.org/standards-search>

The present document may be made available in electronic versions and/or in print. The content of any electronic and/or print versions of the present document shall not be modified without the prior written authorization of ETSI. In case of any existing or perceived difference in contents between such versions and/or in print, the prevailing version of an ETSI deliverable is the one made publicly available in PDF format at www.etsi.org/deliver.

Users of the present document should be aware that the document may be subject to revision or change of status.

Information on the current status of this and other ETSI documents is available at

<https://portal.etsi.org/TB/ETSIDeliverableStatus.aspx>

If you find errors in the present document, please send your comment to one of the following services:

<https://portal.etsi.org/People/CommitteeSupportStaff.aspx>

If you find a security vulnerability in the present document, please report it through our
Coordinated Vulnerability Disclosure Program:

<https://www.etsi.org/standards/coordinated-vulnerability-disclosure>

Notice of disclaimer & limitation of liability

The information provided in the present deliverable is directed solely to professionals who have the appropriate degree of experience to understand and interpret its content in accordance with generally accepted engineering or other professional standard and applicable regulations.

No recommendation as to products and services or vendors is made or should be implied.

No representation or warranty is made that this deliverable is technically accurate or sufficient or conforms to any law and/or governmental rule and/or regulation and further, no representation or warranty is made of merchantability or fitness for any particular purpose or against infringement of intellectual property rights.

In no event shall ETSI be held liable for loss of profits or any other incidental or consequential damages.

Any software contained in this deliverable is provided "AS IS" with no warranties, express or implied, including but not limited to, the warranties of merchantability, fitness for a particular purpose and non-infringement of intellectual property rights and ETSI shall not be held liable in any event for any damages whatsoever (including, without limitation, damages for loss of profits, business interruption, loss of information, or any other pecuniary loss) arising out of or related to the use of or inability to use the software.

Copyright Notification

No part may be reproduced or utilized in any form or by any means, electronic or mechanical, including photocopying and microfilm except as authorized by written permission of ETSI.

The content of the PDF version shall not be modified without the written authorization of ETSI.

The copyright and the foregoing restriction extend to reproduction in all media.

© ETSI 2022.
All rights reserved.

Intellectual Property Rights

Essential patents

IPRs essential or potentially essential to normative deliverables may have been declared to ETSI. The declarations pertaining to these essential IPRs, if any, are publicly available for **ETSI members and non-members**, and can be found in ETSI SR 000 314: "*Intellectual Property Rights (IPRs); Essential, or potentially Essential, IPRs notified to ETSI in respect of ETSI standards*", which is available from the ETSI Secretariat. Latest updates are available on the ETSI Web server (<https://ipr.etsi.org/>).

Pursuant to the ETSI Directives including the ETSI IPR Policy, no investigation regarding the essentiality of IPRs, including IPR searches, has been carried out by ETSI. No guarantee can be given as to the existence of other IPRs not referenced in ETSI SR 000 314 (or the updates on the ETSI Web server) which are, or may be, or may become, essential to the present document.

Trademarks

The present document may include trademarks and/or tradenames which are asserted and/or registered by their owners. ETSI claims no ownership of these except for any which are indicated as being the property of ETSI, and conveys no right to use or reproduce any trademark and/or tradename. Mention of those trademarks in the present document does not constitute an endorsement by ETSI of products, services or organizations associated with those trademarks.

DECT™, **PLUGTESTS™**, **UMTS™** and the ETSI logo are trademarks of ETSI registered for the benefit of its Members. **3GPP™** and **LTE™** are trademarks of ETSI registered for the benefit of its Members and of the 3GPP Organizational Partners. **oneM2M™** logo is a trademark of ETSI registered for the benefit of its Members and of the oneM2M Partners. **GSM®** and the GSM logo are trademarks registered and owned by the GSM Association.

Legal Notice

This Technical Specification (TS) has been produced by ETSI 3rd Generation Partnership Project (3GPP).

The present document may refer to technical specifications or reports using their 3GPP identities. These shall be interpreted as being references to the corresponding ETSI deliverables.

The cross reference between 3GPP and ETSI identities can be found under <http://webapp.etsi.org/key/queryform.asp>.

Modal verbs terminology

In the present document "**shall**", "**shall not**", "**should**", "**should not**", "**may**", "**need not**", "**will**", "**will not**", "**can**" and "**cannot**" are to be interpreted as described in clause 3.2 of the [ETSI Drafting Rules](#) (Verbal forms for the expression of provisions).

"**must**" and "**must not**" are **NOT** allowed in ETSI deliverables except when used in direct citation.

Contents

Intellectual Property Rights	2
Legal Notice	2
Modal verbs terminology.....	2
Foreword.....	5
1 Scope	7
2 References	7
3 Definitions of terms, symbols and abbreviations	7
3.1 Terms.....	7
3.2 Symbols.....	8
3.3 Abbreviations	8
4 General	8
4.1 Relationship between minimum requirements and test requirements	8
4.2 Applicability of minimum requirements	8
4.2.1 General.....	8
4.2.1 UE mechanical modes	8
4.3 Applicability rules for testing of FR1 SA and NSA UEs	9
4.4 Applicability rules for testing of power class capability of UEs	9
5 Frequency bands.....	9
5.1 General	9
5.2 Operating bands.....	9
5.2.1 FR1 Standalone Operating bands	9
5.2.2 FR1 EN-DC band combinations.....	10
6 FR1 TRP requirements.....	13
6.1 General	13
6.2 Minimum requirement.....	13
6.2.1 Minimum requirement for handheld UE.....	13
6.2.1.1 Hand phantom browsing mode	13
6.2.1.1.1 NR FR1.....	13
6.2.1.1.2 NR FR1 in EN-DC mode.....	14
6.2.1.2 Beside the head and hand phantom talk mode	14
6.2.1.2.1 NR FR1.....	14
6.2.1.2.2 NR FR1 in EN-DC mode.....	15
7 FR1 TRS requirements.....	15
7.1 General	15
7.2 Minimum requirement.....	15
7.2.1 Minimum requirement for handheld UE.....	15
7.2.1.1 Hand phantom browsing mode	15
7.2.1.1.1 NR FR1.....	16
7.2.1.1.2 NR FR1 in EN-DC mode.....	16
7.2.1.2 Beside the head and hand phantom position	16
7.2.1.2.1 NR FR1.....	16
7.2.1.2.2 NR FR1 in EN-DC mode.....	16
Annex A (normative): Test methodology	18
A.1 General	18
A.2 UE configuration	18
A.3 Test system of Anechoic Chamber method.....	19
A.3.3.1 General	20
A.3.3.2 TRP Test procedure.....	20
A.3.3.3 TRS Test procedure.....	21

A.4	Preliminary example MU budget	23
Annex B (normative):	Phantoms definition and Positioning	26
B.1	General	26
B.2	Phantom Definition	26
B.3	UE positioning guidelines	27
B.3.1.1	Wide Grip Hand.....	27
B.3.1.2	PDA Grip Hand	28
B.3.2.1	General	29
B.3.2.2	Wide Grip Hand and Head.....	30
B.3.2.1	PDA Grip Hand and Head	30
Annex C (normative):	Environmental requirements.....	31
C.1	General	31
C.2	Environmental	31
C.2.1	Temperature	31
C.2.2	Voltage	31
Annex D (informative):	Change history	32
History	33

Foreword

This Technical Specification has been produced by the 3rd Generation Partnership Project (3GPP).

The contents of the present document are subject to continuing work within the TSG and may change following formal TSG approval. Should the TSG modify the contents of the present document, it will be re-released by the TSG with an identifying change of release date and an increase in version number as follows:

Version x.y.z

where:

- x the first digit:
 - 1 presented to TSG for information;
 - 2 presented to TSG for approval;
 - 3 or greater indicates TSG approved document under change control.
- y the second digit is incremented for all changes of substance, i.e. technical enhancements, corrections, updates, etc.
- z the third digit is incremented when editorial only changes have been incorporated in the document.

In the present document, modal verbs have the following meanings:

- shall** indicates a mandatory requirement to do something
- shall not** indicates an interdiction (prohibition) to do something

The constructions "shall" and "shall not" are confined to the context of normative provisions, and do not appear in Technical Reports.

The constructions "must" and "must not" are not used as substitutes for "shall" and "shall not". Their use is avoided insofar as possible, and they are not used in a normative context except in a direct citation from an external, referenced, non-3GPP document, or so as to maintain continuity of style when extending or modifying the provisions of such a referenced document.

- should** indicates a recommendation to do something
- should not** indicates a recommendation not to do something
- may** indicates permission to do something
- need not** indicates permission not to do something

The construction "may not" is ambiguous and is not used in normative elements. The unambiguous constructions "might not" or "shall not" are used instead, depending upon the meaning intended.

- can** indicates that something is possible
- cannot** indicates that something is impossible

The constructions "can" and "cannot" are not substitutes for "may" and "need not".

- will** indicates that something is certain or expected to happen as a result of action taken by an agency the behaviour of which is outside the scope of the present document
- will not** indicates that something is certain or expected not to happen as a result of action taken by an agency the behaviour of which is outside the scope of the present document
- might** indicates a likelihood that something will happen as a result of action taken by some agency the behaviour of which is outside the scope of the present document

might not indicates a likelihood that something will not happen as a result of action taken by some agency the behaviour of which is outside the scope of the present document

In addition:

is (or any other verb in the indicative mood) indicates a statement of fact

is not (or any other negative verb in the indicative mood) indicates a statement of fact

The constructions "is" and "is not" do not indicate requirements.

1 Scope

The present document establishes the TRP (Total Radiated Power) and TRS (Total Radiated Sensitivity) requirements for NR UEs operating on Range 1 Standalone and Range 1 Interworking operation with other radios.

2 References

The following documents contain provisions which, through reference in this text, constitute provisions of the present document.

- References are either specific (identified by date of publication, edition number, version number, etc.) or non-specific.
- For a specific reference, subsequent revisions do not apply.
- For a non-specific reference, the latest version applies. In the case of a reference to a 3GPP document (including a GSM document), a non-specific reference implicitly refers to the latest version of that document *in the same Release as the present document*.

- [1] 3GPP TR 21.905: "Vocabulary for 3GPP Specifications".
- [2] 3GPP TR 38.834: "Measurements of User Equipment (UE) Over-the-Air (OTA) performance for NR FR1; Total Radiated Power (TRP) and Total Radiated Sensitivity (TRS) test methodology".
- [3] 3GPP TS 38.101-1: "NR; User Equipment (UE) radio transmission and reception; Part 1: Range 1 Standalone".
- [4] 3GPP TS 38.101-3: "NR; User Equipment (UE) radio transmission and reception; Part 3: Range 1 and Range 2 Interworking operation with other radios".
- [5] 3GPP TS 38.521-1: "NR; User Equipment (UE) conformance specification; Radio transmission and reception; Part 1: Range 1 Standalone".
- [6] 3GPP TS 38.521-3: "NR; User Equipment (UE) conformance specification; Radio transmission and reception; Part 3: Range 1 and Range 2 Interworking operation with other radios".
- [7] 3GPP TS 38.508-1: "5GS; User Equipment (UE) conformance specification; Part 1: Common test environment".
- [8] 3GPP TS 37.544: "Universal Terrestrial Radio Access (UTRA) and Evolved Universal Terrestrial Radio Access (E-UTRA); User Equipment (UE) Over The Air (OTA) performance; Conformance testing".
- [9] CTIA Certification™ OTA Test Plan: "CTIA Certification Test Plan for Wireless Device Over-the-Air Performance, Version 3.9.4"; <https://ctiacertification.org/test-plans/>

3 Definitions of terms, symbols and abbreviations

3.1 Terms

For the purposes of the present document, the terms given in 3GPP TR 21.905 [1] and the following apply. A term defined in the present document takes precedence over the definition of the same term, if any, in 3GPP TR 21.905 [1].

Browsing mode usage: This mode corresponds to "data" mode, the device is tested via hand-only phantoms.

Primary mechanical mode: The mode that is most often used for a specific user scenario. Every terminal has at least one primary mechanical mode, if multiple modes are supported, different primary mechanical modes may be applicable for different user scenarios, e.g., different primary mechanical modes for Browsing mode usage and Talk mode usage for the same UE.

Talk mode usage: This mode corresponds to “talk” mode, the device is tested via head&hand phantoms.

3.2 Symbols

For the purposes of the present document, the following symbols apply:

$TRP_{average}$	The average measured total radiated power of low, mid and high channel. When hand phantom is involved, the average is performed with low, mid and high channel from both hand left and hand right.
$TRS_{average}$	The average measured total radiated sensitivity of low, mid and high channel. When hand phantom is involved, the average is performed with low, mid and high channel from both hand left and hand right.

3.3 Abbreviations

For the purposes of the present document, the abbreviations given in 3GPP TR 21.905 [1] and the following apply. An abbreviation defined in the present document takes precedence over the definition of the same abbreviation, if any, in 3GPP TR 21.905 [1].

AC	Anechoic Chamber
DUT	Device Under Test
EIRP	Effective Isotropic Radiated Power
EUT	Equipment Under Test
FR1	Frequency Range 1
NSA	Non-Standalone, a mode of operation where operation of an other radio is assisted with an other radio
OTA	Over The Air
QZ	Quiet Zone
SA	Standalone
SS	System Simulator
TAA	Time-Averaging Algorithm
TAS	Tx Antenna Switching
TRP	Total Radiated Power
TRS	Total Radiated Sensitivity
UE	User Equipment

4 General

4.1 Relationship between minimum requirements and test requirements

The Minimum Requirements given in this specification make no allowance for measurement uncertainty. The test specification in RAN5 will define final test tolerances for FR1 TRP TRS. The test tolerances are used to relax the minimum requirements in this specification to create test requirements.

4.2 Applicability of minimum requirements

4.2.1 General

The minimum requirements apply only to the corresponding primary mechanical mode of UE in the environmental conditions specified in Annex C.4.2.2.

4.2.1 UE mechanical modes

The mechanical modes of a device under test (DUT) are declared by the manufacturer. A DUT shall have at least one mechanical mode. If only one mode is supported, then this is defined as the primary. If multiple modes are supported,

the manufacturer can declare different primary mechanical modes applicable for different user scenarios, e.g., different primary mechanical mode for Browsing mode usage and Talk mode usage for the same UE.

4.3 Applicability rules for testing of FR1 SA and NSA UEs

The applicability and test coverage rules for Non-Standalone (NSA) only capable devices shall include the following:

- For each NR band supported by the device, test the UE in EN-DC mode using any one example configuration containing that NR band or configuration declaration decision tree as per recommended TRP/TRS test procedures in this specification.

The applicability and test coverage rules for Standalone (SA) and NSA (EN-DC) capable devices shall include the following:

- For each NR band in a device, test the UE in Standalone Mode as per the TRP/TRS test procedures in this specification.
- This shall also fulfil coverage for all EN-DC FR1 minimum performance requirements for that NR band and need not be retested in EN-DC mode.

4.4 Applicability rules for testing of power class capability of UEs

The applicability and test coverage rules for PC2 and PC3 UEs shall include the following:

- For UEs that support PC2 in a given band: verify the requirement only with PC2 configuration
- For UEs that only support PC3 in a given band: verify the requirement with PC3 configuration

NOTE 1: The test procedure and requirements in this version of the specification apply only for handheld UEs based on 1 Tx configuration and are not applicable to UEs under TxD and UL MIMO configurations.

5 Frequency bands

5.1 General

The requirements defined in this specification for NR apply to the frequency bands defined in Clause 5.2.

5.2 Operating bands

5.2.1 FR1 Standalone Operating bands

The requirements defined in this specification for FR1 standalone apply to the operating bands defined in Table 5.2.1-1.

Table 5.2.1-1 NR operating bands in FR1 standalone

NR operating band	Uplink (UL) <i>operating band</i> BS receive / UE transmit F _{UL_low} – F _{UL_high}	Downlink (DL) <i>operating band</i> BS transmit / UE receive F _{DL_low} – F _{DL_high}	Duplex Mode
-------------------	---	---	-------------

n1	1920 MHz – 1980 MHz	2110 MHz – 2170 MHz	FDD
n2	1850 MHz – 1910 MHz	1930 MHz – 1990 MHz	FDD
n3	1710 MHz – 1785 MHz	1805 MHz – 1880 MHz	FDD
n5	824 MHz – 849 MHz	869 MHz – 894 MHz	FDD
n7	2500 MHz – 2570 MHz	2620 MHz – 2690 MHz	FDD
n8	880 MHz – 915 MHz	925 MHz – 960 MHz	FDD
n12	699 MHz – 716 MHz	729 MHz – 746 MHz	FDD
n14	788 MHz – 798 MHz	758 MHz – 768 MHz	FDD
n20	832 MHz – 862 MHz	791 MHz – 821 MHz	FDD
n25	1850 MHz – 1915 MHz	1930 MHz – 1995 MHz	FDD
n26	814 MHz – 849 MHz	859 MHz – 894 MHz	FDD
n28	703 MHz – 748 MHz	758 MHz – 803 MHz	FDD
n30	2305 MHz – 2315 MHz	2350 MHz – 2360 MHz	FDD
n34	2010 MHz – 2025 MHz	2010 MHz – 2025 MHz	TDD
n38	2570 MHz – 2620 MHz	2570 MHz – 2620 MHz	TDD
n39	1880 MHz – 1920 MHz	1880 MHz – 1920 MHz	TDD
n40	2300 MHz – 2400 MHz	2300 MHz – 2400 MHz	TDD
n41	2496 MHz – 2690 MHz	2496 MHz – 2690 MHz	TDD
n48	3550 MHz – 3700 MHz	3550 MHz – 3700 MHz	TDD
n50	1432 MHz – 1517 MHz	1432 MHz – 1517 MHz	TDD ¹
n51	1427 MHz – 1432 MHz	1427 MHz – 1432 MHz	TDD
n53	2483.5 MHz – 2495 MHz	2483.5 MHz – 2495 MHz	TDD
n65	1920 MHz – 2010 MHz	2110 MHz – 2200 MHz	FDD ⁴
n66	1710 MHz – 1780 MHz	2110 MHz – 2200 MHz	FDD
n70	1695 MHz – 1710 MHz	1995 MHz – 2020 MHz	FDD
n71	663 MHz – 698 MHz	617 MHz – 652 MHz	FDD
n74	1427 MHz – 1470 MHz	1475 MHz – 1518 MHz	FDD
n75	N/A	1432 MHz – 1517 MHz	SDL
n76	N/A	1427 MHz – 1432 MHz	SDL
n77 ¹²	3300 MHz – 4200 MHz	3300 MHz – 4200 MHz	TDD
n78	3300 MHz – 3800 MHz	3300 MHz – 3800 MHz	TDD
n79	4400 MHz – 5000 MHz	4400 MHz – 5000 MHz	TDD
n80	1710 MHz – 1785 MHz	N/A	SUL
n81	880 MHz – 915 MHz	N/A	SUL
n82	832 MHz – 862 MHz	N/A	SUL
n83	703 MHz – 748 MHz	N/A	SUL
n84	1920 MHz – 1980 MHz	N/A	SUL
n86	1710 MHz – 1780 MHz	N/A	SUL
n95	2010 MHz – 2025 MHz	N/A	SUL

Other operating bands may be considered in future releases.

5.2.2 FR1 EN-DC band combinations

<Editor's note: Example EN-DC combinations can be further added. >

Principle of EN-DC band combinations selection for FR1 TRP TRS OTA testing:

- 1) Focus on the performance of the NR carrier and do not consider multiple permutations between different LTE bands and NR band under test, i.e., for each NR band, only select one EN-DC band combination.
- 2) For UE supporting multiple EN-DC band combinations for the same NR band, consider only those EN-DC configurations which have no MSD impact on either LTE or NR, i.e., the selected EN-DC combination should be no MSD issue identified in TS 38.101-3 Section 7.3B.2.3 (Inter-band EN-DC within FR1).

Table 5.2.2-1 Measurement parameters for example inter-band EN-DC band combinations (two bands)

EN-DC configuration	E-UTRA configurations	NR configurations
DC_3A_n28A	Note1	Note2
DC_2A_n41A	Note1	Note2
DC_1A_n78A	Note1	Note2
DC_1A_n79A	Note1	Note2
Note 1: As per TS 37.544 [8], Clause 5.3 and 5.4 (Measurement frequencies for E-UTRA FDD and TDD). Note 2: As per Table 4.3.3-1 and Table 4.3.3-2 in TR 38.834 [2]. The measurement parameters for NR Low Mid High ranges correspond to E-UTRA Low Mid High ranges respectively.		

With the above basic principle and EN-DC example band combination, the selection logic for testing is defined by the decision tree below.

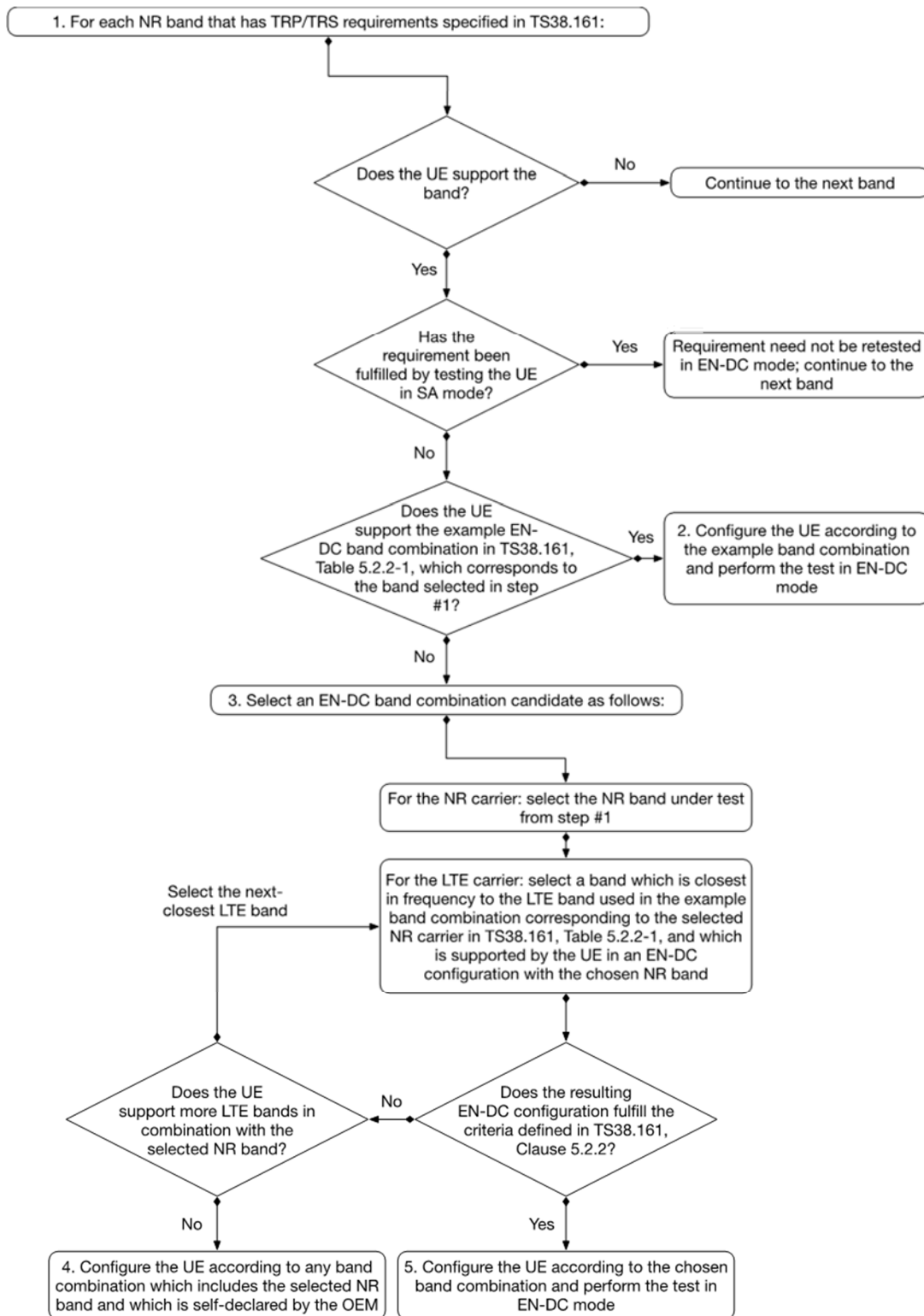

Figure 5.2.2-1: Decision tree to select the EN-DC band combination for TRP/TRS testing

6 FR1 TRP requirements

6.1 General

The TRP requirements specified in Clause 6 apply to handheld UE with TAS off and power back-off functions disabled.

6.2 Minimum requirement

6.2.1 Minimum requirement for handheld UE

The average measured total radiated power (TRP) of low, mid and high channel for handheld UE shall be higher than the average TRP requirement specified in subclauses 6.2.1.1 and 6.2.1.2. The averaging shall be done in linear scale for the TRP results of both right and left side of the phantom head in case of beside the head and hand phantom positions. For the hand phantom browsing mode position the averaging shall be done in linear scale for the TRP results of both right and left hand phantom measurements.

$$TRP_{average} = 10 \log \left[\frac{10^{P_{left,low}/10} + 10^{P_{left,mid}/10} + 10^{P_{left,high}/10} + 10^{P_{right,low}/10} + 10^{P_{right,mid}/10} + 10^{P_{right,high}/10}}{6} \right]$$

For UEs which do not support NR FR1 in stand-alone mode, EN-DC mode requirements apply. SA and EN-DC test case applicability is defined in Clause 4.3, and test case applicability based on power class capability is defined in Clause 4.4. The relevant test methodology is defined in Annexes A and B of this specification.

6.2.1.1 Hand phantom browsing mode

Hand phantom browsing mode positions are defined in Clause B.3.1.

6.2.1.1.1 NR FR1

Handheld UE TRP minimum performance requirement for NR FR1 bands in the hand phantom browsing position and the primary mechanical mode are defined in Tables 6.2.1.1.1-1 and 6.2.1.1.1-2.

Table 6.2.1.1.1-1 Handheld PC3 UE TRP minimum performance requirement for NR FR1 bands in the hand phantom browsing position and the primary mechanical mode

NR Band	Power Class 3	
	Average TRP (dBm)	
	UE width ≤ 72mm	UE width > 72mm
n28		
n41		
n78		
n79		

Table 6.2.1.1-2 Handheld PC2 UE TRP minimum performance requirement for NR FR1 bands in the hand phantom browsing position and the primary mechanical mode

NR Band	Power Class 2	
	Average TRP (dBm)	
	UE width ≤ 72mm	UE width > 72mm
n28		
n41		12.5
n78		13
n79		

6.2.1.1.2 NR FR1 in EN-DC mode

Handheld UE TRP minimum performance requirement for NR FR1 bands (in EN-DC mode) in the hand phantom browsing position and the primary mechanical mode are defined in Tables 6.2.1.1.2-1 and 6.2.1.1.2-2.

Table 6.2.1.1.2-1 Handheld PC3 UE TRP minimum performance requirement for NR FR1 bands (in EN-DC mode) in the hand phantom browsing position and the primary mechanical mode

NR Band	Power Class 3	
	Average TRP (dBm)	
	UE width ≤ 72mm	UE width > 72mm
n28		
n41		
n78		
n79		

Table 6.2.1.1.2-2 Handheld PC2 UE TRP minimum performance requirement for NR FR1 bands (in EN-DC mode) in the hand phantom browsing position and the primary mechanical mode

NR Band	Power Class 2	
	Average TRP (dBm)	
	UE width ≤ 72mm	UE width > 72mm
n28		
n41		
n78		
n79		

6.2.1.2 Beside the head and hand phantom talk mode

Beside the head and hand phantom mode positions are defined in Clause B.3.2 of this specification.

6.2.1.2.1 NR FR1

Handheld UE TRP minimum performance requirement for NR FR1 bands in the beside head and hand phantom talk position and the primary mechanical mode are defined in Tables 6.2.1.2.1-1 and 6.2.1.2.1-2.

Table 6.2.1.2.1-1 Handheld PC3 UE TRP minimum performance requirement for NR FR1 bands in the beside head and hand phantom talk position and the primary mechanical mode

NR Band	Power Class 3	
	Average TRP (dBm)	
	UE width ≤ 72mm	UE width > 72mm
n28		
n41		
n78		
n79		

Table 6.2.1.2.1-2 Handheld PC2 UE TRP minimum performance requirement for NR FR1 bands in the beside head and hand phantom talk position and the primary mechanical mode

NR Band	Power Class 2	
	Average TRP (dBm)	
	UE width ≤ 72mm	UE width > 72mm
n28		
n41		
n78		
n79		

6.2.1.2.2 NR FR1 in EN-DC mode

Handheld UE TRP minimum performance requirement for NR FR1 bands (in EN-DC mode) in the beside head and hand phantom talk position and the primary mechanical mode are defined in Tables 6.2.1.2.2-1 and 6.2.1.2.2-2.

Table 6.2.1.2.2-1 Handheld PC3 UE TRP minimum performance requirement for NR FR1 bands (in EN-DC mode) in the beside head and hand phantom talk position and the primary mechanical mode

NR Band	Power Class 3	
	Average TRP (dBm)	
	UE width ≤ 72mm	UE width > 72mm
n28		
n41		
n78		
n79		

Table 6.2.1.2.2-2 Handheld PC2 UE TRP minimum performance requirement for NR FR1 bands (in EN-DC mode) in the beside head and hand phantom talk position and the primary mechanical mode

NR Band	Power Class 2	
	Average TRP (dBm)	
	UE width ≤ 72mm	UE width > 72mm
n28		
n41		
n78		
n79		

7 FR1 TRS requirements

7.1 General

The TRS requirements specified in Clause 7 apply to handheld UE configured with maximum number of Rx antennas supported for each band, which is specified in TS 38.101-1 Clause 7.3 [3].

7.2 Minimum requirement

7.2.1 Minimum requirement for handheld UE

The average measured total radiated sensitivity (TRS) of low, mid and high channel for handheld UE shall be lower than the average TRS requirement specified in subclauses 7.2.1.1 and 7.2.1.2. The averaging shall be done in linear scale for the TRS results of both right and left side of the phantom head in case of beside the head and hand phantom positions. For the hand phantom browsing mode position the averaging shall be done in linear scale for the TRP results of both right and left hand phantom measurements.

$$TRS_{average} = 10 \log \left[6 / \left(\frac{1}{10^{\frac{P_{left,low}}{10}}} + \frac{1}{10^{\frac{P_{left,mid}}{10}}} + \frac{1}{10^{\frac{P_{left,high}}{10}}} + \frac{1}{10^{\frac{P_{right,low}}{10}}} + \frac{1}{10^{\frac{P_{right,mid}}{10}}} + \frac{1}{10^{\frac{P_{right,high}}{10}}} \right) \right]$$

For UEs which do not support NR FR1 in stand-alone mode, EN-DC mode requirements apply. SA and EN-DC test case applicability is defined in Clause 4.3, and test case applicability based on power class capability is defined in Clause 4.4. The relevant test methodology is defined in Annexes A and B of this specification.

7.2.1.1 Hand phantom browsing mode

Hand phantom browsing mode positions are defined in Clause B.3.1.

7.2.1.1.1 NR FR1

Handheld UE TRS minimum performance requirement for NR FR1 bands in the hand phantom browsing position and the primary mechanical mode are defined in Tables 7.2.1.1.1-1 and 7.2.1.1.1-2.

Table 7.2.1.1.1-1 Handheld PC3 and PC2 UE TRS minimum performance requirement for NR FR1 bands in the hand phantom browsing position and the primary mechanical mode

NR Band	Power Class 3 and Power Class 2	
	Average TRS (dBm)	
	UE width ≤ 72mm	UE width > 72mm
n28		
n41		-80
n78		-81.2
n79		

7.2.1.1.2 NR FR1 in EN-DC mode

Handheld UE TRS minimum performance requirement for NR FR1 bands (in EN-DC mode) in the hand phantom browsing position and the primary mechanical mode are defined in Tables 6.2.1.1.2-1 and 6.2.1.1.2-2.

Table 7.2.1.1.2-1 Handheld PC3 and PC2 UE TRS minimum performance requirement for NR FR1 bands (in EN-DC mode) in the hand phantom browsing position and the primary mechanical mode

NR Band	Power Class 3 and Power Class 2	
	Average TRS (dBm)	
	UE width ≤ 72mm	UE width > 72mm
n28		
n41		
n78		
n79		

7.2.1.2 Beside the head and hand phantom position

Beside the head and hand phantom mode positions are defined in Clause B.3.2.

7.2.1.2.1 NR FR1

Handheld UE TRP minimum performance requirement for NR FR1 bands in the beside head and hand phantom position and the primary mechanical mode are defined in Tables 7.2.1.2.1-1 and 7.2.1.2.1-2.

Table 7.2.1.2.1-1 Handheld PC3 and PC2 UE TRS minimum performance requirement for NR FR1 bands in the beside head and hand phantom position and the primary mechanical mode

NR Band	Power Class 3 and Power Class 2	
	Average TRS (dBm)	
	UE width ≤ 72mm	UE width > 72mm
n28		
n41		
n78		
n79		

7.2.1.2.2 NR FR1 in EN-DC mode

Handheld UE TRS minimum performance requirement for NR FR1 bands (in EN-DC mode) in the beside head and hand phantom position and the primary mechanical mode are defined in Tables 6.2.1.2.2-1 and 6.2.1.2.2-2.

Table 7.2.1.2.2-1 Handheld PC3 and PC2 UE TRS minimum performance requirement for NR FR1 bands (in EN-DC mode) in the beside head and hand phantom position and the primary mechanical mode

NR Band	Power Class 3 and Power Class 2	
	Average TRS (dBm)	
	UE width \leq 72mm	UE width $>$ 72mm
n28		
n41		
n78		
n79		

Annex A (normative): Test methodology

A.1 General

TRP TRS minimum requirement specified in Clause 6 and Clause 7 should be measured with Anechoic Chamber method.

A.2 UE configuration

A.2.1 General

For FR1 TRP and TRS radiated conformance testing, P-MPRc shall be 0 dB.

FR1 TRP and TRS radiated conformance testing shall be performed with the UE consistently operating at maximum power level, e.g., Time-Averaged Algorithm (TAA) and other power back-off functions should be disabled. The above functions OFF should be based on manufacturer declaration, if declared, then the manufacturer is required to provide a mechanism for the test lab to enable/disable the function.

The NR SS should send continuous uplink power control “up” commands to the DUT to ensure the DUT’s transmitter is at maximum output power during the TRP and TRS test.

A.2.2 UE configuration for TRP test

For devices containing multiple Tx antennas, the Tx Antenna Switching (TAS) function should be OFF, and the TRP should be measured for each Tx antenna individually. The antenna with better TRP is identified as the primary antenna, and the corresponding TRP result will be used to determine the pass/fail compliance. Otherwise, the primary antenna should be selected based on manufacturer declaration. To ensure the TAS OFF testing, the manufacture should provide either software/guidance to lab to control which Tx antenna is used, or the pre-configured DUT locked at primary antenna.

For Standalone, the NR System Simulator (SS) and DUT shall be configured per TS 38.521-1 [5], section 6.2.1 (UE maximum output power) using the default settings specified in TS 38.521-1 [5] and TS 38.508-1 [7] as applicable. The measurement should be carried out based on the detailed test parameters for each band, as defined in TR 38.834 Table 4.3.3-1 [2].

For EN-DC, the SS and DUT shall be configured per TS 38.521-3 [6], Section 6.2B.1 (UE Maximum Output Power for EN-DC) using the default settings specified in TS 38.521-3 [6] and TS 38.508 [7] as applicable. The measurement should be carried out based on the detailed test parameters for each band, as defined in TR 38.834 Table 4.3.3-3 [2]. The UL output power of LTE carrier should be set as a constant power of 10dBm, while measuring NR at maximum output power, i.e., with fixed p-MaxEUTRA-r15=10 dBm, and p-NR-FR1 not configured.

A.2.3 UE configuration for TRS test

For TRS measurement, no specific setting is needed for Rx antennas. By default, the maximum number of Rx antennas supported at each band should be enabled during the TRS test.

For Standalone, the NR System Simulator (SS) and DUT shall be configured per section 7.3.2 (Reference sensitivity power level) of TS 38.521-1 [5] using the defaults specified in TS 38.521-1 [5] and TS 38.508-1 [7] as applicable. The measurement should be carried out based on the detailed test parameters for each band, as defined in TR 38.834 Table 4.3.3-2.

For EN-DC, the EN-DC SS and DUT shall be configured per section 7.3B.2 (Reference Sensitivity for EN-DC) of TS 38.521-3 [6], using the defaults specified in TS 38.521-3 [6] and TS 38.508 [7], as applicable. The measurement should be carried out based on the detailed test parameters for each band, as defined in TR 38.834 Table 4.3.3-3 [2]. The UL power configuration for LTE and NR is 50%-50% power splitting, i.e.,

- For PC3, p-MaxEUTRA-r15=20 dBm, and p-NR-FR1= 20dBm;
- For PC2, p-MaxEUTRA-r15=23 dBm, and p-NR-FR1= 23dBm.

A.3 Test system of Anechoic Chamber method

A.3.1 System setup

For FR1 TRP TRS testing, both Single-antenna and multiple-antennas anechoic chambers can be applied. In Figure A.3.1-1, an example TRP TRS test system with combined axes system is presented.

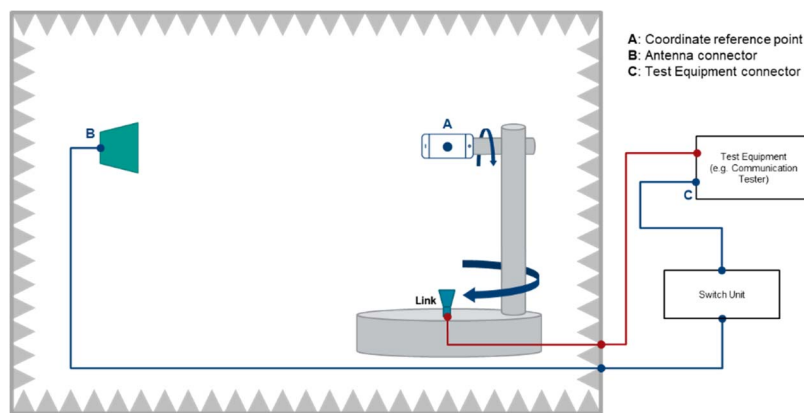

Figure A.3.1-1: Example of a FR1 TRP TRS OTA test system with combined axis

In Figure A.3.1-2, an example TRP TRS test system with distributed axes system is presented.

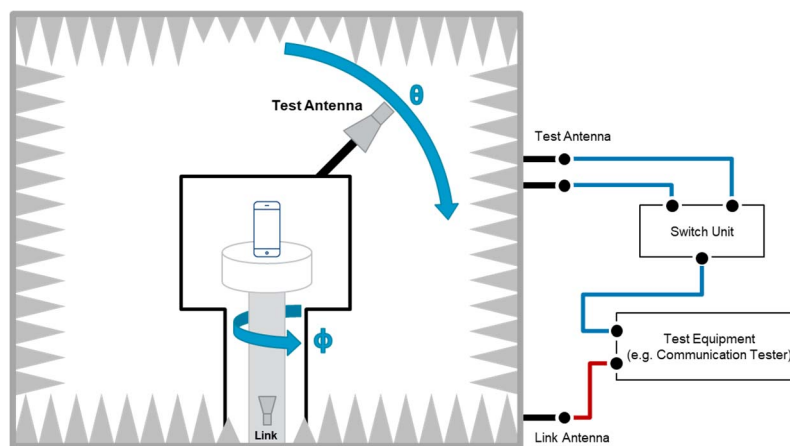

Figure A.3.1-2: Example of a FR1 TRP TRS OTA test system with distributed axis

A.3.2 Calibration procedure

The relative power values of the measurement points will be transformed to absolute radiated power values (in dBm) by performing a range path loss calibration measurement. The system needs to be calibrated by using a reference calibration antenna with known gain values. In the range path loss calibration measurement, the reference antenna is measured in the same place as the DUT, i.e. the center of the QZ, and the attenuation of the complete transmission path (L_{total}) from the DUT to the measurement receiver/BS simulator is calibrated out.

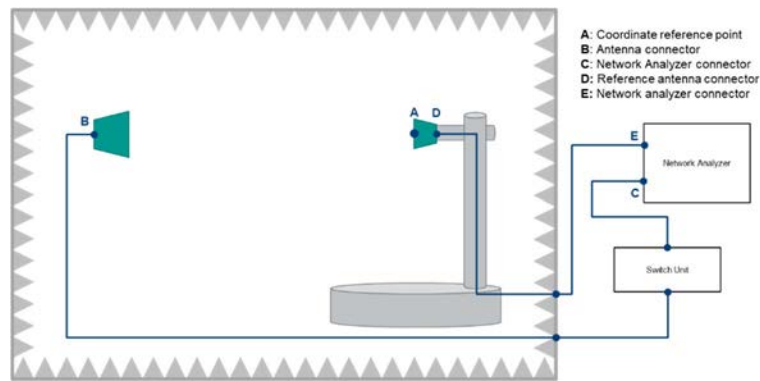

Figure A.3.2-1: Example FR1 TRP TRS calibration setup

The calibration measurement is repeated for each measurement path (two orthogonal polarizations and each signal path). The range path loss calibration measurement is performed in a two-step process including total path loss measurement and cable calibration.

Step 1: Cable calibration: the measurement of path loss L_{DE} , by connecting the cable from D to E to the two ports of VNA, and measure the cable path loss.

Step 2: Total path loss measurement: the measurement of total path loss L_{BC} ;

1. Place the reference calibration antenna (e.g. reference dipole) in the center of the test zone aligned with θ polarization of the measurement antenna, connected to a VNA port E, with the other VNA port C connected to the input of the Switch box – in Figure A.2.2-1.
2. Configure the proper output power of VNA.
3. Measure the response L_{CE} of each path from each θ polarization of the measurement antenna to the reference antenna in the center of QZ.
4. Repeat the steps 1 to 3 with the reference antenna aligned with the ϕ polarization of the measurement antenna.

Then, the $L_{total} = (L_{CE} - L_{DE} + G_{cal})$, Where L_{DE} is cable loss from D to E. G_{cal} is the gain or efficiency of the calibration antenna at the frequency of interest. In TRP and TRS measurements point C is connected to the calibrated input/output port of measurement receiver.

This range path loss calibration procedure is common to both SA and EN-DC measurements.

A.3.3 Test procedure

A.3.3.1 General

For TRP and TRS testing in SA or EN-DC mode, measurements should be only performed at NR carrier. The LTE link antenna in EN-DC mode is used to provide a stable LTE link to the DUT without precise path loss or polarization control.

A.3.3.2 TRP Test procedure

The TRP of the DUT is measured by sampling the radiated transmit power of the DUT with three-dimensional scan at various locations surrounding the device. The measurement is performed with a constant sampling step of 15 degrees in both theta (θ) and phi (ϕ) axes for TRP measurement. This accounts for a total of 266 measurements for each of two orthogonal polarizations since measurements at theta = 0 and 180 degrees only require one measurement each. For some test system can not measure 180° EIRP, then the extrapolation approach can be adopted when generating the 3D antenna pattern. All of the measured power values will be integrated to TRP, as defined in Clause 5.1 in [2].

For TRP measurement, the evaluations shall be performed at maximum transmit power.

The measurement procedure includes the following steps:

- 1) Place the DUT inside the QZ following the positioning guideline defined in Clause 6.
- 2) Connect the SS with the DUT through the link antenna following steps 1 and 2 in section 6.2.1.4.2 of TS 38.521-1 [5] and ensure the DUT transmits with its maximum power.
- 3) Measure the power at each measurement point, and calculate $EIRP(\theta, \phi)$ by adding the composite loss of the entire transmission path.

The TRP value is calculated using the TRP integration approaches outlined in Clause 5.1 in [2].

This TRP test procedure is common to both SA and EN-DC measurements. The detailed UE configurations for TRP test in SA and EN-DC mode are specified in Clause A.2.

A.3.3.3 TRS Test procedure

The TRS of the DUT is measured by sampling effective isotropic sensitivity (EIS) of the DUT with three-dimensional scan at various locations surrounding the device. The measurement is performed with a constant sampling step of 30 degrees in both theta (θ) and phi (ϕ) axes for TRS measurement.

EIS, or receiver sensitivity measurements, is defined as the minimum downlink signal power received at the UE antenna input required to provide a data throughput rate greater than or equal to 95% of the maximum throughput of the reference measurement channel (RMC) (the maximum throughput is per Appendix A of TS 38.521-1 [5]).

For TRS measurement, the evaluations shall be performed at maximum transmit power.

The measurement procedure includes the following steps:

- 1) Place the DUT inside the QZ following the positioning guideline defined in Clause 6.
- 2) Connect the SS with the DUT through the measurement antenna.
- 3) Follow steps 1 through 4 in section 7.3.2.4.2 of TS 38.521-1 [5], with the following exception: determine each EIS, i.e., by adjusting the downlink signal level until the minimum power level at which the throughput exceeds or equal to 95% of the maximum throughput of the specified RMC, at each sampling point. The downlink power step size shall be no more than 0.5 dB when the RF power level is near the NR sensitivity level.

The TRS value is calculated using the equation outlined in Clause 5.2 in [2].

This TRS test procedure is common to both SA and EN-DC measurements. The detailed UE configurations for TRS test in SA and EN-DC mode are specified in Clause A.2.

A.3.4 Minimum Range Length

This sub-section specifies the minimum range lengths for Anechoic-Chamber-based FR1 TRP-TRS OTA systems. The range length is defined as the distance from the centre of the quiet zone to the aperture of the measurement probes/antennas, as illustrated in Figure A.3.4-1.

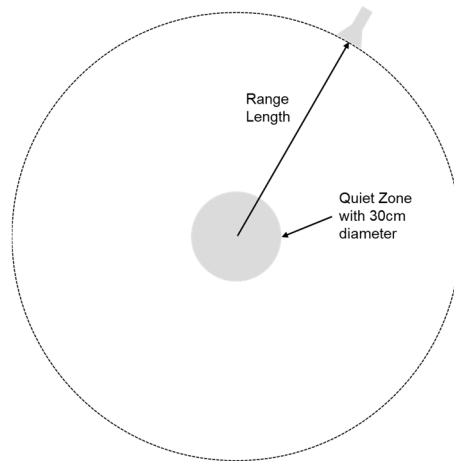

Figure A.3.4-1: Illustration of range length definition

The minimum range length shall be the maximum of the following three limits

- The phase uncertainty limit: $R_{QZ} + 2D_{rad}^2/\lambda$
- The amplitude uncertainty limit: $3D$
- The reactive Near-Field limit: $R_{QZ} + 2\lambda$

where R_{QZ} is defined as the radius of the quiet zone, i.e., $R_{QZ} = D/2$, and D_{rad} is the diameter of the effective radiating aperture. The minimum range length calculations for $D=30\text{cm}$ quiet zone size TRP-TRS OTA test systems shall assume that D_{rad} is 30cm below 1GHz and decrease linearly from 30cm to 5cm from 1GHz to 7.125GHz, respectively. The last column of Table A.3.4-1 shall be considered the minimum range length for NR FR1 TRP-TRS OTA systems with 30cm quiet zone size.

Table A.3.4-1: Minimum Range Length for NR FR1 TRP-TRS OTA systems with 30cm quiet zone size.

F [GHz]	D_{rad} [m]	$R_{QZ} + 2D_{rad}^2/\lambda$	$3D = 6R_{QZ}$	$R_{QZ} + 2\lambda$	$\max(R_{QZ} + 2\lambda, 3D, R_{QZ} + 2D_{rad}^2/\lambda)$
0.41	0.30	0.40	0.9	1.61	1.61
0.6	0.30	0.51	0.9	1.15	1.15
0.7	0.30	0.57	0.9	1.01	1.01
0.8	0.30	0.63	0.9	0.90	0.90
1	0.30	0.75	0.9	0.75	0.90
1.2	0.29	0.83	0.9	0.65	0.90
1.4	0.28	0.90	0.9	0.58	0.90
1.6	0.28	0.96	0.9	0.52	0.96
1.8	0.27	1.01	0.9	0.48	1.01
2	0.26	1.05	0.9	0.45	1.05
2.2	0.25	1.07	0.9	0.42	1.07
2.4	0.24	1.09	0.9	0.40	1.09
2.6	0.23	1.11	0.9	0.38	1.11
2.8	0.23	1.11	0.9	0.36	1.11
3	0.22	1.10	0.9	0.35	1.10
4	0.18	0.99	0.9	0.30	0.99
5	0.14	0.77	0.9	0.27	0.90
6	0.10	0.52	0.9	0.25	0.90
7	0.06	0.29	0.9	0.24	0.90
7.125	0.05	0.27	0.9	0.23	0.90

A.4 Preliminary example MU budget

A.4.1 General

A.4.2 Test system of Anechoic Chamber method

The uncertainty contributions related to TRP are described in Annex B in [2]. A preliminary example uncertainty budget for TRP hand only test case using Anechoic Chamber test system is presented in Table A.4.2-1.

Table A.4.2-1 Preliminary example of uncertainty budget for TRP hand only (browsing mode) measurement for anechoic chamber method for NR FR1 bands

UID	Uncertainty Source	Comment	Uncertainty Value [dB]	Prob Distr	Div	ci	Standard Uncertainty [dB]
Stage 2: DUT measurement							
1	Mismatch of receiver chain	$\Gamma_{\text{power meter}} < 0.05$ $\Gamma_{\text{measurement antenna}} < 0.16$	0.07	U-shaped	1.41	1	0.05
2	Insertion loss of receiver chain	Systematic with Stage 1 (=> cancels)	0	Rectangular	1.73	1	0.00
3	Influence of the measurement antenna cable	Systematic with Stage 1 (=> cancels)	0	Rectangular	1.73	1	0.00
4	Measurement Receiver: uncertainty of the absolute level	Power Meter	0.06	Rectangular	1.73	1	0.03
5	Measurement distance	d=1.6m, $\Delta d=0.05\text{m}$	0.27	Rectangular	1.73	1	0.16
6	Quality of quiet zone	Surface standard deviation of power measurements in ripple test	0.5	Actual	1	1	0.50
7	DUT Tx-power drift	Drift	0.2	Rectangular	1.73	1	0.12
8	Uncertainty related to the use of phantoms	U_e [dB] = 0.20 U_s [dB] = 0.15	0.32	Rectangular	1.73	1	0.18
9	Coarse sampling grid	Negligible 15° sampling grid	0	Actual	1	1	0.00
10	Random Uncertainty	Monoblock, clamshell and PDA design used for testing	0.81	Rectangular	1.73	1	0.47
11	Frequency Response	Average path loss corrected	0	Rectangular	1.73	1	0.00
Stage 1: Calibration measurement, network analyzer method							
12	Uncertainty of network analyzer	Manufacturer's uncertainty	0.5	Rectangular	1.73	1	0.29
13	Mismatch of receiver chain	Taken into account in VNA uncertainty term	0	U-shaped	1.41	1	0.00
14	Insertion loss of receiver chain	Systematic with Stage 2 (=> cancels)	0	Rectangular	1.73	1	0.00
15	Mismatch in the connection of calibration antenna	Taken in to account in VNA setup uncertainty	0	U-shaped	1.41	1	0.00
16	Influence of the calibration antenna feed cable	Gain calibration with a dipole	0.3	Rectangular	1.73	1	0.17
17	Influence of the measurement antenna cable	Systematic with Stage 2 (=> cancels)	0	Rectangular	1.73	1	0.00
18	Uncertainty of the absolute gain/ radiation efficiency of the calibration antenna	Calibration certificate	0.5	Rectangular	1.73	1	0.29

19	Measurement distance	Dipole: aligned with phase center	0	Rectangular	1.73	1	0.00
20	Quality of the Quiet Zone	Peak-to-null ripple	0.5	Rectangular	1.73	1	0.29
Combined standard uncertainty							0.91
Expanded uncertainty (Confidence interval of 95 %)							1.78

The uncertainty contributions related to TRS are described in Annex B in [2]. A preliminary example uncertainty budget TRS hand only test case using Anechoic Chamber test system is presented in Table A.4.2-2.

Table A.4.2-2: Preliminary example of uncertainty budget for TRS hand only (browsing mode) measurement for anechoic chamber method for NR FR1 bands

UID	Uncertainty Source	Comment	Uncertainty Value [dB]	Prob Distr	Div	ci	Standard Uncertainty [dB]
Stage 2: DUT measurement							
1	Mismatch of transmitter chain	$\Gamma_{\text{CommTester}} < 0.13$ $\Gamma_{\text{antenna connection}} < 0.03$	0.07	U-shaped	1.41	1	0.05
2	Insertion loss of transmitter chain	Systematic with Stage 1 (=> cancels)	0	Rectangular	1.73	1	0.00
3	Influence of the measurement antenna cable	Systematic with Stage 1 (=> cancels)	0	Rectangular	1.73	1	0.00
4	Communication Tester: uncertainty of the absolute output level	Manufacturer's data sheet	1	Rectangular	1.73	1	0.58
5	Sensitivity measurement: output level step resolution	Step of 0.5 dB	0.25	Rectangular	1.73	1	0.14
6	Measurement distance	d=1.6m, $\Delta d=0.05\text{m}$	0.27	Rectangular	1.73	1	0.16
7	Quality of quiet zone	Surface standard deviation of power measurements in ripple test	0.5	Actual	1	1	0.5
8	DUT sensitivity drift	Drift measurement	0.2	Rectangular	1.73	1	0.12
9	Uncertainty related to the use of phantoms	U_{ϵ} [dB] = 0.20 U_{σ} [dB] = 0.15	0.32	Rectangular	1.73	1	0.18
10	Coarse sampling grid	30° sampling grid	0.15	Actual	1	1	0.15
11	Random uncertainty	Monoblock, clamshell and PDA used for testing	0.91	Rectangular	1.73	1	0.53
12	Frequency Response	Included in the output level step resolution	0	Rectangular	1.73	1	0.00
Stage 1: Calibration measurement, network analyzer method							
13	Uncertainty of network analyzer	Manufacturer's uncertainty calculator, covers NA setup	0.5	Rectangular	1.73	1	0.29
14	Mismatch of transmitter chain	Taken in to account in VNA setup uncertainty	0	U-shaped	1.41	1	0.00
15	Insertion loss of transmitter chain	Systematic with Stage 2 (=> cancels)	0	Rectangular	1.73	1	0.00
16	Mismatch in the connection of calibration antenna	Taken in to account in VNA setup uncertainty	0	U-shaped	1.41	1	0.00
17	Influence of the calibration antenna feed cable	Gain calibration with dipole	0.3	Rectangular	1.73	1	0.17
18	Influence of the measurement antenna cable	Systematic with Stage 2 (=> cancels)	0	Rectangular	1.73	1	0.00

19	Uncertainty of the absolute gain/ radiation efficiency of the calibration antenna	Calibration certificate	0.5	Rectangular	1.73	1	0.29
20	Measurement distance	Dipole: aligned with phase center	0	Rectangular	1.73	1	0.00
21	Quality of quiet zone	Peak-to-null ripple	0.5	Rectangular	1.73	1	0.29
Combined standard uncertainty							1.12
Expanded uncertainty (Confidence interval of 95 %)							2.20

Annex B (normative): Phantoms definition and Positioning

B.1 General

This Clause defines the phantom definition and positioning guidance for TRP TRS requirement measurement.

B.2 Phantom Definition

B.2.1 Head Phantom

The basic head phantom is based on the “SAM” head phantom in IEEE Std 1528-2003, which is also described in TS 37.544 Annex A.2 [8]. For TRP TRS test, the IEEE SAM head model has been extended to the neck region, which is specified in CTIA Certification OTA Test Plan [9].

The Head phantom defined in CTIA Certification OTA Test Plan section C.2 [9], is used for FR1 TRP TRS requirement testing.

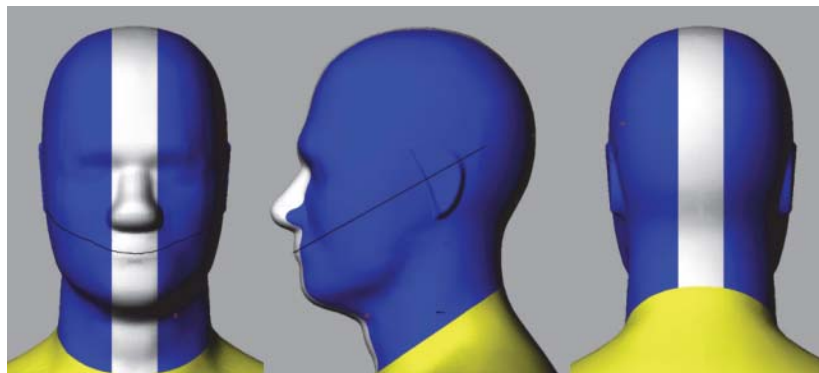

Figure B.2.1-1 Head Phantom (© 2001 – 2022 CTIA Certification. Reproduced with permission.), defined in the CTIA Certification OTA Test Plan

B.2.2 PDA Grip Hand Phantom

The PDA Grip Hand described in TS 37.544 Annex A.2.2 [8], which is identical to that defined in CTIA Certification OTA Test Plan section C.4.8 [9], is adopted for TRP TRS testing for the UE with width $\geq 56\text{mm}$ and $\leq 72\text{mm}$.

B.2.3 Wide Grip Hand Phantom

The Wide Grip hand defined in CTIA Certification OTA Test Plan section C.4.9 [9], is used for FR1 TRP TRS testing for UE with width $> 72\text{mm}$ and $\leq 92\text{mm}$.



Figure B.2.3-1 Wide Grip hand (© 2001 – 2022 CTIA Certification. Reproduced with permission.), defined in the CTIA Certification OTA Test Plan

B.3 UE positioning guidelines

B.3.1 Hand phantom only (Browsing mode)

The positioning specified in this clause is used for the test cases for Browsing Mode with Hand Phantom. The characteristics of the Hand Phantom are specified in Clause B.3.1. Browsing mode is used to simulate user cases where the DUT is held in hand, but not pressed against ear e.g. web browsing and navigation. The DUT should be set as primary mechanical mode for browsing mode scenario, which is declared by manufacturer if the UE support multiple mechanical modes. Then, the DUT shall be mounted in a suitable hand phantom and oriented such that the DUT's main display is tilted 45 degrees from vertical:

- Wide Grip Hand for UE with Width $>72\text{mm}$ and $\leq 92\text{mm}$
- PDA Grip Hand for UE with Width $\geq 56\text{mm}$ and $\leq 72\text{mm}$

Note: the width is the UE width under primary mechanical mode for Browsing mode scenario.

B.3.1.1 Wide Grip Hand

This positioning guideline is suitable for DUTs with width $>72\text{mm}$ and $\leq 92\text{mm}$.

The positioning guideline defined in CTIA Certification OTA Test Plan section A.1.4.4 [9], is used for FR1 TRP TRS testing for UE with width $>72\text{mm}$ and $\leq 92\text{mm}$.

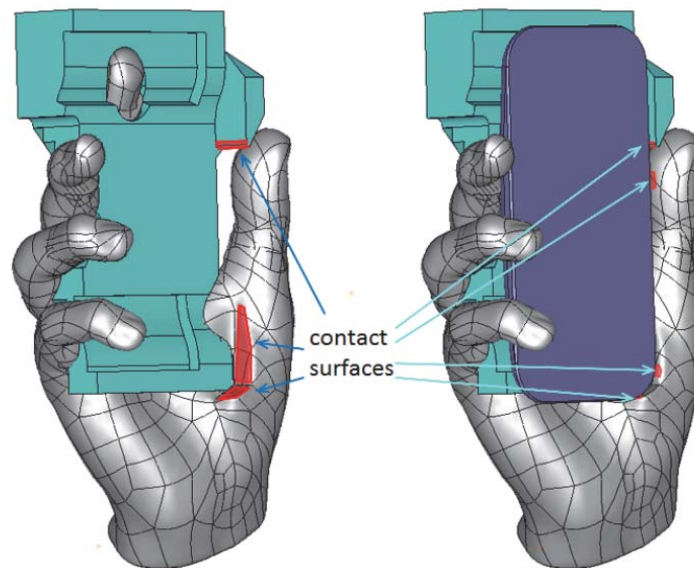

Figure B.3.1.1-1: Positioning guidance for Wide Grip Hand (© 2001 – 2022 CTIA Certification. Reproduced with permission.), defined in the CTIA Certification OTA Test Plan

B.3.1.2 PDA Grip Hand

This positioning guideline is suitable for DUTs with width $\geq 56\text{mm}$ and $\leq 72\text{mm}$.

To help achieve a consistent positioning, the DUT is aligned to a PDA palm spacer. No alignment tool is required. The PDA spacer features side and bottom walls to ensure consistent alignment of DUTs of various sizes.

1. Place the DUT on the PDA spacer between the fingers and align the DUT to the side wall of the PDA.
2. If the DUT is shorter than 135 mm, then align the top of the DUT with the top of the PDA spacer. Otherwise, align the bottom of the DUT with the bottom wall of the PDA spacer.
3. While keeping the DUT in the hand phantom in the position defined in previous steps, place the DUT and the hand phantom against the head phantom in such way that the DUT is in 6° tilt angle as described in Clause B.3.2.1.



Figure 6.2.2-1: Right-handed PDA Grip hand phantom with a spacer

NOTE: Use left-handed (mirror-imaged) spacers with left-handed phantoms.

B.3.2 Head and Hand phantom (Talk Mode)

B.3.2.1 General

The positioning specified in this clause is used for the test cases for Talk Mode using Head & Hand Phantom. The characteristics of the Hand Phantom and Head Phantom are specified in Clause B.3.1.

Talk mode is used to simulate user cases where the DUT is placed into a hand phantom, which is holding the DUT against the SAM head phantom, presenting a realistic voice call operation of the DUT. The DUT should be set as primary mechanical mode for talk mode scenario, which is declared by manufacturer if the UE support multiple mechanical modes. Same as Browsing mode, the DUT for talk mode shall also be mounted in a suitable hand phantom:

- Wide Grip Hand for UE with Width $>72\text{mm}$ and $\leq 92\text{mm}$
- PDA Grip Hand for UE with Width $\geq 56\text{mm}$ and $\leq 72\text{mm}$

Note: the width is the UE width under primary mechanical mode for talk mode scenario.

In this section, the procedure provides the guideline on how to place the DUT+hand against the head phantom. The detailed DUT positioning into hand phantom for talk mode is defined in Clause B.3.1.

For talk mode, the DUT is attached to the head phantom in “cheek” position. The DUT performance is measured on both left and right side of the head. Three points as shown in Figure B.3.2.1-1 define the reference plane: centre of the right ear piece (RE), centre of the left ear piece (LE) and centre of mouth (M).

Definition of the ‘Cheek’ position:

1. Align the ear piece of the phone (see Figure B.3.2.1-1) at the line RE-LE. Then, position the DUT beside the phantom so that the vertical line (see Figure B.3.2.1-3) is parallel to the reference plane in Figure B.3.2.1-2 and is aligned with the line M-RE on the reference plane (see Figure B.3.2.1-3).
2. Position the DUT so that the ear piece of the DUT touches the ear piece of the phantom head on the line RE-LE. Tilt the DUT chassis towards the cheek of the phantom having the vertical line aligned with the reference plane until any point on the front side of the DUT is in contact with the cheek or until the contact with the ear is lost.

NOTE: A holder fixture made of e.g. plastic may be used to position the handset against the phantom.

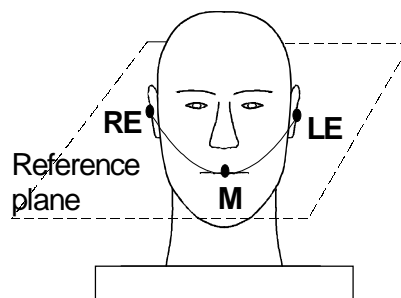

Figure B.3.2.1-1: Reference plane on head phantom, front view

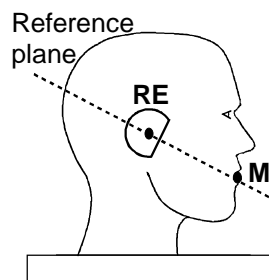

Figure B.3.2.1-2: Reference plane on head phantom, side view

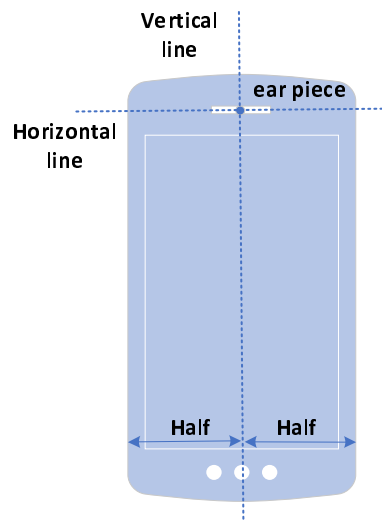

Figure B.3.2.1-3: Reference lines at a mobile handset.

In addition, 6° tilt angle from the cheek is being used instead of having direct contact between the cheek and DUT. A mask may be used to help configuration of cheek + 6° tilt angle. The mask is a 32 mm wide conformal strip, created by sweeping the surface of the head phantom through a 6° rotation about the ear. Direct DUT contact against the mask thus establishes the required 6° spacing away from the cheek, regardless of DUT form factor. The material for the head phantom mask spacer shall have dielectric constant of less than 1.3 and a loss tangent of less than 0.003. Material additions can be used to help fixing of the mask spacer onto the head phantom.

B.3.2.2 Wide Grip Hand and Head

This procedure is suitable for talk mode use with DUTs of width $>72\text{mm}$ and $\leq 92\text{mm}$. The positioning of the DUT in the Wide Grip hand for talk mode is identical to that for browsing mode described in Clause B.3.1.1.

B.3.2.1 PDA Grip Hand and Head

This procedure is suitable for talk mode use with DUTs of width $\geq 56\text{mm}$ and $\leq 72\text{mm}$. The positioning of the DUT in the PDA Grip hand for talk mode is identical to that for browsing mode described in Clause B.3.1.2.

Annex C (normative): Environmental requirements

C.1 General

This normative annex specifies the environmental requirements of the UE. Within these limits the requirements of the present documents shall be fulfilled.

C.2 Environmental

The requirements in this clause apply to all types of UE(s).

C.2.1 Temperature

All the test cases defined in this technical specification should be measured in room temperature e.g. 25°C.

C.2.2 Voltage

All test cases shall be performed with the DUT operated in stand-alone battery powered mode. It is preferable if the UE is fully charged in the beginning of the test.

Annex D (informative): Change history

Change history							
Date	Meeting	TDoc	CR	Rev	Cat	Subject/Comment	New version
2021-11	RAN4#101-e	R4-2120687				Initial Skeleton	0.0.1
2022-01	RAN4#101-bis-e	R4-2200971				R4-2200974 TP to TS 38.161 on requirement applicability	0.1.0
2022-03	RAN4#102-e	R4-2204952				R4-2205174 TP to 38.161 on general aspects R4-2207315 Text proposal on environmental requirements for 38.161 R4-2207323 TP to 38.161 on TRP aspects R4-2207316 TP to TS 38.161 on frequency bands R4-2207322 TP to TS 38.161 on Annex A: Test methodology	0.2.0
2022-05	RAN4#103-e	R4-2208626				R4-2208481 TP to TS 38.161 on primary mechanical mode R4-2210939 TP to 38.161 on EN-DC and PC2 test case applicability rules R4-2210940 TP to 38.161 on TRP aspects R4-2210942 TP to TS 38.161 on test method R4-2210944 TP to TS 38.161 on Phantoms	0.3.0
2022-08	RAN4#104-e	R4-2212810				R4-2214795 TP to TS 38.161 on general aspects R4-2214796 TP to TS 38.161 on TRP TRS requirements	0.4.0
2022-09	RAN#97-e	RP-222321				For one-step approval in RAN Plenary	1.0.0
2022-09	RAN#97-e	RP-222608				Editorial update from Rapporteur	1.1.0
2022-09	RAN#97-e					Under change control	17.0.0

History

Document history		
V17.0.0	October 2022	Publication