

# ETSI TS 138 141-1 V15.1.0 (2019-04)



**5G;  
NR;  
Base Station (BS) conformance testing  
Part 1: Conducted conformance testing  
(3GPP TS 38.141-1 version 15.1.0 Release 15)**



---

Reference

RTS/TSGR-0438141-1v10

---

Keywords

---

5G

**ETSI**

650 Route des Lucioles  
F-06921 Sophia Antipolis Cedex - FRANCE

---

Tel.: +33 4 92 94 42 00 Fax: +33 4 93 65 47 16

Siret N° 348 623 562 00017 - NAF 742 C  
Association à but non lucratif enregistrée à la  
Sous-Préfecture de Grasse (06) N° 7803/88

---

**Important notice**

---

The present document can be downloaded from:

<http://www.etsi.org/standards-search>

The present document may be made available in electronic versions and/or in print. The content of any electronic and/or print versions of the present document shall not be modified without the prior written authorization of ETSI. In case of any existing or perceived difference in contents between such versions and/or in print, the prevailing version of an ETSI deliverable is the one made publicly available in PDF format at [www.etsi.org/deliver](http://www.etsi.org/deliver).

Users of the present document should be aware that the document may be subject to revision or change of status.

Information on the current status of this and other ETSI documents is available at

<https://portal.etsi.org/TB/ETSIDeliverableStatus.aspx>

If you find errors in the present document, please send your comment to one of the following services:

<https://portal.etsi.org/People/CommiteeSupportStaff.aspx>

---

**Copyright Notification**

---

No part may be reproduced or utilized in any form or by any means, electronic or mechanical, including photocopying and microfilm except as authorized by written permission of ETSI.

The content of the PDF version shall not be modified without the written authorization of ETSI.

The copyright and the foregoing restriction extend to reproduction in all media.

© ETSI 2019.

All rights reserved.

**DECT™**, **PLUGTESTS™**, **UMTS™** and the ETSI logo are trademarks of ETSI registered for the benefit of its Members.

**3GPP™** and **LTE™** are trademarks of ETSI registered for the benefit of its Members and of the 3GPP Organizational Partners.

**oneM2M™** logo is a trademark of ETSI registered for the benefit of its Members and of the oneM2M Partners.

**GSM®** and the GSM logo are trademarks registered and owned by the GSM Association.

---

# Intellectual Property Rights

## Essential patents

IPRs essential or potentially essential to normative deliverables may have been declared to ETSI. The information pertaining to these essential IPRs, if any, is publicly available for **ETSI members and non-members**, and can be found in ETSI SR 000 314: *"Intellectual Property Rights (IPRs); Essential, or potentially Essential, IPRs notified to ETSI in respect of ETSI standards"*, which is available from the ETSI Secretariat. Latest updates are available on the ETSI Web server (<https://ipr.etsi.org/>).

Pursuant to the ETSI IPR Policy, no investigation, including IPR searches, has been carried out by ETSI. No guarantee can be given as to the existence of other IPRs not referenced in ETSI SR 000 314 (or the updates on the ETSI Web server) which are, or may be, or may become, essential to the present document.

## Trademarks

The present document may include trademarks and/or tradenames which are asserted and/or registered by their owners. ETSI claims no ownership of these except for any which are indicated as being the property of ETSI, and conveys no right to use or reproduce any trademark and/or tradename. Mention of those trademarks in the present document does not constitute an endorsement by ETSI of products, services or organizations associated with those trademarks.

---

# Foreword

This Technical Specification (TS) has been produced by ETSI 3rd Generation Partnership Project (3GPP).

The present document may refer to technical specifications or reports using their 3GPP identities, UMTS identities or GSM identities. These should be interpreted as being references to the corresponding ETSI deliverables.

The cross reference between GSM, UMTS, 3GPP and ETSI identities can be found under <http://webapp.etsi.org/key/queryform.asp>.

---

# Modal verbs terminology

In the present document "**shall**", "**shall not**", "**should**", "**should not**", "**may**", "**need not**", "**will**", "**will not**", "**can**" and "**cannot**" are to be interpreted as described in clause 3.2 of the [ETSI Drafting Rules](#) (Verbal forms for the expression of provisions).

"**must**" and "**must not**" are **NOT** allowed in ETSI deliverables except when used in direct citation.

# Contents

Intellectual Property Rights .....	2
Foreword.....	2
Modal verbs terminology.....	2
Foreword.....	12
1 Scope .....	13
2 References .....	13
3 Definitions, symbols and abbreviations .....	15
3.1 Definitions .....	15
3.2 Symbols.....	17
3.3 Abbreviations .....	18
4 General conducted test conditions and declarations.....	20
4.1 Measurement uncertainties and test requirements .....	20
4.1.1 General.....	20
4.1.2 Acceptable uncertainty of Test System.....	20
4.1.2.1 General .....	20
4.1.2.2 Measurement of transmitter .....	21
4.1.2.3 Measurement of receiver .....	22
4.1.2.4 Measurement of performance requirements.....	25
4.1.3 Interpretation of measurement results .....	25
4.2 Conducted requirement reference points .....	25
4.2.1 <i>BS type I-C</i> .....	25
4.2.2 <i>BS type I-H</i> .....	26
4.3 Base station classes .....	27
4.4 Regional requirements.....	27
4.5 BS configurations .....	28
4.5.1 <i>BS type I-C</i> .....	28
4.5.1.1 Transmit configurations .....	28
4.5.1.1.1 General .....	28
4.5.1.1.2 Transmission with multiple transmitter antenna connectors.....	28
4.5.1.2 Receive configurations.....	28
4.5.1.2.1 General .....	28
4.5.1.2.2 Reception with multiple receiver antenna connectors, receiver diversity.....	29
4.5.1.3 Duplexers .....	29
4.5.1.4 Power supply options .....	29
4.5.1.5 Ancillary RF amplifiers.....	29
4.5.2 <i>BS type I-H</i> .....	30
4.5.2.1 Transmit configurations .....	30
4.5.2.2 Receive configurations.....	31
4.5.2.3 Power supply options .....	31
4.5.3 BS with integrated Iuant BS modem .....	31
4.6 Manufacturer declarations .....	31
4.7 Test configurations .....	36
4.7.1 General.....	36
4.7.2 Test signal used to build Test Configurations.....	36
4.7.3 NRTC1: Contiguous spectrum operation.....	36
4.7.3.1 NRTC1 generation .....	36
4.7.3.2 NRTC1 power allocation .....	36
4.7.4 NRTC2: Contiguous CA occupied bandwidth.....	36
4.7.4.1 NRTC2 generation .....	37
4.7.4.2 NRTC2 power allocation .....	37
4.7.5 NRTC3: Non-contiguous spectrum operation .....	37
4.7.5.1 NRTC3 generation .....	37
4.7.5.2 NRTC3 power allocation .....	38
4.7.6 NRTC4: Multi-band test configuration for full carrier allocation.....	38

4.7.6.1	NRTC4 generation .....	38
4.7.6.2	NRTC4 power allocation .....	38
4.7.7	NRTC5: Multi-band test configuration with high PSD per carrier .....	38
4.7.7.1	NRTC5 generation .....	38
4.7.7.2	NRTC5 power allocation .....	39
4.8	Applicability of requirements.....	39
4.8.1	General.....	39
4.8.2	Requirement set applicability .....	39
4.8.3	Applicability of test configurations for single-band operation .....	40
4.8.4	Applicability of test configurations for multi-band operation .....	41
4.9	RF channels and test models .....	42
4.9.1	RF channels .....	42
4.9.2	Test models .....	43
4.9.2.1	General .....	43
4.9.2.2	NR FR1 test models .....	43
4.9.2.2.1	NR FR1 test model 1.1 (NR-FR1-TM1.1).....	44
4.9.2.2.2	NR FR1 test model 1.2 (NR-FR1-TM1.2).....	45
4.9.2.2.3	NR FR1 test model 2 (NR-FR1-TM2).....	45
4.9.2.2.4	NR FR1 test model 2a (NR-FR1-TM2a).....	46
4.9.2.2.5	NR FR1 test model 3.1 (NR-FR1-TM3.1).....	46
4.9.2.2.6	NR FR1 test model 3.1a (NR-FR1-TM3.1a) .....	46
4.9.2.2.7	NR FR1 test model 3.2 (NR-FR1-TM3.2).....	47
4.9.2.2.8	NR FR1 test model 3.3 (NR-FR1-TM3.3).....	47
4.9.2.3	Data content of Physical channels and Signals for NR-FR1-TM.....	48
4.9.2.3.1	PDCCH.....	48
4.9.2.3.2	PDSCH .....	48
4.10	Requirements for contiguous and non-contiguous spectrum.....	49
4.11	Requirements for BS capable of multi-band operation .....	49
4.12	Format and interpretation of tests.....	50
5	Operating bands and channel arrangement.....	52
6	Conducted transmitter characteristics .....	53
6.1	General .....	53
6.1.1	BS type 1-C.....	53
6.1.2	BS type 1-H .....	53
6.2	Base station output power .....	53
6.2.1	Definition and applicability .....	53
6.2.2	Minimum requirement .....	54
6.2.3	Test purpose.....	54
6.2.4	Method of test.....	54
6.2.4.1	Initial conditions .....	54
6.2.4.2	Procedure .....	54
6.2.5	Test requirement .....	55
6.3	Output power dynamics.....	55
6.3.1	General.....	55
6.3.2	RE power control dynamic range .....	55
6.3.2.1	Definition and applicability.....	55
6.3.2.2	Minimum requirement .....	55
6.3.2.3	Test purpose .....	55
6.3.3	Total power dynamic range .....	55
6.3.3.1	Definition and applicability.....	55
6.3.3.2	Minimum requirement .....	56
6.3.3.3	Test purpose .....	56
6.3.3.4	Method of test .....	56
6.3.3.4.1	Initial conditions.....	56
6.3.3.4.2	Procedure.....	56
6.3.3.5	Test requirements .....	56
6.4	Transmit ON/OFF power .....	57
6.4.1	Transmitter OFF power .....	57
6.4.1.1	Definition and applicability.....	57
6.4.1.2	Minimum requirement .....	57

6.4.1.3	Test purpose .....	57
6.4.1.4	Method of test .....	57
6.4.1.5	Test requirements .....	57
6.4.2	Transmitter transient period .....	58
6.4.2.1	Definition and applicability .....	58
6.4.2.2	Minimum requirement .....	58
6.4.2.3	Test purpose .....	58
6.4.2.4	Method of test .....	58
6.4.2.4.1	Initial conditions .....	58
6.4.2.4.2	Procedure .....	59
6.4.2.5	Test requirements .....	59
6.5	Transmitted signal quality .....	59
6.5.1	General .....	59
6.5.2	Frequency error .....	59
6.5.2.1	Definition and applicability .....	59
6.5.2.2	Minimum Requirement .....	60
6.5.2.3	Test purpose .....	60
6.5.2.4	Method of test .....	60
6.5.2.5	Test Requirements .....	60
6.5.3	Modulation quality .....	60
6.5.3.1	Definition and applicability .....	60
6.5.3.2	Minimum Requirement .....	60
6.5.3.3	Test purpose .....	60
6.5.3.4	Method of test .....	60
6.5.3.4.1	Initial conditions .....	60
6.5.3.4.2	Procedure .....	61
6.5.3.5	Test requirements .....	61
6.5.4	Time alignment error .....	63
6.5.4.1	Definition and applicability .....	63
6.5.4.2	Minimum requirement .....	63
6.5.4.3	Test purpose .....	63
6.5.4.4	Method of test .....	63
6.5.4.4.1	Initial conditions .....	63
6.5.4.4.2	Procedure .....	63
6.5.4.5	Test requirement .....	64
6.6	Unwanted emissions .....	64
6.6.1	General .....	64
6.6.2	Occupied bandwidth .....	65
6.6.2.1	Definition and applicability .....	65
6.6.2.2	Minimum Requirements .....	65
6.6.2.3	Test purpose .....	65
6.6.2.4	Method of test .....	65
6.6.2.4.1	Initial conditions .....	65
6.6.2.4.2	Procedure .....	66
6.6.2.5	Test requirements .....	66
6.6.3	Adjacent Channel Leakage Power Ratio (ACLR) .....	67
6.6.3.1	Definition and applicability .....	67
6.6.3.2	Minimum requirement .....	67
6.6.3.3	Test purpose .....	67
6.6.3.4	Method of test .....	67
6.6.3.4.1	Initial conditions .....	67
6.6.3.4.2	Procedure .....	67
6.6.3.5	Test requirements .....	68
6.6.3.5.1	General requirements .....	68
6.6.3.5.2	Limits and <i>basic limits</i> .....	68
6.6.3.5.3	<i>BS type 1-C</i> .....	71
6.6.3.5.4	<i>BS type 1-H</i> .....	72
6.6.4	Operating band unwanted emissions .....	72
6.6.4.1	Definition and applicability .....	72
6.6.4.2	Minimum requirement .....	73
6.6.4.3	Test purpose .....	74
6.6.4.4	Method of test .....	74

6.6.4.4.1	Initial conditions .....	74
6.6.4.4.2	Procedure .....	74
6.6.4.5	Test requirements .....	75
6.6.4.5.1	General requirements .....	75
6.6.4.5.2	Basic limits for Wide Area BS (Category A) .....	75
6.6.4.5.3	Basic limits for Wide Area BS (Category B) .....	76
6.6.4.5.3.1	Category B requirements (Option 1) .....	76
6.6.4.5.3.2	Category B requirements (Option 2) .....	77
6.6.4.5.4	Basic limits for Medium Range BS (Category A and B) .....	78
6.6.4.5.5	Basic limits for Local Area BS (Category A and B) .....	80
6.6.4.5.6	Basic limits for additional requirements .....	81
6.6.4.5.6.1	Limits in FCC Title 47 .....	81
6.6.4.5.6.2	Protection of DTT .....	81
6.6.4.5.6.3	Additional operating band unwanted emissions limits for Band n48 .....	81
6.6.4.5.7	<i>BS type 1-C</i> .....	82
6.6.4.5.8	<i>BS type 1-H</i> .....	82
6.6.5	Transmitter spurious emissions .....	82
6.6.5.1	Definition and applicability .....	82
6.6.5.2	Minimum requirement .....	82
6.6.5.3	Test purpose .....	82
6.6.5.4	Method of test .....	83
6.6.5.4.1	Initial conditions .....	83
6.6.5.4.2	Procedure .....	83
6.6.5.5	Test requirements .....	84
6.6.5.5.1	Basic limits .....	84
6.6.5.5.1.1	Tx spurious emissions .....	84
6.6.5.5.1.2	Protection of the BS receiver of own or different BS .....	84
6.6.5.5.1.3	Additional spurious emissions requirements .....	85
6.6.5.5.1.4	Co-location with other base stations .....	92
6.6.5.5.3	<i>BS type 1-C</i> .....	97
6.6.5.5.4	<i>BS type 1-H</i> .....	97
6.7	Transmitter intermodulation .....	97
6.7.1	Definition and applicability .....	97
6.7.2	Minimum requirement .....	98
6.7.3	Test purpose .....	98
6.7.4	Method of test .....	98
6.7.4.1	Initial conditions .....	98
6.7.4.2	Procedure .....	98
6.7.5	Test requirements .....	99
6.7.5.1	<i>BS type 1-C</i> .....	99
6.7.5.1.1	Co-location minimum requirements .....	99
6.7.5.1.2	Additional requirements .....	100
6.7.5.2	<i>BS type 1-H</i> .....	100
6.7.5.2.1	Co-location minimum requirements .....	100
6.7.5.2.2	Intra-system minimum requirements .....	100
6.7.5.2.3	Additional requirements .....	101
7	Conducted receiver characteristics .....	102
7.1	General .....	102
7.2	Reference sensitivity level .....	102
7.2.1	Definition and applicability .....	102
7.2.2	Minimum requirement .....	102
7.2.3	Test purpose .....	102
7.2.4	Method of test .....	102
7.2.4.1	Initial conditions .....	102
7.2.4.2	Procedure .....	103
7.2.5	Test requirements .....	103
7.3	Dynamic range .....	104
7.3.1	Definition and applicability .....	104
7.3.2	Minimum requirement .....	104
7.3.3	Test purpose .....	105
7.3.4	Method of test .....	105

7.3.4.1	Initial conditions .....	105
7.3.4.2	Procedure .....	105
7.3.5	Test requirements.....	105
7.4	In-band selectivity and blocking .....	108
7.4.1	Adjacent Channel Selectivity (ACS) .....	108
7.4.1.1	Definition and applicability.....	108
7.4.1.2	Minimum requirement .....	108
7.4.1.3	Test purpose .....	109
7.4.1.4	Method of test .....	109
7.4.1.4.1	Initial conditions.....	109
7.4.1.4.2	Procedure.....	109
7.4.1.5	Test requirements.....	109
7.4.2	In-band blocking .....	110
7.4.2.1	Definition and applicability.....	110
7.4.2.2	Minimum requirement .....	110
7.4.2.3	Test purpose .....	111
7.4.2.4	Method of test .....	111
7.4.2.4.1	Initial conditions.....	111
7.4.2.4.2	Procedure for general blocking.....	111
7.4.2.4.3	Procedure for narrowband blocking .....	111
7.4.2.5	Test requirements.....	112
7.5	Out-of-band blocking .....	114
7.5.1	Definition and applicability .....	114
7.5.2	Minimum requirement .....	114
7.5.3	Test purpose.....	114
7.5.4	Method of test .....	115
7.5.4.1	Initial conditions .....	115
7.5.4.2	Procedure .....	115
7.5.5	Test requirements.....	115
7.5.5.1	General requirements .....	115
7.5.5.2	Co-location requirements .....	116
7.6	Receiver spurious emissions.....	116
7.6.1	Definition and applicability .....	116
7.6.2	Minimum requirement .....	117
7.6.3	Test purpose.....	117
7.6.4	Method of test .....	117
7.6.4.1	Initial conditions .....	117
7.6.4.2	Procedure .....	117
7.6.5	Test requirements.....	118
7.6.5.1	Basic limits.....	118
7.6.5.2	BS type 1-C.....	118
7.6.5.3	BS type 1-H.....	118
7.7	Receiver intermodulation .....	119
7.7.1	Definition and applicability .....	119
7.7.2	Minimum requirement .....	119
7.7.3	Test purpose.....	119
7.7.4	Method of test .....	119
7.7.4.1	Initial conditions .....	119
7.7.4.2	Procedure .....	119
7.7.5	Test requirements.....	120
7.8	In-channel selectivity .....	123
7.8.1	Definition and applicability .....	123
7.8.2	Minimum requirement .....	123
7.8.3	Test purpose.....	123
7.8.4	Method of test .....	123
7.8.4.1	Initial conditions .....	123
7.8.4.2	Procedure .....	123
7.8.5	Test requirements.....	123
8	Conducted performance characteristics.....	127
8.1	General .....	127
8.1.1	Scope and definitions.....	127



8.1.2	Applicability rule .....	127
8.1.2.1	Applicability of PUSCH performance requirements .....	127
8.1.2.1.1	Applicability of requirements for different subcarrier spacings .....	127
8.1.2.1.2	Applicability of requirements for different channel bandwidths .....	127
8.1.2.2	Applicability of PUCCH performance requirements .....	127
8.1.2.2.1	Applicability of requirements for different formats .....	127
8.1.2.2.2	Applicability of requirements for different subcarrier spacings .....	128
8.1.2.2.3	Applicability of requirements for different channel bandwidths .....	128
8.1.2.3	Applicability of PRACH performance requirements .....	128
8.1.2.3.1	Applicability of requirements for different formats .....	128
8.1.2.3.2	Applicability of requirements for different subcarrier spacings .....	128
8.1.2.3.3	Applicability of requirements for different channel bandwidths .....	128
8.2	Performance requirements for PUSCH .....	128
8.2.1	Performance requirements for PUSCH with transform precoding disabled .....	128
8.2.1.1	Definition and applicability .....	128
8.2.1.2	Minimum Requirement .....	128
8.2.1.3	Test Purpose .....	128
8.2.1.4	Method of test .....	128
8.2.1.4.1	Initial Conditions .....	128
8.2.1.4.2	Procedure .....	129
8.2.1.5	Test Requirement .....	129
8.2.2	Performance requirements for PUSCH with transform precoding enabled .....	136
8.2.2.1	Definition and applicability .....	136
8.2.2.2	Minimum Requirement .....	136
8.2.2.3	Test Purpose .....	136
8.2.2.4	Method of test .....	137
8.2.2.4.1	Initial Conditions .....	137
8.2.2.4.2	Procedure .....	137
8.2.2.5	Test Requirement .....	138
8.3	Performance requirements for PUCCH .....	138
8.3.1	Performance requirements for PUCCH format 0 .....	138
8.3.1.1	Definition and applicability .....	138
8.3.1.2	Minimum Requirement .....	138
8.3.1.3	Test purpose .....	138
8.3.1.4	Method of test .....	139
8.3.1.4.1	Initial conditions .....	139
8.3.1.4.2	Procedure .....	139
8.3.1.5	Test Requirement .....	139
8.3.2	Performance requirements for PUCCH format 1 .....	140
8.3.2.1	NACK to ACK detection .....	140
8.3.2.1.1	Definition and applicability .....	140
8.3.2.1.2	Minimum Requirement .....	140
8.3.2.1.3	Test purpose .....	140
8.3.2.1.4	Method of test .....	140
8.3.2.1.4.1	Initial Conditions .....	140
8.3.2.1.4.2	Procedure .....	141
8.3.2.1.5	Test Requirement .....	141
8.3.2.2	ACK missed detection .....	142
8.3.2.2.1	Definition and applicability .....	142
8.3.2.2.2	Minimum Requirement .....	142
8.3.2.2.3	Test purpose .....	142
8.3.2.2.4	Method of test .....	142
8.3.2.2.4.1	Initial Conditions .....	142
8.3.2.2.4.2	Procedure .....	143
8.3.2.2.5	Test Requirement .....	143
8.3.3	Performance requirements for PUCCH format 2 .....	144
8.3.3.1	ACK missed detection .....	144
8.3.3.1.1	Definition and applicability .....	144
8.3.3.1.2	Minimum requirements .....	144
8.3.3.1.3	Test purpose .....	144
8.3.3.1.4	Method of test .....	145
8.3.3.1.4.1	Initial Condition .....	145

8.3.3.1.4.2	Procedure .....	145
8.3.3.1.5	Test requirements .....	145
8.3.3.2	UCI BLER performance requirements .....	146
8.3.3.2.1	Definition and applicability .....	146
8.3.3.2.2	Minimum Requirement .....	146
8.3.3.2.3	Test purpose .....	146
8.3.3.2.4	Method of test .....	146
8.3.3.2.4.1	Initial Condition .....	146
8.3.3.2.4.2	Procedure .....	146
8.3.3.2.5	Test requirements .....	147
8.3.4	Performance requirements for PUCCH format 3 .....	148
8.3.4.1	Definition and applicability .....	148
8.3.4.2	Minimum requirement .....	148
8.3.4.3	Test purpose .....	148
8.3.4.4	Method of test .....	148
8.3.4.4.1	Initial conditions .....	148
8.3.4.4.2	Procedure .....	148
8.3.4.5	Test requirement .....	149
8.3.5	Performance requirements for PUCCH format 4 .....	150
8.3.5.1	Definition and applicability .....	150
8.3.5.2	Minimum requirement .....	150
8.3.5.3	Test purpose .....	150
8.3.5.4	Method of test .....	150
8.3.5.4.1	Initial conditions .....	150
8.3.5.4.2	Procedure .....	151
8.3.5.5	Test requirement .....	151
8.4	Performance requirements for PRACH .....	152
8.4.1	PRACH false alarm probability and missed detection .....	152
8.4.1.1	Definition and applicability .....	152
8.4.1.2	Minimum requirement .....	153
8.4.1.3	Test purpose .....	153
8.4.1.4	Method of test .....	153
8.4.1.4.1	Initial conditions .....	153
8.4.1.4.2	Procedure .....	153
8.4.1.5	Test requirement .....	154
<b>Annex A (normative): Reference measurement channels .....</b>		<b>156</b>
A.1	Fixed Reference Channels for receiver sensitivity and in-channel selectivity (QPSK, R=1/3) .....	156
A.2	Fixed Reference Channels for dynamic range (16QAM, R=2/3) .....	156
A.3	Fixed Reference Channels for performance requirements (QPSK, R=193/1024) .....	157
A.4	Fixed Reference Channels for performance requirements (16QAM, R=658/1024) .....	160
A.5	Fixed Reference Channels for performance requirements (64QAM, R=567/1024) .....	162
A.6	PRACH test preambles .....	163
<b>Annex B (normative): Environmental requirements for the BS equipment .....</b>		<b>164</b>
B.1	General .....	164
B.2	Normal test environment .....	164
B.3	Extreme test environment .....	164
B.3.1	Extreme temperature .....	164
B.4	Vibration .....	165
B.5	Power supply .....	165
B.6	Measurement of test environments .....	165
<b>Annex C (informative): Test tolerances and derivation of test requirements .....</b>		<b>166</b>

C.1	Measurement of transmitter.....	166
C.2	Measurement of receiver.....	168
C.3	Measurement of performance requirements.....	168
<b>Annex D (informative): Measurement system set-up.....</b>		<b>169</b>
D.1	<i>BS type 1-C</i> transmitter.....	169
D.1.1	Base station output power, output power dynamics, transmitter ON/OFF power, frequency error, EVM, unwanted emissions for BS type 1-C.....	169
D.1.2	Transmitter intermodulation for BS type 1-C.....	169
D.1.3	Time alignment error for BS type 1-C.....	170
D.2	<i>BS type 1-C</i> receiver.....	170
D.2.1	Reference sensitivity level for BS type 1-C.....	170
D.2.2	Dynamic range for BS type 1-C.....	171
D.2.3	In-channel selectivity for BS type 1-C.....	171
D.2.4	Adjacent Channel Selectivity (ACS) and narrowband blocking for BS type 1-C.....	172
D.2.5	Blocking characteristics for BS type 1-C.....	172
D.2.6	Receiver spurious emission for BS type 1-C.....	172
D.2.7	Intermodulation characteristics for BS type 1-C.....	173
D.3	<i>BS type 1-H</i> transmitter.....	173
D.3.1	Base station output power, output power dynamics, transmitter ON/OFF power, frequency error, EVM, unwanted emissions for BS type 1-H.....	173
D.3.2	Transmitter intermodulation for BS type 1-H.....	174
D.3.3	Transmitter spurious emissions for BS type 1-H.....	174
D.4	<i>BS type 1-H</i> receiver.....	176
D.4.1	Reference sensitivity level for BS type 1-H.....	176
D.4.2	Receiver dynamic range for BS type 1-H.....	176
D.4.3	Receiver adjacent channel selectivity and narrowband blocking for BS type 1-H.....	177
D.4.4	Receiver spurious emissions.....	177
D.4.5	Receiver In-channel selectivity for BS type 1-H.....	178
D.4.6	Receiver intermodulation for BS type 1-H.....	179
D.5	<i>BS type 1-C</i> performance requirements.....	179
D.5.1	Performance requirements for PUSCH, single user PUCCH, PRACH on single antenna port in multipath fading conditions.....	179
D.5.2	Performance requirements for PUSCH transmission on two antenna ports in multipath fading conditions..	180
D.5.3	Performance requirements for PRACH in static conditions.....	180
D.6	<i>BS type 1-H</i> performance requirements.....	181
D.6.1	Performance requirements for PUSCH, single user PUCCH, PRACH on single antenna port in multipath fading conditions.....	181
D.6.2	Performance requirements for PUSCH transmission on two antenna ports in multipath fading conditions..	181
D.6.3	Performance requirements for PRACH in static conditions.....	182
<b>Annex E (normative): Characteristics of interfering signals.....</b>		<b>183</b>
<b>Annex F (normative): In-channel Tx tests.....</b>		<b>184</b>
F.1	General.....	184
F.2	Reference point for measurement.....	184
F.3	Basic unit of measurement.....	184
F.4	Modified signal under test.....	185
F.5	Estimation of frequency offset.....	185
F.6	Estimation of time offset.....	185
F.7	Estimation of TX chain amplitude and frequency response parameters.....	186
F.8	Averaged EVM.....	187

<b>Annex G (normative):</b>	<b>Propagation conditions.....</b>	<b>189</b>
G.1	Static propagation condition.....	189
G.2	Multi-path fading propagation conditions.....	189
G.2.1	Delay profiles .....	189
G.2.1.1	Delay profiles for FR1 .....	190
G.2.2	Combinations of channel model parameters .....	191
G.2.3	MIMO channel correlation matrices.....	192
G.2.3.1	MIMO correlation matrices using Uniform Linear Array .....	192
G.2.3.1.1	Definition of MIMO correlation matrices .....	192
G.2.3.1.2	MIMO correlation matrices at high, medium and low level .....	193
G.2.3.2	Multi-antenna channel models using cross polarized antennas.....	195
G.2.3.2.1	Definition of MIMO correlation matrices using cross polarized antennas.....	195
G.2.3.2.2	Spatial correlation matrices at UE and gNB sides.....	196
G.2.3.2.2.1	Spatial correlation matrices at UE side.....	196
G.2.3.2.2.2	Spatial correlation matrices at gNB side .....	196
G.2.3.2.3	MIMO correlation matrices using cross polarized antennas .....	196
<b>Annex H (informative):</b>	<b>Change history .....</b>	<b>197</b>
History .....		203

---

# Foreword

This Technical Specification has been produced by the 3rd Generation Partnership Project (3GPP).

The contents of the present document are subject to continuing work within the TSG and may change following formal TSG approval. Should the TSG modify the contents of the present document, it will be re-released by the TSG with an identifying change of release date and an increase in version number as follows:

Version x.y.z

where:

- x the first digit:
  - 1 presented to TSG for information;
  - 2 presented to TSG for approval;
  - 3 or greater indicates TSG approved document under change control.
- y the second digit is incremented for all changes of substance, i.e. technical enhancements, corrections, updates, etc.
- z the third digit is incremented when editorial only changes have been incorporated in the document.

---

# 1 Scope

The present document specifies the Radio Frequency (RF) test methods and conformance requirements for NR Base Station (BS) *Type 1-C* and *Type 1-H*. These have been derived from, and are consistent with the conducted requirements for *BS Type 1-C* and *BS Type 1-H* in NR BS specification defined in TS 38.104 [2].

A *BS type 1-C* only has conducted requirements so it requires compliance to this specification only.

A *BS type 1-H* has both conducted and radiated requirements so it requires compliance to the applicable requirements of this specification and TS 38.141-2 [3].

*BS type 1-O* and *BS type 2-O* have only radiated requirements so they require compliance to TS 38.141-2 [3] only.

---

# 2 References

The following documents contain provisions which, through reference in this text, constitute provisions of the present document.

- References are either specific (identified by date of publication, edition number, version number, etc.) or non-specific.
- For a specific reference, subsequent revisions do not apply.
- For a non-specific reference, the latest version applies. In the case of a reference to a 3GPP document (including a GSM document), a non-specific reference implicitly refers to the latest version of that document *in the same Release as the present document*.

- [1] 3GPP TR 21.905: "Vocabulary for 3GPP Specifications"
- [2] 3GPP TS 38.104: "NR Base Station (BS) radio transmission and reception"
- [3] 3GPP TS 38.141-2: "NR, Base Station (BS) conformance testing, Part 2: Radiated conformance testing"
- [4] ITU-R Recommendation M.1545, "Measurement uncertainty as it applies to test limits for the terrestrial component of International Mobile Telecommunications-2000"
- [5] ITU-R Recommendation SM.329: "Unwanted emissions in the spurious domain"
- [6] IEC 60 721-3-3: "Classification of environmental conditions - Part 3-3: Classification of groups of environmental parameters and their severities - Stationary use at weather protected locations"
- [7] IEC 60 721-3-4: "Classification of environmental conditions - Part 3: Classification of groups of environmental parameters and their severities - Section 4: Stationary use at non-weather protected locations"
- [8] IEC 60 721: "Classification of environmental conditions"
- [9] IEC 60 068-2-1 (2007): "Environmental testing - Part 2: Tests. Tests A: Cold"
- [10] IEC 60 068-2-2: (2007): "Environmental testing - Part 2: Tests. Tests B: Dry heat"
- [11] IEC 60 068-2-6: (2007): "Environmental testing - Part 2: Tests - Test Fc: Vibration (sinusoidal)"
- [12] ITU-R Recommendation SM.328: "Spectra and bandwidth of emissions"
- [13] Federal Communications Commission: "Title 47 of the Code of Federal Regulations (CFR)"
- [14] ECC/DEC/(17)06: "The harmonised use of the frequency bands 1427-1452 MHz and 1492-1518 MHz for Mobile/Fixed Communications Networks Supplemental Downlink (MFCN SDL)"
- [15] 3GPP TR 25.942: "RF system scenarios"
- [16] 3GPP TS 38.212: "NR; Multiplexing and channel coding"

- [17] 3GPP TR 38.211: "NR; Physical channels and modulation"
- [18] 3GPP TS 38.214: "NR; Physical layer procedures for data"
- [19] 3GPP TS 38.331: "NR; Radio Resource Control (RRC) protocol specification"
- [20] 3GPP TR 38.901: "Study on channel model for frequencies from 0.5 to 100 GHz"

## 3 Definitions, symbols and abbreviations

### 3.1 Definitions

For the purposes of the present document, the terms and definitions given in TR 21.905 [1] and the following apply. A term defined in the present document takes precedence over the definition of the same term, if any, in TR 21.905 [1].

**aggregated BS channel bandwidth:** the RF bandwidth in which a Base Station transmits and receives multiple contiguously aggregated carriers. The *aggregated BS channel bandwidth* is measured in MHz

**antenna connector:** connector at the conducted interface of the *BS type 1-C*

**active transmitter unit:** transmitter unit which is ON, and has the ability to send modulated data streams that are parallel and distinct to those sent from other transmitter units to a *BS type 1-C antenna connector*, or to one or more *BS type 1-H TAB connectors* at the *transceiver array boundary*

**Base Station RF Bandwidth:** RF bandwidth in which a base station transmits and/or receives single or multiple carrier(s) within a supported *operating band*

NOTE: In single carrier operation, the *Base Station RF Bandwidth* is equal to the *BS channel bandwidth*.

**Base Station RF Bandwidth edge:** frequency of one of the edges of the *Base Station RF Bandwidth*

**basic limit:** emissions limit relating to the power supplied by a single transmitter to a single antenna transmission line in ITU-R SM.329 [2] used for the formulation of unwanted emission requirements for FR1

**BS channel bandwidth:** RF bandwidth supporting a single NR RF carrier with the transmission bandwidth configured in the uplink or downlink

NOTE 1: The *BS channel bandwidth* is measured in MHz and is used as a reference for transmitter and receiver RF requirements.

NOTE 2: It is possible for the BS to transmit to and/or receive from one or more UE bandwidth parts that are smaller than or equal to the BS transmission bandwidth configuration, in any part of the BS transmission bandwidth configuration.

**BS type 1-C:** NR base station operating at FR1 with requirements set consisting only of conducted requirements defined at individual *antenna connectors*

**BS type 1-H:** NR base station operating at FR1 with a requirement set consisting of conducted requirements defined at individual *TAB connectors* and OTA requirements defined at RIB

**BS type 1-O:** NR base station operating at FR1 with a requirement set consisting only of OTA requirements defined at the RIB

NOTE: *BS type 1-O* conformance requirements are captured in TS 38.141-2 [3] and are out of scope of this specification.

**BS type 2-O:** NR base station operating at FR2 with a requirement set consisting only of OTA requirements defined at the RIB

NOTE: *BS type 2-O* conformance requirements are captured in TS 38.141-2 [3] and are out of scope of this specification.

**channel edge:** lowest or highest frequency of the NR carrier, separated by the *BS channel bandwidth*

**carrier aggregation:** aggregation of two or more component carriers in order to support wider transmission bandwidths

**carrier aggregation configuration:** a set of one or more *operating bands* across which the BS aggregates carriers with a specific set of technical requirements

**contiguous carriers:** set of two or more carriers configured in a spectrum block where there are no RF requirements based on co-existence for un-coordinated operation within the spectrum block

**contiguous spectrum:** spectrum consisting of a contiguous block of spectrum with no sub-block gap(s)



**highest carrier:** The carrier with the highest carrier frequency transmitted/received in a specified frequency band

**inter-band carrier aggregation:** carrier aggregation of component carriers in different operating bands

NOTE: Carriers aggregated in each band can be contiguous or non-contiguous.

**Inter-band gap:** The frequency gap between two supported consecutive operating bands

**intra-band contiguous carrier aggregation:** *contiguous carriers* aggregated in the same operating band

**intra-band non-contiguous carrier aggregation:** non-contiguous carriers aggregated in the same operating band

**Inter RF Bandwidth gap:** frequency gap between two consecutive Base Station RF Bandwidths that are placed within two supported *operating bands*

**lowest carrier:** the carrier with the lowest carrier frequency transmitted/received in a specified frequency band

**lower sub-block edge:** frequency at the lower edge of one *sub-block*

NOTE: It is used as a frequency reference point for both transmitter and receiver requirements.

**maximum carrier output power:** mean power level measured per carrier at the indicated interface, during the *transmitter ON period* in a specified reference condition

**maximum total output power:** mean power level measured within the *operating band* at the indicated interface, during the *transmitter ON period* in a specified reference condition

**measurement bandwidth:** RF bandwidth in which an emission level is specified

**multi-band connector:** *antenna connector* of the *BS type 1-C* or *TAB connector* of the *BS type 1-H* associated with a transmitter or receiver that is characterized by the ability to process two or more carriers in common active RF components simultaneously, where at least one carrier is configured at a different *operating band* than the other carrier(s) and where this different *operating band* is not a sub-band or superseding-band of another supported operating band

**multi-carrier transmission configuration:** set of one or more contiguous or non-contiguous carriers that a BS is able to transmit simultaneously according to the manufacturer's specification

**non-contiguous spectrum:** spectrum consisting of two or more sub-blocks separated by *sub-block gap(s)*

**operating band:** frequency range in which NR operates (paired or unpaired), that is defined with a specific set of technical requirements

NOTE: The *operating band(s)* for a BS is declared by the manufacturer according to the designations in TS 38.104 [2], tables 5.2-1 and 5.2-2.

**Radio Bandwidth:** frequency difference between the upper edge of the highest used carrier and the lower edge of the lowest used carrier

**rated carrier output power:** mean power level associated with a particular carrier the manufacturer has declared to be available at the indicated interface, during the *transmitter ON period* in a specified reference condition

**rated total output power:** mean power level associated with a particular *operating band* the manufacturer has declared to be available at the indicated interface, during the *transmitter ON period* in a specified reference condition

**requirement set:** one of the NR base station requirement's set as defined for *BS type 1-C*, *BS type 1-H*, *BS type 1-O*, and *BS type 2-O*

**single-band connector:** *antenna connector* of the *BS type 1-C* or *TAB connector* of the *BS type 1-H* supporting operation either in a single *operating band* only, or in multiple *operating bands* but does not meet the conditions for a *multi-band connector*

**sub-band:** sub-band of an operating band contains a part of the uplink and downlink frequency range of the operating band

**sub-block:** one contiguous allocated block of spectrum for transmission and reception by the same base station

NOTE: There may be multiple instances of sub-blocks within a Base Station RF Bandwidth.

**sub-block gap:** frequency gap between two consecutive sub-blocks within a Base Station RF Bandwidth, where the RF requirements in the gap are based on co-existence for un-coordinated operation

**superseding-band:** superseding-band of an operating band includes the whole of the uplink and downlink frequency range of the operating band

**TAB connector:** *transceiver array boundary* connector

**TAB connector RX min cell group:** *operating band* specific declared group of *TAB connectors* to which *BS type I-H* conducted RX requirements are applied

NOTE: Within this definition, the group corresponds to the group of *TAB connectors* which are responsible for receiving a cell when the *BS type I-H* setting corresponding to the declared minimum number of cells with reception on all *TAB connectors* supporting an *operating band*, but its existence is not limited to that condition

**TAB connector TX min cell group:** *operating band* specific declared group of *TAB connectors* to which *BS type I-H* conducted TX requirements are applied.

NOTE: Within this definition, the group corresponds to the group of *TAB connectors* which are responsible for transmitting a cell when the *BS type I-H* setting corresponding to the declared minimum number of cells with transmission on all *TAB connectors* supporting an *operating band*, but its existence is not limited to that condition

**total RF bandwidth:** maximum sum of Base Station RF Bandwidths in all supported *operating bands*

**transceiver array boundary:** conducted interface between the transceiver unit array and the composite antenna

**transmitter OFF period:** time period during which the BS transmitter is not allowed to transmit

**transmitter ON period:** time period during which the BS transmitter is transmitting data and/or reference symbols

**transmitter transient period:** time period during which the transmitter is changing from the OFF period to the ON period or vice versa

**upper sub-block edge:** frequency at the upper edge of one *sub-block*

NOTE: It is used as a frequency reference point for both transmitter and receiver requirements.

## 3.2 Symbols

For the purposes of the present document, the following symbols apply:

$\beta$	Percentage of the mean transmitted power emitted outside the occupied bandwidth on the assigned channel
$BW_{\text{Channel}}$	<i>BS channel bandwidth</i>
$BW_{\text{Channel\_CA}}$	<i>Aggregated BS Channel Bandwidth</i> , expressed in MHz. $BW_{\text{Channel\_CA}} = F_{\text{edge\_high}} - F_{\text{edge\_low}}$ .
$BW_{\text{Channel\_block}}$	<i>Sub-block bandwidth</i> , expressed in MHz. $BW_{\text{Channel\_block}} = F_{\text{edge\_block\_high}} - F_{\text{edge\_block\_low}}$ .
$BW_{\text{Config}}$	<i>Transmission bandwidth configuration</i> , expressed in MHz, where $BW_{\text{Config}} = N_{\text{RB}} \times \text{SCS} \times 12 \text{ kHz}$
$BW_{\text{tot}}$	<i>Total RF bandwidth</i>
$\Delta f$	Separation between the channel edge frequency and the nominal -3 dB point of the measuring filter closest to the carrier frequency
$\Delta f_{\text{max}}$	$f_{\text{offsetmax}}$ minus half of the bandwidth of the measuring filter
$\Delta F_{\text{Global}}$	<i>Global frequency raster granularity</i>
$\Delta f_{\text{OBUE}}$	Maximum offset of the <i>operating band</i> unwanted emissions mask from the downlink <i>operating band</i> edge
$\Delta f_{\text{OOB}}$	Maximum offset of the out-of-band boundary from the uplink <i>operating band</i> edge
$\Delta F_{\text{Raster}}$	<i>Channel raster granularity</i>
$\Delta_{\text{SUL}}$	<i>Channel raster offset for SUL</i>
$F_{\text{C}}$	<i>RF reference frequency</i> on the channel raster
$F_{\text{C,block, high}}$	Fc of the highest transmitted/received carrier in a sub-block
$F_{\text{C,block, low}}$	Fc of the lowest transmitted/received carrier in a sub-block
$F_{\text{C\_low}}$	The Fc of the lowest carrier, expressed in MHz

$F_{C\_high}$	The $F_c$ of the highest carrier, expressed in MHz
$F_{edge\_low}$	The lower edge of <i>Aggregated BS Channel Bandwidth</i> , expressed in MHz. $F_{edge\_low} = F_{C\_low} - F_{offset\_low}$
$F_{edge\_high}$	The upper edge of <i>Aggregated BS Channel Bandwidth</i> , expressed in MHz. $F_{edge\_high} = F_{C\_high} + F_{offset\_high}$
$F_{edge,block,low}$	The lower sub-block edge, where $F_{edge,block,low} = F_{C,block,low} - F_{offset\_low}$
$F_{edge,block,high}$	The upper sub-block edge, where $F_{edge,block,high} = F_{C,block,high} + F_{offset\_high}$
$F_{offset\_high}$	Frequency offset from $F_{C\_high}$ to the upper <i>Base Station RF Bandwidth edge</i> , or from $F_{C,block,high}$ to the upper sub-block edge
$F_{offset\_low}$	Frequency offset from $F_{C\_low}$ to the lower <i>Base Station RF Bandwidth edge</i> , or from $F_{C,block,low}$ to the lower sub-block edge
$F_{DL\_low}$	The lowest frequency of the downlink <i>operating band</i>
$F_{DL\_high}$	The highest frequency of the downlink <i>operating band</i>
$f\_offset$	Separation between the channel edge frequency and the centre of the measuring filter
$f\_offset_{max}$	The offset to the frequency $\Delta f_{OBUe}$ outside the downlink <i>operating band</i>
$F_{REF}$	RF reference frequency
$F_{REF,SUL}$	RF reference frequency for Supplementary Uplink (SUL) bands
$F_{DL\_low}$	The lowest frequency of the downlink <i>operating band</i>
$F_{DL\_high}$	The highest frequency of the downlink <i>operating band</i>
$F_{UL\_low}$	The lowest frequency of the uplink <i>operating band</i>
$F_{UL\_high}$	The highest frequency of the uplink <i>operating band</i>
$I_{uant}$	gNB internal logical interface between the implementation specific O&M function and the RET antennas and TMAs control unit function of the gNB
$N_{cells}$	The declared number corresponding to the minimum number of cells that can be transmitted by an <i>BS type 1-H</i> in a particular <i>operating band</i>
$N_{RB}$	Transmission bandwidth configuration, expressed in resource blocks
$N_{REF}$	NR Absolute Radio Frequency Channel Number (NR-ARFCN)
$N_{RXU,active}$	The number of active receiver units. The same as the number of <i>demodulation branches</i> to which compliance is declared for chapter 8 performance requirements
$N_{RXU,counted}$	The number of active receiver units that are taken into account for conducted Rx spurious emission scaling, as calculated in subclause 7.6.1
$N_{RXU,countedpercell}$	The number of active receiver units that are taken into account for conducted RX spurious emissions scaling per cell, as calculated in subclause 7.6.1
$N_{TXU,counted}$	The number of <i>active transmitter units</i> as calculated in subclause 6.1, that are taken into account for conducted TX output power limit in subclause 6.2.1, and for unwanted TX emissions scaling
$N_{TXU,countedpercell}$	The number of <i>active transmitter units</i> that are taken into account for conducted TX emissions scaling per cell, as calculated in subclause 6.1
$P_{EM,n50,ind}$	Declared emission level for Band n50 in the band 1518-1559 MHz; ind = a, b
$P_{max,c,AC}$	<i>Maximum carrier output power</i> measured per <i>antenna connector</i>
$P_{max,c,cell}$	The <i>maximum carrier output power</i> per <i>TAB connector TX min cell group</i>
$P_{max,c,TABC}$	The <i>maximum carrier output power</i> per <i>TAB connector</i>
$P_{rated,c,AC}$	The <i>rated carrier output power</i> per <i>antenna connector</i>
$P_{rated,c,sys}$	The sum of $P_{rated,c,TABC}$ for all <i>TAB connectors</i> for a single carrier
$P_{rated,c,TABC}$	The <i>rated carrier output power</i> per <i>TAB connector</i>
$P_{rated,t,AC}$	The <i>rated total output power</i> declared at the antenna connector
$P_{rated,t,TABC}$	The <i>rated total output power</i> declared at <i>TAB connector</i>
$P_{REFSENS}$	Conducted Reference Sensitivity power level
$SS_{REF}$	SS block reference frequency position
$W_{gap}$	Sub-block gap or Inter RF Bandwidth gap size

### 3.3 Abbreviations

For the purposes of the present document, the abbreviations given in TR 21.905 [1] and the following apply. An abbreviation defined in the present document takes precedence over the definition of the same abbreviation, if any, in TR 21.905 [1].

AAS	Active Antenna System
ACLR	Adjacent Channel Leakage Ratio
ACS	Adjacent Channel Selectivity
AWGN	Additive White Gaussian Noise
BS	Base Station

BW	Bandwidth
CA	Carrier Aggregation
CACLR	Cumulative ACLR
CW	Continuous Wave
DM-RS	Demodulation Reference Signal
E-UTRA	Evolved UTRA
EVM	Error Vector Magnitude
FDD	Frequency Division Duplex
FR	Frequency Range
GSCN	Global Synchronization Channel Number
GSM	Global System for Mobile communications
ITU-R	Radiocommunication Sector of the International Telecommunication Union
ICS	In-Channel Selectivity
LA	Local Area
LNA	Low Noise Amplifier
MR	Medium Range
NR	New Radio
NR-ARFCN	NR Absolute Radio Frequency Channel Number
OBUE	Operating Band Unwanted Emissions
OTA	Over The Air
RDN	Radio Distribution Network
REFSENS	Reference Sensitivity
RF	Radio Frequency
RIB	Radiated Interface Boundary
RMS	Root Mean Square (value)
RS	Reference Signal
RX	Receiver
SCS	Sub-Carrier Spacing
SDL	Supplementary Downlink
SSB	Synchronization Signal Block
SUL	Supplementary Uplink
TAB	Transceiver Array Boundary
TAE	Time Alignment Error
TDD	Time division Duplex
TX	Transmitter

---

## 4 General conducted test conditions and declarations

### 4.1 Measurement uncertainties and test requirements

#### 4.1.1 General

The requirements of this clause apply to all applicable tests in part 1 of this specification, i.e. to all conducted tests defined for FR1. The frequency ranges FR1 and FR2 are defined in subclause 5.1 of TS 38.104 [2].

The minimum requirements are given in TS 38.104 [2] and the references therein. Test Tolerances for the conducted test requirements explicitly stated in the present document are given in annex C of the present document.

Test Tolerances are individually calculated for each test. The Test Tolerances are used to relax the minimum requirements to create test requirements.

When a test requirement differs from the corresponding minimum requirement, then the Test Tolerance applied for the test is non-zero. The Test Tolerance for the test and the explanation of how the minimum requirement has been relaxed by the Test Tolerance are given in annex C.

#### 4.1.2 Acceptable uncertainty of Test System

##### 4.1.2.1 General

The maximum acceptable uncertainty of the Test System is specified below for each test defined explicitly in the present specification, where appropriate. The maximum acceptable uncertainty of the Test System for test requirements included by reference is defined in the respective referred test specification.

For *BS type I-H* when a requirement is applied per *TAB connector* then the test uncertainty is applied to the measured value. When a requirement is applied for a group of *TAB connectors* then the test uncertainty is applied to sum of the measured power on each *TAB connector* in the group.

The Test System shall enable the stimulus signals in the test case to be adjusted to within the specified tolerance and the equipment under test to be measured with an uncertainty not exceeding the specified values. All tolerances and uncertainties are absolute values, and are valid for a confidence level of 95 %, unless otherwise stated.

A confidence level of 95 % is the measurement uncertainty tolerance interval for a specific measurement that contains 95 % of the performance of a population of test equipment.

For RF tests, it should be noted that the uncertainties in subclause 4.1.2 apply to the Test System operating into a nominal 50 ohm load and do not include system effects due to mismatch between the DUT and the Test System.

## 4.1.2.2 Measurement of transmitter

Table 4.1.2.2-1: Maximum Test System uncertainty for transmitter tests

Subclause	Maximum Test System Uncertainty	Derivation of Test System Uncertainty
6.2 Base Station output power	$\pm 0.7$ dB, $f \leq 3$ GHz $\pm 1.0$ dB, $3 \text{ GHz} < f \leq 6 \text{ GHz}$ (Note)	
6.3 Output power dynamics	$\pm 0.4$ dB	
6.4.1 Transmit ON/OFF power	$\pm 2.0$ dB, $f \leq 3$ GHz $\pm 2.5$ dB, $3 \text{ GHz} < f \leq 6 \text{ GHz}$ (Note)	
6.4.2 Transmitter transient period	N/A	
6.5.1 Frequency error	$\pm 12$ Hz	
6.5.2 EVM	$\pm 1\%$	
6.5.3 Time alignment error	$\pm 25$ ns	
6.6.2 Occupied bandwidth	5 MHz, 10 MHz BS Channel BW: $\pm 100$ kHz 15 MHz, 20 MHz, 25 MHz, 30 MHz, 40 MHz, 50 MHz BS Channel BW: $\pm 300$ kHz 60 MHz, 70 MHz, 80 MHz, 90 MHz, 100 MHz BS Channel BW: $\pm 600$ kHz	
6.6.3 Adjacent Channel Leakage power Ratio (ACLR)	ACLR/ CACLR BW $\leq 20$ MHz: $\pm 0.8$ dB BW $> 20$ MHz: $\pm 1.2$ dB  Absolute power $\pm 2.0$ dB, $f \leq 3$ GHz Absolute power $\pm 2.5$ dB, $3 \text{ GHz} < f \leq 6 \text{ GHz}$ (Note)  CACLR BW $\leq 20$ MHz: $\pm 0.8$ dB BW $> 20$ MHz: $\pm 1.2$ dB  CACLR absolute power $\pm 2.0$ dB, $f \leq 3$ GHz CACLR absolute power $\pm 2.5$ dB, $3 \text{ GHz} < f \leq 6 \text{ GHz}$ (Note)	
6.6.4 Operating band unwanted emissions	$\pm 1.5$ dB, $f \leq 3$ GHz $\pm 1.8$ dB, $3 \text{ GHz} < f \leq 6 \text{ GHz}$ (Note)	
6.6.5.2.1 Transmitter spurious emissions, Mandatory Requirements	9 kHz $< f \leq 4$ GHz: $\pm 2.0$ dB 4 GHz $< f \leq 19$ GHz: $\pm 4.0$ dB 19 GHz $< f \leq 26$ GHz: [ $\pm 4.5$ dB]	
6.6.5.2.2 Transmitter spurious emissions, Protection of BS receiver	$\pm 3.0$ dB	
6.6.5.2.3 Transmitter spurious emissions, Additional spurious emission requirements	$\pm 2.0$ dB for $> -60$ dBm, $f \leq 3$ GHz $\pm 2.5$ dB, $3 \text{ GHz} < f \leq 4.2$ GHz $\pm 3.0$ dB, $4.2 \text{ GHz} < f \leq 6 \text{ GHz}$ $\pm 3.0$ dB for $\leq -60$ dBm, $f \leq 3$ GHz $\pm 3.5$ dB, $3 \text{ GHz} < f \leq 4.2$ GHz $\pm 4.0$ dB, $4.2 \text{ GHz} < f \leq 6 \text{ GHz}$	
6.6.5.2.4 Transmitter spurious emissions, Co-location	$\pm 3.0$ dB	
6.7 Transmitter intermodulation (interferer requirements) This tolerance applies to the stimulus and not the measurements defined in 6.6.6, 6.6.5 and 6.6.3	The value below applies only to the interfering signal and is unrelated to the measurement uncertainty of the tests (6.6.1, 6.6.2 and 6.6.4) which have to be carried out in the presence of the interferer.  $\pm 1.0$ dB	The uncertainty of interferer has double the effect on the result due to the frequency offset
NOTE: Test system uncertainty values for $4.2 \text{ GHz} < f \leq 6 \text{ GHz}$ apply for BS operates in licensed spectrum only.		

#### 4.1.2.3 Measurement of receiver

**Table 4.1.2.3-1: Maximum Test System Uncertainty for receiver tests**

Subclause	Maximum Test System Uncertainty	Derivation of Test System Uncertainty
7.2 Reference sensitivity level	±0.7 dB, $f \leq 3$ GHz ±1.0 dB, $3 \text{ GHz} < f \leq 4.2 \text{ GHz}$ ±1.2 dB, $4.2 \text{ GHz} < f \leq 6 \text{ GHz}$	
7.3 Dynamic range	±0.3 dB	
7.4.1 Adjacent channel selectivity	±1.4 dB, $f \leq 3$ GHz ±1.8 dB, $3 \text{ GHz} < f \leq 4.2 \text{ GHz}$ ±2.1 dB, $4.2 \text{ GHz} < f \leq 6 \text{ GHz}$ (Note 2)	Overall system uncertainty comprises three quantities: 1. Wanted signal level error 2. Interferer signal level error 3. Additional impact of interferer leakage  Items 1 and 2 are assumed to be uncorrelated so can be root sum squared to provide the ratio error of the two signals. The interferer leakage effect is systematic, and is added arithmetically.  Test System uncertainty = [SQRT (wanted_level_error <sup>2</sup> + interferer_level_error <sup>2</sup> )] + leakage effect.  $f \leq 3$ GHz Wanted signal level ±0.7 dB Interferer signal level ±0.7 dB $3 \text{ GHz} < f \leq 4.2 \text{ GHz}$ Wanted signal level ±1.0 dB Interferer signal level ±1.0 dB $4.2 \text{ GHz} < f \leq 6 \text{ GHz}$ Wanted signal level ±1.22 dB Interferer signal level ±1.22 dB  $f \leq 6$ GHz Impact of interferer leakage 0.4 dB
7.4.2 In-band blocking (General blocking)	±1.6 dB, $f \leq 3$ GHz ±2.0 dB, $3 \text{ GHz} < f \leq 4.2 \text{ GHz}$ ±2.2 dB, $4.2 \text{ GHz} < f \leq 6 \text{ GHz}$ (Note 2)	
7.4.2 In-band blocking (Narrow band blocking)	±1.4 dB, $f \leq 3$ GHz ±1.8 dB, $3 \text{ GHz} < f \leq 4.2 \text{ GHz}$ ±2.1 dB, $4.2 \text{ GHz} < f \leq 6 \text{ GHz}$ (Note 2)	
7.5.5.1 Out-of-band blocking (General requirements)	$f_{\text{wanted}} \leq 3 \text{ GHz}$ $1 \text{ MHz} < f_{\text{interferer}} \leq 3 \text{ GHz}$ : ±1.3 dB $3.0 \text{ GHz} < f_{\text{interferer}} \leq 4.2 \text{ GHz}$ : ±1.5 dB $4.2 \text{ GHz} < f_{\text{interferer}} \leq 12.75 \text{ GHz}$ : ±3.2 dB  $3 \text{ GHz} < f_{\text{wanted}} \leq 4.2 \text{ GHz}$ : $1 \text{ MHz} < f_{\text{interferer}} \leq 3 \text{ GHz}$ : ±1.5 dB $3.0 \text{ GHz} < f_{\text{interferer}} \leq 4.2 \text{ GHz}$ : ±1.7 dB $4.2 \text{ GHz} < f_{\text{interferer}} \leq 12.75 \text{ GHz}$ : ±3.3 dB  $4.2 \text{ GHz} < f_{\text{wanted}} \leq 6.0 \text{ GHz}$ : $1 \text{ MHz} < f_{\text{interferer}} \leq 3 \text{ GHz}$ : ±1.7 dB $3.0 \text{ GHz} < f_{\text{interferer}} \leq 4.2 \text{ GHz}$ : ±1.8 dB $4.2 \text{ GHz} < f_{\text{interferer}} \leq 12.75 \text{ GHz}$ : ±3.3 dB	Overall system uncertainty comprises three quantities: 1. Wanted signal level error 2. Interferer signal level error 3. Interferer broadband noise  Items 1 and 2 are assumed to be uncorrelated so can be root sum squared to provide the ratio error of the two signals. The Interferer Broadband noise effect is systematic, and is added arithmetically.  Test System uncertainty = [SQRT (wanted_level_error <sup>2</sup> + interferer_level_error <sup>2</sup> )] + Broadband noise effect.  Out of band blocking, using CW interferer: Wanted signal level: ±0.7 dB up to 3 GHz ±1.0 dB up to 4.2 GHz ±1.22 dB up to 6 GHz  Interferer signal level: ±1.0 dB up to 3 GHz ±1.2 dB up to 4.2 GHz ±3.0 dB up to 12.75 GHz Impact of interferer Broadband noise 0.1 dB



7.5.5.2 Out-of-band blocking (Co-location requirements)	<u>Co-location blocking, using CW interferer:</u> $\pm 2.5$ dB, $f \leq 3.0$ GHz $\pm 2.6$ dB, $3.0$ GHz $< f \leq 4.2$ GHz $\pm 2.7$ dB, $4.2$ GHz $< f \leq 6.0$ GHz	Co-location blocking, using CW interferer: $f \leq 3.0$ GHz Wanted signal level $\pm 0.7$ dB $3.0$ GHz $< f \leq 4.2$ GHz Wanted signal level $\pm 1.0$ dB $4.2$ GHz $< f \leq 6.0$ GHz Wanted signal level $\pm 1.22$ dB  $f \leq 6.0$ GHz Interferer signal level: $\pm 2.0$ dB Interferer ACLR not applicable Impact of interferer Broadband noise 0.4 dB
7.6 Receiver spurious emissions	$30$ MHz $\leq f \leq 4$ GHz: $\pm 2.0$ dB $4$ GHz $< f \leq 19$ GHz: $\pm 4.0$ dB $19$ GHz $< f \leq 26$ GHz: [ $\pm 4.5$ dB]	
7.7 Receiver intermodulation	$\pm 1.8$ dB, $f \leq 3.0$ GHz $\pm 2.4$ dB, $3.0$ GHz $< f \leq 4.2$ GHz $\pm 3.0$ dB, $4.2$ GHz $< f \leq 6.0$ GHz (Note 2)	Overall system uncertainty comprises four quantities: 1. Wanted signal level error 2. CW Interferer level error 3. Modulated Interferer level error 4. Impact of interferer ACLR  The effect of the closer CW signal has twice the effect.  Items 1, 2 and 3 are assumed to be uncorrelated so can be root sum squared to provide the combined effect of the three signals. The interferer ACLR effect is systematic, and is added arithmetically.  Test System uncertainty = $\text{SQRT} [(2 \times \text{CW\_level\_error})^2 + (\text{mod interferer\_level\_error})^2 + (\text{wanted signal\_level\_error})^2] + \text{ACLR effect.}$  $f \leq 3.0$ GHz Wanted signal level $\pm 0.7$ dB CW interferer level $\pm 0.5$ dB Mod interferer level $\pm 0.7$ dB $3.0$ GHz $< f \leq 4.2$ GHz Wanted signal level $\pm 1.0$ dB CW Interferer level $\pm 0.7$ dB Mod Interferer level $\pm 1.0$ dB $4.2$ GHz $< f \leq 6$ GHz Wanted signal level $\pm 1.22$ dB CW Interferer level $\pm 0.98$ dB Mod Interferer level $\pm 1.22$ dB  $f \leq 6$ GHz Impact of interferer ACLR 0.4 dB
7.8 In-channel selectivity	$\pm 1.4$ dB, $f \leq 3$ GHz $\pm 1.8$ dB, $3$ GHz $< f \leq 4.2$ GHz $\pm 2.1$ dB, $4.2$ GHz $< f \leq 6$ GHz (Note 2)	
NOTE 1: Unless otherwise noted, only the Test System stimulus error is considered here. The effect of errors in the throughput measurements or the BER/FER due to finite test duration is not considered. NOTE 2: Test system uncertainty values for $4.2$ GHz $< f \leq 6$ GHz apply for BS operates in licensed spectrum only.		

#### 4.1.2.4 Measurement of performance requirements

**Table 4.1.2.4-1: Maximum Test System Uncertainty for performance requirements**

Subclause	Maximum Test System Uncertainty	Derivation of Test System Uncertainty
8 PUSCH, PUCCH, PRACH with [single antenna port] and fading channel	$\pm [0.6]$ dB	[Overall system uncertainty for fading conditions comprises two quantities: 1. Signal-to-noise ratio uncertainty 2. Fading profile power uncertainty  Items 1 and 2 are assumed to be uncorrelated so can be root sum squared: Test System uncertainty = [SQRT (Signal-to-noise ratio uncertainty <sup>2</sup> + Fading profile power uncertainty <sup>2</sup> )] Signal-to-noise ratio uncertainty $\pm 0.3$ dB Fading profile power uncertainty $\pm 0.5$ dB]
8 PRACH with [single antenna port] and AWGN	$\pm [0.3]$ dB	[Signal-to-noise ratio uncertainty $\pm 0.3$ dB]
8 PUSCH with [two antenna port] and fading channel	$\pm [0.8]$ dB	[Overall system uncertainty for fading conditions comprises two quantities: 1. Signal-to-noise ratio uncertainty 2. Fading profile power uncertainty  Items 1 and 2 are assumed to be uncorrelated so can be root sum squared: Test System uncertainty = [SQRT (Signal-to-noise ratio uncertainty <sup>2</sup> + Fading profile power uncertainty <sup>2</sup> )] Signal-to-noise ratio uncertainty $\pm 0.3$ dB Fading profile power uncertainty $\pm 0.7$ dB for MIMO]

### 4.1.3 Interpretation of measurement results

The measurement results returned by the Test System are compared - without any modification - against the test requirements as defined by the Shared Risk principle.

The Shared Risk principle is defined in Recommendation ITU-R M.1545 [4].

The actual measurement uncertainty of the Test System for the measurement of each parameter shall be included in the test report.

The recorded value for the Test System uncertainty shall be, for each measurement, equal to or lower than the appropriate figure in subclause 4.1.2 of the present document.

If the Test System for a test is known to have a measurement uncertainty greater than that specified in subclause 4.1.2, it is still permitted to use this apparatus provided that an adjustment is made as follows.

Any additional uncertainty in the Test System over and above that specified in subclause 4.1.2 shall be used to tighten the test requirement, making the test harder to pass. For some tests e.g. receiver tests, this may require modification of stimulus signals. This procedure will ensure that a Test System not compliant with subclause 4.1.2 does not increase the chance of passing a device under test where that device would otherwise have failed the test if a Test System compliant with subclause 4.1.2 had been used.

## 4.2 Conducted requirement reference points

### 4.2.1 BS type 1-C

BS type 1-C requirements are applied at the BS antenna connector (port A) for a single transmitter or receiver with a full complement of transceivers for the configuration in normal operating conditions. If any external apparatus such as an amplifier, a filter or the combination of such devices is used, requirements apply at the far end antenna connector (port B).

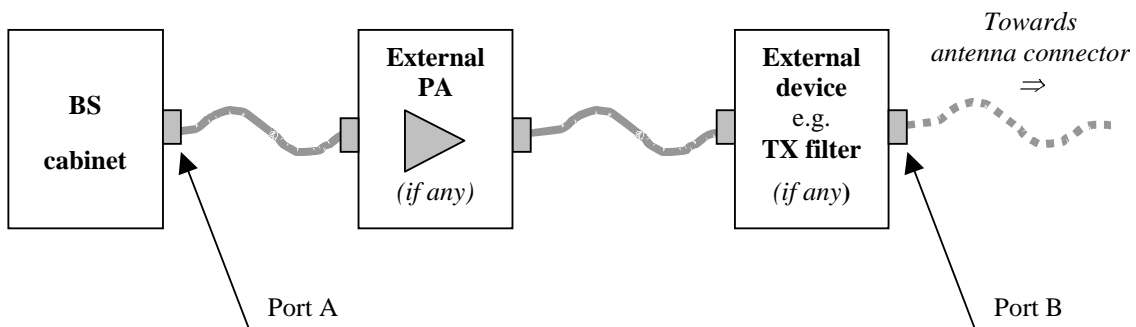

Figure 4.2.1-1: BS type 1-C transmitter interface

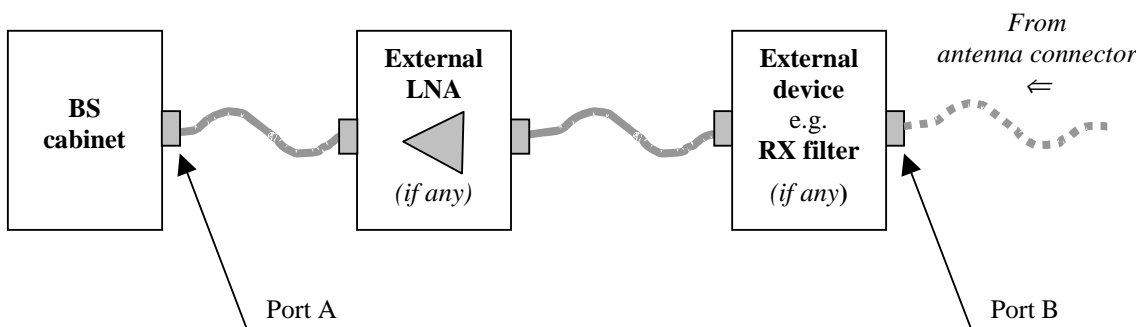

Figure 4.2.1-2: BS type 1-C receiver interface

### 4.2.2 BS type 1-H

BS type 1-H requirements are defined for two points of reference, signified by radiated requirements and conducted requirements.

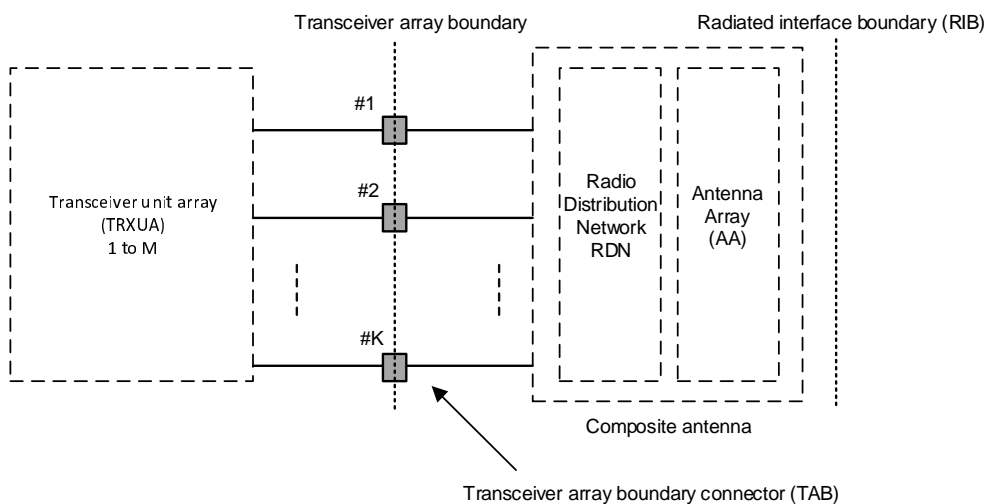

Figure 4.2.2-1: Radiated and conducted reference points for BS type 1-H

Radiated characteristics are defined over the air (OTA), where the *operating band* specific radiated interface is referred to as the *Radiated Interface Boundary (RIB)*. Radiated requirements are also referred to as OTA requirements. The (spatial) characteristics in which the OTA requirements apply are detailed for each requirement.

NOTE: Radiated conformance requirements are captured in TS 38.141-2 [3] and are out of scope of this specification.

Conducted characteristics are defined at individual or groups of *TAB connectors* at the *transceiver array boundary*, which is the conducted interface between the transceiver unit array and the composite antenna.

The transceiver unit array is part of the composite transceiver functionality generating modulated transmit signal structures and performing receiver combining and demodulation.

The transceiver unit array contains an implementation specific number of transmitter units and an implementation specific number of receiver units. Transmitter units and receiver units may be combined into transceiver units. The transmitter/receiver units have the ability to transmit/receive parallel independent modulated symbol streams.

The composite antenna contains a radio distribution network (RDN) and an antenna array. The RDN is a linear passive network which distributes the RF power generated by the transceiver unit array to the antenna array, and/or distributes the radio signals collected by the antenna array to the transceiver unit array, in an implementation specific way.

How a conducted requirement is applied to the *transceiver array boundary* is detailed in the respective requirement subclause.

### 4.3 Base station classes

The requirements in this specification apply to Wide Area Base Stations, Medium Range Base Stations and Local Area Base Stations unless otherwise stated.

BS classes for *BS type 1-C* and *1-H* are defined as indicated below:

- Wide Area Base Stations are characterised by requirements derived from Macro Cell scenarios with a BS to UE minimum coupling loss equal to 70 dB.
- Medium Range Base Stations are characterised by requirements derived from Micro Cell scenarios with a BS to UE minimum coupling loss equals to 53 dB.
- Local Area Base Stations are characterised by requirements derived from Pico Cell scenarios with a BS to minimum coupling loss equal to 45 dB.

### 4.4 Regional requirements

Some requirements in the present document may only apply in certain regions either as optional requirements, or as mandatory requirements set by local and regional regulation. It is normally not stated in the 3GPP specifications under what exact circumstances the regional requirements apply, since this is defined by local or regional regulation.

Table 4.4-1 lists all requirements in the present specification that may be applied differently in different regions.

**Table 4.4-1: List of regional requirements**

Clause number	Requirement	Comments
5	Operating bands	Some NR operating bands may be applied regionally.
6.6.2	Occupied bandwidth	The requirement may be applied regionally. There may also be regional requirements to declare the occupied bandwidth according to the definition in present specification.
6.6.4.5.6.1	Operating band unwanted emissions: Limits in FCC Title 47	The BS may have to comply with the additional requirements, when deployed in regions where those limits are applied, and under the conditions declared by the manufacturer.
6.6.5.5.1.1	Transmitter spurious emissions	Category A or Category B spurious emission limits, as defined in ITU-R Recommendation SM.329 [5], may apply regionally. The emission limits specified as the <i>basic limit</i> + X (dB) are applicable, unless stated differently in regional regulation.
6.6.5.5.1.3	Transmitter spurious emissions: additional requirements	These requirements may be applied for the protection of system operating in frequency ranges other than the BS operating band.
7.6.5.3	Receiver spurious emissions	The emission limits specified as the <i>basic limit</i> + X (dB) are applicable, unless stated differently in regional regulation.

## 4.5 BS configurations

### 4.5.1 BS type 1-C

#### 4.5.1.1 Transmit configurations

##### 4.5.1.1.1 General

Unless otherwise stated, the transmitter characteristics in clause 6 are specified at the BS antenna connector (test port A) with a full complement of transceivers for the configuration in normal operating conditions. If any external apparatus such as a TX amplifier, a filter or the combination of such devices is used, requirements apply at the far end antenna connector (test port B).

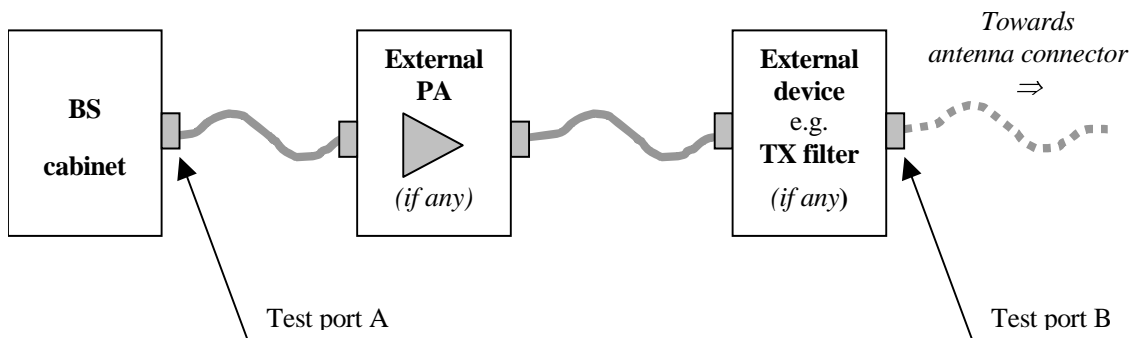

Figure 4.5.1.1.1-1: Transmitter test ports

##### 4.5.1.1.2 Transmission with multiple transmitter antenna connectors

Unless otherwise stated, for the tests in clause 6 of the present document, the requirement applies for each transmitter *antenna connector* in the case of transmission with multiple transmitter *antenna connectors*.

Transmitter requirements are tested at the *antenna connector*, with the remaining *antenna connector(s)* being terminated. If the manufacturer has declared the transmitter paths to be equivalent (D.32), it is sufficient to measure the signal at any one of the transmitter *antenna connectors*.

#### 4.5.1.2 Receive configurations

##### 4.5.1.2.1 General

Unless otherwise stated, the receiver characteristics in clause 7 are specified at the BS *antenna connector* (test port A) with a full complement of transceivers for the configuration in normal operating conditions. If any external apparatus such as a RX amplifier, a filter or the combination of such devices is used, requirements apply at the far end *antenna connector* (test port B).

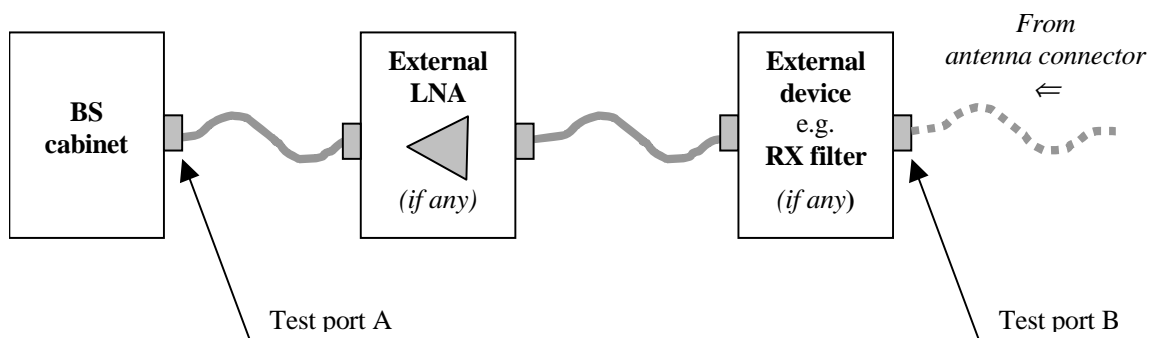

Figure 4.5.1.2.1-1: Receiver test ports

#### 4.5.1.2.2 Reception with multiple receiver antenna connectors, receiver diversity

For the tests in clause 7 of the present document, the requirement applies at each receiver *antenna connector* for receivers with antenna diversity or in the case of multi-carrier reception with multiple receiver *antenna connectors*.

Receiver requirements are tested at the *antenna connector*, with the remaining receiver(s) disabled or their *antenna connector(s)* being terminated. If the manufacturer has declared the receiver paths to be equivalent (D.32), it is sufficient to apply the specified test signal at any one of the receiver *antenna connectors*.

For a *BS type I-C* supporting multi-band operation, multi-band tests for [ACS, blocking and intermodulation] are performed with the interferer(s) applied to each *antenna connector* mapped to the receiver for the wanted signal(s), however only to one *antenna connector* at a time. *Antenna connectors* to which no signals are applied are terminated.

#### 4.5.1.3 Duplexers

The requirements of the present document shall be met with a duplexer fitted, if a duplexer is supplied as part of the BS. If the duplexer is supplied as an option by the manufacturer, sufficient tests should be repeated with and without the duplexer fitted to verify that the BS meets the requirements of the present document in both cases.

The following tests shall be performed with the duplexer fitted, and without it fitted if this is an option:

- 1) Subclause 6.2, base station output power, for the highest static power step only, if this is measured at the antenna connector;
- 2) Subclause 6.6, unwanted emissions; outside the BS transmit band;
- 3) Subclause 6.6.4.5.3, protection of the BS receiver;
- 4) Subclause 6.7, transmit intermodulation; for the testing of conformance, the carrier frequencies should be selected to minimize intermodulation products from the transmitters falling in receive channels.

The remaining tests may be performed with or without the duplexer fitted.

NOTE 1: When performing receiver tests with a duplexer fitted, it is important to ensure that the output from the transmitters does not affect the test apparatus. This can be achieved using a combination of attenuators, isolators and filters.

NOTE 2: When duplexers are used, intermodulation products will be generated, not only in the duplexer but also in the antenna system. The intermodulation products generated in the antenna system are not controlled by 3GPP specifications, and may degrade during operation (e.g. due to moisture ingress). Therefore, to ensure continued satisfactory operation of a BS, an operator will normally select NR-ARFCNs to minimize intermodulation products falling on receive channels. For testing of complete conformance, an operator may specify the NR-ARFCNs to be used.

#### 4.5.1.4 Power supply options

If the BS is supplied with a number of different power supply configurations, it may not be necessary to test RF parameters for each of the power supply options, provided that it can be demonstrated that the range of conditions over which the equipment is tested is at least as great as the range of conditions due to any of the power supply configurations.

This applies particularly if a BS contains a DC rail which can be supplied either externally or from an internal mains power supply. In this case, the conditions of extreme power supply for the mains power supply options can be tested by testing only the external DC supply option. The range of DC input voltages for the test should be sufficient to verify the performance with any of the power supplies, over its range of operating conditions within the BS, including variation of mains input voltage, temperature and output current.

#### 4.5.1.5 Ancillary RF amplifiers

The *BS type I-C* requirements of the present document shall be met with the ancillary RF amplifier fitted. At tests according to clauses 6 and 7 for TX and RX respectively, the ancillary amplifier is connected to the BS by a connecting network (including any cable(s), attenuator(s), etc.) with applicable loss to make sure the appropriate operating conditions of the ancillary amplifier and the BS. The applicable connecting network loss range is declared by the manufacturer (D.35). Other characteristics and the temperature dependence of the attenuation of the connecting network

are neglected. The actual attenuation value of the connecting network is chosen for each test as one of the applicable extreme values. The lowest value is used unless otherwise stated.

Sufficient tests should be repeated with the ancillary amplifier fitted and, if it is optional, without the ancillary RF amplifier to verify that the BS meets the requirements of the present document in both cases.

When testing, the following tests shall be repeated with the optional ancillary amplifier fitted according to the table below, where “x” denotes that the test is applicable:

**Table 4.5.1.5-1: Tests applicable to ancillary RF amplifiers**

	Subclause	TX amplifier only	RX amplifier only	TX/RX amplifiers combined (Note 1, 2)
<b>Receiver tests</b>	7.2		x	x
	7.4 (Narrowband blocking)		x	x
	7.5		x	x
	7.6		x	x
	7.7		x	
<b>Transmitter tests</b>	6.2	x		x
	6.6.2	x		x
	6.6.3	x		x
	6.6.4	x		x
	6.6.5	x		x
	6.7	x		x

NOTE 1: Combining can be by duplex filters or any other network. The amplifiers can either be in RX or TX branch or in both. Either one of these amplifiers could be a passive network.

NOTE 2: Unless otherwise stated, BS with both TX and RX amplifiers are tested once with both amplifiers active for each test.

In base station output power test (subclause 6.2) and reference sensitivity level test (subclause 7.2) highest applicable attenuation value is applied.

## 4.5.2 BS type 1-H

### 4.5.2.1 Transmit configurations

Unless otherwise stated, the conducted transmitter characteristics in clause 6 are specified at the *transceiver array boundary* at the *TAB connector(s)* antenna connector with a full complement of transceiver units for the configuration in normal operating conditions.

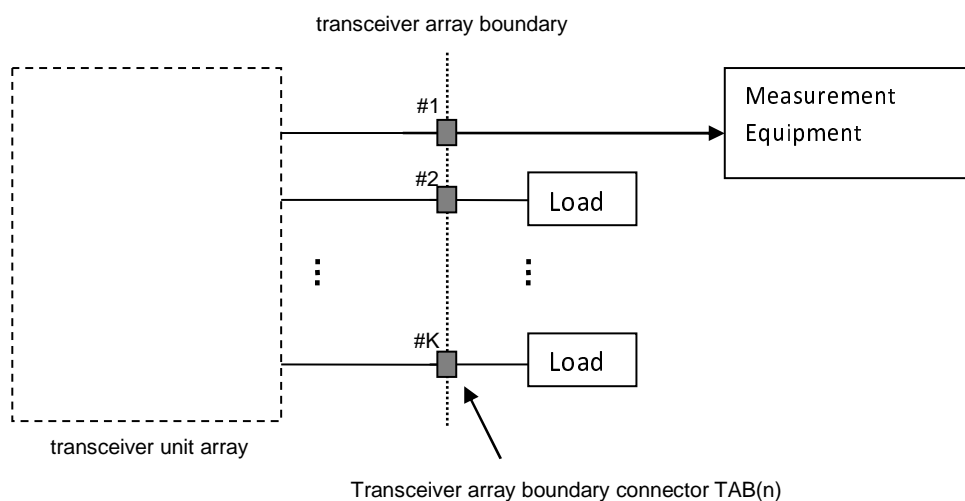
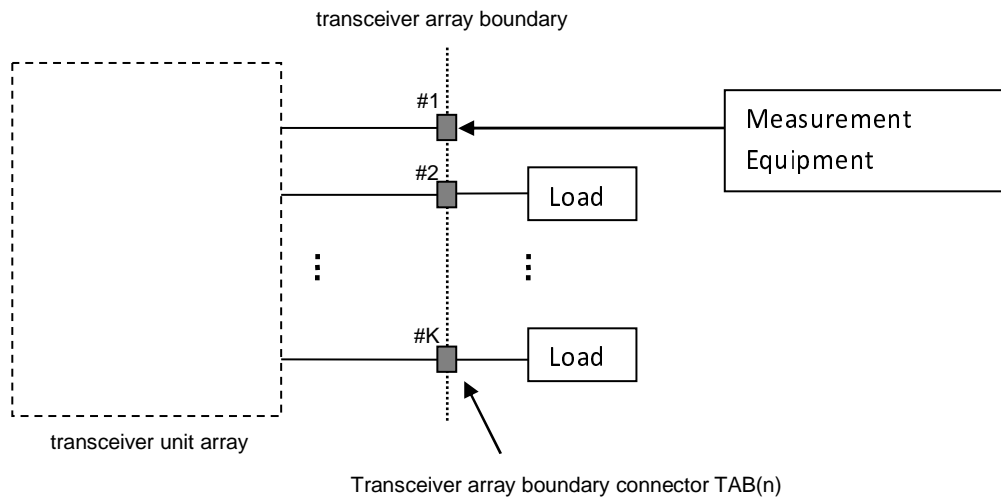

**Figure 4.5.2.1-1: Transmitter test ports**

Unless otherwise stated, for the tests in clause 6 of the present document, the requirement applies for each transmit *TAB connector*.

#### 4.5.2.2 Receive configurations

Unless otherwise stated, the conducted receiver characteristics in clause 7 are specified at the *TAB connector* with a full complement of transceiver units for the configuration in normal operating conditions.



**Figure 4.5.2.2-1: Receiver test ports**

For the tests in clause 7 of the present document, the requirement applies at each receive *TAB connector*.

Conducted receive requirements are tested at the *TAB connector*, with the remaining receiver unit(s) disabled or their *TAB connector*(s) being terminated.

#### 4.5.2.3 Power supply options

If the *BS type 1-H* is supplied with a number of different power supply configurations, it may not be necessary to test RF parameters for each of the power supply options, provided that it can be demonstrated that the range of conditions over which the equipment is tested is at least as great as the range of conditions due to any of the power supply configurations.

### 4.5.3 BS with integrated Iuant BS modem

Unless otherwise stated, for the tests in the present document, the integrated Iuant BS modem shall be switched OFF. Spurious emissions according to subclauses 6.6.5 and 7.6 shall be measured only for frequencies above 20 MHz with the integrated Iuant BS modem switched ON.

## 4.6 Manufacturer declarations

The following BS declarations listed in table 4.6-1, when applicable to the BS under test, are required to be provided by the manufacturer for the conducted requirements testing of the *BS type 1-C* and *BS type 1-H*.

For the *BS type 1-H* declarations required for the radiated requirements testing, refer to TS 38.141-2 [3].



**Table 4.6-1 Manufacturer declarations for BS type 1-C and BS type 1-H conducted test requirements**

Declaration identifier	Declaration	Description	Applicability	
			BS type 1-C	BS type 1-H
D.1	BS requirements set	Declaration of one of the NR base station <i>requirement's set</i> as defined for <i>BS type 1-C</i> , or <i>BS type 1-H</i> .	x	x
D.2	BS class	BS class of the BS, declared as Wide Area BS, Medium Range BS, or Local Area BS.	x	x
D.3	NR <i>operating bands</i>	NR <i>operating bands</i> supported by <i>single-band connector(s)</i> and/or <i>multi-band connector(s)</i> of the BS. Declared per <i>antenna connector</i> for <i>BS type 1-C</i> , or <i>TAB connector</i> for <i>BS type 1-H</i> .	x	x
D.4	Spurious emission category	Declare the BS spurious emission category as either category A or B with respect to the limits for spurious emissions, as defined in Recommendation ITU-R SM.329 [5].	x	x
D.5	Additional operating band unwanted emissions	The manufacturer shall declare whether the BS under test is intended to operate in geographic areas where the additional operating band unwanted emission limits defined in subclause 6.6.4.5.6 apply. (Note 3).	x	x
D.6	Co-existence with other systems	The manufacturer shall declare whether the BS under test is intended to operate in geographic areas where one or more of the systems GSM850, GSM900, DCS1800, PCS1900, UTRA FDD, UTRA TDD, E-UTRA, PHS and/or NR operating in another band are deployed.	x	x
D.7	Co-location with other base stations	The manufacturer shall declare whether the BS under test is intended to operate co-located with Base Stations of one or more of the systems GSM850, GSM900, DCS1800, PCS1900, UTRA FDD, UTRA TDD, E-UTRA and/or NR operating in another band.	x	x
D.8	<i>Single band connector</i> or <i>multi-band connector</i>	Declaration of the single band or multi-band capability of <i>single band connector(s)</i> or <i>multi-band connector(s)</i> , declared for every connector.	x	x
D.9	Contiguous or non-contiguous spectrum operation support	Ability to support contiguous or non-contiguous (or both) frequency distribution of carriers when operating multi-carrier. Declared per <i>single band connector</i> or <i>multi-band connector</i> , per <i>operating band</i> .	x	x
D.10	Maximum <i>Radio Bandwidth</i>	Maximum <i>radio bandwidth</i> that can be supported by the <i>multi-band connector</i> . May be different for transmit and receive. Declared for each supported <i>operating band</i> and operating bands combination (D.27) supported for every <i>multi-band connector</i> .	x	x
D.11	Maximum <i>Base Station RF Bandwidth</i>	Maximum <i>Base Station RF Bandwidth</i> in the <i>operating band</i> for single-band operation. Declared per supported <i>operating band</i> , per <i>antenna connector</i> for <i>BS type 1-C</i> , or <i>TAB connector</i> for <i>BS type 1-H</i> . (Note 2)	x	x
D.12	Maximum <i>Base Station RF Bandwidth</i> for multi-band operation	Maximum <i>Base Station RF Bandwidth</i> for multi-band operation. Declared per supported <i>operating band</i> , per <i>antenna connector</i> for <i>BS type 1-C</i> , or <i>TAB connector</i> for <i>BS type 1-H</i> .	x	x
D.13	Total RF bandwidth ( $BW_{tot}$ )	Total RF bandwidth $BW_{tot}$ of transmitter and receiver, declared per the band combinations (D.27).	x	x
D.14	NR supported channel bandwidths and SCS	NR supported SCS and channel bandwidths per supported SCS. Declared per supported <i>operating band</i> , per <i>antenna connector</i> for <i>BS type 1-C</i> , or <i>TAB connector</i> for <i>BS type 1-H</i> .	x	x
D.15	CA only operation	Declaration of CA-only operation (with equal power spectral density among carriers) but not multiple carriers, declared per <i>operating band</i> per <i>antenna connector</i> for <i>BS type 1-C</i> , or <i>TAB connector</i> for <i>BS type 1-H</i> .	x	x
D.16	Single or multiple carrier	Capable of operating with a single carrier (only) or multiple carriers. Declared per supported <i>operating band</i> , per <i>antenna connector</i> for <i>BS type 1-C</i> , or <i>TAB connector</i> for <i>BS type 1-H</i> .	x	x
D.17	Maximum number of supported carriers per operating band	Maximum number of supported carriers per supported <i>operation band</i> . Declared per supported <i>operating band</i> , per <i>antenna connector</i> for <i>BS type 1-C</i> , or <i>TAB connector</i> for <i>BS type 1-H</i> . (Note 2)	x	x
D.18	Maximum number of supported carriers in multi-band operation	Maximum number of supported carriers in multi-band operation.	x	x

Declaration identifier	Declaration	Description	Applicability	
			BS type 1-C	BS type 1-H
D.19	Total maximum number of supported carriers	Maximum number of supported carriers for all supported <i>operating bands</i> . Declared for all connectors (D.18).	x	x
D.20	Other band combination multi-band restrictions	Declare any other limitations under simultaneous operation in the declared band combinations (D.35) for each <i>multi-band connector</i> which have any impact on the test configuration generation. Declared for every <i>multi-band connector</i> .	x	x
D.21	Rated carrier output power ( $P_{\text{rated,c,AC}}$ , or $P_{\text{rated,c,TABC}}$ )	Conducted rated carrier output power, per <i>single band connector</i> or <i>multi-band connector</i> . Declared per supported <i>operating band</i> , per supported RAT, per <i>antenna connector</i> for BS type 1-C, or <i>TAB connector</i> for BS type 1-H. (Note 1, 2)	x	x
D.22	Rated total output power ( $P_{\text{rated,t,AC}}$ , or $P_{\text{rated,t,TABC}}$ )	Conducted total rated output power. Declared per supported <i>operating band</i> , per <i>antenna connector</i> for BS type 1-C, or <i>TAB connector</i> for BS type 1-H. For <i>multi-band connectors</i> declared for each supported <i>operating band</i> in each supported band combination. (Note 1, 2)	x	x
D.23	Rated multi-band total output power, $P_{\text{rated,MB,TABC}}$	Conducted multi-band rated total output power. Declared per supported operating band combinations, per <i>multi-band connector</i> . (Note 1)	x	x
D.24	$N_{\text{cells}}$	Number corresponding to the minimum number of cells that can be transmitted by a BS in a particular <i>operating band</i> with transmission on all <i>TAB connectors</i> supporting the <i>operating band</i> .		x
D.25	Maximum supported power difference between carriers	Maximum supported power difference between carriers. Declared per supported <i>operating band</i> , per <i>antenna connector</i> for BS type 1-C, or <i>TAB connector</i> for BS type 1-H.	x	x
D.26	Maximum supported power difference between carriers is different <i>operating bands</i>	Supported power difference between any two carriers in any two different supported <i>operating bands</i> . Declared per supported operating band combination, per <i>multi-band connector</i> .	x	x
D.27	Operating band combination support	List of operating bands combinations supported by <i>single-band connector(s)</i> and/or <i>multi-band connector(s)</i> of the BS. Declared per <i>antenna connector</i> for BS type 1-C, or <i>TAB connector</i> for BS type 1-H.	x	x
D.28	Total number of supported carriers for the declared band combinations	Total number of supported carriers for the declared band combinations (D.27).	x	x
D.29	Intra-system interfering signal declaration list	List of <i>single band connector(s)</i> or <i>multi-band connector(s)</i> for which an intra-system interfering signal level is required to be declared. Declaration is required if the intra-system interfering signal level is larger than the co-location interfering signal level.		x
D.30	Intra-system interfering signal level	The interfering signal level in dBm. Declared per supported <i>operating band</i> , per <i>TAB connector</i> for BS type 1-H covered by D.29.		x
D.31	TAE groups	Set of declared <i>TAB connector beam forming groups</i> on which the TAE requirements apply. <i>All TAB connectors</i> belong to at least one <i>TAB connector beam forming group</i> (even if it's a <i>TAB connector beam forming group</i> consisting of one connector). The smallest possible number of <i>TAB connector beam forming groups</i> need to be declared such that there is no <i>TAB connector</i> not contained in at least one of the declared <i>TAB connector beam forming groups</i> . Declared per supported <i>operating band</i> .		x

Declaration identifier	Declaration	Description	Applicability	
			BS type 1-C	BS type 1-H
D.32	Equivalent connectors	List of <i>antenna connectors</i> of BS type 1-C, or <i>TAB connector</i> of BS type 1-H, which have been declared equivalent. Equivalent connectors imply that the <i>antenna connector</i> of BS type 1-C, or <i>TAB connector</i> of BS type 1-H, are expected to behave in the same way when presented with identical signals under the same operating conditions. All declarations made for the <i>antenna connector</i> of BS type 1-C, or <i>TAB connector</i> of BS type 1-H are identical and the transmitter unit and/or receiver unit driving the <i>antenna connector</i> of BS type 1-C or <i>TAB connector</i> of BS type 1-H are of identical design.	x	x
D.33	<i>TAB connector RX min cell group</i>	Declared as a group of <i>TAB connectors</i> to which RX requirements are applied. This declaration corresponds to group of <i>TAB connectors</i> which are responsible for receiving a cell when the BS type 1-H setting corresponding to the declared minimum number of cells ( $N_{\text{cells}}$ ) with transmission on all <i>TAB connectors</i> supporting an <i>operating band</i> .		x
D.34	<i>TAB connector TX min cell group</i>	Declared group of <i>TAB connectors</i> to which TX requirements are applied. This declaration corresponds to group of <i>TAB connectors</i> which are responsible for transmitting a cell when the BS type 1-H setting corresponding to the declared minimum number of cells ( $N_{\text{cells}}$ ) with transmission on all <i>TAB connectors</i> supporting an <i>operating band</i> .		x
D.35	Connecting network loss range for BS testing with ancillary RF amplifiers	Declaration of the range of connecting network losses (in dB) for BS type 1-C testing with ancillary Tx RF amplifier only, or with Rx RF amplifier only, or with combined Tx/Rx RF amplifiers. (Note 4)	x	
D.36	Relation between supported maximum RF bandwidth, number of carriers and Rated total output power	If the rated total output power and total number of supported carriers are not simultaneously supported, the manufacturer shall declare the following additional parameters: - The reduced number of supported carriers at the rated total output power; - The reduced total output power at the maximum number of supported carriers.	x	x
D.37	<i>TAB connectors</i> used for performance requirement testing	To reduce test complexity, declaration of a representative (sub)set of <i>TAB connectors</i> to be used for performance requirement test purposes. At least one <i>TAB connector</i> mapped to each <i>demodulation branch</i> is declared.		x
D.38	Inter-band CA	Band combinations declared to support inter-band CA (per CA capable <i>multi-band connector(s)</i> , as in D.15). Declared for every <i>multi-band connector</i> which support CA.	x	x
D.39	Intra-band contiguous CA	Bands declared to support intra-band contiguous CA (per CA capable <i>single band connector(s)</i> or <i>multi-band connector(s)</i> , as in D.15). Declared per <i>antenna connector</i> for BS type 1-C, or <i>TAB connector</i> for BS type 1-H.	x	x
D.40	Intra-band non-contiguous CA	Bands declared to support intra-band non-contiguous CA (per CA capable <i>single band connector(s)</i> or <i>multi-band connector(s)</i> , as in D.15). Declared per <i>antenna connector</i> for BS type 1-C, or <i>TAB connector</i> for BS type 1-H.	x	x
NOTE 1: If a BS is capable of 256QAM DL operation then two rated output power declarations may be made. One declaration is applicable when configured for 256QAM transmissions and the other declaration is applicable when not configured for 256QAM transmissions.				
NOTE 2: Parameters for contiguous or non-contiguous spectrum operation in the operating band are assumed to be the same unless they are separately declared.				
NOTE 3: If BS is declared to support Band n20 (D.3), the manufacturer shall declare if the BS may operate in geographical areas allocated to broadcasting (DTT). Additionally, related declarations of the emission levels and maximum output power shall be declared.				
NOTE 4: This manufacturer declaration is optional.				

## 4.7 Test configurations

### 4.7.1 General

The test configurations shall be constructed using the methods defined below, subject to the parameters declared by the manufacturer for the supported RF configurations as listed in subclause 4.6. The test configurations to use for conformance testing are defined for each supported RF configuration in subclauses 4.8.3 and 4.8.4.

The applicable test models for generation of the carrier transmit test signal are defined in subclause 4.9.

NOTE: In case, carriers are shifted to align with the channel raster  $F_{\text{offset}}$ .

### 4.7.2 Test signal used to build Test Configurations

The signal's Channel Bandwidth and Subcarrier spacing used to build NR Test Configurations shall be selected according to table 4.7.2-1.

**Table 4.7.2-1: Signal to be used to build NR TCs**

Operating Band characteristics		$F_{\text{DL\_high}} - F_{\text{DL\_low}} < 100 \text{ MHz}$	$F_{\text{DL\_high}} - F_{\text{DL\_low}} \geq 100 \text{ MHz}$
TC signal characteristics	$BW_{\text{channel}}$	5 MHz (Note 1)	20 MHz (Note 1)
	Subcarrier spacing	Smallest supported subcarrier spacing	
Note 1: If this channel bandwidth is not supported, the narrowest supported channel bandwidth shall be used.			

### 4.7.3 NRTC1: Contiguous spectrum operation

The purpose of test configuration NRTC1 is to test all BS requirements excluding CA occupied bandwidth.

For NRTC1 used in receiver tests only the two outermost carriers within each supported operating band need to be generated by the test equipment;

#### 4.7.3.1 NRTC1 generation

NRTC1 shall be constructed on a per band basis using the following method:

- Declared maximum Base Station RF Bandwidth supported for contiguous spectrum operation (D.11) shall be used;
- Select the carrier to be tested according to 4.7.2 and place it adjacent to the lower Base Station RF Bandwidth edge. Place same signal adjacent to the upper Base Station RF Bandwidth edge.
- For transmitter tests, select as many carriers (according to 4.7.2) that the BS supports within an *operating band* and fit in the rest of the declared maximum Base Station RF Bandwidth (D.11). Place the carriers adjacent to each other starting from the upper Base Station RF Bandwidth edge. The nominal channel spacing defined in TS 38.104 [2], subclause 5.4.1 shall apply.

The test configuration should be constructed sequentially on a per band basis for all component carriers of the inter-band CA bands declared to be supported by the BS and are transmitted using the same *antenna connector*. All configured component carriers are transmitted simultaneously in the tests where the transmitter should be ON.

#### 4.7.3.2 NRTC1 power allocation

Set the power spectral density of each carrier to the same level so that the sum of the carrier powers equals the rated total output power ( $P_{\text{rated,t,AC}}$ , or  $P_{\text{rated,t,TABC}}$ , D.22) according to the manufacturer's declaration in subclause 4.6.

### 4.7.4 NRTC2: Contiguous CA occupied bandwidth

NRTC2 in this subclause is used to test CA occupied bandwidth.

#### 4.7.4.1 NRTC2 generation

The CA specific test configuration should be constructed on a per band basis using the following method:

- All component carrier combinations supported by the BS, which have different sum of channel bandwidth of component carrier, shall be tested. For all component carrier combinations which have the same sum of channel bandwidth of component carriers, only one of the component carrier combinations shall be tested.
- Of all component carrier combinations which have same sum of channel bandwidth of component carrier, select those with the narrowest carrier with the smallest supported subcarrier spacing at the lower Base Station RF Bandwidth edge.
- Of the combinations selected in the previous step, select one with the narrowest carrier with the smallest supported subcarrier spacing at the upper Base Station RF Bandwidth edge.
- If there are multiple combinations fulfilling previous steps, select the one with the smallest number of component carrier.
- If there are multiple combinations fulfilling previous steps, select the one with the widest carrier with the smallest supported subcarrier spacing being adjacent to the lowest carrier.
- If there are multiple combinations fulfilling previous steps, select the one with the widest carrier with the smallest supported subcarrier spacing being adjacent to the highest carrier.
- If there are multiple combinations fulfilling previous steps, select the one with the widest carrier with the smallest supported subcarrier spacing being adjacent to the carrier which has been selected in the previous step.
- If there are multiple combinations fulfilling previous steps, repeat the previous step until there is only one combination left.
- The nominal channel spacing defined in TS 38.104 [2], subclause 5.4.1 shall apply.

#### 4.7.4.2 NRTC2 power allocation

Set the power spectral density of each carrier to be the same level so that the sum of the carrier powers equals the rated total output power ( $P_{\text{rated,t,AC}}$ , or  $P_{\text{rated,t,TABC}}$ , D.22) for NR according to the manufacturer's declaration in subclause 4.6.

#### 4.7.5 NRTC3: Non-contiguous spectrum operation

The purpose of NRTC3 is to test all BS requirements excluding CA occupied bandwidth.

For NRTC3 used in receiver tests, outermost carriers for each sub-block need to be generated by the test equipment; other supported carriers are optional to be generated.

##### 4.7.5.1 NRTC3 generation

NRTC3 is constructed on a per band basis using the following method:

- The Base Station RF Bandwidth shall be the maximum Base Station RF Bandwidth supported for non-contiguous spectrum operation (D.11). The Base Station RF Bandwidth consists of one sub-block gap and two sub-blocks located at the edges of the declared maximum supported Base Station RF Bandwidth (D.11).
- Select the carrier to be tested according to 4.7.2. Place it adjacent to the upper Base Station RF Bandwidth edge and another carrier (as described in 4.7.2) adjacent to the lower Base Station RF Bandwidth edge.
- For single-band operation receiver tests, if the remaining gap is at least 15 MHz (or 60 MHz if channel bandwidth of the carrier to be tested is 20 MHz) plus two times the channel BW used in the previous step and the BS supports at least 4 carriers, place a carrier of this BW adjacent to each already placed carrier for each sub-block. The nominal channel spacing defined in TS 38.104 [2], subclause 5.4.1 shall apply.
- The sub-block edges adjacent to the sub-block gap shall be determined using the specified  $F_{\text{Offset}}$  for the carriers adjacent to the sub-block gap.

#### 4.7.5.2 NRTC3 power allocation

Set the power of each carrier to the same level so that the sum of the carrier powers equals the rated total output power ( $P_{\text{rated,t,AC}}$ , or  $P_{\text{rated,t,TABC}}$ , D.22) according to the manufacturer's declaration in subclause 4.6.

### 4.7.6 NRTC4: Multi-band test configuration for full carrier allocation

The purpose of NRTC4 is to test multi-band operation aspects considering maximum supported number of carriers.

#### 4.7.6.1 NRTC4 generation

NRTC4 is based on re-using the previously specified test configurations (NRTC1, NRTC2 and NRTC3) applicable per band involved in multi-band operation. It is constructed using the following method:

- The Base Station RF Bandwidth of each supported operating band shall be the declared maximum Base Station RF Bandwidth in multi-band operation (D.12).
- The number of carriers of each supported *operating band* shall be the declared maximum number of supported carriers in multi-band operation (D.17). Carriers shall be selected according to 4.7.2 and shall first be placed at the outermost edges of the declared maximum Radio Bandwidth. Additional carriers shall next be placed at the Base Station RF Bandwidths edges, if possible.
- The allocated Base Station RF Bandwidth of the outermost bands shall be located at the outermost edges of the declared maximum Radio Bandwidth.
- Each concerned band shall be considered as an independent band and the carrier placement in each band shall be according to NRTC1, where the declared parameters for multi-band operation shall apply. The mirror image of the single-band test configuration shall be used in each alternate band(s) and in the highest band being.
- If only three carriers are supported, two carriers shall be placed in one band according to the relevant test configuration while the remaining carrier shall be placed at the edge of the maximum *Radio Bandwidth* in the other band.
- If the sum of the maximum Base Station RF Bandwidths of each supported *operating bands* is larger than the declared *Total RF Bandwidth*  $BW_{\text{tot}}$  (D.13) of transmitter and receiver for the declared band combinations of the BS, repeat the steps above for test configurations where the Base Station RF Bandwidth of one of the operating band shall be reduced so that the *Total RF Bandwidth* of transmitter and receiver is not exceeded and vice versa.
- If the sum of the maximum number of supported carrier of each supported operating bands in multi-band operation (D.18) is larger than the declared total number of supported carriers for the declared band combinations of the BS (D.28), repeat the steps above for test configurations where in each test configuration the number of carriers of one of the operating band shall be reduced so that the total number of supported carriers is not exceeded and vice versa.

#### 4.7.6.2 NRTC4 power allocation

Unless otherwise stated, set the power of each carrier in all supported *operating bands* to the same power so that the sum of the carrier powers equals the rated total output power ( $P_{\text{rated,t,AC}}$  or  $P_{\text{rated,t,TABC}}$ , D.22) according to the manufacturer's declaration.

If the allocated power of a supported *operating band(s)* exceeds the declared rated total output power of the *operating band(s)* in multi-band operation, the exceeded part shall, if possible, be reallocated into the other band(s). If the power allocated for a carrier exceeds the rated output power declared for that carrier, the exceeded power shall, if possible, be reallocated into the other carriers.

### 4.7.7 NRTC5: Multi-band test configuration with high PSD per carrier

The purpose of NRTC5 is to test multi-band operation aspects considering higher PSD cases with reduced number of carriers and non-contiguous operation (if supported) in multi-band mode.

#### 4.7.7.1 NRTC5 generation

NRTC5 is based on re-using the existing test configuration applicable per band involved in multi-band operation. It is constructed using the following method:

- The Base Station RF Bandwidth of each supported *operating band* shall be the declared maximum Base Station RF Bandwidth in multi-band operation (D.12).
- The allocated Base Station RF Bandwidth of the outermost bands shall be located at the outermost edges of the declared Maximum Radio Bandwidth.
- The maximum number of carriers is limited to two per band. Carriers shall be selected according to 4.7.2 and shall first be placed at the outermost edges of the declared Maximum Radio Bandwidth for outermost bands and at the Base Station RF Bandwidths edges for middle band(s) if any. Additional carriers shall next be placed at the Base Station RF Bandwidths edges, if possible.
- Each concerned band shall be considered as an independent band and the carrier placement in each band shall be according to NRTC3, where the declared parameters for multi-band operation shall apply. [Narrowest supported NR channel bandwidth and smallest subcarrier spacing shall be used in the test configuration].
- If only one carrier can be placed for the concerned band(s), the carrier(s) shall be placed at the outermost edges of the declared maximum radio bandwidth for outermost band(s) and at one of the outermost edges of the supported frequency range within the Base Station RF Bandwidths for middle band(s) if any.
- If the sum of the maximum Base Station RF Bandwidth of each supported operating bands is larger than the declared *Total RF Bandwidth*  $BW_{tot}$  (D.13) of transmitter and receiver for the declared band combinations of the BS, repeat the steps above for test configurations where the Base Station RF Bandwidth of one of the operating band shall be reduced so that the *Total RF Bandwidth*  $BW_{tot}$  of transmitter and receiver is not exceeded and vice versa.

#### 4.7.7.2 NRTC5 power allocation

Unless otherwise stated, set the power of each carrier in all supported *operating bands* to the same power so that the sum of the carrier powers equals the total rated output power ( $P_{rated,t,AC}$  or  $P_{rated,t,TABC}$ , D.22) according to the manufacturer's declaration.

If the allocated power of a supported *operating band(s)* exceeds the declared rated total output power of the *operating band(s)* in multi-band operation, the exceeded part shall, if possible, be reallocated into the other band(s). If the power allocated for a carrier exceeds the rated output power declared for that carrier, the exceeded power shall, if possible, be reallocated into the other carriers.

## 4.8 Applicability of requirements

### 4.8.1 General

### 4.8.2 Requirement set applicability

In table 4.8.2-1, the requirement applicability for each requirement set is defined. For each requirement, the applicable requirement subclause in the specification is identified.



**Table 4.8.2-1: Requirement set applicability**

Requirement	Requirement set	
	1-C	1-H
BS output power	6.2.2.5.1	6.2.2.5.2
Output power dynamics	6.3	6.3
Transmit ON/OFF power	6.4	6.4
Transmitted signal quality	6.5	6.5
Occupied bandwidth	6.6.2	6.6.2
ACLR	6.6.3.5.3	6.6.3.5.4
Operating band unwanted emissions	6.6.4.5.3	6.6.4.5.4
Transmitter spurious emissions	6.6.5.5.3	6.6.5.5.4
Transmitter intermodulation	6.7.5.1	6.7.5.2
Reference sensitivity level	7.2	7.2
Dynamic range	7.3	7.3
In-band selectivity and blocking	7.4	7.4
Out-of-band blocking	7.5	7.5
Receiver spurious emissions	7.6.5.2	7.6.5.3
Receiver intermodulation	7.7	7.7
In-channel selectivity	7.8	7.8
Performance requirements	8	8

### 4.8.3 Applicability of test configurations for single-band operation

The applicable test configurations are specified in the tables below for each the supported RF configuration, which shall be declared according to subclause 4.6. The generation and power allocation for each test configuration is defined in subclause 4.7. This subclause contains the test configurations for a BS capable of single carrier, multi-carrier and/or CA operation in both contiguous and non-contiguous spectrum in single band.

For a BS declared to be capable of single carrier operation only (D.16), a single carrier (SC) shall be used for testing.

For a BS declared to support multi-carrier and/or CA operation in contiguous spectrum within a single band (D.15-D.16), the test configurations in the second column of table 4.8.3-1 shall be used for testing.

For a BS declared to support multi-carrier and/or CA operation in contiguous and non-contiguous spectrum within a single band (D.15-D.16) and where the parameters in the manufacture's declaration according to subclause 4.6 are identical for contiguous (C) and non-contiguous (NC) spectrum operation (D.9), the test configurations in the third column of table 4.8.3-1 shall be used for testing.

For a BS declared to support multi-carrier and/or CA in operation contiguous and non-contiguous spectrum within a single band (D.15-D.16) and where the parameters in the manufacture's declaration according to subclause 4.6 are not identical for contiguous (C) and non-contiguous (NC) spectrum operation (D.9), the test configurations in the fourth column of table 4.8.3-1 shall be used for testing.

Unless otherwise stated, single carrier configuration (SC) tests shall be performed using signal with narrowest supported Channel Bandwidth and the smallest supported sub-carrier spacing.

Table 4.8.3-1: Test configurations for a BS capable of multi-carrier and/or CA in a single band

BS test case	Contiguous spectrum capable BS	C and NC capable BS with identical parameters	C and NC capable BS with different parameters
Base station output power	NRTC1	NRTC1	NRTC1, NRTC3
RE Power control dynamic range	Tested with Error Vector Magnitude	Tested with Error Vector Magnitude	Tested with Error Vector Magnitude
Total power dynamic range	SC	SC	SC
Transmit ON/OFF power (only applied for NR TDD BS)	NRTC1	NRTC1	NRTC1, NRTC3
Frequency error	Tested with Error Vector Magnitude	Tested with Error Vector Magnitude	Tested with Error Vector Magnitude
Error Vector Magnitude	NRTC1	NRTC1	NRTC1, NRTC3
Time alignment error	NRTC1	NRTC1	NRTC1, NRTC3
Occupied bandwidth	SC, NRTC2 (Note 1)	SC, NRTC2 (Note 1)	SC, NRTC2 (Note 1)
Adjacent Channel Leakage power Ratio (ACLR)	NRTC1	NRTC3	NRTC1, NRTC3
Cumulative ACLR requirement in non-contiguous spectrum	-	NRTC3	NRTC3
Operating band unwanted emissions	NRTC1, SC (Note 2)	NRTC1, NRTC3, SC (Note 2)	NRTC1, NRTC3, SC (Note 2)
Transmitter spurious emissions	NRTC1	NRTC3	NRTC1, NRTC3
Transmitter intermodulation	NRTC1	NRTC1, NRTC3	NRTC1, NRTC3
Reference sensitivity level	SC	SC	SC
Dynamic range	SC	SC	SC
Adjacent Channel Selectivity (ACS)	NRTC1	NRTC3	NRTC1, NRTC3
In-band blocking	NRTC1	NRTC3	NRTC1, NRTC3
Out-of-band blocking	NRTC1	NRTC3	NRTC1, NRTC3
Receiver spurious emissions	NRTC1	NRTC3	NRTC1, NRTC3
Receiver intermodulation	NRTC1	NRTC3	NRTC1, NRTC3
In-channel selectivity	SC	SC	SC
Note 1: NRTC2 is only applicable when contiguous CA is supported.			
Note 2: OBUE SC shall be tested using the widest supported Channel Bandwidth and the highest supported sub-carrier spacing.			

#### 4.8.4 Applicability of test configurations for multi-band operation

For a BS declared to be capable of multi-band operation, the test configuration in table 4.8.4-1 and/or table 4.8.3-1 shall be used for testing. In the case where multiple bands are mapped on common *multi-band connector*, the test configuration in the second column of table 4.8.4-1 shall be used. In the case where multiple bands are mapped on common *single-band connector*, the test configuration in table 4.8.3-1 shall be used. In the case where multiple bands are mapped on separate *single-band connector* or *multi-band connector*, the test configuration in the third column of table 4.8.4-1 shall be used.

Unless otherwise stated, single carrier configuration (SC) tests shall be performed using signal with narrowest supported Channel Bandwidth and the smallest supported sub-carrier spacing.

**Table 4.8.4-1: Test configuration for a BS capable of multi-band operation**

BS test case	Test configuration	
	Common connector	Separate connectors
Base station output power	NRTC1/3 (Note 1), NRTC4	NRTC1/3 (Note 1), NRTC4
RE Power control dynamic range	Tested with Error Vector Magnitude	Tested with Error Vector Magnitude
Total power dynamic range	SC	SC
Transmit ON/OFF power (only applied for NR TDD BS)	NRTC4	NRTC4
Frequency error	Tested with Error Vector Magnitude	Tested with Error Vector Magnitude
Error Vector Magnitude	NRTC1/3 (Note 1), NRTC4	NRTC1/3 (Note 1), NRTC4
Time alignment error	NRTC1/3 (Note 1), NRTC5 (Note 2)	NRTC1/3 (Note 1), NRTC5 (Note 2)
Occupied bandwidth	SC, NRTC2 (Note 3)	SC, NRTC2 (Note 3)
Adjacent Channel Leakage power Ratio (ACLR)	NRTC1/3 (Note 1), NRTC5 (Note 4)	NRTC1/3 (Note 1, 5), NRTC5 (Note 4, 5)
Cumulative ACLR requirement in non-contiguous spectrum	NRTC3 (Note 1), NRTC5 (Note 4)	NRTC3 (Note 1, 5)
Operating band unwanted emissions	NRTC1/3 (Note 1), NRTC5, SC (Note 7)	NRTC1/3 (Note 1, 5), NRTC5 (Note 5), SC (Note 7)
Transmitter spurious emissions	NRTC1/3 (Note 1), NRTC5	NRTC1/3 (Note 1, 5), NRTC5 (Note 5)
Transmitter intermodulation	NRTC1/3 (Note 1)	NRTC1/3 (Note 1, 5)
Reference sensitivity level	SC	SC
Dynamic range	SC	SC
Adjacent Channel Selectivity(ACS)	NRTC5	NRTC1/3 (Note 1), NRTC5 (Note 6)
In-band blocking	NRTC5	NRTC1/3 (Note 1), NRTC5 (Note 6)
Out-of-band blocking	NRTC5	NRTC1/3 (Note 1), NRTC5 (Note 6)
Receiver spurious emissions	NRTC1/3 (Note 1), NRTC5	NRTC1/3 (Note 1, 5), NRTC5 (Note 5)
Receiver intermodulation	NRTC5	NRTC1/3 (Note 1), NRTC5 (Note 6)
In-channel selectivity	SC	SC
Note 1: NRTC1 and/or NRTC3 shall be applied in each supported operating band. Note 2: NRTC5 is only applicable when inter-band CA is supported. Note 3: NRTC2 is only applicable when contiguous CA is supported. Note 4: NRTC5 may be applied for Inter RF Bandwidth gap only. Note 5: For single-band operation test, other antenna connector(s) is (are) terminated. Note 6: NRTC5 is only applicable for multi-band receiver. Note 7: OBUE SC shall be tested using the widest supported Channel Bandwidth and the highest supported sub-carrier spacing.		

## 4.9 RF channels and test models

### 4.9.1 RF channels

For the single carrier testing many tests in this TS are performed with appropriate frequencies in the bottom, middle and top channels of the supported frequency range of the BS. These are denoted as RF channels B (bottom), M (middle) and T (top).

Unless otherwise stated, the test shall be performed with a single carrier at each of the RF channels B, M and T.

Many tests in this TS are performed with the maximum Base Station RF Bandwidth located at the bottom, middle and top of the supported frequency range in the operating band. These are denoted as  $B_{RFBW}$  (bottom),  $M_{RFBW}$  (middle) and  $T_{RFBW}$  (top).

Unless otherwise stated, the test shall be performed at  $B_{RFBW}$ ,  $M_{RFBW}$  and  $T_{RFBW}$  defined as following:

- $B_{\text{RFBW}}$ : maximum Base Station RF Bandwidth located at the bottom of the supported frequency range in the operating band.
- $M_{\text{RFBW}}$ : maximum Base Station RF Bandwidth located in the middle of the supported frequency range in the operating band.
- $T_{\text{RFBW}}$ : maximum Base Station RF Bandwidth located at the top of the supported frequency range in the operating band.

Occupied bandwidth test in this TS is performed with the Aggregated BS Channel Bandwidth and sub-block bandwidths located at the bottom, middle and top of the supported frequency range in the operating band. These are denoted as  $B_{\text{BW Channel CA}}$ (bottom),  $M_{\text{BW Channel CA}}$  (middle) and  $T_{\text{BW Channel CA}}$  (top) for contiguous spectrum operation.

Unless otherwise stated, the test for contiguous spectrum operation shall be performed at  $B_{\text{BW Channel CA}}$ ,  $M_{\text{BW Channel CA}}$  and  $T_{\text{BW Channel CA}}$  defined as following:

- $B_{\text{BW Channel CA}}$ : Aggregated BS Channel Bandwidth located at the bottom of the supported frequency range in each operating band;
- $M_{\text{BW Channel CA}}$ : Aggregated BS Channel Bandwidth located close in the middle of the supported frequency range in each operating band;
- $T_{\text{BW Channel CA}}$ : Aggregated BS Channel Bandwidth located at the top of the supported frequency range in each operating band.

For BS capable of multi-band operation, unless otherwise stated, the test shall be performed at  $B_{\text{RFBW}_T}$  and  $B'_{\text{RFBW}_T}$  defined as following:

- $B_{\text{RFBW}_T}$ : the *Base Station RF Bandwidths* located at the bottom of the supported frequency range in the lowest operating band and at the highest possible simultaneous frequency position, within the Maximum Radio Bandwidth, in the highest operating band.
- $B'_{\text{RFBW}_T}$ : the *Base Station RF Bandwidths* located at the top of the supported frequency range in the highest operating band and at the lowest possible simultaneous frequency position, within the Maximum Radio Bandwidth, in the lowest operating band.

NOTE:  $B_{\text{RFBW}_T} = B'_{\text{RFBW}_T} = B_{\text{RFBW}_T}$  when the declared Maximum Radio Bandwidth spans all operating bands.  $B_{\text{RFBW}_T}$  means the *Base Station RF Bandwidths* are located at the bottom of the supported frequency range in the lower operating band and at the top of the supported frequency range in the upper operating band.

When a test is performed by a test laboratory, the position of B, M and T for single carrier,  $B_{\text{RFBW}}$ ,  $M_{\text{RFBW}}$  and  $T_{\text{RFBW}}$  for single band operation,  $B_{\text{BW Channel CA}}$ ,  $M_{\text{BW Channel CA}}$  and  $T_{\text{BW Channel CA}}$  for contiguous spectrum operation in each supported operating band, the position of  $B_{\text{RFBW}_T}$  and  $B'_{\text{RFBW}_T}$  in the supported operating band combinations shall be specified by the laboratory. The laboratory may consult with operators, the manufacturer or other bodies.

## 4.9.2 Test models

### 4.9.2.1 General

The following subclauses will describe the NR FR1 test models needed for *BS type I-C* and *BS type I-H*. Note that the NR FR1 test models are also applicable to *BS type I-O* conformance testing in TS 38.141-2 [3].

### 4.9.2.2 NR FR1 test models

The set-up of physical channels for transmitter tests shall be according to one of the NR FR1 test models (NR-FR1-TM) below. A reference to the applicable test model is made within each test.

The following general parameters are used by all NR test models:

- Duration is 1 radio frame (10 ms) for FDD and 2 radio frames for TDD (20 ms)
- The slots are numbered 0 to  $10 \times 2^\mu - 1$  where  $\mu$  is the numerology corresponding to the subcarrier spacing
- $N_{\text{RB}}$  is the maximum transmission bandwidth configuration seen in table 5.3.2-1 in TS 38.104 [2].

- Normal CP
- Virtual resource blocks of localized type

For NR FR1-TDD, test models are derived based on the uplink/downlink configuration as shown in the table 4.9.2.2-1 using information element *TDD-UL-DL-ConfigCommon* [19].

**Table 4.9.2.2-1: Configurations of TDD for BS type 1-C and BS type 1-H test models**

Field name	Value		
referenceSubcarrierSpacing (kHz)	15	30	60
Periodicity (ms) for dl-UL-TransmissionPeriodicity	5	5	5
nrofDownlinkSlots	3	7	14
nrofDownlinkSymbols	10	6	12
nrofUplinkSlots	1	2	4
nrofUplinkSymbols	2	4	8

Common physical channel parameters for all NR FR1 test models are specified in the following tables: table 4.9.2.2-2 for PDCCH, table 4.9.2.2-3 for PDSCH. Specific physical channel parameters for NR FR1 test models are described in subclauses 4.9.2.2.1 to 4.9.2.2.8.

**Table 4.9.2.2-2: Common physical channel parameters for PDCCH for BS type 1-C and BS type 1-H test models**

Parameter	Value
# of symbols used for control channel	2
Starting symbol number for control channel	0
# of CCEs allocated to PDCCH	1
Starting RB location for PDCCH	0
# of available REGs	6
Aggregation level	1
# of RBs not allocated for PDCCH in each symbol	$N_{RB} - 3$
Ratio of PDCCH EPRE to DM-RS EPRE	0 dB
Boosting level of control region	0 dB

**Table 4.9.2.2-3: Common physical channel parameters for PDSCH for BS type 1-C and BS type 1-H test models**

Parameter	Value
Mapping type	PDSCH mapping type A
<i>dmrs-TypeA-Position</i> for the first DM-RS symbol	'pos2'
<i>dmrs-AdditionalPosition</i> for additional DM-RS symbol(s)	1
<i>dmrs-Type</i> for comb pattern	Configuration type 1
<i>maxLength</i>	1
Ratio of PDSCH EPRE to DM-RS EPRE	0 dB

#### 4.9.2.2.1 NR FR1 test model 1.1 (NR-FR1-TM1.1)

This model shall be used for tests on:

- BS output power
- Transmit ON/OFF power- TAE
- Unwanted emissions
- Occupied bandwidth

- ACLR
- Operating band unwanted emissions
- Transmitter spurious emissions
- Transmitter intermodulation
- Receiver spurious emissions

Common physical channel parameters are defined in subclause 4.9.2.2. Specific physical channel parameters for NR-FR1-TM1.1 are defined in table 4.9.2.2.1-1.

**Table 4.9.2.2.1-1: Specific physical channel parameters of NR-FR1-TM1.1**

Parameter	Value
# of QPSK PDSCH PRBs	$N_{RB}$
Ratio of PDSCH EPRE to PDCCH EPRE	0 dB

#### 4.9.2.2.2 NR FR1 test model 1.2 (NR-FR1-TM1.2)

This model shall be used for tests on:

- Unwanted emissions
  - ACLR
  - Operating band unwanted emissions

Common physical channel parameters are defined in subclause 4.9.2.2. Specific physical channel parameters for NR-FR1-TM1.2 are defined in table 4.9.2.2.2-1.

**Table 4.9.2.2.2-1: Specific physical channel parameters of NR-FR1-TM1.2**

Parameter	Value
Percent of QPSK PDSCH PRBs boosted (target)	$x=40\%$
# of QPSK PDSCH RBGs which are boosted	$N_{RBG} = \min\left(\left\lfloor \frac{xN_{RB}}{P} \right\rfloor, \frac{1}{2}\left(\left\lfloor \frac{N_{RB}}{P} \right\rfloor - \left\lfloor \frac{N_{RB}}{P} \right\rfloor \bmod 2\right) + 1\right)$ , where P is determined from table 5.1.2.2.1-1 from TS 38.214 [18], configuration 1 column using $N_{RB}$
Level of boosting (dB)	3
$N_{RBG}$ location of PDSCH RBGs which are boosted	First $N_{RBG} - 1$ locations: 0, 2, 4, ..., $2(N_{RBG} - 2)$ and last location: $\left\lfloor \frac{N_{RB}}{P} \right\rfloor - 1$
# of QPSK PDSCH PRBs which are deboosted	$N_{RB} - PN_{RBG}$
Level of deboosting (dB)	$10 \log_{10} \frac{N_{RB} - 10^{3/10} PN_{RBG}}{N_{RB} - PN_{RBG}}$

#### 4.9.2.2.3 NR FR1 test model 2 (NR-FR1-TM2)

This model shall be used for tests on:

- Total power dynamic range (lower OFDM symbol power limit at min power)
- EVM of single 64QAM PRB allocation (at min power)
- Frequency error (at min power)

Common physical channel parameters are defined in subclause 4.9.2.2. Specific physical channel parameters for NR-FR1-TM2 are defined in table 4.9.2.2.3-1.

**Table 4.9.2.2.3-1: Specific physical channel parameters of NR-FR1-TM2**

Parameter	Value		
# of 64QAM PDSCH PRBs	1		
Level of boosting (dB)	0		
Location of 64QAM PRB	Slot	RB	n
	$3n$	0	$n = 0, \dots, \left\lfloor \frac{10 \times 2^\mu}{3} \right\rfloor - 1$
	$3n+1$	$\left\lfloor \frac{N_{RB}}{2} \right\rfloor$	$n = 0, \dots, \left\lfloor \frac{10 \times 2^\mu - 1}{3} \right\rfloor - 1$
	$3n+2$	$N_{RB} - 1$	$n = 0, \dots, \left\lfloor \frac{10 \times 2^\mu - 2}{3} \right\rfloor - 1$
# of PDSCH PRBs which are not allocated	$N_{RB} - 1$		

#### 4.9.2.2.4 NR FR1 test model 2a (NR-FR1-TM2a)

This model shall be used for tests on:

- Total power dynamic range (lower OFDM symbol power limit at min power)
- EVM of single 256QAM PRB allocation (at min power)
- Frequency error (at min power)

Physical channel parameters and numbers of the allocated PRB are defined in table 4.9.2.2.3-1 with all 64QAM PDSCH PRBs replaced by 256QAM PDSCH PRBs.

#### 4.9.2.2.5 NR FR1 test model 3.1 (NR-FR1-TM3.1)

This model shall be used for tests on:

- Output power dynamics
- Total power dynamic range (upper OFDM symbol power limit at max power with all 64QAM PRBs allocated)
- Transmitted signal quality
- Frequency error
- EVM for 64QAM modulation (at max power)

Physical channel parameters are defined in table 4.9.2.2.1-1 with all QPSK PDSCH PRBs replaced by 64QAM PDSCH PRBs.

#### 4.9.2.2.6 NR FR1 test model 3.1a (NR-FR1-TM3.1a)

This model shall be used for tests on:

- Output power dynamics
- Total power dynamic range (upper OFDM symbol power limit at max power with all 256QAM PRBs allocated)
- Transmitted signal quality
- Frequency error
- EVM for 256QAM modulation (at max power)

Physical channel parameters are defined in table 4.9.2.2.1-1 with all QPSK PDSCH PRBs replaced by 256QAM PDSCH PRBs.

## 4.9.2.2.7 NR FR1 test model 3.2 (NR-FR1-TM3.2)

This model shall be used for tests on:

- Transmitted signal quality
  - Frequency error
  - EVM for 16QAM modulation

Common physical channel parameters are defined in subclause 4.9.2.2. Specific physical channel parameters for NR-FR1-TM3.2 are defined in table 4.9.2.2.7-1.

**Table 4.9.2.2.7-1: Specific physical channel parameters of NR-FR1-TM3.2**

Parameter	Value
Percent of 16QAM PDSCH PRBs deboosted (target)	$x = 60\%$
# of 16QAM PDSCH RBGs within a slot for which EVM is measured	$N_{RBG} = \min\left(\left\lfloor \frac{xN_{RB}}{P} \right\rfloor, \frac{1}{2}\left(\left\lfloor \frac{N_{RB}}{P} \right\rfloor - \left\lfloor \frac{N_{RB}}{P} \right\rfloor \bmod 2\right) + 1\right)$ , where P is determined from table 5.1.2.2.1-1 from TS 38.214 [18], configuration 1 column using $N_{RB}$
Level of deboosting (dB)	-3
$N_{RBG}$ locations of 16QAM RBGs which are deboosted	First $N_{RBG} - 1$ locations: $0, 2, 4, \dots, 2(N_{RBG} - 2)$ and last location: $\left\lfloor \frac{N_{RB}}{P} \right\rfloor - 1$
# of QPSK PDSCH PRBs within a slot for which EVM is not measured (used for power balancing only)	$N_{RB} - PN_{RBG}$
Level of boosting (dB)	$10 \log_{10} \frac{N_{RB} - 10^{-3/10} PN_{RBG}}{N_{RB} - PN_{RBG}}$

## 4.9.2.2.8 NR FR1 test model 3.3 (NR-FR1-TM3.3)

This model shall be used for tests on:

- Transmitted signal quality
  - Frequency error
  - EVM for QPSK modulation

Common physical channel parameters are defined in subclause 4.9.2.2. Specific physical channel parameters for NR-FR1-TM3.3 are defined in table 4.9.2.2.8-1.

**Table 4.9.2.2.8-1: Specific physical channel parameters of NR-FR1-TM3.3**

Parameter	Value
Percent of QPSK PDSCH PRBs deboosted (target)	$x = 50\%$
# of QPSK PDSCH RBGs within a slot for which EVM is measured	$N_{RBG} = \min\left(\left\lfloor \frac{xN_{RB}}{P} \right\rfloor, \frac{1}{2}\left(\left\lfloor \frac{N_{RB}}{P} \right\rfloor - \left\lfloor \frac{N_{RB}}{P} \right\rfloor \bmod 2\right) + 1\right)$ , where P is determined from table 5.1.2.2.1-1 from TS 38.214 [18], configuration 1 column using $N_{RB}$
Level of deboosting (dB)	-6
$N_{RBG}$ locations of QPSK RBGs which are deboosted	First $N_{RBG} - 1$ locations: $0, 2, 4, \dots, 2(N_{RBG} - 2)$ and last location: $\left\lfloor \frac{N_{RB}}{P} \right\rfloor - 1$
# of 16QAM PDSCH PRBs within a slot for which EVM is not measured (used for power balancing only)	$N_{RB} - PN_{RBG}$
Level of boosting (dB)	$10 \log_{10} \frac{N_{RB} - 10^{-6/10} PN_{RBG}}{N_{RB} - PN_{RBG}}$



### 4.9.2.3 Data content of Physical channels and Signals for NR-FR1-TM

Randomisation of the data content is obtained by utilizing the length-31 Gold sequence scrambling of TS 38.211 [17], subclause 5.2.1 which is invoked by all physical channels prior to modulation and mapping to the RE grid. An appropriate number of '0' bits shall be generated prior to the scrambling.

Initialization of the scrambler and RE-mappers as defined in TS 38.211 [17] use the following additional parameters:

- $N_{ID}^{cell} = 1$  for the lowest configured carrier,  $N_{ID}^{cell} = 2$  for the 2<sup>nd</sup> lowest configured carrier, ...,  $N_{ID}^{cell} = n$  for the n<sup>th</sup> configured carrier
- Antenna ports starting with 1000 for PDSCH
- Antenna ports starting with 2000 for PDCCH
- $q = 0$  (single code word)
- Rank 1 (single layer)

#### 4.9.2.3.1 PDCCH

- $N_{symbol}^{CORESET} = 2$
- PDCCH modulation to be QPSK as described in TS 38.211 [17], subclause 5.1.3
- For each slot the required amount of bits for all PDCCHs is as follows: 1(# of PDCCH) \* 1(# of CCE per PDCCH) \* 6(REG per CCE) \* 9(data RE per REG) \* 2(bits per RE) with these parameters according to the NR-FR1-TM definitions in subclause 4.9.2.2
- Generate this amount of bits according to 'all 0' data
- 1 CCE shall be according to TS 38.211 [17], subclause 7.3.2 using non-interleaved CCE-to-REG mapping. PDCCH occupies the first 2 symbols for 6 resource-element groups, where a resource element group equals one resource block during one OFDM symbol.
- Perform PDCCH scrambling according to TS 38.211 [17], subclause 7.3.2.3
- $N_{ID} = N_{ID}^{cell}$  in DM-RS sequence generation in TS 38.211 [17], subclause 7.4.1.3
- $n_{RNTI} = 0$  in scrambling sequence generation in TS 38.211 [17], subclause 7.3.2.3
- Perform mapping to REs according to TS 38.211 [17], subclause 7.3.2.5.

#### 4.9.2.3.2 PDSCH

- For each slot generate the required amount of bits for all PRBs according to 'all 0' data
- NR-FR1-TMs utilize 1 or 2 user PDSCH transmissions distinguished by  $n_{RNTI}$ . For each NR-FR1-TM, PRBs are mapped to user ( $n_{RNTI}$ ) as follows:

**Table 4.9.2.3.2-1: Mapping of PRBs to  $n_{\text{RNTI}}$  for NR-FR1-TM**

Test model	$n_{\text{RNTI}}$	Number of users
NR-FR1-TM1.1	0 for all PRBs	1
NR-FR1-TM1.2	0 for boosted PRBs 1 for de-boosted PRBs	2
NR-FR1-TM2	0 for all PRBs	1
NR-FR1-TM2a	0 for all PRBs	1
NR-FR1-TM3.1	0 for all PRBs	1
NR-FR1-TM3.1a	0 for all PRBs	1
NR-FR1-TM3.2	0 for QPSK PRBs 1 for 16QAM PRBs	2
NR-FR1-TM3.3	0 for 16QAM PRBs 1 for QPSK PRBs	2

- Perform user specific scrambling according to TS 38.211 [17], subclause 7.3.1.1.
- Perform modulation of the scrambled bits with the modulation scheme defined for each user according to TS 38.211 [17], subclause 7.3.1.1
- $n_{\text{ID}} = N_{\text{ID}}^{\text{cell}}$
- Perform mapping of the complex-valued symbols to layer according to TS 38.211 [17], subclause 7.3.1.3.  
 $x^{(0)}(i) = d^{(0)}(i) M_{\text{symp}}^{\text{layer}} = M_{\text{symp}}^{(0)}$  Complex-valued modulation symbols  $d^{(q)}(0), \dots, d^{(q)}(M_{\text{symp}}^{(q)} - 1)$  for codeword  $q$  shall be mapped onto the layers  $x(i) = [x^{(0)}(i) \dots x^{(v-1)}(i)]^T$ ,  $i = 0, 1, \dots, M_{\text{symp}}^{\text{layer}} - 1$  where  $v$  is equal to number of layers.
- Perform PDSCH mapping according to TS 38.211 [17] using parameters listed in table 4.9.2.2-3.
- DM-RS sequence generation according to TS 38.211 [17], subclause 7.4.1.1.1 where  $l$  is the OFDM symbol number within the slot with the symbols indicated by table 4.9.2.2-3.
- $N_{\text{ID}}^{\text{SCID}} = N_{\text{ID}}^{\text{cell}}$
- $n_{\text{SCID}} = 0$
- DM-RS mapping according to TS 38.211 [17], subclause 7.4.1.1.2 using parameters listed in table 4.9.2.2-3.

## 4.10 Requirements for contiguous and non-contiguous spectrum

A spectrum allocation where a BS operates can either be contiguous or non-contiguous. Unless otherwise stated, the requirements in the present specification apply for BS configured for both contiguous spectrum operation and non-contiguous spectrum operation.

For BS operation in non-contiguous spectrum, some requirements apply both at the Base Station RF Bandwidth edges and inside the sub-block gaps. For each such requirement, it is stated how the limits apply relative to the Base Station RF Bandwidth edges and the sub-block edges respectively.

## 4.11 Requirements for BS capable of multi-band operation

For *multi-band connector* the conducted test requirements in clause 6 and 7 apply separately to each supported *operating band* unless otherwise stated. For some conducted test requirements, it is explicitly stated that specific additions or exclusions to the requirement apply at *multi-band connector(s)* as detailed in the requirement subclause. For BS capable of multi-band operation, various structures in terms of combinations of different transmitter and receiver implementations (multi-band or single band) with mapping of transceivers to one or more *antenna connectors* for *BS type 1-C* or *TAB connectors* for *BS type 1-H* in different ways are possible. For *multi-band connector(s)* the exclusions or provisions for multi-band apply. For *single-band connector(s)*, the following applies:

- Single-band transmitter spurious emissions, *operating band* unwanted emissions, ACLR, transmitter intermodulation and receiver spurious emissions requirements apply to this connector that is mapped to single-band.

- If the BS is configured for single-band operation, *single-band requirements* shall apply to this connector configured for single-band operation and no exclusions or provisions for multi-band capable BS are applicable. *Single-band requirements* are tested separately at the connector configured for single-band operation, with all other connectors terminated.

A BS type 1-H may be capable of supporting operation in multiple *operating bands* with one of the following implementations of *TAB connectors* in the *transceiver array boundary*:

- All *TAB connectors* are *single-band connectors*.
  - Different sets of *single-band connectors* support different *operating bands*, but each *TAB connector* supports only operation in one *single operating band*.
  - Sets of *single-band connectors* support operation in multiple *operating bands* with some *single-band connectors* supporting more than one *operating band*.
- All *TAB connectors* are *multi-band connectors*.
- A combination of single-band sets and multi-band sets of *TAB connectors* provides support of the type BS type 1-H capability of operation in multiple *operating bands*.

Unless otherwise stated all conducted test requirements specified for an *operating band* apply only to the set of *TAB connectors* supporting that *operating band*.

In the case of an *operating band* being supported only by *single-band connectors* in a *TAB connector TX min cell group* or a *TAB connector RX min cell group*, *single-band requirements* apply to that set of *TAB connectors*.

In the case of an *operating band* being supported only by *multi-band connectors* supporting the same *operating band* combination in a *TAB connector TX min cell group* or a *TAB connector RX min cell group*, *multi-band requirements* apply to that set of *TAB connectors*.

The case of an *operating band* being supported by both *multi-band connectors* and *single-band connectors* in a *TAB connector TX min cell group* or a *TAB connector RX min cell group* is FFS and is not covered by the present release of this specification.

The case of an *operating band* being supported by *multi-band connectors* which are not all supporting the same *operating band* combination in a *TAB connector TX min cell group* or a *TAB connector RX min cell group* is FFS and is not covered by the present release of this specification.

For *multi-band connectors* supporting the bands for TDD, the RF requirements in the present specification assume no simultaneous uplink and downlink occur between the bands.

The conducted test requirements for *multi-band connectors* supporting bands for both FDD and TDD are FFS and are not covered by the present release of this specification.

## 4.12 Format and interpretation of tests

Each test has a standard format:

### **X Title**

All tests are applicable to all equipment within the scope of the present document, unless otherwise stated.

### **X.1 Definition and applicability**

This subclause gives the general definition of the parameter under consideration and specifies whether the test is applicable to all equipment or only to a certain subset. Required manufacturer declarations may be included here.

### **X.2 Minimum requirement**

This subclause contains the reference to the subclause to the 3GPP reference (or core) specification which defines the minimum requirement.

### **X.3 Test purpose**

This subclause defines the purpose of the test.

## **X.4 Method of test**

### **X.4.1 General**

In some cases there are alternative test procedures or initial conditions. In such cases, guidance for which initial conditions and test procedures can be applied are stated here. In the case only one test procedure is applicable, that is stated here.

#### **X.4.2y First test method**

##### **X.4.2y.1 Initial conditions**

This subclause defines the initial conditions for each test, including the test environment, the RF channels to be tested and the basic measurement set-up.

##### **X.4.2y.2 Procedure**

This subclause describes the steps necessary to perform the test and provides further details of the test definition like domain (e.g. frequency-span), range, weighting (e.g. bandwidth), and algorithms (e.g. averaging). The procedure may comprise data processing of the measurement result before comparison with the test requirement (e.g. average result from several measurement positions).

##### **X.4.3y Alternative test method (if any)**

If there are alternative test methods, each is described with its initial conditions and procedures.

## **X.5 Test requirement**

This subclause defines the pass/fail criteria for the equipment under test, see subclause 4.1.3 (Interpretation of measurement results). Test requirements for every minimum requirement referred in subclause X.2 are listed here. Cases where minimum requirements do not apply need not be mentioned.

---

## 5 Operating bands and channel arrangement

For the NR operating bands specification, their channel bandwidth configurations, channel spacing and raster, as well as synchronization raster specification, refer to TS 38.104 [2], clause 5 and its relevant subclauses.

For the conducted testing purposes in this specification, only FR1 operating bands are considered.

## 6 Conducted transmitter characteristics

### 6.1 General

#### 6.1.1 BS type 1-C

General test conditions for conducted transmitter tests are given in clause 4, including interpretation of measurement results and configurations for testing. BS configurations for the tests are defined in subclause 4.5.

If a number of *single-band connectors*, or *multi-band connectors* have been declared equivalent (D.32), only a representative one is necessary to demonstrate conformance.

#### 6.1.2 BS type 1-H

General test conditions for conducted transmitter tests are given in clause 4, including interpretation of measurement results and configurations for testing. BS configurations for the tests are defined in subclause 4.5.

If a number of *single-band connectors*, or *multi-band connectors* have been declared equivalent (D.32), only a representative one is necessary to demonstrate conformance.

In subclause 6.6, if representative *TAB connectors* are used then per connector criteria (i.e. option 2 in TS 38.104 [2], subclause 6.6.3.4) shall be applied.

The manufacturer shall declare the minimum number of supported geographical cells (i.e. geographical areas). The minimum number of supported geographical cells ( $N_{\text{cells}}$ , D.24) relates to the BS setting with the minimum amount of cell splitting supported with transmission on all *TAB connectors* supporting the *operating band*. The manufacturer shall also declare *TAB connector TX min cell groups* (D.34). Every *TAB connector* supporting transmission in an *operating band* shall map to one *TAB connector TX min cell group* supporting the same. The mapping of *TAB connectors* to cells is implementation dependent.

The number of *active transmitter units* that are considered when calculating the emissions limit ( $N_{\text{TXU, counted}}$ ) for *BS type 1-H* is calculated as follows:

$$N_{\text{TXU, counted}} = \min(N_{\text{TXU, active}}, 8 \cdot N_{\text{cells}})$$

Further:

$$N_{\text{TXU, counted per cell}} = N_{\text{TXU, counted}} / N_{\text{cells}}$$

$N_{\text{TXU, counted per cell}}$  is used for scaling the *basic limits* as described in subclause 6.6.

NOTE:  $N_{\text{TXU, active}}$  depends on the actual number of *active transmitter units* and is independent to the declaration of  $N_{\text{cells}}$ .

## 6.2 Base station output power

### 6.2.1 Definition and applicability

The conducted BS output power requirements are specified at *single-band connector*, or at *multi-band connector*.

The *rated carrier output power* of the *BS type 1-C* shall be as specified in table 6.2.1-1.

**Table 6.2.1-1: Rated carrier output power limits for BS type 1-C**

BS class	$P_{\text{rated, c, AC}}$
Wide Area BS	(Note)
Medium Range BS	$\leq 38$ dBm
Local Area BS	$\leq 24$ dBm
NOTE: There is no upper limit for the $P_{\text{rated, c, AC}}$ rated output power of the Wide Area Base Station.	

The *rated carrier output power* of the *BS type 1-H* shall be as specified in table 6.2.1-2.

**Table 6.2.1-2: Rated carrier output power limits for BS type 1-H**

BS class	$P_{\text{rated,c,sys}}$	$P_{\text{rated,c,TABC}}$
Wide Area BS	(Note)	(Note)
Medium Range BS	$\leq 38 \text{ dBm} + 10\log(N_{\text{TXU,counted}})$	$\leq 38 \text{ dBm}$
Local Area BS	$\leq 24 \text{ dBm} + 10\log(N_{\text{TXU,counted}})$	$\leq 24 \text{ dBm}$
NOTE: There is no upper limit for the $P_{\text{Rated,c,sys}}$ or $P_{\text{Rated,c,TABC}}$ of the Wide Area Base Station.		

The *maximum carrier output power* ( $P_{\text{max,c,AC}}$ , or  $P_{\text{max,c,TABC}}$ ) for the respective BS shall be compared to the *rated carrier output power* (i.e.  $P_{\text{rated,c,AC}}$ ,  $P_{\text{rated,c,TABC}}$ , or  $P_{\text{rated,c,sys}}$ ) limits in tables 6.2.1-1 and 6.2.1-2 for the declared BS class (D.2). The absolute value of the *maximum carrier output power* is not subject to testing, while its output power accuracy relative to the declared value is.

## 6.2.2 Minimum requirement

The minimum requirement applies per *single-band connector*, or per *multi-band connector* supporting transmission in the *operating band*.

The minimum requirement for *BS type 1-C* is defined in TS 38.104 [2], subclause 6.2.2.

The minimum requirement for *BS type 1-H* is defined in TS 38.104 [2], subclause 6.2.3.

## 6.2.3 Test purpose

The test purpose is to verify the accuracy of the *maximum carrier output power* across the frequency range and under normal and extreme conditions.

## 6.2.4 Method of test

### 6.2.4.1 Initial conditions

Test environment:

- Normal, see annex B.2,
- Extreme, see annex B.3.

RF channels to be tested for single carrier: B, M and T; see subclause 4.9.1

*Base Station RF Bandwidth* positions to be tested for multi-carrier and/or CA:

- $B_{\text{RFBW}}$ ,  $M_{\text{RFBW}}$  and  $T_{\text{RFBW}}$  for *single-band connector(s)*, see subclause 4.9.1.
- $B'_{\text{RFBW}}$ ,  $T'_{\text{RFBW}}$  and  $B'_{\text{RFBW}}T'_{\text{RFBW}}$  for *multi-band connector(s)*, see subclause 4.9.1.

In case of extreme test environment, it is sufficient to test on a single combination of one NR-ARFCN, one RF bandwidth position and with only one applicable test configuration defined in subclauses 4.7 and 4.8.

NOTE: Tests under extreme power supply also test extreme temperature.

### 6.2.4.2 Procedure

For *BS type 1-H* where there may be multiple *TAB connectors*, they may be tested one at a time or multiple *TAB connectors* may be tested in parallel as shown in annex D.3.1. Whichever method is used the procedure is repeated until all *TAB connectors* necessary to demonstrate conformance have been tested.

- 1) Connect the power measuring equipment to *single-band connector(s)* or to *multi-band connector(s)* under test as shown in annex D.1.1 for *BS type 1-C* for in annex D.3.1 for *BS type 1-H*. All connectors not under test shall be terminated.
- 2) For single carrier set the connector under test to transmit according to the applicable test configuration in subclause 4.8 using the corresponding test models or set of physical channels in subclause 4.9.2 at *rated carrier output power*  $P_{\text{rated,c,AC}}$  for *BS type 1-C* and  $P_{\text{rated,c,TABC}}$  for *BS type 1-H* (D.21).

For a connector under test declared to be capable of multi-carrier and/or CA operation (D.15-D.16) set the connector under test to transmit on all carriers configured using the applicable test configuration and corresponding power setting specified in subclauses 4.7 and 4.8 using the corresponding test models or set of physical channels in subclause 4.9.2.

- 3) Measure the *maximum carrier output power* ( $P_{\max,c,AC}$  for *BS type 1-C* and  $P_{\max,c,TABC}$  for *BS type 1-H*) for each carrier at each connector under test.

In addition, for *multi-band connectors*, the following steps shall apply:

- 4) For a *multi-band connectors* and single band tests, repeat the steps above per involved *operating band* where single band test configurations and test models shall apply with no carrier activated in the other *operating band*.

## 6.2.5 Test requirement

For each *single-band connector* or *multi-band connector* under test, the power measured in subclause 6.2.4.2 in step 3 shall remain within the values provided in table 6.2.5-1 for normal and extreme test environments, relative to the manufacturer's declared  $P_{\text{Rated},c,AC}$  for *BS type 1-C*, or relative to the manufacturer's declared  $P_{\text{Rated},c,TABC}$  for *BS type 1-H* (D.21):

**Table 6.2.5-1: Test requirement for conducted BS output power**

	Normal test environment	Extreme test environment
<i>BS type 1-C</i> ,	$f \leq 3.0 \text{ GHz}: \pm 2.7 \text{ dB}$	$f \leq 3.0 \text{ GHz}: \pm 3.2 \text{ dB}$
<i>BS type 1-H</i>	$3.0 \text{ GHz} < f \leq 6.0 \text{ GHz}: \pm 3.0 \text{ dB}$	$3.0 \text{ GHz} < f \leq 6.0 \text{ GHz}: \pm 3.5 \text{ dB}$

## 6.3 Output power dynamics

### 6.3.1 General

The requirements in subclause 6.3 apply during the *transmitter ON period*. Transmit signal quality requirements (as specified in subclause 6.5) shall be maintained for the output power dynamics requirements of this subclause.

### 6.3.2 RE power control dynamic range

#### 6.3.2.1 Definition and applicability

The RE power control dynamic range is the difference between the power of an RE and the average RE power for a BS at *maximum carrier output power* ( $P_{\max,c,TABC}$ , or  $P_{\max,c,AC}$ ) for a specified reference condition.

#### 6.3.2.2 Minimum requirement

The minimum requirement applies per *single-band connector*, or per *multi-band connector* supporting transmission in the *operating band*.

The minimum requirement for *BS type 1-C* and for *BS type 1-H* is defined in TS 38.104 [2], subclause 6.3.2.2.

#### 6.3.2.3 Test purpose

No specific test or test requirements are defined for conducted RE power control dynamic range. The Error Vector Magnitude (EVM) test, as described in subclause 6.5.4 provides sufficient test coverage for this requirement.

## 6.3.3 Total power dynamic range

### 6.3.3.1 Definition and applicability

The BS total power dynamic range is the difference between the maximum and the minimum transmit power of an OFDM symbol for a specified reference condition.

NOTE: The upper limit of the dynamic range is the OFDM symbol power for a BS at maximum output power when transmitting on all RBs. The lower limit of the total power dynamic range is the average power for single RB transmission. The OFDM symbol shall carry PDSCH and not contain RS, or SSB.



### 6.3.3.2 Minimum requirement

The minimum requirement applies per *single-band connector*, or per *multi-band connector*.

The minimum requirement for *BS type I-C* and for *BS type I-H* is in TS 38.104 [2], subclause 6.3.3.2.

### 6.3.3.3 Test purpose

The test purpose is to verify that the total power dynamic range is within the limits specified by the minimum requirement.

### 6.3.3.4 Method of test

#### 6.3.3.4.1 Initial conditions

Test environment: Normal, see annex B.2.

RF channels to be tested: M; see subclause 4.9.1.

Set the channel set-up of the connector under test transmitted signal according to NR-FR1-TM 3.1.

#### 6.3.3.4.2 Procedure

For *BS type I-H* where there may be multiple *TAB connectors*, they may be tested one at a time or multiple *TAB connectors* may be tested in parallel as shown in annex D.3.1. Whichever method is used the procedure is repeated until all *TAB connectors* necessary to demonstrate conformance have been tested.

- 1) Connect the *single-band connector(s)* under test as shown in annex D.1.1 for *BS type I-C* and in annex D.3.1 for *BS type I-H*. All connectors not under test shall be terminated.
- 2) Set each connector under test to transmit according to the applicable test configuration in subclause 4.8 using the corresponding test models in subclause 4.9.2 at *rated carrier output power*  $P_{\text{rated,c,AC}}$  for *BS type I-C* and  $P_{\text{rated,c,TABC}}$  for *BS type I-H* (D.21).
- 3) For *BS type I-C* and *BS type I-H*, set the BS to transmit a signal according to:
  - NR-FR1-TM3.1a if 256QAM is supported by BS without power back off, or
  - NR-FR1-TM3.1 if 256QAM is not supported by BS, or
  - NR-FR1-TM3.1 if 256QAM is supported by BS with power back off;
- 4) Measure the average OFDM symbol power as defined in the annex F.
- 5) For *BS type I-C* and *BS type I-H*, set the BS to transmit a signal according to:
  - NR-FR1-TM2a if 256QAM is supported by BS, or
  - NR-FR1-TM2 if 256QAM is not supported by BS;
- 6) Measure the average OFDM symbol power as defined in the annex F. The measured OFDM symbols shall not contain RS or SSB.

In addition, for *multi-band connectors*, the following steps shall apply:

- 7) For a *multi-band connectors* and single band tests, repeat the steps above per involved *operating band* where single band test configurations and test models shall apply with no carrier activated in the other *operating band*.

### 6.3.3.5 Test requirements

The downlink (DL) total power dynamic range for each NR carrier shall be larger than or equal to the level in table 6.3.4.5-1.

Table 6.3.3.5-1: BS total power dynamic range

NR channel bandwidth (MHz)	Total power dynamic range (dB)		
	15 kHz SCS	30 kHz SCS	60 kHz SCS
5	13.5	10	N/A
10	16.7	13.4	10
15	18.5	15.3	12.1
20	19.8	16.6	13.4
25	20.8	17.7	14.5
30	21.6	18.5	15.3
40	22.9	19.8	16.6
50	23.9	20.8	17.7
60	N/A	21.6	18.5
70	N/A	22.3	19.2
80	N/A	22.9	19.8
90	N/A	23.4	20.4
100	N/A	23.9	20.9

NOTE: Additional test requirements for the EVM at the lower limit of the dynamic range are defined in subclause 6.5.4.

## 6.4 Transmit ON/OFF power

### 6.4.1 Transmitter OFF power

#### 6.4.1.1 Definition and applicability

Transmit OFF power requirements apply only to TDD operation of the BS.

Transmitter OFF power is defined as the mean power measured over  $70/N$  us filtered with a square filter of bandwidth equal to the transmission bandwidth configuration of the BS ( $BW_{\text{Config}}$ ) centred on the assigned channel frequency during the *transmitter OFF period*.  $N = \text{SCS}/15$ , where SCS is Sub Carrier Spacing in kHz.

For *multi-band connectors* and for *single band connectors* supporting transmission in multiple operating bands, the requirement is only applicable during the *transmitter OFF period* in all supported operating bands.

For BS supporting intra-band contiguous CA, the transmitter OFF power is defined as the mean power measured over  $70/N$  us filtered with a square filter of bandwidth equal to the *Aggregated BS Channel Bandwidth*  $BW_{\text{Channel\_CA}}$  centred on  $(F_{\text{edge\_high}} + F_{\text{edge\_low}})/2$  during the *transmitter OFF period*.  $N = \text{SCS}/15$ , where SCS is the smallest supported Sub Carrier Spacing in kHz in the *Aggregated BS Channel Bandwidth*.

#### 6.4.1.2 Minimum requirement

The minimum requirement for *BS type I-C* is in TS 38.104 [2], subclause 6.4.1.2.

The minimum requirement for *BS type I-H* is in TS 38.104 [2], subclause 6.4.1.3.

#### 6.4.1.3 Test purpose

The purpose of this test is to verify the transmitter OFF power is within the limits of the minimum requirements.

#### 6.4.1.4 Method of test

Requirement is tested together with transmitter transient period, as described in subclause 6.4.2.4.

#### 6.4.1.5 Test requirements

The conformance testing of transmit OFF power is included in the conformance testing of transmitter transient period; therefore, see subclause 6.4.2.5 for test requirements.

## 6.4.2 Transmitter transient period

### 6.4.2.1 Definition and applicability

*Transmitter transient period* requirements apply only to TDD operation of the BS.

The *transmitter transient period* is the time period during which the transmitter unit is changing from the OFF period to the ON period or vice versa. The *transmitter transient period* is illustrated in figure 6.4.2.1-1.

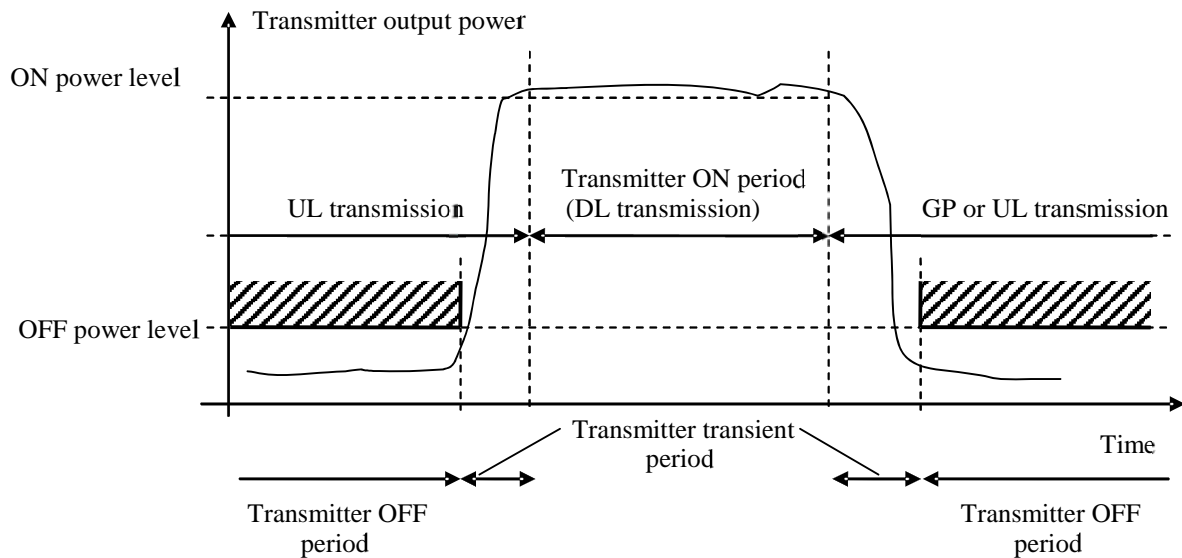

**Figure 6.4.2.1-1: Illustration of the relations of transmitter ON period, transmitter OFF period and transmitter transient period**

This requirement applies at each *antenna connector* or *TAB connector* supporting transmission in the operating band.

### 6.4.2.2 Minimum requirement

The minimum requirement for *BS type 1-C* and *BS type 1-H* is in TS 38.104 [2], subclause 6.4.2.2.

### 6.4.2.3 Test purpose

The purpose of this test is to verify the transmitter transient periods are within the limits of the minimum requirements.

### 6.4.2.4 Method of test

#### 6.4.2.4.1 Initial conditions

Test environment:

- normal; see annex B.2.

RF channels to be tested for single carrier:

- M; see subclause 4.9.1.

RF bandwidth positions to be tested for multi-carrier and/or CA:

- $M_{\text{RFBW}}$  in single-band operation, see subclause 4.9.1;
- $B_{\text{RFBW\_T'RFBW}}$  and  $B'_{\text{RFBW\_T'RFBW}}$  in multi-band operation, see subclause 4.9.1.

#### 6.4.2.4.2 Procedure

The minimum requirement is applied to all *antenna connectors* or *TAB connectors*, they may be tested one at a time or multiple *antenna connectors* or *TAB connectors* may be tested in parallel as shown in annex D.1.1 for *BS type I-C* or in annex D.3.1 for *BS type I-H*. Whichever method is used the procedure is repeated until all *antenna connectors* or *TAB connectors* necessary to demonstrate conformance have been tested.

1) Connect *antenna connector* or *TAB connector* to measurement equipment as shown in annex D.1.1 for *BS type I-C* or in annex D.3.1 for *BS type I-H*. All *antenna connectors* or *TAB connectors* not under test shall be terminated.

As a general rule, the resolution bandwidth of the measuring equipment should be equal to the measurement bandwidth. However, to improve measurement accuracy, sensitivity, efficiency and avoiding e.g. carrier leakage, the resolution bandwidth may be smaller than the measurement bandwidth. When the resolution bandwidth is smaller than the measurement bandwidth, the result should be integrated over the measurement bandwidth in order to obtain the equivalent noise bandwidth of the measurement bandwidth.

2) For single carrier set the *antenna connector* or *TAB connector* under test to transmit according to the applicable test configuration in subclause 4.8 using the corresponding test models or set of physical channels in subclause 4.9.2 at manufacturers declared *rated carrier output power per antenna connector* or *TAB connector* ( $P_{\text{rated,c,AC}}$ , or  $P_{\text{rated,c,TABC}}$ , D.21).

For a connector under test declared to be capable of multi-carrier and/or CA operation (D.15-D.16) set the connector under test to transmit on all carriers configured using the applicable test configuration and corresponding power setting specified in subclauses 4.7 and 4.8 using the corresponding test models or set of physical channels in subclause 4.9.2.

3) Measure the mean power spectral density over  $70/N \mu\text{s}$  filtered with a square filter of bandwidth equal to the RF bandwidth of the *antenna connector* or *TAB connector* centred on the central frequency of the RF bandwidth.  $70/N \mu\text{s}$  average window centre is set from  $35/N \mu\text{s}$  after end of one transmitter ON period +  $10 \mu\text{s}$  to  $35/N \mu\text{s}$  before start of next transmitter ON period –  $10 \mu\text{s}$ .  $N = \text{SCS}/15$ , where SCS is Sub Carrier Spacing in kHz.

4) For an *antenna connector* or *TAB connector* supporting contiguous CA, measure the mean power spectral density over  $70/N \mu\text{s}$  filtered with a square filter of bandwidth equal to the Aggregated Channel Bandwidth  $BW_{\text{Channel\_CA}}$  centred on  $(F_{\text{edge\_high}} + F_{\text{edge\_low}})/2$ .  $70/N \mu\text{s}$  average window centre is set from  $35/N \mu\text{s}$  after end of one transmitter ON period +  $10 \mu\text{s}$  to  $35/N \mu\text{s}$  before start of next transmitter ON period –  $10 \mu\text{s}$ .  $N = \text{SCS}/15$ , where SCS is the smallest supported Sub Carrier Spacing in kHz in the *Aggregated BS Channel Bandwidth*.

In addition, for *multi-band connector(s)*, the following steps shall apply:

5) For *multi-band connectors* and single band tests, repeat the steps above per involved band where single band test configurations and test models shall apply with no carrier activated in the other band.

#### 6.4.2.5 Test requirements

The measured mean power spectral density according to subclause 6.4.2.4.2 shall be less than  $-83 \text{ dBm/MHz}$  for carrier frequency  $f \leq 3.0 \text{ GHz}$ .

The measured mean power spectral density according to subclause 6.4.2.4.2 shall be less than  $-82.5 \text{ dBm/MHz}$  for carrier frequency  $3.0 \text{ GHz} < f \leq 6.0 \text{ GHz}$ .

For *multi-band connector*, the requirement is only applicable during the transmitter OFF period in all supported operating bands.

## 6.5 Transmitted signal quality

### 6.5.1 General

Unless otherwise stated, the requirements in clause 6.5 apply during the *transmitter ON period*.

### 6.5.2 Frequency error

#### 6.5.2.1 Definition and applicability

Frequency error is the measure of the difference between the actual BS transmit frequency and the assigned frequency. The same source shall be used for RF frequency and data clock generation.

It is not possible to verify by testing that the data clock is derived from the same frequency source as used for RF generation. This may be confirmed by the manufacturer's declaration.

For *BS type I-C* this requirement shall be applied at the *antenna connector* supporting transmission in the *operating band*.

For *BS type I-H* this requirement shall be applied at each *TAB connector* supporting transmission in the *operating band*.

### 6.5.2.2 Minimum Requirement

The minimum requirement is in TS 38.104 [2], subclause 6.5.1.2.

### 6.5.2.3 Test purpose

The test purpose is to verify that frequency error is within the limit specified by the minimum requirement.

### 6.5.2.4 Method of test

Requirement is tested together with modulation quality test, as described in subclause 6.5.3.

### 6.5.2.5 Test Requirements

The modulated carrier frequency of each NR carrier configured by the BS shall be accurate to within the accuracy range given in table 6.5.2.5-1 observed over 1 ms.

**Table 6.5.2.5-1: Frequency error test requirement**

BS class	Accuracy
Wide Area BS	$\pm(0.05 \text{ ppm} + 12 \text{ Hz})$
Medium Range BS	$\pm(0.1 \text{ ppm} + 12 \text{ Hz})$
Local Area BS	$\pm(0.1 \text{ ppm} + 12 \text{ Hz})$

## 6.5.3 Modulation quality

### 6.5.3.1 Definition and applicability

Modulation quality is defined by the difference between the measured carrier signal and a reference signal. Modulation quality can e.g. be expressed as Error Vector Magnitude (EVM). The Error Vector Magnitude is a measure of the difference between the ideal symbols and the measured symbols after the equalization. This difference is called the error vector.

For *BS type I-C* this requirement shall be applied at the *antenna connector* supporting transmission in the *operating band*.

For *BS type I-H* this requirement shall be applied at each *TAB connector* supporting transmission in the *operating band*.

### 6.5.3.2 Minimum Requirement

The minimum requirement is in TS 38.104 [2], subclause 6.5.2.2.

### 6.5.3.3 Test purpose

The test purpose is to verify that modulation quality is within the limit specified by the minimum requirement.

### 6.5.3.4 Method of test

#### 6.5.3.4.1 Initial conditions

Test environment: Normal; see annex B.2.

RF channels to be tested for single carrier: B, M and T; see subclause 4.9.1.

RF bandwidth positions to be tested for multi-carrier and/or CA:

- $B_{\text{RFBW}}$ ,  $M_{\text{RFBW}}$  and  $T_{\text{RFBW}}$  in single-band operation, see subclause 4.9.1;

- $B_{\text{RFBW}_T}$  and  $B'_{\text{RFBW}_T}$  in multi-band operation, see subclause 4.9.1.

#### 6.5.3.4.2 Procedure

The minimum requirement is applied to all *antenna connectors* or *TAB connectors*, they may be tested one at a time or multiple *antenna connectors* or *TAB connectors* may be tested in parallel as shown in annex D.1.1 for *BS type 1-C* or in annex D.3.1 for *BS type 1-H*. Whichever method is used the procedure is repeated until all *antenna connectors* or *TAB connectors* necessary to demonstrate conformance have been tested.

1) For an *antenna connector* or *TAB connector* declared to be capable of single carrier operation only (D.16), set the *antenna connector* or the *TAB connector* under test to transmit a signal according to the applicable test configuration in subclause 4.8 using the corresponding test models:

- NR-FR1-TM 3.1a if 256QAM is supported by BS without power back off, or
- NR-FR1-TM3.1a at manufacturer's declared rated output power if 256QAM is supported by BS with power back off, and NR-FR1-TM3.1 at maximum power, or
- NR-FR1-TM3.1 if highest modulation order supported by BS is 64QAM, or
- NR-FR1-TM3.2 if highest modulation order supported by BS is 16QAM, or
- NR-FR1-TM3.3 if highest modulation order supported by BS is QPSK.

For an *antenna connector* or *TAB connector* declared to be capable of multi-carrier and/or CA operation (D.15-D.16), set the *antenna connector* or the *TAB connector* under test to transmit according to the applicable test configuration and corresponding power setting specified in subclauses 4.7 and 4.8 using the corresponding test models on all carriers configured:

- NR-FR1-TM 3.1a if 256QAM is supported by BS without power back off, or
- NR-FR1-TM3.1a at manufacturer's declared rated output power if 256QAM is supported by BS with power back off, and NR-FR1-TM3.1 at maximum power, or
- NR-FR1-TM3.1 if highest modulation order supported by BS is 64QAM, or
- NR-FR1-TM3.2 if highest modulation order supported by BS is 16QAM, or
- NR-FR1-TM3.3 if highest modulation order supported by BS is QPSK.

For NR-FR1-TM3.1a, power back-off shall be applied if it is declared.

2) Measure the EVM and frequency error as defined in annex F.

3) Repeat steps 1 and 2 for NR-FR1-TM2 if 256QAM is not supported by BS or for NR-FR1-TM2a if 256QAM is supported by BS. For NR-FR1-TM2 and NR-FR1-TM2a the OFDM symbol power shall be at the lower limit of the dynamic range according to the test procedure in subclause 6.3.3.4 and test requirements in subclause 6.3.3.5.

In addition, for *multi-band connector(s)*, the following steps shall apply:

4) For *multi-band connectors* and single band tests, repeat the steps above per involved band where single band test configurations and test models shall apply with no carrier activated in the other band.

#### 6.5.3.5 Test requirements

The EVM of each NR carrier for different modulation schemes on PDSCH shall be less than the limits in table 6.5.3.5-1.

**Table 6.5.3.5-1 EVM requirements for *BS type 1-C* and *BS type 1-H***

Modulation scheme for PDSCH	Required EVM (%)
QPSK	18.5 %
16QAM	13.5 %
64QAM	9 %
256QAM	4.5 %

EVM shall be evaluated for each NR carrier over all allocated resource blocks and downlink subframes and with RS density configuration of DM-RS of comb 2 (every other subcarrier) in symbol 3 and 11. Different modulation schemes listed in table 6.5.3.5-1 shall be considered for rank 1.

For NR, for all bandwidths, the EVM measurement shall be performed for each NR carrier over all allocated resource blocks and downlink subframes within 10 ms measurement periods. The boundaries of the EVM measurement periods need not be aligned with radio frame boundaries.

Table 6.5.3.5-2, 6.5.3.5-3, 6.5.3.5-4 below specify the EVM window length ( $W$ ) for normal CP for *BS type I-C* and *BS type I-H*.

**Table 6.5.3.5-2 EVM window length for normal CP for NR, FR1, 15 kHz SCS**

Channel bandwidth (MHz)	FFT size	Cyclic prefix length for symbols 1-6 and 8-13 in FFT samples	EVM window length $W$	Ratio of $W$ to total CP length for symbols 1-6 and 8-13 (%) (Note)
5	512	36	14	40
10	1024	72	28	40
15	1536	108	44	40
20	2048	144	58	40
25	2048	144	72	50
30	3072	216	108	50
40	4096	288	144	50
50	4096	288	144	50

Note: These percentages are informative and apply to a slot's symbols 1 to 6 and 8 to 13. Symbols 0 and 7 have a longer CP and therefore a lower percentage.

**Table 6.5.3.5-3 EVM window length for normal CP for NR, FR1, 30 kHz SCS**

Channel bandwidth (MHz)	FFT size	Cyclic prefix length for symbols 1-13 in FFT samples	EVM window length $W$	Ratio of $W$ to total CP length for symbols 1-13 (%) (Note)
5	256	18	8	40
10	512	36	14	40
15	768	54	22	40
20	1024	72	28	40
25	1024	72	36	50
30	1536	108	54	50
40	2048	144	72	50
50	2048	144	72	50
60	3072	216	130	60
70	3072	216	130	60
80	4096	288	172	60
90	4096	288	172	60
100	4096	288	172	60

Note: These percentages are informative and apply to a slot's symbols 1 through 13. Symbol 0 has a longer CP and therefore a lower percentage.

Table 6.5.3.5-4 EVM window length for normal CP for NR, FR1, 60 kHz SCS

Channel bandwidth (MHz)	FFT size	Cyclic prefix length for symbols 1-13 in FFT samples	EVM window length $W$	Ratio of $W$ to total CP length for symbols 1-13 (%) (Note)
10	256	18	8	40
15	384	27	11	40
20	512	36	14	40
25	512	36	18	50
30	768	54	26	50
40	1024	72	36	50
50	1024	72	36	50
60	1536	108	64	60
70	1536	108	64	60
80	2048	144	86	60
90	2048	144	86	60
100	2048	144	86	60

Note: These percentages are informative and apply to a slot's symbols 1 through 13. Symbol 0 has a longer CP and therefore a lower percentage.

## 6.5.4 Time alignment error

### 6.5.4.1 Definition and applicability

This requirement applies to frame timing in TX diversity, MIMO transmission, carrier aggregation and their combinations.

Frames of the NR signals present at the BS transmitter *antenna connectors* or *TAB connectors* are not perfectly aligned in time and may experience certain timing differences in relation to each other.

For *BS type I-C*, the TAE is defined as the largest timing difference between any two signals belonging to different *antenna connectors* for a specific set of signals/transmitter configuration/transmission mode.

For *BS type I-H*, the TAE is defined as the largest timing difference between any two signals belonging to *TAB connectors* belonging to different transmitter groups at the *transceiver array boundary*, where transmitter groups are associated with the *TAB connectors* in the transceiver unit array corresponding to TX diversity, MIMO transmission, *carrier aggregation* for a specific set of signals/transmitter configuration/transmission mode.

### 6.5.4.2 Minimum requirement

The minimum requirements for *BS type I-C* and *BS type I-H* are in TS 38.104 [2], subclause 6.5.3.2.

### 6.5.4.3 Test purpose

To verify that the time alignment error is within the limit specified by the minimum requirement.

### 6.5.4.4 Method of test

#### 6.5.4.4.1 Initial conditions

Test environment: Normal, see annex B.2.

RF channels to be tested for single carrier:  $M$ ; see subclause 4.9.1.

RF bandwidth positions to be tested for multi-carrier and/or CA:

- $M_{\text{RFBW}}$  in single-band operation, see subclause 4.9.1.
- $B_{\text{RFBW}} \cdot T_{\text{RFBW}}$  and  $B'_{\text{RFBW}} \cdot T_{\text{RFBW}}$  in multi-band operation, see subclause 4.9.1.

#### 6.5.4.4.2 Procedure

For *BS type I-C antenna connectors* to be tested are for a specific set of signals/transmitter configuration/transmission mode.



For *BS type 1-H TAB connectors* to be tested are identified from the declared sets of *TAB connector beam forming groups* in the TAE groups declaration (D.31).

Compliance is to be demonstrated between all pairs of *single-band connectors and/or multi-band connectors*, however it is not required to exhaustively measure TAE between every combination of pairs of representative connectors. Compliance can be demonstrated by comparison of a reduced set of representative measurement results.

1) Conducted measurement setup:

- For *BS type 1-C*: Connect two *antenna connectors* to the measurement equipment according to annex D.1.3. Terminate any unused *antenna connector(s)*.
- For *BS type 1-H*: Connect two representative *TAB connectors* one from separate TAE group (D.31) to the measurement equipment according to annex D.3.x. Terminate any unused *TAB connector(s)*.

2) Set the connectors under test to transmit NR-FR1-TM 1.1 or any DL signal using TX diversity, MIMO transmission or carrier aggregation.

NOTE: For TX diversity and MIMO transmission, different ports may be configured in NR-FR1-TM 1.1.

3) For a connectors declared to be capable of single carrier operation only (D.16), set the representative connectors under test to transmit according to the applicable test configuration in subclause 4.8 using the corresponding test models in subclause 4.9.2 at *rated carrier output power* ( $P_{\text{rated,c,AC}}$ , or  $P_{\text{rated,c,TABC}}$ , D.21).

If the connector under test supports intra band contiguous or non-contiguous CA, set the representative connectors to transmit using the applicable test configuration and corresponding power setting specified in subclauses 4.7 and 4.8.

If the BS supports inter band CA, set the representative connectors to transmit, for each band, a single carrier or all carriers, using the applicable test configuration and corresponding power setting specified in subclauses 4.7 and 4.8.

For a connector declared to be capable of multi-carrier operation (D.15), set the BS to transmit according to the applicable test signal configuration and corresponding power setting specified in subclauses 4.7 and 4.8 using the corresponding test model in subclause 4.9.2 on all carriers configured.

4) Measure the time alignment error between the reference symbols on the carrier(s) from the representative connectors under test.

5) Repeat step 1 - 4 for any other configuration of connectors, which could be required to demonstrate compliance.

In addition, for *multi-band connectors*, the following steps shall apply:

6) For a *multi-band connectors* and single band tests, repeat the steps above per involved *operating band* where single band test configurations and test models shall apply with no carrier activated in the other *operating band*.

### 6.5.4.5 Test requirement

For MIMO or TX diversity transmissions, at each carrier frequency, TAE shall not exceed 90 ns.

For intra-band contiguous CA, with or without MIMO or TX diversity, TAE shall not exceed 285 ns.

For intra-band non-contiguous CA, with or without MIMO or TX diversity, TAE shall not exceed 3.025  $\mu$ s.

For inter-band CA, with or without MIMO or TX diversity, TAE shall not exceed 3.025  $\mu$ s.

## 6.6 Unwanted emissions

### 6.6.1 General

Unwanted emissions consist of out-of-band emissions and spurious emissions according to ITU definitions [5]. In ITU terminology, out of band emissions are unwanted emissions immediately outside the channel bandwidth resulting from the modulation process and non-linearity in the transmitter but excluding spurious emissions. Spurious emissions are emissions which are caused by unwanted transmitter effects such as harmonics emission, parasitic emission, intermodulation products and frequency conversion products, but exclude out of band emissions.

The out-of-band emissions requirement for the BS transmitter is specified both in terms of Adjacent Channel Leakage power Ratio (ACLR) and operating band unwanted emissions (OBUE).

The maximum offset of the operating band unwanted emissions mask from the operating band edge is  $\Delta f_{\text{OBUE}}$ . The operating band unwanted emissions define all unwanted emissions in each supported downlink *operating band* plus the frequency ranges  $\Delta f_{\text{OBUE}}$  above and  $\Delta f_{\text{OBUE}}$  below each band. Unwanted emissions outside of this frequency range are limited by a spurious emissions requirement.

The values of  $\Delta f_{\text{OBUE}}$  are defined in table 6.6.1-1 for the NR *operating bands*.

**Table 6.6.1-1: Maximum offset of OBUE outside the downlink *operating band***

BS type	Operating band characteristics	$\Delta f_{\text{OBUE}}$ (MHz)
BS type 1-C	$F_{\text{DL\_high}} - F_{\text{DL\_low}} \leq 200$ MHz	10
	$200 \text{ MHz} < F_{\text{DL\_high}} - F_{\text{DL\_low}} \leq 900$ MHz	40
BS type 1-H	$F_{\text{DL\_high}} - F_{\text{DL\_low}} < 100$ MHz	10
	$100 \text{ MHz} \leq F_{\text{DL\_high}} - F_{\text{DL\_low}} \leq 900$ MHz	40

For *BS type 1-H* the unwanted emission requirements are applied per the *TAB connector TX min cell groups* for all the configurations supported by the BS. The *basic limits* and corresponding emissions scaling are defined in each relevant subclause.

There is in addition a requirement for occupied bandwidth.

## 6.6.2 Occupied bandwidth

### 6.6.2.1 Definition and applicability

The occupied bandwidth is the width of a frequency band such that, below the lower and above the upper frequency limits, the mean powers emitted are each equal to a specified percentage  $\beta/2$  of the total mean transmitted power.

The value of  $\beta/2$  shall be taken as 0.5%.

The occupied bandwidth requirement shall apply during the *transmitter ON period* for a single transmitted carrier. The minimum requirement below may be applied regionally. There may also be regional requirements to declare the occupied bandwidth according to the definition in the present clause.

For *BS type 1-C* this requirement shall be applied at the *antenna connector* supporting transmission in the *operating band*.

For *BS type 1-H* this requirement shall be applied at each *TAB connector* supporting transmission in the *operating band*.

### 6.6.2.2 Minimum Requirements

The minimum requirement for *BS type 1-C* and *BS type 1-H* is in TS 38.104 [2] subclause 6.6.2

### 6.6.2.3 Test purpose

The test purpose is to verify that the emission at the *antenna connector* or *TAB connector* does not occupy an excessive bandwidth for the service to be provided and is, therefore, not likely to create interference to other users of the spectrum beyond undue limits.

### 6.6.2.4 Method of test

#### 6.6.2.4.1 Initial conditions

Test environment: Normal; see annex B.2.

RF channels to be tested for single carrier: M; see subclause 4.9.1.

Aggregated BS Channel Bandwidth positions to be tested for contiguous carrier aggregation:  $M_{\text{BW Channel CA}}$ ; see subclause 4.9.1.

- 1) Connect the measurement device to the BS *antenna connector* or *TAB connector* as shown in annex D1.1 for BS type 1-C or D3.1 for BS type 1-H.
- 2) For a BS declared to be capable of single carrier operation (D.16), start transmission according to the applicable test configuration in subclause 4.8 using the corresponding test model NR-FR1-TM1.1 at manufacturer's declared rated output power ( $P_{\text{rated,c,AC}}$ , or  $P_{\text{rated,c,TABC}}$ , D.21).

For a BS declared to be capable of contiguous CA operation, set the BS to transmit according to NR-FR1-TM1.1 on all carriers configured using the applicable test configuration and corresponding power setting specified in subclauses 4.7.4 and 4.8.

#### 6.6.2.4.2 Procedure

- 1) Measure the spectrum emission of the transmitted signal using at least the number of measurement points, and across a span, as listed in table 6.6.2.4.2-1. The selected resolution bandwidth (RBW) filter of the analyser shall be 30 kHz or less.

**Table 6.6.2.4.2-1: Span and number of measurement points for OBW measurements**

Bandwidth	BS channel bandwidth $BW_{\text{Channel}}$ (MHz)					Aggregated BS channel bandwidth $BW_{\text{Channel\_CA}}$ (MHz)
	5	10	15	20	> 20	> 20
Span (MHz)	10	20	30	40	$2 \times BW_{\text{Channel}}$	$2 \times BW_{\text{Channel\_CA}}$
Minimum number of measurement points	400	400	400	400	$\left\lceil \frac{2 \times BW_{\text{Channel}}}{100\text{kHz}} \right\rceil$	$\left\lceil \frac{2 \times BW_{\text{Channel\_CA}}}{100\text{kHz}} \right\rceil$

NOTE: The detection mode of the spectrum analyzer will not have any effect on the result if the statistical properties of the out-of-OBW power are the same as those of the inside-OBW power. Both are expected to have the Rayleigh distribution of the amplitude of Gaussian noise. In any case where the statistics are not the same, though, the detection mode must be power responding. The analyser may be set to respond to the average of the power (root-mean-square of the voltage) across the measurement cell.

- 2) Compute the total of the power, P0, (in power units, not decibel units) of all the measurement cells in the measurement span. Compute P1, the power outside the occupied bandwidth on each side. P1 is half of the total power outside the bandwidth. P1 is half of (100 % - (occupied percentage)) of P0. For the occupied percentage of 99 %, P1 is 0.005 times P0.
- 3) Determine the lowest frequency, f1, for which the sum of all power in the measurement cells from the beginning of the span to f1 exceeds P1.
- 4) Determine the highest frequency, f2, for which the sum of all power in the measurement cells from f2 to the end of the span exceeds P1.
- 5) Compute the occupied bandwidth as f2 - f1.

In addition, for a multi-band capable BS, the following step shall apply:

- 6) For multi-band capable BS and single band tests, repeat the steps above per involved band where single carrier test models shall apply, with no carrier activated in the other band. In addition, when contiguous CA is supported, single band test configurations and test models shall apply with no carrier activated in the other band.

#### 6.6.2.5 Test requirements

For NR, the occupied bandwidth for each carrier shall be less than the channel bandwidth as defined in TS 38.104 [2], table 5.3.5-1 for BS type 1-C and BS type 1-H. For contiguous CA, the occupied bandwidth shall be less than or equal to the Aggregated BS Channel Bandwidth as defined in TS 38.104 [2], subclause 5.3A.

## 6.6.3 Adjacent Channel Leakage Power Ratio (ACLR)

### 6.6.3.1 Definition and applicability

Adjacent Channel Leakage power Ratio (ACLR) is the ratio of the filtered mean power centred on the assigned channel frequency to the filtered mean power centred on an adjacent channel frequency.

The requirements shall apply outside the Base Station RF Bandwidth or Radio Bandwidth whatever the type of transmitter considered (single carrier or multi-carrier) and for all transmission modes foreseen by the manufacturer's specification.

For a BS operating in non-contiguous spectrum, the ACLR requirement in subclause 6.6.3.2 shall apply in *sub block gaps* for the frequency ranges defined in table 6.6.3.5.2-3, while the CACLR requirement in subclause 6.6.3.2 shall apply in *sub block gaps* for the frequency ranges defined in table 6.6.3.2-4.

For a *multi-band connector*, the ACLR requirement in subclause 6.6.3.2 shall apply in *Inter RF Bandwidth gaps* for the frequency ranges defined in table 6.6.3.5.2-3, while the CACLR requirement in subclause 6.6.3.2 shall apply in *Inter RF Bandwidth gaps* for the frequency ranges defined in table 6.6.3.2-4.

The requirement applies during the *transmitter ON period*.

### 6.6.3.2 Minimum requirement

The minimum requirement applies per *single-band connector*, or per *multi-band connector* supporting transmission in the *operating band*.

The minimum requirement for *BS type I-C* is defined in TS 38.104 [2], subclause 6.6.3.3.

The minimum requirement for *BS type I-H* is defined in TS 38.104 [2], subclause 6.6.3.4.

### 6.6.3.3 Test purpose

To verify that the adjacent channel leakage power ratio requirement shall be met as specified by the minimum requirement.

### 6.6.3.4 Method of test

#### 6.6.3.4.1 Initial conditions

Test environment: Normal; see annex B.2.

RF channels to be tested for single carrier: B, M and T; see subclause 4.9.1.

*Base Station RF Bandwidth* positions to be tested for multi-carrier and/or CA:

- $B_{\text{RFBW}}$ ,  $M_{\text{RFBW}}$  and  $T_{\text{RFBW}}$  in single-band operation; see subclause 4.9.1.
- $B'_{\text{RFBW}}$ ,  $T'_{\text{RFBW}}$  and  $B'_{\text{RFBW}}T'_{\text{RFBW}}$  in multi-band operation, see subclause 4.9.1.

#### 6.6.3.4.2 Procedure

For *BS type I-H* where there may be multiple *TAB connectors*, they may be tested one at a time or multiple *TAB connectors* may be tested in parallel as shown in annex D.1.1 for *BS type I-C* or in annex D.3.1 for *BS type I-H*. Whichever method is used the procedure is repeated until all *TAB connectors* necessary to demonstrate conformance have been tested.

- 1) Connect the *single-band connector* or *multi-band connector* under test to measurement equipment as shown in annex D.1.1 for *BS type I-C* and in annex D.3.1 for *BS type I-H*. All connectors not under test shall be terminated.

The measurement device characteristics shall be:

- Measurement filter bandwidth: defined in subclause 6.6.3.5.
- Detection mode: true RMS voltage or true average power.

- 2) For a connectors declared to be capable of single carrier operation only (D.16), set the representative connectors under test to transmit according to the applicable test configuration in subclause 4.8 using the corresponding test models NR-FR1-TM 1.1 in subclause 4.9.2 at *rated carrier output power*  $P_{\text{rated,c,AC}}$  for *BS type I-C* and  $P_{\text{rated,c,TABC}}$  for *BS type I-H* (D.21).

For a connector under test declared to be capable of multi-carrier and/or CA operation (D.15-D.16) set the connector under test to transmit on all carriers configured using the applicable test configuration and corresponding power setting specified in subclauses 4.7 and 4.8 using the corresponding test models or set of physical channels in subclause 4.9.2.

- 3) Measure ACLR for the frequency offsets both side of channel frequency as specified in table 6.6.3.5.2-1. In multiple carrier case only offset frequencies below the lowest and above the highest carrier frequency used shall be measured.
- 4) For the ACLR requirement applied inside sub-block gap for non-contiguous spectrum operation, or inside *Inter RF Bandwidth gap* for multi-band operation:
- a) Measure ACLR inside sub-block gap or *Inter RF Bandwidth gap* as specified in subclause 6.6.3.5.2, if applicable.
  - b) Measure CA CLR inside sub-block gap or *Inter RF Bandwidth gap* as specified in subclause 6.6.3.5.2, if applicable.
- 5) Repeat the test with the channel set-up according to NR-FR1-TM 1.2 in subclause 4.9.2.

In addition, for *multi-band connectors*, the following steps shall apply:

- 6) For a *multi-band connectors* and single band tests, repeat the steps above per involved *operating band* where single band test configurations and test models shall apply with no carrier activated in the other *operating band*.

## 6.6.3.5 Test requirements

### 6.6.3.5.1 General requirements

The ACLR requirements in subclause 6.6.3.5.2 shall apply as described in subclauses 6.6.3.5.3 or 6.6.3.5.4.

### 6.6.3.5.2 Limits and *basic limits*

The ACLR is defined with a square filter of bandwidth equal to the transmission bandwidth configuration of the transmitted signal ( $BW_{\text{Config}}$ ) centred on the assigned channel frequency and a filter centred on the adjacent channel frequency according to the tables below.

For operation in paired and unpaired spectrum, the ACLR shall be higher than the value specified in table 6.6.3.5.2-1.

Table 6.6.3.5.2-1: Base station ACLR limit

<b>BS channel bandwidth of lowest/highest NR carrier transmitted</b> <b>BW<sub>Channel</sub> (MHz)</b>	<b>BS adjacent channel centre frequency offset below the lowest or above the highest carrier centre frequency transmitted</b>	<b>Assumed adjacent channel carrier (informative)</b>	<b>Filter on the adjacent channel frequency and corresponding filter bandwidth</b>	<b>ACLR limit</b>
5, 10, 15, 20	BW <sub>Channel</sub>	NR of same BW (Note 2)	Square (BW <sub>Config</sub> )	44.2 dB
	2 x BW <sub>Channel</sub>	NR of same BW (Note 2)	Square (BW <sub>Config</sub> )	44.2 dB
	BW <sub>Channel</sub> / 2 + 2.5 MHz	5 MHz E-UTRA	Square (4.5 MHz)	44.2 dB (NOTE 3)
	BW <sub>Channel</sub> / 2 + 7.5 MHz	5 MHz E-UTRA	Square (4.5 MHz)	44.2 dB (NOTE 3)
25, 30, 40, 50, 60, 70, 80, 90, 100	BW <sub>Channel</sub>	NR of same BW (Note 2)	Square (BW <sub>Config</sub> )	43.8 dB
	2 x BW <sub>Channel</sub>	NR of same BW (Note 2)	Square (BW <sub>Config</sub> )	43.8 dB
	BW <sub>Channel</sub> / 2 + 2.5 MHz	5 MHz E-UTRA	Square (4.5 MHz)	43.8 dB (NOTE 3)
	BW <sub>Channel</sub> / 2 + 7.5 MHz	5 MHz E-UTRA	Square (4.5 MHz)	43.8 dB (NOTE 3)
NOTE 1: BW <sub>Channel</sub> and BW <sub>Config</sub> are the BS channel bandwidth and transmission bandwidth configuration of the lowest/highest NR carrier transmitted on the assigned channel frequency.				
NOTE 2: With SCS that provides largest transmission bandwidth configuration (BW <sub>Config</sub> ).				
NOTE 3: The requirements are applicable when the band is also defined for E-UTRA or UTRA.				

The ACLR absolute *basic limit* is specified in table 6.6.3.5.2-2.

Table 6.6.3.5.2-2: Base station ACLR absolute *basic limit*

<b>BS category / BS class</b>	<b>ACLR absolute <i>basic limit</i></b>
Category A Wide Area BS	-13 dBm/MHz
Category B Wide Area BS	-15 dBm/MHz
Medium Range BS	-25 dBm/MHz
Local Area BS	-32 dBm/MHz

For operation in non-contiguous spectrum or multiple bands, the ACLR shall be higher than the value specified in table 6.6.3.5.2-3.

Table 6.6.3.5.2-3: Base Station ACLR limit in non-contiguous spectrum or multiple bands

<i>BS channel bandwidth of lowest/highest NR carrier transmitted</i> $BW_{\text{Channel}}$ (MHz)	Sub-block or Inter RF Bandwidth gap size ( $W_{\text{gap}}$ ) where the limit applies [MHz]	BS adjacent channel centre frequency offset below or above the sub-block or Base Station RF Bandwidth edge (inside the gap)	Assumed adjacent channel carrier	Filter on the adjacent channel frequency and corresponding filter bandwidth	ACLR limit
5, 10, 15, 20	$W_{\text{gap}} \geq 15$ (Note 3) $W_{\text{gap}} \geq 45$ (Note 4)	2.5 MHz	5 MHz NR (Note 2)	Square ( $BW_{\text{Config}}$ )	44.2 dB
	$W_{\text{gap}} \geq 20$ (Note 3) $W_{\text{gap}} \geq 50$ (Note 4)	7.5 MHz	5 MHz NR (Note 2)		
25, 30, 40, 50, 60, 70, 80, 90, 100	$W_{\text{gap}} \geq 60$ (Note 4) $W_{\text{gap}} \geq 30$ (Note 3)	10 MHz	20 MHz NR (Note 2)	Square ( $BW_{\text{Config}}$ )	43.8 dB
	$W_{\text{gap}} \geq 80$ (Note 4) $W_{\text{gap}} \geq 50$ (Note 3)	30 MHz	20 MHz NR (Note 2)		
<p>NOTE 1: <math>BW_{\text{Config}}</math> is the transmission bandwidth configuration of the assumed adjacent channel carrier.</p> <p>NOTE 2: With SCS that provides largest transmission bandwidth configuration (<math>BW_{\text{Config}}</math>).</p> <p>NOTE 3: Applicable in case the <i>BS channel bandwidth</i> of the NR carrier transmitted at the other edge of the gap is 5, 10, 15, 20 MHz.</p> <p>NOTE 4: Applicable in case the <i>BS channel bandwidth</i> of the NR carrier transmitted at the other edge of the gap is 25, 30, 40, 50, 60, 70, 80, 90, 100 MHz.</p>					

The Cumulative Adjacent Channel Leakage power Ratio (CACLR) in a sub-block gap or the Inter RF Bandwidth gap is the ratio of:

- the sum of the filtered mean power centred on the assigned channel frequencies for the two carriers adjacent to each side of the sub-block gap or the Inter RF Bandwidth gap, and
- the filtered mean power centred on a frequency channel adjacent to one of the respective sub-block edges or Base Station RF Bandwidth edges.

The assumed filter for the adjacent channel frequency is defined in table 6.6.3.5.2-4 and the filters on the assigned channels are defined in table 6.6.3.5.2-6.

For operation in non-contiguous spectrum or multiple bands, the CACLR for NR carriers located on either side of the sub-block gap or the Inter RF Bandwidth gap shall be higher than the value specified in table 6.6.3.5.2-4.

Table 6.6.3.5.2-4: Base station CACLR limit

<b>BS channel bandwidth of lowest/highest NR carrier transmitted <math>BW_{\text{Channel}}</math> (MHz)</b>	<b>Sub-block or Inter RF Bandwidth gap size (<math>W_{\text{gap}}</math>) where the limit applies [MHz]</b>	<b>BS adjacent channel centre frequency offset below or above the sub-block or Base Station RF Bandwidth edge (inside the gap)</b>	<b>Assumed adjacent channel carrier</b>	<b>Filter on the adjacent channel frequency and corresponding filter bandwidth</b>	<b>CACLR limit</b>
5, 10, 15, 20	$5 \leq W_{\text{gap}} < 15$ (Note 3)	2.5 MHz	5 MHz NR (Note 2)	Square ( $BW_{\text{Config}}$ )	44.2 dB
	$5 \leq W_{\text{gap}} < 45$ (Note 4)				
	$10 < W_{\text{gap}} < 20$ (Note 3)	7.5 MHz	5 MHz NR (Note 2)		
	$10 \leq W_{\text{gap}} < 50$ (Note 4)				
25, 30, 40, 50, 60, 70, 80, 90, 100	$20 \leq W_{\text{gap}} < 60$ (Note 4)	10 MHz	20 MHz NR (Note 2)	Square ( $BW_{\text{Config}}$ )	43.8 dB
	$20 \leq W_{\text{gap}} < 30$ (Note 3)				
	$40 < W_{\text{gap}} < 80$ (Note 4)	30 MHz	20 MHz NR (Note 2)		
	$40 \leq W_{\text{gap}} < 50$ (Note 3)				

NOTE 1:  $BW_{\text{Config}}$  is the transmission bandwidth configuration of the assumed adjacent channel carrier.  
NOTE 2: With SCS that provides largest transmission bandwidth configuration ( $BW_{\text{Config}}$ ).  
NOTE 3: Applicable in case the BS channel bandwidth of the NR carrier transmitted at the other edge of the gap is 5, 10, 15, 20 MHz.  
NOTE 4: Applicable in case the BS channel bandwidth of the NR carrier transmitted at the other edge of the gap is 25, 30, 40, 50, 60, 70, 80, 90, 100 MHz.

The CACLR absolute *basic limit* is specified in table 6.6.3.5.2-5.

Table 6.6.3.5.2-5: Base station CACLR absolute *basic limit*

<b>BS category / BS class</b>	<b>CACLR absolute <i>basic limit</i></b>
Category A Wide Area BS	-13 dBm/MHz
Category B Wide Area BS	-15 dBm/MHz
Medium Range BS	-25 dBm/MHz
Local Area BS	-32 dBm/MHz

Table 6.6.3.5.2-6: Filter parameters for the assigned channel

<b>RAT of the carrier adjacent to the sub-block or Inter RF Bandwidth gap</b>	<b>Filter on the assigned channel frequency and corresponding filter bandwidth</b>
NR	NR of same BW with SCS that provides largest transmission bandwidth configuration

### 6.6.3.5.3 BS type 1-C

The ACLR test requirements for BS type 1-C are given in table 6.6.3.5.2-1 or 6.6.3.5.2-3 applies per *antenna connector*. Conformance can be shown by meeting the ACLR limit in table 6.6.3.5.2-1 or 6.6.3.5.2-3, or the absolute *basic limits* in table 6.6.3.5.2-2, whichever is less stringent.

The CACLR test requirements for BS type 1-C are given in table 6.6.3.5.2-4 applies per *antenna connector*. Conformance can be shown by meeting the CALCR limit in table 6.6.3.5.2-4 or the absolute *basic limits* in table 6.6.3.5.2-5, whichever is less stringent.



#### 6.6.3.5.4 BS type 1-H

The ACLR absolute *basic limits* in table 6.6.3.5.2-2+ X (where  $X = 10\log_{10}(N_{\text{TXU, countedpercell}})$ ) or the ACLR *limits* in table 6.6.3.5.2-1, or 6.6.3.5.2-3, whichever is less stringent, shall apply for each *TAB connector TX min cell group*.

The CACLR absolute *basic limits* in table 6.6.3.5.2-5 + X, (where  $X = 10\log_{10}(N_{\text{TXU, countedpercell}})$ ) or the CACLR *limits* in table 6.6.3.5.2-4, whichever is less stringent, shall apply for each *TAB connector TX min cell group*.

Conformance to the *BS type 1-H ACLR (CACLR) limit* can be demonstrated by meeting at least one of the following criteria as determined by the manufacturer

- 1) The ratio of the sum of the filtered mean power measured on each *TAB connector* in the *TAB connector TX min cell group* at the assigned channel frequency to the sum of the filtered mean power measured on each *TAB connector* in the *TAB connector TX min cell group* at the adjacent channel frequency shall be greater than or equal to the ACLR (CACLR) limit of the BS. This shall apply for each *TAB connector TX min cell group*.

Or

- 2) The ratio of the filtered mean power at the *TAB connector* centred on the assigned channel frequency to the filtered mean power at this *TAB connector* centred on the adjacent channel frequency shall be greater than or equal to the ACLR (CACLR) limit of the BS for every *TAB connector* in the *TAB connector TX min cell group*, for each *TAB connector TX min cell group*.

In case the ACLR (CACLR) absolute *basic limit* of *BS type 1-H* are applied, the conformance can be demonstrated by meeting at least one of the following criteria as determined by the manufacturer:

- 1) The sum of the filtered mean power measured on each *TAB connector* in the *TAB connector TX min cell group* at the adjacent channel frequency shall be less than or equal to the ACLR (CACLR) absolute *basic limit* + X (where  $X = 10\log_{10}(N_{\text{TXU, countedpercell}})$ ) of the BS. This shall apply to each *TAB connector TX min cell group*.

Or

- 2) The filtered mean power at each *TAB connector* centred on the adjacent channel frequency shall be less than or equal to the ACLR (CACLR) absolute *basic limit* of the BS scaled by  $X - 10\log_{10}(n)$  for every *TAB connector* in the *TAB connector TX min cell group*, for each *TAB connector TX min cell group*, where  $n$  is the number of *TAB connectors* in the *TAB connector TX min cell group*.

## 6.6.4 Operating band unwanted emissions

### 6.6.4.1 Definition and applicability

Unless otherwise stated, the operating band unwanted emission (OBUE) limits in FR1 are defined from  $\Delta f_{\text{OBUE}}$  below the lowest frequency of each supported downlink *operating band* up to  $\Delta f_{\text{OBUE}}$  above the highest frequency of each supported downlink *operating band*. The values of  $\Delta f_{\text{OBUE}}$  are defined in table 6.6.1-1 for the NR *operating bands*.

The requirements shall apply whatever the type of transmitter considered and for all transmission modes foreseen by the manufacturer's specification. In addition, for a BS operating in non-contiguous spectrum, the requirements apply inside any sub-block gap. In addition, for a BS operating in multiple bands, the requirements apply inside any Inter RF Bandwidth gap.

*Basic limits* are specified in the tables below, where:

- $\Delta f$  is the separation between the channel edge frequency and the nominal -3 dB point of the measuring filter closest to the carrier frequency.
- $f_{\text{offset}}$  is the separation between the channel edge frequency and the centre of the measuring filter.
- $f_{\text{offset}_{\text{max}}}$  is the offset to the frequency  $\Delta f_{\text{OBUE}}$  outside the downlink *operating band*, where  $\Delta f_{\text{OBUE}}$  is defined in table 6.6.1-1.
- $\Delta f_{\text{max}}$  is equal to  $f_{\text{offset}_{\text{max}}}$  minus half of the bandwidth of the measuring filter.

For a *multi-band connector* inside any *Inter RF Bandwidth gaps* with  $W_{\text{gap}} < 2 * \Delta f_{\text{OBUE}}$ , a combined *basic limit* shall be applied which is the cumulative sum of the *basic limits* specified at the *Base Station RF Bandwidth edges* on each side of the *Inter RF Bandwidth gap*. The *basic limit* for *Base Station RF Bandwidth edge* is specified in the subclause 6.6.4.5.2.1 to 6.6.4.5.2.5 below, where in this case:

- $\Delta f$  is the separation between the *Base Station RF Bandwidth edge* frequency and the nominal -3 dB point of the measuring filter closest to the *Base Station RF Bandwidth edge*.
- $f_{\text{offset}}$  is the separation between the *Base Station RF Bandwidth edge* frequency and the centre of the measuring filter.
- $f_{\text{offset}_{\text{max}}}$  is equal to the *Inter RF Bandwidth gap* minus half of the bandwidth of the measuring filter.
- $\Delta f_{\text{max}}$  is equal to  $f_{\text{offset}_{\text{max}}}$  minus half of the bandwidth of the measuring filter.

For a *multi-band connector*, the operating band unwanted emission *basic limits* apply also in a supported operating band without any carrier transmitted, in the case where there are carrier(s) transmitted in another supported operating band. In this case, no cumulative *basic limit* is applied in the *inter-band gap* between a supported downlink operating band with carrier(s) transmitted and a supported downlink operating band without any carrier transmitted and

- In case the *inter-band gap* between a supported downlink operating band with carrier(s) transmitted and a supported downlink operating band without any carrier transmitted is less than  $2 * \Delta f_{\text{OBUE}}$ ,  $f_{\text{offset}_{\text{max}}}$  shall be the offset to the frequency  $\Delta f_{\text{OBUE}}$  MHz outside the outermost edges of the two supported downlink operating bands and the operating band unwanted emission *basic limit* of the band where there are carriers transmitted, as defined in the tables of the present subclause, shall apply across both downlink bands.
- In other cases, the operating band unwanted emission *basic limits* of the band where there are carriers transmitted, as defined in the tables of the present subclause for the largest frequency offset ( $\Delta f_{\text{max}}$ ), shall apply from  $\Delta f_{\text{OBUE}}$  MHz below the lowest frequency, up to  $\Delta f_{\text{OBUE}}$  MHz above the highest frequency of the supported downlink operating band without any carrier transmitted.

For a multicarrier *single-band connector* or a *single-band connector* configured for intra-band contiguous or non-contiguous carrier aggregation the definitions above apply to the lower edge of the carrier transmitted at the lowest carrier frequency and the upper edge of the carrier transmitted at the highest carrier frequency within a specified frequency band.

In addition inside any sub-block gap for a *single-band connector* operating in non-contiguous spectrum, a combined *basic limit* shall be applied which is the cumulative sum of the *basic limits* specified for the adjacent sub blocks on each side of the sub block gap. The *basic limit* for each sub block is specified in the subclause 6.6.4.5.2.1 to 6.6.4.5.2.5 below, where in this case:

- $\Delta f$  is the separation between the sub block edge frequency and the nominal -3 dB point of the measuring filter closest to the sub block edge.
- $f_{\text{offset}}$  is the separation between the sub block edge frequency and the centre of the measuring filter.
- $f_{\text{offset}_{\text{max}}}$  is equal to the sub block gap bandwidth minus half of the bandwidth of the measuring filter.
- $\Delta f_{\text{max}}$  is equal to  $f_{\text{offset}_{\text{max}}}$  minus half of the bandwidth of the measuring filter.

For Wide Area BS, the requirements of either subclause 6.6.4.5.2.1 (Category A limits) or subclause 6.6.4.5.2.2 (Category B limits) shall apply.

For Medium Range BS, the requirements in subclause 6.6.4.5.2.3 shall apply (Category A and B).

For Local Area BS, the requirements of subclause 6.6.4.5.2.4 shall apply (Category A and B).

The application of either Category A or Category B *basic limits* shall be the same as for transmitter spurious emissions in subclause 6.6.5.

## 6.6.4.2 Minimum requirement

The minimum requirement applies per *single-band connector*, or per *multi-band connector* supporting transmission in the *operating band*.

The minimum requirement for *BS type I-C* is defined in TS 38.104 [2], subclause 6.6.4.3.

The minimum requirement for *BS type I-H* is defined in TS 38.104 [2], subclause 6.6.4.4.

### 6.6.4.3 Test purpose

This test measures the emissions close to the assigned channel bandwidth of the wanted signal, while the transmitter is in operation.

### 6.6.4.4 Method of test

#### 6.6.4.4.1 Initial conditions

Test environment: Normal; see annex B.2.

RF channels to be tested for single carrier: B, M and T; see subclause 4.9.1.

*Base Station RF Bandwidth* positions to be tested for multi-carrier:

- $B_{\text{RFBW}}$ ,  $M_{\text{RFBW}}$  and  $T_{\text{RFBW}}$  in single-band operation; see subclause 4.9.1.
- $B'_{\text{RFBW}}$ ,  $T'_{\text{RFBW}}$  and  $B_{\text{RFBW}}T_{\text{RFBW}}$  in multi-band operation, see subclause 4.9.1.

#### 6.6.4.4.2 Procedure

For *BS type I-H* where there may be multiple *TAB connectors*, they may be tested one at a time or multiple *TAB connectors* may be tested in parallel as shown in annex D.3.1. Whichever method is used the procedure is repeated until all *TAB connectors* necessary to demonstrate conformance have been tested.

- 1) Connect the *single-band connector* or *multi-band connector* under test to measurement equipment as shown in annex D.1.1 for *BS type I-C* or in annex D.3.1 for *BS type I-H*. All connectors not under test shall be terminated.

As a general rule, the resolution bandwidth of the measuring equipment should be equal to the measurement bandwidth. However, to improve measurement accuracy, sensitivity, efficiency and avoiding e.g. carrier leakage, the resolution bandwidth may be smaller than the measurement bandwidth. When the resolution bandwidth is smaller than the measurement bandwidth, the result should be integrated over the measurement bandwidth in order to obtain the equivalent noise bandwidth of the measurement bandwidth.

The measurement device characteristics shall be:

- Detection mode: True RMS.
- 2) For a connectors declared to be capable of single carrier operation only, set the representative connectors under test to transmit according to the applicable test configuration in subclause 4.8 at *rated carrier output power*  $P_{\text{rated,c,AC}}$  for *BS type I-C* and  $P_{\text{rated,c,TABC}}$  for *BS type I-H* (D.21). Channel set-up shall be according to NR-FR1-TM 1.1.

For a connector under test declared to be capable of multi-carrier and/or CA operation set the connector under test to transmit on all carriers configured using the applicable test configuration and corresponding power setting specified in subclauses 4.7 and 4.8 using the corresponding test models or set of physical channels in subclause 4.9.2.

- 3) Step the centre frequency of the measurement filter in contiguous steps and measure the emission within the specified frequency ranges with the specified measurement bandwidth. For connector under test declared to operate in multiple bands or non-contiguous spectrum, the emission within the *Inter RF Bandwidth* or *sub-block gap* shall be measured using the specified measurement bandwidth from the closest RF Bandwidth or sub block edge.
- 4) Repeat the test for the remaining test cases, with the channel set-up according to NR-FR1-TM 1.2.

In addition, for *multi-band connectors*, the following steps shall apply:

- 5) For a *multi-band connectors* and single band tests, repeat the steps above per involved *operating band* where single band test configurations and test models shall apply with no carrier activated in the other *operating band*.

## 6.6.4.5 Test requirements

## 6.6.4.5.1 General requirements

## 6.6.4.5.2 Basic limits for Wide Area BS (Category A)

For BS operating in Bands n5, n8, n12, n28, n71, *basic limits* are specified in table 6.6.4.5.2-1.

**Table 6.6.4.5.2-1: Wide Area BS operating band unwanted emission limits (NR bands below 1 GHz) for Category A**

Frequency offset of measurement filter -3dB point, $\Delta f$	Frequency offset of measurement filter centre frequency, $f_{\text{offset}}$	<i>Basic limit</i> (Note 1, 2)	Measurement bandwidth
$0 \text{ MHz} \leq \Delta f < 5 \text{ MHz}$	$0.05 \text{ MHz} \leq f_{\text{offset}} < 5.05 \text{ MHz}$	$-5.5 \text{ dBm} - \frac{7}{5} \cdot \left( \frac{f_{\text{offset}}}{\text{MHz}} - 0.05 \right) \text{ dB}$	100 kHz
$5 \text{ MHz} \leq \Delta f < \min(10 \text{ MHz}, \Delta f_{\text{max}})$	$5.05 \text{ MHz} \leq f_{\text{offset}} < \min(10.05 \text{ MHz}, f_{\text{offset}_{\text{max}}})$	-12.5 dBm	
$10 \text{ MHz} \leq \Delta f \leq \Delta f_{\text{max}}$	$10.05 \text{ MHz} \leq f_{\text{offset}} < f_{\text{offset}_{\text{max}}}$	-13 dBm (Note 3)	
NOTE 1: For a BS supporting non-contiguous spectrum operation within any <i>operating band</i> , the emission limits within sub-block gaps is calculated as a cumulative sum of contributions from adjacent sub blocks on each side of the sub block gap. Exception is $\Delta f \geq 10 \text{ MHz}$ from both adjacent sub blocks on each side of the sub-block gap, where the emission limits within sub-block gaps shall be -13 dBm/100 kHz.			
NOTE 2: For a <i>multi-band connector</i> with Inter RF Bandwidth gap $< 2 \cdot \Delta f_{\text{OBUe}}$ the emission limits within the Inter RF Bandwidth gaps is calculated as a cumulative sum of contributions from adjacent sub-blocks or RF Bandwidth on each side of the Inter RF Bandwidth gap.			
NOTE 3: The requirement is not applicable when $\Delta f_{\text{max}} < 10 \text{ MHz}$ .			

For BS operating in Bands n1, n2, n3, n7, n25, n34, n38, n39, n40, n41, n50, n66, n70, n74, n75, *basic limits* are specified in table 6.6.4.5.2-2:

**Table 6.6.4.5.2-2: Wide Area BS operating band unwanted emission limits (1GHz < NR bands ≤ 3GHz) for Category A**

Frequency offset of measurement filter -3dB point, $\Delta f$	Frequency offset of measurement filter centre frequency, $f_{\text{offset}}$	<i>Basic limit</i> (Note 1, 2)	Measurement bandwidth
$0 \text{ MHz} \leq \Delta f < 5 \text{ MHz}$	$0.05 \text{ MHz} \leq f_{\text{offset}} < 5.05 \text{ MHz}$	$-5.5 \text{ dBm} - \frac{7}{5} \cdot \left( \frac{f_{\text{offset}}}{\text{MHz}} - 0.05 \right) \text{ dB}$	100 kHz
$5 \text{ MHz} \leq \Delta f < \min(10 \text{ MHz}, \Delta f_{\text{max}})$	$5.05 \text{ MHz} \leq f_{\text{offset}} < \min(10.05 \text{ MHz}, f_{\text{offset}_{\text{max}}})$	-12.5 dBm	100 kHz
$10 \text{ MHz} \leq \Delta f \leq \Delta f_{\text{max}}$	$10.5 \text{ MHz} \leq f_{\text{offset}} < f_{\text{offset}_{\text{max}}}$	-13 dBm (Note 3)	1MHz
NOTE 1: For a BS supporting non-contiguous spectrum operation within any <i>operating band</i> , the emission limits within sub-block gaps is calculated as a cumulative sum of contributions from adjacent sub blocks on each side of the sub block gap, where the contribution from the far-end sub-block shall be scaled according to the measurement bandwidth of the near-end sub-block. Exception is $\Delta f \geq 10 \text{ MHz}$ from both adjacent sub blocks on each side of the sub-block gap, where the emission limits within sub-block gaps shall be -13 dBm/1 MHz.			
NOTE 2: For a <i>multi-band connector</i> with Inter RF Bandwidth gap $< 2 \cdot \Delta f_{\text{OBUe}}$ the emission limits within the Inter RF Bandwidth gaps is calculated as a cumulative sum of contributions from adjacent sub-blocks or RF Bandwidth on each side of the Inter RF Bandwidth gap, where the contribution from the far-end sub-block or RF Bandwidth shall be scaled according to the measurement bandwidth of the near-end sub-block or RF Bandwidth.			
NOTE 3: The requirement is not applicable when $\Delta f_{\text{max}} < 10 \text{ MHz}$ .			

For BS operating in Bands n48, n77, n78, n79, *basic limits* are specified in table 6.6.4.5.2-3:

**Table 6.6.4.5.2-3: Wide Area BS operating band unwanted emission limits (NR bands >3GHz) for Category A**

Frequency offset of measurement filter -3dB point, $\Delta f$	Frequency offset of measurement filter centre frequency, $f_{\text{offset}}$	Basic limit (Note 1, 2)	Measurement bandwidth
$0 \text{ MHz} \leq \Delta f < 5 \text{ MHz}$	$0.05 \text{ MHz} \leq f_{\text{offset}} < 5.05 \text{ MHz}$	$-5.2 \text{ dBm} - \frac{7}{5} \cdot \left( \frac{f_{\text{offset}}}{\text{MHz}} - 0.05 \right) \text{ dB}$	100 kHz
$5 \text{ MHz} \leq \Delta f < \min(10 \text{ MHz}, \Delta f_{\text{max}})$	$5.05 \text{ MHz} \leq f_{\text{offset}} < \min(10.05 \text{ MHz}, f_{\text{offset}_{\text{max}}})$	-12.2 dBm	100 kHz
$10 \text{ MHz} \leq \Delta f \leq \Delta f_{\text{max}}$	$10.5 \text{ MHz} \leq f_{\text{offset}} < f_{\text{offset}_{\text{max}}}$	-13 dBm (Note 3)	1MHz
<p>NOTE 1: For a BS supporting non-contiguous spectrum operation within any <i>operating band</i>, the emission limits within sub-block gaps is calculated as a cumulative sum of contributions from adjacent sub blocks on each side of the sub block gap, where the contribution from the far-end sub-block shall be scaled according to the measurement bandwidth of the near-end sub-block. Exception is <math>\Delta f \geq 10\text{MHz}</math> from both adjacent sub blocks on each side of the sub-block gap, where the emission limits within sub-block gaps shall be -13 dBm/1 MHz.</p> <p>NOTE 2: For a <i>multi-band connector</i> with Inter RF Bandwidth gap <math>&lt; 2 \cdot \Delta f_{\text{OBUe}}</math> the emission limits within the Inter RF Bandwidth gaps is calculated as a cumulative sum of contributions from adjacent sub-blocks or RF Bandwidth on each side of the Inter RF Bandwidth gap, where the contribution from the far-end sub-block or RF Bandwidth shall be scaled according to the measurement bandwidth of the near-end sub-block or RF Bandwidth.</p> <p>NOTE 3: The requirement is not applicable when <math>\Delta f_{\text{max}} &lt; 10 \text{ MHz}</math>.</p>			

### 6.6.4.5.3 Basic limits for Wide Area BS (Category B)

For Category B Operating band unwanted emissions, there are two options for the *basic limits* that may be applied regionally. Either the *basic limits* in subclause 6.6.4.2.2.1 or subclause 6.6.4.2.2.2 shall be applied.

#### 6.6.4.5.3.1 Category B requirements (Option 1)

For BS operating in Bands n5, n8, n12, n20, n28, n71, *basic limits* are specified in table 6.6.4.5.3.1-1:

**Table 6.6.4.5.3.1-1: Wide Area BS operating band unwanted emission limits (NR bands below 1 GHz) for Category B**

Frequency offset of measurement filter -3dB point, $\Delta f$	Frequency offset of measurement filter centre frequency, $f_{\text{offset}}$	Basic limit (Note 1, 2)	Measurement bandwidth
$0 \text{ MHz} \leq \Delta f < 5 \text{ MHz}$	$0.05 \text{ MHz} \leq f_{\text{offset}} < 5.05 \text{ MHz}$	$-5.5 \text{ dBm} - \frac{7}{5} \cdot \left( \frac{f_{\text{offset}}}{\text{MHz}} - 0.05 \right) \text{ dB}$	100 kHz
$5 \text{ MHz} \leq \Delta f < \min(10 \text{ MHz}, \Delta f_{\text{max}})$	$5.05 \text{ MHz} \leq f_{\text{offset}} < \min(10.05 \text{ MHz}, f_{\text{offset}_{\text{max}}})$	-12.5 dBm	
$10 \text{ MHz} \leq \Delta f \leq \Delta f_{\text{max}}$	$10.05 \text{ MHz} \leq f_{\text{offset}} < f_{\text{offset}_{\text{max}}}$	-16 dBm (Note 3)	
<p>NOTE 1: For a BS supporting non-contiguous spectrum operation within any <i>operating band</i>, the emission limits within sub-block gaps is calculated as a cumulative sum of contributions from adjacent sub blocks on each side of the sub block gap, where the contribution from the far-end sub-block shall be scaled according to the measurement bandwidth of the near-end sub-block. Exception is <math>\Delta f \geq 10\text{MHz}</math> from both adjacent sub blocks on each side of the sub-block gap, where the emission limits within sub-block gaps shall be -16 dBm/100 kHz.</p> <p>NOTE 2: For a <i>multi-band connector</i> with Inter RF Bandwidth gap <math>&lt; 2 \cdot \Delta f_{\text{OBUe}}</math> the emission limits within the Inter RF Bandwidth gaps is calculated as a cumulative sum of contributions from adjacent sub-blocks or RF Bandwidth on each side of the Inter RF Bandwidth gap, where the contribution from the far-end sub-block or RF Bandwidth shall be scaled according to the measurement bandwidth of the near-end sub-block or RF Bandwidth.</p> <p>NOTE 3: The requirement is not applicable when <math>\Delta f_{\text{max}} &lt; 10 \text{ MHz}</math>.</p>			

For BS operating in Bands n1, n2, n3, n7, n25, n34, n38, n39, n40, n41, n50, n66, n70, n75, *basic limits* are specified in tables 6.6.4.5.3.1-2:

**Table 6.6.4.5.3.1-2: Wide Area BS operating band unwanted emission limits (1GHz < NR bands ≤ 3GHz) for Category B**

Frequency offset of measurement filter -3dB point, $\Delta f$	Frequency offset of measurement filter centre frequency, $f_{\text{offset}}$	Basic limit (Note 1, 2)	Measurement bandwidth
$0 \text{ MHz} \leq \Delta f < 5 \text{ MHz}$	$0.05 \text{ MHz} \leq f_{\text{offset}} < 5.05 \text{ MHz}$	$-5.5 \text{ dBm} - \frac{7}{5} \cdot \left( \frac{f_{\text{offset}}}{\text{MHz}} - 0.05 \right) \text{ dB}$	100 kHz
$5 \text{ MHz} \leq \Delta f < \min(10 \text{ MHz}, \Delta f_{\text{max}})$	$5.05 \text{ MHz} \leq f_{\text{offset}} < \min(10.05 \text{ MHz}, f_{\text{offset}_{\text{max}}})$	-12.5 dBm	100 kHz
$10 \text{ MHz} \leq \Delta f \leq \Delta f_{\text{max}}$	$10.5 \text{ MHz} \leq f_{\text{offset}} < f_{\text{offset}_{\text{max}}}$	-15 dBm (Note 3)	1MHz
<p>NOTE 1: For a BS supporting non-contiguous spectrum operation within any <i>operating band</i>, the emission limits within sub-block gaps is calculated as a cumulative sum of contributions from adjacent sub blocks on each side of the sub block gap, where the contribution from the far-end sub-block shall be scaled according to the measurement bandwidth of the near-end sub-block. Exception is <math>\Delta f \geq 10 \text{ MHz}</math> from both adjacent sub blocks on each side of the sub-block gap, where the emission limits within sub-block gaps shall be -15 dBm/1 MHz.</p> <p>NOTE 2: For a <i>multi-band connector</i> with Inter RF Bandwidth gap &lt; <math>2 \cdot \Delta f_{\text{OBUe}}</math> the emission limits within the Inter RF Bandwidth gaps is calculated as a cumulative sum of contributions from adjacent sub-blocks or RF Bandwidth on each side of the Inter RF Bandwidth gap, where the contribution from the far-end sub-block or RF Bandwidth shall be scaled according to the measurement bandwidth of the near-end sub-block or RF Bandwidth.</p> <p>NOTE 3: The requirement is not applicable when <math>\Delta f_{\text{max}} &lt; 10 \text{ MHz}</math>.</p>			

For BS operating in Bands n48, n77, n78, n79, *basic limits* are specified in tables 6.6.4.5.3.1-3:

**Table 6.6.4.5.3.1-3: Wide Area BS operating band unwanted emission limits (NR bands >3GHz) for Category B**

Frequency offset of measurement filter -3dB point, $\Delta f$	Frequency offset of measurement filter centre frequency, $f_{\text{offset}}$	Basic limit (Note 1, 2)	Measurement bandwidth
$0 \text{ MHz} \leq \Delta f < 5 \text{ MHz}$	$0.05 \text{ MHz} \leq f_{\text{offset}} < 5.05 \text{ MHz}$	$-5.2 \text{ dBm} - \frac{7}{5} \cdot \left( \frac{f_{\text{offset}}}{\text{MHz}} - 0.05 \right) \text{ dB}$	100 kHz
$5 \text{ MHz} \leq \Delta f < \min(10 \text{ MHz}, \Delta f_{\text{max}})$	$5.05 \text{ MHz} \leq f_{\text{offset}} < \min(10.05 \text{ MHz}, f_{\text{offset}_{\text{max}}})$	-12.2 dBm	100 kHz
$10 \text{ MHz} \leq \Delta f \leq \Delta f_{\text{max}}$	$10.5 \text{ MHz} \leq f_{\text{offset}} < f_{\text{offset}_{\text{max}}}$	-15 dBm (Note 3)	1MHz
<p>NOTE 1: For a BS supporting non-contiguous spectrum operation within any <i>operating band</i>, the emission limits within sub-block gaps is calculated as a cumulative sum of contributions from adjacent sub blocks on each side of the sub block gap, where the contribution from the far-end sub-block shall be scaled according to the measurement bandwidth of the near-end sub-block. Exception is <math>\Delta f \geq 10 \text{ MHz}</math> from both adjacent sub blocks on each side of the sub-block gap, where the emission limits within sub-block gaps shall be -15 dBm/1 MHz.</p> <p>NOTE 2: For a <i>multi-band connector</i> with Inter RF Bandwidth gap &lt; <math>2 \cdot \Delta f_{\text{OBUe}}</math> the emission limits within the Inter RF Bandwidth gaps is calculated as a cumulative sum of contributions from adjacent sub-blocks or RF Bandwidth on each side of the Inter RF Bandwidth gap, where the contribution from the far-end sub-block or RF Bandwidth shall be scaled according to the measurement bandwidth of the near-end sub-block or RF Bandwidth.</p> <p>NOTE 3: The requirement is not applicable when <math>\Delta f_{\text{max}} &lt; 10 \text{ MHz}</math>.</p>			

#### 6.6.4.5.3.2 Category B requirements (Option 2)

The limits in this subclause are intended for Europe and may be applied regionally for BS operating in Bands n1, n3, n8.

For a BS operating in Bands n1, n3, n8 *basic limits* are specified in table 6.6.4.5.3.2-1:

**Table 6.6.4.5.3.2-1: Regional Wide Area BS operating band unwanted emission limits for Category B**

Frequency offset of measurement filter -3dB point, $\Delta f$	Frequency offset of measurement filter centre frequency, $f_{\text{offset}}$	Basic limit (Note 1, 2)	Measurement bandwidth
$0 \text{ MHz} \leq \Delta f < 0.2 \text{ MHz}$	$0.015 \text{ MHz} \leq f_{\text{offset}} < 0.215 \text{ MHz}$	-12.5dBm	30 kHz
$0.2 \text{ MHz} \leq \Delta f < 1 \text{ MHz}$	$0.215 \text{ MHz} \leq f_{\text{offset}} < 1.015 \text{ MHz}$	$-12.5 \text{ dBm} - 15 \cdot \left( \frac{f_{\text{offset}}}{\text{MHz}} - 0.215 \right) \text{ dB}$	30 kHz
(Note 4)	$1.015 \text{ MHz} \leq f_{\text{offset}} < 1.5 \text{ MHz}$	-24.5dBm	30 kHz
$1 \text{ MHz} \leq \Delta f \leq \min(10 \text{ MHz}, \Delta f_{\text{max}})$	$1.5 \text{ MHz} \leq f_{\text{offset}} < \min(10.5 \text{ MHz}, f_{\text{offset}_{\text{max}}})$	-11.5dBm	1 MHz
$10 \text{ MHz} \leq \Delta f \leq \Delta f_{\text{max}}$	$10.5 \text{ MHz} \leq f_{\text{offset}} < f_{\text{offset}_{\text{max}}}$	-15 dBm (Note 3)	1 MHz
<p>NOTE 1: For a BS supporting non-contiguous spectrum operation within any operating band, the minimum requirement within sub-block gaps is calculated as a cumulative sum of contributions from adjacent sub blocks on each side of the sub block gap, where the contribution from the far-end sub-block shall be scaled according to the measurement bandwidth of the near-end sub-block. Exception is <math>\Delta f \geq 10\text{MHz}</math> from both adjacent sub blocks on each side of the sub-block gap, where the minimum requirement within sub-block gaps shall be -15dBm/1MHz.</p> <p>NOTE 2: For a <i>multi-band connector</i> with Inter RF Bandwidth gap <math>&lt; 2 \cdot \Delta f_{\text{OBUe}}</math> the minimum requirement within the Inter RF Bandwidth gaps is calculated as a cumulative sum of contributions from adjacent sub-blocks or RF Bandwidth on each side of the Inter RF Bandwidth gap, where the contribution from the far-end sub-block or RF Bandwidth shall be scaled according to the measurement bandwidth of the near-end sub-block or RF Bandwidth.</p> <p>NOTE 3: The requirement is not applicable when <math>\Delta f_{\text{max}} &lt; 10 \text{ MHz}</math>.</p> <p>NOTE 4: This frequency range ensures that the range of values of <math>f_{\text{offset}}</math> is continuous.</p>			

**6.6.4.5.4 Basic limits for Medium Range BS (Category A and B)**

For Medium Range BS in NR bands  $\leq 3\text{GHz}$ , *basic limits* are specified in table 6.6.4.5.4-1 and table 6.6.4.5.4-2.

For Medium Range BS in NR bands  $> 3\text{GHz}$ , *basic limits* are specified in table 6.6.4.5.4-3 and table 6.6.4.5.4-4.

For the tables in this subclause for *BS type I-C*  $P_{\text{rated},x} = P_{\text{rated},c,AC}$ , and for *BS type I-H*  $P_{\text{rated},x} = P_{\text{rated},c,cell} - 10 \cdot \log_{10}(N_{\text{TXU,countedpercell}})$ , and for *BS type I-O*  $P_{\text{rated},x} = P_{\text{rated},c,TRP} - 9 \text{ dB}$ .

**Table 6.6.4.5.4-1: Medium Range BS operating band unwanted emission limits,  $31 < P_{\text{rated},x} \leq 38 \text{ dBm}$  (NR bands  $\leq 3\text{GHz}$ )**

Frequency offset of measurement filter -3dB point, $\Delta f$	Frequency offset of measurement filter centre frequency, $f_{\text{offset}}$	Basic limit (Note 1, 2)	Measurement bandwidth
$0 \text{ MHz} \leq \Delta f < 5 \text{ MHz}$	$0.05 \text{ MHz} \leq f_{\text{offset}} < 5.05 \text{ MHz}$	$P_{\text{rated},x} - 51.5 \text{ dB} - \frac{7}{5} \left( \frac{f_{\text{offset}}}{\text{MHz}} - 0.05 \right) \text{ dB}$	100 kHz
$5 \text{ MHz} \leq \Delta f < \min(10 \text{ MHz}, \Delta f_{\text{max}})$	$5.05 \text{ MHz} \leq f_{\text{offset}} < \min(10.05 \text{ MHz}, f_{\text{offset}_{\text{max}}})$	$P_{\text{rated},x} - 58.5 \text{ dB}$	100 kHz
$10 \text{ MHz} \leq \Delta f \leq \Delta f_{\text{max}}$	$10.05 \text{ MHz} \leq f_{\text{offset}} < f_{\text{offset}_{\text{max}}}$	$\text{Min}(P_{\text{rated},x} - 60 \text{ dB}, -25 \text{ dBm})$ (Note 3)	100 kHz
<p>NOTE 1: For a BS supporting non-contiguous spectrum operation within any <i>operating band</i> the emission limits within sub-block gaps is calculated as a cumulative sum of contributions from adjacent sub blocks on each side of the sub block gap. Exception is <math>\Delta f \geq 10\text{MHz}</math> from both adjacent sub blocks on each side of the sub-block gap, where the emission limits within sub-block gaps shall be <math>\text{Min}(P_{\text{rated},x} - 60 \text{ dB}, -25 \text{ dBm})/100\text{kHz}</math>.</p> <p>NOTE 2: For a <i>multi-band connector</i> with Inter RF Bandwidth gap <math>&lt; 2 \cdot \Delta f_{\text{OBUe}}</math> the emission limits within the Inter RF Bandwidth gaps is calculated as a cumulative sum of contributions from adjacent sub-blocks or RF Bandwidth on each side of the Inter RF Bandwidth gap.</p> <p>NOTE 3: The requirement is not applicable when <math>\Delta f_{\text{max}} &lt; 10 \text{ MHz}</math>.</p>			

**Table 6.6.4.5.4-2: Medium Range BS operating band unwanted emission limits,  $P_{\text{rated},x} \leq 31$  dBm (NR bands  $\leq 3$ GHz)**

Frequency offset of measurement filter -3dB point, $\Delta f$	Frequency offset of measurement filter centre frequency, $f_{\text{offset}}$	Basic limit (Note 1, 2)	Measurement bandwidth
$0 \text{ MHz} \leq \Delta f < 5 \text{ MHz}$	$0.05 \text{ MHz} \leq f_{\text{offset}} < 5.05 \text{ MHz}$	$-20.5 \text{ dBm} - \frac{7}{5} \left( \frac{f_{\text{offset}}}{\text{MHz}} - 0.05 \right) \text{ dB}$	100 kHz
$5 \text{ MHz} \leq \Delta f < \min(10 \text{ MHz}, \Delta f_{\text{max}})$	$5.05 \text{ MHz} \leq f_{\text{offset}} < \min(10.05 \text{ MHz}, f_{\text{offset}_{\text{max}}})$	-27.5 dBm	100 kHz
$10 \text{ MHz} \leq \Delta f \leq \Delta f_{\text{max}}$	$10.05 \text{ MHz} \leq f_{\text{offset}} < f_{\text{offset}_{\text{max}}}$	-29 dBm (Note 3)	100 kHz
<p>NOTE 1: For a BS supporting non-contiguous spectrum operation within any <i>operating band</i> the emission limits within sub-block gaps is calculated as a cumulative sum of contributions from adjacent sub blocks on each side of the sub block gap. Exception is <math>\Delta f \geq 10</math>MHz from both adjacent sub blocks on each side of the sub-block gap, where the emission limits within sub-block gaps shall be -29dBm/100kHz.</p> <p>NOTE 2: For a <i>multi-band connector</i> with Inter RF Bandwidth gap <math>&lt; 2 \cdot \Delta f_{\text{OBUe}}</math> the emission limits within the Inter RF Bandwidth gaps is calculated as a cumulative sum of contributions from adjacent sub-blocks or RF Bandwidth on each side of the Inter RF Bandwidth gap.</p> <p>NOTE 3: The requirement is not applicable when <math>\Delta f_{\text{max}} &lt; 10</math> MHz.</p>			

**Table 6.6.4.5.4-3: Medium Range BS operating band unwanted emission limits,  $31 < P_{\text{rated},x} \leq 38$  dBm (NR bands  $> 3$ GHz)**

Frequency offset of measurement filter -3dB point, $\Delta f$	Frequency offset of measurement filter centre frequency, $f_{\text{offset}}$	Basic limit (Note 1, 2)	Measurement bandwidth
$0 \text{ MHz} \leq \Delta f < 5 \text{ MHz}$	$0.05 \text{ MHz} \leq f_{\text{offset}} < 5.05 \text{ MHz}$	$P_{\text{rated},x} - 51.2 \text{ dB} - \frac{7}{5} \left( \frac{f_{\text{offset}}}{\text{MHz}} - 0.05 \right) \text{ dB}$	100 kHz
$5 \text{ MHz} \leq \Delta f < \min(10 \text{ MHz}, \Delta f_{\text{max}})$	$5.05 \text{ MHz} \leq f_{\text{offset}} < \min(10.05 \text{ MHz}, f_{\text{offset}_{\text{max}}})$	$P_{\text{rated},x} - 58.2 \text{ dB}$	100 kHz
$10 \text{ MHz} \leq \Delta f \leq \Delta f_{\text{max}}$	$10.05 \text{ MHz} \leq f_{\text{offset}} < f_{\text{offset}_{\text{max}}}$	$\text{Min}(P_{\text{rated},x} - 60 \text{ dB}, -25 \text{ dBm})$ (Note 3)	100 kHz
<p>NOTE 1: For a BS supporting non-contiguous spectrum operation within any <i>operating band</i> the emission limits within sub-block gaps is calculated as a cumulative sum of contributions from adjacent sub blocks on each side of the sub block gap. Exception is <math>\Delta f \geq 10</math>MHz from both adjacent sub blocks on each side of the sub-block gap, where the emission limits within sub-block gaps shall be <math>\text{Min}(P_{\text{rated},x} - 60 \text{ dB}, -25 \text{ dBm})/100 \text{ kHz}</math>.</p> <p>NOTE 2: For a <i>multi-band connector</i> with Inter RF Bandwidth gap <math>&lt; 2 \cdot \Delta f_{\text{OBUe}}</math> the emission limits within the Inter RF Bandwidth gaps is calculated as a cumulative sum of contributions from adjacent sub-blocks or RF Bandwidth on each side of the Inter RF Bandwidth gap.</p> <p>NOTE 3: The requirement is not applicable when <math>\Delta f_{\text{max}} &lt; 10</math> MHz.</p>			



**Table 6.6.4.5.4-4: Medium Range BS operating band unwanted emission limits,  $P_{\text{rated},x} \leq 31$  dBm (NR bands >3GHz)**

Frequency offset of measurement filter -3dB point, $\Delta f$	Frequency offset of measurement filter centre frequency, $f_{\text{offset}}$	Basic limit (Note 1, 2)	Measurement bandwidth
$0 \text{ MHz} \leq \Delta f < 5 \text{ MHz}$	$0.05 \text{ MHz} \leq f_{\text{offset}} < 5.05 \text{ MHz}$	$-20.2 \text{ dBm} - \frac{7}{5} \left( \frac{f_{\text{offset}}}{\text{MHz}} - 0.05 \right) \text{ dB}$	100 kHz
$5 \text{ MHz} \leq \Delta f < \min(10 \text{ MHz}, \Delta f_{\text{max}})$	$5.05 \text{ MHz} \leq f_{\text{offset}} < \min(10.05 \text{ MHz}, f_{\text{offset}_{\text{max}}})$	-27.2 dBm	100 kHz
$10 \text{ MHz} \leq \Delta f \leq \Delta f_{\text{max}}$	$10.05 \text{ MHz} \leq f_{\text{offset}} < f_{\text{offset}_{\text{max}}}$	-29 dBm (Note 3)	100 kHz
NOTE 1: For a BS supporting non-contiguous spectrum operation within any <i>operating band</i> the emission limits within sub-block gaps is calculated as a cumulative sum of contributions from adjacent sub blocks on each side of the sub block gap. Exception is $\Delta f \geq 10\text{MHz}$ from both adjacent sub blocks on each side of the sub-block gap, where the emission limits within sub-block gaps shall be -29dBm/100kHz.			
NOTE 2: For a <i>multi-band connector</i> with Inter RF Bandwidth gap < $2 \cdot \Delta f_{\text{OBUe}}$ the emission limits within the Inter RF Bandwidth gaps is calculated as a cumulative sum of contributions from adjacent sub-blocks or RF Bandwidth on each side of the Inter RF Bandwidth gap.			
NOTE 3: The requirement is not applicable when $\Delta f_{\text{max}} < 10$ MHz.			

**6.6.4.5.5 Basic limits for Local Area BS (Category A and B)**

For Local Area BS in NR bands  $\leq 3$  GHz, *basic limits* are specified in table 6.6.4.5.5-1.

For Local Area BS in NR bands > 3 GHz, *basic limits* are specified in table 6.6.4.5.5-2.

**Table 6.6.4.5.5-1: Local Area BS operating band unwanted emission limits (NR bands  $\leq 3$ GHz)**

Frequency offset of measurement filter -3dB point, $\Delta f$	Frequency offset of measurement filter centre frequency, $f_{\text{offset}}$	Basic limit (Note 1, 2)	Measurement bandwidth
$0 \text{ MHz} \leq \Delta f < 5 \text{ MHz}$	$0.05 \text{ MHz} \leq f_{\text{offset}} < 5.05 \text{ MHz}$	$-28.5 \text{ dBm} - \frac{7}{5} \left( \frac{f_{\text{offset}}}{\text{MHz}} - 0.05 \right) \text{ dB}$	100 kHz
$5 \text{ MHz} \leq \Delta f < \min(10 \text{ MHz}, \Delta f_{\text{max}})$	$5.05 \text{ MHz} \leq f_{\text{offset}} < \min(10.05 \text{ MHz}, f_{\text{offset}_{\text{max}}})$	-35.5 dBm	
$10 \text{ MHz} \leq \Delta f \leq \Delta f_{\text{max}}$	$10.05 \text{ MHz} \leq f_{\text{offset}} < f_{\text{offset}_{\text{max}}}$	-37 dBm (Note 3)	
NOTE 1: For a BS supporting non-contiguous spectrum operation within any <i>operating band</i> the emission limits within sub-block gaps is calculated as a cumulative sum of contributions from adjacent sub blocks on each side of the sub block gap. Exception is $\Delta f \geq 10\text{MHz}$ from both adjacent sub blocks on each side of the sub-block gap, where the emission limits within sub-block gaps shall be -37dBm/100kHz.			
NOTE 2: For a <i>multi-band connector</i> with Inter RF Bandwidth gap < $2 \cdot \Delta f_{\text{OBUe}}$ the emission limits within the Inter RF Bandwidth gaps is calculated as a cumulative sum of contributions from adjacent sub-blocks or RF Bandwidth on each side of the Inter RF Bandwidth gap			
NOTE 3: The requirement is not applicable when $\Delta f_{\text{max}} < 10$ MHz.			

Table 6.6.4.5.5-1: Local Area BS operating band unwanted emission limits (NR bands &gt;3GHz)

Frequency offset of measurement filter -3dB point, $\Delta f$	Frequency offset of measurement filter centre frequency, $f_{\text{offset}}$	Basic limit (Note 1, 2)	Measurement bandwidth
$0 \text{ MHz} \leq \Delta f < 5 \text{ MHz}$	$0.05 \text{ MHz} \leq f_{\text{offset}} < 5.05 \text{ MHz}$	$-28.2 \text{ dBm} - \frac{7}{5} \cdot \left( \frac{f_{\text{offset}}}{\text{MHz}} - 0.05 \right) \text{ dB}$	100 kHz
$5 \text{ MHz} \leq \Delta f < \min(10 \text{ MHz}, \Delta f_{\text{max}})$	$5.05 \text{ MHz} \leq f_{\text{offset}} < \min(10.05 \text{ MHz}, f_{\text{offset}_{\text{max}}})$	-35.2 dBm	
$10 \text{ MHz} \leq \Delta f \leq \Delta f_{\text{max}}$	$10.05 \text{ MHz} \leq f_{\text{offset}} < f_{\text{offset}_{\text{max}}}$	-37 dBm (Note 3)	
NOTE 1: For a BS supporting non-contiguous spectrum operation within any <i>operating band</i> the emission limits within sub-block gaps is calculated as a cumulative sum of contributions from adjacent sub blocks on each side of the sub block gap. Exception is $\Delta f \geq 10 \text{ MHz}$ from both adjacent sub blocks on each side of the sub-block gap, where the emission limits within sub-block gaps shall be -37dBm/100kHz.			
NOTE 2: For a <i>multi-band connector</i> with Inter RF Bandwidth gap < $2 \cdot \Delta f_{\text{OBUe}}$ the emission limits within the Inter RF Bandwidth gaps is calculated as a cumulative sum of contributions from adjacent sub-blocks or RF Bandwidth on each side of the Inter RF Bandwidth gap			
NOTE 3: The requirement is not applicable when $\Delta f_{\text{max}} < 10 \text{ MHz}$ .			

### 6.6.4.5.6 Basic limits for additional requirements

#### 6.6.4.5.6.1 Limits in FCC Title 47

In addition to the requirements in subclauses 6.6.4.5.2 to 6.6.4.5.5, the BS may have to comply with the applicable emission limits established by FCC Title 47 [13], when deployed in regions where those limits are applied, and under the conditions declared by the manufacturer.

#### 6.6.4.5.6.2 Protection of DTT

In certain regions the following requirement may apply for protection of DTT. For *BS type 1-C* or *BS type 1-H* operating in Band n20, the level of emissions in the band 470-790 MHz, measured in an 8 MHz filter bandwidth on centre frequencies  $F_{\text{filter}}$  according to table 6.6.4.5.6.2-1, *basic limit* is  $P_{\text{EM,N}}$  declared by the manufacturer. This requirement applies in the frequency range 470-790 MHz even though part of the range falls in the spurious domain.

Table 6.6.4.5.6.2-1: Declared emissions *basic limit* for protection of DTT

Filter centre frequency, $F_{\text{filter}}$	Measurement bandwidth	Declared emission <i>basic limit</i> (dBm)
$F_{\text{filter}} = 8 \cdot N + 306 \text{ (MHz)}$ ; $21 \leq N \leq 60$	8 MHz	$P_{\text{EM,N}}$

Note: The regional requirement is defined in terms of EIRP (effective isotropic radiated power), which is dependent on both the BS emissions at the *antenna connector* and the deployment (including antenna gain and feeder loss). The requirement defined above provides the characteristics of the BS needed to verify compliance with the regional requirement. Compliance with the regional requirement can be determined using the method outlined in TS 36.104 [13], annex G.

#### 6.6.4.5.6.3 Additional operating band unwanted emissions limits for Band n48

The following requirement may apply to BS operating in Band n48 in certain regions. Emissions shall not exceed the maximum levels specified in Table 6.6.4.5.6.3-1.

Table 6.6.4.5.6.3-1: Additional operating band unwanted emission limits for Band n48

Channel bandwidth	Frequency offset of measurement filter -3dB point, $\Delta f$	Frequency offset of measurement filter centre frequency, $f_{\text{offset}}$	Minimum requirement	Measurement bandwidth (Note)
All	$0 \text{ MHz} \leq \Delta f < 10 \text{ MHz}$	$0.5 \text{ MHz} \leq f_{\text{offset}} < 9.5 \text{ MHz}$	-13 dBm	1 MHz

Note: The resolution bandwidth of the measuring equipment should be equal to the measurement bandwidth. However, to improve measurement accuracy, sensitivity and efficiency, the resolution bandwidth may be smaller than the measurement bandwidth. When the resolution bandwidth is smaller than the measurement bandwidth, the result should be integrated over the measurement bandwidth in order to obtain the equivalent noise bandwidth of the measurement bandwidth.

#### 6.6.4.5.7 *BS type 1-C*

The operating band unwanted emissions for *BS type 1-C* for each *antenna connector* shall be below the applicable *basic limits* defined in subclauses 6.6.4.5.2 – 6.6.4.5.6.

#### 6.6.4.5.8 *BS type 1-H*

The operating band unwanted emissions requirements for *BS type 1-H* are that for each *TAB connector TX min cell group* and each applicable *basic limit* in subclauses 6.6.4.5.2 – 6.6.4.5.6, the power summation emissions at the *TAB connectors* of the *TAB connector TX min cell group* shall not exceed a BS limit specified as the *basic limit* + X, where  $X = 10\log_{10}(N_{\text{TXU, countedpercell}})$ .

NOTE: Conformance to the *BS type 1-H* spurious emission requirement can be demonstrated by meeting at least one of the following criteria as determined by the manufacturer:

1) The sum of the emissions power measured on each *TAB connector* in the *TAB connector TX min cell group* shall be less than or equal to the limit as defined in this subclause for the respective frequency span.

Or

2) The unwanted emissions power at each *TAB connector* shall be less than or equal to the *BS type 1-H* limit as defined in this subclause for the respective frequency span, scaled by  $-10\log_{10}(n)$ , where  $n$  is the number of *TAB connectors* in the *TAB connector TX min cell group*.

### 6.6.5 Transmitter spurious emissions

#### 6.6.5.1 Definition and applicability

The transmitter spurious emission limits shall apply from 9 kHz to 12.75 GHz, excluding the frequency range from  $\Delta f_{\text{OBUE}}$  below the lowest frequency of each supported downlink *operating band*, up to  $\Delta f_{\text{OBUE}}$  above the highest frequency of each supported downlink *operating band*, where the  $\Delta f_{\text{OBUE}}$  is defined in table 6.6.1. For some *operating bands*, the upper limit is higher than 12.75 GHz in order to comply with the 5<sup>th</sup> harmonic limit of the downlink *operating band*, as specified in ITU-R recommendation SM.329 [5].

For a *multi-band connector*, each supported *operating band* together with  $\Delta f_{\text{OBUE}}$  around the band is excluded from the transmitter spurious emissions requirement.

The requirements shall apply whatever the type of transmitter considered (single carrier or multi-carrier). It applies for all transmission modes foreseen by the manufacturer's specification.

Unless otherwise stated, all requirements are measured as mean power (RMS).

[For operation in region 2, where the FCC guidance for MIMO systems in [13] is applicable,  $N_{\text{TXU, countedpercell}}$  shall be equal to one for the purposes of calculating the spurious emissions limits in subclauses 6.6.5. For all other unwanted emissions requirements,  $N_{\text{TXU, countedpercell}}$  shall be the value calculated according to subclause 6.1.]

#### 6.6.5.2 Minimum requirement

The minimum requirement applies per *single-band connector*, or per *multi-band connector* supporting transmission in the *operating band*.

The minimum requirement for *BS type 1-C* is defined in TS 38.104 [2], subclause 6.6.5.3.

The minimum requirement for *BS type 1-H* is defined in TS 38.104 [2], subclause 6.6.5.4.

#### 6.6.5.3 Test purpose

This test measures conducted spurious while the transmitter is in operation.

## 6.6.5.4 Method of test

### 6.6.5.4.1 Initial conditions

Test environment: Normal; see annex B.2.

RF channels to be tested for single carrier:

- B when testing the spurious frequencies below  $F_{DL\_low} - \Delta f_{OBUE}$ ,
- T when testing the spurious frequencies above  $F_{DL\_high} + \Delta f_{OBUE}$ ; see subclause 4.9.1.

*Base Station RF Bandwidth* positions to be tested for multi-carrier and/or CA:

- $B_{RFBW}$  when testing the spurious frequencies below  $F_{DL\_low} - \Delta f_{OBUE}$ ;  $T_{RFBW}$  when testing the spurious frequencies above  $F_{DL\_high} + \Delta f_{OBUE}$  in single-band operation; see subclause 4.9.1.
- $B'_{RFBW}$ ,  $T'_{RFBW}$  when testing the spurious frequencies below  $F_{DL\_low} - \Delta f_{OBUE}$  of the lowest operating band;  $B'_{RFBW}$ ,  $T'_{RFBW}$  when testing the spurious frequencies above  $F_{DL\_high} + \Delta f_{OBUE}$  of the highest operating band in multi-band operation, see subclause 4.9.1.

### 6.6.5.4.2 Procedure

For *BS type I-H* where there may be multiple *TAB connectors*, they may be tested one at a time or multiple *TAB connectors* may be tested in parallel as shown in annex D.3.1. Whichever method is used the procedure is repeated until all *TAB connectors* necessary to demonstrate conformance have been tested.

- 1) Connect the *single-band connector* or *multi-band connector* under test to measurement equipment as shown in annex D.1.1 for *BS type I-C* and in annex D.3.1 for *BS type I-H*. All connectors not under test shall be terminated.
- 2) Measurements shall use a measurement bandwidth in accordance to the conditions in subclause 6.6.5.5.

The measurement device characteristics shall be:

- Detection mode: True RMS.
- 3) For a connectors declared to be capable of single carrier operation only (D.16), set the representative connectors under test to transmit according to the applicable test configuration in subclause 4.8 at *rated carrier output power* ( $P_{rated,c,AC}$ , or  $P_{rated,c,TABC}$ , D.21). Channel set-up shall be according to NR-FR1-TM 1.1.

For a connector under test declared to be capable of multi-carrier and/or CA operation (D.15-D.16) set the connector under test to transmit on all carriers configured using the applicable test configuration and corresponding power setting specified in subclauses 4.7 and 4.8 using the corresponding test models or set of physical channels in subclause 4.9.2.

- 4) Measure the emission at the specified frequencies with specified measurement bandwidth and note that the measured value does not exceed the test requirement in subclause 6.6.6.5.

In addition, for *multi-band connectors*, the following steps shall apply:

- 5) For a *multi-band connectors* and single band tests, repeat the steps above per involved *operating band* where single band test configurations and test models shall apply with no carrier activated in the other *operating band*.

## 6.6.5.5 Test requirements

### 6.6.5.5.1 Basic limits

#### 6.6.5.5.1.1 Tx spurious emissions

The limits of either table 6.6.5.5.1.1-1 (Category A limits) or table 6.6.5.5.1.1-2 (Category B limits) shall apply. The application of either Category A or Category B limits shall be the same as for operating band unwanted emissions in subclause 6.6.4, and as declared by the manufacturer (D.4).

**Table 6.6.5.5.1.1-1: General BS transmitter spurious emission limits in FR1, Category A**

Spurious frequency range	Basic limit	Measurement bandwidth	Notes
9 kHz – 150 kHz	-13 dBm	1 kHz	Note 1, Note 4
150 kHz – 30 MHz		10 kHz	Note 1, Note 4
30 MHz – 1 GHz		100 kHz	Note 1
1 GHz – 12.75 GHz		1 MHz	Note 1, Note 2
12.75 GHz – 5 <sup>th</sup> harmonic of the upper frequency edge of the DL <i>operating band</i> in GHz		1 MHz	Note 1, Note 2, Note 3
NOTE 1: Measurement bandwidths as in ITU-R SM.329 [2], s4.1.			
NOTE 2: Upper frequency as in ITU-R SM.329 [2], s2.5 table 1.			
NOTE 3: This spurious frequency range applies only for <i>operating bands</i> for which the 5 <sup>th</sup> harmonic of the upper frequency edge of the DL <i>operating band</i> is reaching beyond 12.75 GHz.			
NOTE 4: This spurious frequency range applies only to <i>BS type 1-C</i> and <i>BS type 1-H</i> .			

**Table 6.6.5.5.1.1-2: General BS transmitter spurious emission limits in FR1, Category B**

Spurious frequency range	Basic limit	Measurement bandwidth	Notes
9 kHz – 150 kHz	-36 dBm	1 kHz	Note 1, Note 4
150 kHz – 30 MHz		10 kHz	Note 1, Note 4
30 MHz – 1 GHz		100 kHz	Note 1
1 GHz – 12.75 GHz	-30 dBm	1 MHz	Note 1, Note 2
12.75 GHz – 5 <sup>th</sup> harmonic of the upper frequency edge of the DL <i>operating band</i> in GHz		1 MHz	Note 1, Note 2, Note 3
NOTE 1: Measurement bandwidths as in ITU-R SM.329 [2], s4.1.			
NOTE 2: Upper frequency as in ITU-R SM.329 [2], s2.5 table 1.			
NOTE 3: This spurious frequency range applies only for <i>operating bands</i> for which the 5 <sup>th</sup> harmonic of the upper frequency edge of the DL <i>operating band</i> is reaching beyond 12.75 GHz.			
NOTE 4: This spurious frequency range applies only to <i>BS type 1-C</i> and <i>BS type 1-H</i> .			

#### 6.6.5.5.1.2 Protection of the BS receiver of own or different BS

This requirement shall be applied for NR FDD operation in order to prevent the receivers of the BSs being desensitised by emissions from a BS transmitter. It is measured at the transmit *antenna connector* for *BS type 1-C* or at the *TAB connector* for *BS type 1-H* for any type of BS which has common or separate Tx/Rx *antenna connectors* / *TAB connectors*.

The *basic limits* are provided in table 6.6.5.5.1.2-1.

**Table 6.6.5.5.1.2-1: BS spurious emissions *basic limits* for protection of the BS receiver**

BS class	Frequency range	Basic limit	Measurement bandwidth
Wide Area BS	$F_{UL\_low} - F_{UL\_high}$	-96 dBm	100 kHz
Medium Range BS		-91 dBm	
Local Area BS		-88 dBm	

#### 6.6.5.5.1.3 Additional spurious emissions requirements

These requirements may be applied for the protection of system operating in frequency ranges other than the BS downlink *operating band*. The limits may apply as an optional protection of such systems that are deployed in the same geographical area as the BS, or they may be set by local or regional regulation as a mandatory requirement for an NR *operating band*. It is in some cases not stated in the present document whether a requirement is mandatory or under what exact circumstances that a limit applies, since this is set by local or regional regulation. An overview of regional requirements in the present document is given in subclause 4.4.

Some requirements may apply for the protection of specific equipment (UE, MS and/or BS) or equipment operating in specific systems (GSM, CDMA, UTRA, E-UTRA, NR, etc.) as listed below.

The power of any spurious emission shall not exceed the *basic limits* of table 6.6.5.5.1.3-1 for a BS where requirements for co-existence with the system listed in the first column apply. For a *multi-band connector*, the exclusions and conditions in the Note column of table 6.6.5.5.1.3-1 apply for each supported *operating band*.

**Table 6.6.5.5.1.3-1: BS spurious emissions limits for BS for co-existence with systems operating in other frequency bands**

System type for NR to co-exist with	Frequency range for co-existence requirement	Basic limit	Measurement bandwidth	Note
GSM900	921 – 960 MHz	-57 dBm	100 kHz	This requirement does not apply to BS operating in band n8
	876 – 915 MHz	-61 dBm	100 kHz	For the frequency range 880-915 MHz, this requirement does not apply to BS operating in band n8, since it is already covered by the requirement in subclause 6.6.5.5.1.2.
DCS1800	1805 – 1880 MHz	-47 dBm	100 kHz	This requirement does not apply to BS operating in band n3.
	1710 – 1785 MHz	-61 dBm	100 kHz	This requirement does not apply to BS operating in band n3, since it is already covered by the requirement in subclause 6.6.5.5.1.2.
PCS1900	1930 – 1990 MHz	-47 dBm	100 kHz	This requirement does not apply to BS operating in band n2, n25 or band n70.
	1850 – 1910 MHz	-61 dBm	100 kHz	This requirement does not apply to BS operating in band n2 or n25 since it is already covered by the requirement in subclause 6.6.5.5.1.2.
GSM850 or CDMA850	869 – 894 MHz	-57 dBm	100 kHz	This requirement does not apply to BS operating in band n5.
	824 – 849 MHz	-61 dBm	100 kHz	This requirement does not apply to BS operating in band n5, since it is already covered by the requirement in subclause 6.6.5.5.1.2.
UTRA FDD Band I or E-UTRA Band 1 or NR Band n1	2110 – 2170 MHz	-52 dBm	1 MHz	This requirement does not apply to BS operating in band n1
	1920 – 1980 MHz	-49 dBm	1 MHz	This requirement does not apply to BS operating in band n1, since it is already covered by the requirement in subclause 6.6.5.5.1.2.
UTRA FDD Band II or E-UTRA Band 2 or NR Band n2	1930 – 1990 MHz	-52 dBm	1 MHz	This requirement does not apply to BS operating in band n2 or n70.
	1850 – 1910 MHz	-49 dBm	1 MHz	This requirement does not apply to BS operating in band n2, since it is already covered by the requirement in subclause 6.6.5.5.1.2.
UTRA FDD Band III or E-UTRA Band 3 or NR Band n3	1805 – 1880 MHz	-52 dBm	1 MHz	This requirement does not apply to BS operating in band n3.
	1710 – 1785 MHz	-49 dBm	1 MHz	This requirement does not apply to BS operating in band n3, since it is already covered by the requirement in subclause 6.6.5.5.1.2.
UTRA FDD Band IV or E-UTRA Band 4	2110 – 2155 MHz	-52 dBm	1 MHz	This requirement does not apply to BS operating in band n66
	1710 – 1755 MHz	-49 dBm	1 MHz	This requirement does not apply to BS operating in band n66, since it is already covered by the requirement in subclause 6.6.5.5.1.2.
UTRA FDD Band V or E-UTRA Band 5 or NR Band n5	869 – 894 MHz	-52 dBm	1 MHz	This requirement does not apply to BS operating in band n5.
	824 – 849 MHz	-49 dBm	1 MHz	This requirement does not apply to BS operating in band n5, since it is already covered by the requirement in subclause 6.6.5.5.1.2.
UTRA FDD Band VI, XIX or E-UTRA Band 6, 18, 19	860 – 890 MHz	-52 dBm	1 MHz	
	815 – 830 MHz	-49 dBm	1 MHz	
	830 – 845 MHz	-49 dBm	1 MHz	
UTRA FDD Band VII or E-UTRA Band 7 or NR Band n7	2620 – 2690 MHz	-52 dBm	1 MHz	This requirement does not apply to BS operating in band n7.
	2500 – 2570 MHz	-49 dBm	1 MHz	This requirement does not apply to BS operating in band n7, since it is already covered by the requirement in subclause 6.6.5.5.1.2.
UTRA FDD Band VIII or E-UTRA Band 8 or NR Band n8	925 – 960 MHz	-52 dBm	1 MHz	This requirement does not apply to BS operating in band n8.
	880 – 915 MHz	-49 dBm	1 MHz	This requirement does not apply to BS operating in band n8, since it is already covered by the requirement in subclause 6.6.5.5.1.2.
	1844.9 – 1879.9 MHz	-52 dBm	1 MHz	This requirement does not apply to BS operating in band n3.



UTRA FDD Band IX or E-UTRA Band 9	1749.9 – 1784.9 MHz	-49 dBm	1 MHz	This requirement does not apply to BS operating in band n3, since it is already covered by the requirement in subclause 6.6.5.5.1.2.
UTRA FDD Band X or E-UTRA Band 10	2110 – 2170 MHz	-52 dBm	1 MHz	This requirement does not apply to BS operating in band n66
	1710 – 1770 MHz	-49 dBm	1 MHz	This requirement does not apply to BS operating in band n66, since it is already covered by the requirement in subclause 6.6.5.5.1.2.
UTRA FDD Band XI or XXI or E-UTRA Band 11 or 21	1475.9 – 1510.9 MHz	-52 dBm	1 MHz	This requirement does not apply to BS operating in Band n50, n74 or n75.
	1427.9 – 1447.9 MHz	-49 dBm	1 MHz	This requirement does not apply to BS operating in Band n50, n51, n74, n75 or n76.
	1447.9 – 1462.9 MHz	-49 dBm	1 MHz	This requirement does not apply to BS operating in Band n50, n74 or n75.
UTRA FDD Band XII or E-UTRA Band 12 or NR Band n12	729 – 746 MHz	-52 dBm	1 MHz	This requirement does not apply to BS operating in band n12.
	699 – 716 MHz	-49 dBm	1 MHz	This requirement does not apply to BS operating in band n12, since it is already covered by the requirement in sub-clause 6.6.5.5.1.2.
UTRA FDD Band XIII or E-UTRA Band 13	746 – 756 MHz	-52 dBm	1 MHz	
	777 – 787 MHz	-49 dBm	1 MHz	
UTRA FDD Band XIV or E-UTRA Band 14	758 – 768 MHz	-52 dBm	1 MHz	
	788 – 798 MHz	-49 dBm	1 MHz	
E-UTRA Band 17	734 – 746 MHz	-52 dBm	1 MHz	
	704 – 716 MHz	-49 dBm	1 MHz	
UTRA FDD Band XX or E-UTRA Band 20 or NR Band n20	791 – 821 MHz	-52 dBm	1 MHz	This requirement does not apply to BS operating in band n20 or n28.
	832 – 862 MHz	-49 dBm	1 MHz	This requirement does not apply to BS operating in band n20, since it is already covered by the requirement in subclause 6.6.5.5.1.2.
UTRA FDD Band XXII or E-UTRA Band 22	3510 – 3590 MHz	-52 dBm	1 MHz	This requirement does not apply to BS operating in band n48, n77 or n78.
	3410 – 3490 MHz	-49 dBm	1 MHz	This is not applicable to BS operating in Band n77 or n78.
E-UTRA Band 24	1525 – 1559 MHz	-52 dBm	1 MHz	
	1626.5 – 1660.5 MHz	-49 dBm	1 MHz	
UTRA FDD Band XXV or E-UTRA Band 25 or NR band n25	1930 – 1995 MHz	-52 dBm	1 MHz	This requirement does not apply to BS operating in band n2, n25 or n70.
	1850 – 1915 MHz	-49 dBm	1 MHz	This requirement does not apply to BS operating in band n25 since it is already covered by the requirement in subclause 6.6.5.5.1.2. For BS operating in Band n2, it applies for 1910 MHz to 1915 MHz, while the rest is covered in subclause 6.6.5.5.1.2.
UTRA FDD Band XXVI or E-UTRA Band 26	859 – 894 MHz	-52 dBm	1 MHz	This requirement does not apply to BS operating in band n5.
	814 – 849 MHz	-49 dBm	1 MHz	For BS operating in Band n5, it applies for 814 MHz to 824 MHz, while the rest is covered in subclause 6.6.5.5.1.2.
E-UTRA Band 27	852 – 869 MHz	-52 dBm	1 MHz	This requirement does not apply to BS operating in Band n5.
	807 – 824 MHz	-49 dBm	1 MHz	This requirement also applies to BS operating in Band n28, starting 4 MHz above the Band n28 downlink <i>operating band</i> (Note 5).
E-UTRA Band 28 or NR Band n28	758 – 803 MHz	-52 dBm	1 MHz	This requirement does not apply to BS operating in band n20 or n28.
	703 – 748 MHz	-49 dBm	1 MHz	This requirement does not apply to BS operating in band n28, since it is already covered by the requirement in subclause 6.6.5.5.1.2.
E-UTRA Band 29	717 – 728 MHz	-52 dBm	1 MHz	

E-UTRA Band 30	2350 – 2360 MHz	-52 dBm	1 MHz	
	2305 – 2315 MHz	-49 dBm	1 MHz	
E-UTRA Band 31	462.5 -467.5 MHz	-52 dBm	1 MHz	
	452.5 -457.5 MHz	-49 dBm	1 MHz	
UTRA FDD band XXXII or E-UTRA band 32	1452 – 1496 MHz	-52 dBm	1 MHz	This requirement does not apply to BS operating in Band n50, n74 or n75.
UTRA TDD Band a) or E-UTRA Band 33	1900 – 1920 MHz	-52 dBm	1 MHz	
UTRA TDD Band a) or E-UTRA Band 34 or NR band n34	2010 – 2025 MHz	-52 dBm	1 MHz	This requirement does not apply to BS operating in Band n34.
UTRA TDD Band b) or E-UTRA Band 35	1850 – 1910 MHz	-52 dBm	1 MHz	
UTRA TDD Band b) or E-UTRA Band 36	1930 – 1990 MHz	-52 dBm	1 MHz	This requirement does not apply to BS operating in Band n2 or n25.
UTRA TDD Band c) or E-UTRA Band 37	1910 – 1930 MHz	-52 dBm	1 MHz	
UTRA TDD Band d) or E-UTRA Band 38 or NR Band n38	2570 – 2620 MHz	-52 dBm	1 MHz	This requirement does not apply to BS operating in Band n38.
UTRA TDD Band f) or E-UTRA Band 39 or NR band n39	1880 – 1920MHz	-52 dBm	1 MHz	This requirement does not apply to BS operating in Band n39.
UTRA TDD Band e) or E-UTRA Band 40 or NR Band n40	2300 – 2400MHz	-52 dBm	1 MHz	This requirement does not apply to BS operating in Band n40.
E-UTRA Band 41 or NR Band n41	2496 – 2690 MHz	-52 dBm	1 MHz	This is not applicable to BS operating in Band n41.
E-UTRA Band 42	3400 – 3600 MHz	-52 dBm	1 MHz	This is not applicable to BS operating in Band n48, n77 or n78.
E-UTRA Band 43	3600 – 3800 MHz	-52 dBm	1 MHz	This is not applicable to BS operating in Band n48, n77 or n78.
E-UTRA Band 44	703 – 803 MHz	-52 dBm	1 MHz	This is not applicable to BS operating in Band n28.
E-UTRA Band 45	1447 – 1467 MHz	-52 dBm	1 MHz	
E-UTRA Band 46	5150 – 5925 MHz	-52 dBm	1 MHz	
E-UTRA Band 47	5855 – 5925 MHz	-52 dBm	1 MHz	
E-UTRA Band 48 or NR Band n48	3550 – 3700 MHz	-52 dBm	1 MHz	This requirement does not apply to BS operating in Band n48, n77 and n78.
E-UTRA Band 50 or NR band n50	1432 – 1517 MHz	-52 dBm	1 MHz	This requirement does not apply to BS operating in Band n50, n51, n74, n75 or n76.
E-UTRA Band 51 or NR Band n51	1427 – 1432 MHz	-52 dBm	1 MHz	This requirement does not apply to BS operating in Band n50, n51, n75 or n76.
E-UTRA Band 65	2110 – 2200 MHz	-52 dBm	1 MHz	This requirement does not apply to BS operating in band n1,

	1920 – 2010 MHz	-49 dBm	1 MHz	For BS operating in Band n1, it applies for 1980 MHz to 2010 MHz, while the rest is covered in subclause 6.6.5.5.1.2.
E-UTRA Band 66 or NR Band n66	2110 – 2200 MHz	-52 dBm	1 MHz	This requirement does not apply to BS operating in band n66.
	1710 – 1780 MHz	-49 dBm	1 MHz	This requirement does not apply to BS operating in band n66, since it is already covered by the requirement in subclause 6.6.5.5.1.2.
E-UTRA Band 67	738 – 758 MHz	-52 dBm	1 MHz	This requirement does not apply to BS operating in Band n28.
E-UTRA Band 68	753 -783 MHz	-52 dBm	1 MHz	This requirement does not apply to BS operating in band n28.
	698-728 MHz	-49 dBm	1 MHz	For BS operating in Band n28, this requirement applies between 698 MHz and 703 MHz, while the rest is covered in subclause 6.6.5.5.1.2.
E-UTRA Band 69	2570 – 2620 MHz	-52 dBm	1 MHz	This requirement does not apply to BS operating in Band n38.
E-UTRA Band 70 or NR Band n70	1995 – 2020 MHz	-52 dBm	1 MHz	This requirement does not apply to BS operating in band n2, n25 or n70
	1695 – 1710 MHz	-49 dBm	1 MHz	This requirement does not apply to BS operating in band n70, since it is already covered by the requirement in subclause 6.6.5.5.1.2.
E-UTRA Band 71 or NR Band n71	617 – 652 MHz	-52 dBm	1 MHz	This requirement does not apply to BS operating in band n71
	663 – 698 MHz	-49 dBm	1 MHz	This requirement does not apply to BS operating in band n71, since it is already covered by the requirement in subclause 6.6.5.5.1.2.
E-UTRA Band 72	461 – 466 MHz	-52 dBm	1 MHz	
	451 – 456 MHz	-49 dBm	1 MHz	
E-UTRA Band 74 or NR Band n74	1475 – 1518 MHz	-52 dBm	1 MHz	This requirement does not apply to BS operating in Band n50, n75 or n75.
	1427 – 1470 MHz	-49 dBm	1MHz	This requirement does not apply to BS operating in Band n50, n51, n74, n75 or n76.
E-UTRA Band 75 or NR Band n75	1432 – 1517 MHz	-52 dBm	1 MHz	This requirement does not apply to BS operating in Band n50, n51, n74, n75 or n76.
E-UTRA Band 76 or NR Band n76	1427 – 1432 MHz	-52 dBm	1 MHz	This requirement does not apply to BS operating in Band n50, n51, n75 or n76.
NR Band n77	3.3 – 4.2 GHz	-52 dBm	1 MHz	This requirement does not apply to BS operating in Band n48, n77 or n78
NR Band n78	3.3 – 3.8 GHz	-52 dBm	1 MHz	This requirement does not apply to BS operating in Band n48, n77 or n78
NR Band n79	4.4 – 5.0 GHz	-52 dBm	1 MHz	This requirement does not apply to BS operating in Band n79
NR Band n80	1710 – 1785 MHz	-49 dBm	1 MHz	This requirement does not apply to BS operating in band n3, since it is already covered by the requirement in subclause 6.6.5.2.2.
NR Band n81	880 – 915 MHz	-49 dBm	1 MHz	This requirement does not apply to BS operating in band n8, since it is already covered by the requirement in subclause 6.6.5.2.2.
NR Band n82	832 – 862 MHz	-49 dBm	1 MHz	This requirement does not apply to BS operating in band n20, since it is already covered by the requirement in subclause 6.6.5.2.2.
NR Band n83	703 – 748 MHz	-49 dBm	1 MHz	This requirement does not apply to BS operating in band n28, since it is already covered by the requirement in subclause 6.6.5.2.2.
NR Band n84	1920 – 1980 MHz	-49 dBm	1 MHz	This requirement does not apply to BS operating in band n1, since it is already covered by the requirement in subclause 6.6.5.2.2.
E-UTRA Band 85	728 - 746 MHz	-52 dBm	1 MHz	This requirement does not apply to BS operating in band n12.
	698 - 716 MHz	-49 dBm	1 MHz	This requirement does not apply to BS operating in band n12, since it is already covered by the requirement in subclause 6.6.5.2.2.
NR Band n86	1710 – 1780 MHz	-49 dBm	1 MHz	This requirement does not apply to BS operating in band n66, since it is already covered by the requirement in subclause 6.6.5.2.2.

NOTE 1: As defined in the scope for spurious emissions in this subclause, except for the cases where the noted requirements apply to a BS operating in Band n28, the co-existence requirements in table 6.6.5.5.1.3-1 do not apply for the  $\Delta f_{\text{OBUE}}$  frequency range immediately outside the downlink *operating band* (see TS 38.104 [2], table 5.2-1). Emission limits for this excluded frequency range may be covered by local or regional requirements.

NOTE 2: Table 6.6.5.5.1.3-1 assumes that two *operating bands*, where the frequency ranges in TS 38.104 [2], table 5.2-1 would be overlapping, are not deployed in the same geographical area. For such a case of operation with overlapping frequency arrangements in the same geographical area, special co-existence requirements may apply that are not covered by the 3GPP specifications.

NOTE 3: TDD base stations deployed in the same geographical area, that are synchronized and use the same or adjacent *operating bands* can transmit without additional co-existence requirements. For unsynchronized base stations, special co-existence requirements may apply that are not covered by the 3GPP specifications.

NOTE 4: For NR Band n28 BS, specific solutions may be required to fulfil the spurious emissions limits for BS for co-existence with E-UTRA Band 27 UL *operating band*.

The following requirement may be applied for the protection of PHS. This requirement is also applicable at specified frequencies falling between  $\Delta f_{\text{OBUE}}$  below the lowest BS transmitter frequency of the downlink *operating band* and  $\Delta f_{\text{OBUE}}$  above the highest BS transmitter frequency of the downlink *operating band*.  $\Delta f_{\text{OBUE}}$  is defined in subclause 6.6.1.

The *basic limits* for this requirement is:

**Table 6.6.5.5.1.3-2: BS spurious emissions *basic limits* for BS for co-existence with PHS**

Frequency range	Basic limit	Measurement bandwidth	Note
1884.5 – 1915.7 MHz	-41 dBm	300 kHz	Applicable when co-existence with PHS system operating in 1884.5 - 1915.7MHz

In certain regions, the following requirement may apply to BS operating in Band n50 and n75 within 1432-1452 MHz, and in Band n51 and Band n76. The *basic limits* are specified in table 6.6.5.5.1.3-4. This requirement is also applicable at the frequency range from  $\Delta f_{\text{OBUE}}$  below the lowest frequency of the BS downlink *operating band* up to  $\Delta f_{\text{OBUE}}$  above the highest frequency of the BS downlink *operating band*.

**Table 6.6.5.5.1.3-4: Additional operating band unwanted emission *basic limits* for BS operating in Band n50 and n75 within 1432-1452 MHz, and in Band 51 and 76**

Filter centre frequency, filter	Basic limit	Measurement bandwidth
$F_{\text{filter}} = 1413.5$ MHz	-42 dBm	27 MHz

In certain regions, the following requirement may apply to BS operating in NR Band n50 within 1492-1517 MHz. The maximum level of emissions, measured on centre frequencies  $F_{\text{filter}}$  with filter bandwidth according to table 6.6.5.5.1.3-5, shall be defined according to the *basic limits*  $P_{\text{EM},n50,a}$  and  $P_{\text{EM},B50,b}$  declared by the manufacturer.

**Table 6.6.5.2.3-5: Operating band n50, n74 and n75 declared emission above 1518 MHz**

Filter centre frequency, $F_{\text{filter}}$	Declared emission <i>basic limit</i> [dBm]	Measurement bandwidth
$1518.5 \text{ MHz} \leq F_{\text{filter}} \leq 1519.5 \text{ MHz}$	$P_{\text{EM},n50,a}$	1 MHz
$1520.5 \text{ MHz} \leq F_{\text{filter}} \leq 1558.5 \text{ MHz}$	$P_{\text{EM},n50,b}$	1 MHz

NOTE: The regional requirement, included in [14], is defined in terms of EIRP, which is dependent on both the BS emissions at the antenna connector and the deployment (including antenna gain and feeder loss). The requirement defined above provides the characteristics of the base station needed to verify compliance with the regional requirement. The assessment of the EIRP level is described in TS 38.104 [2] annex E.

The following requirement may apply to BS operating in Band n48 in certain regions. The power of any spurious emission shall not exceed:

**Table 6.6.5.2.3-6: Additional BS Spurious emissions limits for Band n48**

Frequency range	Maximum Level	Measurement Bandwidth (NOTE)	Note
3530MHz – 3720MHz	-25dBm	1 MHz	Applicable 10MHz from the assigned channel edge
3100MHz – 3530MHz 3720MHz – 4200MHz	-40dBm	1 MHz	

NOTE: The resolution bandwidth of the measuring equipment should be equal to the measurement bandwidth. However, to improve measurement accuracy, sensitivity and efficiency, the resolution bandwidth may be smaller than the measurement bandwidth. When the resolution bandwidth is smaller than the measurement bandwidth, the result should be integrated over the measurement bandwidth in order to obtain the equivalent noise bandwidth of the measurement bandwidth.

#### 6.6.5.5.1.4 Co-location with other base stations

These requirements may be applied for the protection of other BS receivers when GSM900, DCS1800, PCS1900, GSM850, CDMA850, UTRA FDD, UTRA TDD, E-UTRA and/or NR BS are co-located with a BS.

The requirements assume a 30 dB coupling loss between transmitter and receiver and are based on co-location with base stations of the same class.

The *basic limits* are in table 6.6.5.5.1.4-1 for a BS where requirements for co-location with a BS type listed in the first column apply, depending on the declared BS class (D.2). For a *multi-band connector*, the exclusions and conditions in the Note column of table 6.6.5.5.1.4-1 shall apply for each supported *operating band*.

**Table 6.6.5.5.1.4-1: BS spurious emissions *basic limits* for BS co-located with another BS**

Type of co-located BS	Frequency range for co-location requirement	Basic limit			Measurement bandwidth	Note
		WA BS	MR BS	LA BS		
GSM900	876-915 MHz	-98 dBm	-91 dBm	-70 dBm	100 kHz	
DCS1800	1710 – 1785 MHz	-98 dBm	-91 dBm	-80 dBm	100 kHz	
PCS1900	1850 – 1910 MHz	-98 dBm	-91 dBm	-80 dBm	100 kHz	
GSM850 or CDMA850	824 – 849 MHz	-98 dBm	-91 dBm	-70 dBm	100 kHz	
UTRA FDD Band I or E-UTRA Band 1 or NR Band n1	1920 – 1980 MHz	-96 dBm	-91 dBm	-88 dBm	100 kHz	
UTRA FDD Band II or E-UTRA Band 2 or NR Band n2	1850 – 1910 MHz	-96 dBm	-91 dBm	-88 dBm	100 kHz	
UTRA FDD Band III or E-UTRA Band 3 or NR Band n3	1710 – 1785 MHz	-96 dBm	-91 dBm	-88 dBm	100 kHz	
UTRA FDD Band IV or E-UTRA Band 4	1710 – 1755 MHz	-96 dBm	-91 dBm	-88 dBm	100 kHz	
UTRA FDD Band V or E-UTRA Band 5 or NR Band n5	824 – 849 MHz	-96 dBm	-91 dBm	-88 dBm	100 kHz	
UTRA FDD Band VI, XIX or E-UTRA Band 6, 19	830 – 845 MHz	-96 dBm	-91 dBm	-88 dBm	100 kHz	
UTRA FDD Band VII or E-UTRA Band 7 or NR Band n7	2500 – 2570 MHz	-96 dBm	-91 dBm	-88 dBm	100 kHz	
UTRA FDD Band VIII or E-UTRA Band 8 or NR Band n8	880 – 915 MHz	-96 dBm	-91 dBm	-88 dBm	100 kHz	
UTRA FDD Band IX or E-UTRA Band 9	1749.9 – 1784.9 MHz	-96 dBm	-91 dBm	-88 dBm	100 kHz	
UTRA FDD Band X or E-UTRA Band 10	1710 – 1770 MHz	-96 dBm	-91 dBm	-88 dBm	100 kHz	
UTRA FDD Band XI or E-UTRA Band 11	1427.9 – 1447.9 MHz	-96 dBm	-91 dBm	-88 dBm	100 kHz	This is not applicable to BS operating in Band n50, n74 or n75
UTRA FDD Band XII or E-UTRA Band 12 or NR Band n12	699 – 716 MHz	-96 dBm	-91 dBm	-88 dBm	100 kHz	
UTRA FDD Band XIII or E-UTRA Band 13	777 – 787 MHz	-96 dBm	-91 dBm	-88 dBm	100 kHz	
UTRA FDD Band XIV or E-UTRA Band 14	788 – 798 MHz	-96 dBm	-91 dBm	-88 dBm	100 kHz	
E-UTRA Band 17	704 – 716 MHz	-96 dBm	-91 dBm	-88 dBm	100 kHz	
E-UTRA Band 18	815 – 830 MHz	-96 dBm	-91 dBm	-88 dBm	100 kHz	
UTRA FDD Band XX or E-UTRA Band 20 or NR Band n20	832 – 862 MHz	-96 dBm	-91 dBm	-88 dBm	100 kHz	
UTRA FDD Band XXI or E-UTRA Band 21	1447.9 – 1462.9 MHz	-96 dBm	-91 dBm	-88 dBm	100 kHz	This is not applicable to BS operating in Band n50, n74 or n75
UTRA FDD Band XXII or E-UTRA Band 22	3410 – 3490 MHz	-96 dBm	-91 dBm	-88 dBm	100 kHz	This is not applicable to BS operating in Band n48, n77 or n78

E-UTRA Band 23	2000 – 2020 MHz	-96 dBm	-91 dBm	-88 dBm	100 kHz	
E-UTRA Band 24	1626.5 – 1660.5 MHz	-96 dBm	-91 dBm	-88 dBm	100 kHz	
UTRA FDD Band XXV or E-UTRA Band 25 or NR Band n25	1850 – 1915 MHz	-96 dBm	-91 dBm	-88 dBm	100 kHz	
UTRA FDD Band XXVI or E-UTRA Band 26	814 – 849 MHz	-96 dBm	-91 dBm	-88 dBm	100 kHz	
E-UTRA Band 27	807 – 824 MHz	-96 dBm	-91 dBm	-88 dBm	100 kHz	
E-UTRA Band 28 or NR Band n28	703 – 748 MHz	-96 dBm	-91 dBm	-88 dBm	100 kHz	
E-UTRA Band 30	2305 – 2315 MHz	-96 dBm	-91 dBm	-88 dBm	100 kHz	
E-UTRA Band 31	452.5 -457.5 MHz	-96 dBm	-91 dBm	-88 dBm	100 kHz	
UTRA TDD Band a) or E-UTRA Band 33	1900 – 1920 MHz	-96 dBm	-91 dBm	-88 dBm	100 kHz	
UTRA TDD Band a) or E-UTRA Band 34 or NR band n34	2010 – 2025 MHz	-96 dBm	-91 dBm	-88 dBm	100 kHz	This is not applicable to BS operating in Band n34
UTRA TDD Band b) or E-UTRA Band 35	1850 – 1910 MHz	-96 dBm	-91 dBm	-88 dBm	100 kHz	
UTRA TDD Band b) or E-UTRA Band 36	1930 – 1990 MHz	-96 dBm	-91 dBm	-88 dBm	100 kHz	This is not applicable to BS operating in Band n2 or band n25
UTRA TDD Band c) or E-UTRA Band 37	1910 – 1930 MHz	-96 dBm	-91 dBm	-88 dBm	100 kHz	
UTRA TDD Band d) or E-UTRA Band 38 or NR Band n38	2570 – 2620 MHz	-96 dBm	-91 dBm	-88 dBm	100 kHz	This is not applicable to BS operating in Band n38.
UTRA TDD Band f) or E-UTRA Band 39 or NR band n39	1880 – 1920MHz	-96 dBm	-91 dBm	-88 dBm	100 kHz	This is not applicable to BS operating in Band n39
UTRA TDD Band e) or E-UTRA Band 40 or NR Band n40	2300 – 2400MHz	-96 dBm	-91 dBm	-88 dBm	100 kHz	This is not applicable to BS operating in Band n40.
E-UTRA Band 41 or NR Band n41	2496 – 2690 MHz	-96 dBm	-91 dBm	-88 dBm	100 kHz	This is not applicable to BS operating in Band n41
E-UTRA Band 42	3400 – 3600 MHz	-96 dBm	-91 dBm	-88 dBm	100 kHz	This is not applicable to BS operating in Band n48, n77 or n78
E-UTRA Band 43	3600 – 3800 MHz	-96 dBm	-91 dBm	-88 dBm	100 kHz	This is not applicable to BS operating in Band n48, n77 or n78
E-UTRA Band 44	703 – 803 MHz	-96 dBm	-91 dBm	-88 dBm	100 kHz	This is not applicable to BS operating in Band n28
E-UTRA Band 45	1447 – 1467 MHz	-96 dBm	-91 dBm	-88 dBm	100 kHz	
E-UTRA Band 46	5150 – 5925 MHz	N/A	-91 dBm	-88 dBm	100 kHz	



E-UTRA Band 48 or NR Band n48	3550 – 3700 MHz	-96 dBm	-91 dBm	-88 dBm	100 kHz	This is not applicable to BS operating in Band n48, n77 or n78
E-UTRA Band 50 or NR band n50	1432 – 1517 MHz	-96 dBm	-91 dBm	-88 dBm	100 kHz	This is not applicable to BS operating in Band n50, n74 or n75
E-UTRA Band 51 or NR Band n51	1427 – 1432 MHz	N/A	N/A	-88 dBm	100 kHz	This is not applicable to BS operating in Band n50, n74, n75 or n76
E-UTRA Band 65	1920 – 2010 MHz	-96 dBm	-91 dBm	-88 dBm	100 kHz	
E-UTRA Band 66 or NR Band n66	1710 – 1780 MHz	-96 dBm	-91 dBm	-88 dBm	100 kHz	
E-UTRA Band 68	698 – 728 MHz	-96 dBm	-91 dBm	-88 dBm	100 kHz	
E-UTRA Band 70 or NR Band n70	1695 – 1710 MHz	-96 dBm	-91 dBm	-88 dBm	100 kHz	
E-UTRA Band 71 or NR Band n71	663 – 698 MHz	-96 dBm	-91 dBm	-88 dBm	100 kHz	
E-UTRA Band 72	451 – 456 MHz	-96 dBm	-91 dBm	-88 dBm	100 kHz	
E-UTRA Band 74 or NR Band n74	1427 – 1470 MHz	-96 dBm	-91 dBm	-88 dBm	100 kHz	This is not applicable to BS operating in Band n50 and n51
NR Band n77	3.3 – 4.2 GHz	-96 dBm	-91 dBm	-88 dBm	100 kHz	This is not applicable to BS operating in Band n48, n77 or n78
NR Band n78	3.3 – 3.8 GHz	-96 dBm	-91 dBm	-88 dBm	100 kHz	This is not applicable to BS operating in Band n48, n77 or n78
NR Band n79	4.4 – 5.0 GHz	-96 dBm	-91 dBm	-88 dBm	100 kHz	
NR Band n80	1710 – 1785 MHz	-96 dBm	-91 dBm	-88 dBm	100 kHz	
NR Band n81	880 – 915 MHz	-96 dBm	-91 dBm	-88 dBm	100 kHz	
NR Band n82	832 – 862 MHz	-96 dBm	-91 dBm	-88 dBm	100 kHz	
NR Band n83	703 – 748 MHz	-96 dBm	-91 dBm	-88 dBm	100 kHz	
NR Band n84	1920 – 1980 MHz	-96 dBm	-91 dBm	-88 dBm	100 kHz	
E-UTRA Band 85	698 - 716 MHz	-96 dBm	-91 dBm	-88 dBm	100 kHz	
NR Band n86	1710 – 1780 MHz	-96 dBm	-91 dBm	-88 dBm	100 kHz	

NOTE 1: As defined in the scope for spurious emissions in this subclause, the co-location requirements in table 6.6.5.5.1.4-1 do not apply for the frequency range extending  $\Delta f_{\text{OBUE}}$  immediately outside the BS transmit frequency range of a downlink *operating band* (see TS 38.104 [2] table 5.2-1). The current state-of-the-art technology does not allow a single generic solution for co-location with other system on adjacent frequencies for 30dB BS-BS minimum coupling loss. However, there are certain site-engineering solutions that can be used. These techniques are addressed in TR 25.942 [15].

NOTE 2: Table 6.6.5.5.1.4-1 assumes that two *operating bands*, where the corresponding BS transmit and receive frequency ranges in TS 38.104 [2] table 5.2-1 would be overlapping, are not deployed in the same geographical area. For such a case of operation with overlapping frequency arrangements in the same geographical area, special co-location requirements may apply that are not covered by the 3GPP specifications.

NOTE 3: Co-located TDD base stations that are synchronized and using the same or adjacent *operating band* can transmit without special co-locations requirements. For unsynchronized base stations, special co-location requirements may apply that are not covered by the 3GPP specifications.

#### 6.6.5.5.3 *BS type 1-C*

The Tx spurious emissions for *BS type 1-C* for each *antenna connector* shall not exceed the *basic limits* specified in subclause 6.6.5.5.1.

#### 6.6.5.5.4 *BS type 1-H*

The Tx spurious emissions requirements for *BS type 1-H* are that for each *TAB connector TX min cell group* and each applicable *basic limit* in subclause 6.6.5.5.1, the power summation emissions at the *TAB connectors* of the *TAB connector TX min cell group* shall not exceed an OTA limit specified as the *basic limit* + X, where  $X = 10\log_{10}(N_{\text{TXU, counted per cell}})$ , unless stated differently in regional regulation.

NOTE: Conformance to the *BS type 1-H* spurious emission requirement can be demonstrated by meeting at least one of the following criteria as determined by the manufacturer:

1) The sum of the emissions power measured on each *TAB connector* in the *TAB connector TX min cell group* shall be less than or equal to the limit as defined in this subclause for the respective frequency span.

Or

2) The unwanted emissions power at each *TAB connector* shall be less than or equal to the *BS type 1-H* limit as defined in this subclause for the respective frequency span, scaled by  $-10\log_{10}(n)$ , where  $n$  is the number of *TAB connectors* in the *TAB connector TX min cell group*.

## 6.7 Transmitter intermodulation

### 6.7.1 Definition and applicability

The transmitter intermodulation requirement is a measure of the capability of the transmitter unit to inhibit the generation of signals in its non-linear elements caused by presence of the wanted signal and an interfering signal reaching the transmitter unit via the antenna, RDN and antenna array. The requirement shall apply during the transmitter ON period and the *transmitter transient period*.

For *BS type 1-C*, the transmitter intermodulation level is the power of the intermodulation products when an interfering signal is injected into the *antenna connector*.

For *BS type 1-H*, the transmitter intermodulation level is the power of the intermodulation products when an interfering signal is injected into the *TAB connector*.

For *BS type 1-H*, there are two types of transmitter intermodulation cases captured by the transmitter intermodulation requirement:

- 1) Co-location transmitter intermodulation in which the interfering signal is from a co-located base station.
- 2) Intra-system transmitter intermodulation in which the interfering signal is from other transmitter units within the *BS type 1-H*.

For *BS type 1-H*, the co-location transmitter intermodulation requirement is considered sufficient if the interference signal for the co-location requirement is higher than the declared interference signal for intra-system transmitter (D.30) intermodulation requirement.

## 6.7.2 Minimum requirement

The minimum requirement applies per *single-band connector*, or per *multi-band connector* supporting transmission in the *operating band*.

The minimum requirement for *BS type I-C* is defined in TS 38.104 [2], subclause 6.7.2.

The minimum requirement for *BS type I-H* is defined in TS 38.104 [2], subclause 6.7.3.

## 6.7.3 Test purpose

The test purpose is to verify the ability of the transmitter units associated with the *single-band connectors* or *multi-band connector* under test to restrict the generation of intermodulation products in its nonlinear elements caused by presence of the wanted signal and an interfering signal reaching the transmitter via the antenna to below specified levels.

## 6.7.4 Method of test

### 6.7.4.1 Initial conditions

Test environment: Normal; see annex B.2.

RF channels to be tested for single carrier: M; see subclause 4.9.1.

*Base Station RF Bandwidth* positions to be tested for multi-carrier and/or CA:

- $M_{\text{RFBW}}$  in single-band operation; see subclause 4.9.1.
- $B_{\text{RFBW\_T\_RFBW}}$  and  $B'_{\text{RFBW\_T\_RFBW}}$  in multi-band operation, see subclause 4.9.1.

NOTE: When testing in M (or MRFBW), if the interferer is fully or partially located outside the supported frequency range, then the test shall be done instead in B (or BRFBW) and T (or TRFBW), and only with the interferer located inside the supported frequency range.

### 6.7.4.2 Procedure

For *BS type I-H* where there may be multiple *TAB connectors*, they may be tested one at a time or multiple *TAB connectors* may be tested in parallel as shown in annex D.3.1. Whichever method is used the procedure is repeated until all *TAB connectors* necessary to demonstrate conformance have been tested.

- 1) Connect the *single-band connector* or *multi-band connector* under test to measurement equipment as shown in annex D.1.2 for *BS type I-C* and in annex D.3.2 for *BS type I-H*. All connectors not under test shall be terminated.
- 2) The measurement device characteristics shall be:
  - Detection mode: True RMS.
- 3) For a connectors declared to be capable of single carrier operation only (D.16), set the representative connectors under test to transmit according to the applicable test configuration in subclause 4.8 at *rated carrier output power*  $P_{\text{rated,c,AC}}$  for *BS type I-C* and  $P_{\text{rated,c,TABC}}$  for *BS type I-H* (D.21). Channel set-up shall be according to NR-FR1-TM 1.1.

For a connector under test declared to be capable of multi-carrier and/or CA operation (D.15-D.16) set the connector under test to transmit on all carriers configured using the applicable test configuration and corresponding power setting specified in subclauses 4.7 and 4.8 using the corresponding test models or set of physical channels in subclause 4.9.2.

- 4) Generate the interfering signal according to NR-FR1-TM 1.1, as defined in subclause 4.9.2, with the supported minimum channel bandwidth ( $BW_{\text{Channel}}$ ) with 15 kHz SCS of the band and a centre frequency offset from the lower/upper edge of the wanted signal or edge of sub-block inside a sub-block gap  $f_{\text{offset}} = \pm BW_{\text{Channel}} \left( n - \frac{1}{2} \right)$ , for  $n = 1, 2$  and  $3$ , but exclude interfering frequencies that are outside of the allocated downlink operating band or interfering frequencies that are not completely within the sub-block gap or within the *Inter RF Bandwidth gap*.

- 5) Adjust ATT attenuator (as in the test setup in annex D.1.2 for *BS type I-C* and in annex D.3.2 for *BS type I-H*) so that level of the interfering signal is as defined in subclause 6.7.5.
- 6) Perform the unwanted emission tests specified in subclauses 6.6.3 and 6.6.4 for all third and fifth order intermodulation products which appear in the frequency ranges defined in subclauses 6.6.3 and 6.6.4. The width of the intermodulation products shall be taken into account.
- 7) Perform the transmitter spurious emissions test as specified in subclause 6.6.5, for all third and fifth order intermodulation products which appear in the frequency ranges defined in subclause 6.6.5. The width of the intermodulation products shall be taken into account.
- 8) Verify that the emission level does not exceed the required level in subclause 6.7.5 with the exception of interfering signal frequencies.
- 9) Repeat the test for the remaining interfering signal centre frequency offsets according to step 4.
- 10) Repeat the test for the remaining test signals defined in subclause 6.7.5 for additional requirements and for *BS type I-H* intra-system requirements.

In addition, for *multi-band connectors*, the following steps shall apply:

- 11) For a *multi-band connectors* and single band tests, repeat the steps above per involved *operating band* where single band test configurations and test models shall apply with no carrier activated in the other *operating band*.

NOTE: The third order intermodulation products are centred at  $2F1 \pm F2$  and  $2F2 \pm F1$ . The fifth order intermodulation products are centred at  $3F1 \pm 2F2$ ,  $3F2 \pm 2F1$ ,  $4F1 \pm F2$ , and  $4F2 \pm F1$  where  $F1$  represents the test signal centre frequency or centre frequency of each sub-block and  $F2$  represents the interfering signal centre frequency. The widths of intermodulation products are:

- $(n \cdot BW_{F1} + m \cdot BW_{F2})$  for the  $nF1 \pm mF2$  products;
- $(n \cdot BW_{F2} + m \cdot BW_{F1})$  for the  $nF2 \pm mF1$  products;

where  $BW_{F1}$  represents the test wanted signal RF bandwidth or channel bandwidth in case of single carrier, or sub-block bandwidth and  $BW_{F2}$  represents the interfering signal channel bandwidth.

## 6.7.5 Test requirements

### 6.7.5.1 BS type 1-C

#### 6.7.5.1.1 Co-location minimum requirements

For *BS type I-C*, the wanted signal and interfering signal centre frequency is specified in table 6.7.5.1.1-1, where interfering signal level is *rated total output power* ( $P_{\text{rated,t,AC}}$ ) at *antenna connector* in the *operating band* – 30 dB.

The requirement is applicable outside the Base Station RF Bandwidth or Radio Bandwidth. The interfering signal offset is defined relative to the Base Station RF Bandwidth edges or Radio Bandwidth edges.

For a BS operating in non-contiguous spectrum, the requirement is also applicable inside a sub-block gap for interfering signal offsets where the interfering signal falls completely within the sub-block gap. The interfering signal offset is defined relative to the sub-block edges.

For a *multi-band connector*, the requirement shall apply relative to the Base Station RF Bandwidth edges of each supported operating band. In case the Inter RF Bandwidth gap is less than  $3 \cdot BW_{\text{Channel}}$  MHz (where  $BW_{\text{Channel}}$  is the minimal *BS channel bandwidth* of the band), the requirement in the gap shall apply only for interfering signal offsets where the interfering signal falls completely within the Inter RF Bandwidth gap.

The transmitter intermodulation level shall not exceed the unwanted emission limits in subclauses 6.6.3, 6.6.4 and 6.6.5 in the presence of an NR interfering signal according to table 6.7.5.1.1-1.

**Table 6.7.5.1.1-1: Interfering and wanted signals for the co-location transmitter intermodulation requirement**

Parameter	Value
Wanted signal type	NR single carrier, or multi-carrier, or multiple intra-band contiguously or non-contiguously aggregated carriers
Interfering signal type	NR signal, the supported minimum <i>BS channel bandwidth</i> ( $BW_{\text{Channel}}$ ) with 15 kHz SCS of the band
Interfering signal level	Rated total output power ( $P_{\text{rated,t,AC}}$ ) in the <i>operating band</i> – 30 dB
Interfering signal centre frequency offset from the lower/upper edge of the wanted signal or edge of sub-block inside a sub-block gap	$f_{\text{offset}} = \pm BW_{\text{Channel}} \left( n - \frac{1}{2} \right)$ , for $n=1, 2$ and $3$
NOTE:	Interfering signal positions that are partially or completely outside of any downlink <i>operating band</i> of the BS are excluded from the requirement, unless the interfering signal positions fall within the frequency range of adjacent downlink <i>operating bands</i> in the same geographical area.

### 6.7.5.1.2 Additional requirements

### 6.7.5.2 BS type 1-H

#### 6.7.5.2.1 Co-location minimum requirements

The transmitter intermodulation level shall not exceed the unwanted emission limits in subclauses 6.6.3, 6.6.4 and 6.6.5 in the presence of an NR interfering signal according to table 6.7.5.2.1-1.

The requirement is applicable outside the *Base Station RF Bandwidth edges*. The interfering signal offset is defined relative to the *Base Station RF Bandwidth edges* or *Radio Bandwidth edges*.

For *TAB connectors* supporting operation in *non-contiguous spectrum*, the requirement is also applicable inside a *sub-block gap* for interfering signal offsets where the interfering signal falls completely within the *sub-block gap*. The interfering signal offset is defined relative to the *sub-block edges*.

For *multi-band connector*, the requirement shall apply relative to the *Base Station RF Bandwidth edges* of each operating band. In case the inter *RF Bandwidth gap* is less than  $3 \cdot BW_{\text{Channel}}$  MHz (where  $BW_{\text{Channel}}$  is the minimal *BS channel bandwidth* of the band), the requirement in the gap shall apply only for interfering signal offsets where the interfering signal falls completely within the inter *RF Bandwidth gap*.

**Table 6.7.5.2.1-1: Interfering and wanted signals for the co-location transmitter intermodulation requirement**

Parameter	Value
Wanted signal type	NR single carrier, or multi-carrier, or multiple intra-band contiguously or non-contiguously aggregated carriers
Interfering signal type	NR signal, the minimum supported <i>BS channel bandwidth</i> ( $BW_{\text{Channel}}$ ) with 15 kHz SCS of the band
Interfering signal level	Rated total output power per <i>TAB connector</i> ( $P_{\text{rated,t,TABC}}$ ) in the <i>operating band</i> – 30 dB
Interfering signal centre frequency offset from the lower/upper edge of the wanted signal or edge of <i>sub-block</i> inside a gap	$f_{\text{offset}} = \pm BW_{\text{Channel}} \left( n - \frac{1}{2} \right)$ , for $n=1, 2$ and $3$
NOTE:	Interfering signal positions that are partially or completely outside of any downlink <i>operating band</i> of the TAB connector are excluded from the requirement, unless the interfering signal positions fall within the frequency range of adjacent downlink <i>operating bands</i> in the same geographical area.

#### 6.7.5.2.2 Intra-system minimum requirements

The transmitter intermodulation level shall not exceed the unwanted emission limits in subclauses 6.6.3 and 6.6.4 in the presence of an NR interfering signal according to table 6.7.5.2.2-1.

**Table 6.7.5.2.2-1: Interfering and wanted signals for intra-system transmitter intermodulation requirement**

Parameter	Value
Wanted signal type	NR signal
Interfering signal type	NR signal of the same <i>BS channel bandwidth</i> and SCS as the wanted signal (Note 1).
Interfering signal level	Power level declared by the BS manufacturer in D.29 (Note 2).
Frequency offset between interfering signal and wanted signal	0 MHz
NOTE 1: The interfering signal shall be incoherent with the wanted signal.	
NOTE 2: The declared interfering signal power level at each <i>TAB connector</i> is the sum of the co-channel leakage power coupled via the combined RDN and Antenna Array from all the other <i>TAB connectors</i> , but does not comprise power radiated from the Antenna Array and reflected back from the environment. The power at each of the interfering <i>TAB connectors</i> is $P_{\text{rated,c.TABC}}$ .	

### 6.7.5.2.3 Additional requirements

## 7 Conducted receiver characteristics

### 7.1 General

Conducted receiver characteristics are specified at the *antenna connector* for *BS type 1-C* and at the *TAB connector* for *BS type 1-H*, with full complement of transceivers for the configuration in normal operating condition.

Unless otherwise stated, the following arrangements apply for conducted receiver characteristics requirements in clause 7:

- Requirements apply during the BS receive period.
- Requirements shall be met for any transmitter setting.
- For FDD operation the requirements shall be met with the transmitter unit(s) ON.
- Throughput requirements defined for the conducted receiver characteristics do not assume HARQ retransmissions.
- When BS is configured to receive multiple carriers, all the throughput requirements are applicable for each received carrier.
- For ACS, blocking and intermodulation characteristics, the negative offsets of the interfering signal apply relative to the lower edge and positive offsets of the interfering signal apply relative to the higher edge.

NOTE 1: In normal operating condition the BS in FDD operation is configured to transmit and receive at the same time.

NOTE 2: In normal operating condition the BS in TDD operation is configured to TX OFF power during *receive period*.

For *BS type 1-H* if a number of *TAB connectors* have been declared equivalent (D.32), only a representative one is necessary to demonstrate conformance.

In subclause 7.6.5.3, if representative *TAB connectors* are used then per connector criteria (option 2) shall be applied.

### 7.2 Reference sensitivity level

#### 7.2.1 Definition and applicability

The reference sensitivity power level  $P_{\text{REFSENS}}$  is the minimum mean power received at the *antenna connector* for *BS type 1-C* or *TAB connector* for *BS type 1-H* at which a throughput requirement shall be met for a specified reference measurement channel.

#### 7.2.2 Minimum requirement

The minimum requirement for *BS type 1-C* is in TS 38.104 [2], subclause 7.2.2.

The minimum requirement for *BS type 1-H* is in TS 38.104 [2], subclause 7.2.2.

#### 7.2.3 Test purpose

To verify that for the *BS type 1-C* receiver and each *BS type 1-H TAB connector* at the reference sensitivity level the throughput requirement shall be met for a specified reference measurement channel.

#### 7.2.4 Method of test

##### 7.2.4.1 Initial conditions

Test environment: Normal; see annex B.2.

RF channels to be tested for single carrier: B, M and T; see subclause 4.9.1.

On each of B, M and T, the test shall be performed under extreme power supply as defined in annex B.5.

NOTE: Tests under extreme power supply also test extreme temperature.

### 7.2.4.2 Procedure

The minimum requirement is applied to all connectors under test.

For BS type 1-H the procedure is repeated until all *TAB connectors* necessary to demonstrate conformance have been tested; see subclause 7.1.

- 1) Connect the connector under test to measurement equipment as shown in annex D.2.1 for *BS type 1-C* and in annex D.4.1 for *BS type 1-H*. All connectors not under test shall be terminated.
- 2) Set the BS to transmit a signal according to subclause 4.9.2, for *BS type 1-C* set the *antenna connector* to the manufacturers declared *rated carrier output power* ( $P_{\text{Rated,c,AC}}$  or  $P_{\text{Rated,c,TABC}}$ , D.21).
- 3) Start the signal generator for the wanted signal to transmit the Fixed Reference Channels for reference sensitivity according to annex A.
- 4) Set the signal generator for the wanted signal power as specified in subclause 7.2.5.
- 5) Measure the throughput.

In addition, for a *multi-band connector*, the following steps shall apply:

- 6) For *multi-band connector* and single band tests, repeat the steps above per involved band where single band test configurations and test models shall apply with no carrier activated in the other band.

### 7.2.5 Test requirements

For NR, the throughput shall be  $\geq 95\%$  of the maximum throughput of the reference measurement channel as specified in Annex A with parameters specified in table 7.2.5-1 for Wide Area BS, in table 7.2.5-2 for Medium Range BS and in table 7.2.5-3 for Local Area BS.

**Table 7.2.5-1: NR Wide Area BS reference sensitivity levels**

BS channel bandwidth (MHz)	Sub-carrier spacing (kHz)	Reference measurement channel	Reference sensitivity power level, $P_{\text{REFSENS}}$ (dBm)		
			$f \leq 3.0$ GHz	$3.0$ GHz $< f \leq 4.2$ GHz	$4.2$ GHz $< f \leq 6.0$ GHz
5, 10, 15	15	G-FR1-A1-1	-101	-100.7	-100.5
10, 15	30	G- FR1-A1-2	-101.1	-100.8	-100.6
10, 15	60	G- FR1-A1-3	-98.2	-97.9	-97.7
20, 25, 30, 40, 50	15	G- FR1-A1-4	-94.6	-94.3	-94.1
20, 25, 30, 40, 50, 60, 70, 80, 90, 100	30	G- FR1-A1-5	-94.9	-94.6	-94.4
20, 25, 30, 40, 50, 60, 70, 80, 90, 100	60	G- FR1-A1-6	-95	-94.7	-94.5

NOTE:  $P_{\text{REFSENS}}$  is the power level of a single instance of the reference measurement channel. This requirement shall be met for each consecutive application of a single instance of the reference measurement channel mapped to disjoint frequency ranges with a width corresponding to the number of resource blocks of the reference measurement channel each, except for one instance that might overlap one other instance to cover the full *BS channel bandwidth*.



Table 7.2.5-2: NR Medium Area BS reference sensitivity levels

BS channel bandwidth (MHz)	Sub-carrier spacing (kHz)	Reference measurement channel	Reference sensitivity power level, P <sub>REFSENS</sub> (dBm)		
			f ≤ 3.0 GHz	3.0 GHz < f ≤ 4.2 GHz	4.2 GHz < f ≤ 6.0 GHz
5, 10, 15	15	G-FR1-A1-1	-96	-95.7	-95.5
10, 15	30	G- FR1-A1-2	-96.1	-95.8	-95.63
10, 15	60	G- FR1-A1-3	-93.2	-92.9	-92.7
20, 25, 30, 40, 50	15	G- FR1-A1-4	-89.6	-89.3	-89.1
20, 25, 30, 40, 50, 60, 70, 80, 90, 100	30	G- FR1-A1-5	-89.9	-89.6	-89.4
20, 25, 30, 40, 50, 60, 70, 80, 90, 100	60	G- FR1-A1-6	-90	-89.7	-89.5

NOTE: P<sub>REFSENS</sub> is the power level of a single instance of the reference measurement channel. This requirement shall be met for each consecutive application of a single instance of the reference measurement channel mapped to disjoint frequency ranges with a width corresponding to the number of resource blocks of the reference measurement channel each, except for one instance that might overlap one other instance to cover the full BS channel bandwidth.

Table 7.2.5-3: NR Local Area BS reference sensitivity levels

BS channel bandwidth (MHz)	Sub-carrier spacing (kHz)	Reference measurement channel	Reference sensitivity power level, P <sub>REFSENS</sub> (dBm)		
			f ≤ 3.0 GHz	3.0 GHz < f ≤ 4.2 GHz	4.2 GHz < f ≤ 6.0 GHz
5, 10, 15	15	G-FR1-A1-1	-93	-92.7	-92.5
10, 15	30	G- FR1-A1-2	-93.1	-92.8	-92.6
10, 15	60	G- FR1-A1-3	-90.2	-89.9	-89.7
20, 25, 30, 40, 50	15	G- FR1-A1-4	-86.6	-86.3	-86.1
20, 25, 30, 40, 50, 60, 70, 80, 90, 100	30	G- FR1-A1-5	-86.9	-86.6	-86.4
20, 25, 30, 40, 50, 60, 70, 80, 90, 100	60	G- FR1-A1-6	-87	-86.7	-86.5

NOTE: P<sub>REFSENS</sub> is the power level of a single instance of the reference measurement channel. This requirement shall be met for each consecutive application of a single instance of the reference measurement channel mapped to disjoint frequency ranges with a width corresponding to the number of resource blocks of the reference measurement channel each, except for one instance that might overlap one other instance to cover the full BS channel bandwidth.

## 7.3 Dynamic range

### 7.3.1 Definition and applicability

The dynamic range is specified as a measure of the capability of the receiver to receive a wanted signal in the presence of an interfering signal at the *antenna connector* for BS type I-C or *TAB connector* for BS type I-H inside the received BS channel bandwidth. In this condition, a throughput requirement shall be met for a specified reference measurement channel. The interfering signal for the dynamic range requirement is an AWGN signal.

### 7.3.2 Minimum requirement

The minimum requirement for BS type I-C is in TS 38.104 [2], subclause 7.3.2.

The minimum requirement for BS type I-H is in TS 38.104 [2], subclause 7.3.2.

### 7.3.3 Test purpose

To verify that the *BS type 1-C* receiver and each *BS type 1-H TAB connector* receiver dynamic range, the relative throughput shall fulfil the specified limit.

### 7.3.4 Method of test

#### 7.3.4.1 Initial conditions

Test environment: Normal; see annex B.2.

RF channels to be tested for single carrier: M; see subclause 4.9.1.

#### 7.3.4.2 Procedure

The minimum requirement is applied to all connectors under test.

For *BS type 1-H* the procedure is repeated until all *TAB connectors* necessary to demonstrate conformance have been tested; see subclause 7.1.

- 1) Connect the connector under test to measurement equipment as shown in annex D.2.2 for *BS type 1-C* and in annex D.4.2 for *BS type 1-H*. All connectors not under test shall be terminated.
- 2) Set the signal generator for the wanted signal to transmit as specified in table 7.3.5-1 to table 7.3.5-3 according to the appropriate BS class.
- 3) Set the Signal generator for the AWGN interfering signal at the same frequency as the wanted signal to transmit as specified in table 7.3.5-1 to table 7.3.5-3 according to the appropriate BS class.
- 4) Measure the throughput.

In addition, for a *multi-band connector*, the following steps shall apply:

- 5) For *multi-band connector* and single band tests, repeat the steps above per involved band where single band test configurations and test models shall apply with no carrier activated in the other band.

### 7.3.5 Test requirements

For NR, the throughput shall be  $\geq 95\%$  of the maximum throughput of the reference measurement channel as specified in Annex A with parameters specified in table 7.3.2-1 for Wide Area BS, in table 7.3.2-2 for Medium Range BS and in table 7.3.2-3 for Local Area BS.

Table 7.3.5-1: Wide Area BS dynamic range

<i>BS channel bandwidth (MHz)</i>	<i>Subcarrier spacing (kHz)</i>	<i>Reference measurement channel</i>	<i>Wanted signal mean power (dBm)</i>	<i>Interfering signal mean power (dBm) / BW<sub>Config</sub></i>	<i>Type of interfering signal</i>
5	15	G-FR1-A2-1	-70.4	-82.5	AWGN
	30	G- FR1-A2-2	-71.1		
10	15	G-FR1-A2-1	-70.4	-79.3	AWGN
	30	G- FR1-A2-2	-71.1		
	60	G- FR1-A2-3	-68.1		
15	15	G-FR1-A2-1	-70.4	-77.5	AWGN
	30	G- FR1-A2-2	-71.1		
	60	G- FR1-A2-3	-68.1		
20	15	G- FR1-A2-4	-64.2	-76.2	AWGN
	30	G- FR1-A2-5	-64.2		
	60	G- FR1-A2-6	-64.5		
25	15	G- FR1-A2-4	-64.2	-75.2	AWGN
	30	G- FR1-A2-5	-64.2		
	60	G- FR1-A2-6	-64.5		
30	15	G- FR1-A2-4	-64.2	-74.4	AWGN
	30	G- FR1-A2-5	-64.2		
	60	G- FR1-A2-6	-64.5		
40	15	G- FR1-A2-4	-64.2	-73.1	AWGN
	30	G- FR1-A2-5	-64.2		
	60	G- FR1-A2-6	-64.5		
50	15	G- FR1-A2-4	-64.2	-72.2	AWGN
	30	G- FR1-A2-5	-64.2		
	60	G- FR1-A2-6	-64.5		
60	30	G- FR1-A2-5	-64.2	-71.4	AWGN
	60	G- FR1-A2-6	-64.5		
70	30	G- FR1-A2-5	-64.2	-70.8	AWGN
	60	G- FR1-A2-6	-64.5		
80	30	G- FR1-A2-5	-64.2	-70.1	AWGN
	60	G- FR1-A2-6	-64.5		
90	30	G- FR1-A2-5	-64.2	-69.6	AWGN
	60	G- FR1-A2-6	-64.5		
100	30	G- FR1-A2-5	-64.2	-69.1	AWGN
	60	G- FR1-A2-6	-64.5		

NOTE: The wanted signal mean power is the power level of a single instance of the corresponding reference measurement channel. This requirement shall be met for each consecutive application of a single instance of the reference measurement channel mapped to disjoint frequency ranges with a width corresponding to the number of resource blocks of the reference measurement channel each, except for one instance that might overlap one other instance to cover the full *BS channel bandwidth*.

Table 7.3.5-2: Medium Range BS dynamic range

<i>BS channel bandwidth (MHz)</i>	<i>Subcarrier spacing (kHz)</i>	<i>Reference measurement channel</i>	<i>Wanted signal mean power (dBm)</i>	<i>Interfering signal mean power (dBm) / BW<sub>Config</sub></i>	<i>Type of interfering signal</i>
5	15	G-FR1-A2-1	-65.4	-77.5	AWGN
	30	G- FR1-A2-2	-66.1		
10	15	G-FR1-A2-1	-65.4	-74.3	AWGN
	30	G- FR1-A2-2	-66.1		
	60	G- FR1-A2-3	-63.1		
15	15	G-FR1-A2-1	-65.4	-72.5	AWGN
	30	G- FR1-A2-2	-66.1		
	60	G- FR1-A2-3	-63.1		
20	15	G- FR1-A2-4	-59.2	-71.2	AWGN
	30	G- FR1-A2-5	-59.2		
	60	G- FR1-A2-6	-59.5		
25	15	G- FR1-A2-4	-59.2	-70.2	AWGN
	30	G- FR1-A2-5	-59.2		
	60	G- FR1-A2-6	-59.5		
30	15	G- FR1-A2-4	-59.2	-69.4	AWGN
	30	G- FR1-A2-5	-59.2		
	60	G- FR1-A2-6	-59.5		
40	15	G- FR1-A2-4	-59.2	-68.1	AWGN
	30	G- FR1-A2-5	-59.2		
	60	G- FR1-A2-6	-59.5		
50	15	G- FR1-A2-4	-59.2	-67.2	AWGN
	30	G- FR1-A2-5	59.8		
	60	G- FR1-A2-6	-59.5		
60	30	G- FR1-A2-5	-59.2	-66.4	AWGN
	60	G- FR1-A2-6	-59.5		
70	30	G- FR1-A2-5	-59.2	-65.8	AWGN
	60	G- FR1-A2-6	-59.5		
80	30	G- FR1-A2-5	-59.2	-65.1	AWGN
	60	G- FR1-A2-6	-59.5		
90	30	G- FR1-A2-5	-59.2	-64.6	AWGN
	60	G- FR1-A2-6	-59.5		
100	30	G- FR1-A2-5	-59.2	-64.1	AWGN
	60	G- FR1-A2-6	-59.5		

NOTE: The wanted signal mean power is the power level of a single instance of the corresponding reference measurement channel. This requirement shall be met for each consecutive application of a single instance of the reference measurement channel mapped to disjoint frequency ranges with a width corresponding to the number of resource blocks of the reference measurement channel each, except for one instance that might overlap one other instance to cover the full *BS channel bandwidth*.

Table 7.3.5-3: Local Area BS dynamic range

<i>BS channel bandwidth (MHz)</i>	<i>Subcarrier spacing (kHz)</i>	<i>Reference measurement channel</i>	<i>Wanted signal mean power (dBm)</i>	<i>Interfering signal mean power (dBm) / BW<sub>Config</sub></i>	<i>Type of interfering signal</i>
5	15	G-FR1-A2-1	-62.4	-74.5	AWGN
	30	G- FR1-A2-2	-63.1		
10	15	G-FR1-A2-1	-62.4	-71.3	AWGN
	30	G- FR1-A2-2	-63.1		
	60	G- FR1-A2-3	-60.1		
15	15	G-FR1-A2-1	-62.4	-69.5	AWGN
	30	G- FR1-A2-2	-63.1		
	60	G- FR1-A2-3	-60.1		
20	15	G- FR1-A2-4	-56.2	-68.2	AWGN
	30	G- FR1-A2-5	-56.2		
	60	G- FR1-A2-6	-56.5		
25	15	G- FR1-A2-4	-56.2	-67.2	AWGN
	30	G- FR1-A2-5	-56.2		
	60	G- FR1-A2-6	-56.5		
30	15	G- FR1-A2-4	-56.2	-66.4	AWGN
	30	G- FR1-A2-5	-56.2		
	60	G- FR1-A2-6	-56.5		
40	15	G- FR1-A2-4	-56.2	-65.1	AWGN
	30	G- FR1-A2-5	-56.2		
	60	G- FR1-A2-6	-56.5		
50	15	G- FR1-A2-4	-56.2	-64.2	AWGN
	30	G- FR1-A2-5	-56.2		
	60	G- FR1-A2-6	-56.5		
60	30	G- FR1-A2-5	-56.2	-63.4	AWGN
	60	G- FR1-A2-6	-56.5		
70	30	G- FR1-A2-5	-56.2	-62.8	AWGN
	60	G- FR1-A2-6	-56.5		
80	30	G- FR1-A2-5	-56.2	-62.1	AWGN
	60	G- FR1-A2-6	-56.5		
90	30	G- FR1-A2-5	-56.2	-61.6	AWGN
	60	G- FR1-A2-6	-56.5		
100	30	G- FR1-A2-5	-56.2	-61.1	AWGN
	60	G- FR1-A2-6	-56.5		

NOTE: The wanted signal mean power is the power level of a single instance of the corresponding reference measurement channel. This requirement shall be met for each consecutive application of a single instance of the reference measurement channel mapped to disjoint frequency ranges with a width corresponding to the number of resource blocks of the reference measurement channel each, except for one instance that might overlap one other instance to cover the full *BS channel bandwidth*.

## 7.4 In-band selectivity and blocking

### 7.4.1 Adjacent Channel Selectivity (ACS)

#### 7.4.1.1 Definition and applicability

Adjacent channel selectivity (ACS) is a measure of the receiver's ability to receive a wanted signal at its assigned channel frequency at the *antenna connector* for *BS type 1-C* or *TAB connector* for *BS type 1-H* in the presence of an adjacent channel signal with a specified centre frequency offset of the interfering signal to the band edge of a victim system.

#### 7.4.1.2 Minimum requirement

The minimum requirement for *BS type 1-C* and *BS type 1-H* are in TS 38.104 [2], subclause 7.4.1.2.

### 7.4.1.3 Test purpose

The test purpose is to verify the ability of the BS receiver filter to suppress interfering signals in the channels adjacent to the wanted channel.

### 7.4.1.4 Method of test

#### 7.4.1.4.1 Initial conditions

Test environment: Normal; see annex B.2.

RF channels to be tested for single carrier (SC): M; see subclause 4.9.1.

*Base Station RF Bandwidth* positions to be tested for multi-carrier (MC):

- $M_{\text{RFBW}}$  for *single-band connector(s)*, see subclause 4.9.1,
- $B_{\text{RFBW}_T} T_{\text{RFBW}}$  and  $B'_{\text{RFBW}_T} T_{\text{RFBW}}$  for *multi-band connector(s)*, see subclause 4.9.1.

#### 7.4.1.4.2 Procedure

The minimum requirement is applied to all connectors under test.

For *BS type 1-H* the procedure is repeated until all *TAB connectors* necessary to demonstrate conformance have been tested; see subclause 7.1.

- 1) Connect the connector under test to measurement equipment as shown in annex D.2.3 for *BS type 1-C* and in annex D.4.3 for *BS type 1-H*. All connectors not under test shall be terminated.
- 2) Set the BS to transmit:
  - For single carrier operation set the connector under test to transmit at manufacturers declared *rated carrier output power* ( $P_{\text{Rated,c,AC}}$  or  $P_{\text{Rated,c,TABC}}$ , D.21).
  - For a connector under test declared to be capable of multi-carrier and/or CA operation (D.15-D.16) set the connector under test to transmit on all carriers configured using the applicable test configuration and corresponding power setting specified in subclauses 4.7 and 4.8 using the corresponding test models or set of physical channels in subclause 4.9.2
- 3) Set the signal generator for the wanted signal to transmit as specified in table 7.4.1.5-1.
- 4) Set the signal generator for the interfering signal to transmit at the frequency offset and as specified in table 7.4.1.5-1 and 7.4.1.5-2.
- 5) Measure the throughput.

In addition, for a *multi-band connector*, the following steps shall apply:

- 6) For *multi-band connector* and single band tests, repeat the steps above per involved band where single band test configurations and test models shall apply with no carrier activated in the other band.

### 7.4.1.5 Test requirements

The throughput shall be  $\geq 95\%$  of the maximum throughput of the reference measurement channel.

For BS, the wanted and the interfering signal coupled to the *BS type 1-C antenna connector* or *BS type 1-H TAB connector* are specified in table 7.4.1.5-1 and the frequency offset between the wanted and interfering signal in table 7.4.1.5-2 for ACS. The reference measurement channel for the wanted signal is identified in table 7.2.5-1, 7.2.5-2 and 7.2.5-3 for each channel bandwidth and further specified in annex A. The characteristics of the interfering signal is further specified in annex E.

The ACS requirement is applicable outside the Base Station RF Bandwidth or Radio Bandwidth. The interfering signal offset is defined relative to the Base station RF Bandwidth edges or Radio Bandwidth edges.

For a BS operating in non-contiguous spectrum within any *operating band*, the ACS requirement shall apply in addition inside any sub-block gap, in case the sub-block gap size is at least as wide as the NR interfering signal in table 7.4.1.5-1. The interfering signal offset is defined relative to the sub-block edges inside the sub-block gap.

For a *multi-band connector*, the ACS requirement shall apply in addition inside any Inter RF Bandwidth gap, in case the Inter RF Bandwidth gap size is at least as wide as the NR interfering signal in table 7.4.1.5-2. The interfering signal offset is defined relative to the Base Station RF Bandwidth edges inside the Inter RF Bandwidth gap

Conducted requirement is defined at the *antenna connector* for *BS type I-C* and at the *TAB connector* for *BS type I-H*.

**Table 7.4.1.5-1: Base station ACS requirement**

<b>BS channel bandwidth of the lowest/highest carrier received (MHz)</b>	<b>Wanted signal mean power (dBm)</b>	<b>Interfering signal mean power (dBm)</b>
5, 10, 15, 20, 25, 30, 40, 50, 60, 70, 80, 90, 100 (Note 1)	$P_{\text{REFSENS}} + 6\text{dB}$	Wide Area: -52 Medium Range: -47 Local Area: -44
NOTE 1: The SCS for the lowest/highest carrier received is the lowest SCS supported by the BS for that bandwidth.		
NOTE 2: $P_{\text{REFSENS}}$ depends on the <i>BS channel bandwidth</i> as specified in TS 38.104 [2], table 7.2.2-1, 7.2.2-2 and 7.2.2-3.		

**Table 7.4.1.5-2: Base Station ACS interferer frequency offset values**

<b>BS channel bandwidth of the lowest/highest carrier received (MHz)</b>	<b>Interfering signal centre frequency offset from the lower/upper Base Station RF Bandwidth edge or sub-block edge inside a sub-block gap (MHz)</b>	<b>Type of interfering signal</b>
5	$\pm 2.5025$	5 MHz DFT-s-OFDM NR signal SCS: 15kHz, 25 RB
10	$\pm 2.5075$	
15	$\pm 2.5125$	
20	$\pm 2.5025$	
25	$\pm 9.535$	20 MHz DFT-s-OFDM NR signal SCS: 15kHz, 100 RB
30	$\pm 9.585$	
40	$\pm 9.535$	
50	$\pm 9.485$	
60	$\pm 9.585$	
70	$\pm 9.535$	
80	$\pm 9.485$	
90	$\pm 9.585$	
100	$\pm 9.535$	

## 7.4.2 In-band blocking

### 7.4.2.1 Definition and applicability

The in-band blocking characteristics is a measure of the receiver's ability to receive a wanted signal at its assigned channel at the *antenna connector* for *BS type I-C* or *TAB connector* for *BS type I-H* in the presence of an unwanted interferer, which is an NR signal for general blocking or an NR signal with one resource block for narrowband blocking.

### 7.4.2.2 Minimum requirement

The minimum requirements for *BS type I-C* and *BS type I-H* are in TS 38.104 [2], subclause 7.4.2.2.

### 7.4.2.3 Test purpose

The test purpose is to verify the ability of the BS receiver to withstand high-levels of in-band interference from unwanted signals at specified frequency offsets without undue degradation of its sensitivity.

### 7.4.2.4 Method of test

#### 7.4.2.4.1 Initial conditions

Test environment: Normal; see annex B.2.

RF channels to be tested for single carrier (SC): M; see subclause 4.9.1

*Base Station RF Bandwidth* positions to be tested for multi-carrier (MC) and/or CA:

- $M_{\text{RFBW}}$  for *single-band connector(s)*, see subclause 4.9.1,
- $B_{\text{RFBW}}T_{\text{RFBW}}$  and  $B'_{\text{RFBW}}T_{\text{RFBW}}$  for *multi-band connector(s)*, see subclause 4.9.1.

NOTE: When testing in M (or MRFBW), if the interferer is fully or partially located outside the supported frequency range, then the test shall be done instead in B (or BRFBW) and T (or TRFBW), and only with the interferer located inside the supported frequency range.

#### 7.4.2.4.2 Procedure for general blocking

The minimum requirement is applied to all connectors under test.

For *BS type I-H* the procedure is repeated until all *TAB connectors* necessary to demonstrate conformance have been tested; see subclause 7.1.

- 1) Connect the connector under test to measurement equipment as shown in annex D.2.3 for *BS type I-C* and in annex D.4.3 for *BS type I-H*. All connectors not under test shall be terminated.
- 2) Set the BS to transmit:
  - For single carrier operation set the connector under test to transmit at manufacturers declared *rated carrier output power* ( $P_{\text{Rated,c,AC}}$  or  $P_{\text{Rated,c,TABC}}$ , D.21).
  - For a connector under test declared to be capable of multi-carrier and/or CA operation (D.15-D.16) set the connector under test to transmit on all carriers configured using the applicable test configuration and corresponding power setting specified in subclauses 4.7 and 4.8 using the corresponding test models or set of physical channels in subclause 4.9.2.
- 3) Set the signal generator for the wanted signal to transmit as specified in table 7.4.2.5-1.
- 4) Set the signal generator for the interfering signal to transmit at the frequency offset and as specified in table 7.4.2.5-1. The interfering signal shall be swept with a step size of 1 MHz starting from the minimum offset to the channel edges of the wanted signals as specified in table 7.4.2.5-1.
- 5) Measure the throughput.

In addition, for a *multi-band connector*, the following steps shall apply:

- 6) For *multi-band connector* and single band tests, repeat the steps above per involved band where single band test configurations and test models shall apply with no carrier activated in the other band.

#### 7.4.2.4.3 Procedure for narrowband blocking

The minimum requirement is applied to all connectors under test.

For *BS type I-H* the procedure is repeated until all *TAB connectors* necessary to demonstrate conformance have been tested; see subclause 7.1.

- 1) Connect the connector under test to measurement equipment as shown in annex D.2.3 for *BS type I-C* and in annex D.4.3 for *BS type I-H*. All connectors not under test shall be terminated.
- 2) Set the BS to transmit:



- For single carrier operation set the connector under test to transmit at manufacturers declared *rated carrier output power* ( $P_{\text{Rated,c,AC}}$  or  $P_{\text{Rated,c,TABC}}$ , D.21).
  - For a connector under test declared to be capable of multi-carrier and/or CA operation (D.15-D.16) set the connector under test to transmit on all carriers configured using the applicable test configuration and corresponding power setting specified in subclauses 4.7 and 4.8 using the corresponding test models or set of physical channels in subclause 4.9.2.
- 3) Set the signal generator for the wanted signal to transmit as specified in table 7.4.2.5-2.
  - 4) Set the signal generator for the interfering signal to transmit at the frequency offset and as specified in table 7.4.2.5-2 and 7.4.2.5-3. Set-up and sweep the interfering RB centre frequency offset to the channel edge of the wanted signal according to table 7.4.2.5-3.
  - 5) Measure the throughput.

In addition, for a *multi-band connector*, the following steps shall apply:

- 6) For *multi-band connector* and single band tests, repeat the steps above per involved band where single band test configurations and test models shall apply with no carrier activated in the other band.

### 7.4.2.5 Test requirements

The throughput shall be  $\geq 95\%$  of the maximum throughput of the reference measurement channel, with a wanted and an interfering signal coupled to *BS type 1-C antenna connector* or *BS type 1-H TAB connector* using the parameters in tables 7.4.2.5-1, 7.4.2.5-2 and 7.4.2.5-3 for general blocking and narrowband blocking requirements. The reference measurement channel for the wanted signal is identified in subclause 7.2.5 for each channel bandwidth and further specified in annex A. The characteristics of the interfering signal is further specified in annex E.

The in-band blocking requirements apply outside the Base Station RF Bandwidth or Radio Bandwidth. The interfering signal offset is defined relative to the Base Station RF Bandwidth edges or Radio Bandwidth edges.

For *BS type 1-C* and *BS type 1-H*, the in-band blocking requirement applies from  $F_{\text{UL,low}} - \Delta f_{\text{OOB}}$  to  $F_{\text{UL,high}} + \Delta f_{\text{OOB}}$ , excluding the downlink frequency range of the *operating band*. The  $\Delta f_{\text{OOB}}$  for *BS type 1-C* and *BS type 1-H* is defined in table 7.4.2.5-0.

Minimum conducted requirement is defined at the *antenna connector* for *BS type 1-C* and at the *TAB connector* for *BS type 1-H*.

**Table 7.4.2.5-0:  $\Delta f_{\text{OOB}}$  offset for NR operating bands**

BS type	Operating band characteristics	$\Delta f_{\text{OOB}}$ (MHz)
BS type 1-C	$F_{\text{UL,high}} - F_{\text{UL,low}} \leq 200$ MHz	20
	$200$ MHz $< F_{\text{UL,high}} - F_{\text{UL,low}} \leq 900$ MHz	60
BS type 1-H	$F_{\text{UL,high}} - F_{\text{UL,low}} < 100$ MHz	20
	$100$ MHz $\leq F_{\text{UL,high}} - F_{\text{UL,low}} \leq 900$ MHz	60

For a BS operating in non-contiguous spectrum within any *operating band*, the in-band blocking requirements apply in addition inside any sub-block gap, in case the sub-block gap size is at least as wide as twice the interfering signal minimum offset in table 7.4.2.5-1. The interfering signal offset is defined relative to the sub-block edges inside the sub-block gap.

For a *multi-band connector*, the blocking requirements apply in the in-band blocking frequency ranges for each supported *operating band*. The requirement applies in addition inside any Inter RF Bandwidth gap, in case the Inter RF Bandwidth gap size is at least as wide as twice the interfering signal minimum offset in table 7.4.2.5-1.

For a BS operating in non-contiguous spectrum within any operating band, the narrowband blocking requirement applies in addition inside any sub-block gap, in case the sub-block gap size is at least as wide as the channel bandwidth of the NR interfering signal in table 7.4.2.5-3. The interfering signal offset is defined relative to the sub-block edges inside the sub-block gap.

For a *multi-band connector*, the narrowband blocking requirement applies in addition inside any Inter RF Bandwidth gap, in case the Inter RF Bandwidth gap size is at least as wide as the NR interfering signal in table 7.4.2.5-3. The interfering signal offset is defined relative to the Base Station RF Bandwidth edges inside the Inter RF Bandwidth gap.

Table 7.4.2.5-1: Base station general blocking requirement

<i>BS channel bandwidth of the lowest/highest carrier received (MHz)</i>	<i>Wanted signal mean power (dBm)</i>	<i>Interfering signal mean power (dBm)</i>	<i>Interfering signal centre frequency minimum offset from the lower/upper Base Station RF Bandwidth edge or sub-block edge inside a sub-block gap (MHz)</i>	<i>Type of interfering signal</i>
5, 10, 15, 20	$P_{\text{REFSENS}} + 6$ dB	Wide Area: -43 Medium Range: -38 Local Area: -35	$\pm 7.5$	5 MHz DFT-s-OFDM NR signal SCS: 15 kHz, 25 RB
25, 30, 40, 50, 60, 70, 80, 90, 100	$P_{\text{REFSENS}} + 6$ dB	Wide Area: -43 Medium Range: -38 Local Area: -35	$\pm 30$	20 MHz DFT-s-OFDM NR signal SCS: 15 kHz, 100 RB
NOTE: $P_{\text{REFSENS}}$ depends on the <i>BS channel bandwidth</i> as specified in TS 38.104 [2], table 7.2.2-1, 7.2.2-2 and 7.2.2-3.				

Table 7.4.2.5-2: Base station narrowband blocking requirement

<i>BS channel bandwidth of the lowest/highest carrier received (MHz)</i>	<i>Wanted signal mean power (dBm)</i>	<i>Interfering signal mean power (dBm)</i>
5, 10, 15, 20, 25, 30, 40, 50, 60, 70, 80, 90, 100 (Note 1)	$P_{\text{REFSENS}} + 6$ dB	Wide Area: -49 Medium Range: -44 Local Area: -41
NOTE 1: The SCS for the lowest/highest carrier received is the lowest SCS supported by the BS for that <i>BS channel bandwidth</i>		
NOTE 2: $P_{\text{REFSENS}}$ depends on the <i>BS channel bandwidth</i> as specified in TS 38.104 [2], table 7.2.2-1, 7.2.2-2 and 7.2.2-3.		

Table 7.4.2.5-3: Base station narrowband blocking interferer frequency offsets

<i>BS channel bandwidth of the lowest/highest carrier received (MHz)</i>	<i>Interfering RB centre frequency offset to the lower/upper Base Station RF Bandwidth edge or sub-block edge inside a sub-block gap (kHz)</i>	<i>Type of interfering signal</i>
5	$\pm([342.5]+m*180)$ , m=0, 1, 2, 3, 4, 9, 14, 19, 24	5 MHz DFT-s-OFDM NR signal, 1 RB SCS: 15 kHz
10	$\pm([347.5]+m*180)$ , m=0, 1, 2, 3, 4, 9, 14, 19, 24	
15	$\pm([352.5]+m*180)$ , m=0, 1, 2, 3, 4, 9, 14, 19, 24	
20	$\pm([342.5]+m*180)$ , m=0, 1, 2, 3, 4, 9, 14, 19, 24	
25	$\pm([557.5]+m*180)$ , m=0, 1, 2, 3, 4, 29, 54, 79, 100	20 MHz DFT-s-OFDM NR signal, 1 RB SCS: 15 kHz
30	$\pm([562.5]+m*180)$ , m=0, 1, 2, 3, 4, 29, 54, 79, 100	
40	$\pm([557.5]+m*180)$ , m=0, 1, 2, 3, 4, 29, 54, 79, 100	
50	$\pm([552.5]+m*180)$ , m=0, 1, 2, 3, 4, 29, 54, 79, 100	
60	$\pm([562.5]+m*180)$ , m=0, 1, 2, 3, 4, 29, 54, 79, 100	
70	$\pm([557.5]+m*180)$ , m=0, 1, 2, 3, 4, 29, 54, 79, 100	
80	$\pm([552.5]+m*180)$ , m=0, 1, 2, 3, 4, 29, 54, 79, 100	
90	$\pm([562.5]+m*180)$ , m=0, 1, 2, 3, 4, 29, 54, 79, 100	
100	$\pm([557.5]+m*180)$ , m=0, 1, 2, 3, 4, 29, 54, 79, 100	
NOTE: Interfering signal consisting of one resource block positioned at the stated offset, the <i>channel bandwidth</i> of the interfering signal is located adjacently to the lower/upper Base Station RF Bandwidth edge or sub-block edge inside a sub-block gap.		

## 7.5 Out-of-band blocking

### 7.5.1 Definition and applicability

The out-of-band blocking characteristics is a measure of the receiver ability to receive a wanted signal at its assigned channel at the *antenna connector* for *BS type I-C* or *TAB connector* for *BS type I-H* in the presence of an unwanted interferer out of the *operating band*, which is a CW signal for out-of-band blocking.

### 7.5.2 Minimum requirement

The minimum requirements for *BS type I-C* and *BS type I-H* are in TS 38.104 [2], subclause 7.5.2.

### 7.5.3 Test purpose

To verify that the *BS type I-C* receiver and each *BS type I-H TAB connector* receiver dynamic range, the relative throughput shall fulfil the specified limit.

## 7.5.4 Method of test

### 7.5.4.1 Initial conditions

Test environment: Normal; see annex B.2.

RF channels to be tested for single carrier (SC):

- M; see subclause 4.9.1

Base Station RF Bandwidth positions to be tested for multi-carrier (MC):

- $M_{\text{RFBW}}$  for *single-band connector(s)*, see subclause 4.9.1,
- $B'_{\text{RFBW}}T'_{\text{RFBW}}$  and  $B'_{\text{RFBW}}T_{\text{RFBW}}$  for *multi-band connector(s)*, see subclause 4.9.1.

In addition, for a multi-band *connector*:

- For  $B_{\text{RFBW}}T'_{\text{RFBW}}$ , out-of-band blocking testing above the highest operating band may be omitted.
- For  $B'_{\text{RFBW}}T_{\text{RFBW}}$ , out-of-band blocking testing below the lowest operating band may be omitted.

### 7.5.4.2 Procedure

The minimum requirement is applied to all connectors under test.

For BS type 1-H the procedure is repeated until all *TAB connectors* necessary to demonstrate conformance have been tested; see subclause 7.1.

- 1) Connect the connector under test to measurement equipment as shown in annex D.2.5 for *BS type 1-C* and in annex D.4.3 for *BS type 1-H*. All connectors not under test shall be terminated.
- 2) Set the BS to transmit a signal according to subclause 4.9.2, connector under test to transmit on all carriers configured using the applicable test configuration and corresponding power setting specified in subclauses 4.7 and 4.8.

The transmitter may be turned off for the out-of-band blocker tests when the frequency of the blocker is such that no IM2 or IM3 products fall inside the bandwidth of the wanted signal.

- 3) Set the signal generator for the wanted signal as defined in subclause 7.5.5 to transmit as specified in table 7.5.5.1-1 and 7.5.5.2-1.
- 4) Set the Signal generator for the interfering signal to transmit at the frequency offset and as specified in table 7.5.5.1-1 and 7.5.5.2-1. The CW interfering signal shall be swept with a step size of [1 MHz] over than range 1 MHz to  $(F_{\text{UL\_low}} - \Delta f_{\text{OOB}})$  MHz and  $(F_{\text{UL\_high}} + \Delta f_{\text{OOB}})$  MHz to 12750 MHz.
- 5) Measure the throughput.

In addition, for a *multi-band connector*, the following steps shall apply:

- 6) For *multi-band connector* and single band tests, repeat the steps above per involved band where single band test configurations and test models shall apply with no carrier activated in the other band.

## 7.5.5 Test requirements

### 7.5.5.1 General requirements

The throughput shall be  $\geq 95\%$  of the maximum throughput of the reference measurement channel, with a wanted and an interfering signal coupled to *BS type 1-C antenna connector* or *BS type 1-H TAB connector* using the parameters in table 7.5.2-1. The reference measurement channel for the wanted signal is identified in subclause 7.2.2 for each channel bandwidth and further specified in annex A. The characteristics of the interfering signal is further specified in annex E.

For *BS type 1-C* and *BS type 1-H* the out-of-band blocking requirement apply from 1 MHz to  $F_{\text{UL\_low}} - \Delta f_{\text{OOB}}$  and from  $F_{\text{UL\_high}} + \Delta f_{\text{OOB}}$  up to 12750 MHz, including the downlink frequency range of the *operating band*. The  $\Delta f_{\text{OOB}}$  for or *BS type 1-C* and *BS type 1-H* is defined in table 7.4.2.5-0.

Minimum conducted requirement is defined at the *antenna connector* for *BS type 1-C* and at the *TAB connector* for *BS type 1-H*.

[For a BS capable of multi-band operation, the requirement in the out-of-band blocking frequency ranges apply for each *operating band*, with the exception that the in-band blocking frequency ranges of all supported *operating bands* according to subclause 7.4.2.5 shall be excluded from the out-of-band blocking requirement.]

**Table 7.5.5.1-1: Out-of-band blocking performance requirement for NR**

Wanted signal mean power (dBm)	Interfering signal mean power (dBm)	Type of interfering signal
P <sub>REFSENS</sub> +6 dB (Note)	-15	CW carrier
NOTE: P <sub>REFSENS</sub> depends on the <i>BS channel bandwidth</i> as specified in TS 38.104 [2], table 7.2.2-1, 7.2.2-2 and 7.2.2-3.		

## 7.5.5.2 Co-location requirements

This additional blocking requirement may be applied for the protection of NR BS receivers when GSM, CDMA, UTRA, E-UTRA BS or NR BS operating in a different frequency band are co-located with a NR BS. The requirement is applicable to all channel bandwidths supported by the NR BS.

The requirements in this clause assume a 30 dB coupling loss between interfering transmitter and NR BS receiver and are based on co-location with base stations of the same class.

The throughput shall be  $\geq 95\%$  of the maximum throughput of the reference measurement channel, with a wanted and an interfering signal coupled to BS antenna input using the parameters in table 7.5.5.2-1 for all the BS classes. The reference measurement channel for the wanted signal is identified in tables 7.2.5-1, 7.2.5-2 and 7.2.5-3 for each channel bandwidth and further specified in Annex A. The characteristics of the interfering signal is further specified in annex E.

For *BS type 1-C* and *BS type 1-H* blocking requirement for co-location with BS in other bands is applied for all operating bands for which co-location protection is provided.

Minimum conducted requirement is defined at the *antenna connector* for *BS type 1-C* and at the *TAB connector* for *BS type 1-H*.

**Table 7.5.5.2-1: Blocking performance requirement for NR BS when co-located with BS in other frequency bands.**

Frequency range of interfering signal	Wanted signal mean power for WA BS (dBm)	Interfering signal mean power for WA BS (dBm)	Interfering signal mean power for MR BS (dBm)	Interfering signal mean power for LA BS (dBm)	Type of interfering signal
Frequency range of co-located downlink operating band	P <sub>REFSENS</sub> +6dB (Note 1)	+16	+8	x (Note 2)	CW carrier
NOTE 1: P <sub>REFSENS</sub> depends on the <i>BS channel bandwidth</i> as specified in TS 38.104 [2], table 7.2.2-1, 7.2.2-2 and 7.2.2-3.					
NOTE 2: x = -7 dBm for NR BS co-located with Pico GSM850 or Pico CDMA850 x = -4 dBm for NR BS co-located with Pico DCS1800 or Pico PCS1900 x = -6 dBm for NR BS co-located with UTRA bands or E-UTRA bands or NR bands					
NOTE 3: The requirement does not apply when the interfering signal falls within any of the supported uplink operating band(s) or in $\Delta f_{\text{OOB}}$ immediately outside any of the supported uplink operating band(s).					

## 7.6 Receiver spurious emissions

### 7.6.1 Definition and applicability

The receiver spurious emissions power is the power of emissions generated or amplified in a receiver unit that appear at the *antenna connector* (for *BS type 1-C*) or at the *TAB connector* (for *BS type 1-H*). The requirements apply to all BS with separate RX and TX *antenna connectors* / *TAB connectors*.

NOTE: In this case for FDD operation the test is performed when both TX and RX are ON, with the TX *antenna connectors* / *TAB connectors* terminated.

For *antenna connectors / TAB connectors* supporting both RX and TX in TDD, the requirements apply during the *transmitter OFF period*. For *antenna connectors / TAB connectors* supporting both RX and TX in FDD, the RX spurious emissions requirements are superseded by the TX spurious emissions requirements, as specified in subclause 6.6.5.

For RX-only *multi-band connectors*, the spurious emissions requirements are subject to exclusion zones in each supported *operating band*. For *multi-band connectors* that both transmit and receive in *operating band* supporting TDD, RX spurious emissions requirements are applicable during the *TX OFF period*, and are subject to exclusion zones in each supported *operating band*.

For *BS type 1-H* manufacturer shall declare *TAB connector RX min cell groups* (D.33). Every *TAB connector* of *BS type 1-H* supporting reception in an *operating band* shall map to one *TAB connector RX min cell group*, where mapping of *TAB connectors* to cells/beams is implementation dependent.

The number of active receiver units that are considered when calculating the conducted RX spurious emission limits ( $N_{\text{RXU,counted}}$ ) for *BS type 1-H* is calculated as follows:

$$N_{\text{RXU,counted}} = \min(N_{\text{RXU,active}}, 8 \times N_{\text{cells}})$$

$N_{\text{RXU,countedpercell}}$  is used for scaling of *basic limits* and is derived as  $N_{\text{RXU,countedpercell}} = N_{\text{RXU,counted}} / N_{\text{cells}}$ , where  $N_{\text{cells}}$  is defined in subclause 6.1.

NOTE:  $N_{\text{RXU,active}}$  is the number of actually active receiver units and is independent to the declaration of  $N_{\text{cells}}$ .

## 7.6.2 Minimum requirement

The minimum requirements for *BS type 1-C* and *BS type 1-H* are in TS 38.104 [2], subclause 7.6.2.

## 7.6.3 Test purpose

The test purpose is to verify the ability of the BS to limit the interference caused by receiver spurious emissions to other systems.

## 7.6.4 Method of test

### 7.6.4.1 Initial conditions

Test environment: Normal; see annex B.2.

RF channels to be tested for single carrier: M; see subclause 4.9.1.

*Base Station RF Bandwidth* positions to be tested for multi-carrier:

- $M_{\text{RFBW}}$  in single-band operation, see subclause 4.9.1,
- $B_{\text{RFBW}}'T_{\text{RFBW}}$  and  $B_{\text{RFBW}}'T_{\text{RFBW}}$  in multi-band operation, see subclause 4.9.1.

### 7.6.4.2 Procedure

The minimum requirement is applied to all connectors under test,

For *BS type 1-H* where there may be multiple *TAB connectors* they may be tested one at a time or multiple *TAB connectors* may be tested in parallel as shown in annex D.4.4. Whichever method is used the procedure is repeated until all *TAB connectors* necessary to demonstrate conformance have been tested.

- 1) Connect the connector under test to measurement equipment as shown in annex D.2.6 for *BS type 1-C* and in annex D.4.4 for *BS type 1-H*. All connectors not under test shall be terminated.
- 2) For separate RX only connectors with single carrier operation set the connector under test to transmit at manufacturers declared *rated carrier output power* ( $P_{\text{Rated,c,AC}}$  or  $P_{\text{Rated,c,TABC}}$ , D.21). Channel set-up shall be according to NR-FR1-TM 1.1.

For separate RX only connectors declared to be capable of multi-carrier and/or CA operation (D.15-D.16) set the connector under test to transmit on all carriers configured using the applicable test configuration and

corresponding power setting specified in subclauses 4.7 and 4.8 using the corresponding test models or set of physical channels in subclause 4.9.

For TDD connectors capable of transmit and receive ensure the transmitter is OFF.

- 3) Set the measurement equipment parameters as specified in table 7.6.5.1-1.
- 4) Measure the spurious emissions over each frequency range described in subclause 7.6.5.1-1.

In addition, for a *multi-band connector*, the following steps shall apply:

- 5) For *multi-band connector* and single band tests, repeat the steps above per involved band where single band test configurations and test models shall apply with no carrier activated in the other band.

## 7.6.5 Test requirements

### 7.6.5.1 Basic limits

The receiver spurious emissions limits are provided in table 7.6.5.1-1.

**Table 7.6.5.1-1: General BS receiver spurious emissions limits**

Spurious frequency range	Basic limit	Measurement bandwidth	Notes
30 MHz – 1 GHz	-57 dBm	100 kHz	Note 1
1 GHz – 12.75 GHz	-47 dBm	1 MHz	Note 1, Note 2
12.75 GHz – 5 <sup>th</sup> harmonic of the upper frequency edge of the UL <i>operating band</i> in GHz	-47 dBm	1 MHz	Note 1, Note 2, Note 3
NOTE 1: Measurement bandwidths as in ITU-R SM.329 [2], s4.1.			
NOTE 2: Upper frequency as in ITU-R SM.329 [2], s2.5 table 1.			
NOTE 3: This spurious frequency range applies only for <i>operating bands</i> for which the 5 <sup>th</sup> harmonic of the upper frequency edge of the UL <i>operating band</i> is reaching beyond 12.75 GHz.			
NOTE 4: The frequency range from $\Delta f_{\text{OBUE}}$ below the lowest frequency of the BS transmitter operating band to $\Delta f_{\text{OBUE}}$ above the highest frequency of the BS transmitter <i>operating band</i> , may be excluded from the requirement. $\Delta f_{\text{OBUE}}$ is defined in subclause 6.6.1.			
NOTE 5: For <i>multi-band connectors</i> , the exclusion applies for all supported <i>operating bands</i> .			

### 7.6.5.2 BS type 1-C

The RX spurious emissions requirements for *BS type 1-C* are that for each *antenna connector*, the power of emissions shall not exceed *basic limits* specified in table 7.6.5.1-1.

### 7.6.5.3 BS type 1-H

The RX spurious emissions requirements for *BS type 1-H* are that for each applicable *basic limit* specified in table 7.6.2-1 for each *TAB connector RX min cell group*, the power sum of emissions at respective *TAB connectors* shall not exceed the BS limits specified as the *basic limits* + X, where  $X = 10\log_{10}(N_{\text{RXU, counted per cell}})$ , unless stated differently in regional regulation.

The RX spurious emission requirements are applied per the *TAB connector RX min cell group* for all the configurations supported by the BS.

NOTE: Conformance to the BS receiver spurious emissions requirement can be demonstrated by meeting at least one of the following criteria as determined by the manufacturer:

- 1) The sum of the spurious emissions power measured on each *TAB connector* in the *TAB connector RX min cell group* shall be less than or equal to the BS limit above for the respective frequency span.

Or

- 2) The spurious emissions power at each *TAB connector* shall be less than or equal to the BS limit as defined above for the respective frequency span, scaled by  $-10\log_{10}(n)$ , where  $n$  is the number of *TAB connectors* in the *TAB connector RX min cell group*.

## 7.7 Receiver intermodulation

### 7.7.1 Definition and applicability

Third and higher order mixing of the two interfering RF signals can produce an interfering signal in the band of the desired channel. Intermodulation response rejection is a measure of the capability of the receiver to receive a wanted signal on its assigned channel frequency at the *antenna connector* for *BS type 1-C* or *TAB connector* for *BS type 1-H* in the presence of two interfering signals which have a specific frequency relationship to the wanted signal.

### 7.7.2 Minimum requirement

The minimum requirements for *BS type 1-C* and *BS type 1-H* are in TS 38.104 [2], subclause 7.7.2.

### 7.7.3 Test purpose

To verify that the *BS type 1-C* receiver and each *BS type 1-H TAB connector* receiver dynamic range, the relative throughput shall fulfil the specified limit.

### 7.7.4 Method of test

#### 7.7.4.1 Initial conditions

Test environment: Normal; see annex B.2.

RF channels to be tested for single carrier (SC): M; see subclause 4.9.1

*Base Station RF Bandwidth* positions to be tested for multi-carrier (MC) and/or CA:

- $M_{\text{RFBW}}$  for *single-band connector(s)*, see subclause 4.9.1,
- $B_{\text{RFBW\_T\_RFBW}}$  and  $B'_{\text{RFBW\_T\_RFBW}}$  for *multi-band connector(s)*, see subclause 4.9.1.

NOTE: When testing in M (or MRFBW), if the interferer is fully or partially located outside the supported frequency range, then the test shall be done instead in B (or BRFBW) and T (or TRFBW), and only with the interferer located inside the supported frequency range.

#### 7.7.4.2 Procedure

The minimum requirement is applied to all connectors under test.

For *BS type 1-H* the procedure is repeated until all *TAB connectors* necessary to demonstrate conformance have been tested; see subclause 7.1.

- 1) Connect the connector under test to measurement equipment as shown in annex D.2.7 for *BS type 1-C* and in annex D.4.6 for *BS type 1-H*. All connectors not under test shall be terminated.
- 2) Set the BS to transmit:
  - For single carrier operation set the connector under test to transmit at manufacturers declared *rated carrier output power* ( $P_{\text{Rated,c,AC}}$  OF  $P_{\text{Rated,c,TABC}}$ , D.21).
  - For a connector under test declared to be capable of multi-carrier and/or CA operation (D.15-D.16) set the connector under test to transmit on all carriers configured using the applicable test configuration and corresponding power setting specified in subclauses 4.7 and 4.8 using the corresponding test models or set of physical channels in subclause 4.9.2.
- 3) Set the signal generator for the wanted signal to transmit as specified in table 7.7.5-1 and 7.7.5-3.
- 4) Set the signal generator for the interfering signal to transmit at the frequency offset and as specified in table 7.7.5-2 and 7.7.5-4.



5) Measure the throughput.

In addition, for a *multi-band connector*, the following steps shall apply:

6) For *multi-band connector* and single band tests, repeat the steps above per involved band where single band test configurations and test models shall apply with no carrier activated in the other band.

## 7.7.5 Test requirements

For NR, the throughput shall be  $\geq 95\%$  of the maximum throughput of the reference measurement channel, with a wanted signal at the assigned channel frequency and two interfering signals coupled to the *BS type 1-C antenna connector* or *BS type 1-H TAB connector*, with the conditions specified in tables 7.7.5-1 and 7.7.5-2 for intermodulation performance and in tables 7.7.5-3, and 7.7.5-4 for narrowband intermodulation performance. The reference measurement channel for the wanted signal is identified in table 7.2.5-1 and table 7.2.5-3 for each channel bandwidth and further specified in annex A. The characteristics of the interfering signal is further specified in annex E.

The subcarrier spacing for the modulated interfering signal shall in general be the same as the subcarrier spacing for the wanted signal, except for the case of wanted signal subcarrier spacing 60 kHz and BS channel bandwidth  $\leq 20$  MHz, for which the subcarrier spacing of the interfering signal should be 30 kHz.

The receiver intermodulation requirement is applicable outside the Base Station RF Bandwidth or Radio Bandwidth edges. The interfering signal offset is defined relative to the Base Station RF Bandwidth edges or Radio Bandwidth edges.

For a BS operating in non-contiguous spectrum within any *operating band*, the narrowband intermodulation requirement applies in addition inside any sub-block gap in case the sub-block gap is at least as wide as the channel bandwidth of the NR interfering signal in table 7.7.5-2 or 7.7.5-4. The interfering signal offset is defined relative to the sub-block edges inside the sub-block gap.

[For a *multi-band connectors*, the intermodulation requirement applies in addition inside any Inter RF Bandwidth gap, in case the gap size is at least twice as wide as the NR interfering signal centre frequency offset from the Base Station RF Bandwidth edge.]

[For a *multi-band connectors*, the narrowband intermodulation requirement applies in addition inside any Inter RF Bandwidth gap in case the gap size is at least as wide as the NR interfering signal in tables 7.7.5-2 and 7.7.5-4. The interfering signal offset is defined relative to the Base Station RF Bandwidth edges inside the Inter RF Bandwidth gap.]

**Table 7.7.5-1: General intermodulation requirement**

Base Station Type	Wanted Signal mean power (dBm)	Mean power of interfering signals (dBm)	Type of interfering signal
Wide Area BS	$P_{\text{REFSENS}} + 6$ dB	-52	See table 7.7.5-2
Medium Range BS	$P_{\text{REFSENS}} + 6$ dB	-47	
Local Area BS	$P_{\text{REFSENS}} + 6$ dB	-44	
NOTE: $P_{\text{REFSENS}}$ depends on the BS class and on the <i>BS channel bandwidth</i> as specified in TS 38.104 [2], table 7.2.2-1, 7.2.2-2 and 7.2.2-3.			

Table 7.7.5-2: Interfering signals for intermodulation requirement

<i>BS channel bandwidth of the lowest/highest carrier received (MHz)</i>	<i>Interfering signal centre frequency offset from the lower/upper Base Station RF Bandwidth edge (MHz)</i>	<i>Type of interfering signal</i>
5	±7.5	CW
	±17.5	5 MHz DFT-s-OFDM NR signal, (Note 1)
10	±7.45	CW
	±17.5	5 MHz DFT-s-OFDM NR signal, (Note 1)
15	±7.43	CW
	±17.5	5 MHz DFT-s-OFDM NR signal, (Note 1)
20	±7.38	CW
	±17.5	5 MHz DFT-s-OFDM NR signal, (Note 1)
25	±7.45	CW
	±25	20MHz DFT-s-OFDM NR signal, (Note 2)
30	±7.43	CW
	±25	20 MHz DFT-s-OFDM NR signal, (Note 2)
40	±7.45	CW
	±25	20 MHz DFT-s-OFDM NR signal, (Note 2)
50	±7.35	CW
	±25	20 MHz DFT-s-OFDM NR signal, (Note 2)
60	±7.49	CW
	±25	20 MHz DFT-s-OFDM NR signal, (Note 2)
70	±7.42	CW
	±25	20 MHz DFT-s-OFDM NR signal, (Note 2)
80	±7.44	CW
	±25	20 MHz DFT-s-OFDM NR signal, (Note 2)
90	±7.43	CW
	±25	20 MHz DFT-s-OFDM NR signal, (Note 2)
100	±7.45	CW
	±25	20 MHz DFT-s-OFDM NR signal, (Note 2)

NOTE 1: For the 15 kHz subcarrier spacing, the number of RB is 25. For the 30 kHz subcarrier spacing, the number of RB is 10.

NOTE 2: For the 15 kHz subcarrier spacing, the number of RB is 100. For the 30 kHz subcarrier spacing, the number of RB is 50. For the 60 kHz subcarrier spacing, the number of RB is 24.

Table 7.7.5-3: Narrowband intermodulation performance requirement in FR1

<b>BS type</b>	<b>Wanted signal mean power (dBm) (NOTE)</b>	<b>Interfering signal mean power (dBm)</b>	<b>Type of interfering signal</b>
Wide Area BS	$P_{\text{REFSENS}} + 6$ dB	-52	See table 7.7.5-4
Medium Range BS	$P_{\text{REFSENS}} + 6$ dB	-47	
Local Area BS	$P_{\text{REFSENS}} + 6$ dB	-44	

NOTE:  $P_{\text{REFSENS}}$  depends on the *BS channel bandwidth* as specified in TS 38.104 [2], table 7.2.2-1, 7.2.2-2 and 7.2.2-3.

Table 7.7.5-4: Interfering signals for narrowband intermodulation requirement in FR1

<b>BS channel bandwidth of the lowest/highest carrier received (MHz)</b>	<b>Interfering RB centre frequency offset from the lower/upper Base Station RF Bandwidth edge or sub-block edge inside a sub-block gap (kHz)</b>	<b>Type of interfering signal</b>
5	±360	CW
	±1420	5 MHz DFT-s-OFDM NR signal, 1 RB (Note 1)
10	±325	CW
	±1780	5 MHz DFT-s-OFDM NR signal, 1 RB (Note 1)
15 (Note 2)	±380	CW
	±1600	5 MHz DFT-s-OFDM NR signal, 1 RB (Note 1)
20 (Note 2)	±345	CW
	±1780	5 MHz DFT-s-OFDM NR signal, 1 RB (Note 1)
25 (Note 2)	±325	CW
	±1990	20 MHz DFT-s-OFDM NR signal, 1 RB (Note 1)
30 (Note 2)	±320	CW
	±1990	20 MHz DFT-s-OFDM NR signal, 1 RB (Note 1)
40 (Note 2)	±310	CW
	±2710	20 MHz DFT-s-OFDM NR signal, 1 RB (Note 1)
50 (Note 2)	±330	CW
	±3250	20 MHz DFT-s-OFDM NR signal, 1 RB (Note 1)
60 (Note 2)	±350	CW
	±3790	20 MHz DFT-s-OFDM NR signal, 1 RB (Note 1)
70 (Note 2)	±400	CW
	±4870	20 MHz DFT-s-OFDM NR signal, 1 RB (Note 1)
80 (Note 2)	±390	CW
	±4870	20 MHz DFT-s-OFDM NR signal, 1 RB (Note 1)
90 (Note 2)	±340	CW
	±5770	20 MHz DFT-s-OFDM NR signal, 1 RB (Note 1)
100 (Note 2)	±340	CW
	±5770	20 MHz DFT-s-OFDM NR signal, 1 RB (Note 1)
NOTE 1: Interfering signal consisting of one resource block positioned at the stated offset, the <i>BS channel bandwidth</i> of the interfering signal is located adjacently to the lower/upper Base Station RF Bandwidth edge or sub-block edge inside a sub-block gap.		
NOTE 2: This requirement shall apply only for a G-FRC mapped to the frequency range at the channel edge adjacent to the interfering signals.		

## 7.8 In-channel selectivity

### 7.8.1 Definition and applicability

In-channel selectivity (ICS) is a measure of the receiver ability to receive a wanted signal at its assigned resource block locations at the *antenna connector* for *BS type 1-C* or *TAB connector* for *BS type 1-H* in the presence of an interfering signal received at a larger power spectral density. In this condition a throughput requirement shall be met for a specified reference measurement channel. The interfering signal shall be an NR signal which is time aligned with the wanted signal.

### 7.8.2 Minimum requirement

The minimum requirements for *BS type 1-C* and *BS type 1-H* are in TS 38.104 [2], subclause 7.8.2.

### 7.8.3 Test purpose

The purpose of this test is to verify the BS receiver ability to suppress the IQ leakage.

### 7.8.4 Method of test

#### 7.8.4.1 Initial conditions

Test environment: Normal; see annex B.2.

RF channels to be tested for single carrier: M; see subclause 4.9.1.

#### 7.8.4.2 Procedure

The minimum requirement is applied to all connectors under test.

For *BS type 1-H* the procedure is repeated until all *TAB connectors* necessary to demonstrate conformance have been tested; see subclause 7.1.

- 1) Set the signal generator for the wanted signal to transmit as specified from table 7.8.5-1 to 7.8.5-3.
- 2) Set the signal generator for the interfering signal to transmit at the frequency offset and as specified from table 7.8.5-1 to 7.8.5-3.
- 3) Measure the throughput.

In addition, for a *multi-band connector*, the following steps shall apply:

- 4) For *multi-band connector* and single band tests, repeat the steps above per involved band where single band test configurations and test models shall apply with no carrier activated in the other band.

### 7.8.5 Test requirements

For *BS type 1-C* and *1-H*, the throughput shall be  $\geq 95\%$  of the maximum throughput of the reference measurement channel as specified in annex A with parameters specified in table 7.8.5-1 for Wide Area BS, in table 7.8.5-2 for Medium Range BS and in table 7.8.5-3 for Local Area BS. The reference measurement channel for the wanted signal is identified in tables 7.8.2-1, 7.8.2-2 and 7.8.2-3 for each *BS channel bandwidth* and further specified in annex A. The characteristics of the interfering signal is further specified in annex E.

Table 7.8.5-1: Wide Area BS in-channel selectivity

NR channel bandwidth (MHz)	Subcarrier spacing (KHz)	Reference measurement channel	Wanted signal mean power (dBm)			Interfering signal mean power (dBm)	Type of interfering signal
			$f \leq 3.0 \text{ GHz}$	$3.0 \text{ GHz} < f \leq 4.2 \text{ GHz}$	$4.2 \text{ GHz} < f \leq 6.0 \text{ GHz}$		
5	15	G-FR1-A1-7	-99.2	-98.8	-98.5	-81.4	DFT-s-OFDM NR signal, SCS 15 kHz, 10 RB
10, 15, 20, 25, 30	15	G-FR1-A1-1	-97.3	-96.9	-96.6	-77.4	DFT-s-OFDM NR signal, SCS 15 kHz, 25 RB
40, 50	15	G-FR1-A1-4	-90.9	-90.5	-90.2	-71.4	NR signal, SCS 15 kHz, 100 RB
5	30	G-FR1-A1-8	-99.9	-99.5	-99.2	-81.4	DFT-s-OFDM NR signal, SCS 30 kHz, 5 RB
10, 15, 20, 25, 30	30	G-FR1-A1-2	-97.4	-97	-96.7	-78.4	DFT-s-OFDM NR signal, SCS 30 kHz, 10 RB
40, 50, 60, 70, 80, 90, 100	30	G-FR1-A1-5	-91.2	-90.8	-90.5	-71.4	DFT-s-OFDM NR signal, SCS 30 kHz, 50 RB
10, 15, 20, 25, 30	60	G-FR1-A1-9	-96.8	-96.4	-96.1	-78.4	DFT-s-OFDM NR signal, SCS 60 kHz, 5 RB
40, 50, 60, 70, 80, 90, 100	60	G-FR1-A1-6	-91.3	-90.9	-90.6	-71.6	DFT-s-OFDM NR signal, SCS 60 kHz, 24 RB
NOTE: Wanted and interfering signal are placed adjacently around $F_c$ , where the $F_c$ is defined for <i>BS channel bandwidth</i> of the wanted signal according to the table 5.4.2.2-1 in TS 38.104 [2]. The aggregated wanted and interferer signal shall be centred in the BS channel bandwidth of the wanted signal.							

Table 7.8.5-2: Medium Range BS in-channel selectivity

NR channel bandwidth (MHz)	Subcarrier spacing (KHz)	Reference measurement channel	Wanted signal mean power (dBm)			Interfering signal mean power (dBm)	Type of interfering signal
			$f \leq 3.0$ GHz	3.0 GHz < $f \leq 4.2$ GHz	4.2 GHz < $f \leq 6.0$ GHz		
5	15	G-FR1-A1-7	-94.2	-93.8	-93.5	-76.4	DFT-s-OFDM NR signal, SCS 15 kHz, 10 RB
10, 15, 20, 25, 30	15	G-FR1-A1-1	-92.3	-91.9	-91.6	-72.4	DFT-s-OFDM NR signal, SCS 15 kHz, 25 RB
40, 50	15	G-FR1-A1-4	-85.9	-85.5	-85.2	-66.4	DFT-s-OFDM NR signal, SCS 15 kHz, 100 RB
5	30	G-FR1-A1-8	-94.9	-94.5	-94.2	-76.4	DFT-s-OFDM NR signal, SCS 30 kHz, 5 RB
10, 15, 20, 25, 30	30	G-FR1-A1-2	-92.4	-92	-91.7	-73.4	DFT-s-OFDM NR signal, SCS 30 kHz, 10 RB
40, 50, 60, 70, 80, 90, 100	30	G-FR1-A1-5	-86.2	-85.8	-85.5	-66.4	DFT-s-OFDM NR signal, SCS 30 kHz, 50 RB
10, 15, 20, 25, 30	60	G-FR1-A1-9	-91.8	-91.4	-91.1	-73.4	DFT-s-OFDM NR signal, SCS 60 kHz, 5 RB
40, 50, 60, 70, 80, 90, 100	60	G-FR1-A1-6	-86.3	-85.9	-85.6	-66.6	DFT-s-OFDM NR signal, SCS 60 kHz, 24 RB
NOTE: Wanted and interfering signal are placed adjacently around $F_c$ , where the $F_c$ is defined for <i>BS channel bandwidth</i> of the wanted signal according to the table 5.4.2.2-1 in TS 38.104 [2]. The aggregated wanted and interferer signal shall be centred in the BS channel bandwidth of the wanted signal.							

Table 7.8.5-3: Local area BS in-channel selectivity

NR channel bandwidth (MHz)	Subcarrier spacing (kHz)	Reference measurement channel	Wanted signal mean power (dBm)			Interfering signal mean power (dBm)	Type of interfering signal
			$f \leq 3.0$ GHz	3.0 GHz < $f \leq 4.2$ GHz	4.2 GHz < $f \leq 6.0$ GHz		
5	15	G-FR1-A1-7	-91.2	-90.8	-90.5	-73.4	DFT-s-OFDM NR signal, SCS 15 kHz, 10 RB
10, 15, 20, 25, 30	15	G-FR1-A1-1	-89.3	-88.9	-88.6	-69.4	DFT-s-OFDM NR signal, SCS 15 kHz, 25 RB
40, 50	15	G-FR1-A1-4	-82.9	-82.5	-82.2	-63.4	DFT-s-OFDM NR signal, SCS 15 kHz, 100 RB
5	30	G-FR1-A1-8	-91.9	-91.5	-91.2	-73.4	DFT-s-OFDM NR signal, SCS 30 kHz, 5 RB
10, 15, 20, 25, 30	30	G-FR1-A1-2	-89.4	-89	-88.7	-70.4	DFT-s-OFDM NR signal, SCS 30 kHz, 10 RB
40, 50, 60, 70, 80, 90, 100	30	G-FR1-A1-5	-83.2	-82.8	-82.5	-63.4	DFT-s-OFDM NR signal, SCS 30 kHz, 50 RB
10, 15, 20, 25, 30	60	G-FR1-A1-9	-88.8	-88.4	-88.1	-70.4	DFT-s-OFDM NR signal, SCS 60 kHz, 5 RB
40, 50, 60, 70, 80, 90, 100	60	G-FR1-A1-6	-83.3	-82.9	-82.6	-63.6	DFT-s-OFDM NR signal, SCS 60 kHz, 24 RB
NOTE: Wanted and interfering signal are placed adjacently around $F_c$ , where the $F_c$ is defined for <i>BS channel bandwidth</i> of the wanted signal according to the table 5.4.2.2-1 in TS 38.104 [2]. The aggregated wanted and interferer signal shall be centred in the BS channel bandwidth of the wanted signal.							

## 8 Conducted performance characteristics

### 8.1 General

#### 8.1.1 Scope and definitions

Conducted performance requirements specify the ability of the *BS type 1-C* or *BS type 1-H* to correctly demodulate signals in various conditions and configurations. Conducted performance requirements are specified at the *antenna connector(s)* (for *BS type 1-C*) and at the *TAB connector(s)* (for *BS type 1-H*).

Conducted performance requirements for the BS are specified for the fixed reference channels and the propagation conditions defined in TS 38.104 [2] annex A and annex F, respectively. The requirements only apply to those FRCs that are supported by the BS.

Unless stated otherwise, performance requirements apply for a single carrier only. Performance requirements for a BS supporting CA are defined in terms of single carrier requirements.

For FDD operation the requirements in clause 8 shall be met with the transmitter units associated with *antenna connectors* (for *BS type 1-C*) or *TAB connectors* (for *BS type 1-H*) in the *operating band* turned ON.

**NOTE:** In normal operating conditions *antenna connectors* (for *BS type 1-C*) or *TAB connectors* (for *BS type 1-H*) in FDD operation are configured to transmit and receive at the same time. The associated transmitter unit(s) may be OFF for some of the tests.

The SNR used in this clause is specified based on a single carrier and defined as:

$$\text{SNR} = S / N$$

Where:

*S* is the total signal energy in a slot on a single *antenna connector* (for *BS type 1-C*) or on a single *TAB connector* (for *BS type 1-H*).

*N* is the noise energy in a bandwidth corresponding to the transmission bandwidth over the duration of a slot.

#### 8.1.2 Applicability rule

##### 8.1.2.1 Applicability of PUSCH performance requirements

###### 8.1.2.1.1 Applicability of requirements for different subcarrier spacings

Unless otherwise stated, PUSCH requirement tests shall apply only for each subcarrier spacing declared to be supported.

###### 8.1.2.1.2 Applicability of requirements for different channel bandwidths

For each subcarrier spacing declared to be supported, the tests for a specific channel bandwidth shall apply only if the BS supports it.

Unless otherwise stated, for each subcarrier spacing declared to be supported, the tests shall be done only for the widest supported channel bandwidth. If performance requirement is not specified for this widest supported channel bandwidth, the tests shall be done by using performance requirement for the closest channel bandwidth lower than this widest supported bandwidth; the tested PRBs shall then be centered in this widest supported channel bandwidth.

##### 8.1.2.2 Applicability of PUCCH performance requirements

###### 8.1.2.2.1 Applicability of requirements for different formats

Unless otherwise stated, PUCCH requirement tests shall apply only for each PUCCH format declared to be supported.



#### 8.1.2.2.2 Applicability of requirements for different subcarrier spacings

Unless otherwise stated, PUCCH requirement tests shall apply only for each subcarrier spacing declared to be supported.

#### 8.1.2.2.3 Applicability of requirements for different channel bandwidths

For each subcarrier spacing declared to be supported by the BS, the tests for a specific channel bandwidth shall apply only if the BS supports it.

Unless otherwise stated, for each subcarrier spacing declared to be supported, the tests shall be done only for the widest supported channel bandwidth. If performance requirement is not specified for this widest supported channel bandwidth, the tests shall be done by using performance requirement for the closest channel bandwidth lower than this widest supported bandwidth; the tested PRBs shall then be centered in this widest supported channel bandwidth.

#### 8.1.2.3 Applicability of PRACH performance requirements

##### 8.1.2.3.1 Applicability of requirements for different formats

Unless otherwise stated, PRACH requirement tests shall apply only for each PRACH format declared to be supported.

##### 8.1.2.3.2 Applicability of requirements for different subcarrier spacings

Unless otherwise stated, for each PRACH format with short sequence declared to be supported, for each FR, the tests shall apply only for the smallest supported subcarrier spacing in the FR.

##### 8.1.2.3.3 Applicability of requirements for different channel bandwidths

Unless otherwise stated, for the subcarrier spacing to be tested, the tests shall apply only for anyone channel bandwidth declared to be supported.

## 8.2 Performance requirements for PUSCH

### 8.2.1 Performance requirements for PUSCH with transform precoding disabled

#### 8.2.1.1 Definition and applicability

The performance requirement of PUSCH is determined by a minimum required throughput for a given SNR. The required throughput is expressed as a fraction of maximum throughput for the FRCs listed in Annex A. The performance requirements assume HARQ re-transmissions.

Which specific test is applicable to BS is based on the test applicability rule defined in section TBD.

#### 8.2.1.2 Minimum Requirement

The minimum requirement is in TS 38.104 [2] subclause 8.2.1.

#### 8.2.1.3 Test Purpose

The test shall verify the receiver's ability to achieve throughput under multipath fading propagation conditions for a given SNR.

#### 8.2.1.4 Method of test

##### 8.2.1.4.1 Initial Conditions

Test environment: Normal, see annex B.2.

RF channels to be tested: M; see subclause 4.9.1.

1) Connect the BS tester generating the wanted signal, multipath fading simulators and AWGN generators to all BS antenna connectors for diversity reception via a combining network as shown in Annex D.5 and D.6 for *BS type I-C* and *type I-H* respectively.

## 8.2.1.4.2 Procedure

- 1) Adjust the AWGN generator, according to the channel bandwidth, defined in table 8.2.1.4.2-1.

**Table 8.2.1.4.2-1: AWGN power level at the BS input**

Sub-carrier spacing (kHz)	Channel bandwidth (MHz)	AWGN power level
15 kHz	5	[-83.5] dBm / 4.5MHz
	10	[-80.3] dBm / 9.36MHz
	20	[-77.2] dBm / 19.08MHz
30 kHz	10	[-80.7] dBm / 8.64MHz
	20	[-77.4] dBm / 18.36MHz
	40	[-74.2] dBm / 38.16MHz
	100	[-70.1] dBm / 98.28MHz

- 2) The characteristics of the wanted signal shall be configured according to the corresponding UL reference measurement channel defined in annex A and the test parameters in table 8.2.1.4.2-2.

**Table 8.2.1.4.2-2: Test parameters for testing PUSCH**

Parameter		Value
Transform precoding		Disabled
Uplink-downlink allocation for TDD		15 kHz SCS: 3D1S1U, S=10D:2G:2U 30 kHz SCS: 7D1S2U, S=6D:4G:4U
HARQ	Maximum number of HARQ transmissions	4
	RV sequence	0, 2, 3, 1
DMRS	DMRS configuration type	1
	Maximum number of OFDM symbols for front loaded DMRS	1
	Number of additional DMRS symbols	0, 1
	Number of DMRS CDM group(s) without data	2
	EPRE ratio of PUSCH to DMRS	-3 dB
	DMRS port	{0}, {0, 1}
DMRS sequence generation		$N_{ID}=0, n_{SCID}=0$
Time domain resource	PUSCH mapping type	A
	PUSCH starting symbol index	0
	PUSCH symbol length	14
Frequency domain resource	RB assignment	Full applicable test bandwidth
	Frequency hopping	Disabled
TPMI index for 2Tx two layer spatial multiplexing transmission		0
Code block group based PUSCH transmission		Disabled

- 3) The multipath fading emulators shall be configured according to the corresponding channel model defined in annex G.
- 4) Adjust the equipment so that required SNR specified in table 8.2.1.5-1 to 8.2.1.5-7 is achieved at the BS input.
- 5) For each of the reference channels in table 8.2.1.5-1 to 8.2.1.5-7 applicable for the base station, measure the throughput.

## 8.2.1.5 Test Requirement

The throughput measured according to subclause 8.2.1.4.2 shall not be below the limits for the SNR levels specified in table 8.2.1.5-1 to 8.2.1.5-7.

Table 8.2.1.5-1: Test requirements for PUSCH, 5 MHz Channel Bandwidth, 15 kHz SCS

Number of TX antennas	Number of RX antennas	Cyclic prefix	Propagation conditions and correlation matrix (Annex G)	Fraction of maximum throughput	FRC (Annex A)	DMRS configuration	SNR (dB)
1	2	Normal	TDLB100-400 Low	70 %	G-FR1-A3-1	1+0	[2,68]
					G-FR1-A3-8	1+1	[-1,39]
		Normal	TDLC300-100 Low	70 %	G-FR1-A4-1	1+0	[13,37]
					G-FR1-A4-8	1+1	[11,14]
		Normal	TDLA30-10 Low	70 %	G-FR1-A5-1	1+0	[14,39]
					G-FR1-A5-8	1+1	[14,29]
	4	Normal	TDLB100-400 Low	70 %	G-FR1-A3-1	1+0	[-1,93]
					G-FR1-A3-8	1+1	[-4,97]
		Normal	TDLC300-100 Low	70 %	G-FR1-A4-1	1+0	[7,97]
					G-FR1-A4-8	1+1	[7,13]
		Normal	TDLA30-10 Low	70 %	G-FR1-A5-1	1+0	[10,14]
					G-FR1-A5-8	1+1	[9,98]
8	Normal	TDLB100-400 Low	70 %	G-FR1-A3-1	1+0	[-5,51]	
				G-FR1-A3-8	1+1	[-7,84]	
	Normal	TDLC300-100 Low	70 %	G-FR1-A4-1	1+0	[4,10]	
				G-FR1-A4-8	1+1	[3,67]	
	Normal	TDLA30-10 Low	70 %	G-FR1-A5-1	1+0	[6,62]	
				G-FR1-A5-8	1+1	[6,53]	
2	2	Normal	TDLB100-400 Low	70 %	G-FR1-A3-22		[TBD]
					G-FR1-A4-22		[18,89]
	4	Normal	TDLB100-400 Low	70 %	G-FR1-A3-15		[TBD]
					G-FR1-A3-22		[-0,98]
		Normal	TDLC300-100 Low	70 %	G-FR1-A4-15		[TBD]
					G-FR1-A4-22		[11,58]
	8	Normal	TDLB100-400 Low	70 %	G-FR1-A3-15		[TBD]
					G-FR1-A3-22		[TBD]
		Normal	TDLC300-100 Low	70 %	G-FR1-A4-15		[8,43]
					G-FR1-A4-22		[7,33]

Table 8.2.1.5-2: Test requirements for PUSCH, 10 MHz Channel Bandwidth, 15 kHz SCS

Number of TX antennas	Number of RX antennas	Cyclic prefix	Propagation conditions and correlation matrix (Annex G)	Fraction of maximum throughput	FRC (Annex A)	DMRS configuration	SNR (dB)	
1	2	Normal	TDLB100-400 Low	70 %	G-FR1-A3-2	1+0	[1,67]	
					G-FR1-A3-9	1+1	[-1,91]	
		Normal	TDLC300-100 Low	70 %	G-FR1-A4-2	1+0	[13,37]	
					G-FR1-A4-9	1+1	[11,14]	
		Normal	TDLA30-10 Low	70 %	G-FR1-A5-2	1+0	[13,82]	
					G-FR1-A5-9	1+1	[14,05]	
	4	Normal	TDLB100-400 Low	70 %	G-FR1-A3-2	1+0	[-2,47]	
					G-FR1-A3-9	1+1	[-5,24]	
		Normal	TDLC300-100 Low	70 %	G-FR1-A4-2	1+0	[8,34]	
					G-FR1-A4-9	1+1	[7,18]	
		Normal	TDLA30-10 Low	70 %	G-FR1-A5-2	1+0	[9,91]	
					G-FR1-A5-9	1+1	[9,97]	
	8	Normal	TDLB100-400 Low	70 %	G-FR1-A3-2	1+0	[-5,91]	
					G-FR1-A3-9	1+1	[-8,11]	
		Normal	TDLC300-100 Low	70 %	G-FR1-A4-2	1+0	[4,39]	
					G-FR1-A4-9	1+1	[3,74]	
		Normal	TDLA30-10 Low	70 %	G-FR1-A5-2	1+0	[6,55]	
					G-FR1-A5-9	1+1	[6,33]	
	2	2	Normal	TDLB100-400 Low	70 %	G-FR1-A3-23	1+1	[1,23]
			Normal	TDLC300-100 Low	70 %	G-FR1-A4-23	1+1	[19,13]
		4	Normal	TDLB100-400 Low	70 %	G-FR1-A3-16	1+0	[TBD]
						G-FR1-A3-23	1+1	[-0,78]
		Normal	TDLC300-100 Low	70 %	G-FR1-A4-16	1+0	[TBD]	
					G-FR1-A4-23	1+1	[11,71]	
8		Normal	TDLB100-400 Low	70 %	G-FR1-A3-16	1+0	[TBD]	
					G-FR1-A3-23	1+1	[-4,41]	
		Normal	TDLC300-100 Low	70 %	G-FR1-A4-16	1+0	[8,53]	
					G-FR1-A4-23	1+1	[7,32]	

**Table 8.2.1.5-3: Test requirements for PUSCH, 20 MHz Channel Bandwidth, 15 kHz SCS**

Number of TX antennas	Number of RX antennas	Cyclic prefix	Propagation conditions and correlation matrix (Annex G)	Fraction of maximum throughput	FRC (Annex A)	DMRS configuration	SNR (dB)
1	2	Normal	TDLB100-400 Low	70 %	G-FR1-A3-3	1+0	[TBD]
					G-FR1-A3-10	1+1	[-1,20]
		Normal	TDLC300-100 Low	70 %	G-FR1-A4-3	1+0	[14,16]
					G-FR1-A4-10	1+1	[11,13]
		Normal	TDLA30-10 Low	70 %	G-FR1-A5-3	1+0	[14,08]
					G-FR1-A5-10	1+1	[13,73]
	4	Normal	TDLB100-400 Low	70 %	G-FR1-A3-3	1+0	[2,03]
					G-FR1-A3-10	1+1	[-4,71]
		Normal	TDLC300-100 Low	70 %	G-FR1-A4-3	1+0	[8,43]
					G-FR1-A4-10	1+1	[7,18]
		Normal	TDLA30-10 Low	70 %	G-FR1-A5-3	1+0	[10,20]
					G-FR1-A5-10	1+1	[9,77]
8	Normal	TDLB100-400 Low	70 %	G-FR1-A3-3	1+0	[-2,12]	
				G-FR1-A3-10	1+1	[-7,83]	
	Normal	TDLC300-100 Low	70 %	G-FR1-A4-3	1+0	[4,31]	
				G-FR1-A4-10	1+1	[3,72]	
	Normal	TDLA30-10 Low	70 %	G-FR1-A5-3	1+0	[6,72]	
				G-FR1-A5-10	1+1	[6,34]	
2	2	Normal	TDLB100-400 Low	70 %	G-FR1-A3-24	1+1	[TBD]
		Normal	TDLC300-100 Low	70 %	G-FR1-A4-24	1+1	[19,17]
	4	Normal	TDLB100-400 Low	70 %	G-FR1-A3-17	1+0	[TBD]
					G-FR1-A3-24	1+1	[TBD]
		Normal	TDLC300-100 Low	70 %	G-FR1-A4-17	1+0	[TBD]
					G-FR1-A4-24	1+1	[11,65]
	8	Normal	TDLB100-400 Low	70 %	G-FR1-A3-17	1+0	[TBD]
					G-FR1-A3-24	1+1	[TBD]
		Normal	TDLC300-100 Low	70 %	G-FR1-A4-17	1+0	[8,80]
					G-FR1-A4-24	1+1	[7,35]

Table 8.2.1.5-4: Test requirements for PUSCH, 10 MHz Channel Bandwidth, 30 kHz SCS

Number of TX antennas	Number of RX antennas	Cyclic prefix	Propagation conditions and correlation matrix (Annex G)	Fraction of maximum throughput	FRC (Annex A)	DMRS configuration	SNR (dB)
1	2	Normal	TDLB100-400 Low	70 %	G-FR1-A3-4	1+0	[-1,20]
					G-FR1-A3-11	1+1	[-1,89]
		Normal	TDLC300-100 Low	70 %	G-FR1-A4-4	1+0	[11,32]
					G-FR1-A4-11	1+1	[11,08]
		Normal	TDLA30-10 Low	70 %	G-FR1-A5-4	1+0	[13,22]
					G-FR1-A5-11	1+1	[13,44]
	4	Normal	TDLB100-400 Low	70 %	G-FR1-A3-4	1+0	[-4,85]
					G-FR1-A3-11	1+1	[-5,26]
		Normal	TDLC300-100 Low	70 %	G-FR1-A4-4	1+0	[7,04]
					G-FR1-A4-11	1+1	[6,78]
		Normal	TDLA30-10 Low	70 %	G-FR1-A5-4	1+0	[TBD]
					G-FR1-A5-11	1+1	[8,56]
8	Normal	TDLB100-400 Low	70 %	G-FR1-A3-4	1+0	[-8,03]	
				G-FR1-A3-11	1+1	[-8,23]	
	Normal	TDLC300-100 Low	70 %	G-FR1-A4-4	1+0	[3,54]	
				G-FR1-A4-11	1+1	[3,53]	
	Normal	TDLA30-10 Low	70 %	G-FR1-A5-4	1+0	[5,75]	
				G-FR1-A5-11	1+1	[TBD]	
2	2	Normal	TDLB100-400 Low	70 %	G-FR1-A3-25	1+1	[1,92]
		Normal	TDLC300-100 Low	70 %	G-FR1-A4-25	1+1	[19,12]
	4	Normal	TDLB100-400 Low	70 %	G-FR1-A3-18	1+0	[-1,11]
					G-FR1-A3-25	1+1	[-1,60]
	Normal	TDLC300-100 Low	70 %	G-FR1-A4-18	1+0	[12,80]	
				G-FR1-A4-25	1+1	[11,86]	
	8	Normal	TDLB100-400 Low	70 %	G-FR1-A3-18	1+0	[-3,83]
					G-FR1-A3-25	1+1	[-4,56]
		Normal	TDLC300-100 Low	70 %	G-FR1-A4-18	1+0	[8,16]
					G-FR1-A4-25	1+1	[7,58]

Table 8.2.1.5-5: Test requirements for PUSCH, 20 MHz Channel Bandwidth, 30 kHz SCS

Number of TX antennas	Number of RX antennas	Cyclic prefix	Propagation conditions and correlation matrix (Annex G)	Fraction of maximum throughput	FRC (Annex A)	DMRS configuration	SNR (dB)
1	2	Normal	TDLB100-400 Low	70 %	G-FR1-A3-5	1+0	[-1,43]
					G-FR1-A3-12	1+1	[-2,27]
		Normal	TDLC300-100 Low	70 %	G-FR1-A4-5	1+0	[11,48]
					G-FR1-A4-12	1+1	[11,00]
		Normal	TDLA30-10 Low	70 %	G-FR1-A5-5	1+0	[13,39]
					G-FR1-A5-12	1+1	[13,32]
	4	Normal	TDLB100-400 Low	70 %	G-FR1-A3-5	1+0	[-5,05]
					G-FR1-A3-12	1+1	[-5,60]
		Normal	TDLC300-100 Low	70 %	G-FR1-A4-5	1+0	[7,20]
					G-FR1-A4-12	1+1	[6,71]
		Normal	TDLA30-10 Low	70 %	G-FR1-A5-5	1+0	[8,88]
					G-FR1-A5-12	1+1	[8,56]
8	Normal	TDLB100-400 Low	70 %	G-FR1-A3-5	1+0	[-7,89]	
				G-FR1-A3-12	1+1	[-8,45]	
	Normal	TDLC300-100 Low	70 %	G-FR1-A4-5	1+0	[3,64]	
				G-FR1-A4-12	1+1	[3,43]	
	Normal	TDLA30-10 Low	70 %	G-FR1-A5-5	1+0	[5,99]	
				G-FR1-A5-12	1+1	[TBD]	
2	2	Normal	TDLB100-400 Low	70 %	G-FR1-A3-26	1+1	[1,80]
		Normal	TDLC300-100 Low	70 %	G-FR1-A4-26	1+1	[19,88]
	4	Normal	TDLB100-400 Low	70 %	G-FR1-A3-19	1+0	[-0,44]
					G-FR1-A3-26	1+1	[-1,65]
	Normal	TDLC300-100 Low	70 %	G-FR1-A4-19	1+0	[12,66]	
				G-FR1-A4-26	1+1	[11,92]	
	8	Normal	TDLB100-400 Low	70 %	G-FR1-A3-19	1+0	[-3,43]
					G-FR1-A3-26	1+1	[-4,69]
		Normal	TDLC300-100 Low	70 %	G-FR1-A4-19	1+0	[8,04]
					G-FR1-A4-26	1+1	[7,40]

Table 8.2.1.5-6: Test requirements for PUSCH, 40 MHz Channel Bandwidth, 30 kHz SCS

Number of TX antennas	Number of RX antennas	Cyclic prefix	Propagation conditions and correlation matrix (Annex G)	Fraction of maximum throughput	FRC (Annex A)	DMRS configuration	SNR (dB)
1	2	Normal	TDLB100-400 Low	70 %	G-FR1-A3-6	1+0	[-1,09]
					G-FR1-A3-13	1+1	[-2,13]
		Normal	TDLC300-100 Low	70 %	G-FR1-A4-6	1+0	[11,33]
					G-FR1-A4-13	1+1	[10,77]
		Normal	TDLA30-10 Low	70 %	G-FR1-A5-6	1+0	[12,75]
					G-FR1-A5-13	1+1	[12,73]
	4	Normal	TDLB100-400 Low	70 %	G-FR1-A3-6	1+0	[-4,32]
					G-FR1-A3-13	1+1	[-5,41]
		Normal	TDLC300-100 Low	70 %	G-FR1-A4-6	1+0	[7,08]
					G-FR1-A4-13	1+1	[6,63]
		Normal	TDLA30-10 Low	70 %	G-FR1-A5-6	1+0	[9,34]
					G-FR1-A5-13	1+1	[TBD]
8	Normal	TDLB100-400 Low	70 %	G-FR1-A3-6	1+0	[-7,74]	
				G-FR1-A3-13	1+1	[-8,33]	
	Normal	TDLC300-100 Low	70 %	G-FR1-A4-6	1+0	[3,56]	
				G-FR1-A4-13	1+1	[3,37]	
	Normal	TDLA30-10 Low	70 %	G-FR1-A5-6	1+0	[6,02]	
				G-FR1-A5-13	1+1	[5,64]	
2	2	Normal	TDLB100-400 Low	70 %	G-FR1-A3-27	1+1	[1,88]
		Normal	TDLC300-100 Low	70 %	G-FR1-A4-27	1+1	[19,97]
	4	Normal	TDLB100-400 Low	70 %	G-FR1-A3-20	1+0	[0,17]
					G-FR1-A3-27	1+1	[-1,77]
		Normal	TDLC300-100 Low	70 %	G-FR1-A4-20	1+0	[12,64]
	G-FR1-A4-27				1+1	[11,90]	
	8	Normal	TDLB100-400 Low	70 %	G-FR1-A3-20	1+0	[-3,17]
					G-FR1-A3-27	1+1	[-4,62]
		Normal	TDLC300-100 Low	70 %	G-FR1-A4-20	1+0	[7,93]
					G-FR1-A4-27	1+1	[7,51]



Table 8.2.1.5-7: Test requirements for PUSCH, 100 MHz Channel Bandwidth, 30 kHz SCS

Number of TX antennas	Number of RX antennas	Cyclic prefix	Propagation conditions and correlation matrix (Annex G)	Fraction of maximum throughput	FRC (Annex A)	DMRS configuration	SNR (dB)
1	2	Normal	TDLB100-400 Low	70 %	G-FR1-A3-7	1+0	[-0,49]
					G-FR1-A3-14	1+1	[-2,32]
		Normal	TDLC300-100 Low	70 %	G-FR1-A4-7	1+0	[11,55]
	G-FR1-A4-14				1+1	[10,88]	
	Normal	TDLA30-10 Low	70 %	G-FR1-A5-7	1+0	[TBD]	
				G-FR1-A5-14	1+1	[TBD]	
	4	Normal	TDLB100-400 Low	70 %	G-FR1-A3-7	1+0	[TBD]
					G-FR1-A3-14	1+1	[-5,51]
		Normal	TDLC300-100 Low	70 %	G-FR1-A4-7	1+0	[7,25]
	G-FR1-A4-14				1+1	[6,77]	
	Normal	TDLA30-10 Low	70 %	G-FR1-A5-7	1+0	[10,44]	
				G-FR1-A5-14	1+1	[TBD]	
8	Normal	TDLB100-400 Low	70 %	G-FR1-A3-7	1+0	[-6,74]	
				G-FR1-A3-14	1+1	[-8,38]	
	Normal	TDLC300-100 Low	70 %	G-FR1-A4-7	1+0	[3,62]	
G-FR1-A4-14				1+1	[3,45]		
Normal	TDLA30-10 Low	70 %	G-FR1-A5-7	1+0	[TBD]		
			G-FR1-A5-14	1+1	[TBD]		
2	2	Normal	TDLB100-400 Low	70 %	G-FR1-A3-28	1+1	[1,83]
					G-FR1-A4-28	1+1	[19,47]
	4	Normal	TDLB100-400 Low	70 %	G-FR1-A3-21	1+0	[TBD]
					G-FR1-A3-28	1+1	[-1,72]
	Normal	TDLC300-100 Low	70 %	G-FR1-A4-21	1+0	[13,16]	
				G-FR1-A4-28	1+1	[12,07]	
	8	Normal	TDLB100-400 Low	70 %	G-FR1-A3-21	1+0	[-2,65]
					G-FR1-A3-28	1+1	[-4,68]
	Normal	TDLC300-100 Low	70 %	G-FR1-A4-21	1+0	[8,19]	
				G-FR1-A4-28	1+1	[7,57]	

## 8.2.2 Performance requirements for PUSCH with transform precoding enabled

### 8.2.2.1 Definition and applicability

The performance requirement of PUSCH is determined by a minimum required throughput for a given SNR. The required throughput is expressed as a fraction of maximum throughput for the FRCs listed in Annex A. The performance requirements assume HARQ re-transmissions.

A test for a specific channel bandwidth is only applicable if the BS supports it.

The applicability of tests in 38.104 with different SCS and BW combinations is according to the following principle:

*Editor's note: Applicability rule is FFS.*

### 8.2.2.2 Minimum Requirement

The minimum requirement is in TS 38.104 [2] subclause 8.2.2.

### 8.2.2.3 Test Purpose

The test shall verify the receiver's ability to achieve throughput under multipath fading propagation conditions for a given SNR.

## 8.2.2.4 Method of test

### 8.2.2.4.1 Initial Conditions

Test environment: Normal, see annex B.2.

RF channels to be tested: M; see subclause 4.9.1.

1) Connect the BS tester generating the wanted signal, multipath fading simulators and AWGN generators to all BS antenna connectors for diversity reception via a combining network as shown in annex D.5 and D.6 for *BS type I-C* and *type I-H* respectively.

### 8.2.2.4.2 Procedure

1) Adjust the AWGN generator, according to the SCS and channel bandwidth, defined in table 8.2.2.4.2-1.

**Table 8.2.2.4.2-1: AWGN power level at the BS input**

Sub-carrier spacing (kHz)	Channel bandwidth [MHz]	AWGN power level
15 kHz	5	[-83.5] dBm / 4.5MHz
30 kHz	10	[-80.7] dBm / 8.64MHz

2) The characteristics of the wanted signal shall be configured according to the corresponding UL reference measurement channel defined in annex A and the test parameters in table 8.2.2.4.2-2.

**Table 8.2.2.4.2-2: Test parameters for testing PUSCH**

Parameter		Value
Transform precoding		Enabled
Uplink-downlink allocation for TDD		15 kHz SCS: 3D1S1U, S=10D:2G:2U 30 kHz SCS: 7D1S2U, S=6D:4G:4U
HARQ	Maximum number of HARQ transmissions	4
	RV sequence	0, 2, 3, 1
DMRS	DMRS configuration type	1
	Maximum number of OFDM symbols for front loaded DMRS	1
	Number of additional DMRS symbols	0, 1
	Number of DMRS CDM group(s) without data	2
	EPRE ratio of PUSCH to DMRS	-3 dB
	DMRS port	0
DMRS sequence generation		$N_{ID}=0$ , group hopping and sequence hopping are disabled
Time domain resource	PUSCH mapping type	A
	PUSCH starting symbol index	0
	PUSCH symbol length	14
Frequency domain resource	RB assignment	15 kHz SCS: 25 PRBs in the middle of the test bandwidth 30 kHz SCS: 24 PRBs in the middle of the test bandwidth
	Frequency hopping	Disabled
Code block group based PUSCH transmission		Disabled

3) The multipath fading emulators shall be configured according to the corresponding channel model defined in [TBD].

4) Adjust the equipment so that required SNR specified in table 8.2.2.5-1 to 8.2.2.5-2 is achieved at the BS input.

5) For each of the reference channels in table 8.2.2.5-1 to 8.2.2.5-2 applicable for the base station, measure the throughput, according to [TBD].

### 8.2.2.5 Test Requirement

The throughput measured according to subclause 8.2.2.4.2 shall not be below the limits for the SNR levels specified in table 8.2.2.5-1 to 8.2.2.5-2.

**Table 8.2.2.5-1: Test requirements for PUSCH, 5 MHz Channel Bandwidth, 15 kHz SCS**

Number of TX antennas	Number of RX antennas	Cyclic prefix	Propagation conditions and correlation matrix (Annex TBD)	Fraction of maximum throughput	FRC (Annex A)	DMRS configuration	SNR (dB)
1	2	Normal	TDLB100-400	70 %	G-FR1-A3-29	1+0	[2.2]
					G-FR1-A3-31	1+1	[-1.9]
	4	Normal	TDLB100-400	70 %	G-FR1-A3-29	1+0	[-2.9]
					G-FR1-A3-31	1+1	[-5.8]
	8	Normal	TDLB100-400	70 %	G-FR1-A3-29	1+0	[-6.3]
					G-FR1-A3-31	1+1	[-7.7]

**Table 8.2.2.5-2: Test requirements for PUSCH, 10 MHz Channel Bandwidth, 30 kHz SCS**

Number of TX antennas	Number of RX antennas	Cyclic prefix	Propagation conditions and correlation matrix (Annex TBD)	Fraction of maximum throughput	FRC (Annex A)	DMRS configuration	SNR (dB)
1	2	Normal	TDLB100-400	70 %	G-FR1-A3-30	1+0	[-1.2]
					G-FR1-A3-32	1+1	TBD
	4	Normal	TDLB100-400	70 %	G-FR1-A3-30	1+0	[-5.0]
					G-FR1-A3-32	1+1	[-5.3]
	8	Normal	TDLB100-400	70 %	G-FR1-A3-30	1+0	TBD
					G-FR1-A3-32	1+1	[-8.1]

## 8.3 Performance requirements for PUCCH

### 8.3.1 Performance requirements for PUCCH format 0

#### 8.3.1.1 Definition and applicability

The performance requirement of single user PUCCH format 0 for ACK missed detection is determined by the two parameters: probability of false detection of the ACK and the probability of detection of ACK. The performance is measured by the required SNR at probability of detection equal to 0.99. The probability of false detection of the ACK shall be 0.01 or less.

The probability of false detection of the ACK is defined as a conditional probability of erroneous detection of the ACK when input is only noise.

The probability of detection of ACK is defined as conditional probability of detection of the ACK when the signal is present.

A test for a specific combination of channel bandwidth and SCS is only applicable if the BS supports it. For a BS supporting multiple channel bandwidths, the applicable rule is [TBD].

*Editor's note: Applicability rule is FFS.*

#### 8.3.1.2 Minimum Requirement

The minimum requirements are in TS 38.104 [2] subclause 8.3.1 and 8.3.2.

#### 8.3.1.3 Test purpose

The test shall verify the receiver's ability to detect ACK under multipath fading propagation conditions for a given SNR.

8.3.1.4 Method of test

8.3.1.4.1 Initial conditions

Test environment: Normal, see annex B.2.

RF channels to be tested: single carrier (SC) M; see subclause 4.9.1.

1) Connect the BS tester generating the wanted signal, multipath fading simulators and AWGN generators to all BS antenna connectors for diversity reception via a combining network as shown in annex D.5 and D.6 for *BS type I-C* and *type I-H* respectively.

8.3.1.4.2 Procedure

1) Adjust the AWGN generator, according to the channel bandwidth and sub-carrier spacing defined in table 8.3.1.4.2-1.

**Table 8.3.1.4.2-1: AWGN power level at the BS input**

Subcarrier spacing (kHz)	Channel bandwidth (MHz)	AWGN power level
15 kHz	5	[-83.5] dBm / 4.5 MHz
	10	[-80.3] dBm / 9.36 MHz
	20	[-77.2] dBm / 19.08 MHz
30 kHz	10	[-80.7] dBm / 8.64 MHz
	20	[-77.4] dBm / 18.36 MHz
	40	[-74.2] dBm / 38.16 MHz
	100	[-70.1] dBm / 98.28 MHz

2) The characteristics of the wanted signal shall be configured according to TS 38.211 [17] and the specific test parameters are configured as mentioned in table 8.3.1.4.2-2:

**Table 8.3.1.4.2-2: Test Parameters**

Parameter	Test
nrofBits	1
nrofPRBs	1
startingPRB	0
intraSlotFrequencyHopping	enabled
secondHopPRB	The largest PRB index - nrofPRBs
initialCyclicShift	0
startingSymbolIndex	13 for 1 symbol 12 for 2 symbols

3) The multipath fading emulators shall be configured according to the corresponding channel model defined in Annex B.

4) Adjust the equipment so that the SNR specified in table 8.3.1.5-1 or table 8.3.1.5-2 is achieved at the BS input during the ACK transmissions.

5) The signal generator sends a test pattern with the pattern outlined in figure 8.3.1.4.2-1. The following statistics are kept: the number of ACKs detected in the idle periods and the number of missed ACKs.



**Figure 8.3.1.4.2-1: Test signal pattern for single user PUCCH format 0 demodulation tests**

8.3.1.5 Test Requirement

The fraction of falsely detected ACKs shall be less than 1% and the fraction of correctly detected ACKs shall be larger than 99% for the SNR listed in table 8.3.1.5-1 and in table 8.3.1.5-2.

Table 8.3.1.5-1 Test requirements for PUCCH format 0 and 15 kHz SCS

Number of TX antennas	Number of RX antennas	Propagation conditions and correlation matrix (Annex G)	Number of OFDM symbols	Channel bandwidth / SNR (dB)		
				5 MHz	10 MHz	20 MHz
1	2	TDLC-300-100 Low	1	[9.9]	[9.5]	[9.7]
			2	TBD	[5.5]	[4.2]
1	4	TDLC-300-100 Low	1	TBD	[3.7]	TBD
			2	TBD	TBD	TBD
1	8	TDLC-300-100 Low	1	TBD	[-0.4]	TBD
			2	TBD	[-3.0]	TBD

Table 8.3.1.5-2 Test requirements for PUCCH format 0 and 30 kHz SCS

Number of TX antennas	Number of RX antennas	Propagation conditions and correlation matrix (Annex G)	Number of OFDM symbols	Channel bandwidth / SNR (dB)			
				10 MHz	20 MHz	40 MHz	100 MHz
1	2	TDLC-300-100 Low	1	TBD	TBD	[11.0]	TBD
			2	TBD	TBD	TBD	TBD
1	4	TDLC-300-100 Low	1	TBD	TBD	[4.0]	TBD
			2	TBD	TBD	[0.3]	TBD
1	8	TDLC-300-100 Low	1	TBD	TBD	[-0.2]	TBD
			2	TBD	TBD	[-3.1]	TBD

## 8.3.2 Performance requirements for PUCCH format 1

### 8.3.2.1 NACK to ACK detection

#### 8.3.2.1.1 Definition and applicability

The performance requirement of PUCCH format 1 for NACK to ACK detection is determined by the two parameters: probability of false detection of the ACK and the NACK to ACK detection probability. The performance is measured by the required SNR at probability of the NACK to ACK detection equal to 0.1% or less. The probability of false detection of the ACK shall be 0.01 or less.

The probability of false detection of the ACK is defined as a conditional probability of erroneous detection of the ACK at particular bit position when input is only noise. Each false bit detection is counted as one error.

The NACK to ACK detection probability is the probability of detecting an ACK bit when an NACK bit was sent on particular bit position. Each NACK bit erroneously detected as ACK bit is counted as one error. Erroneously detected NACK bits in the definition do not contain the NACK bits which are mapped from DTX, i.e. NACK bits received when DTX is sent should not be considered.

A test for a specific combination of SCS and channel bandwidth is only applicable if the BS declares to support it.

For a BS supporting multiple combinations of SCS and channel bandwidth, the applicable rule is 8.1.2.2.

#### 8.3.2.1.2 Minimum Requirement

The minimum requirement is in TS 38.104 [2] subclause 8.3.3.

#### 8.3.2.1.3 Test purpose

The test shall verify the receiver's ability not to falsely detect NACK bits as ACK bits under multipath fading propagation conditions for a given SNR.

#### 8.3.2.1.4 Method of test

##### 8.3.2.1.4.1 Initial Conditions

Test environment: Normal; see annex B.2.

RF channels to be tested: for single carrier (SC): M; see sub-clause 4.9.1.

1) Connect the BS tester generating the wanted signal, multipath fading simulators and AWGN generators to all BS antenna connectors for diversity reception via a combining network as shown in annex D.5 and D.6 for BS type *I-C* and type *I-H* respectively.

#### 8.3.2.1.4.2 Procedure

1) Adjust the AWGN generator, according to the combinations of SCS and channel bandwidth defined in table 8.3.2.1.4.2-1.

**Table 8.3.2.1.4.2-1: AWGN power level at the BS input**

Sub-carrier spacing (kHz)	Channel bandwidth (MHz)	AWGN power level
15 kHz	5	[-83.5] dBm / 4.5 MHz
	10	[-80.3] dBm / 9.36 MHz
	20	[-77.2] dBm / 19.08 MHz
30 kHz	10	[-80.7] dBm / 8.64 MHz
	20	[-77.4] dBm / 18.36 MHz
	40	[-74.2] dBm / 38.16 MHz
	100	[-70.1] dBm / 98.28 MHz

2) The characteristics of the wanted signal shall be configured according to TS 38.211 [17], and the specific test parameters are configured as below:

**Table 8.3.2.1.4.2-2: Test parameters**

Parameter	Values
nrofBits	2
nrofPRBs	1
nrofSymbols	14
startingPRB	0
intraSlotFrequencyHopping	enabled
secondHopPRB	The largest PRB index - nrofPRBs
initialCyclicShift	0
startingSymbolIndex	0
Index of orthogonal sequence (time-domain-OCC)	0

3) The multipath fading emulators shall be configured according to the corresponding channel model defined in annex G.

4) Adjusting the equipment so that the SNR specified in table 8.3.2.1.5-1 and table 8.3.2.1.5-2 is achieved at the BS input during the transmissions.

5) The signal generator sends random codeword from applicable codebook, in regular time periods. The following statistics are kept: the number of ACK bits detected in the idle periods and the number of NACK bits detected as ACK.

#### 8.3.2.1.5 Test Requirement

The fraction of falsely detected ACK bits shall be less than 1% and the fraction of NACK bits falsely detected as ACK shall be less than 0.1% for the SNR listed in tables 8.3.2.1.5-1 and table 8.3.2.1.5-2.

**Table 8.3.2.1.5-1: Required SNR for PUCCH format 1 with 15 kHz SCS**

Number of TX antennas	Number of RX antennas	Cyclic Prefix	Propagation conditions and correlation matrix (Annex G)	Channel Bandwidth / SNR (dB)		
				5 MHz	10 MHz	20 MHz
1	2	Normal	TDLC-300-100 Low	[-3.1]	[-3.0]	[-3.0]
	4	Normal	TDLC-300-100 Low	[-7.8]	[-6.8]	[-7.7]
	8	Normal	TDLC-300-100 Low	[-11.0]	[-10.7]	[-10.9]

**Table 8.3.2.1.5-2: Required SNR for PUCCH format 1 with 30 kHz SCS**

Number of TX antennas	Number of RX antennas	Cyclic Prefix	Propagation conditions and correlation matrix (Annex G)	Channel Bandwidth / SNR (dB)			
				10 MHz	20 MHz	40 MHz	100 MHz
1	2	Normal	TDLC-300-100 Low	[-3.4]	[TBD]	[-2.3]	[TBD]
	4	Normal	TDLC-300-100 Low	[-7.1]	[-8.2]	[-6.4]	[TBD]
	8	Normal	TDLC-300-100 Low	[-10.8]	[-10.6]	[-10.7]	[-10.8]

## 8.3.2.2 ACK missed detection

### 8.3.2.2.1 Definition and applicability

The performance requirement of PUCCH format 1 for ACK missed detection is determined by the two parameters: probability of false detection of the ACK and the probability of detection of ACK. The performance is measured by the required SNR at probability of detection equal to 0.99. The probability of false detection of the ACK shall be 0.01 or less.

The probability of false detection of the ACK is defined as a conditional probability of erroneous detection of the ACK when input is only noise.

The probability of detection of ACK is defined as conditional probability of detection of the ACK when the signal is present.

A test for a specific combination of SCS and channel bandwidth is only applicable if the BS declares to support it.

For a BS supporting multiple combinations of SCS and channel bandwidth, the applicable rule is defined in 8.1.2.2.

### 8.3.2.2.2 Minimum Requirement

The minimum requirement is in TS 38.104 [2] subclause 8.3.3.

### 8.3.2.2.3 Test purpose

The test shall verify the receiver's ability to detect ACK bits under multipath fading propagation conditions for a given SNR.

### 8.3.2.2.4 Method of test

#### 8.3.2.2.4.1 Initial Conditions

Test environment: Normal; see annex B.2.

RF channels to be tested: for single carrier (SC): M; see sub-clause 4.9.1.

1) Connect the BS tester generating the wanted signal, multipath fading simulators and AWGN generators to all BS antenna connectors for diversity reception via a combining network as shown in annex D.5 and D.6 for *BS type I-C* and *type I-H* respectively.

#### 8.3.2.2.4.2 Procedure

1) Adjust the AWGN generator, according to the combinations of SCS and channel bandwidth defined in table 8.3.2.2.4.2-1.

**Table 8.3.2.2.4.2-1: AWGN power level at the BS input**

Sub-carrier spacing (kHz)	Channel bandwidth (MHz)	AWGN power level
15 kHz	5	[-83.5] dBm / 4.5 MHz
	10	[-80.3] dBm / 9.36 MHz
	20	[-77.2] dBm / 19.08 MHz
30 kHz	10	[-80.7] dBm / 8.64 MHz
	20	[-77.4] dBm / 18.36 MHz
	40	[-74.2] dBm / 38.16 MHz
	100	[-70.1] dBm / 98.28 MHz

2) The characteristics of the wanted signal shall be configured according to TS 38.211 [17], and the specific test parameters are configured as below:

**Table 8.3.2.2.4.2-2: Test parameters**

Parameter	Values
nrofBits	2
nrofPRBs	1
nrofSymbols	14
startingPRB	0
intraSlotFrequencyHopping	enabled
secondHopPRB	The largest PRB index - nrofPRBs
initialCyclicShift	0
startingSymbolIndex	0
Index of orthogonal sequence (time-domain-OCC)	0

3) The multipath fading emulators shall be configured according to the corresponding channel model defined in annex G.

4) Adjusting the equipment so that the SNR specified in table 8.3.2.2.5-1 and table 8.3.2.2.5-2 is achieved at the BS input during the transmissions.

5) The signal generator sends a test pattern with the pattern outlined in figure 8.3.2.2.4.2-1. The following statistics are kept: the number of ACKs detected in the idle periods and the number of missed ACKs.



**Figure 8.3.2.2.4.2-1: Test signal pattern for PUCCH format 1 demodulation tests**

#### 8.3.2.2.5 Test Requirement

The fraction of falsely detected ACK bits shall be less than 1% and the fraction of correctly detected ACK bits shall be larger than 99% for the SNR listed in tables 8.3.2.2.5-1 and table 8.3.2.2.5-2.



Table 8.3.2.2.5-1 Required SNR for PUCCH format 1 with 15 kHz SCS

Number of TX antennas	Number of RX antennas	Cyclic Prefix	Propagation conditions and correlation matrix (Annex G)	Channel Bandwidth / SNR (dB)		
				5 MHz	10 MHz	20 MHz
1	2	Normal	TDLC-300-100 Low	[-4.2]	[-3.7]	[-4.3]
	4	Normal	TDLC-300-100 Low	[-8.0]	[-7.4]	[-7.9]
	8	Normal	TDLC-300-100 Low	[-10.9]	[-10.7]	[-10.7]

Table 8.3.2.2.5-2 Required SNR for PUCCH format 1 with 30 kHz SCS

Number of TX antennas	Number of RX antennas	Cyclic Prefix	Propagation conditions and correlation matrix (Annex G)	Channel Bandwidth(MHz) / SNR (dB)			
				10	20	40	100
1	2	Normal	TDLC-300-100 Low	[-3.4]	[-3.8]	[-3.8]	[-3.7]
	4	Normal	TDLC-300-100 Low	[-7.3]	[-7.7]	[-7.7]	[-7.7]
	8	Normal	TDLC-300-100 Low	[-10.5]	[-10.6]	[-10.7]	[-10.5]

### 8.3.3 Performance requirements for PUCCH format 2

#### 8.3.3.1 ACK missed detection

##### 8.3.3.1.1 Definition and applicability

The performance requirement of PUCCH format 2 for ACK missed detection is determined by the two parameters: probability of false detection of the ACK and the probability of detection of ACK. The performance is measured by the required SNR at probability of detection equal to 0.99. The probability of false detection of the ACK shall be 0.01 or less.

The probability of false detection of the ACK is defined as a conditional probability of erroneous detection of the ACK when input is only noise.

The probability of detection of ACK is defined as conditional probability of detection of the ACK when the signal is present.

A test for a specific combination of SCS and channel bandwidth is only applicable if the BS declares to support it.

The applicability of tests in TS 38.104 [2] with different SCS and channel bandwidth combination is according to the following principle:

*Editor's note: Applicability rule is FFS.*

##### 8.3.3.1.2 Minimum requirements

The minimum requirements are in TS 38.104 [2] subclause 8.3.4.

##### 8.3.3.1.3 Test purpose

The test shall verify the receiver's ability to detect ACK bits under multipath fading propagation conditions for a given SNR.

8.3.3.1.4 Method of test

8.3.3.1.4.1 Initial Condition

Test environment: Normal, see annex B.2.

RF channels to be tested: for single carrier (SC): M; see subclause 4.9.1

- 1) Connect the BS tester generating the wanted signal, multipath fading simulators and AWGN generators to all BS antenna connectors for diversity reception via a combining network as shown in annex D.5 and D.6 for BS type I-C and type I-H respectively.

8.3.3.1.4.2 Procedure

- 1) Adjust the AWGN generator, according to the channel bandwidth defined in table 8.3.3.1.4.2-1.

**Table 8.3.3.1.4.2-1: AWGN power level at the BS input**

Sub-carrier spacing (kHz)	Channel bandwidth (MHz)	AWGN power level
15	5	[-83.5] dBm / 4.5 MHz
	10	[-80.3] dBm / 9.36 MHz
	20	[-77.2] dBm / 19.08MHz
30	10	[-80.7] dBm / 8.64 MHz
	20	[-77.4] dBm / 18.36 MHz
	40	[-74.2] dBm / 38.16 MHz
	100	[-70.1] dBm / 98.28 MHz

- 2) The characteristics of the wanted signal shall be configured according to TS 38.211 [17], and the specific test parameters are configured as blow:

**Table 8.3.3.1.4.2-2: Test parameters**

Parameter	Value
Modulation	QPSK
startingPRB	0
intraSlotFrequencyHopping	enabled
secondHopPRB	The largest PRB index - nrofPRBs
nrofPRBs	4
nrofSymbols	1
the number of UCI bits	4
startingSymbolIndex	13

- 3) The multipath fading emulators shall be configured according to the corresponding channel model defined in annex G.
- 4) Adjust the equipment so that the SNR specified in table 8.3.3.1.5-1 and table 8.3.3.1.5-2 is achieved at the BS input during the UCI transmissions.
- 5) The signal generator sends a test pattern with the pattern outlined in figure 8.3.3.1.4.2-1. The following statistics are kept: the number of ACKs detected in the idle periods and the number of missed ACKs.



**Figure 8.3.3.1.4.2-1: Test signal pattern for PUCCH format 2 demodulation tests**

8.3.3.1.5 Test requirements

The fraction of falsely detected ACKs shall be less than 1% and the fraction of correctly detected ACKs shall be larger than 99% for the SNR listed in table 8.3.3.1.5-1 and table 8.3.3.1.5-2.

Table 8.3.3.1.5-1: Required SNR for PUCCH format 2 with 15 kHz SCS

Number of TX antennas	Number of RX antennas	Cyclic Prefix	Propagation conditions and correlation matrix (Annex G)	Channel Bandwidth / SNR [dB]		
				5 MHz	10 MHz	20 MHz
1	2	Normal	TDLC300-100 Low	[TBD]	[6.1]	[TBD]
	4	Normal	TDLC300-100 Low	[TBD]	[TBD]	[TBD]
	8	Normal	TDLC300-100 Low	[TBD]	[TBD]	[TBD]

Table 8.3.3.1.5-2: Required SNR for PUCCH format 2 with 30 kHz SCS

Number of TX antennas	Number of RX antennas	Cyclic Prefix	Propagation conditions and correlation matrix (Annex G)	Channel Bandwidth/ SNR (dB)			
				10MHz	20MHz	40MHz	100MHz
1	2	Normal	TDLC300-100 Low	[TBD]	[TBD]	[TBD]	[TBD]
	4	Normal	TDLC300-100 Low	[TBD]	[TBD]	[TBD]	[TBD]
	8	Normal	TDLC300-100 Low	[TBD]	[TBD]	[TBD]	[TBD]

### 8.3.3.2 UCI BLER performance requirements

#### 8.3.3.2.1 Definition and applicability

The performance is measured by the required SNR at UCI block error probability not exceeding 1%.

The UCI block error probability is defined as the conditional probability of incorrectly decoding the UCI information when the UCI information is sent. All UCI information shall be decoded.

A test for a specific combination of SCS and channel bandwidth is only applicable if the BS declares to support it.

The applicability of tests in TS 38.104 [2] with different SCS and channel bandwidth combination is according to the following principle:

*Editor's note: Applicability rule is FFS.*

#### 8.3.3.2.2 Minimum Requirement

The minimum requirement is TS 38.104 [2] subclause 8.3.4.

#### 8.3.3.2.3 Test purpose

The test shall verify the receiver's ability to detect UCI under multipath fading propagation conditions for a given SNR.

#### 8.3.3.2.4 Method of test

##### 8.3.3.2.4.1 Initial Condition

Test environment: Normal, see annex B.2.

RF channels to be tested: for single carrier (SC): M; see subclause 4.9.1

- 1) Connect the BS tester generating the wanted signal, multipath fading simulators and AWGN generators to all BS antenna connectors for diversity reception via a combining network as shown in annex D.5 and D.6 for *BS type I-C* and *BS type I-H* respectively.

##### 8.3.3.2.4.2 Procedure

- 1) Adjust the AWGN generator, according to the channel bandwidth defined in table 8.3.3.2.4.2-1.

**Table 8.3.3.2.4.2-1: AWGN power level at the BS input**

Subcarrier spacing (kHz)	Channel bandwidth (MHz)	AWGN power level
15	5	[-83.5] dBm / 4.5MHz
	10	[-80.3] dBm / 9.36MHz
	20	[-77.2] dBm / 19.08MHz
30	10	[-80.7] dBm / 8.64MHz
	20	[-77.4] dBm / 18.36MHz
	40	[-74.2] dBm / 38.16MHz
	100	[-70.1] dBm / 98.28MHz

- 2) The characteristics of the wanted signal shall be configured according to TS 38.211 [17], and the specific test parameters are configured as blow:

**Table 8.3.3.2.4.2-2: Test parameters**

Parameter	Value
Modulation	QPSK
startingPRB	0
intraSlotFrequencyHopping	enabled
secondHopPRB	The largest PRB index - nrofPRBs
nrofPRBs	9
nrofSymbols	2
the number of UCI bits	22
startingSymbolIndex	12

- 3) The multipath fading emulators shall be configured according to the corresponding channel model defined in Annex G.
- 4) Adjust the equipment so that the SNR specified in table 8.3.3.2.5-1 or table 8.3.3.2.5-2 is achieved at the BS input during the UCI transmissions.
- 5) The signal generator sends a test pattern with the pattern outlined in figure 8.3.3.2.4.2-1. The following statistics are kept: the number of incorrectly decoded UCI.



**Figure 8.3.3.2.4.2-1: Test signal pattern for PUCCH format 2 demodulation tests**

**8.3.3.2.5 Test requirements**

The fraction of incorrectly decoded UCI shall be less than 1% for the SNR listed in table 8.3.3.2.5-1 and table 8.3.3.2.5-2.

**Table 8.3.3.2.5-1: Required SNR for PUCCH format 2 with 15 kHz SCS**

Number of TX antennas	Number of RX antennas	Cyclic Prefix	Propagation conditions and correlation matrix (Annex G)	Channel Bandwidth / SNR [dB]		
				5 MHz	10 MHz	20 MHz
1	2	Normal	TDLC300-100 Low	[TBD]	[1.7]	[TBD]
	4	Normal	TDLC300-100 Low	[TBD]	[TBD]	[TBD]
	8	Normal	TDLC300-100 Low	[-6.0]	[-5.9]	[-5.9]

Table 8.3.3.2.5-2: Required SNR for PUCCH format 2 with 30 kHz SCS

Number of TX antennas	Number of RX antennas	Cyclic Prefix	Propagation conditions and correlation matrix (Annex G)	Channel Bandwidth/ SNR (dB)			
				10MHz	20MHz	40MHz	100MHz
1	2	Normal	TDLC300-100 Low	[TBD]	[TBD]	[1.0]	[TBD]
	4	Normal	TDLC300-100 Low	[TBD]	[TBD]	[TBD]	[TBD]
	8	Normal	TDLC300-100 Low	[TBD]	[TBD]	[TBD]	[TBD]

NOTE: If the above Test Requirement differs from the Minimum Requirement then the Test Tolerance applied for this test is non-zero. The Test Tolerance for this test and the explanation of how the Minimum Requirement has been relaxed by the Test Tolerance is given in Annex C.

## 8.3.4 Performance requirements for PUCCH format 3

### 8.3.4.1 Definition and applicability

The performance is measured by the required SNR at UCI block error probability not exceeding 1%.

The UCI block error probability is defined as the conditional probability of incorrectly decoding the UCI information when the UCI information is sent. All UCI information shall be decoded.

Which specific test is applicable to BS is based on the test applicability rule defined in section 8.1.2.2.

A test with or without additional DMRS configured is only applicable if the BS support it.

### 8.3.4.2 Minimum requirement

The minimum requirement is in TS 38.104 [2] subclause 8.3.5.

### 8.3.4.3 Test purpose

The test shall verify the receiver's ability to detect UCI under multipath fading propagation conditions for a given SNR.

### 8.3.4.4 Method of test

#### 8.3.4.4.1 Initial conditions

Test environment: Normal; see annex B.2.

RF channels to be tested for single carrier (SC): M; see subclause 4.9.1

1) Connect the BS tester generating the wanted signal, multipath fading simulators and AWGN generators to all BS antenna connectors for diversity reception via a combining network as shown in annex D.5 and D.6 for *BS type I-C* and *BS type I-H* respectively.

#### 8.3.4.4.2 Procedure

1) Adjust the AWGN generator, according to the subcarrier spacing and channel bandwidth defined in table 8.3.4.4.2-1.

Table 8.3.4.4.2-1: AWGN power level at the BS input

Subcarrier spacing (kHz)	Channel bandwidth (MHz)	AWGN power level
15	5	[-83.5] dBm / 4.5MHz
	10	[-80.3] dBm / 9.36MHz
	20	[-77.2] dBm / 19.08MHz
30	10	[-80.7] dBm / 8.64MHz
	20	[-77.4] dBm / 18.36MHz
	40	[-74.2] dBm / 38.16MHz
	100	[-70.1] dBm / 98.28MHz

2) The characteristics of the wanted signal shall be configured according to TS 38.211 [17]. The specific test parameters are configured as below:

**Table 8.3.4.4.2-2: Test parameters**

Parameter	Test 1	Test 2
Modulation	QPSK	
startingPRB	0	
intraSlotFrequencyHopping	enabled	
secondHopPRB	The largest PRB index - nrofPRBs	
nrofPRBs	1	3
nrofSymbols	14	4
the number of UCI bits	16	16
startingSymbolIndex	0	0

3) The multipath fading emulators shall be configured according to the corresponding channel model defined in Annex G.

4) Adjust the equipment so that the SNR specified in table 8.3.4.5-1 or table 8.3.4.5-2 is achieved at the BS input during the UCI transmissions.

5) The signal generator sends a test pattern with the pattern outlined in figure 8.3.4.4.2-1. The following statistics are kept: the number of incorrectly decoded UCI.



**Figure 8.3.4.4.2-1: Test signal pattern for PUCCH format 3 demodulation tests**

**8.3.4.5 Test requirement**

The fraction of incorrectly decoded UCI is shall be less than 1% for the SNR listed in table 8.3.4.5-1 and table 8.3.4.5-2.

**Table 8.3.4.5-1: Required SNR for PUCCH format 3 with 15kHz SCS**

Test Number	Number of TX antennas	Number of RX antennas	Cyclic Prefix	Propagation conditions and correlation matrix (Annex G)	Additional DMRS configuration	Channel Bandwidth / SNR (dB)		
						5 MHz	10 MHz	20 MHz
1	1	2	Normal	TDLC300-100 Low	No additional DM-RS	TBD	[1.7]	TBD
					Additional DMRS	TBD	[1.1]	[0.4]
		4	Normal	TDLC300-100 Low	No additional DM-RS	TBD[-3.1]	TBD[-2.8]	TBD[-3.2]
					Additional DMRS	TBD[-3.8]	TBD[-3.4]	TBD[-3.9]
		8	Normal	TDLC300-100 Low	No additional DM-RS	TBD[-6.4]	TBD[-6.1]	TBD[-6.2]
					Additional DMRS	TBD[-7.1]	TBD[-6.9]	TBD[-7.1]
2	1	2	Normal	TDLC300-100 Low	No additional DM-RS	TBD	[2.5]	TBD
		4	Normal	TDLC300-100 Low	No additional DM-RS	TBD	TBD	TBD
		8	Normal	TDLC300-100 Low	No additional DM-RS	TBD	TBD	TBD

Table 8.3.4.5-2: Required SNR for PUCCH format 3 with 30kHz SCS

Test Number	Number of TX antennas	Number of RX antennas	Cyclic Prefix	Propagation conditions and correlation matrix (Annex G)	Additional DMRS configuration	Channel Bandwidth / SNR (dB)			
						10 MHz	20 MHz	40 MHz	100 MHz
1	1	2	Normal	TDLC300-100 Low	No additional DM-RS	TBD	TBD	[1.1]	TBD
					Additional DMRS	TBD	TBD	[1.5]	TBD
		4	Normal	TDLC300-100 Low	No additional DM-RS	TBD[-2.3]	TBD[-2.8]	TBD[-2.7]	TBD
					Additional DMRS	TBD[-3.0]	TBD[-3.6]	TBD[-3.4]	TBD
		8	Normal	TDLC300-100 Low	No additional DM-RS	TBD[-5.8]	TBD[-6.0]	TBD[-6.2]	TBD
					Additional DMRS	TBD[-6.7]	TBD[-6.9]	TBD[-6.9]	TBD
2	1	2	Normal	TDLC300-100 Low	No additional DM-RS	TBD	TBD	[1.5]	TBD
		4	Normal	TDLC300-100 Low	No additional DM-RS	TBD	TBD	TBD	TBD
		8	Normal	TDLC300-100 Low	No additional DM-RS	TBD	TBD	TBD	TBD

## 8.3.5 Performance requirements for PUCCH format 4

### 8.3.5.1 Definition and applicability

The performance is measured by the required SNR at UCI block error probability not exceeding 1%.

The UCI block error probability is defined as the conditional probability of incorrectly decoding the UCI information when the UCI information is sent. All UCI information shall be decoded.

Which specific test is applicable to BS is based on the test applicability defined in section 8.1.2.2.

A test with or without additional DMRS configured is only applicable if the BS support it.

### 8.3.5.2 Minimum requirement

The minimum requirement is in TS 38.104 [2] subclause 8.3.6.

### 8.3.5.3 Test purpose

The test shall verify the receiver's ability to detect UCI under multipath fading propagation conditions for a given SNR.

### 8.3.5.4 Method of test

#### 8.3.5.4.1 Initial conditions

Test environment: Normal; see annex B.2.

RF channels to be tested for single carrier (SC): M; see subclause 4.9.1

1) Connect the BS tester generating the wanted signal, multipath fading simulators and AWGN generators to all BS antenna connectors for diversity reception via a combining network as shown in annex D.5 and D.6 for *BS type I-C* and *BS type I-H* respectively.

8.3.5.4.2 Procedure

- 1) Adjust the AWGN generator, according to the subcarrier spacing and channel bandwidth defined in table 8.3.5.4.2-1.

**Table 8.3.5.4.2-1: AWGN power level at the BS input**

Subcarrier spacing(SCS) (kHz)	Channel bandwidth (MHz)	AWGN power level
15 kHz	5	[-83.5] dBm / 4.5MHz
	10	[-80.3] dBm / 9.36MHz
	20	[-77.2] dBm / 19.08MHz
30 kHz	10	[-80.7] dBm / 8.64MHz
	20	[-77.4] dBm / 18.36MHz
	40	[-74.2] dBm / 38.16MHz
	100	[-70.1] dBm / 98.28MHz

- 2) The characteristics of the wanted signal shall be configured according to TS 38.211 [17]. The test parameters are configured as below:

**Table 8.3.5.4.2-2: Test parameters**

Parameter	Value
Modulation	QPSK
startingPRB	0
intraSlotFrequencyHopping	enabled
secondHopPRB	The largest PRB index - nrofPRBs
nrofSymbols	14
the number of UCI bits	22
startingSymbolIndex	0
occ-Length	n2
occ-Index	n0

- 3) The multipath fading emulators shall be configured according to the corresponding channel model defined in annex G.
- 4) Adjust the equipment so that the SNR specified in table 8.3.5.5-1 or table 8.3.5.5-2 is achieved at the BS input during the UCI transmissions.
- 5) The signal generator sends a test pattern with the pattern outlined in figure 8.3.5.4.2-1. The following statistics are kept: the number of incorrectly decoded UCI.



**Figure 8.3.5.4.2-1: Test signal pattern for PUCCH format 4 demodulation tests**

8.3.5.5 Test requirement

The fraction of incorrectly decoded UCI is shall be less than 1% for the SNR listed in table 8.3.5.5-1 and table 8.3.5.5-2.



Table 8.3.5.5-1: Required SNR for PUCCH format 4 with 15 kHz SCS

Number of TX antennas	Number of RX antennas	Cyclic Prefix	Propagation conditions and correlation matrix (Annex G)	Additional DMRS configuration	Channel Bandwidth / SNR (dB)		
					5 MHz	10 MHz	20 MHz
1	2	Normal	TDLC300-100 Low	No additional DM-RS	[2.4]	[3.1]	[2.7]
				Additional DMRS	[2.2]	[2.9]	[2.4]
	4	Normal	TDLC300-100 Low	No additional DM-RS	[-1.9]	[-1.6]	[-1.8]
				Additional DMRS	[-2.4]	[-2.2]	[-2.3]
	8	Normal	TDLC300-100 Low	No additional DM-RS	[-5.1]	[-5.2]	[-5.1]
				Additional DMRS	[-5.8]	[-5.8]	[-5.8]

Table 8.3.5.5-2: Required SNR for PUCCH format 4 with 30 kHz SCS

Number of TX antennas	Number of RX antennas	Cyclic Prefix	Propagation conditions and correlation matrix (Annex G)	Additional DMRS configuration	Channel Bandwidth / SNR (dB)			
					10 MHz	20 MHz	40 MHz	100 MHz
1	2	Normal	TDLC300-100 Low	No additional DM-RS	[3.8]	[2.9]	[3.7]	TBD
				Additional DMRS	[3.6]	[2.9]	[3.4]	TBD
	4	Normal	TDLC300-100 Low	No additional DM-RS	[-0.9]	[-1.5]	[-1.3]	TBD
				Additional DMRS	[-1.5]	[-2.0]	[-2.0]	TBD
	8	Normal	TDLC300-100 Low	No additional DM-RS	[-4.7]	[-4.9]	[-5.0]	TBD
				Additional DMRS	[-5.3]	[-5.5]	[-5.8]	TBD

## 8.4 Performance requirements for PRACH

### 8.4.1 PRACH false alarm probability and missed detection

#### 8.4.1.1 Definition and applicability

*Editor's notes: Applicability rule for normal mode tests are FFS.*

The performance requirement of PRACH for preamble detection is determined by the two parameters: total probability of false detection of the preamble (Pfa) and the probability of detection of preamble (Pd). The performance is measured by the required SNR at probability of detection, Pd of 99%. Pfa shall be 0.1% or less.

Pfa is defined as a conditional total probability of erroneous detection of the preamble (i.e. erroneous detection from any detector) when input is only noise.

Pd is defined as conditional probability of detection of the preamble when the signal is present. The erroneous detection consists of several error cases – detecting different preamble than the one that was sent, not detecting a preamble at all or correct preamble detection but with the wrong timing estimation.

For AWGN and TDLC300-100, a timing estimation error occurs if the estimation error of the timing of the strongest path is larger than the time error tolerance values given in table 8.4.1.1-1.

Table 8.4.1.1-1: Time error tolerance for AWGN and TDLC300-100

PRACH preamble	PRACH SCS (kHz)	Time error tolerance	
		AWGN	TDLC300-100
0	1.25	1.04 us	2.55 us
A1, A2, A3, B4, C0, C2	15	0.52 us	2.03 us
	30	0.26 us	1.77 us

The test preambles for normal mode are listed in table A.6-1.

8.4.1.2 Minimum requirement

The minimum requirement is in TS 38.104 [2] subclause 8.4.1.2 and 8.4.2.2.

8.4.1.3 Test purpose

The test shall verify the receiver’s ability to detect PRACH preamble under static conditions and multipath fading propagation conditions for a given SNR.

8.4.1.4 Method of test

8.4.1.4.1 Initial conditions

Test environment: Normal; see annex B.2.

RF channels to be tested: for single carrier (SC): M; see subclause 4.9.1.

1) Connect the BS tester generating the wanted signal, multipath fading simulators and AWGN generators to all BS antenna connectors for diversity reception via a combining network as shown in annex D.5 and D.6 for BS type I-C and BS type I-H respectively.

8.4.1.4.2 Procedure

1) Adjust the AWGN generator, according to the SCS and channel bandwidth.

**Table 8.4.1.4.2-1: AWGN power level at the BS input**

Sub-carrier spacing (kHz)	Channel bandwidth (MHz)	AWGN power level
15	5	[-83.5] dBm / 4.5MHz
	10	[-80.3] dBm / 9.36MHz
	20	[-77.2] dBm / 19.08MHz
30	10	[-80.7] dBm / 8.64MHz
	20	[-77.4] dBm / 18.36MHz
	40	[-74.2] dBm / 38.16MHz
	100	[-70.1] dBm / 98.28MHz

2) The characteristics of the wanted signal shall be configured according to the corresponding UL reference measurement channel defined in annex A.

3) The multipath fading emulators shall be configured according to the corresponding channel model defined in annex B.

4) Adjust the frequency offset of the test signal according to table 8.4.1.5-1 or 8.4.1.5-2 or 8.4.1.5-3.

5) Adjust the equipment so that the SNR specified in table 8.4.1.5-1 or 8.4.1.5-2 or 8.4.1.5-3 is achieved at the BS input during the PRACH preambles.

6) The test signal generator sends a preamble and the receiver tries to detect the preamble. This pattern is repeated as illustrated in figure 8.4.1.4.2-1. The preambles are sent with certain timing offsets as described below. The following statistics are kept: the number of preambles detected in the idle period and the number of missed preambles.



**Figure 8.4.1.4.2-1: PRACH preamble test pattern**

The timing offset base value for PRACH preamble format 0 is set to 50% of Ncs. This offset is increased within the loop, by adding in each step a value of 0.1us, until the end of the tested range, which is 0.9us. Then the loop is being reset and the timing offset is set again to 50% of Ncs. The timing offset scheme for PRACH preamble format 0 is presented in figure 8.4.1.4.2-2.

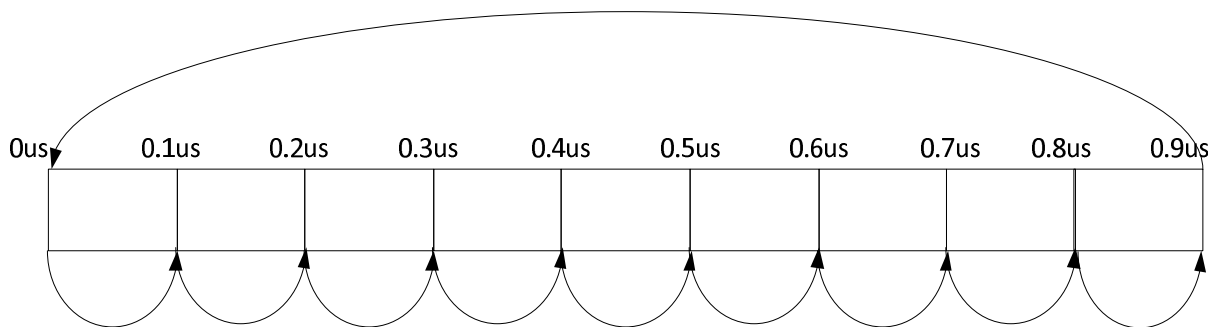

**Figure 8.4.1.4.2-2: Timing offset scheme for PRACH preamble format 0**

The timing offset base value for PRACH preamble format A1, A2, A3, B4, C0 and C2 is set to 0. This offset is increased within the loop, by adding in each step a value of 0.1us, until the end of the tested range, which is 0.8 us. Then the loop is being reset and the timing offset is set again to 0. The timing offset scheme for PRACH preamble format A1, A2, A3, B4, C0 and C2 is presented in figure 8.4.1.4.2-3.

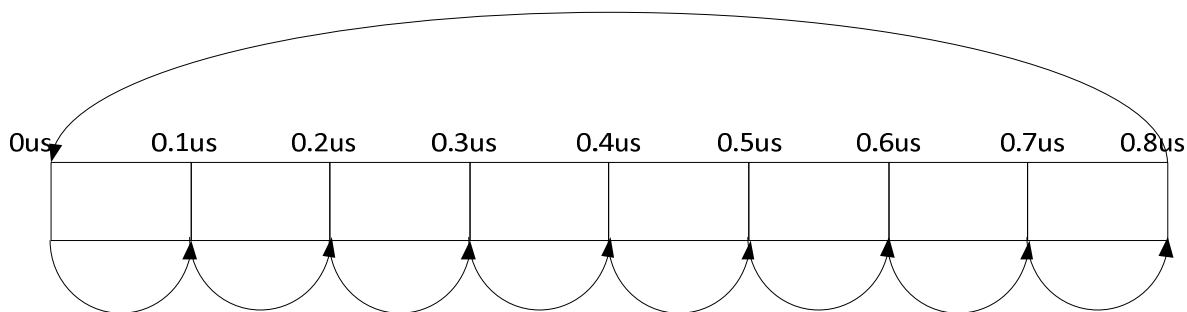

**Figure 8.4.1.4.2-3: Timing offset scheme for PRACH preamble format A1, A2, A3, B4, C0 and C2**

**8.4.1.5 Test requirement**

Pfa shall not exceed 0.1%. Pd shall not be below 99% for the SNRs in tables 8.4.1.5-1 to 8.4.1.5-3.

**Table 8.4.1.5-1: PRACH missed detection test requirements for Normal Mode, 1.25 kHz SCS**

Number of TX antennas	Number of RX antennas	Propagation conditions and correlation matrix (Annex G)	Frequency offset	SNR (dB)
				Burst format 0
1	2	AWGN	0	[-14.2]
		TDLC300-100 Low	400 Hz	[-6.0]
	4	AWGN	0	[-17.0]
		TDLC300-100 Low	400 Hz	[-11.6]
	8	AWGN	0	[-18.6]
		TDLC300-100 Low	400 Hz	[-15.2]

**Table 8.4.1.5-2: PRACH missed detection test requirements for Normal Mode, 15 kHz SCS**

Number of TX antennas	Number of RX antennas	Propagation conditions and correlation matrix (Annex G)	Frequency offset	SNR (dB)					
				Burst format A1	Burst format A2	Burst format A3	Burst format B4	Burst format C0	Burst format C2
1	2	AWGN	0	[-9.0]	TBD	[-14.0]	[-16.6]	[-6.0]	TBD
		TDL300-100	400 Hz	[-1.6]	[-4.2]	[-6.2]	[-8.2]	[1.3]	[-4.3]
	4	AWGN	0	[-11.9]	[-14.7]	[-16.1]	[-18.8]	TBD	[-14.7]
		TDL300-100	400 Hz	TBD	[-9.6]	[-11.0]	[-13.2]	TBD	[-9.6]
	8	AWGN	0	[-13.7]	[-16.8]	[-18.4]	[-20.9]	[-10.8]	[-16.8]
		TDL300-100	400 Hz	[-10.5]	[-13.4]	[-14.9]	[-16.7]	[-7.6]	[-13.4]

**Table 8.4.1.5-3: PRACH missed detection test requirements for Normal Mode, 30 kHz SCS**

Number of TX antennas	Number of RX antennas	Propagation conditions and correlation matrix (Annex G)	Frequency offset	SNR (dB)					
				Burst format A1	Burst format A2	Burst format A3	Burst format B4	Burst format C0	Burst format C2
1	2	AWGN	0	[-8.8]	[-11.7]	[-13.6]	[-16.3]	[-5.8]	[-11.7]
		TDL300-100 Low	400 Hz	[-2.2]	[-5.2]	[-6.9]	[-9.5]	[0.6]	[-5.1]
	4	AWGN	0	[-11.7]	[-14.6]	[-16.0]	[-18.7]	TBD	[-14.5]
		TDL300-100 Low	400 Hz	TBD	[-9.8]	[-11.4]	[-13.9]	TBD	[-9.9]
	8	AWGN	0	[-13.5]	[-16.6]	[-18.2]	[-20.7]	[-10.7]	[-16.3]
		TDL300-100 Low	400 Hz	[-10.1]	[-13.2]	[-14.8]	[-17.0]	[-7.4]	[-13.3]

## Annex A (normative): Reference measurement channels

### A.1 Fixed Reference Channels for receiver sensitivity and in-channel selectivity (QPSK, R=1/3)

The parameters for the reference measurement channels are specified in table A.1-1 for FR1 receiver sensitivity and in-channel selectivity.

**Table A.1-1: FRC parameters for FR1 receiver sensitivity and in-channel selectivity**

Reference channel	G-FR1-A1-1	G-FR1-A1-2	G-FR1-A1-3	G-FR1-A1-4	G-FR1-A1-5	G-FR1-A1-6	G-FR1-A1-7	G-FR1-A1-8	G-FR1-A1-9
Subcarrier spacing (kHz)	15	30	60	15	30	60	15	30	60
Allocated resource blocks	25	11	11	106	51	24	15	6	6
CP-OFDM Symbols per slot (Note 1)	12	12	12	12	12	12	12	12	12
Modulation	QPSK	QPSK	QPSK	QPSK	QPSK	QPSK	QPSK	QPSK	QPSK
Code rate (Note 2)	1/3	1/3	1/3	1/3	1/3	1/3	1/3	1/3	1/3
Payload size (bits)	2152	984	984	9224	4352	2088	1320	528	528
Transport block CRC (bits)	16	16	16	24	24	16	16	16	16
Code block CRC size (bits)	-	-	-	24	-	-	-	-	-
Number of code blocks - C	1	1	1	2	1	1	1	1	1
Code block size including CRC (bits) (Note 3)	2168	1000	1000	4648	4376	2104	1336	544	544
Total number of bits per slot	7200	3168	3168	30528	14688	6912	4320	1728	1728
Total symbols per slot	3600	1584	1584	15264	7344	3456	2160	864	864
NOTE 1: $UL-DMRS-config-type = 1$ with $UL-DMRS-max-len = 1$ , $UL-DMRS-add-pos = 1$ with $l_0 = 2$ , $l = 11$ as per table 6.4.1.1.3-3 of TS 38.211 [17].									
NOTE 2: MCS index 4 and target coding rate = 308/1024 are adopted to calculate payload size for receiver sensitivity and in-channel selectivity.									
NOTE 3: Code block size including CRC (bits) equals to $K'$ in TS 38.212 [16], subclause 5.2.2.									

### A.2 Fixed Reference Channels for dynamic range (16QAM, R=2/3)

The parameters for the reference measurement channels are specified in table A.2-1 for dynamic range.

Table A.2-1: FRC parameters for dynamic range

Reference channel	G-FR1-A2-1	G-FR1-A2-2	G-FR1-A2-3	G-FR1-A2-4	G-FR1-A2-5	G-FR1-A2-6
Subcarrier spacing (kHz)	15	30	60	15	30	60
Allocated resource blocks	25	11	11	106	51	24
CP-OFDM Symbols per slot (Note 1)	12	12	12	12	12	12
Modulation	16QAM	16QAM	16QAM	16QAM	16QAM	16QAM
Code rate (Note 2)	2/3	2/3	2/3	2/3	2/3	2/3
Payload size (bits)	9224	4032	4032	38936	18960	8968
Transport block CRC (bits)	24	24	24	24	24	24
Code block CRC size (bits)	24	-	-	24	24	24
Number of code blocks - C	2	1	1	5	3	2
Code block size including CRC (bits) (Note 3)	4648	4056	4056	7816	6352	4520
Total number of bits per slot	14400	6336	6336	61056	29376	13824
Total symbols per slot	3600	1584	1584	15264	7344	3456
NOTE 1: $UL-DMRS-config-type = 1$ with $UL-DMRS-max-len = 1$ , $UL-DMRS-add-pos = 1$ with $l_0 = 2$ , $l = 11$ as per table 6.4.1.1.3-3 of TS 38.211 [17].						
NOTE 2: MCS index 16 and target coding rate = 658/1024 are adopted to calculate payload size for dynamic range.						
NOTE 3: Code block size including CRC (bits) equals to $K'$ in TS 38.212 [16], subclause 5.2.2.						

### A.3 Fixed Reference Channels for performance requirements (QPSK, R=193/1024)

The parameters for the reference measurement channels are specified in table A.3-1 to table A.3-6 for FR1 PUSCH performance requirements:

- FRC parameters are specified in table A.3-1 for FR1 PUSCH with transform precoding disabled,  $UL-DMRS-add-pos = 0$  and 1 transmission layer.
- FRC parameters are specified in table A.3-2 for FR1 PUSCH with transform precoding disabled,  $UL-DMRS-add-pos = 1$  and 1 transmission layer.
- FRC parameters are specified in table A.3-3 for FR1 PUSCH with transform precoding disabled,  $UL-DMRS-add-pos = 0$  and 2 transmission layers.
- FRC parameters are specified in table A.3-4 for FR1 PUSCH with transform precoding disabled,  $UL-DMRS-add-pos = 1$  and 2 transmission layers.
- FRC parameters are specified in table A.3-5 for FR1 PUSCH with transform precoding enabled,  $UL-DMRS-add-pos = 0$  and 1 transmission layer.
- FRC parameters are specified in table A.3-6 for FR1 PUSCH with transform precoding enabled,  $UL-DMRS-add-pos = 1$  and 1 transmission layer.

**Table A.3-1: FRC parameters for FR1 PUSCH performance requirements, transform precoding disabled,  $UL\text{-DMRS}\text{-add}\text{-pos} = 0$  and 1 transmission layer (QPSK,  $R=193/1024$ )**

Reference channel	G-FR1-A3-1	G-FR1-A3-2	G-FR1-A3-3	G-FR1-A3-4	G-FR1-A3-5	G-FR1-A3-6	G-FR1-A3-7
Subcarrier spacing (kHz)	15	15	15	30	30	30	30
Allocated resource blocks	25	52	106	24	51	106	273
CP-OFDM Symbols per slot (Note 1)	13	13	13	13	13	13	13
Modulation	QPSK	QPSK	QPSK	QPSK	QPSK	QPSK	QPSK
Code rate (Note 2)	193/1024	193/1024	193/1024	193/1024	193/1024	193/1024	193/1024
Payload size (bits)	1480	3104	6280	1416	2976	6280	16136
Transport block CRC (bits)	16	16	24	16	16	24	24
Code block CRC size (bits)	-	-	24	-	-	24	24
Number of code blocks - C	1	1	2	1	1	2	5
Code block size including CRC (bits) (Note 2)	1496	3120	3176	1432	2992	3176	3256
Total number of bits per slot	7800	16224	33072	7488	15912	33072	85176
Total symbols per slot	3900	8112	16536	3744	7956	16536	42588
NOTE 1: $UL\text{-DMRS}\text{-config}\text{-type} = 1$ with $UL\text{-DMRS}\text{-max}\text{-len} = 1$ and the number of DM-RS CDM groups without data is 2, $UL\text{-DMRS}\text{-add}\text{-pos} = 0$ with $l_0 = 2$ as per table 6.4.1.1.3-3 of TS 38.211 [17].							
NOTE 2: Code block size including CRC (bits) equals to $K'$ in sub-clause 5.2.2 of TS 38.212 [16].							

**Table A.3-2: FRC parameters for FR1 PUSCH performance requirements, transform precoding disabled,  $UL\text{-DMRS}\text{-add}\text{-pos} = 1$  and 1 transmission layer (QPSK,  $R=193/1024$ )**

Reference channel	G-FR1-A3-8	G-FR1-A3-9	G-FR1-A3-10	G-FR1-A3-11	G-FR1-A3-12	G-FR1-A3-13	G-FR1-A3-14
Subcarrier spacing (kHz)	15	15	15	30	30	30	30
Allocated resource blocks	25	52	106	24	51	106	273
CP-OFDM Symbols per slot (Note 1)	12	12	12	12	12	12	12
Modulation	QPSK	QPSK	QPSK	QPSK	QPSK	QPSK	QPSK
Code rate (Note 2)	193/1024	193/1024	193/1024	193/1024	193/1024	193/1024	193/1024
Payload size (bits)	1352	2856	5768	1320	2792	5768	14856
Transport block CRC (bits)	16	16	24	16	16	24	24
Code block CRC size (bits)	-	-	24	-	-	24	24
Number of code blocks - C	1	1	2	1	1	2	4
Code block size including CRC (bits) (Note 2)	1368	2872	2920	1336	2808	2920	3744
Total number of bits per slot	7200	14976	30528	6912	14688	30528	78624
Total symbols per slot	3600	7488	15264	3456	7344	15264	39312
NOTE 1: $UL\text{-DMRS}\text{-config}\text{-type} = 1$ with $UL\text{-DMRS}\text{-max}\text{-len} = 1$ and the number of DM-RS CDM groups without data is 2, $UL\text{-DMRS}\text{-add}\text{-pos} = 1$ with $l_0 = 2$ , $l = 11$ as per table 6.4.1.1.3-3 of TS 38.211 [17].							
NOTE 2: Code block size including CRC (bits) equals to $K'$ in sub-clause 5.2.2 of TS 38.212 [16].							

**Table A.3-3: FRC parameters for FR1 PUSCH performance requirements, transform precoding disabled,  $UL-DMRS-add-pos = 0$  and 2 transmission layers (QPSK,  $R=193/1024$ )**

Reference channel	G-FR1-A3-15	G-FR1-A3-16	G-FR1-A3-17	G-FR1-A3-18	G-FR1-A3-19	G-FR1-A3-20	G-FR1-A3-21
Subcarrier spacing (kHz)	15	15	15	30	30	30	30
Allocated resource blocks	25	52	106	24	51	106	273
CP-OFDM Symbols per slot (Note 1)	13	13	13	13	13	13	13
Modulation	QPSK	QPSK	QPSK	QPSK	QPSK	QPSK	QPSK
Code rate (Note 2)	193/1024	193/1024	193/1024	193/1024	193/1024	193/1024	193/1024
Payload size (bits)	2976	6152	12552	2856	6024	12552	32304
Transport block CRC (bits)	16	24	24	16	24	24	24
Code block CRC size (bits)	-	24	24	-	24	24	24
Number of code blocks - C	1	2	4	1	2	4	9
Code block size including CRC (bits) (Note 2)	2992	3112	3168	2872	3048	3168	3616
Total number of bits per slot	15600	32448	66144	14976	31824	66144	170352
Total symbols per slot	7800	16224	33072	7488	15912	33072	85176
NOTE 1: $UL-DMRS-config-type = 1$ with $UL-DMRS-max-len = 1$ and the number of DM-RS CDM groups without data is 2, $UL-DMRS-add-pos = 0$ with $l_0 = 2$ as per table 6.4.1.1.3-3 of TS 38.211 [17].							
NOTE 2: Code block size including CRC (bits) equals to $K'$ in sub-clause 5.2.2 of TS 38.212 [16].							

**Table A.3-4: FRC parameters for FR1 PUSCH performance requirements, transform precoding disabled,  $UL-DMRS-add-pos = 1$  and 2 transmission layers (QPSK,  $R=193/1024$ )**

Reference channel	G-FR1-A3-22	G-FR1-A3-23	G-FR1-A3-24	G-FR1-A3-25	G-FR1-A3-26	G-FR1-A3-27	G-FR1-A3-28
Subcarrier spacing (kHz)	15	15	15	30	30	30	30
Allocated resource blocks	25	52	106	24	51	106	273
CP-OFDM Symbols per slot (Note 1)	12	12	12	12	12	12	12
Modulation	QPSK	QPSK	QPSK	QPSK	QPSK	QPSK	QPSK
Code rate (Note 2)	193/1024	193/1024	193/1024	193/1024	193/1024	193/1024	193/1024
Payload size (bits)	2728	5640	11528	2600	5512	11528	29736
Transport block CRC (bits)	16	24	24	16	24	24	24
Code block CRC size (bits)	-	24	24	-	24	24	24
Number of code blocks - C	1	2	4	1	2	4	8
Code block size including CRC (bits) (Note 2)	2744	2856	2912	2616	2792	2912	3744
Total number of bits per slot	14400	29952	61056	13824	29376	61056	157248
Total symbols per slot	7200	14976	30528	6912	14688	30528	78624
NOTE 1: $UL-DMRS-config-type = 1$ with $UL-DMRS-max-len = 1$ and the number of DM-RS CDM groups without data is 2, $UL-DMRS-add-pos = 1$ with $l_0 = 2$ , $l = 11$ as per table 6.4.1.1.3-3 of TS 38.211 [17].							
NOTE 2: Code block size including CRC (bits) equals to $K'$ in subclause 5.2.2 of TS 38.212 [16].							



**Table A.3-5: FRC parameters for FR1 PUSCH performance requirements, transform precoding enabled,  $UL\text{-DMRS-add-pos} = 0$  and 1 transmission layer (QPSK,  $R=193/1024$ )**

Reference channel	G-FR1-A3-29	G-FR1-A3-30
Subcarrier spacing [kHz]	15	30
Allocated resource blocks	25	24
DFT-s-OFDM Symbols per slot (Note 1)	13	13
Modulation	QPSK	QPSK
Code rate (Note 2)	193/1024	193/1024
Payload size (bits)	1480	1416
Transport block CRC (bits)	16	16
Code block CRC size (bits)	-	-
Number of code blocks - C	1	1
Code block size including CRC (bits) (Note 2)	1496	1432
Total number of bits per slot	7800	7488
Total symbols per slot	3900	3744
NOTE 1: $UL\text{-DMRS-config-type} = 1$ with $UL\text{-DMRS-max-len} = 1$ and the number of DM-RS CDM groups without data is 2, $UL\text{-DMRS-add-pos} = 0$ with $l_0 = 2$ as per table 6.4.1.1.3-3 of TS 38.211 [17].		
NOTE 2: Code block size including CRC (bits) equals to $K'$ in subclause 5.2.2 of TS 38.212 [15].		

**Table A.3-6: FRC parameters for FR1 PUSCH performance requirements, transform precoding enabled,  $UL\text{-DMRS-add-pos} = 1$  and 1 transmission layer (QPSK,  $R=193/1024$ )**

Reference channel	G-FR1-A3-31	G-FR1-A3-32
Subcarrier spacing [kHz]	15	30
Allocated resource blocks	25	24
DFT-s-OFDM Symbols per slot (Note 1)	12	12
Modulation	QPSK	QPSK
Code rate (Note 2)	193/1024	193/1024
Payload size (bits)	1352	1320
Transport block CRC (bits)	16	16
Code block CRC size (bits)	-	-
Number of code blocks - C	1	1
Code block size including CRC (bits) (Note 2)	1368	1336
Total number of bits per slot	7200	6912
Total symbols per slot	3600	3456
NOTE 1: $UL\text{-DMRS-config-type} = 1$ with $UL\text{-DMRS-max-len} = 1$ and the number of DM-RS CDM groups without data is 2, $UL\text{-DMRS-add-pos} = 1$ with $l_0 = 2$ , $l = 11$ as per table 6.4.1.1.3-3 of TS 38.211 [17].		
NOTE 2: Code block size including CRC (bits) equals to $K'$ in subclause 5.2.2 of TS 38.212 [15].		

## A.4 Fixed Reference Channels for performance requirements (16QAM, $R=658/1024$ )

The parameters for the reference measurement channels are specified in table A.4-1 for FR1 PUSCH performance requirements with transform precoding disabled,  $UL\text{-DMRS-add-pos} = 0$  and 1 transmission layer.

The parameters for the reference measurement channels are specified in table A.4-2 for FR1 PUSCH performance requirements with transform precoding disabled,  $UL\text{-DMRS-add-pos} = 1$  and 1 transmission layer.

The parameters for the reference measurement channels are specified in table A.4-3 for FR1 PUSCH performance requirements with transform precoding disabled,  $UL\text{-DMRS-add-pos} = 0$  and 2 transmission layers.

The parameters for the reference measurement channels are specified in table A.4-4 for FR1 PUSCH performance requirements with transform precoding disabled,  $UL\text{-DMRS-add-pos} = 1$  and 2 transmission layers.

**Table A.4-1: FRC parameters for FR1 PUSCH performance requirements, transform precoding disabled,  $UL\text{-DMRS-add-pos} = 0$  and 1 transmission layer (16QAM,  $R=658/1024$ )**

Reference channel	G-FR1-A4-1	G-FR1-A4-2	G-FR1-A4-3	G-FR1-A4-4	G-FR1-A4-5	G-FR1-A4-6	G-FR1-A4-7
Subcarrier spacing (kHz)	15	15	15	30	30	30	30
Allocated resource blocks	25	52	106	24	51	106	273
CP-OFDM Symbols per slot (Note 1)	13	13	13	13	13	13	13
Modulation	16QAM	16QAM	16QAM	16QAM	16QAM	16QAM	16QAM
Code rate (Note 2)	658/1024	658/1024	658/1024	658/1024	658/1024	658/1024	658/1024
Payload size (bits)	9992	21000	42016	9480	20496	42016	108552
Transport block CRC (bits)	24	24	24	24	24	24	24
Code block CRC size (bits)	24	24	24	24	24	24	24
Number of code blocks - C	2	3	5	2	3	5	13
Code block size including CRC (bits) (Note 2)	5032	7032	8432	4776	6864	8432	8376
Total number of bits per slot	15600	32448	66144	14976	31824	66144	170352
Total symbols per slot	3900	8112	16536	3744	7956	16536	42588
NOTE 1: $UL\text{-DMRS-config-type} = 1$ with $UL\text{-DMRS-max-len} = 1$ and the number of DM-RS CDM groups without data is 2, $UL\text{-DMRS-add-pos} = 0$ with $l_0 = 2$ as per table 6.4.1.1.3-3 of TS 38.211 [17].							
NOTE 2: Code block size including CRC (bits) equals to $K'$ in subclause 5.2.2 of TS 38.212 [16].							

**Table A.4-2: FRC parameters for FR1 PUSCH performance requirements, transform precoding disabled,  $UL\text{-DMRS-add-pos} = 1$  and 1 transmission layer (16QAM,  $R=658/1024$ )**

Reference channel	G-FR1-A4-8	G-FR1-A4-9	G-FR1-A4-10	G-FR1-A4-11	G-FR1-A4-12	G-FR1-A4-13	G-FR1-A4-14
Subcarrier spacing (kHz)	15	15	15	30	30	30	30
Allocated resource blocks	25	52	106	24	51	106	273
CP-OFDM Symbols per slot (Note 1)	12	12	12	12	12	12	12
Modulation	16QAM	16QAM	16QAM	16QAM	16QAM	16QAM	16QAM
Code rate (Note 2)	658/1024	658/1024	658/1024	658/1024	658/1024	658/1024	658/1024
Payload size (bits)	9224	19464	38936	8968	18960	38936	100392
Transport block CRC (bits)	24	24	24	24	24	24	24
Code block CRC size (bits)	24	24	24	24	24	24	24
Number of code blocks - C	2	3	5	2	3	5	12
Code block size including CRC (bits) (Note 2)	4648	6052	7816	4520	6352	7816	8392
Total number of bits per slot	14400	29952	61056	13824	29376	61056	157248
Total symbols per slot	3600	7488	15264	3456	7344	15264	39312
NOTE 1: $UL\text{-DMRS-config-type} = 1$ with $UL\text{-DMRS-max-len} = 1$ and the number of DM-RS CDM groups without data is 2, $UL\text{-DMRS-add-pos} = 1$ with $l_0 = 2$ , $l = 11$ as per table 6.4.1.1.3-3 of TS 38.211 [17].							
NOTE 2: Code block size including CRC (bits) equals to $K'$ in subclause 5.2.2 of TS 38.212 [16].							

**Table A.4-3: FRC parameters for FR1 PUSCH performance requirements, transform precoding disabled,  $UL-DMRS-add-pos = 0$  and 2 transmission layers (16QAM,  $R=658/1024$ )**

Reference channel	G-FR1-A4-15	G-FR1-A4-16	G-FR1-A4-17	G-FR1-A4-18	G-FR1-A4-19	G-FR1-A4-20	G-FR1-A4-21
Subcarrier spacing (kHz)	15	15	15	30	30	30	30
Allocated resource blocks	25	52	106	24	51	106	273
CP-OFDM Symbols per slot (Note 1)	13	13	13	13	13	13	13
Modulation	16QAM	16QAM	16QAM	16QAM	16QAM	16QAM	16QAM
Code rate (Note 2)	658/1024	658/1024	658/1024	658/1024	658/1024	658/1024	658/1024
Payload size (bits)	19968	42016	83976	19464	40976	83976	217128
Transport block CRC (bits)	24	24	24	24	24	24	24
Code block CRC size (bits)	24	24	24	24	24	24	24
Number of code blocks - C	3	5	10	3	5	10	26
Code block size including CRC (bits) (Note 2)	6688	8432	8424	6520	8224	8424	8376
Total number of bits per slot	31200	64896	132288	29952	63648	132288	340704
Total symbols per slot	7800	16224	33072	7488	15912	33072	85176
NOTE 1: $UL-DMRS-config-type = 1$ with $UL-DMRS-max-len = 1$ and the number of DM-RS CDM groups without data is 2, $UL-DMRS-add-pos = 0$ with $l_0 = 2$ as per table 6.4.1.1.3-3 of TS 38.211 [17].							
NOTE 2: Code block size including CRC (bits) equals to $K'$ in subclause 5.2.2 of TS 38.212 [16].							

**Table A.4-4: FRC parameters for FR1 PUSCH performance requirements, transform precoding disabled,  $UL-DMRS-add-pos = 1$  and 2 transmission layers (16QAM,  $R=658/1024$ )**

Reference channel	G-FR1-A4-22	G-FR1-A4-23	G-FR1-A4-24	G-FR1-A4-25	G-FR1-A4-26	G-FR1-A4-27	G-FR1-A4-28
Subcarrier spacing (kHz)	15	15	15	30	30	30	30
Allocated resource blocks	25	52	106	24	51	106	273
CP-OFDM Symbols per slot (Note 1)	12	12	12	12	12	12	12
Modulation	16QAM	16QAM	16QAM	16QAM	16QAM	16QAM	16QAM
Code rate (Note 2)	658/1024	658/1024	658/1024	658/1024	658/1024	658/1024	658/1024
Payload size (bits)	18432	38936	77896	17928	37896	77896	200808
Transport block CRC (bits)	24	24	24	24	24	24	24
Code block CRC size (bits)	24	24	24	24	24	24	24
Number of code blocks - C	3	5	10	3	5	10	24
Code block size including CRC (bits) (Note 2)	6176	7816	7816	6008	7608	7816	8392
Total number of bits per slot	28800	59904	122112	27648	58752	122112	314496
Total symbols per slot	7200	14976	30528	6912	14688	30528	78624
NOTE 1: $UL-DMRS-config-type = 1$ with $UL-DMRS-max-len = 1$ and the number of DM-RS CDM groups without data is 2, $UL-DMRS-add-pos = 1$ with $l_0 = 2$ , $l = 11$ as per table 6.4.1.1.3-3 of TS 38.211 [17].							
NOTE 2: Code block size including CRC (bits) equals to $K'$ in subclause 5.2.2 of TS 38.212 [16].							

## A.5 Fixed Reference Channels for performance requirements (64QAM, $R=567/1024$ )

The parameters for the reference measurement channels are specified in table A.5-1 for FR1 PUSCH performance requirements with transform precoding disabled,  $UL-DMRS-add-pos = 0$  and 1 transmission layer.

The parameters for the reference measurement channels are specified in table A.5-2 for FR1 PUSCH performance requirements with transform precoding disabled,  $UL-DMRS-add-pos = 1$  and 1 transmission layer.

**Table A.5-1: FRC parameters for FR1 PUSCH performance requirements, transform precoding disabled,  $UL\text{-}DMRS\text{-}add\text{-}pos = 0$  and 1 transmission layer (64QAM,  $R=567/1024$ )**

Reference channel	G-FR1-A5-1	G-FR1-A5-2	G-FR1-A5-3	G-FR1-A5-4	G-FR1-A5-5	G-FR1-A5-6	G-FR1-A5-7
Subcarrier spacing (kHz)	15	15	15	30	30	30	30
Allocated resource blocks	25	52	106	24	51	106	273
CP-OFDM Symbols per slot (Note 1)	13	13	13	13	13	13	13
Modulation	64QAM	64QAM	64QAM	64QAM	64QAM	64QAM	64QAM
Code rate (Note 2)	567/1024	567/1024	567/1024	567/1024	567/1024	567/1024	567/1024
Payload size (bits)	13064	27144	55304	12296	26632	55304	143400
Transport block CRC (bits)	24	24	24	24	24	24	24
Code block CRC size (bits)	24	24	24	24	24	24	24
Number of code blocks - C	2	4	7	2	4	7	18
Code block size including CRC (bits) (Note 2)	6568	6816	7928	6184	6688	7928	7992
Total number of bits per slot	23400	48672	99216	22464	47736	99216	255528
Total symbols per slot	3900	8112	16536	3744	7956	16536	42588

NOTE 1:  $UL\text{-}DMRS\text{-}config\text{-}type = 1$  with  $UL\text{-}DMRS\text{-}max\text{-}len = 1$  and the number of DM-RS CDM groups without data is 2,  $UL\text{-}DMRS\text{-}add\text{-}pos = 0$  with  $l_0 = 2$  as per table 6.4.1.1.3-3 of TS 38.211 [17].

NOTE 2: Code block size including CRC (bits) equals to  $K'$  in subclause 5.2.2 of TS 38.212 [16].

**Table A.5-2: FRC parameters for FR1 PUSCH performance requirements, transform precoding disabled,  $UL\text{-}DMRS\text{-}add\text{-}pos = 1$  and 1 transmission layer (64QAM,  $R=567/1024$ )**

Reference channel	G-FR1-A5-8	G-FR1-A5-9	G-FR1-A5-10	G-FR1-A5-11	G-FR1-A5-12	G-FR1-A5-13	G-FR1-A5-14
Subcarrier spacing (kHz)	15	15	15	30	30	30	30
Allocated resource blocks	25	52	106	24	51	106	273
CP-OFDM Symbols per slot (Note 1)	12	12	12	12	12	12	12
Modulation	64QAM	64QAM	64QAM	64QAM	64QAM	64QAM	64QAM
Code rate (Note 2)	567/1024	567/1024	567/1024	567/1024	567/1024	567/1024	567/1024
Payload size (bits)	12040	25104	50184	11528	24576	50184	131176
Transport block CRC (bits)	24	24	24	24	24	24	24
Code block CRC size (bits)	24	24	24	24	24	24	24
Number of code blocks - C	2	3	6	2	3	6	16
Code block size including CRC (bits) (Note 2)	6056	8400	8392	5800	8224	8392	8224
Total number of bits per slot	21600	44928	91584	20736	44064	91584	235872
Total symbols per slot	3600	7488	15264	3456	7344	15264	39312

NOTE 1:  $UL\text{-}DMRS\text{-}config\text{-}type = 1$  with  $UL\text{-}DMRS\text{-}max\text{-}len = 1$  and the number of DM-RS CDM groups without data is 2,  $UL\text{-}DMRS\text{-}add\text{-}pos = 1$  with  $l_0 = 2$ ,  $l = 11$  as per table 6.4.1.1.3-3 of TS 38.211 [17].

NOTE 2: Code block size including CRC (bits) equals to  $K'$  in subclause 5.2.2 of TS 38.212 [16].

## A.6 PRACH test preambles

**Table A.6-1 Test preambles for Normal Mode in FR1**

Burst format	SCS (kHz)	Ncs	Logical sequence index	v
0	1.25	13	22	32
A1, A2, A3, B4, C0, C2	15	23	0	0
	30	46	0	0

**Table A.6-2 Void**

## Annex B (normative): Environmental requirements for the BS equipment

### B.1 General

For each test in the present document, the environmental conditions under which the BS is to be tested are defined.

### B.2 Normal test environment

When a normal test environment is specified for a test, the test should be performed within the minimum and maximum limits of the conditions stated in table B.1.

**Table B.1: Limits of conditions for normal test environment**

Condition	Minimum	Maximum
Barometric pressure	86 kPa	106 kPa
Temperature	15 °C	30 °C
Relative humidity	20 %	85 %
Power supply	Nominal, as declared by the manufacturer	
Vibration	Negligible	

The ranges of barometric pressure, temperature and humidity represent the maximum variation expected in the uncontrolled environment of a test laboratory. If it is not possible to maintain these parameters within the specified limits, the actual values shall be recorded in the test report.

NOTE: This may, for instance, be the case for measurements of radiated emissions performed on an open field test site.

### B.3 Extreme test environment

The manufacturer shall declare one of the following:

- 1) The equipment class for the equipment under test, as defined in the IEC 60 721-3-3 [6];
- 2) The equipment class for the equipment under test, as defined in the IEC 60 721-3-4 [7];
- 3) The equipment that does not comply with the mentioned classes, the relevant classes from IEC 60 721 [8] documentation for temperature, humidity and vibration shall be declared.

NOTE: Reduced functionality for conditions that fall outside of the standard operational conditions is not tested in the present document. These may be stated and tested separately.

#### B.3.1 Extreme temperature

When an extreme temperature test environment is specified for a test, the test shall be performed at the standard minimum and maximum operating temperatures defined by the manufacturer's declaration for the equipment under test.

##### Minimum temperature:

The test shall be performed with the environment test equipment and methods including the required environmental phenomena into the equipment, conforming to the test procedure of IEC 60 068-2-1 [9].

##### Maximum temperature:

The test shall be performed with the environmental test equipment and methods including the required environmental phenomena into the equipment, conforming to the test procedure of IEC 60 068-2-2 [10].

NOTE: It is recommended that the equipment is made fully operational prior to the equipment being taken to its lower operating temperature.

---

## B.4 Vibration

When vibration conditions are specified for a test, the test shall be performed while the equipment is subjected to a vibration sequence as defined by the manufacturer's declaration for the equipment under test. This shall use the environmental test equipment and methods of inducing the required environmental phenomena in to the equipment, conforming to the test procedure of IEC 60 068-2-6 [11]. Other environmental conditions shall be within the ranges specified in annex B.2.

NOTE: The higher levels of vibration may induce undue physical stress in to equipment after a prolonged series of tests. The testing body should only vibrate the equipment during the RF measurement process.

---

## B.5 Power supply

When extreme power supply conditions are specified for a test, the test shall be performed at the standard upper and lower limits of operating voltage defined by manufacturer's declaration for the equipment under test.

### Upper voltage limit:

The equipment shall be supplied with a voltage equal to the upper limit declared by the manufacturer (as measured at the input terminals to the equipment). The tests shall be carried out at the steady state minimum and maximum temperature limits declared by the manufacturer for the equipment, to the methods described in IEC 60 068-2-1 [9] Test Ab/Ad and IEC 60 068-2-2 [10] Test Bb/Bd: Dry heat.

### Lower voltage limit:

The equipment shall be supplied with a voltage equal to the lower limit declared by the manufacturer (as measured at the input terminals to the equipment). The tests shall be carried out at the steady state minimum and maximum temperature limits declared by the manufacturer for the equipment, to the methods described in IEC 60 068-2-1 [9] Test Ab/Ad and IEC 60 068-2-2 [10] Test Bb/Bd: Dry heat.

---

## B.6 Measurement of test environments

The measurement accuracy of the BS test environments defined in annex B shall be:

Pressure:	±5 kPa
Temperature:	±2 degrees
Relative humidity:	±5 %
DC voltage:	±1.0 %
AC voltage:	±1.5 %
Vibration:	10 %
Vibration frequency:	0.1 Hz

The above values shall apply unless the test environment is otherwise controlled and the specification for the control of the test environment specifies the uncertainty for the parameter.

---

## Annex C (informative): Test tolerances and derivation of test requirements

### C.1 Measurement of transmitter

**Table C.1-1: Derivation of test requirements (Transmitter tests)**

Test	Minimum requirement in TS 38.104 [2]	Test Tolerance (TT)	Test requirement in the present document
6.2 Base station output power	See TS 38.104 [2], subclause 6.2	Normal condition and extreme condition: 0.7 dB, $f \leq 3.0$ GHz 1.0 dB, $3.0$ GHz $< f \leq 6$ GHz (Note)	Formula: Upper limit + TT, Lower limit - TT
6.3 Output power dynamics	See TS 38.104 [2], subclause 6.3	0.4 dB	Formula: Total power dynamic range – TT (dB)
6.4.1 Transmitter OFF power	See TS 38.104 [2], subclause 6.4.1	2.0 dB , $f \leq 3.0$ GHz 2.5 dB, $3.0$ GHz $< f \leq 6$ GHz (Note)	Formula: Minimum Requirement + TT
6.5.2 Transient period	See TS 38.104 [2], subclause 6.4.2	N/A	
6.5.1 Frequency error	See TS 38.104 [2], subclause 6.5.1	12 Hz	Formula: Frequency Error limit + TT
6.5.2 Time alignment error	See TS 38.104 [2], subclause 6.5.2	25ns	Formula: EVM limit + TT
6.5.3 Modulation quality (EVM)	See TS 38.104 [2], subclause 6.5.3	1%	Formula: Time alignment error limit + TT
6.6.2 Occupied bandwidth	See TS 38.104 [2], subclause 6.6.2	0 Hz	Formula: Minimum Requirement + TT
6.6.3 Adjacent Channel Leakage Power Ratio (ACLR)	See TS 38.104 [2], subclause 6.6.3	ACLR/CACLR: BW $\leq 20$ MHz: 0.8dB  BW $> 20$ MHz: 1.2 dB  Absolute ACLR/CACLR: 0 dB	Formula: ACLR Minimum Requirement - TT Absolute limit + TT
6.6.4 Operating band unwanted emissions	See TS 38.104 [2], subclause 6.7.4	Offsets $< 10$ MHz 1.5 dB, $f \leq 3.0$ GHz 1.8 dB, $3.0$ GHz $< f \leq 6$ GHz (Note)  Offsets $\geq 10$ MHz 0dB	Formula: Minimum Requirement + TT
6.6.5.2.1 General transmitter spurious emissions requirements Category A	See TS 38.104 [2], subclause 6.7.5.2.1	0dB	Formula: Minimum Requirement + TT
6.6.5.2.1 General transmitter spurious emissions requirements Category B	See TS 38.104 [2], subclause 6.7.5.2.1	0dB	Formula: Minimum Requirement + TT
6.6.5.2.2 Protection of the BS receiver of own or different BS	See TS 38.104 [2], subclause 6.7.5.2.2	0dB	Formula: Minimum Requirement + TT
6.6.5.2.3 Additional spurious emissions requirements	See TS 38.104 [2], subclause 6.7.5.2.3	0dB	Formula: Minimum Requirement + TT
6.6.5.2.4 Co-location with other base stations	See TS 38.104 [2], subclause 6.7.5.2.4	0dB	Formula: Minimum Requirement + TT
6.7 Transmitter intermodulation	See TS 38.104 [2], subclause 6.7	0dB	Formula: Ratio + TT
NOTE: TT values for $4.2$ GHz $< f \leq 6.0$ GHz apply for BS operates in licensed spectrum only.			



## C.2 Measurement of receiver

Table C.2-1: Derivation of test requirements (Receiver tests)

Test	Minimum requirement in TS 38.104 [2]	Test Tolerance (TT)	Test requirement in the present document
7.2 Reference sensitivity level	See TS 38.104 [2], subclause 7.2	0.7 dB, $f \leq 3.0$ GHz 1.0 dB, $3.0 \text{ GHz} < f \leq 4.2 \text{ GHz}$ 1.2 dB, $4.2 \text{ GHz} < f \leq 6.0 \text{ GHz}$	Formula: Reference sensitivity power level + TT
7.3 Dynamic range	See TS 38.104 [2], subclause 7.3	0.3 dB	Formula: Wanted signal power + TT
7.4 In-band selectivity and blocking	See TS 38.104 [2], subclause 7.4	0dB	Formula: Wanted signal power + TT
7.5 Out-of-band blocking	See TS 38.104 [2], subclause 7.5	0dB	Formula: Wanted signal power + TT
7.6 Receiver spurious emissions	See TS 38.104 [2], subclause 7.6	0dB	Formula: Minimum Requirement + TT
7.7 Receiver intermodulation	See TS 38.104 [2], subclause 7.7	0dB	Formula: Wanted signal power + TT
7.8 In-channel selectivity	See TS 38.104 [2], subclause 7.8	1.4 dB, $f \leq 3.0$ GHz 1.8 dB, $3.0 \text{ GHz} < f \leq 4.2 \text{ GHz}$ 2.1 dB, $4.2 \text{ GHz} < f \leq 6.0 \text{ GHz}$	Formula: Wanted signal power + TT

## C.3 Measurement of performance requirements

Table C.3-1: Derivation of Test Requirements (Performance tests)

Test	Minimum Requirement in TS 38.104 [2]	Test Tolerance (TT)	Test requirement in the present document
8.2.1 Performance requirements for PUSCH with transmission precoding disabled	SNRs as specified	[0.6]dB for 1Tx cases [0.8]dB for 2Tx cases	Formula: SNR + TT T-put limit unchanged
8.2.2 Performance requirements for PUSCH with transmission precoding enabled	SNRs as specified	[0.6]dB	Formula: SNR + TT T-put limit unchanged
8.3.1 Performance requirements for PUCCH format 0	SNRs as specified	[0.6]dB	Formula: SNR + TT False ACK limit unchanged Correct ACK limit unchanged
8.3.2 Performance requirements for PUCCH format 1	SNRs as specified	[0.6]dB	Formula: SNR + TT False ACK limit unchanged Correct ACK limit unchanged Correct NACK limit unchanged
8.3.3 Performance requirements for PUCCH format 2	SNRs as specified	[0.6] dB	Formula: SNR + TT False ACK limit unchanged Correct ACK limit unchanged Correct UCI limit unchanged
8.3.4 Performance requirements for PUCCH format 3	SNRs as specified	[0.6]dB	Formula: SNR + TT Correct UCI limit unchanged
8.3.5 Performance requirements for PUCCH format 4	SNRs as specified	[0.6]dB	Formula: SNR + TT Correct UCI limit unchanged
8.4.1 PRACH false alarm probability and missed detection	SNRs as specified	[0.6] dB for fading cases [0.3] dB for AWGN cases	Formula: SNR + TT PRACH false detection limit unchanged PRACH detection limit unchanged

## Annex D (informative): Measurement system set-up

### D.1 *BS type 1-C* transmitter

D.1.1 Base station output power, output power dynamics, transmitter ON/OFF power, frequency error, EVM, unwanted emissions for BS type 1-C

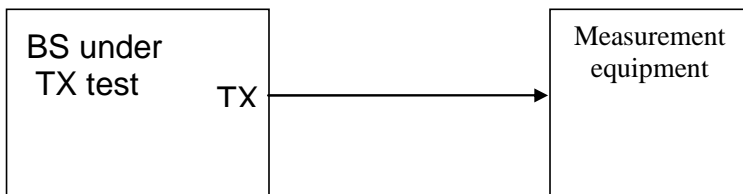

Figure D.1.1-1: Measuring system set-up for *BS type 1-C* output power, output power dynamics, frequency error, EVM, unwanted emissions

### D.1.2 Transmitter intermodulation for BS type 1-C

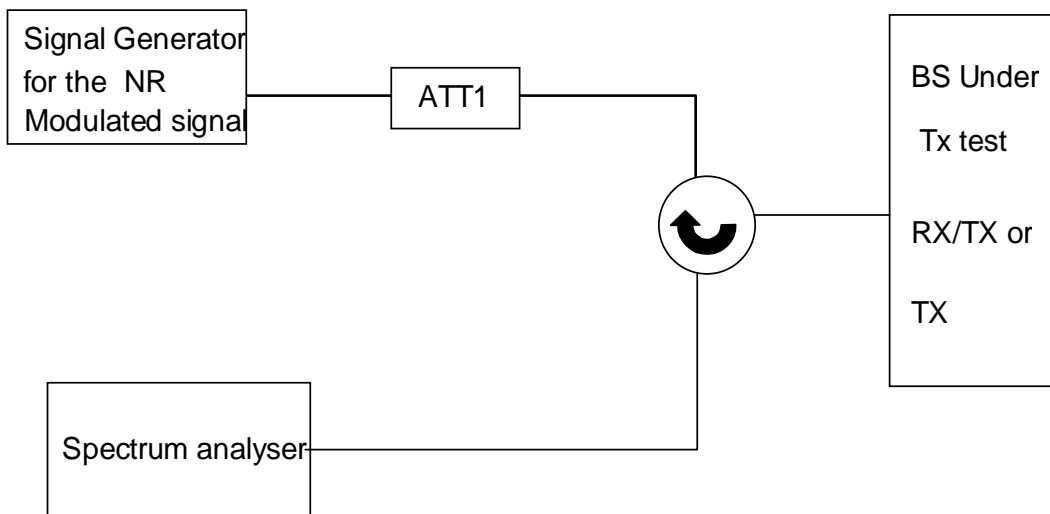

Figure D.1.2-1: Measuring system set-up for *BS type 1-C* transmitter intermodulation

### D.1.3 Time alignment error for BS type 1-C

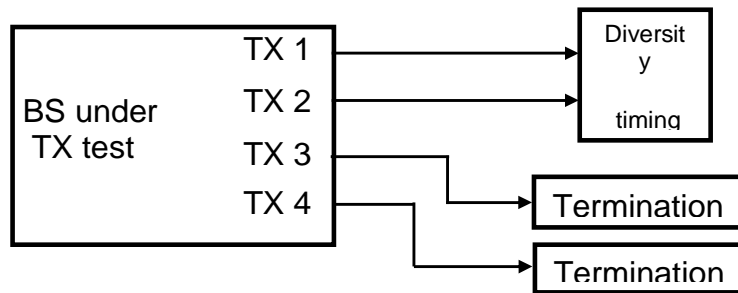

Figure D.1.3-1: Measuring system set-up for *BS type 1-C* test of time alignment error

## D.2 BS type 1-C receiver

### D.2.1 Reference sensitivity level for BS type 1-C

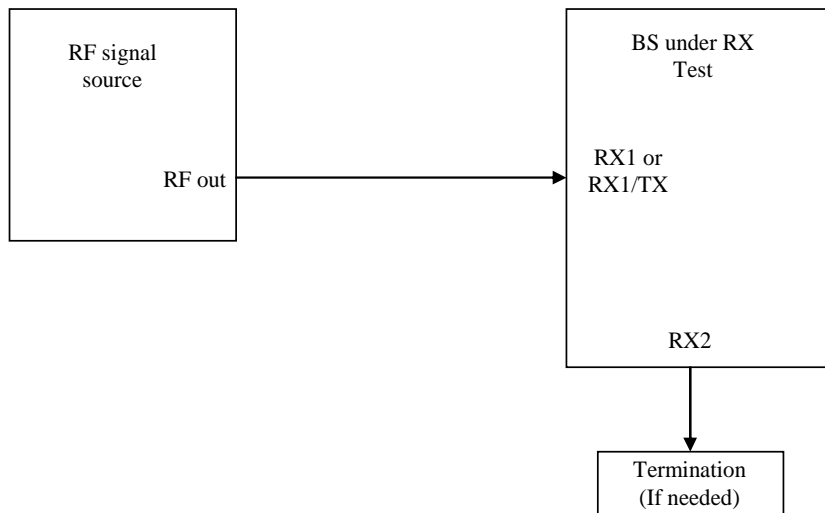

Figure D.2.1-1: Measuring system set-up for *BS type 1-C* reference sensitivity level test

### D.2.2 Dynamic range for BS type 1-C

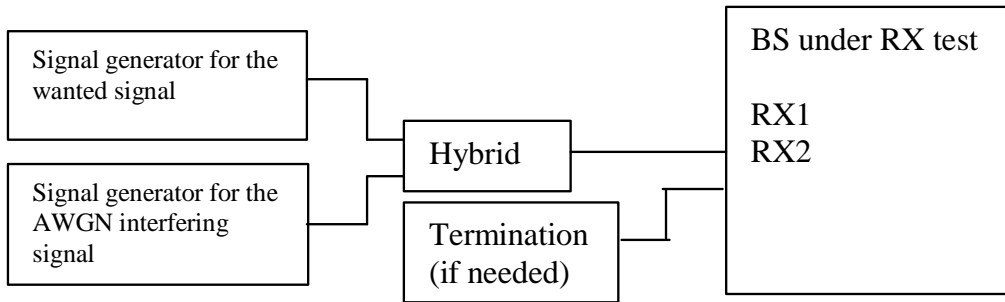

Figure D.2.2-1: Measuring system set-up for *BS type 1-C* dynamic range

### D.2.3 In-channel selectivity for BS type 1-C

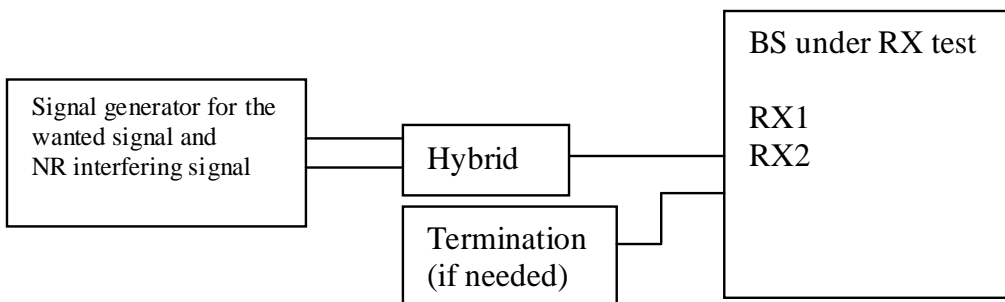

Figure D.2.3-1: Measuring system Set-up for *BS type 1-C* in-channel selectivity

### D.2.4 Adjacent Channel Selectivity (ACS) and narrowband blocking for BS type 1-C

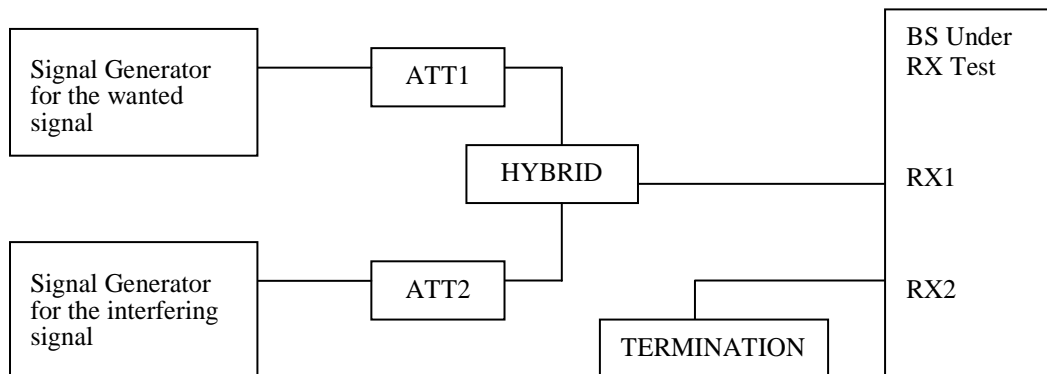

Figure D.2.4-1: Measuring system set-up for *BS type 1-C* adjacent channel selectivity and narrowband blocking

### D.2.5 Blocking characteristics for BS type 1-C

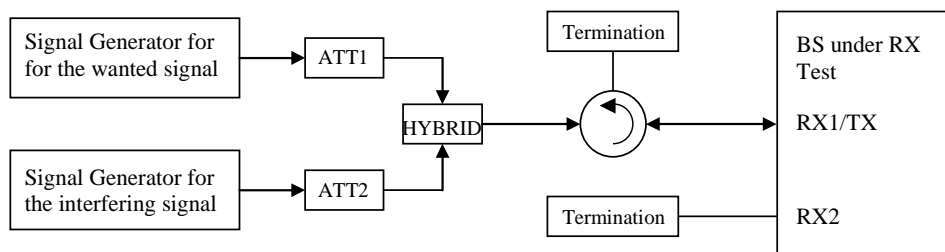

Figure D.2.5-1: Measuring system set-up for *BS type 1-C* blocking characteristics

### D.2.6 Receiver spurious emission for BS type 1-C

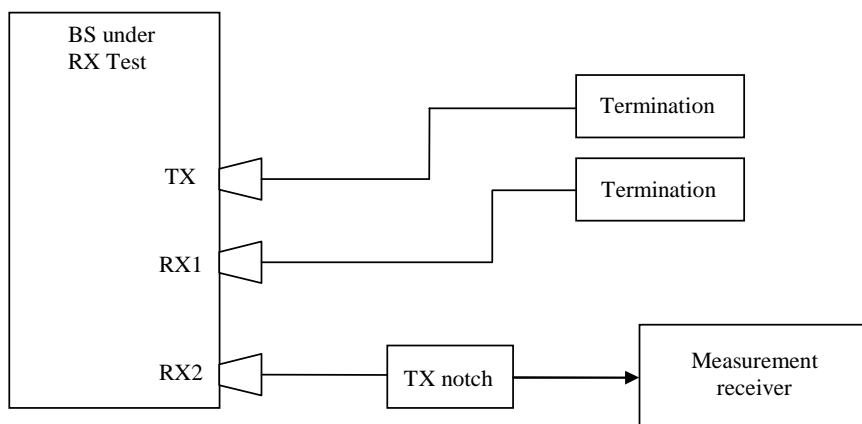

Figure D.2.6-1: Measuring system set-up for *BS type 1-C* receiver spurious emission

## D.2.7 Intermodulation characteristics for BS type 1-C

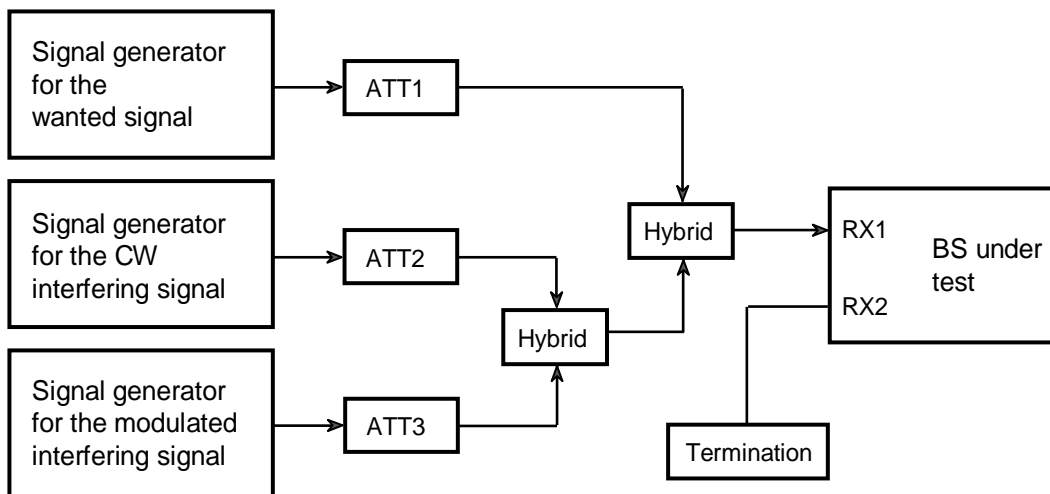

Figure D.2.7-1: Measuring system set-up for BS type 1-C intermodulation characteristics

## D.3 BS type 1-H transmitter

### D.3.1 Base station output power, output power dynamics, transmitter ON/OFF power, frequency error, EVM, unwanted emissions for BS type 1-H

TAB connectors may be connected to the measurement equipment singularly and tested one at a time (figure D.3.1-1), or may be tested simultaneously in groups (figure D.3.1-2) where the group size may range from two to all the TAB connectors which are subject to particular transmitter test in this test setup.

In all cases the measurement is per TAB connector but the measurement may be done in parallel.

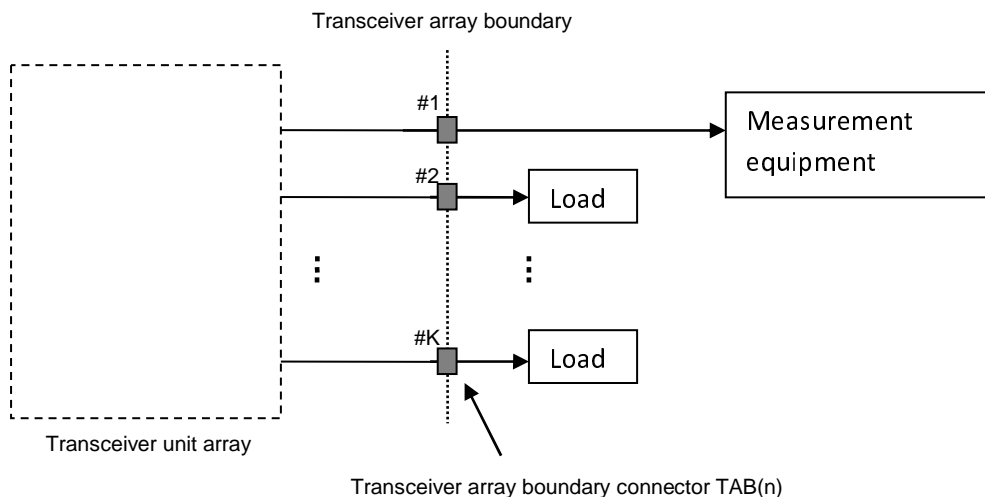
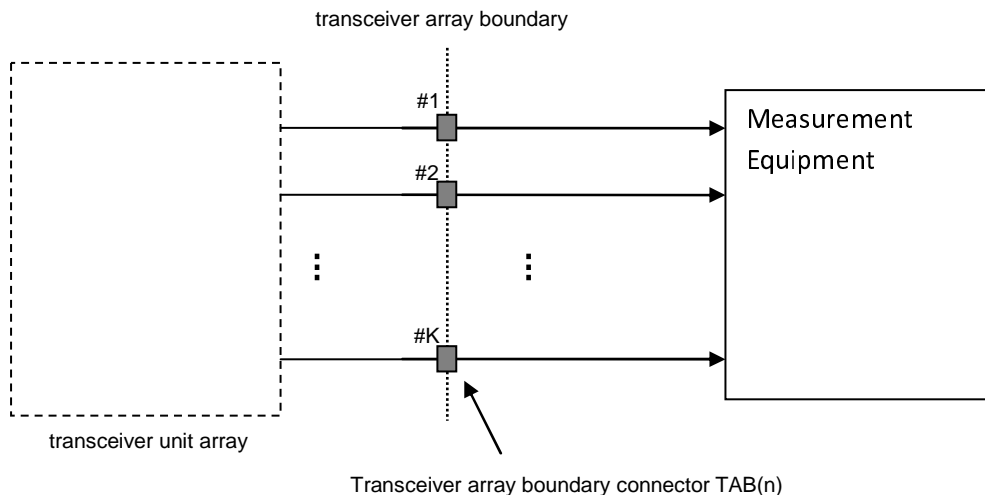
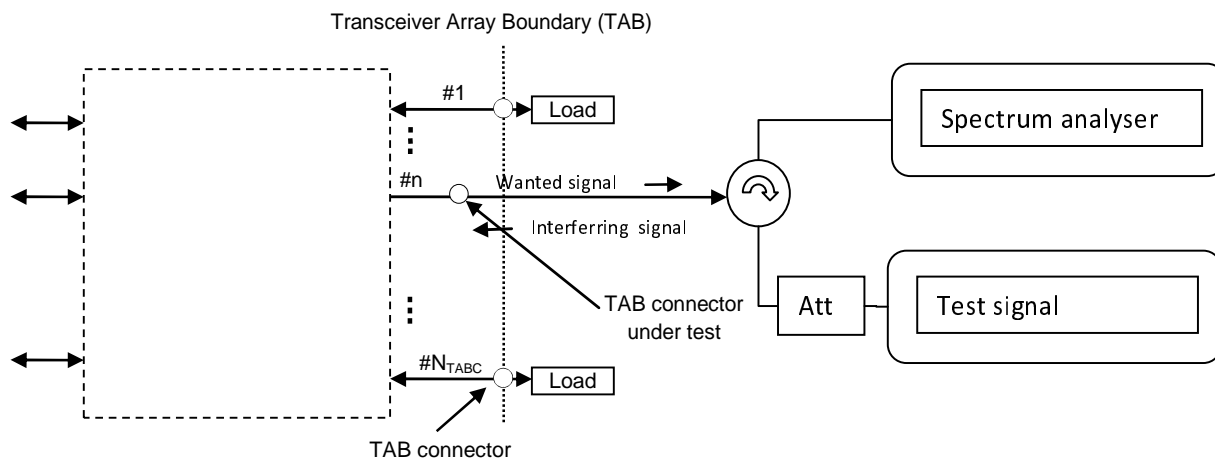

Figure D.3.1-1: Measuring system set-up for BS type 1-H output power, output power dynamics, transmitter ON/OFF power, frequency error, EVM, unwanted emissions for a single TAB connector



**Figure D.3.1-2: Measuring system set-up for *BS type 1-H* output power, output power dynamics, transmitter ON/OFF power, frequency error, EVM, unwanted emissions for multiple *TAB* connectors**

### D.3.2 Transmitter intermodulation for BS type 1-H

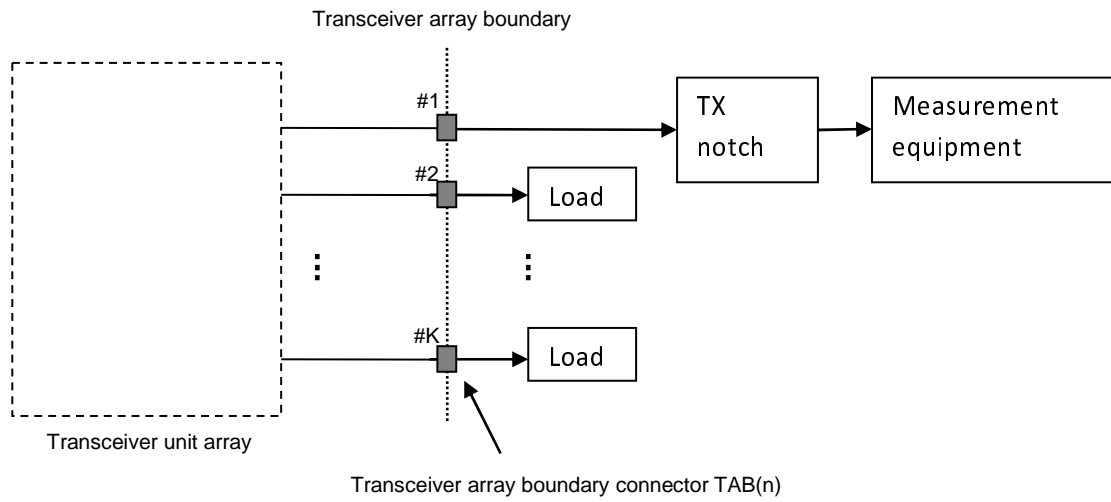

**Figure D.3.2-1: Measuring system set-up for *BS type 1-H* transmitter intermodulation**

### D.3.3 Transmitter spurious emissions for BS type 1-H

*TAB connectors* may be connected to the measurement equipment singularly and tested one at a time (figure D.3.3-1), or may be tested simultaneously in groups (figure D.3.3-2) where the group size may range from two to all the *TAB connectors* which are subject to transmitter spurious emissions test.

In all cases the measurement is per *TAB connector* but the measurement may be done in parallel.



**Figure D.3.3-1: Measuring system set-up for transmitter spurious emissions for a single *TAB* connector**

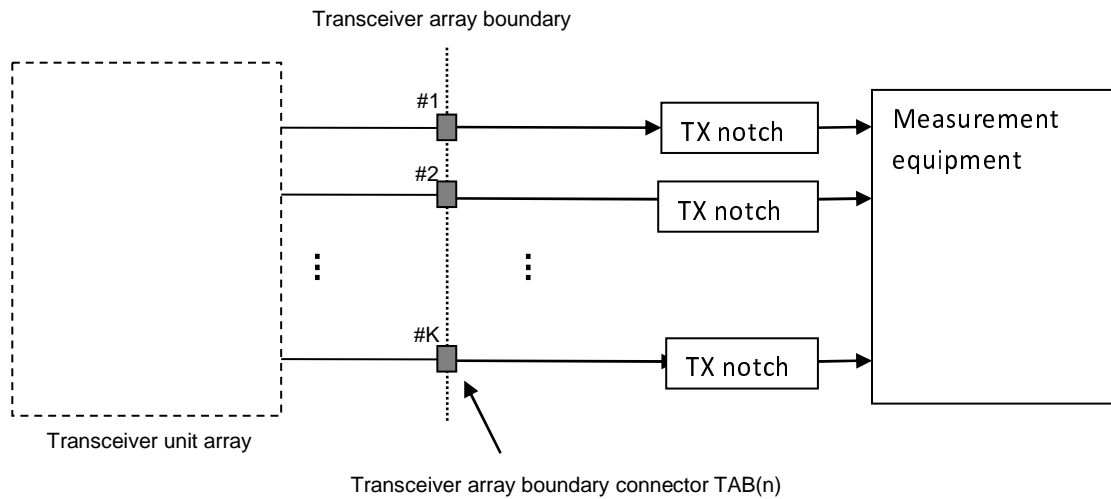

**Figure D.3.3-2: Measuring system set-up for transmitter spurious emissions for multiple *TAB* connectors in parallel test**



## D.4 BS type 1-H receiver

### D.4.1 Reference sensitivity level for BS type 1-H

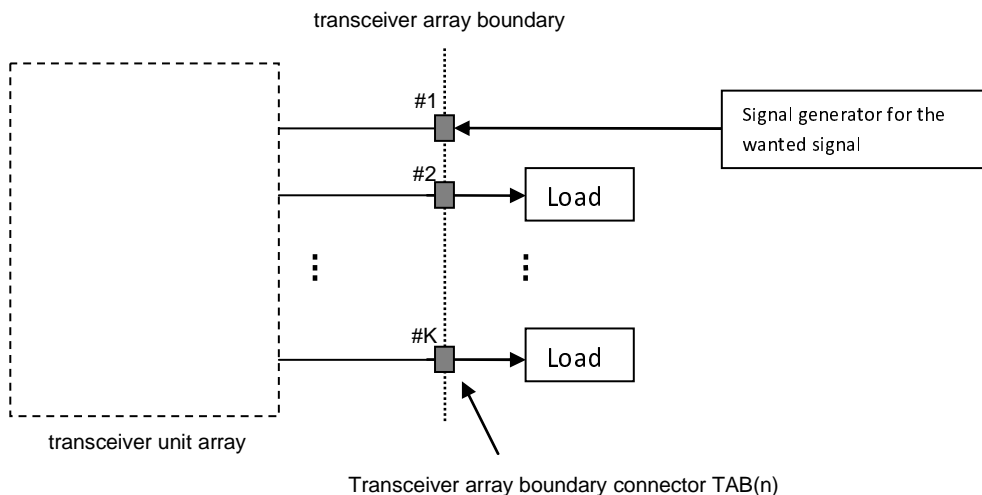

Figure D.4.1-1: Measuring system set-up for *BS type 1-H* reference sensitivity level test

### D.4.2 Receiver dynamic range for BS type 1-H

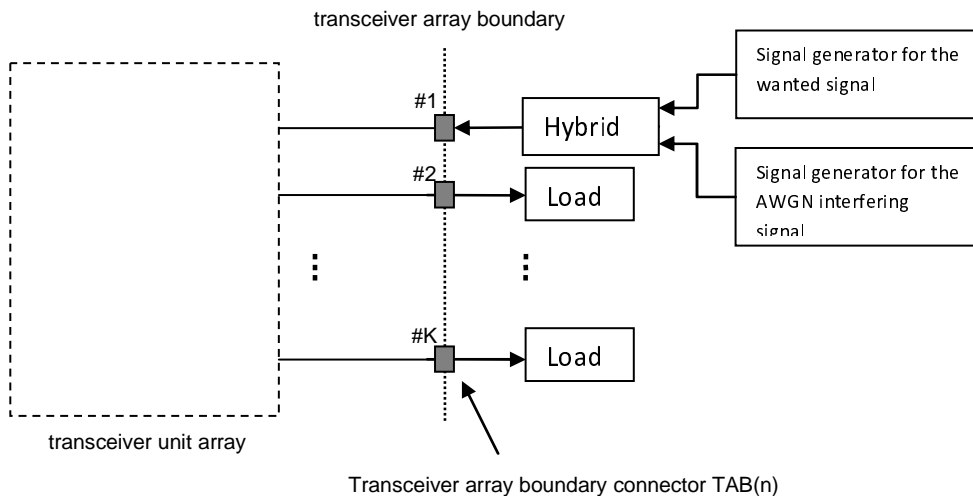

Figure D.4.2-1: Measuring system set-up for *BS type 1-H* dynamic range test

### D.4.3 Receiver adjacent channel selectivity and narrowband blocking for BS type 1-H

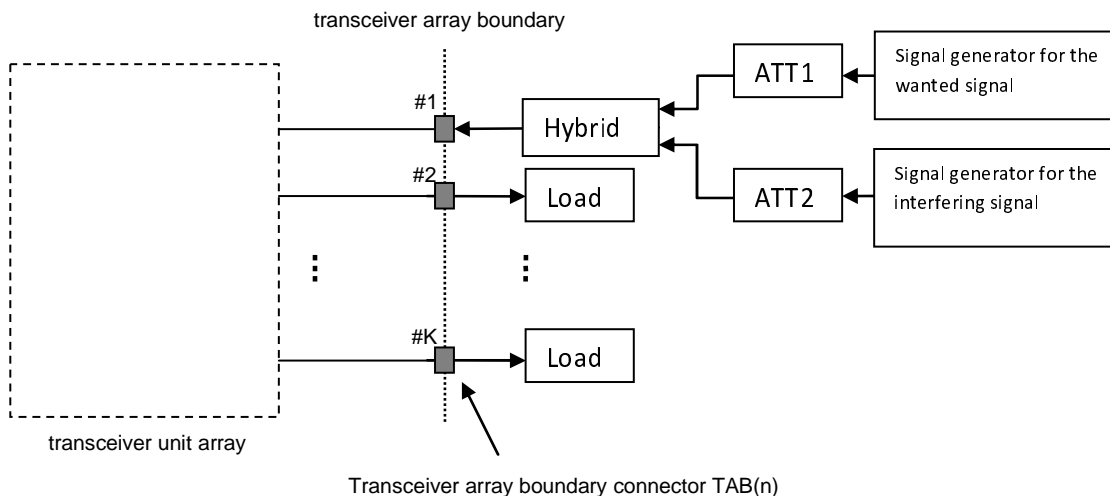

Figure D.4.3-1: Measuring system set-up for BS type 1-H adjacent channel selectivity and narrowband blocking test

### D.4.4 Receiver spurious emissions

TAB connector(s) may be connected to the measurement equipment singularly and tested one at a time (figure D.4.2-1), or may be tested simultaneously in groups (figure D.4.2-2) where the group size may range from 2 to all the TAB connectors.

In all cases the measurement is per TAB connector but the measurement may be done in parallel.

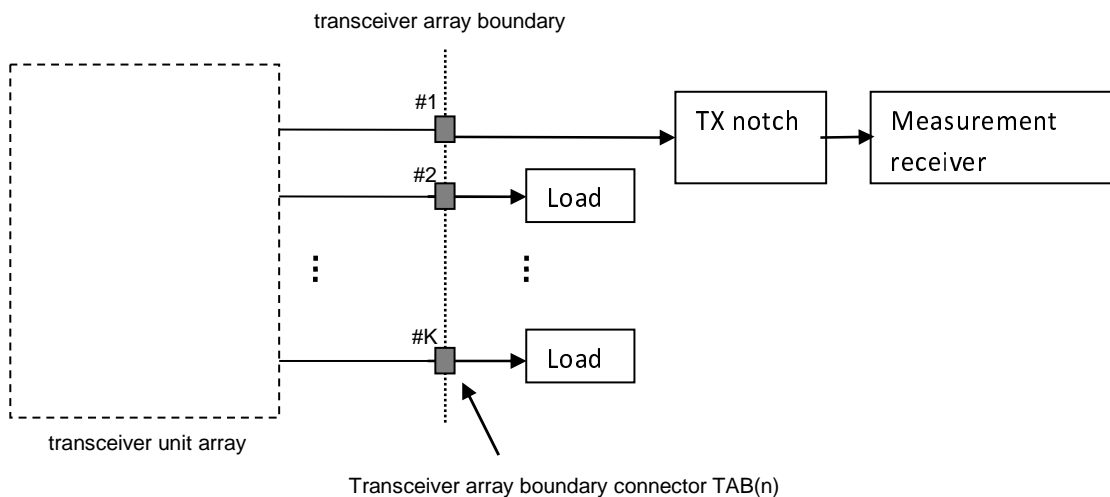
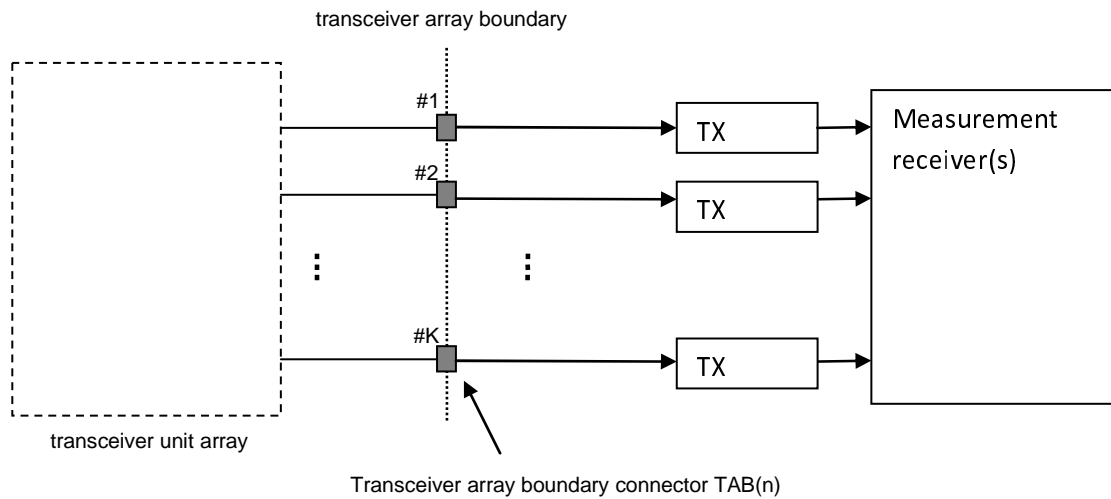
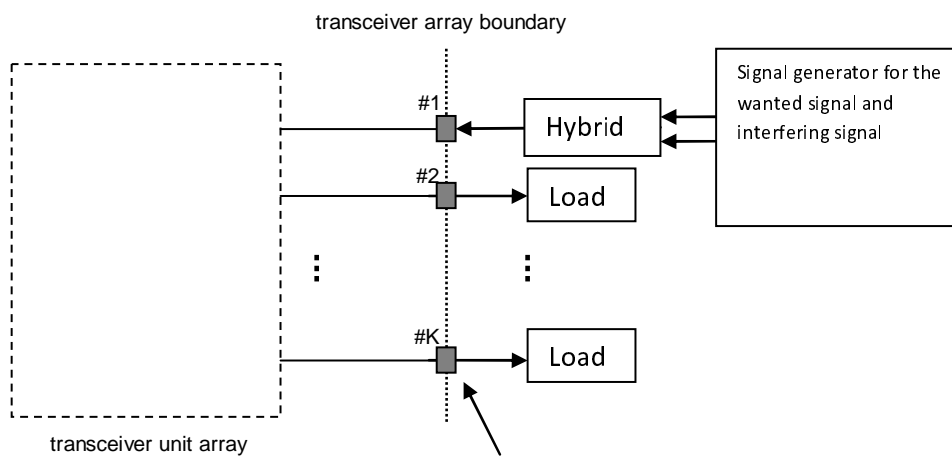

Figure D.4.4-1: Measuring system set-up for BS type 1-H receiver spurious emissions for a single TAB connector



**Figure D.4.4-2: Measuring system set-up for *BS type 1-H* receiver spurious emissions for multiple *TAB* connectors**

### D.4.5 Receiver In-channel selectivity for BS type 1-H



**Figure D.4.5-1: Measuring system set-up for *BS type 1-H* in-channel selectivity test**

### D.4.6 Receiver intermodulation for BS type 1-H

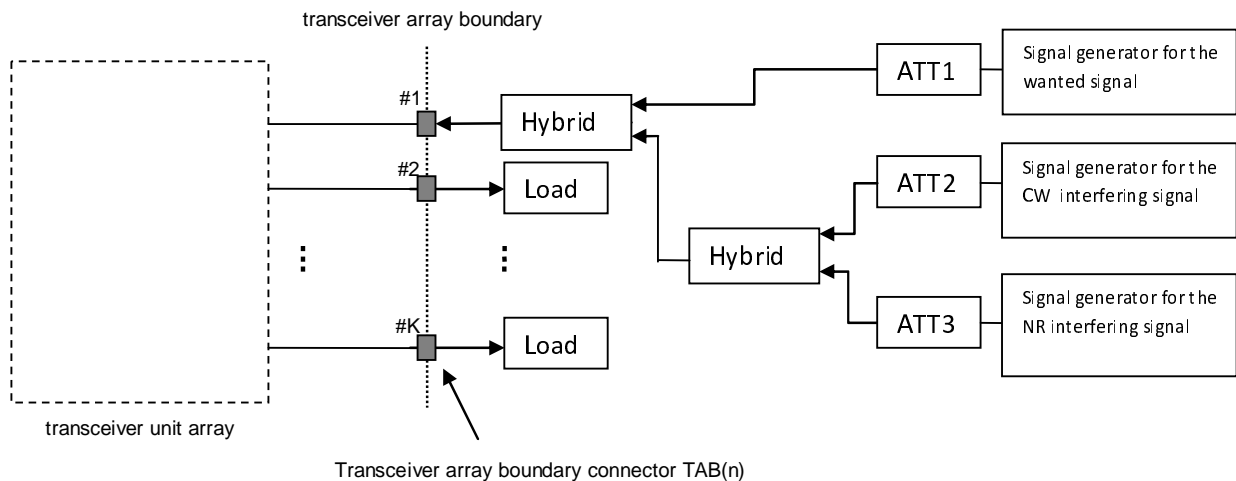

Figure D.4.6-1: Measuring system set-up for *BS type 1-H* receiver intermodulation test

## D.5 *BS type 1-C* performance requirements

### D.5.1 Performance requirements for PUSCH, single user PUCCH, PRACH on single antenna port in multipath fading conditions

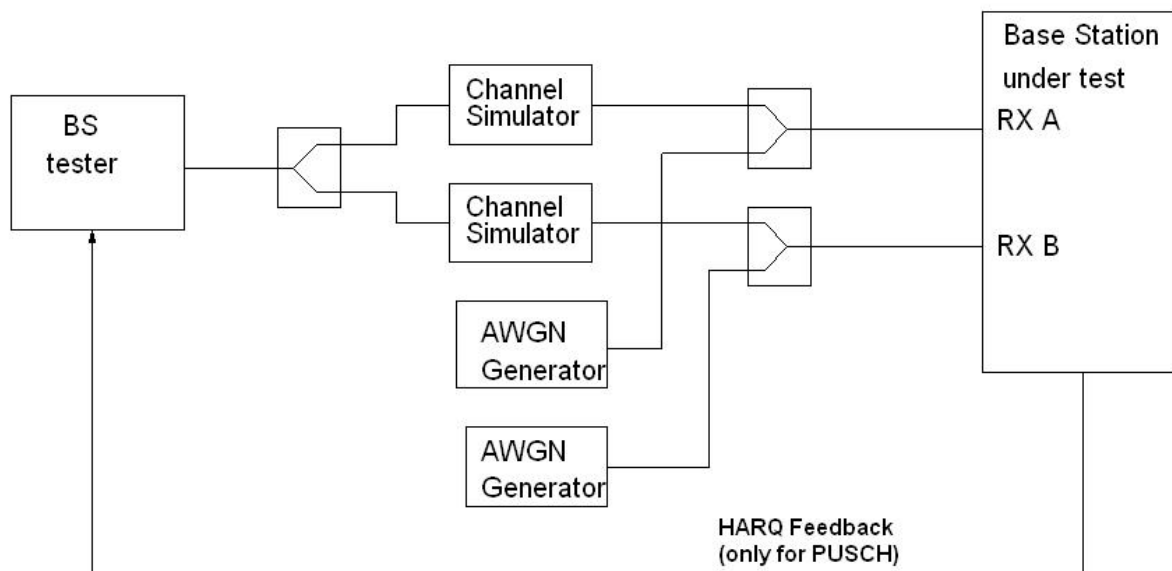

Figure D.5.1-1: Functional set-up for performance requirements for PUSCH, single user PUCCH, PRACH on single antenna port in multipath fading conditions for BS with Rx diversity (2 Rx case shown)

NOTE: The HARQ Feedback could be done as an RF feedback or as a digital feedback. The HARQ Feedback should be error free.

### D.5.2 Performance requirements for PUSCH transmission on two antenna ports in multipath fading conditions

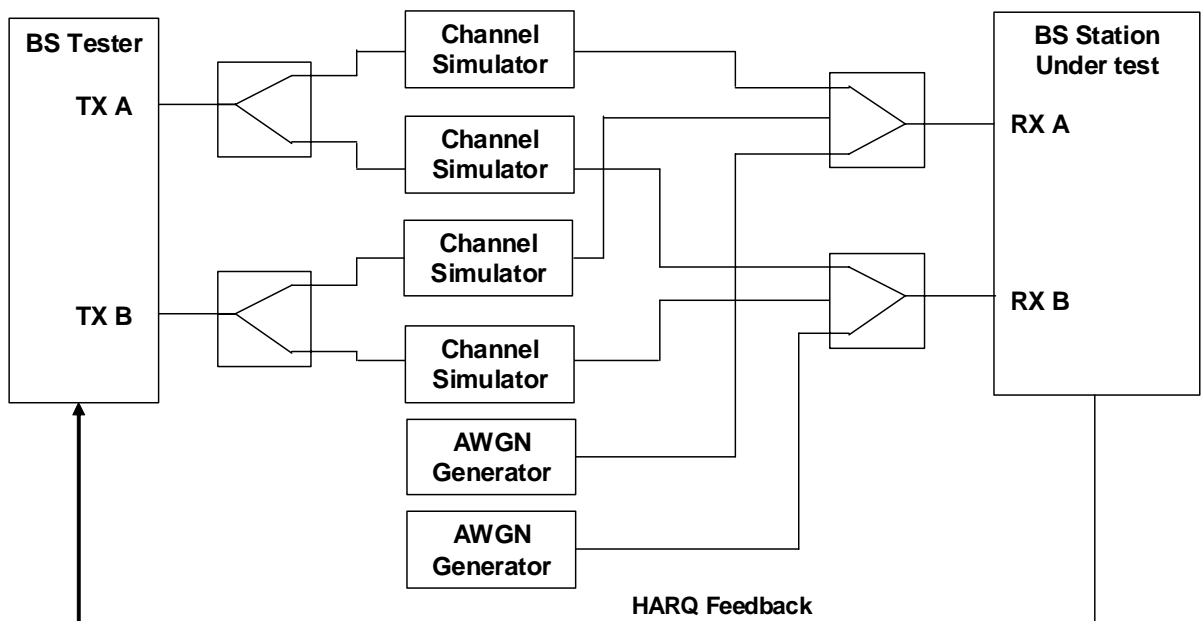

Figure D.5.2-1: Functional set-up for performance requirements for PUSCH transmission on two antenna ports in multipath fading conditions (2 Rx case shown)

### D.5.3 Performance requirements for PRACH in static conditions

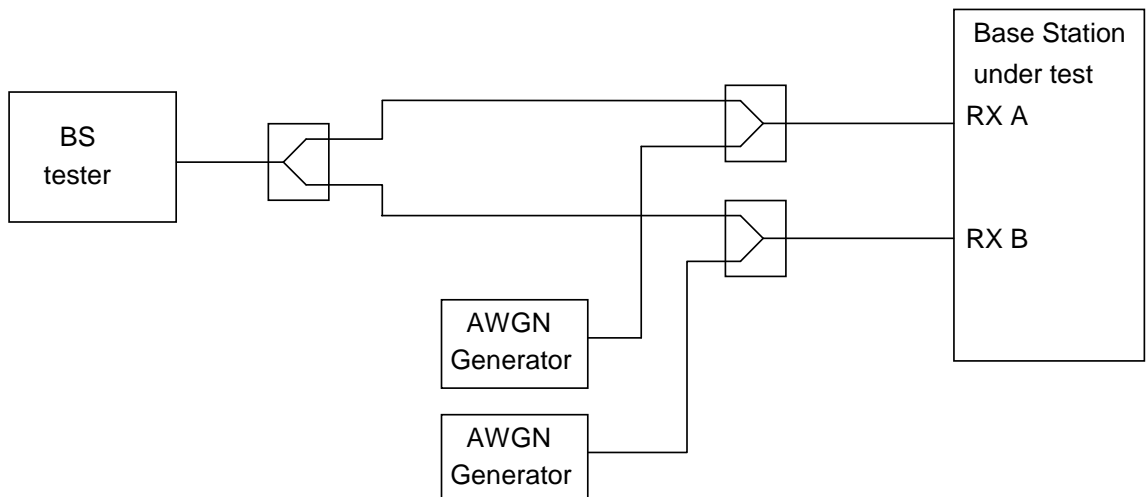
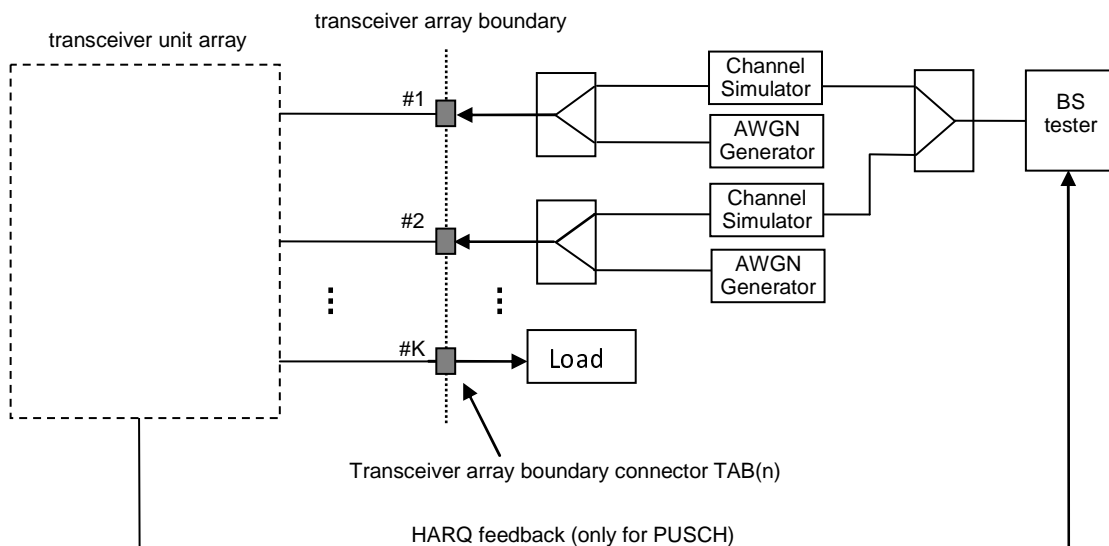

Figure D.5.3-1: Functional set-up for performance requirements for PRACH in static conditions for BS with Rx diversity (2 Rx case shown)

## D.6 BS type 1-H performance requirements

### D.6.1 Performance requirements for PUSCH, single user PUCCH, PRACH on single antenna port in multipath fading conditions



**Figure D.6.1-1: Functional set-up for performance requirements for PUSCH, single user PUCCH, PRACH on single antenna port in multipath fading conditions for BS with Rx diversity (2 Rx case shown)**

NOTE: The HARQ Feedback could be done as an RF feedback or as a digital feedback. The HARQ Feedback should be error free.

### D.6.2 Performance requirements for PUSCH transmission on two antenna ports in multipath fading conditions

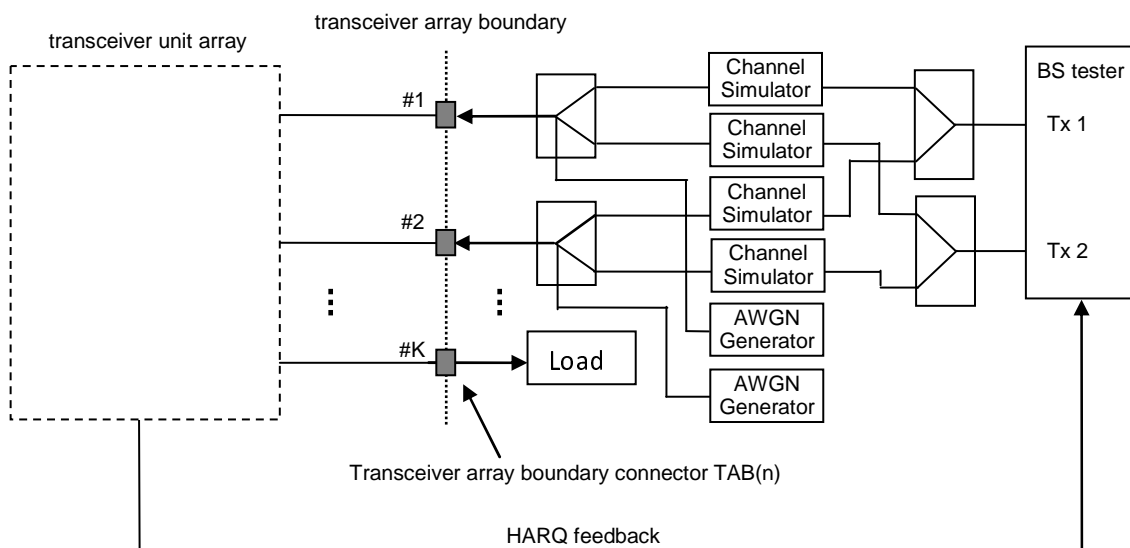

**Figure D.6.2-1: Functional set-up for performance requirements for PUSCH transmission on two antenna ports in multipath fading conditions (2 Rx case shown)**

### D.6.3 Performance requirements for PRACH in static conditions

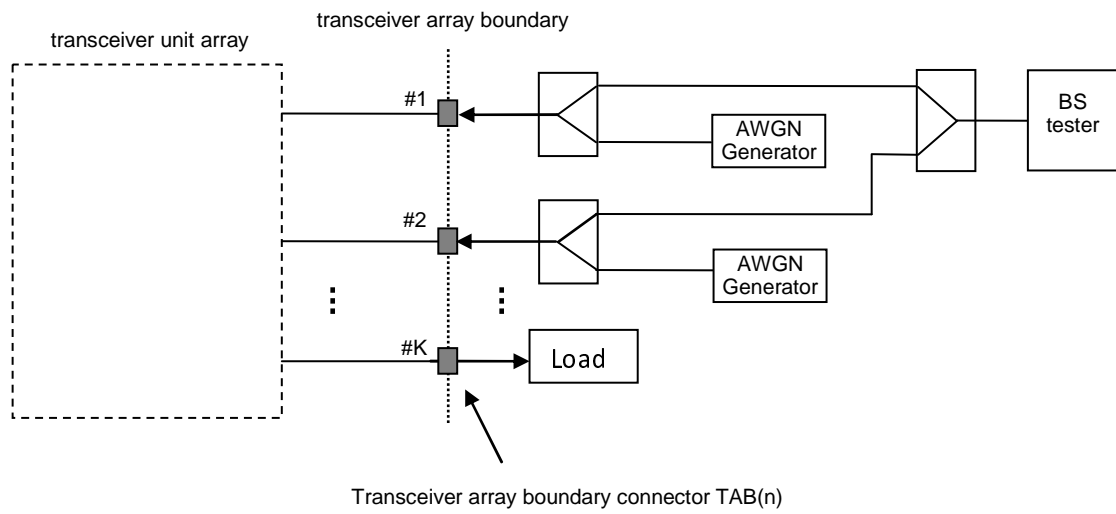

**Figure D.6.3-1: Functional set-up for performance requirements for PRACH in static conditions for BS with Rx diversity (2 Rx case shown)**

---

## Annex E (normative): Characteristics of interfering signals

The interfering signal shall be a PUSCH containing data and DMRS symbols. Normal cyclic prefix is used. The data content shall be uncorrelated to the wanted signal and modulated according to clause 6 of TS 38.211 [17]. Mapping of PUSCH modulation to receiver requirement are specified in table E-1.

**Table E-1: Modulation of the interfering signal**

Receiver requirement	Modulation
In-channel selectivity	16QAM
Adjacent channel selectivity and narrow-band blocking	QPSK
General blocking	QPSK
Receiver intermodulation	QPSK



# Annex F (normative): In-channel Tx tests

## F.1 General

*Editor’s note: Placeholder for the remaining elements of the “Global in-channel Tx test”, e.g. reuse of the E-UTRA annex for frequency error measurement description which is performed together with the EVM.*

## F.2 Reference point for measurement

The EVM shall be measured at the point after the FFT and a zero-forcing (ZF) equalizer in the receiver, as depicted for FR1 in figure F.2-1.

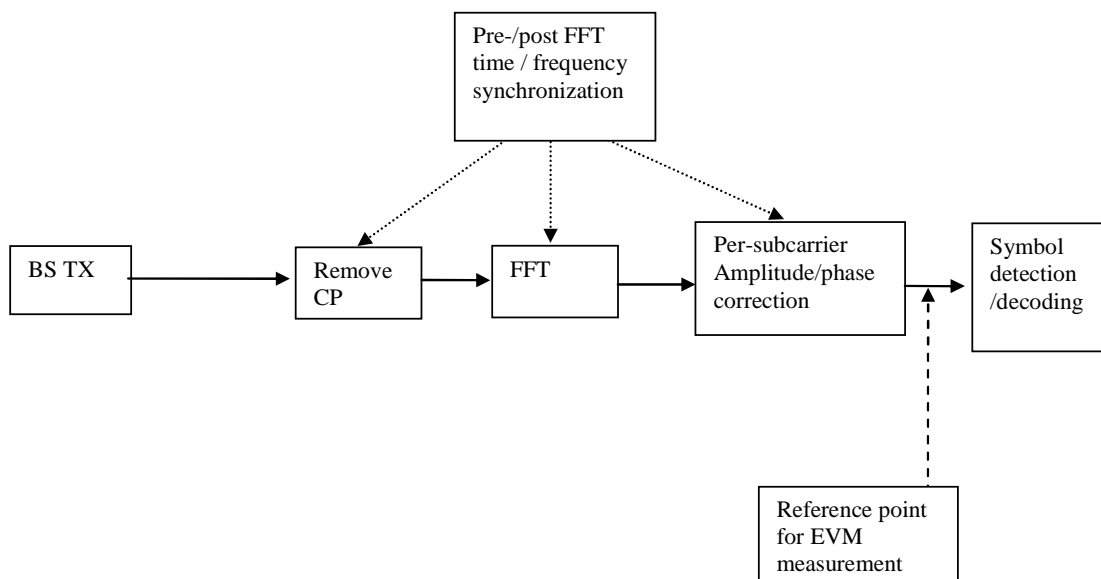

**Figure F.2-1: Reference point for FR1 EVM measurement**

## F.3 Basic unit of measurement

The basic unit of EVM measurement is defined over one subframe (1ms) in the time domain and  $N_{\text{BW}}^{\text{RB}}$  subcarriers (180 kHz) in the frequency domain:

$$EVM = \sqrt{\frac{\sum_{t \in T} \sum_{f \in F(t)} |Z'(t, f) - I(t, f)|^2}{\sum_{t \in T} \sum_{f \in F(t)} |I(t, f)|^2}}$$

where

$T$  is the set of symbols with the considered modulation scheme being active within the subframe,

$F(t)$  is the set of subcarriers within the  $N_{\text{BW}}^{\text{RB}}$  subcarriers with the considered modulation scheme being active in symbol  $t$ ,

$I(t, f)$  is the ideal signal reconstructed by the measurement equipment in accordance with relevant Tx models,

$Z'(t, f)$  is the modified signal under test defined in annex F.4.

NOTE: Although the basic unit of measurement is one subframe, the equalizer is calculated over 10 subframe measurement periods to reduce the impact of noise in the reference symbols. The boundaries of the 10 subframe measurement periods need not be aligned with radio frame boundaries.

---

## F.4 Modified signal under test

Implicit in the definition of EVM is an assumption that the receiver is able to compensate a number of transmitter impairments. The signal under test is equalised and decoded according to:

$$Z'(t, f) = \frac{FFT \left\{ z(v - \Delta\tilde{t}) \cdot e^{-j2\pi\Delta\tilde{f}v} \right\} e^{j2\pi f\Delta\tilde{t}}}{\tilde{a}(f) \cdot e^{j\tilde{\varphi}(f)}}$$

where

$z(v)$  is the time domain samples of the signal under test.

$\Delta\tilde{t}$  is the sample timing difference between the FFT processing window in relation to nominal timing of the ideal signal. Note that two timing offsets are determined, the corresponding EVM is measured and the maximum used as described in annex F.8.

$\Delta\tilde{f}$  is the RF frequency offset.

$\tilde{\varphi}(f)$  is the phase response of the TX chain.

$\tilde{a}(f)$  is the amplitude response of the TX chain.

---

## F.5 Estimation of frequency offset

The observation period for determining the frequency offset  $\Delta\tilde{f}$  shall be [1 ms].

---

## F.6 Estimation of time offset

The observation period for determining the sample timing difference  $\Delta\tilde{t}$  shall be 1 ms.

In the following  $\Delta\tilde{c}$  represents the middle sample of the EVM window of length  $W$  (defined in subclause 6.6.3.5) or the last sample of the first window half if  $W$  is even.

$\Delta\tilde{c}$  is estimated so that the EVM window of length  $W$  is centred on the measured cyclic prefix of the considered OFDM symbol. To minimize the estimation error the timing shall be based on the primary synchronization signal and reference signals. To limit time distortion of any transmit filter the reference signals in the 1 outer RBs are not taken into account in the timing estimation

Two values for  $\Delta\tilde{t}$  are determined:

$$\Delta\tilde{t}_l = \Delta\tilde{c} + \alpha - \left\lfloor \frac{W}{2} \right\rfloor \text{ and}$$

$$\Delta\tilde{t}_h = \Delta\tilde{c} + \left\lceil \frac{W}{2} \right\rceil \text{ where } \alpha = 0 \text{ if } W \text{ is odd and } \alpha = 1 \text{ if } W \text{ is even.}$$

When the cyclic prefix length varies from symbol to symbol then  $T$  shall be further restricted to the subset of symbols with the considered modulation scheme being active and with the considered cyclic prefix length type.

## F.7 Estimation of TX chain amplitude and frequency response parameters

The equalizer coefficients  $\tilde{a}(f)$  and  $\tilde{\varphi}(f)$  are determined as follows:

1. Calculate the complex ratios (amplitude and phase) of the post-FFT acquired signal  $Z'(t, f)$  and the post-FFT Ideal signal  $I_2(t, f)$ , for each reference symbol, over [10 subframes]. This process creates a set of complex ratios:

$$a(t, f).e^{j\varphi(t, f)} = \frac{Z'(t, f)}{I_2(t, f)}$$

Where the post-FFT Ideal signal  $I_2(t, f)$  is constructed by the measuring equipment according to the relevant TX specifications, using the following parameters: restricted content: i.e. nominal Reference Symbols and the Primary Synchronisation Channel, (all other modulation symbols are set to 0 V), nominal carrier frequency, nominal amplitude and phase for each applicable subcarrier, nominal timing.

2. Perform time averaging at each reference signal subcarrier of the complex ratios, the time-averaging length is [10 subframes]. Prior to the averaging of the phases  $\varphi(t_i, f)$  an unwrap operation must be performed according to the following definition: The unwrap operation corrects the radian phase angles of  $\varphi(t_i, f)$  by adding multiples of  $2\pi$  when absolute phase jumps between consecutive time instances  $t_i$  are greater than or equal to the jump tolerance of  $\pi$  radians. This process creates an average amplitude and phase for each reference signal subcarrier (i.e. every second subcarrier with the exception of the reference subcarrier spacing across the DC subcarrier).

$$a(f) = \frac{\sum_{i=1}^N a(t_i, f)}{N}$$

$$\varphi(f) = \frac{\sum_{i=1}^N \varphi(t_i, f)}{N}$$

Where  $N$  is the number of reference symbol time-domain locations  $t_i$  from  $Z'(f, t)$  for each reference signal subcarrier  $f$ .

3. The equalizer coefficients for amplitude and phase  $\hat{a}(f)$  and  $\hat{\varphi}(f)$  at the reference signal subcarriers are obtained by computing the moving average in the frequency domain of the time-averaged reference signal subcarriers, i.e. every second subcarrier. The moving average window size is 19. For reference subcarriers at or near the edge of the channel the window size is reduced accordingly as per figure F.7-1.
4. Perform linear interpolation from the equalizer coefficients  $\hat{a}(f)$  and  $\hat{\varphi}(f)$  to compute coefficients  $\tilde{a}(f)$ ,  $\tilde{\varphi}(f)$  for each subcarrier.

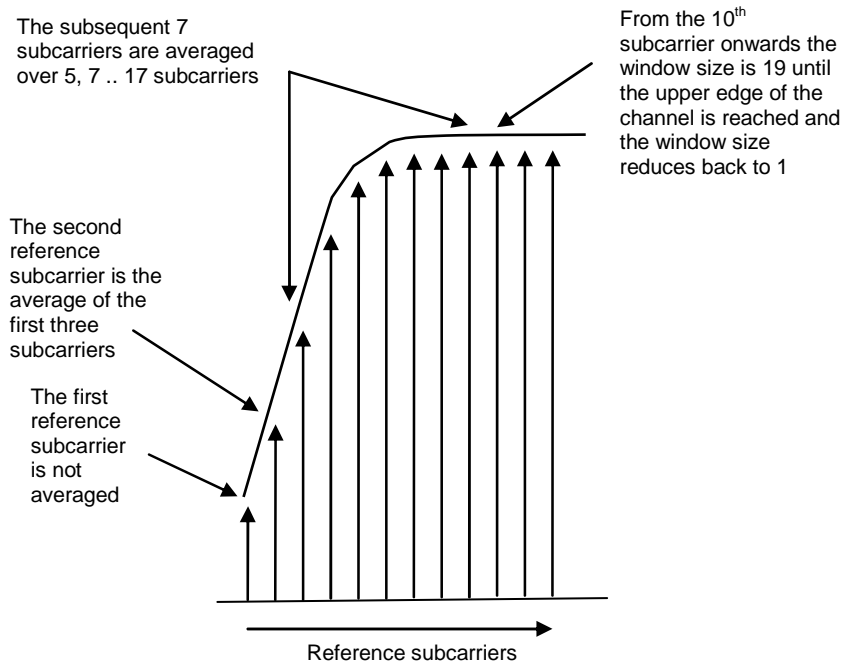

Figure F.7-1: Reference subcarrier smoothing in the frequency domain

## F.8 Averaged EVM

EVM is averaged over all allocated downlink resource blocks with the considered modulation scheme in the frequency domain, and a minimum of 10 downlink subframes:

For FDD the averaging in the time domain equals the 10 subframe duration of the 10 subframes measurement period from the equalizer estimation step.

For TDD the averaging in the time domain can be calculated from subframes of different frames and should have a minimum of [10] subframes averaging length. TDD special fields (i.e. GP) are not included in the averaging.

$$\overline{EVM}_{frame} = \sqrt{\frac{1}{\sum_{i=1}^{N_{dl}} Ni} \sum_{i=1}^{N_{dl}} \sum_{j=1}^{Ni} EVM_{i,j}^2}$$

Where  $Ni$  is the number of resource blocks with the considered modulation scheme in subframe  $i$  and  $N_{dl}$  is the number of allocated downlink subframes in one frame.

The EVM requirements shall be tested against the maximum of the RMS average at the window  $W$  extremities of the EVM measurements:

Thus  $\overline{EVM}_{frame,1}$  is calculated using  $\Delta\tilde{t} = \Delta\tilde{t}_l$  in the expressions above and  $\overline{EVM}_{frame,h}$  is calculated using  $\Delta\tilde{t} = \Delta\tilde{t}_h$  in the  $\overline{EVM}_{frame}$  calculation.

Thus we get:

$$EVM_{frame} = \max(\overline{EVM}_{frame,1}, \overline{EVM}_{frame,h})$$

The averaged EVM with the minimum averaging length of at least [10] subframes is then achieved by further averaging of the  $EVM_{frame}$  results

$$\overline{EVM} = \sqrt{\frac{1}{N_{frame}} \sum_{k=1}^{N_{frame}} EVM_{frame,k}^2}, \quad N_{frame} = \left\lceil \frac{10}{N_{dl}} \right\rceil$$

---

# Annex G (normative): Propagation conditions

---

## G.1 Static propagation condition

The propagation for the static performance measurement is an Additive White Gaussian Noise (AWGN) environment. No fading or multi-paths exist for this propagation model.

---

## G.2 Multi-path fading propagation conditions

The multipath propagation conditions consist of several parts:

- A delay profile in the form of a "tapped delay-line", characterized by a number of taps at fixed positions on a sampling grid. The profile can be further characterized by the r.m.s. delay spread and the maximum delay spanned by the taps.
- A combination of channel model parameters that include the Delay profile and the Doppler spectrum that is characterized by a classical spectrum shape and a maximum Doppler frequency.
- Different models are used for FR1 (410 MHz - 7.125 GHz) and FR2 (24.25 GHz – 52.6 GHz).

### G.2.1 Delay profiles

The delay profiles are simplified from the TR 38.901 [20] TDL models. The simplification steps are shown below for information. These steps are only used when new delay profiles are created. Otherwise, the delay profiles specified in G.2.1.1 can be used as such.

- Step 1: Use the original TDL model from TR 38.901 [20].
- Step 2: Re-order the taps in ascending delays
- Step 3: Perform delay scaling according to the procedure described in subclause 7.7.3 in TR 38.901 [20].
- Step 4: Apply the quantization to the delay resolution 5 ns. This is done simply by rounding the tap delays to the nearest multiple of the delay resolution.
- Step 5: If multiple taps are rounded to the same delay bin, merge them by calculating their linear power sum.
- Step 6: If there are more than 12 taps in the quantized model, merge the taps as follows
  - Find the weakest tap from all taps (both merged and unmerged taps are considered)
    - If there are two or more taps having the same value and are the weakest, select the tap with the smallest delay as the weakest tap.
  - When the weakest tap is the first delay tap, merge taps as follows
    - Update the power of the first delay tap as the linear power sum of the weakest tap and the second delay tap.
    - Remove the second delay tap.
  - When the weakest tap is the last delay tap, merge taps as follows
    - Update the power of the last delay tap as the linear power sum of the second-to-last tap and the last tap.
    - Remove the second-to-last tap.
  - Otherwise

- For each side of the weakest tap, identify the neighbour tap that has the smaller delay difference to the weakest tap.
  - When the delay difference between the weakest tap and the identified neighbour tap on one side equals the delay difference between the weakest tap and the identified neighbour tap on the other side.
    - Select the neighbour tap that is weaker in power for merging.
  - Otherwise, select the neighbour tap that has smaller delay difference for merging.
- To merge, the power of the merged tap is the linear sum of the power of the weakest tap and the selected tap.
- When the selected tap is the first tap, the location of the merged tap is the location of the first tap. The weakest tap is removed.
- When the selected tap is the last tap, the location of the merged tap is the location of the last tap. The weakest tap is removed.
- Otherwise, the location of the merged tap is based on the average delay of the weakest tap and selected tap. If the average delay is on the sampling grid, the location of the merged tap is the average delay. Otherwise, the location of the merged tap is rounded towards the direction of the selected tap (e.g. 10 ns & 20 ns → 15 ns, 10 ns & 25 ns → 20 ns, if 25 ns had higher or equal power; 15 ns, if 10 ns had higher power). The weakest tap and the selected tap are removed.
- Repeat step 6 until the final number of taps is 12.
- Step 7: Round the amplitudes of taps to one decimal (e.g. -8.78 dB → -8.8 dB)
- Step 8: If the delay spread has slightly changed due to the tap merge, adjust the final delay spread by increasing or decreasing the power of the last tap so that the delay spread is corrected.
- Step 9: Re-normalize the highest tap to 0 dB.

Note: Some values of the delay profile created by the simplification steps may differ from the values in tables G.2.1.1-2, G.2.1.1-3, and G.2.1.1-4 for the corresponding model.

### G.2.1.1 Delay profiles for FR1

The delay profiles for FR1 are selected to be representative of low, medium and high delay spread environment. The resulting model parameters are specified in G.2.1.1-1 and the tapped delay line models are specified in tables G.2.1.1-2 ~ table G.2.1.1-4.

**Table G.2.1.1-1: Delay profiles for NR channel models**

Model	Number of channel taps	Delay spread (r.m.s.)	Maximum excess tap delay (span)	Delay resolution
TDLA30	12	30 ns	290 ns	5 ns
TDLB100	12	100 ns	480 ns	5 ns
TDLC300	12	300 ns	2595 ns	5 ns

**Table G.2.1.1-2: TDLA30 (DS = 30 ns)**

Tap #	Delay (ns)	Power (dB)	Fading distribution
1	0	-15.5	Rayleigh
2	10	0	
3	15	-5.1	
4	20	-5.1	
5	25	-9.6	
6	50	-8.2	
7	65	-13.1	
8	75	-11.5	
9	105	-11.0	
10	135	-16.2	
11	150	-16.6	
12	290	-26.2	

**Table G.2.1.1-3: TDLB100 (DS = 100ns)**

Tap #	Delay (ns)	Power (dB)	Fading distribution
1	0	0	Rayleigh
2	10	-2.2	
3	20	-0.6	
4	30	-0.6	
5	35	-0.3	
6	45	-1.2	
7	55	-5.9	
8	120	-2.2	
9	170	-0.8	
10	245	-6.3	
11	330	-7.5	
12	480	-7.1	

**Table G.2.1.1-4: TDLC300 (DS = 300 ns)**

Tap #	Delay (ns)	Power (dB)	Fading distribution
1	0	-6.9	Rayleigh
2	65	0	
3	70	-7.7	
4	190	-2.5	
5	195	-2.4	
6	200	-9.9	
7	240	-8.0	
8	325	-6.6	
9	520	-7.1	
10	1045	-13.0	
11	1510	-14.2	
12	2595	-16.0	

## G.2.2 Combinations of channel model parameters

The propagation conditions used for the performance measurements in multi-path fading environment are indicated as a combination of a channel model name and a maximum Doppler frequency, i.e., TDLA<DS>-<Doppler>, TDLB<DS>-<Doppler> or TDLC<DS>-<Doppler> where '<DS>' indicates the desired delay spread and '<Doppler>' indicates the maximum Doppler frequency (Hz).

Table G.2.2-1 show the propagation conditions that are used for the performance measurements in multi-path fading environment for low, medium and high Doppler frequencies for FR1.



**Table G.2.2-1: Channel model parameters for FR1**

Combination name	Model	Maximum Doppler frequency
TDLA30-5	TDLA30	5 Hz
TDLA30-10	TDLA30	10 Hz
TDLB100-400	TDLB100	400 Hz
TDLC300-100	TDLC300	100 Hz

### G.2.3 MIMO channel correlation matrices

The MIMO channel correlation matrices defined in annex G.2.3 apply for the antenna configuration using uniform linear arrays at both gNB and UE and for the antenna configuration using cross polarized antennas.

#### G.2.3.1 MIMO correlation matrices using Uniform Linear Array

The MIMO channel correlation matrices defined in annex G.2.3.1 apply for the antenna configuration using uniform linear array (ULA) at both gNB and UE.

##### G.2.3.1.1 Definition of MIMO correlation matrices

Table G.2.3.1.1-1 defines the correlation matrix for the gNB.

**Table G.2.3.1.1-1: gNB correlation matrix**

	One antenna	Two antennas	Four antennas
gNB correlation	$R_{gNB} = 1$	$R_{gNB} = \begin{pmatrix} 1 & \alpha \\ \alpha^* & 1 \end{pmatrix}$	$R_{gNB} = \begin{pmatrix} 1 & \alpha^{1/9} & \alpha^{4/9} & \alpha \\ \alpha^{1/9*} & 1 & \alpha^{1/9} & \alpha^{4/9} \\ \alpha^{4/9*} & \alpha^{1/9*} & 1 & \alpha^{1/9} \\ \alpha^* & \alpha^{4/9*} & \alpha^{1/9*} & 1 \end{pmatrix}$

Table G.2.3.1.1-2 defines the correlation matrix for the UE:

**Table G.2.3.1.1-2: UE correlation matrix**

	One antenna	Two antennas	Four antennas
UE correlation	$R_{UE} = 1$	$R_{UE} = \begin{pmatrix} 1 & \beta \\ \beta^* & 1 \end{pmatrix}$	$R_{UE} = \begin{pmatrix} 1 & \beta^{1/9} & \beta^{4/9} & \beta \\ \beta^{1/9*} & 1 & \beta^{1/9} & \beta^{4/9} \\ \beta^{4/9*} & \beta^{1/9*} & 1 & \beta^{1/9} \\ \beta^* & \beta^{4/9*} & \beta^{1/9*} & 1 \end{pmatrix}$

Table G.2.3.1.1-3 defines the channel spatial correlation matrix  $R_{spa}$ . The parameters,  $\alpha$  and  $\beta$  in table G.2.3.1.1-3 defines the spatial correlation between the antennas at the gNB and UE respectively.

**Table G.2.3.1.1-3:  $R_{spat}$  correlation matrices**

1x2 case	$R_{spat} = R_{gNB} = \begin{bmatrix} 1 & \alpha \\ \alpha^* & 1 \end{bmatrix}$
1x4 case	$R_{spat} = R_{gNB} = \begin{pmatrix} 1 & \alpha^{1/9} & \alpha^{4/9} & \alpha \\ \alpha^{1/9*} & 1 & \alpha^{1/9} & \alpha^{4/9} \\ \alpha^{4/9*} & \alpha^{1/9*} & 1 & \alpha^{1/9} \\ \alpha^* & \alpha^{4/9*} & \alpha^{1/9*} & 1 \end{pmatrix}$
2x2 case	$R_{spat} = R_{UE} \otimes R_{gNB} = \begin{pmatrix} 1 & \beta \\ \beta^* & 1 \end{pmatrix} \otimes \begin{pmatrix} 1 & \alpha \\ \alpha^* & 1 \end{pmatrix} = \begin{pmatrix} 1 & \alpha & \beta & \beta\alpha \\ \alpha^* & 1 & \beta\alpha^* & \beta \\ \beta^* & \beta^*\alpha & 1 & \alpha \\ \beta^*\alpha^* & \beta^* & \alpha^* & 1 \end{pmatrix}$
2x4 case	$R_{spat} = R_{UE} \otimes R_{gNB} = \begin{pmatrix} 1 & \beta \\ \beta^* & 1 \end{pmatrix} \otimes \begin{pmatrix} 1 & \alpha^{1/9} & \alpha^{4/9} & \alpha \\ \alpha^{1/9*} & 1 & \alpha^{1/9} & \alpha^{4/9} \\ \alpha^{4/9*} & \alpha^{1/9*} & 1 & \alpha^{1/9} \\ \alpha^* & \alpha^{4/9*} & \alpha^{1/9*} & 1 \end{pmatrix}$
4x4 case	$R_{spat} = R_{UE} \otimes R_{gNB} = \begin{pmatrix} 1 & \beta^{1/9} & \beta^{4/9} & \beta \\ \beta^{1/9*} & 1 & \beta^{1/9} & \beta^{4/9} \\ \beta^{4/9*} & \beta^{1/9*} & 1 & \beta^{1/9} \\ \beta^* & \beta^{4/9*} & \beta^{1/9*} & 1 \end{pmatrix} \otimes \begin{pmatrix} 1 & \alpha^{1/9} & \alpha^{4/9} & \alpha \\ \alpha^{1/9*} & 1 & \alpha^{1/9} & \alpha^{4/9} \\ \alpha^{4/9*} & \alpha^{1/9*} & 1 & \alpha^{1/9} \\ \alpha^* & \alpha^{4/9*} & \alpha^{1/9*} & 1 \end{pmatrix}$

For cases with more antennas at either gNB or UE or both, the channel spatial correlation matrix can still be expressed as the Kronecker product of  $R_{UE}$  and  $R_{gNB}$  according to  $R_{spat} = R_{UE} \otimes R_{gNB}$ .

**G.2.3.1.2 MIMO correlation matrices at high, medium and low level**

The  $\alpha$  and  $\beta$  for different correlation types are given in table G.2.3.1.2-1.

**Table G.2.3.1.2-1: Correlation for high, medium and low level**

Low correlation		Medium correlation		High correlation	
$\alpha$	$\beta$	$\alpha$	$\beta$	$\alpha$	$\beta$
0	0	0.9	0.3	0.9	0.9

The correlation matrices for high, medium and low correlation are defined in table G.2.3.1.2-2, G.2.3.1.2-3 and G.2.3.1.2-4 as below.

The values in table G.2.3.1.2-2 have been adjusted for the 2x4 and 4x4 high correlation cases to insure the correlation matrix is positive semi-definite after round-off to 4 digit precision. This is done using the equation:

$$\mathbf{R}_{high} = [\mathbf{R}_{spatial} + a\mathbf{I}_n]/(1+a)$$

Where the value “a” is a scaling factor such that the smallest value is used to obtain a positive semi-definite result. For the 2x4 high correlation case, a = 0.00010. For the 4x4 high correlation case, a = 0.00012.

The same method is used to adjust the 4x4 medium correlation matrix in table G.2.3.1.2-3 to insure the correlation matrix is positive semi-definite after round-off to 4 digit precision with a = 0.00012.



**Table G.2.3.1.2-4: MIMO correlation matrices for low correlation**

1x2 case	$R_{low} = \mathbf{I}_2$
1x4 case	$R_{low} = \mathbf{I}_4$
2x2 case	$R_{low} = \mathbf{I}_4$
2x4 case	$R_{low} = \mathbf{I}_8$
4x4 case	$R_{low} = \mathbf{I}_{16}$

In table G.2.3.1.2-4,  $\mathbf{I}_d$  is a  $d \times d$  identity matrix.

NOTE: For completeness, the 1x2 cases were defined for high, medium and low correlation but performance requirements exist only for low correlation.

## G.2.3.2 Multi-antenna channel models using cross polarized antennas

The MIMO channel correlation matrices defined in annex G.2.3.2 apply to two cases as presented below:

- One TX antenna and multiple RX antennas case, with cross polarized antennas used at gNB
- Multiple TX antennas and multiple RX antennas case, with cross polarized antennas used at both UE and gNB

The cross-polarized antenna elements with +/-45 degrees polarization slant angles are deployed at gNB. For one TX antenna case, antenna element with +90 degree polarization slant angle is deployed at UE. For multiple TX antennas case, cross-polarized antenna elements with +90/0 degrees polarization slant angles are deployed at UE.

For the cross-polarized antennas, the N antennas are labelled such that antennas for one polarization are listed from 1 to N/2 and antennas for the other polarization are listed from N/2+1 to N, where N is the number of TX or RX antennas.

### G.2.3.2.1 Definition of MIMO correlation matrices using cross polarized antennas

For the channel spatial correlation matrix, the following is used:

$$R_{spat} = P_{UL} (R_{UE} \otimes \Gamma_{UL} \otimes R_{gNB}) P_{UL}^T$$

Where

- $R_{UE}$  is the spatial correlation matrix at the UE with same polarization,
- $R_{gNB}$  is the spatial correlation matrix at the gNB with same polarization,
- $\Gamma_{UL}$  is a polarization correlation matrix,
- $P_{UL}$  is a permutation matrix, and
- $(\bullet)^T$  denotes transpose.

Table G.2.3.2.1-1 defines the polarization correlation matrix.

**Table G.2.3.2.1-1: Polarization correlation matrix**

	One TX antenna	Multiple TX antennas
Polarization correlation matrix	$\Gamma_{UL} = \begin{bmatrix} 1 & -\gamma \\ -\gamma & 1 \end{bmatrix}$	$\Gamma_{UL} = \begin{bmatrix} 1 & -\gamma & 0 & 0 \\ -\gamma & 1 & 0 & 0 \\ 0 & 0 & 1 & \gamma \\ 0 & 0 & \gamma & 1 \end{bmatrix}$

The matrix  $P_{UL}$  is defined as

$$\mathbf{P}_{UL}(a,b) = \begin{cases} 1 & \text{for } a = (j-1)Nr + i \text{ and } b = 2(j-1)Nr + i, & i = 1, \dots, Nr, j = 1, \dots, \lceil Nt/2 \rceil \\ 1 & \text{for } a = (j-1)Nr + i \text{ and } b = 2(j - Nt/2)Nr - Nr + i, & i = 1, \dots, Nr, j = \lceil Nt/2 \rceil + 1, \dots, Nt \\ 0 & \text{otherwise} \end{cases}$$

where  $Nt$  and  $Nr$  is the number of TX and RX antennas respectively, and  $\lceil \bullet \rceil$  is the ceiling operator.

The matrix  $\mathbf{P}_{UL}$  is used to map the spatial correlation coefficients in accordance with the antenna element labelling system described in G.2.3.2.

### G.2.3.2.2 Spatial correlation matrices at UE and gNB sides

#### G.2.3.2.2.1 Spatial correlation matrices at UE side

For 1-antenna transmitter,  $R_{UE} = 1$ .

For 2-antenna transmitter using one pair of cross-polarized antenna elements,  $R_{UE} = 1$ .

For 4-antenna transmitter using two pairs of cross-polarized antenna elements,  $R_{UE} = \begin{pmatrix} 1 & \beta \\ \beta^* & 1 \end{pmatrix}$ .

#### G.2.3.2.2.2 Spatial correlation matrices at gNB side

For 2-antenna receiver using one pair of cross-polarized antenna elements,  $R_{gNB} = 1$ .

For 4-antenna receiver using two pairs of cross-polarized antenna elements,  $R_{gNB} = \begin{bmatrix} 1 & \alpha \\ \alpha^* & 1 \end{bmatrix}$ .

For 8-antenna receiver using four pairs of cross-polarized antenna elements,  $R_{gNB} = \begin{pmatrix} 1 & \alpha^{1/9} & \alpha^{4/9} & \alpha \\ \alpha^{1/9*} & 1 & \alpha^{1/9} & \alpha^{4/9} \\ \alpha^{4/9*} & \alpha^{1/9*} & 1 & \alpha^{1/9} \\ \alpha^* & \alpha^{4/9*} & \alpha^{1/9*} & 1 \end{pmatrix}$ .

### G.2.3.2.3 MIMO correlation matrices using cross polarized antennas

The values for parameters  $\alpha$ ,  $\beta$  and  $\gamma$  for low spatial correlation are given in table G.2.3.2.3-1.

**Table G.2.3.2.3-1: Values for parameters  $\alpha$ ,  $\beta$  and  $\gamma$**

Low spatial correlation		
$\alpha$	$\beta$	$\gamma$
0	0	0
Note 1: Value of $\alpha$ applies when more than one pair of cross-polarized antenna elements at gNB side.		
Note 2: Value of $\beta$ applies when more than one pair of cross-polarized antenna elements at UE side.		

The correlation matrices for low spatial correlation are defined in table G.2.3.2.3-2 as below.

**Table G.2.3.2.3-2: MIMO correlation matrices for low spatial correlation**

1x8 case	$R_{low} = \mathbf{I}_8$
2x8 case	$R_{low} = \mathbf{I}_{16}$

In table G.2.3.2.3-2,  $\mathbf{I}_d$  is a  $d \times d$  identity matrix.

## Annex H (informative): Change history

Change history							
Date	Meeting	TDoc	CR	Re v	Cat	Subject/Comment	New version
2017-11	RAN4#84 bis	R4-1711982	-	-	-	TS skeleton	0.0.1
2018-04	RAN4#86 bis	R4-1803913	-	-	-	R4-1803410 Draft CR to TS 38.141-1: Addition of applicability table in sub-clause 4.7 R4-1803411 TP to TS 38.141-1 Applicability of requirements sub-clause (4.7)	0.1.0
2018-04	RAN4#86 bis	R4-1805424, R4-1806022	-	-	-	Implementation of TPs agreed during RAN4#86bis, on top of the agreed R4-1803913: - R4-1805424 TP to TS 38.141-1 v0.1.0 Sections 1-3 - R4-1806022 TP to TS 38.141-1 v0.1.0 Section 4	0.2.0
2018-06	RAN4#87	R4-1808321, R4-1808322, R4-1808324, R4-1808326, R4-1808482	-	-	-	Implementation of TPs agreed during RAN4#87, on top of R4-1807254: - R4-1808321 TP to TS 38.141-1: conducted manufacturers declarations for NR BS (4.6) - R4-1808322 TP to TS 38.141-1: removal of OTA terms and definitions - R4-1808324 TP to TS 38.141-1: NR channel numbering correction - R4-1808326 TP to TS 38.141-1: Correction of the BS type 1-H architecture figure - R4-1808482 TP to TS 38.141-1: multi-band operation	0.3.0
2018-07	RAN4- AH-1807	R4-1808980, R4-1808981, R4-1808987, R4-1808991, R4-1808992, R4-1808994, R4-1808995, R4-1808997, R4-1809464, R4-1809469, R4-1809470, R4-1809471, R4-1809472, R4-1809474, R4-1809475, R4-1809476, R4-1809478, R4-1809479, R4-1809481, R4-1809482, R4-1809483, R4-1809484, R4-1809558, R4-1809560, R4-1809563, R4-1809564	-	-	-	Implementation of TPs approved during RAN4-AH-1807, on top of R4-1809264 (TS 38.141-1, v0.3.0): - R4-1808980 TP to TS 38.141-1: Conducted TAE requirements (6.5.4) - R4-1808981 TP to TS 38.141-1: General section for unwanted emission requirements (6.6.1) - R4-1808987 TP to TS 38.141-1: General (7.1) - R4-1808991 TP to TS 38.141-1: Out-of-band blocking (7.5) - R4-1808992 TP to TS 38.141-1: Receiver spurious emissions (7.6) - R4-1808994 TP to TS 38.141-1: In-channel selectivity (7.8) - R4-1808995 TP to TS 38.141-1: Environmental requirements for the BS equipment (Annex B) - R4-1808997 TP to TS 38.141-1: General sections (1-5) - R4-1809464 TP to TS 38.141-1 - 4.7 Test Configurations - R4-1809469 TP to TS 38.141-1: MU and TT for NR BS - R4-1809470 TP to TS 38.141-1: Applicability of test configurations - R4-1809471 TP to TS 38.141-1: Conducted BS output power requirements (6.2) - R4-1809472 TP to TS 38.141-1: Conducted output power dynamics requirements (6.3) - R4-1809474 TP to TS38.141-1: Frequency error (6.5.2) - R4-1809475 TP to TS38.141-1: Modulation quality (6.5.3) - R4-1809476 TP to TS 38.141-1: Conducted ACLR requirements (6.6.3) - R4-1809478 TP to TS 38.141-1: Conducted Tx spurious emission requirements (6.6.5) - R4-1809479 TP to TS 38.141-1: Conducted Tx IMD requirements (6.7) - R4-1809481 TP to TS 38.141-1: Reference sensitivity level (7.2) - R4-1809482 TP to TS 38.141-1: Dynamic range (7.3) - R4-1809483 TP to TS 38.141-1: In-band selectivity and blocking (7.4) - R4-1809484 TP to TS 38.141-1: Receiver intermodulation (7.7) - R4-1809558 TP to TS 38.141-1: General section for conducted Tx requirements (6.1) - R4-1809560 TP to TS38.141-1: Transmit ON/OFF power (6.4) - R4-1809563 TP to TS 38.141-1: NR BS conducted declarations corrections - R4-1809564 TP for TS38.141-1: Occupied bandwidth (section 4.1.2 and 6.7.2)	0.4.0

2018-08	RAN4#88	R4-1809711, R4-1810355, R4-1810813, R4-1810814, R4-1810825, R4-1811537, R4-1811617, R4-1811622, R4-1811625, R4-1811627, R4-1811628, R4-1811630, R4-1811631, R4-1811632, R4-1811761, R4-1811764, R4-1811765, R4-1811843	-	-	-	<p>Implementation of TPs approved during RAN4#88, on top of R4-1810575 (TS 38.141-1, v0.4.0):</p> <ul style="list-style-type: none"> <li>- R4-1809711 TP to TR 38.141-1: NR BS manufacturers declarations for conducted test requirements (4.6)</li> <li>- R4-1810355 TP to TS 38.141-1: NR BS occupied bandwidth (6.6.2)</li> <li>- R4-1810813 TP to TS 38.141-1: Operating bands and channel arrangement (5)</li> <li>- R4-1810814 TP to TS 38.141-1: Requirements for contiguous and non-contiguous spectrum (4.10)</li> <li>- R4-1810825 TP to TS 38.141-1: cleanup</li> <li>- R4-1811537 TP for introduction of band n74 for TS38.141-1</li> <li>- R4-1811617 Correction on general clause for 38.141-1</li> <li>- R4-1811622 TP to TS 38.141-1 Test configuration(Sections 4.7)</li> <li>- R4-1811625 TP to TS 38.141-1: NR Test Models</li> <li>- R4-1811627 TBDs on acceptable uncertainty of Test System (4.1.2)</li> <li>- R4-1811628 TP to TS 38.141-1:Annex</li> <li>- R4-1811630 TP to TS 38.141-1: Regional requirements (4.4)</li> <li>- R4-1811631 TP to TS 38.141-1: Ancillary RF amplifiers (4.5.1.5)</li> <li>- R4-1811632 TP to TS 38.141-1: 6.6.4 Operating band unwanted emissions</li> <li>- R4-1811761 TP: Add parameters band n50 in TS 38.141-1</li> <li>- R4-1811764 TP to TS 38.141-1: Remaining issues on conducted declarations (4.6)</li> <li>- R4-1811765 TP to TS 38.141-1: Conducted declarations renumbering (4.6)</li> <li>- R4-1811843 TP for TR38.141-1: RF channel for BS conducted conformance test</li> </ul>	0.5.0
2018-09	RAN#81	RP-181663	-	-	-	Presented to TSG RAN for information.	1.0.0



2018-11	RAN4#88 bis	R4-1812583 R4-1812675 R4-1812676 R4-1812680 R4-1813307 R4-1813531 R4-1813535 R4-1813746 R4-1813748 R4-1813750 R4-1813751 R4-1813752 R4-1813753 R4-1813876 R4-1813880 R4-1813886 R4-1813887 R4-1813888 R4-1813889 R4-1813891 R4-1813892 R4-1813893 R4-1813894 R4-1814063 R4-1814119 R4-1814178	-	-	<p>Implementation of TPs approved during RAN4#88bis, on top of RP-181663 (TS 38.141-1, v1.0.0):</p> <ul style="list-style-type: none"> <li>- R4-1812583 TP to TS 38.141-1: Correction on NOTE for wanted signal mean power for NR BS RX requirements</li> <li>- R4-1812675 TP to TS 38.141-1: Update on MU and TT</li> <li>- R4-1812676 TP to TS 38.141-1: Correction on reference sensitivity level</li> <li>- R4-1812680 TP to TS 38.141-1: Clarification Note on non-zero Test Tolerance</li> <li>- R4-1813307 TP to TS 38.141-1: connecting network loss declaration for BS type 1-C</li> <li>- R4-1813531 TP to TS 38.141-1: Corrections to Modulation quality test in Clause 6.5.3</li> <li>- R4-1813535 TP to TS 38.141-1: Correction to clause 4.7.2 Test signal used to build Test Configurations</li> <li>- R4-1813746 TP to TS 38.141-1: Conducted performance requirements (8)</li> <li>- R4-1813748 TP to TS 38.141-1: Conducted performance requirements for DFT-s-OFDM based PUSCH</li> <li>- R4-1813750 TP to TS38.141-1: PUCCH format 1 conducted conformance test</li> <li>- R4-1813751 Draft TP for 38.141-1 clause 8 about PUCCH formats 3 and 4 conformance testing</li> <li>- R4-1813752 TP to TS38.141-1: Performance requirements for PRACH</li> <li>- R4-1813753 TP to TS 38.141-1: FRC definitions for NR FR1 PUSCH demodulation requirements</li> <li>- R4-1813876 TP for TS38.141-1: Adding a note for some specific requirements on RF channel</li> <li>- R4-1813880 TP to TS 38.141-1: Data content for FR1</li> <li>- R4-1813886 TP to TS 38.141-1: Corrections to align with 38.104 update</li> <li>- R4-1813887 TP to 38.141-1: Clause 4.6 - correction for manufacturer declaration</li> <li>- R4-1813888 TP to TS 38.141-1: operating bands applicable for spurious emissions testing above 12.75 GHz</li> <li>- R4-1813889 TP to TS 38.141-1: Update for NR BS occupied bandwidth requirement (6.6.2)</li> <li>- R4-1813891 TP to TS 38.141-1: Correction of interferer for the RX intermodulation requirement</li> <li>- R4-1813892 TP to TS 38.141-1: In-channel selectivity (7.8)</li> <li>- R4-1813893 TP to TS 38.141-1: Measurement system set-up and test tolerances for NR BS performance requirements</li> <li>- R4-1813894 TP to TS 38.141-1: Inclusion of MU for performance requirements</li> <li>- R4-1814063 TP for 38.141 on NR PUSCH test requirements with CP-OFDM and FR1</li> <li>- R4-1814119 TP to TS 38.141-1: Correction on the FRCs in Annex A1 and A2</li> <li>- R4-1814178 TP to TS 38.141-1: Clean up on method of test</li> </ul>	1.1.0
---------	-------------	--	---	---	---	-------

2018-11	RAN4#89	R4-1815282 R4-1814435 R4-1814443 R4-1814620 R4-1815284 R4-1815292 R4-1815295 R4-1815372 R4-1815688 R4-1816273 R4-1816276 R4-1816282 R4-1816283 R4-1816284 R4-1816287 R4-1816308 R4-1816352 R4-1816355 R4-1816358 R4-1816373 R4-1816378 R4-1816442 R4-1816592 R4-1816691 R4-1816719 R4-1816724 R4-1816725 R4-1816730 R4-1816731	-	-	-	Implementation of TPs approved during RAN4#89, on top of R4-1815276 (TS 38.141-1, v1.1.0): - R4-1815282 TP to TS 38.141-1: Cleanup - R4-1814435 TP to TS 38.141-1: Measurement system set-up for BS type 1-H performance requirements - R4-1814443 TP to TS 38.141-1: FRC definitions for FR1 DFT-s-OFDM based PUSCH - R4-1814620 TP to TS 38.141-1 on Characteristics of the interfering signals - R4-1815284 TP to TS 38.141-1: Corrections on additional spurious emissions requirements - R4-1815292 TP to TS 38.141-1: Section 6.6.5 – correction of RF channels for test - R4-1815295 TP to TS 38.141-1: Correction to Section 7.1 Conducted receiver characteristics - R4-1815372 TP to TS 38.141-1: Interpretation of measurement results and the Shared Risk principle - R4-1815688 TP to TS 38.141-1: Out-of-band blocking co-location requirement (7.5) - R4-1816273 TP to TS 38.141-1: Transmit ON/OFF power (Section 6.4) - R4-1816276 TP to TS 38.141-1: Remaining annexes - R4-1816282 TP to TS 38.141-1 on manufacturer declarations for NR conducted requirements testing - R4-1816283 TP to TS 38.141-1: On Applicability of test configurations - R4-1816284 TP to TS 38.141-1: Correction to description of ACLR test limits - R4-1816287 TP to TS 38.141-1: Addition of declaration of TAB connectors used for demodulation testing - R4-1816308 TP to TS 38.141-1 Corrections on transmitter intermodulation (section 3.2 and 6.7) - R4-1816352 TP to TS 38.141-1: Update of AWGN power level and FRC index for DFT-s-OFDM based PUSCH demodulation requirements - R4-1816355 TP for TS 38.141-1 on NR PUCCH format2 conducted performance requirements - R4-1816358 TP to TS38.141-1: Performance requirements for PRACH - R4-1816373 TP for 38.141-1 on PUSCH requirements with CP-OFDM and FR1 - R4-1816378 TP for introducing propagation conditions in TS 38.141-1 - R4-1816442 TP to TS 38.141-1: Cleanup to conducted requirements text - R4-1816592 TP to TS 38.141-1: PUCCH format 0 requirement testing - R4-1816691 TP for TS38.141-1 conductive requirements for PUCCH format 1 performance - R4-1816719 TP for updating 38.141-1 clause 8 about PUCCH formats 3 and 4 conformance testing - R4-1816724 TP for TS38.141-1 base conformation test models (Section 4.9.2.2) - R4-1816725 TP to TS 38.141-1: 4.9.2.3 Data content of Physical channels and Signals for NR-FR1-TM - R4-1816730 TP to TS38.141-1: total power dynamic range(Section 6.3.3) - R4-1816731 TP to TS 38.141-1: transmitted signal quality (Section 6.5)	1.2.0
2018-12	RAN#82	RP-182583				Presented to TSG RAN for approval.	2.0.0
2018-12	RAN#82					Approved by plenary – Rel-15 spec under change control	15.0.0

2019-03	RAN#83	RP-190403	0001		B	<p>CR to TS 38.141-1</p> <p>Implementation of the following draft CRs, which were Endorsed during RAN4#90, on top of v15.0.0:</p> <ul style="list-style-type: none"> <li>- R4-1900285 Draft CR on NR PUCCH format2 conducted performance requirements for TS 38.141-1</li> <li>- R4-1900390 CR to 38.141-1: Introduction of n48</li> <li>- R4-1900764 Draft CR to TS 38.141-1: Update of test requirement numbers for DFT-s-OFDM based PUSCH</li> <li>- R4-1900969 Draft CR for 38.141-1: Conducted test requirements for NR PUCCH format 1</li> <li>- R4-1901324 Draft CR to 38.141-1: 6.3.3 Total power dynamic range - correction</li> <li>- R4-1901331 Draft CR to 38.141-1: Updates for Abbreviations section</li> <li>- R4-1901373 CR to TS 38.141-1: Editorial Changes to Align Texts Throughout</li> <li>- R4-1901388 Draft CR to TS 38.141-1 BS demodulation PUCCH format 0 requirements</li> <li>- R4-1901475 Draft CR to TS 38.141-1: Corrections on transmitter co-existence and co-location requirements</li> <li>- R4-1901484 Draft CR to TS 38.141-1: Corrections on in-band blocking requirements</li> <li>- R4-1901744 DraftCR to TS 38.141-1: Removal of FR2 remainings</li> <li>- R4-1901748 DraftCR to TS 38.141-1: Band 85 correction for Tx spur coexistence</li> <li>- R4-1902266 DraftCR to TS 38.141-1: addition of the lunt BS modem section</li> <li>- R4-1902269 CR to TS 38.141-1: Adding subclause 4.8 reference to test procedures</li> <li>- R4-1902270 Draft CR to TS 38.141-1_Correction on test procedures for single-carrier and multi-carrier operation for Tx requirements</li> <li>- R4-1902292 Draft CR for TS 38.141-1: Correction on TM applicability</li> <li>- R4-1902294 Corrections to 38.141-1 subclause 4.9.2 base conformation test models</li> <li>- R4-1902326 Draft CR to TS 38.141-1 on Correction of unwanted emissions scaling</li> <li>- R4-1902342 CR to TS 38.141-1: FR frequency limit corrections</li> <li>- R4-1902384 Draft CR to TS 38.141-1: Applicability rule for BS conducted demodulation test</li> <li>- R4-1902390 draftCR for 38.141-1: Conducted test requirements for CP-OFDM based PUSCH in FR1</li> <li>- R4-1902397 draftCR: Updates to PUCCH formats 3 and 4 conducted conformance testing in TS 38.141-1</li> <li>- R4-1902400 Draft CR for updating PRACH performance requirements in TS38.141-1</li> <li>- R4-1902572 Corrections to 38.141-1 Delay profile calculation</li> <li>- R4-1902646 Draft CR to TS 38.141-1: Data Content of physical channels and signals for NR-FR1-TM (Section 4.9.2.3)</li> <li>- R4-1902654 DraftCR to TS 38.141-1: corrections for the single-band / multi-band connector terminology</li> </ul>	15.1.0
---------	--------	-----------	------	--	---	--	--------

---

# History

<b>Document history</b>		
V15.0.0	April 2019	Publication
V15.1.0	April 2019	Publication