

ETSI TS 138 115-1 V18.11.0 (2026-04)



TECHNICAL SPECIFICATION

**5G;
NR;
Repeater conformance testing -
Part 1: Conducted conformance testing
(3GPP TS 38.115-1 version 18.11.0 Release 18)**



Reference

RTS/TSGR-0438115-1vib0

Keywords

5G

ETSI

650 Route des Lucioles
F-06921 Sophia Antipolis Cedex - FRANCE

Tel.: +33 4 92 94 42 00 Fax: +33 4 93 65 47 16

Siret N° 348 623 562 00017 - APE 7112B
Association à but non lucratif enregistrée à la
Sous-Préfecture de Grasse (06) N° w061004871

Important notice

The present document can be downloaded from the
[ETSI Search & Browse Standards](#) application.

The present document may be made available in electronic versions and/or in print. The content of any electronic and/or print versions of the present document shall not be modified without the prior written authorization of ETSI. In case of any existing or perceived difference in contents between such versions and/or in print, the prevailing version of an ETSI deliverable is the one made publicly available in PDF format on [ETSI deliver](#) repository.

Users should be aware that the present document may be revised or have its status changed, this information is available in the [Milestones listing](#).

If you find errors in the present document, please send your comments to the relevant service listed under [Committee Support Staff](#).

If you find a security vulnerability in the present document, please report it through our [Coordinated Vulnerability Disclosure \(CVD\)](#) program.

Notice of disclaimer & limitation of liability

The information provided in the present deliverable is directed solely to professionals who have the appropriate degree of experience to understand and interpret its content in accordance with generally accepted engineering or other professional standard and applicable regulations.

No recommendation as to products and services or vendors is made or should be implied.

No representation or warranty is made that this deliverable is technically accurate or sufficient or conforms to any law and/or governmental rule and/or regulation and further, no representation or warranty is made of merchantability or fitness for any particular purpose or against infringement of intellectual property rights.

In no event shall ETSI be held liable for loss of profits or any other incidental or consequential damages.

Any software contained in this deliverable is provided "AS IS" with no warranties, express or implied, including but not limited to, the warranties of merchantability, fitness for a particular purpose and non-infringement of intellectual property rights and ETSI shall not be held liable in any event for any damages whatsoever (including, without limitation, damages for loss of profits, business interruption, loss of information, or any other pecuniary loss) arising out of or related to the use of or inability to use the software.

Copyright Notification

No part may be reproduced or utilized in any form or by any means, electronic or mechanical, including photocopying and microfilm except as authorized by written permission of ETSI.

The content of the PDF version shall not be modified without the written authorization of ETSI.

The copyright and the foregoing restriction extend to reproduction in all media.

© ETSI 2026.
All rights reserved.

Intellectual Property Rights

Essential patents

IPRs essential or potentially essential to normative deliverables may have been declared to ETSI. The declarations pertaining to these essential IPRs, if any, are publicly available for **ETSI members and non-members**, and can be found in ETSI SR 000 314: "*Intellectual Property Rights (IPRs); Essential, or potentially Essential, IPRs notified to ETSI in respect of ETSI standards*", which is available from the ETSI Secretariat. Latest updates are available on the [ETSI IPR online database](#).

Pursuant to the ETSI Directives including the ETSI IPR Policy, no investigation regarding the essentiality of IPRs, including IPR searches, has been carried out by ETSI. No guarantee can be given as to the existence of other IPRs not referenced in ETSI SR 000 314 (or the updates on the ETSI Web server) which are, or may be, or may become, essential to the present document.

Trademarks

The present document may include trademarks and/or tradenames which are asserted and/or registered by their owners. ETSI claims no ownership of these except for any which are indicated as being the property of ETSI, and conveys no right to use or reproduce any trademark and/or tradename. Mention of those trademarks in the present document does not constitute an endorsement by ETSI of products, services or organizations associated with those trademarks.

DECT™, **PLUGTESTS™**, **UMTS™** and the ETSI logo are trademarks of ETSI registered for the benefit of its Members. **3GPP™**, **LTE™** and **5G™** logo are trademarks of ETSI registered for the benefit of its Members and of the 3GPP Organizational Partners. **oneM2M™** logo is a trademark of ETSI registered for the benefit of its Members and of the oneM2M Partners. **GSM®** and the GSM logo are trademarks registered and owned by the GSM Association.

Legal Notice

This Technical Specification (TS) has been produced by ETSI 3rd Generation Partnership Project (3GPP).

The present document may refer to technical specifications or reports using their 3GPP identities. These shall be interpreted as being references to the corresponding ETSI deliverables.

The cross reference between 3GPP and ETSI identities can be found at [3GPP to ETSI numbering cross-referencing](#).

Modal verbs terminology

In the present document "**shall**", "**shall not**", "**should**", "**should not**", "**may**", "**need not**", "**will**", "**will not**", "**can**" and "**cannot**" are to be interpreted as described in clause 3.2 of the [ETSI Drafting Rules](#) (Verbal forms for the expression of provisions).

"**must**" and "**must not**" are **NOT** allowed in ETSI deliverables except when used in direct citation.

Contents

Intellectual Property Rights	2
Legal Notice	2
Modal verbs terminology.....	2
Foreword.....	11
1 Scope	13
2 References	13
3 Definitions of terms, symbols and abbreviations	14
3.1 Terms.....	14
3.2 Symbols.....	15
3.3 Abbreviations	16
4 General conducted test conditions and declarations.....	17
4.1 Measurement uncertainties and test requirements	17
4.1.1 General.....	17
4.1.2 Acceptable uncertainty of Test System.....	17
4.1.2.1 General	17
4.1.2.2 Conducted characteristics measurements	18
4.1.3 Interpretation of measurement results	20
4.2 Conducted requirement reference points	21
4.2.1 RF Repeater	21
4.2.2 NCR type 1-C	21
4.2.3 NCR type 1-H.....	22
4.3 Repeater classes.....	22
4.3.1 Repeater class for downlink.....	22
4.3.2 Repeater class for uplink.....	23
4.3A NCR classes.....	23
4.3A.1 NCR class for downlink.....	23
4.3A.2 NCR class for uplink and MT	23
4.4 Regional requirements.....	23
4.5 Repeater configurations.....	24
4.5.1 General configurations.....	24
4.5.2 Transmission with multiple BS-side antenna connectors for RF repeater and NCR type 1-C.....	24
4.5.2A Transmission with multiple BS-side antenna connectors for NCR type 1-H.....	24
4.5.3 Transmission with multiple UE-side antenna connectors for RF repeater and NCR type 1-C.....	24
4.5.3A Transmission with multiple UE-side antenna connectors for NCR type 1-H	24
4.5.4 Duplexers.....	25
4.5.5 Power supply options.....	25
4.5.6 Ancillary RF amplifiers	25
4.5.7 Combining of repeaters.....	26
4.6 Manufacturer declarations	26
4.7 Test configurations	32
4.7.1 General.....	32
4.7.2 Test signal used to build Test Configurations.....	33
4.7.3 RTC1: Contiguous spectrum operation for RF repeater	33
4.7.3.1 RTC1 generation	33
4.7.3.2 RTC1 power allocation	33
4.7.5 RTC2: Non-contiguous spectrum operation for RF repeater	33
4.7.5.1 RTC2 generation	33
4.7.5.2 RTC2 power allocation	34
4.7.6 RTC3: Multi-band test configuration for full carrier allocation for RF repeater	34
4.7.6.1 RTC3 generation	34
4.7.6.2 RTC3 power allocation	34
4.7.7 RTC4: Multi-band test configuration with high PSD per carrier for RF repeater.....	34
4.7.7.1 RTC4 generation	34
4.7.7.2 RTC4 power allocation	35

4.7.8	NCRTC1: Contiguous spectrum operation for NCR	35
4.7.8.1	NCRTC1 generation.....	35
4.7.8.2	NCRTC1 power allocation.....	35
4.7.9	NCRTC2: Non-contiguous spectrum operation for NCR	35
4.7.9.1	NCRTC2 generation.....	36
4.7.9.2	NCRTC2 power allocation.....	36
4.7.10	NCRTC3: Multi-band test configuration for full carrier allocation for NCR	36
4.7.10.1	NCRTC3 generation.....	36
4.7.10.2	NCRTC3 power allocation.....	36
4.7.11	NCRTC4: Multi-band test configuration with high PSD per carrier for NCR.....	37
4.7.11.1	NCRTC4 generation.....	37
4.7.11.2	NCRTC4 power allocation.....	37
4.8	Applicability of requirements.....	37
4.8.1	General.....	37
4.8.2	Applicability of test configurations for single-band operation	37
4.8.4	Applicability of test configurations for multi-band operation	38
4.9	RF channels and test models	40
4.9.1	RF channels	40
4.9.2	Test models	41
4.9.2.1	General	41
4.9.2.2	FR1 test models for repeater type 1-C for DL.....	41
4.9.2.3	FR1 test models for repeater type 1-C for UL.....	41
4.9.2.3.1	General	41
4.9.2.3.2	FR1 test model 1.1 (RUL-FR1-TM1.1).....	42
4.9.2.3.3	FR1 test model 2 (RUL-FR1-TM2).....	43
4.9.2.3.3a	FR1 test model 2a (RUL-FR1-TM2a)	43
4.9.2.3.4	FR1 test model 3.1 (RUL-FR1-TM3.1).....	43
4.9.2.3.5	FR1 test model 3.1a (RUL-FR1-TM3.1a)	44
4.9.2.4	Data content of Physical channels and Signals for RUL-FR1-TM	44
4.9.2.4.1	General	44
4.9.2.4.2	PUSCH	44
4.9A	RF channels and test models for NCR.....	44
4.9A.1	RF channels	44
4.9A.2	Test models	45
4.9A.2.1	General	45
4.9A.2.2	FR1 test models for NCR for DL	45
4.9A.2.3	FR1 test models for NCR for UL	46
4.9A.2.3.1	General	46
4.9A.2.3.2	FR1 test model 1.1 (NCRUL-FR1-TM1.1)	46
4.9A.2.3.3	FR1 test model 2 (NCRUL-FR1-TM2)	47
4.9A.2.3.3a	FR1 test model 2a (NCRUL-FR1-TM2a).....	47
4.9A.2.3.4	FR1 test model 3.1 (NCRUL-FR1-TM3.1)	48
4.9A.2.3.5	FR1 test model 3.1a (NCRUL-FR1-TM3.1a).....	48
4.9A.2.4	Data content of Physical channels and Signals for NCRUL-FR1-TM.....	48
4.9A.2.4.1	General	48
4.9A.2.4.2	PUSCH	49
4.10	Requirements for contiguous and non-contiguous spectrum.....	49
4.11	Requirements for repeater capable of multi-band operation	49
4.12	Format and interpretation of tests	50
5	Operating bands and channel arrangement.....	50
6	Conducted characteristics	51
6.1	General	51
6.2	Repeater output power.....	51
6.2.1	Definition and applicability	51
6.2.2	Minimum requirement	52
6.2.3	Test purpose.....	53
6.2.4	Method of test	53
6.2.4.1	Initial conditions	53
6.2.4.2	Procedure.....	53
6.2.5	Test requirement	54

6.3	Frequency stability	54
6.3.1	Definition and applicability	54
6.3.2	Minimum Requirement	54
6.3.3	Test purpose.....	54
6.3.4	Method of test	54
6.3.5	Test Requirements	54
6.4	Out of band gain	55
6.4.1	Definition and applicability	55
6.4.2	Minimum Requirement	55
6.4.3	Test purpose.....	55
6.4.4	Method of test	55
6.4.4.1	Initial conditions	55
6.4.4.2	Procedure	55
6.4.5	Test Requirements	55
6.5	Unwanted emissions.....	56
6.5.1	General.....	56
6.5.2	Adjacent Channel Leakage Power Ratio (ACLR)	57
6.5.2.1	Definition and applicability.....	57
6.5.2.2	Minimum requirement	57
6.5.2.3	Test purpose	57
6.5.2.4	Method of test	57
6.5.2.4.1	Initial conditions	57
6.5.2.4.2	Procedure.....	57
6.5.2.5	Test requirements for RF repeater.....	58
6.5.2.6	Test requirement for <i>NCR</i>	63
6.5.2.6.1	Test requirements for <i>NCR-Fwd</i>	63
6.5.2.6.2	Test requirement for <i>NCR-MT</i>	64
6.5.3	Operating band unwanted emissions	64
6.5.3.1	Definition and applicability.....	64
6.5.3.2	Minimum requirement	66
6.5.3.3	Test purpose	66
6.5.3.4	Method of test	66
6.5.3.4.1	Initial conditions.....	66
6.5.3.4.2	Procedure for RF repeater.....	66
6.5.3.4a	Test requirements for RF repeater.....	67
6.5.3.4a.1	Operating band unwanted emission limits for <i>Wide Area repeater type 1-C (Category A)</i>	67
6.5.3.4a.2	Operating band unwanted emission limits for <i>Wide Area repeater type 1-C (Category B)</i>	68
6.5.3.4a.2.1	Category B requirements (Option 1)	68
6.5.3.4a.2.2	Category B requirements (Option 2)	70
6.5.3.4a.3	Operating band unwanted emission limits for <i>Medium Range repeater type 1-C (Category A and B) for DL</i>	71
6.5.3.4a.4	Operating band unwanted emission limits for <i>Local Area repeater type 1-C (Category A and B)</i>	72
6.5.3.4a.5	Additional operating band unwanted emission requirements	73
6.5.3.5	Void.....	74
6.5.3.6	Test requirement for <i>NCR</i>	74
6.5.3.6.1	Test requirement for <i>NCR-Fwd</i>	74
6.5.3.6.2	Test requirement for <i>NCR-MT</i>	74
6.5.4	Transmitter spurious emissions.....	75
6.5.4.1	Definition and applicability.....	75
6.5.4.2	Minimum requirement	76
6.5.4.3	Test purpose	76
6.5.4.4	Method of test	76
6.5.4.4.1	Initial conditions	76
6.5.4.4.2	Procedure for RF repeater.....	76
6.5.4.5	Test requirements for RF repeater.....	77
6.5.4.5.1	General transmitter spurious emissions requirements	77
6.5.4.5.2	Additional spurious emissions requirements	78
6.5.4.5.3	Co-location with base stations and <i>repeater</i>	89
6.5.4.6	Test requirements for <i>NCR</i>	95
6.5.4.6.1	Test requirement for <i>NCR-Fwd</i>	95
6.5.4.6.2	Test requirement for <i>NCR-MT</i>	95

6.5.5	Receiver spurious emissions	96
6.5.5.1	Definition and applicability	96
6.5.5.2	Minimum requirement	96
6.5.5.3	Test purpose	96
6.5.5.4	Method of test	96
6.5.5.4.1	Initial conditions	96
6.5.5.4.2	Procedure	97
6.5.5.5	Test requirements	97
6.5.5.6	Test requirements for <i>NCR</i>	97
6.5.5.6.1	Test requirement for <i>NCR-Fwd</i>	97
6.6	Repeater Error Vector Magnitude	98
6.6.1	Downlink repeater error vector magnitude	98
6.6.1.1	General	98
6.6.1.2	Minimum requirements	98
6.6.1.3	Test purpose	99
6.6.1.4	Method of test	99
6.6.1.4.1	Initial conditions	99
6.6.1.4.2	Procedure	99
6.6.1.5	Test requirement	100
6.6.2	Uplink repeater error vector magnitude	100
6.6.2.1	General	100
6.6.2.2	Minimum requirement	101
6.6.2.3	Test purpose	101
6.6.2.3	Method of test	101
6.6.2.3.1	Initial conditions	101
6.6.2.3.2	Procedure	101
6.6.2.4	Test requirement	102
6.7	Input intermodulation	103
6.7.1	Definition and applicability	103
6.7.1.1	General	103
6.7.1.2	Minimum requirements	103
6.7.1.3	Test purpose	103
6.7.1.4	Method of test	103
6.7.1.4.1	Initial conditions	103
6.7.1.4.2	Procedure	103
6.7.1.5	Test requirements	104
6.7.1.5.1	General requirement	104
6.7.1.5.2	Co-location with BS/Repeater in other systems	104
6.7.1.5.3	Co-existence with other systems	105
6.8	Output intermodulation	106
6.8.1	Definition and applicability	106
6.8.1.1	General	106
6.8.1.2	Minimum requirements	106
6.8.1.3	Test purpose	106
6.8.1.4	Method of test	106
6.8.1.4.1	Initial conditions	106
6.8.1.4.2	Procedure	106
6.8.1.5	Test requirements	107
6.8.1.5.1	General requirements	107
6.8.1.5.2	Additional requirements	107
6.9	Adjacent Channel Rejection Ratio (ACRR)	108
6.9.1	Definitions and applicability	108
6.9.2	Co-existence with UTRA, E-UTRA and NR	108
6.9.2.1	Minimum requirements	108
6.9.2.2	Test purpose	108
6.9.2.3	Method of test	108
6.9.2.3.1	Initial conditions	108
6.9.2.3.2	Procedure	109
6.9.2.3.3	Test Requirements	109
6.10	Transmit ON/OFF power	111
6.10.1	Transmitter OFF power	111
6.10.1.1	Definition and applicability	111

6.10.1.2	Minimum requirement	111
6.10.1.3	Test purpose	111
6.10.1.4	Method of test	111
6.10.1.5	Test requirements	111
6.10.2	Transmitter transient period	111
6.10.2.1	Definition and applicability	111
6.10.2.2	Minimum requirement	112
6.10.2.3	Test purpose	112
6.10.2.4	Method of test	112
6.10.2.4.1	Initial conditions	112
6.10.2.4.2	Procedure	113
6.11	Output power dynamics for NCR-MT	114
6.11.1	Definition and applicability	114
6.11.2	Minimum requirement	114
6.11.2.1	Minimum requirement for transmit OFF power for NCR-MT	114
6.11.2.2	Minimum requirement for transmit ON/OFF time mask for NCR-MT	114
6.11.2.3	Minimum requirement for power control for NCR-MT	114
6.11.3	Test purpose	114
6.12	Transmit signal quality for NCR-MT	114
6.12.1	Definition and applicability	114
6.12.2	Minimum requirement	115
6.12.2.1	Minimum requirement for frequency error requirements for NCR-MT	115
6.12.2.2	Minimum requirement for transmit modulation quality	115
6.12.3	Test purpose	115
6.12.4	Method of test	115
6.12.4.1	Initial conditions	115
6.12.4.2	Procedure	115
6.12.5	Test requirements	116
6.13	Transmit intermodulation for NCR-MT	117
6.13.1	Definition and applicability	117
6.13.2	Minimum requirement for NCR-MT	117
6.13.3	Test purpose	118
6.13.4	Method of test	118
6.13.4.1	Initial conditions	118
6.13.4.2	Procedure	118
6.13.5	Test requirements	119
6.13.5.1	Co-location minimum requirements	119
6.13.5.2	Intra-system minimum requirements	120
6.13.5.3	Additional requirements	120
6.14	Reference sensitivity for NCR-MT	121
6.14.1	Definition and applicability	121
6.14.2	Minimum requirements for NCR-MT type 1-C and 1-H	121
6.14.3	Test purpose	121
6.14.4	Method of test	121
6.14.4.1	Initial conditions	121
6.14.4.2	Procedure	121
6.14.5	Test requirements for NCR-MT	122
6.15	Maximum input level for NCR-MT	122
6.15.1	Definition and applicability	122
6.15.2	Minimum requirement	122
6.15.3	Test purpose	122
6.15.4	Method of test	123
6.15.4.1	Initial conditions	123
6.15.4.2	Procedure	123
6.15.5	Test requirements	123
6.16	Adjacent channel selectivity for NCR-MT	123
6.16.1	Definition and applicability	123
6.16.2	Minimum requirement	124
6.16.3	Test purpose	124
6.16.4	Method of test	124
6.16.4.1	Initial conditions	124
6.16.4.2	Procedure	124

6.16.5	Test requirements for NCR-MT.....	124
6.16.6	Void	125
6.17	Blocking characteristics for NCR-MT	125
6.17.1	Definition and applicability	125
6.17.2	Minimum requirement	125
6.17.3	Test purpose.....	125
6.17.4	Method of test	125
6.17.4.1	Initial conditions	125
6.17.4.2	Procedure for general blocking	125
6.17.4.3	Procedure for narrowband blocking.....	126
6.17.4.4	Procedure for out of band blocking.....	126
6.17.5	Test requirements for NCR-MT.....	127
6.18	Transmitter spurious response for NCR-MT	127
6.18.1	Definition and applicability	127
6.18.2	Minimum requirement	127
6.18.3	Test purpose.....	127
6.18.4	Method of test	127
6.18.4.1	Initial conditions	127
6.18.4.2	Procedure	127
6.18.5	Test requirements.....	128
6.19	Receiver intermodulation characteristics for NCR-MT.....	128
6.19.1	Definition and applicability	128
6.19.2	Minimum requirement	128
6.19.3	Test purpose.....	128
6.19.4	Method of test	128
6.19.4.1	Initial conditions	128
6.19.4.2	Procedure	128
6.19.5	Test requirements for NCR-MT.....	129
6.20	Receiver spurious emissions for NCR-MT	129
6.20.1	Definition and applicability	129
6.20.2	Minimum requirement	129
6.20.3	Test purpose.....	129
6.20.4	Method of test	130
6.20.4.1	Initial conditions	130
6.20.4.2	Procedure	130
6.20.5	Test requirements.....	130
6.20.5.1	Basic limits for NCR-MT.....	130
6.20.5.2	Test requirement for NCR-MT	131
7.1.3	CSI reporting requirements.....	136
7.1.3.1	General	136
7.1.3.1.1	Applicability rule for NCR-MT.....	136
7.1.3.1.2	Common test parameters	137
7.1.3.2	Reporting Channel Quality Indicator (CQI).....	138
7.1.3.2.1	Definition and applicability	138
7.1.3.2.2	Minimum requirement.....	138
7.1.3.2.3	Test purpose	138
7.1.3.2.4	Method of test.....	138
7.1.3.2.5	Test requirement	142
Annex A (normative): Repeater stimulus signals		143
A.1	Repeater stimulus signal 1.....	143
A.2	Repeater stimulus signal 2.....	143
A.3	Repeater stimulus signal spectral purity requirements.....	143
Annex B (normative): Environmental requirements for the repeater.....		145
B.1	General	145
B.2	Normal test environment.....	145
B.3	Extreme test environment.....	145

B.3.1	Extreme temperature	145
B.4	Vibration.....	146
B.5	Power supply	146
B.6	Measurement of test environments.....	146
Annex C (informative): Test tolerances and derivation of test requirements.....		147
C.1	Measurement of conducted characteristics.....	148
Annex D (informative): Measurement system set-up.....		149
D.1	Repeater output power and transmit ON/OFF power.....	149
D.2	Out of band gain.....	149
D.3	Unwanted emission: Operating band unwanted emission, transmitter spurious emission, and ACLR	150
D.4	Modulation Accuracy: Repeater Error Vector Magnitude and Frequency Stability	150
D.5	Input intermodulation.....	151
D.6	Output Intermodulation	151
D.7	Adjacent Channel Rejection Ratio	152
D.8	Rx spurious emission requirement	152
D.9	NCR-MT type 1-C PDCCH and PDSCH demodulation testing	152
D.10	NCR-MT type 1-C CQI testing	153
D.11	NCR-MT type 1-H PDCCH and PDSCH demodulation testing	154
D.12	NCR-MT type 1-H CQI testing.....	155
Annex E (normative): In-channel TX tests		157
E.1	General	157
E.2	Basic principles	157
E.2.1	Output signal of the repeater under test.....	157
E.2.2	Ideal signal	157
E.2.3	Measurement results.....	158
E.2.4	Measurement points	158
E.3	Pre-FFT minimization process	159
E.4	Timing of the FFT window	159
E.5	Resource element TX power	160
E.6	Post-FFT equalisation.....	161
E.7	EVM.....	162
E.7.0	General	162
E.7.1	Averaged EVM (FDD).....	163
E.7.2	Averaged EVM (TDD).....	163
Annex F (normative): NCR-MT Reference measurement channels.....		165
F.1	NCR-MT Demodulation Performance Fixed Reference Channels	165
F.1.1	Fixed Reference Channels for PDSCH performance requirements.....	165
F.1.2	Fixed Reference Channels for PDCCH performance requirements	165
F.1.3	Fixed Reference Channels for CSI reporting performance	166
F.2	Fixed Reference Channels for reference sensitivity level, ACS, in-band blocking, out-of-band blocking and receiver intermodulation (QPSK, R=1/3).....	167

Annex G (normative): Propagation conditions	167
G.1 Static propagation condition.....	167
G.1.1 NCR-MT receiver with 2RX.....	167
G.1.2 NCR-MT Receiver with 4Rx.....	167
G.2 Multi-path fading propagation conditions.....	168
G.2.1 General.....	168
G.2.2 Delay profiles.....	168
G.2.2.1 General.....	168
G.2.2.2 Delay profiles for FR1.....	169
G.2.3 Combinations of channel model parameters.....	170
G.2.4 MIMO channel correlation matrices.....	171
G.2.4.1 General.....	171
G.2.4.2 MIMO correlation matrices using Uniform Linear Array.....	171
G.2.4.2.1 General.....	171
G.2.4.2.2 Definition of MIMO correlation matrices.....	171
G.2.4.2.3 MIMO correlation matrices at high, medium and low level.....	172
G.2.4.3 Multi-antenna channel models using cross polarized antennas.....	173
G.2.4.3.1 General.....	173
G.2.4.3.2 Definition of MIMO correlation matrices using cross polarized antennas.....	174
G.2.4.3.3 Spatial correlation matrices at NCR-MT and gNB sides.....	174
G.2.4.3.3.1 Spatial correlation matrices at NCR-MT side.....	174
G.2.4.3.3.2 Spatial correlation matrices at gNB side.....	175
G.2.4.3.4 MIMO correlation matrices using cross polarized antennas.....	175
G.2.4.3.5 Beam steering approach.....	175
Annex H (informative): Change history	177
History.....	179

Foreword

This Technical Specification has been produced by the 3rd Generation Partnership Project (3GPP).

The contents of the present document are subject to continuing work within the TSG and may change following formal TSG approval. Should the TSG modify the contents of the present document, it will be re-released by the TSG with an identifying change of release date and an increase in version number as follows:

Version x.y.z

where:

- x the first digit:
 - 1 presented to TSG for information;
 - 2 presented to TSG for approval;
 - 3 or greater indicates TSG approved document under change control.
- y the second digit is incremented for all changes of substance, i.e. technical enhancements, corrections, updates, etc.
- z the third digit is incremented when editorial only changes have been incorporated in the document.

In the present document, modal verbs have the following meanings:

- shall** indicates a mandatory requirement to do something
- shall not** indicates an interdiction (prohibition) to do something

The constructions "shall" and "shall not" are confined to the context of normative provisions, and do not appear in Technical Reports.

The constructions "must" and "must not" are not used as substitutes for "shall" and "shall not". Their use is avoided insofar as possible, and they are not used in a normative context except in a direct citation from an external, referenced, non-3GPP document, or so as to maintain continuity of style when extending or modifying the provisions of such a referenced document.

- should** indicates a recommendation to do something
- should not** indicates a recommendation not to do something
- may** indicates permission to do something
- need not** indicates permission not to do something

The construction "may not" is ambiguous and is not used in normative elements. The unambiguous constructions "might not" or "shall not" are used instead, depending upon the meaning intended.

- can** indicates that something is possible
- cannot** indicates that something is impossible

The constructions "can" and "cannot" are not substitutes for "may" and "need not".

- will** indicates that something is certain or expected to happen as a result of action taken by an agency the behaviour of which is outside the scope of the present document
- will not** indicates that something is certain or expected not to happen as a result of action taken by an agency the behaviour of which is outside the scope of the present document
- might** indicates a likelihood that something will happen as a result of action taken by some agency the behaviour of which is outside the scope of the present document

might not indicates a likelihood that something will not happen as a result of action taken by some agency the behaviour of which is outside the scope of the present document

In addition:

is (or any other verb in the indicative mood) indicates a statement of fact

is not (or any other negative verb in the indicative mood) indicates a statement of fact

The constructions "is" and "is not" do not indicate requirements.

1 Scope

The present document specifies the Radio Frequency (RF) test methods and conformance requirements for RF repeater *type 1-C*, *network controlled repeater type (NCR) 1-C* and *1-H*. These have been derived from, and are consistent with the conducted requirements for *repeater type 1-C*, *network controlled repeater type 1-C* and *1-H* in NR repeater specification defined in TS 38.106 [2].

RF *repeater type 1-C* and *NCR type 1-C* only have conducted requirements so they require compliance to this specification only.

NCR type 1-H has both conducted and radiated requirements so it requires compliance to this specification and TS 38.115-2 [3].

RF *repeater type 2-O* and *NCR type 2-O* have only radiated requirements so they require compliance to TS 38.115-2 [3] only.

2 References

The following documents contain provisions which, through reference in this text, constitute provisions of the present document.

- References are either specific (identified by date of publication, edition number, version number, etc.) or non-specific.
- For a specific reference, subsequent revisions do not apply.
- For a non-specific reference, the latest version applies. In the case of a reference to a 3GPP document (including a GSM document), a non-specific reference implicitly refers to the latest version of that document *in the same Release as the present document*.

- [1] 3GPP TR 21.905: "Vocabulary for 3GPP Specifications".
- [2] 3GPP TS 38.106: "NR; Repeater Radio Transmission and Reception"
- [3] 3GPP TS 38.115-2: "NR; Repeater conformance testing, Part 2: Radiated conformance testing"
- [4] ITU-R Recommendation SM.329: "Unwanted emissions in the spurious domain"
- [5] 3GPP TS 38.104: "NR; Base Station (BS) radio transmission and reception"
- [6] 3GPP TS 36.104: "Evolved Universal Terrestrial Radio Access (E-UTRA); Base Station (BS) radio transmission and reception"
- [7] 3GPP TS 38.141-1: "NR; Base Station (BS) conformance testing, Part 1: Conducted conformance testing"
- [8] 3GPP TS 38.211: "NR; Physical channels and modulation"
- [9] 3GPP TS 38.101-1: "NR; User Equipment (UE) radio transmission and reception; Part 1: Range 1 Standalone"
- [10] 3GPP TS 38.331: "NR; Radio Resource Control (RRC) protocol specification"
- [11] ITU-R Recommendation M.1545: "Measurement uncertainty as it applies to test limits for the terrestrial component of International Mobile Telecommunications – 2000"
- [12] ITU-T Recommendation O.150, "Equipment for the measurement of digital and analogue/digital parameters"
- [13] Federal Communications Commission: "Title 47 of the Code of Federal Regulations (CFR) "
- [14] ECC/DEC/(17)06: "The harmonised use of the frequency bands 1427-1452 MHz and 1492-1518 MHz for Mobile/Fixed Communications Networks Supplemental Downlink (MFCN SDL)"

- [15] 3GPP TR 25.942: "RF system scenarios"
- [16] IEC 60 721-3-3: "Classification of environmental conditions - Part 3-3: Classification of groups of environmental parameters and their severities - Stationary use at weather protected locations"
- [17] IEC 60 721-3-4: "Classification of environmental conditions - Part 3: Classification of groups of environmental parameters and their severities - Clause 4: Stationary use at non-weather protected locations"
- [18] IEC 60 721: "Classification of environmental conditions"
- [19] IEC 60 068-2-1 (2007): "Environmental testing - Part 2: Tests. Tests A: Cold"
- [20] IEC 60 068-2-2: (2007): "Environmental testing - Part 2: Tests. Tests B: Dry heat"
- [21] IEC 60 068-2-6: (2007): "Environmental testing - Part 2: Tests - Test Fc: Vibration (sinusoidal)"
- [22] Void
- [23] 3GPP TS 38.214: "NR; Physical layer procedures for data"
- [24] 3GPP TR 38.901: "Study on channel model for frequencies from 0.5 to 100 GHz"
- [25] 3GPP TS 38.521-1: "User Equipment (UE) conformance specification; Radio transmission and reception; Part 1: Range 1 Standalone"[26] 3GPP TR 38.174: "NR; Integrated Access and Backhaul (IAB) radio transmission and reception"

3 Definitions of terms, symbols and abbreviations

3.1 Terms

For the purposes of the present document, the terms given in 3GPP TR 21.905 [1] and the following apply. A term defined in the present document takes precedence over the definition of the same term, if any, in 3GPP TR 21.905 [1].

Antenna connector: connector at the conducted interface of the *repeater type I-C* **gap between passbands:** frequency gap between two consecutive passbands that belong to the same *operating band*, where the RF requirements in the gap are based on co-existence for un-coordinated operation

Inter-passband gap: The frequency gap between two supported consecutive *passbands* that belong to different operating bands.

Maximum passband output power: mean power level measured per *passband* at the *antenna connector*, during the *transmitter ON state* in a specified reference condition.

multi-band connector: *Antenna Connector* for a *Multi-band repeater*.

Multi-band repeater: *Repeater Type I-C* whose *antenna connector* is associated with a transmitter and/or receiver that is characterized by the ability to process two or more *passband(s)* in common active RF components simultaneously, where at least one *passband* is configured at a different operating band than the other *passband(s)* and where this different operating band is not a sub-band or superseding-band of another supported operating band

NCR type 1-C: NCR-MT or NCR-Fwd at FR1 with a *requirement set* consisting only of conducted requirements defined at individual antenna connectors.

NCR type 1-H: NCR-MT or NCR-Fwd operating at FR1 with a *requirement set* consisting of conducted requirements defined at individual TAB connectors and OTA requirements defined at RIB. **Nominal channel bandwidth:** Bandwidth calculated as $\min(100\text{MHz}, BW_{\text{passband}})$ in FR1 or $\min(400\text{MHz}, BW_{\text{passband}})$ in FR2. If this bandwidth is not defined for BS channel bandwidth for the operating band, *nominal channel bandwidth* shall be defined as the widest BS channel bandwidth for the operating band which is narrower than BW_{passband} .

Non-contiguous spectrum: spectrum consisting of two or more *passbands* separated by *inter-passband gap(s)*.

Operating band: frequency range in which NR operates (paired or unpaired), that is defined with a specific set of technical requirements

Passband: The frequency range in which the repeater operates in with operational configuration, this frequency range can correspond to one or several consecutive nominal channels, if they are not consecutive each subset of channels shall be considered as an individual *passband*, a repeater can have one or several *passbands*, all channels within the *passband(s)* shall belong to a single operator or collaborating operators.

passband edge: Frequency at the edge of the passband

Repeater type 1-C: Repeater operating at FR1 with a requirement set consisting only of conducted requirements defined at individual *antenna connectors*.

Requirement set: one of the NR requirements set as defined for *NR repeater*

single-band connector: *Repeater type 1-C antenna connector* supporting operation either in a single *operating band* only, or in multiple *operating bands* but does not meet the conditions for a *multi-band connector*.

Sub-band: A *sub-band* of an operating band contains a part of the uplink and downlink frequency range of the operating band.

sub-block: one contiguous allocated block of spectrum for transmission and reception by the repeater.

Superseding-band: A *superseding-band* of an operating band includes the whole of the uplink and downlink frequency range of the operating band.

TAB connector: *transceiver array boundary connector*

transceiver array boundary: conducted interface between the transceiver unit array and the composite antenna

Transmitter OFF state: Time period during which the repeater downlink or uplink is not allowed to transmit in the corresponding direction.

Transmitter ON state: Time period during which the repeater is transmitting downlink or uplink signals in the corresponding direction.

Transmitter transient period: Time period during which the repeater is changing from the OFF state to the ON state or vice versa.

3.2 Symbols

For the purposes of the present document, the following symbols apply:

BW_{Config}	Transmission bandwidth configuration, where $BW_{\text{Config}} = N_{\text{RB}} \times \text{SCS} \times 12$
BW_{Nominal}	Nominal channel bandwidth
BW_{Passband}	<i>Passband</i> bandwidth
Δf	Separation between the <i>passband edge</i> frequency and the nominal -3 dB point of the measuring filter closest to the carrier frequency
Δf_{max}	$f_{\text{offset}_{\text{max}}}$ minus half of the bandwidth of the measuring filter
Δf_{OBUE}	Maximum offset of the <i>operating band</i> unwanted emissions mask from the <i>operating band edge</i>
$F_{\text{DL,low}}$	The lowest frequency of the downlink <i>operating band</i>
$F_{\text{DL,high}}$	The highest frequency of the downlink <i>operating band</i>
F_{filter}	Filter centre frequency
$F_{\text{offset,high}}$	Frequency offset from $F_{\text{C,high}}$ to the upper <i>passband edge</i>
$F_{\text{offset,low}}$	Frequency offset from $F_{\text{C,low}}$ to the lower <i>passband edge</i>
f_{offset}	Separation between the <i>passband edge</i> frequency and the centre of the measuring filter
$f_{\text{offset}_{\text{max}}}$	The offset to the frequency Δf_{OBUE} outside the <i>operating band</i>
$F_{\text{UL,low}}$	The lowest frequency of the uplink <i>operating band</i>
$F_{\text{UL,high}}$	The highest frequency of the uplink <i>operating band</i>
$P_{\text{EM,n50/n75,ind}}$	Declared emission level for Band n50/n75; ind = a, b
$P_{\text{EM,n54,ind}}$	Declared emission level for Band n54 in the band 1518-1559 MHz; ind = a, b, c, d, e, f
$P_{\text{max,p,AC}}$	<i>Maximum passband output power</i> measured per <i>antenna connector</i>

$P_{\max,c,TABC}$	The maximum carrier output power per TAB connector
$P_{\text{rated},c,AC}$	The rated carrier output power per antenna connector
$P_{\text{rated},c,\text{sys}}$	The sum of $P_{\text{rated},c,TABC}$ for all TAB connectors for a single carrier
$P_{\text{rated},c,TABC}$	The rated carrier output power per TAB connector
$P_{\text{rated},in}$	Rated pass band input power to the repeater for the test per antenna connector
$P_{\text{rated},p,AC}$	Rated passband output power per antenna connector
$P_{\text{rated},p,\text{sys}}$	The sum of $P_{\text{rated},c,TABC}$ for all TAB connectors for passband
$P_{\text{rated},p,TABC}$	The rated passband output power per TAB connector
$P_{\text{rated},t,AC}$	Rated total output power declared per antenna connector
$P_{\text{rated},t,TABC}$	The rated total output power declared at TAB connector
$P_{in,p,AC}$	Input power intended to produce the maximum rated output power ($P_{\text{rated},p,AC}$) at the antenna connector
$P_{in,p,TABC}$	Input power intended to produce the maximum rated output power ($P_{\text{rated},p,AC}$) at the antenna connector
$P_{\max,p,AC}$	Maximum passband output power measured per antenna connector
$P_{\max,p,TABC}$	The maximum passband output power per TAB connector
W_{gap}	Inter passband Bandwidth gap size

3.3 Abbreviations

For the purposes of the present document, the abbreviations given in 3GPP TR 21.905 [1] and the following apply. An abbreviation defined in the present document takes precedence over the definition of the same abbreviation, if any, in 3GPP TR 21.905 [1].

ACLR	Adjacent Channel Leakage Ratio
ACS	Adjacent Channel Selectivity
BW	Bandwidth
CACLR	Cumulative ACLR
CP-OFDM	Cyclic Prefix-OFDM
CW	Continuous Wave
DFT-s-OFDM	Discrete Fourier Transform-spread-OFDM
DL	Downlink
EVM	Error Vector Magnitude
FR	Frequency Range
ITU-R	Radiocommunication Sector of the International Telecommunication Union
LA	Local Area
MR	Medium Range
NCR	Network Controlled Repeater
NCR-MT	NCR Mobile Termination
NCR-Fwd	NCR Forward
NR	New Radio
OBUE	Operating Band Unwanted Emissions
OOB	Out-of-band
QAM	Quadrature Amplitude Modulation
RF	Radio Frequency
RX	Receiver
SCS	Sub-Carrier Spacing
TAB	Transceiver Array Boundary
TX	Transmitter
UL	Uplink
WA	Wide Area

4 General conducted test conditions and declarations

4.1 Measurement uncertainties and test requirements

4.1.1 General

The requirements of this clause apply to all applicable tests in part 1 of this specification, i.e. to all conducted tests defined for FR1. The frequency ranges FR1 and FR2 are defined in clause 5.1 of TS 38.106 [2].

The minimum requirements are given in TS 38.106 [2]. Test Tolerances for the conducted test requirements explicitly stated in the present document are given in annex C of the present document.

Test Tolerances are individually calculated for each test. The Test Tolerances are used to relax the minimum requirements to create test requirements.

When a test requirement differs from the corresponding minimum requirement, then the Test Tolerance applied for the test is non-zero. The Test Tolerance for the test and the explanation of how the minimum requirement has been relaxed by the Test Tolerance are given in annex C.

4.1.2 Acceptable uncertainty of Test System

4.1.2.1 General

The maximum acceptable uncertainty of the Test System is specified below for each test defined explicitly in the present specification, where appropriate. The maximum acceptable uncertainty of the Test System for test requirements included by reference is defined in the respective referred test specification.

The Test System shall enable the stimulus signals in the test case to be adjusted to within the specified tolerance and the equipment under test to be measured with an uncertainty not exceeding the specified values. All tolerances and uncertainties are absolute values, and are valid for a confidence level of 95 %, unless otherwise stated.

A confidence level of 95 % is the measurement uncertainty tolerance interval for a specific measurement that contains 95 % of the performance of a population of test equipment.

For RF tests, it should be noted that the uncertainties in clause 4.1.2 apply to the Test System operating into a nominal 50 ohm load and do not include system effects due to mismatch between the DUT and the Test System.

4.1.2.2 Conducted characteristics measurements

Table 4.1.2.2-1: Maximum Test System uncertainty for conducted characteristics tests

Clause	Maximum Test System Uncertainty	Derivation of Test System Uncertainty
6.2 Repeater output power	± 0.7 dB, $f \leq 3$ GHz ± 1.0 dB, 3 GHz $< f \leq 7.125$ GHz	
6.3 Frequency stability	± 12 Hz Measurement results of ± 500 Hz	
6.4 Out of band gain	± 0.5 dB, $f \leq 3.0$ GHz ± 0.8 dB, 3.0 GHz $< f \leq 4.2$ GHz Calibration of test set-up shall be made without DUT in order to achieve the accuracy	
6.5.2 ACLR/ CACLR	BW ≤ 20 MHz: ± 0.8 dB BW > 20 MHz: ± 1.2 dB Absolute power ± 2.0 dB, $f \leq 3$ GHz Absolute power ± 2.5 dB, 3 GHz $< f \leq 7.125$ GHz	
6.5.3 Operating band unwanted emission	± 1.5 dB, $f \leq 3.0$ GHz ± 1.8 dB, 3.0 GHz $< f \leq 4.2$ GHz The interference from the signal generator ACLR shall be minimum 10 dB below that of a NR repeater according to clause 6.5.2.	
6.5.4 Spurious emissions	In NR and coexistence receive bands: for results > -60 dBm ± 2.0 dB for results < -60 dBm ± 3.0 dB Outside above range: emission power; 9 kHz $< f \leq 4$ GHz ± 2.0 dB 4 GHz $< f \leq 19$ GHz ± 4.0 dB. The interference from the signal generator ACLR shall be minimum 10 dB below that of a NR repeater according to clause 6.5.2.	
6.6 EVM	1% signal analyser 2% stimulus signal	
6.7 Input intermodulation	± 1.2 dB	Formula: RSS CW1 level error, 2 x CW2 level error, and measurement error (using all errors = ± 0.5 dB)
6.8 Output intermodulation	For operating band unwanted emission: ± 2.1 dB The interference from the signal generator ACLR shall be minimum 10 dB below that of a NR repeater according to clause 6.5.2. For spurious emission: In NR and coexistence receive bands: for results > -60 dBm ± 2.0 dB for results < -60 dBm ± 3.0 dB Outside above range: emission power; 9 kHz $< f \leq 4$ GHz ± 2.0 dB; 4GHz $< f \leq 19$ GHz ± 4.0 dB. The interference signal must have a spurious emission level at least 10 dB below the spurious levels required in 6.5.4 and 6.5.5.	Formula: RSS 2x Interference signal level error and operating band unwanted emission measurement level error. (1 dB interference signal level error is assumed).
6.9 ACRR	± 0.7 dB	
6.10.1 Transmit ON/OFF power	± 2.0 dB, $f \leq 3$ GHz ± 2.5 dB, 3 GHz $< f \leq 7.125$ GHz	
6.10.1 Transmit OFF power	N/A	
6.11 Output power dynamics for NCR-MT	± 0.4 dB	

Clause	Maximum Test System Uncertainty	Derivation of Test System Uncertainty
6.12.1 Frequency Error Requirements for NCR-MT	± 12 Hz	
6.12.2 Transmit Modulation Quality for NCR-MT	$\pm 1\%$	
6.13 Transmitter intermodulation for NCR-MT	The value below applies only to the interfering signal and is unrelated to the measurement uncertainty of the tests in 6.6.3 (ACLR), 6.6.4 (OBUE) and 6.6.5 (spurious emissions) which have to be carried out in the presence of the interferer. ± 1.0 dB	The uncertainty of interferer has double the effect on the result due to the frequency offset
6.14 Reference Sensitivity for NCR-MT	± 0.7 dB, $f \leq 3$ GHz ± 1.0 dB, 3 GHz $< f \leq 4.2$ GHz ± 1.2 dB, 4.2 GHz $< f \leq 6$ GHz	
6.15 Maximum Input Level for NCR-MT	± 0.3 dB	
6.16 Adjacent channel selectivity for NCR-MT	± 1.4 dB, $f \leq 3$ GHz ± 1.8 dB, 3 GHz $< f \leq 4.2$ GHz ± 2.1 dB, 4.2 GHz $< f \leq 6$ GHz (NOTE 2)	
6.17 Blocking Characteristics for NCR-MT	General blocking: ± 1.6 dB, $f \leq 3$ GHz ± 2.0 dB, 3 GHz $< f \leq 4.2$ GHz ± 2.2 dB, 4.2 GHz $< f \leq 6$ GHz (NOTE 2) Narrowband blocking: ± 1.4 dB, $f \leq 3$ GHz ± 1.8 dB, 3 GHz $< f \leq 4.2$ GHz ± 2.1 dB, 4.2 GHz $< f \leq 6$ GHz (NOTE 2)	
6.18 Spurious response for NCR-MT	N/A	
6.19 Receiver intermodulation characteristics for NCR-MT	± 1.8 dB, $f \leq 3.0$ GHz ± 2.4 dB, 3.0 GHz $< f \leq 4.2$ GHz ± 3.0 dB, 4.2 GHz $< f \leq 6.0$ GHz (NOTE 2)	
6.20 Receiver spurious emissions for NCR-MT	30 MHz $\leq f \leq 4$ GHz: ± 2.0 dB 4 GHz $< f \leq 19$ GHz: ± 4.0 dB 19 GHz $< f \leq 26$ GHz: ± 4.5 dB	
NOTE 1: Unless otherwise noted, only the Test System stimulus error is considered here. The effect of errors in the throughput measurements due to finite test duration is not considered.		
NOTE 2: Test system uncertainty values for 4.2 GHz $< f \leq 6$ GHz apply for NCR operates in licensed spectrum only.		

4.1.3 Interpretation of measurement results

The measurement results returned by the Test System are compared - without any modification - against the test requirements as defined by the Shared Risk principle.

The Shared Risk principle is defined in Recommendation ITU-R M.1545 [11].

The actual measurement uncertainty of the Test System for the measurement of each parameter shall be included in the test report.

The recorded value for the Test System uncertainty shall be, for each measurement, equal to or lower than the appropriate figure in clause 4.1.2 of the present document.

If the Test System for a test is known to have a measurement uncertainty greater than that specified in clause 4.1.2, it is still permitted to use this apparatus provided that an adjustment is made as follows.

Any additional uncertainty in the Test System over and above that specified in clause 4.1.2 shall be used to tighten the test requirement, making the test harder to pass. For some tests e.g. receiver tests, this may require modification of stimulus signals. This procedure will ensure that a Test System not compliant with clause 4.1.2 does not increase the chance of passing a device under test where that device would otherwise have failed the test if a Test System compliant with clause 4.1.2 had been used.

4.2 Conducted requirement reference points

4.2.1 RF Repeater

For *repeater type 1-C*, the requirements are applied at the repeater *antenna connector* (BS-side connector or UE-side connector) for downlink or uplink for the configuration in normal operating conditions.

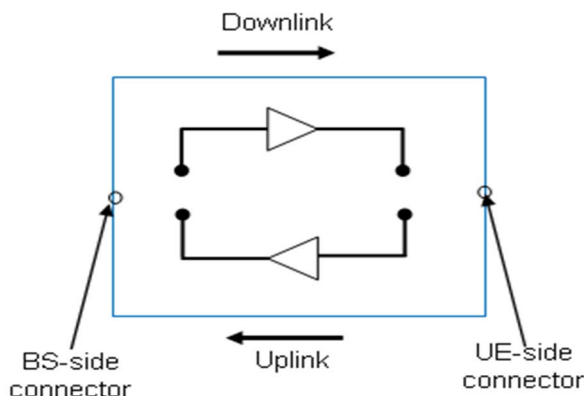

Figure 4.2.1-1: *Repeater type 1-C* downlink and uplink interface

4.2.2 NCR type 1-C

For *NCR type 1-C*, the NCR-Fwd RF requirements are applied at the NCR *antenna connector* (BS-side connector or UE-side connector) for downlink or uplink for the configuration in normal operating conditions.

For *NCR type 1-C*, the NCR-MT RF requirements are applied at the NCR *antenna connector* (BS-side connector) for the configuration in normal operating conditions.

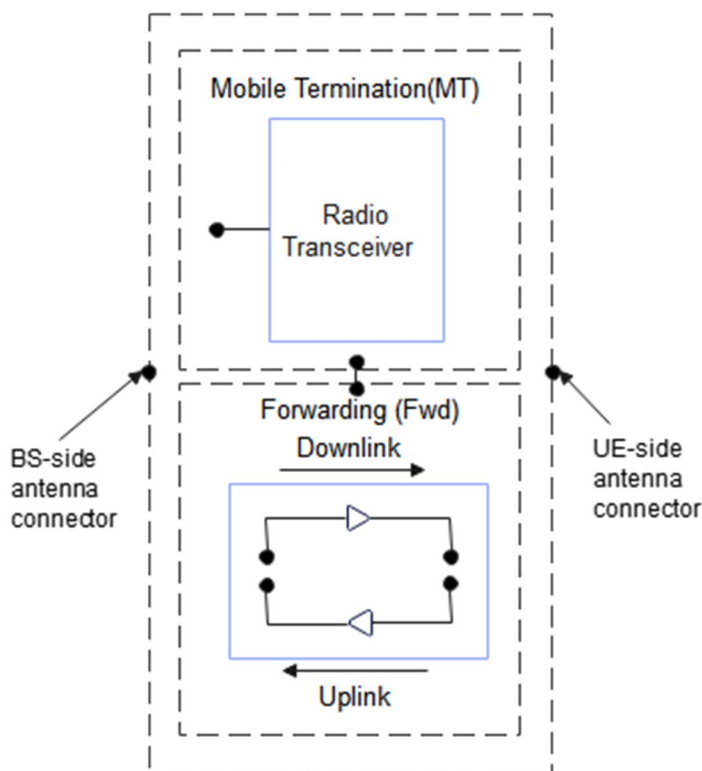

Figure 4.2.2-1: Network controlled *repeater type 1-C* downlink and uplink interface

NOTE 1: the NCR-MT and NCR-Fwd may have the same or separate antenna connectors.

4.2.3 NCR type 1-H

For *NCR type 1-H*, the requirements are defined for two points of reference, signified by radiated requirements and conducted requirements.

For *NCR type 1-H*, the NCR-Fwd conducted RF requirements are applied at the NCR individual or groups of *TAB connectors* at the *transceiver array boundary* (BS-side *TAB connector* or UE-side *TAB connector*) for downlink or uplink for the configuration in normal operating conditions.

For *NCR type 1-H*, the NCR-MT conducted RF requirements are applied at the NCR individual or groups of *TAB connectors* at the *transceiver array boundary* (BS-side *TAB connector*) for the configuration in normal operating conditions.

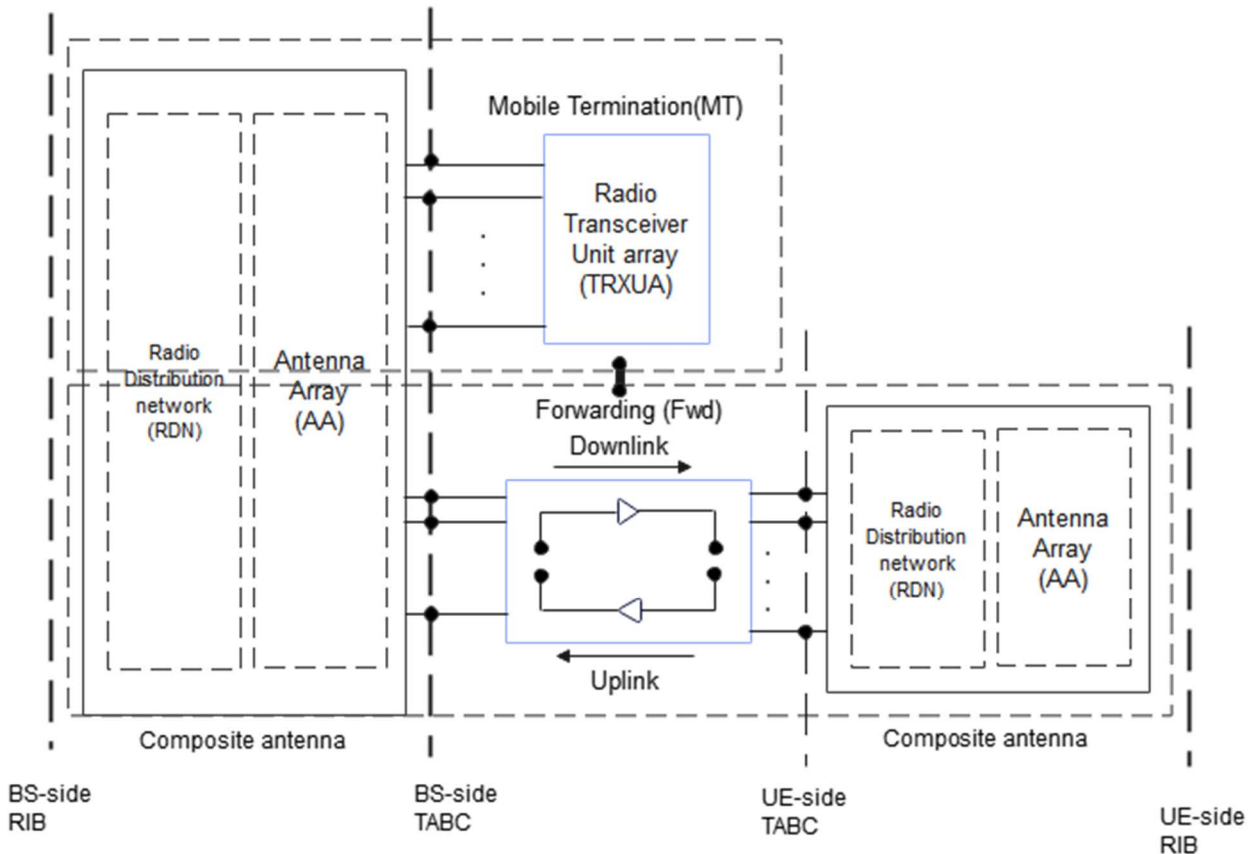

Figure 4.2.3-1: Network controlled *repeater type 1-H* downlink and uplink interface

NOTE 1: the NCR-MT and NCR-Fwd may have the same or separate TAB connectors.

4.3 Repeater classes

4.3.1 Repeater class for downlink

The requirements in this specification apply to downlink Wide Area repeaters, downlink Medium Range repeaters and downlink Local Area repeaters unless otherwise stated. The associated deployment scenarios for each class are exactly the same for repeater with and without connectors.

For *repeater type 1-C*, repeater downlink classes are defined as indicated below:

- Wide Area repeaters are characterised by requirements derived from Macro Cell scenarios with a repeater to UE minimum distance along the ground equal to 35 m.

- Medium Range repeaters are characterised by requirements derived from Micro Cell scenarios with a repeater to UE minimum distance along the ground equal to 5 m.
- Local Area repeaters are characterised by requirements derived from Pico Cell scenarios with a repeater to UE minimum distance along the ground equal to 2 m.

4.3.2 Repeater class for uplink

The requirements in this specification apply to uplink Wide Area repeaters and uplink Local Area repeaters unless otherwise stated. The associated deployment scenarios for each class are exactly the same for repeater with and without connectors.

For *repeater type 1-C*, repeater uplink classes are defined as indicated below:

- Wide Area repeaters are characterised by requirements derived from Macro Cell and/or Micro Cell scenarios.
- Local Area repeaters are characterised by requirements derived from Pico Cell and/or Micro Cell scenarios.

4.3A NCR classes

4.3A.1 NCR class for downlink

The requirements in this specification apply to downlink Wide Area NCR, downlink Medium Range NCR and downlink Local Area NCR unless otherwise stated. The associated deployment scenarios for each class are exactly the same for NCR with and without connectors.

For *NCR type 1-C and type 1-H*, NCR downlink classes are defined as indicated below:

- Wide Area NCR are characterised by requirements derived from Macro Cell scenarios with a NCR to UE minimum distance along the ground equal to 35 m.
- Medium Range NCR are characterised by requirements derived from Micro Cell scenarios with a NCR to UE minimum distance along the ground equal to 5 m.
- Local Area NCR are characterised by requirements derived from Pico Cell scenarios with a NCR to UE minimum distance along the ground equal to 2 m or from Femto Cell scenarios.

4.3A.2 NCR class for uplink and MT

The requirements in this specification apply to uplink Wide Area NCR and uplink Local Area NCR unless otherwise stated. The associated deployment scenarios for each class are exactly the same for NCR with and without connectors.

For *NCR type 1-C and type 1-H*, NCR uplink classes and MT classes are defined as indicated below:

- Wide Area NCR are characterised by requirements derived from Macro Cell and/or Micro Cell scenarios.
- Local Area NCR are characterised by requirements derived from Pico Cell and/or Micro Cell scenarios.

4.4 Regional requirements

Some requirements in the present document may only apply in certain regions either as optional requirements, or as mandatory requirements set by local and regional regulation. It is normally not stated in the 3GPP specifications under what exact circumstances the regional requirements apply, since this is defined by local or regional regulation.

Table 4.4-1 lists all requirements in the present specification that may be applied differently in different regions.

4.5 Repeater configurations

4.5.1 General configurations

For *repeater type 1-C* and *NCR type 1-C*, the requirements are applied at the repeater *antenna connector* (BS-side connector or UE-side connector) for downlink or uplink for the configuration in normal operating conditions.

For *NCR type 1-H*, the requirements are applied at the repeater *TAB connectors* (BS-side connector or UE-side connectors) for downlink or uplink for the configuration in normal operating conditions.

4.5.2 Transmission with multiple BS-side antenna connectors for RF repeater and NCR type 1-C

Unless otherwise stated, for the tests in clause 6 of the present document, the requirement applies for each BS-side *antenna connector* in the case of transmission with multiple BS-side *antenna connectors*.

Requirements are tested at the *antenna connector*, with the remaining *antenna connector(s)* being terminated. If the manufacturer has declared the antenna connectors to be equivalent (D.13), it is sufficient to measure the signal at any one of the BS-side *antenna connectors*.

4.5.2A Transmission with multiple BS-side antenna connectors for NCR type 1-H

The manufacturer shall declare a set of the input/output pairs and/or groups to indicate the mapping between input-side and output-side *TAB connectors*. The set of declared input/output pairs and/or groups should include all *TAB connectors*.

Unless otherwise stated, for the tests in clause 6 of the present document, the requirement applies for each BS-side *TAB connector* group in the case of transmission with multiple BS-side *TAB connectors* groups.

Requirements are tested at the *TAB connectors* in each group, with the remaining *TAB connector(s)* being terminated. If the manufacturer has declared the *TAB connector* groups to be equivalent (D.13), it is sufficient to measure the signal at any one of the BS-side *TAB connectors* groups.

4.5.3 Transmission with multiple UE-side antenna connectors for RF repeater and NCR type 1-C

Unless otherwise stated, for the tests in clause 6 of the present document, the requirement applies for each UE-side *antenna connector* in the case of transmission with multiple UE-side *antenna connectors*.

Requirements are tested at the *antenna connector*, with the remaining *antenna connector(s)* being terminated. If the manufacturer has declared the antenna connectors to be equivalent (D.13), it is sufficient to measure the signal at any one of the UE-side *antenna connectors*.

4.5.3A Transmission with multiple UE-side antenna connectors for NCR type 1-H

The manufacturer shall declare a set of the input/output pairs and/or groups to indicate the mapping between input-side and output-side *TAB connectors*. The set of declared input/output pairs and/or groups should include all *TAB connectors*.

Unless otherwise stated, for the tests in clause 6 of the present document, the requirement applies for each UE-side *TAB connector* group in the case of transmission with multiple UE-side *TAB connectors* groups.

Requirements are tested at the *TAB connectors* in each group, with the remaining *TAB connector(s)* being terminated. If the manufacturer has declared the *TAB connector* groups to be equivalent (D.13), it is sufficient to measure the signal at any one of the UE-side *TAB connectors* groups.

4.5.4 Duplexers

The requirements of the present document shall be met with a duplexer fitted, if a duplexer is supplied as part of the repeater. If the duplexer is supplied as an option by the manufacturer, sufficient tests should be repeated with and without the duplexer fitted to verify that the repeater meets the requirements of the present document in both cases.

The following tests shall be performed with the duplexer fitted, and without it fitted if this is an option:

- 1) clause 6.2, repeater output power, for the highest static power step only, if this is measured at the antenna connector;
- 2) clause 6.4, out of band gain; outside the repeater downlink or uplink band;
- 3) clause 6.5, unwanted emissions; outside the repeater downlink or uplink band;
- 4) clause 6.8, output intermodulation; for the testing of conformance, the carrier frequencies should be selected to minimize intermodulation products from the transmitters falling in receive channels.
- 5) clause 6.9, Adjacent Channel Rejection Ratio; outside the repeater downlink or uplink band.

The remaining tests may be performed with or without the duplexer fitted.

NOTE 1: When performing receiver tests with a duplexer fitted, it is important to ensure that the output from the transmitters does not affect the test apparatus. This can be achieved using a combination of attenuators, isolators and filters.

NOTE 2: When duplexers are used, intermodulation products will be generated, not only in the duplexer but also in the antenna system. The intermodulation products generated in the antenna system are not controlled by 3GPP specifications, and may degrade during operation (e.g. due to moisture ingress). Therefore, to ensure continued satisfactory operation of a repeater, an operator will normally select NR-ARFCNs to minimize intermodulation products falling on receive channels. For testing of complete conformance, an operator may specify the NR-ARFCNs to be used.

4.5.5 Power supply options

If the repeater is supplied with a number of different power supply configurations, it may not be necessary to test RF parameters for each of the power supply options, provided that it can be demonstrated that the range of conditions over which the equipment is tested is at least as great as the range of conditions due to any of the power supply configurations.

4.5.6 Ancillary RF amplifiers

The *repeater type I-C* or *NCR type I-C* requirements of the present document shall be met with the ancillary RF amplifier fitted. At tests, the ancillary amplifier is connected to the repeater by a connecting network (including any cable(s), attenuator(s), etc.) with applicable loss to make sure the appropriate operating conditions of the ancillary amplifier and the repeater. The applicable connecting network loss range is declared by the manufacturer (D.14). Other characteristics and the temperature dependence of the attenuation of the connecting network are neglected. The actual attenuation value of the connecting network is chosen for each test as one of the applicable extreme values. The lowest value is used unless otherwise stated.

Sufficient tests should be repeated with the ancillary amplifier fitted and, if it is optional, without the ancillary RF amplifier to verify that the repeater meets the requirements of the present document in both cases.

When testing, the following tests shall be repeated with the optional ancillary amplifier fitted according to the table below, where "x" denotes that the test is applicable:

Table 4.5.6-1: Tests applicable to ancillary RF amplifiers

Clause	Ancillary RF amplifier needed
6.2	x
6.4	x
6.5	x
6.7	x
6.8	x
6.9	x

In repeater output power test (clause 6.2) highest applicable attenuation value is applied.

4.5.7 Combining of repeaters

If the *repeater type 1-C* or *NCR type 1-C* is intended for combination with additional apparatus connected to a repeater port and this combination is supplied as a system, the combination of repeater together with the additional apparatus shall also fulfil the repeater requirements. E.g. if the repeater is intended for combination such that multiple repeaters amplify the same signals into the same ports the combination shall also fulfil the repeater requirements.

An example of such a configuration is shown in figure 4.5.7-1.

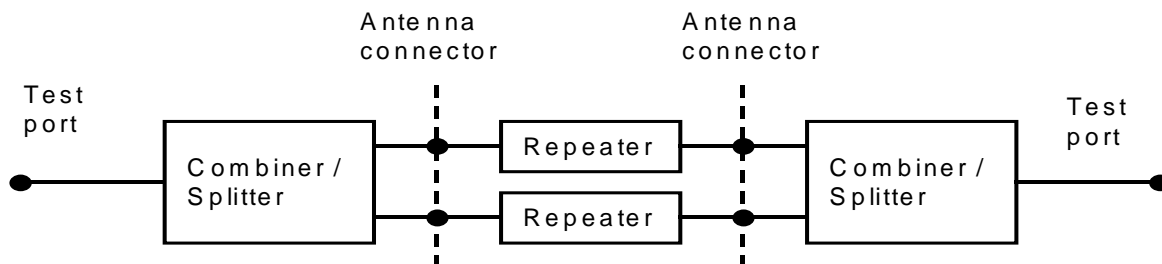

Figure 4.5.7-1: Example of repeater configuration

4.6 Manufacturer declarations

The following repeater declarations listed in table 4.6-1, when applicable to the repeater under test, are required to be provided by the manufacturer for the conducted requirements testing of the *repeater type 1-C*. Declarations can be made independently for UL and DL.

Table 4.6-1: Manufacturer declarations for *repeater type 1-C* conducted test requirements

Declaration identifier	Declaration	Description
D.1	Repeater class	Repeater class of the repeater, declared as Wide Area repeater, Medium Range repeater, or Local Area repeater.
D.2	<i>Operating bands</i> and passband frequency ranges	List of NR <i>operating band(s)</i> supported by <i>single-band connector(s)</i> and/or <i>multi-band connector(s)</i> of the repeater and passband frequency range(s) within the <i>operating band(s)</i> that the repeater can operate in. Declarations shall be made per <i>antenna connector</i> .
D.3	Spurious emission category	Declare the repeater spurious emission category as either category A or B with respect to the limits for spurious emissions, as defined in Recommendation ITU-R SM.329 [4].
D.4	Additional operating band unwanted emissions	The manufacturer shall declare whether the repeater under test is intended to operate in geographic areas where the additional operating band unwanted emission limits defined in clause 6.6.4.5.6 apply. (Note 2, Note 3).
D.5	Co-existence with other systems	The manufacturer shall declare whether the repeater under test is intended to operate in geographic areas where one or more of the systems GSM850, GSM900, DCS1800, PCS1900, UTRA FDD, UTRA TDD, E-UTRA, PHS and/or NR operating in another band are deployed.
D.6	Co-location with other base stations, repeaters and IABs	The manufacturer shall declare whether the repeater under test is intended to operate co-located with Base Stations, repeaters and IABs of one or more of the systems GSM850, GSM900, DCS1800, PCS1900, UTRA FDD, UTRA TDD, E-UTRA and/or NR operating in another band.
D.7	<i>Single band connector</i> or <i>multi-band connector</i>	Declaration of the single band or multi-band capability of <i>single band connector(s)</i> or <i>multi-band connector(s)</i> , declared for every connector.
D.8	Other band combination multi-band restrictions	Declare any other limitations under simultaneous operation in the declared band combinations (D.12) for each <i>multi-band connector</i> which have any impact on the test configuration generation. Declared for every <i>multi-band connector</i> .
D.9	Rated output power per passband ($P_{\text{rated,p,AC}}$)	Conducted rated output power per passband, per <i>single band connector</i> or <i>multi-band connector</i> . Declared per supported <i>passband</i> , per <i>antenna connector</i> . (Note 1)
D.10	Rated total output power ($P_{\text{rated,t,AC}}$)	Conducted total rated output power. Declared per supported <i>operating band</i> , per <i>antenna connector</i> . For <i>multi-band connectors</i> declared for each supported <i>operating band</i> in each supported band combination. (Note 1)
D.11	Rated multi-band total output power, $P_{\text{rated,MB,TABC}}$	Conducted multi-band rated total output power. Declared per supported operating band combinations, per <i>multi-band connector</i> . (Note 1)
D.12	Operating band combination support	List of operating bands combinations supported by <i>single-band connector(s)</i> and/or <i>multi-band connector(s)</i> of the repeater. Declared per <i>antenna connector</i> .
D.13	Equivalent connectors	List of <i>antenna connectors</i> which have been declared equivalent. Equivalent connectors imply that the <i>antenna connector</i> are expected to behave in the same way when presented with identical signals under the same operating conditions. All declarations made for the <i>antenna connector</i> are identical and the transmitter unit and/or receiver unit driving the <i>antenna connector</i> are of identical design.
D.14	Connecting network loss range for repeater testing with ancillary RF amplifiers	Declaration of the range of connecting network losses (in dB) for <i>repeater type 1-C</i> testing with ancillary Tx RF amplifier only, or with Rx RF amplifier only, or with combined Tx/Rx RF amplifiers. (Note 4)
D.15	Long delay repeater	Declared only if the repeater internal delay between the input and output for this repeater does not fit within the TDD transient time. The repeater is intended for situations in which it will not cause interference to other nodes. This is achieved by RF isolation or by reservation of longer guard periods, which degrades frame utilization. The length of repeaters internal delay is declared using this declaration.
D.16	Input signal power level for maximum output power	Declaration of input signal power level required to reach maximum output power. Declared per passband.
D.17	Repeater radiating direction	Declaration on whether the repeater is intended to radiate in DL, UL or both. Testing shall be performed only for the direction(s) in which the repeater radiates.

- NOTE 1: If a repeater is capable of 256QAM operation then up to two rated output power declarations may be made. One declaration is applicable when configured for 256QAM operation, and the other declaration is applicable when not configured for 256QAM operation. If a repeater is not capable of 256QAM operation, only one declaration can be made.
- NOTE 2: If repeater is declared to support Band n20 (D.2), the manufacturer shall declare if the repeater may operate in geographical areas allocated to broadcasting (DTT). Additionally, related declarations of the emission levels and maximum output power shall be declared.
- NOTE 3: If repeater is declared to support Band n24 (D.2), the manufacturer shall declare if the repeater may operate in geographical areas where FCC regulations apply. Additionally, related declarations of the emission levels and maximum output power shall be declared.
- NOTE 4: This manufacturer declaration is optional.

The following NCR declarations listed in table 4.6-2, when applicable to the repeater under test, are required to be provided by the manufacturer for the conducted requirements testing of the *NCR type I-C* or *NCR type I-H*. Declarations can be made independently for UL and DL.

Table 4.6-2: Manufacturer declarations for *NCR type 1-C* and *NCR type 1-H* conducted test requirements

Declaration identifier	Declaration	Description	Applicability	
			NCR-Fwd	NCR-MT
D.1	NCR class	NCR class of the NCR, declared as Wide Area NCR, Medium Range NCR, or Local Area NCR.	x	x
D.2	<i>Operating bands</i> and passband frequency ranges	List of NR <i>operating band(s)</i> supported by <i>single-band connector(s)</i> and/or <i>multi-band connector(s)</i> of the NCR and passband frequency range(s) within the <i>operating band(s)</i> that the NCR can operate in. Declarations shall be made per <i>antenna connector</i> .	x	x
D.3	Spurious emission category	Declare the NCR spurious emission category as either category A or B with respect to the limits for spurious emissions, as defined in Recommendation ITU-R SM.329 [4].	x	x
D.4	Additional operating band unwanted emissions	The manufacturer shall declare whether the NCR under test is intended to operate in geographic areas where the additional operating band unwanted emission limits defined in clause 6.6.4.5.6 apply. (Note 2, Note 3).	x	x
D.5	Co-existence with other systems	The manufacturer shall declare whether the NCR under test is intended to operate in geographic areas where one or more of the systems GSM850, GSM900, DCS1800, PCS1900, UTRA FDD, UTRA TDD, E-UTRA, PHS and/or NR operating in another band are deployed.	x	x
D.6	Co-location with other base stations, NCRs and IABs	The manufacturer shall declare whether the NCR under test is intended to operate co-located with Base Stations, NCRs and IABs of one or more of the systems GSM850, GSM900, DCS1800, PCS1900, UTRA FDD, UTRA TDD, E-UTRA and/or NR operating in another band.	x	x
D.7	<i>Single band connector</i> or <i>multi-band connector</i>	Declaration of the single band or multi-band capability of <i>single band connector(s)</i> or <i>multi-band connector(s)</i> , declared for every connector.	x	x
D.8	Other band combination multi-band restrictions	Declare any other limitations under simultaneous operation in the declared band combinations (D.12) for each <i>multi-band connector</i> which have any impact on the test configuration generation. Declared for every <i>multi-band connector</i> .	x	x
D.9	Rated output power per passband ($P_{\text{rated,p,AC}}$)	Conducted rated output power per passband, per <i>single band connector</i> or <i>multi-band connector</i> . Declared per supported <i>passband</i> , per <i>antenna connector</i> . (Note 1)	x	x
D.10	Rated total output power ($P_{\text{rated,t,AC}}$)	Conducted total rated output power. Declared per supported <i>operating band</i> , per <i>antenna connector</i> . For <i>multi-band connectors</i> declared for each supported <i>operating band</i> in each supported band combination. (Note 1)	x	x
D.11	Rated multi-band total output power, $P_{\text{rated,MB,TABC}}$	Conducted multi-band rated total output power. Declared per supported operating band combinations, per <i>multi-band connector</i> . (Note 1)	x	x
D.12	Operating band combination support	List of operating bands combinations supported by <i>single-band connector(s)</i> and/or <i>multi-band connector(s)</i> of the NCR. Declared per <i>antenna connector</i> .	x	x
D.13	Equivalent connectors	List of <i>antenna connectors</i> which have been declared equivalent. Equivalent connectors imply that the <i>antenna connector</i> are expected to behave in the same way when presented with identical signals under the same operating conditions. All declarations made for the <i>antenna connector</i> are identical and the transmitter unit and/or receiver unit driving the <i>antenna connector</i> are of identical design.	x	x
D.14	Connecting network loss range for NCR testing with ancillary RF amplifiers	Declaration of the range of connecting network losses (in dB) for <i>NCR type 1-C</i> testing with ancillary Tx RF amplifier only, or with Rx RF amplifier only, or with combined Tx/Rx RF amplifiers. (Note 4)	x	x

D.15	Long delay NCR	Declared only if the NCR internal delay between the input and output for this NCR does not fit within the TDD transient time. The NCR is intended for situations in which it will not cause interference to other nodes. This is achieved by RF isolation or by reservation of longer guard periods, which degrades frame utilization. The length of NCRs internal delay is declared using this declaration.	x	x
D.16	Input signal power level for maximum output power	Declaration of input signal power level required to reach maximum output power. Declared per passband.	x	x
D.17	NCR radiating direction	Declaration on whether the NCR is intended to radiate in DL, UL or both. Testing shall be performed only for the direction(s) in which the NCR radiates.	x	x
D.18	Support of simultaneous Tx of NCR-Fwd and NCR-MT	Declaration on whether the NCR support the simultaneous Tx of NCR-Fwd and NCR-MT	x	x
D.19	Relationship mapping between input connectors and output connectors for Type 1-H NCR-Fwd	To declare a set of the input/output pairs and/or groups to indicate the mapping between input-side and output-side TAB connectors. The set of declared input/output pairs and/or groups should include all TAB connectors.	x	
D.20	<i>TAB connector RX min cell group</i>	Declared as a group of <i>TAB connectors</i> to which RX requirements are applied. This declaration corresponds to group of <i>TAB connectors</i> which are responsible for receiving a cell when the <i>NCR type 1-H</i> setting corresponding to the declared minimum number of cells (N_{cells}) with transmission on all <i>TAB connectors</i> supporting an <i>operating band</i> .	x	x
D.21	<i>TAB connector TX min cell group</i>	Declared group of <i>TAB connectors</i> to which TX requirements are applied. This declaration corresponds to group of <i>TAB connectors</i> which are responsible for transmitting a cell when the <i>NCR type 1-H</i> setting corresponding to the declared minimum number of cells (N_{cells}) with transmission on all <i>TAB connectors</i> supporting an <i>operating band</i> .		x
D.22	Single or multiple carrier	Capable of operating with a single carrier (only) or multiple carriers. Declared per supported <i>operating band</i> , per <i>antenna connector</i> for <i>NCR type 1-C</i> , or <i>TAB connector</i> for <i>NCR type 1-H</i> .	x	x
<p>NOTE 1: If a NCR is capable of 256QAM operation then up to two rated output power declarations may be made. One declaration is applicable when configured for 256QAM operation, and the other declaration is applicable when not configured for 256QAM operation. If a NCR is not capable of 256QAM operation, only one declaration can be made.</p> <p>NOTE 2: If NCR is declared to support Band n20 (D.2), the manufacturer shall declare if the NCR may operate in geographical areas allocated to broadcasting (DTT). Additionally, related declarations of the emission levels and maximum output power shall be declared.</p> <p>NOTE 3: If NCR is declared to support Band n24 (D.2), the manufacturer shall declare if the NCR may operate in geographical areas where FCC regulations apply. Additionally, related declarations of the emission levels and maximum output power shall be declared.</p> <p>NOTE 4: This manufacturer declaration is optional.</p>				

4.7 Test configurations

4.7.1 General

Test configurations in this specification refer to the configuration of test signals from test equipment that are provided to the repeater input.

The test configurations shall be constructed using the methods defined below, subject to the parameters declared by the manufacturer for the supported RF configurations as listed in clause 4.6. The test configurations to use for conformance testing are defined for each supported RF configuration in clauses 4.8.3 and 4.8.4.

The applicable test models for generation of the carrier transmit test signal are defined in clause 4.9.

NOTE: If required, carriers are shifted to align with the channel raster.

4.7.2 Test signal used to build Test Configurations

The signal's channel bandwidth and subcarrier spacing used to build NR Test Configurations shall be selected according to table 4.7.2-1.

Table 4.7.2-1: Signal to be used to build NR repeater TCs

Operating Band characteristics		$F_{DL_high} - F_{DL_low}$ or $F_{UL_high} - F_{UL_low}$ <100 MHz (Note 2)	$F_{DL_high} - F_{DL_low}$ or $F_{UL_high} - F_{UL_low}$ ≥ 100 MHz (Note 2)
TC signal characteristics	$BW_{channel}$	5 MHz (Note 1)	20 MHz (Note 1)
	Subcarrier spacing	Smallest supported subcarrier spacing of the operating band	
NOTE 1: If this channel bandwidth is not supported for the operating band, the narrowest supported channel bandwidth shall be used.			
NOTE 2: Either the DL operating band characteristics or the UL operating band characteristics should be considered (if different) depending on the tested transmission direction.			

4.7.3 RTC1: Contiguous spectrum operation for RF repeater

The purpose of test configuration RTC1 is to test all repeater requirements that need an input signal in the *passband* when there is only one *passband* per *operating band*.

4.7.3.1 RTC1 generation

RTC1 shall be constructed on a per band basis using the following method:

- Declared maximum *passband* Bandwidth supported shall be used;
- Select the carrier to be tested according to 4.7.2 and place it adjacent to the lower *passband* edge. If the width of the *passband* is at least twice the bandwidth of the signal to be tested then place a second signal adjacent to the upper *passband* edge. Otherwise reposition the carrier to be tested according to the single carrier test frequencies described in section 4.9.1.

The test configuration should be constructed sequentially on a per band basis using the same *antenna connector*. All configured component carriers are transmitted simultaneously in the tests where the repeater should be ON.

4.7.3.2 RTC1 power allocation

Set the power spectral density of each carrier to the same level so that the sum of the carrier powers equals the expected input power to the repeater for the test (i.e., either $P_{rated,in}$ or $P_{rated,in} + 10dB$) according to the manufacturer's declaration in clause 4.6.

4.7.5 RTC2: Non-contiguous spectrum operation for RF repeater

The purpose of RTC2 is to test all repeater requirements that need an input signal in the *passband* when there is more than one *passband* per *operating band*.

4.7.5.1 RTC2 generation

RTC2 is constructed on a per band basis using the following method:

- The repeater *passband* bandwidths shall be the maximum *passband* Bandwidth supported for multiple passbands (D.11). The repeater RF Bandwidth consists of one sub-block gap and the two highest and lowest declared *passbands*.
- For each *passband*, select the carrier to be tested according to 4.7.2. If the the width of the *passband* is at least twice that of the carrier to be tested then place a carrier adjacent to the upper *passband* edge and another carrier

(as described in 4.7.2) adjacent to the lower *passband* edge. Otherwise, tests shall be applied with one carrier adjacent to the lower sub-block edge and one carrier adjacent to the upper sub-block edge for each sub-block gap.

- The sub-block edges adjacent to the sub-block gap shall be determined using the specified $F_{\text{offset_high}}$ and $F_{\text{offset_low}}$ for the carriers adjacent to the sub-block gap.

4.7.5.2 RTC2 power allocation

Set the power of each carrier to the same level so that the sum of the carrier powers equals the expected input power to the repeater for the test (i.e., either $P_{\text{rated,in}}$ or $P_{\text{rated,in}} + 10\text{dB}$) according to the manufacturer's declaration in clause 4.6.

4.7.6 RTC3: Multi-band test configuration for full carrier allocation for RF repeater

The purpose of RTC3 is to test multi-band operation aspects.

4.7.6.1 RTC3 generation

RTC3 is based on re-using the previously specified test configurations applicable per band involved in multi-band operation. It is constructed using the following method:

- The repeater RF Bandwidth of each supported operating band shall be the declared maximum repeater RF Bandwidth in multi-band operation (D.12).
- The number of carriers of each supported *operating band* shall be sufficient to fill all of the *passbands* with one or two carriers (depending on the passband bandwidth). Carriers shall be selected according to 4.7.2 and shall first be placed at the outermost edges of the declared repeater Radio Bandwidth. Additional carriers shall next be placed at the repeater RF Bandwidths edges, if possible.
- Each concerned band shall be considered as an independent band and the carrier placement in each band shall be according to RTC1, where the declared parameters for multi-band operation shall apply. The mirror image of the single-band test configuration shall be used in each alternate band(s) and in the highest band.
- If the bandwidth of any *passband* is insufficient to accommodate two carriers then tests shall be repeated with the test carriers positioned such that there is a carrier adjacent to the lower edge of a sub-block gap or inter-band gap and a carrier adjacent to the upper edge of the sub-block gap or inter-band gap, for each sub-block gap or inter-block gap.

4.7.6.2 RTC3 power allocation

Unless otherwise stated, set the power of each carrier in all supported *operating bands* to the same level so that the sum of the carrier powers equals the expected input power to the repeater for the test (i.e., either $P_{\text{rated,in}}$ or $P_{\text{rated,in}} + 10\text{dB}$) according to the manufacturer's declaration in clause 4.6.

4.7.7 RTC4: Multi-band test configuration with high PSD per carrier for RF repeater

The purpose of RTC4 is to test multi-band operation aspects considering higher PSD cases with reduced number of carriers and non-contiguous operation (if supported) in multi-band mode.

4.7.7.1 RTC4 generation

RTC4 is based on re-using the existing test configuration applicable per band involved in multi-band operation. It is constructed using the following method:

- The repeater RF Bandwidth of each supported *operating band* shall be the declared maximum repeater RF Bandwidth in multi-band operation (D.12).

- The allocated repeater RF Bandwidth of the outermost bands shall be located at the outermost edges of the declared Maximum Radio Bandwidth.
- The maximum number of carriers is limited to two per band. Carriers shall be selected according to 4.7.2 and shall first be placed at the outermost edges of the declared Maximum Radio Bandwidth for outermost bands and at the Repeater RF Bandwidths edges for middle band(s) if any. Additional carriers shall next be placed at the Repeater RF Bandwidths edges, if possible.
- Each concerned band shall be considered as an independent band and the carrier placement in each band shall be according to RTC3, where the declared parameters for multi-band operation shall apply. Narrowest supported NR channel bandwidth and smallest subcarrier spacing shall be used in the test configuration.
- If only one carrier can be placed for the concerned band(s), the carrier(s) shall be placed at the outermost edges of the declared maximum radio bandwidth for outermost band(s) and at one of the outermost edges of the supported frequency range within the Base Station RF Bandwidths for middle band(s) if any.

4.7.7.2 RTC4 power allocation

Unless otherwise stated, set the power of each carrier in all supported operating bands to the same level so that the sum of the carrier powers equals the expected input power to the repeater for the test (i.e., either $P_{\text{rated,in}}$ or $P_{\text{rated,in}} + 10\text{dB}$) according to the manufacturer's declaration in clause 4.6.

4.7.8 NCRTC1: Contiguous spectrum operation for NCR

The purpose of test configuration NCRTC1 is to test all NCR requirements that need an input signal in the *passband* when there is only one *passband* per *operating band*.

4.7.8.1 NCRTC1 generation

NCRTC1 shall be constructed on a per band basis using the following method:

- Declared maximum *passband* Bandwidth supported shall be used;
- Place an NCR-MT carrier at the lower end of the passband. Generate an NR carrier using test equipment at the upper edge of the passband, and a second NR carrier adjacent to the NCR-MT carrier within the passband. If there is insufficient space for the NR carriers then remove firstly the NR carrier adjacent to the NCR-MT carrier and then if needed the NR carrier at the upper end of the passband.
- Place an NCR-MT carrier at the upper end of the passband. Generate an NR carrier using test equipment at the lower edge of the passband, and a second NR carrier adjacent to the NCR-MT carrier within the passband. If there is insufficient space for the NR carriers then remove firstly the NR carrier adjacent to the NCR-MT carrier and then if needed the NR carrier at the lower end of the passband.

The test configuration should be constructed sequentially on a per band basis using the same *antenna connector* or *TAB connector group*. All configured component carriers are transmitted simultaneously in the tests where the repeater should be ON.

4.7.8.2 NCRTC1 power allocation

For the NCR-Fwd, set the power spectral density of each carrier to the same level so that the sum of the carrier powers equals the expected input power to the repeater for the test (i.e., either $P_{\text{rated,in}}$ or $P_{\text{rated,in}} + 10\text{dB}$) according to the manufacturer's declaration in clause 4.6. For the NCR-MT, set the output power according to the manufacturer's declaration in clause 4.6

4.7.9 NCRTC2: Non-contiguous spectrum operation for NCR

The purpose of NCRTC2 is to test all repeater requirements that need an input signal in the *passband* when there is more than one *passband* per *operating band*.

4.7.9.1 NCRTC2 generation

NCRTC2 is constructed on a per band basis using the following method:

- The repeater *passband* bandwidths shall be the maximum *passband* Bandwidth supported for multiple passbands (D.11). The repeater RF Bandwidth consists of one sub-block gap and the two highest and lowest declared *passbands*.
- Place an NCR-MT carrier at the lower end of each passband. Generate an NR carrier using test equipment at the upper edge of each passband, and a second NR carrier adjacent to the NCR-MT carrier within each passband. For each passband, if there is insufficient space for the NR carriers then remove firstly the NR carrier adjacent to the NCR-MT carrier and then if needed the NR carrier at the upper end of the passband.
- Place an NCR-MT carrier at the upper end of each passband. Generate an NR carrier using test equipment at the lower edge of each passband, and a second NR carrier adjacent to the NCR-MT carrier within each passband. For each passband, if there is insufficient space for the NR carriers then remove firstly the NR carrier adjacent to the NCR-MT carrier and then if needed the NR carrier at the lower end of the passband.
- Place an NCR-MT carrier at the lower end of the lower passband and place an NCR-MT carrier at the upper end of the upper passband. Generate an NR carrier using test equipment at the opposite edge of each passband, and a second NR carrier adjacent to the NCR-MT carrier within each passband. For each passband, if there is insufficient space for the NR carriers then remove firstly the NR carrier adjacent to the NCR-MT carrier and then if needed the NR carrier at the opposite end of the passband.
- Place an NCR-MT carrier at the upper end of the lower passband and place an NCR-MT carrier at the lower end of the upper passband. Generate an NR carrier using test equipment at the opposite edge of each passband, and a second NR carrier adjacent to the NCR-MT carrier within each passband. For each passband, if there is insufficient space for the NR carriers then remove firstly the NR carrier adjacent to the NCR-MT carrier and then if needed the NR carrier at the opposite end of the passband.
- The sub-block edges adjacent to the sub-block gap shall be determined using the specified $F_{\text{offset_high}}$ and $F_{\text{offset_low}}$ for the carriers adjacent to the sub-block gap.

4.7.9.2 NCRTC2 power allocation

For NCR-Fwd, set the power of each carrier to the same level so that the sum of the carrier powers equals the expected input power to the repeater for the test (i.e., either $P_{\text{rated,in}}$ or $P_{\text{rated,in}} + 10\text{dB}$) according to the manufacturer's declaration in clause 4.6. For the NCR-MT, set the output power according to the manufacturer's declaration in clause 4.6.

4.7.10 NCRTC3: Multi-band test configuration for full carrier allocation for NCR

The purpose of NCRTC3 is to test multi-band operation aspects.

4.7.10.1 NCRTC3 generation

NCRTC3 is based on re-using the previously specified test configurations applicable per band involved in multi-band operation. It is constructed using the following method:

- The NCR RF Bandwidth of each supported operating band shall be the declared maximum NCR RF Bandwidth in multi-band operation (D.12).
- Each concerned band shall be considered as an independent band and the carrier placement in each band shall be according to NCRTC1, where the declared parameters for multi-band operation shall apply. The mirror image of the single-band test configuration shall be used in each alternate band(s) and in the highest band.

4.7.10.2 NCRTC3 power allocation

For NCR-Fwd, unless otherwise stated, set the power of each carrier in all supported *operating bands* to the same level so that the sum of the carrier powers equals the expected input power to the NCR for the test (i.e., either $P_{\text{rated,in}}$ or $P_{\text{rated,in}} + 10\text{dB}$) according to the manufacturer's declaration in clause 4.6. For the NCR-MT, set the output power according to the manufacturer's declaration in clause 4.6.

4.7.11 NCRTC4: Multi-band test configuration with high PSD per carrier for NCR

The purpose of NCRTC4 is to test multi-band operation aspects considering higher PSD cases with reduced number of carriers and non-contiguous operation (if supported) in multi-band mode.

4.7.11.1 NCRTC4 generation

NCRTC4 is based on re-using the existing test configuration applicable per band involved in multi-band operation. It is constructed using the following method:

- The NCR RF Bandwidth of each supported *operating band* shall be the declared maximum NCR RF Bandwidth in multi-band operation (D.12).
- The allocated NCR RF Bandwidth of the outermost bands shall be located at the outermost edges of the declared Maximum Radio Bandwidth.
- Each concerned band shall be considered as an independent band and the carrier placement in each band shall be according to NCRTC3, where the declared parameters for multi-band operation shall apply. Narrowest supported NR channel bandwidth and smallest subcarrier spacing shall be used in the test configuration.
- If only one carrier can be placed for the concerned band(s), the carrier(s) shall be placed at the outermost edges of the declared maximum radio bandwidth for outermost band(s) and at one of the outermost edges of the supported frequency range within the Base Station RF Bandwidths for middle band(s) if any.

4.7.11.2 NCRTC4 power allocation

For the NCR-Fwd, unless otherwise stated, set the power of each carrier in all supported operating bands to the same level so that the sum of the carrier powers equals the expected input power to the NCR for the test (i.e., either $P_{\text{rated,in}}$ or $P_{\text{rated,in}} + 10\text{dB}$) according to the manufacturer's declaration in clause 4.6. For the NCR-MT, set the output power according to the manufacturer's declaration in clause 4.6.

4.8 Applicability of requirements

4.8.1 General

4.8.2 Applicability of test configurations for single-band operation

The applicable test configurations are specified in the tables below for each the supported RF configuration, which shall be declared according to clause 4.6. The generation and power allocation for each test configuration is defined in clause 4.7. This clause contains the test configurations for RF repeater or NCR-Fwd capable of single passband, and/or multi-passband operation in both contiguous and non-contiguous spectrum in single band. . This clause also contains the test configurations for a NCR-MT capable of single carrier operation in both contiguous and non-contiguous spectrum in single band.

For a RF repeater or NCR declared to support a single *passband* within a single band (D.2), the test configurations in the second column of table 4.8.2-1 (for RF repeater) or table 4.8.2-2 (for NCR) shall be used for testing.

For a RF repeater or NCR declared to support more than one *passband* within a single band (D.2) and where the parameters in the manufacture's declaration according to clause 4.6 are identical for all passbands, the test configurations in the third column of table 4.8.2-1 (for RF repeater) or table 4.8.2-2 (for NCR) shall be used for testing.

For a RF repeater or NCR declared to support more than one *passband* within a single band (D.2) and where the parameters in the manufacture's declaration according to clause 4.6 are not identical for all passbands, the test configurations in the fourth column of table 4.8.2-1 (for RF repeater) or table 4.8.2-2 (for NCR) shall be used for testing.

Table 4.8.2-1: Test configurations for a repeater capable of single or multiple *passbands* in a single band

Test case	Single passband repeater	Multiple passband capable repeater with identical parameters per passband	Multiple passband capable repeater with different parameters per passband
Repeater output power	RTC1	RTC1	RTC1, RTC2
Frequency stability	Tested with Error Vector Magnitude	Tested with Error Vector Magnitude	Tested with Error Vector Magnitude
Out of band gain	N/A	N/A	N/A
Transmit ON/OFF power (only applied for NR TDD repeater)	RTC1	RTC1	RTC1, RTC2
Error Vector Magnitude	RTC1	RTC1	RTC1, RTC2
Adjacent Channel Leakage power Ratio (ACLR)	RTC1	RTC1, RTC2	RTC1, RTC2
Cumulative ACLR requirement in non-contiguous spectrum	-	RTC2	RTC2
Operating band unwanted emissions	RTC1	RTC1, RTC2	RTC1, RTC2
Transmitter spurious emissions	RTC1	RTC1, RTC2	RTC1, RTC2
Output intermodulation	RTC1	RTC1, RTC2	RTC1, RTC2
Input intermodulation	N/A	N/A	N/A
Adjacent Channel Rejection Ratio (ACRR)	RTC1	RTC2	RTC1, RTC2
Receiver spurious emissions	RTC1	RTC1, RTC2	RTC1, RTC2

Table 4.8.2-2: Test configurations for a NCR capable of single or multiple *passbands* in a single band

Test case	Single passband NCR	Multiple passband capable NCR with identical parameters per passband	Multiple passband capable NCR with different parameters per passband
NCR output power	NCRTC1	NCRTC1	NCRTC1, NCRTC2
Frequency stability	Tested with Error Vector Magnitude	Tested with Error Vector Magnitude	Tested with Error Vector Magnitude
Out of band gain	N/A	N/A	N/A
Transmit ON/OFF power (Note 1)	NCRTC1	NCRTC1	NCRTC1, NCRTC2
Error Vector Magnitude	NCRTC1	NCRTC1	NCRTC1, NCRTC2
Adjacent Channel Leakage power Ratio (ACLR)	NCRTC1	NCRTC1, NCRTC2	NCRTC1, NCRTC2
Cumulative ACLR requirement in non-contiguous spectrum	-	NCRTC2	NCRTC2
Operating band unwanted emissions	NCRTC1	NCRTC1, NCRTC2	NCRTC1, NCRTC2
Transmitter spurious emissions	NCRTC1	NCRTC1, NCRTC2	NCRTC1, NCRTC2
Output intermodulation	NCRTC1	NCRTC1, NCRTC2	NCRTC1, NCRTC2
Input intermodulation	N/A	N/A	N/A
Adjacent Channel Rejection Ratio	NCRTC1	NCRTC2	NCRTC1, NCRTC2
Output power dynamics	SC	SC	SC
Transmitter signal quality	Tested with Error Vector Magnitude	Tested with Error Vector Magnitude	Tested with Error Vector Magnitude
Transmit intermodulation	NCRTC1	NCRTC1, NCRTC2	NCRTC1, NCRTC2
Reference sensitivity	SC	SC	SC
Adjacent channel selectivity	NCRTC1	NCRTC2	NCRTC1, NCRTC2
Receiver Blocking characteristics	NCRTC1	NCRTC2	NCRTC1, NCRTC2
Receiver Intermodulation	NCRTC1	NCRTC2	NCRTC1, NCRTC2
Receiver spurious emissions	NCRTC1	NCRTC1, NCRTC2	NCRTC1, NCRTC2

4.8.4 Applicability of test configurations for multi-band operation

For a repeater declared to be capable of multi-band operation, the test configuration in table 4.8.4-1 and/or table 4.8.2-1 shall be used for testing. In the case where multiple bands are mapped on common *multi-band connector*, the test configuration in the second column of table 4.8.4-1 shall be used. In the case where multiple bands are mapped on common *single-band connector*, the test configuration in table 4.8.2-1 shall be used. In the case where multiple bands

are mapped on separate *single-band connector* or *multi-band connector*, the test configuration in the third column of table 4.8.4-1 shall be used.

For a NCR declared to be capable of multi-band operation, the test configuration in table 4.8.4-2 and/or table 4.8.2-2 shall be used for testing. In the case where multiple bands are mapped on common *multi-band connector*, the test configuration in the second column of table 4.8.4-2 shall be used. In the case where multiple bands are mapped on common *single-band connector*, the test configuration in table 4.8.2-2 shall be used. In the case where multiple bands are mapped on separate *single-band connector* or *multi-band connector*, the test configuration in the third column of table 4.8.4-2 shall be used.

Table 4.8.4-1: Test configuration for a repeater capable of multi-band operation

Repeater test case	Test configuration	
	Common connector	Separate connectors
Repeater output power	RTC1/2 (Note 1), RTC3	RTC1/2 (Note 1), RTC3
Frequency stability	Tested with Error Vector Magnitude	Tested with Error Vector Magnitude
Out of band gain	N/A	N/A
Transmit ON/OFF power (only applied for NR TDD repeater)	RTC3	RTC3
Frequency error	Tested with Error Vector Magnitude	Tested with Error Vector Magnitude
Error Vector Magnitude	RTC1/2 (Note 1), RTC3	RTC1/2 (Note 1), RTC3
Adjacent Channel Leakage power Ratio (ACLR)	RTC1/2 (Note 1), RTC4 (Note 2)	RTC1/2 (Note 1, 3), RTC4 (Note 2, 3)
Cumulative ACLR requirement in non-contiguous spectrum	RTC2 (Note 1), RTC4 (Note 2)	RTC2 (Note 1, 3)
Operating band unwanted emissions	RTC1/2 (Note 1), RTC4	RTC1/2 (Note 1, 3), RTC4 (Note 3)
Transmitter spurious emissions	RTC1/2 (Note 1), RTC4	RTC1/2 (Note 1, 3), RTC4 (Note 3)
Output intermodulation	RTC1/2 (Note 1)	RTC1/2 (Note 1, 3)
Input Intermodulation	N/A	N/A
Adjacent Channel Rejection Ratio	RTC1/2 (Note 1), RTC4 (Note 2)	RTC1/2 (Note 1, 3), RTC4 (Note 2, 3)
Receiver spurious emissions	RTC1/2 (Note 1), RTC4	RTC1/2 (Note 1, 3), RTC4 (Note 3)
Note 1:	RTC1 and/or RTC2 shall be applied in each supported operating band.	
Note 2:	RTC4 may be applied for Inter RF Bandwidth gap only.	
Note 3:	For single-band operation test, other antenna connector(s) is (are) terminated.	

Table 4.8.4-2: Test configuration for a NCR capable of multi-band operation

NCR test case	Test configuration	
	Common connector	Separate connectors
NCR output power	NCRTC1/2 (Note 1), NCRTC3	NCRTC1/2 (Note 1), NCRTC3
Frequency stability	Tested with Error Vector Magnitude	Tested with Error Vector Magnitude
Out of band gain	N/A	N/A
Transmit ON/OFF power	NCRTC3	NCRTC3
Frequency error	Tested with Error Vector Magnitude	Tested with Error Vector Magnitude
Error Vector Magnitude	NCRTC1/2 (Note 1), NCRTC3	NCRTC1/2 (Note 1), NCRTC3
Adjacent Channel Leakage power Ratio (ACLR)	NCRTC1/2 (Note 1), NCRTC4 (Note 2)	NCRTC1/2 (Note 1, 3), NCRTC4 (Note 2, 3)
Cumulative ACLR requirement in non-contiguous spectrum	NCRTC2 (Note 1), NCRTC4 (Note 2)	NCRTC2 (Note 1, 3)
Operating band unwanted emissions	NCRTC1/2 (Note 1), NCRTC4	NCRTC1/2 (Note 1, 3), NCRTC4 (Note 3)
Transmitter spurious emissions	NCRTC1/2 (Note 1), NCRTC4	NCRTC1/2 (Note 1, 3), NCRTC4 (Note 3)
Output intermodulation	NCRTC1/2 (Note 1)	NCRTC1/2 (Note 1, 3)
Input Intermodulation	N/A	N/A
Adjacent Channel Rejection Ratio	NCRTC1/2 (Note 1), NCRTC4 (Note 2)	NCRTC1/2 (Note 1, 3), NCRTC4 (Note 2, 3)
Receiver spurious emissions	NCRTC1/2 (Note 1), NCRTC4	NCRTC1/2 (Note 1, 3), NCRTC4 (Note 3)
Output power dynamics	SC	SC
Transmitter signal quality	Tested with Error Vector Magnitude	Tested with Error Vector Magnitude
Transmit intermodulation	NCRTC1	NCRTC1, NCRTC2
Reference sensitivity	SC	SC
Adjacent channel selectivity	NCRTC1	NCRTC2
Receiver Blocking characteristics	NCRTC1	NCRTC2
Receiver Intermodulation	NCRTC1	NCRTC2
Receiver spurious emissions	NCRTC1	NCRTC1, NCRTC2
Note 1:	NCRTC1 and/or NCRTC2 shall be applied in each supported operating band.	
Note 2:	NCRTC4 may be applied for Inter RF Bandwidth gap only.	
Note 3:	For single-band operation test, other antenna connector(s) is (are) terminated.	

4.9 RF channels and test models

4.9.1 RF channels

For the single passband testing many tests in this TS are performed with appropriate frequencies in the bottom, middle and top channels of the supported frequency range of the repeater. These are denoted as RF channels B (bottom), M (middle) and T (top).

Unless otherwise stated, the test shall be performed with a single passband at each of the RF channels B, M and T.

Many tests in this TS are performed with the maximum repeater RF Bandwidth located at the bottom, middle and top of the supported frequency range in the operating band. These are denoted as B_{RFBW} (bottom), M_{RFBW} (middle) and T_{RFBW} (top).

Unless otherwise stated, the test shall be performed at B_{RFBW} , M_{RFBW} and T_{RFBW} defined as following:

- B_{RFBW} : maximum repeater RF Bandwidth located at the bottom of the supported frequency range in the operating band.
- M_{RFBW} : maximum repeater RF Bandwidth located in the middle of the supported frequency range in the operating band.
- T_{RFBW} : maximum repeater RF Bandwidth located at the top of the supported frequency range in the operating band.

For repeater capable of multi-band operation, unless otherwise stated, the test shall be performed at $B_{\text{RFBW_T}'_{\text{RFBW}}}$ and $B'_{\text{RFBW_T}_{\text{RFBW}}}$ defined as following:

- $B_{\text{RFBW_T}'_{\text{RFBW}}}$: the *repeater RF Bandwidths* located at the bottom of the supported frequency range in the lowest operating band and at the highest possible simultaneous frequency position, within the Maximum Radio Bandwidth, in the highest operating band.
- $B'_{\text{RFBW_T}_{\text{RFBW}}}$: the *repeater RF Bandwidths* located at the top of the supported frequency range in the highest operating band and at the lowest possible simultaneous frequency position, within the Maximum Radio Bandwidth, in the lowest operating band.

NOTE: $B_{\text{RFBW_T}'_{\text{RFBW}}} = B'_{\text{RFBW_T}_{\text{RFBW}}} = B_{\text{RFBW_T}_{\text{RFBW}}}$ when the declared Maximum Radio Bandwidth spans all operating bands. $B_{\text{RFBW_T}'_{\text{RFBW}}}$ means the *repeater RF Bandwidths* are located at the bottom of the supported frequency range in the lower operating band and at the top of the supported frequency range in the upper operating band.

When a test is performed by a test laboratory, the position of B, M and T for single passband, B_{RFBW} , M_{RFBW} and T_{RFBW} for single band operation, the position of $B_{\text{RFBW_T}'_{\text{RFBW}}}$ and $B'_{\text{RFBW_T}_{\text{RFBW}}}$ in the supported operating band combinations shall be specified by the laboratory. The laboratory may consult with operators, the manufacturer or other bodies.

4.9.2 Test models

4.9.2.1 General

The following clauses will describe the FR1 test models needed for *repeater type 1-C*.

4.9.2.2 FR1 test models for repeater type 1-C for DL

FR1 test model in clause 4.9.2.2 in TS 38.141-1[7] applies to *repeater type 1-C* as below:

- NR-FR1-TM1.1 applies to RDL-FR1-TM1.1
- NR-FR1-TM1.2 applies to RDL-FR1-TM1.2
- NR-FR1-TM2 applies to RDL-FR1-TM2
- NR-FR1-TM2a applies to RDL-FR1-TM2a
- NR-FR1-TM3.1 applies to RDL-FR1-TM3.1
- NR-FR1-TM3.1a applies to RDL-FR1-TM3.1a
- NR-FR1-TM3.2 applies to RDL-FR1-TM3.2
- NR-FR1-TM3.3 applies to RDL-FR1-TM3.3

Testing models applying to NB-IoT operation in clause 4.9.2.2 in TS 38.141-1[7] are not applicable to repeaters.

4.9.2.3 FR1 test models for repeater type 1-C for UL

4.9.2.3.1 General

The set-up of physical channels for transmitter tests shall be according to one of the FR1 test models (R-TMs) below. A reference to the applicable test model is made within each test.

The following general parameters are used by all repeater test models:

- Duration is 2 radio frames for TDD (20 ms)
- The slots are numbered 0 to $10 \times 2^\mu - 1$ where μ is the numerology corresponding to the subcarrier spacing
- N_{RB} is the maximum transmission bandwidth configuration seen in clause 5.3.2 in TS 38.106 [2].

- Normal CP
- Virtual resource blocks of localized type

Repeater test models are derived based on the uplink/downlink configuration as shown in the table 4.9.2.2.1-1 using information element *TDD-UL-DL-ConfigCommon* as defined in TS 38.331 [10].

Table 4.9.2.3.1-1: Configurations of TDD for repeater type 1-C test models

Field name	Value		
referenceSubcarrierSpacing (kHz)	15	30	60
Periodicity (ms) for dl-UL-TransmissionPeriodicity	5	5	5
nrofDownlinkSlots	3	7	14
nrofDownlinkSymbols	10	6	12
nrofUplinkSlots	1	2	4
nrofUplinkSymbols	2	4	8

Common physical channel parameters for all repeater FR1 test models are specified in table 4.9.2.3.1-2 and table 4.9.2.3.1-3 for PUSCH. Specific physical channel parameters for repeater FR1 test models are described in clauses 4.9.2.3.2 to 4.9.2.3.5.

Table 4.9.2.3.1-2: Common physical channel parameters for PUSCH for repeater type 1-C test models

Parameter	Value
Mapping type	PUSCH mapping type A
<i>dmrs-TypeA-Position</i> for the first DM-RS symbol	pos2
<i>dmrs-AdditionalPosition</i> for additional DM-RS symbol(s)	Pos1
<i>dmrs-Type</i> for comb pattern	Configuration type 1
<i>maxLength</i>	1
Ratio of PUSCH EPRE to DM-RS EPRE	0 dB

Table 4.9.2.3.1-3: Common physical channel parameters for PUSCH by RNTI for repeater type 1-C test models

Parameter	Value
PUSCH $n_{\text{RNTI}} = 0$	

4.9.2.3.2 FR1 test model 1.1 (RUL-FR1-TM1.1)

This model shall be used for tests on:

- Repeater output power
- Out of band gain
- Unwanted emissions
 - ACLR
 - Operating band unwanted emissions
 - Transmitter spurious emissions
 - Receiver spurious emissions
- Transmitter intermodulation
- Input intermodulation
- Output intermodulation
- ACRR

- Transmitter ON/OFF power

Common physical channel parameters are defined in clause 4.9.2.3.1. Specific physical channel parameters for RUL-FR1-TM1.1 are defined in table 4.9.2.3.2-1.

Table 4.9.2.2.2-1: Specific physical channel parameters of RUL-FR1-TM1.1

Parameter	Value
# of PRBs PUSCH	N_{RB}
Modulation PUSCH	QPSK

4.9.2.3.3 FR1 test model 2 (RUL-FR1-TM2)

This model shall be used for tests on:

- Transmitted signal quality
- Uplink repeater EVM of single 64QAM PRB allocation (at lower PSD TX power limit at min power)- Frequency stability (at min power)

Common physical channel parameters are defined in clause 4.9.2.3.1. Specific physical channel parameters for RUL-FR1-TM2 are defined in table 4.9.2.3.3-1.

Table 4.9.2.3.3-1: Specific physical channel parameters of RUL-FR1-TM2

Parameter	Value		
# of 64QAM PUSCH PRBs	1		
Level of boosting (dB)	0		
Location of 64QAM PRB	Slot	RB	n
	$3n$	0	$n = 0, \dots, \left\lfloor \frac{10 \times 2^\mu}{3} \right\rfloor - 1$
	$3n+1$	$\left\lfloor \frac{N_{RB}}{2} \right\rfloor$	$n = 0, \dots, \left\lfloor \frac{10 \times 2^\mu - 1}{3} \right\rfloor - 1$
	$3n+2$	$N_{RB} - 1$	$n = 0, \dots, \left\lfloor \frac{10 \times 2^\mu - 2}{3} \right\rfloor - 1$
# of PUSCH PRBs which are not allocated	$N_{RB} - 1$		

4.9.2.3.3a FR1 test model 2a (RUL-FR1-TM2a)

This model shall be used for tests on:

- Uplink repeater EVM of single 256QAM PRB allocation (at min power)
- Frequency stability (at min power)

Common physical channel parameters are defined in clause 4.9.2.3.3. Physical channel parameters and numbers of the allocated PRB are defined in table 4.9.2.3.3-1 with all 64QAM PUSCH PRBs replaced by 256QAM PUSCH PRBs.

4.9.2.3.4 FR1 test model 3.1 (RUL-FR1-TM3.1)

This model shall be used for tests on:

- Transmitted signal quality
- Frequency stability (at max power)
- Uplink repeater EVM for modulation (at max power)

Common physical channel parameters are defined in clause 4.9.2.3.1. Physical channel parameters are defined in table 4.9.2.3.2-1 with all QPSK PUSCH PRBs replaced with selected modulation order PUSCH PRBs according to the corresponding test procedure.

4.9.2.3.5 FR1 test model 3.1a (RUL-FR1-TM3.1a)

This model shall be used for tests on:

- Transmitted signal quality
- Frequency stability (at max power)
- Uplink repeater EVM for 256QAM modulation (at max power)

Common physical channel parameters are defined in clause 4.9.2.3.1. Physical channel parameters are defined in table 4.9.2.3.2-1 with all QPSK PUSCH PRBs replaced by 256QAM PUSCH PRBs.

4.9.2.4 Data content of Physical channels and Signals for RUL-FR1-TM

4.9.2.4.1 General

Randomisation of the data content is obtained by utilizing a PN sequence generator and the length-31 Gold sequence scrambling of TS 38.211 [8], clause 5.2.1 which is invoked by all physical channels prior to modulation and mapping to the RE grid.

Initialization of the scrambler and RE-mappers as defined in TS 38.211 [8] use the following additional parameters:

- N_{ID}^{cell} , Physical layer cell identity = 1 is used as the default physical layer cell identity
- $q = 0$ (single code word)
- Rank 1, single layer

4.9.2.4.2 PUSCH

- Generate the required amount of bits from the output of the PN23 sequence generator [12]. The PN sequence generator is initialized with a starting seed of "all ones" in the first allocated slot of each frame. The PN sequence is continuous over the slot boundaries.
- Perform user specific scrambling according to TS 38.211 [8], clause 6.3.1.1.
- Perform modulation of the scrambled bits with the modulation scheme defined for each user according to TS 38.211 [8], clause 6.3.1.2
- $n_{ID} = N_{ID}^{cell}$
- Perform mapping of the complex-valued symbols to layer according to TS 38.211 [8], clause 6.3.1.3.
- Perform PUSCH mapping according to TS 38.211 [8] using parameters listed in table 4.9.2.3-2.
- DM-RS sequence generation according to TS 38.211 [8], clause 6.4.1.1.1 where l is the OFDM symbol number within the slot with the symbols indicated by table 4.9.2.2-3.
- $N_{ID}^{n_{SCID}} = N_{ID}^{cell}$
- $n_{SCID} = 0$
- DM-RS mapping according to TS 38.211 [8], clause 6.4.1.1.3 using parameters listed in table 4.9.2.2-3.

4.9A RF channels and test models for NCR

4.9A.1 RF channels

For the single passband or carrier testing many tests in this specification are performed with appropriate frequencies in the bottom, middle and top channels of the supported frequency range of the NCR. These are denoted as RF channels B (bottom), M (middle) and T (top).

Unless otherwise stated, the test shall be performed with a single passband or carrier at each of the RF channels B, M and T.

Many tests in this TS are performed with the maximum NCR RF Bandwidth located at the bottom, middle and top of the supported frequency range in the operating band. These are denoted as B_{RFBW} (bottom), M_{RFBW} (middle) and T_{RFBW} (top).

Unless otherwise stated, the test shall be performed at B_{RFBW} , M_{RFBW} and T_{RFBW} defined as following:

- B_{RFBW} : maximum NCR RF Bandwidth located at the bottom of the supported frequency range in the operating band.
- M_{RFBW} : maximum NCR RF Bandwidth located in the middle of the supported frequency range in the operating band.
- T_{RFBW} : maximum NCR RF Bandwidth located at the top of the supported frequency range in the operating band.

For NCR capable of multi-band operation, unless otherwise stated, the test shall be performed at $B_{\text{RFBW}}T_{\text{RFBW}}$ and $B'_{\text{RFBW}}T_{\text{RFBW}}$ defined as following:

- $B_{\text{RFBW}}T_{\text{RFBW}}$: the *NCR RF Bandwidths* located at the bottom of the supported frequency range in the lowest operating band and at the highest possible simultaneous frequency position, within the Maximum Radio Bandwidth, in the highest operating band.
- $B'_{\text{RFBW}}T_{\text{RFBW}}$: the *NCR RF Bandwidths* located at the top of the supported frequency range in the highest operating band and at the lowest possible simultaneous frequency position, within the Maximum Radio Bandwidth, in the lowest operating band.

NOTE: $B_{\text{RFBW}}T_{\text{RFBW}} = B'_{\text{RFBW}}T_{\text{RFBW}} = B_{\text{RFBW}}T_{\text{RFBW}}$ when the declared Maximum Radio Bandwidth spans all operating bands. $B_{\text{RFBW}}T_{\text{RFBW}}$ means the *NCR RF Bandwidths* are located at the bottom of the supported frequency range in the lower operating band and at the top of the supported frequency range in the upper operating band.

When a test is performed by a test laboratory, the position of B, M and T for single passband or carrier, B_{RFBW} , M_{RFBW} and T_{RFBW} for single band operation, the position of $B_{\text{RFBW}}T_{\text{RFBW}}$ and $B'_{\text{RFBW}}T_{\text{RFBW}}$ in the supported operating band combinations shall be specified by the laboratory. The laboratory may consult with operators, the manufacturer or other bodies.

4.9A.2 Test models

4.9A.2.1 General

The following clauses will describe the FR1 test models needed for *NCR type 1-C* and *NCR type 1-H*.

4.9A.2.2 FR1 test models for NCR for DL

FR1 test model in clause 4.9.2.2 in TS 38.141-1[7] applies to *NCR type 1-C* and *NCR type 1-H* as below:

- NR-FR1-TM1.1 applies to NCRDL-FR1-TM1.1
- NR-FR1-TM1.2 applies to NCRDL-FR1-TM1.2
- NR-FR1-TM2 applies to NCRDL-FR1-TM2
- NR-FR1-TM2a applies to NCRDL-FR1-TM2a
- NR-FR1-TM3.1 applies to NCRDL-FR1-TM3.1
- NR-FR1-TM3.1a applies to NCRDL-FR1-TM3.1a
- NR-FR1-TM3.2 applies to NCRDL-FR1-TM3.2
- NR-FR1-TM3.3 applies to NCRDL-FR1-TM3.3

Testing models applying to NB-IoT operation in clause 4.9.2.2 in TS 38.141-1[7] are not applicable to NCR.

4.9A.2.3 FR1 test models for NCR for UL

4.9A.2.3.1 General

The set-up of physical channels for transmitter tests shall be according to one of the FR1 test models (NCRUL-FR1-TM) below. A reference to the applicable test model is made within each test.

The following general parameters are used by all NCR test models:

- Duration is 2 radio frames for TDD (20 ms)
- The slots are numbered 0 to $10 \times 2^\mu - 1$ where μ is the numerology corresponding to the subcarrier spacing
- N_{RB} is the maximum transmission bandwidth configuration seen in clause 5.3.2 in TS 38.106[2].
- Normal CP
- Virtual resource blocks of localized type

NCR test models are derived based on the uplink/downlink configuration as shown in the table 4.9A.2.3.1-1 using information element *TDD-UL-DL-ConfigCommon* as defined in TS 38.331 [10].

Table 4.9A.2.3.1-1: Configurations of TDD for NCR type 1-C and NCR type 1-H test models

Field name	Value		
referenceSubcarrierSpacing (kHz)	15	30	60
Periodicity (ms) for dl-UL-TransmissionPeriodicity	5	5	5
nrofDownlinkSlots	3	7	14
nrofDownlinkSymbols	10	6	12
nrofUplinkSlots	1	2	4
nrofUplinkSymbols	2	4	8

Common physical channel parameters for all NCR FR1 test models are specified in table 4.9A.2.3.1-2 and table 4.9A.2.3.1-3 for PUSCH. Specific physical channel parameters for NCR FR1 test models are described in clauses 4.9A.2.3.2 to 4.9A.2.3.5.

Table 4.9A.2.3.1-2: Common physical channel parameters for PUSCH for NCR type 1-C and type 1-H test models

Parameter	Value
Mapping type	PUSCH mapping type A
<i>dmrs-TypeA-Position</i> for the first DM-RS symbol	pos2
<i>dmrs-AdditionalPosition</i> for additional DM-RS symbol(s)	Pos1
<i>dmrs-Type</i> for comb pattern	Configuration type 1
<i>maxLength</i>	1
Ratio of PUSCH EPRE to DM-RS EPRE	0 dB

Table 4.9A.2.3.1-3: Common physical channel parameters for PUSCH by RNTI for NCR type 1-C and type 1-H test models

Parameter	Value
PUSCH n_{RNTI}	0

4.9A.2.3.2 FR1 test model 1.1 (NCRUL-FR1-TM1.1)

This model shall be used for tests on:

- NCR output power

- Out of band gain
- Transmit ON/OFF power
- Unwanted emissions
 - ACLR
 - Operating band unwanted emissions
 - Transmitter spurious emissions
 - Receiver spurious emissions
 - Transmitter intermodulation
 - Input intermodulation
- ACRR

Common physical channel parameters are defined in clause 4.9A.2.3.1. Specific physical channel parameters for NCRUL-FR1-TM1.1 are defined in table 4.9A.2.3.2-1.

Table 4.9A.2.3.2-1: Specific physical channel parameters of NCRUL-FR1-TM1.1

Parameter	Value
# of PRBs PUSCH	N_{RB}
Modulation PUSCH	QPSK

4.9A.2.3.3 FR1 test model 2 (NCRUL-FR1-TM2)

This model shall be used for tests on:

- Transmitted signal quality
 - EVM of single 64QAM PRB allocation (at lower PSD TX power limit at min power)
 - Frequency stability (at min power)
 - Frequency error (at min power)

Common physical channel parameters are defined in clause 4.9A.2.3.1. Specific physical channel parameters for NCRUL-FR1-TM2 are defined in table 4.9A.2.3.3-1.

Table 4.9A.2.3.3-1: Specific physical channel parameters of NCRUL-FR1-TM2

Parameter	Value												
# of 64QAM PUSCH PRBs	1												
Level of boosting (dB)	0												
Location of 64QAM PRB	<table border="1"> <thead> <tr> <th>Slot</th> <th>RB</th> <th>n</th> </tr> </thead> <tbody> <tr> <td>$3n$</td> <td>0</td> <td>$n = 0, \dots, \left\lfloor \frac{10 \times 2^{\mu}}{3} \right\rfloor - 1$</td> </tr> <tr> <td>$3n+1$</td> <td>$\left\lfloor \frac{N_{RB}}{2} \right\rfloor$</td> <td>$n = 0, \dots, \left\lfloor \frac{10 \times 2^{\mu} - 1}{3} \right\rfloor - 1$</td> </tr> <tr> <td>$3n+2$</td> <td>$N_{RB} - 1$</td> <td>$n = 0, \dots, \left\lfloor \frac{10 \times 2^{\mu} - 2}{3} \right\rfloor - 1$</td> </tr> </tbody> </table>	Slot	RB	n	$3n$	0	$n = 0, \dots, \left\lfloor \frac{10 \times 2^{\mu}}{3} \right\rfloor - 1$	$3n+1$	$\left\lfloor \frac{N_{RB}}{2} \right\rfloor$	$n = 0, \dots, \left\lfloor \frac{10 \times 2^{\mu} - 1}{3} \right\rfloor - 1$	$3n+2$	$N_{RB} - 1$	$n = 0, \dots, \left\lfloor \frac{10 \times 2^{\mu} - 2}{3} \right\rfloor - 1$
	Slot	RB	n										
	$3n$	0	$n = 0, \dots, \left\lfloor \frac{10 \times 2^{\mu}}{3} \right\rfloor - 1$										
	$3n+1$	$\left\lfloor \frac{N_{RB}}{2} \right\rfloor$	$n = 0, \dots, \left\lfloor \frac{10 \times 2^{\mu} - 1}{3} \right\rfloor - 1$										
$3n+2$	$N_{RB} - 1$	$n = 0, \dots, \left\lfloor \frac{10 \times 2^{\mu} - 2}{3} \right\rfloor - 1$											
# of PUSCH PRBs which are not allocated	$N_{RB} - 1$												

4.9A.2.3.3a FR1 test model 2a (NCRUL-FR1-TM2a)

This model shall be used for tests on:

- EVM of single 256QAM PRB allocation (at min power)
- Frequency stability (at min power)
- Frequency error (at min power)

Common physical channel parameters are defined in clause 4.9A.2.3.3. Physical channel parameters and numbers of the allocated PRB are defined in table 4.9A.2.3.3-1 with all 64QAM PUSCH PRBs replaced by 256QAM PUSCH PRBs.

4.9A.2.3.4 FR1 test model 3.1 (NCRUL-FR1-TM3.1)

This model shall be used for tests on:

- Output power dynamics
 - Total power dynamic range (upper TX PSD power limit at max power with all 64QAM PRBs allocated)
- Transmitted signal quality
 - Frequency error (at max power)
 - Frequency stability (at min power)
 - EVM for modulation (at max power)

Common physical channel parameters are defined in clause 4.9A.2.3.1. Physical channel parameters are defined in table 4.9A.2.3.2-1 with all QPSK PUSCH PRBs replaced with selected modulation order PUSCH PRBs according to the corresponding test procedure.

4.9A.2.3.5 FR1 test model 3.1a (NCRUL-FR1-TM3.1a)

This model shall be used for tests on:

- Output power dynamics
 - Total power dynamic range (upper TX PSD power limit at max power with all 256QAM PRBs allocated)
- Transmitted signal quality
 - Frequency stability (at max power)
 - Frequency error (at max power)
 - EVM for 256QAM modulation (at max power)

Common physical channel parameters are defined in clause 4.9A.2.3.1. Physical channel parameters are defined in table 4.9A.2.3.2-1 with all QPSK PUSCH PRBs replaced by 256QAM PUSCH PRBs.

4.9A.2.4 Data content of Physical channels and Signals for NCRUL-FR1-TM

4.9A.2.4.1 General

Randomisation of the data content is obtained by utilizing a PN sequence generator and the length-31 Gold sequence scrambling of TS 38.211 [8], clause 5.2.1 which is invoked by all physical channels prior to modulation and mapping to the RE grid.

Initialization of the scrambler and RE-mappers as defined in TS 38.211 [8] use the following additional parameters:

- N_{ID}^{cell} , Physical layer cell identity = 1 is used as the default physical layer cell identity
- $q = 0$ (single code word)
- Rank 1, single layer

4.9A.2.4.2 PUSCH

- Generate the required amount of bits from the output of the PN23 sequence generator [15]. The PN sequence generator is initialized with a starting seed of "all ones" in the first allocated slot of each frame. The PN sequence is continuous over the slot boundaries.
- Perform user specific scrambling according to TS 38.211 [8], clause 6.3.1.1.
- Perform modulation of the scrambled bits with the modulation scheme defined for each user according to TS 38.211 [8], clause 6.3.1.2
- $n_{ID} = N_{ID}^{cell}$
- Perform mapping of the complex-valued symbols to layer according to TS 38.211 [8], clause 6.3.1.3.
- Perform PUSCH mapping according to TS 38.211 [8] using parameters listed in table 4.9.2.3-2.
- DM-RS sequence generation according to TS 38.211 [8], clause 6.4.1.1.1 where l is the OFDM symbol number within the slot with the symbols indicated by table 4.9.2.2-3.
- $N_{ID}^{sCID} = N_{ID}^{cell}$
- $n_{sCID} = 0$
- DM-RS mapping according to TS 38.211 [8], clause 6.4.1.1.3 using parameters listed in table 4.9.2.2-3.

4.10 Requirements for contiguous and non-contiguous spectrum

A spectrum allocation where a repeater or NCR operates can either be contiguous or non-contiguous. Unless otherwise stated, the requirements in the present specification apply for repeater or NCR configured for both contiguous spectrum operation and non-contiguous spectrum operation.

For repeater or NCR operation in non-contiguous spectrum, some requirements apply both at the repeater or NCR *passband* edges and inside the sub-block gaps. For each such requirement, it is stated how the limits apply relative to the repeater or NCR *passband* edges and the sub-block edges respectively.

4.11 Requirements for repeater capable of multi-band operation

For *multi-band connector* the conducted test requirements in clause 6 apply separately to each supported *operating band* unless otherwise stated. For some conducted test requirements, it is explicitly stated that specific additions or exclusions to the requirement apply at *multi-band connector(s)* as detailed in the requirement clause. For repeater or NCR capable of multi-band operation, various structures in terms of combinations of different transceivers in downlink and transceivers in uplink implementations (multi-band or single band) with mapping of transceivers to one or more *antenna connectors for repeater* or *NCR type 1-C* or one or more TAB connectors for NCR type 1-H in different ways are possible. For *multi-band connector(s)* the exclusions or provisions for multi-band apply. For *single-band connector(s)*, the following applies:

- Single-band transmitter spurious emissions, *operating band* unwanted emissions, ACLR, output intermodulation, ACRR and receiver spurious emissions requirements apply to this *connector* that is mapped to single-band.
- If the repeater or NCR is configured for single-band operation, *single-band requirements* shall apply to this connector configured for single-band operation and no exclusions or provisions for multi-band capable repeater or NCR are applicable. *Single-band requirements* are tested separately at the connector configured for single-band operation, with all other connectors terminated.

For *multi-band connectors* supporting the bands for TDD, the RF requirements in the present specification assume no simultaneous uplink and downlink occur between the bands.

NOTE 1: The conducted test requirements for multi-band connectors supporting bands for both FDD and TDD are not covered by the present release of this specification.

4.12 Format and interpretation of tests

Each test has a standard format:

X Title

All tests are applicable to all equipment within the scope of the present document, unless otherwise stated.

X.1 Definition and applicability

This clause gives the general definition of the parameter under consideration and specifies whether the test is applicable to all equipment or only to a certain subset. Required manufacturer declarations may be included here.

X.2 Minimum requirement

This clause contains the reference to the clause to the 3GPP reference (or core) specification which defines the minimum requirement.

X.3 Test purpose

This clause defines the purpose of the test.

X.4 Method of test

X.4.1 General

In some cases there are alternative test procedures or initial conditions. In such cases, guidance for which initial conditions and test procedures can be applied are stated here. In the case only one test procedure is applicable, that is stated here.

X.4.2y First test method

X.4.2y.1 Initial conditions

This clause defines the initial conditions for each test, including the test environment, the RF channels to be tested and the basic measurement set-up.

X.4.2y.2 Procedure

This clause describes the steps necessary to perform the test and provides further details of the test definition like domain (e.g. frequency-span), range, weighting (e.g. bandwidth), and algorithms (e.g. averaging). The procedure may comprise data processing of the measurement result before comparison with the test requirement (e.g. average result from several measurement positions).

X.4.3y Alternative test method (if any)

If there are alternative test methods, each is described with its initial conditions and procedures.

X.5 Test requirement

This clause defines the pass/fail criteria for the equipment under test, see clause 4.1.3 (Interpretation of measurement results). Test requirements for every minimum requirement referred in clause X.2 are listed here. Cases where minimum requirements do not apply need not be mentioned.

5 Operating bands and channel arrangement

For the NR repeater operation in NR operating bands specification, their channel bandwidth configurations, channel spacing and raster, as well as synchronization raster specification, refer to TS 38.106 [2], clause 5 and its relevant clauses.

For the conducted testing purposes in this specification, only FR1 operating bands are considered.

6 Conducted characteristics

6.1 General

Unless otherwise stated, the conducted characteristics are specified at the *antenna connector* for *repeater type 1-C* and *NCR type 1-C* configuration and at the individual or groups of *TAB connectors* at the *transceiver array boundary* for *NCR type 1-H* configuration in normal operating conditions.

Requirements apply in both DL and UL.

For repeater type 1-C, NCR type 1-C, NCR type 1-H, the DL the *antenna connectors* / *TAB connectors* on the BS side is the input and the *antenna connector* on the UE side is the output.

For repeater type 1-C, NCR type 1-C, NCR type 1-H, the UL the *antenna connectors* / *TAB connectors* on the UE side is the input and the *antenna connector* on the BS side is the output.

General test conditions for conducted tests of the *repeater type 1-C*, *NCR type 1-C* or *NCR type 1-H* are given in clause 4, including interpretation of measurement results and configurations for testing. Repeater configurations for the tests are defined in clause 4.5.

If a number of *single-band connectors*, or *multi-band connectors* have been declared equivalent (D.13), only a representative one is necessary to be tested to demonstrate conformance.

For *NCR type 1-H* if a number of *TAB connectors* have been declared equivalent (D.13), only a representative one is necessary to demonstrate conformance.

6.2 Repeater output power

6.2.1 Definition and applicability

The repeater conducted output power requirements are specified at *single-band connector*, or at *multi-band connector*.

The *rated passband output power* $P_{\text{rated,p,AC}}$ of the *repeater type 1-C* and *NCR type 1-C* shall be as specified in table 6.2.1-1 and table 6.2.1-2.

Table 6.2.1-1: Repeater type 1-C and NCR-Fwd type 1-C DL transmission classes rated output power limits for repeater classes

Repeater class	$P_{\text{rated,p,AC}}$
Wide Area repeater	Note 1
Medium Range repeater	$\leq 38 \text{ dBm} + X$, Note 2
Local Area repeater	$\leq 24 \text{ dBm} + X$, Note 2
NOTE 1: There is no upper limit for the $P_{\text{rated,p,AC}}$ <i>rated passband output power</i> of the Wide Area repeater.	
NOTE 2: $X = 10 \cdot \log(\text{ceil}(\text{passband bandwidth}/20\text{MHz}))$	

Table 6.2.1-2: Repeater type 1-C and NCR-Fwd type 1-C UL transmission classes rated output power limits for repeater classes

Repeater class	$P_{\text{rated,p,AC}}$
Wide Area repeater	Note 1
Local Area repeater	$\leq 24 \text{ dBm} + X$, Note 2
NOTE 1: There is no upper limit for the $P_{\text{rated,p,AC}}$ <i>rated passband output power</i> of the Wide Area repeater.	
NOTE 2: $X = 10 \cdot \log(\text{ceil}(\text{passband bandwidth}/20\text{MHz}))$	
NOTE 3: For joint transmission of NCR-FWD and NCR-MT, $P_{\text{rated,c,sys}}$ shall apply to the total power of NCR-Fwd and NCR-MT.	

The rated passband output power of the *NCR-Fwd 1-H* shall be as specified in table 6.2.1-3 and table 6.2.1-4.

Table 6.2.1-3: *NCR-Fwd 1-H* DL rated output power limits for NCR classes

Repeater class	$P_{\text{rated,c,sys}}$ (Note 1)	$P_{\text{rated,c,TABC}}$ (Note 1)
Wide Area NCR		
Medium Range NCR	$\leq 38 \text{ dBm} + 10\log(N_{\text{TXU,counted}}) + X$ (NOTE 2)	$\leq 38 \text{ dBm} + X$ (NOTE 2)
Local Area NCR	$\leq 24 \text{ dBm} + 10\log(N_{\text{TXU,counted}}) + X$ (NOTE 2)	$\leq 24 \text{ dBm} + X$ (NOTE 2)
NOTE 1: There is no upper limit for the $P_{\text{rated,c,sys}}$ or $P_{\text{rated,c,TABC}}$ of the Wide Area NCR-Fwd. NOTE 2: $X = 10 \cdot \log(\text{ceil}(\text{passband bandwidth}/20\text{MHz}))$		

Table 6.2.1-4: *NCR-Fwd 1-H* UL rated output power limits for NCR classes

Repeater class	$P_{\text{rated,c,sys}}$ (Note 1)	$P_{\text{rated,c,TABC}}$ (Note 1)
Wide Area NCR		
Local Area NCR	$\leq 24 \text{ dBm} + 10\log(N_{\text{TXU,counted}}) + X$ (NOTE 2, 3)	$\leq 24 \text{ dBm} + X$ (NOTE 2)
NOTE 1: There is no upper limit for the $P_{\text{rated,c,sys}}$ or $P_{\text{rated,c,TABC}}$ of the Wide Area NCR. NOTE 2: $X = 10 \cdot \log(\text{ceil}(\text{passband bandwidth}/20\text{MHz}))$ NOTE 3: For joint transmission of NCR-FWD and NCR-MT, $P_{\text{rated,c,sys}}$ shall apply to the total power of NCR-Fwd and NCR-MT.		

The rated carrier output power of the *NCR-MT type 1-C* shall be as specified in table 6.2.1-5.

Table 6.2.1-5: *NCR-MT type 1-C* UL transmission classes rated output power limits

Repeater class	$P_{\text{rated,c,AC}}$
Wide Area NCR-MT	(Note)
Local Area NCR-MT	$\leq 24 \text{ dBm}$
NOTE 1: There is no upper limit for the $P_{\text{rated,c,AC}}$ <i>rated output power</i> of the Wide Area NCR-MT. NOTE 2: For joint transmission of NCR-Fwd and NCR-MT, $P_{\text{rated,c,sys}}$ shall apply to the total power of NCR-Fwd and NCR-MT	

The rated carrier output power of the *NCR-MT type 1-H* shall be as specified in table 6.2.1-6.

Table 6.2.1-6: *NCR-MT type 1-H* UL transmission classes rated output power limits

Repeater class	$P_{\text{rated,c,sys}}$	$P_{\text{rated,c,TABC}}$
Wide Area NCR-MT	(Note 1)	(Note 1)
Local Area NCR-MT ^{2,3}	$\leq 24 \text{ dBm} + 10\log(N_{\text{TXU,counted}})$	$\leq 24 \text{ dBm}$
NOTE 1: There is no upper limit for the $P_{\text{rated,c,AC}}$ <i>rated output power</i> of the Wide Area NCR-MT. NOTE 2: LA MT cannot exceed highest power class for that band as specified in TS 38.101-1 [9]. NOTE 3: $N_{\text{TXU,counted}} = \min(N_{\text{TXU,active}}, 4)$ NOTE 4: For joint transmission of NCR-Fwd and NCR-MT, $P_{\text{rated,c,sys}}$ shall apply to the total power of NCR-Fwd and NCR-MT		

The output power limit for the respective repeater classes in tables 6.2.1-1, 6.2.1-2, 6.2.1-3 and 6.2.1-4 shall be compared to the rated output power and the declared repeater class. It is not subject to testing.

6.2.2 Minimum requirement

The minimum requirement applies per *single-band connector*, or per *multi-band connector* supporting transmission in the *passband*.

The minimum requirement for *repeater type 1-C* is defined for normal and extreme conditions in TS 38.106 [2], clause 6.2.2.

The minimum requirement for *NCR-Fwd* is defined for normal and extreme conditions in TS 38.106 [2], clause 6.2.3.1.

The minimum requirement for *NCR-MT* is defined for normal and extreme conditions in TS 38.106 [2], clause 6.2.3.2.

6.2.3 Test purpose

The test purpose is to verify that the repeater output power accuracy of the *rated passband output power* across the frequency range and under normal and extreme conditions is within the limit specified by the minimum requirement in 6.2.2.

6.2.4 Method of test

6.2.4.1 Initial conditions

Test environment:

- Normal, see annex B.2,
- Extreme, see annexes B.3 and B.5.

A measurement system set-up is shown in annex D.1.

RF channels to be tested for single carrier: B, M and T; see clause 4.9.1.

RF channels positions to be tested for multi-carrier:

- B_{RFBW} , M_{RFBW} and T_{RFBW} for *single-band connector(s)*, see clause 4.9.1.
- B'_{RFBW} , T'_{RFBW} and $B'_{\text{RFBW}}-T'_{\text{RFBW}}$ for *multi-band connector(s)*, see clause 4.9.1.

Under extreme test environment, it is sufficient to test on one NR-ARFCN or one RF bandwidth position, and with one applicable test configuration defined in clauses 4.7 and 4.8. Testing shall be performed under extreme power supply conditions, as defined in annex B.5.

NOTE: Tests under extreme power supply conditions also test extreme temperatures.

Power levels for repeater type 1-C and NCR type 1-C to be tested:

- The lowest input power ($P_{\text{in,p,AC}}$) that produces the *rated passband output power* ($P_{\text{rated,p,AC}}$).
- The lowest input power ($P_{\text{in,p,AC}}$) that produces the *rated passband output power* ($P_{\text{rated,p,AC}}$), plus 10 dB.

Power levels for NCR type 1-H to be tested:

- The lowest input power ($P_{\text{in,p,TABC}}$) that produces the *rated passband output power* ($P_{\text{rated,p,TABC}}$).
- The lowest input power ($P_{\text{in,p,TABC}}$) that produces the *rated passband output power* ($P_{\text{rated,p,TABC}}$), plus 10 dB.

6.2.4.2 Procedure

- 1) Connect the power measuring equipment to the output *single-band connector(s)* or to *multi-band connector(s)* and the signal generator equipment to the input *single-band connector(s)* or to *multi-band connector(s)* under test as shown in annex D.1.1. All connectors not under test shall be terminated.
- 2) For single carrier set the signal generator to transmit according to the applicable test configuration in clause 4.8 using the corresponding test models or set of physical channels in clause 4.9.2 at power levels to be tested, as in clause 6.2.4.1.

For a connector under test declared to be capable of multi-carrier operation set the connector under test to transmit on all carriers configured using the applicable test configuration and corresponding power setting specified in clauses 4.7 and 4.8 using the corresponding test models or set of physical channels in clause 4.9.2.

- 3) For RF repeater, measure the *maximum passband output power measured per antenna connector* ($P_{\text{max,p,AC}}$) for each carrier at each connector under test.

For NCR-Fwd, measure the *maximum passband output power measured per antenna connector* ($P_{\max,p,AC}$) for NCR type 1-C and per TAB connector ($P_{\max,p,TABC}$) for NCR type 1-H for each carrier under test. For NCR-MT, measure the output power per antenna connector ($P_{\max,p,AC}$) for NCR type 1-C and per TAB connector ($P_{\max,p,TABC}$) for NCR-type 1-H for each carrier under test.

In addition, for *multi-band connectors*, the following steps shall apply:

- 4) For a *multi-band connectors* and single band tests, repeat the steps above per involved *operating band* where single band test configurations and test models shall apply with no carrier activated in the other *operating band*.

6.2.5 Test requirement

For RF repeater, for each *single-band connector* or *multi-band connector* under test, the power measured in clause 6.2.4.2 in step 3 ($P_{\max,p,AC}$) shall remain within the values provided in table 6.2.5-1 for normal and extreme test environments, relative to the manufacturer's declared $P_{\text{rated},p,AC}$ for *repeater type 1-C* (D.9):

Table 6.2.5-1: Test requirements for conducted repeater output power accuracy

Normal test environment	Extreme test environment
$f \leq 3.0 \text{ GHz}: \pm 2.7 \text{ dB}$	$f \leq 3.0 \text{ GHz}: \pm 3.2 \text{ dB}$
$3.0 \text{ GHz} < f \leq 7.125 \text{ GHz}: \pm 3.0 \text{ dB}$	$3.0 \text{ GHz} < f \leq 7.125 \text{ GHz}: \pm 3.5 \text{ dB}$

For NCR, for each *single-band connector* or *multi-band connector* under test, the power measured in clause 6.2.4.2 in step 3 ($P_{\max,p,AC}$ or $P_{\max,p,TABC}$ for both NCR-Fwd and NCR-MT) shall remain within the values provided in table 6.2.5-2 for normal and extreme test environments, relative to the manufacturer's declared $P_{\text{rated},p,AC}$ for NCR type *1-C* and $P_{\text{rated},p,TABC}$ for NCR type *1-H* (D.9):

Table 6.2.5-2: Test requirements for conducted NCR output power accuracy

Normal test environment	Extreme test environment
$f \leq 3.0 \text{ GHz}: \pm 2.7 \text{ dB}$	$f \leq 3.0 \text{ GHz}: \pm 3.2 \text{ dB}$
$3.0 \text{ GHz} < f \leq 7.125 \text{ GHz}: \pm 3.0 \text{ dB}$	$3.0 \text{ GHz} < f \leq 7.125 \text{ GHz}: \pm 3.5 \text{ dB}$

6.3 Frequency stability

6.3.1 Definition and applicability

Frequency stability is the ability to maintain the same frequency on the output signal with respect to the input signal.

6.3.2 Minimum Requirement

The minimum requirement for RF repeater is in TS 38.106 [2], clause 6.3.2.

The minimum requirement for NCR-Fwd is in TS 38.106 [2], clause 6.3.3.

6.3.3 Test purpose

The test purpose is to verify that frequency stability is within the limit specified by the minimum requirement.

6.3.4 Method of test

Requirement is tested together with modulation quality test, as described in clause 6.6.

6.3.5 Test Requirements

The frequency deviation of the output signal with respect to the input signal shall be accurate to within $\pm(0.01 \text{ ppm} + 12 \text{ Hz})$ observed over 1 ms.

6.4 Out of band gain

6.4.1 Definition and applicability

Out of band gain refers to the gain of the repeater outside the *passband*.

6.4.2 Minimum Requirement

The minimum requirement for RF repeater is in TS 38.106 [2], clause 6.4.2.

The minimum requirement for NCR-Fwd is in TS 38.106 [2], clause 6.4.3.

6.4.3 Test purpose

The test purpose is to verify that out of band gain is within the limit specified by the minimum requirement.

6.4.4 Method of test

6.4.4.1 Initial conditions

Test environment:

- Normal, see annex B.2,

6.4.4.2 Procedure

- 1) Connect the CW generator to the input and power measuring equipment to the output *single-band connector(s)* or to *multi-band connector(s)* under test as shown in annex D.1.1. All connectors not under test shall be terminated.
- 2) Set the CW generator to generate a test signal with an input power equivalent to $P_{in,p,AC}$ for RF repeater type 1-C or NCR type 1-C and $P_{in,p,TABC}$ for NCR type 1-H.
- 3) Measure the output for each carrier at each connector under test. The out of band gain at the frequency under test is given by the difference in dB between the measured output power and the power of the input signal.
- 4) Repeat steps 2-3, shifting the offset frequency of the CW from the edge of the *passband* from 200kHz to 10MHz for bands below 2496MHz and 15MHz for other FR1 bands in steps of 200kHz for each *passband* and, for the case of multi-band connectors each operating band.

6.4.5 Test Requirements

The gain outside the *passband* shall not exceed the maximum level specified in table 6.4.5-1 or table 6.4.5-2 or table 6.4.5-3, where:

- f_{offset_CW} is the offset between the outer channel edge frequency of the outer channel in the *passband* and a CW signal.

Table 6.4.5-1: Out of band gain limits 1 for bands below 2496 MHz

Frequency offset, f_{offset_CW}	Maximum gain
$0,2 \leq f_{offset_CW} < 1,0$ MHz	60.5 dB
$1,0 \leq f_{offset_CW} < 5,0$ MHz	45.5 dB
$5,0 \leq f_{offset_CW} < 10,0$ MHz	45.5 dB
$10,0$ MHz $\leq f_{offset_CW}$	35.5 dB

Table 6.4.5-2: Out of band gain limits 1 for bands above 2496 MHz and below 3000 MHz

Frequency offset, $f_{\text{offset_CW}}$	Maximum gain
$[0,2] < f_{\text{offset_CW}} < 4,0$ MHz	60.5 dB
$4,0 < f_{\text{offset_CW}} < 15,0$ MHz	45.5 dB
$15,0$ MHz $< f_{\text{offset_CW}}$	35.5 dB

Table 6.4.5-3: Out of band gain limits 1 for bands above above 3000 MHz

Frequency offset, $f_{\text{offset_CW}}$	Maximum gain
$[0,2] < f_{\text{offset_CW}} < 4,0$ MHz	60.8 dB
$4,0 < f_{\text{offset_CW}} < 15,0$ MHz	45.8 dB
$15,0$ MHz $< f_{\text{offset_CW}}$	35.8 dB

6.5 Unwanted emissions

6.5.1 General

Unwanted emissions consist of out-of-band emissions and spurious emissions according to ITU definitions [4]. In ITU terminology, out of band emissions are unwanted emissions immediately outside the channel bandwidth resulting from the modulation process and non-linearity in the transmitter but excluding spurious emissions. Spurious emissions are emissions which are caused by unwanted transmitter effects such as harmonics emission, parasitic emission, intermodulation products and frequency conversion products, but exclude out of band emissions.

The out-of-band emissions requirement for the Repeater transmitter is specified both in terms of Adjacent Channel Leakage power Ratio (ACLR) and *operating band* unwanted emissions (OBUE).

The maximum offset of the *operating band* unwanted emissions mask from the *operating band* edge is Δf_{OBUE} . The Operating band unwanted emissions define all unwanted emissions in each supported downlink *operating band* of *repeater type 1-C*, *NCR type 1-C* and *NCR type 1-H* DL and uplink *operating band* of *repeater type 1-C*, *NCR type 1-C* and *NCR type 1-H* UL, plus the frequency ranges Δf_{OBUE} above and Δf_{OBUE} below each band. Unwanted emissions outside of this frequency range are limited by a spurious emissions requirement.

The values of Δf_{OBUE} are defined in tables 6.5.1-1 and 6.5.1-2 for the NR *operating bands*.

Table 6.5.1-1: Maximum offset of OBUE outside the downlink *operating band* of *repeater type 1-C*, *NCR-Fwd type 1-C* and *NCR-Fwd type 1-H* DL

Repeater type or NCR	<i>Operating band</i> characteristics	Δf_{OBUE} (MHz)
<i>NCR-Fwd type 1-H</i>	$F_{\text{DL,high}} - F_{\text{DL,low}} < 100$ MHz	10
	$100 \text{ MHz} \leq F_{\text{DL,high}} - F_{\text{DL,low}} \leq 900$ MHz	40
Repeater type 1-C and <i>NCR-Fwd type 1-C</i>	$F_{\text{DL,high}} - F_{\text{DL,low}} < 200$ MHz	10
	$200 \text{ MHz} \leq F_{\text{DL,high}} - F_{\text{DL,low}} \leq 900$ MHz	40

Table 6.5.1-2: Maximum offset of OBUE outside the uplink *operating band* of *repeater 1-C*, *NCR-Fwd type 1-C* and *NCR-Fwd type 1-H* UL

Repeater type or NCR	<i>Operating band</i> characteristics	Δf_{OBUE} (MHz)
<i>NCR-Fwd type 1-H</i>	$F_{\text{DL,high}} - F_{\text{DL,low}} < 100$ MHz	10
	$100 \text{ MHz} \leq F_{\text{DL,high}} - F_{\text{DL,low}} \leq 900$ MHz	40
Repeater type 1-C and <i>NCR-Fwd type 1-C</i>	$F_{\text{UL,high}} - F_{\text{UL,low}} < 200$ MHz	10
	$200 \text{ MHz} \leq F_{\text{UL,high}} - F_{\text{UL,low}} \leq 900$ MHz	40

For *NCR-Fwd type 1-H* the unwanted emission requirements are applied per the *TAB connector TX min cell groups* for all the configurations supported by the NCR. The *basic limits* and corresponding emissions scaling are defined in each relevant clause.

There is no co-location unwanted emission requirement for LA NCR-Fwd type 1-C and repeaters type 1-C deployed in Femto cell scenario.

6.5.2 Adjacent Channel Leakage Power Ratio (ACLR)

6.5.2.1 Definition and applicability

Adjacent Channel Leakage power Ratio (ACLR) is the ratio of the filtered mean power centred on the assigned channel frequency to the filtered mean power centred on an adjacent channel frequency.

The requirements shall apply outside the *repeater type 1-C passband* whatever the type of transmitter considered (single carrier or multi-carrier) and for all transmission modes foreseen by the manufacturer's specification.

For a *repeater* operating in *non-contiguous spectrum*, the ACLR requirement in clause 6.5.2.5 shall apply in *gaps between passbands* for the frequency ranges defined in table 6.5.2.5-3 or 6.5.2.5-3a, while the CAACLR requirement in clause 6.5.2.5 shall apply in *gaps between passbands* for the frequency ranges defined in table 6.5.2.5-4 or 6.5.2.5-4a.

For a *multi-band connector*, the ACLR requirement in clause 6.5.2.5 shall apply in *inter-passband gaps* for the frequency ranges defined in table 6.5.2.5-3 or 6.5.2.5-3a, while the CAACLR requirement in clause 6.5.2.5 shall apply in *inter-passband gaps* for the frequency ranges defined in table 6.5.2.5-4 or 6.5.2.5-4a.

The requirement shall apply during the *transmitter ON state*.

6.5.2.2 Minimum requirement

The minimum requirement applies per *single-band connector*, or per *multi-band connector* supporting transmission in the *operating band*.

The minimum requirement for RF repeater is in TS 38.106 [2], clause 6.5.2.2.

The minimum requirement for NCR is in TS 38.106 [2], clause 6.5.2.4.

6.5.2.3 Test purpose

To verify that the adjacent channel leakage power ratio requirement shall be met as specified by the minimum requirement.

6.5.2.4 Method of test

6.5.2.4.1 Initial conditions

Test environment: Normal; see annex B.2.

RF channels to be tested for single carrier: B, M and T; see clause 4.9.1.

6.5.2.4.2 Procedure

- 1) Connect the *single-band connector* or *multi-band connector* under test to measurement equipment as shown in annex D.3. All connectors not under test shall be terminated.

The measurement device characteristics shall be:

- Measurement filter bandwidth: defined in clause 6.5.2.5.
- Detection mode: true RMS voltage or true average power.

- 2) For RF repeater or NCR-Fwd, set the input signal to the representative connectors under test according to the applicable test configuration in clause 4.7 using the corresponding test models RDL-FR1-TM1.1 and RUL-FR1-TM1.1 in clause 4.9.2 at the input power intended to produce the maximum rated output power for RF repeater and using the corresponding test models NCRDL-FR1-TM1.1 and NCRUL-FR1-TM1.1 in clause 4.9A.2 at the input power intended to produce the maximum rated output power for NCR :

- $P_{in,p,AC} + 10\text{dB}$ for RF repeater,
- $P_{in,p,AC} + 10\text{dB}$ for NCR type 1-C,
- $P_{in,p,TABC} + 10\text{dB}$ for NCR type 1-H.

For NCR-MT, set the NCR-MT transmitting with declared maximum output power according to the applicable test configuration in clause 4.7 using the corresponding test models NCRUL-FR1-TM1.1 in clause 4.9.2.

NOTE: Step 2 applies to NCR if NCR-Fwd and NCR-MT are not transmitting simultaneously. Otherwise, Step 2a applies:

- 2a) If NCR-Fwd and NCR-MT is transmitting simultaneously, set the input signal to the representative connectors under test according to the applicable test configuration in clause 4.7 using the corresponding test models NCRUL-FR1-TM1.1 for NCR-Fwd in clause 4.9.2 at the input power intended to produce the maximum rated output power, $P_{in,p,AC} + 10\text{dB}$ for NCR type 1-C and $P_{in,p,TABC} + 10\text{dB}$ for NCR type 1-H and NCRUL-FR1-TM1.1 for NCR-MT with declared maximum output power.
- 3) Measure ACLR for the frequency offsets both side of the passband edge or carrier edge as specified in clause 6.5.2.5. In multiple carrier case only offset frequencies below the lowest and above the highest carrier frequency used shall be measured.
- 4) For the ACLR requirement applied inside *gap between passbands*, or inside *Inter passband gap* for multi-band operation:
 - a) Measure ACLR inside *gap between passbands* or *Inter passband gap* as specified in clause 6.5.2.5, if applicable.
 - b) Measure CACLR inside *gap between passbands* or *Inter passband gap* as specified in clause 6.5.2.5, if applicable.
- 5) Repeat the test with the channel set-up according to RDL-FR1-TM1.2 for DL and RUL-FR1-TM1.2 for UL in clause 4.9.2.

In addition, for *multi-band connectors*, the following step shall apply:

- 6) For a *multi-band connectors* and single band tests, repeat the steps above per involved *operating band* where single band test configurations and test models shall apply with no carrier activated in the other *operating band*.

6.5.2.5 Test requirements for RF repeater

The ACLR is defined with a square filter of bandwidth equal to the transmission bandwidth configuration of the transmitted signal (BW_{Config}) centred on the assigned channel frequency and a filter centred on the adjacent channel frequency according to the tables below.

The ACLR shall be higher than the value specified in table 6.5.2.5-1 for *repeater type 1-C* for DL and UL for Wide Area class.

For *repeater type 1-C* for DL and for UL for WA class, the ACLR (CACLR) absolute limits in table 6.5.2.5-2, 6.5.2.5-5 or the ACLR (CACLR) *limits* in table 6.5.2.5-1, 6.5.2.5-3 or 6.5.2.5-4, whichever is less stringent, shall apply for each *antenna connector*.

For Band n41 and n90 operation in Japan, absolute ACLR limits shall be applied to the sum of the absolute ACLR power over all *antenna connectors* for *repeater type 1-C*.

Table 6.5.2.5-1: Repeater type 1-C ACLR limit for DL and for UL for Wide Area class

Repeater type 1-C nominal channel bandwidth $BW_{Nominal}$ (MHz)	Repeater type 1-C adjacent channel centre frequency offset below t or above the passband edge	Assumed adjacent channel carrier (informative)	Filter on the adjacent channel frequency and corresponding filter bandwidth	ACLR limit
5, 10, 15, 20	$BW_{Nominal}/2$	NR of same BW (Note 2)	Square (BW_{Config})	44.2 dB (Note 4) 37.2 dB (Note 5)
	$1.5 \times BW_{Nominal}$	NR of same BW (Note 2)	Square (BW_{Config})	44.2 dB (Note 4) 37.2 dB (Note 5)
	2.5 MHz	5 MHz E-UTRA	Square (4.5 MHz)	44.2 dB (Note 3)
	7.5 MHz	5 MHz E-UTRA	Square (4.5 MHz)	44.2 dB (Note 3)
25, 30, 35, 40, 45, 50, 60, 70, 80, 90, 100	$BW_{Nominal}/2$	NR of same BW (Note 2)	Square (BW_{Config})	43.8 dB (Note 4) 36.8 dB (Note 5)
	$1.5 \times BW_{Nominal}$	NR of same BW (Note 2)	Square (BW_{Config})	43.8 dB (Note 4) 36.8 dB (Note 5)
	2.5 MHz	5 MHz E-UTRA	Square (4.5 MHz)	43.8 dB (Note 3)
	7.5 MHz	5 MHz E-UTRA	Square (4.5 MHz)	43.8 dB (Note 3)

NOTE 1: $BW_{Nominal}$ is the nominal channel bandwidth. BW_{Config} is the transmission bandwidth configuration assumed for the adjacent channel.

NOTE 2: With SCS that provides largest transmission bandwidth configuration (BW_{Config}).

NOTE 3: The requirements are applicable when the band is also defined for E-UTRA or UTRA.

NOTE 4: Applicable to bands other than n104.

NOTE 5: Applicable to band n104.

The ACLR absolute limit is specified in table 6.5.2.5-2.

The ACLR shall be higher than the value specified in table 6.5.2.5-1a for repeater type 1-C for UL Local Area.

Table 6.5.2.5-1a: Repeater type 1-C ACLR limit for UL for Local Area

Repeater type 1-C nominal channel bandwidth $BW_{Nominal}$ (MHz)	Repeater type 1-C adjacent channel centre frequency offset below above the passband edge	Assumed adjacent channel carrier (informative)	Filter on the adjacent channel frequency and corresponding filter bandwidth	ACLR limit
5, 10, 15, 20	$BW_{Nominal}/2$	NR of same BW (Note 2)	Square (BW_{Config})	30.2 dB
	$1.5 \times BW_{Nominal}$	NR of same BW (Note 2)	Square (BW_{Config})	30.2 dB
	2.5 MHz	5 MHz E-UTRA	Square (4.5 MHz)	30.2 dB
	7.5 MHz	5 MHz E-UTRA	Square (4.5 MHz)	30.2 dB
25, 30, 35, 40, 45, 50, 60, 70, 80, 90, 100	$BW_{Nominal}/2$	NR of same BW (Note 2)	Square (BW_{Config})	29.8 dB
	$1.5 \times BW_{Nominal}$	NR of same BW (Note 2)	Square (BW_{Config})	29.8 dB
	2.5 MHz	5 MHz E-UTRA	Square (4.5 MHz)	29.8 dB
	7.5 MHz	5 MHz E-UTRA	Square (4.5 MHz)	29.8 dB

NOTE 1: $BW_{Nominal}$ is the nominal channel bandwidth. BW_{Config} is the transmission bandwidth configuration assumed for the adjacent channel.

NOTE 2: With SCS that provides the largest transmission bandwidth configuration (BW_{Config}).

NOTE 3: The requirements are applicable when the band is also defined for E-UTRA or UTRA.

Table 6.5.2.5-2: Repeater type 1-C ACLR absolute limit for DL and UL for WA class, for DL for MR class and for DL for LA class

Repeater category / class	ACLR absolute limit
Category A Wide Area DL and UL	-13 dBm/MHz
Category B Wide Area DL and UL	-15 dBm/MHz
Medium Range DL	-25 dBm/MHz
Local Area DL	-32 dBm/MHz

For operation in non-contiguous spectrum or multiple bands, the ACLR shall be higher than the value specified in Table 6.5.2.5-3 or Table 6.5.2.5-3a.

Table 6.5.2.5-3: Repeater type 1-C ACLR limit in non-contiguous spectrum or multiple bands for DL (all repeater classes) and for UL for Wide Area class

Repeater type 1-C nominal channel bandwidth BW_{Nominal} (MHz)	Gap between passbands or inter-passband gap size (W_{gap}) where the limit applies (MHz)	Repeater type 1-C adjacent channel centre frequency offset below or above the passband edge (inside the gap)	Assumed adjacent channel carrier	Filter on the adjacent channel frequency and corresponding filter bandwidth	ACLR limit
5, 10, 15, 20	$W_{\text{gap}} \geq 15$ (Note 3) $W_{\text{gap}} \geq 45$ (Note 4)	2.5 MHz	5 MHz NR (Note 2)	Square (BW_{Config})	44.2 dB (Note 5) 37.2 dB (Note 6)
	$W_{\text{gap}} \geq 20$ (Note 3) $W_{\text{gap}} \geq 50$ (Note 4)	7.5 MHz	5 MHz NR (Note 2)	Square (BW_{Config})	44.2 dB (Note 5) 37.2 dB (Note 6)
25, 30, 35, 40, 45, 50, 60, 70, 80, 90, 100	$W_{\text{gap}} \geq 60$ (Note 4) $W_{\text{gap}} \geq 30$ (Note 3)	10 MHz	20 MHz NR (Note 2)	Square (BW_{Config})	43.8 dB (Note 5) 36.8 dB (Note 6)
	$W_{\text{gap}} \geq 80$ (Note 4) $W_{\text{gap}} \geq 50$ (Note 3)	30 MHz	20 MHz NR (Note 2)	Square (BW_{Config})	43.8 dB (Note 5) 36.8 dB (Note 6)

NOTE 1: BW_{Nominal} is the nominal channel bandwidth. BW_{Config} is the transmission bandwidth configuration assumed for the adjacent channel.

NOTE 2: With SCS that provides the largest transmission bandwidth configuration (BW_{Config}).

NOTE 3: Applicable in case the repeater type 1-C nominal channel bandwidth at the other edge of the gap is ≤ 20 MHz.

NOTE 4: Applicable in case the repeater type 1-C nominal channel bandwidth at the other edge of the gap is > 20 MHz.

NOTE 5: Applicable to bands other than n104.

NOTE 6: Applicable to band n104.

Table 6.5.2.5-3a: Repeater type 1-C ACLR limit in non-contiguous spectrum or multiple bands for UL for Local Area class

Repeater type 1-C nominal channel bandwidth BW_{Nominal} (MHz)	Gap between passbands or inter-passband gap size (W_{gap}) where the limit applies (MHz)	Repeater type 1-C adjacent channel centre frequency offset below or above the passband edge (inside the gap)	Assumed adjacent channel carrier	Filter on the adjacent channel frequency and corresponding filter bandwidth	ACLR limit
5, 10, 15, 20	$W_{\text{gap}} \geq 15$ (Note 3) $W_{\text{gap}} \geq 45$ (Note 4)	2.5 MHz	5 MHz NR (Note 2)	Square (BW_{Config})	30.2 dB
	$W_{\text{gap}} \geq 20$ (Note 3) $W_{\text{gap}} \geq 50$ (Note 4)	7.5 MHz	5 MHz NR (Note 2)	Square (BW_{Config})	30.2 dB
25, 30, 35, 40, 45, 50, 60, 70, 80, 90, 100	$W_{\text{gap}} \geq 60$ (Note 4) $W_{\text{gap}} \geq 30$ (Note 3)	10 MHz	20 MHz NR (Note 2)	Square (BW_{Config})	29.8 dB
	$W_{\text{gap}} \geq 80$ (Note 4) $W_{\text{gap}} \geq 50$ (Note 3)	30 MHz	20 MHz NR (Note 2)	Square (BW_{Config})	29.8 dB

NOTE 1: BW_{Nominal} is the nominal channel bandwidth. BW_{Config} is the transmission bandwidth configuration assumed for the adjacent channel.

NOTE 2: With SCS that provides the largest transmission bandwidth configuration (BW_{Config}).

NOTE 3: Applicable in case the repeater type 1-C nominal channel bandwidth at the other edge of the gap is ≤ 20 MHz.

NOTE 4: Applicable in case the repeater type 1-C nominal channel bandwidth at the other edge of the gap is > 20 MHz.

The Cumulative Adjacent Channel Leakage power Ratio (CACLR) in a gap between passband or the inter-passband gap is the ratio of:

- the sum of the filtered mean power centred on the assigned channel frequencies for the two carriers adjacent to each side of the gap between passband or the inter-passband gap, and

- b) the filtered mean power centred on a frequency channel adjacent to one of the respective *repeater type 1-C passband edges*.

The assumed filter for the adjacent channel frequency is defined in table 6.5.2.5-4 and 6.5.2.5-4a and the filters on the assigned channels are defined in table 6.5.2.5-6.

For operation in *non-contiguous spectrum* or multiple bands, the CA CLR for *repeater type 1-C* for DL and for UL for WA class for NR carriers located on either side of the *gap between passband* or the *inter-passband gap* shall be higher than the value specified in table 6.5.2.5-4.

Table 6.5.2.5-4: Repeater type 1-C CA CLR limit for DL and for UL for Wide Area class

Repeater type 1-C nominal channel bandwidth BW_{Nominal} (MHz)	Gap between passbands or inter-passband gap size (W_{gap}) where the limit applies (MHz)	Repeater type 1-C adjacent channel centre frequency offset below or above the <i>passband edge</i> (inside the gap)	Assumed adjacent channel carrier	Filter on the adjacent channel frequency and corresponding filter bandwidth	CA CLR limit
5, 10, 15, 20	$5 \leq W_{\text{gap}} < 15$ (Note 3) $5 \leq W_{\text{gap}} < 45$ (Note 4)	2.5 MHz	5 MHz NR (Note 2)	Square (BW_{Config})	44.2 dB
	$10 < W_{\text{gap}} < 20$ (Note 3) $10 \leq W_{\text{gap}} < 50$ (Note 4)	7.5 MHz	5 MHz NR (Note 2)	Square (BW_{Config})	44.2 dB
25, 30, 35, 40, 45, 50, 60, 70, 80, 90, 100	$20 \leq W_{\text{gap}} < 60$ (Note 4) $20 \leq W_{\text{gap}} < 30$ (Note 3)	10 MHz	20 MHz NR (Note 2)	Square (BW_{Config})	43.8 dB
	$40 < W_{\text{gap}} < 80$ (Note 4) $40 \leq W_{\text{gap}} < 50$ (Note 3)	30 MHz	20 MHz NR (Note 2)	Square (BW_{Config})	43.8 dB
NOTE 1: BW_{Nominal} is the <i>nominal channel bandwidth</i> . BW_{Config} is the <i>transmission bandwidth configuration</i> assumed for the adjacent channel.					
NOTE 2: With SCS that provides the largest <i>transmission bandwidth configuration</i> (BW_{Config}).					
NOTE 3: Applicable in case the <i>repeater type 1-C nominal channel bandwidth</i> at the other edge of the gap is ≤ 20 MHz.					
NOTE 4: Applicable in case the <i>repeater type 1-C nominal channel bandwidth</i> at the other edge of the gap is > 20 MHz.					

The CA CLR shall be higher than the value specified in table 6.5.2.5-4a for *repeater type 1-C* for UL Local Area.

Table 6.5.2.5-4a: Repeater type 1-C CACLR limit for UL for Local Area

Repeater type 1-C nominal channel bandwidth $BW_{Nominal}$ (MHz)	Gap between passbands or inter-passband gap size (W_{gap}) where the limit applies (MHz)	Repeater type 1-C adjacent channel centre frequency offset below or above the passband edge (inside the gap)	Assumed adjacent channel carrier	Filter on the adjacent channel frequency and corresponding filter bandwidth	CACLR limit
5, 10, 15, 20	$5 \leq W_{gap} < 15$ (Note 3) $5 \leq W_{gap} < 45$ (Note 4)	2.5 MHz	5 MHz NR (Note 2)	Square (BW_{Config})	30.2 dB
	$10 < W_{gap} < 20$ (Note 3) $10 \leq W_{gap} < 50$ (Note 4)	7.5 MHz	5 MHz NR (Note 2)	Square (BW_{Config})	30.2 dB
25, 30, 35, 40, 45, 50, 60, 70, 80, 90, 100	$20 \leq W_{gap} < 60$ (Note 4) $20 \leq W_{gap} < 30$ (Note 3)	10 MHz	20 MHz NR (Note 2)	Square (BW_{Config})	29.8 dB
	$40 < W_{gap} < 80$ (Note 4) $40 \leq W_{gap} < 50$ (Note 3)	30 MHz	20 MHz NR (Note 2)	Square (BW_{Config})	29.8 dB
<p>NOTE 1: $BW_{Nominal}$ is the <i>nominal channel bandwidth</i>. BW_{Config} is the <i>transmission bandwidth configuration</i> assumed for the adjacent channel.</p> <p>NOTE 2: With SCS that provides the largest <i>transmission bandwidth configuration</i> (BW_{Config}).</p> <p>NOTE 3: Applicable in case the <i>repeater type 1-C nominal channel bandwidth</i> at the other edge of the gap is ≤ 20 MHz.</p> <p>NOTE 4: Applicable in case the <i>repeater type 1-C nominal channel bandwidth</i> at the other edge of the gap is > 20 MHz.</p>					

The CACLR absolute limit is specified in table 6.5.2.5-5.

Table 6.5.2.5-5: Repeater type 1-C CACLR absolute limit for DL and UL for WA class, for DL for MR class and for DL for LA class

Repeater type 1-C category / class	CACLR absolute limit
Category A Wide Area DL and UL	-13 dBm/MHz
Category B Wide Area DL and UL	-15 dBm/MHz
Medium Range DL	-25 dBm/MHz
Local Area DL	-32 dBm/MHz

Table 6.5.2.5-6: Filter parameters for the assigned channel

RAT of the carrier adjacent to the gap between passbands or inter-passband gap	Filter on the assigned channel frequency and corresponding filter bandwidth
NR	NR of same BW with SCS that provides largest <i>transmission bandwidth configuration</i>

6.5.2.6 Test requirement for *NCR*

6.5.2.6.1 Test requirements for *NCR-Fwd*

6.5.2.6.1.1 Test requirements for *NCR-Fwd* type 1-C

The ACLR (CACLR) absolute *basic limits* or the ACLR (CACLR) *limits* as specified in clause 6.5.2.5, whichever is less stringent, shall apply for each *antenna connector*.

For simultaneous *NCR-Fwd* and *NCR-MT* transmission, if the *NCR-MT* carrier is within the passband then the nominal channel bandwidth shall be calculated based on the the bandwidth between the lower edge of the passband and the lower edge of the *NCR-MT* carrier for lower side, or between the upper edge of the passband and the upper edge of the *NCR-MT* carrier for upper side. If the *NCR-MT* carrier is adjacent to the passband then ACLR requirement for *NCR-MT* based on *NCR-MT* channel bandwidth shall be applied for the *NCR-MT* carrier side and the nominal channel bandwidth calculated with the passband bandwidth shall be used for the passband side. If the *NCR-MT* carrier is not adjacent to the passband then CACLR shall be applied in the gap between the passband and the *NCR-MT* carrier.

6.5.2.6.1.2 Test requirement for *NCR-Fwd* type 1-H

The ACLR (CACLR) absolute *basic limits* + X (where $X = 10\log_{10}(N_{\text{TXU, counted per cell}})$ for DL and for WA UL and $X=0$ for LA UL) or the ACLR (CACLR) *limits* as specified in clause 6.5.2.5, whichever is less stringent, shall apply for each *TAB connector TX min cell group*. For joint transmission of *NCR-Fwd* and *NCR-MT* in uplink, the limits shall apply to the sum of emissions from both *NCR-Fwd* and *NCR-MT*.

For simultaneous *NCR-Fwd* and *NCR-MT* transmission, if the *NCR-MT* carrier is within the passband then the nominal channel bandwidth shall be calculated based on the the bandwidth between the lower edge of the passband and the lower edge of the *NCR-MT* carrier for lower side, or between the upper edge of the passband and the upper edge of the *NCR-MT* carrier for upper side. If the *NCR-MT* carrier is adjacent to the passband then ACLR requirement for *NCR-MT* based on *NCR-MT* channel bandwidth shall be applied for the *NCR-MT* carrier side and the nominal channel bandwidth calculated with the passband bandwidth shall be used for the passband side. If the *NCR-MT* carrier is not adjacent to the passband then CACLR shall be applied in the gap between the passband and the *NCR-MT* carrier.

NOTE: Conformance to the *NCR-Fwd* type 1-H ACLR requirement can be demonstrated by meeting at least one of the following criteria as determined by the manufacturer:

- 1) The ratio of the sum of the filtered mean power measured on each *TAB connector* in the *TAB connector TX min cell group* at the assigned channel frequency to the sum of the filtered mean power measured on each *TAB connector* in the *TAB connector TX min cell group* at the adjacent channel frequency shall be greater than or equal to the ACLR *basic limit* of the repeater. This shall apply for each *TAB connector TX min cell group*.

Or

- 2) The ratio of the filtered mean power at the *TAB connector* centred on the assigned channel frequency to the filtered mean power at this *TAB connector* centred on the adjacent channel frequency shall be greater than or equal to the ACLR *basic limit* of the repeater for every *TAB connector* in the *TAB connector TX min cell group*, for each *TAB connector TX min cell group*.

In case the ACLR (CACLR) absolute *basic limit* of *repeater type 1-H* are applied, the conformance can be demonstrated by meeting at least one of the following criteria as determined by the manufacturer:

- 1) The sum of the filtered mean power measured on each *TAB connector* in the *TAB connector TX min cell group* at the adjacent channel frequency shall be less than or equal to the ACLR (CACLR) absolute *basic limit* + X of the repeater. This shall apply to each *TAB connector TX min cell group*.

Or

- 2) The filtered mean power at each *TAB connector* centred on the adjacent channel frequency shall be less than or equal to the ACLR (CACLR) absolute *basic limit* + X of the repeater scaled by $X - 10\log_{10}(n)$ for every *TAB connector* in the *TAB connector TX min cell group*, for each *TAB connector TX min cell group*, where n is the number of *TAB connectors* in the *TAB connector TX min cell group*.

6.5.2.6.2 Test requirement for NCR-MT

6.5.2.6.2.1 Test requirements for NCR-MT type 1-C

For WA NCR-MT type 1-C, the WA BS ACLR test requirements specified in clause 6.5.2.5 apply.

For LA NCR-MT type 1-C, if the measured adjacent channel power is greater than -50 dBm then the NR_{ACLR} shall be higher than the value specified in Table 6.5.2.6.2.1-2.

Table 6.5.2.6.2.1-1: NR ACLR measurement bandwidth

Channel bandwidth	(MHz)	5,10,15,20,25,30,35,40,45,50	60,70,80,90,100
REF_SCS	(kHz)	15	30
NR ACLR measurement bandwidth	(MHz)	$MBW=REF_SCS*(12*N_{RB}+1)/1000$	
NOTE : "N _{RB} " in the formula is the maximum transmission bandwidth configuration as defined in Clause 5.			

Table 6.5.2.6.2.1-2: NR ACLR requirement

	Power class 1	Power class 1.5	Power class 2	Power class 3
NR ACLR	N/A	N/A	31.2 dB for 5, 10, 15, 20 30.8 dB for other bandwidth	N/A
NOTE 1: Void				

For simultaneous transmission the limits apply for sum of NCR-MT transmission and NCR-Fwd transmission.

6.5.2.6.2.2 Test requirements for NCR-MT type 1-H

Limits for NCR-MT type 1-H apply to the sum of emissions across all TAB connectors.

For WA NCR-MT type 1-H, the repeater relative ACLR requirements specified in clause 6.5.2.5 apply. For Absolute ACLR requirements, the following scaling factor should be added on on top of NCR-MT type 1-C basic limit requirements.

$$10\log(N_{TXU, \text{counted}}), \text{ where } N_{TXU, \text{counted}} = \min(N_{TXU, \text{active}}, 8)$$

For LA NCR-MT type 1-H, the NCR-MT ACLR requirements specified in clause 6.5.2.6.2.1 apply.

For simultaneous transmission the limits apply for sum of NCR-MT transmission and NCR-Fwd transmission.

6.5.3 Operating band unwanted emissions

6.5.3.1 Definition and applicability

Unless otherwise stated, the operating band unwanted emission (OBUE) limits for *repeater type 1-C* DL are defined from Δf_{OBUE} below the lowest frequency of each supported downlink *operating band* up to Δf_{OBUE} above the highest frequency of each supported downlink *operating band*. The values of Δf_{OBUE} are defined in table 6.5.1-1 for the NR *operating bands*.

Unless otherwise stated, the operating band unwanted emission (OBUE) limits for *repeater type 1-C* UL are defined from Δf_{OBUE} below the lowest frequency of each supported uplink *operating band* up to Δf_{OBUE} above the highest frequency of each supported uplink *operating band*. The values of Δf_{OBUE} are defined in table 6.5.1-2 for the NR *operating bands*.

The requirements shall apply whatever the type of transmitter considered and for all transmission modes foreseen by the manufacturer's specification. In addition, for *repeater type 1-C* operating in *non-contiguous spectrum*, the requirements apply inside any *gap between passband*. In addition, for a *repeater type 1-C* operating in multiple bands, the requirements apply inside any *inter-passband gap*.

Limits are specified in the tables below, where:

- Δf is the separation between the *passband edge* frequency and the nominal -3dB point of the measuring filter closest to the carrier frequency.
- f_{offset} is the separation between the *passband edge* frequency and the centre of the measuring filter.
- $f_{\text{offset}_{\text{max}}}$ is the offset to the frequency Δf_{OBUE} outside the downlink *operating band of repeater type 1-C DL* and uplink *operating band of repeater type 1-C UL*, where Δf_{OBUE} is defined in tables 6.5.1-1 and 6.5.1-2.
- Δf_{max} is equal to $f_{\text{offset}_{\text{max}}}$ minus half of the bandwidth of the measuring filter.

For a *multi-band connector* inside any *inter-passband gaps* with $W_{\text{gap}} < 2 * \Delta f_{\text{OBUE}}$, a combined minimum requirement shall be applied which is the cumulative sum of the minimum requirement specified at the *repeater type 1-C passband edges* on each side of the *inter-passband gap*.

- Δf is the separation between the *repeater type 1-C passband edge* frequency and the nominal -3 dB point of the measuring filter closest to the *repeater type 1-C passband edge*.
- f_{offset} is the separation from the *repeater type 1-C passband edge* frequency to the centre of the measuring filter.
- $f_{\text{offset}_{\text{max}}}$ is equal to the *inter-passband gap* minus half of the bandwidth of the measuring filter.
- Δf_{max} is equal to $f_{\text{offset}_{\text{max}}}$ minus half of the bandwidth of the measuring filter.

For a *multi-band connector* of *repeater type 1-C DL*, the operating band unwanted emission limits apply also in a supported downlink *operating band* without any carrier transmitted, in the case where there are carrier(s) transmitted in another supported downlink *operating band*. In this case, no cumulative minimum requirement is applied in the *inter-band gap* between a supported downlink *operating band* with carrier(s) transmitted and a supported downlink *operating band* without any carrier transmitted and

- In case the *inter-band gap* between a supported downlink *operating band* with carrier(s) transmitted and a supported downlink *operating band* without any carrier transmitted is less than $2 * \Delta f_{\text{OBUE}}$, $f_{\text{offset}_{\text{max}}}$ shall be the offset to the frequency Δf_{OBUE} MHz outside the outermost edges of the two supported downlink *operating bands* and the operating band unwanted emission minimum requirement of the band where there are carriers transmitted, as defined in the tables of the present clause, shall apply across both downlink bands.
- In other cases, the operating band unwanted emission minimum requirement of the band where there are carriers transmitted, as defined in the tables of the present clause for the largest frequency offset (Δf_{max}), shall apply from Δf_{OBUE} MHz below the lowest frequency, up to Δf_{OBUE} MHz above the highest frequency of the supported downlink *operating band* without any carrier transmitted.

For a *multi-band connector* of *repeater type 1-C UL*, the operating band unwanted emission limits apply also in a supported uplink *operating band* without any carrier transmitted, in the case where there are carrier(s) transmitted in another supported uplink *operating band*. In this case, no cumulative minimum requirement is applied in the *inter-band gap* between a supported uplink *operating band* with carrier(s) transmitted and a supported uplink *operating band* without any carrier transmitted and

- In case the *inter-band gap* between a supported uplink *operating band* with carrier(s) transmitted and a supported uplink *operating band* without any carrier transmitted is less than $2 * \Delta f_{\text{OBUE}}$, $f_{\text{offset}_{\text{max}}}$ shall be the offset to the frequency Δf_{OBUE} MHz outside the outermost edges of the two supported uplink *operating bands* and the operating band unwanted emission minimum requirement of the band where there are carriers transmitted, as defined in the tables of the present clause, shall apply across both uplink bands.
- In other cases, the operating band unwanted emission minimum requirements of the band where there are carriers transmitted, as defined in the tables of the present clause for the largest frequency offset (Δf_{max}), shall apply from Δf_{OBUE} MHz below the lowest frequency, up to Δf_{OBUE} MHz above the highest frequency of the supported uplink *operating band* without any carrier transmitted.

In addition, inside any *gap between passband* for a *single-band connector* operating in *non-contiguous spectrum*, a combined minimum requirement shall be applied which is the cumulative sum of the minimum requirement specified for the adjacent *sub-blocks* on each side of the *gap between passband*.

- Δf is the separation between the *sub-block* edge frequency and the nominal -3 dB point of the measuring filter closest to the *sub-block* edge.
- f_{offset} is the separation between the *sub-block* edge frequency and the centre of the measuring filter.
- $f_{\text{offset}_{\text{max}}}$ is equal to the *gap between passband* bandwidth minus half of the bandwidth of the measuring filter.
- Δf_{max} is equal to $f_{\text{offset}_{\text{max}}}$ minus half of the bandwidth of the measuring filter.

6.5.3.2 Minimum requirement

The minimum requirement applies per *single-band connector*, or per *multi-band connector* supporting transmission in the *operating band*.

The minimum requirement for RF repeater is defined in TS 38.106 [2], clause 6.5.3.2:

The minimum requirement for NCR is defined in TS 38.106 [2], clause 6.5.3.3.

6.5.3.3 Test purpose

This test measures the emissions close to the assigned channel bandwidth of the wanted signal, while the transmitter is in operation.

6.5.3.4 Method of test

6.5.3.4.1 Initial conditions

Test environment: Normal; see annex B.2.

RF channels to be tested for single carrier: B, M and T; see clause 4.9.1.

6.5.3.4.2 Procedure for RF repeater

- 1) Connect the *single-band connector* or *multi-band connector* under test to measurement equipment as shown in annex D.1.1. All connectors not under test shall be terminated.

As a general rule, the resolution bandwidth of the measuring equipment should be equal to the measurement bandwidth. However, to improve measurement accuracy, sensitivity, efficiency and avoiding e.g. carrier leakage, the resolution bandwidth may be smaller than the measurement bandwidth. When the resolution bandwidth is smaller than the measurement bandwidth, the result should be integrated over the measurement bandwidth in order to obtain the equivalent noise bandwidth of the measurement bandwidth.

The measurement device characteristics shall be:

Detection mode: True RMS.

For RF repeater and NCR, set the input signal to the representative connectors under test according to the applicable test configuration in clause 4.8 using the corresponding test models RDL-FR1-TM1.1 and RUL-FR1-TM1.1 in clause 4.9.2 at the input power intended to produce the maximum rated output power for RF repeater and using the corresponding test models NCRDL-FR1-TM1.1 and NCRUL-FR1-TM1.1 in clause 4.9A.2 at the input power intended to produce the maximum rated output power for NCR.

- $P_{\text{in,p,AC}} + 10\text{dB}$ for RF repeater type 1-C;
- $P_{\text{in,p,AC}} + 10\text{dB}$ for NCR type 1-C,
- $P_{\text{in,p,TABC}} + 10\text{dB}$ for NCR type 1-H.

For NCR-MT, set the NCR-MT transmitting with declared maximum output power according to the applicable test configuration in clause 4.7 using the corresponding test models NCRUL-FR1-TM1.1 in clause 4.9.2.

NOTE: Step 2 applies to NCR if NCR-Fwd and NCR-MT are not transmitting simultaneously. Otherwise, Step 2a applies:

- 2a) If NCR-Fwd and NCR-MT is transmitting simultaneously, set the input signal to the representative connectors under test according to the applicable test configuration in clause 4.7 using the corresponding test models NCRUL-FR1-TM1.1 for NCR-Fwd in clause 4.9.2 at the input power intended to produce the maximum rated output power, $P_{in,p,AC} + 10\text{dB}$ for NCR type 1-C and $P_{in,p,TABC} + 10\text{dB}$ for NCR type 1-H and NCRUL-FR1-TM1.1 for NCR-MT with declared maximum output power.
- 3) Step the centre frequency of the measurement filter in contiguous steps and measure the emission within the specified frequency ranges with the specified measurement bandwidth. For connector under test declared to operate in multiple bands or non-contiguous spectrum, the emission within the *Inter passband Bandwidth* or *sub-block gap* shall be measured using the specified measurement bandwidth from the closest RF Bandwidth or sub-block edge.
- 4) Repeat the test for the remaining test cases, with the channel set-up according to NR-FR1-TM 1.2.

In addition, for *multi-band connectors*, the following step shall apply:

- 5) For a *multi-band connectors* and single band tests, repeat the steps above per involved *operating band* where single band test configurations and test models shall apply with no carrier activated in the other *operating band*.

6.5.3.4a Test requirements for RF repeater

6.5.3.4a.1 Operating band unwanted emission limits for Wide Area repeater type 1-C (Category A)

For repeater operating in Bands n5, n8, n12, n13, n14, n18, n26, n28, n29, n31, n71, n72, n85, n106, operating band unwanted emission limits are specified in table 6.5.3.4a.1-1.

Table 6.5.3.4a.1-1: Wide Area repeater type 1-C operating band unwanted emission limits (NR bands below 1 GHz) for Category A

Frequency offset of measurement filter -3dB point, Δf	Frequency offset of measurement filter centre frequency, f_{offset}	Limits (Note 1, 2)	Measurement bandwidth
$0 \text{ MHz} \leq \Delta f < 5 \text{ MHz}$	$0.05 \text{ MHz} \leq f_{\text{offset}} < 5.05 \text{ MHz}$	$-5.5 \text{ dBm} - \frac{7}{5} \cdot \left(\frac{f_{\text{offset}}}{\text{MHz}} - 0.05 \right) \text{ dB}$	100 kHz
$5 \text{ MHz} \leq \Delta f < \min(10 \text{ MHz}, \Delta f_{\text{max}})$	$5.05 \text{ MHz} \leq f_{\text{offset}} < \min(10.05 \text{ MHz}, f_{\text{offset}_{\text{max}}})$	-12.5 dBm	100 kHz
$10 \text{ MHz} \leq \Delta f \leq \Delta f_{\text{max}}$	$10.05 \text{ MHz} \leq f_{\text{offset}} < f_{\text{offset}_{\text{max}}}$	-13 dBm (Note 3)	100 kHz
<p>NOTE 1: For a <i>repeater type 1-C</i> supporting <i>non-contiguous spectrum</i> operation within any <i>operating band</i>, the emission limits within <i>gaps between passbands</i> is calculated as a cumulative sum of contributions from adjacent <i>sub-blocks</i> on each side of the <i>gap between passband</i>. Exception is $\Delta f \geq 10\text{MHz}$ from both adjacent <i>sub-blocks</i> on each side of the <i>gap between passband</i>, where the emission limits within <i>gaps between passbands</i> shall be -13 dBm/1 MHz.</p> <p>NOTE 2: For a <i>multi-band connector</i> with <i>inter-passband gap</i> $< 2 \cdot \Delta f_{\text{OBUe}}$ the emission limits within the <i>inter-passband gaps</i> is calculated as a cumulative sum of contributions from adjacent <i>sub-blocks</i> or <i>passband</i> on each side of the <i>inter-passband gap</i>, where the contribution from the far-end <i>sub-block</i> or <i>passband</i> shall be scaled according to the <i>measurement bandwidth</i> of the near-end <i>sub-block</i> or <i>passband</i>.</p> <p>NOTE 3: The requirement is not applicable when $\Delta f_{\text{max}} < 10 \text{ MHz}$.</p>			

For *repeater type 1-C* operating in Bands n1, n2, n3, n7, n24, n25, n30, n34, n38, n39, n40, n41, n50, n54, n65, n66, n70, n74, n75, n92, n94, n109 operating band unwanted emission limits are specified in table 6.5.3.4a.1-2:

Table 6.5.3.4a.1-2: Wide Area repeater type 1-C operating band unwanted emission limits (1GHz < NR bands ≤ 3GHz) for Category A

Frequency offset of measurement filter -3dB point, Δf	Frequency offset of measurement filter centre frequency, f_{offset}	Limits (Note 1, 2)	Measurement bandwidth
$0 \text{ MHz} \leq \Delta f < 5 \text{ MHz}$	$0.05 \text{ MHz} \leq f_{\text{offset}} < 5.05 \text{ MHz}$	$-5.5 \text{ dBm} - \frac{7}{5} \cdot \left(\frac{f_{\text{offset}}}{\text{MHz}} - 0.05 \right) \text{ dB}$	100 kHz
$5 \text{ MHz} \leq \Delta f < \min(10 \text{ MHz}, \Delta f_{\text{max}})$	$5.05 \text{ MHz} \leq f_{\text{offset}} < \min(10.05 \text{ MHz}, f_{\text{offset}_{\text{max}}})$	-12.5 dBm	100 kHz
$10 \text{ MHz} \leq \Delta f \leq \Delta f_{\text{max}}$	$10.5 \text{ MHz} \leq f_{\text{offset}} < f_{\text{offset}_{\text{max}}}$	-13 dBm (Note 3)	1MHz
<p>NOTE 1: For a repeater supporting non-contiguous spectrum operation within any <i>operating band</i>, the emission limits within sub-block gaps is calculated as a cumulative sum of contributions from adjacent sub blocks on each side of the sub block gap, where the contribution from the far-end sub-block shall be scaled according to the measurement bandwidth of the near-end sub-block. Exception is $\Delta f \geq 10\text{MHz}$ from both adjacent sub blocks on each side of the sub-block gap, where the emission limits within sub-block gaps shall be -13 dBm/1 MHz.</p> <p>NOTE 2: For a <i>multi-band connector</i> with Inter RF Bandwidth gap < $2 \cdot \Delta f_{\text{OBUe}}$ the emission limits within the Inter RF Bandwidth gaps is calculated as a cumulative sum of contributions from adjacent sub-blocks or RF Bandwidth on each side of the Inter RF Bandwidth gap, where the contribution from the far-end sub-block or RF Bandwidth shall be scaled according to the measurement bandwidth of the near-end sub-block or RF Bandwidth.</p> <p>NOTE 3: The requirement is not applicable when $\Delta f_{\text{max}} < 10 \text{ MHz}$.</p>			

For *repeater type 1-C* operating in Bands n48, n77, n78, n79, operating band unwanted emission limits are specified in table 6.5.3.4a.1-3:

Table 6.5.3.4a.1-3: Wide Area repeater type 1-C operating band unwanted emission limits (NR bands >3GHz) for Category A

Frequency offset of measurement filter -3dB point, Δf	Frequency offset of measurement filter centre frequency, f_{offset}	Limits (Note 1, 2)	Measurement bandwidth
$0 \text{ MHz} \leq \Delta f < 5 \text{ MHz}$	$0.05 \text{ MHz} \leq f_{\text{offset}} < 5.05 \text{ MHz}$	$-5.2 \text{ dBm} - \frac{7}{5} \cdot \left(\frac{f_{\text{offset}}}{\text{MHz}} - 0.05 \right) \text{ dB}$	100 kHz
$5 \text{ MHz} \leq \Delta f < \min(10 \text{ MHz}, \Delta f_{\text{max}})$	$5.05 \text{ MHz} \leq f_{\text{offset}} < \min(10.05 \text{ MHz}, f_{\text{offset}_{\text{max}}})$	-12.2 dBm	100 kHz
$10 \text{ MHz} \leq \Delta f \leq \Delta f_{\text{max}}$	$10.5 \text{ MHz} \leq f_{\text{offset}} < f_{\text{offset}_{\text{max}}}$	-13 dBm (Note 3)	1MHz
<p>NOTE 1: For a repeater supporting non-contiguous spectrum operation within any <i>operating band</i>, the emission limits within sub-block gaps is calculated as a cumulative sum of contributions from adjacent sub blocks on each side of the sub block gap, where the contribution from the far-end sub-block shall be scaled according to the measurement bandwidth of the near-end sub-block. Exception is $\Delta f \geq 10\text{MHz}$ from both adjacent sub blocks on each side of the sub-block gap, where the emission limits within sub-block gaps shall be -13 dBm/1 MHz.</p> <p>NOTE 2: For a <i>multi-band connector</i> with Inter RF Bandwidth gap < $2 \cdot \Delta f_{\text{OBUe}}$ the emission limits within the Inter RF Bandwidth gaps is calculated as a cumulative sum of contributions from adjacent sub-blocks or RF Bandwidth on each side of the Inter RF Bandwidth gap, where the contribution from the far-end sub-block or RF Bandwidth shall be scaled according to the measurement bandwidth of the near-end sub-block or RF Bandwidth.</p> <p>NOTE 3: The requirement is not applicable when $\Delta f_{\text{max}} < 10 \text{ MHz}$.</p>			

6.5.3.4a.2 Operating band unwanted emission limits for Wide Area *repeater type 1-C* (Category B)

For Category B Operating band unwanted emissions, there are two options for the limits that may be applied regionally. Either the limits in clause 6.5.3.4a.2.1 or clause 6.5.3.4a.2.2 shall be applied.

6.5.3.4a.2.1 Category B requirements (Option 1)

For *repeater type 1-C* operating in Bands n5, n8, n12, n20, n26, n28, n29, n31, n67, n71, n72, n85, the operating band unwanted emission limits are specified in table 6.5.3.4a.2.1-1:

Table 6.5.3.4a.2.1-1: Wide Area repeater type 1-C operating band unwanted emission limits (NR bands below 1 GHz) for Category B

Frequency offset of measurement filter -3dB point, Δf	Frequency offset of measurement filter centre frequency, f_{offset}	Limits (Note 1, 2)	Measurement bandwidth
$0 \text{ MHz} \leq \Delta f < 5 \text{ MHz}$	$0.05 \text{ MHz} \leq f_{\text{offset}} < 5.05 \text{ MHz}$	$-5.5 \text{ dBm} - \frac{7}{5} \cdot \left(\frac{f_{\text{offset}}}{\text{MHz}} - 0.05 \right) \text{ dB}$	100 kHz
$5 \text{ MHz} \leq \Delta f < \min(10 \text{ MHz}, \Delta f_{\text{max}})$	$5.05 \text{ MHz} \leq f_{\text{offset}} < \min(10.05 \text{ MHz}, f_{\text{offset}_{\text{max}}})$	-12.5 dBm	100 kHz
$10 \text{ MHz} \leq \Delta f \leq \Delta f_{\text{max}}$	$10.05 \text{ MHz} \leq f_{\text{offset}} < f_{\text{offset}_{\text{max}}}$	-16 dBm (Note 3)	100 kHz
<p>NOTE 1: For a <i>repeater type 1-C</i> supporting <i>non-contiguous spectrum</i> operation within any <i>operating band</i>, the emission limits within <i>gaps between passbands</i> is calculated as a cumulative sum of contributions from adjacent <i>sub-blocks</i> on each side of the <i>gap between passband</i>. Exception is $\Delta f \geq 10 \text{ MHz}$ from both adjacent <i>sub-blocks</i> on each side of the <i>gap between passband</i>, where the emission limits within <i>gaps between passbands</i> shall be -15 dBm/1 MHz.</p> <p>NOTE 2: For a <i>multi-band connector</i> with <i>inter-passband gap</i> $< 2 \cdot \Delta f_{\text{OBUE}}$ the emission limits within the <i>inter-passband gaps</i> is calculated as a cumulative sum of contributions from adjacent <i>sub-blocks</i> or <i>passband</i> on each side of the <i>inter-passband gap</i>.</p> <p>NOTE 3: The requirement is not applicable when $\Delta f_{\text{max}} < 10 \text{ MHz}$.</p>			

For *repeater type 1-C* operating in Bands n1, n2, n3, n7, n25, n34, n38, n39, n40, n41, n48, n50, n65, n66, n70, n75, n92, n94, n109, operating band unwanted emission limits are specified in table 6.5.3.4a.2.1-2:

Table 6.5.3.4a.2.1-2: Wide Area repeater type 1-C operating band unwanted emission limits (1GHz < NR bands ≤ 3GHz) for Category B

Frequency offset of measurement filter -3dB point, Δf	Frequency offset of measurement filter centre frequency, f_{offset}	Limits (Note 1, 2)	Measurement bandwidth
$0 \text{ MHz} \leq \Delta f < 5 \text{ MHz}$	$0.05 \text{ MHz} \leq f_{\text{offset}} < 5.05 \text{ MHz}$	$-5.5 \text{ dBm} - \frac{7}{5} \cdot \left(\frac{f_{\text{offset}}}{\text{MHz}} - 0.05 \right) \text{ dB}$	100 kHz
$5 \text{ MHz} \leq \Delta f < \min(10 \text{ MHz}, \Delta f_{\text{max}})$	$5.05 \text{ MHz} \leq f_{\text{offset}} < \min(10.05 \text{ MHz}, f_{\text{offset}_{\text{max}}})$	-12.5 dBm	100 kHz
$10 \text{ MHz} \leq \Delta f \leq \Delta f_{\text{max}}$	$10.5 \text{ MHz} \leq f_{\text{offset}} < f_{\text{offset}_{\text{max}}}$	-15 dBm (Note 3)	1MHz
<p>NOTE 1: For a <i>repeater type 1-C</i> supporting <i>non-contiguous spectrum</i> operation within any <i>operating band</i>, the emission limits within <i>gaps between passbands</i> is calculated as a cumulative sum of contributions from adjacent <i>sub-blocks</i> on each side of the <i>gap between passband</i>, where the contribution from the far-end <i>sub-block</i> shall be scaled according to the <i>measurement bandwidth</i> of the near-end <i>sub-block</i>. Exception is $\Delta f \geq 10 \text{ MHz}$ from both adjacent <i>sub-blocks</i> on each side of the <i>gap between passband</i>, where the emission limits within <i>gaps between passbands</i> shall be -15 dBm/1 MHz.</p> <p>NOTE 2: For a <i>multi-band connector</i> with <i>inter-passband gap</i> $< 2 \cdot \Delta f_{\text{OBUE}}$ the emission limits within the <i>inter-passband gaps</i> is calculated as a cumulative sum of contributions from adjacent <i>sub-blocks</i> or <i>passband</i> on each side of the <i>inter-passband gap</i>, where the contribution from the far-end <i>sub-block</i> or <i>passband</i> shall be scaled according to the <i>measurement bandwidth</i> of the near-end <i>sub-block</i> or <i>passband</i>.</p> <p>NOTE 3: The requirement is not applicable when $\Delta f_{\text{max}} < 10 \text{ MHz}$.</p>			

For *repeater type 1-C* operating in Bands n48, n77, n78, n79, operating band unwanted emission limits are specified in tables 6.5.3.4a.2.1-3:

Table 6.5.3.4a.2.1-3: Wide Area repeater operating band unwanted emission limits (NR bands >3GHz) for Category B

Frequency offset of measurement filter -3dB point, Δf	Frequency offset of measurement filter centre frequency, f_{offset}	Limits (Note 1, 2)	Measurement bandwidth
$0 \text{ MHz} \leq \Delta f < 5 \text{ MHz}$	$0.05 \text{ MHz} \leq f_{\text{offset}} < 5.05 \text{ MHz}$	$-5.2 \text{ dBm} - \frac{7}{5} \cdot \left(\frac{f_{\text{offset}}}{\text{MHz}} - 0.05 \right) \text{ dB}$	100 kHz
$5 \text{ MHz} \leq \Delta f < \min(10 \text{ MHz}, \Delta f_{\text{max}})$	$5.05 \text{ MHz} \leq f_{\text{offset}} < \min(10.05 \text{ MHz}, f_{\text{offset}_{\text{max}}})$	-12.2 dBm	100 kHz
$10 \text{ MHz} \leq \Delta f \leq \Delta f_{\text{max}}$	$10.5 \text{ MHz} \leq f_{\text{offset}} < f_{\text{offset}_{\text{max}}}$	-15 dBm (Note 3)	1 MHz
<p>NOTE 1: For a repeater supporting non-contiguous spectrum operation within any <i>operating band</i>, the emission limits within sub-block gaps is calculated as a cumulative sum of contributions from adjacent sub blocks on each side of the sub block gap, where the contribution from the far-end sub-block shall be scaled according to the measurement bandwidth of the near-end sub-block. Exception is $\Delta f \geq 10 \text{ MHz}$ from both adjacent sub blocks on each side of the sub-block gap, where the emission limits within sub-block gaps shall be -15 dBm/1 MHz.</p> <p>NOTE 2: For a <i>multi-band connector</i> with Inter RF Bandwidth gap $< 2 \cdot \Delta f_{\text{OBUe}}$ the emission limits within the Inter RF Bandwidth gaps is calculated as a cumulative sum of contributions from adjacent sub-blocks or RF Bandwidth on each side of the Inter RF Bandwidth gap, where the contribution from the far-end sub-block or RF Bandwidth shall be scaled according to the measurement bandwidth of the near-end sub-block or RF Bandwidth.</p> <p>NOTE 3: The requirement is not applicable when $\Delta f_{\text{max}} < 10 \text{ MHz}$.</p>			

6.5.3.4a.2.2 Category B requirements (Option 2)

The limits in this clause are intended for Europe and may be applied regionally for *repeater type 1-C* operating in bands n1, n3, n7, n8, n38, n65.

For a *repeater type 1-C* operating in bands n1, n3, n7, n8, n38 or n65, operating band unwanted emission limits are specified in Table 6.5.3.4a.2.2-1:

Table 6.5.3.4a.2.2-1: Regional Wide Area *repeater type 1-C* operating band unwanted emission limits for Category B

Frequency offset of measurement filter -3dB point, Δf	Frequency offset of measurement filter centre frequency, f_{offset}	Limits (Note 1, 2)	Measurement bandwidth
$0 \text{ MHz} \leq \Delta f < 0.2 \text{ MHz}$	$0.015 \text{ MHz} \leq f_{\text{offset}} < 0.215 \text{ MHz}$	-12.5 dBm	30 kHz
$0.2 \text{ MHz} \leq \Delta f < 1 \text{ MHz}$	$0.215 \text{ MHz} \leq f_{\text{offset}} < 1.015 \text{ MHz}$	$-12.5 \text{ dBm} - 15 \cdot \left(\frac{f_{\text{offset}}}{\text{MHz}} - 0.215 \right) \text{ dB}$	30 kHz
(Note 4)	$1.015 \text{ MHz} \leq f_{\text{offset}} < 1.5 \text{ MHz}$	-24.5 dBm	30 kHz
$1 \text{ MHz} \leq \Delta f \leq \min(10 \text{ MHz}, \Delta f_{\text{max}})$	$1.5 \text{ MHz} \leq f_{\text{offset}} < \min(10.5 \text{ MHz}, f_{\text{offset}_{\text{max}}})$	-11.5 dBm	1 MHz
$10 \text{ MHz} \leq \Delta f \leq \Delta f_{\text{max}}$	$10.5 \text{ MHz} \leq f_{\text{offset}} < f_{\text{offset}_{\text{max}}}$	-15 dBm (Note 3)	1 MHz
<p>NOTE 1: For a <i>repeater type 1-C</i> supporting <i>non-contiguous spectrum</i> operation within any <i>operating band</i>, the emission limits within <i>gaps between passbands</i> is calculated as a cumulative sum of contributions from adjacent <i>sub-blocks</i> on each side of the <i>gap between passband</i>, where the contribution from the far-end <i>sub-block</i> shall be scaled according to the <i>measurement bandwidth</i> of the near-end <i>sub-block</i>. Exception is $\Delta f \geq 10 \text{ MHz}$ from both adjacent <i>sub-blocks</i> on each side of the <i>gap between passband</i>, where the emission limits within <i>gaps between passbands</i> shall be -15 dBm/1 MHz.</p> <p>NOTE 2: For a <i>multi-band connector</i> with <i>inter-passband gap</i> $< 2 \cdot \Delta f_{\text{OBUe}}$ the emission limits within the <i>inter-passband gaps</i> is calculated as a cumulative sum of contributions from adjacent <i>sub-blocks</i> or <i>passband</i> on each side of the <i>inter-passband gap</i>, where the contribution from the far-end <i>sub-block</i> or <i>passband</i> shall be scaled according to the <i>measurement bandwidth</i> of the near-end <i>sub-block</i> or <i>passband</i>.</p> <p>NOTE 3: The requirement is not applicable when $\Delta f_{\text{max}} < 10 \text{ MHz}$.</p> <p>NOTE 4: This frequency range ensures that the range of values of f_{offset} is continuous.</p>			

6.5.3.4a.3 Operating band unwanted emission limits for Medium Range *repeater type 1-C* (Category A and B) for DL

For Medium Range *repeater type 1-C* for DL, operating band unwanted emission limits are specified in table 6.5.3.4a.3-1 to table 6.5.3.4a.3-4.

For the tables in this clause for *repeater type 1-C*, $P_{rated,x} = P_{rated,p,AC} - 10 \cdot \log(\text{ceil}(BW_{Passband}/20\text{MHz}))$

Table 6.5.3.4a.3-1: Medium Range *repeater type 1-C* operating band unwanted emission limits, $31 < P_{rated,x} \leq 38$ dBm (NR bands ≤ 3 GHz)

Frequency offset of measurement filter -3dB point, Δf	Frequency offset of measurement filter centre frequency, f_{offset}	Limits (Note 1, 2)	Measurement bandwidth
$0 \text{ MHz} \leq \Delta f < 5 \text{ MHz}$	$0.05 \text{ MHz} \leq f_{offset} < 5.05 \text{ MHz}$	$P_{rated,x} - 51.5 \text{ dB} - \frac{7}{5} \left(\frac{f_{offset}}{\text{MHz}} - 0.05 \right) \text{ dB}$	100 kHz
$5 \text{ MHz} \leq \Delta f < \min(10 \text{ MHz}, \Delta f_{max})$	$5.05 \text{ MHz} \leq f_{offset} < \min(10.05 \text{ MHz}, f_{offset_{max}})$	$P_{rated,x} - 58.5 \text{ dB}$	100 kHz
$10 \text{ MHz} \leq \Delta f \leq \Delta f_{max}$	$10.05 \text{ MHz} \leq f_{offset} < f_{offset_{max}}$	$\text{Min}(P_{rated,x} - 60 \text{ dB}, -25 \text{ dBm})$ (Note 3)	100 kHz
<p>NOTE 1: For a <i>repeater type 1-C</i> DL supporting <i>non-contiguous spectrum</i> operation within any <i>operating band</i> the emission limits within <i>gaps between passbands</i> is calculated as a cumulative sum of contributions from adjacent <i>sub-blocks</i> on each side of the <i>gap between passband</i>. Exception is $\Delta f \geq 10 \text{ MHz}$ from both adjacent <i>sub-blocks</i> on each side of the <i>gap between passband</i>, where the emission limits within <i>gaps between passbands</i> shall be $\text{Min}(P_{rated,x} - 60 \text{ dB}, -25 \text{ dBm})/100 \text{ kHz}$.</p> <p>NOTE 2: For a <i>multi-band connector</i> with <i>inter-passband gap</i> $< 2 \cdot \Delta f_{OBUe}$ the emission limits within the <i>inter-passband gaps</i> is calculated as a cumulative sum of contributions from adjacent <i>sub-blocks</i> or <i>passband</i> on each side of the <i>inter-passband gap</i>.</p> <p>NOTE 3: The requirement is not applicable when $\Delta f_{max} < 10 \text{ MHz}$.</p>			

Table 6.5.3.4a.3-2: Medium Range *repeater type 1-C* operating band unwanted emission limits, $P_{rated,x} \leq 31$ dBm (NR bands ≤ 3 GHz)

Frequency offset of measurement filter -3dB point, Δf	Frequency offset of measurement filter centre frequency, f_{offset}	Limits (Note 1, 2)	Measurement bandwidth
$0 \text{ MHz} \leq \Delta f < 5 \text{ MHz}$	$0.05 \text{ MHz} \leq f_{offset} < 5.05 \text{ MHz}$	$-20.5 \text{ dBm} - \frac{7}{5} \left(\frac{f_{offset}}{\text{MHz}} - 0.05 \right) \text{ dB}$	100 kHz
$5 \text{ MHz} \leq \Delta f < \min(10 \text{ MHz}, \Delta f_{max})$	$5.05 \text{ MHz} \leq f_{offset} < \min(10.05 \text{ MHz}, f_{offset_{max}})$	-27.5 dBm	100 kHz
$10 \text{ MHz} \leq \Delta f \leq \Delta f_{max}$	$10.05 \text{ MHz} \leq f_{offset} < f_{offset_{max}}$	-29 dBm (Note 3)	100 kHz
<p>NOTE 1: For a <i>repeater type 1-C</i> DL supporting <i>non-contiguous spectrum</i> operation within any <i>operating band</i> the emission limits within <i>gaps between passbands</i> is calculated as a cumulative sum of contributions from adjacent <i>sub-blocks</i> on each side of the <i>gap between passband</i>. Exception is $\Delta f \geq 10 \text{ MHz}$ from both adjacent <i>sub-blocks</i> on each side of the <i>gap between passband</i>, where the emission limits within <i>gaps between passbands</i> shall be $-29 \text{ dBm}/100 \text{ kHz}$.</p> <p>NOTE 2: For a <i>multi-band connector</i> with <i>inter-passband gap</i> $< 2 \cdot \Delta f_{OBUe}$ the emission limits within the <i>inter-passband gaps</i> is calculated as a cumulative sum of contributions from adjacent <i>sub-blocks</i> or <i>passband</i> on each side of the <i>inter-passband gap</i>.</p> <p>NOTE 3: The requirement is not applicable when $\Delta f_{max} < 10 \text{ MHz}$.</p>			

Table 6.5.3.4a.3-3: Medium Range repeater *operating band* unwanted emission limits, $31 < P_{\text{rated},x} \leq 38$ dBm (NR bands >3GHz)

Frequency offset of measurement filter -3dB point, Δf	Frequency offset of measurement filter centre frequency, f_{offset}	Limits (Note 1, 2)	Measurement bandwidth
$0 \text{ MHz} \leq \Delta f < 5 \text{ MHz}$	$0.05 \text{ MHz} \leq f_{\text{offset}} < 5.05 \text{ MHz}$	$P_{\text{rated},x} - 51.2 \text{ dB} - \frac{7}{5} \left(\frac{f_{\text{offset}}}{\text{MHz}} - 0.05 \right) \text{ dB}$	100 kHz
$5 \text{ MHz} \leq \Delta f < \min(10 \text{ MHz}, \Delta f_{\text{max}})$	$5.05 \text{ MHz} \leq f_{\text{offset}} < \min(10.05 \text{ MHz}, f_{\text{offset}_{\text{max}}})$	$P_{\text{rated},x} - 58.2 \text{ dB}$	100 kHz
$10 \text{ MHz} \leq \Delta f \leq \Delta f_{\text{max}}$	$10.05 \text{ MHz} \leq f_{\text{offset}} < f_{\text{offset}_{\text{max}}}$	$\text{Min}(P_{\text{rated},x} - 60 \text{ dB}, -25 \text{ dBm})$ (Note 3)	100 kHz
<p>NOTE 1: For a repeater supporting non-contiguous spectrum operation within any <i>operating band</i> the emission limits within sub-block gaps is calculated as a cumulative sum of contributions from adjacent sub blocks on each side of the sub block gap. Exception is $\Delta f \geq 10 \text{ MHz}$ from both adjacent sub blocks on each side of the sub-block gap, where the emission limits within sub-block gaps shall be $\text{Min}(P_{\text{rated},x} - 60 \text{ dB}, -25 \text{ dBm})/100 \text{ kHz}$.</p> <p>NOTE 2: For a <i>multi-band connector</i> with Inter RF Bandwidth gap $< 2 \cdot \Delta f_{\text{OBUe}}$ the emission limits within the Inter RF Bandwidth gaps is calculated as a cumulative sum of contributions from adjacent sub-blocks or RF Bandwidth on each side of the Inter RF Bandwidth gap.</p> <p>NOTE 3: The requirement is not applicable when $\Delta f_{\text{max}} < 10 \text{ MHz}$.</p>			

Table 6.5.3.4a.3-4: Medium Range repeater *operating band* unwanted emission limits, $P_{\text{rated},x} \leq 31$ dBm (NR bands >3GHz)

Frequency offset of measurement filter -3dB point, Δf	Frequency offset of measurement filter centre frequency, f_{offset}	Limits (Note 1, 2)	Measurement bandwidth
$0 \text{ MHz} \leq \Delta f < 5 \text{ MHz}$	$0.05 \text{ MHz} \leq f_{\text{offset}} < 5.05 \text{ MHz}$	$-20.2 \text{ dBm} - \frac{7}{5} \left(\frac{f_{\text{offset}}}{\text{MHz}} - 0.05 \right) \text{ dB}$	100 kHz
$5 \text{ MHz} \leq \Delta f < \min(10 \text{ MHz}, \Delta f_{\text{max}})$	$5.05 \text{ MHz} \leq f_{\text{offset}} < \min(10.05 \text{ MHz}, f_{\text{offset}_{\text{max}}})$	-27.2 dBm	100 kHz
$10 \text{ MHz} \leq \Delta f \leq \Delta f_{\text{max}}$	$10.05 \text{ MHz} \leq f_{\text{offset}} < f_{\text{offset}_{\text{max}}}$	-29 dBm (Note 3)	100 kHz
<p>NOTE 1: For a repeater supporting non-contiguous spectrum operation within any <i>operating band</i> the emission limits within sub-block gaps is calculated as a cumulative sum of contributions from adjacent sub blocks on each side of the sub block gap. Exception is $\Delta f \geq 10 \text{ MHz}$ from both adjacent sub blocks on each side of the sub-block gap, where the emission limits within sub-block gaps shall be $-29 \text{ dBm}/100 \text{ kHz}$.</p> <p>NOTE 2: For a <i>multi-band connector</i> with Inter RF Bandwidth gap $< 2 \cdot \Delta f_{\text{OBUe}}$ the emission limits within the Inter RF Bandwidth gaps is calculated as a cumulative sum of contributions from adjacent sub-blocks or RF Bandwidth on each side of the Inter RF Bandwidth gap.</p> <p>NOTE 3: The requirement is not applicable when $\Delta f_{\text{max}} < 10 \text{ MHz}$.</p>			

6.5.3.4a.4 Operating band unwanted emission limits for Local Area *repeater type 1-C* (Category A and B)

For Local Area *repeater type 1-C* in NR bands $\leq 3 \text{ GHz}$, operating band unwanted emission limits are specified in table 6.5.3.4a.4-1.

For Local Area *repeater type 1-C* in NR bands $> 3 \text{ GHz}$, operating band unwanted emission limits are specified in table 6.5.3.4a.4-2.

Table 6.5.3.4a.4-1: Local Area repeater type 1-C operating band unwanted emission limits (NR bands ≤3GHz)

Frequency offset of measurement filter -3dB point, Δf	Frequency offset of measurement filter centre frequency, f_{offset}	Limits (Note 1, 2)	Measurement bandwidth
$0 \text{ MHz} \leq \Delta f < 5 \text{ MHz}$	$0.05 \text{ MHz} \leq f_{\text{offset}} < 5.05 \text{ MHz}$	$-28.5 \text{ dBm} - \frac{7}{5} \left(\frac{f_{\text{offset}}}{\text{MHz}} - 0.05 \right) \text{ dB}$	100 kHz
$5 \text{ MHz} \leq \Delta f < \min(10 \text{ MHz}, \Delta f_{\text{max}})$	$5.05 \text{ MHz} \leq f_{\text{offset}} < \min(10.05 \text{ MHz}, f_{\text{offset}_{\text{max}}})$	-35.5 dBm	100 kHz
$10 \text{ MHz} \leq \Delta f \leq \Delta f_{\text{max}}$	$10.05 \text{ MHz} \leq f_{\text{offset}} < f_{\text{offset}_{\text{max}}}$	-37 dBm (Note 10)	100 kHz
<p>NOTE 1: For a <i>repeater type 1-C</i> supporting <i>non-contiguous spectrum</i> operation within any <i>operating band</i> the emission limits within <i>gaps between passbands</i> is calculated as a cumulative sum of contributions from adjacent <i>sub-blocks</i> on each side of the <i>gap between passband</i>. Exception is $\Delta f \geq 10 \text{ MHz}$ from both adjacent <i>sub-blocks</i> on each side of the <i>gap between passband</i>, where the emission limits within <i>gaps between passbands</i> shall be -37dBm/100kHz.</p> <p>NOTE 2: For a <i>multi-band connector</i> with <i>inter-passband gap</i> $< 2 \cdot \Delta f_{\text{OBUe}}$ the emission limits within the <i>inter-passband gaps</i> is calculated as a cumulative sum of contributions from adjacent <i>sub-blocks</i> or <i>passband</i> on each side of the <i>inter-passband gap</i></p> <p>NOTE 3: The requirement is not applicable when $\Delta f_{\text{max}} < 10 \text{ MHz}$.</p>			

Table 6.5.3.4a.4-2: Local Area repeater operating band unwanted emission limits (NR bands >3GHz)

Frequency offset of measurement filter -3dB point, Δf	Frequency offset of measurement filter centre frequency, f_{offset}	Limits (Note 1, 2)	Measurement bandwidth
$0 \text{ MHz} \leq \Delta f < 5 \text{ MHz}$	$0.05 \text{ MHz} \leq f_{\text{offset}} < 5.05 \text{ MHz}$	$-28.2 \text{ dBm} - \frac{7}{5} \left(\frac{f_{\text{offset}}}{\text{MHz}} - 0.05 \right) \text{ dB}$	100 kHz
$5 \text{ MHz} \leq \Delta f < \min(10 \text{ MHz}, \Delta f_{\text{max}})$	$5.05 \text{ MHz} \leq f_{\text{offset}} < \min(10.05 \text{ MHz}, f_{\text{offset}_{\text{max}}})$	-35.2 dBm	
$10 \text{ MHz} \leq \Delta f \leq \Delta f_{\text{max}}$	$10.05 \text{ MHz} \leq f_{\text{offset}} < f_{\text{offset}_{\text{max}}}$	-37 dBm (Note 3)	
<p>NOTE 1: For a <i>repeater</i> supporting <i>non-contiguous spectrum</i> operation within any <i>operating band</i> the emission limits within <i>sub-block gaps</i> is calculated as a cumulative sum of contributions from adjacent <i>sub blocks</i> on each side of the <i>sub block gap</i>. Exception is $\Delta f \geq 10 \text{ MHz}$ from both adjacent <i>sub blocks</i> on each side of the <i>sub-block gap</i>, where the emission limits within <i>sub-block gaps</i> shall be -37dBm/100kHz.</p> <p>NOTE 2: For a <i>multi-band connector</i> with <i>Inter RF Bandwidth gap</i> $< 2 \cdot \Delta f_{\text{OBUe}}$ the emission limits within the <i>Inter RF Bandwidth gaps</i> is calculated as a cumulative sum of contributions from adjacent <i>sub-blocks</i> or <i>RF Bandwidth</i> on each side of the <i>Inter RF Bandwidth gap</i></p> <p>NOTE 3: The requirement is not applicable when $\Delta f_{\text{max}} < 10 \text{ MHz}$.</p>			

6.5.3.4a.5 Additional operating band unwanted emission requirements

6.5.3.4a.5.1 Limits in FCC Title 47

In addition to the requirements in clauses 6.5.3.4a.1, 6.5.3.4a.2, 6.5.3.4a.3 and 6.5.3.4a.4, the *repeater type 1-C* may have to comply with the applicable emission limits established by FCC Title 47 [13], when deployed in regions where those limits are applied, and under the conditions declared by the manufacturer.

6.5.3.4a.5.2 Protection of DTT

In certain regions the following requirement may apply for protection of DTT. For *repeater type 1-C* operating in Band n20, the level of emissions in the band 470-790 MHz, measured in an 8 MHz filter bandwidth on centre frequencies F_{filter} according to table 6.5.3.4a.5.2-1, a limit $P_{\text{EM,N}}$ is declared by the manufacturer. This requirement applies in the frequency range 470-790 MHz even though part of the range falls in the spurious domain.

Table 6.5.3.4a.5.2-1: Declared emissions limit for protection of DTT

Filter centre frequency, F_{filter}	Measurement bandwidth	Declared emission limit (dBm)
$F_{\text{filter}} = 8 \cdot N + 306$ (MHz); $21 \leq N \leq 60$	8 MHz	$P_{\text{EM,N}}$

Note: The regional requirement is defined in terms of EIRP (effective isotropic radiated power), which is dependent on both the repeater emissions at the *antenna connector* and the deployment (including antenna gain and feeder loss). The requirement defined above provides the characteristics of the repeater needed to verify compliance with the regional requirement. Compliance with the regional requirement can be determined using the method outlined in TS 36.104 [6], annex E.

6.5.3.5 Void

6.5.3.6 Test requirement for NCR

6.5.3.6.1 Test requirement for NCR-Fwd

6.5.3.6.1.1 Test requirement for NCR-Fwd type 1-C

The operating band unwanted emissions for *NCR-Fwd type 1-C* for each *antenna connector* shall be below the applicable limits defined in clause 6.5.3.5.

The operating band unwanted emissions for *NCR-Fwd type 1-C* for each *antenna connector* shall be below the applicable test requirements defined in clause 6.5.3.5.

For Band n41 and n90 operation in Japan, the operating band unwanted emissions limits shall be applied to the sum of the emission power over all *antenna connectors* for *NCR-Fwd type 1-C*.

For joint transmission of NCR-Fwd and NCR-MT in the uplink, the operating band unwanted emissions limits shall apply to the total emissions from both the NCR-Fwd and NCR-MT.

6.5.3.6.1.2 Test requirement for *NCR-Fwd type 1-H*

The operating band unwanted emissions requirements for *NCR-Fwd type 1-H* are that for each *TAB connector TX min cell group* and each applicable test requirements in clause 6.5.3.5, the power summation emissions at the *TAB connectors* of the *TAB connector TX min cell group* shall not exceed a limit specified as the *basic limit* + X, where $X = 10 \log_{10}(N_{\text{TXU, counted per cell}})$ for DL and for UL WA and $X=0$ for UL LA.

For joint transmission of NCR-Fwd and NCR-MT in the uplink, the operating band unwanted emissions limits shall apply to the total emissions from both the NCR-Fwd and NCR-MT.

NOTE: Conformance to the *repeater type 1-H* spurious emission requirement can be demonstrated by meeting at least one of the following criteria as determined by the manufacturer:

1) The sum of the emissions power measured on each *TAB connector* in the *TAB connector TX min cell group* shall be less than or equal to the limit as defined in this clause for the respective frequency span.

Or

2) The unwanted emissions power at each *TAB connector* shall be less than or equal to the *repeater type 1-H* limit as defined in this clause for the respective frequency span, scaled by $-10 \log_{10}(n)$, where n is the number of *TAB connectors* in the *TAB connector TX min cell group*.

6.5.3.6.2 Test requirement for NCR-MT

6.5.3.6.2.1 Test requirements for NCR-MT type 1-C

For LA NCR-MT type 1-C, regardless of simultaneous transmission with NCR-Fwd is transmitting, the UE spectrum emission mask requirements specified in table 6.5.3.6.2.1-1 applies.

Table 6.5.3.6.2.1-1: General NR spectrum emission mask

Δf_{OoB} (MHz)	Channel bandwidth (MHz) / Spectrum emission limit (dBm)			Measurement bandwidth
	5	10, 15, 20, 25, 30, 35, 40, 45	50, 60, 70, 80, 90, 100	
$\pm 0-1$	$-13 + TT$	$-13 + TT$		1 % of channel BW
$\pm 0-1$			$-24 + TT$	30 kHz
$\pm 1-5$	$-10 + TT$	$-10 + TT$		1 MHz
$\pm 5-6$	$-13 + TT$			
$\pm 6-10$	$-25 + TT$			
$\pm 5-BW_{\text{Channel}}$		$-13 + TT$		
$\pm BW_{\text{Channel}}-(BW_{\text{Channel}}+5)$		$-25 + TT$		

Note 1: The first and last measurement position with a 30 kHz filter is at Δf_{OoB} equals to 0.015 MHz and 0.985 MHz.
Note 2: At the boundary of spectrum emission limit, the first and last measurement position with a 1 MHz filter is the inside of +0.5MHz and -0.5MHz, respectively.
Note 3: The measurements are to be performed above the upper edge of the channel and below the lower edge of the channel.
Note 4: TT for each frequency and channel bandwidth is specified in Table 6.5.2.2.5-2.

Table 6.5.3.6.2.1-2: Test Tolerance (Spectrum Emission Mask)

	$f \leq 3.0\text{GHz}$	$3.0\text{GHz} < f \leq 4.2\text{GHz}$	$4.2\text{GHz} < f \leq 6.0\text{GHz}$
$BW \leq 100\text{MHz}$	1.5 dB	1.8 dB	1.8 dB

For WA NCR-MT type 1-C, regardless of simultaneous transmission between NCR-MT and NCR-Fwd, the BS requirements specified in clause 6.6.3.5 in TS 38.141-1 [7] apply.

For simultaneous transmission the limits apply for sum of NCR-MT transmission and NCR-Fwd transmission.

6.5.3.6.2.2 Test requirements for NCR-MT type 1-H

Limits for NCR-MT type 1-H apply to the sum of emissions across all TAB connectors.

For LA NCR-MT type 1-H, regardless of simultaneous transmission with NCR- Fwd is transmitting, the UE spectrum emission mask requirements specified in clause 6.5.3.6.2.1 applies without scaling factor allowed.

For WA NCR-MT type 1-H, the repeater basic requirements specified in clause 6.5.3.5 relaxed with following scaling factor apply.

$$10\log(N_{\text{TXU,counted}}), \text{ where } N_{\text{TXU,counted}} = \min(N_{\text{TXU,active}}, 8)$$

For simultaneous transmission the limits apply for sum of NCR-MT transmission and NCR-Fwd transmission.

6.5.4 Transmitter spurious emissions

6.5.4.1 Definition and applicability

The transmitter spurious emission limits shall apply from 9 kHz to 12.75 GHz, excluding

- the frequency range from Δf_{OBUE} below the lowest frequency of each supported downlink *operating band*, up to Δf_{OBUE} above the highest frequency of each supported downlink *operating band*, where the Δf_{OBUE} is defined in table 6.5.1-1 for downlink, or
- the frequency range from Δf_{OBUE} below the lowest frequency of each supported uplink operating band, up to Δf_{OBUE} above the highest frequency of each supported uplink operating band, where the Δf_{OBUE} is defined in table 6.5.1-2 for uplink.

For some *operating bands*, the upper limit is higher than 12.75 GHz in order to comply with the 5th harmonic limit of the downlink *operating band*, as specified in ITU-R recommendation SM.329 [4].

For a *multi-band connector*, for each supported *operating band* together with Δf_{OBUE} around the band is excluded from the transmitter spurious emissions requirement.

The requirements shall apply whatever the type of transmitter considered (single carrier or multi-carrier). It applies for all transmission modes foreseen by the manufacturer's specification.

Unless otherwise stated, all requirements are measured as mean power (RMS).

For Band n41 and n90 operation in Japan, the sum of the spurious emissions over all *antenna connectors* for *Repeater type 1-C* and *NCR type 1-C* or over all *TAB connectors* for *NCR type 1-C* shall not exceed the *minimum requirements* defined in clause 6.5.4.5.

6.5.4.2 Minimum requirement

The minimum requirement applies per *single-band connector*, or per *multi-band connector* supporting transmission in the *operating band*.

The minimum requirement for RF repeater is defined in TS 38.106 [2], clause 6.5.4.2.

The minimum requirement for NCR is defined in TS 38.106 [2], clause 6.5.4.4.

6.5.4.3 Test purpose

This test measures conducted spurious emissions while the transmitter is in operation.

6.5.4.4 Method of test

6.5.4.4.1 Initial conditions

Test environment: Normal; see annex B.2.

RF channels to be tested for single carrier:

- B when testing the spurious emissions below $F_{\text{DL_low}} - \Delta f_{\text{OBUE}}$,
- T when testing the spurious emissions above $F_{\text{DL_high}} + \Delta f_{\text{OBUE}}$; see clause 4.9.1.

6.5.4.4.2 Procedure for RF repeater

- 1) Connect the *single-band connector* or *multi-band connector* under test to measurement equipment as shown in annex D.1.1. All connectors not under test shall be terminated.
- 2) Measurements shall use a measurement bandwidth in accordance to the conditions in clause 6.5.4.5.

The measurement device characteristics shall be:

- Detection mode: True RMS.
- 3) For RF repeater and NCR, set the input signal to the representative connectors under test according to the applicable test configuration in clause 4.8 using the corresponding test models RDL-FR1-TM1.1 and RUL-FR1-TM1.1 in clause 4.9.2 at the input power intended to produce the maximum rated output power, $P_{\text{in,p,AC}} + 10\text{dB}$ for for RF repeater and using the corresponding test models NCRDL-FR1-TM1.1 and NCRUL-FR1-TM1.1 in clause 4.9A.2 at the input power intended to produce the maximum rated output power for NCR.
 - $P_{\text{in,p,AC}} + 10\text{dB}$ for RF repeater type 1-C;
 - $P_{\text{in,p,AC}} + 10\text{dB}$ for NCR type 1-C,
 - $P_{\text{in,p,TABC}} + 10\text{dB}$ for NCR type 1-H.

For NCR-MT, set the NCR-MT transmitting with declared maximum output power according to the applicable test configuration in clause 4.7 using the corresponding test models NCRUL-FR1-TM1.1 in clause 4.9.2.

NOTE: Step 2 applies to NCR if NCR-Fwd and NCR-MT are not transmitting simultaneously. Otherwise, Step 4a applies:

- 3a) If NCR-Fwd and NCR-MT is transmitting simultaneously, set the input signal to the representative connectors under test according to the applicable test configuration in clause 4.7 using the corresponding test models NCRUL-FR1-TM1.1 for NCR-Fwd in clause 4.9.2 at the input power intended to produce the maximum rated output power, $P_{in,p,AC} + 10\text{dB}$ for NCR type 1-C and $P_{in,p,TABC} + 10\text{dB}$ for NCR type 1-H and NCRUL-FR1-TM1.1 for NCR-MT with declared maximum output power.
- 4) Measure the emission at the specified frequencies with specified measurement bandwidth.

In addition, for *multi-band connectors*, the following steps shall apply:

- 5) For a *multi-band connectors* and single band tests, repeat the steps above per involved *operating band* where single band test configurations and test models shall apply with no carrier activated in the other *operating band*.

6.5.4.5 Test requirements for RF repeater

6.5.4.5.1 General transmitter spurious emissions requirements

The *minimum requirements* of either table 6.5.4.5.1-1, table 6.5.4.5.1-2 (Category A limits) or table 6.5.4.5.1-3 (Category B limits) shall apply. The application of either Category A or Category B limits shall be the same as for operating band unwanted emissions in clause 6.5.3.

Table 6.5.4.5.1-1: General repeater type 1-C, NCR type 1-C and NCR type 1-H transmitter spurious emission minimum requirements for DL in FR1, Category A

Spurious frequency range	Minimum requirements	Measurement bandwidth	Notes
9 kHz – 150 kHz	-13 dBm	1 kHz	Note 1
150 kHz – 30 MHz		10 kHz	Note 1
30 MHz – 1 GHz		100 kHz	Note 1
1 GHz – 12.75 GHz		1 MHz	Note 1, Note 2
12.75 GHz – 5 th harmonic of the upper frequency edge of the DL <i>operating band</i> in GHz		1 MHz	Note 1, Note 2, Note 3
NOTE 1: <i>Measurement bandwidths</i> as in ITU-R SM.329 [4], s4.1. NOTE 2: Upper frequency as in ITU-R SM.329 [4], s2.5 table 1. NOTE 3: For <i>repeater type 1-C, NCR type 1-C and NCR type 1-H</i> in DL, this spurious frequency range applies only for <i>operating bands</i> for which the 5 th harmonic of the upper frequency edge of the DL <i>operating band</i> is reaching beyond 12.75 GHz.			

Table 6.5.4.5.1-2: General repeater type 1-C, NCR type 1-C and NCR type 1-H transmitter spurious emission minimum requirements for UL in FR1, Category A

Spurious frequency range	Minimum requirements	Measurement bandwidth	Notes
9 kHz – 150 kHz	-36 dBm	1 kHz	Note 1
150 kHz – 30 MHz		10 kHz	Note 1
30 MHz – 1 GHz		100 kHz	Note 1
1 GHz – 12.75 GHz	-30 dBm	1 MHz	Note 1, Note 2
12.75 GHz – 5 th harmonic of the upper frequency edge of the UL <i>operating band</i> in GHz		1 MHz	Note 1, Note 2, Note 3
NOTE 1: <i>Measurement bandwidths</i> as in ITU-R SM.329 [4], s4.1. NOTE 2: Upper frequency as in ITU-R SM.329 [4], s2.5 table 1. NOTE 3: For <i>repeater type 1-C NCR type 1-C and NCR type 1-H</i> in UL, this spurious frequency range applies only for <i>operating bands</i> for which the 5 th harmonic of the upper frequency edge of the UL <i>operating band</i> is reaching beyond 12.75 GHz.			

Table 6.5.4.5.1-3: General repeater type 1-C, NCR type 1-C and NCR type 1-H transmitter spurious emission minimum requirements in FR1, Category B

Spurious frequency range	minimum requirements	Measurement bandwidth	Notes
9 kHz – 150 kHz	-36 dBm	1 kHz	Note 1
150 kHz – 30 MHz		10 kHz	Note 1
30 MHz – 1 GHz		100 kHz	Note 1
1 GHz – 12.75 GHz	-30 dBm	1 MHz	Note 1, Note 2
12.75 GHz – 5 th harmonic of the upper frequency edge of the <i>operating band</i> in GHz		1 MHz	Note 1, Note 2, Note 3
NOTE 1: <i>Measurement bandwidths</i> as in ITU-R SM.329 [4], s4.1. NOTE 2: Upper frequency as in ITU-R SM.329 [4], s2.5 table 1. NOTE 3: For <i>repeater type 1-C, NCR type 1-C and NCR type 1-H DL</i> , this spurious frequency range applies only for <i>operating bands</i> for which the 5 th harmonic of the upper frequency edge of the DL <i>operating band</i> is reaching beyond 12.75 GHz. For <i>repeater type 1-C, NCR type 1-C and NCR type 1-H UL</i> , this spurious frequency range applies only for <i>operating bands</i> for which the 5 th harmonic of the upper frequency edge of the UL <i>operating band</i> is reaching beyond 12.75 GHz.			

6.5.4.5.2 Additional spurious emissions requirements

These requirements may be applied for the protection of system operating in other frequency ranges. The limits may apply as an optional protection of such systems that are deployed in the same geographical area as the repeater-Node, or they may be set by local or regional regulation as a mandatory requirement for an NR *operating band*. It is in some cases not stated in the present document whether a requirement is mandatory or under what exact circumstances that a limit applies, since this is set by local or regional regulation.

Some requirements may apply for the protection of specific equipment (UE, MS and/or BS) or equipment operating in specific systems (GSM, CDMA, UTRA, E-UTRA, NR, etc.) as listed below.

The spurious emission *minimum requirements* are provided in table 6.5.4.5.2-1 where requirements for co-existence with the system listed in the first column apply for *repeater type 1-C, NCR type 1-C and NCR type 1-H*. For a *multi-band connector*, the exclusions and conditions in the Note column of table 6.5.4.5.2-1 apply for each supported *operating band*.

Table 6.5.4.5.2-1: Repeater type 1-C, NCR type 1-C and NCR type 1-H spurious emissions minimum requirements for co-existence with systems operating in other frequency bands

System type to co-exist with	Frequency range for co-existence requirement	Minimum requirements	Measurement bandwidth	Note
GSM900	921 – 960 MHz	-57 dBm	100 kHz	This requirement does not apply to repeater operating in band n8
	876 – 915 MHz	-61 dBm	100 kHz	For the frequency range 880-915 MHz, this requirement does not apply to repeater operating in band n8.
DCS1800	1805 – 1880 MHz	-47 dBm	100 kHz	This requirement does not apply to repeater operating in band n3.
	1710 – 1785 MHz	-61 dBm	100 kHz	This requirement does not apply to repeater operating in band n3.
PCS1900	1930 – 1990 MHz	-47 dBm	100 kHz	This requirement does not apply to repeater operating in band n2, n25 or band n70.
	1850 – 1910 MHz	-61 dBm	100 kHz	This requirement does not apply to repeater operating in band n2 or n25.
GSM850 or CDMA850	869 – 894 MHz	-57 dBm	100 kHz	This requirement does not apply to repeater operating in band n5 or n26.
	824 – 849 MHz	-61 dBm	100 kHz	This requirement does not apply to repeater operating in band n5 or n26.
UTRA FDD Band I or E-UTRA Band 1 or NR Band n1	2110 – 2170 MHz	-52 dBm	1 MHz	This requirement does not apply to repeater operating in band n1 or n65
	1920 – 1980 MHz	-49 dBm	1 MHz	This requirement does not apply to repeater operating in band n1 or n65.
UTRA FDD Band II or E-UTRA Band 2 or NR Band n2	1930 – 1990 MHz	-52 dBm	1 MHz	This requirement does not apply to repeater operating in band n2 or n70.
	1850 – 1910 MHz	-49 dBm	1 MHz	This requirement does not apply to repeater operating in band n2.
UTRA FDD Band III or E-UTRA Band 3 or NR Band n3	1805 – 1880 MHz	-52 dBm	1 MHz	This requirement does not apply to repeater operating in band n3.
	1710 – 1785 MHz	-49 dBm	1 MHz	This requirement does not apply to repeater operating in band n3.
UTRA FDD Band IV or E-UTRA Band 4	2110 – 2155 MHz	-52 dBm	1 MHz	This requirement does not apply to repeater operating in band n66
	1710 – 1755 MHz	-49 dBm	1 MHz	This requirement does not apply to repeater operating in band n66.
UTRA FDD Band V or E-UTRA Band 5 or NR Band n5	869 – 894 MHz	-52 dBm	1 MHz	This requirement does not apply to repeater operating in band n5 or n26.
	824 – 849 MHz	-49 dBm	1 MHz	This requirement does not apply to repeater operating in band n5 or n26.
UTRA FDD Band VI, XIX or E-UTRA Band 6, 18, 19 or NR Band n18	860 – 890 MHz	-52 dBm	1 MHz	This requirement does not apply to repeater operating in band n18.
	815 – 830 MHz	-49 dBm	1 MHz	This requirement does not apply to repeater operating in band n18.
UTRA FDD Band VII or E-UTRA Band 7 or NR Band n7	830 – 845 MHz	-49 dBm	1 MHz	
	2620 – 2690 MHz	-52 dBm	1 MHz	This requirement does not apply to repeater operating in band n7.
	2500 – 2570 MHz	-49 dBm	1 MHz	This requirement does not apply to repeater operating in band n7.

UTRA FDD Band VIII or E-UTRA Band 8 or NR Band n8	925 – 960 MHz	-52 dBm	1 MHz	This requirement does not apply to repeater operating in band n8.
	880 – 915 MHz	-49 dBm	1 MHz	This requirement does not apply to repeater operating in band n8.
UTRA FDD Band IX or E-UTRA Band 9	1844.9 – 1879.9 MHz	-52 dBm	1 MHz	This requirement does not apply to repeater operating in band n3.
	1749.9 – 1784.9 MHz	-49 dBm	1 MHz	This requirement does not apply to repeater operating in band n3.
UTRA FDD Band X or E-UTRA Band 10	2110 – 2170 MHz	-52 dBm	1 MHz	This requirement does not apply to repeater operating in band n66
	1710 – 1770 MHz	-49 dBm	1 MHz	This requirement does not apply to repeater operating in band n66.
UTRA FDD Band XI or XXI or E-UTRA Band 11 or 21	1475.9 – 1510.9 MHz	-52 dBm	1 MHz	This requirement does not apply to repeater operating in band n50, n74, n75, n92 or n94.
	1427.9 – 1447.9 MHz	-49 dBm	1 MHz	This requirement does not apply to repeater operating in band n50, n51, n74, n75, n76, n91, n92, n93 or n94.
	1447.9 – 1462.9 MHz	-49 dBm	1 MHz	This requirement does not apply to repeater operating in band n50, n74, n75, n92 or n94.
UTRA FDD Band XII or E-UTRA Band 12 or NR Band n12	729 – 746 MHz	-52 dBm	1 MHz	This requirement does not apply to repeater operating in band n12 or n85.
	699 – 716 MHz	-49 dBm	1 MHz	This requirement does not apply to repeater operating in band n12 or n85. For NR repeater operating in n29, it applies 1 MHz below the Band n29 downlink operating band (Note 5).
UTRA FDD Band XIII or E-UTRA Band 13	746 – 756 MHz	-52 dBm	1 MHz	This requirement does not apply to repeater operating in band n13.
	777 – 787 MHz	-49 dBm	1 MHz	This requirement does not apply to repeater operating in band n13.
UTRA FDD Band XIV or E-UTRA Band 14 or NR band n14	758 – 768 MHz	-52 dBm	1 MHz	This requirement does not apply to repeater operating in band n14.
	788 – 798 MHz	-49 dBm	1 MHz	This requirement does not apply to repeater operating in band n14.
E-UTRA Band 17	734 – 746 MHz	-52 dBm	1 MHz	
	704 – 716 MHz	-49 dBm	1 MHz	For NR repeater operating in n29, it applies 1 MHz below the Band n29 downlink operating band (Note 5).
UTRA FDD Band XX or E- UTRA Band 20 or NR Band n20	791 – 821 MHz	-52 dBm	1 MHz	This requirement does not apply to repeater operating in band n20 or n28.
	832 – 862 MHz	-49 dBm	1 MHz	This requirement does not apply to repeater operating in band n20.
UTRA FDD Band XXII or E-UTRA Band 22	3510 – 3590 MHz	-52 dBm	1 MHz	This requirement does not apply to repeater operating in band n48, n77 or n78.
	3410 – 3490 MHz	-49 dBm	1 MHz	This requirement does not apply to repeater operating in band n77 or n78.

E-UTRA Band 24	1525 – 1559 MHz	-52 dBm	1 MHz	This requirement does not apply to repeater operating in band n24.
	1626.5 – 1660.5 MHz	-49 dBm	1 MHz	This requirement does not apply to repeater operating in band n24.
UTRA FDD Band XXV or E-UTRA Band 25 or NR band n25	1930 – 1995 MHz	-52 dBm	1 MHz	This requirement does not apply to repeater operating in band n2, n25 or n70.
	1850 – 1915 MHz	-49 dBm	1 MHz	This requirement does not apply to repeater operating in band n25 since it is already covered by the requirement in clause 6.5.4.5.2. For repeater operating in Band n2, it applies for 1910 MHz to 1915 MHz, while the rest is covered in clause 6.5.4.5.2.
UTRA FDD Band XXVI or E-UTRA Band 26 or NR Band n26	859 – 894 MHz	-52 dBm	1 MHz	This requirement does not apply to repeater operating in band n5 or n26.
	814 – 849 MHz	-49 dBm	1 MHz	This requirement does not apply to repeater operating in band n26 since it is already covered by the requirement in clause 6.5.4.5.2. For repeater operating in Band n5, it applies for 814 MHz to 824 MHz, while the rest is covered in clause 6.5.4.5.2.
E-UTRA Band 27	852 – 869 MHz	-52 dBm	1 MHz	This requirement does not apply to repeater operating in Band n5.
	807 – 824 MHz	-49 dBm	1 MHz	This requirement also applies to repeater operating in Band n28, starting 4 MHz above the Band n28 downlink operating band (Note 4).
E-UTRA Band 28 or NR Band n28	758 – 803 MHz	-52 dBm	1 MHz	This requirement does not apply to repeater operating in band n20, n67 or n28.
	703 – 748 MHz	-49 dBm	1 MHz	This requirement does not apply to repeater operating in band n28. For repeater operating in band n67, it applies for 703 MHz to 736 MHz.
E-UTRA Band 29 or NR Band n29	717 – 728 MHz	-52 dBm	1 MHz	This requirement does not apply to repeater operating in Band n29 or n85
E-UTRA Band 30 or NR Band n30	2350 – 2360 MHz	-52 dBm	1 MHz	This requirement does not apply to repeater operating in band n30
	2305 – 2315 MHz	-49 dBm	1 MHz	This requirement does not apply to repeater operating in band n30.
E-UTRA Band 31 or NR Band n31	462.5 – 467.5 MHz	-52 dBm	1 MHz	This requirement does not apply to repeater operating in band n31 or n72.
	452.5 – 457.5 MHz	-49 dBm	1 MHz	This requirement does not apply to repeater operating in band n31, since it is already covered by the requirement in clause 6.5.4.5.2. This requirement does not apply to repeater operating in band n72.
UTRA FDD band XXXII or E-UTRA band 32	1452 – 1496 MHz	-52 dBm	1 MHz	This requirement does not apply to repeater operating in band n50, n74, n75, n92 or n94.
UTRA TDD Band a) or E-UTRA Band 33	1900 – 1920 MHz	-52 dBm	1 MHz	
UTRA TDD Band a) or E-UTRA Band 34 or NR band n34	2010 – 2025 MHz	-52 dBm	1 MHz	This requirement does not apply to repeater operating in Band n34.
UTRA TDD Band b) or E-UTRA Band 35	1850 – 1910 MHz	-52 dBm	1 MHz	

UTRA TDD Band b) or E-UTRA Band 36	1930 – 1990 MHz	-52 dBm	1 MHz	This requirement does not apply to repeater operating in Band n2 or n25.
UTRA TDD Band c) or E-UTRA Band 37	1910 – 1930 MHz	-52 dBm	1 MHz	
UTRA TDD Band d) or E-UTRA Band 38 or NR Band n38	2570 – 2620 MHz	-52 dBm	1 MHz	This requirement does not apply to repeater operating in Band n38.
UTRA TDD Band f) or E-UTRA Band 39 or NR band n39	1880 – 1920MHz	-52 dBm	1 MHz	This requirement does not apply to repeater operating in Band n39.
UTRA TDD Band e) or E-UTRA Band 40 or NR Band n40	2300 – 2400MHz	-52 dBm	1 MHz	This requirement does not apply to repeater operating in Band n30 or n40.
E-UTRA Band 41 or NR Band n41, n90	2496 – 2690 MHz	-52 dBm	1 MHz	This is not applicable to repeater operating in Band n41, n53 or [n90].
E-UTRA Band 42	3400 – 3600 MHz	-52 dBm	1 MHz	This is not applicable to repeater operating in Band n48, n77 or n78.
E-UTRA Band 43	3600 – 3800 MHz	-52 dBm	1 MHz	This is not applicable to repeater operating in Band n48, n77 or n78.
E-UTRA Band 44	703 – 803 MHz	-52 dBm	1 MHz	This is not applicable to repeater operating in Band n28.
E-UTRA Band 45	1447 – 1467 MHz	-52 dBm	1 MHz	
E-UTRA Band 46	5150 – 5925 MHz	-52 dBm	1 MHz	
E-UTRA Band 47	5855 – 5925 MHz	-52 dBm	1 MHz	
E-UTRA Band 48 or NR Band n48	3550 – 3700 MHz	-52 dBm	1 MHz	This is not applicable to repeater operating in Band n48, n77 or n78.
E-UTRA Band 50 or NR band n50	1432 – 1517 MHz	-52 dBm	1 MHz	This requirement does not apply to repeater operating in Band n50, n51, n74, n75, n76, n91, n92, n93, n94 or n109.
E-UTRA Band 51 or NR Band n51	1427 – 1432 MHz	-52 dBm	1 MHz	This requirement does not apply to repeater operating in Band n50, n51, n75, n76, n91, n92, n93, n94 or n109.
E-UTRA Band 53 or NR Band n53	2483.5 - 2495 MHz	-52 dBm	1 MHz	This requirement does not apply to repeater operating in Band n41, n53 or n90.
E-UTRA Band 54 or NR Band n54	1670 – 1675 MHz	-52 dBm	1 MHz	This requirement does not apply to repeater operating in Band n54
E-UTRA Band 65 or NR Band n65	2110 – 2200 MHz	-52 dBm	1 MHz	This requirement does not apply to repeater operating in band n1 or n65.
	1920 – 2010 MHz	-49 dBm	1 MHz	For repeater operating in Band n1, it applies for 1980 MHz to 2010 MHz, while the rest is covered in clause 6.5.4.5.2. This requirement does not apply to repeater operating in band n65.
E-UTRA Band 66 or NR Band n66	2110 – 2200 MHz	-52 dBm	1 MHz	This requirement does not apply to repeater operating in band n66.
	1710 – 1780 MHz	-49 dBm	1 MHz	This requirement does not apply to repeater operating in band n66.
E-UTRA Band 67 or NR Band n67	738 – 758 MHz	-52 dBm	1 MHz	This requirement does not apply to repeater operating in Band n28 or n67.

E-UTRA Band 68	753 -783 MHz	-52 dBm	1 MHz	This requirement does not apply to repeater operating in band n28.
	698-728 MHz	-49 dBm	1 MHz	For repeater operating in Band n28, this requirement applies between 698 MHz and 703 MHz, while the rest is covered in clause 6.5.4.5.2.
E-UTRA Band 69	2570 – 2620 MHz	-52 dBm	1 MHz	This requirement does not apply to repeater operating in Band n38.
E-UTRA Band 70 or NR Band n70	1995 – 2020 MHz	-52 dBm	1 MHz	This requirement does not apply to repeater operating in band n2, n25 or n70
	1695 – 1710 MHz	-49 dBm	1 MHz	This requirement does not apply to repeater operating in band n70..
E-UTRA Band 71 or NR Band n71	617 – 652 MHz	-52 dBm	1 MHz	This requirement does not apply to repeater operating in band n71 or n105.
	663 – 698 MHz	-49 dBm	1 MHz	This requirement does not apply to repeater operating in band n71 or n105.
E-UTRA Band 72 or NR Band n72	461 – 466 MHz	-52 dBm	1 MHz	This requirement does not apply to repeater operating in band n31 or n72.
	451 – 456 MHz	-49 dBm	1 MHz	This requirement does not apply to repeater operating in band n72, since it is already covered by the requirement in clause 6.5.4.5.2. This requirement does not apply to repeater operating in band n31.
E-UTRA Band 74 or NR Band n74	1475 – 1518 MHz	-52 dBm	1 MHz	This requirement does not apply to repeater operating in band n50, n74, n75, n92, n94 or n109.
	1427 – 1470 MHz	-49 dBm	1MHz	This requirement does not apply to repeater operating in band n50, n51, n74, n75, n76, n91, n92, n93, n94 or n109.
E-UTRA Band 75 or NR Band n75	1432 – 1517 MHz	-52 dBm	1 MHz	This requirement does not apply to repeater operating in Band n50, n51, n74, n75, n76, n91, n92, n93, n94 or n109.
E-UTRA Band 76 or NR Band n76	1427 – 1432 MHz	-52 dBm	1 MHz	This requirement does not apply to repeater operating in Band n50, n51, n75, n76, n91, n92, n93, n94 or n109.
NR Band n77	3.3 – 4.2 GHz	-52 dBm	1 MHz	This requirement does not apply to repeater operating in Band n48, n77 or n78
NR Band n78	3.3 – 3.8 GHz	-52 dBm	1 MHz	This requirement does not apply to repeater operating in Band n48, n77 or n78
NR Band n79	4.4 – 5.0 GHz	-52 dBm	1 MHz	This requirement does not apply to repeater operating in Band n79
NR Band n80	1710 – 1785 MHz	-49 dBm	1 MHz	This requirement does not apply to repeater operating in band n3.
NR Band n81	880 – 915 MHz	-49 dBm	1 MHz	This requirement does not apply to repeater operating in band n8.
NR Band n82	832 – 862 MHz	-49 dBm	1 MHz	This requirement does not apply to repeater operating in band n20.
NR Band n83	703 – 748 MHz	-49 dBm	1 MHz	This requirement does not apply to repeater operating in band n28. For repeater operating in Band n67, it applies for 703 MHz to 736 MHz.
NR Band n84	1920 – 1980 MHz	-49 dBm	1 MHz	This requirement does not apply to repeater operating in band n1.
E-UTRA Band 85 or NR Band n85	728 – 746 MHz	-52 dBm	1 MHz	This requirement does not apply to repeater operating in band n12, n29 or n85.
	698 – 716 MHz	-49 dBm	1 MHz	This requirement does not apply to repeater operating in band n12 or n85. For NR repeater operating in n29, it applies 1 MHz below the Band n29 downlink operating band (Note 5).
NR Band n86	1710 – 1780 MHz	-49 dBm	1 MHz	This requirement does not apply to repeater operating in band n66.
E-UTRA Band 87	420 - 425 MHz	-52 dBm	1 MHz	
	410 - 415 MHz	-49 dBm	1 MHz	
E-UTRA Band 88	422 - 427 MHz	-52 dBm	1 MHz	

	412 - 417 MHz	-49 dBm	1 MHz	
NR Band n89	824 – 849 MHz	-49 dBm	1 MHz	This requirement does not apply to repeater operating in band n5.
NR Band n91	1427 – 1432 MHz	-52 dBm	1 MHz	This requirement does not apply to repeater operating in Band n50, n51, n75, n76 or n109.
	832 – 862 MHz	-49 dBm	1 MHz	This requirement does not apply to repeater operating in band n20, since it is already covered by the requirement in clause 6.5.4.5.2.
NR Band n92	1432 – 1517 MHz	-52 dBm	1 MHz	This requirement does not apply to repeater operating in Band n50, n51, n74, n75, n76 or n109.
	832 – 862 MHz	-49 dBm	1 MHz	This requirement does not apply to repeater operating in band n20, since it is already covered by the requirement in clause 6.5.4.5.2.
NR Band n93	1427 – 1432 MHz	-52 dBm	1 MHz	This requirement does not apply to repeater operating in Band n50, n51, n75, n76 or n109.
	880 – 915 MHz	-49 dBm	1 MHz	This requirement does not apply to repeater operating in band n8, since it is already covered by the requirement in clause 6.5.4.5.2.
NR Band n94	1432 – 1517 MHz	-52 dBm	1 MHz	This requirement does not apply to repeater operating in Band n50, n51, n74, n75, n76 or n109.
	880 – 915 MHz	-49 dBm	1 MHz	This requirement does not apply to repeater operating in band n8, since it is already covered by the requirement in clause 6.5.4.5.2.
NR Band n95	2010 – 2025 MHz	-52 dBm	1 MHz	
NR Band n96	5925 – 7125 MHz	-52 dBm	1 MHz	
NR Band n97	2300 – 2400MHz	-52 dBm	1 MHz	
NR Band n98	1880 – 1920MHz	-52 dBm	1 MHz	
NR Band n99	1626.5 – 1660.5 MHz	-49 dBm	1 MHz	This requirement does not apply to repeater operating in band n24.
NR Band n100	919.4 – 925 MHz	-52 dBm	1 MHz	This requirement does not apply to repeater operating in Band n8 or n100.
	874.4 – 880 MHz	-49 dBm	1 MHz	This requirement does not apply to repeater operating in band n100.
NR band n101	1900 – 1910 MHz	-52 dBm	1 MHz	This requirement does not apply to repeater operating in Band n101.
NR Band n102	5925 – 6425 MHz	-52 dBm	1 MHz	
E-UTRA Band 103	757 – 758 MHz	-52 dBm	1 MHz	
	787 – 788 MHz	-49 dBm	1 MHz	
NR Band n104	6425 – 7125 MHz	-52 dBm	1 MHz	This requirement does not apply to repeater operating in Band n104
NR band n105	612 – 652 MHz	-52 dBm	1 MHz	This requirement does not apply to repeater operating in band n71 or n105.
	663 – 703 MHz	-49 dBm	1 MHz	This requirement does not apply to repeater operating in band n105, since it is already covered by the requirement in clause 6.6.5.2.2.
E-UTRA Band 106 or NR band n106	935 - 940 MHz	-52 dBm	1 MHz	This requirement does not apply to repeater operating in band n106.
	896 – 901 MHz	-49 dBm	1 MHz	This requirement does not apply to repeater operating in band n106, since it is already covered by the requirement in clause 6.6.5.2.2. This requirement does not apply to repeater operating in band n5 or n26.
NR band n109	1432 – 1517 MHz	-52 dBm	1 MHz	This requirement does not apply to repeater operating in Band n50, n51, n74, n75, n76, n91, n92, n93, n94 or n109
	703 – 733 MHz	-49 dBm	1 MHz	This requirement does not apply to repeater operating in band n109, since it is already covered by the requirement in clause 6.6.6.5.2.4.

NOTE 1: As defined in the scope for spurious emissions in this clause, except for the cases where the noted requirements apply to a repeater operating in Band n28, the co-existence requirements in table 6.5.4.5.2 - 1 do not apply for the Δf_{OBUE} frequency range immediately outside the downlink *operating band*. Emission limits for this excluded frequency range may be covered by local or regional requirements.

NOTE 2: Table 6.5.4.5.2 -1 assumes that two *operating bands*, where the frequency ranges would be overlapping, are not deployed in the same geographical area. For such a case of operation with overlapping frequency arrangements in the same geographical area, special co-existence requirements may apply that are not covered by the 3GPP specifications.

NOTE 3: For unsynchronized operation, special co-existence requirements may apply that are not covered by the 3GPP specifications.

NOTE 4: For NR Band n28 repeater, specific solutions may be required to fulfil the spurious emissions limits for repeater for co-existence with E-UTRA Band 27 UL *operating band*.

NOTE 5: For NR Band n29 repeater, specific solutions may be required to fulfil the spurious emissions limits for NR repeater for co-existence with UTRA Band XII, E-UTRA Band 12 or NR Band n12 UL *operating band*, E-UTRA Band 17 UL *operating band* or E-UTRA Band 85 UL or NR Band n85 UL *operating band*.

The following requirement may be applied for the protection of PHS. This requirement is also applicable at specified frequencies falling between Δf_{OBUE} below the lowest repeater transmitter frequency of the downlink *operating band* and Δf_{OBUE} above the highest repeater transmitter frequency of the downlink *operating band*. Δf_{OBUE} is defined in clause 6.5.1.

The spurious emission *minimum requirements* for this requirement are:

Table 6.5.4.5.2-2: Repeater spurious emissions minimum requirements for repeater for co-existence with PHS for DL

Frequency range	<i>minimum requirements</i>	<i>Measurement Bandwidth</i>	Note
1884.5 – 1915.7 MHz	-41 dBm	300 kHz	Applicable when co-existence with PHS system operating in 1884.5 – 1915.7 MHz

In certain regions, the following requirement may apply to NR repeater or NCR operating in Band n50 and n75 within the 1432 – 1452 MHz, and in Band n51 and Band n76. The *minimum requirements* are specified in Table 6.5.4.5.2-3. This requirement is also applicable at the frequency range from Δf_{OBUE} below the lowest frequency of the repeater downlink *operating band* up to Δf_{OBUE} above the highest frequency of the repeater downlink *operating band*.

Table 6.5.4.5.2-3: Additional operating band unwanted emission minimum requirement for NR repeater operating in Band n50 and n75 within 1432 – 1452 MHz, and in Band n51 and n76

Filter centre frequency, F_{filter}	<i>Minimum requirements</i>	<i>Measurement Bandwidth</i>
$F_{\text{filter}} = 1413.5 \text{ MHz}$	-42 dBm	27 MHz

In certain regions, the following requirement may apply to repeater operating in NR Band n50 and n75 within 1492-1517 MHz and in Band n74 within 1492-1518 MHz. The maximum level of emissions, measured on centre frequencies F_{filter} with filter bandwidth according to Table 6.5.4.5.2-4, shall be defined according to the *minimum requirements* $P_{\text{EM},n50/n75,a}$ nor $P_{\text{EM},n50/n75,b}$ declared by the manufacturer.

Table 6.5.4.5.2-4: Operating band n50, n74 and n75 declared emission above 1518 MHz

Filter centre frequency, F_{filter}	<i>Declared minimum requirements (dBm)</i>	<i>Measurement bandwidth</i>
$1518.5 \text{ MHz} \leq F_{\text{filter}} \leq 1519.5 \text{ MHz}$	$P_{\text{EM},n50/n75,a}$	1 MHz
$1520.5 \text{ MHz} \leq F_{\text{filter}} \leq 1558.5 \text{ MHz}$	$P_{\text{EM},n50/n75,b}$	1 MHz

In certain regions, the following requirement shall be applied to repeater operating in Band n13 and n14 to ensure that appropriate interference protection is provided to 700 MHz public safety operations. This requirement is also applicable at the frequency range from 10 MHz below the lowest frequency of the repeater downlink *operating band* up to 10 MHz above the highest frequency of the repeater downlink *operating band*.

The power of any spurious emission shall not exceed:

Table 6.5.4.5.2-5: Repeater spurious emissions limits for protection of 700 MHz public safety operations

Operating Band	Frequency range	Maximum Level	Measurement Bandwidth
n13	763 - 775 MHz	-46 dBm	6.25 kHz
n13	793 - 805 MHz	-46 dBm	6.25 kHz
n14	769 - 775 MHz	-46 dBm	6.25 kHz
n14	799 - 805 MHz	-46 dBm	6.25 kHz

In certain regions, the following requirement may apply to NR repeater operating in Band n30. This requirement is also applicable at the frequency range from 10 MHz below the lowest frequency of the repeater downlink operating band up to 10 MHz above the highest frequency of the repeater downlink operating band.

The power of any spurious emission shall not exceed:

Table 6.5.4.5.2-6: Additional NR repeater spurious emissions minimum requirements for Band n30

Frequency range	Minimum requirements	Measurement Bandwidth	Note
2200 – 2345 MHz	-45 dBm	1 MHz	
2362.5 – 2365 MHz	-25 dBm	1 MHz	
2365 – 2367.5 MHz	-40 dBm	1 MHz	
2367.5 – 2370 MHz	-42 dBm	1 MHz	
2370 – 2395 MHz	-45 dBm	1 MHz	

The following requirement may apply to repeater operating in Band n48 in certain regions. The power of any spurious emission shall not exceed:

Table 6.5.4.5.2-7: Additional repeater spurious emissions limits for Band n48

Frequency range	Maximum Level	Measurement Bandwidth (NOTE)	Note
3530 MHz – 3720 MHz	-25 dBm	1 MHz	Applicable 10 MHz from the assigned <i>passband edge</i>
3100 MHz – 3530 MHz 3720 MHz – 4200 MHz	-40 dBm	1 MHz	

NOTE: The resolution bandwidth of the measuring equipment should be equal to the measurement bandwidth. However, to improve measurement accuracy, sensitivity and efficiency, the resolution bandwidth may be smaller than the measurement bandwidth. When the resolution bandwidth is smaller than the measurement bandwidth, the result should be integrated over the measurement bandwidth in order to obtain the equivalent noise bandwidth of the measurement bandwidth.

NOTE: The regional requirement, included in [14], is defined in terms of EIRP, which is dependent on both the repeater emissions at the *antenna connector* and the deployment (including antenna gain and feeder loss). The requirement defined above provides the characteristics of the base station needed to verify compliance with the regional requirement. The assessment of the EIRP level is described in TS 38.104[5], Annex F.

The following requirement shall be applied to repeater operating in Band n26 to ensure that appropriate interference protection is provided to 800 MHz public safety operations. This requirement is also applicable at the frequency range from 10 MHz below the lowest frequency of the repeater downlink operating band up to 10 MHz above the highest frequency of the repeater downlink operating band.

The power of any spurious emission shall not exceed:

Table 6.5.4.5.2-8: Repeater spurious emissions limits for protection of 800 MHz public safety operations

Operating Band	Frequency range	Maximum Level	Measurement Bandwidth	Note
n26	851 - 859 MHz	-13 dBm	100 kHz	Applicable for offsets > 37.5kHz from the <i>passband</i> edge

The following requirement may apply to Repeater for Band n41 and n90 operation in Japan. This requirement is also applicable at the frequency range from Δf_{OBUE} below the lowest frequency of the Repeater downlink operating band up to Δf_{OBUE} above the highest frequency of the Repeater downlink operating band.

The power of any spurious emission shall not exceed:

Table 6.5.4.5.2-9: Additional repeater spurious emissions minimum requirements for Band n41 and n90

Frequency range	Minimum requirement	Measurement Bandwidth
2505 MHz – 2535 MHz	-42 dBm	1 MHz
NOTE: This requirement applies for carriers allocated within 2545-2645 MHz.		

The following requirement may apply to repeater operating in 3.45-3.55 GHz in Band n77 in certain regions. Emissions shall not exceed the maximum levels specified in table 6.5.4.2.3-11.

Table 6.5.4.5.2-10: Additional repeater spurious emissions limits for Band n77

Channel bandwidth [MHz]	Frequency range [MHz]	Filter centre frequency, F_{filter} [MHz]	Minimum requirement [dBm]	Measurement bandwidth [MHz]
All	3430 – 3440	$3430.5 \leq F_{\text{filter}} < 3439.5$	-25	1
	3560 – 3570	$3560.5 \leq F_{\text{filter}} < 3569.5$		
All	≤ 3430	$F_{\text{filter}} < 3429.5$	-40	1
	> 3570	$3570.5 \leq F_{\text{filter}}$		

NOTE: The resolution bandwidth of the measuring equipment should be equal to the measurement bandwidth. However, to improve measurement accuracy, sensitivity and efficiency, the resolution bandwidth may be smaller than the measurement bandwidth. When the resolution bandwidth is smaller than the measurement bandwidth, the result should be integrated over the measurement bandwidth in order to obtain the equivalent noise bandwidth of the measurement bandwidth.

The following requirement may also apply to repeater operating in Band n54 in certain regions. The level of emissions in the 1541 – 1650 MHz band, measured in measurement bandwidth according to Table 6.5.4.5.2-11 shall not exceed the maximum emission levels $P_{\text{EM},n54,a}$, $P_{\text{EM},n54,b}$, $P_{\text{EM},n54,c}$, $P_{\text{EM},n54,d}$, $P_{\text{EM},n54,e}$ and $P_{\text{EM},n54,f}$ declared by the manufacturer.

Table 6.5.4.5.2-11: Declared Band n54 emissions levels for protection of the 1541-1650 MHz band

Operating Band	Frequency range	Declared emission level (dBW) (Measurement bandwidth = 1 MHz)	Declared emission level (dBW) of discrete emissions of less than 700 Hz bandwidth (Measurement bandwidth = 1 kHz)	Declared emission level (dBW) of discrete emissions of less than 2 kHz bandwidth (Measurement bandwidth = 1 kHz)
n54	1541 - 1559 MHz	$P_{\text{EM},n54,a}$		$P_{\text{EM},n54,f}$
	1559 - 1610 MHz	$P_{\text{EM},n54,b}$	$P_{\text{EM},n54,d}$	
	1610 - 1650 MHz	$P_{\text{EM},n54,c}$	$P_{\text{EM},n54,e}$	

Note: The regional requirements specified in attachment to the FCC reference document, 0007135419 are defined in terms of EIRP (effective isotropic radiated power), which is dependent on both the repeater emissions at the antenna connector and the deployment (including antenna gain and feeder loss). The EIRP level is calculated using: $P_{\text{EIRP}} = P_{\text{E}} + G_{\text{ant}}$ where P_{E} denotes the repeater unwanted emission level at the antenna connector, G_{ant} equals the repeater antenna gain minus feeder loss. The requirement defined above provides the characteristics of the base station needed to verify compliance with the regional requirement.

6.5.4.5.3 Co-location with base stations and *repeater*

These requirements may be applied for the protection of other BS, IAB-DU, IAB-MT and *repeater* receivers when GSM900, DCS1800, PCS1900, GSM850, CDMA850, UTRA FDD, UTRA TDD, E-UTRA, NR BS, IAB-DU, IAB-MT, or *repeater* are co-located with *repeater*.

The requirements assume a 30 dB coupling loss between transmitter and receiver and are based on co-location with same class.

The *minimum requirements* are in table 6.5.4.5.3-1 for a *repeater*. Requirements for co-location with a system listed in the first column apply, depending on the declared *repeater* class. For a *multi-band connector*, the exclusions and conditions in the Note column of table 6.5.4.5.3-1 shall apply for each supported *operating band*.

Table 6.5.4.5.3-1: Repeater type 1-C spurious emissions minimum requirements for co-location with BS, IAB-Node or repeater-Node

Type of co-located BS	Frequency range for co-location requirement	Minimum requirements			Measurement bandwidth	Note
		WA repeater	MR repeater	LA repeater		
GSM900	876 – 915 MHz	-98 dBm	-91 dBm	-70 dBm	100 kHz	
DCS1800	1710 – 1785 MHz	-98 dBm	-91 dBm	-80 dBm	100 kHz	
PCS1900	1850 – 1910 MHz	-98 dBm	-91 dBm	-80 dBm	100 kHz	
GSM850 or CDMA850	824 – 849 MHz	-98 dBm	-91 dBm	-70 dBm	100 kHz	
UTRA FDD Band I or E-UTRA Band 1 or NR Band n1	1920 – 1980 MHz	-96 dBm	-91 dBm	-88 dBm	100 kHz	
UTRA FDD Band II or E-UTRA Band 2 or NR Band n2	1850 – 1910 MHz	-96 dBm	-91 dBm	-88 dBm	100 kHz	
UTRA FDD Band III or E-UTRA Band 3 or NR Band n3	1710 – 1785 MHz	-96 dBm	-91 dBm	-88 dBm	100 kHz	
UTRA FDD Band IV or E-UTRA Band 4	1710 – 1755 MHz	-96 dBm	-91 dBm	-88 dBm	100 kHz	
UTRA FDD Band V or E-UTRA Band 5 or NR Band n5	824 – 849 MHz	-96 dBm	-91 dBm	-88 dBm	100 kHz	
UTRA FDD Band VI, XIX or E-UTRA Band 6, 19	830 – 845 MHz	-96 dBm	-91 dBm	-88 dBm	100 kHz	
UTRA FDD Band VII or E-UTRA Band 7 or NR Band n7	2500 – 2570 MHz	-96 dBm	-91 dBm	-88 dBm	100 kHz	
UTRA FDD Band VIII or E-UTRA Band 8 or NR Band n8	880 – 915 MHz	-96 dBm	-91 dBm	-88 dBm	100 kHz	
UTRA FDD Band IX or E-UTRA Band 9	1749.9 – 1784.9 MHz	-96 dBm	-91 dBm	-88 dBm	100 kHz	
UTRA FDD Band X or E-UTRA Band 10	1710 – 1770 MHz	-96 dBm	-91 dBm	-88 dBm	100 kHz	
UTRA FDD Band XI or E-UTRA Band 11	1427.9 – 1447.9 MHz	-96 dBm	-91 dBm	-88 dBm	100 kHz	This is not applicable to repeater operating in Band n50, n75, n91, n92, n93 or n94
UTRA FDD Band XII or E-UTRA Band 12 or NR Band n12	699 – 716 MHz	-96 dBm	-91 dBm	-88 dBm	100 kHz	
UTRA FDD Band XIII or E-UTRA Band 13 or NR Band n13	777 – 787 MHz	-96 dBm	-91 dBm	-88 dBm	100 kHz	
UTRA FDD Band XIV or E-UTRA Band 14 or NR Band n14	788 – 798 MHz	-96 dBm	-91 dBm	-88 dBm	100 kHz	
E-UTRA Band 17	704 – 716 MHz	-96 dBm	-91 dBm	-88 dBm	100 kHz	
E-UTRA Band 18 or NR Band n18	815 – 830 MHz	-96 dBm	-91 dBm	-88 dBm	100 kHz	
UTRA FDD Band XX or E-UTRA Band 20 or NR Band n20	832 – 862 MHz	-96 dBm	-91 dBm	-88 dBm	100 kHz	
UTRA FDD Band XXI or E-UTRA Band 21	1447.9 – 1462.9 MHz	-96 dBm	-91 dBm	-88 dBm	100 kHz	This is not applicable to repeater operating in Band n50, n75, n92 or n94

UTRA FDD Band XXII or E-UTRA Band 22	3410 – 3490 MHz	-96 dBm	-91 dBm	-88 dBm	100 kHz	This is not applicable to repeater operating in Band n48, n77 or n78
E-UTRA Band 24 or NR Band n24	1626.5 – 1660.5 MHz	-96 dBm	-91 dBm	-88 dBm	100 kHz	
UTRA FDD Band XXV or E-UTRA Band 25 or NR Band n25	1850 – 1915 MHz	-96 dBm	-91 dBm	-88 dBm	100 kHz	
UTRA FDD Band XXVI or E-UTRA Band 26 or NR Band n26	814 – 849 MHz	-96 dBm	-91 dBm	-88 dBm	100 kHz	
E-UTRA Band 27	807 – 824 MHz	-96 dBm	-91 dBm	-88 dBm	100 kHz	
E-UTRA Band 28 or NR Band n28	703 – 748 MHz	-96 dBm	-91 dBm	-88 dBm	100 kHz	
E-UTRA Band 30 or NR Band n30	2305 – 2315 MHz	-96 dBm	-91 dBm	-88 dBm	100 kHz	
E-UTRA Band 31 or NR Band n31	452.5 – 457.5 MHz	-96 dBm	-91 dBm	-88 dBm	100 kHz	
UTRA TDD Band a) or E-UTRA Band 33	1900 – 1920 MHz	-96 dBm	-91 dBm	-88 dBm	100 kHz	
UTRA TDD Band a) or E-UTRA Band 34 or NR band n34	2010 – 2025 MHz	-96 dBm	-91 dBm	-88 dBm	100 kHz	This is not applicable to repeater operating in Band n34
UTRA TDD Band b) or E-UTRA Band 35	1850 – 1910 MHz	-96 dBm	-91 dBm	-88 dBm	100 kHz	
UTRA TDD Band b) or E-UTRA Band 36	1930 – 1990 MHz	-96 dBm	-91 dBm	-88 dBm	100 kHz	This is not applicable to repeater operating in Band n2 or band n25
UTRA TDD Band c) or E-UTRA Band 37	1910 – 1930 MHz	-96 dBm	-91 dBm	-88 dBm	100 kHz	
UTRA TDD Band d) or E-UTRA Band 38 or NR Band n38	2570 – 2620 MHz	-96 dBm	-91 dBm	-88 dBm	100 kHz	This is not applicable to repeater operating in Band n38.
UTRA TDD Band f) or E-UTRA Band 39 or NR band n39	1880 – 1920MHz	-96 dBm	-91 dBm	-88 dBm	100 kHz	This is not applicable to repeater operating in Band n39
UTRA TDD Band e) or E-UTRA Band 40 or NR Band n40	2300 – 2400MHz	-96 dBm	-91 dBm	-88 dBm	100 kHz	This is not applicable to repeater operating in Band n30 or n40.
E-UTRA Band 41 or NR Band n41, n90	2496 – 2690 MHz	-96 dBm	-91 dBm	-88 dBm	100 kHz	This is not applicable to repeater operating in Band n41, n53 or [n90]
E-UTRA Band 42	3400 – 3600 MHz	-96 dBm	-91 dBm	-88 dBm	100 kHz	This is not applicable to repeater operating in Band n48, n77 or n78

E-UTRA Band 43	3600 – 3800 MHz	-96 dBm	-91 dBm	-88 dBm	100 kHz	This is not applicable to repeater operating in Band n48, n77 or n78
E-UTRA Band 44	703 – 803 MHz	-96 dBm	-91 dBm	-88 dBm	100 kHz	This is not applicable to repeater operating in Band n28
E-UTRA Band 45	1447 – 1467 MHz	-96 dBm	-91 dBm	-88 dBm	100 kHz	
E-UTRA Band 46 or NR Band n46	5150 – 5925 MHz	N/A	-91 dBm	-88 dBm	100 kHz	This is not applicable to repeater operating in Band n46 or n96
E-UTRA Band 48 or NR Band n48	3550 – 3700 MHz	-96 dBm	-91 dBm	-88 dBm	100 kHz	This is not applicable to repeater operating in Band n48, n77 or n78
E-UTRA Band 50 or NR Band n50	1432 – 1517 MHz	-96 dBm	-91 dBm	-88 dBm	100 kHz	This is not applicable to repeater operating in Band n51, n74, n75, n91, n92, n93 or n94
E-UTRA Band 51 or NR Band n51	1427 – 1432 MHz	N/A	N/A	-88 dBm	100 kHz	This is not applicable to repeater operating in Band n50, n74, n75, n76, n91, n92, n93 or n94
E-UTRA Band 53 or NR Band n53	2483.5 – 2495 MHz	N/A	-91 dBm	-88 dBm	100 kHz	This is not applicable to repeater operating in Band n41, n53 or n90
E-UTRA Band 54 or NR Band n54	1670 – 1675 MHz	-96 dBm	-91 dBm	-88 dBm	100 kHz	This is not applicable to repeater operating in Band n54
E-UTRA Band 65 or NR Band n65	1920 – 2010 MHz	-96 dBm	-91 dBm	-88 dBm	100 kHz	
E-UTRA Band 66 or NR Band n66	1710 – 1780 MHz	-96 dBm	-91 dBm	-88 dBm	100 kHz	
E-UTRA Band 68	698 – 728 MHz	-96 dBm	-91 dBm	-88 dBm	100 kHz	
E-UTRA Band 70 or NR Band n70	1695 – 1710 MHz	-96 dBm	-91 dBm	-88 dBm	100 kHz	
E-UTRA Band 71 or NR Band n71	663 – 698 MHz	-96 dBm	-91 dBm	-88 dBm	100 kHz	
E-UTRA Band 72 or NR Band n72	451 – 456 MHz	-96 dBm	-91 dBm	-88 dBm	100 kHz	
E-UTRA Band 74 or NR Band n74	1427 – 1470 MHz	-96 dBm	-91 dBm	-88 dBm	100 kHz	This is not applicable to repeater operating in Band n50, n51, n91, n92, n93 or n94

NR Band n77	3.3 – 4.2 GHz	-96 dBm	-91 dBm	-88 dBm	100 kHz	This is not applicable to repeater operating in Band n48, n77 or n78
NR Band n78	3.3 – 3.8 GHz	-96 dBm	-91 dBm	-88 dBm	100 kHz	This is not applicable to repeater operating in Band n48, n77 or n78
NR Band n79	4.4 – 5.0 GHz	-96 dBm	-91 dBm	-88 dBm	100 kHz	
NR Band n80	1710 – 1785 MHz	-96 dBm	-91 dBm	-88 dBm	100 kHz	
NR Band n81	880 – 915 MHz	-96 dBm	-91 dBm	-88 dBm	100 kHz	
NR Band n82	832 – 862 MHz	-96 dBm	-91 dBm	-88 dBm	100 kHz	
NR Band n83	703 – 748 MHz	-96 dBm	-91 dBm	-88 dBm	100 kHz	
NR Band n84	1920 – 1980 MHz	-96 dBm	-91 dBm	-88 dBm	100 kHz	
E-UTRA Band 85 or NR Band n85	698 – 716 MHz	-96 dBm	-91 dBm	-88 dBm	100 kHz	
NR Band n86	1710 – 1780 MHz	-96 dBm	-91 dBm	-88 dBm	100 kHz	
E-UTRA Band 87	410 – 415 MHz	-96 dBm	-91 dBm	-88 dBm	100 kHz	
E-UTRA Band 88	412 – 417 MHz	-96 dBm	-91 dBm	-88 dBm	100 kHz	
NR Band n89	824 – 849 MHz	-96 dBm	-91 dBm	-88 dBm	100 kHz	
NR Band n91	832 – 862 MHz	N/A	N/A	-88 dBm	100 kHz	
NR Band n92	832 – 862 MHz	-96 dBm	-91 dBm	-88 dBm	100 kHz	
NR Band n93	880 – 915 MHz	N/A	N/A	-88 dBm	100 kHz	
NR Band n94	880 – 915 MHz	-96 dBm	-91 dBm	-88 dBm	100 kHz	
NR Band n95	2010 – 2025 MHz	-96 dBm	-91 dBm	-88 dBm	100 kHz	
NR Band n96	5925 – 7125 MHz	N/A	-90 dBm	-87 dBm	100 kHz	
NR Band n97	2300 – 2400MHz	-96 dBm	-91 dBm	-88 dBm	100 kHz	
NR Band n98	1880 – 1920MHz	-96 dBm	-91 dBm	-88 dBm	100 kHz	
NR Band n99	1626.5 – 1660.5 MHz	-96 dBm	-91 dBm	-88 dBm	100 kHz	
NR Band n102	5925 – 6425 MHz	N/A	-90 dBm	-87 dBm	100 kHz	
E-UTRA Band 103	787 – 788 MHz	-96 dBm	-91 dBm	-88 dBm	100 kHz	
NR Band n104	6425 – 7125 MHz	-95 dBm	-90 dBm	-87 dBm	100 kHz	This requirement does not apply to repeater operating in Band n104.
NR Band n105	663 – 703 MHz	-96 dBm	-91 dBm	-88 dBm	100 kHz	
E-UTRA Band 106 or NR Band n106	896 – 901 MHz	-96 dBm	-91 dBm	-88 dBm	100 kHz	
NR Band n109	703 – 733 MHz	-96 dBm	-91 dBm	-88 dBm	100 kHz	

NOTE 1: As defined in the scope for spurious emissions in this clause, the co-location requirements in table 6.5.4.5.3-1 do not apply for the frequency range extending Δf_{OBUE} immediately outside the transmit frequency range of a *repeater type 1-C*. The current state-of-the-art technology does not allow a single generic solution for co-location with other system on adjacent frequencies for 30dB antenna to antenna minimum coupling loss. However, there are certain site-engineering solutions that can be used. These techniques are addressed in TR 25.942 [15].

NOTE 2: Table 6.5.4.5.3-1 assumes that two *operating bands*, where the corresponding transmit and receive frequency ranges would be overlapping, are not deployed in the same geographical area. For such a case of operation with overlapping frequency arrangements in the same geographical area, special co-location requirements may apply that are not covered by the 3GPP specifications.

6.5.4.6 Test requirements for *NCR*

6.5.4.6.1 Test requirement for *NCR-Fwd*

6.5.4.6.1.1 Test requirement for *NCR-Fwd type 1-C*

The Tx spurious emissions for *NCR-Fwd type 1-C* for each *antenna connector* shall not exceed the *basic limits* specified in clause 6.5.4.5.

For Band n41 and n90 operation in Japan, the sum of the spurious emissions over all *antenna connectors* for *NCR-Fwd type 1-C* shall not exceed the *basic limits* defined in clause 6.5.4.5.

For joint transmission of *NCR-Fwd* and *NCR-MT* in the uplink, the spurious emissions limits shall apply to the total emissions from both the *NCR-Fwd* and *NCR-MT*.

6.5.4.6.1.2 Test requirement for *NCR-Fwd type 1-H*

The Tx spurious emissions requirements for *NCR-Fwd type 1-H* are that for each *TAB connector TX min cell group* and each applicable *basic limit* in clause 6.5.4.5, the power summation emissions at the *TAB connectors* of the *TAB connectors* of the *TAB connector TX min cell group* shall not exceed a limit specified as the *basic limit* + X, where $X = 10\log_{10}(N_{\text{TXU, counted per cell}})$ for DL and for WA UL and $X=0$ for LA UL, unless stated differently in regional regulation.

NOTE: Conformance to the *NCR-Fwd type 1-H* spurious emission requirement can be demonstrated by meeting at least one of the following criteria as determined by the manufacturer:

1) The sum of the emissions power measured on each *TAB connector* in the *TAB connector TX min cell group* shall be less than or equal to the limit as defined in this clause for the respective frequency span.

Or

2) The unwanted emissions power at each *TAB connector* shall be less than or equal to the *NCR-Fwd type 1-H* limit as defined in this clause for the respective frequency span, scaled by $-10\log_{10}(n)$, where n is the number of *TAB connectors* in the *TAB connector TX min cell group*.

For joint transmission of *NCR-Fwd* and *NCR-MT* in the uplink, the spurious emissions limits shall apply to the total emissions from both the *NCR-Fwd* and *NCR-MT*.

6.5.4.6.2 Test requirement for *NCR-MT*

6.5.4.6.2.1 Test requirements for *NCR-MT type 1-C*

When *NCR-MT* and *NCR-Fwd* are not transmitting simultaneously, the requirements in clause 6.5.4.5 applies for WA *NCR-MT type 1-C* and the requirements in clause 6.5.3 in TS 38.101-1 [9] applies for LA *NCR-MT type 1-C*.

When NCR-MT and NCR-Fwd are transmitting simultaneously, the requirements in clause 6.5.3 in TS 38.101-1 [9] applies for LA NCR-MT type 1-C for sum of NCR-MT transmission and NCR-Fwd transmission.

6.5.4.6.2.2 Test requirements for NCR-MT type 1-H

Limits for NCR-MT type 1-H apply to the sum of emissions across all TAB connectors.

When WA NCR-MT and NCR-Fwd are not transmitting simultaneously, the requirements in clause 6.5.4.5 relaxed with the following scaling factor applies for WA NCR-MT type 1-H.

$$10\log(N_{\text{TXU,counted}}), \text{ where } N_{\text{TXU,counted}} = \min(N_{\text{TXU,active}}, 8)$$

When WA NCR-MT and NCR-Fwd are transmitting simultaneously, the requirements in clause 6.5.4.5 relaxed with the following scaling factor applies for the sum of NCR-MT transmission and NCR-Fwd transmission.

When LA NCR-MT and NCR-Fwd are not transmitting simultaneously, the requirements in clause 6.5.3 in TS 38.101-1 [9] applies for LA NCR-MT type 1-H without scaling factor allowed for the sum of the spurious emissions.

When NCR-MT and NCR-Fwd are transmitting simultaneously, the requirements in clause 6.5.3 in TS 38.101-1 [9] applies for sum of NCR-MT transmission and NCR-Fwd transmission.

6.5.5 Receiver spurious emissions

6.5.5.1 Definition and applicability

The receiver spurious emissions power is the power of emissions generated or amplified in a receiver unit that appear at the *antenna connector*. The requirements only apply to *repeater type 1-C*, *NCR type 1-C* and *NCR type 1-H* for TDD operation.

For each *antenna connectors* or *TAB connectors* on BS-side and UE-side supporting both RX and TX in TDD, the requirements apply during the *transmitter OFF state*. For *antenna connectors* or *TAB connectors* on both BS-side and UE-side in FDD, the RX spurious emissions requirements are superseded by the TX spurious emissions requirements, as specified in clause 6.5.4.5.

For *multi-band connectors* that both transmit and receive in *operating band* supporting TDD, RX spurious emissions requirements are applicable during the *TX OFF state*, and are subject to exclusion zones in each supported *operating band*.

For Band n41 and n90 operation in Japan, the sum of receiver spurious emissions requirements over all *antenna connectors* for *repeater type 1-C*, *NCR type 1-C* and *NCR type 1-H* shall not exceed *minimum requirements* defined in clause 6.5.5.5.

6.5.5.2 Minimum requirement

The minimum requirements for RF repeater are in TS 38.106 [2], clause 6.5.5.2.

The minimum requirements for NCR are in TS 38.106 [2], clause 6.5.5.4.

6.5.5.3 Test purpose

The test purpose is to verify the ability of the repeater or NCR to limit the interference caused by receiver spurious emissions to other systems.

6.5.5.4 Method of test

6.5.5.4.1 Initial conditions

Test environment: Normal; see annex B.2.

RF channels to be tested for single carrier: M; see clause 4.9.1.

6.5.5.4.2 Procedure

The minimum requirement is applied to all connectors under test,

- 1) Connect the connector under test to measurement equipment as shown in annex D.9.
- 2) Ensure the transmitter is OFF.
- 3) Set the measurement equipment parameters as specified in table 6.5.5.5-1.
- 4) Measure the spurious emissions over each frequency range described in table 6.5.5.5-1.

In addition, for a *multi-band connector*, the following steps shall apply:

- 5) For *multi-band connector* and single band tests, repeat the steps above per involved band where single band test configurations and test models shall apply with no carrier activated in the other band.

6.5.5.5 Test requirements

The receiver spurious emissions requirements for *repeater type 1-C* are that for each *antenna connector*, the power of emissions shall not exceed the value specified in table 6.5.5.5-1.

Table 6.5.5.5-1: Repeater type 1-C receiver spurious emissions limits

Spurious frequency range	Basic limits	Measurement bandwidth	Note
30 MHz – 1 GHz	-57 dBm	100 kHz	Note 1
1 GHz – 12.75 GHz	-47 dBm	1 MHz	Note 1, Note 2
12.75 GHz – 5 th harmonic of the upper frequency edge of the UL <i>operating band</i> in GHz	-47 dBm	1 MHz	Note 1, Note 2, Note 3
12.75 GHz - 26 GHz	-47 dBm	1 MHz	Note 1, Note 2
NOTE 1: <i>Measurement bandwidths</i> as in ITU-R SM.329 [4], s4.1. NOTE 2: Upper frequency as in ITU-R SM.329 [4], s2.5 table 1. NOTE 3: This spurious frequency range applies only for <i>operating bands</i> for which the 5 th harmonic of the upper frequency edge of the UL <i>operating band</i> is reaching beyond 12.75 GHz. NOTE 4: The frequency range from Δf_{OBUE} below the lowest frequency of the repeater transmitter <i>operating band</i> to Δf_{OBUE} above the highest frequency of the repeater transmitter <i>operating band</i> may be excluded from the requirement. Δf_{OBUE} is defined in clause 6.5.1. For <i>multi-band connectors</i> , the exclusion applies for all supported <i>operating bands</i> .			

6.5.5.6 Test requirements for NCR

6.5.5.6.1 Test requirement for NCR-Fwd

6.5.5.6.1.1 Test requirement for NCR-Fwd type 1-C

The RX spurious emissions requirements for *NCR-Fwd type 1-C* are that for each *antenna connector*, the power of emissions shall not exceed *basic limits* specified in table 6.5.5.5-1.

For Band n41 and n90 operation in Japan, the sum of RX spurious emissions requirements over all *antenna connectors* for *NCR-Fwd type 1-C* shall not exceed *basic limits* specified in table 6.5.5.5-1.

For joint reception of NCR-Fwd and NCR-MT in the uplink, the receiver spurious emissions limits shall apply to the total emissions from both the NCR-Fwd and NCR-MT.

6.5.5.6.1.2 Test requirement for NCR-Fwd type 1-H

The RX spurious emissions requirements for *NCR-Fwd type 1-H* are that for each applicable *basic limit* specified in table 6.5.5.5-1 for each *TAB connector RX min cell group*, the power sum of emissions at respective *TAB connectors*

shall not exceed the limits specified as the *basic limits* + X, where $X = 10\log_{10}(N_{\text{RXU, counted per cell}})$ for DL and for WA UL and $X=0$ for LA UL, unless stated differently in regional regulation.

The RX spurious emission requirements are applied per the *TAB connector RX min cell group* for all the configurations supported by the repeater.

NOTE: Conformance to the repeater receiver spurious emissions requirement can be demonstrated by meeting at least one of the following criteria as determined by the manufacturer:

1) The sum of the spurious emissions power measured on each *TAB connector* in the *TAB connector RX min cell group* shall be less than or equal to the limit above for the respective frequency span.

Or

2) The spurious emissions power at each *TAB connector* shall be less than or equal to the limit as defined above for the respective frequency span, scaled by $-10\log_{10}(n)$, where n is the number of *TAB connectors* in the *TAB connector RX min cell group*.

For joint reception of NCR-Fwd and NCR-MT in the uplink, the receiver spurious emissions limits shall apply to the total emissions from both the NCR-Fwd and NCR-MT.

6.6 Repeater Error Vector Magnitude

6.6.1 Downlink repeater error vector magnitude

6.6.1.1 General

The Repeater Error Vector Magnitude (EVM) is a measure of the difference between the symbols provided at the input of repeater and the measured signal symbols at the output of the repeater after the equalization by the measurement equipment. This difference is called the error vector. Details about how the repeater EVM is determined are the same as specified in TS 38.104 [5] Annex B for FR1. The repeater EVM result is defined as the square root of the ratio of the mean error vector power to the mean reference power expressed in percent. The accuracy of the input symbols is counted in the measurement uncertainty.

The repeater EVM requirement is applicable for a repeater operating at an input power in the range from what is required to reach the maximum output power to the minimum power level in table 6.6.1.1-1.

Table 6.6.1.1-1: Minimum input power for repeater EVM

Repeater DL class	Minimum input power spectral density (dBm/MHz)	
	QPSK, 16 QAM, 64QAM	256QAM ¹
WA	-82	-75
MR	-77	-70
LA	-74	-67
Note 1: support of 256QAM is based on the declaration		

For *repeater type 1-C* and *NCR-Fwd type 1-C*, this requirement shall be applied at the *antenna connector* supporting transmission in the *operating band*.

For *NCR-Fwd type 1-H* this requirement shall be applied at each *TAB connector* supporting transmission in the *operating band*.

6.6.1.2 Minimum requirements

The minimum requirement for *repeater type 1-C* is defined in TS 38.106 [2] clause 6.6.1.2.

The minimum requirement for *NCR-Fwd type 1-C* is defined in TS 38.106 [2], clause 6.6.1.2A.1.1.

The minimum requirement for *NCR-Fwd type 1-H* is defined in TS 38.106 [2], clause 6.6.1.2A.1.2.

6.6.1.3 Test purpose

To verify that the downlink repeater EVM deterioration is within the limit specified by the minimum requirements after the signal passed through the Repeater.

6.6.1.4 Method of test

6.6.1.4.1 Initial conditions

Test environment: Normal; see annex B.2.

RF channels to be tested for single carrier: B, M and T; see clause 4.9.1.

RF bandwidth positions to be tested for multi-carrier:

- B_{RFBW} , M_{RFBW} and T_{RFBW} in single-band operation, see clause 4.9.1;
- B'_{RFBW} , T'_{RFBW} and $B'_{\text{RFBW}}T_{\text{RFBW}}$ in multi-band operation, see clause 4.9.1.

6.6.1.4.2 Procedure

The minimum requirement is applied to all *antenna connectors* or *TAB connectors*, they may be tested one at a time or multiple *antenna connectors* or *TAB connectors* may be tested in parallel as shown in annex D.4. Whichever method is used the procedure is repeated until all *antenna connectors* or *TAB connectors* necessary to demonstrate conformance have been tested.

- 1) For an *antenna connector* or *TAB connector* declared to be capable of single carrier operation only (D.22), set the *antenna connector* or *TAB connector* under test to transmit a signal according to the applicable test configuration in clause 4.8 using the corresponding test models:

For RF repeater:

- RDL-FR1-TM3.1a if 256QAM is supported by repeater without power back off, or
- RDL-FR1-TM3.1a at manufacturer's declared rated output power if 256QAM is supported by repeater with power back off, and RDL-FR1-TM3.1 at maximum power, or
- RDL-FR1-TM3.1 if highest modulation order supported by repeater is 64QAM, or
- RDL-FR1-TM3.2 if highest modulation order supported by repeater is 16QAM, or
- RDL-FR1-TM3.3 if highest modulation order supported by repeater is QPSK.

For NCR:

- NCRDL-FR1-TM3.1a if 256QAM is supported by repeater without power back off, or
- NCRDL-FR1-TM3.1a at manufacturer's declared rated output power if 256QAM is supported by repeater with power back off, and NCRDL-FR1-TM3.1 at maximum power, or
- NCRDL-FR1-TM3.1 if highest modulation order supported by repeater is 64QAM, or
- NCRDL-FR1-TM3.2 if highest modulation order supported by repeater is 16QAM, or
- NCRDL-FR1-TM3.3 if highest modulation order supported by repeater is QPSK.

For an *antenna connector* or *TAB connector* declared to be capable of multi-carrier operation (D.22), set the *antenna connector* or *TAB connector* under test to transmit according to the applicable test configuration and corresponding power setting specified in clauses 4.7 and 4.8 using the corresponding test models on all carriers configured:

For RF repeater:

- RDL-FR1-TM3.1a if 256QAM is supported by repeater without power back off, or

- RDL-FR1-TM3.1a at manufacturer's declared rated output power if 256QAM is supported by repeater with power back off, and RDL-FR1-TM3.1 at maximum power, or
- RDL-FR1-TM3.1 if highest modulation order supported by repeater is 64QAM, or
- RDL-FR1-TM3.2 if highest modulation order supported by repeater is 16QAM, or
- RDL-FR1-TM3.3 if highest modulation order supported by repeater is QPSK.

For NCR:

- NCRDL-FR1-TM3.1a if 256QAM is supported by repeater without power back off, or
- NCRDL-FR1-TM3.1a at manufacturer's declared rated output power if 256QAM is supported by repeater with power back off, and NCRDL-FR1-TM3.1 at maximum power, or
- NCRDL-FR1-TM3.1 if highest modulation order supported by repeater is 64QAM, or
- NCRDL-FR1-TM3.2 if highest modulation order supported by repeater is 16QAM, or
- NCRDL-FR1-TM3.3 if highest modulation order supported by repeater is QPSK.

For RDL-FR1-TM3.1a for RF repeater or NCRDL-FR1-TM3.1a for NCR, power back-off shall be applied if it is declared.

- 2) Measure the repeater EVM and frequency error as defined in annex E.
- 3) For RF repeater, repeat steps 1 and 2 for RDL-FR1-TM2 if 256QAM is not supported by repeater or for RDL-FR1-TM2a if 256QAM is supported by repeater.

For NCR, repeat steps 1 and 2 for NCRDL-FR1-TM2 if 256QAM is not supported by repeater or for NCRDL-FR1-TM2a if 256QAM is supported by repeater.

In addition, for *multi-band connector(s)*, the following steps shall apply:

- 4) For *multi-band connectors* and single band tests, repeat the steps above per involved band where single band test configurations and test models shall apply with no carrier activated in the other band.

6.6.1.5 Test requirement

The downlink of the Repeater EVM levels for different modulation schemes shall not exceed values in table 6.6.1.5-1.

Table 6.6.1.5-1: Repeater EVM test requirements

Parameter	Required test repeater EVM
QPSK, 16QAM, 64QAM	9.25 %
256QAM	4.75 % ¹
Note 1: support of 256QAM is based on the declaration.	

6.6.2 Uplink repeater error vector magnitude

6.6.2.1 General

The Repeater Error Vector Magnitude is a measure of the difference between the reference waveform provided at the input of the repeater and the measured waveform at the output of the repeater. This difference is called the error vector. Details about how the repeater EVM is determined are the same as specified in TS 38.101-1[9] Annex F. Before calculating the repeater EVM the measured waveform is corrected by the sample timing offset and RF frequency offset. Then the carrier leakage shall be removed from the measured waveform before calculating the repeater EVM.

The measured waveform is further equalised using the channel estimates subjected to the repeater EVM equaliser spectrum flatness requirement specified in TS 38.101-1[9] clause 6.4.2.4. For DFT-s-OFDM waveforms, the repeater EVM result is defined after the front-end FFT and IDFT as the square root of the ratio of the mean error vector power to the mean reference power expressed as a %. For CP-OFDM waveforms, the repeater EVM result is defined after the

front-end FFT as the square root of the ratio of the mean error vector power to the mean reference power expressed as a %. The accuracy of the input waveform is counted in the measurement uncertainty.

The basic repeater EVM measurement interval in one slot in the time domain. The repeater EVM measurement interval is reduced by any symbols that contains an allowable power transient in the measurement interval, as defined in TS 38.101-1 [9] clause 6.3.3 for EVM for UE.

The repeater EVM requirement is applicable for a repeater operating at an input power in the range from what is required to reach the maximum output power to the minimum power level in table 6.6.2.1-1.

Table 6.6.2.1-1: Minimum input power for repeater EVM

Repeater UL class	Minimum input power spectral density (dBm/MHz)	
	QPSK, 16 QAM, 64QAM	256QAM ¹
WA	-82	-75
LA	-74	-67
Note 1: support of 256QAM is based on the declaration		

6.6.2.2 Minimum requirement

The minimum requirement for *repeater type 1-C* is defined in TS 38.106 [2] clause 6.6.2.2.

The minimum requirement for *NCR-Fwd type 1-C* is defined in TS 38.106 [2], clause 6.6.2.3.1.1.

The minimum requirement for *NCR-Fwd type 1-H* is defined in TS 38.106 [2], clause 6.6.2.3.1.2.

6.6.2.3 Test purpose

To verify that the uplink repeater EVM deterioration is within the limit specified by the minimum requirements after the signal passed through the Repeater.

6.6.2.3 Method of test

6.6.2.3.1 Initial conditions

Test environment: Normal; see annex B.2.

RF channels to be tested for single carrier: B, M and T; see clause 4.9.1.

RF bandwidth positions to be tested for multi-carrier

- B_{RFBW} , M_{RFBW} and T_{RFBW} in single-band operation, see clause 4.9.1;
- B'_{RFBW} , T'_{RFBW} and B'_{RFBW} , T'_{RFBW} in multi-band operation, see clause 4.9.1.

6.6.2.3.2 Procedure

For repeater, the minimum requirement is applied to all *antenna connectors*, they may be tested one at a time or multiple *antenna connectors* may be tested in parallel as shown in annex D.1.1 for *repeater type 1-C*. Whichever method is used the procedure is repeated until all *antenna connectors* necessary to demonstrate conformance have been tested.

- 1) For an *antenna connector* or *TAB connector* declared to be capable of single carrier operation only (D..22), set the *antenna connector* or *TAB connector* under test to transmit a signal according to the applicable test configuration in clause 4.8 using the corresponding test models:

For RF repeater,

- RUL-TM3.1a if 256QAM is supported by repeater without power back off, or
- RUL-FR1-TM3.1a at manufacturer's declared rated output power if 256QAM is supported by repeater with power back off, and RUL-FR1-TM3.1 at maximum power, or

- RUL-FR1-TM3.1 with highest modulation order supported by repeater.

For NCR,

- NCRUL-TM3.1a if 256QAM is supported by repeater without power back off, or
- NCRUL-FR1-TM3.1a at manufacturer's declared rated output power if 256QAM is supported by repeater with power back off, and RUL-FR1-TM3.1 at maximum power, or
- NCRUL-FR1-TM3.1 with highest modulation order supported by NCR.

For an *antenna connector* or *TAB connector* declared to be capable of multi-carrier operation (D.22), set the *antenna connector* or *TAB connector* under test to transmit according to the applicable test configuration and corresponding power setting specified in clauses 4.7 and 4.8 using the corresponding test models on all carriers configured:

For RF repeater

- RUL-FR1-TM3.1a if 256QAM is supported by repeater without power back off, or
- RUL-FR1-TM3.1a at manufacturer's declared rated output power if 256QAM is supported by repeater with power back off, and RUL-FR1-TM3.1 at maximum power, or
- RUL-FR1-TM3.1 with highest modulation order supported by repeater.

For NCR

- NCRUL-FR1-TM3.1a if 256QAM is supported by repeater without power back off, or
- NCRUL-FR1-TM3.1a at manufacturer's declared rated output power if 256QAM is supported by NCR with power back off, and NCRUL-FR1-TM3.1 at maximum power, or
- NCRUL-FR1-TM3.1 with highest modulation order supported by NCR.

For RUL-FR1-TM3.1a for RF repeater or NCRUL-FR1-TM3.1a for NCR, power back-off shall be applied if it is declared.

- 2) Measure the repeater EVM and frequency error as defined in annex E.
- 3) For RF repeater, repeat steps 1 and 2 for RUL-FR1-TM2 if 256QAM is not supported by repeater or for RUL-FR1-TM2a if 256QAM is supported by repeater.

For NCR, repeat steps 1 and 2 for NCRUL-FR1-TM2 if 256QAM is not supported by repeater or for NCRUL-FR1-TM2a if 256QAM is supported by repeater.

In addition, for *multi-band connector(s)*, the following steps shall apply:

- 4) For *multi-band connectors* and single band tests, repeat the steps above per involved band where single band test configurations and test models shall apply with no carrier activated in the other band.

6.6.2.4 Test requirement

The uplink of the Repeater EVM levels for different modulation schemes shall not exceed values in table 6.6.2.4-1.

Table 6.6.2.4-1: Repeater EVM test requirements

Parameter	Required test repeater EVM
QPSK, 16QAM, 64QAM	[9.25 %]
256QAM	[4.75 %] ¹
Note 1: support of 256QAM is based on the declaration.	

6.7 Input intermodulation

6.7.1 Definition and applicability

6.7.1.1 General

The input intermodulation is a measure of the capability of the Repeater to inhibit the generation of interference in the passband, in the presence of interfering signals on frequencies other than the passband.

Third and higher order mixing of the two interfering RF signals can produce an interfering signal in the band of the desired channel. Intermodulation response rejection is a measure of the capability of the Repeater to maintain the wanted frequency free of internally created interference.

The measurements shall apply to both uplink and downlink paths of the Repeater, during the *transmitter ON state* at maximum gain.

6.7.1.2 Minimum requirements

The minimum requirement for *repeater type I-C* is in TS 38.106 [2], clauses 6.7.1.2, 6.7.2.2 and 6.7.3.2.

The minimum requirement for *NCR-Fwd type I-C* is defined in TS 38.106 [2], clauses 6.7.1.3.1.1, 6.7.2.3.1.1, and 6.7.3.3.1.1.

The minimum requirement for *NCR-Fwd type I-H* is defined in TS 38.106 [2], clauses 6.7.1.3.1.2, 6.7.2.3.1.2, and 6.7.3.3.1.2.

6.7.1.3 Test purpose

The purpose of this test is to verify that the Repeater meets the intermodulation characteristics requirements as specified by the minimum requirements.

6.7.1.4 Method of test

6.7.1.4.1 Initial conditions

Test environment: normal; see Annex B.2

A measurement system set-up is shown in Annex D.

- 1) Set the RF repeater or NCR to maximum gain.
- 2) Connect two signal generators with a combining circuit or one signal generator with the ability to generate several CW carriers to the input.
- 3) Connect a spectrum analyser to the output of the RF repeater or NCR.

6.7.1.4.2 Procedure

- 1) Adjust the frequency of the input signals, either below or above the passband, so that one carrier, f_1 , is 1 MHz outside the channel edge frequency of the first or last channel in the passband, and the lowest order intermodulation product from the two carriers is positioned in the centre of the passband.
- 2) Measure the increase in output power in the passband when the interferer is applied.
- 3) Repeat the measurement for the opposite path of the RF repeater or NCR.

6.7.1.5 Test requirements

6.7.1.5.1 General requirement

The intermodulation performance should be met when the following signals are applied to the RF repeater or NCR:

Table 6.7.1.5.1-1: Input intermodulation requirement

f_1 offset	Interfering Signal Levels	Type of signals	Measurement bandwidth
1,0 MHz	-40 dBm	2 CW carriers	1 MHz

f_1 offset is the offset from the channel edge frequency of the first or last channel in the passband of the closer carrier.

For the parameters specified in Table 6.7.1.5.1-1, the power in the pass band shall not increase by more than [10+TT] dB at the output of the Repeater as measured in the centre of the pass band, compared to the level obtained without interfering signals applied.

6.7.1.5.2 Co-location with BS/Repeater in other systems

This additional input intermodulation requirement may be applied for the protection of repeater receivers when GSM, CDMA, UTRA, E-UTRA, NR BS or repeater operating in a different frequency band are co-located with a repeater.

The following requirement applies for interfering signals depending on the repeaters *passband*.

This requirement applies to the uplink and downlink of the repeater. If the BS side is declared to meet co-location requirements, then it should meet input intermodulation co-location requirements for the downlink. If the UE side is declared to meet co-location requirements, then it should meet input intermodulation co-location requirements for the uplink.

Table 6.7.1.5.2-1: input intermodulation requirement for repeater DL when co-located with BS/repeater in other frequency bands.

Frequency range of interfering signal	Interfering signal mean power for repeater with WA UE side (dBm)	Interfering signal mean power for repeater with MR UE side(dBm)	Interfering signal mean power for repeater with LA UE side(dBm)	Type of interfering signals
Frequency range of co-located BS's downlink operating band or located repeater's <i>passband</i>	+16	+8	x (Note 1)	2 CW carriers
NOTE 1: x = -7 dBm for repeater co-located with Pico GSM850 or Pico CDMA850 x = -4 dBm for repeater co-located with Pico DCS1800 or Pico PCS1900 x = -6 dBm for repeater co-located with UTRA bands or E-UTRA bands or NR bands NOTE 2: The requirement does not apply when the interfering signal falls within the <i>passband</i> . NOTE 3: For unsynchronized base stations or repeaters (except in band n46 and n96), special co-location requirements may apply that are not covered by the 3GPP specifications.				

Table 6.7.1.5.2-2: input intermodulation requirement for repeater UL when co-located with BS/repeater in other frequency bands.

Frequency range of interfering signal	Interfering signal mean power for repeater with WA BS side(dBm)	Interfering signal mean power for repeater with LA BS side(dBm)	Type of interfering signals
Frequency range of co-located BS's downlink operating band or located repeater's <i>passband</i>	+16	$P_{\text{rated,p,AC}} - 30$	2 CW carriers
NOTE 1: The requirement does not apply when the interfering signal falls within the <i>passband</i> .			
NOTE 2: For unsynchronized base stations or repeaters (except in band n46 and n96), special co-location requirements may apply that are not covered by the 3GPP specifications.			

NOTE 1: The co-location requirements in Table 6.7.1.5.2-1 and 6.7.1.5.2-2 do not apply when the Repeaters passband frequency range is adjacent to the frequency range of the co-location requirement in the Table 6.7.1.5.2-1 or Table 6.7.1.5.2-2. The current state-of-the-art technology does not allow a single generic solution for co-location with other system on adjacent frequencies for 30dB Repeater-BS minimum coupling loss. However, there are certain site-engineering solutions that can be used. These techniques are addressed in TR 25.942 [15].

NOTE 2: The Table 6.7.1.5.2-1 and Table 6.7.1.5.2-2 assumes that two operating bands, where the corresponding BS or Repeater transmit and receive frequency ranges would be overlapping, are not deployed in the same geographical area. For such a case of operation with overlapping frequency arrangements in the same geographical area, special co-location requirements may apply that are not covered by the 3GPP specifications.

For the parameters specified in table Table 6.7.1.5.2-1 and 6.7.1.5.2-2, the power in the passband shall not increase with more than $[10 + TT]$ dB at the output of the repeater as measured in the centre of the passband, compared to the level obtained without interfering signals applied.

6.7.1.5.3 Co-existence with other systems

This input intermodulation existence requirement may be applied for the protection of repeater receivers when GSM, CDMA, UTRA, E-UTRA, NR BS or repeater operating in another frequency band co-exist with a repeater.

The intermodulation performance should be met when the signals in Table 6.7.1.5.3-1 are applied to the Repeater:

Table 6.7.1.5.3-1: input intermodulation requirement for repeater when co-exist with BS/repeater in other non-overlapping frequency bands

Frequency range of interfering signal	Interfering signal mean power (dBm)	Type of interfering signals	Measurement bandwidth
Frequency range of co-existence system operating band	-15	2 CW carriers	1MHz
NOTE 1: All the interfering signals should be limited into the frequency ranges that are either X MHz higher than $F_{UL,high}$ or X MHz lower than $F_{UL,low}$, where X equals to 20MHz when $F_{UL,high} - F_{UL,low}$ is not larger than 200MHz, otherwise X equals to 60MHz			

NOTE 1: The co-existence requirements in Table 6.7.1.5.3-1 do not apply when the repeaters passband frequency range is adjacent to the frequency range of the co-existence requirement in the Table 6.7.1.5.3-1. The current state-of-the-art technology does not allow a single generic solution for co-existence.

NOTE 2: The Table 6.7.1.5.3-1 assumes that two operating bands, where the frequency ranges would be overlapping, are not deployed in the same geographical area. For such a case of operation with overlapping frequency arrangements in the same geographical area, special co-existence requirements may apply that are not covered by the 3GPP specifications.

For the parameters specified in Table 6.7.1.5.3-1, the power in the pass band shall not increase with more than [10 + TT] dB at the output of the repeater as measured in the centre of the pass band, compared to the level obtained without interfering signals applied.

6.8 Output intermodulation

6.8.1 Definition and applicability

6.8.1.1 General

The output intermodulation requirement is a measure of the capability of the repeater to inhibit the generation of signals in its non-linear elements caused by presence of the wanted signal and an interfering signal reaching the repeater via the output port. The requirement shall apply during the *transmitter ON state* and the *transmitter transient period*.

The requirement shall apply to the uplink and downlink of the Repeater.

The output intermodulation level is the power of the intermodulation products when an interfering signal is injected into the *antenna connector* or *TAB connector*.

6.8.1.2 Minimum requirements

The minimum requirement for *repeater type I-C* is defined in TS 38.106 [2] clause 6.8.2.

The minimum requirement for *NCR-Fwd type I-C* is defined in TS 38.106 [2], clause 6.8.3.1.1.

The minimum requirement for *NCR-Fwd type I-H* is defined in TS 38.106 [2], clause 6.8.3.1.3.

6.8.1.3 Test purpose

The test purpose is to verify the ability of the repeater to restrict the generation of intermodulation products in the presence of a subject signal on the repeater input and output ports, and an interfering signal applied at the repeater output port.

6.8.1.4 Method of test

6.8.1.4.1 Initial conditions

Test environment: normal; see Annex B.2

A measurement system set-up is shown in Annex D.

- 1) Connect a signal generator to the input port of the Repeater (wanted signal). Connect a signal generator to the output port (interfering signal) and make sure the signal generator power is directed to the repeater output port.
- 2) Detection mode: True RMS.

6.8.1.4.2 Procedure

- 1) Set the RF repeater or NCR to maximum gain.
- 2) Set the signal generator at the repeater input port (wanted signal) to generate a signal in accordance to test model R-FR1-TM1.1 for RF repeater and NCR-FR1-TM1.1 for NCR, with a bandwidth as defined in Table 6.8.1.5.1-1, at the level which produce the manufacturer specified maximum output power at maximum gain.
- 3) Set the signal generator at the repeater output port (interference signal) to generate a signal in accordance to test model R-FR1-TM1.1 for RF repeater and NCR-FR1-TM1.1 for NCR, with a bandwidth, level and frequency offset as defined in Table 6.8.1.5.1-1.
- 4) Measure the emission at the specified frequencies with specified measurement bandwidth as described in the test requirements and note that the measured value does not exceed the specified value. Measurements in the band of

the interfering signal shall be excluded. The measurements can be limited to the power of all third and fifth order intermodulation products.

- 5) Repeat the test from step 3 on until all interfering signal centre frequency offsets in Table 6.8.1.5.1-1 has been tested, but exclude interfering signal frequencies that are outside of the allocated frequency band for NR downlink.
- 6) For repeater supporting Band n41 and n90 operation in Japan, repeat the test using wanted and interfering signal parameters as defined in Table 6.8.1.5.2-1.

NOTE: As a general rule the resolution bandwidth of the measuring equipment should be equal to the measurement bandwidth. However, to improve measurement accuracy, sensitivity and efficiency, the resolution bandwidth can be smaller than the measurement bandwidth. When the resolution bandwidth is smaller than the measurement bandwidth, the result should be integrated over the measurement bandwidth in order to obtain the equivalent noise bandwidth of the measurement bandwidth.

6.8.1.5 Test requirements

6.8.1.5.1 General requirements

For *repeater type 1-C*, *NCR-Fwd type 1-C*, or *NCR-Fwd type 1-H*, the wanted signal and interfering signal centre frequency is specified in table 6.8.5.1-1, where interfering signal level is *rated total output power at antenna connector* ($P_{\text{rated,t,AC}}$) or at TAB connector ($P_{\text{rated,t,TABC}}$) in the *passband* – 30 dB.

Table 6.8.1.5.1-1: Interfering and wanted signals for the output intermodulation requirement

Parameter	Value
Wanted signal type	NR signal, filling all supported <i>passbands</i> in the operating band and with sufficient carriers to fill each <i>passband</i> . Minimum defined SCS for the operating band
Interfering signal type	NR signal, with the minimum SCS and channel bandwidth defined in the operating band in [2]
Interfering signal level	<i>Rated total output power</i> ($P_{\text{rated,t,AC}}$ or $P_{\text{rated,t,TABC}}$) in the <i>passband</i> – 30 dB
Interfering signal centre frequency offset from the lower/upper edge of the wanted signal or edge of <i>sub-block</i> inside a <i>sub-block gap</i>	$f_{\text{offset}} = \pm \text{minimum pass band} \left(n - \frac{1}{2} \right)$, for n=1, 2 and 3
NOTE 1: Interfering signal positions that are partially or completely outside of any downlink operating band of the repeater are excluded from the requirement, unless the interfering signal positions fall within the frequency range of adjacent downlink operating bands in the same geographical area.	
NOTE 2: In Japan, NOTE 1 is not applied in Band n77, n78, n79.	

For *repeater type 1-C*, *NCR-Fwd type 1-C*, or *NCR-Fwd type 1-H*, the output intermodulation level shall not exceed the unwanted emission limits in clauses 6.5.2, 6.5.3, and 6.5.4 in the presence of an NR interfering signal according to table 6.7.5.1.1-1.

6.8.1.5.2 Additional requirements

For *repeater type 1-C*, *NCR-Fwd type 1-C*, or *NCR-Fwd type 1-H*, supporting Band n41 and n90 operation in Japan, the sum of output intermodulation level over all *antenna connectors* or *TAB connectors* shall not exceed the unwanted emission limits in clauses 6.5.2, 6.5.3, and 6.5.4 in the presence of an NR interfering signal according to table 6.8.1.5.2-1.

Table 6.8.1.5.2-1: Interfering and wanted signals for the additional output intermodulation requirement for Band n41 and n90

Parameter	Value
Wanted signal	NR signal (NOTE)
Interfering signal type	NR signal of 10 MHz <i>passband bandwidth</i>
Interfering signal level	<i>Rated total output power</i> ($P_{\text{rated,t,AC}}$ or $P_{\text{rated,t,TABC}}$) in the <i>passband</i> – 30 dB
Interfering signal centre frequency offset from the lower/upper <i>passband</i> centre frequency of the wanted signal	± 5 MHz ± 15 MHz ± 25 MHz
NOTE: This requirement applies for <i>passband</i> allocated within 2545-2645 MHz.	

6.9 Adjacent Channel Rejection Ratio (ACRR)

6.9.1 Definitions and applicability

Adjacent Channel Rejection Ratio (ACRR) is the ratio of the average gain over a carrier of the repeater in the *passband* to the average gain of the repeater over an adjacent channel outside the repeater *passband*. The carrier in the *passband* and in the adjacent channel shall be of the same type (reference carrier) with bandwidths as defined by *nominal channel bandwidth*. In case of Local Area repeater above 2496 MHz, the channel within the *passband* and the adjacent channel are assumed to have a bandwidth of 10 MHz

The requirement is differentiated between uplink and downlink.

The requirement shall apply during the *transmitter ON state*.

6.9.2 Co-existence with UTRA, E-UTRA and NR

This requirement shall be applied for the protection of UTRA, E-UTRA and NR signals in geographic areas in which NR Repeater, NR BS, E-UTRA BS and UTRA BS are deployed so that they serve adjacent channels. The reference carrier is a NR carrier.

6.9.2.1 Minimum requirements

The minimum requirement for *repeater type I-C* is defined in TS 38.106 [2] sub-clause 6.9.2.

The minimum requirement for *NCR-Fwd type I-C* is defined in TS 38.106 [2], clause 6.9.3.1.1.

The minimum requirement for *NCR-Fwd type I-H* is defined in TS 38.106 [2], clause 6.9.3.1.3.

6.9.2.2 Test purpose

To verify that the Repeater ACRR requirement is met as specified in sub-clause 6.9.2.1.

6.9.2.3 Method of test

6.9.2.3.1 Initial conditions

Test environment: normal; see Annex B.2.

RF channels to be tested for single carrier: B, T; see clause 4.9.1.

Repeater RF Bandwidth positions to be tested for multi-carrier:

- B_{RFBW} and T_{RFBW} in single-band operation, see clause 4.9.1;
- B'_{RFBW}_T and T'_{RFBW}_B in multi-band operation, see clause 4.9.1.

6.9.2.3.2 Procedure

- 1) Set the signal generator to transmit a signal modulated with test model RDL-FR1-TM1.1 for downlink and test model RUL-FR1-TM1.1 for uplink as defined in section 4.9 at the first or last channel with channel offset from frequency range of passband defined in section 6.9.2.3.3 within the pass band.
- 2) Adjust the input power to the Repeater to create the maximum nominal Repeater output power at maximum gain
- 3) Measure the RRC filtered mean power at the RF output port over a certain slot.
- 4) Set the signal generator to transmit the same signal and the same input power at one of the channel offsets outside the repeater pass band according to Tables in section 6.9.2.3.3.
- 5) Measure the filtered mean power at the RF output port over a certain slot.
- 6) Calculate the ratio of the measured power in the pass band to the measured power at the channel offset.
- 7) Repeat step 4) to 6) until all channel offsets in Tables in section 6.9.2.3.3 are measured.

6.9.2.3.3 Test Requirements

For a *repeater type 1-C* operating at *passband* below 2496 MHz, the ACRR requirements in table 6.9.2.3.3-1 shall apply in downlink. In normal conditions the ACRR for downlink shall be higher than the value specified in the Table 6.9.2.3.3-1.

For a *NCR-Fwd type 1-H* operating at *passband* below 2496 MHz, the ACRR requirements in table 6.9.2.3.3-1 shall apply in downlink. In normal conditions the ACRR for downlink between corresponding input/output TAB connectors shall be higher than the value specified in the Table 6.9.2.3.3-1.

Table 6.9.2.3.3-1: Repeater Downlink ACRR below 2496MHz

Co-existence with other systems	Repeater Class	Channel offset from frequency edge of <i>passband</i> (MHz)	Filter on the adjacent channel frequency and corresponding filter bandwidth	ACRR limit
UTRA, E-UTRA, NR	Wide Area repeater	$BW_{Nominal}/2$	Square (BW_{Config})	44.3dB
	Medium Range repeater	$BW_{Nominal}/2$	Square (BW_{Config})	44.3dB
	Local Area repeater	$BW_{Nominal}/2$	Square (BW_{Config})	32.3dB (Note 1)
NOTE 1: This requirement does not applicable if the <i>passband</i> occupies the entire <i>operating band</i> .				
NOTE 2: $BW_{Nominal}$ is the <i>nominal channel bandwidth</i> . BW_{Config} is the <i>transmission bandwidth configuration</i> assumed for the adjacent channel.				
NOTE 3: With SCS that provides largest <i>transmission bandwidth configuration</i> (BW_{Config}).				

For a *repeater type 1-C* operating at *passband* above 2496 MHz, the ACRR requirements in table 6.9.2.3.3-1a shall apply in downlink. In normal conditions the ACRR for downlink shall be higher than the value specified in the Table 6.9.2.3.3-1a.

For a *NCR-Fwd type 1-H* operating at *passband* above 2496 MHz, the ACRR requirements in table 6.9.2.3.3-1a shall apply in downlink. In normal conditions the ACRR for downlink between corresponding input/output TAB connectors shall be higher than the value specified in the Table 6.9.2.3.3-1a.

Table 6.9.2.3.3-1a: Repeater Downlink ACRR above 2496 MHz

Co-existence with other systems	Repeater Class	Channel offset from frequency edge of <i>passband</i> (MHz)	Filter on the adjacent channel frequency and corresponding filter bandwidth	ACRR limit
UTRA, E-UTRA, NR	Wide Area repeater	$BW_{Nominal}/2$	Square (BW_{Config})	32.3dB
	Medium Range repeater	$BW_{Nominal}/2$	Square (BW_{Config})	32.3dB
	Local Area repeater	$BW_{Nominal}/2$	Square (BW_{Config})	32.3dB (Note 1)
NOTE 1: This requirement does not applicable if the <i>passband</i> occupies the entire <i>operating band</i> .				
NOTE 2: $BW_{Nominal}$ is the <i>nominal channel bandwidth</i> . BW_{Config} is the <i>transmission bandwidth configuration</i> assumed for the adjacent channel.				
NOTE 3: With SCS that provides largest <i>transmission bandwidth configuration</i> (BW_{Config}).				

For a *repeater type 1-C* operating at *passband* below 2496 MHz, the ACRR requirements in table 6.9.2.3.3-2 shall apply in uplink. In normal conditions the ACRR for uplink shall be higher than the value specified in the Table 6.9.2.3.3-2.

For a *NCR-Fwd type 1-H* operating at *passband* below 2496 MHz, the ACRR requirements in table 6.9.2.3.3-2 shall apply in uplink. In normal conditions the ACRR for uplink between corresponding input/output TAB connectors shall be higher than the value specified in the Table 6.9.2.3.3-2.

Table 6.9.2.3.3-2: Repeater Uplink ACRR below 2496 MHz

Co-existence with other systems	Repeater Class	Channel offset from frequency edge of <i>passband</i> (MHz)	Filter on the adjacent channel frequency and corresponding filter bandwidth	ACRR limit
UTRA, E-UTRA, NR	Wide Area repeater	$BW_{Nominal}/2$	Square (BW_{Config})	32.3dB
	Local Area repeater	$BW_{Nominal}/2$	Square (BW_{Config})	32.3dB (Note 1)
NOTE 1: This requirement does not applicable if the <i>passband</i> occupies the entire <i>operating band</i> .				
NOTE 2: $BW_{Nominal}$ is the <i>nominal channel bandwidth</i> . BW_{Config} is the <i>transmission bandwidth configuration</i> assumed for the adjacent channel.				
NOTE 3: With SCS that provides largest <i>transmission bandwidth configuration</i> (BW_{Config}).				

For a *repeater type 1-C* operating at *passband* above 2496 MHz, the ACRR requirements in table 6.9.2.3.3-2a shall apply in uplink. In normal conditions the ACRR for uplink shall be higher than the value specified in the Table 6.9.2.3.3-2a.

For a *NCR-Fwd type 1-H* operating at *passband* above 2496 MHz, the ACRR requirements in table 6.9.2.3.3-2a shall apply in uplink. In normal conditions the ACRR for uplink between corresponding input/output TAB connectors shall be higher than the value specified in the Table 6.9.2.3.3-2a.

Table 6.9.2.3.3-2a: Repeater Uplink ACRR above 2496 MHz

Co-existence with other systems	Repeater Class	Channel offset from frequency edge of <i>passband</i> (MHz)	Filter on the adjacent channel frequency and corresponding filter bandwidth	ACRR limit
UTRA, E-UTRA, NR	Wide Area repeater	$BW_{Nominal}/2$	Square (BW_{Config})	32.3dB
	Local Area repeater	5MHz	9 MHz	19.3dB (Note 1, Note 2)
		$BW_{Nominal}/2$	Square (BW_{Config})	32.3dB (Note 1)
NOTE 1: This requirement does not applicable if the <i>passband</i> occupies the entire <i>operating band</i> .				
NOTE 2: In this case, the channel within the <i>passband</i> and the adjacent channel are assumed to have a bandwidth of 10 MHz				
NOTE 3: $BW_{Nominal}$ is the <i>nominal channel bandwidth</i> . BW_{Config} is the <i>transmission bandwidth configuration</i> assumed for the adjacent channel.				
NOTE 4: With SCS that provides largest <i>transmission bandwidth configuration</i> (BW_{Config}).				

6.10 Transmit ON/OFF power

6.10.1 Transmitter OFF power

6.10.1.1 Definition and applicability

Transmit OFF power requirements apply only to TDD operation of the repeater. The requirement applies to both downlink and uplink of the repeater.

Transmitter OFF power is defined as the mean power measured over $70/N$ us filtered with a square filter of bandwidth equal to the *passband bandwidth* of the repeater (BW_{passband}) centred on the assigned channel frequency during the *transmitter OFF state*. $N = \text{SCS}/15$, where SCS is Sub Carrier Spacing in kHz of the input signal.

For *multi-band connectors* and for *single band connectors* supporting transmission in multiple *operating bands*, the requirement is only applicable during the *transmitter OFF state* in all supported *operating bands*.

6.10.1.2 Minimum requirement

The minimum requirement for *repeater type I-C* is defined in TS 38.106 [2], clause 6.10.1.2.

The minimum requirement for *NCR-Fwd type I-C* is defined in TS 38.106 [2], clause 6.10.1.3.1.1.

The minimum requirement for *NCR-Fwd type I-H* is defined in TS 38.106 [2], clause 6.10.1.3.1.2.

6.10.1.3 Test purpose

The purpose of this test is to verify the transmitter OFF power is within the limits of the minimum requirements.

6.10.1.4 Method of test

Requirement is tested together with transmitter transient period, as described in clause 6.10.2.4.

6.10.1.5 Test requirements

The conformance testing of transmit OFF power is included in the conformance testing of transmitter transient period; therefore, see clause 6.10.2.5 for test requirements.

6.10.2 Transmitter transient period

6.10.2.1 Definition and applicability

Transmitter transient period requirements apply only to TDD operation of the repeater. The requirement applies to both downlink and uplink of the repeater.

The *transmitter transient state* is the time period during which the transmitter is changing from the *transmitter OFF state* to the *transmitter ON period* or vice versa. The *transmitter transient period* is illustrated in figure 6.10.2.1-1.

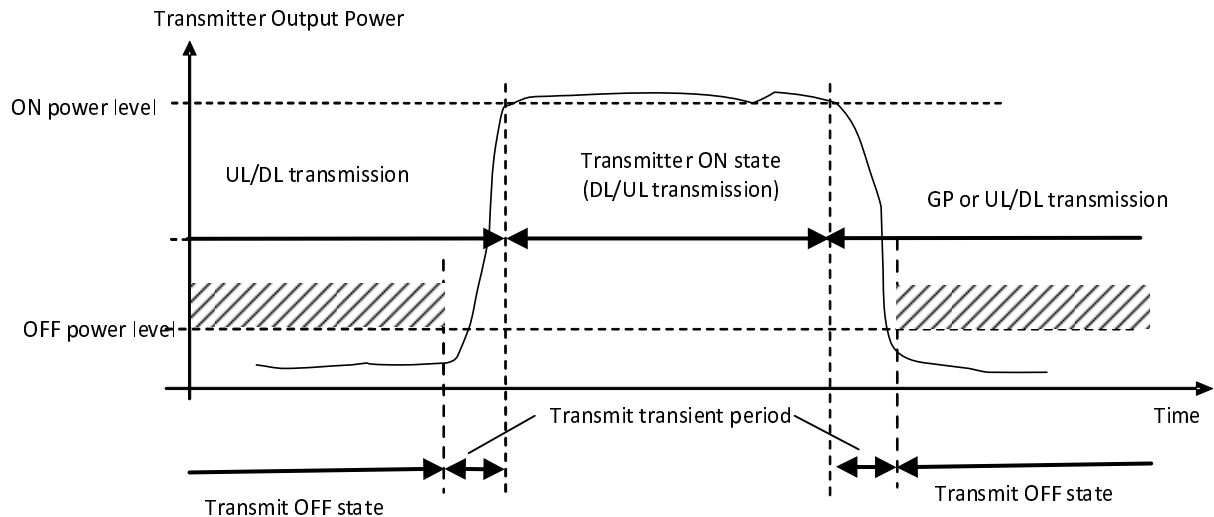

Figure 6.10.2.1-1: Example of relations between transmitter *ON state*, transmitter *OFF state* and transmitter *transient period*

For *repeater type 1-C* or *NCR-type 1-C* this requirement shall be applied at the *antenna connector* supporting transmission in the *operating band*.

For *NCR-type 1-H* this requirement shall be applied at the *TAB connector* supporting transmission in the *operating band*.

For a repeater that is not declared to be a long delay repeater (D.15), the beginning and end point of downlink and uplink bursts are referenced to the slot timing at the input.

For a repeater that is declared to be a long delay repeater (D.15), the beginning and end point of downlink and uplink bursts are referenced to the slot timing at the input plus the declared repeater delay.

6.10.2.2 Minimum requirement

The minimum requirement for *repeater type 1-C* is defined in TS 38.106 [2], clause 6.10.2.2.

The minimum requirement for *NCR-Fwd type 1-C* is defined in TS 38.106 [2], clause 6.10.2.3.1.1.

The minimum requirement for *NCR-Fwd type 1-H* is defined in TS 38.106 [2], clause 6.10.2.3.1.2.

6.10.2.3 Test purpose

The purpose of this test is to verify the transmitter transient periods are within the limits of the minimum requirements.

6.10.2.4 Method of test

6.10.2.4.1 Initial conditions

Test environment:

- normal; see annex B.2.

RF channels to be tested for single carrier:

- M; see clause 4.9.1.

6.10.2.4.2 Procedure

The minimum requirement is applied to all *antenna connectors* or *TAB connectors*, they may be tested one at a time or multiple *antenna connectors* or *TAB connectors* may be tested in parallel as shown in annex D.1.1. Whichever method is used the procedure is repeated until all *antenna connectors* or *TAB connectors* necessary to demonstrate conformance have been tested.

- 1) Connect *antenna connector* or *TAB connector* for input and output signals to measurement equipment as shown in annex D.1.1. All *antenna connectors* or *TAB connectors* not under test shall be terminated.

As a general rule, the resolution bandwidth of the measuring equipment should be equal to the measurement bandwidth. However, to improve measurement accuracy, sensitivity, efficiency and avoiding e.g. carrier leakage, the resolution bandwidth may be smaller than the measurement bandwidth. When the resolution bandwidth is smaller than the measurement bandwidth, the result should be integrated over the measurement bandwidth in order to obtain the equivalent noise bandwidth of the measurement bandwidth.

- 2) For RF repeater and NCR, set the input signal to the representative connectors under test according to the applicable test configuration in clause 4.8 using the corresponding test models in clause 4.9.2 at the input power intended to produce the maximum rated output power.

- $P_{in,p,AC} + 10\text{dB}$ for RF repeater type 1-C;

- $P_{in,p,AC} + 10\text{dB}$ for NCR type 1-C,

- $P_{in,p,TABC} + 10\text{dB}$ for NCR type 1-H.

Set the input signal to the representative connectors under test according to the applicable test configuration in clause 4.8 using the corresponding test models in clause 4.9.2 at the input power intended to produce the maximum rated output power, $P_{rated,in, AC} + 10\text{dB}$.

- 3) Measure the mean power spectral density over $70/N \mu\text{s}$ filtered with a square filter of bandwidth equal to the RF bandwidth of the *antenna connector* or *TAB connector* centred on the central frequency of the RF bandwidth. $70/N \mu\text{s}$ average window centre is set from $35/N \mu\text{s}$ after end of one transmitter ON state + $10 \mu\text{s}$ to $35/N \mu\text{s}$ before start of next transmitter ON state – $10 \mu\text{s}$. $N = \text{SCS}/15$, where SCS is Sub Carrier Spacing in kHz.

In addition, for *multi-band connector(s)*, the following steps shall apply:

- 4) For *multi-band connectors* or *TAB connectors* and single band tests, repeat the steps above per involved band where single band test configurations and test models shall apply with no carrier activated in the other band.

6.10.2.5 Test requirements

For *repeater type 1-C* or *NCR-Fwd type 1-C downlink*, the requirements for transmitter OFF power spectral density shall be less than -83 dBm/MHz per *antenna connector* for carrier frequency $f \leq 3.0 \text{ GHz}$.

For *repeater type 1-C* or *NCR-Fwd type 1-C downlink*, the requirements for transmitter OFF power spectral density shall be less than -82.5 dBm/MHz per *antenna connector* for carrier frequency $3.0 \text{ GHz} < f \leq 6.0 \text{ GHz}$.

For *repeater type 1-C* or *NCR-Fwd type 1-C uplink*, the requirements for transmitter OFF power spectral density shall be less than $-48\text{dBm} / (\text{SCS} * (12 * N_{RB} + 1) / 1000) \text{ MHz}$ per *antenna connector*, where SCS is Sub Carrier Spacing in kHz for carrier frequency $f \leq 3.0 \text{ GHz}$.

For *repeater type 1-C* or *NCR-Fwd type 1-C uplink*, the requirements for transmitter OFF power spectral density shall be less than $-47.5\text{dBm} / (\text{SCS} * (12 * N_{RB} + 1) / 1000) \text{ MHz}$ per *antenna connector*, where SCS is Sub Carrier Spacing in kHz for carrier frequency $3.0 \text{ GHz} < f \leq 6.0 \text{ GHz}$.

For *NCR-Fwd type 1-H downlink*, the requirements for transmitter OFF power spectral density shall be less than -83 dBm/MHz per *antenna connector* for carrier frequency $f \leq 3.0 \text{ GHz}$.

For *NCR-Fwd type 1-H downlink*, the requirements for transmitter OFF power spectral density shall be less than -82.5 dBm/MHz per *antenna connector* for carrier frequency $3.0 \text{ GHz} < f \leq 6.0 \text{ GHz}$.

For *NCR-Fwd type 1-H uplink*, the requirements for transmitter OFF power spectral density shall be less than $-48\text{dBm} / (\text{SCS} * (12 * N_{RB} + 1) / 1000) \text{ MHz}$ per *antenna connector*, where SCS is Sub Carrier Spacing in kHz for carrier frequency $f \leq 3.0 \text{ GHz}$.

For *NCR-Fwd type 1-H uplink*, the requirements for transmitter OFF power spectral density shall be less than $-47.5\text{dBm} / (\text{SCS} \cdot (12 \cdot N_{\text{RB}} + 1) / 1000)$ MHz per *antenna connector*, where SCS is Sub Carrier Spacing in kHz for carrier frequency $3.0\text{ GHz} < f \leq 6.0\text{ GHz}$.

For *multi-band connector*, the requirement is only applicable during the transmitter OFF state in all supported operating bands.

6.11 Output power dynamics for NCR-MT

Output power dynamics is specified in terms of: OFF power, ON/OFF time mask and power control requirements.

6.11.1 Definition and applicability

The requirements in clause 6.11 apply during the *transmitter ON period*. Transmit signal quality requirements (as specified in clause 6.5) shall be maintained for the output power dynamics requirements of this clause.

6.11.2 Minimum requirement

6.11.2.1 Minimum requirement for transmit OFF power for NCR-MT

For WA NCR-MT type 1-C and NCR-MT type 1-H, the BS requirements specified in clause 6.4.1.2 in TS 38.104 [5] applies.

For LA NCR-MT type 1-C and NCR-MT type 1-H, the UE requirement specified in clause 6.3.2 in TS 38.101-1 [9] applies.

6.11.2.2 Minimum requirement for transmit ON/OFF time mask for NCR-MT

For WA NCR-MT type 1-C and NCR-MT type 1-H, the BS requirements specified in clause 6.4.2.2 in TS 38.104 [5] applies.

For LA NCR-MT type 1-C and NCR-MT type 1-H, the UE requirements specified in clause 6.3.3 in TS 38.101-1 [9] applies.

6.11.2.3 Minimum requirement for power control for NCR-MT

For WA NCR-MT, the IAB-MT requirements specified in clause 6.3.2 output dynamic range requirement, 6.3.3.1 relative power tolerance and 6.3.3.2 aggregated power tolerance requirements in TS 38.174 [26] applies.

For LA NCR-MT, the UE requirements specified in clause 6.3.4.3 of relative power tolerance and clause 6.3.4.4 of aggregate power tolerance in TS 38.101-1 [9] applies.

6.11.3 Test purpose

No specific test or test requirements are defined for conducted output power dynamics. The Error Vector Magnitude (EVM) test, as described in clause 6.12 provides sufficient test coverage for this requirement.

6.12 Transmit signal quality for NCR-MT

Transmit signal quality is specified in terms of: frequency error and transmit modulation quality requirements.

6.12.1 Definition and applicability

Unless otherwise stated, the requirements in clause 6.12 apply during the *transmitter ON period*.

6.12.2 Minimum requirement

6.12.2.1 Minimum requirement for frequency error requirements for NCR-MT

The IAB-MT requirements specified in clause 6.5.1.2 in TS 38.174 [26] apply to both NCR-MT type 1-C and NCR-MT type 1-H.

6.12.2.2 Minimum requirement for transmit modulation quality

The IAB-MT requirements specified in clause 6.5.2.2 in TS 38.174 [26] apply to both NCR-MT type 1-C and NCR-MT type 1-H.

6.12.3 Test purpose

The test purpose is to verify that modulation quality is within the limit specified by the minimum requirement.

6.12.4 Method of test

6.12.4.1 Initial conditions

Test environment: Normal; see annex B.2.

RF channels to be tested for single carrier: B, M and T; see clause 4.9.1.

RF bandwidth positions to be tested for multi-carrier:

- B_{RFBW} , M_{RFBW} and T_{RFBW} in single-band operation, see clause 4.9.1;
- B'_{RFBW} , T'_{RFBW} and B'_{RFBW} , T'_{RFBW} in multi-band operation, see clause 4.9.1.

6.12.4.2 Procedure

For NCR-MT, the minimum requirement is applied to all antenna connectors or *TAB connectors*, they may be tested one at a time or multiple *TAB connectors* may be tested in parallel as shown in annex D.1.1 for *NCR type 1-H*.

Whichever method is used the procedure is repeated until all *TAB connectors* necessary to demonstrate conformance have been tested.

- 1) For an antenna connector or *TAB connector* declared to be capable of single carrier operation only (D.22), set the antenna connector or *TAB connector* under test to transmit a signal according to the applicable test configuration in clause 4.8 using the corresponding test models:

- NCRUL-FR1-TM3.1a if 256QAM is supported by NCR-MT without power back off, or
- NCRUL-FR1-TM3.1a at manufacturer's declared rated output power if 256QAM is supported by NCR-MT with power back off, and NCRUL-FR1-TM3.1 at maximum power, or
- NCRUL-MT-FR1-TM3.1 with highest modulation order supported by NR-MT.

For a antenna connector or *TAB connector* declared to be capable of multi-carrier operation (D.22), set the antenna connector or *TAB connector* under test to transmit according to the applicable test configuration and corresponding power setting specified in clauses 4.7 and 4.8 using the corresponding test models on all carriers configured:

- NCRUL-FR1-TM3.1a if 256QAM is supported by NCR-MT without power back off, or
- NCRUL-FR1-TM3.1a at manufacturer's declared rated output power if 256QAM is supported by NCR-MT with power back off, and NCRUL-FR1-TM3.1 at maximum power, or
- NCRUL-FR1-TM3.1 with highest modulation order supported by NCR-MT.

For NCRUL-FR1-TM3.1a, power back-off shall be applied if it is declared.

- 2) Measure the EVM and frequency error as defined in annex E.
- 3) Repeat steps 1 and 2 for NCRUL-FR1-TM2 if 256QAM is not supported by NCR-MT or for NCRUL-FR1-TM2a if 256QAM is supported by NCR-MT. For NCRUL-FR1-TM2 and NCRUL-FR1-TM2a the OFDM symbol TX power (OSTP) shall be at the lower limit of the dynamic range according to the test procedure in clause 6.3.3.4 and test requirements in clause 6.3.3.5.

In addition, for *multi-band connector(s)*, the following steps shall apply:

- 4) For *multi-band connectors* and single band tests, repeat the steps above per involved band where single band test configurations and test models shall apply with no carrier activated in the other band.

6.12.5 Test requirements

The EVM of each NR carrier for different modulation schemes on PUSCH shall be less than the limits in table 6.12.5-1.

Table 6.12.5-1: EVM requirements for NCR-MT type 1-H

Modulation scheme for PDSCH or PUSCH	Required EVM (%)
QPSK	18.5 %
16QAM	13.5 %
64QAM	9 %
256QAM	4.5 %

EVM shall be evaluated for each NR carrier over all allocated resource blocks and uplink slots for NCR-MT. Different modulation schemes listed in table 6.12.5-1 shall be considered for rank 1.

For all bandwidths, the EVM measurement shall be performed for each NR carrier over all allocated resource blocks uplink slots for NCR-MT within 10 ms measurement periods. The boundaries of the EVM measurement periods need not be aligned with radio frame boundaries.

Table 6.12.5-2, 6.12.5-3, 6.12.5-4 below specify the EVM window length (W) for normal CP for NCR type 1-H.

Table 6.12.5-2: EVM window length for normal CP for NR, FR1, 15 kHz SCS

Channel bandwidth (MHz)	FFT size	Cyclic prefix length for symbols 1-6 and 8-13 in FFT samples	EVM window length W	Ratio of W to total CP length for symbols 1-6 and 8-13 (%) (Note)
10	1024	72	28	40
15	1536	108	44	40
20	2048	144	58	40
25	2048	144	72	50
30	3072	216	108	50
35	3072	216	108	50
40	4096	288	144	50
45	4096	288	144	50
50	4096	288	144	50

NOTE: These percentages are informative and apply to a slot's symbols 1 to 6 and 8 to 13. Symbols 0 and 7 have a longer CP and therefore a lower percentage.

Table 6.12.5-3: EVM window length for normal CP for NR, FR1, 30 kHz SCS

Channel bandwidth (MHz)	FFT size	Cyclic prefix length for symbols 1-13 in FFT samples	EVM window length W	Ratio of W to total CP length for symbols 1-13 (%) (Note)
10	512	36	14	40
15	768	54	22	40
20	1024	72	28	40
25	1024	72	36	50
30	1536	108	54	50
35	1536	108	54	50
40	2048	144	72	50
45	2048	144	72	50
50	2048	144	72	50
60	3072	216	130	60
70	3072	216	130	60
80	4096	288	172	60
90	4096	288	172	60
100	4096	288	172	60

NOTE: These percentages are informative and apply to a slot's symbols 1 through 13. Symbol 0 has a longer CP and therefore a lower percentage.

Table 6.12.5-4: EVM window length for normal CP for NR, FR1, 60 kHz SCS

Channel bandwidth (MHz)	FFT size	Cyclic prefix length in FFT samples	EVM window length W	Ratio of W to total CP length (%) (Note)
10	256	18	8	40
15	384	27	11	40
20	512	36	14	40
25	512	36	18	50
30	768	54	26	50
35	768	54	26	50
40	1024	72	36	50
45	1024	72	36	50
50	1024	72	36	50
60	1536	108	64	60
70	1536	108	64	60
80	2048	144	86	60
90	2048	144	86	60
100	2048	144	86	60

NOTE: These percentages are informative and apply to all OFDM symbols within subframe except for symbol 0 of slot 0 and slot 2. Symbol 0 of slot 0 and slot 2 has a longer CP and therefore a lower percentage.

6.13 Transmit intermodulation for NCR-MT

The transmit intermodulation performance is a measure of the capability of the transmitter to inhibit the generation of signals in its non linear elements caused by presence of the wanted signal and an interfering signal reaching the transmitter via the antenna.

6.13.1 Definition and applicability

NCR-MT transmit intermodulation is defined by the ratio of the mean power of the wanted signal to the mean power of the intermodulation product when an interfering signal is added at a level below the wanted signal at each transmitter antenna port with the other antenna port(s) if any terminated.

6.13.2 Minimum requirement for NCR-MT

The Tx IMD requirements for IAB-MT specified in clause 6.7 of Rel-16 TS 38.174 [26] apply for WA and LA NCR-MT. The IM interference level is based on NCR-Fwd link.

6.13.3 Test purpose

The test purpose is to verify the ability of the transmitter units associated with the *single-band connectors* or *multi-band connector* under test to restrict the generation of intermodulation products in its nonlinear elements caused by presence of the wanted signal and an interfering signal reaching the transmitter via the antenna to below specified levels.

6.13.4 Method of test

6.13.4.1 Initial conditions

Test environment: Normal; see annex B.2.

RF channels to be tested for single carrier: M; see clause 4.9.1.

Passband positions to be tested for multi-carrier:

- M_{RFBW} in single-band operation; see clause 4.9.1.
- $B_{\text{RFBW_T}_{\text{RFBW}}}$ and $B'_{\text{RFBW_T}_{\text{RFBW}}}$ in multi-band operation, see clause 4.9.1.

NOTE: When testing in M (or M_{RFBW}), if the interferer is fully or partially located outside the supported frequency range, then the test shall be done instead in B (or B_{RFBW}) and T (or T_{RFBW}), and only with the interferer located inside the supported frequency range.

6.13.4.2 Procedure

For *NCR-MT type 1-H* where there may be multiple *TAB connectors*, they may be tested one at a time or multiple *TAB connectors* may be tested in parallel as shown in annex D.1.2. Whichever method is used the procedure is repeated until all *TAB connectors* necessary to demonstrate conformance have been tested.

- 1) Connect the *single-band connector* or *multi-band connector* under test to measurement equipment as shown in annex D.1.2 for *NCR-MT*. All connectors not under test shall be terminated.
- 2) The measurement device characteristics shall be:
 - Detection mode: True RMS.
- 3) For a connectors declared to be capable of single carrier operation only (D.22), set the representative connectors under test to transmit according to the applicable test configuration in clause 4.8 at *rated carrier output power* $P_{\text{rated,c,AC}}$ for *NCR type 1-C* (D.21) and $P_{\text{rated,c,TABC}}$ for *NCR type 1-H* (D.21). Channel set-up shall be according to NCRUL-FR1-TM 1.1 for *NCR-MT*.

For a connector under test declared to be capable of multi-carrier operation (D.22) set the connector under test to transmit on all carriers configured using the applicable test configuration and corresponding power setting specified in clauses 4.7 and 4.8 using the corresponding test models or set of physical channels in clause 4.9.2 for *NCR-MT*.

- 4) For *NCR-MT*, generate the interfering signal according to NCRUL-FR1-TM1.1, as defined in clause 4.9.2, with the minimum channel bandwidth (BW_{Channel}) with 15 kHz SCS of the band defined in clause 5.3.5 and a centre frequency offset from the lower/upper edge of the wanted signal or edge of sub-block inside a sub-block gap

$$f_{\text{offset}} = \pm BW_{\text{Channel}} \left(n - \frac{1}{2} \right), \text{ for } n = 1, 2 \text{ and } 3, \text{ but exclude interfering frequencies that are outside of the allocated}$$

downlink operating band or interfering frequencies that are not completely within the sub-block gap or within the Inter RF Bandwidth gap.

- 5) Adjust ATT attenuator (as in the test setup in annex D.1.2 for *NCR-MT*) so that level of the interfering signal is as defined in clause 6.7.5.
- 6) Perform the unwanted emission tests specified in clauses 6.6.3 and 6.6.4 for all third and fifth order intermodulation products which appear in the frequency ranges defined in clauses 6.6.3 and 6.6.4. The width of the intermodulation products shall be taken into account.

- 7) Perform the transmitter spurious emissions test as specified in clause 6.6.5, for all third and fifth order intermodulation products which appear in the frequency ranges defined in clause 6.6.5. The width of the intermodulation products shall be taken into account.
- 8) Verify that the emission level does not exceed the required level in clause 6.7.5 with the exception of interfering signal frequencies.
- 9) Repeat the test for the remaining interfering signal centre frequency offsets according to step 4.
- 10) Repeat the test for the remaining test signals defined in clause 6.7.5 for additional requirements and for *NCR type I-H* intra-system requirements.

In addition, for *multi-band connectors*, the following steps shall apply:

- 11) For a *multi-band connectors* and single band tests, repeat the steps above per involved *operating band* where single band test configurations and test models shall apply with no carrier activated in the other *operating band*.

NOTE: The third order intermodulation products are centred at $2F1 \pm F2$ and $2F2 \pm F1$. The fifth order intermodulation products are centred at $3F1 \pm 2F2$, $3F2 \pm 2F1$, $4F1 \pm F2$, and $4F2 \pm F1$ where $F1$ represents the test signal centre frequency or centre frequency of each sub-block and $F2$ represents the interfering signal centre frequency. The widths of intermodulation products are:

- $(n \cdot BW_{F1} + m \cdot BW_{F2})$ for the $nF1 \pm mF2$ products;
- $(n \cdot BW_{F2} + m \cdot BW_{F1})$ for the $nF2 \pm mF1$ products;

Where BW_{F1} represents the test wanted signal RF bandwidth or channel bandwidth in case of single carrier, or sub-block bandwidth and BW_{F2} represents the interfering signal channel bandwidth.

6.13.5 Test requirements

6.13.5.1 Co-location minimum requirements

The transmitter intermodulation level shall not exceed the unwanted emission limits in clauses 6.13.2 in the presence of an NR interfering signal according to table 6.13.5.1-1.

The requirement is applicable outside the *Passband edges*. The interfering signal offset is defined relative to the *Passband* or *Radio Bandwidth* edges.

For *TAB connectors* supporting operation in *non-contiguous spectrum*, the requirement is also applicable inside a *sub-block gap* for interfering signal offsets where the interfering signal falls completely within the *sub-block gap*. The interfering signal offset is defined relative to the *sub-block* edges.

For *multi-band connector*, the requirement shall apply relative to the *Passband edges* of each operating band. In case the inter RF Bandwidth gap is less than $3 \cdot BW_{\text{Channel}}$ MHz (where BW_{Channel} is the minimal *passband* of the band), the requirement in the gap shall apply only for interfering signal offsets where the interfering signal falls completely within the inter RF Bandwidth gap.

Table 6.13.5.1-1: Interfering and wanted signals for the co-location transmitter intermodulation requirement

Parameter	Value
Wanted signal type	NR single carrier, or multi-carrier, or multiple intra-band contiguously or non-contiguously aggregated carriers
Interfering signal type	NR signal, the minimum NCR- <i>MT channel bandwidth</i> ($BW_{Channel}$) with 15 kHz SCS of the band defined in clause 5.3.5.
Interfering signal level	Rated total output power per <i>TAB connector</i> ($P_{rated,t,TABC}$) in the <i>operating band</i> – 30 dB
Interfering signal centre frequency offset from the lower/upper edge of the wanted signal or edge of <i>sub-block</i> inside a gap	$f_{offset} = \pm BW_{Channel} \left(n - \frac{1}{2} \right)$, for $n=1, 2$ and 3
NOTE 1: Interfering signal positions that are partially or completely outside of any downlink <i>operating band</i> of the <i>TAB connector</i> are excluded from the requirement, unless the interfering signal positions fall within the frequency range of adjacent downlink <i>operating bands</i> in the same geographical area.	
NOTE 2: In Japan, NOTE 1 is not applied in Band n77, n78, n79.	

6.13.5.2 Intra-system minimum requirements

The transmitter intermodulation level shall not exceed the unwanted emission limits in clauses 6.13.2 in the presence of an NR interfering signal according to table 6.13.5.2-1.

Table 6.13.5.2-1: Interfering and wanted signals for intra-system transmitter intermodulation requirement

Parameter	Value
Wanted signal type	NR signal
Interfering signal type	NR signal of the NCR- <i>MT channel bandwidth</i> and SCS as the wanted signal (Note 1).
Interfering signal level	Power level declared by the NCR manufacturer (Note 2).
Frequency offset between interfering signal and wanted signal	0 MHz
NOTE 1: The interfering signal shall be incoherent with the wanted signal.	
NOTE 2: The declared interfering signal power level at each <i>TAB connector</i> is the sum of the co-channel leakage power coupled via the combined RDN and Antenna Array from all the other <i>TAB connectors</i> , but does not comprise power radiated from the Antenna Array and reflected back from the environment. The power at each of the interfering <i>TAB connectors</i> is $P_{rated,c,TABC}$.	

6.13.5.3 Additional requirements

For Band n41 operation in Japan, the transmitter intermodulation level shall not exceed the unwanted emission limits in clauses 6.13.2 in the presence of an NR interfering signal according to table 6.13.5.3-1.

Table 6.13.5.3-1 Interfering and wanted signals for the additional transmitter intermodulation requirement for Band n41

Parameter	Value
Wanted signal	NR single carrier (NOTE)
Interfering signal type	NR signal of 10 MHz <i>channel bandwidth</i>
Interfering signal level	Rated total output power in the operating band – 30 dB
Interfering signal centre frequency offset from the lower/upper carrier centre frequency of the wanted signal	± 5 MHz ± 15 MHz ± 25 MHz
NOTE: This requirement applies for NR carriers allocated within 2545-2645 MHz.	

6.14 Reference sensitivity for NCR-MT

6.14.1 Definition and applicability

The reference sensitivity power level P_{REFSENS} is the minimum mean power received at the antenna connector for *NCR-MT type 1-C* or *TAB connector for NCR-MT type 1-H* at which a throughput requirement shall be met for a specified reference measurement channel.

6.14.2 Minimum requirements for NCR-MT type 1-C and 1-H

The minimum requirement for MT connectors of *NCR type 1-C* is defined in TS 38.106 [2] clause 6.16.1.2.

The minimum requirement for MT connectors of *NCR type 1-H* is defined in TS 38.106 [2] clause 6.16.1.2.

6.14.3 Test purpose

To verify that for each *NCR TAB connector or antenna connector* at the reference sensitivity level the throughput requirement shall be met for a specified reference measurement channel.

6.14.4 Method of test

6.14.4.1 Initial conditions

Test environment:

- Normal; see annex B.2.
- Extreme, see annexes B.3 and B.5.

RF channels to be tested for single carrier: B, M and T; see clause 4.9.1.

Under extreme test environment, the test shall be performed on each of B, M and T under extreme power supply conditions as defined in annex B.5.

NOTE: Tests under extreme power supply conditions also test extreme temperatures.

6.14.4.2 Procedure

The minimum requirement is applied to all connectors under test.

For NCR-MT type 1-H the procedure is repeated until all *TAB connectors* necessary to demonstrate conformance have been tested; see clause 6.1.

- 1) Connect the connector under test to measurement equipment as shown in annex D.2.1 for NCR-MT type 1-C and in annex D.4.1 for NCR-MT type 1-H.
- 2) Start the signal generator for the wanted signal to transmit the Fixed Reference Channels for reference sensitivity in clause 6.14.5 and according to annex A.1.
- 3) Set the signal generator for the wanted signal power as specified in clause 6.14.5.
- 4) Measure the throughput according to annex A.1.

In addition, for a *multi-band connector*, the following steps shall apply:

- 5) For *multi-band connector* and single band tests, repeat the steps above per involved band where single band test configurations and test models shall apply with no carrier activated in the other band.

6.14.5 Test requirements for NCR-MT

The throughput shall be $\geq 95\%$ of the maximum throughput of the reference measurement channel as specified in annex F.2 with parameters specified in table 6.14.5-1 for Wide Area NCR-MT.

Table 6.14.5-1: Wide Area NCR-MT reference sensitivity levels

NCR-MT channel bandwidth (MHz)	Sub-carrier spacing (kHz)	Reference measurement channel	Reference sensitivity power level, P_{REFSENS} (dBm)		
			$f \leq 3.0$ GHz	3.0 GHz < $f \leq 4.2$ GHz	4.2 GHz < $f \leq 6.0$ GHz
5,10,15	15	G-FR1-A1-27 (Note 1)	-100.8	-100.5	-100.3
10, 15	30	G-FR1-A1-22 (Note 1)	-101.3	-101	-100.8
10, 15	60	G-FR1-A1-23 (Note 1)	-98.3	-98	-97.8
20, 25, 30, 35, 40, 45, 50	15	G-FR1-A1-24 (Note 1)	-94.5	-94.2	-94
20, 25, 30, 35, 40, 45, 50, 60, 70, 80, 90, 100	30	G-FR1-A1-25 (Note 1)	-94.7	-94.4	-94.2
20, 25, 30, 35, 40, 45, 50, 60, 70, 80, 90, 100	60	G-FR1-A1-26 (Note 1)	-94.9	-94.6	-94.4
NOTE 1: P_{REFSENS} is the power level of a single instance of the reference measurement channel. This requirement shall be met for each consecutive application of a single instance of the reference measurement channel mapped to disjoint frequency ranges with a width corresponding to the number of resource blocks of the reference measurement channel each, except for one instance that might overlap one other instance to cover the full <i>passband</i> .					

For Local Area NCR-MT reference sensitivity levels are defined in TS 38.101-1 [9] in clause 7.3.2 plus measurement uncertainty.

Table 6.14.5-2: measurement uncertainty for reference sensitivity levels

	The applicable frequency range		
	$f \leq 3$ GHz	3 GHz < $f \leq 4.2$ GHz	4.2 GHz < $f \leq 6$ GHz
REFSENS	± 0.7 dB	± 1.0 dB	± 1.2 dB

6.15 Maximum input level for NCR-MT

6.15.1 Definition and applicability

Maximum input level is defined as the maximum mean power received at the Local Area *NCR-MT type I-C* antenna port or *NCR-MT type I-H* TAB connectors, at which the specified relative throughput shall meet or exceed the minimum requirements for the specified reference measurement channel.

6.15.2 Minimum requirement

For Local Area NCR-MT, the throughput shall be $\geq 95\%$ of the maximum throughput of the reference measurement channels as specified in 38.101-1 [9] Annex A.3.2 and Annex A.3.3 (with one sided dynamic OCNG Pattern OP.1 FDD/TDD as described in Annex A.5.1.1/A.5.2.1) with parameters specified in TS 38.101-1 [9] in Table 7.4-1.

6.15.3 Test purpose

Maximum input level tests the NCR-MT ability to receive data with a given average throughput for a specified reference measurement channel, under conditions of high signal level, ideal propagation and no added noise.

6.15.4 Method of test

Test description for NCR-MT conducted maximum input level is s specified in TS 38.521-1 [25] clause 7.4.4.

6.15.4.1 Initial conditions

Test environment: Normal; see annex B.2.

RF channels to be tested for single carrier: M; see clause 4.9.1.

6.15.4.2 Procedure

The minimum requirement is applied to all connectors under test.

For NCR-MT *type 1-H* the procedure is repeated until all *TAB connectors* necessary to demonstrate conformance have been tested.

- 1) Connect the connector under test to measurement equipment.
- 2) Set the signal generator for the wanted signal to transmit as specified in Table 6.15.5-1 in clause 6.15.5.
- 3) Measure the throughput.

6.15.5 Test requirements

The throughput measurement derived in test procedure shall be $\geq 95\%$ of the maximum throughput of the reference measurement channels as specified in Annex A.3.2 and A.3.3 with parameters specified in Tables 6.15.5-1.

Table 6.15.5-1: Maximum input level

Rx Parameter	Units	Channel bandwidth (MHz)		
		5, 10, 15, 20	25, 30, 35, 40, 45, 50	60, 70, 80, 90, 100
Power in Transmission Bandwidth Configuration ⁴	dBm	-25 ² -TT	-25 + 10log ₁₀ (BW _{Channel} /20) ^{Note 2} -TT	-20 ² -TT
		-27 ³ -TT	-27 + 10log ₁₀ (BW _{Channel} /20) ^{Note 3} -TT	-22 ³ -TT
NOTE 1: The transmitter shall be set to 4 dB below P _{C_{MAX}L,f,c} at the minimum uplink configuration specified in Table 7.3.2-3 with P _{C_{MAX}L,f,c} as defined in clause 6.2.4 in TS 38.101-1 [9].				
NOTE 2: Reference measurement channel is A.3.2.3 or A.3.3.3 for 64 QAM.				
NOTE 3: Reference measurement channel is A.3.2.4 or A.3.3.4 for 256 QAM.				
NOTE 4: 10log ₁₀ (x) is rounded to the nearest 0.5dB value.				

Table 6.15.5-2: Test Tolerance (Maximum input level)

f ≤ 3.0GHz	3.0GHz < f ≤ 6.0GHz
0.7 dB	1.0 dB

6.16 Adjacent channel selectivity for NCR-MT

6.16.1 Definition and applicability

Adjacent channel selectivity (ACS) is a measure of the receiver's ability to receive a wanted signal at its assigned channel frequency at the antenna connector for NCR-MT type 1-C or TAB connector for NCR-MT type 1-H in the presence of an adjacent channel signal with a specified centre frequency offset of the interfering signal to the band edge of a victim system.

This requirement applies to NCR-MT.

6.16.2 Minimum requirement

The minimum requirement for NCR-MT type 1-C is defined in TS 38.106 [2] clause 6.18.1.2.

The minimum requirement for NCR-MT type 1-H is defined in TS 38.106 [2] clause 6.18.1.2.

6.16.3 Test purpose

The test purpose is to verify the ability of the NCR receiver filter to suppress interfering signals in the channels adjacent to the wanted channel.

6.16.4 Method of test

6.16.4.1 Initial conditions

Test environment: Normal; see annex B.2.

RF channels to be tested for single carrier (SC): M; see clause 4.9.1.

Repeater RF Bandwidth positions to be tested for multi-carrier (MC):

- M_{RFBW} for *single-band connector(s)*, see clause 4.9.1,
- $B'_{\text{RFBW}}T'_{\text{RFBW}}$ and $B'_{\text{RFBW}}T_{\text{RFBW}}$ for *multi-band connector(s)*, see clause 4.9.1.

6.16.4.2 Procedure

The minimum requirement is applied to all connectors under test.

For *NCR type 1-H* the procedure is repeated until all *TAB connectors* necessary to demonstrate conformance have been tested; see clause 6.1.

- 1) Connect the connector under test to measurement equipment as shown in annex D.13.
- 2) For FDD operation, set the NCR to transmit:
 - For single carrier operation set the connector under test to transmit at manufacturers declared *rated output power per passband* (D.9).
 - For a connector under test declared to be capable of multi-carrier operation (D.22) set the connector under test to transmit on all carriers configured using the applicable test configuration and corresponding power setting specified in clauses 4.7 and 4.8 using the corresponding test models or set of physical channels in clause 4.9.2.
- 3) Set the signal generator for the wanted signal to transmit as specified in clause 6.16.5:
- 4) Set the signal generator for the interfering signal to transmit at the frequency offset and as specified in clause 6.16.5:
- 5) Measure the throughput according to TS 38.106 [2] annex B.1.5.

In addition, for a *multi-band connector*, the following steps shall apply:

- 6) For *multi-band connector* and single band tests, repeat the steps above per involved band where single band test configurations and test models shall apply with no carrier activated in the other band.

6.16.5 Test requirements for NCR-MT

For wide area *NCR-MT type 1-C* and *NCR-MT type 1-H*, the requirement formulation and interferer levels for test requirement for Wide Area BS type 1-C and BS type 1-H in clause 7.4.1.5 for conducted adjacent channel selectivity of TS 38.141-1 apply. The P_{REFSENS} used for wanted signal mean power in TS 38.141-1 is specified in table 6.16.1.2-1 of TS 38.106.

For local area *NCR-MT type 1-C* and *NCR-MT type 1-H*, the test requirements in clause 7.5.5 for adjacent channel selectivity of TS 38.521-1 [25] apply.

For local area NCR-MT, the test requirements in clause 7.5 of TS 38.521-1 [25] apply.

6.16.6 Void

6.17 Blocking characteristics for NCR-MT

6.17.1 Definition and applicability

The in-band blocking characteristics is a measure of the receiver's ability to receive a wanted signal at its assigned channel at the *TAB connector* for *NCR type 1-C* and *NCR 1-H* in the presence of an unwanted interferer, which is an NR signal for general blocking or an NR signal with one resource block for narrowband blocking.

Conducted blocking characteristics requirement applies only to NCR-MT connectors.

6.17.2 Minimum requirement

The minimum requirement for MT connectors of *NCR type 1-C* is defined in TS 38.106 [2] clause 6.19.2.

The minimum requirement for MT connectors of *NCR type 1-H* is defined in TS 38.106 [2] clause 6.19.2.

6.17.3 Test purpose

The test purpose is to verify the ability of the NCR receiver (at MT connectors) to withstand high-levels of in-band interference from unwanted signals at specified frequency offsets without undue degradation of its sensitivity.

6.17.4 Method of test

6.17.4.1 Initial conditions

Test environment: Normal; see annex B.2.

RF channels to be tested for single carrier (SC): M; see clause 4.9A.1.

NCR RF Bandwidth positions to be tested for multi-carrier (MC):

- M_{RFBW} for *single-band connector(s)*, see clause 4.9A.1,
- $B_{\text{RFBW}}'T_{\text{RFBW}}$ and $B_{\text{RFBW}}'T_{\text{RFBW}}$ for *multi-band connector(s)*, see clause 4.9A.1.

6.17.4.2 Procedure for general blocking

The minimum requirement is applied to all connectors under test.

For *NCR type 1-H* the procedure is repeated until all *TAB connectors* necessary to demonstrate conformance have been tested;

- 1) Connect the connector under test to measurement equipment
- 2) For FDD operation, set the NCR to transmit:
 - For single carrier operation set the connector under test to transmit at manufacturers declared *rated output power per passband* (D.9).
 - For a connector under test declared to be capable of multi-carrier operation (D.22) set the connector under test to transmit on all carriers configured using the applicable test configuration and corresponding power setting specified in clauses 4.7 and 4.8 using the corresponding test models or set of physical channels in clause 4.9A.2.

- 3) Set the signal generator for the wanted signal to transmit as specified in clause 6.17.5.
- 4) Set the signal generator for the interfering signal to transmit at the frequency offset and as specified in clause 6.17.5. The interfering signal shall be swept with a step size of 1 MHz starting from the minimum offset to the channel edges of the wanted signals as specified in clause 6.17.5.
- 5) Measure the throughput.

In addition, for a *multi-band connector*, the following steps shall apply:

- 6) For *multi-band connector* and single band tests, repeat the steps above per involved band where single band test configurations and test models shall apply with no carrier activated in the other band.

6.17.4.3 Procedure for narrowband blocking

The minimum requirement is applied to all connectors under test.

For *NCR type I-H* the procedure is repeated until all *TAB connectors* necessary to demonstrate conformance have been tested;

- 1) Connect the connector under test to measurement equipment;
- 2) For FDD operation, set the NCR-MT to transmit:
 - For single carrier operation set the connector under test to transmit at manufacturers declared *rated carrier output power* (D.9).
 - For a connector under test declared to be capable of multi-carrier operation (D.22) set the connector under test to transmit on all carriers configured using the applicable test configuration and corresponding power setting specified in clauses 4.7 and 4.8 using the corresponding test models or set of physical channels in clause 4.9A.2.
- 3) Set the signal generator for the wanted signal to transmit as specified in clause 6.17.5.
- 4) Set the signal generator for the interfering signal to transmit at the frequency offset and as specified in clause 6.17.5 Set-up and sweep the interfering RB centre frequency offset to the channel edge of the wanted signal as specified in clause 6.17.5.
- 5) Measure the throughput.

In addition, for a *multi-band connector*, the following steps shall apply:

- 6) For *multi-band connector* and single band tests, repeat the steps above per involved band where single band test configurations and test models shall apply with no carrier activated in the other band

6.17.4.4 Procedure for out of band blocking

The minimum requirement is applied to all connectors under test.

For *NCR type I-H* the procedure is repeated until all *TAB connectors* necessary to demonstrate conformance have been tested;

- 1) Connect the connector under test to measurement equipment
- 2) For NCR-MT, set the signal generator for the wanted signal as defined in clause 6.17.5 to transmit.
- 3) For NCR-MT, set the Signal generator for the interfering signal to transmit at the frequency offset and as specified in clause 6.17.5. The CW interfering signal shall be swept with a step size of 1 MHz over than range 1 MHz to $(F_{UL_low} - \Delta f_{OOB})$ MHz and $(F_{UL_high} + \Delta f_{OOB})$ MHz to 12750 MHz.
- 4) Measure the throughput.

6.17.5 Test requirements for NCR-MT

For wide area *NCR-MT type 1-C* and *NCR-MT type 1-H*, the requirement formulation and interferer levels for test requirement for Wide Area BS type 1-C and BS type 1-H in clause 7.4.2.5 for in-band blocking and 7.5.5 for out-of-band blocking of TS 38.141-1 [7] apply. The P_{REFSENS} used for wanted signal mean power in TS 38.141-1 is specified in table 6.16.1.2-1 of TS 38.106 [2].

For local area *NCR-MT type 1-C* and *NCR-MT type 1-H*, the test requirements in clause 7.6.2.5 for in-band blocking, 7.6.3.5 for out-of-band blocking and 7.6.4.5 for Narrow band blocking of TS 38.521-1 [25] apply.

6.18 Transmitter spurious response for NCR-MT

6.18.1 Definition and applicability

Third and higher order mixing of the two interfering RF signals can produce an interfering signal in the band of the desired channel. Intermodulation response rejection is a measure of the capability of the receiver to receive a wanted signal on its assigned channel frequency at the *antenna connector* for *NCR-MT type 1-C* or *TAB connector* for *NCR-MT type 1-H* in the presence of two interfering signals which have a specific frequency relationship to the wanted signal.

This requirement applies at MT connectors.

6.18.2 Minimum requirement

The minimum requirement for MT connectors of local area *NCR type 1-C* and *NCR type 1-H* is defined in TS 38.101-1 [9], clause 7.7.

6.18.3 Test purpose

Spurious response is a measure of the ability of the receiver to receive a wanted signal on its assigned channel frequency without exceeding a given degradation due to the presence of an unwanted CW interfering signal at any other frequency for which a response is obtained.

The lack of the spurious response ability decreases the coverage area when other unwanted interfering signal exists at any other frequency.

6.18.4 Method of test

6.18.4.1 Initial conditions

Test environment: Normal; see annex B.2.

RF channels to be tested for single carrier (SC): M; see clause 4.9A.1

NCR RF Bandwidth positions to be tested for multi-carrier (MC):

- M_{RFBW} for *single-band connector(s)*, see clause 4.9A.1,
- $B_{\text{RFBW}}T_{\text{RFBW}}$ and $B'_{\text{RFBW}}T_{\text{RFBW}}$ for *multi-band connector(s)*, see clause 4.9A.1.

6.18.4.2 Procedure

The minimum requirement is applied to all connectors under test.

For *NCR-MT type 1-H* the procedure is repeated until all *TAB connectors* necessary to demonstrate conformance have been tested;

- 1) Connect the connector under test to measurement equipment. All connectors not under test shall be terminated.
- 2) Set the signal generator for the wanted signal to transmit as specified in clause 6.18.5 for NCR-MT.

- 3) Set the signal generator for the interfering signal to transmit at the frequency offset and as specified in clause 6.18.5 for NCR-MT.
- 4) Measure the throughput.

In addition, for a *multi-band connector*, the following steps shall apply:

- 5) For multi-band connector and single band tests, repeat the steps above per involved band where single band test configurations and test models shall apply with no carrier activated in the other band

6.18.5 Test requirements

For *NCR type I-C* and *NCR type I-H*, the test requirement for conducted spurious response is defined in TS 38.521-1 [25], clause 7.7.5. This test requirement applies at MT connectors only.

6.19 Receiver intermodulation characteristics for NCR-MT

6.19.1 Definition and applicability

Third and higher order mixing of the two interfering RF signals can produce an interfering signal in the band of the desired channel. Intermodulation response rejection is a measure of the capability of the receiver to receive a wanted signal on its assigned channel frequency at the antenna connector for *NCR-MT type I-C* or *TAB connector* for *NCR-MT type I-H* in the presence of two interfering signals which have a specific frequency relationship to the wanted signal.

This requirement applies at MT connectors only.

6.19.2 Minimum requirement

The minimum requirement for MT connectors of *NCR type I-C* is defined in TS 38.106 [2] clause 6.21.2.

The minimum requirement for MT connectors of *NCR type I-H* is defined in TS 38.106 [2] clause 6.21.2.

6.19.3 Test purpose

The test purpose is to verify the ability of the receiver to inhibit the generation of intermodulation products in its non-linear elements caused by the presence of two high-level interfering signals at frequencies with a specific relationship to the frequency of the wanted signal.

6.19.4 Method of test

6.19.4.1 Initial conditions

Test environment: Normal; see annex B.2.

RF channels to be tested for single carrier (SC): M; see clause 4.9A.1

NCR RF Bandwidth positions to be tested for multi-carrier (MC):

- M_{RFBW} for *single-band connector(s)*, see clause 4.9A.1,
- $B_{\text{RFBW}} \cdot T_{\text{RFBW}}$ and $B'_{\text{RFBW}} \cdot T_{\text{RFBW}}$ for *multi-band connector(s)*, see clause 4.9A.1.

6.19.4.2 Procedure

The minimum requirement is applied to all connectors under test.

For *NCR-MT type I-H* the procedure is repeated until all *TAB connectors* necessary to demonstrate conformance have been tested;

- 1) Connect the connector under test to measurement equipment . All connectors not under test shall be terminated.

- 2) Set the signal generator for the wanted signal to transmit as specified in clause 6.19.5 for NCR-MT.
- 3) Set the signal generator for the interfering signal to transmit at the frequency offset and as specified in clause 6.19.5 for NCR-MT.
- 4) Measure the throughput.

In addition, for a *multi-band connector*, the following steps shall apply:

- 5) For *multi-band connector* and single band tests, repeat the steps above per involved band where single band test configurations and test models shall apply with no carrier activated in the other band

6.19.5 Test requirements for NCR-MT

For wide area *NCR-MT type 1-C* and *NCR-MT type 1-H*, the requirement formulation and interferer levels for test requirement for Wide Area BS type 1-C and BS type 1-H conducted intermodulation characteristics in TS 38.141-1 [7], clause 7.7.5 apply. The P_{REFSENS} used for wanted signal mean power in TS 38.141-1 is specified in table 6.16.1.2-1 of TS 38.106.

For local area *NCR-MT type 1-C* and *NCR-MT type 1-H*, the test requirement for conducted intermodulation characteristics in clause 7.8.2.5 of TS 38.521-1 [25] apply.

6.20 Receiver spurious emissions for NCR-MT

6.20.1 Definition and applicability

The receiver spurious emissions power is the power of emissions generated or amplified in a receiver unit that appear at the *antenna connector for NCR-MT type 1-C* and at the *TAB connector for NCR-MT type 1-H*. The requirements apply to all NCR-MT with separate RX and TX *TAB connectors*.

For *TAB connectors* supporting both RX and TX in TDD, the requirements apply during the *transmitter OFF period*.

For RX-only *multi-band connectors*, the spurious emissions requirements are subject to exclusion zones in each supported *operating band*. For *multi-band connectors* that both transmit and receive in *operating band* supporting TDD, RX spurious emissions requirements are applicable during the *TX OFF period*, and are subject to exclusion zones in each supported *operating band*.

For *NCR-MT type 1-H* manufacturer shall declare *TAB connector RX min cell groups*. Every *TAB connector* of *NCR-MT type 1-H* supporting reception in an *operating band* shall map to one *TAB connector RX min cell group*, where mapping of *TAB connectors* to cells/beams is implementation dependent.

The number of active receiver units that are considered when calculating the conducted RX spurious emission limits ($N_{\text{RXU,counted}}$) for Wide Area *NCR-MT type 1-H* is calculated as follows:

$$N_{\text{RXU,counted}} = \min(N_{\text{RXU,active}}, 8)$$

NOTE: $N_{\text{RXU,active}}$ is the number of actually active receiver units.

6.20.2 Minimum requirement

The minimum requirement for MT connectors of NCR is defined in TS 38.106 [2] clause 6.22.2.

6.20.3 Test purpose

The test purpose is to verify the ability of the NCR-MT to limit the interference caused by receiver spurious emissions to other systems.

6.20.4 Method of test

6.20.4.1 Initial conditions

Test environment: Normal; see annex B.2.

RF channels to be tested for single carrier: M; see clause 4.9A.1.

NCR RF Bandwidth positions to be tested for multi-carrier:

- M_{RFBW} in single-band operation, see clause 4.9A.1,
- $B'_{RFBW_T'_{RFBW}}$ and $B'_{RFBW_T_{RFBW}}$ in multi-band operation, see clause 4.9A.1.

6.20.4.2 Procedure

The minimum requirement is applied to all connectors under test,

For *NCR type 1-H* where there may be multiple *TAB connectors* they may be tested one at a time or multiple *TAB connectors* may be tested in parallel. Whichever method is used the procedure is repeated until all *TAB connectors* necessary to demonstrate conformance have been tested.

- 1) Connect the connector under test to measurement equipment .
- 2) For NCR-MT, set the measurement equipment parameters as specified in table 6.20.5.1-1.
- 3) For NCR-MT, measure the spurious emissions over each frequency range described in table 6.20.5.1-1.

In addition, for a *multi-band connector*, the following steps shall apply:

- 4) For *multi-band connector* and single band tests, repeat the steps above per involved band where single band test configurations and test models shall apply with no carrier activated in the other band.

6.20.5 Test requirements

6.20.5.1 Basic limits for NCR-MT

The NCR-MT receiver spurious emissions *basic limits* are provided in table 6.20.5.1-1.

Table 6.20.5.1-1: General NCR-MT receiver spurious emissions limits

Spurious frequency range	Basic requirements	Measurement bandwidth	Note
30 MHz – 1 GHz	-57 dBm	100 kHz	Note 1
1 GHz – 12.75 GHz	-47 dBm	1 MHz	Note 1, Note 2
12.75 GHz – 5 th harmonic of the upper frequency edge of the UL <i>operating band</i> in GHz	-47 dBm	1 MHz	Note 1, Note 2, Note 3, Note 5
12.75 GHz - 26 GHz	-47 dBm	1 MHz	Note 1, Note 2, Note 6
NOTE 1: <i>Measurement bandwidths</i> as in ITU-R SM.329 [4], s4.1. NOTE 2: Upper frequency as in ITU-R SM.329 [4], s2.5 table 1. NOTE 3: This spurious frequency range applies only for <i>operating bands</i> for which the 5 th harmonic of the upper frequency edge of the UL <i>operating band</i> is reaching beyond 12.75 GHz. NOTE 4: The frequency range from Δf_{OBUE} below the lowest frequency of the repeater transmitter <i>operating band</i> to Δf_{OBUE} above the highest frequency of the repeater transmitter <i>operating band</i> may be excluded from the requirement. Δf_{OBUE} is defined in clause 6.5.1. For <i>multi-band connectors</i> , the exclusion applies for all supported <i>operating bands</i> . NOTE 5: Does not apply for band n104. NOTE 6: Applies only for band n104.			

6.20.5.2 Test requirement for NCR-MT

The RX spurious emissions requirements for *NCR type 1-H* are that for each applicable *basic limit* specified in table 6.20.5.1-1 for each *TAB connector RX min cell group*, the power sum of emissions at respective *TAB connectors* shall not exceed the NCR-MT limits specified as the *basic limits* + X, where $X = 10\log_{10}(N_{\text{RXU,counted}})$, unless stated differently in regional regulation.

$$N_{\text{RXU,counted}} = \min(N_{\text{RXU,active}}, 8)$$

NOTE: $N_{\text{RXU,active}}$ is the number of actually active receiver units .

The RX spurious emission requirements are applied per the *TAB connector RX min cell group* for all the configurations supported by the NCR-MT.

NOTE: Conformance to the NCR-MT receiver spurious emissions requirement can be demonstrated by meeting at least one of the following criteria as determined by the manufacturer:

- 1) The sum of the spurious emissions power measured on each *TAB connector* in the *TAB connector RX min cell group* shall be less than or equal to the NCR-MT limit above for the respective frequency span.

Or

- 2) The spurious emissions power at each *TAB connector* shall be less than or equal to the NCR-MT limit as defined above for the respective frequency span, scaled by $-10\log_{10}(n)$, where n is the number of *TAB connectors* in the *TAB connector RX min cell group*.

7 Conducted performance requirements

7.1 NCR-MT Performance requirements

7.1.1 General

7.1.1.1 Scope and definitions

Conducted performance requirements specify the ability of the NCR-MT to correctly demodulate signals in various conditions and configurations. Conducted performance requirements are specified at the antenna connectors (NCR-MT type 1-C) or TAB connector(s) (NCR type 1-H).

Conducted performance requirements for the NCR-MT are specified for the fixed reference channels and the propagation conditions defined in TS 38.106 [2] annex F and annex G, respectively.

The SNR used in this clause is specified based on a single carrier and defined as:

$$\text{SNR} = S / N$$

Where:

S is the total signal energy in a slot on a single *antenna connector* or *TAB connector*.

N is the noise energy in a bandwidth corresponding to the transmission bandwidth over the duration of a slot.

7.1.2 Demodulation performance requirements

7.1.2.1 General

7.1.2.2 Performance requirements for PDSCH

7.1.2.2.1 Definition and applicability

The performance requirement of PDSCH is determined by two means; a minimum required throughput for a given SNR and a minimum SNR at which 1% BLER for the first transmission is achieved. The required throughput is expressed as a fraction of maximum throughput for the FRCs listed in annex F. The throughput performance requirements assume HARQ re-transmissions, whereas the first transmission BLER requirements do not consider HARQ.

7.1.2.2.2 Minimum requirement

The minimum requirement is in TS 38.106 [2] clause 8.3.1.

7.1.2.2.3 Test purpose

The test shall verify the receiver's ability to achieve throughput and 1st transmission BLER under multipath fading propagation conditions for a given SNR.

7.1.2.2.4 Method of test

7.1.2.2.4.1 Initial conditions

Test environment: Normal, see annex B.2.

RF channels to be tested for single carrier:M; see clause 4.9.1.

RF channels to be tested for carrier aggregation: $M_{\text{BW Channel CA}}$; see clause 4.9.1.

7.1.2.2.4.2 Procedure

- 1) Connect the NCR tester generating the wanted signal, multipath fading simulators and AWGN generators to all NCR-MT *TAB connectors* or *antenna connectors* for diversity reception via a combining network as shown in annex D.9 or D.11.
- 2) Adjust the AWGN generator and adjust the AWGN power level to -77.2 dBm / 38.16MHz.
- 3) The characteristics of the wanted signal shall be configured according to the corresponding DL reference measurement channel defined in annex F and the test parameters in table 7.1.2.2.4.2-1.

Table 7.1.2.4.2-1: Test parameters for testing PDSCH

Parameter		Unit	Value
Duplex mode			TDD
Active BWP index			1
Default TDD UL-DL pattern (Note 1)			7D1S2U, S=6D:4G:4U
PDSCH transmission scheme			Transmission scheme 1
Carrier configuration	Offset between Point A and the lowest usable subcarrier on this carrier (Note 1)	RBs	0
	Subcarrier spacing	kHz	30
DL BWP configuration #1	Cyclic prefix		Normal
	RB offset	RBs	0
	Number of contiguous PRB	PRBs	106
PDSCH DMRS configuration	Antenna ports indexes		{1000} for Rank 1 tests {1000, 1001} for Rank 2 tests {1000-1002} for Rank 3 tests {1000-1003} for Rank 4 tests
	Position of the first DMRS for PDSCH mapping type A		2
	Number of PDSCH DMRS CDM group(s) without data		1 for Rank 1 and Rank 2 tests 2 for Rank 3 and Rank 4 tests
	DMRS Type		Type 1
	Number of additional DMRS		1
	Maximum number of OFDM symbols for DL front loaded DMRS		1
PDSCH configuration	Mapping type		Type A
	k0		0
	Starting symbol (S)		2
	Length (L)		Specific to each Reference channel
	PDSCH aggregation factor		1
	PRB bundling type		Static
	PRB bundling size		2
	Resource allocation type		Type 0
	RBG size		Config2
	VRB-to-PRB mapping type		Non-interleaved
VRB-to-PRB mapping interleaver bundle size		N/A	
PT-RS configuration			PT-RS is not configured
Maximum number of code block groups for ACK/NACK feedback			1
Maximum number of HARQ transmission			4
HARQ ACK/NACK bundling			Multiplexed
Redundancy version coding sequence			{0,2,3,1}
PDSCH & PDSCH DMRS Precoding configuration			Single Panel Type I, Random precoder selection updated per slot, with equal probability of each applicable i_1, i_2 combination, and with PRB bundling granularity
NOTE 1: The same requirements are applicable to TDD with different UL-DL patterns.			
NOTE 2: Point A coincides with minimum guard band as specified in TS 38.101-1 [9] for tested channel bandwidth and subcarrier spacing.			

- 4) The multipath fading emulators shall be configured according to the corresponding channel model defined in annex F.
- 5) Adjust the equipment so that required SNR specified in table 7.1.2.2.5.1-1 is achieved at the NCR-MT input.
- 6) For each of the reference channels in table 7.1.2.2.5.1-1 measure the throughput and the 1st transmission BLER.

7.1.2.2.5 Test requirement

The throughput measured according to clause 7.1.2.2.4.2 shall not be below the limits for the SNR levels specified in table 7.1.2.2.5-1.

Table 7.1.2.2.5-1: Minimum performance PDSCH

Test num.	Reference channel	Bandwidth (MHz) / Subcarrier spacing (kHz)	MCS	Propagation condition	Correlation matrix and antenna configuration	Reference value	
						Test metric	SNR (dB)
1	M-FR1-NCR.1.1-1	10 / 15	4	TDLA30-10	2x2	70% TPUT	-0.1
2	M-FR1-NCR.1.1-1	10 / 15	4	TDLA30-10	2x2	1% BLER	5.7
3	M-FR1-NCR.1.1-1	10 / 15	4	TDLA30-10	2x4	70% TPUT	-3.1
4	M-FR1-NCR.1.1-1	10 / 15	4	TDLA30-10	2x4	1% BLER	0.9
5	M-FR1-NCR.1.1-3	10 / 15	13	TDLA30-10	2x2	70% TPUT	7.6
6	M-FR1-NCR.1.1-3	10 / 15	13	TDLA30-10	2x2	1% BLER	13.7
7	M-FR1-NCR.1.1-3	10 / 15	13	TDLA30-10	2x4	70% TPUT	4.3
8	M-FR1-NCR.1.1-3	10 / 15	13	TDLA30-10	2x4	1% BLER	8.5
9	M-FR1-NCR.1.1-2	40 / 30	4	TDLA30-10	2x2	70% TPUT	-0.2
10	M-FR1-NCR.1.1-2	40 / 30	4	TDLA30-10	2x2	1% BLER	5.1
11	M-FR1-NCR.1.1-2	40 / 30	4	TDLA30-10	2x4	70% TPUT	-3.1
12	M-FR1-NCR.1.1-2	40 / 30	4	TDLA30-10	2x4	1% BLER	0.3
13	M-FR1-NCR.1.1-4	40 / 30	13	TDLA30-10	2x2	70% TPUT	7.6
14	M-FR1-NCR.1.1-4	40 / 30	13	TDLA30-10	2x2	1% BLER	12.7
15	M-FR1-NCR.1.1-4	40 / 30	13	TDLA30-10	2x4	70% TPUT	4.4
16	M-FR1-NCR.1.1-4	40 / 30	13	TDLA30-10	2x4	1% BLER	7.8

7.1.2.3 Performance requirements for PDCCH

7.1.2.3.1 Definition and applicability

The performance requirement of PDCCH is determined by a maximum allowed missed detection rate for a given SNR. The required missed detection rate is expressed for the FRCs listed in annex F.

7.1.2.3.2 Minimum requirement

The minimum requirement is in TS 38.106 [2] clause 8.3.2.

7.1.2.3.3 Test purpose

The test shall verify the receiver's ability to achieve missed detection rate under multipath fading propagation conditions for a given SNR.

7.1.2.3.4 Method of test

7.1.2.3.4.1 Initial conditions

Test environment: Normal, see annex B.2.

RF channels to be tested for single carrier: M ; see clause 4.9.1.

RF channels to be tested for carrier aggregation: $M_{\text{BW Channel CA}}$; see clause 4.9.1.

7.1.2.3.4.2 Procedure

- 1) Connect the NCR tester generating the wanted signal, multipath fading simulators and AWGN generators to all NCR-MT *TAB connectors* or *antenna connectors* for diversity reception via a combining network as shown in annex D.9 or D.11.
- 2) Adjust the AWGN generator and adjust the AWGN power level to -77.2 dBm / 38.16MHz.
- 3) The characteristics of the wanted signal shall be configured according to the corresponding DL reference measurement channel defined in annex A and the test parameters in table 7.1.2.3.4.2-1.

Table 7.1.2.3.4.2-1: Test parameters for testing PDCCH

Parameter	Unit	1 Tx Antenna	2 Tx Antenna
CCE to REG mapping type		interleaved	interleaved
Interleaver size		3	
REG bundle size		2	6
Shift Index		0	

- 4) The multipath fading emulators shall be configured according to the corresponding channel model defined in annex F.
- 5) Adjust the equipment so that required SNR specified in table 7.1.2.3.5.1-1 is achieved at the NCR-MT input.
- 6) For each of the reference channels in table 7.1.2.3.5.1-1, applicable for the NCR-MT, measure the missed detection.

7.1.2.3.5 Test requirement

For the parameters specified in Table 7.1.2.3.4.2.1-1, the average probability of a missed downlink scheduling grant ($P_{\text{m-dsg}}$) shall be below the specified value in Table 7.1.2.3.5-1 for SCS supported by the NCR-MT.

Table 7.1.2.3.5-1: Minimum performance for PDCCH

Test number	Bandwidth (MHz)	SCS	CORESET RB	CORESET duration	Aggregation level	Reference Channel	Propagation Condition	Antenna configuration and correlation Matrix	Reference value	
									Pm-dsg (%)	SNR (dB)
1	10	15	24	2	2	M-FR1-NCR.1.2-1	TDLA30-10	1x2	1	8.7
2	10	15	24	2	2	M-FR1-NCR.1.2-1	TDLA30-10	1x4	1	2.8
3	10	15	48	2	4	M-FR1-NCR.1.2-2	TDLA30-10	1x2	1	6.1
4	10	15	48	2	4	M-FR1-NCR.1.2-2	TDLA30-10	1x4	1	0.8
5	10	15	48	1	8	M-FR1-NCR.1.2-3	TDLA30-10	2x2	1	0.6
6	10	15	48	1	8	M-FR1-NCR.1.2-3	TDLA30-10	2x4	1	-1.7
7	40	30	102	1	2	M-FR1-NCR.1.2-4	TDLA30-10	1x2	1	7.6
8	40	30	102	1	2	M-FR1-NCR.1.2-4	TDLA30-10	1x4	1	2.7
9	40	30	102	1	4	M-FR1-NCR.1.2-5	TDLA30-10	1x2	1	5.5
10	40	30	102	1	4	M-FR1-NCR.1.2-5	TDLA30-10	1x4	1	1.3
11	40	30	90	1	8	M-FR1-NCR.1.2-6	TDLA30-10	2x2	1	0.1
12	40	30	90	1	8	M-FR1-NCR.1.2-6	TDLA30-10	2x4	1	-3.3

7.1.3 CSI reporting requirements

7.1.3.1 General

7.1.3.1.1 Applicability rule for NCR-MT

7.1.3.1.1.1 General

Unless otherwise stated, for an NCR-MT declared to support more than 4 antenna connectors (for *NCR type 1-C*), the performance requirement tests for 4 RX antennas shall apply, and the specific connectors used for testing is up to NCR-MT implementation.

7.1.3.1.1.2 Applicability of requirements for different subcarrier spacings

Unless otherwise stated, the tests shall apply only for each subcarrier spacing declared to be supported (see D.14 in table 4.6-1).

7.1.3.1.1.3 Applicability of requirements for TDD with different UL-DL patterns

Unless otherwise stated, for each subcarrier spacing declared to be supported, if NCR-MT supports multiple TDD UL-DL patterns, only one of the supported TDD UL-DL patterns shall be used for all tests.

7.1.3.1.1.4 Applicability of requirements for NCR-MT features

Unless otherwise stated, for *NCR type 1-C*, the CSI reporting tests shall apply only in case the number of NZP-CSI-RS ports in the test case satisfies maximum number of ports across all configured NZP-CSI-RS resources per CC declared to be supported (see D.201 in table 4.6-1, *maxConfigNumberPortsAcrossNZP-CSI-RS-PerCC*).

Note: Applicability information may be obtained based on vendor declaration (Section 4.6) or alternatively from reading capability signaling.

7.1.3.1.2 Common test parameters

Parameters specified in Table 7.1.3.1.2-1 are applied for all test cases in this clause unless otherwise stated.

Table 7.1.3.1.2-1: Test parameters for CSI test cases

Parameter		Unit	Value
PDSCH transmission scheme			Transmission scheme 1
Duplex mode			TDD
PTRS epre-Ratio			N/A
Actual carrier configuration	Offset between Point A and the lowest usable subcarrier on this carrier (Note 3)	RBs	0
	Subcarrier spacing	kHz	30
DL BWP configuration #1	Cyclic prefix		Normal
	RB offset	RBs	0
	Number of contiguous PRB	PRBs	106
Active DL BWP index			1
PDSCH configuration	Mapping type		Type A
	k0		0
	Starting symbol (S)		2
	Length (L)		12
	PDSCH aggregation factor		1
	PRB bundling type		Static
	PRB bundling size		2
	Resource allocation type		Type 0
	VRB-to-PRB mapping type		Non-interleaved
VRB-to-PRB mapping interleaver bundle size		N/A	
PDSCH DMRS configuration	DMRS Type		Type 1
	Number of additional DMRS		1
	Maximum number of OFDM symbols for DL front loaded DMRS		1
	DMRS ports indexes		{1000} for Rank1 {1000,1001} for Rank2 {1000,1001,1002} for Rank3 {1000,1001,1002,1003} for Rank4
	Number of PDSCH DMRS CDM group(s) without data		2
PTRS configuration	Frequency density (K_{PTRS})		N/A
	Time density (L_{PTRS})		N/A
	Resource Element Offset		N/A
NZP CSI-RS for CSI acquisition	Frequency Occupation		Start PRB 0 Number of PRB = BWP size
Redundancy version coding sequence			{0,2,3,1}
NOTE 1: PDSCH is not scheduled on slots containing CSI-RS or slots which are not full DL.			
NOTE 2: Point A coincides with minimum guard band as specified in Table 5.3.3-1 from TS 38.101-1 [9] for tested channel bandwidth and subcarrier spacing.			

7.1.3.2 Reporting Channel Quality Indicator (CQI)

7.1.3.2.1 Definition and applicability

The reporting accuracy of the channel quality indicator (CQI) under frequency non-selective conditions is determined by the reporting variance and the BLER performance using the transport format indicated by the reported CQI median. The purpose is to verify that the reported CQI values are in accordance with the CQI definition given in TS 38.214 [23]. To account for sensitivity of the input SNR the reporting definition is considered to be verified if the reporting accuracy is met for at least one of two SNR levels separated by an offset of 1 dB.

Which specific test(s) are applicable to NCR-MT is based on the test applicability rules defined in clause 7.1.3.1.1.

7.1.3.2.2 Minimum requirement

The minimum requirement is in TS 38.106 [2] clause 8.2.3.

7.1.3.2.3 Test purpose

The test shall verify the receiver's ability to report CQI values accordance with the CQI definition given in TS 38.214 [23].

7.1.3.2.4 Method of test

7.1.3.2.4.1 Initial conditions

Test environment: Normal, see annex B.2.

RF channels to be tested for single carrier: M; see clause 4.9.1.

7.1.3.2.4.2 Test procedure

- 1) Connect the NCR-MT tester generating the wanted signal and AWGN generators to all NCR-MT *TAB* connectors for diversity reception via a combining network as shown in annex D.5 and D.6.
- 2) Adjust the AWGN generator, according to the channel bandwidth, defined in table 7.1.3.2.4.2-1.

Table 7.1.3.2.4.2-1: AWGN power level at the NCR-MT input

Sub-carrier spacing (kHz)	Channel bandwidth (MHz)	AWGN power level
15 kHz	10	-83.3 dBm / 38.16MHz
30 kHz	40	-77.2 dBm / 38.16MHz

- 3) The characteristics of the wanted signal shall be configured according to the corresponding DL reference measurement channel defined in annex A and the test parameters in table 7.1.3.2.4.2-2 to table 7.1.3.2.4.2-5.

Table 7.1.3.2.4.2-2: Test parameters for testing CQI reporting

Parameter		Unit	Test 1	Test 2
Bandwidth		MHz	10	
Subcarrier spacing		kHz	15	
Default TDD UL-DL pattern (Note 1)			7D1S2U, S=6D:4G:4U	
SNR		dB	8	9 14 15
Propagation channel			AWGN	
Antenna configuration			2x2	
Beamforming Model			As specified in Annex J.3	
NZP CSI-RS for CSI acquisition	CSI-RS resource Type		Periodic	
	Number of CSI-RS ports (X)		2	
	CDM Type		FD-CDM2	
	Density (ρ)		1	
	First subcarrier index in the PRB used for CSI-RS (k_0, k_1)		Row 3,(6,-)	
	First OFDM symbol in the PRB used for CSI-RS (l_0)		13	
NZP CSI-RS-timeConfig periodicity and offset		slot	5/1	
ReportConfigType			Periodic	
CQI-table			Table 2	
reportQuantity			cri-RI-PMI-CQI	
cqi-FormatIndicator			Wideband	
pmi-FormatIndicator			Wideband	
Sub-band Size		RB	8	
Csi-ReportingBand			1111111	
CSI-Report periodicity and offset		slot	5/0	
Codebook configuration	Codebook Type		type1-SinglePanel	
	Codebook Mode		1	
	CodebookSubsetRestriction		010000	
	RI Restriction		N/A	
CQI/RI/PMI delay		ms	8	
Maximum number of HARQ transmission			1	
Measurement channel			M-FR1-NCR.1.3-1	
NOTE 1: The same requirements are applicable for TDD with different UL-DL pattern.				

Table 7.1.3.2.4.2-3: Test parameters for testing CQI reporting

Parameter		Unit	Test 1	Test 2
Bandwidth		MHz	10	
Subcarrier spacing		kHz	15	
Default TDD UL-DL pattern (Note 1)			7D1S2U, S=6D:4G:4U	
SNR		dB	6	7 12 13
Propagation channel			AWGN	
Antenna configuration			2x4	
Beamforming Model			As specified in Annex J.3	
NZIP CSI-RS for CSI acquisition	CSI-RS resource Type		Periodic	
	Number of CSI-RS ports (X)		2	
	CDM Type		FD-CDM2	
	Density (ρ)		1	
	First subcarrier index in the PRB used for CSI-RS (k_0, k_1)		Row 3,(6,-)	
	First OFDM symbol in the PRB used for CSI-RS (l_0)		13	
NZP CSI-RS-timeConfig periodicity and offset		slot	5/1	
ReportConfigType			Periodic	
CQI-table			Table 2	
reportQuantity			cri-RI-PMI-CQI	
cqi-FormatIndicator			Wideband	
pmi-FormatIndicator			Wideband	
Sub-band Size		RB	8	
Csi-ReportingBand			1111111	
CSI-Report periodicity and offset		slot	5/0	
Codebook configuration	Codebook Type		type1-SinglePanel	
	Codebook Mode		1	
	CodebookSubsetRestriction		010000	
	RI Restriction		N/A	
CQI/RI/PMI delay		ms	8	
Maximum number of HARQ transmission			1	
Measurement channel			M-FR1-NCR.1.3-1	
NOTE 1: The same requirements are applicable for TDD with different UL-DL pattern.				

Table 7.1.3.2.4.2-4: Test parameters for testing CQI reporting

Parameter		Unit	Test 1	Test 2
Bandwidth		MHz	40	
Subcarrier spacing		kHz	30	
Default TDD UL-DL pattern (Note 1)			7D1S2U, S=6D:4G:4U	
SNR		dB	8	9 14 15
Propagation channel			AWGN	
Antenna configuration			2x2	
Beamforming Model			As specified in Annex J.3	
NZP CSI-RS for CSI acquisition	CSI-RS resource Type		Periodic	
	Number of CSI-RS ports (X)		2	
	CDM Type		FD-CDM2	
	Density (ρ)		1	
	First subcarrier index in the PRB used for CSI-RS (k_0, k_1)		Row 3,(6,-)	
	First OFDM symbol in the PRB used for CSI-RS (l_0)		13	
NZP CSI-RS-timeConfig periodicity and offset		slot	10/1	
ReportConfigType			Periodic	
CQI-table			Table 2	
reportQuantity			cri-RI-PMI-CQI	
cqi-FormatIndicator			Wideband	
pmi-FormatIndicator			Wideband	
Sub-band Size		RB	16	
Csi-ReportingBand			1111111	
CSI-Report periodicity and offset		slot	10/9	
Codebook configuration	Codebook Type		type1-SinglePanel	
	Codebook Mode		1	
	CodebookSubsetRestriction		010000	
	RI Restriction		N/A	
CQI/RI/PMI delay		ms	9.5	
Maximum number of HARQ transmission			1	
Measurement channel			M-FR1-NCR.1.3-2	
NOTE 1: The same requirements are applicable for TDD with different UL-DL pattern.				

Table 7.1.3.2.4.2-5: Test parameters for testing CQI reporting

Parameter		Unit	Test 1	Test 2
Bandwidth		MHz	40	
Subcarrier spacing		kHz	30	
Default TDD UL-DL pattern (Note 1)			7D1S2U, S=6D:4G:4U	
SNR		dB	5	6 11 12
Propagation channel			AWGN	
Antenna configuration			2x4	
Beamforming Model			As specified in Annex J.3	
NZP CSI-RS for CSI acquisition	CSI-RS resource Type		Periodic	
	Number of CSI-RS ports (X)		2	
	CDM Type		FD-CDM2	
	Density (ρ)		1	
	First subcarrier index in the PRB used for CSI-RS (k_0, k_1)		Row 3,(6,-)	
	First OFDM symbol in the PRB used for CSI-RS (l_0)		13	
NZP CSI-RS-timeConfig periodicity and offset		slot	10/1	
ReportConfigType			Periodic	
CQI-table			Table 2	
reportQuantity			cri-RI-PMI-CQI	
cqi-FormatIndicator			Wideband	
pmi-FormatIndicator			Wideband	
Sub-band Size		RB	16	
Csi-ReportingBand			1111111	
CSI-Report periodicity and offset		slot	10/9	
Codebook configuration	Codebook Type		type1-SinglePanel	
	Codebook Mode		1	
	CodebookSubsetRestriction		010000	
	RI Restriction		N/A	
CQI/RI/PMI delay		ms	9.5	
Maximum number of HARQ transmission			1	
Measurement channel			M-FR1-NCR.1.3-2	
NOTE 1: The same requirements are applicable for TDD with different UL-DL pattern.				

- 4) Adjust the equipment so that required SNR specified in table 7.1.3.2.4.2-2 to 7.1.3.2.4.2-5 is achieved at the NCR-MT input.
- 5) For each test specified in table 7.1.3.2.4.2-2 to 7.1.3.2.4.2-5 applicable for the NCR-MT, measure the median CQI and the BLER at median CQI and (median CQI+1 or median CQI-1) as per clause 7.1.3.2.5.

7.1.3.2.5 Test requirement

For the parameters specified in Table 7.1.3.2.4.2-2 to 7.1.3.2.4.2-5, and using the downlink physical channels specified in Annex A, the test requirements are specified by the following:

- a) The reported CQI value according to the reference channel shall be in the range of ± 1 of the reported median more than 90% of the time.
- b) If the PDSCH BLER using the transport format indicated by median CQI is less than or equal to 0.1, then the BLER using the transport format indicated by the (median CQI+1) shall be greater than 0.1. If the PDSCH BLER using the transport format indicated by the median CQI is greater than 0.1, then the BLER using transport format indicated by (median CQI-1) shall be less than or equal to 0.1.

Annex A (normative): Repeater stimulus signals

A.1 Repeater stimulus signal 1

This repeater stimulus signal shall be used for the following tests:

- Uplink maximum output power
- Uplink operating band unwanted emissions
- Uplink spurious emissions

Two uplink fixed reference channels for performance requirements (16QAM $\frac{3}{4}$) for FDD according to the TS38.141-1 [7], [A.4 table A.4-1, channel reference AX-X of 5] MHz bandwidth generated on separate centre frequencies with equal power and combined with a time difference of 266,7 μ s (4 OFDM symbols)

The PUSCH data payload shall contain only zeroes (0000 0000).

Each reference channel shall be subjected to time windowing and filtering so that it fulfils the spectral purity requirements defined in A.3.

A.2 Repeater stimulus signal 2

This repeater stimulus signal shall be used for the following tests:

- Downlink operating band unwanted emissions
- Downlink spurious emissions

Two NR-FR1-TM1.1 channels according to the TS38.141-1 [7] of 5 MHz bandwidth generated on separate centre frequencies with equal power and combined with a time difference of [1400 μ s (21 OFDM symbols)].

Each NR-FR1-TM1.1 channel shall be subjected to time windowing and filtering so that it fulfils the spectral purity requirements defined in A.3.

A.3 Repeater stimulus signal spectral purity requirements

The reference channels or test models constituting the repeater stimulus signal shall fulfil the spectral purity requirements defined in table A.3-1 and A.3-2, where:

- the minimum spectral density suppression is related to the reference spectral density.

Table A.3-1: Repeater stimulus signal spectral purity requirements for nominal channel bandwidth of passband ≤ 20 MHz

Center frequency of measurement filter	Minimum requirements	Measurement filter type and filter bandwidth	Integration bandwidth
50.0 kHz outside from channel edge	46.8 dBc (Note 1)	Square (100 kHz)	100 kHz
Center of adjacent channel frequency with same nominal channel BW	46.8 dBc (Note 2)	Square (nominal channel BW)	Nominal channel BW
NOTE 1: the reference spectral density shall be taken at the carrier center frequency with an integration bandwidth of 100 kHz. NOTE 2: the reference spectral density shall be taken at the carrier center frequency with an integration bandwidth of nominal carrier BW			

Table A.3-2: Repeater stimulus signal spectral purity requirements for nominal channel bandwidth of passband > 20 MHz

Center frequency of measurement filter	Minimum requirements	Measurement filter type and filter bandwidth	Integration bandwidth
50.0 kHz outside from channel edge	47.2 dBc (Note 1)	Square (100 kHz)	100 kHz
Center of adjacent channel frequency with same nominal channel BW	47.2 dBc (Note 2)	Square (nominal channel BW)	Nominal channel BW
NOTE 1: the reference spectral density shall be taken at the carrier center frequency with an integration bandwidth of 100 kHz. NOTE 2: the reference spectral density shall be taken at the carrier center frequency with an integration bandwidth of nominal carrier BW			

Annex B (normative): Environmental requirements for the repeater

B.1 General

For each test in the present document, the environmental conditions under which the repeater is to be tested are defined.

B.2 Normal test environment

When a normal test environment is specified for a test, the test should be performed within the minimum and maximum limits of the conditions stated in table B.1.

Table B.1: Limits of conditions for normal test environment

Condition	Minimum	Maximum
Barometric pressure	86 kPa	106 kPa
Temperature	15 °C	30 °C
Relative humidity	20 %	85 %
Power supply	Nominal, as declared by the manufacturer	
Vibration	Negligible	

The ranges of barometric pressure, temperature and humidity represent the maximum variation expected in the uncontrolled environment of a test laboratory. If it is not possible to maintain these parameters within the specified limits, the actual values shall be recorded in the test report.

NOTE: This may, for instance, be the case for measurements of radiated emissions performed on an open field test site.

B.3 Extreme test environment

The manufacturer shall declare one of the following:

- 1) The equipment class for the equipment under test, as defined in the IEC 60 721-3-3 [16];
- 2) The equipment class for the equipment under test, as defined in the IEC 60 721-3-4 [17];
- 3) The equipment that does not comply with the mentioned classes, the relevant classes from IEC 60 721 [18] documentation for temperature, humidity and vibration shall be declared.

NOTE: Reduced functionality for conditions that fall outside of the standard operational conditions is not tested in the present document. These may be stated and tested separately.

B.3.1 Extreme temperature

When an extreme temperature test environment is specified for a test, the test shall be performed at the standard minimum and maximum operating temperatures defined by the manufacturer's declaration for the equipment under test.

Minimum temperature:

The test shall be performed with the environment test equipment and methods including the required environmental phenomena into the equipment, conforming to the test procedure of IEC 60 068-2-1 [19].

Maximum temperature:

The test shall be performed with the environmental test equipment and methods including the required environmental phenomena into the equipment, conforming to the test procedure of IEC 60 068-2-2 [20].

NOTE: It is recommended that the equipment is made fully operational prior to the equipment being taken to its lower operating temperature.

B.4 Vibration

When vibration conditions are specified for a test, the test shall be performed while the equipment is subjected to a vibration sequence as defined by the manufacturer's declaration for the equipment under test. This shall use the environmental test equipment and methods of inducing the required environmental phenomena in to the equipment, conforming to the test procedure of IEC 60 068-2-6 [21]. Other environmental conditions shall be within the ranges specified in annex B.2.

NOTE: The higher levels of vibration may induce undue physical stress in to equipment after a prolonged series of tests. The testing body should only vibrate the equipment during the RF measurement process.

B.5 Power supply

When extreme power supply conditions are specified for a test, the test shall be performed at the standard upper and lower limits of operating voltage defined by manufacturer's declaration for the equipment under test.

Upper voltage limit:

The equipment shall be supplied with a voltage equal to the upper limit declared by the manufacturer (as measured at the input terminals to the equipment). The tests shall be carried out at the steady state minimum and maximum temperature limits declared by the manufacturer for the equipment, to the methods described in IEC 60 068-2-1 [19] Test Ab/Ad and IEC 60 068-2-2 [20] Test Bb/Bd: Dry heat.

Lower voltage limit:

The equipment shall be supplied with a voltage equal to the lower limit declared by the manufacturer (as measured at the input terminals to the equipment). The tests shall be carried out at the steady state minimum and maximum temperature limits declared by the manufacturer for the equipment, to the methods described in IEC 60 068-2-1 [19] Test Ab/Ad and IEC 60 068-2-2 [20] Test Bb/Bd: Dry heat.

B.6 Measurement of test environments

The measurement accuracy of the repeater test environments defined in annex B shall be:

Pressure: ± 5 kPa

Temperature: ± 2 degrees

Relative humidity: ± 5 %

DC voltage: ± 1.0 %

AC voltage: ± 1.5 %

Vibration: 10 %

Vibration frequency: 0.1 Hz

The above values shall apply unless the test environment is otherwise controlled and the specification for the control of the test environment specifies the uncertainty for the parameter.

Annex C (informative): Test tolerances and derivation of test requirements

C.1 Measurement of conducted characteristics

Table C.1-1: Derivation of test requirements (conducted tests)

Test	Minimum requirement in TS 38.106 [2]	Test Tolerance (TT)	Test requirement in the present document
6.2 Repeater output power	See TS 38.106 [2], clause 6.2	Normal and extreme conditions: 0.7 dB, $f \leq 3.0$ GHz 1.0 dB, $3.0 \text{ GHz} < f \leq 7.125\text{GHz}$	Formula: Upper limit + TT, Lower limit – TT
6.3 Frequency stability	See TS 38.106 [2], clause 6.3	12 Hz	Formula: Frequency Error limit + TT
6.4 Out of band gain	See TS 38.106 [2], clause 6.4	0.5 dB, $f \leq 3.0$ GHz 0.8 dB, $3.0 \text{ GHz} < f \leq 7.125\text{GHz}$	Formula: Minimum Requirement + TT
6.5.2 ACLR/ CACLR	See TS 38.106 [2], clause 6.5.2	Relative ACLR/CACLR: BW $\leq 20\text{MHz}$: 0.8 dB BW $> 20\text{MHz}$: 1.2 dB Absolute ACLR/CACLR: 0 dB	Formula: ACLR Minimum Requirement - TT Absolute limit +TT
6.5.3 Operating band unwanted emission	See TS 38.106 [2], clause 6.5.3	Offsets $< 10\text{MHz}$: 1.5 dB, $f \leq 3.0\text{GHz}$ 1.8 dB, $3.0\text{GHz} < f \leq 7.125 \text{ GHz}$ Offsets $\geq 10\text{MHz}$: 0 dB	Formula: Minimum Requirement + TT
6.5.4 Spurious emissions	See TS 38.106 [2], clause 6.5.4	0 dB	Formula: Minimum Requirement + TT
6.6 EVM	See TS 38.106 [2], clause 6.6	1.25%	Formula: EVM limit + TT
6.7 Input intermodulation	See TS 38.106 [2], clause 6.7	0 dB	Formula: Minimum Requirement + TT
6.8 Output intermodulation	See TS 38.106 [2], clause 6.8	0 dB	Formula: Minimum Requirement + TT
6.9 ACRR	See TS 38.106 [2], clause 6.9	0.7 dB	Formula: Minimum Requirement – TT
6.10.1 Transmit ON/OFF power	See TS 38.106 [2], clause 6.10.1	2.0 dB, $f \leq 3.0$ GHz 2.5 dB, $3.0 \text{ GHz} < f \leq 7.125 \text{ GHz}$	Formula: Minimum Requirement + TT
6.10.2 Transmitter transient period	See TS 38.106 [2], clause 6.10.2	N/A	
6.11 Output power dynamics	See TS 38.106 [2], clause 6.11.2, 6.11.3 and 6.11.4		
6.12 Transmit signal quality	See TS 38.106 [2], clause 6.12.2, 6.12.3		
6.13 Transmit intermodulation	See TS 38.106 [2], clause 6.13.2		
6.14 Conducted reference sensitivity	See TS 38.106 [2], clause 6.16.1.2		
6.15 Conducted maximum input level	See TS 38.106 [2], clause 6.17		
6.16 Conducted adjacent channel	See TS 38.106 [2], clause 6.18.1.2 and 6.18.1.3		
6.17 Conducted blocking characteristics	See TS 38.106 [2], clause 6.19.2 and 6.19.3		
6.18 Conducted spurious response	See TS 38.106 [2], clause 6.20.2		
6.19 Conducted intermodulation characteristics	See TS 38.106 [2], clause 6.21.2 and See TS 38.106 [2], clause 6.21.3		
6.20 Conducted spurious emissions	See TS 38.106 [2], clause 6.21.2 and See TS 38.106 [2], clause 6.22.2		

NOTE: TT values are applicable for normal condition unless otherwise stated.

Annex D (informative): Measurement system set-up

Example of measurement system set-ups are attached below as an informative annex.

The following measurement system set up is applicable for both repeater type 1-C and NCR type 1-C.

For the measurement setup for NCR-MT type 1-H, the existing measurement setup in Annex D.1 and D.2 of TS 38.176-1 is applicable.

For the measurement setup for NCR-MT type 1-C, the existing measurement setup in Annex D.1 and D.2 of TS 38.176-1 is applicable with the TAB connectors replaced with antenna connectors.

D.1 Repeater output power and transmit ON/OFF power

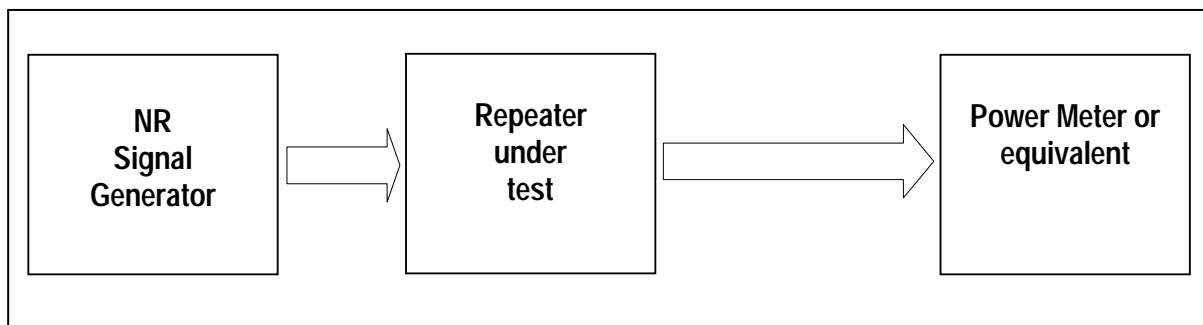

Figure D.1-1: Measuring system set-up for repeater output power and transmit ON/OFF power

Note 1: The repeater is a bi-directional device. The signal generator may need protection.

Note 2: UL/DL timing can be provided to the repeater.

Note 3: For NCR-MT output power and transmit ON/OFF power measurement, the external signal generator is not needed.

D.2 Out of band gain

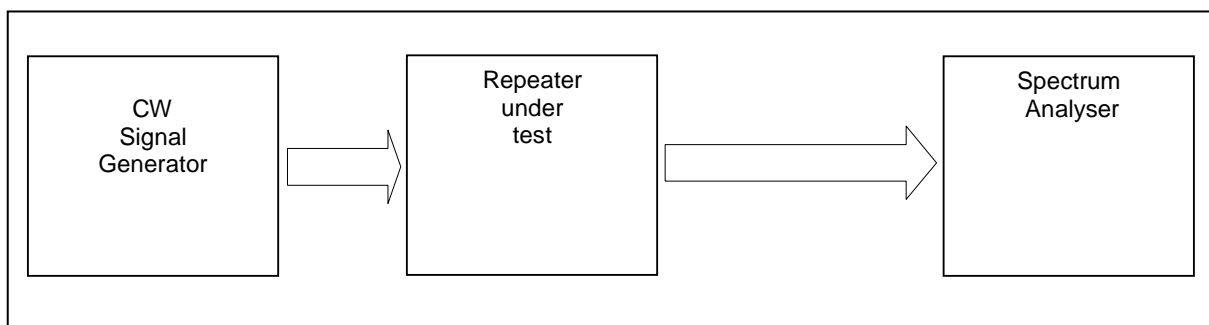

Figure D.2-1: Measuring system set-up for out of band gain

Note 1: The repeater is a bi-directional device. The signal generator may need protection.

Note 2: This requirement is not applicable for NCR-MT.

D.3 Unwanted emission: Operating band unwanted emission, transmitter spurious emission, and ACLR

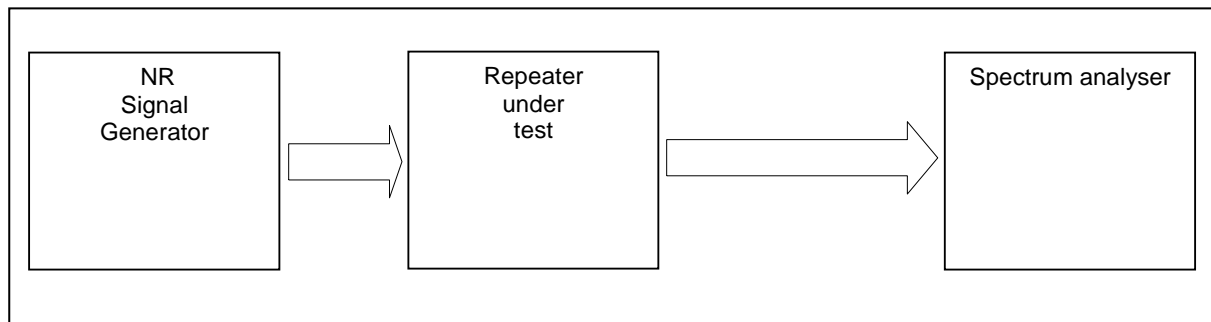

Figure D.3-1: Measuring system set-up for unwanted emission: Operating band unwanted emission, transmitter spurious emission, and ACLR

Note 1: The repeater is a bi-directional device. The signal generator may need protection.

Note 2: UL/DL timing can be provided to the repeater.

Note 3: For NCR-MT output power and transmit ON/OFF power measurement, the external signal generator is not needed.

D.4 Modulation Accuracy: Repeater Error Vector Magnitude and Frequency Stability

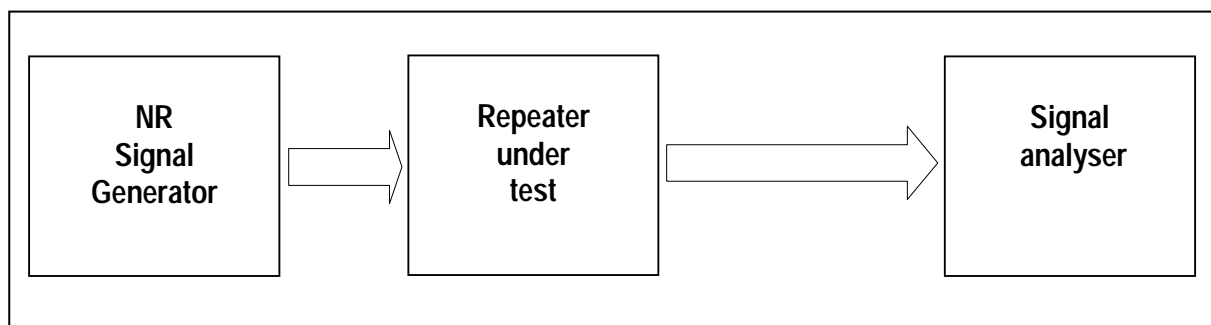

Figure D.4-1: Measuring system set-up for repeater error vector magnitude and frequency stability

Note 1: The repeater is a bi-directional device. The signal generator may need protection.

Note 2: UL/DL timing can be provided to the repeater.

Note 3: This requirement is not applicable for NCR-MT.

D.5 Input intermodulation

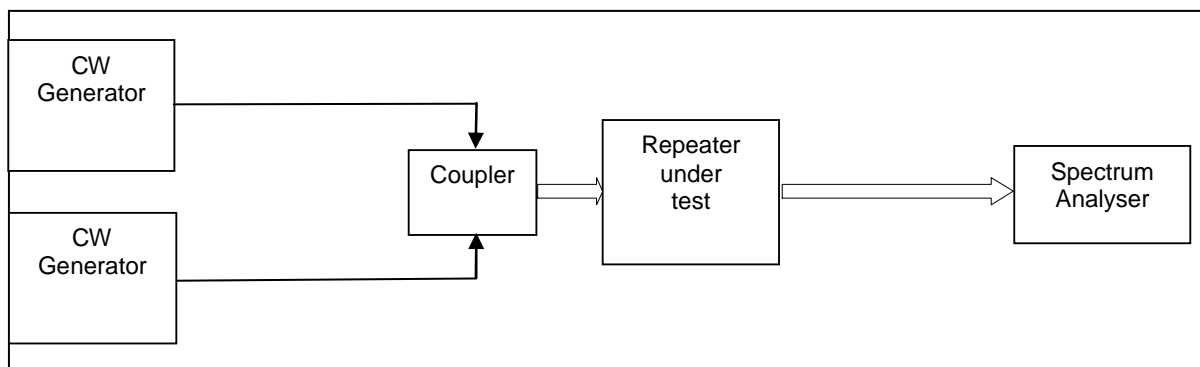

Figure D.5-1: Measuring system set-up for input intermodulation.

Note 1: The repeater is a bi-directional device. The signal generator may need protection.

Note 2: This requirement is not applicable for NCR-MT.

D.6 Output Intermodulation

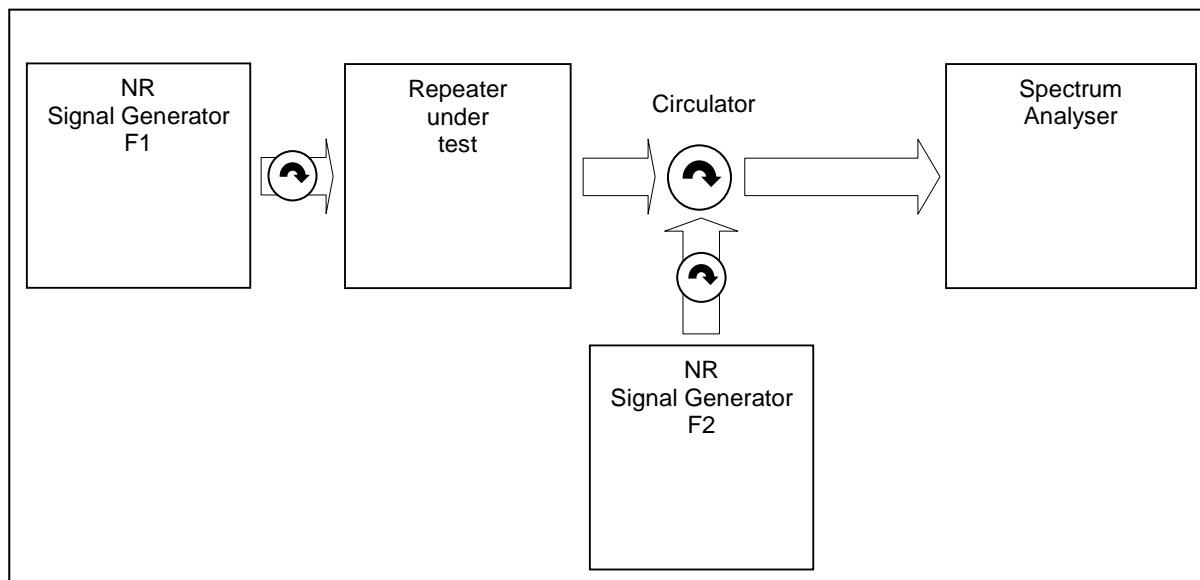

Figure D.6-1: Measuring system set-up for output intermodulation.

Note 1: The repeater is a bi-directional device. The signal generator may need protection.

Note 2: UL/DL timing can be provided to the repeater.

D.7 Adjacent Channel Rejection Ratio

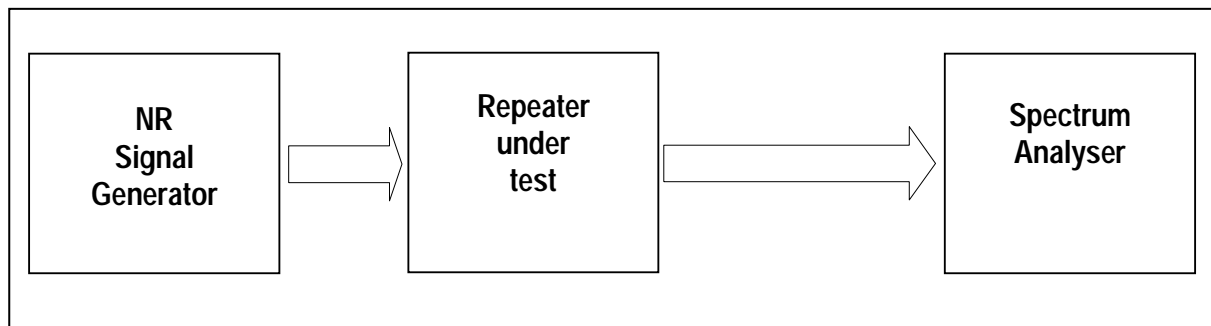

Figure D.7-1: Measuring system set-up for Adjacent Channel Rejection Ratio

Note 1: The repeater is a bi-directional device. The signal generator may need protection.

Note 2: UL/DL timing can be provided to the repeater.

Note 3: This requirement is not applicable for NCR-MT.

D.8 Rx spurious emission requirement

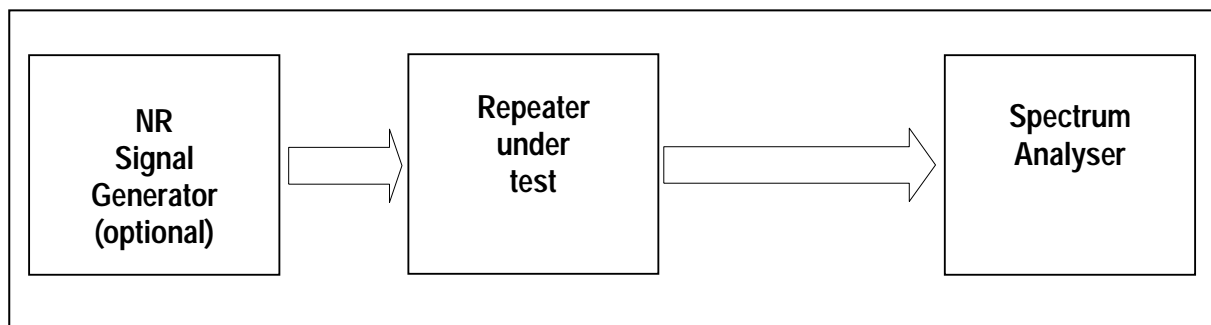

Figure D.8-1: Measuring system set-up for receiver spurious emission

Note 1: The repeater is a bi-directional device. The signal generator may need protection.

Note 2: UL/DL timing can be provided to the repeater.

Note 3: For NCR-MT output power and transmit ON/OFF power measurement, the external signal generator is not needed.

D.9 NCR-MT type 1-C PDCCH and PDSCH demodulation testing

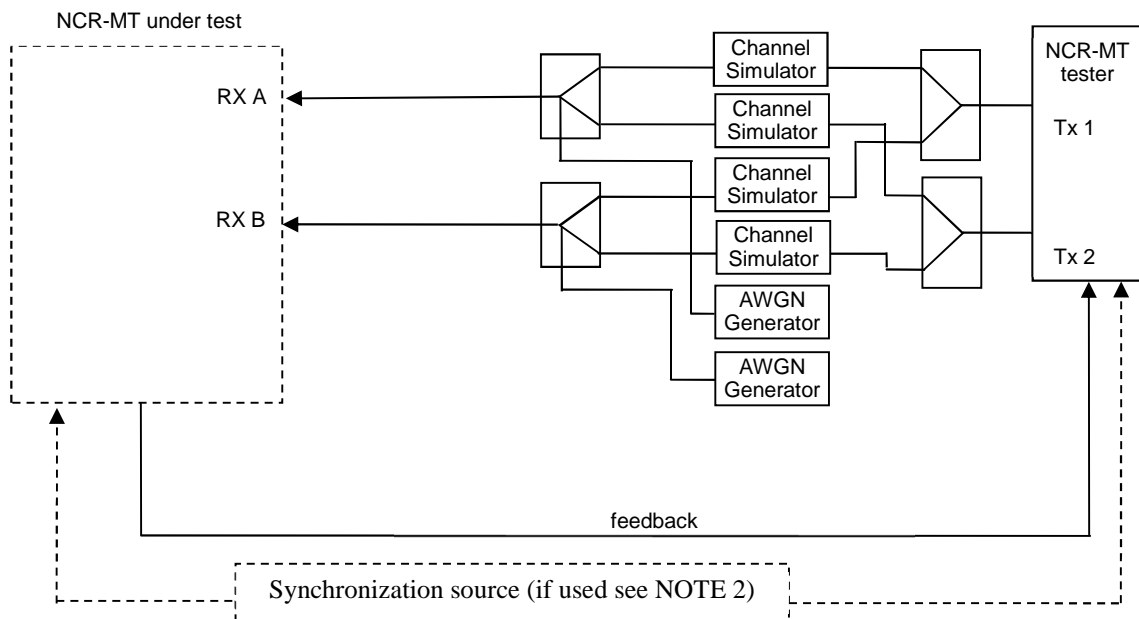

Figure D.9-1: Functional set-up for performance requirements for PDSCH and PDCCH transmission on two antenna ports in multipath fading conditions (2 Rx case shown)

NOTE 1: The feedback could be done as an RF feedback, either using NR channels or using other means, or as a digital feedback. The HARQ Feedback should be error free.

NOTE 2: In tests performed with signal generators, a synchronization signal may be provided between the NCR-MT node and the signal generator, or a common (e.g., GNSS) source may be provided to both NCR-MT node and the signal generator, to enable correct timing of the wanted signal. The method of synchronization with the TE is left to test implementation.

NOTE 3: It is left up to implementation how L1/L2 is configured for testing.

D.10 NCR-MT type 1-C CQI testing

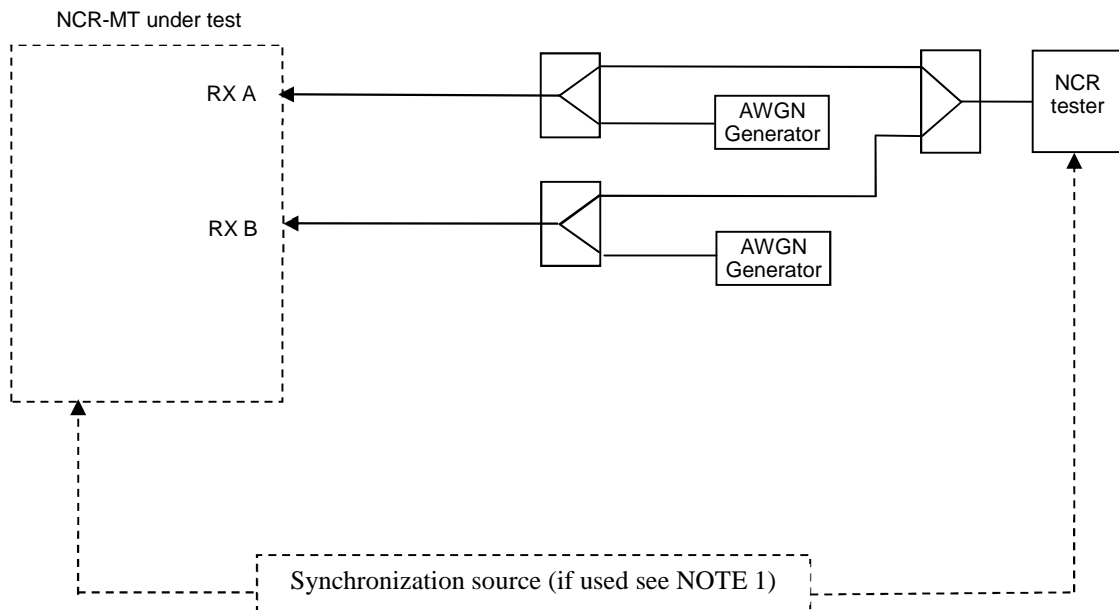

Figure D.10-1: Functional set-up for performance requirements for CQI in static conditions for NCR-MT with Rx diversity (2 Rx case shown)

NOTE 1: In tests performed with signal generators, a synchronization signal may be provided between the NCR node and the signal generator, or a common (e.g., GNSS) source may be provided to both NCR node and the signal generator, to enable correct timing of the wanted signal. The method of synchronization with the TE is left to test implementation.

NOTE 2: It is left up to implementation how L1/L2 is configured for testing.

D.11 NCR-MT type 1-H PDCCH and PDSCH demodulation testing

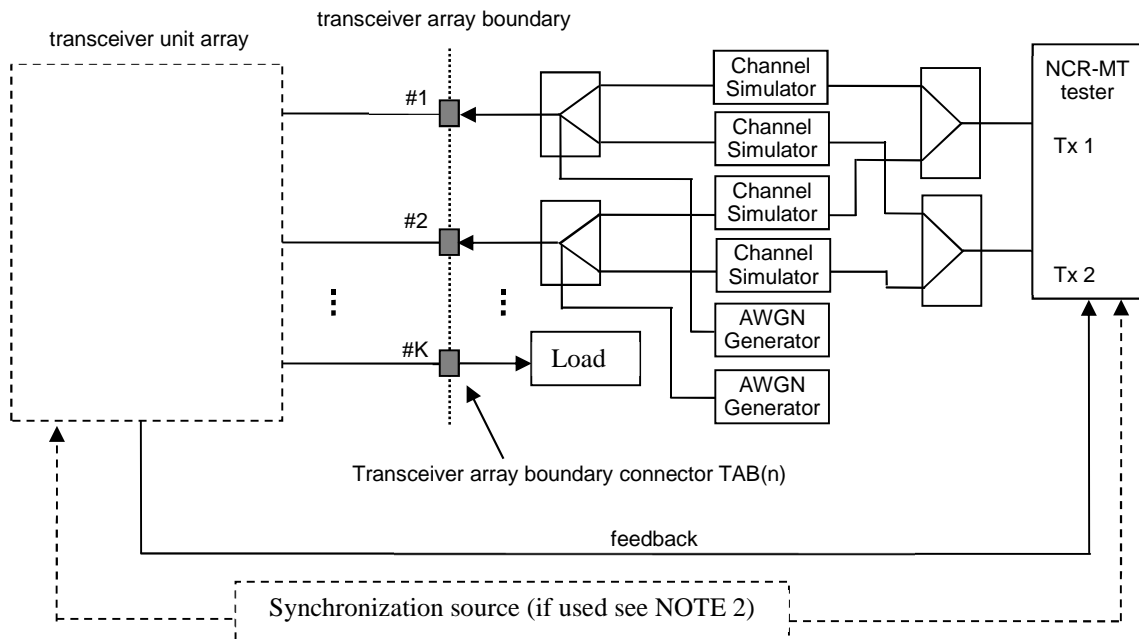

Figure D.11-1: Functional set-up for performance requirements for PDSCH and PDCCH transmission on two antenna ports in multipath fading conditions (2 Rx case shown)

NOTE 1: The feedback could be done as an RF feedback, either using NR channels or using other means, or as a digital feedback. The HARQ Feedback should be error free.

NOTE 2: In tests performed with signal generators, a synchronization signal may be provided between the NCR-MT node and the signal generator, or a common (e.g., GNSS) source may be provided to both NCR-MT node and the signal generator, to enable correct timing of the wanted signal. The method of synchronization with the TE is left to test implementation.

NOTE 3: It is left up to implementation how L1/L2 is configured for testing.

D.12 NCR-MT type 1-H CQI testing

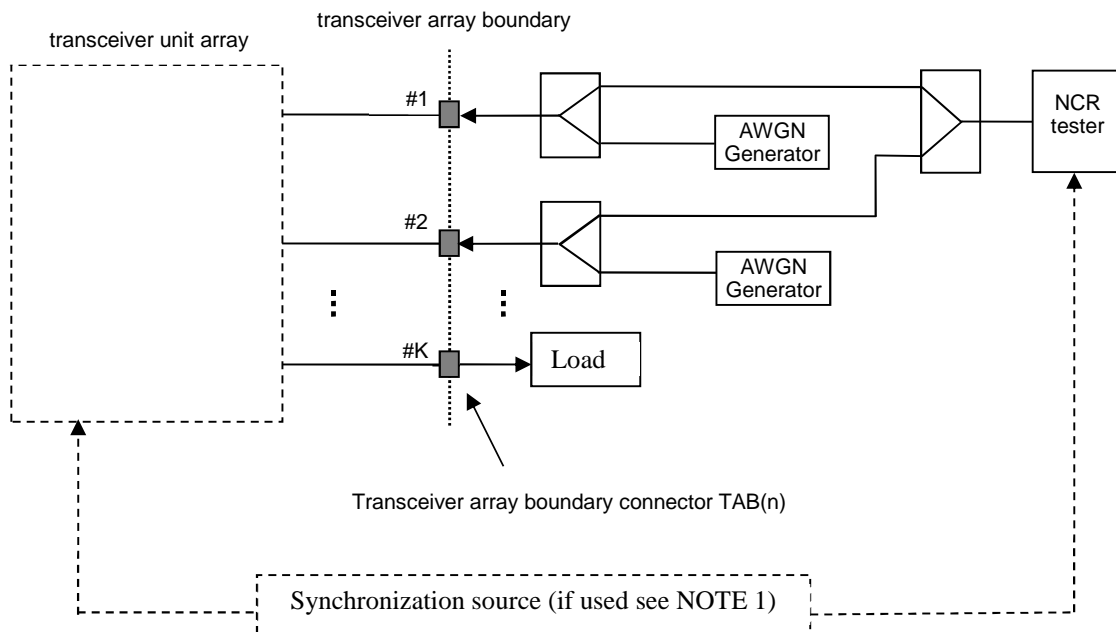

Figure D.12-1: Functional set-up for performance requirements for CQI in static conditions for NCR-MT with Rx diversity (2 Rx case shown)

NOTE 1: In tests performed with signal generators, a synchronization signal may be provided between the NCR node and the signal generator, or a common (e.g., GNSS) source may be provided to both NCR node and the signal generator, to enable correct timing of the wanted signal. The method of synchronization with the TE is left to test implementation.

NOTE 2: It is left up to implementation how L1/L2 is configured for testing.

Annex E (normative): In-channel TX tests

E.1 General

The in-channel TX test enables the measurement of all relevant parameters that describe the in-channel quality of the output signal of the repeater under test in a single measurement process.

The parameters describing the in-channel quality of a transmitter, however, are not necessarily independent. The algorithm chosen for description inside this annex places particular emphasis on the exclusion of all interdependencies among the parameters.

E.2 Basic principles

The process is based on the comparison of the actual output signal of the repeater under test, received by an ideal receiver, with an ideal signal, that is generated by the measuring equipment and represents an ideal error free received signal. All signals are represented as equivalent (generally complex) baseband signals.

The description below uses numbers and illustrations as examples only. These numbers are taken from a FDD frame structure with normal CP length, 30 kHz SCS and a transmission bandwidth configuration of 100 MHz ($N_{RB} = 273$). The application of the text below, however, is not restricted to this parameter set.

E.2.1 Output signal of the repeater under test

The output signal of the repeater under test is acquired by the measuring equipment and stored for further processing. It is sampled at a sampling rate which is the product of the SCS and the *FFT size*, and it is named $s(t)$. The *FFT size* is determined by the transmission bandwidth in table 6.6.3.5-2 for 15 kHz SCS, table 6.6.3.5-3 for 30 kHz SCS and table 6.5.3.5-4 for 60 kHz SCS in [6]. In the time domain, it comprises at least 10 ms. It is modelled as a signal with the following parameters:

- demodulated data content,
- carrier frequency,
- amplitude and phase for each subcarrier.

For the example in the annex, the *FFT size* is 4096 based on table 6.6.3.5-3 in [6]. The sampling rate of 122.88 Msps is the product of the *FFT size* and SCS.

E.2.2 Ideal signal

Two types of ideal signals are defined:

The first ideal signal $i_1(t)$ is constructed by the measuring equipment according to the relevant TX specifications, using the following parameters:

- demodulated data content,
- nominal carrier frequency,
- nominal amplitude and phase for each subcarrier.

It is represented as a sequence of samples at the sampling rate determined from annex E.2.1 in the time domain. The structure of the signal is described in the test models.

The second ideal signal $\tilde{x}_2(t)$ is constructed by the measuring equipment according to the relevant TX specifications, using the following parameters:

- nominal demodulation reference signals (all other modulation symbols are set to 0 V),
- nominal carrier frequency,
- nominal amplitude and phase for each applicable subcarrier,
- nominal timing.

It is represented as a sequence of samples at the sampling rate determined from annex E.2.1 in the time domain.

E.2.3 Measurement results

The measurement results, achieved by the in-channel TX test are the following:

- Carrier frequency stability
- EVM

E.2.4 Measurement points

The EVM shall be measured at the point after the FFT and a zero-forcing (ZF) equalizer in the receiver, as depicted for FR1 in figure F.2.4-1. The FFT window of $FFT\ size$ samples out of $(FFT\ size + \text{cyclic prefix length})$ samples in the time domain is selected in the "Remove CP" box. The $FFT\ size$ and the cyclic prefix length are obtained from table 6.6.3.5-2 for 15 kHz SCS, table 6.6.3.5-3 for 30 kHz SCS and table 6.6.3.5-4 for 60 kHz SCS in [6].

In one subframe, there are two symbols with the length of the cyclic prefix larger than the values listed in tables 6.6.3.5-2, 6.6.3.5-3 and 6.6.3.5-4 in [6]. Table F.2.4-1 lists the slot number and the symbol number and the formula how to compute the length of cyclic prefix for those two symbols according to the sampling rate.

Table E.2.4-1: Slot number and symbol number identifying the longer CP length for normal CP

SCS (kHz)	# slots in subframe	Symbol # and slot # with longer CP	Longer CP length
15	1	(symbol 0, slot 0) (symbol 7, slot 0)	CP length + $FFT\ size / 128$
30	2	(symbol 0, slot 0) (symbol 0, slot 1)	CP length + $FFT\ size / 64$
60	4	(symbol 0, slot 0) (symbol 0, slot 2)	CP length + $FFT\ size / 32$

For the example used in the annex, the "Remove CP" box selects 4096 samples out of 4384 samples. Symbol 0 has 64 more samples in the cyclic prefix than the other 13 symbols in the slot (the longer CP length = 352).

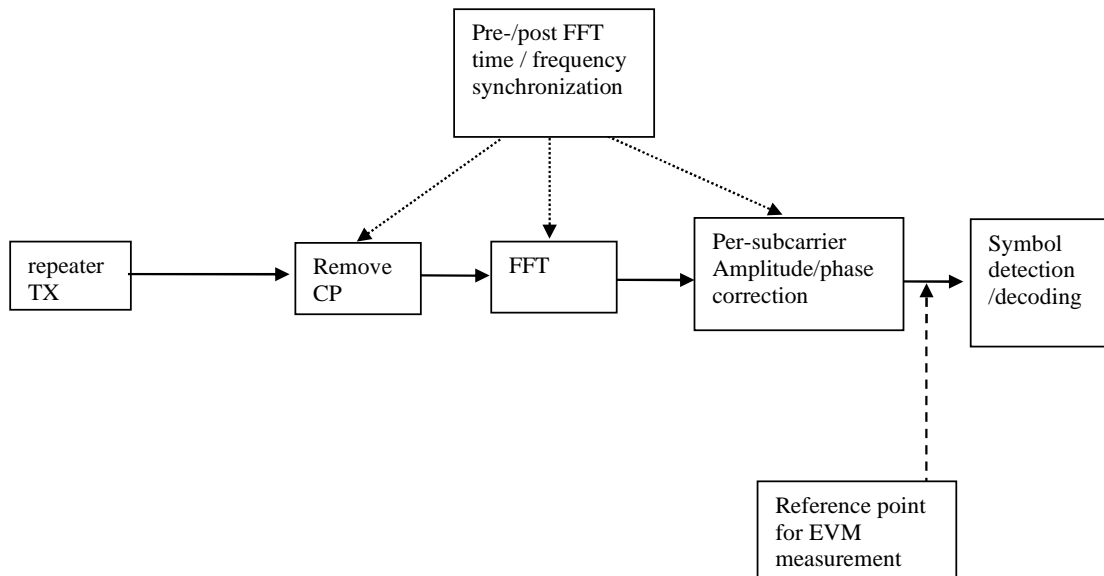

Figure E.2.4-1: Reference point for FR1 EVM measurements

E.3 Pre-FFT minimization process

Sample Timing, Carrier Frequency in $z(w)$ are varied in order to minimise the difference between $z(w)$ and $t_1(w)$, after the amplitude ratio of $z(w)$ and $t_1(w)$ has been scaled. Best fit (minimum difference) is achieved when the RMS difference value between $z(w)$ and $t_1(w)$ is an absolute minimum.

The carrier frequency variation is the measurement result: carrier frequency stability.

From the acquired samples, one value of carrier frequency stability can be derived.

NOTE 1: The minimisation process, to derive the RF error can be supported by post-FFT operations. However the minimisation process defined in the pre-FFT domain comprises all acquired samples (i.e. it does not exclude the samples inbetween the FFT widths and it does not exclude the bandwidth outside the transmission bandwidth configuration).

NOTE 2: The algorithm would allow to derive carrier frequency error and sample frequency error of the TX under test separately. However there are no requirements for sample frequency error. Hence the algorithm models the RF and the sample frequency commonly (not independently). It returns one error and does not distinguish between both.

After this process, the samples $z(w)$ are called $z^0(w)$.

E.4 Timing of the FFT window

The FFT window length is $FFT\ size$ samples per OFDM symbol. For FDD, there are $14N_{dt}$ FFTs performed where N_{dt} is the number of slots in a 10 ms measurement interval, and the number of symbols in a slot for normal CP is 14.

The position in time for the FFT shall be determined.

For the example used in the annex, the FFT window length is 4096 samples per OFDM symbol. 280 FFTs (i.e. 1,146,880 samples) cover less than the acquired number of samples (i.e. 1,228,800 samples in 10 ms).

In an ideal signal, the FFT may start at any instant within the cyclic prefix without causing an error. The TX filter, however, reduces the window. The EVM requirements shall be met within a window $W < CP$. There are three different instants for FFT:

- Centre of the reduced window, called Δt ,

- $\Delta c - W/2$, and
- $\Delta c + W/2$.

The value of EVM window length W is obtained from tables 6.6.3.5-2 for 15 kHz SCS, 6.6.3.5-3 for 30 kHz SCS and 6.6.3.5-4 for 60 kHz SCS in [6] and the transmission bandwidth.

The repeater shall transmit a signal according to the test models intended for EVM. The demodulation reference signal of the second ideal signal shall be used to find the centre of the FFT window.

The timing of the measured signal is determined in the pre-FFT domain as follows, using $z^p(v)$ and $t_2(v)$:

1. The measured signal is delay spread by the TX filter. Hence the distinct borders between the OFDM symbols and between data and CP are also spread and the timing is not obvious.
2. In the ideal signal $t_2(v)$, the timing is known.

Correlation between bullet (1) and (2) will result in a correlation peak. The meaning of the correlation peak is approximately the "impulse response" of the TX filter.

3. The meaning of "impulse response" assumes that the autocorrelation of the ideal signal $t_2(v)$ is a Dirac peak and that the correlation between the ideal signal $t_2(v)$ and the data in the measured signal is 0. The correlation peak, (the highest, or in case of more than one highest, the earliest) indicates the timing in the measured signal.

The number of samples used for FFT is reduced compared to $z^p(v)$. This subset of samples is called $z'(v)$.

From the acquired samples one timing can be derived.

The timing of the centre Δc is determined according to the cyclic prefix length of the OFDM symbols. For normal CP, there are two values for Δc in a 1 ms period:

- $\Delta c = \text{length of cyclic prefix} / 2$,
- $\Delta c = \text{Longer CP length} - \text{length of cyclic prefix} / 2$,

Where the length of cyclic prefix is obtained from table 6.6.3.5-2 for 15 kHz SCS, table 6.6.3.5-3 for 30 kHz SCS and table 6.6.3.5-4 for 60 kHz SCS in [6], and the longer CP length is obtained from table F.2.4-1.

As per the example values:

- $\Delta c = 144$ within the CP of length 288 for OFDM symbols 1 to 13 of a slot,
- $\Delta c = 208 = 352 - 144$ within the CP of length 352 for OFDM symbol 0 of a slot.

E.5 Resource element TX power

Perform FFT on $z'(v)$ with the FFT window timing Δc . The result is called $Z'(t, f)$. The RE TX power (RETP) is then defined as:

$$RETP = |Z'(t, f)|^2 SCS$$

Where SCS is the subcarrier spacing in Hz.

From RETP the OFDM Symbol TX power (OSTP) is derived as follows:

$$OSTP = \frac{1}{N_{sym}} \sum RETP$$

Where the summation accumulates $N_{RB} N_{SC}^{RB}$ RETP values of all N_{sym} OFDM symbols that carry PDSCH and not containing PDCCH, RS or SSB within a slot.

From the acquired samples, N_{dl} values for each OSTP can be obtained and averaged where N_{dl} is the number of slots in a 10 ms measurement interval for FDD. For TDD, N_{dl} is the number of slots with downlink symbols in a 10 ms measurement interval and is computed according to the values in table 4.9.2.2-1 in [6].

For the example used in the annex, $N_{\text{dl}} = 20$ and $N_{\text{RB}} = 273$.

E.6 Post-FFT equalisation

Perform $14N_{\text{dl}}$ FFTs on $z'(v)$, one for each OFDM symbol within 10 ms measurement interval with the FFT window timing to produce an array of samples, $14N_{\text{dl}}$ in the time axis t by *FFT size* in the frequency axis f .

For the example in the annex, 280 FFTs are performed on $z'(v)$. The result is an array of samples, 280 in the time axis by 4096 in the frequency axis.

The equalizer coefficients $\hat{a}(f)$ and $\hat{\phi}(f)$ are determined as follows:

1. Calculate the complex ratios (amplitude and phase) of the post-FFT acquired signal $Z'(t, f)$ and the post-FFT ideal signal $I_2(t, f)$ for each demodulation reference signal, over 10 ms measurement interval. This process creates a set of complex ratios:

$$a(t, f)e^{j\phi(t, f)} = \frac{Z'(t, f)}{I_2(t, f)}$$

2. Perform time averaging at each demodulation reference signal subcarrier of the complex ratios, the time-averaging length is 10 ms measurement interval. Prior to the averaging of the phases $\phi(t_i, f)$ an unwrap operation must be performed according to the following definition:
 - The unwrap operation corrects the radian phase angles of $\phi(t_i, f)$ by adding multiples of $2 * \pi$ when absolute phase jumps between consecutive time instances t_i are greater than or equal to the jump tolerance of π radians.
 - This process creates an average amplitude and phase for each demodulation reference signal subcarrier (i.e. every second subcarrier).

$$\hat{a}(f) = \frac{\sum_{i=1}^N a(t_i, f)}{N}$$

and

$$\hat{\phi}(f) = \frac{\sum_{i=1}^N \phi(t_i, f)}{N}$$

Where N is the number of demodulation reference signals time-domain locations t_i from $Z'(t, f)$ for each demodulation reference signal subcarrier f .

3. The equalizer coefficients for amplitude and phase $\hat{a}(f)$ and $\hat{\phi}(f)$ at the demodulation reference signal subcarriers are obtained by computing the moving average in the frequency domain of the time-averaged demodulation reference signal subcarriers. The moving average window size is 19 and averaging is over the DM-RS subcarriers in the allocated RBs. For DM-RS subcarriers at or near the edge of the channel, or when the number of available DM-RS subcarriers within a set of contiguously allocated RBs is smaller than the moving average window size, the window size is reduced accordingly as per figure F.6-1.
4. Perform linear interpolation from the equalizer coefficients $\hat{a}(f)$ and $\hat{\phi}(f)$ to compute coefficients $\hat{a}(f)$, $\hat{\phi}(f)$ for each subcarrier.

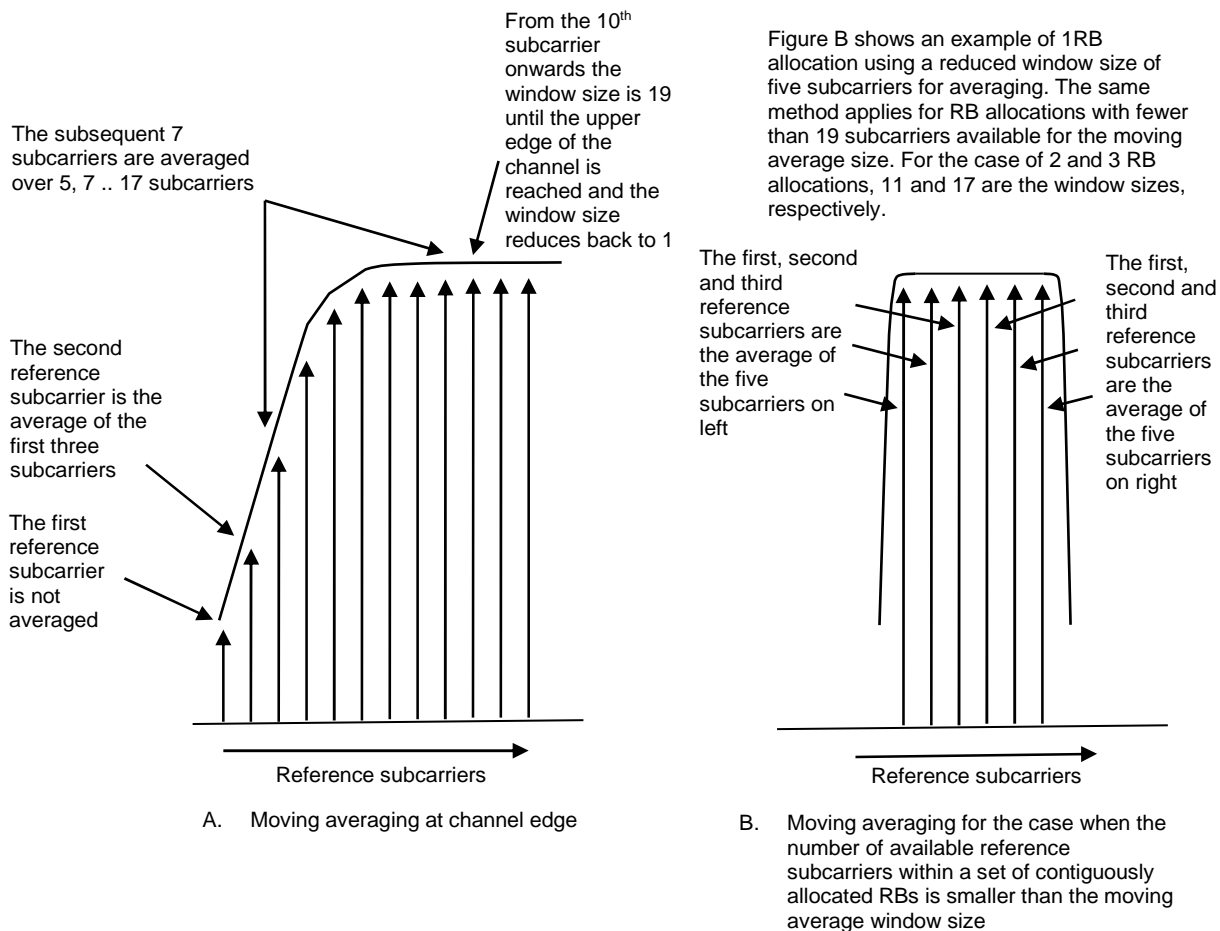

Figure E.6-1: Reference subcarrier smoothing in the frequency domain

E.7 EVM

E.7.0 General

For EVM create two sets of $Z_{eq}^i(t, f)$, according to the timing $(\Delta c - W/2)$ and $(\Delta c + W/2)$, using the equalizer coefficients from F.6.

The equivalent ideal samples are calculated from $i_1(w)$ (annex E.2.2) and are called $I(t, f)$.

The EVM is the difference between the ideal signal and the equalized measured signal.

$$EVM = \sqrt{\frac{\sum_{t \in T} \sum_{f \in F(t)} |Z_{eq}^i(t, f) - I(t, f)|^2}{\sum_{t \in T} \sum_{f \in F(t)} |I(t, f)|^2}}$$

Where:

- T is the set of symbols with the considered modulation scheme being active within the slot,
- $F(t)$ is the set of subcarriers within the resource blocks with the considered modulation scheme being active in symbol t ,
- $I(t, f)$ is the ideal signal reconstructed by the measurement equipment in accordance with relevant test models,

- $Z_{eq}(t, f)$ is the equalized signal under test.

NOTE: Although the basic unit of measurement is one slot, the equalizer is calculated over the entire 10 ms measurement interval to reduce the impact of noise in the reference signals.

E.7.1 Averaged EVM (FDD)

EVM is averaged over all allocated downlink resource blocks with the considered modulation scheme in the frequency domain, and a minimum of N_{dl} slots where N_{dl} is the number of slots in a 10 ms measurement interval. The averaging in the time domain equals the N_{dl} slot duration of the 10 ms measurement interval from the equalizer estimation step.

$$\overline{EVM}_{frame} = \sqrt{\frac{1}{\sum_{i=1}^{N_{dl}} N_i} \sum_{l=1}^{N_{dl}} \sum_{j=1}^{N_i} EVM_{i,j}^2}$$

Where N_i is the number of resource blocks with the considered modulation scheme in slot i .

The EVM requirements shall be tested against the maximum of the RMS average at the window W extremities of the EVM measurements:

Thus $\overline{EVM}_{frame,l}$ is calculated using $t = \Delta t_l$ in the expressions above and $\overline{EVM}_{frame,h}$ is calculated using $t = \Delta t_h$ in the \overline{EVM}_{frame} calculation where l and h , low and high; where low is the timing $(\Delta c - W/2)$ and high is the timing $(\Delta c + W/2)$.

Thus:

$$EVM = \max(\overline{EVM}_{frame,l}, \overline{EVM}_{frame,h})$$

The resulting \overline{EVM} is compared against the limit.

E.7.2 Averaged EVM (TDD)

Let N_{dl}^{TDD} be the number of slots with downlink symbols within a 10 ms measurement interval. For TDD, the averaging in the time domain can be calculated from N_{dl}^{TDD} slots of different 10 ms measurement intervals and should have a minimum of N_{dl} slots averaging length where N_{dl} is the number of slots in a 10 ms measurement interval.

\overline{EVM}_{frame} is derived by: Square the EVM results in each 10 ms measurement interval. Sum the squares, divide the sum by the number of EVM relevant locations, square-root the quotient (RMS).

$$\overline{EVM}_{frame} = \sqrt{\frac{1}{\sum_{i=1}^{N_{dl}^{TDD}} N_i} \sum_{l=1}^{N_{dl}^{TDD}} \sum_{j=1}^{N_i} EVM_{i,j}^2}$$

Where N_i is the number of resource blocks with the considered modulation scheme in slot i .

The \overline{EVM}_{frame} is calculated, using the maximum of \overline{EVM}_{frame} at the window W extremities. Thus $\overline{EVM}_{frame,l}$ is calculated using $t = \Delta t_l$ and $\overline{EVM}_{frame,h}$ is calculated using $t = \Delta t_h$ (l and h , low and high; where low is the timing $(\Delta c - W/2)$ and and high is the timing $(\Delta c + W/2)$).

$$EVM_{frame} = \max(\overline{EVM}_{frame,l}, \overline{EVM}_{frame,h})$$

In order to unite at least N_{dl} slots, consider the minimum integer number of 10 ms measurement intervals, where N_{frame} is determined by.

$$N_{frame} = \left\lceil \frac{N_{dl} \times N_{slot}}{N_{dl}^{TDD}} \right\rceil$$

and $N_{\text{slot}} = 1$ for 15 kHz SCS, $N_{\text{slot}} = 2$ for 30 kHz SCS and $N_{\text{slot}} = 4$ for 60 kHz SCS normal CP.

Units by RMS.

$$EVM = \sqrt{\frac{1}{N_{\text{frame}}} \sum_{R=1}^{N_{\text{frame}}} EVM_{\text{frame},k}^2}$$

The resulting EVM is compared against the limit.

Annex F (normative): NCR-MT Reference measurement channels

F.1 NCR-MT Demodulation Performance Fixed Reference Channels

F.1.1 Fixed Reference Channels for PDSCH performance requirements

The parameters for the reference measurement channels are specified in table F.7.1.1-1 for FR1 PDSCH performance requirements.

Table F.7.1.1-1: FRC parameters for FR1 PDSCH performance requirements, 1 transmission layers

Parameter	Unit	Value			
		M-FR1-NCR..1.1-1	M-FR1-NCR.1.1-2	M-FR1-NCR.1.1-3	M-FR1-NCR.1.1-4
Reference channel					
Channel bandwidth	MHz	10	40	10	40
Subcarrier spacing	kHz	15	30	15	30
Allocated resource blocks	PRBs	52	106	52	106
Number of consecutive PDSCH symbols		12	12	12	12
MCS table		64QAM	64QAM	64QAM	64QAM
MCS index		4	4	13	13
Modulation		QPSK	QPSK	16QAM	16QAM
Target Coding Rate		0.3	0.30	0.48	0.48
Number of MIMO layers		1	1	1	1
Number of DMRS REs		12	12	12	12
Overhead for TBS determination		0	0	0	0
Information Bit Payload per Slot		4096	8456	13064	26632
Transport block CRC per Slot		24	24	24	24
Number of Code Blocks per Slot		1	2	2	4
Binary Channel Bits Per Slot		13728	27984	27456	55968

F.1.2 Fixed Reference Channels for PDCCH performance requirements

The parameters for the reference measurement channels are specified in table F.1.2-1 for FR1 PDCCH performance requirements.

Table F.1.2-1 . FR1 PDCCH Reference Channels

Parameter	Unit	Value					
		M-FR1-NCR.1.2-1	M-FR1-NCR.1.2-2	M-FR1-NCR.1.2-3	M-FR1-NCR.1.2-4	M-FR1-NCR.1.2-5	M-FR1-NCR.1.2-6
Reference channel							
Subcarrier spacing	kHz	15	15	15	30	30	30
CORESET frequency domain allocation		24	48	48	102	102	102
CORESET time domain allocation		2	2	1	1	1	1
Aggregation level		2	4	8	2	4	8
DCI Format		1_0	1_1	1_1	1_0	1_1	1_1
Payload (without CRC)	Bits	39	52	52	41	53	53

F.1.3 Fixed Reference Channels for CSI reporting performance

This clause defines the DL signal applicable to the reporting of channel status information.

Tables in this clause specifies the mapping of CQI index to Information Bit payload, which complies with the CQI definition specified in clause 5.2.2.1 of TS 38.214 [23] and with MCS definition specified in clause 5.1.3 of TS 38.214 [23].

Table F.1.3-1: Fixed Reference Channels for FR1 CSI reporting with CQI table 2 and MCS table 2

Reference channel				M-FR1-NCR.1.3-1	M-FR1-NCR.1.3-2
Number of allocated PDSCH resource blocks				52	106
Number of consecutive PDSCH symbols				12	12
Number of PDSCH MIMO layers				1	2
Number of DMRS REs (Note 1)				24	24
Overhead for TBS determination				0	0
Available RE-s for PDSCH				6240	12720
CQI index	Spectral efficiency	MCS index	Modulation	Information Bit Payload per Slot	
0	0OR	0OR	0OR	N/A	N/A
1	0.1523	0	QPSK	1480	2976
2	0.3770	1		2408	4744
3	0.8770	3		5504	11016
4	1.4766	5	16QAM	9224	18960
5	1.9141	7		12040	24576
6	2.4063	9		15112	30728
7	2.7305	11	64QAM	16896	34816
8	3.3223	13		20496	42016
9	3.9023	15		24576	49176
10	4.5234	17	256QAM	28168	57376
11	5.1152	19		31752	65576
12	5.5547	21		34816	69672
13	6.2266	23		38936	79896
14	6.9141	25		43032	88064
15	7.4063	27	46104	94248	

NOTE 1: Number of DMRS REs includes the overhead of the DM-RS CDM groups without data
NOTE 2: PDSCH is only scheduled on slots which are full DL

F.2 Fixed Reference Channels for reference sensitivity level, ACS, in-band blocking, out-of-band blocking and receiver intermodulation (QPSK, R=1/3)

The parameters for the FR1 WA NCR-MT reference measurement channels are specified in tables F.2-1 for FR1 reference sensitivity level, ACS, in-band blocking, out-of-band blocking, receiver intermodulation.

Table F.2-1: FRC parameters for FR1 reference sensitivity level for FR1 WA NCR-MT

Reference channel	G-FR1-A1-22	G-FR1-A1-23	G-FR1-A1-24	G-FR1-A1-25	G-FR1-A1-26	G-FR1-A1-27
Subcarrier spacing (kHz)	30	60	15	30	60	15
Allocated resource blocks	11	11	106	51	24	25
CP-OFDM Symbols per slot (Note 1)	9	9	9	9	9	9
Modulation	QPSK	QPSK	QPSK	QPSK	QPSK	QPSK
Code rate (Note 2)	1/3	1/3	1/3	1/3	1/3	1/3
NOTE 1: <i>DL-DMRS-config-type</i> = 1 with <i>DL-DMRS-max-len</i> = 1, <i>DL-DMRS-add-pos</i> = pos2 with <i>l₀</i> = 2, <i>l</i> = 6 and 9 as per Table 7.4.1.1.2-3 of TS 38.211 [3].						
NOTE 2: MCS index 4 and target coding rate = 308/1024 are adopted to calculate payload size for receiver sensitivity						

Annex G (normative): Propagation conditions

G.1 Static propagation condition

The propagation for the static performance measurement is an Additive White Gaussian Noise (AWGN) environment. No fading or multi-paths exist for this propagation model.

G1.1 NCR-MT receiver with 2RX

For 1 port transmission the channel matrix is defined in the frequency domain by:

$$\mathbf{H} = \begin{pmatrix} 1 \\ 1 \end{pmatrix}.$$

For 2 port transmission the channel matrix is defined in the frequency domain by:

$$\mathbf{H} = \begin{pmatrix} 1 & j \\ 1 & -j \end{pmatrix}.$$

G.1.2 NCR-MT Receiver with 4Rx

For 1 port transmission the channel matrix is defined in the frequency domain by

$$\mathbf{H} = \begin{bmatrix} 1 \\ 1 \\ 1 \\ 1 \end{bmatrix}.$$

For 2 port transmission the channel matrix is defined in the frequency domain by

$$\mathbf{H} = \begin{bmatrix} 1 & j \\ 1 & -j \\ 1 & j \\ 1 & -j \end{bmatrix}$$

G.2 Multi-path fading propagation conditions

G.2.1 General

The multipath propagation conditions consist of several parts:

- A delay profile in the form of a "tapped delay-line", characterized by a number of taps at fixed positions on a sampling grid. The profile can be further characterized by the r.m.s. delay spread and the maximum delay spanned by the taps.
- A combination of channel model parameters that include the Delay profile and the Doppler spectrum that is characterized by a classical spectrum shape and a maximum Doppler frequency.

G.2.2 Delay profiles

G.2.2.1 General

The delay profiles are simplified from the TR 38.901 [24] TDL models. The simplification steps are shown below for information. These steps are only used when new delay profiles are created. Otherwise, the delay profiles specified in G.2.2.1 can be used as such.

- Step 1: Use the original TDL model from TR 38.901 [24].
- Step 2: Re-order the taps in ascending delays.
- Step 3: Perform delay scaling according to the procedure described in clause 7.7.3 in TR 38.901 [24].
- Step 4: Apply the quantization to the delay resolution 5 ns. This is done simply by rounding the tap delays to the nearest multiple of the delay resolution.
- Step 5: If multiple taps are rounded to the same delay bin, merge them by calculating their linear power sum.
- Step 6: If there are more than 12 taps in the quantized model, merge the taps as follows:
 - Find the weakest tap from all taps (both merged and unmerged taps are considered):
 - If there are two or more taps having the same value and are the weakest, select the tap with the smallest delay as the weakest tap.
 - When the weakest tap is the first delay tap, merge taps as follows:
 - Update the power of the first delay tap as the linear power sum of the weakest tap and the second delay tap.
 - Remove the second delay tap.
 - When the weakest tap is the last delay tap, merge taps as follows:
 - Update the power of the last delay tap as the linear power sum of the second-to-last tap and the last tap.

- Remove the second-to-last tap.
- Otherwise:
 - For each side of the weakest tap, identify the neighbour tap that has the smaller delay difference to the weakest tap.
- When the delay difference between the weakest tap and the identified neighbour tap on one side equals the delay difference between the weakest tap and the identified neighbour tap on the other side.
- Select the neighbour tap that is weaker in power for merging.
- Otherwise, select the neighbour tap that has smaller delay difference for merging.- To merge, the power of the merged tap is the linear sum of the power of the weakest tap and the selected tap:
 - When the selected tap is the first tap, the location of the merged tap is the location of the first tap. The weakest tap is removed.
 - When the selected tap is the last tap, the location of the merged tap is the location of the last tap. The weakest tap is removed.
 - Otherwise, the location of the merged tap is based on the average delay of the weakest tap and selected tap. If the average delay is on the sampling grid, the location of the merged tap is the average delay. Otherwise, the location of the merged tap is rounded towards the direction of the selected tap (e.g. 10 ns & 20 ns → 15 ns, 10 ns & 25 ns → 20 ns, if 25 ns had higher or equal power; 15 ns, if 10 ns had higher power). The weakest tap and the selected tap are removed.
- Repeat step 6 until the final number of taps is 12.
- Step 7: Round the amplitudes of taps to one decimal (e.g. -8.78 dB → -8.8 dB)
- Step 8: If the delay spread has slightly changed due to the tap merge, adjust the final delay spread by increasing or decreasing the power of the last tap so that the delay spread is corrected.
- Step 9: Re-normalize the highest tap to 0 dB.

NOTE 1: Some values of the delay profile created by the simplification steps may differ from the values in tables G.2.2.2-2, G.2.2.2-3, and G.2.1.1-4 for the corresponding model.

NOTE 2: For Step 5 and Step 6, the power values are expressed in the linear domain using 6 digits of precision. The operations are in the linear domain.

G.2.2.2 Delay profiles for FR1

The delay profiles for FR1 are selected to be representative of low, medium and high delay spread environment. The resulting model parameters are specified in G.2.2.2-1 and the tapped delay line models are specified in tables G.2.2.2-2 ~ table G.2.2.2-4.

Table G.2.2.2-1: Delay profiles for NR channel models

Model	Number of channel taps	Delay spread (r.m.s.)	Maximum excess tap delay (span)	Delay resolution
TDLA30	12	30 ns	290 ns	5 ns
TDLB100	12	100 ns	480 ns	5 ns
TDLC300	12	300 ns	2595 ns	5 ns

Table G.2.2.2-2: TDLA30 (DS = 30 ns)

Tap #	Delay (ns)	Power (dB)	Fading distribution
1	0	-15.5	Rayleigh
2	10	0	
3	15	-5.1	
4	20	-5.1	
5	25	-9.6	
6	50	-8.2	
7	65	-13.1	
8	75	-11.5	
9	105	-11.0	
10	135	-16.2	
11	150	-16.6	
12	290	-26.2	

Table G.2.2.2-3: TDLB100 (DS = 100ns)

Tap #	Delay (ns)	Power (dB)	Fading distribution
1	0	0	Rayleigh
2	10	-2.2	
3	20	-0.6	
4	30	-0.6	
5	35	-0.3	
6	45	-1.2	
7	55	-5.9	
8	120	-2.2	
9	170	-0.8	
10	245	-6.3	
11	330	-7.5	
12	480	-7.1	

Table G.2.2.2-4: TDLC300 (DS = 300 ns)

Tap #	Delay (ns)	Power (dB)	Fading distribution
1	0	-6.9	Rayleigh
2	65	0	
3	70	-7.7	
4	190	-2.5	
5	195	-2.4	
6	200	-9.9	
7	240	-8.0	
8	325	-6.6	
9	520	-7.1	
10	1045	-13.0	
11	1510	-14.2	
12	2595	-16.0	

G.2.3 Combinations of channel model parameters

The propagation conditions used for the performance measurements in multi-path fading environment are indicated as a combination of a channel model name and a maximum Doppler frequency, i.e., TDLA<DS>-<Doppler>, TDLB<DS>-<Doppler> or TDLC<DS>-<Doppler> where '<DS>' indicates the desired delay spread and '<Doppler>' indicates the maximum Doppler frequency (Hz).

Table G.2.3-1 show the propagation conditions that are used for the performance measurements in multi-path fading environment for low, medium and high Doppler frequencies for FR1.

Table G.2.3-1: Channel model parameters for FR1

Combination name	Model	Maximum Doppler frequency
TDLA30-5	TDLA30	5 Hz
TDLA30-10	TDLA30	10 Hz
TDLB100-400	TDLB100	400 Hz
TDLC300-100	TDLC300	100 Hz

G.2.4 MIMO channel correlation matrices

G.2.4.1 General

The MIMO channel correlation matrices defined in annex G.2.4 apply for the antenna configuration using uniform linear arrays at both gNB and NCR-MT and for the antenna configuration using cross polarized antennas.

G.2.4.2 MIMO correlation matrices using Uniform Linear Array

G.2.4.2.1 General

The MIMO channel correlation matrices defined in annex G.2.4.2 apply for the antenna configuration using uniform linear array (ULA) at both gNB and NCR-MT.

G.2.4.2.2 Definition of MIMO correlation matrices

Table G.2.4.2.2-1 defines the correlation matrix for the gNB.

Table G.2.4.2.2-1: gNB correlation matrix

	gNB correlation
One antenna	$R_{gNB} = 1$
Two antennas	$R_{gNB} = \begin{pmatrix} 1 & \alpha \\ \alpha^* & 1 \end{pmatrix}$

NOTE: The matrix applies to the gNB for NCR-MT requirements.

Table G.2.4.2.2-2 defines the correlation matrix for the NCR-MT:

Table G.2.4.2.2-2: NCR-MT correlation matrix

	NCR-MT correlation
Two antennas	$R_{UE} = \begin{pmatrix} 1 & \beta \\ \beta^* & 1 \end{pmatrix}$
Four antennas	$R_{UE} = \begin{pmatrix} 1 & \beta^{1/9} & \beta^{4/9} & \beta \\ \beta^{1/9*} & 1 & \beta^{1/9} & \beta^{4/9} \\ \beta^{4/9*} & \beta^{1/9*} & 1 & \beta^{1/9} \\ \beta^* & \beta^{4/9*} & \beta^{1/9*} & 1 \end{pmatrix}$

NOTE: The correlation matrix R_{UE} applies to NCR-MT for NCR-MT requirements

Table G.2.4.2.2-3 defines the channel spatial correlation matrix R_{spatial} . The parameters, α and β in table G.2.4.2.2-3 defines the spatial correlation between the antennas at the gNB and NCR-MT respectively.

Table G.2.4.2.2-3: R_{spat} correlation matrices

1x2 case	$R_{spat} = R_{UE} = \begin{bmatrix} 1 & \beta \\ \beta^* & 1 \end{bmatrix}$
1x4 case	$R_{spat} = R_{UE} = \begin{bmatrix} 1 & \beta^{1/9} & \beta^{4/9} & \beta \\ \beta^{1/9*} & 1 & \beta^{1/9} & \beta^{1/9} \\ \beta^{4/9*} & \beta^{1/9*} & 1 & \beta^{1/9} \\ \beta^* & \beta^{4/9*} & \beta^{1/9*} & 1 \end{bmatrix}$
2x2 case	$R_{spat} = R_{gNB} \otimes R_{UE} = \begin{bmatrix} 1 & \alpha \\ \alpha^* & 1 \end{bmatrix} \otimes \begin{bmatrix} 1 & \beta \\ \beta^* & 1 \end{bmatrix} = \begin{bmatrix} 1 & \beta & \alpha & \alpha\beta \\ \beta^* & 1 & \alpha\beta^* & \alpha \\ \alpha^* & \alpha^*\beta & 1 & \beta \\ \alpha^*\beta^* & \alpha^* & \beta^* & 1 \end{bmatrix}$
2x4 case	$R_{spat} = R_{gNB} \otimes R_{UE} = \begin{bmatrix} 1 & \alpha \\ \alpha^* & 1 \end{bmatrix} \otimes \begin{bmatrix} 1 & \beta^{1/9} & \beta^{4/9} & \beta \\ \beta^{1/9*} & 1 & \beta^{1/9} & \beta^{1/9} \\ \beta^{4/9*} & \beta^{1/9*} & 1 & \beta^{1/9} \\ \beta^* & \beta^{4/9*} & \beta^{1/9*} & 1 \end{bmatrix}$
<p>NOTE 1: R_{gNB} refers to the correlation matrix of gNB for NCR-MT requirements. NOTE 2: R_{UE} refers to the correlation matrix of NCR-MT for NCR-MT requirements</p>	

For cases with more antennas at either gNB or NCR-MT or both, the channel spatial correlation matrix can still be expressed as the Kronecker product of R_{gNB} and R_{UE} according to $R_{spat} = R_{gNB} \otimes R_{UE}$.

G.2.4.2.3 MIMO correlation matrices at high, medium and low level

The α and β for different correlation types are given in table G.2.4.2.3-1.

Table G.2.4.2.3-1: Correlation for high, medium and low level

Low correlation		Medium correlation		High correlation	
α	β	α	β	α	β
0	0	0.3	0.9	0.9	0.9

The correlation matrices for high, medium and low correlation are defined in table G.2.4.2.3-2, G.2.4.2.3-3 and G.2.4.2.3-4 as below.

The values in table G.2.4.2.3-2 have been adjusted for the 2x4 high correlation case to ensure the correlation matrix is positive semi-definite after round-off to 4 digit precision. This is done using the equation:

$$\mathbf{R}_{high} = [\mathbf{R}_{spatial} + a\mathbf{I}_n] / (1 + a)$$

Where the value "a" is a scaling factor such that the smallest value is used to obtain a positive semi-definite result. For the 2x4 high correlation case, a = 0.00010.

Table G.2.4.2.3-2: MIMO correlation matrices for high correlation

1x2 case	$R_{high} = \begin{pmatrix} 1 & 0.9 \\ 0.9 & 1 \end{pmatrix}$
2x2 case	$R_{high} = \begin{pmatrix} 1 & 0.9 & 0.9 & 0.81 \\ 0.9 & 1 & 0.81 & 0.9 \\ 0.9 & 0.81 & 1 & 0.9 \\ 0.81 & 0.9 & 0.9 & 1 \end{pmatrix}$
2x4 case	$R_{high} = \begin{pmatrix} 1.0000 & 0.9883 & 0.9542 & 0.8999 & 0.8999 & 0.8894 & 0.8587 & 0.8099 \\ 0.9883 & 1.0000 & 0.9883 & 0.9542 & 0.8894 & 0.8999 & 0.8894 & 0.8587 \\ 0.9542 & 0.9883 & 1.0000 & 0.9883 & 0.8587 & 0.8894 & 0.8999 & 0.8894 \\ 0.8999 & 0.9542 & 0.9883 & 1.0000 & 0.8099 & 0.8587 & 0.8894 & 0.8999 \\ 0.8999 & 0.8894 & 0.8587 & 0.8099 & 1.0000 & 0.9883 & 0.9542 & 0.8999 \\ 0.8894 & 0.8999 & 0.8894 & 0.8587 & 0.9883 & 1.0000 & 0.9883 & 0.9542 \\ 0.8587 & 0.8894 & 0.8999 & 0.8894 & 0.9542 & 0.9883 & 1.0000 & 0.9883 \\ 0.8099 & 0.8587 & 0.8894 & 0.8999 & 0.8999 & 0.9542 & 0.9883 & 1.0000 \end{pmatrix}$

Table G.2.4.2.3-3: MIMO correlation matrices for medium correlation

1x2 case	[N/A]
2x2 case	$R_{medium} = \begin{pmatrix} 1.0000 & 0.9000 & 0.3000 & 0.2700 \\ 0.9000 & 1.0000 & 0.2700 & 0.3000 \\ 0.3000 & 0.2700 & 1.0000 & 0.9000 \\ 0.2700 & 0.3000 & 0.9000 & 1.0000 \end{pmatrix}$
2x4 case	$R_{medium} = \begin{pmatrix} 1.0000 & 0.9884 & 0.9543 & 0.9000 & 0.3000 & 0.2965 & 0.2863 & 0.2700 \\ 0.9884 & 1.0000 & 0.9884 & 0.9543 & 0.2965 & 0.3000 & 0.2965 & 0.2863 \\ 0.9543 & 0.9884 & 1.0000 & 0.9884 & 0.2863 & 0.2965 & 0.3000 & 0.2965 \\ 0.9000 & 0.9543 & 0.9884 & 1.0000 & 0.2700 & 0.2863 & 0.2965 & 0.3000 \\ 0.3000 & 0.2965 & 0.2863 & 0.2700 & 1.0000 & 0.9884 & 0.9543 & 0.9000 \\ 0.2965 & 0.3000 & 0.2965 & 0.2863 & 0.9884 & 1.0000 & 0.9884 & 0.9543 \\ 0.2863 & 0.2965 & 0.3000 & 0.2965 & 0.9543 & 0.9884 & 1.0000 & 0.9884 \\ 0.2700 & 0.2863 & 0.2965 & 0.3000 & 0.9000 & 0.9543 & 0.9884 & 1.0000 \end{pmatrix}$

Table G.2.4.2.3-4: MIMO correlation matrices for low correlation

1x2 case	$R_{low} = \mathbf{I}_2$
1x4 case	$R_{low} = \mathbf{I}_4$
2x2 case	$R_{low} = \mathbf{I}_4$
2x4 case	$R_{low} = \mathbf{I}_8$

In table G.2.4.2.3-4, \mathbf{I}_d is a $d \times d$ identity matrix.

NOTE: For completeness, the correlation matrices were defined for high, medium and low correlation but performance requirements exist only for low correlation.

G.2.4.3 Multi-antenna channel models using cross polarized antennas

G.2.4.3.1 General

The MIMO channel correlation matrices defined in annex G.2.4.3 apply to two cases as presented below:

- One TX antenna and multiple RX antennas case, with cross polarized antennas used at gNB
- Multiple TX antennas and multiple RX antennas case, with cross polarized antennas used at both NCR-MT and gNB

The cross-polarized antenna elements with +/-45 degrees polarization slant angles are deployed at gNB. For one TX antenna case, antenna element with +90 degree polarization slant angle is deployed at NCR-MT. For multiple TX antennas case, cross-polarized antenna elements with +90/0 degrees polarization slant angles are deployed at NCR-MT.

For the cross-polarized antennas, the N antennas are labelled such that antennas for one polarization are listed from 1 to $N/2$ and antennas for the other polarization are listed from $N/2+1$ to N , where N is the number of TX or RX antennas.

G.2.4.3.2 Definition of MIMO correlation matrices using cross polarized antennas

For the channel spatial correlation matrix, the following is used:

$$R_{spat} = P_{UL} (R_{UE} \otimes \Gamma_{UL} \otimes R_{gNB}) P_{UL}^T$$

Where

- R_{UE} is the spatial correlation matrix at the NCR-MT (NCR-MT requirements) with same polarization,
- R_{gNB} is the spatial correlation matrix at the gNB (NCR-MT requirements) with same polarization,
- Γ_{UL} is a polarization correlation matrix,
- P_{UL} is a permutation matrix, and
- $(\bullet)^T$ denotes transpose.

Table G.2.4.3.2-1 defines the polarization correlation matrix.

Table G.2.4.3.2-1: Polarization correlation matrix

	One TX antenna	Multiple TX antennas
Polarization correlation matrix	$\Gamma_{UL} = \begin{bmatrix} 1 & -\gamma \\ -\gamma & 1 \end{bmatrix}$	$\Gamma_{UL} = \begin{bmatrix} 1 & -\gamma & 0 & 0 \\ -\gamma & 1 & 0 & 0 \\ 0 & 0 & 1 & \gamma \\ 0 & 0 & \gamma & 1 \end{bmatrix}$

The matrix P_{UL} is defined as

$$P_{UL}(a,b) = \begin{cases} 1 & \text{for } a = (j-1)Nr + i \text{ and } b = 2(j-1)Nr + i, \quad i = 1, \dots, Nr, j = 1, \dots, \lceil Nt/2 \rceil \\ 1 & \text{for } a = (j-1)Nr + i \text{ and } b = 2(j - Nt/2)Nr - Nr + i, \quad i = 1, \dots, Nr, j = \lceil Nt/2 \rceil + 1, \dots, Nt \\ 0 & \text{otherwise} \end{cases}$$

where Nt and Nr is the number of TX and RX antennas respectively, and $\lceil \bullet \rceil$ is the ceiling operator.

The matrix P_{UL} is used to map the spatial correlation coefficients in accordance with the antenna element labelling system described in G.2.4.3.

G.2.4.3.3 Spatial correlation matrices at NCR-MT and gNB sides

G.2.4.3.3.1 Spatial correlation matrices at NCR-MT side

In this subclause, R_{UE} refers to an NCR-MT for NCR-MT requirements.

For 2-antenna receiver using one pair of cross-polarized antenna elements, $R_{UE} = 1$.

For 4-antenna receiver using two pairs of cross-polarized antenna elements, $R_{UE} = \begin{pmatrix} 1 & \beta \\ \beta^* & 1 \end{pmatrix}$.

G.2.4.3.3.2 Spatial correlation matrices at gNB side

In this subclause, R_{gNB} refers to a gNB for NCR-MT requirements.

For 1-antenna transmitter, $R_{gNB} = 1$.

For 2-antenna transmitter using one pair of cross-polarized antenna elements, $R_{gNB} = 1$.

G.2.4.3.4 MIMO correlation matrices using cross polarized antennas

The values for parameters α , β and γ for low spatial correlation are given in table G.2.4.3.4-1.

Table G.2.4.3.4-1: Values for parameters α , β and γ

Low spatial correlation		
α	β	γ
0	0	0
NOTE 1: Value of α applies when more than one pair of cross-polarized antenna elements at gNB side. NOTE 2: Value of β applies when more than one pair of cross-polarized antenna elements at NCR-MT side.		

G.2.4.3.5 Beam steering approach

For the 2D cross-polarized antenna array at gNB, given the channel spatial correlation matrix in G.2.4.3.2, G.2.4.3.3 and G.2.4.3.4, the corresponding random channel matrix H can be calculated. The signal model for the k -th slot is denoted as

$$y = HD_{\theta_{k,1}, \theta_{k,2}} Wx + n$$

And the steering matrix is further expressed as following:

$$D_{\theta_{k,1}, \theta_{k,2}} = \begin{bmatrix} 1 & 0 \\ 0 & 1 \end{bmatrix} \otimes (D_{\theta_{k,1}}(N_1) \otimes D_{\theta_{k,2}}(N_2))$$

where

- H is the $Nr \times Nt$ channel matrix per subcarrier.
- $D_{\theta_{k,1}, \theta_{k,2}}$ is the steering matrix,
- $D_{\theta_{k,1}}(N_1)$ is the steering matrix in first dimension with same polarization,
- $D_{\theta_{k,2}}(N_2)$ is the steering matrix in second dimension with same polarization,
- N_1 is the number of antenna elements in first dimension with same polarization,
- N_2 is the number of antenna elements in second dimension with same polarization,
- For antenna array with only one direction, number of antenna element in second direction N_2 equals 1.

For 1 antenna element with the same polarization in one direction,

$$D_{\theta_{k,i}}(\mathbf{1}) = 1$$

For 2 antenna elements with the same polarization in one direction,

$$D_{\theta_{k,i}}(2) = \begin{bmatrix} 1 & 0 \\ 0 & e^{j3\theta_{k,i}} \end{bmatrix}$$

where the index $i=1,2$ stands for first dimension and second dimension respectively.

- $\theta_{k,i}$ controls the phase variation in first dimension and second dimension respectively, and the phase for k-th subframe is denoted by $\theta_{k,i} = \theta_{0,i} + \Delta\theta k$, where $\theta_{0,i}$ is the random start value with the uniform distribution, i.e., $\theta_{0,i} \in [0, 2\pi]$, $\Delta\theta$ is the step of phase variation, which is defined in Table G.2.4.3.5-1, and k is the linear increment of $2^{-\mu}$ for every slot throughout the simulation, the index $i=1,2$ stands for first dimension and second dimension respectively.
- W is the precoding matrix for Nt transmission antennas,
- y is the received signal, x is the transmitted signal, and n is AWGN.
- μ corresponds to subcarrier spacing configuration, $\Delta f = 2^{\mu} \cdot 15$ [kHz]

For the 1D cross-polarized antenna array at gNB, the corresponding random channel matrix H can be calculated by letting $N_2=1$, i.e.,

$$D_{\theta_{k,1}} = \begin{bmatrix} 1 & 0 \\ 0 & 1 \end{bmatrix} \otimes D_{\theta_{k,1}}(N_1)$$

Table G.2.4.3.5-1: The step of phase variation

Variation Step	Value (rad/ms)
$\Delta\theta$	1.2566×10^{-3}

Annex H (informative): Change history

Change history							
Date	Meeting	TDoc	CR	Rev	Cat	Subject/Comment	New version
2022-05	RAN4#103e					TS skeleton	0.0.1
2022-08	RAN4#104e	R4-2211701				TP for TS 38.115-1: Clause 5 operating bands	0.1.0
2022-08	RAN4#104e	R4-2212840				TP to TS 38.115-1 clause 6.8 Output intermodulation - conducted	0.1.0
2022-08	RAN4#104e	R4-2213719				TP for TS 38.115-1: section 4.10-4.12	0.1.0
2022-08	RAN4#104e	R4-2213976				TP to TS 38.115-1 Annex A Repeater stimulus signals	0.1.0
2022-08	RAN4#104e	R4-2214740				TP for TS 38.115-1: Clause 3 definitions	0.1.0
2022-08	RAN4#104e	R4-2214741				TP for TS 38.115-1: Clause 4.2-4.5	0.1.0
2022-08	RAN4#104e	R4-2214785				TP to TS 38.115-1: Test Configurations and Requirement applicability	0.1.0
2022-08	RAN4#104e	R4-2214787				TP to TS 38.115-1: Frequency Stability, Out of band gain, unwanted emissions	0.1.0
2022-08	RAN4#104e	R4-2214789				TP to TS 38.115-1: In-band measurements Annex	0.1.0
2022-08	RAN4#104e	R4-2214791				TP to TS 38.115-1: TDD Switching	0.1.0
2022-08	RAN4#104e	R4-2214801				TP to TS 38.115-1: Manufacturer declarations for NR FR1 repeaters	0.1.0
2022-08	RAN4#104e	R4-2214803				TP to TS 38.115-1 clause 6.7 Input intermodulation - conducted	0.1.0
2022-08	RAN4#104e	R4-2214840				TP for TS 38.115-1: Section 6.9	0.1.0
2022-08	RAN4#104e	R4-2214841				TP for TS 38.115-1: Annex D	0.1.0
2022-08	RAN4#104e	R4-2214865				TP to TS 38.115-1 clause 4.9 RF channels and test models	0.1.0
2022-08	RAN4#104e	R4-2214867				TP to TS 38.115-1 clause 6.6 EVM - conducted	0.1.0
2022-10	RAN4#104be	R4-2216839				TP to TS 38.115-1: Annex B: Environmental requirements for the repeater	0.2.0
2022-10	RAN4#104be	R4-2216840				TP to TS 38.115-1: Annex C: Test tolerances and derivation of test requirements	0.2.0
2022-10	RAN4#104be	R4-2216841				TP to TS 38.115-1: Annex E: Characteristics of interfering signals	0.2.0
2022-10	RAN4#104be	R4-2217293				TP to TS 38.115-1: Repeater output power (6.1, 6.2)	0.2.0
2022-10	RAN4#104be	R4-2217296				TP for TS 38.115-1: scope and reference	0.2.0
2022-10	RAN4#104be	R4-2217297				TP to TS 38.115-1: Measurement uncertainties and test requirements (4.1)	0.2.0
2022-11	RAN4#105	R4-2218486				Correction TP for TS 38.115-1	0.3.0
2022-11	RAN4#105	R4-2220214				TP to 38.115-1: ACLR requirement	0.3.0
2022-11	RAN4#105	R4-2220217				TP to 38.115-1: EVM requirement	0.3.0
2022-11	RAN4#105	R4-2220226				Draft CR to 38.115-1: Spectrum purity	0.3.0
2022-11	RAN4#105	R4-2220270				TP to 38.115-1: ACRR requirement	0.3.0
2022-12	RAN#98e	RP-222843				Editorial update for 1.0.0 version	1.0.0

Change history							
Date	Meeting	TDoc	CR	Rev	Cat	Subject/Comment	New version
2022-12	RAN#98-e					Approved by plenary – Rel-17 spec under change control	17.0.0
2023-03	RAN#99	RP-230518	0001	1	F	CR for TS 38.115-1: Correction of some errors	17.1.0
2023-03	RAN#99	RP-230518	0003	1	B	CR to TS38.106 the introduction of band n104	17.1.0
2023-03	RAN#99	RP-230518	0005		F	CR to 38.115-1: Correction on repeater EVM test procedure	17.1.0
2023-03	RAN#99	RP-230518	0006		F	CR to 38.115-1: Correction on repeater ACLR requirement	17.1.0
2023-03	RAN#99	RP-230518	0007		F	CR to 38.115-1: NR repeater measurement system set-up	17.1.0

Change history							
Date	Meeting	TDoc	CR	Rev	Cat	Subject/Comment	New version
2023-03	RAN#99	RP-230535	0002		B	CR to 38.115-1 on introduction of Band n54	18.0.0
2023-03	RAN#99	RP-230533	0004		B	CR to TS38.115-1 the introduction of APT600MHz	18.0.0
2023-06	RAN#100	RP-231339	0009		A	CR for TS 38.115-1, Add manufacturer declarations for test configurations and RF channels	18.1.0
2023-06	RAN#100	RP-231339	0011		A	CR to 38.115-1: Corrections on repeater transient period requirements (Rel-18)	18.1.0
2023-06	RAN#100	RP-231339	0013		A	CR to TS 38.115-1: Addition of missing bands for repeater co-existence and co-location requirements	18.1.0
2023-06	RAN#100	RP-231339	0015		A	CR to TS 38.115-1: Clarifications for repeater test models	18.1.0
2023-09	RAN#101	RP-232496	0017		A	[NR_repeater] CR to 38.115-1: Input intermodulation	18.2.0
2023-12	RAN#102	RP-233366	0018		B	CR to TS38.115-1: introduction of NR bands n31 and n72	18.3.0
2023-12	RAN#102	RP-233366	0019	1	B	CR to TS38.115-1: introduction of band n106	18.3.0
2023-12	RAN#102	RP-233366	0020		B	CR to TS 38.115-1 - Introduction of band n109	18.3.0
2023-12	RAN#102	RP-233350	0022		A	CR to 38.115-1: Correction of terminologies for NR repeaters (Rel-18)	18.3.0
2023-12	RAN#102	RP-233350	0024		F	CR to TS 38.115-1 with correction of co-existence and co-location requirements	18.3.0
2024-03	RAN#103	RP-240574	0026		A	(NR_repeater-Perf) CR for TS 38.115-1, Correction on manufacturer declarations	18.4.0
2024-03	RAN#103	RP-240574	0028		A	CR to 38.115-1: NR repeater transmitter spurious emissions requirements (rel-18)	18.4.0
2024-03	RAN#103	RP-240588	0029		B	BigCR for introduction of performance requirements for NCR-MT in TS 38.115-1	18.4.0
2024-06	RAN#104	RP-241422	0033		F	CR on FRCs of NCR MT Demodulation Performance in 38.115-1	18.5.0
2024-06	RAN#104	RP-241422	0034		F	CR on Propagation Condition of NCR-MT for 38.115-1	18.5.0
2024-06	RAN#104	RP-241422	0030	1	B	BigCR to TS 38.115-1	18.5.0
2024-06	RAN#104	RP-241422	0032	1	F	Draft BigCR for introduction of performance requirements for NCR-MT (TS38.115-1, Rel-18)	18.5.0
2024-09	RAN#105	RP-242172	0035	1	F	Maintenance CR to TS 38.115-1: NCR conformance part	18.6.0
2024-09	RAN#105	RP-242172	0036	1	F	(NR_netcon_repeater-Perf)CR for TS 38.115-1, Correction on network controlled repeater classes for NCR	18.6.0
2024-09	RAN#105	RP-242172	0037	1	F	(NR_netcon_repeater-Perf)CR for TS 38.115-1, Correction on requirement for 5MHz channel bandwidth for NCR MT	18.6.0
2024-09	RAN#105	RP-242172	0044	1	F	CR on 38.115-1 for NCR conformance testing	18.6.0
2024-09	RAN#105	RP-242172	0045	1	F	CR to TS 38.115-1 with updates and corrections	18.6.0
2024-12	RAN#106	RP-243031	0047		A	(LTE410_Europe_PPDR-Perf) CR to Rel-18 38.115-1: Add missing LTE band 87 and band 88	18.7.0
2024-12	RAN#106	RP-243053	0048	1	F	CR on Correlation Matrix of NCR Demodulation in 38.115-1	18.7.0
2024-12	RAN#106	RP-243053	0051		F	CR to 38.115-1: Operating band unwanted emissions (rel-18)	18.7.0
2024-12	RAN#106	RP-243053	0052	1	F	CR to 38.115-1: ACLR requirements for NCR	18.7.0
2024-12	RAN#106	RP-243053	0053	1	F	CR to TS 38.115-1 with co-location requirements for repeaters	18.7.0
2025-03	RAN#107	RP-250592	0058	1	F	CR to TS 38.115-1 with clauses corrections	18.8.0
2025-03	RAN#107	RP-250611	0060		F	(TEI18) CR to 38.115-1 on corrections to co-existence table [bands_coex_req]	18.8.0
2025-03	RAN#107	RP-250592	0062		F	CR on NCR-MT Correlation Matrix in 38.115-1	18.8.0
2025-06	RAN#108	RP-250929	0064		F	CR on NCR Mimo Correlation Matrices in 38.115-1	18.9.0
2025-12	RAN#110	RP-253680	0070		A	(NR_repeater-Perf) CR to TS 38.115-1 with updates to Repeater ACRR test	18.10.0
2026-03	RAN#111	RP-260464	0073		F	CR for TS 38.115-1, correction on Annex	18.11.0

History

Version	Date	Status
V18.4.0	May 2024	Publication
V18.5.0	August 2024	Publication
V18.6.0	October 2024	Publication
V18.7.0	January 2025	Publication
V18.8.0	April 2025	Publication
V18.9.0	July 2025	Publication
V18.10.0	February 2026	Publication
V18.11.0	April 2026	Publication