

ETSI TS 136 508 V10.2.0 (2012-10)



Technical Specification

**LTE;
Evolved Universal Terrestrial Radio Access (E-UTRA)
and Evolved Packet Core (EPC);
Common test environments for User Equipment (UE)
conformance testing
(3GPP TS 36.508 version 10.2.0 Release 10)**



Reference

RTS/TSGR-0536508va20

Keywords

LTE

ETSI

650 Route des Lucioles
F-06921 Sophia Antipolis Cedex - FRANCE

Tel.: +33 4 92 94 42 00 Fax: +33 4 93 65 47 16

Siret N° 348 623 562 00017 - NAF 742 C
Association à but non lucratif enregistrée à la
Sous-Préfecture de Grasse (06) N° 7803/88

Important notice

Individual copies of the present document can be downloaded from:

<http://www.etsi.org>

The present document may be made available in more than one electronic version or in print. In any case of existing or perceived difference in contents between such versions, the reference version is the Portable Document Format (PDF). In case of dispute, the reference shall be the printing on ETSI printers of the PDF version kept on a specific network drive within ETSI Secretariat.

Users of the present document should be aware that the document may be subject to revision or change of status. Information on the current status of this and other ETSI documents is available at

<http://portal.etsi.org/tb/status/status.asp>

If you find errors in the present document, please send your comment to one of the following services:

http://portal.etsi.org/chaicor/ETSI_support.asp

Copyright Notification

No part may be reproduced except as authorized by written permission.
The copyright and the foregoing restriction extend to reproduction in all media.

© European Telecommunications Standards Institute 2012.
All rights reserved.

DECT™, **PLUGTESTS™**, **UMTS™** and the ETSI logo are Trade Marks of ETSI registered for the benefit of its Members.
3GPP™ and **LTE™** are Trade Marks of ETSI registered for the benefit of its Members and
of the 3GPP Organizational Partners.
GSM® and the GSM logo are Trade Marks registered and owned by the GSM Association.

Intellectual Property Rights

IPRs essential or potentially essential to the present document may have been declared to ETSI. The information pertaining to these essential IPRs, if any, is publicly available for **ETSI members and non-members**, and can be found in ETSI SR 000 314: *"Intellectual Property Rights (IPRs); Essential, or potentially Essential, IPRs notified to ETSI in respect of ETSI standards"*, which is available from the ETSI Secretariat. Latest updates are available on the ETSI Web server (<http://ipr.etsi.org>).

Pursuant to the ETSI IPR Policy, no investigation, including IPR searches, has been carried out by ETSI. No guarantee can be given as to the existence of other IPRs not referenced in ETSI SR 000 314 (or the updates on the ETSI Web server) which are, or may be, or may become, essential to the present document.

Foreword

This Technical Specification (TS) has been produced by ETSI 3rd Generation Partnership Project (3GPP).

The present document may refer to technical specifications or reports using their 3GPP identities, UMTS identities or GSM identities. These should be interpreted as being references to the corresponding ETSI deliverables.

The cross reference between GSM, UMTS, 3GPP and ETSI identities can be found under <http://webapp.etsi.org/key/queryform.asp>.

Contents

Intellectual Property Rights	2
Foreword.....	2
Foreword.....	14
Introduction	14
1 Scope	15
2 References	15
3 Definitions, symbols and abbreviations	17
3.1 Definitions	17
3.2 Symbols.....	17
3.3 Abbreviations	18
4 Common test environment	18
4.1 Environmental conditions.....	18
4.1.1 Temperature.....	18
4.1.2 Voltage.....	19
4.2 Common requirements of test equipment.....	19
4.2.1 General functional requirements.....	19
4.2.2 Minimum functional requirements	20
4.2.2.1 Supported Cell Configuration	20
4.2.2.1.1 Supported Channels.....	20
4.2.2.2 Support of T_{cell} timing offset	21
4.3 Reference test conditions.....	21
4.3.1 Test frequencies	21
4.3.1.1 FDD Mode Test frequencies	22
4.3.1.1.1 FDD reference test frequencies for operating band 1	22
4.3.1.1.1A FDD reference test frequencies for CA in operating band 1.....	23
4.3.1.1.2 FDD reference test frequencies for operating band 2	23
4.3.1.1.3 FDD reference test frequencies for operating band 3	24
4.3.1.1.4 FDD reference test frequencies for operating band 4	24
4.3.1.1.5 FDD reference test frequencies for operating band 5	25
4.3.1.1.6 FDD reference test frequencies for operating band 6	25
4.3.1.1.7 FDD reference test frequencies for operating band 7	25
4.3.1.1.8 FDD reference test frequencies for operating band 8	26
4.3.1.1.9 FDD reference test frequencies for operating band 9	26
4.3.1.1.10 FDD reference test frequencies for operating band 10	26
4.3.1.1.11 FDD reference test frequencies for operating band 11	27
4.3.1.1.12 FDD reference test frequencies for operating band 12	27
4.3.1.1.13 FDD reference test frequencies for operating band 13	27
4.3.1.1.14 FDD reference test frequencies for operating band 14	28
4.3.1.1.15 FDD reference test frequencies for operating band 15	28
4.3.1.1.16 FDD reference test frequencies for operating band 16	28
4.3.1.1.17 FDD reference test frequencies for operating band 17	28
4.3.1.1.18 FDD reference test frequencies for operating band 18	28
4.3.1.1.19 FDD reference test frequencies for operating band 19	28
4.3.1.1.20 FDD reference test frequencies for operating band 20	29
4.3.1.1.21 FDD reference test frequencies for operating band 21	29
4.3.1.1.22 FDD reference test frequencies for operating band 22	29
4.3.1.1.23 FDD reference test frequencies for operating band 23	30
4.3.1.1.24 FDD reference test frequencies for operating band 24	30
4.3.1.1.25 FDD reference test frequencies for operating band 25	30
4.3.1.1.26 FDD reference test frequencies for operating band 26	31
4.3.1.2 TDD Mode Test frequencies	31
4.3.1.2.1 TDD reference test frequencies for Operating Band 33	31
4.3.1.2.2 TDD reference test frequencies for Operating Band 34	31

4.3.1.2.3	TDD reference test frequencies for Operating Band 35	32
4.3.1.2.4	TDD reference test frequencies for Operating Band 36	32
4.3.1.2.5	TDD reference test frequencies for Operating Band 37	32
4.3.1.2.6	TDD reference test frequencies for Operating Band 38	33
4.3.1.2.7	TDD reference test frequencies for Operating Band 39	33
4.3.1.2.8	TDD reference test frequencies for Operating Band 40	33
4.3.1.2.8A	TDD reference test frequencies for CA in operating band 40	34
4.3.1.2.9	TDD reference test frequencies for Operating Band 41	34
4.3.1.2.10	TDD reference test frequencies for Operating Band 42	34
4.3.1.2.11	TDD reference test frequencies for Operating Band 43	35
4.3.1.3	HRPD Test frequencies	35
4.3.1.3.1	HRPD test frequencies for Band Class 0	35
4.3.1.3.2	HRPD test frequencies for Band Class 1	35
4.3.1.3.3	HRPD test frequencies for Band Class 3	35
4.3.1.3.4	HRPD test frequencies for Band Class 4	36
4.3.1.3.5	HRPD test frequencies for Band Class 6	36
4.3.1.3.6	HRPD test frequencies for Band Class 10	36
4.3.1.3.7	HRPD test frequencies for Band Class 15	36
4.3.1.4	1xRTT Test frequencies	36
4.3.1.4.1	1xRTT test frequencies for Band Class 0	36
4.3.1.4.2	1xRTT test frequencies for Band Class 1	37
4.3.1.4.3	1xRTT test frequencies for Band Class 3	37
4.3.1.4.4	1xRTT test frequencies for Band Class 4	37
4.3.1.4.5	1xRTT test frequencies for Band Class 6	37
4.3.1.4.6	1xRTT test frequencies for Band Class 10	37
4.3.1.4.7	1xRTT test frequencies for Band Class 15	37
4.3.2	Radio conditions	38
4.3.2.1	Normal propagation condition	38
4.3.3	Physical channel allocations	38
4.3.3.1	Antennas	38
4.3.3.2	Downlink physical channels and physical signals	38
4.3.3.3	Mapping of downlink physical channels and signals to physical resources	39
4.3.3.4	Uplink physical channels and physical signals	42
4.3.3.5	Mapping of uplink physical channels and signals to physical resources	42
4.3.4	Signal levels	42
4.3.4.1	Downlink signal levels	42
4.3.4.2	Uplink signal levels	42
4.3.5	Standard test signals	42
4.3.5.1	Downlink test signals	42
4.3.5.2	Uplink test signals	42
4.3.6	Physical layer parameters	43
4.3.6.1	Downlink physical layer parameters	43
4.3.6.1.1	Physical layer parameters for DCI format 0	43
4.3.6.1.2	Physical layer parameters for DCI format 1	44
4.3.6.1.3	Physical layer parameters for DCI format 1A	44
4.3.6.1.3A	Physical layer parameters for DCI format 1B	45
4.3.6.1.4	Physical layer parameters for DCI format 1C	45
4.3.6.1.5	Physical layer parameters for DCI format 2	46
4.3.6.1.6	Physical layer parameters for DCI format 2A	47
4.4	Reference system configurations	47
4.4.1	Simulated network scenarios	47
4.4.1.1	Single cell network scenarios	47
4.4.1.2	E-UTRA single mode multi cell network scenarios	48
4.4.1.3	E-UTRA dual mode multi cell network scenarios	48
4.4.1.4	3GPP Inter-RAT network scenarios	48
4.4.1.5	3GPP2 Inter-RAT network scenarios	48
4.4.1.6	WLAN Inter-RAT network scenarios	48
4.4.2	Simulated cells	48
4.4.3	Common parameters for simulated E-UTRA cells	51
4.4.3.1	Common configurations of system information blocks	51
4.4.3.1.1	Combinations of system information blocks	51
4.4.3.1.2	Scheduling of system information blocks	54

4.4.3.2	Common contents of system information messages	57
-	<i>MasterInformationBlock</i>	57
-	<i>SystemInformation</i>	57
-	<i>SystemInformationBlockType1</i>	58
4.4.3.3	Common contents of system information blocks	59
-	<i>SystemInformationBlockType2</i>	59
-	<i>SystemInformationBlockType3</i>	60
-	<i>SystemInformationBlockType4</i>	60
-	<i>SystemInformationBlockType5</i>	61
-	<i>SystemInformationBlockType6</i>	64
-	<i>SystemInformationBlockType7</i>	65
-	<i>SystemInformationBlockType8</i>	67
-	<i>SystemInformationBlockType9</i>	69
-	<i>SystemInformationBlockType10</i>	70
-	<i>SystemInformationBlockType11</i>	71
-	<i>SystemInformationBlockType12</i>	73
-	<i>SystemInformationBlockType13</i>	74
4.4.3.4	Channel-bandwidth-dependent parameters in system information blocks	74
4.4.4	Common parameters for simulated UTRA cells	75
4.4.4.1	Common contents of system information blocks for UTRA cells	76
-	System Information Block type 19	76
4.4.4.2	UTRA SIB scheduling for inter EUTRA - UTRA test	77
4.4.4.3	UTRA SIB scheduling for inter EUTRA - UTRA - GERAN test	77
4.4.5	Common parameters for simulated GERAN cells	78
4.4.6	Common parameters for simulated CDMA2000 cells	80
4.4.7	Default parameters specific for simulated cells	80
4.4.7.1	Common contents of HRPD Overhead messages	80
4.4.7.2	Common contents of 1XRTT Overhead messages	84
4.4.7.2.1	Configuration sequence number	84
4.4.7.2.2	Over Head messages	85
4.5	Generic procedures	92
4.5.1	UE test states	92
4.5.2	UE Registration (State 2)	95
4.5.2.1	Initial conditions	95
4.5.2.2	Definition of system information messages	95
4.5.2.3	Procedure	96
4.5.2.4	Specific message contents	97
4.5.2A	UE Registration, UE Test Mode Activated (State 2A)	98
4.5.2A.1	Initial conditions	98
4.5.2A.2	Definition of system information messages	98
4.5.2A.3	Procedure	99
4.5.2A.4	Specific message contents	99
4.5.2B	UE Registration, pre-registration on HRPD (State 2B)	100
4.5.2B.1	Initial conditions	100
4.5.2B.2	Definition of system information messages	100
4.5.2B.3	Procedure	101
4.5.2B.4	Specific message contents	105
4.5.2C	UE Registration, pre-registration on 1xRTT (State 2C)	106
4.5.2C.1	Initial conditions	106
4.5.2C.2	Definition of system information messages	106
4.5.2C.3	Procedure	108
4.5.2C.4	Specific message contents	108
4.5.3	Generic Radio Bearer Establishment (State 3)	113
4.5.3.1	Initial conditions	114
4.5.3.2	Definition of system information messages	114
4.5.3.3	Procedure	115
4.5.3.4	Specific message contents	116
4.5.3A	Generic Radio Bearer Establishment, UE Test Mode Activated (State 3A)	116
4.5.3A.1	Initial conditions	116
4.5.3A.2	Definition of system information messages	116
4.5.3A.3	Procedure	116
4.5.3A.4	Specific message contents	116

4.5.3B	Generic Radio Bearer Establishment, pre-registered on HRPD (State 3B)	117
4.5.3B.1	Initial conditions	117
4.5.3B.2	Definition of system information messages	117
4.5.3B.3	Procedure	117
4.5.3B.4	Specific message contents	117
4.5.3C	Generic Radio Bearer Establishment, pre-registered on 1xRTT (State 3C)	117
4.5.3C.1	Initial conditions	117
4.5.3C.2	Definition of system information messages	117
4.5.3C.3	Procedure	117
4.5.3C.4	Specific message contents	117
4.5.4	Loopback Activation (State 4)	118
4.5.4.1	Initial conditions	118
4.5.4.2	Definition of system information messages	118
4.5.4.3	Procedure	118
4.5.4.4	Specific message contents	118
4.5.5	HRPD registration (State H2)	118
4.5.5.1	Initial conditions	118
4.5.5.2	Definition of system information messages	118
4.5.5.3	Procedure	119
4.5.5.4	Specific message contents	119
4.5.5A	HRPD registration, pre-registration on E-UTRAN (State H2A)	119
4.5.5A.1	Initial conditions	119
4.5.5A.2	Definition of system information messages	119
4.5.5A.3	Procedure	119
4.5.5A.4	Specific message contents	119
4.5.6	HRPD session establishment (State H3)	119
4.5.6.1	Initial conditions	119
4.5.6.2	Definition of system information messages	119
4.5.6.3	Procedure	120
4.5.6.4	Specific message contents	120
4.5.6A	HRPD session establishment, pre-registered on E-UTRAN (State H3A)	120
4.5.6A.1	Initial conditions	120
4.5.6A.2	Definition of system information messages	120
4.5.6A.3	Procedure	120
4.5.6A.4	Specific message contents	120
4.5A	Other generic procedures	120
4.5A.1	Procedure for IP address allocation in the U-plane	120
4.5A.2	Tracking area updating procedure	121
4.5A.3	Procedure for IMS signalling	122
4.5A.4	Generic Test Procedure for IMS Emergency call establishment in EUTRA: Normal Service	123
4.5A.4.1	Initial conditions	123
4.5A.4.2	Definition of system information messages	123
4.5A.4.3	Procedure	123
4.5A.4.4	Specific message contents	125
4.5A.5	Generic Test Procedure for IMS Emergency call establishment in EUTRA: Limited Service	127
4.5A.5.1	Initial conditions	127
4.5A.5.2	Definition of system information messages	127
4.5A.5.3	Procedure	128
4.5A.5.4	Specific message contents	130
4.5A.6	Generic Test Procedure for IMS MO speech call establishment in E-UTRA	131
4.5A.6.1	Initial conditions	131
4.5A.6.2	Definition of system information messages	131
4.5A.6.3	Procedure	132
4.5A.6.4	Specific message contents	133
4.5A.7	Generic Test Procedure for IMS MT Speech call establishment in E-UTRA	133
4.5A.7.1	Initial conditions	133
4.5A.7.2	Definition of system information messages	133
4.5A.7.3	Procedure	134
4.5A.7.4	Specific message contents	134
4.5A.8	Generic Test Procedure for IMS MO video call establishment in E-UTRA	134
4.5A.8.1	Initial conditions	134
4.5A.8.2	Definition of system information messages	135

4.5A.8.3	Procedure	136
4.5A.8.4	Specific message contents	137
4.5A.9	Generic Test Procedure for IMS MT video call establishment in E-UTRA	137
4.5A.9.1	Initial conditions	137
4.5A.9.2	Definition of system information messages	137
4.5A.9.3	Procedure	138
4.5A.9.4	Specific message contents	138
4.6	Default RRC message and information elements contents	138
4.6.1	Contents of RRC messages	139
-	<i>CounterCheck</i>	139
-	<i>CounterCheckResponse</i>	139
-	<i>CSFBParametersRequestCDMA2000</i>	139
-	<i>CSFBParametersResponseCDMA2000</i>	140
-	<i>DLInformationTransfer</i>	140
-	<i>HandoverFromEUTRAPreparationRequest</i>	141
-	<i>LoggedMeasurementConfiguration</i>	142
-	<i>MBMSCountingRequest</i>	143
-	<i>MBMSCountingResponse</i>	143
-	<i>MBSFNAreaConfiguration</i>	144
-	<i>MeasurementReport</i>	144
-	<i>MobilityFromEUTRACommand</i>	145
-	<i>Paging</i>	145
-	<i>RRCConnectionReconfiguration</i>	146
-	<i>RRCConnectionReconfigurationComplete</i>	147
-	<i>RRCConnectionReestablishment</i>	148
-	<i>RRCConnectionReestablishmentComplete</i>	148
-	<i>RRCConnectionReestablishmentReject</i>	148
-	<i>RRCConnectionReestablishmentRequest</i>	149
-	<i>RRCConnectionReject</i>	149
-	<i>RRCConnectionRelease</i>	149
-	<i>RRCConnectionRequest</i>	150
-	<i>RRCConnectionSetup</i>	150
-	<i>RRCConnectionSetupComplete</i>	150
-	<i>SecurityModeCommand</i>	151
-	<i>SecurityModeComplete</i>	151
-	<i>SecurityModeFailure</i>	151
-	<i>UECapabilityEnquiry</i>	152
-	<i>UECapabilityInformation</i>	153
-	<i>UEInformationRequest</i>	157
-	<i>UEInformationResponse</i>	158
-	<i>ULHandoverPreparationTransfer</i>	158
-	<i>ULInformationTransfer</i>	159
4.6.2	System information blocks	159
4.6.3	Radio resource control information elements	159
-	BCCH-Config-DEFAULT	159
-	CQI-ReportAperiodic-r10-DEFAULT	159
-	CQI-ReportConfig-DEFAULT	160
-	CQI-ReportConfig-r10-DEFAULT	160
-	CQI-ReportConfigSCell-r10-DEFAULT	161
-	CQI-ReportPeriodic-r10-DEFAULT	161
-	DRB-ToAddModList-RECONFIG	162
-	PCCH-Config-DEFAULT	162
-	PHICH-Config-DEFAULT	162
-	PDSCH-ConfigCommon-DEFAULT	163
-	PDSCH-ConfigDedicated-DEFAULT	163
-	PhysicalConfigDedicatedSCell-r10-DEFAULT	164
-	PRACH-Config-DEFAULT	165
-	PRACH-ConfigSIB-DEFAULT	165
-	PUCCH-ConfigCommon-DEFAULT	166
-	PUCCH-ConfigDedicated-DEFAULT	166
-	PUSCH-ConfigCommon-DEFAULT	167
-	PUSCH-ConfigDedicated-DEFAULT	167

-	RACH-ConfigCommon-DEFAULT	168
-	Rach-ConfigDedicated-DEFAULT	169
-	RadioResourceConfigCommon-DEFAULT	169
-	RadioResourceConfigCommonSCell-r10-DEFAULT	170
-	RadioResourceConfigCommonSIB-DEFAULT	171
-	RadioResourceConfigDedicated-SRB1	171
-	RadioResourceConfigDedicated-SRB2-DRB(n,m)	172
-	RadioResourceConfigDedicated-DRB(n,m)	173
-	RadioResourceConfigDedicated-HO-TO-EUTRA(n,m)	174
-	RadioResourceConfigDedicated-AM-DRB-ADD(bid)	175
-	RadioResourceConfigDedicated-UM-DRB-ADD(bid)	175
-	RadioResourceConfigDedicated- DRB-REL(bid)	176
-	RadioResourceConfigDedicated-HO	176
-	RadioResourceConfigDedicatedSCell-r10-DEFAULT	176
-	RLC-Config-DRB-AM-RECONFIG	177
-	RLC-Config-DRB-UM-RECONFIG	177
-	RLC-Config-SRB-AM-RECONFIG	177
-	SCellToAddMod-r10-DEFAULT	178
-	SchedulingRequest-Config-DEFAULT	178
-	SoundingRS-UL-ConfigCommon-DEFAULT	179
-	SoundingRS-UL-ConfigDedicated-DEFAULT	179
-	SoundingRS-UL-ConfigDedicatedAperiodic-r10-DEFAULT	180
-	SRB-ToAddModList-RECONFIG	180
-	TDD-Config-DEFAULT	180
-	TPC-PDCCH-Config-DEFAULT	181
-	UplinkPowerControlCommon-DEFAULT	181
-	UplinkPowerControlCommonSCell-r10-DEFAULT	182
-	UplinkPowerControlCommon-v1020-DEFAULT	182
-	UplinkPowerControlDedicated-DEFAULT	182
-	UplinkPowerControlDedicated-v1020-DEFAULT	183
-	UplinkPowerControlDedicatedSCell-r10-DEFAULT	183
-	RadioResourceConfigDedicated-DRB-Mod	183
4.6.4	Security control information elements	184
-	SecurityConfigHO-DEFAULT	184
-	SecurityConfigSMC-DEFAULT	184
4.6.5	Mobility control information elements	185
-	MobilityControlInfo-HO	185
4.6.6	Measurement information elements	186
-	MeasConfig-DEFAULT	186
-	MeasGapConfig-GP1	186
-	MeasGapConfig-GP2	187
-	MeasObjectCDMA2000-GENERIC	187
-	MeasObjectEUTRA-GENERIC	188
-	MeasObjectGERAN-GENERIC	188
-	MeasObjectUTRA-GENERIC	189
-	QuantityConfig-DEFAULT	189
-	ReportConfigEUTRA-A1	190
-	ReportConfigEUTRA-A2	190
-	ReportConfigEUTRA-A3	191
-	ReportConfigEUTRA-A6	191
-	ReportConfigEUTRA-PERIODICAL	192
-	ReportConfigInterRAT-B1-GERAN	192
-	ReportConfigInterRAT-B1-UTRA	193
-	ReportConfigInterRAT-B2-CDMA2000	194
-	ReportConfigInterRAT-B2-GERAN	195
-	ReportConfigInterRAT-B2-UTRA	196
-	ReportConfigInterRAT-PERIODICAL	196
4.6.7	Other information elements	197
-	RRC-TransactionIdentifier-DL	197
-	RRC-TransactionIdentifier-UL	197
4.6.8	Channel-bandwidth-dependent parameters	197
4.7	Default NAS message and information element contents	197

4.7.1	Security protected NAS messages	198
4.7.2	Contents of EMM messages	199
-	ATTACH ACCEPT	199
-	ATTACH COMPLETE	201
-	ATTACH REJECT	201
-	ATTACH REQUEST.....	202
-	AUTHENTICATION FAILURE.....	203
-	AUTHENTICATION REJECT	203
-	AUTHENTICATION REQUEST.....	204
-	AUTHENTICATION RESPONSE.....	204
-	CS SERVICE NOTIFICATION	205
-	DETACH ACCEPT (UE originating detach).....	205
-	DETACH ACCEPT (UE terminated detach).....	205
-	DETACH REQUEST (UE originating detach).....	206
-	DETACH REQUEST (UE terminated detach)	206
-	DOWNLINK NAS TRANSPORT.....	207
-	EMM INFORMATION	207
-	EMM STATUS	207
-	EXTENDED SERVICE REQUEST.....	208
-	GUTI REALLOCATION COMMAND	208
-	GUTI REALLOCATION COMPLETE	209
-	IDENTITY REQUEST	209
-	IDENTITY RESPONSE	209
-	SECURITY MODE COMMAND	210
-	SECURITY MODE COMPLETE	211
-	SECURITY MODE REJECT	211
-	SERVICE REJECT	211
-	SERVICE REQUEST	212
-	TRACKING AREA UPDATE ACCEPT	213
-	TRACKING AREA UPDATE COMPLETE.....	214
-	TRACKING AREA UPDATE REJECT	215
-	TRACKING AREA UPDATE REQUEST.....	216
-	UPLINK NAS TRANSPORT.....	217
4.7.3	Contents of ESM messages.....	217
-	ACTIVATE DEDICATED EPS BEARER CONTEXT ACCEPT.....	217
-	ACTIVATE DEDICATED EPS BEARER CONTEXT REJECT.....	218
-	ACTIVATE DEDICATED EPS BEARER CONTEXT REQUEST	219
-	ACTIVATE DEFAULT EPS BEARER CONTEXT ACCEPT	220
-	ACTIVATE DEFAULT EPS BEARER CONTEXT REJECT	220
-	ACTIVATE DEFAULT EPS BEARER CONTEXT REQUEST.....	221
-	BEARER RESOURCE ALLOCATION REJECT	223
-	BEARER RESOURCE ALLOCATION REQUEST.....	223
-	BEARER RESOURCE MODIFICATION REJECT	224
-	BEARER RESOURCE MODIFICATION REQUEST	224
-	DEACTIVATE EPS BEARER CONTEXT ACCEPT	225
-	DEACTIVATE EPS BEARER CONTEXT REQUEST.....	226
-	ESM INFORMATION REQUEST.....	226
-	ESM INFORMATION RESPONSE.....	227
-	ESM STATUS	227
-	MODIFY EPS BEARER CONTEXT ACCEPT.....	228
-	MODIFY EPS BEARER CONTEXT REJECT.....	228
-	MODIFY EPS BEARER CONTEXT REQUEST	229
-	PDN CONNECTIVITY REJECT	230
-	PDN CONNECTIVITY REQUEST	231
-	PDN DISCONNECT REJECT	232
-	PDN DISCONNECT REQUEST.....	232
4.7A	Default TC message and information element contents	232
-	ACTIVATE TEST MODE	233
-	ACTIVATE TEST MODE COMPLETE.....	233
-	CLOSE UE TEST LOOP.....	234
-	CLOSE UE TEST LOOP COMPLETE.....	234
-	DEACTIVATE TEST MODE	234

-	DEACTIVATE TEST MODE COMPLETE	235
-	OPEN UE TEST LOOP	235
-	OPEN UE TEST LOOP COMPLETE	235
-	UE TEST LOOP MODE C MBMS PACKET COUNTER REQUEST	235
-	UE TEST LOOP MODE C MBMS PACKET COUNTER RESPONSE	236
4.7B	Default UTRA message and information element contents	237
4.7B.1	UTRA RRC messages	237
-	HANDOVER TO UTRAN COMMAND	237
-	HANDOVER FROM UTRAN COMMAND	246
-	MEASUREMENT CONTROL.....	246
-	MEASUREMENT REPORT	248
-	PHYSICAL CHANNEL RECONFIGURATION	248
-	PHYSICAL CHANNEL RECONFIGURATION COMPLETE	250
-	RRC CONNECTION REQUEST	250
-	SECURITY MODE COMMAND	251
-	SECURITY MODE COMPLETE	251
-	UTRAN MOBILITY INFORMATION.....	252
-	UTRAN MOBILITY INFORMATION CONFIRM.....	252
4.7B.2	UTRA NAS messages	252
4.7C	Default DS-MIPv6 message and information element contents.....	260
4.7C.1	IKEv2 messages.....	260
-	IKEv2 IKE_SA_INIT Request.....	260
-	IKE_SA_INIT Response.....	262
-	IKE_AUTH_Request	263
-	IKE_AUTH Response.....	265
4.7C.2	Messages used to perform DS-MIPv6 registration and deregistration.....	268
-	Router Advertisement	268
-	Binding Update	269
-	Binding Acknowledgement.....	270
-	Binding Revocation Indication.....	271
-	Binding Revocation Acknowledgement.....	272
4.7D	Default GERAN message and information element contents	273
4.7D.1	GPRS message	273
-	PS HANDOVER COMMAND.....	273
4.8	Reference radio bearer configurations.....	274
4.8.1	General.....	274
4.8.2	SRB and DRB parameters and combinations	274
4.8.2.1	SRB and DRB parameters.....	274
4.8.2.1.1	SRB configurations	274
4.8.2.1.2	DRB PDCP configurations.....	274
4.8.2.1.3	DRB RLC configurations	275
4.8.2.1.4	DRB Logical Channel configurations	276
4.8.2.1.5	MAC configurations	277
4.8.2.1.6	Physical Layer configurations	279
4.8.2.1.7	DRB configurations.....	280
4.8.2.2	SRB and DRB combinations.....	281
4.8.2.2.1	Combinations on DL-SCH and UL-SCH	281
4.8.3	UTRA reference radio parameters and combinations	281
4.8.4	GERAN reference PDP context parameters	281
4.9	Common test USIM, CSIM and ISIM parameters	281
4.9.1	General.....	282
4.9.1.1	Definitions.....	282
4.9.1.2	Definition of the test algorithm for authentication	282
4.9.1.2.1	Authentication and key derivation in the test USIM, CSIM and ISIM and SS	282
4.9.1.2.2	Generation of re-synchronization parameters in the USIM, CSIM and ISIM	282
4.9.1.2.3	Using the authentication test algorithm for UE conformance testing	282
4.9.2	Default parameters for the test USIM, CSIM and ISIM	282
4.9.3	Default settings for the Elementary Files (EFs).....	282
4.9.3.1	Modified contents of the USIM Elementary Files	282
4.9.3.2	Modified contents of the CSIM Elementary Files.....	283
5	Test environment for RF test.....	295

5.1	Requirements of <i>test</i> equipment	295
5.2	RF Reference system configurations	295
5.2.1	Common parameters for simulated E-UTRA cells	295
5.2.1.1	Combinations of system information blocks	295
5.2.1.2	Scheduling of system information blocks	295
5.2.1.3	Common contents of system information messages	296
5.2A	Generic RF procedures	297
5.2A.1	UE RF test states	297
5.2A.2	Generic Default Radio Bearer Establishment, UE Test Mode Activated (State 3A-RF)	297
5.2A.2.1	Initial conditions	297
5.2A.2.2	Definition of system information messages	297
5.2A.2.3	Procedure	297
5.2A.2.4	Specific message contents	297
5.2A.3	Void	298
5.2 A.4	Generic Default Radio Bearer Establishment, UE Test Mode Activated (State 3A-RF-CA)	298
5.2 A.4.1	Initial conditions	298
5.2 A.4.2	Definition of system information messages	298
5.2 A.4.3	Procedure	298
5.2 A.4.4	Specific message contents	298
5.3	Default RRC message and information elements contents	299
5.3.1	Radio resource control information elements	299
5.4	Default NAS message and information elements contents	300
5.5	Reference radio bearer configurations	300
5.5.1	SRB and DRB parameters	300
5.5.1.1	MAC configurations	300
5.5.1.2	Physical Layer configurations	301
5.5.1.3	SRB and DRB combinations	302
5.5.1.3.1	Combinations on DL-SCH and UL-SCH	302
6	Test environment for Signalling test	303
6.1	Requirements of test equipment	303
6.2	Reference test conditions	303
6.2.1	Physical channel allocations	303
6.2.1.1	Antennas	303
6.2.1.2	Downlink physical channels and physical signals	303
6.2.1.3	Mapping of downlink physical channels and signals to physical resources	304
6.2.1.4	Uplink physical channels and physical signals	304
6.2.1.5	Mapping of uplink physical channels and signals to physical resources	304
6.2.2	Signal levels	304
6.2.2.1	Downlink signal levels	304
6.2.2.2	Measurement accuracy and side conditions	305
6.2.3	Default test frequencies	306
6.2.3.1	Test frequencies for signalling test	306
6.3	Reference system configurations	308
6.3.1	Default parameter specific for simulated cells	308
6.3.1.1	Intra-frequency neighbouring cell list in SIB4 for E-UTRA cells	308
6.3.1.2	Inter-frequency carrier frequency list in SIB5 for E-UTRA cells	308
6.3.1.3	UTRA carrier frequency list in SIB6 for E-UTRA cells	309
6.3.1.4	GERAN carrier frequency group list in SIB7 for E-UTRA cells	310
6.3.1.5	CDMA2000 HRPD carrier frequency list in SIB8 for E-UTRA cells	310
6.3.1.6	CDMA2000 1xRTT carrier frequency list in SIB8 for E-UTRA cells	311
6.3.1.7	E-UTRA carrier frequency list in SIB19 for UTRA cells	311
6.3.2	Default configurations for NAS test cases	311
6.3.2.1	Simulated network scenarios for NAS test cases	311
6.3.2.2	Simulated NAS cells	311
6.3.2.3	Broadcast system information	313
6.3.2.3.1	Intra-frequency neighbouring cell list in SIB4 for E-UTRA NAS cells	313
6.3.2.3.2	Inter-frequency carrier frequency list in SIB5 for E-UTRA NAS cells	313
6.3.3	Cell configurations	314
6.3.3.1	Full cell configuration	314
6.3.3.2	Minimum uplink cell configuration	314
6.3.3.3	Broadcast only cell configuration	315

6.3.3.3A	Virtual cell configuration	315
6.3.3.4	Application of different cell configurations	315
6.4	Generic procedures	315
6.4.1	Initial UE states and setup procedures	316
6.4.1.1	Initial UE states and setup procedures	316
6.4.1.2	Dedicated Bearer Establishment (to state 5)	316
6.4.1.2.1	Initial conditions	316
6.4.1.2.2	Definition of system information messages	316
6.4.1.2.3	Procedure	317
6.4.1.2.4	Specific message contents	317
6.4.1.3	Loopback Activation (to state 6)	317
6.4.1.3.1	Initial conditions	317
6.4.1.3.2	Definition of system information messages	317
6.4.1.3.3	Procedure	317
6.4.1.3.4	Specific message contents	318
6.4.2	Test procedures	318
6.4.2.1	Introduction	318
6.4.2.2	Test procedure to check RRC_IDLE state	318
6.4.2.3	Test procedure to check RRC_CONNECTED state	319
6.4.2.4	Test procedure Paging (for NAS testing)	319
6.4.2.5	Test procedure for no response to paging (for NAS testing)	319
6.4.2.6	Test procedure to check that a dedicated EPS bearer context is active (for NAS testing)	319
6.4.2.7	Test procedure to check that UE is camped on a new E-UTRAN cell	320
6.4.2.7A	Test procedure to check that UE is camped on E-UTRAN cell upon mobility from another RAT	320
6.4.2.8	Test procedure to check that UE is camped on a new UTRAN cell	323
6.4.2.9	Test procedure to check that UE is camped on a new GERAN cell	324
6.4.2.10	Test procedure to check that UE performs tracking area updating procedure without ISR and security reconfiguration after successful completion of handover from UTRA	325
6.4.3	Reference test procedures for TTCN development	327
6.4.3.1	UE triggered establishment of a dedicated EPS bearer context	328
6.4.3.2	UE triggered establishment of a default EPS bearer context associated with an additional PDN	329
6.4.3.3	UE triggered modification of an EPS bearer context	331
6.4.3.4	UE triggered deletion of an EPS bearer context	332
6.4.3.5	UE triggered CS call	333
6.4.3.6	UE triggered MO SMS over SGs	334
6.4.3.7	CS fallback to UTRAN procedures (LAI of UTRAN cell same as the LAI received in combined Attach procedure in EUTRA cell)	334
6.4.3.7.1	CS fallback to UTRAN with redirection / MT call (PS bearers not established)	335
6.4.3.7.2	CS fallback to UTRAN with redirection / MO call (PS bearers not established)	336
6.4.3.7.3	CS fallback to UTRAN with redirection / MT call (PS bearer established)	337
6.4.3.7.4	CS fallback to UTRAN with redirection / MO call (PS bearer established)	337
6.4.3.7.5	CS fallback to UTRAN with Handover / MT call	338
6.4.3.7.5.1	Specific message contents	339
6.4.3.7.6	CS fallback to UTRAN with Handover / MO call	340
6.4.3.7.6.1	Specific message contents	341
6.4.3.7.7	CS fallback to UTRAN with Handover / emergency call	342
6.4.3.7.7.1	Specific message contents	343
6.4.3.8	CS fallback to GERAN procedures (LAI of GERAN cell same as the LAI received in combined Attach procedure in EUTRA cell)	343
6.4.3.8.1	CS fallback to GERAN with redirection or CCO / MT call (DTM not supported)	344
6.4.3.8.2	CS fallback to GERAN with redirection or CCO / MO call (DTM not supported)	345
6.4.3.8.3	CS fallback to GERAN with PS Handover / MT call (EDTM not supported)	345
6.4.3.8.4	CS fallback to GERAN with PS Handover / MO call (EDTM not supported)	345
6.4.3.8.5	CS fallback to GERAN with PS Handover / MT call (EDTM supported)	345
6.4.3.9	SRVCC Handover to UTRA	345
6.4.3.9.1	Specific message contents	346
6.4.3A	Test case postambles	346
6.4.3A.1	Introduction	346
6.4.3A.2	Reference end states	347
6.5	Default RRC message and information element contents	349
6.5.1	Measurement information elements	349
-	MeasConfig-DEFAULT	349

-	MeasGapConfig-GP1	350
-	MeasGapConfig-GP2	350
6.6	Default NAS message and information element contents	350
6.6.1	Reference default EPS bearer contexts	350
6.6.2	Reference dedicated EPS bearer contexts	351
6.6A	Default SMS over SGs message and information element contents	354
6.6A.1	CM-sublayer messages	355
-	CP-ACK	355
-	CP-DATA	355
6.6A.2	Short Message Relay Layer (SM-RL) messages	355
-	RP-ACK RPDU	355
-	RP-DATA RPDU	356
6.6A.3	Short Message Transfer Layer (SM-TL) messages	356
-	SMS-DELIVER	356
-	SMS-SUBMIT	357
6.6B	Reference radio bearer configurations	357
6.6B.1	SRB and DRB parameters and combinations	357
6.6B.1.1	SRB and DRB parameters	357
6.6B.1.1.1	Physical Layer configurations	357
6.7	Timer Tolerances	358
7	Test environment for RRM tests	358
7.1	Requirements of <i>test</i> equipment	358
7.2	RRM Reference system configurations	358
7.2.1	Common parameters for simulated E-UTRA cells	358
7.2.1.1	Combinations of system information blocks	358
7.2.1.2	Scheduling of system information blocks	358
7.2.1.3	Common contents of system information messages	359
7.2.2	Common parameters for simulated GERAN cells	359
7.2.2.1	Mapping of GERAN cells	359
7.2A	Generic RRM procedures	360
7.2A.1	UE RRM test states	360
7.2A.2	UE Registration, UE Test Mode Activated (State 2A)	360
7.2A.3	Generic Default Radio Bearer Establishment, UE Test Mode Activated (State 3A-RF)	361
7.2A.4	Generic Default Radio Bearer Establishment, UE Test Mode Activated, pre-registration on HRPD (State 3B-RF)	361
7.2A.4.1	Initial conditions	361
7.2A.4.2	Definition of system information messages	361
7.2A.4.3	Procedure	361
7.2A.4.4	Specific message contents	361
7.2A.5	Generic Default Radio Bearer Establishment, UE Test Mode Activated (State 3A-RF-CA)	361
7.2B	Other generic RRM procedures	361
7.2B.1	Tracking area updating procedure	361
7.3	Default RRC message and information elements contents	363
7.3.1	Contents of RRC messages	363
7.3.2	Radio resource control information elements	363
7.3.3	Measurement information elements	363
Annex A (informative):	Connection Diagrams	365
Annex B (informative):	Change history	388
History		403

Foreword

This Technical Specification has been produced by the 3rd Generation Partnership Project (3GPP).

The contents of the present document are subject to continuing work within the TSG and may change following formal TSG approval. Should the TSG modify the contents of the present document, it will be re-released by the TSG with an identifying change of release date and an increase in version number as follows:

Version x.y.z

where:

x the first digit:

- 1 presented to TSG for information;
- 2 presented to TSG for approval;
- 3 or greater indicates TSG approved document under change control.

y the second digit is incremented for all changes of substance, i.e. technical enhancements, corrections, updates, etc.

z the third digit is incremented when editorial only changes have been incorporated in the document.

Introduction

The definition of the Conformance Tests for UE in E-UTRAN will be a complex task as the complete test suite covers RF, EMC and Protocol aspects of the UE.

Each test requires a Test Environment to be defined in which the UE has to operate to defined standards, constraints and performance. The overall task can be simplified if there are a number of well defined and agreed Common Test Environments where every one can be used for a number of tests. Hence the present document defines testing conditions that are common to several tests avoiding the need to duplicate the same information for every single test.

The present document defines default values for a variety of common areas. Where values are not specified in test cases, the defaults in the present document will apply. If specified, the test case values will take precedence.

1 Scope

The present document contains definitions of reference conditions and test signals, default parameters, reference radio bearer configurations used in radio bearer interoperability testing, common radio bearer configurations for other test purposes, common requirements for test equipment and generic set-up procedures for use in conformance tests for the 3rd Generation E-UTRAN User Equipment (UE).

2 References

The following documents contain provisions which, through reference in this text, constitute provisions of the present document.

- References are either specific (identified by date of publication, edition number, version number, etc.) or non-specific.
- For a specific reference, subsequent revisions do not apply.
- For a non-specific reference, the latest version applies. In the case of a reference to a 3GPP document (including a GSM document), a non-specific reference implicitly refers to the latest version of that document in the same Release as the present document.

- [1] 3GPP TR 21.905: "Vocabulary for 3GPP Specifications".
- [2] 3GPP TS 23.003: "Numbering, addressing and identification".
- [3] 3GPP TS 23.122: "Non-Access-Stratum functions related to Mobile Station (MS) in idle mode".
- [4] 3GPP TS 24.008: "Mobile radio interface Layer 3 specification; Core network protocols; Stage 3".
- [5] 3GPP TS 34.108: "Common Test Environments for User Equipment (UE); Conformance testing".
- [6] 3GPP TS 34.109: "Terminal logical test interface; Special conformance testing functions".
- [7] 3GPP TS 34.123-1: "User Equipment (UE) conformance specification; Part 1: Protocol conformance specification".
- [8] 3GPP TS 34.123-2: "User Equipment (UE) conformance specification; Part 2: Implementation conformance statement (ICS) specification".
- [9] 3GPP TS 34.123-3: "User Equipment (UE) conformance specification; Part 3: Abstract test suites (ATs)".
- [10] 3GPP TS 36.300: "Evolved Universal Terrestrial Radio Access (E-UTRA) and Evolved Universal Terrestrial Radio Access Network (E-UTRAN); Overall description; Stage 2".
- [11] 3GPP TS 36.302: "Evolved Universal Terrestrial Radio Access (E-UTRA); Services provided by the physical layer".
- [12] 3GPP TS 36.304: "Evolved Universal Terrestrial Radio Access (E-UTRA); User Equipment (UE) procedures in idle mode".
- [13] 3GPP TS 36.306: "Evolved Universal Terrestrial Radio Access (E-UTRA); User Equipment (UE) radio access capabilities".
- [14] 3GPP TS 36.321: "Evolved Universal Terrestrial Radio Access (E-UTRA); Medium Access Control (MAC) protocol specification".
- [15] 3GPP TS 36.322: "Evolved Universal Terrestrial Radio Access (E-UTRA); Radio Link Control (RLC) protocol specification".

- [16] 3GPP TS 36.323: "Evolved Universal Terrestrial Radio Access (E-UTRA); Packet Data Convergence Protocol (PDCP) specification".
- [17] 3GPP TS 36.331: "Evolved Universal Terrestrial Radio Access (E-UTRA); Radio Resource Control (RRC); Protocol Specification".
- [18] 3GPP TS 36.523-1: "Evolved Universal Terrestrial Radio Access (E-UTRA) and Evolved Packet Core (EPC); User Equipment (UE) conformance specification; Part 1: Protocol conformance specification".
- [19] 3GPP TS 36.523-2: "Evolved Universal Terrestrial Radio Access (E-UTRA) and Evolved Packet Core (EPC); User Equipment (UE) conformance specification; Part 2: Implementation Conformance Statement (ICS) proforma specification".
- [20] 3GPP TS 36.523-3: "Evolved Universal Terrestrial Radio Access (E-UTRA) and Evolved Packet Core (EPC); User Equipment (UE) conformance specification; Part 3: Abstract Test Suites (ATS)".
- [21] 3GPP TS 36.521-1: "Evolved Universal Terrestrial Radio Access (E-UTRA); User Equipment (UE) conformance specification; Radio transmission and reception; Part 1: conformance testing".
- [22] 3GPP TS 36.521-2: "Evolved Universal Terrestrial Radio Access (E-UTRA); User Equipment (UE) conformance specification; Radio transmission and reception; Part 2: Implementation Conformance Statement (ICS)".
- [23] 3GPP TR 24.801: "3GPP System Architecture Evolution; CT WG1 aspects".
- [24] 3GPP TS 23.401: "General Packet Radio Service(GPRS) enhancements for Evolved Universal Terrestrial Access Network (E-UTRAN) access".
- [25] 3GPP TS 51.010-1: "Mobile Station (MS) conformance specification; Part 1: Conformance specification".
- [26] ISO/IEC 9646 (all parts): "Information technology - Open Systems Interconnection - Conformance testing methodology and framework".
- [27] 3GPP TS 36.101: "Evolved Universal Terrestrial Radio Access (E-UTRA); User Equipment (UE) radio transmission and reception".
- [28] 3GPP TS 24.301: "Non-Access-Stratum (NAS) protocol for Evolved Packet System (EPS); Stage 3".
- [29] 3GPP TS 36.213: "Evolved Universal Terrestrial Radio Access (E-UTRA); Physical layer procedures".
- [30] 3GPP TS 36.104: "Evolved Universal Terrestrial Radio Access (E-UTRA); Base Station (BS) radio transmission and reception".
- [31] 3GPP TS 33.401: "3GPP System Architecture Evolution (SAE); Security architecture".
- [32] 3GPP TS 31.101: "UICC-terminal interface; Physical and logical characteristics".
- [33] 3GPP TS 31.102: "Characteristics of the Universal Subscriber Identity Module (USIM) application".
- [34] 3GPP TS 36.521-3: "Evolved Universal Terrestrial Radio Access (E-UTRA); User Equipment (UE) conformance specification; Radio transmission and reception; Part 3: Radio Resource Management conformance testing".
- [35] 3GPP TS 36.211: "Evolved Universal Terrestrial Radio Access (E-UTRA); Physical channels and modulation".
- [36] 3GPP2 TSG-C C.S0038-A v2.0: "Signalling Conformance Specification for High Rate Packet Data Air Interface".

- [37] 3GPP2 TSG-C C.S0043-0 v1.0: "Signalling Conformance Test Specification for cdma2000 Spread Spectrum Systems".
- [38] 3GPP TS 36.509: "Evolved Universal Terrestrial Radio Access (E-UTRA); Special conformance testing functions for User Equipment (UE)"
- [39] 3GPP TS 36.133: "Evolved Universal Terrestrial Radio Access (E-UTRA); Requirements for support of radio resource management"
- [40] 3GPP TS 24.229: "IP multimedia call control protocol based on Session Initiation Protocol (SIP) and Session Description Protocol (SDP); Stage 3"
- [41] 3GPP TS 23.402: "Architecture enhancements for non-3GPP accesses"
- [42] 3GPP2 X.S0057-0 "E-UTRAN - eHRPD Connectivity and Interworking: Core Network Aspects"
- [43] 3GPP TS 34.229-1: "Internet Protocol (IP) multimedia call control protocol based on Session Initiation Protocol (SIP) and Session Description Protocol (SDP); User Equipment (UE) conformance specification; Part 1: Protocol conformance specification".
- [44] 3GPP2 C.S0024-A v3.0: "cdma2000 High Rate Packet Data Air Interface Specification".
- [45] 3GPP TS 31.103: "Characteristics of the IP Multimedia Services Identity Module (ISIM) application".
- [46] 3GPP TS 34.229-1: "Internet Protocol (IP) multimedia call control protocol based on Session Initiation Protocol (SIP) and Session Description Protocol (SDP); User Equipment (UE) conformance specification; Part 1: Protocol conformance specification".
- [47] 3GPP TS 34.229-3: "Internet Protocol (IP) multimedia call control protocol based on Session Initiation Protocol (SIP) and Session Description Protocol (SDP); User Equipment (UE) conformance specification; Part 3: Abstract Test Suite (ATS)".
- [48] 3GPP2 C.S0065-B: "cdma2000 Application on UICC for Spread Spectrum Systems".
- [49] 3GPP2 C.S0005-A v6.0: "Upper Layer (Layer 3) Signalling Standard for cdma2000 Spread Spectrum Systems – Release A, Addendum 2".
- [50] 3GPP TS 34.121-1: "User Equipment (UE) conformance specification; Radio transmission and reception (FDD);Part 1: Conformance specification".
- [51] 3GPP TS 34.122: "Terminal conformance specification; Radio transmission and reception (TDD)".

3 Definitions, symbols and abbreviations

3.1 Definitions

For the purposes of the present document, the terms and definitions given in TR 21.905 [1] apply, unless specified below:

B: a value followed by "B" is a binary value.

H: a value followed by "H" is a hexadecimal value.

3.2 Symbols

For the purposes of the present document, the following symbols apply:

N_{DL}	Downlink EARFCN
N_{RB}	Transmission bandwidth configuration, expressed in units of resource blocks

N_{RB_agg}	Aggregated Transmission Bandwidth Configuration. The number of the aggregated RBs within the fully allocated Aggregated Channel bandwidth.
N_{UL}	Uplink EARFCN

3.3 Abbreviations

For the purposes of the present document, the abbreviations specified in TR 21.905 [1] apply, with any additional abbreviations specified below:

1xRTT	1x Radio Transmission Technology
CA	Carrier Aggregation
CC	Component Carrier
DRB	(user) Data Radio Bearer
EARFCN	E-UTRA Absolute Radio Frequency Channel Number
ECM	EPS Connection Management
EMM	EPS Mobility Management
ENB	Evolved Node B
EPRE	Energy Per Resource Element
ESM	EPS Session Management
HRPD	High Rate Packet Data
MAC	Media Access Control
OFDM	Orthogonal Frequency Division Multiplexing
RBs	Resource Blocks
ROHC	Robust Header Compression
SS	System Simulator
TH	Temperature High
TL	Temperature Low
VH	Higher extreme Voltage
VL	Lower extreme Voltage
xCH_RA	xCH -to-RS EPRE ratio for the channel xCH in all transmitted OFDM symbols not containing RS
xCH_RB	xCH -to-RS EPRE ratio for the channel xCH in all transmitted OFDM symbols containing RS

4 Common test environment

4.1 Environmental conditions

The requirements in this clause apply to all types of UE(s).

4.1.1 Temperature

The UE shall fulfil all the requirements in the full temperature range of:

Table 4.1.1-1: Temperature Test Environment

+15°C to +35°C	for normal conditions (with relative humidity up to 75 %)
-10°C to +55°C	for extreme conditions (see IEC publications 68-2-1 and 68-2-2)

Outside this temperature range the UE, if powered on, shall not make ineffective use of the radio frequency spectrum. In no case shall the UE exceed the transmitted levels as defined in TS 36.101 [27] for extreme operation.

The normative reference for this requirement is TS 36.101 [27] Annex E.1.

Some tests are performed also in extreme temperature conditions. These test conditions are denoted as TL (temperature low, -10°C) and TH (temperature high, +55°C).

4.1.2 Voltage

The UE shall fulfil all the requirements in the full voltage range, i.e. the voltage range between the extreme voltages.

The manufacturer shall declare the lower and higher extreme voltages and the approximate shutdown voltage. For the equipment that can be operated from one or more of the power sources listed below, the lower extreme voltage shall not be higher, and the higher extreme voltage shall not be lower than that specified below.

Table 4.1.2-1: Voltage Test Environment

Power source	Lower extreme voltage	Higher extreme voltage	Normal conditions voltage
AC mains	0,9 * nominal	1,1 * nominal	nominal
Regulated lead acid battery	0,9 * nominal	1,3 * nominal	1,1 * nominal
Non regulated batteries:			
Leclanché	0,85 * nominal	Nominal	Nominal
Lithium	0,95 * nominal	1,1 * Nominal	1,1 * Nominal
Mercury/nickel & cadmium	0,90 * nominal		Nominal

Outside this voltage range the UE if powered on, shall not make ineffective use of the radio frequency spectrum. In no case shall the UE exceed the transmitted levels as defined in TS 36.101 [27] for extreme operation. In particular, the UE shall inhibit all RF transmissions when the power supply voltage is below the manufacturer declared shutdown voltage.

The normative reference for this requirement is TS 36.101 [27] Annex E.2.

Some tests are performed also in extreme voltage conditions. These test conditions are denoted as VL (lower extreme voltage) and VH (higher extreme voltage).

4.2 Common requirements of test equipment

Mobile conformance testing can be categorized into 3 distinct areas:

- RF Conformance Testing.
- EMC Conformance Testing.
- Signalling Conformance Testing.

The test equipment required for each category of testing may or not be different, depending on the supplier of the test equipment. However, there will be some generic requirements of the test equipment that are essential for all three categories of test, and these are specified in this clause.

In addition, there will be requirements to test operation in multi-system configurations (e.g. EUTRAN plus UTRAN). However, these would not form a common test equipment requirement for the three test areas and are not considered in the present document.

The test equipment shall use the same number of Tx antennas for all parts of the tests, Initial condition and Test procedure, as specified in the minimum requirement.

4.2.1 General functional requirements

NOTE: This clause has been written such that it does not constrain the implementation of different architectures and designs of test equipment.

All test equipment used to perform conformance testing on a UE shall provide a platform suitable for testing UE's that are either:

- a) FDD Mode; or
- b) TDD Mode; or
- c) both FDD/TDD Modes.

All test equipment shall provide (for the mode(s) supported) the following minimum functionality.

- The capability of emulating a single E-UTRA cell with the appropriate channels to allow the UE to register on the cell.
- The capability to allow the UE to set up an RRC connection with the system simulator, and to maintain the connection for the duration of the test.
- The capability (for the specific test):
 - to select and support an appropriate radio bearer for the downlink;
 - to set the appropriate downlink power levels;
 - to set up and support the appropriate radio bearer for the uplink;
 - to set and control the uplink power levels.

4.2.2 Minimum functional requirements

4.2.2.1 Supported Cell Configuration

The System Simulator shall provide the capability to simulate a minimum number of cells (of the appropriate E-UTRA Mode) whose number and capabilities are governed by the test cases that need to be performed (test cases are defined in 3GPP TS 36.523-1 [18](Signalling), 3GPP TS 36.521-1 [21] (RF) and 3GPP TS 36.521-3 [34] (RRM)). For this purpose test cases can be split into two different categories: Tests that require only one cell and Tests that require several cells.

To perform test cases requiring one cell, the system simulator must provide a cell offering the capabilities to perform all the test cases in this category.

To perform test cases requiring several cells, additional cells must be provided by the system simulator. The additional cells, however, need only provide a minimum set of capabilities so as to support the first cell in carrying out the multi-cell test cases.

The type and number of channels (especially physical channels) constitute an important set of capabilities for a cell. The following clauses list possible channels that may be supported by the SS. Each channel type, however, and the minimum number of channels needed are only mandatory if specific test cases require them.

The mapping between Logical and Transport channels is as described in 3GPP TS 36.321 [14]. Similarly the mapping between Transport channels and Physical channels is as described in 3GPP TS 36.211, TS 36.302 and TS 36.212. The reference measurement channels (mapping between Transport channels and Physical channels for PDSCH/PDCCH) are defined in 3GPP TS 36.521-1[21] annex A

4.2.2.1.1 Supported Channels

4.2.2.1.1.1 Logical channels

Logical channel	Minimum number	Comments
BCCH	1	
CCCH	1	
DCCH	2	
PCCH	1	
DTCH	n <FFS>	Depending on SS's support for RB service testing (See clause 12 of 3GPP TS 36.523-1 [?])

4.2.2.1.1.2 Transport channels

Transport channel	Minimum number	Comments
BCH	1	
PCH	1	
RACH	1	

DL-SCH	n <FFS>	
UL-SCH	n <FFS>	

4.2.2.1.1.3 Physical channels

Physical channel	Minimum number	Comments
PBCH	1	Physical Broadcast Channel
PCFICH	1	The physical control format indicator channel carries information about the number of OFDM symbols used for transmission of PDCCHs in a subframe
PDCCH	1	The physical downlink control channel carries scheduling assignments and other control information.
PDSCH	1	Physical Downlink Shared Channel
PHICH	[1]	The PHICH carries the hybrid-ARQ ACK/NAK
PUCCH	1	The physical uplink control channel carries uplink control information
PUSCH	1	Physical Uplink Shared Channel
PRACH	1	Physical Random Access Channel

4.2.2.1.1.4 Physical signals

Physical signal	Minimum number	Comments
Demodulation reference signal	NA	UL
Sounding Reference signal	NA	UL TBD, if applicable
Cell-specific Reference Signal	NA	DL
UE-specific reference signal	NA	DL
Primary synchronisation signal	NA	DL
Secondary synchronisation signal	NA	DL

4.2.2.2 Support of T_{cell} timing offset

The timing offset in terms of frame start timing between any pair of TDD cells shall be < [3us]. For FDD cells there is no such restriction.

4.3 Reference test conditions

This clause contains the reference test conditions, which apply to all test cases unless otherwise specified.

4.3.1 Test frequencies

The test frequencies are based on the E-UTRA frequency bands defined in the core specifications.

The raster spacing is 100 KHz.

E-UTRA/FDD is designed to operate in paired bands of 3GPP TS 36.101 [27]. The reference test frequencies for the RF and Signalling test environment for each of the operating bands are defined in sub clause 4.3.1.1.

E-UTRA/TDD is designed to operate in unpaired bands of 3GPP TS 36.101 [27]. The reference test frequencies for the RF and Signalling test environment for each of the operating bands are defined in sub clause 4.3.1.2.

For Signalling testing, E-UTRA frequency to be tested is mid range and E-UTRA channel bandwidth to be tested is 5MHz for all operating bands for all test cases as the default configuration unless specific channel bandwidth is specified for the operating band below:

For Band 11, 13, 18 and 20, channel bandwidth to be tested is 10 MHz as the default configuration.

For Band 38, 39, 40 and 41, channel bandwidth to be tested is 20 MHz as the default configuration

For RF testing, E-UTRA frequencies to be tested are low range, mid range and high range for all supported operating bands by default. E-UTRA channel bandwidths to be tested are lowest bandwidth, 5MHz bandwidth and highest bandwidth for all supported operating bands by default. Actual test configurations are specified case by case and stated in test case itself as the initial conditions.

The lowest bandwidth, 5MHz bandwidth and highest bandwidth are selected from the combined table which includes nominal and additional channel bandwidth.

In the case 5MHz bandwidth is not supported by the UE, E-UTRA channel bandwidth to be tested is only lowest bandwidth and highest bandwidth.

If channel bandwidth to be tested is equal to the lowest or highest channel bandwidth, then the same channel bandwidth is not required to be tested twice.

In addition to the default channel bandwidths to be tested specified above, for Bands 4, 18, 20 and 25, an industry requirement of testing in 10MHz channel bandwidth is allowed for test cases in chapters 6 and 7 in TS 36.521-1 [21].

Editor's note: For RF testing, an industry requirement of testing in 10MHz channel bandwidth is requested for Bands 4, 18, 20 and 25 for test cases in chapters 6 and 7 in TS 36.521-1[21], changing the existing test points to address this is being discussed in RAN5 and will be considered pending technical justification.

For A-GNSS testing in TS 37.571-1, the E-UTRA frequency and channel bandwidth to be tested follow the same rules as for Signalling testing above.

4.3.1.1 FDD Mode Test frequencies

4.3.1.1.1 FDD reference test frequencies for operating band 1

Table 4.3.1.1.1-1: Test frequencies for E-UTRA channel bandwidth for operating band 1

Test Frequency ID	Bandwidth [MHz]	N _{UL}	Frequency of Uplink [MHz]	N _{DL}	Frequency of Downlink [MHz]
Low Range	5	18025	1922.5	25	2112.5
	10	18050	1925	50	2115
	15	18075	1927.5	75	2117.5
	20	18100	1930	100	2120
Mid Range	5/10/15/20	18300	1950	300	2140
High Range	5	18575	1977.5	575	2167.5
	10	18550	1975	550	2165
	15	18525	1972.5	525	2162.5
	20	18500	1970	500	2160

4.3.1.1.1A FDD reference test frequencies for CA in operating band 1

Table 4.3.1.1.1A-1: Test frequencies for CA_1C

Test Frequency	CC Combination / N _{RB_agg}	CC N _{RB}	N _{UL}	Frequency of Uplink [MHz]	N _{DL}	Frequency of Downlink [MHz]
Low Range	75 + 75	PCC 75	18075	1927.5	75	2117.5
		SCC 75	18225	1942.5	225	2132.5
	100 + 100	PCC 100	18100	1930	100	2120
		SCC 100	18298	1949.8	298	2139.8
Mid Range	75 + 75	PCC 75	18225	1942.5	225	2132.5
		SCC 75	18375	1957.5	375	2147.5
	100 + 100	PCC 100	18200	1940	200	2130
		SCC 100	18398	1959.8	398	2149.8
High Range	75 + 75	PCC 75	18375	1957.5	375	2147.5
		SCC 75	18525	1972.5	525	2162.5
	100 + 100	PCC 100	18302	1950.2	302	2140.2
		SCC 100	18500	1970	500	2160

4.3.1.1.2 FDD reference test frequencies for operating band 2

Table 4.3.1.1.2-1: Test frequencies for E-UTRA channel bandwidth for operating band 2

Test Frequency ID	Bandwidth [MHz]	N _{UL}	Frequency of Uplink [MHz]	N _{DL}	Frequency of Downlink [MHz]
Low Range	1.4	18607	1850.7	607	1930.7
	3	18615	1851.5	615	1931.5
	5	18625	1852.5	625	1932.5
	10	18650	1855	650	1935
	15 ^[1]	18675	1857.5	675	1937.5
	20 ^[1]	18700	1860	700	1940
Mid Range	1.4/3/5/10 15 ^[1] /20 ^[1]	18900	1880	900	1960
High Range	1.4	19193	1909.3	1193	1989.3
	3	19185	1908.5	1185	1988.5
	5	19175	1907.5	1175	1987.5
	10	19150	1905	1150	1985
	15 ^[1]	19125	1902.5	1125	1982.5
	20 ^[1]	19100	1900	1100	1980

NOTE 1: Bandwidth for which a relaxation of the specified UE receiver sensitivity requirement (TS 36.101 [27] Clause 7.3) is allowed.

4.3.1.1.3 FDD reference test frequencies for operating band 3

Table 4.3.1.1.3-1: Test frequencies for E-UTRA channel bandwidth for operating band 3

Test Frequency ID	Bandwidth [MHz]	N _{UL}	Frequency of Uplink [MHz]	N _{DL}	Frequency of Downlink [MHz]
Low Range	1.4	19207	1710.7	1207	1805.7
	3	19215	1711.5	1215	1806.5
	5	19225	1712.5	1225	1807.5
	10	19250	1715	1250	1810
	15 ^[1]	19275	1717.5	1275	1812.5
	20 ^[1]	19300	1720	1300	1815
Mid Range	1.4/3/5/10 15 ^[1] /20 ^[1]	19575	1747.5	1575	1842.5
High Range	1.4	19943	1784.3	1943	1879.3
	3	19935	1783.5	1935	1878.5
	5	19925	1782.5	1925	1877.5
	10	19900	1780	1900	1875
	15 ^[1]	19875	1777.5	1875	1872.5
	20 ^[1]	19850	1775	1850	1870
NOTE 1: Bandwidth for which a relaxation of the specified UE receiver sensitivity requirement (TS 36.101 [27] Clause 7.3) is allowed.					

4.3.1.1.4 FDD reference test frequencies for operating band 4

Table 4.3.1.1.4-1: Test frequencies for E-UTRA channel bandwidth for operating band 4

Test Frequency ID	Bandwidth [MHz]	N _{UL}	Frequency of Uplink [MHz]	N _{DL}	Frequency of Downlink [MHz]
Low Range	1.4	19957	1710.7	1957	2110.7
	3	19965	1711.5	1965	2111.5
	5	19975	1712.5	1975	2112.5
	10	20000	1715	2000	2115
	15	20025	1717.5	2025	2117.5
	20	20050	1720	2050	2120
Mid Range	1.4/3/5/10/15/20	20175	1732.5	2175	2132.5
High Range	1.4	20393	1754.3	2393	2154.3
	3	20385	1753.5	2385	2153.5
	5	20375	1752.5	2375	2152.5
	10	20350	1750	2350	2150
	15	20325	1747.5	2325	2147.5
	20	20300	1745	2300	2145

4.3.1.1.5 FDD reference test frequencies for operating band 5

Table 4.3.1.1.5-1: Test frequencies for E-UTRA channel bandwidth for operating band 5

Test Frequency ID	Bandwidth [MHz]	N _{UL}	Frequency of Uplink [MHz]	N _{DL}	Frequency of Downlink [MHz]
Low Range	1.4	20407	824.7	2407	869.7
	3	20415	825.5	2415	870.5
	5	20425	826.5	2425	871.5
	10 ^[1]	20450	829	2450	874
Mid Range	1.4/3/5 10 ^[1]	20525	836.5	2525	881.5
High Range	1.4	20643	848.3	2643	893.3
	3	20635	847.5	2635	892.5
	5	20625	846.5	2625	891.5
	10 ^[1]	20600	844	2600	889

NOTE 1: Bandwidth for which a relaxation of the specified UE receiver sensitivity requirement (TS 36.101 [27] Clause 7.3) is allowed.

4.3.1.1.6 FDD reference test frequencies for operating band 6

Table 4.3.1.1.6-1: Test frequencies for E-UTRA channel bandwidth for operating band 6

Test Frequency ID	Bandwidth [MHz]	N _{UL}	Frequency of Uplink [MHz]	N _{DL}	Frequency of Downlink [MHz]
Low Range	5	20675	832.5	2675	877.5
	10 ^[1]	20700	835	2700	880
Mid Range	5 10 ^[1]	20700	835	2700	880
High Range	5	20725	837.5	2725	882.5
	10 ^[1]	20700	835	2700	880

NOTE 1: Bandwidth for which a relaxation of the specified UE receiver sensitivity requirement (TS 36.101 [27] Clause 7.3) is allowed.

NOTE: For Band VI testing, the Mobile Country Code shall be set to (MCC = '442/443').

4.3.1.1.7 FDD reference test frequencies for operating band 7

Table 4.3.1.1.7-1: Test frequencies for E-UTRA channel bandwidth for operating band 7

Test Frequency ID	Bandwidth [MHz]	N _{UL}	Frequency of Uplink [MHz]	N _{DL}	Frequency of Downlink [MHz]
Low Range	5	20775	2502.5	2775	2622.5
	10	20800	2505	2800	2625
	15	20825	2507.5	2825	2627.5
	20 ^[1]	20850	2510	2850	2630
Mid Range	5/10/15 20 ^[1]	21100	2535	3100	2655
High Range	5	21425	2567.5	3425	2687.5
	10	21400	2565	3400	2685
	15	21375	2562.5	3375	2682.5
	20 ^[1]	21350	2560	3350	2680

NOTE 1: Bandwidth for which a relaxation of the specified UE receiver sensitivity requirement (TS 36.101 [27] Clause 7.3) is allowed.

4.3.1.1.8 FDD reference test frequencies for operating band 8

Table 4.3.1.1.8-1: Test frequencies for E-UTRA channel bandwidth for operating band 8

Test Frequency ID	Bandwidth [MHz]	N _{UL}	Frequency of Uplink [MHz]	N _{DL}	Frequency of Downlink [MHz]
Low Range	1.4	21457	880.7	3457	925.7
	3	21465	881.5	3465	926.5
	5	21475	882.5	3475	927.5
	10 ^[1]	21500	885	3500	930
Mid Range	1.4/3/5 10 ^[1]	21625	897.5	3625	942.5
High Range	1.4	21793	914.3	3793	959.3
	3	21785	913.5	3785	958.5
	5	21775	912.5	3775	957.5
	10 ^[1]	21750	910	3750	955

NOTE 1: Bandwidth for which a relaxation of the specified UE receiver sensitivity requirement (TS 36.101 [27] Clause 7.3) is allowed.

4.3.1.1.9 FDD reference test frequencies for operating band 9

Table 4.3.1.1.9-1: Test frequencies for E-UTRA channel bandwidth for operating band 9

Test Frequency ID	Bandwidth [MHz]	N _{UL}	Frequency of Uplink [MHz]	N _{DL}	Frequency of Downlink [MHz]
Low Range	5	21825	1752.4	3825	1847.4
	10	21850	1754.9	3850	1849.9
	15 ^[1]	21875	1757.4	3875	1852.4
	20 ^[1]	21900	1759.9	3900	1854.9
Mid Range	5/10 15 ^[1] /20 ^[1]	21975	1767.4	3975	1862.4
High Range	5	22125	1782.4	4125	1877.4
	10	22100	1779.9	4100	1874.9
	15 ^[1]	22075	1777.4	4075	1872.4
	20 ^[1]	22050	1774.9	4050	1869.9

NOTE 1: Bandwidth for which a relaxation of the specified UE receiver sensitivity requirement (TS 36.101 [27] Clause 7.3) is allowed.

4.3.1.1.10 FDD reference test frequencies for operating band 10

Table 4.3.1.1.10-1: Test frequencies for E-UTRA channel bandwidth for operating band 10

Test Frequency ID	Bandwidth [MHz]	N _{UL}	Frequency of Uplink [MHz]	N _{DL}	Frequency of Downlink [MHz]
Low Range	5	22175	1712.5	4175	2112.5
	10	22200	1715	4200	2115
	15	22225	1717.5	4225	2117.5
	20	22250	1720	4250	2120
Mid Range	5/10/15/20	22450	1740	4450	2140
High Range	5	22725	1767.5	4725	2167.5
	10	22700	1765	4700	2165
	15	22675	1762.5	4675	2162.5
	20	22650	1760	4650	2160

4.3.1.1.11 FDD reference test frequencies for operating band 11

Table 4.3.1.1.11-1: Test frequencies for E-UTRA channel bandwidth for operating band 11

Test Frequency ID	Bandwidth [MHz]	N _{UL}	Frequency of Uplink [MHz]	N _{DL}	Frequency of Downlink [MHz]
Low Range	5	22775	1430.4	4775	1478.4
	10 ^[1]	22800	1432.9	4800	1480.9
Mid Range	5 / 10 ^[1]	22850	1437.9	4850	1485.9
High Range	5	22925	1445.4	4925	1493.4
	10 ^[1]	22900	1442.9	4900	1490.9

NOTE 1: Bandwidth for which a relaxation of the specified UE receiver sensitivity requirement (TS 36.101 [27] Clause 7.3) is allowed.

4.3.1.1.12 FDD reference test frequencies for operating band 12

Table 4.3.1.1.12-1: Test frequencies for E-UTRA channel bandwidth for operating band 12

Test Frequency ID	Bandwidth [MHz]	N _{UL}	Frequency of Uplink [MHz]	N _{DL}	Frequency of Downlink [MHz]
Low Range	1.4	23017	699.7	5017	729.7
	3	23025	700.5	5025	730.5
	5 ^[1]	23035	701.5	5035	731.5
	10 ^[1]	23060	704	5060	734
Mid Range	1.4/3 5 ^[1] /10 ^[1]	23095	707.5	5095	737.5
High Range	1.4	23173	715.3	5173	745.3
	3	23165	714.5	5165	744.5
	5 ^[1]	23155	713.5	5155	743.5
	10 ^[1]	23130	711	5130	741

NOTE 1: Bandwidth for which a relaxation of the specified UE receiver sensitivity requirement (TS 36.101 [27] Clause 7.3) is allowed.

4.3.1.1.13 FDD reference test frequencies for operating band 13

Table 4.3.1.1.13-1: Test frequencies for E-UTRA channel bandwidth for operating band 13

Test Frequency ID	Bandwidth [MHz]	N _{UL}	Frequency of Uplink [MHz]	N _{DL}	Frequency of Downlink [MHz]
Low Range	5 ^[1]	23205	779.5	5205	748.5
	10 ^[1]	23230	782	5230	751
Mid Range	5 ^[1] /10 ^[1]	23230	782	5230	751
High Range	5 ^[1]	23255	784.5	5255	753.5
	10 ^[1]	23230	782	5230	751

NOTE 1: Bandwidth for which a relaxation of the specified UE receiver sensitivity requirement (TS 36.101 [27] Clause 7.3) is allowed.

4.3.1.1.14 FDD reference test frequencies for operating band 14

Table 4.3.1.1.14-1: Test frequencies for E-UTRA channel bandwidth for operating band 14

Test Frequency ID	Bandwidth [MHz]	N _{UL}	Frequency of Uplink [MHz]	N _{DL}	Frequency of Downlink [MHz]
Low Range	5 ^[1]	23305	790.5	5305	760.5
	10 ^[1]	23330	793	5330	763
Mid Range	5 ^[1] /10 ^[1]	23330	793	5330	763
High Range	5 ^[1]	23355	795.5	5355	765.5
	10 ^[1]	23330	793	5330	763

NOTE 1: Bandwidth for which a relaxation of the specified UE receiver sensitivity requirement (TS 36.101 [27] Clause 7.3) is allowed.

4.3.1.1.15 FDD reference test frequencies for operating band 15

[FFS; not yet specified in TS 36.101]

4.3.1.1.16 FDD reference test frequencies for operating band 16

[FFS; not yet specified in TS 36.101]

4.3.1.1.17 FDD reference test frequencies for operating band 17

Table 4.3.1.1.17-1: Test frequencies for E-UTRA channel bandwidth for operating band 17

Test Frequency ID	Bandwidth [MHz]	N _{UL}	Frequency of Uplink [MHz]	N _{DL}	Frequency of Downlink [MHz]
Low Range	5 ^[1]	23755	706.5	5755	736.5
	10 ^[1]	23780	709	5780	739
Mid Range	5 ^[1] /10 ^[1]	23790	710	5790	740
High Range	5 ^[1]	23825	713.5	5825	743.5
	10 ^[1]	23800	711	5800	741

NOTE 1: Bandwidth for which a relaxation of the specified UE receiver sensitivity requirement (TS 36.101 [27] Clause 7.3) is allowed.

4.3.1.1.18 FDD reference test frequencies for operating band 18

Table 4.3.1.1.18-1: Test frequencies for E-UTRA channel bandwidth for operating band 18

Test Frequency ID	Bandwidth [MHz]	N _{UL}	Frequency of Uplink [MHz]	N _{DL}	Frequency of Downlink [MHz]
Low Range	5	23875	817.5	5875	862.5
	10 ^[1]	23900	820	5900	865
	15 ^[1]	23925	822.5	5925	867.5
Mid Range	5/10 ^[1] /15 ^[1]	23925	822.5	5925	867.5
High range	5	23975	827.5	5975	872.5
	10 ^[1]	23950	825	5950	870
	15 ^[1]	23925	822.5	5925	867.5

NOTE 1: Bandwidth for which a relaxation of the specified UE receiver sensitivity requirement (TS 36.101 [27] Clause 7.3) is allowed.

4.3.1.1.19 FDD reference test frequencies for operating band 19

Table 4.3.1.1.19-1: Test frequencies for E-UTRA channel bandwidth for operating band 19

Test Frequency ID	Bandwidth [MHz]	N _{UL}	Frequency of Uplink [MHz]	N _{DL}	Frequency of Downlink [MHz]
Low Range	5	24025	832.5	6025	877.5

	10 ^[1]	24050	835	6050	880
	15 ^[1]	24075	837.5	6075	882.5
Mid Range	5/10 ^[1] /15 ^[1]	24075	837.5	6075	882.5
High range	5	24125	842.5	6125	887.5
	10 ^[1]	24100	840	6100	885
	15 ^[1]	24075	837.5	6075	882.5

NOTE 1: Bandwidth for which a relaxation of the specified UE receiver sensitivity requirement (TS 36.101 [27] Clause 7.3) is allowed.

4.3.1.1.20 FDD reference test frequencies for operating band 20

Table 4.3.1.1.19-1: Test frequencies for E-UTRA channel bandwidth for operating band 20

Test Frequency ID	Bandwidth [MHz]	N _{UL}	Frequency of Uplink [MHz]	N _{DL}	Frequency of Downlink [MHz]
Low Range	5	24175	834.5	6175	793.5
	10 ^[1]	24200	837	6200	796
	15 ^[1]	24225	839.5	6225	798.5
	20 ^[1]	24250	842	6250	801
Mid Range	5/10 ^[1] /15 ^[1] /20 ^[1]	24300	847	6300	806
High range	5	24425	859.5	6425	818.5
	10 ^[1]	24400	857	6400	816
	15 ^[1]	24375	854.5	6375	813.5
	20 ^[1]	24350	852	6350	811

NOTE 1: Bandwidth for which a relaxation of the specified UE receiver sensitivity requirement (TS 36.101 [27] Clause 7.3) is allowed.

4.3.1.1.21 FDD reference test frequencies for operating band 21

Table 4.3.1.1.21-1: Test frequencies for E-UTRA channel bandwidth for operating band 21

Test Frequency ID	Bandwidth [MHz]	N _{UL}	Frequency of Uplink [MHz]	N _{DL}	Frequency of Downlink [MHz]
Low Range	5	24475	1450.4	6475	1498.4
	10 ^[1]	24500	1452.9	6500	1500.9
	15 ^[1]	24525	1455.4	6525	1503.4
Mid Range	5/10 ^[1] /15 ^[1]	24525	1455.4	6525	1503.4
High range	5	24575	1460.4	6575	1508.4
	10 ^[1]	24550	1457.9	6550	1505.9
	15 ^[1]	24525	1455.4	6525	1503.4

NOTE 1: Bandwidth for which a relaxation of the specified UE receiver sensitivity requirement (TS 36.101 [27] Clause 7.3) is allowed.

4.3.1.1.22 FDD reference test frequencies for operating band 22

Table 4.3.1.1.22-1: Test frequencies for E-UTRA channel bandwidth for operating band 22

Test Frequency ID	Bandwidth [MHz]	N _{UL}	Frequency of Uplink [MHz]	N _{DL}	Frequency of Downlink [MHz]
Low Range	5	24625	3412.5	6625	3512.5
	10	24650	3415	6650	3515
	15	24675	3417.5	6675	3517.5
	20	24700	3420	6700	3520
Mid Range	5/10/15/20	25000	3450	7000	3550
High Range	5	25375	3487.5	7375	3587.5
	10	25350	3485	7350	3585
	15	25325	3482.5	7325	3582.5
	20	25300	3480	7300	3580

4.3.1.1.23 FDD reference test frequencies for operating band 23

Table 4.3.1.1.23-1: Test frequencies for E-UTRA channel bandwidth for operating band 23

Test Frequency ID	Bandwidth [MHz]	N _{UL}	Frequency of Uplink [MHz]	N _{DL}	Frequency of Downlink [MHz]
Low Range	1.4	25507	2000.7	7507	2180.7
	3	25515	2001.5	7515	2181.5
	5	25525	2002.5	7525	2182.5
	10	25550	2005	7550	2185
Mid Range	1.4/3 5/10	25600	2010	7600	2190
High Range	1.4	25693	2019.3	7693	2199.3
	3	25685	2018.5	7685	2198.5
	5	25675	2017.5	7675	2197.5
	10	25650	2015	7650	2195

4.3.1.1.24 FDD reference test frequencies for operating band 24

Table 4.3.1.1.24-1: Test frequencies for E-UTRA channel bandwidth for operating band 24

Test Frequency ID	Bandwidth [MHz]	N _{UL}	Frequency of Uplink [MHz]	N _{DL}	Frequency of Downlink [MHz]
Low Range	5	25725	1629	7725	1527.5
	10	25750	1631.5	7750	1530
Mid Range	5/10	25870	1643.5	7870	1542
High Range	5	26015	1658	8015	1556.5
	10	25990	1655.5	7990	1554

4.3.1.1.25 FDD reference test frequencies for operating band 25

Table 4.3.1.1.25-1: Test frequencies for E-UTRA channel bandwidth for operating band 25

Test Frequency ID	Bandwidth [MHz]	N _{UL}	Frequency of Uplink [MHz]	N _{DL}	Frequency of Downlink [MHz]
Low Range	1.4	26047	1850.7	8047	1930.7
	3	26055	1851.5	8055	1931.5
	5	26065	1852.5	8065	1932.5
	10	26090	1855	8090	1935
	15 ^[1]	26115	1857.5	8115	1937.5
	20 ^[1]	26140	1860	8140	1940
Mid Range	1.4/3/5/10 15 ^[1] /20 ^[1]	26365	1882,5	8365	1962.5
High Range	1.4	26683	1914.3	8683	1994.3
	3	26675	1913.5	8675	1993.5
	5	26665	1912.5	8665	1992.5
	10	26640	1910	8640	1990
	15 ^[1]	26615	1907.5	8615	1987.5
	20 ^[1]	26590	1905	8590	1985

NOTE 1: Bandwidth for which a relaxation of the specified UE receiver sensitivity requirement (TS 36.101 [27] Clause 7.3) is allowed.

4.3.1.1.26 FDD reference test frequencies for operating band 26

Table 4.3.1.1.26-1: Test frequencies for E-UTRA channel bandwidth for operating band 26

Test Frequency ID	Bandwidth [MHz]	N _{UL}	Frequency of Uplink [MHz]	N _{DL}	Frequency of Downlink [MHz]
Low Range	1.4	26697	814.7	8697	859.7
	3	26705	815.5	8705	860.5
	5	26715	816.5	8715	861.5
	10 ^[1]	26800	820	8800	865
	15 ^[1]	26825	822.5	8825	867.5
Mid Range	1.4/3/5/10 ^[1] 15 ^[1]	26865	831.5	8865	876.5
High Range	1.4	27033	848.3	9033	893.3
	3	27025	847.5	9025	892.5
	5	27015	846.5	9015	891.5
	10 ^[1]	26990	844	8990	889
	15 ^[1]	26965	841.5	8965	886.5

NOTE 1: Bandwidth for which a relaxation of the specified UE receiver sensitivity requirement (TS 36.101 [27] Clause 7.3) is allowed.

4.3.1.2 TDD Mode Test frequencies

4.3.1.2.1 TDD reference test frequencies for Operating Band 33

Table 4.3.1.2.1-1: Test frequencies for E-UTRA channel bandwidth for operating band 33

Test Frequency ID	Bandwidth [MHz]	EARFCN	Frequency (UL and DL) [MHz]
Low Range	5	36025	1902.5
	10	36050	1905
	15	36075	1907.5
	20	36100	1910
Mid Range	5/10/15/20	36100	1910
High Range	5	36175	1917.5
	10	36150	1915
	15	36125	1912.5
	20	36100	1910

4.3.1.2.2 TDD reference test frequencies for Operating Band 34

Table 4.3.1.2.2-1: Test frequencies for E-UTRA channel bandwidth for operating band 34

Test Frequency ID	Bandwidth [MHz]	EARFCN	Frequency (UL and DL) [MHz]
Low Range	5	36225	2012.5
	10	36250	2015
	15	36275	2017.5
Mid Range	5/10/15	36275	2017.5
High Range	5	36325	2022.5
	10	36300	2020
	15	36275	2017.5

4.3.1.2.3 TDD reference test frequencies for Operating Band 35

Table 4.3.1.2.3-1: Test frequencies for E-UTRA channel bandwidth for operating band 35

Test Frequency ID	Bandwidth [MHz]	EARFCN [MHz]	Frequency (UL and DL) [MHz]
Low Range	1.4	36357	1850.7
	3	36365	1851.5
	5	36375	1852.5
	10	36400	1855
	15	36425	1857.5
	20	36450	1860
Mid Range	1.4/3/5/10/15/20	36650	1880
High Range	1.4	36943	1909.3
	3	36935	1908.5
	5	36925	1907.5
	10	36900	1905
	15	36875	1902.5
	20	36850	1900

4.3.1.2.4 TDD reference test frequencies for Operating Band 36

Table 4.3.1.2.4-1: Test frequencies for E-UTRA channel bandwidth for operating band 36

Test Frequency ID	Bandwidth [MHz]	EARFCN [MHz]	Frequency (UL and DL) [MHz]
Low Range	1.4	36957	1930.7
	3	36965	1931.5
	5	36975	1932.5
	10	37000	1935
	15	37025	1937.5
	20	37050	1940
Mid Range	1.4/3/5/10/15/20	37250	1960
High Range	1.4	37543	1989.3
	3	37535	1988.5
	5	37525	1987.5
	10	37500	1985
	15	37475	1982.5
	20	37450	1980

4.3.1.2.5 TDD reference test frequencies for Operating Band 37

Table 4.3.1.2.5-1: Test frequencies for E-UTRA channel bandwidth for operating band 37

Test Frequency ID	Bandwidth [MHz]	EARFCN [MHz]	Frequency (UL and DL) [MHz]
Low Range	5	37575	1912.5
	10	37600	1915
	15	37625	1917.5
	20	37650	1920
Mid Range	5/10/15/20	37650	1920
High Range	5	37725	1927.5
	10	37700	1925
	15	37675	1922.5
	20	37650	1920

4.3.1.2.6 TDD reference test frequencies for Operating Band 38

Table 4.3.1.2.6-1: Test frequencies for E-UTRA channel bandwidth for operating band 38

Test Frequency ID	Bandwidth [MHz]	EARFCN	Frequency (UL and DL) [MHz]
Low Range	5	37775	2572.5
	10	37800	2575
	15	37825	2577.5
	20	37850	2580
Mid Range	5/10/15/20	38000	2595
High Range	5	38225	2617.5
	10	38200	2615
	15	38175	2612.5
	20	38150	2610

4.3.1.2.7 TDD reference test frequencies for Operating Band 39

Table 4.3.1.2.7-1: Test frequencies for E-UTRA channel bandwidth for operating band 39

Test Frequency ID	Bandwidth [MHz]	EARFCN	Frequency (UL and DL) [MHz]
Low Range	5	38275	1882.5
	10	38300	1885
	15	38325	1887.5
	20	38350	1890
Mid Range	5/10/15/20	38450	1900
High Range	5	38625	1917.5
	10	38600	1915
	15	38575	1912.5
	20	38550	1910

4.3.1.2.8 TDD reference test frequencies for Operating Band 40

Table 4.3.1.2.8-1: Test frequencies for E-UTRA channel bandwidth for operating band 40

Test Frequency ID	Bandwidth [MHz]	EARFCN	Frequency (UL and DL) [MHz]
Low Range	5	38675	2302.5
	10	38700	2305
	15	38725	2307.5
	20	38750	2310
Mid Range	5/10/15/20	39150	2350
High Range	5	39625	2397.5
	10	39600	2395
	15	39575	2392.5
	20	39550	2390

4.3.1.2.8A TDD reference test frequencies for CA in operating band 40

Table 4.3.1.2.8A-1: Test frequencies for CA_40C

Test Frequency ID	CC Combination / N _{RB_agg}	CC N _{RB}	EARFCN	Frequency (UL and DL) [MHz]
Low Range	50 + 100	PCC 100	38750	2310
		SCC 50	38894	2324.4
	50 + 100	PCC 50	38725	2305
		SCC 100	38869	2319.4
	75 + 75	PCC 75	38725	2307.5
		SCC 75	38875	2322.5
	100 + 100	PCC 100	38750	2310
		SCC 100	38948	2329.8
Mid Range	50 + 100	PCC 100	39100	2345
		SCC 50	39244	2359.4
	50 + 100	PCC 50	39050	2340
		SCC 100	39194	2354.4
	75 + 75	PCC 75	39075	2342.5
		SCC 75	39225	2357.5
	100 + 100	PCC 100	39050	2340
		SCC 100	39248	2359.8
High Range	50 + 100	PCC 100	39456	2380.6
		SCC 50	39600	2395
	50 + 100	PCC 50	39406	2375.6
		SCC 100	39550	2390
	75 + 75	PCC 75	39575	2377.5
		SCC 75	39425	2392.5
	100 + 100	PCC 100	39552	2370.2
		SCC 100	39350	2390

4.3.1.2.9 TDD reference test frequencies for Operating Band 41

Table 4.3.1.2.9-1: Test frequencies for E-UTRA channel bandwidth for operating band 41

Test Frequency ID	Bandwidth [MHz]	EARFCN	Frequency (UL and DL) [MHz]
Low Range	5	39675	2498.5
	10	39700	2501
	15	39725	2503.5
	20	39750	2506
Mid Range	5/10/15/20	40620	2593
High Range	5	41565	2687.5
	10	41540	2685
	15	41515	2682.5
	20	41490	2680

4.3.1.2.10 TDD reference test frequencies for Operating Band 42

Table 4.3.1.2.10-1: Test frequencies for E-UTRA channel bandwidth for operating band 42

Test Frequency ID	Bandwidth [MHz]	EARFCN	Frequency (UL and DL) [MHz]
Low Range	5	41615	3402.5
	10	41640	3405
	15	41665	3407.5
	20	41690	3410
Mid Range	5/10/15/20	42590	3500
High Range	5	43565	3597.5
	10	43540	3595

	15	43515	3592.5
	20	43490	3590

4.3.1.2.11 TDD reference test frequencies for Operating Band 43

Table 4.3.1.2.11-1: Test frequencies for E-UTRA channel bandwidth for operating band 43

Test Frequency ID	Bandwidth [MHz]	EARFCN	Frequency (UL and DL) [MHz]
Low Range	5	43615	3602.5
	10	43640	3605
	15	43665	3607.5
	20	43690	3610
Mid Range	5/10/15/20	44590	3700
High Range	5	45565	3797.5
	10	45540	3795
	15	45515	3792.5
	20	45490	3790

4.3.1.3 HRPD Test frequencies

4.3.1.3.1 HRPD test frequencies for Band Class 0

Table 4.3.1.3.1-1: Test frequencies for HRPD in Band Class 0

Test Frequency ID	Bandwidth [MHz]	Channel Number	Frequency of Uplink [MHz]	Frequency of Downlink [MHz]
Low Range	1.23	1013	824.70	869.70
Mid Range	1.23	356	835.68	880.68
High Range	1.23	779	848.37	893.37

4.3.1.3.2 HRPD test frequencies for Band Class 1

Table 4.3.1.3.2-1: Test frequencies for HRPD in Band Class 1

Test Frequency ID	Bandwidth [MHz]	Channel Number	Frequency of Uplink [MHz]	Frequency of Downlink [MHz]
Low Range	1.25	25	1851.25	1931.25
Mid Range	1.25	600	1880.00	1960.00
High Range	1.25	1175	1908.75	1988.75

4.3.1.3.3 HRPD test frequencies for Band Class 3

Table 4.3.1.3.3-1: Test frequencies for HRPD in Band Class 3

Test Frequency ID	Bandwidth [MHz]	Channel Number	Frequency of Uplink [MHz]	Frequency of Downlink [MHz]
Low Range	1.25	1120	888.00	833.00
Mid Range	1.25	872	898.90	843.90
High Range	1.25	76	915.95	860.95

4.3.1.3.4 HRPD test frequencies for Band Class 4

Table 4.3.1.3.4-1: Test frequencies for HRPD in Band Class 4

Test Frequency ID	Bandwidth [MHz]	Channel Number	Frequency of Uplink [MHz]	Frequency of Downlink [MHz]
Low Range	1.25	100	1755.00	1845.00
Mid Range	1.25	300	1765.00	1855.00
High Range	1.25	525	1776.25	1866.25

4.3.1.3.5 HRPD test frequencies for Band Class 6

Table 4.3.1.3.5-1: Test frequencies for HRPD in Band Class 6

Test Frequency ID	Bandwidth [MHz]	Channel Number	Frequency of Uplink [MHz]	Frequency of Downlink [MHz]
Low Range	1.25	125	1926.25	2116.25
Mid Range	1.25	200	1930.00	2120.00
High Range	1.25	350	1937.50	2127.50

4.3.1.3.6 HRPD test frequencies for Band Class 10

Table 4.3.1.3.6-1: Test frequencies for HRPD in Band Class 10

Test Frequency ID	Bandwidth [MHz]	Channel Number	Frequency of Uplink [MHz]	Frequency of Downlink [MHz]
Low Range	1.25	100	808.50	853.50
Mid Range	1.25	500	821.00	866.00
High Range	1.25	820	898.50	937.50

4.3.1.3.7 HRPD test frequencies for Band Class 15

Table 4.3.1.3.7-1: Test frequencies for HRPD in Band Class 15

Test Frequency ID	Bandwidth [MHz]	Channel Number	Frequency of Uplink [MHz]	Frequency of Downlink [MHz]
Low Range	1.25	75	1713.75	2113.75
Mid Range	1.25	450	1732.50	2132.50
High Range	1.25	800	1750.00	2150.00

4.3.1.4 1xRTT Test frequencies

4.3.1.4.1 1xRTT test frequencies for Band Class 0

Table 4.3.1.4.1-1: Test frequencies for 1xRTT in Band Class 0

Test Frequency ID	Bandwidth [MHz]	Channel Number	Frequency of Uplink [MHz]	Frequency of Downlink [MHz]
Low Range	1.23	1013	824.70	869.70
Mid Range	1.23	356	835.68	880.68
High Range	1.23	779	848.37	893.37

4.3.1.4.2 1xRTT test frequencies for Band Class 1

Table 4.3.1.4.2-1: Test frequencies for 1xRTT in Band Class 1

Test Frequency ID	Bandwidth [MHz]	Channel Number	Frequency of Uplink [MHz]	Frequency of Downlink [MHz]
Low Range	1.25	25	1851.25	1931.25
Mid Range	1.25	600	1880.00	1960.00
High Range	1.25	1175	1908.75	1988.75

4.3.1.4.3 1xRTT test frequencies for Band Class 3

Table 4.3.1.4.3-1: Test frequencies for 1xRTT in Band Class 3

Test Frequency ID	Bandwidth [MHz]	Channel Number	Frequency of Uplink [MHz]	Frequency of Downlink [MHz]
Low Range	1.25	1120	888.00	833.00
Mid Range	1.25	872	898.90	843.90
High Range	1.25	76	915.95	860.95

4.3.1.4.4 1xRTT test frequencies for Band Class 4

Table 4.3.1.4.4-1: Test frequencies for 1xRTT in Band Class 4

Test Frequency ID	Bandwidth [MHz]	Channel Number	Frequency of Uplink [MHz]	Frequency of Downlink [MHz]
Low Range	1.25	100	1755.00	1845.00
Mid Range	1.25	300	1765.00	1855.00
High Range	1.25	525	1776.25	1866.25

4.3.1.4.5 1xRTT test frequencies for Band Class 6

Table 4.3.1.4.5-1: Test frequencies for 1xRTT in Band Class 6

Test Frequency ID	Bandwidth [MHz]	Channel Number	Frequency of Uplink [MHz]	Frequency of Downlink [MHz]
Low Range	1.25	225	1931.25	2121.25
Mid Range	1.25	275	1933.75	2123.75
High Range	1.25	375	1938.75	2128.75

4.3.1.4.6 1xRTT test frequencies for Band Class 10

Table 4.3.1.4.6-1: Test frequencies for 1xRTT in Band Class 10

Test Frequency ID	Bandwidth [MHz]	Channel Number	Frequency of Uplink [MHz]	Frequency of Downlink [MHz]
Low Range	1.25	100	808.50	853.50
Mid Range	1.25	500	821.00	866.00
High Range	1.25	820	898.50	937.50

4.3.1.4.7 1xRTT test frequencies for Band Class 15

Table 4.3.1.4.7-1: Test frequencies for 1xRTT in Band Class 15

Test Frequency ID	Bandwidth [MHz]	Channel Number	Frequency of Uplink [MHz]	Frequency of Downlink [MHz]
Low Range	1.25	75	1713.75	2113.75

Mid Range	1.25	450	1732.50	2132.50
High Range	1.25	800	1750.00	2150.00

4.3.2 Radio conditions

4.3.2.1 Normal propagation condition

The downlink connection between the System Simulator and the UE is without Additive White Gaussian Noise, and has no fading or multipath effects.

The uplink connection between the UE and System Simulator is without Additive White Gaussian Noise, and has no fading or multipath effects.

4.3.3 Physical channel allocations

4.3.3.1 Antennas

If the UE has two Rx antennas, the same downlink signal is applied to each one. Both UE Rx antennas shall be connected unless otherwise stated in the test case.

If the UE has one Rx antenna, the downlink signal is applied to it.

4.3.3.2 Downlink physical channels and physical signals

The Downlink Physical channels and Physical signals used and their relative powers are specified for single SS Tx antenna in table 4.3.3.2-1 and for two SS Tx antennas in table 4.3.3.2-2. The details of downlink power allocation for PDSCH channel are described in TS 36.213 [29] clause 5.2.

Table 4.3.3.2-1: Power allocation for OFDM symbols and reference signals, single SS Tx antenna

Physical Channel	EPRE Ratio
PBCH	PBCH_RA = 0 dB
	PBCH_RB = 0 dB
PSS	PSS_RA = 0 dB
SSS	SSS_RA = 0 dB
PCFICH	PCFICH_RB = 0 dB
PDCCH	PDCCH_RA = 0 dB
	PDCCH_RB = 0 dB
PDSCH	PDSCH_RA = 0 dB
	PDSCH_RB = 0 dB
PHICH	PHICH_RB = 0 dB

Table 4.3.3.2-2: Power allocation for OFDM symbols and reference signals, two SS Tx antennas

Physical Channel	EPRE Ratio
PBCH	PBCH_RA = 0 dB
	PBCH_RB = 0 dB
PSS	PSS_RA = 0 dB
SSS	SSS_RA = 0 dB
PCFICH	PCFICH_RB = 0 dB
PDCCH	PDCCH_RA = 0 dB
	PDCCH_RB = 0 dB
PDSCH	PDSCH_RA = -3 dB
	PDSCH_RB = -3 dB
PHICH	PHICH_RB = 0 dB

4.3.3.3 Mapping of downlink physical channels and signals to physical resources

Parameters for mapping of downlink physical channels and signals are specified as follows.

- Normal Cyclic Prefix
- N_{ID}^{cell} , Physical layer cell identity = 0 is used as the default physical layer cell identity
- CFI = 3 for 1.4, 3 and 5 MHz system bandwidths
= 2 for 10, 15 and 20 MHz system bandwidths
- $N_g = 1$
- PHICH duration = Normal

For Signalling testing, the default system bandwidth is 5/10/20 MHz and single SS Tx antenna is used unless specified otherwise in the test case. The mapping of downlink physical channels to physical resources for Single Tx Antenna is described in table 4.3.3.3-1 for 5/10MHz system bandwidth FDD and table 4.3.3.3-2 for 5/20MHz system bandwidth TDD.

For RF testing, the mapping of DL physical channels to resource element is defined TS 36.521-1 [21] Annex C.1.

Table 4.3.3.3-1: Mapping of DL Physical Channels to Resource Elements for Single SS Tx Antenna and 5/10 MHz System Bandwidth (FDD)

Physical channel	Time Domain Location	Frequency Domain Location	Note
PBCH	Symbols 0 to 3 of slot 1 of subframe 0 of each radio frame	Occupies 72 subcarriers centred on the DC subcarrier	Mapping rule is specified in TS36.211 [35] sub clause 6.6.4
PSS	Symbol 6 of slot 0 and 10 of each radio frame	Occupies 62 subcarriers centred on the DC subcarrier. Additional 10 subcarriers (5 on each side) adjacent to the centred 62 subcarriers are reserved.	Mapping rule is specified in TS36.211 [35] sub clause 6.11.1.2
SSS	Symbol 5 of slots 0 and 10 of each radio frame	Occupies 62 subcarriers centred on the DC subcarrier. Additional 10 subcarriers (5 on each side) adjacent to the centred 62 subcarriers are reserved.	Mapping rule is specified in TS36.211 [35] sub clause 6.11.2.2
PCFICH	Symbol 0 of each subframe	Maps into 4 REGs uniformly spread in the frequency domain over the whole system bandwidth.	Mapping rule is specified in TS36.211 [35] sub clause 6.7.4 - CELL_ID = 0
PHICH	Symbol 0 of each subframe	Each PHICH group maps into 3 REGs in the frequency domain on the REGs not assigned to PCFICH over the whole system bandwidth,	Mapping rule is specified in TS36.211 [35] sub clause 6.9.3 - CELL_ID = 0 - Number of PHICH groups = $4(BW=5\text{ MHz})/7(BW=10\text{MHz})$
PDCCH	Symbols 0, 1, 2 of each subframe (BW=5MHz)	The remaining REGs not allocated to both PCFICH and PHICH are used for PDCCH	Mapping rule is specified in TS36.211 [35] sub clause 6.8.5 - CFI = 3 (BW=5MHz)
	Symbols 0, 1 of each subframe (BW=10MHz)		Mapping rule is specified in TS36.211 [35] sub clause 6.8.5 - CFI = 2(BW=10MHz)
PDSCH	All remaining OFDM symbols of each subframe not allocated to PDCCH	For Subframe 0, REs not allocated to RS, PSS, SSS and PBCH is allocated to PDSCH For Subframe 5, REs not allocated to RS, PSS and SSS is allocated to PDSCH For other subframes, REs not allocated to RS is allocated to PDSCH	

NOTE: In case a single cell-specific RS is configured, cell-specific RS shall be assume to be present on antenna ports 0 and 1 for the purpose of mapping a symbol-quadruplet to a REG (resource element group). (See TS 36.211 [35] sub clause 6.2.4)

Table 4.3.3.3-2: Mapping of DL Physical Channels to Resource Elements for Single SS Tx Antenna and 5/20 MHz System Bandwidth (TDD)

Physical channel	Time Domain Location	Frequency Domain Location	Note
PBCH	Symbols 0 to 3 of slot 1 of subframe 0 of each radio frame	Occupies 72 subcarriers centred on the DC subcarrier	Mapping rule is specified in TS36.211 [35] subclause 6.6.4
PSS	Symbol 2 of slot 2 and 12 of each radio frame	Occupies 62 subcarriers centred on the DC subcarrier. Additional 10 subcarriers (5 on each side) adjacent to the centred 62 subcarriers are reserved.	Mapping rule is specified in TS36.211 [35] subclause 6.11.1.2
SSS	Symbol 6 of slots 1 and 11 of each radio frame	Occupies 62 subcarriers centred on the DC subcarrier. Additional 10 subcarriers (5 on each side) adjacent to the centred 62 subcarriers are reserved.	Mapping rule is specified in TS36.211 [35] subclause 6.11.2.2
PCFICH	Symbol 0 of each downlink subframe and Special subframe	Maps into 4 REGs uniformly spread in the frequency domain over the whole system bandwidth.	Mapping rule is specified in TS36.211 [35] subclause 6.7.4 - CELL_ID = 0
PHICH	Symbol 0 of each downlink subframe and Special subframe	Each PHICH group maps into 3 REGs in the frequency domain on the REGs not assigned to PCFICH over the whole system bandwidth,	Mapping rule is specified in TS36.211 [35] subclause 6.9.3 - CELL_ID = 0 - Number of PHICH groups = $4(BW=5MHz)/13(BW=20MHz)$
PDCCH	Symbols 0, 1 of subframe 1, 6 and Symbols 0, 1, 2 of other downlink subframes (BW=5MHz)	The remaining REGs not allocated to both PCFICH and PHICH are used for PDCCH	Mapping rule is specified in TS36.211 [35] subclause 6.8.5 - CFI = 3 (BW=5MHz)
	Symbols 0, 1 of subframe 1, 6 and Symbols 0, 1 of other downlink subframes (BW=20MHz)		Mapping rule is specified in TS36.211 [35] subclause 6.8.5 - CFI = 2 (BW=20MHz)
PDSCH	All remaining OFDM symbols of each downlink subframe and DwPTS not allocated to PDCCH	<p>For Subframe 0, REs not allocated to RS, SSS and PBCH is allocated to PDSCH</p> <p>For Subframe 5, REs not allocated to RS and SSS is allocated to PDSCH</p> <p>For Subframe 1 and 6, REs not allocated to RS, PSS, GP and UpPTS is allocated to PDSCH</p> <p>For other downlink subframes, REs not allocated to RS is allocated to PDSCH</p>	

NOTE 1: In case a single cell-specific RS is configured, cell-specific RS shall be assume to be present on antenna ports 0 and 1 for the purpose of mapping a symbol-quadruplet to a REG (resource element group). (See TS 36.211 [35] subclause 6.2.4)

NOTE 2: In case the default TDD configuration for subframe assignment and special subframe patterns (see subclause 4.6.3)

4.3.3.4 Uplink physical channels and physical signals

[FFS].

4.3.3.5 Mapping of uplink physical channels and signals to physical resources

[FFS].

4.3.4 Signal levels

4.3.4.1 Downlink signal levels

The downlink power settings in table 4.3.4.1-1 are used unless otherwise specified in a test case.

Table 4.3.4.1-1: Default Downlink power levels

	Unit	Channel bandwidth					
		1.4 MHz	3 MHz	5 MHz	10 MHz	15 MHz	20 MHz
Number of RBs		6	15	25	50	75	100
Channel BW Power	dBm	-66	-62	-60	-57	-55	-54
RS EPRE	dBm/15kHz	-85	-85	-85	-85	-85	-85
Note 1: The channel bandwidth powers are informative, based on -85dBm/15kHz RS_EPRES, then scaled according to the number of RBs and rounded to the nearest integer dBm value. Full RE allocation with no boost or deboost is assumed.							
Note 2: The power level is specified at each UE Rx antenna.							

It is [FFS] whether there is a requirement to specify constant power throughout all OFDM symbols, and if so how unallocated Resource elements should be treated.

The default signal level uncertainty is +/-3dB at each test port, for any level specified. If the uncertainty value is critical for the test purpose a tighter uncertainty is specified for the related test case in TS 36.521-1 [21] Annex F or in TS 36.521-3 [34] Annex F

4.3.4.2 Uplink signal levels

[FFS]

4.3.5 Standard test signals

4.3.5.1 Downlink test signals

[FFS]

4.3.5.2 Uplink test signals

[FFS]

4.3.6 Physical layer parameters

4.3.6.1 Downlink physical layer parameters

4.3.6.1.1 Physical layer parameters for DCI format 0

Default physical layer parameters for DCI format 0 are specified in table 4.3.6.1.1-1.

Table 4.3.6.1.1-1: Physical layer parameters for DCI format 0

Parameter	Value	Value in binary
Flag for format 0/format 1A differentiation	format 0	"0"
Hopping flag	w/o Hopping	"0"
Resource block assignment and hopping resource allocation	Depending on test parameters	-
Modulation and coding scheme and redundancy version	Depending on test parameters	-
New data indicator	Set for every data transmission/retransmission according to the rules specified in TS 36.321	-
TPC command for scheduled PUSCH	0 dB (accumulated TPC)	"01"
Cyclic shift for DM RS	0	"000"
UL index (TDD only)	2 bits as defined in sections 5.1.1.1 and 8 of TS 36.213. This field is present only for TDD configuration 0	-
Downlink Assignment Index (TDD only)	2 bits as defined in Table 7.3-X in TS 36.213. It represents the total number of PDSCH subframes with and without PDCCH and PDCCH indicating downlink SPS release in the window. This field is present only for TDD configuration 1-6	-
CQI request	w/o aperiodic CQI	"0"

4.3.6.1.2 Physical layer parameters for DCI format 1

Default physical layer parameters for DCI format 1 are specified in table 4.3.6.1.2-1.

Table 4.3.6.1.2-1: Physical layer parameters for DCI format 1

Parameter	Value	Value in binary
Resource allocation header	Resource allocation type 0	"0"
Resource block assignment	Depending on test parameters	-
Modulation and coding scheme	Depending on test parameters	-
HARQ process number	Depending on test parameters, 3bits for FDD, 4 bits for TDD.	-
New data indicator	Set for every data transmission/retransmission according to the rules specified in TS 36.321	-
Redundancy version	Depending on test parameters	"00"
TPC command for PUCCH	0 dB (accumulated TPC)	"01"
Downlink Assignment Index (TDD only)	2 bits as defined in Table 7.3-X in TS 36.213. It represents the number of PDSCH with PDCCH and PDCCH indicating downlink SPS release in the window up to the present subframe. This is present for all the uplink-downlink configurations and only applies to uplink -downlink configuration 1-6	-

4.3.6.1.3 Physical layer parameters for DCI format 1A

Default physical layer parameters for DCI format 1A are specified in table 4.3.6.1.3-1.

Table 4.3.6.1.3-1: Physical layer parameters for DCI format 1A

Parameter	Value	Value in binary
Flag for format 0/format 1A differentiation	format 1A	"1"
Localized/Distributed VRB assignment flag	Localized VRB assignment	"0"
Resource block assignment	Depending on test parameters	-
Modulation and coding scheme	Depending on test parameters	-
HARQ process number	Depending on test parameters, 3bits for FDD, 4 bits for TDD.	-
New data indicator	Set for every data transmission/retransmission according to the rules specified in TS 36.321	-
Redundancy version	Depending on test parameters	"00"
TPC command for PUCCH	0 dB (accumulated TPC)	"01"
Downlink Assignment Index (TDD only)	2 bits as defined in Table 7.3-X in TS 36.213. It represents the number of PDSCH with PDCCH and PDCCH indicating downlink SPS release in the window up to the present subframe. This is present for all the uplink-downlink configurations and only applies to uplink -downlink configuration 1-6	-

4.3.6.1.3A Physical layer parameters for DCI format 1B

Default physical layer parameters for DCI format 1B are specified in table 4.3.6.1.3A-1.

Table 4.3.6.1.3A-1: Physical layer parameters for DCI format 1B

Parameter	Value	Value in binary
Localized/Distributed VRB assignment flag	Localized VRB assignment	"0"
Resource block assignment	Depending on test parameters	-
Modulation and coding scheme	Depending on test parameters	-
HARQ process number	Depending on test parameters, 3bits for FDD, 4 bits for TDD.	-
New data indicator	Set for every data transmission/retransmission according to the rules specified in TS 36.321	-
Redundancy version	Depending on test parameters	"00"
TPC command for PUCCH	0 dB (accumulated TPC)	"01"
Downlink Assignment Index (TDD only)	2 bits as defined in Table 7.3-X in TS 36.213. It represents the number of PDSCH with PDCCH and PDCCH indicating downlink SPS release in the window up to the present subframe. This is present for all the uplink-downlink configurations and only applies to uplink -downlink configuration 1-6	-
TPMI information for precoding	Set for codebook index according to TS 36.211 Table 6.3.4.2.3-1 for 2 Tx antenna ports and Table 6.3.4.2.3-2 for 4 Tx antenna ports corresponding to the single layer transmission	-
PMI confirmation for precoding	Set for every transmission, 1 for precoding according to the latest reported PMI on PUSCH, 0 for precoding according to the indicated TPMI in the TPMI information field	-

4.3.6.1.4 Physical layer parameters for DCI format 1C

Default physical layer parameters for DCI format 1C are specified in table 4.3.6.1.4-1.

Table 4.3.6.1.4-1: Physical layer parameters for DCI format 1C

Parameter	Value	Value in binary
gap value ($N_{RB} \geq 50$)	gap1	"0"
Resource block assignment	depending on test parameters	-
Transport block size index	depending on test parameters	-

4.3.6.1.5 Physical layer parameters for DCI format 2

Default physical layer parameters for DCI format 2 are specified in table 4.3.6.1.5-1.

Table 4.3.6.1.5-1: Physical layer parameters for DCI format 2

Parameter	Value	Value in binary
Resource allocation header	Resource allocation type 0	"0"
Resource block assignment	Depending on test parameters	-
TPC command for PUCCH	0 dB (accumulated TPC)	"01"
Downlink Assignment Index (TDD only)	2 bits as defined in Table 7.3-X in TS 36.213. It represents the number of PDSCH with PDCCH and PDCCH indicating downlink SPS release in the window up to the present subframe. This is present for all the uplink-downlink configurations and only applies to uplink -downlink configuration 1-6	-
HARQ process number	Depending on test parameters, 3bits for FDD, 4 bits for TDD.	-
Transport block to codeword swap flag	No swap	"0"
Modulation and coding scheme (transport block 1)	Depending on test parameters	-
New data indicator (transport block 1)	Set for every data transmission/retransmission according to the rules specified in TS 36.321	-
Redundancy version (transport block 1)	Depending on test parameters	-
Modulation and coding scheme (transport block 2)	Depending on test parameters	-
New data indicator (transport block 2)	Set for every data transmission/retransmission according to the rules specified in TS 36.321	-
Redundancy version (transport block 2)	Depending on test parameters	-
Precoding information	Set for every transmission according to 36.212 Table 5.3.3.1.5-4 for 2 Tx antenna ports and Table 5.3.3.1.5-5 for 4 Tx antenna ports	-

4.3.6.1.6 Physical layer parameters for DCI format 2A

Default physical layer parameters for DCI format 2A are specified in table 4.3.6.1.6-1.

Table 4.3.6.1.6-1: Physical layer parameters for DCI format 2A

Parameter	Value	Value in binary
Resource allocation header	Resource allocation type 0	"0"
Resource block assignment	depending on test parameters	-
TPC command for PUCCH	0 dB (accumulated TPC)	"01"
Downlink Assignment Index (TDD only)	2 bits as defined in Table 7.3-X in TS 36.213. It represents the number of PDSCH with PDCCH and PDCCH indicating downlink SPS release in the window up to the present subframe. This is present for all the uplink-downlink configurations and only applies to uplink-downlink configuration 1-6	-
HARQ process number	depending on test parameters, 3bits for FDD, and 4 bits for TDD.	-
Transport block to codeword swap flag	No swap	"0"
Modulation and coding scheme (transport block 1)	depending on test parameters	-
New data indicator (transport block 1)	Set for every data transmission/retransmission according to the rules specified in TS 36.321	-
Redundancy version (transport block 1)	depending on test parameters	-
Modulation and coding scheme (transport block 2)	depending on test parameters	-
New data indicator (transport block 2)	Set for every data transmission/retransmission according to the rules specified in TS 36.321	-
Redundancy version (transport block 2)	depending on test parameters	-
Precoding information	N/A for 2 Tx antenna ports. For 4 Tx antenna ports, set for every transmission according to 36.212 Table 5.3.3.1.5A-2	-

4.4 Reference system configurations

The reference system configurations specified in this sub clause apply to all test cases unless otherwise specified.

4.4.1 Simulated network scenarios

The UE will eventually have to operate in either single mode networks (FDD or TDD), dual mode networks (FDD+TDD), or inter-RAT networks ((FDD or TDD) + (UTRA FDD, UTRA TDD, GSM, HRPD or 1xRTT)).

Simulated network scenarios to be tested are listed in this sub clause.

NOTE 1: The number of cells specified does not necessarily correspond to the maximum number of resources to be configured simultaneously in test equipment. Please refer to Table 6.1-1 for such information.

NOTE 2: For NAS test cases see sub clause 6.3.2.

4.4.1.1 Single cell network scenarios

For FDD and TDD basic single cell environment, Cell 1 is used.

4.4.1.2 E-UTRA single mode multi cell network scenarios

For FDD or TDD basic intra-frequency multi cell environment, Cell 1, Cell 2 and Cell 4 are used.

For FDD or TDD basic inter-frequency multi cell environment, Cell 1, Cell 3 and Cell 6 are used.

For FDD or TDD basic inter-band cell environment, Cell 1 and Cell 10 are used.

For FDD or TDD multi tracking area intra-frequency multi cell environment, Cell 1 and Cell 11 are used.

For FDD or TDD multi tracking area inter-frequency multi cell environment, Cell 1 and Cell 23 are used.

For FDD or TDD multi PLMN inter-frequency multi cell environment, Cell 1, Cell 12, Cell 13 and Cell 14 are used.

4.4.1.3 E-UTRA dual mode multi cell network scenarios

For FDD and TDD basic multi cell environment, Cell 1 and Cell 10 are used.

For FDD and TDD multi PLMN multi cell environment, Cell 1, Cell 28, Cell 29 and Cell 30 are used.

In addition, E-UTRA single mode multi cell network scenarios defined in clause 4.4.1.2 are combined with the dual mode scenarios defined in this clause when additional intra or inter-frequency cells are used.

4.4.1.4 3GPP Inter-RAT network scenarios

For FDD and TDD basic inter-RAT cell environment with UTRA FDD or UTRA TDD, Cell 1 and Cell 5 are used.

For FDD and TDD inter-RAT cell environment with multi UTRA FDD or UTRA TDD cells, Cell 1 and Cell 7, Cell 8 and Cell 9 is used.

For FDD and TDD inter-RAT cell environment with GERAN, Cell 1 and Cell 24 are used.

For FDD and TDD inter-RAT cell environment with multi GERAN cells, Cell 1 and Cell 25, Cell 26 are used.

For FDD and TDD inter-RAT cell environment with (UTRA FDD or UTRA TDD) and GERAN, Cell 1, Cell 5 and Cell 24 are used.

4.4.1.5 3GPP2 Inter-RAT network scenarios

For FDD and TDD inter-RAT cell environment with HRPD, Cell 1 and Cell 15 are used.

For FDD and TDD inter-RAT cell environment with multi HRPD cells, Cell 1 and Cell 15, Cell 16 and Cell 17 are used.

For FDD and TDD inter-RAT cell environment with 1xRTT, Cell 1 and Cell 19 are used.

For FDD and TDD inter-RAT cell environment with multi 1xRTT cells, Cell 1 and Cell 19, Cell 20 and Cell 21 are used.

4.4.1.6 WLAN Inter-RAT network scenarios

For FDD and TDD inter-RAT cell environment with WLAN, Cell 1 and Cell 27 are used.

4.4.2 Simulated cells

NOTE: For NAS test cases see subclause 6.3.2.

NOTE: Test frequency and range defined in table 4.4.2-1 do not apply to 36.521-1 test cases.

Test frequencies and simulated cells are defined in table 4.4.2-1. For E-UTRA cells, f1 is the default test frequency. For UTRA cells, f8 is the default test frequency. For GERAN cells, f11 is the default test frequency. For CDMA2000 HRPD cells, f14 is the default test frequency. For CDMA 2000 1xRTT cells, f17 is the default test frequency. For WLAN cells, f20 is the default test frequency.

Default parameters for simulated cells are specified in table 4.4.2-1A and table 4.4.2-2.

Common parameters for simulated cells are specified in subclauses 4.4.3 to 4.4.6A.

Other cell specific parameters are specified in subclause 4.4.7.

Table 4.4.2-1: Definition of test frequencies and simulated cells

Test frequency	RAT	Operating band	Range	Simulated cells
f1	E-UTRA	Operating band under test	Mid (Note 1)	Cell 1, Cell 2, Cell 4, Cell 11 (Note 4)
f2	E-UTRA	Operating band under test	High (Note 1)	Cell 3, Cell 12, Cell 23
f3	E-UTRA	Operating band under test	Low (Note 1)	Cell 6, Cell 13
f4	E-UTRA	Operating band under test	(Note 1)	Cell 14
f5	E-UTRA	Operating band for inter-band cells	Mid (Note 1)	Cell 10, Cell30
f6	E-UTRA	Operating band for inter-band cells	High (Note 1)	Cell 28, Cell29
f7	E-UTRA	Operating band for inter-band cells	Low (Note 1)	
f8	UTRA	Operating band for UTRA cells	Mid (Note 2)	Cell 5, Cell 7
f9	UTRA	Operating band for UTRA cells	High (Note 2)	Cell 8
f10	UTRA	Operating band for UTRA cells	Low (Note 2)	Cell 9
f11	GERAN	Operating band for GERAN cells	Mid (Note 3)	Cell 24
f12	GERAN	Operating band for GERAN cells	High (Note 3)	Cell 25
f13	GERAN	Operating band for GERAN cells	Low (Note 3)	Cell 26
f14	CDMA2000 HRPD	Operating band for CDMA2000 HRPD cells	Mid	Cell 15, Cell 16
f15	CDMA2000 HRPD	Operating band for CDMA2000 HRPD cells	High	Cell 17
f16	CDMA2000 HRPD	Operating band for CDMA2000 HRPD cells	Low	Cell 18
f17	CDMA2000 1xRTT	Operating band for CDMA2000 1xRTT cells	Mid	Cell 19, Cell 20
f18	CDMA2000 1xRTT	Operating band for CDMA2000 1xRTT cells	High	Cell 21
f19	CDMA2000 1xRTT	Operating band for CDMA2000 1xRTT cells	Low	Cell 22
f20	WLAN	Operating band for WLAN cells	FFS	Cell 27
Note 1:	For signalling test, see clause 6.2.3.1.			
Note 2:	See TS 34.108 [5] clause 5.1.			
Note 3:	For signalling test, see clause 6.3.1.4. For RRM test, see clause 7.2.2.1.			
Note 4:	For signalling test, simultaneous co-existence of Cell 2 with Cell 11 is not allowed.			

Table 4.4.2-1A: Default E-UTRA parameters for simulated cells

cell ID	E-UTRAN Cell Identifier		Physical layer cell identity	rootSequenceIndex FDD	rootSequenceIndex TDD
	eNB Identifier	Cell Identity			
Cell 1	'0000 0000 0000 0000 0001'B	'0000 0000'B	0	22	0
Cell 2	'0000 0000 0000 0000 0001'B	'0000 0010'B	2	86	8
Cell 3	'0000 0000 0000 0000 0010'B	'0000 0011'B	3	22	0
Cell 4	'0000 0000 0000 0000 0011'B	'0000 0100'B	4	150	16
Cell 6	'0000 0000 0000 0000 0100'B	'0000 0110'B	6	22	0
Cell 10	'0000 0000 0000 0000 0101'B	'0000 1010'B	10	22	0
Cell 11	'0000 0000 0000 0000 0110'B	'0000 1011'B	11	214	24
Cell 12	'0000 0000 0000 0000 0010'B	'0000 1100'B	12	86	8
Cell 13	'0000 0000 0000 0000 0100'B	'0000 1101'B	13	86	8
Cell 14	'0000 0000 0000 0000 0111'B	'0000 1110'B	14	22	0
Cell 23	'0000 0000 0000 0000 0110'B	'0001 0111'B	23	150	16
Cell 28	'0000 0000 0000 0000 0010'B	'0001 1100'B	28	86	8
Cell 29	'0000 0000 0000 0000 0100'B	'0001 1101'B	29	86	8
Cell 30	'0000 0000 0000 0000 0111'B	'0001 1110'B	30	22	0

Table 4.4.2-2: Default NAS parameters for simulated cells

cell ID	Tracking Area			TA# list (Note 1)	GUTI (Note 2)		M-TMSI	
	TA#	PLMN			TAC	MME Identifier		
		MCC	MNC			MME Group ID		MME Code
Cell 1	TAI-1	(Note 3)		1	TAI-1	32769	1	Arbitrarily selected according to TS 23.003 subclause 2.8 [2].
Cell 2	TAI-1	(Note 3)		1	TAI-1	32769	1	
Cell 3	TAI-1	(Note 3)		1	TAI-1	32769	1	
Cell 4	TAI-1	(Note 3)		1	TAI-1	32769	1	
Cell 6	TAI-1	(Note 3)		1	TAI-1	32769	1	
Cell 10	TAI-1	(Note 3)		1	TAI-1	32769	1	
Cell 11	TAI-2	(Note 3)		2	TAI-2	32769	1	
Cell 23	TAI-2	(Note 3)		2	TAI-2	32769	1	
Cell 12, Cell 28	TAI-3	002	11	1	TAI-3	32769	1	
Cell 13, Cell 29	TAI-4	003	21	1	TAI-4	32769	1	
Cell 14, Cell 30	TAI-5	004	31	1	TAI-5	32769	1	
Note 1:	The value(s) in the column TA# list indicates TAI(s) included in the response messages of the registration procedure (ATTACH ACCEPT or TRACKING AREA UPDATE ACCEPT) when the UE performs the registration procedure on a corresponding cell.							
Note 2:	The value in the column GUTI indicates GUTI included in the response messages of the registration procedure (ATTACH ACCEPT or TRACKING AREA UPDATE ACCEPT) when the UE performs the registration procedure on a corresponding cell.							
Note 3:	Set to the same Mobile Country Code and Mobile Network Code stored in EF _{IMSI} on the test USIM card (subclause 4.9.3).							

Table 4.4.2-3: Default HRPD parameters for simulated cells

Cell ID	SectorID	ColorCode	Pilot PN Offset	CountryCode
Cell 15	Set according to PIXIT parameter	Set according to PIXIT parameter	50	(Note 1)
Cell 16	Set according to PIXIT parameter	Set according to PIXIT parameter	100	(Note 1)
Cell 17	Set according to PIXIT parameter	Set according to PIXIT parameter	150	(Note 1)
Cell 18	Set according to PIXIT parameter	Set according to PIXIT parameter	200	(Note 1)
Note 1: Set to the same Mobile Country Code stored in EFIMSI on the test USIM card (subclause 4.9.3).				

Table 4.4.2-4: Default 1XRTT parameters for simulated cells

Cell ID	SID	NID	BASE_ID	Pilot PN Offset	REG_ZONE	MCC	IMSI_11_12
Cell 19	Set according to PIXIT parameter	Set according to PIXIT parameter	Set according to PIXIT parameter	50	1	Note 1	Note 2
Cell 20	Set according to PIXIT parameter	Set according to PIXIT parameter	Set according to PIXIT parameter	100	1	Note 1	Note 2
Cell 21	Set according to PIXIT parameter	Set according to PIXIT parameter	Set according to PIXIT parameter	150	2	Note 1	Note 2
Cell 22	Set according to PIXIT parameter	Set according to PIXIT parameter	Set according to PIXIT parameter	200	3	Note 1	Note 2
Note 1: Set to the same Mobile Country Code stored in EFIMSI on the test USIM card (subclause 4.9.3).							
Note 2: Set to the same Mobile Network Code stored in EFIMSI on the test USIM card (subclause 4.9.3).							

Table 4.4.2-5: Neighbouring cell list for 1XRTT cells

Cell ID	Intra Frequency	Inter Frequency Cells		
Cell 19	cell 20	Cell 21	cell 22	X
Cell 20	cell 19	Cell 21	cell 22	X
Cell 21	X	cell 19	cell 20	cell 22
Cell 22	X	cell 19	cell 20	cell 21

4.4.3 Common parameters for simulated E-UTRA cells

The parameters specified in this sub clause apply to all simulated E-UTRA cells unless otherwise specified.

4.4.3.1 Common configurations of system information blocks

4.4.3.1.1 Combinations of system information blocks

The combination of system information blocks required by a test case depends on the test case scenario. In this clause, the following combinations of system information blocks are defined.

Combination 1 is the default combination which applies to the following test case scenarios:

- E-UTRA FDD single cell scenario
- E-UTRA TDD single cell scenario
- E-UTRA FDD intra-frequency multi cell scenario

- E-UTRA TDD intra-frequency multi cell scenario
- E-UTRA FDD and E-UTRA TDD dual mode multi cell roaming scenario

Combination 2 applies to the following test case scenarios:

- E-UTRA FDD intra-frequency multi cell scenario with neighbouring cell related information
- E-UTRA TDD intra-frequency multi cell scenario with neighbouring cell related information

Combination 3 applies to the following test case scenarios:

- E-UTRA FDD inter-frequency multi cell scenario
- E-UTRA TDD inter-frequency multi cell scenario
- E-UTRA FDD inter-band multi cell scenario
- E-UTRA TDD inter-band multi cell scenario
- E-UTRA FDD and E-UTRA TDD dual mode multi cell non-roaming scenario
- E-UTRA FDD intra-band carrier aggregation component carriers cell scenario
- E-UTRA FDD inter-band carrier aggregation component carriers cell scenario
- E-UTRA TDD intra-band carrier aggregation component carriers cell scenario

Combination 4 applies to the following test case scenarios:

- 3GPP inter-RAT E-UTRA FDD + UTRA FDD multi cell scenario
- 3GPP inter-RAT E-UTRA TDD + UTRA LCR TDD multi cell scenario
- 3GPP inter-RAT E-UTRA TDD + UTRA FDD multi cell scenario

Combination 5 applies to the following test case scenarios:

- 3GPP inter-RAT E-UTRA FDD + GERAN multi cell scenario
- 3GPP inter-RAT E-UTRA TDD + GERAN multi cell scenario

Combination 6 applies to the following test case scenarios:

- 3GPP2 inter-RAT E-UTRA FDD + HRPD multi cell scenario
- 3GPP2 inter-RAT E-UTRA TDD + HRPD multi cell scenario
- 3GPP2 inter-RAT E-UTRA FDD + 1xRTT multi cell scenario
- 3GPP2 inter-RAT E-UTRA TDD + 1xRTT multi cell scenario

Editor's note: 3GPP2 Inter-RAT multi cell scenarios with E-UTRA + HRPD + 1xRTT are FFS.

Combination 7 applies to the following test case scenarios:

- E-UTRA FDD + home eNB multi cell scenario
- E-UTRA TDD + home eNB multi cell scenario

Combination 8 applies to the following test case scenarios:

- E-UTRA FDD ETWS single cell scenario
- E-UTRA TDD ETWS single cell scenario

Combination 9 applies to the following test case scenarios:

- E-UTRA FDD inter-frequency + 3GPP inter-RAT UTRA multi-cell scenario

- E-UTRA TDD inter-frequency + 3GPP inter-RAT UTRA multi-cell scenario

Combination 10 applies to the following test case scenarios:

- 3GPP inter-RAT E-UTRA FDD + UTRA FDD + GERAN multi cell scenario
- 3GPP inter-RAT E-UTRA TDD + UTRA LCR TDD + GERAN multi cell scenario.

Combination 10a applies to the following test case scenarios:

- E-UTRA FDD inter-frequency + 3GPP inter-RAT E-UTRA FDD + UTRA FDD + GERAN multi cell scenario
- E-UTRA TDD inter-frequency + 3GPP inter-RAT E-UTRA TDD + UTRA LCR TDD + GERAN multi cell scenario

Combination 11 applies to the following test case scenarios:

- 3GPP inter-RAT E-UTRA FDD + UTRA FDD + home eNB multi cell scenario
- 3GPP inter-RAT E-UTRA TDD + UTRA LCR TDD + home eNB multi cell scenario

Combination 12 applies to the following test case scenarios:

- E-UTRA FDD inter-frequency + GERAN cell scenario
- E-UTRA TDD inter-frequency + GERAN cell scenario

Combination 13 applies to the following test case scenarios:

- E-UTRA FDD inter-frequency + home eNB
- E-UTRA TDD inter-frequency + home eNB

Combination 14 applies to the following test case scenarios:

- 3GPP inter-RAT E-UTRA FDD + GERAN + home eNB multi cell scenario
- 3GPP inter-RAT E-UTRA TDD + GERAN + home eNB multi cell scenario

Combination 15 applies to the following test case scenarios:

- 3GPP E-UTRA FDD + MBMS
- 3GPP E-UTRA TDD + MBMS

Combination 16 applies to the following test case scenarios:

- 3GPP E-UTRA FDD + MBMS
- 3GPP E-UTRA TDD + MBMS

Combination 17 applies to the following test case scenarios:

- 3GPP E-UTRA FDD + CMAS single cell scenario
- 3GPP E-UTRA TDD + CMAS single cell scenario

Table 4.4.3.1.1-1: Combinations of system information blocks

Combination No.	System information block type											
	SIB2	SIB3	SIB4	SIB5	SIB6	SIB7	SIB8	SIB9	SIB10	SIB11	SIB12	SIB13
1	X	X										
2	X	X	X									
3	X	X		X								
4	X	X			X							
5	X	X				X						
6	X	X					X					
7	X	X	X					X				
8	X	X							X	X		
9	X	X		X	X							
10	X	X			X	X						
10a	X	X		X	X	X						
11	X	X	X		X			X				
12	X	X		X		X						
13	X	X	X	X				X				
14	X	X	X			X		X				
15	X	X										
16	X	X	X									X
17	X	X									X	

4.4.3.1.2 Scheduling of system information blocks

The scheduling configurations for combinations of system information blocks are defined in the following tables.

Table 4.4.3.1.2-1: Scheduling for combination 1

Scheduling Information No.	Periodicity [radio frames]	Mapping of system information blocks
1	16	SIB2
2	See sub clause 4.4.3.4	SIB3

Table 4.4.3.1.2-2: Scheduling for combination 2

Scheduling Information No.	Periodicity [radio frames]	Mapping of system information blocks
1	16	SIB2
2	See sub clause 4.4.3.4	SIB3
3	See sub clause 4.4.3.4	SIB4

Table 4.4.3.1.2-3: Scheduling for combination 3

Scheduling Information No.	Periodicity [radio frames]	Mapping of system information blocks
1	16	SIB2
2	See sub clause 4.4.3.4	SIB3
3	See sub clause 4.4.3.4	SIB5

Table 4.4.3.1.2-4: Scheduling for combination 4

Scheduling Information No.	Periodicity [radio frames]	Mapping of system information blocks
1	16	SIB2
2	See sub clause 4.4.3.4	SIB3
3	See sub clause 4.4.3.4	SIB6

Table 4.4.3.1.2-5: Scheduling for combination 5

Scheduling Information No.	Periodicity [radio frames]	Mapping of system information blocks
1	16	SIB2
2	See sub clause 4.4.3.4	SIB3
3	See sub clause 4.4.3.4	SIB7

Table 4.4.3.1.2-6: Scheduling for combination 6

Scheduling Information No.	Periodicity [radio frames]	Mapping of system information blocks
1	16	SIB2
2	See sub clause 4.4.3.4	SIB3
3	See sub clause 4.4.3.4	SIB8

Table 4.4.3.1.2-7: Scheduling for combination 7

Scheduling Information No.	Periodicity [radio frames]	Mapping of system information blocks
1	16	SIB2
2	See sub clause 4.4.3.4	SIB3
3	See sub clause 4.4.3.4	SIB4
4	See sub clause 4.4.3.4	SIB9

Table 4.4.3.1.2-8: Scheduling for combination 8

Scheduling Information No.	Periodicity [radio frames]	Mapping of system information blocks
1	16	SIB2
2	See sub clause 4.4.3.4	SIB3
3	See sub clause 4.4.3.4	SIB11
4	See sub clause 4.4.3.4	SIB10

Table 4.4.3.1.2-9: Scheduling for combination 9

Scheduling Information No.	Periodicity [radio frames]	Mapping of system information blocks
1	16	SIB2
2	See sub clause 4.4.3.4	SIB3
3	See sub clause 4.4.3.4	SIB5, SIB6

Table 4.4.3.1.2-10: Scheduling for combination 10

Scheduling Information No.	Periodicity [radio frames]	Mapping of system information blocks
1	16	SIB2
2	See sub clause 4.4.3.4	SIB3
3	See sub clause 4.4.3.4	SIB6
4	See sub clause 4.4.3.4	SIB7

Table 4.4.3.1.2-10a: Scheduling for combination 10a

Scheduling Information No.	Periodicity [radio frames]	Mapping of system information blocks
1	16	SIB2
2	See sub clause 4.4.3.4	SIB3
3	See sub clause 4.4.3.4	SIB5, SIB6
4	See sub clause 4.4.3.4	SIB7

Table 4.4.3.1.2-11: Scheduling for combination 11

Scheduling Information No.	Periodicity [radio frames]	Mapping of system information blocks
1	16	SIB2
2	See sub clause 4.4.3.4	SIB3
3	See sub clause 4.4.3.4	SIB4
4	See sub clause 4.4.3.4	SIB6
5	See sub clause 4.4.3.4	SIB9

Table 4.4.3.1.2-12: Scheduling for combination 12

Scheduling Information No.	Periodicity [radio frames]	Mapping of system information blocks
1	16	SIB2
2	See sub clause 4.4.3.4	SIB3
3	See sub clause 4.4.3.4	SIB5
4	See sub clause 4.4.3.4	SIB7

Table 4.4.3.1.2-13: Scheduling for combination 13

Scheduling Information No.	Periodicity [radio frames]	Mapping of system information blocks
1	16	SIB2
2	See sub clause 4.4.3.4	SIB3
3	See sub clause 4.4.3.4	SIB4
4	See sub clause 4.4.3.4	SIB5

Table 4.4.3.1.2-14: Scheduling for combination 14

Scheduling Information No.	Periodicity [radio frames]	Mapping of system information blocks
1	16	SIB2
2	See sub clause 4.4.3.4	SIB3
3	See sub clause 4.4.3.4	SIB4
4	See sub clause 4.4.3.4	SIB7
5	See sub clause 4.4.3.4	SIB9

Table 4.4.3.1.2-15: Scheduling for combination 15

Scheduling Information No.	Periodicity [radio frames]	Mapping of system information blocks
1	16	SIB2
2	See sub clause 4.4.3.4	SIB3
3	See sub clause 4.4.3.4	SIB13

Table 4.4.3.1.2-16: Scheduling for combination 16

Scheduling Information No.	Periodicity [radio frames]	Mapping of system information blocks
1	16	SIB2
2	See sub clause 4.4.3.4	SIB3
3	See sub clause 4.4.3.4	SIB4
4	See sub clause 4.4.3.4	SIB13

Table 4.4.3.1.2-17: Scheduling for combination 17

Scheduling Information No.	Periodicity [radio frames]	Mapping of system information blocks
1	16	SIB2
2	See sub clause 4.4.3.4	SIB3
3	See sub clause 4.4.3.4	SIB12

4.4.3.2 Common contents of system information messages

- *MasterInformationBlock*

The *MasterInformationBlock* includes the system information transmitted on BCH.

Table 4.4.3.2-1: *MasterInformationBlock*

Derivation Path: 36.331 clause 6.2.2			
Information Element	Value/remark	Comment	Condition
MasterInformationBlock ::= SEQUENCE {			
dl-Bandwidth	Downlink system bandwidth under test.		
plich-Config SEQUENCE {}	PHICH-Config-DEFAULT	See subclause 4.6.3	
systemFrameNumber	A valid value as defined in TS 36.331 [17]		
spare	'0000 0000 00'B		
}			

- *SystemInformation*

The *SystemInformation* message is used to convey one or more System Information Blocks. All the SIBs included are transmitted with the same periodicity.

Table 4.4.3.2-2: *SystemInformation*

Derivation Path: 36.331 clause 6.2.2			
Information Element	Value/remark	Comment	Condition
SystemInformation ::= SEQUENCE {			
criticalExtensions CHOICE {			
systemInformation-r8 SEQUENCE {			
sib-TypeAndInfo SEQUENCE (SIZE (1..maxSIB)) OF CHOICE {}	See subclause 4.4.3.1		
criticalExtensionsFuture SEQUENCE {}	Not present		
}			
}			
}			

SystemInformationBlockType1

SystemInformationBlockType1 contains information relevant when evaluating if a UE is allowed to access a cell and defines the scheduling of other system information.

Table 4.4.3.2-3: SystemInformationBlockType1

Derivation Path: 36.331 clause 6.2.2			
Information Element	Value/remark	Comment	Condition
SystemInformationBlockType1 ::= SEQUENCE {			
cellAccessRelatedInfo SEQUENCE {			
plmn-IdentityList SEQUENCE (SIZE (1..6)) OF SEQUENCE {	1 entry		
plmn-Identity[1] SEQUENCE {			
mcc SEQUENCE (SIZE (3)) OF MCC-NMC-Digit	See table 4.4.2-2	For NAS test cases, see table 6.3.2.2-1.	
mnc SEQUENCE (SIZE (2..3)) OF MCC-NMC-Digit	See table 4.4.2-2	For NAS test cases, see table 6.3.2.2-1.	
}			
cellReservedForOperatorUse[1]	notReserved		
}			
trackingAreaCode	See table 4.4.2-2	For NAS test cases, see table 6.3.2.2-1.	
cellIdentity	Cell ID for the simulated cell		
cellBarred	notBarred		
intraFreqReselection	notAllowed		
csg-Indication	FALSE		
csg-Identity	Not present		
}			
cellSelectionInfo SEQUENCE {			
q-RxLevMin	-70 (-140 dBm)	For RF/RRM test cases	
	-106 dBm	For signalling test cases	
q-RxLevMinOffset	Not present		
}			
p-Max	Not present		
freqBandIndicator	Operating band under test.		
schedulingInfoList SEQUENCE (SIZE (1..maxSI-Message)) OF SEQUENCE {}	See subclause 4.4.3.1		
tdd-Config SEQUENCE {}	Not present		FDD
tdd-Config SEQUENCE {}	TDD-Config-DEFAULT	See subclause 4.6.3	TDD
si-WindowLength	ms20	To allow sufficient number of retransmissions.	
systemInfoValueTag	0		
nonCriticalExtension SEQUENCE {			
lateNonCriticalExtension	Not present		
nonCriticalExtension SEQUENCE {			
ims-EmergencySupport-r9	True	Support IMS emergency call in limited service mode.	
cellSelectionInfo-v920 SEQUENCE {}	Not present		
cellSelectionInfo-v920 SEQUENCE {}			QBASED
q-QualMin-r9	-20 (-20dB)		
q-QualMinOffset-r9	Not present		
}			
nonCriticalExtension	Not present		
}			
}			
}			

Condition	Explanation
-----------	-------------

FDD	FDD cell environment
TDD	TDD cell environment
QBASSED	This condition applies to Quality based cell (re)selection signalling test cases.

4.4.3.3 Common contents of system information blocks

- *SystemInformationBlockType2*

The IE *SystemInformationBlockType2* contains radio resource configuration information that is common for all UEs.

Table 4.4.3.3-1: *SystemInformationBlockType2*

Derivation Path: 36.331 clause 6.3.1			
Information Element	Value/remark	Comment	Condition
SystemInformationBlockType2 ::= SEQUENCE {			
ac-BarringInfo SEQUENCE {}	Not present		
radioResourceConfigCommon SEQUENCE {}	RadioResourceCo nfigCommonSIB- DEFAULT	See subclause 4.6.3	
ue-TimersAndConstants SEQUENCE {			
t300	ms1000	Typical value in real network	
t301	ms1000	Typical value in real network	
t310	ms1000	Typical value in real network	
n310	n1		
t311	ms10000	Typical value in real network	
n311	n1		
}			
freqInfo SEQUENCE {			
ul-CarrierFreq	Not present	Default UL EARFCN applies	
ul-Bandwidth	Not Present		
additionalSpectrumEmission	1 (NS_01)	A-MPR doesn't apply by default. See TS 36.101 table 6.2.4-1.	
}			
mbsfn-SubframeConfiguration	Not present		
timeAlignmentTimerCommon	sf750	'sf750' is applicable to the widest range of mobility (up to about 360km/h).	
}			

- *SystemInformationBlockType3*

The IE *SystemInformationBlockType3* contains cell re-selection information common for intra-frequency, inter-frequency and/or inter-RAT cell re-selection (i.e. applicable for more than one type of cell re-selection but not necessarily all) as well as intra-frequency cell re-selection information other than neighbouring cell related.

Table 4.4.3.3-2: SystemInformationBlockType3

Derivation Path: 36.331 clause 6.3.1			
Information Element	Value/remark	Comment	Condition
SystemInformationBlockType3 ::= SEQUENCE {			
cellReselectionInfoCommon SEQUENCE {			
q-Hyst	dB0	To reduce interference between intra-frequency multiple cells	
speedStateReselectionPars SEQUENCE {}	Not present		
}			
cellReselectionServingFreqInfo SEQUENCE {			
s-NonIntraSearch	Not present		
threshServingLow	0 (0 dB)	Typical value in real network	
cellReselectionPriority	4	A middle value in the range has been selected.	
}			
intraFreqCellReselectionInfo SEQUENCE {			
q-RxLevMin	-70 (-140 dBm)	For RF/RRM test cases	
	-106 dBm	For signalling test cases	
p-Max	Not present		
s-IntraSearch	Not present		
allowedMeasBandwidth	Not present	The downlink bandwidth of the serving cell applies.	
presenceAntennaPort1	FALSE		
neighCellConfig	'01'B (No MBSFN subframes are present in all neighbour cells)	MBSFN doesn't apply by default.	
t-ReselectionEUTRA	0	Typical value in real network	
t-ReselectionEUTRA-SF	Not present		
}			
lateNonCriticalExtension {			
s-IntraSearch-v920 SEQUENCE {}	Not present		
s-NonIntraSearch-v920 SEQUENCE {}	Not present		
q-QualMin-r9	Not present		
	-20 (-20dB)		QBASED
threshServingLowQ-r9	Not present		
	3 (3dB)		QBASED
}			
}			

Condition	Explanation
QBASED	See the definition below table 4.4.3.2-3.

- *SystemInformationBlockType4*

The IE *SystemInformationBlockType4* contains neighbouring cell related information relevant only for intra-frequency cell re-selection. The IE includes cells with specific re-selection parameters as well as blacklisted cells.

Table 4.4.3.3-3: *SystemInformationBlockType4*

Derivation Path: 36.331 clause 6.3.1			
Information Element	Value/remark	Comment	Condition
SystemInformationBlockType4 ::= SEQUENCE {			
intraFreqNeighCellList SEQUENCE (SIZE (1..maxCellIntra)) OF SEQUENCE {	Not present	Not required unless Qoffset configuration is tested. When Qoffset configuration is tested, see table 6.3.1.1-1.	
intraFreqBlackCellList SEQUENCE (SIZE (1..maxCellBlack)) OF SEQUENCE {	Not present	Not required unless Blacklisted cell list configuration is tested. When Blacklisted cell list configuration is tested, see table 6.3.1.1-1.	
csg-PhysCellIdRange SEQUENCE {	Not present		NonCSG
csg-PhysCellIdRange SEQUENCE {			CSG
start	Physical Cell ID of the cell on which this SIB is transmitted		
range	Not present	The UE shall apply value 1 in case the field is absent, in which case only the physical cell identity value indicated by <i>start</i> applies.	
}			
}			

Condition	Explanation
NonCSG	SIB4 transmitted on a non-CSG cell
CSG	SIB4 transmitted on a CSG cell

- *SystemInformationBlockType5*

The IE *SystemInformationBlockType5* contains information relevant only for inter-frequency cell re-selection i.e. information about other E-UTRA frequencies and inter-frequency neighbouring cells relevant for cell re-selection. The IE includes cell re-selection parameters common for a frequency as well as cell specific re-selection parameters.

Table 4.4.3.3-4: SystemInformationBlockType5

Derivation Path: 36.331 clause 6.3.1			
Information Element	Value/remark	Comment	Condition
SystemInformationBlockType5 ::= SEQUENCE { interFreqCarrierFreqList SEQUENCE (SIZE (1..maxFreq)) OF SEQUENCE {			
interFreqCarrierFreqList SEQUENCE (SIZE (1..maxFreq)) OF SEQUENCE {	The same number of entries as the configured inter-freq carriers. For Signalling test cases except NAS, see table 6.3.1.2-1. For NAS test cases when cells are on same PLMN, see table 6.3.2.3.2-1.	n denotes the index of the entry	
dl-CarrierFreq[n]	Downlink EARFCN under test For Signalling test cases except NAS, see table 6.3.1.2-1. For NAS test cases when cells are on same PLMN, see table 6.3.2.3.2-1.		
q-RxLevMin[n]	-65 (-130 dBm)	For RF/RRM test cases	
	-106 dBm	For signalling test cases	
p-Max[n]	Not present		
t-ReselectionEUTRA[n]	0	Typical value in real network	
t-ReselectionEUTRA-SF[n]	Not present	Not required unless speed-dependent cell re-selection is tested.	
threshX-High[n]	2 (4 dB)	This value should be higher than threshServingLow of the serving cell to avoid ping-pong with lower priority cells.	
threshX-Low[n]	1 (2 dB)		
allowedMeasBandwidth[n]	See subclause 4.4.3.4	Channel-bandwidth-dependent parameter	
presenceAntennaPort1[n]	FALSE		
cellReselectionPriority[n]	4	The same priority as the one used for serving cell in SIB 3.	
neighCellConfig[n]	'01'B (No MBSFN subframes are present in all neighbour cells)	MBSFN doesn't apply by default.	
q-OffsetFreq[n]	dB0	Q_{offset} doesn't apply by default.	
interFreqNeighCellList[n] SEQUENCE (SIZE (1..maxCellInter)) OF SEQUENCE {}	Not present	Not required unless Q_{offset} configuration is tested.	
interFreqBlackCellList[n] SEQUENCE (SIZE (1..maxCellBlack)) OF SEQUENCE {}	Not present	Not required unless Blacklisted cell list configuration is tested.	
q-QualMin-r9[n]	Not present		
	-20 (-20dB)		QBASED
threshX-Q-r9[n] SEQUENCE {}	Not present		

threshX-Q-r9[n] SEQUENCE {			QBASED
threshX-HighQ-r9	5 (5dB)		
threshX-LowQ-r9	5 (5dB)		
}			
}			
}			

Condition	Explanation
QBASED	See the definition below table 4.4.3.2-3.

- SystemInformationBlockType6

The IE *SystemInformationBlockType6* contains information relevant only for inter-RAT cell re-selection i.e. information about UTRA frequencies and UTRA neighbouring cells relevant for cell re-selection. The IE includes cell re-selection parameters common for a frequency.

Table 4.4.3.3-5: SystemInformationBlockType6

Derivation Path: 36.331 clause 6.3.1			
Information Element	Value/remark	Comment	Condition
SystemInformationBlockType6 ::= SEQUENCE {			
carrierFreqListUTRA-FDD SEQUENCE (SIZE (1..maxUTRA-FDD-Carrier)) OF SEQUENCE {	Not present		UTRA-TDD
carrierFreqListUTRA-FDD SEQUENCE (SIZE (1..maxUTRA-FDD-Carrier)) OF SEQUENCE {	The same number of entries as the configured UTRA FDD carriers For Signalling test cases, see table 6.3.1.3-1	<i>n</i> denotes the index of the entry	UTRA-FDD
carrierFreq[<i>n</i>]	Downlink UARFCN under test For Signalling test cases, see table 6.3.1.3-1		
cellReselectionPriority[<i>n</i>]	3		
threshX-High[<i>n</i>]	2 (4 dB)		
threshX-Low[<i>n</i>]	1 (2 dB)		
q-RxLevMin[<i>n</i>]	-40 (-79 dBm)	The same value as defined in TS 34.108 [5], table 6.1.1.	
p-MaxUTRA[<i>n</i>]	21 (21 dBm)	The same value as defined in TS 34.108 [5], table 6.1.1.	
q-QualMin[<i>n</i>]	-24 (-24 dB)	The same value as defined in TS 34.108 [5], table 6.1.1.	
threshX-Q-r9[<i>n</i>] SEQUENCE {	Not present		
threshX-Q-r9[<i>n</i>] SEQUENCE {			QBASED
threshX-HighQ-r9	9 (9dB)		
threshX-LowQ-r9	9 (9dB)		
}			
}			
carrierFreqListUTRA-TDD SEQUENCE (SIZE (1..maxUTRA-TDD-Carrier)) OF SEQUENCE {	Not present		UTRA-FDD
carrierFreqListUTRA-TDD SEQUENCE (SIZE (1..maxUTRA-TDD-Carrier)) OF SEQUENCE {	The same number of entries as the configured UTRA TDD carriers For Signalling test cases, see table 6.3.1.3-1	<i>n</i> denotes the index of the entry	UTRA-TDD
carrierFreq[<i>n</i>]	Downlink UARFCN under test For Signalling test cases, see table 6.3.1.3-1		
cellReselectionPriority[<i>n</i>]	3		
threshX-High[<i>n</i>]	2 (4 dB)		
threshX-Low[<i>n</i>]	1 (2 dB)		
q-RxLevMin[<i>n</i>]	-41 (-81 dBm)	The same value as defined in TS 34.108 [5], table 6.1.6a	
p-MaxUTRA[<i>n</i>]	21 (21 dBm)	The same value as defined in TS 34.108 [5], table 6.1.6a	
}			
}			

t-ReselectionUTRA	0	Typical value in real network	
t-ReselectionUTRA-SF	Not present		
}			

Condition	Explanation
UTRA-FDD	UTRA FDD cell environment
UTRA-TDD	UTRA TDD cell environment
QBASED	See the definition below table 4.4.3.2-3.

Editor's note: Need for condition 'UTRA-FDD-TDD' where both UTRA FDD cell and UTRA TDD cell exist simultaneously is FFS.

- *SystemInformationBlockType7*

The IE *SystemInformationBlockType7* contains information relevant only for inter-RAT cell re-selection i.e. information about GERAN frequencies relevant for cell re-selection. The IE includes cell re-selection parameters for each frequency.

Table 4.4.3.3-6: SystemInformationBlockType7

Derivation Path: 36.331 clause 6.3.1			
Information Element	Value/remark	Comment	Condition
SystemInformationBlockType7 ::= SEQUENCE {			
t-ReselectionGERAN	0		
t-ReselectionGERAN-SF	Not present		
carrierFreqsInfoListSEQUENCE (SIZE (1..maxGNFG)) OF SEQUENCE {	The same number of entries as the configured GERAN carriers For RRM test cases, see table 7.2.2.1-1 For Signalling test cases, see table 6.3.1.4-1	<i>n</i> denotes the index of the entry	
carrierFreqs [<i>n</i>] SEQUENCE {			
startingARFCN[<i>n</i>]	Set the corresponding starting ARFCN of the GERAN cells under test. For RRM test cases, see table 7.2.2.1-1 For Signalling test cases, see table 6.3.1.4-1		
bandIndicator[<i>n</i>]	Set according to the band used for GERAN cells under test		
followingARFCNs[<i>n</i>] CHOICE {			
explicitListOfARFCNs[<i>n</i>]	Set the corresponding ARFCN of GERAN cells under test For RRM test cases, see table 7.2.2.1-1 For Signalling test cases, see table 6.3.1.4-1		
}			
}			
commonInfo[<i>n</i>] SEQUENCE {			
cellReselectionPriority[<i>n</i>]	2		
ncc-Permitted[<i>n</i>]	'11111111'B		
q-RxLevMin[<i>n</i>]	2		
p-MaxGERAN[<i>n</i>]	0		
threshX-High[<i>n</i>]	2		
threshX-Low[<i>n</i>]	2		
}			
}			

- SystemInformationBlockType8

The IE *SystemInformationBlockType8* contains information relevant only for inter-RAT cell re-selection i.e. information about CDMA2000 frequencies and CDMA2000 neighbouring cells relevant for cell re-selection. The IE includes cell re-selection parameters common for a frequency as well as cell specific re-selection parameters.

Table 4.4.3.3-7: SystemInformationBlockType8

Derivation Path: 36.331 clause 6.3.1			
Information Element	Value/remark	Comment	Condition
SystemInformationBlockType8 ::= SEQUENCE {			
systemTimeInfo SEQUENCE {			
cdma-EUTRA-Synchronisation	TRUE		
cdma-SystemTime CHOICE {			
synchronousSystemTime	A valid value as per TS 36.331 and calculated by the SS		
}			
}			
searchWindowSize	5		
parametersHRPD SEQUENCE {}	Not present		1XRTT
parametersHRPD SEQUENCE {			HRPD
preRegistrationInfoHRPD SEQUENCE {			
preRegistrationAllowed	FALSE		
preRegistrationZoneId	Not present		
secondaryPreRegistrationZoneIdList	Not present		
}			
cellReselectionParametersHRPD SEQUENCE {			
bandClassList SEQUENCE (SIZE (1..maxCDMA -BandClass)) OF SEQUENCE {	1 entry		
bandClass	Operating band class under test.	ENUMERATED {bc0, bc1, bc2, bc3, bc4, bc5, bc6, bc7, bc8, bc9, bc10, bc11, bc12, bc13, bc14, bc15, bc16, bc17, spare14, spare13, spare12, spare11, spare10, spare9, spare8, spare7, spare6, spare5, spare4, spare3, spare2, spare1, ...}	
cellReselectionPriority	1		
threshX-High	30(-30)	INTEGER (0..63)	
threshX-Low	32(-32)	INTEGER (0..63)	
}			
neighCellList SEQUENCE (SIZE (1..16)) OF SEQUENCE {	1 entry		
bandClass	Operating band class under test	ENUMERATED {bc0, bc1, bc2, bc3, bc4, bc5, bc6, bc7, bc8, bc9, bc10, bc11, bc12, bc13, bc14, bc15, bc16, bc17, spare14, spare13, spare12, spare11, spare10, spare9, spare8, spare7, spare6, spare5, spare4, spare3, spare2, spare1, ...}	
neighCellsPerFreqList SEQUENCE (SIZE	The same number of	<i>n</i> denotes the	

(1..16)) OF SEQUENCE {	entries as the configured CDMA2000 HRPD frequencies For Signalling test cases, see table 6.3.1.5-1	index of the entry	
arfcn[n]	ARFCN of the CDMA2000 HRPD frequency For Signalling test cases, see table 6.3.1.5-1	INTEGER (0..2047)	
physCellIdList[n] SEQUENCE (SIZE (1..16)) OF {INTEGER (0..maxPNOffset) }	Physical Cell ID List of the CDMA2000 HRPD frequency For Signalling test cases, see table 6.3.1.5-1	INTEGER (0..maxPNOffset)	
}			
t-ReselectionCDMA2000	0	INTEGER (0..7)	
t-ReselectionCDMA2000-SF	Not Present		
}			
parameters1XRTT SEQUENCE {	Not present		HRPD
parameters1XRTT SEQUENCE {			1XRTT
csfb-RegistrationParam1XRTT SEQUENCE {			
sid	SID under test For Signalling test cases, see table 4.4.2-4	BIT STRING (SIZE (15))	
nid	NID under test For Signalling test cases, see table 4.4.2-4	BIT STRING (SIZE (16))	
multipleSID	FALSE	BOOLEAN	
multipleNID	FALSE	BOOLEAN	
homeReg	TRUE	BOOLEAN	
foreignSIDReg	TRUE	BOOLEAN	
foreignNIDReg	TRUE	BOOLEAN	
parameterReg	FALSE	BOOLEAN	
powerUpReg	TRUE	BOOLEAN	
registrationPeriod	'0000000'	BIT STRING (SIZE (7))	
registrationZone	Registration zone under test For Signalling test cases, see table 4.4.2-4	BIT STRING (SIZE (12))	
totalZone	'001'B	BIT STRING (SIZE (3))	
zoneTimer	'000'B or '001'B	BIT STRING (SIZE (3))	
}			
longCodeState1XRTT	A valid value, calculated and updated by the SS	BIT STRING (SIZE (42)) OPTIONAL	
cellReselectionParameters1XRTT SEQUENCE {			
bandClassList SEQUENCE (SIZE (1..maxCDMA -BandClass)) OF SEQUENCE {	1 entry		
bandClass	Operating band class under test	ENUMERATED {bc0, bc1, bc2, bc3, bc4, bc5, bc6, bc7, bc8, bc9, bc10, bc11, bc12, bc13, bc14, bc15, bc16, bc17, spare14, spare13, spare12, spare11, spare10, spare9, spare8, spare7, spare6, spare5, spare4, spare3,	

		spare2, spare1, ...}	
cellReselectionPriority	0		
threshX-High	30(-30)	INTEGER (0..63)	
threshX-Low	32(-32)	INTEGER (0..63)	
}			
neighCellList SEQUENCE (SIZE (1..16)) OF SEQUENCE {	1 entry		
bandClass	Operating band class under test	ENUMERATED {bc0, bc1, bc2, bc3, bc4, bc5, bc6, bc7, bc8, bc9, bc10, bc11, bc12, bc13, bc14, bc15, bc16, bc17, spare14, spare13, spare12, spare11, spare10, spare9, spare8, spare7, spare6, spare5, spare4, spare3, spare2, spare1, ...}	
neighCellsPerFreqList SEQUENCE (SIZE (1..16)) OF SEQUENCE {	The same number of entries as the configured CDMA2000 1xRTT frequencies For Signalling test cases, see table 6.3.1.6-1	<i>n</i> denotes the index of the entry	
arfcn[n]	ARFCN of the CDMA2000 1xRTT frequency For Signalling test cases, see table 6.3.1.6-1	INTEGER (0..2047)	
physCellIdList[n] SEQUENCE (SIZE (1..16)) OF {INTEGER (0..maxPNOffset) }	Physical Cell ID List of the CDMA2000 1xRTT frequency For Signalling test cases, see table 6.3.1.6-1	INTEGER (0..maxPNOffset)	
}			
}			
t-ReselectionCDMA2000	0	INTEGER (0..7)	
t-ReselectionCDMA2000-SF	Not Present		
}			
}			
}			

Condition	Explanation
HRPD	CDMA2000 HRPD cell environment
1XRTT	CDMA2000 1XRTT cell environment

Editor’s note: Need for condition ‘HRPD-1XRTT’ where both CDMA2000 HRPD cell and CDMA2000 1xRTT cell exist simultaneously is FFS.

SystemInformationBlockType9

The IE *SystemInformationBlockType9* contains a home eNB name (HNB Name).

Table 4.4.3.3-8: *SystemInformationBlockType9*

Derivation Path: 36.331 clause 6.3.1			
Information Element	Value/remark	Comment	Condition
SystemInformationBlockType9 ::= SEQUENCE {			
hnb-Name	"3gppTest"		
}			

- *SystemInformationBlockType10*

The IE *SystemInformationBlockType10* contains an ETWS primary notification.

Table 4.4.3.3-9: *SystemInformationBlockType10*

Derivation Path: 36.331 clause 6.3.1			
Information Element	Value/remark	Comment	Condition
SystemInformationBlockType10 ::= SEQUENCE {			
messageIdentifier	'0001 0001 0000 0010'B	ETWS message identifier for earthquake and tsunami message [see TS 23.041]	
serialNumber - Geographical Scope (2 bit) - Message Code (10 bit) - Emergency User Alert (1 bit) - Popup (1 bit) - Update Number (4 bit)	'0011 0000 0000 0000'B Octet 1 bit 7 ~ 6 Octet 1 bit 5 ~ Octet 2 bit 4 Octet 1 bit 5 Octet 1 bit 4 Octet 2 bit 3 ~ 0	Cell wide; '11 0000 0000'B Activate emergency user alert; Activate popup; For each update, incremented by one. [see TS 23.041]	
warningType - Warning Type Value (7 bit) - Emergency User Alert (1 bit) - Popup (1 bit) - Padding (7 bit)	'0000 0101 1000 0000'B Octet 1 bit 7 ~ 1 Octet 1 bit 0 Octet 2 bit 7 Octet 2 bit 6 ~ bit 0	Earthquake and Tsunami; Activate emergency user alert; Activate Popup. [see TS 23.041] '000 0000'B	
warningSecurityInfo	Not present		
}			

- *SystemInformationBlockType11*

The IE *SystemInformationBlockType11* contains an ETWS secondary notification.

Table 4.4.3.3-10: *SystemInformationBlockType11* (1st Segment)

Derivation Path: 36.331 clause 6.3.1			
Information Element	Value/remark	Comment	Condition
<i>SystemInformationBlockType11</i> ::= SEQUENCE {			
<i>messageIdentifier</i>	'0001 0001 0000 0010'B	ETWS message identifier for earthquake and tsunami message [see TS 23.041]	
<i>serialNumber</i> - Geographical Scope (2 bit) - Message Code (10 bit) - Emergency User Alert (1 bit) - Popup (1 bit) - Update Number (4 bit)	'0011 0000 0000 0000'B Octet 1 bit 7 ~ 6 Octet 1 bit 5 ~ Octet 2 bit 4 Octet 1 bit 5 Octet 1 bit 4 Octet 2 bit 3 ~ 0	Cell wide; '11 0000 0000'B Activate emergency user alert; Activate popup; For each update, incremented by one. [see TS 23.041]	
<i>warningMessageSegmentType</i>	notLastSegment		
<i>warningMessageSegmentNumber</i>	0		
<i>warningMessageSegment</i>	Octetstring of N	where $N \geq 1$ and less than 1246. [see TS 23.041]	
<i>dataCodingScheme</i>	Bitstring (8) ID of the alphabet/coding and the applied language [see TS 23.041]		
}			

Table 4.4.3.3-11: SystemInformationBlockType11 (2nd Segment)

Derivation Path: 36.331 clause 6.3.1			
Information Element	Value/remark	Comment	Condition
SystemInformationBlockType11 ::= SEQUENCE {			
messageIdentifier	'0001 0001 0000 0010'B	ETWS message identifier for earthquake and tsunami message [see TS 23.041]	
serialNumber - Geographical Scope (2 bit)	'0011 0000 0000 0000'B Octet 1 bit 7 ~ 6	Cell wide;	
- Message Code (10 bit)	Octet 1 bit 5 ~ Octet 2 bit 4	'11 0000 0000'B	
- Emergency User Alert (1 bit)	Octet 1 bit 5	Activate emergency user alert;	
- Popup (1 bit)	Octet 1 bit 4	Activate popup;	
- Update Number (4 bit)	Octet 2 bit 3 ~ 0	For each update, incremented by one. [see TS 23.041]	
warningMessageSegmentType	notLastSegment		
warningMessageSegmentNumber	1		
warningMessageSegment	Octetstring of N	where N ≥ 1 and less than 1246. [see TS 23.041]	
dataCodingScheme	Not present		
}			

Table 4.4.3.3-12: SystemInformationBlockType11 (3rd Segment)

Derivation Path: 36.331 clause 6.3.1			
Information Element	Value/remark	Comment	Condition
SystemInformationBlockType11 ::= SEQUENCE {			
messageIdentifier	'0001 0001 0000 0010'B	ETWS message identifier for earthquake and tsunami message [see TS 23.041]	
serialNumber - Geographical Scope (2 bit)	'0011 0000 0000 0000'B Octet 1 bit 7 ~ 6	Cell wide;	
- Message Code (10 bit)	Octet 1 bit 5 ~ Octet 2 bit 4	'11 0000 0000'B	
- Emergency User Alert (1 bit)	Octet 1 bit 5	Activate emergency user alert;	
- Popup (1 bit)	Octet 1 bit 4	Activate popup;	
- Update Number (4 bit)	Octet 2 bit 3 ~ 0	For each update, incremented by one. [see TS 23.041]	
warningMessageSegmentType	lastSegment		
warningMessageSegmentNumber	2		
warningMessageSegment	Octetstring of N	where N ≥ 1 and less than 1246. [see TS 23.041]	
dataCodingScheme	Not present		
}			

- *SystemInformationBlockType12*

The IE *SystemInformationBlockType12* contains an CMAS notification.

Table 4.4.3.3-12a: *SystemInformationBlockType12* (1st Segment)

Derivation Path: 36.331 clause 6.3.1			
Information Element	Value/remark	Comment	Condition
<i>SystemInformationBlockType12</i> ::= SEQUENCE {			
messageIdentifier-r9	'0001 0001 0001 0010'B	CMAS CBS Message Identifier for CMAS Presidential Level Alerts (see TS 23.041))	
serialNumber-r9	'0011 0000 0000 0000'B		
warningMessageSegmentType	notLastSegment		
warningMessageSegmentNumber	0		
warningMessageSegment	Octetstring of N	where N ≥ 1 and less than 1246. (see TS 23.041)	
dataCodingScheme	'0000 0001'B	English (See TS 23.038)	
lateNonCriticalExtension	Not present		
}			

Table 4.4.3.3-12b: *SystemInformationBlockType12* (2nd Segment)

Derivation Path: 36.331 clause 6.3.1			
Information Element	Value/remark	Comment	Condition
<i>SystemInformationBlockType12</i> ::= SEQUENCE {			
messageIdentifier-r9	'0001 0001 0001 0010'B	CMAS CBS Message Identifier for CMAS Presidential Level Alerts (see TS 23.041)	
serialNumber-r9	'0011 0000 0000 0000'B		
warningMessageSegmentType	notLastSegment		
warningMessageSegmentNumber	1		
warningMessageSegment	Octetstring of N	where N ≥ 1 and less than 1246. (see TS 23.041)	
dataCodingScheme	Not present		
lateNonCriticalExtension	Not present		
}			

Table 4.4.3.3-12c: *SystemInformationBlockType12* (3rd Segment)

Derivation Path: 36.331 clause 6.3.1			
Information Element	Value/remark	Comment	Condition
SystemInformationBlockType11 ::= SEQUENCE {			
messageIdentifier-r9	'0001 0001 0001 0010'B	CMAS CBS Message Identifier for CMAS Presidential Level Alerts (see TS 23.041)	
serialNumber-r9	'0011 0000 0000 0000'B		
warningMessageSegmentType	lastSegment		
warningMessageSegmentNumber	2		
warningMessageSegment	Octetstring of N	where N ≥ 1 and less than 1246. (see TS 23.041)	
dataCodingScheme	Not present		
lateNonCriticalExtension	Not present		
}			

SystemInformationBlockType13

The IE *SystemInformationBlockType13* contains the information required to acquire the MBMS control information associated with one or more MBSFN areas..

Table 4.4.3.3-13: *SystemInformationBlockType13*

Derivation Path: 36.331 clause 6.3.1			
Information Element	Value/remark	Comment	Condition
SystemInformationBlockType13 ::= SEQUENCE {			
MBSFN-AreaInfo-r9 SEQUENCE			
(SIZE(1..maxMBSFN-Area)) OF SEQUENCE {			
mbsfn-Areaid-r9	0		
non-MBSFNregionLength	1		
notificationIndicator-r9	0		
mcch-Config-r9 SEQUENCE {			
mcch-RepetitionPeriod-r9	rf32		
mcch-Offset-r9	0		
mcch-ModificationPeriod-r9	rf512		
sf-AllocInfo-r9	'100000'		
signallingMCS-r9	n2		
}			
}			
}			

4.4.3.4 Channel-bandwidth-dependent parameters in system information blocks

The default values of parameters in system information blocks which depend on the channel bandwidth are defined in table 4.4.3.4-1.

Table 4.4.3.4-1: Channel-bandwidth-dependent parameters

Information Element	Channel bandwidth						Comment
	1.4 MHz	3 MHz	5 MHz	10 MHz	15 MHz	20MHz	
SIB3 periodicity	64	64	32	32	32	32	
SIB4 periodicity	128	128	64	64	64	64	
SIB5 periodicity	128	128	64	64	64	64	
SIB6 periodicity	128	128	64	64	64	64	
SIB7 periodicity	128	128	64	64	64	64	
SIB8 periodicity	128	128	64	64	64	64	
measurement Bandwidth in SIB5	mbw6	mbw15	mbw25	mbw50	mbw75	mbw100	
SIB9 periodicity	128	128	64	64	64	64	
SIB10 periodicity	64	64	32	32	32	32	
SIB11 periodicity	64	64	32	32	32	32	
SIB12 periodicity	64	64	32	32	32	32	
SIB13 periodicity	64	64	32	32	32	32	

4.4.4 Common parameters for simulated UTRA cells

The parameters specified in this subclause apply to all simulated UTRA cells unless otherwise specified.

Default UTRA parameters for simulated cells are specified in table 4.4.4-1 and table 4.4.4-2.

Other parameters are specified in TS 34.108 [5].

Table 4.4.4-1: Default parameters for simulated UTRA cells

cell ID	Primary scrambling code for FDD	Cell parameters ID for TDD
Cell 5	100	0
Cell 7	150	4
Cell 8	200	8
Cell 9	250	12

Table 4.4.4-2: Default NAS parameters for simulated UTRA cells

	PLMN		Location Area Identification		Routing Area Identification		TMSI	P-TMSI signature
	MCC	MNC	LA#	LAC	RA#	RAC		
Cell 5	(Note 1)		LAI-1	1	RAI-1	1	Arbitrarily selected according to TS 23.003 subclause 2.4 [2].	Arbitrarily selected according to TS 23.003 subclause 2.7 [2].
Cell 7	(Note 1)		LAI-1	1	RAI-1	1		
Cell 8	(Note 1)		LAI-1	1	RAI-1	1		
Cell 9	(Note 1)		LAI-1	1	RAI-1	1		
Note 1:	Set to the same Mobile Country Code and Mobile Network Code stored in EF _{IMSI} on the test USIM card (subclause 4.9.3).							

4.4.4.1 Common contents of system information blocks for UTRA cells

- System Information Block type 19

The system information block type 19 contains Inter-RAT frequency and priority information to be used in the cell.

Table 4.4.4.1-1: System Information Block type 19

Derivation Path: 25.331 clause 11.3			
Information Element	Value/remark	Comment	Condition
SysInfoType19 ::= SEQUENCE {			
utra-PriorityInfoList SEQUENCE {			
utra-ServingCell SEQUENCE {			
priority	3		
s-PrioritySearch1	0 (0dB)		
s-PrioritySearch2	Not present	default value is 0	
threshServingLow	0 (0dB)		
}			
utran-FDD-FrequencyList SEQUENCE (SIZE(1..maxNumFDDFreqs)) OF SEQUENCE {}	Not present		
utran-TDD-FrequencyList SEQUENCE (SIZE(1..maxNumTDDFreqs)) OF SEQUENCE {}	Not present		
gsm-PriorityInfoList SEQUENCE (SIZE (1..maxNumGSMCellGroup)) OF SEQUENCE {}	Not present		
eutra-FrequencyAndPriorityInfoList SEQUENCE (SIZE (1..maxNumEUTRAFreqs)) OF SEQUENCE	The same number of entries as the configured eutra carriers For Signalling test cases, see table 6.3.1.7-1	<i>n</i> denotes the index of the entry	
earfcn[<i>n</i>]	Downlink EARFCN under test For Signalling test cases, see table 6.3.1.7-1		
measurementBandwidth[<i>n</i>]	See subclause 4.4.3.4		
priority[<i>n</i>]	4		
qRxLevMinEUTRA[<i>n</i>]	-53 (-106 dBm)	For signalling test cases	
	-70 (-140 dBm)	For RF/RRM test cases	
threshXhigh[<i>n</i>]	2 (4 dB)		
threshXlow[<i>n</i>]	1 (2 dB)		
eutra-blackListedCellList[<i>n</i>]	Not present		
eutraDetection[<i>n</i>]	TRUE		
}			
v920NonCriticalExtensions SEQUENCE {}	Not present		
v920NonCriticalExtensions SEQUENCE {}			QBASED
sysInfoType19-v920ext SEQUENCE {			
utra-PriorityInfoList-v920ext SEQUENCE {			
threshServingLow2	7 (7dB)	default value is 0	
}			
eutra-FrequencyAndPriorityInfoList-v920ext (SIZE (1..maxNumEUTRAFreqs)) OF SEQUENCE {			
qQualMinEUTRA[<i>n</i>]	-20 (-20dB)		
threshXhigh2[<i>n</i>]	5 (5dB)		
threshXlow2[<i>n</i>]	5 (5dB)		
}			
}			
nonCriticalExtensions SEQUENCE {}	Not present		
}			
}			

Condition	Explanation
QBASED	See the definition below table 4.4.3.2-3.

4.4.4.2 UTRA SIB scheduling for inter EUTRA - UTRA test

Table 4.4.4.2-1: UTRA SIB schedule

Block Type	MIB	SB1	SIB1	SIB2	SIB3	SIB4	SIB5/SIB5bis	SIB6	SIB7	SIB11	SIB12	SIB18	SIB19
SIB_REP	8	16	64	64	64	64	64	64	16	64	64	64	64
SEG_COUNT	1	1	1	1	1	1	4	4	1	3	1	1	2

Table 4.4.4.2-2: UTRA SIB-repeat period

Frame No / SIB_POS	0	2	4	6	8	10	12	14
Block Type	MIB	SB1	SIB7	SIB6	MIB	SIB6	SIB6	SIB6
Frame No / SIB_POS	16	18	20	22	24	26	28	30
Block Type	MIB	SB1	SIB7/SIB3	SIB1/SIB2	MIB	SIB12	SIB19	SIB19
Frame No / SIB_POS	32	34	36	38	40	42	44	46
Block Type	MIB	SB1	SIB7/SIB18	SIB5/SIB5bis	MIB	SIB5/SIB5bis	SIB5/SIB5bis	SIB5/SIB5bis
Frame No / SIB_POS	48	50	52	54	56	58	60	62
Block Type	MIB	SB1	SIB7/SIB4	-	MIB	SIB11	SIB11	SIB11

4.4.4.3 UTRA SIB scheduling for inter EUTRA – UTRA - GERAN test

Table 4.4.4.3-1: UTRA SIB schedule

Block Type	MIB	SB1	SIB1	SIB2	SIB3	SIB4	SIB5/SIB5bis	SIB7	SIB11	SIB16	SIB18	SIB19
SIB Rep	8	16	128	128	64	64	128	32	128	128	128	128
Max. No of seg.	1	2	1	1	1	1	4	1	3	8	1	3

Table 4.4.4.3-2: UTRA SIB-repeat period

Frame No / SIB_POS	0	2	4	6	8	10	12	14
Block Type	MIB	SB1	SB1	-	MIB	SIB1	SIB18	SIB2
Frame No / SIB_POS	16	18	20	22	24	26	28	30
Block Type	MIB	SB1	SB1	SIB7	MIB	SIB3	-	SIB4
Frame No / SIB_POS	32	34	36	38	40	42	44	46
Block Type	MIB	SB1	SB1	SIB5/ SIB5bis	MIB	SIB5/ SIB5bis	SIB5/ SIB5bis	SIB5/ SIB5bis
Frame No / SIB_POS	48	50	52	54	56	58	60	62
Block Type	MIB	SB1	SB1	SIB7	MIB	SIB11	SIB11	SIB11
Frame No / SIB_POS	64	66	68	70	72	74	76	78
Block Type	MIB	SB1	SB1	SIB16	MIB	SIB16	SIB16	SIB16
Frame No / SIB_POS	80	82	84	86	88	90	92	94
Block Type	MIB	SB1	SB1	SIB7	MIB	SIB3	SIB19	SIB4
Frame No / SIB_POS	96	98	100	102	104	106	108	110
Block Type	MIB	SB1	SB1	SIB16	MIB	SIB16	SIB16	SIB16
Frame No / SIB_POS	112	114	116	118	120	122	124	126
Block Type	MIB	SB1	SB1	SIB7	MIB	SIB19	SIB19	-

4.4.5 Common parameters for simulated GERAN cells

The parameters specified in this subclause apply to all simulated GERAN cells unless otherwise specified.

See TS 51.010 [25].

The contents of SYSTEM INFORMATION TYPE 2 Quarter message specified below are identical for all GERAN cells.

Table 4.4.5-1: System Information 2 Quater

Derivation Path: 44.018 Table 10.5.2.33b.1			
Information Element	Value/remark	Comment	Condition
System information 2Quater			
L2 pseudo length	1		
PROTOCOL DISCRIMINATOR	'0110'B	RR management Protocol	
SKIP INDICATOR	'0000'B		
MESSAGE TYPE	'00000111'B		
SI 2QUATER REST OCTETS			
BA Indicator	0		
3G BA Indicator	0		
MP Change Mark	0		
SI2Q Index	0		
SI2Q Count	0		
Measurement_Parameters Description	0	Not Present	
GPRS_Real Time Difference Description	0	Not Present	
GPRS_BSIC Description	0	Not Present	
GPRS_REPORT PRIORITY Description	0	Not Present	
GPRS_MEASUREMENT_Parameters Description	0	Not Present	
NC Measurement Parameters	0	Not Present	
extension length	0	Not Present	
3G Neighbour Cell Description	0	Not Present	
3G Measurement Parameters Description	0	Not Present	
GPRS_3G_MEASUREMENT Parameters Description	0	Not Present	
Additions in release 5	H		
3G Additional Measurement Parameters Description	0	Not Present	
3G ADDITIONAL MEASUREMENT Parameters Description 2	0	Not Present	
Additions in release 6	H		
3G_CCN_ACTIVE	0		
Additions in release 7	H		
700_REPORTING_OFFSET	0	Not Present	
810_REPORTING_OFFSET	0	Not Present	
Additions in release 8	H		
Priority and E-UTRAN Parameters Description	1	Present	
Serving Cell Priority Parameters Description	1	Present	
		Note : Values as defined from TS 45.008, section 10.4 Table 3	
GERAN_PRIORITY	2		
THRESH_Priority_Search	15 (always)		
THRESH_GSM_low	0		
H_PRIO	0		
T_Reselection	0		
3G Priority Parameters Description	0	Not Present	
E-UTRAN Parameters Description	1	Present	
E-UTRAN_CCN_ACTIVE	0	CCN not supported	
E-UTRAN_Start	1		
E-UTRAN_Stop	1		
E-UTRAN Measurement Parameters Description	0	Not Present	
GPRS E-UTRAN Measurement Parameters Description	0	Not Present	
Repeated E-UTRAN Neighbour Cells	1	Present	
{			
EARFCN	Same as cell 1	This field specifies the E-UTRA Absolute Radio Frequency	

		Channel Number as defined in 3GPP TS 36.104.	
Measurement Bandwidth	Set according to EUTRA band under test		
E-UTRAN_PRIORITY	'100'B	Same as cell 1 as defined in 3GPP TS 36.104.	
THRESH_E-UTRAN_high	'00010'B	Actual value =4 dB	
THRESH_E-UTRAN_low	'00010'B	Actual value =4 dB	
E-UTRAN_QRXLEVMIN	17 (-106 dBm)	For signalling test cases	
	0 (-140 dBm)	For RF/RRM test cases	
}** 0		End of Repeated E-UTRAN Neighbour cells structure Note: When this message is used in Tics where more than one E-UTRA cells are active, this structure needs to be specified for each cell. EARFCN and EUTRAN_PRIORITY will then need to be configured to the corresponding EUTRAN cell	
Repeated E-UTRAN Not Allowed Cells	0	Not Present	
Repeated E-UTRAN PCID to TA mapping	0	Not Present	
3G CSG Description	0		
E-UTRAN CSG Description	0		
Additions in release 9	L		
spare padding	spare padding		

4.4.6 Common parameters for simulated CDMA2000 cells

The parameters specified in this subclause apply to all simulated HRPD or 1xRTT cells unless otherwise specified.

See C.S0038-A [36] for HRPD cells and C.S0043-0 [37] for 1xRTT cells.

4.4.7 Default parameters specific for simulated cells

Default parameters specific for simulated cells are specified in this subclause.

4.4.7.1 Common contents of HRPD Overhead messages

- QuickConfig

The QuickConfig message is used to indicate a change in the overhead messages' contents and to provide frequently changing information.

Table 4.4.7.1-1: QuickConfig

Derivation Path: C.S0024-B clause 7.11.6.2.1			
Information Element	Value/remark	Comment	Condition
MessageID	0x0	0-255;	
ColorCode	See table 4.4.2-3	0 – 255	
SectorID24	Least significant 24 bits of Sector ID given in table 4.4.2-3	24 bits	
SectorSignature	A valid value and same as used for SectorParameters	16 bits	
AccessSignature	A valid value and same as used for AccessParameters	16 bits	
Redirect	0X0	0-1	
RPCCount63To0	A valid value corresponding to the value of px_MACIndex	0-63	
ForwardTrafficValid63To0	A valid value corresponding to the value of px_MACIndex	0-1; RPCCount63To0 occurrences	
RPCCount127To64Included	A valid value corresponding to the value of px_MACIndex	0 or 1 bits	
RPCCount127To64	A valid value corresponding to the value of px_MACIndex	0 or 6 bits	
ForwardTrafficValid127To64	A valid value corresponding to the value of px_MACIndex	0 or 1 bits;RPCCount127To64 occurrences	
RPCCount130To383Included	Not Present or a valid value corresponding to the value of px_MACIndex	0 or 1 bits	
RPCCount130To383	Not Present or a valid value corresponding to the value of px_MACIndex	0 or 8 bits	
ForwardTrafficValid130To383	Not Present or a valid value corresponding to the value of px_MACIndex	0 or 1 bits	
Reserved	0X0	0 – 7 bits as needed all set to zero	

- SectorParameters

The SectorParameters message is used to convey sector specific information to the access terminals.

Table 4.4.7.1-2: SectorParameters

Derivation Path: C.S0024-B clause 7.11.6.2.2			
Information Element	Value/remark	Comment	Condition
MessageID	0x01	0-255	
CountryCode	See table 4.4.2-3	0 – 999; Depends on test case	
SectorID	See table 4.4.2-3	128 bit value	
SubnetMask	0x40	8 bits	
SectorSignature	Any valid value	16 bits	
Latitude	Any valid value	22 bits	
Longitude	Any valid value	23 bits	
RouteUpdateRadiusOverhead	0x0	11 bits	
LeapSeconds	'A valid value, calculated and updated by the SS'	8 bits	
LocalTimeOffset	Any valid value	11 bits	
ReverseLinkSilenceDuration	0x1 or 0x0	2 bits	
ReverseLinkSilencePeriod	0x1 or 0x0	2 bits	
ChannelCount	0x1 or 0x0	5 bits	
Channel		24 bits; ChannelCount occurrences; Sub-clause 13.1 in 3GPP2 C.S0024-B v3.0	
SystemType	0x00	8 bits	
BandClass	Set according to PIXIT parameter	5 bits; Depends on test case	
ChannelNumber	Set according to PIXIT parameter	11 bits; Depends on BandClass	
NeighborCount	0x0	5 bits	No_NeighPN Inc
	16		NeighPNInc
NeighborPilotPN	Not Present		No_NeighPN Inc
	Pilots PN's of configured cells [FFS]		NeighPNInc
NeighborChannelIncluded	0x0	1 bit; NeighbourCount occurrences	NeighPNInc
	Not Present		No_NeighPN Inc
NeighborChannel	Not Present	0 or 24 bits; NeighbourCount occurrences	
NeighborSearchWindowSizeIncluded	0x0	1 bit	
NeighborSearchWindowSize	Not Present	0 or 4 bits; NeighbourCount occurrences	
NeighborSearchWindowOffsetIncluded	0x0	1 bit	
NeighborSearchWindowOffset	Not Present	0 or 3 bits; NeighbourCount occurrences	
ExtendedChannelIncluded	0x0 or Not Present	0 or 1 bits; The number of cdma2000 high rate packet data extended channels available to the access terminal on this sector; Note 1;	
ExtendedChannelCount	Not Present	0 or 5 bits	
ExtendedChannel	Not Present	24 bits; 0 or ExtendedChannelCount occurrences	
AccessHashingChannelMaskIncluded	0x0 or Not Present	0 or 1 bits; AccessHashingChannelMaskL length occurrences of this field and AccessHashingChannelMask if set as AccessHashingChannelMask; Note 1;	

AccessHashingMaskLength	Not Present	0 or 4 bits; 0<=AccessHashingChannelMaskLength<=(ChannelCount + ExtendedChannelCount),	
AccessHashingChannelMaskSameAsPrevious	Not Present	1 bit; AccessHashingChannelMaskLength occurrences of this field and AccessHashingChannelMask if set as AccessHashingChannelMask	
AccessHashingChannelMask	Not Present	0 or AccessHashingMaskLength+1	
RouteUpdateTriggerCodeIncluded	0x0 or Not Present	0 or 1 bits; Note 1;	
RouteUpdateTriggerCode	Not Present	0 or 12 bits	
RouteUpdateTriggerMaxAge	Not Present	0 or 4 bits	
PriorSessionGAUP	0x0 or Not Present	0 or 1 bits; Note 1;	
FPDCHSupportedInclude	0x0 or Not Present	0 or 1 bits; Note 1;	
FPDCHSupported	Not Present	0 or 1 bits	
SecondaryColorCodeIncluded	0x0 or Not Present	0 or 1 bits; Note 1;	
SecondaryColorCodeCount	Not Present	0 or 3 bits	
SecondaryColorCode	Not Present	8 bits	
PilotGroupIDLoopIncluded	0x0 or Not Present	0 or 1 bits; Note 1;	
PilotGroupIDIncluded	Not Present	0 or 1 bits	
PilotGroupID	Not Present	0 or 3 bits	
IsSectorMultiCarrierCapable	0x0 or Not Present	0 or 1 bits; Note 1;	
ReverseBandClass	Not Present	0 or 5 bits	
ReverseChannelNumber	Not Present	0 or 11 bits	
Reserved	0X0	0 – 7 bits as needed all set to zero	
Note 1: As no Non reserved fields following this are included, it can be Not Present; If not present, AT assumes as 0x0.			

Condition	Explanation
No_NeighPNInc	No neighbour Pilot PN included
NeighPNInc	Neighbor Pilot PN's included

- AccessParameters

The AccessParameters message is used to convey Access Channel information to the access terminals.

Table 4.4.7.1-3: AccessParameters

Derivation Path: C.S0024-B clause 9.4.6.2.6			
Information Element	Value/remark	Comment	Condition
MessageID	0x1	0-255	
Access Cycle Duration	16 slots or 64 slots	16,12,64,128 slots	
Access Signature	Any valid value	16 bits Note1.	
OpenLoopAdjust	Set according to PIXIT parameter for default open loop adjust	8bits(-84 – 115 dB); Actual value is -1 times	
ProbeInitialAdjust	0x0(0 dB)	5 bits(-16 – 15 db)	
ProbeNumStep	0x5	4bits(1 – 15)	
PowerStep	0x8(4 dB)	4 bits(0 – 7.5 dB)	
PreambleLength	0x2	3bits(1 – 7)	
CapsuleLengthMax	0x2 or 0x4	4 bits	
APersistence	0x0 or 0x1	6 bits; 'NACMPAPersist = 4' occurrences	
APersistence	0x0 or 0x1	6 bits	
APersistence	0x0 or 0x1	6 bits	
APersistence	0x0 or 0x1	6 bits	
Reserved	0X0	0 – 7 bits as needed all set to zero	
Note 1: The value specified is the value to be used when the AccessParameters is being sent first time. At every change of content of AccessParameters message it is incremented by 1.			

- Sync

The access network broadcasts the Sync message to convey basic network and timing information

Table 4.4.7.1-4: Sync

Derivation Path: C.S0024-B clause 7.3.6.2.1			
Information Element	Value/remark	Comment	Condition
MessageID	0x0	0-255	
MaximumRevision	0x1	8 bits ; Clause 1.15 of 3GPP2 C.S0024-B v3.0	
MinimumRevision	0x1	8 bits; Clause 1.15 of 3GPP2 C.S0024-B v3.0	
Pilot PN Offset	See table 4.4.2-3	0 – 511	
CDMA System Time	A valid value, calculated and updated by the SS	37 bits	

Editor's Note: This section is reserved for cell specific default parameters.

4.4.7.2 Common contents of 1XRTT Overhead messages

4.4.7.2.1 Configuration sequence number

In general, a base station maintains a configuration sequence number CONFIG_SEQ for configuration messages transmitted on the Paging channel and increments by 1 modulo 64 whenever any of the following messages being transmitted are modified:

System Parameters Message

Neighbor List Message (Band Class 0 only)

CDMA Channel List Message

Extended System Parameters Message

Extended Neighbor List Message (band classes other than Band Class 0).

For simplicity reasons the System Simulator may use any value for this configuration sequence number CONFIG_SEQ.

4.4.7.2.2 Over Head messages

- CDMA Channel List Message

Table 4.4.7.2.2-1: CDMA Channel List Message

Derivation Path: C.S0005 clause 3.7.2.3.2.4			
Information Element	Value/remark	Comment	Condition
PILOT_PN	See table 4.4.2-4	9 bits;	
CONFIG_MSG_SEQ	Set to 'CONFIG_SEQ' of base station as per clause 4.4.7.2.1	6 bits;	
CDMA_FREQ	Set according to PIXIT parameter or as per clause 4.3.1.4	11 bits	

System Parameters Message

Table 4.4.7.2.2-2: System Parameters Message

Derivation Path: C.S0005 clause 3.7.2.3.2.1			
Information Element	Value/remark	Comment	Condition
PILOT_PN	See table 4.4.2-4	9 bits	
CONFIG_MSG_SEQ	Set to 'CONFIG_SEQ' of base station as per clause 4.4.7.2.1	6 bits	
SID	See table 4.4.2-4	15 bits	
NID	See table 4.4.2-4	16 bits	
REG_ZONE	See table 4.4.2-4	12 bits	
TOTAL_ZONES	1	3 bits	
ZONE_TIMER	0 or 1	3 bits; 1 or 2 minutes	
MULT_SIDS	0 or 1	1 bits; Mobile shall not or shall store SID_NID_List containing different SID's	
MULT_NIDS	0 or 1	1 bits; Mobile shall not or shall store SID_NID_List containing different NID's	
BASE_ID	See table 4.4.2-4	16 bits	
BASE_CLASS	1	4 bits	BandClass1_4
	0		Not BandClass1_4
PAGE_CHAN	1	3 bits; Number of Paging Channels	
MAX_SLOT_CYCLE_INDEX	1 or 0	3 bits; Maximum Slot Cycle index	
HOME_REG	1	1 bits; Home registration enabled	
FOR_SID_REG	1	1 bits; SID roamer registration enabled	
FOR_NID_REG	1	1 bits; NID roamer registration enabled	
POWER_UP_REG	1	1 bits; power-up registration enabled	
POWER_DOWN_REG	Set according to PIXIT parameter	1 bits; power-down registration enabled as per PIXIT	
PARAMETER_REG	0 or 1	1 bits; parameter change registration disabled or enabled	
REG_PRD	0	7 bits; registration period; No timer Based Registration	
BASE_LAT	Any valid value	22 bits; Base Station Latitude	
BASE_LONG	Any valid value	23 bits; Base Station Longitude	
REG_DIST	0	11 bits; Distance based registration disabled	
SRCH_WIN_A	8	4 bits; Search Window size for Active Set; 60 PN Chips	
SRCH_WIN_N	8	4 bits; Search Window Size for the neighbor set; 60 PN Chips	
SRCH_WIN_R	8	4 bits; Search window size for the remaining set; 60 PN Chips	
NGHBR_MAX_AGE	0	4 bits; Minimum Neighbour set age	
PWR_REP_THRESH	0, 1 or 5	5 bits; Power control reporting threshold	
PWR_REP_FRAMES	0, 4 or 7	4 bits; power control reporting frame count; 5 or 28 frames	

PWR_THRESH_ENABLE	0	1 bits; threshold report mode disabled	
PWR_PERIOD_ENABLE	0	1 bits; periodic report mode disabled	
PWR_REP_DELAY	0 or 14	5 bits; 0 or 56 frames	
RESCAN	0	1 bit; re-initialize and re-acquire the system	
T_ADD	28 (-14 dB Ec/Io)	6 bits; Pilot detection threshold (-14 dB Ec/Io)	
T_DROP	32	6 bits; Pilot drop threshold (-16 dB Ec/Io)	
T_COMP	5	4; Active set versus candidate set comparison threshold (2.5 dB)	
T_TDROPT	3	4 bits; Drop timer value (4 sec)	
EXT_SYS_PARAMETER	1	1 bit; Extended System Parameters message present	
EXT_NGHR_LST	1	1 bit; Extended neighbor list not present	BandClass1_3_4
	0		Not BandClass1_3_4
GEN_NGHR_LST	0	1 bit; General neighbor list not sent	
GLOBAL_REDIRECT	0	1 bit; Global service redirection message not transmitted	
PRI_NGHR_LST	0	1 bit; Private neighbor list message not transmitted	
USER_ZONE_ID	0	1 bit; User zone Identification not transmitted	
EXT_GLOBAL_REDIRECT	0	1 bit; Extended global redirection not transmitted	
EXT_CHAN_LST	0	1 bit; Extended channel list not sent	

Condition	Explanation
BandClass1_4	If Band Class is 1 or 4
BandClass1_3_4	If Band Class is 1 or 3 or 4

Access Parameters Message

Table 4.4.7.2.2-3: Access Parameters message

Derivation Path: C.S0005 clause 3.7.2.3.2.2			
Information Element	Value/remark	Comment	Condition
PILOT_PN	See table 4.4.2-4	9 bits;	
ACC_MSG_SEQ	0,1,2..63	6 bits; Access Message Sequence; 0 is used in initial transmission and incremented by 1 modulo 64 every time Access Parameters message is modified; for simplicity reasons any value may be used	
ACC_CHAN	0	5 bits; Number of access channels -1	
NOM_PWR	0	4 bits; Nominal transmit power offset in dB	
INIT_PWR	0	5 bits; Initial power offset in dB	
PWR_STEP	1 or 3	3 bits; Power increment	
NUM_STEP	Any valid value	4 bits; 5 access probes/sequence	
MAX_CAP_SZ	2 or 7	3 bits; Maximum Access channel message capsule size =2 or 7 +3 frames	
PAM_SZ	Any valid value	4 bits; Access Channel preamble length = 2+1 frames	
PSIST(0-9)	0	6 bits; Persistence value for access overload classes 0-9	
PSIST(10)	0	3 bits; Persistence value for access overload classes 10	
PSIST(11)	0	3 bits; Persistence value for access overload classes 11 (emergency)	
PSIST(12)	0	3 bits; Persistence value for access overload classes 12	
PSIST(13)	0	3 bits; Persistence value for access overload classes 13	
PSIST(14)	0	3 bits; Persistence value for access overload classes 14	
PSIST(15)	0	3 bits; Persistence value for access overload classes 15	
MSG_PSIST	0	3 bits; Persistence modifier for access channel attempts for message transmissions	
REG_PSIST	0	3 bits; Persistence modifier for Access Channel attempts for registrations	
PROBE_PN_RAN	4 or 0	4 bits; Time Randomization for Access Channel probes= 0 to 15 PN chips	
ACC_TMO	3, 4 or 5	4 bits; Acknowledgement timeout = (value +2) * 80 ms	
PROBE_BKOFF	1 or 0	4 bits; Access Channel probe back off = no back off	
BKOFF	1 or 0	4 bits; Access channel probe sequence backoff range =no back off	
MAX_REQ_SEQ	Any valid value	4 bits; Max number of access probe sequences for an access channel request	
MAX_RSP_SEQ	Any valid value	4 bits; Max number of access probe sequences for an access channel response	
AUTH	0	2 bits; No authentication data	

		in access channel messages	
RAND	Not present	0 or 32 bits	
NOM_PWR_EXT	0	1 bits; Extended nominal transmit power	

Extended System Parameters Message

Table 4.4.7.2.2-4: Extended System Parameters Message

Derivation Path: C.S0005 clause 3.7.2.3.2.13			
Information Element	Value/remark	Comment	Condition
PILOT_PN	See table 4.4.2-4	9 bits	
CONFIG_MSG_SEQ	Set to 'CONFIG_SEQ' of base station as per clause 4.4.7.2.1	6 bits	
DELETE_FOR_TMSI	0	1 bits; Delete foreign TMSI	
USE_TMSI	0 or 1	1 bits; Use TMSI indicator	
PREF_MSID_TYPE	3	2 bits; Preferred Access Channel MSID Type	
MCC	See table 4.4.2-4	10 bits	
IMSI_11_12	See table 4.4.2-4	7 bits; 11th and 12th digits of the IMSI	
TMSI_ZONE_LEN	1 or 0	4 bits	
TMSI_ZONE	1 or Not present	8 bits if present	
BCAST_INDEX	0	3 bits	
IMSI_T_SUPPORTED	0	1 bits	
P_REV	6	8 bits	
MIN_P_REV	6	8 bits	
SOFT_SLOPE	0	6 bits	
ADD_INTERCEPT	0	6 bits; 0 dB	
DROP_INTERCEPT	0	6 bits; 0 dB	
PACKET_ZONE_ID	0	8 bits; Packet data service zone not supported	
MAX_NUM_ALT_SO	0	3 bits	
RESELECT_INCLUDED	0	1 bits; System reselection parameters not included	
EC_THRESH	Not present	0 or 5 bits	
EC_I0_THRESH	Not present	0 or 5 bits	
PILOT_REPORT	1 or 0	1 bits; Pilot Report indicator; the MS reports or does not report additional pilots which have strengths exceeding T_ADD	
NGHBR_SET_ENTRY_INFO	0	1 bits	
ACC_ENT_HO_ORDER	Not present	0 or 1 bits	
NGHBR_SET_ACCESS_INFO	0	1 bits	
ACCESS_HO	Not present	0 or 1 bits	
ACCESS_HO_MSG_RSP	Not present	0 or 1 bits	
ACCESS_PROBE_HO	Not present	0 or 1 bits	
ACC_HO_LIST_UPD	Not present	0 or 1 bits	
ACC_PROBE_HO_OTHER_MSG	Not present	0 or 1 bits	
MAX_NUM_PROBE_HO	Not present	0 or 3 bits	
NGHBR_SET_SIZE	Not present	0 or 6 bits	
ACCESS_ENTRY_HO	Not present	1 bits; Access Entry Handoff not permitted	
ACCESS_HO_ALLOWED	Not present	1 bits	
BROADCAST_GPS_ASST	0	1 bits; Broad cast GPS not supported	
QPCH_SUPPORTED	0	1 bits; Quick PCH not supported	
NUM_QPCH	Not present	0 or 2 bits	
QPCH_RATE	Not present	0 or 1 bits	
QPCH_POWER_LEVEL_PAGE	Not present	0 or 3 bits	
QPCH_CCI_SUPPORTED	Not present	0 or 1 bits	
QPCH_POWER_LEVEL_CONFIG	Not present	0 or 3 bits	
SDB_SUPPORTED	0	1 bits; Short Data burst not supported	
RLGAIN_TRAFFIC_PILOT	0	6 bits; 0 dB Gain adjustment of Reverse traffic channel	

REV_PWR_CNTL_DELAY_INCL	0	1 bits	
REV_PWR_CNTL_DELAY	Not present	0 or 2 bits	

- Neighbor List Message

Table 4.4.7.2.2-6: Neighbor List Message

This message is sent when EXT_NGHBR_LST in Systems parameter message is set as '0'B i.e. the band class is 0;

Derivation Path: C.S0005 clause 3.7.2.3.2.3			
Information Element	Value/remark	Comment	Condition
PILOT_PN	See table 4.4.2-4	9 bits	
CONFIG_MSG_SEQ	Set to 'CONFIG_SEQ' of base station as per clause 4.4.7.2.1	6 bits	
PILOT_INC	10 or 1	4 bits; Pilot PN Sequence offset index increment = $n * 50$	
NGHBR_CONFIG(n)	0 or Not present		
NGHBR_PN(n)	See table 4.4.2-4 or Not Present	9 bits if present	
Note 1: the elements with index n are repeated as per table 4.4.2-5			

- Extended Neighbor List Message

Table 4.4.7.2.2-7: Extended Neighbor List Message

This message is sent when EXT_NGHBR_LST in Systems parameter message is set as '1'B i.e. the band class is not 0;

Derivation Path: C.S0005 clause 3.7.2.3.2.14			
Information Element	Value/remark	Comment	Condition
PILOT_PN	See table 4.4.2-4	9 bits	
CONFIG_MSG_SEQ	Set to 'CONFIG_SEQ' of base station as per clause 4.4.7.2.1	6 bits	
PILOT_INC	10 or 1	4 bits; Pilot PN Sequence offset index increment = $n * 50$	
NGHBR_CONFIG(n)	0 or Not present	3 bits if present; Neighbor configuration where neighbor base station has same number of frequencies having paging channels as the current base station;	
NGHBR_PN(n)	See table 4.4.2-4 or Not present	9 bits if present	
SEARCH_PRIORITY(n)	1, 2 or Not present	2 bits if present; Medium search priority	
FREQ_INCL(n)	1	1 bit	InterFreqCell
	0 or Not present		
NGHBR_BAND(n)	Set according to PIXIT parameter	0 or 5 bits	InterFreqCell
	Not present		
NGHBR_FREQ(n)	Set according to PIXIT parameter	0 or 11 bits	InterFreqCell
	Not Present		
Note 1: The elements with index n are repeated as per table 4.4.2-5. The SS can transmit up to 7 neighbour intra frequency cell information. The parameters for the first cell should be set as per table 4.4.2-4.			

Condition	Explanation
-----------	-------------

InterFreqCell	If the configured neighbour cell is on a different frequency compared to the cell in which Extended Neighbour list message is being transmitted
---------------	---

- Sync channel Messages

Table 4.4.7.2.2-8: Sync Channel Message

Derivation Path: C.S0005 clause 3.7.2.3.2.26			
Information Element	Value/remark	Comment	Condition
P_REV	6	8 bits; Protocol revision level	
MIN_P_REV	6	8 bits; Minimum protocol revision level	
SID	See table 4.4.2-4	15 bits	
NID	See table 4.4.2-4	16 bits	
PILOT_PN	See table 4.4.2-4	9 bits	
LC_STATE	A valid value, calculated and updated by the SS	42 bits; Long code State	
SYS_TIME	A valid value, calculated and updated by the SS	36 bits; System time	
LP_SEC	A valid value, calculated and updated by the SS	8 bits; The number of leap seconds	
LTM_OFF	A valid value, calculated and updated by the SS	6 bits; Offset of local time from System time	
DAYLT	A valid value, calculated and updated by the SS	1 bits; Daylight savings indicator	
PRAT	0	2 bits; Paging Channel Data rate=9600 bps	
CDMA_FREQ	Set according to PIXIT parameter or as per clause 4.3.1.4	11 bits; Frequency assignment	
EXT_CDMA_FREQ	Set according to PIXIT parameter or as per clause 4.3.1.4	11 bits; Extended frequency assignment	

4.5 Generic procedures

This clause describes UE test states which can be used in the initial condition of many test cases defined in TS 36.521-1 [21], TS 36.523-1 [18] and TS 36.523-3 [34] or other procedures defined in this specification. This section also defines a set of procedures to bring the UE into these states.

4.5.1 UE test states

NOTE: The need to have a procedure for the transition from State 4/State 3 to State 2 is for further study and it can added if the technical motivation for this procedure can be justified.

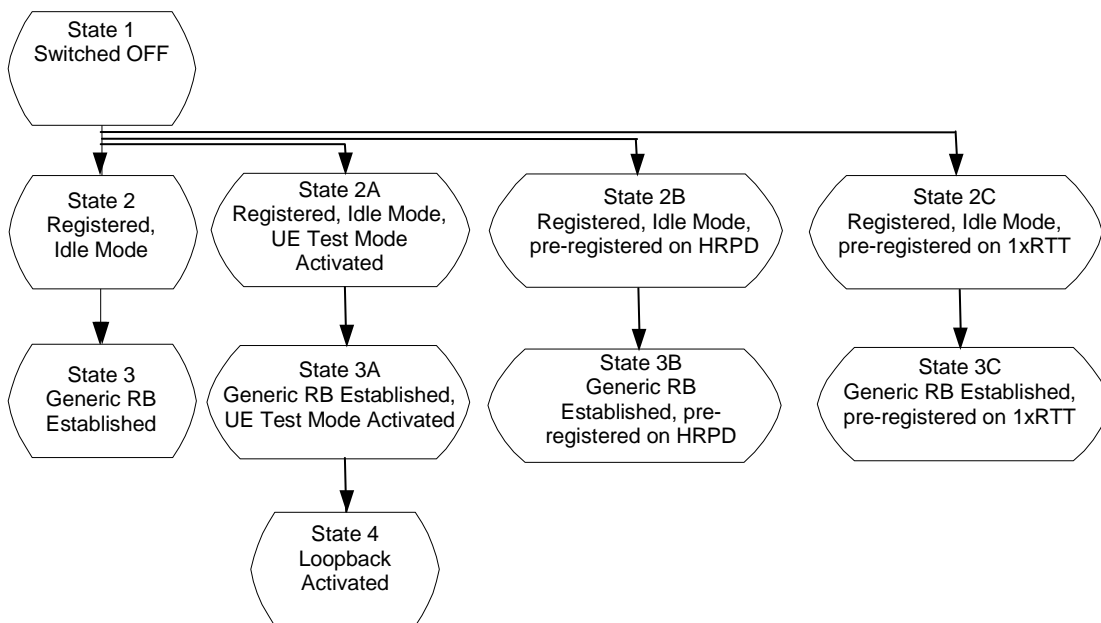

Figure 4.5.1-1: E-UTRAN UE Test States for Basic Generic Procedures

In order that the UE can set up a call or session in E-UTRAN, there are a number of procedures to be undertaken in a hierarchical sequence to move between known states. The sequences are shown in figure 4.5.1-1 and the status of the relevant protocols in the UE in the different states are given in table 4.5.1-1.

Table 4.5.1-1: The E-UTRAN UE states

		RRC	ECM	EMM	ESM	UE Test Mode
State 1	Switched OFF	-----	-----	-----	-----	-----
State 2	Registered, Idle Mode	RRC_IDLE	ECM-IDLE	EMM-REGISTERED	1 default EPS bearer context active.	Not active
State 2A	Registered, Idle Mode, UE Test Mode Activated	RRC_IDLE	ECM-IDLE	EMM-REGISTERED	1 default EPS bearer context active.	Active
State 2B	Registered, Idle Mode, pre-registered on HRPD	RRC_IDLE	ECM-IDLE	EMM-REGISTERED	1 default EPS bearer context active.	Active
State 2C	Registered, Idle Mode, pre-registered on 1xRTT	RRC_IDLE	ECM-IDLE	EMM-REGISTERED	1 default EPS bearer context active.	Active
State 3	Generic RB Established	RRC_CONNECTED 1 + N (0 ≤ N ≤ 7) data radio bearers configured as specified in the test cases	ECM-CONNECTED	EMM-REGISTERED	1 default EPS bearer context active and N (0 ≤ N ≤ 7) dedicated EPS bearers active as specified in the test cases	Not active
State 3A	Generic RB Established, UE Test Mode Activated	RRC_CONNECTED 1 + N (0 ≤ N ≤ 7) data radio bearers configured as specified in the test cases	ECM-CONNECTED	EMM-REGISTERED	1 default EPS bearer context active and N (0 ≤ N ≤ 7) dedicated EPS bearers active as specified in the test cases	Active
State 3B	Generic RB Established, pre-registered on HRPD	RRC_CONNECTED 1 + N (0 ≤ N ≤ 7) data radio bearers configured as specified in the test cases	ECM-CONNECTED	EMM-REGISTERED	1 default EPS bearer context active and N (0 ≤ N ≤ 7) dedicated EPS bearers active as specified in the test cases	Active
State 3C	Generic RB Established, pre-registered on 1xRTT	RRC_CONNECTED 1 + N (0 ≤ N ≤ 7) data radio bearers configured as specified in the test cases	ECM-CONNECTED	EMM-REGISTERED	1 default EPS bearer context active and N (0 ≤ N ≤ 7) dedicated EPS bearers active as specified in the test cases	Active
State 4	Loopback Activated	RRC_CONNECTED 1 + N (0 ≤ N ≤ 7) data radio bearers configured as specified in the test cases	ECM-CONNECTED	EMM-REGISTERED	1 default EPS bearer context active and N (0 ≤ N ≤ 7) dedicated EPS bearers active as specified in the test cases	Active

NOTE: Refer to TS 24.301 [28] subclause 5.5.1.1 for more details on the ESM state.

NOTE: Refer to TS 36.509 [38] for details regarding UE test mode and UE Loopback.

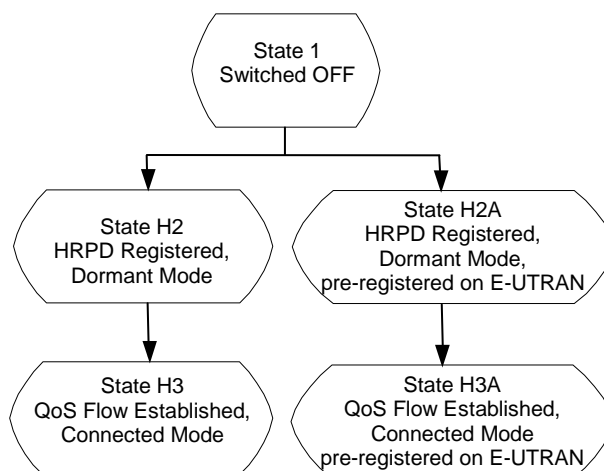

Figure 4.5.1-2: HRPD UE Test States for Basic Generic Procedures

In order for the UE to set up a session in an HRPD RAN, there is a number of procedures that need to be performed in a certain sequence to move between known UE states. These states and sequences are shown in figure 4.5.1-2. HRPD UE states are described in table 4.5.1-2.

Table 4.5.1-2: Description of HRPD UE states

State	Description
H2	The UE is registered on the HRPD network, but has no active connection to the network. The Inter-RAT Idle State Protocol (IR-ISP) is in Monitor State. The UE should be ready to perform a non-optimised cell reselection to E-UTRAN (as per [41] cl. 8 and [42] cl. 14.1).
H3	The UE is registered on the HRPD network, and has an active network connection. The UE should be ready to perform a non-optimised handover to E-UTRAN (as per [41] cl. 8).
H2A	Same state as State H2, but the UE is also pre-registered in E-UTRAN. The UE should be ready to perform an optimised cell reselection to E-UTRAN (as per [41] cl. 9.6).
H3A	Same state as State H3, but the UE is also pre-registered in E-UTRAN. The UE should be ready to perform an optimised handover to E-UTRAN (as per [41] cl. 9.5).

4.5.2 UE Registration (State 2)

4.5.2.1 Initial conditions

System Simulator:

- 1 cell, default parameters.
- The procedure shall be performed under ideal radio conditions as defined in clause 5

User Equipment:

- The Test USIM shall be inserted.

4.5.2.2 Definition of system information messages

The default system information messages are used.

4.5.2.3 Procedure

Table 4.5.2.3-1: UE registration procedure (state 1 to state 2)

Step	Procedure	U - S	Message Sequence Message
1		<--	RRC: SYSTEM INFORMATION (BCCH)
2	UE transmits an <i>RRCConnectionRequest</i> message.	-->	RRC: <i>RRCConnectionRequest</i>
3	SS transmits an <i>RRCConnectionSetup</i> message.	<--	RRC: <i>RRCConnectionSetup</i>
4	The UE transmits an <i>RRCConnectionSetupComplete</i> message to confirm the successful completion of the connection establishment and to initiate the Attach procedure by including the ATTACH REQUEST message. The PDN CONNECTIVITY REQUEST message is piggybacked in ATTACH REQUEST	-->	RRC: <i>RRCConnectionSetupComplete</i> NAS: ATTACH REQUEST NAS: PDN CONNECTIVITY REQUEST
5	The SS transmits an AUTHENTICATION REQUEST message to initiate the EPS authentication and AKA procedure.	<--	RRC: <i>DLInformationTransfer</i> NAS: AUTHENTICATION REQUEST
6	The UE transmits an AUTHENTICATION RESPONSE message and establishes mutual authentication.	-->	RRC: <i>ULInformationTransfer</i> NAS: AUTHENTICATION RESPONSE
7	The SS transmits a NAS SECURITY MODE COMMAND message to activate NAS security.	<--	RRC: <i>DLInformationTransfer</i> NAS: SECURITY MODE COMMAND
8	The UE transmits a NAS SECURITY MODE COMPLETE message and establishes the initial security configuration.	-->	RRC: <i>ULInformationTransfer</i> NAS: SECURITY MODE COMPLETE
-	EXCEPTION: Steps 9a1 to 9a2 describe behaviour that depends on UE configuration; the "lower case letter" identifies a step sequence that take place if the UE has ESM information which needs to be transferred.	-	-
9a1	IF the UE sets the ESM information transfer flag in the last PDN CONNECTIVITY REQUEST message THEN the SS transmits an ESM INFORMATION REQUEST message to initiate exchange of protocol configuration options and/or APN.	<--	RRC: <i>DLInformationTransfer</i> NAS: ESM INFORMATION REQUEST
9a2	The UE transmits an ESM INFORMATION RESPONSE message to transfer protocol configuration options and/or APN.	-->	RRC: <i>ULInformationTransfer</i> NAS: ESM INFORMATION RESPONSE
10	The SS transmits a <i>SecurityModeCommand</i> message to activate AS security.	<--	RRC: <i>SecurityModeCommand</i>
11	The UE transmits a <i>SecurityModeComplete</i> message and establishes the initial security configuration.	-->	RRC: <i>SecurityModeComplete</i>
12	The SS transmits a <i>UECapabilityEnquiry</i> message to initiate the UE radio access capability transfer procedure.	<--	RRC: <i>UECapabilityEnquiry</i>
13	The UE transmits a <i>UECapabilityInformation</i> message to transfer UE radio access capability.	-->	RRC: <i>UECapabilityInformation</i>
14	The SS transmits an <i>RRCConnectionReconfiguration</i> message to establish the default bearer with condition SRB2-DRB(1, 0) according to 4.8.2.2.1.1. This message includes the ATTACH ACCEPT message. The ACTIVATE DEFAULT EPS BEARER CONTEXT REQUEST message is piggybacked in ATTACH ACCEPT.	<--	RRC: <i>RRCConnectionReconfiguration</i> NAS: ATTACH ACCEPT NAS: ACTIVATE DEFAULT EPS BEARER CONTEXT REQUEST
15	The UE transmits an <i>RRCConnectionReconfigurationComplete</i> message to confirm the establishment of	-->	RRC: <i>RRCConnectionReconfigurationComplete</i>

	default bearer.		
-	EXCEPTION: In parallel to the event described in step 16 below, if initiated by the UE the generic procedure for IP address allocation in the U-plane specified in TS 36.508 subclause 4.5A.1 takes place performing IP address allocation in the U-plane.		
-	EXCEPTION: In parallel to the event described in step 16 below the generic procedure for IMS signalling in the U-plane specified in TS 36.508 subclause 4.5A.3 takes place if requested by the UE		
16	This message includes the ATTACH COMPLETE message. The ACTIVATE DEFAULT EPS BEARER CONTEXT ACCEPT message is piggybacked in ATTACH COMPLETE.	-->	RRC: <i>ULInformationTransfer</i> NAS: ATTACH COMPLETE NAS: ACTIVATE DEFAULT EPS BEARER CONTEXT ACCEPT
17	The SS transmits an <i>RRCConnectionRelease</i> message to release RRC connection and move to RRC_IDLE (State 2).	<--	RRC: <i>RRCConnectionRelease</i>

4.5.2.4 Specific message contents

All specific message contents shall be referred to clause 4.6 and 4.7 with the exceptions below.

Table 4.5.2.4-1: *RRCConnectionRequest* (Step 2)

Derivation Path: Table 4.6.1-16			
Information Element	Value/remark	Comment	Condition
<i>RRCConnectionRequest</i> ::= SEQUENCE {			
criticalExtensions CHOICE {			
<i>rrcConnectionRequest-r8</i> SEQUENCE {			
ue-Identity	Any allowed value		
}			
}			
}			

Table 4.5.2.4-2: *UECapabilityInformation* (Step 13)

Derivation Path: Table 4.6.1-23			
Information Element	Value/remark	Comment	Condition
<i>UECapabilityInformation</i> ::= SEQUENCE {			
criticalExtensions CHOICE {			
c1 CHOICE{			
ueCapabilityInformation-r8	Any allowed value		
}			
}			
}			

Table 4.5.2.4-3: ACTIVATE DEFAULT EPS BEARER CONTEXT REQUEST (Step 14)

Derivation Path: Table 4.7.3-6			
Information Element	Value/remark	Comment	Condition
PDN address			IPv4_addresses_only
Length of PDN address contents	5 octets		
PDN type value	'001'B	IPv4	
PDN address information	IPv4 address	The SS provides a valid IPv4 address	NOT IPv4-DHCP
	0.0.0.0	DHCPv4 is to be used to allocate the IPv4 address	IPv4-DHCP
ESM cause	IF "PDN type" IE in step 4 is 'IPv4v6' THEN '00110010'B ELSE Not present	"PDN type IPv4 only allowed"	

NOTE: The default message contents specified in table 4.7.3-6 apply unless the condition IPv4_address_only in table 4.5.2.4-3 is true.

Condition	Explanation
IPv4_address_only	This condition applies if the test case preamble description indicates that the UE is allocated an IPv4 address.
IPv4-DHCP	If in the last PDN CONNECTIVITY REQUEST sent prior to this message, the IE Protocol configuration options contains a configuration protocol option = '000B00H' ("IPv4 address allocation via DHCPv4", length of contents = 0). Note: This condition is used in conjunction with IPv4 or IPv4v6 as indicated in the "PDN address row" just above.

4.5.2A UE Registration, UE Test Mode Activated (State 2A)

4.5.2A.1 Initial conditions

System Simulator:

- 1 cell, default parameters.
- The procedure shall be performed under ideal radio conditions as defined in clause 5

User Equipment:

- The Test USIM shall be inserted.

4.5.2A.2 Definition of system information messages

The default system information messages are used.

4.5.2A.3 Procedure

Table 4.5.2A.3-1: UE registration with test mode activation procedure (state 1 to state 2A)

Step	Procedure	Message Sequence	
		U - S	Message
1 to 9a2	Same procedure for steps 1 to 9a2 as specified in the procedure in clause 4.5.2.3	-	-
10	The SS transmits an ACTIVATE TEST MODE message to activate UE radio bearer test mode procedure.	<--	RRC: <i>DLInformationTransfer</i> TC: ACTIVATE TEST MODE
11	The UE transmits an ACTIVATE TEST MODE COMPLETE message.	-->	RRC: <i>ULInformationTransfer</i> TC: ACTIVATE TEST MODE COMPLETE
12	The SS transmits a <i>SecurityModeCommand</i> message to activate AS security.	<--	RRC: <i>SecurityModeCommand</i>
13	The UE transmits a <i>SecurityModeComplete</i> message and establishes the initial security configuration.	-->	RRC: <i>SecurityModeComplete</i>
14	The SS transmits a <i>UECapabilityEnquiry</i> message to initiate the UE radio access capability transfer procedure.	<--	RRC: <i>UECapabilityEnquiry</i>
15	The UE transmits a <i>UECapabilityInformation</i> message to transfer UE radio access capability.	-->	RRC: <i>UECapabilityInformation</i>
16	The SS transmits an <i>RRCCONNECTIONRECONFIGURATION</i> message to establish the default bearer with condition SRB2-DRB(1, 0) according to 4.8.2.2.1.1. This message includes the ATTACH ACCEPT message. The ACTIVATE DEFAULT EPS BEARER CONTEXT REQUEST message is piggybacked in ATTACH ACCEPT.	<--	RRC: <i>RRCCONNECTIONRECONFIGURATION</i> NAS: ATTACH ACCEPT NAS: ACTIVATE DEFAULT EPS BEARER CONTEXT REQUEST
17	The UE transmits an <i>RRCCONNECTIONRECONFIGURATIONCOMPLETE</i> message to confirm the establishment of default bearer.	-->	RRC: <i>RRCCONNECTIONRECONFIGURATIONCOMPLETE</i>
-	EXCEPTION: In parallel to the event described in step 18 below the generic procedure for IP address allocation in the U-plane specified in TS 36.508 subclause 4.5A.1 takes place performing IP address allocation in the U-plane if requested by the UE.		
-	EXCEPTION: In parallel to the event described in step 18 below the generic procedure for IMS signalling in the U-plane specified in TS 36.508 subclause 4.5A.3 takes place if requested by the UE		
18	This message includes the ATTACH COMPLETE message. The ACTIVATE DEFAULT EPS BEARER CONTEXT ACCEPT message is piggybacked in ATTACH COMPLETE.	-->	RRC: <i>ULInformationTransfer</i> NAS: ATTACH COMPLETE NAS: ACTIVATE DEFAULT EPS BEARER CONTEXT ACCEPT
19	The SS transmits an <i>RRCCONNECTIONRELEASE</i> message to release RRC connection and move to RRC_IDLE (State 2A).	<--	RRC: <i>RRCCONNECTIONRELEASE</i>

4.5.2A.4 Specific message contents

All specific message contents shall be referred to clause 4.6, 4.7 and 4.7A with the exceptions below.

Table 4.5.2A.4-1: RRCConnectionRequest (Step 2)

Derivation Path: Table 4.6.1-16			
Information Element	Value/remark	Comment	Condition
RRCConnectionRequest ::= SEQUENCE {			
criticalExtensions CHOICE {			
rrcConnectionRequest-r8 SEQUENCE {			
ue-Identity	Any allowed value		
}			
}			
}			

Table 4.5.2A.4-2: UECapabilityInformation (Step 15)

Derivation Path: Table 4.6.1-23			
Information Element	Value/remark	Comment	Condition
UECapabilityInformation ::= SEQUENCE {			
criticalExtensions CHOICE {			
c1 CHOICE {			
ueCapabilityInformation-r8	Any allowed value		
}			
}			
}			

4.5.2B UE Registration, pre-registration on HRPD (State 2B)

4.5.2B.1 Initial conditions

System Simulator:

- Cell 1
- Cell 1 is transmitting SystemInformationBlockType8

User Equipment:

- The Test USIM shall be inserted.

4.5.2B.2 Definition of system information messages

Table 4.5.2B.2-1: SystemInformationBlockType1 for cell 1 (Steps 1-41, Table 4.5.2B.3-2)

Derivation Path: 36.508 Table 4.4.3.2-3			
Information Element	Value/remark	Comment	Condition
SystemInformationBlockType1 ::= SEQUENCE {			
schedulingInformation ::= SEQUENCE (SIZE (1..maxSI-Message)) OF SEQUENCE {}	Combination 6 in TS 36.508 section 4.4.3.1	SIB2, SIB3 and SIB 8 are transmitted	
}			

Table 4.5.2B.2-2: SystemInformationBlockType8 for cell 1 (Steps 1-41, Table 4.5.2B.3-2)

Derivation Path: 36.508 Table 4.4.3.3-7, condition HRPD			
Information Element	Value/remark	Comment	Condition
SystemInformationBlockType8 ::= SEQUENCE {			
parametersHRPD SEQUENCE {			
preRegistrationInfoHRPD SEQUENCE {			
preRegistrationAllowed	TRUE		
preRegistrationZoneId	ColorCode		
secondaryPreRegistrationZoneIdList	Not present		
SEQUENCE (SIZE (1..2)) OF SEQUENCE {			
PreRegistrationZoneIdHRPD	Not present		
}			
}			
cellReselectionParametersHRPD SEQUENCE {			
bandClassList SEQUENCE (SIZE (1..maxCDMA -BandClass)) OF SEQUENCE {	1 entry		
bandClass	Band Class of frequency under test	ENUMERATED {bc0, bc1, bc2, bc3, bc4, bc5, bc6, bc7, bc8, bc9, bc10, bc11, bc12, bc13, bc14, bc15, bc16, bc17, spare14, spare13, spare12, spare11, spare10, spare9, spare8, spare7, spare6, spare5, spare4, spare3, spare2, spare1, ...}	
cellReselectionPriority	3		
threshX-High	30(-30)	INTEGER (0..63)	
threshX-Low	32(-32)	INTEGER (0..63)	
}			
neighCellList SEQUENCE (SIZE (1..16)) OF SEQUENCE {	1 entry		
bandClass	Band Class of frequency under test	ENUMERATED {bc0, bc1, bc2, bc3, bc4, bc5, bc6, bc7, bc8, bc9, bc10, bc11, bc12, bc13, bc14, bc15, bc16, bc17, spare14, spare13, spare12, spare11, spare10, spare9, spare8, spare7, spare6, spare5, spare4, spare3, spare2, spare1, ...}	
}			
}			
t-ReselectionCDMA2000	3	INTEGER (0..7)	
}			
}			
}			

4.5.2B.3 Procedure

Table 4.5.2B.3-1 shows the cell power levels during the procedure.

Table 4.5.2B.3-1: Time instances of cell power level and parameter changes

	Parameter	Unit	Cell 1		Remark
T0	Cell-specific RS EPRE	dBm/15kHz	-75		-

Table 4.5.2B.3-2: UE registration with HRPD pre-registration procedure (state 1 to state 2B)

Step	Procedure	Message Sequence	
		U - S	Message
1 to 16	Same procedure for steps 1 to 16 as specified in the procedure in clause 4.5.2.3	-	-
17	The UE transmits an <i>ULInformationTransfer</i> containing a tunneled <i>UATIRequest</i> message on Cell 1.	-->	<i>ULInformationTransfer</i>
18	The SS transmits a <i>DLInformationTransfer</i> containing a tunneled <i>UATIAssignment</i> message on Cell 1.	<--	<i>DLInformationTransfer</i>
19	The UE transmits an <i>ULInformationTransfer</i> containing a tunneled <i>UATIComplete</i> message on Cell 1.	-->	<i>ULInformationTransfer</i>
20	The UE transmits an <i>ULInformationTransfer</i> containing a tunneled <i>AlternateLinkOpenReq</i> message on Cell 1.	-->	<i>ULInformationTransfer</i>
21	The SS transmits a <i>DLInformationTransfer</i> containing a tunneled <i>AlternateLinkOpenConf</i> message on Cell 1.	<--	<i>DLInformationTransfer</i>
22	The UE transmits an <i>ULInformationTransfer</i> containing a tunneled <i>AlternateLinkOpenComplete</i> on Cell 1.	-->	<i>ULInformationTransfer</i>
23	The UE transmits an <i>ULInformationTransfer</i> containing a tunneled <i>ConfigurationRequest</i> message for SCP configuration on Cell 1.	-->	<i>ULInformationTransfer</i>
24	The SS transmits a <i>DLInformationTransfer</i> containing a tunneled <i>ConfigurationResponse</i> message for SCP configuration on Cell 1.	<--	<i>DLInformationTransfer</i>
25	The UE transmits an <i>ULInformationTransfer</i> containing a tunneled <i>ConfigurationRequest</i> message for Stream protocol on Cell 1.	-->	<i>ULInformationTransfer</i>
26	The SS transmits a <i>DLInformationTransfer</i> containing a tunneled <i>ConfigurationResponse</i> message for Stream protocol accepting EMPA bound to service network on Cell 1.	<--	<i>DLInformationTransfer</i>
27	The UE transmits an <i>ULInformationTransfer</i> containing a tunneled <i>EMPA ConfigurationRequest</i> message or <i>MMPA ConfigurationRequest</i> message on Cell 1.	-->	<i>ULInformationTransfer</i>
28	The SS transmits a <i>DLInformationTransfer</i> containing a tunneled <i>EMPA ConfigurationResponse</i> message or <i>MMPA ConfigurationResponse</i> message on Cell 1.	<--	<i>DLInformationTransfer</i>
29	The UE transmits an <i>ULInformationTransfer</i> containing a tunneled <i>ConfigurationComplete</i> message on Cell 1.	-->	<i>ULInformationTransfer</i>
30	The SS transmits a <i>DLInformationTransfer</i> containing a tunneled <i>EMPA ConfigurationRequest</i> message or <i>MMPA ConfigurationRequest</i> message on Cell 1.	<--	<i>DLInformationTransfer</i>
30A	The UE transmits an <i>ULInformationTransfer</i> containing a tunneled <i>EMPA ConfigurationResponse</i> message or <i>MMPA ConfigurationResponse</i> message on Cell 1.	-->	<i>ULInformationTransfer</i>
30B	The SS transmits an <i>DLInformationTransfer</i> containing a tunneled <i>SoftConfigurationComplete</i> message on Cell 1.	<--	<i>DLInformationTransfer</i>
30C	The UE transmits an <i>ULInformationTransfer</i> containing a tunneled <i>AlternateLinkCloseReq</i> message on Cell 1.	-->	<i>ULInformationTransfer</i>
30D	The SS transmits a <i>DLInformationTransfer</i> containing a tunneled <i>AlternateLinkCloseConf</i> message on Cell 1.	<--	<i>DLInformationTransfer</i>
31	Optionally tunneled device level	<-->	-

	authentication may take place on Cell 1.		
32	Optionally tunneled Location Update procedure may take place if the SS is configured to support it.	<-->	-
32A	The UE transmits an <i>ULInformationTransfer</i> containing a tunneled <i>AlternateLinkOpenReq</i> message on Cell 1.	-->	<i>ULInformationTransfer</i>
32B	The SS transmits a <i>DLInformationTransfer</i> containing a tunneled <i>AlternateLinkOpenConf</i> message on Cell 1.	<--	<i>DLInformationTransfer</i>
32C	The UE transmits an <i>ULInformationTransfer</i> containing a tunneled <i>AlternateLinkOpenComplete</i> message on Cell 1.	-->	<i>ULInformationTransfer</i>
33	Tunneled PPP LCP negotiation is performed between the UE and the SS. EAP-AKA' is selected as the authentication protocol.	<-->	-
33A	After entering PPP LCP Open State, optionally tunneled PPP Version Capability Indication and/or Max PPP Inactivity Timer negotiation may take place.	<-->	-
34	Tunneled EAP-AKA' is performed between the UE and the SS.	<-->	-
35	The UE transmits an <i>ULInformationTransfer</i> containing a tunneled <i>VSNCP Configure-Request</i> message, including a PDN-ID, PDN Type, APN, PDN Address, Protocol Configuration Options, and Attach Type = "handover". The Address Allocation Preference option contained in the Protocol Configuration Options indicates whether the UE wants to perform the IP address allocation during the attach procedure or deferred IP address allocation. PDN Type indicates the UE's IP capability (IPv4, IPv6 or IPv4/v6)	-->	<i>ULInformationTransfer</i>
36	The SS transmits a <i>DLInformationTransfer</i> containing a tunneled <i>VSNCP Configure-Ack</i> message.	<--	<i>DLInformationTransfer</i>
37	The SS transmits a <i>DLInformationTransfer</i> containing a tunneled <i>VSNCP Configure-Request</i> message including the PDN-ID configuration option.	<--	<i>DLInformationTransfer</i>
38	The UE transmits an <i>ULInformationTransfer</i> containing a tunneled <i>VSNCP Configure-Ack</i> message.	-->	<i>ULInformationTransfer</i>
39	Optionally deferred IP address allocation using tunnelled IETF messages can take place depending on the Address Allocation Preference indicated by the UE at Step 35.	<-->	
39A	The UE transmits an <i>ULInformationTransfer</i> containing a tunneled <i>AlternateLinkCloseReq</i> message on Cell 1.	-->	<i>ULInformationTransfer</i>
39B	The SS transmits a <i>DLInformationTransfer</i> containing a tunneled <i>AlternateLinkCloseConf</i> message on Cell 1.	<--	<i>DLInformationTransfer</i>
40	Void.		
41	The SS transmits an <i>RRCCConnectionRelease</i> message on Cell 1.	<--	<i>RRCCConnectionRelease</i>
Note 1: The sequence in steps 17-40 lists important eHRPD procedures. More protocol negotiations can happen based on UE capability and SS emulation.			
Note 2: Message contents of tunnelled CDMA2000 messages (steps 17-40) are not checked in terms of conformance testing.			

NOTE: If step 31 is performed, an alternative link establishment procedure is also performed.

4.5.2B.4 Specific message contents

All specific message contents shall be referred to clause 4.6, 4.7 and 4.7A with the exceptions below.

Table 4.5.2B.4-1: RRCConnectionRequest (Step 2, Table 4.5.2B.3-2)

Derivation Path: Table 4.6.1-16			
Information Element	Value/remark	Comment	Condition
RRCConnectionRequest ::= SEQUENCE {			
criticalExtensions CHOICE {			
rrcConnectionRequest-r8 SEQUENCE {			
ue-Identity	Any allowed value		
}			
}			
}			

Table 4.5.2B.4-2: UECapabilityInformation (Step13, Table 4.5.2B.3-2)

Derivation Path: Table 4.6.1-23			
Information Element	Value/remark	Comment	Condition
UECapabilityInformation ::= SEQUENCE {			
criticalExtensions CHOICE {			
c1 CHOICE{			
ueCapabilityInformation-r8	Any allowed value		
}			
}			
}			

Table 4.5.2B.4-3: UATI Request message (Step 17, Table 4.5.2B.3-2)

Field	Value/remark	Comment	Condition
SAPState	'0'B	SAP Header	
SessionConfigurationToken	16 bits, Set by UE		
ConnectionLayerFormat	1 bit, Set by UE		
ATI Record	34 bits, RATI set by UE		
Reserved	'0000'B		
MessageID	'00000000'B	UATI Request	
TransactionID	8 bits, Set by UE		

Table 4.5.2B.4-4: UATI Assignment message (Step 18, Table 4.5.2B.3-2)

Field	Value/remark	Comment	Condition
SAPState	'1'B	SAP Header	
SessionConfigurationToken	'0'		
ConnectionLayerFormat	1 bit, Set by SS		
ATI Record	34 bits, RATI set in UATI Request		
Reserved	'0000'B		
MessageID	'00000001'B	UATI Assignment	
MessageSequence	8 bits, Set by SS		
Reserved1	'0000000'B		
SubnetIncluded	'1'B		
UATISubnetMask	'1101000'B		
UATI104	104 bits, Set by SS		
UATIColorCode	8 bits, Set to ColorCode		
UATI024	24 bits, Set by SS		
UpperOldUATILength	'0000'B		
Reserved2	'0000'B		

4.5.2C UE Registration, pre-registration on 1xRTT (State 2C)

4.5.2C.1 Initial conditions

System Simulator:

- Cell 1
- Cell 1 is transmitting SystemInformationBlockType8

User Equipment:

- The Test USIM shall be inserted.
- The UE is switched OFF.

4.5.2C.2 Definition of system information messages

Table 4.5.2C.2-1: SystemInformationBlockType1 for cell 1 (Steps 1-19, Table 4.5.2C.3-2)

Derivation Path: 36.508 Table 4.4.3.2-3			
Information Element	Value/remark	Comment	Condition
SystemInformationBlockType1 ::= SEQUENCE {			
schedulingInformation ::= SEQUENCE (SIZE (1..maxSI-Message)) OF SEQUENCE {}	Combination 6 in TS 36.508 section 4.4.3.1	SIB2, SIB3 and SIB 8 are transmitted	
}			

Table 4.5.2C.2-2: SystemInformationBlockType8 for cell 1 (Steps 1-19, Table 4.5.2C.3-2)

Derivation Path: 36.508 Table 4.4.3.3-7, condition 1XR TT			
Information Element	Value/remark	Comment	Condition
SystemInformationBlockType8 ::= SEQUENCE {			
parameters1XR TT SEQUENCE {			
csfb-RegistrationParam1XR TT SEQUENCE {			
Sid	SID under test For Signalling test cases, see table 4.4.2-4	BIT STRING (SIZE (15))	
Nid	NID under test For Signalling test cases, see table 4.4.2-4	BIT STRING (SIZE (16))	
multipleSID	TRUE	BOOLEAN	
multipleNID	TRUE	BOOLEAN	
homeReg	TRUE	BOOLEAN	
foreignSIDReg	TRUE	BOOLEAN	
foreignNIDReg	TRUE	BOOLEAN	
parameterReg	TRUE	BOOLEAN	
powerUpReg	TRUE	BOOLEAN	
registrationPeriod	'0000000'	BIT STRING (SIZE (7))	
registrationZone	Registration zone under test For Signalling test cases, see table 4.4.2-4	BIT STRING (SIZE (12))	
totalZone	'001'B	BIT STRING (SIZE (3))	
zoneTimer	'000'B or '001'B	BIT STRING (SIZE (3))	
}			
longCodeState1XR TT	A valid value, calculated and updated by the SS	BIT STRING (SIZE (42)) OPTIONAL	
cellReselectionParameters1XR TT SEQUENCE {			
bandClassList SEQUENCE (SIZE (1..maxCDMA -BandClass)) OF SEQUENCE {	1 entry		
bandClass	Band Class of frequency under test	ENUMERATED {bc0, bc1, bc2, bc3, bc4, bc5, bc6, bc7, bc8, bc9, bc10, bc11, bc12, bc13, bc14, bc15, bc16, bc17, spare14, spare13, spare12, spare11, spare10, spare9, spare8, spare7, spare6, spare5, spare4, spare3, spare2, spare1, ...}	
cellReselectionPriority	3		
threshX-High	30(-30)	INTEGER (0..63)	
threshX-Low	32(-32)	INTEGER (0..63)	
}			
}			
csfb-RegistrationParam1XR TT-v920{			
powerDownReg-r9	TRUE		
}			
}			

4.5.2C.3 Procedure

Table 4.5.2C.3-1 shows the cell power levels after the preamble.

Table 4.5.2C.3-1: Time instances of cell power level and parameter changes

	Parameter	Unit	Cell 1		Remark
T0	Cell-specific RS EPRE	dBm/15kHz	-60		-

Table 4.5.2C.3-2: UE registration with 1xRTT pre-registration procedure (state 1 to state 2C)

Step	Procedure	Message Sequence	
		U - S	Message
1 to 16	Same procedure for steps 1 to 16 as specified in the procedure in clause 4.5.2.3	-	-
16A	The UE transmits a <i>CSFBParametersRequestCDMA2000</i> on Cell 1?	-->	<i>CSFBParametersRequestCDMA2000</i>
16B	The SS transmits a <i>CSFBParametersResponseCDMA2000</i> on Cell 1.	<--	<i>CSFBParametersResponseCDMA2000</i>
17	The UE transmits an <i>ULInformationTransfer</i> containing a 1xRTT GCSNA Encapsulated Registration message on Cell 1.	-->	<i>ULInformationTransfer</i>
17A	The SS transmits a <i>DLInformationTransfer</i> containing a GCSNA Ack message on Cell 1.	<--	<i>DLInformationTransfer</i>
18	The SS transmits a <i>DLInformationTransfer</i> containing a 1x RTT GCSNA Encapsulated Registration Accept Order on Cell 1.	<--	<i>DLInformationTransfer</i>
19	The SS transmits an <i>RRCConnectionRelease</i> message on Cell 1.	<--	<i>RRCConnectionRelease</i>
Note: Message contents of tunnelled CDMA2000 messages (steps 17-18) are not checked in terms of conformance testing.			

Table 4.5.2C.3-3: Void

4.5.2C.4 Specific message contents

All specific message contents shall be referred to clause 4.6, 4.7 and 4.7A with the exceptions below.

Table 4.5.2C.4-1: *RRCConnectionRequest* (Step 2, Table 4.5.2C.3-2)

Derivation Path: Table 4.6.1-16			
Information Element	Value/remark	Comment	Condition
<i>RRCConnectionRequest</i> ::= SEQUENCE {			
criticalExtensions CHOICE {			
<i>rrcConnectionRequest-r8</i> SEQUENCE {			
ue-Identity	Any allowed value		
}			
}			
}			

Table 4.5.2C.4-2: UECapabilityInformation (Step 13, Table 4.5.2C.3-2)

Derivation Path: Table 4.6.1-23			
Information Element	Value/remark	Comment	Condition
UECapabilityInformation ::= SEQUENCE {			
criticalExtensions CHOICE {			
c1 CHOICE{			
ueCapabilityInformation-r8	Any allowed value		
}			
}			
}			

Table 4.5.2C.4-3: Void**Table 4.5.2C.4-4: Void****Table 4.5.2C.4-5: CSFBParametersResponseCDMA2000 (Step 16B, Table 4.5.2C.3-2)**

Derivation Path: 36.508 Table 4.6.1-2			
Information Element	Value/remark	Comment	Condition
CSFBParametersResponseCDMA2000 ::= SEQUENCE {			
criticalExtensions CHOICE {			
csfbParametersResponseCDMA2000-r8			
SEQUENCE {			
Rand	Random Challenge Data set by SS		
mobilityParameters	Set according to Table 4.5.2C.4-6		
}			
}			

Table 4.5.2C.4-6: GCSNA Encapsulated *mobilityParameters* (Step 16B, Table 4.5.2C.3-2)

Information Element	Value/remark	Comment	Condition
MessageID	'00000101'B	GCSNA1xParameters	
UnsolicitedMessage	'1'B	Not sent in response to GCSNA1xParametersRequest	
MessageSequence	6 bits, Set by SS		
Reserved	'0'B		
Length	Length of the remainder of the message beyond this field. Set by the SS		
RecordType	'00000000'B		
SIDIncluded	'1'B		
SID	The same as SIB8		
NIDIncluded	'1'B		
NID	The same as SIB8		
REG_ZONEIncluded	'1'B		
REG_ZONE	The same as SIB8		
TOTAL_ZONESIncluded	'1'B		
TOTAL_ZONES	The same as SIB8		
ZONE_TIMERIncluded	'1'B		
ZONE_TIMER	The same as SIB8		
PACKET_ZONE_IDIncluded	'0'B		
PACKET_ZONE_ID	Not present		
PZIDHystParametersIncluded	'0'B		
PZ_HYST_ENABLED	Not present		
PZ_HYST_INFO_INCL	Not present		
PZ_HYST_LIST_LEN	Not present		
PZ_HYST_ACT_TIMER	Not present		
PZ_HYST_TIMER_MUL	Not present		
PZ_HYST_TIMER_EXP	Not present		
P_REVIncluded	'1'B		
P_REV	'00000110'B		
MIN_P_REVIncluded	'1'B		
MIN_P_REV	'00000110'B		
'0'B NEG_SLOT_CYCLE_INDEX_SUPIncluded			
NEG_SLOT_CYCLE_INDEX_SUP	Not present		
ENCRYPT_MODEIncluded	'0'B		
ENCRYPT_MODE	Not present		
ENC_SUPPORTEDIncluded	'0'B		
ENC_SUPPORTED	Not present		
SIG_ENCRYPT_SUPIncluded	'0'B		
SIG_ENCRYPT_SUP	Not present		
MSG_INTEGRITY_SUPIncluded	'0'B		
MSG_INTEGRITY_SUP	Not present		
SIG_INTEGRITY_SUP_INCLIncluded	'0'B		
SIG_INTEGRITY_SUP_INCL	Not present		
SIG_INTEGRITY_SUPIncluded	'0'B		
SIG_INTEGRITY_SUP	Not present		
AUTHIncluded	'1'B		
AUTH	'00'B		
MAX_NUM_ALT_SOIncluded	'1'B		
MAX_NUM_ALT_SO	'000'B		
USE_SYNC_IDIncluded	'0'B		
USE_SYNC_ID	Not present		
MS_INIT_POS_LOC_SUP_INDIncluded	'0'B		
MS_INIT_POS_LOC_SUP_IND	Not present		
MOB_QOSIncluded	'0'B		
MOB_QOS	Not present		
BAND_CLASS_INFO_REQIncluded	'0'B		
BAND_CLASS_INFO_REQ	Not present		
BAND_CLASSIncluded	'1'B		
BAND_CLASS	'00000'B		

BYPASS_REG_INDIncluded	'0'B		
BYPASS_REG_IND	Not present		
'0'B ALT_BAND_CLASSIncluded			
ALT_BAND_CLASS	Not present		
MAX_ADD_SERV_INSTANCEIncluded	'0'B		
MAX_ADD_SERV_INSTANCE	Not present		
HOME_REGIncluded	'1'B		
HOME_REG	The same as SIB8		
FOR_SID_REGIncluded	'1'B		
FOR_SID_REG	The same as SIB8		
FOR_NID_REGIncluded	'1'B		
FOR_NID_REG	The same as SIB8		
POWER_UP_REGIncluded	'1'B		
POWER_UP_REG	The same as SIB8		
POWER_DOWN_REGIncluded	'1'B		
POWER_DOWN_REG	The same as SIB8		
PARAMETER_REGIncluded	'1'B		
PARAMETER_REG	The same as SIB8		
REG_PRDIncluded	'1'B		
REG_PRD	The same as SIB8		
REG_DISTIncluded	'0'B		
REG_DIST	Not present		
PREF_MSID_TYPEIncluded	'1'B		
PREF_MSID_TYPE	'11'B		
EXT_PREF_MSID_TYPEIncluded	'0'B		
EXT_PREF_MSID_TYPE	Not present		
MEID_REQDIncluded	'0'B		
MEID_REQD	Not present		
MCCIncluded	'1'B		
MCC	See the Table 4.4.2-4 Note 1, Note 2		
IMSI_11_12Included	'1'B		
IMSI_11_12	See the Table 4.4.2-4 Note 1, Note 2		
IMSI_T_SUPPORTEDIncluded	'1'B		
IMSI_T_SUPPORTED	'0'B		
RECONNECT_MSG_INDIncluded	'0'B		
RECONNECT_MSG_IND	Not present		
RER_MODE_SUPPORTEDIncluded	'0'B		
RER_MODE_SUPPORTED	Not present		
TKZ_MODE_SUPPORTEDIncluded	'0'B		
TKZ_MODE_SUPPORTED	Not present		
TKZ_IDIncluded	'0'B		
TKZ_ID	Not present		
PILOT_REPORTIncluded PILOT_REPORT	'0'B		
PILOT_REPORT	Not present		
SDB_SUPPORTEDIncluded	'0'B		
SDB_SUPPORTED	Not present		
AUTO_FCISO_ALLOWEDIncluded	'0'B		
AUTO_FCISO_ALLOWED	Not present		
SDB_IN_RCNM_INDIncluded	'0'B		
SDB_IN_RCNM_IND	Not present		
FPC_FCH_Included	'1'B		
FPC_FCH_INIT_SETPT_RC3	'00011000'B		
FPC_FCH_INIT_SETPT_RC4	'00011000'B		
FPC_FCH_INIT_SETPT_RC5	'00011000'B		
FPC_FCH_INIT_SETPT_RC11	'00000000'B		
FPC_FCH_INIT_SETPT_RC12	'00000000'B		
T_ADD_Included	'0'B		
T_ADD	Not present		
PILOT_INC_Included	'1'B		
PILOT_INC	'0010'B		
RAND_Included	'0'B		
RAND	Not present		
LP_SEC_Included	'1'B		

LP_SEC	'00000000'B		
LTM_OFF_Included	'1'B		
LTM_OFF	'000000'B		
DAYLT_Included	'1'B		
DAYLT	'0'B		
GCSNAL2AckTimer_Included	'1'B		
GCSNAL2AckTimer	'00000001'B		
GCSNASequenceContextTimer_Included	'1'B		
GCSNASequenceContextTimer	'00000101'B		

Table 4.5.2C.4-7: ULInformationTransfer (Step 17, Table 4.5.2C.3-2)

Derivation Path: 36.508 Table 4.6.1-25			
Information Element	Value/remark	Comment	Condition
ULInformationTransfer ::= SEQUENCE {			
criticalExtensions CHOICE {			
c1 CHOICE {			
ullInformationTransfer-r8 SEQUENCE {			
dedicatedInformationType CHOICE {			
dedicatedInfoCDMA2000-1XRTT	Set according to Table 4.5.2C.4-8		
}			
}			
}			
}			
}			

Table 4.5.2C.4-8: 1xRTT GCSNA Encapsulated Registration message (Step 17, Table 4.5.2C.3-2)

Information Element	Value/remark	Comment	Condition
MessageID	'00000001'B	GCSNA1xCircuitS ervice message	
GCSNAOption	'00000001'B		
AlternativeGCSNAOption_INCL	'0'B		
IWSIDIncl	'0'B		
AckRequired	'1'B		
StopDupDetect	'0'B		
MessageSequence	Set by UE		
NumTLACEncapsulated1xL3PDU	'00'B		
Reserved	'0000'B		
1xLogicalChannel	'0'B		
1xProtocolRevision	'00000110'B		
MsgType	'00000001'B	Registration message	
NumTLACHeaderRecords	'0001'B		
TLACHeaderRecordType	'0000'B		
TLACHeaderRecordLength	8 bits, Set by UE		
MSID_TYPE	'011'B		
MSID_LEN	4 bits, Set by UE		
MSID	Variable, Set by UE		
Reserved	'0000000'B		
1xL3PDULength	16 bits, Set by UE		
REG_TYPE	'0001'B	Power up registration	
SLOT_CYCLE_INDEX	'010'B		
MOB_P_REV	8 bits, Set by UE		
SCM	8 bits, Set by UE		
MOB_TERM	'1'B		
RETURN_CAUSE	'1'B		
QPCH_SUPPORTED	'1'B		
ENHANCED_RC	'1'B		
UZID_INCL	'0'B		

Table 4.5.2C.4-9: 1xRTT CS Registration Accept Order (Step 18, Table 4.5.2C.3-2)

Information Element	Value/remark	Comment	Condition
MessageID	'00000001'B		
GCSNAOption	'00000001'B		
AlternativeGCSNAOption_INCL	'0'B		
IWSIDIncl	'0'B		
AckRequired	'0'B		
StopDupDetect	'0'B		
MessageSequence	6 bits, Set by SS		
NumTLACEncapsulated1xL3PDU	'00'B		
Reserved	'0000'B		
1xLogicalChannel	'0'B		
1xProtocolRevision	'00000110'B		
MsgType	'00000111'B	Order message	
NumTLACHeaderRecords	'0000'B		
Reserved	'000'B		
1xL3PDULength	16 bits, Set by SS		
ORDER	'011011'B	Registration Accept Order	
ADD_RECORD_LEN	'001'B		
ORDQ	'00000000'B		

4.5.3 Generic Radio Bearer Establishment (State 3)

Editor note: The default parameter and system information will depend on progress in Clause 4.4, once it is finalised RAN5 can refer to them accordingly.

4.5.3.1 Initial conditions

System Simulator:

- Parameters are set to the default parameters for the basic single cell environment, as defined in subclause 4.4, unless otherwise specified in the test case.

User Equipment:

- The UE shall be in Registered, Idle Mode state (State 2).

4.5.3.2 Definition of system information messages

The default system information messages are used.

4.5.3.3 Procedure

The establishment of generic radio bearer connection is assumed to always be mobile terminated.

Table 4.5.3.3-1: Generic Radio Bearer establishment procedure (state 2 to state 3)

Step	Procedure	U - S	Message Sequence Message
1		<--	RRC: SYSTEM INFORMATION (BCCH)
2	SS sends a <i>Paging</i> message to the UE on the appropriate paging block, and including the UE identity in one entry of the IE <i>pagingRecordLists</i> .	<--	RRC: <i>Paging</i> (PCCH)
3	UE transmits an <i>RRCConnectionRequest</i> message.	-->	RRC: <i>RRCConnectionRequest</i>
4	SS transmit an <i>RRCConnectionSetup</i> message.	<--	RRC: <i>RRCConnectionSetup</i>
5	The UE transmits an <i>RRCConnectionSetupComplete</i> message to confirm the successful completion of the connection establishment and to initiate the session management procedure by including the SERVICE REQUEST message. (State3)	-->	RRC: <i>RRCConnectionSetupComplete</i> NAS: SERVICE REQUEST
6	The SS transmits a <i>SecurityModeCommand</i> message to activate AS security.	<--	RRC: <i>SecurityModeCommand</i>
7	The UE transmits a <i>SecurityModeComplete</i> message and establishes the initial security configuration.	-->	RRC: <i>SecurityModeComplete</i>
8	The SS configures a new data radio bearer, associated with the default EPS bearer context. IF the test case using state 3 as an initial state is using N additional data radio bearers ($0 \leq N \leq 7$), the <i>RRCConnectionReconfiguration</i> message contains the configuration of these additional data radio bearers in the drb-ToAddModify IE and one ACTIVATE DEDICATED EPS BEARER CONTEXT REQUEST message per additional data radio bearer. The <i>RRCConnectionReconfiguration</i> message is using condition SRB2-DRB(1+n, m) where n and m are the number of DRBs associated with dedicated EPS bearer contexts and configured respectively with RLC-AM and RLC-UM ($n+m = N$).	<--	RRC: <i>RRCConnectionReconfiguration</i> NAS: ACTIVATE DEDICATED EPS BEARER CONTEXT REQUEST ... ACTIVATE DEDICATED EPS BEARER CONTEXT REQUEST
-	EXCEPTION: the steps 9 and 10a1 to 10a3 (if present) happen in any order.	-	-
9	The UE transmits an <i>RRCConnectionReconfigurationComplete</i> message to confirm the establishment of the new data radio bearer, associated with the default EPS bearer context.	-->	RRC: <i>RRCConnectionReconfigurationComplete</i>
10a1	IF $N \geq 1$ (see step 8), the UE transmits an ACTIVATE DEDICATED EPS BEARER CONTEXT ACCEPT message matching with the 1st ACTIVATE DEDICATED EPS BEARER CONTEXT REQUEST message included in step 8.	-->	RRC: ULInformationTransfer NAS: ACTIVATE DEDICATED EPS BEARER CONTEXT ACCEPT
10a2	IF $N \geq 2$ (see step 8), the UE transmits an ACTIVATE DEDICATED EPS BEARER CONTEXT ACCEPT message matching with the 2nd ACTIVATE DEDICATED EPS BEARER CONTEXT REQUEST message included in step 8.	-->	RRC: ULInformationTransfer NAS: ACTIVATE DEDICATED EPS BEARER CONTEXT ACCEPT
10a3	IF $N \geq 3$ (see step 8), the UE transmits an ACTIVATE DEDICATED EPS BEARER	-->	RRC: ULInformationTransfer NAS: ACTIVATE DEDICATED EPS

	CONTEXT ACCEPT message matching with the 3rd ACTIVATE DEDICATED EPS BEARER CONTEXT REQUEST message included in step 8.		BEARER CONTEXT ACCEPT
10a4	IF $N \geq 4$ (see step 8), the UE transmits an ACTIVATE DEDICATED EPS BEARER CONTEXT ACCEPT message matching with the 4th ACTIVATE DEDICATED EPS BEARER CONTEXT REQUEST message included in step 8.	-->	RRC: ULInformationTransfer NAS: ACTIVATE DEDICATED EPS BEARER CONTEXT ACCEPT
10a5	IF $N \geq 5$ (see step 8), the UE transmits an ACTIVATE DEDICATED EPS BEARER CONTEXT ACCEPT message matching with the 5th ACTIVATE DEDICATED EPS BEARER CONTEXT REQUEST message included in step 8.	-->	RRC: ULInformationTransfer NAS: ACTIVATE DEDICATED EPS BEARER CONTEXT ACCEPT
10a6	IF $N \geq 6$ (see step 8), the UE transmits an ACTIVATE DEDICATED EPS BEARER CONTEXT ACCEPT message matching with the 6th ACTIVATE DEDICATED EPS BEARER CONTEXT REQUEST message included in step 8.	-->	RRC: ULInformationTransfer NAS: ACTIVATE DEDICATED EPS BEARER CONTEXT ACCEPT
10a7	IF $N = 7$ (see step 8), the UE transmits an ACTIVATE DEDICATED EPS BEARER CONTEXT ACCEPT message matching with the 7th ACTIVATE DEDICATED EPS BEARER CONTEXT REQUEST message included in step 8.	-->	RRC: ULInformationTransfer NAS: ACTIVATE DEDICATED EPS BEARER CONTEXT ACCEPT

4.5.3.4 Specific message contents

All specific message contents shall be referred to clause 4.6 and 4.7.

4.5.3A Generic Radio Bearer Establishment, UE Test Mode Activated (State 3A)

Editor note: The default parameter and system information will depend on progress in Clause 4.4, once it is finalised RAN5 can refer to them accordingly.

4.5.3A.1 Initial conditions

System Simulator:

- Parameters are set to the default parameters for the basic single cell environment, as defined in subclause 4.4, unless otherwise specified in the test case.

User Equipment:

- The UE shall be in Registered, Idle Mode state, UE Test Mode Activated (State 2A).

4.5.3A.2 Definition of system information messages

The default system information messages are used.

4.5.3A.3 Procedure

Same procedure as specified in the procedure in clause 4.5.3.3.

4.5.3A.4 Specific message contents

All specific message contents shall be referred to clause 4.6, 4.7 and 4.7A.

4.5.3B Generic Radio Bearer Establishment, pre-registered on HRPD (State 3B)

Editor note: The default parameter and system information will depend on progress in Clause 4.4, once it is finalised RAN5 can refer to them accordingly.

4.5.3B.1 Initial conditions

System Simulator:

- Parameters are set to the default parameters for the basic single cell environment, as defined in subclause 4.4, unless otherwise specified in the test case.

User Equipment:

- The UE shall be in Registered, Idle Mode state, pre-registered on HRPD (State 2B).

4.5.3B.2 Definition of system information messages

The default system information messages are used.

4.5.3B.3 Procedure

Same procedure as specified in the procedure in clause 4.5.3.3.

4.5.3B.4 Specific message contents

All specific message contents shall be referred to clause 4.6, 4.7 and 4.7A.

4.5.3C Generic Radio Bearer Establishment, pre-registered on 1xRTT (State 3C)

Editor note: The default parameter and system information will depend on progress in Clause 4.4, once it is finalised RAN5 can refer to them accordingly.

4.5.3C.1 Initial conditions

System Simulator:

- Parameters are set to the default parameters for the basic single cell environment, as defined in subclause 4.4, unless otherwise specified in the test case.

User Equipment:

- The UE shall be in Registered, Idle Mode state, pre-registered on 1xRTT (State 2C).

4.5.3C.2 Definition of system information messages

The default system information messages are used.

4.5.3C.3 Procedure

Same procedure as specified in the procedure in clause 4.5.3.3.

4.5.3C.4 Specific message contents

All specific message contents shall be referred to clause 4.6, 4.7 and 4.7A.

4.5.4 Loopback Activation (State 4)

4.5.4.1 Initial conditions

System Simulator:

- Parameters are set to the default parameters for the basic single cell environment, as defined in subclause 4.4, unless otherwise specified in the test case.

User Equipment:

- The UE shall be in Generic RB Establishment state, UE Test Mode Activated (State 3A).

4.5.4.2 Definition of system information messages

The default system information messages are used.

4.5.4.3 Procedure

Table 4.5: 4.3-1: Loopback activation procedure (state 3A to state 4)

Step	Procedure	Direction	Message Sequence
		UE - SS	Message
1	The SS transmits a CLOSE UE TEST LOOP message to enter the UE test loop mode.	<--	RRC: <i>DLInformationTransfer</i> TC: CLOSE UE TEST LOOP
2	The UE transmits a CLOSE UE TEST LOOP COMPLETE message to confirm that loopback entities for the radio bearer(s) have been created and loop back is activated (State 4).	-->	RRC: <i>ULInformationTransfer</i> TC: CLOSE UE TEST LOOP COMPLETE

4.5.4.4 Specific message contents

All specific message contents shall be referred to clause 4.6 and 4.7A.

4.5.5 HRPD registration (State H2)

Editor's note: The default parameter and system information will depend on progress in Clause 4.4, once it is finalised RAN5 can refer to them accordingly.

4.5.5.1 Initial conditions

System Simulator:

- Cell 1 and Cell 15.
- Cell 1 has a lower reselection priority than Cell 15.
- Cell 15 is transmitting default overhead messages.

User Equipment:

- The Test USIM shall be inserted (State 1).

4.5.5.2 Definition of system information messages

The default overhead messages as specified in clause 4.4 are used.

4.5.5.3 Procedure

Editor note: procedure needs to be specified.

4.5.5.4 Specific message contents

Editor's note: message contents need to be specified where necessary.

4.5.5A HRPD registration, pre-registration on E-UTRAN (State H2A)

Editor's note: The default parameter and system information will depend on progress in Clause 4.4, once it is finalised RAN5 can refer to them accordingly.

4.5.5A.1 Initial conditions

System Simulator:

- Cell 1 and Cell 15.
- Cell 1 has a lower reselection priority than Cell 15.
- Cell 15 is transmitting default overhead messages.

User Equipment:

- The Test USIM shall be inserted (State 1).

4.5.5A.2 Definition of system information messages

The default overhead messages as specified in clause 4.4 are used.

4.5.5A.3 Procedure

Editor's note: procedure needs to be specified.

4.5.5A.4 Specific message contents

Editor's note: message contents need to be specified where necessary.

4.5.6 HRPD session establishment (State H3)

Editor's note: The default parameter and system information will depend on progress in Clause 4.4, once it is finalised RAN5 can refer to them accordingly.

4.5.6.1 Initial conditions

System Simulator:

- Parameters are set to the default parameters for the basic single cell environment, as defined in subclause 4.4, unless otherwise specified in the test case.

User Equipment:

- The UE shall be in HRPD Registered, Dormant Mode state (State H2).

4.5.6.2 Definition of system information messages

The default overhead messages as specified in clause 4.4 are used.

4.5.6.3 Procedure

Editor's note: procedure needs to be specified.

4.5.6.4 Specific message contents

Editor's note: message contents need to be specified where necessary.

4.5.6A HRPD session establishment, pre-registered on E-UTRAN (State H3A)

Editor's note: The default parameter and system information will depend on progress in Clause 4.4, once it is finalised RAN5 can refer to them accordingly.

4.5.6A.1 Initial conditions

System Simulator:

- Parameters are set to the default parameters for the basic single cell environment, as defined in subclause 4.4, unless otherwise specified in the test case.

User Equipment:

- The UE shall be in HRPD Registered, Dormant Mode, pre-registered on E-UTRAN state (State H2A).

4.5.6A.2 Definition of system information messages

The default overhead messages as specified in clause 4.4 are used.

4.5.6A.3 Procedure

Same procedure as specified in the procedure in clause 4.5.6.3

4.5.6A.4 Specific message contents

Editor's note: message contents need to be specified where necessary.

4.5A Other generic procedures

4.5A.1 Procedure for IP address allocation in the U-plane

The purpose of this procedure is to allow the successful completion of IP address allocation if it is initiated by the UE therefore the result from the execution of the Procedure for IP address allocation in the U-plane shall not lead to assignment of a verdict.

Depending on the UE configuration there may be unpredictable delay in the start of the procedure. A guarding time of 1.2 sec is suggested within which the procedure is expected to start. If the timer expires then the test procedure, from which the Procedure for IP address allocation in the U-plane is called, shall advance to the next specified step.

Table 4.5A.1-1: Procedure for IP address allocation in the U-plane

Step	Procedure	Message Sequence	
		U - S	Message
-	EXCEPTION: Step 1 below and Step 1 in Table 4.5A.1-2 describe behaviour that depends on the contents of the latest PDN CONNECTIVITY REQUEST message sent by the UE prior to this procedure.	-	-
-	EXCEPTION: In parallel to the event described in step 1 below the step specified in Table 4.5A.1-2 may take place.	-	-
1	If the "PDN type" in the latest PDN CONNECTIVITY REQUEST message prior to this procedure was 'IPv4' or 'IPv4v6' then, IPv4 address allocation by DHCPv4 may occur on the user plane bearer established for the default EPS bearer context activated with the latest ACTIVATE DEFAULT EPS BEARER CONTEXT message prior to this procedure.	-	-

Table 4.5A.1-2: Procedure for IP address allocation in the U-plane, parallel behaviour

Step	Procedure	Message Sequence	
		U - S	Message
1	If the "PDN type" in the latest PDN CONNECTIVITY REQUEST message prior to this procedure was 'IPv6' or 'IPv4v6' then stateless address auto configuration occurs on the user plane bearer established for the default EPS bearer context activated with the latest ACTIVATE DEFAULT EPS BEARER CONTEXT message prior to this procedure.	-	-

4.5A.2 Tracking area updating procedure

The procedure is defined in table 4.5A.2.1-1.

Table 4.5A.2.1-1: Tracking area updating procedure

Step	Procedure	Message Sequence	
		U - S	Message
1	The SS transmits system information on the cell specified in the test case.	<--	RRC: SYSTEM INFORMATION (BCCH)
2	The UE transmits an <i>RRCCConnectionRequest</i> message on the cell specified in the test case.	-->	RRC: <i>RRCCConnectionRequest</i>
3	SS transmits an <i>RRCCConnectionSetup</i> message.	<--	RRC: <i>RRCCConnectionSetup</i>
4	The UE transmits an <i>RRCCConnectionSetupComplete</i> message to confirm the successful completion of the connection establishment and a TRACKING AREA UPDATE REQUEST message is sent to update the registration of the actual tracking area.	-->	RRC: <i>RRCCConnectionSetupComplete</i> NAS: TRACKING AREA UPDATE REQUEST
5	SS responds with TRACKING AREA UPDATE ACCEPT message.	<--	RRC: <i>DLInformationTransfer</i> NAS: TRACKING AREA UPDATE ACCEPT
6	The UE transmits a TRACKING AREA UPDATE COMPLETE	-->	RRC: <i>ULInformationTransfer</i> NAS: TRACKING AREA UPDATE COMPLETE
7	The SS transmits an <i>RRCCConnectionRelease</i> message to release RRC connection and move to RRC_IDLE.	<--	RRC: <i>RRCCConnectionRelease</i>

NOTE 1: The periodic tracking area updating timer T3412 is deactivated by default during the attach procedure (TS 36.508 clause 4.7.2).

NOTE 2: The SS does not initiate authentication and NAS SECURITY MODE COMMAND are not performed (reuse of keys allocated during the attach procedure).

4.5A.3 Procedure for IMS signalling

The purpose of this procedure is to allow the successful completion of IMS signalling if it is initiated by the UE.

The UE may initiate IMS registration according TS 24.229 [40] clause 5.1. The procedure is applicable for UEs with IMS support (TS 36.523-2 A.4.4-1/25).

Table 4.5A.3-1: Procedure for IMS signalling in the U-plane

Step	Procedure	Message Sequence	
		U - S	Message
1-9	Void	-	-
-	EXCEPTION: Steps 10a1 to 10a2b1 describe a transaction that depends on the UE capability		
10a1	IF pc_IMS then the SS starts timer Timer_1 = 10 s (Note 1)	-	-
-	EXCEPTION: Steps 10a2a1 to 10a2b1 describe a transaction that depends on the UE implementation	-	-
10a2 a1- 10a2 a9	Registration procedure according TS 34.229-1 [43] subclause C.2 (steps 3-11) Note: SS cancels timer Timer_1 at step 10a2a1.	-	-
10a2 b1	The SS waits for Timer_1 expiry	-	-
Note 1:	Depending on the UE configuration there may be unpredictable delay in the start of the procedure. A guarding time of [10] sec is suggested within which the procedure is expected to start. If the timer expires then the test procedure, from which the Procedure for IMS signalling U-plane is called, shall advance to the next specified step		

4.5A.4 Generic Test Procedure for IMS Emergency call establishment in EUTRA: Normal Service

4.5A.4.1 Initial conditions

System Simulator:

- Parameters are set to the default parameters for the basic single cell environment, as defined in subclause 4.4, unless otherwise specified in the test case.

User Equipment:

- The UE shall be in Registered, Idle Mode state (State 2).

4.5A.4.2 Definition of system information messages

The default system information messages are used.

4.5A.4.3 Procedure

The establishment of IMS emergency call is assumed to always be mobile originated.

Table 4.5A.4.3-1: EUTRA/EPS signalling for IMS Emergency Call

St	Procedure	Message Sequence	
		U - S	Message
1	Make the UE attempt an IMS emergency call	-	-
2	The UE transmits an <i>RRCCONNECTIONREQUEST</i> message with 'establishmentCause' set to 'emergency'.	-->	<i>RRCCONNECTIONREQUEST</i>
3	SS transmit an <i>RRCCONNECTIONSETUP</i> message.	<--	RRC: <i>RRCCONNECTIONSETUP</i>
4	The UE transmits an <i>RRCCONNECTIONSETUPCOMPLETE</i> message to confirm the successful completion of the connection establishment and to initiate the session management procedure by including the SERVICE REQUEST message.	-->	RRC: <i>RRCCONNECTIONSETUPCOMPLETE</i> NAS: SERVICE REQUEST
5	The SS transmits a <i>SECURITYMODECOMMAND</i> message to activate AS security.	<--	RRC: <i>SECURITYMODECOMMAND</i>
6	The UE transmits a <i>SECURITYMODECOMPLETE</i> message and establishes the initial security configuration.	-->	RRC: <i>SECURITYMODECOMPLETE</i>
7	The SS configures a new data radio bearer, associated with the default EPS bearer context. The <i>RRCCONNECTIONRECONFIGURATION</i> message is using condition SRB2-DRB(1, 0). The DRB associated with default EPS bearer context obtained during the attach procedure is established	<--	RRC: <i>RRCCONNECTIONRECONFIGURATION</i>
8	The UE transmits an <i>RRCCONNECTIONRECONFIGURATIONCOMPLETE</i> message to confirm the establishment of the new data radio bearer, associated with the default EPS bearer context.	-->	RRC: <i>RRCCONNECTIONRECONFIGURATIONCOMPLETE</i>
9	The UE transmits a PDN CONNECTIVITY REQUEST message to request an additional PDN, with 'Request type' set to 'emergency ('0100'B)'.	-->	PDN CONNECTIVITY REQUEST
10	The SS configures a new data radio bearer, associated with the default EPS bearer context. <i>RRCCONNECTIONRECONFIGURATION</i> message contains the ACTIVATE DEFAULT EPS BEARER CONTEXT REQUEST message. Note: The APN is set to the test APN defined for emergency bearer services.	<--	RRC: <i>RRCCONNECTIONRECONFIGURATION</i> NAS: ACTIVATE DEFAULT EPS BEARER CONTEXT REQUEST
-	EXCEPTION: In parallel to the events described in steps 11 to 15 below, the behaviour in table 4.5A.4.3-2 occurs. (Optional IP address allocation followed by IMS emergency registration and IMS emergency speech call establishment)	-	-
11	The UE transmits an <i>RRCCONNECTIONRECONFIGURATIONCOMPLETE</i> message to confirm the establishment of the new data radio bearer, associated with the default EPS bearer for emergency call.	-->	RRC: <i>RRCCONNECTIONRECONFIGURATIONCOMPLETE</i>
12	The UE transmits an ACTIVATE DEFAULT EPS BEARER CONTEXT ACCEPT message.	-->	RRC: ULInformationTransfer NAS:ACTIVATE DEFAULT EPS BEARER CONTEXT ACCEPT
13	The SS configures a new RLC-UM data radio bearer, associated with the dedicated EPS bearer context. <i>RRCCONNECTIONRECONFIGURATION</i> message contains the ACTIVATE DEDICATED EPS BEARER CONTEXT REQUEST message. Note: the same PDN address is applicable because the linked EPS bearer ID refers to the default EBC allocated in step 10	<--	RRC: <i>RRCCONNECTIONRECONFIGURATION</i> NAS: ACTIVATE DEDICATED EPS BEARER CONTEXT REQUEST
14	The UE transmits an <i>RRCCONNECTIONRECONFIGURATIONCOMPLETE</i> message to confirm the establishment of the new data radio bearer, associated with the default EPS bearer for emergency IMS signalling.	-->	RRC: <i>RRCCONNECTIONRECONFIGURATIONCOMPLETE</i>

15	The UE transmits an ACTIVATE DEDICATED EPS BEARER CONTEXT ACCEPT message.	-->	RRC: ULInformationTransfer NAS:ACTIVATE DEDICATED EPS BEARER CONTEXT ACCEPT
----	---	-----	--

Table 4.5A.4.3-2: Parallel behaviour

St	Procedure	Message Sequence	
		U - S	Message
-	EXCEPTION: Step 1 describes behaviour that depends on the UE behaviour.	-	-
1	If initiated by the UE the generic procedure for IP address allocation in the U-plane specified in TS 36.508 subclause 4.5A.1 takes place performing IP address allocation in the U-plane.	-	-
2-5	Steps 1-4 expected sequence defined in annex C.20 of TS 34.229-1 [35]. Emergency registration procedure is performed.	-	-
6-10	Steps 1-5 defined in annex C.22 of TS 34.229-1 [35]. IMS Emergency call for EPS is established.	-	-

4.5A.4.4 Specific message contents

All specific message contents shall be referred to clause 4.6 and 4.7 with the exceptions below.

Table 4.5A.4.4-1: Message ACTIVATE DEFAULT EPS BEARER CONTEXT REQUEST (step 10, Table 4.5A.4.3-1)

Derivation path: Table 4.7.3-6 and table 4.6.1-8 with condition AM-DRB-ADD(2)			
Information Element	Value/Remark	Comment	Condition
EPS bearer identity	6	SS assigns an additional EPS Bearer Id different from default EPS Bearer Id between 5 and 15	
Procedure transaction identity	PTI-1	SS re-uses the particular PTI defined by UE for this present additional PDN connectivity request procedure	
Access point name	APN-1	SS uses the test APN defined for emergency bearer services	

Table 4.5A.4.4-2: Message ACTIVATE DEFAULT EPS BEARER CONTEXT ACCEPT (step 12, Table 4.5A.4.3-1)

Derivation path: Table 4.7.3-4			
Information Element	Value/Remark	Comment	Condition
EPS bearer identity	6	Same value as in ACTIVATE DEFAULT EPS BEARER CONTEXT REQUEST	
Procedure transaction identity	0	No procedure transaction identity assigned	

Table 4.5A.4.4-3: Message ACTIVATE DEDICATED EPS BEARER CONTEXT REQUEST (step 13, Table 4.5A.4.3-1)

Derivation path: Table 4.7.3-3 and table 4.6.1-8 with condition UM-DRB-ADD(3)			
Information Element	Value/Remark	Comment	Condition
EPS bearer identity	7	SS assigns a dedicated bearer Id different from default EBIId and additional EBIId and between 5 and 15	
Procedure transaction identity	0	No procedure transaction identity assigned	
Linked EPS bearer identity	Default EBIId-2 (same value like in table 4.5A.4.4-1)		
EPS QoS	According to reference dedicated EPS bearer context #1 - in table 6.6.2-1	SS defines an additional dedicated EPS QoS	
TFT	According to reference dedicated EPS bearer context #1 - in table 6.6.2-1		

Table 4.5A.4.4-4: Message ACTIVATE DEDICATED EPS BEARER CONTEXT ACCEPT (step 15, Table 4.5A.4.3-1)

Derivation path: Table 4.7.3-1			
Information Element	Value/Remark	Comment	Condition
EPS bearer identity	7	Same value as in ACTIVATE DEDICATED EPS BEARER CONTEXT REQUEST in step 13	
Procedure transaction identity	0	No procedure transaction identity assigned	

4.5A.5 Generic Test Procedure for IMS Emergency call establishment in EUTRA: Limited Service

4.5A.5.1 Initial conditions

System Simulator:

- Parameters are set to the default parameters for the basic single cell environment, as defined in subclause 4.4, unless otherwise specified in the test case.

User Equipment:

- The UE is switched on and camped on the cell in EMM-DEREGISTERED.LIMITED-SERVICE state.

4.5A.5.2 Definition of system information messages

The default system information messages are used.

4.5A.5.3 Procedure

The establishment of IMS emergency call is assumed to always be mobile originated.

Table 4.5A.5.3-1: EUTRA/EPS signalling for IMS Emergency Call in limited service

St	Procedure	Message Sequence	
		U - S	Message
1	Make the UE attempt an IMS emergency call	-	-
2	The UE transmits an <i>RRCCONNECTIONREQUEST</i> message with 'establishmentCause' set to 'emergency'.	-->	<i>RRCCONNECTIONREQUEST</i>
3	SS transmits an <i>RRCCONNECTIONSETUP</i> message.	<--	RRC: <i>RRCCONNECTIONSETUP</i>
4	The UE transmits an <i>RRCCONNECTIONSETUPCOMPLETE</i> message to confirm the successful completion of the connection establishment and to initiate the Attach procedure by including the ATTACH REQUEST message, EPS attach type set to "EPS emergency attach" ('0110'B). The PDN CONNECTIVITY REQUEST message is piggybacked in ATTACH REQUEST, with 'Request type' set to 'emergency' ('0100'B)'.	-->	RRC: <i>RRCCONNECTIONSETUPCOMPLETE</i> NAS: ATTACH REQUEST NAS: PDN CONNECTIVITY REQUEST
5	The SS transmits an AUTHENTICATION REQUEST message to initiate the EPS authentication and AKA procedure.	<--	RRC: <i>DLInformationTransfer</i> NAS: AUTHENTICATION REQUEST
-	EXCEPTION: Steps 6a1 to 6b1 describe behaviour that depends on the UE status; the "lower case letter" identifies a step sequence that takes place depending on the UE state.	-	-
6a1	UE transmits an AUTHENTICATION RESPONSE message and establishes mutual authentication.	-->	RRC: <i>ULInformationTransfer</i> NAS: AUTHENTICATION RESPONSE
6b1	UE transmits an AUTHENTICATION FAILURE message with EMM cause #20 "MAC failure" or EMM cause #21 "synch failure". (Note 2)	-->	RRC: <i>ULInformationTransfer</i> NAS: AUTHENTICATION FAILURE
7	The SS transmits a NAS SECURITY MODE COMMAND message to activate NAS security selecting. If UE has sent Authentication Failure in step 6b1, KSI value is set to "000" and EIA0 (NULL integrity), and EEA0 (NULL ciphering) algorithms are used.	<--	RRC: <i>DLInformationTransfer</i> NAS: SECURITY MODE COMMAND
8	The UE transmits a NAS SECURITY MODE COMPLETE message and establishes the initial security configuration.	-->	RRC: <i>ULInformationTransfer</i> NAS: SECURITY MODE COMPLETE
-	EXCEPTION: Steps 9a1 to 9a2 describe behaviour that depends on UE configuration; the "lower case letter" identifies a step sequence that take place if the UE has ESM information which needs to be transferred.	-	-
9a1	IF the UE sets the ESM information transfer flag in the last PDN CONNECTIVITY REQUEST message THEN the SS transmits an ESM INFORMATION REQUEST message to initiate exchange of protocol configuration options and/or APN.	<--	RRC: <i>DLInformationTransfer</i> NAS: ESM INFORMATION REQUEST
9a2	The UE transmits an ESM INFORMATION RESPONSE message to transfer protocol configuration options and/or APN.	-->	RRC: <i>ULInformationTransfer</i> NAS: ESM INFORMATION RESPONSE
10	The SS transmits a <i>SecurityModeCommand</i> message to activate AS security. If UE has sent Authentication Failure in step 6b1, eia0 (NULL integrity), and eea0 (NULL ciphering) algorithms are used.	<--	RRC: <i>SecurityModeCommand</i>
11	The UE transmits a <i>SecurityModeComplete</i> message and establishes the initial security	-->	RRC: <i>SecurityModeComplete</i>

	configuration.		
12	The SS transmits a <i>UECapabilityEnquiry</i> message to initiate the UE radio access capability transfer procedure.	<--	RRC: <i>UECapabilityEnquiry</i>
13	The UE transmits a <i>UECapabilityInformation</i> message to transfer UE radio access capability.	-->	RRC: <i>UECapabilityInformation</i>
14	The SS transmits an <i>RRCCConnectionReconfiguration</i> message to establish the default bearer with condition SRB2-DRB(1, 0) according to 4.8.2.2.1.1. This message includes the ATTACH ACCEPT message. The ACTIVATE DEFAULT EPS BEARER CONTEXT REQUEST message is piggybacked in ATTACH ACCEPT. Note: The APN is set to the test APN defined for emergency bearer services	<--	RRC: <i>RRCCConnectionReconfiguration</i> NAS: ATTACH ACCEPT NAS: ACTIVATE DEFAULT EPS BEARER CONTEXT REQUEST
-	EXCEPTION: In parallel to the events described in steps 15 to 19 below, the behaviour in table 4.5A.5.3-2 occurs. (Optional IP address allocation followed by IMS emergency speech call establishment)	-	-
15	The UE transmits an <i>RRCCConnectionReconfigurationComplete</i> message to confirm the establishment of default bearer.	-->	RRC: <i>RRCCConnectionReconfigurationComplete</i>
16	This message includes the ATTACH COMPLETE message. The ACTIVATE DEFAULT EPS BEARER CONTEXT ACCEPT message is piggybacked in ATTACH COMPLETE.	-->	RRC: <i>ULInformationTransfer</i> NAS: ATTACH COMPLETE NAS: ACTIVATE DEFAULT EPS BEARER CONTEXT ACCEPT
17	The SS configures a new RLC-UM data radio bearer, associated with the dedicated EPS bearer context. <i>RRCCConnectionReconfiguration</i> message contains the ACTIVATE DEDICATED EPS BEARER CONTEXT REQUEST message. Note: the same PDN address is applicable because the linked EPS bearer ID refers to the default EBC allocated in step 10	<--	RRC: <i>RRCCConnectionReconfiguration</i> NAS: ACTIVATE DEDICATED EPS BEARER CONTEXT REQUEST
18	The UE transmits an <i>RRCCConnectionReconfigurationComplete</i> message to confirm the establishment of the new data radio bearer, associated with the default EPS bearer for emergency IMS signalling.	-->	RRC: <i>RRCCConnectionReconfigurationComplete</i>
19	The UE transmits an ACTIVATE DEDICATED EPS BEARER CONTEXT ACCEPT message.	-->	RRC: <i>ULInformationTransfer</i> NAS:ACTIVATE DEDICATED EPS BEARER CONTEXT ACCEPT
Note 1: Void			
Note 2: EMM cause #26 "non-EPS authentication unacceptable" is not expected to happen as SS will not set the "separation bit" in the AMF field of AUTN as 0			

Table 4.5A.5.3-2: Parallel behaviour

St	Procedure	Message Sequence	
		U - S	Message
-	EXCEPTION: Step 1 describes behaviour that depends on the UE behaviour.	-	-
1	If initiated by the UE the generic procedure for IP address allocation in the U-plane specified in TS 36.508 subclause 4.5A.1 takes place performing IP address allocation in the U-plane.	-	-
2-6	Steps 1-5 defined in annex C.22 of TS 34.229-1 [35]. IMS Emergency call for EPS is established.	-	-

4.5A.5.4 Specific message contents

All specific message contents shall be referred to clause 4.6 and 4.7 with the exceptions below.

Table 4.5A.5.4-1: SECURITY MODE COMMAND (step 7, Table 4.5A.5.3-1)

Derivation Path: Table 4.7.2-19			
Information Element	Value/remark	Comment	Condition
Type of integrity protection algorithm	Set according to PIXIT parameter for default integrity protection algorithm [FFS]		NOT NullAlgorithmUsed
	EIA0		NullAlgorithmUsed
Type of ciphering algorithm	Set according to PIXIT parameter for default ciphering algorithm [FFS]		NOT NullAlgorithmUsed
	EEA0		NullAlgorithmUsed
NAS key set identifier			
NAS key set identifier	The valid NAS key set identifier.		NOT NullAlgorithmUsed
	'000'B		NullAlgorithmUsed
TSC	'0'B	native security context (for KS_{ASME})	
Spare half octet	'0000'B		

Condition	Explanation
NullAlgorithmUsed	UE has sent Authentication Failure in step 6b1

Table 4.5A.5.4-2: SecurityModeCommand (step 10, Table 4.5A.5.3-1)

Derivation Path: Table 4.6.1-19			
Information Element	Value/remark	Comment	Condition
SecurityModeCommand ::= SEQUENCE {			
rrc-TransactionIdentifier	RRC-TransactionIdentifier-DL		
criticalExtensions CHOICE {			
c1 CHOICE {			
securityModeCommand-r8 SEQUENCE {			
securityConfigSMC	SecurityConfigSMC-LimitedService	Table 4.5A.5.4-3	
nonCriticalExtension SEQUENCE {}	Not present		
}			
}			
}			
}			

Table 4.5A.5.4-3: SecurityConfigSMC-LimitedService (Table 4.5A.5.4-2)

Derivation Path: Table 4.6.4-2			
Information Element	Value/remark	Comment	Condition
SecurityConfigSMC- LimitedService ::= SEQUENCE {			
securityAlgorithmConfig SEQUENCE {			
cipheringAlgorithm	Set according to PIXIT parameter for default ciphering algorithm [FFS]		NOT NullAlgorithmUsed
	eea0		NullAlgorithmUsed
integrityProtAlgorithm	Set according to PIXIT parameter for default integrity protection algorithm [FFS]		NOT NullAlgorithmUsed
	eia0		NullAlgorithmUsed
}			

Condition	Explanation
NullAlgorithmUsed	UE has sent Authentication Failure in step 6b1

4.5A.6 Generic Test Procedure for IMS MO speech call establishment in E-UTRA

4.5A.6.1 Initial conditions

System Simulator:

- Parameters are set to the default parameters for the basic single cell environment, as defined in subclause 4.4, unless otherwise specified in the test case.

User Equipment:

- The UE shall be in Registered, Idle Mode state (State 2).

4.5A.6.2 Definition of system information messages

The default system information messages are used.

4.5A.6.3 Procedure

Table 4.5A.6.3-1: EUTRA/EPS signalling for IMS MO speech call

St	Procedure	Message Sequence	
		U - S	Message
1	Make the UE attempt an IMS speech call	-	-
2	The UE transmits an <i>RRCConnectionRequest</i> message with 'establishmentCause' set to 'mo-Data'.	-->	<i>RRCConnectionRequest</i>
3	SS transmit an <i>RRCConnectionSetup</i> message.	<--	RRC: <i>RRCConnectionSetup</i>
4	The UE transmits an <i>RRCConnectionSetupComplete</i> message to confirm the successful completion of the connection establishment and to initiate the session management procedure by including the SERVICE REQUEST message.	-->	RRC: <i>RRCConnectionSetupComplete</i> NAS: SERVICE REQUEST
5	The SS transmits a <i>SecurityModeCommand</i> message to activate AS security.	<--	RRC: <i>SecurityModeCommand</i>
6	The UE transmits a <i>SecurityModeComplete</i> message and establishes the initial security configuration.	-->	RRC: <i>SecurityModeComplete</i>
7	The SS configures a new data radio bearer, associated with the default EPS bearer context. The <i>RRCConnectionReconfiguration</i> message is using condition SRB2-DRB(1, 0). The DRB associated with default EPS bearer context obtained during the attach procedure is established	<--	RRC: <i>RRCConnectionReconfiguration</i>
-	EXCEPTION: In parallel to the events described in steps 8 below, the behaviour in table 4.5A.6.3-2 occurs. (IMS MTSI MO speech call establishment)	-	-
8	The UE transmits an <i>RRCConnectionReconfigurationComplete</i> message to confirm the establishment of the new data radio bearer, associated with the default EPS bearer context.	-->	RRC: <i>RRCConnectionReconfigurationComplete</i>
9-11	Steps 3-4 expected sequence defined in annex C.21 of TS 34.229-1 [35]. MTSI MO speech call for EPS.	-	-
12	The SS configures a new RLC-UM data radio bearer with condition DRB (0,1), associated with the dedicated EPS bearer context. <i>RRCConnectionReconfiguration</i> message contains the ACTIVATE DEDICATED EPS BEARER CONTEXT REQUEST message. EPS bearer context #4 (QCI 1) according to table 6.6.2-1: Reference dedicated EPS bearer contexts.	<--	RRC: <i>RRCConnectionReconfiguration</i> NAS: ACTIVATE DEDICATED EPS BEARER CONTEXT REQUEST
-	EXCEPTION: In parallel to the events described in steps 13-14 below, the behaviour in table 4.5A.6.3-3 occurs. (IMS MTSI MO speech call establishment)	-	-
13	The UE transmits an <i>RRCConnectionReconfigurationComplete</i> message to confirm the establishment of the new data radio bearer, associated with the dedicated EPS bearer.	-->	RRC: <i>RRCConnectionReconfigurationComplete</i>
14	The UE transmits an ACTIVATE DEDICATED EPS BEARER CONTEXT ACCEPT message.	-->	RRC: ULInformationTransfer NAS:ACTIVATE DEDICATED EPS BEARER CONTEXT ACCEPT

Table 4.5A.6.3-2: Parallel behaviour

St	Procedure	Message Sequence	
		U - S	Message
1	Step 2 expected sequence defined in annex C.21 of TS 34.229-1 [35]. UE sends INVITE.	-	-

Table 4.5A.6.3-3: Parallel behaviour

St	Procedure	Message Sequence	
		U - S	Message
1-8	Steps 5-13 expected sequence defined in annex C.21 of TS 34.229-1 [35]. MTSI MO speech call for EPS.	-	-

4.5A.6.4 Specific message contents

All specific message contents shall be referred to clause 4.6 and 4.7.

4.5A.7 Generic Test Procedure for IMS MT Speech call establishment in E-UTRA

4.5A.7.1 Initial conditions

System Simulator:

- Parameters are set to the default parameters for the basic single cell environment, as defined in subclause 4.4, unless otherwise specified in the test case.

User Equipment:

- The UE shall be in Registered, Idle Mode state (State 2).

4.5A.7.2 Definition of system information messages

The default system information messages are used.

4.5A.7.3 Procedure

Table 4.5A.7.3-1: EUTRA/EPS signaling for IMS MT speech call

St	Procedure	Message Sequence	
		U - S	Message
1	SS sends a <i>Paging</i> message to the UE on the appropriate paging block, and including the UE identity in one entry of the IE <i>pagingRecordLists</i> .	<--	RRC: <i>Paging</i> (PCCH)
2	The UE transmits an <i>RRCConnectionRequest</i> message with 'establishmentCause' set to 'mt-Access'.	-->	<i>RRCConnectionRequest</i>
3	SS transmit an <i>RRCConnectionSetup</i> message.	<--	RRC: <i>RRCConnectionSetup</i>
4	The UE transmits an <i>RRCConnectionSetupComplete</i> message to confirm the successful completion of the connection establishment and to initiate the session management procedure by including the SERVICE REQUEST message.	-->	RRC: <i>RRCConnectionSetupComplete</i> NAS: SERVICE REQUEST
5	The SS transmits a <i>SecurityModeCommand</i> message to activate AS security.	<--	RRC: <i>SecurityModeCommand</i>
6	The UE transmits a <i>SecurityModeComplete</i> message and establishes the initial security configuration.	-->	RRC: <i>SecurityModeComplete</i>
7	The SS configures a new data radio bearer, associated with the default EPS bearer context. The <i>RRCConnectionReconfiguration</i> message is using condition SRB2-DRB(1, 0). The DRB associated with default EPS bearer context obtained during the attach procedure is established	<--	RRC: <i>RRCConnectionReconfiguration</i>
8	The UE transmits an <i>RRCConnectionReconfigurationComplete</i> message to confirm the establishment of the new data radio bearer, associated with the default EPS bearer context.	-->	RRC: <i>RRCConnectionReconfigurationComplete</i>
9-12	Steps 1-4 expected sequence defined in annex C.11 of TS 34.229-1 [35]. MTSI MT speech call.	-	-
13	The SS configures a new RLC-UM data radio bearer with condition DRB (0,1), associated with the dedicated EPS bearer context. <i>RRCConnectionReconfiguration</i> message contains the ACTIVATE DEDICATED EPS BEARER CONTEXT REQUEST message.	<--	RRC: <i>RRCConnectionReconfiguration</i> NAS: ACTIVATE DEDICATED EPS BEARER CONTEXT REQUEST
14	The UE transmits an <i>RRCConnectionReconfigurationComplete</i> message to confirm the establishment of the new data radio bearer, associated with the dedicated EPS bearer.	-->	RRC: <i>RRCConnectionReconfigurationComplete</i>
15	The UE transmits an ACTIVATE DEDICATED EPS BEARER CONTEXT ACCEPT message.	-->	RRC: <i>ULInformationTransfer</i> NAS:ACTIVATE DEDICATED EPS BEARER CONTEXT ACCEPT
16-26	Steps 5-15 expected sequence defined in annex C.11 of TS 34.229-1 [35]. MTSI MT speech.	-	-

4.5A.7.4 Specific message contents

All specific message contents shall be referred to clause 4.6 and 4.7.

4.5A.8 Generic Test Procedure for IMS MO video call establishment in E-UTRA

4.5A.8.1 Initial conditions

System Simulator:

- Parameters are set to the default parameters for the basic single cell environment, as defined in subclause 4.4, unless otherwise specified in the test case.

User Equipment:

- The UE shall be in Registered, Idle Mode state (State 2).

4.5A.8.2 Definition of system information messages

The default system information messages are used.

4.5A.8.3 Procedure

Table 4.5A.8.3-1: EUTRA/EPS signalling for IMS MO video call

St	Procedure	Message Sequence	
		U - S	Message
1	Make the UE attempt an IMS video call	-	-
2	The UE transmits an <i>RRConnectionRequest</i> message with 'establishmentCause' set to 'mo-Data'.	-->	<i>RRConnectionRequest</i>
3	SS transmit an <i>RRConnectionSetup</i> message.	<--	RRC: <i>RRConnectionSetup</i>
4	The UE transmits an <i>RRConnectionSetupComplete</i> message to confirm the successful completion of the connection establishment and to initiate the session management procedure by including the SERVICE REQUEST message.	-->	RRC: <i>RRConnectionSetupComplete</i> NAS: SERVICE REQUEST
5	The SS transmits a <i>SecurityModeCommand</i> message to activate AS security.	<--	RRC: <i>SecurityModeCommand</i>
6	The UE transmits a <i>SecurityModeComplete</i> message and establishes the initial security configuration.	-->	RRC: <i>SecurityModeComplete</i>
7	The SS configures a new data radio bearer, associated with the default EPS bearer context. The <i>RRConnectionReconfiguration</i> message is using condition SRB2-DRB(1, 0). The DRB associated with default EPS bearer context obtained during the attach procedure is established	<--	RRC: <i>RRConnectionReconfiguration</i>
-	EXCEPTION: In parallel to the events described in steps 8 below, the behaviour in table 4.5A.8.3-2 occurs. (IMS MTSI MO video call establishment)	-	-
8	The UE transmits an <i>RRConnectionReconfigurationComplete</i> message to confirm the establishment of the new data radio bearer, associated with the default EPS bearer context.	-->	RRC: <i>RRConnectionReconfigurationComplete</i>
9-11	Steps 3-4 expected sequence defined in annex C.25 of TS 34.229-1 [35]. MTSI MO video call for EPS.	-	-
12	The SS configures two new RLC-UM data radio bearers with condition DRB (0,2), associated with the dedicated EPS bearer context. <i>RRConnectionReconfiguration</i> message contains one ACTIVATE DEDICATED EPS BEARER CONTEXT REQUEST message per additional data radio bearer. One EPS bearer context #4 (QCI 1) and one EPS bearer context #3 (QCI 2) according table 6.6.2-1: Reference dedicated EPS bearer contexts.	<--	RRC: <i>RRConnectionReconfiguration</i> NAS: ACTIVATE DEDICATED EPS BEARER CONTEXT REQUEST ACTIVATE DEDICATED EPS BEARER CONTEXT REQUEST
-	EXCEPTION: In parallel to the events described in steps 13-14 below, the behaviour in table 4.5A.8.3-3 occurs. (IMS MTSI MO video call establishment).	-	-
13	The UE transmits an <i>RRConnectionReconfigurationComplete</i> message to confirm the establishment of the new data radio bearer, associated with the dedicated EPS bearer. EPS bearer context #4 (QCI 1) according table to 6.6.2-1: Reference dedicated EPS bearer contexts.	-->	RRC: <i>RRConnectionReconfigurationComplete</i>
14	The UE transmits an ACTIVATE DEDICATED EPS BEARER CONTEXT ACCEPT message for the first bearer.	-->	RRC: ULInformationTransfer NAS:ACTIVATE DEDICATED EPS BEARER CONTEXT ACCEPT
15	The UE transmits an ACTIVATE DEDICATED EPS BEARER CONTEXT ACCEPT message for the second bearer.	-->	RRC: ULInformationTransfer NAS:ACTIVATE DEDICATED EPS BEARER CONTEXT ACCEPT

Table 4.5A.8.3-2: Parallel behaviour

St	Procedure	Message Sequence	
		U - S	Message
1	Step 2 expected sequence defined in annex C.25 of TS 34.229-1 [35]. UE sends INVITE.	-	-

Table 4.5A.8.3-3: Parallel behaviour

St	Procedure	Message Sequence	
		U - S	Message
1-8	Steps 5-13 expected sequence defined in annex C.25 of TS 34.229-1 [35]. MTSI MO video call for EPS.	-	-

4.5A.8.4 Specific message contents

All specific message contents shall be referred to clause 4.6 and 4.7.

4.5A.9 Generic Test Procedure for IMS MT video call establishment in E-UTRA

4.5A.9.1 Initial conditions

System Simulator:

- Parameters are set to the default parameters for the basic single cell environment, as defined in subclause 4.4, unless otherwise specified in the test case.

User Equipment:

- The UE shall be in Registered, Idle Mode state (State 2).

4.5A.9.2 Definition of system information messages

The default system information messages are used.

4.5A.9.3 Procedure

Table 4.5A.9.3-1: EUTRA/EPS signalling for IMS MT video call

St	Procedure	Message Sequence	
		U - S	Message
1	SS sends a <i>Paging</i> message to the UE on the appropriate paging block, and including the UE identity in one entry of the IE <i>pagingRecordLists</i> .	<--	RRC: <i>Paging</i> (PCCH)
2	The UE transmits an <i>RRCConnectionRequest</i> message with 'establishmentCause' set to 'mt-Access'.	-->	<i>RRCConnectionRequest</i>
3	SS transmit an <i>RRCConnectionSetup</i> message.	<--	RRC: <i>RRCConnectionSetup</i>
4	The UE transmits an <i>RRCConnectionSetupComplete</i> message to confirm the successful completion of the connection establishment and to initiate the session management procedure by including the SERVICE REQUEST message.	-->	RRC: <i>RRCConnectionSetupComplete</i> NAS: SERVICE REQUEST
5	The SS transmits a <i>SecurityModeCommand</i> message to activate AS security.	<--	RRC: <i>SecurityModeCommand</i>
6	The UE transmits a <i>SecurityModeComplete</i> message and establishes the initial security configuration.	-->	RRC: <i>SecurityModeComplete</i>
7	The SS configures a new data radio bearer, associated with the default EPS bearer context. The <i>RRCConnectionReconfiguration</i> message is using condition SRB2-DRB(1, 0). The DRB associated with default EPS bearer context obtained during the attach procedure is established	<--	RRC: <i>RRCConnectionReconfiguration</i>
8	The UE transmits an <i>RRCConnectionReconfigurationComplete</i> message to confirm the establishment of the new data radio bearer, associated with the default EPS bearer context.	-->	RRC: <i>RRCConnectionReconfigurationComplete</i>
9-12	Steps 1-4 expected sequence defined in annex C.26 of TS 34.229-1 [35]. MTSI MT video call.	-	-
13	The SS configures a new RLC-UM data radio bearer with condition DRB (0,2), associated with the dedicated EPS bearer context. <i>RRCConnectionReconfiguration</i> message contains one ACTIVATE DEDICATED EPS BEARER CONTEXT REQUEST message per additional data radio bearer. One EPS bearer context #4 (QCI 1) and one EPS bearer context #3 (QCI 2) according table 6.6.2-1: Reference dedicated EPS bearer contexts.	<--	RRC: <i>RRCConnectionReconfiguration</i> NAS: ACTIVATE DEDICATED EPS BEARER CONTEXT REQUEST ACTIVATE DEDICATED EPS BEARER CONTEXT REQUEST
14	The UE transmits an <i>RRCConnectionReconfigurationComplete</i> message to confirm the establishment of the new data radio bearer, associated with the dedicated EPS bearer.	-->	RRC: <i>RRCConnectionReconfigurationComplete</i>
15	The UE transmits an ACTIVATE DEDICATED EPS BEARER CONTEXT ACCEPT message for the first bearer.	-->	RRC: ULInformationTransfer NAS:ACTIVATE DEDICATED EPS BEARER CONTEXT ACCEPT
16	The UE transmits an ACTIVATE DEDICATED EPS BEARER CONTEXT ACCEPT message for the second bearer.	-->	RRC: ULInformationTransfer NAS:ACTIVATE DEDICATED EPS BEARER CONTEXT ACCEPT
17-27	Steps 5-15 expected sequence defined in annex C.26 of TS 34.229-1 [35]. MTSI MT video call for EPS.	-	-

4.5A.9.4 Specific message contents

All specific message contents shall be referred to clause 4.6 and 4.7.

4.6 Default RRC message and information elements contents

This clause contains the default values of common RRC messages and information elements, which unless indicated otherwise in specific clauses of TS 36.521-1 [21], TS 36.521-3 [34], TS 36.523-1 [18] and other clauses in this specification. All the messages and information elements are listed in alphabetical order.

4.6.1 Contents of RRC messages

– *CounterCheck*

Table 4.6.1-0a: CounterCheck

Derivation Path: 36.331 clause 6.2.2			
Information Element	Value/remark	Comment	Condition
CounterCheck ::= SEQUENCE {			
rrc-TransactionIdentifier	RRC-TransactionIdentifier-DL		
criticalExtensions CHOICE {			
c1 CHOICE {			
counterCheck-r8 SEQUENCE {			
drb-CountMSB-InfoList	Set according to specific message content		
nonCriticalExtension SEQUENCE {}	Not present		
}			
}			
}			
}			

– *CounterCheckResponse*

Table 4.6.1-0b: CounterCheckResponse

Derivation Path: 36.331 clause 6.2.2			
Information Element	Value/remark	Comment	Condition
CounterCheckResponse ::= SEQUENCE {			
rrc-TransactionIdentifier	RRC-TransactionIdentifier-UL		
criticalExtensions CHOICE {			
counterCheckResponse-r8 SEQUENCE {			
drb-CountInfoList	Set according to specific message content		
nonCriticalExtension SEQUENCE {}	Not checked		
}			
}			
}			

– *CSFBParametersRequestCDMA2000*

Table 4.6.1-1: CSFBParametersRequestCDMA2000

Derivation Path: 36.331 clause 6.2.2			
Information Element	Value/remark	Comment	Condition
CSFBParametersRequestCDMA2000 ::= SEQUENCE {			
criticalExtensions CHOICE {			
csfbParametersRequestCDMA2000-r8 SEQUENCE {			
nonCriticalExtension SEQUENCE {}	Not checked		
}			
}			
}			

– *CSFBParametersResponseCDMA2000***Table 4.6.1-2: CSFBParametersResponseCDMA2000**

Derivation Path: 36.331 clause 6.2.2			
Information Element	Value/remark	Comment	Condition
CSFBParametersResponseCDMA2000 ::= SEQUENCE {			
rrc-TransactionIdentifier	RRC-TransactionIdentifier-DL		
criticalExtensions CHOICE {			
csfbParametersResponseCDMA2000-r8 SEQUENCE {			
rand	Set according to specific message content		
mobilityParameters	Set according to specific message content		
nonCriticalExtension SEQUENCE {}	Not present		
}			
}			
}			

– *DLInformationTransfer***Table 4.6.1-3: DLInformationTransfer**

Derivation Path: 36.331 clause 6.2.2			
Information Element	Value/remark	Comment	Condition
DLInformationTransfer ::= SEQUENCE {			
rrc-TransactionIdentifier	RRC-TransactionIdentifier-DL		
criticalExtensions CHOICE {			
c1 CHOICE {			
dlInformationTransfer-r8 SEQUENCE {			
dedicatedInfoType CHOICE {			
dedicatedInfoNAS	Set according to specific message content		
}			
nonCriticalExtension SEQUENCE {}	Not present		
}			
}			
}			

– *HandoverFromEUTRAPreparationRequest*

Table 4.6.1-4: *HandoverFromEUTRAPreparationRequest*

Derivation Path: 36.331 clause 6.2.2			
Information Element	Value/remark	Comment	Condition
HandoverFromEUTRAPreparationRequest ::= SEQUENCE {			
rrc-TransactionIdentifier	RRC-TransactionIdentifier-DL		
criticalExtensions CHOICE {			
c1 CHOICE {			
handoverFromEUTRAPreparationRequest-r8			
SEQUENCE {			
cdma2000-Type	type1XRTT		
rand	A random value, generated by the SS		
mobilityParameters	Set according to specific message content		
nonCriticalExtension SEQUENCE {}	Not present		
}			
}			
}			

- LoggedMeasurementConfiguration

Table 4.6.1-4.0A: LoggedMeasurementConfiguration

Derivation Path: 36.331 clause 6.2.2			
Information Element	Value/remark	Comment	Condition
LoggedMeasurementConfiguration-r10 ::= SEQUENCE {			
criticalExtensions CHOICE {			
c1 CHOICE {			
loggedMeasurementConfiguration-r10 SEQUENCE {			
traceReference-r10 SEQUENCE {			
plmn-Identity-r10 SEQUENCE {			
mcc SEQUENCE (SIZE (3)) OF MCC-NMC-Digit	See table 4.4.2-2		
mnc SEQUENCE (SIZE (2..3)) OF MCC-NMC-Digit	See table 4.4.2-2		
}			
traceId-r10	'0EF'H	OCTET STRING (SIZE (3))	
}			
traceRecordingSessionRef-r10	'1A'H	OCTET STRING (SIZE (2))	
tce-Id-r10	'5'H	OCTET STRING (SIZE (1))	
absoluteTimeInfo-r10	Set to value corresponding to the absolute time when the message is sent	BIT STRING (SIZE (48)), see TS 36.331 clause 6.3.6 for format.	
areaConfiguration-r10	Not present		
loggingDuration-r10	min120	ENUMERATED { min10, min20, min40, min60, min90, min120, spare2, spare1}	
loggingInterval-r10	ms10240	ENUMERATED { ms1280, ms2560, ms5120, ms10240, ms20480, ms30720, ms40960, ms61440}	
nonCriticalExtension SEQUENCE {}	Not present		
}			
}			
}			
}			

– *MBMScountingRequest***Table 4.6.1-4AA: MBMScountingRequest**

Derivation Path: 36.331 clause 6.2.2			
Information Element	Value/remark	Comment	Condition
MBMScountingRequest-r10 ::= SEQUENCE {			
CountingRequestList-r10 SEQUENCE (SIZE (1..			
maxServiceCount)) OF SEQUENCE {			
tmgi-r10 SEQUENCE {			
plmn-Id-r9 CHOICE{			
plmn-Index-r9	1		
}			
serviceId-r9	'000'		
}			
}			
lateNonCriticalExtension	Not present		
nonCriticalExtension SEQUENCE {}	Not present		
}			

– *MBMScountingResponse***Table 4.6.1-4AB: MBMScountingResponse**

Derivation Path: 36.331 clause 6.2.2			
Information Element	Value/remark	Comment	Condition
criticalExtensions CHOICE {			
c1 CHOICE{			
countingResponse-r10 OF SEQUENCE {			
mbsfn-AreaIndex-r10	0		
countingResponseList-r10 SEQUENCE (SIZE			
(1... maxServiceCount)) OF SEQUENCE {			
countingResponseService-r10	0		
}			
}			
lateNonCriticalExtension	Not present		
nonCriticalExtension SEQUENCE {}	Not present		
}			
}			

MBSFNAreaConfiguration

Table 4.6.1-4A: MBSFNAreaConfiguration

Derivation Path: 36.331 clause 6.2.2			
Information Element	Value/remark	Comment	Condition
MBSFNAreaConfiguration-r9 ::= SEQUENCE {			
commonSF-Alloc-r9 SEQUENCE (SIZE (1..maxMBSFN-Allocations)) OF SEQUENCE {			
radioframeAllocationPeriod	n4		
radioframeAllocationOffset	0		
subframeAllocation CHOICE {			
oneFrame	'100000'		
}			
commonSF-AllocPeriod-r9	rf8		
pmch-InfoList-r9 SEQUENCE (SIZE (0..maxPMCH-PerMBSFN)) OF SEQUENCE {			
pmch-Config-r9 SEQUENCE {			
sf-AllocEnd-r9	1		
dataMCS-r9	0		
mch-SchedulingPeriod-r9	rf8		
}			
mbms-SessionInfoList-r9 SEQUENCE (SIZE (0..maxSessionPerPMCH)) OF SEQUENCE {			
MBMS-SessionInfo-r9 SEQUENCE {			
tmgi-r9 SEQUENCE {			
plmn-Id-r9 CHOICE{			
plmn-Index-r9	1		
}			
serviceId-r9	'000'		
}			
logicalChannelIdentity-r9	1		
}			
}			
}			

MeasurementReport

Table 4.6.1-5: MeasurementReport

Derivation Path: 36.331 clause 6.2.2			
Information Element	Value/remark	Comment	Condition
MeasurementReport ::= SEQUENCE {			
criticalExtensions CHOICE {			
c1 CHOICE {			
measurementReport-r8 SEQUENCE {			
measResults	Set according to specific message content		
nonCriticalExtension SEQUENCE {}	Not checked		
}			
}			
}			
}			

– *MobilityFromEUTRACommand***Table 4.6.1-6: *MobilityFromEUTRACommand***

Derivation Path: 36.331 clause 6.2.2			
Information Element	Value/remark	Comment	Condition
MobilityFromEUTRACommand ::= SEQUENCE {			
rrc-TransactionIdentifier	RRC-TransactionIdentifier-DL		
criticalExtensions CHOICE {			
c1 CHOICE {			
mobilityFromEUTRACommand-r8 SEQUENCE {			
csFallbackIndicator	Set according to specific message content		
purpose CHOICE {	Set according to specific message content		
handover			
cellChangeOrder			
}			
nonCriticalExtension SEQUENCE {}	Not present		
}			
}			
}			

– *Paging***Table 4.6.1-7: *Paging***

Derivation Path: 36.331 clause 6.2.2			
Information Element	Value/remark	Comment	Condition
Paging ::= SEQUENCE {			
pagingRecordList SEQUENCE (SIZE (1..maxPageRec)) OF SEQUENCE {	1 entry		
ue-Identity[1] CHOICE {			
s-TMSI	Set to the value of the S-TMSI of the UE		
}			
cn-Domain[1]	ps		
}			
systemInfoModification	Not present		
etws-Indication	Not present		
nonCriticalExtension SEQUENCE {}	Not present		
}			

– *RRCConnectionReconfiguration***Table 4.6.1-8: RRCConnectionReconfiguration**

Derivation Path: 36.331 clause 6.2.2			
Information Element	Value/remark	Comment	Condition
RRCConnectionReconfiguration ::= SEQUENCE {			
rrc-TransactionIdentifier	RRC-TransactionIdentifier-DL		
criticalExtensions CHOICE {			
c1 CHOICE {			
rrcConnectionReconfiguration-r8 SEQUENCE {			
measConfig	Not present		
	MeasConfig-DEFAULT		MEAS
mobilityControllInfo	Not present		
	MobilityControllInfo-HO		HO, HO-TO-EUTRA
dedicatedInfoNASList	Not present		
	Set according to specific message content		SRB2-DRB(n, m) DRB(n, m) SRB1-SRB2-DRB(n,m) AM-DRB-ADD(bid) UM-DRB-ADD(bid) DRB-REL(bid) DRB-Mod
radioResourceConfigDedicated	Not present		
	RadioResourceConfigDedicated-SRB2-DRB(n, m)		SRB2-DRB(n, m)
	RadioResourceConfigDedicated-DRB(n, m)		DRB(n, m)
	RadioResourceConfigDedicated-AM-DRB-ADD(bid)		AM-DRB-ADD(bid)
	RadioResourceConfigDedicated-UM-DRB-ADD(bid)		UM-DRB-ADD(bid)
	RadioResourceConfigDedicated-DRB-REL(bid)		DRB-REL(bid)
	RadioResourceConfigDedicated-HO		HO
	RadioResourceConfigDedicated-HO-TO-EUTRA(n, m)		HO-TO-EUTRA(n, m)
	RadioResourceConfigDedicated-DRB-Mod		DRB-Mod
securityConfigHO	Not present		
	SecurityConfigHO-DEFAULT		HO, HO-TO-EUTRA
nonCriticalExtension SEQUENCE {			
lateNonCriticalExtension	Not present		
nonCriticalExtension SEQUENCE {			
otherConfig-r9	Not present		
fullConfig-r9	Not present		
nonCriticalExtension SEQUENCE {			
sCellToReleaseList-r10	Not present		
sCellToAddModList-r10	Not present		
sCellToAddModList-r10 SEQUENCE (SIZE (1..maxSCell-r10)) OF SEQUENCE {	1 entry		SCell_AddMod
sCellToAddMod[1]	SCellToAddMod-r10-DEFAULT		

}			
nonCriticalExtension	Not present		
}			
}			
}			
}			
}			
}			
}			

Condition	Explanation
SRB2-DRB(n,m)	Establishment of a SRB and DRB combination with n x AM DRB and m x UM DRB (including establishment of SRB2)
DRB(n,m)	Establishment of additional n x AM DRB:s and m x UM DRB:s (SRB2 should already be established)
AM-DRB-ADD(bid)	Establishment of a single additional AM DRB with bearer identity bid (SRB2 should already be established)
UM-DRB-ADD(bid)	Establishment of a single additional UM DRB with bearer identity bid (SRB2 should already be established)
DRB-REL(bid)	Release of the DRB with bearer identity bid
HO	Intra LTE handover
MEAS	A measurement is configured
HO-TO-EUTRA(n,m)	Inter-RAT handover to E-UTRA including the establishment of a SRB1, SRB2 and n x AM DRB plus m x UM DRB
DRB-Mod	Modification of already established DRB ID 2 and is used for sending Modify EPS Bearer Context Request message (SRB2 should already be established)
SCell_AddMod	Addition or modification of SCell

– *RRCCONNECTIONRECONFIGURATIONCOMPLETE*

Table 4.6.1-9: RRCCONNECTIONRECONFIGURATIONCOMPLETE

Derivation Path: 36.331 clause 6.2.2			
Information Element	Value/remark	Comment	Condition
RRCCONNECTIONRECONFIGURATIONCOMPLETE ::= SEQUENCE {			
rrc-TransactionIdentifier	RRC-TransactionIdentifier-UL		
criticalExtensions CHOICE {			
rrcConnectionReconfigurationComplete-r8			
SEQUENCE {			
nonCriticalExtension SEQUENCE {}	Not checked		
}			
}			
}			

– *RRCConnectionReestablishment*

Table 4.6.1-10: RRCConnectionReestablishment

Derivation Path: 36.331 clause 6.2.2			
Information Element	Value/remark	Comment	Condition
RRCConnectionReestablishment ::= SEQUENCE {			
rrc-TransactionIdentifier	RRC-TransactionIdentifier-DL		
criticalExtensions CHOICE {			
c1 CHOICE {			
rrcConnectionReestablishment-r8 SEQUENCE			
{			
radioResourceConfigDedicated	RadioResourceConfigDedicated-SRB1		
nextHopChainingCount	0		
nonCriticalExtension SEQUENCE {}	Not present		
}			
}			
}			
}			

– *RRCConnectionReestablishmentComplete*

Table 4.6.1-11: RRCConnectionReestablishmentComplete

Derivation Path: 36.331 clause 6.2.2			
Information Element	Value/remark	Comment	Condition
RRCConnectionReestablishmentComplete ::= SEQUENCE {			
rrc-TransactionIdentifier	RRC-TransactionIdentifier-UL		
criticalExtensions CHOICE {			
rrcConnectionReestablishmentComplete-r8 SEQUENCE {			
nonCriticalExtension SEQUENCE {}	Not checked		
}			
}			
}			

– *RRCConnectionReestablishmentReject*

Table 4.6.1-12: RRCConnectionReestablishmentReject

Derivation Path: 36.331 clause 6.2.2			
Information Element	Value/remark	Comment	Condition
RRCConnectionReestablishmentReject ::= SEQUENCE {			
criticalExtensions CHOICE {			
rrcConnectionReestablishmentReject-r8 SEQUENCE {			
nonCriticalExtension SEQUENCE {}	Not present		
}			
}			
}			

– *RRCCONNECTIONREESTABLISHMENTREQUEST***Table 4.6.1-13: RRCCONNECTIONREESTABLISHMENTREQUEST**

Derivation Path: 36.331 clause 6.2.2			
Information Element	Value/remark	Comment	Condition
RRCCONNECTIONREESTABLISHMENTREQUEST ::= SEQUENCE {			
criticalExtensions CHOICE {			
rrcConnectionReestablishmentRequest-r8 SEQUENCE {			
ue-Identity	Set according to specific message content		
reestablishmentCause	Set according to specific message content		
spare	Present but contents not checked		
}			
}			
}			

– *RRCCONNECTIONREJECT***Table 4.6.1-14: RRCCONNECTIONREJECT**

Derivation Path: 36.331 clause 6.2.2			
Information Element	Value/remark	Comment	Condition
RRCCONNECTIONREJECT ::= SEQUENCE {			
criticalExtensions CHOICE {			
c1 CHOICE {			
rrcConnectionReject-r8 SEQUENCE {			
waitTime	3(seconds)		
nonCriticalExtension SEQUENCE {}	Not present		
}			
}			
}			
}			

– *RRCCONNECTIONRELEASE***Table 4.6.1-15: RRCCONNECTIONRELEASE**

Derivation Path: 36.331 clause 6.2.2			
Information Element	Value/remark	Comment	Condition
RRCCONNECTIONRELEASE ::= SEQUENCE {			
rrc-TransactionIdentifier	RRC-TransactionIdentifier-DL		
criticalExtensions CHOICE {			
c1 CHOICE {			
rrcConnectionRelease-r8 SEQUENCE {			
releaseCause	other		
redirectedCarrierInfo	Not present		
idleModeMobilityControlInfo	Not present		
nonCriticalExtension SEQUENCE {}	Not present		
}			
}			
}			
}			

– *RRCConnectionRequest***Table 4.6.1-16: RRCConnectionRequest**

Derivation Path: 36.331 clause 6.2.2			
Information Element	Value/remark	Comment	Condition
RRCConnectionRequest ::= SEQUENCE {			
criticalExtensions CHOICE {			
rrcConnectionRequest-r8 SEQUENCE {			
ue-Identity CHOICE {			
s-TMSI	Any allowed value		
}			
establishmentCause	Present but contents not checked		
spare	Present but contents not checked		
}			
}			
}			

– *RRCConnectionSetup***Table 4.6.1-17: RRCConnectionSetup**

Derivation Path: 36.331 clause 6.2.2			
Information Element	Value/remark	Comment	Condition
RRCConnectionSetup ::= SEQUENCE {			
rrc-TransactionIdentifier	RRC-TransactionIdentifier-DL		
criticalExtensions CHOICE {			
c1 CHOICE {			
rrcConnectionSetup-r8 SEQUENCE {			
radioResourceConfigDedicated	RadioResourceConfigDedicated-SRB1		
nonCriticalExtension SEQUENCE {}	Not present		
}			
}			
}			
}			

– *RRCConnectionSetupComplete***Table 4.6.1-18: RRCConnectionSetupComplete**

Derivation Path: 36.331 clause 6.2.2			
Information Element	Value/remark	Comment	Condition
RRCConnectionSetupComplete ::= SEQUENCE {			
rrc-TransactionIdentifier	RRC-TransactionIdentifier-UL		
criticalExtensions CHOICE {			
c1 CHOICE {			
rrcConnectionSetupComplete-r8 SEQUENCE {			
selectedPLMN-Identity	1		
registeredMME	Not checked		
dedicatedInfoNAS	Present but contents not checked		
nonCriticalExtension SEQUENCE {}	Not checked		
}			
}			
}			
}			

– *SecurityModeCommand***Table 4.6.1-19: SecurityModeCommand**

Derivation Path: 36.331 clause 6.2.2			
Information Element	Value/remark	Comment	Condition
SecurityModeCommand ::= SEQUENCE {			
rrc-TransactionIdentifier	RRC-TransactionIdentifier-DL		
criticalExtensions CHOICE {			
c1 CHOICE{			
securityModeCommand-r8 SEQUENCE {			
securityConfigSMC	SecurityConfigSMC-DEFAULT		
nonCriticalExtension SEQUENCE {}	Not present		
}			
}			
}			
}			

– *SecurityModeComplete***Table 4.6.1-20: SecurityModeComplete**

Derivation Path: 36.331 clause 6.2.2			
Information Element	Value/remark	Comment	Condition
SecurityModeComplete ::= SEQUENCE {			
rrc-TransactionIdentifier	RRC-TransactionIdentifier-UL		
criticalExtensions CHOICE {			
securityModeComplete-r8 SEQUENCE {			
nonCriticalExtension SEQUENCE {}	Not checked		
}			
}			
}			

– *SecurityModeFailure***Table 4.6.1-21: SecurityModeFailure**

Derivation Path: 36.331 clause 6.2.2			
Information Element	Value/remark	Comment	Condition
SecurityModeFailure ::= SEQUENCE {			
rrc-TransactionIdentifier	RRC-TransactionIdentifier-UL		
criticalExtensions CHOICE {			
securityModeFailure-r8 SEQUENCE {			
nonCriticalExtension SEQUENCE {}	Not checked		
}			
}			
}			

– *UECapabilityEnquiry***Table 4.6.1-22: UECapabilityEnquiry**

Derivation Path: 36.331 clause 6.2.2			
Information Element	Value/remark	Comment	Condition
UECapabilityEnquiry ::= SEQUENCE {			
rrc-TransactionIdentifier	RRC-TransactionIdentifier-DL		
criticalExtensions CHOICE {			
c1 CHOICE {			
ueCapabilityEnquiry-r8 SEQUENCE {			
ue-CapabilityRequest	eutra		
nonCriticalExtension SEQUENCE {}	Not present		
}			
}			
}			
}			

– UECapabilityInformation

Table 4.6.1-23: UECapabilityInformation

Derivation Path: 36.331 clause 6.2.2			
Information Element	Value/remark	Comment	Condition
UECapabilityInformation ::= SEQUENCE {			
rrc-TransactionIdentifier	RRC-TransactionIdentifier-UL		
criticalExtensions CHOICE {			
c1 CHOICE {			
ueCapabilityInformation-r8 SEQUENCE {			
ue-CapabilityRAT-ContainerList SEQUENCE (SIZE (1..maxRAT-Capabilities)) OF SEQUENCE {	1 entry		
rat-Type	Set according to specific message content		
ueCapabilityRAT-Container			
ue-EUTRA-Capability SEQUENCE {			
accessStratumRelease	Same as indicated in TC applicability of 36.523-2		
ue-Category	Not checked		
pdcp-Parameters SEQUENCE {			
supportedROHC-Profiles			
SEQUENCE {			
profile0x0001	Not checked		
profile0x0001	true		ROHC
profile0x0002	Not checked		
profile0x0002	true		ROHC
profile0x0003	Not checked		
profile0x0004	Not checked		
profile0x0006	Not checked		
profile0x0101	Not checked		
profile0x0102	Not checked		
profile0x0103	Not checked		
profile0x0104	Not checked		
}			
maxNumberROHC-ContextSessions	Not checked		
}			
phyLayerParameters	Not checked		
rf-Parameters	Not checked		
measParameters	Not checked		
featureGroupIndicators			
-- FGI 1	Not checked		
-- FGI 2	Not checked		
-- FGI 3	Not checked		
-- FGI 4	Not checked		
-- FGI 5	Not checked		Rel-8
-- FGI 5	'1'B		>Rel-8
-- FGI 6	Not checked		Rel-8
-- FGI 6	'1'B		>Rel-8
-- FGI 7	Not checked		
-- FGI 8	Not checked		
-- FGI 8	'1'B		>Rel-8 AND eFDD-UTRA
-- FGI 9	Not checked		
-- FGI 10	Not checked		
-- FGI 11	Not checked		
-- FGI 12	Not checked		
-- FGI 13	Not checked		
-- FGI 14	Not checked		
-- FGI 15	Not checked		
-- FGI 16	Not checked		Rel-8
-- FGI 16	'1'B		>Rel-8
-- FGI 17	Not checked		Rel-8
-- FGI 17	'1'B		>Rel-8

-- FGI 18	Not checked		Rel-8
-- FGI 18	'1'B		>Rel-8
-- FGI 19	Not checked		
-- FGI 20	Not checked		Rel-8
-- FGI 20	'1'B		>Rel-8
-- FGI 21	Not checked		
-- FGI 22	Not checked		
-- FGI 22	'1'B		>Rel-8 AND eFDD-UTRA
-- FGI 23	Not checked		
-- FGI 24	Not checked		
-- FGI 24	'1'B		>Rel-8 AND enhanced1x RTT-CSFB
-- FGI 25	Not checked		
-- FGI 25	'1'B		>Rel-8 OR InterModeH O
-- FGI 26	Not checked		
-- FGI 26	'1'B		>Rel-8 AND eFDD- HRPD
-- FGI 27	Not checked		
-- FGI 28	Not checked		
-- FGI 29	Not checked		
-- FGI 30	Not checked		
-- FGI 30	'1'B		InterModeH O
-- FGI 31-32	'0'B (Undefined)		
interRAT-Parameters SEQUENCE {			
utraFDD	Not checked		
utraTDD128	Not checked		
utraTDD384	Not checked		
utraTDD768	Not checked		
geran	Not checked		
cdma2000-HRPD	Not checked		
cdma2000-1xRTT	Not checked		
cdma2000-1xRTT	Not checked		
}			
nonCriticalExtension SEQUENCE {			
phyLayerParameters-v920	Not checked		
interRAT-ParametersGERAN-v920	Not checked		
interRAT-ParametersUTRA-v920	Not checked		
interRAT-ParametersCDMA2000-	Not checked		
v920			
deviceType-r9	Not checked		
csg-ProximityIndicationParameters-r9	Not checked		
neighCellSI-AcquisitionParameters-r9	Not checked		
son-Parameters-r9	Not checked		
nonCriticalExtension SEQUENCE {			
lateNonCriticalExtension			
UE-EUTRA-Capability-v9a0-IEs			
featureGroupIndRel9Add-r9			
-- FGI 33	Not checked		
-- FGI 34	Not checked		
-- FGI 35	Not checked		
-- FGI 36	Not checked		
-- FGI 37-64	'0'B (Undefined)		
fdd-Add-UE-EUTRA-			
Capabilities-r9 SEQUENCE {			
phyLayerParameters-r9	Not checked		
featureGroupIndicators-r9		BITSTRING 32	
-- FGI 1F	Not checked		
-- FGI 2F	Not checked		
-- FGI 3F	Not checked		FDD = TDD
-- FGI 4F	Not checked		

	-- FGI 5F	Not checked		FDD = TDD
	-- FGI 6F	Not checked		FDD = TDD
	-- FGI 7F	Not checked		FDD = TDD
	-- FGI 8F	Not checked		
	-- FGI 9F	Not checked		
	-- FGI 10F	Not checked		
	-- FGI 11F	Not checked		
	-- FGI 12F	Not checked		
	-- FGI 13F	Not checked		FDD = TDD
	-- FGI 14F	Not checked		FDD = TDD
	-- FGI 15F	Not checked		
	-- FGI 16F	Not checked		FDD = TDD
	-- FGI 17F	Not checked		FDD = TDD
	-- FGI 18F	Not checked		FDD = TDD
	-- FGI 19F	Not checked		
	-- FGI 20F	Not checked		FDD = TDD
	-- FGI 21F	Not checked		FDD = TDD
	-- FGI 22F	Not checked		
	-- FGI 23F	Not checked		
	-- FGI 24F	Not checked		
	-- FGI 25F	Not checked		FDD = TDD
	-- FGI 26F	Not checked		
	-- FGI 27F	Not checked		
	-- FGI 28F	Not checked		
	-- FGI 29F	Not checked		
	-- FGI 30F	Not checked		FDD = TDD
	-- FGI 31F-32F	'0'B (Undefined) if present		
	featureGroupIndRel9Add-r9		BITSTRING 32	
	-- FGI 33F	Not checked		
	-- FGI 34F	Not checked		
	-- FGI 35F	Not checked		
	-- FGI 36F	Not checked		
	-- FGI 37F-64F	'0'B (Undefined) if present		
r9	interRAT-ParametersGERAN-	Not checked		
	interRAT-ParametersUTRA-r9	Not checked		
r9	interRAT-ParametersGERAN-	Not checked		
	interRAT-ParametersCDMA2000-r9	Not checked		
	neighCellSI-AcquisitionParameters-r9	Not checked		
	}			
	tdd-Add-UE-EUTRA-Capabilities-r9 SEQUENCE {			
	phyLayerParameters-r9	Not checked		
	featureGroupIndicators-r9		BITSTRING 32	
	-- FGI 1T	Not checked		
	-- FGI 2T	Not checked		
	-- FGI 3T	Not checked		FDD = TDD
	-- FGI 4T	Not checked		
	-- FGI 5T	Not checked		FDD = TDD
	-- FGI 6T	Not checked		FDD = TDD
	-- FGI 7T	Not checked		FDD = TDD
	-- FGI 8T	Not checked		
	-- FGI 9T	Not checked		
	-- FGI 10T	Not checked		
	-- FGI 11T	Not checked		
	-- FGI 12T	Not checked		
	-- FGI 13T	Not checked		FDD = TDD
	-- FGI 14T	Not checked		FDD = TDD
	-- FGI 15T	Not checked		
	-- FGI 16T	Not checked		FDD = TDD
	-- FGI 17T	Not checked		FDD = TDD

	-- FGI 18T	Not checked		FDD = TDD
	-- FGI 19T	Not checked		
	-- FGI 20T	Not checked		FDD = TDD
	-- FGI 21T	Not checked		FDD = TDD
	-- FGI 22T	Not checked		
	-- FGI 23T	Not checked		
	-- FGI 24T	Not checked		
	-- FGI 25T	Not checked		FDD = TDD
	-- FGI 26T	Not checked		
	-- FGI 27T	Not checked		
	-- FGI 28T	Not checked		
	-- FGI 29T	Not checked		
	-- FGI 30T	Not checked		FDD = TDD
	-- FGI 31T-32T	'0'B (Undefined) if present		
	featureGroupIndRel9Add-r9		BITSTRING 32	
	-- FGI 33T	Not checked		
	-- FGI 34T	Not checked		
	-- FGI 35T	Not checked		
	-- FGI 36T	Not checked		
	-- FGI 37T-64T	'0'B (Undefined) if present		
r9	interRAT-ParametersGERAN-	Not checked		
	interRAT-ParametersUTRA-r9	Not checked		
r9	interRAT-ParametersGERAN-	Not checked		
	interRAT-ParametersCDMA2000-r9	Not checked		
	neighCellSI-AcquisitionParameters-r9	Not checked		
	}			
	nonCriticalExtension	Not checked		
SEQUENCE {}	nonCriticalExtension SEQUENCE {			
	ue-Category-v1020	Not checked		
	phyLayerParameters-v1020	Not checked		
	rf-Parameters-v1020	Not checked		
	measParameters-v1020	Not checked		
	featureGroupIndRel10-r10		BITSTRING 32	
	-- FGI 101	Not checked		
	-- FGI 102	Not checked		
	-- FGI 103	Not checked		
	-- FGI 104	Not checked		
	-- FGI 105	Not checked		
	-- FGI 106	Not checked		
	-- FGI 107	Not checked		
	-- FGI 108	Not checked		
	-- FGI 109	Not checked		
	-- FGI 110	Not checked		
	-- FGI 111	Not checked		
	-- FGI 112	Not checked		
	-- FGI 113	Not checked		
	-- FGI 114	Not checked		
	-- FGI 115	Not checked		
	-- FGI 116	Not checked		
	-- FGI 117-132	'0'B (Undefined) if present		
v1020	interRAT-ParametersCDMA2000-	Not checked		
	ue- BasedNetwPerfMeasParameters-r10	Not checked		

v1020	interRAT-ParametersUTRA-TDD-	Not checked		
	nonCriticalExtension SEQUENCE	Not checked		
	{			
	}			
	}			
	}			
	}			
	nonCriticalExtension SEQUENCE {}	Not checked		
	}			
	}			
	}			
	}			

Condition	Explanation
Rel-8	Only for Rel-8
>Rel-8	For Rel-9 or later Releases (Note 2)
ROHC	Support of ROHC profile0x0001 and ROHC profile0x0002 (TS 36.523-2 table A.4.4-1/40 and A.4.4-1/41).
eFDD-UTRA	eFDD and UTRA supported
enhanced1xRTT-CSFB	Enhanced 1xRTT CSFB supported
eFDD-HRPD	HRPD supported
InterModeHO	Mobility in connected state between FDD and TDD
FDD = TDD	UE is not allowed to signal different values for FDD and TDD, is not checked per default

Note2: For this version, FGI bits for ">Rel-8" are not checked.

UEInformationRequest

Table 4.6.1-23A: UEInformationRequest

Derivation Path: 36.331 clause 6.2.2			
Information Element	Value/remark	Comment	Condition
UEInformationRequest-r9 ::= SEQUENCE {			
rrc-TransactionIdentifier	RRC-TransactionIdentifier-DL		
criticalExtensions CHOICE {			
c1 CHOICE{			
ueInformationRequest-r9 SEQUENCE {			
rach-ReportReq-r9	FALSE		
rlf-ReportReq-r9	FALSE		
nonCriticalExtension SEQUENCE {			
lateNonCriticalExtension	Not present		
nonCriticalExtension SEQUENCE {}	Not present		
nonCriticalExtension SEQUENCE {			Logged MDT
logMeasReportReq-r10	TRUE		
nonCriticalExtension SEQUENCE {}	Not present		
}			
}			
}			
}			
}			

Condition	Explanation
Logged MDT	Used for Logged MDT test cases

– *UEInformationResponse*Table 4.6.1-23B: *UEInformationResponse*

Derivation Path: 36.331 clause 6.2.2			
Information Element	Value/remark	Comment	Condition
UEInformationResponse-r9 ::= SEQUENCE {			
rrc-TransactionIdentifier	RRC-TransactionIdentifier-UL		
criticalExtensions CHOICE {			
c1 CHOICE {			
ueInformationResponse-r9 SEQUENCE {			
rach-Report-r9 SEQUENCE {}	Not checked		
rlf-Report-r9 SEQUENCE {}	Not checked		
nonCriticalExtension SEQUENCE {			
lateNonCriticalExtension	Not checked		
nonCriticalExtension SEQUENCE {			
logMeasReport-r10 SEQUENCE {}	Not checked		
nonCriticalExtension SEQUENCE {	Not checked		
}			
}			
}			
}			
}			
}			

- *ULHandoverPreparationTransfer*Table 4.6.1-24: *ULHandoverPreparationTransfer*

Derivation Path: 36.331 clause 6.2.2			
Information Element	Value/remark	Comment	Condition
ULHandoverPreparationTransfer ::= SEQUENCE {			
criticalExtensions CHOICE {			
c1 CHOICE {			
ulHandoverPreparationTransfer-r8 SEQUENCE			
{			
cdma2000-Type	type1XRTT		
meid	Set to the 56 bit CDMA2000 mobile identification number of the UE		
dedicatedInfo	Set according to specific message content		
nonCriticalExtension SEQUENCE {}	Not checked		
}			
}			
}			
}			

– *ULInformationTransfer***Table 4.6.1-25: *ULInformationTransfer***

Derivation Path: 36.331 clause 6.2.2			
Information Element	Value/remark	Comment	Condition
ULInformationTransfer ::= SEQUENCE {			
criticalExtensions CHOICE {			
c1 CHOICE {			
ulInformationTransfer-r8 SEQUENCE {			
dedicatedInfoType CHOICE {			
dedicatedInfoNAS	Present but contents not checked		
}			
nonCriticalExtension SEQUENCE {}	Not checked		
}			
}			
}			

4.6.2 System information blocks

See subclause 4.4.3.3 in this document.

4.6.3 Radio resource control information elements**Table 4.6.3-0A: Void****Table 4.6.3-0B: Void**– **BCCH-Config-DEFAULT****Table 4.6.3-1: BCCH-Config-DEFAULT**

Derivation Path: 36.331 clause 6.3.2			
Information Element	Value/remark	Comment	Condition
BCCH-Config-DEFAULT ::= SEQUENCE {			
modificationPeriodCoeff	n4	To provide reliable delivery of SI change notifications.	
}			

– **CQI-ReportAperiodic-r10-DEFAULT****Table 4.6.3-1A: CQI-ReportAperiodic-r10-DEFAULT**

Derivation Path: 36.331 clause 6.3.2			
Information Element	Value/remark	Comment	Condition
CQI-ReportAperiodic-r10 ::= CHOICE {			
setup SEQUENCE {			
cqi-ReportModeAperiodic-r10	rm30		
aperiodicCSI-Trigger-r10	Not present		
}			
}			

– CQI-ReportConfig-DEFAULT

Table 4.6.3-2: CQI-ReportConfig-DEFAULT

Derivation Path: 36.331 clause 6.3.2			
Information Element	Value/remark	Comment	Condition
CQI-ReportConfig-DEFAULT ::= SEQUENCE {			
cqi-ReportModeAperiodic	rm30		
nomPDSCH-RS-EPRE-Offset	0		
cqi-ReportPeriodic	Not present		
cqi-ReportPeriodic CHOICE {			CQI_PERIODIC
setup SEQUENCE {			
cqi-PUCCH-ResourceIndex	0		
cqi-pmi-ConfigIndex	25	(see Table 7.2.2-1A in TS 36.213)	FDD
	24	(see Table 7.2.2-1C in TS 36.213)	TDD
cqi-FormatIndicatorPeriodic CHOICE {			
widebandCQI	NULL		
}			
ri-ConfigIndex	483	(see Table 7.2.2-1B in TS 36.213)	FDD
	484	(see Table 7.2.2-1B in TS 36.213) This value for TDD is selected together with cqi-pmi-ConfigIndex based on TDD configuration 1.	TDD
simultaneousAckNackAndCQI	FALSE		
}			
}			

Condition	Explanation
CQI_PERIODIC	When periodic CQI reporting should be enabled
FDD	FDD cell environment
TDD	TDD cell environment

– CQI-ReportConfig-r10-DEFAULT

Table 4.6.3-2AA: CQI-ReportConfig-r10-DEFAULT

Derivation Path: 36.331 clause 6.3.2			
Information Element	Value/remark	Comment	Condition
CQI-ReportConfig-r10 ::= SEQUENCE {			
cqi-ReportAperiodic-r10	CQI-ReportAperiodic-r10-DEFAULT		
nomPDSCH-RS-EPRE-Offset	0		
cqi-ReportPeriodic-r10	Not present		
	CQI-ReportPeriodic-r10-DEFAULT		CQI_PERIODIC
pmi-RI-Report-r9	Not present		
csi-SubframePatternConfig-r10	Not present		
}			

Condition	Explanation
-----------	-------------

CQI_PERIODIC	When periodic CQI reporting should be enabled
--------------	---

– CQI-ReportConfigSCell-r10-DEFAULT

Table 4.6.3-2AB: CQI-ReportConfigSCell-r10-DEFAULT

Derivation Path: 36.331 clause 6.3.2			
Information Element	Value/remark	Comment	Condition
CQI-ReportConfigSCell-r10 ::= SEQUENCE {			
cqi-ReportModeAperiodic-r10	rm30		
nomPDSCH-RS-EPRE-Offset-r10	0		
cqi-ReportPeriodicSCell-r10	Not present		
	CQI-ReportPeriodic-r10-DEFAULT		CQI_PERIODIC
pmi-RI-Report-r10	Not present		
}			

Condition	Explanation
CQI_PERIODIC	When periodic CQI reporting should be enabled

– CQI-ReportPeriodic-r10-DEFAULT

Table 4.6.3-2AC: CQI-ReportPeriodic-r10-DEFAULT

Derivation Path: 36.331 clause 6.3.2			
Information Element	Value/remark	Comment	Condition
CQI-ReportPeriodic-r10 ::= CHOICE {			
setup SEQUENCE {			
cqi-PUCCH-ResourceIndex-r10	0		
cqi-PUCCH-ResourceIndexP1-r10	Not present		
cqi-pmi-ConfigIndex	25		FDD
	24		TDD
cqi-FormatIndicatorPeriodic-r10 CHOICE {			
widebandCQI-r10 SEQUENCE {			
csi-ReportMode-r10	Not present		
}			
}			
ri-ConfigIndex	483		FDD
	484		TDD
simultaneousAckNackAndCQI	FALSE		
cqi-Mask-r9	Not present		
csi-ConfigIndex-r10	Not present		
}			

Condition	Explanation
FDD	FDD cell environment
TDD	TDD cell environment

Table 4.6.3-2AD: Void

Table 4.6.3-2AE: Void

– DRB-ToAddModList-RECONFIG

Table 4.6.3-2A: DRB-ToAddModList-RECONFIG

Derivation Path: 36.331 clause 6.3.2			
Information Element	Value/remark	Comment	Condition
DRB-ToAddModList ::= SEQUENCE (SIZE (1..maxDRB)) OF SEQUENCE {	2 Entries		
eps-BearerIdentity[1]	Not present		
drb-Identity[1]	1		
pdcP-Config[1]	Not present		
rlc-Config[1]	RLC-Config-DRB-AM-RECONFIG		
logicalChannelIdentity[1]	Not present		
logicalChannelConfig[1]	Not present		
eps-BearerIdentity[2]	Not present		
drb-Identity[2]	2		
pdcP-Config[2]	Not present		
rlc-Config[2]	RLC-Config-DRB-AM-RECONFIG		
logicalChannelIdentity[2]	Not present		
logicalChannelConfig[2]	Not present		
}			

– PCCH-Config-DEFAULT

Table 4.6.3-3: PCCH-Config-DEFAULT

Derivation Path: 36.331 clause 6.3.2			
Information Element	Value/remark	Comment	Condition
PCCH-Config-DEFAULT ::= SEQUENCE {			
defaultPagingCycle	rf128	Typical value in real network.	
nB	oneT		
}			

– PHICH-Config-DEFAULT

Table 4.6.3-4: PHICH-Config-DEFAULT

Derivation Path: 36.331 clause 6.3.2			
Information Element	Value/remark	Comment	Condition
PHICH-Config-DEFAULT ::= SEQUENCE {			
phich-Duration	normal		
phich-Resource	one	Ng=1 has been selected to ensure enough PHICH resources from the real network point of view.	
}			

– PDSCH-ConfigCommon-DEFAULT

Table 4.6.3-5: PDSCH-ConfigCommon-DEFAULT

Derivation Path: 36.331 clause 6.3.2			
Information Element	Value/remark	Comment	Condition
PDSCH-ConfigCommon-DEFAULT ::= SEQUENCE {			
referenceSignalPower	18 (dBm)		
p-b	0 ($\rho_B / \rho_A = 1$)		1TX
	1 ($\rho_B / \rho_A = 1$)		2TX
}			

Condition	Explanation
1TX	1 SS Tx antenna environment
2TX	2 SS Tx antenna environment

– PDSCH-ConfigDedicated-DEFAULT

Table 4.6.3-6: PDSCH-ConfigDedicated-DEFAULT

Derivation Path: 36.331 clause 6.3.2			
Information Element	Value/remark	Comment	Condition
PDSCH-ConfigDedicated-DEFAULT ::= SEQUENCE {			
p-a	dB-3 for signalling test cases; dB0 for others	dB-3 for signalling test cases to reduce interference from PDSCH of intra-frequency neighbour cells	1TX
	dB-3		2TX
}			

– PhysicalConfigDedicatedSCell-r10-DEFAULT

Table 4.6.3-6A: PhysicalConfigDedicatedSCell-r10-DEFAULT

Derivation Path: 36.331 clause 6.3.2			
Information Element	Value/remark	Comment	Condition
PhysicalConfigDedicatedSCell-r10 ::= SEQUENCE {			
nonUL-Configuration-r10 SEQUENCE {			
antennaInfo-r10	Not present		
crossCarrierSchedulingConfig-r10	Not present		
csi-RS-Config-r10	Not present		
pdsch-ConfigDedicated-r10	PDSCH- ConfigDedicated- DEFAULT		
}			
ul-Configuration-r10	Not present		
ul-Configuration-r10 SEQUENCE {			UL CA
antennaInfoUL-r10	Not present		
pusch-ConfigDedicatedSCell-r10	Not present		
uplinkPowerControlDedicatedSCell-r10	UplinkPowerControlDedic atedSCell-r10-DEFAULT		
cqi-ReportConfigSCell-r10	CQI-ReportConfigSCell- r10-DEFAULT		
soundingRS-UL-ConfigDedicated-r10	Not present		
soundingRS-UL-ConfigDedicated-v1020	Not present		
soundingRS-UL-ConfigDedicatedAperiodic-r10	Not present		
}			
}			

Condition	Explanation
UL CA	When UL Carrier Aggregation is used.

– PRACH-Config-DEFAULT

Table 4.6.3-7: PRACH-Config-DEFAULT

Derivation Path: 36.331 clause 6.3.2			
Information Element	Value/remark	Comment	Condition
PRACH-Config-DEFAULT ::= SEQUENCE {			
rootSequenceIndex	See clause 4.4.2, Table 4.4.2-1A and clause 6.3.2.2 Table 6.3.2.2-2	See table 5.7.2-4 in TS 36.211 for PRACH format 0-3	FDD
	See clause 4.4.2, Table 4.4.2-1A and clause 6.3.2.2 Table 6.3.2.2-2	See table 5.7.2-5 in TS 36.211 for PRACH format 4	TDD
prach-ConfigInfo SEQUENCE {			
prach-ConfigIndex	3	Typical value in real network for FDD (see table 5.7.1-1 and 5.7.1-2 in TS 36.211)	FDD
	51	Typical value in real network for TDD (see table 5.7.1-3 and 5.7.1-4 in TS 36.211)	TDD
highSpeedFlag	FALSE (Unrestricted set)	High speed train configuration doesn't apply by default.	
zeroCorrelationZoneConfig	5 (N_{cs} configuration = 5)	Assuming cell radius is up to approximately 3 km.	FDD
	4 (N_{cs} configuration = 4)	Assuming cell radius is up to approximately 1 km.	TDD
prach-FreqOffset	See subclause 4.6.8	Channel-bandwidth-dependent parameter	
}			
}			
Note: Although PRACH format 0-3 is applicable for both FDD and TDD, the PRACH format 4 is used as default for testing for TDD.			

Condition	Explanation
FDD	FDD cell environment
TDD	TDD cell environment

– PRACH-ConfigSIB-DEFAULT

Table 4.6.3-7a: PRACH-ConfigSIB-DEFAULT

Derivation Path: 36.508 clause 4.6.3 Table 4.6.3-7 PRACH-Config-DEFAULT

– PUCCH-ConfigCommon-DEFAULT

Table 4.6.3-8: PUCCH-ConfigCommon-DEFAULT

Derivation Path: 36.331 clause 6.3.2			
Information Element	Value/remark	Comment	Condition
PUCCH-ConfigCommon-DEFAULT ::= SEQUENCE {			
deltaPUCCH-Shift	ds2	Assuming typical values of the maximum delay spread	
nRB-CQI	See subclause 4.6.8	Channel-bandwidth-dependent parameter	
nCS-AN	6		
n1PUCCH-AN	0		
}			

– PUCCH-ConfigDedicated-DEFAULT

Table 4.6.3-9: PUCCH-ConfigDedicated-DEFAULT

Derivation Path: 36.331 clause 6.3.2			
Information Element	Value/remark	Comment	Condition
PUCCH-ConfigDedicated-DEFAULT ::= SEQUENCE {			
ackNackRepetition CHOICE {			
release	NULL		
}			
tddAckNackFeedbackMode	Not present		FDD
	multiplexing	Multiplexing is selected as default to align with RAN4's assumptions in RF tests.	TDD
}			

Condition	Explanation
FDD	FDD cell environment
TDD	TDD cell environment

Table 4.6.3-9A: Void

– PUSCH-ConfigCommon-DEFAULT

Table 4.6.3-10: PUSCH-ConfigCommon-DEFAULT

Derivation Path: 36.331 clause 6.3.2			
Information Element	Value/remark	Comment	Condition
PUSCH-ConfigCommon-DEFAULT ::= SEQUENCE {			
pusch-ConfigBasic SEQUENCE {			
n-SB	1	Typical configuration in real network	
hoppingMode	interSubFrame	Typical configuration in real network	
pusch-HoppingOffset	See subclause 4.6.8	Channel-bandwidth-dependent parameter	
enable64QAM	FALSE		
}			
ul-ReferenceSignalsPUSCH SEQUENCE {			
groupHoppingEnabled	TRUE	In accordance with "the RAN5 LTE UE Feature list".	
groupAssignmentPUSCH	0	Typical value in real network	
sequenceHoppingEnabled	FALSE	In accordance with "the RAN5 LTE UE Feature list".	
cyclicShift	0		
}			
}			

– PUSCH-ConfigDedicated-DEFAULT

Table 4.6.3-11: PUSCH-ConfigDedicated-DEFAULT

Derivation Path: 36.331 clause 6.3.2			
Information Element	Value/remark	Comment	Condition
PUSCH-ConfigDedicated-DEFAULT ::= SEQUENCE {			
betaOffset-ACK-Index	9		
betaOffset-RI-Index	6		
betaOffset-CQI-Index	6		
}			

Table 4.6.3-11A: Void

– RACH-ConfigCommon-DEFAULT

Table 4.6.3-12: RACH-ConfigCommon-DEFAULT

Derivation Path: 36.331 clause 6.3.2			
Information Element	Value/remark	Comment	Condition
RACH-ConfigCommon-DEFAULT ::= SEQUENCE {			
preambleInfo SEQUENCE {			
numberOfRA-Preambles	n52	Assuming the number of dedicated preambles is 12.	
preamblesGroupAConfig SEQUENCE {}	Not present		
}			
powerRampingParameters SEQUENCE {			
powerRampingStep	dB2		
preambleInitialReceivedTargetPower	dBm-104 (default)	Thermal noise = -113 dBm NF = 5 dB IoT = 6 dB Required SNR = -8 dB (See table 8.4.2-1 in TS 36.104 [30]) -> -110 dB (default value is acceptable)	
}			
ra-SupervisionInfo SEQUENCE {			
preambleTransMax	n6	Under the condition of Case 1 in RAN1 simulation assumptions, an UE with pathloss of CDF = 90% reaches the maximum transmit power in 4 successive retransmissions. 6 has been selected considering the margin of 2.	
ra-ResponseWindowSize	sf10	The maximum value is preferable.	
mac-ContentionResolutionTimer	sf48	Allows for a sufficient number of msg3 retransmissions.	
}			
maxHARQ-Msg3Tx	4	Under the condition of Target SIR = 2 dB, the probability of 2 transmissions is less than 1%. 4 has been selected considering the margin of 2.	
}			

– Rach-ConfigDedicated-DEFAULT

Table 4.6.3-12A: Rach-ConfigDedicated-DEFAULT

Derivation Path: 36.331 clause 6.3.2			
Information Element	Value/remark	Comment	Condition
Rach-ConfigDedicated-DEFAULT ::= SEQUENCE {			
ra-PreambleIndex	52		
ra-PRACH-MaskIndex	0		
}			

– RadioResourceConfigCommon-DEFAULT

Table 4.6.3-13: RadioResourceConfigCommon-DEFAULT

Derivation Path: 36.331 clause 6.3.2			
Information Element	Value/remark	Comment	Condition
RadioResourceConfigCommon-DEFAULT ::= SEQUENCE {			
rach-ConfigCommon	RACH-ConfigCommon-DEFAULT		
prach-Config	PRACH-Config-DEFAULT		
pdsch-ConfigCommon	Not present		
	PDSCH-ConfigCommon-DEFAULT		FullConfig, HO-to-EUTRA
pusch-ConfigCommon	PUSCH-ConfigCommon-DEFAULT		
phich-Config	Not present		
	PHICH-Config-DEFAULT		FullConfig, HO-to-EUTRA
pucch-ConfigCommon	Not present		SAME-BW
	PUCCH-ConfigCommon-DEFAULT		DIFF-BW, FullConfig, HO-to-EUTRA
soundingRSUL-ConfigCommon	SoundingRS-UL-ConfigCommon-DEFAULT		
uplinkPowerControlCommon	Not present		
	UplinkPowerControlCommon-DEFAULT		FullConfig, HO-to-EUTRA
antennaInfoCommon	Not present		
antennaInfoCommon SEQUENCE {			2TX
antennaPortsCount	an2		
}			
antennaInfoCommon SEQUENCE {			FullConfig, HO-to-EUTRA
antennaPortsCount	an1		
}			
p-Max	Not present		
tdd-Config	Not present		FDD
	TDD-Config-DEFAULT		TDD
ul-CyclicPrefixLength	len1		
uplinkPowerControlCommon-v1020	UplinkPowerControlCommon-v1020-DEFAULT		UL CA
	Not present		
}			

Condition	Explanation
FDD	FDD cell environment
TDD	TDD cell environment
2TX	Used for cells with two antenna ports
SAME-BW	Source and target cell are configured with same bandwidth
DIFF-BW	Source and target cell are configured with different bandwidth
UL CA	When UL Carrier Aggregation is used.
FullConfig	Handover with full configuration option (Rel-9 or later)
HO-to-EUTRA	Inter-RAT handover to E-UTRA

– RadioResourceConfigCommonSCell-r10-DEFAULT

Table 4.6.3-13A: RadioResourceConfigCommonSCell-r10-DEFAULT

Derivation Path: 36.331 clause 6.3.2			
Information Element	Value/remark	Comment	Condition
RadioResourceConfigCommonSCell-r10 ::= SEQUENCE {			
nonUL-Configuration-r10 SEQUENCE {			
dl-Bandwidth-r10	Same downlink bandwidth as used for target SCell		
antennaInfoCommon-r10	an2		
mbsfn-SubframeConfigList-r10	Not present		
pich-Config-r10	PHICH-Config-DEFAULT		
pdsch-ConfigCommon-r10	PDSCH-ConfigCommon-DEFAULT		
tdd-Config-r10	Not present		FDD
	TDD-Config-DEFAULT		TDD
}			
ul-Configuration-r10	Not present		
ul-Configuration-r10 SEQUENCE {			UL CA
ul-FreqInfo-r10 SEQUENCE {			
ul-CarrierFreq-r10	Not present		
ul-Bandwidth-r10	Not present		
additionalSpectrumEmissionSCell-r10	1 (CA_NS_01)		
}			
p-Max-r10	Not present		
uplinkPowerControlCommonSCell-r10	UplinkPowerControlCommonSCell-r10-DEFAULT		
soundingRS-UL-ConfigCommon-r10	SoundingRS-UL-ConfigCommon-DEFAULT		
ul-CyclicPrefixLength-r10	len1		
prach-ConfigSCell-r10	Not present		FDD
	FFS		TDD
pusch-ConfigCommon-r10	PUSCH-ConfigCommon-DEFAULT		
}			
}			

Condition	Explanation
FDD	FDD cell environment
TDD	TDD cell environment
UL CA	When UL Carrier Aggregation is used.

RadioResourceConfigCommonSIB-DEFAULT

Table 4.6.3-14: RadioResourceConfigCommonSIB-DEFAULT

Derivation Path: 36.331 clause 6.3.2			
Information Element	Value/remark	Comment	Condition
RadioResourceConfigCommonSIB-DEFAULT ::= SEQUENCE {			
rach-ConfigCommon	RACH-ConfigCommon-DEFAULT		
bcch-Config	BCCH-Config-DEFAULT		
pcch-Config	PCCH-Config-DEFAULT		
prach-Config	PRACH-ConfigSIB-DEFAULT		
pdsch-ConfigCommon	PDSCH-ConfigCommon-DEFAULT		
pusch-ConfigCommon	PUSCH-ConfigCommon-DEFAULT		
pucch-ConfigCommon	PUCCH-ConfigCommon-DEFAULT		
soundingRS-UL-ConfigCommon	SoundingRS-UL-ConfigCommon-DEFAULT		
uplinkPowerControlCommon	UplinkPowerControlCommon-DEFAULT		
ul-CyclicPrefixLength	len1		
uplinkPowerControlCommon-v1020	Not present		
	UplinkPowerControlCommon-v1020-DEFAULT		UL CA
}			

Condition	Explanation
UL CA	When UL Carrier Aggregation is used.

RadioResourceConfigDedicated-SRB1

Table 4.6.3-15: RadioResourceConfigDedicated-SRB1

Derivation Path: 36.331 clause 6.3.2			
Information Element	Value/remark	Comment	Condition
RadioResourceConfigDedicated-SRB1 ::= SEQUENCE {			
srb-ToAddModList SEQUENCE (SIZE (1..2)) OF SEQUENCE {	1 entry, with value SRB-ToAddMod-DEFAULT using condition SRB1		
drb-ToAddModList	Not present		
drb-ToReleaseList	Not present		
mac-MainConfig CHOICE {			
explicitValue	MAC-MainConfig-SRB	See subclause 4.8.2	
}			
sps-Config	Not present		
physicalConfigDedicated	PhysicalConfigDedicated-DEFAULT using condition SRB1	See subclause 4.8.2	
}			

RadioResourceConfigDedicated-SRB2-DRB(n,m)

Table 4.6.3-16: RadioResourceConfigDedicated-SRB2-DRB(n,m)

Derivation Path: 36.331 clause 6.3.2			
Information Element	Value/remark	Comment	Condition
RadioResourceConfigDedicated-SRB2-DRB(n, m) ::= SEQUENCE {		n is the number of AM RLC DRBs (1..N) m is the number of UM RLC DRBs (0..M)	
srb-ToAddModList SEQUENCE (SIZE (1..2)) OF SEQUENCE {	1 entry		
srb-ToAddMod[1]	SRB-ToAddMod-DEFAULT using condition SRB2	See subclause 4.8.2	
}			
drb-ToAddModList SEQUENCE (SIZE (1..maxDRB)) OF SEQUENCE {	n+m entries		
drb-ToAddMod[k, k=1..n]	DRB-ToAddMod-DEFAULT (k) using condition AM	n AM RLC DRBs See subclause 4.8.2	
drb-ToAddMod[k, k=n+1..n+m]	DRB-ToAddMod-DEFAULT (k) using condition UM	m UM RLC DRBs See subclause 4.8.2	m>0
}			
drb-ToReleaseList	Not present		
mac-MainConfig CHOICE {			
explicitValue	MAC-MainConfig-RBC using condition DRX_L (note)	See subclause 4.8.2	m=0
	MAC-MainConfig-RBC using condition DRX_S (note)	See subclause 4.8.2	m>0
}			
sps-Config	Not present		
physicalConfigDedicated	PhysicalConfigDedicated - DEFAULT using condition RBC	See subclause 4.8.2	
}			
NOTE: In cases where no RLC-UM bearer is configured, large DRX Cycle length is used. In cases where at least one RLC-UM bearer is configured, small DRX Cycle length is used.			

Condition	Explanation
m=0	m is equal to zero
m>0	m is greater than zero

RadioResourceConfigDedicated-DRB(n,m)

Table 4.6.3-17: RadioResourceConfigDedicated-DRB(n,m)

Derivation Path: 36.331 clause 6.3.2			
Information Element	Value/remark	Comment	Condition
RadioResourceConfigDedicated-DRB(n, m) ::= SEQUENCE {		n is the number of AM RLC DRBs (0..N) m is the number of UM RLC DRBs (0..M)	
srb-ToAddModList	Not present		
drb-ToAddModList SEQUENCE (SIZE (1..maxDRB)) OF SEQUENCE {	n+m entries	BID is the total number of established DRBs in the UE, before applying the contents of this IE	
drb-ToAddMod[k, k=BID+1..BID+n]	DRB-ToAddMod-DEFAULT (k) using condition AM	n AM RLC DRBs See subclause 4.8.2	n>0
drb-ToAddMod[k, k= BID+1+n.. BID+n+m]	DRB-ToAddMod-DEFAULT (k) using condition UM	m UM RLC DRBs See subclause 4.8.2	m>0
}			
drb-ToReleaseList	Not present		
mac-MainConfig	Not present (note)		m=0
mac-MainConfig CHOICE {			m>0
explicitValue	MAC-MainConfig-RBC using condition DRX_S (note)	See subclause 4.8.2	
}			
sps-Config	Not present		
physicalConfigDedicated	Not present		
}			
NOTE: In cases where no RLC-UM bearer is added, existing DRX configuration is used without modification. In cases where at least one RLC-UM bearer is added, small DRX Cycle length is used.			

Condition	Explanation
n>0	n is greater than zero
m=0	m is equal to zero
m>0	m is greater than zero

– RadioResourceConfigDedicated-HO-TO-EUTRA(n,m)

Table 4.6.3-18: RadioResourceConfigDedicated-HO-TO-EUTRA(n,m)

Derivation Path: 36.331 clause 6.3.2			
Information Element	Value/remark	Comment	Condition
RadioResourceConfigDedicated-HO-TO-EUTRA(n, m) ::= SEQUENCE {		n is the number of AM RLC DRBs (1..N) m is the number of UM RLC DRBs (0..M)	
srb-ToAddModList SEQUENCE (SIZE (1..2)) OF SEQUENCE {	2 entries		
srb-ToAddMod[1]	SRB-ToAddMod-DEFAULT using condition SRB1	See subclause 4.8.2	
srb-ToAddMod[2]	SRB-ToAddMod-DEFAULT using condition SRB2	See subclause 4.8.2	
}			
drb-ToAddModList SEQUENCE (SIZE (1..maxDRB)) OF SEQUENCE {	n+m entries		
drb-ToAddMod[k, k=1..n]	DRB-ToAddMod-DEFAULT (k) using condition AM	n AM RLC DRBs See subclause 4.8.2	
drb-ToAddMod[k, k=n+1..n+m]	DRB-ToAddMod-DEFAULT (k) using condition UM	m UM RLC DRBs See subclause 4.8.2	m>0
}			
drb-ToReleaseList	Not present		
mac-MainConfig CHOICE {			
explicitValue	MAC-MainConfig-RBC using condition DRX_L (note)	See subclause 4.8.2	m=0
	MAC-MainConfig-RBC using condition DRX_S (note)	See subclause 4.8.2	m>0
}			
sps-Config	Not present		
physicalConfigDedicated	PhysicalConfigDedicated - DEFAULT using condition RBC	See subclause 4.8.2	
}			
NOTE: In cases where no RLC-UM bearer is configured, large DRX Cycle length is used. In cases where at least one RLC-UM bearer is configured, small DRX Cycle length is used.			

Condition	Explanation
m=0	m is equal to zero
m>0	m is greater than zero

- RadioResourceConfigDedicated-AM-DRB-ADD(bid)

Table 4.6.3-18A: RadioResourceConfigDedicated-AM-DRB-ADD(bid)

Derivation Path: 36.331 clause 6.3.2			
Information Element	Value/remark	Comment	Condition
RadioResourceConfigDedicated-AM-DRB-ADD(bid) ::= SEQUENCE {		bid is the bearer identity	
srb-ToAddModList	Not present		
drb-ToAddModList SEQUENCE (SIZE (1..maxDRB)) OF SEQUENCE {	one entry		
drb-ToAddMod[1]	DRB-ToAddMod-DEFAULT (bid) using condition AM	See subclause 4.8.2	
}			
drb-ToReleaseList	Not present		
mac-MainConfig	Not present		
sps-Config	Not present		
physicalConfigDedicated	Not present		
}			

- RadioResourceConfigDedicated-UM-DRB-ADD(bid)

Table 4.6.3-18B: RadioResourceConfigDedicated-UM-DRB-ADD(bid)

Derivation Path: 36.331 clause 6.3.2			
Information Element	Value/remark	Comment	Condition
RadioResourceConfigDedicated-UM-DRB-ADD(bid) ::= SEQUENCE {		bid is the bearer identity	
srb-ToAddModList	Not present		
drb-ToAddModList SEQUENCE (SIZE (1..maxDRB)) OF SEQUENCE {	one entry		
drb-ToAddMod[1]	DRB-ToAddMod-DEFAULT (bid) using condition UM	See subclause 4.8.2	
}			
drb-ToReleaseList	Not present		
mac-MainConfig CHOICE {			
explicitValue	MAC-MainConfig-RBC using condition DRX_S (note)	See subclause 4.8.2	
}			
sps-Config	Not present		
physicalConfigDedicated	Not present		
}			
NOTE: Since one RLC-UM bearer is added, small DRX Cycle length is used.			

- RadioResourceConfigDedicated- DRB-REL(bid)

Table 4.6.3-18C: RadioResourceConfigDedicated-DRB-REL(bid)

Derivation Path: 36.331 clause 6.3.2			
Information Element	Value/remark	Comment	Condition
RadioResourceConfigDedicated-DRB-REL(bid) ::= SEQUENCE {		bid is the bearer identity	
srb-ToAddModList	Not present		
drb-ToAddModList	Not present		
drb-ToReleaseList SEQUENCE (SIZE (1..maxDRB)) OF	one entry		
drb-Identity[1]	bid		
mac-MainConfig	Not present		
sps-Config	Not present		
physicalConfigDedicated	Not present		
}			

- RadioResourceConfigDedicated-HO

Table 4.6.3-19: RadioResourceConfigDedicated-HO

Derivation Path: 36.331 clause 6.3.2			
Information Element	Value/remark	Comment	Condition
RadioResourceConfigDedicated-HO ::= SEQUENCE {			
srb-ToAddModList	Not present		
drb-ToAddModList	Not present		
drb-ToReleaseList	Not present		
mac-MainConfig	Not present		
sps-Config	Not present		
physicalConfigDedicated	PhysicalConfigDedicated-DEFAULT using condition RBC-HO	See subclause 4.8.2	
}			

- RadioResourceConfigDedicatedSCell-r10-DEFAULT

Table 4.6.3-19AA: RadioResourceConfigDedicatedSCell-r10-DEFAULT

Derivation Path: 36.331 clause 6.3.2			
Information Element	Value/remark	Comment	Condition
RadioResourceConfigDedicatedSCell-r10 ::= SEQUENCE {			
physicalConfigDedicatedSCell-r10	PhysicalConfigDedicatedSCell-r10-DEFAULT		
}			

– RLC-Config-DRB-AM-RECONFIG

Table 4.6.3-19A: RLC-Config-DRB-AM-RECONFIG

Derivation Path: 36.508 table 4.8.2.1.3.2-1: RLC-Config-DRB-AM			
Information Element	Value/remark	Comment	Condition
RLC-Config-DRB-AM-RECONFIG ::= CHOICE {			
am SEQUENCE {			
ul-AM-RLC SEQUENCE {			
t-PollRetransmit	ms855		
pollPDU	p64		
pollByte	kB250		
maxRetxThreshold	t8		
}			
dl-AM-RLC SEQUENCE {			
t-Reordering	ms85		
t-StatusProhibit	ms50		
}			
}			
}			

– RLC-Config-DRB-UM-RECONFIG

Table 4.6.3-19B: RLC-Config-DRB-UM-RECONFIG

Derivation Path: 36.508 table 4.8.2.1.3.1-1: RLC-Config-DRB-UM			
Information Element	Value/remark	Comment	Condition
RLC-Config-DRB-UM-RECONFIG ::= CHOICE {			
um-Bi-Directional SEQUENCE {			
ul-UM-RLC SEQUENCE {			
sn-FieldLength	Size10		
}			
dl-UM-RLC SEQUENCE {			
sn-FieldLength	Size10		
t-Reordering	ms55		
}			
}			
}			

– RLC-Config-SRB-AM-RECONFIG

Table 4.6.3-19C: RLC-Config-SRB-AM-RECONFIG

Derivation Path: 36.331 clause 6.3.2, 9.2.1			
Information Element	Value/remark	Comment	Condition
RLC-Config-SRB-AM-RECONFIG ::= CHOICE {			
am SEQUENCE {			
ul-AM-RLC SEQUENCE {			
t-PollRetransmit	ms50		
pollPDU	pInfinity	Default	
pollByte	kBinfinity	Default	
maxRetxThreshold	t6		
}			
dl-AM-RLC SEQUENCE {			
t-Reordering	ms40		
t-StatusProhibit	ms0	Default	
}			
}			
}			

– SCellToAddMod-r10-DEFAULT

Table 4.6.3-19D: SCellToAddMod-r10-DEFAULT

Derivation Path: 36.331 clause 6.2.2			
Information Element	Value/remark	Comment	Condition
SCellToAddMod-r10 ::= SEQUENCE {			
sCellIndex-r10	Set according to specific message content		
cellIdentification-r10 SEQUENCE {			
physCellId-r10	Set according to specific message content		
dl-CarrierFreq-r10	Set according to specific message content		
}			
radioResourceConfigCommonSCell-r10	RadioResourceConfigCommonSCell-r10-DEFAULT		
radioResourceConfigDedicatedSCell-r10	RadioResourceConfigDedicatedSCell-r10-DEFAULT		
...			
}			

– SchedulingRequest-Config-DEFAULT

Table 4.6.3-20: SchedulingRequest-Config-DEFAULT

Derivation Path: 36.331 clause 6.3.2			
Information Element	Value/remark	Comment	Condition
SchedulingRequest-Config-DEFAULT ::= CHOICE {			
setup SEQUENCE {			
sr-PUCCH-ResourceIndex	See subclause 4.6.8	Channel-bandwidth-dependent parameter	
sr-ConfigIndex	30		FDD
	27		TDD
dsr-TransMax	n4		
}			
}			

Condition	Explanation
FDD	FDD cell environment
TDD	TDD cell environment

Table 4.6.3-20A: Void

– SoundingRS-UL-ConfigCommon-DEFAULT

Table 4.6.3-21: SoundingRS-UL-ConfigCommon-DEFAULT

Derivation Path: 36.331 clause 6.3.2			
Information Element	Value/remark	Comment	Condition
SoundingRS-UL-ConfigCommon-DEFAULT ::= SEQUENCE {			
setup SEQUENCE {			
-srs-BandwidthConfig	See subclause 4.6.8	Channel-bandwidth-dependent parameter	
srs-SubframeConfig	sc0	Assuming SRS density is high (see Table 5.5.3.3-1 in TS 36.211)	FDD
	sc4	Assuming SRS density is high (see Table 5.5.3.3-2 in TS 36.211)	TDD
ackNackSRS-SimultaneousTransmission	TRUE	Typical value in real network	
srs-MaxUpPts	Not Present		
}			
}			

Condition	Explanation
FDD	FDD cell environment
TDD	TDD cell environment

– SoundingRS-UL-ConfigDedicated-DEFAULT

Table 4.6.3-22: SoundingRS-UL-ConfigDedicated-DEFAULT

Derivation Path: 36.331 clause 6.3.2			
Information Element	Value/remark	Comment	Condition
SoundingRS-UL-ConfigDedicated-DEFAULT ::= CHOICE {			
setup SEQUENCE {			
srs-Bandwidth	bw0	bw0 used with no frequency hopping. bw3 used with frequency hopping	
srs-HoppingBandwidth	hbw0		
freqDomainPosition	0		
duration	TRUE		
srs-ConfigIndex	20	See Table 8.2-1 in TS 36.213	FDD
	31	INTEGER (0..1023) See Table 8.2-2 in TS 36.213	TDD
transmissionComb	0		
cyclicShift	cs0		
}			
}			

Condition	Explanation
FDD	FDD cell environment
TDD	TDD cell environment

Table 4.6.3-22AA: Void

– SoundingRS-UL-ConfigDedicatedAperiodic-r10-DEFAULT

Table 4.6.3-22AB: SoundingRS-UL-ConfigDedicatedAperiodic-r10-DEFAULT

Derivation Path: 36.331 clause 6.3.2			
Information Element	Value/remark	Comment	Condition
SoundingRS-UL-ConfigDedicatedAperiodic-r10 ::= CHOICE {			
setup SEQUENCE {			
srs-ConfigIndexAp-r10	10		
srs-ConfigApDCI-Format4-r10	Not present		
srs-ActivateAp-r10	Not present		
}			
}			

– SRB-ToAddModList-RECONFIG

Table 4.6.3-22A: SRB-ToAddModList-RECONFIG

Derivation Path: 36.331 clause 6.3.2			
Information Element	Value/remark	Comment	Condition
SRB-ToAddModList ::= SEQUENCE (SIZE (1..2)) OF SEQUENCE {	2 Entries		
srb-Identity[1]	1		
rlc-Config[1] CHOICE {			
explicitValue	RLC-Config-SRB-AM-RECONFIG		
logicalChannelConfig[1] CHOICE {			
defaultValue	NULL		
}			
srb-Identity[2]	2		
rlc-Config[2] CHOICE {			
explicitValue	RLC-Config-SRB-AM-RECONFIG		
}			
logicalChannelConfig[2] CHOICE {			
defaultValue	NULL		
}			
}			

– TDD-Config-DEFAULT

Table 4.6.3-23: TDD-Config-DEFAULT

Derivation Path: 36.331 clause 6.3.2			
Information Element	Value/remark	Comment	Condition
TDD-Config-DEFAULT ::= SEQUENCE {			
subframeAssignment	sa1		
specialSubframePatterns	Ssp6		
}			

– TPC-PDCCH-Config-DEFAULT

Table 4.6.3-24: TPC-PDCCH-Config-DEFAULT

Derivation Path: 36.331 clause 6.3.2			
Information Element	Value/remark	Comment	Condition
TPC-PDCCH-Config-DEFAULT ::= CHOICE {			
setup SEQUENCE {			
tpc-RNTI	'03FF'H		PUCCH
	'01FA'H		PUSCH
tpc-Index CHOICE {			
indexOfFormat3	1		
}			
}			
}			

Condition	Explanation
PUCCH	For PUCCH
PUSCH	For PUSCH

– UplinkPowerControlCommon-DEFAULT

Table 4.6.3-25: UplinkPowerControlCommon-DEFAULT

Derivation Path: 36.331 clause 6.3.2			
Information Element	Value/remark	Comment	Condition
UplinkPowerControlCommon-DEFAULT ::= SEQUENCE {			
p0-NominalPUSCH	-85 (-85 dBm)	Typical value in real network	
alpha	al08 (0.8)	Typical value in real network	
p0-NominalPUCCH	-117 (-117 dBm)	Thermal noise = -121 dBm NF = 5 dB IoT = 6 dB Required SNR = -7.5 dB (1-bit A/N) -> -117 dB	
deltaFList-PUCCH SEQUENCE {			
deltaF-PUCCH-Format1	deltaF0	In accordance with RAN1 simulation results	
deltaF-PUCCH-Format1b	deltaF3	In accordance with RAN1 simulation results	
deltaF-PUCCH-Format2	deltaF0	In accordance with RAN1 simulation results	
deltaF-PUCCH-Format2a	deltaF0	In accordance with RAN1 simulation results	
deltaF-PUCCH-Format2b	deltaF0	In accordance with RAN1 simulation results	
}			
deltaPreambleMsg3	4		
}			

– UplinkPowerControlCommonSCell-r10-DEFAULT

Table 4.6.3-25A: UplinkPowerControlCommonSCell-r10-DEFAULT

Derivation Path: 36.331 clause 6.3.2			
Information Element	Value/remark	Comment	Condition
UplinkPowerControlCommonSCell-r10 ::= SEQUENCE {			
p0-NominalPUSCH-r10	-85 (-85 dBm)		
alpha-r10	alpha08 (0.8)		
}			

– UplinkPowerControlCommon-v1020-DEFAULT

Table 4.6.3-25AA: UplinkPowerControlCommon-v1020-DEFAULT

Derivation Path: 36.331 clause 6.3.2			
Information Element	Value/remark	Comment	Condition
UplinkPowerControlCommon-v1020-DEFAULT ::= SEQUENCE {			
deltaF-PUCCH-Format3-r10	deltaF0		RM coding
	deltaF4		Dual RM coding
deltaF-PUCCH-Format1bCS-r10	deltaF1		
}			

Condition	Explanation
RM coding	Used for Reed-Muller coding
Dual RM coding	Used for Dual Reed-Muller coding

– UplinkPowerControlDedicated-DEFAULT

Table 4.6.3-26: UplinkPowerControlDedicated-DEFAULT

Derivation Path: 36.331 clause 6.3.2			
Information Element	Value/remark	Comment	Condition
UplinkPowerControlDedicated-DEFAULT ::= SEQUENCE {			
p0-UE-PUSCH	0		
deltaMCS-Enabled	en0		
accumulationEnabled	TRUE		
p0-UE-PUCCH	0		
pSRS-Offset	3 (-6 dB)		
filterCoefficient	fc4		
}			

– UplinkPowerControlDedicated-v1020-DEFAULT

Table 4.6.3-26A: UplinkPowerControlDedicated-v1020-DEFAULT

Derivation Path: 36.331 clause 6.3.2			
Information Element	Value/remark	Comment	Condition
UplinkPowerControlDedicated-v1020 ::= SEQUENCE {			
deltaTxD-OffsetListPUCCH-r10	Not Present		
deltaTxD-OffsetListPUCCH-r10 SEQUENCE {			TxD
deltaTxD-OffsetPUCCH-Format1-r10	dB0		
deltaTxD-OffsetPUCCH-Format1a1b-r10	dB0		
deltaTxD-OffsetPUCCH-Format2a2b-r10	dB0		
deltaTxD-OffsetPUCCH-Format3-r10	dB0		
}			
pSRS-OffsetAp-r10	0		
}			

Condition	Explanation
TxD	When PUCCH Transmission Diversity is performed.

– UplinkPowerControlDedicatedSCell-r10-DEFAULT

Table 4.6.3-26B: UplinkPowerControlDedicatedSCell-r10-DEFAULT

Derivation Path: 36.331 clause 6.3.2			
Information Element	Value/remark	Comment	Condition
UplinkPowerControlDedicatedSCell-r10 ::= SEQUENCE {			
p0-UE-PUSCH-r10	0		
deltaMCS-Enabled-r10	en0		
accumulationEnabled-r10	TRUE		
pSRS-Offset-r10	7		
pSRS-OffsetAp-r10	7		
filterCoefficient-r10	fc4		
pathlossReferenceLinking-r10	sCell		
}			

- RadioResourceConfigDedicated-DRB-Mod

Table 4.6.3-27: RadioResourceConfigDedicated-DRB-Mod

Derivation Path: 36.331 clause 6.3.2			
Information Element	Value/remark	Comment	Condition
RadioResourceConfigDedicated-DRB ::= SEQUENCE {			
srb-ToAddModList	Not present		
drb-ToAddModList	DRB-ToAddModList-RECONFIG		
}			
drb-ToReleaseList	Not present		
mac-MainConfig	Not present		
sps-Config	Not present		
physicalConfigDedicated	Not present		
}			

4.6.4 Security control information elements

– SecurityConfigHO-DEFAULT

Table 4.6.4-1: SecurityConfigHO-DEFAULT

Derivation Path: 36.331 clause 6.2,2, 6.3.3			
Information Element	Value/remark	Comment	Condition
SecurityConfigHO-DEFAULT ::= SEQUENCE {			
handoverType CHOICE {			
intraLTE SEQUENCE {			
securityAlgorithmConfig	Not present		
keyChangeIndicator	FALSE		
nextHopChainingCount	0		
}			
}			
}			

– SecurityConfigSMC-DEFAULT

Table 4.6.4-2: SecurityConfigSMC-DEFAULT

Derivation Path: 36.331 clause 6.2,2, 6.3.3			
Information Element	Value/remark	Comment	Condition
SecurityConfigSMC-DEFAULT ::= SEQUENCE {			
securityAlgorithmConfig SEQUENCE {			
cipheringAlgorithm	Set according to PIXIT parameter for default ciphering algorithm [FFS]		For SIG
	eea0		For RF
integrityProtAlgorithm	Set according to PIXIT parameter for default integrity protection algorithm [FFS]		For SIG
	spare1 or eia0-v920	This IE is set to one of the algorithms supported by the UE as indicated in the IE "UE network capability" in the ATTACH REQUEST message.	For RF
	eia1		
	eia2		
}			
}			

Condition	Explanation
For SIG	Used for signalling test cases
For RF	Used for RF/RRM test cases

4.6.5 Mobility control information elements

– MobilityControlInfo-HO

Table 4.6.5-1: MobilityControlInfo-HO

Derivation Path: 36.331 clause 6.3.4			
Information Element	Value/remark	Comment	Condition
MobilityControlInfo-HO ::= SEQUENCE {			
targetPhysCellId	Set according to specific message content		
carrierFreq	Set according to specific message content		
carrierBandwidth	Not present		SAME-BW
carrierBandwidth SEQUENCE {			DIFF-BW
dl-Bandwidth	Same downlink bandwidth as used for target cell		
ul-Bandwidth	Not present		
}			
additionalSpectrumEmission	Not present		
	1		HO-to-EUTRA
t304	ms1000		
newUE-Identity	SS arbitrarily selects a value between '003C'H and 'FFF2'H.		
radioResourceConfigCommon	RadioResourceConfigCommon-DEFAULT		
rach-ConfigDedicated	Not present		
	Rach-ConfigDedicated-DEFAULT		FullConfig, HO-to-EUTRA
}			

Condition	Explanation
SAME-BW	Source and target cell are configured with same bandwidth
DIFF-BW	Source and target cell are configured with different bandwidth

4.6.6 Measurement information elements

- MeasConfig-DEFAULT

Table 4.6.6-1: MeasConfig-DEFAULT

Derivation Path: 36.331, clause 6.3.5			
Information Element	Value/remark	Comment	Condition
MeasConfig-DEFAULT ::= SEQUENCE {			
measObjectToRemoveList	Not present		
measObjectToAddModList	Not present		
reportConfigToRemoveList	Not present		
reportConfigToAddModList	Not present		
measIdToRemoveList	Not present		
measIdToAddModList	Not present		
quantityConfig	QuantityConfig-DEFAULT		
measGapConfig	Not present		
	MeasGapConfig-GP1		INTER-FREQ, UTRAN
	MeasGapConfig-GP2		GERAN, INTER-RAT
s-Measure	Not present		
preRegistrationInfoHRPD	Not present		
speedStatePars	Not present		
}			
Note: For signalling test, table 6.5.1-1 is applied.			

Condition	Explanation
INTER-FREQ	For E-UTRA inter-freq measurements
UTRAN	For inter-RAT measurements with UTRAN
GERAN	For inter-RAT measurements with GERAN
INTER-RAT	For inter-RAT measurements with UTRAN and GERAN

- MeasGapConfig-GP1

Table 4.6.6-1A: MeasGapConfig-GP1

Derivation Path: 36.331, clause 6.3.5			
Information Element	Value/remark	Comment	Condition
MeasGapConfig-GP1 ::= CHOICE {			
setup SEQUENCE {			
gapOffset CHOICE {			
gp0	0	TGRP = 40 ms	
}			
}			
}			

- MeasGapConfig-GP2

Table 4.6.6-1B: MeasGapConfig-GP2

Derivation Path: 36.331, clause 6.3.5			
Information Element	Value/remark	Comment	Condition
MeasGapConfig-GP2 ::= CHOICE {			
setup SEQUENCE {			
gapOffset CHOICE {			
gp1	0	TGRP = 80 ms	
}			
}			
}			

- MeasObjectCDMA2000-GENERIC

Table 4.6.6-1C: MeasObjectCDMA2000-GENERIC

Derivation Path: 36.331 clause 6.3.5			
Information Element	Value/remark	Comment	Condition
MeasObjectCDMA2000-GENERIC ::= SEQUENCE {			
cdma2000-Type	As per specific message content	[type1XRTT, typeHRPD]	
carrierFreq SEQUENCE {			
bandClass	As per specific message content	Should be one of the following: bc0, bc1, bc2, bc3, bc4, bc5, bc6, bc7, bc8, bc9, bc10, bc11, bc12, bc13, bc14, bc15, bc16, bc17, spare14, spare13, spare12, spare11, spare10, spare9, spare8, spare7, spare6, spare5, spare4, spare3, spare2, spare1, ...	
arfcn	Downlink channel number	INTEGER (0 to 2047)	
}			
searchWindowSize	As per specific message content	INTEGER (0..15)	
offsetFreq	0 (0 dB)		
cellsToRemoveList	Not present		
cellsToAddModList	[Not present]		
cellForWhichToReportCGI	Not present		
}			

- MeasObjectEUTRA-GENERIC

Table 4.6.6-2: MeasObjectEUTRA-GENERIC(Freq)

Derivation Path: 36.331 clause 6.3.5			
Information Element	Value/remark	Comment	Condition
MeasObjectEUTRA-GENERIC(Freq) ::= SEQUENCE			
{			
carrierFreq	Downlink EARFCN for Freq		
allowedmeasBandwidth	The number of the resource blocks for Freq		
presenceAntennaPort1	FALSE		
neighbourCellConfig	'01'B (No MBSFN subframes are present in all neighbour cells)	MBSFN doesn't apply by default.	
offsetFreq	0 (dB 0)		
cellsToRemoveList	Not present		
cellsToAddModList	Not present		
blackCellsToRemoveList	Not present		
blackCellsToAddModList	Not present		
cellForWhichToReportCGI	Not present		
measCycleSCell-r10	sf512		SCell_EXIST
measSubframePatternConfigNeigh-r10	Not present		
}			

Condition	Explanation
SCell_EXIST	When SCell exists on the carrier frequency indicated by carrierFreq

- MeasObjectGERAN-GENERIC

Table 4.6.6-2A: MeasObjectGERAN-GENERIC(Freq)

Derivation Path: 36.331 clause 6.3.5			
Information Element	Value/remark	Comment	Condition
MeasObjectGERAN-GENERIC(Freq) ::= SEQUENCE			
{			
carrierFreqs SEQUENCE {			
startingARFCN	Downlink GERAN ARFCN of Freq		
bandIndicator	Set according to the band used for GERAN cells under test		
followingARFCNs CHOICE {			
explicitListOfARFCNs	Set the corresponding ARFCN of GERAN cells under test		
}			
}			
offsetFreq	0 (dB 0)		
ncc-Permitted	Not present		
cellForWhichToReportCGI	Not present		
}			

- MeasObjectUTRA-GENERIC

Table 4.6.6-3: MeasObjectUTRA-GENERIC(Freq)

Derivation Path: 36.331 clause 6.3.5			
Information Element	Value/remark	Comment	Condition
MeasObjectUTRA-GENERIC(Freq) ::= SEQUENCE {			
carrierFreq	Downlink UARFCN of Freq		
offsetFreq	0 (dB 0)		
cellsToRemoveList	Not present		
cellsToAddModList	Not present	For UTRA, the neighbouring cell list needs to be provided in specific test cases.	
cellForWhichToReportCGI	Not present		
}			

- QuantityConfig-DEFAULT

Table 4.6.6-3A: QuantityConfig-DEFAULT

Derivation Path: 36.331, clause 6.3.5			
Information Element	Value/remark	Comment	Condition
QuantityConfig-DEFAULT ::= SEQUENCE {			
quantityConfigEUTRA SEQUENCE {			
filterCoefficientRSRP	Not present	DEFAULT fc4	
filterCoefficientRSRQ	Not present	DEFAULT fc4	
}			
quantityConfigUTRA SEQUENCE {}	Not present		
quantityConfigUTRA SEQUENCE {			UTRAN
measQuantityUTRA-FDD	cpich-EcN0		
measQuantityUTRA-TDD	pccpch-RSCP		
filterCoefficient	Not present	DEFAULT fc4	
}			
quantityConfigGERAN SEQUENCE {}	Not present		
quantityConfigGERAN SEQUENCE {			GERAN
measQuantityGERAN	rssi		
filterCoefficient	Not present	DEFAULT fc2	
}			
quantityConfigCDMA2000 SEQUENCE {}	Not present		
quantityConfigCDMA2000 SEQUENCE {			CDMA2000
measQuantityCDMA2000	[FFS]		
}			
}			

Condition	Explanation
UTRAN	For inter-RAT measurements with UTRAN
GERAN	For inter-RAT measurements with GERAN
CDMA2000	For inter-RAT measurements with CDMA2000

- ReportConfigEUTRA-A1

Table 4.6.6-4: ReportConfigEUTRA-A1(Thres)

Derivation Path: 36.331 clause 6.3.5			
Information Element	Value/remark	Comment	Condition
ReportConfigEUTRA-A1(Thres) ::= SEQUENCE {			
triggerType CHOICE {			
event SEQUENCE {			
eventId CHOICE {			
eventA1 SEQUENCE {			
a1-Threshold CHOICE {			
threshold-RSRP	Thres+140	Thres is actual threshold value in dBm	
}			
}			
}			
hysteresis	0 (0 dB)		
timeToTrigger	ms256		
}			
triggerQuantity	rsrp		
reportQuantity	both		
maxReportCells	1		
reportInterval	ms1024		
reportAmount	r1		
}			

- ReportConfigEUTRA-A2

Table 4.6.6-5: ReportConfigEUTRA-A2(Thres)

Derivation Path: 36.331 clause 6.3.5			
Information Element	Value/remark	Comment	Condition
ReportConfigEUTRA-A2(Thres) ::= SEQUENCE {			
triggerType CHOICE {			
event SEQUENCE {			
eventId CHOICE {			
eventA2 SEQUENCE {			
a2-Threshold CHOICE {			
threshold-RSRP	Thres+140	Thres is actual threshold value in dBm	
}			
}			
}			
hysteresis	0 (0 dB)		
timeToTrigger	ms320		
}			
triggerQuantity	rsrp		
reportQuantity	both		
maxReportCells	1		
reportInterval	ms1024		
reportAmount	r1		
}			

- ReportConfigEUTRA-A3

Table 4.6.6-6: ReportConfigEUTRA-A3

Derivation Path: 36.331 clause 6.3.5			
Information Element	Value/remark	Comment	Condition
ReportConfigEUTRA-A3 ::= SEQUENCE {			
triggerType CHOICE {			
event SEQUENCE {			
eventId CHOICE {			
eventA3 SEQUENCE {			
a3-Offset	0 (0 dB)	To reduce interference between intra-frequency multiple cells	
reportOnLeave	FALSE		
}			
}			
hysteresis	0 (0 dB)		
timeToTrigger	ms640		
}			
triggerQuantity	rsrp		
reportQuantity	both		
maxReportCells	1		
reportInterval	ms1024		
reportAmount	r1		
}			

- ReportConfigEUTRA-A6

Table 4.6.6-6A: ReportConfigEUTRA-A6

Derivation Path: 36.331 clause 6.3.5			
Information Element	Value/remark	Comment	Condition
ReportConfigEUTRA-A6 ::= SEQUENCE {			
triggerType CHOICE {			
event SEQUENCE {			
eventId CHOICE {			
eventA6-r10 SEQUENCE {			
a6-Offset-r10	0 (0 dB)		
a6-ReportOnLeave-r10	FALSE		
}			
}			
hysteresis	0 (0 dB)		
timeToTrigger	ms640		
}			
triggerQuantity	rsrp		
reportQuantity	both		
maxReportCells	1		
reportInterval	ms1024		
reportAmount	r1		
si-RequestForHO-r9	Not Present		
ue-RxTxTimeDiffPeriodical-r9	Not Present		
includeLocationInfo-r10	Not Present		
reportAddNeighMeas-r10	Not Present		
}			

- ReportConfigEUTRA-PERIODICAL

Table 4.6.6-7: ReportConfigEUTRA-PERIODICAL

Derivation Path: 36.331 clause 6.3.5			
Information Element	Value/remark	Comment	Condition
ReportConfigEUTRA-PERIODICAL ::= SEQUENCE {			
triggerType CHOICE {			
periodical SEQUENCE {			
purpose	reportStrongestCells		
}			
}			
triggerQuantity	rsrp		
reportQuantity	both		
maxReportCells	1		
reportInterval	ms1024		
reportAmount	infinity		
}			

- ReportConfigInterRAT-B1-GERAN

Table 4.6.6-7A: ReportConfigInterRAT-B1-GERAN(GERAN-Thres)

Derivation Path: 36.331 clause 6.3.5			
Information Element	Value/remark	Comment	Condition
ReportConfigInterRAT-B1-GERAN(GERAN-Thres) ::= SEQUENCE {			
triggerType CHOICE {			
event SEQUENCE {			
eventId CHOICE {			
eventB1 SEQUENCE {			
b1-Threshold CHOICE {			
b1-ThresholdGERAN	(GERAN-Thres + 110)	GERAN-Thres is actual value in dBm	
}			
}			
}			
hysteresis	FFS	INTEGER(0..30)	
timeToTrigger	ms0		
}			
maxReportCells	6	In line with RAN4 requirement	
reportInterval	ms1024		
reportAmount	r1		
}			

- ReportConfigInterRAT-B1-UTRA

Table 4.6.6-7B: ReportConfigInterRAT-B1-UTRA(UTRA-Thres)

Derivation Path: 36.331 clause 6.3.5			
Information Element	Value/remark	Comment	Condition
ReportConfigInterRAT-B1-UTRA(UTRA-Thres) ::= SEQUENCE {			
triggerType CHOICE {			
event SEQUENCE {			
eventId CHOICE {			
eventB1 SEQUENCE {			
b1-Threshold CHOICE {			
b1-ThresholdUTRA CHOICE {			
utra-EcN0	(UTRA-Thres * 2 + 49)	UTRA-Thres is actual Ec/NO value in dB	UTRA-FDD
utra-RSCP	UTRA-Thres + 115	UTRA-Thres is actual RSCP value in dBm	UTRA-TDD
}			
}			
}			
}			
}			
hysteresis	3 (1.5 dB)		
timeToTrigger	ms0		
}			
}			
maxReportCells	6	In line with RAN4 requirement	
reportInterval	ms1024		
reportAmount	r1		
}			

Condition	Explanation
UTRA-FDD	UTRA FDD cell environment
UTRA-TDD	UTRA TDD cell environment

- ReportConfigInterRAT-B2-CDMA2000

Table 4.6.6-7C: ReportConfigInterRAT-B2-CDMA2000(EUTRA-Thres, CDMA2000-Thres)

Derivation Path: 36.331 clause 6.3.5			
Information Element	Value/remark	Comment	Condition
ReportConfigInterRAT-B2-CDMA2000(EUTRA-Thres, CDMA2000-Thres) ::= SEQUENCE {			
triggerType CHOICE {			
event SEQUENCE {			
eventId CHOICE {			
eventB2 SEQUENCE {			
b2-Threshold1 CHOICE {			
threshold-RSRP	EUTRA-Thres+140	EUTRA-Thres is actual threshold value in dBm	
}			
b2-Threshold2 CHOICE {			
b2-Threshold2CDMA2000	[30 (-15 dB)]	Integer (0..63)	
}			
}			
}			
hysteresis	[2 (1 dB)]	INTEGER(0..30)	
timeToTrigger	ms0		
}			
maxReportCells	[8]		
reportInterval	[ms2048]	Range: ms120, ms240, ms480, ms640, ms1024, ms2048, ms5120, ms10240, min1, min6, min12, min30, min60, spare3, spare2, spare1	
reportAmount	[r1]	Range: r1, r2, r4, r8, r16, r32, r64, infinity	
}			

Table 4.6.6-7D: void

- ReportConfigInterRAT-B2-GERAN

Table 4.6.6-7E: ReportConfigInterRAT-B2-GERAN(EUTRA-Thres, GERAN-Thres)

Derivation Path: 36.331 clause 6.3.5			
Information Element	Value/remark	Comment	Condition
ReportConfigInterRAT-B2-GERAN(EUTRA-Thres, GERAN-Thres) ::= SEQUENCE {			
triggerType CHOICE {			
event SEQUENCE {			
eventId CHOICE {			
eventB2 SEQUENCE {			
b2-Threshold1 CHOICE {			
threshold-RSRP	EUTRA-Thres+140	EUTRA-Thres is actual threshold value in dBm	
}			
b2-Threshold2 CHOICE {			
b2-Threshold2GERAN	GERAN-Thres + 110	GERAN-Thres is actual value in dBm	
}			
}			
}			
hysteresis	FFS	INTEGER(0..30)	
timeToTrigger	ms0		
}			
maxReportCells	6	In line with RAN4 requirement	
reportInterval	ms1024		
reportAmount	r1		
}			

- ReportConfigInterRAT-B2-UTRA

Table 4.6.6-8: ReportConfigInterRAT-B2-UTRA(EUTRA-Thres, UTRA-Thres)

Derivation Path: 36.331 clause 6.3.5			
Information Element	Value/remark	Comment	Condition
ReportConfigInterRAT-B2-UTRA(EUTRA-Thres, UTRA-Thres) ::= SEQUENCE {			
triggerType CHOICE {			
event SEQUENCE {			
eventId CHOICE {			
eventB2 SEQUENCE {			
b2-Threshold1 CHOICE {			
threshold-RSRP	EUTRA-Thres+140	EUTRA-Thres is actual threshold value in dBm	
}			
b2-Threshold2 CHOICE {			
b2-Threshold2UTRA CHOICE {			
utra-EcN0	UTRA-Thres * 2 + 49	UTRA-Thres is actual Ec/NO value in dB	UTRA-FDD
utra-RSCP	UTRA-Thres + 115	UTRA-Thres is actual RSCP value in dBm	UTRA-TDD
}			
}			
}			
}			
hysteresis	3 (1.5 dB)		
timeToTrigger	ms0		
}			
}			
maxReportCells	6	In line with RAN4 requirement	
reportInterval	ms1024		
reportAmount	r1		
}			

Condition	Explanation
UTRA-FDD	UTRA FDD cell environment
UTRA-TDD	UTRA TDD cell environment

- ReportConfigInterRAT-PERIODICAL

Table 4.6.6-9: ReportConfigInterRAT-PERIODICAL

Derivation Path: 36.331 clause 6.3.5			
Information Element	Value/remark	Comment	Condition
ReportConfigInterRAT-PERIODICAL ::= SEQUENCE {			
triggerType CHOICE {			
periodical SEQUENCE {			
purpose	reportStrongestCells		
}			
}			
maxReportCells	1		
reportInterval	ms1024		
reportAmount	infinity		
}			

4.6.7 Other information elements

– RRC-TransactionIdentifier-DL

Table 4.6.7-1: RRC-TransactionIdentifier-DL

Derivation Path: 36.331 clause 6.3.6			
Information Element	Value/remark	Comment	Condition
RRC-TransactionIdentifier-DL ::=	0..3		

– RRC-TransactionIdentifier-UL

Table 4.6.7-2: RRC-TransactionIdentifier-UL

Derivation Path: 36.331 clause 6.3.6			
Information Element	Value/remark	Comment	Condition
RRC-TransactionIdentifier-UL ::=	0..3	The same value as the value of RRC-TransactionIdentifier-DL in the downlink message initiating the procedure	

4.6.8 Channel-bandwidth-dependent parameters

The default values of parameters which depend on the channel bandwidth are defined in table 4.6.8-1.

Table 4.6.8-1: Channel-bandwidth-dependent parameters

Information Element	Channel bandwidth						Comment
	1.4 MHz	3 MHz	5 MHz	10 MHz	15 MHz	20MHz	
Prach-FrequencyOffset	FFS	FFS	2	4	6	8	Typical value in real network
nRB-CQI	FFS	FFS	2	4	6	8	Selected based on typical maximum number of UEs.
Pusch-HoppingOffset	FFS	FFS	4	8	12	16	Typical value in real network
sr-PUCCH-ResourceIndex	FFS	FFS	20	41	62	84	
srs-BandwidthConfig	FFS	FFS	bw3 ($m_{SRS,b}$, N_b) = (20, 1), (4, 5), (4, 1), (4, 1)	bw2 ($m_{SRS,b}$, N_b) = (40, 1), (20, 2), (4, 5), (4, 1)	bw2 ($m_{SRS,b}$, N_b) = (60, 1), (20, 3), (4, 5), (4, 1)	bw2 ($m_{SRS,b}$, N_b) = (80, 1), (40, 2), (20, 2), (4, 5)	Selected in accordance with pucch-ResourceSize.

4.7 Default NAS message and information element contents

This clause contains the default values of common NAS messages and information elements, which apply to all test cases unless otherwise specified. All the messages and information elements are listed in alphabetical order.

4.7.1 Security protected NAS messages

In subclauses 4.7.2 and 4.7.3 in this document, all the NAS messages are described in the plain NAS message format.

When a NAS message is security protected, the message shall be contained by SECURITY PROTECTED NAS MESSAGE unless contained by another NAS message.

The default contents of SECURITY PROTECTED NAS MESSAGE message are defined in table 4.7.1-1.

Table 4.7.1-1: SECURITY PROTECTED NAS MESSAGE

Derivation Path: 24.301 clause 8.2.23			
Information Element	Value/remark	Comment	Condition
Protocol discriminator	EMM		
Security header type	'0001'B	Integrity protected	UNCIPHERED
	'0010'B	Integrity protected and ciphered	CIPHERED
	'0011'B	Integrity protected with new EPS security context	UNCIPHERED-NEW
	'0100'B	Integrity protected and ciphered with new EPS security context	CIPHERED-NEW
Message authentication code	The calculated value of MAC-I for this message.	The value of MAC-I is calculated by SS using Sequence number sent by UE.	SENT-BY-SS
	The same value as the XMAC-I value calculated by SS.		SENT-BY-UE
Sequence number	The internal counter of the SS		SENT-BY-SS
	Any allowed value		SENT-BY-UE
NAS message	Set according to specific message content		

Condition	Explanation
UNCIPHERED	This condition applies to unciphered NAS message exchange
CIPHERED	This condition applies to ciphered NAS message exchange
UNCIPHERED-NEW	This condition applies to unciphered NAS message exchange with new EPS security context
CIPHERED-NEW	This condition applies to ciphered NAS message exchange with new EPS security context
SENT-BY-SS	Use for the message sent from SS to UE
SENT-BY-UE	Use for the message sent from UE to SS

4.7.2 Contents of EMM messages

- ATTACH ACCEPT

This message is sent by the SS to the UE.

Table 4.7.2-1: ATTACH ACCEPT

Derivation Path: 24.301 clause 8.2.1			
Information Element	Value/remark	Comment	Condition
Protocol discriminator	EMM		
Security header type	'0000'B	Plain NAS message, not security protected	
Attach accept message identity	'0100 0010'B	Attach accept	
EPS attach result	'0001'B	EPS only	EPS_only
	'0010'B	combined EPS/IMSI attach	combined_EPS_IMSI
Spare half octet	'0000'B		
T3412 value			
Timer value	'0 0000'B		
Unit	'111'B	value indicates that the timer is deactivated.	
TAI list			
Length of tracking area identity list contents	'0000 0110'B	6 octets	
Partial tracking area identity list 1			
Number of elements	'0 0000'B	1 element	
Type of list	'00'B	list of TACs belonging to one PLMN, with non-consecutive TAC values	
MCC	See table 4.4.2-2 in this document	For NAS test cases, see table 6.3.2.2-1.	
MNC	See table 4.4.2-2 in this document	For NAS test cases, see table 6.3.2.2-1.	
TAC 1	See table 4.4.2-2 in this document	For NAS test cases, see table 6.3.2.2-1.	
ESM message container	ACTIVATE DEFAULT EPS BEARER CONTEXT REQUEST message to activate the default bearer		
GUTI			
Length of EPS mobile identity contents	'0000 1011'B	11 octets	
Type of identity	'110'B	GUTI	
Odd/even indication	'0'B	even number of identity digits and also when the GUTI is used	
MCC	See table 4.4.2-2 in this document	For NAS test cases, see table 6.3.2.2-1.	
MNC	See table 4.4.2-2 in this document	For NAS test cases, see table 6.3.2.2-1.	
MME Group ID	See table 4.4.2-2 in this document	For NAS test cases, see table 6.3.2.2-1.	
MME Code	See table 4.4.2-2 in this document	For NAS test cases, see table 6.3.2.2-1.	

M-TMSI	See table 4.4.2-2 in this document	For NAS test cases, see table 6.3.2.2-1.	
Location area identification	Not present		EPS_only
Location area identification			combined_E PS_IMSI
MCC	MCC of the EUTRA cell from which this message is sent		
MNC	MCC of the EUTRA cell from which this message is sent		
LAC	1		
MS identity	Not present		EPS_only
MS identity			combined_E PS_IMSI
Length of mobile identity contents	'0000 0101'B	5 octets	
Type of identity	'100'B	TMSI/P-TMSI/M-TMSI	
Odd/even indication	'0'B	even number of identity digits and also when the TMSI/P-TMSI or TMGI and optional MBMS Session Identity is used	
TMSI	TMSI-1		
EMM cause	Not present		
T3402 value	Not present		
T3423 value	Not present		
Equivalent PLMNs	Not present		
Emergency number list	Not present		
EPS network feature support	'0000 0001'B	IMS voice over PS session in S1 mode supported	
EPS network feature support	'0000 0011'B	IMS voice over PS session in S1 mode supported, emergency bearer services in S1 mode supported	Rel-9
Additional update result	Not present		
Additional update result	'10' B	"SMS only"	additional_u pdate_result _SMS

Condition	Explanation
EPS_only	This condition applies if the UE is configured to initiate EPS attach or if explicitly specified.
combined_EPS_IMSI	This condition applies if the UE is configured to initiate combined EPS/IMSI attach or if explicitly specified.
additional_update_result_SMS	If the UE requested "SMS only" in the Additional update type IE and combined_EPS_IMSI condition applies

NOTE: This message is always sent within SECURITY PROTECTED NAS MESSAGE message.

- ATTACH COMPLETE

This message is sent by the UE to the SS.

Table 4.7.2-2: ATTACH COMPLETE

Derivation Path: 24.301 clause 8.2.2			
Information Element	Value/remark	Comment	Condition
Protocol discriminator	EMM		
Security header type	'0000'B	Plain NAS message, not security protected	
Attach complete message identity	'0100 0011'B	Attach complete	
ESM message container	ACTIVATE DEFAULT EPS BEARER CONTEXT ACCEPT message		

NOTE: This message is always sent within SECURITY PROTECTED NAS MESSAGE message.

- ATTACH REJECT

This message is sent by the SS to the UE.

Table 4.7.2-3: ATTACH REJECT

Derivation Path: 24.301 clause 8.2.3			
Information Element	Value/remark	Comment	Condition
Protocol discriminator	EMM		
Security header type	'0000'B	Plain NAS message, not security protected	
Attach reject message identity	'0100 0100'B	Attach reject	
EMM cause	Set according to specific message content.		
ESM message container	Set according to specific message content.		

NOTE: If this message includes the EMM cause set to #25, it is sent within SECURITY PROTECTED NAS MESSAGE message. Otherwise this message is sent without integrity protection.

- ATTACH REQUEST

This message is sent by the UE to the SS.

Table 4.7.2-4: ATTACH REQUEST

Derivation Path: 24.301 clause 8.2.4			
Information Element	Value/remark	Comment	Condition
Protocol discriminator	EMM		
Security header type	'0000'B	Plain NAS message, not security protected	
Attach request message identity	'0100 0001'B	Attach request	
EPS attach type	'0001'B	EPS attach	EPS_only
	'0010'B	combined EPS/IMSI attach	combined_EPS_IMSI
NAS key set identifier	Any allowed value		
Old GUTI or IMSI	Any allowed value		
UE network capability	Any allowed value		
ESM message container	PDN CONNECTIVITY REQUEST message to request PDN connectivity to the default PDN		
Old P-TMSI signature	Not present or any allowed value		
Additional GUTI	Not present or any allowed value		
Last visited registered TAI	Not present or any allowed value		
DRX parameter	Not present or any allowed value		
MS network capability	Not present or any allowed value		
Old location area identification	Not present or any allowed value		
TMSI status	Not present or any allowed value		
Mobile station classmark 2	Not present or any allowed value		
Mobile station classmark 3	Not present or any allowed value		
Supported Codecs	Not present or any allowed value		
Additional update type	Not present		EPS_only
Additional update type	Not present or any allowed value		combined_EPS_IMSI
Old GUTI type	Not present or any allowed value		

Condition	Explanation
EPS_only	See the definition below table 4.7.2-1.
combined_EPS_IMSI	See the definition below table 4.7.2-1.

NOTE: This message is sent integrity protected when a valid security context exists and without integrity protection otherwise.

- AUTHENTICATION FAILURE

This message is sent by the UE to the SS.

Table 4.7.2-5: AUTHENTICATION FAILURE

Derivation Path: 24.301 clause 8.2.5			
Information Element	Value/remark	Comment	Condition
Protocol discriminator	EMM		
Security header type	'0000'B	Plain NAS message, not security protected	
Authentication failure message type	'0101 1100'B	Authentication failure	
EMM cause	'0001 0100'B	Mac failure	
Authentication failure parameter	Not present	See TS 24.301 [28] subclause 8.2.5.2	

NOTE: The security protection of this message is the same as the previous AUTHENTICATION REQUEST message.

- AUTHENTICATION REJECT

This message is sent by the SS to the UE.

Table 4.7.2-6: AUTHENTICATION REJECT

Derivation Path: 24.301 clause 8.2.6			
Information Element	Value/remark	Comment	Condition
Protocol discriminator	EMM		
Security header type	'0000'B	Plain NAS message, not security protected	
Authentication reject message type	'0101 0100'B	Authentication reject	

NOTE: This message is sent without integrity protection.

- AUTHENTICATION REQUEST

This message is sent by the SS to the UE.

Table 4.7.2-7: AUTHENTICATION REQUEST

Derivation Path: 24.301 clause 8.2.7			
Information Element	Value/remark	Comment	Condition
Protocol discriminator	EMM		
Security header type	'0000'B	Plain NAS message, not security protected	
Authentication request message type	'0101 0010'B	Authentication request	
NAS key set identifier _{ASME}			
NAS key set identifier	An arbitrarily selected value between '000'B and '110'B, different from the valid NAS key set identifier of the UE if such a value exists.		
TSC	'0'B	native security context (for KSI _{ASME})	
Spare half octet	'0000'B		
Authentication parameter RAND (EPS challenge)	An arbitrarily selected 128 bits value		
Authentication parameter AUTN (EPS challenge)	See TS 24.301 [28] subclause 9.9.3.2		

NOTE: Within a test execution this message is sent without integrity protection before NAS security mode control procedure has been successfully completed; and sent integrity protected and ciphered within SECURITY PROTECTED NAS MESSAGE message after NAS security mode control procedure has been successfully completed. SS does not maintain information for NAS security mode control procedure after a TC is completed.

- AUTHENTICATION RESPONSE

This message is sent by the UE to the SS.

Table 4.7.2-8: AUTHENTICATION RESPONSE

Derivation Path: 24.301 clause 8.2.8			
Information Element	Value/remark	Comment	Condition
Protocol discriminator	EMM		
Security header type	'0000'B	Plain NAS message, not security protected	
Authentication response message type	'0101 0011'B	Authentication response	
Authentication response parameter	See TS 24.301 [28] subclause 9.9.3.4		

NOTE: When sent in response to an AUTHENTICATION REQUEST message which is not integrity protected and not ciphered, the AUTHENTICATION RESPONSE message may be sent integrity protected when a valid security context exists and without integrity protection otherwise.

- CS SERVICE NOTIFICATION

This message is sent by the SS to the UE.

Table 4.7.2-8A: CS SERVICE NOTIFICATION

Derivation Path: 24.301 clause 8.2.9			
Information Element	Value/remark	Comment	Condition
Protocol discriminator	EMM		
Security header type	'0000'B	Plain NAS message, not security protected	
CS service notification message identity	'01100100'B	CS Service notification	
Paging identity	'1'B	TMSI	
CLI	Not present		
SS Code	Not present		
LCS indicator	Not present		
LCS client identity	Not present		

NOTE: This message is always sent within SECURITY PROTECTED NAS MESSAGE message.

- DETACH ACCEPT (UE originating detach)

This message is sent by the SS to the UE.

Table 4.7.2-9: DETACH ACCEPT

Derivation Path: 24.301 clause 8.2.10.1			
Information Element	Value/remark	Comment	Condition
Protocol discriminator	EMM		
Security header type	'0000'B	Plain NAS message, not security protected	
Detach accept message identity	'0100 0110'B	Detach accept	

NOTE: This message is sent using the same security protection as in the previous DETACH REQUEST message received from the UE.

- DETACH ACCEPT (UE terminated detach)

This message is sent by the UE to the SS.

Table 4.7.2-10: DETACH ACCEPT

Derivation Path: 24.301 clause 8.2.10.2			
Information Element	Value/remark	Comment	Condition
Protocol discriminator	EMM		
Security header type	'0000'B	Plain NAS message, not security protected	
Detach accept message identity	'0100 0110'B	Detach accept	

NOTE: This message is sent without integrity protection before NAS security mode control procedure has been successfully completed and sent within SECURITY PROTECTED NAS MESSAGE message after NAS security mode control procedure has been successfully completed.

- DETACH REQUEST (UE originating detach)

This message is sent by the UE to the SS.

Table 4.7.2-11: DETACH REQUEST

Derivation Path: 24.301 clause 8.2.11.1			
Information Element	Value/remark	Comment	Condition
Protocol discriminator	EMM		
Security header type	'0000'B	Plain NAS message, not security protected	
Detach request message identity	'0100 0101'B	Detach request	
Detach type			
Type of detach	'001'B	EPS detach	EPS_only
	'011'B	combined EPS/IMSI detach	Combined_EPS_IMSI
Switch off	'1'B	switch off	
NAS key set identifier			
NAS key set identifier	The valid NAS key set identifier.		
TSC	Any Value		
GUTI or IMSI	If the UE has a valid GUTI, set to the GUTI, otherwise set to the IMSI of the UE.		

Condition	Explanation
EPS_only	See the definition below table 4.7.2-1.
Combined_EPS_IMSI	See the definition below table 4.7.2-1.

NOTE: This message is sent with integrity protection before SS has started the ciphering and integrity and ciphered protected after SS has started the ciphering.

- DETACH REQUEST (UE terminated detach)

This message is sent by the SS to the UE.

Table 4.7.2-12: DETACH REQUEST

Derivation Path: 24.301 clause 8.2.11.2			
Information Element	Value/remark	Comment	Condition
Protocol discriminator	EMM		
Security header type	'0000'B	Plain NAS message, not security protected	
Detach request message identity	'0100 0101'B	Detach request	
Detach type	Set according to specific message content.		
Spare half octet	'0000'B		
EMM cause	Set according to specific message content.		

NOTE: This message is always sent within SECURITY PROTECTED NAS MESSAGE message.

- DOWNLINK NAS TRANSPORT

This message is sent by the SS to the UE.

Table 4.7.2-12A: DOWNLINK NAS TRANSPORT

Derivation Path: 24.301 clause 8.2.12			
Information Element	Value/remark	Comment	Condition
Protocol discriminator	EMM		
Security header type	'0000'B	Plain NAS message, not security protected	
Downlink NAS transport message identity	'0110 0010'B	Downlink NAS transport	
NAS message container	Set according to specific message content		

NOTE: This message is always sent within SECURITY PROTECTED NAS MESSAGE message.

- EMM INFORMATION

This message is sent by the SS to the UE.

Table 4.7.2-13: EMM INFORMATION

Derivation Path: 24.301 clause 8.2.13			
Information Element	Value/remark	Comment	Condition
Protocol discriminator	EMM		
Security header type	'0000'B	Plain NAS message, not security protected	
EMM information message identity	'0110 0001'B	EMM information	
Full name for network	Set according to specific message content.		
Short name for network	Set according to specific message content.		
Local time zone	Set according to specific message content.		
Universal time and local time zone	Set according to specific message content.		
Network daylight saving time	Set according to specific message content.		

NOTE: This message is always sent within SECURITY PROTECTED NAS MESSAGE message.

- EMM STATUS

This message is sent by the UE or by the SS.

Table 4.7.2-14: EMM STATUS

Derivation Path: 24.301 clause 8.2.14			
Information Element	Value/remark	Comment	Condition
Protocol discriminator	EMM		
Security header type	'0000'B	Plain NAS message, not security protected	
EMM status message identity	'0110 0000'B	EMM status	
EMM cause	Set according to specific message content.		

NOTE: This message is always sent within SECURITY PROTECTED NAS MESSAGE message.

- EXTENDED SERVICE REQUEST

This message is sent by the UE to the SS.

Table 4.7.2-14A: EXTENDED SERVICE REQUEST

Derivation Path: 24.301 clause 8.2.15			
Information Element	Value/remark	Comment	Condition
Protocol discriminator	EMM		
Security header type	'0000'B	Plain NAS message, not security protected	
Extended service request message identity	'0100 1100'B	Extended service request	
Service type	'0001'B	mobile terminating CS fallback or 1xCS fallback	
NAS key set identifier			
NAS key set identifier	The valid NAS key set identifier.		
TSC	'0'B	native security context (for KSI _{ASME})	
M-TMSI	If the UE has a valid M-TMSI, set to the M-TMSI, otherwise set to the IMSI of the UE.		
CSFB response	'001'B	CS fallback accepted by the UE	

NOTE: This message is always sent within SECURITY PROTECTED NAS MESSAGE message.

- GUTI REALLOCATION COMMAND

This message is sent by the SS to the UE.

Table 4.7.2-15: GUTI REALLOCATION COMMAND

Derivation Path: 24.301 clause 8.2.16			
Information Element	Value/remark	Comment	Condition
Protocol discriminator	EMM		
Security header type	'0000'B	Plain NAS message, not security protected	
GUTI reallocation command message identity	'0101 0000'B	GUTI reallocation command	
GUTI	Set according to specific message content.		
TAI list	Set according to specific message content.		

NOTE: This message is always sent within SECURITY PROTECTED NAS MESSAGE message.

- **GUTI REALLOCATION COMPLETE**

This message is sent by the UE to the SS.

Table 4.7.2-16: GUTI REALLOCATION COMPLETE

Derivation Path: 24.301 clause 8.2.17			
Information Element	Value/remark	Comment	Condition
Protocol discriminator	EMM		
Security header type	'0000'B	Plain NAS message, not security protected	
GUTI reallocation complete message identity	'0101 0001'B	GUTI reallocation complete	

NOTE: This message is always sent within SECURITY PROTECTED NAS MESSAGE message.

- **IDENTITY REQUEST**

This message is sent by the SS to the UE.

Table 4.7.2-17: IDENTITY REQUEST

Derivation Path: 24.301 clause 8.2.18			
Information Element	Value/remark	Comment	Condition
Protocol discriminator	EMM		
Security header type	'0000'B	Plain NAS message, not security protected	
Identity request message identity	'0101 0101'B	Identity request	
Identity type	'0001'B	IMSI	
Spare half octet	'0000'B		

NOTE: This message is sent without integrity protection before NAS security mode control procedure has been successfully completed and sent within SECURITY PROTECTED NAS MESSAGE message after NAS security mode control procedure has been successfully completed.

- **IDENTITY RESPONSE**

This message is sent by the UE to the SS.

Table 4.7.2-18: IDENTITY RESPONSE

Derivation Path: 24.301 clause 8.2.19			
Information Element	Value/remark	Comment	Condition
Protocol discriminator	EMM		
Security header type	'0000'B	Plain NAS message, not security protected	
Identity response message	'0101 0110'B	Identity response	
Mobile identity	IMSI of the UE		

NOTE: This message is sent without integrity protection before NAS security mode control procedure has been successfully completed and sent within SECURITY PROTECTED NAS MESSAGE message after NAS security mode control procedure has been successfully completed.

SECURITY MODE COMMAND

This message is sent by the SS to the UE.

Table 4.7.2-19: SECURITY MODE COMMAND

Derivation Path: 24.301 clause 8.2.20			
Information Element	Value/remark	Comment	Condition
Protocol discriminator	EMM		
Security header type	'0000'B	Plain NAS message, not security protected	
Security mode command message identity	'0101 1101'B	Security mode command	
Selected NAS security algorithms			
Type of integrity protection algorithm	Set according to PIXIT parameter for default integrity protection algorithm [FFS]		For SIG
	0(reserved or eia0)	This IE is set to one of the algorithms supported by the UE as indicated in the IE "UE network capability" in the ATTACH REQUEST message.	For RF
	eia1		
	eia2		
Type of ciphering algorithm	Set according to PIXIT parameter for default ciphering algorithm [FFS]		For SIG
	eea0		For RF
NAS key set identifier			
NAS key set identifier	The valid NAS key set identifier.		
TSC	'0'B	native security context (for KSI _{ASME})	
Spare half octet	'0000'B		
Replayed UE security capabilities	Set according to the received UE security capabilities		
IMEISV request	Not present		
Replayed nonce _{UE}	Not present		
Nonce _{MME}	Not present		

Condition	Explanation
For SIG	Used for signalling test cases
For RF	Used for RF/RRM test cases

NOTE: This message is always sent integrity protected with new EPS security context.

- SECURITY MODE COMPLETE

This message is sent by the UE to the SS.

Table 4.7.2-20: SECURITY MODE COMPLETE

Derivation Path: 24.301 clause 8.2.21			
Information Element	Value/remark	Comment	Condition
Protocol discriminator	EMM		
Security header type	'0000'B	Plain NAS message, not security protected	
Security mode complete message identity	'0101 1110'B	Security mode complete	
IMEISV	Not present		

NOTE: This message is always sent within SECURITY PROTECTED NAS MESSAGE message with new EPS security context.

- SECURITY MODE REJECT

This message is sent by the UE to the SS.

Table 4.7.2-21: SECURITY MODE REJECT

Derivation Path: 24.301 clause 8.2.22			
Information Element	Value/remark	Comment	Condition
Protocol discriminator	EMM		
Security header type	'0000'B	Plain NAS message, not security protected	
Security mode reject message identity	'0101 1111'B	Security mode reject	
EMM cause	The value is set according to specific message content.		

NOTE: This message is sent without integrity protection before NAS security mode control procedure has been successfully completed and sent within SECURITY PROTECTED NAS MESSAGE message after NAS security mode control procedure has been successfully completed.

- SERVICE REJECT

This message is sent by the SS to the UE.

Table 4.7.2-22: SERVICE REJECT

Derivation Path: 24.301 clause 8.2.24			
Information Element	Value/remark	Comment	Condition
Protocol discriminator	EMM		
Security header type	'0000'B	Plain NAS message, not security protected	
Service reject message identity	'0100 1110'B	Service reject	
EMM cause	Set according to specific message content.		
T3442 value	Not present		

NOTE: If this message includes the EMM cause set to #25, it is sent within SECURITY PROTECTED NAS MESSAGE message. Otherwise this message is sent without integrity protection.

- SERVICE REQUEST

This message is sent by the UE to the SS.

Table 4.7.2-23: SERVICE REQUEST

Derivation Path: 24.301 clause 8.2.25			
Information Element	Value/remark	Comment	Condition
Protocol discriminator	EMM		
Security header type	'1100'B	Security header for the SERVICE REQUEST message	
KSI and sequence number			
Sequence number (short)	The 5 least significant bits of the NAS COUNT value applicable when this message is sent for sequence number.		
KSI	The effective KSI value.		
Message authentication code (short)	The 2 least significant octets of the resulting message authentication code		

- TRACKING AREA UPDATE ACCEPT

This message is sent by the SS to the UE.

Table 4.7.2-24: TRACKING AREA UPDATE ACCEPT

Derivation Path: 24.301 clause 8.2.26			
Information Element	Value/remark	Comment	Condition
Protocol discriminator	EMM		
Security header type	'0000'B	Plain NAS message, not security protected	
Tracking area update accept message identity	'0100 1001'B	Tracking area update accept	
EPS update result	'0000'B	TA updated	TA_only
	'0001'B	combined TA/LA updated	combined_TA_LA
Spare half octet	'0000'B		
T3412 value	Not present		Periodic
T3412 value			
Timer value	'0 0000'B		
Unit	'111'B	value indicates that the timer is deactivated.	
GUTI			
Length of EPS mobile identity contents	'0000 1011'B	11 octets	
Type of identity	'110'B	GUTI	
Odd/even indication	'0'B	even number of identity digits and also when the GUTI is used	
MCC	See table 4.4.2-2 in this document	For NAS test cases, see table 6.3.2.2-1.	
MNC	See table 4.4.2-2 in this document	For NAS test cases, see table 6.3.2.2-1.	
MME Group ID	See table 4.4.2-2 in this document	For NAS test cases, see table 6.3.2.2-1.	
MME Code	See table 4.4.2-2 in this document	For NAS test cases, see table 6.3.2.2-1.	
M-TMSI	See table 4.4.2-2 in this document	For NAS test cases, see table 6.3.2.2-1.	
TAI list			
Length of tracking area identity list contents	'0000 0110'B	6 octets	
Partial tracking area identity list 1			
Number of elements	'0 0000'B	1 element	
Type of list	'00'B	list of TACs belonging to one PLMN, with non-consecutive TAC values	
MCC	See table 4.4.2-2 in this document	For NAS test cases, see table 6.3.2.2-1.	
MNC	See table 4.4.2-2 in this document	For NAS test cases, see table 6.3.2.2-1.	
TAC 1	See table 4.4.2-2 in this document	For NAS test cases, see table 6.3.2.2-1.	
EPS bearer context status	The same value as the value set in TRACKING AREA UPDATE		

	REQUEST message		
Location area identification	Not present		TA_only
Location area identification			combined_TA_LA
MCC	MCC of the EUTRA cell from which this message is sent		
MNC	MCC of the EUTRA cell from which this message is sent		
LAC	1		
MS identity	Not present		TA_only
MS identity			combined_TA_LA
Length of mobile identity contents	'0000 0101'B	5 octets	
Type of identity	'100'B	TMSI/P-TMSI/M-TMSI	
Odd/even indication	'0'B	even number of identity digits and also when the TMSI/P-TMSI or TMGI and optional MBMS Session Identity is used	
TMSI	TMSI-1		
EMM cause	Not present		
T3402 value	Not present		
T3423 value	Not present		
Equivalent PLMNs	Not present		
Emergency number list	Not present		
EPS network feature support	0000 0001'B	IMS voice over PS session in S1 mode supported	
Additional update result	Not present		
Additional update result	'10' B	"SMS only"	TAU_additional_update_result_SMS

Condition	Explanation
TA_only	This condition applies if the UE is configured to initiate EPS attach or if explicitly specified.
combined_TA_LA	This condition applies if the UE is configured to initiate combined EPS/IMSI attach or if explicitly specified.
Periodic	This condition applies if in the last TRACKING AREA UPDATE REQUEST sent prior to this message, the EPS update type Value = '011'B (periodic updating).
TAU_additional_update_result_SMS	If the UE requested "SMS only" in the Additional update type IE and combined_TA_LA.

NOTE: This message is always sent within SECURITY PROTECTED NAS MESSAGE message.

- TRACKING AREA UPDATE COMPLETE

This message is sent by the UE to the SS.

Table 4.7.2-25: TRACKING AREA UPDATE COMPLETE

Derivation Path: 24.301 clause 8.2.27			
Information Element	Value/remark	Comment	Condition
Protocol discriminator	EMM		
Security header type	'0000'B	Plain NAS message, not security protected	
Tracking area update complete message identity	'0100 1010'B	Tracking area update complete	

NOTE: This message is always sent within SECURITY PROTECTED NAS MESSAGE message.

- TRACKING AREA UPDATE REJECT

This message is sent by the SS to the UE.

Table 4.7.2-26: TRACKING AREA UPDATE REJECT

Derivation Path: 24.301 clause 8.2.28			
Information Element	Value/remark	Comment	Condition
Protocol discriminator	EMM		
Security header type	'0000'B	Plain NAS message, not security protected	
Tracking area update reject message identity	'0100 1011'B	Tracking area update reject	
EMM cause	Set according to specific message content.		

NOTE: If this message includes the EMM cause set to #25, it is sent within SECURITY PROTECTED NAS MESSAGE message. Otherwise this message is sent without integrity protection.

- TRACKING AREA UPDATE REQUEST

This message is sent by the UE to the SS.

Table 4.7.2-27: TRACKING AREA UPDATE REQUEST

Derivation Path: 24.301 clause 8.2.29			
Information Element	Value/remark	Comment	Condition
Protocol discriminator	EMM		
Security header type	'0000'B	Plain NAS message, not security protected	
Tracking area update request message identity	'0100 1000'B	Tracking area update request	
EPS update type			
EPS update type Value	'000'B	TA updating	TA_only
	'001'B	Combined TA/LA updating	combined_TA_LA
"Active" flag	'0'B	No bearer establishment requested	
NAS key set identifier			
NAS key set identifier	The valid NAS key set identifier of the UE		
TSC	'0'B	native security context (for KSI _{ASME})	
Old GUTI	Any allowed value		
Non-current native NAS key set identifier	Not present		
GPRS ciphering key sequence number	Not present		
Old P-TMSI signature	Not present		
Additional GUTI	Not present		
Nonce _{UE}	Not present		
UE network capability	Not present or any allowed value		
Last visited registered TAI	Not present or any allowed value		
DRX parameter	Not present or any allowed value		
UE radio capability information update needed	Not present or any allowed value		
EPS bearer context status	Not present or (octet 3 = '00100000'B and octet 4 = '00000000'B)		
MS network capability	Not present or any allowed value		
Old location area identification	Not present or any allowed value		
TMSI status	Not present or any allowed value		
Mobile station classmark 2	Not present or any allowed value		
Mobile station classmark 3	Not present or any allowed value		
Supported Codecs	Not present or any allowed value		
Additional update type	Not present		TA_only
Additional update type	Not present or any allowed value		combined_TA_LA
Old GUTI type	Not present or any allowed value		

Condition	Explanation
-----------	-------------

TA_only	See the definition below table 4.7.2-24.
combined_TA_LA	See the definition below table 4.7.2-24.

NOTE: This message is always sent within SECURITY PROTECTED NAS MESSAGE message.

- UPLINK NAS TRANSPORT

This message is sent by the UE to the SS.

Table 4.7.2-27A: UPLINK NAS TRANSPORT

Derivation Path: 24.301 clause 8.2.30			
Information Element	Value/remark	Comment	Condition
Protocol discriminator	EMM		
Security header type	'0000'B	Plain NAS message, not security protected	
Uplink NAS transport message identity	'0100 0011'B	Uplink NAS transport	
NAS message container	Set according to specific message content		

NOTE: This message is always sent within SECURITY PROTECTED NAS MESSAGE message.

4.7.3 Contents of ESM messages

- ACTIVATE DEDICATED EPS BEARER CONTEXT ACCEPT

This message is sent by the UE to the SS.

Table 4.7.3-1: ACTIVATE DEDICATED EPS BEARER CONTEXT ACCEPT

Derivation Path: 24.301 clause 8.3.1			
Information Element	Value/remark	Comment	Condition
Protocol discriminator	ESM		
EPS bearer identity	The same value as the value set in ACTIVATE DEDICATED EPS BEARER CONTEXT REQUEST message		
Procedure transaction identity	'0000 0000'B	No procedure transaction identity assigned	
Activate dedicated EPS bearer context accept message identity	'1100 0110'B	Activate dedicated EPS bearer context accept	
Protocol configuration options	Not present or any allowed value		

NOTE: This message is always sent within SECURITY PROTECTED NAS MESSAGE message.

- ACTIVATE DEDICATED EPS BEARER CONTEXT REJECT

This message is sent by UE to the SS.

Table 4.7.3-2: ACTIVATE DEDICATED EPS BEARER CONTEXT REJECT

Derivation Path: 24.301 clause 8.3.2			
Information Element	Value/remark	Comment	Condition
Protocol discriminator	ESM		
EPS bearer identity	The same value as the value set in ACTIVATE DEDICATED EPS BEARER CONTEXT REQUEST message.		
Procedure transaction identity	'0000 0000'B	No procedure transaction identity assigned	
Activate dedicated EPS bearer context reject message identity	'1100 0111'B	Activate dedicated EPS bearer context reject	
ESM cause	The value is set according to specific message content.		
Protocol configuration options	Not present		

NOTE: This message is always sent within SECURITY PROTECTED NAS MESSAGE message.

- ACTIVATE DEDICATED EPS BEARER CONTEXT REQUEST

This message is sent by the SS to the UE.

Table 4.7.3-3: ACTIVATE DEDICATED EPS BEARER CONTEXT REQUEST

Derivation Path: 24.301 clause 8.3.3			
Information Element	Value/remark	Comment	Condition
Protocol discriminator	ESM		
EPS bearer identity	Arbitrarily selected value between '0101'B and '1111'B.		
Procedure transaction identity	'0000 0000'B	No procedure transaction identity assigned	NETWORK-INITIATED
	The same value as the value set in BEARER RESOURCE MODIFICATION REQUEST message or BEARER RESOURCE ALLOCATION REQUEST message		UE-INITIATED
Activate dedicated EPS bearer context request message identity	'1100 0101'B	Activate dedicated EPS bearer context request	
Linked EPS bearer identity	The EPS bearer identity of the associated default bearer		
Spare half octet	'0000'B		
EPS QoS	See Reference dedicated EPS bearer context #1 in table 6.6.2-1		
TFT	See Reference dedicated EPS bearer context #1 in table 6.6.2-1		
Transaction identifier	Not present		
	Distinct value between 0 and 127 calculated on basis of the EPS bearer identity.		pc_UTRAN AND/OR pc_GERAN
Negotiated QoS	See Reference dedicated EPS bearer context #1 in table 6.6.2-1		
Negotiated LLC SAPI	See Reference dedicated EPS bearer context #1 in table 6.6.2-1		
Radio priority	See Reference dedicated EPS bearer context #1 in table 6.6.2-1		
Packet flow Identifier	Not present		
	'0000 0000'B	Best Effort	pc_GERAN
Protocol configuration options	See Reference dedicated EPS bearer context #1 in table 6.6.2-1		

Condition	Explanation
NETWORK-INITIATED	Network initiated ESM procedures
UE-INITIATED	UE initiated ESM procedures

NOTE: This message is always sent within SECURITY PROTECTED NAS MESSAGE message.

- **ACTIVATE DEFAULT EPS BEARER CONTEXT ACCEPT**

This message is sent by the UE to the SS.

Table 4.7.3-4: ACTIVATE DEFAULT EPS BEARER CONTEXT ACCEPT

Derivation Path: 24.301 clause 8.3.4			
Information Element	Value/remark	Comment	Condition
Protocol discriminator	ESM		
EPS bearer identity	The same value as the value set in ACTIVATE DEFAULT EPS BEARER CONTEXT REQUEST message		
Procedure transaction identity	'0000 0000'B	No procedure transaction identity assigned	
Activate default EPS bearer context accept message identity	'1100 0010'B	Activate default EPS bearer context accept	
Protocol configuration options	Not present or any allowed value		

NOTE: This message is always sent within SECURITY PROTECTED NAS MESSAGE message.

- **ACTIVATE DEFAULT EPS BEARER CONTEXT REJECT**

This message is sent by UE to the SS.

Table 4.7.3-5: ACTIVATE DEFAULT EPS BEARER CONTEXT REJECT

Derivation Path: 24.301 clause 8.3.5			
Information Element	Value/remark	Comment	Condition
Protocol discriminator	ESM		
EPS bearer identity	The same value as the value set in ACTIVATE DEFAULT EPS BEARER CONTEXT REQUEST message.		
Procedure transaction identity	'0000 0000'B	No procedure transaction identity assigned	
Activate default EPS bearer context reject message identity	'1100 0011'B	Activate default EPS bearer context reject	
ESM cause	The value is set according to specific message content.		
Protocol configuration options	Not present		

NOTE: This message is always sent within SECURITY PROTECTED NAS MESSAGE message.

- ACTIVATE DEFAULT EPS BEARER CONTEXT REQUEST

This message is sent by the SS to the UE.

Table 4.7.3-6: ACTIVATE DEFAULT EPS BEARER CONTEXT REQUEST

Derivation Path: 24.301 clause 8.3.6			
Information Element	Value/remark	Comment	Condition
Protocol discriminator	ESM		
EPS bearer identity	An arbitrarily selected value between '0101'B and '1111'B.		
Procedure transaction identity	The same value as the value set in the latest PDN CONNECTIVITY REQUEST message sent prior to this message.		
Activate default EPS bearer context request message identity	'1100 0001'B	Activate default EPS bearer context request	
EPS QoS	See Reference default EPS bearer context #1 in table 6.6.1-1		NOT IMS APN
EPS QoS	See Reference default EPS bearer context #2 in table 6.6.1-1		IMS APN
Access point name	The SS defines a Default APN or, if the UE transmits an ESM INFORMATION RESPONSE message providing an APN, the SS shall use this value		NOT IMS APN
Access point name	IMS.apn.epc.mnc<MNC>.mcc<MCC>.3gppnetwork.org The <MNC> and <MCC> are set to the same values as in IMSI.		IMS APN
PDN address			IPv4
Length of PDN address contents	5 octets		
PDN type value	'001'B	IPv4	
PDN address information	IPv4 address	The SS provides a valid IPv4 address	NOT IPv4-DHCP
	0.0.0.0	DHCPv4 is to be used to allocate the IPv4 address	IPv4-DHCP
PDN address			IPv6
Length of PDN address contents	9 octets		
PDN type value	'010'B	IPv6	
PDN address information	IPv6 interface identifier	The SS provides a valid IPv6 interface identifier	
PDN address			IPv4v6
Length of PDN address contents	13 octets		
PDN type value	'011'B	IPv4v6	
PDN address information (Octets 4 to 11)	IPv6 interface identifier	The SS provides a valid IPv6 interface identifier	
PDN address information (Octets 12 to 15)	IPv4 address	The SS provides a valid IPv4 address	NOT IPv4-DHCP
	0.0.0.0	DHCPv4 is to be used to allocate the IPv4 address	IPv4-DHCP
Transaction identifier	Not present		
	Distinct value between 0 and 127 calculated on		pc_UTRAN AND/OR

	basis of the EPS bearer identity.		pc_GERAN
Negotiated QoS	See Reference default EPS bearer context #1 in table 6.6.1-1		
Negotiated LLC SAPI	See Reference default EPS bearer context #1 in table 6.6.1-1		
Radio priority	See Reference default EPS bearer context #1 in table 6.6.1-1		
Packet flow Identifier	Not present		
	'0000 0000'B	Best Effort	pc_GERAN
APN-AMBR	See Reference default EPS bearer context #1 in table 6.6.1-1		
ESM cause	Not present		
Protocol configuration options			
Configuration protocol	See Reference default EPS bearer context #1 in table 6.6.1-1		
Container ID 1	'0001'H		P-CSCF IPv6
Length of container ID 1 contents		Length value determined by the TTCN implementation	
Container ID 1 contents	IPv6 address	P-CSCF IPv6 Address	
Container ID 1	'000C'H		P-CSCF IPv4
Length of container ID 1 contents		Length value determined by the TTCN implementation	
Container ID 1 contents	IPv4 address	P-CSCF IPv4 Address	

Condition	Explanation
IPv4	If in the last PDN CONNECTIVITY REQUEST sent prior to this message, the PDN type = '001'B
IPv6	If in the last PDN CONNECTIVITY REQUEST sent prior to this message, the PDN type = '010'B
IPv4v6	If in the last PDN CONNECTIVITY REQUEST sent prior to this message, the PDN type = '011'B
IPv4-DHCP	If in the last PDN CONNECTIVITY REQUEST sent prior to this message, the IE Protocol configuration options contains a configuration protocol option = '000B00H' ("IPv4 address allocation via DHCPv4", length of contents = 0). Note: This condition is used in conjunction with IPv4 or IPv4v6 as indicated in the "PDN address row" just above.
P-CSCF IPv6	If in the last PDN CONNECTIVITY REQUEST sent prior to this message, the Protocol configuration options and the additional parameter list was included with a "P-CSCF IPv6 Address Request" Note: This condition is only applicable for UEs with IMS support (TS 36.523-2 A.4.4-1/25).
P-CSCF IPv4	If in the last PDN CONNECTIVITY REQUEST sent prior to this message, the Protocol configuration options and the additional parameter list was included with a "P-CSCF IPv4 Address Request" Note: This condition is only applicable for UEs with IMS support (TS 36.523-2 A.4.4-1/25).
IMS APN	If the UE indicate IMS support (TS 36.523-2 A.4.4-1/25).

NOTE: This message is always sent within SECURITY PROTECTED NAS MESSAGE message.

- BEARER RESOURCE ALLOCATION REJECT

This message is sent by the SS to the UE.

Table 4.7.3-6A: BEARER RESOURCE ALLOCATION REJECT

Derivation Path: 24.301 clause 8.3.7			
Information Element	Value/remark	Comment	Condition
Protocol discriminator	ESM		
EPS bearer identity	'0000'B	No EPS bearer identity assigned	
Procedure transaction identity	The value indicated in BEARER RESOURCE ALLOCATION REQUEST message.		
Bearer resource allocation reject message identity	'1101 0101'B	Bearer resource allocation reject	
ESM cause	Set according to specific message content.		
Protocol configuration options	Not present		

NOTE: This message is always sent within SECURITY PROTECTED NAS MESSAGE message.

- BEARER RESOURCE ALLOCATION REQUEST

This message is sent by the UE to the SS.

Table 4.7.3-6B: BEARER RESOURCE ALLOCATION REQUEST

Derivation Path: 24.301 clause 8.3.8			
Information Element	Value/remark	Comment	Condition
Protocol discriminator	ESM		
EPS bearer identity	'0000'B	No EPS bearer identity assigned	
Procedure transaction identity	Any value from 1 to 254		
Bearer resource allocation request message identity	'1101 0100'B	Bearer resource allocation request	
Linked EPS bearer identity	The EPS bearer identity of the associated default bearer.		
Spare half octet	'0000'B		
Traffic flow aggregate			
Number of packet filters	Greater than 0 and less than or equal to 16		
E bit	Any allowed value		
TFT operation code	'001'B	Create new TFT	
Packet filter list	Any allowed value		
Parameters list	Not present or any allowed value		
Required traffic flow QoS	Any allowed value		
Protocol configuration options	Not present or any allowed value		

NOTE: This message is always sent within SECURITY PROTECTED NAS MESSAGE message.

- BEARER RESOURCE MODIFICATION REJECT

This message is sent by the SS to the UE.

Table 4.7.3-7: BEARER RESOURCE MODIFICATION REJECT

Derivation Path: 24.301 clause 8.3.9			
Information Element	Value/remark	Comment	Condition
Protocol discriminator	ESM		
EPS bearer identity	'0000'B	No EPS bearer identity assigned	
Procedure transaction identity	The value indicated in BEARER RESOURCE MODIFICATION REQUEST message.		
Bearer resource modification reject message identity	'1101 0111'B	Bearer resource modification reject	
ESM cause	Set according to specific message content.		
Protocol configuration options	Not present		

NOTE: This message is always sent within SECURITY PROTECTED NAS MESSAGE message.

- BEARER RESOURCE MODIFICATION REQUEST

This message is sent by the UE to the SS.

Table 4.7.3-8: BEARER RESOURCE MODIFICATION REQUEST

Derivation Path: 24.301 clause 8.3.10			
Information Element	Value/remark	Comment	Condition
Protocol discriminator	ESM		
EPS bearer identity	'0000'B	No EPS bearer identity assigned	
Procedure transaction identity	Any value from 1 to 254		
Bearer resource modification request message identity	'1101 0110'B	Bearer resource modification request	
EPS bearer identity for packet filter	The EPS bearer identity of the associated dedicated EPS bearer related with packet filter.		
Spare half octet	'0000'B		
Traffic flow aggregate	Any allowed value		
Traffic flow aggregate			RELEASE-REQUESTED
Number of packet filters	Greater than 0 and less than or equal to 16		
E bit	Any allowed value		
TFT operation code	'101'B	Delete packet filters from existing TFT	
Packet filter list	Any allowed value		
Parameters list	Not present or any allowed value		
Required traffic flow QoS	Not present or any allowed value		
ESM cause	Not present		
	'0010 0100'B	Regular deactivation	RELEASE-REQUESTED
Protocol configuration options	Not present or any allowed value		

Condition	Explanation
-----------	-------------

RELEASE-REQUESTED	UE requests the release of bearer resources.
-------------------	--

NOTE: This message is always sent within SECURITY PROTECTED NAS MESSAGE message.

Table 4.7.3-9: (Void)

Table 4.7.3-10: (Void)

- DEACTIVATE EPS BEARER CONTEXT ACCEPT

This message is sent by the UE to the SS.

Table 4.7.3-11: DEACTIVATE EPS BEARER CONTEXT ACCEPT

Derivation Path: 24.301 clause 8.3.9			
Information Element	Value/remark	Comment	Condition
Protocol discriminator	ESM		
EPS bearer identity	The same value as the value set in DEACTIVATE EPS BEARER CONTEXT REQUEST message.		
Procedure transaction identity	'0000 0000'B	No procedure transaction identity assigned	
Deactivate EPS bearer context accept message identity	'1100 1110'B	Deactivate EPS bearer context accept	
Protocol configuration options	Not present or any allowed value		

NOTE: This message is always sent within SECURITY PROTECTED NAS MESSAGE message.

- DEACTIVATE EPS BEARER CONTEXT REQUEST

This message is sent by the SS to the UE.

Table 4.7.3-12: DEACTIVATE EPS BEARER CONTEXT REQUEST

Derivation Path: 24.301 clause 8.3.10			
Information Element	Value/remark	Comment	Condition
Protocol discriminator	ESM		
EPS bearer identity	Set according to specific message content.		
Procedure transaction identity	'0000 0000'B	No procedure transaction identity assigned	NETWORK-INITIATED
	The same value as the value set in PDN DISCONNECT REQUEST message or BEARER RESOURCE MODIFICATION REQUEST message.		UE-INITIATED
Deactivate EPS bearer context request message identity	'1100 1101'B	Deactivate EPS bearer context request	
ESM cause	Set according to specific message content.		
Protocol configuration options	Not present		

Condition	Explanation
NETWORK-INITIATED	Network initiated ESM procedures
UE-INITIATED	UE initiated ESM procedures

NOTE: This message is always sent within SECURITY PROTECTED NAS MESSAGE message.

- ESM INFORMATION REQUEST

This message is sent by the SS to the UE.

Table 4.7.3-13: ESM INFORMATION REQUEST

Derivation Path: 24.301 clause 8.3.11			
Information Element	Value/remark	Comment	Condition
Protocol discriminator	ESM		
EPS bearer identity	'0000'B	No EPS bearer identity assigned	
Procedure transaction identity	The value indicated in PDN CONNECTIVITY REQUEST message.		
ESM information request message identity	'1101 1001'B	ESM information request	

NOTE: This message is always sent within SECURITY PROTECTED NAS MESSAGE message.

- **ESM INFORMATION RESPONSE**

This message is sent by the UE to the SS.

Table 4.7.3-14: ESM INFORMATION RESPONSE

Derivation Path: 24.301 clause 8.3.12			
Information Element	Value/remark	Comment	Condition
Protocol discriminator	ESM		
EPS bearer identity	'0000'B	No EPS bearer identity assigned	
Procedure transaction identity	The same value as the value set in ESM INFORMATION REQUEST message.		
ESM information response message identity	'1101 1010'B	ESM information response	
Access point name	Not present or any allowed value		
Protocol configuration options	Not present or any allowed value		

NOTE: This message is always sent within SECURITY PROTECTED NAS MESSAGE message.

- **ESM STATUS**

This message is sent by the UE or by the SS.

Table 4.7.3-15: ESM STATUS

Derivation Path: 24.301 clause 8.3.13			
Information Element	Value/remark	Comment	Condition
Protocol discriminator	ESM		
EPS bearer identity	Set according to specific message content.		
Procedure transaction identity	'0000 0000'B	No procedure transaction identity assigned	
ESM status message identity	'1110 1000'B	ESM status	
ESM cause	Set according to specific message content.		

NOTE: This message is always sent within SECURITY PROTECTED NAS MESSAGE message.

- MODIFY EPS BEARER CONTEXT ACCEPT

This message is sent by the UE to the SS.

Table 4.7.3-16: MODIFY EPS BEARER CONTEXT ACCEPT

Derivation Path: 24.301 clause 8.3.14			
Information Element	Value/remark	Comment	Condition
Protocol discriminator	ESM		
EPS bearer identity	The same value as the value set in MODIFY EPS BEARER CONTEXT REQUEST message.		
Procedure transaction identity	'0000 0000'B	No procedure transaction identity assigned	
Modify EPS bearer context accept message identity	'1100 1010'B	Modify EPS bearer context accept	
Protocol configuration options	Not present or any allowed value		

NOTE: This message is always sent within SECURITY PROTECTED NAS MESSAGE message.

- MODIFY EPS BEARER CONTEXT REJECT

This message is sent by the UE to the SS.

Table 4.7.3-17: MODIFY EPS BEARER CONTEXT REJECT

Derivation Path: 24.301 clause 8.3.15			
Information Element	Value/remark	Comment	Condition
Protocol discriminator	ESM		
EPS bearer identity	The same value as the value set in MODIFY EPS BEARER CONTEXT REQUEST message.		
Procedure transaction identity	'0000 0000'B	No procedure transaction identity assigned	
Modify EPS bearer context reject message identity	'1100 1011'B	Modify EPS bearer context reject	
ESM cause	The value is set according to specific message content.		
Protocol configuration options	Not present		

NOTE: This message is always sent within SECURITY PROTECTED NAS MESSAGE message.

- MODIFY EPS BEARER CONTEXT REQUEST

This message is sent by the SS to the UE.

Table 4.7.3-18: MODIFY EPS BEARER CONTEXT REQUEST

Derivation Path: 24.301 clause 8.3.16			
Information Element	Value/remark	Comment	Condition
Protocol discriminator	ESM		
EPS bearer identity	Set according to specific message content.		
Procedure transaction identity	'0000 0000'B	No procedure transaction identity assigned	NETWORK-INITIATED
	The same value as the value set in BEARER RESOURCE MODIFICATION REQUEST message or BEARER RESOURCE ALLOCATION REQUEST message.		UE-INITIATED
Modify EPS bearer context request message identity	'1100 1001'B	Modify EPS bearer context request	
New EPS QoS	Use the same value as used in Activate EPS Bearer Context Request message		
TFT	According to reference dedicated EPS bearer context #2 except for TFT operation code which is set to '100'B and TFT identifier is set to '00110000'B..		
New QoS	Not Present.		
Negotiated LLC SAPI	Not Present.		
Radio priority	Not Present.		
Packet flow Identifier	Not Present.		
	'0000 0000'B	Best Effort	pc_GERAN
APN-AMBR	Not Present.		
Protocol configuration options	Not present		

Condition	Explanation
NETWORK-INITIATED	Network initiated ESM procedures
UE-INITIATED	UE initiated ESM procedures

NOTE: This message is always sent within SECURITY PROTECTED NAS MESSAGE message.

- PDN CONNECTIVITY REJECT

This message is sent by the SS to the UE.

Table 4.7.3-19: PDN CONNECTIVITY REJECT

Derivation Path: 24.301 clause 8.3.17			
Information Element	Value/remark	Comment	Condition
Protocol discriminator	ESM		
EPS bearer identity	'0000'B	No EPS bearer identity assigned	
Procedure transaction identity	The same value as the value set in PDN CONNECTIVITY REQUEST message.		
PDN connectivity reject message identity	'1101 0001'B	PDN connectivity reject	
ESM cause	The value is set according to specific message content.		
Protocol configuration options	Not present		

NOTE: This message is sent without integrity protection before NAS security mode control procedure has been successfully completed and sent within SECURITY PROTECTED NAS MESSAGE message after NAS security mode control procedure has been successfully completed.

- PDN CONNECTIVITY REQUEST

This message is sent by the UE to the SS.

Table 4.7.3-20: PDN CONNECTIVITY REQUEST

Derivation Path: 24.301 clause 8.3.18			
Information Element	Value/remark	Comment	Condition
Protocol discriminator	ESM		
EPS bearer identity	'0000'B	No EPS bearer identity assigned	
Procedure transaction identity	Any value from 1 to 254		
PDN connectivity request message identity	'1101 0000'B	PDN connectivity request	
Request type	'0001'B	initial request	
PDN type	Any value between '001'B, '010'B, '011'B and '100'B	The allowed values are respectively IPv4, IPv6, IPv4v6 and "unused but interpreted as IPv6 by the network"	
ESM information transfer flag	Not present or any allowed value		
Access point name	Not present	The value is mandatory when the PDN CONNECTIVITY REQUEST message is sent together with an ATTACH REQUEST message.	
Protocol configuration options	Not present or any allowed value	The value received from the UE does not affect the possible verdict associated with the message when received by the SS. The SS shall remember if this IE is present and its contents because this affects subsequent SS behaviour, e.g. coding of ACTIVATE DEFAULT EPS BEARER CONTEXT REQUEST.	

NOTE: This message is sent without integrity protection before NAS security mode control procedure has been successfully completed and sent within SECURITY PROTECTED NAS MESSAGE message after NAS security mode control procedure has been successfully completed.

- PDN DISCONNECT REJECT

This message is sent by the SS to the UE.

Table 4.7.3-21: PDN DISCONNECT REJECT

Derivation Path: 24.301 clause 8.3.19			
Information Element	Value/remark	Comment	Condition
Protocol discriminator	ESM		
EPS bearer identity	'0000'B	No EPS bearer identity assigned	
Procedure transaction identity	The value indicated in PDN DISCONNECT REQUEST message.		
PDN disconnect reject message identity	'1101 0011'B	PDN disconnect reject	
ESM cause	Set according to specific message content.		
Protocol configuration options	Not present		

NOTE: This message is always sent within SECURITY PROTECTED NAS MESSAGE message.

- PDN DISCONNECT REQUEST

This message is sent by the UE to the SS.

Table 4.7.3-22: PDN DISCONNECT REQUEST

Derivation Path: 24.301 clause 8.3.20			
Information Element	Value/remark	Comment	Condition
Protocol discriminator	ESM		
EPS bearer identity	'0000'B	No EPS bearer identity assigned	
Procedure transaction identity	Any value from 1 to 254		
PDN disconnect request message identity	'1101 0010'B	PDN disconnect request	
Linked EPS bearer identity	The EPS bearer identity of the associated default bearer.		
Spare half octet	'0000'B		
Protocol configuration options	Not present or any allowed value		

NOTE: This message is always sent within SECURITY PROTECTED NAS MESSAGE message.

4.7A Default TC message and information element contents

This clause contains the default values of common TC (Test Control, see [38]) messages and information elements, which apply to all test cases unless otherwise specified. All the messages and information elements are listed in alphabetical order.

- ACTIVATE TEST MODE

This message is sent by the SS to the UE embedded in a RRC *DLInformationTransfer* message.

Table 4.7A-1: ACTIVATE TEST MODE

Derivation Path: 36.509 clause 6.5			
Information Element	Value/remark	Comment	Condition
Protocol discriminator	1 1 1 1		
Skip indicator	0 0 0 0		
Message type	1 0 0 0 0 1 0 0		
UE test loop mode	0 0 0 0 0 0 0 0	UE test loop mode A	UE TEST LOOP MODE A (default)
UE test loop mode	0 0 0 0 0 0 0 1	UE test loop mode B	UE TEST LOOP MODE B
UE test loop mode	0 0 0 0 0 0 1 0	UE test loop mode C	UE TEST LOOP MODE C

Condition	Explanation
UE TEST LOOP MODE A	UE test loop function configured for UE test loop mode A operation.
UE TEST LOOP MODE B	UE test loop function configured for UE test loop mode B operation.
UE TEST LOOP MODE C	UE test loop function configured for UE test loop mode C operation.

- ACTIVATE TEST MODE COMPLETE

This message is sent by the UE to the SS embedded in a RRC *ULInformationTransfer* message.

Table 4.7A-2: ACTIVATE TEST MODE COMPLETE

Derivation Path: 36.509 clause 6.6			
Information Element	Value/remark	Comment	Condition
Protocol discriminator	1 1 1 1		
Skip indicator	0 0 0 0		
Message type	1 0 0 0 0 1 0 1		

- CLOSE UE TEST LOOP

This message is sent by the SS to the UE embedded in a RRC *DLInformationTransfer* message.

Table 4.7A-3: CLOSE UE TEST LOOP

Derivation Path: 36.509 clause 6.1			
Information Element	Value/remark	Comment	Condition
Protocol discriminator	1 1 1 1		
Skip indicator	0 0 0 0		
Message type	1 0 0 0 0 0 0 0		
UE test loop mode	0 0 0 0 0 0 0 0	UE test loop mode A	UE TEST LOOP MODE A (default)
UE test loop mode A LB setup			
Length of UE test loop mode A LB setup list in bytes	0	No LB setup list. No scaling (UL RLC SDU size will be equal to the received DL SDU size)	
UE test loop mode B LB setup	Not present		
UE test loop mode C LB setup	Not present		
UE test loop mode	0 0 0 0 0 0 0 1	UE test loop mode B	UE TEST LOOP MODE B
UE test loop mode A LB setup	Not present		
UE test loop mode B LB setup			
IP PDU delay	0 0 0 0 0 0 0 0	No delay	
UE test loop mode C LB setup	Not present		
UE test loop mode	0 0 0 0 0 0 1 0	UE test loop mode C	UE TEST LOOP MODE C
UE test loop mode A LB setup	Not present		
UE test loop mode B LB setup	Not present		
UE test loop mode C LB setup			
MTCH ID	FFS		

Condition	Explanation
UE TEST LOOP MODE A	UE test loop function configured for UE test loop mode A operation.
UE TEST LOOP MODE B	UE test loop function configured for UE test loop mode B operation.
UE TEST LOOP MODE C	UE test loop function configured for UE test loop mode C operation.

- CLOSE UE TEST LOOP COMPLETE

This message is sent by the UE to the SS embedded in a RRC *ULInformationTransfer* message.

Table 4.7A-4: CLOSE UE TEST LOOP

Derivation Path: 36.509 clause 6.2			
Information Element	Value/remark	Comment	Condition
Protocol discriminator	1 1 1 1		
Skip indicator	0 0 0 0		
Message type	1 0 0 0 0 0 0 1		

- DEACTIVATE TEST MODE

This message is sent by the SS to the UE embedded in a RRC *DLInformationTransfer* message.

Table 4.7A-5: DEACTIVATE TEST MODE

Derivation Path: 36.509 clause 6.7			
Information Element	Value/remark	Comment	Condition
Protocol discriminator	1 1 1 1		
Skip indicator	0 0 0 0		
Message type	1 0 0 0 0 1 1 0		

- DEACTIVATE TEST MODE COMPLETE

This message is sent by the UE to the SS embedded in a RRC *ULInformationTransfer* message.

Table 4.7A-6: DEACTIVATE TEST MODE COMPLETE

Derivation Path: 36.509 clause 6.8			
Information Element	Value/remark	Comment	Condition
Protocol discriminator	1 1 1 1		
Skip indicator	0 0 0 0		
Message type	1 0 0 0 0 1 1 1		

- OPEN UE TEST LOOP

This message is sent by the SS to the UE embedded in a RRC *DLInformationTransfer* message.

Table 4.7A-7: OPEN UE TEST LOOP

Derivation Path: 36.509 clause 6.3			
Information Element	Value/remark	Comment	Condition
Protocol discriminator	1 1 1 1		
Skip indicator	0 0 0 0		
Message type	1 0 0 0 0 0 1 0		

- OPEN UE TEST LOOP COMPLETE

This message is sent by the UE to the SS embedded in a RRC *ULInformationTransfer* message.

Table 4.7A-8: OPEN UE TEST LOOP COMPLETE

Derivation Path: 36.509 clause 6.4			
Information Element	Value/remark	Comment	Condition
Protocol discriminator	1 1 1 1		
Skip indicator	0 0 0 0		
Message type	1 0 0 0 0 0 1 1		

- UE TEST LOOP MODE C MBMS PACKET COUNTER REQUEST

This message is sent by the SS to the UE embedded in a RRC *DLInformationTransfer* message.

Table 4.7A-9: UE TEST LOOP MODE C MBMS PACKET COUNTER REQUEST

Derivation Path: 36.509 clause 6.10			
Information Element	Value/remark	Comment	Condition
Protocol discriminator	1 1 1 1		
Skip indicator	0 0 0 0		
Message type	1 0 0 0 1 0 0 1		

- UE TEST LOOP MODE C MBMS PACKET COUNTER RESPONSE

This message is sent by the UE to the SS embedded in a RRC *ULInformationTransfer* message.

Table 4.7A-10: UE TEST LOOP MODE C MBMS PACKET COUNTER RESPONSE

Derivation Path: 36.509 clause 6.11			
Information Element	Value/remark	Comment	Condition
Protocol discriminator	1 1 1 1		
Skip indicator	0 0 0 0		
Message type	1 0 0 0 1 0 1 1		
MBMS Packet Counter Value			

4.7B Default UTRA message and information element contents

4.7B.1 UTRA RRC messages

– HANDOVER TO UTRAN COMMAND

Table 4.7B.1-1: HANDOVER TO UTRAN COMMAND

Derivation Path: 25.331, clause 10.2.16a			
Information Element	Value/remark	Comment	Condition
New U-RNTI	U-RNTI-Short		
- SRNC identity	0000 0000 0001B		
- S-RNTI-2	00 0000 0001B		
Ciphering algorithm	UEA0 or UEA1. The indicated algorithm must be one of the algorithms supported by the UE.		
RNC support for change of UE capability	FALSE		
New H-RNTI	Not present		UTRA FDD PS RB, UTRA TDD PS RB, UTRA Speech, UTRA PS RB + Speech
	'1010 1010 1010 1010'		UTRA HSDPA RB, UTRA HSUPA/H SDPA RB
New Primary E-RNTI	Not present		UTRA FDD PS RB, UTRA TDD PS RB, UTRA HSDPA RB, UTRA Speech, UTRA PS RB + Speech
	'1010 1010 1010 1010'		UTRA HSUPA/H SDPA RB
New Secondary E-RNTI	Not present		
Default configuration for CELL_FACH	Not present		
CHOICE <i>specification mode</i>	Complete specification		
- Signalling RB information to setup List	Same as the corresponding IE in the RRC CONNECTION SETUP message (Transition to CELL_DCH or HS-PDSCH in CELL_FACH) using condition A1 in TS 34.108 clause 9.1.1 for UTRA-FDD. Same as the corresponding IE in the RRC CONNECTION SETUP message in TS 34.108 clause 9.1.2 for UTRA-TDD.		UTRA FDD PS RB, UTRA HSDPA RB, UTRA Speech, UTRA PS RB + Speech

	Same as the corresponding IE in the RRC CONNECTION SETUP message in TS 34.108 clause 9.2.2		UTRA TDD PS RB
	Same as the corresponding IE in the RRC CONNECTION SETUP message (Transition to CELL_DCH or HS-PDSCH in CELL_FACH) using condition A3 in TS 34.108 clause 9.1.1 for UTRA-FDD. Same as the corresponding IE in the RRC CONNECTION SETUP (Transition to CELL_DCH) (1.28 Mcps TDD option) message in TS 34.108 clause 9.1.2 for UTRA-TDD.		UTRA HSUPA/H SDPA RB
- RAB information to setup list	Same as the corresponding IE in the RADIO BEARER SETUP message using condition A2 in TS 34.108 clause 9.1.1 for UTRA-FDD. Same as the corresponding IE in the RADIO BEARER SETUP message (1.28 Mcps TDD) using condition A2 in TS 34.108 clause 9.1.2 for UTRA-TDD.		UTRA Speech, UTRA PS RB + Speech
	Same as the corresponding IE in the RADIO BEARER SETUP message using condition A3 in TS 34.108 clause 9.1.1 for UTRA-FDD. Same as the corresponding IE in the RADIO BEARER SETUP message (1.28 Mcps TDD) using condition A3 in TS 34.108 clause 9.1.2 for UTRA-TDD.		UTRA FDD PS RB, UTRA PS RB + Speech
	Same as the corresponding IE in the RADIO BEARER SETUP message (1.28 Mcps TDD) using condition A3 in TS 34.108 clause 9.2.2 for UTRA-TDD.		UTRA TDD PS RB
	Same as the corresponding IE in the RADIO BEARER SETUP message using condition A10 in TS 34.108 clause 9.1.1 for UTRA-FDD. Same as the corresponding IE in the RADIO BEARER SETUP message (1.28 Mcps TDD) using condition A10 in TS 34.108 clause		UTRA HSDPA RB

	9.1.2 for UTRA-TDD. Same as the corresponding IE in the RADIO BEARER SETUP message using condition A14 in TS 34.108 clause 9.1.1 for UTRA-FDD. Same as the corresponding IE in the RADIO BEARER SETUP message (1.28 Mcps TDD) using condition A13 in TS 34.108 clause 9.1.2 for UTRA-TDD.		UTRA HSUPA/H SDPA RB
- UL Transport channel information common for all transport channels	Same as the corresponding IE in the RADIO BEARER SETUP message using condition A2 in TS 34.108 clause 9.1.1 for UTRA-FDD Same as the corresponding IE in the RADIO BEARER SETUP message (1.28 Mcps TDD) using condition A2 in TS 34.108 clause 9.1.2 for UTRA-TDD		UTRA Speech, UTRA PS RB + Speech
	Same as the corresponding IE in the RADIO BEARER SETUP message using condition A3 in TS 34.108 clause 9.1.1 UTRA-FDD. Same as the corresponding IE in the RADIO BEARER SETUP message (1.28 Mcps TDD) using condition A3 in TS 34.108 clause 9.2.2 UTRA-TDD.		UTRA FDD PS RB, UTRA TDD PS RB
	Same as the corresponding IE in the RADIO BEARER SETUP message using condition A10 in TS 34.108 clause 9.1.1 for UTRA-FDD. Same as the corresponding IE in the RADIO BEARER SETUP message (1.28 Mcps TDD) using condition A10 in TS 34.108 clause 9.1.2 for UTRA-TDD.		UTRA HSDPA RB
	Same content as the corresponding IE in the RADIO BEARER SETUP message using condition A14 in TS 34.108 clause 9.1.1 for UTRA-FDD. Same content as the corresponding IE in the RADIO BEARER SETUP message (1.28 Mcps TDD) using condition A13 in TS 34.108 clause 9.1.2 for UTRA-TDD.		UTRA HSUPA/H SDPA RB
- Added or Reconfigured UL TrCH information	Same as the corresponding IE in the		UTRA Speech,

	RADIO BEARER SETUP message using condition A2 in TS 34.108 clause 9.1.1 for UTRA-FDD. Same as the corresponding IE in the RADIO BEARER SETUP message (1.28 Mcps TDD) using condition A2 in TS 34.108 clause 9.1.2 for UTRA-TDD		UTRA PS RB + Speech
	Same as the corresponding IE in the RADIO BEARER SETUP message using condition A3 in TS 34.108 clause 9.1.1		UTRA FDD PS RB
	Same as the corresponding IE in the RADIO BEARER SETUP message using condition A10 in TS 34.108 clause 9.1.1 for UTRA-FDD. Same as the corresponding IE in the RADIO BEARER SETUP message (1.28 Mcps TDD) using condition A10 in TS 34.108 clause 9.1.2 for UTRA-TDD.		UTRA HSDPA RB
	Same as the corresponding IE in the RADIO BEARER SETUP message using condition A14 in TS 34.108 clause 9.1.1 for UTRA-FDD. Same as the corresponding IE in the RADIO BEARER SETUP message (1.28 Mcps TDD) using condition A13 in TS 34.108 clause 9.1.2 for UTRA-TDD.		UTRA HSUPA/HSDPA RB
- Added or Reconfigured UL TrCH information	2 Entries		UTRA TDD PS RB
- Added or Reconfigured UL TrCH information[1]	Same as the corresponding IE in the RRC CONNECTION SETUP message (1.28 Mcps TDD) in TS 34.108 clause 9.2.2.		UTRA TDD PS RB
- Added or Reconfigured UL TrCH information[2]	Same as the corresponding IE in the RADIO BEARER SETUP message (1.28 Mcps TDD) using condition A3 in TS 34.108 clause 9.2.2.		UTRA TDD PS RB
- DL Transport channel information common for all transport channels	Same as the corresponding IE in the RADIO BEARER SETUP message using condition A2 in TS 34.108 clause 9.1.1 for UTRA-FDD. Same as the corresponding IE in the RADIO BEARER SETUP message (1.28 Mcps		UTRA Speech, UTRA PS RB + Speech

	TDD) using condition A2 in TS 34.108 clause 9.1.2 for UTRA-TDD.		
	Same as the corresponding IE in the RADIO BEARER SETUP message using condition A3 in TS 34.108 clause 9.1.1		UTRA FDD PS RB
	Same as the corresponding IE in the RADIO BEARER SETUP message (1.28 Mcps TDD) using condition A3 in TS 34.108 clause 9.2.2.		UTRA TDD PS RB
	Same as the corresponding IE in the RADIO BEARER SETUP message using condition A10 in TS 34.108 clause 9.1.1 for UTRA-FDD. Same as the corresponding IE in the RADIO BEARER SETUP message (1.28 Mcps TDD) using condition A10 in TS 34.108 clause 9.1.2 for UTRAT-TDD.		UTRA HSDPA RB
	Same content as the corresponding IE in the RADIO BEARER SETUP message using condition A14 in TS 34.108 clause 9.1.1 for UTRA-FDD. Same as the corresponding IE in the RADIO BEARER SETUP message (1.28 Mcps TDD) using condition A13 in TS 34.108 clause 9.1.2 for UTRA-TDD.		UTRA HSUPA/HSDPA RB
- Added or Reconfigured DL TrCH information	Same as the corresponding IE in the RADIO BEARER SETUP message using condition A2 in TS 34.108 clause 9.1.1 for UTRA-FDD. Same as the corresponding IE in the RADIO BEARER SETUP message (1.28 Mcps TDD) using condition A2 in TS 34.108 clause 9.1.2 for UTRA-TDD.		UTRA Speech, UTRA PS RB + Speech
	Same as the corresponding IE in the RADIO BEARER SETUP message using condition A3 in TS 34.108 clause 9.1.1		UTRA FDD PS RB
	Same as the corresponding IE in the RADIO BEARER SETUP message using condition A10 in TS 34.108 clause 9.1.1 for UTRA-FDD. Same as the		UTRA HSDPA RB

	corresponding IE in the RADIO BEARER SETUP message (1.28 Mcps TDD) using condition A10 in TS 34.108 clause 9.1.2 for UTRA-TDD.		
	Same as the corresponding IE in the RADIO BEARER SETUP message using condition A14 in TS 34.108 clause 9.1.1 for UTRA-FDD. Same as the corresponding IE in the RADIO BEARER SETUP message (1.28 Mcps TDD) using condition A13 in TS 34.108 clause 9.1.2 for UTRA-TDD.		UTRA HSUPA/H SDPA RB
- Added or Reconfigured DL TrCH information	2 Entries		UTRA TDD PS RB
- Added or Reconfigured DL TrCH information[1]	Same as the corresponding IE in the RRC CONNECTION SETUP message (1.28 Mcps TDD) in TS 34.108 clause 9.2.2.		UTRA TDD PS RB
- Added or Reconfigured DL TrCH information[2]	Same as the corresponding IE in the RADIO BEARER SETUP message (1.28 Mcps TDD) using condition A3 in TS 34.108 clause 9.2.2.		UTRA TDD PS RB
- Uplink DPCH info	Same as the corresponding IE in the RADIO BEARER SETUP message using condition A2 in TS 34.108 clause 9.1.1 for UTRA-FDD. Same as the corresponding IE in the RADIO BEARER SETUP message (1.28 Mcps TDD) using condition A13 in TS 34.108 clause 9.1.2 for UTRA-TDD.		UTRA Speech, UTRA PS RB + Speech
	Same as the corresponding IE in the RADIO BEARER SETUP message using condition A3 in TS 34.108 clause 9.1.1		UTRA FDD PS RB
	Same as the corresponding IE in the RADIO BEARER SETUP message (1.28 Mcps TDD) using condition A3 in TS 34.108 clause 9.2.2.		UTRA TDD PS RB
	Same as the corresponding IE in the RADIO BEARER SETUP message using condition A10 in TS 34.108 clause 9.1.1 for UTRA-FDD. Same as the corresponding IE in the		UTRA HSDPA RB

	RADIO BEARER SETUP message (1.28 Mcps TDD) using condition A10 in TS 34.108 clause 9.1.2 for UTRA-TDD.		
	Same as the corresponding IE in the RADIO BEARER SETUP message using condition A14 in TS 34.108 clause 9.1.1 for UTRA-FDD. Same as the corresponding IE in the RADIO BEARER SETUP message (1.28 Mcps TDD) using condition A13 in TS 34.108 clause 9.1.2 for UTRA-TDD.		UTRA HSUPA/H SDPA RB
- E-DCH Info	Not present		UTRA FDD PS RB, UTRA TDD PS RB, UTRA HSDPA RB, UTRA Speech, UTRA PS RB + Speech
	Same as the corresponding IE in the RADIO BEARER SETUP message using condition A14 in TS 34.108 clause 9.1.1 for UTRA-FDD. Same as the corresponding IE in the RADIO BEARER SETUP message (1.28 Mcps TDD) using condition A13 in TS 34.108 clause 9.1.2 for UTRA-TDD.		UTRA HSUPA/H SDPA RB
- Downlink HS-PDSCH Information	Not present		UTRA FDD PS RB, UTRA TDD PS RB, UTRA Speech, UTRA PS RB + Speech
	Same as the corresponding IE in the RADIO BEARER SETUP message using condition A10 in TS 34.108 clause 9.1.1 for UTRA-FDD. Same as the corresponding IE in the RADIO BEARER SETUP message (1.28 Mcps TDD) using condition A10 in TS 34.108 clause 9.1.2 for UTRA-TDD.		UTRA HSDPA RB
	Same as the corresponding IE in the RADIO BEARER SETUP message using condition		UTRA HSUPA/H SDPA RB

	A14 in TS 34.108 clause 9.1.1 for UTRA-FDD. Same as the corresponding IE in the RADIO BEARER SETUP message (1.28 Mcps TDD) using condition A13 in TS 34.108 clause 9.1.2 for UTRA-TDD.		
- Downlink information common for all radio links	Same as the corresponding IE in the RADIO BEARER SETUP message using condition A2 in TS 34.108 clause 9.1.1 for UTRA-FDD. Same as the corresponding IE in the RADIO BEARER SETUP message (1.28 Mcps TDD) using condition A2 in TS 34.108 clause 9.1.2 for UTRA-TDD.		UTRA Speech, UTRA PS RB + Speech
	Same as the corresponding IE in the RADIO BEARER SETUP message using condition A4 in TS 34.108 clause 9.1.1		UTRA FDD PS RB
	Same as the corresponding IE in the RADIO BEARER SETUP message (1.28 Mcps TDD) using condition A3 in TS 34.108 clause 9.2.2.		UTRA TDD PS RB
	Same as the corresponding IE in the RADIO BEARER SETUP message using condition A10 in TS 34.108 clause 9.1.1 for UTRA-FDD. Same as the corresponding IE in the RADIO BEARER SETUP message (1.28 Mcps TDD) using condition A10 in TS 34.108 clause 9.1.2 for UTRA-TDD.		UTRA HSDPA RB
	Same as the corresponding IE in the RADIO BEARER SETUP message using condition A14 in TS 34.108 clause 9.1.1 for UTRA-FDD. Same as the corresponding IE in the RADIO BEARER SETUP message (1.28 Mcps TDD) using condition A13 in TS 34.108 clause 9.1.2 for UTRA-TDD.		UTRA HSUPA/HSDPA RB
	Same as the corresponding IE in the RADIO BEARER SETUP message using condition A2 in TS 34.108 clause 9.1.1 for UTRA-FDD. Same as the		UTRA Speech, UTRA PS RB + Speech
- Downlink information for each radio link list	Same as the corresponding IE in the RADIO BEARER SETUP message using condition A2 in TS 34.108 clause 9.1.1 for UTRA-FDD. Same as the		UTRA Speech, UTRA PS RB + Speech

	corresponding IE in the RADIO BEARER SETUP message (1.28 Mcps TDD) using condition A2 in TS 34.108 clause 9.1.2 for UTRA-TDD.		
	Same as the corresponding IE in the RADIO BEARER SETUP message using condition A3 in TS 34.108 clause 9.1.1		UTRA FDD PS RB
	Same as the corresponding IE in the RADIO BEARER SETUP message (1.28 Mcps TDD) using condition A3 in TS 34.108 clause 9.2.2.		UTRA TDD PS RB
	Same as the corresponding IE in the RADIO BEARER SETUP message using condition A10 in TS 34.108 clause 9.1.1 for UTRA-FDD. Same as the corresponding IE in the RADIO BEARER SETUP message (1.28 Mcps TDD) using condition A10 in TS 34.108 clause 9.1.2 for UTRA-TDD.		UTRA HSDPA RB
	Same as the corresponding IE in the RADIO BEARER SETUP message using condition A14 in TS 34.108 clause 9.1.1 for UTRA-FDD. Same as the corresponding IE in the RADIO BEARER SETUP message (1.28 Mcps TDD) using condition A13 in TS 34.108 clause 9.1.2 for UTRA-TDD.		UTRA HSUPA/HSDPA RB
Frequency info	Set according to the frequency of the target UTRA cell.		
Multi-frequency Info	Not present		
Maximum allowed UL TX power	21dBm		

Condition	Explanation
UTRA Speech	Establishment of the UTRA reference configuration as specified in Table 4.8.3-1 using the condition "UTRA Speech".
UTRA FDD PS RB	Establishment of the UTRA FDD reference configuration as specified in Table 4.8.3-1 using the condition "UTRA FDD PS RB".
UTRA TDD PS RB	Establishment of the UTRA TDD reference configuration as specified in Table 4.8.3-1 using the condition "UTRA TDD PS RB".
UTRA HSDPA RB	Establishment of the UTRA reference configuration as specified in Table 4.8.3-1 using the condition "UTRA HSDPA RB".
UTRA HSUPA/HSDPA RB	Establishment of the UTRA reference configuration as specified in Table 4.8.3-1 using the condition "UTRA HSUPA/HSDPA RB".
UTRA PS RB + Speech	Establishment of the UTRA reference configuration as specified in Table 4.8.3-1 using the condition "UTRA PS RB + Speech".

– HANOVER FROM UTRAN COMMAND

Table 4.7B.1-2: HANOVER FROM UTRAN COMMAND

Derivation Path: 25.331, clause 10.2.15			
Information Element	Value/remark	Comment	Condition
Message Type			
Integrity check info			
- Message authentication code	SS calculates the value of MAC-I for this message and writes to this IE. The first/ leftmost bit of the bit string contains the most significant bit of the MAC-I.		
- RRC Message sequence number	SS provides the value of this IE, from its internal counter.		
SR-VCC Info	Not present		
Activation time	Now		
RAB Info			
- RAB identity	0000 0101B The first/ leftmost bit of the bit string contains the most significant bit of the RAB identity.		
- CN domain identity	PS domain		
- NAS Synchronization Indicator	Not present		
- Re-establishment timer	Use T315		
Inter-system message			
- CHOICE System type	E-UTRA		
- E-UTRA message	RRConnectionReconfiguration using condition HO-TO-EUTRA(1,0)	See Table 4.6.1-8	

– MEASUREMENT CONTROL

Table 4.7B.1-3: MEASUREMENT CONTROL

Derivation Path: 25.331, clause 10.2.17			
Information Element	Value/remark	Comment	Condition
Message Type			
RRC transaction identifier	Arbitrarily selects an unused integer between 0 to 3		
Integrity check info			
- Message authentication code	SS calculates the value of MAC-I for this message and writes to this IE. The first/ leftmost bit of the bit string contains the most significant bit of the MAC-I.		
- RRC message sequence number	SS provides the value of this IE, from its internal counter.		
Measurement Identity	3		
Measurement Command	Setup		
Measurement Reporting Mode			
- Measurement Report Transfer Mode	Acknowledged mode RLC		
- Periodical Reporting/Event Trigger Reporting Mode	Event trigger		
Additional measurement list	Not present		

CHOICE Measurement type	Inter-RAT measurement		
- CHOICE Inter-RAT measurement objects	E-UTRA frequency list		
- CHOICE E-UTRA frequency removal	Remove no frequencies		
- New frequencies			
- E-UTRA carrier frequency	Downlink EARFCN of E-UTRA Cell		
- Measurement bandwidth	Same downlink system bandwidth as used for E-UTRA Cell		
- Blacklisted cells list	Not present		
- Inter-RAT measurement quantity			
- Measurement quantity for UTRAN quality estimate			
- Filter coefficient	0		
- CHOICE mode	FDD		FDD_UTRA
- Measurement quantity	CPICH Ec/N0		
- CHOICE mode	TDD		TDD_UTRA
- Measurement quantity	Primary CCPCH RSCP		
- CHOICE system	E-UTRA		
- Measurement quantity	RSRP		
- Filter coefficient	0		
- Inter-RAT reporting quantity			
- UTRAN estimated quality	FALSE		
- CHOICE system	E-UTRA		
- Reporting quantity	both		
- Reporting cell status	Not present		
- CHOICE report criteria	Inter-RAT measurement reporting criteria		
- Parameters required for each event	1 entry		
- Inter-RAT event identity	Set according to specific test.		
- Threshold own system	-66 dB		
- W	0		
- Threshold other system	-55 (-80 dBm)	When measurement quantity is RSRP, range should be (-115..-19), the actual value = Threshold other system - 25 [dBm]	
- Hysteresis	0		
- Time to trigger	10 ms		
- Reporting cell status			
- CHOICE reported cell	Report cells within active set or within virtual active set or of the other RAT		
- Maximum number of reported cells	2		
- Idle Interval Information	Not present		
DPCH Compressed mode status info			FDD_UTRA
- TGPS reconfiguration CFN	(Current CFN + (250 – TTI/10msec)) mod 256		
- Transmission gap pattern sequence	1 entry		
- TGPSI	1		
- TGPS Status Flag	activate		
- TGCFN	(Current CFN + (252 – TTI/10msec)) mod 256		
DPCH Compressed mode status info	Not present		TDD_UTRA

Condition	Explanation
FDD_UTRA	FDD UTRA cell environment
TDD_UTRA	TDD UTRA cell environment

– MEASUREMENT REPORT

Table 4.7B.1-4: MEASUREMENT REPORT

Derivation Path: 25.331, clause 10.2.19			
Information Element	Value/remark	Comment	Condition
Message Type			
Integrity check info			
- Message authentication code	This IE is checked to see if it is present. The value is compared against the XMAC-I value computed by SS. The first/ leftmost bit of the bit string contains the most significant bit of the MAC-I.		
- RRC Message sequence number	This IE is checked to see if it is present. The value is used by SS to compute the XMAC-I value.		
Activation time	$(256 + \text{CFN} - (\text{CFN} \bmod 8 + 8)) \bmod 256$		
Measurement identity	3		
Measured Results	Not present		
Measured results on RACH	Not present		
Additional measured results	Not present		
Event results	Not present		
Inter-RAT cell info indication	Not present		
E-UTRA Measured Results			
- E-UTRA measured results list	1 entry		
- E-UTRA Carrier Frequency			
- Measured E-UTRA cells	1 entry		
- Physical Cell Identity	PhysicalCellIdentity of E-UTRA Cell		
- RSRP	Set according to specific test.		
- RSRQ	Set according to specific test.		
E-UTRA Event Results			
- Inter-RAT event identity	Set according to specific test.		
- E-UTRA events results list	1 entry		
- E-UTRA Carrier Frequency	Downlink EARFCN of E-UTRA Cell		
- Reported cells	1 entry		
- Physical Cell Identity	PhysicalCellIdentity of E-UTRA Cell		

– PHYSICAL CHANNEL RECONFIGURATION

Table 4.7B.1-5: PHYSICAL CHANNEL RECONFIGURATION

Derivation Path: 25.331, clause 10.2.22			
Information Element	Value/remark	Comment	Condition
Message Type			
RRC transaction identifier	Arbitrarily selects an unused integer between 0 to 3		
Integrity check info			

- Message authentication code	SS calculates the value of MAC-I for this message and writes to this IE. The first/ leftmost bit of the bit string contains the most significant bit of the MAC-I.		
- RRC message sequence number	SS provides the value of this IE, from its internal counter.		
Integrity protection mode info	Not Present		
Ciphering mode info	Not Present		
Activation time	Not Present		
Delay restriction flag	Not Present		
New U-RNTI	Not Present		
New C-RNTI	Not Present		
New H-RNTI	Not Present		
New Primary E-RNTI	Not Present		
New Secondary E-RNTI	Not Present		
RRC State indicator	CELL_DCH		
UE Mobility State Indicator	Not Present		
UTRAN DRX cycle length coefficient	Not Present		
CN information info	Not Present		
URA identity	Not Present		
RNC support for change of UE capability	Not Present		
Reconfiguration in response to requested change of UE capability	Not Present		
Downlink counter synchronization info	Not Present		
Frequency info	Not Present		
DTX-DRX timing information	Not Present		
DTX-DRX Information	Not Present		
HS-SCCH less Information	Not Present		
MIMO parameters	Not Present		
HARQ Info	Not Present		
Maximum allowed UL TX power	Not Present		
CHOICE channel requirement	Not Present		
E-DCH Info	Not Present		
Downlink HS-PDSCH Information	Not Present		
Downlink information common for all radio links			
- Downlink DPCH info common for all RL	Not Present		
- DPCH compressed mode info	Not Present		TDD
- DPCH compressed mode info			FDD
- TGPSI	1		
- TGPS Status Flag	Deactivate		
- TGCFN	Not Present		
- Transmission gap pattern sequence configuration parameters			
- TGMP	E-UTRA measurement		
- TGPRC	Infinity		
- TGSN	8		
- TGL1	10		
- TGL2	Not Present		
- TGD	undefined		
- TGPL1	12		
- TGPL2	Not Present		
- RPP	Mode 0		
- ITP	Mode 0		
- CHOICE UL/DL Mode	UL and DL, UL only or DL only (depending on the UE capability)		
method			
- Downlink compressed mode	HLS(or not sent, depending on the UE capability)		
- Uplink compressed mode method	HLS(or not sent, depending on the UE capability)		

- Downlink frame type	B		
- DeltaSIR1	20 (2.0)		
- DeltaSIRAfter1	10 (1.0)		
- DeltaSIR2	Not Present		
- DeltaSIRAfter2	Not Present		
- N identify abort	Not Present		
- T Reconfirm abort	Not Present		
- TX Diversity mode	Not Present		
- SSDT information	Not Present		
- Default DPCH Offset Value	Not Present		
Downlink information for each radio link	Not Present		
MBMS PL Service Restriction Information	Not Present		

– PHYSICAL CHANNEL RECONFIGURATION COMPLETE

Table 4.7B.1-6: PHYSICAL CHANNEL RECONFIGURATION COMPLETE

Derivation Path: 25.331, clause 10.2.23			
Information Element	Value/remark	Comment	Condition
Message Type			
Integrity check info			
- Message authentication code	This IE is checked to see if it is present. The value is compared against the XMAC-I value computed by SS. The first/ leftmost bit of the bit string contains the most significant bit of the MAC-I.		
- RRC Message sequence number	This IE is checked to see if it is present. The value is used by SS to compute the XMAC-I value.		
Uplink integrity protection activation info	Not checked		
COUNT-C activation time	Not checked		
Uplink counter synchronization info	Not checked		

– RRC CONNECTION REQUEST

Table 4.7B.1-7: RRC CONNECTION REQUEST

Derivation Path: 25.331, clause 10.2.39			
Information Element	Value/remark	Comment	Condition
Message Type			
Predefined configuration status information	To be checked against requirement if specified		
Initial UE identity			
- CHOICE UE id type			
- TMSI and LAI (GSM-MAP)	Set to the UE's TMSI and LAI.		

Establishment cause	To be checked against requirement if specified		
Protocol error indicator	FALSE		
UE Specific Behaviour Information 1 idle	This IE will not be checked by default behaviour, but in specific test case.		
Domain indicator	Not checked		
Call type	Not checked		
UE capability indication	Not checked		
MBMS Selected Services	Not checked		
Support for F-DPCH	Not checked		
UE Mobility State Indicator	Not Present		
Support for Enhanced F-DPCH	Not checked		
HS-PDSCH in CELL_FACH	Not checked		
MAC-ehs support	Not checked		
DPCCH Discontinuous Transmission support	Not checked		
Support of common E-DCH	Not checked	REL-8	
Multi cell support	Not checked	REL-8	
Pre-redirection info	Not checked	REL-8	
Support of MAC-i/is	Not checked	REL-8	
Support of SPS operation	Not checked	REL-8	
Support for CS Voice over HSPA	Not checked	REL-8	
Dual cell MIMO support	Not checked	REL-9	
System Information Container Stored Indicator	Not checked	REL-9	
Measured results on RACH	Not checked		
Access stratum release indicator	Not checked		

– SECURITY MODE COMMAND

Table 4.7B.1-n: SECURITY MODE COMMAND

Derivation Path: 25.331, clause 10.2.43			
Information Element	Value/remark	Comment	Condition
FFS			

– SECURITY MODE COMPLETE

Table 4.7B.1-n: SECURITY MODE COMPLETE

Derivation Path: 25.331, clause 10.2.44			
Information Element	Value/remark	Comment	Condition
FFS			

– UTRAN MOBILITY INFORMATION

Table 4.7B.1-n: UTRAN MOBILITY INFORMATION

Derivation Path: 34.108 clause 9.1.1 (UTRAN MOBILITY INFORMATION message)			
Information Element	Value/remark	Comment	Condition
UTRAN MOBILITY INFORMATION			
CN information info			
- PLMN identity	Not present		
- CN common GSM-MAP NAS system information			
- GSM-MAP NAS system information	00 01H		
- CN domain related information			
- CN domain identity	PS		
- CN domain specific NAS system information			
- GSM-MAP NAS system information	01 00H		
- CN domain specific DRX cycle length coefficient	7		
- CN domain identity	CS		
- CN domain specific NAS system information			
- GSM-MAP NAS system information	1E 01H		
- CN domain specific DRX cycle length coefficient	7		

– UTRAN MOBILITY INFORMATION CONFIRM

Table 4.7B.1-n: UTRAN MOBILITY INFORMATION CONFIRM

Derivation Path: 34.108 clause 9.1.1 (UTRAN MOBILITY INFORMATION CONFIRM message)

4.7B.2 UTRA NAS messages

This section contains default message contents for UTRA NAS messages.

In 3GPP TS 36.523-1 [18]:

- UTRA NAS messages are defined as exceptions, IE by IE, to the messages defined in this section;
- UTRA NAS messages not defined in this section are specified completely.

The following messages are not specified in this section:

- AUTHENTICATION REQUEST (CS)
- AUTHENTICATION RESPONSE (CS)
- DETACH REQUEST (CS & PS)
- DETACH ACCEPT (CS & PS)
- IDENTITY REQUEST (CS & PS)
- IDENTITY RESPONSE (CS & PS)
- P-TMSI REALLOCATION COMMAND (PS)
- P-TMSI REALLOCATION COMPLETE (PS)
- SERVICE REQUEST (PS)

Table 4.7B.2-1: ROUTING AREA UPDATE REQUEST

Derivation path: 24.008 table 9.4.14			
Information Element	Value/Remark	Comment	Condition
Update type	000 'RA updating' or 001 'combined RA/LA updating'	In NMO I, depending on capability and domain preference for voice and SMS, the UE may initiate either PS only or CS/PS registration procedures.	
GPRS ciphering key sequence number	Any allowed value		
Old routing area identification	Any allowed value		
MS Radio Access capability	Any allowed value	The checking of this IE is expected to be covered in UMTS test cases.	
Old P-TMSI signature	Not present or any allowed value	For test cases where no "UE" statement indicates that a PTMSI signature was previously registered, whether or not the UE includes this IE depends on previous USIM contents.	
Requested READY timer value	Not present or any allowed value	The checking of this IE is expected to be covered in UMTS test cases.	
DRX parameter	Not present or any allowed value	The checking of this IE is expected to be covered in UMTS test cases.	
TMSI status	0 'no valid TMSI available' or not present		
P-TMSI	Not present or any allowed value		
MS network capability	Any allowed value	The checking of this IE is expected to be covered in UMTS test cases.	
PDP context status	Any allowed value	The checking of this IE is expected to be covered in UMTS test cases.	
PS LCS Capability	Not present or any allowed value	The checking of this IE is expected to be covered in UMTS test cases.	
MBMS context status	Not present		
UE network capability	Any allowed value (must be present)	No detailed checking by default but should be aligned with PICS	
Additional mobile identity	Not present or any allowed value		
Additional old routing area identification	Not present or any allowed value		
Mobile station classmark 2	Not present or any	This IE shall be	

	allowed value	included if the MS supports SRVCC to GERAN or UTRAN.	
Mobile station classmark 3	Not present or any allowed value	This IE shall be included if the MS supports SRVCC to GERAN.	
Supported Codecs	Not present or any allowed value		
Voice domain preference and UE's usage setting	Not present or any allowed value	Rel-9	
P-TMSI type	Any allowed value	Rel-10	

Table 4.7B.2-2: ROUTING AREA UPDATE ACCEPT

Derivation path: 24.008 table 9.4.15			
Information Element	Value/Remark	Comment	Condition
Force to standby	0 'Force to standby not indicated'		
Update result	000 'RA updated'		IF the UE indicated 000 'RA updating' in the previous RAU request message
	001 'combined RA/LA updated'		IF the UE indicated 001 'combined RA/LA updating' in the previous RAU request message
Periodic RA update timer	111 (deactivated)		
Routing area identification	1	Value in table 4.4.4-2 for simulated UTRA cells.	
P-TMSI signature	Arbitrary value		
Allocated P-TMSI	Arbitrary value	2 most significant bits = 11 to indicate SGSN	
MS identity	Not present	Is never present in case of RA only procedure, and RA/LA procedures do not necessarily change TMSI	
List of Receive N PDU Numbers	Not present	Realistic network value	
Negotiated READY timer value	Not present		
GMM cause	Not present		
T3302 value	Not present		
Cell Notification	Not present	This IE is for A/Gb mode only.	
Equivalent PLMNs	Not present		
PDP context status	Not present		
Network feature support	Not present		
Emergency Number List	Not present		
MBMS context status	Not present		
Requested MS Information	Not present		
T3319 value	Not present		
T3323 value	Not present		

Table 4.7B.2-3: ROUTING AREA UPDATE COMPLETE

Derivation path: 24.008 table 9.4.16			
Information Element	Value/Remark	Comment	Condition
List of Receive N PDU Numbers	Not present		
Inter RAT handover information	Not present		
E-UTRAN inter RAT handover information	Not present		

Table 4.7B.2-4: LOCATION UPDATING REQUEST

Derivation path: 24.008 table 9.2.17			
Information Element	Value/Remark	Comment	Condition
Location updating type	Any allowed value		
Ciphering key sequence number	Any allowed value		
Location area identification	Any allowed value		
Mobile station classmark	Any allowed value		
Mobile identity	Any allowed value		
Mobile station classmark for UMTS	Any allowed value		
Additional update parameters	Not present or any allowed value		

Table 4.7B.2-5: LOCATION UPDATING ACCEPT

Derivation path: 24.008 table 9.2.15			
Information Element	Value/Remark	Comment	Condition
Location area identification	1		
Mobile identity			
TMSI	Arbitrary value	2 most significant bits = 00 to indicate VLR	
Follow on proceed	Present	This IE is unnecessary in non-CS fallback test cases.	
CTS permission	Absent		
Equivalent PLMNs	Absent		
Emergency Number List	Absent		

Table 4.7B.2-6: ATTACH REQUEST

Derivation path: 24.008 table 9.4.1			
Information Element	Value/Remark	Comment	Condition
MS network capability	Any allowed value		
Attach type	001 'GPRS attach' or 011 'Combiner GPRS/IMS attach'		
GPRS ciphering key sequence number	Any allowed value		
DRX parameter	Any allowed value		
P-TMSI or IMSI	Any allowed value		
Old routing area identification	Any allowed value		
MS Radio Access capability	Any allowed value		
Old P-TMSI signature	Not present or any allowed value		
Requested READY timer value	Not present or any allowed value		
TMSI status	0 'no valid TMSI available' or not present		
PS LCS Capability	Not present or any allowed value		
Mobile station classmark 2	Not present or any allowed value		
Mobile station classmark 3	Not present or any allowed value		
Supported Codecs	Not present or any allowed value		
UE network capability	Any allowed value (must be present)		
Additional mobile identity	Not present or any allowed value		
Additional old routing area identification	Not present or any allowed value		
Voice domain preference and UE's usage setting	Not present or any allowed value	Rel-9	
P-TMSI type	Not present or any allowed value	Rel-10	

Table 4.7B.2-7: ATTACH ACCEPT

Derivation path: 24.008 table 9.4.2			
Information Element	Value/Remark	Comment	Condition
Attach result	001 'GPRS only attached'		IF the UE indicated 001 'GPRS attach' in the previous attach request message
	011 'combined GPRS/IMSI attached'		IF the UE indicated 011 'Combined GPRS/IMS I attach' in the previous attach request message
Force to standby	000 'Force to standby not indicated'		
Periodic RA update timer	111 (deactivated)		
Radio priority for SMS	100 'priority level 4 (lowest)'		
Radio priority for TOM8	100 'priority level 4 (lowest)'		
Routing area identification	1		
P-TMSI signature	Arbitrary value		
Negotiated READY timer value	Not present		
Allocated P-TMSI	Arbitrary value	2 most significant bits = 11 to indicate SGSN	
MS identity	Not present		IF the UE indicated 001 'GPRS attach' in the previous attach request message
	Arbitrary value	2 most significant bits = 00 to indicate VLR	IF the UE indicated 011 'Combined GPRS/IMS I attach' in the previous attach request message
GMM cause	Not present		
T3302 value	Not present		
Cell Notification	Not present		
Equivalent PLMNs	Not present		
Network feature support	Not present		
Emergency Number List	Not present		
Requested MS Information	Not present		
T3319 value	Not present		
T3323 value	Not present		

Table 4.7B.2-8: ATTACH COMPLETE

Derivation path: 24.008 table 9.4.3			
Information Element	Value/Remark	Comment	Condition
Inter RAT handover information	Not present		
E-UTRAN inter RAT handover information	Not present		

Table 4.7B.2-9: AUTHENTICATION AND CIPHERING REQUEST

Derivation path: 24.008 table 9.4.9			
Information Element	Value/Remark	Comment	Condition
Ciphering algorithm	Any allowed value		
IMEISV request	000 'IMEISV not requested'		
Force to standby	000 'Force to standby not indicated'		
A&C reference number	Any allowed value		

Table 4.7B.2-10: AUTHENTICATION AND CIPHERING RESPONSE

Derivation path: 24.008 table 9.4.10			
Information Element	Value/Remark	Comment	Condition
A&C reference number	Arbitrary value		
Spare half octet	0000		

Table 4.7B.2-11: TMSI REALLOCATION COMMAND

Derivation path: 24.008 table 9.2.20			
Information Element	Value/Remark	Comment	Condition
Location area identification	Any allowed value		
Mobile identity	Any allowed value		

Table 4.7B.2-12: TMSI REALLOCATION COMPLETE

Derivation path: 24.008 table 9.2.21			
--------------------------------------	--	--	--

Table 4.7B.2-XX: CM SERVICE REQUEST

Derivation path: 24.008 table 9.2.11			
Information Element	Value/Remark	Comment	Condition
CM service type	Any allowed value		
Ciphering key sequence number	Any allowed value		
Mobile station classmark	Any allowed value		
Mobile identity	Any allowed value		
Priority	Not present or any allowed value		
Additional update parameters	Not present or any allowed value		

4.7C Default DS-MIPv6 message and information element contents

4.7C.1 IKEv2 messages

- IKEv2 IKE_SA_INIT Request

This message is sent by the UE to the SS.

Table 4.7C.1-1: Message IKE_SA_INIT Request

Field	Value/remark	Comment	Condition
IKE Header			
Initiator's IKE_SA SPI	Set by the UE		
Responder's IKE_SA SPI	0	First message in IKE_SA_INIT exchange	
Next Payload	'00100001'B	SA	
Exchange Type	'00100010'B	IKE_SA_INIT	
Security Association Payload			
Next Payload	'00100010'B	KE	
More proposal	'00000010'B		
Proposal #	'00000001'B	First cryptographic suite (section 6.5 of TS 33.234)	
Protocol ID	'00000001'B	IKE	
SPI size	'00000000'B		
Number of transforms	'00000010'B		
More transform	'00000011'B	This is the transform for confidentiality	
Transform type	'00000001'B	Encryption	
Transform ID	'00000011'B	3DES in CBC mode (ENCR_3DES)	
More transform	'00000011'B	This is the transform for prf	
Transform type	'00000010'B	PRF	
Transform ID	'00000010'B	PRF_HMAC_SHA1 (HMAC-SHA1)	
More transform	'00000011'B	This is the transform for integrity	
Transform type	'00000011'B	Integrity	
Transform ID	'00000010'B	HMAC-SHA1-96 (AUTH_HMAC_SHA1_96)	
Last transform	'00000000'B	This is the transform for DH	
Transform type	'00000100'B	DH	
Transform ID	'00000010'B	Diffie-Hellman group 2 (1024-bit MODP)	
Last proposal	'00000000'B		
Proposal #	'00000010'B	Second cryptographic suite (section 6.5 of TS 33.234)	
Protocol ID	'00000001'B	IKE	
SPI size	'00000000'B		
Number of transforms	'00000010'B		
More transform	'00000011'B	This is the transform for	

		confidentiality	
Transform type	'00000001'B	Encryption	
Transform ID	'00001011'B	AES with 128-bit keys in CBC mode (ENCR_AES_CBC)	
More transform	'00000011'B	This is the transform for prf	
Transform type	'00000010'B	PRF	
Transform ID	'00000100'B	PRF_AES128_XCBC_AES-XCBC-PRF-128	
More transform	'00000011'B	This is the transform for integrity	
Transform type	'00000011'B	Integrity	
Transform ID	'00000101'B	AES-XCBC-MAC-96 (AUTH_AES-XCBC-96)	
Last transform	'00000000'B	This is the transform for DH	
Transform type	'00000100'B	DH	
Transform ID	'00000010'B	Diffie-Hellman group 2 (1024-bit MODP)	
Key Exchange Payload			
Next Payload	'00101000'B	Nonce	
DH Group #	'0000000000000010'B	DH group 2	
Key Exchange data	Set by the UE		
Nonce Payload			
Next Payload	'00101001'B	Notify	UE IKE INIT HA
Nonce data	Random number set by the UE		
REDIRECT_SUPPORTED Notify Payload			UE IKE INIT HA
Next Payload	'00000000'B	No Next Payload	UE IKE INIT HA
Protocol ID	'00000000'B	Notification is not specific to a particular security association	UE IKE INIT HA
SPI size	'00000000'B	SPI field not present	UE IKE INIT HA
Notify Message Type	'0100000000010110'B	REDIRECT_SUPPORTED	UE IKE INIT HA
REDIRECT_FROM Notify Payload			UE IKE INIT HA Redirected
Next Payload	'00000000'B	No next payload	UE IKE INIT HA Redirected
Protocol ID	'00000000'B	Notification is not specific to a particular security association	UE IKE INIT HA Redirected
SPI size	'00000000'B	SPI field not present	UE IKE INIT HA Redirected
Notify Message Type	'0100000000010110'B	REDIRECT_FROM	UE IKE INIT HA Redirected
GW Ident Type	Any allowed value (IPv6 or IPv4 or HA FQDN)	Set depending on how the UE has discovered the HA in the preamble	UE IKE INIT HA Redirected

New Responder GW Identity	Depends on GW Ident type		UE IKE INIT HA Redirected
---------------------------	--------------------------	--	---------------------------

Condition	Explanation
UE IKE INIT HA	Part of IKE_INIT_SA request message sent to HA only
UE IKE INIT HA Redirected	Part of IKE_INIT_SA request message sent to HA only after a REDIRECT payload was received in a previous IKEV2 messages exchange

- IKE_SA_INIT Response

This message is sent by the SS to the UE.

Table 4.7C.1-2: Message IKE_SA_INIT Response

Field	Value/remark	Comment	Condition
IKE Header			
Initiator's IKE_SA SPI	Same as that set by the UE in IKE_SA_INIT request		
Responder's IKE_SA SPI	Set by the SS		
Next Payload	'00100001'B	SA	
Exchange Type	'00100010'B	IKE_SA_INIT	
Security Association Payload			
Next Payload	'00100010'B	KE	
Proposal	One of the 2 proposals included in IKE_SA_INIT at Step 1		
Key Exchange Payload			
Next payload	'00 101000'B	Nonce	
DH Group #	'0000000000000010'B	DH group 2	
Key Exchange data	Set by the SS		
Nonce Payload			
Next t payload	'00000000'B	No Next Payload	
Nonce data	Set by the SS		

- IKE_AUTH_Request

This message is sent by the UE to the SS.

Table 4.7C.1-3: Message IKE_AUTH Request

Field	Value/remark	Comment	Condition
IKE Header			
Initiator's IKE_SA SPI	Same as that set by the UE in IKE_INIT_SA Request		
Responder's IKE_SA SPI	Same as that set by the SS in IKE_INIT_SA Response		
Next Payload	'00101110'B	E	
Exchange Type	'00100011'B	IKE_AUTH	
Encrypted Payload			
Next Payload	'00100011'B	Idi	UE IKE AUTH1
Initialization Vector	Random value set by the UE		UE IKE AUTH1
Encrypted IKE Payloads			UE IKE AUTH1
Identification – Initiator Payload			UE IKE AUTH1
Next Payload	'00101111'B	CP	UE IKE AUTH1
ID Type	00000010B		UE IKE AUTH1
ID	Set to MN-NAI		UE IKE AUTH1
Configuration Payload			UE IKE AUTH1
Next Payload	'00100001'B	SA	UE IKE AUTH1
CFG Type	'00000001'B	Request	UE IKE AUTH1
Configuration Attribute	'00010000'B	MIP6_HOME_PR EFIX attribute	UE IKE AUTH1 HA
Length	'0000000000000000'B		UE IKE AUTH1 HA
Security Association Payload			UE IKE AUTH1
Next Payload	'00101100'B	TSi	UE IKE AUTH1
Proposals	Any set of allowed values		UE IKE AUTH1
Traffic Selector – Initiator Payload			UE IKE AUTH1
Next Payload	'00101100'B	TSr	UE IKE AUTH1
Traffic selector data	Any allowed set of values		UE IKE AUTH1
Traffic Selector – Responder Payload			UE IKE AUTH1
Next Payload	'00100100'B	IDr	UE IKE AUTH1
Traffic selector data	Any allowed set of values		UE IKE AUTH1
Identification – Responder Payload			UE IKE AUTH1
Next Payload	'00000000'B	No Next Payload	UE IKE AUTH1
ID Type	'00000010'B		UE IKE AUTH1
ID	APN		UE IKE

			AUTH1
Next Payload	'00110000'B	EAP	UE IKE AUTH2
Initialization Vector	Random value set by the UE		UE IKE AUTH2
Encrypted IKE Payloads			UE IKE AUTH2
Extensible Authentication Payload			UE IKE AUTH2
Next Payload	'00000000'B	No Next Payload	UE IKE AUTH2
Code	'00000010'B	Response	UE IKE AUTH2
Type	'00010111'B	AKA	UE IKE AUTH2
Subtype		AKA-Challenge	UE IKE AUTH2
Attribute type	'00000011'B	AT_RES	UE IKE AUTH2
AT_RES	See TS 24.301 [28] subclause 9.9.3.4		UE IKE AUTH2
Next Payload	'00100111'B	AUTH	UE IKE AUTH3
Initialization Vector	Random value set by the UE		UE IKE AUTH3
Encrypted IKE Payloads			UE IKE AUTH3
Authentication Payload			UE IKE AUTH3
Next Payload	'00000000'B	No Next Payload	UE IKE AUTH3
Auth Method	'00000010'B	Shared Key Integrity code	UE IKE AUTH3
Auth Data	derived from the MSK obtained from AKA exchange	RFC 4306 defines the function to derive this key (section 2.15)	UE IKE AUTH3
Padding	Set by the UE	Fields from Encrypted payload	
Pad Length	Set by the UE	Fields from Encrypted payload	
Integrity checksum data	Set by the UE	Fields from Encrypted payload	

Condition	Explanation
UE IKE AUTH1	Part of IKE_AUTH request message sent to HA or ePDG after the reception of IKE_INIT_SA response
UE IKE AUTH1 HA	Part of IKE_AUTH request message sent to HA after the reception of IKE_INIT_SA response
UE IKE AUTH2	Part of IKE_AUTH request message sent to HA or ePDG after the reception of IKE_SA response message containing the certificate payload CERT
UE IKE AUTH3	Part of IKE_AUTH request message sent to HA or ePDG after the reception of IKE_SA response containing EAP and encryption payloads only

- IKE_AUTH Response

This message is sent by the SS to the UE.

Table 4.7C.1-4: Message IKE_AUTH Response

Field	Value/remark	Comment	Condition
IKE Header			
Initiator's IKE_SA SPI	Same as that set by the UE in IKE_SA_INIT request		
Responder's IKE_SA SPI	Same as that set by the SS in IKE_SA_INIT response		
Next Payload	'00101110'B	E	
Exchange Type	'00100011'B	IKE_AUTH	
Encrypted Payload			
Next Payload	'00100100'B	IDr	SS IKE AUTH1
Initialization Vector	Set by the SS		SS IKE AUTH1
Encrypted IKE Payloads			SS IKE AUTH1
Identification – Responder Payload			SS IKE AUTH1
Next Payload	'00100101'B	CERT	SS IKE AUTH1
ID Type	'00000010'B		SS IKE AUTH1
ID	APN		SS IKE AUTH1
Certificate Payload			SS IKE AUTH1
Next Payload	'00110000'B	EAP	SS IKE AUTH1
Cert encoding	'00000100'B	X.509 certificate - signature	SS IKE AUTH1
Certificate data	Set by the SS	DER encoded X.509 certificate	SS IKE AUTH1
Extensible Authentication Payload			SS IKE AUTH1
Next Payload	'00000000'B	No Next Payload	SS IKE AUTH1
Code	'00000001'B	Request	SS IKE AUTH1
Type	'00010111'B	AKA	SS IKE AUTH1
Subtype		AKA-Challenge	SS IKE AUTH1
Attribute type	'00000001'B	AT_RAND	SS IKE AUTH1
AT_RAND	An arbitrarily selected 128 bits value		SS IKE AUTH1
Attribute Type	'00000010'B	AT_AUTN	SS IKE AUTH1
AT_AUTN	See TS 24.301 [28] subclause 9.9.3.2		SS IKE AUTH1
Next Payload	'00110000'B	EAP	SS IKE AUTH2
Initialization Vector	Set by the SS		SS IKE AUTH2
Encrypted IKE Payloads			SS IKE AUTH2
Extensible Authentication Payload			SS IKE AUTH2
Next Payload	'00000000'B	No Next Payload	SS IKE

			AUTH2
Code	'00000011'B	Success	SS IKE AUTH2
Next Payload	'00101111'B	CP	SS IKE AUTH3
Auth Method	'00000010'B	Shared Key Integrity code	SS IKE AUTH3
Auth Data	derived from the MSK obtained from AKA exchange	RFC 4306 defines the function to derive this key (section 2.15)	SS IKE AUTH3
Configuration Payload			SS IKE AUTH3
Next Payload	'00100001'B	SA	SS IKE AUTH3
CFG Type	'00000010'B	Reply	SS IKE AUTH3
Configuration Attribute	'00010000'B	MIP6_HOME_PR EFIX attribute	SS IKE AUTH3 HA
Length	'0000000000010101'B		SS IKE AUTH3 HA
Prefix lifetime	Any allowed value		SS IKE AUTH3 HA
Home Prefix	IPv6 prefix – 16 bytes		SS IKE AUTH3 HA
Prefix length	'10000000'B	Prefix length must be 64	SS IKE AUTH3 HA
Notify Payload			SS IKE AUTH3 HA redirect
Next Payload	'00100001'B	SA	SS IKE AUTH3 HA redirect
Protocol ID	'00000000'B	Notification is not specific to a particular security association	SS IKE AUTH3 HA redirect
SPI Size	'00000000'B	SPI field not present	SS IKE AUTH3 HA redirect
Notify Message Type Length	'0100000000010111'B	REDIRECT	SS IKE AUTH3 HA redirect
GW Ident Type	'00000101'B		SS IKE AUTH3 HA redirect
New Responder GW Identity	IPv6 address of the HA to relocate		SS IKE AUTH3 HA redirect
GW Ident Type	'00000001'B		SS IKE AUTH3 HA redirect
New Responder GW Identity	IPv4 address of the HA to relocate	Optional	SS IKE AUTH3 HA redirect
Security Association Payload			SS IKE AUTH3
Next Payload	'00101101'	TSi	SS IKE AUTH3
Proposal	One of the 2 proposals included in IKE_AUTH Request at Step 3		SS IKE AUTH3
Traffic Selector – Initiator Payload			SS IKE AUTH3
Next Payload	'00101100'B	TSr	SS IKE AUTH3
Traffic Selector data	Any allowed set of values		SS IKE

			AUTH3
Traffic Selector – Responder Payload			SS IKE AUTH3
Next Payload	'00000000'B	No Next Payload	SS IKE AUTH3
Padding	Set by the SS	Fields from Encryption payload	
Pad Length	Set by the SS	Fields from Encryption payload	
Integrity checksum data	Set by the SS	Fields from Encryption payload	

Condition	Explanation
SS IKE AUTH1	Part of IKE_AUTH request message sent to the UE as part of the first IKE_AUTH Response message
SS IKE AUTH2	Part of IKE_AUTH request message sent to the UE as part of the second IKE_AUTH Response message
SS IKE AUTH3	Part of IKE_AUTH request message sent to the UE as part of the third IKE_AUTH Response message
SS IKE AUTH3 HA	Part of IKE_AUTH request message sent to the UE as part of the third IKE_AUTH Response message when the UE interacts with HA
SS IKE AUTH3 HA_redirect	Part of IKE_AUTH request message sent to the UE as part of the third IKE_AUTH Response message when the UE interacts with HA and the UE gets redirected

4.7C.2 Messages used to perform DS-MIPv6 registration and deregistration

- Router Advertisement

This message is sent by the SS to the UE.

Table 4.7C.2-1: Message Router Advertisement

Field	Value/remark	Comment	Condition
Type	'10000110'B		
Code	'00000000'B		
Checksum	Set by SS	ICMP checksum	
Cur Hop Limit	'00000000'B	Unspecified	
M	Set by the SS		
O	Set by the SS	Depends on access network specific settings	
H	'0'B		
Prf	Set by the SS	Depends on access network specific settings	
Prf	Set by the SS	Depends on access network specific settings	
P	Set by the SS	Depends on access network specific settings	
Reserved	'00000'B		
Router Lifetime	Set by the SS		
Reachable Time	Set by the SS		
Retrans Timer	Set by the SS		
type	'00000011'B	Prefix Information Option	
Length	'00000100'B		
Prefix length	Set by the SS		
L	'1'B		
A	Set by the SS		
Valid Lifetime	Set by the SS		
Preferred Lifetime	Set by the SS		
Prefix	Set as per specific message content		

- Binding Update

This message is sent by the UE to the SS.

Table 4.7C.2-2: Message Binding Update

Information Element	Value/remark	Comment	Condition
IPv4 Source Address	UE IPv4 CoA (IPv4 address acquired by UE during network attachment)		UE IPv4
IPv4 Destination Address	IPv4 of Home Agent discovered during preamble		UE IPv4
UDP header			UE IPv4
Source Port	Set by UE		UE IPv4
Destination port	'0001000001011111'B		UE IPv4
IPv6 Source Address	UE IPv6 CoA (IPv6 address acquired by the UE during network attachment)		IPv6 visited
	IPv6 Home Address configured by the UE from Home Network Prefix assigned to UE during preamble		UE IPv6-home, UE IPv4
IPv6 Destination Address	IPv6 of Home Agent discovered during preamble		
Destination Header	IPv6 Home Address configured by the UE from Home Network Prefix assigned to the UE during preamble		IPv6 visited
Payload Proto	'00111011'B		
MH Type	'00000101'B	Binding Update message	
Sequence Number	Any allowed value		
Lifetime	Any allowed non-zero value		IPv6 visited
	'0000000000000000'B		UE IPv6-home
A	'1'B		
H	'1'B		
L	Not checked		
K	'1'B		
M	'0'B		
R	'1'B		
P	'0'B		
F	'0'B		
IPv4 Home Address option	Set to the value "0.0.0.0" to request allocation for the UE. The "P" flag is set to '0'B. The Prefix Length is set to the requested prefix length of '32'.	Optional	
Alternate Care-of Address option	Same IPv6 address as that inserted in the IP Source Address field		UE IPv6-visited

Condition	Explanation
-----------	-------------

UE IPv4	UE is in an IPv4 visited network (see RFC 5555)
UE IPv6-home	UE is in an IPv6 home network (see RFC 5555)
UE IPv6-visited	UE is in an IPv6 visited network (see RFC 5555)

- Binding Acknowledgement

This message is sent by the SS to the UE.

Table 4.7C.2-3: Message Binding Acknowledgement

Information Element	Value/remark	Comment	Condition
IPv4 Source Address	IPv4 Home Agent address		UE IPv4
IPv4 Destination Address	Same value as UE IPv4 CoA in IP Source Address from Binding Update		UE IPv4
UDP header			UE IPv4
Source Port	'0001000001011111'B		UE IPv4
Destination port	Same as Source port in Binding Update		UE IPv4
IPv6 Source Address	IPv6 Home Agent address		
IPv6 Destination Address	Same value as UE IPv6 CoA in IP Source Address from Binding Update		UE IPv6-visited
	IPv6 Home Address		UE IPv6-home, UE IPv4
Routing Header	Same value as UE IPv6 Home Address in Destination Header from Binding Update		UE IPv6-visited
Payload Proto	'00111011'B		
MH Type	'00000110'B	Binding Acknowledgement message	
Status	'00000000'B	Binding Update accepted	
K	Set by the SS		
R	'1'B		
P	'0'B		
Sequence Number	Same value as that sent by the UE in the Binding Update		
Lifetime	'0000000010010110'B	10 min	UE IPv6-visited, UE IPv4
	'0000000000000000'B		UE IPv6-home
IPv4 Address Acknowledgement option	IPv4 Home Address allocated to the UE	Present if IPv4 Home Address option was included by the UE in Binding Update	
Binding Refresh Advice option	'0000000010010110'B	10 min	

Condition	Explanation
UE IPv4	UE is in an IPv4 visited network (see RFC 5555)
UE IPv6-home	UE is in an IPv6 home network (see RFC 5555)
UE IPv6-visited	UE is in an IPv6 visited network (see RFC 5555)

- Binding Revocation Indication

This message is sent by the SS to the UE.

Table 4.7C.2-4: Binding Revocation Indication

Field	Value/remark	Comment	Condition
IPv4 Header			UE IPv4
IPv4 Source Address	UE IPv4 Home Agent address		UE IPv4
UDP header			UE IPv4
Source Port	Set by SS		UE IPv4
Destination port	'0001000001011111'B		UE IPv4
IPv6 Header			
IPv6 Source Address	IPv6 Home Agent address		
IPv6 Destination Address	IPv6 Home Address configured by UE from Home Network Prefix assigned to UE during preamble		UE IPv4
	IPv6 CoA		UE IPv6-visited
Routing Header	IPv6 Home Address configured by the UE from Home Network Prefix assigned to the UE during preamble		UE IPv6-visited
B.R. Type	'00000001'B	B.R.I	
Sequence Number	Set by the SS		
Revocation Trigger	'00000001'B		
P	'0'B		
G	'0'B		
V	'0'B		

Condition	Explanation
UE IPv4	UE is in an IPv4 visited network (see RFC 5555)
UE IPv6-visited	UE is in an IPv6 visited network (see RFC 5555)

- Binding Revocation Acknowledgement

This message is sent by the UE to the SS.

Table 4.7C.2-5: Binding Revocation Acknowledgement

Information Element	Value/remark	Comment	Condition
IPv4 Header			UE IPv4
IPv4 Source Address	IPv4 CoA		UE IPv4
IPv4 Destination Address	UE IPv4 Home Agent Address		UE IPv4
UDP header		UDP header	UE IPv4
Source Port	'0001000001011111'B	Source Port	UE IPv4
Destination port	Same as Source port in Binding Revocation	Destination port	UE IPv4
IPv6 Header			
IPv6 Source Address	IPv6 Home Address configured by UE		UE IPv4
	IPv6 CoA		UE IPv6-visited
IPv6 Destination Address	IPv6 of Home Agent address	IPv6 Destination Address	
Destination Header	IPv6 Home Address configured by the UE		UE IPv6-visited
B.R. Type	'00000010'B	B.R.A	
Sequence Number	Same value as Sequence Number sent by the SS in Binding Revocation		
Status	'00000000'B	Success	
P	'0'B		
G	'0'B		
V	'0'B		

Condition	Explanation
UE IPv4	UE is in an IPv4 visited network (see RFC 5555)
UE IPv6-visited	UE is in an IPv6 visited network (see RFC 5555)

4.7D Default GERAN message and information element contents

4.7D.1 GPRS message

– PS HANDOVER COMMAND

Table 4.7D.1-1: PS HANDOVER COMMAND

Derivation Path: 44.060 clause 11.2.43.1			
Information Element	Value/remark	Comment	Condition
PAGE_MODE	Default		
Global TFI	TFI of mobile station uplink TBF		
CONTAINER_ID	00		
PS Handover to A/Gb Mode Payload	00	PS Handover RR Info	
PS Handover RR Info flag	00		
PS Handover Radio Resources IE	Present		
Handover Reference	0		
ARFCN	default ARFCN for BCCH of GERAN cell		
SI	00	Non-synchronized	
NCI	0		
BSIC	BSIC of GERAN cell		
0 <CCN_ACTIVE>	not present		
0 <3G_CCN_ACTIVE>	not present		
0 <CCN Support Description>	not present		
Frequency Parameters	default PDTCH of GERAN cell		
NETWORK_CONTROL_ORDER	2		
0 <Global Packet Timing Advance>	not present		
EXTENDED_DYNAMIC_ALLOCATION	0		
RLC_RESET	1	RLC is reset	
0 <PO>	not present		
0 <Uplink Control Timeslot>	not present		
0 GPRS mode	Uplink TBF assignment for default PDTCH of GERAN cell		
0 <NAS Container for PS Handover IE>	not present		

4.8 Reference radio bearer configurations

4.8.1 General

4.8.2 SRB and DRB parameters and combinations

4.8.2.1 SRB and DRB parameters

4.8.2.1.1 SRB configurations

Table 4.8.2.1.1-1: SRB-ToAddMod-DEFAULT

Derivation Path: 36.331 clause 6.3.2			
Information Element	Value/remark	Comment	Condition
SRB-ToAddMod-DEFAULT ::= SEQUENCE {			
srb-Identity	1		SRB1
	2		SRB2
rlc-Config CHOICE {			
defaultValue			
}			
logicalChannelConfig CHOICE {			
defaultValue			
}			
}			

4.8.2.1.2 DRB PDCP configurations

4.8.2.1.2.1 DRB PDCP configurations for UM RLC

Table 4.8.2.1.2.1-1: PDCP-Config-DRB-UM

Derivation Path: 36.331 clause 6.3.2			
Information Element	Value/remark	Comment	Condition
PDCP-Config-DRB-UM ::= SEQUENCE {			
discardTimer	ms100	Suitable for real time services	
rlc-AM SEQUENCE {}	Not present		
rlc-UM SEQUENCE {			
pdcpc-SN-Size	Len12bits		
}			
headerCompression CHOICE {			
notUsed	NULL		
}			
}			

4.8.2.1.2.2 DRB PDCP configurations for AM RLC

Table 4.8.2.1.2.2-1: PDCP-Config-DRB-AM

Derivation Path: 36.331 clause 6.3.2			
Information Element	Value/remark	Comment	Condition
PDCP-Config-DRB-AM ::= SEQUENCE {			
discardTimer	Infinity		
rlc-AM SEQUENCE {			
statusReportRequired	TRUE		
}			
rlc-UM SEQUENCE { }	Not present		
headerCompression CHOICE {			
notUsed	NULL		
}			
}			

4.8.2.1.3 DRB RLC configurations

4.8.2.1.3.1 DRB UM RLC configurations

Table 4.8.2.1.3.1-1: RLC-Config-DRB-UM

Derivation Path: 36.331 clause 6.3.2			
Information Element	Value/remark	Comment	Condition
RLC-Config-DRB-UM ::= CHOICE {			
um-Bi-Directional SEQUENCE {			
ul-UM-RLC SEQUENCE {			
sn-FieldLength	Size10		
}			
dl-UM-RLC SEQUENCE {			
sn-FieldLength	Size10		
t-Reordering	ms50	ms50 provides sufficient margin	
}			
}			
}			

4.8.2.1.3.2 DRB AM RLC configurations

Table 4.8.2.1.3.2-1: RLC-Config-DRB-AM

Derivation Path: 36.331 clause 6.3.2			
Information Element	Value/remark	Comment	Condition
RLC-Config-DRB-AM ::= CHOICE {			
am SEQUENCE {			
ul-AM-RLC SEQUENCE {			
t-PollRetransmit	ms80		
pollPDU	p128		
pollByte	kB125		
maxRetxThreshold	t4		
}			
dl-AM-RLC SEQUENCE {			
t-Reordering	ms80	Is sufficient for 5 HARQ transmissions	
t-StatusProhibit	Ms60	Should be equal to or smaller than t-PollRetransmit.	
}			
}			
}			

4.8.2.1.4 DRB Logical Channel configurations

Table 4.8.2.1.4-1: LogicalChannelConfig-DRB

Derivation Path: 36.331 clause 6.3.2			
Information Element	Value/remark	Comment	Condition
LogicalChannelConfig-DRB ::= SEQUENCE {			
ul-SpecificParameters SEQUENCE {			
priority	6		HI
	13		LO
prioritisedBitRate	infinity	PBR is disabled.	
bucketSizeDuration	ms100		
logicalChannelGroup	1		HI
	2		LO
}			
}			

Condition	Explanation
HI	Used for DRBs with high logical channel priority
LO	Used for DRBs with low logical channel priority

4.8.2.1.5 MAC configurations

Table 4.8.2.1.5-1: MAC-MainConfig-RBC

Derivation Path: 36.331 clause 6.3.2			
Information Element	Value/remark	Comment	Condition
MAC-MainConfig-RBC ::= SEQUENCE {			
ul-SCH-Config SEQUENCE {			
maxHARQ-Tx	n5		
periodicBSR-Timer	sf20		
	Infinity		no_periodic_BSR_or_PHR
retxBSR-Timer	sf320		
	sf10240		no_periodic_BSR_or_PHR
ttiBundling	FALSE		
}			
drx-Config	Not present		NOT pc_FeatGrp_5
drx-Config CHOICE {			pc_FeatGrp_5 AND DRX_S
setup SEQUENCE {			
onDurationTimer	psf2		
drx-InactivityTimer	psf100		
drx-RetransmissionTimer	psf16		
longDRX-CycleStartOffset CHOICE {		sf40 typical value in real network for real-time services.	
sf40	4		For SIG
	0		For RF
}			
shortDRX	Not present		
}			
}			
drx-Config CHOICE {			pc_FeatGrp_5 AND DRX_L
setup SEQUENCE {			
onDurationTimer	psf6		
drx-InactivityTimer	psf1920		
drx-RetransmissionTimer	psf16		
longDRX-CycleStartOffset CHOICE {		sf1280 typical value in real network for best-effort services.	
sf1280	4		For SIG
	0		For RF
}			
shortDRX	Not present		
}			
}			
timeAlignmentTimerDedicated	sf750		
phr-Config CHOICE {			no_periodic_BSR_or_PHR
release	NULL		
}			
phr-Config CHOICE {			
setup SEQUENCE {			
periodicPHR-Timer	sf500		
prohibitPHR-Timer	sf200		

dl-PathlossChange	dB3		
}			
}			
sr-ProhibitTimer-r9	Not present		
mac-MainConfig-v1020	Not present		
mac-MainConfig-v1020SEQUENCE {			SCell_AddMod
sCellDeactivationTimer-r10	rf32		
extendedBSR-Sizes-r10	setup		
extendedPHR-r10	setup		
}			
}			

Condition	Explanation
DRX_S	Used for DRX configuration with small DRX cycle length
DRX_L	Used for DRX configuration with large DRX cycle length
no_periodic_BSR_or_PHR	Used to disable BSR and PHR
For SIG	Used for DRX configuration in Protocol testing
For RF	Used for DRX configuration in RRM testing
SCell_AddMod	Addition or modification of SCell

Table 4.8.2.1.5-2: MAC-MainConfig-SRB

Derivation Path: 36.331 clause 6.3.2				
Information Element	Value/remark	Comment	Condition	
MAC-MainConfig-SRB ::= SEQUENCE {				
ul-SCH-Config SEQUENCE {				
maxHARQ-Tx	n5			
periodicBSR-Timer	sf20			
retxBSR-Timer	sf320			
ttxBundling	FALSE			
}				
drx-Config CHOICE {				
release	NULL			
}				
timeAlignmentTimerDedicated	sf750			
phr-Config CHOICE {				
setup SEQUENCE {				
periodicPHR-Timer	sf500			
prohibitPHR-Timer	sf200			
dl-PathlossChange	dB3			
}				
}				
}				

4.8.2.1.6 Physical Layer configurations

Table 4.8.2.1.6-1: PhysicalConfigDedicated-DEFAULT

Derivation Path: 36.331 clause 6.3.2			
Information Element	Value/remark	Comment	Condition
PhysicalConfigDedicated-DEFAULT ::= SEQUENCE {			
pdsch-ConfigDedicated	PDSCH-ConfigDedicated-DEFAULT	See subclause 4.6.3	SRB1 or HO-TO-EUTRA
	Not present		RBC or RBC-HO
pucch-ConfigDedicated	PUCCH-ConfigDedicated-DEFAULT	See subclause 4.6.3	SRB1 or RBC-HO or HO-TO-EUTRA
	Not present		RBC
pusch-ConfigDedicated	PUSCH-ConfigDedicated-DEFAULT	See subclause 4.6.3	SRB1 or HO-TO-EUTRA
	Not present		RBC or RBC-HO
uplinkPowerControlDedicated	UplinkPowerControlDedicated-DEFAULT	See subclause 4.6.3	SRB1 or HO-TO-EUTRA
	Not present		RBC or RBC-HO
tpc-PDCCH-ConfigPUCCH	Not present		SRB1
	TPC-PDCCH-Config-DEFAULT using condition PUCCH	See subclause 4.6.3	RBC or RBC-HO or HO-TO-EUTRA
tpc-PDCCH-ConfigPUSCH	Not present		SRB1
	TPC-PDCCH-Config-DEFAULT using condition PUSCH	See subclause 4.6.3	RBC or RBC-HO or HO-TO-EUTRA
cqi-ReportConfig	CQI-ReportConfig-DEFAULT	See subclause 4.6.3	SRB1 or HO-TO-EUTRA
	CQI-ReportConfig-DEFAULT using condition CQI_PERIODIC	See subclause 4.6.3	RBC or RBC-HO
	Not present		SCell_AddMod
soundingRS-LU-ConfigDedicated	Not present		SRB1 or HO-TO-EUTRA 1
	SoundingRS-UI-ConfigDedicated-DEFAULT	See subclause 4.6.3	RBC or RBC-HO
antennaInfo CHOICE {			
explicitValue SEQUENCE {			2TX
transmissionMode	tm3		
codebookSubsetRestriction CHOICE {			
n2TxAntenna-tm3	'11'	BIT STRING (SIZE (2))	
}			
ue-TransmitAntennaSelection CHOICE {			
Release	NULL		
}			
}			
defaultValue	NULL		
}			
schedulingRequestConfig	SchedulingRequest-Config-DEFAULT	See subclause 4.6.3	SRB1 or RBC-H or

			HO-TO-EUTRA O
	Not present		RBC
cqi-ReportConfig-v920	Not present		
antennaInfo-v920	Not present		
antennaInfo-r10	Not present		
antennaInfoUL-r10	Not present		
cif-Presence-r10	FALSE		
cqi-ReportConfig-r10	CQI-ReportConfig-r10-DEFAULT		SCell_AddMod
	Not present		
csi-RS-Config-r10	Not present		
pucch-ConfigDedicated-v1020	Not present		
pusch-ConfigDedicated-v1020	PUSCH-ConfigDedicated-v1020-DEFAULT		SCell_AddMod
	Not present		
schedulingRequestConfig-v1020	Not present		
soundingRS-UL-ConfigDedicated-v1020	Not present		
soundingRS-UL-ConfigDedicatedAperiodic-r10	Not present		
uplinkPowerControlDedicated-v1020	UplinkPowerControlDedicated-v1020-DEFAULT		SCell_AddMod
	Not present		
additionalSpectrumEmissionCA-r10	Not present		
additionalSpectrumEmissionCA-r10 CHOICE {			SCell_AddMod
setup SEQUENCE {			
additionalSpectrumEmissionPCell-r10	1 (CA_NS_01)		
}			
}			
}			

Note: For signalling test, table 6.6B.1.1.1-1 is applied.

Condition	Explanation
SRB1	Used at configuration of SRB1 during RRC connection (re-)establishment
RBC	Used at configuration of a radio bearer combination during SRB2+DRB establishment
2TX	Used for cells with two antenna ports
RBC-HO	Used during Handover
SCell_AddMod	Addition or modification of SCell
HO-TO-EUTRA	Inter-RAT handover to E-UTRA

4.8.2.1.7 DRB configurations

Table 4.8.2.1.7-1: DRB-ToAddMod-DEFAULT(bid)

Derivation Path: 36.331 clause 6.3.2			
Information Element	Value/remark	Comment	Condition
DRB-ToAddMod-DEFAULT(bid) ::= SEQUENCE {		bid is the bearer identity (1..8)	
eps-BearerIdentity	bid+4		
drb-Identity	bid		
pdcp-Config	PDCCP-Config-DRB-AM		AM
	PDCCP-Config-DRB-UM		UM
rlc-Config	RLC-Config-DRB-AM		AM
	RLC-Config-DRB-UM		UM
logicalChannelIdentity	bid+2		
logicalChannelConfig	LogicalChannelConfig-DRB using condition HI		UM
	LogicalChannelConfig-DRB using condition LO		AM
}			

Condition	Explanation
AM	Used for AM DRB
UM	Used for UM DRB

4.8.2.2 SRB and DRB combinations

4.8.2.2.1 Combinations on DL-SCH and UL-SCH

4.8.2.2.1.1 SRB1 and SRB2 for DCCH + n x AM DRB + m x UM DRB, where n=1..N and m=0..M

This SRB and DRB combination is setup with UE Registration procedure and the Generic Radio Bearer Establishment or Generic Radio Bearer Establishment, UE Test Mode Activated procedure using specific message content - the default *RRConnectionReconfiguration* message with condition SRB2-DRB(n, m).

4.8.3 UTRA reference radio parameters and combinations

Table 4.8.3-1 defines UTRA reference radio parameters and combinations to be used in E-UTRA and UTRA inter-RAT test cases.

Table 4.8.3-1: UTRA reference radio parameters and combinations

Condition	Reference configuration	Comment
UTRA Speech	TS 34.108 subclause 6.10.2.4.1.4	Conversational / speech / UL:12.2 DL:12.2 kbps / CS RAB + UL:3.4 DL:3.4 kbps SRBs for DCCH
UTRA FDD PS RB	TS 34.108 subclause 6.10.2.4.1.26	Interactive or background / UL:64 DL: 64 kbps / PS RAB + UL:3.4 DL:3.4 kbps SRBs for DCCH
UTRA HSDPA RB	TS 34.108 subclause 6.10.2.4.5.1	Interactive or background / UL:64 DL: [max bit rate depending on UE category] / PS RAB + UL:3.4 DL:3.4 kbps SRBs for DCCH
UTRA HSUPA/HSDPA RB	TS 34.108 subclause 6.10.2.4.6.3	Streaming or interactive or background / UL: [max bit rate depending on UE category and TTI] DL: [max bit rate depending on UE category] / PS RAB + UL: [max bit rate depending on UE category and TTI] DL: [max bit rate depending on UE category] SRBs for DCCH on E-DCH and HS-DSCH
UTRA PS RB + Speech	TS 34.108 subclause 6.10.2.4.1.40	Conversational / speech / UL:12.2 DL:12.2 kbps / CS RAB + Interactive or background / UL:64 DL:64 kbps / PS RAB+ UL:3.4 DL: 3.4 kbps SRBs for DCCH

4.8.4 GERAN reference PDP context parameters

Table 4.8.4-1 defines GERAN reference PDP context parameters to be used in E-UTRA and GERAN inter-RAT test cases.

Table 4.8.4-1: GERAN reference PDP context parameters

Condition	Reference configuration	Comment
GPRS	TS 51.010-1 subclause 40.5, Test PDP context3.	Test PDP context3 is the default Test PDP context which is used in the GERAN Inter-RAT GPRS test cases where no particular Test PDP contexts are specified. Compression is always turned off if nothing else is stated explicitly in the test case.

4.9 Common test USIM, CSIM and ISIM parameters

This clause defines default parameters for programming the elementary files of the test UICC when running conformance test cases defined in 3GPP TS 36.523-1[18].

4.9.1 General

See clause 8.1 in 3GPP TS 34.108 [5].

4.9.1.1 Definitions

See clause 8.1.1 in 3GPP TS 34.108 [5].

4.9.1.2 Definition of the test algorithm for authentication

Same as clause 8.1.2 in 3GPP TS 34.108[5].

4.9.1.2.1 Authentication and key derivation in the test USIM, CSIM and ISIM and SS

UE and SS calculate Ck, Ik, AUTN, RES[XRES] as in clause 8.1.2.1 in 3GPP TS 34.108 [5]. Derivation of K_{ASME} and other E-UTRA Keys shall be as defined in Annex A of 3GPP TS 33.401 [31], using Key derivation function HMAC-SHA-256 algorithm.

4.9.1.2.2 Generation of re-synchronization parameters in the USIM, CSIM and ISIM

Same as clause 8.1.2.1 in 3GPP TS 34.108[5].

4.9.1.2.3 Using the authentication test algorithm for UE conformance testing

See clause 8.1.2.3 in 3GPP TS 34.108 [5].

4.9.2 Default parameters for the test USIM, CSIM and ISIM

Same as clause 8.2 in 3GPP TS 34.108 [5].

4.9.3 Default settings for the Elementary Files (EFs)

The format and coding of elementary files of the USIM are defined in 3GPP TS 31.101 [32] and 3GPP TS 31.102 [33]. Those of the ISIM are defined in 3GPP TS 31.101 [32] and 3GPP TS 31.103 [45]. Those of the CSIM are defined in 3GPP2 C.S0065-B [48].

The settings of the elementary files at the MF and USIM ADF (Application DF) level resp. the ISIM ADF (Application DF) level are the same as section 8.3 in 3GPP TS 34.108 [5] resp. section 4.2 in 3GPP TS 34.229-1 Annex E [46] and 3GPP TS 34.229-3 Annex B.1 [47] with the exceptions listed below. The settings of the elementary files at the CSIM ADF (Application DF) level as as specified below. Note that some files may be updated by the UE based on information received from the SS.

4.9.3.1 Modified contents of the USIM Elementary Files

EF_{EPSLOCi} (EPS location information)

File size: 18 Bytes

Default values: Bytes 1 to 12 (HEX): FF FF FF FF FF FF FF FF FF FF FF FF(GUTI)

Bytes 13 to 17 (HEX): 42 F6 18 FF FE (Last visited registered TAI)

Byte 18 (BIN): 00000001 (EPS update status = "not updated")

Bytes 13 to 17: TAI-MCC = 246 (bytes 13 to 14) and TAI-MNC = 81 (byte 15) are frequently used. The TAC (bytes 16 to 17) is set to "FF FE" since this, in conjunction with byte 18 setting of "01", is used to ensure that the UE performs Attach at the beginning of a test.

Bytes in this file (e.g. GUTI in bytes 1 to 12) may be updated as a result of a tracking area update attempt by the UE.

EF_{EPSNSC} (EPS NAS Security Context)

The programming of this EF follows default parameter written in 3GPP TS 31.102 [23], annex E.

EF_{UST} (USIM Service Table):

Services		Activated	Version
Service n°15:	Cell Broadcast Message Identifier	Optional	
Service n°16:	Cell Broadcast Message Identifier Ranges	Optional	
Service n°85	EPS Mobility Management Information	Yes	
Service n°87	Call control on EPS PDN connection by USIM	No	

4.9.3.2 Modified contents of the CSIM Elementary Files

EF_{COUNT} (Call Count)

The programming of this EF follows default parameter written in 3GPP2 C.S0065-B [48], Annex E.

EF_{IMSI_M} (IMSI_M)

The programming of this EF follows default parameter written in 3GPP2 C.S0065-B [48], Annex E.

EF_{IMSI_T} (IMSI_T)

The programming of this EF follows default parameter written in 3GPP2 C.S0065-B [48], Annex E.

EF_{TMSI} (TMSI)

The programming of this EF follows default parameter written in 3GPP2 C.S0065-B [48], Annex E.

EF_{AH} (Analog Home SID)

The programming of this EF follows default parameter written in 3GPP2 C.S0065-B [48], Annex E.

EF_{AOP} (Analog Operational Parameters)

The programming of this EF is a test house option.

EF_{ALOC} (Analog Location and Registration Indicators)

The programming of this EF is a test house option.

EF_{CDMAHOME} (CDMA Home SID, NID)

Record size: 5 Bytes

Record count: 6

Record 1:

Default values: Bytes 1 to 2 (HEX): E8 03 (CDMA Home SID (SIDp): 1000)
 Bytes 3 to 4 (HEX): AE 08 (CDMA Home NID (NIDp): 2222)
 Bytes 5 (HEX): 00 (Band Class: 0 (800 MHz cellular band))

Record 2:

Default values: Bytes 1 to 2 (HEX): E8 03 (CDMA Home SID (SIDp): 1000)
 Bytes 3 to 4 (HEX): AE 08 (CDMA Home NID (NIDp): 2222)

Bytes 5 (HEX): 01 (Band Class: 1 (1.8 to 2.0 GHz PCS band))

Record 3:

Default values: Bytes 1 to 2 (HEX): E8 03 (CDMA Home SID (SIDp): 1000)

Bytes 3 to 4 (HEX): AE 08 (CDMA Home NID (NIDp): 2222)

Bytes 5 (HEX): 03 (Band Class: 3 (832 to 925 MHz JTACS band))

Record 4:

Default values: Bytes 1 to 2 (HEX): E8 03 (CDMA Home SID (SIDp): 1000)

Bytes 3 to 4 (HEX): AE 08 (CDMA Home NID (NIDp): 2222)

Bytes 5 (HEX): 04 (Band Class: 4 (1.75 to 1.87 GHz Korean PCS band))

Record 5:

Default values: Bytes 1 to 2 (HEX): E8 03 (CDMA Home SID (SIDp): 1000)

Bytes 3 to 4 (HEX): AE 08 (CDMA Home NID (NIDp): 2222)

Bytes 5 (HEX): 05 (Band Class: 5 (450 MHz NMT band))

Record 6:

Default values: Bytes 1 to 2 (HEX): E8 03 (CDMA Home SID (SIDp): 1000)

Bytes 3 to 4 (HEX): AE 08 (CDMA Home NID (NIDp): 2222)

Bytes 5 (HEX): 06 (Band Class: 6 (2 GHz IMT-2000 band))

EF_{ZNREGI} (CDMA Zone-Based Registration Indicators)

The programming of this EF follows default parameter written in 3GPP2 C.S0065-B [48], Annex E.

EF_{SNREGI} (CDMA System-Network Registration Indicators)

The programming of this EF is a test house option.

EF_{DISTREGI} (CDMA Distance-Based Registration Indicators)

The programming of this EF follows default parameter written in 3GPP2 C.S0065-B [48], Annex E.

EF_{ACCOLC} (Access Overload Class ACCOLCp)

The 4 LSB of this 1 byte file are der-bit access overload class indicator is derived from the last digit of the associated decimal representation of the IMSI_M via decimal to binary conversion.

File size: 1 byte

Default value: Bits 4 to 7 are reserved and set to '0000'. Bits 0 to 3 are derived from the last digit of the associated decimal representation of the IMSI_M via decimal to binary conversion.

EF_{TERM} (Call Termination Mode Preferences)

The programming of this EF is a test house option.

EF_{SSCI} (Suggested Slot Cycle Index)

The programming of this EF is a test house option.

EF_{ACP} (Analog Channel Preferences)

The programming of this EF is a test house option.

EF_{PRL} (Preferred Roaming List)

File size: 18 Bytes

Default values: Bytes 1 to 18 (HEX): 00 12 00 00 00 00 40 01 21 00 02 80 00 50 00 00 6E DB

The interpretation of the default values read as follows:

PRL ID – 0

Preferred only – 0

Default roaming indication – 0

Number of Acquisition Records – 1

Number of system records – 1

EF_{RUIMID} (Removable UIMID)

This EF stores a 32-bit electronic identification number (ID) unique to the CSIM or a 32-bit pseudo-UIMID of the CSIM. It is specified by the CSIM manufacturer.

EF_{CSIM_ST} (CSIM Service Table)

Services will be allocated and activated as follows.

Services		Activated	Version
Service n°1 :	Local Phone Book	Option	
Service n°2 :	Fixed Dialling Numbers (FDN)	Option	
Service n°3 :	Extension 2	Option	
Service n°4 :	Service Dialling Numbers (SDN)	Option	
Service n°5 :	Extension3	Option	
Service n°6:	Short Message Storage	Yes	
Service n°7:	Short Message Parameters (SMP)	Yes	
Service n°8:	HRPD	Yes	
Service n°9:	Service Category Program for BC-SMS	Option	
Service n°10:	CDMA Home Service Provider Name	Yes	
Service n°11:	Data Download via SMS Broadcast (for CCAT)	Option	
Service n°12:	Data Download via SMS-PP (for CCAT)	Option	
Service n°13:	Call Control (for CCAT)	Option	
Service n°14:	3GPD-SIP	Option	
Service n°15:	3GPD-MIP	Option	
Service n°16:	AKA	Yes	
Service n°17:	IP-based Location Services (LCS)	Option	
Service n°18:	BCMCS	Option	
Service n°19:	Multimedia Messaging Service (MMS)	Option	
Service n°20:	Extension 8	Option	
Service n°21:	MMS User Connectivity Parameters	Option	
Service n°22:	Application Authentication	Option	
Service n°23:	Group Identifier Level 1	Option	
Service n°24:	Group Identifier Level 2	Option	
Service n°25:	De-Personalization Control Keys	Option	
Service n°26:	Cooperative Network List	Option	
Service n°27:	Outgoing Call Information (OCI)	Option	
Service n°28:	Incoming Call Information (ICI)	Option	
Service n°29:	Extension 5	Option	
Service n°30:	Multimedia Storage	Option	
Service n°31:	Image (EFIMG)	Option	
Service n°32:	Enabled Services Table	Yes	

Services		Activated	Version
Service n°33:	Capability Configuration Parameters (CCP)	Option	
Service n°34:	SF_EUIMID-based EUIMID	Option	
Service n°35:	Messaging and 3GPD Extensions	Option	
Service n°36:	Root Certificates	Option	
Service n°37:	WAP Browser	Option	
Service n°38:	Java	Option	
Service n°39:	Reserved for CDG	No	
Service n°40:	Reserved for CDG	No	
Service n°41:	IPv6	Option	
Service n°42:	Proactive CSIM (for CCAT)	Option	

EF_{SPC} (Service Programming Code)

The programming of this EF follows default parameter written in 3GPP2 C.S0065-B [48], Annex E.

EF_{OTAPASPC} (OTAPA/SPC_Enabled)

The programming of this EF follows default parameter written in 3GPP2 C.S0065-B [48], Annex E.

EF_{NAMLOCK} (NAM_LOCK)

The programming of this EF is a test house option.

EF_{OTA} (OTASP/OTAPA Features)

The programming of this EF is a test house option.

EF_{SP} (Service Preferences)

The programming of this EF is a test house option.

EF_{ESN_MEID_ME} (ESN_ME or MEID_ME)

The programming of this EF follows default parameter written in 3GPP2 C.S0065-B [48], Annex E.

EF_{LI} (Language Indication)

The programming of this EF is a test house option.

EF_{FDN} (Fixed Dialling Numbers)

The programming of this EF is a test house option.

EF_{SMS} (Short Messages)

The programming of this EF follows default parameter written in 3GPP2 C.S0065-B [48], Annex E.

EF_{SMSP} (Short Message Service Parameters)

Record size: 12 Bytes

Record count: 1

Record 1:

Default values: Bytes 1 to 23 (HEX): 00 02 10 02 5D FE FF FF 02 F5 FF FF FF FF FF FF FF
08 03 08 01 C0

The interpretation of the default values in this record read as follows:

Teleservice Identifier: CDMA Cellular Messaging Teleservice [CMT-95]

Parameter Indicators: MSG_ENCODING, Validity Period, Bearer Data

Message Encoding: 7-bit ASCII

Validity Period: Indefinite

Bearer Data:

Priority Indicator: Emergency

EF_{SMSS} (SMS Status)

The programming of this EF follows default parameter written in 3GPP2 C.S0065-B [48], Annex E.

EF_{SSFC} (Supplementary Services Feature Code Table)

The programming of this EF is a test house option.

EF_{SPN} (CDMA Home Service Provider Name)

File size: 35 Bytes

Default values: Bytes 1 to 35 (HEX): 01 02 01 44 65 66 61 75 6C 74 20 53 65 72 76 69 63 65 20 50 72 6F
76 69 64 65 72 20 4E 61 6D 65 FF FF FF

The interpretation of the default values read as follows:

Display Condition: Display of registered system is required

Character Encoding: 7-bit ASCII

Language Indicator: 1 (English)

Service Provider Name: "Default Service Provider Name"

EF_{USGIND} (UIMID/SF_EUIMID Usage Indicator)

The programming of this EF is a test house option.

EF_{AD} (Administrative Data)

The programming of this EF follows default parameter written in 3GPP2 C.S0065-B [48], Annex E.

EF_{MDN} (Mobile Directory Number)

The programming of this EF is a test house option.

EF_{MAXPRL} (Maximum PRL)

The programming of this EF is a test house option.

EF_{SPCS} (SPC Status)

If EF_{SPC} is set to default value of '00 00 00', then EF_{SPCS} shall be set to '00', otherwise it shall be set to '01'.

EF_{ECC} (Emergency Call Codes)

The programming of this EF follows default parameter written in 3GPP2 C.S0065-B [48], Annex E.

EF_{ME3GPDOPC} (ME 3GPD Operation Capability)

The programming of this EF follows default parameter written in 3GPP2 C.S0065-B [48], Annex E.

EF_{3GPDOPM} (3GPD Operation Mode)

The programming of this EF is a test house option.

EF_{SIPCAP} (SimpleIP Capability Parameters)

The programming of this EF is a test house option.

EF_{MIPCAP} (MobileIP Capability Parameters)

The programming of this EF is a test house option.

EF_{SIPUPP} (SimpleIP User Profile Parameters)

The programming of this EF is a test house option.

EF_{MIPUPP} (MobileIP User Profile Parameters)

The programming of this EF is a test house option.

EF_{SIPSP} (SimpleIP Status Parameters)

The programming of this EF is a test house option.

EF_{MIPSP} (MobileIP Status Parameters)

The programming of this EF is a test house option.

EF_{SIPPAPSS} (SimpleIP PAP SS Parameters)

The programming of this EF is a test house option.

EF_{PUZL} (Preferred User Zone List)

The programming of this EF is a test house option.

EF_{MAXPUZL} (Maximum PUZL)

The programming of this EF is a test house option.

EF_{MECRP} (ME-specific Configuration Request Parameters)

The programming of this EF follows default parameter written in 3GPP2 C.S0065-B [48], Annex E.

EF_{HRPDCAP} (HRPD Access Authentication Capability Parameters)

File size: 3 Bytes

Default values: Bytes 1 to 3 (HEX): 20 F8 80

The interpretation of the default values read as follows:

Maximum NAI Length: 32

Maximum Length of Shared Secret: 31

Authentication Algorithms: PPP CHAP

EF_{HRPDUPP} (HRPD Access Authentication User Profile Parameters)

File size: 14 Bytes

Default values: Bytes 1 to 14 (HEX): 0D 0B 61 62 63 40 78 79 7A 2E 63 6F 6D 10

The interpretation of the default values read as follows:

HRPD Profile NAI: "abc@xyz.com"

HRPD Profile Authentication Algorithm: CHAP

EF_{CSSPR} (CUR_SSPR_P_REV)

The programming of this EF follows default parameter written in 3GPP2 C.S0065-B [48], Annex E.

EF_{ATC} (Access Terminal Class)

The programming of this EF is a test house option.

EF_{EPRL} (Extended Preferred Roaming List)

File size: 112 Bytes

Default values: Bytes 1 to 16 (HEX): 00 70 02 9A 03 00 01 80 00 03 00 0A 04 31 13 31

Bytes 17 to 32 (HEX): 13 0B 04 30 C8 30 C8 0A 04 01 64 01 64 0B 04 01

Bytes 33 to 48 (HEX): 64 01 64 0A 04 0A 58 0A 58 0B 04 0A 58 0A 58 38

Bytes 49 to 64 (HEX): C0 08 00 01 80 00 38 E0 18 00 01 80 00 38 E0 28

Bytes 65 to 80 (HEX): 00 01 80 00 71 E0 02 00 10 1F 01 00 00 FF FF 01

Bytes 81 to 96 (HEX): 80 00 71 E0 12 00 10 1F 01 00 00 FF FF 01 80 00

Bytes 97 to 112 (HEX): 71 E0 22 00 10 1F 01 00 00 FF FF 01 80 00 19

The interpretation of the default values read as follows:

PRL ID – 666

List Type: IS-683D

Preferred only – 0

Default roaming indication – 0

Number of acquisition records – 6

- Index: 0, Type: CDMA Generic, Band: 6, Channel: 275
- Index: 1, Type: HDR Generic Band: 6, Channel: 200
- Index: 2, Type: CDMA Generic, Band: 0, Channel: 356
- Index: 3, Type: HDR Generic, Band: 0, Channel: 356
- Index: 4, Type: CDMA Generic, Band: 1, Channel: 600
- Index: 5, Type: HDR Generic, Band: 1, Channel: 600

Number of records in the Common Subnet Table – 0

Number of system records – 6

- Acquisition Index: 1, Type: IS-856, Subnet ID: /0

- Acquisition Index: 3, Type: IS-856, Subnet ID: /0
- Acquisition Index: 5, Type: IS-856, Subnet ID: /0
- Acquisition Index: 0, Type: MCC-MNC-based, Roam Indicator: 1, Subnet ID: MCC-MNC SID/NID, MCC: 001, MNC: 01, SID: 0, NID: 65535
- Acquisition Index: 2, Type: MCC-MNC-based, Roam Indicator: 1, Subnet ID: MCC-MNC SID/NID, MCC: 001, MNC: 01, SID: 0, NID: 65535
- Acquisition Index: 4, Type: MCC-MNC-based, Roam Indicator: 1, Subnet ID: MCC-MNC SID/NID, MCC: 001, MNC: 01, SID: 0, NID: 65535

EF_{MSPL} (Multimode system selection System Priority List)

File size: 18 Bytes

Default values: Bytes 1 to 18 (HEX): 00 0F 01 00 01 01 01 03 07 08 02 0C 00 3E 00 FF FF FF

The interpretation of the default values read as follows:

Current MMSS_P_REV – 1

MLPL Version ID – 1

MLPL Identification – 1

Number of MLPL Records – 1

- Index: 1, Location Parameter Type Value: default, MSPL Index: 1

EF_{MLPL} (Multimode system selection Location associated Priority List)

File size: 18 Bytes

Default values: Bytes 1 to 18 (HEX): 00 09 01 00 01 01 01 00 01 FF FF FF FF FF FF FF FF

The interpretation of the default values read as follows:

Current MMSS_P_REV – 1

MSPL Version ID – 1

MSPL Block 1:

MSPL Identification – 1,

Number of MSPL ID1 records – 3

- Index 1: System Type: EUTRA, Priority Class: Home Only, System Priority: 1, Higher Priority Search Time: 64 minutes, Network Capability Indicator: no Network CAP used
- Index 2: System Type: cdma2000 HRPD, Priority Class: Home + Preferred, System Priority: 1, Higher Priority Search Time: 64 minutes, Network Capability Indicator: no Network CAP used
- Index 3: System Type: cdma2000 AI, Priority Class: Any, System Priority: 1, Higher Priority Search Time: 64 minutes, Network Capability Indicator: no Network CAP used

EF_{BCSMScfg} (Broadcast Short Message Configuration)

The programming of this EF is a test house option.

EF_{BCSMSpref} (Broadcast Short Message Preference)

The programming of this EF follows default parameter written in 3GPP2 C.S0065-B [48], Annex E.

EF_{BSCSMStable} (Broadcast Short Message Table)

The programming of this EF follows default parameter written in 3GPP2 C.S0065-B [48], Annex E.

EF_{BSCSMSP} (Broadcast Short Message Parameter)

The programming of this EF follows default parameter written in 3GPP2 C.S0065-B [48], Annex E.

EF_{BAKPARA} (Currently used BAK Parameters)

The programming of this EF is a test house option.

EF_{UpBAKPARA} (Updated BAK Parameters)

The programming of this EF is a test house option.

EF_{MMSN} (MMS Notification)

The programming of this EF follows default parameter written in 3GPP2 C.S0065-B [48], Annex E.

EF_{EXT8} (Extension 8)

The programming of this EF follows default parameter written in 3GPP2 C.S0065-B [48], Annex E.

EF_{MMSICP} (MMS Issuer Connectivity Parameters)

The programming of this EF follows default parameter written in 3GPP2 C.S0065-B [48], Annex E.

EF_{MMSUP} (MMS User Preferences)

The programming of this EF follows default parameter written in 3GPP2 C.S0065-B [48], Annex E.

EF_{MMSUCP} (MMS User Connectivity Parameters)

The programming of this EF follows default parameter written in 3GPP2 C.S0065-B [48], Annex E.

EF_{AuthCapability} (Authentication Capability)

The programming of this EF follows default parameter written in 3GPP2 C.S0065-B [48], Annex E.

EF_{3GCIK} (3G Cipher and Integrity Keys)

The programming of this EF is a test house option.

EF_{DCK} (De-Personalization Control Keys)

The programming of this EF is a test house option.

EF_{GID1} (Group Identifier Level 1)

The programming of this EF is a test house option.

EF_{GID2} (Group Identifier Level 2)

The programming of this EF is a test house option.

EF_{CDMACNL} (CDMA Co-operative Network List)

The programming of this EF is a test house option.

EF_{HOME_TAG} (Home System Tag)

The programming of this EF is a test house option.

EF_{GROUP_TAG} (Group Tag List)

The programming of this EF is a test house option.

EF_{SPECIFIC_TAG} (Specific Tag List)

The programming of this EF is a test house option.

EF_{CALL_PROMPT} (Call Prompt List)

The programming of this EF is a test house option.

EF_{SF_EUIMID} (Short Form EUIMID)

Specified by CSIM Manufacturer.

EF_{EST} (Enabled Service Table)

The programming of this EF is a test house option.

EF_{HiddenKey} (Key for hidden phone book entries)

The programming of this EF is a test house option.

EF_{LCSVER} (LCS Protocol Version)

The programming of this EF is a test house option.

EF_{LCSCP} (LCS Connectivity Parameter)

The programming of this EF is a test house option.

EF_{SDN} (Service Dialling Numbers)

The programming of this EF is a test house option.

EF_{EXT2}(Extension2)

The programming of this EF is a test house option.

EF_{EXT3}(Extension3)

The programming of this EF is a test house option.

EF_{ICI} (Incoming Call Information)

The programming of this EF is a test house option.

EF_{OCI} (Outgoing Call Information)

The programming of this EF is a test house option.

EF_{EXT5} (Extension 5)

The programming of this EF is a test house option.

EF_{CCP2} (Capability Configuration Parameters 2)

The programming of this EF is a test house option.

EF_{AppLabels} (Application Labels)

The programming of this EF is a test house option.

EF_{Model} (Device Model Information)

The programming of this EF follows default parameter written in 3GPP2 C.S0065-B [48], Annex E.

EF_{RC} (Root Certificates)

The programming of this EF is a test house option.

EF_{SMSCAP} (SMS Capabilities)

File size: 4 Bytes

Default values: Bytes 1 to 4 (HEX): 3C 08 07 01

The interpretation of the default values read as follows:

SMS Retry Period: 60 seconds

SMS Retry Interval: 8 seconds

SMS Flags:

Send On Access: True

Send on Traffic: True

Send as Standard EMS: True

SMS Preferred Service Option: SO 6

EF_{MIPFlags} (MobileIP Flags)

The programming of this EF is a test house option.

EF_{3GPDUPPEExt} (3GPD User Profile Parameters Extension)

The programming of this EF is a test house option.

EF_{IPv6CAP} (IPv6 Capabilities)

The programming of this EF is a test house option.

EF_{TCPConfig} (TCp Configurations)

The programming of this EF is a test house option.

EF_{DGC} (Data Generic Configurations)

The programming of this EF is a test house option.

EF_{WAPBrowserCP} (WAP Browser Connectivity Parameters)

The programming of this EF is a test house option.

EF_{WAPBrowserBM} (WAP Browser Bookmarks)

The programming of this EF follows default parameter written in 3GPP2 C.S0065-B [48], Annex E.

EF_{MMSConfig} (MMS Configuration)

The programming of this EF is a test house option.

EF_{JDL} (Java Download URL)

The programming of this EF is a test house option.

5 Test environment for RF test

This section contains all the exceptions of the common test parameters specified in clause 4 for specific needs of test cases defined in TS 36.521-1 [21]. Exceptions specified in clause 5 overwrite the parameter settings of clause 4; exceptions defined within the test cases overwrite parameter settings of clause 4 and 5.

5.1 Requirements of *test* equipment

No common RF test environment requirements are specified in addition to the common requirements described in clause 4.2. Specific RF requirements are indicated within the test cases defined in TS 36.521-1 [21].

5.2 RF Reference system configurations

5.2.1 Common parameters for simulated E-UTRA cells

5.2.1.1 Combinations of system information blocks

The combination of system information blocks required by a test case depends on the test case scenario. In this clause, the following combinations of system information blocks are defined.

Combination 1 is the default combination which applies to the following test case scenarios:

- E-UTRA FDD single cell scenario
- E-UTRA TDD single cell scenario
- E-UTRA FDD intra-frequency multi cell scenario
- E-UTRA TDD intra-frequency multi cell scenario

Combination 2 applies to the following test case scenarios:

- E-UTRA FDD + MBMS
- E-UTRA TDD + MBMS

The combinations of system information blocks for test cases in TS 36.521-1 [21] is defined in table 5.2.1.1-1.

Table 5.2.1.1-1: Combinations of system information blocks

Combination No.	System information block type											
	SIB2	SIB3	SIB4	SIB5	SIB6	SIB7	SIB8	SIB9	SIB10	SIB11	SIB12	SIB13
1	X	X										
2	X	X										X

5.2.1.2 Scheduling of system information blocks

The scheduling configurations for combinations of system information blocks are defined in the following tables. SIB1 will be transmitted during subframes#5 which $\text{SFN mod } 2 = 0$, and SIB2+SIB3 will be transmitted during subframes#5 which $\text{SFN mod } 2 = 1$ with 8 radio frames periodicity.

Table 5.2.1.2-1: Scheduling for combination 1

Scheduling Information No.	Periodicity [radio frames]	Mapping of system information blocks
1	8	SIB2, SIB3

Table 5.2.1.2-2: Scheduling for combination 2

Scheduling Information No.	Periodicity [radio frames]	Mapping of system information blocks
1	8	SIB2, SIB3
2	64	SIB13

- SystemInformationBlockType2

As defined in Table 4.4.3.3-1 with the following exceptions:

Table 5.2.1.2-2: SystemInformationBlockType2 exceptions

Derivation Path: 36.331 clause 6.3.1			
Information Element	Value/remark	Comment	Condition
SystemInformationBlockType2 ::= SEQUENCE {			
timeAlignmentTimerCommon	infinity		
}			

5.2.1.3 Common contents of system information messages

- MasterInformationBlock

As defined in Table 5.2.1.3-1 without exceptions.

Table 5.2.1.3-1: SystemInformation

Derivation Path: 36.331 clause 6.2.2			
Information Element	Value/remark	Comment	Condition
SystemInformation ::= SEQUENCE {			
criticalExtensions CHOICE {			
systemInformation-r8 SEQUENCE {			
sib-TypeAndInfo SEQUENCE (SIZE (1..maxSIB)) OF CHOICE {}	See subclause 5.2.1.1 and 5.2.1.2		
criticalExtensionsFuture SEQUENCE {}	Not present		
}			
}			
}			

- SystemInformation

As defined in Table 4.4.3.2-2 without exceptions.

- SystemInformationBlockType1

As defined in Table 4.4.3.2-3 with the following exceptions:

Table 5.2.1.3-2: SystemInformationBlockType1 exceptions

Derivation Path: 36.331 clause 6.2.2			
Information Element	Value/remark	Comment	Condition
SystemInformationBlockType1 ::= SEQUENCE {			
si-WindowLength	ms40		
}			

5.2A Generic RF procedures

Editor's note: The UE test state used for testing is specified in the individual test cases in the corresponding test specification TS 36.521-1 [21] or TS 36.521-3 [34].

This clause describes UE test states which can be used in the initial condition of many test cases defined in TS 36.521-1 [21] and TS 36.521-3 [34].

5.2A.1 UE RF test states

Table 5.2A.1-1: The E-UTRAN UE states

		RRC	ECM	EMM	ESM	UE Test Mode
State 3A-RF	Generic Default RB Established, UE Test Mode Activated	RRC_CONNECTED 1 data radio bearer configured	ECM-CONNECTED	EMM-REGISTERED	1 default EPS bearer context active	Active
State 3A-RF-CA	Generic Default RB Established, UE Test Mode Activated	RRC_CONNECTED 1 data radio bearer configured	ECM-CONNECTED	EMM-REGISTERED	1 default EPS bearer context active	Active

5.2A.2 Generic Default Radio Bearer Establishment, UE Test Mode Activated (State 3A-RF)

5.2A.2.1 Initial conditions

System Simulator:

- 1 cell, default parameters.
- The procedure shall be performed under ideal radio conditions as defined in clause 5

User Equipment:

- The Test USIM shall be inserted.

5.2A.2.2 Definition of system information messages

The default system information messages are used.

5.2A.2.3 Procedure

Table 5.2A.2.3-1: UE registration with default EPS bearer establishment and test mode activation procedures

Step	Procedure	Message Sequence	
		U - S	Message
1 to 18	Same procedure for steps 1 to 18 as specified in the procedure in clause 4.5.2A.3	-	-

5.2A.2.4 Specific message contents

All specific message contents shall be referred to clause 4.5.2A.4, with the exceptions below.

**Table 5.2A.2.4-1: ACTIVATE DEFAULT EPS BEARER CONTEXT REQUEST
(Step 16 in Table 4.5.2A.3-1)**

Derivation Path: Table 4.7.3-6			
Information Element	Value/remark	Comment	Condition
PDN address			
Length of PDN address contents	5 octets		
PDN type value	'001'B	IPv4	
PDN address information	IPv4 address	The SS provides a valid IPv4 address	
ESM cause	IF "PDN type" IE in step 4 is 'IPv4v6' THEN '00110010'B ELSE Not present	"PDN type IPv4 only allowed"	

5.2A.3 Void

5.2 A.4 Generic Default Radio Bearer Establishment, UE Test Mode Activated (State 3A-RF-CA)

5.2 A.4.1 Initial conditions

System Simulator:

- 2 cells(one each for configuring PCC and SCC), default parameters.
- The procedure shall be performed under ideal radio conditions as defined in clause 5

User Equipment:

- The Test USIM shall be inserted.

5.2 A.4.2 Definition of system information messages

The default system information messages are used.

5.2 A.4.3 Procedure

Table 5.2 A.4.3-1: UE registration with default EPS bearer establishment and test mode activation procedures

Step	Procedure	Message Sequence	
		U - S	Message
1 to 18	Same procedure for steps 1 to 17 as specified in the procedure in clause 4.5.2A.3	-	-
19	The SS transmits an <i>RRConnectionReconfiguration(sCellToAddModList)</i> message to establish the SCC with single UL	<--	RRC: <i>RRConnectionReconfiguration</i>
20	The UE transmits an <i>RRConnectionReconfigurationComplete</i>	-->	RRC: <i>RRConnectionReconfigurationComplete</i>

5.2 A.4.4 Specific message contents

All specific message contents shall be referred to clause 4.5.2A.4, with exceptions below.

**Table 5.2 A.4.4-1: ACTIVATE DEFAULT EPS BEARER CONTEXT REQUEST
(Step 16 in Table 4.5.2A.3-1)**

Derivation Path: Table 4.7.3-6			
Information Element	Value/remark	Comment	Condition
PDN address			
Length of PDN address contents	5 octets		
PDN type value	'001'B	IPv4	
PDN address information	IPv4 address	The SS provides a valid IPv4 address	
ESM cause	IF "PDN type" IE in step 4 is 'IPv4v6' THEN '00110010'B ELSE Not present	"PDN type IPv4 only allowed"	

5.3 Default RRC message and information elements contents

5.3.1 Radio resource control information elements

As defined in clause 4.6.3 with the following exceptions:

Table 5.3.1-1: TDD-Config-DEFAULT

Derivation Path: 36.331 clause 6.3.2			
Information Element	Value/remark	Comment	Condition
TDD-Config-DEFAULT ::= SEQUENCE {			
subframeAssignment	sa1		
specialSubframePatterns	ssp4		RF
}			

Condition	Explanation
RF	For all the RF tests specified in 36.521-1

Table 5.3.1-2: RadioResourceConfigCommonSIB-DEFAULT

Derivation Path: 36.331 clause 6.3.2			
Information Element	Value/remark	Comment	Condition
RadioResourceConfigCommonSIB-DEFAULT ::= SEQUENCE {			
rach-ConfigCommon	RACH-ConfigCommon-DEFAULT		
bcch-Config	BCCH-Config-DEFAULT		
pcch-Config	PCCH-Config-DEFAULT		
prach-Config	PRACH-ConfigSIB-DEFAULT		
pdsch-ConfigCommon	PDSCH-ConfigCommon-DEFAULT		
pusch-ConfigCommon	PUSCH-ConfigCommon-DEFAULT		
pucch-ConfigCommon	PUCCH-ConfigCommon-DEFAULT		
soundingRS-UL-ConfigCommon CHOICE {			
release	NULL		
}			
uplinkPowerControlCommon	UplinkPowerControlCommon-DEFAULT		
ul-CyclicPrefixLength	len1		
}			

Table 5.3.1-3: PRACH-Config-DEFAULT

Derivation Path: 36.508 clause 4.6.3 Table 4.6.3-7			
Information Element	Value/remark	Comment	Condition
PRACH-Config-DEFAULT ::= SEQUENCE {			
prach-ConfigInfo SEQUENCE {			
prach-ConfigIndex	3		TDD
}			
}			

Condition	Explanation
TDD	TDD cell environment

Table 5.3.1-4: RadioResourceConfigCommonSCell-r10-DEFAULT

Derivation Path: Clause 4.6.3 Table 4.6.3-13A			
Information Element	Value/remark	Comment	Condition
RadioResourceConfigCommonSCell-r10 ::= SEQUENCE {			
ul-Configuration-r10	Not Present		
ul-Configuration-r10 SEQUENCE {	Not Present		
}			
}			

Table 5.3.1-5: PhysicalConfigDedicatedSCell-r10-DEFAULT

Derivation Path: Clause 4.6.3 Table 4.6.3-6A			
Information Element	Value/remark	Comment	Condition
PhysicalConfigDedicatedSCell-r10 ::= SEQUENCE {			
ul-Configuration-r10	Not Present		
ul-Configuration-r10 SEQUENCE {	Not Present		
}			
}			

5.4 Default NAS message and information elements contents

5.5 Reference radio bearer configurations

5.5.1 SRB and DRB parameters

5.5.1.1 MAC configurations

As defined in clause 4.8.2.1.5 with the following exceptions:

Table 5.5.1.1-1: MAC-MainConfig-RBC

Derivation Path: TS 36.508 clause 4.8.2.1.5, Table 4.8.2.1.5-1			
Information Element	Value/remark	Comment	Condition
MAC-MainConfig-RBC ::= SEQUENCE {			
ul-SCH-Config SEQUENCE {			
maxHARQ-Tx	n1	Only one transmission per UL HARQ	
}			
drx-Config CHOICE {			
release	NULL		
}			
timeAlignmentTimerDedicated	infinity		
}			

5.5.1.2 Physical Layer configurations

Table 5.5.1.2-1: PhysicalConfigDedicated-DEFAULT

Derivation Path: 36.331 clause 6.3.2			
Information Element	Value/remark	Comment	Condition
PhysicalConfigDedicated-DEFAULT ::= SEQUENCE {			
pdsch-ConfigDedicated	PDSCH-ConfigDedicated-DEFAULT	See subclause 4.6.3	SRB1
	Not present		RBC
pucch-ConfigDedicated	PUCCH-ConfigDedicated-DEFAULT	See subclause 4.6.3	SRB1
	Not present		RBC
pusch-ConfigDedicated	PUSCH-ConfigDedicated-DEFAULT	See subclause 4.6.3	SRB1
	Not present		RBC
uplinkPowerControlDedicated	UplinkPowerControlDedicated-DEFAULT	See subclause 4.6.3	SRB1
	Not present		RBC
tpc-PDCCH-ConfigPUCCH	Not present		SRB1
	TPC-PDCCH-Config-DEFAULT using condition PUCCH	See subclause 4.6.3	RBC
tpc-PDCCH-ConfigPUSCH	Not present		SRB1
	TPC-PDCCH-Config-DEFAULT using condition PUSCH	See subclause 4.6.3	RBC
cqi-ReportConfig	Not present		SRB1
	Not present		RBC
soundingRS-UL-ConfigDedicated	Not present		SRB1
	Not present		RBC
antennaInfo CHOICE {			
defaultValue	NULL		
}			
schedulingRequestConfig	Not present		SRB1
	Not present	See subclause 4.6.3	RBC
}			

Condition	Explanation
SRB1	Used at configuration of SRB1 during RRC connection (re-)establishment
RBC	Used at configuration of a radio bearer combination during SRB2+DRB establishment

5.5.1.3 SRB and DRB combinations

5.5.1.3.1 Combinations on DL-SCH and UL-SCH

5.5.1.3.1.1 SRB1 and SRB2 for DCCH + n x AM DRB + m x UM DRB, where $n=1$ and $m=0$

This SRB and DRB combination is setup in UE Registration procedure and the Generic Radio Bearer Establishment with UE Test Mode Activated using specific message content - the default *RRCConnectionReconfiguration* message with condition SRB2-DRB(n , m).

6 Test environment for Signalling test

6.1 Requirements of test equipment

The requirements of test equipment specified in this subclause apply to Signalling test cases defined in TS 36.523-1 [18], in addition to the common requirements of test equipment specified in clause 4.2 of this specification.

Test equipment shall be able to simulate cells of Radio Access Technology (RAT) E-UTRA, UTRA, GSM or HRPD / 1xRTT. Regardless of respective RAT, the overall number and configuration of cells to be simulated simultaneously by test equipment shall not exceed the resources specified in the following Table 6.1-1:

Table 6.1-1: Maximum resources in terms of number / configuration of cells to be simulated simultaneously in a test setup

Simulation of	Max. number / configuration of cells (SISO / SIMO)	Max. number / configuration of cells (MIMO)
E-UTRA single-mode networks (FDD or TDD)	3x cells	n/a
E-UTRA dual-mode networks (FDD and TDD)	3x cells	n/a
E-UTRA networks involving Carrier Aggregation	4x cells	n/a
Mixed E-UTRA / UTRA networks	3x cells	n/a
Mixed E-UTRA / GSM networks	3x cells	n/a
Mixed E-UTRA / HRPD or 1xRTT networks	3x cells	n/a
Mixed E-UTRA / UTRA / GSM networks	3x cells	n/a
Note 1:	No differentiation between cell configuration types (as defined in clause 6.3.3) here, because these types are relevant to specific test cases and their TTCN-3 implementation only.	
Note 2:	Only network scenarios specified in clause 4.4.1 and 6.3.2.1 have been covered.	
Note 4:	In case of Carrier Aggregation, each cell can act as a PCell, an SCell, or a standalone cell (not used as a CA component carrier). In Release 10 a maximum of 1 SCell can be aggregated with a PCell.	
Note 5:	Virtual Cells are not included in the maximum cell number as they do not require resources in the SS.	

Exceptions to the requirements outlined above are possible but need special evidence to be provided explicitly in the test case prose and should be allowed only if the test case purpose cannot be met otherwise.

6.2 Reference test conditions

The reference test conditions specified in this subclause apply to all Signalling test cases defined in TS 36.523-1 [18] unless otherwise specified, in addition to the common reference test conditions specified in subclause 4.3 of this specification.

6.2.1 Physical channel allocations

6.2.1.1 Antennas

If the UE has two Rx antennas, the same downlink signal is applied to each one, except if MIMO is tested. Both UE Rx antennas shall be connected.

If the UE has one Rx antenna, the downlink signal is applied to it.

6.2.1.2 Downlink physical channels and physical signals

Power allocation of downlink physical channels for Signalling test cases is specified in table 6.2.1.2-1.

Table 6.2.1.2-1: Power allocation for OFDM symbols and reference signals for Signalling test cases

Physical Channel	EPRE Ratio	Comment
PBCH	PBCH_RA = 0 dB	
	PBCH_RB = 0 dB	
PSS	PSS_RA = 0 dB	
SSS	SSS_RA = 0 dB	
PCFICH	PCFICH_RB = 0 dB	
PDCCH	PDCCH_RA = 0 dB	
	PDCCH_RB = 0 dB	
PDSCH (BCCH, CCCH, PCCH)	PDCCH_RA = 0 dB	To be consistent with default physical channel configuration in 36.331 [17], 9.2.4
	PDCCH_RB = 0 dB	
PDSCH (DCCH, DTCH)	PDSCH_RA = -3 dB	To reduce interference from PDSCH of intra-frequency neighbour cells
	PDSCH_RB = -3 dB	To reduce interference from PDSCH of intra-frequency neighbour cells
PHICH	PHICH_RB = 0 dB	

6.2.1.3 Mapping of downlink physical channels and signals to physical resources

Same as clause 4.3.3.3

6.2.1.4 Uplink physical channels and physical signals

[FFS].

6.2.1.5 Mapping of uplink physical channels and signals to physical resources

[FFS].

6.2.2 Signal levels

6.2.2.1 Downlink signal levels

The default settings of suitable cells and non-suitable cells for E-UTRA are specified in table 6.2.2.1-1.

Cells which are expected to be undetectable for UE under test shall fulfil the condition of non-suitable “Off” cell in table 6.2.2.1-1.

Table 6.2.2.1-1: Default settings of suitable / non-suitable cells

Power level type	E-UTRAN (Note 1-3)		UTRAN	GERAN
	Unit	Power level		
Serving cell	dBm/15kHz	-85	Table 6.1.1 (FDD) / 6.1.6a (TDD) [5]	Table 6.1.10 [5]
Suitable neighbour intra-frequency cell	dBm/15kHz	-91	Table 6.1.2 (FDD) / 6.1.7 (TDD) [5]	n/a
Suitable neighbour inter-frequency cell	dBm/15kHz	-97	Table 6.1.2 (FDD) / 6.1.7 (TDD) [5]	Table 6.1.10 [5]
Non-suitable cell	dBm/15kHz	-115	Table 6.1.3 (FDD) / 6.1.8 (TDD) [5]	Table 6.1.11 [5]
Non-suitable "Off" cell	dBm/15kHz	≤ -145	Table 6.1.4 (FDD) / 6.1.9 (TDD) [5]	Cell is switched-off
Note 1: The power level is specified in terms of cell-specific RS EPRE instead of RSRP as RSRP is a measured value and cannot be directly controlled by the SS.				
Note 2: Power levels are specified based on the precondition that q-Hyst, a3-Offset and hysteresis are 0 dB.				
Note 3: The power level is specified at each UE Rx antenna.				

The default signal level uncertainty is specified in table 6.2.2.1-2 for any level specified, unless a tighter uncertainty is specified by a test case in TS 36.523-1 [18].

Table 6.2.2.1-2: SS signal level uncertainty

	Absolute signal level uncertainty for each cell	Relative signal level uncertainty between multiple cells
Intra-frequency	+/-3 dB at each test port	+/-3 dB
Inter-frequency	+/-3 dB at each test port	See Note 1
Note 1: For Inter-frequency cells the relative signal level uncertainty between multiple cells is determined by the absolute uncertainty of each cell, and does not have any additional constraint.		

Cell-specific RS EPRE setting should be equal to or higher than -115 dBm except for Non-suitable "Off" cell. The figure is chosen to ensure that for all bands the DL signal is within the RSRP measurement range specified in TS 36.133 [39] clauses 9.1.2 and 9.1.3, taking into account the SS default absolute signal level uncertainty.

NOTE: (The power spectral density of a white noise source; specified in TS 36.133 [39]) can be assumed to be -Infinity [dBm/15kHz] for all intra and inter frequency test cases. It is applicable to both idle mode and connected mode in TS 36.523-1 [18], unless otherwise specified in specific test cases.

6.2.2.2 Measurement accuracy and side conditions

Measurement accuracy shall be considered in setting downlink power levels.

RSRP measurement accuracy in E-UTRA RRC_IDLE state is specified in table 6.2.2.2-1, derived from TS 36.133 [39] clauses 4.2.2.3 and 4.2.2.4. This measurement accuracy is applicable to idle mode test cases specified in TS 36.523-1 [18]. For the serving cell and suitable neighbour cells, the following side conditions shall be satisfied including the effect of signal level uncertainty.

- RSRP ≥ -121 dBm
- RSRP \hat{E}_s/I_{ot} ≥ -4 dB
- SCH_RP ≥ -121 dBm
- SCH \hat{E}_s/I_{ot} ≥ -4 dB

Table 6.2.2.2-1: RSRP measurement accuracy in E-UTRA RRC_IDLE state

	Absolute RSRP measurement accuracy	Relative RSRP measurement accuracy
Intra-frequency	+/-6 dB	+/-3 dB
Inter-frequency	+/-6 dB	+/-5 dB

RSRP measurement accuracy in E-UTRA RRC_CONNECTED state is specified in table 6.2.2.2-2, derived from TS 36.133 [39] clauses 9.1.2 and 9.1.3 selecting Normal condition. The ranges and side conditions in TS 36.133 [39] clauses 9.1.2 and 9.1.3 apply. This measurement accuracy is applicable to connected mode test cases specified in TS 36.523-1 [18]. For the serving cell and suitable neighbour cells, the following side conditions shall be satisfied including the effect of signal level uncertainty.

- RSRP \geq -124 dBm
- RSRP $\hat{E}_s/I_{ot} > -6$ dB- I_o : -118 dBm/15kHz ... -70 dBm/BWChannel (for absolute RSRP measurement accuracy)
- I_o : -118 dBm/15kHz ... -50 dBm/BWChannel (for relative RSRP measurement accuracy)

Table 6.2.2.2-2: RSRP measurement accuracy in E-UTRA RRC_CONNECTED state

	Absolute RSRP measurement accuracy	Relative RSRP measurement accuracy
Intra-frequency	+/-6 dB	+/-3 dB
Inter-frequency	+/-6 dB	+/-6 dB

Signal level difference between the serving cell and any suitable intra-frequency neighbour cell shall be nominally 6 dB to satisfy the measurement accuracy requirement and its side conditions specified in TS 36.133 [39]. This figure is chosen based on the following preconditions for intra-frequency cells.

- Interference to reference signals from reference signals of other cells is eliminated by Physical Cell Identity shifting as specified in TS 36.523-3 [20].
- Interference to reference signals from PDSCH with SI-RNTI of other cells is negligible because it's sparse enough.
- Interference to reference signals from PDSCH of the serving cell is controlled by satisfying the conditions of clauses 6.2.2.1 and 6.2.2.2.
- Interference to P-SS/S-SS from P-SS/S-SS of other cells is eliminated by frame timing shifting as specified in TS 36.523-3 [20].
- Interference to P-SS/S-SS from PDSCH of other cells is eliminated by PDSCH resource allocation as specified in TS 36.523-3 [20].

6.2.3 Default test frequencies

The default channel bandwidth of 5/10/20 MHz is applied to the signalling test. The test frequencies are defined so that no frequency overlapping takes place, in order to avoid unnecessary inter-frequency interference.

For Band 13, only one test frequency f_1 is defined. All operating Bands except Band 13 can accommodate at least two test frequencies f_1 and f_2 ($f_1 < f_2$). An additional test frequency f_3 can be defined for the operating Bands with at least triple of the default bandwidth. The fourth test frequency f_4 ($f_3 < f_1 < f_4 < f_2$) is applicable to the operating Bands which have at least quadruple of the default bandwidth.

To the single cell signalling test with channel bandwidth different from the default bandwidths of the operating bands, Mid Range defined in clause 4.3.1 is applied.

6.2.3.1 Test frequencies for signalling test

Test frequencies for signalling test are specified in table 6.2.3.1-1 and 6.2.3.1-1a for FDD and table 6.2.3.1-2 and 6.2.3.1-2a for TDD. Except f_4 and a few f_1 , f_5 which are specified according to EARFCN of the concerned operating

Bands, the majority of the test frequencies in table 6.2.3.1-1, 6.2.3.1-1a, 6.2.3.1-2 and 6.2.3.1-2a are specified in terms of Low, Mid and High which are referred to the Low Range, Mid Range and High Range in clause 4.3.1.

Table 6.2.3.1-1: Test frequencies for E-UTRA FDD(5MHz)

E-UTRA Operating Band	Bandwidth [MHz]	f1, f5		f2, f6		f3, f7		f4	
		N _{UL}	N _{DL}	N _{UL}	N _{DL}	N _{UL}	N _{DL}	N _{UL}	N _{DL}
1	60	Mid	Mid	High	High	Low	Low	18350	350
2	60	Mid	Mid	High	High	Low	Low	18950	950
3	75	Mid	Mid	High	High	Low	Low	19625	1625
4	45	Mid	Mid	High	High	Low	Low	20225	2225
5	25	Mid	Mid	High	High	Low	Low	20575	2575
6	10	Low	Low	High	High	N/A	N/A	N/A	N/A
7	70	Mid	Mid	High	High	Low	Low	21150	3150
8	35	Mid	Mid	High	High	Low	Low	21675	3675
9	35	Mid	Mid	High	High	Low	Low	22025	4025
10	60	Mid	Mid	High	High	Low	Low	22500	4500
12	17	Mid	Mid	High	High	Low	Low	N/A	N/A
14	10	Low	Low	High	High	N/A	N/A	N/A	N/A
...									
17	12	Low	Low	High	High	N/A	N/A	N/A	N/A
19	15	Mid	Mid	High	High	Low	Low	N/A	N/A
21	15	Mid	Mid	High	High	Low	Low	N/A	N/A
22	80	Mid	Mid	High	High	Low	Low	24950	6950
...									
23	20	25575	7575	High	High	Low	Low	25625	7625
24	34	Mid	Mid	High	High	Low	Low	25920	7920
25	65	Mid	Mid	High	High	Low	Low	26390	8390
26	35	Mid	Mid	High	High	Low	Low	26865	8865

Table 6.2.3.1-1a: Test frequencies for E-UTRA FDD(10MHz)

E-UTRA Operating Band	Bandwidth [MHz]	f1, f5		f2, f6		f3, f7		f4	
		N _{UL}	N _{DL}	N _{UL}	N _{DL}	N _{UL}	N _{DL}	N _{UL}	N _{DL}
11	20	Low	Low	High	High	N/A	N/A	N/A	N/A
13	10	Mid	Mid	N/A	N/A	N/A	N/A	N/A	N/A
18	15	Low	Low	N/A	N/A	N/A	N/A	N/A	N/A
20	30	Mid	Mid	High	High	Low	Low	N/A	N/A
23	20	Low	Low	High	High	N/A	N/A	N/A	N/A

Table 6.2.3.1-2: Test frequencies for E-UTRA TDD (5MHz)

E-UTRA Operating Band	Bandwidth [MHz]	f1, f5	f2, f6	F3, f7	f4
33	20	36075	High	Low	36125
34	15	Mid	High	Low	N/A
35	60	Mid	High	Low	36700
36	60	Mid	High	Low	37300
37	20	37625	High	Low	37675
...					
42	100	Mid	High	Low	42640
43	100	Mid	High	Low	44640

Table 6.2.3.1-2a: Test frequencies for E-UTRA TDD(20MHz)

E-UTRA Operating Band	Bandwidth [MHz]	f1, f5	f2, f6	f3, f7	f4
38	50	Low	High	N/A	N/A
39	40	Low	High	N/A	N/A
40	100	Mid	High	Low	39350
41	194	Mid	High	Low	40970

6.3 Reference system configurations

The reference system configurations specified in this subclause apply to all Signalling test cases defined in TS 36.523-1 [18] unless otherwise specified, in addition to the common reference system configurations specified in subclause 4.4 of this specification.

For Signalling testing, MIMO (Multiple Input Multiple Output) is not applied for all cell configurations regardless of UE MIMO functionality. Only one SS Tx antenna is used.

One or two UE antennas are used for all signalling test cases. (*1)

(*1) Two UE antennas configuration is possible for UE diversity case.

6.3.1 Default parameter specific for simulated cells

Default parameters specific for simulated cells are specified in this subclause.

6.3.1.1 Intra-frequency neighbouring cell list in SIB4 for E-UTRA cells

Intra-frequency neighbouring cell list for signalling test cases is defined in table 6.3.1.1-1. This table is referred to in the default contents of IE *intraFreqNeighbouringCellList* in *SystemInformationBlockType4* defined in table 4.4.3.3-3.

Table 6.3.1.1-1: Intra-frequency neighbouring cell lists for E-UTRA cells

cell ID	Test Frequency	intra-frequency neighbouring cell list						
		number of entries	physCellId[n]			q-OffsetCell [n]		
			1	2	3	1	2	3
Cell 1	f1	3	Cell 2	Cell 4	Cell 11	dB0	dB0	dB0
Cell 2	f1	3	Cell 1	Cell 4	Cell 11	dB0	dB0	dB0
Cell 4	f1	3	Cell 1	Cell 2	Cell 11	dB0	dB0	dB0
Cell 11	f1	3	Cell 1	Cell 2	Cell 4	dB0	dB0	dB0
Cell 3	f2	1	Cell 23	-	-	dB0	-	-
Cell 23	f2	1	Cell 3	-	-	dB0	-	-

NOTE: The intra-frequency E-UTRA neighbouring cell list for signalling NAS test cases when cells are on same PLMN is defined in table 6.3.2.3.1-1.

6.3.1.2 Inter-frequency carrier frequency list in SIB5 for E-UTRA cells

Inter-frequency E-UTRA carrier frequency list for signalling test cases is defined in table 6.3.1.2-1. This table is referred to in the default contents of IE *interFreqCarrierFreqList* in *SystemInformationBlockType5* defined in table 4.4.3.3-4.

Table 6.3.1.2-1: Inter-frequency carrier frequency lists for E-UTRA cells

cell ID	Test Frequency	interFreqCarrierFreqList			
		number of entries	dl-CarrierFreq[n]		
			1	2	3
Cell 1 Cell 2 Cell 4 Cell 11	f1	3	f2	f3	f5
Cell 3 Cell 23	f2	3	f1	f3	f5
Cell 6	f3	3	f1	f2	f5
Cell 10	f5	3	f1	f2	f3
Note 1:	The inter-frequency E-UTRA carrier frequency list for signalling NAS test cases when cells are on same PLMN is defined in table 6.3.2.3.2-1.				
Note 2:	Depending on the Band under test, f3 may not be applicable.				
Note 3:	In case of Test frequency f1, f2 and f3, dl-CarrierFreq f5 as part of inter-frequency list is applicable only in case of multi-band scenarios.				
Note 4:	In case of Test frequency f5, dl-CarrierFreq f1 as part of inter-frequency list is applicable only in case of multi-band scenarios.				

In the case of dual mode multi-cell network scenarios as defined in subclause 4.4.1.3, inter-frequency E-UTRA carrier frequency list for signalling test cases is defined in table 6.3.1.2-2.

Table 6.3.1.2-2: Inter-frequency carrier frequency lists for E-UTRA cells in dual mode scenario

cell ID	Test Frequency	interFreqCarrierFreqList			
		number of entries	dl-CarrierFreq[n]		
			1	2	3
Cell 1 Cell 2 Cell 4	f1	3	f2	f5	f6
Cell 3	f2	3	f1	f5	f6
Cell 10, Cell 30	f5	3	f1	f2	f6
Cell 28, Cell 29	f6	3	f1	f2	f5

6.3.1.3 UTRA carrier frequency list in SIB6 for E-UTRA cells

UTRA carrier frequency list for signalling test cases is defined in table 6.3.1.3-1. This table is referred to in the default contents of IE *carrierFreqListUTRA-FDD* and *carrierFreqListUTRA-TDD* in *SystemInformationBlockType6* defined in table 4.4.3.3-5.

Table 6.3.1.3-1: UTRA carrier frequency lists for E-UTRA cells

interFreqCarrierFreqList			
number of entries	carrierFreq[n]		
	1	2	3
3	f8	f9	f10
Note: Band VI has two entries.			

Table 6.3.1.3-2: Mapping of UTRA cell with TS 34.108 [5]

UTRA cell	Frequency	UTRA cell in TS 34.108, clause 6.1	UTRA frequency in TS 34.108
Cell 5	f8	Cell 1	High
Cell 7	f8	Cell 2	High
Cell 8	f9	Cell 4	Mid (Note 2)
Cell 9	f10	Cell 7	Low
Note 1: The following simultaneous co-existences in the test are not allowed: <ul style="list-style-type: none"> - cells on f1 (eUTRA cell 1, cell 2, cell 4, cell 11) and f9 (UTRA cell 8); - cells on f2 (eUTRA cell 3, cell 12, cell 23) and f8 (UTRA cell 5, cell 7); - cells on f3 (eUTRA cell 6, Cell 13) and f10 (UTRA cell 9). Note 2: On UTRA Band VI, the Low range test frequency is applied to f9 for Cell 8.			

6.3.1.4 GERAN carrier frequency group list in SIB7 for E-UTRA cells

GERAN carrier frequency group list for signalling test cases is defined in table 6.3.1.4-1. This table is referred to in the default contents of IE *carrierFreqsInfoList* in *SystemInformationBlockType7* defined in table 4.4.3.3-6.

Table 6.3.1.4-1: GERAN carrier frequency group list for E-UTRA cells

carrierFreqsInfoList				
number of entries	index (n)	carrierFreqs[n]		
		startingARFCN[n]	explicitListOfARFCNs[n]	
			number of entries	ARFCN-ValueGERAN
1	1	f11	2	f12, f13

Table 6.3.1.4-2: Mapping of GERAN cells with TS 51.010-1 [25]

GERAN cell	Frequency	GERAN cell in TS 51.010-1, clause 40
Cell 24	f11	Cell A
Cell 25	f12	Cell D
Cell 26	f13	Cell B

NOTE 2: Unless otherwise stated, GERAN cells 24/25/26 take the default values of GERAN cells A/B/D as defined in TS 51.010 clause 40.

6.3.1.5 CDMA2000 HRPD carrier frequency list in SIB8 for E-UTRA cells

CDMA2000 HRPD carrier frequency list for signalling test cases is defined in table 6.3.1.5-1. This table is referred to in the default contents of IE *cellReselectionParametersHRPD* in *SystemInformationBlockType8* defined in table 4.4.3.3-7.

Table 6.3.1.5-1: CDMA2000 HRPD carrier frequency list for E-UTRA cells

neighCellsPerFreqList					
number of entries	index (n)	arfcn[n]	physCellIdList[n]		
			number of entries	index	PhysCellIdCDMA2000
3	1	f14	2	1	Cell 15
				2	Cell 16
	2	f15	1	1	Cell 17
	3	f16	1	1	Cell 18

6.3.1.6 CDMA2000 1xRTT carrier frequency list in SIB8 for E-UTRA cells

CDMA2000 1xRTT carrier frequency list for signalling test cases is defined in table 6.3.1.6-1. This table is referred to in the default contents of IE *cellReselectionParameters1XRTT* in *SystemInformationBlockTyp8* defined in table 4.4.3.3-7.

Table 6.3.1.6-1: CDMA2000 1xRTT carrier frequency list for E-UTRA cells

neighCellsPerFreqList					
number of entries	index (n)	arfcn[n]	physCellIdList[n]		
			number of entries	index	PhysCellIdCDMA2000
3	1	f17	2	1	Cell 19
				2	Cell 20
	2	f18	1	1	Cell 21
				3	f19

6.3.1.7 E-UTRA carrier frequency list in SIB19 for UTRA cells

E-UTRA carrier frequency list for signalling test cases is defined in table 6.3.1.7-1. This table is referred to in the default contents of IE *utra-FrequencyAndPriorityInfoList* in System Information Block type 19 defined in table 4.4.4.1-1.

Table 6.3.1.7-1: E-UTRA carrier frequency list for UTRA cells

utra-FrequencyAndPriorityInfoList					
number of entries	earfcn[n]				
	1	2	3	4	-
4	f1	f2	f3	f4	-
Note: Depending on the Band under test, f2, f3 and f4 may not be applicable.					

6.3.2 Default configurations for NAS test cases

The default configurations specified in this subclause apply only to NAS test cases. They apply to all NAS test cases unless otherwise specified.

6.3.2.1 Simulated network scenarios for NAS test cases

Simulated network scenarios for NAS test cases to be tested are specified in the pre-test conditions of each individual test case.

NOTE: The number of cells specified does not necessarily correspond to the maximum number of resources to be configured simultaneously in test equipment. Please refer to Table 6.1-1 for such information.

Any combination is allowed with the following restrictions:

- Cell E should not be used if Cell G or Cell H is used, otherwise two different PLMNs will be operated on the same frequency
- a maximum 3 cells on the same frequency can be used, i.e. only 3 cells out of cells A, B, C, D and M may be used simultaneously in each individual test case when cells in the test case are in different PLMNs (refer to Table 6.3.2.2-3).

6.3.2.2 Simulated NAS cells

Simulated NAS cells and default parameters are specified in table 6.3.2.2-1.

Unless otherwise specified, the default parameters specified in section 4 also apply to all NAS cells.

Table 6.3.2.2-1: Default parameters for simulated NAS cells

NAS cell ID	Tracking Area			TA# list (Note 1)	GUTI (Note 2)		M-TMSI	
	TA#	PLMN			TAC	MME Identifier		
		MCC	MNC			MME Group ID		MME Code
Cell A	TAI-1	(Note 3)		1	TAI-1	32769	Arbitrarily selected according to TS 23.003 subclause 2.8 [2].	
Cell B	TAI-2	(Note 3)		2	TAI-2	32770		
Cell C	TAI-3	(Note 3)		3	TAI-3	32771		
Cell D	TAI-4	(Note 3)		4	TAI-4	32772		
Cell E	TAI-12	002	101	3	TAI-12	32777		
Cell F								
Cell G	TAI-7	(Note 4)	02	1	TAI-7	32775		
Cell H	TAI-8	(Note 4)	02	2	TAI-8	32776		
Cell I	TAI-9	002	101	1	TAI-9	32777		
Cell J	TAI-10	003	101	1	TAI-10	32778		
Cell K	TAI-9	002	101	1	TAI-9	32777		
Cell L	TAI-11	002	101	2	TAI-11	32779		
Cell M	TAI-1	(Note 3)		1	TAI-1	32769		
<p>Note 1: The value(s) in the column TA# list indicates TAI(s) included in the response messages of the registration procedure (ATTACH ACCEPT or TRACKING AREA UPDATE ACCEPT) when the UE performs the registration procedure on a corresponding cell.</p> <p>Note 2: The value in the column GUTI indicates GUTI included in the response messages of the registration procedure (ATTACH ACCEPT or TRACKING AREA UPDATE ACCEPT) when the UE performs the registration procedure on a corresponding cell.</p> <p>Note 3: Set to the same Mobile Country Code and Mobile Network Code stored in EF_{IMSI} on the test USIM card (subclause 4.9.3).</p> <p>Note 4: Set to the same Mobile Country Code stored in EF_{IMSI} on the test USIM card (subclause 4.9.3).</p> <p>Note 5: Cell A is a serving cell and the other cells are suitable neighbour cells. The definitions are specified in subclause 6.2.2.1.</p>								

Table 6.3.2.2-2: Default cell identifiers for simulated NAS cells when cells are in same PLMN

NAS cell ID	Frequency	E-UTRAN Cell Identifier		Physical layer cell identity	rootSequenceIndex FDD	rootSequenceIndex TDD
		eNB Identifier	Cell Identity			
Cell A	f1	'0000 0000 0000 0001 0001'B	'0000 0001'B	1	22	0
Cell B	f1	'0000 0000 0000 0001 0001'B	'0000 0010'B	2	86	8
Cell C	f2	'0000 0000 0000 0001 0010'B	'0000 0011'B	3	22	0
Cell D	f1	'0000 0000 0000 0001 0001'B	'0000 0100'B	4	150	16
Cell E	NA	NA	NA	NA	NA	NA
Cell F	NA	NA	NA	NA	NA	NA
Cell G	NA	NA	NA	NA	NA	NA
Cell H	NA	NA	NA	NA	NA	NA
Cell I	NA	NA	NA	NA	NA	NA
Cell J	NA	NA	NA	NA	NA	NA
Cell M	f2	'0000 0000 0000 0010 0001'B	'0001 0001'B	17	86	8

Table 6.3.2.2-3: Default cell identifiers for simulated NAS cells when cells are in different PLMNs

NAS cell ID	PLMN	Frequency	E-UTRAN Cell Identifier		Physical layer cell identity	rootSequenceIndex FDD	rootSequenceIndex TDD
			eNB Identifier	Cell Identity			
Cell A	MCC/MNC= MCC/MNC in USIM	f1	'0000 0000 0000 0010 0001'B	'0000 0001'B	1	22	0
Cell B	MCC/MNC= MCC/MNC in USIM	f1	'0000 0000 0000 0010 0001'B	'0000 0010'B	2	86	8
Cell C	MCC/MNC= MCC/MNC in USIM	f1	'0000 0000 0000 0010 0001'B	'0000 0011'B	3	150	16
Cell D	MCC/MNC= MCC/MNC in USIM	f1	'0000 0000 0000 0010 0001'B	'0000 0100'B	4	214	24
Cell E (Note 2)	MCC=002 MNC=101	f2	'0000 0000 0000 0011 0101'B	'0001 0111'B	23	22	0
Cell F	NA	NA	NA	NA	NA	NA	NA
Cell G (Note 2)	MCC = MCC in USIM MNC=02	f2	'0000 0000 0000 0010 0010'B	'0000 1011'B	11	86	8
Cell H (Note 2)	MCC= MCC in USIM MNC=02	f2	'0000 0000 0000 0010 0010'B	'0000 1100'B	12	150	16
Cell I	MCC=002 MNC=101	f3 (Note 1)	'0000 0000 0000 0010 0011'B	'0000 1101'B	13	22	0
Cell J	MCC=003 MNC=101	f4 (Note 1)	'0000 0000 0000 0010 0100'B	'0000 1110'B	14	22	0
Cell K	MCC=002 MNC=101	f3 (Note 1)	'0000 0000 0000 0010 0011'B	'0000 1111'B	15	86	8
Cell L	MCC=002 MNC=101	f3 (Note 1)	'0000 0000 0000 0010 0011'B	'0001 0000'B	16	150	16
Cell M	MCC/MNC= MCC/MNC in USIM	f1	'0000 0000 0000 0010 0001'B	'0001 0001'B	17	278	32

Note 1: The test frequency f3 or f4 is allocated to the cell if f1 and f2 are already allocated to the cells in the test. Otherwise, f1 or f2 is allocated, instead.

6.3.2.3 Broadcast system information

6.3.2.3.1 Intra-frequency neighbouring cell list in SIB4 for E-UTRA NAS cells

Intra-frequency neighbouring cell list of the same PLMN for the NAS signalling test is defined in table 6.3.2.3.1-1 when SIB4 to be broadcast.

Table 6.3.2.3.1-1: Intra-freq. lists in SIB4 for NAS test cases (same PLMN)

NAS cell ID	Test Frequency	Intra-frequency neighbouring cell list		
		number of entries	physCellId[n]	
			1	2
Cell A	f1	2	Cell B	Cell D
Cell B	f1	2	Cell A	Cell D
Cell D	f1	2	Cell A	Cell B
Cell C	f2	1	Cell M	N/A
Cell M	f2	1	Cell C	N/A

6.3.2.3.2 Inter-frequency carrier frequency list in SIB5 for E-UTRA NAS cells

Inter-frequency neighbouring carrier and cell lists for NAS signalling test cases are defined in table 6.3.2.3.2-1 for same PLMN and table 6.3.2.3.2-2 for different PLMN.

Table 6.3.2.3.2-1: Inter-freq. lists in SIB5 for NAS test cases (same PLMN)

NAS cell ID	Test Frequency	interFreqCarrierFreqList		
		number of entries	dl-CarrierFreq[n]	
			1	2
Cell A Cell B Cell D	f1	1	f2	NA
Cell C Cell M	f2	1	f1	NA
NOTE: Operating on Band 13, SIB5 is not broadcast.				

Table 6.3.2.3.2-2: Inter-freq. lists in SIB5 for NAS test cases (different PLMN)

NAS cell ID	Test Frequency	interFreqCarrierFreqList			Condition
		number of entries	dl-CarrierFreq[n]		
			1	2	
Cell A Cell B Cell C Cell D Cell M	f1	0	NA	NA	
Cell G Cell H	f2	0	NA	NA	
Cell I Cell K Cell L	f3	0	NA	NA	E-NOT-CONF
		1	f2		E-CONF
Cell J	f4	0	NA	NA	
Cell E	f2	1	f3	NA	

Condition	Explanation
E-NOT-CONF	cell E is not configured in the test
E-CONF	cell E is configured in the test

6.3.3 Cell configurations

For the purpose of test not involving Carrier Aggregation, three types of SS cell configurations are defined, full (Active) cell configuration, broadcast only cell configuration and minimum uplink cell configuration.

The abovementioned configurations can also be used in Carrier Aggregation test cases, either for PCells or SCells. However another configuration, the virtual cell configuration, can additionally be used for an SCell that is not active.

6.3.3.1 Full cell configuration

Full cell configuration is also called active cell configuration. The cell configuration, in minimum, has all defined DL and UL physical channels configured, i.e.

in DL: PBCH, PCFICH, PDCCH, PDSCH, PHICH,

in UL: PRACH, PUCCH, PUSCH.

The DL and UL Reference and synchronization (both primary and secondary) signals are also configured.

6.3.3.2 Minimum uplink cell configuration

In this cell configuration,

in DL: physical channels capable of transmission, i.e. PBCH, PCFICH, PDCCH, PDSCH are configured;

DL physical reference and synchronization (both primary and secondary) signals are also configured.

In UL: PRACH is configured. SS shall report any detection of PRACH preambles, in order to assign test verdicts. Decoding the preambles is not required.

6.3.3.3 Broadcast only cell configuration

In this cell configuration,

in DL: physical channels capable of transmission, i.e. PBCH, PCFICH, PDCCH, PDSCH are configured;

DL physical reference and synchronization (both primary and secondary) signals are also configured.

in UL: no physical resources are configured, neither channels, nor signals.

6.3.3.3A Virtual cell configuration

In this cell configuration,

in DL: no physical resources are configured, neither channels, nor signals;

in UL: no physical resources are configured, neither channels, nor signals.

6.3.3.4 Application of different cell configurations

By default, the cells specified in 36.523-1 are defined with the full cell configuration, unless it is explicitly specified as either the broadcast only, minimum uplink, or virtual cell configuration. The full cell configuration is suitable for UE to start camping, establish RRC connection or hand over from another active cell.

The broadcast only cells identified as 'DL only' can be applied in some RRC measurement test cases to those neighbour cells which UE shall not camp on during the test case execution.

The capability of a minimum uplink cell is much weaker than a full cell, but stronger than a broadcast only cell in UL. This cell configuration identified as 'min UL' can be applied in the idle mode test cases to those neighbour cells which a conformant UE shall not camp on during the test case execution.

The virtual cell configuration can only be used in Carrier Aggregation test cases as an SCell which is not active, i.e. the UE has it configured via RRC signalling but does not need to send or receive anything in this SCell.

If a cell configuration is specified in a test case it shall remain unchanged throughout the test case specification. In addition, there shall not be any requirement in the test specification or test implementation for a cell reconfiguration from one of the above configurations to the other.

For the UE conformance test, the broadcast only cell configuration can be replaced and implemented with the minimum uplink or full cell configurations. The minimum uplink cell configuration can also be implemented with the full cell configuration. The replacements in the implementation have no impact on the test purposes and the test requirements. The implementation guidelines are referred to 36.523-3.

6.4 Generic procedures

This clause describes UE test states which can be used in the initial condition of many test cases defined in TS 36.523-1 [18] in addition to the states already specified in clause 4.5 of this specification.

6.4.1 Initial UE states and setup procedures

6.4.1.1 Initial UE states and setup procedures

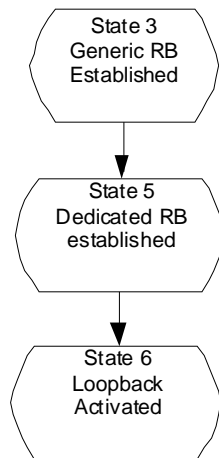

Figure 6.4.1.1-1: Initial UE states

In order that the UE can set up a call or session in E-UTRAN, there are a number of setup procedures to be undertaken in a hierarchical sequence to move between known states. The sequences are shown in figure 6.4.1.1-1 and the status of the relevant protocols in the UE in the different states are given in table 6.4.1.1-1. State 3 is defined in clause 4.5.1.

Table 6.4.1.1-1: Protocol state for each initial UE state

		RRC	ECM	EMM	ESM
State 5	Dedicated RB established	RRC_CONNECTED	ECM_CONNECTED	EMM-REGISTERED	1 default EPS bearer context active N dedicated EPS bearer context(s) active
State 6	Loopback Activated	RRC_CONNECTED	ECM_CONNECTED	EMM-REGISTERED	1 default EPS bearer context active N dedicated EPS bearer context(s) active

6.4.1.2 Dedicated Bearer Establishment (to state 5)

6.4.1.2.1 Initial conditions

System Simulator:

- Parameters are set to the default parameters for the basic single cell environment, as defined in subclause 4.4, unless otherwise specified in the test case.

User Equipment:

- The UE shall be in Generic RB established (State 3).

6.4.1.2.2 Definition of system information messages

The default system information messages are used.

6.4.1.2.3 Procedure

The establishment of dedicated radio bearer connection is assumed to always be mobile terminated.

Table 6.4.1.2.3-1: Procedure for dedicated bearer establishment

Step	Procedure	Message Sequence	
		U - S	Message
1	The SS configures new data radio bearer(s) and the associated dedicated EPS bearer context(s).	<--	RRC: RRCConnectionReconfiguration NAS: ACTIVATE DEDICATED EPS BEARER CONTEXT REQUEST
2	The UE transmits an <i>RRCConnectionReconfigurationComplete</i> message to confirm the establishment of the new data radio bearer(s), associated with the dedicated EPS bearer context(s) in the NAS message.	-->	RRC: RRCConnectionReconfigurationComplete
3	The UE transmits an ACTIVATE DEDICATED EPS BEARER CONTEXT ACCEPT message.	-->	NAS: ACTIVATE DEDICATED EPS BEARER CONTEXT ACCEPT

6.4.1.2.4 Specific message contents

All specific message contents shall be referred to clause 4.6 and 4.7.

6.4.1.3 Loopback Activation (to state 6)

Editor's Note: This section will be completed when message for loopback activation is defined in TS 36.509. The table below is just an example and should be aligned with TS 36.509.

6.4.1.3.1 Initial conditions

System Simulator:

- Parameters are set to the default parameters for the basic single cell environment, as defined in subclause 4.4, unless otherwise specified in the test case.

User Equipment:

- The UE shall be in Dedicated Radio Bearer Established (State 5).

6.4.1.3.2 Definition of system information messages

The default system information messages are used.

6.4.1.3.3 Procedure

Table 6.4.1.3.3-1: Procedure for loopback activation

Step	Procedure	Message Sequence	
		U - S	Message
1	The SS transmits an ACTIVATE RB TEST MODE message to activate UE radio bearer test mode procedure.	<--	RRC: DLInformationTransfer TC: ACTIVATE RB TEST MODE
2	The UE transmits an ACTIVATE RB TEST MODE COMPLETE message.	-->	RRC: ULInformationTransfer TC: ACTIVATE RB TEST MODE COMPLETE
3	The SS transmits a CLOSE UE TEST LOOP message to enter the UE test loop mode.	<--	RRC: DLInformationTransfer TC: CLOSE UE TEST LOOP
4	The UE transmits a CLOSE UE TEST LOOP COMPLETE message to confirm that loopback entities for the radio bearer(s) have been created and loop back is activated (State 6).	-->	RRC: ULInformationTransfer TC: CLOSE UE TEST LOOP COMPLETE

6.4.1.3.4 Specific message contents

All specific message contents shall be referred to clause 4.6, 4.7 and 4.7A.

6.4.2 Test procedures

6.4.2.1 Introduction

This section defines test procedures which can be used within test procedure sequences for test steps where checking the UE state is needed.

For each test procedure,

- at the start of the test procedure,
 - the System Simulator condition and the value of system information messages are the ones applicable in the test case referring to this test procedure, as they are after the execution of the test step immediately preceding the test step where the test procedure is used;
 - the initial UE condition is one indicated in the test case referring to this procedure, as it is after the execution of the test step immediately preceding the test step where the test procedure is used.
- at the end of the test procedure,
 - the System Simulator condition after the test procedure execution is complete is the same as before it is started (this should not be changed by the test procedure).

6.4.2.2 Test procedure to check RRC_IDLE state

This procedure aims at checking whether the UE is in RRC_IDLE on a certain cell of a test case or not.

Table 6.4.2.2-1: Test procedure sequence

St	Procedure	Message Sequence		TP	Verdict
		U - S	Message/PDU/SDU		
0	The SS waits 1 second.	-	-	-	-
1	The SS sends RRC <i>Paging</i> message with UE S-TMSI on the cell(s) specified in the test case.	<--	RRC: <i>Paging</i> (PCCH)	-	-
2	Check: Does the UE send an <i>RRCConnectionRequest</i> message on the cell specified in the test case ?	-->	RRC: <i>RRCConnectionRequest</i>	-	P
3	The SS transmits a <i>RRCConnectionSetup</i> message	<--	RRC: <i>RRCConnectionSetup</i>	-	-
4	The UE transmits an <i>RRCConnectionSetupComplete</i> message to confirm the successful completion of the connection establishment and to initiate the session management procedure by including the SERVICE REQUEST message.	-->	RRC: <i>RRCConnectionSetupComplete</i> NAS: SERVICE REQUEST	-	-
5 - 6	Void	-	-	-	-
7	The SS transmits a <i>SecurityModeCommand</i> message to activate AS security.	<--	RRC: <i>SecurityModeCommand</i>	-	-
8	The UE transmits a <i>SecurityModeComplete</i> message.	-->	RRC: <i>SecurityModeComplete</i>	-	-
9	The SS transmits a <i>RRCConnectionReconfiguration</i> message to establish the default bearer with condition SRB2-DRB(1, 0) according to 4.8.2.2.1.1,	<--	RRC: <i>RRCConnectionReconfiguration</i>	-	-
10	The UE transmits an <i>RRCConnectionReconfigurationComplete</i> message.	-->	RRC: <i>RRCConnectionReconfigurationComplete</i>	-	-
11	The SS release the RRC connection.	<--	RRC: <i>RRCConnectionRelease</i>	-	-

6.4.2.3 Test procedure to check RRC_CONNECTED state

Table 6.4.2.3-1: Test procedure sequence

St	Procedure	Message Sequence		TP	Verdict
		U - S	Message/PDU/SDU		
1	The SS sends <i>UECapabilityEnquiry</i> message to the UE.	<--	<i>UECapabilityEnquiry</i>	-	-
2	Check: Does the UE send a <i>UECapabilityInformation</i> message?	-->	<i>UECapabilityInformation</i>		P

6.4.2.4 Test procedure Paging (for NAS testing)

This procedure aims at checking whether the UE is in registered with a certain S-TMSI.

For the PS domain this procedure is identical to the procedure in 6.4.2.2 except that the S-TMSI as indicated in step 1 is the one explicitly specified in the test step calling this procedure.

For the CS domain the test procedure is FFS (i.e. it shall be avoided to make use of CS paging in the test case design).

6.4.2.5 Test procedure for no response to paging (for NAS testing)

This procedure aims at checking that the UE ignores paging messages with a specified identity.

The procedure is defined in table 6.4.2.5-1.

Table 6.4.2.5-1: Test procedure sequence

St	Procedure	Message Sequence		TP	Verdict
		U - S	Message		
0	The SS waits 1 second.	-	-	-	-
1	The SS transmits a paging message using the UE identity and the CN domain which are both specified in the referring test step, and on the cell which is specified in the referring test step.	<--	Paging	-	-
2	Check: Does the UE send an <i>RRCConnectionRequest</i> message on the cell where the paging was transmitted within the next 3s?	-->	<i>RRCConnectionRequest</i>		F

6.4.2.6 Test procedure to check that a dedicated EPS bearer context is active (for NAS testing)

This procedure aims at checking that a dedicated EPS bearer context is active.

The procedure is defined in table 6.4.2.6-1.

Table 6.4.2.6-1: Test procedure sequence

St	Procedure	Message Sequence		TP	Verdict
		U - S	Message		
1	The SS modifies existing data radio bearer(s) and the associated EPS bearer context(s) with Bearer QoS update.	<--	RRC: <i>RRCConnectionReconfiguration</i> NAS: MODIFY EPS BEARER CONTEXT REQUEST	-	-
2	The UE transmits an <i>RRCConnectionReconfigurationComplete</i> message to confirm the modification of the existing data radio bearer(s), associated with the EPS bearer context(s) in the NAS message.	-->	RRC: <i>RRCConnectionReconfigurationComplete</i>	-	-
3	Check: Does the UE transmit a MODIFY EPS BEARER CONTEXT ACCEPT message?	-->	RRC: <i>ULInformationTransfer</i> NAS: MODIFY EPS BEARER CONTEXT ACCEPT		P

6.4.2.7 Test procedure to check that UE is camped on a new E-UTRAN cell

This procedure aims at checking whether the UE is camping on a new E-UTRAN cell with different TAI of a test case or not.

The procedure is defined in table 6.4.2.7-1.

Table 6.4.2.7-1: Test procedure sequence

St	Procedure	Message Sequence		TP	Verdict
		U - S	Message		
1	The UE transmits an <i>RRCConnectionRequest</i> message on the cell specified in the test case.	-->	RRC: <i>RRCConnectionRequest</i>	-	-
2	SS transmit an <i>RRCConnectionSetup</i> message.	<--	RRC: <i>RRCConnectionSetup</i>	-	-
3	The UE transmits an <i>RRCConnectionSetupComplete</i> message to confirm the successful completion of the connection establishment and a TRACKING AREA UPDATE REQUEST message is sent to update the registration of the actual tracking area.	-->	RRC: <i>RRCConnectionSetupComplete</i> NAS: TRACKING AREA UPDATE REQUEST	-	-
4	SS responds with TRACKING AREA UPDATE ACCEPT message.	<--	RRC: <i>DLInformationTransfer</i> NAS: TRACKING AREA UPDATE ACCEPT	-	-
5	Check: Does the UE send a TRACKING AREA UPDATE COMPLETE on the cell specified in the test case?	-->	RRC: <i>ULInformationTransfer</i> NAS: TRACKING AREA UPDATE COMPLETE	-	P
6	The SS transmits an <i>RRCConnectionRelease</i> message to release RRC connection and move to RRC_IDLE.	<--	RRC: <i>RRCConnectionRelease</i>	-	-

NOTE 1: The periodic tracking area updating timer T3412 is deactivated by default during the attach procedure (TS 36.508 clause 4.7.2).

NOTE 2: The SS does not initiate authentication and NAS SECURITY MODE COMMAND are not performed (reuse of keys allocated during the attach procedure).

6.4.2.7A Test procedure to check that UE is camped on E-UTRAN cell upon mobility from another RAT

This procedure aims at checking whether the UE is camping on a E-UTRAN cell upon mobility from another RAT after Inter RAT reselection.

The procedure if PDP context was established before inter RAT reselection, is defined in table 6.4.2.7A-1.

Table 6.4.2.7A-1: Test procedure sequence

St	Procedure	Message Sequence		TP	Verdict
		U - S	Message		
1	The UE transmits a <i>RRCConnectionRequest</i> message on the cell specified in the test case.	-->	RRC: <i>RRCConnectionRequest</i>	-	-
2	SS transmit an <i>RRCConnectionSetup</i> message.	<--	RRC: <i>RRCConnectionSetup</i>	-	-
3	The UE transmits a <i>RRCConnectionSetupComplete</i> message to confirm the successful completion of the connection establishment and a TRACKING AREA UPDATE REQUEST message is sent to update the registration of the actual tracking area.	-->	RRC: <i>RRCConnectionSetupComplete</i> NAS: TRACKING AREA UPDATE REQUEST	-	-
4	The SS transmits a NAS SECURITY MODE COMMAND message to activate NAS security (mapped security context) (Note 1).	<--	RRC: <i>DLInformationTransfer</i> NAS: SECURITY MODE COMMAND	-	-
5	The UE transmits a NAS SECURITY MODE COMPLETE message and establishes the initial security configuration.	-->	RRC: <i>ULInformationTransfer</i> NAS: SECURITY MODE COMPLETE	-	-
6	SS responds with TRACKING AREA UPDATE ACCEPT message.	<--	RRC: <i>DLInformationTransfer</i> NAS: TRACKING AREA UPDATE ACCEPT	-	-
7	Check: Does the UE send a TRACKING AREA UPDATE COMPLETE on the cell specified in the test case?	-->	RRC: <i>ULInformationTransfer</i> NAS: TRACKING AREA UPDATE COMPLETE	-	P
8	The SS transmits an <i>RRCConnectionRelease</i> message to release RRC connection and move to RRC_IDLE.	<--	RRC: <i>RRCConnectionRelease</i>	-	-
Note 1: Step 4 and 5 are executed only when UE and SS does not have a native security context.					

The procedure if PDP context was not established before inter RAT reselection, is defined in table 6.4.2.7A-2.

Table 6.4.2.7A-2: Test procedure sequence

St	Procedure	Message Sequence		TP	Verdict
		U - S	Message		
-	EXCEPTION: For Rel-8 and Rel-9 steps 1 to 6 are optional and depend on UE implementation. A Rel-10 UE directly starts attach procedure from step 6.	-	-	-	-
1	The UE transmits a <i>RRCCONNECTIONREQUEST</i> message on the cell specified in the test case.	-->	RRC: <i>RRCCONNECTIONREQUEST</i>	-	-
2	SS transmit an <i>RRCCONNECTIONSETUP</i> message.	<--	RRC: <i>RRCCONNECTIONSETUP</i>	-	-
3	The UE transmits a <i>RRCCONNECTIONSETUPCOMPLETE</i> message to confirm the successful completion of the connection establishment and a TRACKING AREA UPDATE REQUEST message is sent to update the registration of the actual tracking area.	-->	RRC: <i>RRCCONNECTIONSETUPCOMPLETE</i> NAS: TRACKING AREA UPDATE REQUEST	-	-
4	The SS transmits a TRACKING AREA UPDATE REJECT message with cause #40 (No EPS bearer context activated) to force attach the UE	<--	RRC: <i>DLINFORMATIONTRANSFER</i> NAS: TRACKING AREA UPDATE REJECT	-	-
-	EXCEPTION: Step 5 describes the behaviour that depends on UE behaviour (Note 1).	-	-	-	-
5	The SS transmits an <i>RRCCONNECTIONRELEASE</i> message to release RRC connection and move to RRC_IDLE.	<--	RRC: <i>RRCCONNECTIONRELEASE</i>	-	-
-	EXCEPTION: Step 6 describes a behaviour which depends on the UE capability	-	-	-	-
6	IF NOT <i>pc_Auto_Attach_after_TAU_Reject</i> , the user initiates an attach by MMI or by AT command.	-	-	-	-
7-22	Steps 2 to 17 of the generic UE Registration procedure (4.5 .2.3-1) are executed to successfully complete the Attach procedure.	-	-	-	-
Note 1: SS waits for 1 second to receive the Attach Request on the existing RRC Connection. In case Attach Request is not received within 1 second, existing RRC Connection is released.					

6.4.2.7A.1 Specific message contents

Table 6.4.2.7A.1-1: TRACKING AREA UPDATE REQUEST (Step 3, table 6.4.2.7A-1, 6.4.2.7A-2)

Derivation Path: 36.508 clause 4.7.2			
Information Element	Value/remark	Comment	Condition
EPS update type			
EPS update type Value	'000'B	TA updating	TA_only
	'001'B	Combined TA/LA updating	No_LAU_CombinedRAU_GERAN_UTRA
	'010'B	Combined TA/LA updating with IMSI attach	LAU_CombinedRAU_GERAN_UTRA
"Active" flag	Any allowed value		
NAS key set identifier			
NAS key set identifier	The valid NAS key set identifier of the UE		
TSC	'0'B	native security context (for KSI _{ASME})	Native_Security_Context
	'1'B	mapped security context (for KSI _{SGSN})	Mapped_Security_Context
GPRS ciphering key sequence number	Not present or any allowed value		
Old P-TMSI signature	Any allowed value		
Additional GUTI	Not present or any allowed value		
Nonce _{UE}	Not present or any allowed value		
UE radio capability information update needed	Not present or any allowed value		
EPS bearer context status	Not present or (octet 3 = '00100000'B and octet 4 = '00000000'B)		Bearer_Established
	Not present or (octet 3 = '00000000'B and octet 4 = '00000000'B)		No_Bearer_Established

Condition	Explanation
TA_only	See the definition below table 4.7.2-24.
combined_TA_LA	See the definition below table 4.7.2-24.
Native_Security_Context	UE has performed AKA on the EUTRA Cell
Mapped_Security_Context	UE has performed AKA on the UTRA/GERAN Cell
No_LAU_CombinedRAU_GERAN_UTRA	UE has not performed location area update procedure or a combined routing area update procedure in A/Gb or lu mode
LAU_CombinedRAU_GERAN_UTRA	UE has performed location area update procedure or a combined routing area update procedure in A/Gb or lu mode
Bearer_Established	Bearer is Established when UE earlier camped at UTRAN/GERAN cell or UE previously successfully camped in EUTRA cell.
No_Bearer_Established	Bearer is not Established when UE earlier camped at UTRAN/GERAN cell and UE did not previously camped in EUTRA cell.

This message is sent integrity protected when a valid security context exists and without integrity protection otherwise.

6.4.2.8 Test procedure to check that UE is camped on a new UTRAN cell

This procedure aims at checking whether the UE is camping on a new UTRAN cell of a test case or not.

The procedure is defined in table 6.4.2.8-1.

Table 6.4.2.8-1: Test procedure sequence

St	Procedure	Message Sequence		TP	Verdict
		U - S	Message		
1	The UE transmits a RRC CONNECTION REQUEST message on the cell specified in the test case.	-->	RRC: RRC CONNECTION REQUEST	-	-
2	The SS transmits an RRC CONNECTION SETUP message.	<--	RRC: RRC CONNECTION SETUP	-	-
3	The UE transmits an RRC CONNECTION SETUP COMPLETE message.	-->	RRC: RRC CONNECTION SETUP COMPLETE	-	-
4	The UE transmits a ROUTING AREA UPDATE REQUEST message.	-->	RRC: INITIAL DIRECT TRANSFER NAS: ROUTING AREA UPDATE REQUEST	-	-
5	The SS transmits a SECURITY MODE COMMAND message.	<--	RRC: SECURITY MODE COMMAND	-	-
6	The UE transmits a SECURITY MODE COMPLETE message.	-->	RRC: SECURITY MODE COMPLETE	-	-
7	The SS transmits a ROUTING AREA UPDATE ACCEPT message.	<--	RRC: DOWNLINK DIRECT TRANSFER NAS: ROUTING AREA UPDATE ACCEPT	-	-
8	The UE transmits a ROUTING AREA UPDATE COMPLETE message.	-->	RRC: UPLINK DIRECT TRANSFER NAS: ROUTING AREA UPDATE COMPLETE	-	-
9	The SS transmits a RRC CONNECTION RELEASE message.	<--	RRC: RRC CONNECTION RELEASE	-	-
10	Check: Does the UE transmit an RRC CONNECTION RELEASE COMPLETE message on the cell specified in the test?	-->	RRC: RRC CONNECTION RELEASE COMPLETE	-	P

NOTE: The TS 34.108 [5] and TS 34.123-1 [7] use Network Mode of Operation I as default, for this reason a combined MM/GMM procedure is performed.

6.4.2.9 Test procedure to check that UE is camped on a new GERAN cell

This procedure aims at checking whether the UE is camping on a new GERAN cell of a test case or not.

The procedure is defined in table 6.4.2.9-1.

Table 6.4.2.9-1: Test procedure sequence

St	Procedure	Message Sequence		TP	Verdict
		U - S	Message		
1	Check: Does the UE send a CHANNEL REQUEST message on the cell(s) specified in the test case?	-->	CHANNEL REQUEST	-	-
2	An uplink TBF is established in order to allow the UE to transmit a ROUTING AREA UPDATE REQUEST message signalling.	-	-	-	-
3	The UE transmits a ROUTING AREA UPDATE REQUEST message.	-->	ROUTING AREA UPDATING REQUEST	-	-
4	A downlink TBF is established by the SS in order to transmit the AUTHENTICATION AND CIPHERING REQUEST message	-	-	-	-
5	The SS transmits an AUTHENTICATION AND CIPHERING REQUEST message.	<--	AUTHENTICATION AND CIPHERING REQUEST	-	-
6	An uplink TBF is established in order to allow the UE to transmit an AUTHENTICATION AND CIPHERING RESPONSE message	-	-	-	-
7	The UE transmits a AUTHENTICATION AND CIPHERING RESPONSE message.	-->	AUTHENTICATION AND CIPHERING RESPONSE	-	-
8	A downlink TBF is established by the SS in order to transmit the ROUTING AREA UPDATE ACCEPT message	-	-	-	-
9	The SS transmits a ROUTING AREA UPDATE ACCEPT message.	<--	ROUTING AREA UPDATING ACCEPT	-	-
10	An uplink TBF is established in order to allow the UE to transmit a ROUTING AREA UPDATE COMPLETE message			-	-
11	The UE transmits a ROUTING AREA UPDATE COMPLETE message.	-->	ROUTING AREA UPDATING COMPLETE	-	P

NOTE: The TS 51.010-1 [25] uses Network Mode of Operation I as default, for this reason a combined MM/GMM procedure is performed.

6.4.2.10 Test procedure to check that UE performs tracking area updating procedure without ISR and security reconfiguration after successful completion of handover from UTRA

This procedure aims at checking whether the UE performs tracking area updating procedure where ISR is not activated and security reconfiguration after successful completion of handover from UTRA.

The procedure is defined in table 6.4.2.10-1.

Table 6.4.2.10-1: Test procedure sequence

St	Procedure	Message Sequence		TP	Verdict
		U - S	Message		
1	The UE transmits an <i>ULInformationTransfer</i> message on the cell specified in the test case. This message includes a TRACKING AREA UPDATE REQUEST message.	-->	RRC: <i>ULInformationTransfer</i> NAS: TRACKING AREA UPDATE REQUEST	-	-
2	The SS transmits a <i>DLInformationTransfer</i> message on the cell specified in the test case. This message includes a TRACKING AREA UPDATE ACCEPT message.	<--	RRC: <i>DLInformationTransfer</i> NAS: TRACKING AREA UPDATE ACCEPT	-	-
3	The UE transmits an <i>ULInformationTransfer</i> message on the cell specified in the test case. This message includes a TRACKING AREA UPDATE COMPLETE message.	-->	RRC: <i>ULInformationTransfer</i> NAS: TRACKING AREA UPDATE COMPLETE	-	-
-	EXCEPTION: Steps 4a1 to 4a2 describe behaviour that depends on the IE included in TRACKING AREA UPDATE REQUEST in step 1.	-	-	-	-
4a1	IF TRACKING AREA UPDATE REQUEST transmitted in step 1 does not contain a valid KSI_{ASME} THEN the SS transmits a <i>DLInformationTransfer</i> message on the cell specified in the test case. This message includes an AUTHENTICATION REQUEST message.	<--	RRC: <i>DLInformationTransfer</i> NAS: AUTHENTICATION REQUEST	-	-
4a2	The UE transmits an <i>ULInformationTransfer</i> message on the cell specified in the test case. This message includes an AUTHENTICATION RESPONSE message.	-->	RRC: <i>ULInformationTransfer</i> NAS: AUTHENTICATION RESPONSE	-	-
5	The SS transmits a <i>DLInformationTransfer</i> message on the cell specified in the test case. This message includes a SECURITY MODE COMMAND message to take the native EPS security context into use.	<--	RRC: <i>DLInformationTransfer</i> NAS: SECURITY MODE COMMAND	-	-
6	The UE transmits an <i>ULInformationTransfer</i> message on the cell specified in the test case. This message includes a SECURITY MODE COMPLETE message.	-->	RRC: <i>ULInformationTransfer</i> NAS: SECURITY MODE COMPLETE	-	-
7	The SS transmits an <i>RRCConnectionReconfiguration</i> message to perform intra cell handover and security reconfiguration on the cell specified in the test case.	<--	RRC: <i>RRCConnectionReconfiguration</i>	-	-
8	Check: Does the UE transmit an <i>RRCConnectionReconfigurationComplete</i> message on the cell specified in the test case?	-->	RRC: <i>RRCConnectionReconfigurationComplete</i>	-	P

Table 6.4.2.10-2: Message TRACKING AREA UPDATE REQUEST (step 1, Table 6.4.2.10-1)

Derivation Path: 36.508 clause 4.7.2-27			
Information Element	Value/remark	Comment	Condition
NAS key set identifier			
NAS key set identifier	The valid NAS key set identifier of the UE	mapped security context (for KSI _{SGSN})	
TSC	1		
Non-current native NAS key set identifier			
NAS key set identifier	The valid NAS key set identifier of the UE	native security context (for KSI _{ASME})	
TSC	0		
Old P-TMSI signature	any allowed value		
Additional GUTI	any allowed value		

Table 6.4.2.10-3: RRCConnectionReconfiguration (step 7, Table 6.4.2.10-1)

Derivation Path: 36.508, Table 4.6.1-8
--

Table 6.4.2.10-4: SecurityConfigHO (IE in RRCConnectionReconfiguration, Table 6.4.2.10-3)

Derivation Path: 36.508, Table 4.6.4-1			
Information Element	Value/remark	Comment	Condition
SecurityConfigHO ::= SEQUENCE {			
handoverType CHOICE {			
intraLTE SEQUENCE {			
keyChangeIndicator	TRUE		
nextHopChainingCount	0		
}			
}			
}			

6.4.3 Reference test procedures for TTCN development

This clause describes reference test procedures for the purpose of TTCN development.

6.4.3.1 UE triggered establishment of a dedicated EPS bearer context

Table 6.4.3.1-1: Test procedure sequence

St	Procedure	Message Sequence	
		U - S	Message
1	Cause the UE to request bearer resource allocation of dedicated EPS bearer associated with first PDN connectivity. (see Note 1)	-	-
-	EXCEPTION: Steps 2a1 to 2a7 describe behaviour that depends on RRC state; the "lower case letter" identifies a step sequence that takes place if the UE is in RRC_IDLE state.	-	-
2a1	IF the UE is in RRC_IDLE state THEN the UE transmits an <i>RRCCConnectionRequest</i> message.	-->	RRC: <i>RRCCConnectionRequest</i>
2a2	The SS transmits an <i>RRCCConnectionSetup</i> message.	<--	RRC: <i>RRCCConnectionSetup</i>
2a3	The UE transmits an <i>RRCCConnectionSetupComplete</i> including the SERVICE REQUEST message.	-->	RRC: <i>RRCCConnectionSetupComplete</i> NAS: SERVICE REQUEST
2a4	The SS transmits a <i>SecurityModeCommand</i> message to activate AS security.	<--	RRC: <i>SecurityModeCommand</i>
2a5	The UE transmits a <i>SecurityModeComplete</i> message and establishes the initial security configuration.	-->	RRC: <i>SecurityModeComplete</i>
2a6	The SS transmits an <i>RRCCConnectionReconfiguration</i> message to configure data radio bearer(s) associated with the existing EPS bearer context. The <i>RRCCConnectionReconfiguration</i> message is using condition SRB2-DRB(n, m) where n and m are the number of DRBs associated with existing EPS bearer contexts and configured respectively with RLC-AM and RLC-UM.	<--	RRC: <i>RRCCConnectionReconfiguration</i>
2a7	The UE transmits an <i>RRCCConnectionReconfigurationComplete</i> message.	-->	RRC: <i>RRCCConnectionReconfigurationComplete</i>
3	The UE transmits an <i>ULInformationTransfer</i> message including the BEARER RESOURCE ALLOCATION REQUEST message.	-->	RRC: <i>ULInformationTransfer</i> NAS: BEARER RESOURCE ALLOCATION REQUEST
4	The SS transmits an <i>RRCCConnectionReconfiguration</i> message including the ACTIVATE DEDICATED EPS BEARER CONTEXT REQUEST message to establish the dedicated EPS bearer context.	<--	RRC: <i>RRCCConnectionReconfiguration</i> NAS: ACTIVATE DEDICATED EPS BEARER CONTEXT REQUEST
5	The UE transmits an <i>RRCCConnectionReconfigurationComplete</i> message.	-->	RRC: <i>RRCCConnectionReconfigurationComplete</i>
6	The UE transmits an <i>ULInformationTransfer</i> message including the ACTIVATE DEDICATED EPS BEARER CONTEXT ACCEPT message.	-->	RRC: <i>ULInformationTransfer</i> NAS: ACTIVATE DEDICATED EPS BEARER CONTEXT ACCEPT
Note 1: The request is assumed to be triggered by AT command +CGDSCONT, and +CGACT (activated).			
Note 2: If UE sends IP related data this shall be handled by the SS.			

6.4.3.2 UE triggered establishment of a default EPS bearer context associated with an additional PDN

Table 6.4.3.2-1: Test procedure sequence

St	Procedure	Message Sequence	
		U - S	Message
1	Cause the UE to request connectivity to an additional PDN. (see Note 1)	-	-
-	EXCEPTION: Steps 2a1 to 2a7 describe behaviour that depends on RRC state; the "lower case letter" identifies a step sequence that takes place if the UE is in RRC_IDLE state.	-	-
2a1	IF the UE is in RRC_IDLE state THEN the UE transmits an <i>RRCCONNECTIONREQUEST</i> message.	-->	RRC: <i>RRCCONNECTIONREQUEST</i>
2a2	The SS transmits an <i>RRCCONNECTIONSETUP</i> message.	<--	RRC: <i>RRCCONNECTIONSETUP</i>
2a3	The UE transmits an <i>RRCCONNECTIONSETUPCOMPLETE</i> including the SERVICE REQUEST message.	-->	RRC: <i>RRCCONNECTIONSETUPCOMPLETE</i> NAS: SERVICE REQUEST
2a4	The SS transmits a <i>SECURITYMODECOMMAND</i> message to activate AS security.	<--	RRC: <i>SECURITYMODECOMMAND</i>
2a5	The UE transmits a <i>SECURITYMODECOMPLETE</i> message and establishes the initial security configuration.	-->	RRC: <i>SECURITYMODECOMPLETE</i>
2a6	The SS transmits an <i>RRCCONNECTIONRECONFIGURATION</i> message to configure data radio bearer(s) associated with the existing EPS bearer context. The <i>RRCCONNECTIONRECONFIGURATION</i> message is using condition SRB2-DRB(n, m) where n and m are the number of DRBs associated with existing EPS bearer contexts and configured respectively with RLC-AM and RLC-UM.	<--	RRC: <i>RRCCONNECTIONRECONFIGURATION</i>
2a7	The UE transmits an <i>RRCCONNECTIONRECONFIGURATIONCOMPLETE</i> message.	-->	RRC: <i>RRCCONNECTIONRECONFIGURATIONCOMPLETE</i>
3	The UE transmits an <i>ULINFORMATIONTRANSFER</i> message including the PDN CONNECTIVITY REQUEST message.	-->	RRC: <i>ULINFORMATIONTRANSFER</i> NAS: PDN CONNECTIVITY REQUEST
4	The SS transmits an <i>RRCCONNECTIONRECONFIGURATION</i> message including the ACTIVATE DEFAULT EPS BEARER CONTEXT REQUEST message to establish the default EPS bearer context.	<--	RRC: <i>RRCCONNECTIONRECONFIGURATION</i> NAS: ACTIVATE DEFAULT EPS BEARER CONTEXT REQUEST
5	The UE transmits an <i>RRCCONNECTIONRECONFIGURATIONCOMPLETE</i> message.	-->	RRC: <i>RRCCONNECTIONRECONFIGURATIONCOMPLETE</i>
6	The UE transmits an <i>ULINFORMATIONTRANSFER</i> message including the ACTIVATE DEFAULT EPS BEARER CONTEXT ACCEPT message.	-->	RRC: <i>ULINFORMATIONTRANSFER</i> NAS: ACTIVATE DEFAULT EPS BEARER CONTEXT ACCEPT
Note 1: The request is assumed to be triggered by AT command +CGDCONT and +CGACT (activated).			
Note 2: If UE sends IP related data this shall be handled by the SS.			

Table 6.4.3.2-2: Message PDN CONNECTIVITY REQUEST (step 3, Table 6.4.3.2-1)

Derivation Path: TS 36.508 Table 4.7.3-20			
Information Element	Value/remark	Comment	Condition
EPS bearer identity	0000	No EPS bearer identity assigned	
Procedure transaction identity	PTI-1	UE assigns a particular PTI not yet used between 1 and 254	
ESM information transfer flag	Not present	This IE is only used during an attach procedure.	
Access point name	APN-1(New PDN name)	The requested PDN is different from default PDN	

6.4.3.3 UE triggered modification of an EPS bearer context

Table 6.4.3.3-1: Test procedure sequence

St	Procedure	Message Sequence	
		U - S	Message
1	Cause the UE to request bearer resource modification of EPS bearer associated with first PDN connectivity. (see Note 1)	-	-
-	EXCEPTION: Steps 2a1 to 2a7 describe behaviour that depends on RRC state; the "lower case letter" identifies a step sequence that takes place if the UE is in RRC_IDLE state.	-	-
2a1	IF the UE is in RRC_IDLE state THEN the UE transmits an <i>RRCCONNECTIONREQUEST</i> message.	-->	RRC: <i>RRCCONNECTIONREQUEST</i>
2a2	The SS transmits an <i>RRCCONNECTIONSETUP</i> message.	<--	RRC: <i>RRCCONNECTIONSETUP</i>
2a3	The UE transmits an <i>RRCCONNECTIONSETUPCOMPLETE</i> including the SERVICE REQUEST message.	-->	RRC: <i>RRCCONNECTIONSETUPCOMPLETE</i> NAS: SERVICE REQUEST
2a4	The SS transmits a <i>SECURITYMODECOMMAND</i> message to activate AS security.	<--	RRC: <i>SECURITYMODECOMMAND</i>
2a5	The UE transmits a <i>SECURITYMODECOMPLETE</i> message and establishes the initial security configuration.	-->	RRC: <i>SECURITYMODECOMPLETE</i>
2a6	The SS transmits an <i>RRCCONNECTIONRECONFIGURATION</i> message to configure data radio bearer(s) associated with the existing EPS bearer context. The <i>RRCCONNECTIONRECONFIGURATION</i> message is using condition SRB2-DRB(n, m) where n and m are the number of DRBs associated with existing EPS bearer contexts and configured respectively with RLC-AM and RLC-UM.	<--	RRC: <i>RRCCONNECTIONRECONFIGURATION</i>
2a7	The UE transmits an <i>RRCCONNECTIONRECONFIGURATIONCOMPLETE</i> message.	-->	RRC: <i>RRCCONNECTIONRECONFIGURATIONCOMPLETE</i>
3	The UE transmits an <i>ULINFORMATIONTRANSFER</i> message including the BEARER RESOURCE MODIFICATION REQUEST message.	-->	RRC: <i>ULINFORMATIONTRANSFER</i> NAS: BEARER RESOURCE MODIFICATION REQUEST
4	The SS transmits an <i>RRCCONNECTIONRECONFIGURATION</i> message including the MODIFY EPS BEARER CONTEXT REQUEST message to modify the EPS bearer context.	<--	RRC: <i>RRCCONNECTIONRECONFIGURATION</i> NAS: MODIFY EPS BEARER CONTEXT REQUEST
5	The UE transmits an <i>RRCCONNECTIONRECONFIGURATIONCOMPLETE</i> message.	-->	RRC: <i>RRCCONNECTIONRECONFIGURATIONCOMPLETE</i>
6	Check: Does the UE transmit an <i>ULINFORMATIONTRANSFER</i> message including the MODIFY EPS BEARER CONTEXT ACCEPT message?	-->	RRC: <i>ULINFORMATIONTRANSFER</i> NAS: MODIFY EPS BEARER CONTEXT ACCEPT
Note 1: The request is assumed to be triggered by AT command +CGCMOD.			
Note 2: If UE sends IP related data this shall be handled by the SS.			

6.4.3.4 UE triggered deletion of an EPS bearer context

Table 6.4.3.4-1: Test procedure sequence

St	Procedure	Message Sequence	
		U - S	Message
1	Cause the UE to request bearer resource release of dedicated EPS bearer associated with first PDN connectivity. (see Note 1)	-	-
-	EXCEPTION: Steps 2a1 to 2a7 describe behaviour that depends on RRC state; the "lower case letter" identifies a step sequence that takes place if the UE is in RRC_IDLE state.	-	-
2a1	IF the UE is in RRC_IDLE state THEN the UE transmits an <i>RRCCConnectionRequest</i> message.	-->	RRC: <i>RRCCConnectionRequest</i>
2a2	The SS transmits an <i>RRCCConnectionSetup</i> message.	<--	RRC: <i>RRCCConnectionSetup</i>
2a3	The UE transmits an <i>RRCCConnectionSetupComplete</i> including the SERVICE REQUEST message.	-->	RRC: <i>RRCCConnectionSetupComplete</i> NAS: SERVICE REQUEST
2a4	The SS transmits a <i>SecurityModeCommand</i> message to activate AS security.	<--	RRC: <i>SecurityModeCommand</i>
2a5	The UE transmits a <i>SecurityModeComplete</i> message and establishes the initial security configuration.	-->	RRC: <i>SecurityModeComplete</i>
2a6	The SS transmits an <i>RRCCConnectionReconfiguration</i> message to configure data radio bearer(s) associated with the existing EPS bearer context. The <i>RRCCConnectionReconfiguration</i> message is using condition SRB2-DRB(n, m) where n and m are the number of DRBs associated with existing EPS bearer contexts and configured respectively with RLC-AM and RLC-UM.	<--	RRC: <i>RRCCConnectionReconfiguration</i>
2a7	The UE transmits an <i>RRCCConnectionReconfigurationComplete</i> message.	-->	RRC: <i>RRCCConnectionReconfigurationComplete</i>
3	The UE transmits an <i>ULInformationTransfer</i> message including the BEARER RESOURCE MODIFICATION REQUEST message.	-->	RRC: <i>ULInformationTransfer</i> NAS: BEARER RESOURCE MODIFICATION REQUEST
4	The SS transmits an <i>RRCCConnectionReconfiguration</i> message including the DEACTIVATE EPS BEARER CONTEXT REQUEST message to delete EPS bearer context.	<--	RRC: <i>RRCCConnectionReconfiguration</i> NAS: DEACTIVATE EPS BEARER CONTEXT REQUEST
5	The UE transmits an <i>RRCCConnectionReconfigurationComplete</i> message	-->	RRC: <i>RRCCConnectionReconfigurationComplete</i>
6	The UE transmits an <i>ULInformationTransfer</i> message including the DEACTIVATE EPS BEARER CONTEXT ACCEPT message.	-->	RRC: <i>ULInformationTransfer</i> NAS: DEACTIVATE EPS BEARER CONTEXT ACCEPT
Note 1: The request is assumed to be triggered by AT command +CGACT (deactivated).			
Note 2: If UE sends IP related data this shall be handled by the SS.			

6.4.3.5 UE triggered CS call

Table 6.4.3.5-1: Test procedure sequence

St	Procedure	Message Sequence	
		U - S	Message
1	Cause the UE to originate CS call. (see Note 1)	-	-
-	EXCEPTION: Steps 2a1 to 2b1 describe behaviour that depends on RRC state; the "lower case letter" identifies a step sequence that takes place depending on RRC state.	-	-
2a1	IF the UE is in RRC_IDLE state THEN the UE transmits an <i>RRCCoordinateRequest</i> message.	-->	RRC: <i>RRCCoordinateRequest</i>
2a2	The SS transmits an <i>RRCCoordinateSetup</i> message.	<--	RRC: <i>RRCCoordinateSetup</i>
2a3	The UE transmits an <i>RRCCoordinateSetupComplete</i> including the EXTENDED SERVICE REQUEST message.	-->	RRC: <i>RRCCoordinateSetupComplete</i> NAS: EXTENDED SERVICE REQUEST
2b1	ELSE The UE transmits an <i>ULInformationTransfer</i> message including the EXTENDED SERVICE REQUEST message.	-->	RRC: <i>ULInformationTransfer</i> NAS: EXTENDED SERVICE REQUEST
Note 1: The request is assumed to be triggered by AT command D.			

6.4.3.6 UE triggered MO SMS over SGs

Table 6.4.3.6-1: Test procedure sequence

St	Procedure	Message Sequence	
		U - S	Message
1	Cause the UE to originate SMS message. (see Note 1)	-	-
-	EXCEPTION: Steps 2a1 to 2a7 describe behaviour that depends on RRC state; the "lower case letter" identifies a step sequence that takes place if the UE is in RRC_IDLE state.	-	-
2a1	IF the UE is in RRC_IDLE state THEN the UE transmits an <i>RRCCConnectionRequest</i> message.	-->	RRC: <i>RRCCConnectionRequest</i>
2a2	The SS transmits an <i>RRCCConnectionSetup</i> message.	<--	RRC: <i>RRCCConnectionSetup</i>
2a3	The UE transmits an <i>RRCCConnectionSetupComplete</i> including the SERVICE REQUEST message.	-->	RRC: <i>RRCCConnectionSetupComplete</i> NAS: SERVICE REQUEST
2a4	The SS transmits a <i>SecurityModeCommand</i> message to activate AS security.	<--	RRC: <i>SecurityModeCommand</i>
2a5	The UE transmits a <i>SecurityModeComplete</i> message and establishes the initial security configuration.	-->	RRC: <i>SecurityModeComplete</i>
2a6	The SS transmits an <i>RRCCConnectionReconfiguration</i> message to configure data radio bearer(s) associated with the existing EPS bearer context. The <i>RRCCConnectionReconfiguration</i> message is using condition SRB2-DRB(n, m) where n and m are the number of DRBs associated with existing EPS bearer contexts and configured respectively with RLC-AM and RLC-UM.	<--	RRC: <i>RRCCConnectionReconfiguration</i>
2a7	The UE transmits an <i>RRCCConnectionReconfigurationComplete</i> message.	-->	RRC: <i>RRCCConnectionReconfigurationComplete</i>
3	The UE transmits an <i>ULInformationTransfer</i> message including the UPLINK NAS TRANSPORT message to send the SMS message.	-->	RRC: <i>ULInformationTransfer</i> NAS: UPLINK NAS TRANSPORT
4	The SS transmits a <i>DLInformationTransfer</i> message including the DOWNLINK NAS TRANSPORT message to acknowledge receipt of the SMS message.	<--	RRC: <i>DLInformationTransfer</i> NAS: DOWNLINK NAS TRANSPORT
5	The SS transmits a <i>DLInformationTransfer</i> message including the DOWNLINK NAS TRANSPORT message to send the delivery report.	<--	RRC: <i>DLInformationTransfer</i> NAS: DOWNLINK NAS TRANSPORT
6	The UE transmits an <i>ULInformationTransfer</i> message including the UPLINK NAS TRANSPORT message to acknowledge receipt of the delivery report.	-->	RRC: <i>ULInformationTransfer</i> NAS: UPLINK NAS TRANSPORT
Note 1: The request is assumed to be triggered by AT command +CMGW and +CMSS.			

6.4.3.7 CS fallback to UTRAN procedures (LAI of UTRAN cell same as the LAI received in combined Attach procedure in EUTRA cell)

All procedures specified in this clause are referred to the UTRA target cell where the UE has been redirected or handed over from the EUTRA cell after a CS call requested. The default message contents are found in TS 34.108 [5], clause 9.

The procedures in 6.4.3.7.1 – 6.4.3.7.4 are applied if the UE supports (EUTRA) RRC connection release with redirection and Multi Cell System Information to UTRAN. The procedures in 6.4.3.7.5 - 6.4.3.7.7 are applied if the UE supports PS HO from EUTRA to UTRAN.

6.4.3.7.1 CS fallback to UTRAN with redirection / MT call (PS bearers not established)

Table 6.4.3.7.1-1: Test procedure sequence

St	Procedure	Message Sequence		TP	Verdict
		U - S	Message		
1	The UE transmits an RRC CONNECTION REQUEST message.	-->	RRC CONNECTION REQUEST	-	-
2	The SS transmits an RRC CONNECTION SETUP message.	<--	RRC CONNECTION SETUP	-	-
3	The UE transmits an RRC CONNECTION SETUP COMPLETE message.	-->	RRC CONNECTION SETUP COMPLETE	-	-
-	EXCEPTION: In parallel to the events described in step 4 to 15 the step specified in Table 6.4.3.7.1-2 takes place.	-	-	-	-
4	Check: Does the UE transmit a PAGING RESPONSE message?	-->	PAGING RESPONSE	-	P
5-15	Steps 7 to 17 of the generic test procedure in TS 34.108 [5] subclause 7.2.3.1.3 are performed using the UTRA reference radio bearer parameters and combination "UTRA Speech" according to subclause 4.8.3 and Table 4.8.3-1. NOTE: Mobile terminating CS call is established.	-	-	-	-
16	The SS transmits a SECURITY MODE COMMAND message for the PS domain. See Note 1.	<--	SECURITY MODE COMMAND	-	-
17	The UE transmits a SECURITY MODE COMPLETE message.	-->	SECURITY MODE COMPLETE	-	-
18	The SS transmits a ROUTING AREA UPDATE ACCEPT message.	<--	ROUTING AREA UPDATE ACCEPT	-	-
19	The UE transmits a ROUTING AREA UPDATE COMPLETE message.	-->	ROUTING AREA UPDATE COMPLETE	-	-
Note 1: A real network will initiate the security mode command procedure for the PS domain immediately after receiving the ROUTING AREA UPDATE REQUEST, but in this test procedure it was chosen to complete the procedure for CS domain first, in order to avoid the possibility of a security mode command procedure running in parallel with another RRC procedure.					

Table 6.4.3.7.1-2: Parallel behaviour

St	Procedure	Message Sequence		TP	Verdict
		U - S	Message		
1	The UE transmits a ROUTING AREA UPDATE REQUEST message.	-->	ROUTING AREA UPDATE REQUEST	-	-

6.4.3.7.2 CS fallback to UTRAN with redirection / MO call (PS bearers not established)

Table 6.4.3.7.2-1: Test procedure sequence

St	Procedure	Message Sequence		TP	Verdict
		U - S	Message		
1	The UE transmits an RRC CONNECTION REQUEST message.	-->	RRC CONNECTION REQUEST	-	-
2	The SS transmits an RRC CONNECTION SETUP message.	<--	RRC CONNECTION SETUP	-	-
3	The UE transmits an RRC CONNECTION SETUP COMPLETE message.	-->	RRC CONNECTION SETUP COMPLETE	-	-
-	EXCEPTION: In parallel to the events described in step 4 to 15 the step specified in Table 6.4.3.7.2-2 takes place.	-	-	-	-
4	Check: Does the UE transmit a CM SERVICE REQUEST message?	-->	CM SERVICE REQUEST	-	P
5-15	Steps 6 to 16 of the generic test procedure in TS 34.108 [5] subclause 7.2.3.2.3 are performed using the UTRA reference radio bearer parameters and combination "UTRA Speech" according to subclause 4.8.3 and Table 4.8.3-1. NOTE: Mobile originating CS call is established.	-	-	-	-
16	The SS transmits a SECURITY MODE COMMAND message for the PS domain. See Note 1.	<--	SECURITY MODE COMMAND	-	-
17	The UE transmits a SECURITY MODE COMPLETE message.	-->	SECURITY MODE COMPLETE	-	-
18	The SS transmits a ROUTING AREA UPDATE ACCEPT message.	<--	ROUTING AREA UPDATE ACCEPT	-	-
19	The UE transmits a ROUTING AREA UPDATE COMPLETE message.	-->	ROUTING AREA UPDATE COMPLETE	-	-
Note 1: A real network will initiate the security mode command procedure for the PS domain immediately after receiving the ROUTING AREA UPDATE REQUEST, but in this test procedure it was chosen to complete the procedure for CS domain first, in order to avoid the possibility of a security mode command procedure running in parallel with another RRC procedure.					

Table 6.4.3.7.2-2: Parallel behaviour

St	Procedure	Message Sequence		TP	Verdict
		U - S	Message		
1	The UE transmits a ROUTING AREA UPDATE REQUEST message.	-->	ROUTING AREA UPDATE REQUEST	-	-

6.4.3.7.3 CS fallback to UTRAN with redirection / MT call (PS bearer established)

Table 6.4.3.7.3-1: Test procedure sequence

St	Procedure	Message Sequence		TP	Verdict
		U - S	Message		
1-19	Steps 1-19 of table 6.4.3.7.1-1. NOTE: Mobile terminating CS call is established and Routing Area Update procedure is performed			-	-
20	Check: Does the UE transmit a SERVICE REQUEST message?	-->	SERVICE REQUEST	-	P
21	SS transmits a RADIO BEARER SETUP message, using the UTRA reference radio bearer parameters and combination "UTRA PS RB + Speech" according to subclause 4.8.3 and Table 4.8.3-1. NOTE: Mobile originating packet switched session is established.	<--	RADIO BEARER SETUP	-	-
22	The UE transmits a RADIO BEARER SETUP COMPLETE message	-->	RADIO BEARER SETUP COMPLETE	-	-

6.4.3.7.4 CS fallback to UTRAN with redirection / MO call (PS bearer established)

Table 6.4.3.7.4-1: Test procedure sequence

St	Procedure	Message Sequence		TP	Verdict
		U - S	Message		
1-19	Steps 1-19 of table 6.4.3.7.2-1. NOTE: Mobile originating CS call is set up and Routing Area Update procedure is performed	-	-	-	-
20	Check: Does the UE transmit a SERVICE REQUEST message?	-->	SERVICE REQUEST	-	P
21	SS transmits a RADIO BEARER SETUP message, using the UTRA reference radio bearer parameters and combination "UTRA PS RB + Speech" according to subclause 4.8.3 and Table 4.8.3-1. NOTE: Mobile originating packet switched session is established.	<--	RADIO BEARER SETUP	-	-
22	The UE transmits a RADIO BEARER SETUP COMPLETE message	-->	RADIO BEARER SETUP COMPLETE	-	-

6.4.3.7.5 CS fallback to UTRAN with Handover / MT call

Table 6.4.3.7.5-1: Test procedure sequence

St	Procedure	Message Sequence		TP	Verdict
		U - S	Message		
1	Check: Does the UE transmit a HANDOVER TO UTRAN COMPLETE message?	-->	HANDOVER TO UTRAN COMPLETE	-	P
-	EXCEPTION: In parallel to the events described in step 2a1 to 9 the steps specified in table 6.4.3.7.5-2 takes place.	-	-	-	-
-	Exception: Steps 2a1 to 2a10 and 2b1 to 2b9 describe behaviour that depends on the UE capability; the "lower case letter" identifies a step sequence that takes place if a capability is supported. Note: One sequence of steps 2a1 to 2a10 or 2b1 to 2b9 are executed	-	-	-	-
2a1	IF the UE does not determine the LAI of the new UTRAN cell, THEN Check: Does the UE transmit a LOCATION UPDATING REQUEST message?	-->	LOCATION UPDATING REQUEST	-	P
2a2	The SS transmits AUTHENTICATION REQUEST	<--	AUTHENTICATION REQUEST	-	-
2a3	The UE transmits AUTHENTICATION RESPONSE	-->	AUTHENTICATION RESPONSE	-	-
2a4	The SS transmits a SECURITY MODE COMMAND message for the CS domain.	<--	SECURITY MODE COMMAND	-	-
2a5	The UE transmits a SECURITY MODE COMPLETE message.	-->	SECURITY MODE COMPLETE	-	-
2a6	The SS transmits a LOCATION UPDATING ACCEPT message.	<--	LOCATION UPDATING ACCEPT	-	-
2a7	The SS transmits a SECURITY MODE COMMAND message for the PS domain.	<--	SECURITY MODE COMMAND	-	-
2a8	The UE transmits a SECURITY MODE COMPLETE message.	-->	SECURITY MODE COMPLETE	-	-
2a9	The SS transmits an UTRAN MOBILITY INFORMATION message to notify CN information.	<--	UTRAN MOBILITY INFORMATION	-	-
2a10	The UE transmits an UTRAN MOBILITY INFORMATION CONFIRM message.	-->	UTRAN MOBILITY INFORMATION CONFIRM	-	-
	Exception: Steps 2b1 to 2b4 takes place if pc_UMI_ProcNeeded_DuringCSFB				
2b1	The SS transmits a SECURITY MODE COMMAND message for the PS domain.	<--	SECURITY MODE COMMAND	-	-
2b2	The UE transmits a SECURITY MODE COMPLETE message.	-->	SECURITY MODE COMPLETE	-	-
2b3	The SS transmits an UTRAN MOBILITY INFORMATION message to notify CN information.	<--	UTRAN MOBILITY INFORMATION	-	-
2b4	The UE transmits an UTRAN MOBILITY INFORMATION CONFIRM message.	-->	UTRAN MOBILITY INFORMATION CONFIRM	-	-
2b5	Check: Does the UE transmit a PAGING RESPONSE?	-->	PAGING RESPONSE	-	P
2b6	The SS transmits AUTHENTICATION REQUEST	<--	AUTHENTICATION REQUEST	-	-
2b7	The UE transmits AUTHENTICATION RESPONSE	-->	AUTHENTICATION RESPONSE	-	-
2b8	The SS transmits a SECURITY MODE COMMAND message for the CS domain.	<--	SECURITY MODE COMMAND	-	-
2b9	The UE transmits a SECURITY MODE COMPLETE message.	-->	SECURITY MODE COMPLETE	-	-
3-9	Steps 11 to 17 of the generic test procedure in TS 34.108 subclause 7.2.3.1.3 are performed using the UTRA reference radio bearer parameters and combination "UTRA PS RB + Speech" according to subclause 4.8.3 and	-	-	-	-

	Table 4.8.3-1. NOTE: Mobile terminating CS call is established.				
10	The SS transmits a ROUTING AREA UPDATE ACCEPT.	<--	ROUTING AREA UPDATE ACCEPT	-	-
11	The UE sends ROUTING AREA UPDATE COMPLETE.	-->	ROUTING AREA UPDATE COMPLETE	-	-

Table 6.4.3.7.5-2: Parallel behaviour

St	Procedure	Message Sequence		TP	Verdict
		U - S	Message		
1	The UE transmits a ROUTING AREA UPDATE REQUEST message.	-->	ROUTING AREA UPDATE REQUEST	-	-

6.4.3.7.5.1 Specific message contents

Table 6.4.3.7.5.1-1: Void**Table 6.4.3.7.5.1-2: LOCATION UPDATING ACCEPT (step 2a6 of table 6.4.3.7.5-1)**

Derivation Path: TS 36.508 Table 4.7B.2-5			
Information Element	Value/remark	Comment	Condition
Mobile identity	Not present		

6.4.3.7.6 CS fallback to UTRAN with Handover / MO call

Table 6.4.3.7.6-1: Test procedure sequence

St	Procedure	Message Sequence		TP	Verdict
		U - S	Message		
1	Check: Does the UE transmit a HANDOVER TO UTRAN COMPLETE message?	-->	HANDOVER TO UTRAN COMPLETE	-	P
-	EXCEPTION: In parallel to the events described in step 2a1 to 9 the steps specified in table 6.4.3.7.6-2 takes place.	-	-	-	-
-	Exception: Steps 2a1 to 2a11 and 2b1 to 2b9 describe behaviour that depends on the UE capability; the "lower case letter" identifies a step sequence that takes place if a capability is supported. Note: One sequence of steps 2a1 to 2a11 or 2b1 to 2b9 are executed	-	-	-	-
2a1	IF the UE does not determine the LAI of the new UTRAN cell, THEN Check: Does the UE transmit a LOCATION UPDATING REQUEST message?	-->	LOCATION UPDATING REQUEST	-	P
2a2	The SS transmits AUTHENTICATION REQUEST	<--	AUTHENTICATION REQUEST	-	-
2a3	The UE transmits AUTHENTICATION RESPONSE	-->	AUTHENTICATION RESPONSE	-	-
2a4	The SS transmits a SECURITY MODE COMMAND message for the CS domain.	<--	SECURITY MODE COMMAND	-	-
2a5	The UE transmits a SECURITY MODE COMPLETE message.	-->	SECURITY MODE COMPLETE	-	-
2a6	The SS transmits a LOCATION UPDATING ACCEPT message.	<--	LOCATION UPDATING ACCEPT	-	-
2a7	Check: Does the UE transmit a CM SERVICE REQUEST?	-->	CM SERVICE REQUEST	-	P
2a8	The SS transmits a SECURITY MODE COMMAND message for the PS domain.	<--	SECURITY MODE COMMAND	-	-
2a9	The UE transmits a SECURITY MODE COMPLETE message.	-->	SECURITY MODE COMPLETE	-	-
2a10	The SS transmits an UTRAN MOBILITY INFORMATION message to notify CN information.	<--	UTRAN MOBILITY INFORMATION	-	-
2a11	The UE transmits an UTRAN MOBILITY INFORMATION CONFIRM message. Exception: Steps 2b1 to 2b4 takes place if pc_UMI_ProcNeeded_DuringCSFB	-->	UTRAN MOBILITY INFORMATION CONFIRM	-	-
2b1	The SS transmits a SECURITY MODE COMMAND message for the PS domain.	<--	SECURITY MODE COMMAND	-	-
2b2	The UE transmits a SECURITY MODE COMPLETE message.	-->	SECURITY MODE COMPLETE	-	-
2b3	The SS transmits an UTRAN MOBILITY INFORMATION message to notify CN information.	<--	UTRAN MOBILITY INFORMATION	-	-
2b4	The UE transmits an UTRAN MOBILITY INFORMATION CONFIRM message.	-->	UTRAN MOBILITY INFORMATION CONFIRM	-	-
2b5	Check: Does the UE transmit a CM SERVICE REQUEST?	-->	CM SERVICE REQUEST	-	P
2b6	The SS transmits AUTHENTICATION REQUEST	<--	AUTHENTICATION REQUEST	-	-
2b7	The UE transmits AUTHENTICATION RESPONSE	-->	AUTHENTICATION RESPONSE	-	-
2b8	The SS transmits a SECURITY MODE COMMAND message for the CS domain.	<--	SECURITY MODE COMMAND	-	-
2b9	The UE transmits a SECURITY MODE COMPLETE message.	-->	SECURITY MODE COMPLETE	-	-
3	The UE transmits a SETUP message.	-->	SETUP	-	-
4-9	Steps 11 to 16 of the generic test procedure in TS 34.108 subclause 7.2.3.2.3 are performed	-	-	-	-

	using the UTRA reference radio bearer parameters and combination "UTRA PS RB + Speech" according to subclause 4.8.3 and Table 4.8.3-1. NOTE: Mobile originating CS call is established.				
10	The SS transmits a ROUTING AREA UPDATE ACCEPT.	<--	ROUTING AREA UPDATE ACCEPT	-	-
11	The UE sends ROUTING AREA UPDATE COMPLETE.	-->	ROUTING AREA UPDATE COMPLETE	-	-

Table 6.4.3.7.6-2: Parallel behaviour

St	Procedure	Message Sequence		TP	Verdict
		U - S	Message		
1	The UE transmits a ROUTING AREA UPDATE REQUEST message.	-->	ROUTING AREA UPDATE REQUEST	-	-

6.4.3.7.6.1 Specific message contents

None.

Table 6.4.3.7.6.1-1: LOCATION UPDATING ACCEPT (step 2a6 of table 6.4.3.7.6-1)

Derivation Path: TS 36.508 Table 4.7B.2-5			
Information Element	Value/remark	Comment	Condition
Mobile identity	Not present		

6.4.3.7.7 CS fallback to UTRAN with Handover / emergency call

Table 6.4.3.7.7-1: Test procedure sequence

St	Procedure	Message Sequence		TP	Verdict
		U - S	Message		
1	Check: Does the UE transmit a HANDOVER TO UTRAN COMPLETE message?	-->	HANDOVER TO UTRAN COMPLETE	-	P
-	EXCEPTION: In parallel to the events described in step 2a1 to 9 the steps specified in table 6.4.3.7.7-2 takes place.	-	-	-	-
-	Exception: Steps 2a1 to 2a11 and 2b1 to 2b9 describe behaviour that depends on the UE capability; the "lower case letter" identifies a step sequence that takes place if a capability is supported. Note: One sequence of steps 2a1 to 2a11 or 2b1 to 2b9 are executed	-	-	-	-
2a1	IF the UE does not determine the LAI of the new UTRAN cell, THEN Check: Does the UE transmit a LOCATION UPDATING REQUEST message?	-->	LOCATION UPDATING REQUEST	-	P
2a2	The SS transmits AUTHENTICATION REQUEST	<--	AUTHENTICATION REQUEST	-	-
2a3	The UE transmits AUTHENTICATION RESPONSE	-->	AUTHENTICATION RESPONSE	-	-
2a4	The SS transmits a SECURITY MODE COMMAND message for the CS domain.	<--	SECURITY MODE COMMAND	-	-
2a5	The UE transmits a SECURITY MODE COMPLETE message.	-->	SECURITY MODE COMPLETE	-	-
2a6	The SS transmits a LOCATION UPDATING ACCEPT message.	<--	LOCATION UPDATING ACCEPT	-	-
2a7	Check: Does the UE transmit a CM SERVICE REQUEST?	-->	CM SERVICE REQUEST	-	P
2a8	The SS transmits a SECURITY MODE COMMAND message for the PS domain.	<--	SECURITY MODE COMMAND	-	-
2a9	The UE transmits a SECURITY MODE COMPLETE message.	-->	SECURITY MODE COMPLETE	-	-
2a10	The SS transmits an UTRAN MOBILITY INFORMATION message to notify CN information.	<--	UTRAN MOBILITY INFORMATION	-	-
2a11	The UE transmits an UTRAN MOBILITY INFORMATION CONFIRM message. Exception: Steps 2b1 to 2b4 takes place if pc_UMI_ProcNeeded_DuringCSFB	-->	UTRAN MOBILITY INFORMATION CONFIRM	-	-
2b1	The SS transmits a SECURITY MODE COMMAND message for the PS domain.	<--	SECURITY MODE COMMAND	-	-
2b2	The UE transmits a SECURITY MODE COMPLETE message.	-->	SECURITY MODE COMPLETE	-	-
2b3	The SS transmits an UTRAN MOBILITY INFORMATION message to notify CN information.	<--	UTRAN MOBILITY INFORMATION	-	-
2b4	The UE transmits an UTRAN MOBILITY INFORMATION CONFIRM message.	-->	UTRAN MOBILITY INFORMATION CONFIRM	-	-
2b5	Check: Does the UE transmit a CM SERVICE REQUEST?	-->	CM SERVICE REQUEST	-	P
2b6	The SS transmits AUTHENTICATION REQUEST	<--	AUTHENTICATION REQUEST	-	-
2b7	The UE transmits AUTHENTICATION RESPONSE	-->	AUTHENTICATION RESPONSE	-	-
2b8	The SS transmits a SECURITY MODE COMMAND message for the CS domain.	<--	SECURITY MODE COMMAND	-	-
2b9	The UE transmits a SECURITY MODE COMPLETE message.	-->	SECURITY MODE COMPLETE	-	-
3	The UE transmits an EMERGENCY SETUP message.	-->	EMERGENCY SETUP	-	-
4-9	Steps 12 to 17 of the test procedure in TS	-	-	-	-

	34.123-1 [7] subclause 13.2.1.1 are performed using the UTRA reference radio bearer parameters and combination "UTRA PS RB + Speech" according to subclause 4.8.3 and Table 4.8.3-1. NOTE: Emergency call is established..				
10	The SS transmits a ROUTING AREA UPDATE ACCEPT.	<--	ROUTING AREA UPDATE ACCEPT	-	-
11	The UE sends ROUTING AREA UPDATE COMPLETE.	-->	ROUTING AREA UPDATE COMPLETE	-	-

Table 6.4.3.7.7-2: Parallel behaviour

St	Procedure	Message Sequence		TP	Verdict
		U - S	Message		
1	The UE transmits a ROUTING AREA UPDATE REQUEST message.	-->	ROUTING AREA UPDATE REQUEST	-	-

6.4.3.7.7.1 Specific message contents

UTRAN MOBILITY INFORMATION (step 2a10 & 2b1 of table 6.4.3.7.7-1): same as Table 6.4.3.7.5.1-1

Table 6.4.3.7.7.1-1: LOCATION UPDATING ACCEPT (step 2a6 of table 6.4.3.7.7-1)

Derivation Path: TS 36.508 Table 4.7B.2-5			
Information Element	Value/remark	Comment	Condition
Mobile identity	Not present		

6.4.3.8 CS fallback to GERAN procedures (LAI of GERAN cell same as the LAI received in combined Attach procedure in EUTRA cell)

All procedures specified in this clause are referred to the GERAN target cell where the UE has been redirected or handed over from the EUTRA cell after a CS call requested. The default message contents are found in TS 34.108 [5], clause 9.

The procedures in 6.4.3.8.1 – 6.4.3.8.4 are applied if the UE supports (EUTRA) RRC connection release with redirection or Cell Change order and Multi Cell System Information to GERAN.

6.4.3.8.1 CS fallback to GERAN with redirection or CCO / MT call (DTM not supported)

Table 6.4.3.8.1-1: Test procedure sequence

St	Procedure	Message Sequence		TP	Verdict
		U - S	Message		
1	The UE transmits a CHANNEL REQUEST message.	-->	CHANNEL REQUEST	-	-
2	The SS transmits an IMMEDIATE ASSIGNMENT message.	<--	IMMEDIATE ASSIGNMENT	-	-
3	Void	-	-	-	-
-	EXCEPTION: In parallel to the events described in step 4 to 19 the steps specified in table 6.4.3.8.1-2 takes place	-	-	-	-
4	Check: Does the UE transmit a PAGING RESPONSE message?	-->	PAGING RESPONSE	-	P
4A	The UE transmits a <i>Classmark Change</i> message	-->	CLASSMARK CHANGE	-	-
-	EXCEPTION: Step 4B describes behaviour that depends on the UE capability.	-	-	-	-
4B	IF <i>pc_UTRA</i> then the UE transmits a <i>Utran Classmark</i> message	-->	UTRAN CLASSMARK CHANGE	-	-
5-19	Steps 5 to 19 of the generic test procedure in TS 51.010-1 sub clause 10.3.3 are performed NOTE: Mobile terminating CS call is established.	-	-	-	-
20	The SS transmits DISCONNECT.	<--	DISCONNECT	-	-
21	The UE transmits RELEASE..	-->	RELEASE	-	-
22	The SS transmits RELEASE COMPLETE.	<--	RELEASE COMPLETE	-	-
23	The SS transmits CHANNEL RELEASE, with GPRS Resumption Field set to 1	<--	CHANNEL RELEASE	-	-
24-34	Steps 1 to 11 of the generic test procedure in sub clause 6.4.2.9 are performed.	-	-	-	-

Table 6.4.3.8.1-2: Parallel behaviour

St	Procedure	Message Sequence		TP	Verdict
		U - S	Message		
1	The UE transmits a GPRS SUSPENSION REQUEST message.	-->	GPRS SUSPENSION REQUEST	-	-

6.4.3.8.2 CS fallback to GERAN with redirection or CCO / MO call (DTM not supported)

Table 6.4.3.8.2-1: Test procedure sequence

St	Procedure	Message Sequence		TP	Verdict
		U - S	Message		
1	The UE transmits a CHANNEL REQUEST message.	-->	CHANNEL REQUEST	-	-
2	The SS transmits an IMMEDIATE ASSIGNMENT message.	<--	IMMEDIATE ASSIGNMENT	-	-
3	Void	-	-	-	-
-	EXCEPTION: In parallel to the events described in step 4 to 17 the steps specified in table 6.4.3.8.2-2 takes place	-	-	-	-
4	Check: Does the UE transmit a CM SERVICE REQUEST message?	-->	CM SERVICE REQUEST	-	P
4A	The UE transmits a <i>Classmark Change</i> message	-->	CLASSMARK CHANGE	-	-
-	EXCEPTION: Step 4B describes behaviour that depends on the UE capability.	-	-	-	-
4B	IF <i>pc_UTRA</i> then the UE transmits a <i>Utran Classmark</i> message	-->	UTRAN CLASSMARK CHANGE	-	-
5-17	Steps 5 to 17 of the generic test procedure in TS 51.010-1 sub clause 10.2.3 are performed NOTE: Mobile originating CS call is established.	-	-	-	-
18	The SS transmits DISCONNECT.	<--	DISCONNECT	-	-
19	The UE transmits RELEASE..	-->	RELEASE	-	-
20	The SS transmits RELEASE COMPLETE.	<--	RELEASE COMPLETE	-	-
21	The SS transmits CHANNEL RELEASE, with GPRS Resumption Field set to 1	<--	CHANNEL RELEASE	-	-
22-32	Steps 1 to 11 of the generic test procedure in sub clause 6.4.2.9 are performed.	-	-	-	-

Table 6.4.3.8.2-2: Parallel behaviour

St	Procedure	Message Sequence		TP	Verdict
		U - S	Message		
1	The UE transmits a GPRS SUSPENSION REQUEST message.	-->	GPRS SUSPENSION REQUEST	-	-

6.4.3.8.3 CS fallback to GERAN with PS Handover / MT call (EDTM not supported)

Same as test procedure sequence in 36.523-1 [18] clause 13.1.11.3.2 from steps 11 to end.

6.4.3.8.4 CS fallback to GERAN with PS Handover / MO call (EDTM not supported)

Same as test procedure sequence in 36.523-1 [18] clause 13.1.12.3.2 from steps 4 to end.

6.4.3.8.5 CS fallback to GERAN with PS Handover / MT call (EDTM supported)

Same as test procedure sequence in 36.523-1 [18] clause 13.1.13.3.2 from steps 7 to end.

6.4.3.9 SRVCC Handover to UTRA

The procedure specified in this clause are referred to the UTRA target cell where the UE has been SRVCC handed over from the EUTRA cell. The default message contents are found in TS 34.108 [5], clause 9.

Table 6.4.3.9-1: Test procedure sequence

St	Procedure	Message Sequence		TP	Verdict
		U - S	Message		
1	Check: Does the UE transmit a HANDOVER TO UTRAN COMPLETE message?	-->	HANDOVER TO UTRAN COMPLETE	-	P
-	EXCEPTION: In parallel to the events described in step 2 to 7 the steps specified in table 6.4.3.9-2 takes place.	-	-	-	-
2	The SS transmits a SECURITY MODE COMMAND message for the CS domain.	<--	SECURITY MODE COMMAND	-	-
3	The UE transmits a SECURITY MODE COMPLETE message.	-->	SECURITY MODE COMPLETE	-	-
4	The SS transmits a UTRAN MOBILITY INFORMATION message to notify CN information.	<--	UTRAN MOBILITY INFORMATION	-	-
5	The UE transmits an UTRAN MOBILITY INFORMATION CONFIRM message.	-->	UTRAN MOBILITY INFORMATION CONFIRM	-	-
6	The SS transmits a TMSI REALLOCATION COMMAND message.	<--	TMSI REALLOCATION COMMAND	-	-
7	The UE transmits a TMSI REALLOCATION COMPLETE message.	-->	TMSI REALLOCATION COMPLETE	-	-
8	The SS transmits a ROUTING AREA UPDATE ACCEPT.	<--	ROUTING AREA UPDATE ACCEPT	-	-
9	The UE sends ROUTING AREA UPDATE COMPLETE.	-->	ROUTING AREA UPDATE COMPLETE	-	-

Table 6.4.3.9-2: Parallel behaviour

St	Procedure	Message Sequence		TP	Verdict
		U - S	Message		
1	The UE transmits a ROUTING AREA UPDATE REQUEST message.	-->	ROUTING AREA UPDATE REQUEST	-	-

6.4.3.9.1 Specific message contents

Table 6.4.3.9.1-1: SECURITY MODE COMMAND (step 2, Table 8.4.1.2.3.2-1)

Derivation Path: 34.108 clause 9.1.1 (SECURITY MODE COMMAND message)		
Information Element	Condition	Value/remark
Ciphering mode info		Not Present

6.4.3A Test case postambles

6.4.3A.1 Introduction

In order to make test cases perfectly reproducible, the UE under test is switched off after the test procedure sequence of a test case is complete. In order to make it possible to run a number of test cases without any manual operation, it is important that the SS can properly handle any possible signalling from the UE between the end of the test procedure sequence and until the UE is off.

After the last verdict of a test procedure sequence is assigned, it is necessary to:

- terminate any ongoing signalling procedure,
- switch off the UE.

Usually, this can be performed by completing necessary TAU/LAU/RAU procedures, completing any ongoing voice call (CS or IMS), and switching off the UE with a detach procedure.

6.4.3A.2 Reference end states

Test procedures in TS 36.523-1 may only partially terminate ongoing signalling procedures, provided they indicate a reference end state at the end of the test procedure sequence, so that a matching procedure in TS 36.523-3 can be executed to switch off the UE.

Reference end states definitions include the necessary pieces of information to predict UE behaviour during the postambles.

If any extra information was stored in the UE or the USIM due to the test procedure sequence, it should be removed explicitly by the test procedure sequence, before the UE can be left in a reference end state.

Table 6.4.3A.2-1: Reference end states

Name	Description	Optional information
E-UTRA idle (E1)	The UE: - is camped on an E-UTRA cell, and RRC idle and - registered for EPS services and EPS update status is "updated" and - is registered for non-EPS services and update status is updated (if CS fallback or SMS over SGs is supported) and - has one or more default EPS bearer context are active, zero or more dedicated EPS bearer contexts are active.	The test case may indicate that the UE is not registered for non-EPS services, though the UE supports CS fallback or SMS over SGs.
E-UTRA connected (E2)	Same as E-UTRA idle , except that: - the UE is RRC connected and - DRBs for all active EPS bearer contexts are established.	Same as for E-UTRA idle .
E-UTRA connected, T3440 started (E2_T3440)	Same as E-UTRA idle , except that: - the UE is RRC connected and - Timer T3440 is started in UE.	Same as for E-UTRA idle .
E-UTRA test mode (E3)	Same as E-UTRA connected and - test mode is active and - test loop is closed.	Same as for E-UTRA idle .
E-UTRA deregistered (E4)	The UE is: - camped on an E-UTRA cell, and idle and - not registered of EPS services and - not registered for non-EPS services.	
UTRA idle (U1)	The UE is: - camped on a UTRA cell, RRC idle and - IMSI attached and update status is "updated" (if the UE supports CS domain) and - GPRS attached, GPRS update state is "updated", and zero or one or several PDP context(s) with interactive or background QoS are active.	The test case may indicate that the UE is not IMSI attached though the UE supports CS domain.
UTRA connected (U2)	Same as UTRA idle , except that: - the UE is in CELL_DCH state and - a RAB associated with the active PDP context is established.	The test case may indicate that the UE is not IMSI attached though the UE supports CS domain.
UTRA handover (U3)	The UE: - was E-UTRA connected and - has completed a handover to UMTS and - hasn't yet sent or received any NAS signalling on the target UTRAN cell.	Same as for UTRA connected .
UTRA CS fallback (U4)	The UE: - was E-UTRA idle or E-UTRA connected and - has transmitted an EXTENDED SERVICE REQUEST message due to MO or MT CS fallback call and - either the UE has completed a handover to UMTS or the UE has been redirected to UMTS and has established the RRC connection to a UTRA cell, and the target UTRA cell has activated security and RABs for all previously active EPS bearer contexts were established and - the UE hasn't yet sent or received any NAS signalling on the target UTRAN cell	
UTRA CS call (U5)	The UE was in UTRAN CS fallback and the UE has completed LAU/RAU procedure if necessary and has established a CS call or the UE was in E-UTRAN connected and the UE has completed LAU/RAU procedure if necessary and has performed a handover to UTRAN with SRVCC.	
UTRA deregistered (U6)	The UE is: - camped on a UTRA cell, and idle and - not registered GPRS/non-GPRS services	
GERAN idle (G1)	The UE: - is camped on an GERAN cell, in idle mode and GPRS idle state and - is registered for PS services and GPRS update status is "updated" and zero or one or several PDP context(s) with interactive or background QoS are active. - is IMSI attached (if CS domain is supported)	
GERAN PS handover (G2)	The UE: - was E-UTRA connected and	

	- has performed a PS handover procedure to a GERAN cell and - hasn't yet sent or received any NAS signalling on the target GERAN cell.	
GERAN CS fallback (G3)	The UE: - was E-UTRA idle or E-UTRA connected and - has transmitted an EXTENDED SERVICE REQUEST message due to MO or MT CS fallback call and - either the UE has completed a PS handover to GERAN or a CCO to GERAN or the UE has been redirected to GERAN and has entered dedicated mode, and if DTM is supported, - the UE hasn't yet sent or received any NAS signalling on the target GERAN cell	
GERAN CS call (G4)	The UE was in GERAN CS fallback and the UE has established a CS call or the UE was in E-UTRAN connected and has performed a handover to GERAN with SRVCC.	
GERAN deregistered (G5)	The UE is: - camped on a GERAN cell, and idle and - not registered GPRS/non-GPRS services	
1xRTT state 1 (1x1)	FFS	
...	...	
HRPD state 1 (H1)	FFS	
...	...	

6.5 Default RRC message and information element contents

The default RRC message and information element contents specified in this subclause apply to all Signalling test cases defined in TS 36.523-1 [18] unless otherwise specified, in addition to the default RRC message and information element contents specified in subclause 4.6 of this specification.

6.5.1 Measurement information elements

- MeasConfig-DEFAULT

Table 6.5.1-1: MeasConfig-DEFAULT

Derivation Path: 36.331, clause 6.3.5			
Information Element	Value/remark	Comment	Condition
MeasConfig-DEFAULT ::= SEQUENCE {			
measObjectToRemoveList	Not present		
measObjectToAddModList	Not present		
reportConfigToRemoveList	Not present		
reportConfigToAddModList	Not present		
measIdToRemoveList	Not present		
measIdToAddModList	Not present		
quantityConfig	QuantityConfig-DEFAULT		
measGapConfig	Not present		
	MeasGapConfig-GP1		INTER-FREQ, UTRAN
	MeasGapConfig-GP2		GERAN, INTER-RAT
s-Measure	Not present		
preRegistrationInfoHRPD	Not present		
speedStatePars	Not present		
}			

Condition	Explanation
-----------	-------------

INTER-FREQ	For E-UTRA inter-freq measurements
UTRAN	For inter-RAT measurements with UTRAN
GERAN	For inter-RAT measurements with GERAN
INTER-RAT	For inter-RAT measurements with UTRAN and GERAN

- MeasGapConfig-GP1

Table 6.5.1-2: MeasGapConfig-GP1

Derivation Path: 36.331, clause 6.3.5			
Information Element	Value/remark	Comment	Condition
MeasGapConfig-GP1 ::= CHOICE {			
setup SEQUENCE {			
gapOffset CHOICE {			
gp0	30	TGRP = 40 ms	
}			
}			
}			

- MeasGapConfig-GP2

Table 6.5.1-3: MeasGapConfig-GP2

Derivation Path: 36.331, clause 6.3.5			
Information Element	Value/remark	Comment	Condition
MeasGapConfig-GP2 ::= CHOICE {			
setup SEQUENCE {			
gapOffset CHOICE {			
gp1	30	TGRP = 80 ms	
}			
}			
}			

6.6 Default NAS message and information element contents

The default NAS message and information element contents specified in this subclause apply to all Signalling test cases defined in TS 36.523-1 [18] unless otherwise specified, in addition to the default NAS message and information element contents specified in subclause 4.7 of this specification.

6.6.1 Reference default EPS bearer contexts

The following table defines Reference default EPS bearer contexts. Default EPS bearer context1 is the default "default EPS bearer context" which is used in the common procedures and test cases where no particular default EPS bearer context is specified.

Table 6.6.1-1: Reference default EPS bearer contexts

Parameters	Reference default EPS bearer context #1	Reference default EPS bearer context #2	Reference default EPS bearer context #3
EPS QoS			
QCI (Note 1)	9 (non-GBR QCI)	5 (non-GBR QCI)	FFS
Maximum bit rate for uplink	64 kbps (Note 2)	64 kbps (Note 2)	FFS
Maximum bit rate for downlink	64 kbps (Note 2)	64 kbps (Note 2)	FFS
Guaranteed bit rate for uplink	64 kbps (Note 2)	64 kbps (Note 2)	FFS
Guaranteed bit rate for downlink	64 kbps (Note 2)	64 kbps (Note 2)	FFS
Maximum bit rate for uplink (extended)	0	0	FFS
Maximum bit rate for downlink (extended)	0	0	FFS
Guaranteed bit rate for uplink (extended)	0	0	FFS
Guaranteed bit rate for downlink (extended)	0	0	FFS
Negotiated QoS	Note 3, Note 4	Note 3, Note 4	FFS
Negotiated LLC SAPI	Note 4	Note 4	FFS
Radio priority	Note 4	Note 4	FFS
APN-AMBR	Not present	Not present	FFS
Configuration protocol	PPP	PPP	FFS
Note 1: For all non-GBR QCIs, the maximum and guaranteed bit rates shall be ignored.			
Note 2: According to TS 24.301, the UE ignores these parameters for a non-GBR QCI.			
Note 3: Parameters included for UEs capable of UTRAN according to TS 34.123-3 clause 8.10.			
Note 4: Parameters included for UEs capable of GERAN according to TS 51.010 subclause 40.5.			

6.6.2 Reference dedicated EPS bearer contexts

The following table defines Reference dedicated EPS bearer contexts. Dedicated EPS bearer context #1 is the default "dedicated EPS bearer context" which is used in the common procedures and test cases where no particular dedicated EPS bearer context is specified.

Table 6.6.2-1: Reference dedicated EPS bearer contexts

Parameters	Reference dedicated EPS bearer context #1	Reference dedicated EPS bearer context #2	Reference dedicated EPS bearer context #3	Reference dedicated EPS bearer context #4
Linked EPS bearer identity	Reference default EPS bearer #1	Reference default EPS bearer #1	Reference default EPS bearer #2	Reference default EPS bearer #3
EPS QoS				
QCI (Note 1)	1 (GBR QCI)	5 (non-GBR QCI)	2 (GBR QCI)	1 (GBR QCI)
Maximum bit rate for uplink	384 kbps	384 kbps (Note 2)	432 kbps	384 kbps
Maximum bit rate for downlink	384 kbps	384 kbps (Note 2)	432 kbps	384 kbps
Guaranteed bit rate for uplink	128 kbps	128 kbps (Note 2)	432 kbps	128 kbps
Guaranteed bit rate for downlink	128 kbps	128 kbps (Note 2)	432 kbps	128 kbps
Maximum bit rate for uplink (extended)	0	0	0	0
Maximum bit rate for downlink (extended)	0	0	0	0
Guaranteed bit rate for uplink (extended)	0	0	0	0
Guaranteed bit rate for downlink (extended)	0	0	0	0
TFT				
TFT operation code	"create new TFT"	"create new TFT"	"create new TFT"	"create new TFT"
E bit	0	0	0	0
Packet filters (Note 5)	1, 2	3	3	1, 2
Negotiated QoS				
Traffic Class	conversational	See PDP context3 (Note 3, Note 6)	conversational	conversational
Delivery Order	'yes'	See PDP context3 (Note 3, Note 6)	'no'	'yes'
Delivery of erroneous SDU	'no'	See PDP context3 (Note 3, Note 6)	'no'	'no'
Maximum SDU size	150	See PDP context3 (Note 3, Note 6)	1400	150
Maximum bit rate for uplink	384 kbps	See PDP context3 (Note 3, Note 6)	432 kbps	384 kbps
Maximum bit rate for downlink	384 kbps	See PDP context3 (Note 3, Note 6)	432 kbps	384 kbps
Residual BER	$5 \cdot 10^{-2}$	See PDP context3 (Note 3, Note 6)	10^{-5}	$5 \cdot 10^{-2}$
SDU error ratio	10^{-2}	See PDP context3 (Note 3, Note 6)	$7 \cdot 10^{-3}$	10^{-2}
Transfer delay	80 ms	See PDP context3 (Note 3, Note 6)	130 ms	80 ms
Traffic Handling priority	0	See PDP context3 (Note 3, Note 6)	0	0
Guaranteed bit rate for uplink	0	See PDP context3 (Note 3, Note 6)	0	0
Guaranteed bit rate for downlink	0	See PDP context3 (Note 3, Note 6)	0	0
Signalling Indication	0	See PDP context3 (Note 3, Note 6)	0	0
Source Statistics Descriptor	0	See PDP context3 (Note 3, Note 6)	0	1
Maximum bit rate for downlink (extended)	0	See PDP context3 (Note 3, Note 6)	0	0
Guaranteed bit rate for downlink (extended)	0	See PDP context3 (Note 3, Note 6)	0	0
Maximum bit rate for uplink (extended)	0	See PDP context3 (Note 3, Note 6)	0	0
Guaranteed bit rate for uplink (extended)	0	See PDP context3 (Note 3, Note 6)	0	0

Negotiated LLC SAPI	3 (Note 6)	See PDP context3 (Note 6)	-	3 (Note 6)
Radio priority	1 (Note 6)	See PDP context3 (Note 6)	-	1 (Note 6)
Protocol configuration options	-	-	-	-

Note 1: For all non-GBR QCI, the maximum and guaranteed bit rates shall be ignored.

Note 2: According to TS 24.301, the UE ignores these parameters for a non-GBR QCI.

Note 3: Parameters included for UEs capable of UTRAN according to TS 34.123-3 clause 8.10.

Note 5: This row refers to the reference packet filters defined in the tables below. For each reference dedicated EPS bearer context of reference packet filter numbers is provided.

Note 6: Parameter included for UEs capable of GERAN when value is not provided then value from TS 51.010 subclause 40.5 is :

Table 6.6.2-2: Reference packet filter #1

Derivation path: 24.008 table 10.5.162			
Information Element	Value/Remark	Comment	Condition
Identifier	0 0 0 1 0 0 0 0	DL only filter, ID=0	
Evaluation precedence	(0 0 0 0 0 0 0 0) + EPS Bearer ID - 6	0 to 7	
Component type 1 ID	0 0 0 1 0 0 0 0	IPv4 remote address type	remotelPv 4
	0 0 1 0 0 0 0 0	IPv6 remote address type	remotelPv 6
Component type 1 Value	remoteAddress 255.255.255.255	See note 1	remotelPv 4
	remoteAddress ff:ff:ff:ff:ff:ff:ff:ff:ff:ff:ff:ff:ff:ff:ff:ff	See note 1	remotelPv 6
Component type 2 ID	0 1 0 1 0 0 0 0	Single remote port type	
Component type 2 Value	31 160 + EPS Bearer ID - 6		
Component type 3 ID	0 0 1 1 0 0 0 0	Protocol identifier/Next header type	
Component type 3 Value	17	UDP	
Note 1: remoteAddress should be set to the address of an IP server able to send a flow of downlink IP/UDP packets to the UE. remotelPv4 applies if the UE has acquired an IPv4 address only, remotelPv6 applies if the UE has acquired an IPv6 address only, or both an IPv6 and an IPv4 address.			

Table 6.6.2-3: Reference packet filter #2

Derivation path: 24.008 table 10.5.162			
Information Element	Value/Remark	Comment	Condition
Identifier	0 0 1 0 0 0 0 1	UL only filter, ID=1	
Evaluation precedence	(0 0 0 0 0 0 0 0) + EPS Bearer ID - 6 + 8	8 to 15	
Component type 1 ID	0 0 0 1 0 0 0 0	IPv4 remote address type	remotelPv 4
	0 0 1 0 0 0 0 0	IPv6 remote address type	remotelPv 6
Component type 1 Value	remoteAddress 255.255.255.255	See note 1	remotelPv 4
	remoteAddress ff:ff:ff:ff:ff:ff:ff:ff: ff:ff:ff:ff:ff:ff:ff:ff	See note 1	remotelPv 6
Component type 2 ID	0 1 0 1 0 0 0 0	Single remote port type	
Component type 2 Value	61 000 + EPS Bearer ID - 6		
Component type 3 ID	0 0 1 1 0 0 0 0	Protocol identifier/Next header type	
Component type 3 Value	17	UDP	
Note 1: remoteAddress should be set to the address of an IP server able to process a flow of uplink IP/UDP packets received from the UE. When configured together with packet filter #1, remoteAddress is the same as that for packet filter #1. remotelPv4 applies if the UE has acquired an IPv4 address only, remotelPv6 applies if the UE has acquired an IPv6 address only, or both an IPv6 and an IPv4 address.			

Table 6.6.2-4: Reference packet filter #3

Derivation path: 24.008 table 10.5.162			
Information Element	Value/Remark	Comment	Condition
Identifier	0 0 1 1 0 0 1 0	Bidirectional filter, ID=2	
Evaluation precedence	0 0 0 0 1 1 1 1	Lowest priority	
Component type 1 ID	0 0 0 1 0 0 0 0	IPv4 remote address type	remotelPv 4
	0 0 1 0 0 0 0 0	IPv6 remote address type	remotelPv 6
Component type 1 Value	remoteAddress 255.255.255.255	See note 1	remotelPv 4
	remoteAddress ff:ff:ff:ff:ff:ff:ff:ff: ff:ff:ff:ff:ff:ff:ff:ff	See note 1	remotelPv 6
Note 1: remoteAddress should be set to the address of an IP server able to process a uplink IP packets from the UE and transmit downlink IP packets to the UE. remotelPv4 applies if the UE has acquired an IPv4 address only, remotelPv6 applies if the UE has acquired an IPv6 address only, or both an IPv6 and an IPv4 address.			

6.6A Default SMS over SGs message and information element contents

The default SMS over SGs message and information element contents specified in this subclause apply to all SMS over SGs Signalling test cases defined in TS 36.523-1 [18] unless otherwise specified. All the messages and information elements are listed in alphabetical order.

6.6A.1 CM-sublayer messages

- CP-ACK

This message is sent between the SS and the UE, in both directions.

Table 6.6A.1-1: Message CP-ACK

Derivation Path: 24.011 clause 7.2.2			
Information Element	Value/remark	Comment	Condition
Protocol discriminator	'1001'B	SMS messages	
Transaction identifier	Any allowed value		
Message type	'00000100'B	CP-ACK	

- CP-DATA

This message is sent between the SS and the UE, in both directions.

Table 6.6A.1-2: Message CP-DATA

Derivation Path: 24.011 clause 7.2.1			
Information Element	Value/remark	Comment	Condition
Protocol discriminator	'1001'B	SMS messages	
Transaction identifier	Any allowed value		
Message type	'00000001'B	CP-DATA	
CP-User data	RP-ACK RPDU or RP-DATA RPDU (as specified in the test case)		

6.6A.2 Short Message Relay Layer (SM-RL) messages

- RP-ACK RPDU

This message is sent between the SS and the UE, in both directions.

Table 6.6A.2-1: Message RP-ACK RPDU

Derivation Path: 24.011 clause 7.3.3			
Information Element	Value/remark	Comment	Condition
RP-Message Type	'010'B	RP-ACK_PDU uplink	Uplink_SMS
	'011'B	RP-ACK_PDU downlink	Downlink_SMS
RP-Message Reference	Same as in associated (preceding) RP-DATA RPDU		
RP-User Data	Not present or any allowed value		Uplink_SMS
	Not present		Downlink_SMS

Condition	Explanation
Uplink_SMS	This condition applies when the message is sent by the UE to the SS.
Downlink_SMS	This condition applies when the message is sent by the SS to the UE.

- RP-DATA RPDU

This message is sent between the SS and the UE, in both directions.

Table 6.6A.2-2: Message RP-DATA RPDU

Derivation Path: 24.301 clause 8.2.23			
Information Element	Value/remark	Comment	Condition
RP-Message Type	'001'B	RP-DATA_PDU downlink	Downlink_S MS
	'000'B	RP-DATA_PDU uplink	Uplink_SMS
RP-Message Reference	Any allowed value		
RP-Originator Address	Any allowed value	originating Service Centre address	Downlink_S MS
	Not present		Uplink_SMS
RP-Destination Address	Not present		Downlink_S MS
	Any allowed value	destination Service Centre address	Uplink_SMS
RP-User Data	SMS-SUBMIT or SMS- DELIVER (as set in the test case)		

Condition	Explanation
Uplink_SMS	See the definition below table 6.6A.2-1.
Downlink_SMS	See the definition below table 6.6A.2-1.

6.6A.3 Short Message Transfer Layer (SM-TL) messages

- SMS-DELIVER

This message is sent by the SS to the UE.

Table 6.6A.3-1: Message SMS-DELIVER

Derivation Path: 23.040 clause 9.2.2.1			
Information Element	Value/remark	Comment	Condition
TP-MTI	'00'B	SMS-DELIVER	
TP-MMS	'1'B	No more messages are waiting for the MS in this SC	
TP-RP	Any allowed value		
TP-UDHI	'0'B		
TP-SRI	'0'B		
TP-OA	Any allowed value		
TP-PID	'0000000'B		
TP-DCS	Any allowed value		
TP-SCTS	Any allowed value		
TP-UDL	160		
TP-UD (140 octets)	text of message (160 characters)	The 160 characters in TP- UD shall include at least one occurrence of each character in the default alphabet (see 3GPP TS 23.038, clause 6.2.1).	

- SMS-SUBMIT

This message is sent by the UE to the SS.

Table 6.6A.3-2: Message SMS-SUBMIT

Derivation Path: 23.040 clause 9.2.2.2			
Information Element	Value/remark	Comment	Condition
TP-MTI	'01'B	SMS-SUBMIT	
TP-RD	Any allowed value		
TP-VPF	Any allowed value		
TP-RP	Any allowed value		
TP-UDHI	Not present or any allowed value		
TP-SRR	Not present or any allowed value		
TP-MR	Any allowed value		
TP-DA	Any allowed value		
TP-PID	'00000000'B		
TP-DCS	Any allowed value		
TP-VP	Not present or any allowed value		
TP-UDL	160		
TP-UD (140 octets)	text of message (160 characters)		

6.6B Reference radio bearer configurations

6.6B.1 SRB and DRB parameters and combinations

6.6B.1.1 SRB and DRB parameters

6.6B.1.1.1 Physical Layer configurations

Table 6.6B.1.1.1-1: PhysicalConfigDedicated-DEFAULT

Derivation Path: TS 36.508 clause 4.8.2.1.6, Table 4.8.2.1.6-1			
Information Element	Value/remark	Comment	Condition
PhysicalConfigDedicated-DEFAULT ::= SEQUENCE {			
cqi-ReportConfig	CQI-ReportConfig-DEFAULT using condition CQI_PERIODIC	See subclause 4.6.3	SRB1 or RBC or RBC-HO or HO-TO-EUTRA
soundingRS-UL-ConfigDedicated	SoundingRS-UL-ConfigDedicated-DEFAULT	See subclause 4.6.3	SRB1 or RBC or RBC-HO or HO-TO-EUTRA
}			

Condition	Explanation
SRB1	Used at configuration of SRB1 during RRC connection (re-)establishment
RBC	Used at configuration of a radio bearer combination during SRB2+DRB establishment
2TX	Used for cells with two antenna ports
RBC-HO	Used during Handover
HO-TO-EUTRA	Inter-RAT handover to E-UTRA

6.7 Timer Tolerances

The timer tolerances specified for the test environment in this subclause apply to all Signalling test cases defined in TS 36.523-1 [18] unless otherwise specified

All the timers used during testing are within a tolerance margin given by the equation below. If for a specific test a different tolerance value is required then this should be specified in the relevant test document (i.e. the document where the test is described).

Timer tolerance = 10%, or $5 \times \text{RTT}$, whichever value is the greater.

Where $\text{RTT} = 8 \text{ TTIs}$ for FDD, and $\text{RTT} = \text{Maximum RTT}$ from Table 6.7-1 for TDD (see Note).

NOTE: Since the exact RTT for TDD varies depending on the UL/DL configurations and subframe number [29], the maximum RTT is defined in Table 6.7-1.

Table 6.7-1: Maximum RTT for TDD UL/DL configurations

UL/DL Configuration	Maximum RTT (TTIs)
0	10
1*	11
2	12
3	15
4	16
5	TBD
6	11
*Note: Default UL/DL configuration defined in Table 4.6.3-23 of TS 36.508	

7 Test environment for RRM tests

This section contains all the exceptions of the common test parameters specified in clause 4 for specific needs of test cases defined in TS 36.521-3 [34], TS 34.121-1 [50] and TS 34.122[51]. Exceptions specified in clause 7 overwrite the parameter settings of clause 4; exceptions defined within the test cases overwrite parameter settings of clause 4 and 7.

This clause describes UE test states which can be used in the initial condition for TS 36.521-3 [34], TS 34.121-1 [50] and TS 34.122[51].

7.1 Requirements of *test* equipment

<void>

7.2 RRM Reference system configurations

7.2.1 Common parameters for simulated E-UTRA cells

7.2.1.1 Combinations of system information blocks

<void>

7.2.1.2 Scheduling of system information blocks

<void>

7.2.1.3 Common contents of system information messages

- SystemInformationBlockType2

As defined in Table 4.4.3.3-1 with the following exceptions:

Table 7.2.1.3-1: SystemInformationBlockType2 exceptions

Derivation Path: Clause 4.4.3.3, Table 4.4.3.3-1 SystemInformationBlockType2			
Information Element	Value/remark	Comment	Condition
mbsfn-SubframeConfig ::= SEQUENCE {			FDD
radioframeAllocationPeriod	n1	Every radio frame is with MBSFN subframe	
radioframeAllocationOffset	0		
subframeAllocation CHOICE {			
oneFrame	111111	Subframe 1, 2, 3, 6, 7, 8 is used for MBSFN	

- SystemInformationBlockType3

As defined in Table 4.4.3.3-2 with the following exceptions:

Table 7.2.1.3-2: SystemInformationBlockType3 exceptions

Derivation Path: Clause 4.4.3.3, Table 4.4.3.3-2 SystemInformationBlockType3			
Information Element	Value/remark	Comment	Condition
neighCellConfig	'10'B (The MBSFN subframe allocations of all neighbour cells are identical to or subsets of that in the serving cell)		FDD with E-UTRA FDD neighbour cell

- SystemInformationBlockType5

As defined in Table 4.4.3.3-3 with the following exceptions:

Table 7.2.1.3-3: SystemInformationBlockType5 exceptions

Derivation Path: Clause 4.4.3.3, Table 4.4.3.3-4 SystemInformationBlockType5			
Information Element	Value/remark	Comment	Condition
neighCellConfig[n]	'10'B (The MBSFN subframe allocations of all neighbour cells are identical to or subsets of that in the serving cell)		FDD with E-UTRA FDD neighbour cell
	'11'B (Different UL/DL allocation in neighbouring cells for TDD compared to the serving cell)		FDD with E-UTRA TDD neighbour cell, TDD with E-UTRA FDD neighbour cell

7.2.2 Common parameters for simulated GERAN cells

7.2.2.1 Mapping of GERAN cells

Unless otherwise stated, GERAN cells take the default values defined in Table 7.2.2.1-1.

Table 7.2.2.1-1: Mapping of GERAN cells with TS 51.010-1 [25]

GERAN cell	Frequency	GERAN cell in TS 51.010-1, clause 40
Cell 24	f11	Cell A
Cell 25	f12	Cell D
Cell 26	f13	Cell B

7.2A Generic RRM procedures

7.2A.1 UE RRM test states

Table 7.2A.1-1: The E-UTRAN UE states

		RRC	ECM	EMM	ESM	UE Test Mode
State 2A	Registered, Idle Mode, UE Test Mode Activated	Refer to Table 4.5.1-1	Refer to Table 4.5.1-1	Refer to Table 4.5.1-1	Refer to Table 4.5.1-1	Refer to Table 4.5.1-1
State 3A-RF	Generic Default RB Established, UE Test Mode Activated	Refer to Table 5.2A.1-1	Refer to Table 5.2A.1-1	Refer to Table 5.2A.1-1	Refer to Table 5.2A.1-1	Refer to Table 5.2A.1-1
State 3B-RF	Generic Default RB Established, UE Test Mode Activated, pre-registered on HRPD	RRC_CONNECTED 1 data radio bearer configured	ECM-CONNECTED	EMM-REGISTERED	1 default EPS bearer context active	Active
State 3A-RF-CA	Generic Default RB Established, UE Test Mode Activated	Refer to Table 5.2A.1-1	Refer to Table 5.2A.1-1	Refer to Table 5.2A.1-1	Refer to Table 5.2A.1-1	Refer to Table 5.2A.1-1

7.2A.2 UE Registration, UE Test Mode Activated (State 2A)

As described in clause 4.5.2A with following exceptions:

Table 7.2A.2-1: ACTIVATE DEFAULT EPS BEARER CONTEXT REQUEST (Step 16 in Table 4.5.2A.3-1)

Derivation Path: Table 4.7.3-6			
Information Element	Value/remark	Comment	Condition
PDN address			
Length of PDN address contents	5 octets		
PDN type value	'001'B	IPv4	
PDN address information	IPv4 address	The SS provides a valid IPv4 address	
ESM cause	IF "PDN type" IE in step 4 is 'IPv4v6' THEN '00110010'B ELSE Not present	"PDN type IPv4 only allowed"	

7.2A.3 Generic Default Radio Bearer Establishment, UE Test Mode Activated (State 3A-RF)

As described in clause 5.2A.2.

7.2A.4 Generic Default Radio Bearer Establishment, UE Test Mode Activated, pre-registration on HRPD (State 3B-RF)

Editor's note: This section is incomplete. The following aspects are either missing or not yet determined: Other than UATI Request message and UATI Assignment message are FFS

7.2A.4.1 Initial conditions

System Simulator:

- Cell 1
- Cell 1 is transmitting SystemInformationBlockType8

User Equipment:

- The Test USIM shall be inserted.

7.2A.4.2 Definition of system information messages

As described in clause 4.5.2B.2.

7.2A.4.3 Procedure

Table 7.2A.4.3-1: UE registration with default EPS bearer establishment, test mode activation and HRPD pre-registration procedures (state 1 to state 3B-RF)

Step	Procedure	Message Sequence	
		U - S	Message
1 to 18	Same procedure for steps 1 to 18 as specified in the procedure in clause 4.5.2A.3 and 7.2A.2	-	-
19 to 36	Same procedure for steps 17 to 30D as specified in the procedure in clause 4.5.2B.3		

7.2A.4.4 Specific message contents

As described in clauses 4.5.2B.4 and 7.2A.2.

7.2A.5 Generic Default Radio Bearer Establishment, UE Test Mode Activated (State 3A-RF-CA)

As described in clause 5.2A.4.

7.2B Other generic RRM procedures

7.2B.1 Tracking area updating procedure

The procedure is defined in table 7.2B.1-1.

Table 7.2B.1-1: Tracking area updating procedure

Step	Procedure	Message Sequence	
		U - S	Message
1	The SS transmits system information on the cell specified in the test case.	<--	RRC: SYSTEM INFORMATION (BCCH)
-	EXCEPTION: If all EPS bearer context is inactive in UE, for Rel-8 and Rel-9 steps 2 to 8a are optional and depend on UE implementation. A Rel-10 UE directly starts attach procedure from step 8a.	-	-
2	The UE transmits an <i>RRCConnectionRequest</i> message on the cell specified in the test case.	-->	RRC: <i>RRCConnectionRequest</i>
3	The SS transmits an <i>RRCConnectionSetup</i> message.	<--	RRC: <i>RRCConnectionSetup</i>
4	The UE transmits an <i>RRCConnectionSetupComplete</i> message to confirm the successful completion of the connection establishment and a TRACKING AREA UPDATE REQUEST message is sent to update the registration of the actual tracking area.	-->	RRC: <i>RRCConnectionSetupComplete</i> NAS: TRACKING AREA UPDATE REQUEST
-	EXCEPTION: If all EPS bearer context is marked as inactive in the EPS bearer context status IE included in the TRACKING AREA UPDATE REQUEST message then, events described in steps 5a to 24a. Otherwise, events described in steps 5 to 7.		
5	The SS responds with TRACKING AREA UPDATE ACCEPT message.	<--	RRC: <i>DLInformationTransfer</i> NAS: TRACKING AREA UPDATE ACCEPT
6	The UE transmits a TRACKING AREA UPDATE COMPLETE	-->	RRC: <i>ULInformationTransfer</i> NAS: TRACKING AREA UPDATE COMPLETE
7	The SS transmits an <i>RRCConnectionRelease</i> message to release RRC connection and move to RRC_IDLE.	<--	RRC: <i>RRCConnectionRelease</i>
5a	The SS responds with TRACKING AREA UPDATE REJECT message.	<--	RRC: <i>DLInformationTransfer</i> NAS: TRACKING AREA UPDATE REJECT
6a	EXCEPTION: Step 7a describes the behaviour that depends on UE behaviour (Note 3).	-	-
7a	The SS transmits an <i>RRCConnectionRelease</i> message to release RRC connection and move to RRC_IDLE.	<--	RRC: <i>RRCConnectionRelease</i>
8a	IF NOT <i>pc_Auto_Attach_after_TAU_Reject</i> , the user initiates an attach by MMI or by AT command.	-	-
9a-24a	Steps 2 to 17 of the generic UE Registration procedure (4.5.2a.3 and 7.2A.2) are executed to successfully complete the Attach procedure.	-	-

NOTE 1: The periodic tracking area updating timer T3412 is deactivated by default during the attach procedure (TS 36.508 clause 4.7.2).

NOTE 2: The SS does not initiate authentication and NAS SECURITY MODE COMMAND are not performed (reuse of keys allocated during the attach procedure).

NOTE 3: The SS waits for 1 second to receive the Attach Request on the existing RRC Connection. In case Attach Request is not received within 1 second, existing RRC Connection is released.

7.3 Default RRC message and information elements contents

7.3.1 Contents of RRC messages

FFS.

7.3.2 Radio resource control information elements

Editor's note: Unless otherwise stated in the test parameters or messages exceptions in the respective test cases in TS 36.521-3 [34], PRACH configuration index and exceptional message as specified in Table 7.3.2-1 is used.

As defined in clause 4.6.3 with the following exceptions:

Table 7.3.2-1: PRACH-Config-DEFAULT

Derivation Path: Clause 4.6.3 Table 4.6.3-7			
Information Element	Value/remark	Comment	Condition
PRACH-Config-DEFAULT ::= SEQUENCE {			
prach-ConfigIndex	3		TDD
}			

Condition	Explanation
TDD	TDD cell environment

Table 7.3.2-2: RadioResourceConfigCommonSCell-r10-DEFAULT

Derivation Path: Clause 4.6.3 Table 4.6.3-13A			
Information Element	Value/remark	Comment	Condition
RadioResourceConfigCommonSCell-r10 ::= SEQUENCE {			
ul-Configuration-r10	Not Present		
}			

Table 7.3.2-3: PhysicalConfigDedicatedSCell-r10-DEFAULT

Derivation Path: Clause 4.6.3 Table 4.6.3-6A			
Information Element	Value/remark	Comment	Condition
PhysicalConfigDedicatedSCell-r10 ::= SEQUENCE {			
ul-Configuration-r10	Not Present		
}			

7.3.3 Measurement information elements

As defined in clause 4.6.6 with the following exceptions:

Table 7.3.4-1: MeasObjectEUTRA-GENERIC (Freq)

Derivation Path: Clause 4.6.6, Table 4.6.6-2			
Information Element	Value/remark	Comment	Condition
neighCellConfig	10'B (The MBSFN subframe allocations of all neighbour cells are identical to or subsets of that in the serving cell)		FDD with E-UTRA FDD neighbour cell
	'11'B (Different UL/DL allocation in neighbouring cells for TDD compared to the serving cell)		FDD with E-UTRA TDD neighbour cell, TDD with E-UTRA FDD neighbour cell

Annex A (informative): Connection Diagrams

Definition of Terms

System Simulator or SS – A device or system, that is capable of generating simulated Node B signalling and analysing UE signalling responses on one or more RF channels, in order to create the required test environment for the UE under test. It will also include the following capabilities:

1. Measurement and control of the UE Tx output power through TPC commands
2. Measurement of Throughput
3. Measurement of signalling timing and delays
4. Ability to simulate UTRAN and/or E-UTRAN and/or GERAN signalling

Test System – A combination of devices brought together into a system for the purpose of making one or more measurements on a UE in accordance with the test case requirements. A test system may include one or more System Simulators if additional signalling is required for the test case. The following diagrams are all examples of Test Systems.

NOTE 1: The above terms are logical definitions to be used to describe the test methods used in the documents TS36.521-1 , TS 36.523-1 and TS36.521-3 in practice, real devices called 'System Simulators' may also include additional measurement capabilities or may only support those features required for the test cases they are designed to perform.

NOTE 2: Components in the connection diagrams:

The components in the connection diagrams represent ideal components. They are intended to display the wanted signal flow. They don't mandate real implementations. An alternative to Fig. A3 is shown below as an example: It is nearer to real implementations. The signal levels are the same as in Fig A3. The signal flow cannot be displayed as detailed as in Fig A.3.

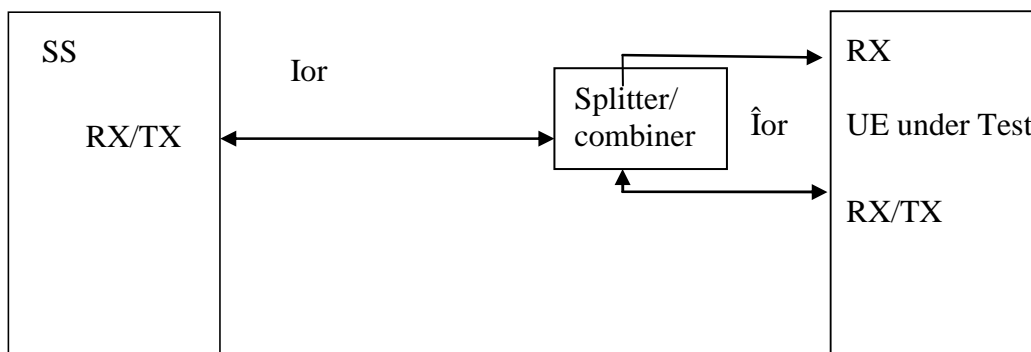

Alternative to Figure A.3

Connection: Each connection is displayed as a one or two sided arrow, showing the intended signal flow.

Circulator: The signal, entering one port, is conducted to the adjacent port, indicated by the arrow. The attenuation among the above mentioned ports is ideally 0 and the isolation among the other ports is ideally ∞ .

Splitter: a splitter has one input and 2 or more outputs. The signal at the input is equally divided to the outputs. The attenuation from input to the outputs is ideally 0 and the isolation between the outputs is ideally ∞ .

Combiner: a combiner has one output and 2 or more inputs. The signals at the inputs are conducted to the output, all with the same, ideally 0 attenuation. The isolation between the inputs is ideally ∞ .

Switch: contacts a sink (or source) alternatively to two or more sources (or sinks).

Fader: The fader has one input and one output. The MIMO fading channel is represented by several single faders (e.g. 8 in case of a MIMO antenna configuration 4x2) The correlation among the faders is described in TS 36.521-1 clause B.2.2

Attenuator: TBD

Figure A.1: Void

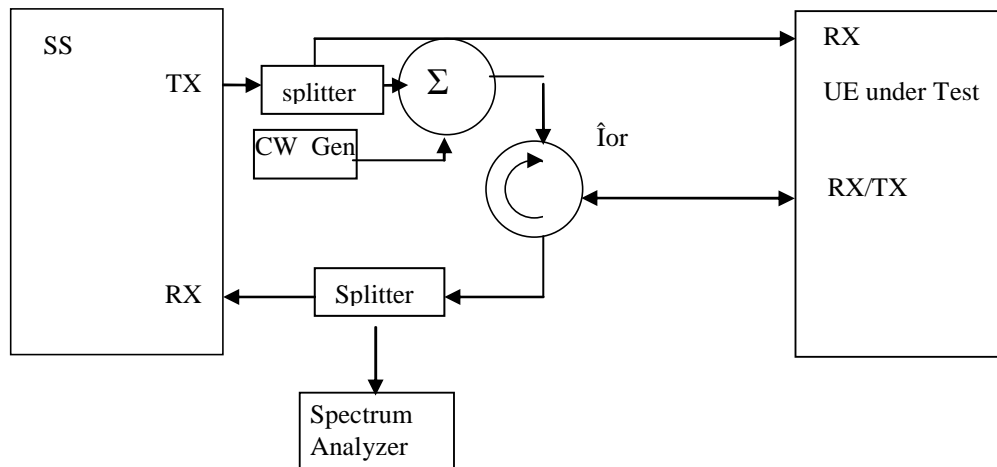

Figure A.2: Connection for Transmitter Intermodulation tests

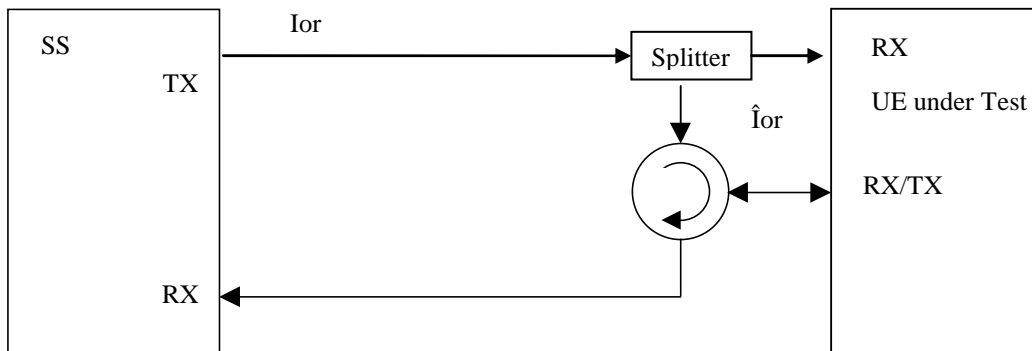

Figure A.3: Connection for basic single cell, RX and TX tests

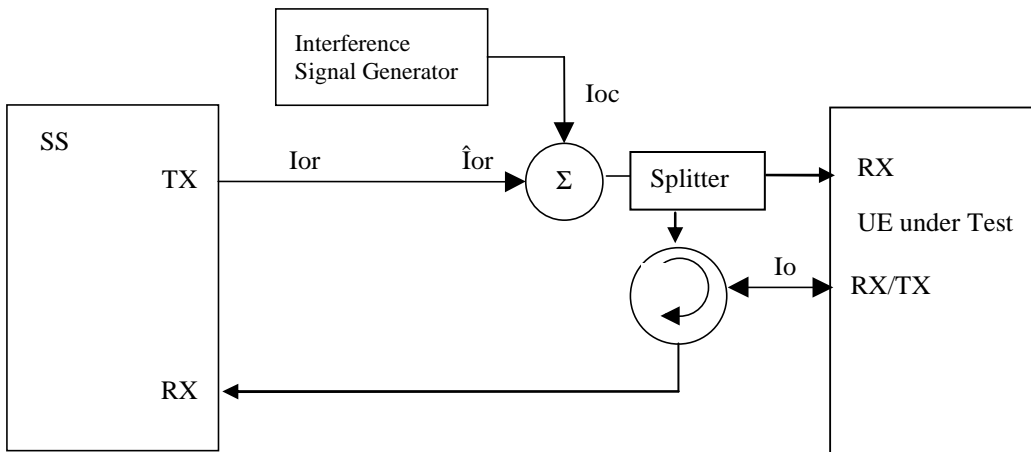

Figure A.4: Connection for Receiver tests with E-UTRA-Interference

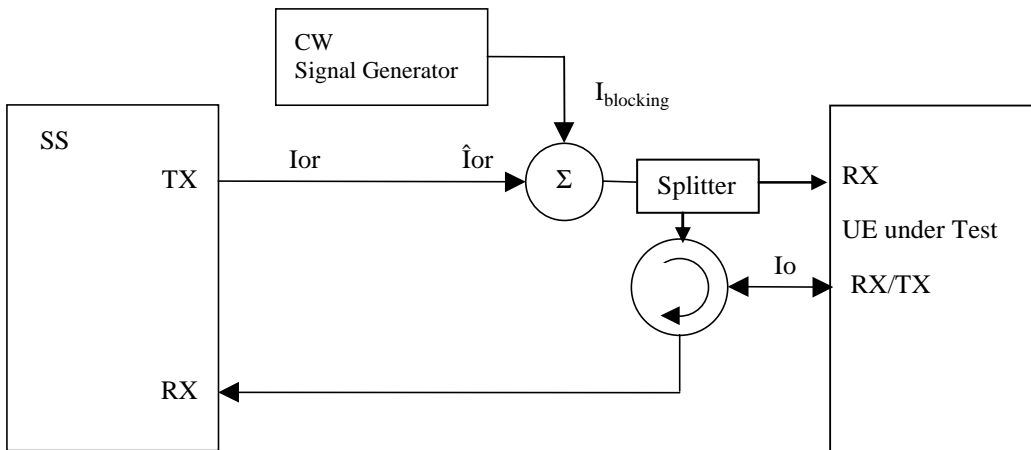

Figure A.5: Connection for Receiver tests with CW interferer

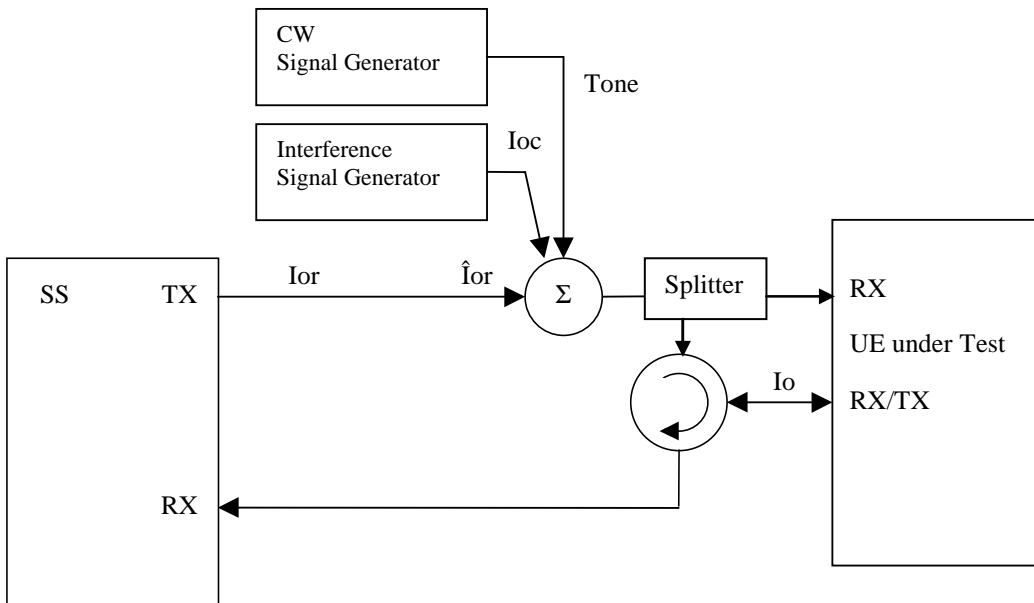

Figure A.6: Connection for Receiver tests with both E-UTRA Interference and additional CW signal

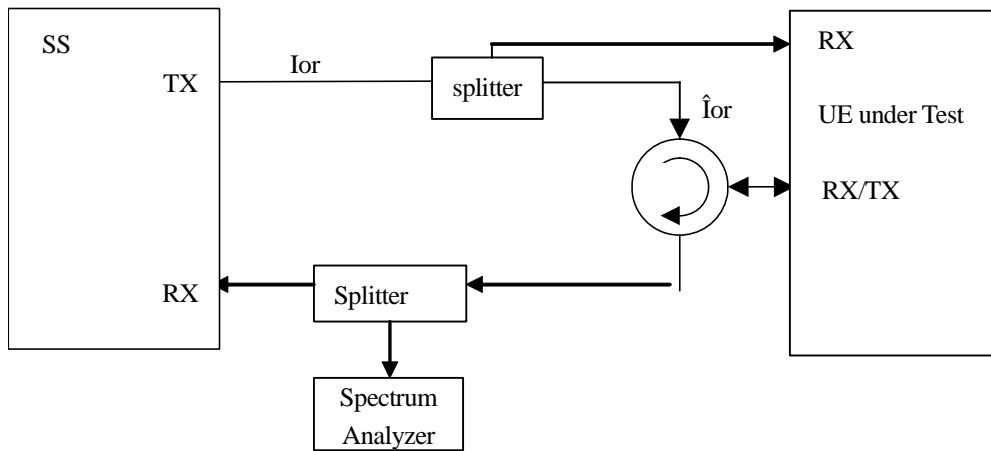

Figure A.7: Connection for TX-tests with additional Spectrum Analyzer

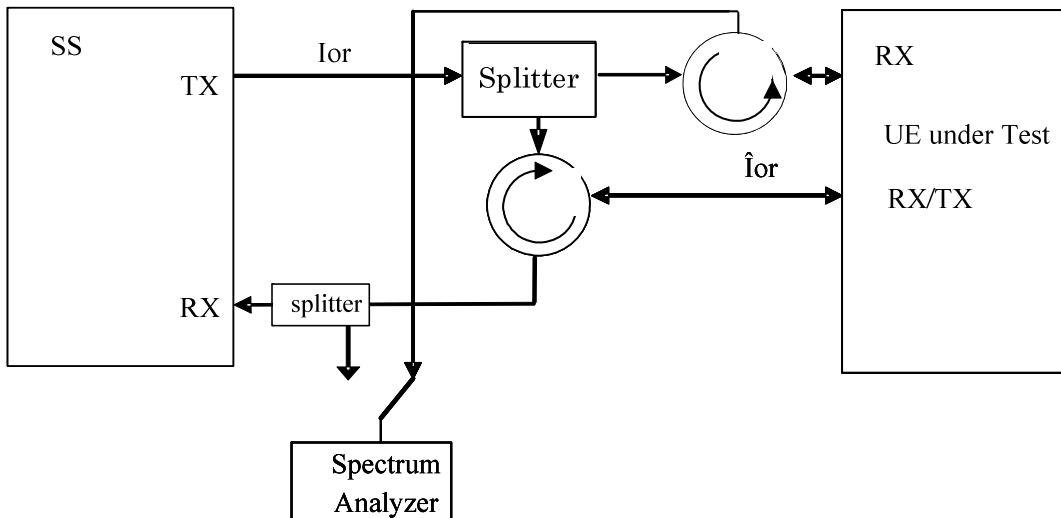

Figure A.8: Connection for RX-tests with additional Spectrum Analyzer

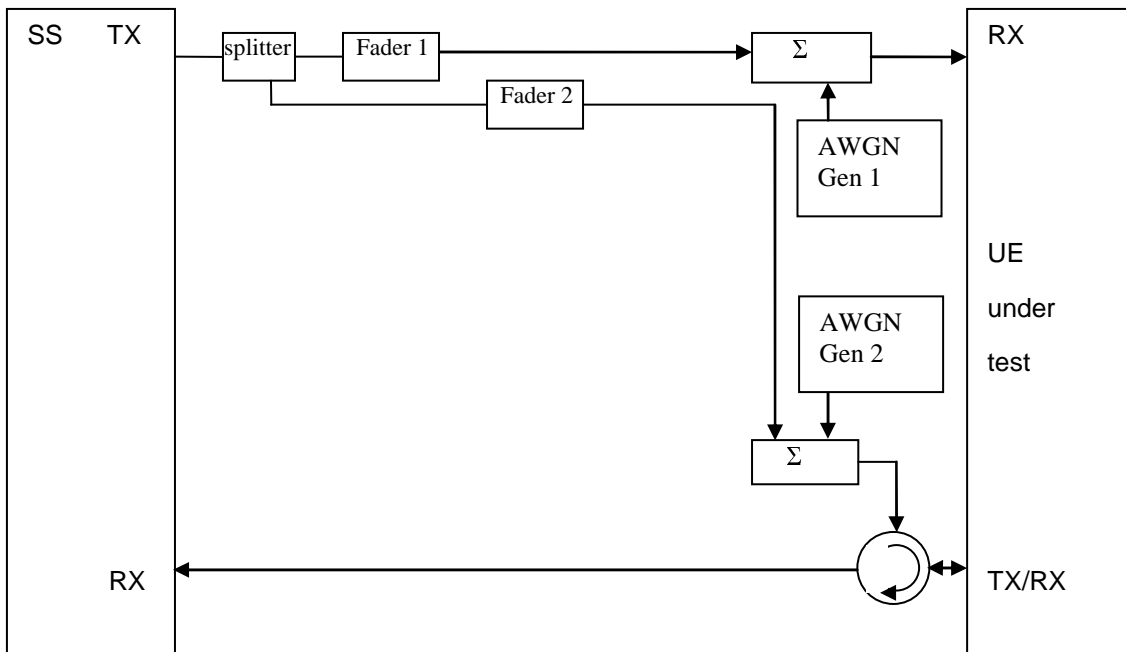

Figure A.9: Connection for RX performance tests with antenna configuration 1x2 (single antenna port)

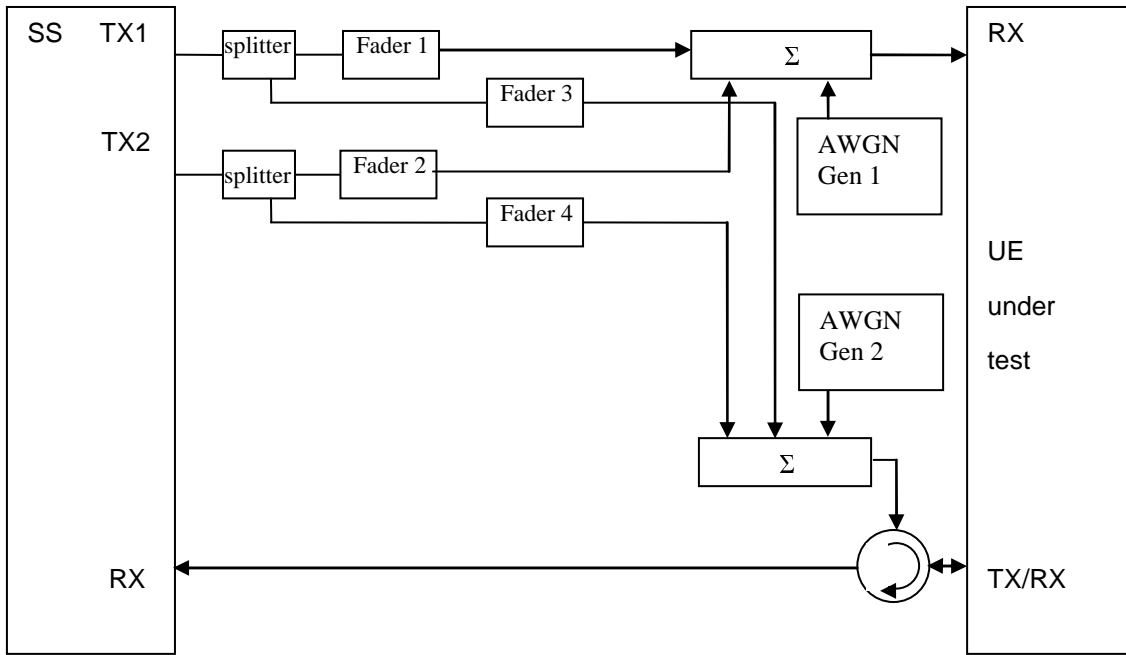

Figure A.10: Connection for RX performance tests with antenna configuration 2x2 (transmit diversity)

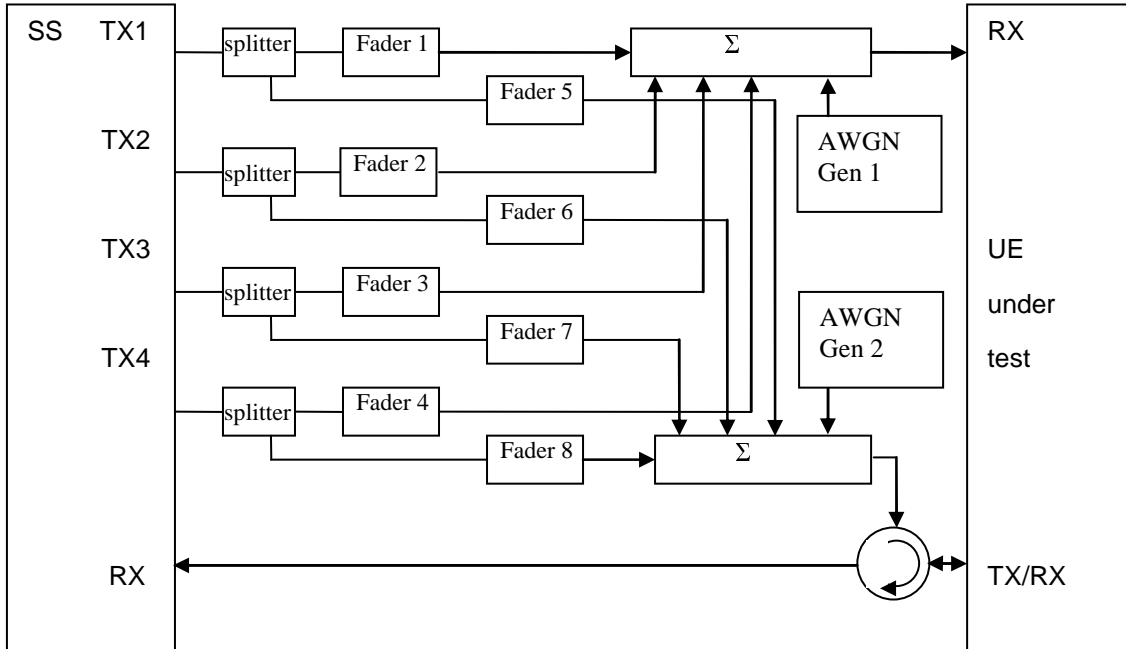

Figure A.11: Connection for RX performance tests with antenna configuration 4x2 (transmit diversity)

Figure A.12: Void

Figure A.13: Void

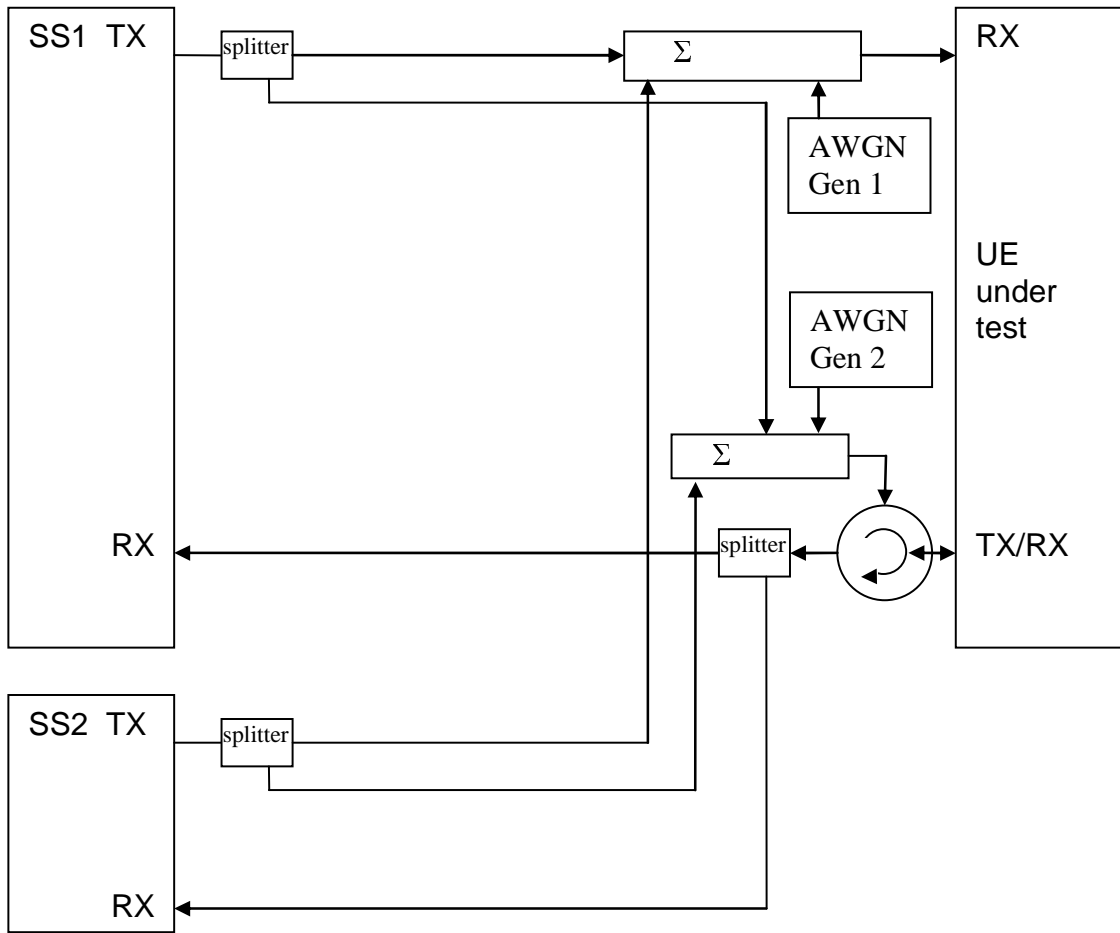

Figure A.14: Connection for 2 cells with static propagation and receive diversity

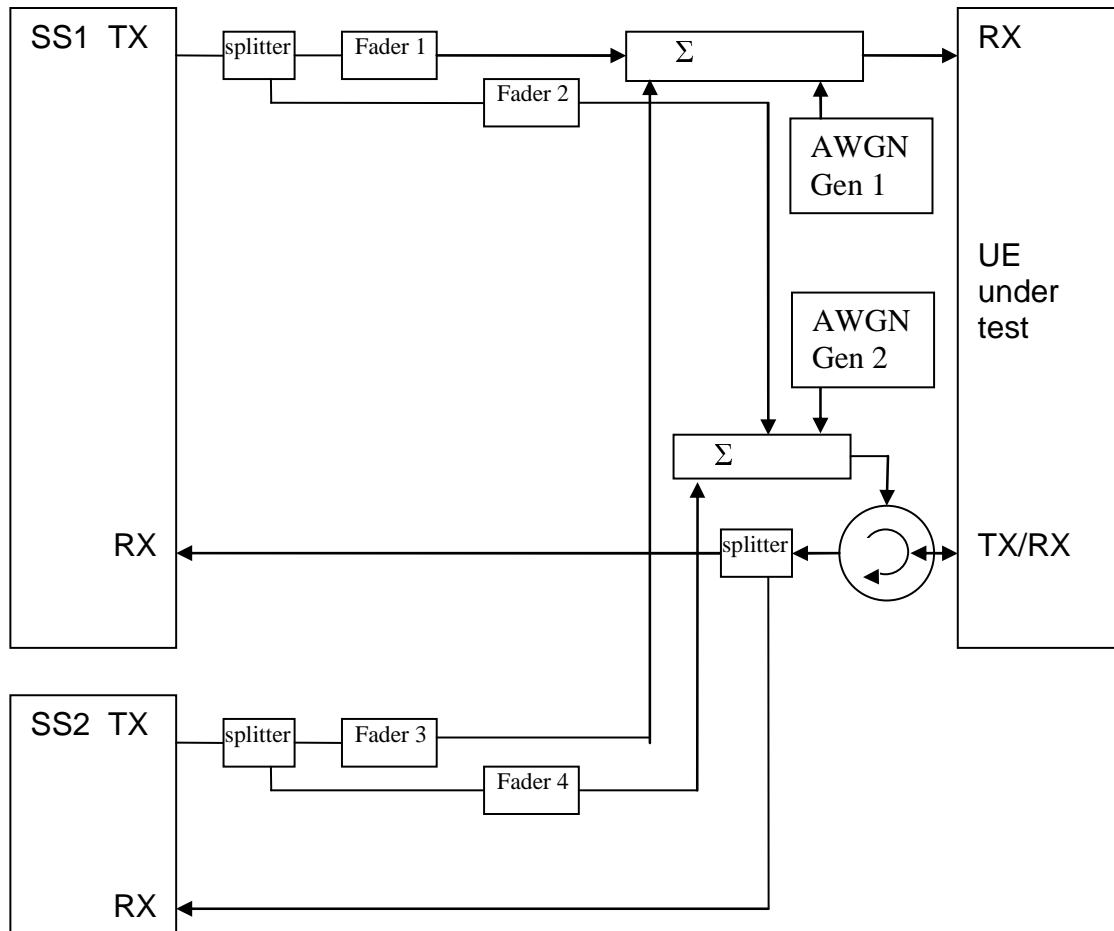

Figure A.15: Connection for 2 cells with multipath fading propagation and receive diversity

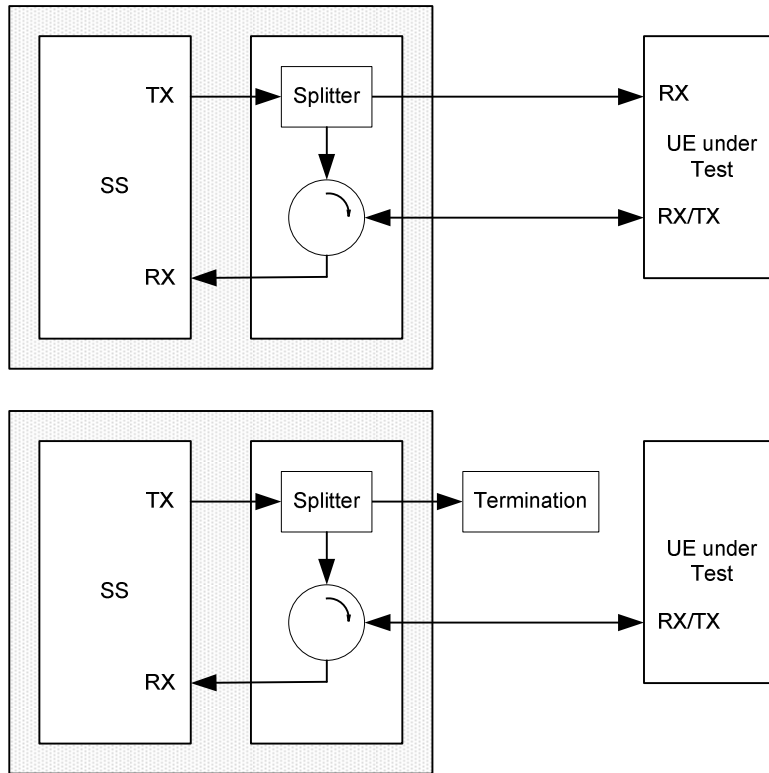

Figure A.16: Connection for single cell Signalling tests

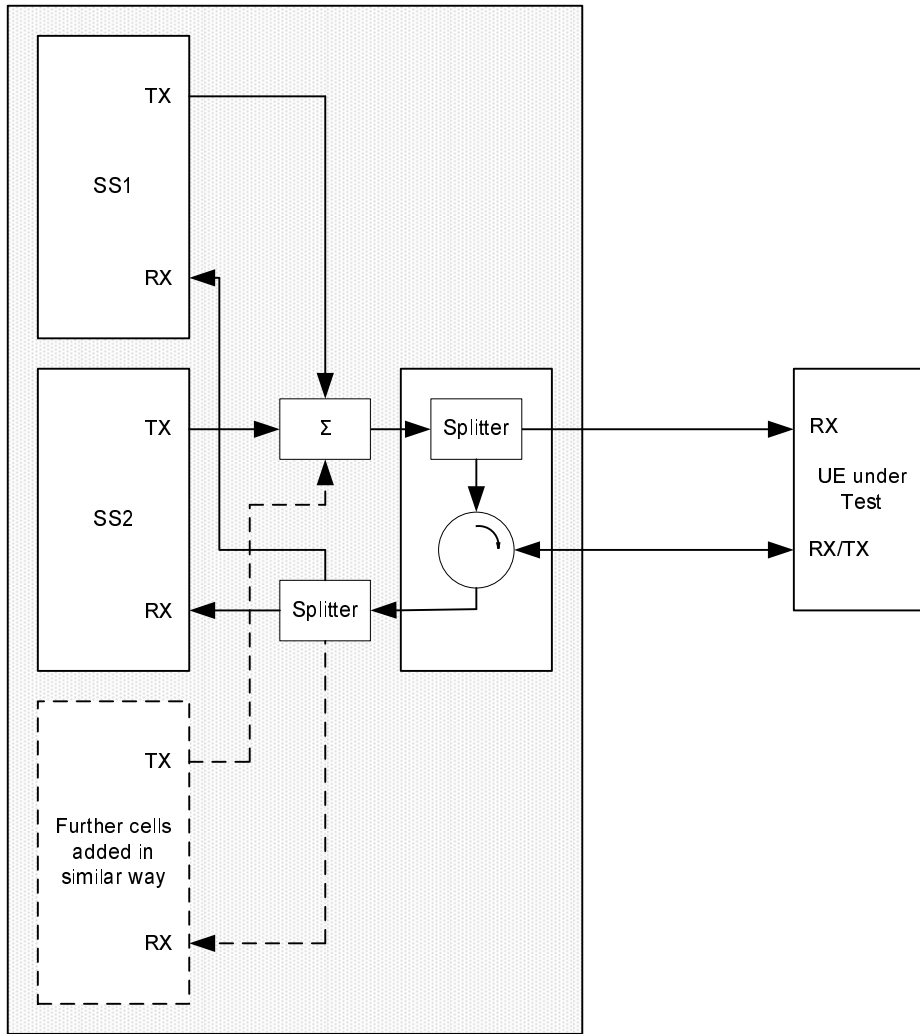

Figure A.17: Connection for multiple cells Signalling tests

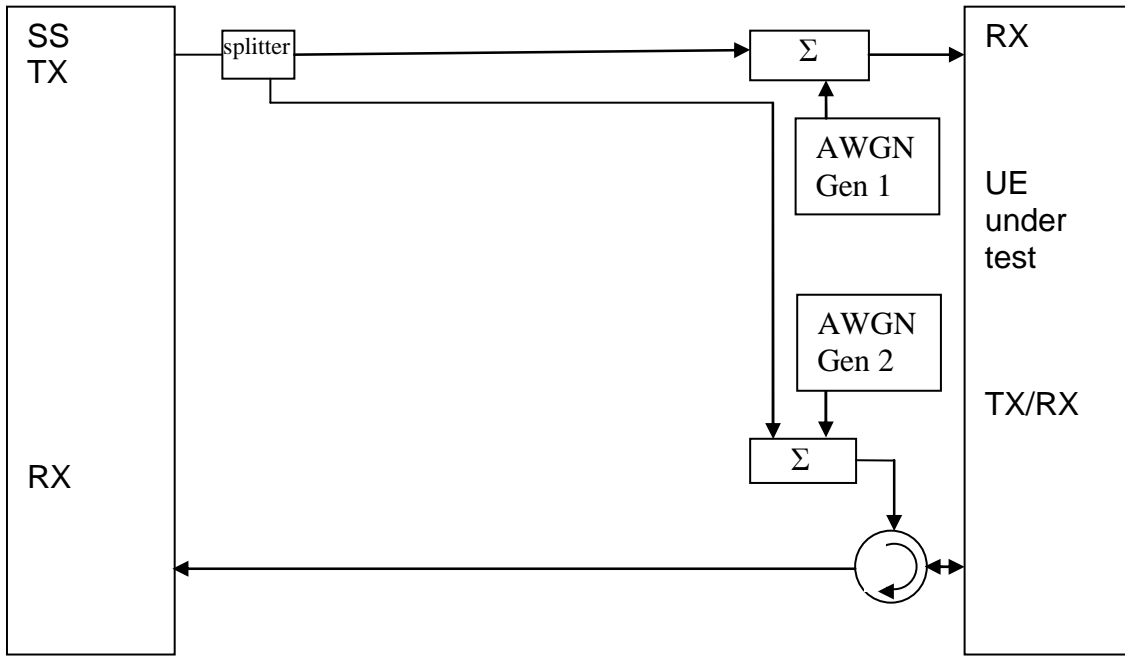

Figure A.18: Connection for 1 cell with antenna configuration 1x2 in static propagation conditions

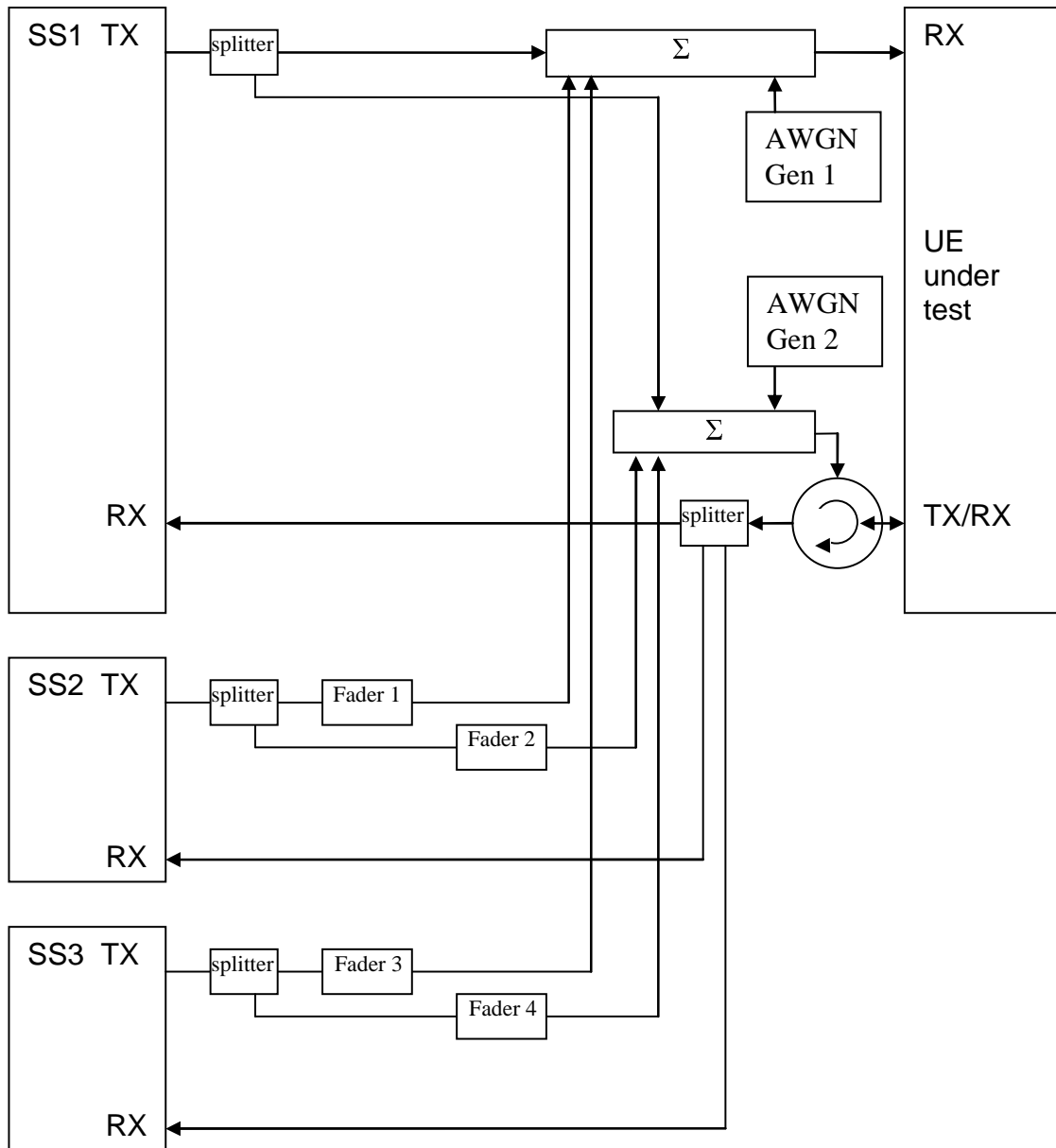

Figure A.19: Connection for 3 cells with antenna configuration 1x2 in static (cell 1) and multipath fading (cell 2 and 3) propagation conditions and receive diversity

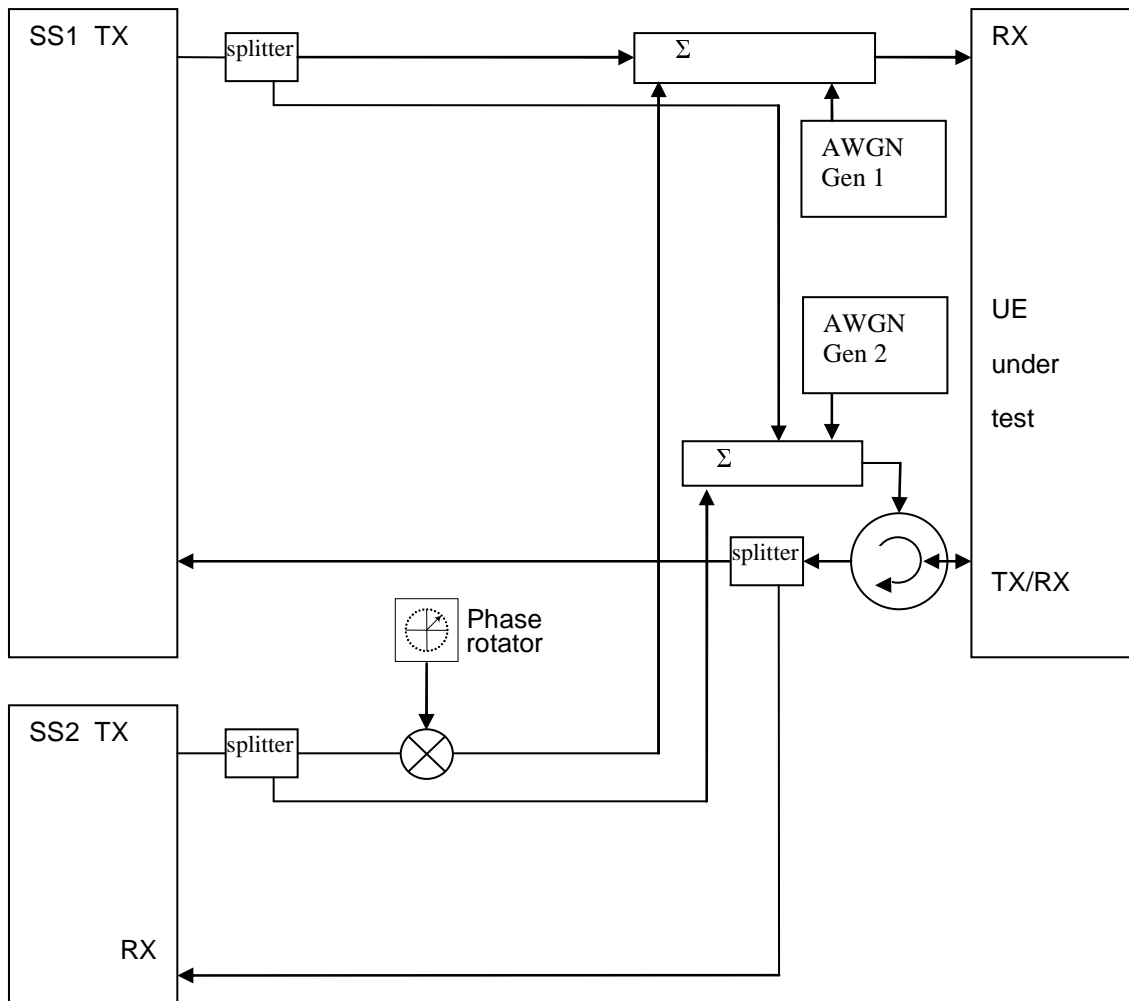

Figure A.20: Connection for 2 cells with static propagation and receive diversity with phase rotator (The frequency offset used in phase rotator is 5 Hz)

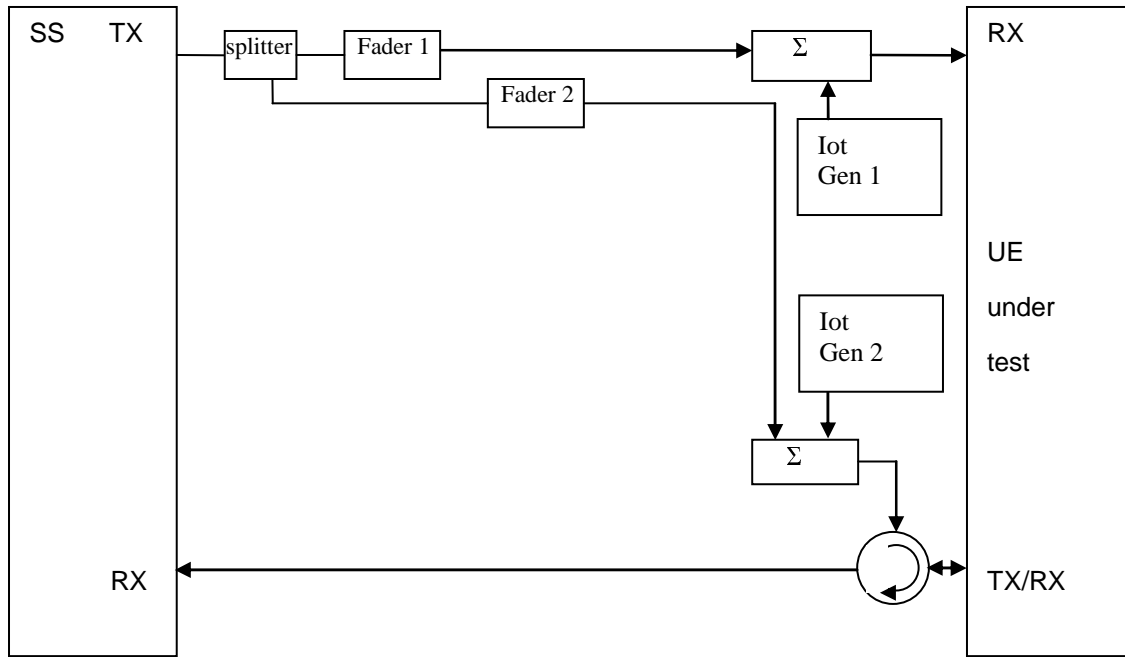

Figure A.21: Connection for frequency-selective interference with multipath fading propagation and receive diversity

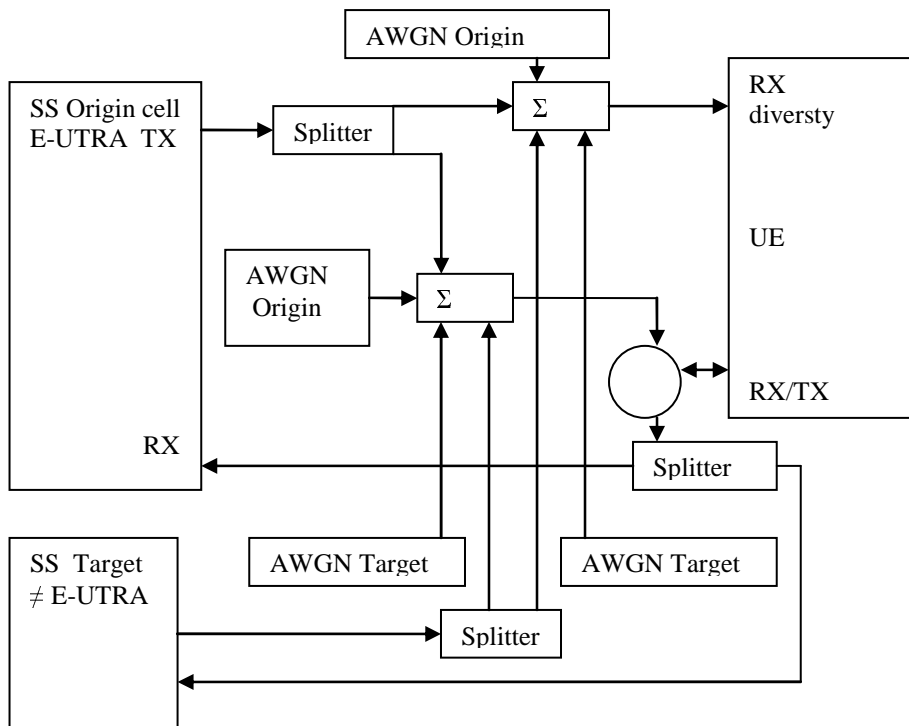

Figure A.22: Connection for 2 cells with static propagation condition. Origin(E-UTRAN)- and target cell (≠ E-UTRAN) received with RX diversity

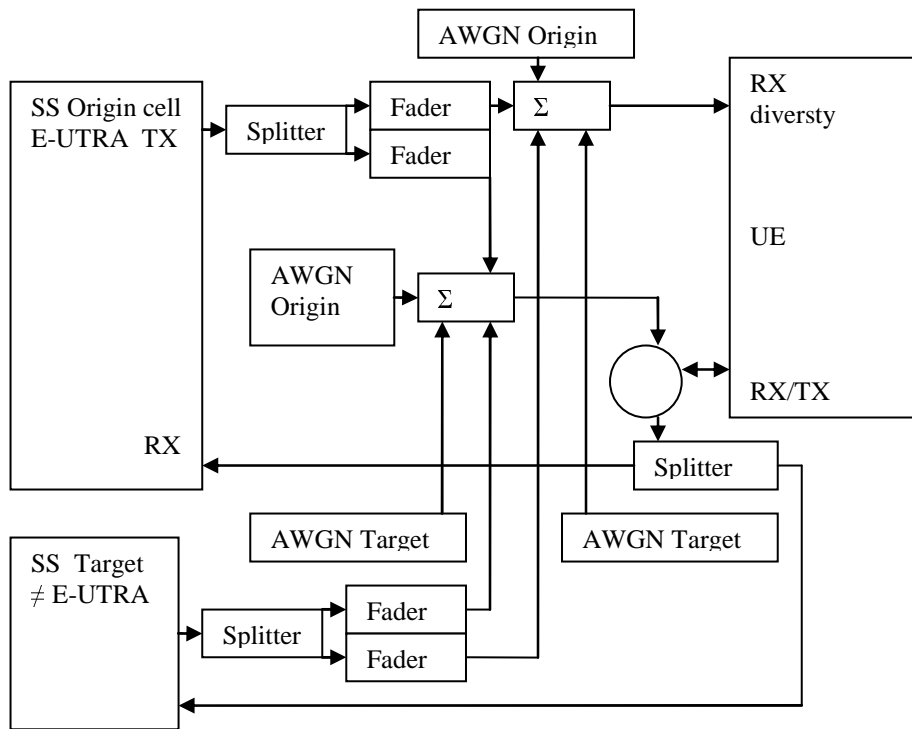

Figure A.23: Connection for 2 cells with multipath fading propagation condition. Origin (E-UTRAN)- and target cell (\neq E-UTRAN) received with RX diversity

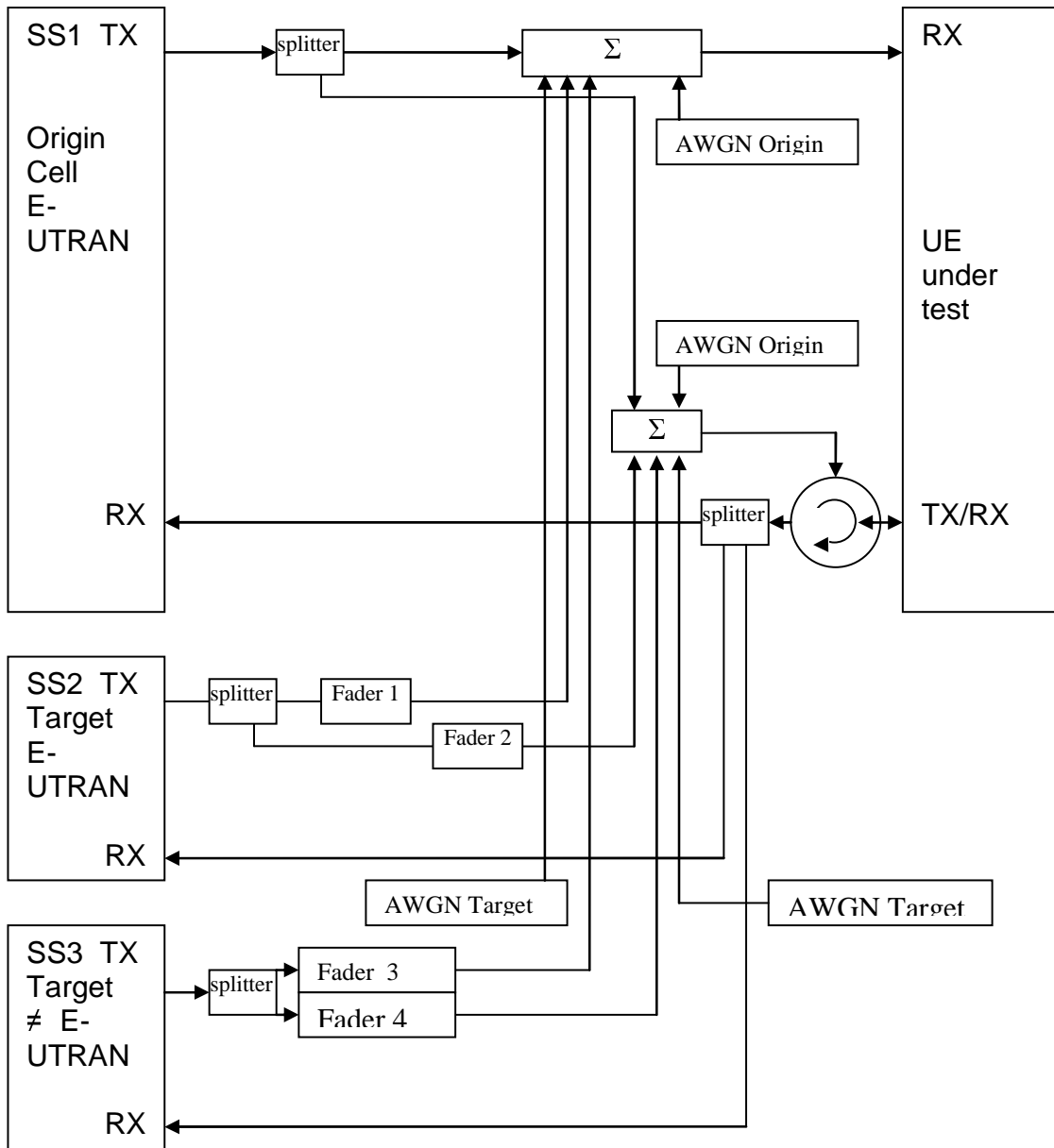

Figure A.24: Connection for 3 cells with antenna configuration 1x2 in static (cell 1) and multipath fading conditions (cell 2 and 3) and multiple RAT and receive diversity

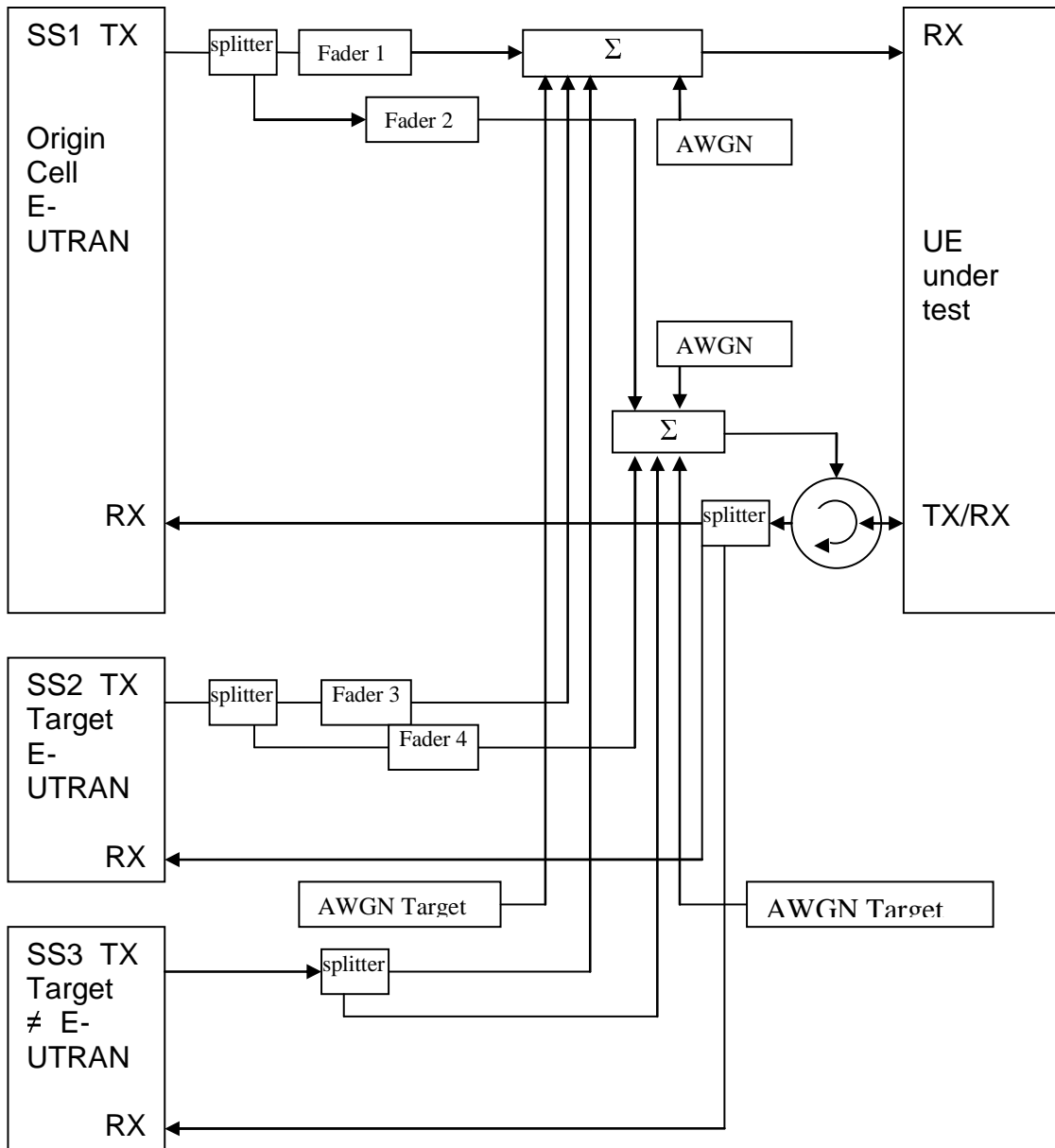

Figure A.25: Connection for 3 cells with antenna configuration 1x2 in multipath fading (cell 1 and 2) and multiple RAT (cell 3 static) and receive diversity

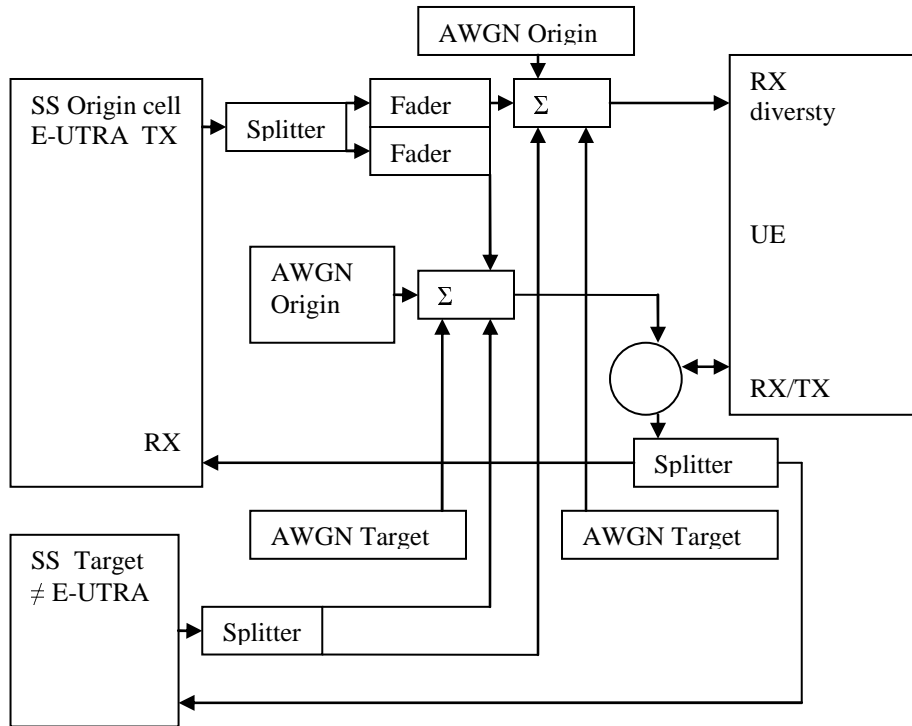

Figure A.26: Connection for 2 cells. Origin (E-UTRAN, multipath fading)- and target cell (≠ E-UTRAN, static) received with RX diversity

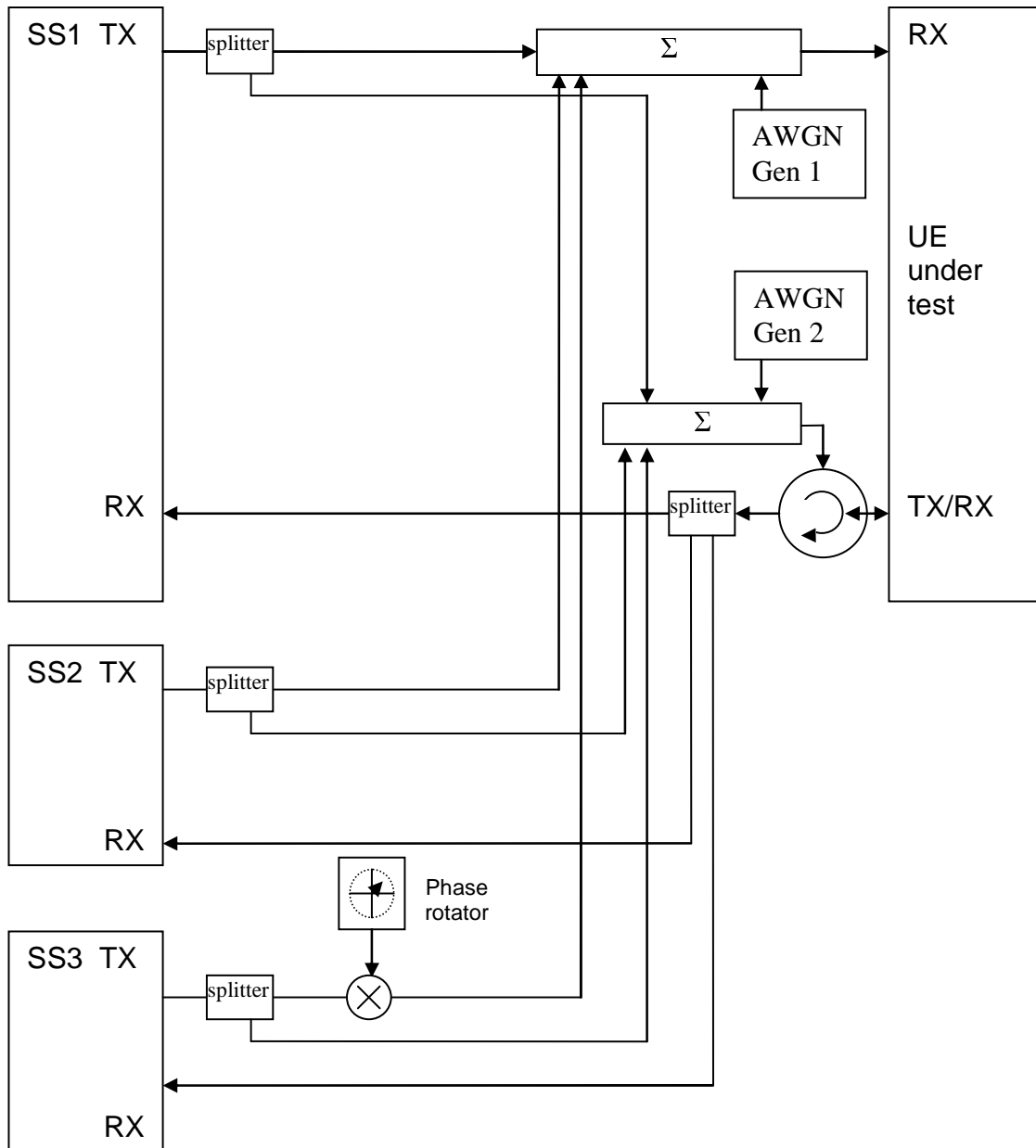

Figure A.27: Connection for 3 cells with static propagation and receive diversity

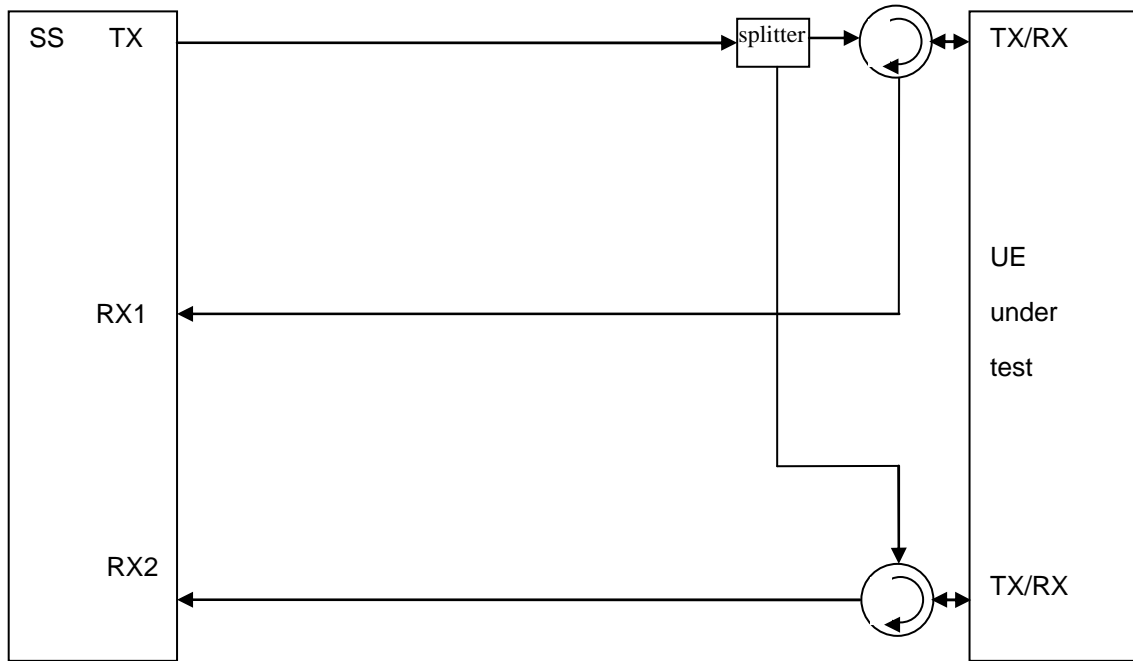

Figure A.28: Connection for basic UL MIMO with receive diversity

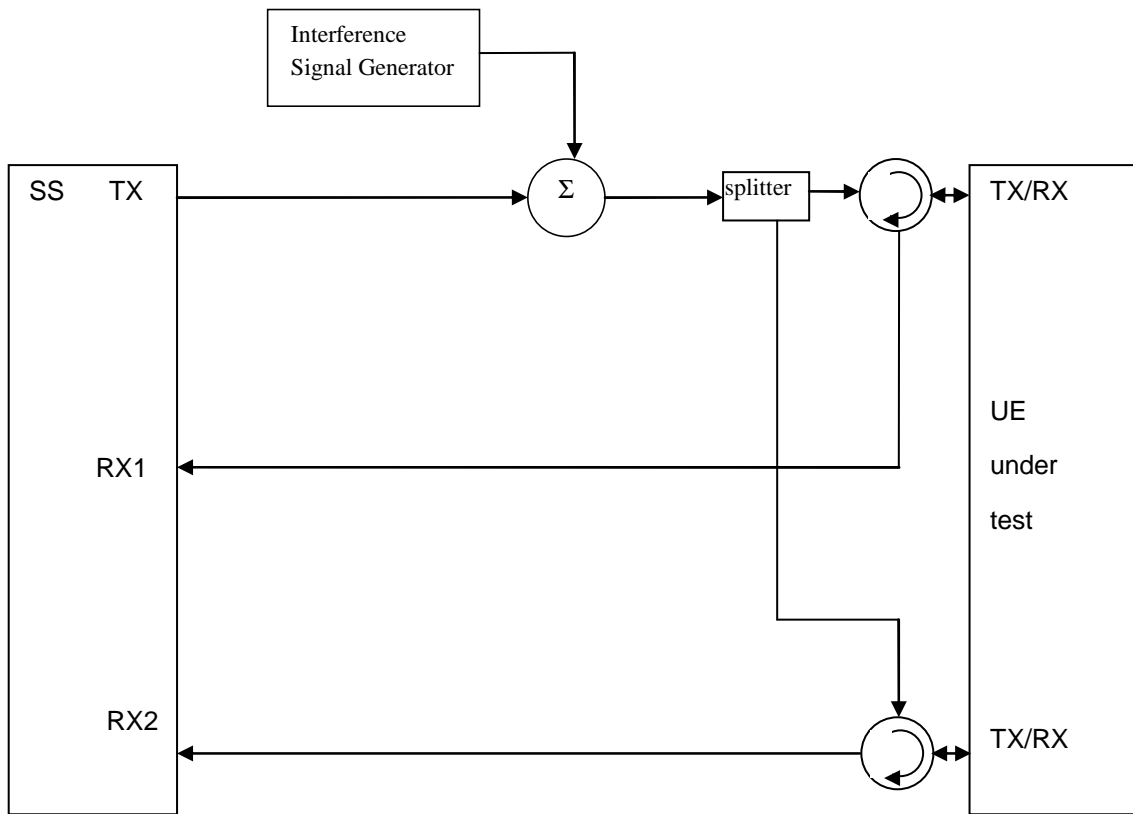

Figure A.29: Connection for UL MIMO Receiver tests with E-UTRA-Interference

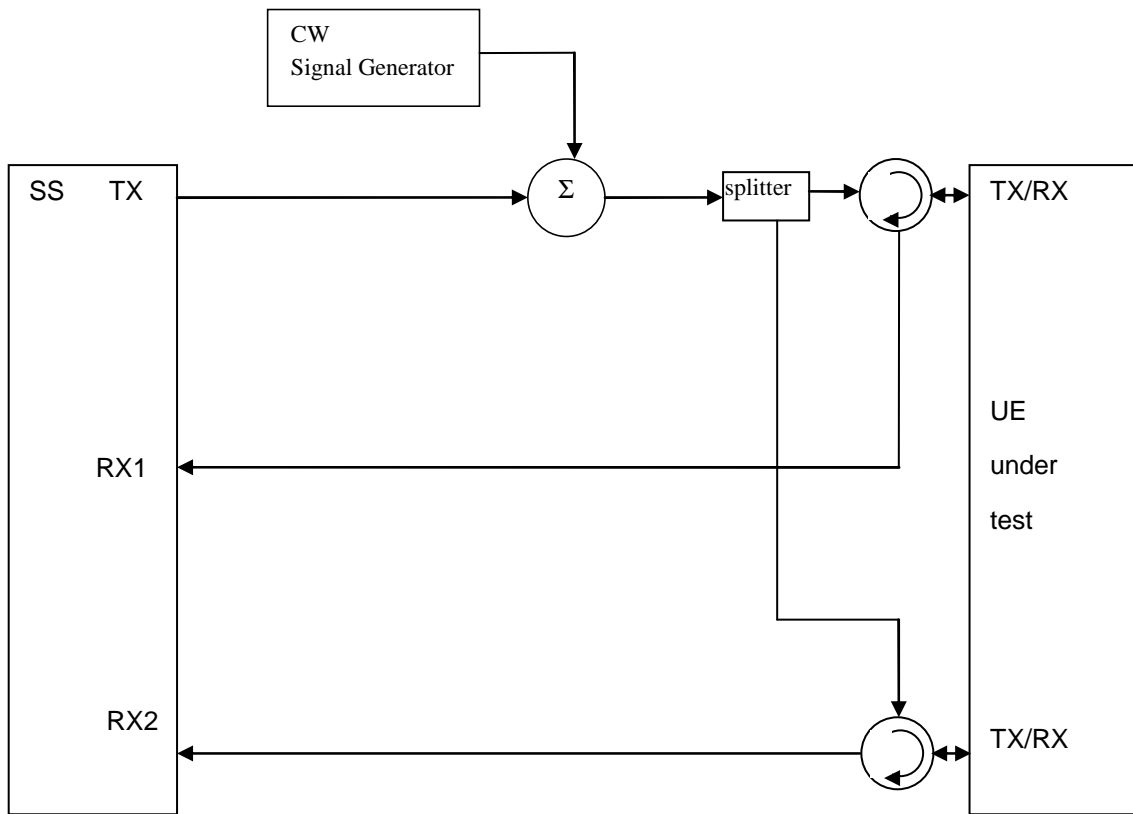

Figure A.30: Connection for UL MIMO Receiver tests with CW Interference

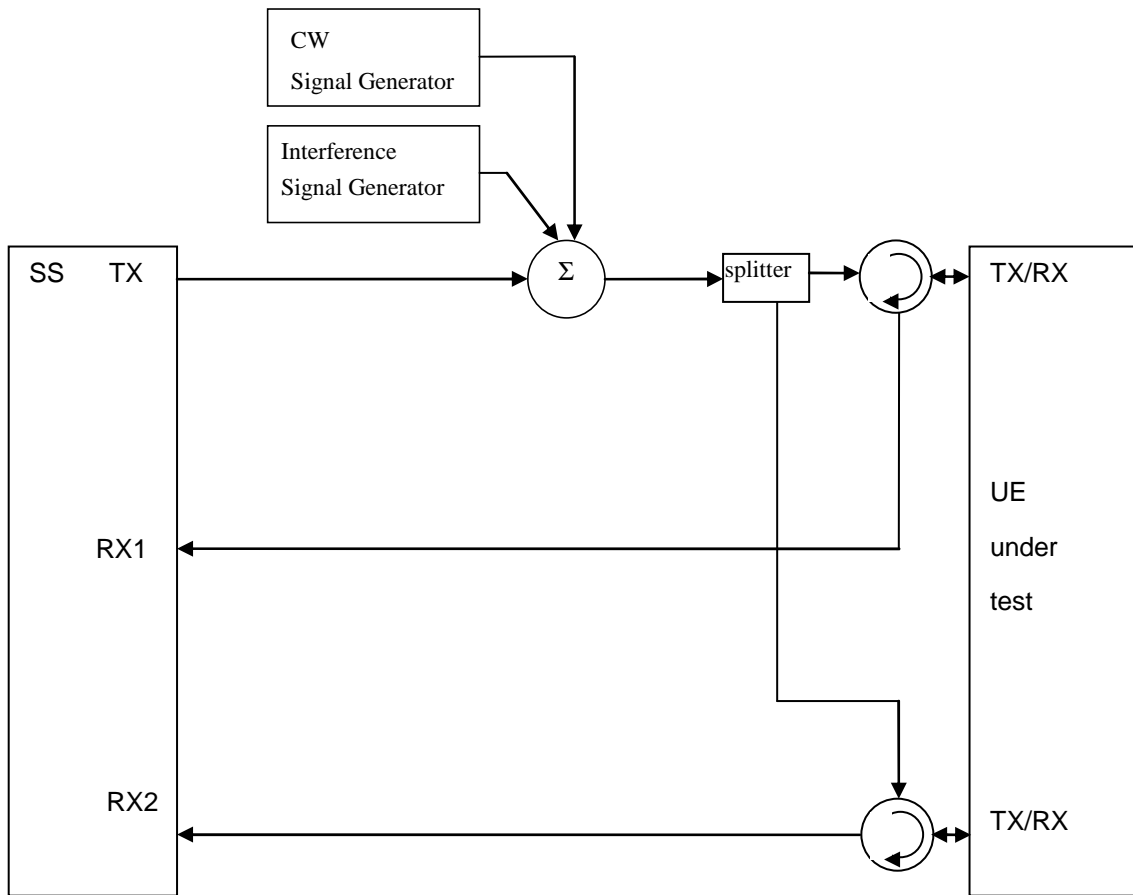

Figure A.31: Connection for UL MIMO Receiver tests with both E-UTRA-Interference and additional CW signal

Annex B (informative): Change history

Meeting-1st-Level	Doc-1st-Level	CR	Rev	Subject	Cat	Version-Current	Version-New	Doc-2nd-Level
RAN5 #37	R5-073107			Skeleton proposed for RAN5#37 Jeju			0.0.1	
RAN5 LTE workshop	R5w080007			Proposed for RAN5 LTE workshop, Sophia Antipolis		0.0.1	0.0.2	
RAN5 #39	R5-081167			Following proposals have been incorporated: R5w080046 R5w080026 R5w080036		0.0.2	0.0.3	
RAN5 #39	R5-081615			Following proposals and many editorial corrections have been incorporated: R5-081564, R5-081561, R5-081248, R5-081530, R5-081126, R5-081443, R5-081382, R5-081200		0.0.3	0.1.0	
RAN5 #39bis	R5-082141			Following proposals and many editorial corrections have been incorporated: R5-082149, "Updates of reference test conditions for TS 36.508" R5-082148, "Addition of E-UTRA TDD Test frequencies for TS36.508" R5-082150, "Default downlink signal channel powers for LTE UE test" R5-082146, "Addition of Cell Environment for multi Cell Configuration" R5-082140, "Proposal of LTE reference system configurations for TS 36.508" R5-082204, "Addition of Cell and UE configuration for TS 36.508" R5-082090, "Update of default RRC message contents" R5-082100, "Proposal on Structure of Default Message Contents for TS 36.508" R5-082091, "Addition of SRB and DRB radio bearer combinations to 36.508" R5-082173, "Connection Diagrams for TX and RX tests"		0.1.0	0.2.0	
RAN5 #40	R5-083399			Following proposals have been incorporated: R5-083800, "Mapping of DL physical channels to physical resources for TS 36.508", NEC R5-083403, "Addition of New Cell Environment for multi Cell Configuration", NTT DOCOMO R5-083529, "Proposal on default system information contents for TS 36.508", NTT DOCOMO R5-083395, "Corrections to generic procedures in TS 36.508", NTT DOCOMO R5-083623, "Update of RRC default message contents and RB combination parameters", Ericsson R5-083622, "Radio Resource Configuration specification for TS 36.508", NEC R5-083397, "Addition of Default NAS message contents in TS 36.508", NTT DOCOMO		0.2.0	1.0.0	
RAN5 #40bis	R5-084102			Following proposals have been incorporated: R5-084101, "Missing corrections to TS 36.508" R5-084110, "Updates of Test frequencies for TS 36.508" R5-084144, "The mapping of DL physical channels to physical resources for TS 36.508" R5-084198, "Update of RA and RB power ratios definition in TS 36.508" R5-084199, "Update of Reference System Configuration in 36.508" R5-084109, "Addition of default RRC message contents to TS 36.508" R5-084202, "Update of RRC Message Contents and RB Configurations in 36.508" R5-084265, "Addition of default RRC message contents for handover" R5-084162, "Connection Diagrams for performance		1.0.0	1.1.0	

Meeting-1st-Level	Doc-1st-Level	CR	Rev	Subject	Cat	Version-Current	Version-New	Doc-2nd-Level
				tests"				
RAN5 #41	R5-085145			Following proposals have been incorporated: R5-085087, "Updates of Test frequencies for TS 36.508" R5-085701, "Cleaning up section 5 in TS 36.508" R5-085252, "Correction to Section 4.3.3.2 of TS 36.508" R5-085315, "Connection Diagrams: delete the editorial note" R5-085454, "Addition of timer tolerances" R5-085566, "Addition of default settings of suitable / non-suitable cells in TS 36.508" R5-085541, "Update to default configurations of simulated cells in TS 36.508" R5-085514, "Update to default configurations of system information blocks in TS 36.508" R5-085472, "Addition of default settings of suitable / non-suitable cells in TS 36.508" R5-085394, "Update of Reference system configurations in 36.508" R5-085457, "Update to generic procedure in TS 36.508" R5-085458, "Addition of new generic procedure to check the UE does not answer to paging" R5-085523, "Update of default RRC message contents" R5-085381, "Addition to default RRC IE contents for measurement configuration" R5-085469, "Update to default NAS message contents in TS 36.508" R5-085451, "Parameter settings for reference RB configurations" R5-085556, "Common test USIM parameters for EPS testing"		1.1.0	2.0.0	
RAN#42	RP-085145			Approval of version 2.0.0 at RAN#42, then updated to v 8.0.0.		2.0.0	8.0.0	
				Editorial corrections.		8.0.0	8.0.1	
RAN5 #41bis	R5-086021	0001	-	Introduction of half cell configurations in eUTRA SS		8.0.1	8.1.0	
RAN5 #41bis	R5-086166	0002	-	Removal of Redundant Environmental Conditions		8.0.1	8.1.0	
RAN5 #41bis	R5-086221	0003	-	CR to 36.508: correction of EARFCN		8.0.1	8.1.0	
RAN5 #41bis	R5-086226	0004	-	Correction to the default system informations in TS 36.508		8.0.1	8.1.0	
RAN5 #41bis	R5-086236	0005	-	Connection diagrams for RRM		8.0.1	8.1.0	
RAN5 #41bis	R5-086346	0006	-	Update of the default message AUTHENTICATION FAILURE		8.0.1	8.1.0	
RAN5 #41bis	R5-086362	0007	-	update of reference configuration systems for CDMA2000 in 36.508		8.0.1	8.1.0	
RAN5 #41bis	R5-086363	0008	-	Updated of common and default parameters for CDMA2000 cells		8.0.1	8.1.0	
RAN5 #41bis	R5-086364	0009	-	Update of SystemInformationBlockType8 in 36.508		8.0.1	8.1.0	
RAN5 #41bis	R5-086369	0010	-	Addition of reference EPS bearer contexts		8.0.1	8.1.0	
RAN5 #41bis	R5-086370	0011	-	Mapping of default DL Physical Channels for TDD in 36.508		8.0.1	8.1.0	
RAN5 #41bis	R5-086400	0012	-	Addition of RS_EPRE powers to default DL signal levels		8.0.1	8.1.0	
RAN5 #42	R5-090084	0013	-	Test procedure to verify that an EPS bearer context is active		8.0.1	8.1.0	
RAN5 #42	R5-090362	0014	-	Correction to the definition of simulated NAS cells in TS 36.508		8.0.1	8.1.0	
RAN5 #42	R5-090464	0015	-	Clean up the test algorithm for authentication		8.0.1	8.1.0	
RAN5 #42	R5-090586	0016	-	Add specific information elements for RRC reconfiguration		8.0.1	8.1.0	
RAN5 #42	R5-090630	0017	-	Introduction of alternative DRX configurations		8.0.1	8.1.0	
RAN5 #42	R5-090681	0018	-	Correction to the default NAS message contents in TS 36.508		8.0.1	8.1.0	
RAN5 #42	R5-090682	0019	-	Correction to the definition of simulated cells in TS 36.508		8.0.1	8.1.0	

Meeting-1st-Level	Doc-1st-Level	CR	Rev	Subject	Cat	Version-Current	Version-New	Doc-2nd-Level
RAN5 #42	R5-090698	0020	-	Update of 4.5 generic procedures in 36.508		8.0.1	8.1.0	
RAN5 #42	R5-090699	0021	-	TDD RTT correction for timer tolerance		8.0.1	8.1.0	
RAN5 #42	R5-090759	0022	-	Correction to the default RRC message contents in TS 36.508		8.0.1	8.1.0	
RAN5 #42	R5-091000	0023	-	Correction to clause 4.3.3.3		8.0.1	8.1.0	
RAN5 #42	R5-091001	0024	-	LTE-RF: Clarification to 36.508 Simulated Cells for RF tests		8.0.1	8.1.0	
RAN5 #43	RP-090447	0025	-	Correction to Cell off power		8.1.0	8.2.0	R5-092086
RAN5 #43	RP-090447	0026	-	LTE Signalling Tests: UE Rx antenna connection		8.1.0	8.2.0	R5-092087
RAN5 #43	RP-090448	0027	-	CR to 36.508 for subclause 4.3.1 channel bandwidth clarification for RF tests (re-submit no changes)		8.1.0	8.2.0	R5-092124
RAN5 #43	RP-090448	0028	-	Text for 4.2.2: Minimum functional requirements		8.1.0	8.2.0	R5-092128
RAN5 #43	RP-090448	0029	-	Annex A: transition from 1 to 2 RX antenna		8.1.0	8.2.0	R5-092132
RAN5 #43	RP-090447	0030	-	Update of SN length in UM RLC default configuration		8.1.0	8.2.0	R5-092202
RAN5 #43	RP-090448	0031	-	TP for simulated UTRA TDD cell parameter		8.1.0	8.2.0	R5-092275
RAN5 #43	RP-090447	0032	-	Correction to specific message contents in setup procedure in TS 36.508		8.1.0	8.2.0	R5-092349
RAN5 #43	RP-090447	0033	-	Correction to the definition of simulated NAS cells in TS 36.508		8.1.0	8.2.0	R5-092352
RAN5 #43	RP-090447	0034	-	CR on 6.7 TDD Timer Tolerance in 36.508		8.1.0	8.2.0	R5-092363
RAN5 #43	RP-090448	0044	-	Update of 4.5.2A in 36.508 (Re-submit not change)		8.1.0	8.2.0	R5-092457
RAN5 #43	RP-090448	0035	-	Default value of q-RxLevMin for RF TCs		8.1.0	8.2.0	R5-092458
RAN5 #43	RP-090598	0045	-	CR to 36.508 Addition of test frequencies for band 18 and band 19		8.1.0	8.2.0	R5-092535
RAN5 #43	RP-090447	0036	-	Update of the default NAS message contents in TS 36.508		8.1.0	8.2.0	R5-092708
RAN5 #43	RP-090447	0037	-	Correction to reference radio bearer configurations		8.1.0	8.2.0	R5-092721
RAN5 #43	RP-090447	0038	-	Definition of default Test Control (TC) messages		8.1.0	8.2.0	R5-092734
RAN5 #43	RP-090448	0039	-	Modification of procedures in section 4.5.2.3 /4.5.2A		8.1.0	8.2.0	R5-092735
RAN5 #43	RP-090447	0040	-	Addition of default physical layer parameters		8.1.0	8.2.0	R5-092736
RAN5 #43	RP-090447	0041	-	Correction to default RRC message contents		8.1.0	8.2.0	R5-092738
RAN5 #43	RP-090447	0042	-	Introduction in 36.508 of a common tracking/routing area update procedure for Idle mode and RRC connection release test cases		8.1.0	8.2.0	R5-092765
RAN5 #43	RP-090447	0043	-	Corrections to default system configurations in TS 36.508		8.1.0	8.2.0	R5-092773
RAN5 #43	RP-090447	0046	-	Max. resources for signalling test cases		8.1.0	8.2.0	R5-092723
-	-	-	-	Editorial corrections and merging of all sections together		8.2.0	8.2.1	-
RAN5 #44	RP-090802	0047	-	Correction to the default value of ul-Bandwidth in TS 36.508	F	8.2.1	8.3.0	R5-094059
RAN5 #44	RP-090802	0048	-	UTRAN SIB scheduling for LTE interRAT test	F	8.2.1	8.3.0	R5-094072
RAN5 #44	RP-090802	0049	-	Correction to the default NAS message contents	F	8.2.1	8.3.0	R5-094141
RAN5 #44	RP-090802	0050	-	TDD fields in default physical layer parameters	F	8.2.1	8.3.0	R5-094279
RAN5 #44	RP-090802	0051	-	Addition of UTRA reference radio bearer parameters and GERAN reference PDP context parameters for E-UTRA Inter-RAT testing	F	8.2.1	8.3.0	R5-094304
RAN5 #44	RP-090801	0052	-	System information scheduling for RF testing	F	8.2.1	8.3.0	R5-094311
RAN5 #44	RP-090801	0053	-	Connection for 1 cell with antenna configuration 1x2 in static propagation conditions	F	8.2.1	8.3.0	R5-094364
RAN5	RP-090801	0054	-	Correction to 4.3.1.2.5 TDD reference test frequencies	F	8.2.1	8.3.0	R5-094373

Meeting-1st-Level	Doc-1st-Level	CR	Rev	Subject	Cat	Version-Current	Version-New	Doc-2nd-Level
#44				for Operating Band 37				
RAN5 #44	RP-090801	0055	-	LTE RF: Physical Layer configurations for RF/RRM testing	F	8.2.1	8.3.0	R5-094421
RAN5 #44	RP-090802	0056	-	Update of SN length in PDCP default configuration	F	8.2.1	8.3.0	R5-094533
RAN5 #44	RP-090802	0057	-	Corrections to default RRC message and IE contents	F	8.2.1	8.3.0	R5-094639
RAN5 #44	RP-090801	0058	-	Update of TDD reference test frequencies for operating band 40	F	8.2.1	8.3.0	R5-094786
RAN5 #44	RP-090810	0059	-	TDD special subframe pattern update	F	8.2.1	8.3.0	R5-094901
RAN5 #44	RP-090802	0060	-	corrections to reference RB configurations	F	8.2.1	8.3.0	R5-095064
RAN5 #44	RP-090802	0061	-	Correction of test procedure 6.4.2.7 in TS 36.508	F	8.2.1	8.3.0	R5-095093
RAN5 #44	RP-090802	0062	-	Adding new elementary files to the default USIM settings	F	8.2.1	8.3.0	R5-095100
RAN5 #44	RP-090802	0063	-	Correction to the Test procedure to check RRC_IDLE state	F	8.2.1	8.3.0	R5-095102
RAN5 #44	RP-090802	0064	-	Introduction of UE mode of operation into NAS default message contents	F	8.2.1	8.3.0	R5-095138
RAN5 #44	RP-090802	0065	-	TDD ACK/NACK feedback mode update	F	8.2.1	8.3.0	R5-095152
RAN5 #44	RP-090802	0066	-	Corrections to default signal levels	F	8.2.1	8.3.0	R5-095206
RAN5 #44	RP-090802	0067	-	Update to default messages in regard to IP address allocation	F	8.2.1	8.3.0	R5-095218
RAN5 #45	RP-091121	0068	-	Correction to 4.3.1.2.6 TDD reference test frequencies for Operating Band 38	F	8.3.0	8.4.0	R5-095486
RAN5 #45	RP-091121	0069	-	Correction CR to 36.508: Set the default parameter for offsetFreq in MeasObjectGERAN Information Element	F	8.3.0	8.4.0	R5-095514
RAN5 #45	RP-091470	0070	-	Addition of HSPA UTRA reference radio bearer parameters for E-UTRA Inter-RAT testing	F	8.3.0	8.4.0	R5-095555
RAN5 #45	RP-091122	0071	-	Introduction of RS power boosting to reduce interference	F	8.3.0	8.4.0	R5-095594
RAN5 #45	RP-091122	0072	-	Corrections to default RRC message contents	F	8.3.0	8.4.0	R5-095651
RAN5 #45	RP-091122	0073	-	Clarification for Cell Configuration Identifiers in 36.508	F	8.3.0	8.4.0	R5-096005
RAN5 #45	RP-091122	0074	-	Correction to the generic procedure for IP allocation and more	F	8.3.0	8.4.0	R5-096114
RAN5 #45	RP-091122	0075	-	Addition of new generic procedure for TAU after inter-RAT HO from UTRA	F	8.3.0	8.4.0	R5-096115
RAN5 #45	RP-091122	0076	-	Update of header chapter 5.2 in 36.508	F	8.3.0	8.4.0	R5-096202
RAN5 #45	RP-091122	0077	-	Correction to the default NAS message contents	F	8.3.0	8.4.0	R5-096403
RAN5 #45	RP-091122	0078	-	cell frequency allocation	F	8.3.0	8.4.0	R5-096440
RAN5 #45	RP-091122	0079	-	Correction for IP address allocation	F	8.3.0	8.4.0	R5-096447
RAN5 #45	RP-091122	0080	-	LAI and TMSI in ATTACH ACCEPT and TAU ACCEPT messages	F	8.3.0	8.4.0	R5-096449
RAN5 #45	RP-091122	0081	-	Addition of generic procedure for IP address allocation / configuration in U-plane	F	8.3.0	8.4.0	R5-096455
RAN5 #45	RP-091122	0082	-	Correction of test procedures in TS 36.508	F	8.3.0	8.4.0	R5-096456
RAN5 #45	RP-091122	0083	-	Update of MAC configuration for disabling PHR and BSR for L2 test cases	F	8.3.0	8.4.0	R5-096458
RAN5 #45	RP-091122	0084	-	Addition of default UTRA message contents to TS 36.508	F	8.3.0	8.4.0	R5-096461
RAN5 #45	RP-091122	0085	-	Clarification to the mapping of GERAN cells and the default parameter values	F	8.3.0	8.4.0	R5-096462
RAN5 #45	RP-091122	0086	-	Correction of TFTs for reference dedicated EPS bearer contexts	F	8.3.0	8.4.0	R5-096464
RAN5 #45	RP-091122	0087	-	Cleanup of default NAS message contents	F	8.3.0	8.4.0	R5-096465
RAN5 #45	RP-091122	0088	-	LTE-Sig: Assignment of different rootSequenceIndex for cells at the same frequency	F	8.3.0	8.4.0	R5-096641
RAN5 #46	RP-100143	0089	-	Correction of SIB19 scheduling position in the neighbouring UTRA cell	F	8.4.0	8.5.0	R5-100086

Meeting-1st-Level	Doc-1st-Level	CR	Rev	Subject	Cat	Version-Current	Version-New	Doc-2nd-Level
RAN5 #46	RP-100143	0091	-	Correction of Quantity Configuration for EUTRA	F	8.4.0	8.5.0	R5-100110
RAN5 #46	RP-100143	0092	-	Correction for the offset value of RSRP in EUTRA	F	8.4.0	8.5.0	R5-100111
RAN5 #46	RP-100143	0093	-	SIB10 and SIB11 periodicity	F	8.4.0	8.5.0	R5-100112
RAN5 #46	RP-100143	0094	-	Assignment of rootSequenceIndex for simulated NAS cells in different PLMNs	F	8.4.0	8.5.0	R5-100260
RAN5 #46	RP-100143	0095	-	Editorial correction to the default value of 'p-a'	F	8.4.0	8.5.0	R5-100261
RAN5 #46	RP-100142	0096	-	New chapter: Test environment for RRM tests	F	8.4.0	8.5.0	R5-100396
RAN5 #46	RP-100143	0097	-	Remove UM in DRB reconfiguration	F	8.4.0	8.5.0	R5-100487
RAN5 #46	RP-100143	0098	-	Addition of default power allocation for two TX antennas	F	8.4.0	8.5.0	R5-100518
RAN5 #46	RP-100143	0099	-	Correction to TFT parameters used in ACTIVATE DEDICATED EPS BEARER CONTEXT REQUEST message	F	8.4.0	8.5.0	R5-100771
RAN5 #46	RP-100143	0100	-	Update to RRC common messages for support of test cases for MIMO	F	8.4.0	8.5.0	R5-100786
RAN5 #46	RP-100152	0101	-	Adding band 20 in 36.508	F	8.4.0	8.5.0	R5-100846
RAN5 #46	RP-100154	0102	-	CR to 36.508: Update test frequencies with extended LTE1500 operating bands	F	8.4.0	8.5.0	R5-100847
RAN5 #46	RP-100143	0103	-	Defining default message contents for ATTACH/TAU REQUEST/ACCEPT messages according to UE capability	F	8.4.0	8.5.0	R5-101021
RAN5 #46	RP-100143	0104	-	Limitation of simultaneous co-existence of intra-freq cells to reduce interference	F	8.4.0	8.5.0	R5-101029
RAN5 #46	RP-100143	0105	-	An additional option for IP address allocation in test cases using UE test mode	F	8.4.0	8.5.0	R5-101045
RAN5 #46	RP-100143	0106	-	Specify default UL NAS check	F	8.4.0	8.5.0	R5-101051
RAN5 #46	RP-100143	0107	-	Correct default requirement for some mandatory information elements	F	8.4.0	8.5.0	R5-101052
RAN5 #46	RP-100142	0108	-	Addition of Tracking area updating procedure	F	8.4.0	8.5.0	R5-101136
RAN5 #46	RP-100143	0109	-	Clarification of Security Protection for NAS Messages	F	8.4.0	8.5.0	R5-101147
RAN5 #46	RP-100143	0110	-	Update to layer 2 UM test cases to increase the drx-Inactivity Timer to psf200	F	8.4.0	8.5.0	R5-101178
RAN5 #46	RP-100143	0111	-	Addition of new generic procedure for bearer establishment for MO call.	F	8.4.0	8.5.0	R5-101187
RAN5 #46	RP-100143	0112	-	update of default bandwidth configuration for signalling	F	8.4.0	8.5.0	R5-101207
RP#47	-	-	-	Moved to v9.0.0 with no change	-	8.5.0	9.0.0	-
RP#48	RP-100510	0143	-	Clarification of security protection when NAS security mode procedure has taken place outside of a TC sequence	F	9.0.0	9.1.0	R5-103085
RP#48	RP-100523	0113	-	CR to 36.508: Update of EARFCN for band 21	F	9.0.0	9.1.0	R5-103101
RP#48	RP-100510	0114	-	Correction to the default message contents of EXTENDED SERVICE REQUEST	F	9.0.0	9.1.0	R5-103128
RP#48	RP-100510	0115	-	Removal of unrealistic network behaviour from generic procedures	F	9.0.0	9.1.0	R5-103223
RP#48	RP-100510	0116	-	Correction of table numbers in clause 6.2.3.1	F	9.0.0	9.1.0	R5-103232
RP#48	RP-100510	0117	-	Correction to default values for PhysicalConfigDedicated and MIMO	F	9.0.0	9.1.0	R5-103287
RP#48	RP-100510	0118	-	Correction to SR-ConfigIndex for LTE TDD signalling test cases	F	9.0.0	9.1.0	R5-103290
RP#48	RP-100510	0119	-	Correction to MME Group ID to set MSB to 1	F	9.0.0	9.1.0	R5-103298
RP#48	RP-100500	0144	-	Connection diagram for test 8.11.2 (3 cells)	F	9.0.0	9.1.0	R5-103311
RP#48	RP-100510	0120	-	New combination of system information blocks for CSG Cell in TS 36.508	F	9.0.0	9.1.0	R5-103363
RP#48	RP-100510	0121	-	Clarification of security protection for detach request message	F	9.0.0	9.1.0	R5-103368

Meeting-1st-Level	Doc-1st-Level	CR	Rev	Subject	Cat	Version-Current	Version-New	Doc-2nd-Level
RP#48	RP-100510	0122	-	Corrections to cell numbers for 3GPP2 Inter-RAT network scenarios	F	9.0.0	9.1.0	R5-103374
RP#48	RP-100510	0140	-	Clarification to default message content for Modify EPS Bearer Context Request message	F	9.0.0	9.1.0	R5-103625
RP#48	RP-100510	0141	-	Clarification to default message content for RRC Connection Reconfiguration message	F	9.0.0	9.1.0	R5-103626
RP#48	RP-100524	0123	-	Addition of WLAN test cell	F	9.0.0	9.1.0	R5-103647
RP#48	RP-100524	0124	-	Addition of default message contents for mobility management based on DSMIPv6 testing	F	9.0.0	9.1.0	R5-103648
RP#48	RP-100510	0125	-	Update default message contents for EPS attach conditions	F	9.0.0	9.1.0	R5-103673
RP#48	RP-100510	0126	-	Update default message with network support for IMS voice	F	9.0.0	9.1.0	R5-103674
RP#48	RP-100510	0127	-	Correction to Generic Test Procedure in TS 36.508	F	9.0.0	9.1.0	R5-103675
RP#48	RP-100510	0128	-	Default settings of suitable - non-suitable cells for UTRAN/GERAN	F	9.0.0	9.1.0	R5-103677
RP#48	RP-100510	0129	-	Correction to IE schedulingRequestConfig during Handover	F	9.0.0	9.1.0	R5-103678
RP#48	RP-100510	0130	-	Update generic procedures for IMS	F	9.0.0	9.1.0	R5-103679
RP#48	RP-100510	0131	-	Aligning E-UTRAN USIM parameters for multi-RAT devices	F	9.0.0	9.1.0	R5-103680
RP#48	RP-100510	0132	-	Adding Additional Update Result handling to the default messages	F	9.0.0	9.1.0	R5-103681
RP#48	RP-100509	0133	-	Connection diagram update for intra-freq measurement with phase rotator	F	9.0.0	9.1.0	R5-103770
RP#48	RP-100509	0134	-	Update of default bandwidth configuration for Signalling for Band 38	F	9.0.0	9.1.0	R5-103813
RP#48	RP-100524	0135	-	Addition of generic procedures for mobility management based on DSMIPv6 testing	F	9.0.0	9.1.0	R5-103858
RP#48	RP-100510	0136	-	Addition of new generic procedure for MO SMS over SGs and clarifications	F	9.0.0	9.1.0	R5-103869
RP#48	RP-100510	0137	-	Addition of generic procedures for HRPD and 1xRTT pre-registration	F	9.0.0	9.1.0	R5-103870
RP#48	RP-100510	0138	-	Introduction of reference information for test case postambles	F	9.0.0	9.1.0	R5-103875
RP#48	RP-100509	0139	-	Physical layer parameter correction to DCI formats used in RF tests	F	9.0.0	9.1.0	R5-103885
RP#49	RP-100812	0145	-	Update of tested channel bandwidths for Bands 13, 14 and 17	F	9.1.0	9.2.0	R5-104089
RP#49	RP-100816	0146	-	Correction to remove special configurations for UM Bearer test cases	F	9.1.0	9.2.0	R5-104106
RP#49	RP-100816	0147	-	Clarification to the procedure: UE triggered establishment of a default EPS bearer context associated with an additional PDN	F	9.1.0	9.2.0	R5-104128
RP#49	RP-100816	0148	-	Correction to Inter-frequency carrier frequency list in SIB5 and E-UTRA carrier frequency list in SIB19	F	9.1.0	9.2.0	R5-104169
RP#49	RP-100816	0149	-	Update of 6.2.3 of 36.508 - description of default frequency for the single cell signalling test	F	9.1.0	9.2.0	R5-104220
RP#49	RP-100831	0150	-	Update of default message contents for DSMIPv6 testing	F	9.1.0	9.2.0	R5-104392
RP#49	RP-100837	0151	-	Addition of UE test state model for HRPD	F	9.1.0	9.2.0	R5-104454
RP#49	RP-100812	0152	-	Correction to Qrxlevmin in SIB 1 for RF and RRM	F	9.1.0	9.2.0	R5-104503
RP#49	RP-100816	0153	-	Specification of HRPD specific values in SIB8	F	9.1.0	9.2.0	R5-104547
RP#49	RP-100816	0154	-	Update of default bandwidth configuration for signalling	F	9.1.0	9.2.0	R5-104685
RP#49	RP-100816	0155	-	Clarification to packet filter identifier and precedence in TFT	F	9.1.0	9.2.0	R5-104702
RP#49	RP-100816	0156	-	Add P-CSCF method II for IMS	F	9.1.0	9.2.0	R5-104703
RP#49	RP-100816	0157	-	Update generic procedures for IMS	F	9.1.0	9.2.0	R5-104704
RP#49	RP-100816	0158	-	Correction of clause 4.3.3.4	F	9.1.0	9.2.0	R5-104705
RP#49	RP-100816	0159	-	Correction to Downlink Frequency for N_DL 4850	F	9.1.0	9.2.0	R5-104706

Meeting-1st-Level	Doc-1st-Level	CR	Rev	Subject	Cat	Version-Current	Version-New	Doc-2nd-Level
RP#49	RP-100816	0160	-	Default message contents for UTRAN and GERAN	F	9.1.0	9.2.0	R5-104707
RP#49	RP-100812	0161	-	Addition of the new connection diagram for the CSI test case	F	9.1.0	9.2.0	R5-104884
RP#49	RP-100816	0162	-	Correction to reference end states	F	9.1.0	9.2.0	R5-105003
RP#49	RP-100837	0163	-	Correction for Timer Tolerances	F	9.1.0	9.2.0	R5-105050
RP#49	RP-100885	0165	-	Introduction of default message contents for HRPD overhead messages	F	9.1.0	9.2.0	-
GP#49	GP-101743	0166	-	Update of Common parameters for simulated GERAN cells for supporting GERAN-EUTRAN Inter-RAT cell reselection	F	9.2.0	9.3.0	GP-101743
RP#50	RP-101138	0167	-	MBSFN configuration for RRM tests using E-UTRA FDD cells	F	9.2.0	9.3.0	R5-106070
RP#50	RP-101155	0169	-	CR to 36.508: Update test frequencies for EUTRA TDD LTE band 41.	F	9.2.0	9.3.0	R5-106105
RP#50	RP-101142	0168	-	CR to 36.508: Correction to HRPD Overhead messages (subclause 4.4.7.1)	F	9.2.0	9.3.0	R5-106116
RP#50	RP-101142	0170	-	Addition of test frequencies for LTE-C2k interworking test cases	F	9.2.0	9.3.0	R5-106298
RP#50	RP-101142	0172	-	Addition of UTRA reference radio parameters and combination for PS RB and Speech	F	9.2.0	9.3.0	R5-106383
RP#50	RP-101142	0175	-	Correction to EUTRA carrier frequency list in SIB19	F	9.2.0	9.3.0	R5-106421
RP#50	RP-101142	0171	-	Correction to the IDENTITY RESPONSE (with IMSI) message	F	9.2.0	9.3.0	R5-106551
RP#50	RP-101142	0178	-	Correction for DRX offset start time	F	9.2.0	9.3.0	R5-106552
RP#50	RP-101142	0177	-	Correction of specific message content for generic procedures (state 2 and state 2A)	F	9.2.0	9.3.0	R5-106596
RP#50	RP-101138	0180	-	LTE-RF state 3A	F	9.2.0	9.3.0	R5-106597
RP#50	RP-101142	0176	-	Correction to security protection header for Identity Request message	F	9.2.0	9.3.0	R5-106611
RP#50	RP-101142	0173	-	Addition of new system information combinations	F	9.2.0	9.3.0	R5-106616
RP#50	RP-101142	0174	-	Remove SS requirement for IMS in UTRA	F	9.2.0	9.3.0	R5-106690
RP#50	RP-101159	0179	-	Corrections to default settings for Elementary Files (EFs) on Test USIM	F	9.2.0	9.3.0	R5-106819
RP#50	RP-101138	0181	-	Update of the RF exceptional RRC message	F	9.2.0	9.3.0	R5-106820
RP#51	RP-110161	0182	-	Update of HRPD overhead message parameters AccessSignature, SectorSignature	F	9.3.0	9.4.0	R5-110069
RP#51	RP-110161	0183	-	Add a new eUTRA sub-end state E2_T3440	F	9.3.0	9.4.0	R5-110105
RP#51	RP-110161	0184	-	Correction for NAS message NOTE	F	9.3.0	9.4.0	R5-110229
RP#51	RP-110161	0185	-	Addition of CSIM default contents	F	9.3.0	9.4.0	R5-110331
RP#51	RP-110161	0186	-	Update of Table 4.4.2-1 with HRPD/1xRTT frequency range info	F	9.3.0	9.4.0	R5-110332
RP#51	RP-110157	0187	-	Update of the RF exceptional RRC message	F	9.3.0	9.4.0	R5-110410
RP#51	RP-110161	0188	-	Editorial correction for IMS signalling	F	9.3.0	9.4.0	R5-110433
RP#51	RP-110161	0189	-	Correction to SIB combinations related to HeNB Cells	F	9.3.0	9.4.0	R5-110471
RP#51	RP-110161	0190	-	Correction to default message content for Detach Request message	F	9.3.0	9.4.0	R5-110472

Meeting-1st-Level	Doc-1st-Level	CR	Rev	Subject	Cat	Version-Current	Version-New	Doc-2nd-Level
RP#51	RP-110157	0191	-	Removal of Lower Humidity Limit in Normal Conditions	F	9.3.0	9.4.0	R5-110534
RP#51	RP-110157	0192	-	Correction of EARFCN numbers for band 41	F	9.3.0	9.4.0	R5-110542
RP#51	RP-110161	0193	-	Removal of "Modified contents of the EFs at the ISIM ADF (application DF) level"	F	9.3.0	9.4.0	R5-110593
RP#51	RP-110161	0194	-	Correction of the IEs for compressed mode in table 4.7B.1-5	F	9.3.0	9.4.0	R5-110601
RP#51	RP-110161	0195	-	Update to default message content for TRACKING AREA UPDATE REQUEST message	F	9.3.0	9.4.0	R5-110703
RP#51	RP-110161	0196	-	Add default APN for IMS	F	9.3.0	9.4.0	R5-110708
RP#51	RP-110161	0197	-	Introduction of over head messages for CDMA2000 1XRTT	F	9.3.0	9.4.0	R5-110710
RP#51	RP-110161	0198	-	Addition of default SMS over SGs message contents	F	9.3.0	9.4.0	R5-110875
RP#51	RP-110161	0199	-	Correction to 'Test procedure to check that UE is camped on E-UTRAN cell upon mobility from another RAT'	F	9.3.0	9.4.0	R5-110746
RP#51	RP-110161	0200	-	Correction of frequency allocations	F	9.3.0	9.4.0	R5-110788
RP#51	RP-110161	0201	-	Update of Reference packet filters contents	F	9.3.0	9.4.0	R5-110789
RP#51	RP-110157	0202	-	Correction to FDD Reference Test Frequencies for Operating Band 12	F	9.3.0	9.4.0	R5-110846
RP#51	RP-110157	0203	-	LTE RF: state 3A-RF update	F	9.3.0	9.4.0	R5-110937
RP#51	RP-110172	0204	-	Add test frequencies for bands 42, 43 (3500MHz)	F	9.3.0	9.4.0	R5-110968
RP#52	RP-110647	0205	-	Correction to default message content of LOCATION UPDATING REQUEST message	F	9.4.0	9.5.0	R5-112114
RP#52	RP-110647	0206	-	Correction to default message content of TRACKING AREA UPDATE REQUEST message	F	9.4.0	9.5.0	R5-112120
RP#52	RP-110643	0207	-	PRACH-Config-DEFAULT for RF-tests TDD: Correction to derivation path	F	9.4.0	9.5.0	R5-112146
RP#52	RP-110643	0208	-	Correction to connection diagram for CQI with uneven interference test (A.21)	F	9.4.0	9.5.0	R5-112147
RP#52	RP-110647	0209	-	Update to Common contents of system information blocks	F	9.4.0	9.5.0	R5-112161
RP#52	RP-110647	0210	-	Addition of missing labels in Figure 4.5.1-1	F	9.4.0	9.5.0	R5-112278
RP#52	RP-110647	0211	-	Corrections to Table 4.3.7-6	F	9.4.0	9.5.0	R5-112279
RP#52	RP-110647	0212	-	Update of CSIM default contents	F	9.4.0	9.5.0	R5-112285
RP#52	RP-110660	0213	-	Add emergency bearer support	F	9.4.0	9.5.0	R5-112289
RP#52	RP-110667	0214	-	Band 24 Addition to TS 36.508	F	9.4.0	9.5.0	R5-112381
RP#52	RP-110643	0215	-	New connection diagrams to Annex A	F	9.4.0	9.5.0	R5-112458
RP#52	RP-110647	0216	-	Correction to Derivation Path for RB Setup on UTRA side (condition UTRA PS RB)	F	9.4.0	9.5.0	R5-112571
RP#52	RP-110647	0217	-	Update APN check at attach	F	9.4.0	9.5.0	R5-112598
RP#52	RP-110647	0218	-	Update of SIB7 default message contents	F	9.4.0	9.5.0	R5-112599
RP#52	RP-110647	0219	-	Clarification to conditions for IP address configuration over user plane	F	9.4.0	9.5.0	R5-112600

Meeting-1st-Level	Doc-1st-Level	CR	Rev	Subject	Cat	Version-Current	Version-New	Doc-2nd-Level
RP#52	RP-110666	0220	-	Introduction of UE Test Loop Mode C for LTE MBMS testing	F	9.4.0	9.5.0	R5-112675
RP#52	RP-110647	0222	-	Update 36.508 QoS definition for InterRat test cases	F	9.4.0	9.5.0	R5-112698
RP#52	RP-110666	0221	-	Addition of some MBMS related message definitions in TS36.508	F	9.4.0	9.5.0	R5-112748
RP#52	RP-110647	0223	-	Introduction of generic CS fall back procedures for UTRAN and GERAN	F	9.4.0	9.5.0	R5-112751
RP#52	RP-110643	0224	-	Default Bandwidth Configuration for RF Testing	F	9.4.0	9.5.0	R5-112760
RP#52	RP-110643	0225	-	Update for PRACH-Config-DEFAULT for the default TDD RRM message	F	9.4.0	9.5.0	R5-112872
RP#52	RP-110647	0205	-	Correction to default message content of LOCATION UPDATING REQUEST message	F	9.4.0	9.5.0	R5-112114
RP#52	RP-110647	0206	-	Correction to default message content of TRACKING AREA UPDATE REQUEST message	F	9.4.0	9.5.0	R5-112120
RP#52	RP-110643	0207	-	PRACH-Config-DEFAULT for RF-tests TDD: Correction to derivation path	F	9.4.0	9.5.0	R5-112146
RP#52	RP-110643	0208	-	Correction to connection diagram for CQI with uneven interference test (A.21)	F	9.4.0	9.5.0	R5-112147
RP#52	RP-110647	0209	-	Update to Common contents of system information blocks	F	9.4.0	9.5.0	R5-112161
RP#52	RP-110647	0210	-	Addition of missing labels in Figure 4.5.1-1	F	9.4.0	9.5.0	R5-112278
RP#52	RP-110647	0211	-	Corrections to Table 4.3.7-6	F	9.4.0	9.5.0	R5-112279
RP#52	RP-110647	0212	-	Update of CSIM default contents	F	9.4.0	9.5.0	R5-112285
RP#52	RP-110660	0213	-	Add emergency bearer support	F	9.4.0	9.5.0	R5-112289
RP#52	RP-110667	0214	-	Band 24 Addition to TS 36.508	F	9.4.0	9.5.0	R5-112381
RP#52	RP-110643	0215	-	New connection diagrams to Annex A	F	9.4.0	9.5.0	R5-112458
RP#52	RP-110647	0216	-	Correction to Derivation Path for RB Setup on UTRA side (condition UTRA PS RB)	F	9.4.0	9.5.0	R5-112571
RP#52	RP-110647	0217	-	Update APN check at attach	F	9.4.0	9.5.0	R5-112598
RP#52	RP-110647	0218	-	Update of SIB7 default message contents	F	9.4.0	9.5.0	R5-112599
RP#52	RP-110647	0219	-	Clarification to conditions for IP address configuration over user plane	F	9.4.0	9.5.0	R5-112600
RP#52	RP-110647	0222	-	Update 36.508 QoS definition for InterRat test cases	F	9.4.0	9.5.0	R5-112698
RP#52	RP-110666	0221	-	Addition of some MBMS related message definitions in TS36.508	F	9.4.0	9.5.0	R5-112748
RP#52	RP-110647	0223	-	Introduction of generic CS fall back procedures for UTRAN and GERAN	F	9.4.0	9.5.0	R5-112751
RP#52	RP-110643	0224	-	Default Bandwidth Configuration for RF Testing	F	9.4.0	9.5.0	R5-112760
RP#52	RP-110643	0225	-	Update for PRACH-Config-DEFAULT for the default TDD RRM message	F	9.4.0	9.5.0	R5-112872
RP#53	RP-111138	0226	-	Correction for generic CS fallback procedures for UTRAN	F	9.5.0	9.6.0	R5-113033
RP#53	RP-111138	0227	-	Correction to paging test procedure	F	9.5.0	9.6.0	R5-113163
RP#53	RP-111138	0228	-	Deletion of 'EPSONlyAttachForced' in common part	F	9.5.0	9.6.0	R5-113195

Meeting-1st-Level	Doc-1st-Level	CR	Rev	Subject	Cat	Version-Current	Version-New	Doc-2nd-Level
RP#53	RP-111135	0229	-	Deletion of 'EPSONlyAttachForced' in RF part	F	9.5.0	9.6.0	R5-113213
RP#53	RP-111135	0230	-	Correction to PhysicalConfigDedicated-DEFAULT for HO case	F	9.5.0	9.6.0	R5-113450
RP#53	RP-111138	0231	-	Addition of the 'Expanded 1900 MHz band' as operating band 25 to TS 36.508	F	9.5.0	9.6.0	R5-113500
RP#53	RP-111153	0232	-	Band 24 Details for Signalling part of 36.508	F	9.5.0	9.6.0	R5-113521
RP#53	RP-111138	0233	-	Add new SI combination	F	9.5.0	9.6.0	R5-113658
RP#53	RP-111138	0234	-	Update of HRPD/1xRTT test frequencies, pre-registration procedures and message contents	F	9.5.0	9.6.0	R5-113659
RP#53	RP-111138	0235	-	Correction to test procedures specific message contents	F	9.5.0	9.6.0	R5-113660
RP#53	RP-111138	0236	-	Correction to 'Test procedure to check that UE is camped on E-UTRAN cell upon mobility from another RAT'	F	9.5.0	9.6.0	R5-113661
RP#53	RP-111138	0237	-	Correction for the default NAS message contents	F	9.5.0	9.6.0	R5-113662
RP#53	RP-111138	0238	-	Update UTRA RRC messages	F	9.5.0	9.6.0	R5-113663
RP#53	RP-111138	0239	-	Update UTRA NAS messages	F	9.5.0	9.6.0	R5-113664
RP#53	RP-111138	0240	-	Addition of default GERAN message PS HANDOVER COMMAND	F	9.5.0	9.6.0	R5-113665
RP#53	RP-111138	0241	-	Update test procedure 6.4.3.7.6	F	9.5.0	9.6.0	R5-113666
RP#53	RP-111138	0242	-	Update test procedure 6.4.3.7.5	F	9.5.0	9.6.0	R5-113667
RP#53	RP-111155	0243	-	Update test frequencies for FDD LTE Band 23 in 36.508	F	9.5.0	9.6.0	R5-113749
RP#53	RP-111138	0244	-	Correction on the IE ReportConfigEUTRA-PERIODICAL definition	F	9.5.0	9.6.0	R5-113751
RP#53	RP-111148	0245	-	Correction to TS36.508 subclause 4.6.1	F	9.5.0	9.6.0	R5-113761
RP#53	RP-111145	0246	-	Combined parallel procedures between EUTRA/EPC and IMS emergency call	F	9.5.0	9.6.0	R5-113801
RP#53	RP-111135	0247	-	RF/RRM State 3A-RF: Editors note	F	9.5.0	9.6.0	R5-114037
RP#54	RP-111579	0248	-	Correction of the default message contents of Transaction Identifiers in Activate Default EPS Bearer Context and Activate Dedicated EPS Bearer Context messages	F	9.6.0	9.7.0	R5-115091
RP#54	RP-111596	0250	-	Adding band 22 (3500MHz FDD) to 36.508	F	9.6.0	9.7.0	R5-115185
RP#54	RP-111579	0251	-	Update of UE Registration pre-registration on 1xRTT registrationPeriod	F	9.6.0	9.7.0	R5-115264
RP#54	RP-111579	0252	-	Update UTRA RRC message for handover to UTRAN	F	9.6.0	9.7.0	R5-115533
RP#54	RP-111579	0253	-	Add reference default EPS bearer context for QCI 5	F	9.6.0	9.7.0	R5-115537
RP#54	RP-111579	0254	-	Correction of EPS Bearer Contexts	F	9.6.0	9.7.0	R5-115585
RP#54	RP-111579	0255	-	Correction to ESM default messages	F	9.6.0	9.7.0	R5-115618
RP#54	RP-111579	0256	-	Introduction of Combined Generic test procedure for IMS Speech call	F	9.6.0	9.7.0	R5-115619
RP#54	RP-111576	0257	-	default band configuration for RF testing in band 25	F	9.6.0	9.7.0	R5-115633
RP#54	RP-111579	0258	-	Complete the system configuration for dual mode network scenario	F	9.6.0	9.7.0	R5-115694

Meeting-1st-Level	Doc-1st-Level	CR	Rev	Subject	Cat	Version-Current	Version-New	Doc-2nd-Level
RP#54	RP-111579	0259	-	Correction to IE PhysicalConfigDedicated-DEFAULT definition in Table 4.8.2.1.6-1	F	9.6.0	9.7.0	R5-115696
RP#54	RP-111579	0260	-	Updates for 1xRTT pre-registration scenario	F	9.6.0	9.7.0	R5-115708
RP#54	RP-111579	0261	-	Update of UE 1xRTT registrationPeriod in SystemInformationBlock type8	F	9.6.0	9.7.0	R5-115750
RP#54	RP-111579	0262	-	Correction to 1xRTT Overhead Message contents	F	9.6.0	9.7.0	R5-115791
RP#55	RP-120176	0263	-	Correction to measurement control and report in default UTRA message	F	9.7.0	9.8.0	R5-120311
RP#55	RP-120176	0264	-	Update of E-UTRAN_QRXLEVMIN in SIB19 and SI2 Quarter	F	9.7.0	9.8.0	R5-120312
RP#55	RP-120176	0265	-	Update of RF Reference system configurations	F	9.7.0	9.8.0	R5-120313
RP#55	RP-120179	0266	-	Correction of Physical Layer configurations	F	9.7.0	9.8.0	R5-120497
RP#55	RP-120179	0267	-	Correction of E2_T3440 state definition	F	9.7.0	9.8.0	R5-120566
RP#55	RP-120179	0268	-	Correction of default PCO value in some ESM messages	F	9.7.0	9.8.0	R5-120572
RP#55	RP-120179	0269	-	Correction to the default message content of GERAN carrier frequency group list for E-UTRA cells	F	9.7.0	9.8.0	R5-120604
RP#55	RP-120179	0270	-	Update of SystemInformationBlockType1	F	9.7.0	9.8.0	R5-120616
RP#55	RP-120179	0271	-	Update the default configuration of channel bandwidth for Band 39 for signalling testing	F	9.7.0	9.8.0	R5-120617
RP#55	RP-120179	0272	-	Correction for UE pre-registration on CDMA2000 system	F	9.7.0	9.8.0	R5-120618
RP#55	RP-120179	0273	-	Update to Reference default EPS bearer context #2	F	9.7.0	9.8.0	R5-120619
RP#55	RP-120179	0274	-	Correction to the default (UTRA) Physical Channel Reconfiguration message	F	9.7.0	9.8.0	R5-120620
RP#55	RP-120179	0275	-	Correction of default measurement gap offset	F	9.7.0	9.8.0	R5-120621
RP#55	RP-120179	0276	-	Correction to carrier bandwidth	F	9.7.0	9.8.0	R5-120677
RP#55	RP-120192	0277	-	Update generic procedure 4.5A.4	F	9.7.0	9.8.0	R5-120693
RP#55	RP-120192	0278	-	Update generic procedure 4.5A.5	F	9.7.0	9.8.0	R5-120694
RP#55	RP-120200	0280	-	Addition of the default value of Carrier Aggregation parameters	F	9.7.0	9.8.0	R5-120726
RP#55	RP-120179	0282	-	Correction of UE Release in UE capability	F	9.7.0	9.8.0	R5-120752
RP#55	RP-120179	0283	-	Introduction of generic test procedure for SRVCC call handover to UTRA	F	9.7.0	9.8.0	R5-120753
RP#55	RP-120179	0284	-	Correction to test procedure sequence 6.4.2.7A for check that UE is camped on E-UTRAN cell upon mobility from another RAT	F	9.7.0	9.8.0	R5-120754
RP#55	RP-120179	0285	-	Addition of Default UTRA RRC Connection Request message	F	9.7.0	9.8.0	R5-120756
RP#55	RP-120176	0286	-	TS 36.508: Band 23 test frequencies correction	F	9.7.0	9.8.0	R5-120800
RP#55	RP-120179	0287	-	Remove IPv4viaNAS_TestMode	F	9.7.0	9.8.0	R5-120908
RP#55	GP-120009	0288	-	Section 4.4.5 Common parameters for simulated GERAN cells – Correction to SI2 Quarter	F	9.7.0	9.8.0	GP-120009
RP#55	RP-120203	0279	-	Addition of two MBMS counting related messages in TS	F	9.8.0	10.0.0	R5-120723

Meeting-1st-Level	Doc-1st-Level	CR	Rev	Subject	Cat	Version-Current	Version-New	Doc-2nd-Level
				36.508				
RP#55	RP-120199	0281	-	Introduction of new RRC default messages for Rel-10 and MDT	F	9.8.0	10.0.0	R5-120737
RP#56	RP-120644	0290	-	Correction of power ratio allocation on PDSCH for common logical channels	F	10.0.0	10.1.0	R5-121089
RP#56	RP-120644	0291	-	Correction to default mobilityParameters message contents	F	10.0.0	10.1.0	R5-121121
RP#56	RP-120644	0292	-	Corrections to default overhead messages for HRPD	F	10.0.0	10.1.0	R5-121122
RP#56	RP-120644	0293	-	Corrections to default overhead messages for 1xRTT	F	10.0.0	10.1.0	R5-121123
RP#56	RP-120644	0294	-	Update of CSFBParametersRequest/ResponseCDMA2000 process in Registration	F	10.0.0	10.1.0	R5-121276
RP#56	RP-120641	0295	-	RRM: Definition of parameters for simulated GSM cells	F	10.0.0	10.1.0	R5-121357
RP#56	RP-120662	0296	-	SIB Combination for CA test scenarios	F	10.0.0	10.1.0	R5-121383
RP#56	RP-120644	0297	-	Addition of default value of RSRQ Cell Reselection parameters	F	10.0.0	10.1.0	R5-121384
RP#56	RP-120641	0298	-	Test frequencies for inter-band cells in RRM tests	F	10.0.0	10.1.0	R5-121407
RP#56	RP-120644	0299	-	Update generic procedure 4.5A.6	F	10.0.0	10.1.0	R5-121413
RP#56	RP-120644	0300	-	Update generic procedure 4.5A.7	F	10.0.0	10.1.0	R5-121414
RP#56	RP-120644	0301	-	Update generic procedure 4.5A.3	F	10.0.0	10.1.0	R5-121439
RP#56	RP-120644	0302	-	Correction to RadioResourceConfigCommon-DEFAULT	F	10.0.0	10.1.0	R5-121447
RP#56	RP-120641	0304	-	Removing 5.2A.3 for State 2A	F	10.0.0	10.1.0	R5-121521
RP#56	RP-120641	0305	-	Addition of A-GNSS testing to Test frequencies clause 4.3.1	F	10.0.0	10.1.0	R5-121543
RP#56	RP-120641	0306	-	Ensuring all SS TX antennas are in use for whole test sequence	F	10.0.0	10.1.0	R5-121544
RP#56	RP-120641	0307	-	Connection diagram for RRM 3 cell TCs with static propagation	F	10.0.0	10.1.0	R5-121556
RP#56	RP-120644	0308	-	Correction of Physical Layer configurations tables	F	10.0.0	10.1.0	R5-121665
RP#56	RP-120644	0309	-	Update of default bandwidth configuration for E-UTRA FDD band 11 and 18	F	10.0.0	10.1.0	R5-121712
RP#56	RP-120644	0310	-	Correction to default SIB4 contents for CSG cells	F	10.0.0	10.1.0	R5-121733
RP#56	RP-120644	0311	-	Update of CDMA2000 Band Class data and addition of CDMA2000 Band Class 10	F	10.0.0	10.1.0	R5-121734
RP#56	RP-120644	0312	-	Update to Reference dedicated EPS bearer context #3	F	10.0.0	10.1.0	R5-121735
RP#56	RP-120644	0313	-	Add generic procedure MO video call	F	10.0.0	10.1.0	R5-121736
RP#56	RP-120644	0314	-	Add generic procedure MT video call	F	10.0.0	10.1.0	R5-121737
RP#56	RP-120644	0315	-	Clarifications to UICC requirements for LTE-C2K testing	F	10.0.0	10.1.0	R5-121809
RP#56	RP-120644	0316	-	Update UE capability information	F	10.0.0	10.1.0	R5-121847
RP#56	RP-120658	0317	-	Introduction of System information for PWS	F	10.0.0	10.1.0	R5-121854
RP#56	RP-120662	0318	-	Update of the default value of Carrier Aggregation parameters	F	10.0.0	10.1.0	R5-121856

Meeting-1st-Level	Doc-1st-Level	CR	Rev	Subject	Cat	Version-Current	Version-New	Doc-2nd-Level
RP#56	RP-120644	0319	-	Correction to reference system configurations for dual mode scenarios	F	10.0.0	10.1.0	R5-121888
RP#56	RP-120667	0320	-	Adding operating band 26 to TS 36.508	F	10.0.0	10.1.0	R5-121905
RP#56	RP-120641	0321	-	Addition of State 3B-RF in 36.508	F	10.0.0	10.1.0	R5-121919
RP#56	RP-120641	0322	-	Correction to Tracking area updating procedure in 36.508	F	10.0.0	10.1.0	R5-121936
RP#56	RP-120662	0323	-	Addition of Test mode call procedure for CA test cases	F	10.0.0	10.1.0	R5-121982
RP#56	RP-120641	0303	-	Correction to Handover to UTRAN commands for UTRA RRC messages in 36.508	F	10.0.0	10.1.0	R5-122018
RP#56	RP-120662	0324	-	36.508 - Test frequencies for CA_1C and CA_40C	F	10.0.0	10.1.0	R5-122134
RP#56	RP-120649	0289	-	Removal of technical content in 36.508 v9.8.0 and substitution with pointer to the next Release	F	10.0.0	10.1.0	R5-121078
RP#56	RP-120644	0290	-	Correction of power ratio allocation on PDSCH for common logical channels	F	10.0.0	10.1.0	R5-121089
RP#56	RP-120644	0291	-	Correction to default mobilityParameters message contents	F	10.0.0	10.1.0	R5-121121
RP#56	RP-120644	0292	-	Corrections to default overhead messages for HRPD	F	10.0.0	10.1.0	R5-121122
RP#56	RP-120644	0293	-	Corrections to default overhead messages for 1xRTT	F	10.0.0	10.1.0	R5-121123
RP#56	RP-120644	0294	-	Update of CSFBParametersRequest/ResponseCDMA2000 process in Registration	F	10.0.0	10.1.0	R5-121276
RP#56	RP-120641	0295	-	RRM: Definition of parameters for simulated GSM cells	F	10.0.0	10.1.0	R5-121357
RP#56	RP-120662	0296	-	SIB Combination for CA test scenarios	F	10.0.0	10.1.0	R5-121383
RP#56	RP-120644	0297	-	Addition of default value of RSRQ Cell Reselection parameters	F	10.0.0	10.1.0	R5-121384
RP#56	RP-120641	0298	-	Test frequencies for inter-band cells in RRM tests	F	10.0.0	10.1.0	R5-121407
RP#56	RP-120644	0299	-	Update generic procedure 4.5A.6	F	10.0.0	10.1.0	R5-121413
RP#56	RP-120644	0300	-	Update generic procedure 4.5A.7	F	10.0.0	10.1.0	R5-121414
RP#56	RP-120644	0301	-	Update generic procedure 4.5A.3	F	10.0.0	10.1.0	R5-121439
RP#56	RP-120644	0302	-	Correction to RadioResourceConfigCommon-DEFAULT	F	10.0.0	10.1.0	R5-121447
RP#56	RP-120641	0304	-	Removing 5.2A.3 for State 2A	F	10.0.0	10.1.0	R5-121521
RP#56	RP-120641	0305	-	Addition of A-GNSS testing to Test frequencies clause 4.3.1	F	10.0.0	10.1.0	R5-121543
RP#56	RP-120641	0306	-	Ensuring all SS TX antennas are in use for whole test sequence	F	10.0.0	10.1.0	R5-121544
RP#56	RP-120641	0307	-	Connection diagram for RRM 3 cell TCs with static propagation	F	10.0.0	10.1.0	R5-121556
RP#56	RP-120644	0308	-	Correction of Physical Layer configurations tables	F	10.0.0	10.1.0	R5-121665
RP#56	RP-120644	0309	-	Update of default bandwidth configuration for E-UTRA FDD band 11 and 18	F	10.0.0	10.1.0	R5-121712
RP#56	RP-120644	0310	-	Correction to default SIB4 contents for CSG cells	F	10.0.0	10.1.0	R5-121733
RP#56	RP-120644	0311	-	Update of CDMA2000 Band Class data and addition of CDMA2000 Band Class 10	F	10.0.0	10.1.0	R5-121734

Meeting-1st-Level	Doc-1st-Level	CR	Rev	Subject	Cat	Version-Current	Version-New	Doc-2nd-Level
RP#56	RP-120644	0312	-	Update to Reference dedicated EPS bearer context #3	F	10.0.0	10.1.0	R5-121735
RP#56	RP-120644	0313	-	Add generic procedure MO video call	F	10.0.0	10.1.0	R5-121736
RP#56	RP-120644	0314	-	Add generic procedure MT video call	F	10.0.0	10.1.0	R5-121737
RP#56	RP-120644	0315	-	Clarifications to UICC requirements for LTE-C2K testing	F	10.0.0	10.1.0	R5-121809
RP#56	RP-120644	0316	-	Update UE capability information	F	10.0.0	10.1.0	R5-121847
RP#56	RP-120658	0317	-	Introduction of System information for PWS	F	10.0.0	10.1.0	R5-121854
RP#56	RP-120662	0318	-	Update of the default value of Carrier Aggregation parameters	F	10.0.0	10.1.0	R5-121856
RP#56	RP-120644	0319	-	Correction to reference system configurations for dual mode scenarios	F	10.0.0	10.1.0	R5-121888
RP#56	RP-120667	0320	-	Adding operating band 26 to TS 36.508	F	10.0.0	10.1.0	R5-121905
RP#56	RP-120641	0321	-	Addition of State 3B-RF in 36.508	F	10.0.0	10.1.0	R5-121919
RP#56	RP-120641	0322	-	Correction to Tracking area updating procedure in 36.508	F	10.0.0	10.1.0	R5-121936
RP#56	RP-120662	0323	-	Addition of Test mode call procedure for CA test cases	F	10.0.0	10.1.0	R5-121982
RP#56	RP-120641	0303	-	Correction to Handover to UTRAN commands for UTRA RRC messages in 36.508	F	10.0.0	10.1.0	R5-122018
RP#56	RP-120662	0324	-	36.508 - Test frequencies for CA_1C and CA_40C	F	10.0.0	10.1.0	R5-122134
RP#57	RP-121098	0325	-	Correction to default message content of UTRA NAS attach accept message	F	10.1.0	10.2.0	R5-123114
RP#57	RP-121098	0326	-	Correction default message content for Tracking Area Update Request message	F	10.1.0	10.2.0	R5-123117
RP#57	RP-121095	0327	-	RF: Addition of messages and SIB combination informations for RF MBMS tests	F	10.1.0	10.2.0	R5-123211
RP#57	RP-121098	0328	-	Clarify requirements for ROHC	F	10.1.0	10.2.0	R5-123259
RP#57	RP-121098	0329	-	Updates to cl 6.x regarding use of MIMO	F	10.1.0	10.2.0	R5-123304
RP#57	RP-121113	0330	-	Update of default parameters for Carrier Aggregation	F	10.1.0	10.2.0	R5-123305
RP#57	RP-121098	0331	-	Addition of default value of Additional update parameters	F	10.1.0	10.2.0	R5-123306
RP#57	RP-121098	0332	-	Addition of default value of Explicit Signalling Indication parameters	F	10.1.0	10.2.0	R5-123307
RP#57	RP-121095	0333	-	Update of NeighCellConfig for RRM tests	F	10.1.0	10.2.0	R5-123328
RP#57	RP-121095	0334	-	Correction to HO commands for UTRAN TDD	F	10.1.0	10.2.0	R5-123329
RP#57	RP-121116	0335	-	Addition of new connection diagrams for UL-MIMO Testing	F	10.1.0	10.2.0	R5-123390
RP#57	RP-121098	0336	-	Correction to generic test procedure CS fallback to GERAN with redirection or CCO / MT call(DTM not supported)	F	10.1.0	10.2.0	R5-123629
RP#57	RP-121098	0337	-	Correction to RRC Connection Reconfiguration message during Handover from UTRA to EUTRA	F	10.1.0	10.2.0	R5-123630
RP#57	RP-121098	0338	-	Update to Reference dedicated EPS bearer context #3	F	10.1.0	10.2.0	R5-123632
RP#57	RP-121098	0339	-	Update generic procedure 4.5A.6	F	10.1.0	10.2.0	R5-123633
RP#57	RP-121098	0340	-	Update generic procedure 4.5A.7	F	10.1.0	10.2.0	R5-123634

Meeting-1st-Level	Doc-1st-Level	CR	Rev	Subject	Cat	Version-Current	Version-New	Doc-2nd-Level
RP#57	RP-121098	0341	-	Update generic procedure 4.5A.8	F	10.1.0	10.2.0	R5-123635
RP#57	RP-121098	0342	-	Update generic procedure 4.5A.9	F	10.1.0	10.2.0	R5-123636
RP#57	RP-121098	0343	-	Update the default value of IE RadioResourceConfigCommon and IE additionalSpectrumEmission	F	10.1.0	10.2.0	R5-123712
RP#57	RP-121098	0344	-	Correction to test procedure 6.4.2.10	F	10.1.0	10.2.0	R5-123720
RP#57	RP-121098	0345	-	Corrections to CDMA2000 message sequences	F	10.1.0	10.2.0	R5-123728
RP#57	RP-121098	0346	-	Update of UE Capability Information	F	10.1.0	10.2.0	R5-123729
RP#57	RP-121098	0347	-	Update of Paging test procedure (for NAS test cases)	F	10.1.0	10.2.0	R5-123730
RP#57	RP-121098	0348	-	Addition of guard timer to the procedure for IMS signalling	F	10.1.0	10.2.0	R5-123731
RP#57	RP-121098	0349	-	Update to cl. 6.4.2.7A and 7.2B.1	F	10.1.0	10.2.0	R5-123734
RP#57	RP-121113	0351	-	Extension of cell configurations for Carrier Aggregation	F	10.1.0	10.2.0	R5-123751
RP#57	RP-121113	0352	-	Maximum number of cells simultaneously used in Carrier Aggregation test cases	F	10.1.0	10.2.0	R5-123752
RP#57	RP-121098	0353	-	Update of default MSPL and MLPL contents in Test UICC	F	10.1.0	10.2.0	R5-123767
RP#57	RP-121113	0354	-	Correction to the CA test state references	F	10.1.0	10.2.0	R5-123949

History

Document history		
V10.0.0	April 2012	Publication
V10.1.0	August 2012	Publication
V10.2.0	October 2012	Publication