

ETSI TS 136 401 V15.1.0 (2019-04)



**LTE;
Evolved Universal Terrestrial
Radio Access Network (E-UTRAN);
Architecture description
(3GPP TS 36.401 version 15.1.0 Release 15)**



Reference

RTS/TSGR-0336401vf10

Keywords

LTE

ETSI

650 Route des Lucioles
F-06921 Sophia Antipolis Cedex - FRANCE

Tel.: +33 4 92 94 42 00 Fax: +33 4 93 65 47 16

Siret N° 348 623 562 00017 - NAF 742 C
Association à but non lucratif enregistrée à la
Sous-Préfecture de Grasse (06) N° 7803/88

Important notice

The present document can be downloaded from:

<http://www.etsi.org/standards-search>

The present document may be made available in electronic versions and/or in print. The content of any electronic and/or print versions of the present document shall not be modified without the prior written authorization of ETSI. In case of any existing or perceived difference in contents between such versions and/or in print, the prevailing version of an ETSI deliverable is the one made publicly available in PDF format at www.etsi.org/deliver.

Users of the present document should be aware that the document may be subject to revision or change of status.

Information on the current status of this and other ETSI documents is available at

<https://portal.etsi.org/TB/ETSIDeliverableStatus.aspx>

If you find errors in the present document, please send your comment to one of the following services:

<https://portal.etsi.org/People/CommitteeSupportStaff.aspx>

Copyright Notification

No part may be reproduced or utilized in any form or by any means, electronic or mechanical, including photocopying and microfilm except as authorized by written permission of ETSI.

The content of the PDF version shall not be modified without the written authorization of ETSI.

The copyright and the foregoing restriction extend to reproduction in all media.

© ETSI 2019.

All rights reserved.

DECT™, **PLUGTESTS™**, **UMTS™** and the ETSI logo are trademarks of ETSI registered for the benefit of its Members.

3GPP™ and **LTE™** are trademarks of ETSI registered for the benefit of its Members and of the 3GPP Organizational Partners.

oneM2M™ logo is a trademark of ETSI registered for the benefit of its Members and of the oneM2M Partners.

GSM® and the GSM logo are trademarks registered and owned by the GSM Association.

Intellectual Property Rights

Essential patents

IPRs essential or potentially essential to normative deliverables may have been declared to ETSI. The information pertaining to these essential IPRs, if any, is publicly available for **ETSI members and non-members**, and can be found in ETSI SR 000 314: *"Intellectual Property Rights (IPRs); Essential, or potentially Essential, IPRs notified to ETSI in respect of ETSI standards"*, which is available from the ETSI Secretariat. Latest updates are available on the ETSI Web server (<https://ipr.etsi.org/>).

Pursuant to the ETSI IPR Policy, no investigation, including IPR searches, has been carried out by ETSI. No guarantee can be given as to the existence of other IPRs not referenced in ETSI SR 000 314 (or the updates on the ETSI Web server) which are, or may be, or may become, essential to the present document.

Trademarks

The present document may include trademarks and/or tradenames which are asserted and/or registered by their owners. ETSI claims no ownership of these except for any which are indicated as being the property of ETSI, and conveys no right to use or reproduce any trademark and/or tradename. Mention of those trademarks in the present document does not constitute an endorsement by ETSI of products, services or organizations associated with those trademarks.

Foreword

This Technical Specification (TS) has been produced by ETSI 3rd Generation Partnership Project (3GPP).

The present document may refer to technical specifications or reports using their 3GPP identities, UMTS identities or GSM identities. These should be interpreted as being references to the corresponding ETSI deliverables.

The cross reference between GSM, UMTS, 3GPP and ETSI identities can be found under <http://webapp.etsi.org/key/queryform.asp>.

Modal verbs terminology

In the present document "**shall**", "**shall not**", "**should**", "**should not**", "**may**", "**need not**", "**will**", "**will not**", "**can**" and "**cannot**" are to be interpreted as described in clause 3.2 of the [ETSI Drafting Rules](#) (Verbal forms for the expression of provisions).

"**must**" and "**must not**" are **NOT** allowed in ETSI deliverables except when used in direct citation.

Contents

Intellectual Property Rights	2
Foreword.....	2
Modal verbs terminology.....	2
Foreword.....	5
1 Scope	6
2 References	6
3 Definitions and abbreviations.....	7
3.1 Definitions	7
3.2 Abbreviations	7
4 General principles	8
5 General architecture	9
5.1 General	9
5.2 User plane.....	9
5.3 Control plane.....	9
6 E-UTRAN architecture.....	10
6.1 Overview	10
6.2 E-UTRAN identifiers	11
6.2.1 Principle of handling Application Protocol Identities.....	11
6.2.2 PLMN Identity.....	12
6.2.3 Globally Unique MME Identifier (GUMMEI)	12
6.2.4 Global eNB ID.....	12
6.2.5 E-UTRAN Cell Global Identifier (ECGI).....	12
6.2.6 Tracking Area Identity.....	12
6.2.7 E-RAB ID	13
6.2.8 UE Identifiers.....	13
6.2.8.1 Radio Network Temporary Identifiers (RNTI)	13
6.2.8.2 S-Temporary Mobile Subscriber Identity (S-TMSI).....	13
6.3 Transport addresses	13
6.4 UE associations in eNB	13
7 E-UTRAN functions description.....	14
7.1 List of functions	14
7.2 Functions description	14
7.2.1 Transfer of user data	14
7.2.2 Radio channel ciphering and deciphering	15
7.2.3 Integrity protection	15
7.2.4 Header compression.....	15
7.2.5 Mobility control functions	15
7.2.5.1 Handover	15
7.2.5.2 void	15
7.2.5.3 void	15
7.2.5.4 Dual Connectivity	15
7.2.6 Inter-cell interference coordination.....	15
7.2.7 Connection set-up and release	15
7.2.8 Load balancing.....	16
7.2.9 Distribution function for NAS messages	16
7.2.10 NAS node selection function	16
7.2.11 Synchronization	16
7.2.12 Radio Access Network (RAN) sharing.....	16
7.2.13 MBMS function	16
7.2.14 Subscriber and equipment trace.....	16
7.2.15 RAN Information Management (RIM).....	16
7.2.16 Paging	17

7.2.17	Positioning	17
7.2.18	Delivery of warning messages	17
8	Mobility management.....	17
8.1	Signalling connection	17
8.2	Consequences for mobility handling	17
9	Synchronization.....	18
9.1	eNB Synchronization	18
9.2	eNB and MME Synchronization	19
10	void.....	19
11	E-UTRAN interfaces.....	19
11.1	General protocol model for E-UTRAN interfaces.....	19
11.1.1	Radio Network Layer (RNL) and Transport Network Layer (TNL)	19
11.1.2	Control plane	19
11.1.3	User plane	19
11.2	Iuant interface - general principles	20
Annex A (informative): Change history		21
History		22

Foreword

This Technical Specification has been produced by the 3rd Generation Partnership Project (3GPP).

The contents of the present document are subject to continuing work within the TSG and may change following formal TSG approval. Should the TSG modify the contents of the present document, it will be re-released by the TSG with an identifying change of release date and an increase in version number as follows:

Version x.y.z

where:

- x the first digit:
 - 1 presented to TSG for information;
 - 2 presented to TSG for approval;
 - 3 or greater indicates TSG approved document under change control.
- y the second digit is incremented for all changes of substance, i.e. technical enhancements, corrections, updates, etc.
- z the third digit is incremented when editorial only changes have been incorporated in the document.

1 Scope

The present document describes the overall architecture of the E-UTRAN, including internal interfaces and assumptions on the radio, S1 and X2 interfaces.

2 References

The following documents contain provisions which, through reference in this text, constitute provisions of the present document.

- References are either specific (identified by date of publication, edition number, version number, etc.) or non-specific.
- For a specific reference, subsequent revisions do not apply.
- For a non-specific reference, the latest version applies. In the case of a reference to a 3GPP document (including a GSM document), a non-specific reference implicitly refers to the latest version of that document *in the same Release as the present document*.

- [1] 3GPP TR 21.905: "Vocabulary for 3GPP Specifications".
- [2] 3GPP TS 36.300: "Evolved Universal Terrestrial Radio Access (E-UTRA) and Evolved Universal Terrestrial Radio Access Network (E-UTRAN) Overall description Stage 2".
- [3] 3GPP TS 23.401: "General Packet Radio Service (GPRS) enhancements for Evolved Universal Terrestrial Radio Access Network (E-UTRAN) access".
- [4] 3GPP TS 36.414: "Evolved Universal Terrestrial Access Network (E-UTRAN); S1 data transport".
- [5] 3GPP TS 36.424: "Evolved Universal Terrestrial Access Network (E-UTRAN); X2 data transport".
- [6] 3GPP TS 36.440: "Evolved Universal Terrestrial Radio Access Network (E-UTRAN); General aspects and principles for interfaces supporting Multimedia Broadcast Multicast Service (MBMS) within E-UTRAN".
- [7] ITU-T Recommendation G.823 (2000-03): "The control of jitter and wander within digital networks which are based on the 2048 kbit/s hierarchy".
- [8] ITU-T Recommendation G.824 (2000-03): "The control of jitter and wander within digital networks which are based on the 1544 kbit/s hierarchy".
- [9] ITU-T Recommendation G.825 (2001-08): "The control of jitter and wander within digital networks which are based on the synchronous digital hierarchy (SDH)".
- [10] ITU-T Recommendation G.8261/Y.1361 (2008-04): "Timing and Synchronization aspects in Packet networks".
- [11] 3GPP TS 23.003: "Numbering, addressing and identification".
- [12] 3GPP TR 44.901: "External Network Assisted Cell Change (NACC)".
- [13] 3GPP TS 48.018: "General Packet Radio Service (GPRS); Base Station System (BSS) - Serving GPRS Support Node (SGSN); BSS GPRS Protocol (BSSGP)".
- [14] 3GPP TS 23.251: "Network Sharing; Architecture and functional description".
- [15] 3GPP TS 22.268: "Public Warning System (PWS) requirements".
- [16] 3GPP TS 33.401: "3GPP System Architecture Evolution (SAE); Security architecture".
- [17] 3GPP TS 32.421: "Telecommunication management; Subscriber and equipment trace; Trace concepts and requirements".

- [18] 3GPP TS 32.422: "Telecommunication management; Subscriber and equipment trace; Trace control and configuration management".
- [19] 3GPP TS 32.423: "Telecommunication management; Subscriber and equipment trace; Trace data definition and management".
- [20] 3GPP TS 32.441: "Telecommunication management; Trace Management Integration Reference Point (IRP); Requirements".
- [21] 3GPP TS 32.442: "Telecommunication management; Trace Management Integration Reference Point (IRP); Information Service (IS)".
- [22] 3GPP TS 32.446: "Telecommunication management; Trace Management Integration Reference Point (IRP); Solution Set (SS) definitions".
- [23] 3GPP TS 25.411: "UTRAN Iu interface layer 1".
- [24] 3GPP TS 23.682: "Architecture enhancements to facilitate communications with packet data networks and applications".

3 Definitions and abbreviations

3.1 Definitions

For the purposes of the present document, the terms and definitions given in TR 21.905 [1] and the following apply. A term defined in the present document takes precedence over the definition of the same term, if any, in TR 21.905 [1].

Dual Connectivity: Defined in TS 36.300 [2].

E-RAB: An E-RAB uniquely identifies the concatenation of an S1 Bearer and the corresponding Data Radio Bearer. When an E-RAB exists, there is a one-to-one mapping between this E-RAB and an EPS bearer of the Non Access Stratum (NAS) as defined in TS 23.401 [3].

S1: logical interface between an eNB and an EPC, providing an interconnection point between the E-UTRAN and the EPC. It is also considered as a reference point.

X2: logical interface between two eNBs. Whilst logically representing a point-to-point link between eNBs, the physical realization need not be a point-to-point link.

3.2 Abbreviations

For the purposes of the present document, the terms and definitions given in TR 21.905 [1] and the following apply. A term defined in the present document takes precedence over the definition of the same term, if any, in TR 21.905 [1].

AP	Application Protocol
AS	Access Stratum
CGI	Cell Global Identifier
CIoT	Cellular IoT
CMAS	Commercial Mobile Alert Service
C-RNTI	Cell RNTI
ECGI	E-UTRAN Cell Global Identifier
ECM	EPS Connection Management
EEC	Ethernet Equipment Clock
eNB	E-UTRAN Node B
EMM	EPS Mobility Management
E-RAB	E-UTRAN Radio Access Bearer
ESM	EPS Session Management
E-SMLC	Evolved Serving Mobile Location Centre
ETWS	Earthquake and Tsunami Warning System
EPC	Evolved Packet Core
EPS	Evolved Packet System
E-UTRA	Evolved UTRA

E-UTRAN	Evolved UTRAN
FDD	Frequency Division Duplex
GUMMEI	Globally Unique MME Identifier
ID	Identity
IP	Internet Protocol
LTE	Long Term Evolution
MBMS	Multimedia Broadcast Multicast Service
MBSFN	Multimedia Broadcast multicast service Single Frequency Network
MeNB	Master eNB
NDS	Network Domain Security
MME	Mobility Management Entity
NAS	Non-Access Stratum
OTDOA	Observed Time Difference Of Arrival (positioning method)
PLMN	Public Land Mobile Network
PWS	Public Warning System
RA-RNTI	Random Access RNTI
RET	Remote Electrical Tilting
RIM	RAN Information Management
RNL	Radio Network Layer
RNTI	Radio Network Temporary Identifier
RRC	Radio Resource Control
RTP	Real-time Transport Protocol
QoS	Quality of Service
SFN	System Frame Number
S-GW	Serving Gateway
SAP	Service Access Point
SCG	Secondary Cell Group
SeNB	Secondary eNB
SON	Self Organizing Networks
S-TMSI	S-Temporary Mobile Subscriber Identity
TCP	Transmission Control Protocol
TDD	Time Division Duplex
TDM	Time Division Multiplexing
TMA	Tower Mounted Amplifier
TNL	Transport Network Layer
UDP	User Datagram Protocol
UE	User Equipment
UMTS	Universal Mobile Telecommunication System
UTDOA	Uplink Time Difference of Arrival

4 General principles

The general principles guiding the definition of E-UTRAN architecture as well as the E-UTRAN interfaces are the following:

- Logical separation of signalling and data transport networks.
- E-UTRAN and EPC functions are fully separated from transport functions. Addressing scheme used in E-UTRAN and EPC shall not be tied to the addressing schemes of transport functions. The fact that some E-UTRAN or EPC functions reside in the same equipment as some transport functions does not make the transport functions part of the E-UTRAN or the EPC.
- Mobility for RRC connection is fully controlled by the E-UTRAN.
- When defining the E-UTRAN interfaces the following principles were followed:
 - The functional division across the interfaces shall have as few options as possible;
 - Interfaces should be based on a logical model of the entity controlled through this interface;
 - One physical network element can implement multiple logical nodes.

5 General architecture

5.1 General

The protocols over Uu and S1 interfaces are divided into two structures:

- **User plane protocols**
These are the protocols implementing the actual E-RAB service, i.e. carrying user data through the access stratum.
- **Control plane protocols**
These are the protocols for controlling the E-RABs and the connection between the UE and the network from different aspects (including requesting the service, controlling different transmission resources, handover etc.). Also a mechanism for transparent transfer of NAS messages is included.

5.2 User plane

The E-RAB service is offered from SAP to SAP by the Access Stratum. Figure 5.2-1 shows the protocols on the Uu and S1 interfaces that linked together provide this E-RAB service.

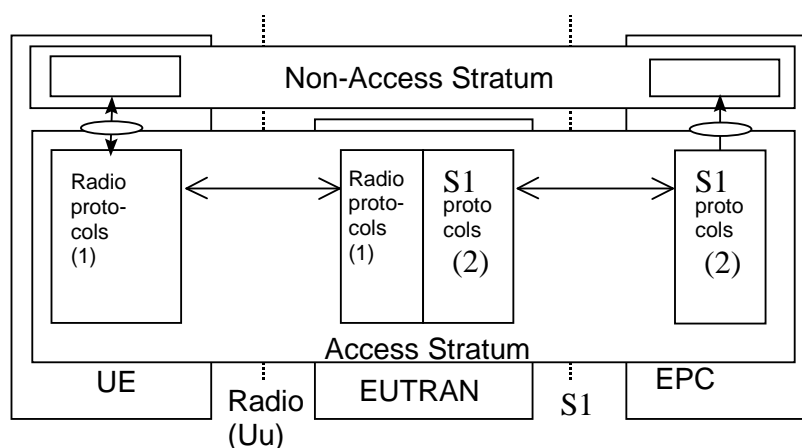

Note 1: The radio interface protocols are defined in 3GPP TS 36.2xx and TS 36.3xx.

Note 2: The S1 interface protocols are defined in 3GPP TS 36.41x.

Figure 5.2-1: S1 and Uu user plane

5.3 Control plane

Figure 5.3-1 shows the control plane (signalling) protocol stacks on S1 and Uu interfaces.

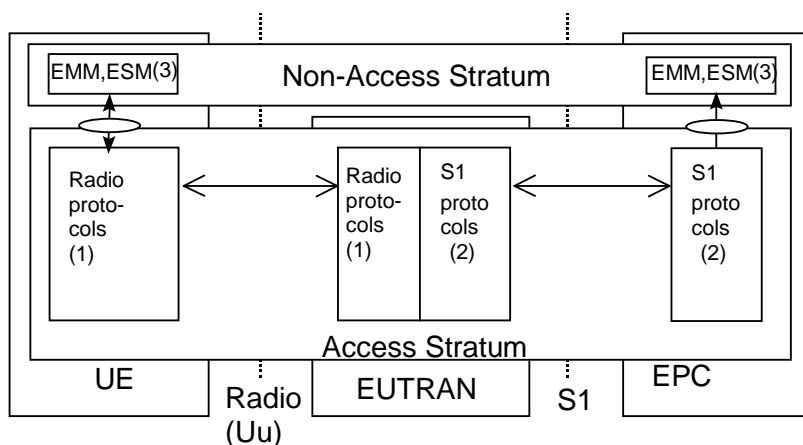

- Note 1: The radio interface protocols are defined in 3GPP TS 36.2xx and TS 36.3xx.
- Note 2: The protocol is defined in 3GPP TS 36.41x. (Description of S1 interface).
- Note 3: **EMM, ESM:** This exemplifies a set of NAS control protocols between UE and EPC. The evolution of the protocol architecture for these protocols is outside the scope of the present document.

Figure 5.3-1: S1 and Uu control plane

NOTE: Both the Radio protocols and the S1 protocols contain a mechanism to transparently transfer NAS messages.

6 E-UTRAN architecture

6.1 Overview

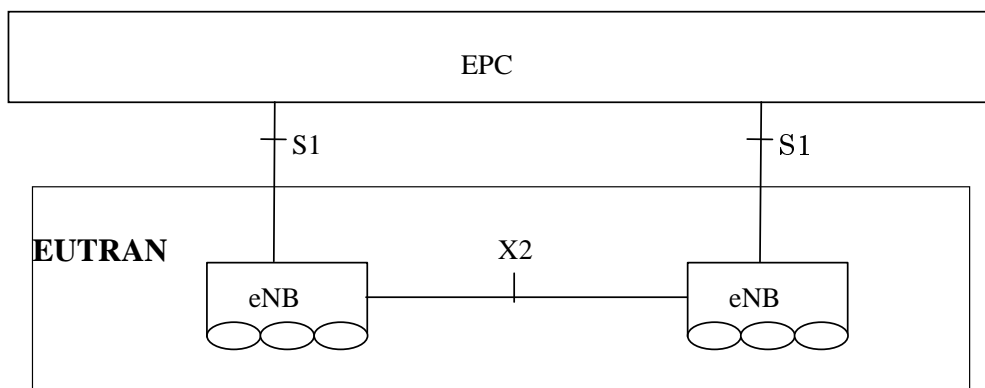

Figure 6.1-1 Overall architecture

The LTE architecture can be further described as follows:

The E-UTRAN consists of a set of eNBs connected to the EPC through the S1.

An eNB can support FDD mode, TDD mode or dual mode operation.

eNBs can be interconnected through the X2.

S1 and X2 are logical interfaces.

The E-UTRAN is layered into a Radio Network Layer (RNL) and a Transport Network Layer (TNL).

The E-UTRAN architecture, i.e. the E-UTRAN logical nodes and interfaces between them, is defined as part of the RNL.

For each E-UTRAN interface (S1, X2) the related TNL protocol and the functionality are specified. The TNL provides services for user plane transport, signalling transport.

In S1-Flex configuration, each eNB is connected to all EPC nodes within a pool area. The pool area is defined in 3GPP TS 23.401 [3].

If security protection for control plane and user plane data on TNL of E-UTRAN interfaces has to be supported, NDS/IP (3GPP TS 33.401 [16]) shall be applied.

The eMBMS architecture is defined in 3GPP TS 36.440 [6].

6.2 E-UTRAN identifiers

This subclause shows those identifiers that are used in E-UTRAN.

6.2.1 Principle of handling Application Protocol Identities

An Application Protocol Identity (AP ID) is allocated when a new UE-associated logical connection is created in an eNB, or an MME, or in a WT. An AP ID shall uniquely identify a logical connection associated to a UE over the S1 interface, or X2 interface, or Xw interface within a node (eNB, or MME, or WT). Upon receipt of a message that has a new AP ID from the sending node, the receiving node shall store the AP ID of the sending node for the duration of the logical connection. The receiving node shall assign the AP ID to be used to identify the logical connection associated to the UE and include it as well as the previously received new AP ID from the sending node, in the first returned message to the sending node. In all subsequent messages to and from sending node, both AP IDs of sending node and receiving node shall be included.

The definitions of AP IDs as used on S1 interface, or X2 interface, or Xw interface are shown below:

eNB UE S1AP ID:

An eNB UE S1AP ID shall be allocated so as to uniquely identify the UE over the S1 interface within an eNB. When an MME receives an eNB UE S1AP ID it shall store it for the duration of the UE-associated logical S1-connection for this UE. Once known to an MME this is included in all UE associated S1-AP signalling. The eNB UE S1AP ID shall be unique within the eNB logical node.

MME UE S1AP ID:

A MME UE S1AP ID shall be allocated so as to uniquely identify the UE over the S1 interface within the MME. When an eNB receives MME UE S1AP ID it shall store it for the duration of the UE-associated logical S1-connection for this UE. Once known to an eNB this ID is included in all UE associated S1-AP signalling. The MME UE S1AP ID shall be unique within the MME logical node.

Old eNB UE X2AP ID:

An Old eNB UE X2AP ID shall be allocated so as to uniquely identify the UE over the X2 interface within a source eNB. When a target eNB receives an Old eNB UE X2AP ID it shall store it for the duration of the UE-associated logical X2-connection for this UE. Once known to a target eNB this ID is included in all UE associated X2-AP signalling. The Old eNB UE X2AP ID shall be unique within the eNB logical node.

New eNB UE X2AP ID:

A New eNB UE X2AP ID shall be allocated so as to uniquely identify the UE over the X2 interface within a target eNB. When a source eNB receives a New eNB UE X2AP ID it shall store it for the duration of the UE-associated logical X2-connection for this UE. Once known to source eNB this ID is included in all UE associated X2-AP signalling. The New eNB UE X2AP ID shall be unique within the eNB logical node.

eNB1 Measurement ID:

An eNB1 Measurement ID shall be allocated so as to uniquely identify the measurement configuration over the X2 interface within the eNB that requests the measurement. The eNB1 Measurement ID shall be unique within the eNB logical node.

eNB2 Measurement ID:

An eNB2 Measurement ID shall be allocated so as to uniquely identify the measurement configuration over the X2 interface within the eNB that performs the measurement. The eNB2 Measurement ID shall be unique within the eNB logical node.

MeNB UE X2AP ID:

A MeNB UE X2AP ID shall be allocated so as to uniquely identify the UE over X2 interface within a MeNB for dual connectivity. When a SeNB receives a MeNB UE X2AP ID it shall store it for the duration of the UE-associated logical X2-connection for this UE. Once known to a SeNB this ID is included in all UE associated X2-AP signalling. The MeNB UE X2AP ID shall be unique within the eNB logical node.

SeNB UE X2AP ID:

A SeNB UE X2AP ID shall be allocated so as to uniquely identify the UE over X2 interface within a SeNB for dual connectivity. When a MeNB receives a SeNB UE X2AP ID it shall store it for the duration of the UE-associated logical X2-connection for this UE. Once known to a MeNB this ID is included in all UE associated X2-AP signalling. The SeNB UE X2AP ID shall be unique within the eNB logical node.

eNB UE XwAP ID:

An eNB UE XwAP ID shall be allocated so as to uniquely identify the UE over Xw interface within an eNB for LWA. When a WT receives an eNB UE XwAP ID, it shall store it for the duration of the UE-associated logical Xw-connection for this UE. Once known to a WT, this ID is included in all UE associated Xw-AP signalling. The eNB UE XwAP ID shall be unique within the eNB logical node.

WT UE XwAP ID:

A WT UE XwAP ID shall be allocated so as to uniquely identify the UE over Xw interface within a WT for LWA. When an eNB receives a WT UE XwAP ID, it shall store it for the duration of the UE-associated logical Xw-connection for this UE. Once known to an eNB, this ID is included in all UE associated Xw-AP signalling. The WT UE XwAP ID shall be unique within the WT logical node.

gNB UE X2AP ID:

A gNB UE X2AP ID shall be allocated so as to uniquely identify the UE over X2 interface within a SgNB for EN-DC. When a MeNB receives a gNB UE X2AP ID it shall store it for the duration of the UE-associated logical X2-connection for this UE. Once known to a MeNB, this ID is included in all UE associated X2-AP signalling. The gNB UE X2AP ID shall be unique within the gNB logical node.

6.2.2 PLMN Identity

A Public Land Mobile Network is uniquely identified by its PLMN Identity.

6.2.3 Globally Unique MME Identifier (GUMMEI)

The Globally Unique MME Identifier consists of a PLMN Identity, a MME Group Identity and a MME Code, as defined in 3GPP TS 23.003 [11].

An MME logical node may be associated with one or more GUMMEI, but each GUMMEI uniquely identifies an MME logical node (3GPP TS 23.003 [11]).

6.2.4 Global eNB ID

The Global eNB ID, used to globally identify an eNB, is defined in 3GPP TS 36.300 [2].

6.2.5 E-UTRAN Cell Global Identifier (ECGI)

The ECGI, used to globally identify a cell, is defined in 3GPP TS 36.300 [2].

6.2.6 Tracking Area Identity

The Tracking Area Identity, used to identify tracking areas, is defined in 3GPP TS 36.300 [2].

6.2.7 E-RAB ID

An E-RAB ID uniquely identifies an E-RAB for one UE accessing via E-UTRAN.

6.2.8 UE Identifiers

6.2.8.1 Radio Network Temporary Identifiers (RNTI)

Radio Network Temporary Identifiers (RNTI) are used as UE identifiers within E-UTRAN and in signalling messages between UE and E-UTRAN. Some types of RNTI exist:

1) C-RNTI

The C-RNTI provides a unique UE identification at the cell level identifying RRC connection.

2) RA-RNTI

The RA-RNTI is used during some transient states, the UE is temporarily identified with a random value for contention resolution purposes.

6.2.8.2 S-Temporary Mobile Subscriber Identity (S-TMSI)

The S-TMSI is a temporary UE identity in order to support the subscriber identity confidentiality. This S-TMSI is allocated by MME.

6.3 Transport addresses

The transport layer address parameter is transported in the radio network application signalling procedures that result in establishment of transport bearer connections.

The transport layer address parameter shall not be interpreted in the radio network application protocols and reveal the addressing format used in the transport layer.

The formats of the transport layer addresses are further described in 3GPP TS 36.414 [4], 3GPP TS 36.424 [5].

6.4 UE associations in eNB

There are several types of UE associations needed in the eNB: the "eNB UE context" used to store all information needed for a UE and the associations between the UE and the logical S1 and X2 connections used for S1/X2-AP UE associated messages. An "eNB UE context" exists for a UE in ECM_CONNECTED, and may continue to exist after the UE transitions to ECM_IDLE if the UE was enabled to use User Plane CIoT EPS Optimization (see TS 23.401 [3]).

Definitions:

eNB UE context:

An eNB UE context is a block of information in an eNB associated to one UE. The block of information contains the necessary information required to maintain the E-UTRAN services towards the active UE. An eNB UE context is established when the transition to active state for a UE is completed or in target eNB after completion of handover resource allocation during handover preparation, in which case at least UE state information, security information, UE capability information and the identities of the UE-associated logical S1-connection shall be included in the eNB UE context. If the UE is enabled to use User Plane CIoT EPS Optimization (see TS 23.401 [3]) the UE-associated logical S1-connection may be kept after the UE transitions to ECM_IDLE.

For Dual Connectivity an eNB UE context is also established in the SeNB after completion of SeNB Addition Preparation.

UE-associated logical S1-connection/ UE-associated logical X2-connection:

On the logical S1 or X2 connection, control plane messages (S1AP, X2AP) associated with the UE are sent. This connection is established during the first S1/X2AP message exchange between the S1/X2 peer nodes. The connection is maintained as long as UE associated S1/X2AP messages need to be exchanged over S1/X2. The UE-associated logical S1-connection uses the identities MME UE S1AP ID and eNB UE S1AP ID. The UE-associated logical X2-connection uses the identities Old eNB UE X2AP ID and New eNB UE X2AP ID, or

MeNB UE X2AP ID and SeNB UE X2AP ID.

When a node (MME or eNB) receives a UE associated S1/X2AP message the node retrieves the associated UE based on the S1/X2AP ID.

UE-associated signalling:

UE-associated signalling is an exchange of S1/X2-AP messages associated with one UE over the UE-associated logical S1/X2-connection.

NOTE: The UE-associated logical S1-connection may exist before the eNB UE context is setup in eNB.
The UE-associated logical X2-connection may exist before the eNB UE context is setup in the target eNB.

7 E-UTRAN functions description

7.1 List of functions

- Transfer of user data
- Radio channel ciphering and deciphering
- Integrity protection
- Header compression
- Mobility control functions:
 - Handover
 - Dual Connectivity
- Inter-cell interference coordination
- Connection setup and release
- Load balancing
- Distribution function for NAS messages
- NAS node selection function
- Synchronization
- Radio access network sharing
- MBMS function
- Subscriber and equipment trace
- RAN Information Management (RIM)
- Paging
- Positioning
- Delivery of warning messages

7.2 Functions description

7.2.1 Transfer of user data

This function provides user data transfer capability across the E-UTRAN between the S1 and Uu interfaces.

7.2.2 Radio channel ciphering and deciphering

This function is a pure computation function whereby the radio transmitted data can be protected against a non-authorized third-party. Ciphering and deciphering may be based on the usage of a session-dependent key, derived through signalling and/or session dependent information.

7.2.3 Integrity protection

This function is a pure computation function whereby the transmitted data can be protected against a non-authorized third-party from alteration.

7.2.4 Header compression

This function provides a header compression specifically to the particular network layer, transport layer or upper layer protocol combination e.g. TCP/IP and RTP/UDP/IP.

7.2.5 Mobility control functions

7.2.5.1 Handover

This function manages the mobility of the radio interface. It is based on radio measurements and it is used to maintain the Quality of Service (QoS) requested by the EPC. It contains the function of transferring the context data between source node and target node.

Handover may be directed to/from another system (e.g. LTE to UMTS handover).

The handover preparation is done in the target network side and final handover decision is done in the source network side.

7.2.5.2 void

7.2.5.3 void

7.2.5.4 Dual Connectivity

E-UTRAN supports Dual Connectivity operation whereby a UE with appropriate capabilities is configured to utilise radio resources provided by two cells (or cell groups) served by two eNBs (MeNB and SeNB) connected via a non-ideal backhaul over the X2 interface.

7.2.6 Inter-cell interference coordination

This function is to manage radio resources (i.e. the radio resource blocks) such that inter-cell interference is kept under control. This function is a multi-cell RRM function that needs to take into account information (e.g. the resource usage status and the traffic load situation) from multiple cells.

7.2.7 Connection set-up and release

This function is responsible for the control of connection element set-up and release in the E-UTRAN. The purpose of this function is:

- 1) to participate in the processing of the end-to-end connection set-up and release; and
- 2) to manage and maintain the element of the end-to-end connection which is located in the E-UTRAN.

In the former case, this function is activated by request from other functional entities at call set-up/release. In the latter case, i.e. when the end-to-end connection has already been established, this function may also be invoked to cater for in-call service modification, at handover execution or in case of connection suspend and resume.

At suspend the UE is triggered to transition from active to idle state while causing the UE/eNB/MME to retain context information, and at resume the connection continues to use the previously stored context information.

7.2.8 Load balancing

Load balancing has the task of handling uneven distribution of the traffic load over multiple cells. The purpose of load balancing is thus to influence the load distribution in such a manner that radio resources over multiple cells remain highly utilized and the QoS of in-progress sessions is maintained to the greatest extent possible and call dropping probabilities are kept sufficiently small. Load balancing algorithms may result in intra-LTE or inter-RAT handover or cell reselection decisions with the purpose of redistributing traffic from highly loaded cells to under-utilized cells. The algorithms may also result in adaptation of mobility parameter settings via exchanges over the X2 interface.

7.2.9 Distribution function for NAS messages

In the RRC protocol and the S1AP, messages from the NAS shall be transparently transferred within the Access Stratum.

7.2.10 NAS node selection function

The interconnection of E-UTRAN to multiple MME / S-GWs is supported in the E-UTRAN architecture. Therefore a NAS node selection function is located in the E-UTRAN to determine the MME association of the UE, based on the UE's temporary identifier, which was assigned to the UE by the MME.

7.2.11 Synchronization

The network synchronization is to maintain the synchronization of the timing between different nodes within the network. As no single method can cover all E-UTRAN applications a logical port at eNB may be used for reception of timing input independent of synchronization method chosen.

7.2.12 Radio Access Network (RAN) sharing

This function is to enable multiple PLMNs to share a Radio Access Network (RAN). This function has mechanisms to direct the UE to the appropriate PLMN at the network sharing border and to restrict UE measurement and reselection to cells that are entitled to access. The E-UTRAN can broadcast multiple PLMN-IDs in the radio interface. The UE can choose one amongst the broadcasted PLMN-IDs.

An eNB is allowed to handover a UE to a target cell with multiple PLMN identities if at least one of the target cell PLMN identities is listed as allowed in the roaming and access restriction information for the UE, i.e. listed as serving PLMN or an equivalent PLMN.

This function is also to enable the SCG selection at the MeNB during Dual Connectivity operation.

7.2.13 MBMS function

This function enables the E-UTRAN to transmit the same data to multiple recipients and allows network and radio resources to be shared.

7.2.14 Subscriber and equipment trace

Support for subscriber and equipment trace for LTE and EPS shall be as specified in 3GPP TS 32.421 [17], TS 32.422 [18], TS 32.423 [19] and TS 32.441 [20], TS 32.442 [21] and TS 32.446 [22].

All traces are initiated by the core network, even if the trace is to be carried out in the radio network.

A trace set-up in the radio network is propagated on the X2 interface at handover and on the S1 interface if the handover is carried out between MMEs.

7.2.15 RAN Information Management (RIM)

The RAN Information Management (RIM) function is a generic mechanism that allows the request and the transfer of information (e.g. GERAN system information) between two RAN nodes via the core network as described in 3GPP TR 44.901 [12] and TS 48.018 [13]. The RIM function includes the request and transfer of SON-related information between RATs.

7.2.16 Paging

This function provides the capability to request an UE to contact the E-UTRAN when UE is in ECM_IDLE state or to be addressed of an incoming warning message (PWS) when UE is in ECM_CONNECTED state.

7.2.17 Positioning

This function provides the capability to determine the E-UTRAN CGI of the serving cell where a UE is currently located.

This function also provides the E-SMLC with uplink positioning measurements for Enhanced Cell ID positioning, uplink assistance data for UTDOA positioning, or other information needed by the E-SMLC which is sent as assistance data to the UE for OTDOA positioning.

7.2.18 Delivery of warning messages

This function provides the capability to schedule and broadcast warning notification messages to UEs related to alerts (earthquake, tsunami, etc..) to meet regional regulatory requirements. ETWS, CMAS and the other warning services which use the same AS mechanisms as CMAS as described in 3GPP TS 36.300 [2] are the E-UTRAN services related to warning deliveries.

In ETWS one warning message at a time is delivered over the radio. In CMAS and the other warning services which use the same AS mechanisms as CMAS as described in 3GPP TS 36.300 [2] multiple concurrent warning messages can be broadcast over the radio.

ETWS includes the scheduling and transmission of a primary warning notification subject to stringent delay that may be followed by a secondary notification providing complementary information about the threat.

PWS is supported in RAN sharing configuration as described in 3GPP TS 23.251 [14] and TS 22.268 [15].

8 Mobility management

8.1 Signalling connection

A UE associated logical S1 connection may either exist or not exist for a UE:

- 1) When a UE associated logical S1 connection exists and the UE is in ECM_CONNECTED, the EPC can reach the UE by the UE associated logical S1 connection on the EPC side, and the E-UTRAN has a context with the UE and the EPC for this particular connection. This context is erased when the connection is released. The UE associated logical S1 connection can be initiated from the UE only.
- 2) When a UE associated logical S1 connection does not exist, the EPC must reach the UE via the common procedure. The message sent to the UE can be a request to the UE to establish a UE associated logical S1 connection. The UE is addressed with a user/terminal identity within a tracking area.
- 3) When a UE associated logical S1 connection exists and the UE is in ECM_IDLE and was enabled to use User Plane CIoT EPS Optimization (see TS 23.401 [3]), the UE may re-connect to the existing UE associated logical S1 connection and the EPC must reach the UE via the common procedure.

8.2 Consequences for mobility handling

In general, the radio access specific procedures should be handled within E-UTRAN. This means that all cell level mobility should be handled within E-UTRAN.

When there exists a dedicated connection to the UE, the E-UTRAN handles the radio interface mobility of the UE. This includes the Handover procedure in the ECM_CONNECTED state.

When a dedicated connection between the E-UTRAN and the UE does not exist and the UE is not enabled to use User Plane CIoT EPS Optimization (see TS 23.401 [3]), no UE context information is stored in E-UTRAN. When a dedicated connection between the E-UTRAN and the UE does not exist and the UE is enabled to use User Plane CIoT EPS Optimization UE context information is stored in E-UTRAN. For UEs in ECM_IDLE, the mobility is handled directly between UE and EPC outside access stratum (e.g. by means of registration procedures). When paging the UE,

the EPC indicates a 'geographical area' that is translated within E-UTRAN to the actual cells that shall be paged. A 'geographical area' could be a tracking area or a list of tracking areas.

Thus, the E-UTRAN does not contain any permanent 'location registers' for the UE, but only temporary UE contexts information.

9 Synchronization

9.1 eNB Synchronization

The eNB shall support a logical synchronization port for phase-, time- and/or frequency synchronization.

Logical synchronization port for phase- and time-synchronization shall provide

- 1) accuracy that allows to meet the eNB requirements on maximum relative phase difference for all eNBs in synchronized TDD-unicast area and FDD/TDD-multicast MBSFN synchronization area;
- 2) continuous time without leap seconds traceable to common time reference for all eNBs in synchronized TDD-unicast area and FDD/TDD-multicast MBSFN synchronization area;

A logical synchronization port for phase- and time-synchronization may also be provided for e.g., all eNBs in FDD time domain inter-cell interference coordination synchronization area.

Furthermore common SFN initialization time shall be provided for all eNBs in synchronized TDD-unicast area and FDD/TDD-multicast MBSFN synchronization area.

Based on this information, the eNB may derive the SFN according to the following formula

$$SFN = \{time\} \bmod \{period(SFN)\},$$

where

time	time adjusted by the common SFN initialization time, in units of 10 ms to match the length of radio frame and accuracy accordingly;
period(SFN)	SFN period.

NOTE: When eNB is connected via TDM interfaces, these could be used to synchronize frequency the eNB. The characteristics of these interfaces are described in 3GPP TS 25.411 [23].

In case eNB is connected via TDM interface, it may be used to synchronize frequency the eNB. The characteristics of the clock in the eNB shall be designed taking into account that the jitter and wander performance requirements on the interface are in accordance with network limits for output wander at traffic interfaces of either ITU-T Rec. G.823 [7], ITU-T Rec. G.824 [8] or network limits for the maximum output jitter and wander at any hierarchical interface of ITU-T Rec. G.825 [9], whichever is applicable.

In case eNB is connected via Ethernet interface and the network supports Synchronous Ethernet, the eNB may use this interface to get frequency synchronization. In this case the design of the eNB clock should be done considering the jitter and wander performance requirements on the interface are as specified for output jitter and wander at EEC interfaces of ITU-T Rec. G.8261/Y.1361 [10], defined in clause 9.2.1. Further considerations on Synchronous Ethernet recommendations and architectural aspects are defined in clause 12.2.1 and Annex A of ITU-T Rec. G.8261/Y.1361 [10].

A configurable LTE TDD-offset of start frame shall be supported by all eNBs in synchronized TDD-unicast areas and/or TDD-multicast MBSFN synchronization areas in order to achieve interoperability in coexistence scenarios.

The logical synchronization port of the HeNB for the time/phase synchronization may be connected to the surrounding E-UTRAN cells. However, different surrounding E-UTRAN cells may have different SFN initialization times and phase drift.

9.2 eNB and MME Synchronization

When paging in extended Idle mode DRX, Hyper SFN synchronization requirements are specified in TS 23.682 [24].

10 void

11 E-UTRAN interfaces

11.1 General protocol model for E-UTRAN interfaces

The general protocol model for E-UTRAN interfaces is depicted in figure 11.1-1, and described in detail in the following subclauses. The structure is based on the principle that the layers and planes are logically independent of each other. Therefore, as and when required, the standardization body can easily alter protocol stacks and planes to fit future requirements.

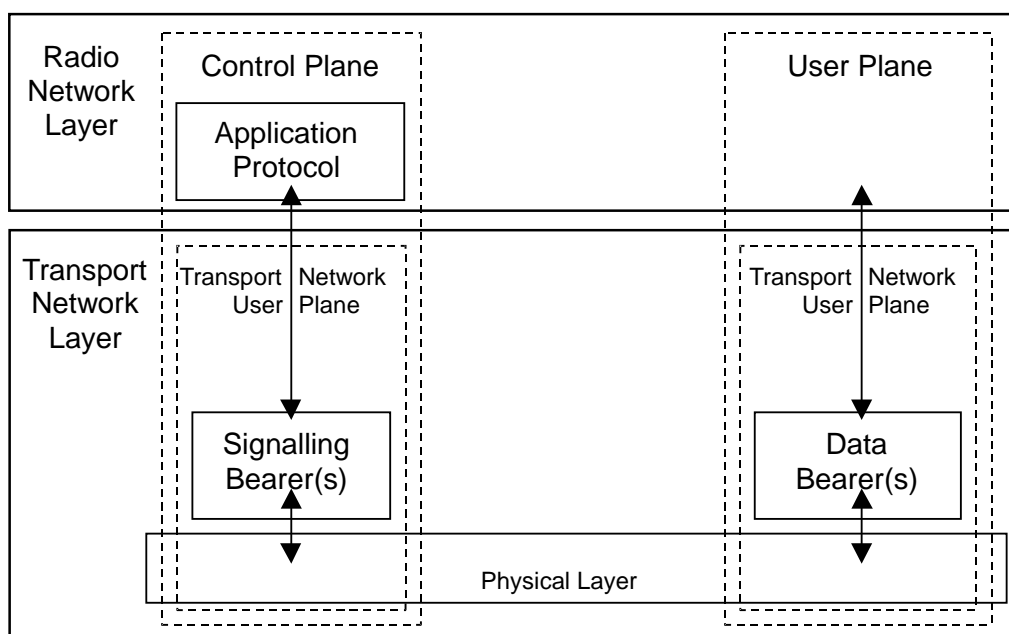

Figure 11.1-1: General protocol model for E-UTRAN interfaces

11.1.1 Radio Network Layer (RNL) and Transport Network Layer (TNL)

The protocol structure consists of two main layers, Radio Network Layer (RNL) and Transport Network Layer (TNL). E-UTRAN functions are realized in the RNL and the TNL represents standard transport technology that is selected to be used for E-UTRAN.

11.1.2 Control plane

The control plane includes the Application Protocol (AP), i.e. S1AP and X2AP and the Signalling Bearer for transporting the AP messages.

The AP is used e.g. for setting up bearers (i.e. E-RAB) in the RNL. The bearer parameters in the AP are not directly tied to the user plane technology, but are rather general bearer parameters.

11.1.3 User plane

The user plane includes the data bearer(s) for the data stream(s). The data stream(s) is characterized by a tunnelling protocol in the TNL.

11.2 Iuant interface - general principles

The Iuant interface for the control of RET antennas or TMAs is a logical part of the E-UTRAN.

The support of any standardised antenna interface technique shall not be prevented; e.g. AISG (Antenna interface standards group) specifications may be used.

Annex A (informative): Change history

TSG #	TSG Doc.	CR	Rev	Subject/Comment	New
2007-12	-	-	-	Specification approved at TSG-RAN 38 and placed under change control	8.0.0
RP-39	RP-080079	0009	-	RAN3 agreed changes for TS 36.401	8.1.0
RP-40	RP-080303	0011	1	RAN3 agreed changes for TS 36.401	8.2.0
RP-41	RP-080582	0016		Uniqueness of eNB UE X2AP ID	8.3.0
RP-41	RP-080582	0017	1	Completion of Cell and eNB identifiers	8.3.0
RP-41	RP-080582	0019		Updating the Control Plane Protocol Stack	8.3.0
RP-41	RP-080582	0020		Correction of the description of subscriber and equipment trace	8.3.0
RP-42	RP-080844	0022		Clarify the relation between GUMMEI and MME UE S1AP ID	8.4.0
RP-42	RP-080844	0023		Proposed way forward of FFS item in 36.401	8.4.0
RP-42	RP-080844	0024	1	Adding the reference and correction on the GUMMEI definition reference	8.4.0
RP-42	RP-080844	0025		Correction on the eNB UE Context descriptions	8.4.0
RP-42	RP-080844	0026	1	RIM support in E-UTRAN	8.4.0
RP-42	RP-080845	0027		Correction of SAE Bearer	8.4.0
RP-42	RP-080844	0029		Correction of reference error	8.4.0
RP-43	RP-090246	0031	1	GUMMEI usage for NNSF	8.5.0
RP-43	RP-090245	0032		Measurement ID	8.5.0
RP-43	RP-090089	0034		Description place for Paging Function	8.5.0
RP-44	RP-090636	0035	1	Clarification on the Paging Function in E-UTRAN	8.6.0
RP-45	RP-090964	0036		Coexistence of LTE-TDD systems	8.7.0
12/2009	-	-	-	Creation of Rel-9 version based on v8.7.0	9.0.0
RP-47	RP-100230	0040		Support of time and frequency synchronization for HeNB	9.1.0
RP-48	RP-100600	0041	2	Handling of Positioning Functions	9.2.0
RP-48	RP-100599	0042	2	Handling of CMAS and ETWS	9.2.0
RP-48	RP-100597	0043		Correction of support of eMBMS	9.2.0
RP-48	RP-100598	0044	1	Updating the description of the Load Balancing and RIM functions	9.2.0
12/2010				Created Rel-10 version based on v 9.2.0	10.0.0
SP-49	SP-100629			Clarification on the use of References (TS 21.801 CR#0030)	10.1.0
RP-51	RP-110237	0047	3	Introduction of new synchronization use case for TD ICIC	10.1.0
RP-51	RP-110226	0048	1	Support of PWS in RAN Sharing	10.1.0
RP-52	RP-110689	0049		Limitations of PWS operation in RAN sharing	10.2.0
RP-52	RP-110685	0050	1	Correction to the References in 36.401	10.2.0
RP-53	RP-111196	0052		Correction to the References in 36.401	10.3.0
RP-56	RP-120744	0054	1	Introduction of KPAS delivery function	10.4.0
09/2012				Update to Rel-11 version (MCC)	11.0.0
RP-58	RP-121737	0059	1	Rapporteur update of 36.401	11.1.0
RP-61	RP-131182	0060	1	Correction on LPPa Signalling Transport Function to support UTDPA	11.2.0
RP-61	RP-131183	0061	1	Correction of terminology concerning the mobility restriction function	11.2.0
09/2013				MCC Cleanup	11.2.0
09/2014				Update to Rel-12 version (MCC)	12.0.0
RP-66	RP-142089	0064	4	Introduction of dual connectivity	12.1.0
RP-66	RP-142090	0068		Generic use of the logical synchronisation port	12.1.0
RP-67	RP-150351	0069	1	Correction on AP IDs for Dual Connectivity	12.2.0
RP-70	RP-152085	0072	3	Correction on UE associations in eNB	12.3.0
12/2015				Update to Rel-13 version (MCC)	13.0.0
RP-70	RP-152102	0076	1	Extension of X2AP IDs	13.0.0
RP-71	RP-160443	0079		Addition of loose-SFN synchronisation for extended Idle mode DRX	13.1.0
RP-72	RP-161042	0078	5	Introduction of the UE context resume function	13.2.0

Change history							
Date	Meeting	TDoc	CR	Rev	Cat	Subject/Comment	New version
03/2017	RP-75	RP-170535	0083		F	Clarification that the Xw UE ID is unique within relevant node	14.0.0
12/2017	RP-78	RP-172672	0084		B	Addition of the gNB UE X2AP ID usage	15.0.0
12/2018	RP-82	RP-182447	0086	1	F	EN-DC Antenna Interface Function support	15.1.0

History

Document history		
V15.0.0	September 2018	Publication
V15.1.0	April 2019	Publication