

ETSI TS 136 302 V12.7.0 (2016-08)



**LTE;
Evolved Universal Terrestrial Radio Access (E-UTRA);
Services provided by the physical layer
(3GPP TS 36.302 version 12.7.0 Release 12)**



Reference

RTS/TSGR-0236302vc70

Keywords

LTE

ETSI

650 Route des Lucioles
F-06921 Sophia Antipolis Cedex - FRANCE

Tel.: +33 4 92 94 42 00 Fax: +33 4 93 65 47 16

Siret N° 348 623 562 00017 - NAF 742 C
Association à but non lucratif enregistrée à la
Sous-Préfecture de Grasse (06) N° 7803/88

Important notice

The present document can be downloaded from:
<http://www.etsi.org/standards-search>

The present document may be made available in electronic versions and/or in print. The content of any electronic and/or print versions of the present document shall not be modified without the prior written authorization of ETSI. In case of any existing or perceived difference in contents between such versions and/or in print, the only prevailing document is the print of the Portable Document Format (PDF) version kept on a specific network drive within ETSI Secretariat.

Users of the present document should be aware that the document may be subject to revision or change of status. Information on the current status of this and other ETSI documents is available at
<https://portal.etsi.org/TB/ETSIDeliverableStatus.aspx>

If you find errors in the present document, please send your comment to one of the following services:
<https://portal.etsi.org/People/CommiteeSupportStaff.aspx>

Copyright Notification

No part may be reproduced or utilized in any form or by any means, electronic or mechanical, including photocopying and microfilm except as authorized by written permission of ETSI.

The content of the PDF version shall not be modified without the written authorization of ETSI.
The copyright and the foregoing restriction extend to reproduction in all media.

© European Telecommunications Standards Institute 2016.
All rights reserved.

DECT™, PLUGTESTS™, UMTS™ and the ETSI logo are Trade Marks of ETSI registered for the benefit of its Members.
3GPP™ and LTE™ are Trade Marks of ETSI registered for the benefit of its Members and of the 3GPP Organizational Partners.
GSM® and the GSM logo are Trade Marks registered and owned by the GSM Association.

Intellectual Property Rights

IPRs essential or potentially essential to the present document may have been declared to ETSI. The information pertaining to these essential IPRs, if any, is publicly available for **ETSI members and non-members**, and can be found in ETSI SR 000 314: *"Intellectual Property Rights (IPRs); Essential, or potentially Essential, IPRs notified to ETSI in respect of ETSI standards"*, which is available from the ETSI Secretariat. Latest updates are available on the ETSI Web server (<https://ipr.etsi.org>).

Pursuant to the ETSI IPR Policy, no investigation, including IPR searches, has been carried out by ETSI. No guarantee can be given as to the existence of other IPRs not referenced in ETSI SR 000 314 (or the updates on the ETSI Web server) which are, or may be, or may become, essential to the present document.

Foreword

This Technical Specification (TS) has been produced by ETSI 3rd Generation Partnership Project (3GPP).

The present document may refer to technical specifications or reports using their 3GPP identities, UMTS identities or GSM identities. These should be interpreted as being references to the corresponding ETSI deliverables.

The cross reference between GSM, UMTS, 3GPP and ETSI identities can be found under <http://webapp.etsi.org/key/queryform.asp>.

Modal verbs terminology

In the present document "**shall**", "**shall not**", "**should**", "**should not**", "**may**", "**need not**", "**will**", "**will not**", "**can**" and "**cannot**" are to be interpreted as described in clause 3.2 of the [ETSI Drafting Rules](#) (Verbal forms for the expression of provisions).

"**must**" and "**must not**" are **NOT** allowed in ETSI deliverables except when used in direct citation.

Contents

| | |
|---|-----------|
| Intellectual Property Rights | 2 |
| Foreword..... | 2 |
| Modal verbs terminology..... | 2 |
| Foreword..... | 4 |
| 1 Scope | 5 |
| 2 References | 5 |
| 3 Definitions and abbreviations..... | 5 |
| 3.1 Definitions | 5 |
| 3.2 Abbreviations | 6 |
| 4 Void..... | 7 |
| 4.1 Void..... | 7 |
| 4.2 Void..... | 7 |
| 5 Services and functions of the physical layer | 7 |
| 5.1 General | 7 |
| 5.2 Overview of L1 functions..... | 8 |
| 5.3 Void..... | 8 |
| 6 Model of physical layer of the UE | 8 |
| 6.1 Uplink model..... | 8 |
| 6.1.1 Uplink Shared Channel | 8 |
| 6.1.2 Random-access Channel | 10 |
| 6.2 Downlink model..... | 10 |
| 6.2.1 Downlink-Shared Channel..... | 10 |
| 6.2.2 Broadcast Channel | 11 |
| 6.2.3 Paging Channel | 12 |
| 6.2.4 Multicast Channel | 13 |
| 6.3 Sidelink model..... | 14 |
| 6.3.1 Sidelink Broadcast Channel | 14 |
| 6.3.2 Sidelink Discovery Channel | 15 |
| 6.3.3 Sidelink Shared Channel..... | 16 |
| 7 Void..... | 17 |
| 8 Parallel transmission of simultaneous Physical Channels and SRS | 18 |
| 8.1 Uplink..... | 18 |
| 8.2 Downlink | 20 |
| 8.3 Sidelink | 22 |
| 9 Measurements provided by the physical layer | 23 |
| 9.1 Void..... | 23 |
| 9.2 UE Measurements | 23 |
| 9.3 E-UTRAN Measurements | 24 |
| Annex A (informative): Change history | 25 |
| History | 27 |

Foreword

This Technical Specification has been produced by the 3rd Generation Partnership Project (3GPP).

The contents of the present document are subject to continuing work within the TSG and may change following formal TSG approval. Should the TSG modify the contents of the present document, it will be re-released by the TSG with an identifying change of release date and an increase in version number as follows:

Version x.y.z

where:

- x the first digit:
 - 1 presented to TSG for information;
 - 2 presented to TSG for approval;
 - 3 or greater indicates TSG approved document under change control.
- y the second digit is incremented for all changes of substance, i.e. technical enhancements, corrections, updates, etc.
- z the third digit is incremented when editorial only changes have been incorporated in the document.

1 Scope

The present document is a technical specification of the services provided by the physical layer of E-UTRA to upper layers.

2 References

The following documents contain provisions which, through reference in this text, constitute provisions of the present document.

- References are either specific (identified by date of publication, edition number, version number, etc.) or non-specific.
- For a specific reference, subsequent revisions do not apply.
- For a non-specific reference, the latest version applies. In the case of a reference to a 3GPP document (including a GSM document), a non-specific reference implicitly refers to the latest version of that document *in the same Release as the present document*.

- | | |
|------|--|
| [1] | Void |
| [2] | Void |
| [3] | 3GPP TR 21.905: "Vocabulary for 3GPP Specifications". |
| [4] | Void |
| [5] | Void |
| [6] | Void |
| [7] | Void |
| [8] | 3GPP TS 36.211: "Evolved Universal Terrestrial Radio Access (E-UTRA); Physical channels and modulation". |
| [9] | Void |
| [10] | Void |
| [11] | 3GPP TS 36.214: "Evolved Universal Terrestrial Radio Access (E-UTRA); Physical layer; Measurements". |
| [12] | 3GPP TS 36.321: "Evolved Universal Terrestrial Radio Access (E-UTRA); Medium Access Control (MAC) protocol specification". |
| [13] | 3GPP TS 36.306: "Evolved Universal Terrestrial Radio Access (E-UTRA); User Equipment (UE) radio access capabilities". |
| [14] | 3GPP TS 23.303: "Technical Specification Group Services and System Aspects; Proximity-based services (ProSe)". |

3 Definitions and abbreviations

3.1 Definitions

For the purposes of the present document, the terms and definitions given in TR 21.905 [3] and the following apply. A term defined in the present document takes precedence over the definition of the same term, if any, in TR 21.905 [3].

Carrier frequency: center frequency of the cell.

Frequency layer: set of cells with the same carrier frequency.

Sidelink: UE to UE interface for sidelink communication and sidelink discovery. The sidelink corresponds to the PC5 interface as defined in TS 23.303 [14].

Sidelink communication: AS functionality enabling ProSe Direct Communication as defined in TS 23.303 [14], between two or more nearby UEs, using E-UTRA technology but not traversing any network node.

Sidelink discovery: AS functionality enabling ProSe Direct Discovery as defined in TS 23.303 [14], using E-UTRA technology but not traversing any network node.

Timing Advance Group: See the definition in [12].

3.2 Abbreviations

For the purposes of the present document, the abbreviations given in TR 21.905 [3] and the following apply. An abbreviation defined in the present document takes precedence over the definition of the same abbreviation, if any, in TR 21.905 [3].

For the purposes of the present document, the following abbreviations apply:

| | |
|---------|---|
| ACK | Acknowledgement |
| ARQ | Automatic Repeat Request |
| BCCCH | Broadcast Control Channel |
| BCH | Broadcast Channel |
| CG | Cell Group |
| CMAS | Commercial Mobile Alert System |
| CP | Cyclic Prefix |
| C-plane | Control Plane |
| CRC | Cyclic Redundancy Check |
| CSI | Channel State Information |
| DC | Dual Connectivity |
| DCCH | Dedicated Control Channel |
| DL | Downlink |
| DRX | Discontinuous Reception |
| DTCH | Dedicated Traffic Channel |
| DTX | Discontinuous Transmission |
| eNB | E-UTRAN NodeB |
| eIMTA | Enhanced Interference Management and Traffic Adaptation |
| EPDCCH | Enhanced physical downlink control channel |
| E-UTRA | Evolved UTRA |
| E-UTRAN | Evolved UTRAN |
| FDD | Frequency Division Duplex |
| FDM | Frequency Division Multiplexing |
| GERAN | GSM EDGE Radio Access Network |
| GSM | Global System for Mobile communication |
| HARQ | Hybrid ARQ |
| LTE | Long Term Evolution |
| MAC | Medium Access Control |
| MBMS | Multimedia Broadcast Multicast Service |
| MBSFN | Multimedia Broadcast multicast service Single Frequency Network |
| MCCH | Multicast Control Channel |
| MIMO | Multiple Input Multiple Output |
| MTCH | Multicast Traffic Channel |
| NACK | Negative Acknowledgement |
| OFDM | Orthogonal Frequency Division Multiplexing |
| OFDMA | Orthogonal Frequency Division Multiple Access |
| PBCH | Physical broadcast channel |
| PDCCH | Physical downlink control channel |
| PDSCH | Physical downlink shared channel |

| | |
|---------|---|
| PHY | Physical layer |
| PMCH | Physical multicast channel |
| PRACH | Physical random access channel |
| PRB | Physical Resource Block |
| ProSe | Proximity based Services |
| PSBCH | Physical Sidelink Broadcast CHannel |
| PSCCH | Physical Sidelink Control Channel |
| PSCell | Primary SCell |
| PSDCH | Physical Sidelink Discovery Channel |
| PSSCH | Physical Sidelink Shared CHannel |
| PUCCH | Physical uplink control channel |
| PUSCH | Physical uplink shared channel |
| QAM | Quadrature Amplitude Modulation |
| RACH | Random Access Channel |
| RF | Radio Frequency |
| RRC | Radio Resource Control |
| SAP | Service Access Point |
| SBCCH | Sidelink Broadcast Control CHannel |
| SC-FDMA | Single Carrier – Frequency Division Multiple Access |
| SCell | Secondary Cell |
| SL-BCH | Sidelink Broadcast Channel |
| SL-DCH | Sidelink Discovery Channel |
| SL-SCH | Sidelink Shared Channel |
| SRS | Sounding Reference Symbol |
| STCH | Sidelink Traffic Channel |
| TAG | Timing Advance Group |
| TB | Transport Block |
| TDD | Time Division Duplex |
| TTI | Transmission Time Interval |
| UE | User Equipment |
| UL | Uplink |
| UMTS | Universal Mobile Telecommunication System |
| U-plane | User plane |
| UTRA | Universal Terrestrial Radio Access |
| UTRAN | Universal Terrestrial Radio Access Network |

4 Void

4.1 Void

4.2 Void

5 Services and functions of the physical layer

5.1 General

The physical layer offers data transport services to higher layers.

The access to these services is through the use of transport channels via the MAC sub-layer.

A transport block is defined as the data delivered by MAC layer to the physical layer and vice versa. Transport blocks are delivered once every TTI.

5.2 Overview of L1 functions

The physical layer offers data transport services to higher layers. The access to these services is through the use of a transport channel via the MAC sub-layer. The physical layer is expected to perform the following functions in order to provide the data transport service:

- Error detection on the transport channel and indication to higher layers
- FEC encoding/decoding of the transport channel
- Hybrid ARQ soft-combining
- Rate matching of the coded transport channel to physical channels
- Mapping of the coded transport channel onto physical channels
- Power weighting of physical channels
- Modulation and demodulation of physical channels
- Frequency and time synchronisation
- Radio characteristics measurements and indication to higher layers
- Multiple Input Multiple Output (MIMO) antenna processing
- Transmit Diversity (TX diversity)
- Beamforming
- RF processing.

L1 functions are modelled for each transport channel in subclauses 6.1, 6.2 and 6.3.

5.3 Void

6 Model of physical layer of the UE

The E-UTRA physical-layer model captures those characteristics of the E-UTRA physical-layer that are relevant from the point-of-view of higher layers. More specifically, the physical-layer model captures:

- The structure of higher-layer data being passed down to or up from the physical layer;
- The means by which higher layers can configure the physical layer;
- The different indications (error indications, channel-quality indications, etc.) that are provided by the physical layer to higher layers;
- Other (non-transport-channel-based) higher-layer peer-to-peer signalling supported by the physical layer.

6.1 Uplink model

6.1.1 Uplink Shared Channel

The physical-layer model for Uplink Shared Channel transmission is described based on the corresponding physical-layer-processing chain, see Figure 6.1.1-1. Processing steps that are relevant for the physical-layer model, e.g. in the sense that they are configurable by higher layers, are highlighted in blue. It should be noted that, in case PUSCH, the scheduling decision is fully done at the network side. The uplink transmission control in the UE then configures the uplink physical-layer processing, based on uplink transport-format and resource-assignment information received on the downlink.

- **Higher-layer data passed to/from the physical layer**
- One transport block of dynamic size delivered to the physical layer once every TTI.
- **CRC and transport-block-error indication**
- Transport-block-error indication delivered to higher layers.
- **FEC and rate matching**
- Channel coding rate is implicitly given by the combination of transport block size, modulation scheme and resource assignment;
- Physical layer model support of HARQ: in case of Incremental Redundancy, the corresponding Layer 2 Hybrid-ARQ process controls what redundancy version is to be used for the physical layer transmission for each TTI.
- **Interleaving**
- No control of interleaving by higher layers.
- **Data modulation**
- Modulation scheme is decided by MAC Scheduler (QPSK, 16QAM and 64QAM).
- **Mapping to physical resource**
- L2-controlled resource assignment.
- **Multi-antenna processing**
- MAC Scheduler partly configures mapping from assigned resource blocks to the available number of antenna ports.
- **Support of L1 control signalling**
- Transmission of ACK/NACK and CSI feedback related to DL data transmission

The model of Figure 6.1.1-1 also captures

- Transport via physical layer of Hybrid-ARQ related information associated with the PUSCH, to the peer HARQ process at the transmitter side;
- Transport via physical layer of corresponding HARQ acknowledgements to PUSCH transmitter side.

If a UE is configured with one or more SCells, the physical-layer-processing chain in Figure 6.1.1-1 is repeated for every UL Serving Cell.

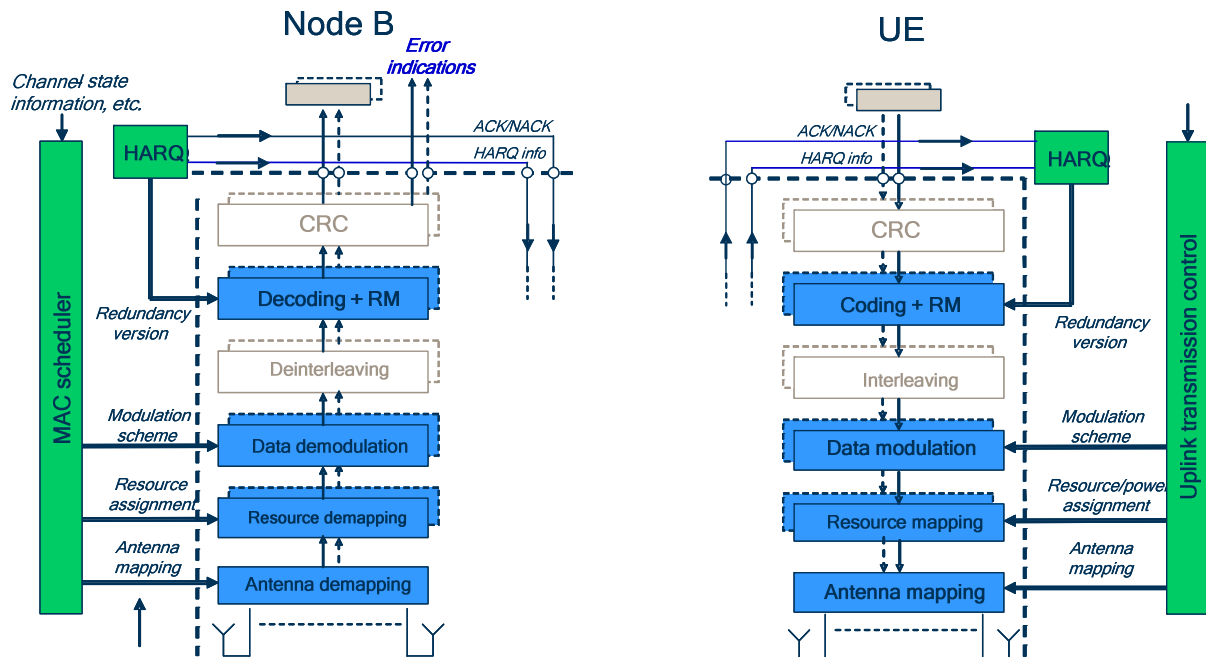

Figure 6.1.1-1: Physical-layer model for UL-SCH transmission

6.1.2 Random-access Channel

The physical-layer model for RACH transmission is characterized by a random access burst that consists of a cyclic prefix, a preamble, and a guard time during which nothing is transmitted.

The random access preambles are generated from Zadoff-Chu sequences with zero correlation zone (ZC-ZCZ), generated from one or several root Zadoff-Chu sequences.

6.2 Downlink model

6.2.1 Downlink-Shared Channel

The physical-layer model for Downlink Shared Channel transmission is described based on the corresponding PDSCH physical-layer-processing chain, see Figure 6.2.1-1. Processing steps that are relevant for the physical-layer model, e.g. in the sense that they are configurable by higher layers, are highlighted in blue on the figure.

- **Higher-layer data passed to/from the physical layer**
- N (up to two) transport blocks of dynamic size delivered to the physical layer once every TTI.
- **CRC and transport-block-error indication**
- Transport-block-error indication delivered to higher layers.
- **FEC and rate matching**
- Channel coding rate is implicitly given by the combination of transport block size, modulation scheme and resource assignment;
- Physical layer model support of HARQ: in case of Incremental Redundancy, the corresponding Layer 2 Hybrid-ARQ process controls what redundancy version is to be used for the physical layer transmission for each TTI.
- **Data modulation**
- Modulation scheme is decided by MAC Scheduler (QPSK, 16QAM, 64 QAM and 256QAM).

Multi-antenna processing

- MAC Scheduler partly configures mapping from modulated code words (for each stream) to the available number of antenna ports.
- **Mapping to physical resource**
- L2-controlled resource assignment.
- **Support of L1 control signalling**
- Transmission of scheduler related control signals.
- **Support for Hybrid-ARQ-related signalling**

The model of Figure 6.2.1-1 also captures:

- Transport via physical layer of Hybrid-ARQ related information associated with the PDSCH, to the peer HARQ process at the receiver side;
- Transport via physical layer of corresponding HARQ acknowledgements to PDSCH transmitter side.

If a UE is configured with one or more SCells, the physical-layer-processing chain in Figure 6.2.1-1 is repeated for every DL Serving Cell.

NOTE: The signalling of transport-format and resource-allocation is not captured in the physical-layer model. At the transmitter side, this information can be directly derived from the configuration of the physical layer. The physical layer then transports this information over the radio interface to its peer physical layer, presumably multiplexed in one way or another with the HARQ-related information. On the receiver side, this information is, in contrast to the HARQ-related information, used directly within the physical layer for PDSCH demodulation, decoding etc., without passing through higher layers.

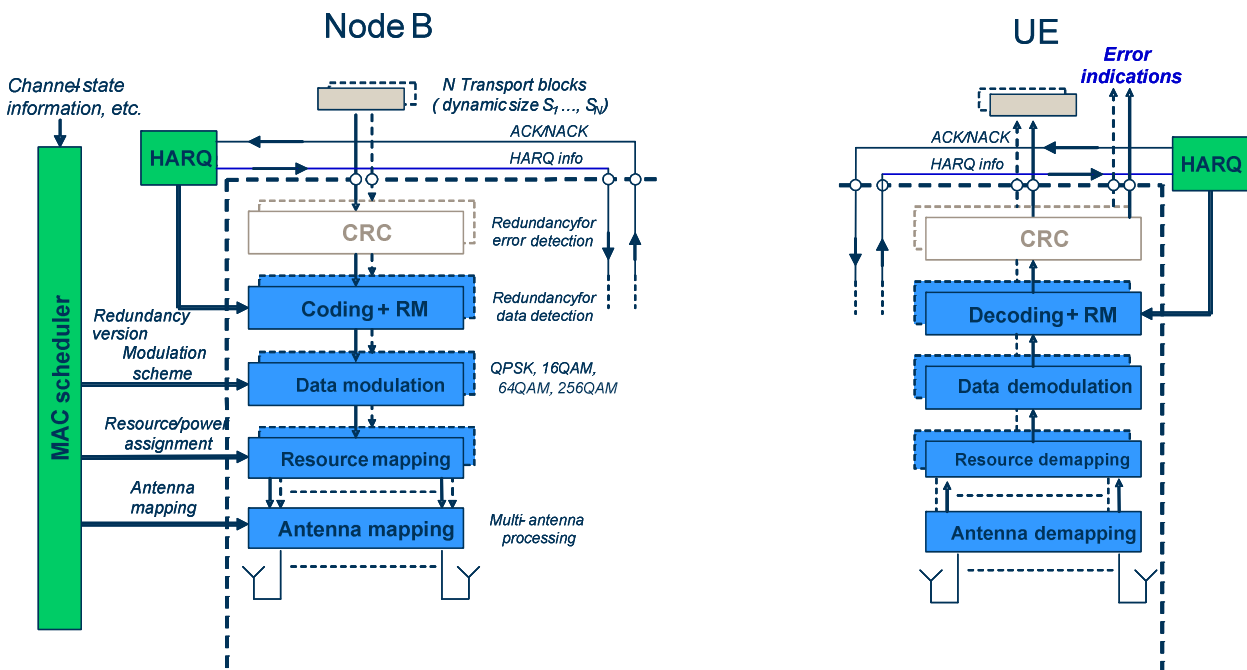

Figure 6.2.1-1: Physical-layer model for DL-SCH transmission

6.2.2 Broadcast Channel

The physical-layer model for BCH transmission is characterized by a fixed pre-defined transport format. The TTI (repetition rate) of the BCH is 40 ms. The BCH physical-layer model is described based on the corresponding BCH physical-layer-processing chain, see Figure 6.2.2-1:

- **Higher-layer data passed to/from the physical layer**

- A single (fixed-size) transport block per TTI.
- **CRC and transport-block-error indication**
- Transport-block-error indication delivered to higher layers.
- **FEC and rate matching**
- Channel coding rate is implicitly given by the combination of transport block size, modulation scheme and resource assignment;
- No BCH Hybrid ARQ, i.e. no higher-layer control of redundancy version.
- **Data modulation**
- Fixed modulation scheme (QPSK), i.e. no higher-layer control.
- **Mapping to physical resource**
- Fixed pre-determined transport format and resource allocation, i.e. no higher-layer control.
- **Multi-antenna processing**
 - Fixed pre-determined processing, i.e. no higher-layer control.
- **Support for Hybrid-ARQ-related signalling**
- No Hybrid ARQ.

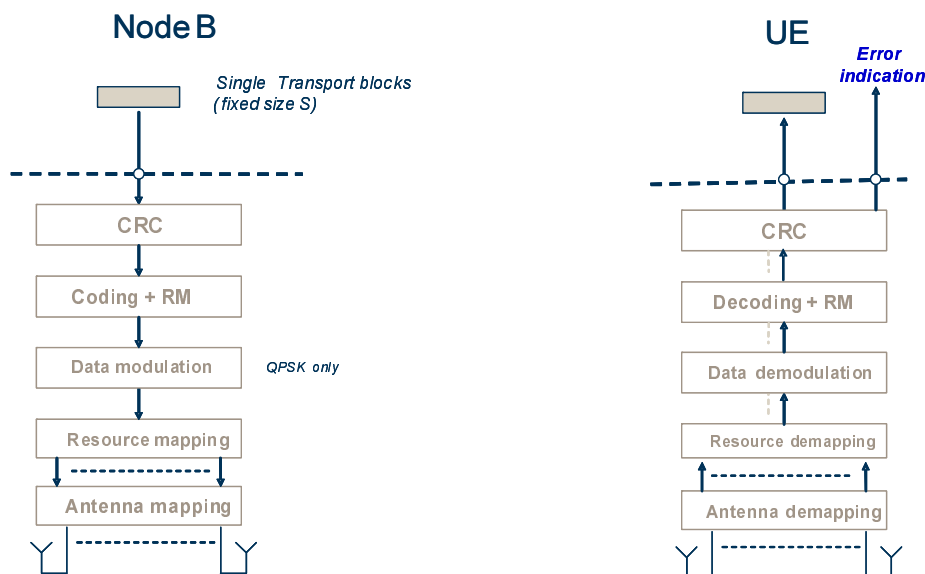

Figure 6.2.2-1: Physical-layer model for BCH transmission

6.2.3 Paging Channel

The physical-layer model for PCH transmission is described based on the corresponding PCH physical-layer-processing chain, see Figure 6.2.3-1. Processing steps that are relevant for the physical-layer model, e.g. in the sense that they are configurable by higher layers, are highlighted in blue on the figure.

- **Higher-layer data passed to/from the physical layer**
- A single transport block per TTI.
- **CRC and transport-block-error indication**
- Transport-block-error indication delivered to higher layers.

- **FEC and rate matching**
 - Channel coding rate is implicitly given by the combination of transport block size, modulation scheme and resource assignment;
 - No PCH Hybrid ARQ, i.e. no higher-layer control of redundancy version.
 - **Data modulation**
 - Modulation scheme is decided by MAC Scheduler.
 - **Mapping to physical resource**
 - L2 controlled resource assignment;
 - Possible support of dynamic transport format and resource allocation.
 - **Multi-antenna processing**
 - MAC Scheduler partly configures mapping from assigned resource blocks to the available number of antenna ports.
 - **Support for Hybrid-ARQ-related signalling**
- No Hybrid ARQ.

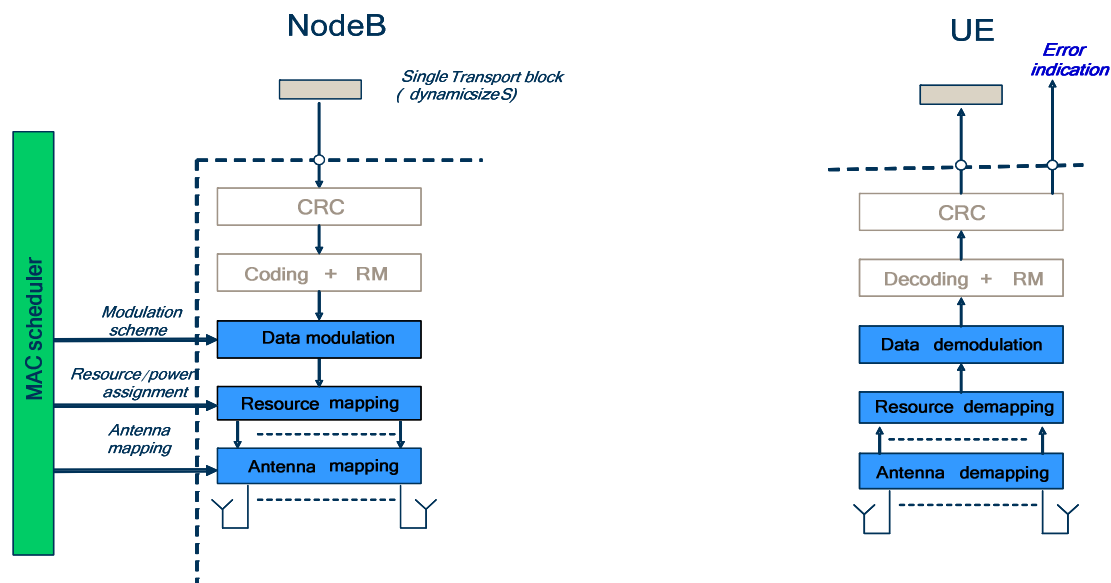

Figure 6.2.3-1: Physical-layer model for PCH transmission

6.2.4 Multicast Channel

The physical-layer model for MCH transmission is characterized by the support for multi-cell reception at the UE (a.k.a. "MBSFN" transmission). This implies that only semi-static configuration of the MCH transport format and resource assignment is possible. The MCH physical-layer model is described based on the corresponding MCH physical-layer-processing chain, see Figure 6.2.4-1. Processing steps that are relevant for the physical-layer model, e.g. in the sense that they are configurable by higher layers, are highlighted in blue.

- **Higher-layer data passed to/from the physical layer**
- One transport block delivered to physical layer once every TTI.
- **CRC and transport-block-error indication**
- Transport-block-error indication delivered to higher layers.
- **FEC and rate matching**

- Channel coding rate is implicitly given by the combination of transport block size, modulation scheme and resource assignment;
- No MCH Hybrid ARQ, i.e. no higher-layer control of redundancy version.
- **Data modulation**
- Modulation scheme is configured by RRC layer.
- **Mapping to physical resource**
- L2 controlled semi-static resource assignment.
- **Multi-antenna processing**
- MAC Scheduler partly configures mapping from assigned resource blocks (for each stream) to the available number of antenna ports.
- **Support for Hybrid-ARQ-related signalling**
- No Hybrid ARQ.

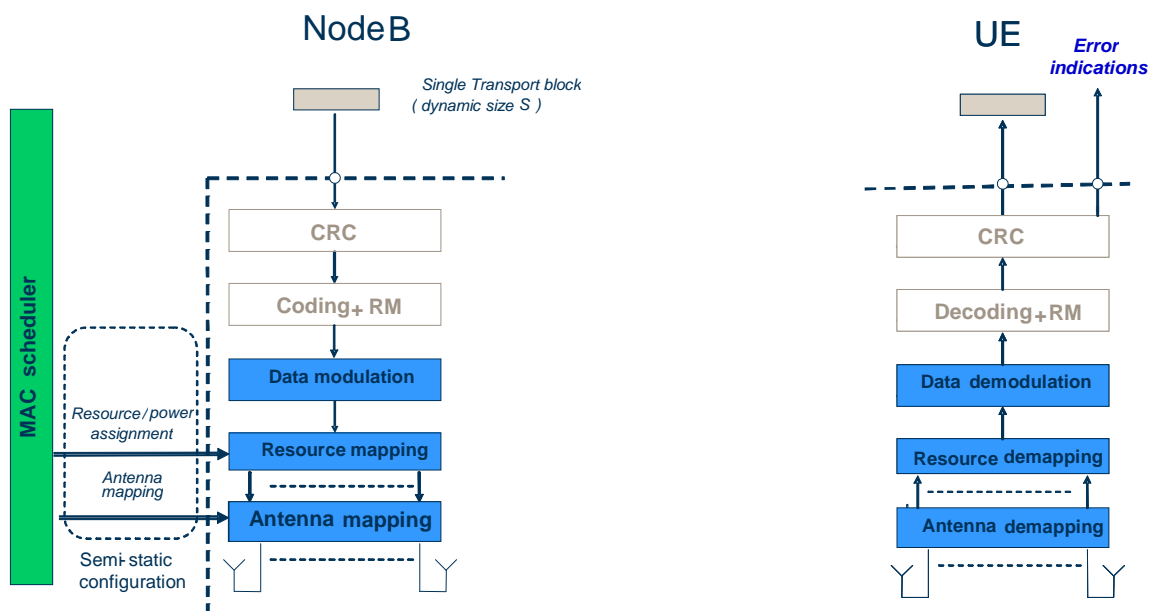

Figure 6.2.4-1: Physical-layer model for MCH transmission

6.3 Sidelink model

6.3.1 Sidelink Broadcast Channel

The physical-layer model for Sidelink Broadcast Channel transmission is characterized by a fixed pre-defined transport format. The TTI (repetition rate) of the SL-BCH is 40ms if a UE is configured to transmit on SL-BCH. The SL-BCH physical-layer model is described based on the corresponding SL-BCH physical-layer-processing chain, see Figure 6.3.1-1.

- **Higher-layer data passed to/from the physical layer**
- A single (fixed-size) transport block per TTI.
- **CRC and transport-block-error indication**
- Transport-block-error indication delivered to higher layers.

- **FEC and rate matching**
- Channel coding rate is implicitly given by the combination of transport block size, modulation scheme and resource assignment;
- No SL-BCH Hybrid ARQ, i.e. no higher-layer control of redundancy version.
- **Data modulation**
- Fixed modulation scheme (QPSK), i.e. no higher-layer control.
- **Mapping to physical resource**
- Fixed pre-determined transport format i.e. no higher-layer control.
- RRC controlled semi-static resource assignment.
- **Multi-antenna processing**
- Single antenna port is used.
- **Support for Hybrid-ARQ-related signalling**
- No Hybrid ARQ.

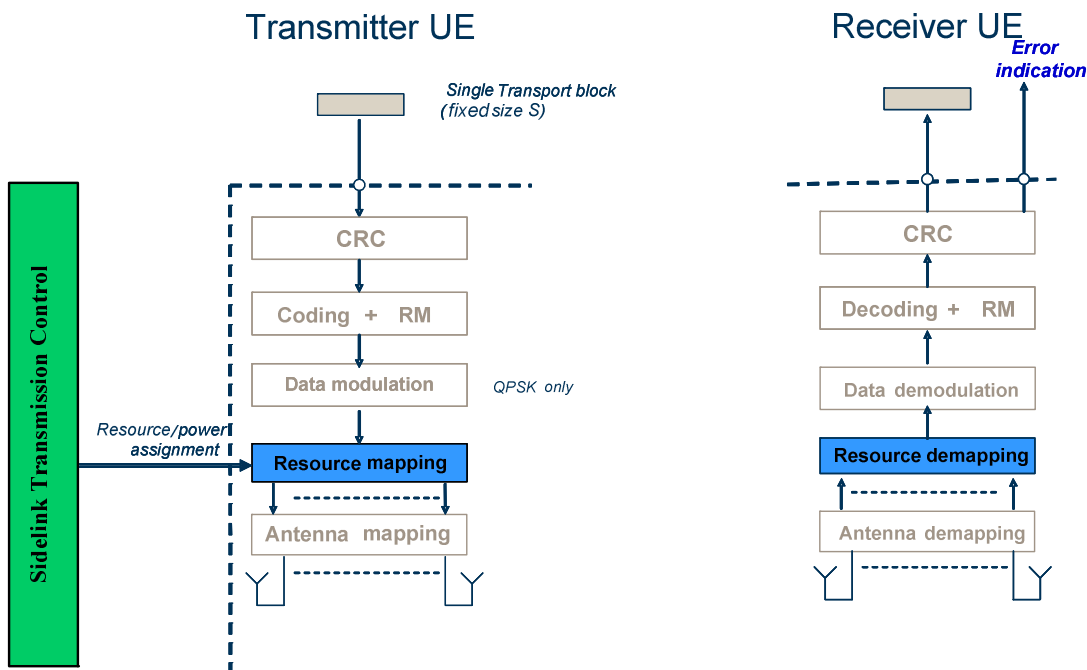

Figure 6.3.1-1: Physical-layer model for SL-BCH transmission

6.3.2 Sidelink Discovery Channel

The physical-layer model for Sidelink Discovery Channel transmission is characterized by a fixed pre-defined transport format. The SL-DCH physical-layer model is described based on the corresponding SL-DCH physical-layer-processing chain, see Figure 6.3.2-1. Processing steps that are relevant for the physical-layer model, e.g. in the sense that they are configurable by higher layers, are highlighted in blue. It should be noted that, in case scheduled resource allocation of SL-DCH, the scheduling decision is fully done by network side. The sidelink transmission control in the UE configures the sidelink physical-layer processing, based on sidelink transport-format and resource-assignment information received on the downlink. In case UE autonomous resource selection of SL-DCH, the scheduling decision is done by UE side. The sidelink transmission control in the UE configures the sidelink physical-layer processing, based on pre-defined sidelink transport-format and UE randomly selected resource-assignment.

- **Higher-layer data passed to/from the physical layer**

- A single (fixed-size) transport block per TTI.
- **CRC and transport-block-error indication**
- Transport-block-error indication delivered to higher layer.
- **FEC and rate matching**
- Channel coding rate is implicitly given by the combination of transport block size, modulation scheme and resource assignment;
- Support for soft combining, but no support for ACK/NACK feedback.
- **Data modulation**
- Fixed modulation scheme (QPSK), i.e. no higher-layer control.
- **Mapping to physical resource**
- RRC controlled semi-static resource assignment;
- **Multi-antenna processing**
- Single antenna port is used.

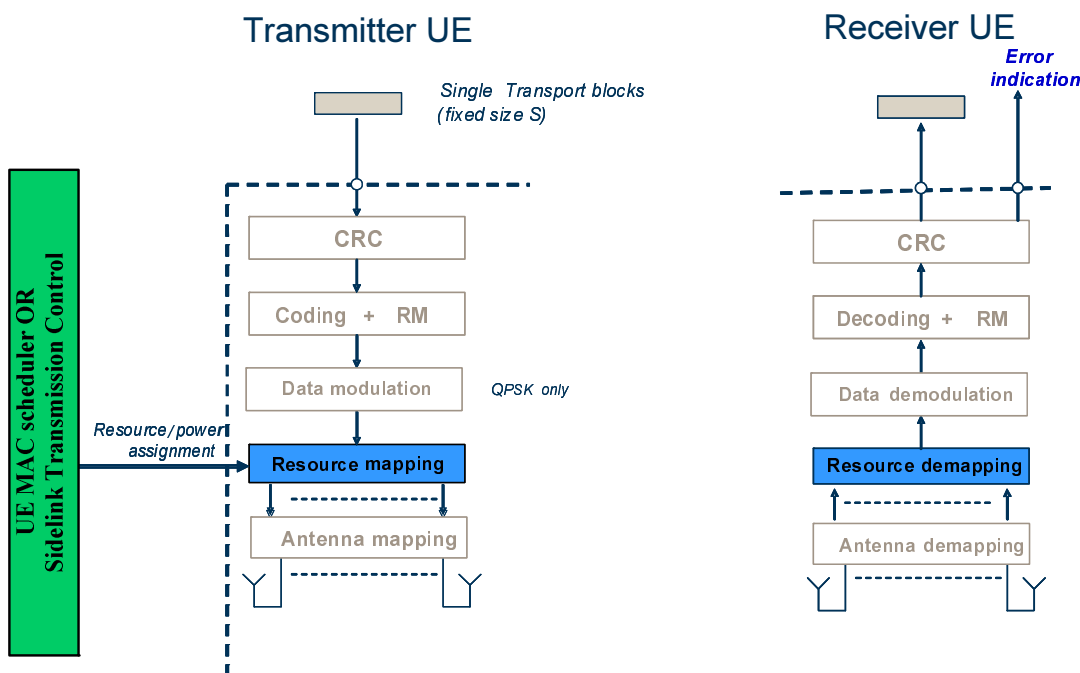

Figure 6.3.2-1: Physical-layer model for SL-DCH transmission

6.3.3 Sidelink Shared Channel

The physical-layer model for Sidelink Shared Channel transmission is described based on the corresponding SL-SCH physical-layer-processing chain, see Figure 6.3.3-1. Processing steps that are relevant for the physical-layer model, e.g. in the sense that they are configurable by higher layers, are highlighted in blue on the figure. It should be noted that, in case of scheduled resource allocation, the SL-SCH scheduling decision is done by network side. The sidelink transmission control in the UE configures the sidelink physical-layer processing, based on sidelink transport-format and resource-assignment information received on the downlink. In case of UE autonomous resource selection, the SL-SCH scheduling decision is done by UE side, and the MAC scheduler in the UE configures the sidelink physical-layer processing, based on the sidelink transport-format autonomously decided by the UE and randomly selected resource-assignment.

- **Higher-layer data passed to/from the physical layer**
- One transport block of dynamic size delivered to the physical layer once every TTI.
- **CRC and transport-block-error indication**
- Transport-block-error indication delivered to higher layers.
- **FEC and rate matching**
- Channel coding rate is implicitly given by the combination of transport block size, modulation scheme and resource assignment;
- Support for soft combining, but no support for ACK/NACK feedback.
- **Data modulation**
- For scheduled resource allocation, modulation scheme is decided by higher layer signaling from eNB.
- For UE autonomous resource selection, modulation scheme is decided by MAC scheduler (QPSK, 16QAM) in transmitter UE.
- **Mapping to physical resource**
- L2-controlled resource assignment.
- **Multi-antenna processing**
- Single antenna port is used.

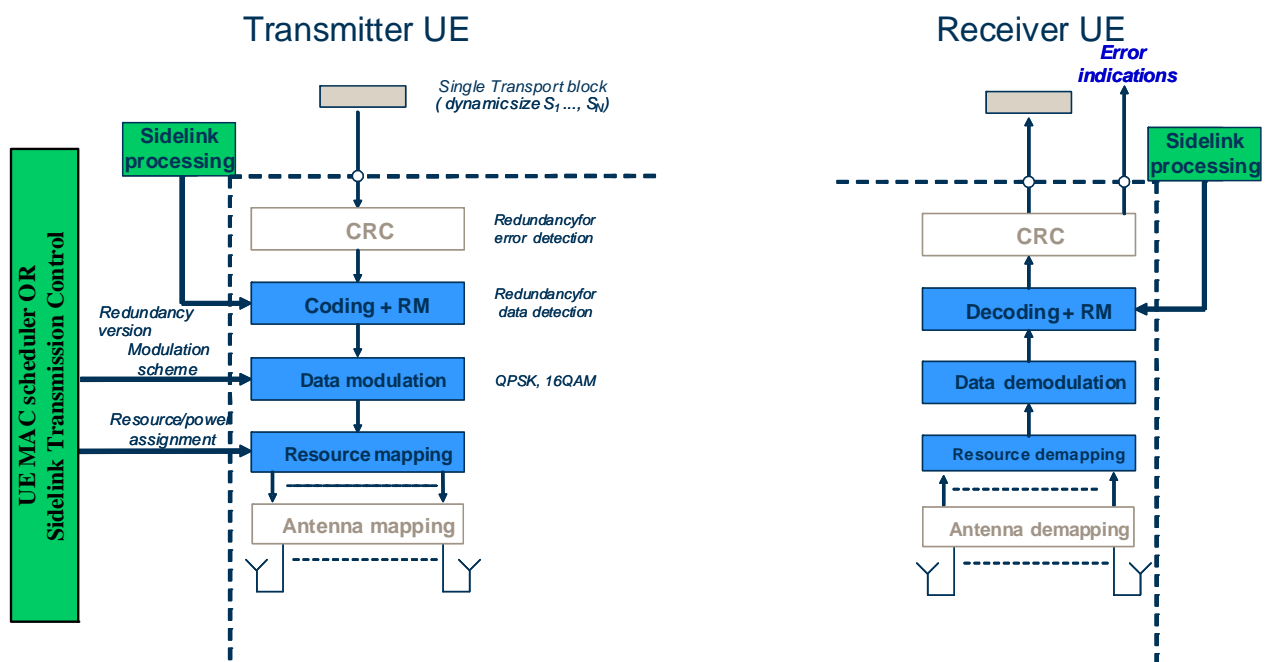

Figure 6.3.3-1: Physical-layer model for SL-SCH transmission

8 Parallel transmission of simultaneous Physical Channels and SRS

This clause describes the requirements from the UE to send and receive on multiple Physical and Transport Channels and SRS simultaneously depending on the service capabilities and requirements.

8.1 Uplink

The table 8.1-1 describes the possible combinations of physical channels that can be sent in parallel in the uplink within the same subframe.

Table 8.1-1: Uplink

| | Physical Channel Combination | Transport Channel Combination | Mandatory dependent on UE radio access capabilities | Comment |
|---|---|--------------------------------------|---|---|
| 1 | $q \times \text{PUSCH}$ | UL-SCH | Mandatory | Note 1, Note 2 |
| 2 | $k \times \text{PRACH}$ | RACH | Mandatory | Note 4 |
| 3 | $k \times \text{PUCCH}$ | N/A | Mandatory | CSI and Scheduling Requests are provided to Layer 2. Note 4 |
| 4 | $q \times \text{PUSCH} + k \times \text{PUCCH}$ | UL-SCH | Mandatory for UEs supporting simultaneous transmission of PUSCH and PUCCH | Note1, Note 2, Note 4 |
| 5 | $k \times \text{PRACH} + (q-k) \times \text{PUSCH}$ | RACH UL-SCH | Mandatory for UEs supporting multiple TAGs | Note 1, Note 2, Note 3, Note 4 |
| 6 | $k \times \text{PRACH} + k \times \text{PUCCH}$ | RACH | Mandatory for UEs supporting multiple TAGs | Note 3, Note 4 |
| 7 | $k \times \text{PRACH} + (q-k) \times \text{PUSCH} + k \times \text{PUCCH}$ | RACH UL-SCH | Mandatory for UEs supporting simultaneous transmission of PUSCH and PUCCH and multiple TAGs | Note 1, Note 2, Note 3, Note 4 |
| Note 1: One PUSCH per UL CC. Note 2: q is the number of UL CCs supported by the UE. $q = 1$ implies non-CA capable UE. Note 3: PRACH and PUSCH/PUCCH are from cells in different Timing Advance Groups [12]. Note 4: k is the number of CGs supported by the UE. $k = 1$ implies non-DC capable UE. $k = 2$ implies DC capable UE, and one PUCCH and one PRACH per CG. | | | | |

The table 8.1-2 describes the possible combinations of SRS and physical channels that can be sent in parallel in uplink in the last symbol within the same subframe by one UE.

Table 8.1-2: Uplink in combinations with SRS

| | Physical Channel and SRS Combination | Transport Channel Combination | Mandatory dependent on UE radio access capabilities | Comment |
|---|---|-------------------------------|---|--|
| 1 | $q \times \text{SRS}$ | N/A | Mandatory | Note 2, Note 4 |
| 2 | $k \times \text{PRACH} + (q-k) \times \text{SRS}$ | RACH | Mandatory for UEs supporting multiple TAGs | Note 2, Note 3, Note 4, Note 7 |
| 3 | $n \times \text{PUSCH} + (q-n) \times \text{SRS}$ | UL-SCH | Mandatory for UEs supporting multiple TAGs | Note 1, Note 2, Note 4, Note 5, Note 6 |
| 4 | $k \times \text{PUCCH} + (q-k) \times \text{SRS}$ | N/A | Mandatory for UEs supporting multiple TAGs | Note 2, Note 4, Note 6, Note 7 |
| 5 | $n \times \text{PUSCH} + k \times \text{PUCCH} + (q-n) \times \text{SRS}$ | UL-SCH | Mandatory for UEs supporting simultaneous transmission of PUSCH and PUCCH and multiple TAGs | Note 1, Note 2, Note 4, Note 5, Note 6, Note 7 |
| 6 | $k \times \text{PRACH} + n \times \text{PUSCH} + (q-n-k) \times \text{SRS}$ | RACH UL-SCH | Mandatory for UEs supporting multiple TAGs | Note 1, Note 2, Note 3, Note 4, Note 5, Note 6, Note 7 |
| 7 | $k \times \text{PRACH} + k \times \text{PUCCH} + (q-2 \times k) \times \text{SRS}$ | RACH | Mandatory for UEs supporting multiple TAGs | Note 2, Note 3, Note 4, Note 6, Note 7 |
| 8 | $k \times \text{PRACH} + n \times \text{PUSCH} + k \times \text{PUCCH} + (q-n-k) \times \text{SRS}$ | RACH UL-SCH | Mandatory for UEs supporting simultaneous transmission of PUSCH and PUCCH and multiple TAGs | Note 1, Note 2, Note 3, Note 4, Note 5, Note 6, Note 7 |
| Note 1: One PUSCH per UL CC. Note 2: q is the number of UL CCs supported by the UE. $q = 1$ implies non-CA capable UE. Note 3: PRACH and PUSCH/PUCCH/SRS are from cells in different TAGs [12]. Note 4: One SRS per UL CC. Note 5: $n = 1, 2, \dots, q-k$. Note 6: If UE is not configured with multiple TAGs, then SRS and PUSCH/PUCCH are not transmitted in parallel; otherwise, if UE is configured with multiple TAGs, then SRS and PUSCH/PUCCH are transmitted in parallel from different serving cells of the same TAG or different TAGs. Note 7: k is the number of CGs supported by the UE. $k = 1$ implies non-DC capable UE. $k = 2$ implies DC capable UE, and one PUCCH and one PRACH per CG. | | | | |

8.2 Downlink

The table describes the possible combinations of physical channels that can be received in parallel in the downlink in the same subframe by one UE. In one subframe, the UE shall be able to receive all TBs according to the indication on PDCCH.

Table 8.2-1: Downlink "Reception Types"

| "Reception Type" | Physical Channel(s) | Monitored RNTI | Associated Transport Channel |
|------------------|-------------------------------|--|------------------------------|
| A | PBCH | N/A | BCH |
| B | PDCCH+PDSCH | SI-RNTI | DL-SCH |
| C | PDCCH+PDSCH | P-RNTI | PCH |
| D | PDCCH+PDSCH | RA-RNTI (Note 3) | DL-SCH |
| | | Temporary C-RNTI (Note 3) (Note 4) | DL-SCH |
| | (PDCCH/EPDCCH)+PDSCH | C-RNTI and Semi-Persistent Scheduling C-RNTI | DL-SCH |
| D1 | (PDCCH/EPDCCH)+PDSCH (Note 9) | C-RNTI | DL-SCH |
| E | PDCCH/EPDCCH (Note 1) | C-RNTI | N/A |
| F | PDCCH | Temporary C-RNTI (Note 5) | UL-SCH |
| | PDCCH/EPDCCH | C-RNTI and Semi-Persistent Scheduling C-RNTI | UL-SCH |
| F1 | PDCCH/EPDCCH (Note 9) | C-RNTI | UL-SCH |
| G | PDCCH | TPC-PUCCH-RNTI | N/A |
| H | PDCCH | TPC-PUSCH-RNTI | N/A |
| I | PDCCH/EPDCCH | Semi-Persistent Scheduling C-RNTI (Note 6) | N/A |
| J | PDCCH/EPDCCH | Semi-Persistent Scheduling C-RNTI (Note 7) | N/A |
| K | PDCCH | M-RNTI (Note 8) | N/A |
| L | PMCH | N/A (Note 8) | MCH |
| M | PDCCH | eIMTA-RNTI | N/A |
| N | PDCCH/EPDCCH | SL-RNTI | N/A |

Note 1: PDCCH or EPDCCH is used to convey PDCCH order for Random Access.
Note 2: Void.
Note 3: RA-RNTI and Temporary C-RNTI are mutually exclusive and only applicable during Random Access procedure.
Note 4: Temporary C-RNTI is only applicable when no valid C-RNTI is available.
Note 5: Temporary C-RNTI is only applicable during contention-based Random Access procedure.
Note 6: Semi-Persistent Scheduling C-RNTI is used for DL Semi-Persistent Scheduling release.
Note 7: Semi-Persistent Scheduling C-RNTI is used for UL Semi-Persistent Scheduling release.
Note 8: In MBSFN subframes only
Note 9: DL-SCH reception corresponding to D1, and UL-SCH transmission corresponding to F1, are only applicable to SCeLLs.

Table 8.2-2: Downlink "Reception Type" Combinations

| | PCell | PSCell | SCell | Non-serving cell |
|---|--|--|------------------------------|--------------------|
| 1. RRC_IDLE | | | | |
| 1.1 All UEs | A + B + C + D | | | |
| | Remarks: The combination for Random Access procedure is only required, related to D. | | | |
| 1.2 UEs supporting MBMS | K + L | | | |
| 2. RRC_CONNECTED | | | | |
| 2.1 All UEs | A + B + (D or E or G or I) + (F or H or J) + M | A + (D or E or G or I) + (F or H or J) + M | (E or D1) + F1 | |
| | Remarks: Combination involving EPDCCH is optional and required only for UE supporting EPDCCH. | | | |
| 2.2 UEs supporting FS2 | A + B + (D or E or G or I) + (F or H or J) + F + M | A + (D or E or G or I) + (F or H or J) + F + M | (E or D1) + F1 | |
| | Remarks: For TDD UL/DL configuration 0, two PDCCHs or EPDCCHs can be received in the same subframe for UL-SCH in two different uplink subframes. Remarks: Combination involving EPDCCH is optional and required only for UE supporting EPDCCH. | | | |
| 2.3 UEs supporting MBMS | ((E or G or I) + L + K) or (A + B + D) + (F or H or J) + M | ((E or G or I) + L + K) or (A + B + D) + (F or H or J) + M | (E + L + K) or (D1 + B) + F1 | (A + B) or (L + K) |
| | Remarks: Combination involving EPDCCH is optional and required only for UE supporting EPDCCH. Remarks: The combination is the requirement when MBMS reception is on PCell and/or any other cell. r is the number of DL CCs on which the UE supports MBMS reception according to the MBMSInterestIndication. The number of L and the number of $K \leq r$. Remarks: It is not required to simultaneously receive EPDCCH and PMCH on the same cell. | | | |
| 2.4 MBMS UEs supporting FS2 | ((E or G or I) + L + K) or (A + B + D) + 1x(F or H or J) + F + M | ((E or G or I) + L + K) or (A + B + D) + 1x(F or H or J) + F + M | (E + L + K) or (D1 + B) + F1 | (A + B) or (L + K) |
| | Remarks: For TDD UL/DL configuration 0, two PDCCHs or EPDCCHs can be received in the same subframe for UL-SCH in two different uplink subframes. Remarks: The combination is the requirement when MBMS reception is on PCell and/or any other cell. r is the number of DL CCs on which the UE supports MBMS reception according to the MBMSInterestIndication. The number of L and the number of $K \leq r$. Remarks: Combination involving EPDCCH is optional and required only for UE supporting EPDCCH. Remarks: It is not required to simultaneously receive EPDCCH and PMCH on the same cell. | | | |
| 2.5 UEs supporting ETWS and CMAS | A + B + C + (D or E or G or I) + (F or H or J) + M | A + (D or E or G or I) + (F or H or J) + M | (E or D1) + F1 | |
| | Remarks: Combination involving EPDCCH is optional and required only for UE supporting EPDCCH. | | | |
| 2.6 ETWS and CMAS UEs supporting FS2 | A + B + C + (D or E or G or I) + (F or H or J) + F + M | A + (D or E or G or I) + (F or H or J) + F + M | (E or D1) + F1 | |
| | Remarks: For TDD UL/DL configuration 0, two PDCCHs or EPDCCHs can be received in the same subframe for UL-SCH in two different uplink subframes. Remarks: Combination involving EPDCCH is optional and required only for UE supporting EPDCCH. | | | |
| 2.7 UEs supporting sidelink communication | A + B + (D or E or G or I) + (F or H or J) + M + N | | | |
| | Remarks: Combination involving EPDCCH is optional and required only for UE supporting EPDCCH. Remarks: The combination is the requirement when the UE is configured in scheduled resource | | | |

| | |
|-------|---|
| | allocation mode. |
| NOTE: | p is the number of DL CCs supported by the UE. The number of D1 is $\leq (p-1)$. q is the number of UL CCs supported by the UE. For UE not supporting FS2, the number of F1 is $\leq (q-1)$. For UE supporting FS2, the number of F1 is $\leq 2 \times (q-1)$. $q = p = 1$ implies non-CA capable UE. Only 1xE is possible at any subframe over all serving cells. 1xM is included if UE supports eIMTA. |
| NOTE: | The UE is only required to receive one PDSCH, pertaining to D or D1, per DL CC. |
| NOTE: | If a UE indicating category 0 is scheduled with PDSCH transmissions exceeding its processing capability as specified in TS 36.306 [13], the prioritization between these PDSCH transmissions is up to the UE implementation. |

NOTE: Any subset of the combinations specified in table 8.2-2 is also supported.

8.3 Sidelink

The table 8.3-1 describes the possible combinations of physical channels that can be sent in parallel from UE perspective in the sidelink within the same subframe. Table 8.3-2 describes the possible combinations of physical channels that can be received in parallel from UE perspective in the sidelink within the same subframe.

Table 8.3-1: Sidelink transmission

| | Physical Channel Combination | Transport Channel Combination | Mandatory dependent on UE radio access capabilities | Comment |
|-------|---|-------------------------------|---|--|
| 1 | PSDCH | SL-DCH | Mandatory for UE supporting sidelink discovery | The UE supporting sidelink discovery transmits sidelink discovery messages on the camped cell (idle) or PCell (connected). |
| 2 | PSBCH | SL-BCH | Mandatory for UE supporting sidelink communication | The UE supporting sidelink communication transmits MasterInformationBlock-SL messages in PSBCH on one preconfigured frequency. |
| 3 | PSSCH | SL-SCH | Mandatory for UE supporting sidelink communication | The UE supporting sidelink communication transmits sidelink data in PSSCH on one preconfigured frequency. |
| 4 | PSCCH | N/A | Mandatory for UE supporting sidelink communication | The UE supporting sidelink communication transmits sidelink control information in PSCCH on one preconfigured frequency. |
| NOTE: | Depending on the UE capability, the UE may be able to perform simultaneous Uplink and Sidelink transmissions. If the UE is unable to perform simultaneous Uplink and Sidelink transmissions, the UE prioritises the Uplink transmissions. | | | |
| NOTE: | Depending on the UE capability, the UE may be able to perform simultaneous sidelink communication transmissions (PSBCH or PSSCH or PSCCH) and sidelink discovery transmission (PSDCH). If the UE is unable to perform simultaneous transmission of sidelink communication and discovery, the UE prioritises sidelink communication transmissions. | | | |

Table 8.3-2: Sidelink reception

| | Physical Channel Combination | Transport Channel Combination | Mandatory dependent on UE radio access capabilities | Comment |
|--|------------------------------|-------------------------------|---|---------|
| 1 | PSDCH | SL-DCH | Mandatory for UE supporting sidelink discovery | |
| 2 | PSBCH | SL-BCH | Mandatory for UE supporting sidelink communication | |
| 3 | PSSCH | SL-SCH | Mandatory for UE supporting sidelink communication | |
| 4 | PSCCH | N/A | Mandatory for UE supporting sidelink communication | |
| NOTE: For sidelink communication, the UE shall be able to perform simultaneous Downlink and sidelink communication reception. For sidelink discovery, depending on the UE capability, the UE may be able to perform simultaneous Downlink and sidelink discovery receptions. If the UE is unable to perform simultaneous Downlink and sidelink discovery receptions, the UE prioritises the Downlink receptions. | | | | |
| NOTE: If the configured resources for reception of sidelink communication and sidelink discovery are overlapped, the UE prioritises sidelink communication reception. | | | | |

9 Measurements provided by the physical layer

9.1 Void

9.2 UE Measurements

The detailed UE measurements definition is provided in [11]:

UE measurement: **Reference signal received power (RSRP)**: Reference signal received power (RSRP) is determined for a considered cell as the linear average over the power contributions (in [W]) of the resource elements that carry cell-specific reference signals within the considered measurement frequency bandwidth. For RSRP determination the cell-specific reference signals R_0 and if available R_1 according to [8] can be used.

If receiver diversity is in use by the UE, the reported value shall be in accordance with [11].

UE measurement: **Sidelink Reference Signal Received Power (S-RSRP)**: Sidelink Reference Signal Received Power (S-RSRP) is defined as the linear average over the power contributions (in [W]) of the resource elements that carry demodulation reference signals associated with PSBCH, within the central 6 PRBs of the applicable subframes.

If receiver diversity is in use by the UE, the reported value shall be in accordance with [11].

UE measurement: **Reference Signal Received Quality (RSRQ)**: Reference Signal Received Quality (RSRQ) is defined as the ratio $N \times \text{RSRP} / (\text{E-UTRA carrier RSSI})$, where N is the number of RB"s of the E-UTRA carrier RSSI measurement bandwidth. The measurements in the numerator and denominator shall be made over the same set of resource blocks.

E-UTRA Carrier Received Signal Strength Indicator (RSSI), comprises the linear average of the total received power (in [W]) observed only in OFDM symbols containing reference symbols for antenna port 0, in the measurement bandwidth, over N number of resource blocks by the UE from all sources, including co-channel serving and non-serving cells, adjacent channel interference, thermal noise etc.

If receiver diversity is in use by the UE, the reported value shall be in accordance with [11].

9.3 E-UTRAN Measurements

The detailed E-UTRAN measurements definition is provided in [11]:

eNode B measurement: **DL RS TX power**: Downlink reference signal transmit power is determined for a considered cell as the linear average over the power contributions (in [W]) of the resource elements that carry cell-specific reference signals which are transmitted by the eNode B within its operating system bandwidth.

For DL RS TX power determination the cell-specific reference signals R_0 and if available R_1 according to [8] can be used.

The reference point for the DL RS TX power measurement shall be the TX antenna connector.

Annex A (informative): Change history

| Change history | | | | | | | |
|----------------|----------|-----------|------|-----|--|--------|--------|
| Date | TSG # | TSG Doc. | CR | Rev | Subject/Comment | Old | New |
| 11/2006 | RP-34 | RP-060795 | - | | First version : presented at TSG-RAN #34 and TSG-RAN WG2 #56 (11/2006) | - | 0.0.0 |
| 05/2007 | RP-36 | RP-xyztu | | | Update including physical layer modelling: submitted at TSG-RAN WG2 #58 (05/2006) | 0.0.0 | 0.0.1 |
| 06/2007 | RP-37 | R2-072502 | | | Update including physical Services and functions of the Physical Layer: presented and TSG-RAN WG2 #58bis (06/2006) | 0.0.1 | 0.0.2 |
| 06/2007 | RP-37 | R2-072931 | | | Update after presentation at TSG-RAN WG2 #58bis : physical channel channel terminology used | 0.0.2 | 0.1.0 |
| 09/2007 | RP-37 | RP-070686 | | | Removal of editor"s notes. Presented at TSG-RAN #37 for information | 0.1.0 | 1.0.0 |
| 10/2007 | R2-59bis | R2-074579 | | | Agreements in RAN1 LS received at RAN2#59 have to be implemented in the specification (by RAN2#59bis): Parallel reception of Physical Broadcast Channel (PBCH) and DL-SCH in the same TTI is feasible; 2 new measurements were introduced for LTE, UE measurement "Reference Signal Received Quality (RSRQ)" and eNode B measurement "DL RS TX power". | 1.0.1 | 1.0.2 |
| 10/2007 | R2-59bis | R2-074584 | | | Removal of incorrect Parallel reception of physical channels | 1.0.2 | 1.0.3 |
| 11/2007 | RP-38 | RP-070914 | | | Submission to RAN for RAN#38 approval | 1.0.3 | 2.0.0 |
| 12/2007 | RP-38 | - | | | Apprvped at TSG RAN-38 and placed under change control | 2.0.0 | 8.0.0 |
| 03/2009 | RP-43 | RP-090124 | 0002 | - | Proposed CR on Parallel reception in LTE | 8.0.0 | 8.1.0 |
| | RP-43 | RP-090124 | 0004 | - | Correction of out-of-date information | 8.0.0 | 8.1.0 |
| 06/2009 | RP-44 | RP-090509 | 0005 | 1 | Correction of MBMS | 8.1.0 | 8.2.0 |
| | RP-44 | RP-090509 | 0006 | - | Downlink reception types | 8.1.0 | 8.2.0 |
| | RP-44 | RP-090509 | 0009 | - | Simultaneous reception of transport channels in the LTE | 8.1.0 | 8.2.0 |
| | RP-44 | RP-090509 | 0010 | - | Clarification on the parallel receptions for PDSCHs | 8.1.0 | 8.2.0 |
| 12/2009 | RP-46 | RP-091341 | 0011 | - | Addition of MBMS reception types | 8.2.0 | 9.0.0 |
| | RP-46 | RP-091346 | 0012 | - | Remove FFSs from RAN2 specifications | 8.2.0 | 9.0.0 |
| | RP-46 | RP-091345 | 0014 | - | Proposed CR to 36.302 on Introduction of CMAS | 8.2.0 | 9.0.0 |
| 03/2010 | RP-47 | RP-100308 | 0019 | 1 | Correction to RSRP and RSRQ definition with Receiver Diversity to align with TS 36.214 | 9.0.0 | 9.1.0 |
| 06/2010 | RP-48 | RP-100556 | 0020 | - | Correction to RSRQ definition to align with TS 36.214 | 9.1.0 | 9.2.0 |
| 12/2010 | RP-50 | RP-101226 | 0021 | 3 | Introduction of CA to TS36.302 | 9.2.0 | 10.0.0 |
| 03/2011 | RP-51 | RP-110289 | 0022 | 1 | Correction to parallel reception and transmission for CA | 10.0.0 | 10.1.0 |
| | RP-51 | RP-110270 | 0025 | - | Corrections to TS36.302 on MBMS | 10.0.0 | 10.1.0 |
| | RP-51 | RP-110289 | 0026 | - | Update and correction to TS36.302 for CA | 10.0.0 | 10.1.0 |
| 06/2011 | RP-52 | RP-110839 | 0028 | - | DL Assignment in MBSFN Subframe | 10.1.0 | 10.2.0 |
| 12/2011 | RP-54 | RP-111716 | 0029 | - | Corrections to channel model | 10.2.0 | 10.3.0 |
| 03/2012 | RP-55 | RP-120326 | 0030 | 1 | Correction to the combination of physical uplink channels | 10.3.0 | 10.4.0 |
| 09/2012 | RP-57 | RP-121350 | 0031 | - | Introduction of parallel PRACH and PUSCH/PUCCH/SRS transmission | 10.4.0 | 11.0.0 |
| 12/2012 | RP-58 | RP-121951 | 0036 | - | Correction to parallel PRACH, SRS and PUSCH/PUCCH transmission | 11.0.0 | 11.1.0 |
| | RP-58 | RP-121956 | 0037 | - | Introduction of EPDCCH in TS 36.302 | 11.0.0 | 11.1.0 |
| 03/2013 | RP-59 | RP-130245 | 0041 | - | Correction to parallel SRS and PUSCH/PUCCH transmission | 11.1.0 | 11.2.0 |
| 06/2013 | RP-60 | RP-130808 | 0043 | - | Clarification on EPDCCH reception in MBSFN subframes | 11.2.0 | 11.3.0 |
| | RP-60 | RP-130808 | 0044 | - | Correction on downlink reception type combinations for UEs supporting multiple TAGs | 11.2.0 | 11.3.0 |
| | RP-60 | RP-130808 | 0045 | - | Downlink Reception Type Combinations for MBMS capable UE | 11.2.0 | 11.3.0 |
| 09/2013 | RP-61 | RP-131311 | 0047 | - | Miscellaneous correction to 36.302 | 11.3.0 | 11.4.0 |
| 03/2014 | RP-63 | RP-140355 | 0049 | - | MBMS reception on any configured or configurable SCell | 11.4.0 | 11.5.0 |
| 06/2014 | RP-64 | RP-140884 | 0050 | - | Introduction of the Downlink Reception Types for TDD eIMTA | 11.5.0 | 12.0.0 |
| | RP-64 | RP-140892 | 0051 | - | Correction on simultaneous DL physical channels for idle UE | 11.5.0 | 12.0.0 |
| 09/2014 | RP-65 | RP-141506 | 0054 | 1 | Updates for low complexity UEs, and the improvements for the representation of the reception requirements | 12.0.0 | 12.1.0 |
| 12/2014 | RP-66 | RP-142135 | 0056 | - | Introduction of dual connectivity | 12.1.0 | 12.2.0 |
| 03/2015 | RP-67 | RP-150376 | 0059 | - | Removal of unnecessary requirement to receive MIB on SCell | 12.2.0 | 12.3.0 |
| 06/2015 | RP-68 | RP-150921 | 0060 | - | Introduction of ProSe | 12.3.0 | 12.4.0 |
| 09/2015 | RP-69 | RP-151443 | 0061 | 1 | TS36.302 rapporteur's cleanup | 12.4.0 | 12.5.0 |
| 12/2015 | RP-70 | RP-152053 | 0062 | - | Corrections to Sidelink in TS 36.302 | 12.5.0 | 12.6.0 |

| Change history | | | | | | | |
|----------------|-------|-----------|------|-----|---|--------|--------|
| Date | TSG # | TSG Doc. | CR | Rev | Subject/Comment | Old | New |
| 06/2016 | RP-72 | RP-161078 | 0069 | - | Corrections on the data modulation of Downlink-Shared Channel | 12.6.0 | 12.7.0 |

History

| Document history | | |
|-------------------------|----------------|-------------|
| V12.1.0 | September 2014 | Publication |
| V12.2.0 | February 2015 | Publication |
| V12.3.0 | April 2015 | Publication |
| V12.4.0 | July 2015 | Publication |
| V12.5.0 | October 2015 | Publication |
| V12.6.0 | January 2016 | Publication |
| V12.7.0 | August 2016 | Publication |