

ETSI TS 134 171 V9.2.0 (2011-07)

Technical Specification

**Universal Mobile Telecommunications System (UMTS);
Terminal conformance specification;
Assisted Global Positioning System (A-GPS);
Frequency Division Duplex (FDD)
(3GPP TS 34.171 version 9.2.0 Release 9)**



Reference

RTS/TSGR-0534171v920

Keywords

UMTS

ETSI

650 Route des Lucioles
F-06921 Sophia Antipolis Cedex - FRANCE

Tel.: +33 4 92 94 42 00 Fax: +33 4 93 65 47 16

Siret N° 348 623 562 00017 - NAF 742 C
Association à but non lucratif enregistrée à la
Sous-Préfecture de Grasse (06) N° 7803/88

Important notice

Individual copies of the present document can be downloaded from:

<http://www.etsi.org>

The present document may be made available in more than one electronic version or in print. In any case of existing or perceived difference in contents between such versions, the reference version is the Portable Document Format (PDF). In case of dispute, the reference shall be the printing on ETSI printers of the PDF version kept on a specific network drive within ETSI Secretariat.

Users of the present document should be aware that the document may be subject to revision or change of status. Information on the current status of this and other ETSI documents is available at

<http://portal.etsi.org/tb/status/status.asp>

If you find errors in the present document, please send your comment to one of the following services:

http://portal.etsi.org/chaicor/ETSI_support.asp

Copyright Notification

No part may be reproduced except as authorized by written permission.
The copyright and the foregoing restriction extend to reproduction in all media.

© European Telecommunications Standards Institute 2011.
All rights reserved.

DECT™, **PLUGTESTS™**, **UMTS™** and the ETSI logo are Trade Marks of ETSI registered for the benefit of its Members.
3GPP™ and **LTE™** are Trade Marks of ETSI registered for the benefit of its Members and of the 3GPP Organizational Partners.
GSM® and the GSM logo are Trade Marks registered and owned by the GSM Association.

Intellectual Property Rights

IPRs essential or potentially essential to the present document may have been declared to ETSI. The information pertaining to these essential IPRs, if any, is publicly available for **ETSI members and non-members**, and can be found in ETSI SR 000 314: *"Intellectual Property Rights (IPRs); Essential, or potentially Essential, IPRs notified to ETSI in respect of ETSI standards"*, which is available from the ETSI Secretariat. Latest updates are available on the ETSI Web server (<http://ipr.etsi.org>).

Pursuant to the ETSI IPR Policy, no investigation, including IPR searches, has been carried out by ETSI. No guarantee can be given as to the existence of other IPRs not referenced in ETSI SR 000 314 (or the updates on the ETSI Web server) which are, or may be, or may become, essential to the present document.

Foreword

This Technical Specification (TS) has been produced by ETSI 3rd Generation Partnership Project (3GPP).

The present document may refer to technical specifications or reports using their 3GPP identities, UMTS identities or GSM identities. These should be interpreted as being references to the corresponding ETSI deliverables.

The cross reference between GSM, UMTS, 3GPP and ETSI identities can be found under <http://webapp.etsi.org/key/queryform.asp>.

Contents

Intellectual Property Rights	2
Foreword.....	2
Foreword.....	6
1 Scope	7
2 References	7
3 Definitions, symbols, abbreviations and equations	8
3.1 Definitions	8
3.2 Symbols.....	8
3.3 Abbreviations	8
3.4 Equations.....	9
4 General test conditions	9
4.1 GPS test conditions	9
4.1.1 GPS signals.....	9
4.1.2 GPS frequency	9
4.2 UTRA test conditions.....	9
4.2.1 UTRA frequency band and frequency range	9
4.2.2 UTRA frequency	9
5 Performance requirements for A-GPS.....	9
5.1 General	9
5.1.1 Measurement parameters	10
5.1.1.1 UE based A-GPS measurement parameters	10
5.1.1.2 UE assisted A-GPS measurement parameters.....	10
5.1.1.3 2D position error	10
5.1.1.4 Response time	10
5.2 Sensitivity.....	10
5.2.1 Sensitivity Coarse Time Assistance.....	10
5.2.1.1 Definition and applicability.....	10
5.2.1.2 Minimum requirements.....	10
5.2.1.3 Test purpose	11
5.2.1.4 Method of test	11
5.2.1.4.1 Initial conditions.....	11
5.2.1.4.2 Procedure.....	11
5.2.1.5 Test Requirements.....	12
5.2.2 Sensitivity Fine Time Assistance.....	12
5.2.2.1 Definition and applicability.....	12
5.2.2.2 Minimum requirements	12
5.2.2.3 Test purpose	13
5.2.2.4 Method of test	13
5.2.2.4.1 Initial conditions	13
5.2.2.4.2 Procedure.....	13
5.2.2.5 Test Requirements.....	14
5.3 Nominal Accuracy.....	14
5.3.1 Definition and applicability	14
5.3.2 Minimum requirements.....	14
5.3.3 Test purpose.....	15
5.3.4 Method of test	15
5.3.4.1 Initial conditions	15
5.3.4.2 Procedure	15
5.3.5 Test Requirements	16
5.4 Dynamic Range	16
5.4.1 Definition and applicability	16
5.4.2 Minimum requirements.....	16
5.4.3 Test purpose.....	17

5.4.4	Method of test	17
5.4.4.1	Initial conditions	17
5.4.4.2	Procedure	17
5.4.5	Test Requirements	18
5.5	Multi-path Performance	19
5.5.1	Definition and applicability	19
5.5.2	Minimum requirements.....	19
5.5.3	Test purpose.....	19
5.5.4	Method of test.....	19
5.5.4.1	Initial conditions	19
5.5.4.2	Procedure	19
5.5.5	Test Requirements	20
5.6	Moving Scenario and Periodic Update Performance.....	21
5.6.1	Definition and applicability	21
5.6.2	Minimum requirements.....	21
5.6.3	Test purpose.....	21
5.6.4	Method of test.....	21
5.6.4.1	Initial conditions	21
5.6.4.2	Procedure	22
5.6.5	Test Requirements	23
Annex A (informative): Connection Diagrams		24
Annex B (normative): Converting UE-assisted measurement reports into position estimates.....		26
B.1	Introduction	26
B.2	UE measurement reports	26
B.3	WLS position solution.....	26
Annex C (normative): Propagation Conditions.....		29
C.1	General	29
C.2	Propagation Conditions for GPS Signals	29
C.2.1	Static propagation conditions	29
C.2.2	Multi-path conditions	29
Annex D (normative): Generic procedures.....		30
D.1	General	30
D.2	UTRAN connection set up	30
D.2.1	Initial conditions.....	30
D.2.2	Procedures	30
D.2.3	Specific message contents	31
D.3	UTRAN connection release.....	31
D.3.1	Procedure.....	31
D.3.2	Specific message contents	32
Annex E (normative): Environmental conditions		33
E.1	General	33
E.2	Environmental requirements	33
E.2.1	Temperature	33
E.2.2	Voltage	33
Annex F (normative): General test conditions and declarations.....		34
F.1	Acceptable uncertainty of Test System	34
F.1.1	Measurement of test environments.....	34
F.1.2	A-GPS Performance requirements	35
F.2	Test Tolerances (This clause is informative).....	36

F.2.1	A-GPS Performance requirements	36
F.3	Interpretation of measurement results	36
F.4	Derivation of Test Requirements (This clause is informative).....	37
F.5	Acceptable uncertainty of Test Equipment (This clause is informative)	38
F.5.1	A-GPS Performance measurements	38
F.6	General rules for statistical testing	38
F.6.1	Statistical testing of 2 D position error and TTFF	38
F.6.1.1	Test Method	38
F.6.1.2	Error Ratio (ER)	38
F.6.1.3	Test Design	38
F.6.1.3.1	Confidence level	38
F.6.1.3.2	Introduction: Supplier Risk versus Customer Risk	39
F.6.1.3.3	Supplier Risk versus Customer Risk	39
F.6.1.3.4	Introduction: Standard test versus early decision concept.....	40
F.6.1.3.5	Standard test versus early decision concept	40
F.6.1.3.6	Selectivity.....	40
F.6.1.3.7	Design of the test.....	41
F.6.1.4	Pass fail decision.....	43
F.6.1.4.1	Numerical definition of the pass fail limits	43
F.6.1.4.2	Pass fail decision rules	43
F.6.1.4.3	Background information to the pass fail limits	44
Annex G (normative):	Test case applicability and ICS proforma for 3rd Generation User Equipment	45
G.1	Recommended test case applicability.....	45
G.2	Guidance for completing the ICS proforma	46
G.2.1	Purposes and structure.....	46
G.2.2	Abbreviations and conventions	46
G.2.3	Instructions for completing the ICS proforma.....	47
G.3	Identification of the User Equipment	47
G.3.1	Date of the statement	47
G.3.2	User Equipment Under Test (UEUT) identification.....	47
G.3.3	Product supplier.....	48
G.3.4	Client	48
G.3.5	ICS contact person.....	49
G.4	Identification of the protocol.....	49
G.5	ICS proforma tables.....	49
G.5.1	UE Implementation Types.....	49
G.5.2	UE Service Capabilities.....	50
G.5.3	Additional information	50
Annex H (informative):	Change history	51
History		52

Foreword

This Technical Specification has been produced by the 3rd Generation Partnership Project (3GPP).

The contents of the present document are subject to continuing work within the TSG and may change following formal TSG approval. Should the TSG modify the contents of the present document, it will be re-released by the TSG with an identifying change of release date and an increase in version number as follows:

Version x.y.z

where:

- x the first digit:
 - 1 presented to TSG for information;
 - 2 presented to TSG for approval;
 - 3 or greater indicates TSG approved document under change control.
- y the second digit is incremented for all changes of substance, i.e. technical enhancements, corrections, updates, etc.
- z the third digit is incremented when editorial only changes have been incorporated in the document.

1 Scope

The present document specifies the measurement procedures for the conformance test of the minimum performance requirements for FDD mode of UTRA user equipment (UE) where the only Assisted Global Navigation Satellite System (A-GNSS) supported is Assisted Global Positioning System (A-GPS) L1 C/A. The procedures for UEs that support other or additional A-GNSSs are specified in 3GPP TS 34.172 [18].

Tests are only applicable to those mobiles that are intended to support the appropriate functionality. To indicate the circumstances in which tests apply, this is noted in the "*definition and applicability*" part of the test.

2 References

The following documents contain provisions which, through reference in this text, constitute provisions of the present document.

- References are either specific (identified by date of publication, edition number, version number, etc.) or non-specific.
- For a specific reference, subsequent revisions do not apply.
- For a non-specific reference, the latest version applies. In the case of a reference to a 3GPP document (including a GSM document), a non-specific reference implicitly refers to the latest version of that document *in the same Release as the present document*.
 - For a Release 1999 UE, references to 3GPP documents are to version 3.x.y.
 - For a Release 4 UE, references to 3GPP documents are to version 4.x.y.
 - For a Release 5 UE, references to 3GPP documents are to version 5.x.y.
 - For a Release 6 UE, references to 3GPP documents are to version 6.x.y.
 - For a Release 7 UE, references to 3GPP documents are to version 7.x.y.
 - For a Release 8 UE, references to 3GPP documents are to version 8.x.y.

- [1] 3GPP TR 21.905: "Vocabulary for 3GPP Specifications".
- [2] 3GPP TR 25.990: "Vocabulary for UTRAN".
- [3] 3GPP TS 34.108: "Common test environments for User Equipment (UE) conformance testing".
- [4] 3GPP TS 34.109: "Terminal logical test interface; Special conformance testing functions".
- [5] 3GPP TS 25.331: "Radio Resource Control (RRC) protocol specification".
- [6] 3GPP TS 25.171: "Requirements for support of Assisted Global Positioning System (A-GPS); Frequency Division Duplex (FDD)".
- [7] 3GPP TS 25.302: "Services provided by the physical layer".
- [8] Navstar GPS Space Segment/Navigation User Interfaces, ICD-GPS 200, Rev. C.
- [9] P. Axelrad, R.G. Brown, "GPS Navigation Algorithms", in Chapter 9 of "Global Positioning System: Theory and Applications", Volume 1, B.W. Parkinson, J.J. Spilker (Ed.), Am. Inst. of Aeronautics and Astronautics Inc., 1996.
- [10] S.K. Gupta, "Test and Evaluation Procedures for the GPS User Equipment", ION-GPS Red Book, Volume 1, p. 119.
- [11] 3GPP TS 25.215: "Physical layer; Measurements (FDD)".

- [12] IEC 60068-2-1: "Environmental testing - Part 2: Tests. Tests A: Cold".
- [13] IEC 60068-2-2: "Environmental testing - Part 2: Tests. Tests B: Dry heat".
- [14] ETSI TR 102 273-2-1: "Electromagnetic compatibility and Radio spectrum Matters (ERM); Improvement on Radiated Methods of Measurement (using test site) and evaluation of the corresponding measurement uncertainties; Part 1: Uncertainties in the measurement of mobile radio equipment characteristics; Sub-part 2: Examples and annexes".
- [15] 3GPP TS 34.123-2: " User Equipment (UE) conformance specification; Part 2: Implementation Conformance Statement (ICS) proforma specification".
- [16] 3GPP TS 25.101: "UE radio Transmission and Reception (FDD)".
- [17] 3GPP TS 25.306: "UE Radio Access Capabilities".
- [18] 3GPP TS 34.172: "Terminal conformance specification; Assisted Global Navigation Satellite Systems (A-GNSS); Frequency Division Duplex (FDD)

3 Definitions, symbols, abbreviations and equations

3.1 Definitions

For the purpose of the present document, the terms and definitions given in 3GPP TR 21.905 [1], 3GPP TR 25.990 [2] and the following apply:

Horizontal Dilution Of Precision (HDOP): measure of position determination accuracy that is a function of the geometrical layout of the satellites used for the fix, relative to the receiver antenna.

L1: L band GPS transmission frequency of 1575.42 MHz.

3.2 Symbols

For the purposes of the present document, the symbols given in 3GPP TR 21.905 [1], 3GPP TR 25.990 [2] and the following apply:

- [...] A value included in square bracket must be considered for further study, because a decision about that value has not been taken

3.3 Abbreviations

For the purpose of the present document, the abbreviations given in 3GPP TR 21.905 [1], 3GPP TR 25.990 [2] and the following apply:

A-GPS	Assisted - Global Positioning System
A-GNSS	Assisted Global Navigation Satellite System
AWGN	Additive White Gaussian Noise
C/A	Coarse/Acquisition
ECEF	Earth Centred, Earth Fixed
GPS	Global Positioning System
GNSS	Global Navigation Satellite System
GSS	GPS System Simulator
HDOP	Horizontal Dilution Of Precision
LOS	Line Of Sight
OCNS	Orthogonal Channel Noise Simulator

NOTE: A mechanism used to simulate the users or control signals on the other orthogonal channels of a downlink.

SS	System Simulator
----	------------------

NOTE: See annex A for description.

WLS Weighted Least Square

3.4 Equations

For the purpose of the present document, the following equations apply:

4 General test conditions

4.1 GPS test conditions

4.1.1 GPS signals

The GPS signal is defined at the A-GPS antenna connector of the UE. For UE with integral antenna only, a reference antenna with a gain of 0 dBi is assumed.

4.1.2 GPS frequency

The GPS signals shall be transmitted with a frequency accuracy of ± 0.025 PPM.

4.2 UTRA test conditions

4.2.1 UTRA frequency band and frequency range

The tests in the present document are performed at mid range of the UTRA operating frequency band of the UE. The UARFCNs to be used for mid range are defined in 3GPP TS 34.108 [3], clause 5.1.1.

If the UE supports multiple frequency bands then the Sensitivity tests in clause 5.2 shall be repeated in each supported frequency band.

4.2.2 UTRA frequency

For all tests the UTRA frequency shall be offset with respect to the nominal frequency by an amount equal to the sum of +0.025 PPM and the offset in PPM of the actual transmitted GPS carrier frequency with respect to the nominal GPS frequency.

5 Performance requirements for A-GPS

5.1 General

This section defines the minimum performance requirements for both UE based and UE assisted FDD A-GPS terminals. If a terminal supports both modes then it shall be tested in both modes.

The requirements are defined for CELL_DCH and CELL_FACH states. All tests shall be performed in CELL_DCH state and the Nominal Accuracy Performance test case shall be also performed in CELL_FACH state.

5.1.1 Measurement parameters

5.1.1.1 UE based A-GPS measurement parameters

In case of UE-based A-GPS, the measurement parameters are contained in the RRC UE POSITIONING POSITION ESTIMATE INFO IE. The measurement parameter is the horizontal position estimate reported by the UE and expressed in latitude/longitude.

5.1.1.2 UE assisted A-GPS measurement parameters

In case of UE-assisted A-GPS, the measurement parameters are contained in the RRC UE POSITIONING GPS MEASURED RESULTS IE. The measurement parameters are the UE GPS Code Phase measurements, as specified in 3GPP TS 25.302 [7] and 3GPP TS 25.215 [11]. The UE GPS Code Phase measurements are converted into a horizontal position estimate using the procedure detailed in annex B.

5.1.1.3 2D position error

The 2D position error is defined by the horizontal difference in meters between the ellipsoid point reported or calculated from the UE Measurement Report and the actual simulated position of the UE in the test case considered.

5.1.1.4 Response time

Max Response Time is defined as the time starting from the moment that the UE has received the final RRC measurement control message containing reporting criteria different from "No Reporting" sent before the UE sends the measurement report containing the position estimate or the GPS measured result, and ending when the UE starts sending the measurement report containing the position estimate or the GPS measured result on the Uu interface. The response times specified for all test cases are Time-to-First-Fix (TTFF) unless otherwise stated, i.e. the UE shall not re-use any information on GPS time, location or other aiding data that was previously acquired or calculated and stored internally in the UE. A dedicated test message 'RESET UE POSITIONING STORED INFORMATION' specified in 3GPP TS 34.109 [4], clause 5.4, has been defined for the purpose of deleting this information.

5.2 Sensitivity

5.2.1 Sensitivity Coarse Time Assistance

5.2.1.1 Definition and applicability

Sensitivity with coarse time assistance is the minimum level of GPS satellite signals required for the UE to make an A-GPS position estimate to a specific accuracy and within a specific response time when the network only provides coarse time assistance.

The requirements and this test apply to all types of UTRA for the FDD UE that supports A-GPS.

5.2.1.2 Minimum requirements

The first fix position estimates shall meet the accuracy and response time requirements in table 5.2.1.2 for the parameters specified in table 5.2.1.1.

Table 5.2.1.1: Test parameters for Sensitivity Coarse Time Assistance

Parameters	Unit	Value
Number of generated satellites	-	8
HDOP Range	-	1.1 to 1.6
Propagation conditions	-	AWGN
GPS Coarse Time assistance error range	seconds	± 2
GPS Signal for one satellite	dBm	-142
GPS Signal for remaining satellites	dBm	-147

Table 5.2.1.2: Minimum requirements for Sensitivity Coarse Time Assistance

Success rate	2-D position error	Max response time
95 %	100 m	20 s

The reference for this requirement is 3GPP TS 25.171 [6], clause 5.1.1.1.

5.2.1.3 Test purpose

To verify the UE's first position estimate meets the minimum requirements under GPS satellite signal conditions that represent weak signal conditions and with only Coarse Time Assistance provided by the SS.

5.2.1.4 Method of test

5.2.1.4.1 Initial conditions

Test environment: normal; see clause E.2.

1. Connect SS and GSS to the UE antenna connector or antenna connectors as shown in figures A.1 or A.2.
2. Set the GPS test parameters as specified in table 5.2.1.3 for GPS scenario #1. Select the first satellite PRN defined in the table in 3GPP TS 34.108 [3] clause 10.1.2.5 for the one satellite with the higher level.
3. Switch on the UE.

5.2.1.4.2 Procedure

1. Start GPS scenario #1 as specified in 3GPP TS 34.108 [3] clause 10.1.2 with the UE location randomly selected to be within 3 km of the Reference Location and the altitude of the UE randomly selected between 0 m to 500 m above WGS-84 reference ellipsoid using the method described in 3GPP TS 34.108 [3] clause 10.1.2.4
2. Set up a connection using the procedure in clause D.2.
3. Send a RESET UE POSITIONING STORED INFORMATION message followed by RRC MEASUREMENT CONTROL messages containing appropriate assistance data; as specified in 3GPP TS 34.108 [3], clauses 10.2 and 10.6 for UE based testing; or clauses 10.4 and 10.6 for UE assisted testing with the value of GPS TOW msec offset by a random value as specified in 3GPP TS 34.108 [3] clause 10.6.2; as required to obtain a fix using the procedure specified in 3GPP TS 34.108 [3], clauses 7.5.1 or 7.5.4.
4. If the UE returns a valid result in the MEASUREMENT REPORT message within the Max response time specified in table 5.2.1.4 then record the result and process it as specified in step 5. If the UE does not return a valid result within the Max response time specified in table 5.2.1.4 or reports a UE positioning error in the MEASUREMENT REPORT message then record one Bad Result.
5. For UE based testing compare the reported position estimate in the MEASUREMENT REPORT message against the simulated position of the UE used in step 1, and calculate the 2D position error as specified in clause 5.1.1.3. Compare the 2D position error against the value in table 5.2.1.4 and record one Good Result or Bad Result as appropriate; or

For UE assisted testing convert the GPS measured results reported in the MEASUREMENT REPORT message to a 2D position using the method described in Annex B and then compare the result against the simulated position of the UE, used in step 1, and calculate the 2D position error as specified in clause 5.1.1.3. Compare the 2D position error against the value in table 5.2.1.4 and record one Good Result or Bad Result as appropriate.

6. Release the connection using the procedure in clause D.3.
7. Repeat steps 1 to 6 using GPS scenario #2 instead of #1 so that the reference location changes sufficiently such that the UE shall have to use the new assistance data. Select the first satellite PRN defined in the table in 3GPP TS 34.108 [3] clause 10.1.2.5 for the one satellite with the higher level. Use new random values for the UE location and altitude in step 1 and for the GPS TOW msec offset in step 3.
8. Repeat steps 1 to 7 until the statistical requirements of clause 5.2.1.5 are met. Each time scenario #1 or #2 is used, the start time of the GPS scenario shall be advanced by 2 minutes from the time used previously for that scenario. Once a scenario reaches the end of its viable running time, restart it from its nominal start time again. Each time scenario #1 or #2 is used select the next satellite PRN from the one used previously, defined in the table in 3GPP TS 34.108 [3] clause 10.1.2.5, for the one satellite with the higher level.

5.2.1.5 Test Requirements

For the parameters specified in table 5.2.1.3 the UE shall meet the requirements and the success rate specified in table 5.2.1.4 with a confidence level of 95% according to annex F.6.1.

Table 5.2.1.3: Test parameters for Sensitivity Coarse Time Assistance

Parameters	Unit	Value
Number of generated satellites	-	8
HDOP Range	-	1.1 to 1.6
Propagation conditions	-	AWGN
GPS Coarse Time assistance error range	seconds	± 1.8
GPS Signal for one satellite	dBm	-141
GPS Signal for remaining satellites	dBm	-146

Table 5.2.1.4: Test requirements for Sensitivity Coarse Time Assistance

Success rate	2-D position error	Max response time
95 %	101.3 m	20.3 s

NOTE: If the above Test Requirement differs from the Minimum Requirement then the Test Tolerance applied for this test is non-zero. The Test Tolerance for this test is defined in clause F.2 and the explanation of how the Minimum Requirement has been relaxed by the Test Tolerance is given in clause F.4.

5.2.2 Sensitivity Fine Time Assistance

5.2.2.1 Definition and applicability

Sensitivity with fine time assistance is the minimum level of GPS satellite signals required for the UE to make an A-GPS position estimate to a specific accuracy and within a specific response time when the network provides fine time assistance in addition to coarse time assistance.

The requirements and this test apply to all types of UTRA for the FDD UE that supports A-GPS and that is capable of providing an enhanced performance when the network provides Fine Time Assistance.

5.2.2.2 Minimum requirements

The first fix position estimates shall meet the accuracy and response time requirements in table 5.2.2.2 for the parameters specified in table 5.2.2.1.

Table 5.2.2.1: Test parameters for Sensitivity Fine Time Assistance

Parameters	Unit	Value
Number of generated satellites	-	8
HDOP Range	-	1.1 to 1.6
Propagation conditions	-	AWGN
GPS Coarse time assistance error range	seconds	±2
GPS Fine Time assistance error range	µs	±10
GPS Signal for all satellites	dBm	-147

Table 5.2.2.2: Minimum requirements for Sensitivity Fine Time Assistance

Success rate	2-D position error	Max response time
95 %	100 m	20 s

The reference for this requirement is 3GPP TS 25.171 [6], clause 5.1.2.1.

5.2.2.3 Test purpose

To verify the UE's first position estimate meets the minimum requirements under GPS satellite signal conditions that represent weak signal conditions and with Fine Time Assistance provided by the SS.

5.2.2.4 Method of test

5.2.2.4.1 Initial conditions

Test environment: normal; see clause E.2.

1. Connect SS and GSS to the UE antenna connector or antenna connectors as shown in figures A.1 or A.2.
2. Set the GPS test parameters as specified in table 5.2.2.3 for GPS scenario #1.
3. Switch on the UE.

5.2.2.4.2 Procedure

1. Start GPS scenario #1 as specified in 3GPP TS 34.108 [3] clause 10.1.2 with the UE location randomly selected to be within 3 km of the Reference Location and the altitude of the UE randomly selected between 0 m to 500 m above WGS-84 reference ellipsoid using the method described in 3GPP TS 34.108 [3] clause 10.1.2.4
2. Set up a connection using the procedure in clause D.2.
3. Send a RESET UE POSITIONING STORED INFORMATION message followed by RRC MEASUREMENT CONTROL messages containing appropriate assistance data; as specified in 3GPP TS 34.108 [3], clauses 10.2 and 10.6 for UE based testing; or clauses 10.4 and 10.6 for UE assisted testing with the values of GPS TOW msec and UTRAN GPS timing of cell frames offset by random values as specified in 3GPP TS 34.108 [3] clause 10.6.2; as required to obtain a fix using the procedure specified in 3GPP TS 34.108 [3], clauses 7.5.1 or 7.5.4.
4. If the UE returns a valid result in the MEASUREMENT REPORT message within the Max response time specified in table 5.2.2.4 then record the result and process it as specified in step 5. If the UE does not return a valid result within the Max response time specified in table 5.2.2.4 or reports a UE positioning error in the MEASUREMENT REPORT message then record one Bad Result.
5. For UE based testing compare the reported position estimate in the MEASUREMENT REPORT message against the simulated position of the UE used in step 1, and calculate the 2D position error as specified in clause 5.1.1.3. Compare the 2D position error against the value in table 5.2.2.4 and record one Good Result or Bad Result as appropriate; or

For UE assisted testing convert the GPS measured results reported in the MEASUREMENT REPORT message to a 2D position using the method described in Annex B and then compare the result against the simulated position of the UE used in step 1, and calculate the 2D position error as specified in clause 5.1.1.3. Compare the 2D position error against the value in table 5.2.2.4 and record one Good Result or Bad Result as appropriate.

6. Release the connection using the procedure in clause D.3.
7. Repeat steps 1 to 6 using GPS scenario #2 instead of #1 so that the reference location changes sufficiently such that the UE shall have to use the new assistance data. Use new random values for the UE location and altitude in step 1 and for the GPS TOW msec and UTRAN GPS timing of cell frames offsets in step 3.
8. Repeat steps 1 to 7 until the statistical requirements of clause 5.2.2.5 are met. Each time scenario #1 or #2 is used, the start time of the GPS scenario shall be advanced by 2 minutes from the time used previously for that scenario. Once a scenario reaches the end of its viable running time, restart it from its nominal start time again.

5.2.2.5 Test Requirements

For the parameters specified in table 5.2.2.3 the UE shall meet the requirements and the success rate specified in table 5.2.2.4 with a confidence level of 95% according to annex F.6.1.

Table 5.2.2.3: Test parameters for Sensitivity Fine Time Assistance

Parameters	Unit	Value
Number of generated satellites	-	8
HDOP Range	-	1.1 to 1.6
Propagation conditions	-	AWGN
GPS Coarse time assistance error range	seconds	± 1.8
GPS Fine Time assistance error range	μs	± 9
GPS Signal for all satellites	dBm	-146

Table 5.2.2.4: Test requirements for Sensitivity Fine Time Assistance

Success rate	2-D position error	Max response time
95 %	101.3 m	20.3 s

NOTE: If the above Test Requirement differs from the Minimum Requirement then the Test Tolerance applied for this test is non-zero. The Test Tolerance for this test is defined in clause F.2 and the explanation of how the Minimum Requirement has been relaxed by the Test Tolerance is given in clause F.4.

5.3 Nominal Accuracy

5.3.1 Definition and applicability

Nominal accuracy is the accuracy of the UE's A-GPS position estimate under ideal GPS signal conditions.

The requirements and this test apply to all types of UTRA for the FDD UE that supports A-GPS.

5.3.2 Minimum requirements

The first fix position estimates shall meet the accuracy and response time requirements in table 5.3.2 for the parameters specified in table 5.3.1.

Table 5.3.1: Test parameters for Nominal Accuracy

Parameters	Unit	Value
Number of generated satellites	-	8
HDOP Range	-	1.1 to 1.6
Propagation conditions	-	AWGN
GPS Coarse Time assistance error range	seconds	± 2
GPS Signal for all satellites	dBm	-130

Table 5.3.2: Minimum requirements for Nominal Accuracy

Success rate	2-D position error	Max response time
95 %	30 m	20 s

The reference for this requirement is 3GPP TS 25.171 [6], clause 5.2.1.

5.3.3 Test purpose

To verify the UE's first position estimate meets the minimum requirements under GPS satellite signal conditions that represent ideal conditions.

5.3.4 Method of test

5.3.4.1 Initial conditions

Test environment: normal; see clause E.2.

1. Connect SS and GSS to the UE antenna connector or antenna connectors as shown in figures A.1 or A.2.
2. Set the GPS test parameters as specified in table 5.3.3 for GPS scenario #1.
3. Switch on the UE.

5.3.4.2 Procedure

1. Start GPS scenario #1 as specified in 3GPP TS 34.108 [3] clause 10.1.2 with the UE location randomly selected to be within 3 km of the Reference Location and the altitude of the UE randomly selected between 0 m to 500 m above WGS-84 reference ellipsoid using the method described in 3GPP TS 34.108 [3] clause 10.1.2.4
2. Set up a connection using the procedure in clause D.2.
3. Send a RESET UE POSITIONING STORED INFORMATION message followed by RRC MEASUREMENT CONTROL messages containing appropriate assistance data; as specified in 3GPP TS 34.108 [3], clauses 10.2 and 10.6 for UE based testing; or clauses 10.4 and 10.6 for UE assisted testing with the value of GPS TOW msec offset by a random value as specified in 3GPP TS 34.108 [3] clause 10.6.2; using the exception to the RRC MEASUREMENT CONTROL message listed in table 5.3.2A; as required to obtain a fix using the procedure specified in 3GPP TS 34.108 [3], clauses 7.5.1 or 7.5.4.

Table 5.3.2A: Contents of RRC MEASUREMENT CONTROL message

Information Element	Value/Remark
- UE positioning reporting quantity - Horizontal accuracy	10 (15.9 m)

4. If the UE returns a valid result in the MEASUREMENT REPORT message within the Max response time specified in table 5.3.4 then record the result and process it as specified in step 5. If the UE does not return a valid result within the Max response time specified in table 5.3.4 or reports a UE positioning error in the MEASUREMENT REPORT message then record one Bad Result.

5. For UE based testing compare the reported position estimate in the MEASUREMENT REPORT message against the simulated position of the UE used in step 1, and calculate the 2D position error as specified in clause 5.1.1.3. Compare the 2D position error against the value in table 5.3.4 and record one Good Result or Bad Result as appropriate; or

For UE assisted testing convert the GPS measured results reported in the MEASUREMENT REPORT message to a 2D position using the method described in Annex B and then compare the result against the simulated position of the UE used in step 1, and calculate the 2D position error as specified in clause 5.1.1.3. Compare the 2D position error against the value in table 5.3.4 and record one Good Result or Bad Result as appropriate.

6. Release the connection using the procedure in clause D.3.
7. Repeat steps 1 to 6 using GPS scenario #2 instead of #1 so that the reference location changes sufficiently such that the UE shall have to use the new assistance data. Use new random values for the UE location and altitude in step 1 and for the GPS TOW msec offset in step 3.
8. Repeat steps 1 to 7 until the statistical requirements of clause 5.3.5 are met. Each time scenario #1 or #2 is used, the start time of the GPS scenario shall be advanced by 2 minutes from the time used previously for that scenario. Once a scenario reaches the end of its viable running time, restart it from its nominal start time again.

5.3.5 Test Requirements

For the parameters specified in table 5.3.3 the UE shall meet the requirements and the success rate specified in table 5.3.4 with a confidence level of 95% according to annex F.6.1.

Table 5.3.3: Test parameters for Nominal Accuracy

Parameters	Unit	Value
Number of generated satellites	-	8
HDOP Range	-	1.1 to 1.6
Propagation conditions	-	AWGN
GPS Coarse Time assistance error range	seconds	± 1.8
GPS Signal for all satellites	dBm	-130

Table 5.3.4: Test requirements for Nominal Accuracy

Success rate	2-D position error	Max response time
95 %	31.3 m	20.3 s

NOTE: If the above Test Requirement differs from the Minimum Requirement then the Test Tolerance applied for this test is non-zero. The Test Tolerance for this test is defined in clause F.2 and the explanation of how the Minimum Requirement has been relaxed by the Test Tolerance is given in clause F.4.

5.4 Dynamic Range

5.4.1 Definition and applicability

Dynamic Range is the maximum difference in level of the GPS signals from a number of satellites that allows the UE to make an A-GPS position estimate with a specific accuracy and a specific response time.

The requirements and this test apply to all types of UTRA for the FDD UE that supports A-GPS.

5.4.2 Minimum requirements

The first fix position estimates shall meet the accuracy and response time requirements in table 5.4.2 for the parameters specified in table 5.4.1.

Table 5.4.1: Test parameters for Dynamic Range

Parameters	Unit	Value
Number of generated satellites	-	6
HDOP Range	-	1.4 to 2.1
GPS Coarse Time assistance error range	seconds	±2
Propagation conditions	-	AWGN
GPS Signal for 1 st satellite	dBm	-129
GPS Signal for 2 nd satellite	dBm	-135
GPS Signal for 3 rd satellite	dBm	-141
GPS Signal for 4 th satellite	dBm	-147
GPS Signal for 5 th satellite	dBm	-147
GPS Signal for 6 th satellite	dBm	-147

Table 5.4.2: Minimum requirements for Dynamic Range

Success rate	2-D position error	Max response time
95 %	100 m	20 s

The reference for this requirement is 3GPP TS 25.171 [6], clause 5.3.1.

5.4.3 Test purpose

To verify the UE's first position estimate meets the minimum requirements under GPS satellite signal conditions that have a wide dynamic range. Strong satellites are likely to degrade the acquisition of weaker satellites due to their cross-correlation products.

5.4.4 Method of test

5.4.4.1 Initial conditions

Test environment: normal; see clause E.2.

1. Connect SS and GSS to the UE antenna connector or antenna connectors as shown in figures A.1 or A.2.
2. Set the GPS test parameters as specified in table 5.4.3 for GPS scenario #1. Select the first three satellite PRNs defined in the table in 3GPP TS 34.108 [3] clause 10.1.2.5 for the three satellites with the higher levels.
3. Switch on the UE.

5.4.4.2 Procedure

1. Start GPS scenario #1 as specified in 3GPP TS 34.108 [3] clause 10.1.2 with the UE location randomly selected to be within 3 km of the Reference Location and the altitude of the UE randomly selected between 0 m to 500 m above WGS-84 reference ellipsoid using the method described in 3GPP TS 34.108 [3] clause 10.1.2.4
2. Set up a connection using the procedure in clause D.2.
3. Send a RESET UE POSITIONING STORED INFORMATION message followed by RRC MEASUREMENT CONTROL messages containing appropriate assistance data; as specified in 3GPP TS 34.108 [3], clauses 10.2 and 10.6 for UE based testing; or clauses 10.4 and 10.6 for UE assisted testing with the value of GPS TOW msec offset by a random value as specified in 3GPP TS 34.108 [3] clause 10.6.2; as required to obtain a fix using the procedure specified in 3GPP TS 34.108 [3], clauses 7.5.1 or 7.5.4.
4. If the UE returns a valid result in the MEASUREMENT REPORT message within the Max response time specified in table 5.4.4 then record the result and process it as specified in step 5. If the UE does not return a valid result within the Max response time specified in table 5.4.4 or reports a UE positioning error in the MEASUREMENT REPORT message then record one Bad Result.

5. For UE based testing compare the reported position estimate in the MEASUREMENT REPORT message against the simulated position of the UE used in step 1, and calculate the 2D position error as specified in clause 5.1.1.3. Compare the 2D position error against the value in table 5.4.4 and record one Good Result or Bad Result as appropriate; or

For UE assisted testing convert the GPS measured results reported in the MEASUREMENT REPORT message to a 2D position using the method described in Annex B and then compare the result against the simulated position of the UE used in step 1, and calculate the 2D position error as specified in clause 5.1.1.3. Compare the 2D position error against the value in table 5.4.4 and record one Good Result or Bad Result as appropriate.

6. Release the connection using the procedure in clause D.3.
7. Repeat steps 1 to 6 using GPS scenario #2 instead of #1 so that the reference location changes sufficiently such that the UE shall have to use the new assistance data. Select the first three satellite PRNs defined in the table in 3GPP TS 34.108 [3] clause 10.1.2.5 for the three satellites with the higher levels. Use new random values for the UE location and altitude in step 1 and for the GPS TOW msec offset in step 3.
8. Repeat steps 1 to 7 until the statistical requirements of clause 5.4.5 are met. Each time scenario #1 or #2 is used, the start time of the GPS scenario shall be advanced by 2 minutes from the time used previously for that scenario. Once a scenario reaches the end of its viable running time, restart it from its nominal start time again. Each time scenario #1 or #2 is used, increment the set of three satellite PRNs by one from the ones used previously, defined in the table in 3GPP TS 34.108 [3] clause 10.1.2.5, for the three satellites with the higher levels (i.e. if the set of satellites is a, b, c, d, e, f and the first set used was a, b, c, the second set shall be b, c, d and so on).

5.4.5 Test Requirements

For the parameters specified in table 5.4.3 the UE shall meet the requirements and the success rate specified in table 5.4.4 with a confidence level of 95% according to annex F.6.1.

Table 5.4.3: Test parameters for Dynamic Range

Parameters	Unit	Value
Number of generated satellites	-	6
HDOP Range	-	1.4 to 2.1
GPS Coarse Time assistance error range	seconds	$\pm 2 + TT$
Propagation conditions	-	AWGN
GPS Signal for 1 st satellite	dBm	-128.2
GPS Signal for 2 nd satellite	dBm	-134
GPS Signal for 3 rd satellite	dBm	-140
GPS Signal for 4 th satellite	dBm	-146
GPS Signal for 5 th satellite	dBm	-146
GPS Signal for 6 th satellite	dBm	-146

Table 5.4.4: Test requirements for Dynamic Range

Success rate	2-D position error	Max response time
95 %	101.3 m	20.3 s

NOTE: If the above Test Requirement differs from the Minimum Requirement then the Test Tolerance applied for this test is non-zero. The Test Tolerance for this test is defined in clause F.2 and the explanation of how the Minimum Requirement has been relaxed by the Test Tolerance is given in clause F.4.

5.5 Multi-path Performance

5.5.1 Definition and applicability

Multi-path performance measures the accuracy and response time of the UE's A-GPS position estimate in a specific GPS signal multi-path environment.

The requirements and this test apply to all types of UTRA for the FDD UE that supports A-GPS.

5.5.2 Minimum requirements

The first fix position estimates shall meet the accuracy and response time requirements in table 5.5.2 for the parameters specified in table 5.5.1.

Table 5.5.1: Test parameters for Multi-path Performance

Parameters	Unit	Value
Number of generated satellites (see note)	-	5
GPS Coarse Time assistance error range	seconds	± 2
HDOP Range	-	1.8 to 2.5
GPS signal for Satellite 1, 2 (see note)	dBm	-130
GPS signal for Satellite 3, 4, 5 (see note)	dBm	LOS signal of -130 dBm, multi-path signal of -136 dBm

NOTE: Satellites 1, 2 no multi-path. Satellites 3, 4, 5 multi-path defined in clause C.2.2.

Table 5.5.2: Minimum requirements for Multi-path Performance

Success rate	2-D position error	Max response time
95 %	100 m	20 s

The reference for this requirement is 3GPP TS 25.171 [6], clause 5.4.1.

5.5.3 Test purpose

To verify the UE's first position estimate meets the minimum requirements under GPS satellite signal conditions that represent simple multi-path conditions.

5.5.4 Method of test

5.5.4.1 Initial conditions

Test environment: normal; see clause E.2.

1. Connect SS and GSS to the UE antenna connector or antenna connectors as shown in figures A.1 or A.2.
2. Set the GPS test parameters as specified in table 5.5.3 for GPS scenario #1. Select the first two satellite PRNs defined in the table in 3GPP TS 34.108 [3] clause 10.1.2.5 for the two satellites with the higher levels.
3. Switch on the UE.

5.5.4.2 Procedure

1. Start GPS scenario #1 as specified in 3GPP TS 34.108 [3] clause 10.1.2 with the UE location randomly selected to be within 3 km of the Reference Location and the altitude of the UE randomly selected between 0 m to 500 m above WGS-84 reference ellipsoid using the method described in 3GPP TS 34.108 [3] clause 10.1.2.4. The initial carrier phase difference between taps of the multi-path model shall be randomly selected between 0 and 2π radians by selecting the next random number from a standard uniform random number generator, in the range 0 to 2π , representing radians with a resolution of 0.1, representing 0.1 radians.

2. Set up a connection using the procedure in clause D.2.
3. Send a RESET UE POSITIONING STORED INFORMATION message followed by RRC MEASUREMENT CONTROL messages containing appropriate assistance data; as specified in 3GPP TS 34.108 [3], clauses 10.2 and 10.6 for UE based testing; or clauses 10.4 and 10.6 for UE assisted testing with the value of GPS TOW msec offset by a random value as specified in 3GPP TS 34.108 [3] clause 10.6.2; as required to obtain a fix using the procedure specified in 3GPP TS 34.108 [3], clauses 7.5.1 or 7.5.4.
4. If the UE returns a valid result in the MEASUREMENT REPORT message within the Max response time specified in table 5.5.4 then record the result and process it as specified in step 5. If the UE does not return a valid result within the Max response time specified in table 5.5.4 or reports a UE positioning error in the MEASUREMENT REPORT message then record one Bad Result.
5. For UE based testing compare the reported position estimate in the MEASUREMENT REPORT message against the simulated position of the UE used in step 1, and calculate the 2D position error as specified in clause 5.1.1.3. Compare the 2D position error against the value in table 5.5.4 and record one Good Result or Bad Result as appropriate; or

For UE assisted testing convert the GPS measured results reported in the MEASUREMENT REPORT message to a 2D position using the method described in Annex B and then compare the result against the simulated position of the UE used in step 1, and calculate the 2D position error as specified in clause 5.1.1.3. Compare the 2D position error against the value in table 5.5.4 and record one Good Result or Bad Result as appropriate.

6. Release the connection using the procedure in clause D.3.
7. Repeat steps 1 to 6 using GPS scenario #2 instead of #1 so that the reference location changes sufficiently such that the UE shall have to use the new assistance data. Select the first two satellite PRNs defined in the table in 3GPP TS 34.108 [3] clause 10.1.2.5 for the two satellites with the higher levels. Use new random values for the UE location and altitude, and the initial carrier phase difference between taps of the multi-path model in step 1 and for the GPS TOW msec offset in step 3.
8. Repeat steps 1 to 7 until the statistical requirements of clause 5.5.5 are met. Each time scenario #1 or #2 is used, the start time of the GPS scenario shall be advanced by 2 minutes from the time used previously for that scenario. Once a scenario reaches the end of its viable running time, restart it from its nominal start time again. Each time scenario #1 or #2 is used, increment the set of two satellite PRNs by one from the ones used previously, defined in the table in 3GPP TS 34.108 [3] clause 10.1.2.5, for the two satellites with the higher level (i.e. if the set of satellites is a, b, c, d, e and the first set used was a, b the second set shall be b, c and so on).

5.5.5 Test Requirements

For the parameters specified in table 5.5.3 the UE shall meet the requirements and the success rate specified in table 5.5.4 with a confidence level of 95% according to annex F.6.1.

Table 5.5.3: Test parameters for Multi-path Performance

Parameters	Unit	Value
Number of generated satellites (see note)	-	5
GPS Coarse Time assistance error range	seconds	$\pm 2+TT$
HDOP Range	-	1.8 to 2.5
GPS signal for Satellite 1, 2 (see note)	dBm	-130
GPS signal for Satellite 3, 4, 5 (see note)	dBm	LOS signal of -130 dBm, multi-path signal of -136.2 dBm
NOTE: Satellites 1, 2 no multi-path. Satellites 3, 4, 5 multi-path defined in clause C.2.2.		

Table 5.5.4: Test requirements for Multi-path Performance

Success rate	2-D position error	Max response time
95 %	101.3 m	20.3 s

NOTE: If the above Test Requirement differs from the Minimum Requirement then the Test Tolerance applied for this test is non-zero. The Test Tolerance for this test is defined in clause F.2 and the explanation of how the Minimum Requirement has been relaxed by the Test Tolerance is given in clause F.4.

5.6 Moving Scenario and Periodic Update Performance

5.6.1 Definition and applicability

Moving scenario and periodic update performance measures the accuracy of the UE's A-GPS position estimates and the periodic update capability of the UE in a moving scenario.

The requirements and this test apply to all types of UTRA for the FDD UE that supports A-GPS.

5.6.2 Minimum requirements

The position estimates, after the first reported position estimate, shall meet the accuracy requirement in table 5.6.2 with the periodical reporting interval of 2 seconds for the parameters specified in table 5.6.1.

NOTE: In the actual testing the UE may report error messages until it has been able to acquire GPS measured results or a position estimate. The SS shall only consider the first measurement report different from an error message as the first position estimate in the requirement in table 5.6.2.

Table 5.6.1: Test parameters for Moving Scenario and Periodic Update Performance

Parameters	Unit	Value
Number of generated satellites	-	5
HDOP Range	-	1.8 to 2.5
Propagation condition	-	AWGN
GPS signal for all satellites	dBm	-130

Table 5.6.2: Minimum requirements for Moving Scenario and Periodic Update Performance

Success Rate	2-D position error
95 %	100 m

The reference for this requirement is 3GPP TS 25.171 [6], clause 5.5.1.

5.6.3 Test purpose

To verify the UE's position estimates, after the first reported position estimate, meet the minimum requirements under GPS satellite signal conditions that simulate a moving scenario. A good tracking performance, with regular position estimate reporting is essential for certain location services.

5.6.4 Method of test

5.6.4.1 Initial conditions

Test environment: normal; see clause E.2.

The UE is requested to use periodical reporting with a reporting interval of 2 seconds.

The GPS signals simulate the UE moving on a rectangular trajectory of 940 m by 1 440 m with rounded corners defined in figure 5.6.1 and table 5.6.3. The initial reference is first defined followed by acceleration to final speed of 100 km/h in 250 m. The UE then maintains the speed for 400 m. This is followed by deceleration to final speed of 25 km/h in 250 m. The UE then turn 90 degrees with turning radius of 20 m at 25 km/h. This is followed by acceleration to final speed of 100 km/h in 250 m. The sequence is repeated to complete the rectangle.

Table 5.6.3: Trajectory Parameters for Moving Scenario and Periodic Update Performance test case

Parameter	Distance (m)	Speed (km/h)
$l_{11}, l_{15}, l_{21}, l_{25}$	20	25
$l_{12}, l_{14}, l_{22}, l_{24}$	250	25 to 100 and 100 to 25
l_{13}	400	100
l_{23}	900	100

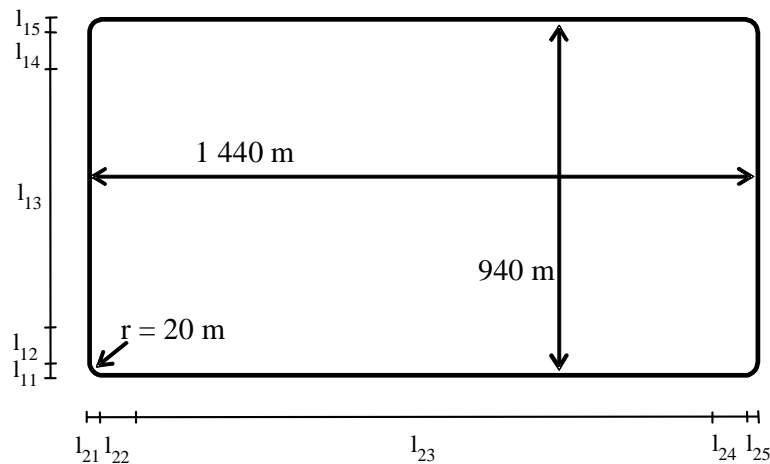

Figure 5.6.1: Rectangular Trajectory for Moving Scenario and Periodic Update Performance test case

1. Connect SS and GSS to the UE antenna connector or antenna connectors as shown in figures A.1 or A.2.
2. Set the GPS test parameters as specified in table 5.6.4 for GPS scenario #3.
3. Switch on the UE.
4. Set up a connection using the procedure in clause D.2.

5.6.4.2 Procedure

1. Start GPS scenario #3 as specified in 3GPP TS 34.108 [3], clause 10.1.2
2. Send a RESET UE POSITIONING STORED INFORMATION message followed by RRC MEASUREMENT CONTROL messages containing appropriate assistance data; as specified in 3GPP TS 34.108 [3], clauses 10.2 and 10.6 for UE based testing; or clauses 10.4 and 10.6 for UE assisted testing; as required to obtain fixes using the procedure specified in 3GPP TS 34.108 [3], clauses 7.5.2 or 7.5.5.
3. Ignore any error messages that the UE may report in MEASUREMENT REPORT messages until it has been able to acquire the GPS signals and reports the first GPS measured result or position estimate.
4. Discard the first GPS measured result or position estimate.
5. Record the time of reception of the next MEASUREMENT REPORT message after reception of the first GPS measured result or position estimate.
6. After the reception of the first GPS measured result or position estimate reported in a MEASUREMENT REPORT message, every time the UE returns a GPS measured result or position estimate in the MEASUREMENT REPORT message record the time of reception and the result. If the difference between the time of reception and the time of reception of the previous result is less than 1.5 seconds or greater than 2.5 seconds, or if the UE reports a UE positioning error in any MEASUREMENT REPORT messages, then record one Bad Result. Otherwise process the result as specified in step 7.
7. For UE based testing compare the reported position estimate in the MEASUREMENT REPORT message against the simulated position of the UE at the time of applicability reported in the position estimate and

calculate the 2D position error as specified in clause 5.1.1.3. Compare the 2D position error against the value in table 5.6.5 and record one Good Result or Bad Result as appropriate; or

For UE assisted testing convert the GPS measured results reported in the MEASUREMENT REPORT message to a 2D position using the method described in Annex B and then compare the result against the simulated position of the UE at the time of applicability reported in the GPS measured results and calculate the 2D position error as specified in clause 5.1.1.3. Compare the 2D position error against the value in table 5.6.5 and record one Good Result or Bad Result as appropriate.

8. If the UE sends the first MEASUREMENT REPORT that contains a measured result or position estimate later than 240s after the start of the GPS scenario, fail the UE and stop the test early. Otherwise collect MEASUREMENT REPORTs during 900s, starting from the time recorded in step 5. If at any time the difference between the times of reception of two consecutive results is greater than 240s, fail the UE and stop the test early. Use the collected Good Results and Bad Results to determine the PASS/FAIL according to clause 5.6.5.
9. Release the connection using the procedure in clause D.3.

5.6.5 Test Requirements

For the parameters specified in table 5.6.4, after the first reported position estimate, the UE shall meet the accuracy requirement and the success rate specified in table 5.6.5 with a periodical reporting interval of 2 seconds +/- 20% plus measurement system uncertainty of 100ms.

Note: Due to the statistical nature of the results it is not possible to design a test with predefined confidence level for the success rate in Table 5.6.5, therefore a simple PASS/FAIL of the results gathered against this success rate is used.

Table 5.6.4: Test parameters for Moving Scenario and Periodic Update Performance

Parameters	Unit	Value
Number of generated satellites	-	5
HDOP Range	-	1.8 to 2.5
Propagation condition	-	AWGN
GPS signal for all satellites	dBm	-130

Table 5.6.5: Test requirements for Moving Scenario and Periodic Update Performance

Success Rate	2-D position error
95 %	101.3 m

NOTE 1: If the above Test Requirement differs from the Minimum Requirement then the Test Tolerance applied for this test is non-zero. The Test Tolerance for this test is defined in clause F.2 and the explanation of how the Minimum Requirement has been relaxed by the Test Tolerance is given in clause F.4.

NOTE 2: In the actual testing the UE may report error messages until it has been able to acquire GPS measured results or a position estimate. The test equipment shall only consider the first measurement report different from an error message as the first position estimate in the requirement in table 5.6.5.

Annex A (informative): Connection Diagrams

Definition of Terms

System Simulator or SS: A device or system, that is capable of generating simulated Node B signalling and analysing UE signalling responses on one RF channel, in order to create the required test environment for the UE under test. It will also include the following capabilities:

1. Control of the UE Tx output power through TPC commands.
2. Measurement of signalling timing and delays.
3. Ability to simulate UTRAN signalling.

GPS System Simulator or GSS: A device or system, that is capable of generating simulated GPS satellite transmissions in order to create the required test environment for the UE under test. It will also include the following capabilities:

1. Control of the output power of individual satellites and the simulation of atmospheric delays and multi-path.
2. Generation of appropriate assistance data to be transmitted to the UE via the SS.
3. Ability to synchronize with UTRAN timing in the SS.

Test System: A combination of devices brought together into a system for the purpose of making one or more measurements on a UE in accordance with the test case requirements. The following diagrams are all examples of Test Systems.

NOTE: The above terms are logical definitions to be used to describe the test methods used in the present document, in practice, real devices called "System Simulators" may also include additional measurement capabilities or may only support those features required for the test cases they are designed to perform.

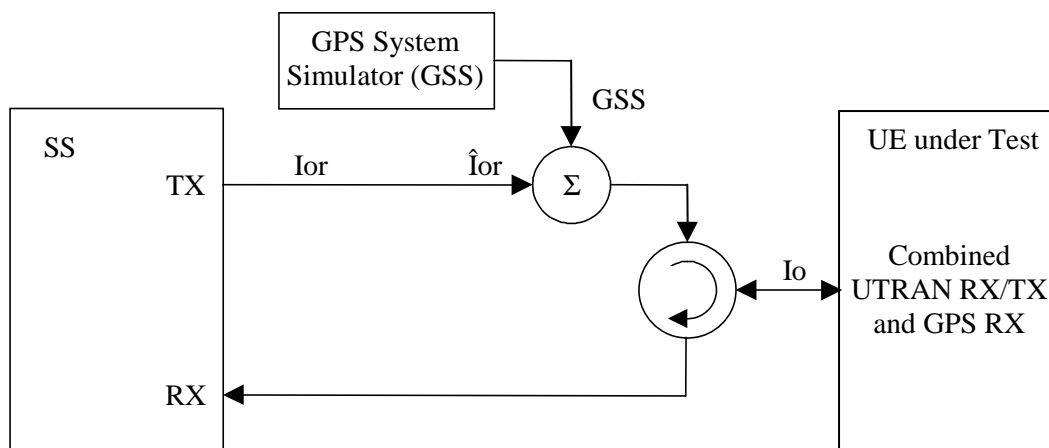

Figure A.1: Connection for A-GPS Performance requirements tests for UE with combined UTRAN / GPS antenna

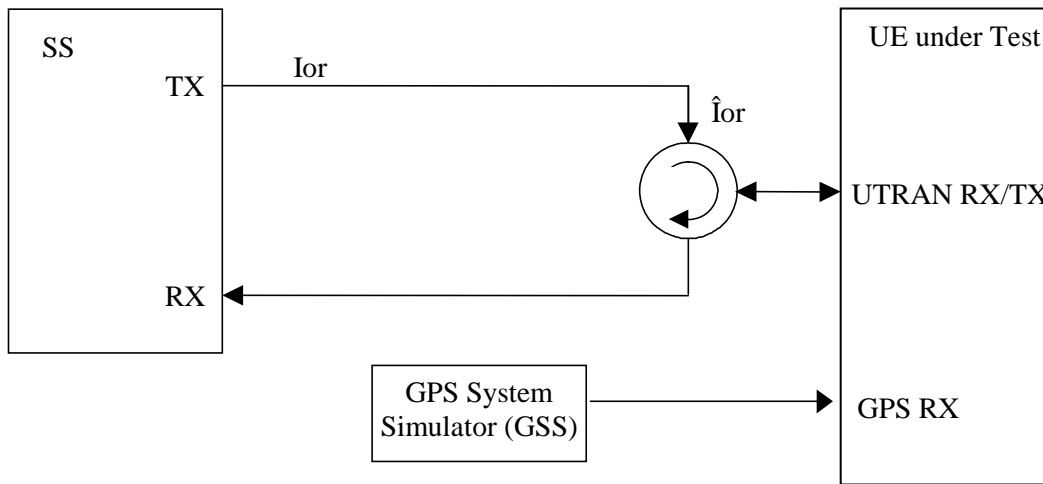

Figure A.2: Connection for A-GPS Performance requirements tests for UE with separate UTRAN and GPS antennas

Annex B (normative): Converting UE-assisted measurement reports into position estimates

B.1 Introduction

To convert the UE measurement reports in case of UE-assisted mode of A-GPS into position errors, a transformation between the "measurement domain" (code-phases, etc.) into the "state" domain (position estimate) is necessary. Such a transformation procedure is outlined in the following clauses. The details can be found in [8], [9] and [10].

B.2 UE measurement reports

In case of UE-assisted A-GPS, the measurement parameters are contained in the RRC UE POSITIONING GPS MEASURED RESULTS IE (clause 10.3.7.93 in 3GPP TS 25.331 [5]). The measurement parameters required for calculating the UE position are:

- 1) Reference Time: The UE has two choices for the Reference Time:
 - a) "UE GPS timing of cell frames";
 - b) "GPS TOW msec".
- 2) Measurement Parameters: 1 to <maxSat>:
 - a) "Satellite ID (SV PRN)";
 - b) "Whole GPS chips";
 - c) "Fractional GPS Chips";
 - d) "Pseudorange RMS Error".

Additional information required at the system simulator:

- 1) "UE positioning GPS reference UE position" (clause 10.3.8.4c in 3GPP TS 25.331 [5]):
Used for initial approximate receiver coordinates.
- 2) "UE positioning GPS navigation model" (clause 10.3.7.94 in 3GPP TS 25.331 [5]):
Contains the GPS ephemeris and clock correction parameters as specified in [8]; used for calculating the satellite positions and clock corrections.
- 3) "UE positioning GPS ionospheric model" (clause 10.3.7.92 in 3GPP TS 25.331 [5]):
Contains the ionospheric parameters which allow the single frequency user to utilize the ionospheric model as specified in [8] for computation of the ionospheric delay.

B.3 WLS position solution

The WLS position solution problem is concerned with the task of solving for four unknowns; x_u , y_u , z_u the receiver coordinates in a suitable frame of reference (usually ECEF) and b_u the receiver clock bias. It typically requires the following steps:

Step 1: Formation of pseudo-ranges

The observation of code phase reported by the UE for each satellite SV_i is related to the pseudo-range/c modulo 1 ms (the length of the C/A code period). For the formation of pseudo-ranges, the integer number of milliseconds to be added to each code-phase measurement has to be determined first. Since 1 ms corresponds to a travelled distance of 300 km, the number of integer ms can be found with the help of reference location and satellite ephemeris. The distance between the reference location and each satellite SV_i is calculated and the integer number of milliseconds to be added to the UE code phase measurements is obtained.

Step 2: Formation of weighting matrix

The UE reported "Pseudorange RMS Error" values are used to calculate the weighting matrix for the WLS algorithm [9]. According to 3GPP TS 25.331 [5], the encoding for this field is a 6 bit value that consists of a 3 bit mantissa, X_i and a 3 bit exponent, Y_i for each SV_i :

$$w_i = RMSError = 0.5 \times \left(1 + \frac{X_i}{8} \right) \times 2^{Y_i}$$

The weighting Matrix \mathbf{W} is defined as a diagonal matrix containing the estimated variances calculated from the "Pseudorange RMS Error" values:

$$\mathbf{W} = \text{diag}\left\{1/w_1^2, 1/w_2^2, \dots, 1/w_n^2\right\}$$

Step 3: WLS position solution

The WLS position solution is described in reference [9] and usually requires the following steps:

- 1) Computation of satellite locations at time of transmission using the ephemeris parameters and user algorithms defined in [8], section 20.3.3.4.3.
- 2) Computation of clock correction parameters using the parameters and algorithms as defined in [8], section 20.3.3.3.1.
- 3) Computation of atmospheric delay corrections using the parameters and algorithms defined in [8], section 20.3.3.5.2.5 for the ionospheric delay, and using the Gupta model in reference [10], p. 121 equation (2) for the tropospheric delay.
- 4) The WLS position solution starts with an initial estimate of the user state (position and clock offset). The Reference Location is used as initial position estimate. The following steps are required:
 - a) Calculate geometric range (corrected for Earth rotation) between initial location estimate and each satellite included in the UE measurement report.
 - b) Predict pseudo-ranges for each measurement including clock and atmospheric biases as calculated in 1) to 3) above and defined in [8] and [9].
 - c) Calculate difference between predicted and measured pseudo-ranges $\Delta \mathbf{p}$
 - d) Calculate the "Geometry Matrix" \mathbf{G} as defined in [9]:

$$\mathbf{G} \equiv \begin{bmatrix} -\hat{\mathbf{1}}_1^T & 1 \\ -\hat{\mathbf{1}}_2^T & 1 \\ \vdots & \vdots \\ -\hat{\mathbf{1}}_n^T & 1 \end{bmatrix} \text{ with } \hat{\mathbf{1}}_i \equiv \frac{\mathbf{r}_{si} - \hat{\mathbf{r}}_u}{|\mathbf{r}_{si} - \hat{\mathbf{r}}_u|} \text{ where } \mathbf{r}_{si} \text{ is the Satellite position vector for } SV_i \text{ (calculated in 1)}$$

above), and $\hat{\mathbf{r}}_u$ is the estimate of the user location.

- e) Calculate the WLS solution according to [9]:

$$\Delta \hat{\mathbf{x}} = \left(\mathbf{G}^T \mathbf{W} \mathbf{G} \right)^{-1} \mathbf{G}^T \mathbf{W} \Delta \mathbf{p}$$

- f) Adding the $\Delta \hat{\mathbf{x}}$ to the initial state estimate gives an improved estimate of the state vector:

$$\hat{\mathbf{x}} \rightarrow \hat{\mathbf{x}} + \Delta\hat{\mathbf{x}}.$$

- 5) This new state vector $\hat{\mathbf{x}}$ can be used as new initial estimate and the procedure is repeated until the change in $\hat{\mathbf{x}}$ is sufficiently small.

Step 4: Transformation from Cartesian coordinate system to Geodetic coordinate system

The state vector $\hat{\mathbf{x}}$ calculated in Step 3 contains the UE position in ECEF Cartesian coordinates together with the UE receiver clock bias. Only the user position is of further interest. It is usually desirable to convert from ECEF coordinates x_u, y_u, z_u to geodetic latitude φ , longitude λ and altitude h on the WGS84 reference ellipsoid.

Step 5: Calculation of "2-D Position Errors"

The latitude φ / longitude λ obtained after Step 4 is used to calculate the 2-D position error.

Annex C (normative): Propagation Conditions

C.1 General

C.2 Propagation Conditions for GPS Signals

C.2.1 Static propagation conditions

The propagation for the static performance measurement is an Additive White Gaussian Noise (AWGN) environment. No fading and multi-paths exist for this propagation model.

C.2.2 Multi-path conditions

Doppler frequency difference between direct and reflected signal paths is applied to the carrier and code frequencies. The Carrier and Code Doppler frequencies of LOS and multi-path for GPS L1 signal are defined in table C.2.2.1.

Table C.2.2.1: Multi-path Conditions for GPS Signals

Initial relative Delay [GPS chip]	Carrier Doppler frequency of tap [Hz]	Code Doppler frequency of tap [Hz]	Relative mean Power [dB]
0	F_d	F_d / N	0
0.5	$F_d - 0.1$	$(F_d - 0.1) / N$	-6
NOTE: Discrete Doppler frequency is used for each tap.			

$N = f_{\text{GPSL1}} / f_{\text{chip}}$, where f_{GPSL1} is the nominal carrier frequency of the GPS L1 signal (1575.42 MHz) and f_{chip} is the GPS L1 C/A code chip rate (1.023 Mc/s).

The initial carrier phase difference between taps shall be randomly selected between $[0, 2\pi]$. The initial value shall have uniform random distribution.

Annex D (normative): Generic procedures

D.1 General

This normative annex specifies the set up and release procedure that shall be used for each test case.

D.2 UTRAN connection set up

D.2.1 Initial conditions

System Simulator:

- 1 cell, default parameters. The default system information, as specified in clause 6.1 of TS 34.108, is broadcast with the exceptions of SIB15, SIB15.1, SIB15.2 and SIB15.3 which are not broadcast.

User Equipment:

- The UE shall be operated in Normal Propagation Conditions as specified in clause 5.2.1 of TS 34.108.
- The UE is in state "MM idle" state with valid TMSI and CKSN.
- The UE is in state "PMM idle" with valid P-TMSI.

D.2.2 Procedures

CS Domain

Step	Direction		Message	Comments
	UE	SS		
1	<--		SYSTEM INFORMATION (BCCH)	Broadcast
2	<--		PAGING TYPE1 (PCCH)	Paging (CS domain, TMSI)
3	-->		RRC CONNECTION REQUEST (CCCH)	RRC
4	<--		RRC CONNECTION SETUP (CCCH)	RRC
5	-->		RRC CONNECTION SETUP COMPLETE (DCCH)	RRC
6	-->		PAGING RESPONSE	RR
7	<--		AUTHENTICATION REQUEST	MM
8	-->		AUTHENTICATION RESPONSE	MM
9	<--		SECURITY MODE COMMAND	RRC
10	-->		SECURITY MODE COMPLETE	RRC

PS Domain

Step	Direction		Message	Comments
	UE	SS		
1	<--		PAGING TYPE1 (PCCH)	Paging (PS domain, PMSI or IMSI)
2	-->		RRC CONNECTION REQUEST (CCCH)	RRC
3	<--		RRC CONNECTION SETUP (CCCH)	RRC
4	-->		RRC CONNECTION SETUP COMPLETE (DCCH)	RRC (Transport Channel: DCH or FACH)
5	-->		SERVICE REQUEST	GMM
6	<--		AUTHENTICATION REQUEST	GMM
7	-->		AUTHENTICATION RESPONSE	GMM
8	<--		SECURITY MODE COMMAND	RRC
9	-->		SECURITY MODE COMPLETE	RRC

D.2.3 Specific message contents

The default message contents specified in clause 9.1 of TS 34.108 will be used for the Moving Scenario and Periodic Update test. For all Minimum Performance TTFF Tests the default message contents specified in clause 9.1 of TS 34.108 will be used with the following exception.

Contents of PAGING TYPE1:

Information Element	Value/remark
Paging Cause	Terminating High Priority Signalling

Contents of RRC CONNECTION SETUP:

For A-GPS performance testing in CELL_DCH state: The RRC Connection Setup is defined in clause 9.1.1 of TS 34.108 "Contents of RRC CONNECTION SETUP message: UM (Transition to CELL_DCH)".

For A-GPS performance testing in CELL_FACH state: The RRC Connection Setup is defined in clause 9.1.1 of TS 34.108 "Contents of RRC CONNECTION SETUP message: UM (Transition to CELL_FACH)".

Contents of RRC CONNECTION SETUP COMPLETE:

Information Element	Value/remark
UE radio access capability - UE positioning capability	Defines the A-GPS mode the UE supports (UE-based, UE-assisted, or both). UE shall be tested for all modes it supports.

D.3 UTRAN connection release

D.3.1 Procedure

Step	Direction		Message	Comments
	UE	SS		
1	<--		RRC CONNECTION RELEASE	RRC
2	-->		RRC CONNECTION RELEASE COMPLETE	RRC

D.3.2 Specific message contents

The default message contents specified in clause 9.1 of TS 34.108 are used.

Annex E (normative): Environmental conditions

E.1 General

This normative annex specifies the environmental requirements of the UE. Within these limits the requirements of the present documents shall be fulfilled.

E.2 Environmental requirements

The requirements in this clause apply to all types of UE(s).

E.2.1 Temperature

The UE shall fulfil all the requirements in the full temperature range of:

Table E.2.1.1

+15°C to +35°C	for normal conditions (with relative humidity up to 75 %)
-10°C to +55°C	for extreme conditions (see IEC 60068-2-1 [12] and IEC 60068-2-2 [13])

Some tests in the present document may be performed also in extreme temperature conditions. These test conditions are denoted as TL (temperature low, -10°C) and TH (temperature high, +55°C).

E.2.2 Voltage

The UE shall fulfil all the requirements in the full voltage range, i.e. the voltage range between the extreme voltages.

The manufacturer shall declare the lower and higher extreme voltages and the approximate shutdown voltage. For the equipment that can be operated from one or more of the power sources listed below, the lower extreme voltage shall not be higher, and the higher extreme voltage shall not be lower than that specified below.

Table E.2.2.1

Power source	Lower extreme voltage	Higher extreme voltage	Normal conditions voltage
AC mains	0.9 × nominal	1.1 × nominal	nominal
Regulated lead acid battery	0.9 × nominal	1.3 × nominal	1.1 × nominal
Non regulated batteries:			
- Leclanché / lithium	0.85 × nominal	Nominal	Nominal
- Mercury/nickel and cadmium	0.90 × nominal	Nominal	Nominal

Some tests in the present document may be performed also in extreme voltage conditions. These test conditions are denoted as VL (lower extreme voltage) and VH (higher extreme voltage).

Annex F (normative): General test conditions and declarations

The requirements of this clause apply to all applicable tests in the present document.

In all the relevant clauses in this clause all 2 D position error measurements shall be carried out according to the general rules for statistical testing in clause F.6.

F.1 Acceptable uncertainty of Test System

The maximum acceptable uncertainty of the Test System is specified below for each test, where appropriate. The Test System shall enable the stimulus signals in the test case to be adjusted to within the specified range, and the equipment under test to be measured with an uncertainty not exceeding the specified values. All ranges and uncertainties are absolute values, and are valid for a confidence level of 95 %, unless otherwise stated.

A confidence level of 95 % is the measurement uncertainty tolerance interval for a specific measurement that contains 95 % of the performance of a population of test equipment.

It should be noted that the uncertainties in clause F.1 apply to the Test System operating into a nominal 50 ohm load and do not include system effects due to mismatch between the DUT and the Test System.

F.1.1 Measurement of test environments

The measurement accuracy of the UE environmental test conditions, defined in annex E, shall be:

Pressure	±5 kPa
Temperature	±2 degrees
Relative Humidity	±5 %
DC Voltage	±1.0 %
AC Voltage	±1.5 %
Vibration	10 %
Vibration frequency	0.1 Hz

The above values shall apply unless the test environment is otherwise controlled and the specification for the control of the test environment specifies the uncertainty for the parameter.

F.1.2 A-GPS Performance requirements

Table F.1.2: Maximum Test System Uncertainty for A-GPS Performance tests

Clause	Maximum Test System Uncertainty	Derivation of Test System Uncertainty
5.2.1 Sensitivity Coarse Time Assistance	Coarse Time Assistance ±200 ms	
	Absolute GPS signal level ±1 dB	
	Position error ±0.05 m	Position error consists of ±0.05 m system error. The effect of position reporting resolution of approximately ±1.2 m (see note) is not included in the allowable test system uncertainty but is included in the test tolerances since this resolution limitation limits the reporting capability of the UE. For simplicity the combined test tolerance is given as ±1.3 m
	Response time ± 300 ms	
5.2.2 Sensitivity Fine Time Assistance	Coarse Time Assistance ±200 ms	
	Fine Time Assistance ±1 us	
	Absolute GPS signal level ±1 dB	
	Position error ±0.05 m	Position error as above
	Response time ± 300 ms	
5.3 Nominal Accuracy	Coarse Time Assistance ±200 ms	
	Absolute GPS signal level ±1 dB	
	Position error ±0.05 m	Position error as above
	Response time ± 300 ms	
5.4 Dynamic Range	Coarse Time Assistance ±200 ms	
	Absolute GPS signal level ±1 dB	
	Relative GPS signal level ±0.2 dB	
	Position error ±0.05 m	Position error as above
	Response time ± 300 ms	
5.5 Multi-path Performance	Coarse Time Assistance ±200 ms	
	Absolute GPS signal level ±1 dB	
	Relative GPS signal level ±0.2 dB	
	Position error ±0.05 m	Position error as above
	Response time ± 300 ms	
5.6 Moving Scenario and Periodic Update Performance	Absolute GPS signal level ±1 dB	
	Position error ±0.05 m	Position error as above
	Differential response time ± 100 ms	

Note: For UE based mode the effect of position reporting resolution is given by:

$$\sqrt{\left(\frac{90 \times 2 \times \pi \times R}{2E23 \times 360}\right)^2 + \left(\frac{360 \times 2 \times \pi \times R \times \cos \phi}{2E24 \times 360}\right)^2}$$

where R is the radius of the earth and ϕ is the latitude of the location. For the two GPS scenarios defined in TS 34.108 [3] this equates to approximately 2.32 m and 2.24 m. For simplicity this is given as ±1.2 m.

For UE assisted mode it is assumed that the output from the WLS position solution calculation in clause B.3 is coded using the same position coding method as for UE based mode before being used to calculate position error. Therefore the effect of reporting resolution will be the same as for UE based mode.

F.2 Test Tolerances (This clause is informative)

The Test Tolerances defined in this clause have been used to relax the Minimum Requirements in the present document to derive the Test Requirements.

The Test Tolerances are derived from Test System uncertainties, regulatory requirements and criticality to system performance. As a result, the Test Tolerances may sometimes be set to zero.

The test tolerances should not be modified for any reason e.g. to take account of commonly known test system errors (such as mismatch, cable loss, etc.).

F.2.1 A-GPS Performance requirements

Table F.2.1: Test Tolerances for A-GPS Performance tests

Clause	Test Tolerance	
5.2.1 Sensitivity Coarse Time Assistance	Coarse Time Assistance	200 ms
	Absolute GPS signal level	1 dB
	Position error	1.3 m
	Response time	300 ms
5.2.2 Sensitivity Fine Time Assistance	Coarse Time Assistance	200 ms
	Fine Time Assistance	1 us
	Absolute GPS signal level	1 dB
	Position error	1.3 m
	Response time	300 ms
5.3 Nominal Accuracy	Coarse Time Assistance	200 ms
	Absolute GPS signal level	0 dB
	Position error	1.3 m
	Response time	300 ms
5.4 Dynamic Range	Coarse Time Assistance	200 ms
	Absolute GPS signal level	0 dB
	Relative GPS signal level	0.2 dB
	Position error	1.3 m
	Response time	300 ms
5.5 Multi-path Performance	Coarse Time Assistance	200 ms
	Absolute GPS signal level	0 dB
	Relative GPS signal level	0.2 dB
	Position error	1.3 m
	Response time	300 ms
5.6 Moving Scenario and Periodic Update Performance	Absolute GPS signal level	0 dB
	Position error	1.3 m
	Differential Response Time	100 ms

F.3 Interpretation of measurement results

The measurement results returned by the Test System are compared - without any modification - against the Test Requirements as defined by the shared risk principle.

The Shared Risk principle is defined in TR 102 273-1-2 [14], clause 6.5.

The actual measurement uncertainty of the Test System for the measurement of each parameter shall be included in the test report.

The recorded value for the Test System uncertainty shall be, for each measurement, equal to or lower than the appropriate figure in clause F.1.

If the Test System for a test is known to have a measurement uncertainty greater than that specified in clause F.1, it is still permitted to use this apparatus provided that an adjustment is made value as follows.

Any additional uncertainty in the Test System over and above that specified in clause F.1 shall be used to tighten the Test Requirement - making the test harder to pass. (This may require modification of stimulus signals). This procedure will ensure that a Test System not compliant with clause F.1 does not increase the chance of passing a device under test where that device would otherwise have failed the test if a Test System compliant with clause F.1 had been used.

F.4 Derivation of Test Requirements (This clause is informative)

The Test Requirements in the present document have been calculated by relaxing the Minimum Requirements of the core specification using the Test Tolerances defined in clause F.2. When the Test Tolerance is zero, the Test Requirement will be the same as the Minimum Requirement. When the Test Tolerance is non-zero, the Test Requirements will differ from the Minimum Requirements, and the formula used for this relaxation is given in table F.4.1.

Table F.4.1: Derivation of Test Requirements (A-GPS tests)

Test	Minimum Requirement in 3GPP TS 25.171 [6]	Test Tolerance (TT)	Test Requirement in the present document
5.2.1 Sensitivity Coarse Time Assistance	Coarse Time Assistance ± 2 s	200 ms	Formulas: UL-TT, LL+TT: ± 1.8 s
	Absolute GPS signal level -142, -147 dBm	1 dB	Level + TT: -141, -146 dBm
	Position error 100 m	1.3 m	Error +TT: 101.3 m
	Response time 20 s	300 ms	Time + TT: 20.3 s
5.2.2 Sensitivity Fine Time Assistance	Coarse Time Assistance ± 2 s	200 ms	Formulas: UL-TT, LL+TT: ± 1.8 s
	Fine Time Assistance ± 10 μ s	1 μ s	UL-TT, LL+TT: ± 9 μ s
	Absolute GPS signal level -147 dBm	1 dB	Level + TT: -146 dBm
	Position error 100 m	1.3 m	Error +TT: 101.3 m
5.3 Nominal Accuracy	Coarse Time Assistance ± 2 s	200 ms	Formulas: UL-TT, LL+TT: ± 1.8 s
	Absolute GPS signal level -130 dBm	0 dB	Level + TT: -130 dBm
	Position error 30 m	1.3 m	Error +TT: 31.3 m
	Response time 20 s	300 ms	Time + TT: 20.3 s
5.4 Dynamic Range	Coarse Time Assistance ± 2 s	200 ms	Formulas: UL-TT, LL+TT: ± 1.8 s
	Absolute GPS signal level -129 to -147 dBm	1 dB	Level + TT: each level +1 dBm
	Relative GPS signal level 18 dB	0.2 dB	Level - TT: highest level - 0.2 dB: -128.2 dBm
	Position error 100 m	1.3 m	Error +TT: 101.3 m
	Response time 20 s	300 ms	Time + TT: 20.3 s
5.5 Multi-path Performance	Coarse Time Assistance ± 2 s	200 ms	Formulas: UL-TT, LL+TT: ± 1.8 s
	Absolute GPS signal level -130 dBm	0 dB	Level + TT: -130 dBm
	Relative GPS signal level 6 dB	0.2 dB	Level + TT: lower level - 0.2 dB: -136.2 dBm
	Position error 100 m	1.3 m	Error +TT: 101.3 m
5.6 Moving Scenario and Periodic Update Performance	Response time 20 s	300 ms	Time + TT: 20.3 s
	Absolute GPS signal level -130 dBm	0 dB	Formulas: Level + TT: -130 dBm
	Position error 100 m	1.3 m	Error +TT: 101.3 m
	Differential response time 2s \square 20 %	100 ms	Time +TT: 1.5 s and 2.5 s

F.5 Acceptable uncertainty of Test Equipment (This clause is informative)

This informative clause specifies the critical parameters of the components of an overall Test System (e.g. Signal generators, Signal Analyzers etc.) which are necessary when assembling a Test System that complies with clause F.1 Acceptable Uncertainty of Test System. These Test Equipment parameters are fundamental to the accuracy of the overall Test System and are unlikely to be improved upon through System Calibration.

F.5.1 A-GPS Performance measurements

Table F.5.1: Equipment accuracy for A-GPS performance measurements

Clause	Equipment accuracy	Test conditions
5.2.1 to 5.6	FFS	FFS

F.6 General rules for statistical testing

F.6.1 Statistical testing of 2 D position error and TTFF

F.6.1.1 Test Method

Each test is performed in the following manner:

- a) Setup the required test conditions.
- b) Measure the 2D position and Time to First Fix (if applicable) repeated times. Start each repetition after having applied the message "RESET UE POSITIONING STORED INFORMATION". This ensures that each result is independent from the previous one. The results, measured, are simplified to:
 - good result, if the 2D position and TTFF (if applicable) are \leq limit.
 - bad result, if the 2D position or TTFF(if applicable) or both are $>$ limit
- c) Record the number of results (ns) and the number of bad results (ne)
- d) Stop the test at a pass or an fail event.
- e) Once the test is stopped, decide according to the pass fail decision rules (F.6.1.4.2)

F.6.1.2 Error Ratio (ER)

The Error Ratio (ER) is defined as the ratio of bad results (ne) to all results (ns).
(1-ER is the success ratio)

F.6.1.3 Test Design

A statistical test is characterised by:

Test-time, Selectivity and Confidence level

F.6.1.3.1 Confidence level

The outcome of a statistical test is a decision. This decision may be correct or in-correct. The Confidence Level CL describes the probability that the decision is a correct one. The complement is the wrong decision probability (risk) $D = 1-CL$

F.6.1.3.2 Introduction: Supplier Risk versus Customer Risk

There are two targets of decision:

- a) A measurement on the pass-limit shows, that the DUT has the specified quality or is better with probability CL (CL e.g.95%) This shall lead to a 'pass decision'

The pass-limit is on the good side of the specified DUT-quality. A more stringent CL (CL e.g.99%) shifts the pass-limit further into the good direction. Given that the quality of the DUTs is distributed, a greater CL passes less and better DUTs.

A measurement on the bad side of the pass-limit is simply 'not pass' (undecided)

- aa) Complementary:

A measurement on the fail-limit shows, that the DUT is worse than the specified quality with probability CL.

The fail-limit is on the bad side of the specified DUT-quality. A more stringent CL shifts the fail-limit further into the bad direction. Given that the quality of the DUTs is distributed, a greater CL fails less and worse DUTs.

A measurement on the good side of the fail-limit is simply 'not fail'.

- b) A DUT, known to have the specified quality, shall be measured and decided pass with probability CL. This leads to the pass limit.

For CL e.g. 95%, the pass limit is on the bad side of the specified DUT-quality. CL e.g.99% shifts the pass-limit further into the bad direction. Given that the DUT-quality is distributed, a greater CL passes more and worse DUTs.

- bb) A DUT, known to be an ($\epsilon \rightarrow 0$) beyond the specified quality, shall be measured and decided fail with probability CL.

For CL e.g.95%, the fail limit is on the good side of the specified DUT-quality.

Note the different sense for CL in (a), (aa) versus (b), (bb)

Note, for constant CL in all 4 bullets (a) is equivalent to (bb) and (aa) is equivalent to (b)

F.6.1.3.3 Supplier Risk versus Customer Risk

The table below summarizes the different targets of decision.

Table F.6.1.3.3 Equivalent statements

	Equivalent statements, using different cause-to-effect-directions, and assuming CL = constant >0.5	
cause-to-effect-directions	Known measurement result → estimation of the DUT's quality	Known DUT's quality → estimation of the measurement's outcome
Supplier Risk	A measurement on the pass-limit shows, that the DUT has the specified quality or is better (a)	A DUT, known to have an ($\epsilon \rightarrow 0$) beyond the specified DUT-quality, shall be measured and decided fail (bb)
Customer Risk	A measurement on the fail-limit shall shows, that the DUT is worse than the specified quality (aa)	A DUT, known to have the specified quality, shall be measured and decided pass (b)

Note: The bold text shows the obvious interpretation of Supplier Risk and Customer Risk. The same statements can be based on other DUT-quality-definitions.

F.6.1.3.4 Introduction: Standard test versus early decision concept

In standard statistical tests, a certain number of results (n_s) is predefined in advance of the test. After n_s results the number of bad results (n_e) is counted and the error ratio (ER) is calculated as n_e/n_s .

Applying statistical theory, a decision limit can be designed, against which the calculated ER is compared to derive the decision. Such a limit is one decision point and is characterised by:

- D: the wrong decision probability (a predefined parameter)
- n_s : the number of results (a fixed predefined parameter)
- n_e : the number of bad results (the limit based on just n_s)

In the formula for the limit, D and n_s are parameters and n_e is the variable. In the standard test n_s and D are constant. The property of such a test is: It discriminates between two states only, depending on the test design:

- pass (with CL) / undecided (undecided in the sense: finally undecided)
- fail (with CL) / undecided (undecided in the sense: finally undecided)
- pass(with CL) / fail (with CL) (however against two limits).

In contrast to the standard statistical tests, the early decision concept predefines a set of (n_e, n_s) co-ordinates, representing the limit-curve for decision. After each result a preliminary ER is calculated and compared against the limit-curve. After each result one may make the decision or not (undecided for later decision). The parameters and variables in the limit-curve for the early decision concept have a similar but not equal meaning:

- D: the wrong decision probability (a predefined parameter)
- n_s : the number of results (a variable parameter)
- n_e : the number of bad results (the limit. It varies together with n_s)

To avoid a 'final undecided' in the standard test, a second limit must be introduced and the single decision co-ordinate (n_e, n_s) needs a high n_e , leading to a fixed (high) test time. In the early decision concept, having the same selectivity and the same confidence level an 'undecided' does not need to be avoided, as it can be decided later. A perfect DUT will hit the decision coordinate (n_e, n_s) with $n_e=0$. This test time is short.

F.6.1.3.5 Standard test versus early decision concept

For Supplier Risk:

The wrong decision probability D in the standard test is the probability, to decide a DUT in-correctly in the single decision point. In the early decision concept there is a probability of in-correct decisions d at each point of the limit-curve. The sum of all those wrong decision probabilities accumulate to D. Hence $d < D$

For Customer Risk:

The correct decision probability CL in the standard test is the probability, to decide a DUT correctly in the single decision point. In the early decision concept there is a probability of correct decisions cl at each point of the limit-curve. The sum of all those correct decision probabilities accumulate to CL. Hence $cl < CL$ or $d > D$

F.6.1.3.6 Selectivity

There is no statistical test which can discriminate between a limit-DUT-quality and a DUT-quality which is an ($\epsilon \rightarrow 0$) apart from the limit in finite time and confidence level $CL > 1/2$. Either the test discriminates against one limit with the results pass (with CL)/undecided or fail (with CL)/undecided, or the test ends in a result pass (with CL)/fail (with CL) but this requires a second limit.

For $CL > 0.5$, a (measurement-result = specified-DUT-quality), generates undecided in test 'supplier risk against pass limit' (a in clause F.6.1.3.2) and also in the equivalent test against the fail limit (aa in clause F.6.1.3.2)

For $CL > 0.5$, a DUT, known to be on the limit, will be decided pass for the test 'customer risk against pass limit' (b in clause F.6.1.3.2) and also in the equivalent test against fail limit (bb in clause F.6.1.3.2).

This overlap or undecided area is not a fault or a contradiction, however it can be avoided by introducing a Bad or a Good DUT quality according to:

- Bad DUT quality: specified DUT-quality * M (M>1)
- Good DUT quality: specified DUT-quality * m (m<1)

Using e.g M>1 and CL=95% the test for different DUT qualities yield different pass probabilities:

Figure F.6.1.3.6: Pass probability versus DUT quality

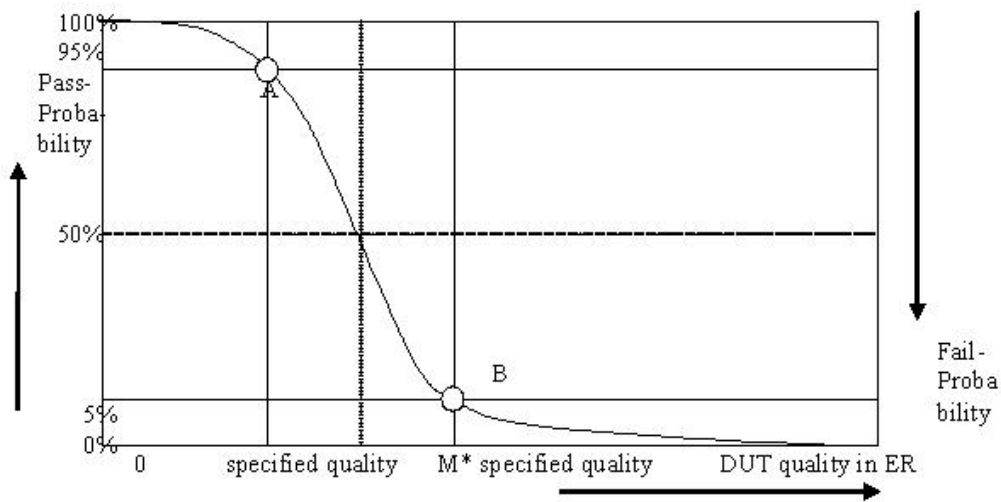

F.6.1.3.7 Design of the test

The test is defined according to the following design principles:

1. The early decision concept is applied.
2. A second limit is introduced: Bad DUT factor M>1
3. To decide the test pass:

Supplier risk is applied based on the Bad DUT quality

To decide the test fail

Customer Risk is applied based on the specified DUT quality

The test is defined using the following parameters:

1. Specified DUT quality: ER = 0.05
2. Bad DUT quality: M=1.5 (selectivity)
3. Confidence level CL = 95% (for specified DUT and Bad DUT-quality)

This has the following consequences:

- a) A measurement on the fail limit is connected with 2 equivalent statements:

A measurement on the fail-limit shows, that the DUT is worse than the specified DUT-quality	A DUT, known to have the specified quality, shall be measured and decided pass
---	--

A measurement on the pass limit is connected with the complementary statements:

A measurement on the pass limit shows, that the DUT is better than the Bad DUT-quality.	A DUT, known to have the Bad DUT quality, shall be measured and decided fail
---	--

The left column is used to decide the measurement.

The right column is used to verify the design of the test by simulation.

The simulation is based on the two fulcrums A and B only in Figure F.6.1.3.6. There is freedom to shape the remainder of the function.

b) Test time

1. The minimum and maximum test time is fixed.
2. The average test time is a function of the DUT"s quality.
3. The individual test time is not predictable (except ideal DUT).

c) The number of decision co-ordinates (ne,ns) in the early decision concept is responsible for the selectivity of the test and the maximum test time. Having fixed the number of decision co-ordinates there is still freedom to select the individual decision co-ordinates in many combinations, all leading to the same confidence level.

F.6.1.4 Pass fail decision

F.6.1.4.1 Numerical definition of the pass fail limits

ne	ns _p	ns _f	ne	ns _p	ns _f	ne	ns _p	ns _f	ne	ns _p	ns _f
0	77	NA	43	855	576	86	1525	1297	129	2173	2050
1	106	NA	44	871	592	87	1540	1314	130	2188	2067
2	131	NA	45	887	608	88	1556	1331	131	2203	2085
3	154	NA	46	903	625	89	1571	1349	132	2218	2103
4	176	NA	47	919	641	90	1586	1366	133	2233	2121
5	197	NA	48	935	657	91	1601	1383	134	2248	2139
6	218	42	49	951	674	92	1617	1401	135	2263	2156
7	238	52	50	967	690	93	1632	1418	136	2277	2174
8	257	64	51	982	706	94	1647	1435	137	2292	2192
9	277	75	52	998	723	95	1662	1453	138	2307	2210
10	295	87	53	1014	739	96	1677	1470	139	2322	2227
11	314	100	54	1030	756	97	1692	1487	140	2337	2245
12	333	112	55	1046	772	98	1708	1505	141	2352	2263
13	351	125	56	1061	789	99	1723	1522	142	2367	2281
14	369	139	57	1077	805	100	1738	1540	143	2381	2299
15	387	152	58	1093	822	101	1753	1557	144	2396	2317
16	405	166	59	1108	839	102	1768	1574	145	2411	2335
17	422	180	60	1124	855	103	1783	1592	146	2426	2352
18	440	194	61	1140	872	104	1798	1609	147	2441	2370
19	457	208	62	1155	889	105	1813	1627	148	2456	2388
20	474	222	63	1171	906	106	1828	1644	149	2470	2406
21	492	237	64	1186	922	107	1844	1662	150	2485	2424
22	509	251	65	1202	939	108	1859	1679	151	2500	2442
23	526	266	66	1217	956	109	1874	1697	152	2515	2460
24	543	281	67	1233	973	110	1889	1714	153	2530	2478
25	560	295	68	1248	990	111	1904	1732	154	2544	2496
26	577	310	69	1264	1007	112	1919	1750	155	2559	2513
27	593	325	70	1279	1024	113	1934	1767	156	2574	2531
28	610	341	71	1295	1040	114	1949	1785	157	2589	2549
29	627	356	72	1310	1057	115	1964	1802	158	2603	2567
30	643	371	73	1326	1074	116	1979	1820	159	2618	2585
31	660	387	74	1341	1091	117	1994	1838	160	2633	2603
32	676	402	75	1357	1108	118	2009	1855	161	2648	2621
33	693	418	76	1372	1126	119	2024	1873	162	2662	2639
34	709	433	77	1387	1143	120	2039	1890	163	2677	2657
35	725	449	78	1403	1160	121	2054	1908	164	2692	2675
36	742	465	79	1418	1177	122	2069	1926	165	2707	2693
37	758	480	80	1433	1194	123	2084	1943	166	2721	2711
38	774	496	81	1449	1211	124	2099	1961	167	2736	2729
39	790	512	82	1464	1228	125	2114	1979	168	2751	2747
40	807	528	83	1479	1245	126	2128	1997	169	2765	NA
41	823	544	84	1495	1263	127	2143	2014			
42	839	560	85	1510	1280	128	2158	2032			

Note: The first column is the number of bad results (ne)
The second column is the number of results for the pass limit (ns_p)
The third column is the number of results for the fail limit (ns_f)

F.6.1.4.2 Pass fail decision rules

Having observed 0 bad results, pass the test at ≥ 77 results, otherwise continue

Having observed 1 bad result, pass the test at ≥ 106 results, otherwise continue

Having observed 2 bad result, pass the test at ≥ 131 results, otherwise continue

etc. until

Having observed 6 bad result, pass the test at ≥ 218 results, fail the test at ≤ 42 results, otherwise continue

Having observed 7 bad result, pass the test at ≥ 238 results, fail the test at ≤ 52 results, otherwise continue

etc. until

Having observed 168 bad result, pass the test at ≥ 2751 results, fail the test at ≤ 2747 results, otherwise continue

Having observed 169 bad result, pass the test at ≥ 2765 results, otherwise fail

Note: an ideal DUT passes after 77 results. The maximum test time is 2765 results.

F.6.1.4.3 Background information to the pass fail limits

There is freedom to design the decision co-ordinates (ne,ns).

The binomial distribution and its inverse is used to design the pass and fail limits. Note that this method is not unique and that other methods exist.

$$\text{fail}(ne, d_f) := \frac{ne}{(ne + \text{qnbinom}(d_f, ne, ER))}$$

$$\text{pass}(ne, cl_p, M) := \frac{ne}{(ne + \text{qnbinom}(cl_p, ne, ER \cdot M))}$$

Where

fail(..) is the error ratio for the fail limit

pass(..) is the error ratio for the pass limit

ER is the specified error ratio 0.05

ne is the number of bad results. This is the variable in both equations

M is the Bad DUT factor M=1.5

d_f is the wrong decision probability of a single (ne,ns) co-ordinate for the fail limit.
It is found by simulation to be $d_f = 0.004$

cl_p is the confidence level of a single (ne,ns) co-ordinate for the pass limit.
It is found by simulation to be $cl_p = 0.9975$

qnbinom(..): The inverse cumulative function of the negative binomial distribution

The simulation works as follows:

A large population of limit DUTs with true ER = 0.05 is decided against the pass and fail limits.

cl_p and d_f are tuned such that CL (95%) of the population passes and D (5%) of the population fails.

A population of Bad DUTs with true ER = M*0.05 is decided against the same pass and fail limits.

cl_p and d_f are tuned such that CL (95%) of the population fails and D (5%) of the population passes.

This procedure and the relationship to the measurement is justified in clause F.6.1.3.7. The number of DUTs decrease during the simulation, as the decided DUTs leave the population. That number decreases with an approximately exponential characteristics. After 169 bad results all DUTs of the population are decided.

Note: The exponential decrease of the population is an optimal design goal for the decision co-ordinates (ne,ns), which can be achieved with other formulas or methods as well.

Annex G (normative): Test case applicability and ICS proforma for 3rd Generation User Equipment

Notwithstanding the provisions of the copyright related to the text of the present document, The Organizational Partners of 3GPP grant that users of the present document may freely reproduce the ICS proforma in this annex so that it can be used for its intended purposes and may further publish the completed ICS.

G.1 Recommended test case applicability

The applicability of each individual test is identified in the table G.1. This is just a recommendation based on the purpose for which the test case was written.

The applicability of every test is formally expressed by the use of Boolean expression that are based on parameters (ICS) included in annex G.5 of the present document.

The columns in table 1 have the following meaning:

Clause

The clause column indicates the clause number of the present document that contains the test body.

Title

The title column describes the name of the test.

Release

The release column indicates the earliest release from which each testcase is applicable, except if otherwise stated of an individual test case.

Applicability

The following notations are used for the applicability column:

R	recommended - the test case is recommended
O	optional – the test case is optional
N/A	not applicable - in the given context, the test case is not recommended.
Ci	conditional - the test is recommended ("R") or not ("N/A") depending on the support of other items. "i" is an integer identifying a unique conditional status expression which is defined immediately following the table. For nested conditional expressions, the syntax "IF ... THEN (IF ... THEN ... ELSE...) ELSE ..." is used to avoid ambiguities.

Comments

This column contains a verbal description of the condition included in the applicability column.

Table G.1: Applicability of tests

Clause	Title	Release	Applicability	Comments
5.2.1	Sensitivity Course Time Assistance	Rel-6	C_RF1	All UEs supporting FDD and UE-Based A-GPS L1 C/A only or UE-Assisted A-GPS L1 C/A only
5.2.2	Sensitivity Fine Time Assistance	Rel-6	C_RF2	All UEs supporting FDD and UE-Based A-GPS L1 C/A only or UE-Assisted A-GPS L1 C/A only and Fine Time Assistance
5.3	Nominal Accuracy	Rel-6	C_RF1	All UEs supporting FDD and UE-Based A-GPS L1 C/A only or UE-Assisted A-GPS L1 C/A only
5.4	Dynamic Range	Rel-6	C_RF1	All UEs supporting FDD and UE-Based A-GPS L1 C/A only or UE-Assisted A-GPS L1 C/A only
5.5	Multi-path Performance	Rel-6	C_RF1	All UEs supporting FDD and UE-Based A-GPS L1 C/A only or UE-Assisted A-GPS L1 C/A only
5.6	Moving Scenario and Periodic Update Performance	Rel-6	C_RF1	All UEs supporting FDD and UE-Based A-GPS L1 C/A only or UE-Assisted A-GPS L1 C/A only

C_RF1	IF G.2/1 AND (G.3/12 OR G.3/13) AND NOT (G3A/5 OR G3A/6) THEN R ELSE N/A	
C_RF2	IF G.2/1 AND (G.3/12 OR G.3/13) AND NOT (G3A/5 OR G3A/6) AND G.4/1 THEN R ELSE N/A	

G.2 Guidance for completing the ICS proforma

G.2.1 Purposes and structure

The purpose of this ICS proforma is to provide a mechanism whereby a supplier of an implementation of the requirements defined in relevant specifications may provide information about the implementation in a standardised manner.

The ICS proforma is subdivided into clauses for the following categories of information:

- instructions for completing the ICS proforma;
- identification of the implementation;
- identification of the protocol;
- ICS proforma tables (for example: UE implementation types, Teleservices, etc).

G.2.2 Abbreviations and conventions

The ICS proforma contained in this annex is comprised of information in tabular form in accordance with the guidelines presented in ISO/IEC 9646-7.

Item column

The item column contains a number which identifies the item in the table.

Item description column

The item description column describes in free text each respective item (e.g. parameters, timers, etc.). It implicitly means "is <item description> supported by the implementation?".

Reference column

The reference column gives reference to the relevant 3GPP core specifications.

Release column

The release column indicates the earliest release from which the capability or option is relevant.

Comments column

This column is left blank for particular use by the reader of the present document.

References to items

For each possible item answer (answer in the support column) within the ICS proforma there exists a unique reference, used, for example, in the conditional expressions. It is defined as the table identifier, followed by a solidus character "/", followed by the item number in the table. If there is more than one support column in a table, the columns shall be discriminated by letters (a, b, etc.), respectively.

EXAMPLE 1: A.7/14 is the reference to the answer of item 14 in table A.7.

G.2.3 Instructions for completing the ICS proforma

The supplier of the implementation may complete the ICS proforma in each of the spaces provided. More detailed instructions are given at the beginning of the different clauses of the ICS proforma.

G.3 Identification of the User Equipment

Identification of the User Equipment should be filled in so as to provide as much detail as possible regarding version numbers and configuration options.

The product supplier information and client information should both be filled in if they are different.

A person who can answer queries regarding information supplied in the ICS should be named as the contact person.

G.3.1 Date of the statement

.....

G.3.2 User Equipment Under Test (UEUT) identification

UEUT name:

.....
.....

Hardware configuration:

.....
.....
.....

Software configuration:

.....
.....

.....

G.3.3 Product supplier

Name:

.....

Address:

.....
.....
.....

Telephone number:

.....

Facsimile number:

.....

E-mail address:

.....

Additional information:

.....
.....
.....

G.3.4 Client

Name:

.....

Address:

.....
.....
.....

Telephone number:

.....

Facsimile number:

.....

E-mail address:

.....

Additional information:

.....

.....

.....

G.3.5 ICS contact person

Name:

.....

Telephone number:

.....

Facsimile number:

.....

E-mail address:

.....

Additional information:

.....

.....

G.4 Identification of the protocol

This ICS proforma applies to the 3GPP standards listed in the normative references clause of the present document.

G.5 ICS proforma tables

Note: For ease of use Capability Tables G.2-G.3A are copied from TS 34.123-2 [15].

G.5.1 UE Implementation Types

Table G.2: UE Radio Technologies

Item	UE Radio Technologies	Ref.	Release	Comments
1	FDD (DS)	25.101	R99	
2	TDD 3.84 Mcps	25.102	R99	
3	TDD 1.28 Mcps (LCR)	25.102	Rel-4	
4	GSM	21.904, 5	R99	
5	GPRS	23.060	R99	
6	MultiRAT_Capability	23.060	R99	

G.5.2 UE Service Capabilities

Table G.3: FDD Layer 1 UE Radio Access Capabilities

Item	FDD Layer 1 UE Radio Access Capabilities	Ref.	Release	Comments
1	Support of turbo decoding	25.306, 4.5.1	R99	
2	Support of turbo encoding	25.306, 4.5.2	R99	
3	Support for SF 512 (downlink)	25.306, 4.5.3	R99	
4	Support of PDSCH	25.306, 4.5.3	R99 and Rel-4 only	
5	Simultaneous reception of SCCPCH and DPCH	25.306, 4.5.3	R99	
6	Simultaneous reception of SCCPCH, DPCH and PDSCH	25.306, 4.5.3	R99 and Rel-4 only	
7	Support of PCPCH	25.306, 4.5.4	R99 and Rel-4 only	
8	Support of uplink compressed mode only	25.306, 4.9	R99	
9	Support of downlink compressed mode only	25.306, 4.9	R99	
10	Support of uplink and downlink compressed mode	25.306, 4.9	R99	
11	void			
12	Support of UE based Network Assisted GPS L1 C/A	25.306, 4.8	R99	
13	Support of UE assisted Network Assisted GPS L1 C/A	25.306, 4.8	R99	
14	Support of HS-PDSCH	25.306, 4.5.3	Rel-5	
15	Support of E-DPDCH	25.306, 4.5.4	Rel-6	
16	Support of MBMS	25.306, 4.13	Rel-6	
17	Support of HS-SCCHless HS-DSCH	25.306, 4.5.3	Rel-7	

Table G.3A: UE positioning capability

Item	Services Capabilities	Ref.	Release	Comments
1	Support for IPDL	25.306, 4.8	R99	
2	Support of GPS timing of cell frames	25.306, 4.8	R99	
3	UE-based OTDOA is supporting by UE	25.306, 4.8	R99	
4	Standalone location method is supporting by UE	25.306, 4.8	R99	
5	Support of UE-Based A-GANSS	25.306, 4.8	Rel-7	
6	Support of UE-Assisted A-GANSS	25.306, 4.8	Rel-7	
7	Support for GLONASS	25.306, 4.8	Rel-8	Note
8	Support for Modernized GPS	25.306, 4.8	Rel-8	Note
9	Support for Galileo	25.306, 4.8	Rel-7	Note

Note: If the capability is supported by the UE, then G.3A/5 or G.3A/6 must be supported as well.

G.5.3 Additional information

Table G.4: Additional capabilities

Item	Capability	Ref.	Release	Comments
1	Support of Fine Time Assistance	25.171, 4.4	Rel-6	

Annex H (informative): Change history

Meeting	Document	CR	Rev	Subject	Cat	Version - old	Version - new	WG Document
RP-28	RP-050264	-	-	Approved to go under change control	-	2.0.0	6.0.0	R5-050832
RP-29	RP-050512	0001	-	Addition of test tolerances to TS 34.171	F	6.0.0	6.1.0	R5-051075
RP-29	RP-050512	0002	-	Addition of maximum permitted test time to test 5.6	F	6.0.0	6.1.0	R5-051290
RP-29	RP-050512	0003	-	Statistical testing in A-GPS	F	6.0.0	6.1.0	R5-051435
RP-29	RP-050512	0004	-	Change to method of selecting satellites in tests 5.4 and 5.5	F	6.0.0	6.1.0	R5-051437
RP-30	RP-050720	0005	-	Changes to test procedure in Test Case 5.6	F	6.1.0	6.2.0	R5-052322
RP-31	RP-060166	0006	-	Correction of SIBs to be broadcast	F	6.2.0	6.3.0	R5-060006
RP-31	RP-060166	0007	-	Correction of '5.6 Moving scenario and periodic updating' concerning statistics	F	6.2.0	6.3.0	R5-060589
RP-32	RP-060331	0008	-	Correction to allowable GPS Simulator Positioning Uncertainty	F	6.3.0	6.4.0	R5-061229
RP-32	RP-060331	0009	-	Horizontal accuracy IE change for nominal accuracy test	F	6.3.0	6.4.0	R5-061230
RP-33	RP-060560	0010	-	Implementation change for Moving Scenario and Periodic Update Performance Test	F	6.4.0	6.5.0	R5-062028
RP-33	RP-060560	0011	-	Test procedure change to A-GPS Minimum Performance TTF test cases	F	6.4.0	6.5.0	R5-062029
RP-33	RP-060560	0012	-	Change to UE Simulated Altitude	F	6.4.0	6.5.0	R5-062093
RP-36	RP-070354	0013	-	Change to Pass/Fail criteria for Moving Scenario test case 5.6	F	6.5.0	6.6.0	R5-071344
				Without change in technical content the spec has been upgraded to Release-7 (v7.0.0)		6.6.0	7.0.0	
				Completion of previous entry in history table		7.0.0	7.0.1	
RP-39	RP-080098	0014		Addition of test case applicability and ICS proforma to TS 34.171	F	7.0.1	7.1.0	R5-080400
RP-40	RP-080363	0015		Deletion of PICS "Support of UE assisted Network Assisted GPS" from 34.171	F	7.1.0	7.2.0	R5-081347
RP-43	RP-090205	0016		Update of TS 34.171 from Rel-7 to Rel-8	F	7.2.0	8.0.0	R5-090762
-	-	-		Update without change to 8.1.0		8.0.0	8.1.0	-
RP-47	-	-		Update without change to 9.0.0		8.1.0	9.0.0	-
RP-51	RP-110173	0017	-	Clarification of Scope and ICS	F	9.0.0	9.1.0	R5-110126
RP-52	RP-110652	0018	-	Removal of lower humidity limit	F	9.1.0	9.2.0	R5-112143

History

Document history		
V9.0.0	April 2010	Publication
V9.1.0	April 2011	Publication
V9.2.0	July 2011	Publication