

ETSI TS 134 124 V7.2.0 (2005-12)

Technical Specification

**Universal Mobile Telecommunications System (UMTS);
Electromagnetic compatibility (EMC) requirements for
mobile terminals and ancillary equipment
(3GPP TS 34.124 version 7.2.0 Release 7)**



Reference

RTS/TSGR-0434124v720

Keywords

UMTS

ETSI

650 Route des Lucioles
F-06921 Sophia Antipolis Cedex - FRANCE

Tel.: +33 4 92 94 42 00 Fax: +33 4 93 65 47 16

Siret N° 348 623 562 00017 - NAF 742 C
Association à but non lucratif enregistrée à la
Sous-Préfecture de Grasse (06) N° 7803/88

Important notice

Individual copies of the present document can be downloaded from:

<http://www.etsi.org>

The present document may be made available in more than one electronic version or in print. In any case of existing or perceived difference in contents between such versions, the reference version is the Portable Document Format (PDF). In case of dispute, the reference shall be the printing on ETSI printers of the PDF version kept on a specific network drive within ETSI Secretariat.

Users of the present document should be aware that the document may be subject to revision or change of status. Information on the current status of this and other ETSI documents is available at

<http://portal.etsi.org/tb/status/status.asp>

If you find errors in the present document, please send your comment to one of the following services:

http://portal.etsi.org/chaicor/ETSI_support.asp

Copyright Notification

No part may be reproduced except as authorized by written permission.
The copyright and the foregoing restriction extend to reproduction in all media.

© European Telecommunications Standards Institute 2005.
All rights reserved.

DECTTM, **PLUGTESTS**TM and **UMTS**TM are Trade Marks of ETSI registered for the benefit of its Members.
TIPHONTM and the **TIPHON logo** are Trade Marks currently being registered by ETSI for the benefit of its Members.
3GPPTM is a Trade Mark of ETSI registered for the benefit of its Members and of the 3GPP Organizational Partners.

Intellectual Property Rights

IPRs essential or potentially essential to the present document may have been declared to ETSI. The information pertaining to these essential IPRs, if any, is publicly available for **ETSI members and non-members**, and can be found in ETSI SR 000 314: "*Intellectual Property Rights (IPRs); Essential, or potentially Essential, IPRs notified to ETSI in respect of ETSI standards*", which is available from the ETSI Secretariat. Latest updates are available on the ETSI Web server (<http://webapp.etsi.org/IPR/home.asp>).

Pursuant to the ETSI IPR Policy, no investigation, including IPR searches, has been carried out by ETSI. No guarantee can be given as to the existence of other IPRs not referenced in ETSI SR 000 314 (or the updates on the ETSI Web server) which are, or may be, or may become, essential to the present document.

Foreword

This Technical Specification (TS) has been produced by ETSI 3rd Generation Partnership Project (3GPP).

The present document may refer to technical specifications or reports using their 3GPP identities, UMTS identities or GSM identities. These should be interpreted as being references to the corresponding ETSI deliverables.

The cross reference between GSM, UMTS, 3GPP and ETSI identities can be found under <http://webapp.etsi.org/key/queryform.asp>.

Contents

Intellectual Property Rights	2
Foreword.....	2
Foreword.....	5
1 Scope	6
2 References	6
3 Definitions and abbreviations.....	8
3.1 Definitions	8
3.2 Abbreviations	9
4 Test conditions	10
4.1 General	10
4.2 Arrangements for establishing a communication link	10
4.3 Narrow band responses on receivers	11
4.3.1 FDD and 3,84Mcps TDD option	11
4.3.2 1,28Mcps TDD option	11
4.4 Receiver exclusion band.....	11
5 Performance assessment.....	12
5.1 General	12
5.2 Equipment which can provide a continuous communication link	13
5.3 Equipment which can only provide a discontinuous communication link (packet data/transmission).....	13
5.4 Equipment which does not provide a communication link.....	13
5.5 Conformance of ancillary equipment	13
5.6 Equipment classification	13
6 Performance criteria	13
6.1 Performance criteria for continuous phenomena	14
6.2 Performance criteria for Transient phenomena	14
7 Applicability overview tables.....	15
7.1 Emission	15
7.2 Immunity	16
8 Methods of measurement and limits for EMC emissions	16
8.1 Test configurations	16
8.2 Radiated Emission	17
8.2.1 Definition.....	17
8.2.2 Test method	17
8.2.3 Limits.....	17
8.2.3.1 FDD and 3,84 Mcps TDD option.....	17
8.2.3.2 1,28 Mcps TDD option	18
8.2.4 Interpretation of the measurement results	18
8.3 Conducted emission DC power input/output port	19
8.3.1 Definition.....	19
8.3.2 Test method	19
8.3.3 Limits.....	19
8.4 Conducted emissions, AC mains power input/output port	19
8.4.1 Definition.....	20
8.4.2 Test method	20
8.4.3 Limits.....	20
8.5 Harmonic current emissions (AC mains input port).....	20
8.6 Voltage fluctuations and flicker (AC mains input port)	20
9 Test methods and levels for immunity tests	20
9.1 Test configurations	20
9.2 RF electromagnetic field (80 MHz - 1000 MHz and 1400 MHz to 2000 MHz).....	21

9.2.1	Definition.....	21
9.2.2	Test method and level.....	21
9.2.3	Performance criteria.....	22
9.3	Electrostatic discharge.....	22
9.3.1	Definition.....	22
9.3.2	Test method and level.....	22
9.3.3	Performance criteria.....	22
9.4	Fast transients common mode.....	22
9.4.1	Definition.....	22
9.4.2	Test method and level.....	22
9.4.3	Performance criteria.....	23
9.5	RF common mode (0,15 MHz to 80 MHz).....	23
9.5.1	Definition.....	23
9.5.2	Test method and level.....	23
9.5.3	Performance criteria.....	23
9.6	Transients and surges, vehicular environment.....	23
9.6.1	Definition.....	24
9.6.2	Test method and level.....	24
9.6.2.1	12 V DC powered equipment.....	24
9.6.2.2	24 V DC powered equipment.....	24
9.6.3	Performance criteria.....	25
9.7	Voltage dips and interruptions.....	25
9.7.1	Definition.....	25
9.7.2	Test method and level.....	25
9.7.3	Performance criteria.....	25
9.8	Surges, common and differential mode.....	25
9.8.1	Definition.....	25
9.8.2	Test method and level.....	25
9.8.3	Performance criteria.....	26
Annex A (normative): Performance assessment voice call. Audio break through.....		27
A.1	Calibration of audio levels.....	27
A.2	Measurement of audio levels.....	28
Annex B (normative): Performance assessment of data transfer call. Error Ratios.....		29
B.1	Calibration of data transfer.....	29
B.2	Derivation of Error Ratios.....	29
B.3	EUT without data application ancillary.....	29
B.4	EUT with data application ancillary.....	30
Annex C (informative): Change History.....		31
History.....		33

Foreword

This Technical Specification has been produced by the 3rd Generation Partnership Project (3GPP).

The contents of the present document are subject to continuing work within the TSG and may change following formal TSG approval. Should the TSG modify the contents of the present document, it will be re-released by the TSG with an identifying change of release date and an increase in version number as follows:

Version x.y.z

where:

- x the first digit:
 - 1 presented to TSG for information;
 - 2 presented to TSG for approval;
 - 3 or greater indicates TSG approved document under change control.
- y the second digit is incremented for all changes of substance, i.e. technical enhancements, corrections, updates, etc.
- z the third digit is incremented when editorial only changes have been incorporated in the document.

1 Scope

The present document establishes the essential EMC requirements for "3rd generation" digital cellular mobile terminal equipment and ancillary accessories in combination with a 3GPP user equipment (UE).

The equipment conforming to the requirements laid out in the present document and used in its intended electromagnetic environment in accordance with the manufacturers instructions

- shall not generate electromagnetic disturbances at a level which may interfere with the intended operation of other equipment;
- has an adequate level of intrinsic immunity to electromagnetic disturbances to operate as intended;

The present document specifies the applicable EMC tests, the methods of measurement, the frequency range, the limits and the minimum performance criteria for all types of UTRA UE's operating in FDD or TDD modes and their accessories. The TDD has two options. The two options are the 3,84Mcps and 1,28Mcps options respectively. The requirements are listed in different subsections only if the parameters deviate. Base station equipment operating within network infrastructure is outside the scope of the present document. However, the present document does cover mobile and portable equipment that is intended to be operated in a fixed location while connected to the AC mains. Base stations in the radio access network are covered by the technical specification TS25.113 [1].

Requirements for the radiated emission from the enclosure port of integral antenna equipment and ancillaries have been included. Technical specifications for conducted emissions from the antenna connector are found in the 3GPP specifications for the radio interface, e.g. TS34.121 [2] and TS34.122 [3], for the effective use of the radio spectrum.

The immunity requirements have been selected to ensure an adequate level of compatibility for apparatus in residential, commercial, light industrial and vehicular environments. The levels however, do not cover extreme cases, which may occur in any location but with low probability of occurrence.

The environment classification used in the present document refers to the environment classification used in the Generic Standards IEC 61000-6-1 [4], IEC 61000-6-3 [5], except the vehicular environment class which refers to ISO 7637 Part 1 [6] and Part 2 [7].

Compliance of radio equipment to the requirements of the present document does not signify compliance to any requirement related to the use of the equipment (i.e. licensing requirements).

Compliance to the requirements of the present document does not signify compliance to any safety requirement. However, any temporary or permanent unsafe condition caused by EMC is considered as non-compliance.

2 References

The following documents contain provisions, which, through reference in this text, constitute provisions of the present document.

- References are either specific (identified by date of publication, edition number, version number, etc.) or non-specific;
- for a specific reference, subsequent revisions do not apply;
- for a non-specific reference, subsequent revisions do apply. In the case of a reference to a 3GPP document (including a GSM document), a non-specific reference implicitly refers to the latest version of that document *in the same Release as the present document*.

[1] 3GPP TS 25.113: "3rd Generation Partnership Project; Technical Specification Group (TSG) RAN WG4; Base station EMC".

[2] 3GPP TS 34.121: "3rd Generation Partnership Project; Technical Specification Group (TSG) T WG1; Terminal Conformance Specification; Radio transmission and reception (FDD)".

[3] 3GPP TS 34.122: "3rd Generation Partnership Project; Technical Specification Group (TSG) T WG1; Terminal Conformance Specification; Radio transmission and reception (TDD)".

- [4] IEC 61000-6-1 (1997): "Electromagnetic compatibility (EMC) – Part 6: Generic standards - Section 1: Immunity standard for residential, commercial and light-industrial environments".
- [5] IEC 61000-6-3 (1996): "Electromagnetic compatibility (EMC) – Part 6: Generic standards - Section 3: Emission standard for residential, commercial and light-industrial environments.
- [6] ISO 7637-1 (1990): "Road vehicles - Electrical disturbance by conduction and coupling - Part 1: Passenger cars and light commercial vehicles with nominal 12 V supply voltage - Electrical transient conduction along supply lines only".
- [7] ISO 7637-2 (1990): "Road vehicles - Electrical disturbance by conduction and coupling - Part 2: Commercial vehicles with nominal 24 V supply voltage - Electrical transient conduction along supply lines only".
- [8] 3GPP TR 25.990; 3rd Generation Partnership Project; Technical Specification Group Radio Access Network (RAN); Vocabulary
3GPP TR 21 905: "3rd Generation Partnership Project; Technical Specification Group Services and System Aspects; Vocabulary for 3GPP specifications".
- [9] IEC 60050(161): "International Electrotechnical Vocabulary - Chapter 161: Electromagnetic compatibility".
- [10] 3GPP TS 34.108: "3rd Generation Partnership Project (3GPP); Technical Specification Group (TSG) Terminal; Common test environments for user equipment (UE). Conformance Testing".
- [11] ITU-R Recommendation SM.329: "Unwanted emissions in the spurious domain ".
- [12] 3GPP TS 25.101: "3rd Generation Partnership Project (3GPP); Technical Specification Group (TSG) RAN WG4; UTRA (UE) FDD; Radio transmission and Reception".
- [13] 3GPP TS 25.102: "3rd Generation Partnership Project (3GPP); Technical Specification Group (TSG) RAN WG4; UTRA (UE) TDD; Radio transmission and Reception".
- [14] IEC CISPR publication 22;: "Information technology equipment; Radio disturbance characteristics – Limits and methods of measurement".
- [15] 3GPP TS 34.109: "3rd Generation Partnership Project (3GPP); Technical Specification Group (TSG) Terminal. Terminal Logical Test Interface; Special conformance testing functions".
- [16] IEC CISPR publication 16-1; "Specification for radio disturbance and immunity measuring apparatus and methods".
- [17] IEC 61000-3-2; (2000): "Electromagnetic compatibility; Part 3 - Limits; section 2 – Limits for harmonic current emissions (equipment input current ≤ 16 A per phase)"; Am.1 (1997-09)".
- [18] IEC 61000-3-3; (19952): "Electromagnetic compatibility; Part 3 - Limits; section 2 – Limitation of voltage fluctuations and flicker in low-voltage supply systems for equipment with rated current ≤ 16 A"
- [19] IEC 61000-4-2: "Electromagnetic compatibility (EMC) – Part 4: Testing and measurement techniques – section 2: Electrostatic discharge immunity test – Basic EMC publication".
- [20] IEC 61000-4-3: "Electromagnetic compatibility (EMC) – Part 4: Testing and measurement techniques – section 3: Radiated, radio-frequency electromagnetic field immunity test".
- [21] IEC 61000-4-4: "Electromagnetic compatibility (EMC) – Part 4: Testing and measurement techniques – section 4: Electrical fast transient/burst immunity test – Basic EMC publication".
- [22] IEC 61000-4-5: "Electromagnetic compatibility (EMC) – Part 4: Testing and measurement techniques – section 5: Surge immunity test".
- [23] IEC 61000-4-6: "Electromagnetic compatibility (EMC) – Part 4: Testing and measurement techniques – section 6: immunity to conducted disturbances induced by radio frequency fields".
- [24] IEC 61000-4-11: "Electromagnetic compatibility (EMC) – Part 4: Testing and measurement techniques – section 11: Voltage dips, short interruptions, and voltage variations immunity test".

- [25] ETR 027 (1991): "Radio Equipment and Systems (RES); Methods of measurement for private mobile radio equipment".
- [26] ITU-T Recommendation P.64: "Telephone transmission quality, Telephone installations, Local line networks, Objective electro-acoustical measurements. Determination of sensitivity/frequency characteristics of local telephone systems".
- [27] ITU-T Recommendation P.76: "Telephone transmission quality, Measurements related to speech loudness, Determination of loudness ratings; Fundamental principles, Annex A".
- [28] ITU-R Recommendation SM.1539 (2001): "Variation of the boundary between the out-of-band and spurious domains required for the application of Recommendations ITU-R SM.1541 and ITU-R SM.329".

3 Definitions and abbreviations

3.1 Definitions

For the purposes of the present document, the following terms and definitions apply.

Ancillary equipment: Equipment (apparatus), used in connection with a user equipment (UE) is considered as an ancillary equipment (apparatus) if:

- the equipment is intended for use in conjunction with a UE to provide additional operational and/or control features to the UE, (e.g. to extend control to another position or location); and
- the equipment cannot be used on a stand alone basis to provide user functions independently of a UE; and
- the UE to which it is connected, is capable of providing some intended operation such as transmitting and/or receiving without the ancillary equipment (i.e. it is not a sub-unit of the main equipment essential to the main equipment basic functions).

BLER (BLoCk Error Ratio): BLER is block error ratio. The BLER calculation shall be based on evaluating the CRC on each transport block .

Camped on a cell: The UE is in idle mode and has completed the cell selection/reselection process and has chosen a cell. The UE monitors system information and (in most cases) paging information. Note that the services may be limited, and that the PLMN may not be aware of the existence of the UE within the chosen cell.

Continuous phenomena (continuous disturbance): Electromagnetic disturbance, the effects of which on a particular device or equipment cannot be resolved into a succession of distinct effects (IEC 60050-161 [9]).

Data application ancillary: ancillary which provides send and/or receive data access to UMTS services via UE

Enclosure port: physical boundary of the apparatus through which electromagnetic fields may radiate or impinge. In the case of integral antenna equipment, this port is inseparable from the antenna port.

End- User data: Manufacturer defined data patterns for data transfer testing. Represents EUT's typical user application (eg. photo, video, textfile, message) in its characteristics.

Idle mode: Idle mode is the state of User Equipment (UE) when switched on but with no Radio Resource Control (RRC) connection.

Integral antenna: antenna designed to be connected directly to the equipment with or without the use of an external connector and considered to be part of the equipment. An integral antenna may be fitted internally or externally to the equipment.

Average power: The average transmitter output power obtained over any specified time interval, including periods with no transmission, when the transmit time slots are at the maximum power setting.

Necessary bandwidth: For a given class of emission, the width of the frequency band which is just sufficient to ensure the transmission of information at the rate and with the quality required under specified conditions.

Out of band emissions: Emission on a frequency or frequencies immediately outside the necessary bandwidth, which results from, the modulation process, but excluding spurious emissions.

NOTE: Any unwanted emission which falls at frequencies separated from the centre frequency of the emission by less than 250% of the necessary bandwidth of the emission will generally be considered out-of-band emission.

Port: particular interface, of the specified equipment (apparatus), with the electromagnetic environment. For example, any connection point on an equipment intended for connection of cables to or from that equipment is considered as a port (see figure 1).

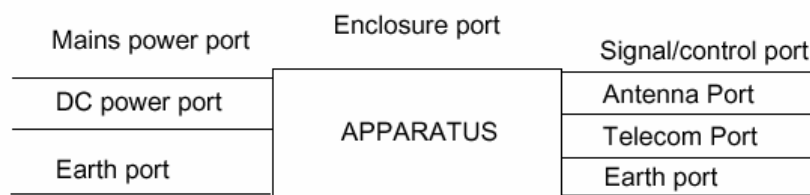

Figure 1: Examples of ports

Spurious emission from ITU-R SM 329 [11]: Emission on a frequency, or frequencies, which are outside the necessary bandwidth and the level of which may be reduced without affecting the corresponding transmission of information. Spurious emissions include harmonic emissions, parasitic emissions, intermodulation products and frequency conversion products but exclude out-of-band emissions.

Telecommunication port: ports which are intended to be connected to telecommunication networks (e.g. public switched telecommunication networks, integrated services digital networks), local area networks (e.g. Ethernet, Token Ring) and similar networks (see CISPR 22 [14]).

Transient phenomena: Pertaining to or designating a phenomena or a quantity which varies between two consecutive steady states during a time interval short compared with the time-scale of interest (IEC 60050-161 [9])

Traffic mode: is the state of User Equipment (UE) when switched on and with Radio Resource Control (RRC) connection established.

Universal mobile telecommunications system (UMTS): The telecommunications system, incorporating mobile cellular and other functionality, that is the subject of specifications produced by 3GPP

User equipment (UE): is a "Mobile Station" (MS) which is an entity capable of accessing a set of UMTS services via one or more radio interfaces. This entity may be stationary or in motion within the UMTS service area while accessing the UMTS services, and may simultaneously serve one or more users.

3.2 Abbreviations

For the purposes of the present document, the following abbreviations apply:

AC	Alternating Current
BCCH	Broadcast Control Channel *)
BS	Base Station
BSS	Base Station System
BTS	Base Transceiver Station
CCCH	Common Control Channel *)
CW	Continuous Wave (unmodulated carrier wave)
DC	Direct Current
DL	Down Link (From BTS to UE)
DTX	Discontinuous Transmission *)
EMC	Electromagnetic Compatibility
ESD	ElectroStatic Discharge
EUT	Equipment Under Test (UE or UE with ancillaries)
FDD	Frequency Division Duplex
LISN	Line Impedance Stabilizing Network
MRP	Mouth Reference Point (artificial head)
PCCPCH	Primary Common Control Physical Channel
RF	Radio Frequency
rms	root mean square

RRC	Radio Resource Control
SPL	Sound Pressure Level
TCH	Traffic channel
TDD	Time Division Duplex
UARFCN	UTRA Absolute Radio Frequency Channel Number *)
UE	User Equipment
UL	Up Link (From UE to BTS)
UMTS	Universal Mobile Telecommunication System
UTRA	Universal Terrestrial Radio Access network

*) refer to Terminology specifications TS 21.905 and TS 25.990 [8] for further details.

4 Test conditions

4.1 General

The equipment shall be tested under normal test conditions according to the relevant product and basic standards (See Annex D of TS 25.101 and Annex C of TS 25.102 for environmental conditions). If these conditions are not specified then the manufacturers declared range of humidity, temperature and supply voltage shall be used. The test conditions shall be recorded in the test report.

Whenever the Equipment under test (EUT) is provided with a detachable antenna, the EUT shall be tested with the antenna fitted in a manner typical of normal intended use, unless specified otherwise.

Where the equipment incorporates an external 50 Ω RF antenna connector that is normally connected via a coaxial cable, then the wanted signal to establish a communication link also uses a coaxial cable;

Where the equipment has an external 50 Ω RF antenna connector that is not normally connected via a coaxial cable or where the equipment has no external 50 Ω RF connector (i.e., integral antenna equipment), then the wanted signal, to establish a communication link, shall be delivered from the equipment to an antenna located within the test environment;

4.2 Arrangements for establishing a communication link

The wanted RF input signal nominal frequency shall be selected by setting the UTRA Absolute Radio Frequency Channel Number (UARFCN) to an appropriate number.

A communication link shall be set up with a suitable base station simulator (hereafter called "the test system"). The test system shall be located outside of the test environment

When the EUT is required to be in the traffic mode, a call is set up according to the Generic call set-up procedure and the following conditions shall be met:

See TS 34.108 [10] and TS 34.109 [15] Logical Test Interface for details regarding generic call set-up procedure and BER, BLER test loop scenarios.

- set and send continuously Up power control commands to the UE;
- the DTX shall be disabled;
- For FDD and 3.84 Mcps TDD option Inner Loop Power Control shall be enabled, and for 1.28 Mcps TDD option closed loop power control shall be enabled;
- transmitting and/or receiving (UL/DL) bit rate for reference test channel shall be 12.2 kbps;
- adequate measures shall be taken to avoid the effect of the unwanted signal on the measuring equipment;
- For immunity testing, the wanted input signal level shall be set to 40 dB above the reference sensitivity level to provide a stable communication link. The reference sensitivity level is defined in TS 25.101 [12] and in TS 25.102 respectively.

- For emission testing, the wanted input signal level shall be no more than 15 dB above the reference sensitivity level, such that the performance of the measuring receiver is not limited by strong signal effects.

When the EUT is required to be in the idle mode, the following conditions shall be met:

- UE shall be camped on a cell
- UE shall perform Location Registration (LR) before the test, but not during the test;
- UE's neighbour cell list shall be empty;
- Paging repetition period and DRX cycle shall be set to minimum (shortest possible time interval);

For immunity tests subclause 4.3, shall apply and the conditions shall be as follows:

4.3 Narrow band responses on receivers

4.3.1 FDD and 3,84Mcps TDD option

Responses on receivers or duplex transceivers occurring during the test at discrete frequencies, which are narrow band responses (spurious responses), are identified by the following method:

- If during an immunity test the quantity being monitored goes outside the specified tolerances, it is necessary to establish whether the deviation is due to an unwanted effect on the receiver of the UE or on the test system (narrow band response) or to a wide band (EMC) phenomenon. Therefore, the test shall be repeated with the UARFCN increased or decreased by 25 (DL / UL).
- if the deviation does not disappear, the procedure is repeated with the UARFCN increased or decreased by 50 from the original value (DL / UL);
- if the deviation does not disappear with the increased and/or decreased UARFCN, the phenomenon is considered wide band and therefore an EMC problem and the equipment fails the test.

Narrow band responses are disregarded.

The procedure above does not apply to conducted immunity tests in the frequency range 150 kHz to 80 MHz.

4.3.2 1,28Mcps TDD option

Responses on receivers or duplex transceivers occurring during the test at discrete frequencies, which are narrow band responses (spurious responses), are identified by the following method:

- If during an immunity test the quantity being monitored goes outside the specified tolerances, it is necessary to establish whether the deviation is due to an unwanted effect on the receiver of the UE or on the test system (narrow band response) or to a wide band (EMC) phenomenon. Therefore, the test shall be repeated with the UARFCN increased or decreased by 8 (DL / UL).
- if the deviation does not disappear, the procedure is repeated with the UARFCN increased or decreased by 16 from the original value (DL / UL);
- if the deviation does not disappear with the increased and/or decreased UARFCN, the phenomenon is considered wide band and therefore an EMC problem and the equipment fails the test.

Narrow band responses are disregarded.

The procedure above does not apply to conducted immunity tests in the frequency range 150 kHz to 80 MHz.

4.4 Receiver exclusion band

The receiver exclusion band for terminals extends from the lower frequency of the allocated receiver band minus 85 MHz to the upper frequency of the allocated receiver band plus 85 MHz. The exclusions bands are as set out below:

UTRA/FDD

- a) 2025 MHz to 2255 MHz (Band I)
- b) 1845 MHz to 2075 MHz (Band II)
- c) 1720 MHz to 1965 MHz (Band III)
- d) 2025 MHz to 2240 MHz (Band IV)
- e) 784 MHz to 979 MHz (Band V)
- f) 790 MHz to 970 MHz (Band VI)
- g) 2535 MHz to 2775 MHz (Band VII)
- h) 840 MHz to 1045 MHz (Band VIII)
- i) 1759.9 MHz to 1964.9 MHz (Band IX)

UTRA/TDD

- a) 1815 MHz to 2005 MHz
1925 MHz to 2110 MHz
- b) 1765 MHz to 2075 MHz (ITU-R, Region 2)
- c) 1825 MHz to 2015 MHz (ITU-R, Region 2)
- d) 2485 MHz to 2705MHz (ITU-R Region 1)

5 Performance assessment

5.1 General

The manufacturer shall at the time of submission of the equipment for test, supply the following information to be recorded in the test report:

- the primary functions of the radio equipment to be tested during and after the EMC testing;
- if applicable, the method to be used to verify that a communications link is established and maintained;
- the intended functions of the radio equipment which shall be in accordance with the documentation accompanying the equipment;
- the user-control functions and stored data that are required for normal operation and the method to be used to assess whether these have been lost after EMC stress;
- the ancillary equipment to be combined with the radio equipment for testing (where applicable);
- information about ancillary equipment intended to be used with the radio equipment;
- an exhaustive list of ports, classified as either power or signal/control. Power ports shall further be classified as AC or DC power;
- the humidity range, temperature, and supply voltage for all equipment submitted for testing.

5.2 Equipment which can provide a continuous communication link

The test arrangement and signals, given in clause 4, apply to radio equipment or a combination of radio equipment and ancillary equipment that permits the establishment of a communication link. The assessment of equipment performance shall be based on speech call and data transfer according to the criteria in clause 6.

5.3 Equipment which can only provide a discontinuous communication link (packet data/transmission)

If the equipment does not permit or allow for a communications link to be established and maintained during the EMC tests (as in subclause 5.2), the manufacturer shall define the performance assessment. The manufacturer shall provide the method of observing the degradation of performance of the equipment.

5.4 Equipment which does not provide a communication link

If the equipment is of a specialised nature which does not permit a communication link to be established, the manufacturer shall define the method of test to determine the acceptable level of performance or degradation of performance during and/or after the test. The manufacturer shall provide the method of observing the degradation of performance of the equipment.

The performance assessment carried out shall be simple, but at the same time give adequate proof that the primary functions of the equipment are operational.

5.5 Conformance of ancillary equipment

Ancillary equipment shall be tested with it connected to a UE in which case compliance shall be demonstrated to the appropriate clauses of the present document.

5.6 Equipment classification

Equipment is classified according to the source of power.

- if power is derived from a fixed AC or DC supply network installation the equipment is classified "for fixed use";
- if power is derived from a vehicular power supply (car battery + alternator) the equipment is classified "for vehicular use";
- if power is derived from an integral battery the equipment is classified "for portable use";

6 Performance criteria

The maintenance of a communications link shall be assessed by using an indicator, which may be part of the test system or the equipment under test.

Specifically the equipment shall meet the minimum performance criteria as specified in the following subclauses as appropriate.

Portable equipment intended for use whilst powered by the main battery of a vehicle shall additionally fulfil the applicable requirements set out by the present document for mobile equipment for vehicular use.

Portable equipment intended for use whilst powered by AC mains shall additionally fulfil the applicable requirements set out by the present document for equipment for fixed use.

If an equipment is of such nature, that the performance criteria described in the following subclauses are not appropriate, then the manufacturer shall declare, for inclusion in the test report, his own specification for an acceptable level of performance or degradation of performance during and/or after testing, as required by the present document.

The performance criteria specified by the manufacturer shall give the same degree of immunity protection as called for in the following subclauses.

In addition, the test shall also be performed in idle mode to ensure the transmitter does not unintentionally operate.

The requirements apply to all types of UTRA (FDD or TDD) for the UE.

6.1 Performance criteria for continuous phenomena

A communication link shall be established at the start of the test, and maintained during the test, subclauses 4.1 and 4.2.

In the data transfer mode, the performance criteria can be one of the following error ratios:

- if the BER (as referred in TS34.109) is used, it shall not exceed 0.001 during the test sequence;
- if the BLER (as referred in TS34.109) is used, it shall not exceed 0.01 during the test sequence;

In the speech mode, the performance criteria shall be that the up link and downlink speech output levels shall be at least 35 dB less than the recorded reference levels, when measured through an audio band pass filter of width 200 Hz, centred on 1 kHz (Annex A).

NOTE: When there is a high level noise background noise present the filter bandwidth can be reduced down to a minimum of 40 Hz.

At the conclusion of the test, the EUT shall operate as intended with no loss of user control functions or stored data, and the communication link shall have been maintained.

In addition to confirming the above performance in traffic mode, the test shall be performed in idle mode, and the transmitter shall not unintentionally operate.

6.2 Performance criteria for Transient phenomena

A communications link shall be established at the start of the test, subclauses 4.1 and 4.2.

At the conclusion of each exposure the EUT shall operate with no user noticeable loss of the communication link.

At the conclusion of the total test comprising the series of individual exposures, the EUT shall operate as intended with no loss of user control functions or stored data, as declared by the manufacturer, and the communication link shall have been maintained.

In addition to confirming the above performance in traffic mode, the test shall also be performed in idle mode, and the transmitter shall not unintentionally operate.

7 Applicability overview tables

7.1 Emission

Table 1: Emission applicability

Phenomenon	Application	Equipment test requirement			Reference subclause in the present document	Reference Standard
		Equipment connected to fixed AC or DC power installations	Equipment connected to vehicular DC supplies	Equipment powered by integral battery		
Radiated emission	Enclosure	applicable	applicable	applicable	8.2	ITU-R SM.329 [11] TS25.101 [12]
Conducted emission	DC power input/output port	applicable	applicable	not applicable	8.3	CISPR 22 [14], CISPR 16-1 [16]
Conducted emission	AC mains input/output port	applicable	not applicable	not applicable	8.4	CISPR 22 [14],
Harmonic current emissions	AC mains input port	applicable	not applicable	not applicable	8.5	IEC 61000-3-2 [17]
Voltage fluctuations and flicker	AC mains input port	applicable	not applicable	not applicable	8.6	IEC 61000-3-3 [18]

7.2 Immunity

Table 2: Immunity applicability

Phenomenon	Application	Equipment test requirement			Reference subclause in the present document	Reference standard
		Equipment connected to fixed AC or DC power installations	Equipment connected to vehicular DC supplies	Equipment powered by integral battery		
RF electro-magnetic field (80 MHz to 2000 MHz)	Enclosure	applicable	applicable	applicable	9.2	IEC 61000-4-3 [20]
Electrostatic discharge	Enclosure	applicable	applicable	applicable	9.3	IEC 61000-4-2 [19]
Fast transients common mode	Signal and control ports, DC and AC power input ports	applicable	not applicable	not applicable	9.4	IEC 61000-4-4 [21]
RF common mode 0,15 MHz to 80 MHz	Signal and control ports, DC and AC power input ports	applicable	applicable	applicable	9.5	IEC 61000-4-6 [23]
Transients and surges, vehicular environment	DC power input ports	not applicable	applicable	not applicable	9.6	ISO 7637 Part 1 [6] And ISO 7637 Part 2 [7]
Voltage dips and interruptions	AC mains power input ports	applicable	not applicable	not applicable	9.7	IEC 61000-4-11 [24]
Surges, common and differential mode	DC and AC power input ports	applicable	not applicable	not applicable	9.8	IEC 61000-4-5 [22]

8 Methods of measurement and limits for EMC emissions

8.1 Test configurations

This subclause defines the configurations for emission tests as follows:

- the equipment shall be tested under normal test conditions;
- the test configuration shall be as close to normal intended use as possible;
- if the equipment is part of a system, or can be connected to ancillary equipment, then it shall be acceptable to test the equipment while connected to the minimum configuration of ancillary equipment necessary to exercise the ports;
- if the equipment has a large number of ports, then a sufficient number shall be selected to simulate actual operation conditions and to ensure that all the different types of termination are tested;
- the test conditions, test configuration and mode of operation shall be recorded in the test report;

- ports which in normal operation are connected shall be connected to an ancillary equipment or to a representative piece of cable correctly terminated to simulate the input/output characteristics of the ancillary equipment, Radio Frequency (RF) input/output ports shall be correctly terminated;
- ports that are not connected to cables during normal operation, e.g. service connectors, programming connectors; temporary connectors etc. shall not be connected to any cables for the purpose of EMC testing. Where cables have to be connected to these ports, or interconnecting cables have to be extended in length in order to exercise the EUT, precautions shall be taken to ensure that the evaluation of the EUT is not affected by the addition or extension of these cables;
- emission tests shall be performed in two modes of operation:
 - with a communication link established (traffic mode); and
 - in the idle mode.

8.2 Radiated Emission

This test is applicable to radio communications equipment and ancillary equipment.

This test shall be performed on the radio equipment and/or a representative configuration of the ancillary equipment.

8.2.1 Definition

This test assesses the ability of radio equipment and ancillary equipment to limit unwanted emissions from the enclosure port.

8.2.2 Test method

Whenever possible the site shall be a fully anechoic chamber (FAC) simulating the free-space conditions. EUT shall be placed on a non-conducting support. Average power of any spurious components shall be detected by the test antenna and measuring receiver (e.g. a spectrum analyser).

At each frequency at which a component is detected, the EUT shall be rotated to obtain maximum response, and the effective radiated power (e.r.p.) of that component determined by a substitution measurement, which shall be the reference method. The measurement shall be repeated with the test antenna in the orthogonal polarization plane.

NOTE: Effective radiated power e.r.p. refers to the radiation of a half wave tuned dipole instead of an isotropic antenna. There is a constant difference of 2.15 dB between e.i.r.p. and e.r.p.

$$\text{e.r.p. (dBm)} = \text{e.i.r.p. (dBm)} - 2.15 \quad \text{Ref. ITU-R SM. 329 ANNEX 1 [11]}$$

Measurements are made with a tuned dipole antenna or a reference antenna with a known gain referenced to an isotropic antenna.

If a different test site or method is used, this shall be stated in the test report. The results shall be converted to the reference method values and the validity of the conversion shall be demonstrated.

8.2.3 Limits

The references for these requirements are ITU-R SM 329 [11], SM.1539 [28] and TS 25.101 subclauses 6.6.3.1. and 7.9.1. [12] and TS 25.102 subclauses 6.6.3 and 7.9 [13] respectively.

8.2.3.1 FDD and 3,84 Mcps TDD option

The frequency boundary and reference bandwidths for the detailed transitions of the limits between the requirements for out of band emissions and spurious emissions are based on ITU-R SM 329 [11].

These requirements are only applicable for frequencies in the spurious domain.

Table 3: Radiated Spurious emissions requirements

Frequency	Minimum requirement (e.r.p.)/ Reference Bandwidth Idle mode	Minimum requirement (e.r.p.) / Reference Bandwidth Traffic mode
$30 \text{ MHz} \leq f < 1000 \text{ MHz}$	-57dBm / 100 kHz	-36 dBm / 100 kHz
$1 \text{ GHz} \leq f < 12.75 \text{ GHz}$	-47dBm / 1MHz	-30 dBm / 1 MHz
$f_c - 12.5 \text{ MHz} < f < f_c + 12.5 \text{ MHz}$	Not defined	Not defined

NOTE: f_c is the centre frequency of the TCH. The frequency range $f_c \pm 12.5 \text{ MHz}$ are covered by the "Out of Band" emission requirements of TS 34.121[2] and TS 34.122 [3].

8.2.3.2 1,28 Mcps TDD option

The frequency boundary and reference bandwidths for the detailed transitions of the limits between the requirements for out of band emissions and spurious emissions are based on ITU-R SM 329 [11].

These requirements are only applicable for frequencies, which are greater than 4 MHz away from the UE centre carrier frequency

Table 3.1: Radiated Spurious emissions requirements

Frequency	Minimum requirement (e.r.p.)/ Reference Bandwidth Idle mode	Minimum requirement (e.r.p.) / Reference Bandwidth Traffic mode
$30 \text{ MHz} \leq f < 1000 \text{ MHz}$	-57dBm / 100 kHz	-36 dBm / 100 kHz
$1 \text{ GHz} \leq f < 12.75 \text{ GHz}$ $f_c - 4 \text{ MHz} < f < f_c + 4 \text{ MHz}$	-47dBm / 1MHz Not defined	-30 dBm / 1 MHz Not defined

NOTE: f_c is the centre frequency of the TCH. The frequency range $f_c \pm 4 \text{ MHz}$ are covered by the "Out of Band" emission requirements of TS 34.122 [3].

8.2.4 Interpretation of the measurement results

The interpretation of the results recorded in a test report for the radiated emission measurements described in the present document shall be as follows:

- the measured value related to the corresponding limit will be used to decide whether an equipment meets the requirements of the present document;
- the value of the measurement uncertainty for the measurement of each parameter shall be included in the test report;
- the recorded value of the measurement uncertainty shall be, for each measurement, equal to or lower than the figure in table 3B.

Table 3B specifies the Maximum measurement uncertainty of the Test System. The Test System shall enable the equipment under test to be measured with an uncertainty not exceeding the specified values. All tolerances and uncertainties are absolute values, and are valid for a confidence level of 95 %, unless otherwise stated.

A confidence level of 95% is the measurement uncertainty tolerance interval for a specific measurement that contains 95% of the performance of a population of test equipment.

Table 3B: Maximum measurement uncertainty

Parameter	Uncertainty
Effective radiated RF power between 30 MHz and 180 MHz	$\pm 6 \text{ dB}$
Effective radiated RF power between 180 MHz and 12,75 GHz	$\pm 3 \text{ dB}$

NOTE: If the Test System for a test is known to have a measurement uncertainty greater than that specified in table 3B, this equipment can still be used, provided that an adjustment is made follows:

Any additional uncertainty in the Test System over and above that specified in table 3B is used to tighten the Test Requirements - making the test harder to pass. This procedure will ensure that a Test System not compliant with table 3B does not increase the probability of passing an EUT that would otherwise have failed a test if a Test System compliant with table 3B had been used.

8.3 Conducted emission DC power input/output port

This test is applicable to all equipment, which may have DC cables longer than 3 m.

If the DC power cable of the UE and/or the ancillary equipment is intended to be less than 3 m in length, and intended only for direct connection to a dedicated AC to DC power supply, then the measurement shall be performed only on the AC power input of that power supply as specified in subclause 8.4.

This test shall be performed on a representative configuration of the radio equipment or a representative configuration of the combination of radio and ancillary equipment.

8.3.1 Definition

This test assesses the ability of radio equipment and ancillary equipment to limit internal noise from the DC power input/output ports.

8.3.2 Test method

The test method shall be in accordance with CISPR 22 [14], and the Line Impedance Stabilising Networks (LISN) shall be connected to a DC power source.

In the case of DC output ports, the ports shall be connected via a LISN to a load drawing the rated current of the source.

A measuring receiver shall be connected to each LISN measurement port in turn and the conducted emission recorded. The LISN measurement ports not being used for measurement shall be terminated with a 50 Ω load.

The equipment shall be installed with a ground plane as defined in CISPR 22 [14], The reference earth point of the LISNs shall be connected to the reference ground plane with a conductor as short as possible.

The measurement receiver shall be in accordance with the requirements of section one of CISPR 16-1 [16]

8.3.3 Limits

The equipment shall meet the limits defined in table 4 (including the average limit and the quasi-peak limit) when using, respectively, an average detector receiver and a quasi-peak detector receiver and measured in accordance with the method described in subclause 8.2.2 above. If the average limit is met when using a quasi-peak detector, the equipment shall be deemed to meet both limits and measurement with the average detector receiver is not necessary.

Table 4: Limits

Frequency range	Quasi-peak	Average
> 0,15-0,5 MHz	66 - 56 dB μ V	56 - 46 dB μ V
> 0,5- 5 MHz	56 dB μ V	46 dB μ V
> 5-30 MHz	60 dB μ V	50 dB μ V
NOTE: The limit decreases linearly with the logarithm of the frequency in the range 0,15 MHz to 0,50 MHz.		

8.4 Conducted emissions, AC mains power input/output port

This test is applicable to equipment powered by the AC mains.

This test is not applicable to AC output ports, which are connected directly (or via a switch or circuit breaker) to the AC input port.

This test shall be performed on a representative configuration of the radio equipment or a representative configuration of the combination of radio and ancillary equipment.

8.4.1 Definition

This test assesses the ability of radio equipment and ancillary equipment to limit internal noise from the AC mains power input/output ports.

8.4.2 Test method

The test method shall be in accordance with CISPR 22 [14],

Mains connected ancillary equipment which is not part of the EUT shall be connected to the mains via a separate LISN. According to subclause 11.9 of CISPR 16-1 [16], the Protective Earth (PE) wire shall also be terminated by a $50\ \Omega$ //50 μ H common mode RF impedance.

8.4.3 Limits

The equipment shall meet the limits defined in table 5 (including the average limit and the quasi-peak limit) when using, respectively, an average detector receiver and a quasi-peak detector receiver and measured in accordance with the method described in subclause 8.3.2 above. If the average limit is met when using a quasi-peak detector, the equipment shall be deemed to meet both limits and measurement with the average detector receiver is not necessary.

Table 5: Limits for conducted emissions

Frequency range	Quasi-peak	Average
> 0,15-0,5 MHz	66 - 56 dB μ V	56 - 46 dB μ V
> 0.5- 5 MHz	56 dB μ V	46 dB μ V
> 5-30 MHz	60 dB μ V	50 dB μ V
NOTE: The limit decreases linearly with the logarithm of the frequency in the range 0,15 MHz to 0,50 MHz.		

8.5 Harmonic current emissions (AC mains input port)

The requirements of IEC 61000-3-2 [17] for harmonic current emission apply for equipment covered by the scope of the present document.

8.6 Voltage fluctuations and flicker (AC mains input port)

The requirements of IEC 61000-3-3 [18] for voltage fluctuations and flicker apply for equipment covered by the scope of the present document.

9 Test methods and levels for immunity tests

9.1 Test configurations

This subclause defines the configurations for immunity tests as follows:

- the equipment shall be tested under normal test conditions as specified in the core specification ,e.g., TS 34.109 [15];
- the test configuration shall be as close to normal intended use as possible;

- if the equipment is part of a system, or can be connected to ancillary equipment, then it shall be acceptable to test the equipment while connected to the minimum configuration of ancillary equipment necessary to exercise the ports;
- if the equipment has a large number of ports, then a sufficient number shall be selected to simulate actual operation conditions and to ensure that all the different types of termination are tested;
- the test conditions, test configuration and mode of operation shall be recorded in the test report;
- ports which in normal operation are connected shall be connected to an ancillary equipment or to a representative piece of cable correctly terminated to simulate the input/output characteristics of the ancillary equipment, Radio Frequency (RF) input/output ports shall be correctly terminated;
- ports, which are not, connected to cables during normal operation, e.g. service connectors, programming connectors, temporary connectors etc. shall not be connected to any cables for the purpose of EMC testing. Where cables have to be connected to these ports, or interconnecting cables have to be extended in length in order to exercise the EUT, precautions shall be taken to ensure that the evaluation of the EUT is not affected by the addition or extension of these cables;
- the test arrangements for transmitter and receiver sections of the transceiver are described separately for the sake of clarity. However, where possible the test of the transmitter section and receiver section of the EUT may be carried out simultaneously to reduce test time;
- immunity tests shall be performed in two modes of operation:
 - with a communication link established (traffic mode); and
 - in the idle mode.

See subclauses 6.1 and 6.2.

9.2 RF electromagnetic field (80 MHz - 1000 MHz and 1400 MHz to 2000 MHz)

The test shall be performed on a representative configuration of the equipment or a representative configuration of the combination of UE and ancillary equipment.

9.2.1 Definition

This test assesses the ability of UE and ancillary equipment to operate as intended in the presence of a radio frequency electromagnetic field disturbance at the enclosure.

9.2.2 Test method and level

The test method shall be in accordance with IEC 61000-4-3 [20]

- for UE and ancillary equipment the following requirements shall apply;
- the test level shall be 3 V/m amplitude modulated to a depth of 80 % by a sinusoidal audio signal of 1 kHz;
- the stepped frequency increments shall be 1 % of the momentary frequency;
- when using the max hold detector method (see ANNEX A) at each test frequency step initially an unmodulated test signal shall be applied. Then the test modulation shall be applied;
- the test shall be performed over the frequency range 80 MHz to 1 000 MHz and 1400 MHz to 2000 MHz;
- responses in stand alone receivers or receivers which are part of transceivers occurring at discrete frequencies which are narrow band responses, shall be disregarded, see subclause 4.3;
- the frequencies selected during the test shall be recorded in the test report.

9.2.3 Performance criteria

The performance criteria of subclause 6.1 shall apply.

9.3 Electrostatic discharge

The test shall be performed on a representative configuration of the equipment or a representative configuration of the combination of UE and ancillary equipment.

9.3.1 Definition

This test assesses the ability of UE and ancillary equipment to operate as intended in the event of an electrostatic discharge.

9.3.2 Test method and level

The test method shall be in accordance with IEC 61000-4-2 [19]:

- for contact discharge, the equipment shall pass at ± 2 kV and ± 4 kV;
- for air discharge the equipment shall pass at ± 2 kV, ± 4 kV and ± 8 kV (only for non-conducting surfaces, see IEC 61000-4-2 [19]).

NOTE: The EUT shall be fully discharged between each ESD exposure by connecting its ground point (where applicable) to the HCP by a resistive wire with a 470 k Ω . resistor in either end.

9.3.3 Performance criteria

The performance criteria of subclause 6.2 shall apply.

9.4 Fast transients common mode

The test shall be performed on AC mains power input ports.

This test shall be performed on signal ports, control ports and DC power input/output ports if the cables may be longer than 3 m.

Where this test is not carried out on a port or any other ports because the manufacturer declares that it is not intended to be used with cables longer than 3 m, a list of ports which were not tested for this reason shall be included in the test report.

This test shall be performed on a representative configuration of the equipment or a representative configuration of the combination of UE and ancillary equipment.

9.4.1 Definition

This test assesses the ability of UE and ancillary equipment to operate as intended in the event of fast transients present on one of the input/output ports.

9.4.2 Test method and level

The test method shall be in accordance with IEC 61000-4-4 [21]

- the test level for signal and control ports shall be 0,5 kV open circuit voltage as given in IEC 61000-4-4 [21];
- the test level for DC power input/output ports shall be 0,5 kV open circuit voltage as given in IEC 61000-4-4 [21];
- the test level for AC mains power input ports shall be 1 kV open circuit voltage as given in IEC 61000-4-4 [21].

9.4.3 Performance criteria

The performance criteria of subclause 6.2 shall apply.

9.5 RF common mode (0,15 MHz to 80 MHz)

This test is applicable for UE for fixed, mobile, and portable use and for ancillary equipment.

This test shall be performed on signal, control and DC power input/output ports, which may have cables longer than 3 m.

This test shall be performed on AC mains power input/output ports of UE for fixed use and for fixed ancillary equipment. Where this test is not carried out on a port or any other ports because the manufacturer declares that it is not intended to be used with cables longer than stated above, a list of ports which were not tested shall be included in the test report.

This test shall be performed on a representative configuration of the UE or a representative configuration of the combination of UE and ancillary equipment.

9.5.1 Definition

This test assesses the ability of equipment and ancillary equipment to operate as intended in the presence of a radio frequency electromagnetic disturbance.

9.5.2 Test method and level

The test method shall be in accordance with IEC 61000-4-6 [23].

- the test signal shall be amplitude modulated to a depth of 80 % by a sinusoidal audio signal of 1 kHz;
- the stepped frequency increments shall be either 50 kHz or 1 % frequency increment of the momentary frequency in the frequency range 150 kHz - 5 MHz and 1 % frequency increment of the momentary frequency in the frequency range 5 MHz - 80 MHz;
- when using the max hold detector method (see ANNEX A) at each test frequency step initially an unmodulated test signal shall be applied. Then the test modulation shall be applied;
- the test level shall be severity level 2 as given in IEC 61000-4-6 [23] corresponding to 3 V rms, at a transfer impedance of 150 Ω ;
- the test shall be performed over the frequency range 150 kHz - 80 MHz;
- responses of stand alone receivers or receivers which are part of transceivers occurring at discrete frequencies which are narrow band responses, shall be disregarded, see subclause 4.3;
- the frequencies selected during the test and the test method used shall be recorded in the test report.

9.5.3 Performance criteria

The performance criteria of subclause 6.1 shall apply.

9.6 Transients and surges, vehicular environment

The tests are applicable to UE intended for use in a vehicular environment.

These tests shall be performed on 12 V and 24 V DC power input.

These tests shall be performed on a representative configuration of the equipment or a representative configuration of the combination of UE and ancillary equipment.

9.6.1 Definition

These tests assess the ability of UE and ancillary equipment to operate as intended in the event of transients and surges present on the DC power input ports in a vehicular environment.

9.6.2 Test method and level

The test method shall be in accordance with ISO 7637-1 [6] for nominal 12 V DC powered equipment and ISO 7637-2 [7] for nominal 24 V DC powered equipment. The requirements are detailed as follows:

9.6.2.1 12 V DC powered equipment

Where the manufacturer in his installation documentation requires the EUT to have a direct connection to the 12 V main vehicle battery the following requirements in accordance with ISO 7637-1 [6] shall apply:

- pulse 3a and 3b, level II (± 50 V), with the test time reduced to 5 minutes for each;
Supply voltage $V_A = 13,5 \pm 0,5$ V DC
- pulse 4, level II, 5 pulses, with the characteristics as follows:
 $V_S = -5$ V, $V_a = -2,5$ V, $t_G = 25$ ms, $t_g = 5$ s, $t_F = 5$ ms.
Supply voltage $V_B = 12,0 \pm 0,2$ V DC

Where the manufacturer does not require the EUT to have a direct connection to the 12 V main vehicle battery, the following pulses apply in addition:

- pulse 1, level II (-50 V), $t_1 = 2,5$ s, 10 pulses; Supply voltage $V_A = 13,5 \pm 0,5$ V DC;
- pulse 2, level II (+50 V), $t_1 = 2,5$ s, 10 pulses. Supply voltage $V_A = 13,5 \pm 0,5$ V DC.

Where the manufacturer declares that the EUT requires a direct connection to the vehicle battery, and the corresponding tests are not carried out, this shall be stated in the test report.

9.6.2.2 24 V DC powered equipment

Where the manufacturer in his installation documentation requires the EUT to have a direct connection to the 24 V main vehicle battery the following requirements in accordance with ISO 7637-2 [7] shall apply:

- pulse 3a and 3b, level II (± 70 V), with the test time reduced to 5 minutes for each;
Supply voltage $V_A = 27 \pm 1$ V DC
- pulse 4, level II, 5 pulses, with the characteristics as follows:
 $V_S = -10$ V, $V_a = -5$ V, $t_G = 25$ ms, $t_g = 5$ s, $t_F = 5$ ms.
Supply voltage $V_B = 24 \pm 0,4$ V DC

Where the manufacturer does not require the EUT to have a direct connection to the 24 V main vehicle battery, the following pulses apply in addition:

- pulse 1, level II (-100 V), $t_1 = 2,5$ s, 10 pulses; Supply voltage $V_A = 27 \pm 1$ V DC;
- pulse 1b, level II (-550 V), $t_1 = 2,5$ s, 10 pulses $R_i = 100 \Omega$;
Supply voltage $V_A = 27 \pm 1$ V DC;
- pulse 2, level II (+50 V), $t_1 = 2,5$ s, 10 pulses. Supply voltage $V_A = 27 \pm 1$ V DC.

Where the manufacturer declares that the EUT requires a direct connection to the vehicle battery, and the corresponding tests are not carried out, this shall be stated in the test report.

For UE and ancillary equipment designed to operate at both DC voltages and where no manual adjustments are required, the requirement 9.6.2.2 and pulse 4 from 9.6.2.1 shall apply.

For UE designed to operate at 12 V DC power supply, but operating from a 24 V DC power adapter ancillary, then the UE shall comply with the requirements in 9.6.2.1 and the configuration of the UE and the power adapter shall comply with the requirements of 9.6.2.2.

9.6.3 Performance criteria

The performance criteria of subclause 6.2 shall apply. However, where the equipment is powered without the use of a parallel battery back-up, for pulses 1, 1a, 1b, 2 and 4 the communications link need not be maintained and may have to be re-established and volatile user data may have been lost.

9.7 Voltage dips and interruptions

The tests shall be performed on AC mains power input ports.

These tests shall be performed on a representative configuration of the UE or a representative configuration of the combination of UE and ancillary equipment.

9.7.1 Definition

These tests assess the ability of UE and ancillary equipment to operate as intended in the event of voltage dips and interruptions present on the AC mains power input ports.

9.7.2 Test method and level

The following requirements shall apply.

The test method shall be in accordance with IEC 61000-4-11 [24].

The test levels shall be:

- a voltage dip corresponding to a reduction of the supply voltage of 60 % for 5 periods;
- a voltage interruption corresponding to a reduction of the supply voltage of > 95 % for 250 periods.

9.7.3 Performance criteria

The performance criteria of subclause 6.2 shall apply. However, in the case where the equipment is powered solely from the AC mains supply (without the use of a parallel battery back-up the communications link need not be maintained and may have to be re-established and volatile user data may have been lost. In the event of loss of the communications link or in the event of loss of user data, this fact shall be recorded in the test report, the product description and the user documentation.

9.8 Surges, common and differential mode

The tests shall be performed on AC mains power input ports.

These tests shall be performed on a representative configuration of the UE or a representative configuration of the combination of UE and ancillary equipment.

9.8.1 Definition

These tests assess the ability of UE and ancillary equipment to operate as intended in the event of surges being present at the AC mains power input ports.

9.8.2 Test method and level

The test method shall be in accordance with IEC 61000-4-5 [22].

The following requirements and evaluation of test results shall apply:

- the test level for ac mains power input ports shall be 1 kV line to ground and 0,5 kV line to line with the output impedance of the surge generator as given in the IEC 61000-4-5 [22];
- the test generator shall provide the 1,2/50 μ sec pulse as defined in IEC 61000-4-5 [22].

9.8.3 Performance criteria

The performance criteria of sub-clause 6.2 shall apply.

Annex A (normative): Performance assessment voice call. Audio break through

A.1 Calibration of audio levels

For the portable the audio calibration is performed as follows:

Set the EUT volume to provide the nominal audio level if specified by the manufacturer. If no such level is specified, the centre volume step shall be used.

Prior to the test sequence, the reference level of the speech output signal on both the downlink and uplink shall be recorded on the test instrumentation, as shown in figure A.1. The reference level shall be equivalent to the SPL of 0 dBPa at 1 kHz at the input of the acoustical coupler described in ETR 027 [25], for the downlink, and -5 dBPs at 1 kHz at the mouth reference point (MRP) defined in ITU_T recommendation P.64 [26] for the uplink.

NOTE 1: The MRP is defined with respect to an artificial head defined in ITU-T P 76 [27] The handset shall be mounted on the artificial head such that the ear piece is centred at the artificial ear.

NOTE 2: If the equipment does not include acoustical transducers (e.g. a microphone or loudspeaker) the manufacturer shall specify the equivalent electrical reference levels.

The voice processor may often apply noise and echo cancellation algorithms, which attempt to eliminate or reduce steady state audio signals as e.g., the 1 kHz calibration signals. These algorithms may be disabled during the calibration procedure. Specialised test software may be required. If the algorithms can not be disabled then the reference level shall be measured using a max-hold detection on the audio level meter in order to determine the level before the noise and echo cancellation algorithms become effective.

In handsfree applications an external loudspeaker is used. The SPL from the external loudspeaker is normally much higher than from the earpiece of the portable in order to overcome a high ambient noise level. The downlink reference level shall be increased in order to compensate for the difference. Alternatively, the distance between the loudspeaker and the measuring microphone shall be adjusted during the measurement procedure in accordance with the manufacturers specification. It is important that the dynamic range of the test instrumentation is not exceeded.

Normally no corrections are made to the uplink reference level. In case it is not possible to perform the above calibration (e.g., a PC card with headset) the manufacturer shall specify the distance between the MRP and the microphone.

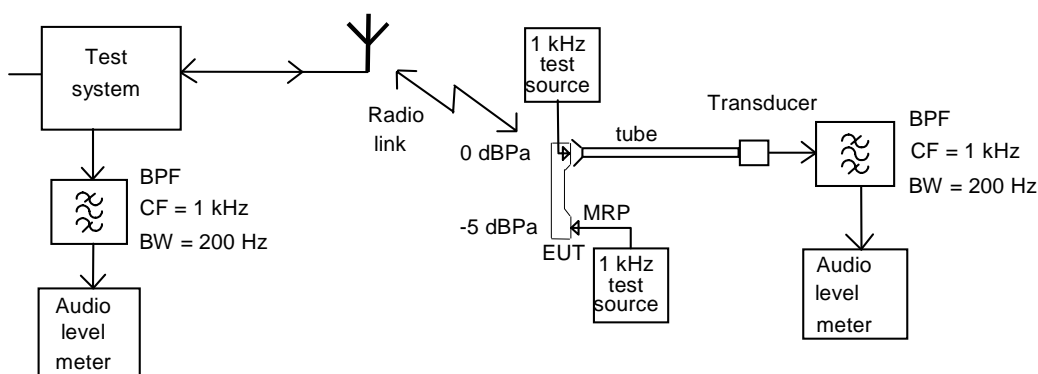

MRP = Mouth Reference Point

Figure A.1: Audio breakthrough measurement, calibration set-up for portable equipment

NOTE: The EUT is in position during calibration of the uplink, but not during calibration of the downlink where the EUT is replaced by the 1 kHz test audio source. During calibration of the uplink the mouthpiece shall be placed with respect to the MRP in a way representing intended use.

A.2 Measurement of audio levels

When the audio levels are measured during testing the EUT software shall be configured for voice applications. If the algorithms for noise and echo cancellation are not disabled, then the level shall be measured using a max-hold detection on the audio level meter in order to determine the level before the noise and echo cancellation algorithms become effective.

The level of the output signal from the downlink speech channel of the EUT at the mobile or portable's ear piece shall be assessed by measuring the Sound Pressure Level (SPL) as shown in figure A.2. When an external loudspeaker is used the acoustical coupler shall be fixed to the loudspeaker in the position used during the calibration. The level of the decoded output signal from the uplink speech channel of the EUT at the analogue output of the test system shall be measured. Pick up of extraneous background noise by the microphone of the EUT shall be minimised.

NOTE: If the equipment is designed for use with external transducers, they shall be included in the test configuration. If the equipment does not include acoustical transducers the line voltage developed across specified termination impedance may be measured

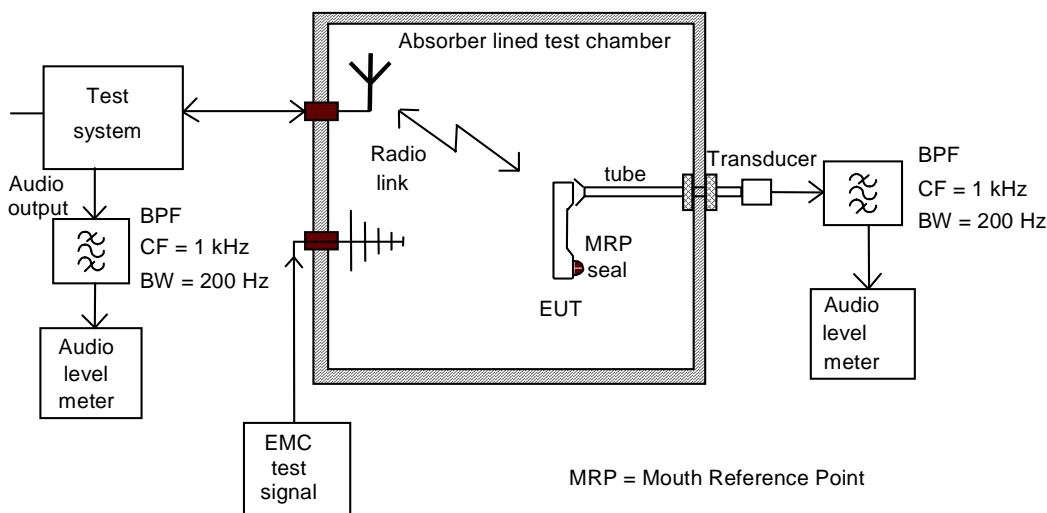

Figure A.2: Audio breakthrough measurement, test set-up for portable equipment

Annex B (normative): Performance assessment of data transfer call. Error Ratios

B.1 Calibration of data transfer

For the EUT, calibration of the data transfer may be performed by assessing the Bit Error Ratio (BER), Block Error Ratio (BLER) or End- User data error ratio before applying the RF immunity test signal (defined in clauses 9.2 and 9.5).

B.2 Derivation of Error Ratios

The manufacturer shall provide the method for calculating the Error Ratio. Known data patterns shall be transferred bi-directionally from end-to-end (the whole of the UL and DL will be exercised). Performance assessment shall be made at each frequency step. Comparison between transmitted known data and received data shall result in the Error Ratio.

The data patterns used should be of sufficient length to give valid results and should be equivalent to the used channel bit rate.

Possible data patterns for assessing the Error Ratio are BER, BLER and User Data. Detailed description of BER and BLER can be found from TS 34.109 [15]

End- User Data may be used where BER and BLER measurements are not appropriate, and is a manufacturers decision (see below):

Note: For example, in the cases when the EUT consists of UE with data application ancillary and the data application ancillary itself does not support a loopback function that can be applied for the assesment of BER or BLER, as specified in TS34.109[15]. This would lead into a situation where the data application ancillary is not exercised, i.e the data transfer loop is not end-to-end.

The characteristics of the End- User Data used for testing (format, size, typical data throughput rate, additional error corrections etc.) and the necessary test equipment shall be delivered to enable the assessment of the EUT.

Following formula may apply to End- User Data:

$$\text{BitErrorRatio} = \left(\frac{\text{erroneuos(bits, bytes, symbols, etc.)}}{\text{correct(bits, bytes, symbols, etc.)}} * 100 \right) = n\%$$

(In case that high Error Ratios exist, ensure that errors are a consequence of EMC stress).

B.3 EUT without data application ancillary

Data monitoring Devices are here considered as part of the Test System. Arrangements should be made by the manufacturer, if needed, to couple the Data monitoring Device by a method which does not affect the radiated electromagnetic field (e.g. ultra sonic or optical).

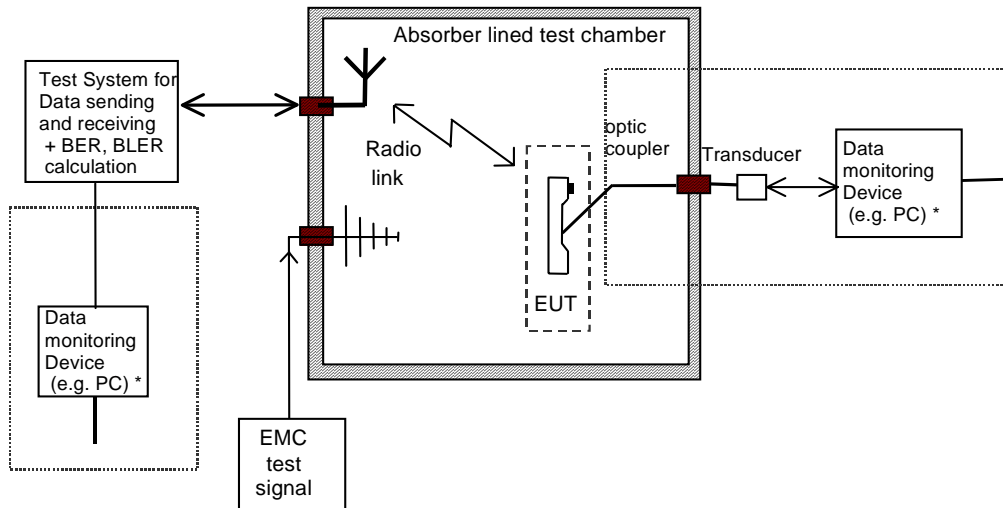

Figure B.1: Error Ratio assessment, test set-up for EUT without data application ancillary.

B.4 EUT with data application ancillary

The Data monitoring Device is here considered as a part of the Test System. The Data application ancillary should be part of the data transfer (UL and DL) loop and is included in the EUT configuration.

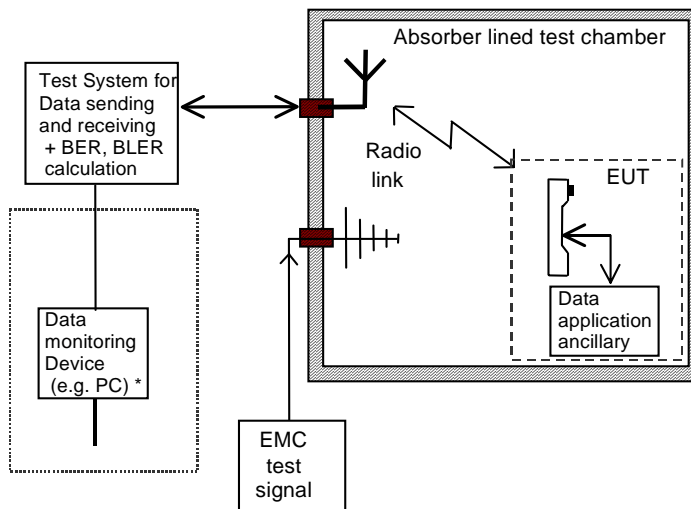

Figure B.2: Error ratio assessment, test set-up for EUT with data application ancillary.

Annex C (informative): Change History

TableC.1: Document history

Version 1.0.0	July 1999	TS xx.xxx 1 st draft
Version 1.0.1	August 1999	TS xx.xxx 2 nd draft
Version 1.1.0	September 1999	TS 34.124: equal to TS xx.xxx v1.0.1 with format changes
Version 1.2.0	October 1999	TS 34.124 3 rd draft
Version 1.2.1	November 1999	Addition of Copyright Notification and Postal address. Format updating
Version 1.2.2	December 1999	Addition of some definitions to clause 3.0 and some editorial changes
Version 1.3.0	February 2000	Update references, abbreviations, and call set-up definitions
Version 2.0.0	February 2000	Discussed and amended by SWG T1 EMC at meeting #08, and unanimously agreed to be submitted to TSG T1 for release 99 in March 2000
Version 2.0.1	March 2000	Editorial correction in table 3.1. Presented to TSG T#7 for approval
Version 3.0.0	March 2000	Approved as v3.0.0 at TSG T#7

Table C.2: Change Requests approved at TSG T

Meeting-1st-Level	Doc-1 st -Level	CR	Rev	Subject	Cat	Version - Current	Version-New	Doc-2nd-Level
TP-09	TP-000136	001		Idle mode conditions and test loops	F	3.0.0	3.1.0	T1-000222
TP-09	TP-000136	002		Adding End- user data besides BER and BLER for EMC data testing	F	3.0.0	3.1.0	T1-000223
TP-09	TP-000136	003		Editorial modifications for purposes of clarification	D	3.0.0	3.1.0	T1-000224
TP-10	TP-000222	004		Editorial modifications for purposes of clarification.	D	3.1.0	3.2.0	T1-000320

Table C.3: Release 1999 Change Request approved at TSG RAN#11

RAN doc	Spec	CR	R	Ph	Subject	Cat	Curr	New
RP-010094	34.124	5		R99	Essential corrections to TS34.124	F	3.2.0	3.3.0

Table C.4: Release 4 Change Request approved at TSG RAN#11

RAN doc	Spec	CR	R	Ph	Subject	Cat	Curr	New
RP-010097	34.124	6		R4	UE electromagnetic compatibility (EMC) for 1.28 Mcps TDD Option	B	3.3.0	4.0.0

Table C.5: Decision at TSG RAN#15

	Title	Curr	New
34.124	Rel-5 version created by TSG RAN decision, no CRs	4.0.0	5.0.0

Table C.6: Release 5 Change Request approved at TSG RAN#17

RAN Tdoc	Spec	CR	R	Ph	Title	Cat	Curr	New	Work Item
RP-020490	34.124	8		Rel-5	Update of reference to ITU-R recommendation SM.329-9	F	5.0.0	5.1.0	LCRTDD-RF

Table C.7: Release 5 Change Request approved at TSG RAN#18

RAN Tdoc	Spec	CR	R	Ph	Title	Cat	Curr	New	Work Item
RP-020792	34.124	010		Rel-5	New exclusion bands and interpretation of measurement results	A	5.1.0	5.2.0	TEI4

Table C.8: Release 5 Change Request approved at TSG RAN#19

RAN Tdoc	Spec	CR	R	Ph	Title	Cat	Curr	New	Work Item
RP-030144	34.124	012	1	Rel-5	Correction to radiated spurious emission measurement bandwidth	A	5.2.0	5.3.0	TEI

Table C.9: Release 5 Change Request approved at TSG RAN#23

RAN Tdoc	Spec	CR	R	Ph	Title	Cat	Curr	New	Work Item
RP-040038	34.124	015		Rel-5	Correction of references to ITU recommendations	F	5.3.0	5.4.0	TEI5

Table C.10: Upgrade on Rel-6 freeze after TSG RAN#26

Spec	Title	Curr	New
34.124	Rel-6 version created on freezing the Release, no CRs	5.4.0	6.0.0

Table C.11: Release 6 Change Request approved at TSG RAN#28

RAN Tdoc	Spec	CR	R	Ph	Title	Cat	Curr	New	Work Item
RP-050208	34.124	017		Rel-6	Correction of receiver exclusion bands	F	6.0.0	6.1.0	TEI6

Table C.12: Release 7 Change Request approved at TSG RAN#28

RAN Tdoc	Spec	CR	R	Ph	Title	Cat	Curr	New	Work Item
RP-050206	34.124	016	1	Rel-7	Introduction of UMTS2600 requirements	B	6.0.0	7.0.0	RInImp-UMTS2600

Table C.13: Release 7 Change Request approved at TSG RAN#29

RAN Tdoc	Spec	CR	R	Ph	Title	Cat	Curr	New	Work Item
RP-050500	34.124	0018		Rel-7	Correction of band VII receiver exclusion band	F	7.0.0	7.1.0	RInImp-UMTS2600

Table C.14: Release 7 Change Requests approved at TSG RAN#30

RAN Tdoc	Spec	CR	R	Ph	Title	Cat	Curr	New	Work Item
RP-050741	34.124	0019		Rel-7	Specification of receiver exclusion band for Band VIII (UMTS900)	B	7.1.0	7.2.0	RInImp-UMTS900
RP-050740	34.124	0020	1	Rel-7	Introduction of UMTS 2.6 GHz requirements in 34.124	B	7.1.0	7.2.0	RInImp-UMTS2600TDD
RP-050742	34.124	0021		Rel-7	Introduction of UMTS1700 requirements	B	7.1.0	7.2.0	RInImp-UMTS1700

History

Document history		
V7.2.0	December 2005	Publication