

ETSI TS 134 122 V3.9.0 (2002-09)

Technical Specification

**Universal Mobile Telecommunications System (UMTS);
Terminal Conformance Specification;
Radio Transmission and Reception (TDD)
(3GPP TS 34.122 version 3.9.0 Release 1999)**



Reference

RTS/TSGT-0134122v390

Keywords

UMTS

ETSI

650 Route des Lucioles
F-06921 Sophia Antipolis Cedex - FRANCE

Tel.: +33 4 92 94 42 00 Fax: +33 4 93 65 47 16

Siret N° 348 623 562 00017 - NAF 742 C
Association à but non lucratif enregistrée à la
Sous-Préfecture de Grasse (06) N° 7803/88

Important notice

Individual copies of the present document can be downloaded from:

<http://www.etsi.org>

The present document may be made available in more than one electronic version or in print. In any case of existing or perceived difference in contents between such versions, the reference version is the Portable Document Format (PDF). In case of dispute, the reference shall be the printing on ETSI printers of the PDF version kept on a specific network drive within ETSI Secretariat.

Users of the present document should be aware that the document may be subject to revision or change of status. Information on the current status of this and other ETSI documents is available at

<http://portal.etsi.org/tb/status/status.asp>

If you find errors in the present document, send your comment to:

editor@etsi.fr

Copyright Notification

No part may be reproduced except as authorized by written permission.
The copyright and the foregoing restriction extend to reproduction in all media.

© European Telecommunications Standards Institute 2002.
All rights reserved.

DECT™, PLUGTESTS™ and UMTS™ are Trade Marks of ETSI registered for the benefit of its Members.
TIPHON™ and the TIPHON logo are Trade Marks currently being registered by ETSI for the benefit of its Members.
3GPP™ is a Trade Mark of ETSI registered for the benefit of its Members and of the 3GPP Organizational Partners.

Intellectual Property Rights

IPRs essential or potentially essential to the present document may have been declared to ETSI. The information pertaining to these essential IPRs, if any, is publicly available for **ETSI members and non-members**, and can be found in ETSI SR 000 314: "*Intellectual Property Rights (IPRs); Essential, or potentially Essential, IPRs notified to ETSI in respect of ETSI standards*", which is available from the ETSI Secretariat. Latest updates are available on the ETSI Web server (<http://webapp.etsi.org/IPR/home.asp>).

Pursuant to the ETSI IPR Policy, no investigation, including IPR searches, has been carried out by ETSI. No guarantee can be given as to the existence of other IPRs not referenced in ETSI SR 000 314 (or the updates on the ETSI Web server) which are, or may be, or may become, essential to the present document.

Foreword

This Technical Specification (TS) has been produced by ETSI 3rd Generation Partnership Project (3GPP).

The present document may refer to technical specifications or reports using their 3GPP identities, UMTS identities or GSM identities. These should be interpreted as being references to the corresponding ETSI deliverables.

The cross reference between GSM, UMTS, 3GPP and ETSI identities can be found under www.etsi.org/key.

Contents

Intellectual Property Rights	2
Foreword.....	2
Foreword.....	11
1 Scope	12
2 References	12
3 Definitions, abbreviations and equations	12
3.1 Definitions	12
3.2 Abbreviations	13
3.3 Equations	14
4 Frequency bands and channel arrangement	14
4.1 General	14
4.2 Frequency bands.....	14
4.3 TX–RX frequency separation.....	14
4.4 Channel arrangement.....	15
4.4.1 Channel spacing.....	15
4.4.2 Channel raster	15
4.4.3 Channel number	15
5 Transmitter Characteristics.....	15
5.1 General	15
5.2 User Equipment maximum output power.....	15
5.2.1 Definition and applicability	15
5.2.2 Minimum Requirements	16
5.2.3 Test purpose.....	16
5.2.4 Method of test	16
5.2.4.1 Initial conditions	16
5.2.4.2 Procedure	17
5.2.5 Test Requirements	17
5.3 UE frequency stability.....	18
5.3.1 Definition and applicability	18
5.3.2 Minimum Requirements	18
5.3.3 Test purpose.....	18
5.3.4 Method of test	18
5.3.4.1 Initial conditions	18
5.3.4.2 Procedure	18
5.3.5 Test Requirements	18
5.4 Output Power Dynamics	19
5.4.1 Uplink power control	19
5.4.1.1 Initial accuracy	19
5.4.1.1.1 Definition and applicability	19
5.4.1.1.2 Minimum requirements	19
5.4.1.1.3 Test purpose	19
5.4.1.1.4 Method of test.....	19
5.4.1.1.4.1 Initial conditions	19
5.4.1.1.4.2 Procedure	20
5.4.1.1.5 Test requirements	20
5.4.1.2 Differential accuracy, controlled input.....	20
5.4.1.2.1 Definition and applicability	20
5.4.1.2.2 Minimum requirements	21
5.4.1.2.3 Test purpose	21
5.4.1.2.4 Method of test.....	21
5.4.1.2.4.1 Initial conditions	21
5.4.1.2.4.2 Procedure	21
5.4.1.2.5 Test requirements	22

5.4.2	Minimum output power	22
5.4.2.1	Definition and applicability.....	22
5.4.2.2	Minimum Requirements.....	22
5.4.2.3	Test purpose	22
5.4.2.4	Method of test	23
5.4.2.4.1	Initial conditions.....	23
5.4.2.4.2	Procedure.....	23
5.4.2.5	Test requirements.....	23
5.4.3	Transmit OFF power.....	23
5.4.3.1	Definition and applicability.....	23
5.4.3.2	Minimum Requirements.....	23
5.4.3.3	Test purpose	23
5.4.3.4	Method of test	24
5.4.3.5	Test requirements.....	24
5.4.4	Transmit ON/OFF Time mask.....	24
5.4.4.1	Definition and applicability.....	24
5.4.4.2	Minimum requirements.....	24
5.4.4.3	Test Purpose.....	24
5.4.4.4	Method of test	25
5.4.4.4.1	Initial conditions.....	25
5.4.4.4.2	Procedure.....	25
5.4.4.5	Test requirements	25
5.4.5	Out-of-synchronisation handling of output power.....	25
5.4.5.1	Definition and applicability.....	25
5.4.5.2	Minimum Requirement	25
5.4.5.3	Test purpose	26
5.4.5.4	Method of test	27
5.4.5.4.1	Initial conditions.....	27
5.4.5.4.2	Procedure.....	27
5.4.5.5	Test Requirements.....	27
5.5	Output RF spectrum emissions.....	28
5.5.1	Occupied bandwidth	28
5.5.1.1	Definition and applicability.....	28
5.5.1.2	Minimum Requirements.....	28
5.5.1.3	Test purpose	28
5.5.1.4	Method of test	28
5.5.1.4.1	Initial conditions.....	28
5.5.1.4.2	Procedure.....	28
5.5.1.5	Test requirements.....	29
5.5.2	Out of band emission.....	29
5.5.2.1	Spectrum emission mask.....	29
5.5.2.1.1	Definition and applicability.....	29
5.5.2.1.2	Minimum Requirements.....	29
5.5.2.1.3	Test purpose	30
5.5.2.1.4	Method of test.....	30
5.5.2.1.5	Test requirements	30
5.5.2.2	Adjacent Channel Leakage power Ratio (ACLR).....	31
5.5.2.2.1	Definition and applicability.....	31
5.5.2.2.2	Minimum Requirements.....	31
5.5.2.2.3	Test purpose	31
5.5.2.2.4	Method of test.....	31
5.5.2.2.5	Test requirements	32
5.5.3	Spurious emissions	32
5.5.3.1	Definition and applicability.....	32
5.5.3.2	Minimum Requirements.....	32
5.5.3.3	Test purpose	33
5.5.3.4	Method of test	33
5.5.3.4.1	Initial conditions.....	33
5.5.3.4.2	Procedure.....	33
5.5.3.5	Test requirements.....	33
5.6	Transmit Intermodulation.....	34
5.6.1	Definition and applicability	34

5.6.2	Minimum Requirements	34
5.6.3	Test purpose.....	34
5.6.4	Method of test	34
5.6.4.1	Initial conditions	34
5.6.4.2	Procedure	34
5.6.5	Test requirements.....	35
5.7	Transmit Modulation	35
5.7.1	Error Vector Magnitude.....	35
5.7.1.1	Definition and applicability.....	35
5.7.1.2	Minimum Requirements.....	35
5.7.1.3	Test purpose	35
5.7.1.4	Method of test	36
5.7.1.4.1	Initial conditions	36
5.7.1.4.2	Procedure.....	36
5.7.1.5	Test requirements.....	36
5.7.2	Peak code domain error	36
5.7.2.1	Definition and applicability.....	36
5.7.2.2	Minimum Requirement	36
5.7.2.3	Test purpose	36
5.7.2.4	Method of test	36
5.7.2.4.1	Initial conditions	36
5.7.2.4.2	Procedure.....	37
5.7.2.5	Test requirements	37
6	Receiver Characteristics	37
6.1	General	37
6.2	Reference sensitivity level.....	38
6.2.1	Definition and applicability	38
6.2.2	Minimum Requirements	38
6.2.3	Test purpose.....	38
6.2.4	Method of test	38
6.2.4.1	Initial conditions	38
6.2.4.2	Procedure	38
6.2.5	Test requirements.....	38
6.3	Maximum Input Level.....	39
6.3.1	Definition and applicability	39
6.3.2	Minimum requirements.....	39
6.3.3	Test purpose.....	39
6.3.4	Method of test	39
6.3.4.1	Initial conditions	39
6.3.4.2	Procedure	40
6.3.5	Test requirements.....	40
6.4	Adjacent Channel Selectivity (ACS).....	40
6.4.1	Definition and applicability	40
6.4.2	Minimum Requirements	40
6.4.3	Test purpose.....	40
6.4.4	Method of test	40
6.4.4.1	Initial conditions	40
6.4.4.2	Procedure	41
6.4.5	Test Requirements	41
6.5	Blocking Characteristics.....	41
6.5.1	Definition and applicability	41
6.5.2	Minimum Requirements	41
6.5.3	Test purpose.....	42
6.5.4	Method of test	42
6.5.4.1	Initial conditions	42
6.5.4.2	Procedure	43
6.5.5	Test requirements.....	43
6.6	Spurious Response	44
6.6.1	Definition and applicability	44
6.6.2	Minimum Requirements	44
6.6.3	Test purpose.....	44

6.6.4	Method of test	44
6.6.4.1	Initial conditions	44
6.6.4.2	Procedure	45
6.6.5	Test requirements.....	45
6.7	Intermodulation Characteristics.....	45
6.7.1	Definition and applicability	45
6.7.2	Minimum Requirements	45
6.7.3	Test purpose.....	46
6.7.4	Method of test.....	46
6.7.4.1	Initial conditions	46
6.7.4.2	Procedure	46
6.7.5	Test requirements.....	46
6.8	Spurious Emissions	47
6.8.1	Definition and applicability	47
6.8.2	Minimum Requirements	47
6.8.3	Test purpose.....	47
6.8.4	Method of test.....	47
6.8.4.1	Initial conditions	47
6.8.4.2	Procedure	48
6.8.5	Test requirements.....	48
7	Performance Requirements	49
7.1	General	49
7.1.2	Definition of Additive White Gaussian Noise (AWGN) Interferer	49
7.2	Demodulation in static propagation conditions	49
7.2.1	Demodulation of DCH.....	49
7.2.1.1	Definition and applicability.....	49
7.2.1.2	Minimum requirements.....	49
7.2.1.3	Test purpose	50
7.2.1.4	Method of test	50
7.2.1.4.1	Initial conditions.....	50
7.2.1.4.2	Procedure.....	50
7.2.1.5	Test requirements.....	50
7.3	Demodulation of DCH in multipath fading conditions	51
7.3.1	Multipath fading Case 1.....	51
7.3.1.1	Definition and applicability.....	51
7.3.1.2	Minimum requirements	51
7.3.1.3	Test purpose	51
7.3.1.4	Method of test	51
7.3.1.4.1	Initial conditions.....	51
7.3.1.4.2	Procedure.....	52
7.3.1.5	Test requirements.....	52
7.3.2	Multipath fading Case 2.....	52
7.3.2.1	Definition and applicability.....	52
7.3.2.2	Minimum requirement	52
7.3.2.3	Test purpose	53
7.3.2.4	Method of test	53
7.3.2.4.1	Initial conditions.....	53
7.3.2.4.2	Procedure.....	53
7.3.2.5	Test requirements.....	53
7.3.3	Multipath fading Case 3.....	53
7.3.3.1	Definition and applicability.....	53
7.3.3.2	Minimum requirements.....	53
7.3.3.3	Test purpose	54
7.3.3.4	Method of test	54
7.3.3.4.1	Initial conditions.....	54
7.3.3.4.2	Procedure.....	54
7.3.3.5	Test requirements	55
7.4	Base station transmit diversity mode.....	55
7.4.1	Demodulation of BCH in SCTD mode.....	55
7.5	Power control in downlink	55
7.5.1	Definition and applicability	55

7.5.2	Minimum requirements.....	55
7.5.3	Test purpose.....	55
7.5.4	Method of test.....	56
7.5.4.1	Initial conditions	56
7.5.4.2	Procedure	56
7.5.5	Test Requirements	56
7.6	Uplink Power Control	56
7.6.1	Definition and applicability	56
7.6.2	Minimum requirements.....	56
7.6.3	Test purpose.....	57
7.6.4	Method of test.....	58
7.6.4.1	Initial conditions	58
7.6.4.2	Procedure	58
7.6.5	Test requirements.....	58
8	Requirements for Support of RRM	59
8.1	General	59
8.2	Idle Mode Tasks	59
8.2.1	Cell Selection.....	59
8.2.2	Cell Re-Selection	59
8.2.2.1	Scenario 1: TDD/TDD cell re-selection single carrier case	59
8.2.2.1.1	Definition and applicability	59
8.2.2.1.2	Minimum requirement.....	59
8.2.2.1.3	Test purpose	59
8.2.2.1.4	Method of test.....	60
8.2.2.1.4.1	Initial conditions	60
8.2.2.1.4.2	Procedure	61
8.2.2.1.5	Test Requirements	61
8.2.2.2	Scenario 2: TDD/TDD cell re-selection multi carrier case	62
8.2.2.2.1	Definition and applicability	62
8.2.2.2.2	Minimum requirement.....	62
8.2.2.2.3	Test purpose	62
8.2.2.2.4	Method of test.....	62
8.2.2.2.4.1	Initial conditions	62
8.2.2.2.4.2	Procedure	64
8.2.2.2.5	Test Requirements	64
8.2.2.3	Scenario 3: TDD/FDD cell re-selection	64
8.2.2.3.1	Definition and applicability	64
8.2.2.3.2	Minimum requirement.....	64
8.2.2.3.3	Test purpose	65
8.2.2.3.4	Method of test.....	65
8.2.2.3.4.1	Initial conditions	65
8.2.2.3.4.2	Procedure	66
8.2.2.3.5	Test Requirements	66
8.2.2.4	Scenario 4: inter RAT cell re-selection	66
8.2.2.4.1	Definition and applicability	66
8.2.2.4.2	Minimum requirement.....	66
8.2.2.4.3	Test purpose	66
8.2.2.4.4	Method of Test	67
8.2.2.4.4.1	Initial conditions	67
8.2.2.4.4.2	Procedure	67
8.2.2.4.5	Test Requirements	68
8.3	UTRAN Connected Mode Mobility	68
8.3.1	TDD/TDD Handover	68
8.3.1.1	Handover to intra-frequency cell.....	68
8.3.1.1.1	Definition and applicability	68
8.3.1.1.2	Minimum requirement.....	68
8.3.1.1.3	Test purpose	68
8.3.1.1.4	Method of test.....	68
8.3.1.1.5	Test requirements	74
8.3.1.2	Handover to inter-frequency cell.....	75
8.3.1.2.1	Definition and applicability	75

8.3.1.2.2	Minimum requirement	75
8.3.1.2.3	Test purpose	75
8.3.1.2.4	Method of test.....	75
8.3.1.2.5	Test requirements	80
8.3.2	TDD/FDD Handover	81
8.3.2.1	Definition and applicability.....	81
8.3.2.2	Minimum requirement	81
8.3.2.3	Test purpose	81
8.3.2.4	Method of test	81
8.3.2.4.1	Initial conditions	81
8.3.2.4.2	Procedure.....	83
8.3.2.5	Test requirements	86
8.3.3	TDD/GSM Handover.....	86
8.3.4	Cell Re-selection in CELL_FACH	86
8.3.4.1	Scenario 1: TDD/TDD cell re-selection single carrier case	86
8.3.4.1.1	Definition and applicability	86
8.3.4.1.2	Minimum requirement.....	87
8.3.4.1.3	Test purpose	87
8.3.4.1.4	Method of test.....	87
8.3.4.1.5	Test Requirements	89
8.3.4.2	Scenario 2: TDD/TDD cell re-selection multi carrier case	89
8.3.4.2.1	Definition and applicability	89
8.3.4.2.2	Minimum requirement.....	89
8.3.4.2.3	Test purpose	89
8.3.4.2.4	Method of test.....	89
8.3.4.2.5	Test Requirements	91
8.3.5	Cell Re-selection in CELL_PCH	92
8.3.5.1	Scenario 1: TDD/TDD cell re-selection single carrier case	92
8.3.5.1.1	Definition and applicability	92
8.3.5.1.2	Minimum requirement.....	92
8.3.5.1.3	Test purpose	92
8.3.5.1.4	Method of test.....	92
8.3.5.1.4.1	Initial conditions	92
8.3.5.1.4.2	Procedure	94
8.3.5.1.5	Test Requirements	94
8.3.5.2	Scenario 2: TDD/TDD cell re-selection multi carrier case	94
8.3.5.2.1	Definition and applicability	94
8.3.5.2.2	Minimum requirement.....	94
8.3.5.2.3	Test purpose	94
8.3.5.2.4	Method of test.....	95
8.3.5.2.4.1	Initial conditions	95
8.3.5.2.4.2	Procedure	96
8.3.5.2.5	Test Requirements	97
8.3.6	Cell Re-selection in URA_PCH.....	97
8.3.6.1	Scenario 1: TDD/TDD cell re-selection single carrier case	97
8.3.6.1.1	Definition and applicability	97
8.3.6.1.2	Minimum requirement.....	97
8.3.6.1.3	Test purpose	97
8.3.6.1.4	Method of test.....	97
8.3.6.1.4.1	Initial conditions	97
8.3.6.1.4.2	Procedure	99
8.3.6.1.5	Test Requirements	99
8.3.6.2	Scenario 2: TDD/TDD cell re-selection multi carrier case	99
8.3.6.2.1	Definition and applicability	99
8.3.6.2.2	Minimum requirement.....	99
8.3.6.2.3	Test purpose	99
8.3.6.2.4	Method of test.....	100
8.3.6.2.4.1	Initial conditions	100
8.3.6.2.4.2	Procedure	101
8.3.6.2.5	Test Requirements	102
8.4	RRC Connection Control	102
8.4.1	RRC connection re-establishment delay	102

8.4.2	Transport Format Combination selection in UE	102
8.5	Timing Characteristics	102
8.5.1	UE Timing Advance	102
8.5.2	UE Transmit Timing	102
8.6	UE Measurements Procedures	102
8.6.1	TDD intra frequency measurements	102
8.6.1.1	Event triggered reporting in AWGN propagation conditions	102
8.6.1.2	Event 1H and 1I triggered reporting in AWGN propagation condition	102
8.6.2	TDD inter frequency measurements	102
8.6.2.1	Correct reporting of neighbours in AWGN propagation condition	102
8.6.3	FDD measurements	103
8.6.3.1	Correct reporting of FDD neighbours in AWGN propagation condition	103
8.7	Measurements Performance Requirements	103
8.7.1	P-CCPCH RSCP	103
8.7.1.1	Intra frequency measurement accuracy	103
8.7.1.1.1	Absolute accuracy requirement	103
8.7.1.1.2	Relative accuracy requirement	105
8.7.1.2	Inter frequency measurement accuracy	106
8.7.1.2.1	Relative accuracy requirement	106
8.7.1.2.1.3	Test Purpose	107
Annex A (informative): Connection Diagrams		109
Annex B (normative): Global In-Channel TX-Test		113
B.1	General	113
B.2	Definition of the process	113
B.2.1	Basic principle	113
B.2.2	Output signal of the TX under test	113
B.2.3	Reference signal	113
B.2.4	void	114
B.2.5	Classification of measurement results	114
B.2.6	Process definition to achieve results of type "deviation"	114
B.2.7	Process definition to achieve results of type "residual"	115
B.2.7.1	Error Vector Magnitude (EVM)	115
B.2.7.2	Peak Code Domain Error (PCDE)	116
B.3	Notes	116
Annex C (normative): Measurement channels		119
C.1	General	119
C.2	UL Reference measurement channels	120
C.2.1	UL reference measurement channel (12.2 kbps)	120
C.2.2	UL multi code reference measurement channel (12.2 kbps)	121
C.2.3	UL reference measurement channel (64 kbps)	122
C.2.4	UL reference measurement channel (144 kbps)	123
C.2.5	UL reference measurement channel (384 kbps)	124
C.3	DL Reference measurement channels	125
C.3.1	DL reference measurement channel (12.2 kbps)	125
C.3.2	DL reference measurement channel (64 kbps)	126
C.3.3	DL reference measurement channel (144 kbps)	127
C.3.4	DL reference measurement channel (384 kbps)	128
C.3.5	BCH reference measurement channel	129
Annex D (normative): Propagation conditions		130
D.1	Test Environments	130
D.2	Propagation Conditions	130
D.2.1	Static propagation condition	130
D.2.2	Multi-path fading propagation conditions	130
Annex E (normative): Common RF test conditions		131
E.1	General	131
E.2	Connection Set-up	131
E.3	During connection	131

E.3.1	Measurement of Tx Characteristics	131
E.3.2	Measurement of Rx Characteristics	132
E.3.3	Measurement of Performance requirements	132
Annex F (normative): General test conditions and declarations.....		133
F.1	Acceptable uncertainty of Test System	133
F.1.1	Measurement of test environments	133
F.1.2	Measurement of transmitter	134
F.1.3	Measurement of receiver	135
F.1.4	Performance requirement.....	135
F.1.5	Requirements for support of RRM	135
F.2	Test Tolerances (This clause is informative).....	135
F.2.1	Transmitter.....	136
F.2.2	Receiver	136
F.2.3	Performance requirements	136
F.2.4	Requirements for support of RRM	137
F.3	Interpretation of measurement results	137
F.4	Derivation of Test Requirements (This clause is informative).....	137
F.5	Acceptable uncertainty of Test Equipment (This clause is informative).....	141
F.5.1	Transmitter measurements	141
F.5.2	Receiver measurements	141
F.5.3	Performance measurements	142
F.6	General rules for statistical testing	142
F.6.1	Statistical testing of receiver BER/BLER performance.....	142
F.6.1.1	Error Definition.....	142
F.6.1.2	Test Method	142
F.6.1.3	Test Criteria.....	142
F.6.1.4	Calculation assumptions.....	142
F.6.1.5	Definition of good pass fail decision.....	143
F.6.1.6	Good balance between testtime and statistical significance.....	143
F.6.1.7	Pass fail decision rules	144
F.6.1.8	Test conditions for BER,BLER tests.....	145
F.6.1.9	Practical Use (informative)	146
F.6.2	Statistical testing of RRM delay performance.....	148
Annex G (normative): Environmental conditions		149
G.1	General	149
G.2	Environmental requirements	149
G.2.1	Temperature	149
G.2.2	Voltage.....	149
G.2.3	Vibration	150
G.2.4	Specified frequency range	150
Annex H (normative): Terminal Baseline and Service Implementation Capabilities (TDD).....		151
H.1	Baseline Implementation Capabilities:.....	151
H.2	Service Implementation Capabilities:.....	151
Annex I (normative): Default Message Contents.....		152
Annex J (informative): Change history		155
History		157

Foreword

This Technical Specification (TS) has been produced by the 3rd Generation Partnership Project (3GPP).

The contents of the present document are subject to continuing work within the TSG and may change following formal TSG approval. Should the TSG modify the contents of the present document, it will be re-released by the TSG with an identifying change of release date and an increase in version number as follows:

Version x.y.z

where:

- x the first digit:
 - 1 presented to TSG for information;
 - 2 presented to TSG for approval;
 - 3 or greater indicates TSG approved document under change control.
- y the second digit is incremented for all changes of substance, i.e. technical enhancements, corrections, updates, etc.
- z the third digit is incremented when editorial only changes have been incorporated in the document.

1 Scope

This present document specifies the measurement procedure for the conformance test of the mobile station that contain transmitting characteristics, receiving characteristics and performance requirements and requirements for support of RRM (Radio Resource Management) in TDD mode.

2 References

The following documents contain provisions which, through reference in this text, constitute provisions of the present document.

- References are either specific (identified by date of publication, edition number, version number, etc.) or non-specific.
- For a specific reference, subsequent revisions do not apply.
- For a non-specific reference, the latest version applies. In the case of a reference to a 3GPP document (including a GSM document), a non-specific reference implicitly refers to the latest version of that document *in the same Release as the present document*.

[1] 3GPP TS 25.102: "UTRA (UE) TDD Radio Transmission and Reception (TDD)".

Note: The current version reflects 3G TS 25.102 version 3.2.0.

In addition CRs agreed on RAN4 level (Meeting #13, Turku, Finland, May 2000) are taken into account.

[2] 3GPP TS 25.123: "Requirements for Support of Radio Resource Management (TDD)".

[3] 3GPP TS 34.108 "Common Test Environments for User Equipment (UE) Conformance Testing"

[4] 3GPP TS 34.109: " Terminal logical test interface; Special conformance testing functions".

[5] 3GPP TS 25.224: "Physical Layer Procedures (TDD)".

[6] 3GPP TR 21.905: "Vocabulary for 3GPP Specifications".

[7] 3GPP TR 25.990: "Vocabulary".

[8] ITU-R Recommendation SM.328-9: "Spectra and bandwidth of emissions".

[9] 3GPP TS 25.331: "Radio Resource Control (RRC) Protocol Specification".

3 Definitions, abbreviations and equations

For the purposes of the present document, the definitions, symbols, abbreviations and equations used in the present document are listed in TR 21.905 [6] and TR 25.990 [7].

3.1 Definitions

For the purpose of the present document, the following definition applies:

Power Spectral Density: The units of Power Spectral Density (PSD) are extensively used in this document. PSD is a function of power versus frequency and when integrated across a given bandwidth, the function represents the mean power in such a bandwidth. When the mean power is normalised to (divided by) the chip-rate it represents the mean energy per chip. Some signals are directly defined in terms of energy per chip, (DPCH_Ec, Ec, and P-CCPCH_Ec) and others defined in terms of PSD (Io, Ioc, Ior and \hat{I} or). There also exist quantities that are a ratio of energy per chip to PSD (DPCH_Ec/Ior, Ec/Ior etc.). This is the common practice of relating energy magnitudes in communication systems.

It can be seen that if both energy magnitudes in the ratio are divided by time, the ratio is converted from an energy ratio to a power ratio, which is more useful from a measurement point of view. It follows that an energy per chip of X dBm/3.84 MHz can be expressed as a mean power per chip of X dBm. Similarly, a signal PSD of Y dBm/3.84 MHz can be expressed as a signal power of Y dBm.

Maximum Output Power: This is a measure of the maximum power the UE can transmit (i.e. the actual power as would be measured assuming no measurement error) in a bandwidth of at least $(1 + \alpha)$ times the chip rate of the radio access mode. The period of measurement shall be a transmit timeslot excluding the guard period.

Mean Power: When applied to a CDMA modulated signal this is the power (transmitted or received) in a bandwidth of at least $(1 + \alpha)$ times the chip rate of the radio access mode. The period of measurement shall be a transmit timeslot excluding the guard period unless otherwise stated.

Output power: The mean power of the UE delivered to a load with resistance equal to the nominal load impedance of the transmitter.

RRC Filtered Mean Power: The mean power as measured through a root raised cosine filter with roll-off factor α and a bandwidth equal to the chip rate of the radio access mode.

Nominal Maximum Output Power: This is the nominal power defined by the UE power class. The period of measurement shall be a transmit timeslot excluding the guard period.

Received Signal Code Power (RSCP): Given only signal power is received, the RRC filtered mean power of the received signal after despreading and combining.

Interference Signal Code Power (ISCP): Given only interference power is received, the RRC filtered mean power of the received signal after despreading to the code and combining. Equivalent to the RSCP value but now only interference is received instead of signal

NOTE 1: The RRC filtered mean power of a perfectly modulated CDMA signal is 0.246 dB lower than the mean power of the same signal.

NOTE 2: The roll-off factor α is defined in section 6.8.1 of [1].

3.2 Abbreviations

For the purpose of the present document, the following abbreviations apply.

ACLR	Adjacent Channel Leakage power Ratio
ACS	Adjacent Channel Selectivity
AFC	Automatic Frequency Control
ATT	Attenuator
CW	Continuous wave (unmodulated signal)
DPCH	Dedicated physical channel
DPCH_Ec	Average energy per PN chip for DPCH
EVM	Error Vector Magnitude
FFS	For Further Study
Fuw	Frequency of unwanted signal. This is specified in bracket in terms of an absolute frequency(s) or frequency offset from the assigned channel frequency.
HYB	Hybrid
I_{BTS}	Interference signal power level at BTS in dBm, which is broadcasted on BCH
I_{oac}	The power spectral density of the adjacent frequency channel as measured at the UE antenna connector
I_{oc}	The power spectral density (integrated in a noise bandwidth equal to the chip rate and normalized to the chip rate) of a band limited white noise source (simulating interference from other cells) as measured at the UE antenna connector.
I_{or}	The total transmit power spectral density (integrated in a bandwidth of $(1+\alpha)$ times the chip rate and normalized to the chip rate) of the downlink signal at the BS antenna connector
\hat{I}_{or}	The received power spectral density (integrated in a bandwidth of $(1+\alpha)$ times the chip rate and normalized to the chip rate) of the downlink signal as measured at the UE antenna connector
I_{owc}	Unwanted signal power level
OBW	Occupied Bandwidth

OCNS	Orthogonal Channel Noise Simulator, a mechanism used to simulate the users or control signals on the other orthogonal channels of a downlink.
PCDE	Peak Code Domain Error
PPM	Parts Per Million
PRBS	Pseudo Random Bit Sequence
RRC	Root-Raised Cosine
SCTD	Space Code Transmit Diversity
SIR	Signal to Interference ratio
SS	System Simulator
TBD	To Be Defined
TPC	Transmit Power Control
TS	Time Slot

3.3 Equations

For the purpose of the present document, the following additional equations apply:

$\frac{DPCH_Ec}{I_{or}}$	The ratio of the average energy per PN chip of the DPCH to the total transmit power spectral density of the downlink at the BS antenna connector
$\frac{\sum DPCH_Ec}{I_{or}}$	The ratio of the sum of DPCH_Ec for one service in case of multicode to the total transmit power spectral density of the downlink at the BS antenna connector

4 Frequency bands and channel arrangement

4.1 General

The information presented in this clause is based on a chip rate of 3,84 Mcps.

NOTE: Other chip rates may be considered in future releases.

4.2 Frequency bands

UTRA/TDD is designed to operate in the following bands;

- a) 1 900 – 1 920 MHz: Uplink and downlink transmission
2 010 – 2 025 MHz: Uplink and downlink transmission
- b) 1 850 – 1 910 MHz: Uplink and downlink transmission (note)
1 930 – 1 990 MHz: Uplink and downlink transmission
- c) 1 910 – 1 930 MHz: Uplink and downlink transmission (note)

NOTE: Used in ITU Region 2.

Additional allocations in ITU region 2 are for further study.

Deployment in existing or other frequency bands is not precluded.

4.3 TX–RX frequency separation

No TX-RX frequency separation is required as Time Division Duplex (TDD) is employed. Each TDMA frame consists of 15 timeslots where each timeslot can be allocated to either transmit or receive.

4.4 Channel arrangement

4.4.1 Channel spacing

The nominal channel spacing is 5 MHz, but this can be adjusted to optimise performance in a particular deployment scenario.

4.4.2 Channel raster

The channel raster is 200 kHz, which means that the carrier frequency must be a multiple of 200 kHz.

4.4.3 Channel number

The carrier frequency is designated by the UTRA absolute radio frequency channel number (UARFCN). The value of the UARFCN in the IMT2000 band is defined as follows:

$$N_t = 5 * F \quad 0,0 \text{ MHz} \leq F \leq 3276,6 \text{ MHz} \quad \text{where } F \text{ is the carrier frequency in MHz}$$

5 Transmitter Characteristics

5.1 General

Transmitting performance test of the UE is implemented during communicating with the SS via air interface. The procedure is uses normal call protocol until the UE is communicating on traffic channel basically. (Refer to TS 34.108 [3] Common Test Environments for User Equipment (UE) Conformance Testing) On the traffic channel, the UE provides special function for testing that is called Logical Test Interface and the UE is tested using this function. (Refer to TS 34.109 [4] Logical Test Interface; Special conformance testing functions).

Unless detailed the transmitter characteristic are specified at the antenna connector of the UE. For UE with integral antenna only, a reference antenna with a gain of 0 dBi is assumed. Transmitter characteristics for UE(s) with multiple antennas/antenna connectors are for further study.

The UE antenna performance has a significant impact on system performance, and minimum requirements on the antenna efficiency are therefore intended to be included in future versions of the present document. It is recognized that different requirements and test methods are likely to be required for the different types of UE.

The common RF test conditions are defined in annex E, and each test conditions in this Clause should refer annex E. Individual test conditions are defined in the paragraph of each test.

5.2 User Equipment maximum output power

5.2.1 Definition and applicability

The nominal maximum output power and its tolerance are defined according to the Power Class of the UE.

The requirements in this test apply to all UTRA – TDD- UEs

Notes copied from TS 25.102 clause 6.2.1:

NOTE 1: For multi-code operation thenominal maximum output power will be reduced by the difference of peak to average ratio between single and multi-code transmission.

NOTE 2: The tolerance allowed for the nominal maximum power applies even at the multi-code transmission mode

NOTE 3: For UE using directive antennas for transmission, a class dependent limit will be placed on the maximum EIRP (Equivalent Isotropic Radiated Power).

5.2.2 Minimum Requirements

The error of the UE maximum output power shall not exceed the tolerance shown in tables 5.2.2 a and b for single and multi-code.

Table 5.2.2.a: Maximum Output Power single code

Power Class	Nominal maximum output power	Tolerance
2	+24 dBm	+1dB/-3dB
3	+21 dBm	+2dB/-2dB

Table 5.2.2.b: Maximum Output Power multi code

Power Class	Nominal maximum output power	Tolerance
2	21 dBm (note)	+1dB/-3dB
3	18 dBm (note)	+2dB/-2dB
NOTE: These figures are not mentioned in 25.102. Instead there is a note, saying: "For multi-code operation the maximum output power will be reduced by the difference of peak to average ratio between single and multi-code transmission." The figures are calculated from maximum output power single code (table 5.2.2.a) and UL multicode reference measurement channel (12,2 kbit/s) (annex C.2.2.) containing two code signals with equal level.		

The normative reference for this requirement is TS 25.102 clause 6.2.

5.2.3 Test purpose

For the following reasons:

Limit interference.

Verify that the maximum output power is achievable.

It is the purpose of the test to verify that the UE's maximum output power is within its tolerance limits under all environmental conditions.

5.2.4 Method of test

5.2.4.1 Initial conditions

Test environment: normal, TL/VL, TL/VH, TH/VL, TH/VH; see clauses G.2.1 and G.2.2.

Frequencies to be tested: low range, mid range, high range; see clause G.2.4.

- 1) Connect the SS to the UE antenna connector as shown in figure A.1.
- 2) Calls are set up according to the Generic call setup procedure using parameters as specified in tables 5.2.4.a and b.
- 3) Enter the UE into loopback test mode and start the loopback test.

Table 5.2.4.a: Test parameters for Maximum Output Power single code

Parameter	Value/description
UL Reference measurement channel	12,2kbps, according to annex C.2.1
Uplink Power Control	SS level and signalling values such that UE transmits maximum power.
Data content	real life (sufficient irregular)

Table 5.2.4.b: Test parameters for Maximum Output Power multicode

Parameter	Value/description
Reference measurement channel	Multicode 12,2kbps, according to annex C.2.2
Uplink Power Control	SS level and signalling values such that UE transmits maximum power
Data content	real life (sufficient irregular)

5.2.4.2 Procedure

- 1) Measure the mean power of the UE output signal.
- 2) Run step 1) on RF channels Low / Mid / High.

5.2.5 Test Requirements

The output power, measured in step 2) of clause 5.2.4.2, shall not exceed the prescribed tolerance in table 5.2.5 a and b.

Table 5.2.5.a: Maximum Output Power single code

Power Class	Nominal maximum output power	Tolerance
2	+24 dBm	+1,7 dB / -3,7dB
3	+21 dBm	+2,7 dB / -2,7dB

Table 5.2.5.b: Maximum Output Power multi code

Power Class	Nominal maximum output power	Tolerance
2	21 dBm	+1,7dB / -3,7 dB
3	18 dBm	+2,7dB / -2,7 dB

NOTE: If the above Test Requirement differs from the Minimum Requirement then the Test Tolerance applied for this test is non-zero. The Test Tolerance for this test is defined in annex F clause F.2 and the explanation of how the Minimum Requirement has been relaxed by the Test Tolerance is given in Annex F clause F.4.

5.3 UE frequency stability

5.3.1 Definition and applicability

The frequency stability is the difference of the modulated carrier frequency between the RF transmission from the UE and the RF transmission from the BS. The UE shall use the same frequency source for both RF frequency generation and chip clocking.

The requirements of this test apply to all types of UTRA- UE.

5.3.2 Minimum Requirements

The UE frequency stability, observed over a period of one timeslot, shall be within $\pm 0,1$ ppm compared to signals received from the BS.

The normative reference for this requirement is TS 25.102 [1] clause 6.3.

5.3.3 Test purpose

Reliable frequency stability of the UE's transmitter in certain tolerance limits is prerequisite for connectivity.

This test stresses the ability of the UE's receiver to derive correct frequency information from the received signal for the transmitter.

5.3.4 Method of test

5.3.4.1 Initial conditions

Test environment: normal, TL/VL, TL/VH, TH/VL, TH/VH, vibration; see clauses G.2.1, G.2.2 and G.2.3.

Frequencies to be tested: low range, mid range, high range; see clause G.2.4.

- 1) Connect the SS to the UE antenna connector as shown in figure A.1.
- 2) A call is set up according to the Generic call setup procedure using parameters as specified in table 5.3.4.1.
- 3) Enter the UE into loopback test mode and start the loopback test.

Table 5.3.4.1: Test parameters for Frequency Stability

Parameter	Value/description
SS level	-105 dBm (reference sensitivity)
UL reference measurement channel	12,2 kbps according to annex C.2.1.
Data content	real life (sufficient irregular)

5.3.4.2 Procedure

- 1) Measure the frequency error delta f across the TS according to annex B.
- 2) Repeat step 1) for 200 bursts (time slots).
- 3) Run Step 1) and 2) for RF channels Low /Mid/ High.

5.3.5 Test Requirements

For all measured bursts (time slots) , the frequency error, derived in clause 5.3.4.2, shall not exceed \pm (0,1 ppm + 10 Hz).

NOTE: If the above Test Requirement differs from the Minimum Requirement then the Test Tolerance applied for this test is non-zero. The Test Tolerance for this test is defined in annex F clause F.2 and the explanation of how the Minimum Requirement has been relaxed by the Test Tolerance is given in annex F clause F.4

5.4 Output Power Dynamics

Power control is used to limit the interference level.

5.4.1 Uplink power control

Uplink power control is the ability of the UE transmitter to set its output power in accordance with measured downlink path loss, values determined by higher layer signalling and path loss weighting parameter α as defined in TS 25.331 [9]. The output power is defined as the RRC filtered mean power of the transmit timeslot.

5.4.1.1 Initial accuracy

5.4.1.1.1 Definition and applicability

Initial Uplink power control is the ability of the UE transmitter to set its output power in accordance with measured downlink path loss, and signalling values: I_{BTS} and Constant value, received from the BCH and applicable for the PRACH

The requirements and this test apply to all types of UTRA - UEs.

5.4.1.1.2 Minimum requirements

The UE power control, initial accuracy, is given in table 5.4.1.1.2.

Table 5.4.1.1.2: Initial uplink power control tolerance

Normal conditions	± 9 dB
Extreme conditions	± 12 dB

The reference for this requirement is TS 25.102 [1] clause 6.4.1.1.

5.4.1.1.3 Test purpose

The power of the received signal at the UE and the BCCH information control the power of the transmitted UE signal with the target to transmit at lowest power, acceptable for proper communication.

The test stresses the ability of the receiver to measure the received power over the receiver dynamic range and to derive from this correct transmitter-power

5.4.1.1.4 Method of test

5.4.1.1.4.1 Initial conditions

Test environment: normal, TL/VL, TL/VH, TH/VL, TH/VH; see clauses G.2.1 and G.2.2.

Frequencies to be tested: low range, mid range, high range; see clause G.2.4.

Connect the SS to the MS antenna connector as shown in figure A.1.

A call is set up according to the generic call setup procedure [3] using parameters as specified in table 5.4.1.1.4. The RACH procedure within the call setup is used for the test.

Table 5.4.1.1.4: Test parameters for uplink Power Control

	RX-Upper dynamic end	RX-middle	RX-Sensitivity level
SS transmit power	-25 dBm/3,84 MHz	-65 dBm/3,84 MHz	-105 dBm/3,84 MHz
Broadcasted transmit-power CCPCH	35 dBm	35 dBm	24 dBm
Simulated path loss = Broadcasted TX – SS TX Power	60 dB	100 dB	129 dB
I _{BTS} (UL interference)	-75 dBm	-100 dBm	-110 dBm
Constant value	-10 dB	-10 dB	-10 dB
Nominal expected UE TX power	-25 dBm	-10 dBm	+9 dBm ²⁾
NOTE 1: While the SS transmit power shall cover the UE receiver input dynamic range, the logical parameters: broadcasted transmit power, I _{BTS} , and RACH constant value are chosen to achieve a UE TX power, located within the TX output power dynamic range of a class 3 UE.			
NOTE 2: Nominal TX output power 9 dBm allows to check the uplink power control algorithm within the entire tolerance range (9 dBm +12 dB: 9 dBm +12 dB =21 dBm = max power class 3).			

5.4.1.1.4.2 Procedure

- 1) Set the SS transmit power according to table 5.4.1.1.4.
- 2) Measure the RACH output power of the UE according to annex B.
- 3) Repeat the test for all SS transmit powers and parameters in table 5.4.1.1.4.

5.4.1.1.5 Test requirements

The deviation with respect to the nominal expected UE TX power (table 5.4.1.1.2), derived in step 2, shall not exceed the prescribed tolerance in table 5.4.1.1.5.

Table 5.4.1.1.5: Test parameters for uplink Power Control

Expected UE TX power, normal conditions	-25 dBm ±10 dB	-10 dBm±10 dB	+9 dBm ±10 dB
Expected UE TX power, extreme conditions	-25 dBm ±13 dB	-10 dBm±13 dB	+9 dBm ±13 dB

NOTE: If the above Test Requirement differs from the Minimum Requirement then the Test Tolerance applied for this test is non-zero. The Test Tolerance for this test is defined in annex F clause F.2 and the explanation of how the Minimum Requirement has been relaxed by the Test Tolerance is given in annex F clause F.4.

5.4.1.2 Differential accuracy, controlled input

5.4.1.2.1 Definition and applicability

Uplink power control, differential accuracy, is the ability of the UE transmitter to sets its output power in accordance with measured downlink path loss, and the signalling values: I_{BTS}, SIR_{Target}, Constant Value, received from higher layers and applicable for the DPCH.

Specifically, the uplink power control, differential accuracy, controlled input, is defined as the error in the UE transmitter power step as a result of a step in SIR_{TARGET} when the path loss weighting parameter $\alpha=0$, α calculated in the UE.

The requirements of this test apply to all types of UTRA -UE.

5.4.1.2.2 Minimum requirements

The step in SIR_{TARGET} shall be rounded to the closest integer dB value. The error shall not exceed the values in table 5.4.1.2.2.

Table 5.4.1.2.2: Transmitter power step tolerance as a result of control power step

ΔSIR_{TARGET} [dB]	Transmitter power step tolerance [dB]
$\Delta SIR_{TARGET} \leq 1$	$\pm 0,5$
$1 < \Delta SIR_{TARGET} \leq 2$	± 1
$2 < \Delta SIR_{TARGET} \leq 3$	$\pm 1,5$
$3 < \Delta SIR_{TARGET} \leq 10$	± 2
$10 < \Delta SIR_{TARGET} \leq 20$	± 4
$20 < \Delta SIR_{TARGET} \leq 30$	± 6
$30 < \Delta SIR_{TARGET}$	± 9 (note)
NOTE: Value is given for normal conditions. For extreme conditions value is ± 12 .	

The reference for this requirement is TS 25.102 [1] clause 6.4.1.2.

5.4.1.2.3 Test purpose

It is verified if the UE sets correct uplink power steps in response to steps in the signalling value SIR_{Target} , signalled via the downlink to the UE.

under the following conditions: keeping the other signalling parameters constant and deactivating any influence due to varying pathloss.

5.4.1.2.4 Method of test

5.4.1.2.4.1 Initial conditions

Test environment: normal; see clauses G.2.1 and G.2.2.

Frequencies to be tested: mid range; see clause G.2.4.

- 1) Connect the SS to the MS antenna connector as shown in figure A.1.
- 2) A call is set up according to the generic call setup procedure using parameters as specified in table 5.4.1.2.4.

Table 5.4.1.2.4: Test parameters for Uplink Power Control, Differential Accuracy, Controlled Input

Parameter	Value/description
UL reference measurement channel	12,2 kbps according to annex C clause C.2.1.
BS Transmit to UE Transmit delay	7 TSS--> $\alpha=0$
SS Transmit power	[-65 dBm]
Reference transmit power broadcast on BCH	[35 dBm]
I_{BTS}	[-100]
Constant value	[-10]
Data content	real life (sufficient irregular)

5.4.1.2.4.2 Procedure

Using the SIR_{Target} -value in the downlink,

cover the UE-transmitter dynamic range by commanding the UEs power with the signalling value SIR_{Target} in a step resolution (positive and negative direction) of:

1 dB	approx. 68 steps up and 68 steps down
2 dB	approx. 34 steps up and 34 steps down
3 dB	approx. 22 steps up and 22 steps down
10 dB	approx. 7 steps up and 7 steps down
20 dB	approx. 3 steps up and 3 steps down
30 dB	approx. 2 step up and 2 step down
maximum stepsize	1 step up and 1 step down

Measure the power according to annex B.

5.4.1.2.5 Test requirements

For the UE output power laying between

Max Power minus tolerance and Min Power

the step response shall not exceed the prescribed tolerance in table 5.4.1.2.5.

Table 5.4.1.2.5: Transmitter power step tolerance as a result of control power step

$\Delta\text{SIR}_{\text{TARGET}}$ [dB]	Transmitter power step tolerance [dB]
$\Delta\text{SIR}_{\text{TARGET}} \leq 1$	$\pm 0,6$
$1 < \Delta\text{SIR}_{\text{TARGET}} \leq 2$	$\pm 1,15$
$2 < \Delta\text{SIR}_{\text{TARGET}} \leq 3$	$\pm 1,7$
$3 < \Delta\text{SIR}_{\text{TARGET}} \leq 10$	$\pm 2,5$
$10 < \Delta\text{SIR}_{\text{TARGET}} \leq 20$	$\pm 4,7$
$20 < \Delta\text{SIR}_{\text{TARGET}} \leq 30$	$\pm 6,7$
$30 < \Delta\text{SIR}_{\text{TARGET}}$	± 10

NOTE: If the above Test Requirement differs from the Minimum Requirement then the Test Tolerance applied for this test is non-zero. The Test Tolerance for this test is defined in annex F clause F.2 and the explanation of how the Minimum Requirement has been relaxed by the Test Tolerance is given in Annex F clause F.4.

5.4.2 Minimum output power

5.4.2.1 Definition and applicability

The minimum controlled output power of the UE is when the power is set to a minimum value. The minimum output power is defined as the mean power in one time slot excluding the guard period.

The normative requirements of this test apply to all types of UTRA- UE.

5.4.2.2 Minimum Requirements

The minimum output power shall be lower than or equal to -44 dBm

The normative reference for this requirement is TS 25.102 [1] clause 6.4.5.1.

5.4.2.3 Test purpose

The test purpose is to verify the ability of the UE to reduce its output power to a specified value.

5.4.2.4 Method of test

5.4.2.4.1 Initial conditions

Test environment: normal, TL/VL, TL/VH, TH/VL, TH/VH; see clauses G.2.1 and G.2.2.

Frequencies to be tested: low range, mid range, high range; see clause G.2.4.

- 1) Connect the SS to the UE antenna connector as shown in figure A.1.
- 2) A call is set up according to the Generic call setup procedure using parameters as specified in table E.3.1.2.
- 3) Enter the UE into loopback test mode and start the loopback test.

5.4.2.4.2 Procedure

- 1) Configure the UE transmitter to enable power control steps of size 1 dB.
- 2) Set and send Down power control commands to the UE. The sequence shall be sufficiently long so that the UE output signal reached its minimum power.
- 2) Measure the mean power of the UE output signal according to annex B.

NOTE: Annex B returns the power in the decision points (displayed as reference power and power offset). This is equivalent to thermal power at the air-interface. Insofar 5.4.2 minimum output power is consistent with 5.2 maximum output power.

- 3) Configure the UE transmitter to enable power control steps of 2 dB and of 3 dB, respectively, and repeat step 2).
- 4) Run step 2) for RF channels Low Mid and High.

5.4.2.5 Test requirements

For all measurements, the minimum output power derived in step 3) and 4) of 5.4.2.4.2 shall be below -43 dBm.

NOTE: If the above Test Requirement differs from the Minimum Requirement then the Test Tolerance applied for this test is non-zero. The Test Tolerance for this test is defined in annex F clause F.2 and the explanation of how the Minimum Requirement has been relaxed by the Test Tolerance is given in annex F clause F.4.

5.4.3 Transmit OFF power

5.4.3.1 Definition and applicability

Transmit OFF power is defined as the RRC filtered mean power measured over one chip when the transmitter is off. The transmit OFF power state is when the UE does not transmit.

The requirements of this test apply to all types of UTRA-UE.

5.4.3.2 Minimum Requirements

The transmit OFF power shall be below -65 dBm.

The normative reference for this requirement is TS 25.102 clause 6.5.1.

5.4.3.3 Test purpose

Refer clause 5.4.4.3.

5.4.3.4 Method of test

Refer clause 5.4.4.4

5.4.3.5 Test requirements

The transmit OFF power shall be below $-63,5$ dBm.

NOTE: If the above Test Requirement differs from the Minimum Requirement then the Test Tolerance applied for this test is non-zero. The Test Tolerance for this test is defined in annex F clause F.2 and the explanation of how the Minimum Requirement has been relaxed by the Test Tolerance is given in annex F clause F.4

5.4.4 Transmit ON/OFF Time mask

5.4.4.1 Definition and applicability

The transmit ON/OFF time mask defines the ramping time allowed for the UE between transmit OFF power and transmit ON power.

This test applies for all UTRA TTD UEs.

5.4.4.2 Minimum requirements

The transmit power level versus time shall meet the mask specified in figure 5.4.4.2, where the transmission period refers to the burst without guard-period for a single transmission slot, and to the period from the beginning of the burst in the first transmission slot to the end of the burst without guard period in the last transmission timeslot for consecutive transmission slots.

The reference for this requirement is TS 25.102 [1] clause 6.5.2.1.

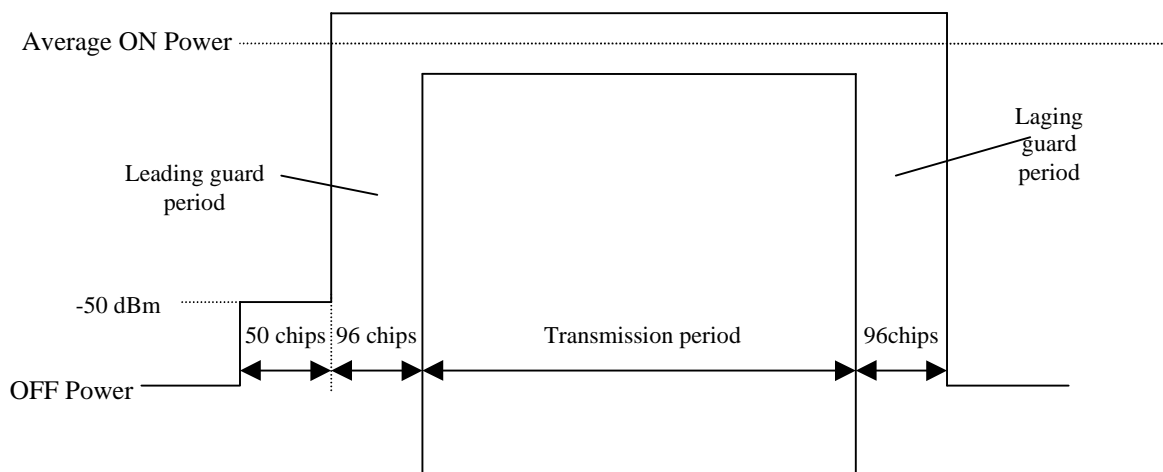

Figure 5.4.4.2: Transmit ON/OFF template

5.4.4.3 Test Purpose

It is tested if the UE TX signal uses the guard period for on-to-off and off-to-on transitions, where the time position of guard period is derived from the burst under test itself.

It is furtheron tested, if the UE TX signal is below certain limits outside transmission period and guard periods where the position in time is derived from the burst under test itself.

With this test interference to other UTRA TDD users are limited.

5.4.4.4 Method of test

5.4.4.4.1 Initial conditions

Test environment: normal, TL/VL, TL/VH, TH/VL, TH/VH; see clauses G.2.1 and G.2.2.

Frequencies to be tested: low range, mid range, high range; see clause G.2.4.

Connect the SS to the UE antenna connector as shown in figure A.1.

A call is set up according to the generic call setup procedure using parameters as specified in table E.3.1.2.

Enter the UE into loopback test mode and start the loopback test.

5.4.4.4.2 Procedure

- 1) The time position of the midamble of the burst under test (TimeSlot s in Frame f) shall be the reference for the time position of the leading and laging guard-periods of the burst under test and, alternatively, for the equivalent guard periods of the next 2 bursts.
- 2) Record the following time periods with at least 2 samples /chip through a matched filter (RRC 0,22, BW equal to the chiprate): TS $s-1$ and TS $s+1$ in frame f or $f+1$ or $f+2$
- 3) Calculate power samples by averaging the recorded samples of one chip duration.

5.4.4.5 Test requirements

Each power sample shall be below the limits (off Power (clause 5.4.3) and -50 dBm), indicated in figure 5.4.4.2.

NOTE: In this test no power limits apply during guard period.

5.4.5 Out-of-synchronisation handling of output power

5.4.5.1 Definition and applicability

The UE shall monitor the DPCH quality in order to detect a loss of the signal on Layer 1, as specified in TS 25.224. [5] The thresholds Q_{out} and Q_{in} specify at what DPCH quality levels the UE shall shut its power off and when it shall turn its power on, respectively. The thresholds are not defined explicitly, but are defined by the conditions under which the UE shall shut its transmitter off and turn it on, as stated in this clause.

The requirement of this clause shall apply to all types of UTRA-UE.

5.4.5.2 Minimum Requirement

When the UE estimates the DPCH quality over the last 160 ms period to be worse than a threshold Q_{out} , the UE shall shut its transmitter off within 40 ms. The UE shall not turn its transmitter on again until the DPCH quality exceeds an acceptable level Q_{in} . When the UE estimates the DPCH quality over the last 160 ms period to be better than a threshold Q_{in} , the UE shall again turn its transmitter on within 40 ms.

The quality levels at the thresholds Q_{out} and Q_{in} correspond to different signal levels depending on the downlink conditions DCH parameters. For the conditions in table 5.4.5.1.a, a signal with the quality at the level Q_{out} is generated by a $\Sigma DPCH_Ec/Ior$ ratio of -13 dB, and a signal with Q_{in} by a $\Sigma DPCH_Ec/Ior$ ratio of -9 dB. In this test, the DL reference measurement channel (12.2) kbps specified in clause C.3.1, where the CRC bits are replaced by data bits, and with static propagation conditions is used.

Table 5.4.5.1: DCH parameters for the Out-of-synch handling test case continuous transmission

Parameter	Unit	Value
\hat{I}_{or}/I_{oc}	dB	-1
I_{oc}	dBm/3,84 MHz	-60
$\frac{\Sigma DPCH_E_c}{I_{or}}$	dB	See figure 5.4.5.1
Information Data Rate	kbps	13
TFCI	-	On

Figure 5.4.5.1 shows an example scenario where the $\Sigma DPCH_E_c/I_{or}$ ratio varies from a level where the DPCH is demodulated under normal conditions, down to a level below Q_{out} where the UE shall shut its power off and then back up to a level above Q_{in} where the UE shall turn the power back on.

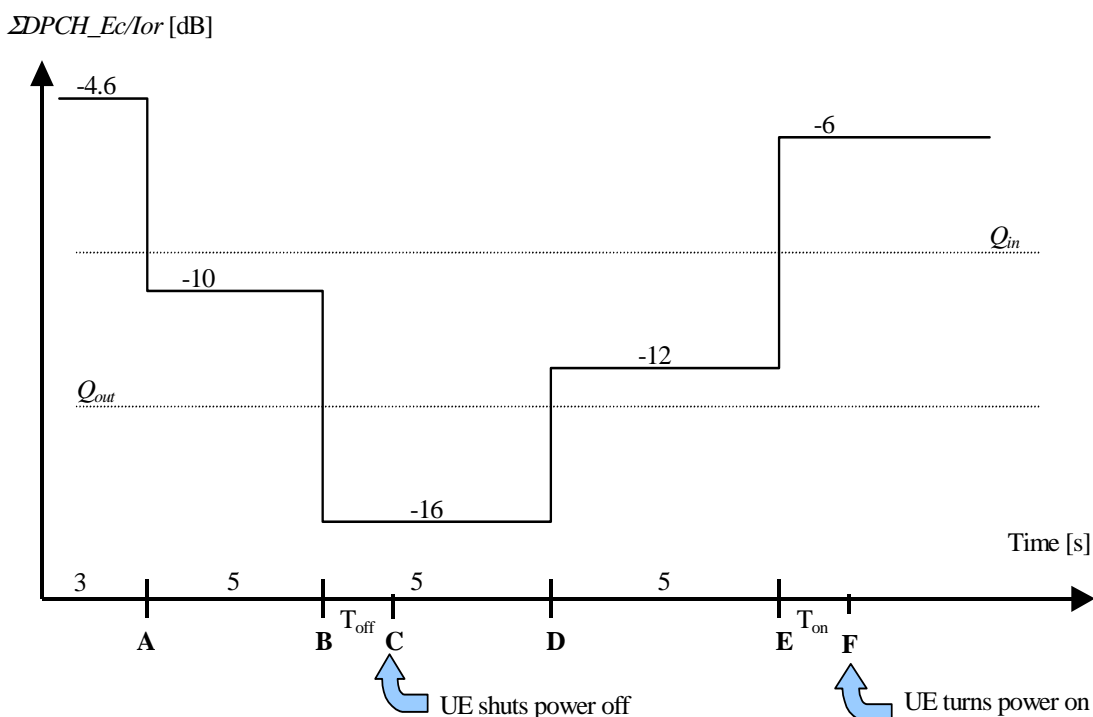

Figure 5.4.5.1: Test case for out-of-synch handling in the UE continuous transmission

In this test case the requirements for the UE are that:

- 1) The UE shall not shut its transmitter off before point B.
- 2) The UE shall shut its transmitter off before point C, which is $T_{off} = 200$ ms after point B
- 3) The UE shall not turn its transmitter on between points C and E.
- 4) The UE shall turn its transmitter on before point F, which is $T_{on} = 200$ ms after Point E.

The normative reference for this test is TS 25.102 [1] clause 6.4.3.

5.4.5.3 Test purpose

To verify that the UE monitors the DPCH quality and turns its transmitter on or off according to DPCH level diagram specified in figure 5.4.5.1.

5.4.5.4 Method of test

5.4.5.4.1 Initial conditions

Test environment: normal; see clauses G.2.1 and G.2.2.

Frequencies to be tested: mid range; see clause G.2.4.

- 1) Connect the SS to the UE antenna connector as shown in figure A.1.
- 2) Calls are set up according to the Generic call setup procedure using parameters as specified in table 5.4.5.1
- 3) Enter the UE into loopback test mode and start the loopback test.
- 4) The handover triggering level shall be set very high [TBD] to ensure that the beacon channel power never exceeds the value of 10dB above it. Therefore the averaging time for signal quality will always be 160 milliseconds.

5.4.5.4.2 Procedure

- 1) SS level and signalling values are set that the UE transmits maximum power (see annex E clause E.3.1)

- 2) Set the SS TX signal quality to $\frac{\Sigma DPCH_E_c}{I_{or}} = -4.6+0,4$ dB and verify that the UE TX signal is on.

- 3) Set the SS TX signal quality to $\frac{\Sigma DPCH_E_c}{I_{or}} = -10+0,4$ dB and verify that the UE TX signal remains on continuously for at least 5 seconds.

- 4) Set the SS TX signal quality to $\frac{\Sigma DPCH_E_c}{I_{or}} = -16-0,4$ dB and verify that the UE TX signal turns off 200 ms or earlier with respect to that instant.

- 5) Set the SS TX signal quality to $\frac{\Sigma DPCH_E_c}{I_{or}} = -12-0,4$ dB and verify that the UE TX signal remains off continuously for at least 5 seconds.

- 6) Set the SS TX signal quality to $\frac{\Sigma DPCH_E_c}{I_{or}} = -6+0,4$ dB and verify that the UE TX signal is switched on 200 ms or earlier with respect to that instant.

5.4.5.5 Test Requirements

The UE TX on-criterion including tolerance window is derived from the initial conditions and is verified with the method of 5.4.2 minimum transmit power. The UE transmitter is considered to be on if the UE transmitted power is higher than the minimum output power.

The UE TX off criterion including tolerance is verified according to clause 5.4.3 of the present document (Transmit off power). The UE transmitter is considered to be off if the UE transmitted power is lower than the transmit OFF power.

To pass the test, steps 1 through 6 of the procedure must be fulfilled.

5.5 Output RF spectrum emissions

5.5.1 Occupied bandwidth

5.5.1.1 Definition and applicability

Occupied bandwidth is a measure of the bandwidth containing 99 % of the total integrated power for transmitted spectrum and is centered on the assigned channel frequency.

The requirements in this clause shall apply to all types of UTRA - UE.

5.5.1.2 Minimum Requirements

The occupied bandwidth shall be less than 5 MHz based on a chip rate of 3,84 Mcps.

The normative reference for this requirement is TS 25.102 [1] clause 6.6.1.

5.5.1.3 Test purpose

The occupied bandwidth, defined in the Radio Regulations of the International Telecommunication Union ITU, is a useful concept for specifying the spectral properties of a given emission in the simplest possible manner; see also ITU-R Recommendation SM.328-9 [8].

The test purpose is to verify that the emission of the UE is sufficiently concentrated in the bandwidth for the service to be provided and is, therefore, not likely to create interference to other users of the spectrum beyond undue limits.

5.5.1.4 Method of test

5.5.1.4.1 Initial conditions

Test environment: normal; see clauses G.2.1 and G.2.2.

Frequencies to be tested: low range, mid range, high range; see clause G.2.4.

- 1) Connect the SS to the UE antenna connector as shown in figure A.1.
- 2) A call is set up according to the generic call setup procedure using parameters as specified in table E.3.1.2.
- 3) Enter the UE into loopback test mode and start the loopback test.

5.5.1.4.2 Procedure

- 1) Measure the power of the transmitted signal with a measurement filter of bandwidth [30 kHz]. The characteristic of the filter shall be approximately Gaussian (typical spectrum analyzer filter). The center frequency of the filter shall be stepped in contiguous 30 kHz steps from a minimum frequency, which shall be [7,5 – 0,015] MHz below the assigned channel frequency of the transmitted signal, up to a maximum frequency, which shall be [7,5 – 0,015] MHz above the assigned channel frequency of the transmitted signal. The step duration shall be sufficient slow to capture the active TS. The measured power shall be recorded for each step.
- 2) Determine the total transmitted power by accumulating the recorded power measurements results of all steps.
- 3) Sum up the power upward from the lower boundary of the measured frequency range in '(2)' and seek the limit frequency point by which this sum becomes 0,5 % of "Total Power" and save this point as "Lower Frequency".
- 4) Sum up the power downward from the upper boundary of the measured frequency range in '(2)' and seek the limit frequency point by which this sum becomes 0,5 % of "Total Power" and save this point as "Upper Frequency".
- 5) Calculate the difference ("Upper Frequency" – "Lower Frequency" = "Occupied Bandwidth") between two limit frequencies obtained in '(4)' and '(5)'.

5.5.1.5 Test requirements

The measured Occupied Bandwidth, derived in step 5), shall not exceed 5 MHz.

NOTE: If the above Test Requirement differs from the Minimum Requirement then the Test Tolerance applied for this test is non-zero. The Test Tolerance for this test is defined in annex F clause F.2 and the explanation of how the Minimum Requirement has been relaxed by the Test Tolerance is given in annex F clause F.4.

5.5.2 Out of band emission

Out of band emissions are unwanted emissions immediately outside the nominal channel resulting from the modulation process and non-linearity in the transmitter but excluding spurious emissions. This out of band emission limit is specified in terms of a spectrum emission mask and adjacent channel leakage power ratio (ACLR).

5.5.2.1 Spectrum emission mask

5.5.2.1.1 Definition and applicability

The spectrum emission mask of the UE is a requirement that applies to frequencies which are between 2,5 MHz and 12,5 MHz on both sides of the UE centre carrier frequency. The out of channel emission is specified relative to the RRC filtered mean power of the UE carrier.

The requirements of this test apply to all types of UTRA-UE.

5.5.2.1.2 Minimum Requirements

The power of any UE emission shall not exceed the levels specified in table 5.5.2.1.2.

The normative reference for this requirement is TS 25.102 clause 6.6.2.1.1

Table 5.5.2.1.2: Spectrum Emission Mask Requirement

Δf in MHz (note 1)	Minimum requirement	Measurement bandwidth
2.5 - 3.5	$\left\{ -35 - 15 \cdot \left(\frac{\Delta f}{\text{MHz}} - 2.5 \right) \right\} \text{dBc}$	30 kHz (note 2)
3.5 - 7.5	$\left\{ -35 - 1 \cdot \left(\frac{\Delta f}{\text{MHz}} - 3.5 \right) \right\} \text{dBc}$	1 MHz (note 3)
7.5 - 8.5	$\left\{ -39 - 10 \cdot \left(\frac{\Delta f}{\text{MHz}} - 7.5 \right) \right\} \text{dBc}$	1 MHz (note 3)
8.5 - 12.5	-49 dBc	1 MHz (note 3)
Note 1: Δf is the separation between the carrier frequency and the centre of the measuring filter Note 2: The first and last measurement position with a 30 kHz filter is at Δf equals to 2.515 MHz and 3.485 MHz. Note 3: The first and last measurement position with a 1 MHz filter is at Δf equals to 4 MHz and 12 MHz. As a general rule, the resolution bandwidth of the measuring equipment should be equal to the measurement bandwidth. To improve measurement accuracy, sensitivity and efficiency, the resolution bandwidth can be different from the measurement bandwidth. When the resolution bandwidth is smaller than the measurement bandwidth, the result should be integrated over the measurement bandwidth in order to obtain the equivalent noise bandwidth of the measurement bandwidth.		
The lower limit shall be $-50\text{dBm}/3.84\text{ MHz}$ or the minimum requirement presented in this table which ever is the higher.		

5.5.2.1.3 Test purpose

This test supplements Occupied Bandwidth (verifying the spectral concentration of the UE's emissions) and Adjacent Channel Leakage Ratio (simulating the perception of other UTRA receivers) in a system independent way. It is the purpose of this test to limit interferences to other systems (wideband or narrowband).

5.5.2.1.4 Method of test

5.5.2.1.4.1 Initial conditions

Test environment: normal; see clauses G.2.1 and G.2.2.

Frequencies to be tested: low range, high range; see clause G.2.4.

- 1) Connect the SS to the UE antenna connector as shown in figure A.1.
- 2) A call is set up according to the generic call setup procedure using parameters as specified in table E.3.1.2.
- 3) Enter the UE into loopback test mode and start the loopback test.

5.5.2.1.4.2 Procedure

- 1) Measure the power of the transmitted signal with a measurement filter of bandwidths according to table 5.5.2.1.2. The characteristic of the filter shall be approximately Gaussian (typical spectrum analyzer filter). The center frequency of the filter shall be stepped in contiguous steps according to table 5.5.2.1.2. The step duration shall be sufficient slow to capture the active TS. The measured power shall be recorded for each step.
- 2) Measure the RRC filtered mean power centered on the assigned channel frequency according to annex B.
- 3) Display the results of 1) in dBc with respect to 2).

5.5.2.1.5 Test requirements

The result 5.5.2.1.4.2 step 3) shall fulfil the requirements of table 5.5.2.1.5.

Table 5.5.2.1.5: Spectrum Emission Mask Requirement

Δf in MHz(note 1)	Minimum requirement	Measurement bandwidth
2.5 - 3.5	$\left\{ -33.5 - 15 \cdot \left(\frac{\Delta f}{\text{MHz}} - 2.5 \right) \right\} \text{dBc}$	30 kHz (note 2)
3.5 - 7.5	$\left\{ -33.5 - 1 \cdot \left(\frac{\Delta f}{\text{MHz}} - 3.5 \right) \right\} \text{dBc}$	1 MHz (note 3)
7.5 - 8.5	$\left\{ -37.5 - 10 \cdot \left(\frac{\Delta f}{\text{MHz}} - 7.5 \right) \right\} \text{dBc}$	1 MHz (note 3)
8.5 - 12.5	-47.5 dBc	1 MHz (note 3)
Note 1: Δf is the separation between the carrier frequency and the centre of the measuring filter. Note 2: The first and last measurement position with a 30 kHz filter is at Δf equals to 2.515 MHz and 3.485 MHz. Note 3: The first and last measurement position with a 1 MHz filter is at Δf equals to 4 MHz and 12 MHz. As a general rule, the resolution bandwidth of the measuring equipment should be equal to the measurement bandwidth. To improve measurement accuracy, sensitivity and efficiency, the resolution bandwidth can be different from the measurement bandwidth. When the resolution bandwidth is smaller than the measurement bandwidth, the result should be integrated over the measurement bandwidth in order to obtain the equivalent noise bandwidth of the measurement bandwidth.		
The lower limit shall be -48.5dBm/3.84 MHz or the minimum requirement presented in this table which ever is the higher.		

NOTE: If the above Test Requirement differs from the Minimum Requirement then the Test Tolerance applied for this test is non-zero. The Test Tolerance for this test is defined in annex F clause F.2 and the explanation of how the Minimum Requirement has been relaxed by the Test Tolerance is given in annex F clause F.4.

5.5.2.2 Adjacent Channel Leakage power Ratio (ACLR)

5.5.2.2.1 Definition and applicability

Adjacent Channel Leakage power Ratio (ACLR) is the ratio of the RRC filtered mean power centered on the assigned channel frequency to the RRC filtered mean power centered on an adjacent channel frequency.

The requirements in this clause shall apply to all types of UTRA-UE.

5.5.2.2.2 Minimum Requirements

If the adjacent channel RRC filtered mean power is greater than -50dBm then the ACLR shall be higher than the value specified in table 5.5.2.2.2.

The normative reference for this requirement is TS 25.102 [1] clause 6.6.2.2.1

Table 5.5.2.2.2: UE ACLR

Power Class	Adjacent channel	ACLR limit
2, 3	UE-channel $\pm 5\text{ MHz}$	33 dB
2, 3	UE-Channel $\pm 10\text{ MHz}$	43 dB

5.5.2.2.3 Test purpose

The test purpose is to verify the ability of the UE to limit the interference produced by the transmitted signal to other UTRA receivers operating at the first or second adjacent RF channel.

5.5.2.2.4 Method of test

5.5.2.2.4.1 Initial conditions

Test environment: normal, TL/VL, TL/VH, TH/VL, TH/VH; see clauses G.2.1 and G.2.2.

Frequencies to be tested: low range, mid range, high range; see clause G.2.4.

- 1) Connect the SS to the UE antenna connector as shown in figure A.1.
- 2) A call is set up according to the generic call setup procedure using parameters as specified in table E.3.1.2.
- 3) Enter the UE into loopback test mode and start the loopback test.

5.5.2.2.4.2 Procedure

- 1) Measure the RRC filtered mean power centered on the assigned channel frequency.
- 2) Average over TBD time slots.
- 3) Measure the RRC filtered mean power centered on the first lower adjacent channel frequency.
- 4) Average over TBD time slots.
- 5) Calculate the ACLR by
Power acc. to 2) / Power acc. to 4).

- 6) Repeat steps 3), 4) and 5) for the second lower adjacent RF channel (center frequency 10 MHz below the assigned channel frequency of the transmitted signal) and also for the first and second upper adjacent RF channel (center frequency 5 MHz and 10 MHz, respectively).
- 7) Run step 1) to 6) for RF channels Low/Mid/High.

5.5.2.2.5 Test requirements

The ACLR calculated in steps 5) and 6) of clause 5.5.2.2.4.2 shall be equal or greater than the limits given in table 5.5.2.2.5.

Table 5.5.2.2.5: UE ACLR

Power Class	Adjacent channel	ACLR limit
2, 3	UE-channel ± 5 MHz	32.2 dB
2, 3	UE-Channel ± 10 MHz	42.2 dB

NOTE: If the above Test Requirement differs from the Minimum Requirement then the Test Tolerance applied for this test is non-zero. The Test Tolerance for this test is defined in annex F clause F.2 and the explanation of how the Minimum Requirement has been relaxed by the Test Tolerance is given in annex F.

5.5.3 Spurious emissions

5.5.3.1 Definition and applicability

Spurious emissions are emissions which are caused by unwanted transmitter effects such as harmonics emission, parasitic emission, intermodulation products and frequency conversion products, but exclude out of band emissions.

The frequency boundary and the detailed transitions of the limits between the requirement for out band emissions and spectrum emissions are based on ITU-R Recommendations SM.329 [8].

5.5.3.2 Minimum Requirements

These requirements are only applicable for frequencies which are greater than 12.5 MHz away from the UE center carrier frequency.

The normative reference for this requirement is TS 25.102 [1] clause 6.6.3.1.

Table 5.5.3.2a: General Spurious emissions requirements

Frequency Bandwidth	Resolution Bandwidth	Minimum requirement
$9 \text{ kHz} \leq f < 150 \text{ kHz}$	1 kHz	-36 dBm
$150 \text{ kHz} \leq f < 30 \text{ MHz}$	10 kHz	-36 dBm
$30 \text{ MHz} \leq f < 1000 \text{ MHz}$	100 kHz	-36 dBm
$1 \text{ GHz} \leq f < 12,75 \text{ GHz}$	1 MHz	-30 dBm

Table 5.5.3.2b: Additional Spurious emissions requirements

Frequency Bandwidth	Resolution Bandwidth	Minimum requirement
$925 \text{ MHz} \leq f \leq 935 \text{ MHz}$	100 kHz	-67 dBm*
$935 \text{ MHz} < f \leq 960 \text{ MHz}$	100 kHz	-79 dBm*
$1805 \text{ MHz} \leq f \leq 1880 \text{ MHz}$	100 kHz	-71 dBm*

NOTE: The measurements are made on frequencies which are integer multiples of 200 kHz. As exceptions, up to five measurements with a level up to the applicable requirements defined in table 5.5.3.2a are permitted for each UARFCN used in the measurement.

5.5.3.3 Test purpose

The test purpose is to verify the ability of the UE to limit the interference caused by unwanted transmitter effects to other systems operating at frequencies which are more than 12,5 MHz away from of the UE's carrier frequency.

5.5.3.4 Method of test

5.5.3.4.1 Initial conditions

Test environment: normal; see clauses G.2.1 and G.2.2.

Frequencies to be tested: low range, mid range, high range; see clause G.2.4.

- 1) Connect the SS to the UE antenna connector as shown in figure A.1.
- 2) A call is set up according to the generic call setup procedure using parameters as specified in table E.3.1.2.
- 3) Enter the UE into loopback test mode and start the loopback test.

5.5.3.4.2 Procedure

Measure the power of the spurious emissions applying measurement filters with bandwidths as specified in the relevant tables of 5.5.3.2. The characteristic of the filters shall be approximately Gaussian (typical spectrum analyzer filters). The center frequency of the filter shall be swept over the frequency bands as given in the tables. The sweep time shall be sufficiently low to capture the active time slots.

5.5.3.5 Test requirements

The spurious emissions measured according to clause 5.5.3.4.2 shall not exceed the limits specified in the relevant tables of 5.5.3.5.a and 5.5.3.5.b.

Table 5.5.3.5a: General Spurious emissions requirements

Frequency Bandwidth	Resolution Bandwidth	Test requirement
$9 \text{ kHz} \leq f < 150 \text{ kHz}$	1 kHz	-36 dBm
$150 \text{ kHz} \leq f < 30 \text{ MHz}$	10 kHz	-36 dBm
$30 \text{ MHz} \leq f < 1000 \text{ MHz}$	100 kHz	-36 dBm
$1 \text{ GHz} \leq f < 12.75 \text{ GHz}$	1 MHz	-30 dBm

Table 5.5.3.5b: Additional Spurious emissions requirements

Frequency Bandwidth	Resolution Bandwidth	Test requirement
$925 \text{ MHz} \leq f \leq 935 \text{ MHz}$	100 kHz	-67 dBm*
$935 \text{ MHz} < f \leq 960 \text{ MHz}$	100 kHz	-79 dBm*
$1805 \text{ MHz} \leq f \leq 1880 \text{ MHz}$	100 kHz	-71 dBm*

NOTE 1: The measurements are made on frequencies which are integer multiples of 200 kHz. As exceptions, up to five measurements with a level up to the applicable requirements defined in table 5.5.3.5a are permitted for each UARFCN used in the measurement.

NOTE 2: If the above Test Requirement differs from the Minimum Requirement then the Test Tolerance applied for this test is non-zero. The Test Tolerance for this test is defined in annex F clause F.2 and the explanation of how the Minimum Requirement has been relaxed by the Test Tolerance is given in annex F clause F.4.

5.6 Transmit Intermodulation

5.6.1 Definition and applicability

The transmit intermodulation performance is a measure of the capability of the transmitter to inhibit the generation of signals in its non linear elements caused by the presence of the wanted signal and an interfering signal reaching the transmitter via the antenna.

User Equipment(s) transmitting in close vicinity of each other can produce intermodulation products, which can fall into the UE, or BS receive band as an unwanted interfering signal. The UE intermodulation attenuation is defined by the ratio of the RRC filtered mean power of the wanted signal to the RRC filtered mean power of the intermodulation product when an interfering CW signal is added at a level below the wanted signal.

The requirements of this test shall apply for all UTRA-UE.

5.6.2 Minimum Requirements

The requirement of transmitting intermodulation for carrier spacing 5 MHz is prescribed in the table below.

The normative reference for this requirement is TS 25.102 [1] clause 6.7.1

Table 5.6.2: Transmit Intermodulation

Interference Signal Frequency Offset	5MHz	10MHz
Interference Signal Level	-40 dBc	
Interferer Modulation	CW	
	Note: BS Test uses a CDMA modulated signal	
Minimum requirement	-31dBc	-41dBc

5.6.3 Test purpose

User Equipment(s) transmitting in close vicinity of each other can produce intermodulation products, which can fall into other UE, or BS receive band as an unwanted interfering signal.

It is the purpose of this test to limit interferences to the own and other systems due to intermodulation products.

5.6.4 Method of test

5.6.4.1 Initial conditions

Test environment: normal; see clauses G.2.1 and G.2.2.

Frequencies to be tested: mid range; see clause G.2.4.

- 1) Connect the SS and the interferer to the UE antenna connector as shown in figure A.2.
- 2) A call is set up according to the generic call setup procedure using parameters as specified in table E.3.1.2.
- 3) Enter the UE into loopback test mode and start the loopback test.

Parameters of the interferer according to table 5.6.2.

5.6.4.2 Procedure

- 1) Measure the unwanted emissions according to 5.6.2. in a carrier offset spacing of 5 MHz and in a frequency range [5 MHz to 12.75 GHz], using an interferer +5MHz offset.

The frequency occupied by the interferer is excluded from the measurement.

- 2) Repeat 1) with the other 3 interferer-configurations (-5MHz, +10 MHz, -10 MHz).
- 3) Measure the wanted power according to annex B.
- 4) Display 1) and 2) in dBc with respect to 3).

5.6.5 Test requirements

The results in 4) from clause 5.6.4.2 shall not exceed the prescribed values in table 5.6.5.

Table 5.6.5: Transmit Intermodulation

Interference Signal Frequency Offset	5MHz	10MHz
Interference Signal Level	-40 dBc	
Interferer Modulation	CW Note: BS Test uses a CDMA modulated signal	
Minimum requirement	[-31+TT] dBc	[-41+TT] dBc

NOTE: If the above Test Requirement differs from the Minimum Requirement then the Test Tolerance applied for this test is non-zero. The Test Tolerance for this test is defined in annex F clause F.2 and the explanation of how the Minimum Requirement has been relaxed by the Test Tolerance is given in annex F clause F.4.

5.7 Transmit Modulation

5.7.1 Error Vector Magnitude

5.7.1.1 Definition and applicability

The Error Vector Magnitude (EVM) is a measure of the difference between the measured waveform and the theoretical modulated waveform (the error vector). It is the square root of the ratio of the mean error vector power to the mean reference signal power expressed as a %. The measurement interval is one timeslot.

The requirement of this clause shall apply to all types of UTRA-UE.

5.7.1.2 Minimum Requirements

The Error Vector Magnitude shall not exceed 17,5 % for the parameters specified in table 5.7.1.2.

Table 5.7.1.2: Test parameters for Error Vector Magnitude/Peak Code Domain Error

Parameter	Level	Unit
UE Output Power	≥ -20	dBm
Operating conditions	Normal conditions	
Power control step size	1	dB

The normative reference for this requirement is TS 25.102 [1] clause 6.8.2.

5.7.1.3 Test purpose

The transmitter shall generate a sufficient precise waveform, to enable the receiver to achieve the specified receiver performances.

5.7.1.4 Method of test

5.7.1.4.1 Initial conditions

Test environment: normal, TL/VL, TL/VH, TH/VL, TH/VH, vibration; see clauses G.2.1, G.2.2 and G.2.3.

Frequencies to be tested: low range, mid range, high range; see clause G.2.4.

- 1) Connect the SS to the UE antenna connector as shown in figure A.1.
- 2) A call is set up according to the generic call setup procedure using parameters as specified in table E.3.1.2.
- 3) Enter the UE into loopback test mode and start the loopback test.

5.7.1.4.2 Procedure

- 1) Starting from the initial conditions, measure EVM (Error Vector Magnitude) of the UE according to annex B.
- 2) Set SS-level and signalling values such that the power level of the UE is between -20 and -19 dBm.
- 3) Measure EVM of the UE according to annex B.

5.7.1.5 Test requirements

The results in step 1) and 2) shall not exceed 17,5 % for parameters specified in table 5.7.1.2.

NOTE: If the above Test Requirement differs from the Minimum Requirement then the Test Tolerance applied for this test is non-zero. The Test Tolerance for this test is defined in annex F clause F.2 and the explanation of how the Minimum Requirement has been relaxed by the Test Tolerance is given in annex F clause F.4.

5.7.2 Peak code domain error

5.7.2.1 Definition and applicability

The code domain error is computed by projecting the error vector power onto the code domain at a specific spreading factor. The error power for each code is defined as the ratio to the mean power of the projection onto the code, to the mean power of the composite reference waveform expressed in dB. And the Peak Code Domain Error is defined as the maximum value for Code Domain Error. The measurement interval is one timeslot.

The present document is applicable for multi-code transmission only.

The requirement of this test applies to all UTRA-UE, applicable for multi-code transmission.

5.7.2.2 Minimum Requirement

The peak code domain error shall not exceed -21 dB at spreading factor 16.

The normative reference for this requirement is TS 25.102 [1] clause 6.8.3.1.

5.7.2.3 Test purpose

It is the purpose of this test to limit crosstalk among codes.

5.7.2.4 Method of test

5.7.2.4.1 Initial conditions

Test environment: normal, TL/VL, TL/VH, TH/VL, TH/VH; see clauses G.2.1 and G.2.2.

Frequencies to be tested: low range, mid range, high range; see clause G.2.4.

- 1) Connect the SS to the UE antenna connector as shown in figure A.1.
- 2) A call is set up according to the generic call setup procedure using parameters as specified in table 5.7.2.4.1.
- 3) Enter the UE into loopback test mode and start the loopback test.

Table 5.7.2.4.1: Test parameters for Peak code Domain Error

Parameter	Value/description
Reference measurement channel	Multicode 12,2kbps, according to annex C.2.2
Uplink Power Control	SS level and signalling values such that UE transmits maximum power
Data content	real life (sufficient irregular)

5.7.2.4.2 Procedure

- 1) Starting from the initial conditions, measure peak code error(PCDE)of the UE according to annex B.
- 2) Set SS-level and signalling values such that the power level of the UE is between -20 and -19 dBm
- 3) Measure PCDE of the UE according to annex B.

5.7.2.5 Test requirements

The results in step 1) and 2) shall not exceed -20 dB. for parameters specified in table 5.7.1.2.

NOTE: If the above Test Requirement differs from the Minimum Requirement then the Test Tolerance applied for this test is non-zero. The Test Tolerance for this test is defined in annex F clause F.2 and the explanation of how the Minimum Requirement has been relaxed by the Test Tolerance is given in annex F clause F.4.

6 Receiver Characteristics

6.1 General

Receiving performance test of the UE is implemented during communicating with the SS via air interface. The procedure uses normal call protocol until the UE is communicating on traffic channel basically. (Refer to TS 34.108 [3] Common Test Environments for User Equipment (UE) Conformance Testing.) On the traffic channel, the UE provides special function for testing that is described in Logical Test Interface and the UE is tested using this function. (Refer to TS 34.109 [3] Logical Test Interface (FDD/TDD) Special conformance testing functions.)

Unless otherwise stated the receiver characteristics are specified at the antenna connector of the UE. For UE(s) with an integral antenna only, a reference antenna with a gain of 0 dBi is assumed. UE with an integral antenna may be taken into account by converting these power levels into field strength requirements, assuming a 0 dBi gain antenna. Receiver characteristics for UE(s) with multiple antennas/antenna connectors are for further study.

The UE antenna performance has a significant impact on system performance, and minimum requirements on the antenna efficiency are therefore intended to be included in future versions of the present document. It is recognized that different requirements and test methods are likely to be required for the different types of UE.

All the parameters in clause 6 are defined using the DL reference measurement channel (12.2 kbps) specified in clause C.3.3.

All Bit Error ratio (BER) measurements in clause 6 shall be performed according to the general rules for statistical testing in Annex F.6.

6.2 Reference sensitivity level

6.2.1 Definition and applicability

The reference sensitivity level is the minimum mean power received at the UE antenna connector at which the BER shall not exceed the specific value.

The requirements in this clause shall apply to all types of UTRA UE.

6.2.2 Minimum Requirements

For the DL reference measurement channel 12.2 kBit/s specified in annex C, the BER shall not exceed 0.001 for the parameters specified in table 6.2.2.

Table 6.2.2. Test parameters for reference sensitivity

Parameter	Level	Unit
$\frac{\Sigma DPCH_{Ec}}{I_{or}}$	0	dB
\hat{I}_{or}	-105	dBm/3,84 MHz

The normative reference for this requirement is TS 25.102 [1] clause 7.3.

6.2.3 Test purpose

The test purpose is to verify the ability of the UE to receive a prescribed test signal at the lower end of the dynamic range under defined conditions (no interference, no multipath propagation) with a BER not exceeding a specified level. This test is also used as a reference case for other tests to allow the assessment of degradations due to various sources of interference.

6.2.4 Method of test

6.2.4.1 Initial conditions

Test environment: normal, TL/VL, TL/VH, TH/VL, TH/VH; see clauses G.2.1 and G.2.2.

Frequencies to be tested: low range, mid range, high range; see clause G.2.4.

- 1) Connect the SS to the UE antenna connector as shown in figure A.3.
- 2) A call is set up according to the Generic call setup procedure.
- 3) Enter the UE into loopback test mode and start the loopback test.
- 4) The level of SS output signal measured at the UE antenna connector shall be -105 dBm.

6.2.4.2 Procedure

- 1) Measure the BER of DCH received from the UE at the SS.

6.2.5 Test requirements

The measured BER, derived in step 1), shall not exceed 0,001 under conditions described in table 6.2.5.

Table 6.2.5: Test parameters for reference sensitivity

Parameter	Level	Unit
$\frac{\Sigma DPCH_Ec}{I_{or}}$	0	dB
\hat{I}_{or}	-104.3	dBm/3,84 MHz

NOTE: If the above Test Requirement differs from the Minimum Requirement then the Test Tolerance applied for this test is non-zero. The Test Tolerance for this test is defined in annex F clause F.2 and the explanation of how the Minimum Requirement has been relaxed by the Test Tolerance is given in annex F clause F.4.

6.3 Maximum Input Level

6.3.1 Definition and applicability

The maximum input level is defined as the maximum mean power received at the UE antenna connector, which does not degrade the specified BER performance.

The requirements in this clause shall apply to all types of UTRA UE.

6.3.2 Minimum requirements

The BER shall not exceed 0,001 for the parameters specified in table 6.3.2.

Table 6.3.2: Maximum input level

Parameter	Level	Unit
$\frac{\Sigma DPCH_Ec}{I_{or}}$	-7	dB
\hat{I}_{or}	-25	dBm/3,84 MHz

The reference for this requirement is TS 25.102 [1] clause 7.4.

6.3.3 Test purpose

The test purpose is to verify the ability of the UE to receive a prescribed test signal at the upper end of the dynamic range under defined conditions (no interference, no multipath propagation) with BER not exceeding a specified value.

6.3.4 Method of test

6.3.4.1 Initial conditions

Test environment: normal; see clauses G.2.1 and G.2.2.

Frequencies to be tested: mid range; see clause G.2.4.

- 1) Connect the SS to the UE antenna connector as shown in figure A.3.
- 2) A call is set up according to the Generic call setup procedure.
- 3) Enter the UE into loopback test mode and start the loopback test.
- 4) The level of SS output signal measured at the UE antenna connector shall be according to table 6.3.2.

6.3.4.2 Procedure

Measure the BER of DCH received from the UE at the SS.

6.3.5 Test requirements

The measured BER, derived in step 1), shall not exceed 0,001.

6.4 Adjacent Channel Selectivity (ACS)

6.4.1 Definition and applicability

Adjacent Channel Selectivity is a measure of a receiver's ability to receive a wanted signal at its assigned channel frequency in the presence of an adjacent channel signal at a given frequency offset from the centre frequency of the assigned channel. ACS is the ratio of the receive filter attenuation on the assigned channel frequency to the receiver filter attenuation on the adjacent channel(s).

The requirements of this test apply to all UTRA UE.

6.4.2 Minimum Requirements

For the UE of power class 2 and 3, the BER shall not exceed 0,001 for parameters specified in table 6.4.2. This test condition is equivalent to the ACS value 33 dB.

Table 6.4.2: Test parameters for Adjacent Channel Selectivity

Parameter	Unit	Level
$\frac{\Sigma DPCH_Ec}{I_{or}}$	dB	0
I_{or}	dBm/3,84 MHz	-91
I_{oac} mean power (modulated)	dBm	-52
F_{UW} offset	MHz	+5 or -5

Explanatory note:

Within the reference sensitivity BER= 0.001 corresponds to a test signal = -105 dBm/3,84 MHz and a noise level -99 dBm /3,84 MHz BW (S/I -6 dB).

Within ACS BER=0.001 is directly verified.

Known from the reference sensitivity, this corresponds to S/I -6dB in the wanted BW.

As a wanted signal of -91 dBm applied, an in-channel-interfering-signal of -85 dBm can be assumed.

Verifying a filter suppression of 33 dB indirectly, an adjacent-channel-interferer of -52 dBm is needed

The normative reference of this requirement is TS 25.102 [1] clause 7.5.

6.4.3 Test purpose

The test purpose is to verify the ability of the UE-receiver to sufficiently suppress the interfering signal in the channel adjacent to the wanted channel.

6.4.4 Method of test

6.4.4.1 Initial conditions

Test environment: normal; see clauses G.2.1 and G.2.2.

Frequencies to be tested: mid range; see clause G.2.4.

- 1) Connect the SS and the interferer to the UE antenna connector as shown in figure A.4.
- 2) A call is set up according to the Generic call setup procedure.
- 3) Enter the UE into loopback test mode and start the loopback test.
- 4) Set the signal generators to produce wanted and interference signals according table 6.4.2. The interference signal shall be equivalent to a continuously running wideband CDMA signal with one code and chip frequency 3,84 Mchip/s and rolloff 0,22.

6.4.4.2 Procedure

- 1) Set the interference signal 5 MHz above the assigned channel frequency of the wanted signal.
- 2) Measure the BER of the wanted signal received from the UE at the SS.
- 3) Set the interference signal 5 MHz below the assigned channel frequency of the wanted signal and repeat 2).

6.4.5 Test Requirements

The measured BER, derived in step 2), shall not exceed 0,001 under conditions described in table 6.4.5.

Table 6.4.5: Test parameters for Adjacent Channel Selectivity

Parameter	Unit	Level
$\frac{\Sigma DPCH_{-} Ec}{I_{or}}$	dB	0
I_{or}	dBm/3,84 MHz	-91
I_{oac} mean power (modulated)	dBm	-52
F_{uw} offset	MHz	+5 or -5

NOTE: If the above Test Requirement differs from the Minimum Requirement then the Test Tolerance applied for this test is non-zero. The Test Tolerance for this test is defined in annex F clause F.2 and the explanation of how the Minimum Requirement has been relaxed by the Test Tolerance is given in annex F clause F.4.

6.5 Blocking Characteristics

6.5.1 Definition and applicability

The blocking characteristics is a measure of the receiver ability to receive a wanted signal at its assigned channel frequency in the presence of an unwanted interferer on frequencies other than those of the spurious response or the adjacent channels without this unwanted input signal causing a degradation of the performance of the receiver beyond a specified limit. The blocking performance shall apply at all frequencies except those at which a spurious response occur.

The requirements of this test apply to all UTRA UE.

6.5.2 Minimum Requirements

The BER shall not exceed 0,001 for the parameters specified in table 6.5.2a and table 6.5.2b. For table 6.5.2b up to 24 exceptions are allowed for spurious response frequencies in each assigned frequency channel when measured using a 1MHz step size for the interference signal.

The normative reference for this requirement is TS 25.102 clause 7.6.1.

Table 6.5.2a: In-band blocking

Parameter	Level		Unit
$\frac{\Sigma DPCH_Ec}{I_{or}}$			dB
\hat{I}_{or}	-102		dBm/3,84 MHz
I_{ouw} mean power (modulated)	-56 (for F_{uw} offset ± 10 MHz)	-44 (for F_{uw} offset ± 15 MHz)	dBm

Table 6.5.2b: Out of band blocking

Parameter	Band 1	Band 2	Band 3	Unit
$\frac{\Sigma DPCH_Ec}{I_{or}}$	0	0	0	dB
\hat{I}_{or}	-102	-102	-102	dBm/3,84 MHz
I_{ouw}	-44	-30	-15	dBm
F_{uw} For operation in frequency bands as defined in clause 4.2(a)	1840 < f < 1885 1935 < f < 1995 2040 < f < 2085	1815 < f < 1840 2085 < f < 2110	1 < f < 1815 2110 < f < 12750	MHz
F_{uw} For operation in frequency bands as defined in clause 4.2(b)	1790 < f < 1835 2005 < f < 2050	1765 < f < 1790 2050 < f < 2075	1 < f < 1765 2075 < f < 12750	MHz
F_{uw} For operation in frequency bands as defined in clause 4.2(c)	1850 < f < 1895 1945 < f < 1990	1825 < f < 1850 1990 < f < 2015	1 < f < 1825 2015 < f < 12750	MHz

NOTE 1: For operation referenced in 4.2(a), from 1885 < f < 1900 MHz, 1920 < f < 1935 MHz, 1995 < f < 2010 MHz and 2025 < f < 2040 MHz, the appropriate in-band blocking or adjacent channel selectivity in clause 6.5.2 shall be applied.

NOTE 2: For operation referenced in 4.2(b), from 1835 < f < 1850 MHz and 1990 < f < 2005 MHz, the appropriate in-band blocking or adjacent channel selectivity in clause 6.5.2 shall be applied.

NOTE 3: For operation referenced in 4.2(c), from 1895 < f < 1910 MHz and 1930 < f < 1945 MHz, the appropriate in-band blocking or adjacent channel selectivity in clause 6.5.2 shall be applied.

6.5.3 Test purpose

"The test stresses the ability of the UE receiver to withstand high-level interference from unwanted signals at frequency offsets of 10 MHz or more, without undue degradation of its sensitivity."

6.5.4 Method of test

6.5.4.1 Initial conditions

For in-band case:

Test environment: normal; see clauses G.2.1 and G.2.2.

Frequencies to be tested: mid range; see clause G.2.4.

For out-of-band case:

Test environment: normal; see clauses G.2.1 and G.2.2.

Frequency to be tested: 1 arbitrary frequency chosen from the low, mid or high range; see clause G.2.4.

- 1) Connect the SS and the interfering Signal generator to the UE antenna connector as shown in figure A.5.
- 2) A call is set up according to the Generic call setup procedure.
- 3) Enter the UE into loopback test mode and start the loopback test.

6.5.4.2 Procedure

- 1) The wanted signal frequency channel is set to mid range frequency. The wanted signal power level shall be set according to table 6.5.5a.
- 2) The interfering Signal Generator is stepped through the frequency range indicated in table 6.5.2.a. with a step size of 1 MHz. The interfering signal level shall be set according to table 6.5.5a.
- 3) The interference signal shall be equivalent to a continuously running wideband CDMA signal with one code and chip frequency 3,84 Mchip/s and rolloff 0,22.
- 4) Measure the BER of the wanted signal received from the UE at the SS for each step of the interferer.
- 5) The wanted signal frequency channel is set to an arbitrary frequency chosen from the low, mid or high range. The level of the wanted signal shall be set according to table 6.5.5b.
- 6) The interfering Signal Generator is stepped through the frequency range indicated in table 6.5.2.b with a step size of 1 MHz. The interfering signal level shall be set according to table 6.5.5b.
- 7) The interference signal is a CW signal.
- 8) Measure the BER of the wanted signal received from the UE at the SS for each step of the interferer.
- 9) Record the frequencies for which BER exceed the test requirements in table 6.5.5b. These frequencies are further proceeding in subclause 6.6 Spurious Response.

NOTE: Due to the large amount of time-consuming BER tests it is recommended to speed up a single BER test by reducing the 0.001-BER confidence level [10 000 bits under test or 10 errors] for screening the critical frequencies. Critical frequencies must be identified using standard BER confidence level. [30 000 bits or 30 errors].

6.5.5 Test requirements

The measured BER, derived in step 4), shall not exceed 0,001 (without exception) under test conditions described in table 6.5.5a.

The measured BER, derived in step 8), shall not exceed 0,001 except for up to 24 different frequencies of the interfering signal under test conditions described in table 6.5.5b.

These frequencies are further processed in clause 6.6 Spurious response.

Table 6.5.5a: Test conditions In-band blocking

Parameter	Level		Unit
$\frac{\Sigma DPCH - Ec}{I_{or}}$	0		dB
I_{or}	-102		dBm/3,84 MHz
I_{ouw} mean power (modulated)	-56 (for $F_{uw\ offset} \pm 10$ MHz)	-44 (for $F_{uw\ offset} \pm 15$ MHz)	dBm

Table 6.5.5b: Test conditions Out of band blocking

Parameter	Band 1	Band 2	Band 3	Unit
$\frac{\Sigma DPCH - Ec}{I_{or}}$	0	0	0	dB
\hat{I}_{or}	-102	-102	-102	dBm/3,84 MHz
I_{ouw}	-44	-30	-15	dBm

NOTE: If the above Test Requirement differs from the Minimum Requirement then the Test Tolerance applied for this test is non-zero. The Test Tolerance for this test is defined in annex F clause F.2 and the explanation of how the Minimum Requirement has been relaxed by the Test Tolerance is given in annex F clause F.4.

6.6 Spurious Response

6.6.1 Definition and applicability

Spurious response is a measure of the receiver's ability to receive a wanted signal on its assigned channel frequency without exceeding a given degradation due to the presence of an unwanted CW interfering signal at any other frequency at which a response is obtained i.e. for which the blocking limit is not met.

The requirements of this test apply to all types of UTRA for the UE.

6.6.2 Minimum Requirements

The BER shall not exceed 0,001 for the parameters specified in table 6.6.2.

The normative reference for this requirement is TS 25.102 [1] clause 7.7.1

Table 6.6.2: Spurious Response

Parameter	Value	Unit
$\frac{\Sigma DPCH - Ec}{I_{or}}$	0	dB
\hat{I}_{or}	-102	dBm/3,84 MHz
I_{ouw}	-44	dBm
F_{uw}	Spurious response frequencies	MHz

6.6.3 Test purpose

Spurious response frequencies, identified in the blocking test, are measured against a less stringent test requirement. The test stresses the ability of the receiver to withstand high level interference signals without undue degradation of its sensitivity due to the receiver's frequency conversion concept.

6.6.4 Method of test

6.6.4.1 Initial conditions

Test environment: normal; see clauses G.2.1 and G.2.2.

Frequency to be tested: the same frequency as chosen in subclause 6.5.4.1 for Blocking characteristics out-of-band case.

- 1) Connect the SS and the unwanted signal to the UE antenna connector as shown in figure A.6.
- 2) A call is set up according to the Generic call setup procedure.
- 3) Enter the UE into loopback test mode and start the loopback test.

6.6.4.2 Procedure

- 1) Set the wanted signal frequency to the frequency used for the out-of-band blocking test. Set the power level of the wanted signal according to table 6.6.2.
- 2) Set the frequency of the interferer signal according the recorded spurious response frequency values obtained from the out-of-band blocking test as described in 6.5.4.2, at which the blocking test failed. Set the power level of the interferer according to table 6.6.5.
- 3) Measure the BER of DCH received from the UE at the SS.

6.6.5 Test requirements

The measured BER, derived in step 3), shall not exceed 0,001 under test conditions described in table 6.6.5.

Table 6.6.5: Test Parameters Spurious Response

Parameter	Value	Unit
$\frac{\Sigma DPCH - Ec}{I_{or}}$	0	dB
\hat{I}_{or}	-102	dBm/3,84 MHz
I_{ouw}	-44	dBm
F_{Uw}	Spurious response frequencies	MHz

NOTE: If the above Test Requirement differs from the Minimum Requirement then the Test Tolerance applied for this test is non-zero. The Test Tolerance for this test is defined in annex F clause F.2 and the explanation of how the Minimum Requirement has been relaxed by the Test Tolerance is given in annex F clause F.4.

6.7 Intermodulation Characteristics

6.7.1 Definition and applicability

Third and higher order mixing of the two interfering RF signals can produce an interfering signal in the band of the desired channel. Intermodulation response rejection is a measure of the capability of the receiver to receive a wanted signal on its assigned channel frequency in the presence of two or more interfering signals which have a specific frequency relationship to the wanted signal.

The requirements of this test shall apply to all UTRA UE.

6.7.2 Minimum Requirements

The BER shall not exceed 0,001 for the parameters specified in table 6.7.2

The normative reference for this requirement is TS 25.102 [1] clause 7.8.1.

Table 6.7.2: Receive intermodulation characteristics

Parameter	Value	Unit
$\frac{\Sigma DPCH - Ec}{I_{or}}$	0	dB

I_{or}	-102	dBm/3,84 MHz
$I_{ouw1}(CW)$	-46	dBm
I_{ouw2} mean power (modulated)	-46	dBm
F_{uw1} (CW)	± 10	MHz
F_{uw2} (Modulated)	± 20	MHz

6.7.3 Test purpose

The test stresses the ability of the receiver to withstand two or more high level interference signals without undue degradation of its sensitivity due to the receiver's non-linear elements.

6.7.4 Method of test

6.7.4.1 Initial conditions

Test environment: normal; see clauses G.2.1 and G.2.2.

Frequencies to be tested: mid range; see clause G.2.4.

- 1) Connect the SS and the unwanted signals to the UE antenna connector as shown in figure A.7.
- 2) A call is set up according to the Generic call setup procedure.
- 3) Enter the UE into loopback test mode and start the loopback test.

6.7.4.2 Procedure

- 1) Set the wanted and interfering signals as indicated in table 6.7.2. with positive offset with respect to the wanted signal.
- 2) Measure the BER of DCH received from the UE at the SS.
- 3) Set the interfering signals as indicated in table 6.7.2. with negative offset with respect to the wanted signal and repeat 2).

6.7.5 Test requirements

The measured BER, derived in step 2) and 3), shall not exceed 0,001 under test conditions described in table 6.7.5.

Table 6.7.5: Test parameters Receive intermodulation characteristics

Parameter	Value	Unit
$\frac{\Sigma DPCH_Ec}{I_{or}}$	0	dB
I_{or} /Wanted Signal Level	-102	dBm/3,84 MHz
$I_{ouw1}(CW)$	-46	dBm
I_{ouw2} mean power (modulated)	-46	dBm
F_{uw1} (CW)	± 10	MHz
F_{uw2} (Modulated)	± 20	MHz

NOTE: If the above Test Requirement differs from the Minimum Requirement then the Test Tolerance applied for this test is non-zero. The Test Tolerance for this test is defined in annex F clause F.2 and the explanation of how the Minimum Requirement has been relaxed by the Test Tolerance is given in annex F clause F.4.

6.8 Spurious Emissions

6.8.1 Definition and applicability

The Spurious Emissions Power is the power of emissions generated or amplified in a receiver that appear at the UE antenna connector.

The requirements of this test are applicable for all UTRA UE.

6.8.2 Minimum Requirements

The power of any spurious emission shall not exceed:

Table 6.8.2: Receiver spurious emission requirements

Band	Maximum level	Measurement Bandwidth	Note
30 MHz – 1 GHz	-57 dBm	100 kHz	
1 GHz – 1,9 GHz and 1,92 GHz – 2,01 GHz and 2,025 GHz – 2,11 GHz	-47 dBm	1 MHz	With the exception of frequencies between 12,5 MHz below the first carrier frequency and 12,5 MHz above the last carrier frequency used by the UE.
1,9 GHz – 1,92 GHz and 2,01 GHz – 2,025 GHz and 2,11 GHz – 2,170 GHz	-60 dBm	3,84 MHz	With the exception of frequencies between 12,5 MHz below the first carrier frequency and 12,5 MHz above the last carrier frequency used by the UE.
2,170 GHz – 12,75 GHz	-47 dBm	1 MHz	

The normative reference for this requirement is TS 25.102 [1] clause 7.9.

6.8.3 Test purpose

The test purpose is to verify the UE's ability to limit interference caused by receiver spurious emissions to the own and the other systems. The test requirements are tighter than in clause 5.5.3 ((TX) Spurious Emissions) because the time of Receive-Only-Operation is generally much longer than RX-TX-Operation.

6.8.4 Method of test

6.8.4.1 Initial conditions

Test environment: normal; see clauses G.2.1 and G.2.2.

Frequencies to be tested: 1 arbitrary frequency selected between low and high range; see clause G.2.4.

- 1) Connect the measurement equipment to the UE antenna connector according to figure A.8.
- 2) RF parameters are setup according to table 6.8.4.1.
- 3) A call is set up according to the setup procedure specified in TS34.108 [3] sub clause 7.3.3, with the following exceptions for information elements in System Information Block type3.

Information Element	Value/Remark
- Cell selection and re-selection info	TDD
- CHOICE mode	0 dB
- Sintrasearch	0 dB
- Sintersearch	This parameter is configurable
- RAT List	0 dB
- Ssearch,RAT	Power level where Pcompensation=0
- Maximum allowed UL TX power	

Note 1: The setup procedure (3) sets the UE into CELL_FACH state. With this state and the SS level (2) it is ensured that UE continuously monitors the S-CCPCH and no cell reselections are performed [see 25.304, subcl. 5.2.3 and 5.2.6]. No transmission of the UE will interfere with the measurement.

Table 6.8.4.1: RF parameters for receiver spurious test

Parameter	Unit	Level
PCCPCH E_c/I_{or}	dB	-3
SCH E_c/I_{or}	dB	-9
\hat{I}_{or}/I_{oc}	dB	9
PCCPCH RSCP	dBm	-64

6.8.4.2 Procedure

Measure the power of spurious emissions by covering the frequency ranges of table 6.8.2. Cover the UTRA/TDD and UTRA/FDD UE receive band in contiguous steps of 200 kHz. Cover the other frequency ranges in contiguous steps of 100 kHz. Apply the corresponding filters of table 6.8.2. The step duration shall be sufficient slow to capture intermittent spurious emissions.

6.8.5 Test requirements

The spurious emissions shall be according to table 6.8.5.

Table 6.8.5: Receiver spurious emission test requirements

Band	Maximum level	Measurement Bandwidth	Note
30 MHz – 1 GHz	-57 dBm	100 kHz	
1 GHz – 1,9 GHz and 1,92 GHz – 2,01 GHz and 2,025 GHz – 2,11 GHz	-47 dBm	1 MHz	With the exception of frequencies between 12,5 MHz below the first carrier frequency and 12,5 MHz above the last carrier frequency used by the UE.
1,9 GHz – 1,92 GHz and 2,01 GHz – 2,025 GHz and 2,11 GHz – 2,170 GHz	-60 dBm	3,84 MHz	With the exception of frequencies between 12,5 MHz below the first carrier frequency and 12,5 MHz above the last carrier frequency used by the UE.
2,170 GHz – 12,75 GHz	-47 dBm	1MHz	

NOTE: If the above Test Requirement differs from the Minimum Requirement then the Test Tolerance applied for this test is non-zero. The Test Tolerance for this test is defined in Annex F.2 and the explanation of how the Minimum Requirement has been relaxed by the Test Tolerance is given in Annex F.4.

7 Performance Requirements

7.1 General

The performance requirements for the UE in this clause is specified for the measurement channels specified in annex C and the test environments specified in annex D.

All Block Error ratio (BLER) measurements in clause 7 shall be performed according to the general rules for statistical testing in Annex F.6.

7.1.2 Definition of Additive White Gaussian Noise (AWGN) Interferer

The minimum bandwidth of the AWGN interferer shall be 1.5 times chip rate of the radio access mode. (e.g. 5.76 MHz for a chip rate of 3.84 Mcps). The flatness across this minimum bandwidth shall be less than ± 0.5 dB and the peak to average ratio at a probability of 0.001% shall exceed 10 dB.

7.2 Demodulation in static propagation conditions

7.2.1 Demodulation of DCH

7.2.1.1 Definition and applicability

The performance requirement of DCH in static propagation conditions is determined by the maximum Block Error Ratio (BLER). The BLER is specified for each individual data rate of the DCH. DCH is mapped into the Dedicated Physical Channel (DPCH).

The UE shall be tested only according to the datarates, supported. The data-rate-corresponding requirements shall apply to the UE.

7.2.1.2 Minimum requirements

For the parameters specified in table 7.2.1.2a the BLER shall not exceed the piece-wise linear BLER curve specified in table 7.2.1.2b. These requirements are applicable for TFCS size 16.

The reference for this requirement is TS 25.102 [1] clause 8.2.1.1.

Table 7.2.1.2a: DCH parameters in static propagation conditions

Parameters	Unit	Test 1	Test 2	Test 3	Test 4
$\frac{\Sigma DPCH - E_c}{I_{or}}$	dB	-6	-3	0	0
I_{oc}	dBm/3,84 MHz	-60			
Information Data Rate	kbps	12.2	64	144	384

Table 7.2.1.2.b: Performance requirements in AWGN channel

Test Number	$\frac{\hat{I}_{or}}{I_{oc}}$ [dB]	BLER
1	0,1	10^{-2}
2	2,3	10^{-1}
	2,6	10^{-2}
3	2,2	10^{-1}
	2,4	10^{-2}
4	1,6	10^{-1}
	1,8	10^{-2}

7.2.1.3 Test purpose

While the receiver tests in clause 6 aims for the RF hardware, this performance requirement aims for the receiver's signal processing.

The test purpose is to verify the ability of the receiver to receive a predefined test signal ,representing a static propagation channel for the wanted and for the co-channel signals from serving and adjacent cells, with a block error ratio (BLER) not exceeding a specified value.

7.2.1.4 Method of test

7.2.1.4.1 Initial conditions

Test environment: normal; see clauses G.2.1 and G.2.2.

Frequencies to be tested: mid range; see clause G.2.4.

- 1) Connect the SS, AWGN Generator and additional components to the UE antenna connector as shown in figure A.9.
- 2) A call is set up according to the Generic call setup procedure. The characteristic of the call shall be according to the DL reference measurement channels (12,2 kbit/s) (64 kbit/s), (144 kbit/s), and (384 kbit/s) specified in annex C.
- 3) Enter the UE into loopback test mode and start the loopback test. (test 1) and/or activate the Ack/Nack test mode (test 1 to test 4).
- 4) The levels of the wanted signal and the co-channel signals are set according to table 7.2.1.2a and b.

7.2.1.4.2 Procedure

Measure the BLER of DCH received from the UE at the SS for all 4 tests.

7.2.1.5 Test requirements

The measured BLER shall not exceed the values indicated in table 7.2.1.2b.

7.3 Demodulation of DCH in multipath fading conditions

7.3.1 Multipath fading Case 1

7.3.1.1 Definition and applicability

The performance requirement of DCH is determined by the maximum Block Error Ratio (BLER). The BLER is specified for each individual data ratio of the DCH. DCH is mapped into the Dedicated Physical Channel (DPCH).

The UE shall be tested only according to the data ratios, supported. The data-ratio-corresponding requirements shall apply to the UE.

7.3.1.2 Minimum requirements

For the parameters specified in table 7.3.1.2a the BLER shall not exceed the piece-wise linear BLER curve specified in table 7.3.1.2b. These requirements are applicable for TFCS size 16.

The reference for this requirement is TS 25.102 [1] clause 8.3.1.1.

Table 7.3.1.2a: DCH parameters in multipath Case 1 channel

Parameters	Unit	Test 1	Test 2	Test 3	Test 4
$\frac{\Sigma DPCH - E_c}{I_{or}}$	dB	-6	-3	0	0
I_{oc}	dBm/3,84 MHz	-60			
Information Data Ratio	kbps	12,2	64	144	384

Table 7.3.1.2b: Performance requirements in multipath Case 1 channel

Test Number	$\frac{\hat{I}_{or}}{I_{oc}}$ [dB]	BLER
1	13,5	10^{-2}
2	13,3	10^{-1}
	19,6	10^{-2}
3	13,3	10^{-1}
	19,7	10^{-2}
4	13,5	10^{-1}
	20,2	10^{-2}

7.3.1.3 Test purpose

While the receiver tests in clause 6 aims for the RF hardware, this performance requirement aims for the receiver's signal processing.

The test purpose is to verify the ability of the receiver to receive a predefined test signal, representing a multipath propagation channel for the wanted and for the co-channel signals from serving and adjacent cells, with a block error ratio (BLER) not exceeding a specified value.

7.3.1.4 Method of test

7.3.1.4.1 Initial conditions

Test environment: normal; see clauses G.2.1 and G.2.2.

Frequencies to be tested: mid range; see clause G.2.4.

- 1) Connect the SS, the fading simulator, the AWGN generator and additional components to the UE antenna connector as shown in figure A.10.
- 2) A call is set up according to the Generic call setup procedure. The characteristic of the call shall be according to the DL reference measurement channels (12,2 kbit/s), (64 kbit/s), (144 kbit/s), and (384 kbit/s) specified in annex C.
- 3) Enter the UE into loopback test mode and start the loopback test. (test 1) and/or activate the Ack/Nack test mode (test 1 to test 4).
- 4) The levels of the wanted signal and the co-channel signals are set according to table 7.3.1.2a and b.

7.3.1.4.2 Procedure

Measure the BLER of DCH received from the UE at the SS for all 4 tests.

7.3.1.5 Test requirements

The measured BLER shall not exceed the values indicated in table 7.3.1.2b.

7.3.2 Multipath fading Case 2

7.3.2.1 Definition and applicability

The performance requirement of DCH is determined by the maximum Block Error Ratio (BLER). The BLER is specified for each individual data rate of the DCH. DCH is mapped into the Dedicated Physical Channel (DPCH).

The UE shall be tested only according to the datarates, supported. The data-rate-corresponding requirements shall apply to the UE.

7.3.2.2 Minimum requirement

For the parameters specified in table 7.3.2.2a the BLER should not exceed the piece-wise linear BLER curve specified in table 7.3.2.2b. . These requirements are applicable for TFCS size 16.

The reference for this requirement is TS 25.102 [1] clause 8.3.2.1.

Table 7.3.2.2a: DCH parameters in multipath Case 2 channel

Parameters	Unit	Test 1	Test 2	Test 3	Test 4
$\frac{\Sigma DPCH - E_c}{I_{or}}$	DB	-3	0	0	0
I_{oc}	dBm/3,84 MHz	-60			
Information Data Rate	kbps	12,2	64	144	384

Table 7.3.2.2b: Performance requirements in multipath Case 2 channel

Test Number	$\frac{\hat{I}_{or}}{I_{oc}}$ [dB]	BLER
1	5,5	10^{-2}
2	5,8	10^{-1}
	9,7	10^{-2}
3	9,5	10^{-1}
	13,2	10^{-2}
4	8,5	10^{-1}
	12,6	10^{-2}

7.3.2.3 Test purpose

While the receiver tests in clause 6 aims for the RF hardware, this performance requirement aims for the receiver's signal processing.

The test purpose is to verify the ability of the receiver to receive a predefined test signal, representing a multipath propagation channel for the wanted and for the co-channel signals from serving and adjacent cells, with a block error ratio (BLER) not exceeding a specified value.

7.3.2.4 Method of test

7.3.2.4.1 Initial conditions

Test environment: normal; see clauses G.2.1 and G.2.2.

Frequencies to be tested: mid range; see clause G.2.4.

- 1) Connect the SS, the fading simulator, the AWGN generator and additional components to the UE antenna connector as shown in figure A.10.
- 2) A call is set up according to the Generic call setup procedure. The characteristic of the call shall be according to the DL reference measurement channels (12,2 kbit/s) (64 kbit/s), (144 kbit/s), and (384 kbit/s) specified in annex C.
- 3) Enter the UE into loopback test mode and start the loopback test. (test 1) and/or activate the Ack/Nack test mode (test 1 to test 4).
- 4) The levels of the wanted signal and the co-channel signals are set according to table 7.3.2.2a and b.

7.3.2.4.2 Procedure

Measure the BLER of DCH received from the UE at the SS for all 4 tests.

7.3.2.5 Test requirements

The measured BLER shall not exceed the values indicated in table 7.3.2.2b.

7.3.3 Multipath fading Case 3

7.3.3.1 Definition and applicability

The performance requirement of DCH is determined by the maximum Block Error Ratio (BLER). The BLER is specified for each individual data rate of the DCH. DCH is mapped into the Dedicated Physical Channel (DPCH).

The UE shall be tested only according to the datarates, supported. The data-rate-corresponding requirements shall apply to the UE.

7.3.3.2 Minimum requirements

For the parameters specified in table 7.3.3.2a the BLER should not exceed the piece-wise linear BLER curve specified in table 7.3.3.2b. These requirements are applicable for TFCS size 16.

The reference for this requirement is TS 25.102 [1] clause 8.3.3.1.

Table 7.3.3.2a: DCH parameters in multipath Case 3 channel

Parameters	Unit	Test 1	Test 2	Test 3	Test 4
$\frac{\Sigma DPCH - E_c}{I_{or}}$	dB	-3	0	0	0
I_{oc}	dBm/3,84 MHz	-60			
Information Data Rate	kbps	12,2	64	144	384

Table 7.3.3.2b: Performance requirements in multipath Case 3 channel

Test Number	$\frac{\hat{I}_{or}}{I_{oc}}$ [dB]	BLER
12.2 kbps	4,7	10^{-2}
64 kbps	5,2	10^{-1}
	8,4	10^{-2}
	12,1	10^{-3}
144 kbps	11,7	10^{-1}
	15,2	10^{-2}
	17,8	10^{-3}
384 kbps	8,2	10^{-1}
	11,3	10^{-2}
	13,0	10^{-3}

7.3.3.3 Test purpose

While the receiver tests in clause 6 aims for the RF hardware, this performance requirement aims for the receiver's signal processing.

The test purpose is to verify the ability of the receiver to receive a predefined test signal, representing a multipath propagation channel for the wanted and for the co-channel signals from serving and adjacent cells, with a block error ratio (BLER) not exceeding a specified value.

7.3.3.4 Method of test

7.3.3.4.1 Initial conditions

Test environment: normal; see clauses G.2.1 and G.2.2.

Frequencies to be tested: mid range; see clause G.2.4.

- 1) Connect the SS, the fading simulator, the AWGN generator and additional components to the UE antenna connector as shown in figure A.10.
- 2) A call is set up according to the Generic call setup procedure. The characteristic of the call shall be according to the DL reference measurement channels (12.2 kbit/s)(64 kbit/s), (144 kbit/s), and (384 kbit/s) specified in annex C.
- 3) Enter the UE into loopback test mode and start the loopback test. (test 1) and/or activate the Ack/Nack test mode (test 1 to test 4).
- 4) The levels of the wanted signal and the co-channel signals are set according to table 7.3.3.2a and b.

7.3.3.4.2 Procedure

Measure the BLER of DCH received from the UE at the SS for all 4 tests.

7.3.3.5 Test requirements

The measured BLER shall not exceed the values indicated in table 7.3.3.2.b.

7.4 Base station transmit diversity mode

7.4.1 Demodulation of BCH in SCTD mode

This is not tested.

7.5 Power control in downlink

7.5.1 Definition and applicability

Power control in the uplink is the ability of the UE to converge to the required link quality set by the network while using minimum uplink power. The requirements of this test shall apply to the UTRA-TDD UE.

7.5.2 Minimum requirements

For the parameters specified in table 7.5.1 the average downlink \hat{I}_{or}/I_{oc} power shall be below the specified value in table 7.5.2 more than 90% of the time. BLER shall be as shown in table 7.5.2. Downlink power control is ON during the test.

Table 7.5.1: Test parameters for downlink power control

Parameter	Unit	Test 1
$\frac{DPCH_E_c}{I_{or}}$	dB	0
I_{oc}	dBm/3,84 MHz	-60
Information Data Rate	kbps	12,2
Target quality value on DTCH	BLER	0,01
Propagation condition		Case 1
DL Power Control step size, Δ_{TPC}	dB	1
Maximum_DL_power (note)	dB	0
Minimum_DL_power (note)	dB	-27
NOTE: Refer to TS 25.224 for description and definition.		

Note: DL power is relative to P-CCPCH power.

Table 7.5.2: Requirements for downlink power control

Parameter	Unit	Test 1
\hat{I}_{or}/I_{oc}	dB	8,0
Measured quality on DTCH	BLER	0,01±30%

The reference for this requirement is TS 25.102 [1] clause 8.5.1.

7.5.3 Test purpose

To verify that the UE receiver is capable of converging to the required link quality set by the network while using as low power as possible.

7.5.4 Method of test

7.5.4.1 Initial conditions

Test environment: normal; see clauses G.2.1 and G.2.2.

Frequencies to be tested: mid range; see clause G.2.4.

- 1) Connect SS, multipath fading simulator and an AWGN source to the UE antenna connector as shown in figure A.10.
- 2) Set up a call according to the Generic call setup procedure.
- 3) RF parameters are set up according to table 7.5.1.
- 4) Enter the UE into loopback test mode and start the loopback test.
- 5) SS signals to UE target quality value on DTCH as specified in table 7.5.1. SS will vary the physical channel power in downlink according to the TPC commands from UE, and at the same time measure BLER. This is continued until the target quality value on DTCH is met, within the minimum accuracy requirement.

See TS 34.108 [3] and TS 34.109 [4] for details regarding generic call setup procedure and loopback test.

7.5.4.2 Procedure

- 1) After the target quality on DTCH is met, BLER is measured. Simultaneously the downlink \hat{I}_{or}/I_{oc} power ratio averaged over one slot is measured. This is repeated until adequate amount of measurements is done to reach the required confidence level.
- 2) The measured quality on DTCH (BLER) and the measured downlink \hat{I}_{or}/I_{oc} power ratio values averaged over one slot are compared to the limits in table 7.5.2.

7.5.5 Test Requirements

- a) The measured quality on DTCH does not exceed the values in table 7.5.2.
- b) The downlink \hat{I}_{or}/I_{oc} power ratio values, which are averaged over one slot, shall be below the values in table 7.5.2 more than 90 % of the time.

7.6 Uplink Power Control

7.6.1 Definition and applicability

Power control in the uplink is the ability of the UE to converge to the required link quality set by the network while using minimum uplink power. The requirements of this test shall apply to all types of the UTRA-TDD UE.

7.6.2 Minimum requirements

During period T1, the PCCPCH and a second Beacon Channel are transmitted in the DL in designated slots within each frame and at the same power level.

The UE transmits, using the channel of TS25.105, Annex A.2.1 UL reference measurement channel (12.2 kbps) in one UL slot. For different parts of the test, different UL slots will be designated.

The values of table 7.6.1, period T1 shall be selected. Then, with the received PCCPCH and Beacon power set at -60 dBm, the value of DPCH constant value shall be adjusted so that the mean UE output power is 5 dBm. These conditions are held steady during period T1.

Periods T1 and T2 are each 5 seconds long.

Table 7.6.1: UL Power Control Test Conditions

		Period T1	Period T2
I_{BTS} all slots	dBm	-60	-60
PCCPCH Power -Broadcast	dBm	18	18
PCCPCH Power - Received	dBm	-60	-70
Mean UE transmit power	dBm	5	According to tables 7.6.2 and 7.6.3
SIR_{TARGET}	dB	6	6
I_{oc} in PCCPCH and Beacon Slots	dBm	-60	-60
IE (information element) Alpha	As defined in 25.331	1.0	1.0
PCCPCH slot position	Integer 0 -14	0	0
Beacon slot position	Integer 0 -14	8	8

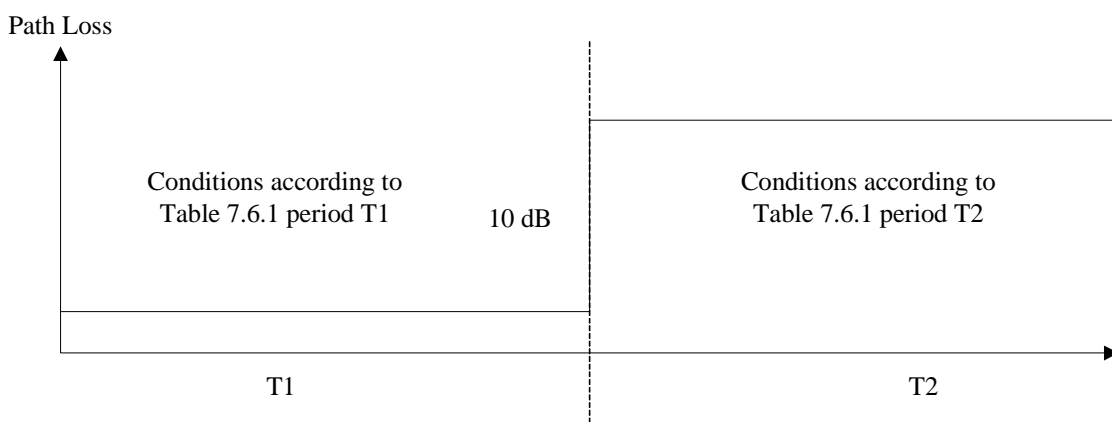

Figure 7.6.1

At the end of period T1, the PCCPCH and Beacon Received power shall be simultaneously decreased by 10 dB. These conditions are summarized in table 7.6.1, period T2.

For the first frame including the change in received power the UE output power shall satisfy the values in table 7.6.2.

For the 20th frame after the change in received power the UE output power shall satisfy the values in table 7.6.3.

Table 7.6.2: Required UE Output Power, Frame Containing Power Level Change

Parameter	Units	Value	
UL transmission slot position		1,9	7,14
UE output power	dBm	15 ±4.0	5 ±0.5

Table 7.6.3: Required UE Output Power, 20 Frames after Power Level Change

Parameter	Units	Value	
UL transmission slot position		1,9	7,14
UE output power	dBm	15 ±4.0	15 ±4.0

7.6.3 Test purpose

To verify the ability of the UE to converge to the required link quality set by the network while using minimum uplink power.

7.6.4 Method of test

7.6.4.1 Initial conditions

Test environment: normal; see clauses G.2.1 and G.2.2.

Frequencies to be tested: mid range; see clause G.2.4.

- 1) Connect SS and an AWGN source to the UE antenna connector as shown in figure A.9.
- 2) Set up a call according to the Generic call setup procedure using SS levels and signalling values as specified in table 7.6.1 for Period P1 and table 7.6.4 . The UE shall be signalled to transmit in timeslot position 1.

Table 7.6.4: Test parameters for Uplink Power Control Test

Parameter	Value/description
UL Reference measurement channel	12,2kbps, according to annex C.2.1
DPCH constant value	0
Data content	real life (sufficient irregular)

- 3) Enter the UE into loopback test mode and start the loopback test.

See TS 34.108 [3] and TS 34.109 [4] for details regarding generic call setup procedure and loopback test.

7.6.4.2 Procedure

- 1) The SS adjusts the DPCH constant value until the UE transmit power is 5 dBm.
- 2) After the UE output power has been held constant at 5 dBm for at least 5 seconds, the received PCCPCH power shall be decreased by 10 dB to -70 dBm as shown in figure 7.6.1.
- 3) Measure the transmit power according to annex B for the first frame including the pathloss change and the 20th frame after the pathloss change.
- 4) Set the received PCCPCH power to -60 dBm.
- 5) SS signals UE to transmit in timeslot 7. Repeat step 1 - 4.
- 6) SS signals UE to transmit in timeslot 9. Repeat step 1 - 4.
- 7) SS signals UE to transmit in timeslot 14. Repeat step 1 - 4.

7.6.5 Test requirements

The measured transmit power shall not exceed the prescribed tolerance in tables 7.6.5 and 7.6.6.

Table 7.6.5: Required UE Output Power, Frame Containing Power Level Change

Parameter	Units	Value	
UL transmission slot position		1,9	7,14
UE output power	dBm	15 ±5.5	5 ±0.5

Table 7.6.6: Required UE Output Power, 20 Frames after Power Level Change

Parameter	Units	Value	
UL transmission slot position		1,9	7,14
UE output power	dBm	15 ±5.5	15 ±5.5

NOTE: If the above Test Requirement differs from the Minimum Requirement then the Test Tolerance applied for this test is non-zero. The Test Tolerance for this test is defined in annex F clause F.2 and the explanation of how the Minimum Requirement has been relaxed by the Test Tolerance is given in Annex F clause F.4.

8 Requirements for Support of RRM

8.1 General

Void.

8.2 Idle Mode Tasks

8.2.1 Cell Selection

Void.

8.2.2 Cell Re-Selection

8.2.2.1 Scenario 1: TDD/TDD cell re-selection single carrier case

8.2.2.1.1 Definition and applicability

The cell re-selection delay is defined as the time from a change of cell levels to the moment when this change causes the UE to camp on a new cell, and starts to send the RRC CONNECTION REQUEST message to perform a Location Registration on the new cell.

The requirements and this test apply to the TDD UE.

8.2.2.1.2 Minimum requirement

The cell re-selection delay shall be less than 8 s when the DRX cycle length is 1,28 s.

The rate of correct cell reselections observed during repeated tests shall be at least 90% with a confidence level of [FFS]%.

NOTE:

The cell re-selection delay can be expressed as: $T_{\text{evaluateTDD}} + T_{\text{SI}}$, where:

$T_{\text{evaluateTDD}}$ A DRX cycle length of 1280ms is assumed for this test case, this leads to a $T_{\text{evaluateTDD}}$ of 6.4s according to table 4.1 in clause 4.2.2.7.

T_{SI} Maximum repetition rate of relevant system info blocks that needs to be received by the UE to camp on a cell. 1280 ms is assumed in this test case.

This gives a total of 7.68 s, allow 8s in the test case.

The normative reference for this requirement is TS 25.123 [2] clauses 4.2.2 and A.4.2.1.

8.2.2.1.3 Test purpose

This test is to verify the requirement for the cell re-selection delay in the single carrier case

8.2.2.1.4 Method of test

8.2.2.1.4.1 Initial conditions

This scenario implies the presence of 1 carrier and 6 cells as given in table 8.2.2.1.1 and table 8.2.2.1.2. Cell 1 and cell 2 shall belong to different Location Areas.

Table 8.2.2.1.1: General test parameters for Cell Re-selection single carrier multi-cell case

Parameter		Unit	Value	Comment
Initial condition	Active cell		Cell1	
	Neighbour cells		Cell2, Cell3, Cell4, Cell5, Cell6	
Final condition	Active cell		Cell2	
HCS			Not used	
UE_TXPWR_MAX_RACH		dBm	21	The value shall be used for all cells in the test.
Qrxlevmin		dBm	-102	The value shall be used for all cells in the test.
Access Service Class (ASC#0) - Persistence value			1	Selected so that no additional delay is caused by the random access procedure. The value shall be used for all cells in the test.
T _{SI}		s	1.28	The value shall be used for all cells in the test.
DRX cycle length		s	1.28	The value shall be used for all cells in the test.
T1		s	15	
T2		s	15	

Table 8.2.2.1.2: Cell re-selection single carrier multi-cell case

Parameter	Unit	Cell 1				Cell 2				Cell 3			
		0		8		0		8		0		8	
Timeslot Number		T1	T2	T1	T2	T1	T2	T1	T2	T1	T2	T1	T2
UTRA RF Channel Number		Channel 1				Channel 1				Channel 1			
PCCPCH_Ec/lor	dB	-3	-3			-3	-3			-3	-3		
SCH_Ec/lor	dB	-9	-9	-9	-9	-9	-9	-9	-9	-9	-9	-9	-9
SCH_offset		0	0	0	0	5	5	5	5	10	10	10	10
PICH_Ec/lor	dB			-3	-3			-3	-3			-3	-3
OCNS_Ec/lor	dB	-3,12	-3,12	-3,12	-3,12	-3,12	-3,12	-3,12	-3,12	-3,12	-3,12	-3,12	-3,12
\hat{I}_{or}/I_{oc}	dB	9	7	9	7	7	9	7	9	-1	-1	-1	-1
PCCPCH RSCP	dBm	-64	-66			-66	-64			-74	-74		
Qoffset1 _{s,n}	dB	C1, C2: 0; C1, C3:0; C1,C4:0 C1, C5:0; C1, C6:0				C2, C1: 0; C2, C3:0; C2,C4:0 C2, C5: 0; C2, C6:0				C3, C1: 0; C3, C2:0; C3,C4:0 C3, C5: 0; C3, C6:0			
Qhyst1 _s	dB	0				0				0			
Treselection	s	0				0				0			
Sintrasearch	dB	not sent				not sent				not sent			
		Cell 4				Cell 5				Cell 6			
Timeslot		0		8		0		8		0		8	
		T1	T2	T1	T2	T1	T2	T1	T2	T1	T2	T1	T2
UTRA RF Channel Number		Channel 1				Channel 1				Channel 1			
PCCPCH_Ec/lor	dB	-3	-3			-3	-3			-3	-3		
SCH_Ec/lor	dB	-9	-9	-9	-9	-9	-9	-9	-9	-9	-9	-9	-9
SCH_offset		15	15	15	15	20	20	20	20	25	25	25	25
PICH_Ec/lor	dB			-3	-3			-3	-3			-3	-3
OCNS_Ec/lor	dB	-3,12	-3,12	-3,12	-3,12	-3,12	-3,12	-3,12	-3,12	-3,12	-3,12	-3,12	-3,12
\hat{I}_{or}/I_{oc}	dB	-1	-1	-1	-1	-1	-1	-1	-1	-1	-1	-1	-1
PCCPCH RSCP	dBm	-74	-74			-74	-74			-74	-74		
Qoffset1 _{s,n}	dB	C4, C1: 0; C4, C2:0; C4,C3:0C4, C5:0; C4, C6:0				C5, C1: 0; C5, C2:0; C5,C3:0 C5, C4:0; C5, C6:0				C6, C1: 0; C6, C2:0; C6,C3:0 C6, C4:0; C6, C5:0			
Qhyst1 _s	dB	0				0				0			
Treselection	s	0				0				0			
Sintrasearch	dB	not sent				not sent				not sent			
I_{oc}	dBm/3, 84 MHz	-70											
Propagation Condition		AWGN											

8.2.2.1.4.2 Procedure

- The SS activates cell 1-6 with T1 defined parameters and monitors cell 1 and 2 for RRC CONNECTION REQUEST messages from the UE.
- The UE is switched on.
- The SS waits until the UE camps on Cell 1 and sends the RRC CONNECTION REQUEST message.
- After 15 s, the parameters are changed as described for T2.
- The SS waits for RRC CONNECTION REQUEST messages from the UE.
- After another 15 s, the parameters are changed as described for T1.
- The SS waits for RRC CONNECTION REQUEST messages from the UE.
- Repeat steps d) to g) [TBD] times.

8.2.2.1.5 Test Requirements

- In step c), after the UE has responded on cell 1, it shall not respond on any other cell (cell selection).

- 2) In step e), the UE shall respond on cell 2 within 8 s.
- 3) In step g), the UE shall respond on cell 1 within 8 s.

For the test to pass, the total number of fulfilled test requirements 2) and 3) shall be more than [FFS]% of the cases.

NOTE: If the above Test Requirement differs from the Minimum Requirement then the Test Tolerance applied for this test is non-zero. The Test Tolerance for this test is defined in clause F.2 and the explanation of how the Minimum Requirement has been relaxed by the Test Tolerance is given in clause F.4.

8.2.2.2 Scenario 2: TDD/TDD cell re-selection multi carrier case

8.2.2.2.1 Definition and applicability

The cell re-selection delay is defined as the time from a change of cell levels to the moment when this change causes the UE to camp on a new cell, and starts to send the RRC CONNECTION REQUEST message to perform a Location Registration on the new cell.

The requirements and this test apply to the TDD UE.

8.2.2.2.2 Minimum requirement

The cell re-selection delay shall be less than 8 s.

The rate of correct cell reselections observed during repeated tests shall be at least 90% with a confidence level of [FFS]%.

The rate of correct cell reselections observed during repeated tests shall be at least 90%.NOTE:

The cell re-selection delay can be expressed as: $T_{\text{evaluateTDD}} + T_{\text{SI}}$, where:

$T_{\text{evaluateTDD}}$ A DRX cycle length of 1280ms is assumed for this test case, this leads to a $T_{\text{evaluateTDD}}$ of 6.4s according to table 4.1 in clause 4.2.2.7.

T_{SI} Maximum repetition rate of relevant system info blocks that needs to be received by the UE to camp on a cell. 1280 ms is assumed in this test case.

This gives a total of 7.68 s, allow 8s in the test case.

The normative reference for this requirement is TS 25.123 [2] clauses 4.2.2 and A.4.2.2.

8.2.2.2.3 Test purpose

This test is to verify the requirement for the cell re-selection delay in the multi carrier case

8.2.2.2.4 Method of test

8.2.2.2.4.1 Initial conditions

This scenario implies the presence of 2 carriers and 6 cells as given in table 8.2.2.2.1 and table 8.2.2.2.2. Cell 1 and cell 2 shall belong to different Location Areas.

Table 8.2.2.1: General test parameters for Cell Re-selection in Multi carrier case

Parameter	Unit	Value	Comment
Initial condition	Active cell	Cell1	
	Neighbour cells	Cell2, Cell3, Cell4, Cell5, Cell6	
Final condition	Active cell	Cell2	
HCS		Not used	
UE_TXPWR_MAX_RACH	dBm	21	The value shall be used for all cells in the test.
Qrxlevmin	dBm	-102	The value shall be used for all cells in the test.
Access Service Class (ASC#0) - Persistence value		1	Selected so that no additional delay is caused by the random access procedure. The value shall be used for all cells in the test.
T_{SI}	s	1.28	The value shall be used for all cells in the test.
DRX cycle length	s	1.28	The value shall be used for all cells in the test.
T1	s	30	
T2	s	15	

Table 8.2.2.2: Cell re-selection multi carrier multi cell case

Parameter	Unit	Cell 1				Cell 2				Cell 3			
		0		8		0		8		0		8	
Timeslot Number		T1	T2	T1	T2	T1	T2	T1	T2	T1	T2	T1	T2
UTRA RF Channel Number		Channel 1				Channel 2				Channel 1			
PCCPCH_Ec/lor	dB	-3	-3			-3	-3			-3	-3		
SCH_Ec/lor	dB	-9	-9	-9	-9	-9	-9	-9	-9	-9	-9	-9	-9
SCH_offset		0	0	0	0	5	5	5	5	10	10	10	10
PICH_Ec/lor	dB			-3	-3			-3	-3			-3	-3
OCNS_Ec/lor	dB	-3,12	-3,12	-3,12	-3,12	-3,12	-3,12	-3,12	-3,12	-3,12	-3,12	-3,12	-3,12
\hat{I}_{or}/I_{oc}	dB	6	0	6	0	0	6	0	6	-3	-3	-3	-3
PCCPCH RSCP	dBm	-67	-73			-73	-67			-76	-76		
Qoffset1 _{s,n}	dB	C1, C2: 0; C1, C3:0; C1,C4:0C1, C5:0; C1, C6:0				C2, C1: 0; C2, C3:0; C2,C4:0C2, C5:0; C2, C6:0				C3, C1: 0; C3, C2:0; C3,C4:0 C3, C5:0; C3, C6:0			
Qhyst1 _s	dB	0				0				0			
Treselection	s	0				0				0			
Sintrasearch	dB	not sent				not sent				not sent			
Sintersearch	dB	not sent				not sent				not sent			
Timeslot		Cell 4				Cell 5				Cell 6			
		0		8		0		8		0		8	
UTRA RF Channel Number		Channel 1				Channel 2				Channel 2			
PCCPCH_Ec/lor	dB	-3	-3			-3	-3			-3	-3		
SCH_Ec/lor	dB	-9	-9	-9	-9	-9	-9	-9	-9	-9	-9	-9	-9
SCH_offset		15	15	15	15	20	20	20	20	25	25	25	25
PICH_Ec/lor	dB			-3	-3			-3	-3			-3	-3
OCNS_Ec/lor	dB	-3,12	-3,12	-3,12	-3,12	-3,12	-3,12	-3,12	-3,12	-3,12	-3,12	-3,12	-3,12
\hat{I}_{or}/I_{oc}	dB	-3	-3	-3	-3	-3	-3	-3	-3	-3	-3	-3	-3
PCCPCH RSCP	dBm	-76	-76			-76	-76			-76	-76		
Qoffset1 _{s,n}	dB	C4, C1: 0; C4, C2:0; C4,C3:0 C4, C5:0; C4, C6:0				C5, C1: 0; C5, C2:0; C5,C3:0 C5, C4:0; C5, C6:0				C6, C1: 0; C6, C2:0; C6,C3:0 C6, C4:0; C6, C5:0			
Qhyst1 _s	dB	0				0				0			
Treselection	s	0				0				0			
Sintrasearch	dB	not sent				not sent				not sent			
Sintersearch	dB	not sent				not sent				not sent			
I_{oc}	dBm/3, 84 MHz	-70											
Propagation Condition		AWGN											

8.2.2.2.4.2 Procedure

- a) The SS activates cell 1-6 with T1 defined parameters and monitors cell 1 and 2 for RRC CONNECTION REQUEST messages from the UE.
- b) The UE is switched on.
- c) The SS waits until the UE camps on Cell 1 and sends the RRC CONNECTION REQUEST message.
- d) After 15 s, the parameters are changed as described for T2.
- e) The SS waits for RRC CONNECTION REQUEST messages from the UE.
- f) After another 15 s, the parameters are changed as described for T1.
- g) The SS waits for RRC CONNECTION REQUEST messages from the UE.
- h) Repeat steps d) to g) [TBD] times.

NOTE: T1 is initially 30 s to allow enough time for the UE to search for cells as it has no prior knowledge of these.

8.2.2.2.5 Test Requirements

- 1) In step c), after the UE has responded on cell 1, it shall not respond on any other cell (cell selection).
- 2) In step e), the UE shall respond on cell 1 within 8 s.
- 3) In step g), the UE shall respond on cell 2 within 8 s.

For the test to pass, the total number of fulfilled test requirements 2) and 3) shall be more than [FFS]% of the cases.

NOTE: If the above Test Requirement differs from the Minimum Requirement then the Test Tolerance applied for this test is non-zero. The Test Tolerance for this test is defined in clause F.2 and the explanation of how the Minimum Requirement has been relaxed by the Test Tolerance is given in clause F.4.

8.2.2.3 Scenario 3: TDD/FDD cell re-selection

8.2.2.3.1 Definition and applicability

The cell re-selection delay is defined as the time from when the cell quality levels change to the moment when this change makes the UE reselect a better ranked cell, and starts to send preambles on the PRACH for sending the RRC CONNECTION REQUEST message to perform a Location Registration on the new cell.

This test is for the case where the UE camps on a TDD cell and reselects to an FDD cell.

The requirements and this test apply to UEs supporting both TDD and FDD.

8.2.2.3.2 Minimum requirement

The cell re-selection delay shall be less than 8 s when the DRX cycle length is 1,28 s.

The rate of correct cell reselections observed during repeated tests shall be at least 90% with a confidence level of [FFS]%.

NOTE:

The cell re-selection delay can be expressed as: $T_{\text{evaluateFDD}} + T_{\text{SI}}$, where:

$T_{\text{evaluateFDD}}$ See TS 25.123 [2] table 4.1 in clause 4.2.2.

T_{SI} Maximum repetition rate of relevant system info blocks that needs to be received by the UE to camp on a cell. 1280 ms is assumed in this test case.

This gives a total of 7.68 s, allow 8s in the test case.

The normative reference for this requirement is TS 25.123 [2] clauses 4.2.2 and A.4.2.3

8.2.2.3.3 Test purpose

This test verifies the UE meets the minimum requirement for the case where the UE camps on a TDD cell and reselects to an FDD cell.

8.2.2.3.4 Method of test

8.2.2.3.4.1 Initial conditions

This scenario implies the presence of 1 TDD and 1 FDD cell as given in table 8.2.2.3.1 and table 8.2.2.3.2. Cell 1 and cell 2 shall belong to different Location Areas.

Table 8.2.2.3.1: General test parameters for the TDD/FDD cell re-selection

Parameter		Unit	Value	Comment
Initial condition	Active cell		Cell1	TDD cell
	Neighbour cells		Cell2	FDD cell
Final condition	Active cell		Cell2	
HCS			Not used	
UE_TXPWR_MAX_RACH		dBm	21	The value shall be used for all cells in the test.
Access Service Class (ASC#0) - Persistence value			1	Selected so that no additional delay is caused by the random access procedure. The value shall be used for all cells in the test.
T _{SI}		s	1.28	The value shall be used for all cells in the test.
DRX cycle length		s	1.28	The value shall be used for all cells in the test.
T1		s	30	
T2		s	15	

Table 8.2.2.3.2: TDD/FDD cell re-selection

Parameter	Unit	Cell 1				Cell 2	
		0		8		n.a.	n.a.
Timeslot Number		T1	T2	T1	T2	T1	T2
UTRA RF Channel Number		Channel 1				Channel 2	
CPICH_Ec/lor	dB	n.a.		n.a.		-10	-10
PCCPCH_Ec/lor	dB	-3	-3			-12	-12
SCH_Ec/lor	dB	-9	-9	-9	-9	-12	-12
SCH _{offset}		0	0	0	0	n.a.	n.a.
PICH_Ec/lor	dB			-3	-3	-15	-15
OCNS_Ec/lor	dB	-3,12	-3,12	-3,12	-3,12	-0,941	-0,941
\hat{I}_{or}/I_{oc}	dB	3	-2	3	-2	-2	3
I_{oc}	dBm/3.8 4 MHz	-70					
CPICH_RSCP	dBm	n.a.		n.a.		-82	-77
PCCPCH_RSCP	dBm	-70	-75			n.a.	n.a.
Cell_selection and reselectionquality _measure		CPICH_RSCP				CPICH_RSCP	
Qrxlevmin	dBm	-102				-115	
Qoffset1 _{s,n}	dB	C1, C2: -12				C2, C1: +12	
Qhyst1 _s	dB	0				0	
Treselection	s	0				0	
Sintersearch	dB	not sent				not sent	
Propagation Condition		AWGN				AWGN	

8.2.2.3.4.2 Procedure

- a) The SS activates cell 1 and cell 2 with T1 defined parameters and monitors them for RRC CONNECTION REQUEST messages from the UE.
- b) The UE is switched on.
- c) The SS waits until the UE camps on Cell 1 and sends the RRC CONNECTION REQUEST message.
- d) After 30 s, the parameters are changed as described for T2.
- e) The SS waits for RRC CONNECTION REQUEST messages from the UE.
- f) After another 15 s, the parameters are changed as described for T1.
- g) The SS waits for RRC CONNECTION REQUEST messages from the UE.
- h) Repeat steps d) to g) [TBD] times.

8.2.2.3.5 Test Requirements

- 1) In step c), after the UE has responded on cell 1, it shall not respond on any other cell (cell selection).
- 2) In step e), the UE shall respond on cell 2 within 8 s.
- 3) In step g), the UE shall respond on cell 1 within 8 s.

For the test to pass, the total number of fulfilled test requirements 2) and 3) shall be more than [FFS]% of the cases.

NOTE: If the above Test Requirement differs from the Minimum Requirement then the Test Tolerance applied for this test is non-zero. The Test Tolerance for this test is defined in clause F.2 and the explanation of how the Minimum Requirement has been relaxed by the Test Tolerance is given in clause F.4.

8.2.2.4 Scenario 4: inter RAT cell re-selection

8.2.2.4.1 Definition and applicability

The cell re-selection delay is defined as the time from when the cell quality levels change to the moment when this change makes the UE reselect a better ranked cell, and starts to send LOCATION UPDATING REQUEST message to perform a Location update to the new cell.

This test is for the case where the UE camps on a TDD cell and reselects to a GSM cell.

The requirements and this test apply to UEs supporting both TDD and GSM.

8.2.2.4.2 Minimum requirement

The cell re-selection delay shall be less than 8 s when the DRX cycle length is 1,28 s. The cell selection parameters in the BCCH of the GSM cell in system info 3 and 4 are transmitted at least every second.

The rate of correct cell reselections observed during repeated tests shall be at least 90% with a confidence level of [FFS]%.

The normative reference for this requirement is TS 25.123 [2] clauses 4.3.2.1 and A.4.2.4

8.2.2.4.3 Test purpose

This test verifies the UE meets the minimum requirement for the case where the UE camps on a TDD cell and reselects to a GSM cell.

8.2.2.4.4 Method of Test

8.2.2.4.4.1 Initial conditions

This scenario implies the presence of 1 TDD and 1 GSM cell as given in table 8.2.2.4.1, 8.2.2.4.2, and 8.2.2.4.3. Cell 1 and cell 2 shall belong to different Location Areas.

Table 8.2.2.4.1: General test parameters for UTRAN to GSM Cell Re-selection

Parameter	Unit	Value	Comment
Initial condition	Active cell	Cell1	TDD Cell
	Neighbour cell	Cell2	GSM Cell
Final condition	Active cell	Cell2	
DRX cycle length	s	1,28	UTRAN cell
BCCH repetition period (GSM cell)	s	1,87	In GSM the system information is scheduled according to an 8 x (51 x 8) cycle (i.e. a system information message is transmitted every 235 ms). The cell selection parameters in system info 3 and 4 are transmitted at least every second. (GSM 05.02)
T1	s	15	
T2	s	15	

Table 8.2.2.4.2: Cell re-selection UTRAN to GSM cell case (cell 1)

Parameter	Unit	Cell 1 (UTRA)			
		0		8	
Timeslot Number		T1	T2	T1	T2
UTRA RF Channel Number		Channel 1		Channel 1	
PCCPCH_Ec/lor	dB	-3	-3		
SCH_Ec/lor	dB	-9	-9	-9	-9
SCH_t_offset		0	0	0	0
PICH_Ec/lor	dB			-3	-3
OCNS_Ec/lor	dB	-3,12	-3,12	-3,12	-3,12
\hat{I}_{or}/I_{oc}	dB	3	-2	3	-2
I_{oc}	dBm/3, 84 MHz	-70		-70	
PCCPCH RSCP	dBm	-70	-75		
Propagation Condition		AWGN		AWGN	
Treselection	s	0			
Ssearch _{RAT}	dB	not sent			

Table 8.2.2.4.3: Cell re-selection UTRAN to GSM cell case (cell 2)

Parameter	Unit	Cell 2 (GSM)	
		T1	T2
Absolute RF Channel Number		ARFCN 1	
RXLEV	dBm	-80	-70
RXLEV_ACCESS_MIN	dBm	-100	
MS_TXPWR_MAX_CCH	dBm	30	

8.2.2.4.4.2 Procedure

- The SS activates cell 1 and 2 with T1 defined parameters and monitors cell 1 and 2 for RRC CONNECTION REQUEST and LOCATION UPDATING REQUEST messages from the UE.
- The UE is switched on.
- The SS waits until the UE camps on Cell 1 and sends the RRC CONNECTION REQUEST message.

- d) After 15 s, the parameters are changed as described for T2.
- e) The SS waits for LOCATION UPDATING REQUEST messages from the UE.
- f) After 15 s, the parameters are changed as described for T1.
- g) The SS waits for RRC CONNECTION REQUEST messages from the UE.
- h) Repeat steps d) to g) [TBD] times.

8.2.2.4.5 Test Requirements

- 1) In step c), after the UE has responded on cell 1, it shall not respond on any other cell (cell selection).
- 2) In step e), the UE shall respond on cell 2 within 8 s.
- 3) In step g), the UE shall respond on cell 1.

For the test to pass, the total number of fulfilled test requirements in step 2) shall be at least 90% of the cases.

NOTE: If the above Test Requirement differs from the Minimum Requirement then the Test Tolerance applied for this test is non-zero. The Test Tolerance for this test is defined in clause F.2 and the explanation of how the Minimum Requirement has been relaxed by the Test Tolerance is given in clause F.4.

8.3 UTRAN Connected Mode Mobility

8.3.1 TDD/TDD Handover

8.3.1.1 Handover to intra-frequency cell

8.3.1.1.1 Definition and applicability

Handover delay of the UE is defined as the time from the end of the last TTI containing an RRC message implying hard handover to the transmission of the new uplink DPCH, excluding the RRC procedure delay as defined in [9].

The requirements and this test apply to the UTRA TDD UE.

8.3.1.1.2 Minimum requirement

The hard handover delay shall be less than 40 ms in the single carrier case when the cell is known by the UE and the SFN of the target cell does not need to be decoded. The rate of correct handovers observed during repeated tests shall be at least 90% with a confidence level of [FFS]%.

The normative reference for this requirement is TS 25.123 [2] clauses 5.1.2 and A.5.1.1.

8.3.1.1.3 Test purpose

The purpose of this test is to verify the requirement for the intra-frequency handover delay in CELL_DCH state in the single carrier case.

8.3.1.1.4 Method of test

8.3.1.1.4.1 Initial conditions

Test environment: normal; see clauses G.2.1 and G.2.2.

Frequencies to be tested: mid range; see clause G.2.4.

The test parameters are given in table 8.3.1.1.1 and 8.3.1.1.2. In the measurement control information it is indicated to the UE that event-triggered reporting with Event 1G shall be used, and that P-CCPCH RSCP and SFN-CFN observed timed difference shall be reported together with Event 1G. The test consists of three successive time periods, with a

time duration of T1, T2 and T3 respectively. At the start of time duration T1, the UE may not have any timing information of cell 2.

UTRAN shall send a Physical Channel reconfiguration message with activation time at the beginning of T3 with a new active cell, cell 2. The Physical Channel reconfiguration message shall be sent to the UE such that the delay between the end of the last received TTI containing the message and the beginning of T3 is at least equal to the RRC procedure delay as defined in [16].

The second Beacon timeslot shall be provided in timeslot 8 for both cell 1 and cell 2. The UL DPCH shall be transmitted in timeslot 12.

Table 8.3.1.1.1: General test parameters for Handover to intra-frequency cell

Parameter		Unit	Value	Comment
DCH parameters			DL Reference Measurement Channel 12.2 kbps	As specified in TS 25.102 clause A.2.2
Power Control			On	
Target quality value on DTCH		BLER	0.01	
Initial conditions	Active cell		Cell 1	
	Neighbour cell		Cell 2	
Final condition	Active cell		Cell 2	
HCS			Not used	
O		dB	0	Cell individual offset. This value shall be used for all cells in the test.
Hysteresis		dB	0	
Time to Trigger		ms	0	
Filter coefficient			0	
Monitored cell list size			6 TDD neighbours on Channel 1	
T1		s	10	
T2		s	10	
T3		s	10	

Table 8.3.1.1.2: Cell specific test parameters for Handover to intra-frequency cell

Parameter	Unit	Cell 1						Cell 2							
		0			4			0			5				
DL timeslot number		T1	T2	T3	T1	T2	T3	T1	T2	T3	T1	T2	T3		
UTRA RF Channel Number		Channel 1						Channel 1							
PCCPCH_Ec/lor	dB	-3			n.a.			-3			n.a.				
SCH_Ec/lor	dB	-9			n.a.			-9			n.a.				
SCH_t _{offset}	dB	0			n.a.			5			n.a.				
DPCH_Ec/lor	dB	n.a.			Note 1		n.a.	n.a.			n.a.		Note 1		
OCNS_Ec/lor	dB	-3,12			Note 2		n.a.	n.a.			-3,12		n.a.	Note 2	
\hat{I}_{or}/I_{oc}	dB	1						-Inf.		3		-Inf.		3	
PCCPCH RSCP	dBm	-72			n.a.			-Inf.		-70		n.a.			
I_{oc}	dBm/ 3,84 MHz	-70													
Propagation Condition		AWGN													
Note 1: The DPCH level is controlled by the power control loop															
Note 2: The power of the OCNS channel that is added shall make the total power from the cell to be equal to lor .															

8.3.1.1.4.2 Procedure

- 1) The RF parameters are set up according to T1.
- 2) The UE is switched on.
- 3) A call is set up according to the test procedure specified in TS 34.108 [3] subclause 7.3.4.

[Editor's note: subclause 7.3.4 in TS 34.108 (Message sequence chart for Handover Test procedure) is not yet specified]

- 4) SS shall transmit a MEASUREMENT CONTROL message.
- 5) After 10 seconds, the SS shall switch the power settings from T1 to T2.
- 6) UE shall transmit a MEASUREMENT REPORT message triggered by event 1G.
- 7) SS shall transmit a PHYSICAL CHANNEL RECONFIGURATION message with activation time at T3.
- 8) After 10 seconds, the SS shall switch the power settings from T2 to T3
- 9) UE shall transmit a PHYSICAL CHANNEL RECONFIGURATION COMPLETE message on the UL DCCH of cell 2. If the UE transmits the UL DPCH to cell 2 less than 40 ms from the beginning of time period T3 then the number of successful tests is increased by one.
- 10) After 10 seconds, the UE is switched off. Any timing information of cell 2 is deleted in the UE.
- 11) Repeat step 1-10 [TBD] times.

Specific Message Contents

All messages indicated above shall use the same content as described in the default message content in clause 9 of 34.108 [3] and in Annex A of 34.123-1 [21], with the following exceptions:

MEASUREMENT CONTROL message (step 4):

Information Element/Group name	Value/Remark
Message Type (10.2.17)	
UE information elements	
-RRC transaction identifier	0
-Integrity check info	Not Present
Measurement Information elements	
-Measurement Identity	1
-Measurement Command (10.3.7.46)	Modify
-Measurement Reporting Mode (10.3.7.49)	
-Measurement Report Transfer Mode	AM RLC
-Periodical Reporting / Event Trigger Reporting Mode	Event trigger
-Additional measurements list (10.3.7.1)	Not Present
-CHOICE <i>Measurement type</i>	Intra-frequency measurement
-Intra-frequency measurement (10.3.7.36)	
-Intra-frequency measurement objects list (10.3.7.33)	Not Present
-Intra-frequency measurement quantity (10.3.7.38)	
-Filter coefficient (10.3.7.9)	0
-CHOICE <i>mode</i>	TDD
-Measurement quantity list	1
-Measurement quantity	Primary CCPCH
-Intra-frequency reporting quantity (10.3.7.41)	
-Reporting quantities for active set cells (10.3.7.5)	
-SFN-SFN observed time difference reporting indicator	No report
-Cell synchronisation information reporting indicator	TRUE (Note 1)
-Cell Identity reporting indicator	TRUE
-CHOICE <i>mode</i>	TDD
-Timeslot ISCP reporting indicator	TRUE
-Primary CCPCH RSCP reporting indicator	TRUE
-Pathloss reporting indicator	TRUE
-Reporting quantities for monitored set cells (10.3.7.5)	
-SFN-SFN observed time difference reporting indicator	No report
-Cell synchronisation information reporting indicator	TRUE (Note 1)
-Cell Identity reporting indicator	TRUE
-CHOICE <i>mode</i>	TDD
-Timeslot ISCP reporting indicator	TRUE
-Proposed TGSN reporting required	FALSE
-Primary CCPCH RSCP reporting indicator	TRUE
-Pathloss reporting indicator	TRUE
-Reporting quantities for detected set cells (10.3.7.5)	Not Present
-Reporting cell status (10.3.7.61)	
-CHOICE <i>reported cell</i>	Report all active set cells + cells within monitored set on used frequency
-Maximum number of reported cells	2
-Measurement validity (10.3.7.51)	Not Present
-CHOICE <i>report criteria</i>	Intra-frequency measurement reporting criteria
-Intra-frequency measurement reporting criteria (10.3.7.39)	
-Parameters required for each event	1
-Intra-frequency event identity	Event 1G
-Triggering condition 2	Not Present
-Reporting Range Constant	Not Present
-Cells forbidden to affect Reporting Range	Not Present
-CHOICE <i>mode</i>	TDD
-Primary CCPCH info (10.3.6.57)	
-CHOICE <i>mode</i>	TDD
-CHOICE <i>TDD option</i>	3.84 Mcps
-CHOICE <i>sync case</i>	Case 2
-Timeslot	0
-Cell parameters ID	0
-SCTD indicator	FALSE
-W	Not Present
-Hysteresis	0 dB
-Threshold used frequency	Not Present
-Reporting deactivation threshold	Not Present
-Replacement activation threshold	Not Present
-Time to trigger	0 ms

Information Element/Group name	Value/Remark
-Amount of reporting -Reporting interval -Reporting cell status	Infinity 0 ms (Note 2) Not Present
Physical channel information elements -DPCH compressed mode status info (10.3.6.34)	Not Present
Note 1: The SFN-CFN observed time difference is calculated from the OFF and Tm parameters contained in the IE "Cell synchronisation information", TS 25.331, clause 10.3.7.6. According to TS 25.331, 8.6.7.7, this IE is included in MEASUREMENT REPORT if IE "Cell synchronisation information reporting indicator" in IE "Cell reporting quantities" TS 25.331, clause 10.3.7.5 is set to TRUE in MEASUREMENT CONTROL.	
Note 2: Reporting interval = 0 ms means no periodical reporting	

PHYSICAL CHANNEL RECONFIGURATION message (step 7):

Information Element	Value/Remark
Message Type	
UE Information Elements	
-RRC transaction identifier	0
-Integrity check info	Not Present
-Integrity protection mode info	Not Present
-Ciphering mode info	Not Present
-Activation time	At T3
-New U-RNTI	Not Present
-New C-RNTI	Not Present
-RRC State Indicator	CELL_DCH
-UTRAN DRX cycle length coefficient	Not Present
CN Information Elements	
-CN Information info	Not Present
UTRAN mobility information elements	
-URA identity	Not Present
RB information elements	
-Downlink counter synchronisation info	Not Present
-RB with PDCP information list	Not Present
-RB with PDCP information	Not Present
PhyCH information elements	
-Frequency info (10.3.6.36)	
-CHOICE <i>mode</i>	TDD
-UARFCN (Nt)	Same UARFCN as used for cell 2
Uplink radio resources	
-Maximum allowed UL TX power	33 dBm
-CHOICE <i>channel requirement</i>	Uplink DPCH info
-Uplink DPCH info (10.3.6.88)	
-Uplink DPCH power control info (10.3.6.91)	
-CHOICE <i>mode</i>	TDD
-CHOICE <i>TDD option</i>	3.84 Mcps TDD
-UL Target SIR	Not Present
-CHOICE <i>UL OL PC info</i>	Individually signalled
-CHOICE <i>TDD option</i>	3.84 Mcps TDD
-Individual Timeslot interference info	1
-Individual timeslot interference (10.3.6.38)	
-Timeslot Number (10.3.6.84)	
-CHOICE <i>TDD option</i>	3.84 Mcps TDD
-Timeslot number	12
-UL Timeslot Interference	-90 dBm
-CHOICE <i>mode</i>	TDD
-Uplink timing advance control (10.3.6.96)	
-CHOICE <i>Timing Advance</i>	Disabled
-UL CCTrCH list	1
-UL Target SIR	TBD dB
-Time Info (10.3.6.83)	
-Activation Time	T3
-Duration	Infinite
-Common timeslot info	Not Present
-Uplink DPCH timeslots and codes (10.3.6.94)	
-Dynamic SF Usage	False
-First individual timeslot info (10.3.6.37)	
-Timeslot Number (10.3.6.84)	
-CHOICE <i>TDD option</i>	3.84 Mcps
-Timeslot number	12
-TFCl existence	True
-Midamble shift and burst type (10.3.6.41)	
-Choice <i>TDD option</i>	3.84 Mcps
-Choice Burst Type	Type 1
-Midamble Allocation Mode	Default
-Midamble configuration burst type 1 and 3	16
-Midamble shift	Not present
-CHOICE <i>TDD option</i>	3.84 Mcps
-First timeslot code list	1
-Channelisation code	8/1
-Choice more timeslots	No more timeslots

Information Element	Value/Remark
Downlink radio resources	
-CHOICE <i>mode</i>	TDD
-Downlink information common for all radio links (10.3.6.24)	
-Downlink DPCH info common for all RL (10.3.6.18)	
-Timing indicator	Initialise
-CFN-targetSFN frame offset	Not Present
-Downlink DPCH power control information (10.3.6.23)	
-CHOICE <i>mode</i>	TDD
-TPC Step size	1 dB
-CHOICE <i>mode</i>	TDD
-CHOICE <i>mode</i>	TDD
-CHOICE <i>TDD option</i>	3.84 Mcps
-TX Diversity mode (10.3.6.86)	None
-Default DPCH Offset Value (10.3.6.16)	0
-Downlink information per radio link list	1
-Downlink information for each radio link (10.3.6.27)	
-CHOICE <i>mode</i>	TDD
-Primary CCPCH info (10.3.6.57)	
-CHOICE <i>mode</i>	TDD
-CHOICE <i>TDD option</i>	3.84 Mcps
-CHOICE <i>sync case</i>	Case 2
-Timeslot	0
-Cell parameters ID	20
-SCTD indicator	False
-Downlink DPCH info for each RL (10.3.6.21)	
-CHOICE <i>mode</i>	TDD
-DL CCTrCH list	1
-TFCS ID	Not Present
-Time Info (10.3.6.83)	
-Activation Time	T3
-Duration	Infinite
-Common timeslot info	Not Present
-Downlink DPCH timeslots and codes (10.3.6.32)	
-First individual timeslot info (10.3.6.37)	
-Timeslot Number (10.3.6.84)	
-CHOICE <i>TDD option</i>	3.84 Mcps
-Timeslot number	5
-TFCI existence	True
-Midamble shift and burst type (10.3.6.41)	
-CHOICE <i>TDD option</i>	3.84 Mcps
-CHOICE <i>Burst Type</i>	Type 1
-Midamble Allocation Mode	Default
-Midamble configuration burst type 1 and 3	16
-Midamble shift	Not present
-CHOICE <i>TDD option</i>	3.84 Mcps
-First timeslot channelisation codes (10.3.6.17)	
-CHOICE <i>codes representation</i>	Consecutive codes
-First channelisation code	16/1
-Last channelisation code	16/2
-CHOICE <i>more timeslots</i>	No more timeslots
-SCCPCH information for FACH (10.3.6.70)	Not Present

MEASUREMENT REPORT message for Intra frequency test cases

This message is common for all intra frequency test cases in clause 8.7 and is described in Annex I.

8.3.1.1.5 Test requirements

For the test to pass, the total number of successful tests shall be more than [FFS] of the cases.

Note: If the above Test Requirement differs from the Minimum Requirement then the Test Tolerance applied for this test is non-zero. The Test Tolerance for this test is defined in clause F.2 and the explanation of how the Minimum Requirement has been relaxed by the Test Tolerance is given in clause F.4.

8.3.1.2 Handover to inter-frequency cell

8.3.1.2.1 Definition and applicability

Handover delay of the UE is defined as the time from the end of the last TTI containing an RRC message implying hard handover to the transmission of the new uplink DPCH, excluding the RRC procedure delay as defined in [9].

The requirements and this test apply to the UTRA TDD UE.

8.3.1.2.2 Minimum requirement

The hard handover delay shall be less than 40 ms in the dual carrier case when the cell is known by the UE and the SFN of the target cell needs to be decoded. The rate of correct handovers observed during repeated tests shall be at least 90% with a confidence level of [FFS]%.

The normative reference for this requirement is TS 25.123 [2] clauses 5.1.2 and A.5.1.2.

8.3.1.2.3 Test purpose

The purpose of this test is to verify the requirement for the inter-frequency handover delay in CELL_DCH state in the dual carrier case.

8.3.1.2.4 Method of test

8.3.1.2.4.1 Initial conditions

Test environment: normal; see clauses G.2.1 and G.2.2.

Frequencies to be tested: mid range; see clause G.2.4.

The test parameters are given in table 8.3.1.2.1 and 8.3.1.2.2. In the measurement control information it is indicated to the UE that event-triggered reporting with Event 2C shall be used. The PCCPCH RSCP and SFN-CFN observed time difference of the best cell on the unused frequency shall be reported together with Event 2C reporting. At the start of time duration T1, the UE may not have any timing information of cell 2.

UTRAN shall send a Physical Channel reconfiguration message with activation time at beginning of T3 with one active cell, cell 2. The Physical Channel reconfiguration message shall be sent to the UE such that the delay between the end of the last received TTI containing the message and the beginning of T3 is at least equal to the RRC procedure delay as defined in [16].

The second Beacon timeslot shall be provided in timeslot 8 for cell 1 and in timeslot 10 for cell 2. The UL DPCH shall be transmitted in timeslot 12.

Table 8.3.1.2.1: General test parameters for Handover to inter-frequency cell

Parameter		Unit	Value	Comment
DCH parameters			DL Reference Measurement Channel 12.2 kbps	As specified in TS 25.102 clause A.2.2
Power Control			On	
Target quality value on DTCH		BLER	0.01	
Initial conditions	Active cell		Cell 1	
	Neighbour cell		Cell 2	
Final condition	Active cell		Cell 2	
HCS			Not used	
O		dB	0	Cell individual offset. This value shall be used for all cells in the test.
Hysteresis		dB	0	Hysteresis parameter for event 2C
Time to Trigger		ms	0	
Threshold non-used frequency		dBm	-80	Applicable for Event 2C
Filter coefficient			0	
Monitored cell list size			6 TDD neighbours on Channel 1 6 TDD neighbours on Channel 2	
T _{SI}		s	1,28	The value shall be used for all cells in the test.
T1		s	10	
T2		s	10	
T3		s	10	

Table 8.3.1.2.2: Cell Specific parameters for Handover to inter-frequency cell

Parameter	Unit	Cell 1						Cell 2					
		0			4			2			5		
DL timeslot number		T1	T2	T3	T1	T2	T3	T1	T2	T3	T1	T2	T3
UTRA RF Channel Number		Channel 1						Channel 2					
PCCPCH_Ec/I _{or}	dB	-3			n.a.			-3			n.a.		
SCH_Ec/I _{or}	dB	-9			n.a.			-9			n.a.		
SCH_t _{offset}	dB	0			n.a.			5			n.a.		
DPCH_Ec/I _{or}	dB	n.a.			Note 1		n.a.	n.a.			n.a.		Note 1
OCNS_Ec/I _{or}	dB	-3,12			Note 2		n.a.	n.a.	-3,12		n.a.		Note 2
\hat{I}_{or}/I_{oc}	dB	1						-Inf.	7		-Inf.	7	
PCCPCH RSCP	dBm	-72			n.a.			-Inf.	-66		n.a.		
I _{oc}	dBm/ 3,84 MHz	-70											
Propagation Condition		AWGN											
Note 1: The DPCH level is controlled by the power control loop													
Note 2: The power of the OCNS channel that is added shall make the total power from the cell to be equal to I _{or} .													

8.3.1.2.4.2 Procedure

- 1) The RF parameters are set up according to T1.
- 2) The UE is switched on.
- 3) A call is set up according to the test procedure specified in TS 34.108 [3] subclause 7.3.4.

[Editor's note: subclause 7.3.4 in TS 34.108 (Message sequence chart for Handover Test procedure) is not yet specified]

- 4) SS shall transmit a MEASUREMENT CONTROL message.

- 5) After 10 seconds, the SS shall switch the power settings from T1 to T2.
- 6) UE shall transmit a MEASUREMENT REPORT message triggered by event 2C.
- 7) SS shall transmit a PHYSICAL CHANNEL RECONFIGURATION message with activation time at T3.
- 8) After 10 seconds, the SS shall switch the power settings from T2 to T3
- 9) UE shall transmit a PHYSICAL CHANNEL RECONFIGURATION COMPLETE message on the UL DCCH of cell 2. If the UE transmits the UL DPCH to cell 2 less than 40 ms from the beginning of time period T3 then the number of successful tests is increased by one.
- 10) After 10 seconds, the UE is switched off. Any timing information of cell 2 is deleted in the UE.
- 11) Repeat step 1-10 [TBD] times.

Specific Message Contents

All messages indicated above shall use the same content as described in the default message content in clause 9 of 34.108 [3] and in Annex A of 34.123-1 [21], with the following exceptions:

MEASUREMENT CONTROL message, event 2C (step 4):

Information Element/Group name	Value/Remark
Message Type (10.2.17)	
UE information elements -RRC transaction identifier -Integrity check info	0 Not Present
Measurement Information elements -Measurement Identity -Measurement Command (10.3.7.46) -Measurement Reporting Mode (10.3.7.49) -Measurement Report Transfer Mode -Periodical Reporting / Event Trigger Reporting Mode -Additional measurements list (10.3.7.1)	1 Modify AM RLC Event trigger Not Present
-CHOICE <i>Measurement type</i> -Inter-frequency measurement (10.3.7.16) -Inter-frequency measurement objects list (10.3.7.13) -Inter-frequency measurement quantity (10.3.7.18) -CHOICE <i>reporting criteria</i> -Inter-frequency reporting criteria -Filter coefficient -CHOICE <i>mode</i> -Measurement quantity for frequency quality estimate	Inter-frequency measurement Not Present Inter-frequency reporting criteria 0 TDD Primary CCPCH RSCP
-Inter-frequency reporting quantity (10.3.7.21) -UTRA Carrier RSSI -Frequency quality estimate -Non frequency related cell reporting quantities (10.3.7.5) -SFN-SFN observed time difference reporting indicator -Cell synchronisation information reporting indicator -Cell Identity reporting indicator -CHOICE <i>mode</i> -Timeslot ISCP reporting indicator -Proposed TGSN reporting required -Primary CCPCH RSCP reporting indicator -Pathloss reporting indicator	FALSE FALSE Type 1 TRUE TRUE TDD TRUE FALSE TRUE TRUE
-Reporting cell status (10.3.7.61) -CHOICE <i>reported cell</i> -Maximum number of reported cells per reported non-used frequency -Measurement validity (10.3.7.51) -Inter-frequency set update (10.3.7.22) -CHOICE <i>report criteria</i>	Report cells within monitored set on non-used frequency 1 Not Present Not Present Inter-frequency measurement reporting criteria
-Inter-frequency measurement reporting criteria (10.3.7.19) -Parameters required for each event -Inter-frequency event identity (10.3.7.14) -Threshold used frequency -W used frequency -Hysteresis -Time to trigger -Reporting cell status (10.3.7.61) -CHOICE <i>reported cell</i> -Maximum number of reported cells per reported non-used frequency -Parameters required for each non-used frequency -Threshold non-used frequency -W non-used frequency	1 Event 2C Not Present Not Present 0 dB 0 ms Report cells within monitored set on non-used frequency 1 1 -80 dBm 1
Physical channel information elements -DPCH compressed mode status info (10.3.6.34)	Not Present

PHYSICAL CHANNEL RECONFIGURATION message (step 7):

Information Element	Value/Remark
Message Type	
UE Information Elements	
-RRC transaction identifier	0
-Integrity check info	Not Present
-Integrity protection mode info	Not Present
-Ciphering mode info	Not Present
-Activation time	At T3
-New U-RNTI	Not Present
-New C-RNTI	Not Present
-RRC State Indicator	CELL_DCH
-UTRAN DRX cycle length coefficient	Not Present
CN Information Elements	
-CN Information info	Not Present
UTRAN mobility information elements	
-URA identity	Not Present
RB information elements	
-Downlink counter synchronisation info	Not Present
-RB with PDCP information list	Not Present
-RB with PDCP information	Not Present
PhyCH information elements	
-Frequency info (10.3.6.36)	TDD
-CHOICE <i>mode</i>	Same UARFCN as used for cell 2
-UARFCN (Nt)	
Uplink radio resources	
-Maximum allowed UL TX power	33 dBm
-CHOICE <i>channel requirement</i>	Uplink DPCH info
-Uplink DPCH info (10.3.6.88)	
-Uplink DPCH power control info (10.3.6.91)	
-CHOICE <i>mode</i>	TDD
-CHOICE <i>TDD option</i>	3.84 Mcps TDD
-UL Target SIR	Not Present
-CHOICE <i>UL OL PC info</i>	Individually signalled
-CHOICE <i>TDD option</i>	3.84 Mcps TDD
-Individual Timeslot interference info	1
-Individual timeslot interference (10.3.6.38)	
-Timeslot Number (10.3.6.84)	
-CHOICE <i>TDD option</i>	3.84 Mcps TDD
-Timeslot number	12
- UL Timeslot Interference	-90 dBm
-CHOICE <i>mode</i>	TDD
-Uplink timing advance control (10.3.6.96)	
-CHOICE <i>Timing Advance</i>	Disabled
-UL CCTrCH list	1
-UL Target SIR	TBD dB
-Time Info (10.3.6.83)	
-Activation Time	T3
-Duration	Infinite
-Common timeslot info	Not Present
-Uplink DPCH timeslots and codes (10.3.6.94)	
-Dynamic SF Usage	False
-First individual timeslot info (10.3.6.37)	
-Timeslot Number (10.3.6.84)	
-CHOICE <i>TDD option</i>	3.84 Mcps
-Timeslot number	12
-TFCl existence	True
-Midamble shift and burst type (10.3.6.41)	
-CHOICE <i>TDD option</i>	3.84 Mcps
-CHOICE <i>Burst Type</i>	Type 1
-Midamble Allocation Mode	Default
-Midamble configuration burst type 1 and 3	16
-Midamble shift	Not present
-CHOICE <i>TDD option</i>	3.84 Mcps
-First timeslot code list	1
-Channelisation code	8/1
-CHOICE <i>more timeslots</i>	No more timeslots

Information Element	Value/Remark
Downlink radio resources	
-CHOICE <i>mode</i>	TDD
-Downlink information common for all radio links (10.3.6.24)	
-Downlink DPCH info common for all RL (10.3.6.18)	
-Timing indicator	Initialise
-CFN-targetSFN frame offset	Not Present
-Downlink DPCH power control information (10.3.6.23)	
-CHOICE <i>mode</i>	TDD
-TPC Step size	1 dB
-CHOICE <i>mode</i>	TDD
-CHOICE <i>mode</i>	TDD
-CHOICE <i>TDD option</i>	3.84 Mcps
-TX Diversity mode (10.3.6.86)	None
-Default DPCH Offset Value (10.3.6.16)	0
-Downlink information per radio link list	1
-Downlink information for each radio link (10.3.6.27)	
-CHOICE <i>mode</i>	TDD
-Primary CCPCH info (10.3.6.57)	
- CHOICE <i>mode</i>	TDD
- CHOICE <i>TDD option</i>	3.84 Mcps
- CHOICE <i>sync case</i>	Case 2
- Timeslot	2
- Cell parameters ID	20
- SCTD indicator	False
-Downlink DPCH info for each RL (10.3.6.21)	
-CHOICE <i>mode</i>	TDD
- DL CCTrCH list	1
-TFCS ID	Not Present
-Time Info (10.3.6.83)	
-Activation Time	T3
-Duration	Infinite
-Common timeslot info	Not Present
- Downlink DPCH timeslots and codes (10.3.6.32)	
- First individual timeslot info (10.3.6.37)	
- Timeslot Number (10.3.6.84)	
- CHOICE <i>TDD option</i>	3.84 Mcps
- Timeslot number	5
- TFCI existence	True
- Midamble shift and burst type (10.3.6.41)	
- CHOICE <i>TDD option</i>	3.84 Mcps
- CHOICE <i>Burst Type</i>	Type 1
- Midamble Allocation Mode	Default
- Midamble configuration burst type 1 and 3	16
- Midamble shift	Not present
- CHOICE <i>TDD option</i>	3.84 Mcps
- First timeslot channelisation codes (10.3.6.17)	
- CHOICE <i>codes representation</i>	Consecutive codes
- First channelisation code	16/1
- Last channelisation code	16/2
- CHOICE <i>more timeslots</i>	No more timeslots
- SCCPCH information for FACH (10.3.6.70)	Not Present

MEASUREMENT REPORT message for Inter frequency test cases

This message is common for all inter frequency TDD test cases in clause 8.7 and is described in Annex I.

8.3.1.2.5 Test requirements

For the test to pass, the total number of successful tests shall be more than [FFS] of the cases.

Note: If the above Test Requirement differs from the Minimum Requirement then the Test Tolerance applied for this test is non-zero. The Test Tolerance for this test is defined in clause F.2 and the explanation of how the Minimum Requirement has been relaxed by the Test Tolerance is given in clause F.4.

8.3.2 TDD/FDD Handover

8.3.2.1 Definition and applicability

Handover delay of the UE is defined as the time from the end of the last TTI containing an RRC message implying hard handover to the transmission of the new uplink DPCCH, excluding the RRC procedure delay as defined in [9].

The requirements and this test apply to the UTRA TDD / FDD UE.

8.3.2.2 Minimum requirement

The hard handover delay shall be less than 100 ms in the single carrier case when the cell is known by the UE and the SFN of the target cell does not need to be decoded. The rate of correct handovers observed during repeated tests shall be at least 90% with a confidence level of [FFS]%.

The normative reference for this requirement is TS 25.123 [2] clauses 5.2 and A.5.2.

8.3.2.3 Test purpose

The purpose of this test is to verify the requirement for the TDD/FDD handover delay in CELL_DCH state.

8.3.2.4 Method of test

8.3.2.4.1 Initial conditions

Test environment: normal; see clauses G.2.1 and G.2.2.

Frequencies to be tested: mid range; see clause G.2.4.

The test parameters are given in table 8.3.2.1, 8.3.2.2 and 8.3.2.3 below. In the measurement control information it is indicated to the UE that event-triggered reporting with Event 1G and 2B shall be used. The CPICH_RSCP of the best cell on the unused frequency shall be reported together with Event 2B reporting. The test consists of three successive time periods, with a time duration of T1, T2 and T3 respectively. At the start of time duration T1, the UE may not have any timing information of cell 2.

UTRAN shall send a Physical Channel reconfiguration message with activation time at the beginning of T3 with a new active cell, cell 2. The Physical Channel reconfiguration message shall be sent to the UE such that the delay between the end of the last received TTI containing the message and the beginning of T3 is at least equal to the RRC procedure delay as defined in [16].

Table 8.3.2.1: General test parameters for TDD/FDD handover

Parameter	Unit	Value	Comment
DCH parameters		DL Reference Measurement Channel 12.2 kbps	As specified in TS 25.102 clause A.2.2
Power Control		On	
Target quality value on DTCH	BLER	0.01	
Initial conditions	Active cell	Cell 1	TDD cell
	Neighbour cell	Cell 2	FDD cell
Final condition	Active cell	Cell 2	FDD cell
HCS		Not used	
O	dB	0	Cell individual offset. This value shall be used for all cells in the test.
Hysteresis	dB	3	Hysteresis parameter for event 2B
Time to Trigger	ms	0	
Absolute threshold used frequency	dBm	-71	Applicable for Event 2B
Threshold non-used frequency	dBm	-80	Applicable for Event 2B
W used frequency		1	Applicable for Event 2B
W non-used frequency		1	Applicable for Event 2B
Filter coefficient		0	
Monitored cell list size		6 TDD neighbours on Channel 1 6 FDD neighbours on Channel 2	
T _{SI}	s	1.28	The value shall be used for all cells in the test.
T1	s	5	
T2	s	15	
T3	s	5	

Table 8.3.2.2: Cell 1 specific test parameters for TDD/FDD handover

Parameter	Unit	Cell 1					
DL timeslot number		0			2		
		T1	T2	T3	T1	T2	T3
UTRA RF Channel Number		Channel 1					
PCCPCH_Ec/I _{or}	dB	-3			n.a.		
SCH_Ec/I _{or}	dB	-9			n.a.		
SCH_t _{offset}	dB	0			n.a.		
DPCH_Ec/I _{or}	dB	n.a.			Note 1		n.a.
OCNS_Ec/I _{or}	dB	-3,12			Note 2		n.a.
\hat{I}_{or}/I_{oc}	dB	5	-1		5	-1	
PCCPCH RSCP	dBm	-68	-74		n.a.		
I _{oc}	dBm/ 3,84 MHz	-70					
Propagation Condition		AWGN					
Note 1: The DPCH level is controlled by the power control loop							
Note 2: The power of the OCNS channel that is added shall make the total power from the cell to be equal to I _{or} .							

Table 8.3.2.3: Cell 2 specific test parameters for TDD/FDD handover

Parameter	Unit	Cell 2	
		T1, T2	T3
CPICH_Ec/I _{or}	dB	-10	
PCCPCH_Ec/I _{or}	dB	-12	
SCH_Ec/I _{or}	dB	-12	
PICH_Ec/I _{or}	dB	-15	
DPCH_Ec/I _{or}	dB	n.a.	Note 1
OCNS_Ec/I _{or}	dB	-0,941	Note 2
CPICH_RSCP	dBm	-83	-77
\hat{I}_{or}/I_{oc}	dB	-3	3
I_{oc}	dBm/3. 84 MHz	-70	
Propagation Condition		AWGN	
Note 1: The DPCH level is controlled by the power control loop			
Note 2 : The power of the OCNS channel that is added shall make the total power from the cell to be equal to I _{or}			

8.3.2.4.2 Procedure

- 1) The RF parameters are set up according to T1.
- 2) The UE is switched on.
- 3) A call is set up according to the test procedure specified in TS 34.108 [3] subclause 7.3.4.

[Editor's note: subclause 7.3.4 in TS 34.108 (Message sequence chart for Handover Test procedure) is not yet specified]

- 4) SS shall transmit a MEASUREMENT CONTROL message.
- 5) After 5 seconds, the SS shall switch the power settings from T1 to T2.
- 6) UE shall transmit a MEASUREMENT REPORT message triggered by event 2B.
- 7) SS shall transmit a PHYSICAL CHANNEL RECONFIGURATION message with activation time at T3.
- 8) After 15 seconds, the SS shall switch the power settings from T2 to T3
- 9) UE shall transmit a PHYSICAL CHANNEL RECONFIGURATION COMPLETE message on the UL DCCH of cell 2. If the UE transmits the UL DPCCCH to cell 2 less than 100 ms from the beginning of time period T3 then the number of successful tests is increased by one.
- 10) After 5 seconds, the UE is switched off. Any timing information of cell 2 is deleted in the UE.
- 11) Repeat step 1-10 [TBD] times.

Specific Message Contents

All messages indicated below shall use the same content as described in the default message content in clause 9 of 34.108 [3] and in Annex A of 34.123-1 [21], with the following exceptions:

MEASUREMENT CONTROL message, event 2B (step 4):

Information Element/Group name	Value/Remark
Message Type (10.2.17)	
UE information elements -RRC transaction identifier -Integrity check info	0 Not Present
Measurement Information elements -Measurement Identity -Measurement Command (10.3.7.46) -Measurement Reporting Mode (10.3.7.49) -Measurement Report Transfer Mode -Periodical Reporting / Event Trigger Reporting Mode -Additional measurements list (10.3.7.1)	1 Modify AM RLC Event trigger Not Present
-CHOICE <i>Measurement type</i> -Inter-frequency measurement (10.3.7.16) -Inter-frequency measurement objects list (10.3.7.13) -Inter-frequency measurement quantity (10.3.7.18) -CHOICE <i>reporting criteria</i> -Inter-frequency reporting criteria -Filter coefficient -CHOICE <i>mode</i> -Measurement quantity for frequency quality estimate	Inter-frequency measurement Not Present Inter-frequency reporting criteria 0 FDD CPICH RSCP
-Inter-frequency reporting quantity (10.3.7.21) -UTRA Carrier RSSI -Frequency quality estimate -Non frequency related cell reporting quantities (10.3.7.5) -SFN-SFN observed time difference reporting indicator -Cell synchronisation information reporting indicator -Cell Identity reporting indicator -CHOICE <i>mode</i> -CPICH Ec/N0 reporting indicator -CPICH RSCP reporting indicator -Pathloss reporting indicator	FALSE FALSE Type 1 TRUE TRUE FDD TRUE TRUE TRUE
-Reporting cell status (10.3.7.61) -CHOICE <i>reported cell</i> -Maximum number of reported cells per reported non-used frequency -Measurement validity (10.3.7.51) -Inter-frequency set update (10.3.7.22) -CHOICE <i>report criteria</i>	Report cells within monitored set on non-used frequency 1 Not Present Not Present Inter-frequency measurement reporting criteria
-Inter-frequency measurement reporting criteria (10.3.7.19) -Parameters required for each event -Inter-frequency event identity (10.3.7.14) -Threshold used frequency -W used frequency -Hysteresis -Time to trigger -Reporting cell status (10.3.7.61) -CHOICE <i>reported cell</i> -Maximum number of reported cells per reported non-used frequency -Parameters required for each non-used frequency -Threshold non-used frequency -W non-used frequency	1 Event 2B -71 dBm 1 0 dB 0 ms Report cells within monitored set on non-used frequency 1 1 -80 dBm 1
Physical channel information elements -DPCH compressed mode status info (10.3.6.34)	Not Present

PHYSICAL CHANNEL RECONFIGURATION message (step 7):

Information Element	Value/Remark
Message Type	
UE Information Elements	
-RRC transaction identifier	0
-Integrity check info	Not Present
-Integrity protection mode info	Not Present
-Ciphering mode info	Not Present
-Activation time	At T3
-New U-RNTI	Not Present
-New C-RNTI	Not Present
-RRC State Indicator	CELL_DCH
-UTRAN DRX cycle length coefficient	Not Present
CN Information Elements	
-CN Information info	Not Present
UTRAN mobility information elements	
-URA identity	Not Present
RB information elements	
-Downlink counter synchronisation info	Not Present
-RB with PDCP information list	Not Present
-RB with PDCP information	Not Present
PhyCH information elements	
-Frequency info (10.3.6.36)	FDD
-CHOICE <i>mode</i>	Same uplink UARFCN as used for cell 2
-UARFCN uplink(Nu)	Same downlink UARFCN as used for cell 2
-UARFCN downlink(Nd)	
Uplink radio resources	
-Maximum allowed UL TX power	33 dBm
-CHOICE <i>channel requirement</i>	Uplink DPCH info
-Uplink DPCH info (10.3.6.88)	
-Uplink DPCH power control info (10.3.6.91)	
-CHOICE <i>mode</i>	FDD
-DPCCH power offset	-6dB
- PC Preamble	1 frame
- SRB delay	7 frames
- Power Control Algorithm	Algorithm1
- TPC step size	1dB
-CHOICE <i>mode</i>	FDD
-Scrambling code type	Long
-Scrambling code number	0 (0 to 16777215)
-Number of DPDCH	Not Present(1)
-Spreading factor	SF is reference to TS34.108 clause 6.10 Parameter Set
-TFCI existence	TRUE
-Number of FBI bit	Not Present(0)
-Puncturing Limit	Reference to TS34.108 clause 6.10 Parameter Set
Downlink radio resources	
-CHOICE <i>mode</i>	FDD
-Downlink PDSCH information	Not Present
-Downlink information common for all radio links (10.3.6.24)	
-Downlink DPCH info common for all RL (10.3.6.18)	
-Timing indicator	Initialise
-CFN-targetSFN frame offset	Not Present
-Downlink DPCH power control information (10.3.6.23)	
-DPC mode	0 (single)
-CHOICE <i>mode</i>	FDD
-Power offset $P_{Pilot-DPDCH}$	TBD
-DL rate matching restriction information	Not Present
-Spreading factor	Reference to TS34.108 clause 6.10 Parameter Set
-Fixed or Flexible Position	Flexible
-TFCI existence	TRUE
-CHOICE <i>SF</i>	Not Present
-Number of bits for Pilot bits(SF=128,256)	Not Present
-CHOICE <i>mode</i>	FDD
-DPCH compressed mode info (10.3.6.33)	Not Present (Note 1)

Information Element	Value/Remark
-TX Diversity mode (10.3.6.86)	None
-SSDT information (10.3.6.77)	Not Present
-Default DPCH Offset Value (10.3.6.16)	0
-Downlink information per radio link list	1
-Downlink information for each radio link (10.3.6.27)	
-CHOICE <i>mode</i>	FDD
-Primary CPICH info (10.3.6.60)	
-Primary scrambling code	350
-PDSCH with SHO DCH info (10.3.6.47)	Not Present
-PDSCH code mapping (10.3.6.43)	Not Present
-Downlink DPCH info for each RL (10.3.6.21)	
-CHOICE <i>mode</i>	FDD
-Primary CPICH usage for channel estimation	Primary CPICH may be used
-DPCH frame offset	0 chips
-Secondary CPICH info	Not Present
-DL channelisation code	
-Secondary scrambling code	1
-Spreading factor	Reference to TS34.108 clause 6.10 Parameter Set
-Code number	SF-1(SF is reference to TS34.108 clause 6.10 Parameter Set)
-Scrambling code change	No change
-TPC combination index	0
-SSDT Cell Identity	-a
-Closed loop timing adjustment mode	Not Present
-SCCPCH information for FACH (10.3.6.70)	Not Present
Note 1: IE "DPCH compressed mode info" is not needed as default values are applied that have previously been received in RADIO BEARER SETUP or RRC CONNECTION SETUP	

MEASUREMENT REPORT message for Inter frequency test cases

This message is common for all inter frequency FDD test cases in clause 8.7 and is described in Annex I.

8.3.2.5 Test requirements

For the test to pass, the total number of successful tests shall be more than [FFS] of the cases.

Note: If the above Test Requirement differs from the Minimum Requirement then the Test Tolerance applied for this test is non-zero. The Test Tolerance for this test is defined in clause F.2 and the explanation of how the Minimum Requirement has been relaxed by the Test Tolerance is given in clause F.4.

8.3.3 TDD/GSM Handover

Void.

8.3.4 Cell Re-selection in CELL_FACH

8.3.4.1 Scenario 1: TDD/TDD cell re-selection single carrier case

8.3.4.1.1 Definition and applicability

The cell re-selection delay is defined as the time from a change of cell levels to the moment when this change causes the UE to camp on a new cell, and starts to send the CELL UPDATE message with cause value "cell reselection" in the new cell.

The requirements and this test apply to the TDD UE.

8.3.4.1.2 Minimum requirement

The cell re-selection delay shall be less than 2,5 s. The rate of correct cell re-selections observed during repeated tests shall be at least 90%.

The normative reference for this requirement is TS 25.123 [2] clauses 5.4.2 and A.5.4.1.

8.3.4.1.3 Test purpose

This test verifies that the UE meets the minimum requirement for the cell re-selection delay in CELL_FACH for the single carrier case.

8.3.4.1.4 Method of test

8.3.4.1.4.1 Initial conditions

This scenario contains 6 cells operating on the same carrier frequency. The test parameters are given in Tables 8.3.4.1.1, 8.3.4.1.2, 8.3.4.1.3, and 8.3.4.1.4.

Table 8.3.4.1.1: General test parameters for Cell Re-selection in CELL_FACH

Parameter		Unit	Value	Comment
Initial condition	Active cell		Cell1	
	Neighbour cells		Cell2, Cell3, Cell4, Cell5, Cell6	
Final condition	Active cell		Cell2	
HCS			Not used	
UE_TXPWR_MAX_RACH		dBm	21	The value shall be used for all cells in the test.
Qrxlevmin		dBm	-102	The value shall be used for all cells in the test.
Access Service Class (ASC#0) - Persistence value		-	1	Selected so that no additional delay is caused by the random access procedure. The value shall be used for all cells in the test.
T _{SI}		s	1,28	The value shall be used for all cells in the test.
T1		s	15	
T2		s	15	

Table 8.3.4.1.2: Physical channel parameters for S-CCPCH.

Parameter	Unit	Level
Channel bit rate	Kbps	24,4
Channel symbol rate	Ksps	12,2
Slot Format #	-	0
Frame allocation	-	Continuous frame allocation
Midamble allocation	-	Default Midamble

Table 8.3.4.1.3: Transport channel parameters for S-CCPCH

Parameter	FACH
Transport Channel Number	1
Transport Block Size	240
Transport Block Set Size	240
Transmission Time Interval	20 ms
Type of Error Protection	Convolutional Coding
Coding Rate	1/2
Rate Matching attribute	256
Size of CRC	16

Table 8.3.4.1.4: Cell specific test parameters for Cell Re-selection in CELL_FACH

Parameter	Unit	Cell 1				Cell 2				Cell 3			
		0		8		0		8		0		8	
Timeslot Number		T1	T2	T1	T2	T1	T2	T1	T2	T1	T2	T1	T2
UTRA RF Channel Number		Channel 1				Channel 1				Channel 1			
PCCPCH_Ec/lor	dB	-3	-3			-3	-3			-3	-3		
SCH_Ec/lor	dB	-9	-9	-9	-9	-9	-9	-9	-9	-9	-9	-9	-9
SCH_offset		0	0	0	0	5	5	5	5	10	10	10	10
PICH_Ec/lor	dB			-3	-3			-3	-3			-3	-3
OCNS_Ec/lor	dB	-4,28	-4,28	-4,28	-4,28	-4,28	-4,28	-4,28	-4,28	-4,28	-4,28	-4,28	-4,28
\hat{I}_{or}/I_{oc}	dB	9	7	9	7	7	9	7	9	-1	-1	-1	-1
PCCPCH RSCP	dBm	-64	-66			-66	-64			-74	-74		
Qoffset1 _{s,n}	dB	C1, C2: 0; C1, C3:0; C1,C4:0 C1, C5:0; C1,C6:0				C2, C1: 0; C2, C3:0; C2,C4:0 C2, C5: 0; C2, C6:0				C3, C1: 0; C3, C2:0; C3,C4:0 C3, C5: 0; C3, C6:0			
Qhyst1 _s	dB	0				0				0			
Treselection		0				0				0			
Sintrasearch	dB	not sent				not sent				not sent			
FACH measurement occasion info		not sent				not sent				not sent			
I_{oc}	dBm/3, 84 MHz	-70											
Propagation Condition		AWGN											
Parameter	Unit	Cell 4				Cell 5				Cell 6			
		0		8		0		8		0		8	
Timeslot		T1	T2	T1	T2	T1	T2	T1	T2	T1	T2	T1	T2
UTRA RF Channel Number		Channel 1				Channel 1				Channel 1			
PCCPCH_Ec/lor	dB	-3	-3			-3	-3			-3	-3		
SCH_Ec/lor	dB	-9	-9	-9	-9	-9	-9	-9	-9	-9	-9	-9	-9
SCH_offset		15	15	15	15	20	20	20	20	25	25	25	25
PICH_Ec/lor	dB			-3	-3			-3	-3			-3	-3
OCNS_Ec/lor	dB	-4,28	-4,28	-4,28	-4,28	-4,28	-4,28	-4,28	-4,28	-4,28	-4,28	-4,28	-4,28
\hat{I}_{or}/I_{oc}	dB	-1	-1	-1	-1	-1	-1	-1	-1	-1	-1	-1	-1
PCCPCH RSCP	dBm	-74	-74			-74	-74			-74	-74		
Qoffset1 _{s,n}	dB	C4, C1: 0; C4, C2:0; C4,C3:0 C4, C5:0; C4, C6:0				C5, C1: 0; C5, C2:0; C5,C3:0 C5, C4:0; C5, C6:0				C6, C1: 0; C6, C2:0; C6,C3:0 C6, C4:0; C6, C5:0			
Qhyst1 _s	dB	0				0				0			
Treselection		0				0				0			
Sintrasearch	dB	not sent				not sent				not sent			
FACH measurement occasion info		not sent				not sent				not sent			
I_{oc}	dBm/3, 84 MHz	-70											
Propagation Condition		AWGN											

Note: S-CCPCH shall not be located in TS0.

8.3.4.1.4.2 Procedure

- The SS activates cell 1-6 with T1 defined parameters.
- The UE is switched on.
- A call is set up according to the generic set-up procedure specified in TS 34.108 [3] subclause 7.4.2 to place the UE in CELL_FACH.
- After 15 s, the parameters are changed as described for T2.
- The SS waits for CELL UPDATE message with cause value "cell reselection" from the UE.

- f) After another 15 s, the parameters are changed as described for T1.
- g) The SS waits for CELL UPDATE message with cause value "cell reselection" from the UE.
- h) Repeat steps d) to g) [TBD] times.

8.3.4.1.5 Test Requirements

- 1) In step d), after the UE has responded on cell 1, it shall not respond on any other cell (cell selection).
- 2) In step e), the UE shall respond on cell 2 within 2,5 s.
- 3) In step g), the UE shall respond on cell 1 within 2,5 s.

For the test to pass, the total number of fulfilled test requirements 2) and 3) shall be more than [FFS]% of the cases.

NOTE: If the above Test Requirement differs from the Minimum Requirement then the Test Tolerance applied for this test is non-zero. The Test Tolerance for this test is defined in clause F.2 and the explanation of how the Minimum Requirement has been relaxed by the Test Tolerance is given in clause F.4.

8.3.4.2 Scenario 2: TDD/TDD cell re-selection multi carrier case

8.3.4.2.1 Definition and applicability

The cell re-selection delay is defined as the time from a change of cell levels to the moment when this change causes the UE to camp on a new cell, and starts to send the CELL UPDATE message with cause value "cell reselection" in the new cell.

The requirements and this test apply to the TDD UE.

8.3.4.2.2 Minimum requirement

The cell re-selection delay shall be less than 3 s. The rate of correct cell re-selections observed during repeated tests shall be at least 90%.

The normative reference for this requirement is TS 25.123 [2] clauses 5.4.2 and A.5.4.2.

8.3.4.2.3 Test purpose

This test verifies that the UE meets the requirement for the cell re-selection delay in CELL_FACH for the multi carrier case.

8.3.4.2.4 Method of test

8.3.4.2.4.1 Initial conditions

This scenario contains 6 cells and 2 carrier frequencies. The test parameters are given in Tables 8.3.4.2.1, 8.3.4.2.2, 8.3.4.2.3, and 8.3.4.2.4.

Table 8.3.4.2.1: General test parameters for Cell Re-selection in CELL_FACH

Parameter	Unit	Value	Comment
Initial condition	Active cell	Cell1	
	Neighbour cells	Cell2, Cell3, Cell4, Cell5, Cell6	
Final condition	Active cell	Cell2	
HCS		Not used	
UE_TXPWR_MAX_RACH	dBm	21	The value shall be used for all cells in the test.
Qrxlevmin	dBm	-102	The value shall be used for all cells in the test.
Access Service Class (ASC#0) - Persistence value	-	1	Selected so that no additional delay is caused by the random access procedure. The value shall be used for all cells in the test.
T _{SI}	s	1,28	The value shall be used for all cells in the test.
T1	s	15	
T2	s	15	

Table 8.3.4.2.2: Physical channel parameters for S-CCPCH.

Parameter	Unit	Level
Channel bit rate	Kbps	24,4
Channel symbol rate	Ksps	12,2
Slot Format #	-	0
Frame allocation	-	Continuous frame allocation
Midamble allocation	-	Default Midamble

Table 8.3.4.2.3: Transport channel parameters for S-CCPCH

Parameter	FACH
Transport Channel Number	1
Transport Block Size	240
Transport Block Set Size	240
Transmission Time Interval	20 ms
Type of Error Protection	Convolutional Coding
Coding Rate	1/2
Rate Matching attribute	256
Size of CRC	16

Table 8.3.4.2.4: Cell specific test parameters for Cell Re-selection in CELL_FACH

Parameter	Unit	Cell 1				Cell 2				Cell 3			
		0	8	0	8	0	8	0	8				
Timeslot Number		T1	T2	T1	T2	T1	T2	T1	T2	T1	T2	T1	T2
UTRA RF Channel Number		Channel 1				Channel 2				Channel 1			
PCCPCH_Ec/lor	dB	-3	-3			-3	-3			-3	-3		
SCH_Ec/lor	dB	-9	-9	-9	-9	-9	-9	-9	-9	-9	-9	-9	-9
SCH _↑ offset		0	0	0	0	5	5	5	5	10	10	10	10
PICH_Ec/lor	dB			-3	-3			-3	-3			-3	-3
OCNS_Ec/lor	dB	-4,28	-4,28	-4,28	-4,28	-4,28	-4,28	-4,28	-4,28	-4,28	-4,28	-4,28	-4,28
\hat{I}_{or}/I_{oc}	dB	9	3	9	3	3	9	3	9	-1	-1	-1	-1
PCCPCH RSCP	dBm	-64	-70			-70	-64			-74	-74		
Qoffset1 _{s,n}	dB	C1, C2: 0; C1, C3:0; C1,C4:0 C1, C5:0; C1,C6:0				C2, C1: 0; C2, C3:0; C2,C4:0 C2, C5: 0; C2, C6:0				C3, C1: 0; C3, C2:0; C3,C4:0 C3, C5: 0; C3, C6:0			
Qhyst1 _s	dB	0				0				0			
Treselection		0				0				0			
Sintrasearch	dB	not sent				not sent				not sent			
Sintersearch	dB	not sent				not sent				not sent			

FACH measurement occasion info		not sent				not sent				not sent			
Inter-frequency TDD measurement indicator		TRUE				TRUE				TRUE			
I_{oc}	dBm/3, 84 MHz	-70											
Propagation Condition		AWGN											
		Cell 4				Cell 5				Cell 6			
Timeslot		0		8		0		8		0		8	
		T1	T2	T1	T2	T1	T2	T1	T2	T1	T2	T1	T2
UTRA RF Channel Number		Channel 1				Channel 2				Channel 2			
PCCPCH_Ec/lor	dB	-3	-3			-3	-3			-3	-3		
SCH_Ec/lor	dB	-9	-9	-9	-9	-9	-9	-9	-9	-9	-9	-9	-9
SCH_offset		15	15	15	15	20	20	20	20	25	25	25	25
PICH_Ec/lor	dB			-3	-3			-3	-3			-3	-3
OCNS_Ec/lor	dB	-4,28	-4,28	-4,28	-4,28	-4,28	-4,28	-4,28	-4,28	-4,28	-4,28	-4,28	-4,28
\hat{I}_{or}/I_{oc}	dB	-1	-1	-1	-1	-1	-1	-1	-1	-1	-1	-1	-1
PCCPCH RSCP	dBm	-74	-74			-74	-74			-74	-74		
Qoffset1 _{s,n}	dB	C4, C1: 0; C4, C2:0; C4,C3:0 C4, C5:0; C4, C6:0				C5, C1: 0; C5, C2:0; C5,C3:0 C5, C4:0; C5, C6:0				C6, C1: 0; C6, C2:0; C6,C3:0 C6, C4:0; C6, C5:0			
Qhyst1 _s	dB	0				0				0			
Treselection		0				0				0			
Sintrasearch	dB	not sent				not sent				not sent			
Sintersearch	dB	not sent				not sent				not sent			
FACH measurement occasion info		not sent				not sent				not sent			
Inter-frequency TDD measurement indicator		TRUE				TRUE				TRUE			
I_{oc}	dBm/3, 84 MHz	-70											
Propagation Condition		AWGN											

Note: S-CCPCH shall not be located in TS0.

8.3.4.2.4.2 Procedure

- a) The SS activates cell 1-6 with T1 defined parameters.
- b) The UE is switched on.
- c) A call is set up according to the generic set-up procedure specified in TS 34.108 [3] subclause 7.4.2 to place the UE in CELL_FACH.
- d) After 15 s, the parameters are changed as described for T2.
- e) The SS waits for CELL UPDATE message with cause value "cell reselection" from the UE.
- f) After another 15 s, the parameters are changed as described for T1.
- g) The SS waits for CELL UPDATE message with cause value "cell reselection" from the UE.
- h) Repeat steps d) to g) [TBD] times.

8.3.4.2.5 Test Requirements

- 1) In step d), after the UE has responded on cell 1, it shall not respond on any other cell (cell selection).
- 2) In step e), the UE shall respond on cell 1 within 3 s.
- 3) In step g), the UE shall respond on cell 2 within 3 s.

For the test to pass, the total number of fulfilled test requirements 2) and 3) shall be more than [FFS]% of the cases.

NOTE: If the above Test Requirement differs from the Minimum Requirement then the Test Tolerance applied for this test is non-zero. The Test Tolerance for this test is defined in clause F.2 and the explanation of how the Minimum Requirement has been relaxed by the Test Tolerance is given in clause F.4.

8.3.5 Cell Re-selection in CELL_PCH

8.3.5.1 Scenario 1: TDD/TDD cell re-selection single carrier case

8.3.5.1.1 Definition and applicability

The cell re-selection delay is defined as the time from a change of cell levels to the moment when this change causes the UE to camp on a new cell, and starts to send the CELL UPDATE message with cause value "cell reselection" in the new cell.

The requirements and this test apply to the TDD UE.

8.3.5.1.2 Minimum requirement

The cell re-selection delay shall be less than 8 s.

NOTE:

The cell re-selection delay can be expressed as: $T_{\text{evaluateTDD}} + T_{\text{SI}}$, where:

$T_{\text{evaluateTDD}}$ A DRX cycle length of 1280ms is assumed for this test case, this leads to a $T_{\text{evaluateTDD}}$ of 6.4s according to TS 25.123 [2] table 4.1 in clause 4.2.2.7.

T_{SI} Maximum repetition period of relevant system info blocks that needs to be received by the UE to camp on a cell. 1280 ms is assumed in this test case.

This gives a total of 7.68 s, allow 8s in the test case.

The normative reference for this requirement is TS 25.123 [2] clauses 5.5 and A.5.5.1.

8.3.5.1.3 Test purpose

This test verifies that the UE meets the minimum requirement for the cell re-selection delay in CELL_PCH for the single carrier case

8.3.5.1.4 Method of test

8.3.5.1.4.1 Initial conditions

This scenario contains 6 cells operating on the same carrier frequency. The test parameters are given in Tables 8.3.5.1.1, and 8.3.5.1.2.

Table 8.3.5.1.1: General test parameters for Cell Re-selection single carrier multi-cell case

Parameter	Unit	Value	Comment
Initial condition	Active cell	Cell1	
	Neighbour cells	Cell2, Cell3, Cell4, Cell5, Cell6	
Final condition	Active cell	Cell2	
HCS		Not used	
UE_TXPWR_MAX_RACH	dBm	21	The value shall be used for all cells in the test.
Qrxlevmin	dBm	-102	The value shall be used for all cells in the test.
Access Service Class (ASC#0) - Persistence value		1	Selected so that no additional delay is caused by the random access procedure. The value shall be used for all cells in the test.
T_{SI}	s	1.28	The value shall be used for all cells in the test.
DRX cycle length	s	1.28	The value shall be used for all cells in the test.
T1	s	15	
T2	s	15	

Table 8.3.5.1.2: Cell re-selection single carrier multi-cell case

Parameter	Unit	Cell 1				Cell 2				Cell 3			
		0		8		0		8		0		8	
Timeslot Number		T1	T2	T1	T2	T1	T2	T1	T2	T1	T2	T1	T2
UTRA RF Channel Number		Channel 1				Channel 1				Channel 1			
PCCPCH_Ec/lor	dB	-3	-3			-3	-3			-3	-3		
SCH_Ec/lor	dB	-9	-9	-9	-9	-9	-9	-9	-9	-9	-9	-9	-9
SCH_offset		0	0	0	0	5	5	5	5	10	10	10	10
PICH_Ec/lor	dB			-3	-3			-3	-3			-3	-3
OCNS_Ec/lor	dB	-4,28	-4,28	-4,28	-4,28	-4,28	-4,28	-4,28	-4,28	-4,28	-4,28	-4,28	-4,28
\hat{I}_{or}/I_{oc}	dB	9	7	9	7	7	9	7	9	-1	-1	-1	-1
PCCPCH RSCP	dBm	-64	-66			-66	-64			-74	-74		
Qoffset1 _{s,n}	dB	C1, C2: 0; C1, C3:0; C1,C4:0 C1, C5:0; C1, C6:0				C2, C1: 0; C2, C3:0; C2,C4:0 C2, C5: 0; C2, C6:0				C3, C1: 0; C3, C2:0; C3,C4:0 C3, C5: 0; C3, C6:0			
Qhyst1 _s	dB	0				0				0			
Treselection	s	0				0				0			
Sintrasearch	dB	not sent				not sent				not sent			
Timeslot		Cell 4				Cell 5				Cell 6			
		0		8		0		8		0		8	
UTRA RF Channel Number		Channel 1				Channel 1				Channel 1			
PCCPCH_Ec/lor	dB	-3	-3			-3	-3			-3	-3		
SCH_Ec/lor	dB	-9	-9	-9	-9	-9	-9	-9	-9	-9	-9	-9	-9
SCH_offset		15	15	15	15	20	20	20	20	25	25	25	25
PICH_Ec/lor	dB			-3	-3			-3	-3			-3	-3
OCNS_Ec/lor	dB	-4,28	-4,28	-4,28	-4,28	-4,28	-4,28	-4,28	-4,28	-4,28	-4,28	-4,28	-4,28
\hat{I}_{or}/I_{oc}	dB	-1	-1	-1	-1	-1	-1	-1	-1	-1	-1	-1	-1
PCCPCH RSCP	dBm	-74	-74			-74	-74			-74	-74		
Qoffset1 _{s,n}	dB	C4, C1: 0; C4, C2:0; C4,C3:0C4, C5:0; C4, C6:0				C5, C1: 0; C5, C2:0; C5,C3:0 C5, C4:0; C5, C6:0				C6, C1: 0; C6, C2:0; C6,C3:0 C6, C4:0; C6, C5:0			
Qhyst1 _s	dB	0				0				0			
Treselection	s	0				0				0			
Sintrasearch	dB	not sent				not sent				not sent			
I_{oc}	dBm/3, 84 MHz	-70											
Propagation Condition		AWGN											

8.3.5.1.4.2 Procedure

- a) The SS activates cell 1-6 with T1 defined parameters.
- b) The UE is switched on.
- c) A call is set up according to the test procedure specified in TS 34.108 [3] subclause 7.4.2.7.1.
- d) After 15 s, the parameters are changed as described for T2.
- e) The SS waits for CELL UPDATE message with cause value "cell reselection" from the UE.
- f) The SS sends the UE CELL UPDATE CONFIRM message with "RRC State Indicator" = "CELL_PCH".
- g) After another 15 s, the parameters are changed as described for T1.
- h) The SS waits for CELL UPDATE message with cause value "cell reselection" from the UE.
- i) Repeat steps d) to g) [TBD] times.

8.3.5.1.5 Test Requirements

- 1) In step d), after the UE has responded on cell 1, it shall not respond on any other cell (cell selection).
- 2) In step e), the UE shall respond on cell 2 within 8 s.
- 3) In step h), the UE shall respond on cell 1 within 8 s.

For the test to pass, the total number of fulfilled test requirements 2) and 3) shall be more than [FFS]% of the cases.

NOTE: If the above Test Requirement differs from the Minimum Requirement then the Test Tolerance applied for this test is non-zero. The Test Tolerance for this test is defined in clause F.2 and the explanation of how the Minimum Requirement has been relaxed by the Test Tolerance is given in clause F.4.

8.3.5.2 Scenario 2: TDD/TDD cell re-selection multi carrier case

8.3.5.2.1 Definition and applicability

The cell re-selection delay is defined as the time from a change of cell levels to the moment when this change causes the UE to camp on a new cell, and starts to send the CELL UPDATE message with cause value "cell reselection" in the new cell.

The requirements and this test apply to the TDD UE.

8.3.5.2.2 Minimum requirement

The cell re-selection delay shall be less than 8 s.

NOTE:

The cell re-selection delay can be expressed as: $T_{\text{evaluateTDD}} + T_{\text{SI}}$, where:

$T_{\text{evaluateTDD}}$ A DRX cycle length of 1280ms is assumed for this test case, this leads to a $T_{\text{evaluateTDD}}$ of 6.4s according to TS 25.123 [2] table 4.1 in clause 4.2.2.7.

T_{SI} Maximum repetition period of relevant system info blocks that needs to be received by the UE to camp on a cell. 1280 ms is assumed in this test case.

This gives a total of 7.68 s, allow 8s in the test case.

The normative reference for this requirement is TS 25.123 [2] clauses 5.5 and A.5.5.2.

8.3.5.2.3 Test purpose

This test verifies that the UE meets the requirement for the cell re-selection delay in CELL_PCH for the multi carrier case.

8.3.5.2.4 Method of test

8.3.5.2.4.1 Initial conditions

This scenario contains 6 cells and 2 carrier frequencies. The test parameters are given in Tables 8.3.5.2.1 and 8.3.5.2.2.

Table 8.3.5.2.1: General test parameters for Cell Re-selection in Multi carrier case

	Parameter	Unit	Value	Comment
Initial condition	Active cell		Cell1	
	Neighbour cells		Cell2, Cell3, Cell4, Cell5, Cell6	
Final condition	Active cell		Cell2	
	HCS		Not used	
	UE_TXPWR_MAX_RACH	dBm	21	The value shall be used for all cells in the test.
	Qrxlevmin	dBm	-102	The value shall be used for all cells in the test.
	Access Service Class (ASC#0) - Persistence value		1	Selected so that no additional delay is caused by the random access procedure. The value shall be used for all cells in the test.
	T _{SI}	s	1.28	The value shall be used for all cells in the test.
	DRX cycle length	s	1.28	The value shall be used for all cells in the test.
	T1	s	30	
	T2	s	15	

Table 8.3.5.2.2: Cell re-selection multi carrier multi cell case

Parameter	Unit	Cell 1				Cell 2				Cell 3			
		0		8		0		8		0		8	
Timeslot Number		T1	T2	T1	T2	T1	T2	T1	T2	T1	T2	T1	T2
UTRA RF Channel Number		Channel 1				Channel 2				Channel 1			
PCCPCH_Ec/lor	dB	-3	-3			-3	-3			-3	-3		
SCH_Ec/lor	dB	-9	-9	-9	-9	-9	-9	-9	-9	-9	-9	-9	-9
SCH_offset		0	0	0	0	5	5	5	5	10	10	10	10
PICH_Ec/lor	dB			-3	-3			-3	-3			-3	-3
OCNS_Ec/lor	dB	-4,28	-4,28	-4,28	-4,28	-4,28	-4,28	-4,28	-4,28	-4,28	-4,28	-4,28	-4,28
\hat{I}_{or}/I_{oc}	dB	6	0	6	0	0	6	0	6	-3	-3	-3	-3
PCCPCH RSCP	dBm	-67	-73			-73	-67			-76	-76		
Qoffset1 _{s,n}	dB	C1, C2: 0; C1, C3:0; C1,C4:0C1, C5:0; C1, C6:0				C2, C1: 0; C2, C3:0; C2,C4:0C2, C5:0; C2, C6:0				C3, C1: 0; C3, C2:0; C3,C4:0 C3, C5:0; C3, C6:0			
Qhyst1 _s	dB	0				0				0			
Treselection	s	0				0				0			
Sintrasearch	dB	not sent				not sent				not sent			
Sintersearch	dB	not sent				not sent				not sent			
Timeslot		Cell 4		Cell 5		Cell 6							
		0	8	0	8	0	8	0	8	0	8	0	8
UTRA RF Channel Number		Channel 1				Channel 2				Channel 2			
PCCPCH_Ec/lor	dB	-3	-3			-3	-3			-3	-3		
SCH_Ec/lor	dB	-9	-9	-9	-9	-9	-9	-9	-9	-9	-9	-9	-9
SCH_offset		15	15	15	15	20	20	20	20	25	25	25	25
PICH_Ec/lor	dB			-3	-3			-3	-3			-3	-3
OCNS_Ec/lor	dB	-4,28	-4,28	-4,28	-4,28	-4,28	-4,28	-4,28	-4,28	-4,28	-4,28	-4,28	-4,28
\hat{I}_{or}/I_{oc}	dB	-3	-3	-3	-3	-3	-3	-3	-3	-3	-3	-3	-3
PCCPCH RSCP	dBm	-76	-76			-76	-76			-76	-76		
Qoffset1 _{s,n}	dB	C4, C1: 0; C4, C2:0; C4,C3:0 C4, C5:0; C4, C6:0				C5, C1: 0; C5, C2:0; C5,C3:0 C5, C4:0; C5, C6:0				C6, C1: 0; C6, C2:0; C6,C3:0 C6, C4:0; C6, C5:0			
Qhyst1 _s	dB	0				0				0			
Treselection	s	0				0				0			
Sintrasearch	dB	not sent				not sent				not sent			
Sintersearch	dB	not sent				not sent				not sent			
I_{oc}	dBm/3, 84 MHz	-70											
Propagation Condition		AWGN											

8.3.5.2.4.2 Procedure

- The SS activates cell 1-6 with T1 defined parameters.
- The UE is switched on.
- A call is set up according to the test procedure specified in TS 34.108 [3] subclause 7.4.2.7.1.
- After 15 s, the parameters are changed as described for T2.
- The SS waits for CELL UPDATE message with cause value "cell reselection" from the UE.
- The SS sends the UE CELL UPDATE CONFIRM message with "RRC State Indicator" = "CELL_PCH".
- After another 15 s, the parameters are changed as described for T1.
- The SS waits for CELL UPDATE message with cause value "cell reselection" from the UE.
- Repeat steps d) to g) [TBD] times.

NOTE: T1 is initially 30 s to allow enough time for the UE to search for cells as it has no prior knowledge of these.

8.3.5.2.5 Test Requirements

- 1) In step d), after the UE has responded on cell 1, it shall not respond on any other cell (cell selection).
- 2) In step e), the UE shall respond on cell 1 within 8 s.
- 3) In step h), the UE shall respond on cell 2 within 8 s.

For the test to pass, the total number of fulfilled test requirements 2) and 3) shall be more than [FFS]% of the cases.

NOTE: If the above Test Requirement differs from the Minimum Requirement then the Test Tolerance applied for this test is non-zero. The Test Tolerance for this test is defined in clause F.2 and the explanation of how the Minimum Requirement has been relaxed by the Test Tolerance is given in clause F.4.

8.3.6 Cell Re-selection in URA_PCH

8.3.6.1 Scenario 1: TDD/TDD cell re-selection single carrier case

8.3.6.1.1 Definition and applicability

The cell re-selection delay is defined as the time from a change of cell levels to the moment when this change causes the UE to camp on a new cell, and starts to send the URA UPDATE message with cause value "change of URA" in the new cell.

The requirements and this test apply to the TDD UE.

8.3.6.1.2 Minimum requirement

The cell re-selection delay shall be less than 8 s.

NOTE:

The cell re-selection delay can be expressed as: $T_{\text{evaluateTDD}} + T_{\text{SI}}$, where:

$T_{\text{evaluateTDD}}$ A DRX cycle length of 1280ms is assumed for this test case, this leads to a $T_{\text{evaluateTDD}}$ of 6.4s according to TS25.123 [2] table 4.1 in clause 4.2.2.7.

T_{SI} Maximum repetition period of relevant system info blocks that needs to be received by the UE to camp on a cell. 1280 ms is assumed in this test case.

This gives a total of 7.68 s, allow 8s in the test case.

The normative reference for this requirement is TS 25.123 [2] clauses 5.6 and A.5.6.1.

8.3.6.1.3 Test purpose

This test verifies that the UE meets the minimum requirement for the cell re-selection delay in URA_PCH for the single carrier case

8.3.6.1.4 Method of test

8.3.6.1.4.1 Initial conditions

This scenario contains 6 cells operating on the same carrier frequency. The test parameters are given in Tables 8.3.6.1.1, and 8.3.6.1.2.

Table 8.3.6.1.1: General test parameters for Cell Re-selection single carrier multi-cell case

Parameter	Unit	Value	Comment
Initial condition	Active cell	Cell1	
	Neighbour cells	Cell2, Cell3, Cell4, Cell5, Cell6	
Final condition	Active cell	Cell2	
HCS		Not used	
UE_TXPWR_MAX_RACH	dBm	21	The value shall be used for all cells in the test.
Qrxlevmin	dBm	-102	The value shall be used for all cells in the test.
Access Service Class (ASC#0) - Persistence value		1	Selected so that no additional delay is caused by the random access procedure. The value shall be used for all cells in the test.
T _{SI}	s	1.28	The value shall be used for all cells in the test.
DRX cycle length	s	1.28	The value shall be used for all cells in the test.
T1	s	15	
T2	s	15	

Table 8.3.6.1.2: Cell re-selection single carrier multi-cell case

Parameter	Unit	Cell 1				Cell 2				Cell 3			
		0		8		0		8		0		8	
Timeslot Number		T1	T2	T1	T2	T1	T2	T1	T2	T1	T2	T1	T2
UTRA RF Channel Number		Channel 1				Channel 1				Channel 1			
PCCPCH_Ec/I _{or}	dB	-3	-3			-3	-3			-3	-3		
SCH_Ec/I _{or}	dB	-9	-9	-9	-9	-9	-9	-9	-9	-9	-9	-9	-9
SCH _{toffset}		0	0	0	0	5	5	5	5	10	10	10	10
PICH_Ec/I _{or}	dB			-3	-3			-3	-3			-3	-3
OCNS_Ec/I _{or}	dB	-3,12	-3,12	-3,12	-3,12	-3,12	-3,12	-3,12	-3,12	-3,12	-3,12	-3,12	-3,12
\hat{I}_{or}/I_{oc}	dB	9	7	9	7	7	9	7	9	-1	-1	-1	-1
PCCPCH RSCP	dBm	-64	-66			-66	-64			-74	-74		
Qoffset1 _{s,n}	dB	C1, C2: 0; C1, C3:0; C1,C4:0 C1, C5:0; C1,C6:0				C2, C1: 0; C2, C3:0; C2,C4:0 C2, C5: 0; C2, C6:0				C3, C1: 0; C3, C2:0; C3,C4:0 C3, C5: 0; C3, C6:0			
Qhyst1 _s	dB	0				0				0			
Treselection	s	0				0				0			
Sintrasearch	dB	not sent				not sent				not sent			
Timeslot		Cell 4				Cell 5				Cell 6			
		0		8		0		8		0		8	
UTRA RF Channel Number		T1	T2	T1	T2	T1	T2	T1	T2	T1	T2	T1	T2
UTRA RF Channel Number		Channel 1				Channel 1				Channel 1			
PCCPCH_Ec/I _{or}	dB	-3	-3			-3	-3			-3	-3		
SCH_Ec/I _{or}	dB	-9	-9	-9	-9	-9	-9	-9	-9	-9	-9	-9	-9
SCH _{toffset}		15	15	15	15	20	20	20	20	25	25	25	25
PICH_Ec/I _{or}	dB			-3	-3			-3	-3			-3	-3
OCNS_Ec/I _{or}	dB	-3,12	-3,12	-3,12	-3,12	-3,12	-3,12	-3,12	-3,12	-3,12	-3,12	-3,12	-3,12
\hat{I}_{or}/I_{oc}	dB	-1	-1	-1	-1	-1	-1	-1	-1	-1	-1	-1	-1
PCCPCH RSCP	dBm	-74	-74			-74	-74			-74	-74		
Qoffset1 _{s,n}	dB	C4, C1: 0; C4, C2:0; C4,C3:0;C4, C5:0; C4, C6:0				C5, C1: 0; C5, C2:0; C5,C3:0 C5, C4:0; C5, C6:0				C6, C1: 0; C6, C2:0; C6,C3:0 C6, C4:0; C6, C5:0			
Qhyst1 _s	dB	0				0				0			
Treselection	s	0				0				0			
Sintrasearch	dB	not sent				not sent				not sent			
I _{oc}	dBm/3, 84 MHz	-70											
Propagation Condition		AWGN											

8.3.6.1.4.2 Procedure

- a) The SS activates cell 1-6 with T1 defined parameters.
- b) The UE is switched on.
- c) A call is set up according to the test procedure specified in TS 34.108 [3] subclause 7.4.2.7.2.
- d) After 15 s, the parameters are changed as described for T2.
- e) The SS waits for URA UPDATE message with cause value "change of URA" from the UE.
- f) The SS sends the UE CELL UPDATE CONFIRM message with "RRC State Indicator" = "URA_PCH".
- g) After another 15 s, the parameters are changed as described for T1.
- h) The SS waits for URA UPDATE message with cause value "change of URA" from the UE.
- i) Repeat steps d) to g) [TBD] times.

8.3.6.1.5 Test Requirements

- 1) In step d), after the UE has responded on cell 1, it shall not respond on any other cell (cell selection).
- 2) In step e), the UE shall respond on cell 2 within 8 s.
- 3) In step h), the UE shall respond on cell 1 within 8 s.

For the test to pass, the total number of fulfilled test requirements 2) and 3) shall be more than [FFS]% of the cases.

NOTE: If the above Test Requirement differs from the Minimum Requirement then the Test Tolerance applied for this test is non-zero. The Test Tolerance for this test is defined in clause F.2 and the explanation of how the Minimum Requirement has been relaxed by the Test Tolerance is given in clause F.4.

8.3.6.2 Scenario 2: TDD/TDD cell re-selection multi carrier case

8.3.6.2.1 Definition and applicability

The cell re-selection delay is defined as the time from a change of cell levels to the moment when this change causes the UE to camp on a new cell, and starts to send the URA UPDATE message with cause value "change of URA" in the new cell.

The requirements and this test apply to the TDD UE.

8.3.6.2.2 Minimum requirement

The cell re-selection delay shall be less than 8 s.

NOTE:

The cell re-selection delay can be expressed as: $T_{\text{evaluateTDD}} + T_{\text{SI}}$, where:

$T_{\text{evaluateTDD}}$ A DRX cycle length of 1280ms is assumed for this test case, this leads to a $T_{\text{evaluateTDD}}$ of 6.4s according to TS 25.123 [2] table 4.1 in clause 4.2.2.7.

T_{SI} Maximum repetition period of relevant system info blocks that needs to be received by the UE to camp on a cell. 1280 ms is assumed in this test case.

This gives a total of 7.68 s, allow 8s in the test case.

The normative reference for this requirement is TS 25.123 [2] clauses 5.6 and A.5.6.2.

8.3.6.2.3 Test purpose

This test verifies that the UE meets the requirement for the cell re-selection delay in URA_PCH for the multi carrier case.

8.3.6.2.4 Method of test

8.3.6.2.4.1 Initial conditions

This scenario contains 6 cells and 2 carrier frequencies. The test parameters are given in Tables 8.3.6.2.1 and 8.3.6.2.2.

Table 8.3.6.2.1: General test parameters for Cell Re-selection in Multi carrier case

	Parameter	Unit	Value	Comment
Initial condition	Active cell		Cell1	
	Neighbour cells		Cell2, Cell3, Cell4, Cell5, Cell6	
Final condition	Active cell		Cell2	
	HCS		Not used	
	UE_TXPWR_MAX_RACH	dBm	21	The value shall be used for all cells in the test.
	Qrxlevmin	dBm	-102	The value shall be used for all cells in the test.
	Access Service Class (ASC#0) - Persistence value		1	Selected so that no additional delay is caused by the random access procedure. The value shall be used for all cells in the test.
	T _{SI}	s	1.28	The value shall be used for all cells in the test.
	DRX cycle length	s	1.28	The value shall be used for all cells in the test.
	T1	s	30	
	T2	s	15	

Table 8.3.6.2.2: Cell re-selection multi carrier multi cell case

Parameter	Unit	Cell 1				Cell 2				Cell 3			
		0		8		0		8		0		8	
Timeslot Number		T1	T2	T1	T2	T1	T2	T1	T2	T1	T2	T1	T2
UTRA RF Channel Number		Channel 1				Channel 2				Channel 1			
PCCPCH_Ec/lor	dB	-3	-3			-3	-3			-3	-3		
SCH_Ec/lor	dB	-9	-9	-9	-9	-9	-9	-9	-9	-9	-9	-9	-9
SCH_offset		0	0	0	0	5	5	5	5	10	10	10	10
PICH_Ec/lor	dB			-3	-3			-3	-3			-3	-3
OCNS_Ec/lor	dB	-4,28	-4,28	-4,28	-4,28	-4,28	-4,28	-4,28	-4,28	-4,28	-4,28	-4,28	-4,28
\hat{I}_{or}/I_{oc}	dB	6	0	6	0	0	6	0	6	-3	-3	-3	-3
PCCPCH RSCP	dBm	-67	-73			-67	-70			-76	-76		
Qoffset1 _{s,n}	dB	C1, C2: 0; C1, C3:0; C1,C4:0C1, C5:0; C1, C6:0				C2, C1: 0; C2, C3:0; C2,C4:0C2, C5:0; C2, C6:0				C3, C1: 0; C3, C2:0; C3,C4:0 C3, C5:0; C3, C6:0			
Qhyst1 _s	dB	0				0				0			
Treselection	s	0				0				0			
Sintrasearch	dB	not sent				not sent				not sent			
Sintersearch	dB	not sent				not sent				not sent			
		Cell 4				Cell 5				Cell 6			
Timeslot		0		8		0		8		0		8	
		T1	T2	T1	T2	T1	T2	T1	T2	T1	T2	T1	T2
UTRA RF Channel Number		Channel 1				Channel 2				Channel 2			
PCCPCH_Ec/lor	dB	-3	-3			-3	-3			-3	-3		
SCH_Ec/lor	dB	-9	-9	-9	-9	-9	-9	-9	-9	-9	-9	-9	-9
SCH_offset		15	15	15	15	20	20	20	20	25	25	25	25
PICH_Ec/lor	dB			-3	-3			-3	-3			-3	-3
OCNS_Ec/lor	dB	-4,28	-4,28	-4,28	-4,28	-4,28	-4,28	-4,28	-4,28	-4,28	-4,28	-4,28	-4,28
\hat{I}_{or}/I_{oc}	dB	-3	-3	-3	-3	-3	-3	-3	-3	-3	-3	-3	-3
PCCPCH RSCP	dBm	-76	-76			-76	-76			-76	-76		
Qoffset1 _{s,n}	dB	C4, C1: 0; C4, C2:0; C4,C3:0 C4, C5:0; C4, C6:0				C5, C1: 0; C5, C2:0; C5,C3:0 C5, C4:0; C5, C6:0				C6, C1: 0; C6, C2:0; C6,C3:0 C6, C4:0; C6, C5:0			
Qhyst1 _s	dB	0				0				0			
Treselection	s	0				0				0			
Sintrasearch	dB	not sent				not sent				not sent			
Sintersearch	dB	not sent				not sent				not sent			
I_{oc}	dBm/3, 84 MHz	-70											
Propagation Condition		AWGN											

8.3.6.2.4.2 Procedure

- The SS activates cell 1-6 with T1 defined parameters.
- The UE is switched on.
- A call is set up according to the test procedure specified in TS 34.108 [3] subclause 7.4.2.7.2.
- After 15 s, the parameters are changed as described for T2.
- The SS waits for URA UPDATE message with cause value "change of URA" from the UE.
- The SS sends the UE CELL UPDATE CONFIRM message with "RRC State Indicator" = "URA_PCH".
- After another 15 s, the parameters are changed as described for T1.
- The SS waits for URA UPDATE message with cause value "change of URA" from the UE.
- Repeat steps d) to g) [TBD] times.

NOTE: T1 is initially 30 s to allow enough time for the UE to search for cells as it has no prior knowledge of these.

8.3.6.2.5 Test Requirements

- 1) In step d), after the UE has responded on cell 1, it shall not respond on any other cell (cell selection).
- 2) In step e), the UE shall respond on cell 1 within 8 s.
- 3) In step h), the UE shall respond on cell 2 within 8 s.

For the test to pass, the total number of fulfilled test requirements 2) and 3) shall be more than [FFS]% of the cases.

NOTE: If the above Test Requirement differs from the Minimum Requirement then the Test Tolerance applied for this test is non-zero. The Test Tolerance for this test is defined in clause F.2 and the explanation of how the Minimum Requirement has been relaxed by the Test Tolerance is given in clause F.4.

8.4 RRC Connection Control

8.4.1 RRC connection re-establishment delay

Void.

8.4.2 Transport Format Combination selection in UE

Void.

8.5 Timing Characteristics

8.5.1 UE Timing Advance

Void.

8.5.2 UE Transmit Timing

Void.

8.6 UE Measurements Procedures

8.6.1 TDD intra frequency measurements

8.6.1.1 Event triggered reporting in AWGN propagation conditions

Void.

8.6.1.2 Event 1H and 1I triggered reporting in AWGN propagation condition

Void.

8.6.2 TDD inter frequency measurements

8.6.2.1 Correct reporting of neighbours in AWGN propagation condition

Void.

8.6.3 FDD measurements

8.6.3.1 Correct reporting of FDD neighbours in AWGN propagation condition

Void.

8.7 Measurements Performance Requirements

Unless explicitly stated:

- Measurement channel is 12.2 kbps as defined in TS 25.102 annex A. This measurement channel is used both in active cell and cells to be measured.
- Cell 1 is the active cell.
- Single task reporting.
- Power control is active.

8.7.1 P-CCPCH RSCP

8.7.1.1 Intra frequency measurement accuracy

8.7.1.1.1 Absolute accuracy requirement

8.7.1.1.1.1 Definition and applicability

The absolute accuracy of P-CCPCH RSCP is defined as the P-CCPCH RSCP measured from one cell compared to the actual P-CCPCH RSCP power from the same cell.

The requirements and this test apply to all types of UTRA TDD UE.

8.7.1.1.1.2 Minimum Requirements

The absolute accuracy requirements in table 8.7.1.1.1.1 are valid under the following conditions:

P-CCPCH RSCP \geq -102 dBm.

$$\left(\frac{P - CCPCH - E_c}{I_o} \right) \Big|_{in \text{ dB}} \geq -8dB$$

$$\left(\frac{SCH - E_c}{I_o} \right) \Big|_{in \text{ dB}} \geq -13dB$$

Table 8.7.1.1.1.1: P-CCPCH_RSCP absolute accuracy

Parameter	Unit	Accuracy [dB]		Conditions
		Normal condition	Extreme condition	Io [dBm]
P-CCPCH_RSCP	dBm	± 6	± 9	-94...-70
	dBm	± 8	± 11	-70...-50

The rate of correct measurements observed during repeated tests shall be at least 90%.

The normative reference for this requirement is TS 25.123 [2] clauses 9.1.1.1.1 and A.9.1.1.1.1.

8.7.1.1.1.3 Test Purpose

The purpose of this test is to verify that the absolute P-CCPCH RSCP measurement accuracy is within the specified limits.

8.7.1.1.1.4 Method of test

8.7.1.1.1.4.1 Initial conditions

Test environment: normal, TL/VL, TL/VH, TH/VL, TH/VH; see clauses G.2.1 and G.2.2.

Frequencies to be tested: mid range; see clause G.2.4.

In this case all cells are on the same frequency. Cell 1 and cell 2 shall be synchronised, i.e. share the same frame and timeslot timing. The DL DPCH shall be transmitted in timeslot 4 and the UL DPCH shall be transmitted in timeslot 12. The second Beacon timeslot shall be provided in timeslot 8 for both cell 1 and cell 2. P-CCPCH RSCP intra frequency absolute accuracy requirements are tested by using test parameters in table 8.7.1.1.1.2.

Table 8.7.1.1.1.2: P-CCPCH RSCP Intra frequency test parameters

Parameter	Unit	Test 1		Test 2		Test 3	
		Cell 1	Cell 2	Cell 1	Cell 2	Cell 1	Cell 2
DL timeslot number		0	0	0	0	0	0
UTRA RF Channel number		Channel 1		Channel 1		Channel 1	
PCCPCH_Ec/Ior	dB	-3		-3		-3	
SCH_Ec/Ior	dB	-9		-9		-9	
SCH_toffset		0	5	0	5	0	5
OCNS_Ec/Ior	dB	-3,12		-3,12		-3,12	
Ioc	dBm / 3.84 MHz	-75.7		-59.8		-98.7	
Ior/Ioc	dB	5	2	9	2	3	0
PCCPCH RSCP, Note 1	dBm	-73.7	-76.7	-53.8	-60.8	-98.7	-101.7
Io, Note 1	dBm / 3.84 MHz	-69		-50		-94	
Propagation condition		AWGN		AWGN		AWGN	
NOTE 1: PCCPCH RSCP and Io levels have been calculated from other parameters for information purposes. They are not settable parameters themselves.							

- 1) A call is set up according to the test procedure specified in TS 34.108 [3] clause 7.3.2.3. The RF parameters for Test 1 are set up according to table 8.7.1.1.1.2.

8.7.1.1.1.4.2 Procedure

- 1) SS shall transmit MEASUREMENT CONTROL message.
- 2) UE shall transmit periodically MEASUREMENT REPORT messages.
- 3) SS shall check PCCPCH_RSCP value in MEASUREMENT REPORT messages. PCCPCH_RSCP power of Cell 1 reported by UE is compared to actual PCCPCH_RSCP power for each MEASUREMENT REPORT message.
- 4) SS shall count number of MEASUREMENT REPORT messages transmitted by UE. After 1000 MEASUREMENT REPORT messages have been received from UE, the RF parameters are set up according to table 8.7.1.1.1.2 for Test 2. While RF parameters are being set up, MEASUREMENT REPORT messages from UE are ignored. SS shall wait for additional 1s and ignore the MEASUREMENT REPORT messages during this period. Then, step 3) above is repeated. After further 1000 MEASUREMENT REPORT messages have been received from UE, the RF parameters are set up according to table 8.7.1.1.1.2 for Test 3. While RF parameters are being set up, MEASUREMENT REPORT messages from UE are ignored. SS shall wait for additional 1s and ignore the MEASUREMENT REPORT messages during this period. Then, step 3) above is repeated.
- 5) After further 1000 MEASUREMENT REPORT messages have been received from UE, the SS shall transmit RRC CONNECTION RELEASE message.
- 6) UE shall transmit RRC CONNECTION RELEASE COMPLETE message.

8.7.1.1.1.5 Test requirements

The PCCPCH RSCP measurement accuracy shall meet the requirements in clause 8.7.1.1.1.2 for at least 900 of the measurement reports at each input level in step 4.

NOTE: If the above Test Requirement differs from the Minimum Requirement then the Test Tolerance applied for this test is non-zero. The Test Tolerance for this test is defined in clause F.2 and the explanation of how the Minimum Requirement has been relaxed by the Test Tolerance is given in clause F.4.

8.7.1.1.2 Relative accuracy requirement

8.7.1.1.2.1 Definition and applicability

The relative accuracy of PCCPCH RSCP is defined as the PCCPCH RSCP measured from one cell compared to the PCCPCH RSCP measured from another cell on the same frequency.

The requirements and this test apply to all types of UTRA TDD UE.

8.7.1.1.2.2 Minimum Requirements

The relative accuracy requirements in table 8.7.1.1.2.1 are valid under the following conditions:

P-CCPCH RSCP \geq -102 dBm.

$$\left(\frac{P - CCPCH - E_c}{I_o} \right)_{in \text{ dB}} \geq -8dB$$

$$\left(\frac{SCH - E_c}{I_o} \right)_{in \text{ dB}} \geq -13dB$$

$$\left| P - CCPCH \text{ RSCP1} \Big|_{in \text{ dB}} - P - CCPCH \text{ RSCP2} \Big|_{in \text{ dB}} \right| \leq 20dB$$

Relative I_o difference [dB] \leq relative RSCP difference [dB]

It is assumed that the measurements of P-CCPCH RSCP1 and P-CCPCH RSCP2 can be performed within 20ms due to slot allocations in the cells concerned.

Table 8.7.1.1.2.1: P-CCPCH_RSCP intra-frequency relative accuracy

Parameter	Unit	Accuracy [dB]		Conditions	
		Normal condition	Extreme condition	Io [dBm]	relative RSCP difference [dbB]
P-CCPCH_RSCP	dBm	± 1	± 1	-94...-50	<2
		± 2	± 2		2...14
		± 3	± 3		>14

The rate of correct measurements observed during repeated tests shall be at least 90%.

The normative reference for this requirement is TS 25.123 [2] clauses 9.1.1.1.2 and A.9.1.1.1.1.

8.7.1.1.2.3 Test Purpose

The purpose of this test is to verify that the relative P-CCPCH RSCP measurement accuracy is within the specified limits.

8.7.1.1.2.4 Method of test

8.7.1.1.2.4.1 Initial conditions

Test environment: normal, TL/VL, TL/VH, TH/VL, TH/VH; see clauses G.2.1 and G.2.2.

Frequencies to be tested: mid range; see clause G.2.4.

In this case all cells are on the same frequency. Cell 1 and cell 2 shall be synchronised, i.e. share the same frame and timeslot timing. The DL DPCH shall be transmitted in timeslot 4 and the UL DPCH shall be transmitted in timeslot 12. The second Beacon timeslot shall be provided in timeslot 8 for both cell 1 and cell 2. P-CCPCH RSCP intra frequency relative accuracy requirements are tested by using test parameters in table 8.7.1.1.1.2.

- 1) A call is set up according to the test procedure specified in TS 34.108 [3] clause 7.3.2.3. The RF parameters for Test 1 are set up according to table 8.7.1.1.1.2.

8.7.1.1.2.4.2 Procedure

- 1) SS shall transmit MEASUREMENT CONTROL message.
- 2) UE shall transmit periodically MEASUREMENT REPORT messages.
- 3) SS shall check PCCPCH_RSCP value of Cell 1 and Cell 2 in MEASUREMENT REPORT messages. PCCPCH RSCP power value measured from Cell 1 is compared to PCCPCH RSCP power value measured from Cell 2 for each MEASUREMENT REPORT message.
- 4) The result of step 3) is compared to actual power level difference of PCCPCH RSCP of Cell 1 and Cell 2.
- 5) SS shall count number of MEASUREMENT REPORT messages transmitted by UE. After 1000 MEASUREMENT REPORT messages have been received from UE, the RF parameters are set up according to table 8.7.1.1.1.2 for Test 2. While RF parameters are being set up, MEASUREMENT REPORT messages from UE are ignored. SS shall wait for additional 1s and ignore the MEASUREMENT REPORT messages during this period. Then, steps 3) and 4) above are repeated. After further 1000 MEASUREMENT REPORT messages have been received from UE, the RF parameters are set up according to table 8.7.1.1.1.2 for Test 3. While RF parameters are being set up, MEASUREMENT REPORT messages from UE are ignored. SS shall wait for additional 1s and ignore the MEASUREMENT REPORT messages during this period. Then, steps 3) and 4) above are repeated.
- 6) After further 1000 MEASUREMENT REPORT messages have been received from UE, the SS shall transmit RRC CONNECTION RELEASE message.
- 7) UE shall transmit RRC CONNECTION RELEASE COMPLETE message.

8.7.1.1.2.5 Test requirements

The PCCPCH RSCP measurement accuracy shall meet the requirements in clause 8.7.1.1.2.2 for at least 900 of the measurement reports at each input level in step 4.

NOTE: If the above Test Requirement differs from the Minimum Requirement then the Test Tolerance applied for this test is non-zero. The Test Tolerance for this test is defined in clause F.2 and the explanation of how the Minimum Requirement has been relaxed by the Test Tolerance is given in clause F.4.

8.7.1.2 Inter frequency measurement accuracy

8.7.1.2.1 Relative accuracy requirement

8.7.1.2.1.1 Definition and applicability

The P-CCPCH_RSCP inter-frequency relative accuracy is defined as the P-CCPCH_RSCP measured from one cell compared to the P-CCPCH_RSCP measured from another cell on a different frequency.

The requirements and this test apply to all types of UTRA TDD UE.

8.7.1.2.1.2 Minimum Requirements

The relative accuracy requirements in table 8.7.1.2.1.1 are valid under the following conditions:

P-CCPCH RSCP \geq -102 dBm.

$$\left| P\text{-CCPCH RSCP1}_{in\ dB} - P\text{-CCPCH RSCP2}_{in\ dB} \right| \leq 20\text{dB}$$

$$\left(\frac{P\text{-CCPCH} - E_c}{I_o} \right)_{in\ dB} \geq -8\text{dB}$$

$$\left(\frac{SCH - E_c}{I_o} \right)_{in\ dB} \geq -13\text{dB}$$

Table 8.7.1.2.1.1: P-CCPCH_RSCP inter-frequency relative accuracy

Parameter	Unit	Accuracy [dB]		Conditions
		Normal condition	Extreme condition	Io [dBm]
P-CCPCH_RSCP	dBm	± 6	± 6	-94...-50

The rate of correct measurements observed during repeated tests shall be at least 90%.

The normative reference for this requirement is TS 25.123 [2] clauses 9.1.1.1.2 and A.9.1.1.

8.7.1.2.1.3 Test Purpose

The purpose of this test is to verify that the relative P-CCPCH RSCP measurement accuracy is within the specified limits for the inter frequency case.

8.7.1.2.1.4 Method of test

8.7.1.2.1.4.1 Initial conditions

Test environment: normal, TL/VL, TL/VH, TH/VL, TH/VH; see clauses G.2.1 and G.2.2.

Frequencies to be tested: mid range; see clause G.2.4.

In this case both cells are on different frequencies. The second Beacon timeslot shall be provided in timeslot 8 for cell 1 and in timeslot 10 for cell 2. P-CCPCH RSCP inter frequency relative accuracy requirements are tested by using test parameters in table 8.7.1.2.1.2.

Table 8.7.1.2.1.2: P-CCPCH RSCP Intra frequency test parameters

Parameter	Unit	Test 1		Test 2		Test 3	
		Cell 1	Cell 2	Cell 1	Cell 2	Cell 1	Cell 2
DL timeslot number		0	2	0	2	0	2
UTRA RF Channel number		Channel 1	Channel 2	Channel 1	Channel 2	Channel 1	Channel 2
PCCPCH_Ec/lor	dB	-3		-3		-3	
SCH_Ec/lor	dB	-9		-9		-9	
SCH_toffset		0	5	0	5	0	5
OCNS_Ec/lor	dB	-3,12		-3,12		-3,12	
lor	dBm / 3.84 MHz	-75.2	-75.2	-57.8	-54.1	-98.7	-97
lor/lor	dB	5	5	7	2	3	0
PCCPCH RSCP, Note 1	dBm	-73.2	-73.2	-54.8	-55.1	-98.7	-100
lo, Note 1	dBm / 3.84 MHz	-69		-50		-94	
Propagation condition		AWGN		AWGN		AWGN	
NOTE 1: PCCPCH RSCP and lo levels have been calculated from other parameters for information purposes. They are not settable parameters themselves.							

- 1) A call is set up according to the test procedure specified in TS 34.108 [3] clause 7.3.2.3. The RF parameters for Test 1 are set up according to table 8.7.1.2.1.2.

8.7.1.2.1.4.2 Procedure

- 1) SS shall transmit PHYSICAL CHANNEL RECONFIGURATION message.
- 2) UE shall transmit PHYSICAL CHANNEL RECONFIGURATION COMPLETE message.
- 3) SS shall transmit MEASUREMENT CONTROL message.
- 4) UE shall transmit periodically MEASUREMENT REPORT messages.
- 5) SS shall check PCCPCH_RSCP value of Cell 1 and Cell 2 in MEASUREMENT REPORT messages. PCCPCH RSCP power value measured from Cell 1 is compared to PCCPCH RSCP power value measured from Cell 2 for each MEASUREMENT REPORT message.
- 6) The result of step 5) is compared to actual power level difference of PCCPCH RSCP of Cell 1 and Cell 2.
- 7) SS shall count number of MEASUREMENT REPORT messages transmitted by UE. After 1000 MEASUREMENT REPORT messages have been received from UE, the RF parameters are set up according to table 8.7.1.2.1.2 for Test 2. While RF parameters are being set up, MEASUREMENT REPORT messages from UE are ignored. SS shall wait for additional 1s and ignore the MEASUREMENT REPORT messages during this period. Then, steps 5) and 6) above are repeated.
- 8) After further 1000 MEASUREMENT REPORT messages have been received from UE, the SS shall transmit RRC CONNECTION RELEASE message.
- 9) UE shall transmit RRC CONNECTION RELEASE COMPLETE message.

8.7.1.2.1.5 Test requirements

The PCCPCH RSCP measurement accuracy shall meet the requirements in clause 8.7.1.2.1.2 for at least 900 of the measurement reports at each input level in step 4.

NOTE: If the above Test Requirement differs from the Minimum Requirement then the Test Tolerance applied for this test is non-zero. The Test Tolerance for this test is defined in clause F.2 and the explanation of how the Minimum Requirement has been relaxed by the Test Tolerance is given in clause F.4.

Annex A (informative): Connection Diagrams

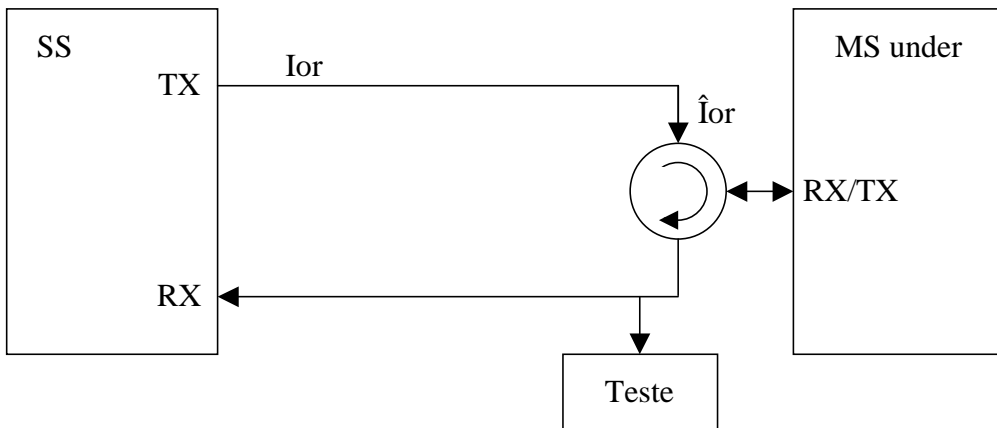

Figure A.1: Connection for Basic TX Test

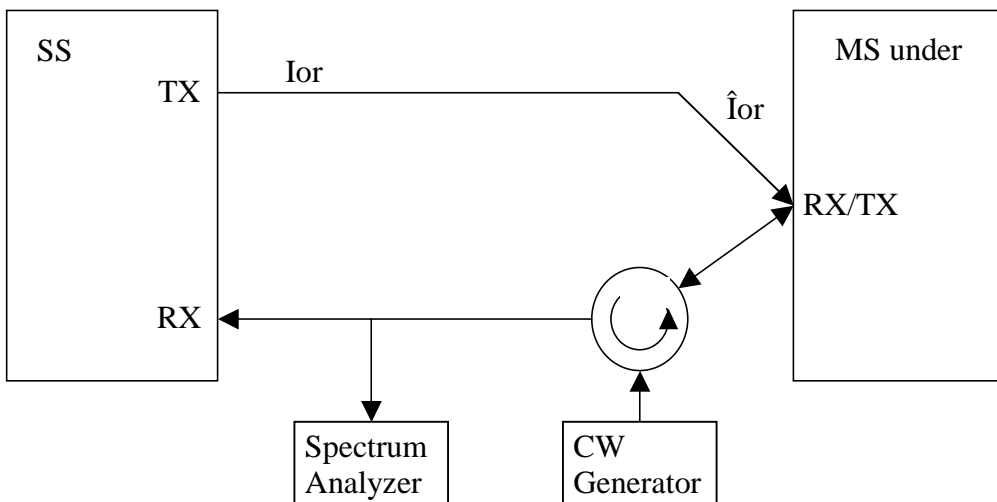

Figure A.2: Connection for TX Intermodulation Test

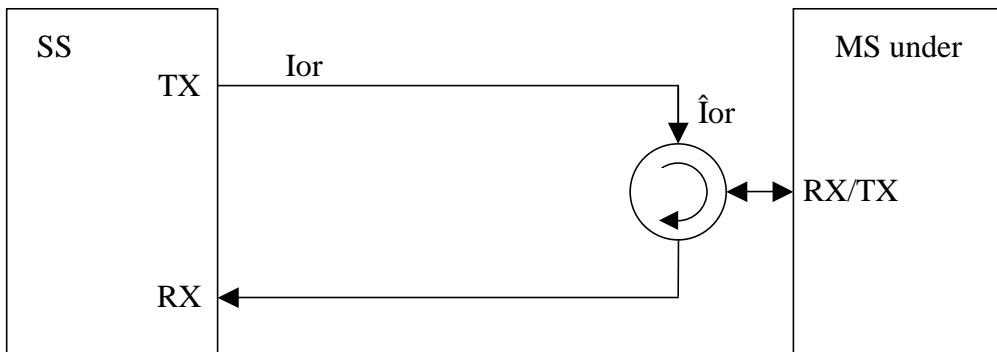

Figure A.3: Connection for Basic RX Test

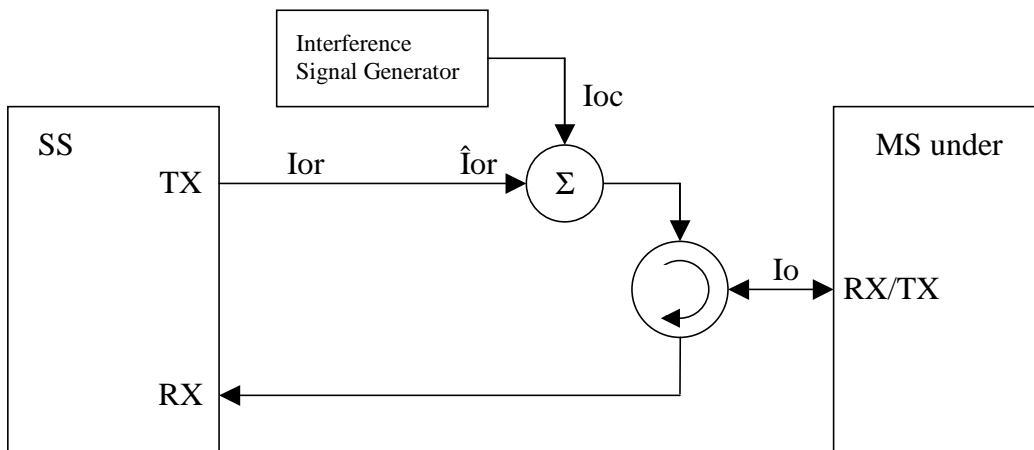

Figure A.4: Connection for RX Test with Interference

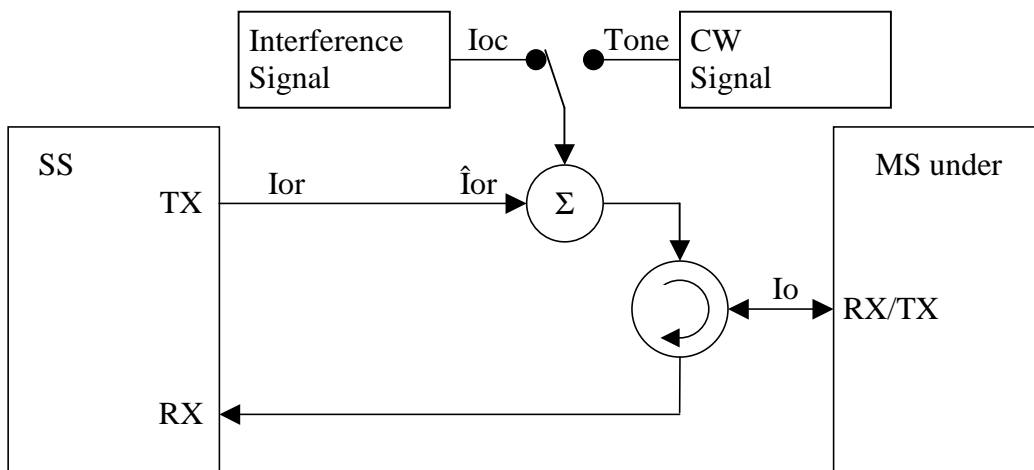

Figure A.5: Connection for RX Test with Interference or additional CW

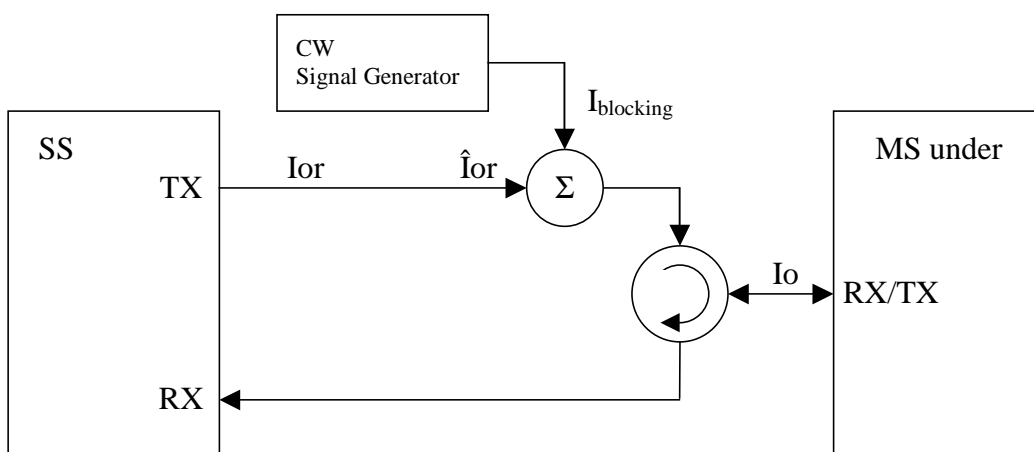

Figure A.6: Connection for RX Test with additional CW

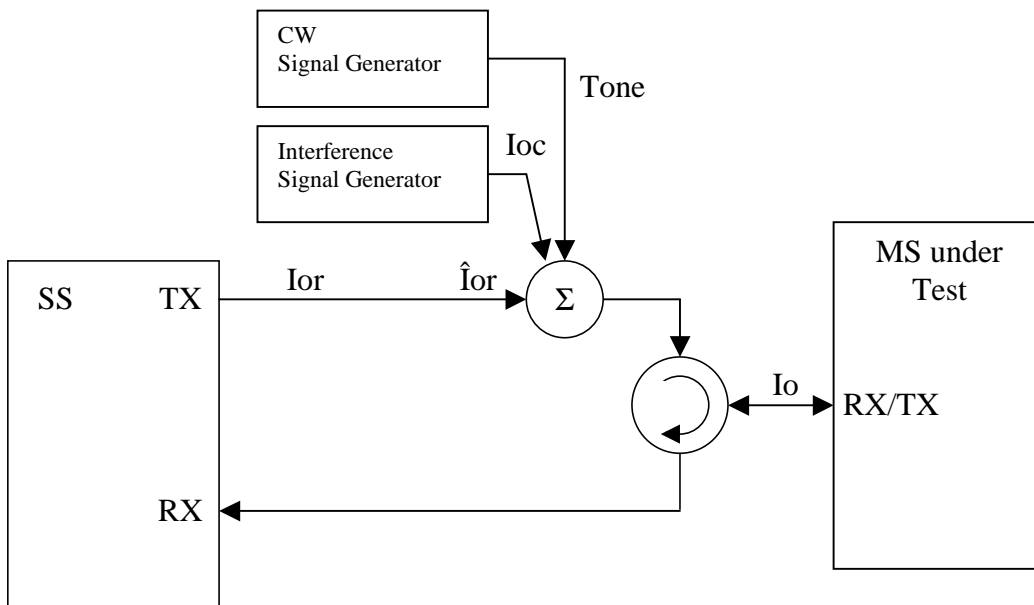

Figure A.7: Connection for RX Test with both Interference and additional CW



Figure A.8: Connection for Spurious Emission Test

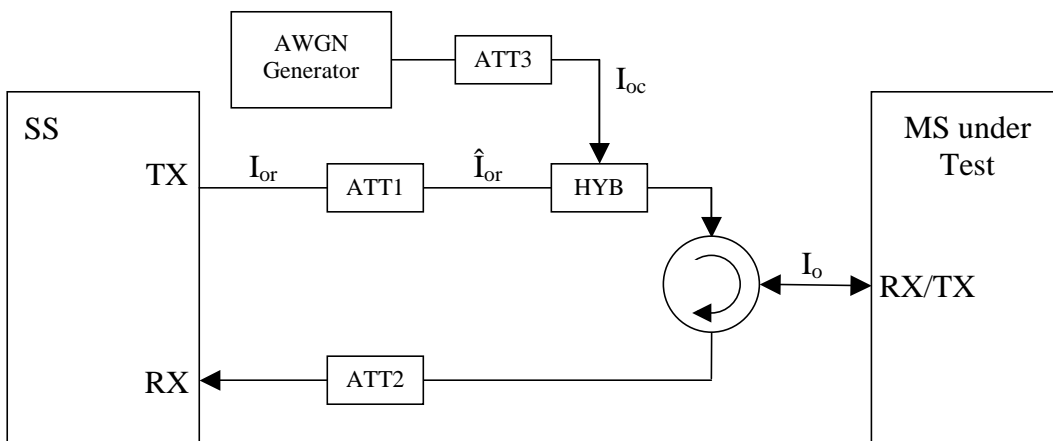

Figure A.9: Connection for Static Channel Test

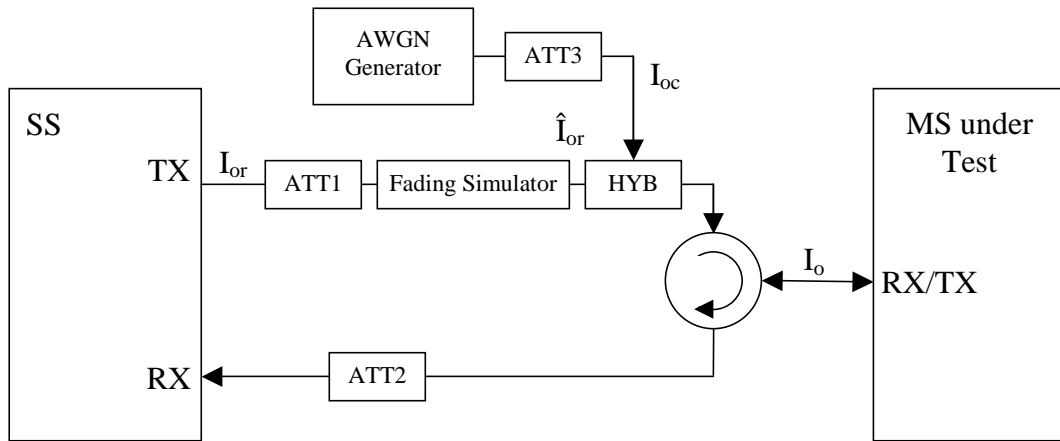

Figure A.10: Connection for Multiple Fading Channel Test

Annex B (normative): Global In-Channel TX-Test

B.1 General

The global in-channel Tx test enables the measurement of all relevant parameters that describe the in-channel quality of the output signal of the Tx under test in a single measurement process.

The parameters describing the in-channel quality of a transmitter, however, are not necessarily independent. The algorithm chosen for description inside this annex places particular emphasis on the exclusion of all interdependencies among the parameters. Any other algorithm (e.g. having better computational efficiency) may be applied, as long as the results are the same within the accuracy limits.

All notes referred in the various clauses of B.2 are put together in B.3.

B.2 Definition of the process

B.2.1 Basic principle

The process is based on the comparison of the actual **output signal of the TX under test**, received by an ideal receiver, with a **reference signal**, that is generated by the measuring equipment and represents an ideal error free received signal. The reference signal shall be composed of the same number of codes at the correct spreading factors as contained in the test signal. Note, for simplification, the notation below assumes only codes of one spreading factor although the algorithm is valid for signals containing multiple spreading factors.

All signals are represented as equivalent (generally complex) baseband signals.

B.2.2 Output signal of the TX under test

The output signal of the TX under test is acquired by the measuring equipment, filtered by a matched filter (RRC 0.22, correct in shape and in position on the frequency axis) and stored for further processing.

The following form represents the physical signal in the entire measurement interval:

one vector **Z**, containing $N = n_s \times sf + m_a$ complex samples;

with

n_s : number of symbols in the measurement interval;

sf : number of chips per symbol. (sf : spreading factor) (see Note: Symbol length)

m_a : number of midamble chips

B.2.3 Reference signal

The reference signal is constructed by the measuring equipment according to the relevant TX specifications.

It is filtered by the same matched filter, mentioned in B.2.2., and stored at the Inter-Symbol-Interference free instants. The following form represents the reference signal in the entire measurement interval:

one vector **R**, containing $N = n_s \times sf + m_a$ complex samples;

n_s , sf , m_a : see B.2.2

B.2.4 void

B.2.5 Classification of measurement results

The measurement results achieved by the global in-channel TX test can be classified into two types:

Results of type "deviation", where the error-free parameter has a non-zero magnitude. (These are the parameters that quantify the integral physical characteristic of the signal). These parameters are:

- RF Frequency
- Power (in case of single code)
- Code Domain Power (in case of multi code)
- Timing

(Additional parameters: see Note: Deviation)

Results of type "residual", where the error-free parameter has value zero. (These are the parameters that quantify the error values of the measured signal, whose ideal magnitude is zero). These parameters are:

- Error Vector Magnitude (EVM);
- Peak Code Domain Error (PCDE).
- (Additional parameters: see Note residual).

B.2.6 Process definition to achieve results of type "deviation"

The reference signal (**R**; see clause B.2.3) and the signal under Test (**Z**; see subclause B.2.2) are varied with respect to the parameters mentioned in clause B.2.5 under "results of type deviation" in order to achieve best fit. Best fit is achieved when the RMS difference value between the varied signal under test and the varied reference signal is an absolute minimum.

Overview:

$$FCT [Z (\tilde{f}, \tilde{t}, \tilde{\varphi}, g_1, g_2, \dots, g_{synch}) - R (f, t, \varphi, \tilde{g}_1, \tilde{g}_2, \dots, \tilde{g}_{synch})] = Minimum !$$

Z : Signal under test.

R: Reference signal,

with frequency f , the timing t , the phase φ , gain of code1 (g_1), gain of code2 (g_2) etc, and the gain of the synch channel g_{synch}

The parameters marked with a tilde in Z and R are varied in order to achieve a best fit.

Detailed formula: see Note: Formula for the minimum process.

The varied reference signal, after the best fit process, will be called **R'**.

The varied signal under test, after the best fit process, will be called **Z'**.

The varying parameters, leading to **R'** and **Z'** represent directly the wanted results of type "deviation". These measurement parameters are expressed as deviation from the reference value with units same as the reference value.

In case of multi code, the type-"deviation"-parameters (frequency, timing and (RF-phase)) are varied commonly for all codes such that the process returns one frequency-deviation, one timing deviation, (one RF-phase –deviation).

(These parameters are not varied on the individual codes signals such that the process would return kr frequency errors... . (kr : number of codes in the reference signal)).

The only type-"deviation"-parameters varied individually are the code domain gain factors (g_1, g_2, \dots).

E.2.5.1 Decision Point Power

The mean-square value of the signal-under-test, sampled at the best estimate of the of Intersymbol-Interference-free points using the process defined in subclause 2.5, is referred to the *Decision Point Power* (DPP):

E.2.5.2 Code-Domain Power

The samples, Z , are separated into symbol intervals to create n_s time-sequential vectors \mathbf{z} with s_f complex samples comprising one symbol interval. The *Code Domain Power* is calculated according to the following steps:

- 1) Take the vectors \mathbf{z} defined above.
- 2) To achieve meaningful results it is necessary to descramble \mathbf{z} , leading to \mathbf{z}'
- 3) Take the orthogonal vectors of the channelization code set \mathbf{C} (all codes belonging to one spreading factor) as defined in TS 25.213 and TS 25.223 (range +1, -1), and normalize by the norm of the vectors to produce $\mathbf{C}_{norm} = \mathbf{C} / \text{sqrt}(s_f)$. (see Note: Symbol length)
- 4) Calculate the inner product of \mathbf{z}' with \mathbf{C}_{norm} . Do this for all symbols of the measurement interval and for all codes in the code space.
This gives an array of format $k \times n_s$, each value representing a specific symbol and a specific code, which can be exploited in a variety of ways.

k : total number of codes in the code space

n_s : number of symbols in the measurement interval

- 5) Calculate k mean-square values, each mean-square value unifying n_s symbols within one code. (These values can be called "*Absolute CodeDomainPower* (CDP)" [Volt^2].) The sum of the k values of CDP is equal to DPP.
- 6) Normalize by the decision point power to obtain

$$\text{Relative CodeDomain Power} = \frac{\text{Absolute CodeDomain Power}}{\text{DecisionPointPower}}$$

B.2.7 Process definition to achieve results of type "residual"

The difference between the varied reference signal (\mathbf{R}' ; see clause B.2.6.) and the varied TX signal under test (\mathbf{Z} ; see clause B.2.6) is the error vector \mathbf{E} versus time:

$$\mathbf{E} = \mathbf{Z}' - \mathbf{R}'.$$

Depending on the parameter to be evaluated, it is appropriate to represent \mathbf{E} in one of the following two different forms:

Form EVM (representing the physical error signal in the entire measurement interval)

One vector \mathbf{E} , containing $N = n_s \times s_f + m_a$ complex samples;

n_s , s_f , m_a : see B.2.2

Form PCDE (derived from Form EVM by separating the samples into symbol intervals)

n_s time-sequential vectors \mathbf{e} with s_f complex samples comprising one symbol interval.

\mathbf{E} gives results of type "residual" applying the two algorithms defined in clauses B 2.7.1 and B 2.7.2.

B.2.7.1 Error Vector Magnitude (EVM)

The Error Vector Magnitude EVM is calculated according to the following steps:

- 1) Take the error vector \mathbf{E} defined in clause B.2.7 (Form EVM) and calculate the RMS value of \mathbf{E} ; the result will be called $\text{RMS}(\mathbf{E})$.

- 2) Take the varied reference vector \mathbf{R}' defined in clause B.2.6 and calculate the RMS value of \mathbf{R}' ; the result will be called $\text{RMS}(\mathbf{R}')$.
- 3) Calculate EVM according to:

$$\text{EVM} = \frac{\text{RMS}(E)}{\text{RMS}(\mathbf{R}')} \times 100\% \quad (\text{here, EVM is relative and expressed in \%})$$

(see note TDD)

(see note: Formula for EVM)

B.2.7.2 Peak Code Domain Error (PCDE)

The Peak Code Domain Error is calculated according to the following steps:

- 1) Take the error vectors \mathbf{e} defined in clause B.2.7 (Form PCDE).
- 2) Take the orthogonal vectors of the channelisation - code set \mathbf{C} (all codes belonging to one spreading factor) as defined in TS 25.213 and TS 25.223 (range +1, -1). (see Note: Symbol length) and normalize by the norm of the vectors to produce $\mathbf{C}_{\text{norm}} = \mathbf{C}/\text{sqrt}(\text{sf})$. (see Note: Symbol length).
- 3) To achieve meaningful results it is necessary to descramble \mathbf{e} , leading to \mathbf{e}' .
- 4) Calculate the inner product of \mathbf{e}' with \mathbf{C}_{norm} . Do this for all symbols of the measurement interval and for all codes in the code space.
This gives an array of format $k \times n_s$, each value representing an error-vector representing a specific symbol and a specific code, which can be exploited in a variety of ways.

k : total number of codes in the code space

n_s : number of symbols in the measurement interval

- 5) Calculate k RMS values, each RMS value unifying n_s symbols within one code.
(These values can be called "*Absolute CodeEVMs*" [Volt].)
- 6) Find the peak value among the k "*Absolute CodeEVMs*".
(This value can be called "*Absolute PeakCodeEVM*" [Volt].)
- 7) Calculate PCDE according to:

$$10 \cdot \lg \frac{(\text{"Absolute PeakCodeEVM"})^2}{(\text{RMS}(\mathbf{R}'))^2} \quad \text{dB} \quad (\text{a relative value in dB}).$$

(see Note: Scrambling code)

(see Note TDD)

B.3 Notes

Note: Symbol length)

A general code multiplexed signal is multicode and multirate. In order to avoid unnecessary complexity, the measurement applications use a unique symbol-length, corresponding to a spreading factor, regardless of the really intended spreading factor. Nevertheless the complexity with a multicode / multirate signal can be mastered by introducing appropriate definitions.

Note: Deviation)

It is conceivable to regard more parameters as type „deviation" e.g. Chip frequency and RF-phase.

As chip-frequency and RF-frequency are linked together by a statement in the core specifications [1] it is sufficient to process RF frequency only.

A parameter RF-phase must be varied within the best fit process (B 2.6.). Although necessary, this parameter-variation doesn't describe any error, as the modulation schemes used in the system don't depend on an absolute RF-phase.

Note: Residual)

It is conceivable to regard more parameters as type „residual" e.g. IQ origin offset. As it is not the intention of the test to separate for different error sources, but to quantify the quality of the signal, all such parameters are not extracted by the best fit process, instead remain part of EVM and PCDE.

Note Scrambling Code)

To interpret the measurement results in practice it should be kept in mind that erroneous code power on unused codes is generally de-scrambled differently under test conditions and under real life conditions, whereas erroneous code power on used codes is generally de-scrambled equally under test conditions and under real life conditions. It might be indicated if a used or unused code hits PCDE.

Note TDD)

EVM covers the midamble part as well as the data part; however PCDE disregards the midamble part.

NOTE: Formula for the minimum process

$$L(\Delta\tilde{f}, \Delta\tilde{t}, \Delta\tilde{\varphi}, \Delta\tilde{g}_c, \dots, \Delta\tilde{g}_{mid}) = \sum_{v=0}^{N-1} |Z(v) - R(v)|^2$$

Legend:

L : the function to be minimised

The parameters to be varied in order to minimize are:

$\Delta\tilde{f}$: the RF frequency offset

$\Delta\tilde{t}$: the timing offset

$\Delta\tilde{\varphi}$: the phase offset

$\Delta\tilde{g}_c \dots$ code power offsets (one offset for each code)

$\Delta\tilde{g}_{mid}$: the power offset of the midamble

Z(v): Samples of the signal under Test

R(v): Samples of the reference signal

$\sum_{v=0}^{N-1}$: counting index v starting at the beginning of the measurement interval and ending at its end.

N = No of chips during the measurement interval.

Z(v): Samples of the signal under Test. It is modelled as a sequence of complex baseband samples $Z(\gamma)$ with a time-shift Δt , a frequency offset Δf , a phase offset $\Delta\varphi$, the latter three with respect to the reference signal.

$$Z(v) = Z(v - \Delta \tilde{t}) * e^{-j2\pi\Delta\tilde{f}v} * e^{-j\Delta\tilde{\phi}}$$

R(v): Samples of the reference signal:

$$R(v) = \sum_{c=1}^{\text{No. of codes}} (g_c + \Delta\tilde{g}_c) * \text{Chip}_c(v) + (g_{mid} + \Delta\tilde{g}_{mid}) * \text{Chip}_{mid}(v)$$

g : nominal gain of the code channel or midamble

$\Delta\tilde{g}$: The gain offset to be varied in the minimum process

Chip(v) is the chipsequence of the code channel or midamble

Indices at g , Δg and Chip:

The index indicates the code channel: $c = 1, 2, \dots$ No of code channels

Range for Chip_c : +1, -1

Note: **Formula for EVM**

$$EVM = \sqrt{\frac{\sum_{v=0}^{N-1} |Z'(v) - R'(v)|^2}{\sum_{v=0}^{N-1} |R'(v)|^2}} * 100 \%$$

Z'(v), R'(v) are the varied measured and reference signals.

Annex C (normative): Measurement channels

C.1 General

Void.

C.2 UL Reference measurement channels

C.2.1 UL reference measurement channel (12.2 kbps)

Parameter	
Information data rate	12.2 kbps
RU's allocated	2 RU
Midamble	512 chips
Interleaving	20 ms
Power control	2 Bit/user
TFCI	16 Bit/user
Inband signalling DCCH	2 kbps
Puncturing level at Code rate 1/3 : DCH / DCCH	5% / 0%

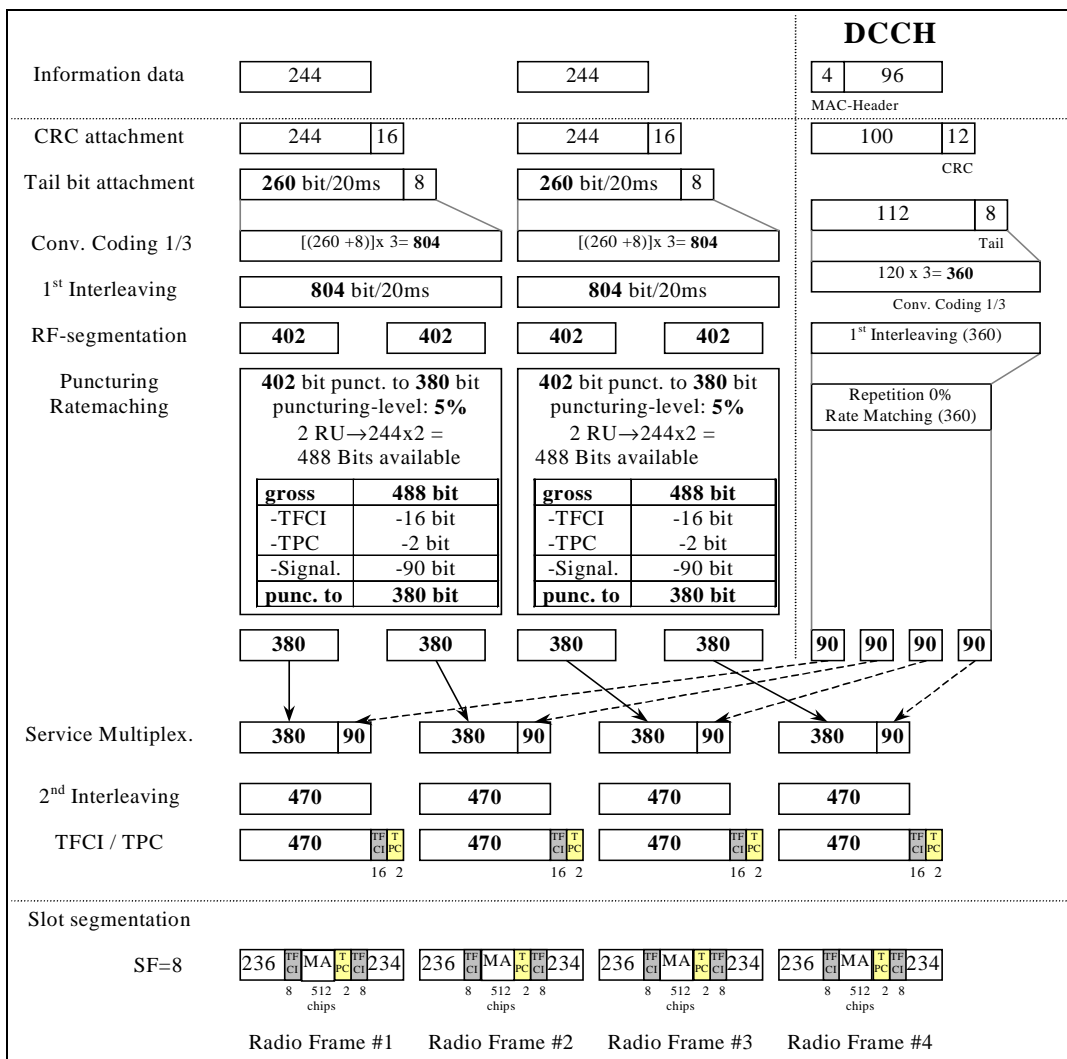

C.2.2 UL multi code reference measurement channel (12.2 kbps)

Parameter	
Information data rate	12.2 kbps
RU's allocated	2 RU
Midamble	512 chips
Interleaving	20 ms
Power control	2 Bit/user
TFCI	16 Bit/user
Inband signalling DCCH	2 kbps
Puncturing level at Code rate 1/3 : DCH / DCCH	5% / 0 %

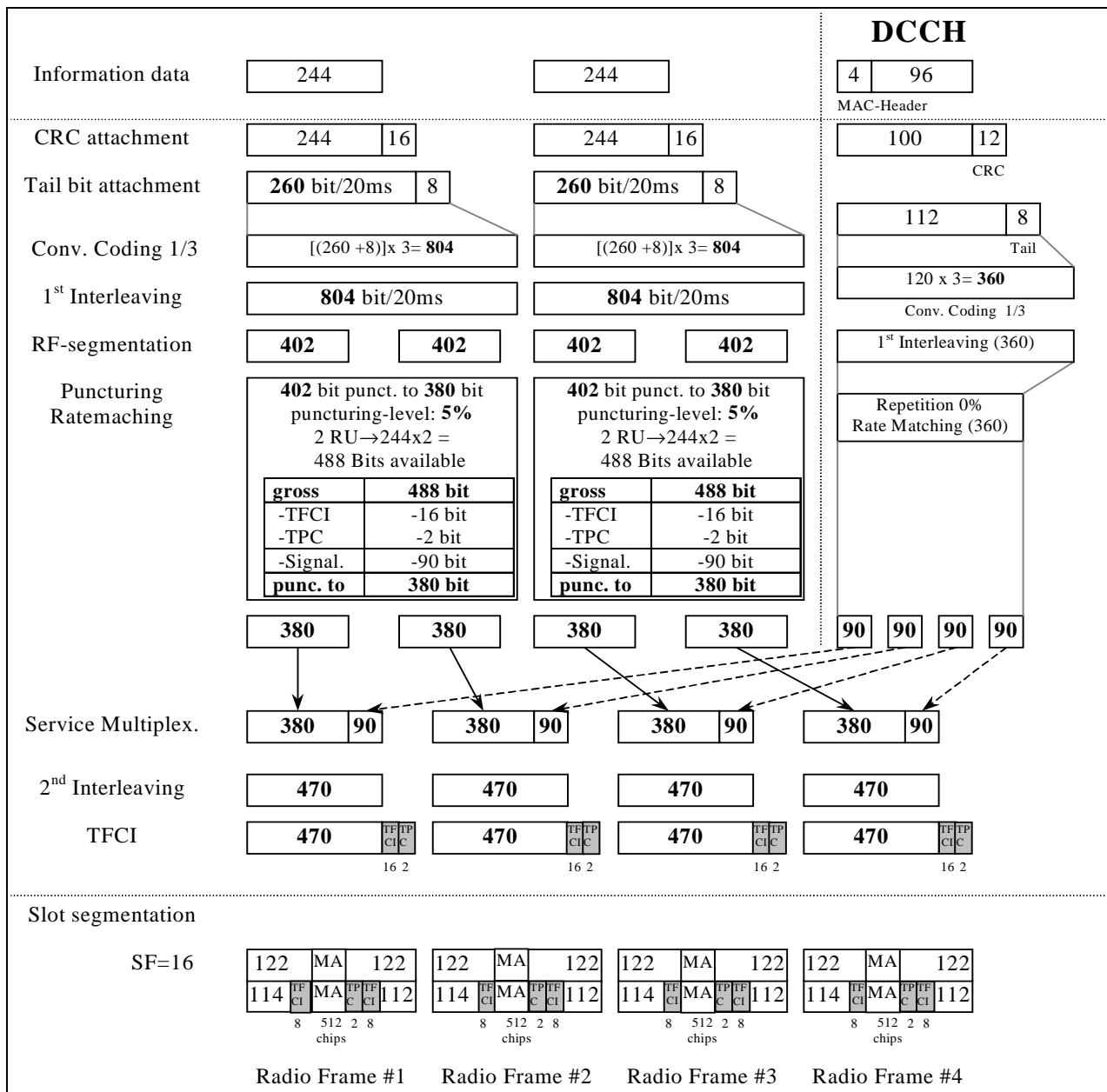

C.2.3 UL reference measurement channel (64 kbps)

Parameter	
Information data rate	64 kbps
RU's allocated	1 SF4 + 1 SF16 = 5RU
Midamble	512 chips
Interleaving	20 ms
Power control	2 Bit/user
TFCI	16 Bit/user
Inband signalling DCCH	2 kbps
Puncturing level at Code rate : 1/3 DCH / 1/2 DCCH	41.2% / 10%

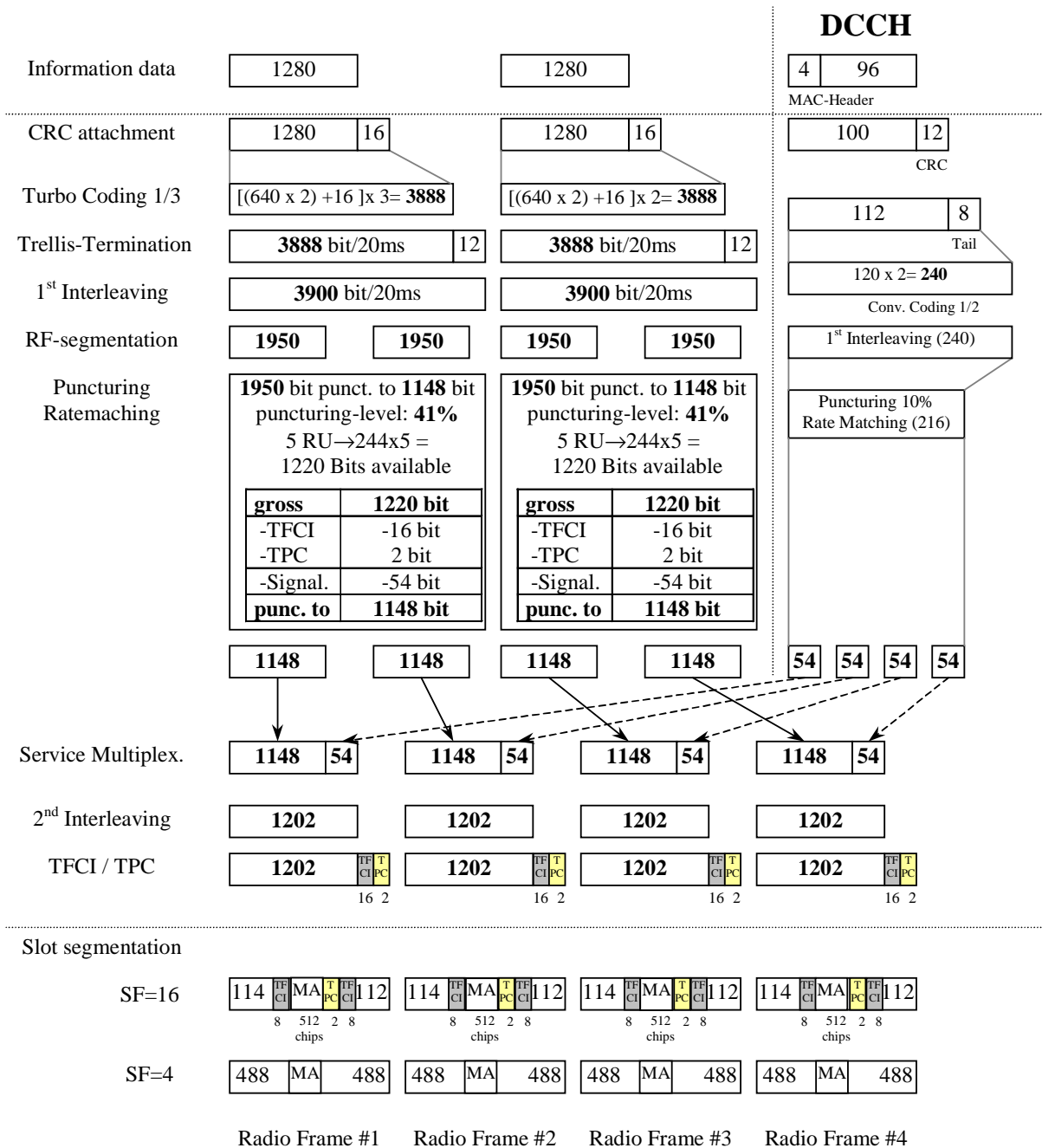

C.2.4 UL reference measurement channel (144 kbps)

Parameter	
Information data rate	144 kbps
RU's allocated	1 SF2 + 1 SF16 = 9RU
Midamble	256 chips
Interleaving	20 ms
Power control	2 Bit/user
TFCI	16 Bit/user
Inband signalling DCCH	2 kbps
Puncturing level at Code rate : 1/3 DCH / 1/2 DCCH	44.4% / 16.6%

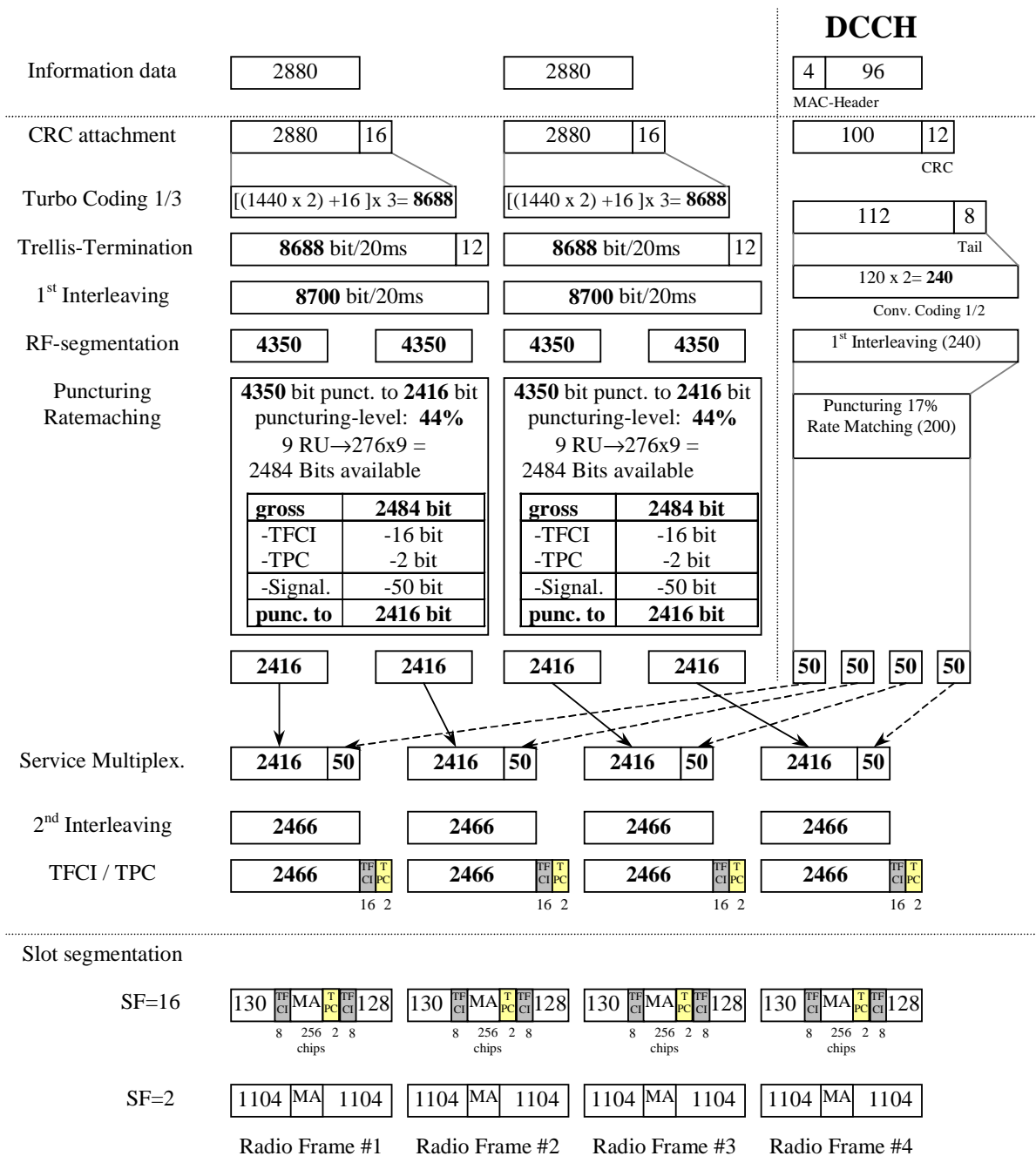

C.2.5 UL reference measurement channel (384 kbps)

Parameter	
Information data rate	384 kbps
RU's allocated	8*3TS = 24RU
Midamble	256 chips
Interleaving	20 ms
Power control	2 Bit/user
TFCI	16 Bit/user
Inband signalling DCCH	2 kbps
Puncturing level at Code rate : 1/3 DCH / 1/2 DCCH	43.4% / 15.3%

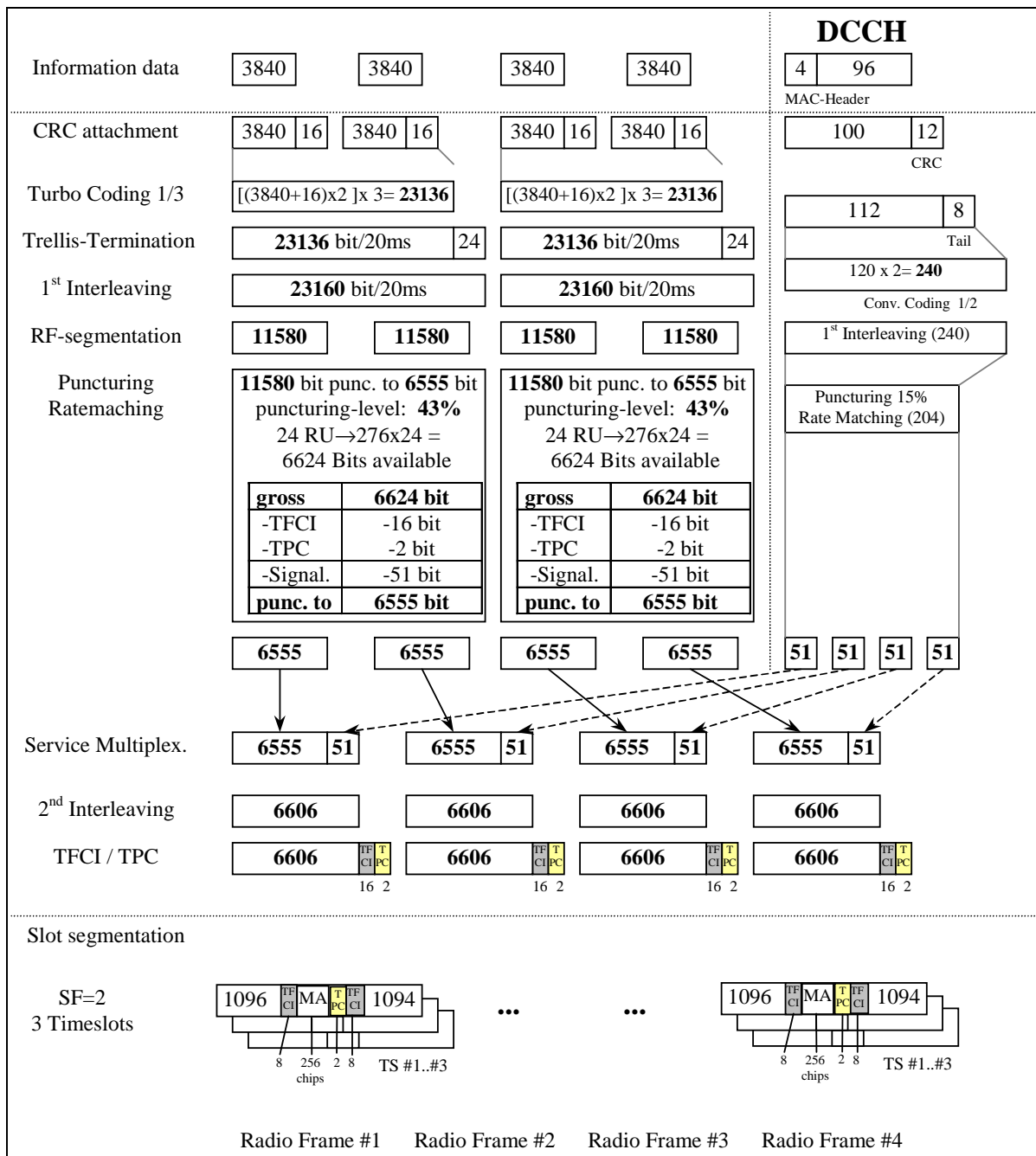

C.3 DL Reference measurement channels

C.3.1 DL reference measurement channel (12.2 kbps)

Parameter	
Information data rate	12.2 kbps
RU's allocated	2 RU
Midamble	512 chips
Interleaving	20 ms
Power control	0 Bit/user
TFCI	16 Bit/user
Inband signalling DCCH	2 kbps
Puncturing level at Code rate 1/3 : DCH / DCCH	5% / 0 %

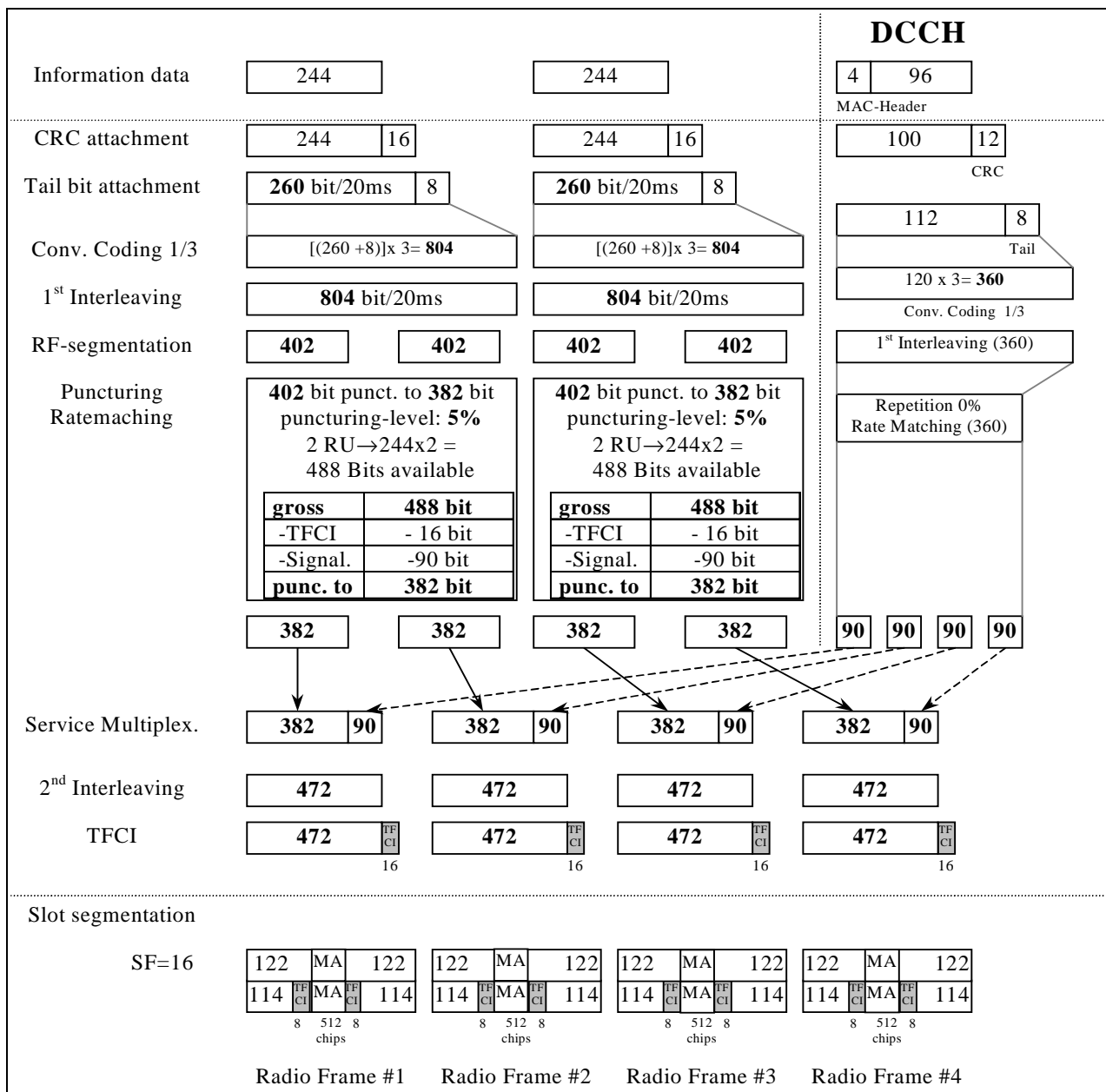

C.3.2 DL reference measurement channel (64 kbps)

Parameter	
Information data rate	64 kbps
RU's allocated	5 codes SF16 = 5RU
Midamble	512 chips
Interleaving	20 ms
Power control	0 Bit/user
TFCI	16 Bit/user
Inband signalling DCCH	2 kbps
Puncturing level at Code rate : 1/3 DCH / 1/2 DCCH	41.1% / 10%

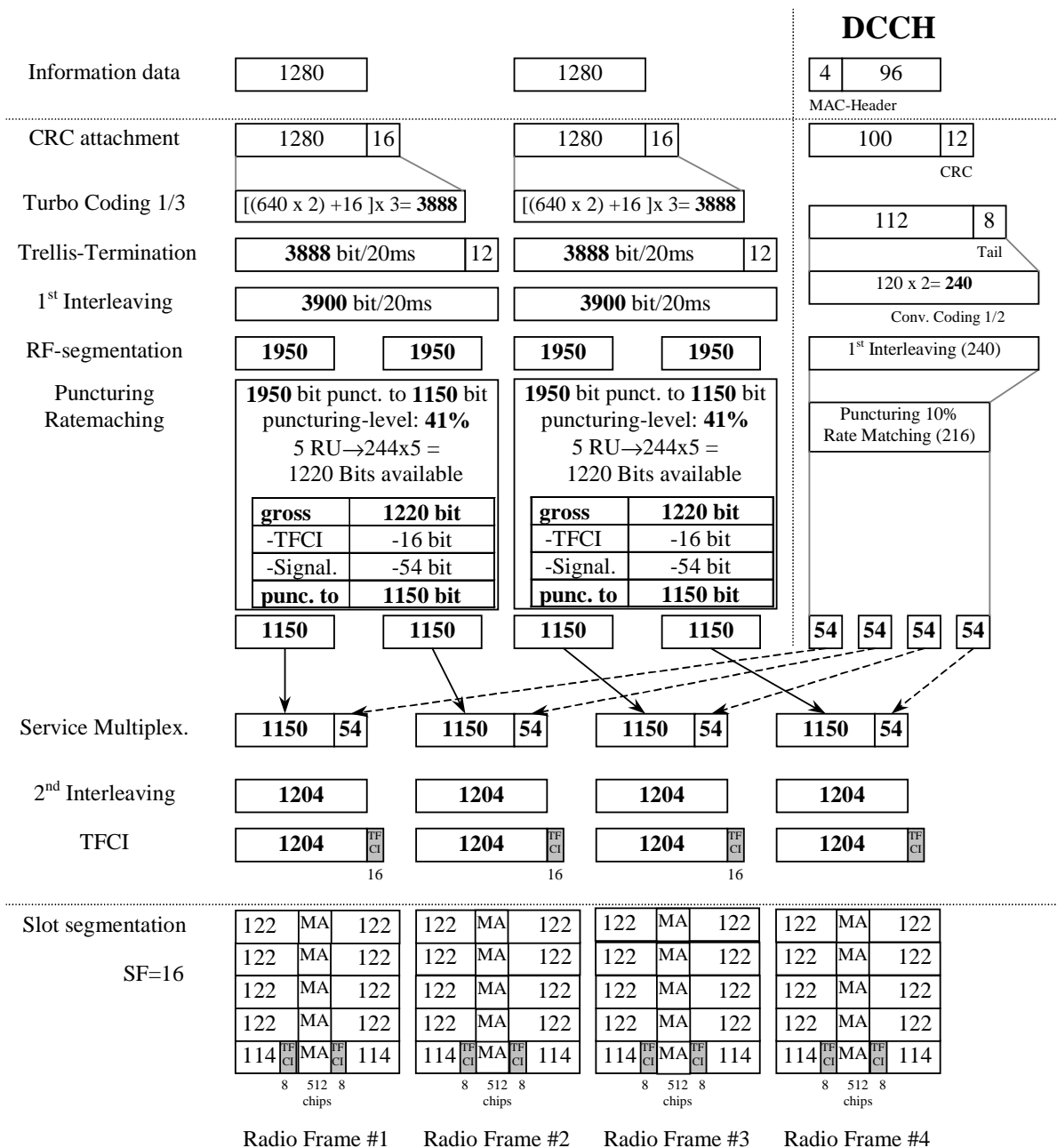

C.3.3 DL reference measurement channel (144 kbps)

Parameter	
Information data rate	144 kbps
RU's allocated	9 codes SF16 = 9RU
Midamble	256 chips
Interleaving	20 ms
Power control	0 Bit/user
TFCI	16 Bit/user
Inband signalling DCCH	2 kbps
Puncturing level at Code rate: 1/3 DCH / 1/2 DCCH	44.5% / 16.6%

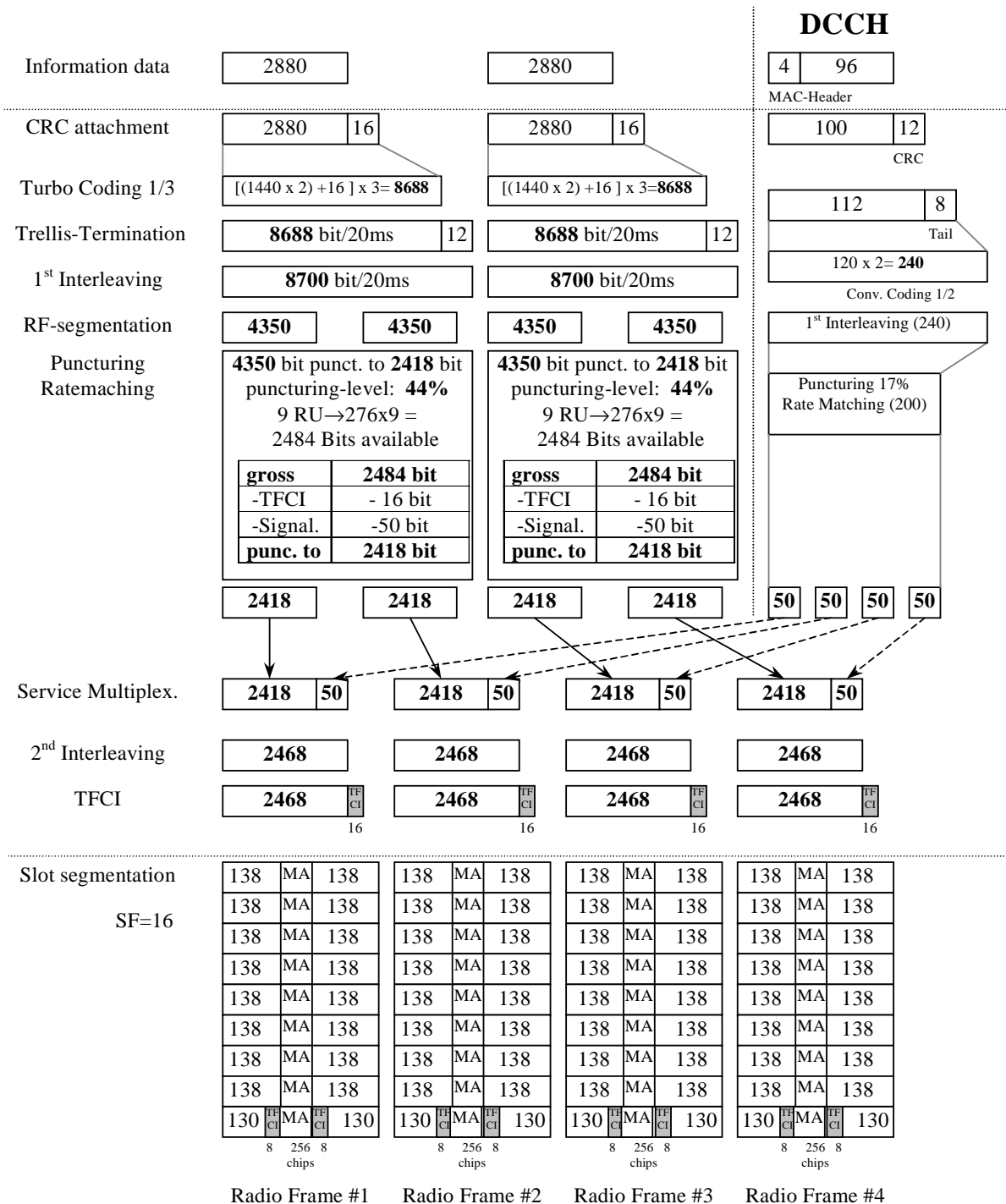

C.3.4 DL reference measurement channel (384 kbps)

Parameter	
Information data rate	384 kbps
RU's allocated	8*3TS = 24RU
Midamble	256 chips
Interleaving	20 ms
Power control	0 Bit/user
TFCI	16 Bit/user
Inband signalling DCCH	2 kbps
Puncturing level at Code rate : 1/3 DCH / 1/2 DCCH	43.4% / 15.3%

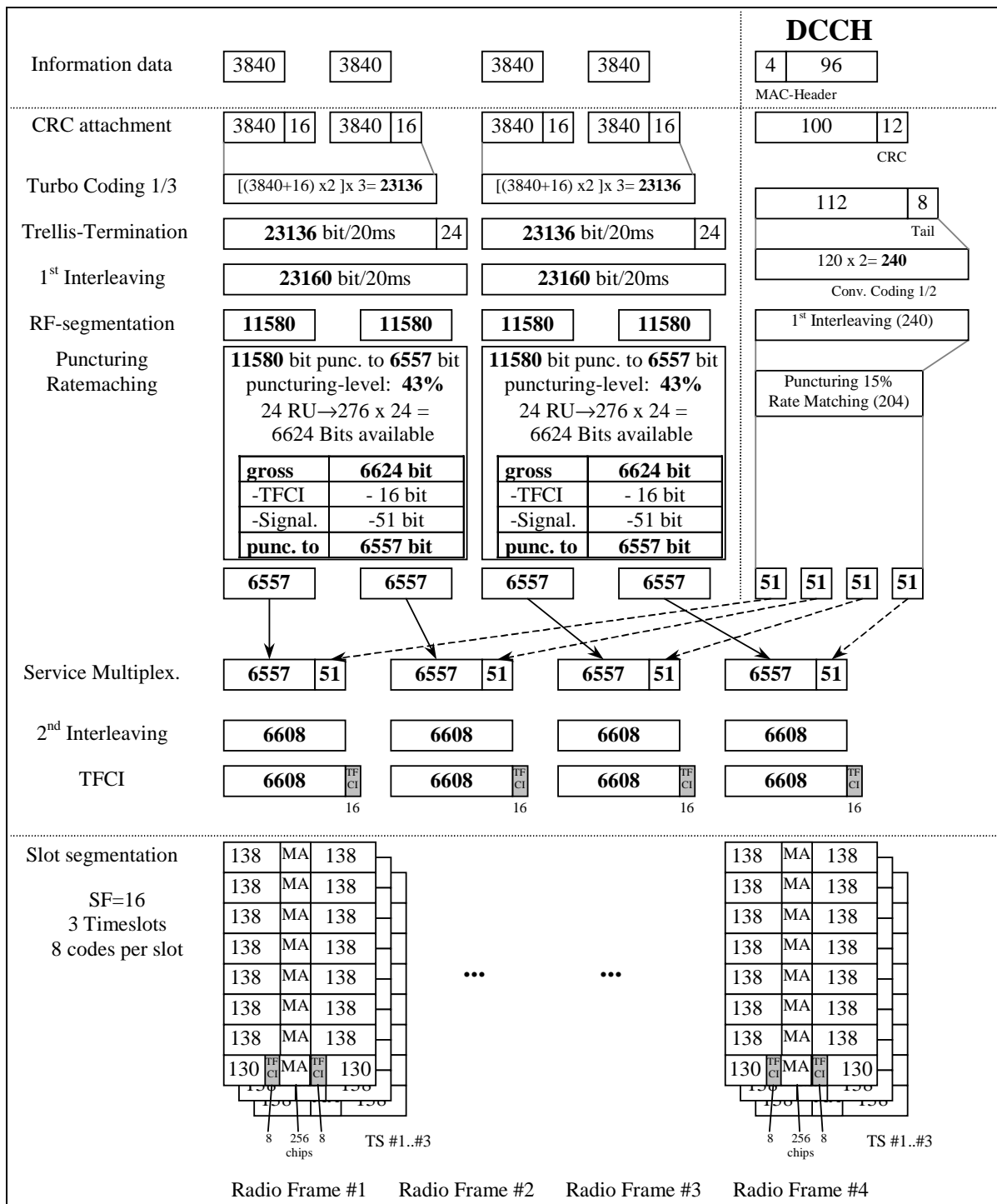

C.3.5 BCH reference measurement channel

[mapped to 1 code SF16]

Parameter	
Information data rate:	12.3 kbps
RU's allocated	1 RU
Midamble	512 chips
Interleaving	20 ms
Power control	0 bit
TFCI	0 bit
Puncturing level	10%

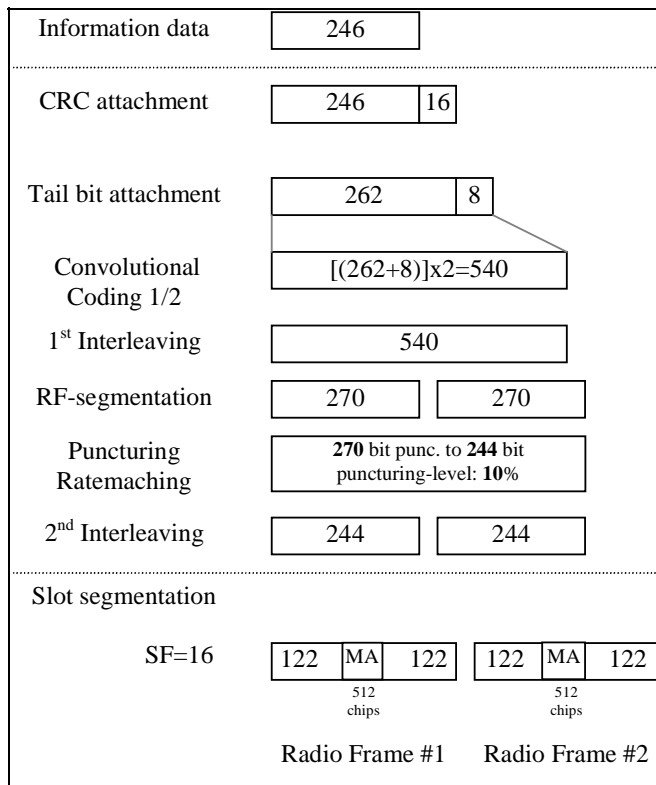

Annex D (normative): Propagation conditions

D.1 Test Environments

Table D.1 details the test services, the information data and the propagation conditions.

Table D.1: Test Environments for UE Performance Specifications

Test Services	Information Data Rate	Static	Multipath Case 1	Multipath Case 2	Multipath Case 3
		Performance metric			
Paging Message			-	-	-
FACH Message			-	-	-
Circuit Switched Services	12.2 kbps	BLER <	BLER <	BLER <	BLER <
	64 kbps	BLER <	BLER <	BLER <	BLER <
	144 kbps	BLER <	BLER <	BLER <	BLER <
	384 kbps	BLER <	BLER <	BLER <	BLER <
	2048 kbps	BLER <	-	-	-
Packet Switched Data	TBD	TBD	TBD	TBD	TBD

D.2 Propagation Conditions

D.2.1 Static propagation condition

The propagation for the static performance measurement is an Additive White Gaussian Noise (AWGN) environment. No fading and multi-paths exist for this propagation model.

D.2.2 Multi-path fading propagation conditions

Table D.2 shows propagation conditions that are used for the performance measurements in multi-path fading environment. All taps have classical Doppler spectrum.

Table D.2: Propagation Conditions for Multi path Fading Environments

Case 1, speed 3km/h		Case 2, speed 3 km/h		Case 3, speed 120 km/h		Case 4, speed 3 km/h	
Relative Delay [ns]	Relative Mean Power [dB]	Relative Delay [ns]	Relative Mean Power [dB]	Relative Delay [ns]	Relative Mean Power [dB]	Relative Delay [ns]	Relative Mean Power [dB]
0	0	0	0	0	0	0	0
976	-10	976	0	260	-3	976	0
		12000	0	521	-6		
				781	-9		

Annex E (normative): Common RF test conditions

E.1 General

This normative annex specifies the common RF test conditions that are needed for setting a connection and channels that are needed during a connection.

E.2 Connection Set-up

Table E.2 describes the downlink Physical Channels that are required for connection set up.

Table E.2: Downlink Physical Channels required for connection set-up

Physical Channel
PSCH
PCCPCH
DPCH
PICH

E.3 During connection

The following clauses describes the uplink and downlink Physical Channels that are transmitted during a connection i.e., when measurements are done.

E.3.1 Measurement of Tx Characteristics

Table E.3.1 is applicable for measurements on the Transmitter Characteristics (Clause 5) with the exception of clause 5.2 (UE maximum output power), 5.3 (Frequency Stability), 5.4.1 (Uplink Power Control). For these cases certain parameters are defined individually.

Table E.3.1.1: Common downlink test condition RF parameters

Physical Channel	Power
DPCH	-93 dBm Data content PRBS
PSCH	TBD
PCCPCH	TBD
PICH	TBD
OCNS	Nothing

Table E.3.1.2: Common TX test parameters

Parameter	Value/description
UL Reference measurement channel	12.2kbps, according to annex C.2.1
Uplink Power Control	SS level and signalling values such that UE transmits maximum power.
Data content	real life (sufficient irregular)

E.3.2 Measurement of Rx Characteristics

Table E.3.2 is applicable for measurements on the Receiver Characteristics (Clause 6)

Table E.3.2: Downlink Physical Channels transmitted during a connection.

Physical Channel	Power
CPICH	TBD
PCCPCH	TBD
SCH	TBD
PICH	TBD
DPCH	TBD

E.3.3 Measurement of Performance requirements

Table E.3.3 is applicable for measurements on the Performance requirements (Clause 7)

Table E.3.3: Downlink Physical Channels transmitted during a connection.

Physical Channel	Power	Note
CPICH	TBD	
PCCPCH	TBD	
SCH	TBD	
PICH	TBD	
DPCH	TBD	
OCNS	TBD	

Annex F (normative): General test conditions and declarations

The requirements of this clause apply to all applicable tests in the present document.

Many of the tests in the present document measure a parameter relative to a value that is not fully specified in the UE specifications. For these tests, the Minimum Requirement is determined relative to a nominal value specified by the manufacturer.

When specified in a test, the manufacturer shall declare the nominal value of a parameter, or whether an option is supported.

In all the relevant clauses in this clause all Bit Error Ratio (BER), Block Error Ratio (BLER) measurements shall be carried out according to the general rules for statistical testing in annex F.6.

F.1 Acceptable uncertainty of Test System

The maximum acceptable uncertainty of the Test System is specified below for each test, where appropriate. The Test System shall enable the stimulus signals in the test case to be adjusted to within the specified range, and the equipment under test to be measured with an uncertainty not exceeding the specified values. All tolerances and uncertainties are absolute values, and are valid for a confidence level of 95 %, unless otherwise stated.

A confidence level of 95% is the measurement uncertainty tolerance interval for a specific measurement that contains 95% of the performance of a population of test equipment.

For RF tests it should be noted that the uncertainties in clause F.1 apply to the Test System operating into a nominal 50 ohm load and do not include system effects due to mismatch between the DUT and the Test System.

F.1.1 Measurement of test environments

The measurement accuracy of the UE test environments defined in Annex G, Test environments shall be.

- Pressure ± 5 kPa.
- Temperature ± 2 degrees.
- Relative Humidity ± 5 %.
- DC Voltage $\pm 1,0$ %.
- AC Voltage $\pm 1,5$ %.
- Vibration 10 %.
- Vibration frequency 0,1 Hz.

The above values shall apply unless the test environment is otherwise controlled and the specification for the control of the test environment specifies the uncertainty for the parameter.

F.1.2 Measurement of transmitter

Table F.1.2 Maximum Test System Uncertainty for transmitter tests

Clause	Maximum Test System Uncertainty
5.2 UE Maximum Output Power	± 0.7 dB
5.3 Frequency Stability	± 10 Hz
5.4.1 Uplink power control	Relative $\pm [0.3]$ dB
5.4.2 Minimum Transmit Power	± 1.0 dB
5.4.3 Transmit OFF Power	± 1.5 dB
5.4.4 Transmit ON/OFF Power	TBD
5.4.5 Out-of-synchronisation handling of output power	± 0.4 dB
5.5.1 Occupied Bandwidth	± 100 kHz
5.5.2.1 Spectrum emission mask	± 1.5 dB
5.5.2.2 ACLR	5 MHz offset: ± 0.8 dB 10 MHz offset: ± 0.8 dB
5.5.3 Spurious emissions	± 2.0 dB for UE and coexistence bands for results > -60 dBm ± 3.0 dB for results < -60 dBm Outside above: f ≤ 2.2 GHz : ± 1.5 dB 2.2 GHz < f ≤ 4 GHz : ± 2.0 dB f > 4 GHz : ± 4.0 dB
5.6 Transmit intermodulation:	Will be based on BS, need to work out freq and level ranges.
5.7.1 Transmit modulation: EVM	± 2.5 %
5.7.2 Transmit modulation: peak code domain error	± 1 dB

F.1.3 Measurement of receiver

Table F.1.3 Maximum Test System Uncertainty for receiver tests

Clause	Maximum Test System Uncertainty
6.2 Reference Sensitivity Level	± 0.7 dB
6.3 maximum input level:	TBD
6.4 Adjacent Channel Selectivity (ACS)	Overall system uncertainty ± 1.1 dB
6.5 Blocking Characteristics	Using ± 0.7 dB for signal and interferer as currently defined, and 68 dB ACLR @ 10 MHz. System error with f < 15 MHz offset: ± 1.4 dB f ≥ 15 MHz offset and f ≤ 2,2 GHz: ±1,0 dB 2,2 GHz < f ≤ 4 GHz : ±1,7 dB f > 4 GHz: ±3,1 dB
6.6 Spurious Response	f < 2,2 GHz: ±1,0dB 2,2 < f < 4GHz: ±1,7dB f > 4 GHz: ±3,1dB
6.7 Intermodulation Characteristics	± 1,3 dB with Formula = $\sqrt{(2 \cdot CW_level_error)^2 + (mod_level_error)^2 + (wanted_signal_level_error)^2}$ (Using CW interferer ±0,5 dB, modulated interferer ±0,5 dB, wanted signal ±0,7 dB)
6.8 Spurious Emissions	± 3,0 dB for UE receive band (-78 dBm) Outside above: f ≤ 2,2GHz : ± 2,0dB (-57 dBm) 2,2 GHz < f ≤ 4 GHz : ± 2,0 dB (-47 dBm) f > 4 GHz : ±4,0 dB (-47 dBm)

F.1.4 Performance requirement

Table F.1.4 Maximum Test System Uncertainty for Performance Requirements

Clause	Maximum Test System Uncertainty
7.6 Uplink Power Control	0.3 dB (relative tolerance for 10 dB stepsize)

F.1.5 Requirements for support of RRM

TBD

F.2 Test Tolerances (This clause is informative)

The Test Tolerances defined in this clause have been used to relax the Minimum Requirements in the present document to derive the Test Requirements.

The Test Tolerances are derived from Test System uncertainties, regulatory requirements and criticality to system performance. As a result, the Test Tolerances may sometimes be set to zero.

The test tolerances should not be modified for any reason e.g. to take account of commonly known test system errors (such as mismatch, cable loss, etc.).

F.2.1 Transmitter

Table F.2.1 Test Tolerances for transmitter tests.

Clause	Test Tolerance
5.2 Maximum Output Power	0,7 dB
5.3 UE Frequency Stability	10 Hz
5.4.1.1 Uplink Power Control, Initial Accuracy	+1,0 dB
5.4.1.2 Uplink Power Control, differential Accuracy	1dB step: 0,1 dB 2 dB step: 0,15 dB 3dB step: 0,2 dB 10 dB step: 0,5 dB 20 dB step: 0,7 dB 30 dB step: 0,7 dB >30 dB step: 1,0 dB
5.4.2 Minimum Transmit Power	1,0 dB
5.4.5 Out-of-synchronisation handling of output power: $\frac{\Sigma DPCH \cdot E_c}{I_{or}}$	0,4 dB
5.4.5 Out-of-synchronisation handling of output power: transmit ON/OFF time	0 ms
5.5.1 Transmit OFF power	1,5 dB
5.5.1 Occupied Bandwidth	0 kHz
5.5.2.1 Spectrum emission mask	1,5 dB
5.5.2.2 Adjacent Channel Leakage Power Ratio (ACLR)	0,8 dB
5.5.3 Spurious Emissions	0 dB
5.6 Transmit Intermodulation	0 dB
5.7.1 Error Vector Magnitude	0%
5.7.2 Peak code domain error	1,0 dB

F.2.2 Receiver

Table F.2.2 Test Tolerances for receiver tests.

Clause	Test Tolerance
6.2 Reference sensitivity level	0.7 dB
6.4 Adjacent channel selectivity	0 dB
6.5 Blocking characteristics	0 dB
6.6 Spurious Response	0 dB
6.7 Intermodulation Characteristics	0 dB
6.8 Spurious emissions	0 dB

F.2.3 Performance requirements

Table F.2.3 Test Tolerances for Performance Requirements.

Clause	Test Tolerance
7.2, Demodulation in Static Propagation Condition	
7.3, Demodulation of DCH in Multipath Fading conditions	
7.4, Base Station Transmit diversity modes	
7.6 Uplink Power Control	0.5 dB (relative tolerance for 10 dB stepsize)

F.2.4 Requirements for support of RRM

TBD

F.3 Interpretation of measurement results

The measurement results returned by the Test System are compared - without any modification - against the Test Requirements as defined by the shared risk principle.

The Shared Risk principle is defined in ETR 273 Part 1 sub-part 2 clause 6.5.

The actual measurement uncertainty of the Test System for the measurement of each parameter shall be included in the test report.

The recorded value for the Test System uncertainty shall be, for each measurement, equal to or lower than the appropriate figure in clause F.1 of the present document.

If the Test System for a test is known to have a measurement uncertainty greater than that specified in clause F.1, it is still permitted to use this apparatus provided that an adjustment is made value as follows.

Any additional uncertainty in the Test System over and above that specified in clause F.1 shall be used to tighten the Test Requirement – making the test harder to pass. (For some tests e.g. receiver tests, this may require modification of stimulus signals). This procedure will ensure that a Test System not compliant with clause F.1 does not increase the chance of passing a device under test where that device would otherwise have failed the test if a Test System compliant with clause F.1 had been used.

F.4 Derivation of Test Requirements (This clause is informative)

The Test Requirements in the present document have been calculated by relaxing the Minimum Requirements of the core specification using the Test Tolerances defined in clause F.2. When the Test Tolerance is zero, the Test Requirement will be the same as the Minimum Requirement. When the Test Tolerance is non-zero, the Test Requirements will differ from the Minimum Requirements, and the formula used for this relaxation is given in table F.4.

Table F.4: Derivation of Test Requirements

Test	Minimum Requirement in TS 25.102	Test Tolerance (TT)	Test Requirement in TS 34.122
5.2 Maximum Output Power	Power single code Power class 2 (24 dBm) Tolerance = +1/-3 dB Power class 3 (21 dBm) Tolerance = +2/-2 dB Power multi code Power class 2 (21 dBm) Tolerance = +1/-3 dB Power class 3 (18 dBm) Tolerance = ±2 dB	0,7 dB	Formula: Upper Tolerance limit + TT Lower Tolerance limit – TT For power class 2 (single and multi): Upper Tolerance limit = +1,7 dB Lower Tolerance limit = -3,7 dB For power class 3 (single and multi): Upper Tolerance limit = +2,7 dB Lower Tolerance limit = -2,7 dB
5.3 UE Frequency Stability	The UE modulated carrier frequency shall be accurate to within ±0.1 ppm compared to the carrier frequency received from the Node B.	10 Hz	Formula: modulated carrier frequency error + TT modulated carrier frequency error = ±(0.1 ppm + 10 Hz).
5.4.1.1 Uplink Pwer Control, Initial accuracy	± 9dB normal conditions ± 12dB extreme conditions	1.0 dB	Formula: Upper Tolerance limit + TT Lower Tolerance limit – TT Nominal expected TX power ± 10dB (normal conditions) ± 13dB (extreme conditions)
5.4.1.2 Uplink Power Control, differential accuracy	SIR Target Pow Step Tol <1 dB 0.5 dB <2dB 1 dB <3 dB 1.5 dB <10 dB 2 dB <20dB 4 dB <30 dB 6 dB > 30 dB 9 dB	TT 0.1 dB 0.15 dB 0.2 dB 0.5 dB 0.7 dB 0.7 dB 1.0 dB	Formula: Upper Tolerance limit + TT Lower Tolerance limit – TT
5.4.2 Minimum Transmit Power	UE minimum transmit power shall be less than –44 dBm	1.0 dB	Formula: UE minimum transmit power + TT UE minimum transmit power = –43 dBm
5.4.5 Out-of-synchronisation handling of output power:	$\frac{\Sigma DPCH_E_c}{I_{or}}$ levels before A –4.6 dB AB: -10 dB BD: -16 dB DE: -12 dB EF: -6 dB transmit ON/OFF time 200ms	0,4 dB for $\frac{\Sigma DPCH_E_c}{I_{or}}$ 0 ms for timing measuremen t	Formulas: Ratio between A and B + TT Ratio between B and D - TT Ratio between D and E - TT Ratio between E and F + TT transmit ON/OFF time + TT timing $\frac{\Sigma DPCH_E_c}{I_{or}}$ levels: Before A: -4.6 AB: -10 + 0,4 dB BD: -16 – 0,4 dB DE: -12 - 0,4 dB EF: -6 + 0,4 dB Uncertainty of OFF power measurement is handled by Transmit OFF power test and uncertainty of ON power measurement is handled by Minimum output power test.transmit ON/OFF time 200ms
5.5.1 Transmit OFF power	Transmit OFF power shall be less than –65 dBm	1.5 dB	Formula: Transmit OFF power + TT Transmit OFF power = –63,5 dBm

5.5.1 Occupied Bandwidth	The occupied channel bandwidth shall be less than 5 MHz based on a chip rate of 3,84 Mcps.	0 kHz	Formula: occupied channel bandwidth: + TT occupied channel bandwidth = 5,0 MHz		
5.5.2.1 Spectrum emission mask	Minimum requirement defined in TS25.101 table 6.10. The lower limit shall be -50 dBm / 3,84 MHz or which ever is higher.	1.5 dB	Formula: Minimum requirement + TT Lower limit + TT Add 1,5 to Minimum requirement entries in TS25.101 table 6.10 The lower limit shall be -48,5 dBm / 3,84 MHz or which ever is higher.		
5.5.2.2 Adjacent Channel Leakage Power Ratio (ACLR)	Power Classes 2 and 3: UE channel +5 MHz or -5 MHz, ACLR limit: 33 dB UE channel +10 MHz or -10 MHz, ACLR limit: 43 dB	0.8 dB	Formula: ACLR limit - TT Power Classes 2 and 3: UE channel +5 MHz or -5 MHz, ACLR limit: 32,2 dB UE channel +10 MHz or -10 MHz, ACLR limit: 42,2 dB		
5.5.3 Spurious Emissions			Formula: Minimum Requirement+ TT Add zero to all the values of Minimum Requirements in table 5.5.3		
	Frequency Band	Minimum Requirement	Frequency Band	Minimum Requirement	
	9 kHz ≤ f < 150 kHz	-36dBm /1kHz	0 dB	9kHz ≤ f < 1GHz	-36dBm /1kHz
	150 kHz ≤ f < 30 MHz	-36dBm /10kHz	0 dB	150 kHz ≤ f < 30 MHz	-36dBm /10kHz
	30 MHz ≤ f < 1000 MHz	-36dBm /100kHz	0 dB	30 MHz ≤ f < 1000 MHz	-36dBm /100kHz
	1 GHz ≤ f < 12.75 GHz	-30dBm /1MHz	0 dB	1 GHz ≤ f < 2,2 GHz	-30dBm /1MHz
0 dB			2,2 GHz ≤ f < 4 GHz	-30dBm /1MHz	
0 dB			4 GHz ≤ f < 12,75 GHz	-30dBm /1MHz	
	925 MHz < f < 935 MHz	-67dBm /100kHz	0 dB	925 MHz < f < 935 MHz	-67dBm /100kHz
	935 MHz ≤ f ≤ 960 MHz	-79dBm /100kHz	0 dB	935 MHz ≤ f ≤ 960 MHz	-79dBm /100kHz
	1805 MHz < f ≤ 1880 MHz	-71dBm /100kHz	0 dB	1805 MHz < f ≤ 1880 MHz	-71dBm /100kHz
	1805 MHz ≤ f ≤ 1880 MHz	-71dBm /100kHz	0 dB	1805 MHz ≤ f ≤ 1880 MHz	-71dBm /100kHz

5.6 Transmit Intermodulation	Intermodulation Product 5MHz -31 dBc 10MHz -41 dBc	0 dB	Formula: Intermodulation Product + TT Intermodulation Product 5MHz -31 dBc 10MHz -41 dBc	
5.7.1 Error Vector Magnitude	The Error Vector Magnitude shall not exceed 17.5 %	0%	Formula: EVM limit + TT EVM limit = 17,5 %	
5.7.2 Peak code domain error	The peak code domain error shall not exceed -21dB	±1.0 dB	Formula: Peak code domain error + TT Peak code domain error = -20 dB	
6.2 Reference sensitivity level	$I_{or} = -105 \text{ dBm} / 3,84 \text{ MHz}$ BER limit = 0.001	0.7 dB	Formula: $I_{or} + T$ BER limit unchanged $\hat{I}_{or} = -104,3 \text{ dBm} / 3,84 \text{ MHz}$	
6.4 Adjacent Channel Selectivity	$I_{or} = -91 \text{ dBm} / 3,84 \text{ MHz}$ $loac \text{ (modulated)} = -52 \text{ dBm} / 3,84 \text{ MHz}$ BER limit = 0.001	0 dB	Formula: I_{or} unchanged $loac - TT$ BER limit unchanged $loac = -52 \text{ dBm} / 3,84 \text{ MHz}$	
6.5 Blocking Characteristics	See table 6.5.2a and 6.5.2b in TS 34.122 BER limit = 0,001	0 dB	Formula: $I_{\text{blocking (modulated)}} - TT$ (dBm/3,84MHz) $I_{\text{blocking (CW)}} - TT$ (dBm) BER limit unchanged	
6.6 Spurious Response	$I_{\text{blocking(CW)}} -44 \text{ dBm}$ F_{uw} : Spurious response frequencies BER limit = 0.001	0 dB	Formula: $I_{\text{blocking (CW)}} - TT$ (dBm) F_{uw} unchanged BER limit unchanged $I_{\text{blocking(CW)}} -44 \text{ dBm}$	
6.7 Intermodulation Characteristics	$lo_{w1} \text{ (CW)} -46 \text{ dBm}$ $lo_{w2} \text{ (modulated)} -46 \text{ dBm} / 3,84 \text{ MHz}$ $F_{uw1} \text{ (offset)} 10 \text{ MHz}$ $F_{uw2} \text{ (offset)} 20 \text{ MHz}$ BER limit = 0.001	0 dB	Formula: TBD BER limit unchanged.	
6.8 Spurious Emissions			Formula: Maximum level+ TT Add zero to all the values of Maximum Level in table 6.8.1.	
	Frequency Band	Maximum level	Frequency Band	Maximum level
	9kHz ≤ f < 1GHz	-57dBm /100kHz	0 dB	9kHz ≤ f < 1GHz -57dBm /100kHz
	1,9-1,92 GHz 2,01-2.025GHz 2,11-2.170GHz	-60 dBm / 3,84MHz	0 dB	1,9-1,92 GHz 2,01-2.025GHz 2,11-2.170GHz -60 dBm / 3,84MHz
	1 -1,9GHz, 1,92-2,01 GHz 2,025-2,11GHz	-47 dBm/1MHz	0 dB	1 -1,9GHz, 1,92-2,01 GHz 2,025-2,11GHz -47 dBm/1MHz
	1GHz ≤ f ≤ 12,75GHz	-47dBm /1MHz	0 dB	1GHz ≤ f ≤ 2,2GHz -47dBm /1MHz
		0 dB	2,2GHz < f ≤ 4GHz -47dBm /1MHz	
		0 dB	4GHz < f ≤ 12,75GHz -47dBm /1MHz	

7.6 Downlink Power Control		TS #1,9	TS #7,14	0.5 dB for 10 dB change in output power, 0 otherwise.	Formula for 10 dB change in transmit power: Upper Tolerance limit + TT Lower Tolerance limit – TT
	1 st frame	15 ±4.0 dBm	5 ±0.5 dBm		
	2 nd frame	15 ±4.0 dBm	15 ±4.0 dBm		

F.5 Acceptable uncertainty of Test Equipment (This clause is informative)

This informative clause specifies the critical parameters of the components of an overall Test System (e.g. Signal generators, Signal Analyzers etc.) which are necessary when assembling a Test System that complies with clause F.1 Acceptable Uncertainty of Test System. These Test Equipment parameters are fundamental to the accuracy of the overall Test System and are unlikely to be improved upon through System Calibration.

F.5.1 Transmitter measurements

Table F.5.1: Equipment accuracy for transmitter measurements

Test	Equipment accuracy	Test conditions
5.2 UE Maximum Output Power	Not applicable	
5.3 Frequency Stability	± 10Hz	
5.4.1 Uplink power control		
5.4.2 Minimum Transmit Power		
5.4.3 Transmit OFF Power		
5.4.4 Transmit ON/OFF Power		
5.4.5 Out-of-synchronisation handling of output power $\frac{DPCCH - E_c}{I_{or}}$		
5.4.5 Out-of-synchronisation handling of output power: transmit ON/OFF time		
5.5.1 Occupied Bandwidth	100 kHz	
5.5.2.1 Spectrum emission mask	Not applicable	
5.5.2.2 ACLR		
5.5.3 Spurious emissions		
5.5.3 Spurious emissions: additional		
5.6 Transmit intermodulation:	Not applicable	
5.7.1 Transmit modulation: EVM	2.5 %	
5.7.2 Transmit modulation: peak code domain error	±[1 dB]	

F.5.2 Receiver measurements

Table F.5.2: Equipment accuracy for receiver measurements

Clause	Equipment accuracy	Test conditions
6.2 Reference Sensitivity Level	Not applicable	
6.3 maximum input level:	Not applicable	
6.4 Adjacent Channel Selectivity (ACS)	Not applicable	
6.5 Blocking Characteristics	Not applicable	
6.6 Spurious Responce	Not applicable	
6.7 Intermodulation Characteristics	Not applicable	
6.8 Spurious Emissions	Not applicable	

F.5.3 Performance measurements

Table G.3 Equipment accuracy for performance measurements

Clause	Equipment accuracy	Test conditions
TBD	TBD	

F.6 General rules for statistical testing

F.6.1 Statistical testing of receiver BER/BLER performance

F.6.1.1 Error Definition

1) Bit Error Ratio (BER)

The Bit Error Ratio is defined as the ratio of the bits wrongly received to all data bits sent. The bits are the information bits above the convolutional/turbo decoder

2) Block Error Ratio (BLER)

A Block Error Ratio is defined as the ratio of the number of erroneous blocks received to the total number of blocks sent. An erroneous block is defined as a Transport Block, the cyclic redundancy check (CRC) of which is wrong.

F.6.1.2 Test Method

Each test is performed in the following manner:

- a) Setup the required test conditions.
- b) Record the number of samples tested and the number of occurred events (bit error or block error)
- c) Stop the test at a stop criterion which is minimum test time or an early pass or an early fail event.
- d) Once the test is stopped decide according to the pass fail decision rules (subclause F.6.1.7)

F.6.1.3 Test Criteria

The test shall fulfil the following requirements:

- a) good pass fail decision
 - 1) to keep reasonably low the probability (risk) of passing a bad unit for each individual test;
 - 2) to have high probability of passing a good unit for each individual test;
- b) good balance between testtime and statistical significance
 - 3) to perform measurements with a high degree of statistical significance;
 - 4) to keep the test time as low as possible.

F.6.1.4 Calculation assumptions

It is assumed, that error events are independent statistical events. Due to the memory of the convolutional / turbo coder in the BER tests this is not quite true. Due to lack of information the assumption of independent error events is applied.

In the BLER test with fading there is the memory of the multipath fading channel which interferes the statistical independency. Independent error events are assumed but a minimum test time is introduced to average fluctuations of the multipath fading channel.

The formulas, applied to describe the BER BLER test, are primarily based on the following experiment:

(1) After having observed a certain number of errors (**ne**) the number of samples are counted to calculate BER BLER.

Provisions are made (note 1) such that the complementary experiment is valid as well:

(2) After a certain number of samples (**ns**) the number of errors, occurred, are counted to calculate BER BLER.

Experiment (1) stipulates to use the following Chi Square Distribution with degree of freedom ne :
 $2 * dchisq(2 * NE, 2 * ne)$ for all calculations.

(NE: average of the distribution)

F.6.1.5 Definition of good pass fail decision.

This is defined by the probability of wrong decision D . The probability of a correct decision is $1-D$

The probability (risk) to fail a good DUT shall be $\leq D$ according to the following definition: A DUT is failed, accepting a probability of $\leq D$ that the DUT is still better than the specified error ratio (Test requirement)

The probability to pass a bad DUT shall be $\leq D$ according to the following definition: A DUT is passed, accepting a probability of $\leq D$ that the DUT is still worse than M times the specified error ratio. ($M \geq 1$ is the bad DUT factor)

This definitions lead to an early pass and an early fail limit:

Early fail: $ber \geq berlim_{fail}$

$$berlim_{fail}(D, ne) = \frac{2 * ne}{qchisq(D, 2 * ne)} \quad (1)$$

For $ne > [5]$

Early pass: $ber \leq berlim_{pass}$

$$berlim_{pass}(D, ne) = \frac{2 * ne * M}{qchisq(1 - D, 2 * ne)} \quad (2)$$

For $ne \geq 1$

With

ber (normalized BER, BLER): BER, BLER according to F.6.1.1 divided by Test requirement

D : wrong decision probability see table F.6.1.8

ne : Number of error events

M : bad DUT factor see table F.6.1.8

$qchisq$: inverse cumulative chi squared distribution

F.6.1.6 Good balance between testtime and statistical significance

3 independent test parameters are introduced into the test and shown in table F.6.1.6.1. These are the obvious basis of testtime and statistical significance. From the first two of them three dependent test parameters are derived. The third independent test parameter is justified separately.

Table F.6.1.6.1 independent and dependent test parameters

Independent test parameters			Dependent test parameters		
Test Parameter	Value	Reference	Test parameter	Value	Reference
Target number of error events	[200]	Table F.6.1.8	Early pass/fail condition	curves	Subclause F.6.1.5 Figure 6.1.9
Probability of wrong pass/fail decision D	[0.2%] [0.02%, Note 3]	Subclause F.6.1.5	Bad DUT factor M	[1.5]	Table 6.1.8
			Test limit factor TL	[1.24]	Table 6.1.8
Minimum test time		Table F.6.1.6.2			

The minimum test time is derived from the following justification:

- 1) For no propagation conditions and static propagation condition

No early fail calculated from fractional number of errors <1 see note 1

- 2) For multipath fading condition

No stop of the test until [10] wavelengths are crossed during relevant UE reception timeslots^{*)} with the speed given in the fading profile. ^{*)} relevant for BER BLER testing

Table F.6.1.6.2 : minimum Test time

Fading profile	Minimum test time
Multipath propagation 3 km/h	[1.8 s*15/TSRX ^{*)}]
Multipath propagation 50 km/h	[0.1 s*15/TSRX]
Multipath propagation 120 km/h	[45 ms*15/TSRX]
Multipath propagation 250 km/h	[22ms*15/TSRX]

^{*)} TSRX = The number of relevant UE reception timeslots per frame, relevant for BER BLER test

15/ TSRX forms the prolongation factor and depend on the user data rate

Table F.6.1.6.3: Prolongation factor for minimum Test time

User Data rate	TSRX
12.2 kbit/s	1
64 kbit/s	1
144 kbit/s	1
384 kbit/s	3

In table F.6.1.8 the minimum test time is converted in minimum number of samples

F.6.1.7 Pass fail decision rules

No decision is allowed before the minimum test time is elapsed

- 1) If minimum Test time < time for target number of error events then the following applies: The required confidence level (= correct decision probability 1-D) shall be achieved. This is fulfilled at an early pass or early fail event.

For BER: For every TTI (Transmit Time Interval) sum up the number of bits (ns) and the number if errors (ne) from the beginning of the test, including the artificial error at the beginning of the test (Note 1) and calculate BER.

If BER is above the early fail limit, fail the DUT.

If BER is below the early pass limit, pass the DUT.

Otherwise continue the test

For BLER: For every block sum up the number of blocks (ns) and the number of erroneous blocks (ne) from the beginning of the test, including the artificial error at the beginning of the test (Note 1) and calculate BLER.

If BLER is below the early pass limit, pass the DUT.

If BLER is above the early fail limit, fail the DUT.

Otherwise continue the test

- 2) If the minimum test time \geq time for target error events, then the test runs for the minimum test time and the decision is done by comparing the result with the test limit.

F.6.1.8 Test conditions for BER,BLER tests

Table F.6.1.8: Test conditions for a single BER/BLER tests

Type of test (BER)	Propagation conditions	Test requirement (BER/BLER)	Test limit (BER/BLER) = Test requirement (BER/BLER) x TL TL	Target number of error events (time)	Minimum number of samples	Prob that good unit will fail = Prob that bad unit will pass [%]	Bad unit BER/BLER factor M
Reference Sensitivity Level	-	0.001	[1.24]	[200] (13.2s)	Note 1	[0.2]	[1.5]
Maximum Input Level	-	0.001	[1.24]	[200] (13.2s)	Note 1	[0.2]	[1.5]
Adjacent Channel Selectivity	-	0.001	[1.24]	[200] (13.2s)	Note 1	[0.2]	[1.5]
Blocking Characteristics Pass condition Note 2	-	0.001	[1.262]	[252] (16.6s)	Note 1	[0.2]	[1.5]
Blocking Characteristics Fail condition Note 2	-	0.001	[1.262]	[252] (16.6s)	Note 1	[0.02]	[1.5]
Spurious Response	-	0.001	[1.24]	[200] (13.2s)	Note 1	[0.2]	[1.5]
Intermodulation Characteristics	-	0.001	[1.24]	[200] (13.2s)	Note 1	[0.2]	[1.5]

Table F.6.1.8-2: Test conditions for BLER tests Type of test (BLER)	Information Bit rate	Test requirement (BER/BLER)	Test limit (BER/BLER) = Test requirement (BER/BLER) x TL TL	Target number of error events (time)	Minimum number of samples	Prob that bad unit will pass = Prob that good unit will fail [%]	Bad unit BER/BLER factor M
Demodulation in Static Propagation conditions	12.2 64 144 384	0.01 0.1 0.01 0.1 0.01	[1.24]	[200] (322.6s) (32.3s) (322.6s) (32.3s) (322.6s) (16.1s) (161.3s)	Note1	[0.2]	[1.5]
Demodulation of DCH in Multi-path Fading conditions							
3km/h (Case 1, Case 2)	12.2 64 144 384	0.01 0.1 0.01 0.1 0.01 0.1 0.01	[1.24]	[200] (322.6s) (32.3s) (322.6s) (32.3s) (322.6s) (16.1s) (161.3s)	[1350] [1350] [1350] [1350] [1350] [450] [450]	[0.2]	[1.5]
120 km/h (Case3)	12.2 64 144 384	0.01 0.1 0.01 0.1 0.01	[1.24]	[200] (322.6s) (32.3s) (322.6s) (32.3s) (322.6s) (16.1s) (161.3s)	[34] [34] [34] [34] [34] [12] [12]	[0.2]	[1.5]
250 km/h							
Power control in the downlink				Not applicable			

F.6.1.9 Practical Use (informative)

See figure F.6.1.9:

The early fail limit represents formula (1) in F.6.1.5 The range of validity is $[ne > 5, > 6$ in case of blocking test] to $[ne = 200]$

The early pass limit represents the formula (2) in F.6.1.5 The range of validity is $ne = 1$ to $[ne = 200]$. See note 1

The intersection co-ordinates of both curves are: Target number of errors $ne = [200]$ and test limit $TL = [1.24]$

The range of validity for TL is $ne > 200$

A typical BER BLER test, calculated from the number of samples and errors (F.6.1.2.(b)) using experimental method (1) or (2) (see F.6.1.4. calculation assumptions) runs along the yellow trajectory. With an errorless sample the trajectory goes down vertically. With an erroneous sample it goes up right. The tester checks if the BER BLER test intersects the early fail or early pass limits. The real time processing can be reduced by the following actions:

BLER is calculated only in case of an error event.

BER is calculated only in case of an error event within a TTI.

So the early fail limit cannot be missed by errorless samples.

The check against the early pass limit may be done by transforming formula (2) in F.6.1.5 such that the tester checks against a Limit-Number-of-samples (NL(ne)) depending on the current number of errors.

Early pass if

$$NL(ne) \geq \frac{qchisq(1 - D, 2 * ne)}{2 * TR * M}$$

TR: test requirement (0.001)

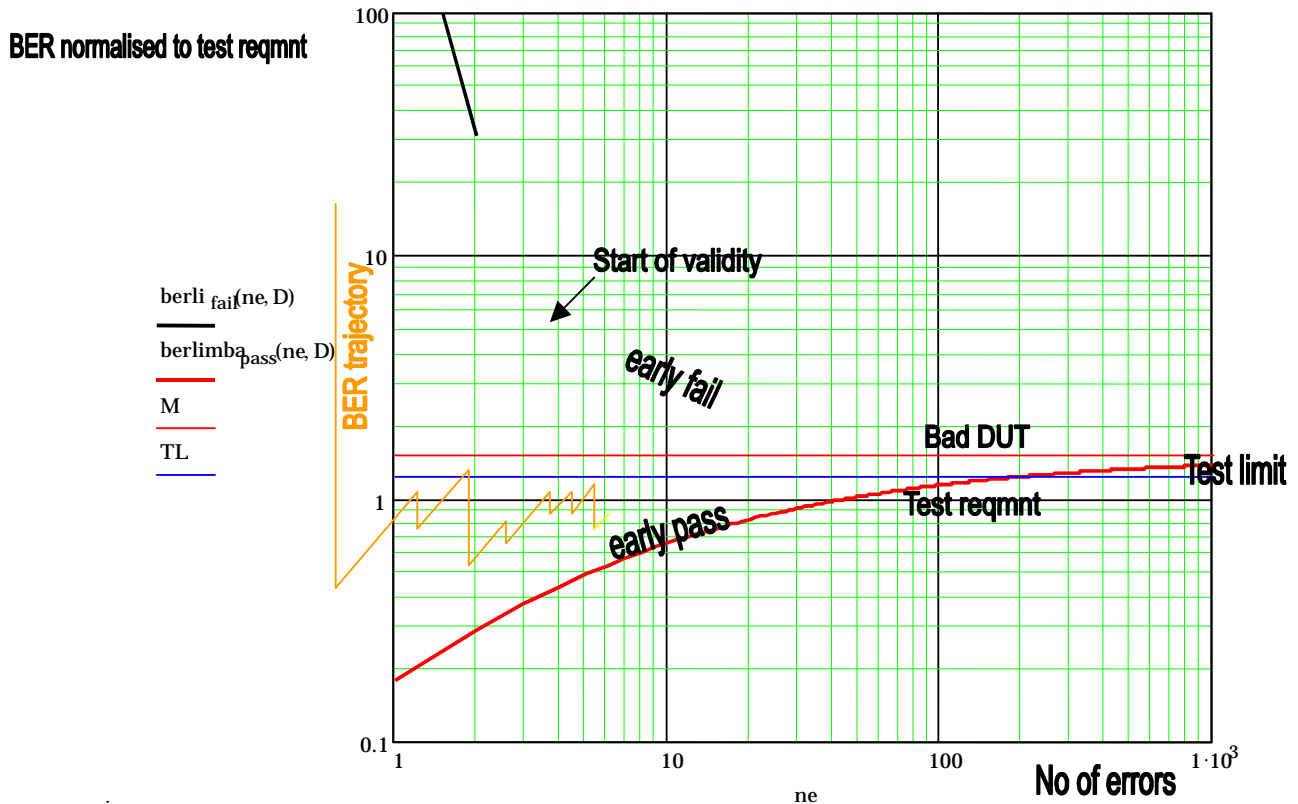

Figure F.6.1.9

Note 1: At the beginning of the test, one artificial erroneous sample is introduced. This ensures that an ideal DUT meets the valid range of the early pass limit. In addition this ensures that the complementary experiment (F.6.1.4. bullet point (2)) is applicable as well.

Due to the nature of the test, namely discrete error events, the early fail condition shall not be valid, when fractional errors <1 are used to calculate the early fail limit: Any early fail decision is postponed until number of errors ne >[5]. In the blocking test any early fail decision is postponed until number of errors ne >[6].

Note2: D=[0.2%] is intended to be used for a test containing a few BER/BLER tests (e.g. receiver sensitivity is repeated 12 times). For a test containing many BER/BLER tests (e.g. blocking test) this value is not appropriate for a single BER/BLER test.

The blocking test contains approx. 12750 single BER tests. A DUT on the limit will fail approx. 25 to 26 times due to statistical reasons (wrong decision probability [0.2%]). 24 fails are allowed in the blocking test but they are reserved for spurious responses. This shall be solved by the following rule:

All passes (based on D=[0.2%]) are accepted, including the wrong decisions due to statistical reasons.

An early fail limit based on D=[0.02%] instead of [0.2%] is established, that ensures that wrong decisions due to statistical reasons are reduced to 2 to 3.

These asymmetric test conditions ensure that a DUT on the test limit consumes hardly more test time for a blocking test than in the symmetric case and on the other hand discriminates sufficiently between statistical fails and spurious response cases.

F.6.2 Statistical testing of RRM delay performance

Delay tests in subclause 8.2 shall be repeated [50] times in order to determine the required success ratio

Note: A statistical approach needs to be developed. The number of repetitions required for the test will target towards a good compromise between test time and wrong decision risk.

Annex G (normative): Environmental conditions

G.1 General

This normative annex specifies the environmental requirements of the UE. Within these limits the requirements of the present document shall be fulfilled.

G.2 Environmental requirements

The requirements in this clause apply to all types of UE(s)

G.2.1 Temperature

The UE shall fulfil all the requirements in the full temperature range of:

+15°C to +35°C	for normal conditions (with relative humidity of 25 % to 75 %)
-10°C to +55°C	for extreme conditions (see IEC publications 68-2-1 and 68-2-2)

Outside this temperature range the UE, if powered on, shall not make ineffective use of the radio frequency spectrum. In no case shall the UE exceed the transmitted levels as defined in TS 25.101 [1] for extreme operation.

Some tests in the present document are performed also in extreme temperature conditions. These test conditions are denoted as TL (temperature low, -10°C) and TH (temperature high, +55°C).

G.2.2 Voltage

The UE shall fulfil all the requirements in the full voltage range, i.e. the voltage range between the extreme voltages.

The manufacturer shall declare the lower and higher extreme voltages and the approximate shutdown voltage. For the equipment that can be operated from one or more of the power sources listed below, the lower extreme voltage shall not be higher, and the higher extreme voltage shall not be lower than that specified below.

Power source	Lower extreme voltage	Higher extreme voltage	Normal conditions voltage
AC mains	0,9 * nominal	1,1 * nominal	nominal
Regulated lead acid battery	0,9 * nominal	1,3 * nominal	1,1 * nominal
Non regulated batteries: Leclanché / lithium Mercury/nickel & cadmium	0,85 * nominal 0,90 * nominal	Nominal Nominal	Nominal Nominal

Outside this voltage range the UE if powered on, shall not make ineffective use of the radio frequency spectrum. In no case shall the UE exceed the transmitted levels as defined in [1] TS 25.101 for extreme operation. In particular, the UE shall inhibit all RF transmissions when the power supply voltage is below the manufacturer declared shutdown voltage.

Some tests in the present document are performed also in extreme voltage conditions. These test conditions are denoted as VL (lower extreme voltage) and VH (higher extreme voltage).

G.2.3 Vibration

The UE shall fulfil all the requirements when vibrated at the following frequency/amplitudes:

Frequency	ASD (Acceleration Spectral Density) random vibration
5 Hz to 20 Hz	0,96 m ² /s ³
20 Hz to 500 Hz	0,96 m ² /s ³ at 20 Hz, thereafter -3 dB/Octave

Outside the specified frequency range the UE, if powered on, shall not make ineffective use of the radio frequency spectrum. In no case shall the UE exceed the transmitted levels as defined in TS 25.101 [1] for extreme operation.

G.2.4 Specified frequency range

The manufacturer shall declare, which of the frequency bands defined in clause 4.2 is supported by the UE.

Some tests in this TS are performed also in low, mid and high range of the operating frequency band of the UE. The UARFCN's to be used for low, mid and high range are defined in TS 34.108 [3] clause 5.1.1.

Annex H (normative): Terminal Baseline and Service Implementation Capabilities (TDD)

H.1 Baseline Implementation Capabilities:

Table H.1: Baseline implementation capabilities

Capability TDD	Clause	UE*	Comments
Chip rate 3,84 Mcps		M	
Frequency bands: (uplink and downlink)			
1900-1920 MHz		M	
2010-2025 MHz		M	
1850-1910 MHz		M	
1930-1990 MHz		M	
1910-1930 MHz		M	
Other spectrum		O	As Declared
Carrier raster 200 kHz		M	
UE maximum output power	6.2.1	M	2, 3

(* M = mandatory, O = optional)

- The special conformance testing functions and the logical test interface as specified in TS 34.109 [3]. This issue is currently under investigation.
- Uplink reference measurement channel 12.2 kbps (FDD), TS 25.102 [1] clause A.2.1.
- Downlink reference measurement channel 12.2 kbps (FDD), TS 25.102 [1] clause A.2.2.

H.2 Service Implementation Capabilities:

- Downlink reference measurement channel 64 kbps (TDD), TS 25.102 clause A.2.3.
- Downlink reference measurement channel 144 kbps (TDD), TS 25.102 clause A.2.4.
- Down-link reference measurement channel 384 kbps (TDD), TS 25.102 clause A.2.5.
- BCH Reference Measurement Channel.

Annex I (normative): Default Message Contents

This Annex contains the default values of common messages, other than those described in TS 34.108. The messages are primarily concerning the RRM test cases in clause 8 and unless indicated otherwise in specific test cases, shall be transmitted and checked by the system simulator. The necessary messages are listed in alphabetical order.

In this Annex, decimal values are normally used. However, sometimes, a hexadecimal value, indicated by an "H", or a binary value, indicated by a "B" is used.

Contents of MEASUREMENT REPORT message for Intra frequency test cases

Information Element	Value/remark
Message Type	
Integrity check info	The presence of this IE is dependent on IXIT statements in TS 34.123-2. If integrity protection is indicated to be active, this IE shall be present with the values of the sub IEs as stated below. Else, this IE and the sub-IEs shall be absent.
- Message authentication code	This IE is checked to see if it is present. The value is compared against the XMAC-I value computed by SS.
- RRC Message sequence number	This IE is checked to see if it is present. The value is used by SS to compute the XMAC-I value.
Measurement identity	1
Measured Results	
- Intra-frequency measured results list	
- Cell measured results	
- Cell Identity	Not present
- SFN-SFN observed time difference	Checked that this IE is present
- Cell synchronisation information	
- CHOICE mode	TDD
- OFF	Checked that this IE is present
- CHOICE mode	TDD
- Cell Parameters ID	4
- Primary CCPCH RSCP	Checked that this IE is present
- Pathloss	Checked that this IE is present
- Timeslot ISCP	Checked that this IE is present
Measured results on RACH	Checked that this IE is absent
Additional measured results	Checked that this IE is absent
Event results	Checked that this IE is absent

Contents of MEASUREMENT REPORT message for Inter frequency TDD test cases

Information Element	Value/remark
Message Type Integrity check info - Message authentication code - RRC Message sequence number	The presence of this IE is dependent on IXIT statements in TS 34.123-2. If integrity protection is indicated to be active, this IE shall be present with the values of the sub IEs as stated below. Else, this IE and the sub-IEs shall be absent. This IE is checked to see if it is present. The value is compared against the XMAC-I value computed by SS. This IE is checked to see if it is present. The value is used by SS to compute the XMAC-I value.
Measurement identity Measured Results - Inter-frequency measured results list - UTRA Carrier RSSI - Inter-frequency cell measurement results - Cell measured results - Cell Identity - SFN-SFN observed time difference - Cell synchronisation information - CHOICE mode - OFF - CHOICE mode - Cell Parameters ID - Primary CCCPCH RSCP - Pathloss - Timeslot ISCP	1 Checked that this IE is present Not present Checked that this IE is present TDD Checked that this IE is present TDD 4 Checked that this IE is present Checked that this IE is present Checked that this IE is present
Measured results on RACH	Checked that this IE is absent
Additional measured results	Checked that this IE is absent
Event results	Checked that this IE is absent

Contents of MEASUREMENT REPORT message for Inter frequency FDD test cases

Information Element	Value/remark
Message Type	
Integrity check info	The presence of this IE is dependent on IXIT statements in TS 34.123-2. If integrity protection is indicated to be active, this IE shall be present with the values of the sub IEs as stated below. Else, this IE and the sub-IEs shall be absent.
- Message authentication code	This IE is checked to see if it is present. The value is compared against the XMAC-I value computed by SS.
- RRC Message sequence number	This IE is checked to see if it is present. The value is used by SS to compute the XMAC-I value.
Measurement identity	1
Measured Results	
- Inter-frequency measured results list	
- UTRA Carrier RSSI	Checked that this IE is present
- Inter-frequency cell measurement results	
- Cell measured results	
- Cell Identity	Not present
- SFN-SFN observed time difference	Checked that this IE is present
- Cell synchronisation information	
-Tm	Checked that this IE is present
- OFF	Checked that this IE is present
- CHOICE mode	FDD
- Primary CPICH info	Checked that this IE is present
- Primary scrambling code	150
- CPICH Ec/N0	Checked that this IE is present
- CPICH RSCP	Checked that this IE is present
- Pathloss	Checked that this IE is present
Measured results on RACH	Checked that this IE is absent
Additional measured results	Checked that this IE is absent
Event results	Checked that this IE is absent

Contents of MEASUREMENT REPORT message for inter – RAT test cases

Information Element	Value/remark
Message Type	
Integrity check info	The presence of this IE is dependent on IXIT statements in TS 34.123-2. If integrity protection is indicated to be active, this IE shall be present with the values of the sub IEs as stated below. Else, this IE and the sub-IEs shall be absent.
- Message authentication code	This IE is checked to see if it is present. The value is compared against the XMAC-I value computed by SS.
- RRC Message sequence number	This IE is checked to see if it is present. The value is used by SS to compute the XMAC-I value.
Measurement identity	1
Measured Results	
- Inter-RAT measured results list	
- CHOICE system	GSM
- Measured GSM cells	Checked that this IE is present
- GSM carrier RSSI	Checked that this IE is present
- Pathloss	Checked that this IE is present
- Observed time difference to GSM cell	Checked that this IE is present
Measured results on RACH	Checked that this IE is absent
Additional measured results	Checked that this IE is absent
Event results	Checked that this IE is absent

Annex J (informative): Change history

Meeting -1st- Level	Doc-1st-Level	CR	Rev	Subject	Cat	Version - Current	Version -New	Doc-2nd- Level
TP-08				Approval of the specification		2.0.0	3.0.0	
TP-09	TP-000134	001		Corrections to EVM and PCDE formulae (B.2.7.1, B2.7.2)	F	3.0.0	3.1.0	T1-000150
TP-10	TP-000217	002		Update of 34.122 according to RAN#9-approved CRs to 25.102	F	3.1.0	3.2.0	T1-000256
TP-10	TP-000217	003		Update according to former CRs to 25.102	F	3.1.0	3.2.0	T1-000257
TP-10	TP-000217	004		editorial corrections for: Global In-Channel TX- Test	D	3.1.0	3.2.0	T1-000259
TP-10	TP-000217	005		Handling of measurement uncertainties in UE conformance testing (TDD)	F	3.1.0	3.2.0	T1-000262
TP-10	TP-000217	006		Uplink Power control	F	3.1.0	3.2.0	T1-000258
TP-10	TP-000217	007		UE maximum output power multicode	F	3.1.0	3.2.0	T1-000260
TP-10	TP-000217	008		Out-of-synchronisation handling of output power	F	3.1.0	3.2.0	T1-000261
TP-11	TP-010020	009		Test tolerance for 5.7.1 TDD EVM	F	3.2.0	3.3.0	T1-010048
TP-11	TP-010020	010		Test tolerance for 5.7.2 TDD PCDE	F	3.2.0	3.3.0	T1-010049
TP-11	TP-010020	011		Test tolerance for 5.2 Maximum Output Power test case	F	3.2.0	3.3.0	T1-010050
TP-11	TP-010020	012		Test tolerance for 5.3 Frequency Stability	F	3.2.0	3.3.0	T1-010051
TP-11	TP-010020	013		Test tolerance for 5.4.2 Minimum Transmit Output Power	F	3.2.0	3.3.0	T1-010052
TP-11	TP-010020	014		Test Tolerance for 5.4.3 Transmit OFF power	F	3.2.0	3.3.0	T1-010053
TP-11	TP-010020	015		Test tolerance for 5.4.5 Out-of-synchronisation handling of output power	F	3.2.0	3.3.0	T1-010054
TP-11	TP-010020	016		Test tolerance for 5.5.1 Occupied Bandwidth	F	3.2.0	3.3.0	T1-010055
TP-11	TP-010020	017		Test tolerance for 5.5.2.1 Spectrum Emission Mask	F	3.2.0	3.3.0	T1-010056
TP-11	TP-010020	018		Test tolerance for 5.5.2.2 ACLR test case	F	3.2.0	3.3.0	T1-010057
TP-11	TP-010020	019		Test Tolerance for 5.5.3 Spurious emissions	F	3.2.0	3.3.0	T1-010058
TP-11	TP-010020	020		Test Tolerance for 5.6 Transmit Intermodulation	F	3.2.0	3.3.0	T1-010059
TP-11	TP-010020	021		Test Tolerance for 6.2 Reference Sensitivity Level	F	3.2.0	3.3.0	T1-010060
TP-11	TP-010020	022		Test Tolerance for 6.4 Adjacent Channel Selectivity	F	3.2.0	3.3.0	T1-010061
TP-11	TP-010020	023		Test tolerances to 6.5 Blocking Characteristics	F	3.2.0	3.3.0	T1-010062
TP-11	TP-010020	024		Test tolerances to 6.6 Spurious Response	F	3.2.0	3.3.0	T1-010063
TP-11	TP-010020	025		Test tolerances to 6.7 Intermodulation Characteristics	F	3.2.0	3.3.0	T1-010064
TP-11	TP-010020	026		Test Tolerance for 6.5 RX Spurious Emissions	F	3.2.0	3.3.0	T1-010065
TP-11	TP-010020	027		Test tolerance for Annex F in TS34.122	F	3.2.0	3.3.0	T1-010068
TP-11	TP-010020	028		Correction concerning the coexistence of TDD and FDD in the same band	F	3.2.0	3.3.0	T1-010045
TP-11	TP-010020	029		Clarification of the mentioned parameter alpha	F	3.2.0	3.3.0	T1-010046
TP-11	TP-010020	030		Correction concerning the channel number calculation	F	3.2.0	3.3.0	T1-010047
TP-11	TP-010020	031		Correction concerning UE maximum output power classes	F	3.2.0	3.3.0	T1-010066
TP-11	TP-010020	032		Correction of Out-of-Sync criteria	F	3.2.0	3.3.0	T1-010067
TP-12	TP-010120	033		CR:New Power Classes require new test tolerances	F	3.3.0	3.4.0	T1-010154
TP-12	TP-010120	034		CR:Test tolerances for Output Power Dynamic	F	3.3.0	3.4.0	T1-010155
TP-13	TP-010185	036		Replacement of Conformance requirements by Minimum requirements	F	3.4.0	3.5.0	T1-010345
TP-13	TP-010185	037		Deletion of the test: Demodulation of BCH in Block STTD mode	F	3.4.0	3.5.0	T1-010344
TP-13	TP-010185	038		Test conditions	F	3.4.0	3.5.0	T1-010347
TP-13	TP-010185	039		Completion of test procedures & test system uncertainties	F	3.4.0	3.5.0	T1-010349
TP-13	TP-010185	040		Maximum Test System Uncertainty for transmitter tests	F	3.4.0	3.5.0	T1-010351
TP-13	TP-010185	041		Correction of Out-of-synchronisation test	F	3.4.0	3.5.0	T1-010353
TP-13	TP-010185	042		UE power classes	F	3.4.0	3.5.0	T1-010354
TP-13	TP-010185	043		Correction of frequency range for receiver spurious emission requirements	F	3.4.0	3.5.0	T1-010365
TP-14	TP-010260	052		Clarification of AWGN definition	F	3.5.0	3.6.0	T1-010502
TP-14	TP-010260	053		RX spurious emissions	F	3.5.0	3.6.0	T1-010503
TP-14	TP-010260	054		Correction of Spurious emissions	F	3.5.0	3.6.0	T1-010504
TP-14	TP-010260	055		Power and ACLR definition corrections	F	3.5.0	3.6.0	T1-010507
TP-14	TP-010260	056		Out of synchronisation handling	F	3.5.0	3.6.0	T1-010509
TP-14	TP-010260	057		Clarification in Spectrum emission mask section	F	3.5.0	3.6.0	T1-010511
TP-14	TP-010260	058		Changes to blocking characteristics and spurious response test cases	F	3.5.0	3.6.0	T1-010513
TP-14	TP-010260	059		maximum output power for multicode transmission	F	3.5.0	3.6.0	T1-010515
TP-14	TP-010260	060		BER/BLER testing based on statistical approach	F	3.5.0	3.6.0	T1-010518
TP-15	TP-020040	070		Corrections to various reference to tables in the document.	F	3.6.0	3.7.0	T1-020150
TP-15	TP-020040	071		Maintenance of Annex B	F	3.6.0	3.7.0	T1-020151

TP-15	TP-020040	072		Power Control in the Downlink	F	3.6.0	3.7.0	T1-020152
TP-15	TP-020040	073		Uplink Power Control Performance Test	F	3.6.0	3.7.0	T1-020153
TP-15	TP-020040	074		Replacement of Block STTD by Space Code Transmit Diversity (SCTD)	F	3.6.0	3.7.0	T1-020154
TP-15	TP-020040	075		New RRM Section Headings	F	3.6.0	3.7.0	T1-020155
TP-15	TP-020040	076		Cell Re-selection in idle mode test cases	F	3.6.0	3.7.0	T1-020156
TP-15	TP-020040	077		Statistical testing of RRM delay performance	F	3.6.0	3.7.0	T1-020157
TP-16	TP-020140	086		Cell Re-selection in CELL_PCH test case Rel99	F	3.7.0	3.8.0	T1-020229
TP-16	TP-020140	087		Cell Re-selection in URA_PCH test case Rel99	F	3.7.0	3.8.0	T1-020230
TP-16	TP-020140	088		TDD/TDD Intra-frequency Handover R99	F	3.7.0	3.8.0	T1-020255
TP-16	TP-020140	089		TDD/TDD Inter-frequency Handover R99	F	3.7.0	3.8.0	T1-020257
TP-16	TP-020140	090		TDD/FDD Handover R99	F	3.7.0	3.8.0	T1-020259
TP-16	TP-020140	091		PCCPCH Measurement Performance R99	F	3.7.0	3.8.0	T1-020261
TP-16	TP-020140	092		Corrections to TDD/TDD Cell Re-selection in CELL_FACH state R99	F	3.7.0	3.8.0	T1-020263
TP-16	TP-020140	093		Power Control in the Downlink for HCR Rel99	F	3.7.0	3.8.0	T1-020424
TP-17	TP-020186	104	-	Message Content for TDD Handover Test Cases	F	3.8.0	3.9.0	T1-020472
TP-17	TP-020186	106	-	General corrections for power definitions and test	F	3.8.0	3.9.0	T1-020487
TP-17	TP-020186	108	-	Correction to Receiver Spurious Emission Test Case	F	3.8.0	3.9.0	T1-020489

History

Document history		
V3.0.0	June 2000	Publication
V3.1.0	September 2000	Publication
V3.2.0	December 2000	Publication
V3.3.0	March 2001	Publication
V3.4.0	June 2001	Publication
V3.5.0	September 2001	Publication
V3.6.0	December 2001	Publication
V3.7.0	March 2002	Publication
V3.8.0	June 2002	Publication
V3.9.0	September 2002	Publication