

ETSI TS 132 293 V13.0.0 (2016-02)



**Digital cellular telecommunications system (Phase 2+);
Universal Mobile Telecommunications System (UMTS);
LTE;
Telecommunication management;
Charging management;
Proxy function
(3GPP TS 32.293 version 13.0.0 Release 13)**



Reference

RTS/TSGS-0532293vd00

Keywords

GSM,LTE,UMTS

ETSI

650 Route des Lucioles
F-06921 Sophia Antipolis Cedex - FRANCE

Tel.: +33 4 92 94 42 00 Fax: +33 4 93 65 47 16

Siret N° 348 623 562 00017 - NAF 742 C
Association à but non lucratif enregistrée à la
Sous-Préfecture de Grasse (06) N° 7803/88

Important noticeThe present document can be downloaded from:
<http://www.etsi.org/standards-search>

The present document may be made available in electronic versions and/or in print. The content of any electronic and/or print versions of the present document shall not be modified without the prior written authorization of ETSI. In case of any existing or perceived difference in contents between such versions and/or in print, the only prevailing document is the print of the Portable Document Format (PDF) version kept on a specific network drive within ETSI Secretariat.

Users of the present document should be aware that the document may be subject to revision or change of status. Information on the current status of this and other ETSI documents is available at
<http://portal.etsi.org/tb/status/status.asp>

If you find errors in the present document, please send your comment to one of the following services:
<https://portal.etsi.org/People/CommitteeSupportStaff.aspx>

Copyright Notification

No part may be reproduced or utilized in any form or by any means, electronic or mechanical, including photocopying and microfilm except as authorized by written permission of ETSI.

The content of the PDF version shall not be modified without the written authorization of ETSI.
The copyright and the foregoing restriction extend to reproduction in all media.

© European Telecommunications Standards Institute 2016.
All rights reserved.

DECT™, **PLUGTESTS™**, **UMTS™** and the ETSI logo are Trade Marks of ETSI registered for the benefit of its Members.
3GPP™ and **LTE™** are Trade Marks of ETSI registered for the benefit of its Members and of the 3GPP Organizational Partners.
GSM® and the GSM logo are Trade Marks registered and owned by the GSM Association.

Intellectual Property Rights

IPRs essential or potentially essential to the present document may have been declared to ETSI. The information pertaining to these essential IPRs, if any, is publicly available for **ETSI members and non-members**, and can be found in ETSI SR 000 314: *"Intellectual Property Rights (IPRs); Essential, or potentially Essential, IPRs notified to ETSI in respect of ETSI standards"*, which is available from the ETSI Secretariat. Latest updates are available on the ETSI Web server (<https://ipr.etsi.org>).

Pursuant to the ETSI IPR Policy, no investigation, including IPR searches, has been carried out by ETSI. No guarantee can be given as to the existence of other IPRs not referenced in ETSI SR 000 314 (or the updates on the ETSI Web server) which are, or may be, or may become, essential to the present document.

Foreword

This Technical Specification (TS) has been produced by ETSI 3rd Generation Partnership Project (3GPP).

The present document may refer to technical specifications or reports using their 3GPP identities, UMTS identities or GSM identities. These should be interpreted as being references to the corresponding ETSI deliverables.

The cross reference between GSM, UMTS, 3GPP and ETSI identities can be found under <http://webapp.etsi.org/key/queryform.asp>.

Modal verbs terminology

In the present document "**shall**", "**shall not**", "**should**", "**should not**", "**may**", "**need not**", "**will**", "**will not**", "**can**" and "**cannot**" are to be interpreted as described in clause 3.2 of the [ETSI Drafting Rules](#) (Verbal forms for the expression of provisions).

"**must**" and "**must not**" are **NOT** allowed in ETSI deliverables except when used in direct citation.

Contents

Intellectual Property Rights	2
Foreword.....	2
Modal verbs terminology.....	2
Foreword.....	4
1 Scope	5
2 References	6
3 Definitions, symbols and abbreviations	8
3.1 Definitions	8
3.2 Symbols.....	9
3.3 Abbreviations	9
4 Required functionality of the Proxy Function.....	11
5 Architectural concept	11
5.1 Architecture reference model for Alternative Roaming Provider (ARP).....	11
5.1.1 Proxy Function for Voice Call Service.....	11
6 Functionalities and message flows	12
6.1 Reference point required functionality	12
6.2 Message flows	12
6.2.1 Mobile Originated Call	12
6.2.2 Mobile Terminated Call.....	13
6.2.3 Mobile Forwarded Call.....	15
7 Definition of charging information	15
Annex A (informative): Change history	16
History	17

Foreword

This Technical Specification has been produced by the 3rd Generation Partnership Project (3GPP).

The contents of the present document are subject to continuing work within the TSG and may change following formal TSG approval. Should the TSG modify the contents of the present document, it will be re-released by the TSG with an identifying change of release date and an increase in version number as follows:

Version x.y.z

where:

- x the first digit:
 - 1 presented to TSG for information;
 - 2 presented to TSG for approval;
 - 3 or greater indicates TSG approved document under change control.
- y the second digit is incremented for all changes of substance, i.e. technical enhancements, corrections, updates, etc.
- z the third digit is incremented when editorial only changes have been incorporated in the document.

1 Scope

The present document is part of a series of documents that specify charging functionality and charging management in GSM/UMTS networks. The GSM/UMTS core network charging architecture and principles are specified in TS 32.240 [1], which provides an umbrella for other charging management TSs that specify:

- the content of the Charging Data Records (CDRs) per domain / subsystem / service (offline charging);
- the content of real-time charging messages per domain / subsystem / service (online charging);
- the functionality of online and offline charging for those domains / subsystems / services;
- the interfaces that are used in the charging framework to transfer the charging information (i.e. CDRs or charging events).

The complete document structure for these TSs is defined in TS 32.240 [1].

The present document specifies the Proxy Function in Domestic Service Provider (DSP).

The present document contains the architecture and functions of the Proxy Function logical components and thereby derives the functionality of the Proxy Function interfaces. This charging description only defines the interworking between CAMEL and Diameter. The Ro interface between the Proxy Function and Online Charging System (OCS) is out of scope of the present document.

The present document is related to other 3GPP charging TSs as follows:

- The common 3GPP charging architecture is specified in TS 32.240 [1];
- Voice Call Service (VCS) charging is specified in TS 32.276[36].

All references, abbreviations, definitions, descriptions, principles and requirements, used in the present document, that are common across 3GPP TSs, are defined in TR 21.905 [100] "Vocabulary for 3GPP Specifications". Those that are common across charging management in GSM/UMTS domains, services or subsystems are provided in the umbrella document TS 32.240 [1] and are copied into clause 3 of the present document for ease of reading. Finally, those items that are specific to the present document are defined exclusively in the present document.

2 References

The following documents contain provisions which, through reference in this text, constitute provisions of the present document.

- References are either specific (identified by date of publication, edition number, version number, etc.) or non-specific.
- For a specific reference, subsequent revisions do not apply.
- For a non-specific reference, the latest version applies. In the case of a reference to a 3GPP document (including a GSM document), a non-specific reference implicitly refers to the latest version of that document *in the same Release as the present document*.

- [1] 3GPP TS 32.240: "Telecommunication management; Charging management; Charging Architecture and Principles".
- [2]-[9] Void.
- [10] 3GPP TS 32.250: "Telecommunication management; Charging management; Circuit Switched (CS) domain charging".
- [11]-[29] Void.
- [30] 3GPP TS 32.270: "Telecommunication management; Charging management; Multimedia Messaging Service (MMS) charging".
- [31] 3GPP TS 32.271: "Telecommunication management; Charging management; Location Services (LCS) charging".
- [32] 3GPP TS 32.272: "Telecommunication management; Charging management; Push-to-Talk over Cellular (PoC) charging".
- [33] 3GPP TS 32.273: "Telecommunication management; Charging management; Multimedia Broadcast/Multicast Service (MBMS) charging".
- [34] 3GPP TS 32.274: "Telecommunication management; Charging management; Short Message Service (SMS) charging".
- [35] 3GPP TS 32.275: "Telecommunication management; Charging management; MultiMedia Telephony (MMTel) charging".
- [36] 3GPP TS 32.276: "Telecommunication management; Charging management; Voice Call Service Charging".
- [37]-[49] Void.
- [50] 3GPP TS 32.299: "Telecommunication management; Charging management; Diameter charging application".
- [51] 3GPP TS 32.298: "Telecommunication management; Charging management; Charging Data Record (CDR) parameter description".
- [52] 3GPP TS 32.297: "Telecommunication management; Charging management; Charging Data Record (CDR) file format and transfer".
- [53] 3GPP TS 32.296: "Telecommunication management; Charging management; Online Charging System (OCS) applications and interfaces".
- [54] 3GPP TS 32.295: "Telecommunication management; Charging management; Charging Data Record (CDR) transfer".
- [55]-[99] Void.

- [100] 3GPP TR 21.905: "Vocabulary for 3GPP Specifications".
- [101] Void.
- [102] Void.
- [103] 3GPP TS 23.002: "Network Architecture".
- [104]-[199] Void.
- [200]-[206] Void.
- [207] 3GPP TS 22.078: "Customized Applications for Mobile network Enhanced Logic (CAMEL); Service description; Stage 1".
- [208]-[211] Void.
- [212] 3GPP TS 23.078: "Customized Applications for Mobile network Enhanced Logic (CAMEL) Phase X; Stage 2".
- [213]-[217] Void.
- [218] 3GPP TS 29.078: "Customized Applications for Mobile network Enhanced Logic (CAMEL) Phase X; CAMEL Application Part (CAP) specification".
- [219]-[297] Void.
- [298] EU Roaming regulation III; Structural Solutions; High Level Technical Specifications
- [299] EU Roaming regulation III; Interface & Protocol; Detailed Technical Specifications
- [300]-[399] Void.
- [400]-[499] Void.

3 Definitions, symbols and abbreviations

3.1 Definitions

For the purposes of the present document, the terms and definitions given in TR 21.905 [100] and the following apply. A term defined in the present document takes precedence over the definition of the same term, if any, in TR 21.905 [100].

alternative roaming provider: A roaming provider different from the domestic provider.

CAMEL: network feature that provides the mechanisms to support operator specific services even when roaming outside HPLMN.

CAMEL subscription information: identifies a subscriber as having CAMEL services.

chargeable event: activity utilizing telecommunication network resources and related services for:

- user to user communication (e.g. a single call, a data communication session or a short message); or
- user to network communication (e.g. service profile administration); or
- inter-network communication (e.g. transferring calls, signalling, or short messages); or
- mobility (e.g. roaming or inter-system handover); and
- that the network operator may want to charge for.

As a minimum, a chargeable event characterises the resource / service usage and indicates the identity of the involved end user(s).

charged party: user involved in a chargeable event who has to pay parts or the whole charges of the chargeable event, or a third party paying the charges caused by one or all users involved in the chargeable event, or a network operator.

charging: function within the telecommunications network and the associated OCS/BD components whereby information related to a chargeable event is collected, formatted, transferred and evaluated in order to make it possible to determine usage for which the charged party may be billed (offline charging) or the subscriber's account balance may be debited (online charging).

charging event: set of charging information forwarded by the CTF towards the CDF (offline charging) or towards the OCS (online charging). Each charging event matches exactly one chargeable event.

charging function: entity inside the core network domain, subsystem or service that is involved in charging for that domain, subsystem or service.

Circuit Switched (CS) domain: domain within GSM / UMTS in which information is transferred in CS mode.

credit control: mechanism which directly interacts in real-time with an account and controls or monitors the charges, related to the service usage. Credit control is a process of: checking if credit is available, credit reservation, deduction of credit from the end user account when service is completed and refunding of reserved credit not used.

domain: part of a communication network that provides network resources using a certain bearer technology.

domestic service provider: An undertaking that provides a roaming customer with domestic mobile communications services, either a Mobile Network Operator or a Mobile Virtual Network Operator.

GSM only: qualifier indicating that this clause or paragraph applies only to a GSM system. For multi-system cases this is determined by the current serving radio access network.

in GSM,...: qualifier indicating that this paragraph applies only to GSM System.

in UMTS,...: qualifier indicating that this paragraph applies only to UMTS System.

"middle tier" (charging) TS: term used for the 3GPP charging TSs that specify the domain / subsystem / service specific, online and offline, charging functionality. These are all the TSs in the numbering range from TS 32.250 to TS

32.279, e.g. TS 32.250 [10] for the CS domain, or TS 32.270 [30] for the MMS service. Currently, there is only one "tier 1" TS in 3GPP, which is TS 32.240 [1] that specifies the charging architecture and principles. Finally, there are a number of top tier TSs in the 32.29x numbering range ([50] ff) that specify common charging aspects such as parameter definitions, encoding rules, the common billing domain interface or common charging applications.

online charging: charging mechanism where charging information **can** affect, in real-time, the service rendered and therefore a direct interaction of the charging mechanism with bearer/session/service control is required.

Online Charging System: the entity that performs real-time credit control. Its functionality includes transaction handling, rating, online correlation and management of subscriber account balances.

real-time: real-time charging and billing information is to be generated, processed, and transported to a desired conclusion in less than 1 second.

roaming customer: a customer of a roaming provider of regulated roaming services, by means of a terrestrial public mobile communications network situated in the Union, whose contract or arrangement with that roaming provider permits Union-wide roaming. **successful call:** connection that reaches the communication or data transfer phase e.g. the "answered" state for speech connections. All other connection attempts are regarded as unsuccessful.

tariff period: part of one (calendar) day during which a particular tariff is applied. Defined by the time at which the period commences (the switch-over time) and the tariff to be applied after switch-over.

tariff: set of parameters defining the network utilisation charges for the use of a particular bearer / session / service.

3.2 Symbols

For the purposes of the present document, the following symbols apply:

CAP	Reference point for CAMEL between a network element with integrated SSF and the OCS.
Ro	Online charging reference point between a Proxy Function and the OCS.

3.3 Abbreviations

For the purposes of the present document, the abbreviations given in TR 21.905 [100] and the following apply. An abbreviation defined in the present document takes precedence over the definition of the same abbreviation, if any, in TR 21.905 [100].

3G	3 rd Generation
3GPP	3 rd Generation Partnership Project
ARP	Alternative Roaming Provider
CAMEL	Customized Applications for Mobile network Enhanced Logic
CAP	CAMEL Application Part
CCA	Credit Control Answer
CCR	Credit Control Request
CGF	Charging Gateway Function
CI	Cell Identity
CS	Circuit Switched
CSE	CAMEL Service Environment
CTF	Charging Trigger Function
DCCA	Diameter Credit Control Application
DSP	Domestic Service Provider
EU	European Union
FCI	Furnish Charging Information
GMSC	Gateway MSC
gsmSCF	GSM Service Control Function
gsmSSF	GSM Service Switching Function
GSM	Global System for Mobile communication
HLR	Home Location Register
HPLMN	Home PLMN
ICA	Initiate Call Attempt
IMEI	International Mobile Equipment Identity
IMSI	International Mobile Subscriber Identity

ISDN	Integrated Services Digital Network
ITU-T	International Telecommunication Union - Telecommunications standardization sector
JIP	Jurisdiction Information Parameter
LAC	Location Area Code
LRN	Location Routing Number
MAP	Mobile Application Part
MCC	Mobile Country Code (part of IMSI)
MLC	Mobile Location Center
MNC	Mobile Network Code (part of IMSI)
MO	Mobile Originated
MOC	Mobile Originated Call (attempt)
MO-LR	Mobile Originated Location Request
MS	Mobile Station
MSC	Mobile services Switching Centre
MSISDN	Mobile Station ISDN number
MSRN	Mobile Station Roaming Number
MT	Mobile Terminated
MTC	Mobile Terminated Call (attempt)
MT-LR	Mobile Terminated Location Request
NE	Network Element
NI-LR	Network Induced Location Request
NP	Number Portability
NPDB	Number Portability Data Base
OCF	Online Charging Function
OCS	Online Charging System
O-CSI	Originating CAMEL Subscription Information
PLMN	Public Land Mobile Network
PSTN	Public Switched Telephony Network
RAC	Routing Area Code
RAN	Radio Access Network
RNC	Radio Network Controller
SAC	Service Area Code
SCI	Subscriber Controlled Input or Send Charging Information
SRF	Specialised Resource Function
SS7	Signalling System No. 7
SSF	Service Switching Function
T-CSI	Terminating CAMEL Subscription Information
TDP	Trigger Detection Point
UMTS	Universal Mobile Telecommunications System
UTRAN	Universal Terrestrial Radio Access Network
VAS	Value Added Service
VCC	Voice Call Continuity
VCS	Voice Call Service
VLR	Visitor Location Register
VMSC	Visited MSC
VPLMN	Visited PLMN
VT-CSI	Visited Terminating CAMEL Subscription Information

4 Required functionality of the Proxy Function

5 Architectural concept

5.1 Architecture reference model for Alternative Roaming Provider (ARP)

5.1.1 Proxy Function for Voice Call Service

Figure 5.1.1.1 shows the Proxy Function for voice control in the framework of the overall Single IMSI architecture for EU Roaming as defined in the high-level technical specification [298].

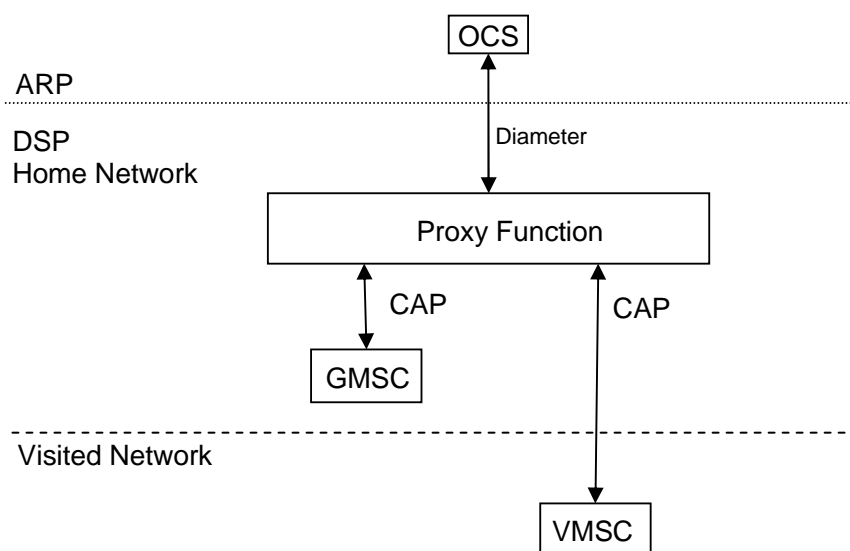

Figure 5.1.1.1: The Proxy Function architecture for Voice Call Service

The Proxy Function entails a functional entity in the DSP's network that handles CAMEL and Diameter interworking.

The signaling between the CS domain elements and the Proxy Function is implemented by CAMEL techniques as described in TS 23.078 [212] and TS 29.078 [218]. The signalling between the ARP OCS and the Proxy Function for online charging is implemented as specified in TS 32.276 [36].

6 Functionalities and message flows

6.1 Reference point required functionality

6.2 Message flows

6.2.1 Mobile Originated Call

This message flow is for illustrative purpose and depicts a Mobile Originated Call in which charging starts at call attempt. The handling of regulated user, routing and call control as defined in EU Roaming regulation III Interface & Protocol Detailed Technical specifications [299] are out of the 32 series charging specifications.

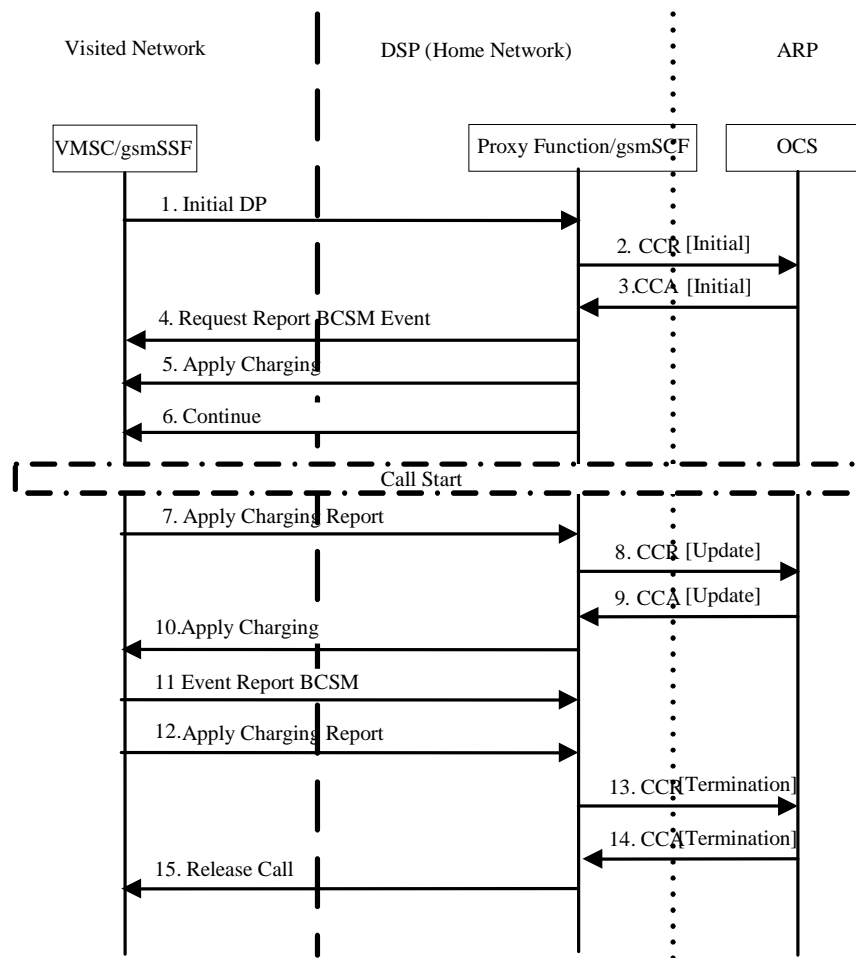

Figure 6.2.1.1 Mobile Originated Call When the ARP subscriber is roaming

1. The Proxy Function/ gsmSCF receives the Initial DP of the CAP dialogue that is initiated from the VMSC/gsmSSF in the VPLMN's network.

Note 1: The Proxy Function further contains service logic that handles the CAP dialogue towards the VPLMN and the Diameter session towards the ARP and that maps information between these two dialogues.

2. The Proxy Function/gsmSCF initiates a Diameter session towards ARP OCS with CCR [Initial] to request the quotas for voice call service.
3. ARP OCS sends the CCA [Initial] with the granted quotas, such as the duration of a call 5 minutes.

4. The Proxy Function/gsmSCF sends Request Report BCSM Event to VMSC/gsmSSF to monitor for a call-related event, and then sends a notification back to the gsmSCF.
5. The Proxy Function/gsmSCF instructs the VMSC/gsmSSF to apply charging mechanisms to control the call duration.
6. The Proxy Function/gsmSCF requests the VMSC/gsmSSF to proceed with call processing.
7. The VMSC/gsmSSF reports to the gsmSCF the information requested in the Apply Charging.
8. The Proxy Function/gsmSCF sends CCR [Update] to request the quotas.
9. ARP OCS sends the CCA [Update] with the granted quotas again, such as more 5 minutes for the duration of a call.
10. The Proxy Function/gsmSCF instructs the VMSC/gsmSSF to apply charging mechanisms to control the call duration.
11. The ARP User as the calling party end the call. The VMSC/gsmSSF sends the Event Report BCSM.
12. The VMSC/gsmSSF reports to the gsmSCF the information requested in the Apply Charging.
13. The Proxy Function/gsmSCF sends the CCR [Termination] to ARP OCS.
14. The ARP OCS answers the request with CCA [Termination].
15. The Proxy Function/gsmSCF tears down the call for all parties involved in the call.

6.2.2 Mobile Terminated Call

This message flow is for illustrative purpose and depicts a Mobile Terminated call at DSP in which charging starts at call attempt. CAMEL control of Mobile Terminated calls may be done through interaction with the GMSC or through interaction with the VMSC. The MT call based VMSC is out of consideration as defined in EU Roaming regulation III Interface & Protocol Detailed Technical specifications [299]. The handling of regulated user, routing and call control as defined in EU Roaming regulation III Interface & Protocol Detailed Technical specifications [299] are also out of scope of this specification.

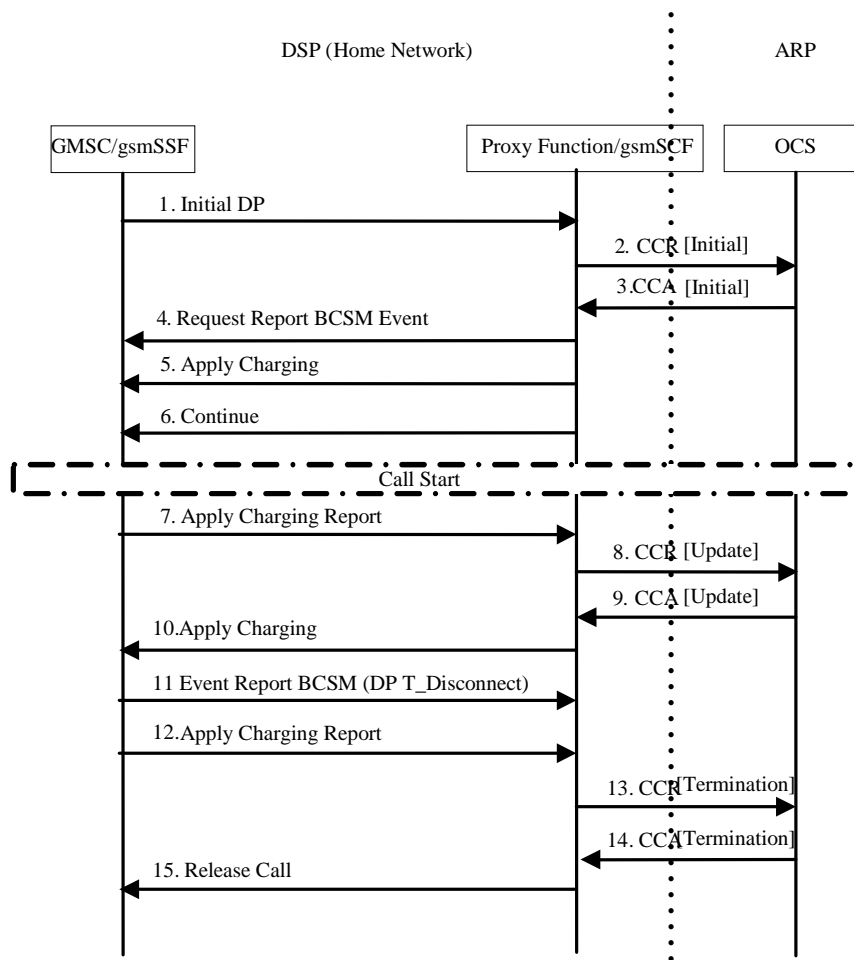

Figure 6.2.2.1 Mobile Terminated Call When the ARP subscriber is roaming

1. The Proxy Function/ gsmSCF receive the Initial DP of the CAP dialogue that is initiated from the GMSC/gsmSSF in the Home network.

Note : The Proxy Function further contains service logic that handles the CAP dialogue towards the HPLMN and the Diameter session towards the ARP and that maps information between these two dialogues.

2. The Proxy Function/gsmSCF initiates a Diameter session towards ARP OCS with CCR [Initial] to request the quotas for voice call service of called party.
3. ARP OCS sends the CCA [Initial] with the granted quotas, such as the duration of a call 5 minutes.
4. The Proxy Function/gsmSCF sends Request Report BCSM Event to GMSC/gsmSSF to monitor for a call-related event, and then sends a notification back to the gsmSCF.
5. The Proxy Function/gsmSCF instructs the GMSC/gsmSSF to apply charging mechanisms to control the call duration.
6. The Proxy Function/gsmSCF requests the GMSC/gsmSSF to proceed with call processing.
7. The GMSC/gsmSSF reports to the gsmSCF the information requested in the Apply Charging.
8. The Proxy Function/gsmSCF sends CCR [Update] to request the quotas.
9. ARP OCS sends CCA [Update] with the granted quotas, such as more 5 minutes for the duration of a call.
10. The Proxy Function/gsmSCF instructs the GMSC/gsmSSF to apply charging mechanisms to control the call duration.

11. The ARP User as the called party end the call. The GMSC/gsmSSF sends the Event Report BCSM with DP-T-Disconnect.
12. The GMSC/gsmSSF reports to the gsmSCF the information requested in the Apply Charging.
13. The Proxy Function/gsmSCF sends the CCR [Termination] to ARP OCS.
14. The ARP OCS answers the request with CCA [Termination].
15. The Proxy Function/gsmSCF tears down the call for all parties involved in the call.

6.2.3 Mobile Forwarded Call

For conditionally and unconditionally call forwarding, the call in different phase would be handled the same as the normal MO call or MT call message flows. For example, the charging provision for B is as normal MT in the call leg between calling-party (A) and the called-party (B), the charging provision for B is as normal MO in the call leg between called-party (B) and the forwarded-to-party(C). In order to avoid the duplication, the detailed message flows of Mobile Forwarded call are not present here.

7 Definition of charging information

Annex A (informative): Change history

Change history							
Date	TSG #	TSG Doc.	CR	Rev	Subject/Comment	Old	New
2013-09					Skeleton		
2013-10					General Sections for Proxy Function (S5-131758)	0.0.0	0.1.0
2013-10					MCC clean-up	0.1.0	0.1.1
2013-11					Editorial refinements and removal of redundancies (S5-131954) Architecture Concept for Proxy Function (S5-132119) Voice Call Service online charging scenarios (S5-132103)	0.1.1	0.2.0
2014-01					The examples of message flow for Proxy Function (S5-140311)	0.2.0	0.3.0
2014-03					Unify the entity name of message flow and description text (S5-140700)	0.3.0	0.4.0
2014-06	SA#64	SP-140328			Presented for information and approval	0.4.0	1.0.0
					Upgrade to Rel-12	1.0.0	12.0.0
2014-09	SA#65				Change of keywords	12.0.0	12.0.1
2016-01					Update to Rel-13 (MCC)	12.0.1	13.0.0

History

Document history		
V13.0.0	February 2016	Publication