

ETSI TS 132 251 V15.4.0 (2019-04)



**Digital cellular telecommunications system (Phase 2+) (GSM);
Universal Mobile Telecommunications System (UMTS);
LTE;
Telecommunication management;
Charging management;
Packet Switched (PS) domain charging
(3GPP TS 32.251 version 15.4.0 Release 15)**



Reference

RTS/TSGS-0532251vf40

Keywords

GSM,LTE,UMTS

ETSI

650 Route des Lucioles
F-06921 Sophia Antipolis Cedex - FRANCE

Tel.: +33 4 92 94 42 00 Fax: +33 4 93 65 47 16

Siret N° 348 623 562 00017 - NAF 742 C
Association à but non lucratif enregistrée à la
Sous-Préfecture de Grasse (06) N° 7803/88

Important notice

The present document can be downloaded from:

<http://www.etsi.org/standards-search>

The present document may be made available in electronic versions and/or in print. The content of any electronic and/or print versions of the present document shall not be modified without the prior written authorization of ETSI. In case of any existing or perceived difference in contents between such versions and/or in print, the prevailing version of an ETSI deliverable is the one made publicly available in PDF format at www.etsi.org/deliver.

Users of the present document should be aware that the document may be subject to revision or change of status.

Information on the current status of this and other ETSI documents is available at

<https://portal.etsi.org/TB/ETSIDeliverableStatus.aspx>

If you find errors in the present document, please send your comment to one of the following services:

<https://portal.etsi.org/People/CommiteeSupportStaff.aspx>

Copyright Notification

No part may be reproduced or utilized in any form or by any means, electronic or mechanical, including photocopying and microfilm except as authorized by written permission of ETSI.

The content of the PDF version shall not be modified without the written authorization of ETSI.

The copyright and the foregoing restriction extend to reproduction in all media.

© ETSI 2019.

All rights reserved.

DECT™, **PLUGTESTS™**, **UMTS™** and the ETSI logo are trademarks of ETSI registered for the benefit of its Members.

3GPP™ and **LTE™** are trademarks of ETSI registered for the benefit of its Members and of the 3GPP Organizational Partners.

oneM2M™ logo is a trademark of ETSI registered for the benefit of its Members and of the oneM2M Partners.

GSM® and the GSM logo are trademarks registered and owned by the GSM Association.

Intellectual Property Rights

Essential patents

IPRs essential or potentially essential to normative deliverables may have been declared to ETSI. The information pertaining to these essential IPRs, if any, is publicly available for **ETSI members and non-members**, and can be found in ETSI SR 000 314: *"Intellectual Property Rights (IPRs); Essential, or potentially Essential, IPRs notified to ETSI in respect of ETSI standards"*, which is available from the ETSI Secretariat. Latest updates are available on the ETSI Web server (<https://ipr.etsi.org/>).

Pursuant to the ETSI IPR Policy, no investigation, including IPR searches, has been carried out by ETSI. No guarantee can be given as to the existence of other IPRs not referenced in ETSI SR 000 314 (or the updates on the ETSI Web server) which are, or may be, or may become, essential to the present document.

Trademarks

The present document may include trademarks and/or tradenames which are asserted and/or registered by their owners. ETSI claims no ownership of these except for any which are indicated as being the property of ETSI, and conveys no right to use or reproduce any trademark and/or tradename. Mention of those trademarks in the present document does not constitute an endorsement by ETSI of products, services or organizations associated with those trademarks.

Foreword

This Technical Specification (TS) has been produced by ETSI 3rd Generation Partnership Project (3GPP).

The present document may refer to technical specifications or reports using their 3GPP identities, UMTS identities or GSM identities. These should be interpreted as being references to the corresponding ETSI deliverables.

The cross reference between GSM, UMTS, 3GPP and ETSI identities can be found under <http://webapp.etsi.org/key/queryform.asp>.

Modal verbs terminology

In the present document "**shall**", "**shall not**", "**should**", "**should not**", "**may**", "**need not**", "**will**", "**will not**", "**can**" and "**cannot**" are to be interpreted as described in clause 3.2 of the [ETSI Drafting Rules](#) (Verbal forms for the expression of provisions).

"**must**" and "**must not**" are **NOT** allowed in ETSI deliverables except when used in direct citation.

Contents

Intellectual Property Rights	2
Foreword.....	2
Modal verbs terminology.....	2
Foreword.....	8
1 Scope	9
2 References	9
3 Definitions, symbols and abbreviations	12
3.1 Definitions	12
3.2 Symbols.....	14
3.3 Abbreviations	15
4 Architecture considerations	18
4.0 General	18
4.1 High-level EPS architecture	18
4.2 PS domain offline charging architecture	19
4.3 PS domain online charging architecture.....	21
5 PS domain charging principles and scenarios	22
5.1 PS charging principles.....	22
5.1.0 General.....	22
5.1.1 Requirements	23
5.1.2 Charging information.....	24
5.1.3 Identifiers and correlation.....	26
5.1.4 UE presence in Presence Reporting Area (PRA).....	27
5.1.4.1 Single Presence Reporting Area (PRA)	27
5.1.4.2 Multiple Presence Reporting Areas (PRAs).....	27
5.1.5 3GPP PS Data Off	28
5.1.6 Flexible Mobile Service Steering.....	28
5.2 PS domain offline charging scenarios	29
5.2.1 Basic principles.....	29
5.2.1.0 General	29
5.2.1.1 IP-CAN bearer charging	30
5.2.1.2 MM context charging.....	31
5.2.1.3 Flow Based bearer Charging (FBC).....	32
5.2.1.4 SMS charging.....	35
5.2.1.5 LCS charging	35
5.2.1.6 MBMS context charging for GPRS	36
5.2.1.6A MBMS context charging for EPS.....	36
5.2.1.7 IP Flow Mobility (IFOM) charging	37
5.2.1.7A Network-Based IP Flow Mobility (NBIFOM) charging	37
5.2.1.8 Sponsored data connectivity charging.....	38
5.2.1.9 Application Based Charging (ABC)	39
5.2.1.9.0 Introduction	39
5.2.1.9.1 Charging per application	39
5.2.1.9.2 Charging per TDF session	41
5.2.1.10 Charging per IP-CAN session.....	42
5.2.1.10.0 General	42
5.2.1.10.1 IP-CAN bearer charging.....	42
5.2.1.10.2 Flow Based Charging (FBC)	45
5.2.1.11 Data Volume Reporting for Secondary RAT usage.....	48
5.2.1.11.1 General	48
5.2.2 Rf message flows.....	49
5.2.2.0 General	49
5.2.2.1 Triggers for charging events from S-GW.....	49
5.2.2.2 Triggers for charging events from P-GW.....	49
5.2.2.3 Triggers for charging events from ePDG	49

5.2.2.4	Triggers for charging events from MME	50
5.2.2.5	Triggers for charging events from TDF	50
5.2.2.6	Triggers for charging events from P-GW when charging per IP-CAN session is active	50
5.2.2.7	Triggers for charging events from TWAG	50
5.2.3	CDR generation	51
5.2.3.0	Introduction	51
5.2.3.1	Triggers for S-CDR charging information collection	52
5.2.3.1.0	General	52
5.2.3.1.1	Triggers for S-CDR charging information addition	52
5.2.3.1.2	Triggers for S-CDR closure	53
5.2.3.2	Triggers for M-CDR charging information collection	54
5.2.3.2.0	General	54
5.2.3.2.1	Triggers for M-CDR charging information addition	54
5.2.3.2.2	Triggers for M-CDR closure	54
5.2.3.3	Triggers for SGW-CDR charging information collection	55
5.2.3.3.0	Introduction	55
5.2.3.3.1	Triggers for SGW-CDR charging information addition	55
5.2.3.3.2	Triggers for SGW-CDR closure	57
5.2.3.4	Triggers for PGW-CDR charging information collection	58
5.2.3.4.0	Introduction	58
5.2.3.4.1	Triggers for PGW-CDR charging information addition	59
5.2.3.4.2	Triggers for PGW-CDR closure	60
5.2.3.5	Triggers for SMS-CDR charging information collection	61
5.2.3.6	Triggers for LCS-CDR charging information collection	61
5.2.3.7	Triggers for S-MB-CDR and G-MB-CDR charging information collection for MBMS context charging for GPRS	62
5.2.3.7.1	Triggers for S-MB-CDR and G-MB-CDR charging information creation	62
5.2.3.7.2	Triggers for S-MB-CDR and G-MB-CDR charging information addition	62
5.2.3.7.3	Triggers for S-MB-CDR and G-MB-CDR closure	62
5.2.3.7A	Triggers for MBMS-GW-CDR charging information collection for MBMS context charging for EPS	63
5.2.3.7A.1	Triggers for MBMS-GW-CDR charging information creation	63
5.2.3.7A.2	Triggers for MBMS-GW-CDR charging information addition	63
5.2.3.7A.3	Triggers for MBMS-GW-CDR closure	63
5.2.3.8	Triggers for ePDG-CDR charging information collection	64
5.2.3.8.0	Introduction	64
5.2.3.8.1	Triggers for ePDG-CDR charging information addition	64
5.2.3.8.2	Triggers for ePDG-CDR closure	65
5.2.3.9	Triggers for TDF-CDR charging information collection	66
5.2.3.9.1	Triggers for TDF-CDR charging information creation	66
5.2.3.9.2	Triggers for TDF-CDR charging information addition	66
5.2.3.9.3	Triggers for TDF-CDR closure	68
5.2.3.10	Triggers for PGW-CDR charging information collection when IP-CAN session charging is active	69
5.2.3.10.1	General	69
5.2.3.10.2	Triggers for PGW-CDR charging information addition when IP-CAN session charging is active	69
5.2.3.10.3	Triggers for PGW-CDR closure when charging per IP-CAN session charging is active	72
5.2.3.11	Triggers for TWAG-CDR charging information collection	73
5.2.3.11.0	Introduction	73
5.2.3.11.1	Triggers for TWAG-CDR charging information addition	73
5.2.3.11.2	Triggers for TWAG-CDR closure	73
5.2.4	Void	74
5.2.5	Ga record transfer flows	74
5.2.6	Bp CDR file transfer	74
5.3	PS domain online charging scenarios	75
5.3.1	Basic principles	75
5.3.1.0	General	75
5.3.1.1	IP-CAN bearer charging	75
5.3.1.2	Flow Based bearer Charging	76
5.3.1.3	PS Furnish Charging Information procedure	79
5.3.1.4	Support of Failure Situations	79

5.3.1.5	Application Based Charging (ABC)	80
5.3.1.5.0	Introduction	80
5.3.1.5.1	Charging per application	80
5.3.1.5.2	Charging per TDF session	81
5.3.1.6	Charging per IP-CAN session	82
5.3.1.6.0	General	82
5.3.1.6.1	IP-CAN bearer charging	82
5.3.1.6.2	Flow Based Charging (FBC)	82
5.3.1.7	Sponsored data connectivity charging	85
5.3.1.8	Network-Based IP Flow Mobility (NBIFOM) charging	85
5.3.2	Ro message flows	86
5.3.2.0	General	86
5.3.2.1	Triggers for IP-CAN bearer online charging	86
5.3.2.1.1	Void	86
5.3.2.1.2	Void	86
5.3.2.2	Triggers for FBC online charging	87
5.3.2.2.0	Introduction	87
5.3.2.2.1	Triggers for starting and stopping an FBC Credit-Control session	88
5.3.2.2.2	Triggers for providing interim information for an FBC Credit-Control session	88
5.3.2.2A	Triggers for ABC online charging	88
5.3.2.2A.0	Introduction	88
5.3.2.2A.1	Triggers for starting and stopping an ABC Credit-Control session	89
5.3.2.2A.2	Triggers for providing interim information for an ABC Credit-Control session	89
5.3.2.2B	Triggers for TDF session online charging	91
5.3.2.2C	Triggers for P-GW when charging per IP-CAN session is active	91
5.3.2.2C.1	General	91
5.3.2.2C.2	Triggers for starting and stopping an FBC Credit-Control session when charging per IP-CAN session is active	91
5.3.2.2C.3	Triggers for providing interim information for an FBC Credit-Control session when charging per IP-CAN session is active	92
5.3.2.3	PS Furnish Charging Information procedure	93
5.3.2.4	Support of Failure Situations	93
6	Definition of charging information	95
6.1A	Rf message content	95
6.1A.0	General	95
6.1A.1	Summary of offline charging message formats	95
6.1A.2	Structure for the charging data message formats	95
6.1A.2.0	General	95
6.1A.2.1	Charging Data Request message	96
6.1A.2.2	Charging Data Response message	96
6.1B	CDR content description on Bp interface	97
6.1B.0	General	97
6.1.1	IP-CAN bearer charging data in SGSN (S-CDR)	98
6.1.2	IP-CAN bearer charging data in S-GW (SGW-CDR)	100
6.1.3	FBC IP-CAN bearer charging data in P-GW (PGW-CDR)	103
6.1.4	Mobile Station mobility management data in SGSN (M-CDR)	110
6.1.5	SMS-MO data in SGSN/MME (S-SMO-CDR)	111
6.1.6	SMS-MT data in SGSN/MME (S-SMT-CDR)	112
6.1.7	Mobile Terminated location request (LCS-MT-CDR)	113
6.1.8	Mobile originated Location request (LCS-MO-CDR)	114
6.1.9	Network induced Location request (LCS-NI-CDR)	115
6.1.10	MBMS bearer context charging data in SGSN (S-MB-CDR)	116
6.1.11	MBMS bearer context charging data in GGSN (G-MB-CDR)	117
6.1.12	MBMS bearer context charging data in MBMS GW (MBMS-GW-CDR)	118
6.1.13	IP-CAN bearer charging data in ePDG (ePDG-CDR)	119
6.1.14	ABC data in TDF (TDF-CDR)	121
6.1.15	IP-CAN bearer charging data in TWAG (TWAG-CDR)	123
6.2	Data description for PS online charging	125
6.2.1	Message contents	125
6.2.1.1	Summary of online charging message formats	125
6.2.1.2	Structure for the Debit / Reserve Units operation message formats	125

6.2.1.2.0	General	125
6.2.1.2.1	Debit / Reserve Units Request message	125
6.2.1.2.2	Debit / Reserve Units Response message	126
6.2.2	Void	126
6.3	PS charging specific parameters	127
6.3.1	Definition of PS charging information	127
6.3.1.0	General	127
6.3.1.1	PS charging information assignment for Service Information	127
6.3.1.1a	"SMS over MME Charging" information assignment for Service Information	128
6.3.1.2	Definition of the PS information	129
6.3.1.3	Multiple Unit Operation information when charging per IP-CAN session is active	134
6.3.1.4	Supported features	135
6.3.2	Detailed message format for offline charging	136
6.3.3	Detailed message format for online charging	141
6.4	Void	144
6.5	Bindings for EPC offline charging	144
Annex A (normative): Charging characteristics		149
A.1	General	149
A.2	Charging Characteristics in Gn/Gp SGSN	153
A.3	Charging Characteristics in S4-SGSN	155
A.4	Charging Characteristics in MME	155
A.5	Charging Characteristics in S-GW	156
A.6	Charging Characteristics in P-GW	156
A.7	Charging Characteristics in TDF	157
Annex B (normative): Tx expiration; Failure Handling procedure and session failover mechanism description		158
Annex C (informative): Bibliography		161
Annex D (normative): Fixed Broadband Access		162
D.1	General	162
D.2	Architecture considerations	162
D.2.1	High level architecture	162
D.2.2	PS domain offline charging architecture	162
D.2.3	PS domain online charging architecture	162
D.3	PS domain charging principles and scenarios	162
D.3.1	PS charging principles	162
D.3.1.0	General	162
D.3.1.1	Requirements	163
D.3.1.1.1	Requirements for IP-Edge [PCEF]	163
D.3.1.1.2	Requirements for TDF	163
D.3.1.2	Charging information	164
D.3.2	PS domain offline charging scenarios	166
D.3.2.1	Basic principles	166
D.3.2.1.0	General	166
D.3.2.1.1	IP-CAN session charging	166
D.3.2.1.2	Flow-based bearer charging	167
D.3.2.1.3	TDF/Application Based Charging	167
D.3.2.2	Rf message flows	169
D.3.2.2.0	General	169
D.3.2.2.1	Triggers for charging events from IP-Edge [PCEF]	169
D.3.2.2.1.0	General	169
D.3.2.2.1.1	Triggers for charging information addition	169
D.3.2.2.1.2	Triggers for charging information closure	169

D.3.2.2.2	Triggers for charging events from TDF	169
D.3.2.2.2.0	Introduction	169
D.3.2.2.2.1	Triggers for charging information addition	169
D.3.2.2.2.2	Triggers for charging information closure	170
D.3.2.3.2	TDF-CDR charging information collection	170
D.3.2.3.2.0	Introduction	170
D.3.2.3.2.1	TDF-CDR charging information addition	170
D.3.2.3.2.2	TDF-CDR closure	170
D.3.2.3	CDR generation	171
D.3.2.3.0	General	171
D.3.2.3.1	IPE-CDR charging information collection	171
D.3.2.3.1.0	General	171
D.3.2.3.1.1	IPE-CDR charging information addition	171
D.3.2.3.1.2	IPE-CDR closure	171
D.3.2.4	Ga record transfer flows	172
D.3.2.5	Bp CDR file transfer	172
D.3.3	PS domain online charging scenarios	173
D.3.3.1	Basic principles	173
D.3.3.1.0	Introduction	173
D.3.3.1.1	IP-CAN session charging	173
D.3.3.1.2	Flow Based bearer Charging	173
D.3.3.1.3	TDF/Application Based Charging	173
D.3.3.2	Ro message flows	174
D.3.3.2.0	Introduction	174
D.3.3.2.1	Triggers for online charging	174
D.3.3.2.1.1	Triggers for starting and stopping a Credit-Control session	174
D.3.3.2.1.2	Triggers for providing interim information for a Credit-Control session	174
D.3.3.2.2	PS Furnish Charging Information procedure	174
D.3.3.2.3	Support of Failure Situations	174
D.4	Definition of charging information	175
D.4.1	Data description for PS offline charging	175
D.4.1.1	Rf message contents	175
D.4.1.2	CDR description on the Bp interface	175
D.4.1.2.1	FBC IP-CAN session charging data in IP-Edge [PCEF] (IPE-CDR)	175
D.4.1.2.2	Application Based Charging data in TDF (TDF-CDR)	177
D.4.2	Data description for PS online charging	178
D.4.2.1	Ro message contents	178
D.4.3	PS Charging specific parameters	178
D.4.3.1	Definition of PS charging information	178
D.4.3.2	Detailed message format for offline charging	179
D.4.3.3	Detailed message format for online charging	179
D.4.4	Bindings for offline charging	179
D.5	Charging Characteristics	180
Annex E (Informative):	Inter-PLMN dedicated profile	181
E.1	General	181
E.2	Principles	181
E.3	Message content	181
E.3.1	General	181
E.3.2	Debit / Reserve Units messages	181
E.3.3	Re-authorization triggers	183
E.3.4	Service information used for PS charging	184
E.4	Fixed broadband access	185
Annex F (informative):	Change history	186
History	194

Foreword

This Technical Specification has been produced by the 3rd Generation Partnership Project (3GPP).

The contents of the present document are subject to continuing work within the TSG and may change following formal TSG approval. Should the TSG modify the contents of the present document, it will be re-released by the TSG with an identifying change of release date and an increase in version number as follows:

Version x.y.z

where:

- x the first digit:
 - 1 presented to TSG for information;
 - 2 presented to TSG for approval;
 - 3 or greater indicates TSG approved document under change control.
- y the second digit is incremented for all changes of substance, i.e. technical enhancements, corrections, updates, etc.
- z the third digit is incremented when editorial only changes have been incorporated in the document.

1 Scope

The present document is part of a series of Technical Specifications (TSs) specifying charging functionality and charging management in Packet Switched networks (GSM/UMTS, EPS). The 3GPP core network charging architecture and principles are specified in TS 32.240 [1], which provides an umbrella for other charging management documents that specify:

- the content of the CDRs per domain / subsystem / service (offline charging);
- the content of real-time charging messages per domain / subsystem /service (online charging);
- the functionality of online and offline charging for those domains / subsystems / services;
- the interfaces that are used in the charging framework to transfer the charging information (i.e. CDRs or charging events).

The complete document structure for the charging TSs is defined in TS 32.240 [1].

The present document specifies the offline and online charging description for the Packet Switched (PS) domain based on the functional stage 2 description in TS 23.060 [201], TS 23.401 [208] and TS 23.402 [209].

The offline and online charging description for the PS domain encompasses also fixed broadband access in the convergent scenario deployment (i.e. both the fixed broadband access network and Evolved Packet Core (EPC) owned by a single operator) based on the functional stage 2 description in the corresponding Annex of TS 23.203 [215].

This charging description includes the offline and online charging architecture and scenarios specific to the PS domain, as well as the mapping of the common 3GPP charging architecture specified in TS 32.240 [1] onto the PS domain.

It further specifies the structure and content of the CDRs for offline charging, and the charging events for online charging. The present document is related to other 3GPP charging TSs as follows:

- The common 3GPP charging architecture is specified in TS 32.240 [1];
- The parameters, abstract syntax and encoding rules for the CDRs are specified in TS 32.298 [51];
- A transaction based mechanism for the transfer of CDRs within the network is specified in TS 32.295 [54];
- The file based mechanism used to transfer the CDRs from the network to the operator's Billing Domain (e.g. the billing system or a mediation device) is specified in TS 32.297 [52];
- The 3GPP Diameter application that is used for PS domain offline and online charging is specified in TS 32.299 [50].

Note that a CAMEL based prepaid function and protocol is also specified for the PS domain (TS 23.078 [206] and TS 29.078 [202]). CAMEL entities and functions are outside the scope of the present document.

All terms, definitions and abbreviations used in the present document, which are common across 3GPP TSs, are defined in TR 21.905 [100]. Those that are common across charging management in PS domains, services or subsystems are provided in the umbrella document TS 32.240 [1] and are copied into clause 3 of the present document for ease of reading. Finally, those items that are specific to the present document are defined exclusively in the present document.

Furthermore, requirements that govern the charging work are specified in TS 22.115 [101].

2 References

The following documents contain provisions which, through reference in this text, constitute provisions of the present document.

References are either specific (identified by date of publication, edition number, version number, etc.) or non-specific.

For a specific reference, subsequent revisions do not apply.

- For a non-specific reference, the latest version applies. In the case of a reference to a 3GPP document (including a GSM document), a non-specific reference implicitly refers to the latest version of that document *in the same Release as the present document*.

- [1] 3GPP TS 32.240: "Telecommunication management; Charging management; Charging architecture and principles".
- [2] - [9] Void.
- [10] 3GPP TS 32.250: "Telecommunication management; Charging management; Circuit Switched (CS) domain charging".
- [11] – [19] Void.
- [20] 3GPP TS 32.260: "Telecommunication management; Charging management; IP Multimedia Subsystem (IMS) charging".
- [21] - [29] Void.
- [30] 3GPP TS 32.270: "Telecommunication management; Charging management; Multimedia Messaging Service (MMS) charging".
- [31] 3GPP TS 32.271: "Telecommunication management; Charging management; Location Services (LCS) charging".
- [32] void.
- [33] 3GPP TS 32.273: "Telecommunication management; Charging management; Multimedia Broadcast and Multicast Service (MBMS) charging".
- [34] 3GPP TS 32.274: "Telecommunication management; Charging management; Short Message Service (SMS) charging".
- [35] - [49] Void.
- [50] 3GPP TS 32.299: "Telecommunication management; Charging management; Diameter charging application".
- [51] 3GPP TS 32.298: "Telecommunication management; Charging management; Charging Data Record (CDR) encoding rules description".
- [52] 3GPP TS 32.297: "Telecommunication management; Charging management; Charging Data Records (CDR) file format and transfer".
- [53] 3GPP TS 32.296: "Telecommunication management; Charging management; Online Charging System (OCS) applications and interfaces".
- [54] 3GPP TS 32.295: "Telecommunication management; Charging management; Charging Data Record (CDR) transfer".
- [55] - [99] Void.
- [100] 3GPP TR 21.905: "Vocabulary for 3GPP Specifications".
- [101] 3GPP TS 22.115: "Service aspects; Charging and billing".
- [102] 3GPP TS 22.011: "Service accessibility".
- [103] 3GPP TS 23.003: "Numbering, Addressing and Identification".
- [104] - [199] Void.
- [200] 3GPP TS 22.060: "General Packet Radio Service (GPRS); Service description; Stage 1".
- [201] 3GPP TS 23.060: "General Packet Radio Service (GPRS); Service description; Stage 2".
- [202] 3GPP TS 29.078: "Customized Applications for Mobile network Enhanced Logic (CAMEL) Phase X; CAMEL Application Part (CAP) specification".
- [203] 3GPP TS 29.060: "General Packet Radio Service (GPRS); GPRS Tunnelling Protocol (GTP) across the Gn and Gp interface".

- [204] Void.
- [205] 3GPP TS 29.061: "Interworking between the Public Land Mobile Network (PLMN) supporting packet based services and Packet Data Networks (PDN)".
- [206] 3GPP TS 23.078: "Customized Applications for Mobile network Enhanced Logic (CAMEL); Phase 4; Stage 2".
- [207] 3GPP TS 23.246: "Multimedia Broadcast/Multicast Service (MBMS); Architecture and functional description".
- [208] 3GPP TS 23.401: "General Packet Radio Service (GPRS) enhancements for Evolved Universal Terrestrial Radio Access Network (E-UTRAN) acces".
- [209] 3GPP TS 23.402: "Architecture enhancements for non-3GPP accesses".
- [210] 3GPP TS 29.274: "3GPP Evolved Packet System (EPS); Evolved General Packet Radio Service (GPRS) Tunnelling Protocol for Control plane (GTPv2-C); Stage 3".
- [211] 3GPP TS 29.275: "Proxy Mobile IPv6 (PMIPv6) based Mobility and Tunnelling protocols; Stage 3".
- [212] 3GPP TS 23.261: "IP flow mobility and seamless Wireless Local Area Network (WLAN) offload; Stage 2".
- [213] 3GPP TS 23.272: "Circuit Switched (CS) fallback in Evolved Packet System (EPS); Stage 2".
- [214] Void.
- [215] 3GPP TS 23.203: "Policy and charging control architecture".
- [216] 3GPP TS 29.212: "Policy and Charging Control (PCC); Reference points".
- [217] 3GPP TS 29.281: "General Packet Radio System (GPRS) Tunnelling Protocol User Plane (GTPv1-U)".
- [218] - [241] Void.
- [242] 3GPP TS 23.161: "Network-based IP flow mobility and Wireless Local Area Network (WLAN) offload; Stage 2".
- [243] - [399] Void.
- [400] Void.
- [401] Void.
- [402] IETF RFC 4006 (2005): "Diameter Credit-Control Application".
- [403] - [599] Void.
- [600] Broadband Forum TR-146: "Internet Protocol (IP) Sessions".
- [601] Broadband Forum TR-134: "Broadband Policy Control Framework (BPCF)".

3 Definitions, symbols and abbreviations

3.1 Definitions

For the purposes of the present document, the terms and definitions defined in TR 21.905 [100], TS 32.240 [1] and TS 22.060 [200], and the following apply:

2G-/3G-: prefixes 2G- and 3G- refer to functionality that supports only GSM or UMTS, respectively, e.g. 2G-SGSN refers only to the GSM functionality of an SGSN

When the term/prefix is omitted, reference is made independently from the GSM or UMTS functionality.

accounting: process of apportioning charges between the Home Environment, Serving Network and Subscriber.

billing: function whereby CDRs generated by the charging function(s) are transformed into bills requiring payment.

Billing Domain (BD): Part of the operator network, which is outside the core network that receives and processes CDR files from the core network charging functions. It includes functions that can provide billing mediation and billing or other (e.g. statistical) end applications. It is only applicable to offline charging (see "Online Charging System" for equivalent functionality in online charging).

CAMEL: network feature that provides the mechanisms to support operator specific services even when roaming outside HPLMN.

CAMEL subscription information: identifies a subscriber as having CAMEL services.

chargeable event: activity utilizing telecommunications network resources and related services for:

- user to user communication (e.g. a single call, a data communication session or a short message); or
- user to network communication (e.g. service profile administration); or
- inter-network communication (e.g. transferring calls, signalling, or short messages); or
- mobility (e.g. roaming or inter-system handover); and
- that the network operator may want to charge for.

As a minimum, a chargeable event characterises the resource / service usage and indicates the identity of the involved end user(s).

charged party: user involved in a chargeable event that has to pay parts or the whole charges of the chargeable event, or a third party paying the charges caused by one or all users involved in the chargeable event, or a network operator.

charging: a function within the telecommunications network and the associated OCS/BD components whereby information related to a chargeable event is collected, formatted and transferred in order to make it possible to determine usage for which the charged party may be billed.

Charging Data Record (CDR): A formatted collection of information about a chargeable event (e.g. time of call set-up, duration of the call, amount of data transferred, etc) for use in billing and accounting. For each party to be charged for parts of or all charges of a chargeable event a separate CDR is generated, i.e. more than one CDR may be generated for a single chargeable event, e.g. because of its long duration, or because more than one charged party is to be charged.

charging event: a set of charging information forwarded by the CTF towards the CDF (offline charging) or towards the OCS (online charging). Each charging event matches exactly one chargeable event.

charging function: entity inside the core network domain, subsystem or service that is involved in charging for that domain, subsystem or service.

Credit-Control: mechanism which directly interacts in real-time with an account and controls or monitors the charges, related to the service usage. Credit-Control is a process of: checking if credit is available, credit reservation, deduction of credit from the end user account when service is completed and refunding of reserved credit not used.

domain: part of a communication network that provides network resources using a certain bearer technology.

Fully Qualified Partial CDR (FQPC): partial CDR that contains a complete set of the fields specified in the present document. This includes all the mandatory and conditional fields as well as those fields that the PLMN operator has provisioned to be included in the CDR. The first Partial CDR shall be a Fully Qualified Partial CDR.

GPRS: packet switched bearer and radio services for GSM and UMTS systems.

GSM only: qualifier indicating that this clause or paragraph applies only to a GSM system. For multi-system cases this is determined by the current serving radio access network.

in GSM,....: qualifier indicating that this paragraph applies only to GSM System.

in UMTS,....: qualifier indicating that this paragraph applies only to UMTS System.

inter-system change: change of radio access between different radio access technologies such as GSM and UMTS.

IP-CAN bearer: An IP transmission path of defined capacity, delay and bit error rate, etc. See TS 21.905 [100] for the definition of bearer.

IP-CAN session: The association between a UE represented by an IPv4 address and/or an IPv6 prefix, and UE identity information, if available, and a PDN represented by a PDN ID (e.g. an APN). An IP-CAN session incorporates one or more IP-CAN bearers. Support for multiple IP-CAN bearers per IP-CAN session is IP-CAN specific. An IP-CAN session exists as long as UE IP addresses are established and announced to the IP network.

middle tier TS: used for the 3GPP charging TSs that specify the domain / subsystem / service specific, online and offline, charging functionality. These are all the TSs in the numbering range from TS 32.250 [10] to TS 32.271 [31], e.g. TS 32.250 [10] for the CS domain, or TS 32.270 [30] for the MMS service. Currently, there is only one "tier 1" TS in 3GPP, which is TS 32.240 [1] that specifies the charging architecture and principles. Finally, there are a number of top tier TSs in the 32.29x numbering range ([50] ff) that specify common charging aspects such as parameter definitions, encoding rules, the common Billing Domain (BD) interface or common charging applications.

near real-time: near real-time charging and billing information is to be generated, processed, and transported to a desired conclusion in less than one (1) minute.

Non-Seamless WLAN Offload (NSWO) is a capability of routing specific IP flows over the WLAN access without traversing the EPC as defined in clause 4.1.5 of TS 23.402 [209].

offline charging: charging mechanism where charging information **does not** affect, in real-time, the service rendered.

online charging: charging mechanism where charging information can affect, in real-time, the service rendered and therefore a direct interaction of the charging mechanism with bearer/session/service control is required.

Online Charging System (OCS): the entity that performs real-time Credit-Control. Its functionality includes transaction handling, rating, online correlation and management of subscriber account balances.

packet switched domain: domain in which data is transferred between core network elements in packet switched mode.

partial CDR: CDR that provides information on part of a subscriber session. A long session may be covered by several partial CDRs. Two formats are considered for partial CDRs. One that contains all of the necessary fields (FQPC); the second has a reduced format (RPC).

Presence Reporting Area: An area defined within 3GPP Packet Domain for the purposes of reporting of UE presence within that area due to policy control and/or charging reasons. There are two types of Presence Reporting Area: "UE-dedicated Presence Reporting Area", and "Core Network pre-configuration Presence Reporting Area".

Real-time: real-time charging and billing information is to be generated, processed, and transported to a desired conclusion in less than one (1) second.

Reduced Partial CDR (RPC): partial CDRs that only provide mandatory fields and information regarding changes in the session parameters relative to the previous partial CDR. For example, location information is not repeated in these CDRs if the subscriber did not change its location.

settlement: payment of amounts resulting from the accounting process.

Selected IP Traffic Offload (SIPTO): Offload of selected types of IP traffic (e.g. internet traffic) towards a defined IP network close to the UE's point of attachment to the access network. SIPTO is applicable to traffic offload for the macro-cellular access network and for the H(e)NB subsystem.

subscriber: A subscriber is an entity (associated with one or more users) that is engaged in a subscription with a service provider. The subscriber is allowed to subscribe and unsubscribe services, to register a user or a list of users authorized to enjoy these services, and also to set the limits relative to the use that associated users make of these services.

tariff period: part of one (calendar) day during which a particular tariff is applied. Defined by the time at which the period commences (the switch-over time) and the tariff to be applied after switch-over.

tariff: set of parameters defining the network utilization charges for the use of a particular bearer / session / service.

UMTS only: qualifier indicating that this clause or paragraph applies only to a UMTS system. For multi-system cases this is determined by the current serving radio access network.

Unused Quota timer: the time period without quota granted or any quota being consumed for any rating group belonging to the Gy session.

NOTE: It is started when initial quota for the session is received from the OCS and it is restarted every time there is a quota consumption.

user: An entity, not part of the 3GPP System that uses network resources by means of a subscription. The user may or may not be identical to the subscriber holding that subscription.

User Equipment (UE): A device allowing a user access to network services. For the purpose of 3GPP specifications the interface between the UE and the network is the radio interface. A UE can be subdivided into a number of domains, the domains being separated by reference points. Currently defined domains are the USIM and ME Domains. The ME Domain can further be subdivided into several components showing the connectivity between multiple functional groups. These groups can be implemented in one or more hardware devices. An example of such connectivity is the TE – MT interface. Further, an occurrence of a User Equipment is an MS for GSM as defined in GSM TS 04.02 (GSM Public Land Mobile Network (PLMN) Access Reference Configuration).

3.2 Symbols

For the purposes of the present document the following symbols apply:

A	Interface between an MSC and a BSC
Bp	Reference point for the CDR file transfer from the Packet Switched CGF to the BD
C	Interface between a HLR and a SMSC
D	Interface between a MSC and a HLR
E	Interface between a MSC and a SMSC
Ga	Reference point between a CDF and the CGF for CDR transfer
Gb	Interface between an SGSN and a BSC
Gc	Interface between an GGSN and an HLR
Gd	Interface between an SMS-GMSC and an SGSN, and between a SMS-IWMSC and an SGSN
Ge	Interface between a SGSN and a CAMEL GSM SCF
Gf	Interface between an SGSN and an EIR
Gi	Interface between the Packet-Switched domain and an external packet data network
Gn	Interface between two GSNs within the same PLMN
Gp	Interface between two GSNs in different PLMNs
Gr	Interface between an SGSN and an HLR
Gs	Interface between an SGSN and an MSC/VLR.
Gx	Interface between a PCEF and a PCRF
Gxa	Interface between a HSGW and a PCRF
Gy	Online charging reference point between a PCEF and an OCS
Gyn	Online charging reference point between a TDF and an OCS
Gz	Offline charging reference point between a PCEF and an OFCS
Gzn	Offline charging reference point between a TDF and an OFCS
Iu	Interface between the 3G SGSN and the UTRAN
kbit/s	Kilobits per second. 1 kbit/s = 2 ¹⁰ bits per second
Mbit/s	Megabits per second. 1 Mbit/s = 2 ²⁰ bits per second
R	Reference point between a non-ISDN compatible TE and MT. Typically this reference point supports a standard serial interface.

Rf	Offline charging reference point between a PCN network element and CDF
Ro	Online charging reference point between a PCN network element and the OCS
Um	Interface between the Mobile Station (MS) and the GSM fixed network part
Uu	Interface between the User Equipment (UE) and the UMTS fixed network part

3.3 Abbreviations

For the purposes of the present document, the abbreviations defined in TR 21.905 [100] and the following apply:

3G	3 rd Generation
ABC	Application Based Charging
ADC	Application Detection and Control
AoC	Advice of Charge
APN	Access Point Name
ARP	Allocation and Retention Priority
BD	Billing Domain
CAMEL	Customised Applications for Mobile network Enhanced Logic
CCA	Credit-Control-Answer
CCR	Credit-Control-Request
CDF	Charging Data Function
CDR	Charging Data Record
CG	Charging Gateway
CGF	Charging Gateway Function
CI	Cell Identity
CIoT	Cellular Internet of Things
CP	Control Plane
CSE	CAMEL Service Environment
CSG	Closed Subscriber Group
CSG ID	Closed Subscriber Group Identity
CTF	Charging Trigger Function
DCCA	Diameter Credit-Control Application
EPC	Evolved Packet Core
ePDG	Evolved Packet Data Gateway
EPS	Evolved Packet System
ECUR	Event Charging with Unit Reservation
E-UTRAN	Evolved Universal Terrestrial Radio Access Network
FBC	Flow Based bearer Charging
FQPC	Fully Qualified Partial CDR
GERAN	GSM EDGE Radio Access Network
GGSN	Gateway GPRS Support Node
GPRS	General Packet Radio Service
GSM	Global System for Mobile communication
GTP	GPRS Tunnelling Protocol
GTP'	The GPRS protocol used for CDR transport. It is derived from GTP with enhancements to improve transport reliability necessary for CDRs.
HeNB	Home eNode B
HNB	Home Node B
H(e)NB	HNB and HeNB
HLR	Home Location Register
HPLMN	Home PLMN
HRPD	High Rate Packet Data
HSGW	HRPD Serving Gateway
IE	Information Element
IEC	Immediate Event Charging
IETF	Internet Engineering Task Force
IFOM	IP Flow Mobility
IMEI	International Mobile Equipment Identity
IMSI	International Mobile Subscriber Identity
IP	Internet Protocol
IP-CAN	IP Connectivity Access Network
IPv4	Internet Protocol version 4
IPv6	Internet Protocol version 6

ISDN	Integrated Services Digital Network
ITU-T	International Telecommunication Union - Telecommunications standardization sector
LAC	Location Area Code
LR	Location Request
M-CDR	Mobility management generated CDR
MAPCON	Multi Access PDN Connectivity
MCC	Mobile Country Code (part of IMSI)
ME	Mobile Equipment
MLC	Mobile Location Center
MME	Mobility Management Entity
MMS	Multimedia Messaging Service
MNC	Mobile Network Code (part of IMSI)
MO	Mobile Originated
MO-LR	Mobile Originated Location Request
MS	Mobile Station
MSISDN	Mobile Station ISDN number
MT	Mobile Terminated
MT-LR	Mobile Terminated Location Request
NBIFOM	Network-based IP flow mobility
NE	Network Element
NI	Network Identifier (part of the APN)
NI-LR	Network Induced - Location Request
NSWO	Non-Seamless WLAN Offload
OAM&P	Operation, Administration, Maintenance and Provisioning
OCF	Online Charging Function
OCS	Online Charging System
OI	Operator Identifier (part of the APN)
P-GW	PDN Gateway
PCC	Policy and Charging Control
PCEF	Policy and Charging Enforcement Function
PCN	Packet switched Core network Node (SGSN, GGSN, S-GW, P-GW, TDF)
PDN	Packet Data Network
PDP	Packet Data Protocol (e.g. IP)
PDU	Packet Data Unit
PGW-CDR	P-GW (enhanced by FBC) generated CDR
PLMN	Public Land Mobile Network
PMIP	Proxy Mobile IP
PPP	Point-to-Point Protocol
PRA	Presence Reporting Area
PS	Packet Switched
QCI	QoS Class Identifier
QoS	Quality of Service
RAB	Radio Access Bearer
RAC	Routing Area Code
RANAP	Radio Access Network Application Part
RG	Residential Gateway
RNC	Radio Network Controller
RPC	Reduced Partial CDR
SAC	Service Area Code
S-CDR	SGSN (IP-CAN bearer) generated CDR
S-GW	Serving Gateway
SCUR	Session Charging with Unit Reservation
SDF	Service Data Flow
SGSN	Serving GPRS Support Node
SGW-CDR	S-GW (IP-CAN bearer) generated CDR
SIPTO	Selected IP Traffic Offload
SMS	Short Message Service
S-SMO-CDR	SGSN delivered Short message Mobile Originated CDR
S-SMT-CDR	SGSN delivered Short message Mobile Terminated CDR
T-PDU	Transport PDU
TDF	Traffic Detection Function
TDF-CDR	TDF generated CDR

TR	Technical Report
TS	Technical Specification
TWAG	Trusted WLAN Access Gateway
TWAN	Trusted WLAN Access Network
UMTS	Universal Mobile Telecommunications System
UP	User Plane
USIM	Universal Subscriber Identity Module
UTRAN	UMTS Terrestrial Radio Access Network
UWAN	Untrusted Wireless Access Network

4 Architecture considerations

4.0 General

This clause describes the functional entities involved in the PS domain charging architecture. It also presents the mappings of the ubiquitous offline and online charging architecture specified in TS 32.240 [1] onto physical implementations that are standardized for the 3GPP PS domain.

4.1 High-level EPS architecture

The 3GPP PS domain provides procedures for packet core networks described in TS 23.060 [201], TS 23.401 [208], TS 23.402 [209] and TS 23.272 [213].

For offline charging the following Packet switched Core network Nodes (PCN) may generate accounting metrics sets for PS domain CDRs:

- the SGSN, to record a user's access to PLMN resources, mobility management activities, SMS and LCS usage;
- the S-GW, to record a user's access to PLMN resources;
- the ePDG, to record a user's access to PLMN resources;
- the TWAG, to record a user's access to PLMN resources (optional) ;
- the P-GW, to record a user's access to external networks ;
- the GGSN, to record a user's access to external networks;
- the MME, to record a user's SMS;
- the TDF, to record a user's access to external networks and applications.

The PCNs send the CDRs to the CGF in near real-time. The responsibility of the CGF is to provide non-volatile CDR storage and the Bp interface towards the Billing Domain (BD). Further details on the CGF can be found in TS 32.240 [1] and TS 32.297 [52].

For more information about online charging in PS domains see clause 4.3.

When P-GW provides connectivity to GERAN/UTRAN (P-GW acts as a GGSN) it employs P-GW charging defined in this specification. When the stand-alone GGSN provides connectivity to GERAN/UTRAN, it employs P-GW charging as defined in the present document:

- Stand-alone GGSN offline charging is based on FBC IP-CAN bearer charging data in P-GW;
- Stand-alone GGSN online charging is based on PS Information used for online charging.

4.2 PS domain offline charging architecture

As described in TS 32.240 [1], the CTF (an integrated component in each charging relevant NE) generates charging events and forwards them to the CDF. The CDF, in turn, generates CDRs which are then transferred to the CGF. Finally, the CGF creates CDR files and forwards them to the BD.

If the PCN generating the charging information has an integrated CDF, then the PCN can produce CDRs. The CGF may also be integrated in the PCN, or it may exist as a physically separate entity.

If the CGF is external to the PCN, then the CDF forwards the CDRs to the CGF across the Ga interface.

In this case, the relationship between PCN/CDF and CGF is m:1.

If the CGF is integrated in the PCN, then there is only an internal interface between the CDF and the CGF.

In this case, the relationship between PCN/CDF and CGF is 1:1. An integrated CGF may support the Ga interface from other PCN/CDFs.

If the CDF is external to the PCN, the charging events are transferred from the PCN to the CDF via the Rf interface specified in TS 32.299 [50]. In this case, the relationship between PCN and CDF is m:1.

When an external CGF is used, this CGF may also be used by other, i.e. non-PS, network elements, according to network design and operator decision. It should be noted that the CGF may also be an integrated component of the BD – in this case, the Bp interface does not exist and is replaced by a proprietary solution internal to the BD.

Figure 4.2.1 depicts the architectural options described above.

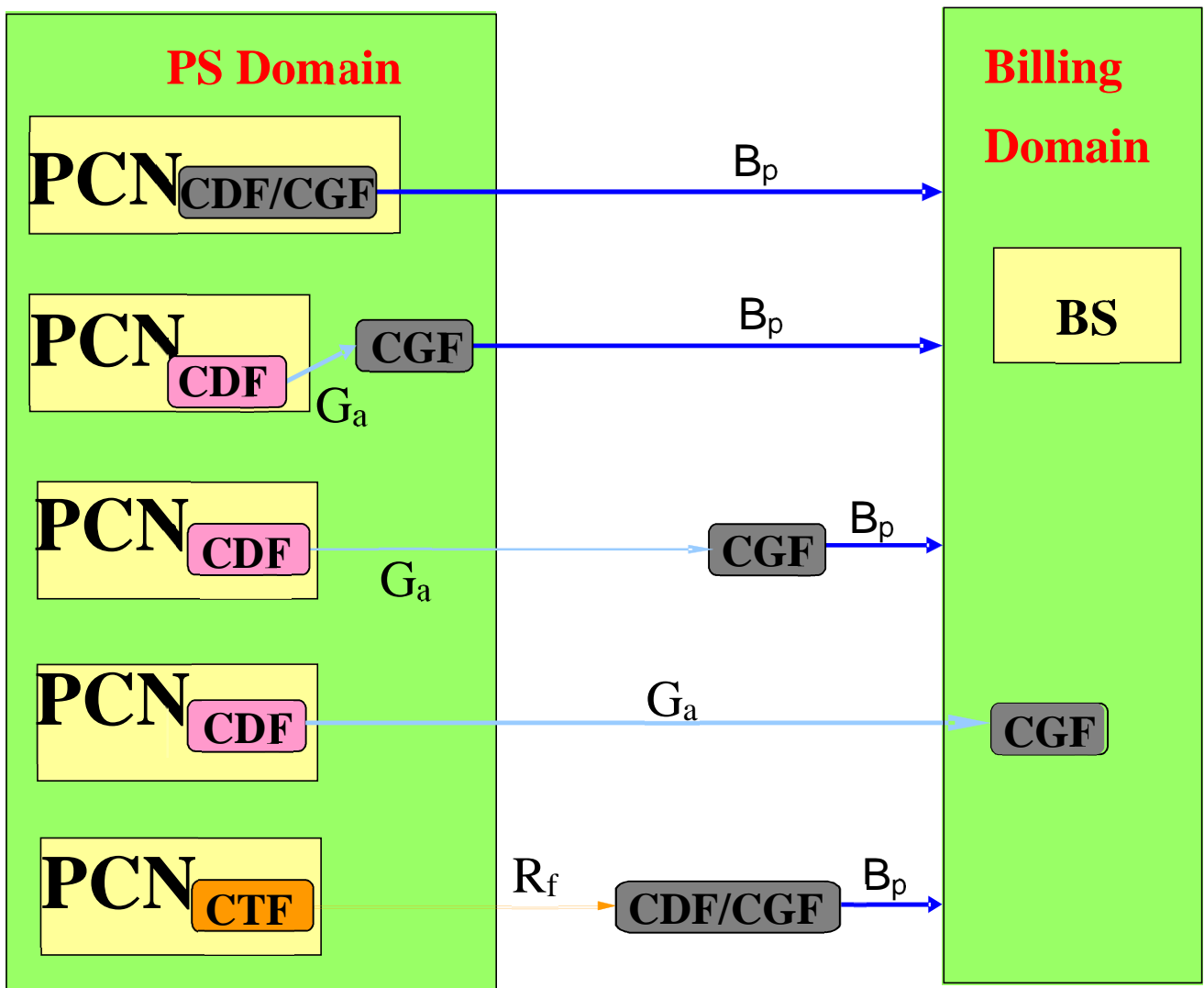

Figure 4.2.1: PS domain offline charging architecture

The P-GW includes a Policy and Charging Enforcement Function (PCEF) to support Flow Based bearer Charging (FBC) functionality; this is not depicted in figure 4.2.1. The Traffic Detection Function (TDF) supports Application Based Charging (ABC) functionality. The Rf, Ga and Bp interfaces include the required functionality, e.g. defined for the Gz/Gzn reference point in TS 23.203 [215]. Refer to clause 5.2.1.3, TS 32.240 [1] and TS 23.203 [215] for further details on FBC.

The PCNs may provide inter-operator charging functionality for Multimedia Broadcast/Multicast Services (MBMS) defined in TS 23.246 [207] and TS 32.273 [33], not for subscriber charging.

It is mandatory to support at least one of the options Rf, Ga or Bp interfaces from the PCN as described in the specification.

NOTE: The Rf interface details are specified for S-GW, ePDG, TWAG, MME, TDF and P-GW in this release.

4.3 PS domain online charging architecture

PS domain online charging based on SGSN functions is implemented by CAMEL techniques as described in TS 23.078 [206] and TS 29.078 [202], i.e. outside the scope of the 32-series of charging TSs. Note, however, that the CDRs described in the present document contains CAMEL information. This is because some of that information is relevant to offline charging in case of CAMEL control of (part of) the session, and thus needs to be captured in the offline charging information. However, this is not related to the online charging functions for the PS domain.

Mechanisms to enable PS domain online charging from the P-GW with included PCEF and the TDF are specified in the present document, utilising the Ro interface and the associated Diameter application as specified in TS 32.299 [50]. The reason for this alternative solution to CAMEL is that operators may enforce the use of HPLMN P-GWs and TDF in the case of roaming, hence P-GW or TDF service control and charging can be executed in the HPLMN in all circumstances. The P-GW and TDF based PS domain online charging architecture is depicted in figure 4.3.1.

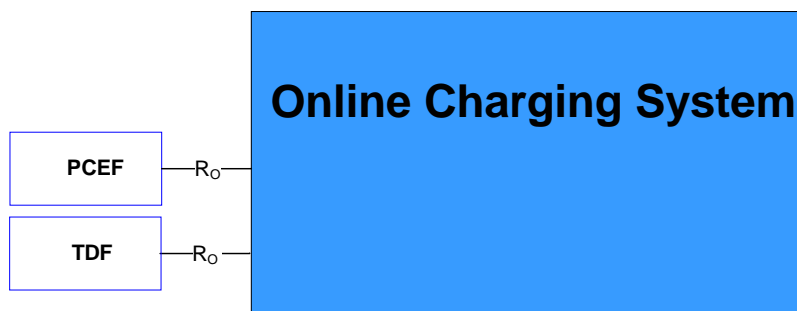

Figure 4.3.1: PS domain online charging architecture

The Ro reference point includes the functionality defined for the Gy reference point (required for the PCEF) and the Gyn reference point (required for the TDF) in TS 23.203 [215]. Refer to clause 5.2.1.3, TS 32.240 [1] and TS 23.203 [215] for further details on FBC.

Details on the interfaces and functions can be found in TS 32.240 [1] for the general architecture components, TS 32.296 [53] for the OCS, and TS 32.299 [50] for the Ro application.

5 PS domain charging principles and scenarios

5.1 PS charging principles

5.1.0 General

The charging functions specified for the PS domain relate to:

- mobility management, refer to TS 23.060 [201];
- SMS transmissions / receptions, refer to TS 23.060 [201] , and TS 23.272 [213];
- IP-CAN bearers, refer to TS 23.060 [201], TS 23.401 [208] and TS 23.402 [209];
- LCS events, refer to TS 32.271 [31];
- service data flows, refer to TS 23.203 [215] , within IP-CAN session and IP-CAN bearer;
- TDF session, refer to TS 23.203 [215];
- network usage for specific applications within a TDF session, refer to TS 23.203 [215] ;
- MBMS bearer contexts, refer to TS 23.246 [207] and TS 32.273 [33].

IP-CAN bearer, when described for PS Charging in S-GW and P-GW, refers to bearer related to IP data and Non-IP data as well.

5.1.1 Requirements

The following are high-level charging requirements specific to the packet domain, derived from the requirements in TS 22.115 [101], TS 23.060 [201], TS 23.401 [208], TS 23.402 [209] and TS 23.203 [215].

- 1) Every IP-CAN bearer shall be assigned a unique identity number for billing purposes. (i.e. the Charging Id).

NOTE: An IP-CAN session is identified by the unique identity number assigned to the default bearer for the IP-CAN session.

- 2) Data volumes on both the uplink and downlink directions shall be counted separately. The data volumes shall reflect the data as delivered to and from the user. When the P-GW includes PCEF, the data volumes shall also reflect the data as delivered to and from the serving node at the bearer level.
 - 3) The charging mechanisms shall provide the duration of the IP-CAN bearer with date and time information.
 - 4) The network operator may define a subset of the charging information specified by PS domain charging standards. This means that it shall be possible to configure the PCN for the CDR information generated.
 - 5) The PCNs shall be capable of handling the Charging Characteristics. Charging Characteristics can be specific for a subscription, subscribed IP-CAN bearer (i.e. per APN) or per TDF session, see annex A for details.
 - 6) The SGSN shall support charging of CAMEL services.
 - 7) The SGSN shall support charging for location requests.
 - 8) The SGSN may support online charging using CAMEL techniques.
 - 9) The P-GW may support online charging using IETF based techniques.
 - 10) The P-GW may be capable of identifying data volumes, elapsed time or events for individual service data flows (Flow Based bearer Charging). One PCC rule identifies one service data flow.
 - 11) When online charging is used in the P-GW/TDF, the Credit-Control shall be per rating group.
 - 12) P-GW/TDF shall allow reporting of the service or detected application /detected application usage per rating group or per combination of the rating group and service id. This reporting level can be activated per PCC/ADC rule.
 - 13) The P-GW shall collect charging information for IP -CAN session as it would for one IP-CAN bearer in case of PMIP based connectivity is used.
 - 14) Charging support in the SGSN shall apply only for SGSN with Gn/Gp connectivity.
 - 15) The data volume shall be counted regardless of whether the subscriber's traffic has been offloaded from the mobile operator's network.
- Editor's Notes: This requirement should be refined after finalization of the architecture for Selected IP Traffic Offload charging.**
- 16) The TDF may support online charging using IETF techniques.
 - 17) The TDF shall be capable of identifying data volumes, elapsed time or events for specific applications (ABC).
 - 18) The charging mechanisms shall provide the duration of the TDF session with date and time information.
 - 19) The P-GW/S-GW shall support charging for Non-IP PDN connection.

These requirements apply equally to PS domain online charging and offline charging.

5.1.2 Charging information

Charging information in the PS domain network is collected for each MS/UE by the SGSNs, MMEs, S-GWs, ePDG, TWAG, P-GWs and TDFs, which are serving that MS/UE. The SGSN, S-GW, ePDG and TWAG collect charging information for each MS/UE related with the radio network usage, while the P-GW and TDF collect charging information for each MS related with the external data network usage. PCNs also collect charging information on usage of the PS domain network resources. For MBMS, charging information in the PS domain network is collected for each MBMS bearer context.

The following paragraphs list the charging information to be collected by the PCNs for both online and offline charging.

For IP-CAN bearers, the PCNs shall collect the following charging information:

1. usage of the radio interface: the charging information shall describe the amount of data transmitted in MO and MT directions categorized with QoS, user protocols, and use of Control Plane CIoT EPS Optimisation as specified in TS 23.401[208];
2. usage duration: duration of IP-CAN bearer is counted as the time interval from IP-CAN bearer activation to IP-CAN bearer deactivation;
3. usage of the general PS domain resources: the charging information shall describe the usage of other PS domain-related resources and the MSs PS domain network activity (e.g. mobility management);
4. destination and source: the charging information shall provide the actual source addresses used by the subscriber for the IP-CAN bearer. The charging information shall describe the destination addresses with a level of accuracy as determined by the Access Point Name (APN);
5. usage of the external data networks: the charging information shall describe the amount of data sent and received to and from the external data network. External networks can be identified by the APN.

NOTE: When charging per IP-CAN session is deployed in the P-GW, the usage of the external data networks is provided only at the session level and not per bearer.

6. location of MS/UE: HPLMN, VPLMN, plus optional higher-accuracy location information.
7. User CSG information: a user consumes network services via a CSG cell or a hybrid cell according to the user CSG information. The charging information shall include CSG ID, access mode and CSG membership indication.
8. User inside/outside of a Presence Reporting Area: the charging information shall include indication on whether the UE is inside or outside of a Presence Reporting Area, and identification of the Presence Reporting Area, and is collected by SGW and PGW

For service data flows defined for FBC, the P-GW shall collect the following charging information:

1. the information described above for IP-CAN bearer charging;
2. the amount of data transmitted in MO and MT directions categorized by rating group or combination of the rating group and service id when volume based charging applies;
3. the duration of service data flows is counted and categorized by rating group or combination of the rating group and service id when time based charging applies;
4. the number of events and corresponding time stamps categorized by rating group or combination of the rating group and service id when event based charging applies.

For TDF sessions, the TDF shall collect the following charging information:

1. usage duration: duration of TDF session is counted as the time interval from TDF session activation to TDF session deactivation;
2. usage of the general PS domain resources: the charging information shall describe the usage of other PS domain-related resources and the MSs PS domain network activity (e.g. mobility management);
3. destination and source: the charging information shall provide the actual source addresses used by the subscriber for the TDF session. The charging information shall describe the destination addresses with a level of accuracy as determined by the APN;

4. usage of the external data networks: the charging information shall describe the amount of data sent and received to and from the external data network. External networks can be identified by the APN.
5. location of MS/UE: HPLMN, VPLMN, plus optional higher-accuracy location information.
6. User CSG information: a user consumes network services via a CSG cell or a hybrid cell according to the user CSG information. The charging information shall include CSG ID, access mode and CSG membership indication.
7. voidFor application traffic defined for ABC, the TDF shall collect the following charging information:
 1. the information described above for TDF session charging;
 2. the amount of data transmitted as specific application in MO and MT directions categorized by rating group or combination of the rating group and service identifier when volume based charging applies;
 3. the duration of application traffic is counted and categorized by rating group or combination of the rating group and service identifier when time based charging applies;
 4. the number of events and corresponding timestamps categorized by rating group or combination of the rating group and service identifier when event based charging applies.

For non-IP-CAN bearer related activities, the SGSN shall collect the following charging information:

1. mobility management actions for GPRS attached UEs/MSs;
2. short messages passing through the SGSN in MO and MT directions;
3. location requests passing through the SGSN, triggered by the UE/MS, by an external source, or by the network.

For MBMS bearer contexts, the PCNs shall collect the following charging information:

1. usage of the radio interface: the charging information shall describe the amount of data transmitted categorized with QoS and MBMS specific information defined in TS 32.273 [33];
2. usage duration: duration of MBMS bearer context is counted as the time interval from the local creation of the MBMS bearer context to the local deletion of the MBMS bearer context;
3. source: the charging information shall provide the source address used by the MBMS bearer service for the MBMS bearer context. The charging information may describe the destination addresses with a level of accuracy as determined by the APN;
4. location information: the charging information shall describe a list of the downstream nodes being sent the MBMS bearer service.

The MME shall collect short messages passing through the MME in MO and MT directions.

5.1.3 Identifiers and correlation

The EPC charging identifier assigned per IP-CAN bearer, is used for correlation purpose within PS domain, as specified in TS 32.240 [1].

Within a single-access PDN connection, the EPS default bearer remains established throughout the lifetime of this PDN connection and is assigned with its "EPS default bearer charging identifier". Other additional IP-CAN bearers (i.e. dedicated bearers) which may be activated and deactivated during this PDN connection, are each assigned with their own "IP-CAN bearer charging identifier". For correlation of charging information for the whole PDN connection, this "EPS default bearer charging identifier" is shared by all these IP-CAN bearers charging sessions activated during this PDN connection, as the "PDN connection charging identifier".

For PMIP based connectivity, an "unique Charging Id" is assigned by the P-GW for the PDN connection (i.e. as it would be one IP-CAN bearer).

For ABC by the TDF:

- in case of GTP based connectivity, an "EPS default bearer charging identifier",
- in case of PMIP based connectivity, an "unique Charging Id"

is assigned by the P-GW and transferred to the TDF via the PCRF for the TDF session.

During handover of a PDN connection between a GTP based connectivity access, and a PMIP based connectivity access for the P-GW (and reversely), the "EPS default bearer charging identifier" and the "unique Charging Id" respectively, are maintained in order to ensure charging continuity for the whole PDN connection over the different accesses.

Upon handover from GTP based connectivity to PMIP based connectivity, the previously assigned "EPS default bearer charging identifier" is used as the "unique Charging Id". Upon handover from PMIP based connectivity to GTP based connectivity, the previously assigned "unique Charging Id" is used as the "EPS default bearer charging identifier".

During handover of a PDN connection between a GTP based connectivity 3GPP access, and a S2a/S2b GTP based connectivity non-3GPP access for the P-GW (and reversely), the "EPS default bearer charging identifier" is maintained for the default bearer, and the "Charging Id" is maintained for the handed-over dedicated bearers (i.e. bearer with the same QCI and ARP in source and target systems). Depending on the active PCC rules, establishment of new dedicated bearers may be required after the handover. In this case each new dedicated bearer is assigned with a new "Charging Id" as per normal procedures.

When multiple simultaneous PDN connections are established for a given APN, each PDN connection is associated with its own "PDN connection charging identifier" or "unique Charging Id" and processed independently from the other PDN connections.

When a "MAPCON capable UE", as defined in TS 23.402 [209], has simultaneous PDN connections through different access networks, each PDN connection is associated with its own "PDN connection charging identifier" or "unique charging Id" over the selected access for the PDN connection. When selective transfer of PDN connections between the different accesses is performed, each PDN connection is transferred, as for a single PDN connection.

When an "IFOM capable UE", as defined in TS 23.402 [209], is simultaneously connected to 3GPP access and WLAN access for different IP flows within the same PDN connection, each service data flow is uniquely identified by a PCC Rule within the PDN connection.

For a PDN connection with NBIFOM support, a "PDN connection charging identifier" is assigned for the PDN connection and is shared by all the IP-CAN bearers for the present as well as for any future accesses used during the PDN connection. Additional IP-CAN bearers (i.e. dedicated bearers as well as any additional default bearer in a new access) which may be activated during this PDN connection, are each assigned with their own "IP-CAN bearer charging identifier."

The "PDN connection charging identifier" shall remain unchanged and be used by all serving nodes for the entire IP-CAN session. When a serving node is changed, e.g. when UE moves PDN connection between LTE and WLAN or when serving gateway relocation is performed, the individual bearer charging identifiers shall be maintained as for a single-access PDN connection.

When SIPTO function applies, as defined in TS 23.060 [201] and TS 23.401 [208] the standard charging behaviour for PDN connection activation/deactivation applies on the respective GW.

For inter-level correlation when charging per IP-CAN session is not active, the charging identifier assigned to the specific bearer serves as the PS domain access network charging identifier used for a dynamic PCC rule. For inter-level correlation when Charging per IP-CAN session is active, the charging identifier assigned to the PDN connection serves as the PS domain access network charging identifier used for a dynamic PCC rule. Transport of PS domain access network charging identifier to an external application function are specified in TS 29.212 [216].

With NBIFOM, specific service data flows can be moved from one access to another. The transfer of the service data flow to the other access causes it to be bound to another bearer (either existing or to be created). When Charging per IP-CAN session is not active, the flow is then using a bearer with a charging identifier which would be different than that originally notified to the application function for inter-level correlation. To maintain a single access network charging identifier for inter-level correlation, when NBIFOM is accepted for a PDN connection, then the charging identifier assigned to the PDN connection serves as the PS domain access network charging identifier used for a dynamic PCC rule.

NOTE: When Charging per IP-CAN session is active the "PDN connection charging identifier" remains unchanged so the information provided to the application function remains unchanged throughout the IP-CAN session.

For non-IP data, the PDN connection established with an unique IP-CAN bearer as specified in TS 23.401 [208], is assigned with an "unique Charging Id" by the P-GW.

5.1.4 UE presence in Presence Reporting Area (PRA)

5.1.4.1 Single Presence Reporting Area (PRA)

The Single Presence Reporting Area is not supported.

Non-support of single Presence Reporting Area is determined by the release included in *Service-Context-Id* AVP.

5.1.4.2 Multiple Presence Reporting Areas (PRAs)

UE presence in multiple presence reporting area (s) charging information, as defined in TS 23.401 [208] and TS 23.203 [215], is collected for each UE by S-GWs, P-GWs which are serving that UE.

During IP-CAN session establishment/modification, and independently from the PCRF, the OCS may provide to the P-GW, a list of:

- Presence Reporting Area (PRA) Identifiers to be activated for Core Network pre-configured Presence Reporting Areas,
- Presence Reporting Area (PRA) Identifiers and their elements for UE-dedicated Presence Reporting Areas.

By providing the corresponding above lists in Presence-Reporting-Area-Information AVP(s), the OCS subscribes to the notifications of change of UE presence status in the PRA(s) through the Trigger-Type AVP. UE presence status in the PRA(s) describes whether the UE is entering or leaving Presence Reporting Area (s) and if the corresponding Presence Reporting Area(s) is set to inactive by the serving node.

The OCS may change the notifications of whether the UE is entering or leaving Presence Reporting Area (s) through Trigger-Type AVP in a CCA, with the Presence-Reporting-Area-Information AVP(s) to replace previous provided list.

The OCS may unsubscribe to the change of UE presence in Presence Reporting Area through Trigger-Type AVP in a CCA without the value of CHANGE_OF_UE_PRESENCE_IN_PRESENCE_REPORTING_AREA_REPORT (73), if it has been provided in the previous CCA.

The UE presence initial status in the PRA(s) at the time of the subscription shall be reported by the P-GW to the OCS for online charging in Debit / Reserve Units Request[Update] when the subscription is activated. The UE presence initial status in the PRA(s) at the time of the subscription shall be reported by the S-GW and P-GW for offline charging in Charging Data Request[Start] / [Interim] when the subscription is activated. Subsequently, whether the UE enters or leaves the PRA(s), shall be reported by the P-GW to the OCS for online charging, and by the S-GW and P-GW for offline charging.

When a PRA set i.e. PRA Identifier was subscribed to, the SGW/PGW additionally receives the PRA Identifier of the PRA set from the serving node, along with the individual PRA Identifier(s) belonging to the PRA set and indication(s) of whether the UE is inside or outside the individual Presence Reporting Area(s) , as described in TS 23.401 [208]. Only the individual PRA Identifier(s) belonging to the PRA set and UE presence status(es) are reported to the OCS according to the corresponding subscription.

For offline charging, the initial status of UE presence in the PRA(s) shall be captured in current counts and reported on first charging event. For online charging, this initial status shall be reported when received by the PCEF if quota have already been requested for the service usage, otherwise this initial status shall be reported on the first quota request.

For PRA(s) subscribed-to by the OCS, the PRA(s) and their UE presence status(es) which are reported to OCS are captured in offline charging from P-GW, with an indication for each PRA, the PRA was subscribed-to by OCS.

For PRA(s) subscribed-to by the PCRF, the PRA(s) and their UE presence status(es) which are reported to PCRF are captured in offline charging from P-GW, with an indication for each PRA, the PRA was subscribed-to by PCRF.

In the S-GW the PRA(s) and their UE presence status(es) are captured in offline charging without any differentiation between OCS and PCRF subscription, since the S-GW is unaware about this difference.

5.1.5 3GPP PS Data Off

When 3GPP PS Data off is activated by the user, PGW prevents downlink traffic except for 3GPP PS Data Off Exempt Services. The 3GPP PS Data Off Exempt Services are a set of operator services, defined in TS 22.011 [102]. And if 3GPP PS Data Off is activated, the UE prevents the sending of uplink IP packets except those related to 3GPP PS Data Off Exempt Services, based on the pre-configured list of Data Off Exempt Services.

The UE reports its 3GPP PS Data Off status in PCO (Protocol Configuration Option) to PGW during Initial Attach procedure and report a change of its 3GPP PS Data Off status in PCO by using Bearer Resource Modification procedure, described in TS 23.401 [208]. The 3GPP PS Data Off status is sent transparently through the MME and the Serving GW from UE to PGW. If the PGW detects that the 3GPP PS Data Off Status has changed, the PGW shall indicate this event to the charging system for offline and online charging.

5.1.6 Flexible Mobile Service Steering

The PGW/PCEF/TDF shall send the Traffic Steering Policy Identifier which has been used by the PGW/PCEF/TDF for sending the service data flow to a specific set of service functions(based on the PCC rule), to the offline charging system for information.

5.2 PS domain offline charging scenarios

5.2.1 Basic principles

5.2.1.0 General

In order to provide the data required for the management activities outlined in TS 32.240 [1] (billing, accounting, statistics etc.), the SGSN shall be able to produce CDRs, and the MME, S-GW, ePDG, TWAG, P-GW and TDF shall be able to produce CDRs or report charging events for CDRs generation by CDF, as specified for each node type in the following:

- Charging data related to IP-CAN bearers in the SGSN (S-CDR), S-GW (SGW-CDR), ePDG (ePDG-CDR), TWAG (TWAG-CDR) and P-GW (PGW-CDR);
- Charging data related to service data flows in the P-GW (PGW-CDR);
- Charging data related to MM contexts (Mobile Station Mobility Management Data) in SGSN (M-CDR);
- SMS Mobile Originated data (S-SMO-CDR) and SMS Mobile Terminated Data (SMS-SMT-CDR) in the SGSN;
- Charging data related to mobile originated location requests (LCS-MO-CDR), mobile terminated location request (LCS-MT-CDR), and network induced location request (LCS-NI-CDR) passing through the SGSN;
- Charging data related to MBMS bearer contexts (S-MB-CDR, G-MB-CDR, and MBMS-GW-CDR).
- SMS Mobile Originated data (S-SMO-CDR) and SMS Mobile Terminated Data (S-SMT-CDR) in the MME;
- Charging data related to TDF session (TDF-CDR) in the TDF;
- Charging data related to application traffic in the TDF (TDF-CDR).

The contents and purpose of each of these CDRs, as well as the chargeable events that trigger CDR creation, information addition, or closure are described in the following clauses. A detailed formal description of the CDR parameters defined in the present document is to be found in TS 32.298 [51].

When the CDF is implemented as a separate entity (for the MME, S-GW, ePDG, TWAG, P-GW and TDF), the charging events triggering and contents for CDRs handling by the CDF, are described in clause 5.2.2.

5.2.1.1 IP-CAN bearer charging

SGSN, ePDG, TWAG, P-GW, and S-GW collect charging information per user per IP-CAN bearer. In case of P-GW is not aware of IP-CAN bearers, i.e. in case of PMIP based connectivity, P-GW collects charging information per IP-CAN session as it would be one IP-CAN bearer. IP-CAN bearer charging allows the PCNs to collect charging information related to data volumes sent to and received by the UE/MS, categorised by the QCI and ARP applied to the IP-CAN bearer. The user can be identified by MSISDN and/or IMSI, while the IP-CAN bearer can be determined by a unique identifier generated by the P-GW when creating a IP-CAN bearer. This identifier is also forwarded to the S-GW/ ePDG/ TWAG/SGSN so as to allow correlation of S-GW/ ePDG/ TWAG/SGSN IP-CAN bearer CDRs with the matching P-GW CDRs in the BD.

NOTE1: The control plane IP address of SGSN or P-GW(acting as GGSN) is the IP address used at Gn/Gp interface.

The control plane IP address of S-GW or P-GW is the IP address used at S5/S8 interface.

The control plane IP address of ePDG or P-GW is the IP address used at S2b interface.

The control plane IP address of TWAG or P-GW is the IP address used at S2a interface.

IP-CAN bearer specific offline charging in P-GW, is achieved by FBC offline charging, with specific rating group/service identifier, see clause 5.2.1.3.

The main collected information items are duration of the IP-CAN bearer and data volume transferred during the lifetime of the IP-CAN bearer. The following chargeable events are defined for SGSN, S-GW, ePDG and TWAG IP-CAN bearer charging:

- Start of IP-CAN bearer. Upon encountering this event, a new CDR for this IP-CAN bearer is created and the data volume is captured for the IP-CAN bearer.
- Access of a multi-access PDN connection becomes unusable: when this event is encountered, the current volume count is captured for the IP-CAN bearer of the unusable access.
- Access of a multi-access PDN connection becomes usable: when this event is encountered, new volume counts are started for the IP-CAN bearer of the access that has become usable.
- End of IP-CAN bearer in the SGSN/S-GW/ePDG/TWAG. The CDR is closed upon encountering this trigger.
- Tracking Area Update of:
 - Inter-SGSN/inter S-GW. The IP-CAN bearer CDR is closed in SGSN/S-GW upon encountering this trigger.
 - Inter-MME. In S-GW a new MME address is added to CDR upon encountering this trigger.
 - S4-SGSN to MME. In S-GW a new MME address is added to CDR upon encountering this trigger.
 - MME to S4-SGSN. In S-GW a new S4-SGSN address is added to CDR upon encountering this trigger.
- Intersystem change (e.g. change of radio interface from GSM to UMTS or vice versa). This event closes the CDR. A new one is opened if the IP-CAN bearer is still active.
- PLMN change visible in the P-GW. This event closes the CDR. A new one is opened if the IP-CAN bearer is still active.
- MS Timezone change visible in the P-GW. This event closes the CDR. A new one is opened if the IP-CAN bearer is still active.
- Expiry of an operator configured time limit per IP-CAN bearer. This event closes the CDR, and a new one is opened if the IP-CAN bearer is still active.
- Expiry of an operator configured data volume limit per IP-CAN bearer. This event closes the CDR, and a new one is opened if the IP-CAN bearer is still active.
- Change of charging condition in the SGSN: e.g. QoS change, tariff time change, user CSG information change or direct tunnel establishment/removal. When this event is encountered, the current volume count is captured and a new volume count is started.
- Change of charging condition in the S-GW: e.g. QoS change, tariff time change, user location change, user CSG information change, change of UE presence in Presence Reporting Area(s), change in User Plane to UE, Serving

PLMN Rate Control change. When this event is encountered, the current volume counts are captured and a new volume counts are started.

- MO exception data counter receipt in the S-GW: This event closes the CDR. A new one is opened if the IP-CAN bearer is still active.
- Change of charging condition in the ePDG: e.g. QoS change, tariff time change. When this event is encountered, the current volume counts are captured and a new volume counts are started.
- Change of charging condition in the TWAG: e.g. QoS change, tariff time change. When this event is encountered, the current volume counts are captured and a new volume counts are started.
- Expiry of an operator configured change of charging condition limit per IP-CAN bearer. This event closes the CDR, and a new one is opened if the IP-CAN bearer is still active.
- Management intervention may also force trigger a chargeable event.

When the CDF is implemented as a separate entity, all these chargeable events defined for IP-CAN bearer, trigger charging events reporting, for CDRs (S-GW, ePDG, TWAG and P-GW CDRs) to be constructed, enriched or closed by CDF, according to description in clause 5.2.2.

NOTE 2: For non-IP type PDN connection in the S-GW:

- Access of a multi-access PDN connection does not apply;
- Mobility occurs between MMEs.

5.2.1.2 MM context charging

The SGSN collects charging information for mobility management actions per attached UE/MS, i.e. per user. The user can be identified by MSISDN and/or IMSI. There can be only one MM context per UE/MS at a time, and only the SGSN is involved. Therefore there is no need for special MM context identifiers. The main information items collected are changes of location pertaining to the UE/MS. The following chargeable events are defined for MM context charging:

- Start of MM context (UE/MS attaches to a SGSN). A new M-CDR is created upon encountering this event.
- End of MM context: explicit or implicit GPRS detach, including SGSN change (inter-SGSN routing area update including intersystem change). This event triggers the closure of the M-CDR.
- Mobility Change, i.e. a change in the Routing Area. The new location information is captured for the M-CDR.
- Expiry of an operator configured time limit. This event triggers the closure of the M-CDR.
- Expiry of an operator configured mobility change limit. This event triggers the closure of the M-CDR.
- Intra-SGSN intersystem change (change of radio interface from GSM to UMTS or vice versa). This event triggers the closure of the M-CDR.

Management intervention may also force trigger a chargeable event.

5.2.1.3 Flow Based bearer Charging (FBC)

IP-CAN bearer charging allows the P-GW to collect charging information related to data volumes sent to and received by the UE/MS, categorised by the QoS applied to the IP-CAN bearer. FBC is supported by the P-GW by the integration of a PCEF. With PCEF, the normal IP-CAN bearer charging is enhanced by the capability to categorise the service data flows within IP-CAN bearer data traffic by rating group or combination of the rating group and service id, i.e., while there is only one uplink and one downlink data volume count per IP-CAN bearer in IP-CAN bearer charging, FBC provides one count per each rating group or combination of the rating group and service id. In case that sponsored connectivity level reporting is active, FBC categorise within IP-CAN bearer data traffic by combination of rating group, sponsor identity and application service provider identity. The level of the reporting is defined per PCC rule. Details of this functionality are specified in TS 23.203 [215] and TS 32.240 [1].

NOTE: The P-GW can only include one QoS Information occurrence per service data container. This implies if an operator wishes to be able to separate usage according to QCI and ARP within their billing system they will need to ensure that services having different QCI and ARP do not have the same:

- rating group in cases where rating reporting is used;
- rating group/service id where rating group/service id reporting is used;
- rating group/sponsor identity/application service provider identity where sponsored connectivity level reporting charging is used.

IP-CAN bearer specific offline charging is achieved with IP-CAN bearer specific rating group/service identifier defined in clause 5.3.1.1.

According to TS 23.203 [215], FBC shall support different charging models per PCC rule. These charging models may be based on volume and/or time and on number of events matching a specific service data flow template in PCC rule. In general the charging of a service data flow shall be linked to the IP-CAN bearer under which the service data flow has been activated. The following chargeable events are defined for FBC:

- Start of IP-CAN bearer. Upon encountering this event, a new PGW-CDR for this context is created.
- Start of service data flow. If service identifier level reporting is required by the PCC rule new counts and time stamps for this combination of the rating group and service id are started. If rating group level reporting is required by the PCC rule needed new counts and time stamps for this rating group are started. If sponsored connectivity level reporting is required by the PCC rule needed new counts and time stamps for this rating group, sponsor identity and application service provider identity are started. The type of counters shall depend on the measurement method configured for the PCC rule. When event based charging applies, the first occurrence of an event matching a service data flow template in PCC rule shall imply that a new count is started. When new events occur, the counter shall be increased. Each event shall be time stamped.
- Termination of service data flow. If service identifier level reporting is required by the PCC rule and this was the last active service data flow for this combination of the rating group and service id or if rating group level reporting is required by the PCC rule and this was the last active service data flow for this rating group, or if sponsored connectivity level reporting is required by the PCC rule and this was the last active service data flow for this combination of rating group, sponsor identity and application service provider identity, the counters and time stamps are closed and added to the PGW-CDR. For information on how the termination of service data flows is detected, refer to TS 23.203 [72].
- Access of a multi-access PDN connection becomes unusable: the Termination of service data flow chargeable event applies for all the service data flows carried under the IP-CAN bearer of the unusable access.
- Access of a multi-access PDN connection becomes usable: the Start of service data flow chargeable event applies for all the service data flows carried under the IP-CAN bearer of the access that has become usable.
- End of IP-CAN bearer in the P-GW. The PGW-CDR is closed upon encountering this trigger.
- Serving node (e.g. SGSN/S-GW/ePDG/TWAG) change in the P-GW. New SGSN/S-GW/ePDG/TWAG address is added to PGW-CDR.
- Expiry of an operator configured time limit per IP-CAN bearer. This event closes the PGW-CDR, and a new one is opened if the IP-CAN bearer is still active.

- Expiry of an operator configured time limit per rating group. The counters and time stamps are closed and added to the PGW-CDR. A new service data flow container is opened if any matching service data flow is still active.
- Expiry of an operator configured data volume limit per IP-CAN bearer. This event closes the PGW-CDR, and a new one is opened if the IP-CAN bearer is still active.
- Expiry of an operator configured data volume limit per rating group. The counters and time stamps are closed and added to the PGW-CDR. A new service data flow container is opened if any matching service data flow is still active.
- Expiry of an operator configured data event limit per rating group. The counters and time stamps are closed and added to the PGW-CDR. A new service data flow container is opened if any matching service data flow is still active.
- Change of charging condition: IP-CAN bearer modification (e.g. QoS change, SGSN change, S-GW change, user location change, user CSG information change, change of UE presence in Presence Reporting Area(s), change of 3GPP PS Data Off status, Serving PLMN Rate Control change, APN Rate Control change), tariff time change or failure handling procedure triggering. When this event is encountered, all current configured counts and time stamps are captured and new counts and time stamps for all active service data flows are started.
- Intersystem change (e.g. change of radio interface from GSM to UMTS, RAT change) visible in the P-GW. This event closes the PGW-CDR, and a new one is opened if the IP-CAN bearer is still active.
- PLMN change visible in the P-GW. This event closes the PGW-CDR. A new one is opened if the IP-CAN bearer is still active.
- MS Timezone change visible in the P-GW. This event closes the PGW-CDR. A new one is opened if the IP-CAN bearer is still active.
- MO exception data counter receipt in the P-GW: This event closes the CDR. A new one is opened if the IP-CAN bearer is still active.
- SGSN change in the P-GW. New SGSN address is added to PGW-CDR.
- Expiry of an operator configured report of service flow data limit per IP-CAN bearer. This event closes the PGW-CDR, and a new one is opened if the IP-CAN bearer is still active.
- Completion of a time envelope as defined in TS 32.299 [50]. This event closes a service data flow container. Further details are described in clause 5.2.3.4.1 "Triggers for PGW-CDR Charging Information Addition". The need for reporting time envelopes may be statically configured for each rating group or dynamically controlled by online charging.

Management intervention may also force trigger a chargeable event.

Relevant service data flows for a certain IP-CAN bearer are determined when FBC is applied. PCC rules are used for this determination. One PCC rule identifies service data flow to be measured but it can also include certain characteristics related to that service data flow.

PCC rules can be activated, deactivated and modified any time during the IP-CAN bearer lifetime. PCC rule activation, deactivation and modification are not chargeable events. However these PCC rule changes may lead to "start of service data flow" and "termination of service data flow" chargeable events.

A PCC rule can contain e.g.:

- service data flow template (service data flow filters or application identifier) to identify packets belonging to certain service data flow,
- charging method to identify whether online/offline/both/neither charging interface is used,
- measurement method for offline charging to identify whether time/volume/events are measured for this service data flow,
- Charging key (i.e. rating group) for that service data flow,
- service identifier for that service data flow,

- Sponsor Identifier (offline charging only),
- Application Service Provider Identifier (offline charging only),
- application function record information to correlate the measurement with application level reports,
- reporting level for the service data flow (rating group, combination of the rating group and service id or combination of the rating group, sponsor identity and application service provider identity),
- precedence to the situations where two or more PCC rules are overlapping,
- allowed access type (for NBIFOM control) See clause 5.2.1.7A..

PCC rules can be:

- pre-defined in P-GW (can be activated either by the PCRF or PCEF itself) or,
- dynamically provisioned and activated by the PCRF over the Gx interface.

This is specified in TS 23.203 [215] and TS 29.212 [216].

According to TS 23.203 [215], the PCRF can modify the following charging information in a dynamic PCC rule which is active in the PCEF: Charging key, Service identifier, Sponsor Identifier, Application Service Provider Identifier, Measurement method, and reporting level. The PCRF can also modify the allowed access type in the case of NBIFOM.. A change of any of this charging or allowed access type information will trigger a "start of service data flow" chargeable event when a valid counter does not exist corresponding to that changed PCC rule. A change of any of this charging or allowed access type information will trigger a "termination of service data flow" chargeable event when this was the last active service data flow for the counter corresponding to the original PCC rule.

When the CDF is implemented as a separate entity, all these FBC related chargeable events, trigger charging events reporting, for P-GW CDRs to be constructed, enriched or closed by CDF, according to description in clause 5.2.2.

Extended packet inspection can be done in the PCEF with pre-defined PCC rules. The PCEF also have the possibility to output service specific information related to the packet inspection in the CDR.

The capability of P-GW to support ABC is achieved with PCRF providing appropriate PCC rules to the P-GW. Such PCC Rule shall be defined with service data flow template including an Application Identifier for the application which needs to be detected, enforced and charged.

For non-IP type PDN connection in the P-GW:

- non-3GPP access types are not supported, a multi-access PDN connections do not apply;
- A single PCC Rule is used with the service data flow descriptor matching the whole non-IP data traffic, and can contain e.g.:
 - service data flow template matching all the packets;
 - charging method to identify whether online/offline/both/neither charging interface is used;
 - measurement method for offline charging to identify whether time/data volume/events are measured for this service data flow;
 - Charging key (i.e. rating group) for that service data flow;
 - service identifier for that service data flow;
 - reporting level for that service data flow:
 - rating group level in case a specific rating group is used for non-IP traffic charging;
 - combination of the rating group and service id in case a specific rating group/service Id is used for non-IP traffic charging.

5.2.1.4 SMS charging

The SGSN and the MME collect charging information for each Short Message sent to, or received by, a MS/UE. There are two chargeable events for SMS charging in the SGSN and MME:

- the transfer of a SM through the SGSN and MME in MO direction;
- the transfer of a SM through the SGSN and MME in MT direction.

Management intervention may also force trigger a chargeable event.

5.2.1.5 LCS charging

The SGSN collects charging information for each Location Request for a MS/UE. The following chargeable events are specified for LCS:

- A location request for a MS/UE triggered by that MS/UE (LCS-MO);
- A location request for a MS/UE triggered by an external entity (LCS-MT);
- A location request for a MS/UE triggered by the network (LCS-NI).

Management intervention may also force trigger a chargeable event.

5.2.1.6 MBMS context charging for GPRS

The SGSN and GGSN collects charging information for each MBMS bearer service activated.

The following chargeable events are specified for MBMS:

- Start of MBMS bearer context. Upon encountering this event, a new CDR for this MBMS bearer context is created and the data volume is captured for the MBMS bearer context.
- End of MBMS bearer context in the SGSN/GGSN. For the SGSN only, this trigger includes inter-SGSN routing area update (e.g. the last UE using the MBMS bearer context leaves the routing area). The MBMS bearer context CDR is closed upon encountering this trigger.
- Expiry of an operator configured time limit per MBMS bearer context. This event closes the MBMS bearer context CDR, and a new one is opened if the MBMS bearer context is still active.
- Expiry of an operator configured data volume limit per MBMS bearer context. This event closes the MBMS bearer context CDR, and a new one is opened if the MBMS bearer context is still active.
- Change of charging condition: tariff time change. When this event is encountered, the current volume count is captured and a new volume count is started.
- Expiry of an operator configured change of charging condition limit per MBMS bearer context. This event closes the MBMS bearer context CDR, and a new one is opened if the MBMS bearer context is still active.

Management intervention may also force trigger a chargeable event.

5.2.1.6A MBMS context charging for EPS

In EPS, MBMS GW is the function entity which may be stand alone or co-located with other network elements such as BM-SC or combined S-GW/PDN-GW. The MBMS GW collects charging information for each MBMS bearer service activated. The following chargeable events are specified for MBMS:

- Start of MBMS bearer context. Upon encountering this event, a new CDR for this MBMS bearer context is created and the data volume is captured for the MBMS bearer context.
- End of MBMS bearer context in the MBMS GW.
- Expiry of an operator configured time limit per MBMS bearer context. This event closes the MBMS bearer context CDR, and a new one is opened if the MBMS bearer context is still active.
- Expiry of an operator configured data volume limit per MBMS bearer context. This event closes the MBMS bearer context CDR, and a new one is opened if the MBMS bearer context is still active.
- Change of charging condition: tariff time change. When this event is encountered, the current volume count is captured and a new volume count is started.
- Expiry of an operator configured change of charging condition limit per MBMS bearer context. This event closes the MBMS bearer context CDR, and a new one is opened if the MBMS bearer context is still active.

Management intervention may also force trigger a chargeable event.

The MBMS control plane function is supported by MME for E-UTRAN access and by SGSN for UTRAN access.

5.2.1.7 IP Flow Mobility (IFOM) charging

An "IFOM capable UE", as defined in TS 23.402 [209], may be simultaneously connected to 3GPP access and WLAN access for different IP flows within the same PDN connection, as described in TS 23.261 [212].

In the P-GW, FBC (as described in clause 5.2.1.3) applies to the corresponding service data flows, carried by appropriate IP-CAN bearer(s) activated for both accesses.

For a PDN connection, charging for each service data flow, is performed within the IP-CAN bearer charging session of the IP-CAN bearer it belongs to, according to its associated PCC Rule.

As described in TS 23.261 [212], the UE may also move one or more IP flow(s) from 3GPP access to WLAN access (and reversely). The transfer of the corresponding service data flow(s) from one access to the other access, results in PCC Rule(s) removed from the IP-CAN bearer(s) of the source access, leading to termination of service data flow", and PCC Rule(s) installed into the IP-CAN bearer(s) of the target access.

For each service data flow, identified by its PCC Rule, this PCC Rule may be provided with a different description depending on the access type where it has to be enforced. In particular, the rating group may differ, as a way to apply charging differentiation per-access type. The charging method, measurement method, reporting level may also potentially be different, in case charging behaviour is not expected to be unified between both domains.

In order to ensure the accurate level of granularity of service data flows charging, the associated PCC Rule shall be defined with the service identifier level reporting.

For the case where dynamic PCC is not deployed, per-access Charging Characteristics and pre-defined PCC Rule(s) in P-GW may be used as a way to apply charging differentiation.

5.2.1.7A Network-Based IP Flow Mobility (NBIFOM) charging

To support Network-Based IP Flow Mobility (NBIFOM), multi-radio (i.e. 3GPP and WLAN) capable UEs establish and maintain a PDN connection over both 3GPP access and WLAN access simultaneously for both S2b and S2a connectivity, as specified in TS 23.161 [242]. When such a multi-access PDN connection is established, there is one default bearer for each access. On a multi-access PDN connection established over both 3GPP access and WLAN access, it is possible to move individual IP flows from one access network to another, when policies determine that flows should be moved and the target access is available for the UE. As described in TS 23.203 [215], it shall be possible to apply different rates depending on the access used to carry a service data flow.

For a multi-access PDN connection, IP-CAN bearer charging as defined in clause 5.2.1.1 and FBC as defined in clause 5.2.1.3 apply for each bearer under each access for this PDN connection, and IP-CAN bearer charging as defined in clauses 5.2.1.10.1 and FBC as defined in clauses 5.2.1.10.2 apply when charging per IP-CAN session is active for this PDN connection, based on:

- Establishment of a multi-access PDN connection and addition of access to a multi-access PDN connection result in the default bearer and potential dedicated bearer(s) creation for this access, to carry the service data flows based on PCC Rule(s).
- Release of a multi-access PDN connection and removal of an access from a multi-access PDN connection result in release of all the IP-CAN bearer(s) for this access.
- Access change for service data flow(s), results in corresponding PCC Rule(s) removed from the IP-CAN bearer(s) of the source access, and PCC Rule(s) installed into the IP-CAN bearer(s) of the target access.
- Access of a multi-access PDN connection becomes unusable: for the service data flows maintained as result from PCC Rules decision, under the IP-CAN bearer that becomes unusable, no traffic will be detected.
- Access of a multi-access PDN connection becomes usable: for the service data flows which were maintained as result from PCC Rules decision under the IP-CAN bearer when detected as usable, the new traffic will be counted.

For each service data flow, identified by its PCC Rule, a different access type is specified where it has to be enforced. A different rating group may be used as a way to apply charging differentiation per-access type. The charging method, measurement method, reporting level may also potentially be different, in case charging behaviour is not expected to be unified between both domains.

For the case where dynamic PCC is not deployed, per-access Charging Characteristics and pre-defined PCC Rule(s) in P-GW may be used as a way to apply charging differentiation.

5.2.1.8 Sponsored data connectivity charging

According to TS 23.203 [215] two deployment scenarios exist for sponsored data connectivity. The Sponsor Identifier and Application Service Provider Identifier are provided for sponsored services to the PCRF from the AF over the Rx interface.

In the first scenario the PCRF assigns a service specific Charging Key (i.e. charging group) for a sponsored IP flow. The Charging Key is used by the PCEF to collect separate charging information for offline charging for the sponsored flows. Correlation of charging information for offline charging from multiple users per sponsor and/or application service provider is then performed using the Charging Key.

In a second scenario the Sponsor Identifier and Application Service Provider Identity is included in PCC-rules from the PCRF to the PCEF. For this scenario, the same Charging Key may be used both for IP flows that are sponsored and for flows that are not sponsored. Charging information generated by the PCEF for offline charging include the Sponsor Identity and the Application Service Provider Identity. Correlation of charging information from multiple users per sponsor and/or application service provider can then be based on Sponsor Identity and Application Service Provider Identity instead of the Charging Key.

5.2.1.9 Application Based Charging (ABC)

5.2.1.9.0 Introduction

For the sub-clauses that follow, a single CDR is defined to handle both TDF session and ABC information when both are to be used. Either TDF session charging, ABC or both may be active as determined by Charging Characteristics. For ABC the opening and closing of CDRs is bound to the TDF session start and end respectively. Many application containers per TDF session can be active simultaneously within the TDF CDR see clause 5.2.3.9.1.

When the CDF is implemented as a separate entity, all of these TDF session and ABC related chargeable events, trigger charging events reporting, for CDRs to be constructed, enriched or closed by CDF, according to clause 5.2.2.

5.2.1.9.1 Charging per application

ABC allows collection of charging information for network usage of application traffic, categorized within the TDF session by rating group or combination of rating group and service identifier. ABC supported by TDF is based on ADC rules. Details of this functionality are specified in TS 23.203 [215].

NOTE: ABC is supported by the P-GW embedding PCEF enhanced with application detection and control functionality as defined in TS 23.203 [215], by mean of appropriate PCC Rules, and therefore specified under FBC clause 5.2.1.3 and clause 5.2.1.10.2.

According to TS 23.203 [215], ABC shall support different charging models per ADC rule. These charging models may be based on volume and/or time and on number of event matching specific detected application traffic in ADC rule. The following chargeable events are defined for ABC when offline charging is activated:

- Start of TDF session. Upon encountering this event, a new TDF-CDR for this context is created.
- Start of application traffic. If service identifier level reporting is required by the ADC rule, new counts and time stamps for this combination of the rating group and service identifier are started. If rating group level reporting is required by the ADC rule new counts and time stamps for this rating group are started. The type of counters shall depend on the measurement method configured for the ADC rule. When event based charging applies, the first occurrence of an event detected by the pre-defined ADC rules shall imply that a new count is started. When new events occur, the counter shall be increased. Each event shall be time stamped.
- Termination of application traffic. If service identifier level reporting is required by the ADC rule or if rating group level reporting is required by the ADC rule, the counters and time stamps are closed and added to the TDF-CDR.
- End of TDF session in the TDF. The TDF-CDR is closed upon encountering this trigger.
- Expiry of an operator configured time limit for keeping a CDR open. This event closes all counters. The resulting containers are data to the CDR and the CDR is closed. A new CDR is opened if the TDF session is still active.
- Expiry of an operator configured time limit per rating group. The counters and time stamps are closed and added to the TDF-CDR. A new application traffic container is opened if any application related to the rating group is still active.
- Expiry of an operator configured data volume limit per TDF session. This event closes the TDF-CDR, and a new one is opened if the TDF session is still active.
- Expiry of an operator configured data volume limit per rating group. The counters and time stamps are closed and added to the TDF-CDR. A new one is opened if any application related to the rating group is still active.
- Expiry of an operator configured data event limit per rating group. The counters and time stamps are closed and added to the TDF-CDR. A new one is opened if any application related to the rating group is still active.
- Expiry of an operator configured data event limit per TDF session. This event closes the TDF-CDRs, and new one is opened if the TDF session is still active.
- Change of charging condition: TDF session modification (e.g. SGSN change, S-GW change, user location change, user CSG information change), tariff time change or failure handling procedure triggering. When this

event is encountered, all current configured counts and time stamps are captured and new counts and time stamps for all active applications are started.

- Intersystem change (e.g. change of radio interface from GSM to UMTS, RAT change) visible in the TDF. This event closes the TDF-CDR, and a new one is opened if the TDF session is still active.
- PLMN change visible in the TDF. This event closes the TDF-CDR. A new one is opened if the TDF session is still active.
- MS Timezone change visible in the TDF. This event closes the TDF-CDR. A new one is opened if the TDF session is still active.
- Completion of a time envelope as defined in TS 32.299 [50]. This event closes an application traffic container. Further details are described in clause 5.2.3.9.2 "Triggers for TDF-CDR Charging Information Addition". The need for reporting time envelopes may be statically configured for each rating group or dynamically controlled by online charging.

Management intervention may also force trigger a chargeable event.

ADC rules can be activated, deactivated and modified any time during the TDF session lifetime. ADC rule activation, deactivation and modification are not chargeable events of ABC. However these rule changes may lead to "start of application traffic" and "termination of application traffic" chargeable events.

Application Detection and Control rule can contain e.g.:

- Application Identifier to identify or service data flow filters to identify the packets belonging to an application detected application,
- charging method to identify whether online/offline/both/neither charging interface is used,
- measurement method for online/offline charging to identify whether time/volume/events are measured for this application,
- Charging key (i.e. rating group) for that application,
- service identifier for that application,
- reporting level for the application (rating group or combination of the rating group and Service identifier),
- precedence to the situations where two or more ADC rules are overlapping.

Application Detection and Control rule can be:

- pre-defined in TDF (can be activated by the PCRF) or,
- dynamically provisioned and activated by the PCRF over the Sd interface.

This is specified in TS 23.203 [215] and TS 29.212 [216].

According to TS 23.203 [215], the PCRF can modify the following charging information in a dynamic ADC rule: Charging key, Service identifier, Measurement method, and Service identifier level reporting. A change of any of this charging information triggers a "start of application traffic" chargeable event when a valid counter does not exist corresponding to that changed ADC rule. A change of any of this charging information triggers a "termination of application traffic" chargeable event when this was the last active application for the counter corresponding to the original ADC rules.

5.2.1.9.2 Charging per TDF session

TDF collects charging information per user per TDF session. TDF session charging allows the TDF to collect charging information related to data volumes sent to and received by the UE/MS for the timeframe since the establishment till the termination of TDF session. The user can be identified by MSISDN and/or IMSI, while the TDF session can be determined by a unique identifier generated by the P-GW (an "EPS default bearer Charging Identifier" for GTP based connectivity or an "unique Charging Id" for PMIP based connectivity) when establishing TDF session.

TDF session specific offline charging in TDF is achieved by ABC offline charging, with a vendor specific rating group/service identifier associated with the TDF session. The main collected information items are duration of the TDF session and data volume transferred during the lifetime of the TDF session. When Charging per TDF session is active, the following chargeable events are defined:

- Start of TDF session. Upon encountering this event, a new TDF-CDR for this context is created.
- End of TDF session in the TDF. The TDF-CDR is closed upon encountering this trigger.
- Expiry of an operator configured time limit for keeping a CDR open. This event closes all counters. The resulting containers are data to the CDR and the CDR is closed. A new CDR is opened if the TDF session is still active.
- Expiry of an operator configured time limit per TDF session. This event closes the CDR, and a new one is opened if the TDF session is still active.
- Expiry of an operator configured data volume limit per TDF session. This event closes the TDF-CDR, and a new one is opened if the TDF session is still active.
- Change of charging condition: TDF session modification (e.g. SGSN change, S-GW change, user location change, user CSG information change), tariff time change or failure handling procedure triggering. When this event is encountered, all current configured counts and time stamps are captured and new counts and time stamps for all active applications are started.
- Intersystem change (e.g. change of radio interface from GSM to UMTS, RAT change) visible in the TDF. This event closes the TDF-CDR, and a new one is opened if the TDF session is still active.
- PLMN change visible in the TDF. This event closes the TDF-CDR. A new one is opened if the TDF session is still active.
- MS Timezone change visible in the TDF. This event closes the TDF-CDR. A new one is opened if the TDF session is still active.

Expiry of an operator configured change of charging condition limit per TDF session. This event closes the CDR, and a new one is opened if the TDF session is still active.

NOTE: All the events defined above are a shared events with ABC in clause 5.2.1.9.1 for the single shared CDR.

Management intervention may also force trigger a chargeable event.

5.2.1.10 Charging per IP-CAN session

5.2.1.10.0 General

Charging per IP-CAN session is an optional capability in the P-GW that provides for a consolidated view of the charging information across all bearers in the IP-CAN session. When charging per IP-CAN session is active, the basic principles in this clause apply to the P-GW instead of the principles in clause 5.2.1.1 and clause 5.2.1.3 above.

For the sub-clauses that follow, a single PGW-CDR is defined to handle both types of charging information when both are to be used. When Charging per IP-CAN session is active, either IP-CAN bearer charging, FBC or both may be active as determined by Charging Characteristics.

When the CDF is implemented as a separate entity, all of these IP-CAN bearer and FBC related chargeable events, trigger charging events reporting, for CDRs to be constructed, enriched or closed by CDF, according to description in clause 5.2.2.

5.2.1.10.1 IP-CAN bearer charging

For the purpose of interoperator charging, the P-GW collects charging information per user per IP-CAN bearer. In case the P-GW is not aware of IP-CAN bearers, i.e. in case of PMIP based connectivity, P-GW collects charging information per IP-CAN session as it would be one IP-CAN bearer. IP-CAN bearer charging allows the P-GW to collect charging information related to data volumes sent to and received by the UE/MS, categorised by the QCI and ARP applied to the IP-CAN bearer. The user can be identified by MSISDN and/or IMSI, while the IP-CAN bearer can be determined by a unique identifier generated by the P-GW when creating an IP-CAN bearer. This identifier is forwarded to the S-GW/ePDG/ TWAG/SGSN so as to allow correlation of S-GW/ePDG/ TWAG/SGSN IP-CAN bearer CDRs with the matching P-GW charging information in the BD.

The amount of data counted in P-GW shall be based on:

- in case of GTP based tunnelling and interworking with external IP networks; the inner IP packets in the GTP-U packet (T-PDU, see TS 29.281 [217])
- in case of GTP based tunnelling and interworking with external networks handling other data services (e.g. non-IP, PPP); the T-PDU packets (see TS 29.281 [217])
- In case of PMIP based protocol; the payload of the GRE tunnel
- In case of DSMIPv6 based protocol; the payload of the tunnelling layer.

As minimum behaviour, the full payload shall be included. Time metering is started when IP-CAN bearer is activated.

NOTE 1: The control plane address of the P-GW, together with the unique charging identifier assigned by the P-GW, enables the correlation of charging information. The control plane IP address of SGSN or P-GW (acting as GGSN) is the IP address used at Gn/Gp interface.
 The control plane IP address of S-GW or P-GW is the IP address used at S5/S8 interface.
 The control plane IP address of ePDG or P-GW is the IP address used at S2b interface.
 The control plane IP address of TWAG or P-GW is the IP address used at S2a interface.

When Charging per IP-CAN session is active and measurements for IP-CAN bearers are captured in the same CDR as FBC measurements, the following chargeable events are defined:

- Start of the default bearer for an IP-CAN session when single access is used or start of the first default bearer for a multi-access PDN connection (i.e., when NBIFOM is accepted by PCRF).
 Upon encountering this event, a new CDR for the IP-CAN session is created and the data volume counts (i.e., uplink and downlink) are started and captured for the IP-CAN bearer.

NOTE 2: Start of the default bearer or start of the first default bearer for an IP-CAN session is a shared event for FBC in clause 5.2.1.10.2 for the single shared CDR.

- Addition of access to a PDN connection.
 Additional volume counts are started and captured for IP-CAN bearers of the access. New SGSN/S-GW/ePDG/TWAG address is added to data for the IP-CAN bearer in the CDR.
- Start of a dedicated bearer for an IP-CAN session.
 Additional volume counts are started and captured for the dedicated bearer.

- End of dedicated bearer in the P-GW.
The counters and time stamps for the IP-CAN bearer are closed and resulting container added to the CDR.
- Removal of access from a multi-access PDN connection.
The counters and time stamps for the IP-CAN bearers of the removed access are closed and resulting containers added to CDR.
- Access of a multi-access PDN connection becomes unusable.
The counters and time stamps for the IP-CAN bearers of the unusable access are closed and resulting containers added to the CDR.
- Access of a multi-access PDN connection becomes usable.
New volume counts are started and captured for all bearers of the access that has become usable. These may not be the same as those that were previously active when the access became unusable due to changes in PCC Rules.
- End of IP-CAN session (i.e. end of the default bearer for a single access PDN connection or end of the last default bearer for a multi-access PDN connection) in the P-GW.
The counters and time stamps for all IP-CAN bearers and the resulting containers added to the CDR. The CDR is closed.

NOTE 3: The End of IP-CAN session event is a shared event for FBC in clause 5.2.1.10.2 for the single shared CDR.

- Serving node (e.g. SGSN/S-GW/ePDG/TWAG) change in the P-GW.
New SGSN/S-GW/ePDG/TWAG address is added to data for the IP-CAN bearer in the CDR.
- Expiry of an operator configured time limit for keeping a CDR open.
This event closes all counters. The resulting containers are added to the CDR and the CDR is closed.
A new CDR is opened if the IP-CAN session is still active.

NOTE 4: The expiry of an operator configured time limit for keeping a CDR open event is a shared event for FBC in clause 5.2.1.10.2 for the single shared CDR.

- Expiry of an operator configured time limit per IP-CAN bearer.
The counters and time stamps for the IP-CAN bearer are closed and added to the CDR. A new IP-CAN bearer traffic volume container is opened if the IP-CAN bearer is still active.
- Expiry of an operator configured data volume limit per IP-CAN session.
This event closes the CDR and a new one is opened if the IP-CAN session is still active.

NOTE 5: The expiry of an operator configured data volume limit per IP-CAN session event is a shared event for FBC in clause 5.2.1.10.2 for the single shared CDR.

- Expiry of an operator configured data volume limit per IP-CAN bearer.
The counters and time stamps are closed and added to the CDR. A new IP-CAN bearer traffic volume container is opened if the IP-CAN bearer is still active.
- Change of charging condition specific to APN-AMBR change.
This event closes the CDR, and a new one is opened if the IP-CAN session is still active.
- Change of charging condition specific to IP-CAN bearer modification QoS change.
When this event is encountered, all counts and time stamps for the modified bearer are captured and new counts and time stamps for the specific bearer are started.
- Change of charging condition.
IP-CAN bearer modification except QoS change (e.g. SGSN change, S-GW change, user location change, user CSG information change, change of UE presence in Presence Reporting Area(s) , change of 3GPP PS Data Off status), or tariff time change. When this event is encountered, all current configured counts and time stamps are captured and new counts and time stamps for all active bearers are started.
IP-CAN bearer modification except QoS change events are associated with one access of a multi-access PDN connection and all counts associated with affected access are identified with the specific event. All counts associated with the other access of a multi-access PDN connection are identified as an indirect change of charging condition.

Editor's Note: The handling of "Serving PLMN Rate Control change", "APN Rate Control change" events when charging per IP-CAN session applies is FFS.

NOTE 7: The change of charging condition event is a shared event for FBC in clause 5.2.1.10.2 for the single shared CDR.

Editor's Note: whether the special case of user location reporting on dedicated bearer release triggers a change of charging condition for the IP-CAN session is ffs.

- Intersystem change (e.g. change of radio interface from GSM to UMTS, RAT change) for any connected access visible in the P-GW.
This event closes the CDR, and a new one is opened if the IP-CAN session is still active.

NOTE 8: The intersystem change event is a shared event for FBC in clause 5.2.1.10.2 for the single shared CDR.

- PLMN change visible in the P-GW. This event closes the CDR.
A new one is opened if the IP-CAN session is still active.

NOTE 9: The PLMN change event is a shared event for FBC in clause 5.2.1.10.2 for the single shared CDR.

- MS Timezone change visible in the P-GW. This event closes the CDR.
A new one is opened if the IP-CAN session is still active.

NOTE 10: The MS Timezone change event is a shared event for FBC in clause 5.2.1.10.2 for the single shared CDR.

- Expiry of an operator configured limit of number of charging condition changes per IP-CAN session.
This event closes the CDR, and a new one is opened if the IP-CAN session is still active.

NOTE 11: The expiry of an operator configured limit of number of charging condition changes event is a shared event for FBC in clause 5.2.1.10.2 for the single shared CDR.

Management intervention may also force trigger a chargeable event.

NOTE 12: For non-IP type PDN connection, the following do not apply:

- Addition of access to a PDN connection;
- Start of a dedicated bearer for an IP-CAN session;
- End of dedicated bearer in the P-GW;
- Removal of access from a multi-access PDN connection;
- Access of a multi-access PDN connection becomes unusable;
- Access of a multi-access PDN connection becomes usable.

5.2.1.10.2 Flow Based Charging (FBC)

For the purpose of end-user charging, FBC is supported by the P-GW by the integration of a PCEF. With PCEF, charging is enhanced by the capability to categorise the service data flows within IP-CAN session data traffic by rating group or combination of the rating group and service id. FBC provides separate counts per each rating group, combination of the rating group and service id or combination of rating group, sponsor identity and application service provider identity. The level of the reporting is defined per PCC rule. Details of this functionality are specified in TS 23.203 [215] and TS 32.240 [1].

NOTE 1: Even though an individual service data flow template is bound to a specific IP-CAN bearer, the assigned rating group or combination of rating group and service id applies to the entire IP-CAN session. As a result, data traffic from multiple bearers can be included in the count maintained for the rating group or combination of the rating group and service id. This implies if an operator wishes to be able to separate usage according to IP-CAN bearer within their billing system they will need to ensure that services having different QCI and ARP do not have the same:

- rating group in cases where rating group reporting is used;
- rating group/service id where rating group/service id reporting is used;
- rating group/sponsor identity/application service provider identity where sponsored connectivity level reporting is used.

NOTE 2: The P-GW can only include one QoS Information occurrence per service data container. This implies if an operator wishes to be able to separate usage according to QCI and ARP within their billing system they will need to ensure that services having different QCI and ARP do not have the same:

- rating group in cases where rating group reporting is used;
- rating group/service id where rating group/service id reporting is used ;
- rating group/sponsor identity/application service provider identity where sponsored connectivity level reporting is used.

NOTE 2a: The P-GW can only include one RAT type per service data container.

This implies if an operator wishes to be able to separate usage according to RAT type within their billing system they will need to ensure that services having different RAT type do not have the same:

- rating group in cases where rating group reporting is used;
- rating group/service id where rating group/service id reporting is used;
- rating group/sponsor identity/application service provider identity where sponsored connectivity level reporting is used.

According to TS 23.203 [215], FBC shall support different charging models per PCC rule. These charging models may be based on volume and/or time and on number of events matching a specific service data flow template in PCC rule.

When Charging per IP-CAN session is active and FBC measurements are captured in the same CDR as measurements for IP-CAN bearers, the following chargeable events are defined:

- Start of the default bearer for an IP-CAN session when single access is used or start of the first default bearer for a multi-access PDN connection (i.e., when NBIFOM is accepted by PCRF). Upon encountering this event, a new CDR for the IP-CAN session is created. No service data flow counters are started.

NOTE 3: The start of the default bearer or the start of the first default bearer for an IP-CAN session event is a shared trigger for IP-CAN bearer charging in clause 5.2.1.10.1 for the single shared CDR.

- Start of service data flow.
If service identifier level reporting is required by the PCC rule, and no counts are present already for this combination of the rating group and service id, then new counts and time stamps for this combination of the rating group and service id are started. If rating group level reporting is required by the PCC rule, and no counts are present already for this rating group, then new counts and time stamps for this rating group are started. If sponsored connectivity level reporting is required by the PCC rule, and no counts are present already for this combination of rating group, sponsor identity and application service provider identity, then new counts and time

stamps for this rating group are started. The type of counters shall be according to the measurement method configured for the PCC rule. When event based charging applies, the first occurrence of an event matching a service data flow template in PCC rule shall imply that a new count is started. When new events occur, the counter shall be increased. Each event shall be time stamped.

- Access change of service data flow.
If service identifier level reporting is required by the PCC rule and all service data flows for this combination of the rating group and service id are changing from one access to another, or if rating group level reporting is required by the PCC rule and all service data flows for this rating group are changing from one access to another, or if sponsored connectivity level reporting is required by the PCC rule and all service data flows for this combination of rating group, sponsor identity and application service provider identity are changing from one access to another, the counters and time stamps are closed and the resulting containers added to the CDR.
- Termination of service data flow. If service identifier level reporting is required by the PCC rule and this was the last active service data flow for this combination of the rating group and service id or if rating group level reporting is required by the PCC rule and this was the last active service data flow for this rating group, or if sponsored connectivity level reporting is required by the PCC rule and this was the last active service data flow for this combination of rating group, sponsor identity and application service provider identity, the counters and time stamps are closed and the resulting containers added to the CDR. For information on how the termination of service data flows is detected, refer to TS 23.203 [215].
- End of IP-CAN session (i.e. end of the default bearer for a single access PDN connection or end of the last bearer for a multi-access PDN connection) in the P-GW.
The counters and time stamps for all rating groups and all combinations of rating group and service id are closed and the resulting containers added to the CDR. The CDR is closed.

NOTE 4: The end of IP-CAN session event is a shared event for IP-CAN Bearer Charging in clause 5.2.1.10.1 for the single shared CDR.

- Expiry of an operator configured time limit for keeping a CDR open.
This event closes all counters. The resulting containers are added to the CDR and the CDR is closed.
A new CDR is opened if the IP-CAN session is still active.

NOTE 5: The end of operator configured time limit for keeping a CDR open event is a shared event for IP-CAN Bearer Charging in clause 5.2.1.10.1 for the single shared CDR.

- Expiry of an operator configured time limit per rating group.
The counters and time stamps are closed and added to the CDR.
A new service data flow container is opened if any matching service data flow is still active.
- Expiry of an operator configured data volume limit per IP-CAN session.
This event closes the CDR and a new one is opened if the IP-CAN session is still active.

NOTE 6: The expiry of an operator configured data volume limit per IP-CAN session event is a shared event for IP-CAN bearer charging in clause 5.2.1.10.1 for the single shared CDR.

- Expiry of an operator configured data volume limit per rating group.
The counters and time stamps are closed and added to the CDR.
A new service data flow container is opened if any matching service data flow is still active.
- Expiry of an operator configured data event limit per IP-CAN session.
This event closes the CDR and a new one is opened if the IP-CAN session is still active.

NOTE 7: The expiry of an operator configured data event limit per IP-CAN session event is a shared event for IP-CAN bearer charging in clause 5.2.1.10.1 for the single shared CDR.

- Expiry of an operator configured data event limit per rating group.
The counters and time stamps are closed and added to the CDR.
A new service data flow container is opened if any matching service data flow is still active.
- Change of charging condition.
IP-CAN bearer modification except QoS change (e.g. SGSN change, S-GW change, user location change, user CSG information change, change of UE presence in Presence Reporting Area(s)), tariff time change or failure handling procedure triggering.
When this event is encountered, all current configured counts and time stamps are captured and new counts and

time stamps for all service data flows are started.

IP-CAN bearer modification except QoS change events are associated with one access of a multi-access PDN connection and all counts associated with affected access are identified with the specific event. All counts associated with the other access of a multi-access PDN connection are identified as an indirect change of charging condition.

Editor's Note: The handling of "Serving PLMN Rate Control change", "APN Rate Control change" events when charging per IP-CAN session applies is FFS.

NOTE 8: The change of charging condition event is a shared event for IP-CAN bearer charging in clause 5.2.1.10.1 for the single shared CDR.

Editor's Note: whether the special case of user location reporting on dedicated bearer release triggers a change of charging condition for the IP-CAN session is ffs.

- Intersystem change (e.g. change of radio interface from GSM to UMTS, RAT change) for any connected access visible in the P-GW.
This event closes the CDR, and a new one is opened if the IP-CAN session is still active.

NOTE 9: The intersystem change event is a shared event for IP-CAN bearer charging in clause 5.2.1.10.1 for the single shared CDR.

- PLMN change visible in the P-GW.
This event closes the CDR. A new one is opened if the IP-CAN session is still active.

NOTE 10: The PLMN change event is a shared event for IP-CAN bearer charging in clause 5.2.1.10.1 for the single shared CDR.

- MS Timezone change visible in the P-GW.
This event closes the CDR. A new one is opened if the IP-CAN session is still active.

NOTE 11: The MS Timezone change event is a shared event for IP-CAN bearer charging in clause 5.2.1.10.1 for the single shared CDR.

- Expiry of an operator configured limit of charging condition changes per IP-CAN session.
This event closes the CDR, and a new one is opened if the IP-CAN session is still active.

NOTE 12: The expiry of an operator configured limit of charging condition changes per IP-CAN session event is a shared event for IP-CAN bearer charging in clause 5.2.1.10.1 for the single shared CDR.

- Completion of a time envelope as defined in TS 32.299 [50].
This event closes a service data flow container. Further details are described in clause 5.2.3.10.1 "Triggers for PGW-CDR charging information addition".
The need for reporting time envelopes may be statically configured for each rating group or dynamically controlled by online charging.

Management intervention may also force trigger a chargeable event.

Relevant service data flows for an IP-CAN session are determined when FBC is applied. PCC rules are used for this determination. One PCC rule identifies service data flow to be measured but it can also include certain characteristics related to that service data flow.

PCC rules can be activated, deactivated and modified any time during the IP-CAN session lifetime.

IP-CAN bearer deactivation also leads to deactivation of all PCC rules associated with that bearer.

PCC rule activation, deactivation and modification are not chargeable events.

However these PCC rule changes may lead to "start of service data flow" and "termination of service data flow" chargeable events.

According to TS 23.203 [215], the PCRF can modify the following charging information in a dynamic PCC rule which is active in the PCEF: Charging key, Service identifier, Sponsor Identifier, Application Service Provider Identifier, IP-CAN types, Measurement method and reporting level. The PCRF can also modify the allowed access type in the case of NBIFOM.

A change of allowed access type in the case of NBIFOM will trigger an "access change for service data flow" chargeable event when all service data flows for the associated counter are changed from one access to another and takes priority over change of charging information.

A change of any of this charging information will trigger a "start of service data flow" chargeable event when a valid counter does not exist corresponding to that changed PCC rule.

A change of any of this charging information will trigger a "termination of service data flow" chargeable event when this was the last active service data flow for the counter corresponding to the original PCC rule.

Removal of an access from a PDN connection is not a trigger for FBC. Subsequent PCC rule handling, may lead to the "access change for a service data flow" or "termination of service data flow" events for the service data flows that were active on the removed access.

Extended packet inspection can be done in the PCEF with pre-defined PCC rules.

The PCEF also have the possibility to output service specific information related to the packet inspection in the CDR.

The capability of P-GW to support ABC is achieved with PCRF providing appropriate PCC rules to the P-GW. Such PCC Rule shall be defined with service data flow template including an Application Identifier for the application which needs to be detected, enforced and charged.

For non-IP type PDN connection:

- non-3GPP access types are not supported;
- multi-access PDN connections do not apply;
- A single PCC Rule is used with the service data flow descriptor matching the whole non-IP data traffic, and can contain e.g.:
 - service data flow template matching all the packets;
 - charging method to identify whether online/offline/both/neither charging interface is used;
 - measurement method for offline charging to identify whether time/data volume/events are measured for this service data flow;
 - Charging key (i.e. rating group) for that service data flow;
 - service identifier for that service data flow;
 - reporting level for that service data flow:
 - rating group level in case a specific rating group is used for non-IP traffic charging;
 - combination of the rating group and service id in case a specific rating group/service Id is used for non-IP traffic charging.

5.2.1.11 Data Volume Reporting for Secondary RAT usage

5.2.1.11.1 General

Volume reporting for Secondary RAT is an optional capability in the S-GW and P-GW that provides accounting functionality when a Secondary RAT is used in conjunction with E-UTRAN. This is valid for both HPLMN and VPLMN.

To align with existing per IP-CAN bearer accounting procedures, the following principles are used:

- The reporting of Secondary RAT Data Volume is controlled by the E-UTRAN.
- The uplink and downlink data volumes for the Secondary RAT are reported (from E-UTRAN to EPC) on a per EPS bearer basis. The report contains Secondary RAT (e.g. NR) resources used for transport of user data and indicated separately for uplink and downlink per EPS bearer and per time interval. The time interval used for the measurements reported (from RAN) may be partitioned to indicate usage that occurred before respectively after an absolute time (that occurs while measurement for secondary RAT usage report is ongoing). For example, the RAN is configured to partition reports in usage, that occurred before respectively after midnight.
- The reporting (performed by E-UTRAN) in association with UE-related control signaling and via standalone reporting is internally triggered by E-UTRAN

5.2.2 Rf message flows

5.2.2.0 General

When the CDF is implemented as a separate entity, the offline charging functionality is based on the PCN nodes (MME, S-GW, ePDG, TWAG, P-GW and TDF) reporting charging information for chargeable events. This reporting is achieved by sending Charging Data Request [Start, Interim, Stop and Event] from the PCN network elements to the CDF.

The PCNs shall use the Charging Characteristics profiles to determine whether Charging events (Charging Data Request[Start, Interim, Stop and Event]) reporting has to be activated or not.

The trigger conditions for the chargeable events described in 5.2.3.5 for the MME, 5.2.3.3 for the S-GW, 5.2.3.8 for the ePDG, 5.2.3.11 for the TWAG, 5.2.3.9 for the TDF and in 5.2.3.4 for the P-GW are also applicable, and charging events are reported to the external CDF when these trigger conditions are met.

The following clauses provide the charging events reporting description for MME, S-GW, ePDG, TWAG, P-GW and TDF.

5.2.2.1 Triggers for charging events from S-GW

When a Charging Event is reported to the CDF, it includes details such as Subscription id (e.g. IMSI.), Charging-id, SGW address etc. and also a container identifying, for the IP-CAN bearer, the volume count (separated for uplink and downlink traffic), with charging condition change information.

As stated above, the same trigger conditions described in 5.2.3.3 are applicable for charging information addition and Charging Data Request closure.

Charging Data Request[Start] is sent at IP-CAN bearer activation.

For an Charging Data Request[Interim] to be sent with only one container reported, the Partial Record Reason "Maximum number of charging condition changes" should be set to value 1.

5.2.2.2 Triggers for charging events from P-GW

When a Charging Event is reported to the CDF, it includes details such as Subscription id (e.g. IMSI), Charging-id, SGW address, ePDG address, TWAG address, FBC specific charging data etc., and also a container identifying per rating group or combination of the rating group and service id within the same IP-CAN bearer; the volume counts (separated for uplink and downlink traffic), elapsed time and/or number of events, with associated charging condition change information.

As stated above, the same trigger conditions described in clause 5.2.3.4 are applicable for charging information addition and Charging Data Request closure.

Charging Data Request[Start] is sent at IP-CAN bearer activation.

For an Charging Data Request[Interim] to be sent with only one container reported, the Partial Record Reason "Maximum number of charging condition changes" should be set to value 1.

Editor's Note : tight interworking with online charging and DCCA failure handling is FFS.

5.2.2.3 Triggers for charging events from ePDG

When a Charging Event is reported to the CDF, it includes details such as Subscription id (e.g. IMSI), Charging-id, ePDG address etc. and also a container identifying for the IP-CAN bearer, the volume count (separated for uplink and downlink traffic), with charging condition change information.

As stated above, the same trigger conditions described in clause 5.2.3.8 are applicable for charging information addition and Charging Data Request closure.

Charging Data Request[Start] is sent at IP-CAN bearer activation.

For an Charging Data Request[Interim] to be sent with only one container reported, the Partial Record Reason "Maximum number of charging condition changes" should be set to value 1.

5.2.2.4 Triggers for charging events from MME

Each Short Message transferred through the MME to/from the SMSC, triggers a Charging Event towards the CDF:

- Short Message received by a UE via the MME (MT direction) from the SMSC;
- Short Message sent by a UE via the MME (MO direction) to the SMSC.

This Charging event reporting is achieved by the MME in Event mode, by sending Charging Data Request[Event] to the CDF, on successful or unsuccessful Short Message transfer transaction with UE.

5.2.2.5 Triggers for charging events from TDF

When a Charging Event is reported to the CDF, it includes details such as Subscription id (e.g. IMSI), Charging-id, SGW address, ePDG address, TWAG address, ABC specific charging data etc., and also a container identifying per rating group or combination of the rating group and service id within the same TDF session; the volume counts (separated for uplink and downlink traffic), elapsed time and/or number of events, with associated charging condition change information TDF session charging is achieved by ABC offline charging with vendor specific rating group or a combination of vendor specific rating group and service id within the same TDF session, see clause 5.2.1.9..

As stated above, the same trigger conditions described in 5.2.3.9 are applicable for charging information addition and Charging Data Request closure.

Charging Data Request Start] is sent at TDF session activation.

For an Charging Data Request[Interim] to be sent with only one container reported, the Partial Record Reason "Maximum number of charging condition changes" should be set to value 1.

5.2.2.6 Triggers for charging events from P-GW when charging per IP-CAN session is active

When a Charging Event is reported to the CDF and charging per IP-CAN session is active, it includes details such as Subscription id (e.g. IMSI), Charging-id, SGW address, ePDG address, TWAG address, FBC specific charging data etc., and contains either one or both of the following different types of containers:

- traffic volumes, used for IP-CAN bearer charging, identifying per QCI/ARP combination, the volume counts (separated for uplink and downlink traffic) with associated charging condition change information
- service data, used for FBC, identifying per rating group or combination of the rating group and service id within the IP-CAN session, the volume counts (separated for uplink and downlink traffic), elapsed time and/or number of events, with associated charging condition change information.

The trigger conditions described in clause 5.2.3.10 are applicable for charging information addition and Charging Data Request closure.

Charging Data Request[Start] is sent at IP-CAN session activation.

For an Charging Data Request[Interim] to be sent with only one container reported, the Partial Record Reason "Maximum number of charging condition changes" should be set to value 1.

5.2.2.7 Triggers for charging events from TWAG

When a Charging Event is reported to the CDF, it includes details such as Subscription id (e.g. IMSI), Charging-id, TWAG address etc. and also a container identifying for the IP-CAN bearer, the volume count (separated for uplink and downlink traffic), with charging condition change information.

As stated above, the same trigger conditions described in clause 5.2.3.11 are applicable for charging information addition and Charging Data Request closure.

Charging Data Request [Start] is sent at IP-CAN bearer activation.

For an Charging Data Request [Interim] to be sent with only one container reported, the Partial Record Reason "Maximum number of charging condition changes" should be set to value 1.

5.2.3 CDR generation

5.2.3.0 Introduction

The S-CDR, M-CDR, S-SMO-CDR, S-SMT-CDR, LCS-MO-CDR, LCS-MT-CDR, LCS-NI-CDR and S-MB-CDR are generated by the SGSN, the S-SMO-CDR, S-SMT-CDR by the MME, the SGW-CDR by the S-GW, the ePDG-CDR by the ePDG, the TWAG-CDR by the TWAG, the PGW-CDR and G-MB-CDR by the P-GW, the TDF-CDR by the TDF to collect charging information that they subsequently transfer to the Charging Gateway Function (CGF).

The PCNs shall use the Charging Characteristics to determine whether to activate or deactivate CDR generation. The Charging Characteristics are also used to set the coherent chargeable event conditions (e.g. time/volume limits that trigger CDR generation or information addition). Multiple Charging Characteristics "profiles" may be configured on the PCNs to allow different sets of trigger values. Further details of this functionality, including the mechanism of conveying the Charging Characteristics data item (HLR -> SGSN -> P-GW, HSS -> MME/ S4-SGSN -> S-GW -> P-GW, AAA -> ePDG -> P-GW, or AAA -> TWAG -> PGW), are specified and then in case of TDF, P-GW -> PCRF -> TDF in annex A.

Charging Characteristics are not applicable to MBMS CDR generation.

If CDR generation is activated, it shall be possible to define separate trigger conditions values per Charging Characteristics profile for the following triggers:

- data volume limit;
- time (duration limit);
- maximum number of charging conditions changes (QoS change, Tariff Time change).

The following clauses describe the trigger conditions for the chargeable events described in clause 5.2.1.1 – 5.2.1.6A. In EPC offline charging, these chargeable events correspond to the triggers for collection of charging information and CDR generation by the SGSN/ MME/S-GW/ePDG/ TWAG/P-GW/TDF.

5.2.3.1 Triggers for S-CDR charging information collection

5.2.3.1.0 General

An S-CDR is used to collect charging information related to the IP-CAN bearer data information for a MS/UE in the SGSN.

If according to the Charging Characteristics, CDR generation is activated an S-CDR shall be opened at IP-CAN bearer activation, and the volume for the context is counted separately in uplink and downlink direction. When a change of charging condition occurs, the volume count is added to the S-CDR and a new count is started. The S-CDR includes details such as Record Type, Served IMSI, Sequence Number etc. Not all of the charging information to be collected is static, and other charging information is directly depending on dynamic Packet-Switched service usage.

The subsequent clauses identify in detail the conditions for adding information to, and closing the S-CDR for generation towards the CGF.

5.2.3.1.1 Triggers for S-CDR charging information addition

The "List of Traffic Volumes" attribute of the S-CDR consists of a set of containers, which are added when specific trigger conditions are met, and identify the volume count per IP-CAN bearer, separated for uplink and downlink traffic, on encountering that trigger condition. Table 5.2.3.1.1.1 identifies which conditions are supported to trigger S-CDR charging information addition.

Table 5.2.3.1.1.1: Triggers for S-CDR charging information addition

Trigger Conditions	Description/Behaviour
QoS Change	A change in the QoS shall result in a "List of Traffic Data Volumes" container being added to the CDR.
Tariff Time Change	On reaching the Tariff Time Change a "List of Traffic Data Volumes" container shall be added to the CDR.
User CSG Information change	A change in user CSG information shall result in a "List of Traffic Data Volumes" container being added to the CDR, if CSG information reporting is required, and a report of User CSG information change is received.
Direct Tunnel establishment/removal	When the SGSN establishes or removes a Direct Tunnel a "List of Traffic Data Volumes" container shall be added to the CDR. See NOTE.
CDR Closure	A list of "List of Traffic Data Volumes" container shall be added to the S-CDR.
NOTE:	When a direct tunnel is established, the SGSN will no longer be able to count data volumes associated with the IP-CAN bearer for which the direct tunnel is established

The first volume container of a IP-CAN bearer identifies the uplink/downlink volume since the IP-CAN bearer was opened. Subsequent volume containers store the volume count accrued since the closure of the last container.

5.2.3.1.2 Triggers for S-CDR closure

The S-CDR shall be closed on encountering some trigger conditions.

Table 5.2.3.1.2.1 identifies which conditions are supported to permit closure of the S-CDR.

Table 5.2.3.1.2.1: Triggers for S-CDR closure

Closure Conditions	Description/Behaviour
End of IP-CAN bearer within the SGSN	Deactivation of the IP-CAN bearer in the SGSN shall result in the CDR being closed. The trigger condition covers: <ul style="list-style-type: none"> - termination of IP-CAN bearer; - SGSN change (inter-SGSN routing area update including intersystem change); - any abnormal release.
Partial Record Reason	OAM&P reasons permit the closure of the CDR for internal reasons. The trigger condition covers: <ul style="list-style-type: none"> - data volume limit; - time (duration) limit; - maximum number of charging condition changes (QoS/tariff time change); - management intervention; - Intra-SGSN intersystem change (change of radio interface from GSM to UMTS or vice versa).

The Partial Record generation trigger thresholds are those associated with the Charging Characteristics.

The Partial Record generation trigger thresholds are GSN configuration parameters defined per Charging Characteristics profile by the operator through OAM&P means, as specified in annex A.

In the event that the S-CDR is closed and the IP-CAN bearer remains active, a further S-CDR shall be opened with an incremented Sequence Number in the SGSN.

5.2.3.2 Triggers for M-CDR charging information collection

5.2.3.2.0 General

An M-CDR is used to collect charging information related to the mobility management of a mobile in the SGSN.

An M-CDR shall be opened for each mobile upon GPRS Attach, indicating the current location information for that MS/UE. When a location change occurs for the attached MS/UE, the new location information is added to the M-CDR. The M-CDR records details such as Record Type, Served IMSI, Sequence Number etc.

Not all of the charging information to be collected is static, and other charging information is directly dependent on the mobility of the MS as provided by the Radio Access Network (RAN). Subsequent partial records may be opened if the M-CDR is closed and the MS is still attached to the network.

The subsequent clauses identify in detail the conditions for adding information to, and closing of the M-CDR for generation towards the CGF.

5.2.3.2.1 Triggers for M-CDR charging information addition

The "Change of Location" attribute of the M-CDR consists of a set of containers, which are added when specific trigger conditions are met, and identify the time stamped routing area on encountering that trigger condition.

Table 5.2.3.2.1.1 identifies which conditions are supported to trigger M-CDR charging information addition.

Table 5.2.3.2.1.1: Triggers for M-CDR charging information addition

Trigger Conditions	Description/Behaviour
Mobility Change	The first "Change of Location" container shall be captured when the MM context is created. Subsequent changes in the Routing Area shall result in a "Change of Location" container being added to the M-CDR.

5.2.3.2.2 Triggers for M-CDR closure

The M-CDR shall be closed on encountering some trigger conditions.

Table 5.2.3.2.2.1 identifies which conditions are supported to permit closures of the M-CDR.

Table 5.2.3.2.2.1: Triggers for M-CDR closure

Closure Conditions	Description/Behaviour
End of MM Context within SGSN	Deactivation of the MM context in the SGSN shall result in the CDR being closed. The trigger condition covers: <ul style="list-style-type: none"> - SGSN change (inter-SGSN routing area update including intersystem change); - GPRS detach; - any abnormal release.
Partial Record Reason	OAM&P reasons permit the closure of the CDR for internal reasons. The trigger condition covers: <ul style="list-style-type: none"> - time (duration) limit; - maximum number of mobility changes; and - Management intervention; - Intra-SGSN intersystem change (change of radio interface from GSM to UMTS or vice versa).

The Partial Record generation trigger thresholds are those associated with the Charging Characteristics.

The Partial Record generation trigger thresholds are SGSN configuration parameters defined per Charging Characteristics profile by the operator through OAM&P means, as specified in annex A.

In the event that the M-CDR is closed and the mobile is still known to the SGSN, a further M-CDR shall be opened with an incremented Sequence Number in the SGSN.

5.2.3.3 Triggers for SGW-CDR charging information collection

5.2.3.3.0 Introduction

A SGW-CDR is used to collect charging information related to the IP-CAN bearer data information for a UE/MS in the S-GW.

SGW-CDR separates collected charging information per QCI/ARP pair. SGW-CDR can include:

- IP-CAN bearer specific container reporting the usage and authorized QCI/ARP for IP-CAN bearer.

Each SGW-CDR includes at least IP-CAN bearer specific container(s).

If, according to the Charging Characteristics, CDR generation is activated a SGW-CDR shall be opened at IP-CAN bearer activation and IP-CAN bearer specific container is opened..

When a change of charging condition occurs, the volume counts are added to the SGW-CDR and new counts are started. The SGW-CDR includes details such as Record Type, Served IMSI, Sequence Number etc.

Not all of the charging information to be collected is static, and other charging information is directly dependent on dynamic Packet-Switched service usage.

The subsequent clauses identify in detail the conditions for adding information to, and closing the SGW-CDR for generation towards the CGF.

5.2.3.3.1 Triggers for SGW-CDR charging information addition

The "List of Traffic Data Volumes" attribute of the SGW-CDR consists of a set of containers, which are added when specific trigger conditions are met, and identify the volume count per QCI/ARP pair, separated for uplink and downlink traffic, on encountering that trigger condition.

Table 5.2.3.3.1.1 identifies which conditions are supported to trigger SGW-CDR charging information addition.

Table 5.2.3.3.1.1: Triggers for SGW-CDR charging information addition

Trigger Conditions	Description/Behaviour
QoS Change	A change in the QoS shall result that open "List of Traffic Data Volumes" containers being closed and added to the CDR and new IP-CAN bearer specific container is opened.
Tariff Time Change	On reaching the Tariff Time Change open "List of Traffic Data Volumes" containers shall be closed and added to the CDR.
User Location Change	A change in the User Location Info (e.g. ECGI, TAI, RAI, SAI or CGI) shall result that open "List of Traffic Data Volumes" containers being closed and added to the CDR, if location reporting is required, and a report of User Location Change is received.
User CSG Information change	A change in the User CSG info (e.g. CSG ID, access mode or CSG membership indication) shall result that open "List of Traffic Data Volumes" containers being closed and added to the CDR, if CSG information reporting is required, and a report of User CSG information change is received.
Change of UE presence in Presence Reporting Area	A change of UE presence in Presence Reporting Area(s) shall result that open "List of Traffic Data Volumes" containers being closed and added to the CDR, if such reporting is required, and a report that user enters/leaves the area or the Presence Reporting Area(s) is set to inactive by the serving node , are received.
Change in UP to UE	A change in the User Plane to UE (i.e. switch between S11-U and S1-U) shall result that open "List of Traffic Data Volumes" containers being closed and added to the CDR and new IP-CAN bearer specific container is opened.
Serving PLMN Rate Control Change	A change in the Serving PLMN Rate Control shall result that open "List of Traffic Data Volumes" containers being closed and added to the CDR and new IP-CAN bearer specific container is opened.
CDR Closure	Open "List of Traffic Data Volumes" containers shall be closed and added to the SGW-CDR.

Volume container identifies the uplink/downlink volume since the closure of the last container.

The "Serving Node Address" attribute of the SGW-CDR consists of a list of serving node (e.g. S4-SGSN/MME) addresses. New serving node address is added to the list when e.g. S4-SGSN/MME changes.

When Charging Event (ACR) is triggered by table 5.2.3.3.1.1 conditions, the Change-Condition sub-field associated to the added volume container, indicating the appropriate condition shall be present, excluding CDR Closure case.

When Charging Event (ACR) is triggered by CDR Closure condition, this Change-Condition sub-field associated to the added volume container shall be omitted, except when CDR closure is due to "maximum number of charging condition changes", where it shall be present with the original condition change.

When Charging Event (ACR) is triggered by "User CSG Information change" as a Change condition, the following shall apply for the added volume container:

- When User enters in a CSG cell or a hybrid cell: the CSG ID, access mode and CSG membership indication (when hybrid), shall be provided together with this "User CSG Information change" Change-Condition.
- User leaves a CSG cell or a hybrid cell: this "User CSG Information change" Change-Condition shall be provided without any CSG ID, access mode and CSG membership indication, unless the user is entering a new CSG cell or hybrid cell.

5.2.3.3.2 Triggers for SGW-CDR closure

The SGW-CDR shall be closed on encountering some trigger conditions.

Table 5.2.3.3.2.1 identifies which conditions are supported to permit closure of the SGW-CDR.

Table 5.2.3.3.2.1: Triggers for SGW-CDR closure

Closure Conditions	Description/Behaviour
End of IP-CAN bearer within the S-GW	Deactivation of the IP-CAN bearer in the S-GW shall result in the CDR being closed. The trigger condition covers: <ul style="list-style-type: none"> - termination of IP-CAN bearer; - inter serving node change; - any abnormal release.
Partial Record Reason	OAM&P reasons permit the closure of the CDR for internal reasons. The trigger condition covers: <ul style="list-style-type: none"> - data volume limit; - time (duration) limit; - maximum number of charging condition changes (QoS/tariff time change); - management intervention; - MS time zone change; - PLMN change; - radio access technology change (RAT Type). - MO exception data counter receipt.

The Partial Record generation trigger thresholds are those associated with the Charging Characteristics.

The Partial Record generation trigger thresholds are S-GW configuration parameters defined per Charging Characteristics profile by the operator through OAM&P means, as specified in annex A.

In the event that the SGW-CDR is closed and the IP-CAN bearer remains active, a further SGW-CDR is opened with an incremented Sequence Number in the S-GW.

When Charging Event (ACR) is triggered by table 5.2.3.3.2.1 conditions, the Change-Condition (at PS information level) associated to the CDR Closure, indicating the appropriate condition shall be present, and it shall be omitted otherwise.

5.2.3.4 Triggers for PGW-CDR charging information collection

5.2.3.4.0 Introduction

An PGW-CDR is used to collect charging information related to the IP-CAN bearer data information for a UE/MS in the P-GW, where the data volumes, elapsed time or number of events within each PGW-CDR are separately counted per rating group or per combination of the rating group and service id. In case of P-GW is not aware of IP-CAN bearers, i.e. in case of PMIP based connectivity, P-GW collects charging information per IP-CAN session as it would be one IP-CAN bearer.

Many service data flow containers per IP-CAN bearer can be active simultaneously in PGW-CDR. A service data flow container is activated when traffic is detected and no matching active service data flow container exist; a service data flow container is closed when the termination of the last service data flow matching to the service data flow container is detected by the P-GW. When event based charging applies, the first occurrence of an event matching a service data flow template shall imply service data flow start. Details on FBC can be found in TS 23.203 [215] and TS 32.240 [1].

If, according to the Charging Characteristics profile, CDR generation is activated an PGW-CDR shall be opened at IP-CAN bearer activation, and the volume (separately in uplink and downlink direction), elapsed time and/or number of events are counted. When a change of charging condition occurs, all containers are added to the PGW-CDR. The PGW-CDR includes details such as Record Type, Served IMSI, Sequence Number etc. and the FBC specific charging data. Not all of the charging information to be collected is static, and other charging information is directly dependent on dynamic Packet-Switched service usage.

It shall be possible to activate both online and offline charging interfaces for the same IP-CAN bearer. The default online and offline charging shall work independently of each other. Optionally it may be possible to operate in a tight interworking between online and offline charging mechanism i.e. only the specified quota re-authorisation triggers armed by OCS (including e.g. tariff time change, returned quotas, etc.) are used to close the service data flow containers for the PGW-CDR charging information addition.

The subsequent clauses identify in detail the conditions for adding information to, and closing the PGW-CDR for generation towards the CGF.

5.2.3.4.1 Triggers for PGW-CDR charging information addition

IP-CAN bearer specific offline charging is achieved with IP-CAN bearer specific rating group/service identifier defined in clause 5.3.1.1.

The "List of Service Data" attribute of the PGW-CDR consists of a set of containers, which are added when specific trigger conditions are met. Each container identifies the configured counts (volume separated for uplink and downlink, elapsed time or number of events) per rating group or combination of the rating group and service id within the same IP-CAN bearer, on encountering that trigger condition. For envelope reporting, the containers represent complete and closed time envelopes determined by mechanisms defined in TS 32.299 [50].

Table 5.2.3.4.1.1 identifies conditions that may be supported as recording triggers under consideration of additional Debit / Reserve Units triggers.

Some of the triggers are non-exclusive (e.g. IP-CAN bearer modification with a couple of reasons, IP-CAN bearer modification reasons that cause PGW-CDR closure).

Table 5.2.3.4.1.1: Triggers for PGW-CDR charging information addition "List of Service Data"

Trigger Conditions	Description/Behaviour
IP-CAN bearer modification	A change of IP-CAN bearer conditions (e.g. QoS change, SGSN/S-GW/ePDG/TWAG change, user location change, user CSG information change, change of UE presence in a Presence Reporting Area(s), Serving PLMN Rate Control, APN Rate Control, change of 3GPP PS Data off Status) shall result in a set of "List of Service Data" containers, i.e. all active service data flow containers, being added to the CDR as described in clause 5.2.1.3. In a tight interworking between online and offline charging the specified quota re-authorization triggers armed by OCS are supported.
Tariff Time Change	On reaching the Tariff Time Change a set of "List of Service Data" containers, i.e. all active service data flow containers, shall be added to the CDR. In a tight interworking between online and offline charging the Debit / Reserve Units tariff time change from OCS is supported.
Failure Handling procedure triggering	When the Credit Control Failure Handling mechanism is triggered a "List of Service Data", i.e. all active service data flow containers shall be added to the CDR. <u>The causes are only relevant in case of simultaneously usage of an active Debit / Reserve Units session.</u>
Service data flow report	In case of independent online and offline charging a "List of Service Data" container for the service data flow shall be added when: <ul style="list-style-type: none"> - expiry of time limit; - expiry of volume limit; - expiry of unit limit; - termination of service data flow. In case of tight interworking online and offline charging a "List of Service Data" container for the service data flow shall be added when: <ul style="list-style-type: none"> - time threshold reached; - volume threshold reached; - unit threshold reached; - time quota exhausted; - volume quota exhausted; - unit quota exhausted; - expiry of quota validity time; - termination of service data flow; - re-authorization request by OCS. - access of a multi-access PDN connection becomes unusable
CDR Closure	All active "List of Service Data" containers shall be added to the PGW-CDR. Note: The trigger condition is a common value that has to be used for CDR closure together with detailed reason.

The first traffic container identifies the data traffic since the IP-CAN bearer was opened. Subsequent data traffic containers store the configured counts accrued since the closure of the last container.

For envelope reporting, each envelope contains information about the data volume transferred in both uplink and downlink and / or the number of events that occurred for the duration that envelope is open. Only completed time envelopes shall be added to the PGW-CDR. The determination of completed envelopes are defined in TS 32.299 [50]. The triggers listed in the previous table 5.2.3.4.1.1 shall not apply to envelope reporting. Envelopes that are not complete when a partial PGW-CDR is closed shall be added to the next PGW-CDR.

The "Serving node Address" attribute of the PGW-CDR consists of a list of SGSN/S-GW/ePDG/TWAG addresses. New SGSN/S-GW/ePDG/TWAG address is added to the list when SGSN/S-GW/ePDG/TWAG changes.

When Charging Event (ACR) is triggered by table 5.2.3.4.1 conditions, the Change-Condition sub-field associated to the added container, indicating the appropriate condition, shall be present, excluding CDR Closure case.

When Charging Event (ACR) is triggered by CDR Closure condition, this Change-Condition sub-field associated to the added container shall be omitted, except when CDR closure is due to "maximum number of charging condition changes", where it shall be present with the original condition change.

When Charging Event (ACR) is triggered by "User CSG Information change" as a Change condition, the following shall apply for the added volume container:

- When User enters in a CSG cell or a hybrid cell: the CSG ID, access mode and CSG membership indication (when hybrid), shall be provided together with this "User CSG Information change" Change-Condition.
- User leaves a CSG cell or a hybrid cell: this "User CSG Information change" Change-Condition shall be provided without any CSG ID, access mode and CSG membership indication, unless the user is entering a new CSG cell or hybrid cell.

5.2.3.4.2 Triggers for PGW-CDR closure

The PGW-CDR shall be closed on encountering trigger conditions.

Table 5.2.3.4.2.1 identifies which conditions are supported to permit closure of the PGW-CDR.

Table 5.2.3.4.2.1: Triggers for PGW-CDR closure

Closure Conditions	Description/Behaviour
End of IP-CAN bearer within the P-GW	Deactivation of the IP-CAN bearer in the P-GW shall result in the CDR being closed. The trigger condition covers: <ul style="list-style-type: none"> - termination of IP-CAN bearer; - any abnormal release.
Partial Record Reason	OAM&P reasons permit the closure of the CDR for internal reasons. The trigger condition covers: <ul style="list-style-type: none"> - data volume limit; - time (duration) limit; - maximum number of charging condition changes (i.e. number of service containers); - management intervention; - MS time zone change; - PLMN change; - radio access technology change (RAT Type). - MO exception data counter receipt.

The Partial Record generation trigger thresholds are those associated with the Charging Characteristics. The Partial Record generation trigger thresholds are P-GW configuration parameters defined per Charging Characteristics profile by the operator through OAM&P means, as specified in annex A.

In the event that the PGW-CDR is closed and the IP-CAN bearer remains active, a further PGW-CDR is opened with an incremented Sequence Number in the P-GW.

When Charging Event (ACR) is triggered by table 5.2.3.4.2.1 conditions, the Change-Condition (at PS information level) associated to the CDR Closure, indicating the appropriate condition shall be present, and it shall be omitted otherwise.

5.2.3.5 Triggers for SMS-CDR charging information collection

The generation of the SMS related CDRs is based on the observation and capture of simple events, i.e. the transfer of Short Messages through the SGSN and MME, in MO or MT direction.

A S-SMO-CDR is used to collect charging information related to the transmission of a SM in MO direction via the SGSN or MME. If, according to the Charging Characteristics, CDR generation is activated a S-SMO-CDR shall be created when the SGSN or MME has successfully forwarded a SM to the SMSC on behalf of the UE/MS. The S-SMO-CDR includes details such as Record Type, Served IMSI, Sequence Number etc.

A S-SMT-CDR is used to collect charging information related to the transmission of a SM in MT direction via the SGSN or MME. If, according to the Charging Characteristics, CDR generation is activated a S-SMT-CDR shall be created when the SGSN or MME has successfully forwarded a SM from the SMSC to the UE/MS. The S-SMT-CDR includes details such as Record Type, Served IMSI, Sequence Number etc.

Note that the above CDR types only capture the SMS events when transferred through the SGSN and MME. Equivalent charging functionality for the CS domain is specified in TS 32.250 [10]. 3GPP specifications do not define service specific charging functionality for SMS.

5.2.3.6 Triggers for LCS-CDR charging information collection

The generation of the LCS related CDRs is based on the observation and capture of simple events, i.e. the invocation of location requests from the UE/MS (LCS-MO-CDR), an external entity (LCS-MT-CDR) or the network (LCS-NI-CDR).

A LCS-MO-CDR is used to collect charging information related to the transmission of a location request, originating from the UE/MS to be located, via the SGSN. If, according to the Charging Characteristics, CDR generation is activated a LCS-MO-CDR shall be created when the SGSN has received the RANAP "Location Report" message from the RNC. The LCS-MO-CDR includes details such as Record Type, Served IMSI, Sequence Number etc.

A LCS-MT-CDR is used to collect charging information related to the transmission of a location request for a UE via the SGSN where the location request originates from an external entity. If, according to the Charging Characteristics, CDR generation is activated a LCS-MT-CDR shall be created when the SGSN has received the RANAP "Location Report" message from the RNC. The LCS-MT-CDR includes details such as Record Type, Served IMSI, Sequence Number etc.

A LCS-NI-CDR is used to collect charging information related to the transmission of a network induced location request via the SGSN. If, according to the Charging Characteristics, CDR generation is activated a LCS-NI-CDR shall be created when the SGSN has received the RANAP "Location Report" message from the RNC. The LCS-MO-CDR includes details such as Record Type, Served IMSI, Sequence Number etc.

Note that the above CDR types only capture the LCS events when transferred through the SGSN. Equivalent charging functionality for the CS domain is specified in TS 32.250 [10]. Service specific charging functionality for LCS is specified in TS 32.271 [31].

5.2.3.7 Triggers for S-MB-CDR and G-MB-CDR charging information collection for MBMS context charging for GPRS

5.2.3.7.1 Triggers for S-MB-CDR and G-MB-CDR charging information creation

S-MB-CDR and G-MB-CDR are used to collect charging information related to the MBMS bearer context data information for a MBMS bearer service in the GSN. The triggers for both S-MB-CDR and G-MB-CDR to start collecting charging information are the same.

S-MB-CDR and G-MB-CDR shall be opened at MBMS bearer context creation. Not all of the charging information to be collected is static, and other charging information is directly dependent on dynamic Packet-Switched service usage.

The subsequent clauses identify in detail the conditions for adding information to, and closing the S-MB-CDR and G-MB-CDR for generation towards the CGF.

5.2.3.7.2 Triggers for S-MB-CDR and G-MB-CDR charging information addition

The "List of Traffic Data Volumes" attribute consists of a set of containers, which are added when specific trigger conditions are met, and identify the volume count per MBMS bearer context, for downlink traffic, on encountering that trigger condition.

Table 5.2.3.7.2.1 identifies which conditions are supported to trigger S-MB-CDR and G-MB-CDR charging information addition.

Table 5.2.3.7.2.1: Triggers for S-MB-CDR and G-MB-CDR charging information addition

Trigger Conditions	Description/Behaviour
Tariff Time Change	On reaching the Tariff Time Change a "List of Traffic Data Volumes" container shall be added to the CDR.
CDR Closure	A list of "List of Traffic Data Volumes" container shall be added to the relevant CDR.

The first volume container of a MBMS bearer context identifies the volume since the record was opened. Subsequent volume containers store the volume count accrued since the closure of the last container.

5.2.3.7.3 Triggers for S-MB-CDR and G-MB-CDR closure

The S-MB-CDR and G-MB-CDR shall be closed on encountering the trigger conditions identified in table 5.2.3.7.3.1.

Table 5.2.3.7.3.1: Triggers for S-MB-CDR and G-MB-CDR closure

Closure Conditions	Description/Behaviour
End of MBMS Bearer Context within the GSN	Deactivation of the MBMS bearer context in the GSN shall result in the CDR being closed. The trigger condition covers: <ul style="list-style-type: none"> - termination of MBMS bearer context; - any abnormal release.
Partial Record Reason	OAM&P reasons permit the closure of the CDR for internal reasons. The trigger condition covers: <ul style="list-style-type: none"> - data volume limit; - time (duration) limit; - change in list of downstream nodes; - management intervention.

The Partial Record generation trigger thresholds are those associated with GSN configured information. In the event that the CDR is closed and the MBMS bearer context remains active, a further CDR is opened with an incremented Sequence Number in the GSN.

5.2.3.7A Triggers for MBMS-GW-CDR charging information collection for MBMS context charging for EPS

5.2.3.7A.1 Triggers for MBMS-GW-CDR charging information creation

MBMS-GW-CDR is used to collect charging information related to the MBMS bearer context data information for a MBMS bearer service in EPS.

MBMS-GW-CDR shall be opened at MBMS bearer context creation. Not all of the charging information to be collected is static, and other charging information is directly dependent on dynamic Evolved Packet System service usage.

The subsequent clauses identify in detail the conditions for adding information to, and closing the MBMS-GW-CDR for generation towards the CGF.

5.2.3.7A.2 Triggers for MBMS-GW-CDR charging information addition

The "List of Traffic Data Volumes" attribute consists of a set of containers, which are added when specific trigger conditions are met, and identify the volume count per MBMS bearer context, for downlink traffic, on encountering that trigger condition.

Table 5.2.3.7A.2.1 identifies which conditions are supported to trigger MBMS-GW-CDR charging information addition.

Table 5.2.3.7A.2.1: Triggers for MBMS-GW-CDR charging information addition

Trigger Conditions	Description/Behaviour
Tariff Time Change	On reaching the Tariff Time Change a "List of Traffic Data Volumes" container shall be added to the CDR.
CDR Closure	A list of "List of Traffic Data Volumes" container shall be added to the relevant CDR.

The first volume container of a MBMS bearer context identifies the volume since the record was opened. Subsequent volume containers store the volume count accrued since the closure of the last container.

5.2.3.7A.3 Triggers for MBMS-GW-CDR closure

The MBMS-GW-CDR shall be closed on encountering the trigger conditions identified in table 5.2.3.7A.3.1.

Table 5.2.3.7A.3.1: Triggers for MBMS-GW-CDR closure

Closure Conditions	Description/Behaviour
End of MBMS Bearer Context within the MBMS GW	Deactivation of the MBMS bearer context in the MBMS GW shall result in the CDR being closed. The trigger condition covers: <ul style="list-style-type: none"> - termination of MBMS bearer context; - any abnormal release.
Partial Record Reason	OAM&P reasons permit the closure of the CDR for internal reasons. The trigger condition covers: <ul style="list-style-type: none"> - data volume limit; - time (duration) limit; - maximum number of charging condition changes; - change in list of downstream nodes; - management intervention.

The Partial Record generation trigger thresholds are those associated with MBMS GW configured information. In the event that the CDR is closed and the MBMS bearer context remains active, a further CDR is opened with an incremented Sequence Number in the MBMS GW.

5.2.3.8 Triggers for ePDG-CDR charging information collection

5.2.3.8.0 Introduction

A ePDG-CDR is used to collect charging information related to the IP-CAN bearer data information for a UE/MS in the ePDG.

If, according to the Charging Characteristics, CDR generation is activated an ePDG-CDR shall be opened at IP-CAN bearer activation and IP-CAN bearer specific container is opened.

When a change of charging condition occurs, the volume counts are added to the ePDG-CDR and new counts are started. The ePDG-CDR includes details such as Record Type, Served IMSI, Sequence Number etc. Not all of the charging information to be collected is static, and other charging information is directly dependent on dynamic Packet-Switched service usage.

The subsequent clauses identify in detail the conditions for adding information to, and closing the ePDG-CDR for generation towards the CGF.

5.2.3.8.1 Triggers for ePDG-CDR charging information addition

The "List of Traffic Data Volumes" attribute of the ePDG-CDR consists of a set of containers, which are added when specific trigger conditions are met, and identify the volume count per Qos, separated for uplink and downlink traffic, on encountering that trigger condition.

Table 5.2.3.8.1.1 identifies which conditions are supported to trigger ePDG-CDR charging information addition.

Table 5.2.3.8.1.1: Triggers for ePDG-CDR charging information addition

Trigger Conditions	Description/Behaviour
QoS Change	A change in the QoS shall result that open "List of Traffic Data Volumes" containers being closed and added to the CDR and new IP-CAN bearer specific container is opened.
Tariff Time Change	On reaching the Tariff Time Change open "List of Traffic Data Volumes" containers shall be closed and added to the CDR.
User Location Change	A change in UWAN User Location Information (e.g. change in UE local IP address within the ePDG) shall result that open "List of Traffic Data Volumes" containers being closed and added to the CDR and new IP-CAN bearer specific container is opened.
CDR Closure	Open "List of Traffic Data Volumes" containers shall be closed and added to the ePDG-CDR.

Volume container identifies the uplink/downlink volume since the closure of the last container.

When Charging Event (ACR) is triggered by table 5.2.3.8.1.1 conditions, the Change-Condition sub-field associated to the added volume container, indicating the appropriate condition, shall be present, excluding CDR Closure case.

When Charging Event (ACR) is triggered by CDR Closure condition, this Change-Condition sub-field associated to the added volume container shall be omitted, except when CDR closure is due to "maximum number of charging condition changes", where it shall be present with the original condition change.

5.2.3.8.2 Triggers for ePDG-CDR closure

The ePDG-CDR shall be closed on encountering some trigger conditions.

Table 5.2.3.8.2.1 identifies which conditions are supported to permit closure of the ePDG-CDR.

Table 5.2.3.8.2.1: Triggers for ePDG-CDR closure

Closure Conditions	Description/Behaviour
End of IP-CAN bearer within the ePDG	Deactivation of the IP-CAN bearer in the ePDG shall result in the CDR being closed. The trigger condition covers: <ul style="list-style-type: none"> - termination of IP-CAN bearer; - any abnormal release; - inter serving node change.
Partial Record Reason	OAM&P reasons permit the closure of the CDR for internal reasons. The trigger condition covers: <ul style="list-style-type: none"> - data volume limit; - time (duration) limit; - maximum number of charging condition changes (QoS/tariff time change); - management intervention;

The Partial Record generation trigger thresholds are those associated with the Charging Characteristics.

The Partial Record generation trigger thresholds are ePDG configuration parameters defined per Charging Characteristics profile by the operator through OAM&P means, as specified in annex A.

In the event that the ePDG-CDR is closed and the IP-CAN bearer remains active, a further ePDG-CDR is opened with an incremented Sequence Number in the ePDG.

When Charging Event (ACR) is triggered by table 5.2.3.8.2.1 conditions, the Change-Condition (at PS information level) associated to the CDR Closure, indicating the appropriate condition shall be present, and it shall be omitted otherwise.

5.2.3.9 Triggers for TDF-CDR charging information collection

5.2.3.9.1 Triggers for TDF-CDR charging information creation

A TDF-CDR is used to collect charging information related to the TDF session information for a UE/MS in the TDF, where the data volumes, elapsed time or number of events within each TDF-CDR are separately counted per rating group or per combination of the rating group and service id.

Many application containers per TDF session can be active simultaneously in TDF-CDR. An application container is activated when application traffic is detected and no matching active application container exist; an application container is closed when the application traffic of the matching application container is terminated as detected by the TDF.

When event based charging applies, the first occurrence of an event matching an application shall imply application traffic start. Details on ABC can be found in TS 23.203 [215] and TS 32.240 [1].

If, according to the Charging Characteristics profile, CDR generation is activated, a TDF-CDR shall be opened at TDF session establishment, and the volume (separately in uplink and downlink direction), elapsed time and/or number of events are counted. When a change of charging condition occurs, all containers are added to the TDF-CDR. The TDF-CDR includes details such as Record Type, Served IMSI, Sequence Number etc. and the ABC specific charging data. Not all of the charging information to be collected is static, and other charging information is directly dependent on dynamic Packet-Switched service usage.

It shall be possible to activate both online and offline charging interfaces for the same TDF session.

The default online and offline charging shall work independently of each other. Optionally it may be possible to operate with tight interworking between the online and offline charging mechanisms such that only the specified quota re-authorization triggers armed by the OCS (including e.g. tariff time change, returned quotas, etc.) are used to close the application containers for the TDF-CDR charging information addition, this information would be provided by the OCS in the Offline-Charging AVP. In this case, the information provided by the OCS shall take precedence over the default configuration at the TDF.

The subsequent clauses identify in detail the conditions for adding information to, and closing the TDF-CDR for generation towards the CGF.

5.2.3.9.2 Triggers for TDF-CDR charging information addition

TDF session specific offline charging is achieved with TDF session specific rating group/service identifier defined in clause 5.2.1.9.2.

The "List of Service Data" attribute of the TDF-CDR consists of a set of containers, which are added when specific trigger conditions are met. Each container identifies the configured counts (volume separated for uplink and downlink, elapsed time or number of events) per rating group or combination of the rating group and service id within the same TDF session, on encountering that trigger condition. For envelope reporting, the containers represent complete and closed time envelopes determined by mechanisms defined in TS 32.299 [50].

Table 5.2.3.9.2.1 identifies conditions that may be supported as recording triggers under consideration of additional Debit / Reserve Units triggers.

Some of the triggers are non-exclusive (e.g. TDF session modification with a couple of reasons, TDF session modification reasons that cause TDF-CDR closure).

Table 5.2.3.9.2.1: Triggers for TDF-CDR charging information addition "List of Service Data"

Trigger Conditions	Description/Behaviour
TDF session modification	A change of TDF session conditions (e.g. SGSN/S-GW/ePDG/TWAG change, user location change, user CSG information change) shall result in a set of "List of Service Data" containers, i.e. all active application containers, being added to the CDR as described in clause 5.2.1.9. In a tight interworking between online and offline charging the specified quota re-authorization triggers armed by OCS are supported.
Tariff Time Change	On reaching the Tariff Time Change a set of "List of Service Data" containers, i.e. all active application containers, shall be added to the CDR. In a tight interworking between online and offline charging the Debit / Reserve Units tariff time change from OCS is supported.
Failure Handling procedure triggering	When the Failure Handling mechanism is triggered a "List of Service Data", i.e. all active application containers shall be added to the CDR. The causes are only relevant in case of simultaneously usage of an active Debit / Reserve Units session.
Application traffic report	In case of independent online and offline charging a "List of Service Data" container for the application shall be added when: <ul style="list-style-type: none"> - expiry of time limit; - expiry of volume limit; - expiry of unit limit; - termination of application traffic.
	In case of tight interworking online and offline charging a "List of Service Data" container for the application shall be added when: <ul style="list-style-type: none"> - time threshold reached; - volume threshold reached; - unit threshold reached; - time quota exhausted; - volume quota exhausted; - unit quota exhausted; - expiry of quota validity time; - termination of application traffic; - re-authorization request by OCS.
CDR Closure	All active "List of Service Data" containers shall be added to the TDF-CDR. NOTE: The trigger condition is a common value that has to be used for CDR closure together with detailed reason.

The first traffic container identifies the data traffic since the TDF session was opened.

Subsequent data traffic containers store the configured counts accrued since the closure of the last container.

For envelope reporting, each envelope contains information about the data volume transferred in both uplink and downlink and / or the number of events that occurred for the duration that envelope is open. Only completed time envelopes shall be added to the TDF-CDR. The determination of completed envelopes are defined in TS 32.299 [50]. The triggers listed in the previous table 5.2.3.9.2.1 shall not apply to envelope reporting. Envelopes that are not complete when a partial TDF-CDR is closed shall be added to the next TDF-CDR.

The "Serving node Address" attribute of the TDF-CDR consists of a list of SGSN/S-GW/ePDG/TWAG addresses. New SGSN/S-GW/ePDG/TWAG address is added to the list when SGSN/S-GW/ePDG/TWAG changes.

When Charging Event (ACR) is triggered by table 5.2.3.9.2.1 conditions, the Change-Condition sub-field associated to the added container, indicating the appropriate condition shall be present, excluding CDR Closure case.

When Charging Event (ACR) is triggered by CDR Closure condition, this Change-Condition sub-field associated to the added container shall be omitted, except when CDR closure is due to "maximum number of charging condition changes", where it shall be present with the original condition change.

When Charging Event (ACR) is triggered by "User CSG Information change" as a Change condition, the following shall apply for the added volume container:

- When User enters in a CSG cell or a hybrid cell: the CSG ID, access mode and CSG membership indication (when hybrid), shall be provided together with this "User CSG Information change" Change-Condition.
- User leaves a CSG cell or a hybrid cell: this "User CSG Information change" Change-Condition shall be provided without any CSG ID, access mode and CSG membership indication, unless the user is entering a new CSG cell or hybrid cell.

5.2.3.9.3 Triggers for TDF-CDR closure

The TDF-CDR shall be closed on encountering specified trigger conditions.

Table 5.2.3.9.3.1 identifies which conditions are supported to permit closure of the TDF-CDR.

Table 5.2.3.9.3.1: Triggers for TDF-CDR closure

Closure Conditions	Description/Behaviour
End of TDF session	TDF session termination shall result in the CDR being closed. The trigger condition covers: <ul style="list-style-type: none"> - termination of TDF session by the PCRF; - any abnormal release.
Partial Record Reason	OAM&P reasons permit the closure of the CDR for internal reasons. The trigger condition covers: <ul style="list-style-type: none"> - data volume limit; - time (duration) limit; - maximum number of charging condition changes (i.e. number of service containers); - management intervention; - MS time zone change; - PLMN change; - radio access technology change (RAT Type).

The Partial Record generation trigger thresholds are those associated with the Charging Characteristics.

The Partial Record generation trigger thresholds are TDF configuration parameters defined per Charging Characteristics profile by the operator through OAM&P means, as specified in Annex A.

In the event that the TDF-CDR is closed and the TDF session remains active, a further TDF-CDR is opened with an incremented Sequence Number in the TDF.

When Charging Event (ACR) is triggered by table 5.2.3.9.3.1 conditions, the Change-Condition (at PS information level) associated to the CDR Closure, indicating the appropriate condition shall be present, and it shall be omitted otherwise.

5.2.3.10 Triggers for PGW-CDR charging information collection when IP-CAN session charging is active

5.2.3.10.1 General

A PGW-CDR is used to collect charging information related to the IP-CAN bearer data information for a UE/MS in the P-GW. When IP-CAN session charging is active, as described in clause 5.2.2.6, two types of data can be collected: traffic volumes used for IP-CAN bearer charging and service data used for FBC.

Many traffic volume and service data flow containers per IP-CAN session can be active simultaneously in PGW-CDR.

A new traffic volume container is activated when an IP-CAN bearer is activated.

A service data flow container is activated when traffic is detected and no matching active service data flow container exist; a service data flow container is closed when the termination of the last service data flow matching to the service data flow container is detected by the P-GW. When event based charging applies, the first occurrence of an event matching a service data flow template shall imply service data flow start. Details on FBC can be found in TS 23.203 [215] and TS 32.240 [1].

If, according to the Charging Characteristics profile, CDR generation is activated, a PGW-CDR shall be opened at IP-CAN session activation, and the volume (separately in uplink and downlink direction), elapsed time and/or number of events are counted.

When a change of charging condition occurs, all containers are added to the PGW-CDR. The PGW-CDR includes details such as Record Type, Served IMSI, Sequence Number etc. and both the traffic data and FBC specific charging data.

Not all of the charging information to be collected is static, and other charging information is directly dependent on dynamic Packet-Switched service usage.

It shall be possible to activate both online and offline charging interfaces for the same IP-CAN bearer.

The default online and offline charging shall work independently of each other. Optionally it may be possible to operate in a tight interworking between online and offline charging mechanism i.e. only the specified quota re-authorisation triggers armed by OCS (including e.g. tariff time change, returned quotas, etc.) are used to close the service data flow containers for the PGW-CDR charging information addition.

The subsequent clauses identify in detail the conditions for adding information to, and closing the PGW-CDR for generation towards the CGF.

5.2.3.10.2 Triggers for PGW-CDR charging information addition when IP-CAN session charging is active

The "List of Traffic Data Volumes" attribute of the PGW-CDR consists of a set of containers, which are added when specific trigger conditions are met, and identify the volume counter per QCI/ARP pair, separated for uplink and downlink traffic, on encountering that trigger conditions. Table 5.2.3.10.2.1 identifies which conditions are supported to trigger PGW-CDR charging information addition for the "List of Traffic Data Volumes" attribute.

The "List of Service Data" attribute of the PGW-CDR consists of a set of containers, which are added when specific trigger conditions are met. Each container identifies the configured counts (volume separated for uplink and downlink, elapsed time or number of events) per rating group or combination of the rating group and service id within the same IP-CAN bearer, on encountering that trigger condition. For envelope reporting, the containers represent complete and closed time envelopes determined by mechanisms defined in TS 32.299 [50]. Table 5.2.3.10.2.2 identifies conditions that may be supported as recording triggers under consideration of additional Debit / Reserve Units triggers.

Some of the triggers are non-exclusive (e.g. IP-CAN bearer modification with a couple of reasons, IP-CAN bearer modification reasons that cause PGW-CDR closure).

Table 5.2.3.10.2.1: Triggers for PGW-CDR charging information addition for List of Traffic Volumes when charging per IP-CAN session is active

Trigger Conditions	Description/Behaviour
End of dedicated bearer in P-GW	The end of a dedicated bearer in P-GW shall result that open "List of Traffic Data Volumes" containers for the dedicated bearer are closed and added to the CDR.
Serving node change	A serving node (e.g., SGSN/S-GW/ePDG/TWAG) change in the P-GW shall result that all open "List of Traffic Data Volumes" containers are closed and added to the CDR. New containers are opened for each bearer.
QoS Change	A change in the QoS shall result that open "List of Traffic Data Volumes" containers for the effected bearer being closed and added to the CDR and new IP-CAN bearer specific container is opened if the IP-CAN bearer is still active.
Tariff Time Change	On reaching the Tariff Time Change open "List of Traffic Data Volumes" containers shall be closed and added to the CDR.
User Location Change	A change in the User Location Info (e.g. ECGI, TAI, RAI, SAI or CGI) shall result that open "List of Traffic Data Volumes" containers being closed and added to the CDR, if location reporting is required, and a report of User Location Change is received.
User CSG Information change	A change in the User CSG info (e.g. CSG ID, access mode or CSG membership indication) shall result that open "List of Traffic Data Volumes" containers being closed and added to the CDR, if CSG information reporting is required, and a report of User CSG information change is received.
Change of UE presence in Presence Reporting Area	A change of UE presence in Presence Reporting Area(s) shall result that open "List of Traffic Data Volumes" containers being closed and added to the CDR, if such reporting is required, and a report that user enters/leaves the area or the Presence Reporting Area(s) is set to inactive by the serving node are received.
Addition of access to a PDN connection	New SGSN/S-GW/ePDG/TWAG address is added to data for the IP-CAN bearer in the CDR.
Removal of access from a multi-access PDN connection	The counters and time stamps for the IP-CAN bearers of the removed access are closed and resulting containers added to CDR
Access of a multi-access PDN connection becomes unusable	The counters and time stamps for the IP-CAN bearers of the unusable access are closed and resulting containers added to the CDR.
Traffic volume report	A "List of Traffic Data Volumes" container for an IP-CAN bearer shall be added when: <ul style="list-style-type: none"> - expiry of time limit per IP-CAN bearer; - expiry of data volume limit per IP-CAN bearer.
CDR Closure	Open "List of Traffic Data Volumes" containers shall be closed and added to the PGW-CDR.

Editor's Note: The individual events associated with change of charging condition must be re-evaluated in the context of NBIFOM. Changes to this event are FFS.

Editor's Note: The handling of "Serving PLMN Rate Control change", "APN Rate Control change" events when charging per IP-CAN session applies is FFS.

Table 5.2.3.10.2.2: Triggers for PGW-CDR charging information addition for "List of Service Data" when charging per IP-CAN session is active

Trigger Conditions	Description/Behaviour
IP-CAN bearer modification except QoS change	A change of IP-CAN bearer conditions (e.g. SGSN/S-GW/ePDG/TWAG change, user location change, user CSG information change, change in UE presence in Presence Reporting Area) shall result in a set of "List of Service Data" containers, i.e. all active service data flow containers, being added to the CDR as described in clause 5.2.1.10.2. In a tight interworking between online and offline charging the specified quota re-authorization triggers armed by OCS are supported.
Tariff Time Change	On reaching the Tariff Time Change a set of "List of Service Data" containers, i.e. all active service data flow containers, shall be added to the CDR. In a tight interworking between online and offline charging the Debit / Reserve Units tariff time change from OCS is supported.
ASR or Failure Handling procedure triggering	When the Debit / Reserve Units session is terminated with ASR or Failure Handling mechanism is triggered a "List of Service Data", i.e. all active service data flow containers shall be added to the CDR. The causes are only relevant in case of simultaneously usage of an active Debit / Reserve Units session.
Service data flow report	In case of independent online and offline charging a "List of Service Data" container for the service data flow shall be added when: <ul style="list-style-type: none"> - expiry of time limit per rating group; - expiry of volume limit per rating group; - expiry of unit or data event limit per rating group; - access change of service data flow and all service data flows for the rating group, combination of rating group and service identifier, or combination of rating group, sponsor identity and application service provider identity are moved from one access to another; - termination of service data flow and this is the last service data flow for the rating group or combination of rating group and service identifier, or combination of rating group, sponsor identity and application service provider identity. In case of tight interworking online and offline charging a "List of Service Data" container for the service data flow shall be added when: <ul style="list-style-type: none"> - time threshold reached; - volume threshold reached; - unit threshold reached; - time quota exhausted; - volume quota exhausted; - unit quota exhausted; - expiry of quota validity time; - access change of service data flow; - termination of service data flow; - re-authorization request by OCS.
CDR Closure	All active "List of Service Data" containers shall be added to the PGW-CDR. Note: The trigger condition is a common value that has to be used for CDR closure together with detailed reason.

Editor's Note: The individual events associated with change of charging condition must be re-evaluated in the context of NBIFOM. Changes to this event are FFS.

Editor's Note: The handling of "Serving PLMN Rate Control change", "APN Rate Control change" events when charging per IP-CAN session applies is FFS.

The first traffic container identifies the data traffic since the IP-CAN session was opened. Subsequent data traffic containers store the configured counts accrued since the closure of the last container.

For envelope reporting, each envelope contains information about the data volume transferred in both uplink and downlink and / or the number of events that occurred for the duration that envelope is open. Only completed time envelopes shall be added to the PGW-CDR. The determination of completed envelopes are defined in TS 32.299 [50]. The triggers listed in the previous table shall not apply to envelope reporting. Envelopes that are not complete when a partial PGW-CDR is closed shall be added to the next PGW-CDR.

The "Serving node Address" attribute of the PGW-CDR consists of a list of SGSN/S-GW/ePDG/TWAG addresses. New SGSN/S-GW/ePDG/TWAG address is added to the list when SGSN/S-GW/ePDG/TWAG changes.

When Charging Event (ACR) is triggered by table 5.2.3.10.2.1 or 5.2.3.10.2.2 conditions, the Change-Condition sub-field associated to the added container, indicating the appropriate condition, shall be present, excluding CDR Closure case.

When Charging Event (ACR) is triggered by CDR Closure condition, this Change-Condition sub-field associated to the added container shall be omitted, except when CDR closure is due to "maximum number of charging condition changes", where it shall be present with the original condition change.

When Charging Event (ACR) is triggered by "User CSG Information change" as a Change condition, the following shall apply for the added volume container:

- When User enters in a CSG cell or a hybrid cell: the CSG ID, access mode and CSG membership indication (when hybrid), shall be provided together with this "User CSG Information change" Change-Condition.
- User leaves a CSG cell or a hybrid cell: this "User CSG Information change" Change-Condition shall be provided without any CSG ID, access mode and CSG membership indication, unless the user is entering a new CSG cell or hybrid cell.

5.2.3.10.3 Triggers for PGW-CDR closure when charging per IP-CAN session charging is active

The PGW-CDR shall be closed on encountering trigger conditions.

Table 5.2.3.10.3.1 identifies which conditions are supported to permit closure of the PGW-CDR.

Table 5.2.3.10.3.1: Triggers for PGW-CDR closure

Closure Conditions	Description/Behaviour
End of IP-CAN session within the P-GW	Deactivation of the IP-CAN session in the P-GW shall result in the CDR being closed. The trigger condition covers: <ul style="list-style-type: none"> - termination of last IP-CAN bearer for the IP-CAN session; - any abnormal release.
Partial Record Reason	OAM&P reasons permit the closure of the CDR for internal reasons. The trigger condition covers: <ul style="list-style-type: none"> - data volume limit per IP-CAN session; - time (duration) limit for keeping a CDR open; - data event limit per IP-CAN session; - maximum number of charging condition changes; - management intervention; - APN-AMBR change; - MS time zone change; - PLMN change; - radio access technology change (RAT Type).

The Partial Record generation trigger thresholds are those associated with the Charging Characteristics. The Partial Record generation trigger thresholds are P-GW configuration parameters defined per Charging Characteristics profile by the operator through OAM&P means, as specified in annex A.

In the event that the PGW-CDR is closed and the IP-CAN session remains active, a further PGW-CDR is opened with an incremented Sequence Number in the P-GW.

When Charging Event (ACR) is triggered by table 5.2.3.10.3.1 conditions, the Change-Condition (at PS information level) associated to the CDR Closure, indicating the appropriate condition shall be present, and it shall be omitted otherwise.

5.2.3.11 Triggers for TWAG-CDR charging information collection

5.2.3.11.0 Introduction

A TWAG-CDR is used to collect charging information related to the IP-CAN bearer data information for a UE/MS in the TWAG.

If, according to the Charging Characteristics, CDR generation is activated a TWAG-CDR shall be opened at IP-CAN bearer activation and IP-CAN bearer specific container is opened.

When a change of charging condition occurs, the volume counts are added to the TWAG-CDR and new counts are started. The TWAG-CDR includes details such as Record Type, Served IMSI, Sequence Number etc. Not all of the charging information to be collected is static, and other charging information is directly dependent on dynamic Packet-Switched service usage.

The subsequent clauses identify in detail the conditions for adding information to, and closing the TWAG-CDR for generation towards the CGF.

5.2.3.11.1 Triggers for TWAG-CDR charging information addition

The "List of Traffic Data Volumes" attribute of the TWAG-CDR consists of a set of containers, which are added when specific trigger conditions are met, and identify the volume count per QoS, separated for uplink and downlink traffic, on encountering that trigger condition.

Table 5.2.3.11.1.1 identifies which conditions are supported to trigger TWAG-CDR charging information addition.

Table 5.2.3.11.1.1: Triggers for TWAG-CDR charging information addition

Trigger Conditions	Description/Behaviour
QoS Change	A change in the QoS shall result that open "List of Traffic Data Volumes" containers being closed and added to the CDR and new IP-CAN bearer specific container is opened.
Tariff Time Change	On reaching the Tariff Time Change open "List of Traffic Data Volumes" containers shall be closed and added to the CDR.
CDR Closure	Open "List of Traffic Data Volumes" containers shall be closed and added to the TWAG-CDR.

Volume container identifies the uplink/downlink volume since the closure of the last container.

When Charging Event (ACR) is triggered by table 5.2.3.11.1.1 conditions, the Change-Condition sub-field associated to the added volume container, indicating the appropriate condition, shall be present, excluding CDR Closure case.

When Charging Event (ACR) is triggered by CDR Closure condition, this Change-Condition sub-field associated to the added volume container shall be omitted, except when CDR closure is due to "maximum number of charging condition changes", where it shall be present with the original condition change.

5.2.3.11.2 Triggers for TWAG-CDR closure

The TWAG-CDR shall be closed on encountering some trigger conditions.

Table 5.2.3.11.2.1 identifies which conditions are supported to permit closure of the TWAG-CDR.

Table 5.2.3.11.2.1: Triggers for TWAG-CDR closure

Closure Conditions	Description/Behaviour
End of IP-CAN bearer within the TWAG	Deactivation of the IP-CAN bearer in the TWAG shall result in the CDR being closed. The trigger condition covers: <ul style="list-style-type: none"> - termination of IP-CAN bearer; - any abnormal release; - inter serving node change.
Partial Record Reason	OAM&P reasons permit the closure of the CDR for internal reasons. The trigger condition covers: <ul style="list-style-type: none"> - data volume limit; - time (duration) limit; - maximum number of charging condition changes (QoS/tariff time change); - management intervention;

The Partial Record generation trigger thresholds are those associated with the Charging Characteristics. The Partial Record generation trigger thresholds are TWAG configuration parameters defined per Charging Characteristics profile by the operator through OAM&P means, as specified in annex A.

In the event that the TWAG-CDR is closed and the IP-CAN bearer remains active, a further TWAG-CDR is opened with an incremented Sequence Number in the TWAG.

When Charging Event (ACR) is triggered by table 5.2.3.11.2.1 conditions, the Change-Condition (at PS information level) associated to the CDR Closure, indicating the appropriate condition shall be present, and it shall be omitted otherwise.

5.2.4 Void

5.2.5 Ga record transfer flows

In EPC, both fully qualified partial CDRs (FQPC) and reduced partial CDRs (RPC), as specified in TS 32.240 [1] may be supported on the Ga interface. In line with TS 32.240 [13], the support of FQPCs is mandatory, the support of RPCs is optional. For further details on the Ga protocol application refer to TS 32.295 [54].

5.2.6 Bp CDR file transfer

In EPC, both fully qualified partial CDRs (FQPC) and reduced partial CDRs (RPC), as specified in TS 32.240 [1] may be supported on the Bp interface. In line with TS 32.240 [13], the support of FQPCs is mandatory, the support of RPCs is optional. For further details on the Bp protocol application refer to TS 32.297 [52].

5.3 PS domain online charging scenarios

5.3.1 Basic principles

5.3.1.0 General

PS domain online charging may be performed in the SGSN using CAMEL techniques. This functionality is specified in TS 23.078 [206] and TS 29.078 [202] and is outside the scope of the present document.

PS domain online charging may be performed by the PCEF in the P-GW and by the TDF using the common Ro based Credit-Control application specified in TS 32.299 [50]. In order to provide the data required for the management activities outlined in TS 32.240 [1] (Credit-Control, accounting, statistics etc.), the PCEF shall be able to perform online charging for each of the following:

- Charging data related to IP-CAN bearers;
- Charging data related to service data flows.

The above items both pertain to sessions (IP-CAN bearers), hence session based online charging (SCUR) with centralized rating and centralized unit determination is required in the PCEF.

The TDF shall be able to perform online charging each of the following:

- Charging data related to TDF session;
- Charging data related to detected application traffic.

The above items pertain to sessions (application traffic), hence SCUR is required in the TDF with centralized or decentralized unit determination and centralized rating.

The Debit / Reserve Units Request and Debit / Reserve Units Response specified for SCUR in TS 32.299 [50] (initial/update/termination) are issued towards the OCS / received from the OCS when certain conditions (chargeable events) are met. The PS domain specific contents and purpose of each of these messages, as well as the chargeable events that trigger them, are described in the following sub-clauses. A detailed formal description of the online charging parameters defined in the present document is to be found in TS 32.299 [50]. Further information on the general principles of the common 3GPP online charging application can also be found in TS 32.299 [50] and TS 32.240 [1].

The Credit-Control is always per rating group but the reporting level can be either per rating group or per combination of the rating group and service id. Reporting level is defined per PCC rule in case of PCEF integrated in the P-GW or per ADC rule in case of TDF. In order to avoid that charging sessions remain inactive for a long period of time, the PCEF or OCS may terminate the online charging session under the condition that no granted quota has been consumed for a certain period of time. The PCEF starts a new online charging session when there is a need for new quota, for the same IP-CAN bearer or IP-CAN session, and the same Charging id as the initial session shall be used.

5.3.1.1 IP-CAN bearer charging

IP-CAN bearer online charging is achieved by FBC online charging, see clause 5.3.1.2. When the IP-CAN bearer is online charged by means of FBC, the quota handling shall also be based on the use of a Rating Group/Service Identifier. The value of this IP-CAN bearer specific Rating Group/Service Identifier shall be vendor specific.

The amount of data counted with IP-CAN bearer specific Rating Group/Service Identifier shall be based on:

- In case of GTP based tunnelling and interworking with external IP networks: the inner IP packets in the GTP-U packet (T-PDU, see TS 29.281 [217]).
- In case of GTP based tunnelling and interworking with external networks handling other data services (e.g. non-IP, PPP): the T-PDU packets (see TS 29.281 [217]).
- In case of PMIP based protocol: the payload of the GRE tunnel.
- In case of DSMIPv6 based protocol: the payload of the tunnelling layer.

As minimum behaviour, the full payload shall be included. Time metering is started when IP-CAN bearer is activated.

NOTE 1: P-GW is aware of bearers in case of GTP based connectivity. In case of any other PMIP based connectivity, P-GW is aware of IP-CAN sessions only. If P-GW is not aware of IP-CAN bearers, P-GW collects charging information per IP-CAN session as it would be just one IP-CAN bearer.

NOTE 2: The control plane IP address of SGSN or P-GW (acting as GGSN) is the IP address used at Gn/Gp interface.

The control plane IP address of S-GW or P-GW is the IP address used at S5/S8 interface.

The control plane IP address of ePDG or P-GW is the IP address used at S2b interface.

The control plane IP address of TWAG or P-GW is the IP address used at S2a interface.

5.3.1.2 Flow Based bearer Charging

IP-CAN bearer charging allows the P-GW to collect charging information related to data volumes sent to and received by the UE/MS, categorised by the QoS applied to the IP-CAN bearer. FBC is supported by the P-GW by the integrated PCEF. When the PCEF is present, the normal IP-CAN bearer charging is enhanced by the capability to categorise the service data flows within IP-CAN bearer data traffic by rating group or combination of the rating group and service id. I.e., while there is only one uplink and one downlink data volume count per IP-CAN bearer in IP-CAN bearer charging, FBC may provide one count per each rating group or combination of the rating group and service id. The level of the reporting is defined per PCC rule. Details of this functionality are specified in TS 23.203 [215] and TS 32.240 [1].

NOTE: The P-GW can only include one QoS Information occurrence per Multiple Unit Operation. This implies if an operator wishes to be able to separate usage according to QCI and ARP within their charging system they will need to ensure that services having different QCI and ARP do not have the same:

- rating group in cases where rating reporting is used;
- rating group/service id where rating group/service id reporting is used.

Extended packet inspection can be done in the PCEF with pre-defined PCC rules. The PCEF also have the possibility to output service specific information related to the packet inspection in the online charging information.

An Application Function (AF) may provide an external charging identifier to be delivered to the PCEF by the PCRF with a dynamic PCC rule. The PCEF includes this AF correlation information in the online charging information for the rating group and service identifier associated with the dynamic PCC rule when service identifier level reporting is requested.

The capability of P-GW to support ABC is achieved with PCRF providing appropriate PCC Rules to the P-GW. Such PCC Rule shall be defined with service data flow template including an Application Identifier for the application which needs to be detected, enforced and charged.

According to TS 23.203 [215], FBC shall support different charging models per PCC rule. These charging models may be based on volume and/or time and on number of events matching a specific service data flow template in PCC rule. In general the charging of a service data flow shall be linked to the IP-CAN bearer under which the service data flow has been activated. In online charging the PCEF shall request the reservation of units prior to service delivery.

The following chargeable events are defined for FBC when online charging is activated:

- Network request for IP-CAN bearer activation before the Initiate IP-CAN bearer Activation message is sent. Associated with the network requested dedicated IP-CAN bearer activation procedure, as defined in TS 23.203 [215] and TS 23.060 [201], upon encountering this event, a Debit / Reserve Units Request[Initial], indicating the request for activation of dedicated IP-CAN bearer is sent toward the OCS. For network requested dedicated IP-CAN bearer activation, if known by the PCEF, the PCEF may provide status of UE presence in Presence Reporting Area(s).
- Start of IP-CAN bearer. Upon encountering this event, a Debit / Reserve Units Request[Initial], indicating the start of the IP-CAN bearer, is sent towards the OCS to authorize the IP-CAN bearer. For network requested dedicated IP-CAN bearer activation, this event triggers a Debit / Reserve Units Request[Update], when the PCEF receives an Update PDP Context Request message with the RAN Procedures Ready flag. If known by the PCEF, the PCEF may provide status of UE presence in Presence Reporting Area(s). PCEF may request quota later when service usage is started.

- Start of service data flow. In case valid quota does not exist a Debit / Reserve Units Request[Update] is generated to request quota. In case charging session does not exist, the request is a Debit/ Reserve Units Request[Initial] sent towards the OCS.
The type of requested quota shall depend on measurement method configured for the PCC rule in case of decentralized unit determination. When event based charging applies, the first occurrence of an event matching a service data flow template in PCC rule shall be considered as the start of a service.
- Termination of service data flow. If reporting is per rating group and this is the last service data flow utilizing that specific rating group or if reporting is per combination of the rating group and service id and this is the last service data flow utilizing that specific rating group and service id, the required counters are updated. Termination of the service data flow itself does not trigger Debit / Reserve Units Request[Update].
- Access of a multi-access PDN connection becomes unusable: the Termination of service data flow chargeable event applies for all the service data flows carried under the IP-CAN bearer of the unusable access.
- Access of a multi-access PDN connection becomes usable: the Start of service data flow chargeable event applies for all the service data flows carried under the IP-CAN bearer of the access that has become usable.
- Expiry of Unused Quota timer for the charging session in PCEF, a Debit / Reserve Units Request[Terminate] is sent to OCS indicating that charging session is terminated, and the IP-CAN bearer is still active. In this case the OCS shall allow for a new session to be started with the same Charging Id.
- End of IP-CAN bearer. Upon encountering this event, a Debit / Reserve Units Request[Terminate], indicating the end of the IP-CAN bearer, is sent towards the OCS together with the final counts.
- Ro specific chargeable events (e.g. threshold reached, QHT expires, quota exhaustion, validity time reached, forced re-authorization). Corresponding counts for the rating group(s) are closed and Debit / Reserve Units Request[Update] is triggered according the rules defined in TS 32.299 [50].
- Change of charging condition: E.g. QoS change, user location change, user CSG information change, change of UE presence in Presence Reporting Area(s), change of 3GPP PS Data Off status, Serving PLMN Rate Control change, and APN Rate Control change.
When this event is encountered and the corresponding re-authorization trigger is armed, all current counts are captured and sent towards the OCS with a Debit / Reserve Units Request[Update].
- Tariff time change. When this event is encountered, all current counts are captured and a new counts are started. The counts are sent to the OCS in next Debit / Reserve Units Request.

Management intervention may also force trigger a chargeable event.

If the PCEF supports the Unused Quota timer it may send its locally configured value to the OCS. The OCS may in this case respond with a new value of the Unused Quota timer to the PCEF, to be used instead of the PCEF configured value.

PCC rules can be activated, deactivated and modified any time during the IP-CAN bearer lifetime. PCC rule activation, deactivation and modification are not chargeable events. However these PCC rule changes may lead to "start of service data flow" and "termination of service data flow" chargeable events.

According to TS 23.203 [215], the PCRF can modify the following charging information in a dynamic PCC rule which is active in the PCEF: Charging key, Service identifier, Measurement method, Service identifier level reporting. The PCRF can also modify the allowed access type in the case of NBIFOM.

Change of Charging key, ServiceIdentifier, IP-CAN type, measurement method or allowed access type will trigger a "start of service data flow" chargeable event when valid quota does not exist corresponding to that changed PCC rule. Change of Charging key, Service Identifier, IP-CAN type, measurement method, Service identifier level reporting or allowed access type will trigger a "termination of service data flow" chargeable event when this is the last service data flow utilizing the quota used for the original PCC rule.

For non-IP type PDN connection in the P-GW:

- non-3GPP access types are not supported, multi-access PDN connections do not apply;
- A single PCC Rule is used with the service data flow descriptor matching the whole non-IP data traffic, and can contain e.g.:
 - service data flow template matching all the packets;

- charging method to identify whether online/offline/both/neither charging interface is used;
- measurement method to identify whether time/volume/events are measured for this service data flow;
- Charging key (i.e. rating group) for that service data flow;
- service identifier for that service data flow,
- reporting level for that service data flow:
 - rating group level in case a specific rating group is used for non-IP traffic charging.
 - combination of the rating group and service id in case a specific rating group/service Id is used for non-IP traffic charging.

5.3.1.3 PS Furnish Charging Information procedure

The OCS online charging function may use this procedure to add online charging session specific information to the PGW-CDR and to the TDF-CDR. The information can be sent per online session and in case FBC is enabled for a specific APN, or ABC is enabled in case of the TDF, the OCS online charging function may also send specific information per each online charged service by means of this procedure.

5.3.1.4 Support of Failure Situations

In case the OCS fails, the P-GW and the TDF shall support the Failure Handling procedure and Failover mechanism described in TS 32.299 [50]. These mechanisms give flexibility to have different failure handling scenarios when the OCS fails.

Three different actions are described in RFC 4006 [402].

P-GW shall support the following actions when the failure handling mechanism is executed:

- Terminate: The online session is finished. The associated IP-CAN bearer session is released (ongoing sessions) or not established (new sessions). Failover for ongoing sessions is not supported. Failover for new sessions is always supported.
- Retry&Terminate: The online session is finished. The associated IP-CAN bearer session is released (ongoing sessions) or not established (new sessions). Failover for ongoing sessions is supported. Failover for new sessions is always supported.
- Continue: The online session is finished. The associated IP-CAN bearer session is established (new sessions) or not released (ongoing sessions). Failover for ongoing sessions is supported. Failover for new sessions is always supported.

TDF shall support the following actions when the failure handling mechanism is based on the directives received previously from the OCS:

- Terminate: This is the default behaviour. The TDF indicates to the PCRF that the charging session was terminated and the OCS does not allow the service to continue. The PCRF determines whether to continue or terminate the associated TDF session.
- Retry&Terminate: If the OCS and TDF support failover procedures and there is an alternate OCS available, the TDF shall attempt to failover to an alternative OCS. Otherwise, the TDF indicates to the PCRF that the charging session was terminated and the OCS does not allow the service to continue. The PCRF determines whether to continue or terminate the associated TDF session.
- Continue: If the OCS and TDF support failover procedures and there is an alternate OCS available, the TDF shall attempt to failover to an alternative OCS. Otherwise, the TDF indicates to the PCRF that the charging session was terminated and the OCS allows the service to continue. The PCRF determines whether to continue or terminate the associated TDF session.

If the user is simultaneously online and offline charged, the failure situation shall be registered in the PGW-CDR/TDF-CDR. When the user is only online charged, the execution of the Failure Handling mechanism with value equal to Continue shall imply that a new PGW-CDR/TDF-CDR is opened.

5.3.1.5 Application Based Charging (ABC)

5.3.1.5.0 Introduction

For the sub-clauses that follow, a single Debit / Reserve Units session is defined to handle both TDF session and application based charging information when both are to be used. Either TDF session charging or ABC but not both may be active as determined by Charging Characteristics.

For ABC the opening and closing of the Debit / Reserve Units session is bound by the TDF session start and end respectively.

5.3.1.5.1 Charging per application

ABC allows collecting charging information related to data volumes sent to and received by the UE/MS, based on the application detection. ABC supported by the TDF, i.e. ADC rules based charging defined in TS 23.203 [215] and TS 29.212 [216], is based on ADC rules. The application traffic within TDF session is categorised by rating group or combination of the rating group and service identifier. The level of the reporting is defined per ADC rule. Details of this functionality are specified in TS 23.203 [215] and TS 32.240 [1].

NOTE: ABC is supported by the P-GW embedding PCEF enhanced with application detection and control functionality as defined in TS 23.203 [215], by mean of appropriate PCC Rules, and therefore specified under FBC clause 5.3.1.2 and clause 5.3.1.6.2.

According to TS 23.203 [215], ABC shall support different charging models per ADC rule. These charging models may be based on volume and/or time or on number of events as the application referred by either application identifier or service data flow filters to identify the packets belonging to an application in ADC rule. In online charging the TDF shall request the reservation of units prior to service delivery.

The following chargeable events are defined for ABC when online charging is activated:

- Start of TDF session. Upon encountering this event, a Debit / Reserve Units Request[Initial] indicating the establishment of the TDF session, is sent towards the OCS to activate the online charging session with the TDF. The quota for each activated ADC rule may be requested in such Debit / Reserve Units Request[Initial] or later when application traffic is detected .
- Start of application traffic. In case valid quota does not exist for the rating group, a Debit / Reserve Units Request[Update] is generated to request quota. The type of requested quota shall depend on measurement method configured for the ADC rule in case of decentralized unit determination. When event based charging applies, the first occurrence of an event detected according to the pre-defined ADC rule shall be considered as the start of a application.
- Termination of application traffic. If reporting is per rating group and this is the last application traffic utilizing that specific rating group or if reporting is per combination of the rating group and service identifier and this is the last application traffic utilizing that specific rating group and service identifier, the required counters are updated.
- End of TDF session in the TDF. Upon encountering this event, a Debit / Reserve Units Request[Terminate], indicating the end of the TDF session, is sent towards the OCS together with the final counts.
- Ro specific chargeable events (e.g. threshold reached, QHT expires, quota exhaustion, validity time reached, forced re-authorization). Corresponding counts for the rating group(s) are closed and Debit / Reserve Units Request[Update] is triggered according the rules defined in TS 32.299 [50].
- Change of charging condition: e.g. user location change, user CSG information change. When this event is encountered and the corresponding re-authorization trigger is armed, all current counts are captured and sent towards the OCS with a Debit / Reserve Units Request[Update].
- Tariff time change. When this event is encountered, all current counts are captured and a new counts are started. The counts are sent to the OCS in next Debit / Reserve Units Request.

Management intervention may also force trigger a chargeable event.

ADC rules can be activated, deactivated and modified any time during the TDF session lifetime. ADC rules activation, deactivation and modification are not chargeable events. However these ADC rules changes may lead to "start of application traffic" and "termination of application traffic" chargeable events.

Application Detection and Control rule can contain e.g.:

- Application Identifier to identify detected application or service data flow filters to identify the packets belonging to an application,
- charging method to identify whether online/offline/both/neither charging interface is used,
- measurement method for online/offline charging to identify whether time/volume/events are measured for this application,
- Charging key (i.e. rating group) for that application,
- service identifier for that application,
- reporting level for the application (rating group or combination of the rating group and service id),
- precedence to the situations where two or more ADC rules are overlapping.

Application Detection and Control rule can be:

- pre-defined in TDF (can be activated by the PCRF) or,
- dynamically provisioned and activated by the PCRF over the Sd interface.

This is specified in TS 23.203 [215] and TS 29.212 [216].

According to TS 23.203 [215], the PCRF can modify the following charging information in a dynamic ADC rule which is active in the TDF: Charging key, Service identifier, Measurement method, Service identifier level reporting. Change of Charging key, Service Identifier, or measurement method will trigger a "start of application traffic" chargeable event when valid quota does not exist. Change of Charging key, Service Identifier or measurement method, or Service identifier level reporting will trigger a "termination of application traffic" chargeable event when this is the last application traffic utilizing the quota used for the Charging key or combination of Charging key and Service identifier of original ADC rule.

5.3.1.5.2 Charging per TDF session

TDF session online charging is achieved by ABC online charging such that the quota handling for the TDF session shall be based on associating a specific Rating Group/Service Identifier with the TDF session. The value of this TDF session specific Rating Group/Service Identifier shall be vendor specific.

The amount of data counted with TDF session specific Rating Group/Service Identifier shall be the user plane payload. Time metering is started when TDF session is activated.

5.3.1.6 Charging per IP-CAN session

5.3.1.6.0 General

Charging per IP-CAN session is an optional capability in the P-GW that provides for a consolidated view of the service data flow charging information across all bearers in the IP-CAN session. When charging per IP-CAN session is active, the basic principles in this clause apply to the P-GW instead of the principles in clause 5.3.1.1 and clause 5.3.1.2 above.

For the sub-clauses that follow, a single Debit / Reserve Units session is defined to handle both types of charging information when both are to be used. When Charging per IP-CAN session is active, either IP-CAN bearer charging or FBC but not both may be active as determined by Charging Characteristics.

5.3.1.6.1 IP-CAN bearer charging

IP-CAN bearer online charging is achieved by FBC online charging, see clause 5.3.1.6.2. When the IP-CAN session is online charged by means of FBC, the quota handling shall also be based on the use of a Rating Group. The value of this IP-CAN bearer specific Rating Group or combination of the Rating Group and Service Identifier shall be vendor specific.

The amount of data counted with IP-CAN bearer specific Rating Group/Service Identifier shall be based on:

- In case of GTP based tunnelling and interworking with external IP networks: the inner IP packets in the GTP-U packet (T-PDU, see TS 29.281 [217])
- In case of GTP based tunnelling and interworking with external networks handling other data services (e.g. non-IP, PPP): the T-PDU packets (see TS 29.281 [217])
- In case of PMIP based protocol: the payload of the GRE tunnel
- In case of DSMIPv6 based protocol: the payload of the tunnelling layer

As minimum behaviour, the full payload shall be included. Time metering is started when IP-CAN session is activated. All bearers in the IP-CAN session are included in the single vendor-specific Rating Group/Service Identifier.

NOTE 1: P-GW is aware of bearers in case of GTP based connectivity. In case of any other PMIP based connectivity, P-GW is aware of IP-CAN sessions only. If P-GW is not aware of IP-CAN bearers, P-GW collects charging information per IP-CAN session as it would be just one IP-CAN bearer.

NOTE 2: The control plane IP address of SGSN or P-GW (acting as GGSN) is the IP address used at Gn/Gp interface.
The control plane IP address of S-GW or P-GW is the IP address used at S5/S8 interface.
The control plane IP address of ePDG or P-GW is the IP address used at S2b interface.
The control plane IP address of TWAG or P-GW is the IP address used at S2a interface.

NOTE 3: The vendor-specific Rating Group/Service Identifier may be configurable through the use of a predefined PCC rule in the P-GW.

5.3.1.6.2 Flow Based Charging (FBC)

FBC is supported by the P-GW by the integration of a PCEF. With PCEF, charging is enhanced by the capability to categorise the service data flows within IP-CAN session data traffic by rating group or combination of the rating group and service id. For online charging, FBC provides credit management for each rating group and may provide reporting (i.e., counts) per each rating group or combination of the rating group and service id. The level of the reporting is defined per PCC rule. Details of this functionality are specified in TS 23.203 [215] and TS 32.240 [1].

NOTE 1: Even though an individual service data flow template is bound to a specific IP-CAN bearer, the assigned rating group or combination of rating group and service id applies to the entire IP-CAN session. As a result, data traffic from multiple bearers can be included in the count maintained for the rating group or combination of the rating group and service id. This implies if an operator wishes to be able to separate usage according to IP-CAN bearer within their charging system they will need to ensure that services having different QCI and ARP do not have the same:

- rating group in cases where rating group reporting is used;
- rating group/service id where rating group/service id reporting is used.

NOTE 2: The P-GW can only include one QoS Information occurrence per Multiple Unit Operation.

This implies if an operator wishes to be able to separate usage according to QCI and ARP within their charging system they will need to ensure that services having different QCI and ARP do not have the same:

- rating group in cases where rating group reporting is used;
- rating group/service id where rating group/service id reporting is used.

NOTE 2a: The P-GW can only include one RAT type per service data container.

This implies if an operator wishes to be able to separate usage according to RAT type within their billing system they will need to ensure that services having different RAT type do not have the same:

- rating group in cases where rating group reporting is used;
- rating group/service id where rating group/service id reporting is used.

Extended packet inspection can be done in the PCEF with pre-defined PCC rules. The PCEF also have the possibility to output service specific information related to the packet inspection in the online charging information.

The capability of P-GW to support ABC is achieved with PCRF providing appropriate PCC Rules to the P-GW. Such PCC Rule shall be defined with service data flow template including an Application Identifier for the application which needs to be detected, enforced and charged.

According to TS 23.203 [215], FBC shall support different charging models per PCC rule. These charging models may be based on volume and/or time and on number of events matching a specific service data flow template in PCC rule. In online charging the PCEF shall request the reservation of units prior to service delivery.

The following chargeable events are defined for FBC when online charging and Charging per IP-CAN session is activated:

- Start of IP-CAN session. Upon encountering this event, a Debit / Reserve Units Request[Initial], indicating the start of the IP-CAN session, is sent towards the OCS to authorize the IP-CAN session. PCEF may request quota later when service usage is started.
- Start of service data flow. If no valid quota has been granted for the rating group, a Debit / Reserve UnitsRequest[Update] is generated to request quota. In case charging session does not exist, the request is a Debit / Reserve Units Request[Initial] sent towards the OCS. The type of requested quota shall depend on measurement method configured for the PCC rule in case of decentralized unit determination. When event based charging applies, the first occurrence of an event matching a service data flow template in PCC rule shall be considered as the start of a service.
- Access change of service data flow.
If service identifier level reporting is required by the PCC rule and all service data flows for this combination of the rating group and service id are changing from one access to another, or if rating group level reporting is required by the PCC rule and all service data flows for this rating group are changing from one access to another, corresponding counts are closed and Debit / Reserve Units Request[Update] is triggered.
- Termination of service data flow. If reporting is per rating group and this is the last service data flow utilizing that specific rating group or if reporting is per combination of the rating group and service id and this is the last service data flow utilizing that specific rating group and service id, the required counters are updated. Termination of the service data flow itself does not trigger Debit / Reserve Units Request[Update].
- Expiry of Unused Quota timer for the charging session in PCEF, a Debit / Reserve Units Request[Terminate] is sent to OCS indicating that charging session is terminated, and the IP-CAN bearer is still active. In this case the OCS shall allow for a new session to be started with the same Charging Id.
- End of IP-CAN session. Upon encountering this event, a Debit / Reserve Units Request[Terminate], indicating the end of the IP-CAN session, is sent towards the OCS together with the final counts.
- Ro specific chargeable events (e.g. threshold reached, QHT expires, quota exhaustion, validity time reached, forced re-authorization). Corresponding counts for the rating group(s) are closed and Debit / Reserve Units Request[Update] is triggered according the rules defined in TS 32.299 [50].

- Change of charging condition specific to APN-AMBR change: When this event is encountered and the corresponding re-authorization trigger is armed, all current counts are captured and sent towards the OCS with a Debit / Reserve Units Request[Update].
- Change of charging condition other than QoS change: E.g. user location change, user CSG information change, change of UE presence in Presence Reporting Area(s) , change of 3GPP PS DataOff status. When this event is encountered and the corresponding re-authorization trigger is armed, all current counts are captured and sent towards the OCS with a Debit / Reserve Units Request[Update].
Change of charging condition other than QoS change events are associated with one access of a multi-access PDN connection and all counts associated with affected access are identified with the specific event. All counts associated with the other access of a multi-access PDN connection are identified as an indirect change of charging condition.

Editor's Note: The handling of "Serving PLMN Rate Control change", "APN Rate Control change" events when charging per IP-CAN session applies is FFS.

- Tariff time change. When this event is encountered, all current counts are captured and new counts are started. The counts are sent to the OCS in next Debit / Reserve Units Request.

Management intervention may also force trigger a chargeable event.

If the PCEF supports the Unused Quota timer it may send its locally configured value to the OCS. The OCS may in this case respond with a new value of the Unused Quota timer to the PCEF, to be used instead of the PCEF configured value.

PCC rules can be activated, deactivated and modified any time during the IP-CAN session lifetime. PCC rule activation, deactivation and modification are not chargeable events. However these PCC rule changes may lead to "start of service data flow" and "termination of service data flow" chargeable events.

According to TS 23.203 [215], the PCRF can modify the following charging information in a dynamic PCC rule which is active in the PCEF: Charging key, Service identifier, Measurement method, Service identifier level reporting. The PCRF can also modify the allowed access type in the case of NBIFOM.

A change of allowed access type in the case of NBIFOM will trigger an "access change for service data flow" chargeable event when all service data flows for the associated counter are changed from one access to another and takes priority over change of charging information.

Change of Charging key, ServiceIdentifier, IP-CAN type or measurement method will trigger a "start of service data flow" chargeable event when valid quota does not exist corresponding to that changed PCC rule. Change of Charging key, Service Identifier, IP-CAN type or measurement method, or Service identifier level reporting will trigger a "termination of service data flow" chargeable event when this is the last service data flow utilizing the quota used for the original PCC rule.

Removal of an access from a PDN connection is not a trigger for FBC. Subsequent PCC rule handling, may lead to the "access change for a service data flow" or "termination of service data flow" events for the service data flows that were active on the removed access.

For non-IP type PDN connection:

- non-3GPP access types are not supported;
- multi-access PDN connections do not apply;
- A single PCC Rule is used with the service data flow descriptor matching the whole non-IP data traffic, and can contain e.g.:
 - service data flow template matching all the packets;
 - charging method to identify whether online/offline/both/neither charging interface is used;
 - measurement method for offline charging to identify whether time/data volume/events are measured for this service data flow;
 - Charging key (i.e. rating group) for that service data flow;
 - service identifier for that service data flow;
 - reporting level for that service data flow:

- rating group level in case a specific rating group is used for non-IP traffic charging;
- combination of the rating group and service id in case a specific rating group/service Id is used for non-IP traffic charging.

5.3.1.7 Sponsored data connectivity charging

According to TS 23.203 [215] two deployment scenarios exist for sponsored data connectivity. The Sponsor Identifier and Application Service Provider Identifier are provided for sponsored services to the PCRF from the AF over the Rx interface.

In the first scenario, the PCRF assigns a service specific Charging Key (i.e. rating group) for a sponsored IP flow. The Charging Key is used by the PCEF to collect charging information for online charging scenarios for the sponsored flows on which the quota allocation in OCS shall be based. Correlation of charging information for online charging from multiple users per sponsor and/or application service provider is then performed using the Charging Key.

The second scenario utilizing explicit reporting of the Sponsor Identity and Application Service Provider Identity for online charging from PCEF has not been specified in this release of the specification.

5.3.1.8 Network-Based IP Flow Mobility (NBIFOM) charging

To support Network-Based IP Flow Mobility (NBIFOM), multi-radio (i.e. 3GPP and WLAN) capable UEs establish and maintain a PDN connection over both 3GPP access and WLAN access simultaneously for both S2b and S2a connectivity, as specified in TS 23.161 [242]. When such a multi-access PDN connection is established, there is one default bearer for each access. On a multi-access PDN connection established over both 3GPP access and WLAN access, it is possible to move individual IP flows from one access network to another, when policies determine that flows should be moved and the target access is available for the UE. As described in TS 23.203 [215], it shall be possible to apply different rates depending on the access used to carry a service data flow.

For a multi-access PDN connection, IP-CAN bearer charging as defined in clause 5.3.1.1 and FBC as defined in clause 5.3.1.2 apply for each bearer under each access for this PDN connection, and IP-CAN bearer charging as defined in clause 5.3.1.6.1 and FBC as defined in clause 6.3.1.6.2 apply when charging per IP-CAN session is active for this PDN connection, based on:

- Establishment of a multi-access PDN connection and addition of access to a multi-access PDN connection result in the default bearer and potential dedicated bearer(s) creation for this access, to carry the service data flows based on PCC Rule(s).
- Release of a multi-access PDN connection and removal of an access from a multi-access PDN connection result in release of all the IP-CAN bearer(s) for this access.
- Access change for service data flow(s), results in corresponding PCC Rule(s) removed from the IP-CAN bearer(s) of the source access, and PCC Rule(s) installed into the IP-CAN bearer(s) of the target access.
- Access of a multi-access PDN connection becomes unusable: for the service data flows maintained as result from PCC Rules decision, under the IP-CAN bearer that becomes unusable, no traffic will be detected.
- Access of a multi-access PDN connection becomes usable: for the service data flows which were maintained as result from PCC Rules decision under the IP-CAN bearer when detected as usable, the new traffic will be counted.

For each service data flow, identified by its PCC Rule, a different access type is specified where it has to be enforced. A different rating group may be used as a way to apply charging differentiation per-access type. The charging method, measurement method, reporting level may also potentially be different, in case charging behaviour is not expected to be unified between both domains.

For the case where dynamic PCC is not deployed, per-access Charging Characteristics and pre-defined PCC Rule(s) in P-GW may be used as a way to apply charging differentiation.

5.3.2 Ro message flows

5.3.2.0 General

Debit / Reserve Units Request[Initial], update and termination, as defined in TS 32.299 [50], are used by the P-GW/TDF to transfer the collected charging information towards the OCS. Debit / Reserve Units Response is used by the OCS to assign quotas for the rating groups, and to instruct the P-GW whether to continue or terminate a service data flow(s) or IP-CAN bearer. Debit / Reserve Units Response is used by the OCS to assign quotas for the rating groups and to instruct the TDF whether to continue or terminate an application's traffic.

Debit / Reserve Units Response is also used to communicate to the PCEF/TDF for the Termination Action, i.e. the P-GW/TDF behaviour when the user has consumed the final granted units. The Termination Action is specified in TS 32.299 [50].

The P-GW and TDF uses Charging Characteristics profile to determine whether to activate or deactivate online charging. Further details of this functionality, including the mechanism of conveying the Charging Characteristics data item (HLR -> SGSN -> P-GW, or HSS->MME/S4-SGSN ->S-GW->P-GW, AAA -> ePDG -> P-GW, or AAA -> TWAG -> P-GW and then in case of TDF, P-GW -> PCRF -> TDF), are specified in annex A.

The following clauses describe the trigger conditions for the chargeable events described in clauses 5.3.1.1, 5.3.1.2, 5.3.1.5 and 5.3.1.6. In FBC and ABC online charging, these chargeable events correspond to the triggers for collection of charging information and Debit / Reserve Units Request emission towards the OCS.

The responses from the OCS and the detailed behaviour of the PCEF/TDF upon receiving those responses are also specified in the sub-clauses below.

5.3.2.1 Triggers for IP-CAN bearer online charging

IP-CAN bearer online charging is achieved by FBC online charging, see clause 5.3.2.2 below.

5.3.2.1.1 Void

5.3.2.1.2 Void

5.3.2.2 Triggers for FBC online charging

5.3.2.2.0 Introduction

Debit / Reserve Units Request[Initial] / [Update] / [Termination] is used to convey charging information related to the IP-CAN bearer and service data flows collected in the PCEF. Debit / Reserve Units Response is used by the OCS to return quotas for rating groups or to instruct the PCEF on the further handling of the IP-CAN bearer (terminate, continue, reroute, etc.). The Debit / Reserve Units Request includes details such as Credit-Control Type, Served IMSI, Sequence Number etc. The Debit / Reserve Units Response includes details such as Credit-Control quotas and session management instructions (continue, terminate, interim interval, etc). Not all of the charging information to be collected is static, and other charging information is directly dependent on dynamic Packet-Switched service usage.

FBC online charging is employed if it is activated for the IP-CAN bearer. The charging method in the PCC rule defines whether service data flow requires the online charging. The PCEF shall request the quota prior to service delivery. If only certain quotas are authorised by the OCS (e.g. due to insufficient credit), the rating groups for which no quota was authorised are handled according the received Result Code value. The quota supervision mechanism is further described in TS 32.299 [50]. Details on FBC can be found in TS 23.203 [215] and TS 29.212 [216].

Debit / Reserve Units Request[Initial] is sent to the OCS during the IP-CAN bearer activation. The OCS supplies a IP-CAN bearer authorisation and may supply volume, time or events quotas for the rating groups, based on the information provided by the PCEF, e.g. QoS, APN.

When start of the service data flow is detected and no valid quota exist, a Debit / Reserve Units Request[Update] is sent to request quota for the rating group, unless the rating group is e.g. blacklisted. In case charging session does not exist, a Debit/Reserve Units Request[Initial] is sent. See TS 32.299 [50] for further information.

When a change of charging condition occurs, and corresponding re-authorization trigger is armed, all MSCC instances are reported to the OCS with a Debit / Reserve Units Request[Update] with Reporting-Reason AVP value set to RATING_CONDITION_CHANGE together with Trigger-Type AVP indicating the accurate reason for the change. When "User CSG Information change" occurs as a change of charging condition, how the changes (i.e. User entering/leaving a CSG cell or a hybrid cell he is member or not) are reported is further detailed in TS 32.299 [50].

At IP-CAN default bearer establishment, the OCS may provide the "Presence Reporting Area identifier" to be activated for Core Network pre-configured Presence Reporting Area(s) and additionally all of PRA Identifier(s) and list(s) of its elements for UE-dedicated Presence Reporting Area(s) to be reported when it subscribes to "Change of UE presence in Presence Reporting Area". The Presence Reporting Area(s) to be reported are applicable at IP-CAN session level.

The OCS may change (activate/modify/remove) the Presence Reporting Area(s) to be reported by providing the updated PRA Identifier(s) to PCEF during any IP-CAN dedicated bearer establishment or during any IP-CAN bearer update.

The OCS may subscribe/unsubscribe to "Change of UE presence in Presence Reporting Area" re-authorization event trigger, during IP-CAN bearer establishment (i.e. CCA answer to CCR initial), or during the lifetime of the IP-CAN bearer. When the initial UE presence status in PRA(s) resulting from subscription by the OCS is received by the PCEF, and the PCEF has previously requested quota, all MSCC instances are reported to the OCS with a CCR update, indicating this initial status. If PCEF has not previously requested quota, this initial status of UE presence in Presence Reporting Area(s) will be sent towards the OCS on CCR update triggered for quota request when service usage is started.

When Ro specific chargeable event (e.g. threshold reached, QHT expires, quota exhaustion, validity time reached, forced re-authorization) occurs required MSCC instances are reported to OCS with a Debit / Reserve Units Request[Update] with corresponding Reporting Reason value. See TS 32.299 [50] for further information.

When tariff time change is encountered, the Tariff Change Usage is used within the Used Service Units to distinguish usage before and after the tariff time change. The MSCC instances are sent to the OCS in next Debit / Reserve Units Request.

The OCS may specify the behaviour on consumption of the final granted units known as termination action. The required termination action is indicated with Final Unit Action and possible values are TERMINATE and REDIRECT. See TS 32.299 [50] for further information.

TS 23.203 [215] specifies that it shall be possible to request online charging quotas for each charging key. Each quota allocated to a Debit / Reserve Units session has a unique Rating Group value. TS 23.203 [215] also specifies that PCEF shall report charging information for each combination of the charging key and service identifier when service identifier level reporting is present. As defined in TS 23.203 [215] the service identifier is a piece of information

which provides the most detailed identification, specified for FBC, of a service data flow.

The charging key is a piece of information used for rating purposes as defined in TS 23.203 [215].

The charging key and Service Identifier are mapped into the Rating Group and the Service Identifier respectively as defined in RFC 4006 [402].

The subsequent clauses identify in detail the conditions for reporting online charging information, management of user and Credit-Control sessions and PS domain quota supervision.

5.3.2.2.1 Triggers for starting and stopping an FBC Credit-Control session

Debit / Reserve Units Request[Initial] is sent to OCS when:

- IP-CAN bearer is activated. For network requested dedicated IP-CAN bearer activation, the Debit / Reserve Units Request[Initial] is sent to the OCS when the PCEF determines a need for the IP-CAN bearer and before any signalling towards a mobile is initiated.
- Start of service data flow is detected and no charging session exists.

Debit / Reserve Units Request[Terminate] is sent to OCS when:

- IP-CAN bearer is deactivated.
- Unused Quota timer expiry.
- Session termination is indicated by the OCS (e.g. Credit Limit Reached, Credit Control Not Applicable)
- Abort-Session-Request is received from the OCS, this also results in network initiated IP-CAN bearer deactivation.
- A Debit / Reserve Units Request[Terminate] sent due to Unused Quota timer expiry shall include an indication to the OCS that the IP-CAN bearer continues and the OCS can expect a later Debit / Reserve Units Request[Initial] request for the same IP-CAN bearer.

5.3.2.2.2 Triggers for providing interim information for an FBC Credit-Control session

Debit / Reserve Units Request[Update] is sent to OCS when:

- User starts to use certain service or application
- Start of service data flow (refer to clause 5.3.1.2)
- Termination of service data flow and this is the last service data flow utilizing corresponding to report level(refer to clause 5.3.1.2)
- Active service or application is removed from the allowed services or applications
- Granted quota runs out
- Validity time for granted quota expires
- Update is requested by the OCS
- Change of charging conditions occur and according re-authorisation trigger re-authorisation is needed
- Management intervention
- Quota Holding Timer is expired
- For network requested dedicated IP-CAN bearer activation, reception of an Update PDP Context Request message with the RAN Procedures Ready flag.

5.3.2.2A Triggers for ABC online charging

5.3.2.2A.0 Introduction

For ABC supported within the TDF, i.e. ADC rules based charging defined in TS 23.203 [215] and TS 29.212 [216], Debit / Reserve Units Request[Initial] / update / termination is used to convey charging information related to the

application traffic detected in the TDF. Debit / Reserve Units Response is used by the OCS to return quotas for rating groups or to instruct the TDF on the further handling of the application traffic (terminate, continue, reroute, etc.). The Debit / Reserve Units Request includes details such as Credit-Control Type, Served IMSI and Sequence Number etc. The Debit / Reserve Units Response includes details such as Credit-Control quotas and session management instructions (continue, terminate, interim interval, etc).

ABC online charging is employed if it is activated for the TDF session defined in TS 23.203[215].

The charging method in the ADC rule defines whether application traffic requires online charging. The TDF shall request the quota prior to service delivery. If only certain quotas are authorised by the OCS (e.g. due to insufficient credit), the rating groups for which no quota was authorised are handled according to the received Result Code value. The quota supervision mechanism is further described in TS 32.299 [50].

Debit / Reserve Units Request[Initial] is sent to the OCS during the TDF session activation. The OCS supplies application traffic authorisation and may supply volume, time or event quotas for the rating groups, based on the information provided by the TDF, e.g. APN.

When start of the application traffic is detected and no valid quota exist in current Ro session, a Debit / Reserve Units Request[Update] is sent to request quota for the rating group unless the rating group is e.g. blacklisted. See TS 32.299 [50] for further information.

When a change of charging condition occurs and corresponding re-authorization trigger is armed, all MSCC instances are reported to the OCS with a Debit / Reserve Units Request[Update] with Reporting Reason value set to RATING_CONDITION_CHANGE together with Trigger-Type AVP indicating the accurate reason for the change. When "User CSG Information change" occurs as a change of charging condition, how the changes (i.e. User entering/leaving a CSG cell or a hybrid cell he is member or not) are reported is further detailed in TS 32.299 [50].

When Ro specific chargeable event (e.g. threshold reached, QHT expires, quota exhaustion, validity time reached, forced re-authorization) occurs required MSCC instances are reported to OCS with a Debit / Reserve Units Request[Update] with corresponding Reporting-Reason AVP value. See TS 32.299 [50] for further information.

When tariff time change is encountered, the Tariff Change Usage is used within the Used Service Units to distinguish usage before and after the tariff time change. The MSCC instances are sent to the OCS in next CCR.

The OCS may specify the behaviour on consumption of the final granted units known as termination action. The required termination action is indicated with Final Unit Action and possible values are TERMINATE and REDIRECT. See TS 32.299 [50] for further information.

TS 23.203 [215] specifies that it shall be possible to request online charging quotas for each charging key. Each quota allocated to a Debit / Reserve Units session has a unique Rating Group value. TS 23.203 [215] also specifies that TDF shall report charging information for each combination of the charging key and service identifier when service identifier level reporting is present. As defined in TS 23.203 [215] the service identifier is a piece of information which provides the most detailed identification, specified for ABC. The charging key is a piece of information used for rating purposes as defined in TS 23.203 [215]. The charging key and Service Identifier are mapped into the Rating Group and the Service Identifier respectively as defined in RFC 4006 [402].

The subsequent clauses identify in detail the conditions for reporting online charging information, management of user and Credit-Control sessions and PS domain quota supervision.

5.3.2.2A.1 Triggers for starting and stopping an ABC Credit-Control session

Debit / Reserve Units Request[Initial] is sent to OCS when TDF session is activated.

Debit / Reserve Units Request[Terminate] is sent to OCS when:

- TDF session is deactivated
- Session termination is indicated by the OCS (e.g. Credit Limit Reached)
- Abort-Session-Request is received from the OCS.

5.3.2.2A.2 Triggers for providing interim information for an ABC Credit-Control session

Debit / Reserve Units Request[Update] is sent to OCS when:

- Start of application traffic, when no valid quota exists

- Granted quota runs out
- Validity time for granted quota expires
- Update is requested by the OCS
- Change of charging conditions occur and according re-authorisation trigger re-authorisation is needed
- Management intervention
- Quota Holding Timer is expired

5.3.2.2B Triggers for TDF session online charging

TDF session online charging is achieved by ABC online charging, see clause 5.3.2.2A.

5.3.2.2C Triggers for P-GW when charging per IP-CAN session is active

5.3.2.2C.1 General

The triggers identified in clause 5.3.2.2 are utilized when charging per IP-CAN session is active with the following changes:

1. When IP-CAN bearer charging is active, the Debit / Reserve Units Response is used by the OCS to return quotas for rating groups or to instruct the PCEF on the further handling of the IP-CAN session or service data flow, not a specific IP-CAN bearer.
2. Charging per IP-CAN session is employed if it is activated for the default IP-CAN bearer. Charging characteristics determine if the IP-CAN bearer charging is active or if the FBC is active. When IP-CAN bearer charging is active, a vendor-specific rating group and, optionally, service identifier, is used to signify that the IP-CAN session traffic is being monitored as per clause 5.3.1.6.1. This vendor-specific rating group is the only rating for which quota is requested from the OCS using the same mechanism as for FBC. When FBC is active, the charging method in the PCC rule defines whether a service data flow requires online charging.
3. In either case in which FBC is utilized, the PCEF shall request the quota prior to service delivery as in clause 5.3.2.2.
4. Debit / Reserve Units Request[Initial] is sent to the OCS during the IP-CAN session activation. No indication is provided to the OCS when an individual IP-CAN bearer is activated.
5. When IP-CAN bearer charging using the vendor-specific rating group, the OCS may only provide volume quotas.
6. At IP-CAN session establishment, the OCS may provide the "Presence Reporting Area identifier(s)" to be activated for Core Network pre-configured Presence Reporting Area(s) and additionally all of PRA Identifier(s) and list(s) of its elements for UE-dedicated Presence Reporting Area(s) to be reported when it subscribes to "Change of UE presence in Presence Reporting Area". OCS subscription to and PCEF reporting of "Change of UE presence in Presence Reporting Area" re-authorization event trigger is the same as in clause 5.3.2.2.
7. When start of the IP-CAN session traffic (if IP-CAN bearer charging is active) or the service data flow is detected and no valid quota exists, a Debit / Reserve Units Request[Update] is sent to request quota for the rating group as in clause 5.3.2.2C.3.

5.3.2.2C.2 Triggers for starting and stopping an FBC Credit-Control session when charging per IP-CAN session is active

Debit / Reserve Units Request[Initial] is sent to OCS when:

- IP-CAN session (i.e., default bearer) is activated.
- Start of service data flow is detected and no charging session exists.

Debit / Reserve Units Request[Terminate] is sent to OCS when:

- IP-CAN session is deactivated.
- Unused Quota timer expiry.
- Session termination is indicated by the OCS (e.g. Credit Limit Reached, Credit Control Not Applicable)
- Abort-Session-Request is received from the OCS, this also results in network-initiated IP-CAN session deactivation.

A Debit / Reserve Units Request[Terminate] sent due to Unused Quota timer expiry shall include an indication to the OCS that the IP-CAN session continues and the OCS can expect a later Debit / Reserve Units Request[Initial] request for the same IP-CAN session.

5.3.2.2C.3 Triggers for providing interim information for an FBC Credit-Control session when charging per IP-CAN session is active

Debit / Reserve Units Request[Update] is sent to OCS when:

- User starts to use certain service
- Start of service data flow (refer to 5.3.1.2)
- Access change of service data flow (refer to 5.3.1.6.2)
- Active service is removed from the allowed services
- Granted quota runs out
- Validity time for granted quota expires
- Update is requested by the OCS
- Change of charging conditions occur and re-authorisation trigger is set
- Management intervention
- Quota Holding Timer is expired

5.3.2.3 PS Furnish Charging Information procedure

The OCS online charging function may use this procedure to add online charging session specific information to the PGW-CDR/TDF-CDR by means of the Debit / Reserve Units operation in the Ro interface. The data can be sent either in one Debit / Reserve Units Response message or several Debit / Reserve Units Response messages with append indicator.

The OCS online charging function can send multiple concatenated PS Furnish Charging Information elements per online charging session in the Ro interface. The OCS online charging function can also send multiple concatenated PS Furnish Information Element per each quota (i.e. per rating group).

The total maximum of free format data is 160 octets per service so the total maximum of free format data per online session is $n \times 160$ octets, where n indicates the number of rating groups activated per online session.

In the OCS online charging function, a PS online charging session shall be identified by the P-GW control plane address and the ChargingId. In the P-GW, the PS online charging session and the PS offline charging session shall be identified by the same ChargingId. Therefore the ChargingId shall allow the P-GW to correlate an online charging session with an offline charging session. In the TDF, the PS online charging session and the PS offline charging session shall be identified by the combination of P-GW control plane address and ChargingId. Therefore the P-GW address/Charging Id shall allow the TDF to correlate an online charging session with an offline charging session.

This procedure can only apply when online and offline charging is performed simultaneously for the same session (IP-CAN bearer or TDF session) or rating group. In any other case, the P-GW/TDF shall discard the additional charging information sent by the OCS in the Debit / Reserve Units Response messages.

When the OCS sends session specific charging information, it must send the PS Furnish Charging Information at command level in the Debit / Reserve Units Response. In this case, the information is added to the main body of the PGW-CDR. When the OCS sends service specific charging information, it must send the PS Furnish Charging Information at MSCC level in the Debit / Reserve Units Response. In this case, the information is added to the specific service container in the PGW-CDR/TDF-CDR.

The PS Furnish Charging Information is described in TS 32.299 [50].

5.3.2.4 Support of Failure Situations

In case the OCS fails the P-GW/TDF must support the Failure Handling procedure and Failover mechanism described in TS 32.299 [50].

The Failure Handling Procedure affects the whole online session so in case FBC/ABC is enabled, the procedure shall affect all services activated during the IP-CAN bearer/TDF session triggering the online charging session.

According to TS 32.299 [50], timer Tx determines the maximum interval the P-GW/TDF shall wait for an answer to each Debit / Reserve Units Request sent to the OCS. In case FBC/ABC is enabled, it is possible that several concurrent Debit / Reserve Units Request messages are triggered for the same online charging session. In this case, each Debit / Reserve Units Request message shall reset the Tx timer. When Tx expires, P-GW/TDF shall execute the Failover and Failure Handling mechanisms according to the behaviour described in Annex B.

Three different actions are described in RFC 4006 [402].

P-GW shall support the following actions when the failure handling mechanism is executed:

- Terminate: The online session is finished. The associated IP-CAN bearer session is released (ongoing sessions) or not established (new sessions). Failover for ongoing sessions is not supported. Failover for new sessions is always supported.
- Retry&Terminate: The online session is finished. The associated IP-CAN bearer session is released (ongoing sessions) or not established (new sessions). Failover for ongoing sessions is supported. Failover for new sessions is always supported.
- Continue: The online session is finished. The associated IP-CAN bearer session is established (new sessions) or not released (ongoing sessions). Failover for ongoing sessions is supported. Failover for new sessions is always supported. It shall be operator configurable to limit the maximum duration of the IP-CAN bearer in this situation.

When charging per IP-CAN session is active, the actions above apply to the entire IP-CAN session instead of the individual IP-CAN bearer.

TDF shall support the following actions when the failure handling mechanism is based on the directives received previously from the OCS:

- Terminate: This is the default behaviour. The TDF indicates to the PCRF that the charging session was terminated and the OCS does not allow the service to continue. The PCRF determines whether to continue or terminate the associated TDF session.
- Retry&Terminate: If the OCS and TDF support failover procedures and there is an alternate OCS available, the TDF shall attempt to failover to an alternative OCS. Otherwise, the TDF indicates to the PCRF that the charging session was terminated and the OCS does not allow the service to continue. The PCRF determines whether to continue or terminate the associated TDF session.
- Continue: If the OCS and TDF support failover procedures and there is an alternate OCS available, the TDF shall attempt to failover to an alternative OCS. Otherwise, the TDF indicates to the PCRF that the charging session was terminated and the OCS allows the service to continue. The PCRF determines whether to continue or terminate the associated TDF session.

In case the user is simultaneously online and offline charged, the failure situation must be registered in the PGW-CDR/TDF-CDR. When the user is only online charged, the execution of the Failure Handling mechanism with value equal to Continue shall imply that a new PGW-CDR/TDF-CDR is opened.

6 Definition of charging information

6.1A Rf message content

6.1A.0 General

This clause is applicable to the ePDG, TWAG, MME, S-GW, P-GW and TDF, when the CDF is provided as an external entity.

6.1A.1 Summary of offline charging message formats

The PS Offline Charging and "SMS over MME Charging" utilises the *Charging Data Transfer* that is specified in the 3GPP accounting application described in TS 32.299 [50].

The *Charging Data Transfer* operation employs the *Charging Data Request* and *Charging Data Response* messages.

The *Charging Data Request* can be of type [Start, Interim, Stop and Event] and includes all charging information. The *Charging Data Response* is an acknowledgement of the *Charging Data Request*.

Table 6.1A.1.1 describes the use of these messages for offline charging.

Table 6.1A.1.1: Offline charging messages reference table

Message	Source	Destination
Charging Data Request	ePDG, TWAG, MME, S-GW, P-GW, TDF	CDF
Charging Data Response	CDF	ePDG, TWAG, MME, S-GW, P-GW, TDF

6.1A.2 Structure for the charging data message formats

6.1A.2.0 General

This clause describes the Information Elements (IE) used in the charging data messages.

Category in table 6.1A.2.1.1 and table 6.1A.2.2.1 shall use the categories according to the charging data configuration defined in clause 5.4 of TS 32.240 [1].

6.1A.2.1 Charging Data Request message

Table 6.1A.2.1.1 illustrates the basic structure of a Charging Data Request message from the MME, S-GW, ePDG, TWAG, P-GW and TDF as used for PS offline charging and "SMS over MME Charging".

Table 6.1A.2.1.1: Charging Data Request message contents

Information Element	Category	Description
Session Identifier	M	Described in TS 32.299 [50]
Originator Host	M	Described in TS 32.299 [50]
Originator Domain	M	Described in TS 32.299 [50]
Destination Domain	M	Described in TS 32.299 [50]
Operation Type	M	Described in TS 32.299 [50]
Operation Number	M	Described in TS 32.299 [50]
Operation Identifier	O _C	Described in TS 32.299 [50]
User Name	O _C	The content of the field corresponds to the Protocol Configuration Options (PCO) field of the Create IP-CAN bearer Request message. (ffs)
Destination Host	O _C	Described in TS 32.299 [50]
Operation Interval	O _C	Described in TS 32.299 [50]
Origination State	O _C	Described in TS 32.299 [50]
Origination Timestamp	O _C	Described in TS 32.299 [50]
Proxy Information	O _C	Described in TS 32.299 [50]
Route Information	O _C	Described in TS 32.299 [50]
Operation Token	O _M	This field identifies the PS domain.
Service Information	O _M	This field holds the PS charging specific parameters described in clause 6.3.

NOTE: Detailed descriptions of the fields are provided in TS 32.299 [50].

6.1A.2.2 Charging Data Response message

Table 6.1A.2.2.1 illustrates the basic structure of a Charging Data Response message as used for the ePDG, TWAG, MME, S-GW, P-GW and TDF.

Table 6.1A.2.2.1 : Charging Data Response message contents

AVP	Category	Description
Session Identifier	M	Described in TS 32.299 [50]
Operation Result	M	Described in TS 32.299 [50]
Originator Host	M	Described in TS 32.299 [50]
Originator Domain	M	Described in TS 32.299 [50]
Operation Type	M	Described in TS 32.299 [50]
Operation Number	O _C	Described in TS 32.299 [50]
Operation Identifier	O _C	Described in TS 32.299 [50]
Operation Interval	O _C	Described in TS 32.299 [50]
Error Reporting Host	O _C	Described in TS 32.299 [50]
Origination State	O _C	Described in TS 32.299 [50]
Origination Timestamp	O _C	Described in TS 32.299 [50]
Proxy Information	O _C	Described in TS 32.299 [50]

NOTE: Detailed descriptions of the fields are provided in TS 32.299 [50].

6.1B CDR content description on Bp interface

6.1B.0 General

This clause describes the CDR parameters used in the CDRs.

The tables in the subsequent parts of this clause specify the designations for the category of a CDR parameter ("field categories") according to the charging data configuration defined in clause 5.4 of TS 32.240 [1].

The following tables 6.1.1.1 - 6.1.14.1 provide a brief description of each CDR parameter. Full definitions of the CDR parameters, sorted by the name in alphabetical order, are provided in TS 32.298 [51].

6.1.1 IP-CAN bearer charging data in SGSN (S-CDR)

If the collection of CDR data is enabled then the SGSN data specified in table 6.1.1.1 shall be available for each IP-CAN bearer.

Table 6.1.1.1: SGSN IP-CAN bearer data (S-CDR)

Field	Category	Description
Record Type	M	SGSN IP-CAN bearer record.
Network Initiated PDP Context	O _C	A flag that is present if this is a network initiated IP-CAN bearer.
Served IMSI	C	IMSI of the served party, if available.
IMSI Unauthenticated Flag	O _C	This field indicates the provided served IMSI is not authenticated (emergency bearer service situation).
Served IMEI	O _C	The IMEI or IMEISV of the ME, if available. It is used for identifying the user in case Served IMSI is not present during emergency bearer service.
SGSN Address	O _M	The IP address of the current SGSN.
MS Network Capability	O _M	The mobile station Network Capability.
Routing Area Code (RAC)	O _M	RAC at the time of "Record Opening Time".
Location Area Code (LAC)	O _M	LAC at the time of "Record Opening Time".
User CSG information	O _C	This field contains the User CSG information of the UE, if available, including CSG ID, access mode and CSG membership indication.
Cell Identifier	O _M	Cell identity for GSM or Service Area Code (SAC) for UMTS at the time of "Record Opening Time".
Charging ID	M	IP-CAN bearer identifier used to identify this IP-CAN bearer in different records created by PCNs.
GGSN Address Used	M	The control plane IP address of the P-GW currently used. The P-GW address is always the same for an activated IP-CAN bearer.
Access Point Name Network Identifier	O _M	The logical name of the connected access point to the external packet data network (network identifier part of APN).
PDP Type	O _M	PDP type, i.e. IPv4, IPv6, IPv4v6, PPP.
Served PDP Address	O _C	PDP address of the served IMSI, i.e. IPv4 address when PDP Type is IPv4 or IPv6 prefix when PDP Type is IPv6 or IPv4v6. This parameter shall be present except when both the PDP type is PPP and dynamic PDP address assignment is used.
Served PDP Address prefix length	O _C	PDP/PDN Address prefix length of an IPv6 typed Served PDP Address. The field needs not available for prefix length of 64 bits.
Served PDP/PDN Address extension	O _C	This field holds IPv4 address of the served IMSI, if available, when PDP type is IPv4v6.
List of Traffic Data Volumes	O _M	A list of changes in charging conditions for this IP-CAN bearer, each change is time stamped. Charging conditions are used to categorize traffic volumes, such as per tariff period. Initial and subsequently changed QoS and corresponding data volumes are also listed.
Record Opening Time	M	Time stamp when IP-CAN bearer is activated in this SGSN or record opening time on subsequent partial records.
Duration	M	Duration of this record in the SGSN.
SGSN Change	C	Present if this is first record after SGSN change.
Cause for Record Closing	M	The reason for closure of the record from this SGSN.
Diagnostics	O _M	A more detailed reason for the release of the connection.
Record Sequence Number	C	Partial record sequence number in this SGSN. Only present in case of partial records.
Node ID	O _M	Name of the recording entity.
Local Record Sequence Number	O _M	Consecutive record number created by this node. The number is allocated sequentially including all CDR types.
APN Selection Mode	O _M	An index indicating how the APN was selected.
Access Point Name Operator Identifier	O _M	The Operator Identifier part of the APN.
Served MSISDN	O _C	The primary MSISDN of the subscriber, if available.
Charging Characteristics	M	The Charging Characteristics applied to the IP-CAN bearer.
Serving Node PLMN Identifier	O _C	This field holds the PLMN Identifier (MCC and MNC) serving the UE during this record. Only one value is included in case multiple PLMN Ids are supported by the SGSN.

Field	Category	Description
CN Operator Selection Entity	O _C	This field indicates whether the Serving Network identified by the "Serving Node PLMN Identifier" has been selected by the UE or by the network, as defined in TS 29.060 [203] for GPRS, and in TS 29.274 [210] for EPC, if available.
RAT Type	O _C	This field indicates the Radio Access Technology (RAT) type currently used by the Mobile Station as defined in TS 29.061 [205], when available.
CAMEL Information	O _C	Set of CAMEL information related to IP-CAN bearer. For more information see Description of Record Fields. This field is present if CAMEL service is activated.
RNC Unsent Downlink Volume	O _C	The downlink data volume, which the RNC has not sent to MS. This field is present when the RNC has provided unsent downlink volume count at RAB release.
Charging Characteristics Selection Mode	O _M	Holds information about how Charging Characteristics were selected.
Dynamic Address Flag	O _C	Indicates whether served PDP address is dynamic, which is allocated during IP-CAN bearer activation. This field is missing if address is static.
Low Priority Indicator	O _C	This field indicates if this IP-CAN bearer has a low priority, i.e. for Machine Type Communication.
Record Extensions	O _C	A set of network operator/manufacturer specific extensions to the record. Conditioned upon the existence of an extension.

6.1.2 IP-CAN bearer charging data in S-GW (SGW-CDR)

If the collection of CDR data is enabled then the S-GW data specified in table 6.1.2.1 shall be available for each IP-CAN bearer.

Table 6.1.2.1: S-GW IP-CAN bearer data (SGW-CDR)

Field	Category	Description
Record Type	M	S-GW IP-CAN bearer record.
Retransmission	O _C	This parameter, when present, indicates that information from retransmitted Charging Data Request has been used in this CDR.
Served IMSI	C	IMSI of the served party, if available.
IMSI Unauthenticated Flag	O _C	This field indicates the provided served IMSI is not authenticated (emergency bearer service situation).
Served IMEI	O _C	The IMEI or IMEISV of the ME, if available. It is used for identifying the user in case Served IMSI is not present during emergency bearer service.
S-GW Address used	M	The control plane IP address of the S-GW used.
S-GW Address IPv6	O _C	The control plane IPv6 address, in case of IPv4v6 dual stack, of the S-GW.
Charging ID	M	IP-CAN bearer Charging identifier used to identify this IP-CAN bearer in different records created by PCNs
PDN Connection Charging Id	O _M	This field holds the explicit Charging Id for the PDN connection if received from the P-GW. Otherwise, the field holds the Charging Id of the EPS default bearer in GTP case, or the unique Charging Id of the IP-CAN session in PMIP case. This field is used to identify different records belonging to same PDN connection.
Serving Node Address	M	List of serving node control plane IP addresses (e.g. S4-SGSN, MME, ...) used during this record.
Serving Node IPv6 Address	O _C	List of serving node control plane IPv6 addresses, in case of IPv4v6 dual stack, (e.g. S4-SGSN, MME, ...) used during this record.
Serving node Type	M	List of serving node types in control plane. The serving node types listed here map to the serving node addresses listed in the field "Serving node Address" in sequence.
S-GW Change	O _C	Present if this is first record after a change from another serving node (i.e. SGW, ePDG, HSGW).
PGW PLMN Identifier	O _C	PLMN identifier (MCC MNC) of the P-GW used.
Access Point Name Network Identifier	O _M	The logical name of the connected access point to the external packet data network (network identifier part of APN).
PDP/PDN Type	O _M	This field indicates PDN type (i.e. IPv4, IPv6 or IPv4v6).
PDP/PDN Type extension	O _M	This field indicates Non-IP PDN type.
Served PDP/PDN Address	O _C	IP address allocated for the PDP context / PDN connection, if available, i.e. IPv4 address when PDN Type is IPv4 or IPv6 prefix when PDN Type is IPv6 or IPv4v6. For non-IP PDN connection, this field is not present
Served PDP/PDN Address prefix length	O _C	PDP/PDN Address prefix length of an IPv6 typed Served PDP Address. The field needs not available for prefix length of 64 bits. For non-IP PDN connection, this field is not present.
Served PDP/PDN Address extension	O _C	This field holds IPv4 address of the served IMSI, if available, when PDN type is IPv4v6. For non-IP PDN connection, this field is not present.
Dynamic Address Flag	O _C	Indicates whether served PDP/PDN address is dynamic, which is allocated during IP-CAN bearer activation, initial attach (E-UTRAN or over S2x) and UE requested PDN connectivity. This field is missing if IPv4 address is static when PDN Type is IPv4, or if IPv6 address is static when PDN Type is IPv6 or IPv4v6.
Dynamic Address Flag extension	O _C	Indicates whether served IPv4 PDP/PDN address is dynamic, which is allocated during IP-CAN bearer activation, initial attach (E-UTRAN or over S2x) and UE requested PDN connectivity with PDP/PDN type IPv4v6. This field is missing if IPv4 address is static.

Field	Category	Description
List of Traffic Data Volumes	O _M	A list of changes in charging conditions for this QCI/ARP pair, each change is time stamped. Charging conditions are used to categorize traffic volumes, such as per tariff period. Initial and subsequently changed QoS and corresponding data values are also listed.
Record Opening Time	M	Time stamp when IP-CAN bearer is activated in this S-GW or record opening time on subsequent partial records.
MS Time Zone	O _C	This field contains the MS Time Zone the MS is currently located as defined in TS 29.060 [203], if available.
Last MS Time Zone	O _C	This field contains the UE Time Zone the UE is located at IP-CAN bearer deactivation, or at default bearer deactivation when IP-CAN session charging is active, when available.
Duration	M	Duration of this record in the S-GW.
Cause for Record Closing	M	The reason for the release of record from this S-GW.
Diagnostics	O _M	A more detailed reason for the release of the IP-CAN bearer, when a single cause is applicable.
Enhanced Diagnostics	O _C	This field holds a more detailed reason for the release of the IP-CAN bearer, when a set of causes is applicable.
Record Sequence Number	C	Partial record sequence number, only present in case of partial records.
Node ID	O _M	Name of the recording entity.
Local Record Sequence Number	O _M	Consecutive record number created by this node. The number is allocated sequentially including all CDR types.
APN Selection Mode	O _M	An index indicating how the APN was selected.
Served MSISDN	O _C	The primary MSISDN of the subscriber, if available.
User Location Information	O _C	This field contains the User Location Information of the MS as defined in TS 29.060 [203] for GPRS case, and in TS 29.274 [210] for EPC case, if available.
User Location Information Time	O _C	This field contains the time at which the user location information was acquired.
Last User Location Information	O _C	This field contains the User Location Information of the UE at IP-CAN bearer deactivation, or at default bearer deactivation when IP-CAN session charging is active, when available.
User CSG information	O _C	This field contains the User CSG information of the UE, if available, including CSG ID, access mode and CSG membership indication.
Presence Reporting Area Information	O _C	This grouped field contains the Presence Reporting Area Identifier for the UE PDN connection and the initial status of the UE presence in the Presence Reporting Area, if available. This field is not applicable to multiple PRA(s)
Charging Characteristics	M	The Charging Characteristics applied to the IP-CAN bearer.
Charging Characteristics Selection Mode	O _M	Holds information about how Charging Characteristics were selected.
IMS Signalling Context	O _C	Included if the IM-CN Subsystem Signalling Flag is set, see TS 23.060 [201] IP-CAN bearer is used for IMS signalling.
P-GW Address used.	O _C	This field is the P-GW IP Address for the Control Plane
P-GW Address IPv6	O _C	This field is the P-GW IPv6 Address, in case of IPv4v6 dual stack, for the Control Plane
Serving Node PLMN Identifier	O _C	This field holds the PLMN Identifier (MCC and MNC) serving the UE during this record, as received in the "Serving Network" IE over S4/S11, if available.
CN Operator Selection Entity	O _C	This field indicates whether the Serving Network identified by the "Serving Node PLMN Identifier" has been selected by the UE or by the network, as defined in TS 29.060 [203] for GPRS, and in TS 29.274 [210] for EPC, if available.

Field	Category	Description
RAT Type	O _C	This field indicates the Radio Access Technology (RAT) type currently used by the Mobile Station as defined in TS 29.061 [205], when available.
Start Time	O _C	This field holds the time when User IP-CAN session starts, available in the CDR for the first bearer in an IP-CAN session.
Stop Time	O _C	This field holds the time when User IP-CAN session is terminated, available in the CDR for the last bearer in an IP-CAN session.
Low Priority Indicator	O _C	This field indicates if this IP-CAN session has a low priority, i.e. for Machine Type Communication.
CP Clot EPS Optimisation indicator	O _C	This field indicates whether CP Clot EPS Optimisation is used during data transfer with the UE (i.e. Control Plane NAS PDU via S11-U between SGW and MME) or not (i.e. User Plane via S1-U between SGW and eNB), if enabled.
UNI PDU CP Only Flag	O _C	This field indicates whether this PDN connection is applied with "Control Plane Only Flag" for UNI PDU transfer, i.e. transfer only using Control Plane NAS PDU (Control Plane Clot EPS optimisation).
Serving PLMN Rate Control	O _C	This field holds the Serving PLMN Rate Control used by the MME during this record.
MO exception data counter	O _C	This field holds the MO exception data counter value with the timestamp indicating the time at which the counter value increased from 0 to 1, as defined in TS 29.274 [210].
Record Extensions	O _C	A set of network operator/manufacture specific extensions to the record. Conditioned upon the existence of an extension.
List of RAN Secondary RAT Usage Reports	O _C	A list of containers with volumes reported from RAN for secondary RAT usage, each container is time stamped.

6.1.3 FBC IP-CAN bearer charging data in P-GW (PGW-CDR)

If FBC is enabled and the collection of CDR data is enabled then the P-GW data specified in table 6.1.3.1 shall be available for each IP-CAN bearer when charging per IP-CAN session is not active, or for each IP-CAN session when charging per IP-CAN session is active.

Table 6.1.3.1: P-GW IP-CAN bearer data (PGW-CDR)

Field	Category	Description
Record Type	M	P-GW IP-CAN bearer record.
Retransmission	O _C	This parameter, when present, indicates that information from retransmitted Charging Data Request has been used in this CDR.
Served IMSI	C	IMSI of the served party, if available.
IMSI Unauthenticated Flag	O _C	This field indicates the provided served IMSI is not authenticated (emergency bearer service situation).
Served IMEI	O _C	The IMEI or IMEISV of the ME, if available. It is used for identifying the user in case Served IMSI is not present during emergency bearer service.
Served 3GPP2 MEID	O _C	MEID of the served party's terminal equipment for 3GPP2 access.
Served MN NAI	O _C	Mobile Node Identifier in NAI format (based on IMSI), if available.
P-GW Address used	M	The control plane IP address of the P-GW used.
P-GW Address IPv6	O _C	The control plane IPv6 address, in case of IPv4v6 dual stack, of the P-GW used.
Charging ID	M	IP-CAN bearer Charging identifier used to identify this IP-CAN bearer in different records created by PCNs. This field holds the unique Charging Id in the PMIP case. When charging per IP-CAN session is active, this field holds the Charging Id of the EPS default bearer. It is the same as the PDN Connection Charging Id.
Charging per IP-CAN Session Indicator	O _C	This field indicates whether charging per IP-CAN session is active. If this field is not present, charging per IP-CAN session is not active.
PDN Connection Charging Id	O _M	This field holds the explicit Charging Id for the PDN connection. When NBIFOM is supported, the PGW will assign an explicit PDN Connection Charging ID for the PDN connection. Otherwise the field holds the Charging Id of the EPS default bearer. This field is used to identify different records belonging to same PDN connection.
Serving node Address	M	List of SGSN/S-GW/TWAG control plane IP addresses, or the ePDG address used during this record.
Serving node IPv6 Address	O _C	List of SGSN/S-GW/TWAG control plane IPv6 addresses, in case of IPv4v6 dual stack, used during this record.
Serving node Type	M	List of serving node types in control plane (SGSN, SGW, ePDG, AGW, TWAG). The serving node types listed here map to the serving node addresses listed in the field "Serving node Address" in sequence.
PGW PLMN Identifier	O _C	PLMN identifier (MCC MNC) of the P-GW.
Access Point Name Network Identifier	O _M	The logical name of the connected access point to the external packet data network (network identifier part of APN).
PDP/PDN Type	O _M	PDP/PDN type, i.e. IPv4, IPv6, IPv4v6, or PDP type PPP.
PDP/PDN Type extension	O _M	This field indicates Non-IP PDN type.
SGi PtP Tunnelling Method	O _C	This field indicates whether SGi PtP tunnelling method based on UDP/IP or other methods are used for this PDN connection when non-IP PDN connection.
SCS/AS Address	O _C	This field holds the Address of SCS/AS for SGi PtP tunnelling.
Served PDP/PDN Address	O _C	IP address allocated for the PDP context / PDN connection, i.e. IPv4 address when PDP/PDN Type is IPv4 or IPv6 prefix when PDP/PDN Type is IPv6 or IPv4v6, or assigned IP address if any when PDP/PDN Type extension is Non-IP. This parameter shall be present except: - when both the PDP type is PPP and dynamic IP-CAN bearer address assignment is used or - when PDP/PDN Type extension is Non-IP, and no IP address has been assigned by the PGW for the PDN connection.
Served PDP/PDN Address prefix length	O _C	PDP/PDN Address prefix length of an IPv6 typed Served PDP Address. The field needs not available for prefix length of 64 bits.

Field	Category	Description
Served PDP/PDN Address extension	O _C	This field holds IPv4 address of the served IMSI, if available, when PDP/PDN type is IPv4v6.
Dynamic Address Flag	O _C	Indicates whether served PDP/PDN address is dynamic, which is allocated during IP-CAN bearer activation, initial attach (E-UTRAN or over S2x) and UE requested PDN connectivity. This field is missing if IPv4 address is static when PDN Type is IPv4, or if IPv6 address is static when PDN Type is IPv6 or IPv4v6.
Dynamic Address Flag extension	O _C	Indicates whether served IPv4 PDP/PDN address is dynamic, which is allocated during IP-CAN bearer activation, initial attach (E-UTRAN or over S2x) and UE requested PDN connectivity with PDP/PDN type IPv4v6. This field is missing if IPv4 address is static.
List of Traffic Data Volumes	O _C	A list of changes in charging conditions for all bearers within the IP-CAN session. Each change is time stamped. Charging conditions are used to categorize traffic volumes, such as per tariff period. Initial and subsequently changed QoS and corresponding data values are also listed. Applicable only for IP-CAN bearer charging when IP-CAN session charging is active. See table 6.1.3.1 for a description of List of Traffic Data Volumes handling.
List of Service Data	O _M	A list of changes in charging conditions for all service data flows within this IP-CAN bearer categorized per rating group or per combination of the rating group and service id or per combination of rating group, sponsor identity and application service provider identity. Each change is time stamped. Charging conditions are used to categorize traffic volumes, elapsed time and number of events, such as per tariff period. Initial and subsequently changed QoS and corresponding data values are also listed. Online charging information (PS Furnish Charging Information) may be added per each service data flow container in case it is sent by the OCS. External charging identifiers may be added per each service data flow container in case sent by the PCRF. Failure-Handling: This field shall be present in case P-GW triggers the Failure-Handling procedure. It shall indicate the Failure Handling scenario and the instant the Failure Action is triggered (see annex B). Scenarios: Continue/New Session; Continue/Ongoing Session; Retry&Terminate/Ongoing Session; Terminate/Ongoing Session. When charging per IP-CAN session is active, see table 6.1.3.2 for a description of List of Service Data handling.
Record Opening Time	M	Time stamp when IP-CAN bearer is activated in this P-GW or record opening time on subsequent partial records.
MS Time Zone	O _C	This field contains the MS Time Zone the MS is currently located as defined in TS 29.060 [203], if available.
Last MS Time Zone	O _C	This field contains the UE Time Zone the UE is located at IP-CAN bearer deactivation, or at default bearer deactivation when IP-CAN session charging is active, when available.
Duration	M	Duration of this record in the P-GW.
Cause for Record Closing	M	The reason for the release of record from this P-GW.
Diagnostics	O _M	A more detailed reason for the release of the IP-CAN bearer, when a single cause is applicable When charging per IP-CAN session is active, this field holds a more detailed reason for the release of the IP-CAN session, when a single cause is applicable.
Enhanced Diagnostics	O _C	This field holds a more detailed reason for the release of the IP-CAN bearer, when a set of causes is applicable. When charging per IP-CAN session is active, this field holds a more detailed reason for the release of the IP-CAN session, when a set of causes is applicable.
Record Sequence Number	C	Partial record sequence number, only present in case of partial records.
Node ID	O _M	Name of the recording entity.
Local Record Sequence Number	O _M	Consecutive record number created by this node. The number is allocated sequentially including all CDR types.
APN Selection Mode	O _M	An index indicating how the APN was selected.
Served MSISDN	O _C	The primary MSISDN of the subscriber, if available.

Field	Category	Description
User Location Information	O _C	This field contains the User Location Information of the MS when the CDR is opened as defined in TS 29.060 [203] for GPRS case, and in TS 29.274 [210] for EPC case, if available.
Last User Location Information	O _C	This field contains the User Location Information of the UE at IP-CAN bearer deactivation, or at default bearer deactivation when IP-CAN session charging is active, when available.
User Location Information Time	O _C	This field contains the time at which the user location information was acquired, if available.
User CSG information	O _C	This field contains the User CSG Information of the UE, if available, including CSG ID, access mode and CSG membership indication.
3GPP2 User Location information	O _C	This field contains the User Location Information of the MS when the CDR is opened as defined in TS 29.212 [71] for 3GPP2 access, if available.
TWAN User Location Information	O _C	This field contains the UE location in a Trusted WLAN Access Network (TWAN) , if available: - "TWAN identifier" as defined in TS 29.274 [210] for S2a GTP-based case, or, -"Access Network Identifier Option IE" as defined in 29.275 [211] for S2a PMIP-based case.
UWAN User Location Information	O _C	This field contains the UE location in an Untrusted Wireless Access Network (UWAN) which includes the UE local IP address and optionally UDP source port number (if NAT is detected) as defined in TS 29.274 [210]. It may also include WLAN location information (SSID and, when available, BSSID of the access point) the ePDG may have received from the 3GPP AAA server about the UE as defined in TS 29.274 [210].
Presence Reporting Area Information	O _C	This grouped field contains the Presence Reporting Area Identifier for the UE PDN connection, additional the list(s) of elements comprising the Presence Reporting Area for a UE-dedicated Presence Reporting Area, and the initial status of the UE presence in the Presence Reporting Area, if available. This field is not applicable to multiple PRA(s).
Charging Characteristics	M	The Charging Characteristics applied to the IP-CAN bearer.
Charging Characteristics Selection Mode	O _M	Holds information about how Charging Characteristics were selected.
IMS Signalling Context	O _C	Included if the IP-CAN default bearer IM-CN Subsystem Signalling Flag is set, see TS 23.060 [201] is used for IMS signalling.
Serving node PLMN Identifier	O _M	This fields holds the PLMN Identifier (MCC and MNC) serving the UE during this record, as received in the "Serving Network" IE over S5/S8 or retrieved from the RAI received over Gn/Gp. When the Serving node is TWAG, this field includes the PLMN identifier used for UE authentication, i.e. the VPLMN in roaming case, and the HPLMN in non-roaming case.
CN Operator Selection Entity	O _C	This field indicates whether the Serving Network identified by the "Serving Node PLMN Identifier" has been selected by the UE or by the network, as defined in TS 29.060 [203] for GPRS, and in TS 29.274 [210] for EPC, if available.

Field	Category	Description
PS Furnish Charging Information	O _C	Online charging session specific information
CAMEL Information	O _C	Set of CAMEL information related to IP-CAN bearer, if available. This field applies only for GPRS. When charging per IP-CAN session is active, this field is not applicable.
RAT Type	O _C	This field indicates the Radio Access Technology (RAT) type currently used by the Mobile Station as defined in TS 29.061 [205], when available. When NBIFOM is accepted by PCRF, this field holds the first default bearer's RAT type when charging per IP-CAN session is active.
Start Time	O _C	This field holds the time when User IP-CAN session starts, available in the CDR for the first bearer in an IP-CAN session. When charging per IP-CAN session is active, this field holds the time when User IP-CAN session starts.
Stop Time	O _C	This field holds the time when User IP-CAN session is terminated, available in the CDR for the last bearer in an IP-CAN session. When charging per IP-CAN session is active, this field holds the time when User IP-CAN session is terminated.
Low Priority Indicator	O _C	This field indicates if this IP-CAN session has a low priority, i.e. for Machine Type Communication.
QoS Information	OC	This field indicates the APN-AMBR uplink and downlink information for the IP-CAN session. Applicable only when charging per IP-CAN session is active.
NBIFOM Support	O _C	This field indicates that NBIFOM was requested by the UE, supported and accepted by the network for the IP-CAN session or if NBIFOM is not supported for the IP-CAN session.
NBIFOM Mode	O _C	This field indicates the NBIFOM mode selected for the PDN connection, when NBIFOM is supported for the IP-CAN session. This field is only present when NBIFOM is accepted.
UNI PDU CP Only Flag	O _C	This field indicates whether this PDN connection is applied with "Control Plane Only Flag" for UNI PDU transfer, i.e. transfer only using Control Plane NAS PDU (Control Plane ClOT EPS optimisation).
Serving PLMN Rate Control	O _C	This field holds the Serving PLMN Rate Control used by the MME during this record
APN Rate Control	O _C	This field holds the APN Rate Controls enforced in the PGW during this record.
MO exception data counter	O _C	This field holds the MO exception data counter value with the timestamp indicating the time at which the counter value increased from 0 to 1, as defined in TS 29.274 [210].
Record Extensions	O _C	A set of network operator/manufacturer specific extensions to the record. Conditioned upon the existence of an extension.
3GPP PS Data Off Status	O _C	This field holds the 3GPP PS Data Off Status.
List of RAN Secondary RAT Usage Reports	O _C	A list of containers with volumes reported from RAN for secondary RAT usage, each container is time stamped.

Table 6.1.3.2 contains special handling for the fields in the List of Traffic Data Volumes in PGW-CDR when charging per IP-CAN session is active and IP-CAN bearer charging is performed.

Table 6.1.3.2: List of Traffic Data Volumes in PGW-CDR when charging per IP-CAN session is active

Field	Category	Description
Data Volume Uplink	O _C	This field includes the number of octets transmitted during the use of the packet data services in the uplink direction.
Data Volume Downlink	O _C	This field includes the number of octets transmitted during the use of the packet data services in the downlink direction.
Change Condition	M	This field defines the reason for closing the container as specified in clause 5.2.1.10.1.
Change Time	M	This field is a time stamp, which defines the moment when the volume container is closed.

Field	Category	Description
User Location Information	O _C	This field contains the location (e.g. CGI/SAI, ECGI/TAI or RAI) where the UE is located and used during the transfer of the data volume captured by the container. This is included in the Traffic data container only if previous container's change condition is "user location change".
UWAN User Location Information	O _C	This field contains the UE location in an Untrusted Wireless Access Network (UWAN) which includes the UE local IP address and optionally UDP or TCP source port number (if NAT is detected) as defined in TS 29.274 [210]. It may also include WLAN location information the ePDG may have received from the 3GPP AAA server about the UE as "WLAN location information" defined in TS 29.274 [210].
TWAN User Location Information	O _C	This field contains the UE location in a Trusted WLAN Access Network (TWAN), if available: - as "TWAN identifier" defined in TS 29.274 [210] for S2a GTP-based case, or, - as "Access Network Identifier Option IE" defined in 29.275 [211] for S2a PMIP-based case.
Presence Reporting Area Status	O _C	This field contains the status of the UE presence in Presence Reporting Area. This field is not applicable to multiple PRA(s).
List of Presence Reporting Area Information	O _C	This field contains a list of Presence Reporting Area Identifier(s) for the UE PDN connection, and the Presence Reporting Area(s) status (UE presence or not, inactive), differentiated between PCRF and OCS subscription.
EPC QoS Information	O _C	This field contains the authorized QoS for the IP-CAN bearer. First container for each QCI/ARP pair includes this field. In following containers this field is present if previous change condition is "QoS change". This field includes: QCI and ARP. For GBR QCI values, this field also includes GBR for the downlink and uplink direction. If the MBR is different than the GBR, then this field also includes the MBR for the downlink and uplink direction. This field does not include the APN-AMBR, which is contained in a separate field in the CDR for the IP-CAN session.
Charging Id	O _C	IP-CAN bearer Charging identifier used to identify this IP-CAN bearer in different records created by PCNs. Charging Id is generated by P-GW at IP-CAN bearer activation and is included in all containers in order to identify the containers which pertain to the IP-CAN bearer.
RAT Type	O _C	This field contains the RAT type for the current IP-CAN bearer.
Access Availability Change Reason	O _C	This field indicates the reason why the availability of an access is changed by the PCEF, i.e. RAN rule indication or Access usable/unusable. This field is only present when one access of a multi-access PDN connection becomes unusable.
Related Change Condition Information	O _C	This field indicates the change condition associated with an alternate access of a multi-access PDN connection that indirectly caused closure of the container. This field includes optional supplemental information associated with the change event (e.g., user location information).
Diagnostics	O _M	A more detailed reason for the release of the IP-CAN bearer, when a single cause is applicable.
Enhanced Diagnostics	O _C	This field holds a more detailed reason for the release of the IP-CAN bearer, when a set of causes is applicable.
3GPP PS Data Off Status	O _C	This field contains the status of the UE's 3GPP PS Data off Status.

Table 6.1.3.3 contains special handling for fields in the List of Service Data when charging per IP-CAN session is active. The complete set of fields in the List of Service Data is defined in TS 32.298 [51].

Table 6.1.3.3: List of Service Data in PGW-CDR when charging per IP-CAN session is active

Field	Category	Description
AF Record Information	O _C	As specified in TS 32.298 [51].
Charging Rule Base Name	O _C	As specified in TS 32.298 [51].
ADC Rule Base Name	O _C	Not applicable to PGW-CDR.

Field	Category	Description
Data Volume Downlink	O _C	As specified in TS 32.298 [51].
Data Volume Uplink	O _C	As specified in TS 32.298 [51].
Event Based Charging Information	O _C	As specified in TS 32.298 [51].
Local Sequence Number	O _C	As specified in TS 32.298 [51].
PS Furnish Charging Information	O _C	As specified in TS 32.298 [51].
EPC QoS Information	O _C	<p>This field contains the authorized QoS for the IP-CAN bearer that is first reported for the Rating Group or Rating Group / Service Identifier in the container. If traffic from multiple bearers is included in the report for the container, only one field is included.</p> <p>This field includes: QCI and ARP. For non-GBR QCI values, this field also includes the MBR for the downlink and uplink direction. For GBR QCI values, this field also includes GBR for the downlink and uplink direction. If the MBR is different than the GBR, then this field also includes the MBR for the downlink and uplink direction.</p> <p>This field does not include the APN-AMBR, which is contained in a separate field in the CDR for the IP-CAN session.</p>
Rating Group	M	As specified in TS 32.298 [51].
Report Time	M	As specified in TS 32.298 [51].
Result Code	O _C	As specified in TS 32.298 [51].
Service Condition Change	M	As specified in TS 32.298 [51]. Only those values specified for the events in clause 5.3.2.X apply.
Service Identifier	O _C	As specified in TS 32.298 [51].
Service Specific Info	O _C	As specified in TS 32.298 [51].
Serving Node Address	O _C	As specified in TS 32.298 [51].
Time of First Usage	O _C	As specified in TS 32.298 [51].
Time of Last Usage	O _C	As specified in TS 32.298 [51].
Tme Usage	O _C	As specified in TS 32.298 [51].
User Location Information	O _C	As specified in TS 32.298 [51].
3GPP2 User Location Information	O _C	As specified in TS 32.298 [51].
UWAN User Location Information	O _C	This field contains the UE location in an Untrusted Wireless Access Network (UWAN) which includes the UE local IP address and optionally UDP or TCP source port number (if NAT is detected) as defined in TS 29.274 [210]. It may also include WLAN location information the ePDG may have received from the 3GPP AAA server about the UE as "WLAN location information" defined in TS 29.274 [210].
Presence Reporting Area Status	O _C	This field contains the status of the UE presence in Presence Reporting Area as defined in TS 29.274[210]. This field is not applicable to multiple PRA(s).
List of Presence Reporting Area Information	O _C	This field contains a list of Presence Reporting Area Identifier(s) for the UE PDN connection, and the Presence Reporting Area(s) status (UE presence or not, inactive), differentiated between PCRF and OCS subscription.
RAT Type	O _C	This field contains the RAT type for the IP-CAN bearer that is first reported for the Rating Group or Rating Group / Service Identifier in the container. If traffic from multiple bearers is included in the report for the container, only one field is included.
Sponsor Identity	O _C	As specified in TS 32.298 [51].
Application Service Provider Identity	O _C	As specified in TS 32.298 [51].
Time Quota Mechanism	O _C	As specified in TS 32.298 [51].
Related Change Condition Information	O _C	This field indicates the change condition associated with an alternate access of a multi-access PDN connection that indirectly caused closure of the container. This field includes optional supplemental information associated with the change event (e.g., user location information).
3GPP PS Data Off Status	O _C	This field contains the status of the UE's 3GPP PS Data Off Status.
Traffic Steering Policy Identifier Uplink	O _C	This field contains the traffic steering policy identifier in the uplink direction.

Field	Category	Description
Traffic Steering Policy Identifier Downlink	O _C	This field contains the traffic steering policy identifier in the downlink direction.

6.1.4 Mobile Station mobility management data in SGSN (M-CDR)

If the collection of MS mobility management data is enabled then the SGSN shall start collecting the information specified in the following table 6.1.4.1 each time the mobile is attached to the SGSN.

Table 6.1.4.1: SGSN Mobile Station mobility management data (M-CDR)

Field	Category	Description
Record Type	M	SGSN mobility management record.
Served IMSI	M	IMSI of the MS.
Served IMEI	O _C	The IMEI or IMEISV of the ME, if available.
SGSN Address	O _M	The IP address of the current SGSN.
MS Network Capability	O _M	The mobile station network capability.
Routing Area Code	O _M	Routing Area at the time of the Record Opening Time.
Local Area Code	O _M	Location Area Code at the time of Record Opening Time.
Cell Identifier	O _M	The Cell Identity for GSM or Service Area Code (SAC) for UMTS at the time of the Record Opening Time.
Cell PLMN Id	O _M	The MCC and MNC of the Cell at the time of Record Opening Time.
Change of Location	O _C	A list of changes in Routing Area Code including MCC and MNC, each with a time stamp. This field is not required if partial records are generated when the location changes.
Record Opening Time	M	Timestamp when MS is attached to this SGSN or record opening time on following partial record.
Duration	O _M	Duration of this record.
SGSN Change	C	Present if this is first record after SGSN change.
Cause for Record Closing	M	The reason for the closure of the record in this SGSN.
Diagnostics	O _M	A more detailed reason for the release of the connection.
Record Sequence Number	C	Partial record sequence number in this SGSN; only present in case of partial records.
Node ID	O _M	Name of the recording entity.
Local Record Sequence Number	O _M	Consecutive record number created by this node. The number is allocated sequentially including all CDR types.
Served MSISDN	O _C	The primary MSISDN of the subscriber, if available.
Charging Characteristics	M	The Charging Characteristics used by the SGSN.
Serving Node PLMN Identifier	O _C	This field holds the PLMN Identifier (MCC and MNC) serving the UE during this record. Only one value is included in case multiple PLMN Ids are supported by the SGSN.
CN Operator Selection Entity	O _C	This field indicates whether the Serving Network identified by the "Serving Node PLMN Identifier" has been selected by the UE or by the network, as defined in TS 29.060 [203] for GPRS, and in TS 29.274 [210] for EPC, if available.
CAMEL Information	O _C	Set of CAMEL information related to Attach/Detach session. For more information see Description of Record Fields. This field is present if CAMEL service is activated.
RAT Type	O _C	This field indicates the Radio Access Technology (RAT) type currently used by the Mobile Station as defined in TS 29.061 [205], when available.
Charging Characteristics Selection Mode	O _M	Holds information about how Charging Characteristics were selected.
Record Extensions	O _C	A set of network operator/manufacture specific extensions to the record. Conditioned upon the existence of an extension.

6.1.5 SMS-MO data in SGSN/MME (S-SMO-CDR)

If enabled, an S-SMO-CDR SGSN/MME Mobile originated SMS record shall be produced for each short message sent by a mobile subscriber via the SGSN/via the MME to the SMSC.

The fields in the record are specified in table 6.1.5.1.

Table 6.1.5.1: SGSN/MME Mobile originated SMS record (S-SMO-CDR)

Field	Category		Description
	SGSN	MME	
Record Type	M	M	SGSN/MME Mobile Originated SMS.
Retransmission	-	O _C	This parameter, when present, indicates that information from retransmitted Charging Data Request has been used in this CDR.
Served IMSI	M	M	The IMSI of the subscriber.
Served IMEI	O _C	O _C	The IMEI or IMEISV of the ME, if available.
Served MSISDN	O _C	O _C	The primary MSISDN of the subscriber, if available. For MSISDN-less subscription, this field holds the Dummy MSISDN as defined in TS 23.003 [103].
MS Network Capability	O _M	-	The mobile station network capability.
Service Centre	O _M	O _M	The address (E.164) of the SMS-service centre.
Serving Node Type	M	M	Type of node handling the SMS (SGSN or MME).
Recording Entity	O _M	O _M	The E.164 number of the SGSN/MME.
Serving Node Address	-	O _M	The address of the MME used.
Serving Node IPv6 Address Address	-	O _C	The IPv6 address, in case of IPv4v6 dual stack, of the MME.
MME Name	-	O _M	The operation Identity of the MME.
MME Realm	-	O _M	The operation Realm Identity of the MME.
Location Area Code	O _M	-	The Location Area Code from which the message originated.
Routing Area Code	O _M	-	The Routing Area Code from which the message originated.
Cell Identifier	O _M	-	The Cell Identity for GSM or Service Area Code (SAC) for UMTS from which the message originated.
User Location Information	-	O _C	This field contains the User Location (User location Information as defined in TS 29.274 [210]) from which the message originated.
User Location Information Time	-	O _C	This field contains the time at which the user location information was acquired.
Message Reference	M	M	A reference provided by the MS uniquely identifying this message.
Event Time Stamp	M	M	The time at which the message was received by the SGSN/MME from the subscriber.
SMS Result	C	C	The result of the attempted delivery if unsuccessful.
Node ID	O _M	O _M	Name of the recording entity.
Local Record Sequence Number	O _M	O _M	Consecutive record number created by this node. The number is allocated sequentially including all CDR types.
Charging Characteristics	M	M	The Charging Characteristics flag set used by the SGSN/MME.
Serving Node PLMN Identifier	O _C	O _C	This field holds the PLMN Identifier (MCC and MNC) serving the UE during this record. Only one value is included in case multiple PLMN Ids are supported by the SGSN/MME.
CN Operator Selection Entity	O _C	O _C	This field indicates whether the Serving Network identified by the "Serving Node PLMN Identifier" has been selected by the UE or by the network, as defined in TS 29.060 [203] for GPRS, and in TS 29.274 [210] for EPC, if available.
RAT Type	O _C	O _C	This field indicates the Radio Access Technology (RAT) type currently used by the Mobile Station as defined in TS 29.061 [205], when available.
Destination Number	O _M	O _M	The destination short message subscriber number.
CAMEL Information	O _C	-	Set of CAMEL information related to SMS session. For more information see Description of Record Fields. This field is present if CAMEL service is activated.
Charging Characteristics Selection Mode	O _M	O _M	Holds information about how Charging Characteristics were selected.
Record Extensions	O _C	O _C	A set of network operator/ manufacturer specific extensions to the record. Conditioned upon the existence of an extension.

6.1.6 SMS-MT data in SGSN/MME (S-SMT-CDR)

If enabled, an SGSN/MME Mobile terminated SMS record shall be produced for each short message received by a mobile subscriber via the SGSN/ from the SMSC via the MME. The fields in the record are specified in table 6.1.6.1.

Table 6.1.6.1: SGSN/MME Mobile terminated SMS record (S-SMT-CDR)

Field	Category		Description
	SGSN	MME	
Record Type	M	M	SGSN/MME Mobile Terminated SMS.
Retransmission	-	O _C	This parameter, when present, indicates that information from retransmitted Charging Data Request has been used in this CDR.
Served IMSI	M	M	The IMSI of the subscriber.
Served IMEI	O _C	O _C	The IMEI or IMEISV of the ME, if available.
Served MSISDN	O _C	O _C	The primary MSISDN of the subscriber.
MS Network Capability	O _M	-	The mobile station network capability.
Service Centre	O _M	O _M	The address (E.164) of the SMS-service centre.
Serving Node Type	M	M	Type of node handling the SMS (SGSN or MME)
Recording Entity	O _M	O _M	The E.164 number of the SGSN/MME.
Serving Node Address	-	O _M	The address of the MME used
Serving Node IPv6 Address Address	-	O _C	The IPv6 address, in case of IPv4v6 dual stack, of the MME.
MME Name	-	O _M	The Diameter Identity of the MME
MME Realm	-	O _M	The Diameter Realm Identity of the MME
Location Area Code	O _M	-	The Location Area Code to which the message was delivered.
Routing Area Code	O _M	-	The Routing Area Code to which the message was delivered.
Cell Identifier	O _M	-	The Cell Identity for GSM or Service Area Code (SAC) for UMTS to which the message was delivered.
User Location Information	-	O _C	This field contains the User Location (User location Information as defined in TS 29.274 [210]) to which the message was delivered, if available.
User Location Information Time	-	O _C	This field contains the time at which the user location information was acquired.
Event Time Stamp	M	M	Delivery time stamp, time at which message was sent to the MS by the SGSN/MME.
SMS Result	C	C	The result of the attempted delivery if unsuccessful.
Node ID	O _M	O _M	Name of the recording entity.
Local Record Sequence Number	O _M	O _M	Consecutive record number created by this node. The number is allocated sequentially including all CDR types.
Charging Characteristics	M	M	The Charging Characteristics flag set used by the SGSN/MME.
Serving Node PLMN Identifier	O _C	O _C	This field holds the PLMN Identifier (MCC and MNC) serving the UE during this record. Only one value is included in case multiple PLMN Ids are supported by the SGSN/MME
CN Operator Selection Entity	O _C	O _C	This field indicates whether the Serving Network identified by the "Serving Node PLMN Identifier" has been selected by the UE or by the network, as defined in TS 29.060 [203] for GPRS, and in TS 29.274 [210] for EPC, if available.
RAT Type	O _C	O _C	This field indicates the Radio Access Technology (RAT) type currently used by the Mobile Station as defined in TS 29.061 [205], when available.
Charging Characteristics Selection Mode	O _M	O _M	Holds information about how Charging Characteristics were selected.
CAMEL Information	O _C	-	Set of CAMEL information related to SMS session. For more information see Description of Record Fields. This field is present if CAMEL service is activated.
Originating Address	O _C	O _C	The address of the originating SME.
Record Extensions	O _C	O _C	A set of network operator/manufacture specific extensions to the record. Conditioned upon the existence of an extension.

6.1.7 Mobile Terminated location request (LCS-MT-CDR)

If enabled, an SGSN Mobile terminated LCS record shall be produced for each mobile terminated location request that is performed via the SGSN. The fields in the record are specified in table 6.1.7.1.

Table 6.1.7.1: SGSN Mobile terminated LCS record (SGSN-LCS-MT)

Field	Category	Description
Record Type	M	SGSN Mobile Terminated LCS.
Recording Entity	M	The E.164 number of the SGSN.
LCS Client Type	M	The type of the LCS client that invoked the LR.
LCS Client Identity	M	Further identification of the LCS client.
Served IMSI	M	The IMSI of the subscriber.
Served MSISDN	O _C	The primary MSISDN of the subscriber, if available.
SGSN Address	O _M	The IP address of the current SGSN.
Location Type	M	The type of the estimated location.
LCS QoS	C	QoS of the LR, if available.
LCS Priority	C	Priority of the LR, if available.
MLC Number	M	The E.164 address of the requesting GMLC.
Event Time stamp	M	The time at which the Perform_Location_Request is sent by the SGSN.
Measurement Duration	O _M	The duration of proceeding the location request.
Notification To MS User	C	The privacy notification to MS user that was applicable when the LR was invoked, if available.
Privacy Override	C	This parameter indicates the override MS privacy by the LCS client, if available.
Location	O _M	The LAC and CI when the LR is received.
Routing Area Code	O _M	The Routing Area Code to which the LCS terminated.
Location Estimate	O _C	The location estimate for the subscriber if contained in geographic position and the LR was successful.
Positioning Data	C	The positioning method used or attempted, if available.
LCS Cause	O _C	The result of the LR if any failure or partial success happened as known at radio interface.
Cause for Record Closing	M	The reason for closure of the record from this SGSN.
Diagnostics	C	A more detailed information about the Cause for Record Closing if any failure or partial success happened.
Node ID	O _M	Name of the recording entity.
Local Record Sequence Number	O _M	Consecutive record number created by this node. The number is allocated sequentially including all CDR types.
Charging Characteristics	M	The Charging Characteristics used by the SGSN. (always use the subscribed CC).
Charging Characteristics Selection Mode	O _M	Holds information about how Charging Characteristics were selected. (only subscribed/home default/visited default).
Serving Node PLMN Identifier	O _C	This field holds the PLMN Identifier (MCC and MNC) serving the UE during this record. Only one value is included in case multiple PLMN Ids are supported by the SGSN.
CN Operator Selection Entity	O _C	This field indicates whether the Serving Network identified by the "Serving Node PLMN Identifier" has been selected by the UE or by the network, as defined in TS 29.060 [203] for GPRS, and in TS 29.274 [210] for EPC, if available.
RAT Type	O _C	This field indicates the Radio Access Technology (RAT) type currently used by the Mobile Station as defined in TS 29.061 [205], when available.
Record Extensions	O _C	A set of network operator/manufacture specific extensions to the record. Conditioned upon the existence of an extension.

6.1.8 Mobile originated Location request (LCS-MO-CDR)

If enabled, an SGSN Mobile originated LCS record shall be produced for each mobile originated location request that is performed via the SGSN. The fields in the record are specified in table 6.1.8.1.

Table 6.1.8.1: SGSN Mobile originated LCS record (SGSN-LCS-MO)

Field	Category	Description
Record Type	M	SGSN Mobile Originated LCS.
Recording Entity	M	The E.164 number of the SGSN.
LCS Client Type	C	The type of the LCS client that invoked the LR, if available.
LCS Client Identity	C	Further identification of the LCS client, if available.
Served IMSI	M	The IMSI of the subscriber.
Served MSISDN	O _C	The primary MSISDN of the subscriber, if available.
SGSN Address	O _M	The IP address of the current SGSN.
Location Method	M	The type of the location request.
LCS QoS	C	QoS of the LR, if available.
LCS Priority	O _C	Priority of the LR, if available.
MLC Number	C	The E.164 address of the involved GMLC, if applicable.
Event Time stamp	M	The time at which the Perform_Location_Request is sent by the SGSN.
Measurement Duration	O _M	The duration of proceeding the location request.
Location	O _M	The LAC and CI when the LR is received.
Routing Area Code	O _M	The Routing Area Code from which the LCS originated.
Location Estimate	O _C	The location estimate for the subscriber if contained in geographic position and the LR was successful.
Positioning Data	C	The positioning method used or attempted, if available.
LCS Cause	O _C	The result of the LR if any failure or partial success happened as known at radio interface.
Cause for Record Closing	M	The reason for closure of the record from this SGSN.
Diagnostics	C	A more detailed information about the Cause for Record Closing if any failure or partial success happened.
Node ID	O _M	Name of the recording entity.
Local Record Sequence Number	O _M	Consecutive record number created by this node. The number is allocated sequentially including all CDR types.
Charging Characteristics	M	The Charging Characteristics flag set used by the SGSN.
Charging Characteristics Selection Mode	O _M	Holds information about how Charging Characteristics were selected.
Serving Node PLMN Identifier	O _C	This field holds the PLMN Identifier (MCC and MNC) serving the UE during this record. Only one value is included in case multiple PLMN Ids are supported by the SGSN.
CN Operator Selection Entity	O _C	This field indicates whether the Serving Network identified by the "Serving Node PLMN Identifier" has been selected by the UE or by the network, as defined in TS 29.060 [203] for GPRS, and in TS 29.274 [210] for EPC, if available.
RAT Type	O _C	This field indicates the Radio Access Technology (RAT) type currently used by the Mobile Station as defined in TS 29.061 [205], when available.
Record Extensions	O _C	A set of network operator/manufacture specific extensions to the record. Conditioned upon the existence of an extension.

6.1.9 Network induced Location request (LCS-NI-CDR)

If enabled, an SGSN Network induced LCS record shall be produced for each network induced location request that is performed via the SGSN. The fields in the record are specified in table 6.1.9.1.

Table 6.1.9.1: SGSN Network induced LCS record (SGSN-LCS-NI)

Field	Category	Description
Record Type	M	SGSN Network Induced LCS.
Recording Entity	M	The E.164 number of the SGSN.
LCS Client Type	C	The type of the LCS client that invoked the LR, if available.
LCS Client Identity	C	Further identification of the LCS client, if available.
Served IMSI	C	The IMSI of the subscriber if supplied.
Served MSISDN	C	The primary MSISDN of the subscriber if supplied.
SGSN Address	O _M	The IP address of the current SGSN.
Served IMEI	O _C	The IMEI or IMEISV of the ME, if available.
LCS QoS	C	QoS of the LR, if available.
LCS Priority	C	Priority of the LR, if available.
MLC Number	C	The E.164 address of the involved GMLC, if applicable.
Event Time stamp	M	The time at which the Perform_Location_Request is sent by the SGSN.
Measurement Duration	O _M	The duration of proceeding the location request.
Location	O _M	The LAC and CI when the LR is received.
Routing Area Code	O _M	The Routing Area Code from which the LCS originated.
Location Estimate	O _C	The location estimate for the subscriber if contained in geographic position and the LR was successful.
Positioning Data	C	The positioning method used or attempted, if available.
LCS Cause	O _C	The result of the LR if any failure or partial success happened as known at radio interface.
Cause for Record Closing	M	The reason for closure of the record from this SGSN.
Diagnostics	C	A more detailed information about the Cause for Record Closing if any failure or partial success happened.
Node ID	O _M	Name of the recording entity.
Local Record Sequence Number	O _M	Consecutive record number created by this node. The number is allocated sequentially including all CDR types.
Charging Characteristics	M	The Charging Characteristics flag set used by the SGSN.
Charging Characteristics Selection Mode	O _M	Holds information about how Charging Characteristics were selected.
Serving Node PLMN Identifier	O _C	This field holds the PLMN Identifier (MCC and MNC) serving the UE during this record. Only one value is included in case multiple PLMN Ids are supported by the SGSN.
CN Operator Selection Entity	O _C	This field indicates whether the Serving Network identified by the "Serving Node PLMN Identifier" has been selected by the UE or by the network, as defined in TS 29.060 [203] for GPRS, and in TS 29.274 [210] for EPC, if available.
RAT Type	O _C	This field indicates the Radio Access Technology (RAT) type currently used by the Mobile Station as defined in TS 29.061 [205], when available.
Record Extensions	O _C	A set of network operator/manufacture specific extensions to the record. Conditioned upon the existence of an extension.

6.1.10 MBMS bearer context charging data in SGSN (S-MB-CDR)

If the collection of CDR data is enabled then the SGSN data specified in table 6.1.10.1 shall be available for each MBMS bearer context.

Table 6.1.10.1: SGSN MBMS bearer context data (S-MB-CDR)

Field	Category	Description
Record Type	M	SGSN MBMS bearer context record.
SGSN Address used	M	The control plane IP address of the SGSN used.
Charging ID	M	Bearer context identifier used to identify this MBMS bearer context in different records created by GSNs
List of RAs	O _C	List of routing areas receiving data used during this record. equivalent to the list of RAs defined in TS 23.246 [207].
Access Point Name Network Identifier	O _M	The logical name of the connected access point to the BM-SC (network identifier part of APN).
PDP Type	O _M	This field indicates PDP type (i.e. IPv4 or IPv6).
Served PDP Address	O _C	Indicates the IP Multicast address used for the MBMS bearer context, i.e. IPv4 or IPv6, if available.
List of Traffic Data Volumes	O _M	A list of changes in charging conditions for this MBMS bearer context, each change is time stamped. Charging conditions are used to categorize traffic volumes, such as per tariff period. It shall include the required bearer capabilities (QoS Negotiated)
Record Opening Time	M	Time stamp when MBMS bearer context is activated in this SGSN or record opening time on subsequent partial records.
Duration	M	Duration of this record in the SGSN.
Cause for Record Closing	M	The reason for the release of record from this SGSN.
Diagnostics	O _M	A more detailed reason for the release of the connection.
Record Sequence Number	C	Partial record sequence number, only present in case of partial records.
Node ID	O _M	Name of the recording entity.
Local Record Sequence Number	O _M	Consecutive record number created by this node. The number is allocated sequentially including all CDR types.
Number of receiving UEs	O _C	Indicates the number of UEs receiving the MBMS bearer service
MBMS Information	O _M	MBMS related information related to MBMS bearer context being charged, defined in TS 32.273 [33].
Record Extensions	O _C	A set of network operator/manufacture specific extensions to the record. Conditioned upon the existence of an extension.

6.1.11 MBMS bearer context charging data in GGSN (G-MB-CDR)

If the collection of CDR data is enabled then the GGSN data specified in table 6.1.11.1 shall be available for each MBMS bearer context.

Table 6.1.11.1: GGSN MBMS bearer context data (G-MB-CDR)

Field	Category	Description
Record Type	M	GGSN MBMS bearer context record.
GGSN Address used	M	The control plane IP address of the GGSN used.
Charging ID	M	Bearer context identifier used to identify this MBMS bearer context in different records created by GSNs
List of Downstream Nodes	M	List of SGSN addresses used during this record. equivalent to the list of downstream nodes defined in TS 23.246 [207].
Access Point Name Network Identifier	O _M	The logical name of the connected access point to the BM-SC (network identifier part of APN).
PDP Type	O _M	This field indicates PDP type (i.e. IPv4 or IPv6).
Served PDP Address	O _C	Indicates the IP Multicast address used for the MBMS bearer context, i.e. IPv4 or IPv6, if available.
List of Traffic Data Volumes	O _M	A list of changes in charging conditions for this MBMS bearer context, each change is time stamped. Charging conditions are used to categorize traffic volumes, such as per tariff period. It shall include the required bearer capabilities (QoS Negotiated).
Record Opening Time	M	Time stamp when MBMS bearer context is activated in this GGSN or record opening time on subsequent partial records.
Duration	M	Duration of this record in the GGSN.
Cause for Record Closing	M	The reason for the release of record from this GGSN.
Diagnostics	O _M	A more detailed reason for the release of the connection.
Record Sequence Number	C	Partial record sequence number, only present in case of partial records.
Node ID	O _M	Name of the recording entity.
Local Record Sequence Number	O _M	Consecutive record number created by this node. The number is allocated sequentially including all CDR types.
MBMS Information	O _M	MBMS related information related to MBMS bearer context being charged, defined in TS 32.273 [33].
Record Extensions	O _C	A set of network operator/manufacture specific extensions to the record. Conditioned upon the existence of an extension.

6.1.12 MBMS bearer context charging data in MBMS GW (MBMS-GW-CDR)

If the collection of CDR data is enabled then the MBMS GW data specified in table 6.1.12.1 shall be available for each MBMS bearer context when MBMS GW doesn't locate in MB-SC.

Table 6.1.12.1: MBMS GW MBMS bearer context data (MBMS-GW-CDR)

Field	Category	Description
Record Type	M	MBMS GW MBMS bearer context record.
MBMS GW Address used	M	The control plane IP address of the MBMS GW used.
Charging ID	M	Bearer context identifier used to identify this MBMS bearer context in different records created by Evolved Packet System core network elements
List of Downstream Nodes	M	List of SGSN/MME addresses used during this record. equivalent to the list of downstream nodes defined in TS 23.246 [207].
Access Point Name Network Identifier	O _M	The logical name of the connected access point to the BM-SC (network identifier part of APN).
PDP/PDN Type	O _M	This field indicates PDN type (i.e. IPv4 or IPv6).
Served PDP/PDN Address	O _C	Indicates the IP Multicast address used for the MBMS bearer context. (i.e. IPv4 or IPv6).
List of Traffic Data Volumes	O _M	A list of changes in charging conditions for this MBMS bearer context, each change is time stamped. Charging conditions are used to categorize traffic volumes, such as per tariff period. It shall include the required bearer capabilities (QoS Negotiated).
Record Opening Time	M	Time stamp when MBMS bearer context is activated in this MBMS GW or record opening time on subsequent partial records.
Duration	M	Duration of this record in the MBMS GW.
Cause for Record Closing	M	The reason for the release of record from this MBMS GW.
Diagnostics	O _M	A more detailed reason for the release of the connection.
Record Sequence Number	C	Partial record sequence number, only present in case of partial records.
Node ID	O _M	Name of the recording entity.
Record Extensions	O _C	A set of network operator/manufacture specific extensions to the record. Conditioned upon the existence of an extension.
Local Record Sequence Number	O _M	Consecutive record number created by this node. The number is allocated sequentially including all CDR types.
MBMS Information	O _M	MBMS related information related to MBMS bearer context being charged, defined in TS 32.273 [33].
C-TEID	O _C	Common Tunnel Endpoint Identifier of MBMS GW for user plane, defined in TS 23.246 [207].
IP multicast and Source address for distribution	O _C	IP addresses identifying the SSM channel used for user plane distribution on the backbone network defined in TS 23.246 [207].

6.1.13 IP-CAN bearer charging data in ePDG (ePDG-CDR)

If the collection of CDR data is enabled then the ePDG data specified in table 6.1.13.1 shall be available for each IP-CAN bearer.

Table 6.1.13.1: ePDG IP-CAN bearer data (ePDG-CDR)

Field	Category	Description
Record Type	M	ePDG IP-CAN bearer record.
Retransmission	O _C	This parameter, when present, indicates that information from retransmitted Charging Data Request has been used in this CDR.
Served IMSI	C	IMSI of the served party, if available.
IMSI Unauthenticated Flag	O _C	This field indicates the provided served IMSI is not authenticated (emergency bearer service situation).
Served IMEI	O _C	The IMEI or IMEISV of the ME, if available.
ePDG Address Used	M	The control plane IP address of the ePDG used.
ePDG IPv6 Address	O _C	The control plane IPv6 address, in case of IPv4v6 dual stack, of the ePDG.
Charging ID	M	IP-CAN bearer Charging identifier used to identify this IP-CAN bearer in different records created by PCNs
PDN Connection Charging Id	O _M	This field holds the explicit Charging Id for the PDN connection. When NBIFOM is supported, the PGW will provide a unique PDN Connection Charging ID for the PDN connection. Otherwise the field holds the Charging Id of the EPS default bearer in GTP case, or the unique Charging Id of the IP-CAN session in PMIP case. This field is used to identify different records belonging to same PDN connection.
SGW Change	O _C	Present if this is first record after a change from another serving node (i.e. SGW, ePDG).
PGW PLMN Identifier	O _C	PLMN identifier (MCC MNC) of the P-GW used.
Access Point Name Network Identifier	O _M	The logical name of the connected access point to the external packet data network (network identifier part of APN).
PDP/PDN Type	O _M	This field indicates PDN type (i.e. IPv4, IPv6 or IPv4v6).
Served PDP/PDN Address	O _C	IP address allocated for the PDP context / PDN connection, if available, i.e. IPv4 address when PDN Type is IPv4 or IPv6 prefix when PDN Type is IPv6 or IPv4v6.
Served PDP/PDN Address prefix length	O _C	PDP/PDN Address prefix length of an IPv6 typed Served PDP Address. The field needs not available for prefix length of 64 bits.
Served PDP/PDN Address extension	O _C	This field holds IPv4 address of the served IMSI, if available, when PDN type is IPv4v6.
Dynamic Address Flag	O _C	Indicates whether served PDP/PDN address is dynamic, which is allocated during IP-CAN bearer activation, initial attach and UE requested PDN connectivity. This field is missing if IPv4 address is static when PDN Type is IPv4, or if IPv6 address is static when PDN Type is IPv6 or IPv4v6.
Dynamic Address Flag extension	O _C	Indicates whether served IPv4 PDP/PDN address is dynamic, which is allocated during IP-CAN bearer activation, initial attach and UE requested PDN connectivity with PDP/PDN type IPv4v6. This field is missing if IPv4 address is static.
List of Traffic Data Volumes	O _M	A list of changes in charging conditions for this QCI/ARP pair, each change is time stamped. Charging conditions are used to categorize traffic volumes, such as per tariff period. Initial and subsequently changed QoS and corresponding data values are also listed.
Record Opening Time	M	Time stamp when IP-CAN bearer is activated in this ePDG or record opening time on subsequent partial records.
Duration	M	Duration of this record in the ePDG.
Cause for Record Closing	M	The reason for the release of record from this ePDG.
Diagnostics	O _M	A more detailed reason for the release of the IP-CAN bearer, when a single cause is applicable.
Enhanced Diagnostics	O _C	This field holds a more detailed reason for the release of the IP-CAN bearer, when a set of causes is applicable.
Record Sequence Number	C	Partial record sequence number, only present in case of partial records.

Field	Category	Description
Node ID	O _M	Name of the recording entity.
Local Record Sequence Number	O _M	Consecutive record number created by this node. The number is allocated sequentially including all CDR types.
APN Selection Mode	O _M	An index indicating how the APN was selected.
Served MSISDN	O _C	The primary MSISDN of the subscriber, if available.
Charging Characteristics	M	The Charging Characteristics applied to the IP-CAN bearer.
Charging Characteristics Selection Mode	O _M	Holds information about how Charging Characteristics were selected.
IMS Signalling Context	O _C	Included if the IM-CN Subsystem Signalling Flag is set, see TS 23.060 [201] IP-CAN bearer is used for IMS signalling.
P-GW Address used.	O _C	This field is the P-GW IP Address for the Control Plane
P-GW IPv6 Address	O _C	This field is the P-GW IPv6 Address, in case of IPv4v6 dual stack, for the Control Plane.
RAT Type	O _C	This field indicates the Radio Access Technology (RAT) type currently used by the Mobile Station as defined in TS 29.061 [205], when available.
Start Time	O _C	This field holds the time when User IP-CAN session starts, available in the CDR for the first bearer in an IP-CAN session.
Stop Time	O _C	This field holds the time when User IP-CAN session is terminated, available in the CDR for the last bearer in an IP-CAN session.
UWAN User Location Information	O _C	This field contains the UE location in an Untrusted Wireless Access Network (UWAN) which includes the UE local IP address and optionally UDP or TCP source port number (if NAT is detected) as defined in TS 29.274 [210]. It may also include WLAN location information "the ePDG may have received from the 3GPP AAA server about the UE as WLAN location information" defined in TS 29.274[210].
User Location Info Time	O _C	This field contains the time at which the user location information was acquired, if available.
Record Extensions	O _C	A set of network operator/manufacture specific extensions to the record. Conditioned upon the existence of an extension.

6.1.14 ABC data in TDF (TDF-CDR)

If ABC is enabled and the collection of CDR data is enabled, then the TDF data specified in table 6.1.14.1 shall be available for each TDF session.

NOTE: An indication that online charging is also active for the session may be provided by using PS Furnish Charging Information.

Table 6.1.14.1: TDF session data (TDF-CDR)

Field	Category	Description
Record Type	M	TDF session record.
Retransmission	O _C	This parameter, when present, indicates that information from retransmitted Charging Data Request has been used in this CDR.
Served IMSI	C	IMSI of the served party, if available.
Served IMEI	O _C	The IMEI or IMEISV of the ME, if available. It is used for identifying the user in case Served IMSI is not present during emergency bearer service.
Served 3GPP2 MEID	O _C	MEID of the served party's terminal equipment for 3GPP2 access.
Served MN NAI	O _C	Mobile Node Identifier in NAI format (based on IMSI), if available.
P-GW Address used	M	The control plane IP address of the P-GW used.
P-GW Address IPv6	O _C	The control plane IPv6 address, in case of IPv4v6 dual stack, of the P-GW used.
TDF Address used	M	The control plane IP address of the TDF used.
TDF Address IPv6	O _C	The control plane IPv6 address, in case of IPv4v6 dual stack, of the TDF used.
PDN Connection Charging ID	M	This field is received from PCRF and holds explicit Charging Id for the PDN connection assigned by P-GW to identify different records belonging to same PDN connection.
Serving node Address	M	List of SGSN/S-GW/TWAG control plane IP addresses, or the ePDG address used during this record.
Serving node IPv6 Address	O _C	List of SGSN/S-GW/TWAG control plane IPv6 addresses, in case of IPv4v6 dual stack, used during this record.
Serving node Type	M	List of serving node types in control plane (SGSN, SGW, ePDG, AGW, TWAG). The serving node types listed here map to the serving node addresses listed in the field "Serving node Address" in sequence.
PGW PLMN Identifier	O _C	PLMN identifier (MCC MNC) of the P-GW.
TDF PLMN Identifier	O _C	PLMN identifier (MCC MNC) of the TDF.
Access Point Name Network Identifier	O _M	The logical name of the connected access point to the external packet data network (network identifier part of APN).
PDP/PDN Type	O _M	PDP/PDN type, i.e. IPv4, IPv6, IPv4v6, or PDP type PPP.
Served PDP/PDN Address	O _C	IP address allocated for the PDP context / PDN connection, i.e. IPv4 address when PDP/PDN Type is IPv4 or IPv6 prefix when PDP/PDN Type is IPv6 or IPv4v6. This parameter shall be present except when both the PDP type is PPP and dynamic IP-CAN bearer address assignment is used.
Served PDP/PDN Address prefix length	O _C	PDP/PDN Address prefix length of an IPv6 typed Served PDP Address. The field needs not available for prefix length of 64 bits.
Served PDP/PDN Address extension	O _C	This field holds IPv4 address of the served IMSI, if available, when PDP/PDN type is IPv4v6.
Dynamic Address Flag	O _C	Indicates whether served PDP/PDN address is dynamic, which is allocated during IP-CAN bearer activation, initial attach (E-UTRAN or over S2x) and UE requested PDN connectivity. This field is missing if IPv4 address is static when PDN Type is IPv4, or if IPv6 address is static when PDN Type is IPv6 or IPv4v6.
Dynamic Address Flag extension	O _C	Indicates whether served IPv4 PDP/PDN address is dynamic, which is allocated during IP-CAN bearer activation, initial attach (E-UTRAN or over S2x) and UE requested PDN connectivity with PDP/PDN type IPv4v6. This field is missing if IPv4 address is static.

Field	Category	Description
List of Service Data	O _M	A list of changes in charging conditions for application traffic within this TDF session categorized per rating group or per combination of the rating group and service id. Each change is time stamped. Charging conditions are used to categorize traffic volumes, elapsed time and number of events, such as per tariff period and subsequently changed maximal bandwidth limitation and corresponding data values are also listed. Online charging information (PS Furnish Charging Information) may be added per each service data container in case it is sent by the OCS. Failure-Handling: This field shall be present in case TDF initiates an interaction with the PCRF in relation to the OCS's guidance for Failure Handling. It shall indicate the Failure Handling scenario and the instant the Failure Action is triggered (see annex B). Scenarios: Continue/New Session; Continue/Ongoing Session; Retry&Terminate/Ongoing Session; Terminate/Ongoing Session.
Record Opening Time	M	Time stamp when TDF session is established or record opening time on subsequent partial records.
MS Time Zone	O _C	This field contains the MS Time Zone the MS is currently located as defined in TS 29.060 [203], if available.
Duration	M	Duration of this record in the TDF.
Cause for Record Closing	M	The reason for closing the record from this TDF.
Diagnostics	O _M	A more detailed reason for closing the record.
Record Sequence Number	C	Partial record sequence number, only present in case of partial records.
Node ID	O _M	Name of the recording entity.
Record Extensions	O _C	A set of network operator/manufacturer specific extensions to the record. Conditioned upon the existence of an extension.
Local Record Sequence Number	O _M	Consecutive record number created by this node. The number is allocated sequentially including all CDR types.
APN Selection Mode	O _M	An index indicating how the APN was selected.
Served MSISDN	O _C	The primary MSISDN of the subscriber, if available.
User Location Information	O _C	This field contains the User Location Information of the MS as defined in TS 29.060 [203] for GPRS case, and in TS 29.274 [210] for EPC case, if available.
User CSG information	O _C	This field contains the User CSG Information of the UE, if available, including CSG ID, access mode and CSG membership indication.
3GPP2 User Location information	O _C	This field contains the User Location Information of the MS as defined in TS 29.212 [216] for 3GPP2 access, if available.
TWAN User Location Information	O _C	This field contains the UE location in a Trusted WLAN Access Network (TWAN) , if available: - as "TWAN identifier" defined in TS 29.274 [210] for S2a GTP-based case, or, - as "Access Network Identifier Option IE" defined in 29.275 [211] for S2a PMIP-based case.
Charging Characteristics	M	The Charging Characteristics applied to the TDF session.
Charging Characteristics Selection Mode	O _M	Holds information about how Charging Characteristics were selected.
Serving node PLMN Identifier	O _M	This field holds the PLMN Identifier (MCC and MNC) serving the UE during this record. When the Serving node is TWAG, this field includes the PLMN identifier used for UE authentication, i.e. the VPLMN in roaming case, and the HPLMN in non-roaming case.
PS Furnish Charging Information	O _C	Online charging session specific information
RAT Type	O _C	This field indicates the Radio Access Technology (RAT) type currently used by the Mobile Station as defined in TS 29.061 [205], when available.
Start Time	O _C	This field holds the time when TDF session starts.
Stop Time	O _C	This field holds the time when TDF session is terminated.

6.1.15 IP-CAN bearer charging data in TWAG (TWAG-CDR)

If the collection of CDR data is enabled then the TWAG data specified in table 6.1.15.1 shall be available for each IP-CAN bearer.

Table 6.1.15.1: TWAG IP-CAN bearer data (TWAG-CDR)

Field	Category	Description
Record Type	M	TWAG IP-CAN bearer record.
Retransmission	O _C	This parameter, when present, indicates that information from retransmitted Charging Data Request has been used in this CDR.
Served IMSI	C	IMSI of the served party, if available.
IMSI Unauthenticated Flag	O _C	This field indicates the provided served IMSI is not authenticated (emergency bearer service situation).
Served IMEI	O _C	The IMEI or IMEISV of the ME, if available.
TWAG Address Used	M	The control plane IP address of the TWAG used.
TWAG IPv6 Address	O _C	The control plane IPv6 address, in case of IPv4v6 dual stack, of the TWAG.
Charging ID	M	IP-CAN bearer Charging identifier used to identify this IP-CAN bearer in different records created by PCNs
PDN Connection Charging Id	O _M	This field holds the explicit Charging Id for the PDN connection. When NBIFOM is supported, the PGW will provide a unique PDN Connection Charging ID for the PDN connection. Otherwise the field holds the Charging Id of the EPS default bearer in GTP case, or the unique Charging Id of the IP-CAN session in PMIP case. This field is used to identify different records belonging to same PDN connection.
SGW Change	O _C	Present if this is first record after a change from another serving node (i.e. SGW, ePDG, TWAG).
PGW PLMN Identifier	O _C	PLMN identifier (MCC MNC) of the P-GW used.
Access Point Name Network Identifier	O _M	The logical name of the connected access point to the external packet data network (network identifier part of APN).
PDP/PDN Type	O _M	This field indicates PDN type (i.e. IPv4, IPv6 or IPv4v6).
Served PDP/PDN Address	O _C	IP address allocated for the PDP context / PDN connection, if available, i.e. IPv4 address when PDN Type is IPv4 or IPv6 prefix when PDN Type is IPv6 or IPv4v6.
Served PDP/PDN Address prefix length	O _C	PDP/PDN Address prefix length of an IPv6 typed Served PDP Address. The field needs not available for prefix length of 64 bits.
Served PDP/PDN Address extension	O _C	This field holds IPv4 address of the served IMSI, if available, when PDN type is IPv4v6.
Dynamic Address Flag	O _C	Indicates whether served PDP/PDN address is dynamic, which is allocated during IP-CAN bearer activation, initial attach and UE requested PDN connectivity. This field is missing if IPv4 address is static when PDN Type is IPv4, or if IPv6 address is static when PDN Type is IPv6 or IPv4v6.
Dynamic Address Flag extension	O _C	Indicates whether served IPv4 PDP/PDN address is dynamic, which is allocated during IP-CAN bearer activation, initial attach and UE requested PDN connectivity with PDP/PDN type IPv4v6. This field is missing if IPv4 address is static.
List of Traffic Data Volumes	O _M	A list of changes in charging conditions for this QCI/ARP pair, each change is time stamped. Charging conditions are used to categorize traffic volumes, such as per tariff period. Initial and subsequently changed QoS and corresponding data values are also listed.
Record Opening Time	M	Time stamp when IP-CAN bearer is activated in this TWAG or record opening time on subsequent partial records.
Duration	M	Duration of this record in the TWAG.
Cause for Record Closing	M	The reason for the release of record from this TWAG.
Diagnostics	O _M	A more detailed reason for the release of the IP-CAN bearer, when a single cause is applicable.
Enhanced Diagnostics	O _C	This field holds a more detailed reason for the release of the IP-CAN bearer, when a set of causes is applicable.
Record Sequence Number	C	Partial record sequence number, only present in case of partial records.

Field	Category	Description
Node ID	O _M	Name of the recording entity.
Local Record Sequence Number	O _M	Consecutive record number created by this node. The number is allocated sequentially including all CDR types.
APN Selection Mode	O _M	An index indicating how the APN was selected.
Served MSISDN	O _C	The primary MSISDN of the subscriber, if available.
TWAN User Location Information	O _C	This field contains the UE location in a Trusted WLAN Access Network (TWAN) , if available: - as "TWAN identifier" defined in TS 29.274 [210] for S2a GTP-based case, or, - as "Access Network Identifier Option IE" defined in 29.275 [211] for S2a PMIP-based case.
Charging Characteristics	M	The Charging Characteristics applied to the IP-CAN bearer.
Charging Characteristics Selection Mode	O _M	Holds information about how Charging Characteristics were selected.
P-GW Address used.	O _C	This field is the P-GW IP Address for the Control Plane
P-GW IPv6 Address	O _C	This field is the P-GW IPv6 Address, in case of IPv4v6 dual stack, for the Control Plane.
RAT Type	O _C	This field indicates the Radio Access Technology (RAT) type currently used by the Mobile Station as defined in TS 29.061 [205], when available.
Start Time	O _C	This field holds the time when User IP-CAN session starts, available in the CDR for the first bearer in an IP-CAN session.
Stop Time	O _C	This field holds the time when User IP-CAN session is terminated, available in the CDR for the last bearer in an IP-CAN session.
Record Extensions	O _C	A set of network operator/manufacture specific extensions to the record. Conditioned upon the existence of an extension.

6.2 Data description for PS online charging

6.2.1 Message contents

6.2.1.1 Summary of online charging message formats

The PS Online Charging uses the Debit / Reserve Units Request and Debit / Reserve Units Response messages defined in TS 32.299 [50].

Table 6.2.1.1.1 describes the use of these messages for online charging.

Table 6.2.1.1.1: Online charging messages reference table

Messages	Source	Destination
Debit / Reserve Units Request	PCEF, TDF	OCS
Debit / Reserve Units Response	OCS	PCEF, TDF

6.2.1.2 Structure for the Debit / Reserve Units operation message formats

6.2.1.2.0 General

This clause describes the AVPs used in the Debit / Reserve Units operation messages.

6.2.1.2.1 Debit / Reserve Units Request message

Table 6.2.1.2.1.1 illustrates the basic structure of a Debit / Reserve Units Request message from the PCEF and TDF as used for PS online charging.

Table 6.2.1.2.1.1: Debit / Reserve Units Request message contents

Information Element	Category	Description
Session Identifier	M	Described in TS 32.299 [50]
Originator Host	M	Described in TS 32.299 [50]
Originator Domain	M	Described in TS 32.299 [50]
Destination Domain	M	Described in TS 32.299 [50]
Operation Identifier	M	Described in TS 32.299 [50]
Operation Token	M	Described in TS 32.299 [50]
Operation Type	M	Described in TS 32.299 [50]
Operation Number	M	Described in TS 32.299 [50]
Destination Host	OM	Described in TS 32.299 [50]
User Name	OM	The content of the field corresponds to the Protocol Configuration Options (PCO) field of the Create IP-CAN bearer Request message.
Origination State	OC	Described in TS 32.299 [50]
Origination Timestamp	OC	Described in TS 32.299 [50]
Subscriber Identifier	OM	Described in TS 32.299 [50]. As a minimum the IMSI and the MSISDN have to be included.
Termination Cause	OC	Described in TS 32.299 [50]
Multiple Operation	OM	Described in TS 32.299 [50]
Multiple Unit Operation	OC	Described in TS 32.299 [50]
User-Equipment-Info	OC	Described in TS 32.299 [50]. Contains the identification of the terminal (IMEI or IMEISV etc.)
Route Information	OC	Described in TS 32.299 [50]
Service Information	OM	Described in clause 6.3.1.1

Editor's Note: Terminal capabilities should be taken into account

The full description of the AVPs is specified in TS 32.299 [50].

6.2.1.2.2 Debit / Reserve Units Response message

The following table 6.2.1.2.2.1 illustrates the basic structure of a Debit / Reserve Units operation message as used for the PCEF and TDF. This message is always used by the OCS as specified below, independent of the receiving PCEF/TDF and the C redit-Control type that is being replied to.

Table 6.2.1.2.2.1: Debit / Reserve Units Response message contents

Information Element	Category	Description
Session Identifier	M	Described in 32.299 [50]
Operation Result	M	Described in 32.299 [50]
Originator Host	M	Described in 32.299 [50]
Originator Domain	M	Described in 32.299 [50]
Operation Identifier	M	Described in 32.299 [50]
Operation Type	M	Described in 32.299 [50]
Operation Number	M	Described in 32.299 [50]
Operation Failover	O _C	Described in 32.299 [50]
Multiple Unit Operation	O _C	Described in 32.299 [50]
Operation Failure Action	O _C	Described in 32.299 [50]
Operation Event Failure Action	O _C	Described in 32.299 [50]
Redirection Host	O _C	Described in 32.299 [50]
Redirection Host Usage	O _C	Described in 32.299 [50]
Route Information	O _C	Described in 32.299 [50]
Failed parameter	O _C	Described in 32.299 [50]
Service Information	O _M	Described in 32.299 [50]

6.2.2 Void

6.3 PS charging specific parameters

6.3.1 Definition of PS charging information

6.3.1.0 General

The PS Information parameter used for PS charging is provided in the Service Information parameter, as defined in clause 6.3.1.1.

The PS Information parameter used for "SMS over MME Charging" is provided in the Service Information parameter as defined in 6.3.1.1a

6.3.1.1 PS charging information assignment for Service Information

The components in the Service Information that are use for PS charging can be found in table 6.3.1.1.1.

Table 6.3.1.1.1: Service Information used for PS Charging

Information Element	Category	Description
Service Information	O _M	This is a structured field and holds the 3GPP specific parameter as defined in TS 32.299 [50].
Subscriber Identifier	O _C	This field contains the identification of the user (e.g. IMSI, MSISDN, NAI) if offline charging applies.
PS Information	O _M	This is a structured field and holds the PS specific parameters. The details are defined in clause 6.3.1.2.
IMS Information	O _M	This is a structured field and holds IMS specific parameters. The complete structure is defined in TS 32.260 [20].
Node Functionality	O _M	This field contains the function of the EPC node (SGW, ePDG, TWAG, PGW, TDF)
NOTE: When Node Functionality is set to "HSGW" the HSGW Access specific charging information are provided as part of the PS Information		

6.3.1.1a "SMS over MME Charging" information assignment for Service Information

The components in the Service Information that are used for "SMS over MME Charging" can be found in table 6.3.1.1a.1.

Table 6.3.1.1a.1: Service Information used for "SMS over MME Charging"

Information Element	Category	Description
Service Information	O _M	This is a structured field and holds the 3GPP specific parameter as defined in TS 32.299 [50].
Subscriber Identifier	O _C	This field contains the identification of the user (e.g. IMSI, MSISDN).
IMS Information	O _M	This is a structured field and holds IMS specific parameters. The complete structure is defined in TS 32.260 [20].
Node Functionality	O _M	This field contains the function of the EPC node (i.e. MME)
PS Information	O _M	This is a structured field and holds the PS specific parameters. The complete structure is defined in clause 6.3.1.2.
Node Id	O _C	This field holds the name of the Node
Serving Node Type	O _C	This field holds the type of the node handling the SMS with the UE (i.e. MME)
Serving Node Address	O _C	This field holds the IP-address of the MME used. It may occur twice in the case when the MME has IPv4v6 dual stack control plane.
MME Number for MT SMS	O _C	This field holds the MME international PSTN/ISDN number
MME Name	O _C	This field holds the operation Identity of the MME used.
MME Realm	O _C	This field holds the operation Realm Identity of the MME used.
Charging Characteristics	O _M	This field contains the Charging Characteristics applicable to the MME
Charging Characteristics Selection Mode	O _M	This field holds information about how the Charging Characteristics were selected.
3GPP User Location Info	O _C	This field holds the information about the location of the subscriber during the SMS transaction.
User Location Info Time	O _C	This field contains the time at which the user location information was acquired.
RAT Type	O _C	This field indicates which Radio Access Technology (RAT) is currently serving the UE as defined in TS 29.061 [205].
Terminal Information	O _C	This field holds the identification of the terminal (IMEI or IMEISV).
SMS Information	O _M	This is a structured field and holds SMS specific parameters. The complete structure is defined in TS 32.274 [34].
Recipient Info	O _M	This field a structured field and holds recipient information for the SM. The complete structure is defined in TS 32.274 [34].
Recipient Address	O _M	This field holds the address of the recipient of the SM. This will typically be an E.164 number or a shortcode.
SMSC Address	O _M	This field holds the address of the SMSC to which the originating or terminating SM is directed to.
MMS Information	O _M	This is a structure field and the following parameters are specific to SMS. The complete structure is defined in TS 32.270 [30]
Originator Address	O _C	This field holds the address of the originator of the SM. This will typically be an E.164 number or a shortcode
Submission Time	O _C	This field holds the time the Short Message is received by the MME from UE or sent by the MME to UE.
Message Id	O _M	This field holds a reference provided by the UE uniquely identifying this message. It contains the TP-Message-Reference (TP-MR) as defined in TS 23.040 [7].

6.3.1.2 Definition of the PS information

PS specific charging information is provided within the PS Information. The fields of the PS Information are indicated with the node (MME, S-GW, ePDG, TWAG, P-GW, TDF) from which the information is sent.

The detailed structure of the PS Information can be found in table 6.3.1.2.1.

Table 6.3.1.2.1: Structure of the PS Information

Information Element	Category	Description
Supported Features	O _C	This field holds the list of features supported by the PCN, CDF or OCF as defined in clause 6.3.1.x.
Charging Id	O _C	This field holds the Charging Id for this IP-CAN bearer (this together with the P-GW Address constitutes a unique identifier for the IP-CAN bearer). This field holds the unique Charging Id in the PMIP case. When charging per IP-CAN session is active, PGW use this field to hold the Charging Id of the EPS default bearer. It is the same as the PDN Connection Charging Id.
Charging per IP-CAN Session Indicator	O _C	This field indicates whether charging per IP-CAN session is active. If this field is not present, charging per IP-CAN session is not active.
Node Id	O _C	This fields holds the name of the Node
PDN Connection Charging Id	O _C	This field holds the explicit Charging Id for the PDN connection. When NBIFOM is supported, the PGW will assign an explicit PDN Connection Charging ID for the PDN connection. Otherwise the field holds the Charging Id of the EPS default bearer. This field is used to identify different records belonging to same PDN connection.
PDP/PDN Type	O _C	This field holds the type of IP-CAN bearer, e.g. IP or PPP, or PDN type (i.e. IPv4, IPv6 or IPv4v6, or Non-IP).
SGi PtP Tunnelling Method	O _C	This field indicates whether SGi PtP tunnelling method based on UDP/IP or other methods are used for this PDN connection when a non-IP PDN type.
SCS/AS Address	O _C	This field holds the Address of SCS/AS for SGi PtP tunnelling.
PDP/PDN Address	O _C	This field holds the IP address of the served IMSI allocated for the PDP context / PDN connection, i.e. IPv4 address or IPv6 prefix, or assigned IP address if any when PDP/PDN Type is Non-IP. This parameter shall be present except: - when both the PDP type is PPP and dynamic PDP address assignment is used or, - when PDP/PDN Type is Non-IP, and no IP address has been assigned by the PGW for the PDN connection. It may occur twice within the PS Information field when PDN type is IPv4v6: first occurrence with IPv6 prefix, second occurrence with IPv4 address.
PDP/PDN Address prefix length	O _C	PDP/PDN Address prefix length of an IPv6 typed Served PDP Address. The field needs not available for prefix length of 64 bits.
Dynamic Address Flag	O _C	This field indicates whether served PDP/PDN address is dynamically allocated. This field is missing if address is static.
Dynamic Address Flag Extension	O _C	Indicates whether served IPv4 PDP/PDN address is dynamic, which is allocated during IP-CAN bearer activation, initial attach (E-UTRAN or over S2x) and UE requested PDN connectivity with PDP/PDN type IPv4v6. This field is missing if IPv4 address is static.
Negotiated QoS Profile	O _C	This field holds the authorized QoS applied to IP-CAN bearer. See NOTE. This field indicates the bandwidth limitation, applied to TDF session in TDF case. When charging per IP-CAN session is active in P-GW, this field indicates the APN-AMBR applied to the IP-CAN session.
Serving Node Address	O _C	This field holds the SGSN/S-GW/TWAG IP address that is used by the control plane for the handling of control messages, or the AGW IP address, or the ePDG address, or the MME address. It may be used to identify the PLMN to which the user is attached. It may occur twice in the case when the serving node has IPv4v6 dual stack control plane.
Serving Node Type	O _C	This field holds the type of the serving node (SGSN/S-GW/ePDG/AGW/TWAG from PGW/TDF, or SGSN/MME from SGW).
SGW Change	O _C	This field is present if this is first Charging Data Request after a change from another serving node (from SGW/ePDG/TWAG/HSGW).
PGW Address	O _C	This field holds the IP-address of the P-GW that generated the Charging Id. It may occur twice in the case when the P-GW has IPv4v6 dual stack control plane.

TDF Address	O _C	The control plane IP address of the TDF used. It may occur twice in the case when the TDF has IPv4v6 dual stack control plane.
SGW Address	O _C	This field holds the IP-address of the S-GW used. It may occur twice in the case when the P-GW has IPv4v6 dual stack control plane.
ePDG Address	O _C	This field holds the IP-address of the ePDG used. It may occur twice in the case when the ePDG has IPv4v6 dual stack control plane.
TWAG Address	O _C	This field holds the IP-address of the TWAG used. It may occur twice in the case when the TWAG has IPv4v6 dual stack control plane.
MME Number for MT SMS	O _C	This field holds the MME international PSTN/ISDN E.164 number used for "SMS over MME Charging".
MME Name	O _C	This field holds the operation Identity of the MME used for "SMS over MME Charging".
MME Realm	O _C	This field holds the operation Realm Identity of the MME used for "SMS over MME Charging".
CG Address	O _C	This field holds the Charging Gateway IP address if available. Only used in EPC Online Charging.
IMSI MCC MNC	O _C	This field holds the MCC and MNC extracted from the user's IMSI (first 5 or 6 digits, as applicable from the presented IMSI).
IMSI Unauthenticated Flag	O _C	This field is present when IMSI is provided in Subscription Id and this IMSI is unauthenticated (due to emergency bearer service situations).
PGW MCC MNC	O _C	This field holds the MCC-MNC of the network the P-GW belongs to.
TDF MCC MNC	O _C	PLMN identifier (MCC MNC) of the TDF.
NSAPI	O _C	This field Identifies a particular IP-CAN bearer for the associated PDN and MSISDN/IMSI from creation to deletion. See NOTE.
Called Station Id	O _C	This field contains the identifier of the access point (APN) the user is connected to.
Session Stop Indicator	O _C	This field indicates to the OCS that the last IP-CAN bearer of a session is released and that the IP-CAN session has been terminated. This field only indicates to the OCS that the TDF session is terminated in TDF case.
Selection Mode	O _C	This field contains the Selection mode for this APN received in the Create PDP context request, on E-UTRAN initial attach and UE requested PDN connectivity, or Attach in WLAN on GTP S2a.
Charging Characteristics	O _C	This field contains the Charging Characteristics for this IP-CAN bearer received in the Create IP-CAN bearer Request Message (only available in R99 and later releases).
Charging Characteristics Selection Mode	O _C	This field holds information about how the "Charging Characteristics" was selected.
Serving Node MCC MNC	O _C	This field holds the MCC and MNC serving the UE: extracted from the RAI within the IP-CAN bearer activation or Update messages received over Gn/Gp, or provided by the SGW in the "Serving Network" IE over S5/S8 or by AGW/TWAG (For TWAN, PLMN identifier used for UE authentication, i.e. the VPLMN in roaming case, and the HPLMN in non-roaming case).
CN Operator Selection Entity	O _C	This field indicates whether the Serving Network identified by the "Serving Node MCC MNC" has been selected by the UE or by the network, as defined in TS 29.060 [203] for GPRS, and in TS 29.274 [210] for EPC, if available.
MS Time Zone	O _C	This field indicates the offset between universal time and local time in steps of 15 minutes of where the MS currently resides.
Charging Rule Base Name	O _C	This field indicates the name of a pre-defined group of PCC rules residing at the PCEF. It may occur several times within the PS Information field.
ADC Rule Base Name	O _C	This field indicates the name of a pre-defined group of ADC rules in TDF case.
User Location Info	O _C	This field indicates details of where the UE is currently located (e.g. SAI, TAI, RAI, CGI, ECGI or access-specific user location information).
User Location Info Time	O _C	This field contains the time at which the user location information was acquired, if available.

User CSG Information	O _C	This field indicates details of the User CSG Information of the UE, if available, including CSG ID, access mode and CSG membership indication.
3GPP2 User Location Info	O _C	This field holds the 3GPP2 User Location Info of where the UE is currently located (i.e. 3GPP2 BSID: Cell-Id, SID, NID), as defined in TS 29.212 [216]
TWAN User Location Information	O _C	This field contains the UE location in a Trusted WLAN Access Network (TWAN) , if available: - as "TWAN identifier" defined in TS 29.274 [210] for S2a GTP-based case, or, - as "Access Network Identifier Option IE" defined in 29.275 [211] for S2a PMIP-based case.
UWAN User Location Information	O _C	This field contains the UE location in an Untrusted Wireless Access Network (UWAN) which includes the UE local IP address and optionally UDP or TCP source port number (if NAT is detected) as defined in TS 29.274 [210]. It may also include WLAN location information the ePDG may have received from the 3GPP AAA server about the UE as "WLAN location information" defined in TS 29.274 [210].
Presence Reporting Area Information	O _C	This field contains part of the Presence Reporting Area Information of UE as defined in TS 29.212 [216], comprising the Presence Reporting Area identifier(s) the Presence Reporting Area(s) status (UE presence or not, inactive), and which Node subscribed-to, or the Presence Reporting Area is set to inactive, if available. It may occur several times within the PS Information field.
RAT Type	O _C	This field indicates which Radio Access Technology (RAT) is currently serving the UE as defined in TS 29.061 [205]. When NBIFOM is accepted by PCRF, this field holds the first default bearer's RAT type when charging per IP-CAN session is active.
Furnish Charging Information	O _C	This field contains the PS Furnish Information Elements.
Offline Charging	O _C	This field contains the Offline Charging parameters to control offline charging.
PDP Context Type	O _C	This field indicates the type of a PDP context (i.e. Primary or Secondary). This field is present when using the Gn/Gp reference point only.
Traffic data volumes	O _C	This field holds the containers associated to a charging condition change on an IP-CAN bearer. This is included when triggers conditions are met (Qos change, tariff time change ...). It may occur several times within the PS Information field.
Service data container	O _C	This field holds the container associated to a service condition change on a service data flow (categorized per rating group or per combination of the rating group and service id) within this IP-CAN bearer. For TDF case, this field holds the container associated to a charging condition change on an application traffic (categorized per rating group or per combination of the rating group and service id) within this TDF session. It may occur several times within the PS Information field.
User Equipment Info	O _C	This field holds the identification of the terminal (IMEI or IMEISV...) It is used for identifying the user in case IMSI is not present during emergency bearer service. Editor's Note: Alignment with online charging is needed.
Terminal Information	O _C	This field holds the identification of the terminal (IMEI or IMEISV, 3GPP2-MEID..).It is used for identifying the user in case IMSI is not present during emergency bearer service. Editor's Note : this parameter is only for offline charging and usage for online charging instead of User-Equipment-info is ffs
Start Time	O _C	Timestamp when User IP-CAN/TDF session starts.
Stop Time	O _C	Timestamp when User IP-CAN/TDF session terminates.
Change Condition	O _C	This field holds the reason for sending Charging Data Request from the PCN Nodes.

Diagnostics	O _C	This field holds a more detailed reason for the release of the IP-CAN bearer, when a single cause is applicable, and complements the "Change Condition" information. When charging per IP-CAN session is active, PGW uses this field to hold a more detailed reason for the release of the IP-CAN session, when a single cause is applicable.
Enhanced Diagnostics	O _C	This field holds a more detailed reason for the release of the connection, when a set of causes is applicable. When charging per IP-CAN session is active, PGW uses this field to hold a more detailed reason for the release of the IP-CAN session, when a set of causes is applicable.
Low Priority Indicator	O _C	This field indicates if this IP-CAN session has a low priority, i.e. for Machine Type Communication.
NBIFOM Support	O _C	This field indicates that NBIFOM was requested by the UE, supported and accepted by the network for the IP-CAN session or if NBIFOM is not supported for the IP-CAN session.
NBIFOM Mode	O _C	This field indicates the NBIFOM mode selected for the PDN connection, when NBIFOM is supported for the IP-CAN session. This field is only present when NBIFOM is accepted.
CP Clot EPS Optimisation indicator	O _C	This field indicates whether CP Clot EPS Optimisation is used during data transfer with the UE (i.e. Control Plane NAS PDU via S11-U between SGW and MME) or not (i.e. User Plane via S1-U between SGW and eNB), if enabled.
UNI PDU CP Only Flag	O _C	This field indicates whether this PDN connection is applied with "Control Plane Only Flag" for UNI PDU transfer, i.e. transfer only using Control Plane NAS PDU (Control Plane Clot EPS optimisation).
Serving PLMN Rate Control	O _C	This field holds the Serving PLMN Rate Control used by the MME.
MO exception data counter	O _C	This field holds the MO exception data counter value with the timestamp indicating the time at which the counter value increased from 0 to 1, as defined in TS 29.274 [210].
APN Rate Control	O _C	This field holds the list of APN Rate Controls enforced in the PGW.
3GPP PS Data Off Status	O _C	This field holds the 3GPP Data off Status when UE's 3GPP Data Off status is Activated or Deactivated.
Unused Quota Timer	O _C	This field holds the threshold for the time period without any quota granted or any quota being consumed for any rating group belonging to the Gy session. It holds either the value configured in PCEF, if it is supported, or the value to be used as received from the OCS. A value of zero indicates that this mechanism shall not be used.

NOTE: For network requested secondary IP-CAN bearer activation, the CCR[Initial] does not contain a value of NSAPI, whilst the Negotiated QoS profile reflects the requested QoS profile used in the activation request.

Editor's Note: The handling of "CP Clot EPS Optimisation" when charging per IP-CAN session applies is FFS.

6.3.1.3 Multiple Unit Operation information when charging per IP-CAN session is active

The components in the Multiple Unit Operation that are used when charging per IP-CAN session is active can be found in table 6.3.1.3.1.

Table 6.3.1.3.1: Structure of the Multiple Unit Operation when charging per IP-CAN session is active

Information Element	Category	Description
Granted Service Unit	O _C	As specified in TS 32.299 [50].
Tariff Time Change	O _C	As specified in TS 32.299 [50].
CC Time	O _C	As specified in TS 32.299 [50].
CC Total Octets	O _C	As specified in TS 32.299 [50].
CC Input Octets	O _C	As specified in TS 32.299 [50].
CC Output Octets	O _C	As specified in TS 32.299 [50].
CC Service Specific Units	O _C	As specified in TS 32.299 [50].
Requested Service Unit	O _C	As specified in TS 32.299 [50].
CC Time	O _C	As specified in TS 32.299 [50].
CC Total Octets	O _C	As specified in TS 32.299 [50].
CC Input Octets	O _C	As specified in TS 32.299 [50].
CC Output Octets	O _C	As specified in TS 32.299 [50].
CC Service Specific Units	O _C	As specified in TS 32.299 [50].
Used Service Unit	O _C	As specified in TS 32.299 [50].
Reporting Reason	O _M	As specified in TS 32.299 [50].
Tariff Change Usage	O _M	As specified in TS 32.299 [50].
CC Time	O _C	As specified in TS 32.299 [50].
CC Total Octets	O _C	As specified in TS 32.299 [50].
CC Input Octets	O _C	As specified in TS 32.299 [50].
CC Output Octets	O _C	As specified in TS 32.299 [50].
CC Service Specific Units	O _C	As specified in TS 32.299 [50].
Event Charging Time Stamp	O _C	As specified in TS 32.299 [50].
Service Identifier	O _C	As specified in TS 32.299 [50].
Rating Group	O _C	As specified in TS 32.299 [50].
Reporting Reason	O _C	As specified in TS 32.299 [50].
Trigger	O _C	As specified in TS 32.299 [50].
Related Trigger	O _C	This field indicates the trigger condition associated with an alternate access of a multi-access PDN connection that indirectly triggered this multiple unit operation.
Refund Information	O _C	As specified in TS 32.299 [50].
Envelope	O _C	As specified in TS 32.299 [50].
AF Correlation Information	O _C	Supported for PS domain charging, as specified in TS 32.299 [50].
Service Specific Info	O _C	Supported for PS domain charging, as specified in TS 32.299 [50].
QoS Information	O _C	<p>This field contains the authorized QoS for the first IP-CAN bearer for which traffic is reported for the Rating Group or Rating Group / Service Identifier. If traffic from multiple bearers is included in the report, only one field is included.</p> <p>This field includes: QCI and ARP. For non-GBR QCI values, this field also includes the MBR for the downlink and uplink direction. For GBR QCI values, this field also includes GBR for the downlink and uplink direction. If the MBR is different than the GBR, then this field also includes the MBR for the downlink and uplink direction.</p> <p>This field also includes the authorized APN-AMBR for the IP-CAN session.</p>

Information Element	Category	Description
RAT Type	O _C	This field contains the RAT Type of the IP-CAN bearer that is first reported for the Rating Group or Rating Group / Service Identifier. If traffic from multiple access types is included in this report, only one field is included. This field is only applicable when NBIFOM is accepted for the IP-CAN session.

Editor's Note: The handling of "Control Plane CIoT EPS Optimisation" when charging per IP-CAN session applies is FFS.

6.3.1.4 Supported features

The Supported features information that is used for PS domain charging is based on the information defined for the supported features mechanism specified in clause 6.5.10 TS 32.299 [50].

The following table defines the features applicable for the feature lists with a Feature-List-ID of 1.

Table 6.3.1.4: Features of Feature-List-ID 1 used in PS charging

Feature bit	Feature	Description	Online/Offline
0	EDCE5-CH	This feature indicates the support of 5G New Radio via Dual Connectivity based on clause 5.2.1.11 Data Volume Reporting for Secondary RAT usage.	Offline
1	eFMSS_CH	This feature indicates the support of Flexible Mobile Service Steering based on clause 5.1.6.	Both
2	WAEPC_CH_Untrusted	This feature indicates the support of extensions of UWAN location information	Both
3	WAEPC_CH_trusted	This feature indicates the support of extensions of TWAN location information	Both
4	EDCE5-CH_Extended-BW-NR	This feature indicates the support of 5G New Radio extended QoS.	Both

Feature bit: The order number of the bit within the Feature-List AVP where the least significant bit is assigned number "0".
Feature: A short name that can be used to refer to the bit and to the feature, e.g. "EPS".
Feature in this table is always mandatory since it relates to the charging functionality of a network feature.
Description: A clear textual description of the feature.

6.3.2 Detailed message format for offline charging

The following clause specifies per Operation Type the charging data that are sent by MME, S-GW, ePDG, TWAG, P-GW and TDF.

The Operation Types are listed in the following order: S (Start)/I (Interim)/S (Stop)/E (Event). Therefore, when all Operation Types are possible it is marked as SISE. If only some Operation Types are allowed for a node, only the appropriate letters are used (i.e. SIS or E) as indicated in the table heading. The omission of an Operation Type for a particular field is marked with "-" (i.e. SI-E). Also, when an entire field is not allowed in a node the entire cell is marked as "-".

Table 6.3.2.1 illustrates the basic structure of the supported fields in the *Charging Data Request* message for PS offline charging.

Table 6.3.2.1: Supported fields in *Charging Data Request* message

Information Element	Node Type	S-GW	ePDG	P-GW	TWAG	TDF
	Supported Operation Types	S/I/S/E	S/I/S/E	S/I/S/E	S/I/S/E	S/I/S/E
Session Identifier		SIS-	SIS-	SIS-	SIS-	SIS-
Originator Host		SIS-	SIS-	SIS-	SIS-	SIS-
Originator Realm		SIS-	SIS-	SIS-	SIS-	SIS-
Destination Domain		SIS-	SIS-	SIS-	SIS-	SIS-
Operation Type		SIS-	SIS-	SIS-	SIS-	SIS-
Operation Number		SIS-	SIS-	SIS-	SIS-	SIS-
Operation Identifier		SIS-	SIS-	SIS-	SIS-	SIS-
User Name		SIS-	SIS-	SIS-	SIS-	SIS-
Destination Host		SIS-	SIS-	SIS-	SIS-	SIS-
Operation Interval		SIS-	SIS-	SIS-	SIS-	SIS-
Origination State		SIS-	SIS-	SIS-	SIS-	SIS-
Origination Timestamp		SIS-	SIS-	SIS-	SIS-	SIS-
Proxy Information		SIS-	SIS-	SIS-	SIS-	SIS-
Route Information		SIS-	SIS-	SIS-	SIS-	SIS-
Operation Token		SIS-	SIS-	SIS-	SIS-	SIS-
Service Information with PS and IMS Information						
Supported Features		SIS-	SIS-	SIS-	SIS-	SIS-
Subscription Id		SIS-	SIS-	SIS-	SIS-	SIS-
IMSI Unauthenticated Flag		SIS-	SIS-	SIS-	SIS-	-
Node Functionality		SIS-	SIS-	SIS-	SIS-	SIS-
Charging Id		SIS-	SIS-	SIS-	SIS-	-
Charging per IP-CAN Session Indicator		-	-	S---	-	-
Node Id		SIS-	SIS-	SIS-	SIS-	SIS-
PDN Connection Charging Id		SIS-	SIS-	SIS-	SIS-	SIS-
PDP/PDN Type		SIS-	SIS-	SIS-	SIS-	-
SGi PtP Tunnelling Method		-	-	SIS-	-	-
SCS/AS Address		-	-	SIS-	-	-
PDP/PDN Address		SIS-	SIS-	SIS-	SIS-	SIS-
PDP/PDN Address prefix length		SIS-	SIS-	SIS-	SIS-	SIS-
Dynamic Address Flag		SIS-	SIS-	SIS-	SIS-	SIS-
Dynamic Address Flag Extension		SIS-	SIS-	SIS-	SIS-	SIS-
Serving Node Address		SIS-	-	SIS-	-	SIS-
Serving Node Type		SIS-	-	SIS-	-	SIS-
SGW Change		S---	S---	-	S---	-
P-GW Address		SIS-	-	SIS-	SIS-	SIS-
TDF Address		-	-	-	-	SIS-
SGW Address		SIS-	-	-	-	-
ePDG Address		-	SIS-	-	-	-
TWAG Address		-	-	SIS-	-	-
CG Address		-	-	-	-	-
IMSI MCC MNC		SIS-	SIS-	SIS-	SIS-	SIS-
PGW MCC MNC		SIS-	SIS-	SIS-	SIS-	SIS-
TDF MCC MNC		-	-	-	-	SIS-
NSAPI		-	-	SIS-	-	-
Called Station Id		SIS-	SIS-	SIS-	SIS-	SIS-
Session Stop Indicator		-	-	--S-	-	--S-
Selection Mode		SIS-	SIS-	SIS-	SIS-	SIS-
Charging Characteristics		SIS-	SIS-	SIS-	SIS-	SIS-
Charging Characteristics Selection Mode		SIS-	SIS-	SIS-	SIS-	SIS-
Serving Node MCC MNC		SIS-	-	SIS-	-	SIS-
MS Time Zone		SIS-	-	SIS-	-	SIS-
Charging Rule Base Name		-	-	SIS-	-	-
ADC Rule Base Name		-	-	-	-	SIS-
User Location Info		SIS-	-	SIS-	-	SIS-
User Location Info Time		SIS-	-	SIS-	-	-
User CSG Information		SIS-	-	SIS-	-	SIS-
3GPP2 User Location Info		SIS-	-	SIS-	-	SIS-
TWAN User Location Information		-	-	SIS-	SIS-	-
UWAN User Location Information		-	SIS-	SIS-	-	-
Presence Reporting Area Information		SIS-	-	SIS-	-	-
RAT Type		SIS-	SIS-	SIS-	SIS-	SIS-
Furnish Charging Information		-	-	SIS-	-	-
Offline Charging		-	-	-	-	-

QoS Information	SIS-	SIS-	SIS-	SIS-	SIS-
Traffic data volumes	-IS-	-IS-	-	-IS-	-
Service data container	-	-	-IS-	-	-IS-
User Equipment Info	-	-	-	-	S---
Terminal-Information	S---	S---	S---	S---	S---
Start time	S---	S---	S---	S---	S---
Stop time	--S-	--S-	--S-	--S-	--S-
Change Condition	-IS-	-IS-	-IS-	-IS-	-IS-
Diagnostics	--S-	--S-	--S-	--S-	--S-
Enhanced Diagnostics	--S-	--S-	--S-	--S-	-
Low Priority Indicator	S---	-	S---	-	-
CN Operator Selection Entity	SIS-	-	SIS-	-	-
NBIFOM Support	-	-	S---	-	-
NBIFOM Mode	-	-	S---	-	-
CP Clot EPS Optimisation Indicator	SIS-	-	-	-	-
UNI PDU CP Only Flag	SIS-	-	SIS-	-	-
Serving PLMN Rate Control	SI--	-	SI--	-	-
APN Rate Control	-	-	SI--	-	-
MO exception data counter	SIS-	-	SIS-	-	-
3GPP PS Data Off Status	-	-	SIS-	-	-
RAN Secondary RAT Usage Reports	-IS-	-	-IS-	-	-

Table 6.3.2.1a illustrates the basic structure of the supported fields in the *Charging Data Request* message for "SMS over MME Charging".

Table 6.3.2.1a: Supported fields in *Charging Data Request* message for "SMS over MME Charging"

Information Element	Node Type	MME
	Supported Operation Types	S/I/S/E
Session Identifier		---E
Originator Host		---E
Originator Realm		---E
Destination Domain		---E
Operation Type		---E
Operation Number		---E
Operation Identifier		---E
User Name		---E
Destination Host		---E
Operation Interval		---E
Origination State		---E
Origination Timestamp		---E
Proxy Information		---E
Route Information		---E
Operation Token		---E
Service Information with PS, IMS, MMS and SMS Information		
Subscription Id		---E
Node Functionality		---E
Node Id		---E
MME Number for MT SMS		---E
MME Name		---E
MME Realm		---E
Serving Node Type		---E
SGSN Address		---E
Charging Characteristics		---E
Charging Characteristics Selection Mode		---E
3GPP User Location Info		---E
User Location Info Time		---E
RAT Type		---E
Terminal Information		---E
Recipient Address		---E
SMSC Address		---E
Originator Address		---E
Submission Time		---E
Message Id		---E
CN Operator Selection Entity		---E

Table 6.3.2.2 illustrates the basic structure of the supported fields in the *Charging Data* Response message for PS offline charging, and "SMS over MME Charging".

Table 6.3.2.2: Supported fields in *Charging Data* Response message

Information Element	Node Type	S-GW	ePDG	TWAG	P-GW	TDF
	Supported Operation Types	S//S/E	S//S/E	S//S/E	S//S/E	S//S/E
Session Identifier		SIS-	SIS-	SIS-	SIS-	SIS-
Operation Result		SIS-	SIS-	SIS-	SIS-	SIS-
Originator Host		SIS-	SIS-	SIS-	SIS-	SIS-
Originator Domain						
Operation Type		SIS-	SIS-	SIS-	SIS-	SIS-
Operation Number		SIS-	SIS-	SIS-	SIS-	SIS-
Operation Identifier		SIS-	SIS-	SIS-	SIS-	SIS-
Operation Interval		SIS-	SIS-	SIS-	SIS-	SIS-
Error Reporting Host		SIS-	SIS-	SIS-	SIS-	SIS-
Origination State		SIS-	SIS-	SIS-	SIS-	SIS-
Origination Timestamp		SIS-	SIS-	SIS-	SIS-	SIS-
Proxy Information		SIS-	SIS-	SIS-	SIS-	SIS-
Route Information		SIS-	SIS-	SIS-	SIS-	SIS-
Service Information with PS Information						
Supported Features		SIS-	SIS-	SIS-	SIS-	SIS-

6.3.3 Detailed message format for online charging

The following table specifies per Operation type the charging data that are sent P-GW and TDF network element for:

The Operation types are listed in the following order: I [initial]/U [update]/T [terminate]/E [event]. Therefore, when all Operation types are possible it is marked as IUTE. If only some Operation types are allowed for a node, only the appropriate letters are used (i.e. IUT or E) as indicated in the table heading. The omission of an Operation type for a particular field is marked with "-" (i.e. IU-E). Also, when an entire field is not allowed in a node the entire cell is marked as "-".

Note that not for all structured fields the individual field members are listed in the table. Detailed descriptions of the fields are provided in TS 32.299 [50].

Table 6.3.3.1 illustrates the basic structure of the supported fields in the Debit / Reserve Units Request for PS online charging.

Table 6.3.3.1: Supported fields in *Debit / Reserve Units Request* message

Information Element	Node Type	P-GW	TDF
	Supported Operation Types	I/U/T/E	I/U/T/E
Session Identifier		IUT-	IUT-
Originator Host		IUT-	IUT-
Originator Domain		IUT-	IUT-
Destination Domain		IUT-	IUT-
Operation Identifier		IUT-	IUT-
Operation Token		IUT-	IUT-
Operation Type		IUT-	IUT-
Operation Number		IUT-	IUT-
Destination Host		IUT-	IUT-
User Name		IUT-	IUT-
Origination State		IUT-	IUT-
Origination Timestamp		IUT-	IUT-
Subscriber Identifier		IUT-	IUT-
Termination Cause		--T-	--T-
Requested Action		IUT-	IUT-
Multiple Operation		IU--	IU--
Multiple Unit Operation		IUT-	IUT-
Subscriber Equipment Number		IUT-	IUT-
Route Information		IUT-	IUT-
Service Information		IUT-	IUT-
Service Information with IMS and PS Information			
Supported Features		IUT-	IUT-
Node Functionality		IUT-	IUT-
Charging Id		IUT-	-
Node Id		IUT-	IUT-
PDN Connection Charging Id		IUT-	IUT-
PDP/PDN Type		IUT-	-
SGi PtP Tunnelling Method		IUT-	-
SCS/AS Address		IUT-	-
PDP/PDN Address		IUT-	IUT-
PDP/PDN Address prefix length		IUT-	IUT-
Dynamic Address Flag		IUT-	IUT-
Dynamic Address Flag Extension		IUT-	IUT-
QoS Information		IUT-	IUT-
Serving Node Address		IUT-	IUT-
Serving Node Type		IUT-	IUT-
SGW Change		-	-
P-GW Address		IUT-	IUT-
TDF Address		-	IUT-
CG Address		IUT-	IUT-
IMSI MCC MNC		IUT-	IUT-
IMSI Unauthenticated Flag		IUT-	-
PGW MCC MNC		IUT-	IUT-
TDF MCC MNC		-	IUT-
NSAPI		IUT-	-
Called Station Id		IUT-	IUT-
Session Stop Indicator		--T-	--T-
Selection Mode		IUT-	IUT-
Charging Characteristics		IUT-	IUT-
Charging Characteristics Selection Mode		IUT-	IUT-
Serving Node MCC MNC		IUT-	IUT-
MS Time Zone		IUT-	IUT-
Charging Rule Base Name		IUT-	-
ADC Rule Base Name		-	IUT-
User Location Info		IUT-	IUT-
User Location Info Time		IUT-	-
User CSG Information		IUT-	IUT-
3GPP2 User Location Info		IUT-	IUT-
TWAN User Location Information		IUT-	IUT-
UWAN User Location Information		IUT-	-
Presence Reporting Area Information		UT-	-
RAT Type		IUT-	IUT-
Furnish Charging Information		-	-

Offline Charging	IUT-	IUT-
PDP Context Type	IUT-	-
Traffic data volumes	-	-
Service data container	-	-
User Equipment Info	-	-
Terminal-Information	-	-
Start time	-	-
Stop time	-	-
Change Condition	-	-
Diagnostics	--T-	--T-
Enhanced Diagnostics	--T-	-
CN Operator Selection Entity	-	-
NBIFOM Support	I---	-
NBIFOM Mode	I---	-
CP IoT EPS Optimisation Indicator	--	-
UNI PDU CP Only Flag	IUT-	-
Serving PLMN Rate Control	IU--	-
APN Rate Control	IU--	-
MO exception data counter	-	-
3GPP PS Data Off Status	IUT-	-
Unused Quota Timer	IU--	-

Table 6.3.3.2 illustrates the basic structure of the supported fields in the Debit / Reserve Units Response for PS online charging.

Table 6.3.3.2: Supported fields in Debit / Reserve Units Response Message

Information Element	Node Type	P-GW	TDF
	Supported Operation Types	I/U/T/E	I/U/T/E
Session Identifier		IUT-	IUT-
Operation Result		IUT-	IUT-
Originator Host		IUT-	IUT-
Originator Domain		IUT-	IUT-
Operation Identifier		IUT-	IUT-
Operation Type		IUT-	IUT-
Operation Number		IUT-	IUT-
Operation Failover		IUT-	IUT-
Multiple Unit Operation		IUT-	IUT-
Operation Failure Action		IUT-	IUT-
Redirection Host		IUT-	IUT-
Redirection Host Usage		IUT-	IUT-
Redirection Cache Time		IUT-	IUT-
Route Information		IUT-	IUT-
Failed parameter		IUT-	IUT-
Service Information		IUT-	IUT-
Service Information with PS Information			
Supported Features		I---	I---
Furnish Charging Information		IUT-	IUT-
Offline Charging		I----	I----
Presence Reporting Area Information		IU--	-
Unused Quota Timer		IU--	-

6.4 Void

6.5 Bindings for EPC offline charging

This clause aims to describe the mapping between the Service Information fields, AVPs and CDR parameter for EPC offline charging.

Table 6.5.1 describes the mapping of the Information Element, AVP and CDR parameter of ePDG-CDR, TWAG-CDR, SGW-CDR, PGW-CDR and TDF-CDR in EPC offline charging.

Table 6.5.1: Bindings of CDR parameter, Information Element and AVP

CDR Parameter	Information Element	AVP
Retransmission	-	-
Record Opening Time	-	-
Duration	-	-
Cause for Record Closing	-	-
Record Sequence Number	-	-
Local Record Sequence Number	-	-
IMS Signalling Context	-	-
CAMEL Information	-	-
Record Extensions	-	-
	Service Information	Service-Information
Served IMSI	Subscriber Identifier	Subscription-Id
Served MN NAI	Subscriber Identifier	Subscription-Id
Served MSISDN	Subscriber Identifier	Subscription-Id
	IMS Information	IMS-Information
Record Type	Node Functionality	Node-Functionality
	PS Information	PS-Information
-	Supported Features	Supported-Features
Charging Id	Charging Id	3GPP-Charging-Id
Charging per IP-CAN Session Indicator	Charging per IP-CAN Session Indicator	Charging-Per-IP-CAN-Session-Indicator
Node ID	Node Id	Node-ID
PDN Connection Charging Id	PDN Connection Charging Id	PDN-Connection-Charging-ID
PDP/PDN Type	PDP/PDN Type	3GPP-PDP-Type
PDP/PDN Type extension	PDP/PDN Type	3GPP-PDP-Type
SGi PtP Tunnelling Method	SGi PtP Tunnelling Method	SGi-PtP-Tunnelling-Method
SCS/AS Address	SCS/AS Address	SCS-AS-Address
Served PDP/PDN Address	PDP/PDN Address	PDP-Address
Served PDP/PDN Address prefix length	PDP/PDN Address prefix length	PDP-Address-Prefix-Length
Served PDP/PDN Address extension	PDP/PDN Address	PDP-Address
Dynamic Address Flag	Dynamic Address Flag	Dynamic-Address-Flag
Dynamic Address Flag extension	Dynamic Address Flag Extension	Dynamic-Address-Flag-Extension
EPC QoS Information/QoS Information	Negotiated QoS Profile	Qos-Information
Serving Node Address	Serving Node Address	SGSN-Address
Serving node IPv6 Address	Serving Node Address	SGSN-Address
Serving Node Type	Serving Node Type	Serving-Node-Type
S-GW Change	SGW Change	SGW-Change
PGW Address Used	PGW Address	GGSN-Address
PGW IPv6 Address	PGW Address	GGSN-Address
TDF Address Used	TDF Address	TDF-IP-Address
TDF IPv6 Address	TDF Address	TDF-IP-Address
S-GW Address used	SGW Address	SGW-Address
S-GW Address IPv6	SGW Address	SGW-Address
ePDG Address Used	ePDG Address	ePDG-Address
ePDG IPv6 Address	ePDG Address	ePDG-Address
TWAG Address Used	TWAG Address	TWAG-Address
TWAG IPv6 Address	TWAG Address	TWAG-Address
-	CG Address	CG-Address
-	IMSI MCC MNC	3GPP-IMSI-MCC-MNC
IMSI Unauthenticated Flag	IMSI Unauthenticated Flag	IMSI-Unauthenticated-Flag
PGW PLMN Identifier	PGW MCC MNC	3GPP-GGSN-MCC-MNC
TDF PLMN Identifier	TDF MCC MNC	3GPP-GGSN-MCC-MNC
-	NSAPI	3GPP-NSAPI
Access Point Name Network Identifier	Called Station Id	Called-Station-Id
-	Session Stop Indicator	3GPP-Session-Stop-Indicator
APN Selection Mode	Selection Mode	3GPP-Selection-Mode
Charging Characteristics	Charging Characteristics	3GPP-Charging-Characteristics

Charging Characteristics Selection Mode	Charging Characteristics Selection Mode	Charging-Characteristics-Selection-Mode
Serving node PLMN Identifier	Serving Node MCC MNC	3GPP-SGSN-MCC-MNC
CN Operator Selection Entity	CN Operator Selection Entity	CN-Operator-Selection-Entity
MS Time Zone	MS Time Zone	3GPP-MS-Time-Zone
Last MS Time Zone	MS Time Zone	3GPP-MS-Time-Zone
User Location Information	User Location Info	3GPP-User-Location-Info
User Location Information Time	User Location Info Time	User-Location-Info-Time
Last User Location Information	User Location Info	3GPP-User-Location-Info
User CSG Information	User CSG Information	User-CSG-Information
3GPP2 User Location information	3GPP2 User Location Info	3GPP2-BSID
TWAN User Location Information	TWAN User Location Information	TWAN-User-Location-Info
UWAN User Location Information	UWAN User Location Information	UWAN-User-Location-Info
Presence Reporting Area Information	Presence Reporting Area Information	Presence-Reporting-Area-Information
RAT Type	RAT Type	3GPP-RAT-Type
PS Furnish Charging Information	Furnish Charging Information	PS-Furnish-Charging-Information
-	Offline Charging	Offline-Charging
-	PDP Context Type	PDP-Context-Type
List of Traffic Data Volumes	Traffic data volumes	Traffic-Data-Volumes
Data Volume Uplink	-	Accounting-Input-Octets
Data Volume Downlink	-	Accounting-Output-Octets
Change Condition	Change Condition	Change-Condition
Change Time	-	Change-Time
Access Availability Change Reason	-	Access-Availability-Change-Reason
List of Service Data	Service data container	Service-Data-Container
AF record information	AF Correlation Information	AF-Correlation-Information
Charging Rule Base Name	Charging Rule Base Name	Charging-Rule-Base-Name
ADC Rule Base Name	ADC Rule Base Name	ADC-Rule-Base-Name
Rating Group	Rating Group	Rating-Group
Service Identifier	Service Identifier	Service-Identifier
Service Specific Info	Service Specific Info	Service-Specific-Info
Report Time	-	Change-Time
Service Condition Change	-	Change-Condition
Result Code	-	Result-Code
Time of First Usage	-	Time-First-Usage
Time of Last Usage	-	Time-Last-Usage
Time Usage	-	Time-Usage
Traffic Steering Policy Identifier DL	Traffic Steering Policy Identifier DL	Traffic-Steering-Policy-Identifier-DL
Traffic Steering Policy Identifier UL	Traffic Steering Policy Identifier UL	Traffic-Steering-Policy-Identifier-UL
-	User Equipment Info	User-Equipment-Info
Served IMEI	Terminal Information	Terminal-Information
Served 3GPP2 MEID	Terminal Information	Terminal-Information
Start Time	Start Time	Start-time
Stop Time	Stop Time	Stop-time
Cause for Record Closing	Change Condition	Change-Condition
Diagnostics	Diagnostics	Diagnostics
Enhanced Diagnostics	Enhanced Diagnostics	Enhanced-Diagnostics
Low Priority Indicator	Low Priority Indicator	Low-Priority-Indicator
NBIFOM Support	NBIFOM Support	NBIFOM-Support
NBIFOM Mode	NBIFOM Mode	NBIFOM-Mode
CP CIoT EPS Optimisation Indicator	CP CIoT EPS Optimisation indicator	CP-CIoT-EPS-Optimisation-Indicator

UNI PDU CP Only Flag	UNI PDU CP Only Flag	UNI-PDU-CP-Only-Flag
Serving PLMN Rate Control	Serving PLMN Rate Control	Serving-PLMN-Rate-Control
MO exception data counter	MO exception data counter	RRC-Cause-Counter
APN Rate Control	APN Rate Control	APN-Rate-Control
3GPP PS Data Off Status	3GPP PS Data Off Status	3GPP-PS-Data-Off-Status
List of RAN Secondary RAT Usage Reports	RAN Secondary RAT Usage Reports	RAN-Secondary-RAT-Usage Report

Table 6.5.2 describes the mapping of the Information Element, AVP and the CDR parameter of S-SMO/S-SMT-CDR in EPC offline charging for SMS.

Table 6.5.2: Bindings of S-SMO/S-SMT-CDR parameter, Information Element and AVP

CDR Parameter	Information Element	AVP
Retransmission	-	-
Local Record Sequence Number	-	-
CAMEL Information	-	-
Record Extensions	-	-
	Service Information	Service-Information
Served IMSI	Subscriber Identifier	Subscription-Id
Served MSISDN	Subscriber Identifier	Subscription-Id
	IMS Information	IMS-Information
Record Type	Node Functionality	Node-Functionality
	PS Information	PS-Information
Recording Entity	MME Number for MT SMS	MME-Number-for-MT-SMS
MME Name	MME Name	MME-Name
MME Realm	MME Realm	MME-Realm
	SMS Information	SMS-Information
Destination Number	Recipient-Address	Recipient-Address
Service Centre	SMSC-Address	SMSC-Address
	MMS Information	MMS-Information
Originating Address	Originator Address	Originator-Address
Event Time Stamp	Submission-Time	Submission-Time
Message Reference	Message Id	MessageId

NOTE: The whole set of ePDG-/TWAG-/MME-/SGW-/PGW-/TDF-CDR parameters is described in the TS 32.298 [51].

Annex A (normative): Charging characteristics

A.1 General

Charging Characteristics can be supplied by the HLR/HSS/AAA to the Gn/Gp SGSN or the HSS to the MME as part of the subscription information. Upon IP-CAN bearer activation, the Gn/Gp SGSN (resp. MME) forwards the Charging Characteristics parameter to the P-GW (resp. S-GW then the P-GW). Upon TDF session establishment, the P-GW forwards the Charging Characteristics parameter to the TDF (resp. PCRF then the TDF). A subscriber may have Charging Characteristics assigned to his subscription and/or his subscribed APNs. Default charging characteristics may also be pre-provisioned on the PCN.

The Charging Characteristics parameter consists of a string of 16 bits designated as Behaviours (B), freely defined by Operators, as shown in TS 32.298 [51]. Each bit corresponds to a specific charging behaviour which is defined on a per operator basis, configured within the PCN and pointed when bit is set to "1" value.

The Gn/Gp SGSN and the PCN may either apply the Charging Characteristics provided by the HLR/HSS or ignore it to apply a default configuration. For example for a foreign subscriber, the network may choose either the Visiting or the Roaming default behaviour. Consequently, the network may apply:

- The Charging Characteristics provided by the HLR/HSS
- The Home default behaviour (the SGSN and the S-GW belong to the Home PLMN)
- The Roaming default behaviour (the P-GW and/or TDF belongs to the Home PLMN of the subscriber, a.k.a. home-routed scenario).
- The Visiting default behaviour (the SGSN, the S-GW and the P-GW and/or the TDF belongs to the Visited PLMN a.k.a. local breakout scenario)

For example, one way to define a charging behaviour could be to associate it to a specific usage designed according to following guidances:

One usage may consist of a set of trigger profiles associated to CDR types, with following trigger sets, e.g.:

- **S-CDR:** activate/deactivate CDRs, time limit, volume limit, maximum number of charging conditions, tariff times;
- **SGW-CDR:** same as S-CDR, plus maximum number of S4-SGSN/MME changes;
- **PGW-CDR:** same as S-CDR, plus maximum number of S-GW changes;
- **M-CDR:** activate/deactivate CDRs, time limit, and maximum number of mobility changes;
- **TDF-CDR:** same as PGW-CDR
- **SMS-MO-CDR:** activate/deactivate CDRs;
- **SMS-MT-CDR:** active/deactivate CDRs.
- **LCS-MO-CDR.**
- **LCS-MT-CDR.**
- **LCS-NI-CDR.**

In addition to these trigger sets, an optional charging gateway address may also be specified:

- If the CGF address is configured in the P-GW's selected Charging Characteristics behaviour, the P-GW shall apply it for the PGW-CDRs. The P-GW applied CGF address is sent to Gn/Gp SGSN/S-GW during IP-CAN bearer activation.
- If the CGF address is configured in the TDF's selected Charging Characteristics behaviour, the TDF shall apply it for the TDF-CDRs pertaining to the TDF session.

- In the home or visiting case, the S-GW shall apply the CGF address received from the P-GW to the SGW-CDRs pertaining to this IP-CAN bearer. In the roaming case, or if no CGF address is received from the P-GW, the S-GW shall use the CGF address from its own applied Charging Characteristics behaviour, or, if it does not exist, it uses the default CGF address. There is no need to send CGF address to S4-SGSN/MME as it does not generate charging data.
- In the home or visiting case, the Gn/Gp SGSN shall apply the CGF address received from the P-GW to the S-CDRs pertaining to this IP-CAN bearer. In the roaming case, or if no CGF address is received from the P-GW, then the Gn/Gp SGSN shall use the CGF address from its own selected Charging Characteristics behaviour, or, if it does not exist, use the default CGF address. For M-CDRs and SMS CDRs, the Gn/Gp SGSN shall use the CGF address configured in the Charging Characteristics behaviour that it applies to the respective CDRs, or if no such address is configured then the default CGF shall be used.

Tables A.1.1, A.1.2 and A.1.3 are informative examples intended for clarification.

Table A.1.1: Example of Charging Characteristics behaviours for SGSN

Behaviour Index bits 0 - 3	CGF Address	S-CDR					M-CDR	
		Active	Time limit	Volume limit	Change cond	Tariff times	Active	...
0	-	Yes	30 min	100 K	2	0-7, 7-12, ...	Yes	..
1	100.128.35.20	No	-	-	-	-	No	..
2	-	Yes	10 min	50 K	1	0-24	Yes	..
..

Charging Characteristics behaviour in S-GW is used for SGW-CDR generation

Table A.1.2: Example of Charging Characteristics behaviours for S-GW

Behaviour Index Bits 0-15	SGW-CDR						
	Primary and Secondary CGF Addresses	Active	Time Limit	Vol Limit	Change Cond.	Tariff times	...
0	100.128.35.20 100.128.35.21	Yes	30 min	100K	2	0-7, 7-12	...
1	100.128.35.21 100.128.35.20	No	-	-	-	-	...
2	100.128.35.21 100.128.35.20	Yes	10 min	50K	1	0-24	...
...

Charging Characteristics behaviour in P-GW is used for PGW-CDR generation / and for online charging.

FBC is always active in P-GW. PCRF, if triggered, may provide default charging method to PCEF (P-GW) per IP-CAN bearer session. If received by the PCEF, it supersedes the "Default charging method" in Charging Characteristics behaviour, see TS 23.203 [215] for more information about default charging method. PCRF may also provide CGF/OCS addresses to P-GW per IP-CAN bearer session. If received by the P-GW it supersedes the "Primary CGF/OCS address" and "Secondary CGF/OCS address" in Charging Characteristics behaviour, see TS 23.203 [215] for more information.

Table A.1.3: Example of Charging Characteristics behaviours for P-GW

Behaviour Index Bits 0-15	Default charging method	Offline charging (PGW-CDR)							Online charging		
		Primary and Secondary CGF addresses	Active	Time Limit	Vol Limit	Change Cond.	Tariff times	...	Primary and Secondary OCS addresses	Active	...
0	Online	100.128.35.20 100.128.35.21	Yes	30 min	100K	2	0-7, 7-12	...	100.128.35.30 100.128.35.31	Yes	...
1	Offline	100.128.35.21 100.128.35.20	No	-	-	-	-	...	-	No	...
2	Online /Offline	100.128.35.21 100.128.35.20	Yes	10 min	50K	1	0-24	...	100.128.35.31 100.128.35.30	Yes	...
...

Table A.1.4: Example of Charging Characteristics behaviours for TDF

Behaviour Index Bits 0-15	Default charging method	Offline charging (TDF-CDR)							Online charging		
		Primary and Secondary CGF addresses	Active	Time Limit	Vol Limit	Change Cond.	Tariff times	...	Primary and Secondary OCS addresses	Active	...
0	Online	100.128.35.20 100.128.35.21	Yes	30 min	100K	2	0-7, 7-12	...	100.128.35.30 100.128.35.31	Yes	...
1	Offline	100.128.35.21 100.128.35.20	No	-	-	-	-	...	-	No	...
2	Online /Offline	100.128.35.21 100.128.35.20	Yes	10 min	50K	1	0-24	...	100.128.35.31 100.128.35.30	Yes	...
...

The TDF may apply ABC per TDF session using either charging characteristics or charging information conveyed via ADC rules that are received from the PCRF.

If Charging Characteristics are received by the PCRF from the P-GW, the PCRF may take them into account when providing Charging information and Default charging method to the TDF.

Upon the initial interaction with the TDF, the PCRF may provide:

- Charging Characteristics, if received from the PCEF, defining how to control TDF behaviour regarding online and offline charging.
- Charging information containing OFCS and/or OCS addresses defining the offline and online charging system addresses respectively. If received by the TDF, it supersedes the Primary OFCS/OCS address and Secondary OFCS/OCS address predefined at the TDF.
- Default charging method indicating what charging method shall be used in the TDF session for every ADC rule where the charging method identifier is omitted. If received by the TDF, it supersedes the defined Default charging method.

NOTE: TDF may also ignore the supplied Charging Characteristics for the cases defined in clause A.7.

In case the TDF receives both Charging Characteristics and Charging information and Default charging method parameters, the Charging Information and Default charging method shall supersede the values received in Charging Characteristics.

Other examples for behaviours are:

- Selection of the applicable idle context purge timer, i.e. use global value or use special value. This feature could be used to distinguish between customers and/or APNs whose IP-CAN bearers should be purged after short (e.g. 30 minutes) or long (e.g. 12 hours) periods of inactivity.
- Use specific charging gateway address (override all other configured/selected CG addresses).
- Deactivate SMS-MO-CDRs for customers of the own PLMN using pre-configured SMSC addresses.
- Disable PGW-CDRs for roamers that use the HPLMN P-GW.
- Allow or inhibit the use of own P-GWs by visitors.
- Allow or inhibit network triggered QoS change (upgrade and/or downgrade).
- Inhibit CDR generation when the user data volume has not reached a minimum configurable value, e.g. to limit the number of no/low-value added CDRs when the user activity is null or very low.
- Inhibit triggering of PCRF in the P-GW by not establishing a Gx session during the IP-CAN session establishment procedure as defined in TS 23.203 [215].
- Inhibit triggering of PCRF in the HSGW by not establishing a Gxa session during the IP-CAN session establishment procedure as defined in TS 23.203 [215].

The Gn/Gp SGSN selects the Charging Characteristics behaviour for M-CDR generation upon the creation of a MM context. Gn/Gp SGSN, S-GW and P-GW select the Charging Characteristics behaviour upon creation of a IP-CAN bearer. Once selected, the Charging Characteristics behaviour shall be maintained throughout the lifetime of the MM or IP-CAN bearer. If the SGSN receives modified subscriber information from the HLR/HSS (e.g. execution of a stand-alone Insert Subscriber Data procedure) which includes changes the Charging Characteristics, the new Charging Characteristics shall be applied only to new IP-CAN bearers. This implies the following:

- the S4-SGSN/MME shall not send IP-CAN bearer modifications for the existing IP-CAN bearer to the S-GW because of Charging Characteristics change;
- the Gn/Gp SGSN shall not send IP-CAN bearer modifications for the existing IP-CAN bearer to the P-GW because of Charging Characteristics change.

A.2 Charging Characteristics in Gn/Gp SGSN

The Gn/Gp SGSN applies a pre-configured default if no Charging Characteristics are supplied by the HLR/HSS. The SGSN shall support three different Charging Characteristics default configurations:

- the home default behaviour for subscribers of the SGSN's PLMN;
- the visiting default behaviour for visitors using a P-GW belonging to the same PLMN as the SGSN;
- the roaming default behaviour for visitors using a P-GW belonging to their home PLMN.

The SGSN can determine the P-GW PLMN from the operator identifier part of the APN. Optionally the SGSN may support several visiting and roaming default behaviours based on the MNC/MCC combination of the subscriber.

In the case of a home subscriber, the Charging Characteristics are selected by the SGSN according to the following procedures. For IP-CAN bearer specific Charging Characteristics (i.e. those used for the S-CDRs that are generated for this IP-CAN bearer):

- If the MS requests a particular APN then:
 - * If the SGSN accepts this request (i.e. it has been verified against the subscription) then:
 - If it has been matched against the wildcard APN then:
 - If Charging Characteristics for the wildcard APN are present in the subscription information then they shall be used;
 - If no Charging Characteristics are present for the wildcard APN but subscription related Charging Characteristics are present, then they shall be chosen;
 - If neither of the two are present then the SGSN home default shall be applied.
 - If it has been matched against a specific subscribed APN then:
 - If Charging Characteristics for this APN are present in the subscription information then they shall be used;
 - If no Charging Characteristics are present for the APN but subscription related Charging Characteristics are present, then they shall be chosen;
 - If neither of the two are present then the SGSN home default shall be applied.
 - * If the SGSN rejects the request then Charging Characteristics selection does not apply.
- If the MS does not request an APN then:
 - * If the SGSN chooses a subscribed APN then:
 - If Charging Characteristics for this APN are present in the subscription information then they shall be used;
 - If no Charging Characteristics are present for the APN but subscription related Charging Characteristics are present, then they shall be chosen;
 - If neither of the two are present then the SGSN home default shall be applied.
 - * If only the wildcard APN is present in the subscription, i.e. the SGSN applies its configured default APN then:
 - If Charging Characteristics for the wildcard APN are present in the subscription information then they shall be used;
 - If no Charging Characteristics are present for the wildcard APN but subscription related Charging Characteristics are present, then they shall be chosen;
 - If neither of the two are present then the SGSN home default shall be applied.

For the non-IP-CAN bearer specific CDR types, i.e. the M-CDRs and the SMS CDRs, the SGSN applies the subscription specific Charging Characteristics, or, if not supplied, it shall choose the home default behaviour as defined above.

In case of subscribers from other PLMNs, the SGSN may be configured to either apply the "home subscriber case" Charging Characteristics selection procedure defined above, or to ignore Charging Characteristics provided by the subscriber's HLR, and apply a default configuration instead. If default Charging Characteristics are selected for the foreign subscriber, then the SGSN shall choose either the visiting or roaming default behaviour for the IP-CAN bearer specific Charging Characteristics, according to the roaming or visiting scenario, as described above. For M-CDRs and SMS CDRs, the operator can configure if the roaming or the visiting behaviour shall be applied, since no P-GW is involved.

Upon activation of a IP-CAN bearer, the SGSN forwards the Charging Characteristics to the P-GW according to the following rules:

- if Charging Characteristics were received from the HLR/HSS, then they shall be sent as provided by the HLR/HSS, regardless of the home, visiting, or roaming case, and regardless of whether the SGSN applies the HLR/HSS supplied Charging Characteristics or chooses to ignore them;
- if no Charging Characteristics were received from the HLR/HSS, then the SGSN does not forward any Charging Characteristics to the P-GW.

If no charging characteristics were received from the HLR/HSS or from another MME or SGSN, then SGSN does not provide any charging characteristics to any MME or SGSN in mobility cases.

If charging characteristics were received from HLR/HSS, but not for all the IP-CAN bearers, then SGSN does not provide any charging characteristics to any MME or SGSN in mobility cases occurring through GTPv1.

A.3 Charging Characteristics in S4-SGSN

The S4-SGSN does not utilize Charging Characteristics as it does not generate charging information.

Upon activation of a IP-CAN session, the S4-SGSN forwards the Charging Characteristics to the S-GW according to the following rules:

- if Charging Characteristics were received from the HLR/HSS, then they shall be sent as provided by the HLR/HSS, regardless of the home, visiting, or roaming case according to the following rules:
 - if Charging Characteristics for the PDN connection (e.g. APN) is present in the subscription information it shall be forwarded;
 - if no Charging Characteristics is present for the PDN connection (e.g. APN) but subscription related Charging Characteristics is present, it shall be forwarded.
- if no Charging Characteristics were received from the HLR/HSS, then the S4-SGSN does not forward any Charging Characteristics to the S-GW.

If no charging characteristics were received from the HLR/HSS or from another MME or SGSN, then SGSN does not provide any charging characteristics to any MME or SGSN in mobility cases.

If charging characteristics were received from HLR/HSS, but not for all the IP-CAN bearers, then SGSN does not provide any charging characteristics to any MME or SGSN in mobility cases occurring through GTPv1.

A.4 Charging Characteristics in MME

The MME applies the subscription specific Charging Characteristics, or, if not supplied, it shall apply a pre-configured default behaviour for generation of SMS CDRs.

Upon activation of a IP-CAN session, the MME forwards the Charging Characteristics to the S-GW according to the following rules:

- if Charging Characteristics were received from the HLR/HSS, then they shall be sent as provided by the HLR/HSS, regardless of the home, visiting, or roaming case according to the following rules:
 - if Charging Characteristics for the PDN connection (e.g. APN) are present in the subscription information they shall be forwarded;
 - if no Charging Characteristics are present for the PDN connection (e.g. APN) but subscription related Charging Characteristics are present, they shall be forwarded.
- if no Charging Characteristics were received from the HLR/HSS, then the MME does not forward any Charging Characteristics to the S-GW.

If no charging characteristics were received from the HLR/HSS or from another MME or SGSN, then MME does not provide any charging characteristics to any MME or SGSN in mobility cases.

If charging characteristics were received from HLR/HSS, but not for all the IP-CAN bearers, then MME does not provide any charging characteristics to any MME or SGSN in mobility cases occurring through GTPv1.

A.5 Charging Characteristics in S-GW

The S-GW shall apply Charging Characteristics to its IP-CAN bearers. It shall either apply the S4-SGSN/MME supplied parameters, or it may be configured to ignore the S4-SGSN/MME supplied Charging Characteristics in any combination of the following cases:

- visiting case, i.e. the the S-GW and the P-GW belong to the same PLMN, the subscriber belongs to a different PLMN;
- roaming case, i.e. the P-GW belongs to a different PLMN;
- home case, i.e. the subscriber belongs to the same PLMN as the S-GW and P-GW; or
- unconditionally, i.e. it always ignores the S4-SGSN/MME supplied parameters.

If the S-GW ignores the parameters supplied by the S4-SGSN/MME, it shall nevertheless accept the IP-CAN session request. It shall then apply its own pre-configured Charging Characteristics as appropriate, i.e. the home, visiting or roaming behaviour. The S-GW shall support the configuration of one set of default Charging Characteristics (i.e. home, visiting, roaming).

Upon activation of a IP-CAN session, the S-GW forwards the Charging Characteristics to the P-GW according to the following rules:

- if Charging Characteristics were received from the S4-SGSN/MME, then they shall be sent as provided by the S4-SGSN/MME, regardless of the home or visiting case;
- if no Charging Characteristics were received from the S4-SGSN/MME, then the S-GW does not forward any Charging Characteristics to the P-GW.

A.6 Charging Characteristics in P-GW

The P-GW shall apply Charging Characteristics to its IP-CAN bearers. It shall either apply the SGSN/S-GW/ePDG supplied parameters, or it may be configured to ignore the SGSN/S-GW/ePDG supplied Charging Characteristics in any combination of the following cases:

- visiting case, i.e. the subscriber belongs to a different PLMN;
- roaming case, i.e. the subscriber belongs to same PLMN and the SGSN/S-GW/ePDG belongs to a different PLMN;
- home case, i.e. the subscriber belongs to the same PLMN as the SGSN/S-GW/ePDG and P-GW; or
- unconditionally, i.e. it always ignores the SGSN/S-GW/ePDG supplied parameters.

If the P-GW ignores the parameters supplied by the SGSN/S-GW/ePDG, it shall nevertheless accept the IP-CAN session request. It shall then apply its own pre-configured Charging Characteristics as appropriate, i.e. the home, visiting or roaming behaviour. The P-GW shall support the configuration of one set of default Charging Characteristics (i.e. home, visiting, roaming) for each of its supported APNs.

A.7 Charging Characteristics in TDF

Upon IP-CAN session establishment, the P-GW forwards the Charging Characteristics parameter to the TDF (resp. PCRF then the TDF). The TDF shall apply Charging Characteristics to its TDF session. It shall either apply the supplied parameters, or it may be configured to ignore the supplied Charging Characteristics in any combination of the following cases:

- visiting case, i.e. the subscriber belongs to a different PLMN;
- roaming case (home routed traffic);
- home case, i.e. the subscriber belongs to the same PLMN as the TDF; or
- unconditionally, i.e. it always ignores the supplied parameters.

If the TDF ignores the supplied parameters, it shall nevertheless accept the TDF session request. It shall then apply its own pre-configured Charging Characteristics as appropriate, i.e. the home, visiting or roaming behaviour. The TDF shall support the configuration of one set of default Charging Characteristics (i.e. home, visiting, roaming) for each of APNs.

Annex B (normative):

Tx expiration; Failure Handling procedure and session failover mechanism description

CREDIT-CONTROL FAILURE HANDLING	Initial CCR, Tx expiration	Initial CCR, Tx expiration	Update CCR, Tx expiration	Update CCR, Tx expiration	Initial CCR, Tx expiration for second OCS	Update CCR, Tx expiration for second OCS
	Session failover enabled	Session failover disabled	Session failover enabled	Session failover disabled		
Failure Action = TERMINATE	P-GW: IP-CAN bearer is not established. TDF: indicates to the PCRF that the charging session was terminated and the OCS does not allow the service to continue.	P-GW: IP-CAN bearer is not established. TDF: indicates to the PCRF that the charging session was terminated and the OCS does not allow the service to continue.	P-GW: IP-CAN bearer is terminated. The PGW-CDR is marked. TDF: indicates to the PCRF that the charging session was terminated and the OCS does not allow the service to continue. The TDF-CDR is marked.	P-GW: IP-CAN bearer is terminated. The PGW-CDR is marked. TDF: indicates to the PCRF that the charging session was terminated and the OCS does not allow the service to continue. The TDF-CDR is marked.	N/A	N/A
Failure Action = RETRY & TERMINATE	After Tx expiration, the P-GW/TDF sends the Reserve Units Request[Initial] to the secondary OCS. The next considerations also apply: <ul style="list-style-type: none"> - Tx is restarted. - Service is not granted yet, i.e. PDP context/TDF session is not accepted/established yet. - If an answer from the first OCS is received after the first Tx expiration, it is ignored. <p>In case the secondary OCS is not available, the behaviour is described in the column: "Initial CCR, Tx expiration for second OCS".</p>	P-GW: IP-CAN bearer is not established. TDF indicates to the PCRF that the charging session was terminated and the OCS does not allow the service to continue.	After Tx expiration, the P-GW/TDF will move all pending Reserve Units Request [Update] for the online session to the secondary OCS. The next considerations also apply: <ul style="list-style-type: none"> - Tx is restarted - Service is only granted until the quota is exhausted. - If an answer from the first OCS is received after first Tx expiration, it is ignored. <p>In case the secondary OCS is not available, the behaviour is described in the column: "Reserve Units Request[Update], Tx expiration for second OCS".</p>	P-GW: IP-CAN bearer is terminated. The PGW-CDR is marked. TDF: indicates to the PCRF that the charging session was terminated and the OCS does not allow the service to continue. The TDF-CDR is marked.	P-GW: IP-CAN bearer is not established. TDF: indicates to the PCRF that the charging session was terminated and the OCS does not allow the service to continue.	P-GW: IP-CAN bearer is terminated. The PGW-CDR is marked. TDF: indicates to the PCRF that the charging session was terminated and the OCS does not allow the service to continue. The TDF-CDR is marked.

<p>Failure Action= CONTINUE</p>	<p>After Tx expiration, the P-GW/TDF sends the Reserve Units Request[Initial] to the secondary OCS. The next considerations also apply:</p> <ul style="list-style-type: none"> - Tx is restarted - Service is not granted yet, i.e. PDP context/TDF session is not accepted/established yet. - If an answer from the first OCS is received after the first Tx expiration, it is ignored. <p>In case the secondary OCS is not available, the behaviour is described in the column: "Initial CCR, Tx expiration for second OCS".</p>	<p>P-GW: The IP-CAN bearer is accepted and the Credit-Control session is considered closed for the P-GW. The operator can limit the duration of the IP-CAN bearer. The PGW-CDR is marked. TDF: indicates to the PCRF that the charging session was terminated and the OCS allows the service to continue. The TDF-CDR is marked.</p>	<p>After Tx expiration, the P-GW/TDF will move all pending update CCRs for the online session to the secondary OCS. The next considerations also apply:</p> <ul style="list-style-type: none"> - Tx is restarted - Service is only granted until the quota is exhausted - If an answer from the first OCS is received after the first Tx expiration, it is ignored. <p>In case the secondary OCS is not available, the behaviour is described in the column: "Update CCR, Tx expiration for second OCS".</p>	<p>After the Tx expiration, the failure handling mechanism is immediately triggered - P-GW: The Credit-Control session is considered closed for the P-GW and access to all services is granted for an operator configurable period of time. The PGW-CDR is marked. TDF: indicates to the PCRF that the charging session was terminated and the OCS allows the service to continue. The TDF-CDR is marked. All active service data flow containers shall be added to the PGW-CDR/TDF-CDR.</p>	<p>After the Tx expiration for the secondary OCS, the failure handling mechanism is immediately triggered: P-GW: The IP-CAN bearer is accepted and the Credit-Control session is considered closed for the P-GW. The operator can limit the duration of the IP-CAN bearer. The PGW-CDR is marked. TDF: indicates to the PCRF that the charging session was terminated and the OCS allows the service to continue. The TDF-CDR is marked.</p>	<p>After Tx expiration for the secondary OCS, the failure handling mechanism is immediately triggered- P-GW: The Credit-Control session is considered closed for the P-GW and access to all services is granted for an operator configurable period of time. The PGW-CDR is marked. TDF: indicates to the PCRF that the charging session was terminated and the OCS allows the service to continue. The TDF-CDR is marked. All active service data flow containers shall be added to the PGW-CDR/TDF-CDR.</p>
--	---	--	---	--	--	---

Annex C (informative): Bibliography

This Annex is a placeholder for documents which are not explicitly cited in this specification.

Annex D (normative): Fixed Broadband Access

D.1 General

This annex specifies the enhancement to PS domain Charging for supporting the convergent scenario, where a single operator owns both the fixed broadband access network and the EPC, and the PCEF is located in the fixed broadband access network, as described in the TS 23.203 [215].

This Annex describes only the exceptions and additions in respect the main body requirements, therefore, if not explicitly mentioned the main body is applicable.

In this Annex, the IP-Edge embedding PCEF will be denoted IP-Edge [PCEF].

As specified in the TS 23.203 [215], Charging for following types of traffic is supported:

- traffic from fixed devices, and
- non-seamless WLAN offload traffic from a 3GPP UE.

Editor's note: this Annex might require some adjustments based on exchanges with BBF.

D.2 Architecture considerations

D.2.1 High level architecture

For offline charging the IP-Edge [PCEF] /TDF may generate accounting metrics sets to record a user's access to external networks based on clause D.2.2 architecture.

Online charging is supported from the IP-Edge [PCEF] /TDF based on clause D.2.3.

D.2.2 PS domain offline charging architecture

The Rf interface is supported from the Policy and Charging Enforcement Function (PCEF) located in IP-Edge, and includes the required FBC functionality of the Gz reference point, adapted to IP-Edge [PCEF] as defined in this Annex.

The Rf, Ga and Bp interfaces are supported from the TDF and includes the required ABC functionality of the Gzn reference point as defined for the PCN in clause 4.2

D.2.3 PS domain online charging architecture

The Ro interface is supported from the Policy and Charging Enforcement Function (PCEF) located in IP-Edge as per clause 4.3 architecture, and includes the required FBC functionality of the Gy reference point, adapted to IP-Edge [PCEF] as defined in this Annex.

The Ro interface is supported from the TDF as per clause 4.3 architecture, and includes the required ABC functionality of the Gyn reference point as defined for the PCN in clause 4.3.

D.3 PS domain charging principles and scenarios

D.3.1 PS charging principles

D.3.1.0 General

IP-CAN session applicable for Fixed Broadband Access, is defined in the TS 23.203 [215], clause S.2.

The charging functions specified for the PCEF located in the IP-Edge relate to:

- IP-CAN session.
- individual service data flows within an IP-CAN session.

The charging functions specified for the TDF relate to:

- TDF session.
- individual applications within a TDF session.

D.3.1.1 Requirements

D.3.1.1.1 Requirements for IP-Edge [PCEF]

The high-level charging requirements 1, 2, 3, 10, 11 and 12 specified in clause 5.1.1 apply with the difference that P-GW is replaced by IP-Edge [PCEF].

Since the IP-Edge [PCEF] does not support individual bearers, the high-level charging requirements 1 and 2 apply to the IP-CAN session instead of an IP-CAN bearer.

Additional high level charging requirement:

- The IP-Edge [PCEF] shall be capable of identifying data volumes, elapsed time or events, categorized per QoS (QoS as defined in TS 23.203 [215]).
- IP-Edge [PCEF] shall support charging for 3GPP UEs in roaming scenario, where the HPLMN has deployed the same charging capabilities as the VPLMN.
- The IP-Edge [PCEF] shall be capable of handling local Charging Characteristics for Fixed users and 3GPP UEs NSWO traffic: see clause D.5 for details.

These requirements apply equally to online charging and offline charging.

D.3.1.1.2 Requirements for TDF

The High level Requirements specified in Clause 5.1.1 for TDF shall apply with the difference that Charging Characteristics shall be as described in clause D.5.

D.3.1.2 Charging information

Charging information is collected for each Fixed user served by the IP-Edge [PCEF] /TDF, and for each 3GPP UE served by the IP-Edge [PCEF] /TDF for the Offloaded (NSWO) traffic, both when served in the conditions specified in TS 23.203 [215] Annex S. The IP-Edge [PCEF] /TDF collects charging information related to the Fixed Broadband access resources and to external data network usage.

Charging information is collected for each existing IP-CAN/TDF session per identified user: 3GPP UE, Fixed device or RG.

Charging information collection per device (i.e. fixed device or 3GPP UE) is possible only when an IP-CAN session exists for the 3GPP UE or fixed device connected behind a RG.

NOTE 1: In case of 3GPP UE or fixed device behind a NATed RG it is not possible to perform charging for that specific device.

NOTE 2 : The cases where it is possible to support an IP-CAN session per device are described in TS 23.203 [215] Annex S.

3GPP UE user is identified by the IMSI, and Fixed user (i.e. fixed device or RG) is identified by a user name or Access line identifier, based on the Subscriber ID as defined in Broadband Forum TR 134 [601].

The Access Line Identifier (physical and logical circuit ID) shall also be collected by the IP-Edge [PCEF] when available, when this Subscriber ID identifies a 3GPP UE or a fixed device behind the RG.

The IP-Edge [PCEF] may provide the following fixed broadband access specific information:

- Location of the subscriber; that may include Access Line Identifier (physical and logical circuit ID), SSID of the Access Point, BSSID of the Access Point.

NOTE: How the location information becomes available to the IP-Edge [PCEF] is out of the scope of 3GPP.

- IP-Edge Operator Identifier (i.e., PLMN Id), if available.

For IP-CAN sessions, the IP-Edge [PCEF] shall collect the following charging information for both online and offline charging:

- 1). Usage of the Fixed Broadband access resources: the charging information shall describe the amount of data transmitted in uplink and downlink directions categorized with QoS.

NOTE 3: QoS information used for charging is based on standardized QoS characteristics as defined TS 23.203 [215]. The Fixed Broadband Access specific QoS attribute converted by the IP-Edge [PCEF] from these QoS parameters are out of scope.2). Usage duration: duration of IP-CAN session is counted as the time interval from IP-CAN session establishment to IP-CAN session termination.

- 3). Usage of the external data networks: the charging information shall describe the amount of data sent and received to and from the external data network. For an IP-CAN session corresponding to a 3GPP UE, the External network can be identified by the NSWO APN.
- 4). Source: the charging information shall provide the actual source addresses used by the subscriber for the IP-CAN session.
- 5). The amount of data transmitted in uplink and downlink directions categorized by rating group or combination of the rating group and service id when volume based charging applies;
- 6). The duration of service data flows categorized by rating group or combination of the rating group and service id when time based charging applies;

For TDF sessions and for application traffic defined for ABC, the TDF shall collect the charging information for both online and offline charging:

- 1) Usage of the Fixed Broadband access resources: the charging information shall describe the amount of data transmitted in uplink and downlink directions categorized with maximal bandwidth;
- 2) Usage duration: duration of TDF session is counted as the time interval from TDF session activation to TDF session deactivation;

- 3) Source: the charging information shall provide the actual source addresses used by the subscriber for the TDF session;
- 4) Usage of the external data networks: the charging information shall describe the amount of data sent and received to and from the external data network. For a TDF session corresponding to a 3GPP UE, the External network can be identified by the APN.
- 5) The amount of data transmitted as specific application in uplink and downlink directions categorized by rating group or combination of the rating group and service identifier when volume based charging applies;
- 6) The duration of application traffic is counted and categorized by rating group or combination of the rating group and service identifier when time based charging applies;
- 7) The number of events and corresponding timestamps categorized by rating group or combination of the rating group and service identifier when event based charging applies.

D.3.2 PS domain offline charging scenarios

D.3.2.1 Basic principles

D.3.2.1.0 General

In order to provide the data required for the management activities outlined in TS 32.240 [1] (billing, accounting, statistics etc.), the IP-Edge [PCEF] /TDF shall be able to report charging events to a CDF implemented as a separate entity for the corresponding IPE-CDR/TDF-CDR generation by CDF for:

- Charging Data related to the IP-CAN session;
- Charging Data related to service data flows (FBC) within an IP-CAN session;
- Charging data related to TDF session (TDF-CDR) in the TDF;
- Charging Data related to application traffic in the TDF (TDF-CDR).

Either Charging Data related to the IP-CAN session, Charging Data related to services data flows (FBC) within an IP-CAN session, or both may be reported for the IPE-CDR generation, as determined by Charging Characteristics. A single IPE-CDR is defined for both types of charging information.

D.3.2.1.1 IP-CAN session charging

IP-Edge [PCEF] collects charging information per user identified as described in clause D.3.1.2, per IP-CAN session.

IP-CAN session charging allows the IP-Edge [PCEF] to collect charging information related to data volumes sent to and received by the user, categorised by the QoS applied, for the timeframe since the establishment till the termination of IP-CAN session, for Fixed user traffic or 3GPP UE NSWO traffic. The IP-CAN session can be determined by a unique identifier generated by the Edge [PCEF] (a "Charging ID") when establishing IP-CAN session. When IP-CAN session charging is active for this IP-Edge [PCEF], the main collected information items are duration of the IP-CAN session and data volume transferred per QoS during the lifetime of the IP-CAN session, and the following chargeable events are defined:

- Start of IP-CAN session in the IP-Edge [PCEF]. Upon encountering this event, a new IPE-CDR for this context is created.

NOTE 1: The start of IP-CAN session event is a shared trigger for FBC in clause D.3.2.1.2 for the single shared CDR- Start of traffic under a QoS within the IP-CAN session: new data volume counts (i.e. uplink and downlink) are started for this QoS.

- Termination of traffic under a QoS within the IP-CAN session: The counters and time stamps for this QoS are closed and resulting containers added to the CDR.
- End of IP-CAN session in the IP-Edge [PCEF]. Upon encountering this trigger, all the counters are closed and added to the CDR, and the IPE-CDR is closed.

NOTE 2: The end of IP-CAN session event is a shared trigger for FBC in clause D.3.2.1.2 for the single shared CDR

- Expiry of an operator configured time limit for keeping a CDR open. This event closes all counters. The resulting containers are added to the CDR and the CDR is closed. A new CDR is opened if the IP-CAN session is still active.

NOTE 3: Expiry of an operator configured time limit for keeping a CDR open event is a shared trigger for FBC in clause D.3.2.1.2 for the single shared CDR

- Expiry of an operator configured time limit per QoS. The counters and time stamps for the QoS are closed and added to the CDR. New QoS traffic volume containers are opened if the QoS is still active.
- Expiry of an operator configured data volume limit per IP-CAN session. This event closes all counters. The resulting containers are added to the CDR and the CDR is closed. A new CDR is opened if the IP-CAN session is still active.

NOTE 4: Expiry of an operator configured data volume limit per IP-CAN session event is a shared trigger for FBC in clause D.3.2.1.2 for the single shared CDR

- Expiry of an operator configured data volume limit per QoS. The counters and time stamps for the QoS are closed and added to the CDR. New QoS traffic volume containers are opened if the QoS is still active.
- Change of charging condition: tariff time change or failure handling procedure triggering. When this event is encountered, all current configured counts and time stamps are captured and new counts and time stamps are started.

NOTE 5: Change of charging condition event is a shared trigger for FBC in clause D.3.2.1.2 for the single shared CDR

- Expiry of an operator configured change of charging condition limit per IP-CAN session. This event closes the CDR, and a new one is opened if the IP-CAN session is still active.

NOTE 6: Expiry of an operator configured change of charging condition limit per IP-CAN session event is a shared trigger for FBC in clause D.3.2.1.2 for the single shared CDR

Management intervention may also force trigger a chargeable event.

D.3.2.1.2 Flow-based bearer charging

FBC functionality defined in clause 5.2.1.3 shall apply when provided by the PCEF located in the IP-Edge, with modifications described below:

- Relates to Fixed user traffic and 3GPP UE NSW0 traffic.
- It is applicable within the context of an IP-CAN session.

The chargeable events defined in clause 5.2.1.3, when offline charging is activated, apply with the difference that P-GW is replaced by IP-Edge [PCEF], and IP-CAN bearer is replaced by IP-CAN session.

Change of charging condition is modified to remove conditions related to SGSN change, S-GW change, user location change, user CSG information change, change of UE presence in Presence Reporting Area(s). The following are the resulting applicable events:

- Change of charging condition: QoS change. When this event is encountered, all current configured counts and time stamps applicable to the QoS level are captured and new counts and time stamps for all service data flows applicable to the new QoS level are started.
- Change of charging condition: tariff time change or failure handling procedure triggering. When this event is encountered, all current configured counts and time stamps are captured and new counts and time stamps for all active service data flows are started.

Following are not applicable:

- Intersystem change.
- PLMN change.
- MS Timezone change.
- SGSN change in the P-GW.

NOTE: A set of chargeable events are shared triggers for IP-CAN session charging in clause D.3.2.1.1 for the single shared IPE-CDR. They are indicated in clause D.3.1.1.

The detailed PCEF behaviour associated to these chargeable events above, are detailed below.

When applicable to the IP-Edge [PCEF], charging information included in the PCC Rule is specified in TS 23.203 [215] Annex S.

D.3.2.1.3 TDF/Application Based Charging

TDF session and ABC functionality defined in clause 5.2.1.9 shall apply with modifications described below:

- Relates to Fixed user traffic and 3GPP UE NSWO traffic.

The chargeable events defined in clause 5.2.1.9, when offline charging is activated, apply except the following:

- Serving node (e.g. SGSN/S-GW/ePDG) change;
- Change of charging condition: TDF session modification (e.g. SGSN change, S-GW change, user location change, user CSG information change);
- Intersystem change (e.g. change of radio interface from GSM to UMTS, RAT change);
- PLMN change;
- MS Timezone change.

The detailed TDF behaviour associated to these chargeable events above, is detailed below.

D.3.2.2 Rf message flows

D.3.2.2.0 General

Charging information reporting is supported from the PCEF located in IP-Edge and by the TDF as defined for PCN in clause 5.2.2.

The trigger conditions for the chargeable events are described in the following clauses.

D.3.2.2.1 Triggers for charging events from IP-Edge [PCEF]

D.3.2.2.1.0 General

Charging event reporting as defined in clause 5.2.2.2 shall apply to the PCEF located in the IP-Edge, with the differences that P-GW is replaced by IP-Edge [PCEF], IP-CAN bearer is replaced by IP-CAN session, and includes, in addition:

- containers identifying per QoS, traffic volumes charging data (separated for uplink and downlink traffic) with associated charging condition change information when IP-CAN session charging is active for this IP-Edge [PCEF].

The trigger conditions applicable are described in following clauses.

D.3.2.2.1.1 Triggers for charging information addition

Charging event for charging information addition and triggers, as defined in clause 5.2.3.4.1 shall apply to the PCEF located in the IP-Edge for FBC (i.e. "List of Service Data" attribute of the IPE-CDR), with following exceptions:

- IP-CAN bearer modification (e.g. QoS change, SGSN/S-GW/ePDG change, user location change, user CSG information change) as trigger conditions is replaced by IP-CAN session modification (e.g. QoS change,..)
- The "Serving node Address" attribute is not applicable.

When IP-CAN session charging is active, the trigger conditions for charging information addition are described in clause D.3.2.3.1.1.

D.3.2.2.1.2 Triggers for charging information closure

Charging event for charging information closure, and triggers as defined in clause 5.2.3.4.2 shall apply to the PCEF located in the IP-Edge, when either FBC or IP-CAN session charging or both are active, with the following differences:

- P-GW is replaced by IP-Edge [PCEF], IP-CAN bearer is replaced by IP-CAN session, and PGW-CDR is replaced by IPE-CDR.
- following Partial Record Reasons: PLMN change, RAT type, and MS time zone change are not applicable.

D.3.2.2.2 Triggers for charging events from TDF

D.3.2.2.2.0 Introduction

Charging event reporting as defined in clause 5.2.2.5 shall apply to the TDF, with the differences that trigger conditions which are not applicable are described in the following clauses.

D.3.2.2.2.1 Triggers for charging information addition

Charging event for charging information addition and triggers, as defined in clause 5.2.3.9.2 shall apply to the TDF, with the following exceptions:

- TDF session modification (e.g. SGSN/S-GW/ePDG change, user location change, user CSG information change, change of UE presence in a Presence Reporting Area);
- The "Serving node Address" attribute is not applicable.

D.3.2.2.2.2 Triggers for charging information closure

Charging event for charging information closure, and triggers as defined in clause 5.2.3.9.3 shall apply to the TDF, with the following exception:

- following Partial Record Reasons: PLMN change, RAT type, and MS time zone change are not applicable.

D.3.2.3.2 TDF-CDR charging information collection

D.3.2.3.2.0 Introduction

Charging information collection as defined in clause 5.2.3.9 shall apply.

D.3.2.3.2.1 TDF-CDR charging information addition

Charging information addition to TDF-CDR shall be based on charging events received from TDF as specified in D.3.2.2.2.1.

D.3.2.3.2.2 TDF-CDR closure

CDR closure shall be based on charging event closure received from the TDF as specified in D.3.2.2.2.2.

D.3.2.3 CDR generation

D.3.2.3.0 General

The IPE-CDR and the TDF-CDR are generated by the Charging Data Function (CDF) for subsequent transfer to the Charging Gateway Function (CGF).

D.3.2.3.1 IPE-CDR charging information collection

D.3.2.3.1.0 General

Charging information collection as defined in clause 5.2.3.4 shall apply, based on charging events from IP-Edge [PCEF], with the differences that P-GW is replaced by IP-Edge [PCEF], IP-CAN bearer is replaced by IP-CAN session, and PGW-CDR is replaced by IPE-CDR, and in addition, when IP-CAN session charging is active:

IPE-CDR is used to collect charging information related to traffic volumes used within the IP-CAN session, identified per QoS.

Many traffic volume containers per QoS can be active simultaneously in IPE-CDR.

A new traffic volume container is activated, when traffic applied with this QoS is detected and no matching active QoS container exists.

When a change of charging condition occurs, all traffic volume containers are added to the IPE-CDR.

When both, IP-CAN session charging and FBC are active, the same IPE-CDR is used for collection of corresponding data.

D.3.2.3.1.1 IPE-CDR charging information addition

Charging information addition to IPE-CDR for FBC, shall be based on charging events received from IP-Edge [PCEF] as specified in D.3.2.2.1.1.

When IP-CAN session charging is active the following behaviour shall apply:

The "List of Traffic Data Volumes" attribute of the IPE-CDR consists of a set of containers, which are added when specific trigger conditions are met, and identify the volume counter per QoS, separated for uplink and downlink traffic, on encountering that trigger conditions. Table D.3.2.3.1.1.1 identifies which conditions are supported to trigger IPE-CDR charging information addition for the "List of Traffic Data Volumes" attribute.

Table D.3.2.3.1.1.1: Triggers for IPE-CDR charging information addition for List of Traffic Volumes

Trigger Conditions	Description/Behaviour
End of QoS in IP-Edge	The end of a QoS enforced in IP-Edge shall result in open "List of Traffic Data Volumes" containers for the QoS are closed and added to the CDR.
Tariff Time Change	On reaching the Tariff Time Change open "List of Traffic Data Volumes" containers shall be closed and added to the CDR.
Traffic volume report	A "List of Traffic Data Volumes" container for a QoS shall be added when: <ul style="list-style-type: none"> - expiry of time limit per QoS; - expiry of data volume limit per QoS.
CDR Closure	Open "List of Traffic Data Volumes" containers shall be closed and added to the IPE-CDR.

When Charging Event (ACR) is triggered by table D.3.2.3.1.1.1 conditions, the Change-Condition sub-field associated to the added container, indicating the appropriate condition, shall be present, excluding CDR Closure case.

When Charging Event (ACR) is triggered by CDR Closure condition, this Change-Condition sub-field associated to the added container shall be omitted, except when CDR closure is due to "maximum number of charging condition changes", where it shall be present with the original condition change.

D.3.2.3.1.2 IPE-CDR closure

CDR closure shall be based on charging event closure received from the IP-Edge [PCEF] as specified in clause D.3.2.2.1.2.

D.3.2.4 Ga record transfer flows

Ga protocol applies between the Charging Data Function (CDF) and the Charging Gateway Function (CGF).

For further details on the Ga protocol application refer to TS 32.295 [54].

Ga is not used from the IP-Edge [PCEF].

D.3.2.5 Bp CDR file transfer

The CGF transfers CDR files to the BD as specified for PCN Nodes in clause 5.2.6.

Bp is not used from the IP-Edge [PCEF].

D.3.3 PS domain online charging scenarios

D.3.3.1 Basic principles

D.3.3.1.0 Introduction

The Chargeable events and messages contents applicable to the IP-Edge [PCEF] and to the TDF are specified under the sub-clauses below.

D.3.3.1.1 IP-CAN session charging

IP-CAN session online charging is achieved by associating a vendor specific rating group or combination of rating group and service id with the IP-CAN session, such that the quota handling for the IP-CAN session shall be based on.

The amount of data counted with IP-CAN session vendor specific rating group or combination of rating group and service id shall be the user plane payload. Time metering is started when IP-CAN session is activated.

Either IP-CAN session charging or FBC but not both may be active at the same time, as determined by Charging Characteristics.

D.3.3.1.2 Flow Based bearer Charging

FBC functionality defined in clause 5.3.1.2 shall apply when provided by the PCEF located in the IP-Edge, with specificities described below:

- Relates to Fixed user traffic and 3GPP UE NSWO traffic.
- It is applicable within the context of an IP-CAN session.

The chargeable events defined in clause 5.3.1.2, when online charging is activated, apply with the difference that P-GW is replaced by IP-Edge [PCEF], and IP-CAN bearer is replaced by IP-CAN session.

Change of charging condition is modified to remove conditions related to user location change, user CSG information change, and change of UE presence in Presence Reporting Area(s). The following are the resulting applicable events:

- Change of charging condition: QoS change. When this event is encountered and the corresponding re-authorization trigger is armed, all current counts applicable to the QoS level are captured and sent towards the OCS with a Debit / Reserve Units Request[Update].

Following is not applicable:

- Network request for IP-CAN bearer activation.

The detailed PCEF behaviour associated to these chargeable events above, are detailed below.

When applicable to the IP-Edge [PCEF], charging information included in the PCC Rule is specified in TS 23.203 [215] Annex S.

D.3.3.1.3 TDF/Application Based Charging

TDF session and ABC functionality defined in clause 5.3.1.5 shall apply when provided by the TDF, with specificities described below:

- Relates to Fixed user traffic and 3GPP UE NSWO traffic.

The chargeable events defined in clause 5.3.1.5, when online charging is activated, apply with the difference that the following chargeable events are not applicable:

- Change of charging condition: e.g. user location change, user CSG information change.

The detailed TDF behaviour associated to these chargeable events above, is detailed below.

D.3.3.2 Ro message flows

D.3.3.2.0 Introduction

Charging information transfer towards the OCS as defined in clause 5.3.2 shall apply to the TDF and to the PCEF located in the IP-Edge, with the differences that P-GW is replaced by IP-Edge [PCEF], IP-CAN bearer is replaced by IP-CAN session, PGW-CDR is replaced by IPE-CDR and Network requested IP-CAN bearer activation is not applicable.

D.3.3.2.1 Triggers for online charging

Triggers for FBC as defined in clause 5.3.2.2 shall apply to the PCEF located in the IP-Edge, with the difference that P-GW is replaced by IP-Edge [PCEF], IP-CAN bearer is replaced by IP-CAN session, and APN is not applicable. The "Change of UE presence in Presence Reporting Area" change of charging condition is not applicable.

Triggers for ABC online charging as defined in clause 5.3.2.2A shall apply to the TDF.

D.3.3.2.1.1 Triggers for starting and stopping a Credit-Control session

The same triggers as defined in clause 5.3.2.2.1 shall apply to the PCEF located in the IP-Edge, with the differences that P-GW is replaced by IP-Edge [PCEF], IP-CAN bearer is replaced by IP-CAN session, and Network requested IP-CAN bearer activation is not applicable.

The same triggers as defined in clause 5.3.2.2A.1 shall apply to the TDF.

D.3.3.2.1.2 Triggers for providing interim information for a Credit-Control session

The same triggers as defined in clause 5.3.2.2.2 shall apply to the PCEF located in the IP-Edge, with the differences that P-GW is replaced by IP-Edge [PCEF], IP-CAN bearer is replaced by IP-CAN session, and Network requested IP-CAN bearer activation is not applicable.

The same triggers as defined in clause 5.3.2.2A.2 shall apply to the TDF.

D.3.3.2.2 PS Furnish Charging Information procedure

The same PS Furnish Charging Information procedure as defined in clause 5.3.1.3 shall apply to the PCEF located in the IP-Edge and to the TDF, with the differences that P-GW is replaced by IP-Edge [PCEF], IP-CAN bearer is replaced by IP-CAN session, and PGW-CDR is replaced by IPE-CDR.

D.3.3.2.3 Support of Failure Situations

Support of Failure Situations as defined in clause 5.3.1.4 shall apply to the PCEF located in the IP-Edge and to the TDF, with the differences that P-GW is replaced by IP-Edge [PCEF], IP-CAN bearer is replaced by IP-CAN session, and PGW-CDR is replaced by IPE-CDR.

D.4 Definition of charging information

D.4.1 Data description for PS offline charging

D.4.1.1 Rf message contents

The Offline Charging message as described in clause 6.1A shall apply to the TDF and the PCEF located in the IP-Edge, with the differences that P-GW is replaced by IP-Edge [PCEF], and table 6.1A.2.1.1 Service-Information is described in D.4.3.

D.4.1.2 CDR description on the Bp interface

D.4.1.2.1 FBC IP-CAN session charging data in IP-Edge [PCEF] (IPE-CDR)

If the collection of CDR data is enabled then the IP-Edge [PCEF] data specified in table D.4.1.2.1.1 shall be available for each IP-CAN session.

Table D.4.1.2.1.1: IP-Edge [PCEF] IP-CAN session data (IPE-CDR)

Field	Category	Description
Record Type	M	IP-Edge [PCEF] IP-CAN session record.
Node ID	O _M	Name of the IP-Edge [PCEF].
Retransmission	O _C	This parameter, when present, indicates that information from retransmitted Charging Data Request has been used in this CDR.
Served IMSI	C	This field holds the IMSI of the served party, if available.
Served MN NAI	O _C	Mobile Node Identifier in NAI format (based on IMSI), if available.
Served MSISDN	O _C	This field holds the MSISDN of the served party, if available.
Served IMEI	O _C	The IMEI or IMEISV of the UE, if available.
Served Fixed Subscriber Id	C	This field holds the identity of the Fixed Device or the RG, as defined in Broadband Forum TR 134 [601].
Access Line Identifier	O _M	This field holds the Access line id (physical and logical circuit ID) serving the 3GPP UE or fixed device, behind the RG (when in bridge mode or in routed mode without NAT), or Access line Id of the RG when in routed mode with NAT.
Fixed User Location Information	O _C	This field contains the UE location in a fixed broadband access network. The location of the subscriber may include Access line id (physical and logical circuit ID), SSID of the Access Point, BSSID of the Access Point, defined in Annex S of TS 23.203 [215].
IP-Edge Address used	M	The control plane IP address of the IP-Edge used.
IP-Edge Address IPv6	O _C	The control plane IPv6 address, in case of IPv4v6 dual stack, of the IP-Edge used.
Charging ID	M	IP-CAN session Charging identifier used to identify this IP-CAN session in different records created for IP-Edge [PCEF].
IP-Edge Operator Identifier	O _C	This field holds the PLMN identifier (MCC MNC) of the Convergent Fixed-Mobile Operator.
Access Point Name Network Identifier	O _M	This field holds the logical name of the connected access point to the external packet data network (network identifier part of APN) reflecting the "NSWO APN", when the served user is a 3GPP UE.
IP-CAN session Type	O _M	IPCAN session type, i.e. IPv4, IPv6, IPv4v6 , or PDN type PPP.
Served IP-CAN session Address	O _C	IP address allocated for the IPCAN session, i.e. IPv4 address when IPCAN session is IPv4 or IPv6 prefix when IP-CAN session is IPv6 or IPv4v6.
Served IP-CAN session Address extension	O _C	This field holds IPv4 address of the served subscriber, if available, when IP-CAN session type is IPv4v6.
Dynamic Address Flag	O _C	Indicates whether served IP-CAN session address is dynamic, which is allocated during IP-CAN session activation. This field is missing if IPv4 address is static when IP-CAN session Type is IPv4, or if IPv6 address is static when IP-CAN session Type is IPv6 or IPv4v6.
Dynamic Address Flag extension	O _C	Indicates whether served IPv4 IP-CAN session address is dynamic, which is allocated during IP-CAN session activation, with IP-CAN session type IPv4v6. This field is missing if IPv4 address is static.

Field	Category	Description
List of Traffic Data Volumes	O _C	A list of changes in charging conditions within the IP-CAN session. Each change is time stamped. Charging conditions are used to categorize traffic volumes, such as per tariff period. This field includes the QoS parameters identifying the QoS applied to traffic volumes.
List of Service Data	O _M	A list of changes in charging conditions for all service data flows within this IP-CAN session categorized per rating group or per combination of the rating group and service id or per combination of rating group, sponsor identity and application service provider identity. Each change is time stamped. Charging conditions are used to categorize traffic volumes, elapsed time and number of events, such as per tariff period. Initial and subsequently changed QoS and corresponding data values are also listed. Online charging information (PS Furnish Charging Information) may be added per each service data flow container in case it is sent by the OCS. Failure-Handling: This field shall be present in case IP-Edge [PCEF] triggers the Failure-Handling procedure. It shall indicate the Failure Handling scenario and the instant the Failure Action is triggered (see annex B). Scenarios: Continue/New Session; Continue/Ongoing Session; Retry&Terminate/Ongoing Session; Terminate/Ongoing Session.
Charging Characteristics	M	The Charging Characteristics applied to the IP-CAN session.
Charging Characteristics Selection Mode	O _M	Holds information about how Charging Characteristics were selected.
PS Furnish Charging Information	O _C	Online charging session specific information
Record Opening Time	M	Time stamp when IP-CAN session is activated in this IP-Edge [PCEF] or record opening time on subsequent partial records.
Duration	M	Duration of this record in the recording entity.
Start Time	O _C	This field holds the time when User IP-CAN session starts,
Stop Time	O _C	This field holds the time when User IP-CAN session is terminated.
Cause for Record Closing	M	The reason for the release of record from this IP-Edge [PCEF].
Diagnostics	O _M	A more detailed reason for the release of the connection.
Record Sequence Number	C	Partial record sequence number, only present in case of partial records.
Local Record Sequence Number	O _M	Consecutive record number created by the CDF, The number is unique within the CDF and allocated sequentially for each partial CDR (or whole CDR) including all CDR types.
Record Extensions	OC	A set of network operator/manufacturer specific extensions to the record. Conditioned upon the existence of an extension.

D.4.1.2.2 Application Based Charging data in TDF (TDF-CDR)

Clause 6.1.14 shall apply, with the following two differences.

The following fields are not applicable:

Table D.4.1.2.2.1: Fields of TDF-CDR not applicable

Served 3GPP2 MEID
Served MN NAI
Serving node Address
Serving node IPv6 Address
Serving node Type
MS Time Zone
APN Selection Mode
Served MSISDN
User Location Information
User CSG information
3GPP2 User Location information
TWAN User Location Information
Serving node PLMN Identifier
RAT Type

The following field also exists, in addition:

Table D.4.1.2.2.2: TDF-CDR additional field

Field	Category	Description
Access Line Identifier	O _C	This field holds the Access line id (physical and logical circuit ID) serving the 3GPP UE or fixed device, behind the RG (when in bridge mode or in routed mode without NAT), or Access line Id of the RG when in routed mode with NAT.
Served Fixed Subscriber Id	C	This field holds the identity of the Fixed Device or the RG, as defined in Broadband Forum TR 134 [601].
Fixed User Location Information	O _C	This field contains the UE location in a fixed broadband access network. The location of the subscriber may include Access line id (physical and logical circuit ID), SSID of the Access Point, BSSID of the Access Point, defined in Annex S of TS 23.203 [215].

D.4.2 Data description for PS online charging

D.4.2.1 Ro message contents

The Online Charging message as described in clause 6.2.1 shall apply to the TDF and PCEF located in the IP-Edge, with the differences that P-GW is replaced by IP-Edge [PCEF], and in table 6.2.1.2.1.1:

- Subscription-Id holds the subscribed Identification for 3GPP UE, or Subscriber ID as defined in Broadband Forum TR 134 [601] for Fixed Device.
- Service Information is described in D.4.3.

D.4.3 PS Charging specific parameters

D.4.3.1 Definition of PS charging information

The Information used for PS charging for the TDF and the IP-Edge [PCEF] is provided in the Service Information parameter, as defined in clause 6.3.1.1, with the following difference:

- Subscription-Id holds the subscribed Identification for 3GPP UE, or Subscriber ID as defined in Broadband Forum TR 134 [601] for Fixed Device.
- PS information as defined in clause 6.3.1.2 shall be applicable to the TDF and the IP-Edge [PCEF], with differences that P-GW is replaced by IP-Edge [PCEF], IP-CAN bearer and PDN Connection are replaced by IP-CAN session, and also that the following fields are not applicable:

Table D.4.3.1.1: Fields of PS Information not applicable

Information Element
PDN Connection Charging Id
Serving Node Address
Serving Node Type
SGW Change
SGW Address
ePDG Address
MME Number for MT SMS
MME Name
MME Realm
NSAPI
Selection Mode
Serving Node MCC MNC
MS Time Zone
User Location Info
User CSG Information
3GPP2 User Location Info
TWAN User Location Information
Presence Reporting Area Information
RAT Type
PDP Context Type
Terminal Information
Low Priority Indicator

The following field exists in addition:

Table D.4.3.1.2: PS Information additional field

Information Element	Category	Description
Access Line Identifier	O _C	This IE holds the Access line id (physical and logical circuit ID) serving the 3GPP UE or fixed device, behind the RG (when in bridge mode or in routed mode without NAT), or Access line Id of the RG when in routed mode with NAT.
<i>Fixed User Location Information</i>	O _C	This IE contains the UE location in a fixed broadband access network. The location of the subscriber may include Access line id (physical and logical circuit ID), SSID of the Access Point, BSSID of the Access Point, defined in Annex S of TS 23.203 [215].

D.4.3.2 Detailed message format for offline charging

The supported fields in table 6.3.2.1 for the PS offline charging message shall apply to the TDF and the IP-Edge [PCEF] for the applicable fields, with the difference that P-GW is replaced by IP-Edge [PCEF], and the table is extended with additional table D.4.3.2.1 fields:

Table D.4.3.2.1: Additional supported fields in Charging Data Request message

Information Element	Node Type	IP-Edge[PCEF]
	Supported Operation Types	S/I/S/E
Service Information with PS Information		
<i>Access Line Identifier</i>		SIS-
<i>Fixed User Location Information</i>		SIS-

D.4.3.3 Detailed message format for online charging

The supported fields in table 6.3.3.1 for the PS online charging message shall apply to the TDF and the IP-Edge [PCEF] for the applicable fields, with the difference that P-GW is replaced by IP-Edge [PCEF], and the table is extended with additional table D.4.3.3.1 fields:

Table D.4.3.3.1: Additional supported fields in Debit / Reserve Units Request message

Information Element	Node Type	IP-Edge[PCEF]
	Supported Operation Types	I/U/T/E
Service Information with PS Information		
<i>Access Line Identifier</i>		IUT-
<i>Fixed User Location Information</i>		IUT-

D.4.4 Bindings for offline charging

The mapping of the Information Element, AVP and the CDR parameter for offline charging as specified in clause 6.5 shall apply to IPE-CDR/TDF-CDR parameters for applicable fields, and in addition:

Table D.4.4.1: Additional bindings of CDR parameter, Information Element and AVP

CDR Parameter	Information Element	AVP
	PS Information	PS-Information
Access Line Identifier	Access Line Identifier	Logical-Access-ID, Physical-Access-ID
Fixed User Location Information	Fixed User Location Information	Fixed-User-Location-Info
IP-CAN session Type	IP-CAN session Type	3GPP-PDP-Type
IP-Edge Operator Identifier	IP-Edge MCC MNC	3GPP-GGSN-MCC-MNC
IP-Edge Address used	IP-Edge Address	GGSN-Address
IP-Edge Address IPv6	IP-Edge Address	GGSN-Address
Served Fixed Subscriber Id	Subscriber Identifier	Subscription-Id
Served IP-CAN session Address	IP-CAN session Address	PDP-Address
Served IP-CAN session Address extension	IP-CAN session Address	PDP-Address

D.5 Charging Characteristics

The Charging Characteristics as specified in annex A.1 shall apply to the IP-Edge [PCEF] and TDF with the following modification:

- Only configured Charging Characteristics are applicable to IP-Edge [PCEF] and TDF
- When a CGF address is included, the IP-Edge [PCEF] shall apply it for the IPE-CDRs
- A set of trigger associated to IPE-CDR may be: activate/deactivate CDRs, time limit, volume limit, maximum number of charging conditions, tariff times, and an example is provided by Table A.1.3 with P-GW replaced by IP-Edge [PCEF].
- Charging Characteristics behaviour in IP-Edge [PCEF] is used for IPE-CDR generation and for online charging
- Default charging method negotiation between the PGW and the PCRF shall apply with P-GW replaced by IP-Edge [PCEF] and IP-CAN bearer replaced by IP-CAN session.
 - The following may be selected by the IP-Edge [PCEF] or TDF for charging behaviour, as appropriate:-
 - The Home behaviour, for 3GPP UE belonging to same PLMN as the IP-Edge [PCEF] or TDF respectively.
 - The Visiting behaviour, for 3GPP UE belonging to a different PLMN than the IP-Edge [PCEF] or TDF respectively.
 - The Fixed behaviour for Fixed users.

Annex E (Informative): Inter-PLMN dedicated profile

E.1 General

This annex provides a profile description for PS domain online charging in a roaming context, targeting IOT simplification between Operators, while allowing accurate charging models for data usage. GSMA defined RCS services, Video over LTE, some Internet's application (e.g. Peer to Peer etc.) requiring online charging control of data usage in roaming are examples of the use cases for deployment of such dedicated profile.

This profile relies on a sub-set of capabilities amongst all those defined within this specification for PS domain online charging. Information to be exchanged over Gy and over Gyn is provided as a sub-set of the full message content.

A dedicate profile is designed for each of the following reference points:

- Gy between OCS residing in HPLMN and PCEF located in PGW VPLMN, as per Evolved 3GPP Packet Switched Domain Roaming Architecture for local breakout defined in TS 23.401 [208].
- Gy between OCS residing in HPLMN and PCEF located in IP-Edge fixed broadband access owned by a Convergent fixed-mobile VPLMN, for Non Seamless WLAN Offload (NSWO) 3GPP UEs traffic defined by annex S of TS 23.203 [215].
- Gyn between OCS residing in HPLMN and TDF located in VPLMN for Local Breakout Roaming, as per "Overall PCC architecture for roaming with PCEF in visited network (local breakout)" defined in TS 23.203[72].
- Gyn between OCS residing in HPLMN and TDF owned by a Convergent fixed-mobile VPLMN, for Non Seamless WLAN Offload (NSWO) 3GPP UEs traffic defined by annex S of TS 23.203 [215].

E.2 Principles

The following principles apply:

- Session charging with Unit Reservation (SCUR) with Centralized Unit Determination and Centralized Rating.
- Categorization of service data flows and of detected applications traffic is achieved by rating groups only.

E.3 Message content

E.3.1 General

This clause describes the messages content applicable for PS domain inter-PLMN online charging, based on the messages content specified in this document and in TS 32.299 [50].

Information Elements are provided with explicit description when specific, and indicated as grey with "Not part of inter-PLMN" to reflect the Information Element is not part of the dedicated profile.

Information Elements indicated as grey with "Not used in 3GPP", or "Not used Debit / Reserve Units Request message" or "Not used Debit / Reserve Units Answer message" are not part of the message content from the original definition.

E.3.2 Debit / Reserve Units messages

The Debit / Reserve Units Request message basic structure in table 6.2.1.2.1.1 with the detailed description for Multiple Unit Operation provided by the table E.3.1 is applicable to inter-PLMN.

Table E.3.1: Structure of the Multiple Unit Operation in message request for inter-PLMN

Information Element	Category	Description
Multiple Unit Operation	O _c	As specified in TS 32.299 [50].
Granted Service Unit	-	Not used in Debit / Reserve Units Request message.
Requested Service Unit	O _c	Sent as empty.
CC Time	-	Not part of inter-PLMN profile.
CC Money	-	Not used in 3GPP.
CC Total Octets	-	Not part of inter-PLMN profile.
CC Input Octets	-	Not part of inter-PLMN profile.
CC Output Octets	-	Not part of inter-PLMN profile.
CC Service Specific Units	-	Not part of inter-PLMN profile.
AVP	-	Not used in 3GPP.
Used Service Unit	O _c	As specified in TS 32.299 [50].
Reporting Reason	O _c	As specified in TS 32.299 [50].
Tariff Change Usage	-	Not part of inter-PLMN profile.
CC Time	O _c	As specified in TS 32.299 [50].
CC Money	-	Not used in 3GPP.
CC Total Octets	O _c	As specified in TS 32.299 [50].
CC Input Octets	O _c	As specified in TS 32.299 [50].
CC Output Octets	O _c	As specified in TS 32.299 [50].
CC Service Specific Units	-	Not part of inter-PLMN profile.
Event Charging TimeStamp	-	Not part of inter-PLMN profile.
AVP	-	Not used in 3GPP.
Tariff Change Usage	-	Not used in 3GPP.
Service Identifier	-	Not part of inter-PLMN profile.
Rating Group	O _c	As specified in TS 32.299 [50].
G-S-U Pool Reference	-	Not used in Debit / Reserve Units Request message.
Validity Time	-	Not used in Debit / Reserve Units Request message.
Operation Result	-	Not used in Debit / Reserve Units Request message.
Final Unit Indication	-	Not used in Debit / Reserve Units Request message.
Time Quota Threshold	-	Not used in Debit / Reserve Units Request message.
Volume Quota Threshold	-	Not used in Debit / Reserve Units Request message.
Unit Quota Threshold	-	Not used in Debit / Reserve Units Request message.
Quota Holding Time	-	Not used in Debit / Reserve Units Request message.
Quota Consumption Time	-	Not used in Debit / Reserve Units Request message.
Reporting Reason	O _c	As specified in TS 32.299 [50].
Trigger	O _c	As specified in TS 32.299 [50].
PS-Furnish-Charging-Information	-	Not used in Debit / Reserve Units Request message.
Refund Information	-	Not part of inter-PLMN profile.
AF Correlation Information	O _c	As specified in TS 32.299 [50].
Envelope	-	Not part of inter-PLMN profile.
Envelope Reporting	-	Not part of inter-PLMN profile.
Time Quota Mechanism	-	Not part of inter-PLMN profile.
Service Specific Info	-	Not part of inter-PLMN profile.
QoS-Information	O _c	As specified in TS 32.299 [50].

The Debit / Reserve Units Response message basic structure in table E.3.2 (as replacement of table 6.2.1.2.2.1) with the detailed description for Multiple Unit Operation provided by the table E.3.3 is applicable to inter-PLMN.

Table E.3.2: Debit / Reserve Units Response message content for inter-PLMN

Information Element	Category	Description
Session Identifier	M	Described in 32.299 [50]
Operation Result	M	Described in 32.299 [50]
Originator Host	M	Described in 32.299 [50]
Originator Domain	M	Described in 32.299 [50]
Operation Identifier	M	Described in 32.299 [50]
Operation Type	M	Described in 32.299 [50]
Operation Number	M	Described in 32.299 [50]
Operation Failover	O _c	Described in 32.299 [50]
Multiple Unit Operation	O _c	Described in 32.299 [50]
Operation Failure Action	O _c	Described in 32.299 [50]

Information Element	Category	Description
Operation Event Failure Action	-	Not part of inter-PLMN profile.
Redirection Host	O _c	Described in 32.299 [50]
Redirection Host Usage	O _c	Described in 32.299 [50]
Route Information	O _c	Described in 32.299 [50]
Failed parameter	O _c	Described in 32.299 [50]
Service Information	O _M	Described in 32.299 [50]

Table E.3.3: Structure of the Multiple Unit Operation in message response for inter-PLMN

Information Element	Category	Description
Multiple Unit Operation	O _c	As specified in TS 32.299 [50].
Granted Service Unit	O _c	As specified in TS 32.299 [50].
Tariff Time Change	-	Not part of inter-PLMN profile.
CC Time	O _c	As specified in TS 32.299 [50].
CC Money	-	Not used in 3GPP.
CC Total Octets	O _c	As specified in TS 32.299 [50].
CC Input Octets	O _c	As specified in TS 32.299 [50].
CC Output Octets	O _c	As specified in TS 32.299 [50].
CC Service Specific Units	-	Not part of inter-PLMN profile.
AVP	-	Not used in 3GPP.
Requested Service Unit	-	Not used in Debit / Reserve Units Answer message.
Used Service Unit	-	Not used in Debit / Reserve Units Answer message.
Tariff Change Usage	-	Not used in 3GPP.
Service Identifier	-	Not part of inter-PLMN profile.
Rating Group	O _c	As specified in TS 32.299 [50].
G-S-U Pool Reference	-	Not part of inter-PLMN profile.
Validity Time	O _c	As specified in TS 32.299 [50].
Operation Result	O _c	As specified in TS 32.299 [50].
Final Unit Indication	O _c	As specified in TS 32.299 [50].
Final Unit Action	M	As specified in TS 32.299 [50].
Restriction Filter Rule	-	Not part of inter-PLMN profile.
Filter Id	-	Not part of inter-PLMN profile.
Redirect Server	O _c	As specified in TS 32.299 [50].
Redirect Address Type	M	As specified in TS 32.299 [50].
Redirect Server Address	M	As specified in TS 32.299 [50].
Time Quota Threshold	O _c	As specified in TS 32.299 [50].
Volume Quota Threshold	O _c	As specified in TS 32.299 [50].
Unit Quota Threshold	-	Not part of inter-PLMN profile.
Quota Holding Time	O _c	As specified in TS 32.299 [50].
Quota Consumption Time	O _c	As specified in TS 32.299 [50].
Reporting Reason	-	Not used in Debit / Reserve Units Answer message.
Trigger	O _c	As specified in TS 32.299 [50].
Trigger Type	O _c	As specified in TS 32.299 [50].
PS Furnish Charging Information	-	Not part of inter-PLMN profile.
Refund Information	-	Not part of inter-PLMN profile.
AF Correlation Information	-	Not used in Debit / Reserve Units Answer message.
Envelope Reporting	-	Not part of inter-PLMN profile.
Time Quota Mechanism	-	Not part of inter-PLMN profile.
Service Specific Info	-	Not used in Debit / Reserve Units Answer message.
Qos Information	-	Not used in Debit / Reserve Units Answer message.
AVP	-	Not used in 3GPP.

E.3.3 Re-authorization triggers

The applicable triggers for quota re-authorization to be requested from the PGW /TDF are:

- "Ro specific chargeable event" triggers occurring with reporting-reason: THRESHOLD, QHT, FINAL, QUOTA_EXHAUSTED, VALIDITY_TIME, FORCED_REAUTHORISATION.

- Specific trigger types occurring with reporting-reason RATING_CONDITION_CHANGE: CHANGE_IN_QOS, CHANGE_IN_RAT, CHANGE_IN_SERVICE_CONDITION.

E.3.4 Service information used for PS charging

The components in the Service Information in table 6.3.1.1.1 with PS information provided in table E.3.4.1 are applicable to inter-PLMN.

Table E.3.4.1: Structure of the PS Information for inter-PLMN

Information Element	Category	Description
Charging Id	O _C	As specified in table 6.3.1.2.1
Node Id	-	Not part of inter-PLMN profile.
PDN Connection Charging Id	O _C	As specified in table 6.3.1.2.1
PDP/PDN Type	O _C	As specified in table 6.3.1.2.1
PDP/PDN Address	O _C	As specified in table 6.3.1.2.1
PDP/PDN Address prefix length	O _C	As specified in table 6.3.1.2.1
Dynamic Address Flag	-	Not part of inter-PLMN profile.
Dynamic Address Flag Extension	-	Not part of inter-PLMN profile.
Negotiated QoS Profile	O _C	As specified in table 6.3.1.2.1
Serving Node Address	-	Not part of inter-PLMN profile.
Serving Node Type	-	Not part of inter-PLMN profile.
SGW Change	-	Not part of Debit / Reserve Units Messages.
PGW Address	O _C	As specified in table 6.3.1.2.1
TDF Address	-	As specified in table 6.3.1.2.1. Applicable only in case of TDF linter-PLMN application based charging.
SGW Address	-	Not part of Debit / Reserve Units Messages.
ePDG Address	-	Not part of Debit / Reserve Units Messages.
MME Number for MT SMS	-	Not part of Debit / Reserve Units Messages.
MME Name	-	Not part of Debit / Reserve Units Messages.
MME Realm	-	Not part of Debit / Reserve Units Messages.
CG Address	-	Not part of inter-PLMN profile.
IMSI MCC MNC	O _C	As specified in table 6.3.1.2.1
IMSI Unauthenticated Flag	-	Not part of inter-PLMN profile.
PGW MCC MNC	O _C	As specified in table 6.3.1.2.1
TDF MCC MNC	-	As specified in table 6.3.1.2.1. Applicable only in case of TDF Inter-PLMN application based charging.
NSAPI	-	Not part of inter-PLMN profile.
Called Station Id	O _C	As specified in table 6.3.1.2.1
Session Stop Indicator	O _C	As specified in table 6.3.1.2.1
Selection Mode	O _C	As specified in table 6.3.1.2.1
Charging Characteristics	-	Not part of inter-PLMN profile.
Charging Characteristics Selection Mode	-	Not part of inter-PLMN profile.
Serving Node MCC MNC	-	Not part of inter-PLMN profile.
CN Operator Selection Entity	-	Not part of inter-PLMN profile.
MS Time Zone	O _C	As specified in table 6.3.1.2.1
Charging Rule Base Name	-	Not part of inter-PLMN profile.
ADC Rule Base Name	-	Not part of Debit / Reserve Units Messages.
User Location Info	O _C	As specified in table 6.3.1.2.1
User Location Info Time	-	Not part of inter-PLMN profile.
User CSG Information	-	Not part of inter-PLMN profile.
3GPP2 User Location Info	-	Not part of inter-PLMN profile.
TWAN User Location Information	-	Not part of inter-PLMN profile.
Presence Reporting Area Information	-	Not part of inter-PLMN profile.
RAT Type	O _C	As specified in table 6.3.1.2.1
Furnish Charging Information	-	Not part of Debit / Reserve Units Messages.
Offline Charging	-	Not part of inter-PLMN profile.
PDP Context Type	-	Not part of inter-PLMN profile.
Traffic data volumes	-	Not part of Debit / Reserve Units Messages.

Service data container	-	Not part of Debit / Reserve Units Messages.
User Equipment Info	-	Not part of Debit / Reserve Units Messages.
Terminal Information	-	Not part of Debit / Reserve Units Messages.
Start Time	-	Not part of Debit / Reserve Units Messages.
Stop Time	-	Not part of Debit / Reserve Units Messages.
Change Condition	-	Not part of Debit / Reserve Units Messages.
Diagnostics	-	Not part of inter-PLMN profile.
Low Priority Indicator	-	Not part of Debit / Reserve Units Messages.

E.4 Fixed broadband access

PS domain online charging performed from a HPLMN OCS for 3GPP UE non-seamless WLAN offload traffic, when served by an IP-Edge [PCEF] or by a TDF owned by a Convergent fixed-mobile VPLMN, can also use a dedicated profile for interoperability simplification.

The dedicated profile to be used in this scenario is the same as the dedicated profile defined by clauses E.2, and E.3 with following differences:

- P-GW is replaced by IP-Edge [PCEF]
- Clause E.3.3 re-authorization specific trigger type CHANGE_IN_RAT is not applicable.
- Table E.3.4.1: MS Time Zone, User Location Info and RAT Type are not applicable.
- Below table E.4.1 applies in addition:

Table E.4.1: PS Information additional field for inter-PLMN

Information Element	Category	Description
Access Line Identifier	O _C	As specified in table D.4.3.1.2
Fixed User Location Information	O _C	As specified in table D.4.3.1.2

Annex F (informative): Change history

Change history									
Date	TSG #	TSG Doc.	CR	Rev	Subject/Comment	Cat	Old	New	Work Item
Sep 2007	SP-37	SP-070619	0061	--	Add service specific charging information for extended packet inspection - Align with 23.203	C	7.5.0	8.0.0	
Oct 2007	--	--	--	--	Correction of typo on previous line of history table	--	8.0.0	8.0.1	
Mar 2008	SP-39	SP-080060	0062	--	Align with the Rel-8 EPC architecture - Align with stage 2 in 23.401/23.402	B	8.0.1	8.1.0	EPC-CH
Mar 2008	SP-39	SP-080060	0063	--	Enhance the PS architecture to correspond with the Rel-8 EPC architecture - Align with stage 2 in 23.401/23.402	B	8.0.1	8.1.0	EPC-CH
Jun 2008	SP-40	SP-080274	0064	--	Impact on Charging trigger for EPC Charging	B	8.1.0	8.2.0	EPC-CH
Sep 2008	SP-41	SP-080462	0065	--	Alignment on Bx interface	D	8.2.0	8.3.0	EPC-CH
Sep 2008	SP-41	SP-080462	0066	--	Impact on Charging trigger for EPC Charging	B	8.2.0	8.3.0	EPC-CH
Dec 2008	SP-42	SP-080852	0069	-	Correction on CDR generation for EPC Charging	F	8.3.0	8.4.0	EPC-CH
Dec 2008	SP-42	SP-080852	0070	-	EPC Offline Charging architecture - Alignment with TS 23.060	B	8.3.0	8.4.0	EPC-CH
Dec 2008	SP-42	SP-080852	0071	-	Clarification on Charging Characteristics for EPC Charging	B	8.3.0	8.4.0	EPC-CH
Dec 2008	SP-42	SP-080852	0074	-	TS 32.251 small refinements on PS Online Charging parameters for non-3GPP access consideration.	B	8.3.0	8.4.0	EPC-CH
Dec 2008	SP-42	SP-080852	0076	-	TS 32.251 PS offline charging - basic principles description enhanced for Rf consideration	B	8.3.0	8.4.0	EPC-CH
Dec 2008	SP-42	SP-080852	0077	-	TS 32.251 PS offline charging- Rf message flows description for S-GW and P-GW	B	8.3.0	8.4.0	EPC-CH
Dec 2008	SP-42	SP-080852	0078	-	Enhancement of Offline Charging Architecture for EPC Charging	B	8.3.0	8.4.0	EPC-CH
Dec 2008	SP-42	SP-080852	0079	-	Correction on CDR data tables for EPC Charging	C	8.3.0	8.4.0	EPC-CH
Dec 2008	SP-42	SP-080852	0081	-	TS 32.251 PS offline charging - data description for Rf messages content	B	8.3.0	8.4.0	EPC-CH
Dec 2008	SP-42	SP-080852	0082	-	TS 32.251 PS offline charging - PS information description extension for EPC offline charging	B	8.3.0	8.4.0	EPC-CH
Dec 2008	SP-42	SP-080852	0083	-	Addition of Rf interface on S-GW and P-GW	B	8.3.0	8.4.0	EPC-CH
Dec 2008	SP-42	SP-080852	0084	-	Addition of non-3GPP access information for EPC Online Charging	C	8.3.0	8.4.0	EPC-CH
Dec 2008	SP-42	SP-080841	0073	-	Correction on Multiple Service Indicator category	A	8.3.0	8.4.0	CH7
Dec 2008	SP-42	SP-080706	0080	-	Add Serving Node Type to PS domain charging	B	8.3.0	8.4.0	CH8
Mar 2009	SP-43	SP-090206	0086	-	PS offline charging - Rf description refinements for EPC offline charging	B	8.4.0	8.5.0	EPC-CH
Mar 2009	SP-43	SP-090206	0087	-	PS offline charging - Refinements on PGW CDR content description and PS-information description	B	8.4.0	8.5.0	EPC-CH
Mar 2009	SP-43	SP-090206	0088	-	Clarifications on EPC charging	C	8.4.0	8.5.0	EPC-CH
Mar 2009	SP-43	SP-090206	0089	-	User Location description enhancement for complying to EPC context	B	8.4.0	8.5.0	EPC-CH
Mar 2009	SP-43	SP-090206	0090	-	Correction of QoS handling in EPC Charging	B	8.4.0	8.5.0	EPC-CH
Mar 2009	SP-43	SP-090206	0091	-	Refinements on SGW CDR content description	C	8.4.0	8.5.0	EPC-CH
Mar 2009	SP-43	SP-090206	0092	-	Subscription identifier added in "service information" description for EPS offline charging	B	8.4.0	8.5.0	EPC-CH
Mar 2009	SP-43	SP-090206	0093	-	Node-Functionality use for Rf in EPC charging	B	8.4.0	8.5.0	EPC-CH
Mar 2009	SP-43	SP-090206	0094	-	Non-3GPP access "CDMA2000 HRPD access" information in EPC charging	B	8.4.0	8.5.0	EPC-CH
Mar 2009	SP-43	SP-090206	0095	-	Mapping ACR to CDR in EPC charging	B	8.4.0	8.5.0	EPC-CH
Mar 2009	SP-43	SP-090206	0096	-	Missing information in PS information for SGW/PGW CDRs in EPS offline charging	B	8.4.0	8.5.0	EPC-CH
Mar 2009	SP-43	SP-090206	0097	-	Add new chargeable events to IP-CAN bearer charging	B	8.4.0	8.5.0	EPC-CH
Mar 2009	SP-43	SP-090206	0098	-	SGW CDR and PGW CDR fields description refinement for fields applicable to GPRS only	B	8.4.0	8.5.0	EPC-CH
Jun 2009	SP-44	SP-090432	0099	-	Correction on Serving Node Address	F	8.5.0	8.6.0	CH8
Jun 2009	SP-44	SP-090432	0100	-	Add missing symbols and abbreviations for EPC	F	8.5.0	8.6.0	CH8

Jun 2009	SP-44	SP-090432	0101	-	Remove generic "Non 3GPP specific information" parameter	F	8.5.0	8.6.0	CH8
Jun 2009	SP-44	SP-090432	0102	-	Clarify "IP-CAN bearer Charging" is achieved by "Flow Based Charging" in P-GW	F	8.5.0	8.6.0	CH8
Jun 2009	SP-44	SP-090432	0103	-	Clarify the SGSN Charging description applies to SGSN with Gn/Gp connectivity only	F	8.5.0	8.6.0	CH8
Jun 2009	SP-44	SP-090432	0104	-	"Mobile Node Identifier" used for PMIP S5/S8 and S2a/S2b	F	8.5.0	8.6.0	CH8
Jun 2009	SP-44	SP-090432	0105	-	Alignment between PS-information used for offline charging and SGW / PGW CDRs	F	8.5.0	8.6.0	CH8
Jun 2009	SP-44	SP-090432	0106	-	Correction on EPC Charging	F	8.5.0	8.6.0	CH8
Jun 2009	SP-44	SP-090296	0107	-	MBMS charging in EPS alignment in MBMS context charging principle	B	8.6.0	9.0.0	MBMS_EPS
Jun 2009	SP-44	SP-090296	0108	-	MBMS charging in EPS alignment in MBMS bearer context charging data	B	8.6.0	9.0.0	MBMS_EPS
Sep 2009	SP-45	SP-090541	0109	-	CR 32.251 Add IP multicast distribution address in eMBMS charging	B	9.0.0	9.1.0	MBMS_EPS
Sep 2009	SP-45	SP-090536	0111	-	Correction for Supported fields in Accounting Request and Response Messages	A	9.0.0	9.1.0	CH8
Sep 2009	SP-45	SP-090541	0112	-	Add MBMS-GW-CDR to basic principles for PS domain offline charging scenarios	F	9.0.0	9.1.0	MBMS_EPS
Sep 2009	SP-45	SP-090536	0114	-	Correction on Qos handling in PS information for EPS	A	9.0.0	9.1.0	CH8
Sep 2009	SP-45	SP-090536	0116	-	Correction on Charging Characteristics description	A	9.0.0	9.1.0	CH8
Sep 2009	SP-45	SP-090536	0118	-	Correction on Charging Characteristics forwarding from MME	A	9.0.0	9.1.0	CH8
Sep 2009	SP-45	SP-090536	0120	-	Correction on supported fields for Credit-Control Request/answer for Online Charging	A	9.0.0	9.1.0	CH8
Sep 2009	SP-45	SP-090537	0121	-	Emergency bearer service consideration for charging	B	9.0.0	9.1.0	CH9
Dec 2009	SP-46	SP-090720	0123	-	PLMN RAT Change removed as conditions for "List of Service Data"	A	9.1.0	9.2.0	CH8
Dec 2009	SP-46	SP-090720	0125	-	Removal of forwarding CGF Address to S4-SGSN from S-GW	A	9.1.0	9.2.0	CH8
Dec 2009	SP-46	SP-090720	0127	-	Re-align Charging description for S4-SGSN	A	9.1.0	9.2.0	CH8
Dec 2009	SP-46	SP-090721	0128	-	Add user CSG information to the CDR	B	9.1.0	9.2.0	CH8
Mar 2010	SP-47	SP-100039	0131	-	Correction to PS Online Charging service context - Alignment with TS 32.299	A	9.2.0	9.3.0	CH7
Mar 2010	SP-47	SP-100040	0133	-	Correction for "Charging Characteristics Selection Mode" parameter for Rf	A	9.2.0	9.3.0	CH8
Mar 2010	SP-47	SP-100040	0135	-	Clarify "Change Condition" settings in PS-information for offline Charging	A	9.2.0	9.3.0	CH8
Mar 2010	SP-47	SP-100041	0136	-	PLMN and RAT Change removed as conditions for "List of Service Data"	F	9.2.0	9.3.0	CH9
Mar 2010	SP-47	SP-100040	0139	-	Correction for offline Charging from PGW for 3GPP2 User location	A	9.2.0	9.3.0	CH8
Mar 2010	SP-47	SP-100043	0140	-	Add definitions, abbreviations and requirements for SIPTO charging to TS 32.251	B	9.3.0	10.0.0	LIPA_SIPTO-CH
Mar 2010	SP-47	SP-100042	0141	-	Add Originating Address in S-SMT-CDR	B	9.3.0	10.0.0	CH10
Jun 2010	SP-48	SP-100267	0142	-	Small Corrections in Text of Descriptions	D	10.0.0	10.1.0	CH10
Sep 2010	SP-49	SP-100495	0150	-	Correction on Charging Rule Based Name - Alignment with TS 23.203	A	10.1.0	10.2.0	CH7
Sep 2010	SP-49	SP-100496	0146	-	Correction for Dual IP addresses associated to one PDN connection	A	10.1.0	10.2.0	CH8
Sep 2010	SP-49	SP-100499	0143	-	Improve PGW Charging description for WLAN access via ePDG/S2b	B	10.1.0	10.2.0	IFOM
Sep 2010	SP-49	SP-100499	0151	-	Charging Identifiers description - simultaneous PDN connections through different access networks	B	10.1.0	10.2.0	IFOM
Dec 2010	SP-50	SP-100759	0153	2	Clarifications on Charging Characteristics	F	10.2.0	10.3.0	CH10
Dec 2010	SP-50	SP-100760	0154	2	Adding PGW Charging description for Non-3GPP access via GTP based ePDG/S2b - Align with TS 23.402	B	10.2.0	10.3.0	IFOM

Dec 2010	SP-50	SP-100760	0155	2	Adding IP Flow Mobility (IFOM) Charging principle description - Align with SA2 TS 23.261	B	10.2.0	10.3.0	IFOM
Mar 2011	SP-51	SP-110107	0160	2	Correcting the condition to deliver SGW-CDR	A	10.3.0	10.4.0	CH8
Mar 2011	SP-51	SP-110105	0156	3	Adding CDR fields needed for Machine Type Communication	B	10.3.0	10.4.0	NIMTC-CH
Mar 2011	SP-51	SP-110099	0161	2	Adding LIPA SIPTO charging description	B	10.3.0	10.4.0	LIPA_SIPTO
Mar 2011	SP-51	SP-110109	0163	1	Clarification on forwarding of Charging Characteristics Information Elements	F	10.3.0	10.4.0	CH10
Mar 2011	SP-51	SP-110110	0164	1	Adding IP Flow Mobility (IFOM) Charging principle description when PCC is not deployed	B	10.3.0	10.4.0	IFOM
Mar 2011	SP-51	SP-110110	0165	-	Add description for User Plane from the PGW for S2b interface	B	10.3.0	10.4.0	IFOM
May 2011	SP-52	SP-110404	0168	1	Correction of Charging Functionalities For Standalone GGSN	A	10.4.0	10.5.0	CH8
May 2011	SP-52	SP-110281	0169	1	Correction of RAT-Type AVP, alignment with TS 29.212, Gx interface	F	10.4.0	10.5.0	CH10
May 2011	SP-52	SP-110404	0172	1	Correction on essential supported fields in EPC Online Charging	A	10.4.0	10.5.0	CH8
May 2011	SP-52	SP-110404	0175	1	Correction on Rf interface for missing information in SGW CDR	A	10.4.0	10.5.0	CH8
May 2011	SP-52	SP-110280	0177	1	Clarification on forwarding of Charging Characteristics for inter-RAT	A	10.4.0	10.5.0	CH9
Sep 2011	SP-53	SP-110528	0180	1	Correction on PDN connection identifier for Charging	A	10.5.0	10.6.0	CH8
Sep 2011	SP-53	SP-110528	0183	-	Correction for dynamic address flags associated to PDN connection of PDP/PDN type IPv4v6	A	10.5.0	10.6.0	CH8
Sep 2011	SP-53	SP-110528	0186	-	Correction on RAT Type - Align with CT3 TS 29.061	A	10.5.0	10.6.0	CH8
Sep 2011	SP-53	SP-110530	0196	-	Correction on Charging identifiers description	F	10.5.0	10.6.0	CH10
Sep 2011	SP-53	SP-110541	0195	1	Addition of Sponsored Data Connectivity charging - Align with TS 23.203	B	10.6.0	11.0.0	PEST-CH
Dec 2011	SP-54	SP-110708	0213	2	Add clarification for control plane address used in IP-CAN Bearer charging	A	11.0.0	11.1.0	CH8
Dec 2011	SP-54	SP-110708	0217	1	Correction on PDP/PDN Address definition - Alignment with TS 23.401	A	11.0.0	11.1.0	CH8
Dec 2011	SP-54	SP-110708	0221	-	Correction of Dynamic Address Flag usage for IPv4v6 PDN Connection in PS Information AVP	A	11.0.0	11.1.0	CH8
Dec 2011	SP-54	SP-110710	0212	-	Correction on duplicated parameters in S/P-GW CDR description	A	11.0.0	11.1.0	CH10
Dec 2011	SP-54	SP-110710	0226	-	Correction on PDP/PDN Address definition - Alignment with TS 23.40	A	11.0.0	11.1.0	CH10
Mar 2012	SP-55	SP-120048	0228	1	Clarification on "SGSN change" for SGW in EPC Charging	A	11.1.0	11.2.0	CH10
Jun-2012	SP-56	SP-120362	0229	-	Correction to PS architecture with ePDG introduction - Alignment with 23.402	F	11.2.0	11.3.0	CH11
Jun-2012	SP-56	SP-120362	0230	-	Correction to PS charging principles with ePDG introduction - Alignment with 23.402	F	11.2.0	11.3.0	CH11
Jun-2012	SP-56	SP-120362	0231	-	Correction to PS charging with ePDG Rf charging introduction - Alignment with 23.402	F	11.2.0	11.3.0	CH11
Jun-2012	SP-56	SP-120362	0232	-	Correction to PGW charging with ePDG as serving Node - Alignment with 23.402	F	11.2.0	11.3.0	CH11
Jun-2012	SP-56	SP-120362	0233	-	Correction to PS charging with ePDG CDR generation description - Alignment with 23.402	F	11.2.0	11.3.0	CH11
Jun-2012	SP-56	SP-120365	0234	1	Correction of charging information for MTC devices	C	11.2.0	11.3.0	SIMTC-CH
Jun-2012	SP-56	SP-120361	0236	2	Correction of the structure of Diameter ACA message for S-GW and P-GW	A	11.2.0	11.3.0	CH10
Jun-2012	SP-56	SP-120362	0237	1	Clarification of visiting case description in Charging Characteristics in the S-GW	F	11.2.0	11.3.0	CH11
Jun-2012	SP-56	SP-120360	0240	1	Correction on SGW and PGW Address reporting, alignment with 29.212	A	11.2.0	11.3.0	CH9
Jun-2012	SP-56	SP-120362	0241	1	Correction of the CDR generation on Ga	F	11.2.0	11.3.0	CH11
Jun-2012	SP-56	SP-120362	0242		Correction to Charging Characteristics conveyance for Ro when serving Node is ePDG	F	11.2.0	11.3.0	CH11
Jun-2012	SP-56	SP-120362	0243	1	Correction to PS charging with ePDG charging (CDR, Rf) description - Alignment with 23.402	F	11.2.0	11.3.0	CH11
Jun-2012	SP-56	SP-120365	0244	1	Introduction of MME in PS Charging architecture for MTC	B	11.2.0	11.3.0	SIMTC-CH
Jun-2012	SP-56	SP-120365	0245	1	Introduction of MME offline charging for SMS	B	11.2.0	11.3.0	SIMTC-CH
Jun-2012	SP-56	SP-120360	0248	1	Rel-11 CR 32.251 Correction of IMSI Unauthenticated Flag usage in PS charging	A	11.2.0	11.3.0	CH9
Sep-2012	SP-57	SP-120566	0250	1	Alignment with the PCC defined in TS 23.203	F	11.3.0	11.4.0	CH11
Sep-2012	SP-57	SP-120566	0251	1	Correction on Supported fields in Accounting Request Message	F	11.3.0	11.4.0	CH11
Sep-2012	SP-57	SP-120568	0252	2	Triggers for SMS offline charging from MME	B	11.3.0	11.4.0	SIMTC-CH

Sep-2012	SP-57	SP-120568	0253	2	SMS CDRs description for SMS in MME	B	11.3.0	11.4.0	SIMTC-CH				
Sep-2012	SP-57	SP-120627	0254	1	Reference list correction to align with the corrected TS 29.212 title	F	11.3.0	11.4.0	TEI11				
Dic-2012	SP-58	SP-120792	0256	3	R11 CR 32251 Introduction Rf description for Offline Charging for SMS in MME	B	11.4.0	11.4.1	SIMTC-CH				
Dic-2012	SP-58	SP-120788	0260	1	R12 CR 32.251 correction on data volume counters requirements	C	11.4.1	12.0.0	CH12				
Mar-2013	SP-59	SP-130054	0263	1	Introduction of Charging for access to Trusted WLAN Access Network in EPC - over S2a - Alignment with TS 23.402	A	12.0.0	12.1.0	CH11				
Jun-2013	SP-60	SP-130270	0265	1	Correction on SSID availability in TWAN User Location	A	12.1.0	12.2.0	CH11				
		SP-130273	0269	1	Correction for use of Charging Characteristics for SMS in MME	A			SIMTC-CH				
		SP-130271	0272	1	Adjustment on IMEI - alignment to TS 29.274	F			CH12				
		SP-130317	0274	1	Adding CDR fields needed for MTC	A			NIMTC-CH				
		SP-130270	0277	-	Binding of TWAN User Location Info and Serving Node Type to Diameter AVP	A			CH11				
		SP-130276	0279	1	Introduction of the principle for TDF supporting application based charging	B			ABC				
Sep-2013	SP-61	SP-130436	0280	1	skeleton for ABC modification of 32251	B	12.2.0	12.3.0	ABC				
		SP-130436	0281	1	Adding new symbols and abbreviations for ABC	B			ABC				
		SP-130436	0282	1	Introduction of the architecture for supporting application based charging	B			ABC				
		SP-130436	0283	1	charging information collected for ABC	B			ABC				
		SP-130435	0287	-	on retransmission indication in PS CDRs	F			CH12				
		SP-130442	0288	1	Introduction of Scope and abbreviations Charging PCEF located in Fixed Broadband access	B			P4C-F-CH_P				
		SP-130442	0289	1	Introduction IP-Edge (PCEF) Charging Offline and Online Charging architectures	B			P4C-F-CH_P				
		SP-130442	0290	1	Introduction IP-Edge (PCEF) Charging High level requirements	B			P4C-F-CH_P				
Dic 2013	SP-62	SP-130436	0291	-	Addition of TDF on Rf and Ro	B	12.3.0	12.4.0	ABC				
		SP-130620	0294	1	Triggers for application based online charging in TDF	B			ABC				
		SP-130616	0300	-	Correction on Serving Node PLMN description in EPC CDRs for Network Sharing	A			CH8				
			0305	1	Correction on Serving Node MCC MNC description in PS information for Network Sharing	A			CH8				
			SP-130625	0310	2	Full applicability of TDF based charging requirements in case of Fixed Broadband Access scenario			B	P4C-F-CH_T			
		SP-130620	0311	2	Requirements for Application Based Charging functionality	B			ABC				
		SP-130626	0312	1	Refinement on Charging architecture description for PCEF located in IP-Edge	B			P4C-F-CH_P				
			0313	2	Introduce Charging principles and additional requirements for PCEF located in IP-Edge	B							
			0314	1	Introduction of Charging Information - PCEF located in Fixed Broadband access	B							
			0315	2	Introduction of Offline Charging scenarios - PCEF located in Fixed Broadband access	B							
			0316	2	Introduction of Online Charging scenarios - PCEF located in Fixed Broadband access	B							
		SP-130620	0317	2	Online charging principles of application based charging	B			ABC				
			0318	2	Offline charging principles of application based charging	B							
		SP-130620	0320	1	Addition of Charging Characteristics for TDF	B			ABC				
		SP-130618	0321	-	Correction for User Location Info Time	A			CH11				
		SP-130626	0323	1	Introduction of Rf and CDR triggers for Offline Charging - PCEF located in Fixed Broadband access	B			P4C-F-CH_P				
			0324	1	Introduction of Ro triggers for Online Charging - PCEF located in Fixed Broadband access	B							
		SP-130616	0329	-	Correction for use of Destination-Host AVP in ACR	A			CH8				
		SP-130620	0330	1	Addition of requirements for Application Based Charging functionality	B			ABC				
			0332	1	Addition of TDF specific charging information to support application based charging	B							
		SP-130622	0338	1	Charging principles for Charging per IP-CAN Session	B			CHIPS				
		SP-130616	0339	2	Correction on missing Serving Network in PS CDRs for Network Sharing	A			CH8				
		Mar-2014	SP-63	SP-140036	0340	1			Requirements and parameters alignment for application based charging	B	12.4.0	12.5.0	ABC
				SP-140154	0341	1			Introduction of TDF/ABC description and alignment within the the normative Annex for fixed broadband access	B			P4C-F-CH_T, P4C-F-CH_P

		SP-140034	0343	1	Application based charging in case of PCEF enhanced with ADC - alignment with TS 23.203	A			CH11
		SP-140044	0348	1	Correction for Partial Record Closure Reason in MBMS-EPS Charging	A			MBMS_EPS
		SP-140038	0351	1	Correction on use of rating group for CHIPS	F			CHIPS
		SP-140042	0353	-	Correction of CDR generated for SMS in the MME	A			SIMTC-CH
		SP-140040	0354	1	Use of Bp Reference Point for CDR files transfer	B			P4C-F-CH_P
			0355	1	Add requirements and clarify miscellaneous charging information	B			P4C-F-CH_P, P4C-F-CH_T
			0356	1	Introduce IPE-CDR description and PS Charging information	B			ABC
		SP-140036	0359	-	Add support for TDF into Failure Situations	B			
		SP-140036	0360	-	Requirements and parameters alignment for application based charging for online scenarios	B			
Jun-2014	SP-64	SP-140337	0360a	1	Requirements and parameters alignment for application based charging	B	12.5.0	12.6.0	ABC
		SP-140340	0361	1	Completion of TDF related requirements for Fixed Broadband Access	B			P4C-F-CH_T, P4C-F-CH_P
		SP-140341	0362	1	Complete Identifiers used for Charging in Convergent scenario	B			P4C-F-CH_P, P4C-F-CH_T
			0363	1	Introduce Binding for IPE-CDR	B			
			0364	1	Introduce IP-CAN session Charging description	B			
		SP-140339	0365	1	Completion of charging per IP-CAN session in PS domain	B			CHIPS
		SP-140334	0370	1	Removal of IMS charging identifier from PGW CDR and command level online charging messages	A			CH8
		SP-140336	0372	1	Introduce Core Network Operator selection origin for Shared Networks	B			CH12
		SP-140337	0373	1	Credit Control Failure Handling for TDF	F			ABC
		SP-140339	0374	-	Inter-level correlation clarification for CHIPS	B			CHIPS
SP-140341	0376	1	Introduce IP-CAN session Offline Charging description	B	P4C-F-CH_P				
SP-140341	0377	-	Introduce Traffic Data Volumes in IPE-CDR description	B	P4C-F-CH_P				
2014-07	-	-	-	-	Rapporteur/MCC: General editorial changes and clean-up.	-	12.6.0	12.6.1	-
2014-09	SP-65	SP-140565	0378	1	Introduction of Presence Reporting Areas for Charging	B	12.6.1	12.7.0	CNO_ULI-CH
		SP-140564	0379	1	Corrections for alignment between charging specifications	F			CH12
		SP-140563	0380	1	Introduction of report the most up to date User Location Information	B			P4C-F-CH_P
		SP-140567	0381	1	Introduce Charging Characteristics in Convergent scenario	B			CH12
		SP-140563	0382	1	Complete ePDG offline charging description	B			P4C-F-CH_P, P4C-F-CH_T
		SP-140567	0383	1	Corrections to include missing fixed user location information for NSWO	F			CHIPS
		SP-140586	0384	-	Minor corrections to CHIPS for clarification	F			
2014-12	SP-66	SP-140805	0388	-	Correction on MS Time zone which is not applicable to ePDG	F	12.7.0	12.8.0	CH12
		SP-140804	0389	3	Correction on Inter Node Change in SGW and ePDG offline charging	F			
			0390	-	Additional corrections for removal of I-WLAN solution	F			
		SP-140805	0391	1	Corrections on definition for parameter category	F			ABC
		SP-140807	0392	1	Clarification of serving node for TDF	F			CH12
SP-140805	0393	1	Clarification on charging Id for handover procedures between GTP based S2a/S2b non-3GPP and 3GPP access	F					
2015-03	SP-67	SP-150067	0395	1	Consistency correction to basic principles for PS Domain online charging	F	12.8.0	12.9.0	CH12
			0396	1	Clarification of charging id usage in CHIPS	F			
		SP-150068	0394	1	Use of Charging Characteristics to Activate PCC Function per UE	F	12.9.0	13.0.0	CH13
2015-06	SP-68	SP-150319	0399	1	Correction on category for MSISDN from Om to Oc for EPC CDRs	A	13.0.0	13.1.0	SIMTC-CH
		SP-150331	0401	1	Correction of offline message content table for ADC rule base name field	F			ABC
			0403	1	Correction TDF as Node Functionality	A			ULRELC-CH
		SP-150318	0404	1	Introduction of multiple Release causes in EPC Charging	B			CH13
SP-150326	0405	1	CRusage of Charging Characteristics for activating PCC function - Alignment with 23.203	B					

2015-09	SP-69	SP-150417	0406	1	Introduction of multiple Release causes in ePDG offline charging	B	13.1.0	13.2.0	ULREL-CH
		SP-150422	0407	1	Correction of sponsor data connectivity charging	A			PEST-CH
		SP-150420	0411	1	New Annex for inter-PLMN PS Online Charging	B			iPLMN-PS-OCH
		SP-150416	0419	1	Introduction of TWAG offline charging – principles et scenarios	B			eSaMOG-CH
2015-12	SP-70	SP-150699	0421	1	Correction for ABC in case of PCEF when CHIPS is active – alignment with TS 23.203	A	13.2.0	13.3.0	CHIPS
		SP-150700	0424	1	Correction of Presence Reporting Area identifier provision	A			CNO_ULI-CH
		SP-150698	0425	1	Clarification of sponsor data connectivity charging	F			CH13,PEST-CH
		SP-150699	0431	1	Correction for when User leaves a CSG	A			CH9
		SP-150703	0432	1	Introduction of TWAG offline charging – charging information	B			eSaMOG-CH
		SP-150706	0433	1	Add NBIFOM related reference abbreviations and basic principles	B			NBIFOM-CH
			0444	1	Add NBIFOM related charging change condition and corresponding data	B			
		SP-150693	0445	1	Addition of TDF to Annex for inter-PLMN PS Online Charging	B			iPLMN-PS-OCH
SP-150706	0449	1	Introduction of NBIFOM Support and NBIFOM Mode information for PS charging	B	NBIFOM-CH				
2016-03	SP-71	SP-160040	0453	1	Charging Id Assignment for NBIFOM	B	13.3.0	13.4.0	NBIFOM-CH
2016-03	SP-71	SP-160040	0454	1	Correction for Access Availability Change Reason	F	13.3.0	13.4.0	NBIFOM-CH
2016-03	SP-71	SP-160037	0455	-	ULI for untrusted wireless access network correction	F	13.3.0	13.4.0	CH13
2016-03	SP-71	SP-160040	0457	1	Introduce NBIFOM charging for per IP-CAN bearer charging	B	13.3.0	13.4.0	NBIFOM-CH

Change history							
Date	Meeting	TDoc	CR	Rev	Cat	Subject/Comment	New version
2016-06	SA#72	SP-160416	0459	-	F	Inclusion of service data flows as an identifier of application related information for TDF - align with TS 23.203	13.5.0
2016-06	SA#72	SP-160420	0460	-	F	Remove Editor's note regarding "PDN connection charging identifier"	13.5.0
2016-06	SA#72	SP-160415	0462	1	A	Correction for QoS information in FBC	13.5.0
2016-06	SA#72	SP-160420	0465	2	B	Enhancement of charging ID description in TDF CDR	13.5.0
2016-06	SA#72	SP-160420	0467	-	B	Completion of access change of service data flow for NBIFOM	13.5.0
2016-06	SA#72	SP-160420	0468	1	B	Completion of change of charging condition for NBIFOM	13.5.0
2016-06	SA#72	SP-160420	0469	-	B	Remove Editor's note regarding access network charging identifier for NBIFOM	13.5.0
2016-06	SA#72	SP-160411	0471	1	B	Introduce Control Plane Clot EPS Optimisation and Clot RAT in PS charging	13.5.0
2016-06	SA#72	SP-160411	0472	1	B	Introduce PS charging for Non-IP data PDN connection	13.5.0
2016-09	SA#73	SP-160621	0475	1	F	Correction on Non-IP PDP type - alignment with TS 29.061	13.6.0
2016-09	SA#73	SP-160622	0476	1	F	Correction on RAT Type for charging SMS in MME	13.6.0
2016-09	SA#73	SP-160621	0477	1	F	Correction on Control Plane Clot EPS Optimisation Indicator in PGW - alignment with 23.401	13.6.0
2016-09	SA#73	SP-160621	0479	1	F	Correction on "MO exception data" RRC establishment cause in offline charging – alignment with TS 23.401	13.6.0
2016-09	SA#73	SP-160623	0473	1	B	Complement of Charging per IP-CAN Session	14.0.0
2016-09	SA#73	SP-160623	0478	1	F	Correction on the general description for service data flows charging	14.0.0
2016-10						Fix of cover page in Draft mode (MCC)	14.0.1
2016-12	SA#74	SP-160844	0480	1	B	Addition of charging support for Multiple PRAs	14.1.0
2016-12	SA#74	SP-160849	0482	-	B	Introduction of Gy session optimization based on unused quota timer	14.1.0
2017-03	SA#75	SP-170144	0483	1	B	Charging enhancement for 3GPP PS Data off	14.2.0
2017-03	SA#75	SP-170129	0484	1	B	Addition of the triggers for AULC	14.2.0
2017-03	SA#75	SP-170129	0485	1	B	Addition on the description of UE Presence in Presence Reporting Areas	14.2.0
2017-03	SA#75	SP-170134	0487	1	B	Definition of Unused Quota timer	14.2.0
2017-03	SA#75	SP-170138	0488	1	C	Remove reference to RFC 3588	14.2.0
2017-03	SA#75	SP-170132	0489	1	B	Improve binding table for EPC charging	14.2.0
2017-06	SA#76	SP-170499	0490	1	B	Addition of the subscription operation for AULC	14.3.0
2017-06	SA#76	SP-170501	0491	1	B	Additional charging trigger for 3GPP PS Data off	14.3.0
2017-06	SA#76	SP-170495	0492	-	B	Adding possibility for OCS to influence Unused Quota Timer	14.3.0
2017-06	SA#76	SP-170500	0494	1	B	Introduce MSISDN-less SMS MO via T4 charging	14.3.0
2017-06	SA#76	SP-170499	0495	1	B	Deletion of the AULC support from TDF	14.3.0
2017-09	SA#77	SP-170650	0498	1	B	Charging enhancement for eFMSS	15.0.0
2018-01	SA#78	SP-170966	0499	1	B	Data Volume Reporting for Secondary RAT usage	15.1.0
2018-01	SA#78	SP-170970	0500	1	B	Bindings of eFMSS for EPC offline charging	15.1.0
2018-01	SA#78	SP-170970	0501	1	B	Charging enhancement on TDF for eFMSS	15.1.0
2018-03	SA#79	SP-180062	0502	1	B	Support for secondary RAT in offline charging	15.2.0
2018-06	SA#80	SP-180427	0503	1	B	Enhance location information in trusted and untrusted WLAN	15.3.0
2018-06	SA#80	SP-180427	0504	-	B	Introduce Emergency services over WLAN	15.3.0
2018-06	SA#80	SP-180428	0505	1	B	Introduce Supported Features mechanism	15.3.0
2018-12	SA#82	SP-181041	0506	1	F	Correction in OCS subscription to multiple PRA(s)	15.4.0
2018-12	SA#82	SP-181041	0507	1	F	Correction on multiple PRA(s) in offline charging	15.4.0
2018-12	SA#82	SP-181053	0508	1	F	Correction of Supported Feature for EDCE5-CH	15.4.0
2018-12	SA#82	SP-181054	0510	2	A	Correction of Data Volume Uplink and Downlink definition	15.4.0
2018-12	SA#82	SP-181041	0511	1	F	PRA Charging Clarification	15.4.0
2018-12	SA#82	SP-181041	0512	1	F	Multi-PRAs charging clarification	15.4.0

History

Document history		
V15.3.0	June 2018	Publication
V15.4.0	April 2019	Publication