

# ETSI TS 132 250 V10.6.0 (2013-01)



Technical Specification

**Digital cellular telecommunications system (Phase 2+);  
Universal Mobile Telecommunications System (UMTS);  
LTE;  
Telecommunication management;  
Charging management;  
Circuit Switched (CS) domain charging  
(3GPP TS 32.250 version 10.6.0 Release 10)**



---

**Reference**

RTS/TSGS-0532250va60

---

**Keywords**

GSM,LTE,UMTS

**ETSI**

650 Route des Lucioles  
F-06921 Sophia Antipolis Cedex - FRANCE

---

Tel.: +33 4 92 94 42 00 Fax: +33 4 93 65 47 16

Siret N° 348 623 562 00017 - NAF 742 C  
Association à but non lucratif enregistrée à la  
Sous-Préfecture de Grasse (06) N° 7803/88

---

**Important notice**

---

Individual copies of the present document can be downloaded from:

<http://www.etsi.org>

The present document may be made available in more than one electronic version or in print. In any case of existing or perceived difference in contents between such versions, the reference version is the Portable Document Format (PDF). In case of dispute, the reference shall be the printing on ETSI printers of the PDF version kept on a specific network drive within ETSI Secretariat.

Users of the present document should be aware that the document may be subject to revision or change of status. Information on the current status of this and other ETSI documents is available at

<http://portal.etsi.org/tb/status/status.asp>

If you find errors in the present document, please send your comment to one of the following services:

[http://portal.etsi.org/chaicor/ETSI\\_support.asp](http://portal.etsi.org/chaicor/ETSI_support.asp)

---

**Copyright Notification**

---

No part may be reproduced except as authorized by written permission.  
The copyright and the foregoing restriction extend to reproduction in all media.

© European Telecommunications Standards Institute 2013.  
All rights reserved.

**DECT™**, **PLUGTESTS™**, **UMTS™** and the ETSI logo are Trade Marks of ETSI registered for the benefit of its Members.  
**3GPP™** and **LTE™** are Trade Marks of ETSI registered for the benefit of its Members and  
of the 3GPP Organizational Partners.  
**GSM®** and the GSM logo are Trade Marks registered and owned by the GSM Association.

---

## Intellectual Property Rights

IPRs essential or potentially essential to the present document may have been declared to ETSI. The information pertaining to these essential IPRs, if any, is publicly available for **ETSI members and non-members**, and can be found in ETSI SR 000 314: *"Intellectual Property Rights (IPRs); Essential, or potentially Essential, IPRs notified to ETSI in respect of ETSI standards"*, which is available from the ETSI Secretariat. Latest updates are available on the ETSI Web server (<http://ipr.etsi.org>).

Pursuant to the ETSI IPR Policy, no investigation, including IPR searches, has been carried out by ETSI. No guarantee can be given as to the existence of other IPRs not referenced in ETSI SR 000 314 (or the updates on the ETSI Web server) which are, or may be, or may become, essential to the present document.

---

## Foreword

This Technical Specification (TS) has been produced by ETSI 3rd Generation Partnership Project (3GPP).

The present document may refer to technical specifications or reports using their 3GPP identities, UMTS identities or GSM identities. These should be interpreted as being references to the corresponding ETSI deliverables.

The cross reference between GSM, UMTS, 3GPP and ETSI identities can be found under <http://webapp.etsi.org/key/queryform.asp>.

# Contents

Intellectual Property Rights .....	2
Foreword.....	2
Foreword.....	6
1 Scope .....	7
2 References .....	7
3 Definitions, symbols and abbreviations .....	9
3.1 Definitions .....	9
3.2 Symbols.....	10
3.3 Abbreviations .....	11
4 Architecture considerations .....	13
4.1 High level CS domain architecture.....	13
4.2 CS domain offline charging architecture.....	14
4.3 CS domain online charging architecture .....	15
5 CS domain charging principles and scenarios.....	16
5.1 CS domain charging principles .....	16
5.1.1 General aspects of Charging Data.....	16
5.1.2 Charging information.....	16
5.1.2.1 Subscriber billing .....	17
5.1.2.2 Settlements of Charges.....	17
5.1.2.2.1 Inter-PLMN accounting.....	17
5.1.2.2.2 "Visitors" from other PLMNs.....	17
5.1.2.2.3 "Home" subscribers roaming in other PLMNs .....	17
5.1.2.2.4 Settlement with other networks .....	17
5.1.2.3 Service Information.....	18
5.1.3 Special cases and considerations .....	18
5.1.3.1 AoC service.....	18
5.1.3.2 CAMEL services.....	19
5.1.3.3 Use of supplementary services.....	19
5.1.3.4 Use of call forwarding.....	19
5.1.3.5 Use of call hold and multi-party services.....	19
5.1.3.6 Partial records .....	20
5.1.3.7 Use of circuit-switched data services .....	21
5.1.3.8 Inter-MSC server handover.....	21
5.1.3.9 Call re-establishment.....	21
5.1.3.10 Restricted directory numbers .....	22
5.1.3.11 IMEI Observation .....	22
5.1.3.12 Triggers for LCS-MT-CDR, LCS-MO-CDR and LCS-NI-CDR Charging Information Collection.....	22
5.1.3.13 BS30 Accounting .....	22
5.1.3.14 CAMEL Call Party Handling service.....	22
5.1.3.15 Service Change and Fallback .....	24
5.1.3.16 CS Fallback and SMS over SGs.....	24
5.1.3.17 Enhanced MSC server for SRVCC support .....	24
5.1.3.18 Mobile Terminating Roaming Forwarding call after successful Retrieval of Routing Information (MTRF) .....	24
5.2 CS domain offline charging scenarios.....	25
5.2.1 Basic principles.....	25
5.2.1.1 Mobile to land (outgoing) call.....	27
5.2.1.2 Land to mobile (incoming) call.....	28
5.2.1.3 Mobile to mobile call within the same network .....	29
5.2.1.4 Incoming call to a roaming subscriber .....	30
5.2.1.5 Incoming call to a PLMN service centre.....	31
5.2.1.6 Call forwarding unconditional .....	32
5.2.1.7 Call forwarding conditional (on busy) .....	33

5.2.1.8	Delivery of a mobile terminated short message .....	34
5.2.1.9	Call hold and multi-party service .....	35
5.2.1.10	Outgoing call handled by CAMEL .....	36
5.2.1.11	Incoming call handled by CAMEL without redirection .....	38
5.2.1.12	Incoming call to a roaming subscriber handled by CAMEL .....	40
5.2.1.13	Incoming call handled by CAMEL with redirection decided and forwarding leg handled by CAMEL .....	42
5.2.1.14	Incoming call handled by CAMEL without redirection and forwarded early using GSM SS but controlled by CAMEL .....	44
5.2.1.15	Incoming call handled by CAMEL without redirection and forwarded late using GSM SS but controlled by CAMEL .....	46
5.2.1.16	Early forwarded call controlled by CAMEL .....	48
5.2.1.17	Late forwarded call controlled by CAMEL .....	50
5.2.1.18	Incoming call handled by CAMEL with redirection initiated by CAMEL feature .....	52
5.2.1.19	CAMEL Scenario for Visiting Terminator Trigger Calls .....	54
5.2.1.20	Outgoing call handled by CAMEL with Dialed CSI Trigger .....	56
5.2.1.21	Incoming call handled by CAMEL with redirection decided and forwarding leg handled by CAMEL with Dialed CSI Trigger .....	58
5.2.1.22	Mobile terminated location request .....	60
5.2.1.23	gsmSCF initiated wake-up call handled by CAMEL CPH .....	61
5.2.1.24	Three party conference handled by CAMEL CPH .....	62
5.2.1.25	Mobile Terminating Roaming Forwarding call after successful Retrieval of Routeing Information (MTRF) .....	64
5.2.1.26	Mobile Terminating Roaming Forwarding call after successful Retrieval of Routeing Information (MTRF) to a roaming subscriber .....	65
5.2.1.27	Mobile Terminating Roaming Forwarding call after successful Retrieval of Routeing Information (MTRF), for a subscriber with Visiting Terminating Trigger Calls .....	66
5.2.2	Diameter message flows .....	67
5.2.3	CDR generation .....	67
5.2.4	GTP' record transfer flows .....	68
5.2.5	B <sub>c</sub> CDR file transfer .....	68
5.3	CS domain online charging scenarios .....	68
5.3.1	Basic principles .....	68
5.3.2	Diameter message flows .....	68
6	Definition of charging information .....	69
6.1	Data description for CS domain offline charging .....	69
6.1.1	Diameter message contents .....	69
6.1.2	GTP' message contents .....	69
6.1.3	CDR description on the B <sub>c</sub> reference point .....	69
6.1.3.1	Mobile originated call attempt .....	71
6.1.3.2	Mobile originated emergency call attempt .....	74
6.1.3.3	Mobile originated call forwarding attempt .....	76
6.1.3.4	Mobile terminated call attempt .....	78
6.1.3.5	Roaming call attempt .....	80
6.1.3.6	Incoming gateway call attempt .....	81
6.1.3.7	Outgoing gateway call attempt .....	82
6.1.3.8	Transit call attempt .....	83
6.1.3.9	Supplementary service actions .....	84
6.1.3.10	HLR interrogation .....	85
6.1.3.11	Location update (VLR) .....	85
6.1.3.12	Location update (HLR) .....	86
6.1.3.13	Short message service, mobile originated .....	86
6.1.3.14	Short message service, mobile terminated .....	87
6.1.3.15	SMS-MO interworking record .....	87
6.1.3.16	SMS-MT gateway record .....	88
6.1.3.17	Common equipment usage record .....	88
6.1.3.18	Terminating CAMEL call attempt .....	89
6.1.3.19	IMEI observation ticket .....	90
6.1.3.20	Mobile terminated location request (MT-LR) .....	91
6.1.3.21	Mobile originated location request (MO-LR) .....	92
6.1.3.22	Network induced location request (NI-LR) .....	93

6.1.3.23	Mobile originated call attempt (CAMEL CPH adapted version) .....	94
6.1.3.24	gsmSCF initiated CAMEL CPH call attempt.....	97
6.1.3.25	New Call Segment in a MO, CF and MT CAMEL Dialogue .....	99
6.1.3.26	Mobile originated call forwarding attempt (CAMEL CPH adapted version) .....	101
6.1.3.27	Terminating CAMEL call attempt (CAMEL CPH adapted version) .....	103
6.1.3.28	SRVCC MSC Call handling in MSC server enhanced for SRVCC .....	105
6.1.3.29	SRVCC CS Emergency Call handling in MSC server enhanced for SRVCC .....	105
6.1.3.30	Mobile Terminating Roaming Forwarding call after successful Retrieval of Routeing Information (MTRF) handling in VMSC .....	106
6.2	Data description for CS domain online charging .....	107
6.2.1	Diameter message contents.....	107
<b>Annex A (informative):</b>	<b>CDR File Transfer compliant with earlier 3GPP releases .....</b>	<b>108</b>
<b>Annex B (informative):</b>	<b>Bibliography.....</b>	<b>109</b>
<b>Annex C (informative):</b>	<b>Charging Support for Voice Call Continuity .....</b>	<b>110</b>
<b>Annex D (informative):</b>	<b>Change history .....</b>	<b>111</b>
History .....		112

---

# Foreword

This Technical Specification has been produced by the 3<sup>rd</sup> Generation Partnership Project (3GPP).

The contents of the present document are subject to continuing work within the TSG and may change following formal TSG approval. Should the TSG modify the contents of the present document, it will be re-released by the TSG with an identifying change of release date and an increase in version number as follows:

Version x.y.z

where:

- x the first digit:
  - 1 presented to TSG for information;
  - 2 presented to TSG for approval;
  - 3 or greater indicates TSG approved document under change control.
- y the second digit is incremented for all changes of substance, i.e. technical enhancements, corrections, updates, etc.
- z the third digit is incremented when editorial only changes have been incorporated in the document.

---

# 1 Scope

The present document is part of a series of documents that specify charging functionality and charging management in GSM/UMTS networks. The GSM/UMTS core network charging architecture and principles are specified in 3GPP TS 32.240 [1], which provides an umbrella for other charging management TSs that specify:

- the content of the CDRs per domain and subsystem (offline charging);
- the content of real-time charging messages per domain / subsystem (online charging);
- the functionality of online and offline charging for those domains and subsystems;
- the interfaces that are used in the charging framework to transfer the charging information (i.e. CDRs or charging events).

The complete document structure for these TSs is defined in 3GPP TS 32.240 [1].

The present document specifies the Offline Charging description for the 3GPP Circuit Switched domain, based on the functional descriptions of the 3GPP bearer-, tele- and supplementary services in 3GPP TS 22.002 [200], 3GPP TS 22.003 [201] and 3PP TS 22.004 [202], respectively. This charging description includes the offline charging architecture and scenarios specific to the CS domain, as well as the mapping of the common charging architecture specified in 3GPP TS 32.240 [1] onto the CS domain. It further specifies the structure and content of the CDRs for offline charging. The present document is related to other 3GPP charging TSs as follows:

- The common 3GPP charging architecture is specified in 3GPP TS 32.240 [1];
- The parameters, abstract syntax and encoding rules for these CDR types are specified in 3GPP TS 32.298 [51].
- The file based mechanism used to transfer the CDRs from the network to the operator's billing domain (e.g. the billing system or a mediation device) is specified in 3GPP TS 32.297 [52].

Note that online charging for the CS domain is solely based on CAMEL (3GPP TS 23.078 [207] and 3GPP TS 29.078 [213]) and therefore outside the scope of the 32 series of charging specifications.

All terms, definitions and abbreviations used in the present document, that are common across 3GPP TSs, are defined in 3GPP TR 21.905 [100]. Those that are common across charging management in GSM/UMTS domains, services or subsystems are provided in the umbrella document 3GPP TS 32.240 [1] and are copied into clause 3 of the present document for ease of reading. Finally, those items that are specific to the present document are defined exclusively in the present document.

Furthermore, requirements that govern the charging work are specified in 3GPP TS 22.115 [102].

---

# 2 References

The following documents contain provisions which, through reference in this text, constitute provisions of the present document.

- References are either specific (identified by date of publication, edition number, version number, etc.) or non-specific.
- For a specific reference, subsequent revisions do not apply.
- For a non-specific reference, the latest version applies. In the case of a reference to a 3GPP document (including a GSM document), a non-specific reference implicitly refers to the latest version of that document *in the same Release as the present document*.

[1] 3GPP TS 32.240: "Telecommunication management; Charging management; Charging architecture and principles".

[2]-[22] Void.



- [23] 3GPP TS 24.086: "Advice of Charge (AoC) Supplementary Service; Stage 3".
- [24]-[49] Void.
- [50] 3GPP TS 32.299: "Telecommunication management; Charging management; Diameter charging application".
- [51] 3GPP TS 32.298: "Telecommunication management; Charging management; Charging Data Record (CDR) encoding rules description".
- [52] 3GPP TS 32.297: "Telecommunication management; Charging management; Charging Data Records (CDR) file format and transfer".
- [53] Void.
- [54] 3GPP TS 32.295: "Telecommunication management; Charging management; Charging Data Record (CDR) transfer".
- [55] 3GPP TS 32.260: "Telecommunication management; Charging management; IP Multimedia Subsystem (IMS) charging".
- [56]-[99] Void.
- [100] 3GPP TR 21.905: "Vocabulary for 3GPP Specifications".
- [101] Void.
- [102] 3GPP TS 22.115: "Service aspects; Charging and billing".
- [103] 3GPP TS 23.002: "Network architecture".
- [104]-[199] Void.
- [200] 3GPP TS 22.002: "Circuit Bearer Services (BS) supported by a Public Land Mobile Network (PLMN)".
- [201] 3GPP TS 22.003: "Circuit Teleservices supported by a Public Land Mobile Network (PLMN)".
- [202] 3GPP TS 22.004: "General on supplementary services".
- [203] 3GPP TS 22.024: "Description of Charge Advice Information (CAI)".
- [204] 3GPP TS 22.086: "Advice of Charge (AoC) supplementary services; Stage 1".
- [205]-[206] Void.
- [207] 3GPP TS 23.078: "Customized Applications for Mobile network Enhanced Logic (CAMEL); Stage 2".
- [208] 3GPP TS 24.008: "Mobile radio interface Layer 3 specification; Core Network protocols; Stage 3".
- [209] 3GPP TS 23.172: "Technical realization of Circuit Switched (CS) multimedia service; UDI/RDI fallback and service modification; Stage 2".
- [210] 3GPP TS 23.206: "Voice Call Continuity between CS and IMS; Stage 2".
- [211] 3GPP TS 23.228: "Functional stage 2 description of IMS"
- [212] 3GPP TS 29.078: "Customized Applications for Mobile network Enhanced Logic (CAMEL); CAMEL Application Part (CAP) specification".
- [213] 3GPP TS 29.007: "General requirements on interworking between the Public Land Mobile Network (PLMN) and the Integrated Services Digital Network (ISDN) or Public Switched Telephone Network (PSTN)".
- [214] 3GPP TS 23.272: "Circuit Switched (CS) fallback in Evolved Packet System (EPS); Stage 2".
- [215] 3GPP TS 23.216: "Single Radio Voice Call Continuity (SRVCC); Stage 2".

[216]	3GPP TS 23.018: "Basic Call Handling; Technical realization".
[217]	3GPP TS 23.272: " Circuit Switched (CS) fallback in Evolved Packet System (EPS );Stage 2".
[218]-[299]	Void.
[300]	ITU-T Recommendation D.93: "Charging and accounting in the international land mobile telephone service (provided via cellular radio systems)".
[301]-[399]	Void.
[400]	IETF RFC 0959 (1985): "File Transfer Protocol".
[401]	Void.
[402]	Void.
[403]	IETF RFC 01350: "TFTP Protocol".
[404]	Void.
[405]	GSM 12.01: "Network Management (NM); Part 2: Common aspects of GSM/DCS 1800 network management".

---

## 3 Definitions, symbols and abbreviations

### 3.1 Definitions

For the purposes of the present document, the terms and definitions given in 3GPP TR 21.905 [50], 3GPP TS 32.240 [1] and the following apply:

**accounting:** process of apportioning charges between the Home Environment, Serving Network and User

**advice of charge:** real-time display of the network utilization charges incurred by the Mobile Station  
The charges are displayed in the form of charging units. If a unit price is stored by the MS then the display may also include the equivalent charge in the home currency.

**Advice of Charge (AoC) service:** combination of one or more services, both basic and supplementary, together with a number of other charging relevant parameters to define a customized service for the purpose of Advice of Charge

**billing:** function whereby CDRs generated by the charging function are transformed into bills requiring payment

**Billing Domain:** part of the operator network, which is outside the core network, that receives and processes charging information from the core network charging functions  
It includes functions that can provide billing mediation and billing end applications.

**CAMEL:** network feature that provides the mechanisms to support operator specific services even when roaming outside HPLMN

**CAMEL subscription information:** identifies a subscriber as having CAMEL services

**CDR field categories:** Defined in 3GPP TS 32.250. They are divided into the following categories:

- **Mandatory:** field that shall be present in the CDR.
- **Conditional:** field that shall be present in a CDR if certain conditions are met.
- **Operator Provisionable: Mandatory:** A field that operators have provisioned to be included in the CDR for all conditions.
- **Operator Provisionable: Conditional:** A field that operators have provisioned to be included in the CDR if certain conditions are met.

**Charging Data Record (CDR):** record generated by a network element for the purpose of billing a subscriber for the provided service

It includes fields identifying the user, the session and the network elements as well as information on the network resources and services used to support a subscriber session. In the traditional circuit domain, CDR has been used to denote "Call Detail Record", which is subsumed by "Charging Data Record" hereafter.

**charged party:** user involved in a chargeable event who has to pay parts or the whole charges of the chargeable event, or a third party paying the charges caused by one or all users involved in the chargeable event, or a network operator

**charging:** function whereby information related to a chargeable event is formatted and transferred in order to make it possible to determine usage for which the charged party may be billed

**charging destination:** also referred to as a destination for charging, this is a nominal reference defining the point of termination of a connection for charging purposes

**charging origin:** nominal reference defining the point of origin of a connection for charging purposes

**circuit switched domain:** domain within UMTS in which information is transferred in circuit mode

**GSM only:** indicates that this clause or paragraph applies only to a GSM system  
For multi-system cases this is determined by the current serving radio access network.

**inter-system change:** change of radio access between different radio access technologies such as GSM and UMTS

**in GSM,...:** qualifier indicating that this paragraph applies only to GSM System

**in UMTS,...:** qualifier indicating that this paragraph applies only to UMTS System

**near real time:** near real time charging and billing information is to be generated, processed, and transported to a desired conclusion in less than 1 minute

**observed IMEI ticket:** record used to describe an EIR relevant event e.g. a blacklisted IMEI

**offline charging:** charging mechanism where charging information **does not** affect, in real-time, the service rendered

**online charging:** charging mechanism where charging information can affect, in real-time, the service rendered and therefore a direct interaction of the charging mechanism with session/service control is required

**real time:** real time charging and billing information is to be generated, processed, and transported to a desired conclusion in less than 1 s

**successful call:** connection that reaches the communication or data transfer phase e.g. the "answered" state for speech connections

All other connection attempts are regarded as unsuccessful.

**tariff period:** part of one (calendar) day during which a particular tariff is applied  
Defined by the time at which the period commences (the switch-over time) and the tariff to be applied after switch-over.

**tariff:** set of parameters defining the network utilization charges for the use of a particular service

**UMTS only:** indicates that this clause or paragraph applies only to a UMTS system  
For multi-system cases this is determined by the current serving radio access network.

## 3.2 Symbols

For the purposes of the present document, the following symbols apply:

A	Interface between an MSC and a BSC
Bc	Reference point for the CDR file transfer from the Circuit Switched CGF to the BD.
Gd	Interface between an SMS-GMSC and an SGSN, and between a SMS-IWMSC and an SGSN
Gs	Interface between an SGSN and an MSC/VLR.
Iu	Interface between the RNS and the core network. It is also considered as a reference point
kbit/s	Kilobits per second. 1 kbit/s = $2^{10}$ bits per second.
Mbit/s	Megabits per second. 1 Mbit/s = $2^{20}$ bits per second.
Mc	Interface between the MGW and (G)MSC server

R	Reference point between a non-ISDN compatible TE and MT. Typically this reference point supports a standard serial interface.
Um	Interface between the Mobile Station (MS) and the GSM fixed network part.
Uu	Interface between the Mobile Station (MS) and the UMTS fixed network part.
PS	Packet Switched
TAP	Transferred Account Procedure
CFB	Call Forwarding on Busy
CFNRY	Call Forwarding on No Reply
ANM	ANswer Message

### 3.3 Abbreviations

For the purposes of the present document, the abbreviations given in 3GPP TR 21.905 [50], 3GPP TS 32.240 [1] and the following apply:

3G	3 <sup>rd</sup> Generation
3GPP	3 <sup>rd</sup> Generation Partnership Project
AoC	Advice of Charge
BD	Billing Domain
BS	Billing System
CAI	Charge Advice Information
CAMEL	Customized Applications for Mobile network Enhanced Logic
CCF	Charging Collection Function
CDF	Charging Data Function
CDR	Charging Data Record
CGF	Charging Gateway Function
CPH	Call Party Handling
CS	Circuit Switched
CTF	Charging Trigger Function
DP	Detection Point
EDP	Event Detection Point
EIR	Equipment Identity Register
EMS-Digits	North American Emergency Service Routing Digits
EMS-Key	North American Emergency Service Routing Key
FCI	Furnish Charging Information
FTAM	File Transfer, Access and Management
GMSC	Gateway MSC
gsmSCF	GSM Service Control Function
gsmSSF	GSM Service Switching Function
HLR	Home Location Register
HPLMN	Home PLMN
HSCSD	High Speed Circuit Switched Data
ICA	Initiate Call Attempt
IMEI	International Mobile Equipment Identity
IMSI	International Mobile Subscriber Identity
ISDN	Integrated Services Digital Network
ITU-T	International Telecommunication Union - Telecommunications standardization sector
JIP	Jurisdiction Information Parameter
LAC	Location Area Code
LCS	LoCation Service
LR	Location Request
LRN	Location Routing Number
MAP	Mobile Application Part
MLC	Mobile Location Center
MOC	Mobile Originated Call (attempt)
MO-LR	Mobile Originated - Location Request
MS	Mobile Station
MSC	Mobile Switching Centre
MSRN	Mobile Station Roaming Number
MTC	Mobile Terminated Call (attempt)
MTRF	Mobile Terminating Roaming Forwarding

MT-LR	Mobile Terminated - Location Request
NE	Network Element
NI-LR	Network Induced - Location Request
OCS	Online Charging System
O-CSI	Originating - CAMEL Subscription Information
PLMN	Public Land Mobile Network
PSTN	Public Switched Telephony Network
RDI	Restricted Digital Information
RNC	Radio Network Controller
SAC	Service Area Code
SCF	Service Control Function
SCI	Subscriber Controlled Input
SCI	Send Charging Information
SCUDIF	Service Change and UDI/RDI Fallback
SMS	Short Message Service
SRF	Specialised Resource Function
T-CSI	Terminating - CAMEL Subscription Information
TDP	Trigger Detection Point
UI	User Interaction
UMTS	Universal Mobile Telecommunications System
USSD	Unstructured Supplementary Service Data
UDI	Unrestricted Digital Information
UTRAN	Universal Terrestrial Radio Access Network
VAS	Value Added Service
VCC	Voice Call Continuity
VLR	Visitor Location Register
VMSC	Visited MSC
VPLMN	Visited PLMN
VT-CSI	Visited Terminating - CAMEL Subscription Information

# 4 Architecture considerations

## 4.1 High level CS domain architecture

Figure 4.1 shows the 3G logical architecture as described in 3GPP TS 23.002 [103]. Refer to 3GPP TS 23.002 [103] for a description of the reference points not covered in the present document.

1.

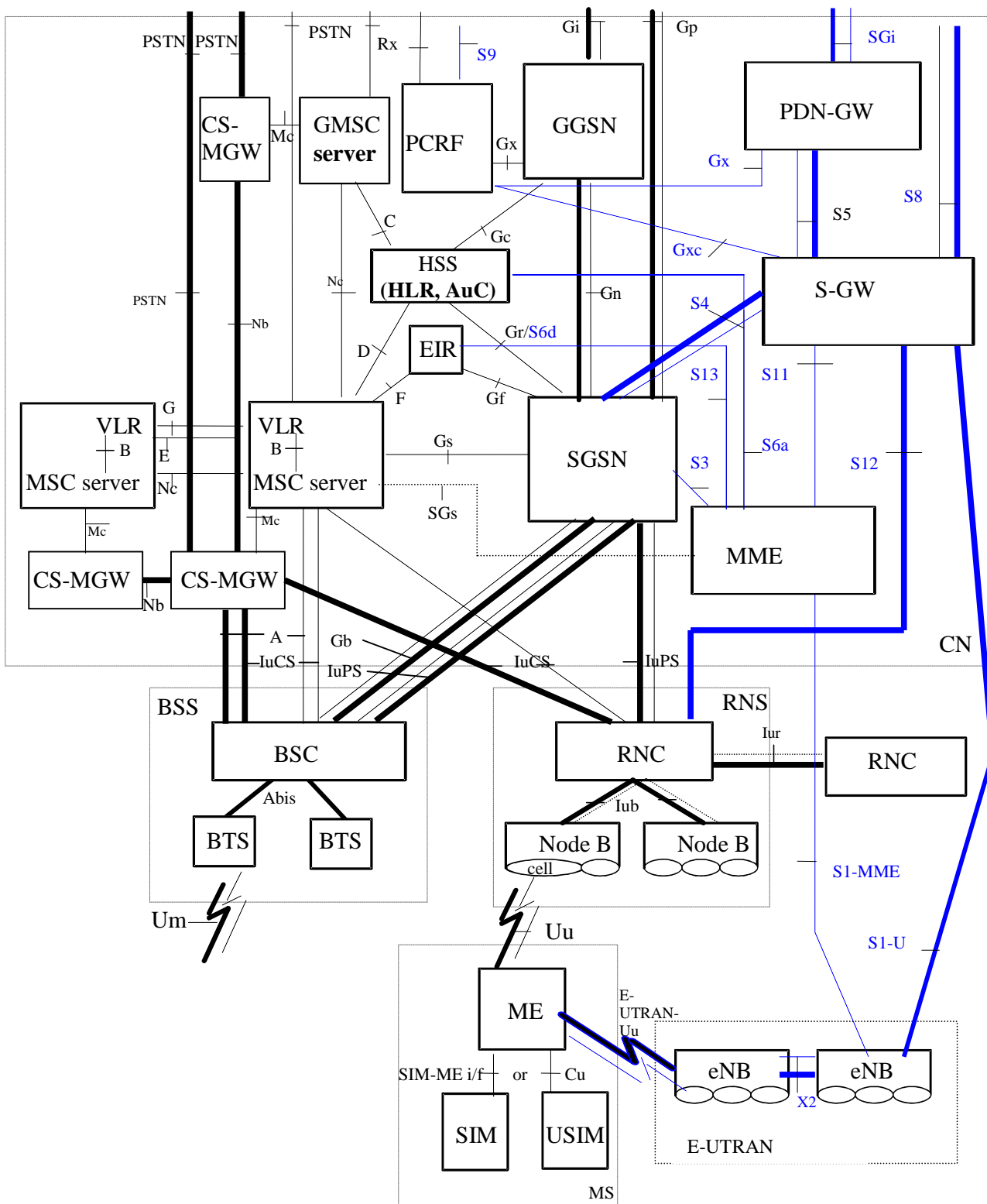

**Figure 4.1: Overview of the 2G, 3G CS and PS and E-UTRAN PS logical architecture**

The 3<sup>rd</sup> Generation Mobile system is logically implemented on the GSM/GPRS structure through the addition of a new air interface supported by two network nodes, the RNC and the Node B. No inference should be drawn about the physical configuration on an interface from figure 4.1.

The CAMEL entities are not shown in figure 4.1. For the relationship ship of the CAMEL entities to the core network entities illustrated above, refer to 3GPP TS 23.002 [103].

## 4.2 CS domain offline charging architecture

Figure 4.2.1 illustrates the 3<sup>rd</sup> Generation charging logical architecture, which is subdivided by the two transmission planes, the Circuit Switched (CS) domain and the Packet Switched (PS) domain. The entities of the CS domain are encircled by the related box on the left hand side of the figure.

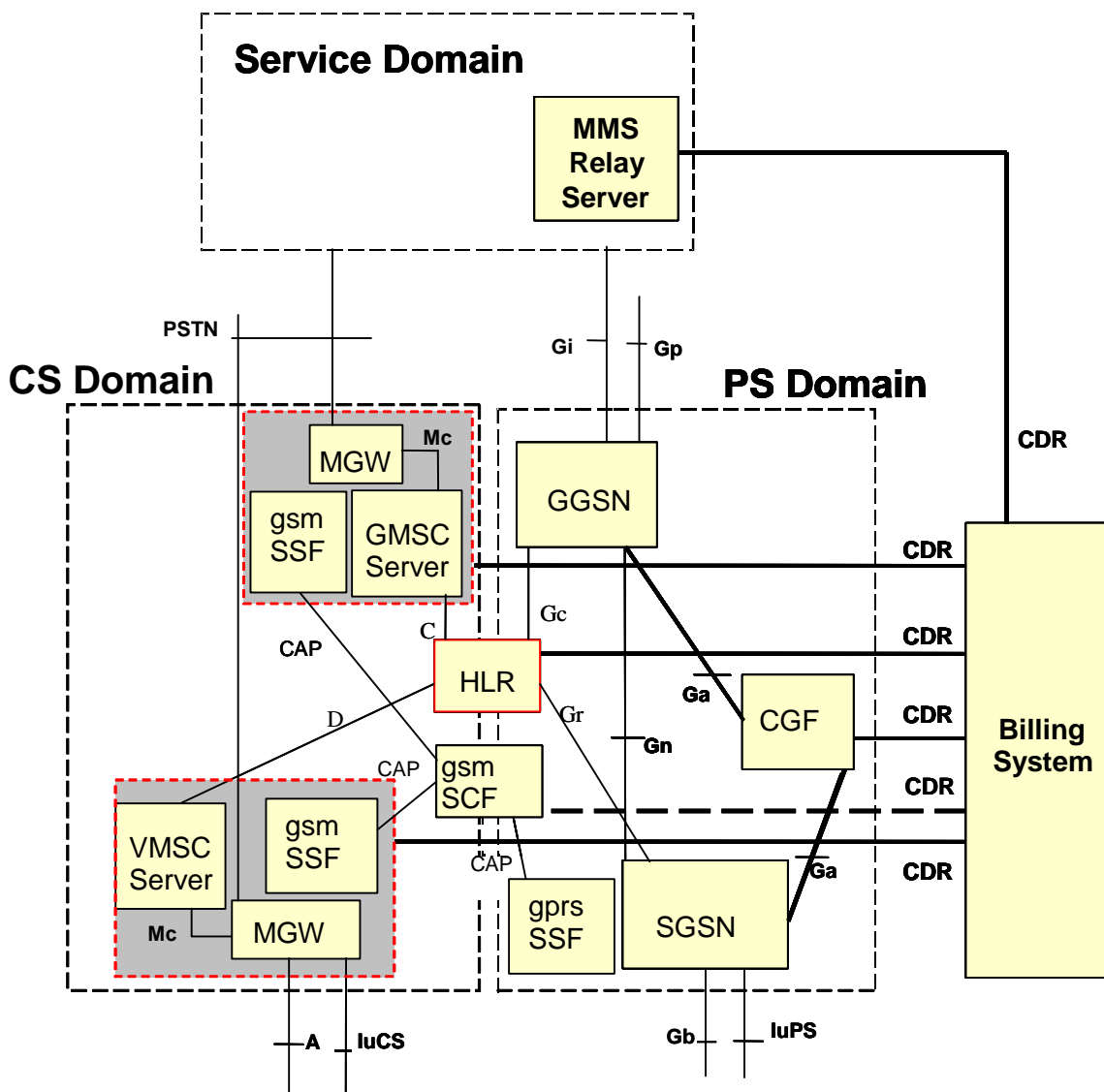

**Figure 4.2.1 : 3G charging logical architecture**

The components grouped in the grey boxes constitute what was referred to as the "MSC" prior to 3GPP Release 4. The boxes which show red lines are those that are relevant for CS domain charging. While not shown explicitly in figure 4.2.1, the VLR may also generate CDRs (cf. figure 4.1 for the relationship between VLR and MSC server). In addition, the gsmSCF may also produce CDRs, however, these are not subject to 3GPP standardization.

Figure 4.2.2 specifies the mapping of the 3GPP common charging architecture, as laid down in 3GPP TS 32.240 [1], onto the CS domain.

As depicted in figure 4.2.2, all charging functions (CTF, CDF and CGF) reside within each CS Network Element (i.e. the MSC server, the VLR, and the HLR). Thus, the CS nodes are connected directly to the Billing Domain via the Bc reference point. This implies that there exists no separate CDF and CGF for the CS domain, and no corresponding open interfaces between any such functions, within the 3GPP standards.

However, vendors may choose to implement separate CDF and CGF for the CS domain. In that case, the interfaces between these functions should comply with the definition of the Rf and Ga reference points (3GPP TS 32.299 [50] and 3GPP TS 32.295 [54], respectively) as much as possible.

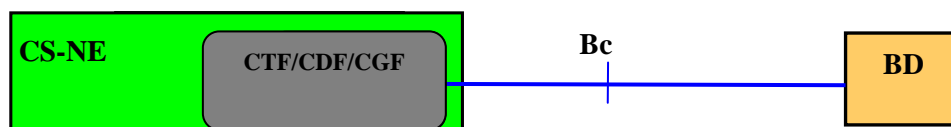

Figure 4.2.2: CS offline charging architecture

### 4.3 CS domain online charging architecture

CS domain online charging is implemented by CAMEL techniques as described in 3GPP TS 23.078 [207] and 3GPP TS 29.078 [212], i.e. outside the scope of the 32 series of charging TSs.

NOTE: that the CDRs described in the present document do contain CAMEL information. This is because some of that information is relevant to offline charging in case of CAMEL control of (part of) the call, and thus needs to be captured in the offline charging information. However, this is not related to the online charging functions for the CS domain.



---

## 5 CS domain charging principles and scenarios

### 5.1 CS domain charging principles

The following high-level requirements summarize the more detailed requirements of 3GPP TS 22.115 [102].

1. to provide a CDR for all charges incurred and requiring settlement between the different commercial roles;
2. to allow itemized billing for all services (including CAMEL) charged to each subscription, including voice and data calls, and services offered by home environments, taking into account:
  - information provided by the user (including authentication parameters, etc.);
  - information provided by the serving network (including Serving Network Id, timestamps, etc.);
  - information provided by the service (including charged party, long calling, multimedia, etc.).
3. to allow fraud control by the Home Environment and the Serving network.

#### 5.1.1 General aspects of Charging Data

Charging Data Record (CDR) generation and contents should be flexible and unnecessary redundancy in data should be avoided. Charging data are collected for successful and selected unsuccessful subscriber transactions. The subscriber transaction is seen as being successful in the MSC server (where the CDR is generated) either if a call is answered or if the Short Message Service Centre has confirmed the successful receipt of a mobile originated short message.

Unsuccessful call attempts are recorded in the case of partial record generation due to CAMEL FollowOnCalls. If in such a call constellation the answer state is reached at least once, subsequent unsuccessful set-up of a connection configuration is also recorded in order to provide a complete sequence of FIRST, INTERMEDIATE and LAST records.

At termination of the subscriber transaction these data are formatted into CDRs. These records are forwarded onto MSC server's CGF which constitutes the source for further transportation of that data to the Billing Domain via the Bc reference point, see 3GPP TS 32.297 [52]. For the purpose of the present document, the CDRs are considered to be collected, in near real-time, by the following network elements: the MSC servers, MGWs, and location registers (VLR/HLR).

The data collected by the network elements are sent to ("pushed"), or collected by ("pulled"), the Billing Domain for storage and further processing. The CDR transfer across the Bc reference point is specified in detail in 3GPP TS 32.297 [52].

Similarly, the tariff data required by the network elements to provide on-line charging information are distributed by the appropriate management system. This function, however, is outside the scope of 3GPP standardization.

#### 5.1.2 Charging information

The MSC server and Gateway MSC server are responsible for the collection of all charging relevant information for each MS and PSTN connection and for the storage of this information in the form of CDRs.

Circuit switched calls can be charged in one MSC server (the anchor MSC server) where all relevant data is available. That is guaranteed by routing all signalling information through the anchor MSC server even if the traffic channel of a call is routed through another MSC server due to handover.

The Gateway MSC server acts as a gateway into other PLMNs or fixed networks. Within the PLMN, the GMSC server is responsible for the generation of CDRs for calls routed from or into other networks.

If subscribed CAMEL services apply to MS, the (G)MSC servers contain CAMEL subscription data providing the information required for invocation of the CAMEL dialogues for controlling the MS terminating and MS originating calls. Charging data record parameters resulting from the CAMEL treatment applying to MS calls is derived from the CAMEL subscription data.

In addition to user subscribed services, specific dialled CAMEL services might be invoked which also influence existing records or even trigger the generation of separate records steered by service logic.

Each CDR captures all charging information relevant to the call, or in case of partial CDRs (see clause 5.1.3.6), the portion of a call that the CDR covers. Depending on the type of CDR and the node producing it, this includes information on tele- and bearer services (which may include radio resource usage) and supplementary service invocation / termination. As far as tele- and bearer services are concerned, all service information is embedded in the appropriate CS CDR, i.e. there are no specific "service CDRs" in the CS domain. For Supplementary Services, the exact treatment is specified in clause 5.1.3.3.

In addition to the information collected from the network elements, network management functions are required for the administration of on-line charging data stored in the MSC servers. This data is employed to drive the charge display in the Mobile Station (MS) as required by the Advice of Charge (AoC) service and defined by 3GPP TS 22.086 [204] and 3GPP TS 22.024 [203].

### 5.1.2.1 Subscriber billing

The charging data collected from the HPLMN, interrogating PLMN, and/or VPLMN network elements is employed to determine the network utilization charges for the basic and supplementary services utilized by the home subscribers of the PLMN. The charges calculated are then combined with the network access (subscription) charges and billed to those customers directly serviced by the PLMN.

For those subscribers handled by Service Providers, the billing information is employed for both wholesale (Network Operator to Service Provider) and retail (Service Provider to Subscriber) billing. Consequently, having been processed by the PLMN Billing System, the charging data collected from the network elements may also be sent to the Service Provider for further processing.

### 5.1.2.2 Settlements of Charges

#### 5.1.2.2.1 Inter-PLMN accounting

Inter-PLMN accounts for roaming traffic are determined in accordance with ITU-T principles (see ITU-T Recommendation D.93 [300]) and are settled by means of the GSM Association's Transferred Account Procedure (TAP).

#### 5.1.2.2.2 "Visitors" from other PLMNs

The CDRs collected from the network also include details of the services employed by visiting (roaming) subscribers. The charges for Mobile Originated Calls (MOCs) and for supplementary services used are calculated as for home subscribers, converted to an agreed accounting currency and included in the CDRs for the TAP. Even if Mobile Terminated Calls (MTCs) are zero-priced in the visited network (VPLMN), in the absence of "optimized routing" the MTC TAP records are still required by the home network (HPLMN) in order to determine the re-routing charges from the HPLMN to the VPLMN.

The TAP records generated are exchanged with each HPLMN on a regular basis. These TAP records form the basis of the invoice submitted by the VPLMN for the traffic carried.

#### 5.1.2.2.3 "Home" subscribers roaming in other PLMNs

The HPLMN receives TAP records from each VPLMN for services employed by home subscribers whilst roaming. These records are employed to verify the invoices from the VPLMN and to bill the home subscribers for the services used. The charges contained in the TAP records are converted from the accounting currency to the local currency and a handling surcharge (mark-up) is added if required. The TAP records are subsequently passed to the subscriber billing process described in clause 5.1.2.1.

#### 5.1.2.2.4 Settlement with other networks

The settlement of accounts with the operators of other networks (fixed / mobile) for traffic carried, is generally performed on a bulk basis according to the principles outlined in the ITU-T Recommendations D-series.

The traffic accounted for in this manner may include:

- outgoing (Mobile to Mobile/Land) traffic;
- incoming (Land/Mobile to Mobile) traffic;
- transit traffic, carried by intermediate networks;
- signalling (MAP/SCCP, CAP/SCCP) traffic such as location updates.

Accounting information may also be required for the use of services provided by other operators such as short message service centres and other Value Added Service (VAS) providers.

The charges for the various traffic shares may be determined on the basis of the CDRs generated by the network elements or on the basis of bulk counters (accounting meter records) in the gateway MSC servers (GMSC servers). For the purpose of the present document, the management information required is assumed to be derived from CDRs. The management of accounting meters is outside the scope of the present document.

In GSM, the radio resources used for various connection types are roughly identical, hence no differentiation of the connection types is needed for the purpose of inter-network accounting. In UMTS, however, the radio bandwidth allocated to a connection may be much higher compared to GSM, even though the connection looks identical from the perspective of the gateway MSC server. Therefore it is necessary that the gateway CDRs capture the cases where "higher-than-normal" radio bandwidth is occupied. An example of a narrow band radio connection is the standard AMR voice call. An example of a wideband service, using the same landline channel but much more radio resources, is the use of BS30 for video telephony.

Given that - in contrast to the serving MSC server - the gateway MSC server cannot distinguish the cases described above, the serving MSC server is capable of returning information on the bearer capability back to the GMSC server so that this information can be added to the gateway CDR for incoming connections. For further details of this functionality, refer to 3GPP TS 29.007 [213].

### 5.1.2.3 Service Information

The charging data collected from the network elements may be used to provide statistical information concerning the use of services, by both home and visiting subscribers, within the network. In addition, the introduction of new services and / or modifications to the tariffs of existing services may also require the distribution of the appropriate tariff information to the network elements for Advice of Charge purposes.

## 5.1.3 Special cases and considerations

The following clauses provide detailed consideration on CS domain specific items and topics.

### 5.1.3.1 AoC service

In addition to the information collected from these Network Elements, network management functions are required for the administration of on-line charging data stored in the MSC server. Two levels of AoC service are available: information level and charging level. The information level is used only to provide AoC information to the user. For the charging level, if no approval of the AoC information by the MS is received in the MSC server, the call is released immediately.

This data is employed to drive the charge display in the Mobile Station (MS) as required by the advice of charge (AoC) service and defined by 3GPP TS 22.086 [64] and 3GPP TS 22.024 [63]. Information used by the AoC service shall include a combination of the following:

- one or more basic services; and/or
- one or more supplementary services; and/or
- one or more network specific services; and/or
- one or more power capability classes (MS classmark); and/or
- the type of radio traffic channel used/ requested;

- the transparency mode of the basic service employed (transparent/non-transparent);
- the type of call or connection (e.g. MOC/MTC).

This list may also be extended to include additional network specific parameters.

Parameters sent to the mobile station during the operation of the AoC service are recorded in the appropriate CDRs.

### 5.1.3.2 CAMEL services

A CAMEL service can be activated for originating, forwarded and terminated calls and originating SMS. Several fields describing CAMEL subscription and free format data are recorded to appropriate CDR. For originating and forwarded calls two different CAMEL services can be active and part of stored information is different depending on the CAMEL call model and which triggers occur. CAMEL fields describing usage level of service, CAMEL modified parameters and CAMEL initiated call forwarding include information for one call leg including impacts on all CAMEL services.

### 5.1.3.3 Use of supplementary services

The recording of supplementary service usage permits the Billing Domain (BD) to specify the supplementary service actions (invocation, registration, etc.).

In addition to specifying the actions to be recorded, the BD may also determine how these events are to be recorded. Non-call related events, such as the administration of supplementary services by the subscriber via the MMI of the MS, shall result in the production of supplementary service action records. Call related events (e.g. invocation of supplementary services) shall be recorded "in-line" in the appropriate CDR and / or in a separate SS-action record depending on the configuration specified by the BD.

Where the use of a supplementary service results in the production of further connections (e.g. call forwarding, multi-party service etc.) additional CDRs shall be produced to describe the relevant connections. The use of such services is described in more detail both in this clause and in the example scenarios.

### 5.1.3.4 Use of call forwarding

When one of the call forwarding services is used, the charging function of the MSC server that forwards the call, shall produce the MOC record for the forwarded part of the call.

For further information concerning the recording of call forwarding services see the example scenarios in clauses 5.2.1.6 and 5.2.1.7.

### 5.1.3.5 Use of call hold and multi-party services

The use of the call hold service shall be recorded either in-line in the appropriate CDR or in a separate supplementary service "invocation" record as described above. The duration for which the call is held, i.e. is inactive, is not recorded.

The use of the multi-party service requires a minimum of 3 subscribers and the use of a conference circuit. For the purpose of the following description the subscriber invoking the service is referred to as the conference originator ("A") and the conference call is regarded as consisting of a number of individual "legs" between the conference originator and the other parties ("B", "C", etc.) in the call.

Normal MOC and MTC CDRs shall be generated for each party and each leg of the call. In addition, if common equipment records are enabled, a common equipment record shall be produced for the conference originator in order to record the use of a conference bridge and to record the total duration of the conference connection.

**EXAMPLE:** Subscriber "C" calls subscriber "A". Subscriber "A" places the call from "C" on hold and makes a second call to subscriber "B". Subscriber "A" then invokes the multi-party service in order to set-up a conference call with "B" and "C".

Assuming that the appropriate types of record are enabled, the following CDRs shall be produced:

- An MOC record for subscriber "C" and the "C"->"A" leg of the call;
- An MTC record for subscriber "A" and the "C"->"A" leg of the call;

- An MOC record for subscriber "A" and the "A"->"B" leg of the call;
- An SS-Action record for the invocation of the call hold service by subscriber "A";
- An MTC record for subscriber "B" and the "A"->"B" leg of the call;
- An SS-Action record for the invocation of the multi-party service by subscriber "A";
- A common equipment record for the use of the conference bridge by subscriber "A".

Each of the MOC/MTC records for the conference originator ("A") shall include the supplementary service code for the multi-party service.

Any subsequent action affecting only one leg of the connection shall be recorded either in a separate supplementary service action record or in-line in the appropriate CDR. Any action affecting the conference as a whole e.g. the originator holding the conference shall be recorded either in a separate supplementary service action record or in the common equipment usage record.

For further information concerning the recording of multi-party services see the example scenario in clause 5.2.1.9.

### 5.1.3.6 Partial records

In order to increase the security of the recording process and to simplify post-processing, it may be desirable to generate a sequence of CDRs to describe a single connection or transaction.

In case of connections of extended duration, the loss of a single CDR may result in an unacceptable loss of revenue. If the connection is, for example, recorded in a number of consecutive partial records generated at say hourly intervals, then the maximum loss of revenue is the equivalent of a one hour continuous connection.

Most modern billing systems employ some form of cumulative credit-limit checking based on the stream of input CDRs. If however, a CDR is only produced at the end of the connection then a subscriber may avoid such credit checking by employing a connection for days, weeks or even months without a single CDR being produced.

All of the records defined in the present document are of variable length and some at least are potentially unlimited in size (SET OF, SEQUENCE OF, etc.). However, the storage capacity of the internal records within the network element is normally subject to strict size limitations. Under such conditions a partial record may be required in order to circumvent internal resource limitations. For example, if an internal MOC record can only support the use of four supplementary service invocations then the use of a fifth may result in the generation of a partial record.

Alternatively, for those manufacturers whose systems are based on fixed length records, partial records may be employed instead of the various lists contained within the present document definitions. In such cases a partial record will be produced each time one of the key fields alters during the connection.

Finally, in case of radio link failure and subsequent call re-establishment partial records shall be generated to record the duration of the call prior to the radio link failure and the subsequent duration of the call once the call has been re-established.

To summarize, the following events may result in the generation of a partial record:

- expiry of the partial record timer;
- change of basic service during a connection;
- change of location (MCC+MNC+ LAC or Cell Id. or the Service Access Code, for UMTS) during a connection;
- change of MS classmark during a connection;
- change of AoC Parameters during a call;
- change of Radio Channel Type (full/half rate) during a call;
- radio link failure and subsequent call re-establishment;
- change of HSCSD Parameters (for GSM only) during a call;
- change of CAMEL destination (CAMEL controlled/initiated) during a call;

- CAMEL CPH operations on call legs.

All partial records for the same connection shall contain the same call reference and shall be ordered via a running sequence number. The time stamps involved shall apply to the individual partial records rather than the connection as a whole i.e. the "end" time stamp (duration) of one record shall, in general, coincide with the "start" time stamp (answer time) of the next. Each time a new partial record is created the cause for termination field of the previous record shall contain the value "partial record". The cause for termination of the final partial record shall contain the true cause for termination of the connection.

It should be noted that the records produced in case of call re-establishment are not contiguous and that the value of the cause for term field in the record that is closed on radio link failure contains the value "partial record call re-establishment".

The partial records generated may repeat each of the non-varying fields contained in the original record. Alternatively, a form of reduced partial record may be generated which includes only those fields required to identify the original record together with the field(s) that actually change.

### 5.1.3.7 Use of circuit-switched data services

If data services are employed in conjunction with a Packet-Switched Public Data Network (PSPDN) then an MOC/MTC CDR may be produced in the originating/terminating MSC server and a gateway record in the gateway/interworking MSC server. If the packet volume is not available within the PLMN then this information may also be provided in the form of a CDR from the PSPDN. In such cases the Billing System is responsible for the correlation of the various records describing the connection. The definition of such PSPDN CDRs is outside the scope of the present document.

### 5.1.3.8 Inter-MSC server handover

In the case of an inter-MSC server handover the controlling MSC server, as defined by 3GPP TS 23.009 [65], remains in control of the connection and shall therefore, produce the CDR. For the avoidance of doubt, it is not necessary to produce CDRs in the subsequent MSC server(s).

### 5.1.3.9 Call re-establishment

In case of radio link failure as described in 3GPP TS 24.008 [68], the MS may attempt to re-establish the call using the procedures described in 3GPP TS 24.008 [68].

For the time period between the detection of the radio link failure by the mobile station and the successful re-establishment of the call, the advice of charge function in the MS is suspended as described in 3GPP TS 24.086 [23]. In order to minimize the difference in charges between the on-line calculations performed by the MS and the off-line processing on the basis of the CDRs, it is necessary to exclude the time taken for the re-establishment phase from the chargeable duration stored in the CDRs.

If the re-establishment attempt fails then an ordinary CDR (MOC/MTC) shall be produced with the cause for termination value "stable call abnormal termination". The chargeable duration stored in this record covers the time period from "Answer" to the detection of the radio link failure by the MSC server.

If, the attempt to re-establish the call succeeds then the current CDR shall be closed with the cause for termination value "partial record call re-establishment" and a new partial record shall be opened for the re-established call. The chargeable duration stored in the original record is once again the time period from "answer" to detection of the radio link failure by the MSC server. Both the "seizure" and "answer" times of the subsequent partial record correspond to the time at which the new traffic channel is allocated for the re-established call.

Further radio link failures during the re-established call may result in the generation of additional partial records as described above. All of the partial records belonging to the same connection are identified by the same call reference and a running sequence number.

**NOTE:** As the MS and MSC server may detect the radio link failure at different points in time, it is not possible to guarantee that the duration used for the AOC display corresponds to that recorded in the CDRs. The purpose of the above procedure is merely to minimize any discrepancies that may occur.

### 5.1.3.10 Restricted directory numbers

In addition to the information pertaining to the served mobile subscriber (IMSI, MSISDN, etc.), the CDRs defined in the present document also contain the directory numbers of other parties involved in the recorded connections or transactions. In order to comply with data protection legislation, it is necessary to distinguish between those numbers that may be passed on to third parties and those that needs to be handled confidentially. As a result, each of the number fields (e.g. calling/connected number) contains the presentation and screening information defined in both TS 24.008 [68] and ISUP signalling. If this information is supported by the network, then even restricted numbers may be included in the appropriate records and suppressed off-line by the administration or billing system. If this information is not supported then the entire directory number shall be suppressed by the MSC server/VLR.

### 5.1.3.11 IMEI Observation

In order to provide the data required by the mobile equipment management activities outlined in the previous clauses, the MSC server shall be capable of producing IMEI tickets for each of the following events:

- usage of a blacklisted IMEI;
- usage of a greylisted IMEI;
- usage of an IMEI not found on the white list.

An observed IMEI ticket is generated whenever greylisted, blacklisted or non-white listed mobile equipment is detected during an IMEI check. The purpose of the ticket is to link the mobile equipment under observation with its current user (IMSI). The ticket also includes information describing when and where the equipment was used to enable the tracking of such equipment. Finally, if the ticket was triggered by a call attempt, a call reference is provided in order to locate the corresponding CDR.

The IMEI tickets are generated by the MSC server performing the IMEI check.

### 5.1.3.12 Triggers for LCS-MT-CDR, LCS-MO-CDR and LCS-NI-CDR Charging Information Collection

The LCS CDRs (LCS-MT-CDR, LCS-MO-CDR and LCS-NI-CDR) are used to collect charging information related to the LCS features that the PLMN provides in the Packet-Switched domain.

These records include details such as Record Type, Served IMSI, Sequence Number etc. The LCS records are generated based on the following trigger conditions:

- the LCS-MO-CDR, when the MSC receives the RANAP "Location report" message from the RNC;
- the LCS-MT-CDR, when the MSC receives the RANAP "Location report" message from the RNC;
- the LCS-NI-CDR, when the MSC receives the RANAP "Location report" message from the RNC.

### 5.1.3.13 BS30 Accounting

BS30 is an example where the serving network may use a substantially higher radio bandwidth than for a standard voice call. While the invocation of this service, including the used radio resources, can be captured in the serving MSC server, this is not possible in the GMSC server. However, if the inter-network accounting is done based on GMSC CDRs, this information is needed by the GMSC server in order to provide the required CDR information. To that end, the serving MSC server can provide this information back to the GMSC server. See clause 5.1.2.2.4 for further details.

### 5.1.3.14 CAMEL Call Party Handling service

The following applies to MSCs that are capable of CAMEL Call Party Handling (CPH):

For calls where CAMEL Call Party Handling (CPH) is involved, one separate record is generated per call segment. The CAMEL CPH service may be applied to originating, forwarded and terminated calls as well as SCP initiated calls.

For MO, MT and CF call attempts, the fields related to the incoming leg are recorded in the main body. The fields related to the outgoing legs of that call segment are recorded in the respective grouped field (CAMEL call leg information) per outgoing leg. User Interactions (UI) are recorded in a separate grouped field like outgoing legs.

Records for gsmSCF initiated call attempts differ to MO, MT and CF records in the following way: no leg information shall be recorded in the main body.

Where the use of CPH result in the creation of further call legs in one call segment, additional grouped fields shall be added to the respective CDR.

Where the use of CPH result in the creation of further call legs in a new call segment, a further CDR shall be generated.

A CDR is closed when the last leg of the call segment disappeared (moved out, disconnected, etc. ) from the call segment.

When a call leg is moved from one call segment to another, the grouped field for that call leg is closed in the respective CDR and a new grouped field is opened in the CDR of the call segment the call leg was moved to.

When the incoming leg (recorded in the main body), is moved from one call segment to another, the grouped field(s) for the outgoing call leg(s) is/are aligned to reflect the new call constellation.

User interactions (announcements etc.) are recorded in the CDR of the related call segment as a separate grouped field similar to call legs.

The leg specific fields listed below shall be recorded in the grouped field 'CAMEL Call Leg Information' instead of using the counterpart in the main body. The counterparts of those fields in the main body are maintained for compatibility reasons to earlier releases.

- CAMEL Destination Number
- Translated Number
- Connected Number
- Roaming Number
- Outgoing TKGP (in 'CAMEL Call Leg Information' this item is called MSC outgoing TKGP)
- Additional Chg. Info
- Default call handling 2
- GsmSCF address 2
- Service key 2
- Free format data 2 (in 'CAMEL Call Leg Information' this item is called Free format data incoming 2)
- Free format data append indicator 2 (in 'CAMEL Call Leg Information' this item is called Free format data append incoming 2)

**Editor's note: both parameters from the second FCI operation should be clarified, also in the CDR table**

- Location Routing Number (LRN)
- LRN Source Indicator
- LRN Query Status Indicator
- JIP Parameter
- JIP Source Indicator
- JIP Query Status Indicator



### 5.1.3.15 Service Change and Fallback

Service Change and UDI/RDI Fallback (SCUDIF) provides the possibility of changing the transport bearer capabilities for circuit switched multimedia applications using 64 kbit/s UDI refer 3GPP TS 23.172 [209].

It allows users to achieve successful call establishment when end to end circuit-switched (CS) multimedia is not possible (fallback to speech) or when signalling of the feature is not possible in the network (fallback to preferred service). Furthermore, it allows the users to swap between a multimedia service and basic speech during an established call.

SCUDIF functionality encloses two sub-functionalities:

- Service-Change: when two services (multimedia and speech) are available during the active call, users may request a Service-Change to switch between the two services.
- Fallback: when two services (multimedia and speech and visa versa) are proposed but only one of them is available or wanted, only the available service is selected, e.g. fallback from multimedia to speech.

**Editor's note: More details for the charging description are needed.**

### 5.1.3.16 CS Fallback and SMS over SGs

CS Fallback is defined in 3GPP TS 23.272 [214] and provides a mechanism to move a UE from EUTRAN PS only access to CS to deliver voice service i.e. over GSM or UMTS access. As a result, charging procedures for call handling are performed as per GSM and UMTS access.

Within SMS over SGs also defined in 3GPP TS 23.272 [214], SMS is delivered in the EUTRAN NAS signalling via the SGs interface between the MME and the MSC/VLR.

### 5.1.3.17 Enhanced MSC server for SRVCC support

The standard MSC behaviour is enhanced for supporting Single Radio Voice Call Continuity (SRVCC) between E-UTRAN access and UTRAN/GERAN accesses, between UTRAN (HSPA) access and UTRAN/GERAN accesses, for voice calls and emergency calls anchored in the IMS, as defined in TS 23.216 [215]. Charging is provided from the MSC server enhanced for SRVCC for successful calls/emergency calls transfer.

When session transfer procedure from IMS to CS is performed by MSC server enhanced for SRVCC interfacing IMS through a SIP interface, according to TS 23.237, this MSC server enhanced for SRVCC behaves as an end-point of the IMS domain, and as such, generates an IMS Charging Identifier (ICID) in order to allow correlation. See TS 32.260 [50] for IMS Charging Identifier (ICID) definition.

### 5.1.3.18 Mobile Terminating Roaming Forwarding call after successful Retrieval of Routeing Information (MTRF)

Mobile Terminating Roaming Forwarding call after successful Retrieval of Routeing Information (MTRF) procedure is described in TS 23.018 [216] and provides a mechanism to reroute a terminating call while the called mobile is simultaneously moving from an old to a new MSC/VLR.

The charging procedures for call handling are performed as for a terminating call in the new MSC/VLR to which the call is rerouted. Dedicated charging is provided by the old MSC/VLR from which the call is rerouted as a result of MTRF procedure, in order to complete the set of CDRs produced along the path of the call and avoid charging duplication.

When the terminating call is rerouted towards a new MSC/VLR which is located in a different PLMN than the Old MSC/VLR, a roaming CDR is produced by the Old MSC/VLR, even when the new MSC/VLR resides in HPLMN.

The same charging behaviour applies for Roaming Forwarding for CS Fallback defined in 3GPP TS 23.272 [214].

## 5.2 CS domain offline charging scenarios

### 5.2.1 Basic principles

This clause contains a number of example scenarios illustrating the purpose and practical usage of the various types of records defined in the previous clauses. These examples are by no means exhaustive.

For the purpose of these examples, the following assumptions have been made:

- that the MSC server and VLR are co-located;
- that the records are sent to a post-processing system;
- that the generation of all of the record types described in this clause has been enabled;
- that the HLR interrogation records are produced in the HLR and not the interrogating MSC server;
- that supplementary service actions are recorded in separate CDRs.

The following conventions have been used for the figures contained within this clause:

- 1) Network connections and signalling transactions are illustrated by means of solid lines and referenced by number e.g. (1);
- 2) Operation & Maintenance actions, such as the transfer of CDRs, are represented by means of dotted lines and referenced by letter e.g. (A);
- 3) The Billing System has been included in some, but not all, of the examples. The only reason for this decision is to simplify the resulting figures. The presence of a Billing System is assumed even if not explicitly included.

The following examples are included:

- 1) Mobile to Land (outgoing) call;
- 2) Land to Mobile (incoming) call;
- 3) Mobile to Mobile call within the same network;
- 4) Incoming call to a roaming subscriber;
- 5) Incoming call to a PLMN Service Centre;
- 6) Call Forwarding Unconditional;
- 7) Call Forwarding conditional (on Busy);
- 8) Delivery of a Mobile Terminated Short Message;
- 9) Call Hold and Multi-party services;
- 10) Outgoing call handled by CAMEL;
- 11) Incoming call handled by CAMEL without redirection;
- 12) Incoming call to a roaming subscriber handled by CAMEL;
- 13) Incoming call handled by CAMEL with redirection decided and forwarding leg handled by CAMEL;
- 14) Incoming call handled by CAMEL without redirection and forwarded early using GSM SS but controlled by CAMEL;
- 15) Incoming call handled by CAMEL without redirection and forwarded late using GSM SS but controlled by CAMEL;
- 16) Early forwarded call controlled by CAMEL;

- 17) Late forwarded call controlled by CAMEL;
- 18) Incoming call handled by CAMEL with redirection initiated by CAMEL feature;
- 19) Incoming call handled by CAMEL in MSC Server without redirection;
- 20) Outgoing call handled by CAMEL Dialed CSI Trigger;
- 21) Incoming call handled by CAMEL with redirection decided and forwarding leg handled by CAMEL;
- 22) gsmSCF initiated wake-up call handled by CAMEL CPH;
- 23) Three party conference handled by CAMEL CPH;
- 24) Mobile terminated location request.

### 5.2.1.1 Mobile to land (outgoing) call

Figure 5.2.1.1 illustrates a simple outgoing call from a PLMN subscriber "A" to a fixed network subscriber "B" (1).

The originating MSC server (MSC-A) shall generate an MOC record for subscriber "A".

The GMSC server shall create an outgoing gateway record for accounting with the fixed network including details of the point at which the call left the PLMN i.e. the GMSC server id. and outgoing trunk group. This record also includes time stamps to determine both the holding time of the outgoing trunk and the duration of the conversation.

Even if the MSC server and GMSC server are co-located both records shall be produced.

The records generated are subsequently transferred to the Billing System of the PLMN (A).

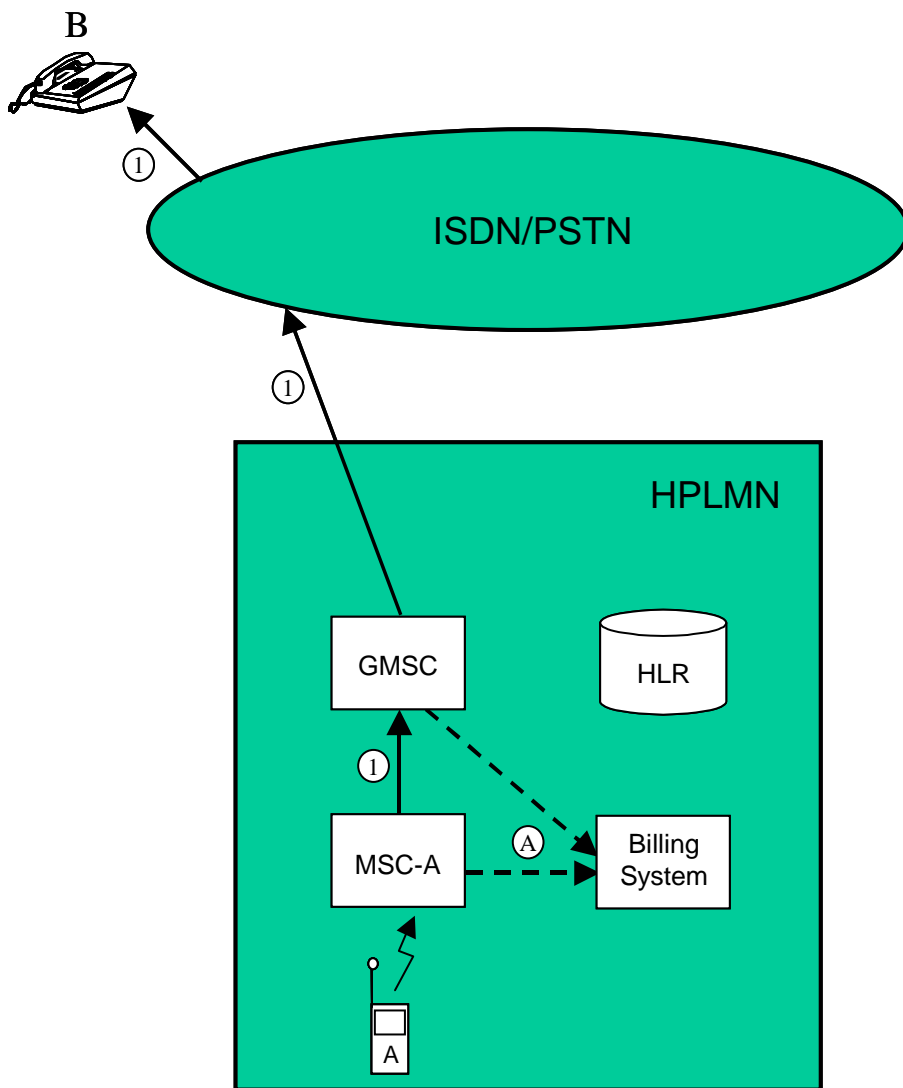

Figure 5.2.1.1: Mobile to land (outgoing) call

### 5.2.1.2 Land to mobile (incoming) call

Figure 5.2.1.2 illustrates a simple incoming call from a fixed network subscriber "A" to a PLMN subscriber "B".

The incoming call is first routed to a GMSC server (1). The GMSC server shall create an incoming gateway record for fixed network accounting purposes to record the point at which the call entered the network together with the time stamps required to calculate the holding time of the incoming trunk and the conversation duration. This gateway record shall contain the IMSI of the called subscriber.

The GMSC server interrogates the HLR of the called subscriber in order to determine his current location (2). The HLR shall create an HLR interrogation CDR.

The GMSC server routes the call to the MSC server at which the subscriber is currently registered (3). This terminating MSC server (MSC-B) shall create an MTC record for subscriber "B".

Even if the MSC server and GMSC server are co-located both the MTC and gateway records shall be produced.

The records generated are subsequently transferred to the Billing System of the PLMN (A).

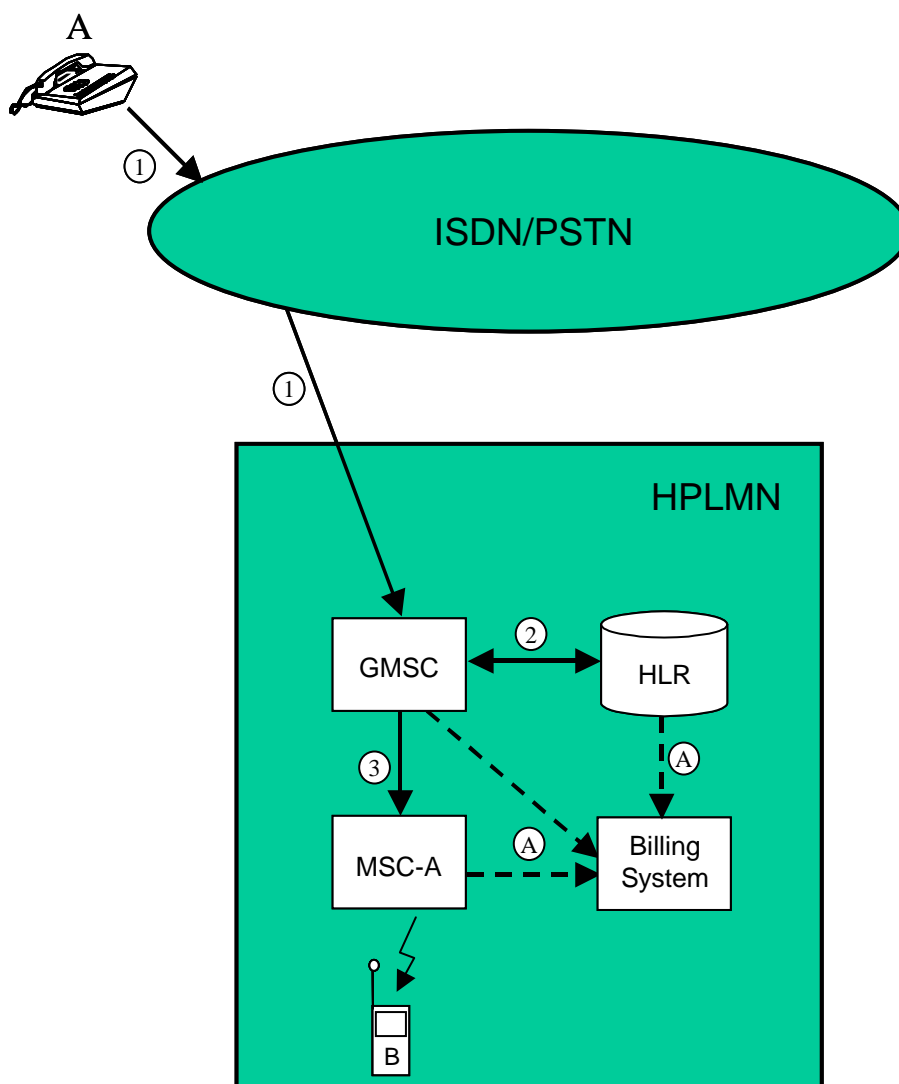

Figure 5.2.1.2: Land to mobile (incoming) call

### 5.2.1.3 Mobile to mobile call within the same network

Figure 5.2.1.3 illustrates a simple mobile to mobile call from subscriber "A" to subscriber "B" both within the same PLMN.

The originating MSC server (MSC-A) shall produce an MOC record for the call to subscriber "B".

Having received a set-up request from subscriber "A" (1), MSC-A interrogates the HLR of the called subscriber in order to determine his current location (2). The HLR shall create an HLR interrogation CDR.

MSC-A routes the call to the MSC server at which subscriber is currently registered (3). This terminating MSC server (MSC-B) shall create an MTC record for subscriber "B". If MSC-A and MSC-B are co-located, then both the MOC and the MTC records shall be produced in the same MSC for this call.

The records generated are subsequently transferred to the Billing System of the PLMN.

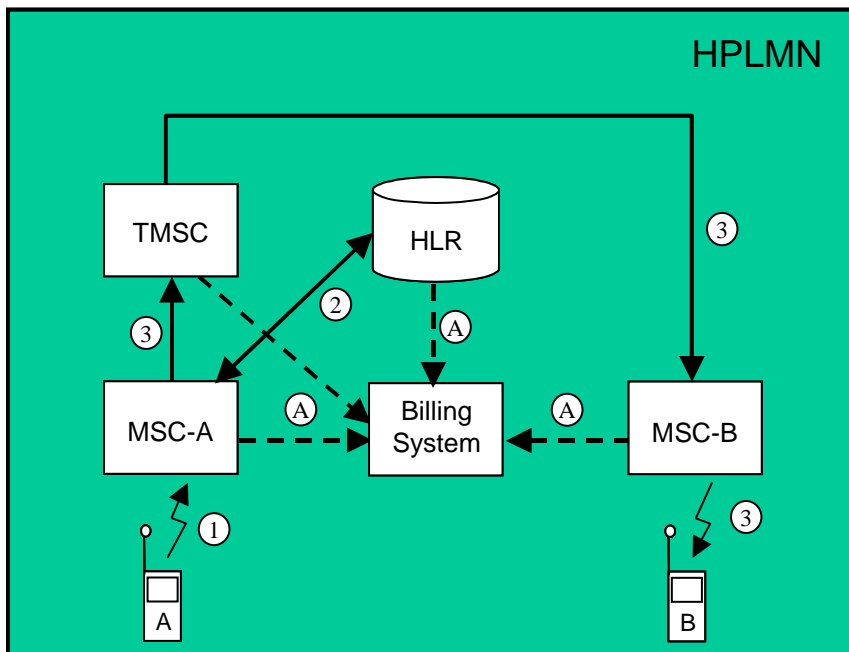

Figure 5.2.1.3: Mobile to mobile call

### 5.2.1.4 Incoming call to a roaming subscriber

Figure 5.2.1.4 illustrates an incoming call from a fixed network subscriber "A" to a PLMN subscriber "B" who is currently roaming in another PLMN.

The call is first routed to a GMSC server (1) and the GMSC server shall create an incoming gateway record for accounting purposes as described in clause 5.2.1.2. The GMSC server interrogates the HLR of the called subscriber in order to determine his current location (2). The HLR shall create an Interrogation event record.

The GMSC server routes the call to the VPLMN in which subscriber "B" is currently located (3). The GMSC server shall create an outgoing gateway record for accounting purposes. The GMSC server shall also create a roaming record. This record includes the IMSI of the "B" subscriber and may be used as a cross-check for the TAP information received from the VPLMN.

The call is then routed by the VPLMN to the MSC server at which the subscriber is currently located (4). The GMSC server of the VPLMN shall produce an incoming gateway record and the terminating MSC server shall create an MTC record for the call to "B".

The records generated are subsequently transferred to the Billing System of the appropriate PLMN (A). The MTC record generated by the terminating MSC server shall be employed to create the appropriate MTC TAP record. The TAP records shall be included in a TAP file and transmitted to the HPLMN (B).

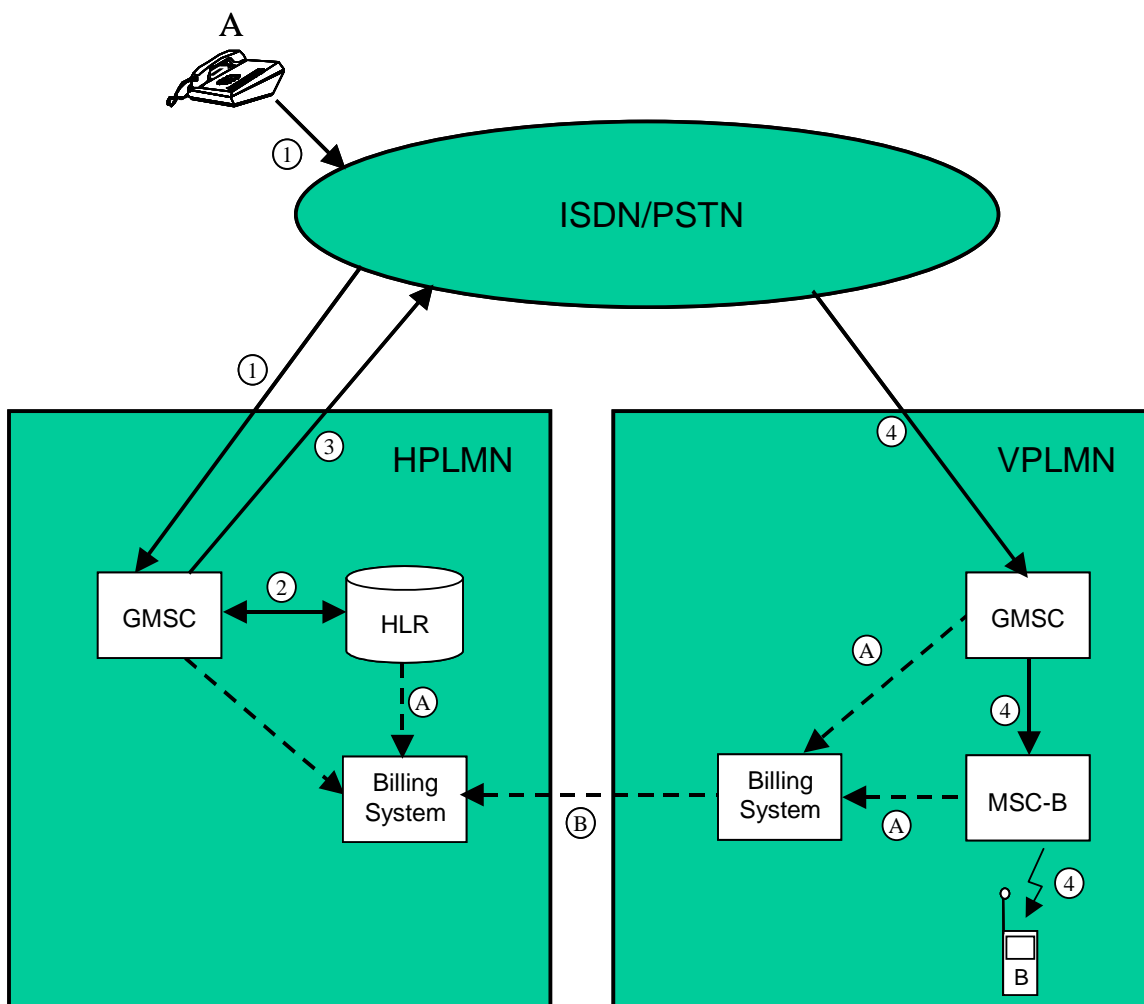

Figure 5.2.1.4: Incoming call to a roaming subscriber

### 5.2.1.5 Incoming call to a PLMN service centre

Figure 5.2.1.5 illustrates an incoming call from a fixed network subscriber "A" to a Service Centre directly connected to an MSC server within a PLMN network. Examples for services provided by such a Service Centre include Voice Mail services, Operator services, etc.

The call is routed to a GMSC server within the PLMN (1). The GMSC server analyses the dialled digits and routes the call directly to the MSC server to which the Service Centre is connected (2).

As HLR interrogation is not required, there will be no HLR Interrogation record. The GMSC server shall however, create an incoming gateway record based on the point at which the call entered the network and the destination (Service Centre) of the call.

The MSC server then connects the calling subscriber to the service centre. As no mobile subscriber is involved, the MSC server will not create an MTC record, however, the MSC server shall create a transit record describing the destination of the call.

The records generated are subsequently transferred to the Billing System of the PLMN (A).

It should be noted that without the transit record, the MSC server would not generate a record for this connection.

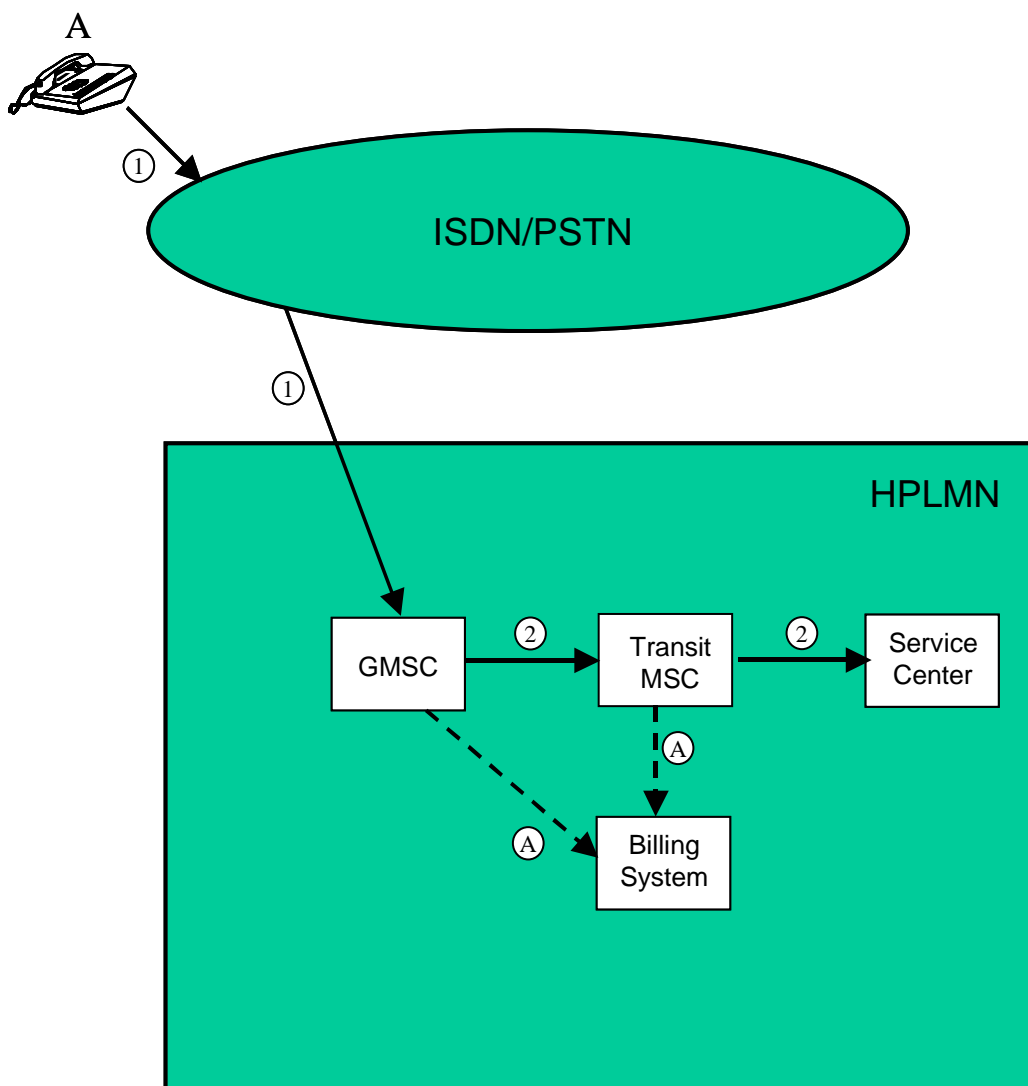

Figure 5.2.1.5: Incoming call to a PLMN service centre



### 5.2.1.6 Call forwarding unconditional

Figure 5.2.1.6 illustrates an incoming call from a fixed network subscriber "A" to a mobile subscriber "B" who has registered and activated Call Forwarding Unconditional (CFU) for the appropriate service. The call is subsequently forwarded to a second fixed network subscriber "C".

For simplicity the registration and activation of CFU have not been included in the diagram. These actions shall of course be recorded in the appropriate supplementary service records.

The incoming call is routed to a GMSC server (1). This part of the connection is identical to the scenario outlined in clause 5.2.1.2.

The GMSC server interrogates the HLR of the called subscriber in order to determine his current location (2). The HLR shall create an HLR interrogation CDR. The HLR informs the GMSC server that "B" has activated CFU to subscriber "C".

The GMSC server forwards the call to the fixed network subscriber "C" (3). The GMSC server shall create an MTC record for the "B" subscriber for the call from "A" and an MOC (call forwarding) record for the "B" subscriber for the call to "C". Both records shall contain the supplementary service employed (CFU). The GMSC server shall also produce an outgoing gateway record as described in clause 5.2.1.1.

The records generated are subsequently transferred to the Billing System of the HPLMN (A).

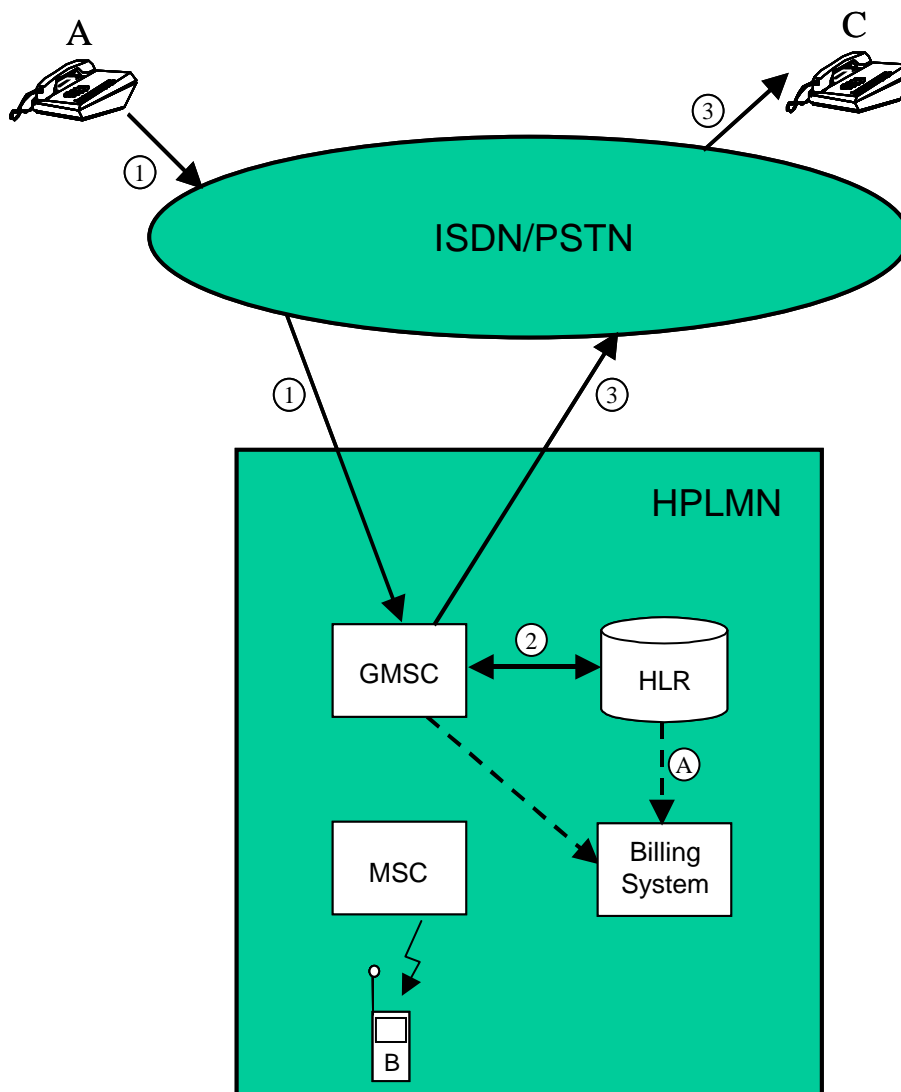

Figure 5.2.1.6: Call forwarding unconditional

### 5.2.1.7 Call forwarding conditional (on busy)

Figure 5.2.1.7 illustrates a mobile originated call from subscriber "A" to a second mobile subscriber "B" who has registered and activated Call Forwarding on Busy (CFB) for the appropriate service. The call is subsequently forwarded to a third mobile subscriber "C". In this example, all three subscribers are currently located within the same (the home) network.

For simplicity the registration and activation of CFB have not been included in the diagram.

Having received a set-up request from subscriber "A" (1), the originating MSC server (MSC-A) interrogates the HLR of subscriber "B" in order to determine his current location (1a). The call is then routed to MSC-B (2).

MSC-A shall create an MOC record for subscriber "A" containing details of the call to "B". The HLR shall produce an HLR interrogation record.

On determining that subscriber "B" is busy and that CFB is active, the forwarding MSC server/VLR (MSC-B) interrogates the HLR of subscriber "C" to determine his current location (2a) and forwards the call accordingly (3).

MSC-B shall produce an MTC record for the "B" subscriber for the call from "A" and an MOC record for the "B" subscriber for the call to "C". Both records shall include the supplementary service employed (CFB). The HLR shall produce an Interrogation record.

The terminating MSC server (MSC-C) shall create a normal MTC record for subscriber "C".

The records generated are subsequently transferred to the Billing System of the PLMN.

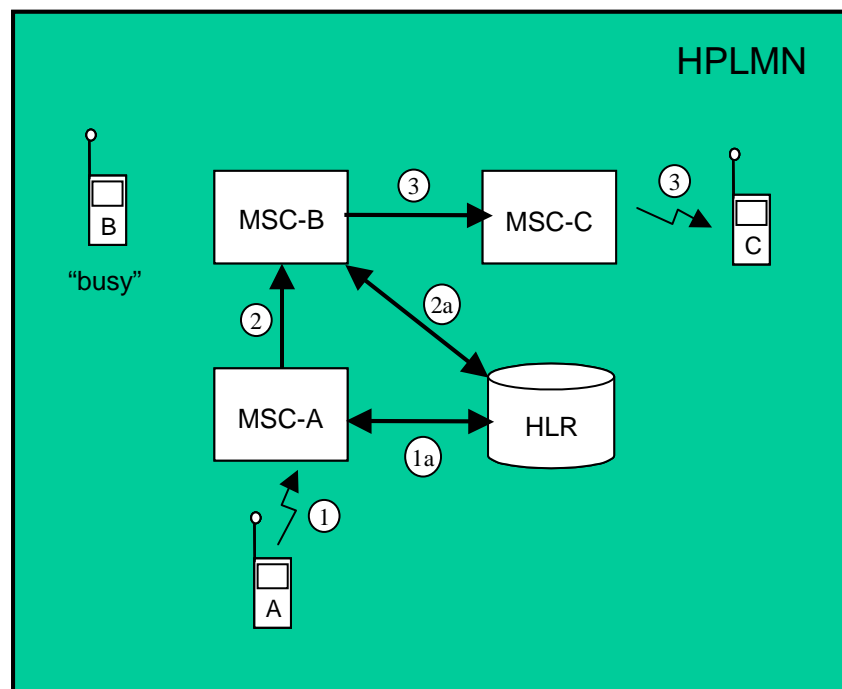

Figure 5.2.1.7: Call forwarding conditional (busy)

### 5.2.1.8 Delivery of a mobile terminated short message

Figure 5.2.1.8 illustrates the delivery of a short message to a mobile subscriber.

The short message service centre delivers the message to a GMSC server or gateway function (1). The GMSC server shall create an SMS gateway MT record.

The GMSC server then interrogates the HLR of the subscriber to determine his current location (2). The HLR shall create an HLR interrogation record.

The message is subsequently transmitted to the MSC server serving the mobile subscriber and finally to the mobile station of that subscriber (3). The MSC server shall create an SMS MT record.

The records generated are subsequently transferred to the post-processing system of the HPLMN (A).

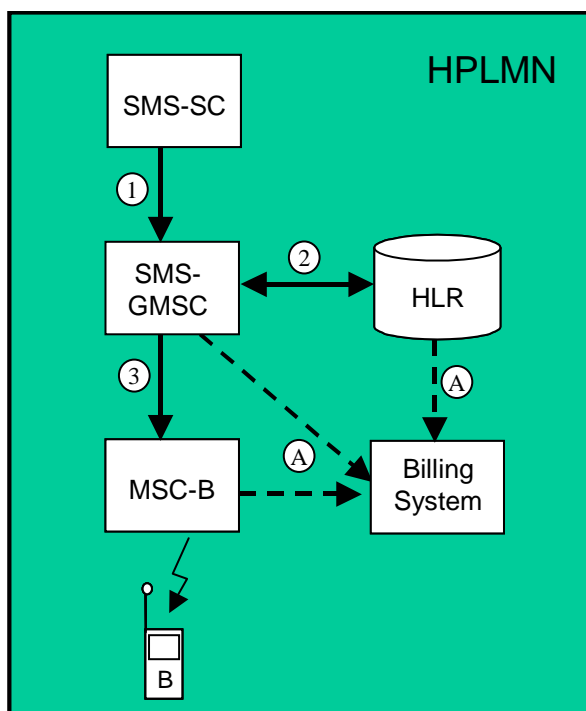

Figure 5.2.1.8: Delivery of a short message to a mobile subscriber

### 5.2.1.9 Call hold and multi-party service

Figure 5.2.1.9 illustrates the use of the call hold and multi-party services.

A mobile subscriber ("A") sets up an outgoing call (1) to an ISDN subscriber ("B"). This call is recorded as outlined in clause 5.2.1.1.

Subscriber "A" then invokes the call hold service. MSC-A shall produce a supplementary service action record for the invocation.

Subscriber "A" then sets up a side-call (2) to a second mobile subscriber ("C") within the same network. This call is recorded as outlined in clause 5.2.1.3.

Subscriber "A" subsequently invokes the multi-party service in order to set up a three-party conference with "B" and "C". MSC-A shall produce a common equipment record for the use of a conference circuit by subscriber "A". This record shall record the duration of the whole conference irrespective of the number of parties subsequently added to, or removed from the conference connection.

Note that the MOC records produced by MSC-A for both the A -> B and A -> C legs of the conference shall contain the supplementary service code for multi-party.

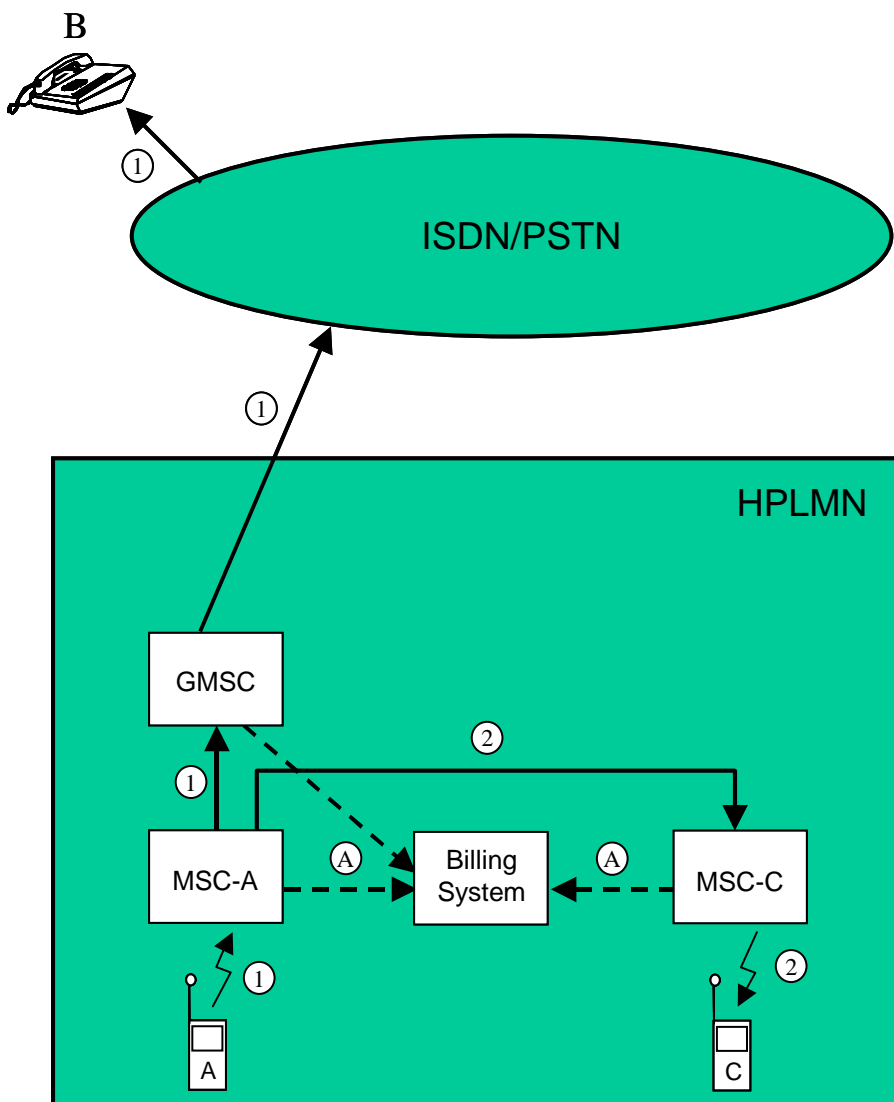

Figure 5.2.1.9: Call hold and multi-party service

### 5.2.1.10 Outgoing call handled by CAMEL

Figure 5.2.1.10 illustrates an outgoing CAMEL call from a mobile CAMEL subscriber "A" to a fixed network subscriber "B" (1).

The "A" subscriber has an active O-CSI (stored in the VLR). Therefore MSC server-A requests instructions from the gsmSSF which passes the CAMEL service key to the gsmSCF to indicate which service logic it should apply (2).

The gsmSCF may interrogate the HLR for subscriber information. As a network option, the operator may refuse to provide the requested information.

When gsmSCF processing is complete the call control is returned to MSC-A.

MSC server-A generates an MOC record for the "A" subscriber. This record may be linked to an optional SCF-record. The record includes O-CSI data.

The GMSC server routes the call to the "B" subscriber (3). The GMSC server shall create an outgoing gateway record as described in clause 5.2.1.1.

The generated records are subsequently transferred to the Billing System of the HPLMN (A).

The following records are generated in HPLMN in this call scenario.

**Table 5.2.1.10: Records Generated for an Outgoing Call Handled by CAMEL**

GMSC server	MSC server	HLR
Outgoing gateway record	MOC record	-

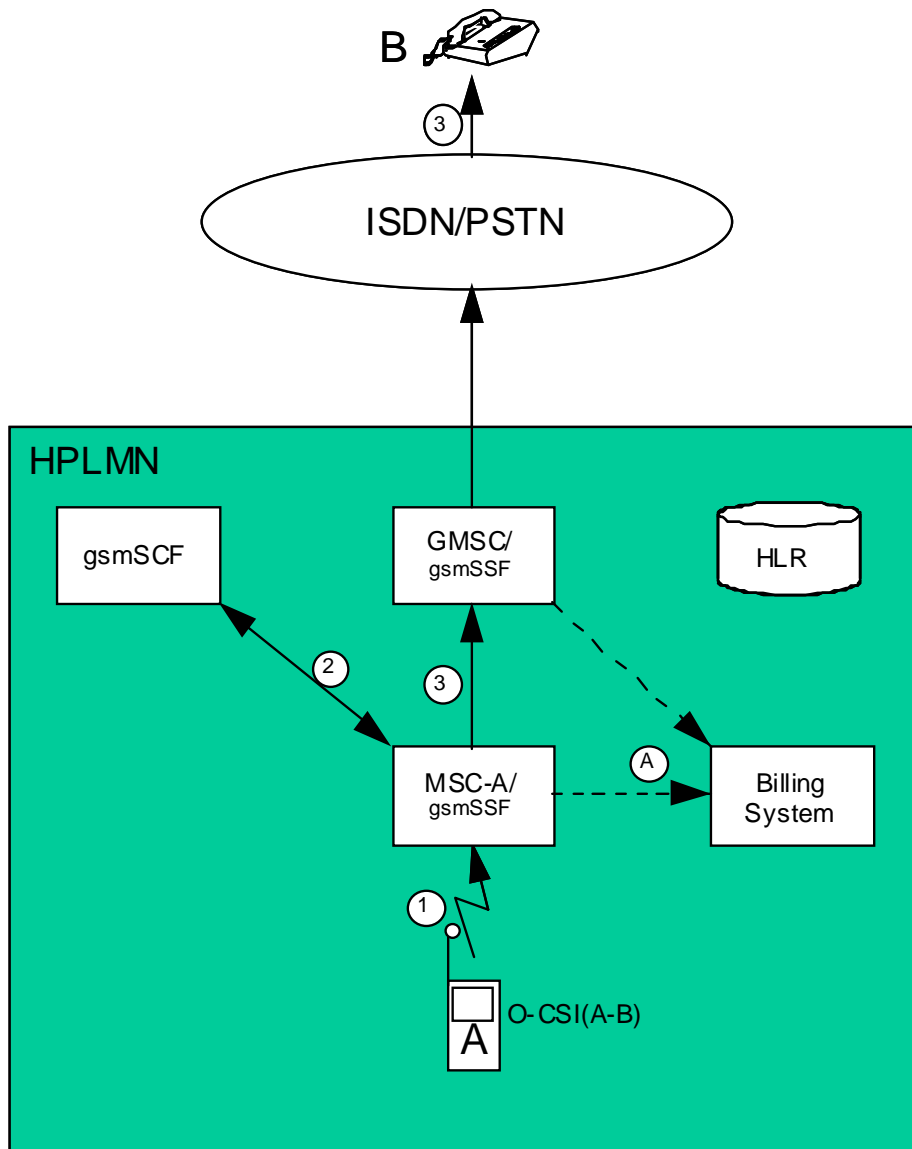

Figure 5.2.1.10: Outgoing call handled by CAMEL

### 5.2.1.11 Incoming call handled by CAMEL without redirection

Figure 5.2.1.11 illustrates an incoming call from a fixed network subscriber "A" to a mobile CAMEL subscriber "B".

The incoming call is first routed to the GMSC server (1). The GMSC server shall create an incoming gateway record for fixed network accounting purposes.

The GMSC server interrogates the HLR of the called subscriber in order to fetch the T-CSI (2). The HLR shall create an HLR interrogation record.

The "B" subscriber has an active T-CSI. Therefore the GMSC server requests instructions from the gsmSSF which passes the CAMEL service key to a gsmSCF to indicate which service logic it should apply (3).

The gsmSCF may interrogate the HLR for subscriber information. As a network option, the operator may refuse to provide the requested information.

When gsmSCF processing is complete the call control is returned to the GMSC server. The GMSC server shall generate a terminating CAMEL record which contains T-CSI data.

The GMSC server interrogates the HLR in order to determine his current location (4). The HLR shall create an HLR interrogation record.

The call is routed to MSC-B (5). An MTC record shall be generated.

For avoidance of doubt, even if the MSC server and GMSC server are co-located both the MTC and gateway records shall be produced.

The generated records are subsequently transferred to the Billing System of the HPLMN (A).

The following records are generated in HPLMN in this call scenario.

**Table 5.2.1.11: Records Generated for an Incoming Call Handled by CAMEL without Re-direction**

GMSC server	MSC server	HLR
Incoming gateway record	MTC record	HLR interrogation record
Terminating CAMEL record		

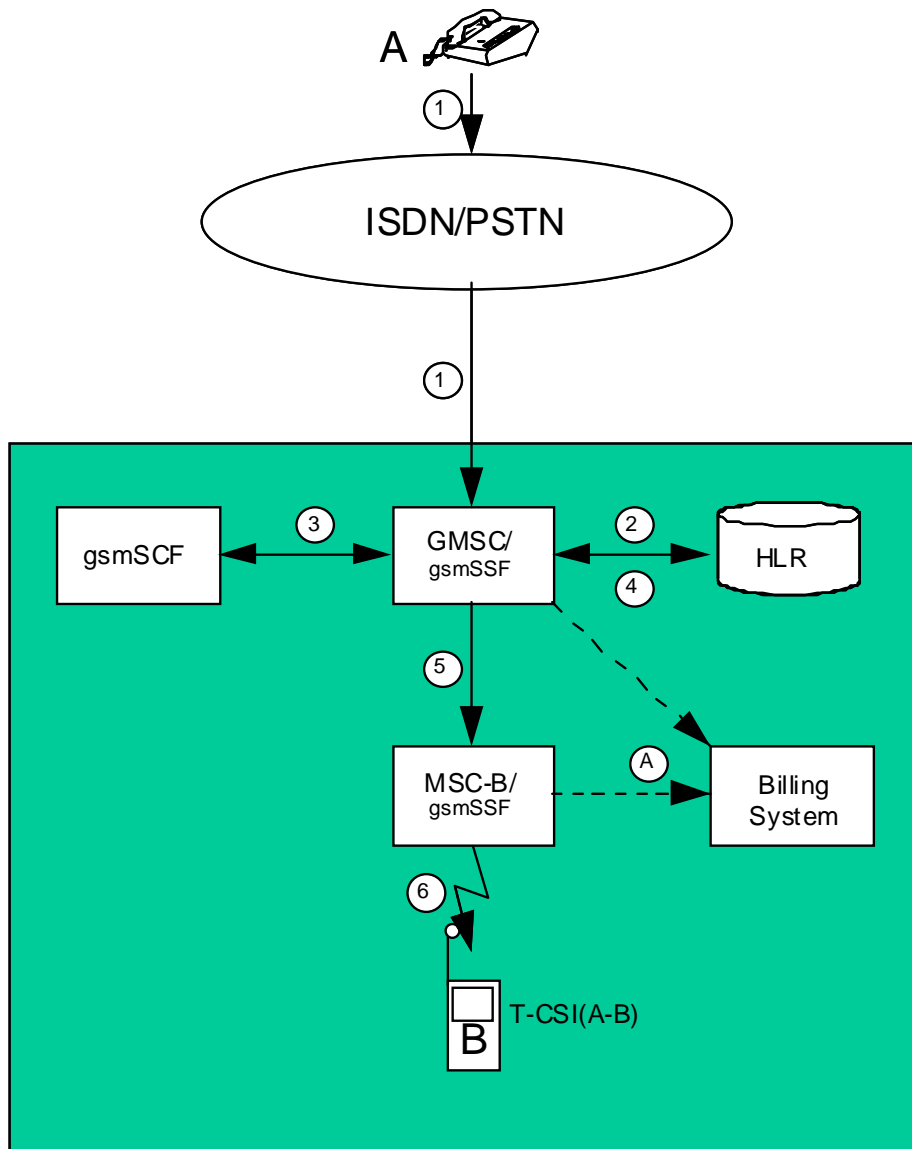

Figure 5.2.1.11: Incoming call handled by CAMEL without redirection



### 5.2.1.12 Incoming call to a roaming subscriber handled by CAMEL

Figure 5.12 illustrates an incoming call from a fixed network subscriber "A" to a mobile CAMEL subscriber "B" who is currently roaming in another PLMN.

The call is first routed to a GMSC server (1) and the GMSC server shall create an incoming gateway record for fixed network accounting purposes.

The GMSC server interrogates the HLR of the called subscriber in order to fetch the T-CSI (2). The HLR shall create an HLR interrogation record.

The "B" subscriber has an active T-CSI. Therefore the GMSC server requests instructions from the gsmSSF which passes the CAMEL service key to a gsmSCF to indicate which service logic it should apply (3).

The gsmSCF may interrogate the HLR for subscriber information. As a network option, the operator may refuse to provide the requested information.

When gsmSCF processing is complete the call control is returned to the GMSC server. The GMSC server shall generate a terminating CAMEL record which contains T-CSI data.

The GMSC server interrogates the HLR in order to determine his current location (4). The HLR shall create an HLR interrogation record.

The GMSC server routes the call to the VPLMN in which subscriber "B" is currently located (5). The GMSC server shall create an outgoing gateway record for accounting purposes. The GMSC server shall also create a roaming record. This record includes the IMSI of the "B" subscriber and may be used as a cross-check for the TAP information received from the VPLMN.

The call is then routed by the VPLMN to the MSC server at which the subscriber is currently located (6). The GMSC server of the VPLMN shall produce an incoming gateway record and the terminating MSC server shall create an MTC record for the call to "B".

The records generated are subsequently transferred to the Billing System of the appropriate PLMN (A). The MTC record generated by the terminating MSC server shall be employed to create the appropriate MTC TAP record. The TAP records shall be included in a TAP file and transmitted to the HPLMN (B).

The following records are generated in HPLMN in this call scenario.

**Table 5.2.1.12.1: Records Generated in the HPLMN for an Incoming Call to a Roaming Subscriber Handled by CAMEL**

GMSC server	MSC server	HLR
Incoming gateway record	-	HLR interrogation record
Terminating CAMEL record		
Roaming record		
Outgoing gateway record		

The following records are generated in VPLMN in this call scenario.

**Table 5.2.1.12.2: Records Generated in the VPLMN for an Incoming Call to a Roaming Subscriber Handled by CAMEL**

GMSC server	MSC server	HLR
Incoming gateway record	MTC record	-

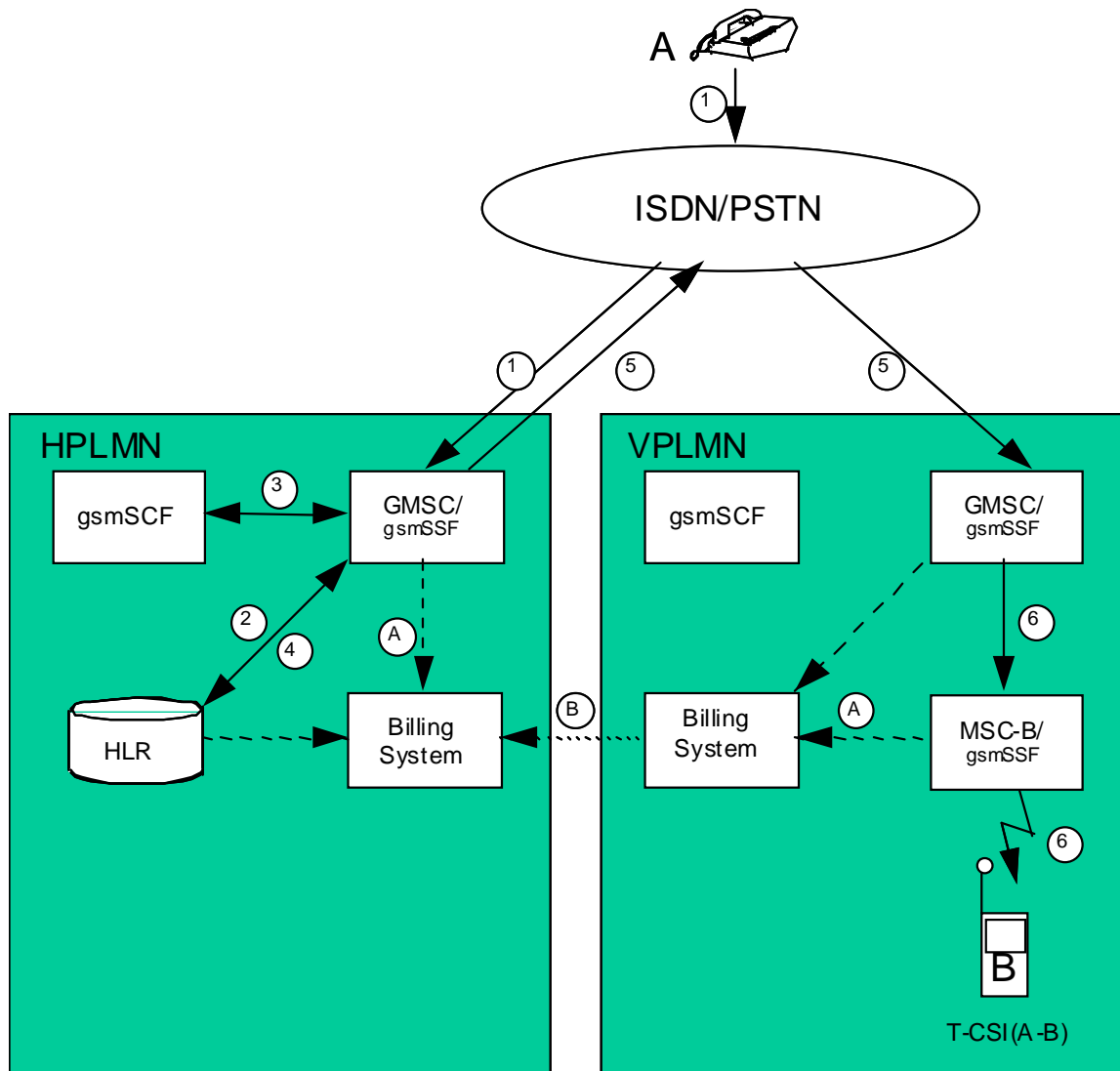

Figure 5.2.1.12: Incoming call to a roaming subscriber handled by CAMEL

### 5.2.1.13 Incoming call handled by CAMEL with redirection decided and forwarding leg handled by CAMEL

Figure 5.2.1.13 illustrates an incoming call from a fixed network subscriber "A" to a mobile CAMEL subscriber "B". The call is subsequently forwarded to a second fixed network subscriber "C" by CAMEL initiated Call Forwarding.

The incoming call is routed to the GMSC server (1). The GMSC server shall create an incoming gateway record for fixed network accounting purposes.

The GMSC server interrogates the HLR of the called subscriber in order to fetch the T-CSI and O-CSI (2).

The "B" subscriber has an active T-CSI. Therefore the GMSC server requests instructions from the gsmSSF which passes the CAMEL service key to a gsmSCF to indicate which service logic it should apply (3).

The gsmSCF may interrogate the HLR for subscriber information. As a network option, the operator may refuse to provide the requested information.

The gsmSCF modifies the Called Party number and sets the CAP parameter 'Apply O-CSI'. When gsmSCF processing is complete the call control is returned to the GMSC server. The GMSC server shall generate a terminating CAMEL record which contains T-CSI data.

The "B" subscriber has an active O-CSI. Therefore the GMSC server requests instructions from the gsmSSF which passes the CAMEL service key to a gsmSCF to indicate which service logic it should apply (4).

The gsmSCF may interrogate the HLR for subscriber information. As a network option, the operator may refuse to provide the requested information.

When gsmSCF processing is complete the call control is returned to the GMSC server.

The GMSC server redirects the call to the fixed network subscriber "C" (5). The GMSC server shall generate an MTC record for the "B" subscriber for the call from "A" and an MOC (call forwarding) record for the "B" subscriber for the call to "C". The MOC record includes O-CSI data and the parameter 'CAMEL initiated CF indicator'. The GMSC server shall also produce an outgoing gateway record as described in clause 5.2.1.1.

The generated records are subsequently transferred to the Billing System of the HPLMN (A).

The following records are generated in HPLMN in this call scenario.

**Table 5.2.1.13: Records Generated in the Incoming Call with Redirection Decided and Forwarded Leg Handled by CAMEL**

GMSC server	MSC server	HLR
Incoming gateway record	-	HLR interrogation record
Terminating CAMEL record		
MTC record		
MOC (CF) record		
Outgoing gateway record		

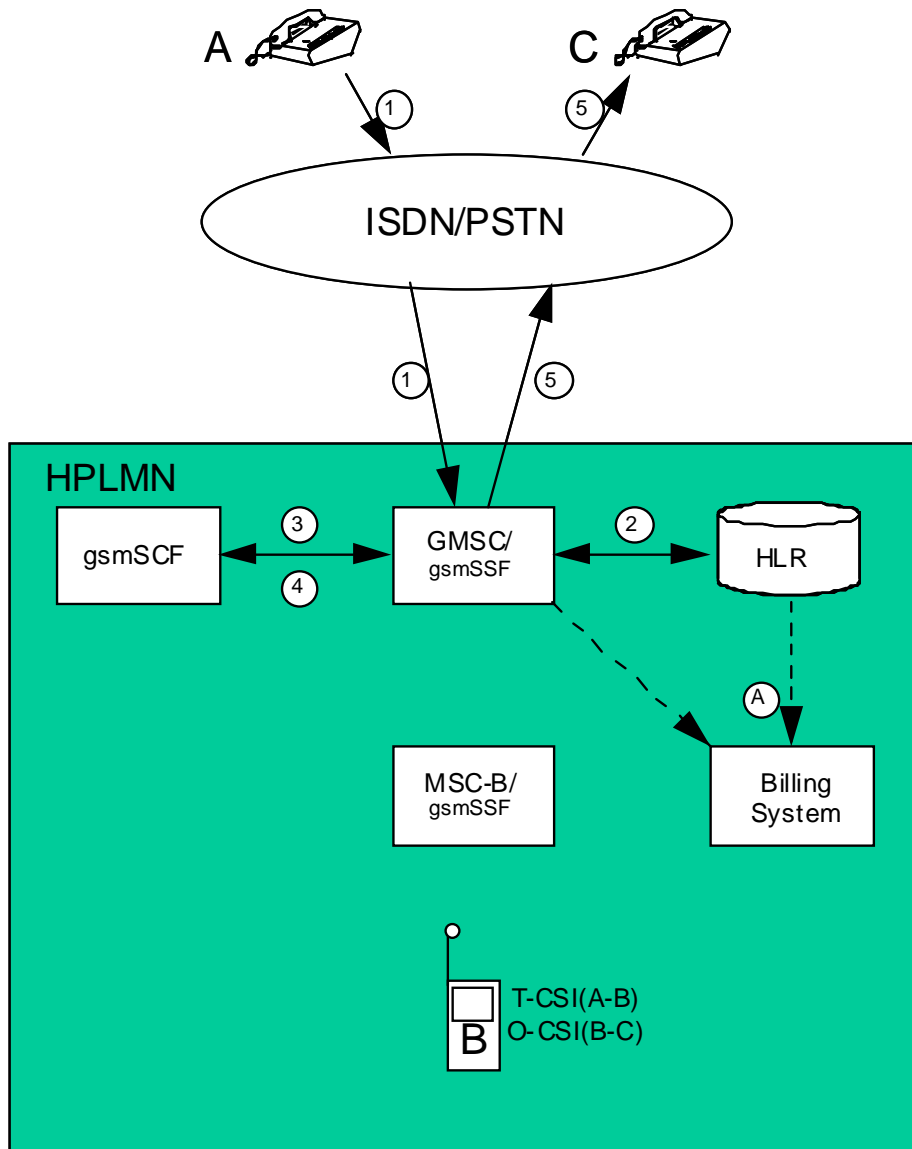

Figure 5.2.1.13: Incoming call handled by CAMEL with redirection decided and forwarding leg handled by CAMEL

### 5.2.1.14 Incoming call handled by CAMEL without redirection and forwarded early using GSM SS but controlled by CAMEL

Figure 5.2.1.14 illustrates an incoming call from a fixed network subscriber "A" to a mobile CAMEL subscriber "B". The call is subsequently forwarded to a second fixed network subscriber "C" by GSM SS Call Forwarding Unconditional (CFU) but controlled by CAMEL.

For simplicity the activation and registration of CFU have not been included in the diagram. These actions shall of course be registered in the appropriate supplementary service records.

The incoming call is routed to the GMSC server (1). The GMSC server shall create an incoming gateway record for fixed network accounting purposes.

The GMSC server interrogates the HLR of the called subscriber in order to fetch the T-CSI and O-CSI (2). The HLR shall create an HLR interrogation record. The HLR informs the GMSC server that "B" has activated CFU.

The "B" subscriber has an active T-CSI. Therefore the GMSC server requests instructions from the gsmSSF which passes the CAMEL service key to a gsmSCF to indicate which service logic it should apply (3).

The gsmSCF may interrogate the HLR for subscriber information. As a network option, the operator may refuse to provide the requested information.

When gsmSCF processing is complete the call control is returned to the GMSC server. The GMSC server shall generate a terminating CAMEL interrogation record which contains T-CSI data.

The "B" subscriber has an active O-CSI. Because the "B" subscriber has activated CFU he acts as the originating party for the forwarded leg. Therefore the GMSC server requests instructions from the gsmSSF which passes the CAMEL service key to a gsmSCF to indicate which service logic it should apply (5).

The gsmSCF may interrogate the HLR for subscriber information. As a network option, the operator may refuse to provide the requested information.

When gsmSCF processing is complete the call control is returned to the GMSC server.

The GMSC server redirects the call to the fixed network subscriber "C" (6). The GMSC server shall generate an MTC record for the "B" subscriber for the call from "A" and an MOC (call forwarding) record for the "B" subscriber for the call to "C". The MOC record includes O-CSI data. The GMSC server shall also produce an outgoing gateway record as described in clause 5.2.1.1.

If the B-subscriber do not have an active O-CSI the call is forwarded to the "C" subscriber after the first gsmSCF invocation, and the GMSC server shall generate an MOC (call forwarding) record for the "B" subscriber for the call to "C".

The generated records are subsequently transferred to the Billing System of the HPLMN (A).

The following records are generated in HPLMN in this call scenario.

**Table 5.2.1.14: Records Generated in the Incoming call handled by CAMEL without redirection and forwarded early using GSM SS but controlled by CAMEL**

GMSC server	MSC server	HLR
Incoming gateway record	-	HLR interrogation record
Terminating CAMEL record		
MTC record		
MOC (CF) record		
Outgoing gateway record		

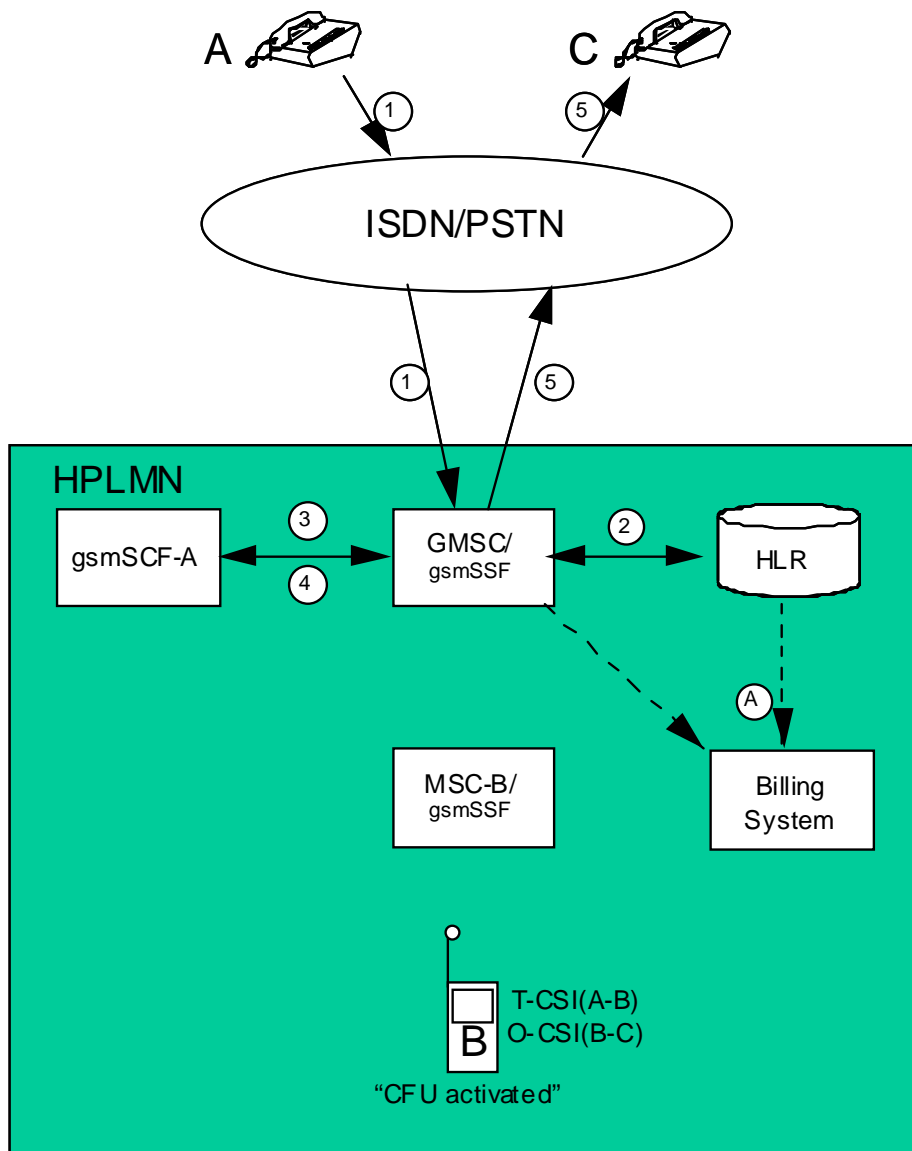

Figure 5.2.1.14: Incoming call handled by CAMEL without redirection and forwarded early using GSM SS but controlled by CAMEL

### 5.2.1.15 Incoming call handled by CAMEL without redirection and forwarded late using GSM SS but controlled by CAMEL

Figure 5.2.1.15 illustrates an incoming call from a fixed network subscriber "A" to a mobile CAMEL subscriber "B" who has registered and activated Call Forwarding on No Reply (CFNRY) for the appropriate service. The call is subsequently forwarded to a second fixed network subscriber "C".

For simplicity the registration and activation of CFNRY have not been included in this diagram. These actions shall be recorded in the appropriate supplementary service records.

The incoming call is routed to the GMSC server (1). The GMSC server shall create an incoming gateway record for fixed network accounting purposes.

The GMSC server interrogates the HLR of the called subscriber in order to fetch the T-CSI and O-CSI (2). The HLR shall create an HLR interrogation record.

The "B" subscriber has an active T-CSI. Therefore the GMSC server requests instructions from the gsmSSF which passes the CAMEL service key to the gsmSCF to indicate which service logic it should apply (3).

The gsmSCF may interrogate the HLR for subscriber information. As a network option, the operator may refuse to provide the requested information.

When gsmSCF processing is complete the call control is returned to the GMSC server. The GMSC server shall generate a terminating CAMEL interrogation record which contains T-CSI data.

The GMSC server interrogates the HLR in order to determine his current location (4). The HLR shall create an HLR interrogation record.

The call is routed to MSC-B (5). The "B" subscriber do not answer the call. MSC-B shall produce an MTC record for the "B" subscriber for the call from "A".

The "B" subscriber has an active O-CSI. Because the "B" subscriber has activated CFNRY he acts as the originating party for the forwarded leg. Therefore MSC-B requests instructions from the gsmSSF which passes the CAMEL service key to the gsmSCF to indicate which service logic it should apply (6).

The gsmSCF may interrogate the HLR for subscriber information. As a network option, the operator may refuse to provide the requested information.

When gsmSCF processing is complete the call control is returned to MSC-B.

MSC-B forwards the call via the GMSC server to the "C" subscriber (7). MSC-B shall produce an MOC (call forwarding) for the "B" subscriber for the call to "C". The record includes O-CSI data. The GMSC server shall also produce an outgoing gateway record as described in clause 5.2.1.1.

If the B-subscriber do not have an active O-CSI the call is forwarded to the "C" subscriber after detecting the call forwarding condition, and the GMSC server shall generate an MOC (call forwarding) record for the "B" subscriber for the call to "C".

The generated records are subsequently transferred to the Billing System of the HPLMN (A).

The following records are generated in HPLMN in this call scenario.

**Table 5.2.1.15: Records Generated in the Incoming call handled by CAMEL without redirection and forwarded late using GSM SS but controlled by CAMEL**

GMSC server	MSC server	HLR
Incoming gateway record	MTC record	-
Terminating CAMEL record	MOC (CF) record	
Outgoing gateway record		

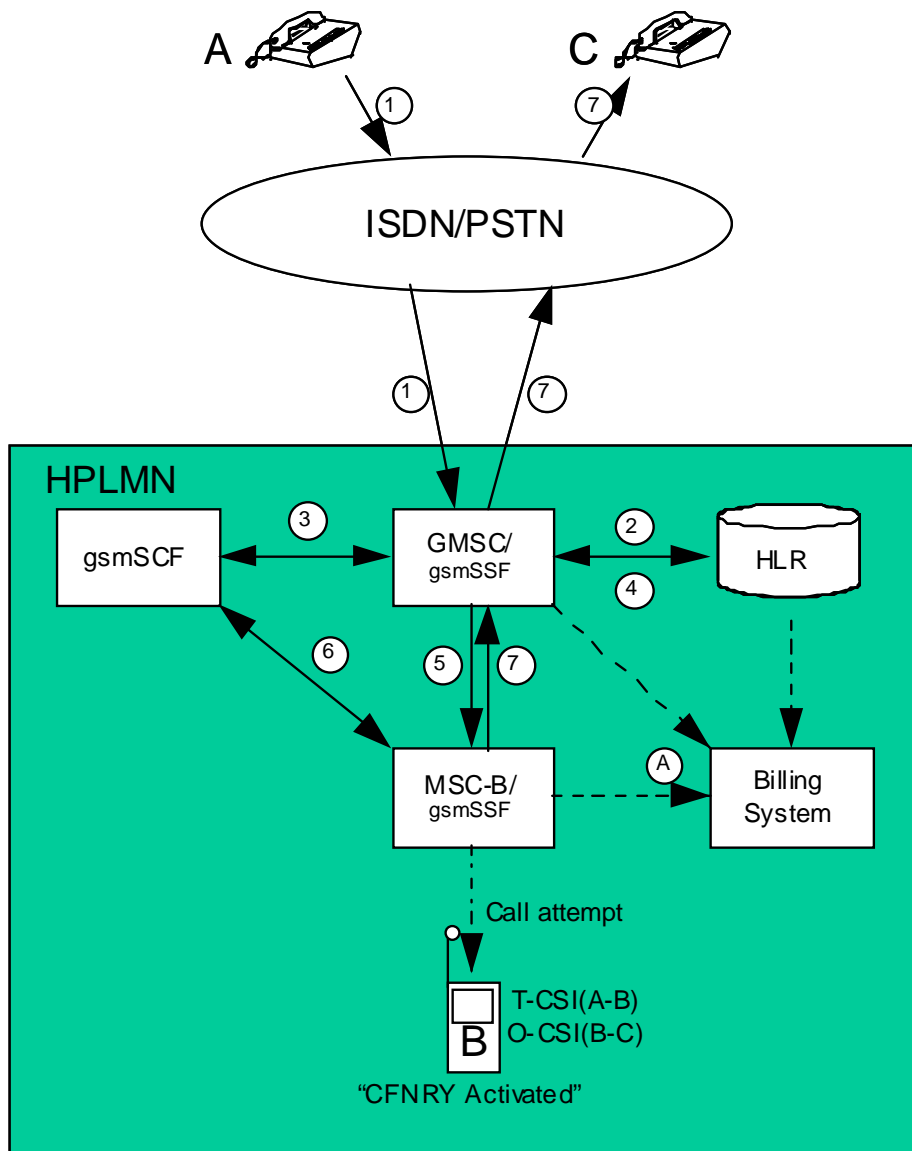

Figure 5.2.1.15: Incoming call handled by CAMEL without redirection and forwarded late using GSM SS but controlled by CAMEL



### 5.2.1.16 Early forwarded call controlled by CAMEL

Figure 5.2.1.16 illustrates an incoming call from a fixed network subscriber "A" to a mobile CAMEL subscriber "B". The call is subsequently forwarded to a second fixed network subscriber "C" by GSM SS Call Forwarding Unconditional (CFU) but controlled by CAMEL.

For simplicity the activation and registration of CFU have not been included in the diagram. These actions shall of course be registered in the appropriate supplementary service records.

The incoming call is routed to the GMSC server (1). The GMSC server shall create an incoming gateway record for fixed network accounting purposes.

The GMSC server interrogates the HLR of the called subscriber in order to fetch the O-CSI (2). The HLR shall create an HLR interrogation record. The HLR informs the GMSC server that "B" has activated CFU.

The "B" subscriber has an active O-CSI. Because the "B" subscriber has activated CFU he acts as the originating party for the forwarded leg. Therefore the GMSC server requests instructions from the gsmSSF which passes the CAMEL service key to a gsmSCF to indicate which service logic it should apply (3).

The gsmSCF may interrogate the HLR for subscriber information. As a network option, the operator may refuse to provide the requested information.

When gsmSCF processing is complete the call control is returned to the GMSC server.

The GMSC server redirects the call to the fixed network subscriber "C" (5). The GMSC server shall generate an MTC record for the "B" subscriber for the call from "A" and an MOC (call forwarding) record for the "B" subscriber for the call to "C". The MOC record includes O-CSI data. The GMSC server shall also produce an outgoing gateway record as described in clause 5.2.1.1.

The generated records are subsequently transferred to the Billing System of the HPLMN (A).

The following records are generated in HPLMN in this call scenario.

**Table 5.2.1.16: Records Generated in the Early forwarded call controlled by CAMEL**

GMSC server	MSC server	HLR
Incoming gateway record	-	HLR interrogation record
MTC record		
MOC (CF) record		
Outgoing gateway record		

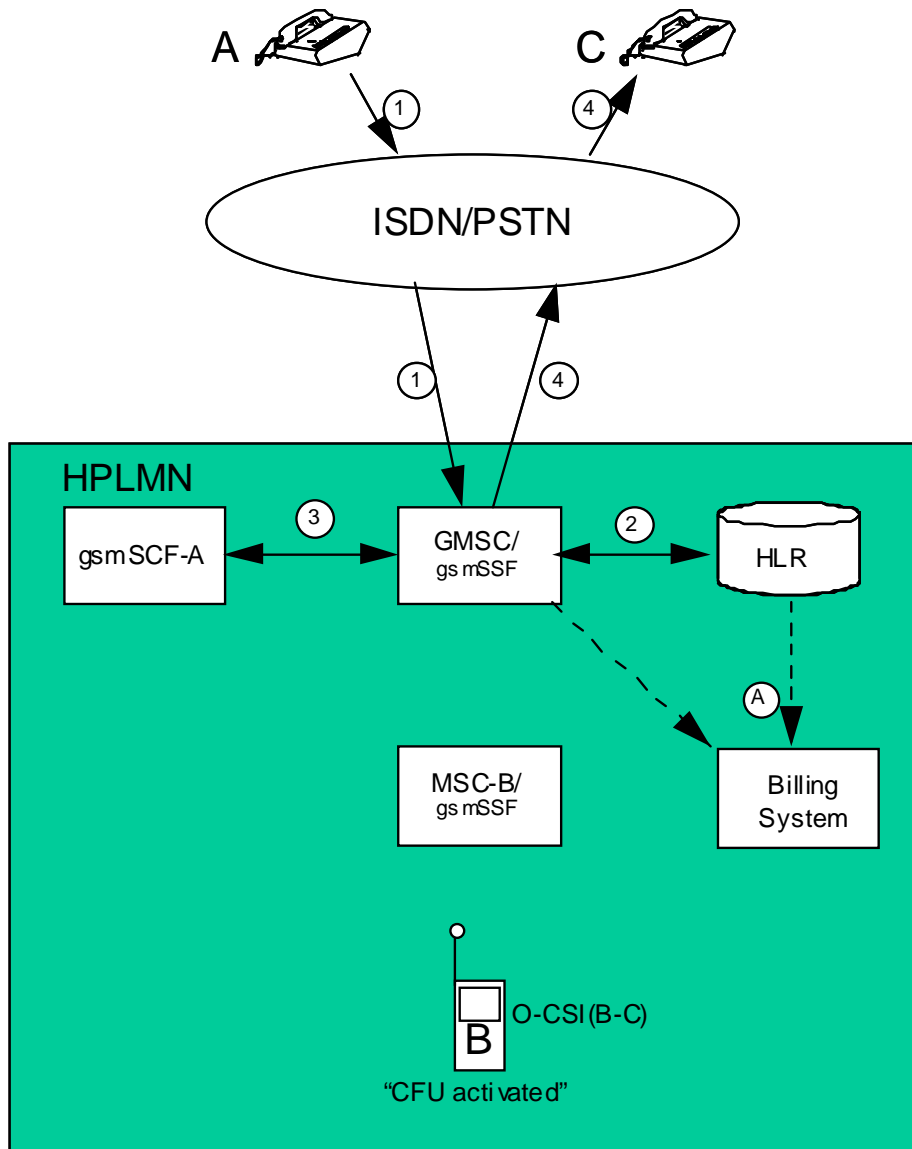

Figure 5.2.1.16: Early forwarded call controlled by CAMEL

### 5.2.1.17 Late forwarded call controlled by CAMEL

Figure 5.2.1.17 illustrates an incoming call from a fixed network subscriber "A" to a mobile CAMEL subscriber "B" who has registered and activated Call Forwarding on No Reply (CFNRY) for the appropriate service. The call is subsequently forwarded to a second fixed network subscriber "C".

For simplicity the registration and activation of CFNRY have not been included in this diagram. These actions shall be recorded in the appropriate supplementary service records.

The incoming call is routed to the GMSC server (1). The GMSC server shall create an incoming gateway record for fixed network accounting purposes.

The GMSC server interrogates the HLR of the called subscriber in order to determine the current location (2). The HLR shall create an HLR interrogation record.

The call is routed to MSC-B (3). The "B" subscriber do not answer the call. MSC-B shall produce an MTC record for the "B" subscriber for the call from "A".

The "B" subscriber has an active O-CSI. Because the "B" subscriber has activated CFNRY he acts as the originating party for the forwarded leg. Therefore MSC-B requests instructions from the gsmSSF which passes the CAMEL service key to gsmSCF-B to indicate which service logic it should apply (4).

The gsmSCF may interrogate the HLR for subscriber information. As a network option, the operator may refuse to provide the requested information.

When gsmSCF processing is complete the call control is returned to MSC-B.

MSC-B forwards the call via the GMSC server to the "C" subscriber (5). MSC-B shall produce an MOC (call forwarding) for the "B" subscriber for the call to "C". The record includes O-CSI data. The GMSC server shall also produce an outgoing gateway record as described in clause 5.2.1.1.

The generated records are subsequently transferred to the Billing System of the HPLMN (A).

The following records are generated in HPLMN in this call scenario.

**Table 5.2.1.17: Records Generated in the Late forwarded call controlled by CAMEL**

GMSC server	MSC server	HLR
Incoming gateway record	MTC record	HLR interrogation record
Outgoing gateway record	MOC (CF) record	

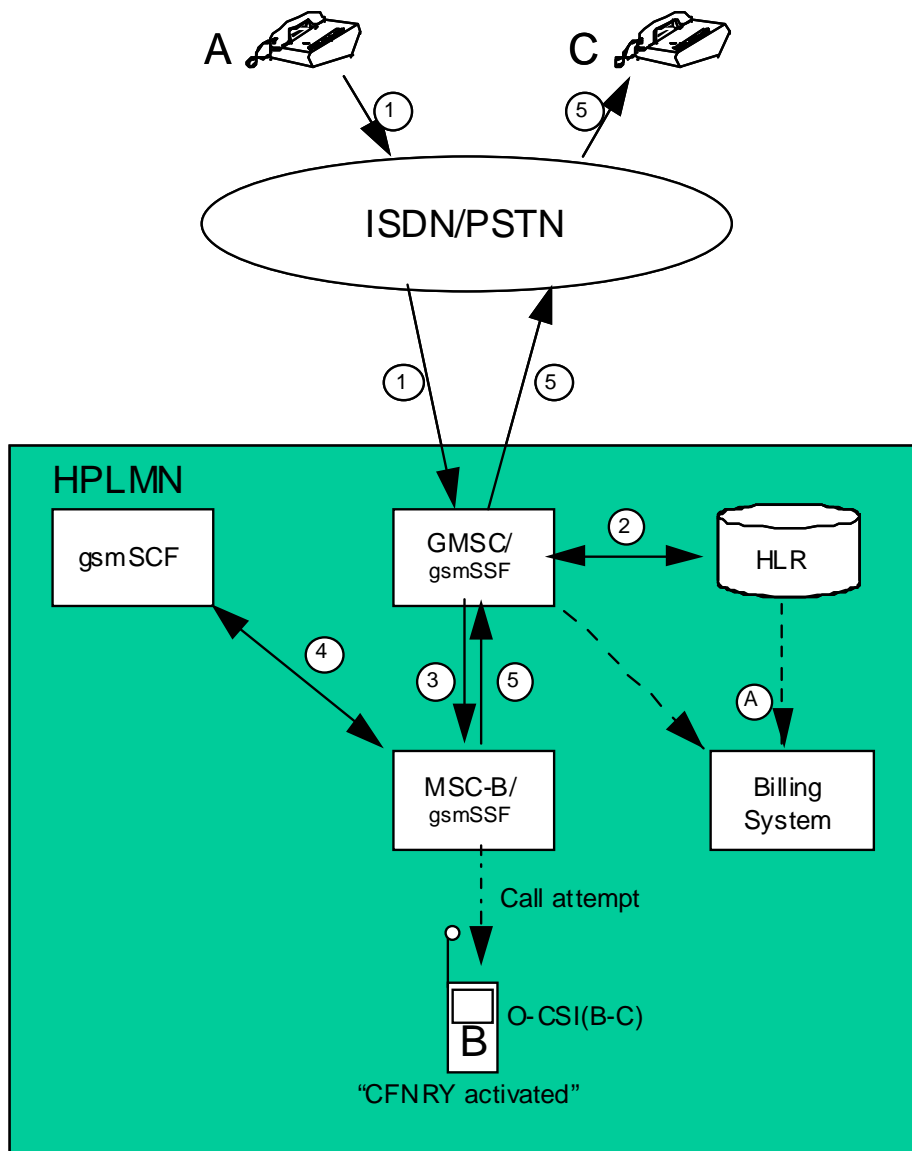

Figure 5.2.1.17: Late forwarded call controlled by CAMEL

### 5.2.1.18 Incoming call handled by CAMEL with redirection initiated by CAMEL feature

Figure 5.2.1.18 illustrates an incoming call from a fixed network subscriber "A" to a mobile CAMEL subscriber "B". The call is subsequently redirected to a second fixed network subscriber "C" by CAMEL initiated redirection.

The incoming call is routed to the GMSC server (1). The GMSC server shall create an incoming gateway record for fixed network accounting purposes.

The GMSC server interrogates the HLR of the called subscriber in order to fetch the T-CSI (2) and the O-CSI (2). The HLR shall create an HLR interrogation record.

Since subscriber "B" has an active T-CSI and the trigger criteria are met the GMSC server requests instructions from the gsmSSF which passes the CAMEL service key to a gsmSCF to indicate which service logic it should apply (3). A terminating CAMEL interrogation record is generated in the GMSC server for invoking the terminating CAMEL call handling.

The gsmSCF may interrogate the HLR for subscriber information. As a network option, the operator may refuse to provide the requested information.

The gsmSCF returns a modified destination routing address to the GMSC server (without the option "apply O-CSI"). Therefore for the redirection leg (B-C) the CAMEL feature is not invoked.

The GMSC server redirects the call to the fixed network subscriber "C" (4). For fixed network accounting purposes the GMSC server shall generate an outgoing gateway record as described in clause 5.2.1.1.

The generated records are subsequently transferred to the Billing System of the HPLMN (A).

The following records are generated in HPLMN in this call scenario.

**Table 5.2.1.18: Records Generated in the Incoming call handled by CAMEL with redirection initiated by CAMEL feature**

GMSC server	MSC server	HLR
Incoming gateway record		HLR interrogation record
Terminating CAMEL interrogation record		
Outgoing gateway record		

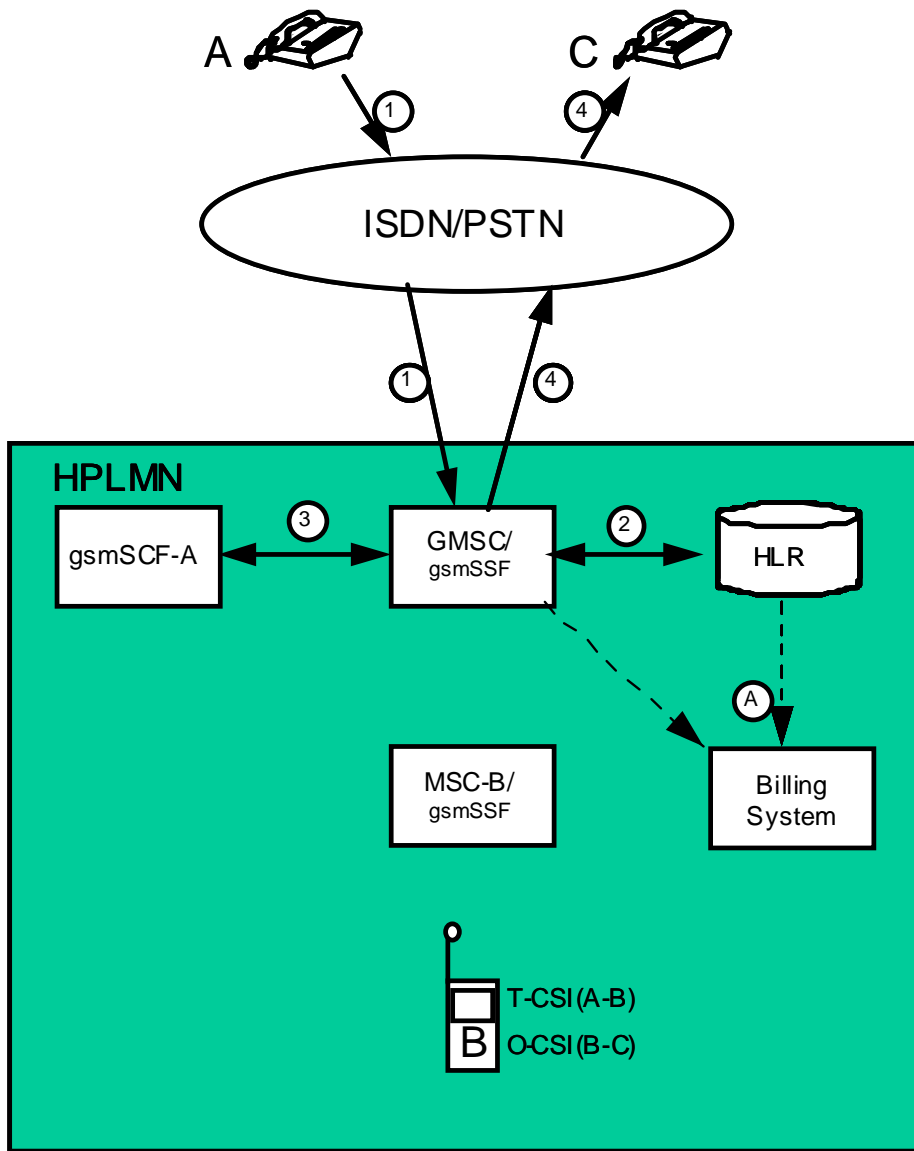

Figure 5.2.1.18: Incoming call handled by CAMEL with redirection initiated and by CAMEL feature

### 5.2.1.19 CAMEL Scenario for Visiting Terminator Trigger Calls

Figure 5.2.1.19 illustrates an incoming call from a fixed network subscriber "A" to a mobile CAMEL subscriber "B".

The incoming call is first routed to the GMSC (1). The GMSC shall create an incoming gateway record for fixed network accounting purposes.

The GMSC interrogates the HLR (2) of the called subscriber. The HLR shall create an HLR interrogation record. The call is routed to MSC-B(3). An MTC record shall be generated in MSC-B.

The "B" subscriber has an active VT-CSI (stored in the VLR). For avoidance of doubt in this scenario, the "B" subscriber does not have an active T-CSI in the HLR. Therefore MSC-B requests instructions from the gsmSSF which passes the CAMEL service key to the gsmSCF to indicate which service logic it should apply (4).

The gsmSCF may interrogate the HLR for subscriber information. As a network option, the operator may refuse to provide the requested information.

When gsmSCF processing is complete the call control is returned to the MSC-B. The MSC-B shall generate a terminating CAMEL (TCR) record which contains VT-CSI data.

The MSC-B routes the call to the "B" subscriber (5).

For avoidance of doubt, even if the MSC and GMSC are co-located both the MTC/TCR and gateway records shall be produced.

The generated records are subsequently transferred to the OS (A) either as event reports following the release of the connection or when collected by the OS.

The following records are generated in HPLMN in this call scenario.

**Table 5.2.1.19: Records Generated for Visiting Terminating Trigger Calls**

GMSC	MSC-B	HLR
Incoming gateway record	MTC record	HLR interrogation record
	Terminating CAMEL record	

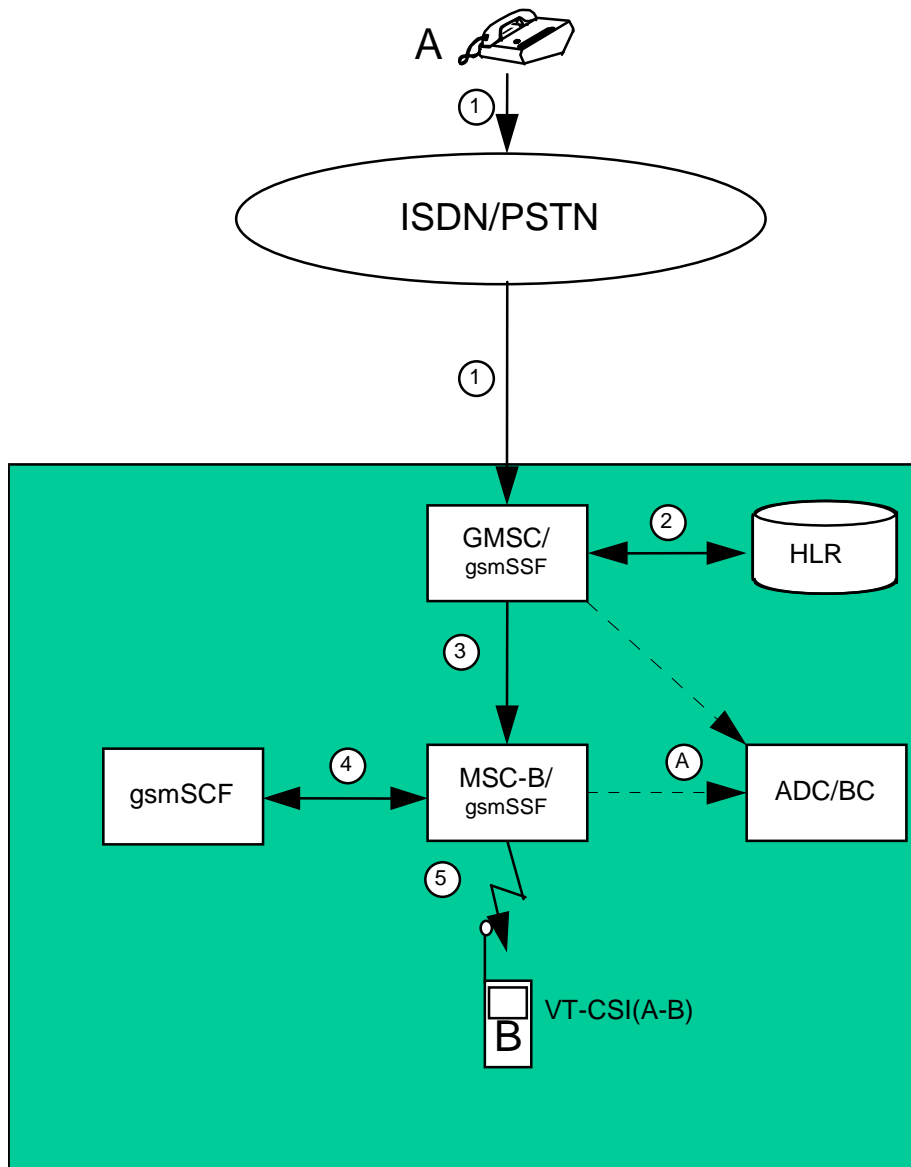

Figure 5.2.1.19: Incoming call handled by CAMEL in MSC Server without redirection



### 5.2.1.20 Outgoing call handled by CAMEL with Dialed CSI Trigger

Figure 5.2.1.20 illustrates an outgoing CAMEL call from a mobile CAMEL subscriber "A" to a fixed network subscriber "B" (1).

The "A" subscriber has an active D-CSI (stored in the VLR and modified Called Party number matches D-CSI). Therefore MSC server-A requests instructions from the gsmSSF which passes the CAMEL service key to the gsmSCF to indicate which service logic it should apply (2).

The gsmSCF may interrogate the HLR for subscriber information. As a network option, the operator may refuse to provide the requested information.

When gsmSCF processing is complete the call control is returned to MSC-A.

MSC server-A generates an MOC record for the "A" subscriber which contains D-CSI data. This record may be linked to an optional SCF-record.

The GMSC server routes the call to the "B" subscriber (3). The GMSC server shall create an outgoing gateway record as described in clause 5.2.1.1.

The generated records are subsequently transferred to the post-processing system (A) either as event reports following the release of the connection or when collected by the post-processing system.

The following records are generated in HPLMN in this call scenario.

**Table 5.2.1.20: Records Generated for an Outgoing Call Handled by CAMEL**

<b>GMSC server</b>	<b>MSC server</b>	<b>HLR</b>
Outgoing gateway record	MOC record	-

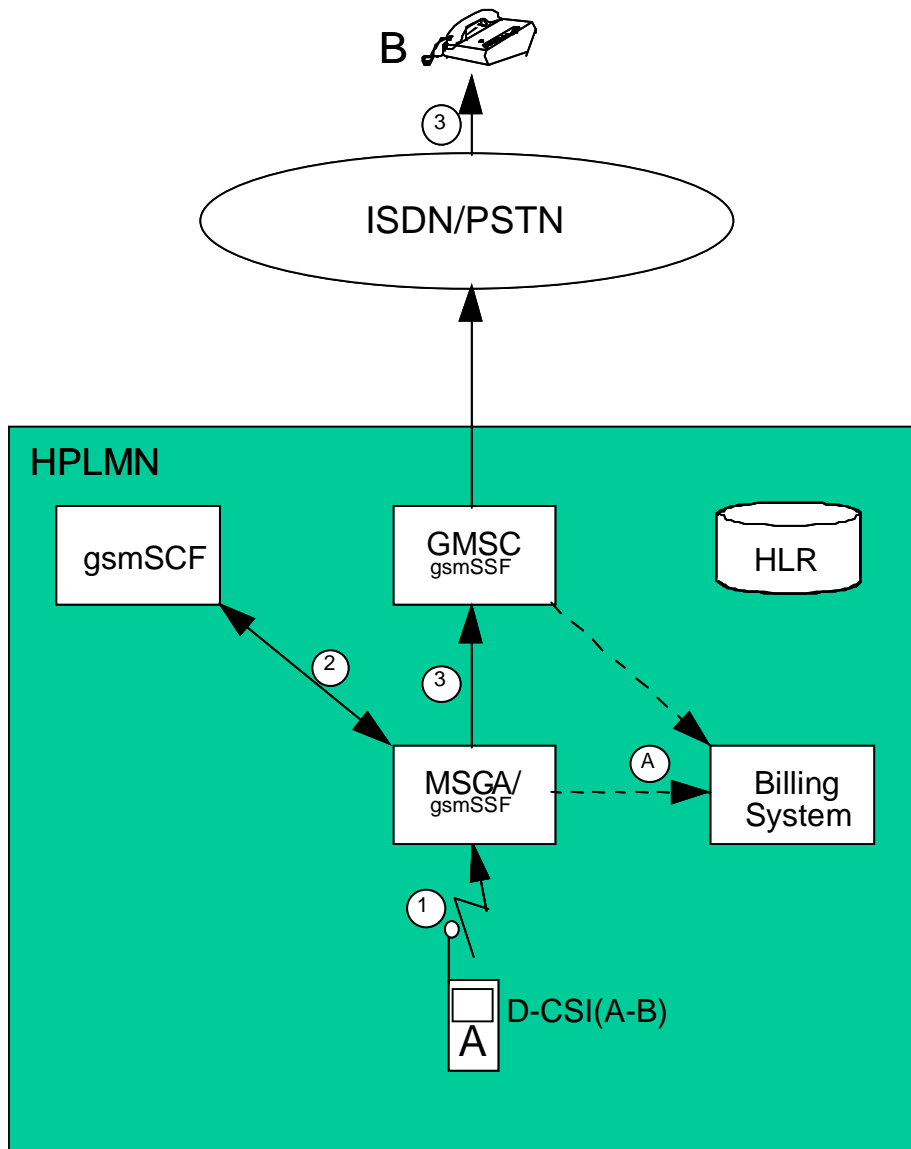

Figure 5.2.1.20: Outgoing call handled by CAMEL with Dialed CSI Trigger

### 5.2.1.21 Incoming call handled by CAMEL with redirection decided and forwarding leg handled by CAMEL with Dialed CSI Trigger

Figure 5.2.1.21 illustrates an incoming call from a fixed network subscriber "A" to a mobile CAMEL subscriber "B". The call is subsequently forwarded to a second fixed network subscriber "C" by CAMEL initiated Call Forwarding.

The incoming call is routed to the GMSC server (1). The GMSC server shall create an incoming gateway record for fixed network accounting purposes.

The GMSC server interrogates the HLR of the called subscriber in order to fetch the T-CSI, O-CSI and D-CSI (2).

The "B" subscriber has an active T-CSI. Therefore the GMSC server requests instructions from the gsmSSF which passes the CAMEL service key to a gsmSCF to indicate which service logic it should apply (3).

The gsmSCF may interrogate the HLR for subscriber information. As a network option, the operator may refuse to provide the requested information.

The gsmSCF modifies the Called Party number and sets the CAP parameter 'Apply O-CSI'. When gsmSCF processing is complete the call control is returned to the GMSC server. The GMSC server shall generate a terminating CAMEL interrogation record which contains T-CSI data.

The "B" subscriber has an active O-CSI. Therefore the GMSC server requests instructions from the gsmSSF which passes the CAMEL service key to a gsmSCF to indicate which service logic it should apply (4).

The gsmSCF may interrogate the HLR for subscriber information. As a network option, the operator may refuse to provide the requested information.

The gsmSCF modifies the Called Party number. When gsmSCF processing is complete the call control is returned to the GMSC server.

The "B" subscriber has an active D-CSI (modified Called Party number matches D-CSI). Therefore the GMSC server requests instructions from the gsmSSF which passes the CAMEL service key to a gsmSCF to indicate which service logic it should apply (5).

The gsmSCF may interrogate the HLR for subscriber information. As a network option, the operator may refuse to provide the requested information. When gsmSCF processing is complete the call control is returned to the GMSC server.

The GMSC server redirects the call to the fixed network subscriber "C" (6). The GMSC server shall generate an MTC record for the "B" subscriber for the call from "A" and an MOC (call forwarding) record for the "B" subscriber for the call to "C". The MOC record includes O-CSI data, the parameter 'CAMEL initiated CF indicator' and D-CSI data. The GMSC server shall also produce an outgoing gateway record as described in clause 5.2.1.1.

The generated records are subsequently transferred to the post-processing system (A) either as event reports following the release of the connection or when collected by the post-processing system.

The following records are generated in HPLMN in this call scenario.

**Table 5.2.1.21: Records Generated in the Incoming Call with Redirection Decided and Forwarded Leg Handled by CAMEL**

GMSC server	MSC server	HLR
Incoming gateway record	-	HLR interrogation record
Terminating CAMEL record		
MTC record		
MOC (CF) record		
Outgoing gateway record		

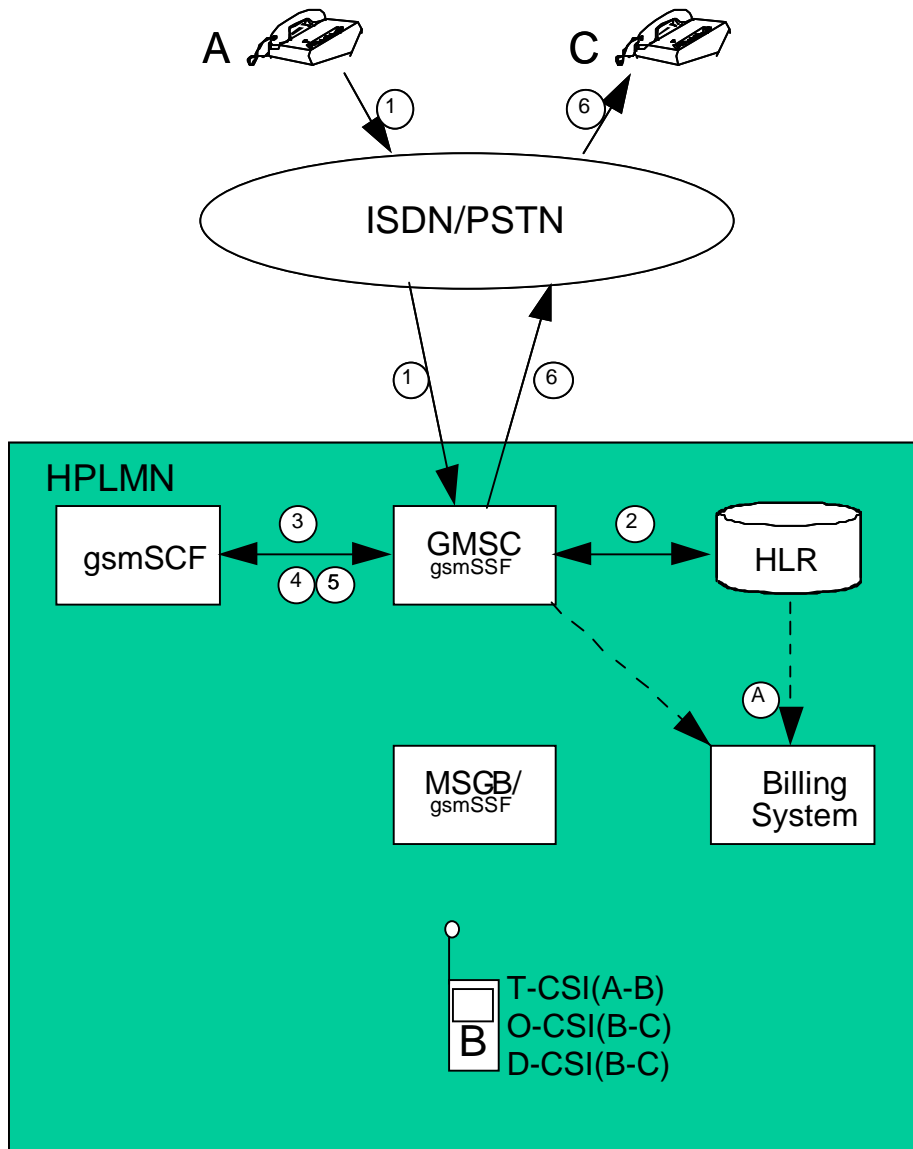

Figure 5.2.1.21: Incoming call handled by CAMEL with redirection decided and forwarding leg handled by CAMEL with Dialed CSI Trigger

### 5.2.1.22 Mobile terminated location request

Figure 5.2.1.22 illustrates general network positioning for LCS clients external to the PLMN.

An external LCS client requests the current location of a target UE from a GMLC (1). In this release the GMLC shall not create any LCS record.

The GMLC server then interrogates the HLR of the target UE to be located to determine his current location (2). The HLR shall create an HLR interrogation record.

The GMLC sends the location service request to the MSC indicated by the HLR. The MSC sends a Location Request message to RAN that initiates the positioning procedure (3). The MSC shall create an LCS-MT record.

The records generated are subsequently transferred to the Billing System of the PLMN (A).

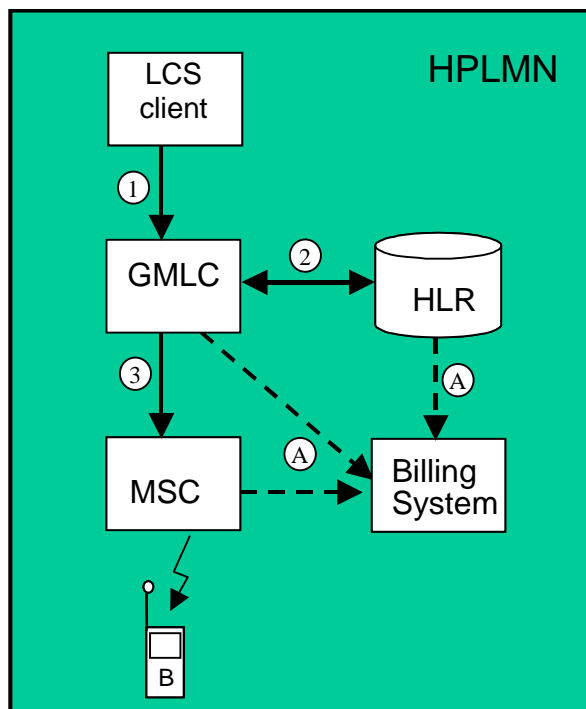

Figure 5.2.1.22: Mobile terminated location request

### 5.2.1.23 gsmSCF initiated wake-up call handled by CAMEL CPH

Figure 5.2.1.23 illustrates a wake-up call initiated by gsmSCF to a mobile CAMEL subscriber "A".

gsmSCF interrogates the HLR in order to determine the current location of subscriber "A" (1). The HLR provides the 'Roaming Number'. The HLR shall create an interrogation record.

gsmSCF initiates set-up of an outgoing leg towards mobile CAMEL subscriber "A" (2). The MSC shall create an adapted version of MOC and MTC record for that call leg.

The user interaction (UI), in this scenario an announcement from the Specialised Resource Function (SRF), is connected to mobile CAMEL subscriber "A" (3). The MSC shall update the MOC record to reflect the UI.

The following records are generated in HPLMN in this call scenario.

**Table 5.2.1.23: Records Generated for an Wake-up Call Handled by CAMEL CPH**

MSC	HLR
MOC record	HLR interrogation record
MTC record	

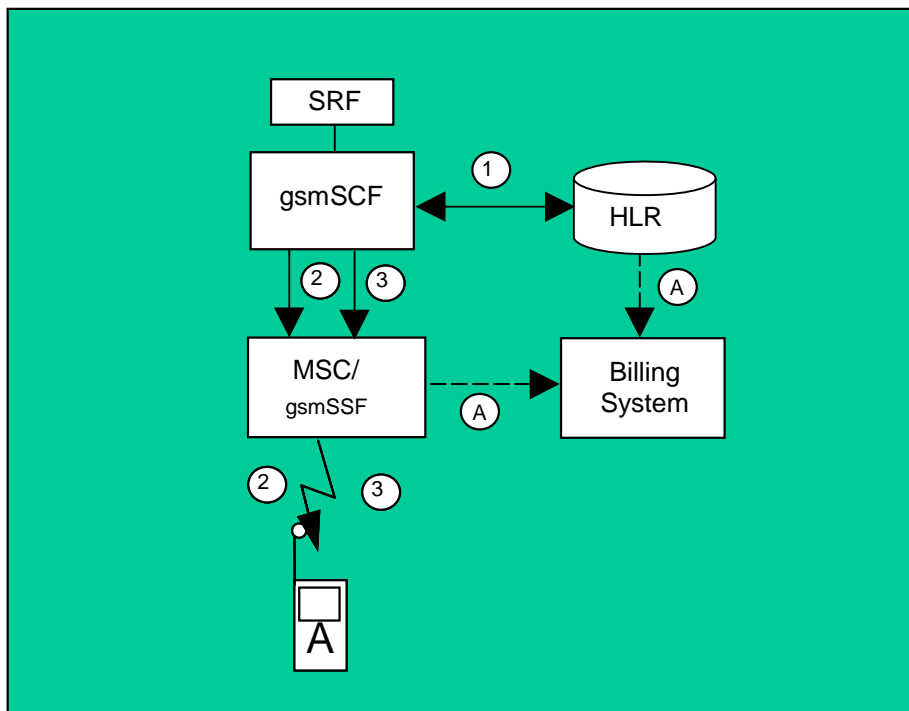

**Figure 5.2.1.23: Wake-up call handled by CAMEL CPH**

### 5.2.1.24 Three party conference handled by CAMEL CPH

Figure 5.2.1.24 illustrates one example for establishment of a three party conference via CAMEL CPH..

A mobile CAMEL subscriber "A" sets up an outgoing call (1) to an ISDN subscriber ("B"). This call is recorded as outlined in clause 5.2.1.1.

gsmSCF then invokes CPH operation 'initiate call attempt' (2). A new call segment (CS#2) with an outgoing leg "C" is created in MSC-A.

MSC-A interrogates the HLR in order to determine the current location of subscriber "C" (3). The HLR shall create an interrogation record.

MSC-A initiates set-up of an outgoing leg towards mobile subscriber "C" (4). MSC-A shall create an MOC record for the leg towards mobile subscriber "C". MSC-C shall create a MTC record for subscriber "C".

gsmSCF then invokes CPH operation 'MoveLeg' to join all three legs in one call segment (5). MSC-A shall close the MOC record for call segment CS#2 to outgoing leg "C". The MOC record for the outgoing call of the mobile CAMEL subscriber "A" to ISDN subscriber "B" shall be updated to cover the additional outgoing CAMEL call leg "C".

The following records are generated in HPLMN in this call scenario.

**Table 5.2.1.24: Records Generated for an Wake-up Call Handled by CAMEL CPH**

<b>GMSC server</b>	<b>MSC-A</b>	<b>MSC-C</b>	<b>HLR</b>
outgoing gateway record	MOC record ("A", "B", "C")	MTC record	HLR interrogation record
	MOC record ("C")		

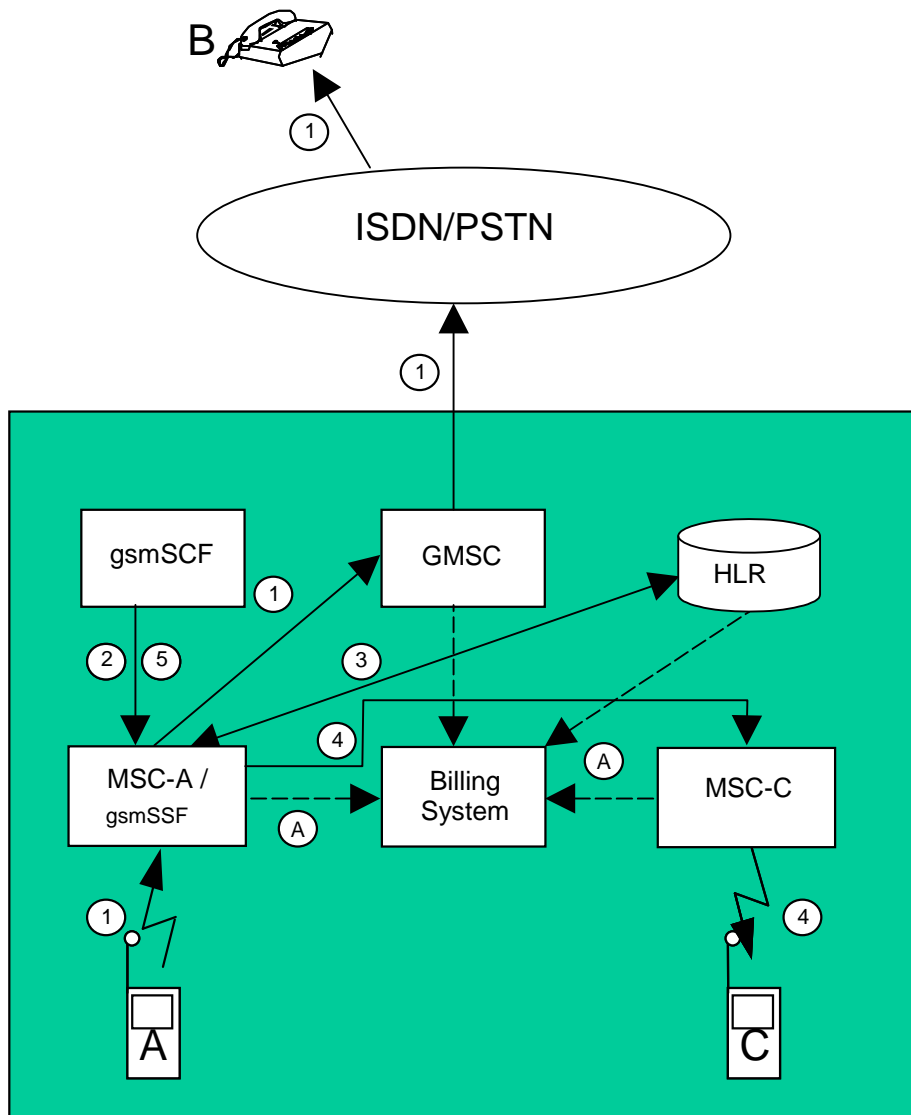

Figure 5.2.1.24: Three Party Conference handled by CAMEL CPH



### 5.2.1.25 Mobile Terminating Roaming Forwarding call after successful Retrieval of Routeing Information (MTRF)

Figure 5.2.1.25 illustrates an incoming call to a PLMN subscriber "B" with roaming forwarding call after successful Retrieval of Routeing Information.

The incoming call is first routed to a GMSC server (1). The GMSC server shall create an incoming gateway record for accounting purposes.

The GMSC server interrogates the HLR of the called subscriber in order to determine his current known location (2). The HLR shall create an HLR interrogation CDR.

The GMSC server routes the call to the MSC server at which the subscriber is currently registered (3). While on-going paging, this MSC server is requested to reroute the call towards a new MSC server (new MSC-B), applying "Mobile Terminating Roaming Forwarding call after successful Retrieval of Routeing Information" procedure (4). This MSC server (old MSC-B) shall create a MTRF record.

The new MSC server (new MSC-B) shall create an MTC record for subscriber "B".

The records generated are subsequently transferred to the Billing System of the PLMN (A).

**Table 5.2.1.25: Records Generated for Mobile Terminating Roaming Forwarding call after successful Retrieval of Routeing Information (MTRF)**

GMSC server	Old MSC server	New MSC server
Incoming gateway record	MTRF Record	MTC record

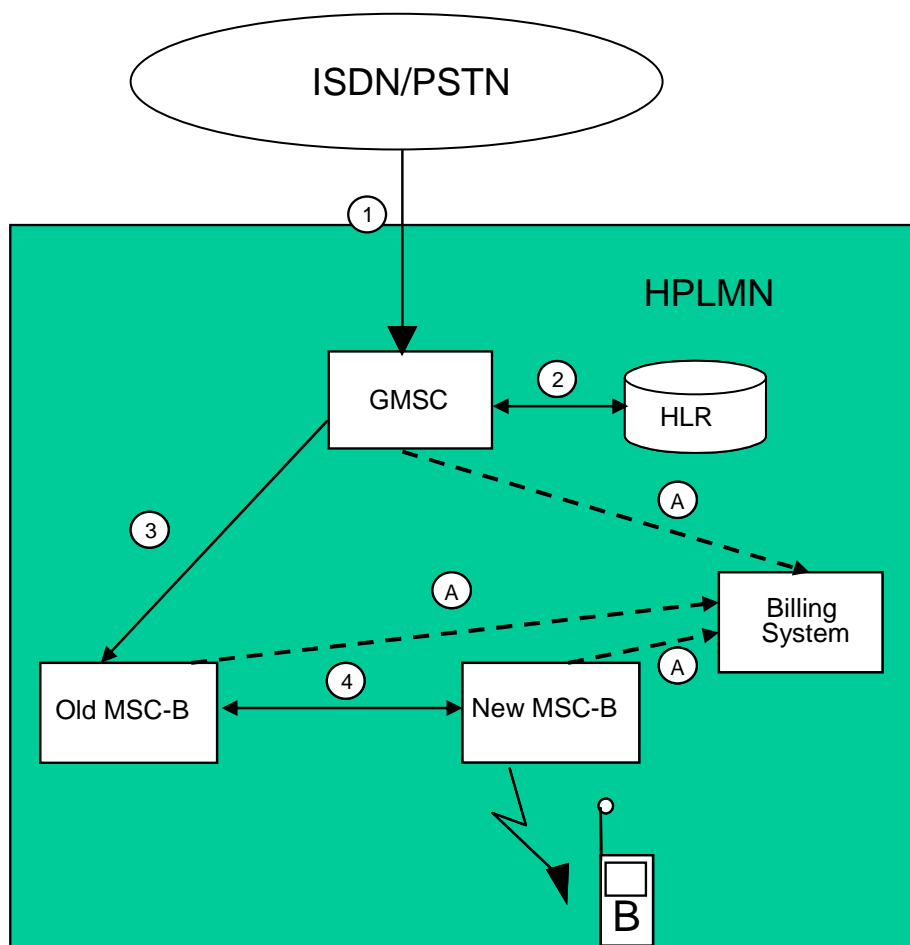

**Figure 5.2.1.25: mobile terminating roaming forwarding call after successful Retrieval of Routeing Information**

### 5.2.1.26 Mobile Terminating Roaming Forwarding call after successful Retrieval of Routeing Information (MTRF) to a roaming subscriber

Figure 5.2.1.26 illustrates an incoming call to a PLMN subscriber "B" with roaming forwarding call after successful Retrieval of Routeing Information, and subscriber "B" is currently roaming in another PLMN

The incoming call is first routed to a GMSC server (1). The GMSC server shall create an incoming gateway record for accounting purposes.

The GMSC server interrogates the HLR of the called subscriber in order to determine his current known location (2). The HLR shall create an HLR interrogation CDR.

The GMSC server routes the call to the MSC server at which the subscriber is currently registered (3). While on-going paging, this MSC server is requested to reroute the call towards a new MSC server (new MSC-B) in VPLMN in which subscriber "B" is actually located, applying "Mobile Terminating Roaming Forwarding call after successful Retrieval of Routeing Information" procedure (4). This MSC server (old MSC-B) shall create a MTRF record, and also a roaming record. These records may be used as a cross-check for the TAP information received from the VPLMN.

The new MSC server (new MSC-B) shall create an MTC record for subscriber "B".

The records generated are subsequently transferred to the Billing System of the appropriate PLMN (A). The MTC record generated by the terminating MSC server shall be employed to create the appropriate MTC TAP record. The TAP records shall be included in a TAP file and transmitted to the HPLMN (B).

**Table 5.2.1.26: Records Generated for Mobile Terminating Roaming Forwarding call after successful Retrieval of Routeing Information (MTRF) - Roaming**

GMSC server	Old MSC server	New MSC server
Incoming gateway record	MTRF Record	MTC record
	Roaming Record	

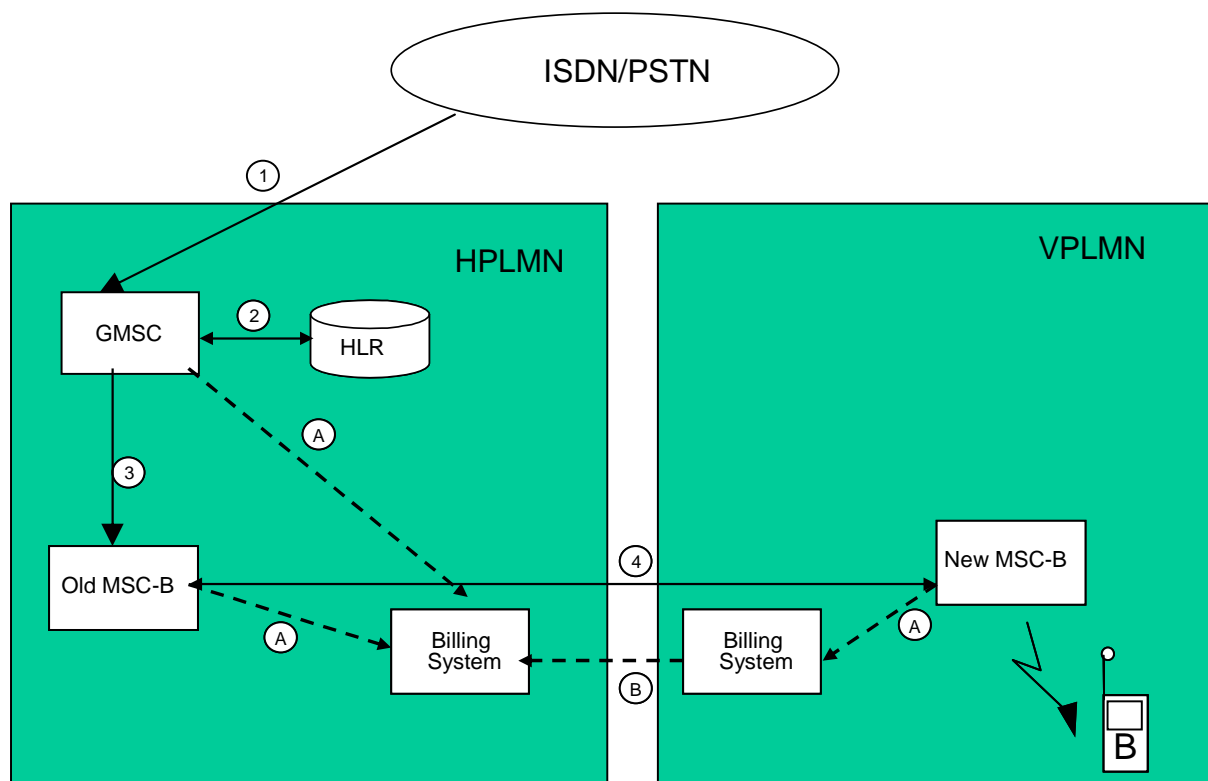

**Figure 5.2.1.26: mobile terminating roaming forwarding call after successful Retrieval of Routeing Information to a roaming subscriber**

### 5.2.1.27 Mobile Terminating Roaming Forwarding call after successful Retrieval of Routeing Information (MTRF), for a subscriber with Visiting Terminating Trigger Calls

When a roaming forwarding call after successful Retrieval of Routeing Information (MTRF) procedure applies for a subscriber "B" having an active VT-CSI (stored in the VLR), on receiving the MSRN from the new MSC, the Old MSC releases dialog previously triggered with gsmSSF, and the new MSC subsequently applies the subscriber VT-CSI trigger to the resulting terminating call.

The Old MSC shall generate a terminating CAMEL (TCR) record which contains VT-CSI triggering and release.

The New MSC shall generate a terminating CAMEL (TCR) record which contains VT-CSI data.

**Table 5.2.1.27: Records Generated for Mobile Terminating Roaming Forwarding call after successful Retrieval of Routeing Information (MTRF) with VT-CSI**

<b>GMSC server</b>	<b>Old MSC server</b>	<b>New MSC server</b>
Incoming gateway record	Terminating CAMEL record (VT-CSI)	Terminating CAMEL record (VT-CSI)
	MTRF Record	MTC Record

## 5.2.2 Diameter message flows

Not applicable, as the separation of the CTF and CDF is not in the scope of the CS domain charging standards. Refer to clause 4.2 for further information.

Vendors may nevertheless implement a separate CDCF and CCF for CS domain charging. In this case, the approach chosen shall conform to the principles and protocol applications specified in 3GPP TS 32.299 [50].

## 5.2.3 CDR generation

In order to provide the data required for the management activities outlined in the previous clauses (billing, accounting, statistics, etc.), the CGF of the MSC server and/or Location Registers shall be able to produce a charging data record for each of the following:

- Mobile originated call attempt;
- Mobile originated emergency call attempt;
- Mobile originated, call forwarding attempt;
- Mobile terminated call attempt;
- Roaming call attempt in a gateway MSC server;
- Incoming call attempt in a gateway MSC server;
- Outgoing call attempt from a gateway MSC server;
- Transit call attempt;
- Terminating CAMEL call attempt;
- CAMEL CPH call attempts/call modifications;
- Supplementary service actions;
- HLR interrogation;
- Location updating (HLR and VLR);
- Short message service (point-to-point), mobile originated;
- Short message service (point-to-point), mobile terminated;
- Short message service (point-to-point), mobile originated interworking MSC server;
- Short message service (point-to-point), mobile terminated gateway MSC server;
- Common equipment usage;
- Mobile terminated location request;
- Mobile originated location request;
- Network induced location request.

A more detailed description of the records is found in clause 6.1. The detailed formal description of the data defined in the present document is to be found in 3GPP TS 32.298 [51].

## 5.2.4 GTP' record transfer flows

Not applicable, as the separation of the CDF and CGF is not in the scope of the CS domain charging standards. Refer to clause 4.2 for further information.

Vendors may nevertheless implement a separate CCF and CGF for CS domain charging. In this case, the approach chosen shall conform to the principles and protocol applications specified in 3GPP TS 32.295 [54].

## 5.2.5 B<sub>C</sub> CDR file transfer

There are two options for the transfer of the above CDRs to the Billing domain:

- 1) use the file based interface specified in earlier 3GPP releases, as documented in annex A of the present document;
- 2) apply the Rel-6 file based interface, B<sub>c</sub>, as specified in 3GPP TS 32.297 [52].

It is left to operator and vendor choice which one (or both) of the above interfaces to implement.

## 5.3 CS domain online charging scenarios

CS domain charging is implemented by CAMEL techniques as described in 3GPP TS 23.078 [207] and 3GPP TS 29.078 [212], i.e. outside the scope of the 32 series of charging TSs.

### 5.3.1 Basic principles

Void. Refer to clause 5.3.

### 5.3.2 Diameter message flows

Void. Refer to clause 5.3.

## 6 Definition of charging information

This clause provides Stage 3 specifications of the CDR type and content for the 3GPP CS domain. For each of the CDR types listed in clause 5.2.3, a parameter table, which gives a short description of the parameters, is provided. The detailed specification of the CDR parameters and their encoding is contained in 3GPP TS 32.298 [51], while annex A and 3GPP TS 32.297 [52] specify the details of the CDR file transfer to the BD.

### 6.1 Data description for CS domain offline charging

#### 6.1.1 Diameter message contents

Not applicable. Refer to clause 5.2.2 for further information.

#### 6.1.2 GTP' message contents

Not applicable. Refer to clause 5.2.4 for further information.

#### 6.1.3 CDR description on the B<sub>C</sub> reference point

Dedicated types of CDRs can be generated in the CS domain, as specified in clause 5.2.3. The content of each CDR type is defined in one of the tables that are part of this clause. For each CDR type the parameter definition includes the parameter name, description and category.

**Editor's note:** align the following text with 3GPP TS 32.240 [1].

Equipment vendors shall be able to provide all of the parameters listed in the CDR content table in order to claim compliance with the present document. However, since CDR processing and transport consume network resources, operators may opt to eliminate some of the parameters that are not essential for their operation. This operator provisionable reduction is specified by the parameter category.

A parameter category can have one of two primary values:

- M** This parameter is **Mandatory** and shall always be present in the CDR;
- C** This parameter shall be present in the CDR only when certain **Conditions** are met. These **Conditions** are specified as part of the parameter definition.

Some of these parameters are designated as **Operator (O)** provisionable. Using TMN management functions or specific tools provided by an equipment vendor, operators may choose, if they wish, to include or omit the parameter from the CDR. Once omitted, this parameter is not generated in a CDR. To avoid any potential ambiguity, a CDR generating element **MUST** be able to provide all these parameters. Only an operator can choose whether or not these parameters should be generated in its system.

Those parameters that the operator may configure to be present or absent are further qualified with the "Operator provisionable" indicator as follows:

- O<sub>M</sub>** This is a parameter that, if provisioned by the operator to be present, shall always be included in the CDRs. In other words, a **O<sub>M</sub>** parameter that is provisioned to be present is a mandatory parameter;
- O<sub>C</sub>** This is a parameter that, if provisioned by the operator to be present, shall be included in the CDRs when the required conditions are met. In other words, a **O<sub>C</sub>** parameter that is configured to be present is a conditional parameter.

The CS nodes shall be able to provide the CDRs at the Billing System interface in the format and content described in the present document. Additional CDR formats and contents, generated by the CS nodes, may be available at the interface to the billing system to meet the requirements of the billing system, these are outside of the scope of 3GPP standardization.

The following tables provide a brief description of each CDR parameter. Full definitions of the parameters, sorted by the parameter name in alphabetical order, are provided in 3GPP TS 32.298 [51]. 3GPP TS 32.298 [51] also specifies the

encoding of the CDRs and their parameters on the  $B_c$  reference point, while the CDR files transferred on  $B_c$  are specified in 3GPP TS 32.297 [52].

### 6.1.3.1 Mobile originated call attempt

If the generation of these records is enabled then an MOC record shall be created for each outgoing call attempt made by a mobile station. These MOC records shall be produced in the originating MSC.

**Table 6.1.3.1: MOC record**

Field	2G	3G	Description
Record Type	M	M	Mobile originated.
Served IMSI	M	M	IMSI of the calling party.
Served IMEI	C	C	IMEI of the calling ME, if available.
Served MSISDN	O <sub>M</sub>	O <sub>M</sub>	The primary MSISDN of the calling party.
Called Number	M	M	The address of the called party i.e. the number dialled by the calling subscriber.
Translated Number	O <sub>C</sub>	O <sub>C</sub>	The called number after digit translation within the MSC (if applicable)
Connected Number	O <sub>C</sub>	O <sub>C</sub>	The number of the connected party if different to the Called Number
Roaming Number	O <sub>C</sub>	O <sub>C</sub>	The Mobile Station Roaming Number employed to route this connection, if applicable.
Recording Entity	M	M	The E.164 number of the visited MSC producing the record.
Incoming TKGP	O <sub>M</sub>	O <sub>C</sub>	The MSC trunk group on which the call originated , usually from the BSS. If available in 3G, this parameter shall be supplied.
Outgoing TKGP	O <sub>M</sub>	O <sub>C</sub>	The trunk group on which the call left the MSC. If available in 3G, this parameter shall be supplied.
Location	M	M	The identity of the cell or the SAC at the time of CDR creation, including the location area code and MCC+MNC.
Change of Location	O <sub>C</sub>	O <sub>C</sub>	A list of changes in Location Area Code / Service Area Code / Cell Id and MCC+MNC. Each time-stamped.
Basic service	M	M	Bearer or teleservice employed.
Rate Indication	O <sub>C</sub>	O <sub>C</sub>	Present if "rate adaption" parameters for the basic service were signalled between the MS/UE and the network, see 3GPP TS 24.008 [208].
Transparency Indicator	C	C	Indicates whether the basic service was used in transparent or non-transparent mode. This parameter is provided only for those basic services which may be employed in both transparent and non-transparent mode.
Change Of Service	O <sub>C</sub>	O <sub>C</sub>	A list of changes of basic service during a connection each time-stamped.
Supp. Services	C	C	Supplementary services invoked as a result of this connection. This field shall be present when one or more supplementary services have been invoked.
AOC Parameters	O <sub>C</sub>	O <sub>C</sub>	The charge advice parameters sent to the MS on call set-up. This field shall be supplied only when AoC parameters have been sent.
Change of AOC Parameters	O <sub>C</sub>	O <sub>C</sub>	New AOC parameters sent to the MS e.g. as a result of a tariff switch over, including the time at which the new set was applied. This field shall be supplied only when AoC parameters have been sent.
MS Classmark	M	M	The mobile station classmark employed on call set-up.
Change of Classmark	O <sub>C</sub>	O <sub>C</sub>	A list of changes to the classmark during the connection each time-stamped
Event time stamps:	C C O <sub>M</sub>	C C O <sub>M</sub>	Seizure time: time of incoming traffic channel seizure (for unsuccessful call attempts) Answer: time of answer (for successful calls) Release time: time of traffic channel release
Call duration	M	M	The chargeable duration of the connection for successful calls, the holding time for call attempts.
Data volume	C	-	The number of data segments transmitted if available at the MSC
Radio Chan. Requested	O <sub>M</sub>	-	The type of radio traffic channel (full / half etc.) requested by the MS.
Radio Chan. Used	M	-	The type of radio channel actually used (full or half rate).
Change of Rad. Chan.	O <sub>C</sub>	-	A list of changes each time stamped
Cause for termination	M	M	The reason for the release of the connection.
Diagnostics	O <sub>M</sub>	O <sub>M</sub>	A more detailed reason for the release of the connection.
Call reference	M	M	A local identifier distinguishing between transactions on the same MS
Sequence no.	C	C	Partial record sequence number, only present in case of partial records.
Additional Chg. Info	O <sub>C</sub>	O <sub>C</sub>	Charge/no charge indicator and additional charging parameters, when available.
Record extensions	O <sub>C</sub>	O <sub>C</sub>	A set of network / manufacturer specific extensions to the record, when available.
GsmSCF address	C	C	Identifies the CAMEL server serving the subscriber. Shall be present only if CAMEL is applied.



Field	2G	3G	Description
Service key	C	C	The CAMEL service logic to be applied. Shall be present only if CAMEL is applied.
Network call reference	C	C	An identifier to correlate transactions on the same call taking place in different network nodes, shall be present if CAMEL is applied.
MSC Address	C	C	This field contains the E.164 number assigned to the MSC that generated the network call reference. Shall be present only if CAMEL is applied.
Default call handling	O <sub>C</sub>	O <sub>C</sub>	Indicates whether or not a CAMEL call encountered default call handling. This field shall be present only if default call handling has been applied.
Number of HSCSD Channels Requested	C	-	The maximum number of HSCSD channels requested as received from the MS at call set-up. Shall only be present for HSCSD connections.
Number of HSCSD Channels Allocated	C	-	The number of HSCSD channels allocated to the MS at call set-up. Shall only be present for HSCSD connections.
Change of HSCSD Parameters	C	-	A list of network or user initiated changes of number of HSCSD channels during a connection each time-stamped. Shall only be present in case of an HSCSD call, if the basic HSCSD parameters are modified due the user or network initiated modification procedure.
Fixed Network User Rate	O <sub>C</sub>	O <sub>C</sub>	Indicates the user data rate applied for the connection in the fixed network. Shall only be present for 2G HSCSD connections and for UMTS data connections.
Air Interface User Rate Requested	C	-	The total Air Interface User Rate Requested by the MS at call set-up. Shall only be present for non-transparent HSCSD connections.
Channel Coding Accepted	C	-	A list of the traffic channels codings accepted by the MS. Shall only be present for HSCSD connections.
Channel Coding Used	C	-	The traffic channels codings negotiated between the MS and the network at call set-up. Shall only be present for HSCSD connections.
Guaranteed bit rate	-	O <sub>C</sub>	Describes the bit-rate the UMTS bearer service shall guarantee to the user or application. Guaranteed Bit Rate may be used to facilitate admission control based on available resources, and for resource allocation within UMTS. Shall only be present for UMTS data connections.
Maximum bit rate	-	O <sub>C</sub>	Maximum Bit Rate can be used to make code reservations in the downlink of the radio interface. Its purpose is: 1) to limit the delivered bit-rate to applications or external networks with such limitations, 2) to allow maximum wanted user bit-rate to be defined for applications able to operate with different rates (e.g. applications with adapting codecs). Shall only be present for UMTS data connections.
Speech Version Supported	O <sub>M</sub>	-	Speech version supported by the MS with highest priority indicated by MS
Speech Version Used	O <sub>M</sub>	-	Speech version used for that call
Number of DP encountered	O <sub>C</sub>	O <sub>C</sub>	Number that counts how often armed detection points (TDP and EDP) were encountered. Shall be present only if CAMEL is applied.
Level of CAMEL service	O <sub>C</sub>	O <sub>C</sub>	Indicator for the complexity of the CAMEL feature used. Shall be present only if CAMEL is applied.
Free format Data	C	C	This field contains data sent by the gsmSCF in the Furnish Charging Information (FCI) message(s). The data can be sent either in one FCI message or several FCI messages with append indicator. Shall be present only if CAMEL is applied.
CAMEL call leg information	C	C	Set of CAMEL information IEs. Each of these IEs contains information related to one outgoing CAMEL call leg. Shall be present only if CAMEL is applied.
Free format data append indicator	C	C	Indicator if free format data from this CDR is to be appended to free format data in previous partial CDR. Shall be present only if CAMEL is applied.
Default call handling 2	O <sub>C</sub>	O <sub>C</sub>	Indicates whether or not a CAMEL call encountered default call handling for 2 <sup>nd</sup> service such as dialled service. This field shall be present only if default call handling has been applied.
GsmSCF address 2	C	C	Identifies the CAMEL server serving the subscriber for 2 <sup>nd</sup> service such as dialled service. Shall be present only if CAMEL is applied for 2 <sup>nd</sup> service.
Service key 2	C	C	The CAMEL service logic to be applied for 2 <sup>nd</sup> service such as dialled service. Shall be present only if CAMEL is applied for 2 <sup>nd</sup> service.
Free format Data 2	C	C	This field contains data sent by the gsmSCF in the FCI message(s) for 2 <sup>nd</sup> service such as dialled service. The data can be sent either in one FCI message or several FCI messages with append indicator. Shall be present only if CAMEL is applied for 2 <sup>nd</sup> service.
Free format data append indicator 2	C	C	Indicator if free format data for 2 <sup>nd</sup> service from this CDR is to be appended to free format data in previous partial CDR. Shall be present only if CAMEL is applied for 2 <sup>nd</sup> service.
System Type	-	M	This field indicates the use of GERAN, UTRAN (or a value of unknown). This field is present when either the UTRAN or GERAN air-interface is used on call set-up. For an open CDR in a 2G NE (responsible for the CDR), the field is not present (even if the call is handed off to a 3G air interface). For a CDR in a 3G NE (responsible for the CDR), the value unknown shall be used after handover.

Field	2G	3G	Description
Location Routing Number (LRN)	-	O <sub>C</sub>	Location Routing Number for Number Portability feature
LRN Source Indicator	-	O <sub>C</sub>	LRN Source Indicator tells the source of the LRN
LRN Query Status Indicator	-	O <sub>C</sub>	Status of Number Portability query.
JIP Parameter	-	O <sub>C</sub>	Jurisdiction Information Parameter
JIP Source Indicator	-	O <sub>C</sub>	JIP Source Indicator tells the source of the JIP
JIP Query Status Indicator	-	O <sub>C</sub>	Status of Number Portability query.
Partial Record Type	O <sub>C</sub>	O <sub>C</sub>	Indicates the event (time limit etc.) that caused the generation of a partial record.
Reason for service change	-	O <sub>C</sub>	Indicates the type of service change and fallback.
Service change initiator	-	O <sub>C</sub>	Indicates the service change initiator.
Redial Attempt	O <sub>C</sub>	O <sub>C</sub>	Indicates to the network that a call is the result of a redial attempt to switch from speech to multimedia or vice-versa

### 6.1.3.2 Mobile originated emergency call attempt

If the generation of MOC records is enabled then an MOC emergency record shall be created for each outgoing emergency call attempt made by a mobile station. These records shall be produced in the originating MSC.

**Table 6.1.3.2: MOC emergency record**

Field	2G	3G	Description
Record Type	M	M	Mobile originated.
Served IMSI	C	C	IMSI of the calling party in case of an emergency call with a SIM card.
Served IMEI	C	C	IMEI of the calling mobile equipment if available.
Served MSISDN	O <sub>C</sub>	O <sub>C</sub>	The primary MSISDN of the calling party, if supplied by the UE.
Translated Number	O <sub>C</sub>	O <sub>C</sub>	The called number after digit translation within the MSC (if applicable)
Recording Entity	M	M	The E.164 number of the visited MSC producing the record.
Incoming TKGP	O <sub>M</sub>	O <sub>C</sub>	The MSC trunk group on which the call originated, usually from the BSS. If available in 3G, this parameter shall be supplied.
Outgoing TKGP	O <sub>M</sub>	O <sub>C</sub>	The trunk group on which the call left the MSC. If available in 3G, this parameter shall be supplied.
Location	M	M	The identity of the cell or the SAC in which the call originated including the location area code and MCC+MNC.
Change of Location	O <sub>C</sub>	O <sub>C</sub>	A list of changes in Location Area Code / Service Area Code / Cell Id and MCC+MNC. Each time-stamped.
Basic service	M	M	Teleservice 'emergency call'.
AOC Parameters	O <sub>C</sub>	O <sub>C</sub>	The charge advice parameters sent to the MS on call set-up. This field shall be supplied only when AoC parameters have been sent.
Change of AOC Parameters	O <sub>C</sub>	O <sub>C</sub>	New AOC parameters sent to the MS e.g. as a result of a tariff switch over, including the time at which the new set was applied. This field shall be supplied only when AoC parameters have been sent.
MS Classmark	M	M	The mobile station classmark employed on call set-up.
Change of classmark	O <sub>C</sub>	O <sub>C</sub>	A list of changes to the classmark during the connection each time-stamped
Event time stamps:	C	C	Seizure time: time of incoming traffic channel seizure (for unsuccessful call attempts)
	C	C	Answer time: time of answer (for successful calls)
	O <sub>M</sub>	O <sub>M</sub>	Release time: time of traffic channel release
Call duration	M	M	The chargeable duration of the connection for successful calls, the holding time for call attempts.
Radio Chan. Requested	O <sub>M</sub>	-	The type of radio traffic channel (full / half etc.) requested by the MS.
Radio Chan. Used	M	-	The type of radio channel used (full or half rate).
Change of Rad. Chan.	O <sub>C</sub>	-	A list of changes each time stamped
Cause for termination	M	M	The reason for the release of the connection.
Diagnostics	O <sub>M</sub>	O <sub>M</sub>	A more detailed reason for the release of the connection.
Call reference	M	M	A local identifier distinguishing between transactions on the same MS
Sequence no.	C	C	Partial record sequence number, only present in case of partial records.
Record extensions	O <sub>C</sub>	O <sub>C</sub>	A set of network/ manufacturer specific extensions to the record, when available.
System Type	-	M	This field indicates the use of GERAN, UTRAN (or a value of unknown). This field is present when either the UTRAN or GERAN air-interface is used on call set-up. For an open CDR in a 2G NE (responsible for the CDR), the field is not present (even if the call is handed off to a 3G air interface). For a CDR in a 3G NE (responsible for the CDR), the value unknown shall be used after handover.

Field	2G	3G	Description
Partial Record Type	-	Oc	Indicates the event (time limit etc.) that caused the generation of a partial record.

### 6.1.3.3 Mobile originated call forwarding attempt

If the generation of MOC records is enabled in the forwarding MSC then the forwarding MSC shall produce an MOC record for the forwarded-leg of the call.

**Table 6.1.3.3: MOC, call forwarding record**

Field	2G	3G	Description
Record Type	M	M	Mobile originated.
Served IMSI	M	M	IMSI of the calling party.
Served MSISDN	O <sub>M</sub>	O <sub>M</sub>	The MSISDN of the forwarding party.
Calling Number	O <sub>c</sub>	O <sub>c</sub>	The address of the calling party.
Called Number	M	M	The address of the "forwarded-to" party.
Translated Number	O <sub>c</sub>	O <sub>c</sub>	The called number after digit translation within the MSC (if applicable)
Connected Number	O <sub>c</sub>	O <sub>c</sub>	The number of the connected party if different to the Called Number
Roaming Number	O <sub>c</sub>	O <sub>c</sub>	The Mobile Station Roaming Number employed to route this connection, if applicable.
Recording Entity	M	M	The E.164 number of the forwarding MSC
Incoming TKGP	O <sub>M</sub>	O <sub>M</sub>	The MSC trunk group on which the call originated at the forwarding MSC.
Outgoing TKGP	O <sub>M</sub>	O <sub>M</sub>	The trunk group on which the call left the forwarding MSC
Basic service	C	C	Bearer or teleservice employed, not always available e.g. in case of call forwarding unconditional.
Rate Adaptation	O <sub>c</sub>	O <sub>c</sub>	Present if "rate adaption" parameters for the basic service were signalled between the MS/UE and the network, see 3GPP TS 24.008 [208]. May not always be available in this CDR type.
Transparency Indicator	C	C	Indicates whether the basic service was used in transparent or non-transparent mode. This parameter is provided only for those basic services which may be employed in both transparent and non-transparent mode.
Fixed Network User Rate	O <sub>c</sub>	O <sub>c</sub>	Indicates the user data rate applied for the connection in the fixed network. Shall only be present for 2G HSCSD connections and for UMTS data connections.
ChangeOfService	O <sub>c</sub>	O <sub>c</sub>	A list of changes of basic service during a connection each time-stamped.
Supplementary Services	C	C	Supplementary services invoked as a result of this connection, if this information is available to the forwarding node. This field shall be present when one or more supplementary services have been invoked.
Event time stamps:	C C O <sub>M</sub>	C C O <sub>M</sub>	Seizure time: time of incoming traffic channel seizure (for unsuccessful call attempts) Answer time: time of answer (for successful calls) Release time: time of traffic channel release
Call duration	M	M	The chargeable duration of the connection for successful calls, the holding time of call attempts.
Data volume	C	-	The number of data segments transmitted if available at the MSC
Cause for termination	M	M	The reason for the release of the connection.
Diagnostics	O <sub>M</sub>	O <sub>M</sub>	A more detailed reason for the release of the connection.
Call reference	M	M	A local identifier distinguishing between transactions on the same MS
Sequence no.	C	C	Partial record sequence number, only present in case of partial records.
Additional Chg. Info	O <sub>c</sub>	O	Charge/no charge indicator and additional charging parameters, when available.
Record extensions	O <sub>c</sub>	O <sub>c</sub>	A set of network/ manufacturer specific extensions to the record, when available.
GsmSCF address	C	C	Identifies the CAMEL server serving the subscriber. Shall be present only if CAMEL is applied.
Service key	C	C	The CAMEL service logic to be applied. Shall be present only if CAMEL is applied.
Network call reference	C	C	An identifier to correlate transactions on the same call taking place in different network nodes, shall be present if CAMEL is applied.
MSC Address	C	C	This field contains the E.164 number assigned to the MSC that generated the network call reference. Shall be present only if CAMEL is applied.
CAMEL initiated CF indicator	C	C	Indicates that the CAMEL server initiated call forwarding. Shall be present only if CAMEL is applied.
Default call handling	O <sub>c</sub>	O <sub>c</sub>	Indicates whether or not a CAMEL call encountered default call handling. This field shall be present only if default call handling has been applied.
Number of DP encountered	O <sub>c</sub>	O <sub>c</sub>	Number that counts how often armed detection points (TDP and EDP) were encountered. Shall be present only if CAMEL is applied.

Field	2G	3G	Description
Level of CAMEL service	O <sub>C</sub>	O <sub>C</sub>	Indicator of the complexity of the CAMEL feature used. Shall be present only if CAMEL is applied.
Free format Data	C	C	This field contains data sent by the gsmSCF in the Furnish Charging Information (FCI) messages. The data can be sent either in one FCI message or several FCI messages with append indicator. Shall be present only if CAMEL is applied.
CAMEL call leg information	C	C	Set of CAMEL information IEs. Each of these IEs contains information related to one outgoing CAMEL call leg. Shall be present only if CAMEL is applied.
Free format data append indicator	C	C	Indicator if free format data from this CDR is to be appended to free format data in previous partial CDR. Shall be present only if CAMEL is applied.
Default call handling 2	O <sub>C</sub>	O <sub>C</sub>	Indicates whether or not a CAMEL call encountered default call handling for 2 <sup>nd</sup> service such as dialled service. This field shall be present only if default call handling has been applied.
GsmSCF address 2	C	C	Identifies the CAMEL server serving the subscriber for 2 <sup>nd</sup> service such as dialled service. Shall be present only if CAMEL is applied for 2 <sup>nd</sup> service.
Service key 2	C	C	The CAMEL service logic to be applied for 2 <sup>nd</sup> service such as dialled service. Shall be present only if CAMEL is applied for 2 <sup>nd</sup> service.
Free format Data 2	C	C	This field contains data sent by the gsmSCF in the FCI message(s) for 2 <sup>nd</sup> service such as dialled service. The data can be sent either in one FCI message or several FCI messages with append indicator. Shall be present only if CAMEL is applied for 2 <sup>nd</sup> service.
Free format data append indicator 2	C	C	Indicator if free format data for 2 <sup>nd</sup> service from this CDR is to be appended to free format data in previous partial CDR. Shall be present only if CAMEL is applied for 2 <sup>nd</sup> service.
Location Routing Number (LRN)	-	O <sub>C</sub>	Location Routing Number for Number Portability feature
LRN Source Indicator	-	O <sub>C</sub>	LRN Source Indicator tells the source of the LRN
LRN Query Status Indicator	-	O <sub>C</sub>	Status of Number Portability query.
JIP Parameter	-	O <sub>C</sub>	Jurisdiction Information Parameter
JIP Source Indicator	-	O <sub>C</sub>	JIP Source Indicator tells the source of the JIP
JIP Query Status Indicator	-	O <sub>C</sub>	Status of Number Portability query.
Partial Record Type	-	O <sub>C</sub>	Indicates the event (time limit etc.) that caused the generation of a partial record.

### 6.1.3.4 Mobile terminated call attempt

If the generation of these records is enabled, then an MTC record shall be created for each incoming call attempt made for a mobile station. The MTC records shall be produced in the terminating MSC.

**Table 6.1.3.4: MTC record**

Field	2G	3G	Description
Record Type	M	M	Mobile Terminated.
Served IMSI	M	M	IMSI of the called party.
Served IMEI	C	C	IMEI of the called ME, if available.
Served MSISDN	O <sub>M</sub>	O <sub>M</sub>	The MSISDN of the called party.
Calling Number	C	C	The number of the calling party if available.
Connected Number	O <sub>C</sub>	O <sub>C</sub>	Only relevant in case of call forwarding where the "forwarded-to" number is recorded.
Recording Entity	M	M	The E.164 number of the visited (terminating) MSC
Incoming TKGP	O <sub>M</sub>	O <sub>M</sub>	The MSC trunk group on which the call originated.
Outgoing TKGP	O <sub>M</sub>	O <sub>C</sub>	The trunk group on which the call left the MSC, usually to the BSS. If available in 3G, this parameter shall be supplied.
Location	C	C	The identity of the cell or the SAC occupied by the called party when the call was set up, including the location area code and MCC+MNC.
Change of Location	O <sub>C</sub>	O <sub>C</sub>	A list of changes in Location Area Code / Service Area Code / Cell Id and MCC+MNC. Each time-stamped.
Basic Service	M	M	Bearer or teleservice employed
Rate Adaptation	O <sub>C</sub>	O <sub>C</sub>	Present if "rate adaption" parameters for the basic service were signalled between the MS/UE and the network, see 3GPP TS 24.008 [208].
Transparency Indicator	C	C	Indicates whether the basic service was used in transparent or non-transparent mode. This parameter is provided only for those basic services which may be employed in both transparent and non-transparent mode.
Change of Service	O <sub>C</sub>	O <sub>C</sub>	A list of changes of basic service during a connection each time-stamped.
Supplementary services	C	C	Supplementary services invoked as a result of this connection. This field shall be present when one or more supplementary services have been invoked.
AOC Parameters	O <sub>C</sub>	O <sub>C</sub>	The charge advice parameters sent to the MS on call set-up. This field shall be supplied only when AoC parameters have been sent.
Change of AOC Parameters.	O <sub>C</sub>	O <sub>C</sub>	New AOC parameters sent to the MS e.g. as a result of a tariff switch-over, including the time at which the new set was applied. This field shall be supplied only when AoC parameters have been sent.
MS Classmark	M	M	The mobile station class mark.
Change of Classmark	O <sub>C</sub>	O <sub>C</sub>	A list of changes to the classmark during the connection each time-stamped
Event time stamps:	C C O <sub>M</sub>	C C O <sub>M</sub>	Seizure time: time of traffic channel seizure for unsuccessful call attempts Answer time: time of answer for successful calls Release time: time of traffic channel release
Call duration	M	M	The chargeable duration of the connection if successful, the holding time of the call if unsuccessful.
Data volume	C	-	The number of data segments transmitted, if available at the MSC
Radio Chan. Requested	O <sub>M</sub>	-	The type of radio traffic channel (full / half etc.) requested by the MS.
Radio Chan. Used	M	-	The type of radio channel used (full or half rate).
Change of Rad. Chan	O <sub>C</sub>	-	A list of changes each time stamped
Cause for termination	M	M	The reason for the release of the call.
Diagnostics	O <sub>M</sub>	O <sub>M</sub>	A more detailed reason for the release of the connection.
Call reference	M	M	A local identifier distinguishing between transactions at the same MS
Sequence no.	C	C	Partial record sequence number, only present in case of partial records.
Additional Chg. Info	O <sub>C</sub>	O <sub>C</sub>	Charge/no charge indicator and additional charging parameters, when available.
Record extensions	O <sub>C</sub>	O <sub>C</sub>	A set of network/ manufacturer specific extensions to the record, when available.
Network call reference	C	C	An identifier to correlate transactions on the same call taking place in different network nodes, shall be present if CAMEL is applied.
MSC Address	C	C	This field contains the E.164 number assigned to the MSC that generated the network call reference. Shall be present only if CAMEL is applied.
Number of HSCSD Channels Requested	O <sub>C</sub>	-	The maximum number of HSCSD channels requested as received from the MS at call set-up. Shall only be present for HSCSD connections.

Field	2G	3G	Description
Number of HSCSD Channels Allocated	O <sub>C</sub>	-	The number of HSCSD channels allocated to the MS at call set-up. Shall only be present for HSCSD connections.
Change of HSCSD Parameters	O <sub>C</sub>	-	A list of network or user initiated changes of number of HSCSD channels during a connection each time-stamped. Shall only be present in case of an HSCSD call, if the basic HSCSD parameters are modified due the user or network initiated modification procedure.
Fixed Network User Rate	O <sub>C</sub>	-	Indicates the user data rate applied for the connection in the fixed network. Shall only be present for 2G HSCSD connections and for UMTS data connections.
Air Interface User Rate Requested	C	C	The total Air Interface User Rate Requested by the MS at call set-up. Shall only be present for non-transparent HSCSD connections.
Channel Coding Accepted	C	-	A list of the traffic channels codings accepted by the MS. Shall only be present for HSCSD connections.
Channel Coding Used	C	-	The traffic channels codings negotiated between the MS and the network at call set-up. Shall only be present for HSCSD connections.
Guaranteed bit rate	-	O <sub>C</sub>	Describes the bit-rate the UMTS bearer service shall guarantee to the user or application. Guaranteed Bit Rate may be used to facilitate admission control based on available resources, and for resource allocation within UMTS. Shall only be present for UMTS data connections.
Maximum bit rate	-	O <sub>C</sub>	Maximum Bit Rate can be used to make code reservations in the downlink of the radio interface. Its purpose is: 1) to limit the delivered bit-rate to applications or external networks with such limitations; 2) to allow maximum wanted user bit-rate to be defined for applications able to operate with different rates (e.g. applications with adapting codecs). Shall only be present for UMTS data connections.
Speech Version Used	O <sub>M</sub>	-	Speech version used for that call
Speech Version Supported	O <sub>M</sub>	-	Speech version supported by the MS with highest priority indicated by MS.
System Type	-	M	This field indicates the use of GERAN, UTRAN (or a value of unknown). This field is present when either the UTRAN or GERAN air-interface is used on call set-up. For an open CDR in a 2G NE (responsible for the CDR), the field is not present (even if the call is handed off to a 3G air interface). For a CDR in a 3G NE (responsible for the CDR), the value unknown shall be used after handover.
Location Routing Number (LRN)	-	O <sub>C</sub>	Location Routing Number for Number Portability feature.
LRN Source Indicator	-	O <sub>C</sub>	LRN Source Indicator tells the source of the LRN.
LRN Query Status Indicator	-	O <sub>C</sub>	Status of Number Portability query.
JIP Parameter	-	O <sub>C</sub>	Jurisdiction Information Parameter
JIP Source Indicator	-	O <sub>C</sub>	JIP Source Indicator tells the source of the JIP.
JIP Query Status Indicator	-	O <sub>C</sub>	Status of Number Portability query.
Partial Record Type	O <sub>C</sub>	O <sub>C</sub>	Indicates the event (time limit, etc.) that caused the generation of a partial record.
Reason for service change	-	O <sub>C</sub>	Indicates the type of service change and fallback.
Service change initiator	-	O <sub>C</sub>	Indicates the service change initiator.



### 6.1.3.5 Roaming call attempt

If the generation of these records is enabled then, a roaming record shall be created for each call redirected to a mobile subscriber roaming outside the HPLMN. These roaming records shall be produced in the GMSC of the roaming subscriber's HPLMN. These roaming records shall be produced by the "Old MSC/VLR" during Mobile Terminating Roaming Forwarding (MTRF) procedure, when the call is re-routed towards a new MSC/VLR located in a different PLMN.

**Table 6.1.3.5: Roaming record**

Field	2G	3G	Description
Record Type	M	M	Roaming record.
Served IMSI	M	M	IMSI of the called (roaming) party.
Served MSISDN	O <sub>M</sub>	O <sub>M</sub>	The MSISDN of the called (roaming) party.
Calling Number	C	C	The address of the calling party, if available.
Roaming Number	M	M	The Mobile Station Roaming Number employed to route this connection.
Recording Entity	M	M	The E.164 number of the GMSC
Incoming TKGP	O <sub>M</sub>	O <sub>M</sub>	The GMSC/VMSC trunk group on which the call originated.
Outgoing TKGP	O <sub>M</sub>	O <sub>M</sub>	The trunk group on which the call left the GMSC/VMSC
Basic service	M	M	Bearer or teleservice employed.
Transparency Indicator	C	C	Indicates whether the basic service was used in transparent or non-transparent mode. This parameter is provided only for those basic services which may be employed in both transparent and non-transparent mode.
ChangeOfService	O <sub>C</sub>	O <sub>C</sub>	A list of changes of basic service during a connection each time-stamped.
Supplementary Services	C	C	Supplementary services invoked as a result of this connection. This field shall be present when one or more supplementary services have been invoked.
Event time stamps	C C O <sub>M</sub>	C C O <sub>M</sub>	Seizure time: time of incoming traffic channel seizure (for unsuccessful call attempts) Answer time: time of answer (for successful calls) Release time: time of traffic channel release
Call duration	M	M	The chargeable duration of the connection for successful calls, the holding time of call attempts.
Data volume	C	C	The number of data segments transmitted if available at the GMSC
Cause for termination	M	M	The reason for the release of the connection.
Diagnostics	O <sub>M</sub>	O <sub>M</sub>	A more detailed reason for the release of the connection.
Call reference	M	M	A local identifier distinguishing between transactions on the same MS
Sequence no.	C	C	Partial record sequence number, only present in case of partial records.
Record extensions	O <sub>C</sub>	O <sub>C</sub>	A set of network/ manufacturer specific extensions to the record, when available.
Network call reference	C	C	An identifier to correlate transactions on the same call taking place in different network nodes, shall be present if CAMEL is applied.
MSC Address	C	C	This field contains the E.164 number assigned to the MSC that generated the network call reference. Shall be present only if CAMEL is applied.
Location Routing Number (LRN)	-	O <sub>C</sub>	Location Routing Number for Number Portability feature
LRN Source Indicator	-	O <sub>C</sub>	LRN Source Indicator tells the source of the LRN
LRN Query Status Indicator	-	O <sub>C</sub>	Status of Number Portability query.
JIP Parameter	-	O <sub>C</sub>	Jurisdiction Information Parameter
JIP Source Indicator	-	O <sub>C</sub>	JIP Source Indicator tells the source of the JIP
JIP Query Status Indicator	-	O <sub>C</sub>	Status of Number Portability query.
Partial Record Type	-	O <sub>C</sub>	Indicates the event (time limit, etc.) that caused the generation of a partial record.

### 6.1.3.6 Incoming gateway call attempt

If generation of these records is enabled, an incoming gateway record shall be created for each incoming call attempt received by a gateway MSC from another network. These records, produced in the gateway MSC, may be used to settle accounts with other networks. The generation of gateway records shall not be influenced by the production of MTC records i.e. even if the GMSC and terminating MSC are co-located a gateway record shall still be produced.

**Table 6.1.3.6: Incoming gateway record**

Field	2G	3G	Description
Record Type	M	M	Incoming gateway record
Calling Number	C	C	The number of the calling party if available at this node.
Called Number	M	M	The address of the called party as seen by the GMSC. This is the number employed by the GMSC for routing.
Recording Entity	M	M	The E.164 number of the GMSC
Incoming TKGP	M	M	The incoming GMSC trunk group on which the call originated.
Outgoing TKGP	O <sub>M</sub>	O <sub>C</sub>	The trunk group on which the call left the GMSC. If available in 3G, this parameter shall be supplied.
Event time stamps:	M C O <sub>M</sub>	M C O <sub>M</sub>	Seizure time: time of incoming trunk seizure Answer time: time of answer (successful calls only) Release time: time of incoming trunk release
Call duration	M	M	The accountable duration (answer -> release of incoming trunk) of the connection if successful, the call holding time of the incoming trunk for call attempts.
Data Volume	C	-	If applicable and known at the GMSC
ISDN Bearer Capability	O <sub>C</sub>	O <sub>C</sub>	Present if this parameter is signalled back from the VMSC to the GMSC in the access transport parameter of the Answer Message (ANM), see 3GPP TS 29.007 [213].
Low Layer Compatibility	O <sub>C</sub>	O <sub>C</sub>	Present if this parameter is signalled back from the VMSC to the GMSC in the access transport parameter of the Answer Message (ANM), see 3GPP TS 29.007 [213].
High Layer Compatibility	O <sub>C</sub>	O <sub>C</sub>	Present if this parameter is signalled back from the VMSC to the GMSC in the access transport parameter of the Answer Message (ANM), see 3GPP TS 29.007 [213].
Cause for termination	M	M	The reason for the release of the connection.
Diagnostics	O <sub>M</sub>	O <sub>M</sub>	A more detailed reason for the release of the connection.
Call Reference	M	M	A local identifier distinguishing between transactions.
Reason for service change	-	O <sub>C</sub>	Indicates the type of service change and fallback.
Service change initiator	-	O <sub>C</sub>	Indicates the service change initiator.
Sequence no.	C	C	Partial record sequence number, if applicable.
Record extensions	O <sub>C</sub>	O <sub>C</sub>	A set of network/ manufacturer specific extensions to the record, when available.
Location Routing Number (LRN)	-	O <sub>C</sub>	Location Routing Number for Number Portability feature
LRN Source Indicator	-	O <sub>C</sub>	LRN Source Indicator tells the source of the LRN
LRN Query Status Indicator	-	O <sub>C</sub>	Status of Number Portability query.
JIP Parameter	-	O <sub>C</sub>	Jurisdiction Information Parameter
JIP Source Indicator	-	O <sub>C</sub>	JIP Source Indicator tells the source of the JIP
JIP Query Status Indicator	-	O <sub>C</sub>	Status of Number Portability query.
Partial Record Type	-	O <sub>C</sub>	Indicates the event (time limit, etc.) that caused the generation of a partial record.

### 6.1.3.7 Outgoing gateway call attempt

If generation of these records is enabled, an outgoing gateway record shall be created for each outgoing call attempt from a gateway MSC to another network. These records, produced in the gateway MSC, may be used to settle accounts with other networks. The generation of gateway records shall not be influenced by the production of MOC records i.e. even if the GMSC and originating MSC are co-located a gateway record shall still be produced.

**Table 6.1.3.7: Outgoing gateway record**

Field	2G	3G	Description
Record Type	M	M	Outgoing gateway record
Calling Number	C	C	The number of the calling party if available at this node.
Called Number	M	M	The address of the called party as seen by the GMSC. This is the number employed by the GMSC for routing.
Recording Entity	M	M	The E.164 number of the GMSC
Incoming TKGP	O <sub>M</sub>	O <sub>C</sub>	The incoming GMSC trunk group on which the call originated. If available in 3G, this parameter shall be supplied.
Outgoing TKGP	M	M	The trunk group on which the call left the GMSC.
Event time stamps:	M C O <sub>M</sub>	M C O <sub>M</sub>	Seizure time: time of outgoing trunk seizure Answer time: time of answer (successful calls only) Release time: time of outgoing trunk release
Call duration	M	M	The accountable duration (answer -> release of outgoing trunk) of the connection if successful, the call holding time of the outgoing trunk for call attempts.
Data Volume	C	-	If applicable and known at the GMSC
Cause for termination	M	M	The reason for the release of the connection.
Diagnostics	O <sub>M</sub>	O <sub>M</sub>	A more detailed reason for the release of the connection.
Call Reference	M	M	A local identifier distinguishing between transactions.
Sequence no.	C	C	Partial record sequence number, if applicable.
Reason for service change	-	O <sub>C</sub>	Indicates the type of service change and fallback.
Service change initiator	-	O <sub>C</sub>	Indicates the service change initiator.
Record extensions	O <sub>C</sub>	O <sub>C</sub>	A set of network/ manufacturer specific extensions to the record, when available.
Location Routing Number (LRN)	-	O <sub>C</sub>	Location Routing Number for Number Portability feature
LRN Source Indicator	-	O <sub>C</sub>	LRN Source Indicator tells the source of the LRN
LRN Query Status Indicator	-	O <sub>C</sub>	Status of Number Portability query.
JIP Parameter	-	O <sub>C</sub>	Jurisdiction Information Parameter
JIP Source Indicator	-	O <sub>C</sub>	JIP Source Indicator tells the source of the JIP
JIP Query Status Indicator	-	O <sub>C</sub>	Status of Number Portability query.
Partial Record Type	-	O <sub>C</sub>	Indicates the event (time limit, etc.) that caused the generation of a partial record.

### 6.1.3.8 Transit call attempt

If generation of these records is enabled then a transit record may be generated for each incoming call attempt received by a Transit MSC i.e. neither originating nor terminating. For the avoidance of doubt, a transit record shall only be produced if no MOC or MTC record is produced for this call attempt by this MSC. The transit records, produced in the TMSC, may be used to record traffic from particular origins or to particular destinations.

**Table 6.1.3.8: Transit record**

Field	2G	3G	Description
Record Type	M	M	Transit.
Recording Entity	M	M	The E.164 number of the transit MSC
Incoming TKGP	M	M	The TMSC trunk group on which the call originated.
Outgoing TKGP	M	M	The trunk group on which the call left the TMSC.
Calling Number	C	C	The number of the calling party if available at this node.
Called Number	M	M	The address of the called party as seen by the TMSC.
ISDN Basic Service	O <sub>M</sub>	O <sub>M</sub>	The ISDN basic service employed
Event time stamps:	C	C	Seizure time: time of incoming trunk seizure for unsuccessful call attempts
	C	C	Answer time: time of answer (successful calls only)
	O <sub>M</sub>	O <sub>M</sub>	Release time: time of traffic channel release
Call duration	M	M	The chargeable duration of the connection if successful, the call holding time for call attempts.
Data Volume	C	-	If applicable and known at the transit MSC
Cause for term.	M	M	The reason for the release of the connection.
Diagnostics	O <sub>M</sub>	O <sub>M</sub>	A more detailed reason for the release of the connection.
Call Reference	M	M	A local identifier distinguishing between transactions.
Sequence no.	C	C	Partial record sequence number, if applicable.
Record extensions	O <sub>C</sub>	O <sub>C</sub>	A set of network/ manufacturer specific extensions to the record, when available.
Location Routing Number (LRN)	-	O <sub>C</sub>	Location Routing Number for Number Portability feature
LRN Source Indicator	-	O <sub>C</sub>	LRN Source Indicator tells the source of the LRN
LRN Query Status Indicator	-	O <sub>C</sub>	Status of Number Portability query.
JIP Parameter	-	O <sub>C</sub>	Jurisdiction Information Parameter
JIP Source Indicator	-	O <sub>C</sub>	JIP Source Indicator tells the source of the JIP
JIP Query Status Indicator	-	O <sub>C</sub>	Status of Number Portability query.
Partial Record Type	-	O <sub>C</sub>	Indicates the event (time limit, etc.) that caused the generation of a partial record.

### 6.1.3.9 Supplementary service actions

A supplementary service record may be produced in the NEF of the appropriate MSC or HLR for each supplementary service action (activation, deactivation, invocation etc.) performed or initiated by the subscriber.

- There are two fundamental types of SS-actions: Call related i.e. as a result of a connection e.g. Invocation of CLIP / CLIR / AoC, etc.
- Non-call related i.e. as a result of Subscriber Controlled Input (SCI) e.g. Registration of call forwarding.

Each supplementary service action shall be performed on one or more basic service groups. If the action applies to all teleservices and all bearer services (i.e. to all basic services) then the basic services field shall be omitted.

SCI actions may be recorded in individual SS-action records. Call related actions may be recorded in either the appropriate call record (MOC/MTC) or in separate SS-action records.

Additional non-standard supplementary service actions may be made available within some networks in the form of Unstructured Supplementary Service Data (USSD). These actions may also be recorded in SS-action records. However, as these actions are non-standard they may not include an appropriate action type, supplementary service code or basic service code.

**Table 6.1.3.9: SS-action record**

Field	2G	3G	Description
Record Type	M	M	Supplementary service action.
Served IMSI	M	M	The IMSI of the MS performing the action.
Served IMEI	O <sub>C</sub>	O <sub>C</sub>	The IMEI of the ME performing the action.
Served MSISDN	O <sub>M</sub>	O <sub>M</sub>	The primary MSISDN of the party performing the action.
MS Classmark	M	M	The mobile station classmark.
Recording Entity	M	M	The E.164 number of the visited MSC / HLR.
Location	O <sub>M</sub>	O <sub>M</sub>	The identity of the cell or the SAC, including the location area code and MCC+MNC, from which the request originated.
Basic Services	C	C	The basic service group(s) to which the supplementary service applies. This field is not provided if the action applies to all basic services.
Supplementary Service	C	C	The supplementary service or group of supplementary services for which the request was made. May not be available in case of USSD.
SS Action	C	C	Activation, deactivation, interrogation etc. May not be available in case of USSD.
SS Action time stamp	M	M	The time at which the action was requested.
SS Parameters	C	C	Service dependent parameters or unstructured supplementary service data, if defined for the SS action recorded in this CDR.
SS Action Result	C	C	Result of the requested transaction if unsuccessful.
Call Reference	M	M	A local identifier distinguishing between transactions at the same MS.
Record extensions	O <sub>C</sub>	O <sub>C</sub>	A set of network/ manufacturer specific extensions to the record, when available.
System Type	-	M	This field is present when either the UTRAN or GERAN air-interface is used. It is omitted when the service is provided by a GSM air interface

### 6.1.3.10 HLR interrogation

If enabled, a HLR interrogation record shall be created for each interrogation performed for a mobile subscriber. These records may be produced in either the HLR itself or the interrogating MSC.

**Table 6.1.3.10: HLR interrogation record**

Field	2G	3G	Description
Record Type	M	M	HLR interrogation.
Served IMSI	C	C	The IMSI of the party being interrogated, if successful
Served MSISDN	M	M	The MSISDN of the subscriber being interrogated.
Recording Entity	M	M	The E.164 Number of the HLR / MSC.
Basic Service	O <sub>C</sub>	O <sub>C</sub>	Only for teleservice 21 (SMS-MT).
Routing Number	C	C	Routing number (MSRN, forwarding no.) provided by the HLR if the interrogation was successful.
Interrogation time stamp	M	M	Time at which the interrogation was invoked.
Number of Forwarding	C	C	The number of times the call has been forwarded if provided by ISUP.
Interrogation Result	C	C	The result of the interrogation request if unsuccessful.
Record extensions	O <sub>C</sub>	O <sub>C</sub>	A set of network/ manufacturer specific extensions to the record, when available.

### 6.1.3.11 Location update (VLR)

If enabled, a VLR location update record shall be produced in the VLR for each location registration or location update received by the VLR for a mobile subscriber.

**Table 6.1.3.11: Location update (VLR) record**

Field	2G	3G	Loc Upd over SGs	Description
Record Type	M	M	M	Location update.
Served IMSI	M	M	M	IMSI of the served MS.
Served MSISDN	O <sub>M</sub>	O <sub>M</sub>	O <sub>M</sub>	The primary MSISDN of the party performing the location update
Recording Entity	M	M	M	The E.164 number of the entity (VLR or MSC/VLR) generating the record.
Old location	C C	C C	- C	Not present for registration: VMSC E.164 Number Location Area Code and MCC+MNC
New location	M  M O <sub>M</sub>	M  M O <sub>M</sub>	M  M O <sub>M</sub>	VMSC E.164 Number . When E-UTRAN location update over SG, this field contains the E.164 number of the entity (VLR or MSC/VLR) generating the record (i.e Recording entity). Location Area Code Cell Identification or Service Area Code and MCC+MNC The Cell Identity contains the 16 least significant bits and the Tracking Area Code is placed in the Location Area Code field if E-UTRAN location update.
Location Extension	□ -	□ -	O <sub>M</sub>	The 12 most significant bits of the E-UTRAN Cell Identity are included if E-UTRAN location update.
MS Classmark	M	M	M	The mobile station classmark. When E-UTRAN location update over SG, this field contains Default classmark 1" 0x7F value".
Update time stamp	M	M	M	Time at which the update was invoked.
Update Result	C	C	C	The result of the location update if unsuccessful.
Record extensions	O <sub>C</sub>	O <sub>C</sub>	O <sub>C</sub>	A set of network/ manufacturer specific extensions to the record, when available.

### 6.1.3.12 Location update (HLR)

If enabled, an HLR location update record shall be produced in the HLR for each location registration or location update received by the HLR for a mobile subscriber including location updates received from subscribers roaming in foreign PLMNs.

**Table 6.1.3.12: Location Update (HLR) record**

Field	2G	3G	Description
Record Type	M	M	Location update.
Served IMSI	M	M	IMSI of the served MS.
Recording Entity	M	M	The E.164 Number of the HLR.
Old location	O <sub>C</sub>	O <sub>C</sub>	VMSC E.164 Number
	O <sub>C</sub>	O <sub>C</sub>	VLR E.164 Number
New location	M	M	VMSC E.164 Number
	M	M	VLR E.164 Number
Update time stamp	M	M	Time at which the update was invoked.
Update Result	C	C	The result of the location update if unsuccessful.
Record extensions	O <sub>C</sub>	O <sub>C</sub>	A set of network/ manufacturer specific extensions to the record, when available.

### 6.1.3.13 Short message service, mobile originated

If enabled, an SMS-MO record shall be produced, within the originating MSC, for each short message sent by a mobile subscriber.

**Table 6.1.3.13: SMS-MO record**

Field	2G	3G	SMS over SGs	Description
Record Type	M	M	M	SMS-Mobile originated.
Served IMSI	M	M	M	The IMSI of the subscriber sending the short message.
Served IMEI	O <sub>C</sub>	O <sub>C</sub>	O <sub>C</sub>	The IMEI of the ME sending the message, if available.
Served MSISDN	O <sub>M</sub>	O <sub>M</sub>	O <sub>M</sub>	The primary MSISDN of the subscriber sending the message.
MS Classmark	M	M	M	The mobile station classmark.
Service Centre	M	M	M	The address (E.164) of the SMS-service centre.
Recording Entity	M	M	M	The E.164 number of the visited MSC.
Location	O <sub>M</sub>	O <sub>M</sub>	O <sub>M</sub>	The Location Area Code and Cell Identity / Service Area Code and MCC+MNC from which the message originated. The Cell Identity contains the 16 least significant bits and the Tracking Area Code is placed in the Location Area Code field if E-UTRAN is used to deliver the SMS.
Event Time stamp	M	M	M	Origination time: The time at which the message was received by the MSC from the subscriber.
Message Reference	M	M	M	A reference, provided by the MS uniquely identifying this message.
SMS Result	C	C	C	The result of the attempted delivery if unsuccessful.
Record extensions	O <sub>C</sub>	O <sub>C</sub>	O <sub>C</sub>	A set of network/ manufacturer specific extensions to the record, when available.
Destination number	O <sub>M</sub>	O <sub>M</sub>	O <sub>M</sub>	The destination number dialled by the MS sending the short message.
CAMELSMSInformation	C	C	C	Set of CAMEL information IEs. Each of these IEs contains information related to CAMEL call leg related for the SMS. Shall be present only if CAMEL is applied.
System Type	-	M	M	This field is present when either the UTRAN or GERAN air-interface is used. It is omitted when the service is provided by a GSM air interface. The field shall be set to "unknown" for SMS delivery using E-UTRAN.
Location Extension	-	-	O <sub>M</sub>	The 12 most significant bits of the E-UTRAN Cell Identity are included if E-UTRAN is used to deliver the SMS.

### 6.1.3.14 Short message service, mobile terminated

If enabled, an SMS-MT record shall be produced, within the terminating MSC, for each short message received by a mobile subscriber.

**Table 6.1.3.14: SMS-MT record**

Field	2G	3G	SMS over SGs	Description
Record Type	M	M	M	SMS-Mobile Terminated.
Service Centre	M	M	M	The E.164 address of the SMS centre.
Served IMSI	M	M	M	The IMSI of the receiving party.
Served IMEI	O <sub>C</sub>	O <sub>C</sub>	O <sub>C</sub>	The IMEI of the receiving party, if available.
Served MSISDN	O <sub>M</sub>	O <sub>M</sub>	O <sub>M</sub>	The MSISDN of the receiving party.
MS Classmark	M	C	C	The mobile station classmark.
Recording Entity	M	M	M	The E.164 number of the visited MSC.
Location	O <sub>M</sub>	O <sub>M</sub>	O <sub>M</sub>	The Location Area Code and Cell Identity /Service Area Code and MCC+MNC to which the message was delivered. The Cell Identity contains the 16 least significant bits and the Tracking Area Code is placed in the Location Area Code filed if E-UTRAN is used to deliver the SMS.
Event time stamp	M	M	M	Delivery time: time at which message was sent to the MS by the MSC.
SMS Result	C	C	C	The result of the attempted delivery if unsuccessful.
Record extensions	O <sub>C</sub>	O <sub>C</sub>	O <sub>C</sub>	A set of network/ manufacturer specific extensions to the record, when available.
System Type	C	M	M	This field is present when either the UTRAN or GERAN air-interface is used. It is omitted when the service is provided by a GSM air interface. The field shall be set to "unknown" for SMS delivery using E-UTRAN.
CAMELSMSInformation	C	C	C	Set of CAMEL information IEs. Each of these IEs contains information related to CAMEL call leg related for the SMS. Shall be present only if CAMEL is applied.
Location Extension	-	-	O <sub>M</sub>	The 12 most significant bits of the E-UTRAN Cell Identity are included if E-UTRAN is used to deliver the SMS.

### 6.1.3.15 SMS-MO interworking record

If enabled, an SMS-MO interworking record shall be produced, within the interworking MSC, for each short message generated by a mobile subscriber. These records may be used to settle accounts between PLMNs and SMS service centres. Where the Interworking MSC is also the originating MSC, an SMS-MO CDR will also be generated.

**Table 6.1.3.15: SMS-MO interworking record**

Field	2G	3G	Description
Record Type	M	M	SMS-MO interworking record.
Service Centre	M	M	The E.164 address of the SMS service centre.
Served IMSI	M	M	The IMSI of the sending party.
Recording Entity	M	M	The E.164 number of the visited MSC.
Event Time stamp	M	M	The time at which the message was received by the interworking function.
SMS Result	C	C	The result of the attempted delivery if unsuccessful, when available.
Record extensions	O <sub>C</sub>	O <sub>C</sub>	A set of network/ manufacturer specific extensions to the record.



### 6.1.3.16 SMS-MT gateway record

If enabled, an SMS-MT gateway record shall be produced, within the gateway MSC, for each short message sent to a mobile subscriber. Where the Gateway MSC is also the terminating MSC, an SMS-MT CDR will also be generated.

**Table 6.1.3.16: SMS-MT gateway record**

Field	2G	3G	Description
Record Type	M	M	SMS-MT gateway record.
Service Centre	M	M	The E.164 address of the SMS service centre.
Served IMSI	M	M	The IMSI of the receiving party.
Served MSISDN	O <sub>M</sub>	O <sub>M</sub>	The MSISDN of the receiving party.
Recording Entity	M	M	The E.164 number of the visited MSC.
Event Time stamp	M	M	The time at which the message was received by the gateway.
SMS Result	C	C	The result of the attempted delivery if unsuccessful.
Record extensions	O <sub>C</sub>	O <sub>C</sub>	A set of network/ manufacturer specific extensions to the record, when available.

### 6.1.3.17 Common equipment usage record

If enabled, a common equipment usage record shall be created in the VMSC to record the usage (duration) of common equipment, e.g. conference circuits, employed by a mobile subscriber.

**Table 6.1.3.17: Common equipment usage record**

Field	2G	3G	Description
Record Type	M	M	Common equipment usage record.
Equipment type	M	M	e.g. Conference circuit.
Equipment Id.	C	C	The local id. Of the equipment employed.
Served IMSI	M	M	The IMSI of the party responsible for the seizure of the equipment..
Served MSISDN	O <sub>M</sub>	O <sub>M</sub>	The primary MSISDN of the served party..
Recording Entity	M	M	The E.164 number of the MSC in which the equipment is located.
Basic service	C	C	Bearer or teleservice employed, if appropriate.
Rate Adaptation	O <sub>C</sub>	O <sub>C</sub>	Present if "rate adaption" parameters for the basic service were signalled between the MS/UE and the network, see 3GPP TS 24.008 [208].
Fixed Network User Rate	O <sub>C</sub>	O <sub>C</sub>	Indicates the user data rate applied for the connection in the fixed network. Shall only be present for 2G HSCSD connections and for UMTS data connections.
ChangeOfService	O <sub>C</sub>	O <sub>C</sub>	A list of changes of basic service during a connection each time-stamped.
Supp. Services	C	C	Supplementary services invoked in connection with this equipment.
Event Time Stamp	M	M	Seizure time: the time at which the equipment was seized.
	O <sub>M</sub>	O <sub>M</sub>	Release time: the time at which the equipment was released.
Call Duration	M	M	The total duration of the usage of the equipment.
Call Reference	M	M	A local identifier distinguishing between transactions.
Sequence no.	C	C	Partial record sequence number if applicable.
Record extensions	O <sub>C</sub>	O <sub>C</sub>	A set of network/ manufacturer specific extensions to the record, when available.
System Type	-	M	This field indicates the use of GERAN, UTRAN (or a value of unknown). This field is present when either the UTRAN or GERAN air-interface is used on call set-up. For an open CDR in a 2G NE (responsible for the CDR), the field is not present (even if the call is handed off to a 3G air interface). For a CDR in a 3G NE (responsible for the CDR), the value unknown shall be used after handover.
Partial Record Type	-	O <sub>C</sub>	Indicates the event (time limit etc.) that caused the generation of a partial record.

### 6.1.3.18 Terminating CAMEL call attempt

If the generation of these records is enabled, a terminating CAMEL call attempt record shall be generated for each call toward a subscriber with a T-CSI or VT-CSI and if the terminating trigger criteria are met. The record is generated in the GMSC/gsmSSF carrying out the terminating CAMEL call handling and in the MSC server/gsmSSF carrying out the visited terminating CAMEL call attempt.

**Table 6.1.3.18: Terminating CAMEL record**

Field	2G	3G	Description
Record Type	M	M	Terminating CAMEL interrogation.
Served IMSI	M	M	IMSI of the called party
Served MSISDN	O <sub>M</sub>	O <sub>M</sub>	The MSISDN of the called party.
Recording Entity	M	M	The E.164 number of the GMSC.
Interrogation time stamp	M	M	Time at which the interrogation was invoked.
CAMEL Destination Number	M	M	The number available for routing after the CAMEL server enquiry.
GsmSCF Address	M	M	The CAMEL server serving the subscriber.
Service key	M	M	The CAMEL service logic to be applied.
Network call reference	M	M	An identifier to correlate transactions on the same call taking place in different network nodes.
MSC Address	M	M	This field contains the E.164 number assigned to the MSC that generated the network call reference.
Default call handling	O <sub>C</sub>	O <sub>C</sub>	Indicates whether or not a CAMEL call encountered default call handling. This field shall be present only if default call handling has been applied.
Record extensions	O <sub>C</sub>	O <sub>C</sub>	A set of network/ manufacturer specific extensions to the record, when available.
Called Number	M	M	The address of the called party as received by the GMSC/gsmSSF.
Calling Number	C	C	The address of the calling party, if available.
Incoming TKGP	O <sub>M</sub>	O <sub>C</sub>	The GMSC trunk group on which the call originated. If available in 3G, this parameter shall be supplied.
Outgoing TKGP	O <sub>M</sub>	O <sub>C</sub>	The trunk group on which the call left the GMSC. If available in 3G, this parameter shall be supplied.
Event time stamps:	C C O <sub>M</sub>	C C O <sub>M</sub>	Seizure time: time of incoming traffic channel seizure (for unsuccessful call attempts) Answer time: time of answer (for successful calls) Release time: time of traffic channel release
Call duration	M	M	The chargeable duration of the connection for successful calls, the holding time of call attempts.
Data volume	C	-	The number of data segments transmitted if available at the GMSC
Cause for termination	M	M	The reason for the release of the connection.
Diagnostics	O <sub>M</sub>	O <sub>M</sub>	A more detailed reason for the release of the connection.
Call reference	M	M	A local identifier distinguishing between transactions on the same MS
Sequence no.	C	C	Partial record sequence number, only present in case of partial records.
Number of DP encountered	O <sub>C</sub>	O <sub>C</sub>	Number that counts how often armed detection points (TDP and EDP) were encountered.
Level of CAMEL service	O <sub>C</sub>	O <sub>C</sub>	Indicator of the complexity of the CAMEL feature used.
Free format Data	C	C	This field contains data sent by the gsmSCF in the Furnish Charging Information (FCI) message(s). The data can be sent either in one FCI message or several FCI messages with append indicator.
CAMEL call leg information	C	C	Set of CAMEL information IEs. Each of these IEs contains information related to one outgoing CAMEL call leg.
Free format data append indicator	C	C	Indicator if free format data from this CDR is to be appended to free format data in previous partial CDR.
MSC server indication	C	C	Indication if the CAMEL call handling is active in the MSC server.
Default call handling 2	O <sub>C</sub>	O <sub>C</sub>	Indicates whether or not a CAMEL call encountered default call handling for 2 <sup>nd</sup> service such as dialled service. This field shall be present only if default call handling has been applied.
GsmSCF address 2	C	C	Identifies the CAMEL server serving the subscriber for 2 <sup>nd</sup> service such as dialled service. Shall be present only if CAMEL is applied for 2 <sup>nd</sup> service.
Service key 2	C	C	The CAMEL service logic to be applied for 2 <sup>nd</sup> service such as dialled service. Shall be present only if CAMEL is applied for 2 <sup>nd</sup> service.

Field	2G	3G	Description
Free format Data 2	C	C	This field contains data sent by the gsmSCF in the FCI message(s) for 2 <sup>nd</sup> service such as dialled service. The data can be sent either in one FCI message or several FCI messages with append indicator. Shall be present only if CAMEL is applied for 2 <sup>nd</sup> service.
Free format data append indicator 2	C	C	Indicator if free format data for 2 <sup>nd</sup> service from this CDR is to be appended to free format data in previous partial CDR. Shall be present only if CAMEL is applied for 2 <sup>nd</sup> service.
Location Routing Number (LRN)	-	O <sub>C</sub>	Location Routing Number for Number Portability feature
LRN Source Indicator	-	O <sub>C</sub>	LRN Source Indicator tells the source of the LRN
LRN Query Status Indicator	-	O <sub>C</sub>	Status of Number Portability query.
JIP Parameter	-	O <sub>C</sub>	Jurisdiction Information Parameter
JIP Source Indicator	-	O <sub>C</sub>	JIP Source Indicator tells the source of the JIP
JIP Query Status Indicator	-	O <sub>C</sub>	Status of Number Portability query.
Partial Record Type	O <sub>C</sub>	O <sub>C</sub>	Indicates the event (time limit etc.) that caused the generation of a partial record.

### 6.1.3.19 IMEI observation ticket

An observed IMEI ticket is generated whenever greylisted, blacklisted or non-white listed mobile equipment is detected during an IMEI check. The purpose of the ticket is to link the mobile equipment under observation with its current user (IMSI). The ticket also includes information describing when and where the equipment was used to enable the tracking of such equipment. Finally, if the ticket was triggered by a call attempt, a call reference is provided in order to locate the corresponding call record.

The IMEI tickets are generated by the NEF of the MSC performing the IMEI check.

**Table 6.1.3.19: IMEI ticket**

Field	2G	3G	Description
Served IMEI	M	M	IMEI of the observed mobile equipment
IMEI Status	M	M	The result of the IMEI check e.g. blacklisted, greylisted, unknown.
Served IMSI	M	M	The IMSI of the subscriber currently using the mobile equipment.
Served MSISDN	C	C	The MSISDN of the subscriber currently using the observed mobile equipment, only available if the event that triggered the IMEI check was an MOC, MTC, SMS-MO or SMS-MT
Recording Entity	M	M	The E.164 number of the recording MSC.
Event Time Stamp	M	M	The time at which the IMEI check was performed.
Location	M	M	The location area code and cell identity of the cell and MCC+MNC from which the mobile equipment was used.
IMEI Check Event	O <sub>M</sub>	O <sub>M</sub>	The event that caused IMEI checking to take place
Call Reference	O <sub>C</sub>	O <sub>C</sub>	Only available if the IMEI check was related to an MOC or MTC
Record extensions	O <sub>C</sub>	O <sub>C</sub>	A set of network/ manufacturer specific extensions to the record, when available.

### 6.1.3.20 Mobile terminated location request (MT-LR)

If enabled, an LCS-MT record shall be produced, within the visited MSC, for each mobile a terminated location request is performed for.

**Table 6.1.3.20: LCS-MT record**

Field	2G	3G	Description
Record Type	M	M	LCS-MT record.
Recording Entity	M	M	The E.164 number of the visited MSC producing the record.
LCS Client Type	M	M	The type of the LCS client that invoked the LR.
LCS Client Identity	M	M	Further identification of the LCS client .
Served IMSI	C	C	The IMSI of the subscriber the LR is invoked for, if available. See NOTE
Served MSISDN	C	C	The MSISDN of the subscriber the LR is invoked for, if available. See NOTE
Served IMEI	C	C	The IMEI of the subscriber the LR is invoked for, if available. See NOTE
Location Type	M	M	The type of the location request.
LCS QoS	C	C	QoS of the LR, if available.
LCS Priority	C	C	Priority of the LR, if available.
MLC Number	M	M	The E.164 address of the requesting GMLC.
Event Time Stamp	M	M	The time at which the LR was received by the MSC.
MeasureDuration	O <sub>M</sub>	O <sub>M</sub>	The duration of proceeding the location request .
Notification To MS User	C	C	The privacy notification to MS user that was applicable when the LR was invoked, if available.
Privacy Override	C	C	This parameter indicates if MS privacy was overridden by the LCS client, if available.
Location	O <sub>M</sub>	-	The LAC and CI and MCC+MNC when the LR is received.
Location Estimate	O <sub>C</sub>	O <sub>C</sub>	The location estimate for the subscriber if contained in geographic position and the LR was successful.
Positioning Data	C	C	The positioning method used or attempted, if available.
LCS Cause	O <sub>C</sub>	O <sub>C</sub>	The result of the LR if any failure or partial success happened as known at the radio interface.
Cause for Termination	M	M	The reason for the termination of the location service.
Diagnostics	C	C	A more detailed information about the Cause for Termination if any failure or partial success happened.
System Type	-	M	This field indicates the use of GERAN or UTRAN at the time of the LCS request. This field is present when either the UTRAN or GERAN air-interface is used on call set-up.
Record extensions	O <sub>C</sub>	O <sub>C</sub>	A set of network/ manufacturer specific extensions to the record.
NOTE: at least one: IMSI, MSISDN or IMEI, shall be present.			

### 6.1.3.21 Mobile originated location request (MO-LR)

If enabled, an LCS-MO record shall be produced, within the visited MSC, for each mobile an originated location request is performed for.

**Table 6.1.3.21: LCS-MO record**

Field	2G	3G	Description
Record Type	M	M	LCS-MO record.
Recording Entity	M	M	The E.164 number of the visited MSC producing the record.
LCS Client Type	C	C	The type of the LCS client that invoked the LR, if available.
LCS Client Identity	C	C	Further identification of the LCS client, if available.
Served IMSI	M	M	The IMSI of the subscriber the LR is invoked for.
Served MSISDN	O <sub>M</sub>	O <sub>M</sub>	The MSISDN of the subscriber the LR is invoked for.
MOLR Type	M	M	The type of the LR.
LCS QoS	C	C	QoS of the LR, if available.
LCS Priority	O <sub>C</sub>	O <sub>C</sub>	Priority of the LR, if available.
MLC Number	C	C	The E.164 address of the involved GMLC, if available.
Event Time Stamp	M	M	The time at which the LR was received by the MSC.
MeasureDuration	O <sub>M</sub>	O <sub>M</sub>	The duration of proceeding the location request .
Location Estimate	O <sub>C</sub>	O <sub>C</sub>	The location estimate for the subscriber if contained in geographic position and the LR was successful.
Positioning Data	C	C	The positioning method used or attempted, if available.
LCS Cause	C	C	The result of the LR if any failure or partial success happened as known at the radio interface.
Cause for Termination	M	M	The reason for the termination of the location service.
Diagnostics	C	C	A more detailed information about the Cause for Termination if any failure or partial success happened.
System Type	-	M	This field indicates the use of GERAN or UTRAN at the time of the LCS request. This field is present when either the UTRAN or GERAN air-interface is used on call set-up.
Record extensions	O <sub>C</sub>	O <sub>C</sub>	A set of network/ manufacturer specific extensions to the record.

### 6.1.3.22 Network induced location request (NI-LR)

If enabled, an LCS-NI record shall be produced, within the visited MSC, for each network induced location request performed for a MS e.g. in case of emergency call.

**Table 6.1.3.22: LCS-NI record**

Field	2G	3G	Description
Record Type	M	M	LCS-NI record.
Recording Entity	M	M	The E.164 number of the visited MSC producing the record.
LCS Client Type	C	C	The type of the LCS client that invoked the LR, if available.
LCS Client Identity	C	C	Further identification of the LCS client, if available.
Served IMSI	C	C	The IMSI of the calling party the LR is executed for if supplied by the UE.
Served MSISDN	C	C	The MSISDN of the calling party the LR is executed for if supplied by the UE.
Served IMEI	C	C	The IMEI of the calling party the LR is executed for if available.
EMS-Digits	O <sub>C</sub>	O <sub>C</sub>	The emergency service routing digits, if emergency call.
EMS-Key	O <sub>C</sub>	O <sub>C</sub>	The emergency service routing key, if emergency call.
LCS QoS	C	C	QoS of the LR, if available.
LCS Priority	C	C	Priority of the LR, if available.
MLC Number	C	C	The E.164 address of the involved GMLC, if available.
Event Time Stamp	M	M	The time at which the LR was received by the MSC.
MeasureDuration	O <sub>M</sub>	O <sub>M</sub>	The duration of proceeding the location request .
Location Estimate	O <sub>C</sub>	O <sub>C</sub>	The location estimate for the subscriber if contained in geographic position and the LR was successful.
Positioning Data	C	C	The positioning method used or attempted, if available.
LCS Cause	C	C	The result of the LR if any failure or partial success happened as known at the radio interface.
Cause for Termination	M	M	The reason for the termination of the location service.
Diagnostics	C	C	A more detailed information about the Cause for Termination if any failure or partial success happened.
System Type	-	M	This field indicates the use of GERAN or UTRAN at the time of the LCS request. This field is present when either the UTRAN or GERAN air-interface is used on call set-up.
Record extensions	O <sub>C</sub>	O <sub>C</sub>	A set of network/ manufacturer specific extensions to the record.

### 6.1.3.23 Mobile originated call attempt (CAMEL CPH adapted version)

If the MSC / gsmSCF is able to provide CAMEL CPH services, this kind of record shall replace records according to section 6.1.3.1 Mobile originated call attempt. This applies to all mobile originated call attempts, even if no CPH operations are used in the individual call. Record fields that are specific to individual outgoing legs are recorded in the grouped field 'Camel Call Leg Information'.

If the generation of this kind of record is enabled then the MSC shall produce one MOC record. The incoming leg is recorded in the main body. Whenever there is a CAMEL dialogue, outgoing legs of the same call segment are recorded in the grouped field "CAMEL call leg information". Further legs in new call segments are recorded in CDRs of type "6.1.3.25 New Call Segment in a MO, CF or MT CAMEL Dialogue".

Examples for call situations where this type of record applies are the following:

- Mobile originating call without CPH being involved,
- Mobile originating call continuing after disconnect of the incoming leg in case of no partial record generation. When partial records are generated, they are of type "6.1.3.25 New Call Segment in a MO, CF or MT CAMEL Dialogue",
- Mobile originating call with more than one outgoing leg on this call segment,
- Mobile originating call in which the original outgoing leg has been disconnected by gsmSCF.

Disconnect of the incoming leg is recorded by filling the related record fields in the main body of the record. Optionally a partial record may be generated. This partial record is of type "6.1.3.24 gsmSSF initiated CAMEL CPH call attempt".

Disappearing (DisconnectLeg, SplitLeg, etc.) of an outgoing leg is recorded by filling the related record fields in the 'Camel Call Leg Information' field for the disappearing leg. Optionally a partial record may be generated. This partial record does not contain information of the leg that disappeared, i.e. it does not contain a 'Camel Call Leg Information' field for that leg.

Connection of a further leg to this call segment is recorded by adding a further field 'Camel Call Leg Information'. Optionally a partial record may be generated.

**Table 6.1.3.23: MOC record (CAMEL CPH adapted version)**

Field	2G	3G	Description
Record Type	M	M	Mobile originated.
Served IMSI	M	M	IMSI of the calling party.
Served IMEI	C	C	IMEI of the calling ME, if available.
Served MSISDN	O <sub>M</sub>	O <sub>M</sub>	The primary MSISDN of the calling party.
Called Number	M	M	The address of the called party i.e. the number dialled by the calling subscriber.
Recording Entity	M	M	The E.164 number of the visited MSC producing the record.
Incoming TKGP	O <sub>M</sub>	O <sub>C</sub>	The MSC trunk group on which the call originated, usually from the BSS. If available in 3G, this parameter shall be supplied.
Location	M	M	The identity of the cell or the SAC and MCC+MNC at the time of CDR creation, including the location area code.
Change of Location	O <sub>C</sub>	O <sub>C</sub>	A list of changes in Location Area Code / Service Area Code / Cell Id and MCC+MNC. Each time-stamped.
Basic service	M	M	Bearer or teleservice employed. 'speech' in case of CAMEL CPH calls.
Supp. Services	C	C	Supplementary services invoked as a result of this connection. This field shall be present when one or more supplementary services have been invoked.
AOC Parameters	O <sub>C</sub>	O <sub>C</sub>	The charge advice parameters sent to the MS on call set-up. This field shall be supplied only when AoC parameters have been sent.
Change of AOC Parameters	O <sub>C</sub>	O <sub>C</sub>	New AOC parameters sent to the MS e.g. as a result of a tariff switch over, including the time at which the new set was applied. This field shall be supplied only when AoC parameters have been sent.
MS Classmark	M	M	The mobile station classmark employed on call set-up.
Change of Classmark	O <sub>C</sub>	O <sub>C</sub>	A list of changes to the classmark during the connection each time-stamped.
Event time stamps:	C C O <sub>M</sub>	C C O <sub>M</sub>	Seizure time: time of incoming traffic channel seizure (for unsuccessful call attempts) Answer: time of answer (for successful calls) Release time: time of traffic channel release for the incoming leg.

Field	2G	3G	Description
Call duration	C	C	The chargeable duration of the connection of the incoming leg for successful calls, the holding time of the incoming leg for call attempts.
Radio Chan. Requested	O <sub>M</sub>	-	The type of radio traffic channel (full / half etc.) requested by the MS.
Radio Chan. Used	M	-	The type of radio channel actually used (full or half rate).
Change of Rad. Chan.	O <sub>C</sub>	-	A list of changes each time stamped.
Cause for termination	M	M	The reason for the release of the connection.
Diagnostics	O <sub>M</sub>	O <sub>M</sub>	A more detailed reason for the release of the connection.
Call reference	M	M	A local identifier distinguishing between transactions on the same MS
Sequence no.	C	C	Partial record sequence number, only present in case of partial records.
Record extensions	O <sub>C</sub>	O <sub>C</sub>	A set of network / manufacturer specific extensions to the record, when available.
GsmSCF address	M	M	Identifies the CAMEL server serving the subscriber.
Service key	C	C	The CAMEL service logic to be applied.
Network call reference	M	M	An identifier to correlate transactions on the same call taking place in different network nodes.
MSC Address	M	M	This field contains the E.164 number assigned to the MSC that generated the network call reference.
Default call handling	O <sub>C</sub>	O <sub>C</sub>	Indicates whether or not a CAMEL call encountered default call handling. This field shall be present only if default call handling has been applied.
Speech Version Supported	O <sub>M</sub>	-	Speech version supported by the MS with highest priority indicated by MS
Speech Version Used	O <sub>M</sub>	-	Speech version used for that call
Number of DP encountered	O <sub>M</sub>	O <sub>M</sub>	Number that counts how often armed detection points (TDP and EDP) were encountered. Sum of all DPs encountered in this call.
Level of CAMEL service	O <sub>M</sub>	O <sub>M</sub>	Indicator for the complexity of the CAMEL feature used.
Free format Data	C	C	This field contains data sent by the gsmSCF in the Furnish Charging Information (FCI) message(s). The data can be sent either in one FCI message or several FCI messages with append indicator.
CAMEL call leg information	C	C	Set of CAMEL information IEs. Each of these IEs contains information related to one outgoing CAMEL call leg.
CAMEL Destination Number			Destination modified by camel service.
Translated Number			Called number after digit translation within the MSC.
Connected Number			Number of connected party if different from 'CAMEL Destination Number'.
Roaming Number			MSRN to route this leg (if applicable).
MSC outgoing TKGP			Trunk on which the leg leaves the MSC.
Seizure Time			Time of traffic channel seizure for this leg.
Answer Time			Time when the answer message is received for this leg.
Release Time			Time when the leg is released or moved into another call segment.
Call Duration			Time between answer and release timestamp of this leg.
Additional Chg. Info			Charge/no charge indicator and additional charging parameters, when available.
Free Format Data			If received in the FCI message from SCF.
Free Format Data Append			If received in the FCI message from SCF.
Free Format Data 2			If provided in the FCI message for a 2 <sup>nd</sup> service.
Free Format Data Append 2			If provided in the FCI message for a 2 <sup>nd</sup> service.
Diagnostics			Detailed reason for disappearing of the leg in this call segment.
Cause for Termination			The reason for disappearing of the leg in this call segment.



Field	2G	3G	Description
Default Call Handling 2			Present if a 2 <sup>nd</sup> service (DP3) is triggered.
gsm-SCF Address 2			Present if a 2 <sup>nd</sup> service (DP3) is triggered.
Service Key 2			Present if a 2 <sup>nd</sup> service (DP3) is triggered.
Free Format Data Incoming 2			If provided in the FCI message for a 2 <sup>nd</sup> service.
Free Format Data Append Incoming 2			If provided in the FCI message for a 2 <sup>nd</sup> service.
Location Routing Number (LRN)			For Number Portability feature, not available in 2G records.
LRN Source Indicator			Source of the LRN, not available in 2G records.
LRN Query Status Indicator			Status of Number Portability query, not available in 2G records.
JIP Parameter			Jurisdiction Information Parameter, not available in 2G records.
JIP Source Indicator			The source of the JIP, not available in 2G records.
JIP Query Status Indicator			Status of Number Portability query, not available in 2G records.
Free Format Data Append Indicator	C	C	Indicator if free format data from this CDR is to be appended to free format data in previous partial CDR. Shall be present only if CAMEL id applied.
System Type	-	M	This field indicates the use of GERAN, UTRAN (or a value of unknown) of the incoming leg. This field is present when either the UTRAN or GERAN air-interface is used on call set-up. For an open CDR in a 2G NE (responsible for the CDR), the field is not present (even if the call is handed off to a 3G air interface). For a CDR in a 3G NE (responsible for the CDR), the value unknown shall be used after handover.
Partial Record Type	-	O <sub>C</sub>	Indicates the event (time limit etc.) that caused the generation of a partial record.
Redial Attempt	O <sub>C</sub>	O <sub>C</sub>	Indicates to the network that a call is the result of a redial attempt to switch from speech to multimedia or vice-versa

### 6.1.3.24 gsmSCF initiated CAMEL CPH call attempt

If the generation of these records is enabled then an MOC record shall be created for each gsmSCF initiated call attempt and for new parties in new call segments, which are created in a new call dialogue. Examples for call situations where this type of record applies are the following:

- gsmSCF initiated call segment association (new call):  
There is only one call segment. It contains the outgoing leg, which is created via CPH initiate call attempt operation (ICA).
  - This outgoing leg can be connected to an SRF, which is recorded in the same record in the field 'Camel Call Leg Information'.
- gsmSCF initiated new party in an already established gsmSCF initiated CAP dialogue (new leg):  
In a new call dialogue a further call leg in a new call segment is initiated via ICA operation.
  - This call segment contains one outgoing leg, which can be connected to an SRF. This leg and if used the SRF are recorded in the record for this call segment in the field 'Camel Call Leg Information'.
  - This leg can be connected to the other outgoing leg. This would terminate the call segment and thus the call record. The 'Cause for Termination' indicates the reason for disappearing of the leg in this call segment. The Timestamps ('Call Duration', 'Release Time', etc.) are filled in. The record of the call segment the leg is moved to records the leg in a further field 'Camel Call Leg Information'.
  - The other leg could be connected to this leg which is recorded by adding a further field 'Camel Call Leg Information'.

Record fields for an incoming leg do not exist, because there is no incoming leg in the call segment this record is created for.

**Table 6.1.3.24: MOC CPH record (gsmSCF initiated)**

Field	2G	3G	Description
Record Type	M	M	Mobile originated.
Served MSISDN	O <sub>M</sub>	O <sub>M</sub>	The number of the initiating party. "Calling Party Number" as received in the ICA operation.
Called Number	M	M	The address of the called party.
Recording Entity	M	M	The E.164 number of the visited MSC producing the record.
Basic service	M	M	Bearer or teleservice employed. 'speech' in case of CAMEL CPH calls.
Cause for termination	M	M	The reason for the release of the connection.
Diagnostics	O <sub>M</sub>	O <sub>M</sub>	A more detailed reason for the release of the connection.
Call reference	M	M	A local identifier distinguishing between transactions on the same MS
Sequence no.	C	C	Partial record sequence number, only present in case of partial records.
Record extensions	O <sub>C</sub>	O <sub>C</sub>	A set of network / manufacturer specific extensions to the record, when available.
GsmSCF address	C	C	Identifies the CAMEL server serving the subscriber (network call reference).
Network call reference	M	M	An identifier to correlate transactions on the same call taking place in different network nodes.
MSC Address	M	M	This field contains the E.164 number assigned to the MSC that generated the record.
Number of DP encountered	O <sub>C</sub>	O <sub>C</sub>	Number that counts how often armed detection points (TDP and EDP) were encountered. Sum of all DPs encountered in this call.
Level of CAMEL service	O <sub>C</sub>	O <sub>C</sub>	Indicator for the complexity of the CAMEL feature used.
CAMEL call leg information	C	C	Set of CAMEL information IEs. Each of these IEs contains information related to one outgoing CAMEL call leg.
CAMEL Destination Number			Destination as received in the ICA operation.
Translated Number			Called number after digit translation within the MSC.
Connected Number			Number of connected party if different from 'CAMEL Destination Number'.
Roaming Number			MSRN to route this leg (if applicable).
MSC outgoing TKGP			Trunk on which the leg leaves the MSC.
Seizure Time			Time of traffic channel seizure for this leg.
Answer Time			Time when the answer message is received for this leg.
Release Time			Time when the leg is released or moved into another call segment.
Call Duration			Time between answer and release timestamp of this leg.

Field	2G	3G	Description
Additional Chg. Info			Charge/no charge indicator and additional charging parameters, when available.
Free Format Data			If received in the FCI message from SCF.
Free Format Data Append			If received in the FCI message from SCF.
Free Format Data 2			If provided in the FCI message for a 2 <sup>nd</sup> service.
Free Format Data Append 2			If provided in the FCI message for a 2 <sup>nd</sup> service.
Diagnostics			Detailed reason for disappearing of the leg in this call segment.
Cause for Termination			The reason for disappearing of the leg in this call segment.
Default Call Handling 2			Present if a 2 <sup>nd</sup> service (DP3) is triggered.
gsm-SCF Address 2			Present if a 2 <sup>nd</sup> service (DP3) is triggered.
Service Key 2			Present if a 2 <sup>nd</sup> service (DP3) is triggered.
Free Format Data Incoming 2			If provided in the FCI message for a 2 <sup>nd</sup> service.
Free Format Data Append Incoming 2			If provided in the FCI message for a 2 <sup>nd</sup> service.
Location Routing Number (LRN)			For Number Portability feature, not available in 2G records.
LRN Source Indicator			Source of the LRN, not available in 2G records.
LRN Query Status Indicator			Status of Number Portability query, not available in 2G records.
JIP Parameter			Jurisdiction Information Parameter, not available in 2G records.
JIP Source Indicator			The source of the JIP, not available in 2G records.
JIP Query Status Indicator			Status of Number Portability query, not available in 2G records.
Partial Record Type	-	O <sub>C</sub>	Indicates the event (time limit etc.) that caused the generation of a partial record.

### 6.1.3.25 New Call Segment in a MO, CF and MT CAMEL Dialogue

If the generation of these records is enabled then an MOC record shall be created for call segments without incoming leg, generated by a CAMEL dialogue for mobile originated, call forwarding or mobile terminating call attempts. Examples for call situations where this type of record applies are the following:

- Additional call segment, which is created by means of a 'SplitLeg' operation or ICA (new party) operation.
  - This call segment contains one outgoing leg, which can be connected to an SRF. This leg and if used the SRF are recorded in the record for this call segment in the field 'Camel Call Leg Information'.
  - This leg can be connected to the other outgoing leg. This would terminate the call segment and thus the call record. The 'Cause for Termination' indicates the reason for disappearing of the leg in this call segment. The Timestamps ('Call Duration', 'Release Time', etc.) are filled in. The record of the call segment the leg is moved to records the leg in a further field 'Camel Call Leg Information'.
  - The other leg could be connected to this leg which is recorded by adding a further field 'Camel Call Leg Information'.
- Call segment where the incoming leg disappeared (e.g. due to SplitLeg or DisconnectLeg operation). A record of this type is generated if partial records are generated.

Although an incoming leg does not exist, the 'IMSI', the 'IMEI' and the 'Service Key' is recorded in the main body.

**Table 6.1.3.25: MOC CPH record (new call segment)**

Field	2G	3G	Description
Record Type	M	M	Mobile originated.
Served IMSI	M	M	IMSI of the served party ('calling party' in case of MOC, 'forwarding party' in case of call forwarding respectively 'called party' in case of MTC).
Served IMEI	C	C	IMEI of the served ME, if available ('calling party' in case of MOC, 'forwarding party' in case of call forwarding respectively 'called party' in case of MTC).
Served MSISDN	O <sub>M</sub>	O <sub>M</sub>	The MSISDN of the served party ('calling party' in case of MOC, 'forwarding party' in case of call forwarding respectively 'called party' in case of MTC).
Called Number	M	M	The address of the called party.
Recording Entity	M	M	The E.164 number of the visited MSC producing the record.
Basic service	M	M	Bearer or teleservice employed. 'speech' in case of CAMEL CPH calls.
Supp. Services	C	C	Supplementary services invoked as a result of this connection. This field shall be present when one or more supplementary services have been invoked.
Cause for termination	M	M	The reason for the release of the connection.
Diagnostics	O <sub>M</sub>	O <sub>M</sub>	A more detailed reason for the release of the connection.
Call reference	M	M	A local identifier distinguishing between transactions on the same MS
Sequence no.	C	C	Partial record sequence number, only present in case of partial records.
Record extensions	O <sub>C</sub>	O <sub>C</sub>	A set of network / manufacturer specific extensions to the record, when available.
GsmSCF address	C	C	Identifies the CAMEL server serving the subscriber.
Service Key	C	C	The CAMEL service logic to be applied.
Network call reference	M	M	An identifier to correlate transactions on the same call taking place in different network nodes.
MSC Address	M	M	This field contains the E.164 number assigned to the MSC that generated the network call reference.
Default call handling	O <sub>C</sub>	O <sub>C</sub>	Indicates whether or not a CAMEL call encountered default call handling. This field shall be present only if default call handling has been applied.
Number of DP encountered	O <sub>C</sub>	O <sub>C</sub>	Number that counts how often armed detection points (TDP and EDP) were encountered. Sum of all DPs encountered in this call.
Level of CAMEL service	O <sub>C</sub>	O <sub>C</sub>	Indicator for the complexity of the CAMEL feature used.

Field	2G	3G	Description
CAMEL call leg information	C	C	Set of CAMEL information IEs. Each of these IEs contains information related to one outgoing CAMEL call leg.
CAMEL Destination Number			Destination as received in the ICA operation.
Translated Number			Called number after digit translation within the MSC.
Connected Number			Number of connected party if different from 'CAMEL Destination Number'.
Roaming Number			MSRN to route this leg (if applicable).
MSC outgoing TKGP			Trunk on which the leg leaves the MSC.
Seizure Time			Time of traffic channel seizure for this leg.
Answer Time			Time when the answer message is received for this leg.
Release Time			Time when the leg is released or moved into another call segment.
Call Duration			Time between answer and release timestamp of this leg.
Additional Chg. Info			Charge/no charge indicator and additional charging parameters, when available.
Free Format Data			If received in the FCI message from SCF.
Free Format Data Append			If received in the FCI message from SCF.
Free Format Data 2			If provided in the FCI message for a 2 <sup>nd</sup> service.
Free Format Data Append 2			If provided in the FCI message for a 2 <sup>nd</sup> service.
Diagnostics			Detailed reason for disappearing of the leg in this call segment.
Cause for Termination			The reason for disappearing of the leg in this call segment.
Default Call Handling 2			Present if a 2 <sup>nd</sup> service (DP3) is triggered.
gsm-SCF Address 2			Present if a 2 <sup>nd</sup> service (DP3) is triggered.
Service Key 2			Present if a 2 <sup>nd</sup> service (DP3) is triggered.
Free Format Data Incoming 2			If provided in the FCI message for a 2 <sup>nd</sup> service.
Free Format Data Append Incoming 2			If provided in the FCI message for a 2 <sup>nd</sup> service.
Location Routing Number (LRN)			For Number Portability feature, not available in 2G records.
LRN Source Indicator			Source of the LRN, not available in 2G records.
LRN Query Status Indicator			Status of Number Portability query, not available in 2G records.
JIP Parameter			Jurisdiction Information Parameter, not available in 2G records.
JIP Source Indicator			The source of the JIP, not available in 2G records.
JIP Query Status Indicator			Status of Number Portability query, not available in 2G records.
Partial Record Type	-	O <sub>C</sub>	Indicates the event (time limit etc.) that caused the generation of a partial record.

### 6.1.3.26 Mobile originated call forwarding attempt (CAMEL CPH adapted version)

If the MSC / gsmSCF is able to provide CAMEL CPH services, this kind of record shall replace records according to section "6.1.3.3 Mobile originated call forwarding attempt". This applies to all mobile originated call forwarding attempts, even if no CPH operations are used in the individual call.

If the generation of MOC records is enabled in the forwarding MSC then the forwarding MSC shall produce an MOC record for the forwarded-leg of the call.

If further legs in new call segments are generated by this CAMEL dialogue, they are recorded in CDRs of type "6.1.3.25 New Call Segment in a MO, CF or MT CAMEL Dialogue".

Connection of a further leg to this call segment is recorded by adding a further field 'Camel Call Leg Information'. Optionally a partial record may be generated.

**Table 6.1.3.26: MOC, call forwarding record (CAMEL CPH adapted version)**

Field	2G	3G	Description
Record Type	M	M	Mobile originated.
Served IMSI	M	M	IMSI of the forwarding party.
Served MSISDN	O <sub>M</sub>	O <sub>M</sub>	The MSISDN of the forwarding party.
Calling Number	O <sub>C</sub>	O <sub>C</sub>	The address of the calling party.
Called Number	M	M	The address of the "forwarded-to" party.
Recording Entity	M	M	The E.164 number of the forwarding MSC
Incoming TKGP	O <sub>M</sub>	O <sub>M</sub>	The MSC trunk group on which the call originated at the forwarding MSC.
Basic service	C	C	'speech' in case of CAMEL CPH, not always available e.g. in case of call forwarding unconditional.
Supplementary Services	C	C	Supplementary services invoked as a result of this connection, if this information is available to the forwarding node. This field shall be present when one or more supplementary services have been invoked.
Event time stamps:	C C O <sub>M</sub>	C C O <sub>M</sub>	Seizure time: time of incoming traffic channel seizure (for unsuccessful call attempts) Answer time: time of answer (for successful calls) Release time: time of traffic channel release
Call duration	C	C	The chargeable duration of the connection for successful calls, the holding time of call attempts.
Cause for termination	M	M	The reason for the release of the connection.
Diagnostics	O <sub>M</sub>	O <sub>M</sub>	A more detailed reason for the release of the connection.
Call reference	M	M	A local identifier distinguishing between transactions on the same MS
Sequence no.	C	C	Partial record sequence number, only present in case of partial records.
Record extensions	O <sub>C</sub>	O <sub>C</sub>	A set of network/ manufacturer specific extensions to the record, when available.
GsmSCF address	C	C	Identifies the CAMEL server serving the subscriber.
Service key	C	C	The CAMEL service logic to be applied.
Network call reference	C	C	An identifier to correlate transactions on the same call taking place in different network nodes.
MSC Address	C	C	This field contains the E.164 number assigned to the MSC that generated the network call reference.
CAMEL initiated CF indicator	O <sub>C</sub>	O <sub>C</sub>	Indicates that the CAMEL server initiated call forwarding. Not available in case of gsm call forwarding.
Default call handling	O <sub>C</sub>	O <sub>C</sub>	Indicates whether or not a CAMEL call encountered default call handling. This field shall be present only if default call handling has been applied.
Number of DP encountered	O <sub>C</sub>	O <sub>C</sub>	Number that counts how often armed detection points (TDP and EDP) were encountered. Sum of all DPs encountered in this call.
Level of CAMEL service	O <sub>C</sub>	O <sub>C</sub>	Indicator of the complexity of the CAMEL feature used.
Free format Data	C	C	This field contains data sent by the gsmSCF in the Furnish Charging Information (FCI) messages. The data can be sent either in one FCI message or several FCI messages with append indicator.

Field	2G	3G	Description
CAMEL call leg information	C	C	Set of CAMEL information IEs. Each of these IEs contains information related to one outgoing CAMEL call leg.
CAMEL Destination Number			Destination modified by CAMEL service.
Translated Number			Called number after digit translation within the MSC.
Connected Number			Number of connected party if different from 'CAMEL Destination Number'.
Roaming Number			MSRN to route this leg (if applicable).
MSC outgoing TKGP			Trunk on which the leg leaves the MSC.
Seizure Time			Time of traffic channel seizure for this leg.
Answer Time			Time when the answer message is received for this leg.
Release Time			Time when the leg is released or moved into another call segment.
Call Duration			Time between answer and release timestamp of this leg.
Additional Chg. Info			Charge/no charge indicator and additional charging parameters, when available.
Free Format Data			If received in the FCI message from SCF.
Free Format Data Append			If received in the FCI message from SCF.
Free Format Data 2			If provided in the FCI message for a 2 <sup>nd</sup> service.
Free Format Data Append 2			If provided in the FCI message for a 2 <sup>nd</sup> service.
Diagnostics			Detailed reason for disappearing of the leg in this call segment.
Cause for Termination			The reason for disappearing of the leg in this call segment.
Default Call Handling 2			Present if a 2 <sup>nd</sup> service (DP3) is triggered.
gsm-SCF Address 2			Present if a 2 <sup>nd</sup> service (DP3) is triggered.
Service Key 2			Present if a 2 <sup>nd</sup> service (DP3) is triggered.
Free Format Data Incoming 2			If provided in the FCI message for a 2 <sup>nd</sup> service.
Free Format Data Append Incoming 2			If provided in the FCI message for a 2 <sup>nd</sup> service.
Location Routing Number (LRN)			For Number Portability feature, not available in 2G records.
LRN Source Indicator			Source of the LRN, not available in 2G records.
LRN Query Status Indicator			Status of Number Portability query, not available in 2G records.
JIP Parameter			Jurisdiction Information Parameter, not available in 2G records.
JIP Source Indicator			The source of the JIP, not available in 2G records.
JIP Query Status Indicator			Status of Number Portability query, not available in 2G records.
Free format data append indicator	C	C	Indicator if free format data from this CDR is to be appended to free format data in previous partial CDR. Shall be present only if CAMEL is applied.
Partial Record Type	-	O <sub>C</sub>	Indicates the event (time limit etc.) that caused the generation of a partial record.

### 6.1.3.27 Terminating CAMEL call attempt (CAMEL CPH adapted version)

If the MSC / gsmSCF is able to provide CAMEL CPH services, this kind of record shall replace records according to section “6.1.3.18 Terminating CAMEL call attempt“. This applies to all terminating CAMEL call attempts, even if no CPH operations are used in the individual call.

If the generation of these records is enabled, a terminating CAMEL call attempt record shall be generated for each call involving CAMEL CPH operations. The record is generated in the GMSC/gsmSSF carrying out the terminating CAMEL call handling and in the MSC server/gsmSSF carrying out the visited terminating CAMEL call attempt.

If further legs in new call segments are generated by this CAMEL dialogue, they are recorded in CDRs of type “6.1.3.25 New Call Segment in a MO, CF or MT CAMEL Dialogue”.

**Table 6.1.3.27: Terminating CAMEL record (CPH adapted version)**

Field	2G	3G	Description
Record Type	M	M	Terminating CAMEL interrogation.
Served IMSI	M	M	IMSI of the called party
Served MSISDN	O <sub>M</sub>	O <sub>M</sub>	The MSISDN of the called party.
Recording Entity	M	M	The E.164 number of the GMSC.
Interrogation time stamp	M	M	Time at which the interrogation was invoked.
GsmSCF Address	M	M	The CAMEL server serving the subscriber.
Service key	M	M	The CAMEL service logic to be applied.
Network call reference	M	M	An identifier to correlate transactions on the same call taking place in different network nodes.
MSC Address	M	M	This field contains the E.164 number assigned to the MSC that generated the network call reference.
Default call handling	O <sub>C</sub>	O <sub>C</sub>	Indicates whether or not a CAMEL call encountered default call handling. This field shall be present only if default call handling has been applied.
Record extensions	O <sub>C</sub>	O <sub>C</sub>	A set of network/ manufacturer specific extensions to the record, when available.
Called Number	M	M	The address of the called party as received by the GMSC/gsmSSF.
Calling Number	C	C	The address of the calling party, if available.
Incoming TKGP	O <sub>M</sub>	O <sub>C</sub>	The GMSC trunk group on which the call originated. If available in 3G, this parameter shall be supplied.
Event time stamps:	C C O <sub>M</sub>	C C O <sub>M</sub>	Seizure time: time of incoming traffic channel seizure (for unsuccessful call attempts) Answer time: time of answer (for successful calls) Release time: time of traffic channel release
Call duration	C	C	The chargeable duration of the connection for successful calls, the holding time of call attempts.
Cause for termination	M	M	The reason for the release of the connection.
Diagnostics	O <sub>M</sub>	O <sub>M</sub>	A more detailed reason for the release of the connection.
Call reference	M	M	A local identifier distinguishing between transactions on the same MS
Sequence no.	C	C	Partial record sequence number, only present in case of partial records.
Number of DP encountered	O <sub>C</sub>	O <sub>C</sub>	Number that counts how often armed detection points (TDP and EDP) were encountered. Sum of all DPs encountered in this call.
Level of CAMEL service	O <sub>C</sub>	O <sub>C</sub>	Indicator of the complexity of the CAMEL feature used.
Free format Data	C	C	This field contains data sent by the gsmSCF in the Furnish Charging Information (FCI) message(s). The data can be sent either in one FCI message or several FCI messages with append indicator.



Field	2G	3G	Description
CAMEL call leg information	C	C	Set of CAMEL information IEs. Each of these IEs contains information related to one outgoing CAMEL call leg.
CAMEL Destination Number			Destination as received in the ICA operation or overwritten by TDP3.
Translated Number			Called number after digit translation within the MSC.
Connected Number			Number of connected party if different from 'CAMEL Destination Number'.
Roaming Number			MSRN or B-party (if applicable).
MSC outgoing TKGP			Trunk on which the leg leaves the MSC.
Seizure Time			Time of traffic channel seizure for this leg.
Answer Time			Time when the answer message is received for this leg.
Release Time			Time when the leg is released or moved into another call segment.
Call Duration			Time between answer and release timestamp of this leg.
CAMEL Init CF Indicator			Indicates that the CAMEL server initiated call forwarding.
Additional Chg. Info			Charge/no charge indicator and additional charging parameters, when available.
Free Format Data			If received in the FCI message from SCF.
Free Format Data Append			If received in the FCI message from SCF.
Free Format Data 2			If provided in the FCI message for a 2 <sup>nd</sup> service.
Free Format Data Append 2			If provided in the FCI message for a 2 <sup>nd</sup> service.
Diagnostics			Detailed reason for disappearing of the leg in this call segment.
Cause for Termination			The reason for disappearing of the leg in this call segment.
Default Call Handling 2			Present if a 2 <sup>nd</sup> service (DP3) is triggered.
gsm-SCF Address 2			Present if a 2 <sup>nd</sup> service (DP3) is triggered.
Service Key 2			Present if a 2 <sup>nd</sup> service (DP3) is triggered.
Free Format Data Incoming 2			If provided in the FCI message for a 2 <sup>nd</sup> service.
Free Format Data Append Incoming 2			If provided in the FCI message for a 2 <sup>nd</sup> service.
Location Routing Number (LRN)			For Number Portability feature, not available in 2G records.
LRN Source Indicator			Source of the LRN, not available in 2G records.
LRN Query Status Indicator			Status of Number Portability query, not available in 2G records.
JIP Parameter			Jurisdiction Information Parameter, not available in 2G records.
JIP Source Indicator			The source of the JIP, not available in 2G records.
JIP Query Status Indicator			Status of Number Portability query, not available in 2G records.
Free format data append indicator	C	C	Indicator if free format data from this CDR is to be appended to free format data in previous partial CDR.
MSC server indication	C	C	Indication if the CAMEL call handling is active in the MSC server.
Partial Record Type	-	O <sub>C</sub>	Indicates the event (time limit etc.) that caused the generation of a partial record.

### 6.1.3.28 SRVCC MSC Call handling in MSC server enhanced for SRVCC

If the generation of these records is enabled then a MSC-SRVCC record shall be created for each voice call transfer from IMS domain to CS domain, for voice calls anchored in the IMS. These MSC-SRVCC records shall be produced in the enhanced MSC Server enhanced for SRVCC.

**Table 6.1.3.28: MSC-SRVCC record**

Field	Category	Description
Record Type	M	MSC-SRVCC
Served IMSI	M	IMSI of PS to CS Request.
Served IMEI	C	Mobile Equipment Identity (IMEI, IMEISV) of the UE, if available
Served MSISDN	M	The Correlation MSISDN of the PS to CS Request.
Called Number	M	Session Transfer Number for Single Radio Voice Call Continuity (STN-SR) for transfer from PS to CS
Recording Entity	M	The E.164 number of the enhanced MSC server producing the record.
Outgoing TKGP	O <sub>M</sub>	The trunk group on which the call left the MSC, if available
IMS Charging Identifier	O <sub>M</sub>	This parameter holds the IMS charging identifier (ICID) as generated by the enhanced MSC server with SIP interface.
Location	M	<a href="#">Location of the UE after the successful SRVCC PS to CS Transfer.</a>
Change of Location	O <sub>C</sub>	A list of changes in Location of the UE. Each time-stamped.
Basic service	M	teleservice speech
Supplementary Services	C	Supplementary services invoked as a result of this connection. This field shall be present when one or more supplementary services have been invoked.
MS Classmark	C	Classmark of MM Context for E-UTRAN SRVCC in PS to CS Request
Event time stamps:	C	Transfer request time: time of PS to CS Request received by enhanced MSC server.
	C	Answer: time of answer received by enhanced MSC server on successful transfer
	O <sub>M</sub>	Release time: time of traffic channel release
ICS I2 active Flag	C	This field indicates that the MSC is IMS registered on the UE's behalf during the session
Call duration	M	The chargeable duration of the connection for successful transferred call.
Cause for termination	M	The reason for the release of the CS media.
Diagnostics	O <sub>M</sub>	A more detailed reason for the release of the CS media
Call reference	M	A local identifier distinguishing between transactions on the same MS
Sequence no.	C	Partial record sequence number, only present in case of partial records.
Record extensions	O <sub>C</sub>	A set of network / manufacturer specific extensions to the record, when available.
Partial Record Type	O <sub>C</sub>	Indicates the event (time limit etc.) that caused the generation of a partial record.

### 6.1.3.29 SRVCC CS Emergency Call handling in MSC server enhanced for SRVCC

If the generation of these records is enabled then a MSC-SRVCC Emergency record shall be created for each emergency call transfer from IMS domain to CS domain, for emergency calls anchored in the IMS. These MSC-SRVCC Emergency records shall be produced in the MSC server enhanced for SRVCC.

**Table 6.1.3.29: MSC-SRVCC Emergency record**

Field	Category	Description
Record Type	M	MSC-SRVCC
Served IMSI	C	IMSI of PS to CS Request, if available.
Served IMEI	C	Mobile Equipment Identity (IMEI, IMEISV) of the UE, if available
Served MSISDN	C	The Correlation MSISDN of the PS to CS Request, if available.
Called Number	M	Emergency Session Transfer Number for SR VCC (E-STN-SR) for transfer from PS to CS.
Recording Entity	M	The E.164 number of the enhanced MSC server producing the record.
Outgoing TKGP	O <sub>M</sub>	The trunk group on which the call left the MSC, if available
IMS Charging Identifier	O <sub>M</sub>	This parameter holds the IMS charging identifier (ICID) as generated by the enhanced MSC server with SIP interface.
Location	M	<a href="#">Location of the UE after the successful SRVCC PS to CS Transfer.</a>
Change of Location	O <sub>C</sub>	A list of changes in Location of the UE. Each time-stamped.
Basic service	M	teleservice emergency
MS Classmark	C	Classmark of MM Context for E-UTRAN SRVCC in PS to CS Request

Field	Category	Description
Event time stamps:	C	Transfer request time: time of PS to CS Request received by enhanced MSC server.
	C	Answer: time of answer received by enhanced MSC server on successful transfer
	O <sub>M</sub>	Release time: time of traffic channel release
ICS I2 active Flag	C	This field indicates that the MSC is IMS registered on the UE's behalf during the session
Call duration	M	The chargeable duration of the connection for successful transferred call.
Cause for termination	M	The reason for the release of the CS media.
Diagnostics	O <sub>M</sub>	A more detailed reason for the release of the CS media
Call reference	M	A local identifier distinguishing between transactions on the same MS
Sequence no.	C	Partial record sequence number, only present in case of partial records.
Record extensions	O <sub>C</sub>	A set of network / manufacturer specific extensions to the record, when available.
Partial Record Type	O <sub>C</sub>	Indicates the event (time limit etc.) that caused the generation of a partial record.

### 6.1.3.30 Mobile Terminating Roaming Forwarding call after successful Retrieval of Routing Information (MTRF) handling in VMSC

If the generation of these records is enabled then a MTRF record shall be created for each call re-routed from an original MSC to a destination MSC, resulting from Mobile Terminating Roaming Forwarding (MTRF) procedure. The MTRF records shall be produced in the MSC/VLR behaving as the Original MSC the call is re-routed from.

**Table 6.1.3.30: MTRF record**

Field	3G	Description
Record Type	M	Mobile Terminating Roaming Forwarding.
Served IMSI	M	IMSI of the called party.
Served IMEI	C	IMEI of the called ME, if available.
Served MSISDN	O <sub>M</sub>	The MSISDN of the called party.
Calling Number	C	The number of the calling party if available.
Roaming Number	M	The Mobile Station Roaming Number employed by the VMSC for routing to the new VMSC.
Recording Entity	M	The E.164 number of the VMSC (i.e Old VMSC the call is re-routed from)
Incoming TKGP	O <sub>M</sub>	The VMSC trunk group on which the call originated.
Outgoing TKGP	O <sub>C</sub>	The trunk group on which the call left the VMSC.
Basic Service	M	teleservice employed
Event time stamps:	C	Seizure time: time of incoming trunk seizure
	C	Answer time: time of answer for successful calls
	O <sub>M</sub>	Release time: time of outgoing trunk release
Call duration	M	The chargeable duration of the connection if successful, the holding time of the incoming trunk for call attempts if unsuccessful.
Cause for termination	M	The reason for the release of the call.
Diagnostics	O <sub>M</sub>	A more detailed reason for the release of the connection.
Call reference	M	A local identifier distinguishing between transactions at the same MS
Sequence no.	C	Partial record sequence number, only present in case of partial records.
Record extensions	O <sub>C</sub>	A set of network/ manufacturer specific extensions to the record, when available.
Partial Record Type	O <sub>C</sub>	Indicates the event (time limit, etc.) that caused the generation of a partial record.

## 6.2 Data description for CS domain online charging

CS domain charging is implemented by CAMEL techniques as described in 3GPP TS 23.078 [67] and 3GPP TS 29.078 [73], i.e. it is outside the scope of the 3GPP 32-series charging TSs.

### 6.2.1 Diameter message contents

Void (refer to clause 6.2).

---

## Annex A (informative): CDR File Transfer compliant with earlier 3GPP releases

This group of TMN functions is concerned with the bulk transfer of call and event records from the NEF record filestore to the NEF.

The call and event records shall be transferred from the NEF to the OSF by the use of FTAM protocol on X.25 or TCP/IP, and FTP or TFTP over TCP/IP. For further details of the use of FTAM see GSM 12.01 [405] and of the use of FTP see RFC 959 [400] and TFTP see [403].

In addition to the simple file transfer services provided by FTAM, peer-to-peer application process communication may be also be supported. The use of CMIS services for the uploading of files from the NEF to the OSF is specified in GSM 12.00 [406].

---

## Annex B (informative): Bibliography

### a) **The 3GPP charging specifications**

- 3GPP TS 32.251: "Telecommunication management; Charging management; Packet Switched (PS) domain charging".
- 3GPP TS 32.252: "Telecommunication management; Charging management; Wireless Local Area Network (WLAN) charging".
- 3GPP TS 32.260: "Telecommunication management; Charging management; IP Multimedia Subsystem (IMS) charging".
- 3GPP TS 32.270: "Telecommunication management; Charging management; Multimedia Messaging Service (MMS) charging".
- 3GPP TS 32.271: "Telecommunication management; Charging management; Location Services (LCS) charging".
- 3GPP TS 32.296: "Telecommunication management; Charging management; On-line Charging System (OCS) applications and interfaces".

### b) **other charging specifications**

-

### c) **Common 3GPP specifications**

- 3GPP TS 22.101: "Service aspects; Service principles".
- 3GPP TS 23.003: "Numbering, addressing and identification".
- 3GPP TS 27.001: "General on Terminal Adaptation Functions (TAF) for Mobile Stations (MS)".

### d) **other Domain and Service specific 3GPP / ETSI specifications**

- 3GPP TS 23.009: "Handover procedures".
- 3GPP TS 23.040: "Technical realization of the Short Message Service (SMS)".
- 3GPP TS 24.080: "Mobile radio Layer 3 supplementary service specification; Formats and coding".
- 3GPP TS 49.031: "Location Services (LCS); Base Station System Application Part LCS Extension (BSSAP-LE)".
- 3GPP TS 29.002: "Mobile Application Part (MAP) specification".

### e) **Relevant ITU Recommendations**

- ITU-T Recommendation E.164: "The international public telecommunication numbering plan".
- ITU-T Recommendation Q.767: "Application of the ISDN user part of CCITT Signalling System No.7 for international ISDN interconnections".
- ITU-T Recommendation X.25: "Interface between Data Terminal Equipment (DTE) and Data Circuit-terminating Equipment (DCE) for terminals operating in the packet mode and connected to public data networks by dedicated circuit".
- ITU-T Recommendation X.121: "International numbering plan for public data networks".
- GSM 12.00: "Network Management (NM); Part 1: Objectives and structure of network management".

---

## Annex C (informative): Charging Support for Voice Call Continuity

Voice Call Continuity is a home IMS application that provides capabilities to transfer voice calls between the CS domain and the IMS. VCC provides functions for voice call originations, voice call terminations and for Domain Transfers between the CS domain and the IMS. This feature is defined in 3GPP TS 23.206 [210].

The following principles apply to VMSC/GMSC that are capable of VCC:

In case of CS Origination call with anchoring in the IMS, the Access Leg is charged as follows: Normal MOC CDR is generated by the VMSC with special handling. One example of special handling is to zero rate the CS resource usage. This can be performed using the "Service Key" parameter in the MOC Record indicating a VCC call. The CDRs generated within the IMS Domain to complete the anchoring mechanism are handled as specified in 3GPP TS 32.260 [55].

In case of IMS origination call, the Access Leg is charged as follows: Normal IMS and IP-CAN (e.g. WLAN or GSM/GPRS) charging mechanism are applied. These mechanisms are defined in 3GPP TS 32.260 [55] and IP-CAN Middle Tier TS respectively.

In case of Incoming call received via CS and routed to IMS, the Remote Leg is charged as follows: Normal MTC CDRs are generated by the GMSC of the terminating network with special handling. One example of special handling is to zero rate the CS resource usage. This can be performed using the "Service Key" parameter in the MTC Records indicating a VCC call. The CDRs generated within the IMS Domain to complete the Domain selection procedure are handled as specified in 3GPP TS 32.260 [55].

In case of Incoming call received via CS and routed to CS with anchoring, the Remote Leg is charged as follows: Normal MTC CDRs are generated by the GMSC and the VMSC in the terminating network with special handling. One example of special handling is to zero rate the CS resource usage. This can be performed using the "Service Key" parameter in the MTC Records indicating a VCC call. The CDRs generated within the IMS Domain to complete the anchoring procedure are handled as specified in 3GPP TS 32.260 [55].

In case of Incoming call received via IMS and routed to IMS, the Remote Leg is charged as follows: Normal IMS and IP-CAN (e.g. WLAN or GSM/GPRS) charging mechanism are applied. These mechanisms are defined in 3GPP TS 32.260 [55] and IP-CAN Middle Tier TS respectively.

In case of Incoming call received via IMS and routed to CS with anchoring, the Remote Leg is charged as follows: Normal MTC CDRs are generated by the GMSC or the VMSC in their terminating network with special handling. One example of special handling is to zero rate the CS resource usage. This can be performed using the "Service Key" parameter in the MTC Records indicating a VCC call. The CDRs generated within the IMS Domain to complete the domain selection procedure are handled as specified in 3GPP TS 32.260 [55].

In case of Domain Transfer from IMS to CS, the Access Leg is charged as follows: Normal MOC CDR is generated by the VMSC of the new Access Leg with special handling. One example of special handling is to zero rate the CS resource usage. This can be performed using the "Service Key" parameter in the MOC Record indicating a VCC call. The IMS CDRs generated to perform Domain Transfer are handled as specified in 3GPP TS 32.260 [55].

In case of Domain Transfer from CS to IMS, the Access Leg is charged as follows: The MOC CDRs of the Source-Access Leg (i.e. the Access leg previously established over CS) are closed when the Source Access Leg is released following normal CDR closure associated with CS call release. The IMS CDRs generated on the new access Leg are handled as specified in 3GPP TS 32.260 [55].

## Annex D (informative): Change history

Change history								
Date	TSG #	TSG Doc.	CR	Rev	Subject/Comment	Cat	Old	New
Mar 2007	SA_35	SP-070039	0010	--	Introduce CS charging implications of VCC	B	6.6.0	7.0.0
Mar 2007	SA_35	SP-070043	0011	--	Add MCC MNC in Location/change of location field	B	6.6.0	7.0.0
Jun 2007	SA_36	SP-070268	0013	--	Correction on MOC CDRs - Align with ITU ISUP Q.763	A	7.0.0	7.1.0
Dec 2008	SA_42	--	--	--	Upgrade to Release 8	--	7.0.0	8.0.0
Sep 2009	SA_45	SP-090536	0014	-	Correction to MO and MT SMS CDRs for SMS over SGs	F	8.0.0	8.1.0
Dec 2009	-	-	-	-	Update to Rel-9 version (MCC)	-	8.1.0	9.0.0
Mar 2010	SA_47	SP-100040	0016	--	Correction on System Type parameter	F	9.0.0	9.1.0
Mar 2011	SA_51	SP-110108	0018	1	Introduction of new CDRs for SRVCC feature in enhanced MSC server - Alignment with 3GPP TS 23.216	F	9.1.0	9.2.0
2011-03	-	-	-	-	Update to Rel-10 version (MCC)		9.2.0	10.0.0
2011-03	-	-	-	-	Correction of Update to Rel-10 version (MCC)		10.0.0	10.0.1
2011-06	SA_52	SP-110281	0020	--	Clarification on Mobile Originating Call Forwarding CDR generation when no O-CSI	F	10.0.1	10.1.0
2011-09	SA_53	SP-110530	0022	1	Correction on MT-LR CDR - Alignment with TS 23.271	F	10.1.0	10.2.0
2011-12	SA_54	SP-110709	0024	1	Correction on MSC-SRVCC CDRs for Suppl services and location	A	10.2.0	10.3.0
Mar 2012	SA_55	SP-120047	0028	1	Correction for E-UTRAN location (TAI and E-CGI) on Location Update (VLR) record	A	10.3.0	10.4.0
Mar 2012	SA_55	SP-120050	0025	1	Correction on Charging for Mobile Terminating Roaming Forwarding (MTRF) – alignment with TS 23.018	F	10.3.0	10.4.0
Jun-2012	SA-56	SP-120360	0030	1	Correction of CDRs for SRVCC	A	10.4.0	10.5.0
Dec-2012	SA-58	SP-120785	0034	-	R10 CR 32250 Remove related ICID from MSC SRVCC and MSC SRVCC emergency	A	10.5.0	10.6.0



---

## History

<b>Document history</b>		
V10.0.1	April 2011	Publication
V10.1.0	June 2011	Publication
V10.2.0	October 2011	Publication
V10.3.0	January 2012	Publication
V10.4.0	March 2012	Publication
V10.5.0	July 2012	Publication
V10.6.0	January 2013	Publication