

ETSI TS 132 215 V5.0.0 (2002-03)

Technical Specification

**Universal Mobile Telecommunications System (UMTS);
3G Telecom Management;
Charging management;
Charging data description for
the Packet Switched (PS) domain
(3GPP TS 32.215 version 5.0.0 Release 5)**



Reference

RTS/TSGS-0532215Uv5

Keywords

UMTS

ETSI

650 Route des Lucioles
F-06921 Sophia Antipolis Cedex - FRANCE

Tel.: +33 4 92 94 42 00 Fax: +33 4 93 65 47 16

Siret N° 348 623 562 00017 - NAF 742 C
Association à but non lucratif enregistrée à la
Sous-Préfecture de Grasse (06) N° 7803/88

Important notice

Individual copies of the present document can be downloaded from:

<http://www.etsi.org>

The present document may be made available in more than one electronic version or in print. In any case of existing or perceived difference in contents between such versions, the reference version is the Portable Document Format (PDF). In case of dispute, the reference shall be the printing on ETSI printers of the PDF version kept on a specific network drive within ETSI Secretariat.

Users of the present document should be aware that the document may be subject to revision or change of status. Information on the current status of this and other ETSI documents is available at

<http://portal.etsi.org/tb/status/status.asp>

If you find errors in the present document, send your comment to:

editor@etsi.fr

Copyright Notification

No part may be reproduced except as authorized by written permission.
The copyright and the foregoing restriction extend to reproduction in all media.

© European Telecommunications Standards Institute 2002.
All rights reserved.

DECTTM, **PLUGTESTS**TM and **UMTS**TM are Trade Marks of ETSI registered for the benefit of its Members.
TIPHONTM and the **TIPHON logo** are Trade Marks currently being registered by ETSI for the benefit of its Members.
3GPPTM is a Trade Mark of ETSI registered for the benefit of its Members and of the 3GPP Organizational Partners.

Intellectual Property Rights

IPRs essential or potentially essential to the present document may have been declared to ETSI. The information pertaining to these essential IPRs, if any, is publicly available for **ETSI members and non-members**, and can be found in ETSI SR 000 314: "*Intellectual Property Rights (IPRs); Essential, or potentially Essential, IPRs notified to ETSI in respect of ETSI standards*", which is available from the ETSI Secretariat. Latest updates are available on the ETSI Web server (<http://webapp.etsi.org/IPR/home.asp>).

Pursuant to the ETSI IPR Policy, no investigation, including IPR searches, has been carried out by ETSI. No guarantee can be given as to the existence of other IPRs not referenced in ETSI SR 000 314 (or the updates on the ETSI Web server) which are, or may be, or may become, essential to the present document.

Foreword

This Technical Specification (TS) has been produced by ETSI 3rd Generation Partnership Project (3GPP).

The present document may refer to technical specifications or reports using their 3GPP identities, UMTS identities or GSM identities. These should be interpreted as being references to the corresponding ETSI deliverables.

The cross reference between GSM, UMTS, 3GPP and ETSI identities can be found under www.etsi.org/key .

Contents

Intellectual Property Rights	2
Foreword.....	2
Foreword.....	5
1 Scope	6
2 References	6
3 Definitions, abbreviations and symbols	7
3.1 Definitions	7
3.2 Abbreviations	8
3.3 Symbols.....	9
4 Record types and contents	9
4.1 CDR Fields	9
4.1.1 CDR Fields on the GSN/CGF (Ga) interface.....	10
4.1.2 CDR Fields on the Core Network-Billing System Interface.....	11
4.2 Charging data in SGSN (S-CDR).....	13
4.3 Charging data in GGSN (G-CDR)	14
4.4 Mobile station mobility management data in SGSN (M-CDR).....	15
4.5 SMS-MO data in SGSN (S-SMO-CDR).....	16
4.6 SMS-MT data in SGSN (S-SMT-CDR).....	17
5 Description of Record Fields.....	17
5.1 Access Point Name (APN) Network/Operator Identifier	17
5.2 APN Selection Mode.....	18
5.3 CAMEL Information.....	18
5.4 Cause for Record Closing.....	19
5.5 Cell Identifier	19
5.6 Charging Characteristics	19
5.7 Charging Characteristics Selection Mode	20
5.8 Charging ID.....	20
5.9 Destination Number	21
5.10 Diagnostics	21
5.11 Duration.....	21
5.12 Dynamic Address Flag	21
5.13 Event Time Stamps	21
5.14 GGSN Address Used.....	21
5.15 List of Traffic Data Volumes	22
5.16 Local Record Sequence Number	23
5.17 Message reference	23
5.18 MS Network Capability.....	23
5.19 Network Initiated PDP Context.....	23
5.20 Node ID.....	23
5.21 PDP Type	23
5.22 QoS Requested/QoS Negotiated.....	23
5.23 Record Extensions	24
5.24 Record Opening Time	24
5.25 Record Sequence Number	24
5.26 Record Type	24
5.27 Recording Entity Number	24
5.28 RNC Unsent Downlink Volume.....	24
5.29 Routing Area Code/Cell Identifier/Change of location	24
5.30 Served IMEI	25
5.31 Served IMSI	25
5.32 Served MSISDN.....	25
5.33 Served PDP Address	25
5.34 Service Centre Address	25

5.35	SGSN Address.....	25
5.36	SGSN Change	25
5.37	Short Message Service (SMS) Result.....	26
5.38	System Type.....	26
6	Charging Data Record Structure	26
6.1	ASN.1 definitions for CDR information	26
7	Charging Protocols	32
7.1	CDR Transport by GTP'	32
7.1.1	SGSN - CGF communication	32
7.1.2	GGSN - CGF communication.....	32
7.1.3	CGF - CGF communication.....	33
7.1.4	Port usage	33
7.1.4.1	UDP as the Path Protocol.....	33
7.1.4.2	TCP as Path Protocol	34
7.1.4.3	Network layer and lower layers	34
7.1.5	Charging related requirements for PS Domain nodes.....	34
7.2	The GTP' charging protocol	34
7.2.1	Usage of GTP Header in charging	34
7.2.2	Information Elements (IEs).....	35
7.3	GTP' Message Types.....	35
7.3.1	List of all GTP' message types.....	35
7.3.2	Reused GTP message types	36
7.3.3	GTP message type modifications implied by GTP'	37
7.3.4	GTP' message types	37
7.3.4.1	Node Alive Request	37
7.3.4.2	Node Alive Response.....	38
7.3.4.3	Redirection Request	38
7.3.4.4	Redirection Response.....	39
7.3.4.5	Data Record Transfer Request	39
7.3.4.5.1	General logic	39
7.3.4.5.2	Information Elements in Data Record Transfer Request.....	42
7.3.4.5.3	Packet Transfer Command IE.....	42
7.3.4.5.4	Data Record Packet IE.....	43
7.3.4.5.5	Sequence Numbers of Released Packets IE.....	44
7.3.4.5.6	Sequence Numbers of Cancelled Packets IE	44
7.3.4.5.7	Private Extension IE	45
7.3.4.6	Data Record Transfer Response.....	45
7.3.4.7	Examples of GTP' messaging cases.....	46
7.3.4.7.1	Case 1: The normal CDR packet transfer	46
7.3.4.7.2	Case 2: The GSN-CGF1 connection breaks before a successful CDR reception	47
7.3.4.7.3	Case 3: The GSN-CGF1 connection breaks after a successful CDR reception	50
7.4	Data Record Format in GTP'	51
7.4.1	Standard Data Record Format.....	52
7.4.2	Private Data Record Formats	52
7.5	Data Record Format Version for CDRs	52
7.6	CGF - BS Protocol Interface	53
7.6.1	The transfer protocols at CGF - BS interface	53
7.6.2	The format of the CDRs at CGF - BS interface.....	53
Annex A (normative):	Charging Characteristics	54
Annex B (informative):	Change history	57
History		58

Foreword

This Technical Specification (TS) has been produced by the 3rd Generation Partnership Project (3GPP).

The contents of the present document are subject to continuing work within the TSG and may change following formal TSG approval. Should the TSG modify the contents of the present document, it will be re-released by the TSG with an identifying change of release date and an increase in version number as follows:

Version x.y.z

where:

- x the first digit:
 - 1 presented to TSG for information;
 - 2 presented to TSG for approval;
 - 3 or greater indicates TSG approved document under change control.
- y the second digit is incremented for all changes of substance, i.e. technical enhancements, corrections, updates, etc.
- z the third digit is incremented when editorial only changes have been incorporated in the document.

1 Scope

The GSM and UMTS PLMN support a wide range of packet based services by means of the General Packet Radio Service (GPRS), as defined in 3GPP TS 22.060 [1] and 3GPP TS 23.060 [2]. In order to enable operators the ability to provide a commercially viable service, there is a need to provide charging functions. For GPRS these functions include the generation of Charging Data Records (CDRs) by the Serving GPRS Support Node (SGSN) and the Gateway GPRS Support Node (GGSN) as well as the transport of these CDRs to a Billing System (BS) through a Charging Gateway Function (CGF).

The present document is part of a series of documents specifying charging functionality in UMTS networks. The UMTS charging architecture and principles are specified in document TS 32.200 [3] which provides an umbrella for other charging documents that specify the structure and content of the CDRs and the interface protocol that is used to transfer them to the collecting node. The CDRs content and transport within the PS domain are described in the present document. The CDRs used in the Circuit Switched (CS) domain are specified in document TS 32.205 [4] while CDRs used for application services are defined in document TS 32.235 [5]. The present document structure is depicted in Figure 1.

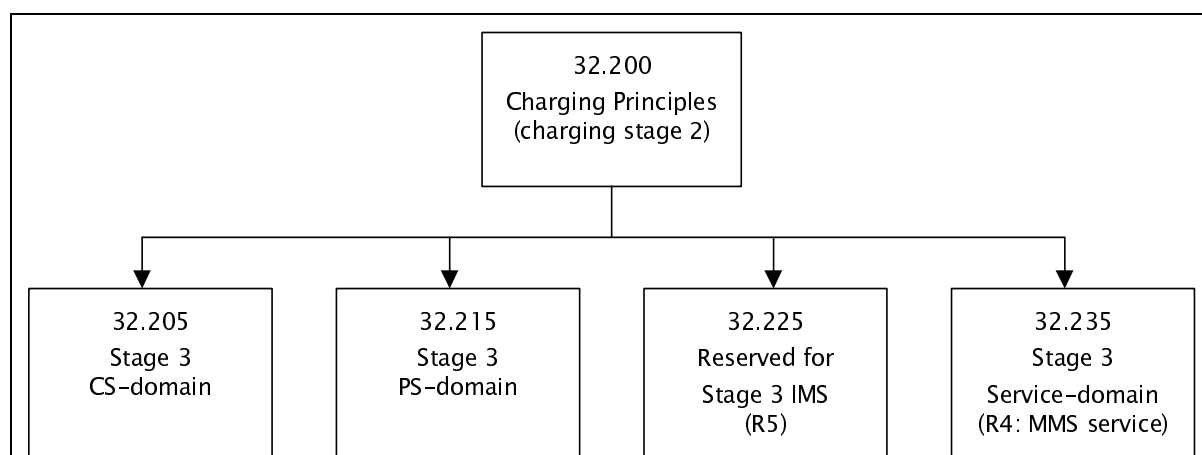

Figure 1: Charging Documents Structure

All references, abbreviations, definitions, descriptions, principles and requirements that are common to charging in UMTS domains or subsystems are provided in the umbrella document [3]. To avoid unnecessary duplications, they are not repeated in the present document unless it is essential.

2 References

The following documents contain provisions which, through reference in this text, constitute provisions of the present document.

- References are either specific (identified by date of publication, edition number, version number, etc.) or non-specific.
- For a specific reference, subsequent revisions do not apply.
- For a non-specific reference, the latest version applies. In the case of a reference to a 3GPP document (including a GSM document), a non-specific reference implicitly refers to the latest version of that document *in the same Release as the present document*.

- [1] 3GPP TS 22.060: "General Packet Radio Service (GPRS); Service description; Stage 1".
- [2] 3GPP TS 23.060: "General Packet Radio Service (GPRS); Service description; Stage 2".
- [3] 3GPP TS 32.200: "Telecommunication management; Charging management; Charging principles".

- [4] 3GPP TS 32.205: "Telecommunication management; Charging management; 3G charging data description for the Circuit Switched (CS) domain".
- [5] 3GPP TS 32.235: "Telecommunication management; Charging management; charging data description for application services".
- [6] 3GPP TR 21.905: "Vocabulary for 3GPP Specifications".
- [7] 3GPP TS 23.003: "Numbering, addressing and identification".
- [8] 3GPP TS 29.060: "General Packet Radio Service (GPRS); GPRS Tunnelling Protocol (GTP) across the Gn and Gp Interface".
- [9] 3GPP TS 29.078: "Customised Applications for Mobile network Enhanced Logic (CAMEL); CAMEL Application Part (CAP) specification - Phase 3".
- [10] 3GPP TS 24.008: "Mobile radio interface layer 3 specification; Core Network protocols - Stage 3".
- [11] 3GPP TS 25.413: "UTRAN Iu Interface RANAP Signalling".
- [12] 3GPP TS 32.015: "Telecommunications Management; Charging and billing; 3G call and event data for the Packet Switched (PS) domain".
- [13] 3GPP TS 29.002: "Mobile Application Part (MAP) specification".
- [14] ITU-T Q.767: "Application of the ISDN user part of CCITT signalling System No.7 for international ISDN interconnections".
- [15] 3GPP TS 23.040: "Technical realisation of the Short Message Service (SMS)".
- [16] ITU-T X.721: "Information Technology; Open Systems Interconnection; Structure Of Management Information: Definition of management information".
- [17] ISO8824 (90)/X.208 (88): "Information technology; Open System Interconnection; Specification of Abstract Syntax Notation One (ASN.1)".
- [18] ISO8824-1 (94)/X.680 (94): "Information technology; Abstract Syntax Notation One (ASN.1): Specification of Basic Notation".
- [19] IETF RFC 768 (1980): "User Datagram Protocol" (STD 6).
- [20] IETF RFC 793 (1981): "Transmission Control Protocol" (STD 7).
- [21] IETF RFC 791 (1981): "Internet Protocol" (STD 5).
- [22] IETF RFC 792 (1981): "Internet Control Message Protocol" (STD 5).

3 Definitions, abbreviations and symbols

3.1 Definitions

For the purposes of the present document, the terms end definitions given in TS 32.200 [3] and in 3GPP TS 22.060 [1] and the following apply :

domain: part of a communication network that provides services using a certain technology

Packet Switched domain: domain within UMTS and GSM in which data is transferred in packet mode

2G-/3G- : The terms 2G and 3G, and the prefixes 2G- and 3G- refer to functionality that supports only GSM or UMTS, respectively, e.g. 2G-SGSN refers only to the GSM functionality of an SGSN. When the term/prefix is omitted, reference is made independently from the GSM or UMTS functionality

CDR (Charging Data Record): record generated by a network element for the purpose of billing a subscriber for the provided service. It includes fields identifying the user, the session and the network elements as well as information on the network resources and services used to support a subscriber session. In the traditional circuit domain, CDR has been used to denote "Call Detail Record", which is subsumed by "Charging Data Record" hereafter.

CDR field Categories: the CDR fields are defined in the present document. They are divided into the following categories:

Mandatory – field that shall be present in the CDR

Conditional – field that shall be present in a CDR if certain conditions are met

Operator Provisionable: Mandatory – A field that operators have provisioned to be included in the CDR for all conditions.

Operator Provisionable: Conditional - A field that operators have provisioned to be included in the CDR if certain conditions are met.

Partial CDR: A CDR that provides information on part of a subscriber session. A long session may be covered by several partial CDRs. Two formats are considered for Partial CDRs. One that contains all of the necessary fields; the second has a reduced format.

Fully qualified Partial CDR (FQPC): partial CDR that contains a complete set of the fields specified in the present document. This includes all the mandatory and conditional fields as well as those fields that the PLMN operator has provisioned to be included in the CDR. The first Partial CDR shall be a Fully qualified Partial CDR.

Reduced Partial CDR (RPC): Partial CDRs that only provide mandatory fields and information regarding changes in the session parameters relative to the previous CDR. For example, location information is not repeated in these CDRs if the subscriber did not change its location.

3.2 Abbreviations

For the purposes of the present document, the abbreviations defined in 3GPP TS 21.905 [6] and the following apply:

APN	Access Point Name
BMD	Billing Mediation Device
BS	Billing System
CAMEL	Customised Applications for Mobile network Enhanced Logic
CDR	Charging Data Record (replaces the previous definition of Call Detail Record)
CG	Charging Gateway
CGF	Charging Gateway Function
CI	Cell Identity
CS	Circuit Switched
CSE	CAMEL Service Environment
DRP	Data Record Packet
EM	Element Management
FCI	Furnish Charging Information
FQPC	Fully qualified Partial CDR
G-CDR	GGSN generated- CDR
GGSN	Gateway GPRS Support Node
GPRS	General Packet Radio Service
GSN	GPRS Support Node (either SGSN or GGSN)
GTP	GPRS Tunnelling Protocol
IE	Information Element
IHOSS:OSP	Internet Hosted Octet Stream Service: Octet Stream Protocol
IMEI	International Mobile Equipment Identity
IMSI	International Mobile Subscriber Identity
IP	Internet Protocol
IPv4	Internet Protocol version 4
IPv6	Internet Protocol version 6
LAC	Location Area Code
M-CDR	Mobility Management generated-Charging Data Record
MCC	Mobile Country Code (part of IMSI)
ME	Mobile Equipment
MNC	Mobile Network Code (part of IMSI)

MS	Mobile Station
MSISDN	Mobile Station ISDN number
NE	Network Element
NI	Network Identifier (part of the APN)
OI	Operator Identifier (part of the APN)
PDP	Packet Data Protocol, e.g. IP
PDU	Packet Data Unit
PLMN	Public Land Mobile Network
PPP	Point-to-Point Protocol
PS	Packet Switched
PT	Protocol Type (Field in GTP' header)
RAB	Radio Access Bearer
RAC	Routing Area Code
RPC	Reduced Partial CDR
S-CDR	SGSN (PDP context) generated – CDR
SAC	Service Area Code
SGSN	Serving GPRS Support Node
S-SMO-CDR	SGSN delivered Short message Mobile Originated – CDR
S-SMT-CDR	SGSN delivered Short message Mobile Terminated – CDR
TID	Tunnel Identifier
TLV	Type, Length, Value (GTP header format)
TV	Type, Value
UMTS	Universal Mobile Telecommunications System
URA	UTRAN Registration Area
USIM	Universal Subscriber Identity Module
UTRAN	UMTS Terrestrial Radio Access Network

3.3 Symbols

For the purposes of the present document the following symbols apply:

Ga	Charging data collection interface between a CDR transmitting unit (e.g. GGSN or SGSN) and a CDR receiving unit (CGF).
GTP'	The GPRS protocol used for CDR transport. It is derived from GTP with enhancements to improve transport reliability necessary for CDRs.

NOTE: This protocol is not used for tunnelling.

4 Record types and contents

4.1 CDR Fields

Five types of CDRs can be generated in the PS domain by the GSNs. As described in document 32.200 [3], the types that can be generated by the SGSN are: S-CDR, M-CDR, S-SMO-CDR and S-SMT-CDR. The GGSN generates a G-CDR. The content of each CDR type is defined in one of the five tables that are part of this clause. For each CDR type the field definition includes the field name, description and category.

Equipment vendors shall be able to provide all of the fields listed in the CDR content table in order to claim compliance with the present document. However, since CDR processing and transport consume network resources, operators may opt to eliminate some of the fields that are not essential for their operation. This operator provisionable reduction is specified by the field category.

A field category can have one of two primary values:

- M** This field is **Mandatory** and shall always be present in the CDR.
- C** This field shall be present in the CDR only when certain **Conditions** are met. These **Conditions** are specified as

part of the field definition.

All other fields are designated as Operator (O) provisionable, which replaced the "Optional" category, specified in earlier releases. Using network management functions or specific tools provided by an equipment vendor, operators may choose if they wish to include or omit the field from the CDR. Once omitted, this field is not generated in a CDR. To avoid any potential ambiguity, a CDR generating element MUST be able to provide all these fields. Only an operator can choose whether or not these fields should be generated in their system.

Those fields that the operator wishes to be present are further divided into a mandatory and conditional categories:

- O_M** This is a field that, if provisioned by the operator to be present, shall always be included in the CDRs. In other words, an O_M parameter that is provisioned to be present is a mandatory parameter.
- O_C** This is a field that, if provisioned by the operator to be present, shall be included in the CDRs when the required conditions are met. In other words, an O_C parameter that is configured to be present is a conditional parameter.

A logical diagram showing the possible field categories is shown in Figure 2.

The content of the CDRs shall be specified on all the open network interfaces that are used for CDR transport. They include the GSN - CGF interface and the outward interface from the core network to the billing system. The rules governing the CDR specifications on these interfaces are summarised in the following clause.

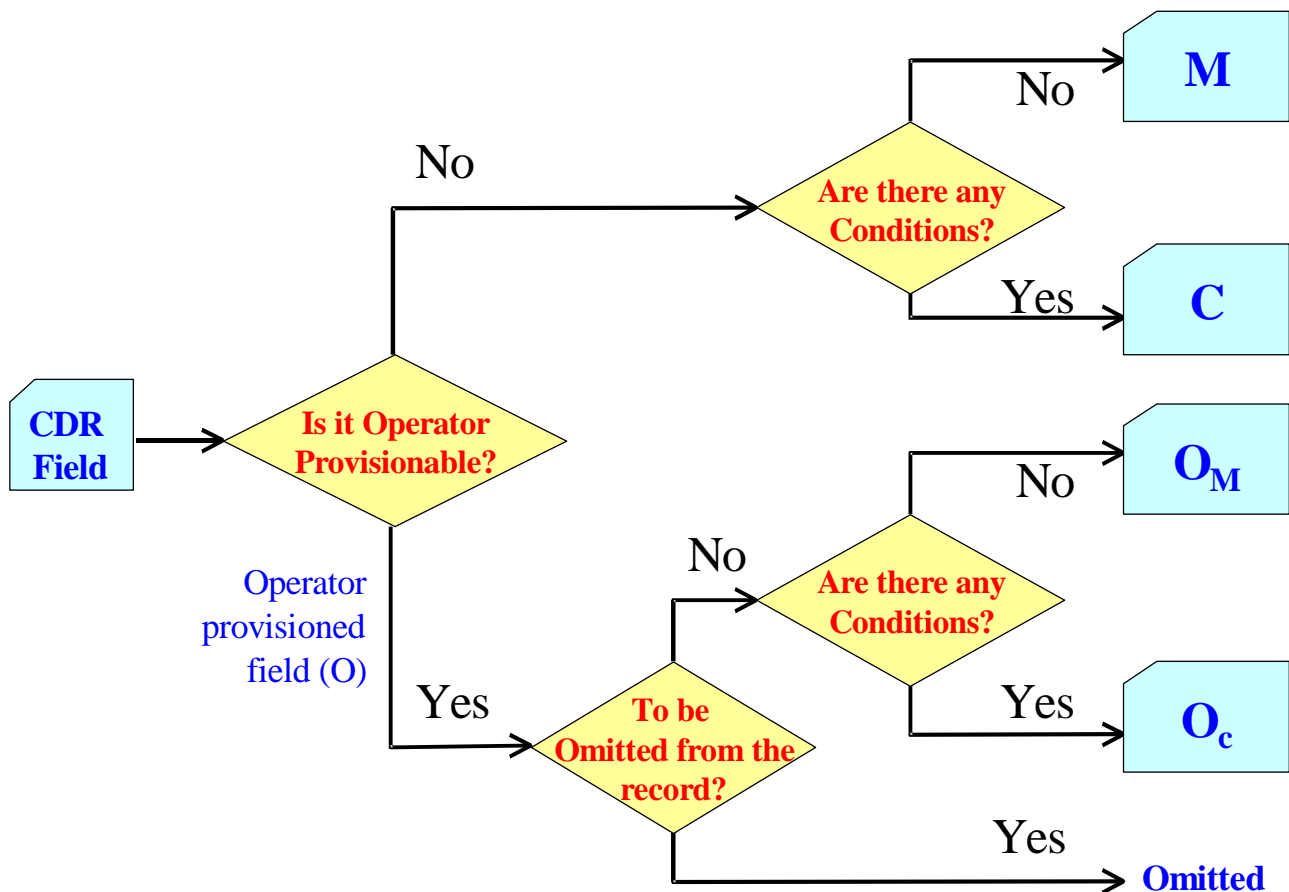

Figure 2: Logical Diagram illustrating the different CDR Field Categories

4.1.1 CDR Fields on the GSN/CGF (Ga) interface

The tables in the subsequent parts of clause 4 specify the Mandatory (M), Conditional (C) and Operator optional (O_M or O_C) designations at the GSN/CGF interface (i.e., the G_a interface). A CDR containing all Mandatory, Conditional and those optional fields provisioned by the operator (O_M and O_C) are considered to be a *Fully Qualified CDR*. The size of the CDRs could be optionally reduced by allowing a reduced format for *Partial CDRs* (see definitions in Clause 3.1).

During a long user session several *Partial CDRs* may be generated for the same session. In this case, some information can be eliminated rather than repeated in all the partial CDRs for that session. Only changes from one CDR to the next, in addition to mandatory information, can be reported. All the missing information can be reconstructed from fields in previous partial CDRs for the session. For example, if a subscriber did not change location, the Reduced Partial CDR would not include any location information.

Therefore, two formats are considered for Partial CDRs:

- a *Fully Qualified Partial CDR* that contains the Complete CDR Fields, and
- a *Reduced Partial CDR* that contains all the Mandatory fields (**M**) and **ONLY** the changes that occurred in any other field relative to the previous Partial CDR.

The first CDR generated when a session is opened shall be a Fully qualified Partial CDR. Subsequent partial CDRs may be *Reduced Partial CDRs*.

Thus, the convention is that when any non-mandatory field is missing from a Reduced Partial CDR, it should be interpreted that the same field as in the previous partial CDR could be used. Only Mandatory (**M**) and changed fields **MUST** always be included.

The GSNs and the CGF from all vendors that comply with the present document shall always be able to generate or receive Fully Qualified Partial CDRs. Generation and reception of Reduced Partial CDRs on the Ga interface is optional. However, if Reduced Partial CDRs are transmitted on the Ga interface they must comply with the rules specified in this clause.

4.1.2 CDR Fields on the Core Network-Billing System Interface

The CGF must be able to provide complete CDRs at the CGF/Billing System (BS) interface in the format and encoding described in the present document. Additional CDR formats and contents, generated by the CGF, may be available at this interface to meet the BS requirements.

If the GSNs are generating Reduced Partial CDRs on the Ga interface, the CGF must be able to convert the CDRs into Fully qualified Partial CDRs. However, if the BS can support Reduced Partial CDRs, no conversion to the fully-qualified partial CDR format is required.

The possible charging configurations that can be supported on both the Ga and the outbound interfaces are illustrated in Figure 3. Configuration a) is the default arrangement that **MUST** be supported by all systems. The other configurations are optional that may be supported **IN ADDITION** to configuration a). Configuration b) illustrates the case where the CGF is converting Reduced to Fully Qualified Partial CDRs. Configuration c) depicts the case where Reduced Partial CDRs can be received in the billing domain and no conversion is needed.

Equipment vendors shall declare if the GSNs, the CGF and the BS domain support Reduced Partial CDRs based on the above rules. If the CGF can not support Reduced Partial CDRs, then all the GSNs shall be provisioned to generate only fully qualified Partial CDRs (i.e., only configuration a) is possible). On the other hand, if the CGF can convert Partial CDRs format then the GSNs may generate Reduced Partial CDRs based on the rules specified above. In this case configurations b) can also be supported. Reduced Partial CDRs may also be generated by the GSNs if the billing domain can support the reduced format regardless of the CGF features (configuration c).

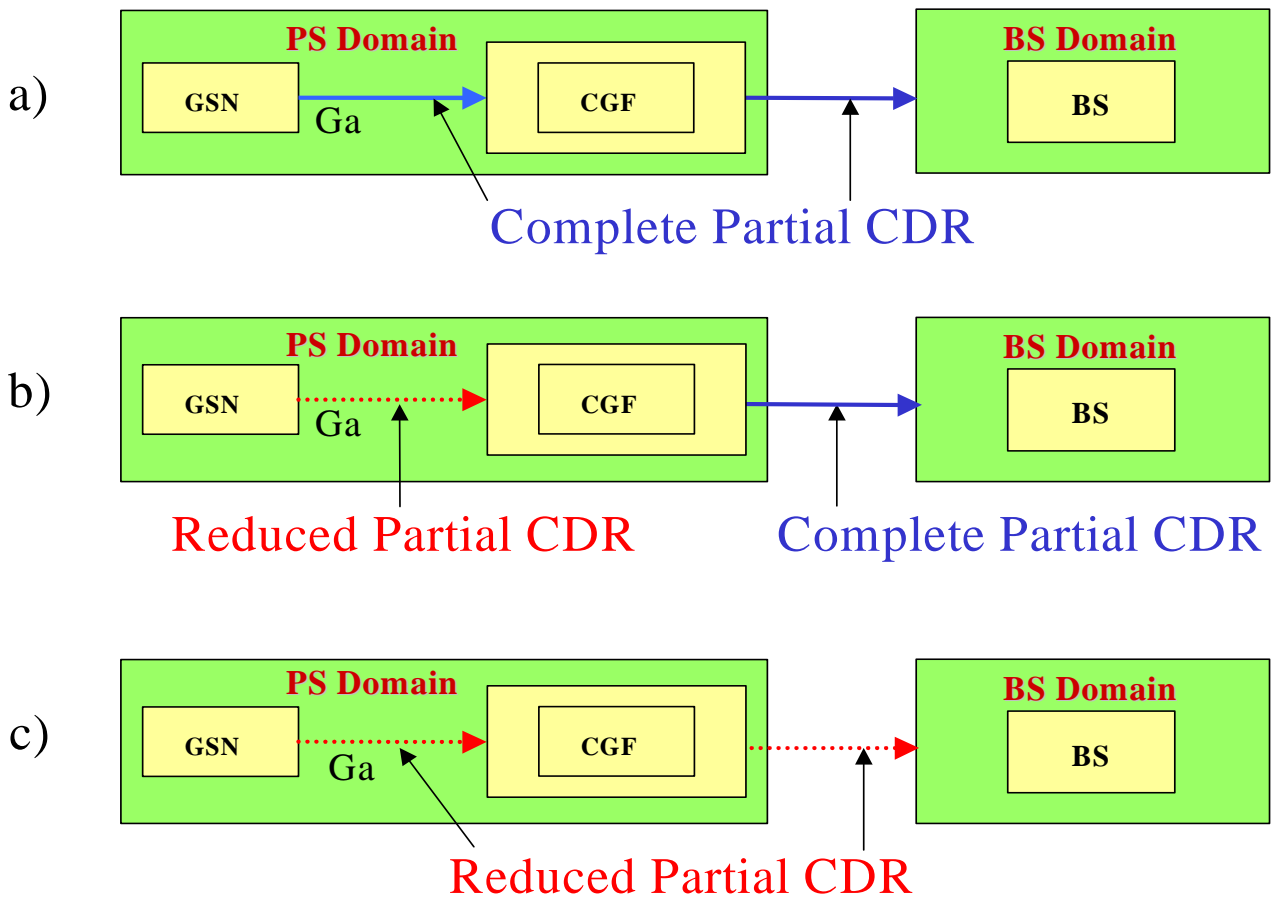

Figure 3: Possible Configurations of CDR Formats that can be supported on the PS domain open interfaces. Configuration a) shall be available in all systems. Other Configurations may be used in addition.

4.2 Charging data in SGSN (S-CDR)

If the collection of CDR data is enabled then the SGSN data specified in Table 1 shall be available for each PDP context. The table provides a brief description of each field. A more elaborate definition of the fields, sorted by the field name in alphabetical order, is provided in Clause 5.

Table 1: SGSN PDP context data (S-CDR)

Field	Category	Description
Record Type	M	SGSN PDP context record.
Network Initiated PDP Context	O _C	A flag that is present if this is a network initiated PDP context.
Served IMSI	M	IMSI of the served party
Served IMEI	O _C	The IMEI of the ME, if available.
SGSN Address	O _M	The IP address of the current SGSN.
MS Network Capability	O _M	The mobile station Network Capability.
Routing Area Code (RAC)	O _M	RAC at the time of "Record Opening Time"
Location Area Code (LAC)	O _M	LAC at the time of "Record Opening Time"
Cell Identifier	O _M	Cell identity for GSM or Service Area Code (SAC) for UMTS at the time of "Record Opening Time".
Charging ID	M	PDP context identifier used to identify this PDP context in different records created by GSNs
GGSN Address Used	M	The control plane IP address of the GGSN currently used. The GGSN address is always the same for an activated PDP context.
Access Point Name Network Identifier	O _M	The logical name of the connected access point to the external packet data network (network identifier part of APN).
PDP Type	O _M	PDP type, i.e. IP, PPP, IHOSS:OSP
Served PDP Address	O _C	PDP address of the served IMSI, i.e. IPv4 or IPv6. This parameter shall be present except when both the PDP type is PPP and dynamic PDP address assignment is used.
List of Traffic Data Volumes	O _M	A list of changes in charging conditions for this PDP context, each change is time stamped. Charging conditions are used to categorise traffic volumes, such as per QoS/tariff period. Initial and subsequently changed QoS and corresponding data volumes are listed.
Record Opening Time	M	Time stamp when PDP context is activated in this SGSN or record opening time on subsequent partial records.
Duration	M	Duration of this record in the SGSN.
SGSN Change	C	Present if this is first record after SGSN change.
Cause for Record Closing	M	The reason for closure of the record from this SGSN.
Diagnostics	O _M	A more detailed reason for the release of the connection.
Record Sequence Number	C	Partial record sequence number in this SGSN. Only present in case of partial records.
Node ID	O _M	Name of the recording entity
Record Extensions	O _C	A set of network operator/manufacturer specific extensions to the record. Conditioned upon the existence of an extension.
Local Record Sequence Number	O _M	Consecutive record number created by this node. The number is allocated sequentially including all CDR types.
APN Selection Mode	O _M	An index indicating how the APN was selected.
Access Point Name Operator Identifier	O _M	The Operator Identifier part of the APN.
Served MSISDN	O _M	The primary MSISDN of the subscriber.
Charging Characteristics	M	The Charging Characteristics applied to the PDP context.
System Type	O _C	Indicates the type of air interface used, e.g. UTRAN. This field is present when either the UTRAN or GERAN air-interface is used. It is omitted when the service is provided by a GSM air interface.
CAMEL Information	O _C	Set of CAMEL information related to PDP context. For more information see Description of Record Fields. This field is present if CAMEL service is activated.
RNC Unsent Downlink Volume	O _C	The downlink data volume which the RNC has not sent to MS. This field is present when the RNC has provided unsent downlink volume count at RAB release.
Charging Characteristics Selection Mode	O _M	Holds information about how Charging Characteristics were selected.
Dynamic Address Flag	O _C	Indicates whether served PDP address is dynamic, which is allocated during PDP context activation. This field is missing if address is static.

4.3 Charging data in GGSN (G-CDR)

If the collection of CDR data is enabled then the GGSN data specified in Table 2 shall be available for each PDP context. The table provides a brief description of each field. A more elaborate definition of the fields, sorted by the field name in alphabetical order, is provided in Clause 5.

Table 2: GGSN PDP context data (G-CDR)

Field	Category	Description
Record Type	M	GGSN PDP context record.
Network initiated PDP context	O _C	A flag that is present if this is a network initiated PDP context.
Served IMSI	M	IMSI of the served party
GGSN Address used	M	The control plane IP address of the GGSN used.
Charging ID	M	PDP context identifier used to identify this PDP context in different records created by GSNs
SGSN Address	M	List of SGSN addresses used during this record.
Access Point Name Network Identifier	O _M	The logical name of the connected access point to the external packet data network (network identifier part of APN).
PDP Type	O _M	PDP type, i.e. IP, PPP, or IHOSS:OSP
Served PDP Address	O _C	PDP address, i.e. IPv4 or IPv6. This parameter shall be present except when both the PDP type is PPP and dynamic PDP address assignment is used.
Dynamic Address Flag	O _C	Indicates whether served PDP address is dynamic, which is allocated during PDP context activation. This field is missing if address is static.
List of Traffic Data Volumes	O _M	A list of changes in charging conditions for this PDP context, each change is time stamped. Charging conditions are used to categorise traffic volumes, such as per tariff period. Initial and subsequently changed QoS and corresponding data values are listed.
Record Opening Time	M	Time stamp when PDP context is activated in this GGSN or record opening time on subsequent partial records.
Duration	M	Duration of this record in the GGSN.
Cause for Record Closing	M	The reason for the release of record from this GGSN.
Diagnostics	O _M	A more detailed reason for the release of the connection.
Record Sequence Number	C	Partial record sequence number, only present in case of partial records.
Node ID	O _M	Name of the recording entity.
Record Extensions	O _C	A set of network operator/manufacturer specific extensions to the record. Conditioned upon the existence of an extension.
Local Record Sequence Number	O _M	Consecutive record number created by this node. The number is allocated sequentially including all CDR types.
APN Selection Mode	O _M	An index indicating how the APN was selected.
Served MSISDN	O _M	The primary MSISDN of the subscriber.
Charging Characteristics	M	The Charging Characteristics applied to the PDP context.
Charging Characteristics Selection Mode	O _M	Holds information about how Charging Characteristics were selected.

4.4 Mobile station mobility management data in SGSN (M-CDR)

If the collection of MS mobility management data is enabled then the SGSN shall start collecting the information specified in Table 3 each time the mobile is attached to the SGSN. The table provides a brief description of each field. A more elaborate definition of the fields, sorted by the field name in alphabetical order, is provided in Clause 5.

Table 3: SGSN Mobile Station mobility management data (M-CDR)

Field	Category	Description
Record Type	M	SGSN mobility management record.
Served IMSI	M	IMSI of the MS.
Served IMEI	O _C	The IMEI of the ME, if available.
SGSN Address	O _M	The IP address of the current SGSN.
MS Network Capability	O _M	The mobile station network capability.
Routing Area Code	O _M	Routing Area at the time of the Record Opening Time.
Local Area Code	O _M	Location Area Code at the time of Record Opening Time.
Cell Identifier	O _M	The Cell Identity for GSM or Service Area Code (SAC) for UMTS at the time of the Record Opening Time.
Change of Location	O _C	A list of changes in Routing Area Code, each with a time stamp. This field is not required if partial records are generated when the location changes.
Record Opening Time	M	Timestamp when MS is attached to this SGSN or record opening time on following partial record.
Duration	O _M	Duration of this record.
SGSN Change	C	Present if this is first record after SGSN change.
Cause for Record Closing	M	The reason for the closure of the record in this SGSN.
Diagnostics	O _M	A more detailed reason for the release of the connection.
Record Sequence Number	C	Partial record sequence number in this SGSN; only present in case of partial records.
Node ID	O _M	Name of the recording entity.
Record Extensions	O _C	A set of network operator/manufacturer specific extensions to the record. Conditioned upon the existence of an extension.
Local Record Sequence Number	O _M	Consecutive record number created by this node. The number is allocated sequentially including all CDR types.
Served MSISDN	O _M	The primary MSISDN of the subscriber.
Charging Characteristics	M	The Charging Characteristics used by the SGSN.
CAMEL Information	O _C	Set of CAMEL information related to Attach/Detach session. For more information see Description of Record Fields. This field is present if CAMEL service is activated.
System Type	O _C	Indicates the type of air interface used, e.g. UTRAN. This field is present when either the UTRAN or GERAN air-interface is used. It is omitted when the service is provided by a GSM air interface.
Charging Characteristics Selection Mode	O _M	Holds information about how Charging Characteristics were selected.

4.5 SMS-MO data in SGSN (S-SMO-CDR)

If enabled, an S-SMO-CDR SGSN Mobile originated SMS record shall be produced for each short message sent by a mobile subscriber via the SGSN. The fields in the record are specified in Table 4. The table provides a brief description of each field. A more elaborate definition of the fields, sorted by the field name in alphabetical order, is provided in Clause 5.

Table 4: SGSN Mobile originated SMS record (S-SMO-CDR)

Field	Category	Description
Record Type	M	SGSN Mobile Originated SMS.
Served IMSI	M	The IMSI of the subscriber.
Served IMEI	O _C	The IMEI of the ME, if available.
Served MSISDN	O _M	The primary MSISDN of the subscriber.
MS Network Capability	O _M	The mobile station network capability.
Service Centre	O _M	The address (E.164) of the SMS-service centre.
Recording Entity	O _M	The E.164 number of the SGSN.
Location Area Code	O _M	The Location Area Code from which the message originated.
Routing Area Code	O _M	The Routing Area Code from which the message originated.
Cell Identifier	O _M	The Cell Identity for GSM or Service Area Code (SAC) for UMTS from which the message originated.
Message Reference	M	A reference provided by the MS uniquely identifying this message.
Event Time Stamp	M	The time at which the message was received by the SGSN from the subscriber.
SMS Result	C	The result of the attempted delivery if unsuccessful.
Record Extensions	O _C	A set of network operator/ manufacturer specific extensions to the record. Conditioned upon the existence of an extension.
Node ID	O _M	Name of the recording entity.
Local Record Sequence Number	O _M	Consecutive record number created by this node. The number is allocated sequentially including all CDR types.
Charging Characteristics	M	The Charging Characteristics flag set used by the SGSN.
System Type	O _C	Indicates the type of air interface used, e.g. UTRAN. This field is present when either the UTRAN or GERAN air-interface is used. It is omitted when the service is provided by a GSM air interface.
Destination Number	O _M	The destination short message subscriber number.
CAMEL Information	O _C	Set of CAMEL information related to SMS session. For more information see Description of Record Fields. This field is present if CAMEL service is activated.
Charging Characteristics Selection Mode	O _M	Holds information about how Charging Characteristics were selected.

4.6 SMS-MT data in SGSN (S-SMT-CDR)

If enabled, an SGSN Mobile terminated SMS record shall be produced for each short message received by a mobile subscriber via the SGSN. The fields in the record are specified in Table 5. The table provides a brief description of each field. A more elaborate definition of the fields, sorted by the field name in alphabetical order, is provided in Clause 5.

Table 5: SGSN Mobile terminated SMS record (S-SMT-CDR)

Field	Category	Description
Record Type	M	SGSN Mobile Terminated SMS.
Served IMSI	M	The IMSI of the subscriber.
Served IMEI	O _C	The IMEI of the ME, if available.
Served MSISDN	O _M	The primary MSISDN of the subscriber.
MS Network Capability	O _M	The mobile station network capability
Service Centre	O _M	The address (E.164) of the SMS-service centre.
Recording Entity	O _M	The E.164 number of the SGSN.
Location Area Code	O _M	The Location Area Code to which the message was delivered.
Routing Area Code	O _M	The Routing Area Code to which the message was delivered.
Cell Identifier	O _M	The Cell Identity for GSM or Service Area Code (SAC) for UMTS to which the message was delivered.
Event Time Stamp	M	Delivery time stamp, time at which message was sent to the MS by the SGSN.
SMS Result	C	The result of the attempted delivery if unsuccessful.
Record Extensions	O _C	A set of network operator/manufacturer specific extensions to the record. Conditioned upon the existence of an extension.
Node ID	O _M	Name of the recording entity.
Local Record Sequence Number	O _M	Consecutive record number created by this node. The number is allocated sequentially including all CDR types.
Charging Characteristics	M	The Charging Characteristics flag set used by the SGSN.
System Type	O _C	Indicates the type of air interface used, e.g. UTRAN. This field is present when either the UTRAN or GERAN air-interface is used. It is omitted when the service is provided by a GSM air interface.
Charging Characteristics Selection Mode	O _M	Holds information about how Charging Characteristics were selected.
CAMEL Information	O _C	Set of CAMEL information related to SMS session. For more information see Description of Record Fields. This field is present if CAMEL service is activated.

5 Description of Record Fields

This clause contains a brief description of each field of the CDRs described in the previous clause. The fields are listed in alphabetical order according to the field name as specified in one of the five tables above.

5.1 Access Point Name (APN) Network/Operator Identifier

These fields contain the actual connected Access Point Name Network/Operator Identifier determined either by MS, SGSN or modified by CAMEL service. An APN can also be a wildcard, in which case the SGSN selects the access point address.

Following TS 23.003 [7], the APN field is specified in the CDR by two variable strings. The first is the APN Network Identifier (NI portion) and the second is the APN Operator Identifier (OI portion). The APN NI may contain one or more label as described in TS 23.003 [7]. The APN OI is composed of three labels. The first and second labels together shall uniquely identify the PLMN operator (e.g. "mnc<operator mnc>.mcc<operator mcc>.gprs").

To represent the APN NI and OI in the GPRS CDRs, the "dot" notation shall be used.

See 3GPP TS 23.003 [7] and 3GPP TS 23.060 [2] for more information about APN format and access point decision rules.

5.2 APN Selection Mode

This field indicates how the SGSN selected the APN to be used. The values and their meaning are as specified in 3GPP TS 29.060 [8] clause 7.9 'Information elements'.

5.3 CAMEL Information

This field includes following CAMEL information elements for PDP context (S-CDR), Attach/Detach session (M-CDR), Mobile originated SMS (S-SMO-CDR) and Mobile terminated SMS (S-SMT-CDR) if corresponding CAMEL service is activated.

- CAMEL Access Point Name NI (S-CDR)

This field contains the network identifier part of APN before modification by the CSE.

- CAMEL Access Point Name OI (S-CDR)

This field contains the operator identifier part of APN before modification by the CSE.

- CAMEL Calling Party Number (S-SMO-CDR, S-SMT-CDR)

This field contains the Calling Party Number modified by the CAMEL service.

- CAMEL Destination Subscriber Number (S-SMO-CDR)

This field contains the short message Destination Number modified by the CAMEL service.

- CAMEL SMSC Address (S-SMO-CDR)

This field contains the SMSC address modified by the CAMEL service.

- SCF address (S-CDR, M-CDR, S-SMO-CDR, S-SMT-CDR)

This field identifies the CAMEL server serving the subscriber. Address is defined in HLR as part of CAMEL subscription information.

- Service key (S-CDR, M-CDR, S-SMO-CDR, S-SMT-CDR)

This field identifies the CAMEL service logic applied. Service key is defined in HLR as part of CAMEL subscription information.

- Default Transaction/SMS Handling (S-CDR, M-CDR, S-SMO-CDR, S-SMT-CDR)

This field indicates whether or not a CAMEL encountered default GPRS- or SMS-handling. This field shall be present only if default call handling has been applied. Parameter is defined in HLR as part of CAMEL subscription information.

- Free Format Data (S-CDR, M-CDR, S-SMO-CDR, S-SMT-CDR)

This field contains charging information sent by the gsmSCF in the Furnish Charging Information GPRS messages as defined in 3GPP TS 29.078 [9]. The data can be sent either in one FCI message or several FCI messages with append indicator. This data is transferred transparently in the CAMEL clauses of the relevant call records.

If the FCI is received more than once during one CAMEL call, the append indicator defines whether the FCI information is appended to previous FCI and stored in the relevant record or the information of the last FCI received is stored in the relevant record (the previous FCI information shall be overwritten).

In the event of partial output the currently valid "Free format data" is stored in the partial record.

- FFD Append Indicator (S-CDR, M-CDR)

This field contains an indicator whether CAMEL free format data is to be appended to free format data stored in previous partial CDR. This field is needed in CDR post processing to sort out valid free format data for that call leg from sequence of partial records. Creation of partial records is independent of received FCIs and thus valid free format data may be divided to different partial records.

If field is missing then free format data in this CDR replaces all received free format data in previous CDRs.

Append indicator is not needed in the first partial record. In following partial records indicator shall get value true if all FCIs received during that partial record have append indicator. If one or more of the received FCIs for that call leg during the partial record do not have append indicator then this field shall be missing.

- Level of CAMEL services (S-CDR, M-CDR)

This field describes briefly the complexity of CAMEL invocation. Categories are the same as in circuit switched services and measure of resource usage in VPLMN requested by HPLMN.

- "Basic" means that CAMEL feature is invoked during the PDP context activation phase only (e.g. to modify APN_NI/APN_OI).

- "Call duration supervision" means that PDP context duration or volume supervision is applied in the gprsSSF of the VPLMN (Apply Charging message is received from the gsmSCF).

- Number of DPs encountered (S-CDR, M-CDR)

This field indicates how many armed CAMEL detection points (TDP and EDP) were encountered and complements "Level of CAMEL service" field.

- smsReferenceNumber (S-SMO-CDR, S-SMT-CDR)

This parameter contains the SMS Reference Number assigned to the Short Message by the SGSN.

5.4 Cause for Record Closing

This field contains a reason for the release of the CDR including the following:

- normal release: PDP context release or GPRS detach;
- partial record generation: data volume limit, time (duration) limit, SGSN change or maximum number of changes in charging conditions;
- abnormal termination (PDP or MM context);
- management intervention (request due to O&M reasons).

A more detailed reason may be found in the diagnostics field.

5.5 Cell Identifier

For GSM, the Cell Identifier is defined as the Cell Id, reference 24.008[10], and for UMTS it is defined as the Service Area Code in TS 25.413 [11].

5.6 Charging Characteristics

The Charging Characteristics field allows the operator to apply different kind of charging methods in the CDRs. A subscriber may have Charging Characteristics assigned to his subscription. These characteristics can be supplied by the HLR to the SGSN as part of the subscription information, and, upon activation of a PDP context, the SGSN forwards the charging characteristics to the GGSN according to the rules specified in Annex A. This information can be used by the GSNs to activate CDR generation and control the closure of the CDR or the traffic volume containers (see clause 5.15). It can also be used in nodes handling the CDRs (e.g., the CGF or the billing system) to influence the CDR processing priority and routing. These functions are accomplished by specifying the charging characteristics as sets of charging profiles and the expected behaviour associated with each profile. The interpretations of the profiles and their

associated behaviours can be different for each PLMN operator and are not subject to standardisation. In the present document only the charging characteristic formats and selection modes are specified.

The functional requirements for the Charging Characteristics as well as the profile and behaviour bits are further defined in normative Annex A, including the definitions of the trigger profiles associated with each CDR type.

The format of charging characteristics field is depicted in Figure 4. Px (x =0..3) refers to the Charging Characteristics Profile index. Bits classified with a "B" may be used by the operator for non-standardised behaviour (see Annex A).

It is possible to ascribe the same semantic meanings to bits P0 through P3 as exists in release 99 technical specification TS 32.015 [12]. That is, the P3 (N) flag in the Charging Characteristics indicates normal charging, the P2 (P) flag indicates prepaid charging, the P1 (F) flag indicates flat rate charging and the P0 (H) flag indicates charging by hot billing. For example, the case where the P0 bit is turned on would correspond to the behaviour associated with the operator's own definition of Hot Billing, such as short time and volume limits for CDR closure as well as priority processing by CDR handling nodes (e.g., CGF and billing system). It is the responsibility of the PLMN operator to exactly define the meaning of the profile bits, P0 to P3, and make them compatible with the R99 flags if so required.

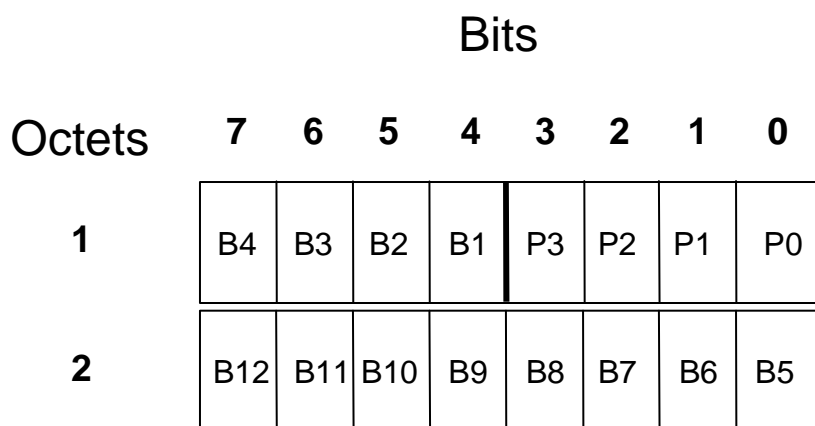

Figure 4: Charging Characteristics flags

5.7 Charging Characteristics Selection Mode

This field indicates the charging characteristic type that the GSNs applied to the CDR. In the SGSN the allowed values are:

- Home default
- Visiting default
- Roaming default
- APN specific
- Subscription specific.

In the GGSN the allowed values are:

- Home default
- Visiting default
- Roaming default
- SGSN supplied.

Further details are provided in Annex A.

5.8 Charging ID

This field is a charging identifier, which can be used together with GGSN address to identify all records produced in SGSN(s) and GGSN involved in a single PDP context. Charging ID is generated by GGSN at PDP context activation and transferred to context requesting SGSN. At inter-SGSN routing area update charging ID is transferred to the new SGSN as part of each active PDP context.

Different GGSNs allocate the charging ID independently of each other and may allocate the same numbers. The CGF and/or BS may check the uniqueness of each charging ID together with the GGSN address and optionally (if still ambiguous) with the record opening time stamp.

5.9 Destination Number

This field contains short message Destination Number requested by the user. See 32.205 [4].

5.10 Diagnostics

This field includes a more detailed technical reason for the release of the connection and may contain one of the following:

- a MAP error from 3GPP TS 29.002 [13]; or
- a Cause from 3GPP TS 29.078 [9]; or
- a Cause from 3GPP TS 24.008 [10]; or
- a Cause from ISUP Q.767 [14].

The diagnostics may also be extended to include manufacturer and network specific information.

5.11 Duration

This field contains the relevant duration in seconds for PDP contexts (S-CDR, G-CDR, and attachment (M-CDR)). It is the duration from Record Opening Time to record closure. For partial records this is the duration of the individual partial record and not the cumulative duration.

It should be noted that the internal time measurements may be expressed in terms of tenths of seconds or even milliseconds and, as a result, the calculation of the duration may result in the rounding or truncation of the measured duration to a whole number of seconds.

Whether or not rounding or truncation is to be used is considered to be outside the scope of the present document subject to the following restrictions:

- 1) A duration of zero seconds shall be accepted providing that the transferred data volume is greater than zero.
- 2) The same method of truncation/rounding shall be applied to both single and partial records.

5.12 Dynamic Address Flag

This field indicates that PDP address has been dynamically allocated for that particular PDP context. This field is missing if address is static i.e. part of PDP context subscription. Dynamic address allocation might be relevant for charging e.g. the duration of PDP context as one resource offered and possible owned by network operator.

5.13 Event Time Stamps

These fields contain the event time stamps relevant for each of the individual record types.

All time-stamps include a minimum of date, hour, minute and second.

5.14 GGSN Address Used

These fields are the current serving GGSN IP Address for the Control Plane.

5.15 List of Traffic Data Volumes

This list includes one or more containers, each includes the following fields:

Data Volume Uplink, Data Volume Downlink, Change Condition and Change Time.

Data Volume, Uplink and/or **Downlink**, includes the number of octets transmitted during the use of the packet data services in the uplink and/or downlink direction, respectively.

Change Condition defines the reason for closing the container (see TS 32.200 [3] Clause 6), such as tariff time change, QoS change or closing of the CDR.

Change Time is a time stamp, which defines the moment when the new volume counts are started or the CDR is closed. All the active PDP contexts do not need to have exactly the same time stamp e.g. due to same tariff time change (variance of the time stamps is implementation and traffic load dependent, and is out of the scope of standardisation).

First container includes following optional fields: QoS Requested (not in G-CDR) and QoS Negotiated. In following containers QoS Negotiated is present if previous change condition is "QoS change". In addition to the QoS Negotiated parameter the QoS Requested parameter is present in following containers if the change condition is "QoS change" and the QoS change was initiated by the MS via a PDP context modification procedure.

Table 6 illustrates an example of a list, which has three containers (sets of volume counts) caused by one QoS change and one tariff time change.

Table 6: Example list of traffic data volumes

QoS Requested = QoS1 QoS Negotiated = QoS1 Data Volume Uplink = 1 Data Volume Downlink = 2 Change Condition = QoS change Time Stamp = TIME1	QoS Requested = QoS2 (if requested by the MS) QoS Negotiated = QoS2 Data Volume Uplink = 5 Data Volume Downlink = 6 Change Condition = Tariff change Time Stamp = TIME2	Data Volume Uplink = 3 Data Volume Downlink = 4 Change Condition = Record closed Time Stamp = TIME3
--	--	--

First container includes initial QoS values and corresponding volume counts. Second container includes new QoS values and corresponding volume counts before tariff time change. Last container includes volume counts after the tariff time change. The total volume counts can be itemised as shown in Table 7 (tariff1 is used before and tariff2 after the tariff time change):

Table 7: Itemised list of total volume count corresponding to Table 6

		Container
QoS1+Tariff1	uplink = 1, downlink = 2	1
QoS2+Tariff1	uplink = 5, downlink = 6	2
QoS2+Tariff2	uplink = 3, downlink = 4	3
QoS1	uplink = 1, downlink = 2	1
QoS2	uplink = 8, downlink = 10	2+3
Tariff1	uplink = 6, downlink = 8	1+2
Tariff2	uplink = 3, downlink = 4	3

The amount of data counted in the GGSN shall be the payload of the GTP-U protocol at the Gn interface. Therefore the data counted already includes the IP PDP bearer protocols i.e. IP or PPP.

The data volume counted in the SGSN is dependent on the system. For GSM SGSN the data volume is the payload of the SNDCP PDUs at the Gb interface. For UMTS-SGSN it is the GTP-U PDUs at the Iu-PS interface. Therefore, in both systems, the data counted already includes the overheads of any PDP bearer protocols.

In GSM, in order to avoid that downstream packets transmitted from the old SGSN to the new SGSN at inter SGSN RA update induce the increase of the PDP CDR downstream volume counters in both SGSN the following rules must be followed:

- For PDP contexts using LLC in unacknowledged mode: an SGSN shall update the PDP CDR when the packet has been sent by the SGSN towards the MS;

For PDP contexts using LLC in acknowledged mode, a GSM-SGSN shall only update the PDP CDR at the reception of the acknowledgement by the MS of the correct reception of a downstream packet. In other words, for inter SGSN RA update, the new SGSN shall update the PDP CDR record when a downstream packet sent by the old SGSN is received by the MS and acknowledged by the MS towards the new SGSN through the RA update complete message.

In UMTS, the not transferred downlink data can be accounted for in the S-CDR with "RNC Unsent Downlink Volume" field, which is the data that the RNC has either discarded or forwarded during handover. Data volumes retransmitted (by RLC or LLC) due to poor radio link conditions shall not be counted.

5.16 Local Record Sequence Number

This field includes a unique record number created by this node. The number is allocated sequentially including all CDR types. The number is unique within one node, which is identified either by field Node ID or by record-dependent node address (SGSN address, GGSN address, Recording Entity).

The field can be used e.g. to identify missing records in post processing system.

5.17 Message reference

This field contains a unique message reference number allocated by the Mobile Station (MS) when transmitting a short message to the service centre. This field corresponds to the TP-Message-Reference element of the SMS_SUBMIT PDU defined in 3GPP TS 23.040 [15].

5.18 MS Network Capability

This MS Network Capability field contains the MS network capability value of the MS network capability information element of the served MS on PDP context activation or on GPRS attachment as defined in 3GPP TS 24.008 [10].

5.19 Network Initiated PDP Context

This field indicates that PDP context is network initiated. The field is missing in case of mobile activated PDP context.

5.20 Node ID

This field contains an optional, operator configurable, identifier string for the node that had generated the CDR. The Node ID may or may not be the DNS host name of the node.

5.21 PDP Type

This field defines the PDP type, e.g. IP, PPP, or IHQSS:OSP (see 3GPP TS 29.060 [8] for exact format).

5.22 QoS Requested/QoS Negotiated

Quality of Service Requested contains the QoS desired by MS at PDP context activation. QoS Negotiated indicates the applied QoS accepted by the network.

If a pre-Release '99 only capable terminal is served, the QoS profile consists of five (5) attributes as follows: reliability, delay, precedence, peak throughput and mean throughput. The encoding of this QoS profile shall be in accordance with GSM 12.15.

In Release 99 and R4, the QoS profile consists of the above 2G parameters plus the following UMTS attributes: Traffic class ("conversational", "streaming", "interactive", "background"), Maximum bit-rate (kbps), Delivery order (y/n), Maximum SDU size (octets), SDU error ratio, Residual bit error ratio, Delivery of erroneous SDUs (y/n/-), Transfer delay (ms), Traffic handling priority, Allocation/Retention Priority. This QoS profile shall be encoded according to the "Quality of Service (QoS) Profile" parameter specified in 3GPP TS 29.060 [8].

5.23 Record Extensions

This field enables network operators and/or manufacturers to add their own recommended extensions to the standard record definitions. This field contains a set of "management extensions" as defined in ITU-T X.721 [16]. This is conditioned upon the existence of an extension.

5.24 Record Opening Time

This field contains the time stamp when the MS is attached to a SGSN (M-CDR) or PDP context is activated in SGSN/GGSN (S-CDR, G-CDR) or record opening time on subsequent partial records (see 3GPP TS 32.205 [4] for exact format).

Record opening reason does not have a separate field. For G-CDR and M-CDR it can be derived from the field "Sequence number"; i.e. either a missing field or a value one (1) means activation of PDP context and GPRS attachment. For the S-CDR the field "SGSN change" also needs to be taken into account.

5.25 Record Sequence Number

This field contains a running sequence number employed to link the partial records generated in the SGSN/GGSN for a particular MM context or PDP context (characterised with the same Charging ID and GGSN address pair). For M-CDR or S-CDR the sequence number always restarts from one (1) after an inter-SGSN routing area update, see field "SGSN change". The Record Sequence Number is missing if the record is the only one produced in the SGSN/GGSN for an MM context or a PDP context CDR (e.g. inter-SGSN routing area update can result to two M-CDR or two S-CDRs without sequence number and field "SGSN change" present in the second record).

5.26 Record Type

The field identifies the type of the record e.g. S-CDR, G-CDR, M-CDR, S-SMO-CDR and S-SMT-CDR.

5.27 Recording Entity Number

This field contains the ITU-T E.164 number assigned to the entity that produced the record. For further details see 3GPP TS 23.003 [7].

5.28 RNC Unsent Downlink Volume

This field contains the unsent downlink volume that the RNC has either discarded or forwarded to 2G-SGSN and already included in S-CDR. This field is present when RNC has provided unsent downlink volume count at RAB release and can be used by a downstream system to apply proper charging for this PDP context.

5.29 Routing Area Code/Cell Identifier/Change of location

The location information contains a combination of the Routing Area Code (RAC) and an optional Cell Identifier of the routing area and cell in which the served party is currently located. In GSM the Cell Identifier is defined by the Cell Identity (CI) and in UMTS by the Service Area Code (SAC). Any change of location (i.e. Routing Area change) may be recorded in the change of location field including the time at which the change took place.

The change of location field is optional and not required if partial records are generated when the location changes.

The RAC and (optionally) CI are coded according to 3G TS 24.008 [10] and the SAC according 3GPP TS 25.413 [11].

5.30 Served IMEI

This field contains the International Mobile Equipment Identity (IMEI) of the equipment served, if available. The term "served" equipment is used to describe the ME involved in the transaction recorded e.g. the called ME in the case of a network initiated PDP context.

The structure of the IMEI is defined in 3GPP TS 23.003 [7].

5.31 Served IMSI

This field contains the International Mobile Subscriber Identity (IMSI) of the served party. The term "served" party is used to describe the mobile subscriber involved in the transaction recorded e.g. the calling subscriber in case of a mobile initiated PDP context.

The structure of the IMSI is defined in 3GPP TS 23.003 [7].

5.32 Served MSISDN

This field contains the Mobile Station (MS) ISDN number (MSISDN) of the served party. The term "served" party is used to describe the mobile subscriber involved in the transaction recorded. In case of multi-numbering the MSISDN stored in a GPRS CDR will be the primary MSISDN of the calling party.

The structure of the MSISDN is defined in 3GPP TS 23.003 [7].

5.33 Served PDP Address

This field contains the PDP address of the served IMSI. This is a network layer address i.e. of type IP version 4 or IP version 6. The address for each PDP type is allocated either temporarily or permanently (see "Dynamic Address Flag"). This parameter shall be present except when both the PDP type is PPP and dynamic PDP address assignment is used.

5.34 Service Centre Address

This field contains a ITU-T E.164 number identifying a particular service centre e.g. Short Message Service (SMS) centre (see 3GPP TS 23.040 [15]).

5.35 SGSN Address

These fields contain one or several IP addresses of SGSN. The IP address of the SGSN can be either control plane address or user plane address.

The S-CDR fields contain single address of current SGSN and GGSN used.

The G-CDR fields contain the address of the current GGSN and a list of SGSNs addresses, which have been connected during the record (SGSN change due to inter SGSN Routing Area update).

The M-CDR fields only contain the address of the current SGSN. It does not provide any information related to active PDP context(s) and thus the connected (used) GGSN(s) cannot be identified.

5.36 SGSN Change

This field is present only in the S-CDR to indicate that this is the first record after an inter-SGSN routing area update.

5.37 Short Message Service (SMS) Result

This field contains the result of an attempt to deliver a short message either to a service centre or to a mobile subscriber (see 3GPP TS 29.002[13]). Note that this field is only provided if the attempted delivery was unsuccessful.

5.38 System Type

This field is present conditionally, indicating the use of the UTRAN or GERAN air-interface for the provision of service recorded by this CDR. In the case of service provided by a GSM air interface, this field is not present.

NOTE: The ASN.1 contains a value of "unknown" which may be used in other domains but not in the PS domain.

6 Charging Data Record Structure

6.1 ASN.1 definitions for CDR information

The ASN.1 definitions are based on ISO8824 (90)/X.208 (88) [17], which has been superseded by ISO8824-1 (94)/X.680 (94)[18]. This newer version not only includes new features but also removes some that were present in ISO8824 (90)/X.208 (88) [17]. Where possible, the GPRS work would be based on those ASN.1 features to both. However, where necessary, the new features in ISO8824-1 (94)/X.680 (94) [18] be used in some places. ISO8824 (90)/X.208 (88) [17] features that are no longer in ISO8824-1 (94)/X.680 (94) [18] will not be used.

```
TS32215-DataTypes {itu-t (0) identified-organization (4) etsi (0) mobileDomain (0) umts-Operation-
Maintenance (3) ts-32-215 (215) informationModel (0) asn1Module (2) version1 (1)}
```

```
DEFINITIONS IMPLICIT TAGS ::=
```

```
BEGIN
```

```
-- EXPORTS everything
```

```
IMPORTS
```

```
CallEventRecordType, CellId, Diagnostics, CallDuration, ManagementExtensions, TimeStamp, MSISDN,
LocationAreaCode, MessageReference, RecordingEntity, SMSResult, LevelOfCAMELService, CalledNumber,
CallingNumber, CallEventRecord
```

```
FROM TS32205-DataTypes {itu-t (0) identified-organization (4) etsi(0) mobileDomain (0)
umts-Operation-Maintenance (3) ts-32-205 (205) informationModel (0) asn1Module (2) version1 (1)}
```

```
IMSI, IMEI
```

```
FROM MAP-CommonDataTypes { ccitt identified-organization (4) etsi(0) mobileDomain (0) gsm-Network
(1) modules (3) map-CommonDataTypes (18) version6 (6) }
```

```
DefaultGPRS-Handling, DefaultSMS-Handling, ServiceKey
```

```
FROM MAP-MS-DataTypes { ccitt identified-organization (4) etsi (0) mobileDomain (0)
gsm-Network (1) modules (3) map-MS-DataTypes (11) version6 (6) }
```

```
CallReferenceNumber
```

```
FROM MAP-CH-DataTypes {ccitt(0) identified-organization(4) etsi(0) mobileDomain(0)
gsm-network(1) modules(3) map-CH-DataTypes(13) version6(6)}
```

```
ManagementExtension
```

```
FROM Attribute-ASN1Module {joint-iso-ccitt ms(9) smi(3) part2 (2) asn1Module(2) 1}
;
```

```
--
```

```
--
```

```
-- CALL AND EVENT RECORDS
```

```
--
```

```
GGSNPDRecord ::= SET
```

```
{
```

```

recordType                [0] CallEventRecordType,
networkInitiation         [1] NetworkInitiatedPDPContext OPTIONAL,
servedIMSI                [3] IMSI,
ggsnAddress               [4] GSNAddress,
chargingID                [5] ChargingID,
sgsnAddress               [6] SEQUENCE OF GSNAddress,
accessPointNameNI        [7] AccessPointNameNI OPTIONAL,
pdpType                   [8] PDPTType OPTIONAL,
servedPDPAddress         [9] PDPAddress OPTIONAL,
dynamicAddressFlag       [11] DynamicAddressFlag OPTIONAL,
listOfTrafficVolumes     [12] SEQUENCE OF ChangeOfCharCondition OPTIONAL,
recordOpeningTime        [13] TimeStamp,
duration                  [14] CallDuration,
causeForRecClosing       [15] CauseForRecClosing,
diagnostics               [16] Diagnostics OPTIONAL,
recordSequenceNumber     [17] INTEGER OPTIONAL,
nodeID                    [18] NodeID OPTIONAL,
recordExtensions         [19] ManagementExtensions OPTIONAL,
localSequenceNumber      [20] LocalSequenceNumber OPTIONAL,
apnSelectionMode        [21] APNSelectionMode OPTIONAL,
servedMSISDN             [22] MSISDN OPTIONAL,
chargingCharacteristics   [23] ChargingCharacteristics,
chChSelectionMode       [24] ChChSelectionMode OPTIONAL
}

```

SGSNMMRecord ::= SET

```

{
  recordType                [0] CallEventRecordType,
  servedIMSI                [1] IMSI,
  servedIMEI                [2] IMEI OPTIONAL,
  ggsnAddress               [3] GSNAddress OPTIONAL,
  msNetworkCapability       [4] MSNetworkCapability OPTIONAL,
  routingArea               [5] RoutingAreaCode OPTIONAL,
  locationAreaCode         [6] LocationAreaCode OPTIONAL,
  cellIdentifier            [7] CellId OPTIONAL,
  changeLocation            [8] SEQUENCE OF ChangeLocation OPTIONAL,
  recordOpeningTime        [9] TimeStamp,
  duration                  [10] CallDuration OPTIONAL,
  sgsnChange                [11] SGSNChange OPTIONAL,
  causeForRecClosing       [12] CauseForRecClosing,
  diagnostics               [13] Diagnostics OPTIONAL,
  recordSequenceNumber     [14] INTEGER OPTIONAL,
  nodeID                    [15] NodeID OPTIONAL,
  recordExtensions         [16] ManagementExtensions OPTIONAL,
  localSequenceNumber      [17] LocalSequenceNumber OPTIONAL,
  servedMSISDN             [18] MSISDN OPTIONAL,
  chargingCharacteristics   [19] ChargingCharacteristics,
  cAMELInformationMM       [20] CAMELInformationMM OPTIONAL,
  systemType               [21] SystemType OPTIONAL,
  chChSelectionMode       [22] ChChSelectionMode OPTIONAL
}

```

SGSNPDPRecord ::= SET

```

{
  recordType                [0] CallEventRecordType,
  networkInitiation         [1] NetworkInitiatedPDPContext OPTIONAL,
  servedIMSI                [3] IMSI,
  servedIMEI                [4] IMEI OPTIONAL,
  ggsnAddress               [5] GSNAddress OPTIONAL,
  msNetworkCapability       [6] MSNetworkCapability OPTIONAL,
  routingArea               [7] RoutingAreaCode OPTIONAL,
  locationAreaCode         [8] LocationAreaCode OPTIONAL,
  cellIdentifier            [9] CellId OPTIONAL,
  chargingID                [10] ChargingID,
  ggsnAddressUsed          [11] GSNAddress,
  accessPointNameNI        [12] AccessPointNameNI OPTIONAL,
  pdpType                   [13] PDPTType OPTIONAL,
  servedPDPAddress         [14] PDPAddress OPTIONAL,
  listOfTrafficVolumes     [15] SEQUENCE OF ChangeOfCharCondition OPTIONAL,
  recordOpeningTime        [16] TimeStamp,
  duration                  [17] CallDuration,
  sgsnChange                [18] SGSNChange OPTIONAL,
  causeForRecClosing       [19] CauseForRecClosing,
  diagnostics               [20] Diagnostics OPTIONAL,
  recordSequenceNumber     [21] INTEGER OPTIONAL,
  nodeID                    [22] NodeID OPTIONAL,
  recordExtensions         [23] ManagementExtensions OPTIONAL,
  localSequenceNumber      [24] LocalSequenceNumber OPTIONAL,
}

```

```

    apnSelectionMode          [25] APNSelectionMode OPTIONAL,
    accessPointNameOI        [26] AccessPointNameOI OPTIONAL,
    servedMSISDN             [27] MSISDN OPTIONAL,
    chargingCharacteristics   [28] ChargingCharacteristics,
    systemType               [29] SystemType OPTIONAL,
    cAMELInformationPDP      [30] CAMELInformationPDP OPTIONAL,
    rNCUnsentDownlinkVolume [31] DataVolumeGPRS OPTIONAL,
    chChSelectionMode        [32] ChChSelectionMode OPTIONAL,
    dynamicAddressFlag       [33] DynamicAddressFlag OPTIONAL
}

```

```
SGSNSMORRecord ::= SET
```

```

{
    recordType                [0] CallEventRecordType,
    servedIMSI               [1] IMSI,
    servedIMEI               [2] IMEI OPTIONAL,
    servedMSISDN             [3] MSISDN OPTIONAL,
    msNetworkCapability      [4] MSNetworkCapability OPTIONAL,
    serviceCentre            [5] AddressString OPTIONAL,
    recordingEntity          [6] RecordingEntity OPTIONAL,
    locationArea             [7] LocationAreaCode OPTIONAL,
    routingArea              [8] RoutingAreaCode OPTIONAL,
    cellIdentifier           [9] CellId OPTIONAL,
    messageReference         [10] MessageReference,
    eventTimeStamp           [11] TimeStamp,
    smsResult                [12] SMSResult OPTIONAL,
    recordExtensions         [13] ManagementExtensions OPTIONAL,
    nodeID                   [14] NodeID OPTIONAL,
    localSequenceNumber      [15] LocalSequenceNumber OPTIONAL,
    chargingCharacteristics   [16] ChargingCharacteristics,
    systemType               [17] SystemType OPTIONAL,
    destinationNumber        [18] CalledNumber OPTIONAL,
    cAMELInformationSMS      [19] CAMELInformationSMS OPTIONAL,
    chChSelectionMode        [20] ChChSelectionMode OPTIONAL
}

```

```
SGSNSMTRRecord ::= SET
```

```

{
    recordType                [0] CallEventRecordType,
    servedIMSI               [1] IMSI,
    servedIMEI               [2] IMEI OPTIONAL,
    servedMSISDN             [3] MSISDN OPTIONAL,
    msNetworkCapability      [4] MSNetworkCapability OPTIONAL,
    serviceCentre            [5] AddressString OPTIONAL,
    recordingEntity          [6] RecordingEntity OPTIONAL,
    locationArea             [7] LocationAreaCode OPTIONAL,
    routingArea              [8] RoutingAreaCode OPTIONAL,
    cellIdentifier           [9] CellId OPTIONAL,
    eventTimeStamp           [10] TimeStamp,
    smsResult                [11] SMSResult OPTIONAL,
    recordExtensions         [12] ManagementExtensions OPTIONAL,
    nodeID                   [13] NodeID OPTIONAL,
    localSequenceNumber      [14] LocalSequenceNumber OPTIONAL,
    chargingCharacteristics   [15] ChargingCharacteristics,
    systemType               [16] SystemType OPTIONAL,
    chChSelectionMode        [17] ChChSelectionMode OPTIONAL,
    cAMELInformationSMS      [18] CAMELInformationSMS OPTIONAL
}

```

```

-----
--
-- COMMON DATA TYPES
--
-----

```

```
AccessPointNameNI ::= IA5String (SIZE(1..63))
```

```

--
-- Network Identifier part of APN in dot representation.
-- For example, if the complete APN is 'apnla.apnlb.apnlc.mnc022.mcc111.gprs'
-- NI is 'apnla.apnlb.apnlc' and is presented in this form in the CDR..

```

```
AccessPointNameOI ::= IA5String (SIZE(1..37))
```

```

--
-- Operator Identifier part of APN in dot representation.
-- In the 'apnla.apnlb.apnlc.mnc022.mcc111.gprs' example, the OI portion is 'mnc022.mcc111.gprs'
-- and is presented in this form in the CDR.

```

```

APNSelectionMode ::= ENUMERATED
{
  --
  -- See Information Elements TS 29.060
  --
  mSorNetworkProvidedSubscriptionVerified      (0),
  mSProvidedSubscriptionNotVerified            (1),
  networkProvidedSubscriptionNotVerified       (2)
}

CAMELAccessPointNameNI ::= AccessPointNameNI

CAMELAccessPointNameOI ::= AccessPointNameOI

CAMELInformationMM ::= SET
{
  sCFAddress          [1] SCFAddress OPTIONAL,
  serviceKey          [2] ServiceKey OPTIONAL,
  defaultTransactionHandling [3] DefaultGPRS-Handling OPTIONAL,
  numberOfDPENcountered [4] NumberOfDPENcountered OPTIONAL,
  levelOfCAMELService [5] LevelOfCAMELService OPTIONAL,
  freeFormatData      [6] FreeFormatData OPTIONAL,
  fFDAppendIndicator  [7] FFDAppendIndicator OPTIONAL
}

CAMELInformationPDP ::= SET
{
  sCFAddress          [1] SCFAddress OPTIONAL,
  serviceKey          [2] ServiceKey OPTIONAL,
  defaultTransactionHandling [3] DefaultGPRS-Handling OPTIONAL,
  CAMELAccessPointNameNI [4] CAMELAccessPointNameNI OPTIONAL,
  CAMELAccessPointNameOI [5] CAMELAccessPointNameOI OPTIONAL,
  numberOfDPENcountered [6] NumberOfDPENcountered OPTIONAL,
  levelOfCAMELService [7] LevelOfCAMELService OPTIONAL,
  freeFormatData      [8] FreeFormatData OPTIONAL,
  fFDAppendIndicator  [9] FFDAppendIndicator OPTIONAL
}

CAMELInformationSMS ::= SET
{
  sCFAddress          [1] SCFAddress OPTIONAL,
  serviceKey          [2] ServiceKey OPTIONAL,
  defaultSMSHandling [3] DefaultSMS-Handling OPTIONAL,
  CAMELCallingPartyNumber [4] CallingNumber OPTIONAL,
  CAMELDestinationSubscriberNumber [5] CalledNumber OPTIONAL,
  CAMELSMSCAddress     [6] AddressString OPTIONAL,
  freeFormatData      [7] FreeFormatData OPTIONAL,
  smsReferenceNumber   [8] CallReferenceNumber OPTIONAL
}

CauseForRecClosing ::= INTEGER
{
  --
  -- In GGSN the value sGSNChange should be used for partial record
  -- generation due to SGSN Address List Overflow
  --
  -- cause codes 0 to 15 are defined in TS 32.205 as 'CauseForTerm' (cause for termination)
  --
  normalRelease          (0),
  abnormalRelease        (4),
  CAMELInitCallRelease   (5),
  volumeLimit            (16),
  timeLimit              (17),
  sGSNChange             (18),
  maxChangeCond          (19),
  managementIntervention (20)
}

ChangeCondition ::= ENUMERATED
{
  qosChange      (0),
  tariffTime     (1),
  recordClosure  (2)
}

ChangeOfCharCondition ::= SEQUENCE
  --
  -- Used in PDP context record only

```

```

--
{
  qosRequested           [1] QoSInformation OPTIONAL,
  qosNegotiated          [2] QoSInformation OPTIONAL,
  dataVolumeGPRSUplink   [3] DataVolumeGPRS,
  dataVolumeGPRSDownlink [4] DataVolumeGPRS,
  changeCondition        [5] ChangeCondition,
  changeTime             [6] TimeStamp
}

ChangeLocation ::= SEQUENCE
--
-- used in SGSNMMRecord only
--
{
  locationAreaCode [0] LocationAreaCode,
  routingAreaCode  [1] RoutingAreaCode,
  cellId           [2] CellId OPTIONAL,
  changeTime       [3] TimeStamp
}

ChargingCharacteristics ::= OCTET STRING (SIZE(2))
--
-- Bit 0-3: Profile Index
-- Bit 4-15: For Behavior
--

ChargingID ::= INTEGER (0..4294967295)
--
-- Generated in GGSN, part of PDP context, see TS 23.060
-- 0..4294967295 is equivalent to 0..2**32-1

ChChSelectionMode ::= ENUMERATED
{
  sGSNSupplied           (0), -- For GGSN only
  subscriptionSpecific   (1), -- For SGSN only
  aPNSpecific            (2), -- For SGSN only
  homeDefault            (3), -- For SGSN and GGSN
  roamingDefault         (4), -- For SGSN and GGSN
  visitingDefault        (5)  -- For SGSN and GGSN
}

DataVolumeGPRS ::= INTEGER
--
-- The volume of data transferred in octets.
--

DynamicAddressFlag ::= BOOLEAN

ETSIAddress ::= AddressString
--
-- First octet for nature of address, and numbering plan indicator (3 for X.121)
-- Other octets TBCD
-- See TS 29.002
--

FFDAppendIndicator ::= BOOLEAN

FreeFormatData ::= OCTET STRING (SIZE(1..160))
--
-- Free formatted data as sent in the FurnishChargingInformationGPRS
-- see TS 29.078
--

GSNAddress ::= IPAddress

IPAddress ::= CHOICE
{
  iPBinaryAddress  IPBinaryAddress,
  iPTextRepresentedAddress IPTextRepresentedAddress
}

IPBinaryAddress ::= CHOICE
{
  iPBinV4Address [0] OCTET STRING (SIZE(4)),
  iPBinV6Address [1] OCTET STRING (SIZE(16))
}

```

```
IPTextRepresentedAddress ::= CHOICE
{
  --
  -- IP address in the familiar "dot" notation
  --
  iPTextV4Address      [2] IA5String (SIZE(7..15)),
  iPTextV6Address      [3] IA5String (SIZE(15..45))
}

LocalSequenceNumber ::= INTEGER (0..4294967295)
--
-- Sequence number of the record in this node
-- 0.. 4294967295 is equivalent to 0..2**32-1, unsigned integer in four octets

MSNetworkCapability ::= OCTET STRING (SIZE(1..8))
-- see 3G TS 24.008

NetworkInitiatedPDPContext ::= BOOLEAN
--
-- Set to true if PDP context was initiated from network side
--

NodeID ::= IA5String (SIZE(1..20))

NumberOfDPENcountered ::= INTEGER
--

PDPAddress ::= CHOICE
{
  iPAddress      [0] IPAddress,
  eTSIAddress    [1] ETSIAddress
}

PDPTType ::= OCTET STRING (SIZE(2))
--
-- OCTET 1: PDP Type Organization
-- OCTET 2: PDP Type Number
-- See TS 29.060
--

QoSInformation ::= OCTET STRING (SIZE (4..12))
--
-- This octet string
-- is a 1:1 copy of the contents (i.e. starting with octet 4) of the "Quality of
-- service Profile" information element specified in 3GPP TS 29.060 [22].

RoutingAreaCode ::= OCTET STRING (SIZE(1))
--
-- See TS 24.008 --
--

SCFAddress ::= AddressString
--
-- See TS 29.002 --
--

SGSNChange ::= BOOLEAN
--
-- present if first record after inter SGSN routing area update
-- in new SGSN
--

SystemType ::= ENUMERATED
-- "unknown" is not to be used in PS domain.
{
  unknown      (0),
  iuUTRAN      (1),
  gGERAN       (2)
}

END
```

7 Charging Protocols

The GTP' charging protocol is optional, and is used for CDR transport between the GSNs and the CGF.

The CGF-BS interface is also described in this clause.

7.1 CDR Transport by GTP'

The GTP' has been designed to deliver packets of data to the CGF(s) from the network elements that generate charging records. This protocol is required when the CGF resides outside the CDR generating nodes and utilizes some aspects of GTP (defined in 3GPP TS 29.060 [8]), which is used for packet data tunnelling in the backbone network.

GTP' operates on the Ga interface and does not imply the use of any specific backbone network.

GTP' contains the following functions:

- CDR-transfer mechanisms between the GSNs and the CGF.
- Re-direction of CDR transfer to another CGF.
- Ability to detect communication failures between the communicating peers using echo messaging.
- Ability of a CDR handling node to advertise to peers about its CDR transfer capability (e.g., after a period of service downtime).
- An ability to prevent duplicate CDRs that might arise during redundancy operations. If so configured, the CDR duplication prevention function may also be carried out by marking potentially duplicated CDR packets, and, delegating the final duplicate deletion task to a CGF or a Billing System - BS (instead of handling the possible duplicates solely by GTP' messaging).

7.1.1 SGSN - CGF communication

As illustrated in Figure 5, the SGSN - CGF communications are carried out using GTP' over UDP/TCP and IP.

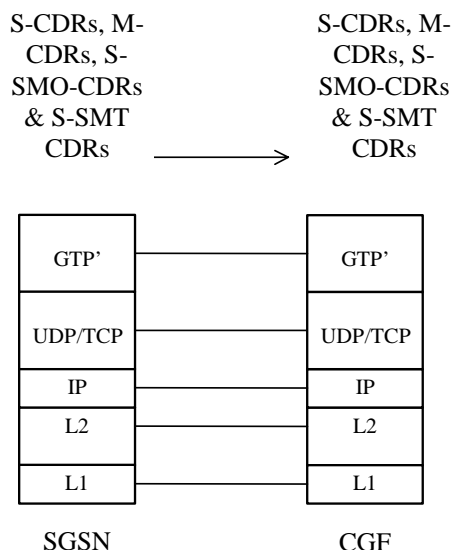

Figure 5: Protocol layers between the SGSN and the CGF

7.1.2 GGSN - CGF communication

The GGSN – CGF communications are conducted using GTP' over UDP/TCP and IP, as depicted in Figure 6:

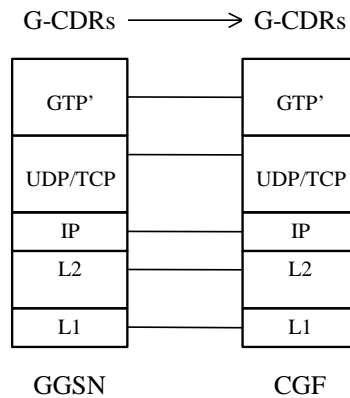

Figure 6: Protocol layers between the GGSN and the CGF

7.1.3 CGF - CGF communication

If necessary, CGF to CGF communications are carried out using GTP' over UDP/TCP and IP. This is illustrated in Figure 7.

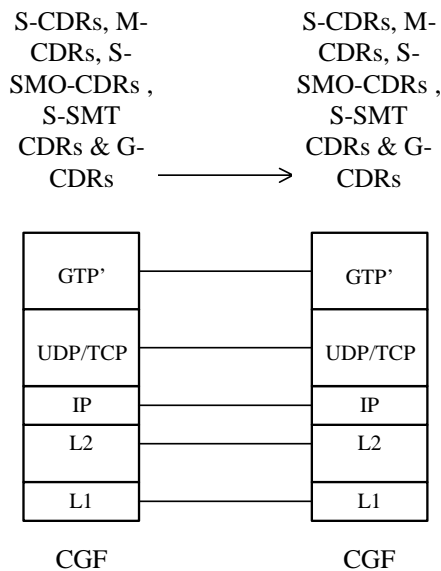

Figure 7: Protocol layers between CGFs

7.1.4 Port usage

Transporting the CDRs from the GSNs to the CGF over the Ga interface may facilitate charging. The Path Protocol may be UDP (compliant with STD 0006[19]) or TCP (compliant with STD 0007[20]) over IP.

7.1.4.1 UDP as the Path Protocol.

Ports for signalling the request messages:

- The UDP Destination Port may be the server port number 3386 which has been reserved for GTP'. Alternatively another port can be used, which has been configured by O&M.
- The UDP Source Port is a locally allocated port number at the sending GSN.

Ports for signalling the response messages:

- The UDP Destination Port value shall be the value of the Source Port of the corresponding request message.

- The UDP Source Port shall be the value from the Destination Port of the corresponding request message.

7.1.4.2 TCP as Path Protocol

The TCP Destination Port may be the server port number 3386, which has been reserved for G-PDUs. Alternatively, another port may be used as configured by O&M. Extra implementation-specific destination ports are possible but all CGFs shall support the server port number.

The TCP Source Port is a random port, locally assigned at the sending GSN.

7.1.4.3 Network layer and lower layers

Beneath the Path Protocol there is the network IP layer, which shall be the Internet Protocol (IP) compliant with STD 0005(see [21] and [22]). Beneath the network IP layer are the L2 and L1 layers, which are not specified, in the present document.

7.1.5 Charging related requirements for PS Domain nodes

Each node (e.g., SGSN, GGSN etc. and CGF) that supports or may support GTP' shall be capable of handling or responding with a "*Service/Version not supported*" message if that node is configured to be addressed by another peer node.

When a new PDP context is activated or after an inter SGSN handover the GGSN will inform the related SGSN which CGF it should send its CDRs to. All other non-PDP context related CDRs are sent to the current default CGF for that CDR generating node. Each CDR generating node will have an O&M configurable CGF address list to which it can send its CDRs. The list will be organized in CGF address priority order. If the Primary CGF is not available (e.g., out of service) then the CDR generating node shall send the CDRs to the Secondary CGF and so on.

Each CDR generating node will only send the records to the CGF(s) of the same PLMN, not to CGF(s) located in other PLMNs.

Each CGF in the PLMN may know of other CGFs' network addresses (e.g., for redundancy reasons, to be able to recommend another CG address with the Redirection Request message). This is achieved by O&M configuration facilities that will enable each CGF to have a configurable list of peer CGF addresses.

7.2 The GTP' charging protocol

This clause describes the features of GTP'. The message types described in clause 7.3.2 ("Reused GTP message types") are also described in the related clauses of 3GPP TS 29.060 [8].

7.2.1 Usage of GTP Header in charging

In GTP' messaging only the signalling plane of GTP is partly reused. The GTP' header is shown in Figure 8.

Bit 5 of octet 1 of the GTP header is the Protocol Type (*PT*) flag and is '0' if the message is GTP'.

The *Version* bits indicate the GTP' protocol version when the Protocol Type flag is '0'.

Bit 1 of octet 1 is not used in GTP' (except in v0), and it is marked '0' in the GTP' header. It is in use in GTP' v0 and distinguishes the used header-length. In the case of GTP' v0, this bit being marked one (1) indicates the usage of the 6 octets header. If the bit is set to '0' (usually the case) the 20-octet header is used. For all other versions of GTP' this bit is not used and is set to '0'. However, this does not suggest the use of the 20-octet header, rather a shorter 6-octet header.

The *Length* indicates the length of payload (number of octets after the GTP' header). The *Sequence Number* of the packet is part of the GTP' header.

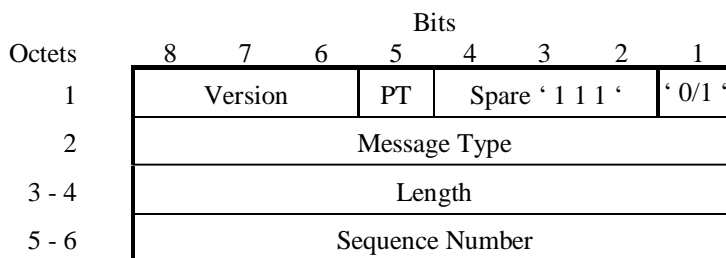

Figure 8: GTP' header

7.2.2 Information Elements (IEs)

The messages may contain several Information Elements (IEs). The TLV (Type, Length, Value) or TV (Type, Value) encoding formats shall be used for the GTP' IEs. The GTP' messages shall have the IEs sorted with the *Type* fields in ascending order. The *Length* field shall contain the IE length excluding the Type and Length fields.

Within the *Type* field the most significant bit will be set to 0 when the TV format is used and set to 1 when the TLV format is used. This is illustrated in Figures 9a and b, respectively.

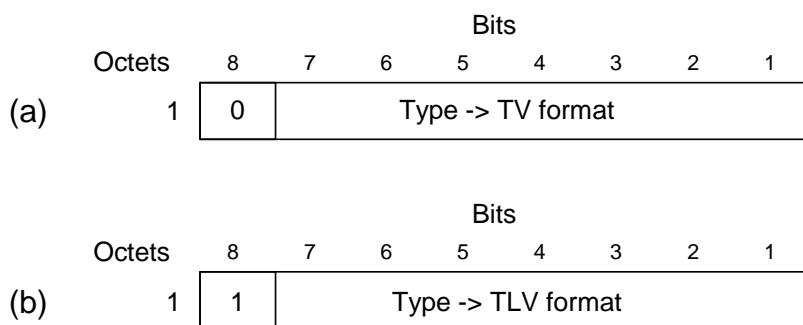

Figure 9: Type field for (a) TV and (b) TLV format

7.3 GTP' Message Types

7.3.1 List of all GTP' message types

GTP' defines a set of messages between two associated nodes. The GTP' messages defined are shown in Table 8. The messages introduced by GTP' are in **boldface** letters. The other messages are inherited from the GTP protocol.

Of the GTP' introduced signalling message types, *Node Alive Request*, *Node Alive Response*, *Redirection Request* and *Redirection Response* belong to the "Path Management messages". The *Data Record Transfer Request* and *Data Record Transfer Response* are form the message type group "Record Transmission messages".

The reserved fields in the signalling messages shall be filled with ones, and are intended for future use.

GTP' reuses the GTP **Cause** values. The message type numbers required for the newly introduced GTP' messages have been derived from the unallocated message type number space specified in the GTP message table defined in 3GPP TS 29.060 [8].

The number ranges allocated for GTP' are as follows:

For Information Elements: 117-127 (TV type fields) and 239-254 (for TLV type fields).

TLV Information Element types introduced in the present document:

- 254 *Address of Recommended Node*
- 253 *Requests Responded*
- 252 *Data Record Packet*
- 251 *Charging Gateway Address* (this IE is also used in 3GPP TS 29.060 [8])
- 250 *Sequence Numbers of Cancelled Packets*

249 *Sequence Numbers of Released Packets*

TV Information Element types introduced in the present document:

127 *Charging ID*126 *Packet Transfer Command*

For **Cause Codes**: **Cause** values used in requests: 49 to 63, **Cause** values used in responses indicating acceptance: 177 to 191, **Cause** values used in responses indicating rejection: 241 to 255.

Charging related **Cause** values introduced for the present document:

In requests:

63 *This node is about to go down*62 *Another node is about to go down*61 *The receive buffers are becoming full*60 *The transmit buffers are becoming full*59 *System failure*

In responses indicating acceptance:

177 *CDR decoding error*

In responses indicating rejection:

255 *Request not fulfilled*254 *Sequence numbers of released/cancelled packets IE incorrect*253 *Request already fulfilled*252 *Request related to possibly duplicated packets already fulfilled*

The charging related message types are listed in Table 8. Brief descriptions of the GTP messages reused in GTP' are provided in clause 7.3.2 ("Reused GTP message types") below. Further details are provided in 3GPP TS 29.060 [8], the GTP specification.

Table 8: GTP' messages

Message Type value (Decimal)	GTP' message
1	Echo Request
2	Echo Response
3	Version Not Supported
4	Node Alive Request
5	Node Alive Response
6	Redirection Request
7	Redirection Response
240	Data Record Transfer Request
241	Data Record Transfer Response
others	reserved for future use

7.3.2 Reused GTP message types

The existing *Echo Request* and *Echo Response* messages defined in 3GPP TS 29.060 [8] are also used in PS domain charging. They may be used by the CDR generating nodes SGSN or GGSN, or by the CGF for checking if another GSN or CGF is alive. If the present document and 3GPP TS 29.060 [8] differ in their description then the 3GPP TS 29.060 [8] is to be taken as the latest specification status of the related Information Elements. If the path protocol is TCP, *Echo Request* and *Echo Response* messages are not required.

The *Version Not Supported* message in the GTP' resembles the corresponding GTP message. It indicates the latest GTP' version that the GTP' entity can support. If a receiving node receives a GTP' message of an unsupported version, then that node shall return a GTP' *Version Not Supported* message indicating in the Version field of the GTP' header the latest GTP' version that that node supports. The received payload data of the GTP' packet shall then be discarded.

The *Version* bits in the GTP' header have currently the following possible values:

- GTP' version 0 (binary '000') identifies the following Message Type values:
 - 3 = Version Not Supported,
 - 4 = Node Alive Request,
 - 5 = Node Alive Response,
 - 6 = Redirection Request,
 - 7 = Redirection Response.

In clause 7.3.4.6 the Requests Responded information element has Length field in place of the Number of Requests Responded field, to make that TLV IE to be handled like normal TLV IEs.

If GTP' v0 is used in parallel with GTP' v2 or a later version, then, a 6-octet header length (with no trailing dummy octets) is used also with v0 (like in GTP' v2).

The mark of the usage of GTP' v0 with 6 octet header (instead of the original 20 octet long header) is then the version bits being 0 and the bit 1 of octet 1 being '1' (instead of '0').

- GTP' version 1 (binary '001') is the same as version 0 but has, in addendum, the duplicate CDR prevention mechanism, introduced in GSM 12.15 version 7.2.1 (1999-07) of the GPRS charging specification.
- GTP' version 2 (binary '010') is the same as version 1, but the header is just 6 octets long (no unused trailing octets). IPv6 address type is also supported (for Address of Recommended Node information element of the Redirection Request).

7.3.3 GTP message type modifications implied by GTP'

The PS domain charging related features in GTP are in the Create PDP Context Response: the Charging ID Information Element (IE) and the Charging Gateway Address IE, in the Update PDP Context Response the Charging ID Information Element (IE) and the Charging Gateway Address IE, in the Create AA PDP Context Response: the Charging ID IE and the Charging Gateway Address IE. Refer to 3GPP TS 29.060 [8] for details.

The general principle is that the CDRs are always sent to a CGF residing in the same network as the CDR generating node. In the case of roaming it is conceivable that some CDRs relating to the same PDP context will be sent to different networks' CGFs. The cost balancing of the roaming traffic is to be agreed between the UMTS Operators.

7.3.4 GTP' message types

7.3.4.1 Node Alive Request

The *Node Alive Request* message may be used to inform that a node in the network has started its service (e.g. after a service break due to software or hardware maintenance or data service interruption after an error condition). A node may send a different Node Address than its own in the Information Element, e.g. informing the "next node in the chain" that the "previous node in the chain" (which is located on the other side of the sender of this message) is now ready for service. This message type is optional if the Path Protocol is TCP.

The *Node Alive Request* message allows a quicker reconnect capability than the *Echo Request* message based polling can provide, and its usage will have a reduced load effect on the network, particularly when the number of network nodes using GTP' is high. It may also be used to inform when a new network node has become available for service. If the *Echo Request* message is also used then the usage of the *Node Alive Request* message allows the interval of *Echo Requests* to be longer than would be otherwise required, thus reducing network loading with many *Echo Requests*. The Information elements in a Node Alive Request message are shown in Table 9.

Table 9: Information Elements in a Node Alive Request

Information Element	Presence requirement
Node Address	Mandatory
Private Extension	Optional

The Node Address format is the same as for the Charging Gateway Address format described in 3GPP TS 29.060 [8].

The optional Private Extension IE contains vendor- or operator-specific information.

7.3.4.2 Node Alive Response

The *Node Alive Response* message, shown in Table 10, shall be sent as a response to a received *Node Alive Request*.

Table 10: Information Elements in a Node Alive Response

Information Element	Presence requirement
Private Extension	Optional

The optional Private Extension IE contains vendor- or operator-specific information.

7.3.4.3 Redirection Request

There are two kinds of usage for the *Redirection Request* message. One is to advise that received CDR traffic is to be redirected to another CGF due to that CGF node is about to stop service (due to an outage for maintenance or an error condition). The second purpose is to inform a CDR generating node (e.g. SGSN) that is currently sending data to this node (e.g. CGF), that the next node in the chain (e.g. a mediator device or Billing Computer) has lost connection to this node (e.g. CGF).

The Information Elements in a *Redirection Request* Message are listed in Table 11. An *Address of Recommended Node* may be given if for example a CGF maintenance outage is handled by first introducing another CGF ready to take incoming CDRs. In this way the network performance can be maintained. The *Address of Recommended Node* shall only describe an intra-PLMN node containing a CGF, and not to a node in any other PLMN.

Table 11: Information Elements in a Redirection Request

Information Element	Presence requirement
Cause	Mandatory
Address of Recommended Node	Optional
Private Extension	Optional

Possible **Cause** values are:

- "This node is about to go down";
- "Another node is about to go down";
- "System failure";
- "Receive buffers becoming full";
- "Send buffers becoming full".

The *Address of Recommended Node* information element, shown in Figure 10, defines the IPv4 or IPv6 format address that the node is identified by in the UMTS network.

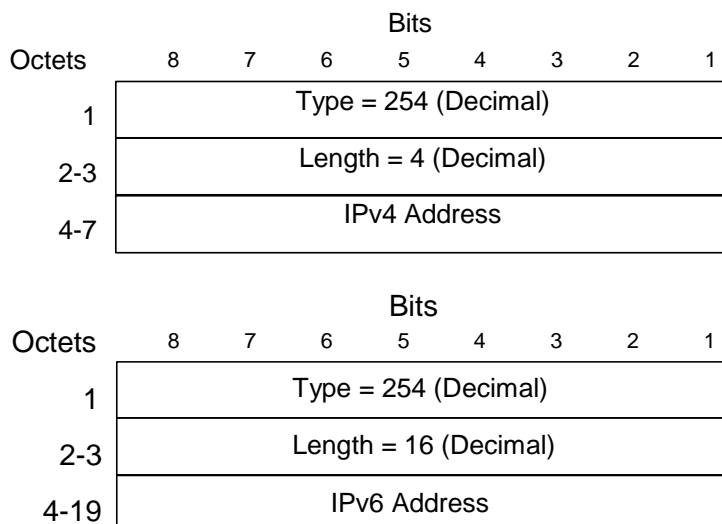

Figure 10: Address of Recommended Node information elements

The optional Private Extension contains vendor- or operator- specific information.

7.3.4.4 Redirection Response

A *Redirection Response* message shall be sent as a response of a received *Redirection Request*. The information elements of this message are listed in Table 12.

Table 12: Information Elements in a Redirection Response

Information Element	Presence requirement
Cause	Mandatory
Private Extension	Optional

Possible **Cause** values are:

- "Request Accepted";
- "No resources available";
- "Service not supported";
- "System failure";
- "Mandatory IE incorrect";
- "Mandatory IE missing";
- "Optional IE incorrect";
- "Invalid message format";
- "Version not supported".

The optional Private Extension contains vendor- or operator-specific information.

7.3.4.5 Data Record Transfer Request

This message is used in PS domain charging to transmit the CDR information. The CDR information is placed in the Data Record information element.

7.3.4.5.1 General logic

This clause is intended to be read together with clause 7.3.4.7 "Examples of GTP' messaging cases". The normal communication would be GSN sending Data Record Packets to a CGF, which answers with "Request Accepted" responses. Under normal condition the CDR transmission uses a Request-Response messaging sequence in the GSN to CGF GTP' protocol communication.

Sometimes a non-PDP context related CDR (e.g. M-CDRs) is transmitted, and thus the GGSN does not pass the CGF address information to the SGSN. The SGSN will in this case direct the CDRs to the current default CGF for the SGSN. This is the configured Primary CGF address, or if that CGF is out of service, then the secondary CGF address etc.

Summary of the CGF redundancy mechanism, that prevents duplicated CDR packets to enter the BS, is described below. This, or other mechanisms are deployed to enhance the reliability of CDR transport.

The general logic of the duplicate CDR packet prevention in CGF redundancy cases is shown in Figure 11, where the messages are numbered sequentially, alternative messages are indicated by an index character ("a" or "b") that follows the arrow sequence number. The main mechanism of the messaging in CGF redundancy cases (when a GSN-CGF link is down or a CGF is not working) is based on GSN (1) first trying to send a CDR packet to CGF1. In case no acknowledgement or a successful response is received (2) from CGF1 due to any reason, e.g. such as the request not reaching CGF1 despite repeated attempts (or the responses from CGF1 to the GSN are lost after the CGF1 has either stored it securely, or, forwarded it towards post-processing (2b)), the unacknowledged CDR packets are redirected to CGF2. The invocation for a re-transmission may be triggered by a time-out mechanism.

The GSN may first test the GSN-CGF2 link by sending an 'Echo Request' message to CGF2, in response to which CGF2 would respond with the 'Echo Response' message. The CDR packets not successfully received by the primary CGF (=CGF1) are sent to CGF2 (3), and are marked as potential duplicates, and CGF2 responds to the request(s) (4). Such CDRs, i.e. CDRs that are marked as potential duplicates would wait there for further commands from GSN.

When the GSN detects (5) & (6) that the primary CGF, in this case CGF1 is again able to communicate with it on receiving *Node Alive Request* (or getting a *Echo Response* from CGF2 to a *Echo Request* sent by the GSN) it answers by *Node Alive Respond*. Then the GSN tests CGF1 with an empty packet (7), retrying continuously if no response is received, using e.g. increasing timeouts (using the old unacknowledged packet's Sequence Number, if the CGF1 would consider the packet to be a new one (8a) or an already received one (8b)). According to the response received from CGF1, the GSN gives the CGF2 a command to either release (9a) or cancel (9b) the corresponding CDR packet from CGF2. CGF2 then confirms the decision (10), and is able to send the CDRs towards the BS (11a).

Error handling: By default, retransmissions after configurable timeouts are used. If after the CGF1 communication failure, the CDR packet sending from GSN to CGF2 does not succeed, the GSN tries to use CGF3 as the intermediate CDR packet storage entity, etc. If no acknowledgement (10) is received by the GSN for its message(s) (9a) or (9b), the GSN will retransmit the message (9a) or (9b) continuously and persistently, using e.g. increasing time intervals. An alarm should be sent to the O&M system if a communication link goes down. It shall be possible to release/cancel CDR packets from CGFs and unacknowledged sequence numbers from GSNs by O&M operations if permanent GSN-CGF link failures would occur. The buffers containing the Sequence Numbers of potentially duplicated packets, and the buffers containing the numbers of unacknowledged CDR packets shall be kept up to date (with CDR packet transfers) using transaction mechanisms. In the case of the GSN-CGF1 communication link being down, any new CDRs generated by the GSN are sent to a properly working CGF2, instead of the CGF1.

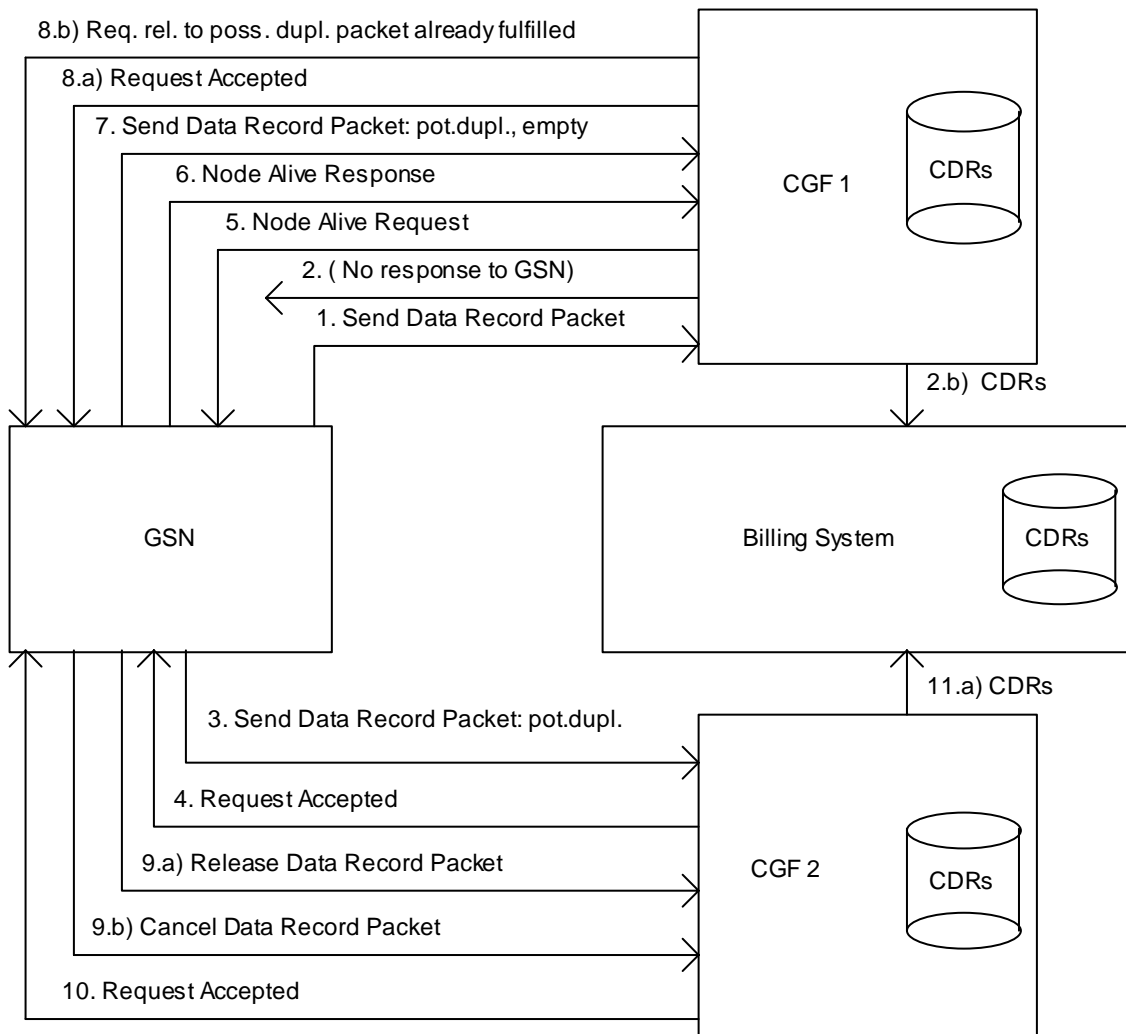

Figure 11: General CGF redundancy messaging scheme

A more detailed description of the CGF redundancy mechanism:

Due to a network failure/network congestion or a temporary node failure, a CGF might not be able to send a response within the configured timeout period to a request it got from a GSN. As a first attempt, retries of requests are to be used as defined in 3GPP TS 29.060 [8], if the response is not received in the configured time.

If a CDR generating node loses its connection to the CGF unexpectedly, it may send the CDRs to the next CGF in the priority list. If the CGF changes, the GSN can continue sending CDRs to different CGF nodes, depending on which CGF has been configured as the receiver of CDRs for a particular PDP context.

Sequence number buffers: The GSN might lose its connection to its primary CGF due to a link failure or CGF going down. In this kind of redundancy condition the GSN attempts to redirect the CDR traffic to a secondary CGF (after possible retries have failed). The GSN maintains an internal buffer for Sequence Numbers of requests not yet successfully responded to by the primary CGF, for the case that it may become capable of communicating to the primary CGF at a later date. The GSN will send the not responded Data Record Packets (DRPs) to the secondary CGF, and the GSN maintains also a buffer for the Sequence Numbers related to those DRPs that have been temporarily stored to this secondary CGF. (If the communication towards the secondary CGF would not work, the transfer of possibly duplicated DRPs and Sequence Number bookkeeping would be done for a tertiary CGF etc.) Also the CGFs maintain Sequence Number buffers for each of their GSN links. The Sequence Numbers may in future be needed in relation to the possibly duplicated CDRs that the CGFs have got from the GSN(s). The Sequence Numbers are stored to wait for a final decision to release them towards the BS (if the primary CGF had not received successfully the packets originally sent by a GSN) or to cancel them (if the primary CGF had received and processed successfully the originally by GSN sent packets).

The GSN is able to instruct CGF2 to cancel (or instruct CGF2 to transfer towards the BS), the CDR packets sent to a secondary CGF if the primary CGF becomes available for service. To make the right decision the GSN first sends an

empty test packet with the 'Send possibly duplicated Data Record Packet' Packet Transfer Command to the primary CGF, using a previously not responded Sequence Number.

In case that the empty test packet to the primary CGF (which was temporarily down (or to which the link was down)) is responded with the **Cause** value "Request Accepted", the GSN will release the corresponding CDRs waiting for final decision in the secondary CGF, towards the Billing System (BS) with the Packet Transfer Command "Release Data Record Packet".

If the primary CGF responses this test message with the **Cause** value "Request related to possibly duplicated packets already fulfilled", the GSN will cancel the corresponding CDRs waiting for final decision in the secondary CGF, using the Packet Transfer Command "Cancel Data Record Packet".

To enable that a GSN failure (destroying its Sequence Number buffers per each CGF link for non-responded requests or possibly duplicated packets) would not cause CDR packets to stay forever in the temporary decision waiting buffers of CGFs, there should also be O&M means of emptying those CGF buffers.

There shall also be a configurable parameter in the CGF for making the final decision, as to whether or not it is able to send the CDRs to the Billing System (BS) for the case where the backup buffering mechanism in the GSN could not be used until the end of the messaging sequence related to a certain CDR packet has been completed. This way the operator can:

- A) Select that the GSNs and CGFs take care of duplicate prevention and the BS is not required to do duplicate checking due to possible duplicates caused by Network Element or CGF redundancy mechanisms.
- B) Select that the BS performs the duplicate prevention. To do this in the most effective way, the CGF may include an additional flag linked to possibly duplicated CDRs sent to the Billing System, indicating that they have not been released by a GSN for BS use (or use special kind of file name if a file protocol is used between CGF and BS). This means that the BS has somewhat more processing work to do, but the BS would anyway get a duplicate free end result. CGF is in this case always authorised to forward CDRs towards the BS, also when they contain possibly duplicated data. For this case the CGFs may also have a configurable flag that *Data Record Packet Cancel/Release* operations are not needed.

7.3.4.5.2 Information Elements in Data Record Transfer Request

The Information Elements in *Data Record Transfer Request* message is specified in Table 13.

Table 13: Information Elements in a Data Record Transfer Request

Information Element	Presence requirement
Packet Transfer Command	Mandatory
Data Record Packet	Conditional
Sequence Numbers of Released Packets	Conditional
Sequence Numbers of Cancelled Packets	Conditional
Private Extension	Optional

7.3.4.5.3 Packet Transfer Command IE

The value of the Packet Transfer Command in its Information Element tells the nature of the message:

- 1 = 'Send Data Record Packet';
- 2 = 'Send possibly duplicated Data Record Packet';
- 3 = 'Cancel Data Record Packet';
- 4 = 'Release Data Record Packet'.

The following describes the usage of each Packet Transfer Command. The first command is for normal CDR transfer while the other values are only used as part of the redundancy mechanism.

1) **Send Data Record Packet.** This is the usual command used for sending CDRs under normal conditions when no error recovery is needed or the redirection mechanism is not involved. It is shown in Figure 12. The other three commands are being used only in error recovery cases. Out of the three conditional IEs shown in Table 13, only the "Data Record Packet" is present in this message.

- 2) **Send possibly duplicated Data Record Packet.** When the CDR packet is redirected to a secondary CGF (by a CDR generating node) because the currently used CGF is not working or the CDR transfer is not working properly, or if there is an error in the link between the CDR generating node and the CGF, then this Packet Transfer Command is used instead of the normal 'Send Data Record Packet'. Of the conditional IEs, the "Data Record Packet" is present in the message, when sending the message to a CGF acting as temporary storage, when the original primary CGF could not be contacted. This Packet Transfer Command is used also when sending "empty" test packets with older (but not yet acknowledged) sequence numbers after a peer node or link recovery, to check if the CGF had received some Data Record Packets (whose acknowledgement did not come to the *Data Record Packet* sending node) before the link to the recipient node became inoperable.
- 3) **Cancel Data Record Packet.** Of the conditional IEs, the "Sequence Numbers of Cancelled Packets" is present in the message.
- 4) **Release Data Record Packet.** Of the conditional IEs, the "Sequence Numbers of Released Packets" is present in the message.

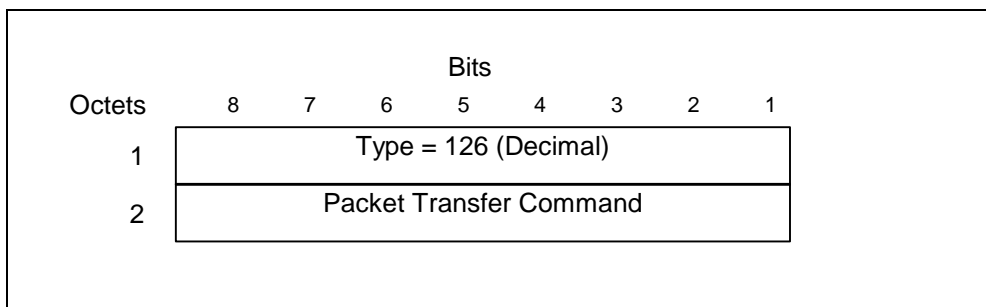

Figure 12: Packet Transfer Command information element

After the CGF has received the *Packet Transfer Command* 'Release Data Record Packet' with the Sequence Number(s) for earlier sent 'Send possibly duplicated Data Record Packet' command(s), it can consider itself authorised to send the *Data Record Packets* previously marked as possibly duplicated towards the Billing System (BS) as normal (not duplicated) CDRs.

7.3.4.5.4 Data Record Packet IE

The *Data Record Packet* element, which is present conditionally if the Packet Transfer Command is 'Send Data Record Packet', may contain one or more data records. This IE is illustrated in Figure 13. If an "empty packet" is to be sent, then the *Data Record Packet* IE contains only the *Type* (with value 252 in decimal) and the *Length* (with value 0) fields.

As shown in Figure 13, there are two fields identifying the CDR format: *Data Record Format* and *Data Record Format Version*. The format of the records is ASN.1 or some other format, as identified by the *Data Record Format*. The *Data Record Format Version* identifies the TS release and version numbers that were used for the CDR encoding. The formats of these two fields are described in detail in section 7.4 and 7.5, respectively.

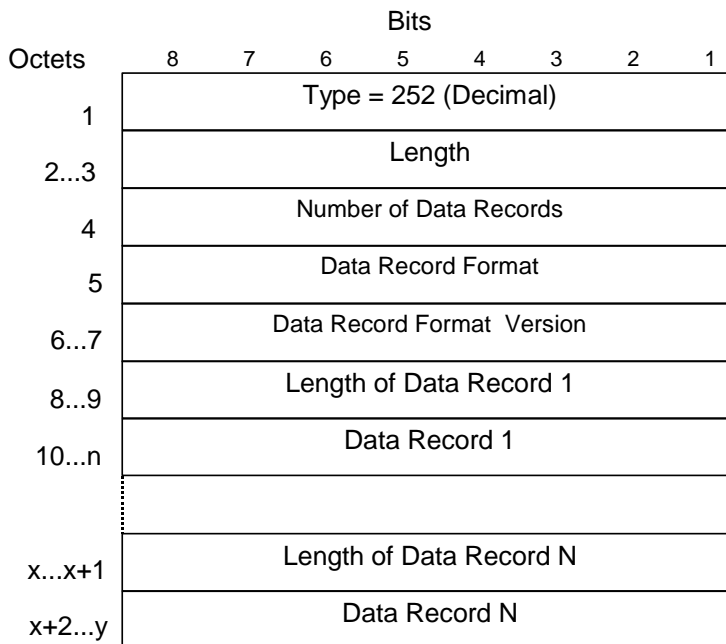

Figure 13: Data Record Packet information element

7.3.4.5.5 Sequence Numbers of Released Packets IE

The *Sequence Numbers of Released Packets* is present if the *Packet Transfer Command* is ‘Cancel Data Record Packet’. The format of the Information Element is described in Figure 14 below:

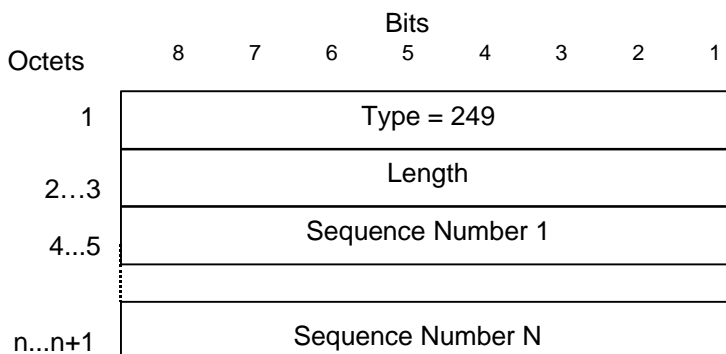

Figure 14: Sequence Numbers of Released Packets information element

7.3.4.5.6 Sequence Numbers of Cancelled Packets IE

The *Sequence Numbers of Cancelled Packets* information element is shown in Figure 15 and contains the IE *Type*, *Length* and the *Sequence Number(s)* (each 2 octets) of the cancelled *Data Record Transfer Request(s)*. It is present if the *Packet Transfer Command* is "Cancel Data Record Packet".

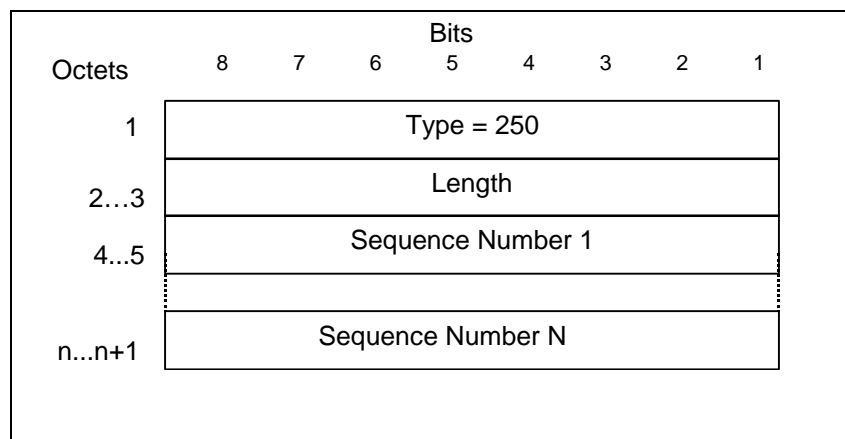

Figure 15: Sequence Numbers of Cancelled Packets information element

7.3.4.5.7 Private Extension IE

The optional *Private Extension* contains vendor or operator specific information.

7.3.4.6 Data Record Transfer Response

The message shall be sent as a response of a received *Data Record Transfer Request*. Also, several *Data Record Transfer Requests* can be responded by a single *Data Record Transfer Response*.

Table 14: Information Elements in a Data Record Transfer Response

Information Element	Presence requirement
Cause	Mandatory
Requests Responded	Mandatory
Private Extension	Optional

The **Cause** value is the same (whatever the value) for all those messages responded by that particular Response.

Possible **Cause** values are:

- "Request Accepted";
- "No resources available";
- "Service not supported";
- "System failure";
- "Mandatory IE incorrect";
- "Mandatory IE missing";
- "Optional IE incorrect";
- "Invalid message format";
- "Version not supported";
- "Request not fulfilled";
- "CDR decoding error";
- "Request already fulfilled";
- "Request related to possibly duplicated packet already fulfilled".

The **cause** value "CDR decoding error" is optional, primarily intended to inform the CDR generating node that the receiving node can not decode the CDR. Thus, special features in the receiving node that are based on information within the CDR would not be operable. This message could alert the operator of a remote generating node of incompatible CDR encoding. It is Optional and no action or response is required.

The Requests Responded information element contains the IE *Type*, *Length* and the *Sequence Numbers* (each 2 octets) of the *Data Record Transfer Requests*. It is shown in Figure 16.

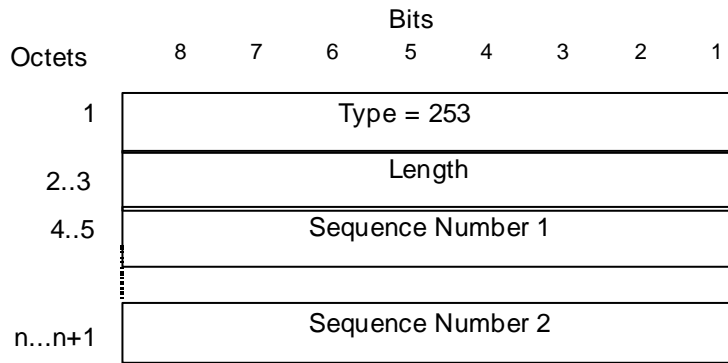

Figure 16: Requests Responded information element

The optional *Private Extension* contains vendor or operator specific information.

Depending on the **Cause** value severity and general occurrence frequency, the node that sent the corresponding *Data Record Transfer Request*, may start to direct its CDRs to another CGF.

7.3.4.7 Examples of GTP' messaging cases

The following example cases represent the three different key *Data Record Transfer Request/Response* messaging related CDR packet handling schemes. Cases 2 and 3 represent situations involving the redundancy mechanism.

Case 1): The normal CDR packet transfer:

GSN sends successfully a CDR packet to the CGF, and since the GSN gets a response (Request Accepted) for the Data Record Transfer Request, there is no need to revert to the CGF redundancy mechanism and redirect the CDR packet traffic flow to an other CGF.

Case 2): The GSN-CGF1 connection breaks before a successful CDR reception:

In this example case the CDR packet sent by the GSN is lost before it is received by the CGF1. (The loss might be caused by a link failure or e.g. a major CGF1 failure.)

Case 3): The GSN-CGF1 connection breaks after a successful CDR reception:

In this example case the CDR packet sent by the GSN is received correctly by the CGF1 and moved to its non-volatile memory (or even to the next NE in the communication chain). Anyhow, the GSN-CGF1 communication stops working, in this example case, before the GSN gets the positive response (Data Record Transfer Response: Request Accepted) that would acknowledge that the CDR packet was successfully received by CGF1.

The next three clauses describe in more detail each of these key *Data Record Transfer Request/Response* messaging schemes.

7.3.4.7.1 Case 1: The normal CDR packet transfer

Figure 17 represents the default mode of CDR transfer from the CDR generating entities (GSNs) to the CDR packet collecting entities (CGFs).

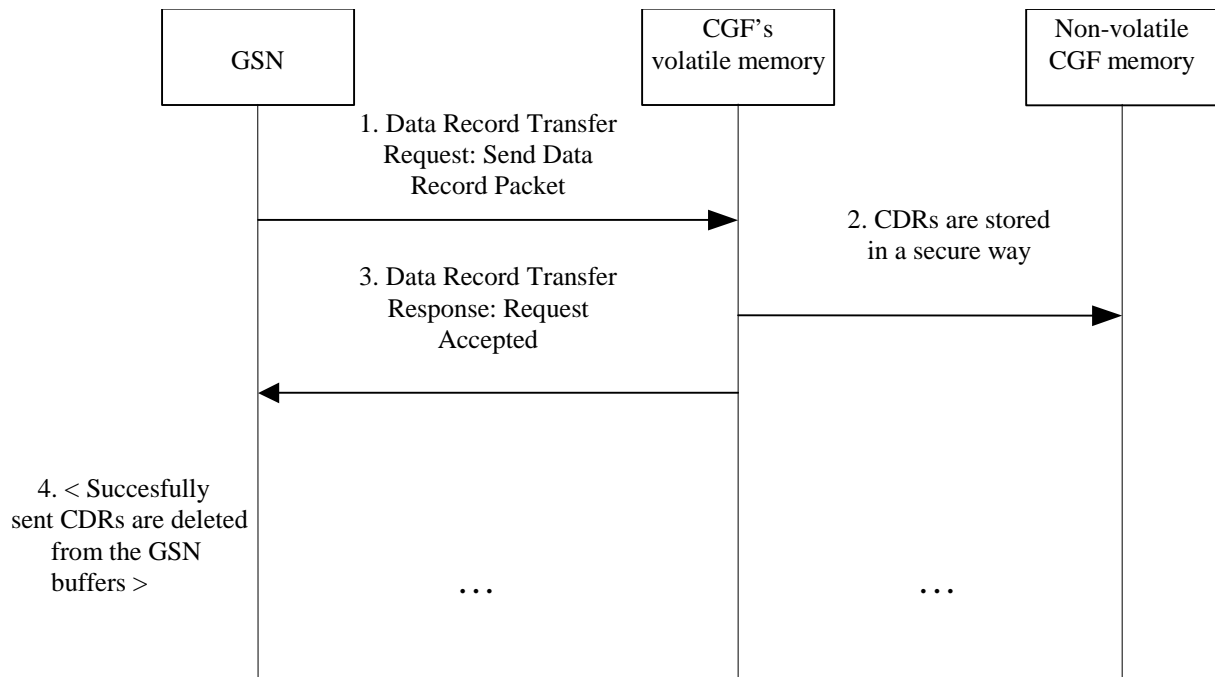

Figure 17: A normal CDR transfer process between a GSN and CGF

- 1) The CDR generating entity (here the GSN symbolises either SGSN or GGSN) sends CDR(s) in a packet to CGF (that is the current primary Charging Gateway Functionality for the specific CDR generating node, "CGF1"). The sending is performed by using the *Data Record Transfer Request* message, with the *Packet Transfer Command IE* having the value "Send Data Record Packet".
- 2) The CGF opens the received message and stores the packet contents in a safe way (to e.g. a redundant RAM memory unit or a mirrored non-volatile memory or even to another node).
- 3) The CDR receiving entity (CGF) sends confirmation of the successful packet reception to the CDR generating node (GSN). The confirmation is performed by using the *Data Record Transfer Response* message, with the **Cause** value being "Request Accepted".
- 4) After the positive response "Request Accepted" is received by the GSN, it may delete the successfully sent CDRs from its send buffer.

The general principle of GTP' to retransmit the request if the response has not been received within a configurable time-out limit, is also followed here in point 1). The maximum amount of retries is a configurable value.

7.3.4.7.2 Case 2: The GSN-CGF1 connection breaks before a successful CDR reception

Figure 18 describes the exceptional case when the CDR transfer from a CDR generating entity (GSN) to the primary CDR packet collecting entity (CGF1) fails in a way that the CGF1 is not able to store the CDR packet sent by the GSN. (The reason for the failure in packet transfer may be e.g. a link failure between the GSN and CGF1, or a capacity exhausting error in the storage device of CGF1, or a general CGF1 system failure or CGF1 maintenance break.)

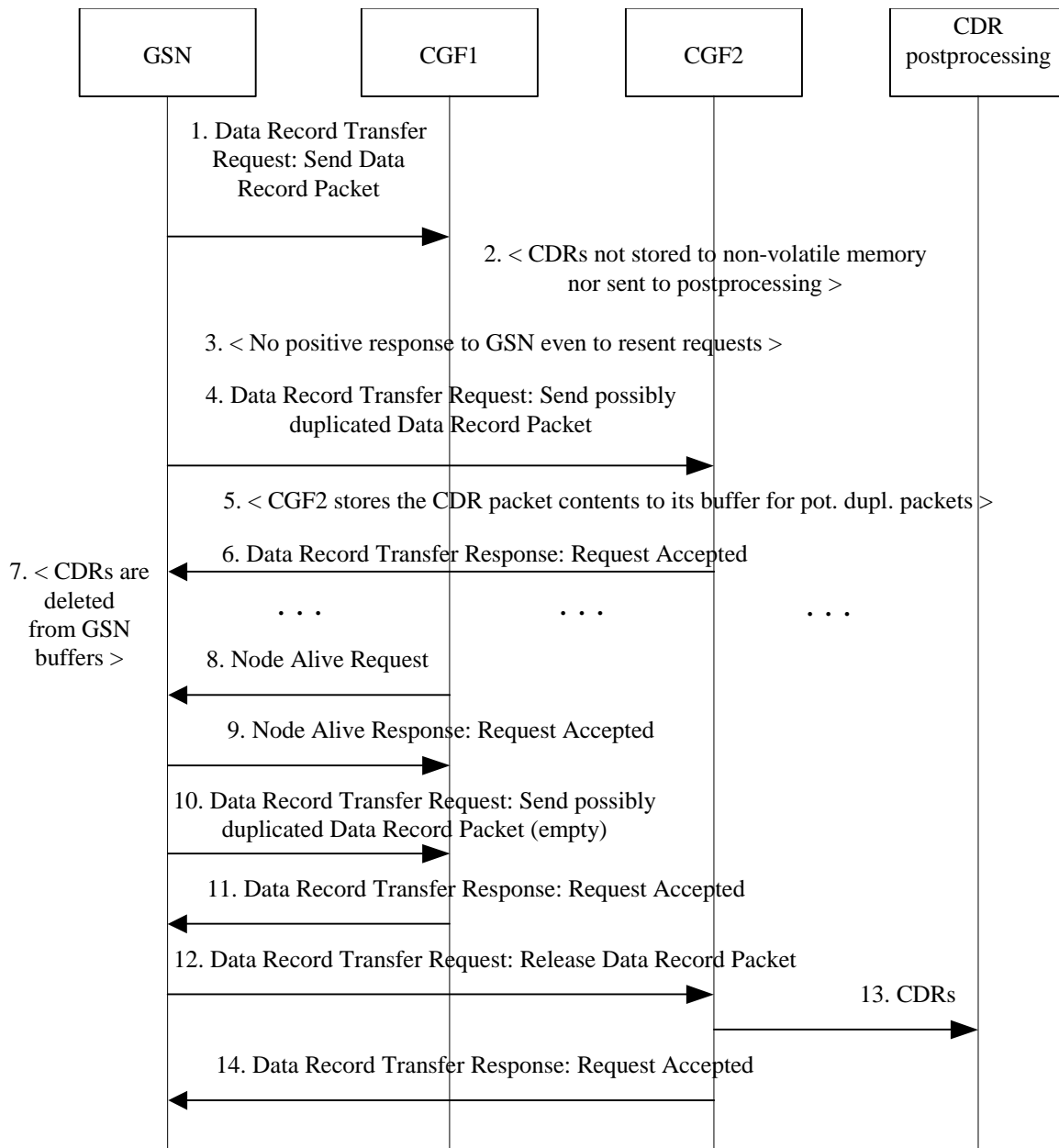

Figure 18: Duplicate prevention case: CDR sending via CGF1 had not succeeded

- 1) The CDR generating entity (GSN) sends CDR(s) in a packet to CGF (that is, the current primary CGF for the specific CDR generating node, "CGF1"). The sending is performed by using the *Data Record Transfer Request* message, with the *Packet Transfer Command* IE having the value "Send Data Record Packet".
- 2) Due to a failure in the GSN-CGF1 communication link of CGF1, the CGF1 is not able to store the packet sent by the GSN in a safe way (to e.g. a redundant RAM memory unit or a mirrored non-volatile memory or to another node).
- 3) Therefore the GSN is not able to get a response (or it could alternatively get a negative response like "No resources available" as the **Cause** value in the *Data Record Transfer Response* message).
- 4) The GSN may now first test the GSN-CGF2 link by an Echo Request message that the CGF2 would respond by the Echo Response.) Then, the GSN sends the same CDR packet that could not be sent to CGF1 to the next CGF in its CGF preference list (here CGF2) using the *Data Record Transfer Request* message, with the *Packet Transfer Command* IE having the value "Send possible duplicated Data Record Packet".

- 5) As the connection to the CGF2 is working, the CGF2 is able to process the CDR packet. Since the packet was marked by the sending GSN to be potentially duplicated, it is stored into the CGF2, but not yet sent forward towards the Billing System.
- 6) The CGF2 sends confirmation of the successful packet reception to the GSN. The confirmation is performed by using the *Data Record Transfer Response* message, with the **Cause** value being "Request Accepted"
- 7) The GSN can now delete the now successfully sent (potentially duplicated) CDRs from its CDR buffer (but it keeps the sequence number(s) of the sent potentially duplicated packet(s) in a buffer dedicated for that.
- 8) When CGF1 is recovering after a system reboot, it sends a *Node Alive Request* message to the configured peer GSN(s), and so the GSN notices that it can again successfully communicate with the CGF1. (The GSN may also detect this by using the *Echo Request* messages, which would be answered by CGF1 by the *Echo Response* message.)
- 9) GSN acknowledges the CGF1 by *Node Alive Response* message.
- 10) For the earlier unacknowledged *Data Record Transfer Request* message(s), the GSN sends CGF1 empty test packet(s) (with no CDR payload in the Data Record Packet IE but just the other parts of the message frame).
- 11) CGF1 responds with *Data Record Transfer Response* message, with the **Cause** value being "Request Accepted", because in this example case CGF1 had lost the communication capability towards GSN before storing the previously received (and by CGF1 unacknowledged) CDR packet.
- 12) Now GSN knows that the CGF1 had not originally been able to process and forward the original version of the CDR packet from the GSN, and it indicates CGF2 that CGF2 can send the CDR packet(s) related to the previously unacknowledged GTP' *Sequence Number(s)* to post-processing. Those packets' *Sequence Numbers* are indicated in the *Sequence Numbers of the Released Packets IE*.
- 13) CGF2 shall now be able to send the released packets towards post-processing.
- 14) CGF2 responds with *Data Record Transfer Response* message, with the **Cause** value being 'Request Accepted'.

After all the potentially duplicated packets are cleared from CGF(s), the GSN can continue in normal way the transfer of CDRs.

7.3.4.7.3 Case 3: The GSN-CGF1 connection breaks after a successful CDR reception

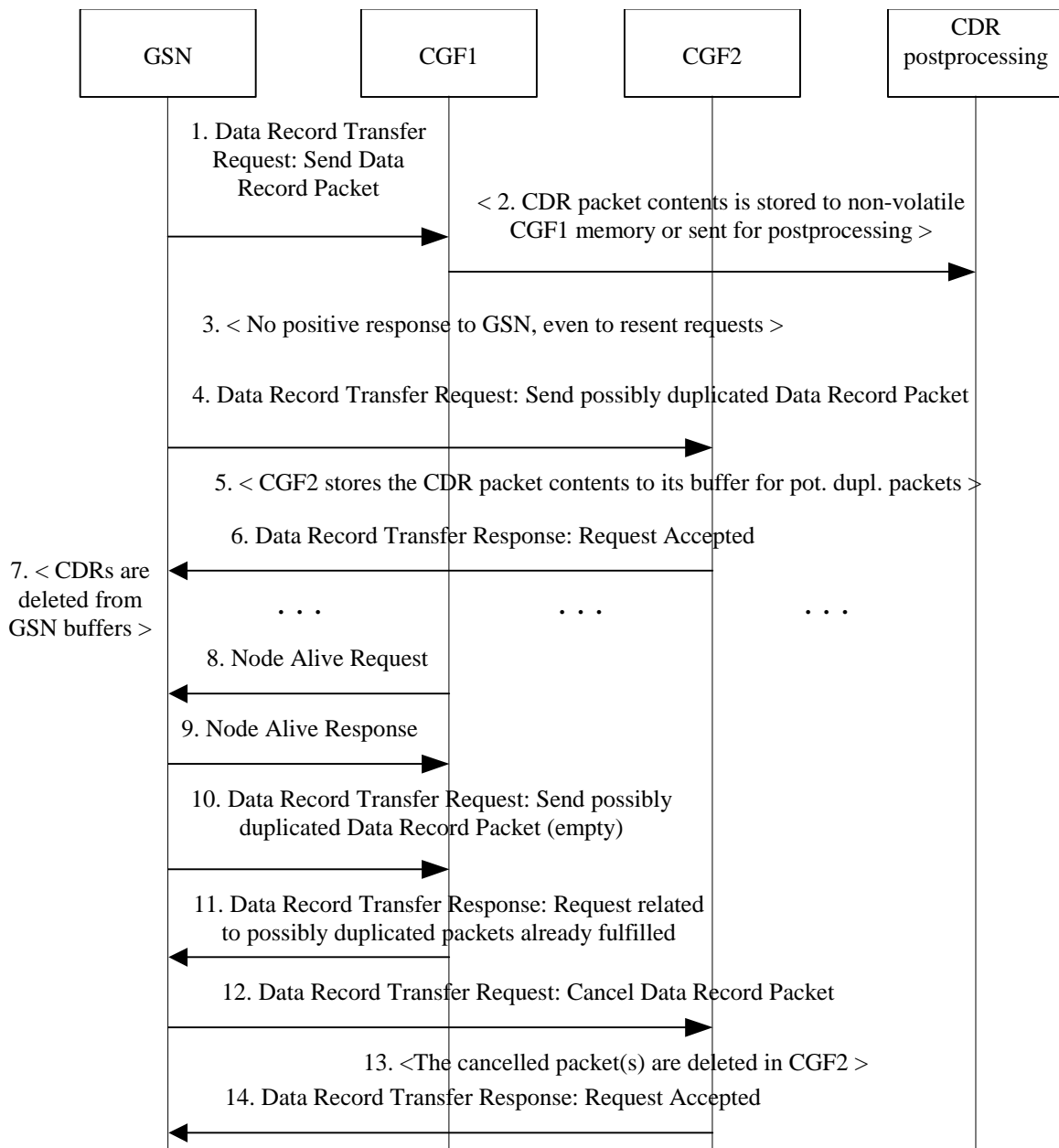

Figure 19: Duplicate prevention case: CDR sending via CGF1 had succeeded

- 1) The CDR generating entity (GSN) sends CDR(s) in a packet to CGF (that is the current primary Charging Gateway Functionality for the specific CDR generating node, "CGF1"). The sending is performed by using the *Data Record Transfer Request* message, with the *Packet Transfer Command* IE having the value "Send Data Record Packet".
- 2) The CGF1 is able to store the packet sent by the GSN in a safe way (to e.g. a redundant RAM memory unit or a mirrored non-volatile memory or to another node).

- 3) Since the GSN-CGF1 communication connection is now broken, the GSN is not able to get the response "Request Accepted" as the **Cause** value in the *Data Record Transfer Response* message.
- 4) Then the GSN sends the same CDR packet that could not be sent to CGF1 to the next CGF in its CGF preference list (here CGF2) a *Data Record Transfer Request* message, with the *Packet Transfer Command* IE having the value "Send possible duplicated Data Record Packet". (That sending may be preceded by the testing of the GSN-CGF2 link by an *Echo Request* message, that the CGF2 would respond by the *Echo Response*.)
- 5) As the connection to CGF2 is working, CGF2 is able to process the CDR packet. Since the packet was marked by the sending GSN to be potentially duplicated, it is stored in CGF2, but not yet sent forward towards the post processing or Billing System.
- 6) The CGF2 sends confirmation of the successful packet reception to the GSN. The confirmation is performed by using the *Data Record Transfer Response* message, with the **Cause** value being "Request Accepted".
- 7) The GSN can now delete the now successfully sent (potentially duplicated) CDRs from its CDR buffer (but it keeps the sequence number(s) of the sent potentially duplicated packet(s) in a buffer dedicated for that.
- 8) When CGF1 is recovering after a system reboot, it sends a *Node Alive Request* message to the configured peer GSN(s), and so the GSN notices that it can again successfully communicate with the CGF1. (The GSN may also detect this by using the *Echo Request* messages, which would be answered by CGF1 by the *Echo Response* message.)
- 9) GSN acknowledges the CGF1 by *Node Alive Response* message.
- 10) For the earlier unacknowledged *Data Record Transfer Request* message(s), the GSN sends CGF1 empty test packet(s) (with no CDR payload in the *Data Record Packet* IE but just the other parts of the message frame).
- 11) CGF1 responds with *Data Record Transfer Response* message, with the **Cause** value being "Request related to possibly duplicated packets already fulfilled", because in this example case CGF1 had lost the communication capability towards GSN after storing the previously received (and by CGF1 unacknowledged) CDR packet.
- 12) Now GSN knows that the CGF1 had originally been able to process and forward the original version of the CDR packet from the GSN, and it indicates CGF2 that CGF2 can cancel the CDR packet(s) related to the previously unacknowledged GTP' GSN-CGF1 Sequence Number(s). Those packets' *Sequence Numbers* are indicated in the *Sequence Numbers of the Cancelled Packets* IE.
- 13) CGF2 shall now delete the cancelled packet(s) from its buffer for potentially duplicated packets.
- 14) CGF2 responds with *Data Record Transfer Response* message, with the **Cause** value being "Request Accepted".

After all the potentially duplicated packets are cleared from CGF(s), the GSN can continue in normal way the transfer of CDRs.

7.4 Data Record Format in GTP'

The format of the CDRs sent between the Network Elements that generate the PS domain CDRs and the CGF are defined by the *Data Record Format*, which is the 5th octet of *Data Record Packet* information element, shown in Figure 13.

The following rules govern the *Data Record Format*:

- This field consists of one octet (#5).
- The value range is 1-255 in decimal. The value '0' should not be used.
- Only the values 1-10 and 51-255 can be used for standards purposes.
- Values in the range of 11-50 are to be configured only by operators, and are not subject to standardization.
- The value '1' identifies ASN.1 format (in PS domain charging). If needed other values are specified in subclause 7.4.1.

7.4.1 Standard Data Record Format

For the PS Domain CDR transfer, defined by the present document, only an ASN.1 format is used. For this format the *Data Record Format* value is '1'. See clause 6 and the ASN.1 language descriptions for the definitions. Basic Encoding Rules (BER) provides the transfer syntax for abstract syntax defined in ASN.1.

7.4.2 Private Data Record Formats

The *Data Record Format identifiers* 11...50 (decimal) are reserved for private (implementation specific) format use.

7.5 Data Record Format Version for CDRs

The CDR release and versions numbers are defined by the '*Data Record Format Version*', in octet 6 and 7 of the *Data Record Packet IE*, shown in Figure 13. The format of this field is depicted in Figure 20.

The first octet (#6 in *Data Record Packet IE*) is divided into two fields each with 4 bits. The first field (octet 6, bits 8-5 in Fig 20) identifies the application. The second field (bits 4-1 of octet 6) identifies the release. For charging purposes, the Application Identifier has a value of '1' (decimal). Other possible applications of GTP' may use different numbers. The Release Identifier indicates the TS release used to encode the CDR. The following values are used to identify the CDR release:

- '2' (decimal) for R98,
- '3' (decimal) for R99, and
- '4' (decimal) for R4.

The second octet (#7) identifies the version of the TS used to encode the CDR. For R98, the version number is 1 for all versions. For R99 and R4 the decimal value of the Version identifies is listed in Table 14a. Note that the value must be '1' or larger.

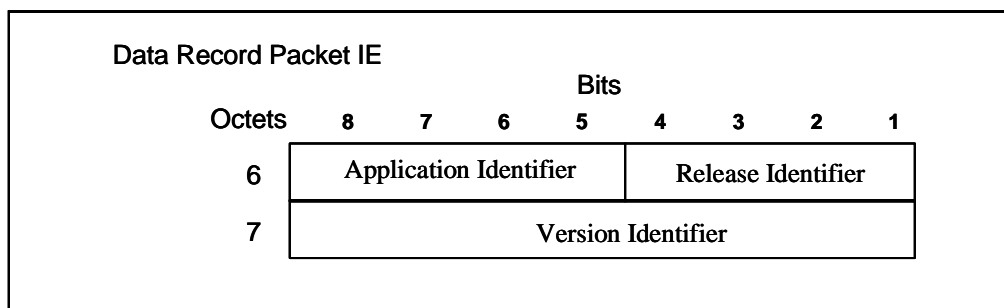

Figure 20: The Format of the *Data Record Format Version* Field

Table 14a: The decimal value of the Version Identifier used in R99 and R4 CDRs

Value	R99	R4
1	TS 32.015 v3.0.0	TS 32.215 v4.0.0
2	TS 32.015 v3.1.0	TS 32.215 v4.1.0
3	TS 32.015 v3.1.1	
4	TS 32.015 v3.2.0	
5	TS 32.015 v3.3.0	
6	TS 32.015 v3.4.0	
7	TS 32.015 v3.5.0	
8	TS 32.015 v3.6.0	
9	TS 32.015 v3.7.0	

7.6 CGF - BS Protocol Interface

7.6.1 The transfer protocols at CGF - BS interface

The present document gives several recommendations for the main protocol layers for the Charging Gateway Functionality - Billing System (BS) interface protocol stack. These recommendations are not strictly specified features, since there are a lot of variations among the existing Billing Systems. The recommendations are FTAM protocol over X.25 or TCP/IP, and FTP over TCP/IP.

7.6.2 The format of the CDRs at CGF - BS interface

The contents of the CDRs sent between the CGF and the Billing System (BS) are defined by the ASN.1 language clause 6, Charging Data Record Structure. In addition, other CDR contents or formats are possible if the CGF provides processing functionality for the CDRs.

Annex A (normative): Charging Characteristics

Charging Characteristics can be supplied by the HLR to the SGSN as part of the subscription information. A subscriber may have charging characteristics assigned to his subscription and/or his subscribed APNs. The SGSN applies a preconfigured default if no charging characteristics are supplied by the HLR. The SGSN shall support three different charging characteristics default configurations:

- * the home default profile for subscribers of the SGSN's PLMN;
- * the visiting default profile for visitors using a GGSN belonging to the same PLMN as the SGSN;
- * the roaming default profile for visitors using a GGSN belonging to their home PLMN.

The SGSN can determine the GGSN PLMN from the operator identifier part of the APN. Optionally the SGSN may support several visiting and roaming default profiles based on the MNC/MCC combination of the subscriber.

In the case of a home subscriber, the charging characteristics are selected by the SGSN according to the following procedures. For PDP context specific charging characteristics (i.e. those used for the S-CDRs that are generated for this PDP context):

- ◆ If the MS requests a particular APN then
 - * If the SGSN accepts this request (i.e. it has been verified against the subscription) then
 - If it has been matched against the wildcard APN then
 - If charging characteristics for the wildcard APN are present in the subscription information then they shall be used;
 - If no charging characteristics are present for the wildcard APN but subscription related charging characteristics are present, then they shall be chosen;
 - If neither of the two are present then the SGSN home default shall be applied.
 - If it has been matched against a specific subscribed APN then
 - If charging characteristics for this APN are present in the subscription information then they shall be used;
 - If no charging characteristics are present for the APN but subscription related charging characteristics are present, then they shall be chosen;
 - If neither of the two are present then the SGSN home default shall be applied.
 - * If the SGSN rejects the request then charging characteristics selection does not apply.
- ◆ If the MS does not request an APN then
 - * If the SGSN chooses a subscribed APN then
 - If charging characteristics for this APN are present in the subscription information then they shall be used;
 - If no charging characteristics are present for the APN but subscription related charging characteristics are present, then they shall be chosen;
 - If neither of the two are present then the SGSN home default shall be applied.

- * If only the wildcard APN is present in the subscription, i.e. the SGSN applies its configured default APN then
 - If charging characteristics for the wildcard APN are present in the subscription information then they shall be used;
 - If no charging characteristics are present for the wildcard APN but subscription related charging characteristics are present, then they shall be chosen;
 - If neither of the two are present then the SGSN home default shall be applied.

For the non-PDP context specific CDR types, i.e. the M-CDRs and the SMS CDRs, the SGSN applies the subscription specific charging characteristics, or, if not supplied, it shall choose the home default profile as defined above.

In case of subscribers from other PLMNs, the SGSN may be configured to either apply the "home subscriber case" charging characteristics selection procedure defined above, or to ignore charging characteristics provided by the subscriber's HLR, and apply a default configuration instead. If default charging characteristics are selected for the foreign subscriber, then the SGSN shall choose either the visiting or roaming default profile for the PDP context specific charging characteristics, according to the roaming or visiting scenario, as described above. For M-CDRs and SMS CDRs, the operator can configure if the roaming or the visiting profile shall be applied, since no GGSN is involved.

Upon activation of a PDP context, the SGSN forwards the charging characteristics to the GGSN according to the following rules:

- * if charging characteristics were received from the HLR, then they shall be sent as provided by the HLR, regardless of the home, visiting, or roaming case, and regardless of whether the SGSN applies the HLR supplied charging characteristics or chooses to ignore them;
- * if no charging characteristics were received from the HLR, then the SGSN does not forward any charging characteristics to the GGSN.

The above procedure implies that no explicit transfer of the Charging Characteristics Selection Mode (see 3GPP TS 23.060) to the GGSN is necessary, because it is implicitly given as "subscribed" when the GGSN receives charging characteristics from the SGSN, and "non-subscribed" otherwise.

The GGSN shall also apply charging characteristics to its PDP contexts. It shall either apply the SGSN supplied parameters, or it may be configured to ignore the SGSN supplied charging characteristics in any combination of the following cases:

- * visiting case, i.e. the subscriber belongs to a different PLMN;
- * roaming case, i.e. the SGSN belongs to a different PLMN;
- * home case, i.e. the subscriber belongs to the same PLMN as the GGSN; or
- * unconditionally, i.e. it always ignores the SGSN supplied parameters.

If the GGSN ignores the parameters supplied by the SGSN, it shall nevertheless accept the PDP context request. It shall then apply its own preconfigured charging characteristics as appropriate, i.e. the home, visiting or roaming profile. The GGSN shall support the configuration of one set of default charging characteristics (i.e. home, visiting, roaming) for each of its supported APNs.

Charging Characteristics consists of a string of 16 bits designated as Profile (P) and Behaviour (B), shown in Figure 4. The first four bits (P) shall be used to select different charging trigger profiles, where each profile consists of the following trigger sets:

- * **S-CDR:** activate/deactivate CDRs, time limit, volume limit, maximum number of charging conditions, tariff times;
- * **G-CDR:** same as SGSN, plus maximum number of SGSN changes;
- * **M-CDR:** activate/deactivate CDRs, time limit, and maximum number of mobility changes;
- * **SMS-MO-CDR:** activate/deactivate CDRs;
- * **SMS-MT-CDR:** activate/deactivate CDRs.

In addition to these trigger sets, the profile may also specify an optional charging gateway address. If this CGF address is configured in the GGSN's selected trigger profile, the GGSN shall apply it for the G-CDRs and send this charging gateway address in its GTP message exchange with the SGSN (overriding any other GGSN configured CGF address). In the home or visiting case, the SGSN shall apply the received CGF address to the S-CDRs pertaining to this PDP context. In the roaming case, or if no address is received from the GGSN, then the SGSN shall use the CGF address from its own selected charging characteristics trigger profile, or, if it does not exist, use the default CGF address. For M-CDRs and SMS CDRs, the SGSN shall use the CGF address configured in the charging characteristics that it applies to the respective CDRs, or if no such address is configured then the default CGF shall be used.

The Table below is an informative example intended for clarification.

Table 15: Example of Charging Characteristics Profiles

Profile Index bits 0 - 3	CGF Address	S-CDR					G-CDR	
		Active	Time limit	Volume limit	Change cond	Tariff times	Active	...
0	-	Yes	30 min	100 K	2	0-7, 7-12, ...		
1	100.128.35.20	No	-	-	-	-		
2	-	Yes	10 min	50 K	1	0-24		
..		

The remaining 12 (B) bits can be freely assigned to particular charging behaviours that the GSNs support. Examples of those behaviours are:

- * Selection of the applicable idle context purge timer, i.e. use global value or use special value. This feature could be used to distinguish between customers and/or APNs whose PDP contexts should be purged after short (e.g. 30 minutes) or long (e.g. 12 hours) periods of inactivity.
- * Use specific charging gateway address (override all other configured/selected CG addresses).
- * Deactivate SMS-MO-CDRs for customers of the own PLMN using preconfigured SMSC addresses.
- * Disable G-CDRs for roamers that use the HPLMN GGSN.
- * Allow or inhibit the use of own GGSNs by visitors.
- * Allow or inhibit network triggered QoS change (upgrade and/or downgrade).

The SGSN selects the charging characteristics for M-CDR generation upon the creation of a MM context. Both SGSN and GGSN select the charging characteristics for PDP context CDR generation (i.e. S-CDR and G-CDR, respectively) upon creation of a PDP context or secondary PDP context. Once selected, the charging characteristics shall be maintained throughout the lifetime of the MM or PDP contexts. If the SGSN receives modified subscriber information from the HLR (e.g. execution of a stand-alone Insert Subscriber Data procedure) which includes changes to the charging characteristics, they shall be applied only to new MM, PDP and secondary PDP contexts, this implies that the SGSN shall not send PDP context modifications for the existing PDP contexts to the GGSN.

Annex B (informative): Change history

Change history							
Date	TSG #	TSG Doc.	CR	Rev	Subject/Comment	Old	New
May 2001	--	--	--	--	Transferred from 3GPP 32.015 v3.5.0.	--	1.0.0
Jun 2001	S_12	SP-010236	--	--	Submitted to TSG SA #12 for Information	1.0.0	1.0.1
Sep 2001	S_13	SP-010464	--	--	Submitted to TSG SA #13 for Approval	2.0.0	4.0.0
Dec 2001	S_14	SP-010633	001	--	Specification of the "Data Record Format" and "Data Record Format Version"	4.0.0	4.1.0
Dec 2001	S_14	SP-010633	002	--	Correction of ASN.1 data item QoSInformation	4.0.0	4.1.0
Dec 2001	S_14	SP-010634	003	--	Correction of ASN.1 statements for backwards compatibility reason	4.0.0	4.1.0
Mar 2002	S_15	SP-020022	004	--	Addition of CAMEL phase 3 extensions in SMS-MO CDR	4.1.0	4.2.0
Mar 2002	S_15	SP-020024	005	--	Addition of "QoSRequested" parameter into "traffic volume containers"	4.1.0	4.2.0
Mar 2002	S_15	SP-020025	006		Addition of CAMEL phase 4 extensions in SMS-MT CDRs	4.2.0	5.0.0

History

Document history		
V5.0.0	March 2002	Publication