

ETSI TS 131 114 V5.3.0 (2003-03)

Technical Specification

Universal Mobile Telecommunications System (UMTS); USAT interpreter protocol and administration (3GPP TS 31.114 version 5.3.0 Release 5)



Reference

RTS/TSGT-033114v530

Keywords

UMTS

ETSI

650 Route des Lucioles
F-06921 Sophia Antipolis Cedex - FRANCE

Tel.: +33 4 92 94 42 00 Fax: +33 4 93 65 47 16

Siret N° 348 623 562 00017 - NAF 742 C
Association à but non lucratif enregistrée à la
Sous-Préfecture de Grasse (06) N° 7803/88

Important notice

Individual copies of the present document can be downloaded from:

<http://www.etsi.org>

The present document may be made available in more than one electronic version or in print. In any case of existing or perceived difference in contents between such versions, the reference version is the Portable Document Format (PDF). In case of dispute, the reference shall be the printing on ETSI printers of the PDF version kept on a specific network drive within ETSI Secretariat.

Users of the present document should be aware that the document may be subject to revision or change of status. Information on the current status of this and other ETSI documents is available at

<http://portal.etsi.org/tb/status/status.asp>

If you find errors in the present document, send your comment to:

editor@etsi.org

Copyright Notification

No part may be reproduced except as authorized by written permission.
The copyright and the foregoing restriction extend to reproduction in all media.

© European Telecommunications Standards Institute 2003.
All rights reserved.

DECTTM, **PLUGTESTS**TM and **UMTS**TM are Trade Marks of ETSI registered for the benefit of its Members.
TIPHONTM and the **TIPHON logo** are Trade Marks currently being registered by ETSI for the benefit of its Members.
3GPPTM is a Trade Mark of ETSI registered for the benefit of its Members and of the 3GPP Organizational Partners.

Intellectual Property Rights

IPRs essential or potentially essential to the present document may have been declared to ETSI. The information pertaining to these essential IPRs, if any, is publicly available for **ETSI members and non-members**, and can be found in ETSI SR 000 314: "*Intellectual Property Rights (IPRs); Essential, or potentially Essential, IPRs notified to ETSI in respect of ETSI standards*", which is available from the ETSI Secretariat. Latest updates are available on the ETSI Web server (<http://webapp.etsi.org/IPR/home.asp>).

All published ETSI deliverables shall include information which directs the reader to the above source of information.

Foreword

This Technical Specification (TS) has been produced by ETSI 3rd Generation Partnership Project (3GPP).

The present document may refer to technical specifications or reports using their 3GPP identities, UMTS identities or GSM identities. These should be interpreted as being references to the corresponding ETSI deliverables.

The cross reference between GSM, UMTS, 3GPP and ETSI identities can be found under <http://webapp.etsi.org/key/queryform.asp> .

Contents

Intellectual Property Rights	2
Foreword.....	2
Foreword.....	6
1 Scope	7
2 References	7
3 Definitions and abbreviations.....	7
3.1 Definitions	7
3.2 Abbreviations	8
3.3 Symbols.....	9
4 TLV Format.....	9
5 Transmission protocol	9
5.1 Transport bearer	10
5.2 TS 23.048 Security	10
5.3 Addressing and key selection	11
5.3.1 Configuration Sets	11
5.3.1.1 Configuration description.....	13
5.3.1.1.1 TAR Value	13
5.3.1.1.2 23.048 Counter UI terminated	13
5.3.1.1.3 23.048 Counter UI originated	13
5.3.1.1.4 23.048 KIc keys.....	13
5.3.1.1.5 23.048 KID keys.....	13
5.3.1.1.6 SPI, KIc and KID bytes to be used for USAT Interpreter originated messages	13
5.3.1.1.7 SPI, KIc and KID list to be checked for USAT Interpreter terminated messages	13
5.3.1.1.8 USAT Command list	14
5.3.1.1.9 USAT Interpreter byte code list.....	14
5.3.1.1.10 USAT Interpreter command list for administration.....	14
5.3.1.1.11 Operational configuration modification	14
5.3.1.1.12 Bearer specific data set modification.....	15
5.3.1.1.13 Linked Pull TAR	15
5.3.1.1.14 Reference to a bearer specific data set.....	15
5.3.1.2 Configuration Selection in Operational Pull Mode	15
5.3.1.3 Configuration Selection in Operational Push Mode.....	15
5.3.1.4 Configuration Selection in Administration Mode	16
5.3.2 Addressing for USAT Interpreter originated messages	16
5.3.2.1 Access Node.....	16
5.3.2.2 Security Node.....	16
5.3.2.3 Key selection in Security Node	16
5.3.2.4 Gateway Selector System.....	16
5.3.2.5 Gateway	17
5.3.3 Addressing for Gateway originated messages	17
5.4 USAT Interpreter originated Application Messages	17
5.4.1 USAT Interpreter originated BER-TLV for Operational Pull messages	17
5.4.1.1 Submit UI-TLV	18
5.4.1.2 RequestID UI-TLV	18
5.4.1.3 Gateway Address UI-TLV	18
5.4.1.4 Additional Information UI-TLV	19
5.4.2 USAT Interpreter originated BER-TLV for Administration Messages	19
5.4.2.1 ADM Response UI-TLV	20
5.4.2.2 RequestID UI-TLV	20
5.5 Gateway originated Application Messages	20
5.5.1 Gateway originated TLVs for Operational Messages	20
5.5.1.1 Page UI-TLV.....	21
5.5.1.2 RequestID UI-TLV	21

5.5.1.3	Inline Value UI-TLV containing the Push Information Text	21
5.5.2	Transport Protocol UIT TLV for Administration Messages	21
5.5.2.1	ADM Request UI-TLV	21
5.5.2.2	RequestID UI-TLV	21
5.6	Handling of Push Messages.....	22
5.7	Handling of Administration Messages	23
5.8	Error handling	24
6	Administration procedures	24
6.1	ADM Request.....	24
6.1.1	Attributes	24
6.1.2	ADM Commands.....	25
6.1.2.1	Install Page.....	25
6.1.2.1.1	Coding of the Install Page command.....	26
6.1.2.1.2	Attributes	26
6.1.2.1.3	TAR Value UI-TLV	26
6.1.2.1.4	Page UI-TLV	26
6.1.2.1.5	Possible errors	26
6.1.2.2	Remove Page.....	27
6.1.2.2.1	Coding of the Remove Page command	27
6.1.2.2.2	Attributes	27
6.1.2.2.3	Page Identification UI-TLV.....	27
6.1.2.2.4	Possible errors	27
6.1.2.3	Configure USAT Interpreter Entering Menu Title.....	27
6.1.2.3.1	Coding of the Configure UI Entering Menu Title command.....	28
6.1.2.3.2	Inline Value UI-TLV	28
6.1.2.3.3	Icon Identifier UI-TLV	28
6.1.2.3.4	Possible errors	28
6.1.2.4	Configure Menu Text for Page.....	28
6.1.2.4.1	Coding of the Configure Menu Text for Page command	29
6.1.2.4.2	Inline Value UI-TLV	29
6.1.2.4.3	Page Identification UI-TLV.....	29
6.1.2.4.4	Possible errors	29
6.1.2.5	Remove Menu Text for Page	29
6.1.2.5.1	Coding of the Remove Menu Text for Page command	29
6.1.2.5.2	Page Identification UI-TLV.....	29
6.1.2.5.3	Possible errors	30
6.1.2.6	Install Event	30
6.1.2.6.1	Coding of the Install Event command	30
6.1.2.6.2	Additional Event Identifier	30
6.1.2.6.3	Page Identification UI-TLV.....	30
6.1.2.6.4	Possible errors	31
6.1.2.7	Remove Event.....	31
6.1.2.8	Modify Environment Variable	31
6.1.2.8.1	Coding of the Modify Environment Variable command	31
6.1.2.8.2	Variable ID	31
6.1.2.8.3	Inline Value UI-TLV	32
6.1.2.8.4	Possible errors	32
6.1.2.9	Modify Wait State Message	32
6.1.2.9.1	Coding of the Modify Wait State Message command	32
6.1.2.9.2	Inline Value UI-TLV	32
6.1.2.9.3	Possible errors	32
6.1.2.10	Modify Configuration Data.....	32
6.1.2.10.1	Coding of the Modify Configuration command	32
6.1.2.10.2	TAR Value	33
6.1.2.10.3	Parameter List.....	33
6.1.2.10.3.1	Parameter: 23.048 Counter UI terminated	33
6.1.2.10.3.2	Parameter: 23.048 Counter UI originated	33
6.1.2.10.3.3	Parameter: 23.048 KIC Keys	33
6.1.2.10.3.4	Parameter: 23.048 KID Keys	34
6.1.2.10.3.5	Parameter: SPI, KIC and KID bytes to be used for UI originated messages	34
6.1.2.10.3.6	Parameter: SPI, KIC and KID list to be checked for UI terminated messages	34

6.1.2.10.3.7	Parameter: USAT command list	35
6.1.2.10.3.8	Parameter: USAT Interpreter byte code list.....	36
6.1.2.10.3.9	Parameter: Linked Pull TAR	37
6.1.2.10.3.10	Parameter: Indication to a bearer specific data set.....	37
6.1.2.10.4	Possible errors	38
6.1.2.11	Modify Bearer Data.....	38
6.1.2.11.1	Coding of the Modify Bearer Data command	38
6.1.2.11.2	Bearer specific data set index	38
6.1.2.11.3	Type of bearer.....	38
6.1.2.11.4	Parameter List for SMS bearer	38
6.1.2.11.5	Parameter List for other bearers	39
6.1.2.11.6	Possible errors	39
6.1.2.12	Install Plug-In.....	39
6.1.2.12.1	Coding of the Install Plug-In command.....	40
6.1.2.12.2	Plug-in Installation Data UI-TLV.....	40
6.1.2.12.3	Possible errors	40
6.1.2.13	Remove Plug-In	40
6.1.2.13.1	Coding of the Remove Plug-In command	40
6.1.2.13.2	Possible errors	40
6.2	ADM Response	41
6.2.1	ADM Response Structure	41
6.2.2	ADM Result UI-TLV.....	41
6.3	Error coding.....	41
7	Used tag values.....	42
7.1	BER-TLV tag values	42
7.2	UI-TLV tag values.....	42
Annex A (informative): Change history		43
History		44

Foreword

This Technical Specification (TS) has been produced by the 3rd Generation Partnership Project (3GPP).

The contents of the present document are subject to continuing work within the TSG and may change following formal TSG approval. Should the TSG modify the contents of the present document, it will be re-released by the TSG with an identifying change of release date and an increase in version number as follows:

Version x.y.z

where:

- x the first digit:
 - 1 presented to TSG for information;
 - 2 presented to TSG for approval;
 - 3 or greater indicates TSG approved document under change control.
- y the second digit is incremented for all changes of substance, i.e. technical enhancements, corrections, updates, etc.
- z the third digit is incremented when editorial only changes have been incorporated in the document.

1 Scope

The present document specifies the transmission protocol to be used to communicate with the USAT Interpreter and the administrative structures and procedures to administer the USAT Interpreter.

The present document does not specify any USAT Interpreter byte code commands.

2 References

The following documents contain provisions which, through reference in this text, constitute provisions of the present document.

- References are either specific (identified by date of publication, edition number, version number, etc.) or non-specific.
- For a specific reference, subsequent revisions do not apply.
- For a non-specific reference, the latest version applies. In the case of a reference to a 3GPP document (including a GSM document), a non-specific reference implicitly refers to the latest version of that document *in the same Release as the present document*.

- [1] 3GPP TS 31.112: "USAT Interpreter Architecture Description; Stage 2"
- [2] 3GPP TS 31.113: "USAT Interpreter Byte Codes"
- [3] 3GPP TS 23.048: "Security Mechanisms for the (U)SIM Application Toolkit; Stage2"
- [4] 3GPP TS 31.111: "USIM Application Toolkit (USAT)"
- [5] ISO/IEC 7816-6 (1995): "Identification cards - Integrated circuit(s) cards with contacts, Part 6: Inter-industry data elements"
- [6] 3GPP TS 23.040: "Technical realization of the Short Message Service (SMS)"
- [7] 3GPP TS 23.038: "Alphabets and language-specific information"
- [8] 3GPP TS 24.011: "Point-to-Point (PP) Short Message Service (SMS) support on mobile radio interface".

3 Definitions and abbreviations

3.1 Definitions

For the purposes of the present document, the following terms and definitions apply:

Access Mode: A Gateway Selector System consists of up to 3 different logical separate Gateway Selectors to handle the different modes of access. The specified modes of access are Operational Pull, Operational Push and Administrative access.

Application Message: The package of commands or data sent from the Sending Application to the Receiving Application, or vice versa, independently of the transport mechanism. An Application Message is transformed with respect to a chosen Transport Layer and chosen level of security into one or more secured packets.

Configuration: A collection of parameters to be used by the USAT Interpreter for the TAR value assigned to that configuration, like keys to be used, counters to be used, Access Node address, Security Node address, security parameters etc.

Configuration Set: A set of up to 16 configurations assigned to an access mode.

Gateway: A network program that translates from a source language to the USAT Interpreter byte codes. The gateway resides between the application provider's server that contains pages written in the source language and a card containing the USAT Interpreter that will render these pages.

Secured Packet: The information flow on top of which the level of required security has been applied. An Application Message is transformed with respect to a chosen Transport Layer and chosen level of security into one or more Secured Packets.

Sending Application: The entity generating an Application Message to be sent. For the present document the Sending Application is the USAT Interpreter or the Gateway.

Sending Entity: This is the entity from which the Secured Packet is sent and where the security mechanisms are invoked. The Sending Entity generates the Secured Packets to be sent. For the present document the Sending Entity is the USAT Interpreter Security Functionality or the Security Node.

Receiving Entity: This is the entity where the Secured Packet is received and where the security mechanisms are utilised. The Receiving Entity processes the Secured Packets. For the present document the Receiving Entity is the USAT Interpreter Security Functionality or the Security Node.

USAT Command: A proactive USIM Application Toolkit command as specified in TS 31.111 [4].

USAT Interpreter Command: A byte code command for the USAT Interpreter as specified in TS 31.113 [2].

3.2 Abbreviations

For the purposes of the present document, the following abbreviations apply

BER	Basic Encoding Rules
C	Conditional
CBC	Cipher Block Chaining
CC	Cryptographic Checksum
Cfg	Configuration
CNTR	Counter
DES	Data Encryption Standard
DCS	Data Coding Scheme
DS	Digital Signature
GO	Gateway Originated
ID	IDentifier
KIc	Key and algorithm Identifier for ciphering
KID	Key and algorithm Identifier for RC/CC/DS
M	Mandatory
MAC	Message Authentication Code
MSB	Most Significant Bit
O	Optional
PoR	Proof of Receipt
RC	Redundancy Check
RFU	Reserved for Future Use
SMS	Short Message Service
SMS-PP	Short Message Service – Point to Point
SPI	Security Parameters Indication
TAR	Toolkit Application Reference
TLV	Tag Length Value
UE	User Equipment
UI	USAT Interpreter
UIO	USAT Interpreter Originated
UI-TLV	USAT Interpreter TLV
URL	Uniform Resource Locators
USAT	USIM Application Toolkit
USIM	Universal Subscriber Identity Module

3.3 Symbols

'0' to '9' and 'A' to 'F':The sixteen hexadecimal digits.

Single bits are identified by b1 to b8, where b1 is the LSB and b8 is the MSB of the byte containing the bit.

RFU bits and bytes are to be set to '0'.

4 TLV Format

USAT Interpreter transmission protocol elements contained in an application message are sent between the USAT Interpreter and the Gateway System as BER-TLV data objects. Each application message shall only contain one BER-TLV object. See ISO/IEC 7816-6 [5] for more information on data objects.

The tag of a BER-TLV is a constant value, length one byte, indicating it is a USAT Interpreter application message.

The length is coded according to ISO/IEC 7816-6 [5].

The value part of the BER-TLV data object consists of USAT Interpreter TLV (UI-TLV) data objects. It is mandatory for UI-TLV data objects to be provided in the order given in the description of each BER-TLV. New UI-TLV data objects can be added to the end of a BER-TLV.

All UI-TLVs specified in the present document shall be coded according to the rules specified in TS 31.113 [2] for TLVs.

Padding characters are not allowed in any TLV objects specified in the present document.

5 Transmission protocol

The transmission protocol is used by the USAT Interpreter and the USAT Interpreter Gateway System to communicate with each other. According to TS 31.112 [1] the USAT Interpreter Gateway System may consist of several logical and functional entities.

It is not mandatory for the USAT Interpreter to support the communication with a USAT Interpreter Gateway System, in that mode in which locally stored pages (resident pages) are rendered by the USAT Interpreter only. If the USAT Interpreter supports the communication with a USAT Interpreter Gateway System, it shall be supported as described in the present document.

The transmission protocol shall be compliant to TS 23.048 [3], where the Gateway is the Sending Application and the USAT Interpreter is the Receiving Application or vice versa. The Sending and Receiving Entities as specified in TS 23.048 [3] are the Security Node and the USAT Interpreter Security functionality (TS 31.112 [1]).

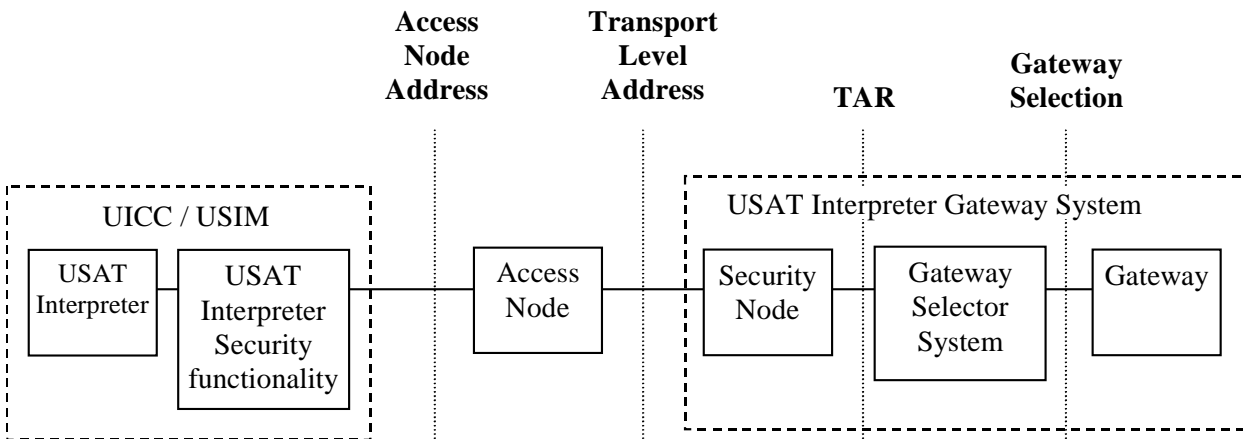

Figure 5.1: System overview

The USAT Interpreter transmission protocol shall fully comply to TS 23.048 [3], if not stated otherwise in the present document.

5.1 Transport bearer

At least, the USAT Interpreter Security Functionality and the Security Node shall support the following transport bearer specified in TS 23.048 [3]:

- SMS-PP: Single Short Message Point to Point and Concatenated Short Message Point to Point

Concatenation of short messages shall be supported for both directions. The available buffer space for concatenated short messages supported by the USAT Interpreter Security functionality in both directions is to be defined by the card issuer and is indicated by the respective USAT Interpreter system information variables as specified in TS 31.113 [2].

Other transport bearers may be supported.

5.2 TS 23.048 Security

This clause specifies the security parameters to be supported for secured packets between the USAT Interpreter Security Functionality and the Security Node. The security parameters shall apply for both directions.

For exchanging information between the USAT Interpreter Security Functionality and the USAT Interpreter Security Node the Command Packet structure as specified in TS 23.048 [3] shall be used in both directions. The execution and handling of the Command Packet shall be independent from the used bearer.

PoR by using SMS-SUBMIT should be supported by the USAT Interpreter Security Functionality, i.e. the Security Node may request a PoR from the USAT Interpreter using SMS-SUBMIT to send the PoR. PoR using SMS-DELIVER-REPORT may be supported by the USAT Interpreter. Additional Response Data (see TS 23.048 [3]) for the PoR is not specified for the present document. Support of PoR in the other direction is optional.

At least the following TS 23.048 [3] security mechanisms shall be supported by the USAT Interpreter Security Functionality and the Security Node:

Authentication (as indicated in SPI b1,b2):

- No RC, CC or DS
- Cryptographic checksum

Encryption (as indicated in SPI b3):

- No ciphering
- Ciphering

Counter (as indicated in SPI b4,b5):

- all modes

For messages originated by the USAT Interpreter, the counter value of the used configuration shall be incremented by 1 for each outgoing message. The first message issued by the USAT Interpreter Security Functionality or the Security Node shall have the counter value '00 00 00 00 32'. There shall be no wrap mechanism, that means, if the counter value reaches 'FF FF FF FF FF', the USAT Interpreter shall not send any messages any more.

The following KIc modes shall be supported by the USAT Interpreter:

Algorithm (as indicated in b1,b2):

- DES

Modes of DES (as indicated in b3,b4):

- DES in CBC mode
- Triple DES in outer CBC mode using 2 different keys

The following KID modes shall be supported by the USAT Interpreter:

Algorithm (as indicated in b1,b2):

- DES

Modes of DES (as indicated in b3,b4):

- DES in CBC mode
- Triple DES in outer CBC mode using 2 different keys

The 8-byte output of the DES based MAC calculation is used as CC in the RC/CC/DS field of the secured messages.

Padding:

According to TS 23.048 [3] the padding value shall be '00'.

The padding counter (PCNTR) may contain the value '00', which means, that no padding was applied to the message. The maximum value of the padding counter depends on the block size of the selected enciphering algorithm. PCNTR is used for ciphering only. For authentication, the message is padded virtually with '00' padding bytes for calculation of the CC if necessary, but no padding bytes are stored or indicated in the command packet.

The number and storage of KIc and KID keys is up the card issuer. It is strongly recommended to use at least one authentication mechanism. The key selection part of KIc and KID (b8-b5) should be seen as an index. A card may support up to 16 keys for KIc and up to 16 keys for KID per TAR value. For Triple-DES with 2 different keys, the length is 16 bytes (8 bytes for each key).

5.3 Addressing and key selection

5.3.1 Configuration Sets

According to TS 31.112 [1] a Gateway Selector System consists of up to 3 different logical separate Gateway Selectors to handle the different modes of access. The modes of access are Operational Pull, Operational Push and Administrative access. The distinction of these access modes is made using different ranges of TAR values:

Table 5.1: TAR values for access mode

Access Mode	TAR Value Range
Operational Pull	'B2 00 00' to 'B2 00 0F' (16 values)
Operational Push	'B2 00 30' to 'B2 00 3F' (16 values)
Administration	'B2 00 70' to 'B2 00 7F' (16 values)

Other TAR values in the USAT Interpreter range of 'B2 00 00' to 'B2 00 FF' are RFU.

For each access mode (and therefore for each TAR value range) the USAT Interpreter shall be able to store a Configuration Set. A Configuration Set consists of up to 16 different configurations, one configuration per TAR value.

Each configuration consists of a collection of parameters to be used by the USAT Interpreter for the assigned TAR value, like keys to be used, counters to be used, security parameters and so on.

The following table provides an overview of the parameters to be stored for each configuration:

Table 5.2: Configurations

Parameter	Operational Pull Configuration Set TAR range 'B2 00 00' to 'B2 00 0F'				Operational Push Configuration Set TAR range 'B2 00 30' to 'B2 00 3F'				Administration Configuration Set TAR range 'B2 00 70' to 'B2 00 7F'			
	Cfg 1	Cfg 2	...	Cfg 16	Cfg 1	Cfg 2	...	Cfg 16	Cfg 1	Cfg 2	...	Cfg 16
TAR Value												
23.048 Counter UI terminated												
23.048 Counter UI originated					--	--	--	--				
23.048 Klc Keys (up to 16 values)												
23.048 KID Keys (up to 16)												
SPI, Klc and KID bytes to be used for USAT Interpreter originated messages					--	--	--	--				
SPI, Klc and KID list to be checked for USAT Interpreter terminated messages												
USAT Command list									--	--	--	--
USAT Interpreter byte code list									--	--	--	--
USAT Interpreter command list for administration	--	--	--	--	--	--	--	--				
Operational Configuration Modification	--	--	--	--	--	--	--	--				
Bearer specific data set Modification	--	--	--	--	--	--	--	--				
Linked Pull TAR	--	--	--	--					--	--	--	--
Reference to a bearer specific data set					--	--	--	--				

-- denotes entries not applicable for the configuration

In addition to the Configuration Sets the USAT Interpreter shall be able to store bearer specific data. Each configuration shall contain a reference to one set of bearer specific data. Bearer specific data shall contain at least the following information:

Table 5.3: Bearer specific data

	Bearer specific data set 0	Bearer specific data set 1	...	Bearer specific data set n
Bearer type	(e.g. SMS)	(e.g. GPRS)	...	
Access Node address	(SMS specific)	(GPRS specific)	...	
Security Node address	(SMS specific)	(GPRS specific)	...	
...				

For the coding of SMS specific bearer information see clause 6.1.2.11.4.

The number of supported bearer specific data sets is up to issuer of the USAT Interpreter.

The coding of other bearer specific data depends on the type of bearer used and is out of the scope of the present document.

5.3.1.1 Configuration description

5.3.1.1.1 TAR Value

This entry defines the TAR value assigned to the configuration. The TAR value shall be part of the TAR value range of the Configuration Set the configuration belongs to. The TAR value shall be unique within the TAR values assigned to the configurations of the Configuration Set.

5.3.1.1.2 23.048 Counter UI terminated

This entry contains the current counter value of the Receiving Entity (the USAT Interpreter Security functionality) for USAT Interpreter terminated messages. The handling of this entry shall be according to TS 23.048[3].

5.3.1.1.3 23.048 Counter UI originated

This entry contains the current counter value of the Sending Entity (the USAT Interpreter Security functionality) for USAT Interpreter originated messages. The handling of this entry shall be according to clause 5.2 of the present document.

5.3.1.1.4 23.048 Klc keys

This entry contains up to 16 different Klc keys to be used for encryption/decryption according to TS 23.048 [3]. The number of available Klc keys may vary. The size of Klc keys may vary depending on the algorithm intended to use a key. Each Klc value shall be uniquely addressable by a 4 bit value within the configuration, the Klc index. The Klc index is reflected in the most significant nibble of the Klc byte within a 23.048 message as specified in TS 23.048 [3].

5.3.1.1.5 23.048 KID keys

This entry contains up to 16 different KID keys to be used for CC/DS generation / verification according to TS 23.048 [3]. The number of available KID keys may vary. The size of KID keys may vary depending on the algorithm intended to use a key. Each KID value shall be uniquely addressable by a 4 bit value within the configuration, the KID index. The KID index is reflected in the most significant nibble of the KID byte within a 23.048 message as specified in TS 23.048 [3].

5.3.1.1.6 SPI, Klc and KID bytes to be used for USAT Interpreter originated messages

The USAT Interpreter Security Functionality shall use the information in this entry, to generate USAT Interpreter originated secured messages. This entry consist of 2 SPI bytes, which specifies the security parameters to be used to generate the secured message, a Klc byte, which specifies the algorithm and the Klc key of the configuration to be used for the encryption of the secured message and a KID byte, which specifies the algorithm and the KID key of the configuration to be used for the CC/DS generation of the secured message.

5.3.1.1.7 SPI, Klc and KID list to be checked for USAT Interpreter terminated messages

This entry consists of a list of security parameters to be compared by the USAT Interpreter functionality with the security parameters of USAT Interpreter terminated secured messages.

Each entry in the list consists of the following information:

- SPI byte
- least significant nibble of Klc
- least significant nibble of KID

The USAT Interpreter security functionality shall check for each USAT Interpreter terminated secured message if the combination of SPI, least significant nibble of Klc and least significant nibble of KID matches a combination included in the list of this entry for the configuration identified by the TAR value. If no match is found, the secured message can not be processed and shall be discarded.

If a match is found, the decryption and authentication shall be executed according to the parameters in SPI, KIC and KID with the KIC key and the KID key of the configuration indicated in the received secured message.

5.3.1.1.8 USAT Command list

This entry specifies, which USAT commands the USAT Interpreter shall allow to be executed using the Execute USAT Command interface (see TS 31.113 [2]) within a page linked to the configuration with the USAT Command list.

USAT Commands not listed in the USAT Command list shall not be executed when triggered by the Execute USAT Command interface (see TS 31.113 [2]).

For a USAT Command being a USAT Interpreter command (a byte code) itself (e.g. Display Text or Get Input byte code, see TS 31.113 [2]) the USAT Interpreter byte code list shall apply.

If the USAT Interpreter is requested to execute a USAT command not allowed according to the USAT Command list, the USAT Interpreter shall issue the error '6F0A' "USAT command not allowed" as specified in TS 31.113 [2].

The USAT command list of the current page linked to the current configuration is reflected in the "USAT Interpreter system information variable '02': USAT Command Filter" with the coding specified in the present document, see TS 31.113 [2].

Coding of the USAT Command list: see clause 6.1.2.10.3.7.

5.3.1.1.9 USAT Interpreter byte code list

This entry specifies, which USAT Interpreter commands the USAT Interpreter shall allow to be executed within a page linked to the configuration with the USAT Interpreter byte code list.

USAT Interpreter commands not listed in the USAT Interpreter byte code list shall not be executed by the USAT Interpreter.

If the USAT Interpreter is requested to execute a USAT Interpreter command not allowed according to the USAT Interpreter byte code list, the USAT Interpreter shall issue the error '6F0A' "USAT command not allowed" as specified in TS 31.113 [2].

The USAT Interpreter byte code list of the current page linked to the current configuration is reflected in the "USAT Interpreter system information variable '0A': USAT Interpreter Byte Code Filter" with the coding specified in the present document, see TS 31.113 [2].

Coding of the USAT Interpreter byte code list: see clause 6.1.2.10.3.8.

5.3.1.1.10 USAT Interpreter command list for administration

This entry specifies, which USAT Interpreter administration commands the USAT Interpreter shall allow to be executed within an Administration Message linked to the configuration with the USAT Interpreter command list for administration.

USAT Interpreter administration commands not listed in the USAT Interpreter command list for administration shall not be executed by the USAT Interpreter.

If the USAT Interpreter is requested to execute a USAT Interpreter administration command not allowed according to the USAT Interpreter command list for administration, the USAT Interpreter shall issue the error '6F0A' "USAT administration command not allowed" as specified in clause 6.3.

5.3.1.1.11 Operational configuration modification

This entry specifies, which of the Operational Pull and Operational Push Configurations may be changed by the Administration Configuration.

Administration Configurations shall not be able to modify other Administration Configurations.

If the USAT Interpreter is requested to modify a not allowed Configuration, the USAT Interpreter shall issue the error '6F0B' "Modify configuration not allowed" as specified in clause 6.3.

5.3.1.1.12 Bearer specific data set modification

This entry specifies, which of the Bearer specific data sets may be changed by the Administration Configuration.

If the USAT Interpreter is requested to modify a not allowed bearer data set, the USAT Interpreter shall issue the error '6FOB' "Modify configuration not allowed" as specified in clause 6.3.

5.3.1.1.13 Linked Pull TAR

This entry is valid only for configurations belonging to the Operational Push Configuration Set.

For messages sent by the USAT Interpreter to the USAT Interpreter System due to the execution of a page received in Operational Push Mode, the USAT Interpreter Security Functionality shall use the configuration of the Operational Pull Configuration Set which is indicated as the "linked Pull TAR" in the configuration of the last received message in Operational Push Mode.

NOTE: By using a dedicated "linked Pull TAR" (TAR value used for that purpose only and known by the Gateway system) a Gateway is able to distinguish between a pull request due to a push message and pull requests not due to a push message.

5.3.1.1.14 Reference to a bearer specific data set

This entry shall contain a link to a bearer specific data set to be used by the USAT Interpreter to send USAT Interpreter originated secured messages. For USAT Interpreter terminated messages, all supported bearers shall be accepted by the USAT Interpreter to receive a secured message.

5.3.1.2 Configuration Selection in Operational Pull Mode

Each USAT Interpreter resident page should have a permanent link to a configuration within the Operational Pull Configuration Set. The link is provided by a TAR value stored together with the resident page. For the coding of the TAR value used to link a resident page with a configuration see clause 6.1.2.1 below.

Pages without having a permanent link can be used to inherit the configuration of a page branching to them. This can be considered as executing a sub-page without changing the current configuration.

For messages sent by the USAT Interpreter to the USAT Interpreter Gateway System due to the execution of a resident page, the USAT Interpreter Security Functionality shall use the linked configuration of the Operational Pull Configuration Set. This used configuration shall be then the current configuration. If the resident page does not have a permanent link to a configuration the current configuration is to be used. If no current configuration is available, the USAT Interpreter shall behave as described in clause 5.8.

For Operational Pull messages (i.e. messages with the TAR value in the Operational Pull Mode TAR value range) received by the USAT Interpreter from the USAT Interpreter Gateway System, the USAT Interpreter Security Functionality shall check, if the received TAR value is equal to the TAR value of the current configuration. If the values are not equal, the received message shall be discarded by the USAT Interpreter Security Functionality. If the TAR values are equal, the message shall be processed by the USAT Interpreter Security Functionality according to the security parameters of the current configuration and the page is permanently linked with this configuration.

For messages sent by the USAT Interpreter to the USAT Interpreter System due to the execution of a page received in Operational Pull Mode, the USAT Interpreter Security Functionality shall use the configuration linked with the page.

5.3.1.3 Configuration Selection in Operational Push Mode

For Operational Push messages (i.e. messages with the TAR value in the Operational Push Mode TAR value range) received by the USAT Interpreter from the USAT Interpreter Gateway System, the USAT Interpreter Security Functionality shall check, if there is a configuration in the Operational Push Configuration Set, which contains the received TAR value of the message. If the matching TAR value is found, the message shall be processed by the USAT Interpreter Security Functionality according to the security parameters of the configuration with the matching TAR value. If no matching TAR value is found, the received message shall be discarded by the USAT Interpreter Security Functionality.

For messages sent by the USAT Interpreter to the USAT Interpreter System due to the execution of a page received in Operational Push Mode, the USAT Interpreter Security Functionality shall use the configuration of the Operational Pull

Configuration Set which is indicated as the "linked Pull TAR" in the configuration of the last received message in Operational Push Mode. This used Operational Pull configuration shall be then the current configuration.

5.3.1.4 Configuration Selection in Administration Mode

For Administration Messages (i.e. messages with the TAR value in the Administration Mode TAR value range) received by the USAT Interpreter from the USAT Interpreter Gateway System, the USAT Interpreter Security Functionality shall check, if there is a configuration in the Administration Configuration Set, which contains the received TAR value of the message. If the matching TAR value is found, the message shall be processed by the USAT Interpreter Security Functionality according to the security parameters of the configuration with the matching TAR value. If no matching TAR value is found, the received message shall be discarded by the USAT Interpreter Security Functionality.

For messages sent by the USAT Interpreter to the USAT Interpreter Gateway System due to the execution of administration commands, the USAT Interpreter Security Functionality shall use the configuration of the Administration Configuration Set which contains the TAR value of the corresponding processed message in Administration Mode.

5.3.2 Addressing for USAT Interpreter originated messages

5.3.2.1 Access Node

The USAT Interpreter shall use the Access Node address within the bearer specific data set linked to the currently selected configuration to address the Access Node. The coding of the Access Node address is bearer dependent and out of the scope of the present document.

E.g. the Access Node address of the Access Node for the SMS case can be the SMSC address.

5.3.2.2 Security Node

The USAT Interpreter shall use the Security Node address within the bearer specific data set linked to the currently selected configuration to address the Security Node. The coding of the Security Node address is bearer dependent and out of the scope of the present document.

E.g. the Security Node address of the Security Node for the SMS case can be the destination address.

5.3.2.3 Key selection in Security Node

If the SPI of the secured message indicates any security applied, the key selection for the security within Security Node shall be done according to the following rules:

- The originator of the message shall be determined by the information provided by the bearer level. E.g., for the SMS case, this can be the originator address. With this information, all transport keys defined for the originator of the message shall be available for the Security Node.
- The TAR value shall be checked by the Security Node. According to the TAR value, the correct set of keys is selected out of the key sets defined for the originator of the message. E.g., different key sets for different TAR values may exist for one USAT Interpreter card.
- Within the selected key set, the KIc and KID values shall be used, as indicated in the 23.048 header (KIc and KID bytes) of the message.

After retrieving the keys, the Security Node shall extract the Application Message according to TS 23.048[3]. If the Application Message could not be extracted due to the failure of the security checks, the message shall not be processed any further.

5.3.2.4 Gateway Selector System

The Gateway Selector System shall be addressed according to the TAR value of the message. If the TAR belongs to the Operational Pull TAR range, the messages is routed to the Operational Pull Gateway Selector, if the TAR belongs to the Administration TAR range, the messages is routed to the Administration Gateway Selector.

Messages with a TAR within the Operational Push TAR range shall never be sent by the USAT Interpreter. The USAT Interpreter shall respond to a received Operational Push mode message with a linked Operational Pull mode message.

5.3.2.5 Gateway

The Gateway shall be addressed by the Gateway Selector using the Gateway Address. The format and coding of the Gateway Address TLV value is out of the scope of the present document. If no Gateway Address TLV is contained in the message or the Gateway Address TLV is the Default Gateway Address (see clause 5.4.1.3), the Gateway Selector shall select the Gateway according to its own rules, which are out of the scope of the present document (e.g. using a default Gateway or examine the information in the Submit TLV).

5.3.3 Addressing for Gateway originated messages

The Gateway Selector shall assign a TAR value according to the source of the message (Operational Pull, Operational Push or Administration).

The Security Node shall generate the Secured Packet according to the security parameters assigned to the addressed USAT Interpreter card and the given TAR value.

5.4 USAT Interpreter originated Application Messages

This chapter specifies the messages sent from the USAT Interpreter to the Gateway.

The general message format is as follows:

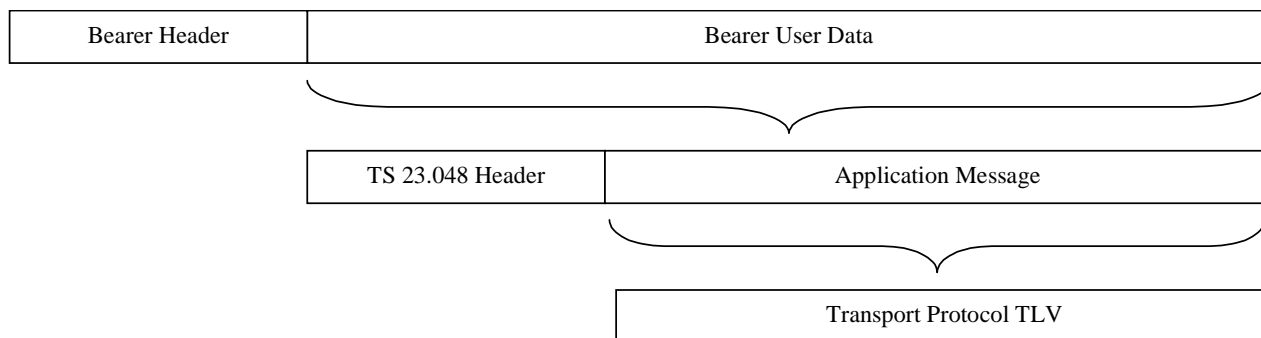

Figure 5.2: Message structure

The content and structure of the bearer header depends on the chosen bearer.

The content of the TS 23.048 header depends on the chosen configuration within the used Configuration Set. The Configuration Set depends on the used access mode, i.e. Operational Pull or Administration.

5.4.1 USAT Interpreter originated BER-TLV for Operational Pull messages

An Application Message sent by the USAT Interpreter to the Gateway in Operational Pull access mode consist of a USAT Interpreter originated TLV with the following content:

Length	Value	Description	M/O
1	'C0'	UIO BER-TLV tag for operational pull messages	M
1-3	A+B+C+D	Length	M
A	UI-TLV	Submit	M
B	UI-TLV	Request ID	C
C	UI-TLV	Gateway Address	C
D	UI-TLV	Additional Information	C

5.4.1.1 Submit UI-TLV

The Submit UI-TLV shall be constructed according to TS 31.113 [2].

5.4.1.2 RequestID UI-TLV

The RequestID UI-TLV contains the RequestID used for Wait State handling of the USAT Interpreter. The RequestID value shall be generated according to TS 31.113 [2].

The RequestID UI-TLV is conditionally incorporated into the UIO BER-TLV for operational pull messages. This UI-TLV shall only be incorporated in the UIO BER-TLV, if requested in the corresponding Submit Configuration UI-TLV (see TS 31.113 [2]).

Length	Value	Description	M/O
1	'40'	RequestID UI-TLV tag	M
1	1	Length	M
1	Data	RequestID value 1 byte binary value	M

The Gateway may distinguish between a pull message and a post message (see 3GPP TS 31.112 [1]) from the USAT Interpreter by checking if the RequestID UI-TLV is part of a USAT Interpreter originated operational pull message.

If the RequestID UI-TLV is part of a USAT Interpreter originated operational pull message, the USAT Interpreter is in wait state and expects a related answer (a GO Pull Response, see clause 5.5.1) from the Gateway (see 3GPP TS 31.112 [1] Pull Mode).

If the RequestID UI-TLV is not part of a USAT Interpreter originated operational pull message, the USAT Interpreter does not expect an immediate and related answer from the Gateway (see 3GPP TS 31.112 [1] Post Mode).

5.4.1.3 Gateway Address UI-TLV

The Gateway Address UI-TLV shall be taken from the Submit Configuration UI-TLV specified in TS 31.113 [2].

The Gateway Address UI-TLV is conditionally incorporated into the UIO BER-TLV for operational pull messages. This UI-TLV shall only be incorporated in the UIO BER-TLV, if contained in the corresponding Submit Configuration UI-TLV (see TS 31.113 [2]) and not containing the Current Gateway Address.

Table 5.4: Gateway Address handling

Submit Configuration UI-TLV contains	Gateway Address UI-TLV to be incorporated into the UIO BER-TLV for operational pull messages
Gateway Address UI-TLV with a Gateway Address other than the Current Gateway Address	Yes
Gateway Address UI-TLV containing the Current Gateway Address	No
No Gateway Address UI-TLV	No

Default Gateway Address

The Default Gateway Address is indicated in the Gateway Address UI-TLV by an empty value part of the Gateway Address UI-TLV (i.e. the length of the Gateway Address UI-TLV is set to '00' for the Default Gateway Address).

The Default Gateway Address is used to indicate to the USAT Interpreter Gateway System, that the USAT Interpreter Gateway System shall use its own mechanisms to address the Gateway.

Current Gateway Address

In order to be able to detect, if the Gateway Address changes, the USAT Interpreter shall maintain a Current Gateway Address.

The Current Gateway Address is set to "none" by the USAT Interpreter after a reset of the USAT Interpreter.

Whenever a Gateway Address UI-TLV is processed by the USAT Interpreter, the USAT Interpreter shall check, if the Gateway Address in the processed Gateway Address UI-TLV is different from the Current Gateway Address. If the Gateway Address is different, the USAT Interpreter shall change the Current Gateway Address to the Gateway Address contained in the processed Gateway Address UI-TLV and include this new current gateway address in the operational pull request message. This applies also to the Default Gateway Address possibly coded in the processed Gateway Address UI-TLV.

The Current Gateway Address mechanism is used to optimise the provisioning of gateway addresses by the USAT Interpreter. Only if the gateway address changes, the information on the new gateway address is transmitted to the USAT Interpreter Gateway System.

5.4.1.4 Additional Information UI-TLV

The Additional Information UI-TLV shall be incorporated into the UIO BER-TLV for operational pull messages under the following conditions:

- A Gateway Address UI-TLV is contained in the corresponding Submit Configuration UI-TLV
- AND
- that Gateway Address TLV has the SendAdditionalInformation bit set in its attribute byte (see TS 31.113 [2])
- AND
- the Current Gateway Address has changed.

All Submit Configuration UI-TLVs contained in locally stored pages (resident pages) having a permanent link to a configuration shall have a Gateway Address UI-TLV.

Coding of the Additional Information UI-TLV:

Length	Value	Description	M/O
1	'41'	Additional Information UI-TLV tag	M
1-3	A	Length	M
A	Data	Additional Information	M

Coding of the additional information data:

The additional information data contains a concatenated list of USAT Interpreter variable entries. Each contained variable entry in the list shall be coded as follows:

Length	Description
1	Variable ID (see TS 31.113 [3])
1-3	length of variable content, coded according to the length coding rules for UI-TLVs
L	current variable content

The following system information variables (see 31.113 [3]) shall be provided at least in the list in the given order:

Variable ID	Variable Name
'01'	USAT Interpreter version
'02'	USAT Interpreter profile
'08'	Hash Value of URL of USAT Interpreter issuer identification
'09'	Reception Buffer Size
'0B'	Transmission Buffer Size

5.4.2 USAT Interpreter originated BER-TLV for Administration Messages

An Application Message sent by the USAT Interpreter to the Gateway in Administration Mode (answer to a received Administration Message) consists of a USAT Interpreter originated BER-TLV for Administration Messages with the following content:

Length	Value	Description	M/O
1	'C1'	UIO BER-TLV tag for Administration Messages	M
1-3	A+B	Length	M
A	UI-TLV	ADM Response	M
B	UI-TLV	RequestID	C

5.4.2.1 ADM Response UI-TLV

The ADM Response UI-TLV shall be coded according to clause 6.2.

5.4.2.2 RequestID UI-TLV

The RequestID UI-TLV shall be incorporated by the USAT Interpreter into the UIO BER-TLV for Administration Messages if the corresponding GO Administration BER-TLV contains a RequestID UI-TLV. The USAT Interpreter shall copy the RequestID UI-TLV from the GO Administration BER-TLV to the UIO BER-TLV for Administration Messages in this case. Therefore, the USAT Interpreter mirrors the received RequestID UI-TLV to the Gateway.

For the coding see clause 5.4.1.2.

5.5 Gateway originated Application Messages

This chapter specifies the messages sent from the Gateway to the USAT Interpreter.

The general message format is as follows:

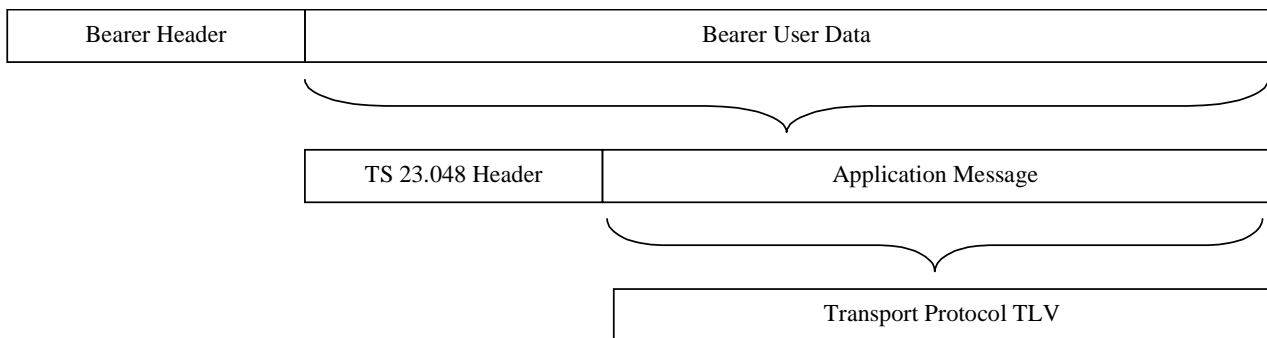

Figure 5.3: Gateway originated Application Messages

The content and structure of the bearer header depends on the chosen bearer.

The content of the TS 23.048 header depends on the chosen configuration within the used Configuration Set. The Configuration Set depends on the used access mode, i.e. Operational Pull, Operational Push or Administration.

If the USAT Interpreter receives a message whose Configuration Set does not match with the access mode, the message shall be discarded (e.g. Configuration Set = "pull" and tag = "GO Administration Message BER-TLV").

5.5.1 Gateway originated TLVs for Operational Messages

An Application Message sent by the Gateway to the USAT Interpreter in Operational Pull (answer to a received Operational Pull message containing a RequestID TLV) consists of a Gateway originated BER-TLV with the following content:

Length	Value	Description	M/O
1	'C2'	GO Pull Response BER-TLV tag	M
1-3	A+B	Length	M
A	UI-TLV	Page	M
B	UI-TLV	RequestID	M

An Application Message sent by the Gateway to the USAT Interpreter in Operational Push consists of a Gateway originated BER-TLV with the following content:

Length	Value	Description	M/O
1	'C3'	GO Push BER-TLV tag	M
1-3	A+B	Length	M
A	UI-TLV	Page	M
B	UI-TLV	Inline Value containing Push Information Text	M

5.5.1.1 Page UI-TLV

The Page UI-TLV shall be constructed according to TS 31.113 [2].

5.5.1.2 RequestID UI-TLV

The RequestID UI-TLV contains the RequestID used for Wait State handling of the USAT Interpreter. The received RequestID shall be checked by the USAT Interpreter according to TS 31.113 [2].

The RequestID UI-TLV shall be incorporated by the Gateway into the GO Pull Response BER-TLV. The Gateway shall copy the RequestID UI-TLV from the UIO BER-TLV tag for operational pull message to the GO Pull Response BER-TLV in this case. Therefore, the Gateway mirrors the received RequestID UI-TLV to the USAT Interpreter.

Coding: See clause 5.4.1.2.

5.5.1.3 Inline Value UI-TLV containing the Push Information Text

The Push Information Text contains a text to be provided to the user prior to the rendering of the Push page. Variable references shall not be contained in this Inline Value UI-TLV.

The handling of Push Messages is described in clause 5.6.

Coding: according to the Inline Value TLV as specified in TS 31.113 [3].

5.5.2 Transport Protocol UIT TLV for Administration Messages

An Application Message sent by the Gateway to the USAT Interpreter in Administration Mode consists of a Gateway originated BER-TLV for Administration Messages with the following content:

Length	Value	Description	M/O
1	'C4'	GO Administration Message BER-TLV tag	M
1-3	A+B	Length	M
A	UI-TLV	ADM Request	M
B	UI-TLV	Request ID	O

5.5.2.1 ADM Request UI-TLV

The ADM Request UI-TLV shall be coded according to clause 6.1.

5.5.2.2 RequestID UI-TLV

The RequestID UI-TLV may be incorporated by the Gateway to be able to logically connect a GO Administration Message with a UIO Administration Message. The USAT Interpreter shall mirror the received RequestID UI-TLV in the response to a GO Administration Message. See clause 5.4.2.2.

The generation of the value for the RequestID is up to the Gateway system and out of the scope of the present document.

Coding: See clause 5.4.1.2.

5.6 Handling of Push Messages

Push messages may reach the USAT Interpreter at any time. Therefore the following table provides the rules, how to handle received push messages in different states the USAT Interpreter may currently be.

Table 5.5: Handling of Push messages

Possible states of the USAT Interpreter	Handling of a received Push message
USAT Interpreter idle mode	render pushed page
about to parse byte code	ask user to execute received Push page
about to parse locally stores pages (resident pages)	ask user to execute received Push page
wait state	ask user to execute received Push page
Terminal Response Handler execution environment (see TS 31.113 [2], e.g. SELECT ITEM)	ask user to execute received Push page
about to parse administrative code received prior to the current message	finalise Administration Message, then execute received Push page
USAT Interpreter idle mode but another running application (another proactive session)	Out of the scope of the present document.

For the option "ask user" a DISPLAY TEXT USAT command shall be issued by the USAT Interpreter to notify the user that the USAT Interpreter has received a Push page. The text provided in the Push Information Text UI-TLV shall ask the user, if the user wants to execute the pushed page and may provide information about the content of the received Push page.

If the user wants to execute the pushed page, the USAT Interpreter shall discard the current state and shall render the Push page. If the user rejects to execute the Push page, the USAT Interpreter shall discard the received Push page and shall continue in the current state.

The text to be used for the text string of the DISPLAY TEXT command shall be taken from the Inline Value TLV of the GO Push BER-TLV.

For the DISPLAY TEXT USAT command the command qualifier option

- "high priority" and " wait for user to clear message" coded as '81'

shall be used.

The USAT Interpreter shall handle the "ask user" option according to the following figure:

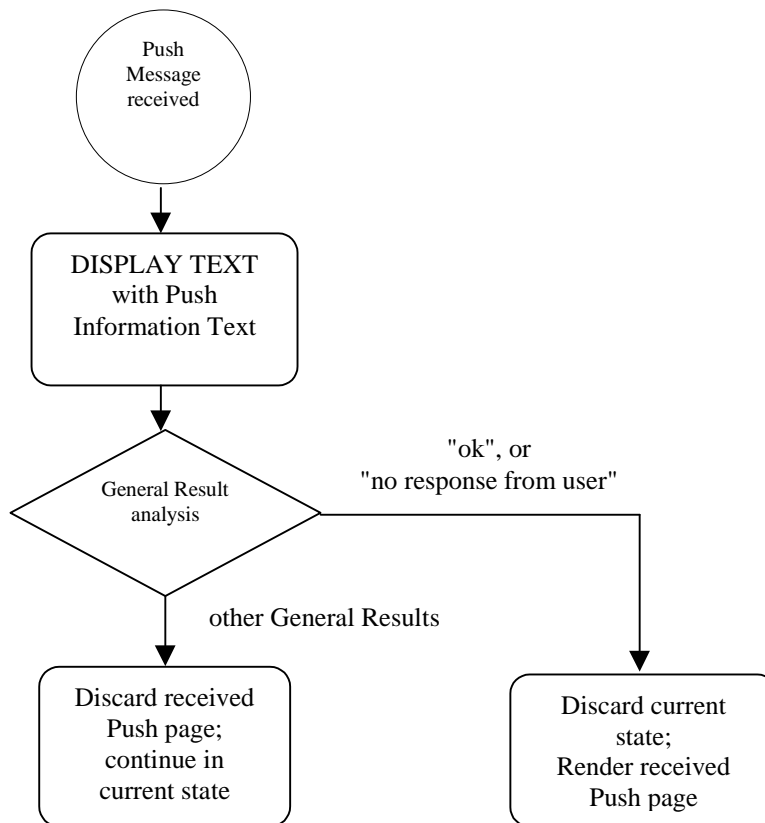

Figure 5.4: "Ask User" flow

5.7 Handling of Administration Messages

Administration Messages may reach the USAT Interpreter at any time. Therefore the following table provides the rules, how to handle received Administration Messages in different states the USAT Interpreter may currently be.

Administration Messages are handled as messages with a low priority to be executed, i.e. Administration Messages are executed only, if the USAT Interpreter is in idle mode.

Table 5.6: Handling of Administration Messages

Possible states of the USAT Interpreter	Handling of a received Administration Message
USAT Interpreter idle mode	execute Administration Message
about to parse byte code	discard Administration Message without indicating an error
about to parse locally stores pages (resident pages)	discard Administration Message without indicating an error
wait state	discard Administration Message without indicating an error
Terminal Response handler execution environment (see TS 31.113 [2], e.g. SELECT ITEM)	discard Administration Message without indicating an error
about to parse administrative code received prior to the current message	discard Administration Message without indicating an error
USAT Interpreter idle mode but another running application (another proactive session)	discard Administration Message without indicating an error

If an Administration Message is discarded by the USAT Interpreter, no corresponding ADM Response shall be generated by the USAT Interpreter.

NOTE: The USAT Interpreter Gateway System is able to detect discarded Administration Messages by checking the reception of the mandatory corresponding ADM Response. If no ADM Response is received, the USAT Interpreter Gateway System should consider the Administration Message as not executed by the USAT Interpreter.

5.8 Error handling

Messages which could not pass the security checks successfully according to the requirements specified in the corresponding configuration or which contain TAR values not supported by one of the Configuration Sets shall be ignored and discarded by the USAT Interpreter.

6 Administration procedures

Administration procedures are used for configuration of the USAT Interpreter.

It is not mandatory for the USAT Interpreter to support administration procedures. If the USAT Interpreter does not support administration procedures the USAT Interpreter configuration (e.g. locally stored pages (resident pages), plug-ins, keys, etc.) cannot be modified in an interoperable way.

If the USAT Interpreter supports administration procedures (even partly), they shall be supported as described in the present document. This implies that the USAT Interpreter supports parts of the Transmission protocol (used for administration) as described in chapter 5.

6.1 ADM Request

All administration commands are contained in an ADM Request UI-TLV. For the case that administration procedures can be handled by the USAT Interpreter a response to an ADM request is mandatory. Clause 5.7 describes conditions for the USAT Interpreter when administration procedures shall be handled. . The ADM Request UI-TLV has the following structure:

Length	Value	Description	M/O
1	'60' / 'E0'	ADM Request UI-TLV tag	M
1-3	A+B+...+X	Length	M
A	Data	Attributes	O
B	UI-TLV	ADM Command 1	M
...		...	
X	UI-TLV	ADM Command n	O

The ADM commands shall be executed in the order given in the ADM Request.

6.1.1 Attributes

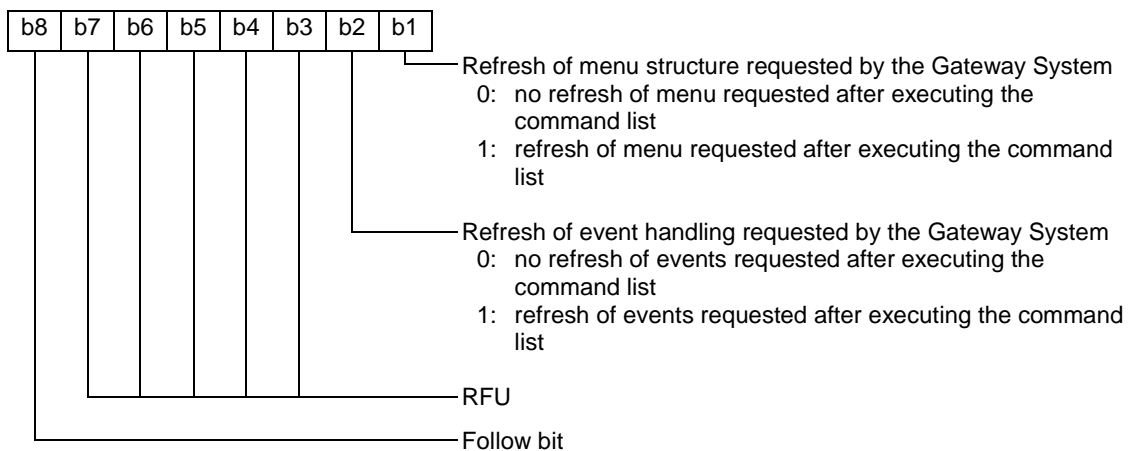

Refresh of menu structure requested by the Gateway System

If this bit is set, the USAT Interpreter shall take the necessary actions to update the UE menu structure with the current menu configuration. E.g. it might be necessary to issue a SETUP MENU USAT command to the UE or to register new

menu entries linked to locally stored pages (resident pages) to a framework provided by the operating system of the UICC.

How the USAT Interpreter ensures, that the current configuration is reflected in the menu structure seen by the user is up to the implementation of the USAT Interpreter and out of the scope of the present document.

If this bit is not set, the USAT Interpreter shall take no actions to update the UE menu structure with the current menu configuration. Modifications shall be reflected after receiving an ADM Request with this bit set or after reset of the USAT Interpreter in this case.

Refresh of event handling requested by the Gateway System

If this bit is set, the USAT Interpreter shall take the necessary actions to update the UE event list with the current event configuration. E.g. it might be necessary to issue a SETUP UP EVENT LIST USAT command to the UE or to register new events linked to locally stored pages (resident pages) to a framework provided by the operating system of the UICC.

How the USAT Interpreter ensures, that the current configuration is reflected in the event list of the UE is up to the implementation of the USAT Interpreter and out of the scope of the present document.

If this bit is not set, the USAT Interpreter shall take no actions to update the UE event list with the current event list configuration. Modifications shall be reflected after receiving an ADM Request with this bit set or after reset of the USAT Interpreter in this case.

6.1.2 ADM Commands

The used Administration Configuration defines the usage of administration commands:

- The entry "USAT Interpreter command list for administration" defines, which administration commands the USAT Interpreter allows to be executed by an Administration Configuration.
- The entry "Operational Configuration Modification" defines, which Operational Mode Configuration may be changed by a specific Administration Configuration.
- The entry "Bearer specific data set Modification" defines, which Bearer specific data sets may be changed by a specific Administration Configuration.

Different Administration Configurations may be configured to change different Operational Mode Configurations and to support different sets of administration commands. Administration Configurations themselves cannot be modified by any command specified in the present document.

The present document does not provide mechanisms to prevent administration entities in USAT Interpreter Gateway System from modifying data of other (independent) administration entities in the same or another USAT Interpreter Gateway System. Here are some examples of potential risks:

- One administration entity could delete a resident page which has been installed by another administration entity.
- One administration entity could install resident pages, which will occupy all available memory in the page pool so other administration entities cannot install their resident pages any more.

This scheme requires co-operation and synchronisation between possible different administration entities in USAT Interpreter Gateway Systems. The synchronisation of administration entities in USAT Interpreter Gateway Systems is out of the scope of the present document.

6.1.2.1 Install Page

The USAT Interpreter shall administer a certain amount of memory to store pages locally (also called resident pages). This amount of memory is called page pool. Pages are stored as Page UI-TLVs with additional parameters given in the attribute and other UI-TLVs of the Install Page command. Locally stored pages are identified by their page identification, which is part of the Page UI-TLV (see TS 31.113 [2]).

The Install Page command receives a page and stores it locally into the page pool. If there is already a page in the page pool with the same page identification as the received page, the received page shall overwrite the existing page.

The memory management of the page pool is up the USAT Interpreter implementation and out of the scope of the present document.

6.1.2.1.1 Coding of the Install Page command

Length	Value	Description	M/O
1	'62' / 'E2'	Install Page UI-TLV tag	M
1-3	A+B+C	Length	M
A	Data	Attributes	O
B	UI-TLV	TAR Value	O
C	UI-TLV	Page	M

6.1.2.1.2 Attributes

Coding of the attributes:

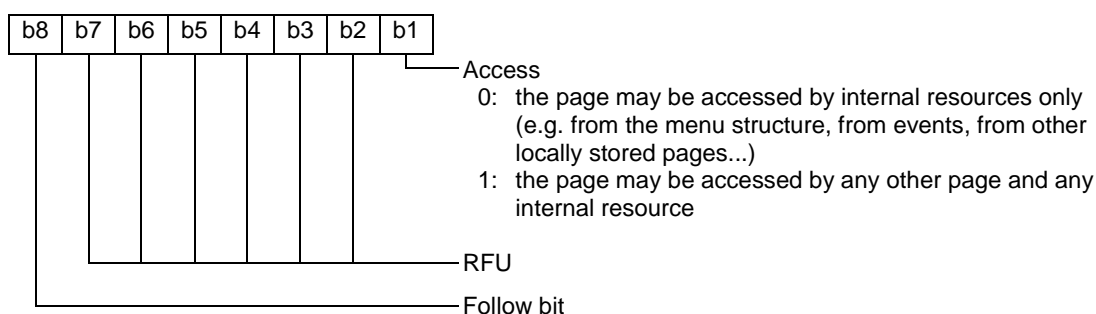

6.1.2.1.3 TAR Value UI-TLV

The TAR Value UI-TLV is used to link the locally stored page with a configuration within the Operational Pull Configuration Set. The TAR value provided by the USAT Interpreter system shall be available as a configuration in the Operational Pull Configuration Set. If no matching configuration is available, the USAT Interpreter shall issue the error "Configuration not available".

Coding:

Length	Value	Description	M/O
1	'42'	TAR Value UI-TLV tag	M
1	3	Length	M
3	Data	TAR Value	M

6.1.2.1.4 Page UI-TLV

The Page UI-TLV shall be constructed according to TS 31.113 [2].

6.1.2.1.5 Possible errors

Error Code	
No error	OK
Not enough memory, additional information: Remaining memory	Not enough memory to store the page. Remaining memory indicated.
Configuration not available	Provided TAR value is not contained in one of the configurations of the Operational Pull Configuration Set.

6.1.2.2 Remove Page

This command is used to remove a locally stored page from the page pool.

6.1.2.2.1 Coding of the Remove Page command

Length	Value	Description	M/O
1	'63' / 'E3'	Remove Page UI-TLV tag	M
1-3	A+B	Length	M
A	Data	Attributes	O
B	UI-TLV	Page Identification	M

6.1.2.2.2 Attributes

Coding of the attributes:

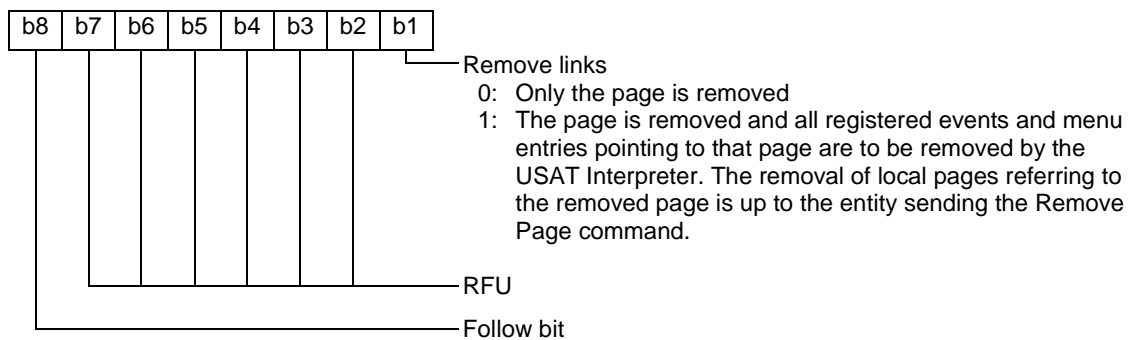

6.1.2.2.3 Page Identification UI-TLV

The Page Identification UI-TLV is used by the USAT Interpreter to find the page to be removed from the page pool and to find all local references to the page.

Coding: According to TS 31.113 [2].

6.1.2.2.4 Possible errors

Error Code	
No error	OK
No error, additional information result code: '6F05' reference to undefined	Referenced page not found For this case the USAT Interpreter shall not stop the execution of ADM request. Nevertheless this information shall be included in the response to the USAT Interpreter Gateway System.

6.1.2.3 Configure USAT Interpreter Entering Menu Title

This command is used to specify a text to be used in the menu structure of the UE to reach the menus provided by the USAT Interpreter. E.g. this text may be used as the alpha-identifier within a SETUP MENU USAT command.

Optionally a reference to an icon may be provided.

If and how this text is used by the USAT Interpreter to provide a menu entry to reach the USAT Interpreter system is up to the implementation of the USAT Interpreter and the card operating system and is out of the scope of the present document.

6.1.2.3.1 Coding of the Configure UI Entering Menu Title command

Length	Value	Description	M/O
1	'64'	Configure UI Entering Menu Title UI-TLV tag	M
1-3	A+B	Length	M
A	UI-TLV	Inline Value containing the text for the UI entering menu title	M
B	UI-TLV	Icon Identifier	O

6.1.2.3.2 Inline Value UI-TLV

The Inline Value UI-TLV contains the text and the DCS information to be used for the USAT Interpreter entering menu title. Variable references shall not be contained in this Inline Value UI-TLV.

Coding: According to TS 31.113 [2].

6.1.2.3.3 Icon Identifier UI-TLV

The Icon Identifier UI-TLV is used to provide a link to an icon which may optionally be used by the USAT Interpreter in conjunction with the USAT Interpreter entering menu title. See TS 31.111 [4].

Coding:

Length	Value	Description	M/O
1	'43'	Icon Identifier UI-TLV tag	M
1	2	Length	M
1	Icon Qualifier byte	as specified in TS 31.111 [4] as Icon Qualifier byte for the Icon Identifier Simple-TLV	M
1	Icon Identifier byte	as specified in TS 31.111 [4] as Icon Identifier byte for the Icon Identifier Simple-TLV	M

6.1.2.3.4 Possible errors

Error Code	
No error	OK, even if the text is not used by the USAT Interpreter
Not enough memory, additional information: Remaining memory	Not enough memory to store the text. Available memory indicated.

6.1.2.4 Configure Menu Text for Page

This command is used to specify the page to be executed, when the USAT Interpreter receives a menu selection related to the text provided in this command. The USAT Interpreter shall verify the existence of the page linked to this text.

If there is already a menu text with the same page identification as the one received in this UI-TLV then menu text of this UI-TLV shall overwrite the existing menu text.

If the user selects a menu entry established with this command, the USAT Interpreter shall execute the page which is linked to the menu entry and identified by the Page identification given in the command.

How the new menu entry is integrated into the menu structure of the UE by the USAT Interpreter is left to the implementation of the USAT Interpreter and the card operating system and is out of the scope of the present document.

When the change in the menu will be made available by the USAT Interpreter for the user is controlled by the "Refresh of menu structure requested by the Gateway System" attribute of the ADM Request.

6.1.2.4.1 Coding of the Configure Menu Text for Page command

Length	Value	Description	M/O
1	'65'	Configure Menu Text for Page UI-TLV tag	M
1-3	A+B	Length	M
A	UI-TLV	Inline Value containing the text for a menu item linked to the referenced page	M
B	UI-TLV	Page Identification	M

6.1.2.4.2 Inline Value UI-TLV

The Inline Value UI-TLV contains the text and the DCS information to be used for the USAT Interpreter menu entry linked to the page identified in the Page Identification UI-TLV. Variable references shall not be contained in this Inline Value UI-TLV.

Coding: According to TS 31.113 [2].

6.1.2.4.3 Page Identification UI-TLV

The Page Identification UI-TLV is used by the USAT Interpreter to identify the page to be linked with the menu entry text provided in the Inline Value UI-TLV.

Coding: According to TS 31.113 [2].

6.1.2.4.4 Possible errors

Error Code	
No error	OK
Reference to undefined	Page referenced not found.
Not enough memory, additional information: Remaining memory	Not enough memory to store the text. Available memory indicated.

6.1.2.5 Remove Menu Text for Page

This command is used to remove the item from the menu linked to the specified page, without removing the linked page itself.

When the change in the menu will be made available by the USAT Interpreter for the user is controlled by the "Refresh of menu structure requested by the Gateway System" attribute of the ADM Request.

6.1.2.5.1 Coding of the Remove Menu Text for Page command

Length	Value	Description	M/O
1	'66'	Remove Menu Text for Page UI-TLV tag	M
1-3	A	Length	M
A	UI-TLV	Page Identification	M

6.1.2.5.2 Page Identification UI-TLV

The Page Identification UI-TLV is used by the USAT Interpreter to identify the page for which the menu entry text and therefore the menu entry shall be removed.

Coding: According to TS 31.113 [2].

6.1.2.5.3 Possible errors

Error Code	
No error	OK
No error, additional information result code: '6F05' reference to undefined	The specified page is not referenced by any menu entry. For this case the USAT Interpreter shall not stop the execution of ADM request. Nevertheless this information shall be included in the response to the USAT Interpreter Gateway System.

6.1.2.6 Install Event

This command specifies the page to be executed, when specific events are detected by the UE. In order to be notified by the UE of the event, the USAT Interpreter or the card operating system shall issue the necessary USAT commands (e.g. SET UP EVENT LIST).

If there is already an event set up with the same Event Identifier as the one received in this UI-TLV then the Page Identification of this UI-TLV shall overwrite the existing Page Identification.

How the new event is integrated into the event handling of the UE by the USAT Interpreter is left to the implementation of the USAT Interpreter and the card operating system and is out of the scope of the present document.

When the change in the event handling will be made available by the USAT Interpreter for the UE is controlled by the "Refresh of event handling requested by the Gateway System" attribute of the ADM Request.

6.1.2.6.1 Coding of the Install Event command

Length	Value	Description	M/O
1	'67'	Install Event UI-TLV tag	M
1-3	1+A	Length	M
1	Data	Event Identifier, coded as specified in 3GPP TS 31.111 [4] for Event List TLV. Additional Event Identifier see below.	M
A	UI-TLV	Page Identification	M

6.1.2.6.2 Additional Event Identifier

In addition to the event identifiers specified in 3GPP TS 31.111 [2], the USAT Interpreter shall support the following USAT Interpreter specific internal events:

Event	Event Identifier Coding	Description
USAT Interpreter initialisation	'A0'	Issued once per initialisation of the USAT Interpreter
'A1' - 'AF'	RFU	

6.1.2.6.3 Page Identification UI-TLV

The Page Identification UI-TLV is used by the USAT Interpreter to identify the page which shall be executed after an event occurs.

Coding: According to TS 31.113 [2].

6.1.2.6.4 Possible errors

Error Code	
No error	OK
Reference to undefined	Page referenced not found.
Not enough memory, additional information: Remaining memory	Not enough memory to store the event. Available memory indicated.

6.1.2.7 Remove Event

This command removes an event from the current event list

Coding of the Remove Event command:

Length	Value	Description	M/O
1	'68'	Remove Event UI-TLV tag	M
1	1	Length	M
1	Data	Event Identifier, as specified in Install Event command	M

Possible errors:

Error Code	
No error	OK
No error, additional information result code: '6F05' reference to undefined	Event Identifier not in current event list. For this case the USAT Interpreter shall not stop the execution of ADM request. Nevertheless this information shall be included in the response to the USAT Interpreter Gateway System.

6.1.2.8 Modify Environment Variable

This command is used to modify the variables of the USIM issuer information partition. According to TS 31.113 [2] the variable IDs of this partition are in the range from '14' to '28'. The usage and the content of these variables are to be specified by the card issuer.

If a variable to be set by this command does not exist, the variable shall be created by the USAT Interpreter.

If a variable to be set by this command does exist already, the content provided by this command shall overwrite the previous content of the variable.

If the Inline Value UI-TLV is not available in the Modify Environment Variable UI-TLV, the variable referenced by the Variable ID shall be removed by the USAT Interpreter. If the referenced variable to be removed does not exist, no error shall be generated by the USAT Interpreter.

6.1.2.8.1 Coding of the Modify Environment Variable command

Length	Value	Description	M/O
1	'69'	Modify Environment Variable UI-TLV tag	M
1-3	1+A	Length	M
1	Data	Variable ID to store the content of the following Inline Value UI-TLV	M
A	UI-TLV	Inline Value containing the content for the variable	O

6.1.2.8.2 Variable ID

The Variable ID to be used to store the content of the corresponding Inline Value UI-TLV.

The valid range is '14' to '28'.

6.1.2.8.3 Inline Value UI-TLV

The Inline Value UI-TLV contains the content to be stored into the variable. Variable references shall not be contained in this Inline Value UI-TLV.

Coding: According to TS 31.113 [2].

6.1.2.8.4 Possible errors

Error Code	
No error	OK
Reference to undefined	The Variable ID is not in the specified range.
Not enough memory, additional information: Remaining memory	Not enough memory to store the variable. Available memory indicated.

6.1.2.9 Modify Wait State Message

This command is used to modify the default message to be shown during Wait State by the USAT Interpreter.

6.1.2.9.1 Coding of the Modify Wait State Message command

Length	Value	Description	M/O
1	'6A'	Modify Wait State Message UI-TLV tag	M
1-3	A	Length	M
A	UI-TLV	Inline Value containing the text for Wait State	M

6.1.2.9.2 Inline Value UI-TLV

The Inline Value UI-TLV contains the text and the DCS information to be used for the Wait State message. Variable references shall not be contained in this Inline Value UI-TLV.

Coding: According to TS 31.113 [2].

6.1.2.9.3 Possible errors

Error Code	
No error	OK
Not enough memory, additional information: Remaining memory	Not enough memory to store the text. Available memory indicated.

6.1.2.10 Modify Configuration Data

This command is used to modify the configuration data for a specific TAR value in the Push Operational or Pull Operational mode.

6.1.2.10.1 Coding of the Modify Configuration command

Length	Value	Description	M/O
1	'6B'	Modify Configuration Data UI-TLV tag	M
1-3	3+A	Length	M
3	Data	TAR Value of configuration to be changed	M
A	UI-TLV	Parameter List	M

6.1.2.10.2 TAR Value

This TAR value identifies the operational mode configuration to be modified. If the addressed operational configuration does not exist, the operational configuration shall be created and stored by the USAT Interpreter.

6.1.2.10.3 Parameter List

This UI-TLV contains the parameters to be created or modified by this command.

Coding of the Parameter List UI-TLV:

Length	Value	Description	M/O
1	'44'	Parameter List UI-TLV tag	M
1-3	A+ ... +Y	Length	M
A	Data	Parameter 1: coded as Index-Length-Value	O
...
Y	Data	Parameter n: coded as Index-Length-Value	O

General coding of parameters:

Length	Entry	Description	M/O
1	Index	One byte index value to identify the parameter Index value ranges: '00' - 'BF' reserved for usage in the present document 'C0' - 'FF' for proprietary use	M
1-3	A	Length coded according to the length coding rules for UI-TLVs	M
A	Data	Parameter data, coding according to the table below.	M

Coding of the configuration parameters:

6.1.2.10.3.1 Parameter: 23.048 Counter UI terminated

Description: see clause 5.3.1.1.

Length	Value	Description	M/O
1	'01'	Index value for 23.048 Counter UI terminated	M
1	5	Length of counter	M
5	Data	5 bytes, interpreted as a 40 bit binary value. The leftmost bit is the most significant bit. The leftmost byte is the most significant byte.	M

6.1.2.10.3.2 Parameter: 23.048 Counter UI originated

Description: see clause 5.3.1.1.

Length	Value	Description	M/O
1	'02'	Index value for 23.048 Counter UI originated	M
1	5	Length of counter	M
5	Data	5 bytes, interpreted as a 40 bit binary value. The leftmost bit is the most significant bit. The leftmost byte is the most significant byte.	M

6.1.2.10.3.3 Parameter: 23.048 KIC Keys

Description: see clause 5.3.1.1.

This parameter contains a list of up to 16 KIC keys. Each KIC key is specified by a KIC index value, the key value length and the key value itself. The length of the key value depends on the algorithm chosen for KIC. E.g. for DES, the key value would have a length of 8 bytes, for 3DES, the key value would have a length of 16 or 24 bytes, depending if 3DES is used in 2 key or 3 key mode.

Length	Value	Description	M/O
1	'03'	Index value for 23.048 Klc keys	M
1-3	1+A+B+ ... +1+X+Y	Length	M
1	Data	Klc Index coded as binary value in the range from '00' to '0F'	M
A(1-3)	Data	Klc key length in bytes, coded according to the length coding rules for UI-TLVs	M
B	Data	Klc key, binary data, coded according to the requirements of the intended Klc algorithm.	M
...
1	Data	Klc Index coded as binary value in the range from '00' to '0F'	O
X(1-3)	Data	Klc key length in bytes, coded according to the length coding rules for UI-TLVs	O
Y	Data	Klc key, binary data, coded according to the requirements of the intended Klc algorithm.	O

6.1.2.10.3.4 Parameter: 23.048 KID Keys

Description: see clause 5.3.1.1.

This parameter contains a list of up to 16 KID keys. Each KID key is specified by a KID index value, the key value length and the key value itself. The length of the key value depends on the algorithm chosen for KID. E.g. for DES, the key value would have a length of 8 bytes, for 3DES, the key value would have a length of 16 or 24 bytes, depending if 3DES is used in 2 key or 3 key mode.

Length	Value	Description	M/O
1	'04'	Index value for 23.048 KID keys	M
1-3	1+A+B+ ... +1+X+Y	Length	M
1	Data	KID Index coded as binary value in the range from '00' to '0F'	M
A(1-3)	Data	KID key length in bytes, coded according to the length coding rules for UI-TLVs	M
B	Data	KID key, binary data, coded according to the requirements of the intended Klc algorithm.	M
...
1	Data	KID Index coded as binary value in the range from '00' to '0F'	O
X(1-3)	Data	KID key length in bytes, coded according to the length coding rules for UI-TLVs	O
Y	Data	KID key, binary data, coded according to the requirements of the intended KID algorithm.	O

6.1.2.10.3.5 Parameter: SPI, Klc and KID bytes to be used for UI originated messages

Description: see clause 5.3.1.1.

Length	Value	Description	M/O
1	'05'	Index value for SPI, Klc and KID to be used for UI originated messages	M
1	4	Length	M
1	Data	First byte of SPI as specified in TS 23.048 [3]	M
1	Data	Second byte of SPI as specified in TS 23.048 [3]	M
1	Data	Klc byte as specified in TS 23.048 [3]	M
1	Data	KID byte as specified in TS 23.048 [3]	M

6.1.2.10.3.6 Parameter: SPI, Klc and KID list to be checked for UI terminated messages

Description: see clause 5.3.1.1.

The number of list entries is limited to 16.

Length	Value	Description	M/O
1	'06'	Index value for SPI, Klc and KID list to be checked for UI terminated messages	M
1	3 + ... + 3	Length	M
1	Data	First byte of SPI as specified in TS 23.048 [3]	M
1	Data	Klc byte as specified in TS 23.048 [3], only the least significant nibble is relevant	M
1	Data	KID byte as specified in TS 23.048 [3], only the least significant nibble is relevant	M
...
1	Data	First byte of SPI as specified in TS 23.048 [3]	O
1	Data	Klc byte as specified in TS 23.048 [3], only the least significant nibble is relevant	O
1	Data	KID byte as specified in TS 23.048 [3], only the least significant nibble is relevant	O

6.1.2.10.3.7 Parameter: USAT command list

Description: see clause 5.3.1.1.

Length	Value	Description	M/O
1	'07'	Index value for USAT command list	M
1	A	Length (1-32)	M
A	Data	USAT Command list bytes. Coding see below.	M

The coding of the USAT Command list is linked with the table in chapter "Type of command and next action indicator" of TS 31.111 [4]. For each possible value in that table one bit is assigned in the coding of the USAT Command list. Therefore the maximum length of the USAT command list is 32 bytes. If the USAT Command list is coded in less than 32 bytes, the missing bytes are assumed to have the value '00', indicating, that the corresponding USAT Commands are not allowed.

b1 of byte 1 of the USAT Command list shall be handled differently from the remaining bits and bytes of the USAT Command list:

If b1 of byte 1 is 0 then the USAT Command list shall be interpreted as specified below. If b1 of byte 1 is 1 then the USAT Interpreter shall allow the execution of all USAT Commands and all the remaining bits in the USAT Command list shall be ignored by the USAT Interpreter.

Byte 1 of USAT Command list:

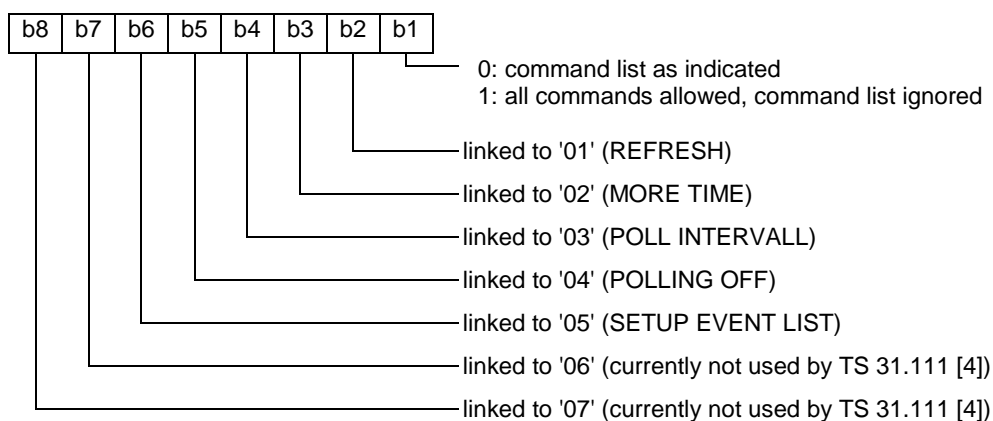

Byte 2 of USAT Command list:

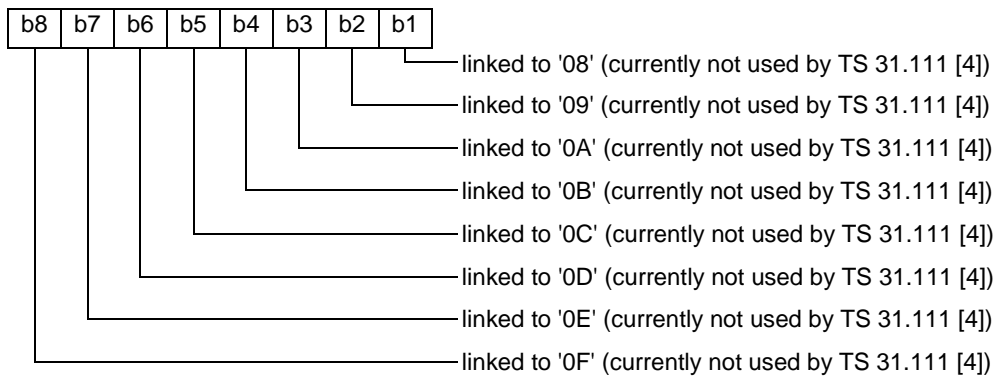

...

Byte 32 of USAT Command list:

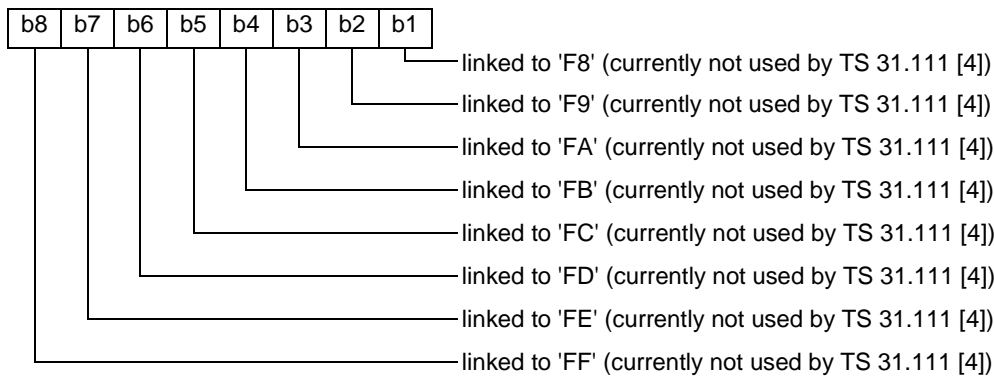

6.1.2.10.3.8 Parameter: USAT Interpreter byte code list

Description: see clause 5.3.1.1.

Length	Value	Description	M/O
1	'08'	Index value for USAT Interpreter byte code list	M
1	A	Length (1-4)	M
A	Data	USAT byte code list. Coding see below.	M

The coding of the USAT Interpreter byte code list is linked with the table in chapter "Tag Values" of TS 31.113 [2]. For each possible value in the range of '40' to '5F' in that table one bit is assigned in the coding of the USAT Interpreter byte code list. Therefore the maximum length of the USAT Interpreter byte code list is 4 bytes. If the USAT Interpreter byte code list is coded in less than 4 bytes, the missing bytes are assumed to have the value '00', indicating, that the corresponding USAT Interpreter commands are not allowed.

Byte 1 of USAT Interpreter byte code list:



...

Byte 4 of USAT Interpreter byte code list:

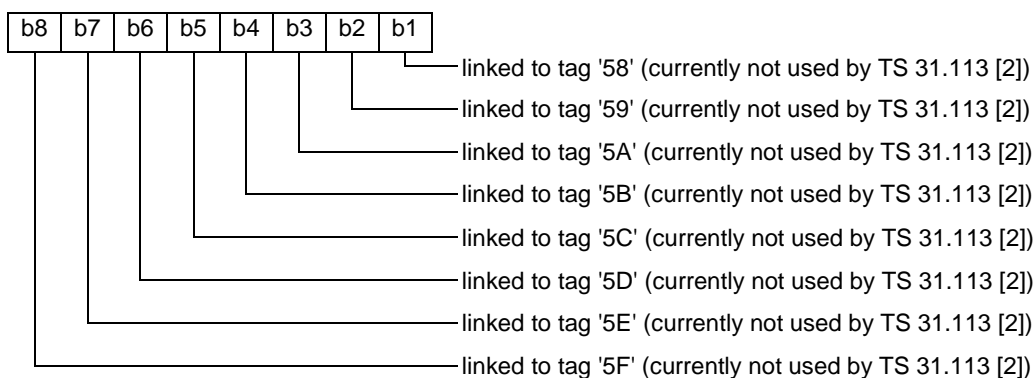

6.1.2.10.3.9 Parameter: Linked Pull TAR

Description: see clause 5.3.1.1.

Length	Value	Description	M/O
1	'09'	Index value for Linked Pull TAR	M
1	3	Length	M
3	Data	TAR value of Operational Pull Configuration Set	M

6.1.2.10.3.10 Parameter: Indication to a bearer specific data set

Description: see clause 5.3.1.1.

Length	Value	Description	M/O
1	'0A'	Index value for Bearer Specific Data Set	M
1	1	Length	M
1	Data	Bearer specific data set index. Coding: One byte binary value in the range '00' to 'FF'.	M

6.1.2.10.4 Possible errors

Error Code	
No error	OK
Bad TAR value	Provided TAR value is not in the range defined for the configurations of one of the operational configuration sets.
Not enough memory, additional information: Remaining memory	Not enough memory to create a new configuration or store data for an existing configuration. Available memory indicated.

6.1.2.11 Modify Bearer Data

This command is used to modify the configuration data for a specific bearer. Currently, only the SMS bearer is specified in the present document.

6.1.2.11.1 Coding of the Modify Bearer Data command

Length	Value	Description	M/O
1	'6C'	Modify Bearer Data UI-TLV tag	M
1-3	2+A	Length	M
1	Data	Bearer specific data set index, binary value coded on 1 byte in the range '00' to 'FF'.	M
1	Data	Type of bearer; coding: '00': SMS-PP bearer '01' - '7F': RFU '80' - 'FF': proprietary use	M
A	UI-TLV	Parameter List	M

6.1.2.11.2 Bearer specific data set index

This entry identifies the bearer specific data set to be modified. If the addressed bearer specific data set does not exist, the bearer specific data set shall be created and stored by the USAT Interpreter.

6.1.2.11.3 Type of bearer

This entry specifies the type of bearer for this bearer specific data set. The following list of parameters is to be interpreted according to this entry.

6.1.2.11.4 Parameter List for SMS bearer

This UI-TLV contains the SMS bearer parameters to be created or modified by this command.

The type of bearer byte in the Modify Bearer Data UI-TLV shall be set to '00', indicating the SMS-PP bearer.

Coding of the parameter list: See clause 6.1.2.10.3.

Parameter: SMS Access Data

This parameter specifies the SMS access data to be used by the USAT Interpreter for UI originated SMS to access the security node.

Length	Value	Description	M/O
1	'0B'	Index value for SMS access data	M
1	'1C'	Length	M
12	Data	TP-Destination Address	M
12	Data	TS-Service Centre Address	M
1	Data	TP-Protocol Identifier	M
1	Data	TP-Data Coding Scheme	M
1	Data	TP-Validity Period	M
1	Data	First byte of TPDU	M

Coding:

Field	Contents	Coding
TP-Destination Address	As defined for SM-TL address fields in TS 23.040 [6]	Unused nibbles are set to 'F'.
TS-Service Centre Address	RP-Destination Address for the Service Centre as defined in TS 24.011 [8]	Unused nibbles are set to 'F'.
TP-Protocol Identifier	As defined in TS 23.040 [6]	
TP-Data Coding Scheme	As defined in TS 23.038 [7]	
TP-Validity Period	As defined in TS 23.040 [6] for the relative time format	
First Byte of TPDU	As defined in TS 23.040 [6]; includes TP- MTI, TP-RD, TP-VPF, TP-RP, TP-UDHI and TP-SRR	'51' if UDHI is set (standard) '11' if UDHI is not set

6.1.2.11.5 Parameter List for other bearers

This is for further study.

6.1.2.11.6 Possible errors

Error Code	
No error	OK
Not enough memory, additional information: Remaining memory	Not enough memory to create a new data set or to store data for an existing data set. Available memory indicated.

6.1.2.12 Install Plug-In

This command is used to extend the functionality of the USAT Interpreter by installing plug-ins. It is strongly recommended, that the loaded code contains a strong authentication which should be checked by the USAT Interpreter in order to install and activate the plug-in. This authentication should verify the source of the code, not just the administration entity in the USAT Interpreter Gateway system sending the command.

The usage and specification of that authentication is out of the scope of the present document.

The handling of downloading plug-in code which exceeds the size of a single secured message (e.g. the USAT Interpreter System may not be able to handle single secured messages of arbitrary length) is out of the scope of the present document. The downloaded code may contain information to handle storage and concatenation of such messages.

If a plug-in is installed successfully by the USAT Interpreter, the NCI value (see TS 31.113 [2]) shall be reflected in the USAT Interpreter system information variable '03' (USAT Interpreter native commands, see TS 31.113 [2]).

If the NCI value given in the Install Plug-in command is already used by an installed plug-in, an error shall be generated. To overwrite an existing plug-in, the Remove Plug-in command shall be used first.

Another mechanism for installing plug-in functionality may be used, namely the mechanism for application (e.g. applet) management as specified in TS 23.048 [3].

6.1.2.12.1 Coding of the Install Plug-In command

Length	Value	Description	M/O
1	'6D'	Install Plug-In UI-TLV tag	M
1-3	2+A	Length	M
2	Data	NCI value for the plug-in to be installed, see TS 31.113 [2]	M
A	UI-TLV	Plug-in Installation Data	M

6.1.2.12.2 Plug-in Installation Data UI-TLV

The Plug-in Installation Data UI-TLV contains the necessary information to make the plug-in available. The coding and contents of the value part of this UI-TLV is out of the scope of the present document. The value part may contain data to verify the source of the information and data to provide means to split the information necessary for the plug-in functionality to several Install Plug-In commands.

Coding:

Length	Value	Description	M/O
1	'46'	Plug-In Installation Data UI-TLV tag	M
1-3	A	Length	M
A	Data	Data representing the plug-in installation data	M

6.1.2.12.3 Possible errors

Error Code	
No error	OK
NCI already in use	The NCI value is already used by another plug-in
Not enough memory, additional information: Remaining memory	Not enough memory to the plug-in. Available memory indicated.

6.1.2.13 Remove Plug-In

This command is used to remove an existing Plug-In.

Another mechanism for removing plug-in functionality may be used, namely the mechanism for application (e.g. applet) management as specified in TS 23.048 [3].

6.1.2.13.1 Coding of the Remove Plug-In command

Length	Value	Description	M/O
1	'6E'	Remove Plug-In UI-TLV tag	M
1	2	Length	M
2	Data	NCI value for the plug-in to be removed	M

6.1.2.13.2 Possible errors

Error Code	
No error	OK
No error, additional information result code: '6F05' reference to undefined	Plug-in with given NCI value not found. For this case the USAT Interpreter shall not stop the execution of ADM request. Nevertheless this information shall be included in the response to the USAT Interpreter Gateway System.

6.2 ADM Response

The USAT Interpreter shall generate an ADM Response UI-TLV contained in an UIO BER-TLV for Administration Messages and shall send this message back to the USAT Interpreter Gateway System. See clauses 5.4.2 and 5.3.1.4.

The ADM Response contains the list of results of each command executed within the ADM Request in the order given in the ADM Request.

The USAT Interpreter shall generate an ADM Response UI-TLV after execution of the command list.

If an error occurs during the execution of the ADM commands no further ADM commands of that ADM Request are executed. Nevertheless the ADM Response shall be sent.

For some results additional information shall be provided by the USAT Interpreter according to clause 6.3.

6.2.1 ADM Response Structure

Length	Value	Description	M/O
1	'61'	ADM Response UI-TLV tag	M
1-3	A+...+X	Length	M
A	UI-TLV	ADM Result 1	M
...		...	
X	UI-TLV	ADM Result n	O

The ADM results shall be given in the order of the corresponding ADM commands.

6.2.2 ADM Result UI-TLV

Length	Value	Description	M/O
1	'45'	ADM Result UI-TLV tag	M
1-3	2+A	Length	M
2	Data	Result code, binary coded in 2 bytes, according to clause 6.3	M
A	Data	Additional information depending on the result code, according to clause 6.3	O

6.3 Error coding

For the indication of errors occurring during execution of administration commands, error codes listed in the following table shall be used by the USAT Interpreter.

Type of error	Coding	Additional information (for ADM Responses only)
No error	'0000'	'XXXX' result code as specified for some ADM commands
Problem in memory management	'6F03'	-
Security problem	'6F04'	-
Reference to undefined	'6F05'	-
USAT administration command not allowed	'6F0A'	-
Modify configuration not allowed	'6F0B'	-
Not enough memory	'6F20'	'XXXX' Memory available binary coded in 2 bytes
Administration command not known	'6F21'	-
Configuration not available	'6F22'	-
Bad TAR value	'6F23'	-
NCI value already in use	'6F24'	-

7 Used tag values

7.1 BER-TLV tag values

Description	Value
UIO Pull Request BER-TLV	'C0'
UIO Administration Message BER-TLV	'C1'
GO Pull Response BER-TLV	'C2'
GO Push BER-TLV	'C3'
GO Administration Message BER-TLV	'C4'

7.2 UI-TLV tag values

Description	Value
Reserved for data structures in TS 31.113 [2]	'01' to '3F'
RequestID UI-TLV tag	'40'
Additional Information UI-TLV tag	'41'
TAR Value UI-TLV	'42'
Icon Identifier UI-TLV	'43'
Parameter List UI-TLV	'44'
ADM Result UI-TLV	'45'
Plug-In Installation Data UI-TLV	'46'
RFU for data structures specified in the present document	'47' to '5F'
ADM Request UI-TLV	'60' / 'E0'
ADM Response UI-TLV	'61'
Install Page UI-TLV	'62' / 'E2'
Remove Page UI-TLV	'63' / 'E3'
Configure UI Entering Menu Title UI-TLV	'64'
Configure Menu Text for Page UI-TLV	'65'
Remove Menu Text for Page UI-TLV	'66'
Install Event UI-TLV	'67'
Remove Event UI-TLV	'68'
Modify Environment Variable UI-TLV	'69'
Modify Wait State Message UI-TLV	'6A'
Modify Configuration Data UI-TLV	'6B'
Modify Bearer Data UI-TLV	'6C'
Install Plug-In UI-TLV	'6D'
Remove Plug-In UI-TLV	'6E'
RFU for commands specified in the present document	'6F' to '7F'

Annex A (informative): Change history

The table below indicates all change requests that have been incorporated into the present document since it was initially approved by 3GPP TSG-T.

Change history								
Date	TSG #	TSG Doc.	CR	Rev	Cat	Subject/Comment	Old	New
2002-03	TP-15	TP-020077	-	-	-	Version 2.0.0 was approved at TSG-T #15	2.0.0	5.0.0
2002-06	TP-16	TP-020116	001		F	Clarification on the USAT Interpreter behaviour if the indicated access mode of a gateway originated message does not match with the tag in transport layer	5.0.0	5.1.0
			002		C	Proof of Receipt management modification		
2002-09	TP-17	TP-020214	003	-	F	Handling of operational pull messages and post mode	5.1.0	5.2.0
2003-03	TP-19	TP-030022	004	-	F	Correction on Byte Code List Value	5.2.0	5.3.0

History

Document history		
V5.0.0	March 2002	Publication
V5.1.0	June 2002	Publication
V5.2.0	September 2002	Publication
V5.3.0	March 2003	Publication