

ETSI TS 129 551 V15.0.0 (2018-07)



**5G;  
5G System;  
Packet Flow Description Management Service;  
Stage 3  
(3GPP TS 29.551 version 15.0.0 Release 15)**



---

Reference

DTS/TSGC-0329551vf00

---

Keywords

5G

**ETSI**

650 Route des Lucioles  
F-06921 Sophia Antipolis Cedex - FRANCE

Tel.: +33 4 92 94 42 00 Fax: +33 4 93 65 47 16

Siret N° 348 623 562 00017 - NAF 742 C  
Association à but non lucratif enregistrée à la  
Sous-Préfecture de Grasse (06) N° 7803/88

---

**Important notice**

The present document can be downloaded from:

<http://www.etsi.org/standards-search>

The present document may be made available in electronic versions and/or in print. The content of any electronic and/or print versions of the present document shall not be modified without the prior written authorization of ETSI. In case of any existing or perceived difference in contents between such versions and/or in print, the only prevailing document is the print of the Portable Document Format (PDF) version kept on a specific network drive within ETSI Secretariat.

Users of the present document should be aware that the document may be subject to revision or change of status.

Information on the current status of this and other ETSI documents is available at

<https://portal.etsi.org/TB/ETSIDeliverableStatus.aspx>

If you find errors in the present document, please send your comment to one of the following services:

<https://portal.etsi.org/People/CommiteeSupportStaff.aspx>

---

**Copyright Notification**

No part may be reproduced or utilized in any form or by any means, electronic or mechanical, including photocopying and microfilm except as authorized by written permission of ETSI.

The content of the PDF version shall not be modified without the written authorization of ETSI.

The copyright and the foregoing restriction extend to reproduction in all media.

© ETSI 2018.

All rights reserved.

**DECT™**, **PLUGTESTS™**, **UMTS™** and the ETSI logo are trademarks of ETSI registered for the benefit of its Members.

**3GPP™** and **LTE™** are trademarks of ETSI registered for the benefit of its Members and of the 3GPP Organizational Partners.

**oneM2M** logo is protected for the benefit of its Members.

**GSM®** and the GSM logo are trademarks registered and owned by the GSM Association.

---

# Intellectual Property Rights

## Essential patents

IPRs essential or potentially essential to normative deliverables may have been declared to ETSI. The information pertaining to these essential IPRs, if any, is publicly available for **ETSI members and non-members**, and can be found in ETSI SR 000 314: *"Intellectual Property Rights (IPRs); Essential, or potentially Essential, IPRs notified to ETSI in respect of ETSI standards"*, which is available from the ETSI Secretariat. Latest updates are available on the ETSI Web server (<https://ipr.etsi.org/>).

Pursuant to the ETSI IPR Policy, no investigation, including IPR searches, has been carried out by ETSI. No guarantee can be given as to the existence of other IPRs not referenced in ETSI SR 000 314 (or the updates on the ETSI Web server) which are, or may be, or may become, essential to the present document.

## Trademarks

The present document may include trademarks and/or tradenames which are asserted and/or registered by their owners. ETSI claims no ownership of these except for any which are indicated as being the property of ETSI, and conveys no right to use or reproduce any trademark and/or tradename. Mention of those trademarks in the present document does not constitute an endorsement by ETSI of products, services or organizations associated with those trademarks.

---

# Foreword

This Technical Specification (TS) has been produced by ETSI 3rd Generation Partnership Project (3GPP).

The present document may refer to technical specifications or reports using their 3GPP identities, UMTS identities or GSM identities. These should be interpreted as being references to the corresponding ETSI deliverables.

The cross reference between GSM, UMTS, 3GPP and ETSI identities can be found under <http://webapp.etsi.org/key/queryform.asp>.

---

# Modal verbs terminology

In the present document "**shall**", "**shall not**", "**should**", "**should not**", "**may**", "**need not**", "**will**", "**will not**", "**can**" and "**cannot**" are to be interpreted as described in clause 3.2 of the [ETSI Drafting Rules](#) (Verbal forms for the expression of provisions).

"**must**" and "**must not**" are **NOT** allowed in ETSI deliverables except when used in direct citation.

# Contents

Intellectual Property Rights .....	2
Foreword.....	2
Modal verbs terminology.....	2
Foreword.....	5
1 Scope .....	6
2 References .....	6
3 Definitions, symbols and abbreviations .....	6
3.1 Definitions .....	6
3.2 Abbreviations .....	7
4 Packet Flow Description Management Service.....	7
4.1 Service Description .....	7
4.1.1 Overview .....	7
4.1.2 Service Architecture .....	7
4.1.3 Network Functions.....	8
4.1.3.1 Packet Flow Description Function (PFDf) .....	8
4.1.3.2 NF Service Consumers.....	8
4.2 Service Operations .....	8
4.2.1 Introduction.....	8
4.2.2 Nnef_PFDmanagement_Fetch Service Operation .....	8
4.2.2.1 General .....	8
4.2.2.2 Retrieval of PFDs.....	8
4.2.3 Nnef_PFDmanagement_Subscribe Service Operation .....	9
4.2.3.1 General .....	9
4.2.3.2 Subscription for event notifications on PFDs change .....	9
4.2.4 Nnef_PFDmanagement_Notify Service Operation.....	10
4.2.4.1 General .....	10
4.2.4.2 Notification of PFD change.....	10
4.2.5 Nnef_PFDmanagement_Unsubscribe Service Operation .....	11
4.2.5.1 General .....	11
4.2.5.2 Unsubscribe from event notifications on PFDs change.....	11
5 Nnef_PFDmanagement API.....	11
5.1 Introduction .....	11
5.2 Usage of HTTP.....	12
5.2.1 General.....	12
5.2.2 HTTP standard headers.....	12
5.2.2.1 General .....	12
5.2.2.2 Content type .....	12
5.2.3 HTTP custom headers.....	12
5.3 Resources .....	12
5.3.1 Resource Structure .....	12
5.3.2 Resource: PFD of applications.....	13
5.3.2.1 Description .....	13
5.3.2.2 Resource definition .....	13
5.3.2.3 Resource Standard Methods.....	13
5.3.2.3.1 GET .....	13
5.3.2.4 Resource Custom Operations .....	14
5.3.3 Resource: Individual application PFD .....	14
5.3.3.1 Description .....	14
5.3.3.2 Resource definition .....	14
5.3.3.3 Resource Standard Methods.....	14
5.3.3.3.1 GET .....	14
5.3.3.4 Resource Custom Operations .....	14
5.3.4 Resource: PFD subscriptions .....	15
5.3.4.1 Description .....	15

5.3.4.2	Resource definition .....	15
5.3.4.3	Resource Standard Methods.....	15
5.3.4.3.1	POST .....	15
5.3.4.4	Resource Custom Operations .....	15
5.3.5	Resource: Individual PFD subscription .....	16
5.3.5.1	Description .....	16
5.3.5.2	Resource definition .....	16
5.3.5.3	Resource Standard Methods.....	16
5.3.5.3.1	DELETE.....	16
5.3.5.4	Resource Custom Operations .....	16
5.4	Custom Operations without associated resources.....	16
5.5	Notifications .....	16
5.5.1	General.....	16
5.5.2	PFD Change Notification.....	17
5.5.2.1	Description .....	17
5.5.2.2	Target URI .....	17
5.5.2.3	Standard Methods .....	17
5.5.2.3.1	POST .....	17
5.6	Data Model.....	18
5.6.1	General.....	18
5.6.2	Structured data types.....	18
5.6.2.1	Introduction .....	18
5.6.2.2	Type: PfdDataForApp.....	18
5.6.2.3	Type: PfdSubscription.....	19
5.6.2.4	Type: PfdChangeNotification .....	19
5.6.2.5	Type: PfdContent .....	19
5.6.2.6	Type: PfdChangeReport.....	20
5.6.3	Simple data types and enumerations.....	20
5.6.3.1	Introduction .....	20
5.6.3.2	Simple data types .....	20
5.6.3.3	Enumeration: <EnumType1>.....	20
5.6.3.4	Enumeration: <EnumType2>.....	20
5.7	Error handling .....	20
5.7.1	General.....	20
5.7.2	Protocol Errors.....	21
5.7.3	Application Errors .....	21
5.8	Feature negotiation.....	21
<b>Annex A (normative):    OpenAPI specification.....</b>		<b>22</b>
A.1	General .....	22
A.2	Nnef_PFDmanagement API.....	22
<b>Annex B (informative):    Change history .....</b>		<b>26</b>
History .....		27

---

# Foreword

This Technical Specification has been produced by the 3rd Generation Partnership Project (3GPP).

The contents of the present document are subject to continuing work within the TSG and may change following formal TSG approval. Should the TSG modify the contents of the present document, it will be re-released by the TSG with an identifying change of release date and an increase in version number as follows:

Version x.y.z

where:

- x the first digit:
  - 1 presented to TSG for information;
  - 2 presented to TSG for approval;
  - 3 or greater indicates TSG approved document under change control.
- y the second digit is incremented for all changes of substance, i.e. technical enhancements, corrections, updates, etc.
- z the third digit is incremented when editorial only changes have been incorporated in the document.

---

# 1 Scope

The present document provides the stage 3 specification of the PFD Management Service of 5G system.

The stage 2 definition and related procedures of the PFD Management Service are contained in 3GPP TS 23.502 [3] and 3GPP TS 23.503 [4]. The 5G System Architecture is defined in 3GPP TS 23.501 [2].

The Technical Realization of the Service Based Architecture and the Principles and Guidelines for Services Definition of the 5G System are specified in 3GPP TS 29.500 [5] and 3GPP TS 29.501 [6].

The Packet Flow Description Function (PFDF) provides the PFD Management Service to the NF consumers (i.e. Session Management Function). The PFDF is functionality within the NEF.

---

# 2 References

The following documents contain provisions which, through reference in this text, constitute provisions of the present document.

- References are either specific (identified by date of publication, edition number, version number, etc.) or non-specific.
- For a specific reference, subsequent revisions do not apply.
- For a non-specific reference, the latest version applies. In the case of a reference to a 3GPP document (including a GSM document), a non-specific reference implicitly refers to the latest version of that document *in the same Release as the present document*.

- [1] 3GPP TR 21.905: "Vocabulary for 3GPP Specifications".
- [2] 3GPP TS 23.501: "System Architecture for the 5G System; Stage 2".
- [3] 3GPP TS 23.502: "Procedures for the 5G System; Stage 2".
- [4] 3GPP TS 23.503: "Policy and Charging Control Framework for the 5G System; Stage 2".
- [5] 3GPP TS 29.500: "5G System; Technical Realization of Service Based Architecture; Stage 3".
- [6] 3GPP TS 29.501: "5G System; Principles and Guidelines for Services Definition; Stage 3".
- [7] IETF RFC 7540: "Hypertext Transfer Protocol Version 2 (HTTP/2)".
- [8] IETF RFC 8259: "The JavaScript Object Notation (JSON) Data Interchange Format".
- [9] OpenAPI: "OpenAPI 3.0.0 Specification", <https://github.com/OAI/OpenAPI-Specification/blob/master/versions/3.0.0.md>.
- [10] 3GPP TS 29.571: "5G System; Common Data Types for Service Based Interfaces Stage 3".
- [11] 3GPP TS 29.122: "T8 reference point for Northbound APIs".
- [12] 3GPP TS 29.251: "Gw and Gwn reference points for sponsored data connectivity".

---

# 3 Definitions, symbols and abbreviations

## 3.1 Definitions

For the purposes of the present document, the terms and definitions given in 3GPP TR 21.905 [1] and the following apply. A term defined in the present document takes precedence over the definition of the same term, if any, in 3GPP TR 21.905 [1].

## 3.2 Abbreviations

For the purposes of the present document, the abbreviations given in 3GPP TR 21.905 [1] and the following apply. An abbreviation defined in the present document takes precedence over the definition of the same abbreviation, if any, in 3GPP TR 21.905 [1].

API	Application Programming Interface
HTTP	Hypertext Transfer Protocol
NF	Network Function
PFDF	Packet Flow Description Function

# 4 Packet Flow Description Management Service

## 4.1 Service Description

### 4.1.1 Overview

The PFD Management Service, as defined as defined in 3GPP TS 23.501 [2], 3GPP TS 23.502 [3] and 3GPP TS 23.503 [4], is provided by the Packet Flow Description Function (PFDF).

The only known NF Service Consumer is the SMF.

This service:

- allows an SMF to subscribe to and unsubscribe from PFD changes;
- notifies an SMF about the changed PFDs; and
- allows an SMF to retrieve PFDs.

### 4.1.2 Service Architecture

The 5G System Architecture is defined in 3GPP TS 23.501 [2]. The Policy and Charging related 5G architecture is also described in 3GPP TS 23.503 [4].

The PFD Management Service is provided by the PFDF to the SMF and shown in the SBI representation model in Figure 4.1.2-1. PFDF is functionality within NEF.

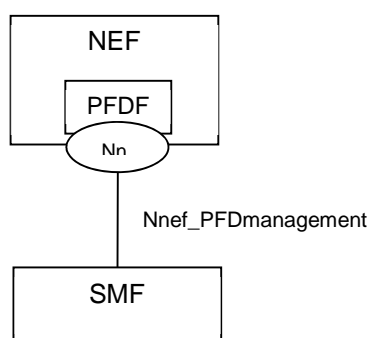

Figure 4.1.2-1: Reference Architecture for the Nnef\_PFDmanagement Service; SBI representation



Figure 4.1.2-2: Reference Architecture for the Nnef\_PFDmanagement Service; reference point representation



## 4.1.3 Network Functions

### 4.1.3.1 Packet Flow Description Function (PFDF)

The Packet Flow Description Function (PFDF):

- provides PFDs associated with one or more Application Identifiers; and
- allows NF consumers to subscribe to and unsubscribe from the notification of changes of PFDs for Application Identifier.

### 4.1.3.2 NF Service Consumers

The SMF shall support:

- requesting and receiving the PFD(s) for one or more Application Identifiers.

## 4.2 Service Operations

### 4.2.1 Introduction

Service operations defined for the Nnef\_PFDmanagement Service are shown in table 4.2.1-1.

**Table 4.2.1-1: Nnef\_PFDmanagement Service Operations**

Service Operation Name	Description	Initiated by
Nnef_PFDmanagement_Fetch	Provides the PFDs for application identifier(s) to the NF service consumer.	SMF
Nnef_PFDmanagement_Subscribe	Allows NF service consumers to subscribe the notification of events when the PFDs for application identifier change.	SMF
Nnef_PFDmanagement_Notify	Notifies NF service consumer to update and/or delete the PFDs for application identifier(s).	PFDF
Nnef_PFDmanagement_Unsubscribe	Allows NF service consumers to unsubscribe the notification of events.	SMF

### 4.2.2 Nnef\_PFDmanagement\_Fetch Service Operation

#### 4.2.2.1 General

The Nnef\_PFDmanagement\_Fetch service operation provides a means for the NF service consumer to retrieve the PFDs for one or more application identifier(s).

The following procedures using the Nnef\_PFDmanagement\_Fetch service operation are supported:

- Retrieval of PFDs.

#### 4.2.2.2 Retrieval of PFDs

This procedure as shown in Figure 4.2.2.2-1 is used to retrieve PFDs for an application identifier from the PFDF.

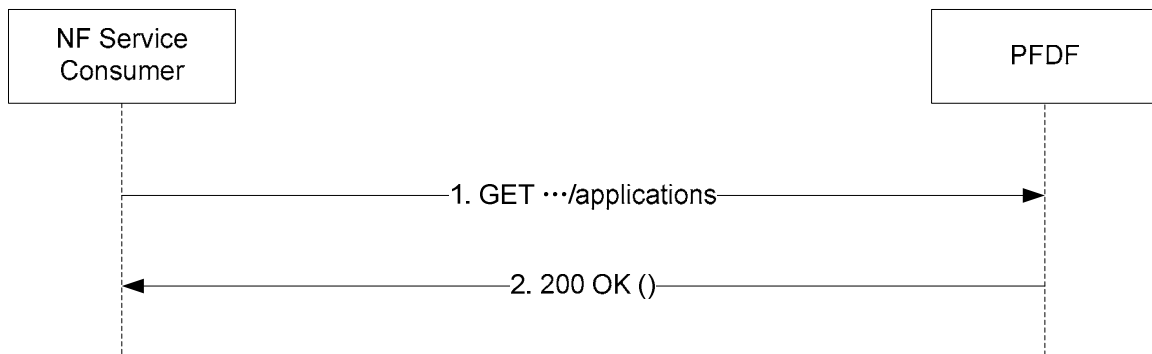

**Figure 4.2.2.2-1: Retrieval of PFDs**

1. The NF service consumer (i.e. SMF) shall send a GET request to the resource representing the PFD for application identifier(s) to be required:
  - for PFD of individual application identifier, the request URI shall include "{apiRoot}/nnef-pfdmanagement/v1/applications/{appId}";
  - for PFD of all application identifiers, the request URI shall include "{apiRoot}/nnef-pfdmanagement/v1/applications"; and
  - for PFD of a collection application identifiers, the request URI shall include "{apiRoot}/nnef-pfdmanagement/v1/applications/" with query parameters indicating the requested application identifiers.
2. On success, "200 OK" shall be returned; the payload body of GET response shall contain a representation of "Individual application PFD" resource or "PFD of applications" resource for the requested application identifier(s). If the resource of one or more requested application identifier(s) is not provided in the response, the SMF shall remove the PFD(s) of the requested application identifier(s) which is not included in the response.

On failure, one of the HTTP status code listed in table 5.3.2.3.1-3 or table 5.3.3.3.1-3 shall be returned. For "404 Not Found", the NF service consumer shall remove:

- all the PFD(s) existing in the NF service consumer if the request is for PFD of all application identifiers;
- the PFD(s) of the requested application identifier(s) in the NF service consumer if the request is for PFD of individual application identifier or a collection of application identifiers.

## 4.2.3 Nnef\_PFDmanagement\_Subscribe Service Operation

### 4.2.3.1 General

The Nnef\_PFDmanagement\_Subscribe service operation enables NF service consumer to subscribe the notification of events when the PFDs for application identifier change.

### 4.2.3.2 Subscription for event notifications on PFDs change

This procedure as shown in Figure 4.2.3.2-1 is used to subscribe the notification of events when the PFDs for application identifier change.

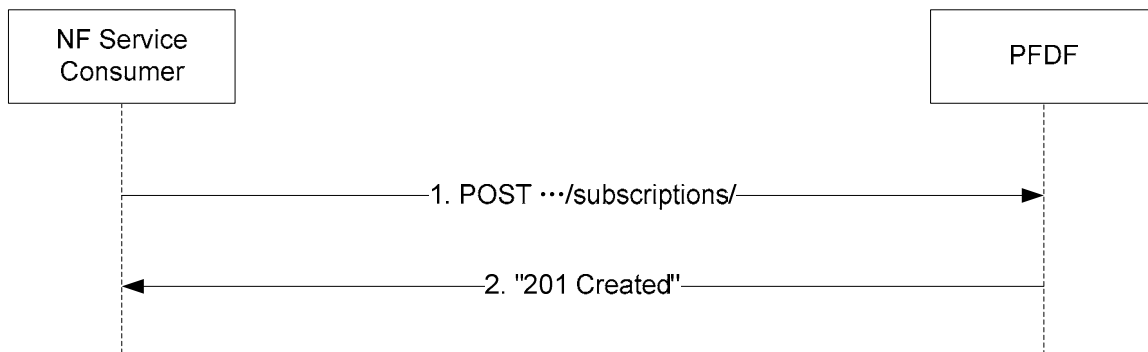

**Figure 4.2.3.2-1: Creation of a subscription**

1. The NF service consumer (i.e. SMF) shall send a POST request to the request URI representing the PFD subscriptions resource "{apiRoot}/nnef-pfdmanagement/v1/subscriptions". The request payload body shall include:
  - subscribed application identifier(s) optionally; and;
  - an URI where to receive the requested notifications as "notifyUri" attribute.
2. If the request is accepted, the PFD shall:
  - create a new subscription;
  - assign an subscriptionId;
  - store the subscription; and
  - send the response with "201 Created". The payload body shall contain a representation of the created subscription, and the Location header shall contain the URI of the created subscription "{apiRoot}/nnef-pfdmanagement/v1/subscriptions/{subscriptionId}".

Otherwise, one of the HTTP status code listed in table 5.3.4.3.1-3 shall be returned.

## 4.2.4 Nnef\_PFDmanagement\_Notify Service Operation

### 4.2.4.1 General

The Nnef\_PFDmanagement\_Notify service operation notifies the NF service consumer to update and/or delete the PFDs for application identifier(s).

The following procedures using the Nnef\_PFDmanagement\_Notify service operation are supported:

- Management of PFDs.

### 4.2.4.2 Notification of PFD change

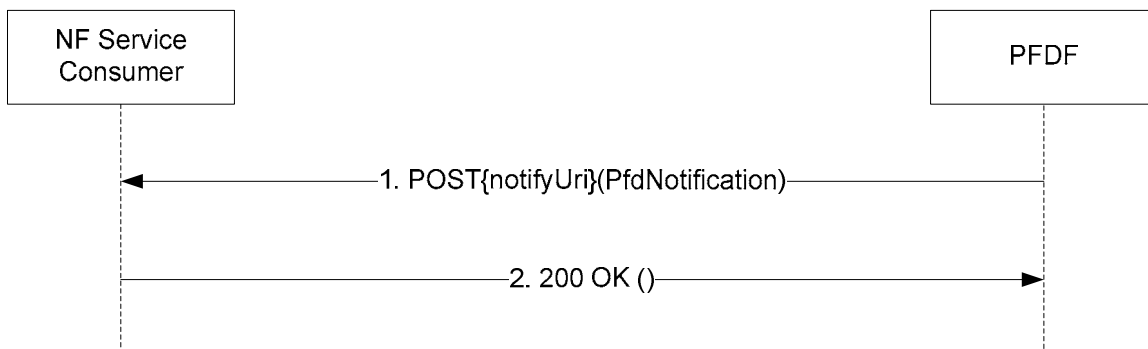

**Figure 4.2.4.2-1: Notification of PFD change**

1. The PFDf shall send a POST request to the NF service consumer (i.e. SMF) using the notifyUri provided during creation of the subscription resource as specified in subclause 5.6.2.3. The payload body of the POST request shall contain the PfdChangeNotification data structure.
2. If the notification is accepted, the NF service consumer shall reply with:
  - "204 No Content" indicating the successful provisioning of all PFDs; or
  - "200 OK" and the payload body of the response shall contain "PfdChangeReport" with detailed information of failed application(s)..

Otherwise, one of the HTTP status code listed in table 5.5.2.3.1-3 shall be returned.

## 4.2.5 Nnef\_PFDmanagement\_Unsubscribe Service Operation

### 4.2.5.1 General

The Nnef\_PFDmanagement\_Unsubscribe service operation is used by the NF service consumer to unsubscribe the notification of events.

### 4.2.5.2 Unsubscribe from event notifications on PFDs change

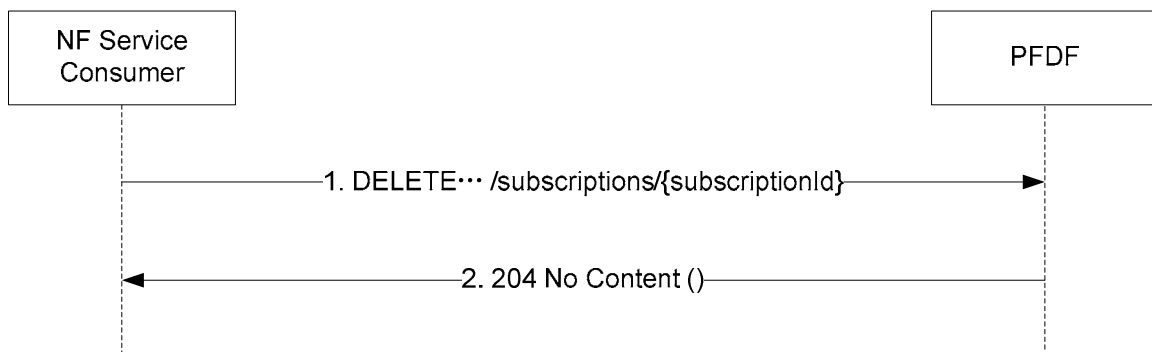

**Figure 4.2.5.2-1: Unsubscribe from event notifications on PFDs change**

1. The NF Service Consumer (i.e. SMF) shall send a DELETE request to the resource URI representing the individual PFD subscription. The request body shall be empty.
2. If the request is accepted, "204 No Content" shall be returned. The response body shall be empty.

Otherwise, one of the HTTP status code listed in table 5.3.5.3.1-3 shall be returned.

## 5 Nnef\_PFDmanagement API

### 5.1 Introduction

The Packet Flow Description Management Service shall use the Nnef\_PFDmanagement API.

The request URI used in HTTP request from the NF service consumer towards the PFDf shall have the structure defined in subclause 4.4.1 of 3GPP TS 29.501 [2], i.e.:

**{apiRoot}/{apiName}/{apiVersion}/{apiSpecificResourceUriPart}**

with the following components:

- The {apiRoot} shall be set as described in 3GPP TS 29.501 [2].
- The {apiName} shall be "nnef-pfdmanagement".
- The {apiVersion} shall be "v1".
- The {apiSpecificResourceUriPart} shall be set as described in subclause 5.3.

## 5.2 Usage of HTTP

### 5.2.1 General

HTTP/2, IETF RFC 7540 [7], shall be used as specified in subclause 5.2 of 3GPP TS 29.500 [5].

HTTP/2 shall be transported as specified in subclause 5.3 of 3GPP TS 29.500 [5].

The OpenAPI [9] specification of HTTP messages and content bodies for the Nnef\_PFDmanagement service is contained in Annex A.

### 5.2.2 HTTP standard headers

#### 5.2.2.1 General

See subclause 5.2.2 of 3GPP TS 29.500 [5] for the usage of HTTP standard headers.

#### 5.2.2.2 Content type

JSON, IETF RFC 8259 [8], shall be used as content type of the HTTP bodies specified in the present specification, as specified in subclause 5.4 of 3GPP TS 29.500 [5].

### 5.2.3 HTTP custom headers

None

## 5.3 Resources

### 5.3.1 Resource Structure

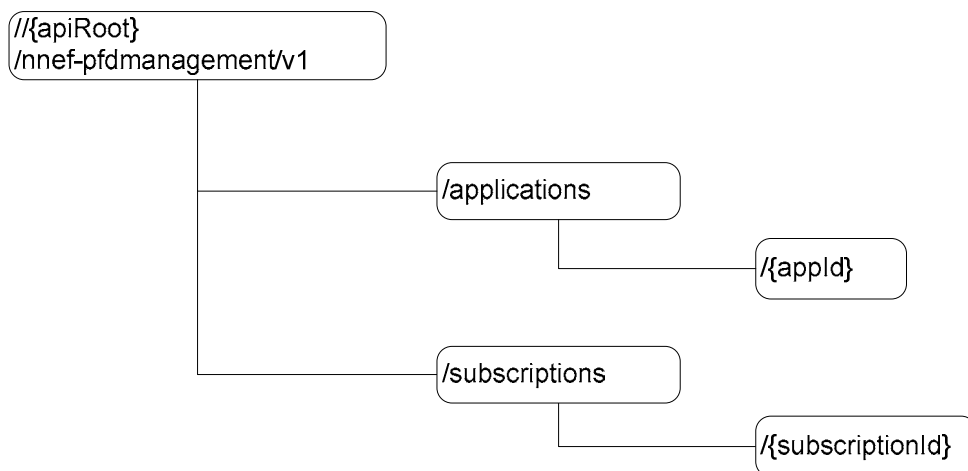

**Figure 5.3.1-1: Resource URI structure of the Nnef\_PFDmanagement API**

Table 5.3.1-1 provides an overview of the resources and applicable HTTP methods.

**Table 5.3.1-1: Resources and methods overview**

Resource name	Resource URI	HTTP method or custom operation	Description
PFD of applications	//apiRoot/ nnef-pfdmanagement/v1 /applications	GET	Nnef_PFDmanagement_Fetch. Retrieve PFDs for all applications or for one or multiple applications with query parameter.

Individual application PFD	://{apiRoot}/ nnef-pfdmanagement/v1 /applications/{appld}	GET	Nnef_PFDmanagement_Fetch. Retrieve the PFD for an application.
PFD subscriptions	://{apiRoot}/ nnef-pfdmanagement/v1 /subscriptions	POST	Nnef_PFDmanagement_Subscribe. Subscribe the notification of PFD changes.
Individual PFD subscription	://{apiRoot}/ nnef-pfdmanagement/v1 /subscriptions/{subscriptionId}	DELETE	Nnef_PFDmanagement_Unsubscribe. Delete a subscription of PFD change notification.

## 5.3.2 Resource: PFD of applications

### 5.3.2.1 Description

This resource represents PFDs for all applications.

### 5.3.2.2 Resource definition

Resource URI: **{apiRoot}/nnef-pfdmanagement/v1/applications**

This resource shall support the resource URI variables defined in table 5.3.2.2-1.

**Table 5.3.2.2-1: Resource URI variables for this resource**

Name	Definition
apiRoot	See subclause 5.1

### 5.3.2.3 Resource Standard Methods

#### 5.3.2.3.1 GET

This method shall support the URI query parameters specified in table 5.3.2.3.1-1.

**Table 5.3.2.3.1-1: URI query parameters supported by the GET method on this resource**

Name	Data type	P	Cardinality	Description
applicationId	ApplicationId	O	0..N	The required application identifier(s) for the returned PFDs

This method shall support the request data structures specified in table 5.3.2.3.1-2 and the response data structures and response codes specified in table 5.3.2.3.1-3.

**Table 5.3.2.3.1-2: Data structures supported by the GET Request Body on this resource**

Data type	P	Cardinality	Description
n/a			

**Table 5.3.2.3.1-3: Data structures supported by the GET Response Body on this resource**

Data type	P	Cardinality	Response codes	Description
PfdDataforApp	M	1..N	200 OK	The PFDs for one or more application identifier(s) in the request URI are returned.
n/a			404 Not Found	No resource exists.
n/a			400 Bad request	Incorrect input parameter(s).
n/a			500 Internal Server Error	The server encountered an unexpected condition that prevented it from fulfilling the request.
n/a			503 Service Unavailable	The server is currently unable to handle the request.

### 5.3.2.4 Resource Custom Operations

None.

## 5.3.3 Resource: Individual application PFD

### 5.3.3.1 Description

This resource represents the PFD identified by an application identifier.

### 5.3.3.2 Resource definition

Resource URI: {apiRoot}/nnef-pfdmanagement/v1/applications/{appId}

This resource shall support the resource URI variables defined in table 5.3.3.2-1.

**Table 5.3.3.2-1: Resource URI variables for this resource**

Name	Definition
apiRoot	See subclause 5.1.
appId	String identifying a set of PFD for an application identifier.

### 5.3.3.3 Resource Standard Methods

#### 5.3.3.3.1 GET

This method shall support the URI query parameters specified in table 5.3.3.3.1-1.

**Table 5.3.3.3.1-1: URI query parameters supported by the GET method on this resource**

Name	Data type	P	Cardinality	Description
n/a				

This method shall support the request data structures specified in table 5.3.3.3.1-2 and the response data structures and response codes specified in table 5.3.3.3.1-3.

**Table 5.3.3.3.1-2: Data structures supported by the GET Request Body on this resource**

Data type	P	Cardinality	Description
n/a			

**Table 5.3.3.3.1-3: Data structures supported by the GET Response Body on this resource**

Data type	P	Cardinality	Response codes	Description
PfdDataForApp	M	1	200 OK	A representation of PFDs for an application in the request URI is returned.
n/a			404 Not Found	The requested individual application PFD does not exist.
n/a			400 Bad request	Incorrect input parameter(s).
n/a			500 Internal Server Error	The server encountered an unexpected condition that prevented it from fulfilling the request.
n/a			503 Service Unavailable	The server is currently unable to handle the request.

### 5.3.3.4 Resource Custom Operations

None.

## 5.3.4 Resource: PFD subscriptions

### 5.3.4.1 Description

This resource represents a collection of subscriptions created by NF service consumers of Nnef\_PFDmanagement service.

### 5.3.4.2 Resource definition

Resource URI: {apiRoot}/nnef-pfdmanagement/v1/subscriptions

This resource shall support the resource URI variables defined in table 5.3.4.2-1.

**Table 5.3.4.2-1: Resource URI variables for this resource**

Name	Definition
apiRoot	See subclause 5.1

### 5.3.4.3 Resource Standard Methods

#### 5.3.4.3.1 POST

This method shall support the URI query parameters specified in table 5.3.4.3.1-1.

**Table 5.3.4.3.1-1: URI query parameters supported by the POST method on this resource**

Name	Data type	P	Cardinality	Description
n/a				

This method shall support the request data structures specified in table 5.3.4.3.1-2 and the response data structures and response codes specified in table 5.3.4.3.1-3.

**Table 5.3.4.3.1-2: Data structures supported by the POST Request Body on this resource**

Data type	P	Cardinality	Description
PfdSubscription	M	1	Create a PfdSubscription resource.

**Table 5.3.4.3.1-3: Data structures supported by the POST Response Body on this resource**

Data type	P	Cardinality	Response codes	Description
PfdSubscription	M	1	201 Created	The creation of a PfdSubscription resource is confirmed and a representation of that resource is returned.
n/a	C	1	404 Not Found.	The requested resource is not found.
ProblemDetails	C	1	400 Bad Request	Incorrect input parameter(s). The "cause" attribute in the ProblemDetails shall be set to MANDAT_ATTRI_MISSING (see table 5.7.3-1) if attribute notifyUri or supportedFeatures is not included in the payload.
ProblemDetails	C	1	500 Internal Server Error	The server encountered an unexpected condition that prevented it from fulfilling the request. The "cause" attribute in the ProblemDetails shall be set to RESOURCE_LIMITATION (see table 5.7.3-1) if there is resource limitation.
n/a			503 Service Unavailable	The server is currently unable to handle the request.

#### 5.3.4.4 Resource Custom Operations

None.



## 5.3.5 Resource: Individual PFD subscription

### 5.3.5.1 Description

This resource represents an individual PFD subscription created by NF service consumers of Nnef\_PFDmanagement service.

### 5.3.5.2 Resource definition

Resource URI: {apiRoot}/nnef-pfdmanagement/v1/subscriptions/{subscriptionId}

This resource shall support the resource URI variables defined in table 5.3.5.2-1.

**Table 5.3.5.2-1: Resource URI variables for this resource**

Name	Definition
apiRoot	See subclause 5.1
subscriptionId	String identifies an individual subscription to the PFD management service

### 5.3.5.3 Resource Standard Methods

#### 5.3.5.3.1 DELETE

This method shall support the URI query parameters specified in table 5.3.5.3.1-1.

**Table 5.3.5.3.1-1: URI query parameters supported by the DELETE method on this resource**

Name	Data type	P	Cardinality	Description
n/a				

This method shall support the request data structures specified in table 5.3.5.3.1-2 and the response data structures and response codes specified in table 5.3.5.3.1-3.

**Table 5.3.5.3.1-2: Data structures supported by the DELETE Request Body on this resource**

Data type	P	Cardinality	Description
n/a			

**Table 5.3.5.3.1-3: Data structures supported by the DELETE Response Body on this resource**

Data type	P	Cardinality	Response codes	Description
n/a			204 No Content	The PfdSubscription resource matching the subscriptionId was deleted successfully.
n/a			404 Not Found	The requested individual PFD subscription to be deleted does not exist.

### 5.3.5.4 Resource Custom Operations

None.

## 5.4 Custom Operations without associated resources

None

## 5.5 Notifications

### 5.5.1 General

Notifications shall comply to subclause 6.2 of 3GPP TS 29.500 [5] and subclause 4.6.2.3 of 3GPP TS 29.501 [6].

**Table 5.5.1-1: Notifications**

Custom operation URI	Mapped HTTP method	Description
{notifyUri}/notify	POST	Notification of PFD change.

## 5.5.2 PFD Change Notification

### 5.5.2.1 Description

The PFD Change Notification is used by the PFD to inform the NF service consumer, which has subscribed to this Notification via the PFD subscriptions resource.

### 5.5.2.2 Target URI

The Notification URI "{notifyUri}/notify" shall be used with the URI variables defined in table 5.5.2.2-1.

**Table 5.5.2.2-1: URI variables**

Name	Definition
notifyUri	String formatted as URI with the Notification Uri as assigned within the PFD subscriptions resource and described within the PfdSubscription data type (see table 5.6.2.3-1).

### 5.5.2.3 Standard Methods

#### 5.5.2.3.1 POST

This method shall support the URI query parameters specified in table 5.5.2.3.1-1.

**Table 5.5.2.3.1-1: URI query parameters supported by the POST method on this resource**

Name	Data type	P	Cardinality	Description
n/a				

This method shall support the request data structures specified in table 5.5.2.3.1-2 and the response data structures and response codes specified in table 5.5.2.3.1-3.

**Table 5.5.2.3.1-2: Data structures supported by the POST Request Body on this resource**

Data type	P	Cardinality	Description
PfdChangeNotification	M	1..N	Provides PFD change information.

**Table 5.5.2.3.1-3: Data structures supported by the POST Response Body on this resource**

Data type	P	Cardinality	Response codes	Description
n/a			204 No Content	The PFD operation in the notification is performed successfully.
array(PfdChangeReport)	M	1..N	200 OK	The PFD operation in the notification is performed and the PfdChangeReport indicates failure reason.
ProblemDetails	C	1	400 Bad Request	Incorrect input parameter(s). The "cause" attribute in the ProblemDetails shall be set to MANDAT_ATTRI_MISSING (see table 5.7.3-1) if the payload is empty.
ProblemDetails	M	1	500 Internal Server Error	The server encountered an unexpected condition that prevented it from fulfilling the request.
n/a			503 Service Unavailable	The server is currently unable to handle the request.

## 5.6 Data Model

### 5.6.1 General

This subclause specifies the application data model supported by the API.

Table 5.6.1-1 specifies the data types defined for the Nnef\_PFDmanagement service based interface protocol.

**Table 5.6.1-1: Nnef\_PFDmanagement specific Data Types**

Data type	Section defined	Description	Applicability
PfdDataForApp	5.6.2.2	Represents the PFDs for an application identifier.	
PfdSubscription	5.6.2.3	Represents a PFD subscription.	
PfdChangeNotification	5.6.2.4	Represents PFD change information.	
PfdContent	5.6.2.x	Represents the content of a PFD for an application identifier.	
PfdChangeReport	5.6.2.y	Represents error of PFD change.	

Table 5.6.1-2 specifies data types re-used by the Nnef\_PFDmanagement service based interface protocol from other specifications, including a reference to their respective specifications and when needed, a short description of their use within the Nnef\_PFDmanagement service based interface.

**Table 5.6.1-2: Nnef\_PFDmanagement re-used Data Types**

Data type	Reference	Comments	Applicability
ApplicationId	3GPP TS 29.571 [10]		
SupportedFeatures	3GPP TS 29.571 [10]		

### 5.6.2 Structured data types

#### 5.6.2.1 Introduction

This subclause defines the structures to be used in resource representations.

Allowed structures are: array, object.

#### 5.6.2.2 Type: PfdDataForApp

**Table 5.6.2.2-1: Definition of type PfdDataForApp**

Attribute name	Data type	P	Cardinality	Description	Applicability
applicationId	ApplicationId	M	1	Identifier of an application.	
pfd	array(pfdContent)	O	0..N	PFDs for the application identifier.	
cachingTime	dateTime	O	0..1	Caching time for an application identifier.	

## 5.6.2.3 Type: PfdSubscription

Table 5.6.2.3-1: Definition of type PfdSubscription

Attribute name	Data type	P	Cardinality	Description	Applicability
applicationId	array(ApplicationId)	O	0..N	Identifiers of applications with PFDs change.	
notifyUri	Uri	M	1	Identifies the recipient of notifications sent by PFD for this subscription.	
supportedFeatures	SupportedFeatures	M	1	List of supported features used as described in subclause 5.8. This parameter shall be provided by the NF service consumer in the POST request that request the creation of a subscription, and shall be provided by the PFD in the response of corresponding request.	

## 5.6.2.4 Type: PfdChangeNotification

Table 5.6.2.4-1: Definition of type PfdChangeNotification

Attribute name	Data type	P	Cardinality	Description	Applicability
applicationId	ApplicationId	M	1	Identifier of an application.	
removalFlag	boolean	C	0..1	Indication of removal of PFDs for an existing application identifier.	
partialFlag	boolean	C	0..1	Indication of partial update of PFDs for an existing application identifier if this operation is supported according to feature negotiation.	PartialUpdate
pfd	array(PfdContent)	C	0..N	PFD creation/update for the application identifier as specified in subclause 6.3.3.5 of 3GPP TS 29.251 [12].	

## 5.6.2.5 Type: PfdContent

Table 5.6.2.5-1: Definition of type PfdContent

Attribute name	Data type	P	Cardinality	Description	Applicability
pfdId	string	C	0..1	Identifies a PFD of an application identifier. If PartialUpdate feature is supported during PFD change event subscription, this attribute shall be provided by the PFD.	
flowDescriptions	array(string)	O	0..N	Represents a 3-tuple with protocol, server ip and server port for UL/DL application traffic.	
urls	array(string)	O	0..N	Indicates a URL or a regular expression which is used to match the significant parts of the URL.	
domainNames	array(string)	O	0..N	Indicates an FQDN or a regular expression as a domain name matching criteria.	

## 5.6.2.6 Type: PfdChangeReport

Table 5.6.2.6-1: PfdChangeReport

Attribute name	Data type	P	Cardinality	Description	Applicability
pfdError	ProblemDetails	M	1	More information on the error shall be provided in the "cause" attribute of the "ProblemDetails" structure. The "cause" attribute in the ProblemDetails shall be set to one of following application errors (see table 5.7.3-1): - MALFUNCTION - RESOURCE_LIMITATION - OTHER_REASON	
applicationId	array(ApplicationId)	M	1..N	Indicates the application identifier(s) which PFD(s) are failed to be added or modified.	

## 5.6.3 Simple data types and enumerations

*This subclause will define simple data types and enumerations that can be referenced from data structures defined in the previous subclauses.*

## 5.6.3.1 Introduction

This subclause defines simple data types and enumerations that can be referenced from data structures defined in the previous subclauses.

## 5.6.3.2 Simple data types

The simple data types defined in table 5.6.3.2-1 shall be supported.

Table 5.6.3.2-1: Simple data types

Type Name	Type Definition	Description	Applicability
	<one simple data type, e.g. boolean, integer, null, number, string>		

## 5.6.3.3 Enumeration: &lt;EnumType1&gt;

*The enumeration <EnumType1> represents <something>. It shall comply with the provisions defined in table 5.6.3.3-1.*

Table 5.6.3.3-1: Enumeration &lt; EnumType1&gt;

Enumeration value	Description	Applicability

## 5.6.3.4 Enumeration: &lt;EnumType2&gt;

*And so on if there are more enumerations to define.*

## 5.7 Error handling

## 5.7.1 General

HTTP error handling shall be supported as specified in subclause 5.2.4 of 3GPP TS 29.500 [5].

## 5.7.2 Protocol Errors

*Editor's Note: the handling of protocol errors is FFS.*

## 5.7.3 Application Errors

The application errors defined for the Nnef\_PFDmanagement service are listed in table 5.7.3-1.

**Table 5.7.3-1: Application errors**

Application Error	HTTP status code	Description
MALFUNCTION	500 Internal Server Error	Something functions wrongly in PFD provisioning or the PFD provisioning does not function at all.
RESOURCE_LIMITATION	500 Internal Server Error	There is limitation for resource storage.
MANDAT_ATTRI_MISSING	400 Bad Request	A mandatory attribute is missing in the request.
OTHER_REASON	500 Internal Server Error	Unspecified reason.

## 5.8 Feature negotiation

The optional features in table 5.8-1 are defined for the Nnef\_PFDmanagement API. They shall be negotiated using the extensibility mechanism defined in subclause 6.6 of 3GPP TS 29.500 [5].

**Table 5.8-1: Supported Features**

Feature number	Feature Name	Description
1	PartialUpdate	The PFDF can use this feature for partial update of PFDs.

# Annex A (normative): OpenAPI specification

## A.1 General

The present Annex contains an OpenAPI [9] specification of HTTP messages and content bodies used by the Nnef\_PFDmanagement API.

In case of conflicts between the main body of the present document and the present Annex, the information in the main body shall be applicable.

## A.2 Nnef\_PFDmanagement API

```

openapi: 3.0.0
info:
  title: Nnef_PFDmanagement Sevice API
  version: "1.PreR15.0.0"
  description: Packet Flow Description Management Service
#
externalDocs:
  description: 3GPP TS 29.551 v0.4.0, 5G system; Packet Flow Description Management Service
  url: 'http://ftp.3gpp.org//Specs/archive/29_series/29.551/'
#
servers:
- url: https://{apiRoot}/nnef-pfdmanagement/v1
  variables:
    apiRoot:
      default: demohost.com
      description: apiRoot as defined in subclause 4.4 of 3GPP TS 29.501 excluding the https// part

paths:
  /applications:
    get:
      summary: Retrieve PFDs for all applications or for one or multiple applications with query
      parameter.
      tags:
      - PFD of applications
      operationId: Nnef_PFDmanagement_Fetch
      parameters:
      - name: applicationId
        description: The required application identifier(s) for the returned PFDs.
        in: path
        required: true
        schema:
          type: string
      responses:
        '200':
          description: The PFDs for one or more application identifier(s) in the request URI are
          returned.
          content:
            application/json:
              schema:
                $ref: '#/components/schemas/PfdDataforApp'
        '404':
          description: No resource exist.
        '400':
          description: Incorrect input parameter(s).
        '500':
          description: The server encountered an unexpected condition that prevented it from
          fulfilling the request.
        '503':
          description: The server is currently unable to handle the request.

  /applications/{appId}:
    get:
      summary: Retrieve the PFD for an application.
      tags:
      - Individual application PFD
      operationId: Nnef_PFDmanagement_Fetch
      responses:
        '200':

```

```

    description: A representation of PFDs for an application in the request URI is returned.
    content:
      application/json:
        schema:
          $ref: '#/components/schemas/PfdDataforApp'
  '404':
    description: No resource exist.
  '400':
    description: Incorrect input parameter(s).
  '500':
    description: The server encountered an unexpected condition that prevented it from
fulfilling the request.
  '503':
    description: The server is currently unable to handle the request.

/subscriptions:
post:
  summary: Subscribe the notification of PFD changes.
  tags:
  - PFD subscriptions
  operationId: Nnef_PFDmanagement_Subscribe
  requestBody:
    description: a PfdSubscription resource to be created.
    required: true
    content:
      application/json:
        schema:
          $ref: '#/components/schemas/PfdSubscription'
  callbacks:
    PfdChangeNotification:
      '{request.body#/notifyUri}':
        post:
          summary: Notification of PFD change.
          tags:
          - PfdChangeNotification data
          operationId: Nnef_PFDmanagement_Notify
          requestBody:
            description:
            required: true
            content:
              application/json:
                schema:
                  $ref: '#/components/schemas/PfdChangeNotification'
          responses:
            '204':
              description: The PFD operation in the notification is performed successfully.
            '200':
              description: The PFD operation in the notification is performed and the
PfdChangeReport indicates failure reason.
            content:
              application/json:
                schema:
                  $ref: '#/components/schemas/PfdChangeReport'
            '400':
              description: Incorrect input parameter(s).
            content:
              application/problem+json:
                schema:
                  $ref: 'TS29571_CommonData.yaml#/components/schemas/ProblemDetails'
            '500':
              description:
            content:
              application/problem+json:
                schema:
                  $ref: 'TS29571_CommonData.yaml#/components/schemas/ProblemDetails'
            '503':
              description: The server is currently unable to handle the request.

  responses:
    '201':
      description: The creation of a PfdSubscription resource is confirmed and a representation of
that resource is returned.
      content:
        application/json:
          schema:
            $ref: '#/components/schemas/PfdSubscription'
    '404':

```



```

    description: The The requested resource is not found.
  '400':
    description: Incorrect input parameter(s).
    content:
      application/problem+json:
        schema:
          $ref: 'TS29571_CommonData.yaml#/components/schemas/ProblemDetails'
  '500':
    description: The server encountered an unexpected condition that prevented it from
fulfilling the request.
    content:
      application/problem+json:
        schema:
          $ref: 'TS29571_CommonData.yaml#/components/schemas/ProblemDetails'
  '503':
    description: The server is currently unable to handle the request.

/subscriptions/{subscriptionId}:
delete:
  summary: Delete a subscription of PFD change notification.
  tags:
  - Individual PFD subscription
  operationId: Nnef_PFDmanagement_Unsubscribe
  responses:
    '204':
      description: The PfdSubscription resource matching the subscriptionId was deleted
successfully.
    '404':
      description: The requested individual PFD subscription to be deleted does not exist.

components:
  schemas:
#
# STRUCTURED DATA TYPES
#
PfdContent:
  type: object
  properties:
    pfdId:
      type: string
      description: Identifies a PDF of an application identifier.
    flowDescriptions:
      type: array
      items:
        type: string
      minItems: 0
      description: Represents a 3-tuple with protocol, server ip and server port for UL/DL
application traffic.
    urls:
      type: array
      items:
        type: string
      minItems: 0
      description: Indicates a URL or a regular expression which is used to match the
significant parts of the URL.
    domainNames:
      type: array
      items:
        type: string
      minItems: 0
      description: Indicates an FQDN or a regular expression as a domain name matching criteria.

PfdDataForApp:
  type: object
  properties:
    applicationId:
      $ref: 'TS29571_CommonData.yaml#/components/schemas/ApplicationId'
    pfd:
      type: array
      items:
        $ref: 'TS29551_CommonData.yaml#/components/schemas/PfdContent'
      minItems: 0
    cachingTime:
      $ref: 'TS29571_CommonData.yaml#/components/schemas/DateTime'
  required:
  - applicationId

PfdSubscription:

```

```
type: object
properties:
  applicationId:
    type: array
    items:
      $ref: 'TS29571_CommonData.yaml#/components/schemas/ApplicationId'
  notifyUri:
    $ref: 'TS29571_CommonData.yaml#/components/schemas/Uri'
  supportedFeatures:
    $ref: 'TS29571_CommonData.yaml#/components/schemas/SupportedFeatures'
required:
- notifyUri
- supportedFeatures

PfdChangeNotification:
type: object
properties:
  applicationId:
    $ref: 'TS29571_CommonData.yaml#/components/schemas/ApplicationId'
  removalFlag:
    type: boolean
    default: false
  partialFlag:
    type: boolean
    default: false
  pfd:
    type: array
    items:
      $ref: 'TS29551_CommonData.yaml#/components/schemas/PfdContent'
    minItems: 0
required:
- applicationId

PfdChangeReport:
type: object
properties:
  pfdError:
    $ref: 'TS29571_CommonData.yaml#/components/schemas/ProblemDetails'
  applicationId:
    type: array
    items:
      $ref: 'TS29571_CommonData.yaml#/components/schemas/ApplicationId'
required:
- pfdError
```

## Annex B (informative): Change history

Change history							
Date	Meeting	TDoc	CR	Rev	Cat	Subject/Comment	New version
2018-01						TS skeleton of PFD Management Service specification	0.0.0
2018-01	CT3#94					Includes the following contribution agreed by CT3 at CT3#94: C3-180045, C3-180270, C3-180271.	0.1.0
2018-03	CT3#95					Includes the following contribution agreed by CT3 at CT3#95: C3-181100, C3-181262, C3-181102, C3-181103, C3-181314.	0.2.0
2018-04	CT3#96					Includes the following contribution agreed by CT3 at CT3#96: C3-182153, C3-182411, C3-182412, C3-182413, C3-182414, C3-182477, C3-182478.	0.3.0
2018-05	CT3#97					Includes the following contribution agreed by CT3 at CT3#97: C3-183115, C3-183557, C3-183558, C3-183560.	0.4.0
2018-06	CT#80	CP-181029				TS sent to plenary for approval	1.0.0
2018-06	CT#80	CP-181029				TS approved by plenary	15.0.0

---

# History

<b>Document history</b>		
V15.0.0	July 2018	Publication