

ETSI TS 129 520 V15.2.0 (2019-04)



**5G;
5G System;
Network Data Analytics Services;
Stage 3
(3GPP TS 29.520 version 15.2.0 Release 15)**



Reference

RTS/TSGC-0329520vf20

Keywords

5G

ETSI

650 Route des Lucioles
F-06921 Sophia Antipolis Cedex - FRANCE

Tel.: +33 4 92 94 42 00 Fax: +33 4 93 65 47 16

Siret N° 348 623 562 00017 - NAF 742 C
Association à but non lucratif enregistrée à la
Sous-Préfecture de Grasse (06) N° 7803/88

Important notice

The present document can be downloaded from:

<http://www.etsi.org/standards-search>

The present document may be made available in electronic versions and/or in print. The content of any electronic and/or print versions of the present document shall not be modified without the prior written authorization of ETSI. In case of any existing or perceived difference in contents between such versions and/or in print, the prevailing version of an ETSI deliverable is the one made publicly available in PDF format at www.etsi.org/deliver.

Users of the present document should be aware that the document may be subject to revision or change of status.

Information on the current status of this and other ETSI documents is available at

<https://portal.etsi.org/TB/ETSIDeliverableStatus.aspx>

If you find errors in the present document, please send your comment to one of the following services:

<https://portal.etsi.org/People/CommitteeSupportStaff.aspx>

Copyright Notification

No part may be reproduced or utilized in any form or by any means, electronic or mechanical, including photocopying and microfilm except as authorized by written permission of ETSI.

The content of the PDF version shall not be modified without the written authorization of ETSI.

The copyright and the foregoing restriction extend to reproduction in all media.

© ETSI 2019.

All rights reserved.

DECT™, **PLUGTESTS™**, **UMTS™** and the ETSI logo are trademarks of ETSI registered for the benefit of its Members.

3GPP™ and **LTE™** are trademarks of ETSI registered for the benefit of its Members and of the 3GPP Organizational Partners.

oneM2M™ logo is a trademark of ETSI registered for the benefit of its Members and of the oneM2M Partners.

GSM® and the GSM logo are trademarks registered and owned by the GSM Association.

Intellectual Property Rights

Essential patents

IPRs essential or potentially essential to normative deliverables may have been declared to ETSI. The information pertaining to these essential IPRs, if any, is publicly available for **ETSI members and non-members**, and can be found in ETSI SR 000 314: *"Intellectual Property Rights (IPRs); Essential, or potentially Essential, IPRs notified to ETSI in respect of ETSI standards"*, which is available from the ETSI Secretariat. Latest updates are available on the ETSI Web server (<https://ipr.etsi.org/>).

Pursuant to the ETSI IPR Policy, no investigation, including IPR searches, has been carried out by ETSI. No guarantee can be given as to the existence of other IPRs not referenced in ETSI SR 000 314 (or the updates on the ETSI Web server) which are, or may be, or may become, essential to the present document.

Trademarks

The present document may include trademarks and/or tradenames which are asserted and/or registered by their owners. ETSI claims no ownership of these except for any which are indicated as being the property of ETSI, and conveys no right to use or reproduce any trademark and/or tradename. Mention of those trademarks in the present document does not constitute an endorsement by ETSI of products, services or organizations associated with those trademarks.

Foreword

This Technical Specification (TS) has been produced by ETSI 3rd Generation Partnership Project (3GPP).

The present document may refer to technical specifications or reports using their 3GPP identities, UMTS identities or GSM identities. These should be interpreted as being references to the corresponding ETSI deliverables.

The cross reference between GSM, UMTS, 3GPP and ETSI identities can be found under <http://webapp.etsi.org/key/queryform.asp>.

Modal verbs terminology

In the present document "**shall**", "**shall not**", "**should**", "**should not**", "**may**", "**need not**", "**will**", "**will not**", "**can**" and "**cannot**" are to be interpreted as described in clause 3.2 of the [ETSI Drafting Rules](#) (Verbal forms for the expression of provisions).

"**must**" and "**must not**" are **NOT** allowed in ETSI deliverables except when used in direct citation.

Contents

Intellectual Property Rights	2
Foreword.....	2
Modal verbs terminology.....	2
Foreword.....	6
1 Scope	7
2 References	7
3 Definitions and abbreviations.....	8
3.1 Definitions	8
3.2 Abbreviations	8
4 Services offered by the NWDAF	8
4.1 Introduction	8
4.2 Nnwdaf_EventsSubscription Service	8
4.2.1 Service Description.....	8
4.2.1.1 Overview.....	8
4.2.1.2 Service Architecture.....	9
4.2.1.3 Network Functions.....	9
4.2.1.3.1 Network Data Analytics Function (NWDAF).....	9
4.2.1.3.2 NF Service Consumers	10
4.2.2 Service Operations	10
4.2.2.1 Introduction.....	10
4.2.2.2 Nnwdaf_EventsSubscription_Subscribe service operation	10
4.2.2.2.1 General	10
4.2.2.2.2 Subscription for event notifications on a specified network slice instance	11
4.2.2.2.3 Update subscription for event notifications on a specified network slice instance.....	11
4.2.2.3 Nnwdaf_EventsSubscription_Unsubscribe service operation.....	12
4.2.2.3.1 General	12
4.2.2.3.2 Unsubscribe from event notifications on a specified network slice instance.....	13
4.2.2.4 Nnwdaf_EventsSubscription_Notify service operation	13
4.2.2.4.1 General	13
4.2.2.4.2 Notification about subscribed event on specified network slice instance.....	13
4.3 Nnwdaf_AnalyticsInfo Service	14
4.3.1 Service Description.....	14
4.3.1.1 Overview.....	14
4.3.1.2 Service Architecture.....	14
4.3.1.3 Network Functions.....	15
4.3.1.3.1 Network Data Analytics Function (NWDAF).....	15
4.3.1.3.2 NF Service Consumers	15
4.3.2 Service Operations.....	15
4.3.2.1 Introduction.....	15
4.3.2.2 Nnwdaf_AnalyticsInfo_Request service operation	16
4.3.2.2.1 General	16
4.3.2.2.2 Request and get from NWDAF load level information for a particular Network Slice instance.....	16
5 API Definitions	17
5.1 Nnwdaf_EventsSubscription Service API.....	17
5.1.1 Introduction.....	17
5.1.2 Usage of HTTP.....	17
5.1.2.1 General	17
5.1.2.2 HTTP standard headers	17
5.1.2.2.1 General	17
5.1.2.2.2 Content type	17
5.1.2.3 HTTP custom headers	17
5.1.3 Resources.....	18
5.1.3.1 Resource Structure	18
5.1.3.2 Resource: NWDAF Events Subscriptions.....	18

5.1.3.2.1	Description	18
5.1.3.2.2	Resource definition.....	18
5.1.3.2.3	Resource Standard Methods	18
5.1.3.2.3.1	POST.....	18
5.1.3.2.4	Resource Custom Operations	19
5.1.3.3	Resource: Individual NWDAF Event Subscription	19
5.1.4	Custom Operations without associated resources	20
5.1.5	Notifications	21
5.1.5.1	General	21
5.1.5.2	Event Notification.....	21
5.1.6	Data Model	21
5.1.6.1	General	21
5.1.6.2	Structured data types	22
5.1.6.2.1	Introduction	22
5.1.6.2.2	Type NnwdafEventsSubscription	23
5.1.6.2.3	Type EventSubscription	23
5.1.6.2.4	Type NnwdafEventsSubscriptionNotification	23
5.1.6.2.5	Type EventNotification	24
5.1.6.2.6	Type SliceLoadLevelInformation.....	24
5.1.6.3	Simple data types and enumerations	24
5.1.6.3.1	Introduction	24
5.1.6.3.2	Simple data types.....	24
5.1.6.3.3	Enumeration: NotificationMethod.....	24
5.1.6.3.4	Enumeration: NwdafEvent	25
5.1.7	Error handling	25
5.1.8	Feature negotiation	25
5.1.9	Security	25
5.2	Nnwdaf_AnalyticsInfo Service API.....	26
5.2.1	Introduction.....	26
5.2.2	Usage of HTTP.....	26
5.2.2.1	General	26
5.2.2.2	HTTP standard headers	26
5.2.2.2.1	General	26
5.2.2.2.2	Content type	26
5.2.2.3	HTTP custom headers	26
5.2.3	Resources.....	27
5.2.3.1	Resource Structure	27
5.2.3.2	Resource: NWDAF Analytics.....	27
5.2.3.2.1	Description	27
5.2.3.2.2	Resource definition.....	27
5.2.3.2.3	Resource Standard Methods	27
5.2.3.2.3.1	GET.....	27
5.2.3.2.4	Resource Custom Operations	28
5.2.4	Custom Operations without associated resources	28
5.2.5	Notifications	28
5.2.6	Data Model	28
5.2.6.1	General	28
5.2.6.2	Structured data types	29
5.2.6.2.1	Introduction	29
5.2.6.2.2	Type AnalyticsData	29
5.2.6.2.3	Type EventFilter	29
5.2.6.3	Simple data types and enumerations	29
5.2.6.3.1	Introduction	29
5.2.6.3.2	Simple data types.....	29
5.2.6.3.3	Enumeration: EventId.....	29
5.2.7	Error handling.....	30
5.2.8	Feature negotiation	30
5.2.9	Security	30
Annex A (normative):	OpenAPI specification.....	31
A.1	General	31

A.2 Nnwdaf_EventsSubscription API.....31

A.3 Nnwdaf_AnalyticsInfo API.....35

Annex B (informative): Change history37

History38

Foreword

This Technical Specification has been produced by the 3rd Generation Partnership Project (3GPP).

The contents of the present document are subject to continuing work within the TSG and may change following formal TSG approval. Should the TSG modify the contents of the present document, it will be re-released by the TSG with an identifying change of release date and an increase in version number as follows:

Version x.y.z

where:

- x the first digit:
 - 1 presented to TSG for information;
 - 2 presented to TSG for approval;
 - 3 or greater indicates TSG approved document under change control.
- y the second digit is incremented for all changes of substance, i.e. technical enhancements, corrections, updates, etc.
- z the third digit is incremented when editorial only changes have been incorporated in the document.

1 Scope

The present specification provides the stage 3 definition of the Network Data Analytics Function Services of the 5G System.

The 5G System Architecture is defined in 3GPP TS 23.501 [2]. The stage 2 definition and related procedures for Network Data Analytics Function Services are specified in 3GPP TS 23.502 [3] and 3GPP TS 23.503 [4].

The 5G System stage 3 call flows are provided in 3GPP TS 29.513 [5].

The Technical Realization of the Service Based Architecture and the Principles and Guidelines for Services Definition are specified in 3GPP TS 29.500 [6] and 3GPP TS 29.501 [7].

The Network Data Analytics Function Services are provided by the Network Data Analytics Function (NWDAF). These services provide NWDAF slice congestion events notification and NWDAF specific analytics.

2 References

The following documents contain provisions which, through reference in this text, constitute provisions of the present document.

- References are either specific (identified by date of publication, edition number, version number, etc.) or non-specific.
- For a specific reference, subsequent revisions do not apply.
- For a non-specific reference, the latest version applies. In the case of a reference to a 3GPP document (including a GSM document), a non-specific reference implicitly refers to the latest version of that document *in the same Release as the present document*.

- [1] 3GPP TR 21.905: "Vocabulary for 3GPP Specifications".
- [2] 3GPP TS 23.501: "System Architecture for the 5G System; Stage 2".
- [3] 3GPP TS 23.502: "Procedures for the 5G System; Stage 2".
- [4] 3GPP TS 23.503: "Policy and Charging Control Framework for the 5G System; Stage 2".
- [5] 3GPP TS 29.513: "5G System; Policy and Charging Control signalling flows and QoS parameter mapping; Stage 3".
- [6] 3GPP TS 29.500: "5G System; Technical Realization of Service Based Architecture; Stage 3".
- [7] 3GPP TS 29.501: "5G System; Principles and Guidelines for Services Definition; Stage 3".
- [8] 3GPP TS 29.571: "5G System; Common Data Types for Service Based Interfaces; Stage 3".
- [9] IETF RFC 7540: "Hypertext Transfer Protocol Version 2 (HTTP/2)".
- [10] IETF RFC 8259: "The JavaScript Object Notation (JSON) Data Interchange Format".
- [11] OpenAPI, "OpenAPI 3.0.0 Specification", <https://github.com/OAI/OpenAPI-Specification/blob/master/versions/3.0.0.md>.
- [12] 3GPP TS 29.510: "5G System; Network Function Repository Services; Stage 3".
- [13] 3GPP TS 33.501: "Security architecture and procedures for 5G system".
- [14] IETF RFC 6749: "The OAuth 2.0 Authorization Framework".
- [15] IETF RFC 7807: "Problem Details for HTTP APIs".

3 Definitions and abbreviations

3.1 Definitions

For the purposes of the present document, the terms and definitions given in 3GPP TR 21.905 [1] and the following apply. A term defined in the present document takes precedence over the definition of the same term, if any, in 3GPP TR 21.905 [1].

3.2 Abbreviations

For the purposes of the present document, the abbreviations given in 3GPP TR 21.905 [1] and the following apply. An abbreviation defined in the present document takes precedence over the definition of the same abbreviation, if any, in 3GPP TR 21.905 [1].

API	Application Programming Interface
JSON	JavaScript Object Notation
HTTP	Hypertext Transfer Protocol
NF	Network Function
NRF	Network Repository Function
NWDAF	Network Data Analytics Function

4 Services offered by the NWDAF

4.1 Introduction

The Nnwdaf services are used for the NWDAF to provide network data analytics (i.e. load level information). These services provide NWDAF slice congestion events notification and NWDAF specific analytics.

The following services are specified for NWDAF:

Table 4.1-1: Services provided by NWDAF

Service Name	Description	Service Operations	Operation Semantics	Example Consumer(s)
Nnwdaf_EventsSubscription	This service enables the NF service consumers to subscribe/unsubscribe for network slice specific congestion events notification from the NWDAF.	Subscribe	Subscribe / Notify	PCF
		Unsubscribe		
		Notify		
Nnwdaf_AnalyticsInfo	This service enables the NF service consumers to request and get specific analytics from NWDAF.	Request	Request / Response	PCF

4.2 Nnwdaf_EventsSubscription Service

4.2.1 Service Description

4.2.1.1 Overview

The NWDAF slice congestion events notification Service, as defined in 3GPP TS 23.501 [2], 3GPP TS 23.502 [3] and 3GPP TS 23.503 [4], is provided by the Network Data Analytics Function (NWDAF).

This service:

- Allows NF consumers to subscribe to and unsubscribe from load events of network slice instance; and
- notifies NF consumers with a corresponding subscription about observed events.

The types of observed events include:

- Load level of network slice instance.

4.2.1.2 Service Architecture

The 5G System Architecture is defined in 3GPP TS 23.501 [2]. The Policy and Charging related 5G architecture is also described in 3GPP TS 23.503 [4] and 3GPP TS 29.513 [5].

The Nnwdaf_EventsSubscription service is part of the Nnwdaf service-based interface exhibited by the Network Data Analytics Function (NWDAF).

Known consumer of the Nnwdaf_EventsSubscription service is:

- Policy Control Function (PCF)

The PCF accesses the Nnwdaf_EventsSubscription service at the NWDAF via the N23 Reference point.

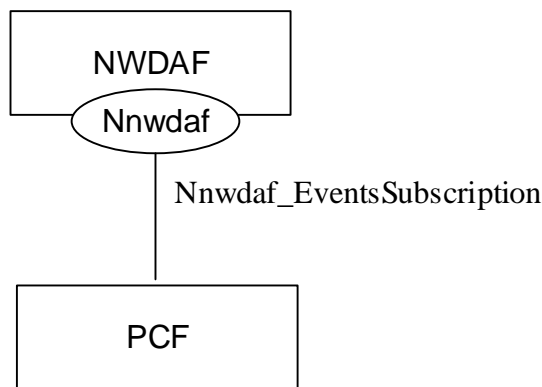

Figure 4.2.1.2-1: Reference Architecture for the Nnwdaf_EventsSubscription Service; SBI representation

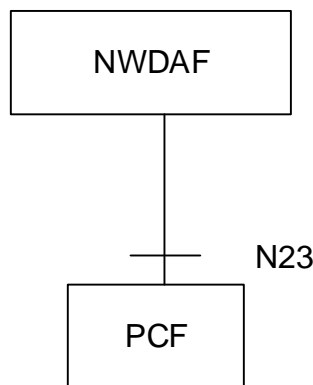

Figure 4.2.1.2-2: Reference Architecture for the Nnwdaf_EventsSubscription Service: reference point representation

4.2.1.3 Network Functions

4.2.1.3.1 Network Data Analytics Function (NWDAF)

The Network Data Analytics Function (NWDAF) provides:

- Identifier of network slice instance; and

- load level information for that network slice instance.

The Network Data Analytics Function (NWDAF) allows NF consumers to subscribe to and unsubscribe from periodic notification and/or notification when a threshold is exceeded.

4.2.1.3.2 NF Service Consumers

The Policy Control Function (PCF):

- Supports taking input from Network Data Analytics Function (NWDAF) into consideration for policies on assignment of network resources and for traffic steering policies.

NOTE: How this information is used by the PCF is not standardized in this release of the specification.

4.2.2 Service Operations

4.2.2.1 Introduction

Table 4.2.2.1-1: Operations of the Nnwdaf_EventsSubscription Service

Service operation name	Description	Initiated by
Nnwdaf_Events_SubscriptionSubscribe	This service operation is used by an NF to subscribe or update subscription for event notifications for a specified network slice instance. Periodic notification and notification upon threshold exceeded can be subscribed.	NF consumer (PCF)
Nnwdaf_Events_SubscriptionUnSubscribe	This service operation is used by an NF to unsubscribe from event notifications.	NF consumer (PCF)
Nnwdaf_Events_SubscriptionNotify	This service operation is used by an NWDAF to notify NF consumers about subscribed events.	NWDAF

4.2.2.2 Nnwdaf_EventsSubscription_Subscribe service operation

4.2.2.2.1 General

The Nnwdaf_EventsSubscription_Subscribe service operation is used by an NF service consumer to subscribe or update subscription for event notifications on a specified network slice instance. The following are the types of events for which a subscription can be made:

- Load level of network slice instance.

To subscribe to event notifications, the NF service consumer shall send an Nnwdaf_EventsSubscription_Subscribe request that shall include:

- Identification(s) of network slice to which the subscription applies via:
 - a) Identifier of network slice instance; or
 - b) all slices;
- event notification method (periodic, upon threshold exceeded); and
- notification URI;

and that may include:

- repetition period for periodic reporting; and
- load level threshold value.

Upon the reception of the Nnwdaf_EventsSubscription_Subscribe request message, the NWDAF shall store the subscription and shall send an Nnwdaf_EventsSubscription_Subscribe response message.

4.2.2.2.2 Subscription for event notifications on a specified network slice instance

Figure 4.2.2.2.2-1 shows a scenario where the NF service consumer sends a request to the NWDAF to subscribe for event notifications (see also 3GPP TS 23.502 [3] figure 4.19.1-1 step 1).

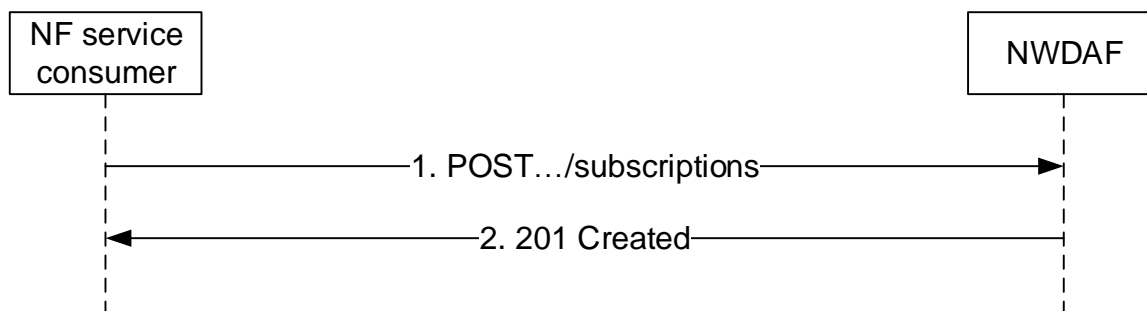

Figure 4.2.2.2.2-1: NF service consumer subscribes to notifications

The NF service consumer shall invoke the `Nnwdaf_EventsSubscription_Subscribe` service operation to subscribe to event notifications on specified network slice instance(s). The NF service consumer shall send an HTTP POST request with "`{apiRoot}/nnwdaf-eventssubscription/v1/subscriptions`" as Resource URI representing the "NWDAF Events Subscriptions", as shown in figure 4.2.2.2.2-1, step 1, to create a subscription for an "Individual NWDAF Event Subscription" according to the information (e.g. identification(s) of network slice(s)) in message body. The `NnwdafEventsSubscription` data structure provided in the request body shall include:

- a description of the subscribed events as "eventSubscriptions" attribute that for each event shall include an event identifier as "event" attribute and may include:
 - a) identification(s) of network slice to which the subscription applies via:
 - 1) identification of network slice(s) by "snsai" attribute; or
 - 2) any slices indication via the "anySlice" attribute;
 - b) event notification method (periodic, upon threshold exceeded) as "notificationMethod" attribute;
 - c) repetition period for periodic reporting as "repetitionPeriod" attribute;
 - d) load level threshold as "loadLevelThreshold" attribute; and
- an URI where to receive the requested notifications as "notificationURI" attribute; and
- list of supported features by the service consumer as "supportedFeatures" attribute.

Upon the reception of an HTTP POST request with "`{apiRoot}/nnwdaf-eventssubscription/v1/subscriptions`" as Resource URI and `NnwdafEventsSubscription` data structure as request body, the NWDAF shall:

- create a new subscription;
- assign an event subscriptionId;
- store the subscription.

If the NWDAF created an "Individual NWDAF Event Subscription" resource, the NWDAF shall respond with "201 Created" with the message body containing a representation of the created subscription, as shown in figure 4.2.2.2.2-1, step 2. The NWDAF shall include a Location HTTP header field. The Location header field shall contain the URI of the created subscription i.e. "`{apiRoot}/nnwdaf-eventssubscription/v1/subscriptions/{subscriptionId}`".

4.2.2.2.3 Update subscription for event notifications on a specified network slice instance

Figure 4.2.2.2.3-1 shows a scenario where the NF service consumer sends a request to the NWDAF to subscribe for event notifications (see also 3GPP TS 23.502 [3] figure 4.19.1-1 step 1).

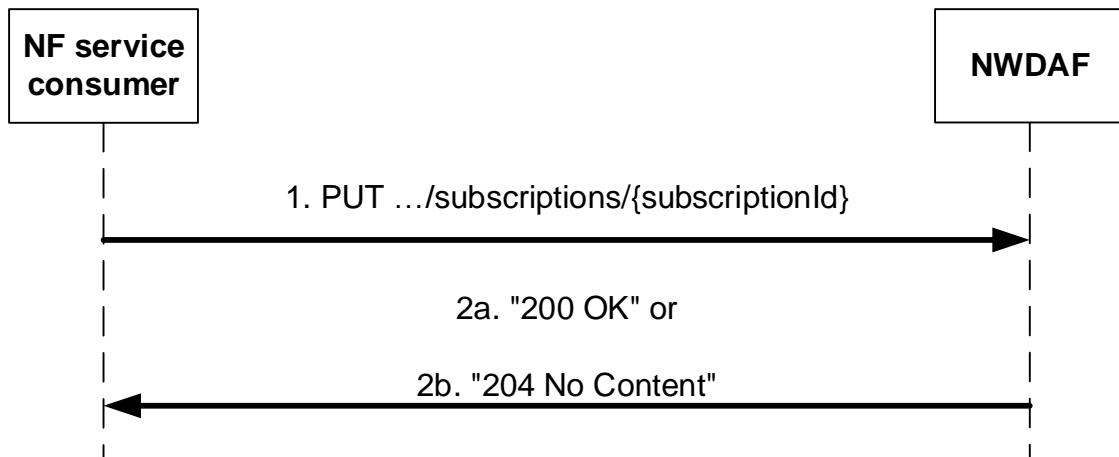

Figure 4.2.2.3-1: NF service consumer updates subscription to notifications

The NF service consumer shall invoke the `Nnwdaf_EventsSubscription_Subscribe` service operation to update subscription to event notifications on specified network slice instance(s). The NF service consumer shall send an HTTP PUT request with "`{apiRoot}/nnwdaf-eventssubscription/v1/subscriptions/{subscriptionId}`" as Resource URI representing the "NWDAF Events Subscriptions", as shown in figure 4.2.2.3-1, step 1, to update the subscription for an "Individual NWDAF Event Subscription" resource identified by the `{subscriptionId}`. The `NnwdafEventsSubscription` data structure provided in the request body may include:

- a description of the subscribed events as "eventSubscriptions" attribute that for each event shall include an event identifier as "event" attribute and may include:
 - a) identification(s) of network slice to which the subscription applies via:
 - 1) identification of network slice(s) by "snssai" attribute; or
 - 2) any slices indication via the "anySlice" attribute;
 - b) event notification method (periodic, upon threshold exceeded) as "notificationMethod" attribute;
 - c) repetition period for periodic reporting as "repetitionPeriod" attribute;
 - d) load level threshold as "loadLevelThreshold" attribute; and
- an URI where to receive the requested notifications as "notificationURI" attribute.

Upon the reception of an HTTP PUT request with: "`{apiRoot}/nnwdaf-eventssubscription/v1/subscriptions/{subscriptionId}`" as Resource URI and `NnwdafEventsSubscription` data structure as request body, the NWDAF shall:

- update the subscription of corresponding `subscriptionId`; and
- store the subscription.

If the NWDAF updated an "Individual NWDAF Event Subscription" resource, the NWDAF shall respond with:

- a) HTTP "200 OK" status code with the message body containing a representation of the updated subscription, as shown in figure 4.2.2.3-1, step 2a; or
- b) HTTP "204 No Content" status code, as shown in figure 4.2.2.3-1, step 2b.

If the Individual NWDAF Event Subscription resource does not exist, the NWDAF shall respond with "404 Not Found".

4.2.2.3 Nnwdaf_EventsSubscription_Unsubscribe service operation

4.2.2.3.1 General

The `Nnwdaf_EventsSubscription_Unsubscribe` service operation is used by an NF service consumer to unsubscribe from event notifications on a specified network slice instance.

To unsubscribe from event notifications, the NF service consumer shall send an Nnwdaf_EventsSubscription_Unsubscribe request.

Upon the reception of the Nnwdaf_EventsSubscription_Unsubscribe request message, the NWDAF shall remove the corresponding subscription and shall send an Nnwdaf_EventsSubscription_Unsubscribe response message.

4.2.2.3.2 Unsubscribe from event notifications on a specified network slice instance

Figure 4.2.2.3.2-1 shows a scenario where the NF service consumer sends a request to the NWDAF to unsubscribe from event notifications (see also 3GPP TS 23.502 [3] figure 4.19.1-1 step 1).

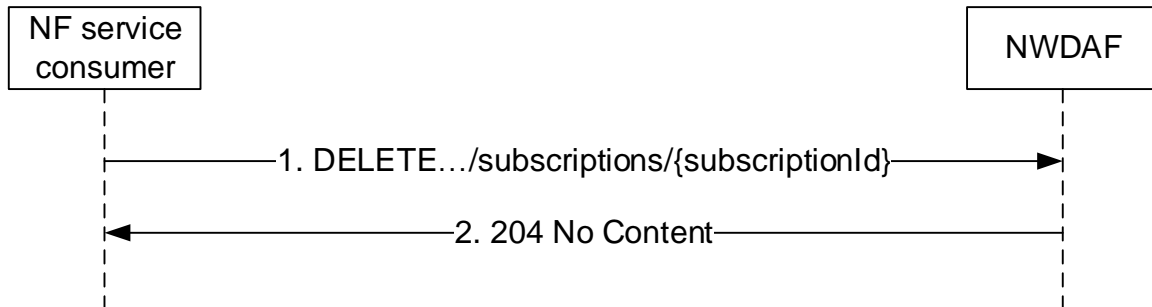

Figure 4.2.2.3.2-1: NF service consumer unsubscribes from notifications

The NF service consumer shall invoke the Nnwdaf_EventsSubscription_UnSubscribe service operation to unsubscribe to event notifications on specified network slice instance(s). The NF service consumer shall send an HTTP DELETE request with: "{apiRoot}/nwdaf-eventssubscription/v1/subscriptions/{subscriptionId}" as Resource URI, where "{subscriptionId}" is the event subscriptionId of the existing subscription that is to be deleted.

Upon the the reception of an HTTP DELETE request with: "{apiRoot}/nwdaf-eventssubscription/v1/subscriptions/{subscriptionId}" as Resource URI, the NWDAF shall:

- remove the corresponding subscription.

If the HTTP request message from the NF service consumer is accepted, the NWDAF shall respond with "204 No Content".

If the Individual NWDAF Event Subscription resource does not exist, the NWDAF shall respond with "404 Not Found".

4.2.2.4 Nnwdaf_EventsSubscription_Notify service operation

4.2.2.4.1 General

The Nnwdaf_EventsSubscription_Notify service operation is used by an NWDAF to notify NF consumers about subscribed events. If the NWDAF observes network slice related event(s) for which an NF service consumer has subscribed to, the NWDAF shall send to that NF service consumer an Nnwdaf_EventsSubscription_Notify request that shall include:

- Identification(s) of network slice to which the subscription applies via:
 - a) Identifier of network slice instance; and
- load level information of network slice instance.

Upon the reception of the Nsmf_EventExposure_Notify request message, the NF shall send an Nsmf_EventExposure_Notify response message.

The NWDAF shall notify the NF service consumer depending upon type of subscription this notification is either on a periodic basis or triggered whenever a threshold is crossed.

4.2.2.4.2 Notification about subscribed event on specified network slice instance

Figure 4.2.2.4.2-1 shows a scenario where the NWDAF sends a request to the NF Service Consumer to notify for event notifications (see also 3GPP TS 23.502 [3] figure 4.19.1-1 step 2).

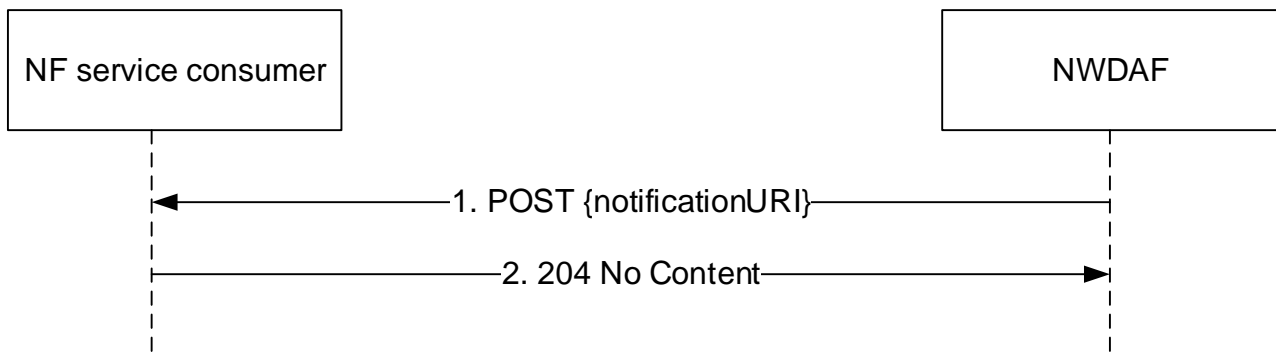

Figure 4.2.2.4.2-1: NWDAF notifies the subscribed event

The NWDAF shall invoke the `Nnwdaf_EventsSubscription_Notify` service operation to notify the subscribed event on specified network slice instance(s). The NWDAF shall send an HTTP POST request with "`{notificationURI}`" received in the `Nnwdaf_EventsSubscription_Subscribe` service operation as Resource URI, as shown in figure 4.2.2.2.2-1, step 1. The `NnwdafEventsSubscriptionNotification` data structure provided in the request body that shall include:

- a description of the notified event as "eventNotifications" attribute that for each event shall include:
 - a) an event identifier as "event" attribute;
 - b) identification(s) of network slice to which the notification applies as "snssai" attribute;
 - c) load level information as "loadLevelInformation" attribute; and
- an event subscriptionId as "subscriptionId" attribute.

Upon the reception of an HTTP POST request with: "`{notificationURI}`" as Resource URI and `NnwdafEventsSubscriptionNotification` data structure as request body, the NF Service Consumer shall:

- store the notification.

If the HTTP request message from the NWDAF is accepted, the NF Service Consumer shall respond with "204 No Content".

4.3 Nnwdaf_AnalyticsInfo Service

4.3.1 Service Description

4.3.1.1 Overview

The `Nnwdaf_AnalyticsInfo` Service as defined in 3GPP TS 23.501 [2], 3GPP TS 23.502 [3] and 3GPP TS 23.503 [4], is provided by the Network Data Analytics Function (NWDAF).

This service:

- allows NF consumers to request and get load level information of network slice instance.

4.3.1.2 Service Architecture

The 5G System Architecture is defined in 3GPP TS 23.501 [2]. The Policy and Charging related 5G architecture is also described in 3GPP TS 23.503 [4] and 3GPP TS 29.513 [5].

The `Nnwdaf_AnalyticsInfo` service is part of the `Nnwdaf` service-based interface exhibited by the Network Data Analytics Function (NWDAF).

Known consumer of the `Nnwdaf_AnalyticsInfo` service is:

- Policy Control Function (PCF).

The PCF accesses the `Nnwdaf_AnalyticsInfo` service at the NWDAF via the N23 Reference point.

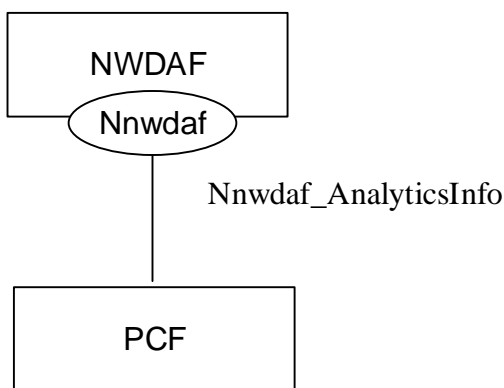

Figure 4.3.1.2-1: Reference Architecture for the Nnwdaf_AnalyticsInfo Service; SBI representation

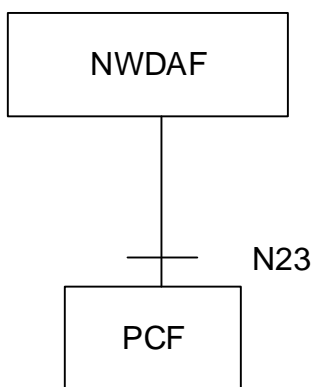

Figure 4.3.1.2-2: Reference Architecture for the Nnwdaf_AnalyticsInfo Service: reference point representation

4.3.1.3 Network Functions

4.3.1.3.1 Network Data Analytics Function (NWDAF)

The Network Data Analytics Function (NWDAF) provides specific analytics:

- Identifier of network slice instance; and
- load level information for that network slice instance.

4.3.1.3.2 NF Service Consumers

The Policy Control Function (PCF):

- Supports taking input from Network Data Analytics Function (NWDAF) into consideration for policies on assignment of network resources and for traffic steering policies.

NOTE: How this information is used by the PCF is not standardized in this release of the specification.

4.3.2 Service Operations

4.3.2.1 Introduction

Table 4.3.2.1-1: Operations of the Nnwdaf_AnalyticsInfo Service

Service operation name	Description	Initiated by
Nnwdaf_AnalyticsInfo_Request	This service operation is used by an NF to request and get specific analytics from NWDAF.	NF consumer (PCF)

4.3.2.2 Nnwdaf_AnalyticsInfo_Request service operation

4.3.2.2.1 General

The Nnwdaf_AnalyticsInfo_Request service operation is used by an NF service consumer to request and get specific analytics on a specified network slice instance. The following are the types of specific analytics:

- Load level information of particular network slice instance.

NOTE: This information has a meaning only in the operator network.

To request the analytics information, the NF service consumer shall send an Nnwdaf_AnalyticsInfo_Request request message that shall include:

- Event ID; and
- Event filters. For Event ID with value of "Load_Level_Information", the Event filters shall contain the list of network slice instance(s).

Upon the reception of the Nnwdaf_AnalyticsInfo_Request request message, the NWDAF shall send a Nnwdaf_AnalyticsInfo_Request response message that shall include:

- Analytic data indicated in the request.

4.3.2.2.2 Request and get from NWDAF load level information for a particular Network Slice instance

Figure 4.3.2.2.2-1 shows a scenario where the NF service consumer (e.g. PCF) sends a request to the NWDAF to request and get from NWDAF load level information for a particular Network Slice instance (see also 3GPP TS 23.502 [3] figure 4.19.2-1 step 1).

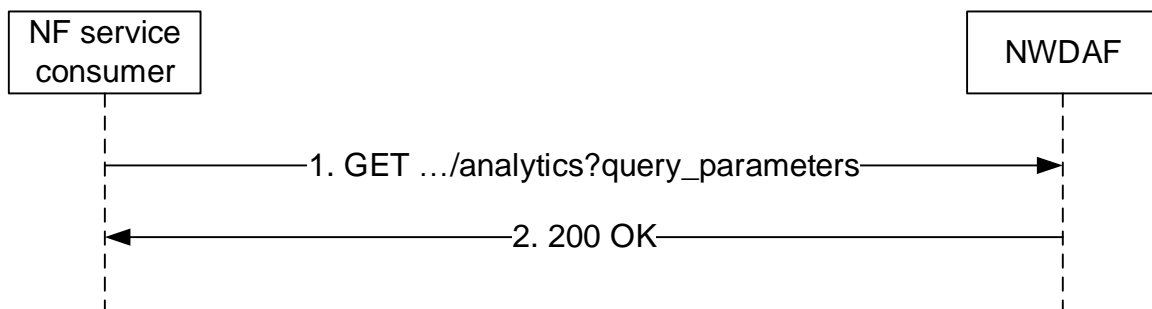

Figure 4.3.2.2.2-1: Requesting a NWDAF load level information

The NF service consumer (e.g. PCF) shall invoke the Nnwdaf_AnalyticsInfo_Request service operation when represent the NWDAF load level information of particular network slice instance. the NF service consumer shall send an HTTP GET request on the resource URI "{apiRoot}/nwdaf-analyticsinfo/v1/analytics " representing the "NWDAF Analytics", as shown in figure 4.3.2.2.2-1, step 1, to request analytics data according to the value of eventId. The EventFilter data structure provided in the request body shall include:

- identification(s) of network slice when the eventId is "LOAD_LEVEL_INFORMATION" via:
 - 1) identification of network slice(s) by "snssai" attribute; or
 - 2) any slices indication via the "anySlice" attribute.

Upon the the reception of the HTTP GET request, the NWDAF shall:

- analyse the requested analytic data. For eventId of "LOAD_LEVEL_INFORMATION", the NWDAF shall analyse the load level information of corresponding network slice instance(s).

If the HTTP request message from the NF service consumer is accepted, the NWDAF shall respond with "200 OK" status code with the message body containing the analytics with parameters as relevant for the requesting NF service consumer. The AnalyticsData data structure in the response body shall include:

- analytics with parameters indicated in the request. For eventId of "LOAD_LEVEL_INFORMATION ", the analytics shall include the load level information of corresponding network slice instance.

If the request NWDaf Analytics data does not exist, the NWDaf shall respond with "204 No Content ".

5 API Definitions

5.1 Nnwdaf_EventsSubscription Service API

5.1.1 Introduction

The Nnwdaf_EventsSubscription Service shall use the Nnwdaf_EventsSubscription API.

The request URI used in each HTTP request from the NF service consumer towards the NWDaf shall have the structure defined in subclause 4.4.1 of 3GPP TS 29.501 [7], i.e.:

{apiRoot}/{apiName}/{apiVersion}/{apiSpecificResourceUriPart}

with the following components:

- The {apiRoot} shall be set as described in 3GPP TS 29.501 [7].
- The {apiName} shall be "nnwdaf-eventssubscription".
- The {apiVersion} shall be "v1".
- The {apiSpecificResourceUriPart} shall be set as described in subclause 5.1.3.

5.1.2 Usage of HTTP

5.1.2.1 General

HTTP/2, IETF RFC 7540 [9], shall be used as specified in clause 5 of 3GPP TS 29.500 [6].

HTTP/2 shall be transported as specified in subclause 5.3 of 3GPP TS 29.500 [6].

The OpenAPI [11] specification of HTTP messages and content bodies for the Nnwdaf_EventsSubscription is contained in Annex A.

5.1.2.2 HTTP standard headers

5.1.2.2.1 General

See subclause 5.2.2 of 3GPP TS 29.500 [6] for the usage of HTTP standard headers.

5.1.2.2.2 Content type

JSON, IETF RFC 8259 [10], shall be used as content type of the HTTP bodies specified in the present specification as specified in subclause 5.4 of 3GPP TS 29.500 [6]. The use of the JSON format shall be signalled by the content type "application/json".

"Problem Details" JSON object shall be used to indicate additional details of the error in a HTTP response body and shall be signalled by the content type "application/problem+json", as defined in IETF RFC 7807 [15].

5.1.2.3 HTTP custom headers

The Nnwdaf_EventsSubscription Service API shall support HTTP custom header fields specified in subclause 5.2.3.2 of 3GPP TS 29.500 [6].

In this release of the specification, no specific custom headers are defined for the Nnwdaf_EventsSubscription Service API.

5.1.3 Resources

5.1.3.1 Resource Structure

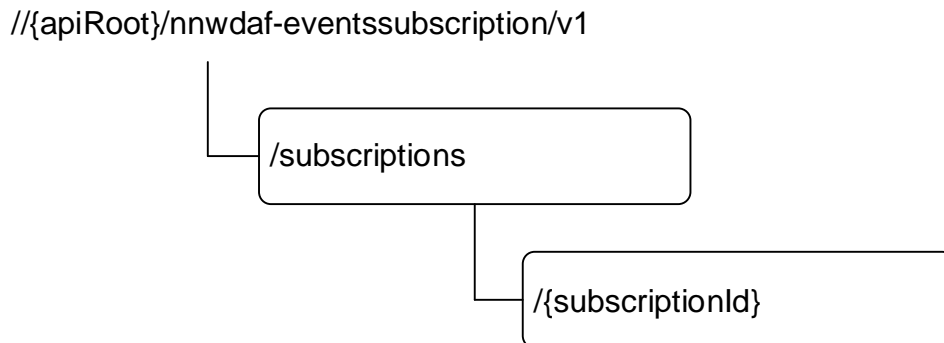

Figure 5.1.3.1-1: Resource URI structure of the Nnwdaf_EventsSubscription API

Table 5.1.3.1-1 provides an overview of the resources and applicable HTTP methods.

Table 5.1.3.1-1: Resources and methods overview

Resource name	Resource URI	HTTP method or custom operation	Description
NWDAF Events Subscriptions	{apiRoot}/nnwdaf-eventssubscription/v1/subscriptions	POST	Creates a new Individual NWDAF Events Subscription resource.
Individual NWDAF Event Subscription	{apiRoot}/nnwdaf-eventssubscription/v1/subscriptions/{subscriptionId}	DELETE	Deletes an Individual NWDAF Events Subscription identified by subresource {subscriptionId}.
		PUT	Modifies an existing Events Subscription subresource.

5.1.3.2 Resource: NWDAF Events Subscriptions

5.1.3.2.1 Description

The NWDAF Events Subscriptions resource represents all subscriptions to the Nnwdaf_EventsSubscription Service at a given NWDAF.

5.1.3.2.2 Resource definition

Resource URI: {apiRoot}/nnwdaf-eventssubscription/v1/subscriptions

This resource shall support the resource URI variables defined in table 5.1.3.2.2-1.

Table 5.1.3.2.2-1: Resource URI variables for this resource

Name	Definition
apiRoot	See subclause 5.1.1

5.1.3.2.3 Resource Standard Methods

5.1.3.2.3.1 POST

This method shall support the URI query parameters specified in table 5.1.3.2.3.1-1.

Table 5.1.3.2.3.1-1: URI query parameters supported by the POST method on this resource

Name	Data type	P	Cardinality	Description
n/a				

This method shall support the request data structures specified in table 5.1.3.2.3.1-2 and the response data structures and response codes specified in table 5.1.3.2.3.1-3.

Table 5.1.3.2.3.1-2: Data structures supported by the POST Request Body on this resource

Data type	P	Cardinality	Description
Nnwdaf_EventsSubscription	M	1	Create a new Individual NWDAF Event Subscription resource.

Table 5.1.3.2.3.1-3: Data structures supported by the POST Response Body on this resource

Data type	P	Cardinality	Response codes	Description
Nnwdaf_EventsSubscription	M	1	201 Created	The creation of an Individual NWDAF Event Subscription resource is confirmed and a representation of that resource is returned.
NOTE: The mandatory HTTP error status codes for the POST method listed in table 5.2.7.1-1 of 3GPP TS 29.500 [6] also apply.				

5.1.3.2.4 Resource Custom Operations

None in this release of the specification.

5.1.3.3 Resource: Individual NWDAF Event Subscription

5.1.3.3.1 Description

The Individual NWDAF Events Subscription resource represents a single subscription to the Nnwdaf_EventsSubscription Service at a given NWDAF.

5.1.3.3.2 Resource definition

Resource URI: {apiRoot}/nnwdaf-eventsubscription/v1/subscriptions/{subscriptionId}

This resource shall support the resource URI variables defined in table 5.1.3.3.2-1.

Table 5.1.3.3.2-1: Resource URI variables for this resource

Name	Definition
apiRoot	See subclause 5.1.1
subscriptionId	String identifying a subscription to the Nnwdaf_EventsSubscription Service

5.1.3.3.3 Resource Standard Methods

5.1.3.3.3.1 DELETE

This method shall support the URI query parameters specified in table 5.1.3.3.3.1-1.

Table 5.1.3.3.3.1-1: URI query parameters supported by the DELETE method on this resource

Name	Data type	P	Cardinality	Description
n/a				

This method shall support the request data structures specified in table 5.1.3.3.3.1-2 and the response data structures and response codes specified in table 5.1.3.3.3.1-3.

Table 5.1.3.3.3.1-2: Data structures supported by the DELETE Request Body on this resource

Data type	P	Cardinality	Description
n/a			

Table 5.1.3.3.3.1-3: Data structures supported by the DELETE Response Body on this resource

Data type	P	Cardinality	Response codes	Description
n/a			204 No Content	Successful case: The Individual NWDAF Event Subscription resource matching the subscriptionId was deleted.
ProblemDetails	M	1	404 Not Found	The Individual NWDAF Event Subscription resource does not exist. (NOTE 2)
NOTE 1: The mandatory HTTP error status codes for the DELETE method listed in table 5.2.7.1-1 of 3GPP TS 29.500 [6] also apply.				
NOTE 2: Failure cases are described in subclause 5.1.7.				

5.1.3.3.3.2 PUT

This method shall support the URI query parameters specified in table 5.1.3.3.3.2-1.

Table 5.1.3.3.3.2-1: URI query parameters supported by the PUT method on this resource

Name	Data type	P	Cardinality	Description
n/a				

This method shall support the request data structures specified in table 5.1.3.3.3.2-2 and the response data structures and response codes specified in table 5.1.3.3.3.2-3.

Table 5.1.3.3.3.2-2: Data structures supported by the PUT Request Body on this resource

Data type	P	Cardinality	Description
NnwdafeventsSubscription	M	1	Parameters to replace a subscription to NWDAF Event Subscription resource.

Table 5.1.3.3.3.2-3: Data structures supported by the PUT Response Body on this resource

Data type	P	Cardinality	Response codes	Description
NnwdafeventsSubscription	M	1	200 OK	The Individual NWDAF Event Subscription resource was modified successfully and a representation of that resource is returned.
n/a			204 No Content	The Individual NWDAF Event Subscription resource was modified successfully.
ProblemDetails	M	1	404 Not Found	The Individual NWDAF Event Subscription resource does not exist. (NOTE 2)
NOTE 1: The mandatory HTTP error status codes for the PUT method listed in table 5.2.7.1-1 of 3GPP TS 29.500 [6] also apply.				
NOTE 2: Failure cases are described in subclause 5.1.7.				

5.1.3.3.4 Resource Custom Operations

None in this release of the specification.

5.1.4 Custom Operations without associated resources

None in this release of the specification.

5.1.5 Notifications

5.1.5.1 General

Notifications shall comply with subclause 6.2 of 3GPP TS 29.500 [6] and subclause 4.6.2.3 of 3GPP TS 29.501 [7].

Table 5.3.3.4.1-1: Notifications

Custom operation URI	Mapped HTTP method	Description
{notificationURI}	POST	Report one or several observed Events.

5.1.5.2 Event Notification

5.1.5.2.1 Description

The Event Notification is used by the NWDAF to report one or several observed Events to a NF service consumer that has subscribed to such Notifications via the Individual NWDAF Event Subscription Resource.

5.1.5.2.2 Operation Definition

URI: {notificationURI}

The operation shall support the URI variables defined in table 5.1.5.2.2-1, the request data structures specified in table 5.1.5.2.2-2 and the response data structure and response codes specified in table 5.1.5.2.2-3.

Table 5.1.5.2.2-1: URI variables

Name	Definition
notificationURI	String formatted as URI with the Notification Uri as assigned within the Individual NWDAF Event Subscription and described within the Nnwdaf_EventsSubscription type (see table 5.1.6.2.2-1).

Table 5.1.5.2.2-2: Data structures supported by the POST Request Body on this resource

Data type	P	Cardinality	Description
array(NnwdafEventsSubscriptionNotification)	M	1..N	Provides Information about observed events

Table 5.1.5.2.2-3: Data structures supported by the POST Response Body on this resource

Data type	P	Cardinality	Response codes	Description
n/a			204 No Content	The receipt of the Notification is acknowledged.
NOTE: The mandatory HTTP error status codes for the POST method listed in table 5.2.7.1-1 of 3GPP TS 29.500 [6] also apply.				

5.1.6 Data Model

5.1.6.1 General

This subclause specifies the application data model supported by the API.

Table 5.1.6.1-1 specifies the data types defined for the Nnwdaf_EventsSubscription service based interface protocol.

Table 5.1.6.1-1: Nnwdaf_EventsSubscription specific Data Types

Data type	Section defined	Description	Applicability
AnySlice	5.1.6.3.2	Represents the any slices.	
EventNotification	5.1.6.2.5	Describes Notifications about events that occurred.	
EventSubscription	5.1.6.2.3	Represents the subscription to a single event.	
LoadLevelInformation	5.1.6.3.2	Represents load level information of the network slice instance	
NwdafEvent	5.1.6.3.4	Describes the NWDAF Events.	
NnwdafEventsSubscription	5.1.6.2.2	Represents an Individual NWDAF Event Subscription resource.	
NnwdafEventsSubscriptionNotification	5.1.6.2.4	Represents an Individual NWDAF Event Subscription Notification resource.	
NotificationMethod	5.1.6.3.3	Represents the notification methods that can be subscribed.	
SliceLoadLevelInformation	5.1.6.2.6	Represents the slices and there load level information.	

Table 5.1.6.1-2 specifies data types re-used by the Nnwdaf_EventsSubscription service based interface protocol from other specifications, including a reference to their respective specifications and when needed, a short description of their use within the Nnwdaf service based interface.

Table 5.1.6.1-2: Nnwdaf_EventsSubscription re-used Data Types

Data type	Reference	Comments	Applicability
DurationSec	3GPP TS 29.571 [8]		
ProblemDetails	3GPP TS 29.571 [8]	Used in error responses to provide more detailed information about an error.	ProblemDetails
Snsai	3GPP TS 29.571 [8]	Identifies the S-NSSAI (Single Network Slice Selection Assistance Information).	
SupportedFeature	3GPP TS 29.571 [8]	Used to negotiate the applicability of the optional features defined in table 5.1.8-1.	
Uri	3GPP TS 29.571 [8]		

5.1.6.2 Structured data types

5.1.6.2.1 Introduction

This subclause defines the structures to be used in resource representations.

5.1.6.2.2 Type NnwdafEventsSubscription

Table 5.1.6.2.2-1: Definition of type NnwdafEventsSubscription

Attribute name	Data type	P	Cardinality	Description	Applicability
eventSubscriptions	array(EventSubscription)	M	1..N	Subscribed events	
notificationURI	Uri	C	1	Identifies the recipient of Notifications sent by the NWDAAF. This parameter shall be supplied by the NF service consumer in the HTTP POST requests that include an object of EventSubscription type.	
supportedFeatures	SupportedFeatures	C	1	List of Supported features used as described in subclause 5.1.8. This parameter shall be supplied by NF service consumer in the POST request that request the creation of an NWDAAF Event Subscriptions resource, and shall be supplied by the NWDAAF in the reply of corresponding request.	

5.1.6.2.3 Type EventSubscription

Table 5.1.6.2.3-1: Definition of type EventSubscription

Attribute name	Data type	P	Cardinality	Description	Applicability
anySlice	AnySlice	C	0..1	Default is "FALSE". (NOTE 1)	
event	NwdafEvent	M	1	Event that is subscribed.	
loadLevelThreshold	integer	C	0..1	Shall be supplied for notification method "THRESHOLD". Indicates that the NWDAAF shall report the corresponding network slice load level to the NF service consumer where the load level of the network slice instance identified by snssai is reached.	
notificationMethod	NotificationMethod	O	0..1	Indicate the notification method. (NOTE 2)	
repetitionPeriod	DurationSec	C	0..1	Shall be supplied for notification Method "PERIODIC".	
snssais	array(Snssai)	C	1..N	Identification(s) of network slice to which the subscription applies. (NOTE 1)	

NOTE 1: When subscribed event is "SLICE_LOAD_LEVEL", either information about slice(s) identified by snssai, or anySlice set to "TRUE" shall be included.

NOTE 2: When notificationMethod is not supplied, the default value is "THRESHOLD".

5.1.6.2.4 Type NnwdafEventsSubscriptionNotification

Table 5.1.6.2.4-1: Definition of type NnwdafEventsSubscriptionNotification

Attribute name	Data type	P	Cardinality	Description	Applicability
eventNotifications	array(EventNotifications)	M	1..N	Notifications about Individual Events	
subscriptionId	string	M	1	String identifying a subscription to the Nnwdaf_EventsSubscription Service	

5.1.6.2.5 Type EventNotification

Table 5.1.6.2.5-1: Definition of type EventNotification

Attribute name	Data type	P	Cardinality	Description	Applicability
event	NwdafEvent	M	1	Event that is notified.	
sliceLoadLevelInfo	SliceLoadLevelInformation	M	1	The slices and there load level information.	

5.1.6.2.6 Type SliceLoadLevelInformation

Table 5.1.6.2.6-1: Definition of type SliceLoadLevelInformation

Attribute name	Data type	P	Cardinality	Description	Applicability
loadLevelInformation	LoadLevelInformation	M	1	Load level information of the network slice instance identified by snssai.	
snssais	array(Snssai)	M	1..N	Identification(s) of network slice to which the subscription.	

5.1.6.3 Simple data types and enumerations

5.1.6.3.1 Introduction

This subclause defines simple data types and enumerations that can be referenced from data structures defined in the previous subclauses.

5.1.6.3.2 Simple data types

The simple data types defined in table 5.1.6.3.2-1 shall be supported.

Table 5.1.6.3.2-1: Simple data types

Type Name	Type Definition	Description	Applicability
AnySlice	boolean	"FALSE" represents not applicable for all slices. "TRUE" represents applicable for all slices.	
LoadLevelInformation	integer	Load level information of the network slice instance.	

5.1.6.3.3 Enumeration: NotificationMethod

Table 5.1.6.3.3-1: Enumeration NotificationMethod

Enumeration value	Description	Applicability
PERIODIC	The subscribe of NWDAF Event is periodically. The periodic of the notification is identified by repetitionPeriod defined in subclause 5.1.6.2.3.	
THRESHOLD	The subscribe of NWDAF Event is upon threshold exceeded. The threshold of the notification is identified by loadLevelThreshold defined in subclause 5.1.6.2.3.	

5.1.6.3.4 Enumeration: NwdafEvent

Table 5.1.6.3.4-1: Enumeration NwdafEvent

Enumeration value	Description	Applicability
SLICE_LOAD_LEVEL	Indicates that the event subscribed is load level information of Network Slice instance	

5.1.7 Error handling

5.1.7.1 General

HTTP error handling shall be supported as specified in subclause 5.2.4 of 3GPP TS 29.500 [6].

For the Nnwdaf_EventsSubscription API, HTTP error responses shall be supported as specified in subclause 4.8 of 3GPP TS 29.501 [7]. Protocol errors and application errors specified in table 5.2.7.2-1 of 3GPP TS 29.500 [6] shall be supported for an HTTP method if the corresponding HTTP status codes are specified as mandatory for that HTTP method in table 5.2.7.1-1 of 3GPP TS 29.500 [6]. In addition, the requirements in the following subclauses shall apply.

5.1.7.2 Protocol Errors

In this Release of the specification, there are no additional protocol errors applicable for the Nnwdaf_EventsSubscription API.

5.1.7.3 Application Errors

The application errors defined for the Nnwdaf_EventsSubscription API are listed in table 5.1.7.3-1. The NWDAF shall include in the HTTP status code a "ProblemDetails" data structure with the "cause" attribute indicating the application error as listed in table 5.7.3-1.

Table 5.1.7.3-1: Application errors

Application Error	HTTP status code	Description
SUBSCRIPTION_NOT_FOUND	404 Not Found	Indicates that the modification or deletion has failed because the specified Individual NWDAF Event Subscription resource does not exist. (NOTE)
NOTE: This application error is included in the responses to the GET and the DELETE requests.		

5.1.8 Feature negotiation

The optional features in table 5.1.8-1 are defined for the Nnwdaf_EventsSubscription API. They shall be negotiated using the extensibility mechanism defined in subclause 6.6 of 3GPP TS 29.500 [6].

Table 5.1.8-1: Supported Features

Feature number	Feature Name	Description

5.1.9 Security

As indicated in 3GPP TS 33.501 [13] and 3GPP TS 29.500 [6], the access to the Nnwdaf_EventsSubscription API may be authorized by means of the OAuth2 protocol (see IETF RFC 6749 [14]), based on local configuration, using the "Client Credentials" authorization grant, where the NRF (see 3GPP TS 29.510 [12]) plays the role of the authorization server.

If OAuth2 is used, a n NF Service Consumer, prior to consuming services offered by the Nnwdaf_EventsSubscription API, shall obtain a "token" from the authorization server, by invoking the Access Token Request service, as described in 3GPP TS 29.510 [12], subclause 5.4.2.2.

NOTE: When multiple NRFs are deployed in a network, the NRF used as authorization server is the same NRF that the NF Service Consumer used for discovering the Nnwdaf_EventsSubscription service.

The Nnwdaf_EventsSubscription API defines a single scope "nwdaf-eventssubscription" for the entire service, and it does not define any additional scopes at resource or operation level.

5.2 Nnwdaf_AnalyticsInfo Service API

5.2.1 Introduction

The Nnwdaf_AnalyticsInfo Service shall use the Nnwdaf_AnalyticsInfo API.

The request URI used in each HTTP request from the NF service consumer towards the NWDAF shall have the structure defined in subclause 4.4.1 of 3GPP TS 29.501 [7], i.e.:

{apiRoot}/{apiName}/{apiVersion}/{apiSpecificResourceUriPart}

with the following components:

- The {apiRoot} shall be set as described in 3GPP TS 29.501 [7].
- The {apiName} shall be "nwdaf-analyticsinfo".
- The {apiVersion} shall be "v1".
- The {apiSpecificResourceUriPart} shall be set as described in subclause 5.2.3.

5.2.2 Usage of HTTP

5.2.2.1 General

HTTP/2, IETF RFC 7540 [9], shall be used as specified in clause 5 of 3GPP TS 29.500 [6].

HTTP/2 shall be transported as specified in subclause 5.3 of 3GPP TS 29.500 [6].

The OpenAPI [11] specification of HTTP messages and content bodies for the Nnwdaf_AnalyticsInfo is contained in Annex A.

5.2.2.2 HTTP standard headers

5.2.2.2.1 General

See subclause 5.2.2 of 3GPP TS 29.500 [6] for the usage of HTTP standard headers.

5.2.2.2.2 Content type

JSON, IETF RFC 8259 [10], shall be used as content type of the HTTP bodies specified in the present specification as specified in subclause 5.4 of 3GPP TS 29.500 [6]. The use of the JSON format shall be signalled by the content type "application/json".

"Problem Details" JSON object shall be used to indicate additional details of the error in a HTTP response body and shall be signalled by the content type "application/problem+json", as defined in IETF RFC 7807 [15].

5.2.2.3 HTTP custom headers

The Nnwdaf_AnalyticsInfo Service API shall support HTTP custom header fields specified in subclause 5.2.3.2 of 3GPP TS 29.500 [6].

In this release of the specification, no specific custom headers are defined for the Nnwdaf_AnalyticsInfo Service API.

5.2.3 Resources

5.2.3.1 Resource Structure

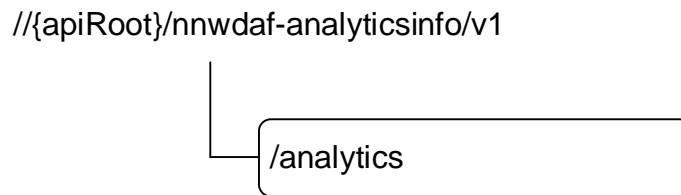

Figure 5.2.3.1-1: Resource URI structure of the Nnwdaf_AnalyticsInfo API

Table 5.2.3.1-1 provides an overview of the resources and applicable HTTP methods.

Table 5.2.3.1-1: Resources and methods overview

Resource name	Resource URI	HTTP method or custom operation	Description
NWDAF Analytics	{apiRoot}/ nnwdaf-analyticsinfo/v1 /analytics	GET	Retrieve the NWDAF analytics

5.2.3.2 Resource: NWDAF Analytics

5.2.3.2.1 Description

The NWDAF Analytics resource represents the analytics to the Nnwdaf_AnalyticsInfo Service at a given NWDAF.

5.2.3.2.2 Resource definition

Resource URI: {apiRoot}/nnwdaf-analyticsinfo/v1/analytics

This resource shall support the resource URI variables defined in table 5.2.3.2.2-1.

Table 5.2.3.2.2-1: Resource URI variables for this resource

Name	Definition
apiRoot	See subclause 5.2.1

5.2.3.2.3 Resource Standard Methods

5.2.3.2.3.1 GET

This method shall support the URI query parameters specified in table 5.2.3.2.3.1-1.

Table 5.2.3.2.3.1-1: URI query parameters supported by the GET method on this resource

Name	Data type	P	Cardinality	Description
event-id	EventId	M	1	Shall be included to identify the analytics.
event-filter	EventFilter	C	0..1	Shall be included to identify the analytics when the eventId is "Load_Level_Information".
supported-features	SupportedFeatures	O	0..1	To filter irrelevant responses related to unsupported features.

This method shall support the request data structures specified in table 5.2.3.2.3.1-2 and the response data structures and response codes specified in table 5.2.3.2.3.1-3.

Table 5.2.3.2.3.1-2: Data structures supported by the GET Request Body on this resource

Data type	P	Cardinality	Description
n/a			

Table 5.2.3.2.3.1-3: Data structures supported by the GET Response Body on this resource

Data type	P	Cardinality	Response codes	Description
AnalyticsData	M	1	200	Containing the analytics with parameters as relevant for the requesting NF service consumer
n/a			204 No Content	If the request NWDAF Analytics data does not exist, the NWDAF shall respond with "204 No Content".
NOTE: The mandatory HTTP error status codes for the GET method listed in table 5.2.7.1-1 of 3GPP TS 29.500 [6] also apply.				

5.2.3.2.4 Resource Custom Operations

None in this release of the specification.

5.2.4 Custom Operations without associated resources

None in this release of the specification.

5.2.5 Notifications

None in this release of the specification.

5.2.6 Data Model

5.2.6.1 General

This subclause specifies the application data model supported by the API.

Table 5.2.6.1-1 specifies the data types defined for the Nnwdaf_AnalyticsInfo service based interface protocol.

Table 5.2.6.1-1: Nnwdaf_AnalyticsInfo specific Data Types

Data type	Section defined	Description	Applicability
EventId	5.2.6.3.3	Describes the type of analytics.	
AnalyticsData	5.2.6.2.2	Describes analytics with parameters indicated in the request	

Table 5.2.6.1-2 specifies data types re-used by the Nnwdaf_AnalyticsInfo service based interface protocol from other specifications, including a reference to their respective specifications and when needed, a short description of their use within the Nnwdaf service based interface.

Table 5.2.6.1-2: Nnwdaf_AnalyticsInfo re-used Data Types

Data type	Reference	Comments	Applicability
AnySlice	5.1.6.3.2		
ProblemDetails	3GPP TS 29.571 [8]	Used in error responses to provide more detailed information about an error.	
SupportedFeatures	3GPP TS 29.571 [8]	Used to negotiate the applicability of the optional features defined in table 5.2.8-1.	
Snsai	3GPP TS 29.571 [8]		
SliceLoadLevelInformation	5.1.6.2.6		

5.2.6.2 Structured data types

5.2.6.2.1 Introduction

This subclause defines the structures to be used in resource representations.

5.2.6.2.2 Type AnalyticsData

Table 5.2.6.2.2-1: Definition of type AnalyticsData

Attribute name	Data type	P	Cardinality	Description	Applicability
sliceLoadLevelInfos	array(SliceLoadLevelInformation)	M	1..N	The slices and there load level information.	
supportedFeatures	SupportedFeatures	M	1	List of Supported features used as described in subclause 5.1.8. This parameter shall be supplied by NWDAF in the reply of GET request that request the analytics resource.	

5.2.6.2.3 Type EventFilter

Table 5.2.6.2.3-1: Definition of type EventFilter

Attribute name	Data type	P	Cardinality	Description	Applicability
anySlice	AnySlice	C	0..1	Default is "FALSE". (NOTE)	
snssais	array(Snssai)	C	1..N	Identification(s) of network slice to which the subscription belongs. (NOTE)	
NOTE: When eventId in the request is "LOAD_LEVEL_INFORMATION ", either information about slice(s) identified by snssai, or anySlice set to "TRUE" shall be included.					

5.2.6.3 Simple data types and enumerations

5.2.6.3.1 Introduction

This subclause defines simple data types and enumerations that can be referenced from data structures defined in the previous subclauses.

5.2.6.3.2 Simple data types

The simple data types defined in table 5.2.6.3.2-1 shall be supported.

Table 5.2.6.3.2-1: Simple data types

Type Name	Type Definition	Description	Applicability
n/a			

5.2.6.3.3 Enumeration: EventId

Table 5.2.6.3.3-1: Enumeration EventId

Enumeration value	Description	Applicability
LOAD_LEVEL_INFORMATION	Represent the analytics of load level information of corresponding network slice instance.	

5.2.7 Error handling

5.2.7.1 General

HTTP error handling shall be supported as specified in subclause 5.2.4 of 3GPP TS 29.500 [6].

For the Nnwdaf_AnalyticsInfo API, HTTP error responses shall be supported as specified in subclause 4.8 of 3GPP TS 29.501 [7]. Protocol errors and application errors specified in table 5.2.7.2-1 of 3GPP TS 29.500 [6] shall be supported for an HTTP method if the corresponding HTTP status codes are specified as mandatory for that HTTP method in table 5.2.7.1-1 of 3GPP TS 29.500 [6]. In addition, the requirements in the following subclauses shall apply.

5.2.7.2 Protocol Errors

In this Release of the specification, there are no additional protocol errors applicable for the Nnwdaf_AnalyticsInfo API.

5.2.7.3 Application Errors

The application errors defined for the Nnwdaf_AnalyticsInfo API are listed in table 5.2.7.3-1. The NWDAF shall include in the HTTP status code a "ProblemDetails" data structure with the "cause" attribute indicating the application error as listed in table 5.2.7.3-1.

Table 5.2.7.3-1: Application errors

Application Error	HTTP status code	Description
n/a		

5.2.8 Feature negotiation

The optional features in table 5.2.8-1 are defined for the Nnwdaf_AnalyticsInfo API. They shall be negotiated using the extensibility mechanism defined in subclause 6.6 of 3GPP TS 29.500 [6].

Table 5.2.8-1: Supported Features

Feature number	Feature Name	Description

5.2.9 Security

As indicated in 3GPP TS 33.501 [13] and 3GPP TS 29.500 [6], the access to the Nnwdaf_AnalyticsInfo API may be authorized by means of the OAuth2 protocol (see IETF RFC 6749 [14]), based on local configuration, using the "Client Credentials" authorization grant, where the NRF (see 3GPP TS 29.510 [12]) plays the role of the authorization server.

If OAuth2 is used, a n NF Service Consumer, prior to consuming services offered by the Nnwdaf_AnalyticsInfo API, shall obtain a "token" from the authorization server, by invoking the Access Token Request service, as described in 3GPP TS 29.510 [12], subclause 5.4.2.2.

NOTE: When multiple NRFs are deployed in a network, the NRF used as authorization server is the same NRF that the NF Service Consumer used for discovering the Nnwdaf_AnalyticsInfo service.

The Nnwdaf_AnalyticsInfo API defines a single scope "nnwdaf-analyticsinfo" for the entire service, and it does not define any additional scopes at resource or operation level.

Annex A (normative): OpenAPI specification

A.1 General

The present Annex contains an OpenAPI [11] specification of HTTP messages and content bodies used by the Nnwdaf_EventsSubscription and the Nnwdaf_AnalyticsInfo API.

In case of conflicts between the main body of the present document and the present Annex, the information in the main body shall be applicable.

A.2 Nnwdaf_EventsSubscription API

```

openapi: 3.0.0
info:
  description: Nnwdaf_EventsSubscription Service API
  version: "1.0.0"
  title: Nnwdaf_EventsSubscription
externalDocs:
  description: 3GPP TS 29.520 V15.2.0; 5G System; Network Data Analytics Services.
  url: 'http://www.3gpp.org/ftp/Specs/archive/29_series/29.520/'
security:
  - {}
  - oAuth2ClientCredentials:
    - nnwdaf-eventssubscription
servers:
  - url: '{apiRoot}/nnwdaf-eventssubscription/v1'
    variables:
      apiRoot:
        default: https://example.com
        description: apiRoot as defined in subclause 4.4 of 3GPP TS 29.501.
paths:
  /subscriptions:
    post:
      requestBody:
        required: true
        content:
          application/json:
            schema:
              $ref: '#/components/schemas/NnwdafEventsSubscription'
      headers:
        Location:
          description: 'Contains the URI of the newly created resource, according to the
structure: {apiRoot}/nnwdaf-eventssubscription/v1/subscriptions/{subscriptionId}'
          required: true
          schema:
            type: string
      responses:
        '201':
          description: Create a new Individual NWDAF Event Subscription resource.
          content:
            application/json:
              schema:
                $ref: '#/components/schemas/NnwdafEventsSubscription'
        '400':
          $ref: 'TS29571_CommonData.yaml#/components/responses/400'
        '401':
          $ref: 'TS29571_CommonData.yaml#/components/responses/401'
        '403':
          $ref: 'TS29571_CommonData.yaml#/components/responses/403'
        '404':
          $ref: 'TS29571_CommonData.yaml#/components/responses/404'
        '411':
          $ref: 'TS29571_CommonData.yaml#/components/responses/411'
        '413':
          $ref: 'TS29571_CommonData.yaml#/components/responses/413'
        '415':
          $ref: 'TS29571_CommonData.yaml#/components/responses/415'
        '429':
          $ref: 'TS29571_CommonData.yaml#/components/responses/429'
        '500':

```



```

    $ref: 'TS29571_CommonData.yaml#/components/responses/500'
  '503':
    $ref: 'TS29571_CommonData.yaml#/components/responses/503'
  default:
    $ref: 'TS29571_CommonData.yaml#/components/responses/default'
callbacks:
  myNotification:
    '{$request.body#/notificationURI}':
      post:
        requestBody:
          required: true
          content:
            application/json:
              schema:
                type: array
                items:
                  $ref: '#/components/schemas/NnwdafEventsSubscriptionNotification'
                minItems: 1
      responses:
        '204':
          description: The receipt of the Notification is acknowledged.
        '400':
          $ref: 'TS29571_CommonData.yaml#/components/responses/400'
        '401':
          $ref: 'TS29571_CommonData.yaml#/components/responses/401'
        '403':
          $ref: 'TS29571_CommonData.yaml#/components/responses/403'
        '404':
          $ref: 'TS29571_CommonData.yaml#/components/responses/404'
        '411':
          $ref: 'TS29571_CommonData.yaml#/components/responses/411'
        '413':
          $ref: 'TS29571_CommonData.yaml#/components/responses/413'
        '415':
          $ref: 'TS29571_CommonData.yaml#/components/responses/415'
        '429':
          $ref: 'TS29571_CommonData.yaml#/components/responses/429'
        '500':
          $ref: 'TS29571_CommonData.yaml#/components/responses/500'
        '503':
          $ref: 'TS29571_CommonData.yaml#/components/responses/503'
        default:
          $ref: 'TS29571_CommonData.yaml#/components/responses/default'
/subscriptions/{subscriptionId}:
  delete:
    parameters:
      - name: subscriptionId
        in: path
        description: String identifying a subscription to the Nnwdaf_EventsSubscription Service
        required: true
        schema:
          type: string
    responses:
      '204':
        description: No Content. The Individual NWDAF Event Subscription resource matching the
        subscriptionId was deleted.
      '400':
        $ref: 'TS29571_CommonData.yaml#/components/responses/400'
      '401':
        $ref: 'TS29571_CommonData.yaml#/components/responses/401'
      '403':
        $ref: 'TS29571_CommonData.yaml#/components/responses/403'
      '404':
        description: The Individual NWDAF Event Subscription resource does not exist.
        content:
          application/problem+json:
            schema:
              $ref: 'TS29571_CommonData.yaml#/components/schemas/ProblemDetails'
      '429':
        $ref: 'TS29571_CommonData.yaml#/components/responses/429'
      '500':
        $ref: 'TS29571_CommonData.yaml#/components/responses/500'
      '501':
        $ref: 'TS29571_CommonData.yaml#/components/responses/501'
      '503':
        $ref: 'TS29571_CommonData.yaml#/components/responses/503'
      default:
        $ref: 'TS29571_CommonData.yaml#/components/responses/default'

```

```

put:
  requestBody:
    required: true
    content:
      application/json:
        schema:
          $ref: '#/components/schemas/NnwdafEventsSubscription'
  parameters:
    - name: subscriptionId
      in: path
      description: String identifying a subscription to the Nnwdaf_EventsSubscription Service
      required: true
      schema:
        type: string
  responses:
    '200':
      description: The Individual NWDAF Event Subscription resource was modified successfully
      and a representation of that resource is returned.
      content:
        application/json:
          schema:
            $ref: '#/components/schemas/NnwdafEventsSubscription'
    '204':
      description: The Individual NWDAF Event Subscription resource was modified successfully.
    '400':
      $ref: 'TS29571_CommonData.yaml#/components/responses/400'
    '401':
      $ref: 'TS29571_CommonData.yaml#/components/responses/401'
    '403':
      $ref: 'TS29571_CommonData.yaml#/components/responses/403'
    '404':
      description: The Individual NWDAF Event Subscription resource does not exist.
      content:
        application/problem+json:
          schema:
            $ref: 'TS29571_CommonData.yaml#/components/schemas/ProblemDetails'
    '411':
      $ref: 'TS29571_CommonData.yaml#/components/responses/411'
    '413':
      $ref: 'TS29571_CommonData.yaml#/components/responses/413'
    '415':
      $ref: 'TS29571_CommonData.yaml#/components/responses/415'
    '429':
      $ref: 'TS29571_CommonData.yaml#/components/responses/429'
    '500':
      $ref: 'TS29571_CommonData.yaml#/components/responses/500'
    '501':
      $ref: 'TS29571_CommonData.yaml#/components/responses/501'
    '503':
      $ref: 'TS29571_CommonData.yaml#/components/responses/503'
    default:
      $ref: 'TS29571_CommonData.yaml#/components/responses/default'
components:
  securitySchemes:
    oAuth2ClientCredentials:
      type: oauth2
      flows:
        clientCredentials:
          tokenUrl: '{nrfApiRoot}/oauth2/token'
          scopes:
            nnwdaf-eventssubscription: Access to the Nnwdaf_EventsSubscription API
  schemas:
    NnwdafEventsSubscription:
      type: object
      properties:
        eventSubscriptions:
          type: array
          items:
            $ref: '#/components/schemas/EventSubscription'
          minItems: 1
          description: Subscribed events
        notificationURI:
          $ref: 'TS29571_CommonData.yaml#/components/schemas/Uri'
        supportedFeatures:
          $ref: 'TS29571_CommonData.yaml#/components/schema/SupportedFeature'
      required:
        - eventSubscriptions
    EventSubscription:

```

```

type: object
properties:
  anySlice:
    $ref: '#/components/schemas/AnySlice'
  event:
    $ref: '#/components/schemas/NwdafEvent'
  loadLevelThreshold:
    type: integer
    description: Shall be supplied for notification method "THRESHOLD". Indicates that the
NWDAF shall report the corresponding network slice load level to the NF service consumer where the
load level of the network slice instance identified by snssai is reached.
  notificationMethod:
    $ref: '#/components/schemas/NotificationMethod'
  repetitionPeriod:
    $ref: 'TS29571_CommonData.yaml#/components/schemas/DurationSec'
  snssai:
    type: array
    items:
      $ref: 'TS29571_CommonData.yaml#/components/schemas/Snssai'
    minItems: 1
    description: Identification(s) of network slice to which the subscription applies. When
subscribed event is "SLICE_LOAD_LEVEL", either information about slice(s) identified by snssai, or
anySlice set to "TRUE" shall be included.
  required:
    - event
NnwdafEventsSubscriptionNotification:
type: object
properties:
  eventNotifications:
    type: array
    items:
      $ref: '#/components/schemas/EventNotification'
    minItems: 1
    description: Notifications about Individual Events
  subscriptionId:
    type: string
    description: String identifying a subscription to the Nnwdaf_EventsSubscription Service
  required:
    - eventNotifications
    - subscriptionId
EventNotification:
type: object
properties:
  event:
    $ref: '#/components/schemas/NwdafEvent'
  sliceLoadLevelInfo:
    $ref: '#/components/schemas/SliceLoadLevelInformation'
  required:
    - event
    - sliceLoadLevelInfo
SliceLoadLevelInformation:
type: object
properties:
  loadLevelInformation:
    $ref: '#/components/schemas/LoadLevelInformation'
  snssais:
    type: array
    items:
      $ref: 'TS29571_CommonData.yaml#/components/schemas/Snssai'
    minItems: 1
    description: Identification(s) of network slice to which the subscription.
  required:
    - loadLevelInformation
    - snssais
AnySlice:
type: boolean
description: FALSE represents not applicable for all slices. TRUE represents applicable for
all slices.
LoadLevelInformation:
type: integer
description: Load level information of the network slice instance.
NotificationMethod:
anyOf:
  - type: string
  enum:
    - PERIODIC
    - THRESHOLD
  - type: string

```

```

description: >
  This string provides forward-compatibility with future
  extensions to the enumeration but is not used to encode
  content defined in the present version of this API.
description: >
  Possible values are
  - PERIODIC: The subscribe of NWDAF Event is periodically. The periodic of the notification is
  identified by repetitionPeriod defined in subclause 5.1.6.2.3.
  - THRESHOLD: The subscribe of NWDAF Event is upon threshold exceeded. The threshold of the
  notification is identified by loadLevelThreshold defined in subclause 5.1.6.2.3.
NwdafEvent:
  anyOf:
  - type: string
    enum:
      - SLICE_LOAD_LEVEL
  - type: string
    description: >
      This string provides forward-compatibility with future
      extensions to the enumeration but is not used to encode
      content defined in the present version of this API.
  description: >
    Possible values are
    - SLICE_LOAD_LEVEL: Indicates that the event subscribed is load level information of Network
    Slice instance

```

A.3 Nnwdaf_AnalyticsInfo API

```

openapi: 3.0.0
info:
  description: Nnwdaf_AnalyticsInfo Service API
  version: "1.0.0"
  title: Nnwdaf_AnalyticsInfo
externalDocs:
  description: 3GPP TS 29.520 V15.2.0; 5G System; Network Data Analytics Services.
  url: 'http://www.3gpp.org/ftp/Specs/archive/29_series/29.520/'
security:
  - {}
  - oAuth2ClientCredentials:
    - nnwdaf-analyticsinfo
servers:
  - url: '{apiRoot}/nnwdaf-analyticsinfo/v1'
    variables:
      apiRoot:
        default: https://example.com
        description: apiRoot as defined in subclause 4.4 of 3GPP TS 29.501.
paths:
  /analytics:
    get:
      parameters:
        - name: event-id
          in: query
          description: Identify the analytics.
          required: true
          schema:
            $ref: '#/components/schemas/EventId'
        - name: event-filter
          in: query
          description: Identify the analytics when the eventId is "Load_Level_Information".
          required: false
          schema:
            $ref: '#/components/schemas/EventFilter'
        - name: supported-features
          in: query
          description: To filter irrelevant responses related to unsupported features
          schema:
            $ref: 'TS29571_CommonData.yaml#/components/schemas/SupportedFeatures'
      responses:
        '200':
          description: The individual PCF session binding information resource
          matching the query parameter(s) is returned.
          content:
            application/json:
              schema:
                $ref: '#/components/schemas/AnalyticsData'
        '400':
          $ref: 'TS29571_CommonData.yaml#/components/responses/400'

```

```

'401':
  $ref: 'TS29571_CommonData.yaml#/components/responses/401'
'403':
  $ref: 'TS29571_CommonData.yaml#/components/responses/403'
'404':
  description: Indicates that the NWDAF Analytics resource does not exist.
  content:
    application/problem+json:
      schema:
        $ref: 'TS29571_CommonData.yaml#/components/schemas/ProblemDetails'
'406':
  $ref: 'TS29571_CommonData.yaml#/components/responses/406'
'414':
  $ref: 'TS29571_CommonData.yaml#/components/responses/414'
'429':
  $ref: 'TS29571_CommonData.yaml#/components/responses/429'
'500':
  $ref: 'TS29571_CommonData.yaml#/components/responses/500'
'503':
  $ref: 'TS29571_CommonData.yaml#/components/responses/503'
default:
  $ref: 'TS29571_CommonData.yaml#/components/responses/default'
components:
  securitySchemes:
    oAuth2ClientCredentials:
      type: oauth2
      flows:
        clientCredentials:
          tokenUrl: '{nrfApiRoot}/oauth2/token'
          scopes:
            nnwdaf-analyticsinfo: Access to the Nnwdaf_AnalyticsInfo API
  schemas:
    AnalyticsData:
      type: object
      properties:
        sliceLoadLevelInfos:
          type: array
          items:
            $ref:
'TS29520_Nnwdaf_EventsSubscription.yaml#/components/schemas/SliceLoadLevelInformation'
          minItems: 1
          description: The slices and there load level information.
    EventFilter:
      type: object
      properties:
        anySlice:
          $ref: 'TS29520_Nnwdaf_EventsSubscription.yaml#/components/schemas/AnySlice'
        snssais:
          type: array
          items:
            $ref: 'TS29571_CommonData.yaml#/components/schemas/Snssai'
          minItems: 1
          description: Identification(s) of network slice to which the subscription belongs. When
eventId is "Load_level_Information", either information about slice(s) identified by snssai, or
anySlice set to "TRUE" shall be included.
      not:
        required: [anySlice, snssais]
    EventId:
      anyOf:
        - type: string
          enum:
            - LOAD_LEVEL_INFORMATION
        - type: string
          description: >
            This string provides forward-compatibility with future
            extensions to the enumeration but is not used to encode
            content defined in the present version of this API.
          description: >
            Possible values are
            - LOAD_LEVEL_INFORMATION: Represent the analytics of load level information of corresponding
            network slice instance.

```

Annex B (informative): Change history

Change history							
Date	TSG #	TSG Doc.	CR	Rev	Cat	Subject/Comment	New
2017-10						TS skeleton of Network Data Analytics Services.	0.0.0
2017-11	CT3#92					Inclusion of documents agreed in CT3#92 C3-175356.	0.1.0
2017-12	CT3#93					Inclusion of documents agreed in CT3#93 C3-176166, C3-176260, C3-176324, C3-176325, C3-176326, and C3-176327.	0.2.0
2018-01	CT3#94					Inclusion of documents agreed in CT3#94 C3-180252, C3-180253, C3-180254, C3-180255, C3-180256, C3-180257, C3-180344, C3-180345, C3-180346, C3-180323 and C3-180347.	0.3.0
2018-03	CT3#95					Inclusion of documents agreed in CT3#95 C3-181253, C3-181255, C3-181256, C3-181257, C3-181260, C3-181312, C3-181342 and C3-181343.	0.4.0
2018-03	CT3#96					Inclusion of documents agreed in CT3#96 C3-182379 and C3-182380.	0.5.0
2018-05	CT3#97					Inclusion of documents agreed in CT3#97 C3-183285, C3-183532, C3-183533, C3-183534 and C3-183535.	0.6.0
2018-06	CT#80	CP-181032				TS sent to plenary for approval	1.0.0
2018-06	CT#80	CP-181032				TS approved by plenary	15.0.0
2018-09	CT#81	CP-182015	0001	3	F	Clarification on mandatory HTTP error status codes	15.1.0
2018-09	CT#81	CP-182209	0002	4	B	OpenAPI for TS 29.520	15.1.0
2018-09	CT#81	CP-182015	0003	1	F	Description of Structured data types	15.1.0
2018-09	CT#81	CP-182015	0004	1	F	Resource structure presentation	15.1.0
2018-12	CT#82	CP-183205	0006		F	Default value for apiRoot	15.2.0
2018-12	CT#82	CP-183205	0007	2	F	Correct Nnwdaf service	15.2.0
2018-12	CT#82	CP-183205	0008	1	F	Cardinality	15.2.0
2018-12	CT#82	CP-183205	0009		F	API version	15.2.0
2018-12	CT#82	CP-183205	0010		F	ExternalDocs OpenAPI field	15.2.0
2018-12	CT#82	CP-183205	0011	1	F	Security	15.2.0
2018-12	CT#82	CP-183205	0012	1	F	Supported content types	15.2.0
2018-12	CT#82	CP-183205	0013	2	F	HTTP Error responses	15.2.0
2018-12	CT#82	CP-183205	0014	2	F	Correct NWDAF resource	15.2.0
2018-12	CT#82	CP-183205	0016	1	F	Adding HTTP status code "204 No Content"	15.2.0
2018-12	CT#82	CP-183205	0019		F	Location header field in OpenAPI	15.2.0

History

Document history		
V15.0.0	July 2018	Publication
V15.1.0	October 2018	Publication
V15.2.0	April 2019	Publication