

# ETSI TS 129 415 V13.0.0 (2016-01)



## Universal Mobile Telecommunications System (UMTS); Core network Nb interface user plane protocols (3GPP TS 29.415 version 13.0.0 Release 13)



---

**Reference**

RTS/TSGC-0329415vd00

---

**Keywords**

LTE

**ETSI**

---

650 Route des Lucioles  
F-06921 Sophia Antipolis Cedex - FRANCE

Tel.: +33 4 92 94 42 00 Fax: +33 4 93 65 47 16

Siret N° 348 623 562 00017 - NAF 742 C  
Association à but non lucratif enregistrée à la  
Sous-Préfecture de Grasse (06) N° 7803/88

---

**Important notice**

The present document can be downloaded from:  
<http://www.etsi.org/standards-search>

The present document may be made available in electronic versions and/or in print. The content of any electronic and/or print versions of the present document shall not be modified without the prior written authorization of ETSI. In case of any existing or perceived difference in contents between such versions and/or in print, the only prevailing document is the print of the Portable Document Format (PDF) version kept on a specific network drive within ETSI Secretariat.

Users of the present document should be aware that the document may be subject to revision or change of status. Information on the current status of this and other ETSI documents is available at  
<http://portal.etsi.org/tb/status/status.asp>

If you find errors in the present document, please send your comment to one of the following services:  
<https://portal.etsi.org/People/CommiteeSupportStaff.aspx>

---

**Copyright Notification**

No part may be reproduced or utilized in any form or by any means, electronic or mechanical, including photocopying and microfilm except as authorized by written permission of ETSI.

The content of the PDF version shall not be modified without the written authorization of ETSI.  
The copyright and the foregoing restriction extend to reproduction in all media.

© European Telecommunications Standards Institute 2016.  
All rights reserved.

**DECT™**, **PLUGTESTS™**, **UMTS™** and the ETSI logo are Trade Marks of ETSI registered for the benefit of its Members.  
**3GPP™** and **LTE™** are Trade Marks of ETSI registered for the benefit of its Members and of the 3GPP Organizational Partners.  
**GSM®** and the GSM logo are Trade Marks registered and owned by the GSM Association.

---

## Intellectual Property Rights

IPRs essential or potentially essential to the present document may have been declared to ETSI. The information pertaining to these essential IPRs, if any, is publicly available for **ETSI members and non-members**, and can be found in ETSI SR 000 314: *"Intellectual Property Rights (IPRs); Essential, or potentially Essential, IPRs notified to ETSI in respect of ETSI standards"*, which is available from the ETSI Secretariat. Latest updates are available on the ETSI Web server (<https://ipr.etsi.org/>).

Pursuant to the ETSI IPR Policy, no investigation, including IPR searches, has been carried out by ETSI. No guarantee can be given as to the existence of other IPRs not referenced in ETSI SR 000 314 (or the updates on the ETSI Web server) which are, or may be, or may become, essential to the present document.

---

## Foreword

This Technical Specification (TS) has been produced by ETSI 3rd Generation Partnership Project (3GPP).

The present document may refer to technical specifications or reports using their 3GPP identities, UMTS identities or GSM identities. These should be interpreted as being references to the corresponding ETSI deliverables.

The cross reference between GSM, UMTS, 3GPP and ETSI identities can be found under <http://webapp.etsi.org/key/queryform.asp>.

---

## Modal verbs terminology

In the present document "**shall**", "**shall not**", "**should**", "**should not**", "**may**", "**need not**", "**will**", "**will not**", "**can**" and "**cannot**" are to be interpreted as described in clause 3.2 of the [ETSI Drafting Rules](#) (Verbal forms for the expression of provisions).

"**must**" and "**must not**" are **NOT** allowed in ETSI deliverables except when used in direct citation.

# Contents

Intellectual Property Rights .....	2
Foreword.....	2
Modal verbs terminology.....	2
Foreword.....	5
Introduction .....	5
1 Scope .....	6
2 References .....	6
3 Definitions, symbols and abbreviations .....	7
3.1 Definitions .....	7
3.2 Symbols.....	7
3.3 Abbreviations .....	7
4 User Plane .....	7
4.1 General aspects.....	7
4.2 Operational and Functional Aspects.....	8
5 Transparent Mode .....	8
6 Support mode for predefined SDU sizes.....	8
6.1 General .....	8
6.2 Nb UP protocol layer services in Support Mode.....	8
6.3 Services expected from the Transport Network Layer .....	8
6.4 Functions of the Nb UP protocol layer in Support Mode.....	9
6.4.1 Functional model of the Nb UP protocol layer in Support Mode .....	9
6.4.2 Frame handler function.....	9
6.4.3 Procedure control functions .....	9
6.4.4 Non Access Stratum data streams specific functions.....	9
6.4.4.1 Frame quality classification .....	9
6.4.4.1.1 General .....	9
6.4.4.1.2 Handling of FQC information .....	10
6.5 Elementary procedures .....	10
6.5.1 Transfer of User Data procedure.....	10
6.5.1.1 Successful operation.....	10
6.5.1.2 Unsuccessful operation .....	10
6.5.2 Initialisation procedure .....	10
6.5.2.1 Successful operation.....	10
6.5.2.2 Unsuccessful operation .....	11
6.5.3 Rate Control.....	11
6.5.3.1 Successful operation.....	11
6.5.3.1.1 Rate control for codecs other than the EVS codec .....	11
6.5.3.1.2 Rate and mode control for the EVS codec.....	11
6.5.3.1.3 Interworking of rate control between compatible AMR-WB and EVS codec configurations.....	11
6.5.3.2 Unsuccessful operation .....	12
6.5.4 Time Alignment.....	12
6.5.4.1 Successful operation.....	12
6.5.4.2 Unsuccessful operation .....	12
6.5.5 Handling of Error Event procedure.....	12
6.5.5.1 Successful operation.....	12
6.5.5.2 Unsuccessful operation .....	12
6.6 Elements for Nb UP communication in Support mode .....	12
6.7 Handling of unknown, unforeseen and erroneous protocol data .....	12
7 Communication Primitives for the Nb UP protocol layer .....	13
7.1 Modelling Principle.....	13

7.2	Primitives towards the upper layers at the CNL-SAP .....	13
7.3	Primitives towards the transport layers at TNL-SAP .....	13
7.3.1	General.....	13
7.3.2	ATM/AAL2 based Transport Layer .....	13
7.3.2.1	General .....	13
7.3.2.2	AAL2 Service Primitives used by the Nb UP protocol.....	13
7.3.3	GTP-U based Transport Layer.....	14
7.3.4	RTP/UDP/IP based Transport Layer.....	14
8	Evolution of Nb UP Protocol .....	14
<b>Annex A (informative): Change history .....</b>		<b>15</b>
History .....		16

---

## Foreword

This Technical Specification has been produced by the 3<sup>rd</sup> Generation Partnership Project (3GPP).

The contents of the present document are subject to continuing work within the TSG and may change following formal TSG approval. Should the TSG modify the contents of the present document, it will be re-released by the TSG with an identifying change of release date and an increase in version number as follows:

Version x.y.z

where:

- x the first digit:
  - 1 presented to TSG for information;
  - 2 presented to TSG for approval;
  - 3 or greater indicates TSG approved document under change control.
- y the second digit is incremented for all changes of substance, i.e. technical enhancements, corrections, updates, etc.
- z the third digit is incremented when editorial only changes have been incorporated in the document.

---

## Introduction

The present document specifies the user plane protocol used between two Media Gateways in the CS core network. Through out the present document this protocol shall be referred to as the Nb UP protocol. The Nb UP protocol is for a large part identical to the Iu UP protocol (see 3GPP TS 25.415 [2]), and only the differences between the two protocols are specified. This specification defines the applicability of the UP, as defined in 3GPP TS 25.415 [2], for the Nb interface only.

Given that the Nb UP uses the same PDU types as the Iu UP, the term IuFP is used to refer to the common framing.

For the purpose of the present document, any occurrence of the term "Iu UP" in the corresponding sections of 3GPP TS 25.415 [2], shall be interpreted as "Nb UP".

# 1 Scope

The present document specifies the user plane protocol of the bearer used between two MGWs within the BICC-based CS core network, called the Nb UP protocol. The present document assumes the implementation of the split between call control and the bearer transport and control, as specified in 3GPP TS 23.205 [1], see figure 1. Note that the present document does not preclude an implementation of a combined MSC Server and MGW.

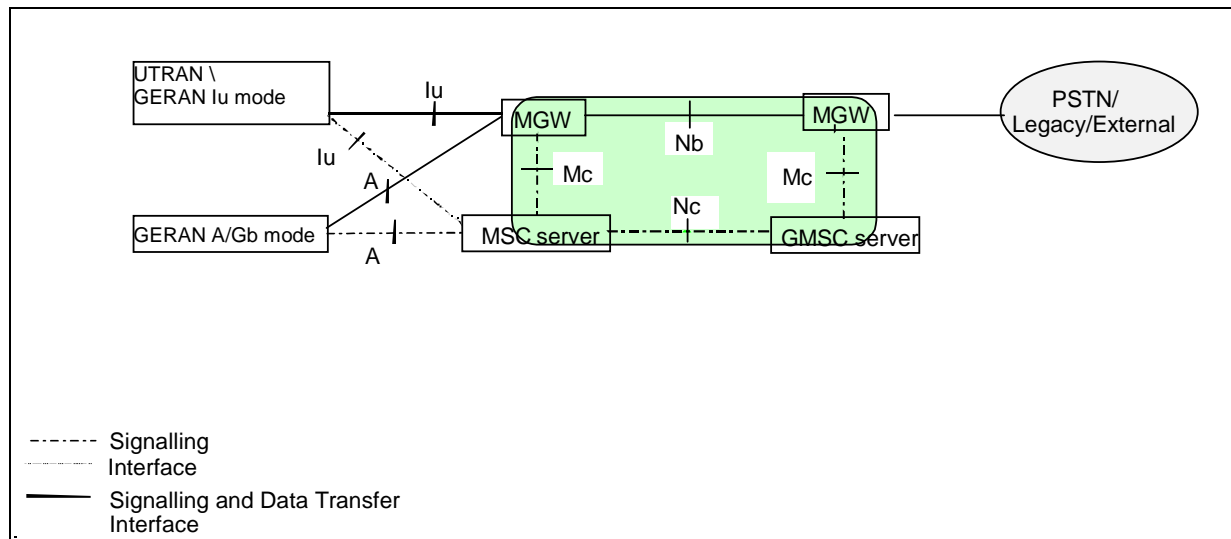

Figure 1: CS core network logical architecture

# 2 References

The following documents contain provisions which, through reference in this text, constitute provisions of the present document.

- References are either specific (identified by date of publication, edition number, version number, etc.) or non-specific.
- For a specific reference, subsequent revisions do not apply.
- For a non-specific reference, the latest version applies. In the case of a reference to a 3GPP document (including a GSM document), a non-specific reference implicitly refers to the latest version of that document *in the same Release as the present document*.

- [1] 3GPP TS 23.205: "Bearer Independent CS Core Network; Stage 2"
- [2] 3GPP TS 25.415: "UTRAN Iu Interface User Plane Protocols"
- [3] 3GPP TS 29.232: "Media Gateway Controller; Media Gateway interface; Stage 3"
- [4] 3GPP TS 29.414: "Core Network Nb Data Transport and Transport Signalling"
- [5] 3GPP TR 41.001: "GSM Release specifications"
- [6] 3GPP TR 21.905: "Vocabulary for 3GPP Specifications"
- [7] IETF RFC 1889: "RTP A Transport Protocol for Real Time Applications"
- [8] ITU-T I.366.1 (06/98): "Segmentation and Reassembly Service Specific Convergence Sublayer for the AAL type 2"
- [9] 3GPP TS 26.445: "Codec for Enhanced Voice Services (EVS); Detailed Algorithmic Description".

---

## 3 Definitions, symbols and abbreviations

### 3.1 Definitions

Definitions used in the present document are listed in 3GPP TR 21.905 [6].

### 3.2 Symbols

For the purposes of the present document, the following symbols apply:

Iu	Interface between the RNS and the core network. It is also considered as a reference point.
Nb	Interface between media gateways.
IuFP	Iu Framing protocol

### 3.3 Abbreviations

For the purposes of the present document, the following abbreviations apply:

AAL	ATM Adaptation Layer
AAL2	AAL Type 2
ATM	Asynchronous Transfer Mode
CN	Core Network
CNL	Core Network Layer
CS	Circuit Switched
EVS	Enhanced Voice Services
FFS	For Further Study
IPTI	Inter PDU Transmission Interval
Iu UP	Iu interface User Plane
MGW	Media GateWay
PDU	Protocol Data Unit
RTP	Real-time Transmission Protocol
SAP	Service Access Point
SDU	Service Data Unit
SRNC	Serving Radio Network Controller

---

## 4 User Plane

### 4.1 General aspects

The Nb UP is located in the user plane of the CS core network over the Nb interface. It is used to convey data between MGWs.

The Nb UP protocol shall be initiated at one MGW and acknowledged by the adjoining MGW.

The Nb UP framing is identical to the Iu UP framing, i.e., the same PDU types are valid for both protocols.

Figure 2 shows the logical location of the Nb UP protocol layer in relation to the Nb interface.



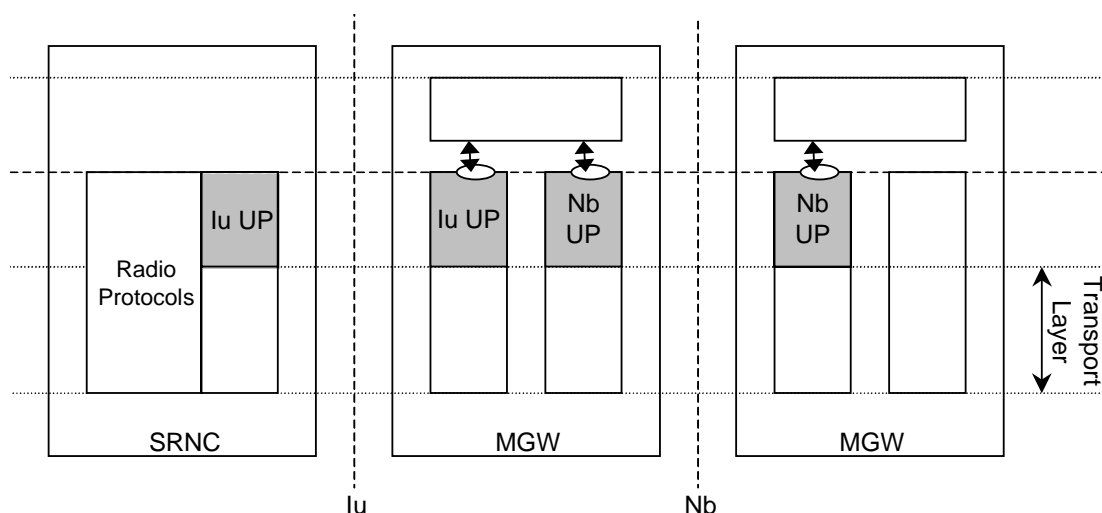

Figure 2: Nb UP protocol layer occurrence in overall architecture.

## 4.2 Operational and Functional Aspects

There are two modes of operation for the Nb UP:

- Transparent mode;
- Support mode for predefined SDU size.

The two modes of operation follow the definition of the corresponding Iu UP modes of operation, as described in 3GPP TS 25.415 [2].

Support mode version 2 is mandatory on the NbUP interface. Support mode version 1 is not required at the Nb but may be used if both MGWs support it, as a result of the version negotiation during the Initialisation procedure.

---

## 5 Transparent Mode

This mode of operation is identical to that of the Iu UP protocol, see the corresponding section in 3GPP TS 25.415 [2].

---

## 6 Support mode for predefined SDU sizes

### 6.1 General

See the corresponding section in 3GPP TS 25.415 [2].

### 6.2 Nb UP protocol layer services in Support Mode

See the corresponding section in 3GPP TS 25.415 [2].

### 6.3 Services expected from the Transport Network Layer

See the corresponding section in 3GPP TS 25.415 [2].

## 6.4 Functions of the Nb UP protocol layer in Support Mode

### 6.4.1 Functional model of the Nb UP protocol layer in Support Mode

See the corresponding section in 3GPP TS 25.415 [2].

### 6.4.2 Frame handler function

See the corresponding section in 3GPP TS 25.415 [2].

### 6.4.3 Procedure control functions

See the corresponding section in 3GPP TS 25.415 [2].

### 6.4.4 Non Access Stratum data streams specific functions

See the corresponding section in 3GPP TS 25.415 [2].

#### 6.4.4.1 Frame quality classification

##### 6.4.4.1.1 General

On the Nb UP in Support Mode the frames are classified with the Frame Quality Classifier (FQC). This classifying is based on frame classification on the preceding link and the setting of the attribute "Delivery of erroneous SDUs". The MSC server shall indicate the value of the attribute "Delivery of erroneous SDUs" see 3GPP TS 29.232 [3].

Figure 4 shows the main input and output information for the frame quality classification function on the Nb UP.

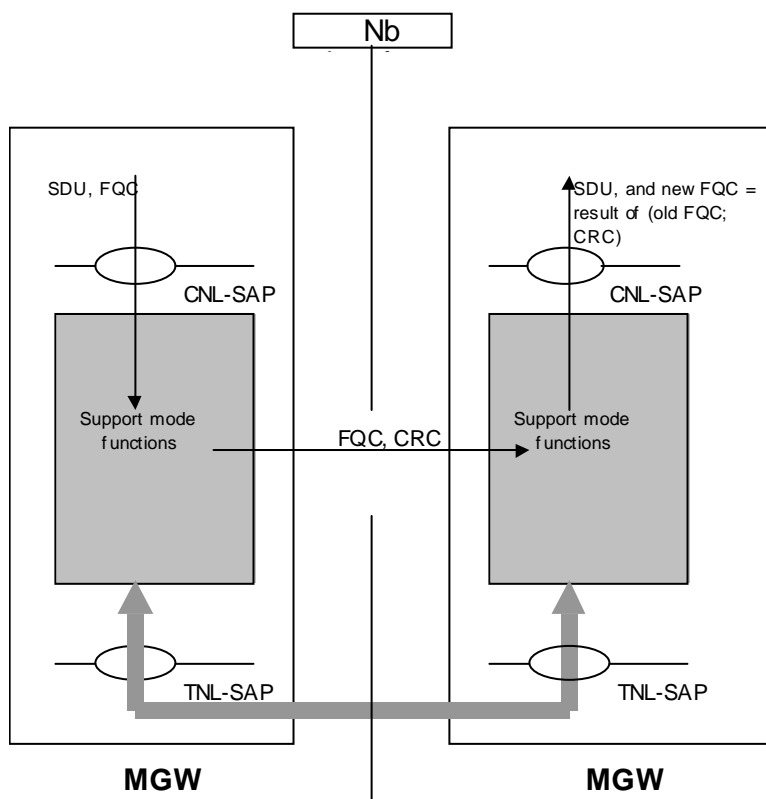

Figure 4: Frame quality classification in Nb UP

### 6.4.4.1.2 Handling of FQC information

The handling of FQC shall be as specified in Table 1.

**Table 1. FQC handling in Nb UP protocol, receiving side**

Input			Action
Delivery of erroneous SDUs	FQC in received PDU	Payload CRC	
'yes' or 'no'	'good'	OK	Leave FQC unchanged. Forward SDU and FQC to upper layer
"yes"	"bad radio"	OK	Leave FQC unchanged. Forward SDU and FQC to upper layer
'yes'	'good' or "bad radio"	Not OK	Set FQC to 'bad'. Forward SDU and FQC to upper layer
"yes"	"bad"	Any	Leave FQC unchanged. Forward SDU and FQC to upper layer
'no'	'good'	Not OK	Drop SDU
"no"	"bad" or "bad radio"	Any	Not applicable. SDUs are dropped at a previous link.
'no-error-detection-consideration'	Any	Any	Leave FQC unchanged. Forward SDU and FQC to upper layer

The FQC handling in the Nb UP protocol entity on the sending side is as follows:

- When the upper layer indicates an FQC value in the Nb-UP-DATA-Request message, an FQC shall be set in the PDU as indicated by the upper layer. If the upper layer does not indicate an FQC value, the FQC in the PDU shall be set to 'good'.
- When the upper layer indicates an FQC with the value 'bad' to the Nb UP protocol layer, the Nb UP support functions may generate an erroneous payload CRC.

An MGW may ignore the settings of the "delivery of erroneous SDUs" property of the 3GUP package if the MGW passes frames transparently through the UP entities as described in 3GPP TS 29.232 [3].

## 6.5 Elementary procedures

### 6.5.1 Transfer of User Data procedure

#### 6.5.1.1 Successful operation

See the corresponding section in 3GPP TS 25.415 [2]. For the purpose of the present document, the MGW replaces the function of the SRNC and the CN, and the Nb replaces the function of the Iu.

When the MGW provides the Frame Number IE it shall be based on time according to the handling on Iu (see 3GPP TS 25.415 [2]) for conversational and streaming traffic class.

NOTE: The IuUP Frame Number IE is based on time also and therefore no interworking of this IE is required.

#### 6.5.1.2 Unsuccessful operation

See the corresponding section in 3GPP TS 25.415 [2]. For the purpose of the present document, the MGW replaces the function of the SRNC and the CN, and the Nb replaces the function of the Iu.

### 6.5.2 Initialisation procedure

#### 6.5.2.1 Successful operation

See the corresponding section in 3GPP TS 25.415 [2].

When an Nb UP layer protocol entity receives an initialisation status request from the upper layer, it shall start the initialisation procedure. See 3GPP TS 29.232 [3], concerning the overall initialisation process. When an Nb UP layer protocol entity receives an initialisation message it shall acknowledge this message and indicate to the upper layer that an initialisation message has been received. When an Nb UP layer protocol entity receives a positive initialisation acknowledgement it shall indicate to the upper layer that a positive initialisation acknowledgement has been received.

### 6.5.2.2 Unsuccessful operation

See the corresponding section in 3GPP TS 25.415 [2]. A negative acknowledgement triggers a repetition of the initialisation message. After  $N_{\text{INIT}}$  unsuccessful repetitions, the initialisation procedure is terminated.

## 6.5.3 Rate Control

### 6.5.3.1 Successful operation

#### 6.5.3.1.1 Rate control for codecs other than the EVS codec

See the corresponding section in 3GPP TS 25.415 [2]. When an Nb UP protocol entity receives a rate control message over the Nb interface, it shall provide an indication of the rate control to the upper layer. The rate control indication is acknowledged on request from the upper layer.

#### 6.5.3.1.2 Rate and mode control for the EVS codec

For the EVS codec:

- On the Iu interface, IuFP provides for rate control via the exchange of RATE CONTROL and RATE CONTROL ACK PDUs.
- On the Iu interface, CMR for EVS provides for in-band rate and mode control via the Codec Mode Request (CMR) field of every codec frame (Speech or SID) and CMR-Only frame.
- On the Nb interface of the BICC-based CS CN, CMR for EVS provides for in-band rate and mode control via the Codec Mode Request (CMR) field of every codec frame.

**Editor's note [WI: EVSoCS-CT, CR#0017]: Whether CMR for EVS in CS will be specified in TS 26.445, or in a new specification, needs to be confirmed by SA4.**

- A MGW receiving a CMR over an Nb interface may modify its contents based on local policies and include the resulting contents into the CMR field of the outgoing speech frame on the Nb interface.
- Interworking of rate control procedures at an MGW between an Nb interface and a corresponding Iu interface only applies when the MGW bridges compatible codec configurations between the interfaces without applying a transcoding function.
- A MGW receiving a CMR from an Nb interface may modify its contents based on local policies and include the resulting contents into the CMR field of the outgoing speech frame on the corresponding Iu interface.
- An MGW receiving a rate control request and a CMR on an Iu interface shall determine the lower limit of the maximum bit rates contained in each request and include the resulting limit into the CMR field of the outgoing speech frame on the corresponding Nb interface, with possible further modifications to the CMR contents based on configured policies.

**Editor's note [WI: EVSoCS-CT, CR#0039]: The rules by which the MGW may filter and modify the CMR contents are FFS and need to be further specified.**

#### 6.5.3.1.3 Interworking of rate control between compatible AMR-WB and EVS codec configurations

The EVS codec includes the EVS AMR-WB IO mode of operation and is therefore TrFO-compatible to the AMR-WB codec. For example, AMR-WB on one MGW termination and EVS on the other MGW termination are TrFO-compatible codecs, if the mode-sets are TrFO-compatible.

If the MGW bridges compatible EVS codec configurations and AMR-WB codec configurations:

- If the codec of the incoming termination is EVS and the codec of the outgoing termination is AMR-WB, then the rate control procedure for AMR-WB shall apply at the outgoing termination, with the maximum rate equal to or lower than the maximum rate received in the CMR.
- If the codec of the incoming termination is AMR-WB and the codec of the outgoing termination is EVS, then the rate control procedure for AMR-WB shall apply on the incoming termination and shall determine the maximum rate included in the CMR sent by the IM-MGW. The MWG shall request the EVS AMR-WB IO mode of operation in the outgoing CMR.
- The MGW may filter and modify the CMR contents

**Editor's note [WI: EVSoCS-CT, CR#0017]:** The rules by which the MGW may filter and modify the CMR contents are FFS and need to be further specified.

### 6.5.3.2 Unsuccessful operation

For codecs other than the EVS codec, see the corresponding section in 3GPP TS 25.415 [2]. Depending on the error cause, a negative acknowledgement is either reported in a status indication to the upper layer, or it triggers a repetition of the control command. After  $N_{RC}$  unsuccessful repetitions, the rate control procedure is terminated.

## 6.5.4 Time Alignment

### 6.5.4.1 Successful operation

See the corresponding section in 3GPP TS 25.415 [2]. When an Nb UP protocol entity receives a time alignment command over the Nb interface, it shall indicate the time alignment to the upper layer. The time alignment is acknowledged on request from the upper layer.

### 6.5.4.2 Unsuccessful operation

See the corresponding section in 3GPP TS 25.415 [2]. Depending on the error cause, a negative acknowledgement is either reported in a status indication to the upper layer, or it triggers a repetition of the control command. After  $N_{TA}$  unsuccessful repetitions, the time alignment procedure is terminated.

## 6.5.5 Handling of Error Event procedure

### 6.5.5.1 Successful operation

See the corresponding section in 3GPP TS 25.415 [2].

### 6.5.5.2 Unsuccessful operation

See the corresponding section in 3GPP TS 25.415 [2].

## 6.6 Elements for Nb UP communication in Support mode

See the corresponding section in 3GPP TS 25.415 [2].

## 6.7 Handling of unknown, unforeseen and erroneous protocol data

See the corresponding section in 3GPP TS 25.415 [2].

## 7 Communication Primitives for the Nb UP protocol layer

### 7.1 Modelling Principle

See the corresponding section in 3GPP TS 25.415 [2].

### 7.2 Primitives towards the upper layers at the CNL-SAP

See the corresponding section in 3GPP TS 25.415 [2].

### 7.3 Primitives towards the transport layers at TNL-SAP

#### 7.3.1 General

Access to the Transport network Layer is performed through a generic SAP: TNL-SAP.

When the Transport Network upper layer consists of AAL2, the TNL SAP maps to the AAL-SAP which allows communication to be performed using specific AAL primitives.

When the Transport Network upper layer consists of RTP/UDP/IP, the TNL-SAP maps to the services provided by IETF RFC 1889 [7].

The choice of communication, specific or generic, through the TNL-SAP is fixed by the Core Network Layer control plane logic. This choice of communication is based on the requirements placed by, e.g. the RAB characteristics, the core network domain requesting the RAB establishment or other operator's choice.

#### 7.3.2 ATM/AAL2 based Transport Layer

##### 7.3.2.1 General

When the Nb UP protocol layer uses the services of an ATM/AAL2 transport, it shall use an established AAL2 connection for transferring frames between the peer TNL-SAPs at both ends of the Nb User plane access points. The Transport Network Control Plane over the Nb interface handles the signalling to establish and release the AAL2 call connections.

##### 7.3.2.2 AAL2 Service Primitives used by the Nb UP protocol

AAL2 services and primitives used at the Service Access Point from the AAL2 layer are shown in table 3.

**Table 4: AAL2 primitives and parameters**

Primitive	Type	Parameters	Comments
SSSAR-UNITDATA	Request	SSSAR-INFO	
		SSSAR-UUI	Not used (note)
SSSAR-UNITDATA	Indication	SSSAR-INFO	
		SSSAR-UUI	Not used (note)
NOTE: The setting of this field is set to not used i.e. decimal value 26 according to ITU-T Q.366.1 [8].			

These primitives are to be used in the Nb UP.

The Transport Network control plane is as specified in 3GPP TS 29.414 [4].

### 7.3.3 GTP-U based Transport Layer

Not applicable.

### 7.3.4 RTP/UDP/IP based Transport Layer

When the Nb UP protocol layer uses the services of an RTP-based transport, it shall use a dynamic payload type that was negotiated for the connection for transferring Nb UP frames between the two endpoints at both ends of the Nb User plane access points. This dynamic payload type is negotiated using the specified bearer control protocol, 3GPP TS 29.414 [4].

---

## 8 Evolution of Nb UP Protocol

See the corresponding section in 3GPP TS 25.415 [2].

## Annex A (informative): Change history

Change history							
Date	TSG #	TSG Doc.	CR	Rev	Subject/Comment	Old	New
03-2001	TSG#11	NP-010037			Approved as Version 4.0.0 to be placed under Change Control	2.0.0	4.0.0
09-2001	TSG#13	NP-010438	001	1	Clarification on FQC handling and alignment with TS 25.415	4.0.0	4.1.0
12-2001	TSG#14	NP-010573	002	1	Correction to Scope clause	4.1.0	4.2.0
12-2001	TSG#14	NP-010573	004	1	Reference to Iu UP	4.1.0	4.2.0
03-2002	TSG#15	NP-020085	005		Add GERAN Iu mode to scope	4.1.0	5.0.0
03-2003	TSG#19	NP-030076	007	1	No backward compatibility to Nb UP FP support mode version 1 required	5.0.0	5.1.0
12-2004	CN#26				Upgraded to v6.0.0	5.1.0	6.0.0
01-2005					Correct typo in version number on cover	6.0.0	6.0.1
12-2006	TSG#34	CP-060619	012	2	Time based Nb frame number	6.0.1	6.1.0
06-2007	TSG#36				Upgraded to v7.0.0	6.1.0	7.0.0
05-2008	TSG#40	CP-080310	013	2	NbFP not used for SIP-I based CS CN	7.0.0	8.0.0
12-2009	TSG#46				Automatic upgrade from previous Release	8.0.0	9.0.0
09-2010	TSG#49	CP-100555	016		Correcting unspecific external reference	9.0.0	9.1.0
03-2011	TSG#51				Automatic upgrade from previous Release version 9.1.0	9.1.0	10.0.0
03-2011	TSG#51				Correction of heading and numbering made by MCC	10.0.0	10.0.1
09-2012	TSG#57				Automatic upgrade from previous Release version 10.0.1	10.0.1	11.0.0
2014-10					Automatic upgrade from previous Release	11.0.0	12.0.0
2015-12	TSG#70	CP-150648	0017	3	Update of TS 29.415 to support EVS over UMTS CS	12.0.0	13.0.0



---

# History

<b>Document history</b>		
V13.0.0	January 2016	Publication