

ETSI TS 129 165 V14.7.0 (2018-06)



**Digital cellular telecommunications system (Phase 2+) (GSM);
Universal Mobile Telecommunications System (UMTS);
LTE;
Inter-IMS Network to Network Interface (NNI)
(3GPP TS 29.165 version 14.7.0 Release 14)**



Reference

RTS/TSGC-0329165ve70

Keywords

GSM,LTE,UMTS

ETSI

650 Route des Lucioles
F-06921 Sophia Antipolis Cedex - FRANCE

Tel.: +33 4 92 94 42 00 Fax: +33 4 93 65 47 16

Siret N° 348 623 562 00017 - NAF 742 C
Association à but non lucratif enregistrée à la
Sous-Préfecture de Grasse (06) N° 7803/88

Important notice

The present document can be downloaded from:

<http://www.etsi.org/standards-search>

The present document may be made available in electronic versions and/or in print. The content of any electronic and/or print versions of the present document shall not be modified without the prior written authorization of ETSI. In case of any existing or perceived difference in contents between such versions and/or in print, the only prevailing document is the print of the Portable Document Format (PDF) version kept on a specific network drive within ETSI Secretariat.

Users of the present document should be aware that the document may be subject to revision or change of status.

Information on the current status of this and other ETSI documents is available at

<https://portal.etsi.org/TB/ETSIDeliverableStatus.aspx>

If you find errors in the present document, please send your comment to one of the following services:

<https://portal.etsi.org/People/CommitteeSupportStaff.aspx>

Copyright Notification

No part may be reproduced or utilized in any form or by any means, electronic or mechanical, including photocopying and microfilm except as authorized by written permission of ETSI.

The content of the PDF version shall not be modified without the written authorization of ETSI.

The copyright and the foregoing restriction extend to reproduction in all media.

© ETSI 2018.

All rights reserved.

DECT™, **PLUGTESTS™**, **UMTS™** and the ETSI logo are trademarks of ETSI registered for the benefit of its Members.

3GPP™ and **LTE™** are trademarks of ETSI registered for the benefit of its Members and of the 3GPP Organizational Partners.

oneM2M logo is protected for the benefit of its Members.

GSM® and the GSM logo are trademarks registered and owned by the GSM Association.

Intellectual Property Rights

Essential patents

IPRs essential or potentially essential to normative deliverables may have been declared to ETSI. The information pertaining to these essential IPRs, if any, is publicly available for **ETSI members and non-members**, and can be found in ETSI SR 000 314: "*Intellectual Property Rights (IPRs); Essential, or potentially Essential, IPRs notified to ETSI in respect of ETSI standards*", which is available from the ETSI Secretariat. Latest updates are available on the ETSI Web server (<https://ipr.etsi.org/>).

Pursuant to the ETSI IPR Policy, no investigation, including IPR searches, has been carried out by ETSI. No guarantee can be given as to the existence of other IPRs not referenced in ETSI SR 000 314 (or the updates on the ETSI Web server) which are, or may be, or may become, essential to the present document.

Trademarks

The present document may include trademarks and/or tradenames which are asserted and/or registered by their owners. ETSI claims no ownership of these except for any which are indicated as being the property of ETSI, and conveys no right to use or reproduce any trademark and/or tradename. Mention of those trademarks in the present document does not constitute an endorsement by ETSI of products, services or organizations associated with those trademarks.

Foreword

This Technical Specification (TS) has been produced by ETSI 3rd Generation Partnership Project (3GPP).

The present document may refer to technical specifications or reports using their 3GPP identities, UMTS identities or GSM identities. These should be interpreted as being references to the corresponding ETSI deliverables.

The cross reference between GSM, UMTS, 3GPP and ETSI identities can be found under <http://webapp.etsi.org/key/queryform.asp>.

Modal verbs terminology

In the present document "**shall**", "**shall not**", "**should**", "**should not**", "**may**", "**need not**", "**will**", "**will not**", "**can**" and "**cannot**" are to be interpreted as described in clause 3.2 of the [ETSI Drafting Rules](#) (Verbal forms for the expression of provisions).

"**must**" and "**must not**" are **NOT** allowed in ETSI deliverables except when used in direct citation.

Contents

Intellectual Property Rights.....	2
Foreword	2
Modal verbs terminology	2
Foreword	8
1 Scope.....	9
2 References.....	9
3 Definitions, symbols and abbreviations.....	17
3.1 Definitions	17
3.2 Symbols	18
3.3 Abbreviations.....	18
4 Overview.....	20
5 Reference model for interconnection between IM CN subsystems	22
5.1 General.....	22
5.2 Functionalities performed by entities at the edge of the network	23
5.2.1 Interconnection Border Control Function (IBCF).....	23
5.2.2 Transition Gateway (TrGW)	23
5.3 Identifying II-NNI traversal scenario.....	24
5.3.1 General	24
5.3.2 Mapping of the "iotl" SIP URI parameter to II-NNI traversal scenario	24
6 Control plane interconnection.....	25
6.1 Definition of Inter-IMS Network to Network Interconnection	25
6.1.1 SIP methods and header fields	25
6.1.1.1 General	25
6.1.1.2 SIP methods.....	25
6.1.1.3 SIP header fields	26
6.1.1.3.0 General.....	26
6.1.1.3.1 Trust and no trust relationship.....	26
6.1.1.3.2 Derivation of applicable SIP header fields from 3GPP TS 24.229 [5].....	29
6.1.1.3.3 Applicability of SIP header fields on a roaming II-NNI	29
6.1.1.3.4 Applicability of SIP header fields on a non-roaming II-NNI.....	30
6.1.1.4 Notations of the codes	30
6.1.1.5 Modes of signalling	30
6.1.2 SDP protocol	30
6.1.2.1 General	30
6.1.3 Major capabilities.....	31
6.1.4 SIP message bodies	37
6.2 Control Plane Transport.....	40
6.2.1 General	40
6.3 SIP timers.....	41
7 User plane Interconnection	43
7.1 Media and Codec	43
7.2 User Plane Transport.....	43
8 Numbering, Naming and Addressing.....	44
8.1 Numbering, Naming and Addressing for SIP message.....	44
8.2 Numbering, Naming and Addressing for SDP.....	45
9 IP Version	45
10 Security	45
11 Charging.....	45
11.1 General.....	45
11.2 Inter-operator accounting.....	45

11.3	Transfer of IP multimedia service tariff information	46
12	Supplementary services associated with the IMS multimedia telephony communication service	47
12.1	General	47
12.2	Malicious Communication IDentification (MCID)	47
12.3	Originating Identification Presentation (OIP) and Originating Identification Restriction (OIR)	47
12.4	Terminating Identification Presentation (TIP) and Terminating Identification Restriction (TIR)	48
12.5	Anonymous Communication Rejection (ACR)	48
12.6	Communication DIVersion (CDIV)	48
12.7	Communication Waiting (CW)	49
12.8	Communication HOLD (HOLD)	49
12.9	Message Waiting Indication (MWI)	49
12.10	Communication Barring (CB)	49
12.10.1	Incoming Communication Barring (ICB)	49
12.10.2	Outgoing Communication Barring (OCB)	50
12.11	Completion of Communications to Busy Subscriber (CCBS)	50
12.12	Completion of Communications by No Reply (CCNR)	51
12.13	Explicit Communication Transfer (ECT)	51
12.13.1	Consultative and blind transfer	51
12.13.2	Assured transfer	52
12.14	Customized Alerting Tone (CAT)	52
12.15	Customized Ringing Signal (CRS)	52
12.16	Closed User Group (CUG)	53
12.17	Personal Network Management (PNM)	53
12.18	Three-Party (3PTY)	53
12.19	Conference (CONF)	53
12.20	Flexible Alerting (FA)	54
12.21	Announcements	54
12.21.1	General	54
12.21.2	Providing announcements during the establishment of a communication session	54
12.21.3	Providing announcements during an established communication session	55
12.21.4	Providing announcements when communication request is rejected	55
12.22	Advice Of Charge (AOC)	55
12.23	Completion of Communications on Not Logged-in (CCNL)	56
12.24	Unstructured Supplementary Service Data (USSD)	56
13	Interoperability of IMS Centralized Services (ICS) over II-NNI	57
13.1	General	57
13.2	IMS Centralized Services (ICS)	57
14	Interoperability of IMS Service Continuity over II-NNI	58
14.1	General	58
14.2	PS to CS Single Radio Voice Call Continuity (SRVCC) and Single Radio Video Call Continuity (vSRVCC)	58
14.2.1	Basic PS to CS SRVCC	58
14.2.2	PS to CS SRVCC for calls in alerting phase	58
14.2.3	Using the ATCF based architecture	58
14.2.4	PS to CS SRVCC for originating calls in pre-alerting phase	59
14.2.5	PS to CS SRVCC with the MSC server assisted mid-call feature	59
14.3	Inter UE Transfer (IUT)	59
14.4	MSC server assisted mid-call feature	59
14.5	CS to PS Single Radio Voice Call Continuity (SRVCC)	60
14.5.1	Basic CS to PS SRVCC	60
14.5.2	CS to PS SRVCC for calls in alerting phase	60
14.5.3	CS to PS SRVCC with the assisted mid-call feature	61
14.6	PS to CS dual radio voice call continuity (DRVCC)	61
14.6.1	Basic PS to CS DRVCC	61
14.6.2	PS to CS DRVCC with the assisted mid-call feature	61
14.6.3	PS to CS DRVCC for calls in alerting phase	61
14.6.4	PS to CS DRVCC for originating calls in pre-alerting phase	62
14.7	CS to PS Dual Radio Voice Call Continuity (DRVCC)	62
14.7.1	Basic CS to PS DRVCC	62
14.7.2	CS to PS DRVCC with the assisted mid-call feature	62

14.7.3	CS to PS DRVCC for calls in alerting phase.....	62
14.7.4	CS to PS DRVCC for originating calls in pre-alerting phase.....	62
14.8	PS to PS access transfer	63
15	Presence service	63
15.0	General.....	63
15.1	Subscription of presence information	63
15.2	Watcher subscribing to Presence List	64
15.3	Subscription to Watcher Information.....	64
15.4	Subscription to state changes in XML documents	64
15.5	Presence enhancements specified in Open Mobile Alliance (OMA) Release 1.1.....	65
15.5.1	General	65
15.5.2	OMA subscription of presence information	65
15.5.3	OMA watcher subscribing to Presence List	65
15.5.4	OMA subscription to Watcher Information.....	65
15.6	Presence enhancements specified in Open Mobile Alliance (OMA) Release 2.0.....	65
15.6.1	General	65
15.6.2	OMA subscription of presence information	65
15.6.3	OMA watcher subscribing to Presence List	66
15.6.4	OMA subscription to Watcher Information.....	66
15.6.5	Subscription to state changes in XML documents	66
15.6.6	Void.....	67
15.6.7	Void.....	67
16	Messaging service.....	67
16.1	General.....	67
16.2	Page-mode messaging.....	67
16.4	Session-mode messaging	67
16.5	Session-mode messaging conferences	67
17	Optimal Media Routeing.....	68
17.1	General.....	68
17.2	OMR related SDP attributes	68
17.3	IP realm names.....	68
18	Inter-UE transfer (IUT).....	68
18.1	General.....	68
18.2	IUT without establishment of a collaborative session.....	68
18.3	IUT using a collaborative session	69
18.3.1	Collaborative session of participants of the same subscription	69
18.3.2	Establishment of a collaborative session during session setup.....	69
18.3.3	Assignment and transfer of control of a collaborative session	69
18.3.4	Collaborative session of participants of different subscriptions	70
18.4	Session replication / media replication	70
18.4.1	Pull mode.....	70
18.4.2	Push mode	70
19	Roaming Architecture for Voice over IMS with Local Breakout.....	71
20	Delivery of Media Resource Broker address information	71
21	Overload control	71
21.1	General.....	71
21.2	Feedback based mechanism.....	72
21.3	The load filter mechanism.....	72
22	Delivery of original destination identity	72
23	Telepresence using IMS.....	72
24	Barring of premium rate numbers	72
25	P-CSCF restoration	73
25.1	General.....	73
25.2	PCRF based P-CSCF restoration	73
25.3	HSS based P-CSCF restoration.....	73

26	Resource sharing	73
27	Service access number translation	73
28	Mission critical services.....	74
28.1	General.....	74
28.2	Interoperability of mission critical services for communication over II-NNI.....	74
28.2.1	Mission Critical services session establishment	74
28.2.2	MBMS transmission usage and location procedures.....	76
28.2.3	Affiliation procedure	76
28.2.3.1	General	76
28.2.3.2	Mandatory mode.....	76
28.2.3.3	Negotiated mode.....	77
28.2.4	Conference event package subscription	77
28.2.5	Mission critical services settings	78
28.2.6	Registration procedures	78
28.2.7	Group regrouping	78
28.2.8	Signalling plane messages for mission critical data	79
29	Calling number verification	79
30	IMS emergency service.....	79
30.1	IMS emergency registration.....	79
30.2	IMS emergency session	80
Annex A (informative): Summary of SIP header fields.....		81
Annex B (informative): Dynamic view of SIP header fields within SIP messages		86
B.1	Scope.....	86
B.2	Methodology	86
B.3	ACK method.....	87
B.4	BYE method.....	88
B.5	CANCEL method.....	92
B.6	INFO method	93
B.7	INVITE method	97
B.8	MESSAGE method.....	104
B.9	NOTIFY method.....	108
B.10	OPTIONS method.....	111
B.11	PRACK method	115
B.12	PUBLISH method.....	118
B.13	REFER method	122
B.14	REGISTER method	126
B.15	SUBSCRIBE method.....	129
B.16	UPDATE method.....	133
Annex C (informative): The list of option items for II-NNI.....		138
C.1	Scope.....	138
C.2	Format of option item table.....	138
C.3	Option item table.....	138
C.3.0	Supported II-NNI traversal scenarios.....	138
C.3.1	Option item table common to roaming, non-roaming II-NNI and loopback traversal scenario.....	139
C.3.2	Option item table specific to roaming II-NNI	147

C.3.3 Option item table specific to non-roaming II-NNI and loopback traversal scenario 150

Annex D (informative): Change history 153

History 156

Foreword

This Technical Specification has been produced by the 3rd Generation Partnership Project (3GPP).

The contents of the present document are subject to continuing work within the TSG and may change following formal TSG approval. Should the TSG modify the contents of the present document, it will be re-released by the TSG with an identifying change of release date and an increase in version number as follows:

Version x.y.z

where:

- x the first digit:
 - 1 presented to TSG for information;
 - 2 presented to TSG for approval;
 - 3 or greater indicates TSG approved document under change control.
- y the second digit is incremented for all changes of substance, i.e. technical enhancements, corrections, updates, etc.
- z the third digit is incremented when editorial only changes have been incorporated in the document.

1 Scope

The objective of this document is to address the Inter-IMS Network to Network Interface (II-NNI) consisting of Ici and Izi reference points between IMS networks in order to support end-to-end service interoperability.

The present document addresses the issues related to control plane signalling (3GPP usage of SIP and SDP protocols, required SIP header fields) as well as other interconnecting aspects like security, numbering/naming/addressing and user plane issues as transport protocol, media and codecs actually covered in a widespread set of 3GPP specifications. A profiling of the Inter-IMS Network to Network Interface (II-NNI) is also provided.

Charging aspects are addressed as far as SIP signalling is concerned.

IMS emergency session establishment between IMS networks is addressed as far as SIP signalling is concerned.

SIP signalling traversing the NNI between a CSCF and MRB, e.g. for media control or Voice Interworking with Enterprise IP-PBX, and SIP signalling traversing the NNI on the Mr interface between the CSCF and the MRFC, or on the Mr' interface between the AS and MRFC, or on the Rc interface between AS and MRB is not considered in the present release of this specification.

SIP signalling traversing the NNI between an application server and the remaining IMS functional entities (e.g. for MCPTT interface SIP-2 in figure 7.3.1-2 in 3GPP TS 23.280 [200]) is not considered in the present release of this specification.

SIP signalling traversing the NNI between an ISC gateway and an AS in an enterprise network, e.g. for media control and voice interworking with enterprise IP-PBX, on the ISC interface between the ISC gateway and the enterprise network is not considered in the present release of this specification.

2 References

The following documents contain provisions which, through reference in this text, constitute provisions of the present document.

- References are either specific (identified by date of publication, edition number, version number, etc.) or non-specific.
- For a specific reference, subsequent revisions do not apply.
- For a non-specific reference, the latest version applies. In the case of a reference to a 3GPP document (including a GSM document), a non-specific reference implicitly refers to the latest version of that document in the same Release as the present document.

- [1] 3GPP TR 21.905: "Vocabulary for 3GPP Specifications".
- [2] IETF RFC 791: "Internet Protocol".
- [3] 3GPP TS 23.002: "Network architecture".
- [4] 3GPP TS 23.228: "IP Multimedia Subsystem (IMS); Stage 2".
- [5] 3GPP TS 24.229: "Internet Protocol (IP) multimedia call control protocol based on Session Initiation Protocol (SIP) and Session Description Protocol (SDP); Stage 3".
- [6] 3GPP TR 24.930: "Signalling flows for the session setup in the IP Multimedia core network Subsystem (IMS) based on Session Initiation Protocol (SIP) and Session Description Protocol (SDP); Stage 3".
- [7] IETF RFC 2460: "Internet Protocol, Version 6 (IPv6) Specification".
- [8] 3GPP TS 29.162: "Interworking between the IM CN subsystem and IP networks".
- [9] 3GPP TS 22.228: "Service requirements for the IP multimedia core network subsystem".
- [10] 3GPP TS 33.210: "3G security; Network Domain Security (NDS); IP network layer security".

- [11] 3GPP TS 26.114: "IP Multimedia Subsystem (IMS); Multimedia Telephony; Media handling and interaction".
- [12] ETSI TS 181 005 V1.1.1: "Telecommunications and Internet converged Services and Protocols for Advanced Networking (TISPAN); Services and Capabilities Requirements".
- [13] IETF RFC 3261: "SIP: Session Initiation Protocol".
- [14] IETF RFC 3966: "The tel URI for Telephone Numbers".
- [15] IETF RFC 3860: "Common Profile for Instant Messaging (CPIM)".
- [16] IETF RFC 3859: "Common Profile for Presence (CPP)".
- [17] IETF RFC 4975: "The Message Session Relay Protocol (MSRP)".
- [18] IETF RFC 3262: "Reliability of provisional responses in Session Initiation Protocol (SIP)".
- [19] IETF RFC 3428: "Session Initiation Protocol (SIP) Extension for Instant Messaging".
- [20] IETF RFC 6665: "SIP-Specific Event Notification".

NOTE: In earlier releases of this document the predecessor IETF RFC 3265 is used.

- [21] IETF RFC 3903: "An Event State Publication Extension to the Session Initiation Protocol (SIP)".
- [22] IETF RFC 3515: "The Session Initiation Protocol (SIP) REFER method".
- [23] IETF RFC 3311: "The Session Initiation Protocol (SIP) UPDATE method".
- [24] IETF RFC 7315: "Private Header (P-Header) Extensions to the Session Initiation Protocol (SIP) for the 3GPP".
- [24A] IETF RFC 7976: "Updates to Private Header (P-Header) Extension Usage in Session Initiation Protocol (SIP) Requests and Responses".
- [24B] IETF RFC 7913: "P-Access-Network-Info ABNF Update".
- [25] IETF RFC 7044: "An Extension to the Session Initiation Protocol (SIP) for Request History Information".
- [26] IETF RFC 6050: "A Session Initiation Protocol (SIP) Extension for the Identification of Services".
- [27] IETF RFC 4168: "The Stream Control Transmission Protocol (SCTP) as a Transport for the Session Initiation Protocol (SIP)".
- [28] Void.
- [29] 3GPP TS 32.260: "Telecommunication management; Charging management; IP Multimedia Subsystem (IMS) charging".
- [30] 3GPP TS 22.173: "IP Multimedia Core Network Subsystem (IMS); Multimedia Telephony Service and supplementary services; Stage 1".
- [31] 3GPP TS 24.173: "IMS multimedia telephony communication service and supplementary services; Stage 3".
- [32] 3GPP TS 24.607: "Originating Identification Presentation (OIP) and Originating Identification Restriction (OIR) using IP Multimedia (IM); Core Network (CN) subsystem".
- [33] 3GPP TS 24.616: "Malicious Communication Identification (MCID) using IP Multimedia (IM) Core Network (CN) subsystem".
- [34] IETF RFC 3323: "A Privacy Mechanism for the Session Initiation Protocol (SIP)".
- [35] 3GPP TS 23.003: "Numbering, addressing and identification".

- [36] 3GPP TS 24.610: "Communication HOLD (HOLD) using IP Multimedia (IM) Core Network (CN) subsystem".
- [37] 3GPP TS 24.615: "Communication Waiting (CW) using IP Multimedia (IM) Core Network (CN) subsystem".
- [38] 3GPP TS 24.628: "Common Basic Communication procedures using IP Multimedia (IM) Core Network (CN) subsystem".
- [39] IETF RFC 6086: "Session Initiation Protocol (SIP) INFO Method and Package Framework".
- [40] IETF RFC 3312: "Integration of resource management and Session Initiation Protocol (SIP)".
- [41] IETF RFC 4032: "Update to the Session Initiation Protocol (SIP) Preconditions Framework".
- [42] IETF RFC 3313: "Private Session Initiation Protocol (SIP) Extensions for Media Authorization".
- [43] IETF RFC 3327: "Session Initiation Protocol Extension Header Field for Registering Non-Adjacent Contacts".
- [44] IETF RFC 3325: "Private Extensions to the Session Initiation Protocol (SIP) for Network Asserted Identity within Trusted Networks".
- [45] IETF RFC 3608: "Session Initiation Protocol (SIP) Extension Header Field for Service Route Discovery During Registration".
- [46] IETF RFC 3486: "Compressing the Session Initiation Protocol (SIP)".
- [47] IETF RFC 3329: "Security Mechanism Agreement for the Session Initiation Protocol (SIP)".
- [48] IETF RFC 3326: "The Reason Header Field for the Session Initiation Protocol (SIP)".
- [49] IETF RFC 6432: "Carrying Q.850 Codes in Reason Header Fields in SIP (Session Initiation Protocol) Responses".
- [50] IETF RFC 3581: "An Extension to the Session Initiation Protocol (SIP) for Symmetric Response Routing".
- [51] IETF RFC 3841: "Caller Preferences for the Session Initiation Protocol (SIP)".
- [52] IETF RFC 4028: "Session Timers in the Session Initiation Protocol (SIP)".
- [53] IETF RFC 3892: "The Session Initiation Protocol (SIP) Referred-By Mechanism".
- [54] IETF RFC 3891: "The Session Initiation Protocol (SIP) 'Replaces' Header".
- [55] IETF RFC 3911: "The Session Initiation Protocol (SIP) 'Join' Header".
- [56] IETF RFC 3840: "Indicating User Agent Capabilities in the Session Initiation Protocol (SIP)".
- [57] IETF RFC 5079: "Rejecting Anonymous Requests in the Session Initiation Protocol (SIP)".
- [58] IETF RFC 4458: "Session Initiation Protocol (SIP) URIs for Applications such as Voicemail and Interactive Voice Response (IVR)".
- [59] IETF RFC 4320: "Actions Addressing Identified Issues with the Session Initiation Protocol's (SIP) Non-INVITE Transaction".
- [60] IETF RFC 4457: "The Session Initiation Protocol (SIP) P-User-Database Private-Header (P-header)".
- [61] IETF RFC 5031: "A Uniform Resource Name (URN) for Emergency and Other Well-Known Services".
- [62] IETF RFC 5627: "Obtaining and Using Globally Routable User Agent (UA) URIs (GRUU) in the Session Initiation Protocol (SIP)".

- [63] Void.
- [64] IETF RFC 5002: "The Session Initiation Protocol (SIP) P-Profile-Key Private Header (P-Header)".
- [65] IETF RFC 5626: "Managing Client-Initiated Connections in the Session Initiation Protocol (SIP)".
- [66] IETF RFC 5768: "Indicating Support for Interactive Connectivity Establishment (ICE) in the Session Initiation Protocol (SIP)".
- [67] IETF RFC 5365: "Multiple-Recipient MESSAGE Requests in the Session Initiation Protocol (SIP)".
- [68] IETF RFC 6442: "Location Conveyance for the Session Initiation Protocol".
- [69] IETF RFC 5368: "Referring to Multiple Resources in the Session Initiation Protocol (SIP)".
- [70] IETF RFC 5366: "Conference Establishment Using Request-Contained Lists in the Session Initiation Protocol (SIP)".
- [71] IETF RFC 5367: "Subscriptions to Request-Contained Resource Lists in the Session Initiation Protocol (SIP)".
- [72] IETF RFC 4967: "Dial String Parameter for the Session Initiation Protocol Uniform Resource Identifier".
- [73] IETF RFC 4964: "The P-Answer-State Header Extension to the Session Initiation Protocol for the Open Mobile Alliance Push to Talk over Cellular".
- [74] IETF RFC 5009: "Private Header (P-Header) Extension to the Session Initiation Protocol (SIP) for Authorization of Early Media".
- [75] IETF RFC 4694: "Number Portability Parameters for the 'tel' URI".
- [76] Void.
- [77] IETF RFC 4411: "Extending the Session Initiation Protocol (SIP) Reason Header for Preemption Events".
- [78] IETF RFC 4412: "Communications Resource Priority for the Session Initiation Protocol (SIP)".
- [79] IETF RFC 5393: "Addressing an Amplification Vulnerability in Session Initiation Protocol (SIP) Forking Proxies".
- [80] IETF RFC 5049: "Applying Signaling Compression (SigComp) to the Session Initiation Protocol (SIP)".
- [81] IETF RFC 5688: "A Session Initiation Protocol (SIP) Media Feature Tag for MIME Application Sub-Types".
- [82] IETF RFC 5360: "A Framework for Consent-Based Communications in the Session Initiation Protocol (SIP)".
- [83] IETF RFC 7433: "A Mechanism for Transporting User-to-User Call Control Information in SIP".
- [83A] IETF RFC 7434: "Interworking ISDN Call Control User Information with SIP".
- [84] IETF RFC 7316: "The Session Initiation Protocol (SIP) P-Private-Network-Indication Private Header (P-Header)".
- [85] IETF RFC 5502: "The SIP P-Served-User Private-Header (P-Header) for the 3GPP IP Multimedia (IM) Core Network (CN) Subsystem".
- [86] Void.
- [87] IETF draft-ietf-insipid-logme-marking-07 (May 2017): "Marking SIP Messages to be Logged".

Editor's note: The above document cannot be formally referenced until it is published as an RFC.

- [88] IETF RFC 6228: "Response Code for Indication of Terminated Dialog".
- [89] IETF RFC 5621: "Message Body Handling in the Session Initiation Protocol (SIP)".
- [90] IETF RFC 6223: "Indication of support for keep-alive".
- [91] IETF RFC 5552: "SIP Interface to VoiceXML Media Services".
- [92] IETF RFC 3862: "Common Presence and Instant Messaging (CPIM): Message Format".
- [93] IETF RFC 5438: "Instant Message Disposition Notification".
- [94] IETF RFC 5373: "Requesting Answering Modes for the Session Initiation Protocol (SIP)".
- [95] Void.
- [96] IETF RFC 3959: "The Early Session Disposition Type for the Session Initiation Protocol (SIP)".
- [97] Void.
- [98] 3GPP TS 24.183: "Customized Ringing Signal (CRS) using IP Multimedia (IM) Core Network (CN) subsystem".
- [99] 3GPP TS 24.259: "Personal Network Management (PNM) using IP Multimedia (IM) Core Network (CN) subsystem".
- [100] 3GPP TS 24.238: "Session Initiation Protocol (SIP) based user configuration".
- [101] 3GPP TS 24.239: "Flexible Alerting (FA) using IP Multimedia (IM) Core Network (CN) subsystem".
- [102] Void.
- [103] 3GPP TS 24.654: "Closed User Group (CUG) using IP Multimedia (IM) Core Network (CN) subsystem".
- [104] Void.
- [105] 3GPP TS 24.605: "Conference (CONF) using IP Multimedia (IM) Core Network (CN) subsystem".
- [106] 3GPP TS 24.147: "Conferencing using the IP Multimedia (IM) Core Network (CN) subsystem".
- [107] Void.
- [108] Void.
- [109] 3GPP TS 24.642: "Completion of Communications to Busy Subscriber (CCBS) Completion of Communications by No Reply (CCNR) using IP Multimedia (IM) Core Network (CN) subsystem".
- [110] Void.
- [111] Void.
- [112] 3GPP TS 24.606: "Message Waiting Indication (MWI) using IP Multimedia (IM) Core Network (CN) subsystem".
- [113] 3GPP TS 24.608: "Terminating Identification Presentation (TIP) and Terminating Identification Restriction (TIR) using IP Multimedia (IM); Core Network (CN) subsystem".
- [114] 3GPP TS 24.611: "Communication Barring (CB) using IP Multimedia (IM); Core Network (CN) subsystem".
- [115] Void.
- [116] 3GPP TS 24.629: "Explicit Communication Transfer (ECT) using IP Multimedia (IM) Core Network (CN) subsystem".

- [117] 3GPP TS 24.604: "Communication DIVersion (CDIV) using IP Multimedia (IM) Core Network (CN) subsystem".
- [118] Void.
- [119] Void.
- [120] 3GPP TS 23.292: "IP Multimedia Subsystem (IMS) Centralized Services; Stage 2".
- [121] 3GPP TS 24.292: "IP Multimedia Core Network subsystem Centralized Services (ICS); Stage 3".
- [122] 3GPP TS 24.647: "Advice Of Charge (AOC) using IP Multimedia (IM) Core Network (CN) subsystem".
- [123] Void.
- [124] IETF RFC 7989: "End-to-End Session Identification in IP-Based Multimedia Communication Networks".
- [125] IETF RFC 6026: "Correct Transaction Handling for 2xx Responses to Session Initiation Protocol (SIP) INVITE Requests".
- [126] IETF RFC 5658: "Addressing Record-Route issues in the Session Initiation Protocol (SIP)".
- [127] IETF RFC 5954: "Essential correction for IPv6 ABNF and URI comparison in RFC3261".
- [128] Void.
- [129] 3GPP TS 24.182: "IP Multimedia Subsystem (IMS) Customized Alerting Tones (CAT)".
- [130] 3GPP TS 29.292: "Interworking between the IP Multimedia (IM) Core Network (CN) subsystem and MSC Server for IMS Centralized Services (ICS)".
- [131] 3GPP TS 24.237: "IP Multimedia (IM) Core Network (CN) subsystem; IP Multimedia Subsystem (IMS) Service Continuity".
- [132] 3GPP TS 24.141: "Presence service using the IP Multimedia (IM) Core Network (CN) subsystem".
- [133] IETF RFC 6794: "A Framework for Session Initiation Protocol (SIP) Session Policies".
- [134] IETF RFC 5875: "An Extensible Markup Language (XML) Configuration Access Protocol (XCAP) Diff Event Package".
- [135] IETF RFC 4488: "Suppression of Session Initiation Protocol (SIP) REFER Method Implicit Subscription".
- [136] IETF RFC 7462: "URNs for the Alert-Info Header Field of the Session Initiation Protocol (SIP)".
- [137] Void.
- [138] OMA-TS-Presence_SIMPLE-V2_0-20120710-A: "Presence SIMPLE Specification".
- [139] 3GPP TS 24.247: "Messaging service using the IP Multimedia (IM) Core Network (CN) subsystem".
- [140] IETF RFC 4538: "Request Authorization through Dialog Identification in the Session Initiation Protocol (SIP)".
- [141] IETF RFC 5318: "The Session Initiation Protocol (SIP) P-Refused-URI-List Private-Header (P-Header)".
- [142] OMA-TS-Presence_SIMPLE-V1_1_1-20100225-A: "Presence SIMPLE Specification".
- [143] IETF RFC 6809: "Mechanism to Indicate Support of Features and Capabilities in the Session Initiation Protocol (SIP)".

- [144] IETF RFC 5839: "An Extension to Session Initiation Protocol (SIP) Events for Conditional Event Notification".
- [145] Void.
- [146] IETF RFC 3264: "An Offer/Answer Model with the Session Description Protocol (SDP)".
- [147] IETF RFC 4566: "SDP: Session Description Protocol".
- [148] 3GPP TS 29.079: "Optimal Media Routeing within the IP Multimedia Subsystem; Stage 3".
- [149] 3GPP TS 24.337: "IP Multimedia Subsystem (IMS) inter-UE transfer".
- [150] IETF RFC 3960: "Early Media and Ringing Tone Generation in the Session Initiation Protocol (SIP)".
- [151] IETF RFC 3550: "RTP: A Transport Protocol for Real-Time Applications".
- [152] IETF RFC 768: "User Datagram Protocol".
- [153] IETF RFC 3551: "RTP Profile for Audio and Video Conferences with Minimal Control".
- [154] IETF RFC 3556: "Session Description Protocol (SDP) Bandwidth Modifiers for RTP Control Protocol (RTCP) Bandwidth".
- [155] IETF RFC 4585: "Extended RTP Profile for Real-time Transport Control Protocol (RTCP)-Based Feedback (RTP/AVPF)".
- [156] IETF RFC 793: "Transmission Control Protocol".
- [157] IETF RFC 4733: "RTP Payload for DTMF Digits, Telephony Tones, and Telephony Signals".
- [158] IETF RFC 4916: "Connected Identity in the Session Initiation Protocol (SIP)".
- [159] 3GPP TS 23.237: "IP Multimedia Subsystem (IMS) Service Continuity".
- [160] IETF RFC 6140: "Registration for Multiple Phone Numbers in the Session Initiation Protocol (SIP)".
- [161] IETF RFC 6230: "Media Control Channel Framework".
- [162] IETF RFC 4145: "TCP-Based Media Transport in the Session Description Protocol (SDP)".
- [163] 3GPP TS 24.390: "Unstructured Supplementary Service Data (USSD)".
- [164] IETF RFC 6357: "Design Considerations for Session Initiation Protocol (SIP) Overload Control".
- [165] IETF RFC 7339: "Session Initiation Protocol (SIP) Overload Control".
- [166] IETF RFC 7415: "Session Initiation Protocol (SIP) Rate Control".
- [167] IETF RFC 7200: "A Session Initiation Protocol (SIP) Load-Control Event Package".
- [168] 3GPP TS 29.163: "Interworking between the IP Multimedia (IM) Core Network (CN) subsystem and Circuit Switched (CS) networks".
- [169] IETF RFC 2046: "Multipurpose Internet Mail Extensions (MIME) Part Two: Media Types".
- [170] IETF RFC 2387: "The MIME Multipart/Related Content-type".
- [171] IETF RFC 3420: "Internet Media Type message/sipfrag".
- [172] IETF RFC 3842: "A Message Summary and Message Waiting Indication Event Package for the Session Initiation Protocol (SIP)".
- [173] IETF RFC 3858: "An Extensible Markup Language (XML) Based Format for Watcher Information".

- [174] IETF RFC 3863: "Presence Information Data Format (PIDF)".
- [175] IETF RFC 3994: "Indication of Message Composition for Instant Messaging".
- [176] IETF RFC 4661: "An Extensible Markup Language (XML) Based Format for Event Notification Filtering".
- [177] IETF RFC 4662: "A Session Initiation Protocol (SIP) Event Notification Extension for Resource Lists".
- [178] IETF RFC 4826: "Extensible Markup Language (XML) Formats for Representing Resource Lists".
- [179] IETF RFC 5262: "Presence Information Data Format (PIDF) Extension for Partial Presence".
- [180] IETF RFC 5874: "An Extensible Markup Language (XML) Document Format for Indicating a Change in XML Configuration Access Protocol (XCAP) Resources".
- [181] Void.
- [182] OMA-SUP-XSD_prs_supnotFilter-V1_0-20120710-A: "Presence - Event notification suppression filter".
- [183] 3GPP TS 32.240: "Telecommunication management; Charging management; Charging architecture and principles".
- [184] IETF RFC 7090: "Public Safety Answering Point (PSAP) Callback".
- [185] IETF RFC 8055: "Session Initiation Protocol (SIP) Via Header Field Parameter to Indicate Received Realm".
- [186] 3GPP TS 29.658: "SIP Transfer of IP Multimedia Service Tariff Information".
- [187] 3GPP TS 22.153: "Multimedia priority service".
- [188] IETF RFC 7549: "3GPP SIP URI Inter Operator Traffic Leg parameter".
- [189] 3GPP TS 24.103: "Telepresence using the IP Multimedia (IM) Core Network (CN) Subsystem (IMS); Stage 3".
- [190] IETF draft-ietf-mmusic-sctp-sdp-26 (April 2017): "Session Description Protocol (SDP) Offer/Answer Procedures For Stream Control Transmission Protocol (SCTP) over Datagram Transport Layer Security (DTLS) Transport".
- Editor's note: The above document cannot be formally referenced until it is published as an RFC.**
- [191] 3GPP TS 24.315: "IP Multimedia Subsystem (IMS) Operator Determined Barring (ODB)".
- [192] 3GPP TR 29.949: "Study on Technical aspects on Roaming End-to-end scenarios with VoLTE IMS and other networks".
- [193] IETF RFC 8119: "SIP "cause" URI Parameter for Service Number Translation".
- [194] IETF RFC 7647: "Clarifications for the Use of REFER with RFC6665".
- [195] IETF RFC 7614: "Explicit Subscriptions for the REFER Method".
- [196] IETF RFC 7621: "A Clarification on the Use of Globally Routable User Agent URIs (GRUUs) in the Session Initiation Protocol SIP Event Notification Framework".
- [197] IETF RFC 2646: "The Text/Plain Format Parameter".
- [198] IETF RFC 1866: "Hypertext Markup Language - 2.0".
- [199] 3GPP TS 22.179: "Mission Critical Push To Talk (MCPTT) over LTE; Stage 1".
- [200] 3GPP TS 23.280: "Common functional architecture to support mission critical services; Stage 2".

- [201] 3GPP TS 24.379: "Mission Critical Push To Talk (MCPTT) call control Protocol specification".
- [202] 3GPP TS 24.380: "Mission Critical Push To Talk (MCPTT) floor control Protocol specification".
- [203] IETF draft-ietf-sipcore-originating-cdiv-parameter-01 (September 2017): "P-Served-User Header Field Parameter for Originating CDIV session case in Session Initiation Protocol (SIP)".

Editor's note: The above document cannot be formally referenced until it is published as an RFC.

- [204] IETF RFC 4575: "A Session Initiation Protocol (SIP) Event Package for Conference State".
- [205] IETF RFC 4354: "A Session Initiation Protocol (SIP) Event Package and Data Format for Various Settings in Support for the Push-to-Talk over Cellular (PoC) Service".
- [206] IETF RFC 8224: "Authenticated Identity Management in the Session Initiation Protocol (SIP)".
- [207] IETF RFC 8197: "A SIP Response Code for Unwanted Calls".
- [208] IETF RFC 6910: "Completion of Calls for the Session Initiation Protocol (SIP)".
- [209] 3GPP TS 22.280: "Mission Critical Services Common Requirements".
- [210] 3GPP TS 24.281: "Mission Critical Video (MCVideo) signalling control; Protocol specification".
- [211] 3GPP TS 24.282: "Mission Critical Data (MCDData) signalling control; Protocol specification".
- [212] 3GPP TS 24.581: "Mission Critical Video (MCVideo) media plane control; Protocol specification".
- [213] 3GPP TS 24.582: "Mission Critical Data (MCDData) media plane control; Protocol specification".
- [214] IETF draft-ietf-sipcore-reason-q850-loc-03 (February 2018): "ISUP Cause Location Parameter for the SIP Reason Header Field".

Editor's note: The above document cannot be formally referenced until it is published as an RFC.

- [215] 3GPP TS 23.167: "IP Multimedia Subsystem (IMS) emergency sessions".

3 Definitions, symbols and abbreviations

3.1 Definitions

For the purposes of the present document, the terms and definitions given in 3GPP TR 21.905 [1] and the following apply. A term defined in the present document takes precedence over the definition of the same term, if any, in 3GPP TR 21.905 [1].

example: text used to clarify abstract rules by applying them literally.

IM CN subsystem: (IP Multimedia CN subsystem) comprises of all CN elements for the provision of IP multimedia applications over IP multimedia sessions, as specified in 3GPP TS 22.228 [9].

IP multimedia session: as specified in 3GPP TS 22.228 [9] an IP multimedia session is a set of multimedia senders and receivers and the data streams flowing from senders to receivers. IP multimedia sessions are supported by the IP multimedia CN Subsystem and are enabled by IP connectivity bearers (e.g. GPRS as a bearer). A user can invoke concurrent IP multimedia sessions.

non-roaming II-NNI: the II-NNI between IMS home networks, or, if the Roaming Architecture for Voice over IMS with Local Breakout is used, alternatively the II-NNI between the caller's visited network and the callee's home network.

roaming II-NNI: the II-NNI between a visited IMS network and the IMS home network; for the Roaming Architecture for Voice over IMS with Local Breakout, the loopback traversal scenario is excluded.

loopback traversal scenario: for the Roaming Architecture for Voice over IMS with Local Breakout, the scenario where the II-NNI between the caller's home network and the caller's visited network is being traversed by an initial

INVITE request from the caller's home network to the caller's visited network or any subsequent SIP message within the same dialogue on the same call leg.

home-to-visited request on roaming II-NNI: SIP request being sent from the callee's home network to the callee's visited network.

home routing: the scenario when the caller's home network routes a dialog creating SIP request directly to the callee's home network without using the loopback traversal scenario.

visited-to-home request on roaming II-NNI: SIP request being sent from the caller's visited network to the caller's home network.

home-to-visited response on roaming II-NNI: SIP response being sent from the caller's home network to the caller's visited network.

visited-to-home response on roaming II-NNI: SIP response being sent from the callee's visited network to the callee's home network.

For the purposes of the present document, the following terms and definitions given in 3GPP TS 23.292 [120] apply:

MSC Server enhanced for ICS

For the purposes of the present document, the following terms and definitions given in 3GPP TS 23.237 [159] apply:

MSC server enhanced for SRVCC

For the purposes of the present document, the following terms and definitions given in 3GPP TS 24.237 [131] apply:

MSC server enhanced for dual radio

3.2 Symbols

For the purposes of the present document, the following symbols apply:

I2	Reference point between the MSC Server enhanced for ICS and the home IMS
Ici	Reference Point between an IBCF and another IBCF belonging to a different IM CN subsystem network
Izi	Reference Point between a TrGW and another TrGW or media handling node belonging to a different IM CN subsystem network
Mi	Reference Point between a BGCF and CSCF
Mm	Reference Point between a CSCF/BGCF/IMS ALG and an IP multimedia network
Mw	Reference Point between a CSCF and another CSCF
Mx	Reference Point between a CSCF/BGCF/MSC Server enhanced for ICS/ MSC Server enhanced for SRVCC / MSC server enhanced for dual radio and IBCF

3.3 Abbreviations

For the purposes of the present document, the abbreviations given in 3GPP TR 21.905 [1] and the following apply. An abbreviation defined in the present document takes precedence over the definition of the same abbreviation, if any, in 3GPP TR 21.905 [1].

18x	A SIP status-code in the range 180 through 189
2xx	A SIP status-code in the range 200 through 299
3PTY	Three-Party
3xx	A SIP status-code in the range 300 through 399
4xx	A SIP status-code in the range 400 through 499
6xx	A SIP status-code in the range 600 through 699
ACR	Anonymous Communication Rejection
AOC	Advice Of Charge
AS	Application Server
ATCF	Access Transfer Control Function
B2BUA	Back 2 Back User Agent
BGCF	Breakout Gateway Control Function
CAT	Customized Alerting Tone

CB	Communication Barring
CCBS	Completion of Communications to Busy Subscriber
CCNL	Completion of Communications on Not Logged-in
CCNR	Communication Completion on No Reply
CDIV	Communication Diversion
CONF	Conference
CRS	Customized Ringing Signal
CW	Communication Waiting
DRVCC	Dual Radio Voice Call Continuity
E-CSCF	Emergency CSCF
ECT	Explicit Communication Transfer
FA	Flexible Alerting
GRUU	Globally Routable User agent URIs
HOLD	Communication HOLD
IBCF	Interconnection Border Control Function
ICB	Incoming Communication Barring
ICID	IMS Charging Identifier
ICS	IMS Centralized Services
I-CSCF	Interrogating CSCF
II-NNI	Inter-IMS Network to Network Interface
IM	Instant Messaging
IMS-ALG	IMS Application Level Gateway
IOI	Inter Operator Identifier
IUT	Inter UE Transfer
MBMS	Multimedia Broadcast Multicast Service
MCDData	Mission Critical Data
MCID	Malicious Communication Identification
MCPTT	Mission Critical Push-To-Talk
MCVideo	Mission Critical Video
MMTEL	Multimedia Telephony
MPS	Multimedia Priority Service
MRB	Media Resource Broker
MRFC	Media Resource Function Controller
MRFP	Multimedia Resource Function Processor
MSRP	Message Session Relay Protocol
MWI	Message Waiting Indication
NA(P)T-PT	Network Address (Port-Multiplexing) Translation-Protocol Translation
NNI	Network to Network Interface
OCB	Outgoing Communication Barring
OIP	Originating Identification Presentation
OIR	Originating Identification Restriction
OMA	Open Mobile Alliance
OMR	Optimal Media Routeing
P-CSCF	Proxy CSCF
PCRF	Policy and Charging Rules Function
PNM	Personal Network Management
PRES	Presence
PSAP	Public Safety Answering Point
PSI	Public Service Identity
RTT	Round-trip Time
SRVCC	Single Radio Voice Call Continuity
STN	Session Transfer Number
TIP	Terminating Identification Presentation
TIR	Terminating Identification Restriction
TRF	Transit and Roaming Function
TrGW	Transition Gateway
vSRVCC	Single Radio Video Call Continuity

4 Overview

Interconnection between two different IM CN subsystems shall be guaranteed in order to support end-to-end service interoperability. For this purpose, Inter-IMS Network to Network Interface (II-NNI) between two IM CN subsystem networks is adopted, according to the assumptions coming from 3GPP TS 23.002 [3] and 3GPP TS 23.228 [4].

NOTE: The end-to-end service interoperability within one IM CN subsystem over the Mi, Mm, Mw and I2 reference points not passing over the Mx reference point as defined in 3GPP TS 23.228 [4] is outside the scope of this document.

Aiming to support the delivery of IMS services between two separated IM CN subsystems, protocol interconnection has to occur:

- at a control plane level, in order that IMS procedures can be supported. In this case the adopted reference point is the Ici; and
- at a user plane level, where media streams are exchanged over the Izi reference point.

IP multimedia sessions are managed by SIP. The transport mechanism for both SIP session signalling and media transport is IPv4 (IETF RFC 791 [2]) or IPv6 (IETF RFC 2460 [7]). The 3GPP profile of SIP defining the usage of SIP within the IM CN subsystem is specified in 3GPP TS 24.229 [5]. Example call flows are provided in 3GPP TR 24.930 [6].

The general interconnection model is shown in figure 4.1.

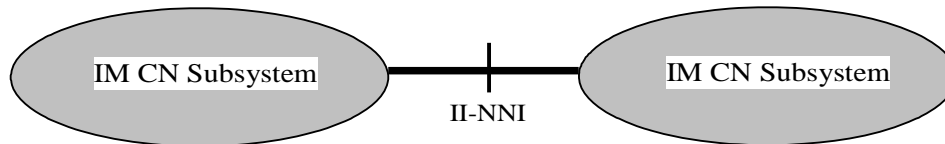
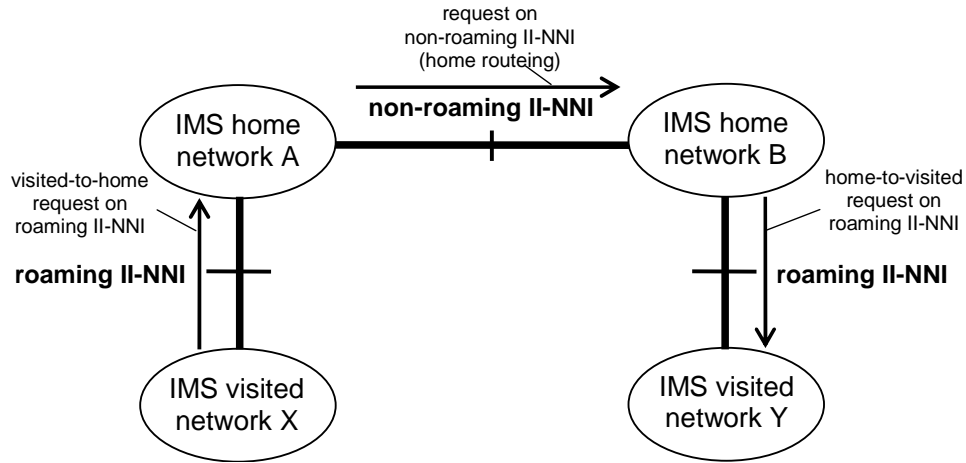

Figure 4.1: Interconnection Model for IM CN subsystems

The II-NNI traversal scenarios in this document are covered in figure 4.2, figure 4.3 and figure 4.4.



- NOTE 1: Any II-NNI can contain intermediate transit network(s). The intermediate transit network can either be an IMS transit network with or without a transit function as specified in 3GPP TS 24.229 [5] or a non-IMS transit network using standards outside the scope of 3GPP.
- NOTE 2: IMS home network A and IMS home network B represent the IMS home network on originating side and terminating side respectively.
- NOTE 3: IMS visited network X and IMS visited network Y represent the IMS visited network on originating side and terminating side respectively.

Figure 4.2: II-NNI traversal scenarios when P-CSCF is located in visited network and when home routing is used

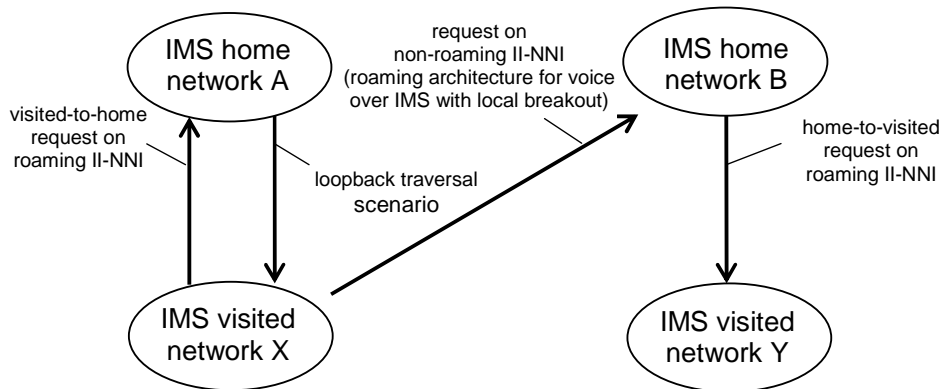

- NOTE 1: Any II-NNI can contain intermediate transit network(s). The intermediate transit network can either be an IMS transit network with or without a transit function as specified in 3GPP TS 24.229 [5] or a non-IMS transit network using standards outside the scope of 3GPP.
- NOTE 2: IMS home network A and IMS home network B represent the IMS home network on originating side and terminating side respectively.
- NOTE 3: IMS visited network X and IMS visited network Y represent the IMS visited network on originating side and terminating side respectively.

Figure 4.3: II-NNI traversal scenarios when P-CSCF is located in visited network and when the roaming architecture for voice over IMS with local breakout is used

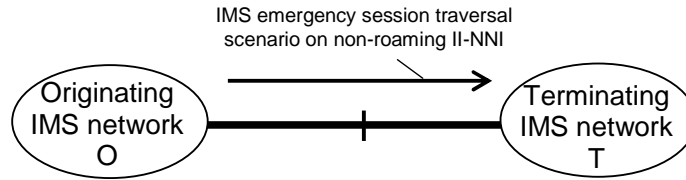

- NOTE 1: Originating IMS network O represents the IMS network to which the originating UE is attached to, and terminating IMS network T represents the IMS network which accomodates a PSAP.
- NOTE 2: Originating IMS network O can be a visited IMS network or a home IMS network.
- NOTE 3: The E-CSCF is located in the originating IMS network O.
- NOTE 4: Any II-NNI between originating IMS network O and terminating IMS network T does not use any specific capabilities for roaming II-NNI, and is treated as non-roaming II-NNI.

Figure 4.4: IMS emergency session traversal scenario on non-roaming II-NNI

The possible functional entities involved in the signalling plane interconnection (IBCF, I-CSCF, P-CSCF, ATCF, S-CSCF, E-CSCF, BGCF, MSC Server enhanced for ICS, MSC server enhanced for SRVCC, MSC server enhanced for dual radio and TRF) and in the user plane interconnection (TrGW) are specified in 3GPP TS 24.229 [5], in 3GPP TS 24.292 [121], 3GPP TS 29.292 [130], 3GPP TS 29.162 [8] and in 3GPP TS 24.237 [131].

IP Version interworking is described within 3GPP TS 29.162 [8].

Examples of usage of the Inter-IMS Network to Network Interface (II-NNI) for roaming scenarios are described in 3GPP TR 29.949 [192].

5 Reference model for interconnection between IM CN subsystems

5.1 General

Figure 5.1.1 illustrates the architecture diagram given in 3GPP TS 23.228 [4] showing the Inter-IMS Network to Network Interface (II-NNI) between two IM CN subsystem networks.

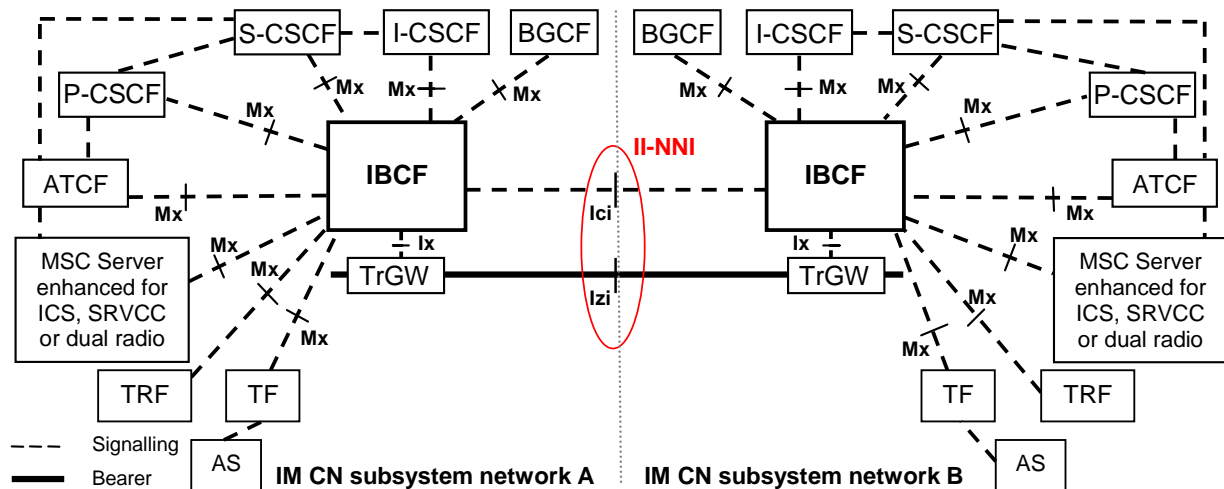

NOTE: The TRF can reside in a stand-alone entity or can be combined with another functional entity.

Figure 5.1.1: Inter-IMS Network to Network Interface between two IM CN subsystem networks

The protocols over the two reference points Ici and Izi make up the Inter-IMS Network to Network Interface.

The Ici reference point allows IBCFs to communicate with each other in order to provide the communication and forwarding of SIP signalling messaging between IM CN subsystem networks. The Izi reference point allows TrGWs to forward media streams between IM CN subsystem networks.

IMS roaming performed by using II-NNI is considered, when the IBCFs are inserted at the network borders. The applicability of roaming scenario by using II-NNI is based on agreement between the operators.

Whenever the Inter-IMS Network to Network Interface is used to interconnect two IM CN subsystem networks belonging to different security domains, security procedures apply as described in 3GPP TS 33.210 [10].

When an IMS transit network is providing application services and interconnecting two IM CN subsystem networks, as described in 3GPP TS 23.228 [4], interfaces on both sides of the IMS transit network are within the scope of this document.

When two IM CN subsystem networks are interconnected for IMS emergency session establishment as described in 3GPP TS 23.167 [215], the interface between these IM CN subsystem networks is within the scope of this document.

5.2 Functionalities performed by entities at the edge of the network

5.2.1 Interconnection Border Control Function (IBCF)

An IBCF provides application specific functions at the SIP/SDP protocol layer in order to perform interconnection between IM CN subsystem networks by using Icf reference point. According to 3GPP TS 23.228 [4], IBCF can act both as an entry point and as an exit point for the IM CN subsystem network.

The functionalities of IBCF are indicated in the 3GPP TS 23.228 [4] and specified in 3GPP TS 24.229 [5]. They include:

- network topology hiding;
- application level gateway (for instance enabling communication between IPv6 and IPv4 SIP applications, or between a SIP application in a private IP address space and a SIP application outside this address space);
- controlling transport plane functions;
- controlling media plane adaptations;
- screening of SIP signalling information;
- selecting the appropriate signalling interconnect;
- generation of charging data records;
- privacy protection;
- additional routing functionality; and
- inclusion of a transit IOI in requests when acting as an entry point for a transit network and in responses when acting as an exit point for a transit network.

Based on local configuration, the IBCF performs transit routing functions as specified in 3GPP TS 24.229 [5] clause I.2.

The IBCF acts as a B2BUA when it performs IMS-ALG functionality.

5.2.2 Transition Gateway (TrGW)

According to 3GPP TS 23.002 [3], the TrGW is located at the network borders within the media path and is controlled by an IBCF. Forwarding of media streams between IM CN subsystem networks is applied over Izi reference point.

The TrGW provides functions like network address/port translation and IPv4/IPv6 protocol translation. NAT-PT binds addresses in IPv6 network with addresses in IPv4 network and vice versa to provide transparent routing between the two IP domains without requiring any changes to end points. NA(P)T-PT provides additional translation of transport identifier (TCP and UDP port numbers). The approach is similar to that one described also in 3GPP TS 29.162 [8].

Further details are described in 3GPP TS 23.228 [4].

5.3 Identifying II-NNI traversal scenario

5.3.1 General

The procedures for identifying the II-NNI traversal scenario using the "iotl" SIP URI parameter defined in IETF RFC 7549 [188] is specified in 3GPP TS 24.229 [5].

This specification uses the following II-NNI traversal scenarios when describing requirements at II-NNI:

- the non-roaming II-NNI traversal scenario;
- the roaming II-NNI traversal scenario; and
- the loopback II-NNI traversal scenario.

When a requirement at II-NNI is dependent on direction the roaming II-NNI traversal scenario is further divided into:

- the home-to-visited II-NNI traversal scenario; and
- the visited-to-home II-NNI traversal scenario.

See figure 4.2 and figure 4.3 for information on how the II-NNI traversal scenarios above are applied between networks.

5.3.2 Mapping of the "iotl" SIP URI parameter to II-NNI traversal scenario

Table 5.3.2.1 describes how the "iotl" SIP URI parameter shall be used to identify the II-NNI traversal scenario. The table 5.3.2.1 contains the following items:

- the first column, named "II-NNI traversal scenario", shows the II-NNI traversal scenarios within the scope of this specification; and
- the second column, named "Value of the "iotl" parameter", shows the value of the "iotl" SIP URI parameter as specified in IETF RFC 7549 [188].

Table 5.3.2.1: Mapping of the "iotl" SIP URI parameter to II-NNI traversal scenario

II-NNI traversal scenario	Value of the "iotl" parameter
Non-roaming II-NNI traversal scenario (NOTE 1)	"homeA-homeB" or "visitedA-homeB"
Loopback traversal scenario	"homeA-visitedA"
Roaming II-NNI traversal scenario	"visitedA-homeA" or "homeB-visitedB" (NOTE 2)
Home-to-visited traversal scenario	"homeB-visitedB"
Visited-to-home traversal scenario	"visitedA-homeA"
NOTE 1: This is the default II-NNI traversal scenario, if the "iotl" SIP URI parameter is not present in the Request-URI or in any of the Route header fields in the SIP request and if an implementation dependent method of identifying the II-NNI traversal scenario is not used.	
NOTE 2: When the requirement at II-NNI is independent on direction any of the "visitedA-homeA" or "homeB-visitedB" can be used to identify the roaming II-NNI traversal scenario.	

6 Control plane interconnection

6.1 Definition of Inter-IMS Network to Network Interconnection

6.1.1 SIP methods and header fields

6.1.1.1 General

The functional entity closest to the border of an II-NNI (see reference model in clause 5) shall provide the capabilities specified for that network element in clause A.2 of 3GPP TS 24.229 [5] with modifications as described in the following clauses.

6.1.1.2 SIP methods

3GPP TS 24.229 [5] defines the methods allowing an IBCF to interconnect to an IBCF placed in another IM CN subsystem.

The following SIP methods are supported on the II-NNI as defined in table 6.1.

The following table is based on table A.5 and table A.163 of 3GPP TS 24.229 [5] and endorsed for this document:

Table 6.1: Supported SIP methods

Item	Method	Ref.	II-NNI	
			Sending	Receiving
1	ACK request	IETF RFC 3261 [13]	m	m
2	BYE request	IETF RFC 3261 [13]	m	m
3	BYE response	IETF RFC 3261 [13]	m	m
4	CANCEL request	IETF RFC 3261 [13]	m	m
5	CANCEL response	IETF RFC 3261 [13]	m	m
5A	INFO request	IETF RFC 6086 [39]	o	o
5B	INFO response	IETF RFC 6086 [39]	o	o
8	INVITE request	IETF RFC 3261 [13]	m	m
9	INVITE response	IETF RFC 3261 [13]	m	m
9A	MESSAGE request	IETF RFC 3428 [19]	O	o
9B	MESSAGE response	IETF RFC 3428 [19]	o	o
10	NOTIFY request	IETF RFC 6665 [20]	c1	c1
11	NOTIFY response	IETF RFC 6665 [20]	c1	c1
12	OPTIONS request	IETF RFC 3261 [13]	m	m
13	OPTIONS response	IETF RFC 3261 [13]	m	m
14	PRACK request	IETF RFC 3262 [18]	m	m
15	PRACK response	IETF RFC 3262 [18]	m	m
15A	PUBLISH request	IETF RFC 3903 [21]	c1	c1
15B	PUBLISH response	IETF RFC 3903 [21]	c1	c1
16	REFER request	IETF RFC 3515 [22]	o	o
17	REFER response	IETF RFC 3515 [22]	o	o
18	REGISTER request	IETF RFC 3261 [13]	c2	c2
19	REGISTER response	IETF RFC 3261 [13]	c2	c2
20	SUBSCRIBE request	IETF RFC 6665 [20]	c1	c1
21	SUBSCRIBE response	IETF RFC 6665 [20]	c1	c1
22	UPDATE request	IETF RFC 3311 [23]	m	m
23	UPDATE response	IETF RFC 3311 [23]	m	m
c1:	In case of roaming II-NNI, the support of the method is m, else o.			
c2:	In case of roaming II-NNI, the support of the method is m, else n/a.			
NOTE:	In the above table, m, o and c and n/a have the meanings indicated in table 6.3			

6.1.1.3 SIP header fields

6.1.1.3.0 General

The IBCF shall provide the capabilities to manage and modify SIP header fields according to clause 5.10 and annex A of 3GPP TS 24.229 [5] with modifications as described in the following clauses.

6.1.1.3.1 Trust and no trust relationship

The IBCF acting as exit point applies the procedures described in clause 5.10.2 of 3GPP TS 24.229 [5] before forwarding the SIP signalling to the IBCF acting as entry point. The IBCF acting as entry point applies the procedures described in clause 5.10.3 of 3GPP TS 24.229 [5].

Additionally, in case there is no trust relationship between the two IM CN subsystems connected by II-NNI, the IBCF applies the procedures described in clause 4.4 of 3GPP TS 24.229 [5], before forwarding the SIP signalling.

These procedures may be utilized on a per header field basis to realize overall trust as well as per service level screening of header fields. Trust relationships and trust domains may be defined by inter-operator agreements for individual services and/or individual SIP header fields.

The management of the SIP header fields (if present) over II-NNI in case of a presence or not of a trust relationship between the two interconnected IM CN subsystems is wrapped up in the following table.

Table 6.2: Management of SIP header fields and parameters over II-NNI in presence or not of a trust relationship

Item	Header field or parameter	Reference	Trust relationship	Not trust relationship
1	P-Asserted-Identity	IETF RFC 3325 [44]	As specified in 3GPP TS 24.229 [5], clause 4.4	As specified in 3GPP TS 24.229 [5], clause 4.4
2	P-Access-Network-Info	IETF RFC 7315 [24]	As specified in 3GPP TS 24.229 [5], clause 4.4	As specified in 3GPP TS 24.229 [5], clause 4.4
3	Resource-Priority	IETF RFC 4412 [78]	As specified in 3GPP TS 24.229 [5], clause 4.4	As specified in 3GPP TS 24.229 [5], clause 4.4
4	History-Info	IETF RFC 7044 [25]	As specified in 3GPP TS 24.229 [5], clause 4.4	As specified in clause 7 of IETF RFC 7044 [25] and in 3GPP TS 24.229 [5], clause 4.4
5	P-Asserted-Service	IETF RFC 6050 [26]	As specified in 3GPP TS 24.229 [5], clause 4.4 (NOTE 3)	As specified in 3GPP TS 24.229 [5], clause 4.4 (NOTE 3)
6	P-Charging-Vector	IETF RFC 7315 [24]	As specified in 3GPP TS 24.229 [5], clause 5.10	As specified in 3GPP TS 24.229 [5], clause 5.10
7	P-Charging-Function-Addresses (NOTE 4)	IETF RFC 7315 [24]	As specified in 3GPP TS 24.229 [5], clause 5.10	As specified in 3GPP TS 24.229 [5], clause 5.10
8	P-Profile-Key (NOTE 2)	IETF RFC 5002 [64]	As specified in 3GPP TS 24.229 [5], clause 4.4	As specified in 3GPP TS 24.229 [5], clause 4.4
9	P-Private-Network-Indication	IETF RFC 7316 [84]	As specified in 3GPP TS 24.229 [5], clause 4.4	As specified in 3GPP TS 24.229 [5], clause 4.4
10	P-Served-User (NOTE 1, NOTE 2)	IETF RFC 5502 [85]	As specified in 3GPP TS 24.229 [5], clause 4.4	As specified in 3GPP TS 24.229 [5], clause 4.4
11	Reason (in a response)	IETF RFC 6432 [49]	As specified in 3GPP TS 24.229 [5], clause 4.4	As specified in 3GPP TS 24.229 [5], clause 4.4
12	P-Early-Media	IETF RFC 5009 [74]	As specified in 3GPP TS 24.229 [5], clause 4.4	As specified in 3GPP TS 24.229 [5], clause 4.4
13	Feature-Caps	IETF RFC 6809 [143]	As specified in 3GPP TS 24.229 [5], clause 4.4	As specified in 3GPP TS 24.229 [5], clause 4.4
14	Priority (NOTE 6)	IETF RFC 7090 [184]	As specified in 3GPP TS 24.229 [5], clause 4.4	As specified in 3GPP TS 24.229 [5], clause 4.4
15	"iotl" SIP URI parameter (NOTE 7)	IETF RFC 7549 [188]	As specified in 3GPP TS 24.229 [5], clause 4.4	As specified in 3GPP TS 24.229 [5], clause 4.4
16	"cpc" tel URI parameter (NOTE 5)	3GPP TS 24.229 [5] clause 7.2A.12	As specified in 3GPP TS 24.229 [5], clause 4.4	As specified in 3GPP TS 24.229 [5], clause 4.4
17	"oli" tel URI parameter (NOTE 5)	3GPP TS 24.229 [5] clause 7.2A.12	As specified in 3GPP TS 24.229 [5], clause 4.4	As specified in 3GPP TS 24.229 [5], clause 4.4
18	Restoration-Info (NOTE 2)	3GPP TS 24.229 [5] clause 7.2.11	As specified in 3GPP TS 24.229 [5], clause 4.4	As specified in 3GPP TS 24.229 [5], clause 4.4
19	Relayed-Charge (NOTE 4)	3GPP TS 24.229 [5] clause 7.2.12	As specified in 3GPP TS 24.229 [5], clause 4.4	As specified in 3GPP TS 24.229 [5], clause 4.4
20	Service-Interact-Info	3GPP TS 24.229 [5] clause 7.2.14	As specified in 3GPP TS 24.229 [5], clause 4.4	As specified in 3GPP TS 24.229 [5], clause 4.4
21	Cellular-Network-Info	3GPP TS 24.229 [5] clause 7.2.15	As specified in 3GPP TS 24.229 [5], clause 4.4	As specified in 3GPP TS 24.229 [5], clause 4.4

22	Response-Source	3GPP TS 24.229 [5] clause 7.2.17	As specified in 3GPP TS 24.229 [5], clause 4.4	As specified in 3GPP TS 24.229 [5], clause 4.4
<p>NOTE 1: For a roaming II-NNI, a trust relationship with respect to this header field is required.</p> <p>NOTE 2: This header field is only applicable on a roaming II-NNI.</p> <p>NOTE 3: In addition, value-dependent operator policies may be applied.</p> <p>NOTE 4: This header field is not applicable at II-NNI.</p> <p>NOTE 5: The tel URI parameters "cpc" and "oli" can be included in the URI in the P-Asserted-Identity header field.</p> <p>NOTE 6: Only the "psap-callback" value is part of the trust domain.</p> <p>NOTE 7: The "iotl" SIP URI parameter can be transported in the Request-URI, Route header field, Path header field, Service-Route header field, "+g.3gpp.trf" header field parameter, "+g.3gpp.atcf-mgmt-uri" header field parameter and in the "ATU-STI" parameter in the "application/vnd.3gpp.srvcc-info+xml" MIME body.</p>				

6.1.1.3.2 Derivation of applicable SIP header fields from 3GPP TS 24.229 [5]

For any method in table 6.1, the SIP header fields applicable on the II-NNI are detailed in the corresponding method tables for the UA role and proxy role sending behaviour in annex A of 3GPP TS 24.229 [5]. Unless other information is specified in the normative part of the present specification, the applicability of header fields at the II-NNI can be derived for each method from the corresponding tables in annex A of 3GPP TS 24.229 [5] as follows:

- All header fields not present in the corresponding tables in annex A of 3GPP TS 24.229 [5] or marked as "n/a" in both the "RFC status" and "profile status" columns for the UA role and proxy role sending behaviour of that tables are not applicable at the II-NNI.

NOTE 1: Operators could choose to apply header fields for other SIP extensions on an II-NNI based on bilateral agreements, but this is outside the scope of the present specification.

- All header fields which are marked as "o" in at least one of the "RFC status" or the "profile status" profile columns for the sending behaviour in the corresponding UA role and proxy role tables in annex A of 3GPP TS 24.229 [5] and as "n/a" or "o" in the other such columns are applicable at II-NNI based on bilateral agreement between operators.
- All header fields which are marked as "m" in at least one of the "RFC status" or the "profile status" columns for the sending behaviour in the corresponding UA role or proxy role table in annex A of 3GPP TS 24.229 [5] and as "n/a", "o", or "m" in the other such columns are applicable at the II-NNI.
- If conditions are specified, they are also applicable at the II-NNI and the above rules are applicable to the "n/a", "o" and "m" values within the conditions.

NOTE 2: In the above rules, the RFC profile columns are taken into account in order to enable interworking with non-3GPP networks.

An informative summary of SIP header fields to be used over the II-NNI is proposed in annex A.

6.1.1.3.3 Applicability of SIP header fields on a roaming II-NNI

The following SIP header fields are applicable on a roaming II-NNI but not on a non-roaming II-NNI:

- Authentication-Info
- Authorization
- P-Associated-URI
- P-Called-Party-ID
- P-Preferred-Service
- P-Profile-Key
- P-Served-User
- P-Visited-Network-ID
- Path

- Priority-Share
- Proxy-Authenticate
- Proxy-Authorization
- Resource-Share
- Restoration-Info
- Service-Route
- WWW-Authenticate

6.1.1.3.4 Applicability of SIP header fields on a non-roaming II-NNI

The following SIP header fields are only applicable on a non-roaming II-NNI:

- P-Refused-URI-List; and
- Identity.

6.1.1.4 Notations of the codes

In the table 6.1 the status codes "m", "o", "c" and "n/a" have the following meanings:

Table 6.3: Key to notation codes for SIP messages

Notation code	Notation name	Sending side	Receiving side
m	mandatory	The message shall be supported at II-NNI. Supporting sending a SIP message at the II-NNI means that this message shall be sent over the II-NNI if received from the serving network. It does not imply that network elements inside the serving network or user equipment connected to this network shall support this message.	Supporting receiving a SIP message at the II-NNI means that this message shall be forwarded to the serving network unless the operator's policy is applied as defined in clause 5.10.1 of 3GPP TS 24.229 [5]. It does not imply that network elements inside the serving network or user equipment connected to this network are supporting this message.
o	optional	The message may or may not be supported at II-NNI. The support of the message is provided based on bilateral agreement between the operators.	Same as for sending side.
n/a	not applicable	It is impossible to use/support the message.	It is impossible to use/support the message. This message will be discarded by the IBCF.
c <integer>	conditional	The requirement on the message ("m", "o" or "n/a") depends on the support of other optional or conditional items. <integer> is the identifier of the conditional expression.	Same as for sending side.

6.1.1.5 Modes of signalling

Overlap signalling may be used if agreement exists between operators to use overlap and which method to be used, otherwise enbloc shall be used at the II-NNI.

6.1.2 SDP protocol

6.1.2.1 General

The functional entity closest to the border of an II-NNI (see reference model in clause 5) shall provide the capabilities specified for that network element in clause A.3 of 3GPP TS 24.229 [5].

The "application/sdp" MIME bodies shall be encoded as described in IETF RFC 3261 [13] and in IETF RFC 4566 [147].

The offer/answer model with the SDP as defined in IETF RFC 3264 [146] shall be applied.

The procedures and the SDP rules as defined in IETF RFC 4145 [162] may be applied if media streams with TCP is used.

6.1.3 Major capabilities

This clause contains the major capabilities to be supported over the II-NNI.

The table 6.1.3.1 specifies which capabilities are applicable for II-NNI. The profile status codes within table 6.1.3.1 are defined in table 6.1.3.2.

For the "Basic SIP" capabilities part of table 6.1.3.1, the last column "Profile status over II-NNI" specifies the general status of applicability of the IETF RFC 3261 [13] main mechanisms described in the 2nd column "Capability over the Ici".

For the "Extensions to basic SIP" capabilities part, the last column "Profile status over II-NNI" specifies the general status of applicability of the RFC referenced in the 2nd column "Capability over the Ici".

If necessary, the applicability of RFCs at the II-NNI level is further detailed in the present Technical Specification.

The columns "Reference item in 3GPP TS 24.229 [5] for the profile status" provide informative references for comparison purposes into the UA and Proxy role major capabilities tables in 3GPP TS 24.229 [5], where the capabilities are defined via additional references.

Table 6.1.3.1: Major capabilities over II-NNI

Item	Capability over the ICI	Reference item in 3GPP TS 24.229 [5] for the profile status		Profile status over II-NNI
		UA Role (NOTE 1)	Proxy role (NOTE 2)	
	Basic SIP (IETF RFC 3261 [13])			
1	registrations	1, 2, 2A	-	c2
2	initiating a session	2B, 3, 4	-	m
3	terminating a session	5	3	m
4	General proxy behaviour	-	4, 5, 14, 15	n/a
5	Managing several responses due to forking	9,10	6	m
6	support of indication of TLS connections in the Record-Route header	-	7, 8	n/a
7	Support of authentication	7, 8, 8A	8A	c2
8	Timestamped requests (Timestamp header field)	6	-	m
9	Presence of date in requests and responses (Date header field)	11	9	m
10	Presence of alerting information data (Alert-info header field)	12	10	o
11	Support and handling of the Require header field for REGISTER and other requests or responses for methods other than REGISTER	-	11, 12, 13	m
12	Support and reading of the Supported and Unsupported header fields	-	16, 17, 18	m
13	Support of the Error-Info header field in 3xx - 6xx responses	-	19	o
14	Support and handling of the Organization header field	-	19A, 19B	m
15	Support and handling of the Call-Info header field	-	19C, 19D	m
16	Support of the Contact header field in 3xx response	-	19E	m
16A	Proxy reading the contents of a body or including a body in a request or response	-	19F	n/a
	Extensions to basic SIP			
16B	3GPP TS 24.237 [131]: proxy modifying the content of a body	-	19G	n/a
17	IETF RFC 6086 [39]: SIP INFO method and package framework	13	20	o
17A	IETF RFC 6086 [39]: legacy INFO usage	13A	20A	o
18	IETF RFC 3262 [18]: reliability of provisional responses in SIP (PRACK method)	14	21	m
19	IETF RFC 3515 [22]: the SIP REFER method	15	22	o
19A	IETF RFC 7647 [194]: Clarifications for the Use of REFER with RFC6665	15A	22A	n/a
19B	IETF RFC 7614 [195]: Explicit Subscriptions for the REFER Method	15B	22B	o
20	IETF RFC 3312 [40] and IETF RFC 4032 [41]: integration of resource management and SIP (Preconditions framework)	2C, 16	23	o
21	IETF RFC 3311 [23]: the SIP UPDATE method	17	24	m
22	IETF RFC 3313 [42]: SIP extensions for media authorization (P-Media-Authorization header field)	19	26	n/a
23	IETF RFC 6665 [20]: SIP specific event notification (SUBSCRIBE/NOTIFY methods)	20, 22, 23	27	c1
23A	IETF RFC 7621 [196]: A Clarification on the Use of Globally Routable User Agent URIs (GRUUs) in the Session Initiation Protocol SIP Event Notification Framework	22A	28	n/a
24	IETF RFC 3327 [43]: session initiation protocol extension header field for registering non-adjacent contacts (Path header field)	24	29	c2
25	IETF RFC 3325 [44]: private extensions to the Session Initiation Protocol (SIP) for network asserted identity within trusted networks	25	30	c4
26	IETF RFC 3325 [44]: the P-Preferred-Identity header field extension	-	-	n/a
27	IETF RFC 3325 [44]: the P-Asserted-Identity header field extension		-	c4
28	IETF RFC 3323 [34], IETF RFC 3325 [44] and IETF RFC 7044 [25]: a privacy mechanism for the Session Initiation Protocol (SIP) (Privacy header field)	26, 26A, 26B, 26C, 26D, 26E, 26F, 26G, 26H	31, 31A, 31B, 31C, 31D, 31E, 31F, 31G, 31H	m

29	IETF RFC 3428 [19]: a messaging mechanism for the Session Initiation Protocol (SIP) (MESSAGE method)	27	33	o
30	IETF RFC 3608 [45]: session initiation protocol extension header field for service route discovery during registration (Service-Route header field)	28	32	c2
31	IETF RFC 3486 [46]: compressing the session initiation protocol	29	34	n/a
32	IETF RFC 7315 [24]: private header extensions to the session initiation protocol for the 3 rd -Generation Partnership Project (3GPP)	30	35	o
32A	IETF RFC 3325 [44]: act as first entity within the trust domain for asserted identity	30A	30A	n/a
32B	IETF RFC 3325 [44]: act as entity within trust network that can route outside the trust network	30B	30B	n/a
32C	IETF RFC 3325 [44]: act as entity passing on identity transparently independent of trust domain	30C	30C	n/a
33	IETF RFC 7315 [24] and IETF RFC 7976 [24A]: the P-Associated-URI header field extension	31	36	c2
34	IETF RFC 7315 [24] and IETF RFC 7976 [24A]: the P-Called-Party-ID header field extension	32	37	c2
35	IETF RFC 7315 [24] and IETF RFC 7976 [24A]: the P-Visited-Network-ID header field extension	33	38, 39	c2
36	IETF RFC 7315 [24], IETF RFC 7976 [24A] and IETF RFC 7913 [24B]: the P-Access-Network-Info header field extension	34	41, 42, 43	c4
37	IETF RFC 7315 [24] and IETF RFC 7976 [24A]: the P-Charging-Function-Addresses header field extension	35	44, 44A	n/a
38	IETF RFC 7315 [24] and IETF RFC 7976 [24A]: the P-Charging-Vector header field extension	36	45, 46	c1
39	IETF RFC 3329 [47]: security mechanism agreement for the session initiation protocol	37	47	n/a
39A	3GPP TS 24.229 [5] clause 7.2A.7: Capability Exchange for Media Plane Security	37A	47A	n/a
40	IETF RFC 3326 [48]: the Reason header field for the session initiation protocol	38	48	o
41	IETF RFC 6432 [49]: carrying Q.850 codes in reason header fields in SIP (Session Initiation Protocol) responses	38A	48A	c4
41A	IETF draft-jesske-sipcore-reason-q850-loc [214]: the Location Parameter for the SIP Reason Header Field	38B	48B	o
42	IETF RFC 3581 [50]: an extension to the session initiation protocol for symmetric response routing	39	49	o
43	IETF RFC 3841 [51]: caller preferences for the session initiation protocol (Accept-Contact, Reject-Contact and Request-Disposition header fields)	40, 40A, 40B, 40C, 40D, 40E, 40F	50, 50A, 50B, 50C, 50D, 50E, 50F	m
44	IETF RFC 3903 [21]: an event state publication extension to the session initiation protocol (PUBLISH method)	41	51	c1
45	IETF RFC 4028 [52]: SIP session timer (Session-Expires and Min-SE headers)	42	52	m
46	IETF RFC 3892 [53]: the SIP Referred-By mechanism	43	53	m
47	IETF RFC 3891 [54]: the Session Initiation Protocol (SIP) "Replaces" header	44	54	o
48	IETF RFC 3911 [55]: the Session Initiation Protocol (SIP) "Join" header	45	55	o
49	IETF RFC 3840 [56]: the callee capabilities	46	56	o
50	IETF RFC 7044 [25]: an extension to the session initiation protocol for request history information (History-Info header field)	47	57	o
50A	IETF RFC 7044 [25]: the "mp" header field parameter	47A	57A	o
50B	IETF RFC 7044 [25]: the "rc" header field parameter	47B	57B	o
50C	IETF RFC 7044 [25]: the "np" header field parameter	47C	57C	o
51	IETF RFC 5079 [57]: Rejecting anonymous requests in the session initiation protocol	48	58	o
52	IETF RFC 4458 [58]: session initiation protocol URIs for applications such as voicemail and interactive voice response (NOTE 3)	49	59	o

52A	IETF RFC 8119 [193]: Session Initiation Protocol (SIP) Cause URI parameter for Service Number translation	49A	59A	o
53	IETF RFC 4320 [59]: Session Initiation Protocol's (SIP) non-INVITE transactions	50	61	m
54	IETF RFC 4457 [60]: the P-User-Database private header field extension	51	60	n/a
55	IETF RFC 5031 [61]: A Uniform Resource Name (URN) for Emergency and Other Well-Known Services	52	62	c7
56	IETF RFC 5627 [62]: obtaining and using GRUUs in the Session Initiation Protocol (SIP)	53	63	c1
57	Void			
58	IETF RFC 4168 [27]: the Stream Control Transmission Protocol (SCTP) as a Transport for the Session Initiation Protocol (SIP)	55	65	o
59	IETF RFC 5002 [64]: the SIP P-Profile-Key private header field extension	56	66, 66A, 66B	c3
60	IETF RFC 5626 [65]: managing client initiated connections in SIP	57	67	c1
61	IETF RFC 5768 [66]: indicating support for interactive connectivity establishment in SIP	58	68	n/a
62	IETF RFC 5365 [67]: multiple-recipient MESSAGE requests in the session initiation protocol	59	69	o if 29, else n/a
63	IETF RFC 6442 [68]: Location conveyance for the Session Initiation Protocol	60	70, 70A, 70B	m
64	IETF RFC 5368 [69]: referring to multiple resources in the session initiation protocol	61	71	o if 19, else n/a
65	IETF RFC 5366 [70]: conference establishment using request-contained lists in the session initiation protocol	62	72	o
66	IETF RFC 5367 [71]: subscriptions to request-contained resource lists in the session initiation protocol	63	73	o if 23, else n/a
67	IETF RFC 4967 [72]: dialstring parameter for the session initiation protocol uniform resource identifier	64	74	c2
68	IETF RFC 4964 [73]: the P-Answer-State header extension to the session initiation protocol for the open mobile alliance push to talk over cellular	65	75	o
69	IETF RFC 5009 [74]: the SIP P-Early-Media private header field extension for authorization of early media	66	76	c4
70	IETF RFC 4694 [75]: number portability parameters for the 'tel' URI	67, 67A, 67B	77, 77A, 77B	o
71	Void			
72	IETF RFC 4411 [77]: extending the session initiation protocol Reason header for preemption events	69	79	o
73	IETF RFC 4412 [78]: communications resource priority for the session initiation protocol (Resource-Priority header field)	70, 70A, 70B	80, 80A, 80B	o
74	IETF RFC 5393 [79]: addressing an amplification vulnerability in session initiation protocol forking proxies	71	81	m
75	IETF RFC 5049 [80]: the remote application identification of applying signalling compression to SIP	72	82	n/a
76	IETF RFC 5688 [81]: a session initiation protocol media feature tag for MIME application sub-types	73	83	c1
77	IETF RFC 6050 [26]: Identification of communication services in the session initiation protocol	74	84, 84A	o
78	IETF RFC 5360 [82]: a framework for consent-based communications in SIP	75, 75A, 75B	85	o
79	IETF RFC 7433 [83]: a mechanism for transporting user-to-user call control information in SIP	76	86	c1
79A	IETF RFC 7434 [83A]: interworking ISDN call control user information with SIP	76A	-	c1
80	IETF RFC 7316 [84]: The SIP P-Private-Network-Indication private header (P-Header)	77	87	c1
81	IETF RFC 5502 [85]: the SIP P-Served-User private header	78	88	c2
82	IETF draft-ietf-sipcore-originating-cdiv-parameter [203]: the SIP P-Served-User header extension for Originating CDIV session case	79	89	n/a
83	IETF draft-ietf-insipid-logme-marking [87]: marking SIP messages to be logged	80	90	o

84	IETF RFC 6228 [88]: the 199 (Early Dialog Terminated) response code	81	91	m
85	IETF RFC 5621 [89]: message body handling in SIP	82	92	m
86	IETF RFC 6223 [90]: indication of support for keep-alive	83	93	o
87	IETF RFC 5552 [91]: SIP Interface to VoiceXML Media Services	84	94	n/a
88	IETF RFC 3862 [92]: common presence and instant messaging (CPIM): message format	85	95	o
89	IETF RFC 5438 [93]: instant message disposition notification	86	96	o
90	IETF RFC 5373 [94]: requesting answering modes for SIP (Answer-Mode and Priv-Answer-Mode header fields)	87	97, 97A	o
91	Void			
92	IETF RFC 3959 [96]: the early session disposition type for SIP	89	99	o
93	Void			
94	IETF RFC 7989 [124]: End-to-End Session Identification in IP-Based Multimedia Communication Networks	91	101	o
95	IETF RFC 6026 [125]: correct transaction handling for 200 responses to Session Initiation Protocol INVITE requests	92	102	m
96	IETF RFC 5658 [126]: addressing Record-Route issues in the Session Initiation Protocol (SIP)	93	103	o
97	IETF RFC 5954 [127]: essential correction for IPv6 ABNF and URI comparison in IETF RFC 3261 [13]	94	104	m
98	IETF RFC 4488 [135]: suppression of session initiation protocol REFER method implicit subscription	95	105	m if 19, else n/a
99	IETF RFC 7462 [136]: Alert-Info URNs for the Session Initiation Protocol	96	106	o
100	3GPP TS 24.229 [5] clause 3.1: multiple registrations	97	107	c2
101	IETF RFC 5318 [141]: the SIP P-Refused-URI-List private-header	98	108	c5
102	IETF RFC 4538 [140]: request authorization through dialog Identification in the session initiation protocol (Target-Dialog header field)	99	109	o
103	IETF RFC 6809 [143]: Mechanism to indicate support of features and capabilities in the Session Initiation Protocol (SIP)	100	110	o
104	IETF RFC 6140 [160]: registration of bulk number contacts	101	111	c3
105	IETF RFC 6230 [161]: media control channel framework	102	112	o
105A	3GPP TS 24.229 [5] clause 4.14: S-CSCF restoration procedures	103	113	c3
106	IETF RFC 6357 [164]: SIP overload control	104	114	o
107	IETF RFC 7339 [165]: feedback control	104A	114A	o
108	IETF RFC 7200 [167]: distribution of load filters	104B	114B	o
109	3GPP TS 24.229 [5] clauses 5.1.2A.1.1, 5.1.3.1, 5.1.6.8, and 5.2.10: Handling of a 380 (Alternative service) response	105	115	n/a
110	IETF RFC 7090 [184]: Public Safety Answering Point (PSAP) Callback	107	117	o
111	IETF RFC 8055 [185]: Via header field parameter to indicate received realm	106	116	n/a
112	IETF RFC 7549 [188]: SIP URI parameter to indicate traffic leg	108	118	o (NOTE 4)
113	3GPP TS 24.229 [5] clause 4.14: PCRF based P-CSCF restoration	109	119	c3
114	3GPP TS 24.229 [5] clause 4.14: HSS based P-CSCF restoration	110	120	c3
115	3GPP TS 24.229 [5] clause 7.2.12: the Relayed-Charge header extension	111	121	n/a
116	3GPP TS 24.229 [5]: resource sharing	112	122	c3
117	3GPP TS 24.229 [5] clause 7.2.15: the Cellular-Network-Info header extension	113	123	c4
118	3GPP TS 24.229 [5] clause 7.2.16: the Priority-Share header field	114	124	c3
119	IETF RFC 8224 [206]: Authenticated Identity Management in the Session Initiation Protocol (SIP)	116	126	c5
120	IETF RFC 8197 [207]: A SIP Response Code for Unwanted Calls	117	127	o

121	3GPP TS 24.229 [5] clause 7.2.17: the Response-Source header extension	115	125	c6
c1: m in case of roaming II-NNI, else o c2: m in case of roaming II-NNI, else n/a c3: o in case of roaming II-NNI, else n/a c4: m in case of trust relationship between the interconnected networks, else n/a c5: o in case of non-roaming II-NNI and loopback traversal scenario, else n/a c6: o in case of trust relationship between the interconnected networks, else n/a c7: m in case of IMS emergency session traversal scenario on non-roaming II-NNI, else n/a NOTE 1: The item numbering corresponds to the one provided in table A.4 in 3GPP TS 24.229 [5]. NOTE 2: The item numbering corresponds to the one provided in table A.162 in 3GPP TS 24.229 [5]. NOTE 3: A common URI namespace is required to apply this feature on the II-NNI. NOTE 4: For the roaming II-NNI the support of this major capability is recommended.				

Table 6.1.3.2: Key to notation codes for major capabilities

Notation code	Notation name	Explanation
m	mandatory	The capability shall be supported at II-NNI. SIP message relating to this capability shall be sent over the II-NNI if received from the serving network, unless they also make use of other unsupported capabilities. SIP headers or other information elements relating to this capability shall be passed over the II-NNI if received from the sending side. This does not imply that network elements inside the serving network or served network or user equipment connected to these networks shall support this capability.
o	optional	The capability may or may not be supported at II-NNI. The support of the capability is provided based on bilateral agreement between the operators.
n/a	not applicable	It is impossible to use/support the capability at the II-NNI.
c <integer>	conditional	The support of the capability ("m", "o" or "n/a") depends on the support of other optional or conditional items. <integer> is the identifier of the conditional expression.

6.1.4 SIP message bodies

The MIME type "application/sdp" and multipart message bodies (multipart/mixed, multipart/related and multipart/alternative) shall be supported according to IETF RFC 5621 [89] over the II-NNI. Other MIME types may be supported over the II-NNI based on agreement between operators.

The SDP message bodies contained in the INVITE request shall not be encrypted over the II-NNI.

NOTE 1: Some MIME types in SIP requests and responses are listed in annex A of 3GPP TS 24.229 [5].

NOTE 2: The multipart message bodies are used for carrying two or more message body types as described in IETF RFC 5621 [89].

NOTE 3: The IBCF can provide the capabilities to examine the length of a SIP message body and take an appropriate action (e.g. reject the request, remove the body) as specified in clause 5.10.6.3 of 3GPP TS 24.229 [5].

NOTE 4: In the INVITE request, the SDP message body is present over the II-NNI, except when the INVITE request without SDP message body is required to provide services (e.g. 3rd party call control).

Table 6.1.4.1: List of MIME bodies

Item	MIME body name	II-NNI requirements in ref (NOTE 1)	Defined in ref (NOTE 2)
1	application/3gpp-ims+xml	-	3GPP TS 24.229 [5], clause 7.6
3	message/cpim	-	IETF RFC 3862 [92]
4	message/imdn+xml	-	IETF RFC 5438 [93]
5	application/im-iscomposing+xml	clause 16.2	IETF RFC 3994 [175]
6	multipart/mixed	clause 15.1, clause 15.4, clause 15.6.2, clause 15.6.3, clause 15.6.4, clause 18.3.3	IETF RFC 2046 [169]
7	multipart/related	clause 15.1, clause 15.2, clause 15.6.5	IETF RFC 2387 [170]
8	multipart/alternative	-	IETF RFC 2046 [169]
9	application/pidf+xml	clause 15.1, clause 28.2.3.2	IETF RFC 3863 [174]
10	application/pidf-diff+xml	clause 15.1	IETF RFC 5262 [179]
11	application/resource-lists+xml	clause 12.19, clause 15.1, clause 15.6.3, clause 16.5, clause 28.2.1, clause 28.2.7	IETF RFC 4826 [178]
12	application/rlmi+xml	clause 15.2, clause 15.6.5	IETF RFC 4662 [177]
13	application/sdp	-	IETF RFC 4566 [147]
14	application/simple-filter+xml	clause 15.1, clause 15.6.4, clause 28.2.3.2	IETF RFC 4661 [176]
15	application/simple-message-summary+xml	clause 12.9	IETF RFC 3842 [172]
16	message/sipfrag	clause 12.13, clause 18.2, clause 18.3.1	IETF RFC 3420 [171]
17	application/vnd.3gpp.access-transfer-events+xml	clause 14.5.3	3GPP TS 24.237 [131], clause D.5.4
18	application/vnd.3gpp.cw+xml	clause 12.7	3GPP TS 24.615 [37], clause C.1.1
19	application/vnd.3gpp.iut+xml	clause 18.3.2, clause 18.3.3	3GPP TS 24.337 [149], clause C.2.3
20	application/vnd.3gpp.mid-call+xml	clause 14.4	3GPP TS 24.237 [131], clause D.1.3
21	application/vnd.3gpp.replication+xml	clause 18.4.1, clause 18.4.2	3GPP TS 24.337 [149], clause C.1.3
22	application/vnd.3gpp.sms	-	
23	application/vnd.3gpp.srvcc-ext+xml	clause 14.5.1	3GPP TS 24.237 [131], clause D.4.4
24	application/vnd.3gpp.srvcc-info+xml	clause 14.2.3	3GPP TS 24.237 [131], clause D.3.4
25	application/vnd.3gpp.state-and-event-info+xml	clause 14.2.2, clause 14.4	3GPP TS 24.237 [131], clause D.2.4
26	application/vnd.3gpp.ussd	clause 12.24	3GPP TS 24.390 [163], clause 5.1.3
27	application/vnd.etsi.aoc+xml	clause 12.22	3GPP TS 24.647 [122], clause E.1.1
28	application/vnd.etsi.cug+xml	clause 12.16	3GPP TS 24.654 [103], clause 4.4.1
29	application/vnd.etsi.mcid+xml	clause 12.2	3GPP TS 24.616 [33], clause 4.4
30	application/vnd.etsi.pstn+xml	-	3GPP TS 29.163 [168], clause F.2
31	application/vnd.oma.suppnot+xml	clause 15.6.2, clause 15.6.3	OMA-SUP-XSD_prs_suppnnotFilter-V1_0 [182]
32	application/watcherinfo+xml	clause 15.3	IETF RFC 3858 [173]
33	application/xcap-diff+xml	clause 15.4, clause 15.6.5	IETF RFC 5874 [180]
34	application/session-info	-	3GPP TS 29.163 [168], clause G.2
35	application/load-control+xml	clause 21	IETF RFC 7200 [167]
36	application/vnd.etsi.sci+xml	clause 11.3	3GPP TS 29.658 [186]
37	text/plain	-	IETF RFC 2646 [197]

38	application/x-www-form-urlencoded	-	IETF RFC 1866 [198], clause 8.2.1 (NOTE 3)
39	application/vnd.3gpp.crs+xml	clause 12.15	3GPP TS 24.183 [98], clause D.1
40	message/sip	-	IETF RFC 3261 [13]
41	application/vnd.3gpp.mcptt-info+xml	clause 28.2.1, clause 28.2.3.2, clause 28.2.3.3, clause 28.2.4, clause 28.2.5, clause 28.2.6, clause 28.2.7	3GPP TS 24.379 [201], clause F.1
42	application/vnd.3gpp.mcptt-mbms-usage-info+xml	clause 28.2.2	3GPP TS 24.379 [201], clause F.2
43	application/vnd.3gpp.mcptt-location-info+xml	clause 28.2.2	3GPP TS 24.379 [201], clause F.3
44	application/conference-info+xml	clause 12.19, clause 28.2.4, clause 16.5	IETF RFC 4575 [204]
45	application/poc-settings+xml	clause 28.2.5	IETF RFC 4354 [205]
46	application/vnd.3gpp.mcptt-floor-request+xml	clause 28.2.7	3GPP TS 24.379 [201], clause F.5
47	application/vnd.3gpp.mcptt-affiliation-command+xml	clause 28.2.3.3	3GPP TS 24.379 [201], clause F.4
47A	application/vnd.3gpp.mcptt-signed+xml	clause 28.2.5, clause 28.2.6	3GPP TS 24.379 [201], clause F.6
48	application/call-completion	clause 12.11, clause 12.12, clause 12.23	IETF RFC 6910 [208]
49	application/vnd.3gpp.mcvideo-info+xml	clause 28.2.1 clause 28.2.3.2, clause 28.2.3.3, clause 28.2.5, clause 28.2.4, clause 28.2.6,	3GPP TS 24.281 [210], clause F.1
50	application/vnd.3gpp.mcvideo-affiliation-command+xml	clause 28.2.3.3	3GPP TS 24.281 [210], clause F.4
51	application/vnd.3gpp.mcdata-signalling	clause 28.2.1, clause 28.2.8	3GPP TS 24.282 [211], clause E.1
52	application/vnd.3gpp.mcdata-payload	clause 28.2.8	3GPP TS 24.282 [211], clause E.2
53	application/vnd.3gpp.mcdata-info+xml	clause 28.2.1 clause 28.2.3.2, clause 28.2.3.3, clause 28.2.5, clause 28.2.6, clause 28.2.8	3GPP TS 24.282 [211], clause D.1.4
54	application/vnd.3gpp.mcdata-affiliation-command+xml	clause 28.2.3.3	3GPP TS 24.282 [211], clause D.3.4
NOTE 1: When no specific II-NNI requirements are defined, the II-NNI requirements may be derived from the additional information about MIME types in SIP requests and responses in annex A of 3GPP TS 24.229 [5].			
NOTE 2: This column references the definition of the MIME body for informative purpose only, the usage is defined in other specifications not listed here.			
NOTE 3: The MIME body contains a string that is coded as described in the IETF RFC 1866 [198].			

Applicable characteristics of the SIP message body MIMEs (i.e. the value(s) of Content-Disposition header field and Content-Language header field) over the II-NNI may be a subject of operator agreements.

6.2 Control Plane Transport

6.2.1 General

The control plane transport of the II-NNI shall comply with clause 4.2A of 3GPP TS 24.229 [5].

Support of SCTP as specified in IETF RFC 4168 [27] is optional for an IBCF connected by II-NNI. Nevertheless this option is favourable if the operators would like to improve reliability over the Ici.

6.3 SIP timers

Table 6.3.1 shows values of SIP timers that should be supported at II-NNI. It contains the following items:

- the first column, titled "SIP Timer", shows the timer names as defined in IETF RFC 3261 [13] or IETF RFC 6026 [125];
- the second column reflects the timer meaning as defined in IETF RFC 3261 [13];
- the third column reflects the reference to the proper clause in the IETF RFC 3261 [13] and in 3GPP TS 24.229 [5] and
- the final column lists the values recommended for the functional entities closest to the border of an II-NNI (see reference model in clause 5).

Table 6.3.1 reports information from 3GPP TS 24.229 [5], table 7.7.1. Values between IM CN subsystem elements shown in the second column in 3GPP TS 24.229 [5], table 7.7.1 are applicable for the II-NNI and are reported in the fourth column of table 6.3.1. If there are any differences between table 6.3.1 and 3GPP TS 24.229 [5], table 7.7.1, the information within 3GPP TS 24.229 [5], table 7.7.1 is applicable.

Table 6.3.1: SIP timers at I-NNI

SIP Timer	Meaning	Reference	Recommended values
T1	RTT estimate	[13] clause 17.1.1.1 [5] table 7.7.1	500ms default (see NOTE)
T2	The maximum retransmit interval for non-INVITE requests and INVITE responses	[13] clause 17.1.2.2 [5] table 7.7.1	4s (see NOTE)
T4	Maximum duration a message will remain in the network	[13] clause 17.1.2.2 [5] table 7.7.1	5s (see NOTE)
Timer A	INVITE request retransmit interval, for UDP only	[13] clause 17.1.1.2 [5] table 7.7.1	initially T1
Timer B	INVITE transaction timeout timer	[13] clause 17.1.1.2 [5] table 7.7.1	64*T1
Timer C	proxy INVITE transaction timeout	[13] clause 16.6 [5] table 7.7.1	> 3min
Timer D	Wait time for response retransmits	[13] clause 17.1.1.2 [5] table 7.7.1	> 32s for UDP
		[13] clause 17.1.1.2 [5] table 7.7.1	0s for TCP/SCTP
Timer E	non-INVITE request retransmit interval, UDP only	[13] clause 17.1.2.2 [5] table 7.7.1	initially T1
Timer F	non-INVITE transaction timeout timer	[13] clause 17.1.2.2 [5] table 7.7.1	64*T1
Timer G	INVITE response retransmit interval	[13] clause 17.2.1 [5] table 7.7.1	initially T1
Timer H	Wait time for ACK receipt.	[13] clause 17.2.1 [5] table 7.7.1	64*T1
Timer I	Wait time for ACK retransmits	[13] clause 17.2.1 [5] table 7.7.1	T4 for UDP
		[13] clause 17.2.1 [5] table 7.7.1	0s for TCP/SCTP
Timer J	Wait time for non-INVITE request retransmits	[13] clause 17.2.2 [5] table 7.7.1	64*T1 for UDP
		[13] clause 17.2.2 [5] table 7.7.1	0s for TCP/SCTP
Timer K	Wait time for response retransmits	[13] clause 17.1.2.2 [5] table 7.7.1	T4 for UDP
		[13] clause 17.1.2.2 [5] table 7.7.1	0s for TCP/SCTP
Timer L	Wait time for accepted INVITE request retransmits	[125] clause 8.11 [5] table 7.7.1	64*T1
Timer M	Wait time for retransmission of 2xx to INVITE or additional 2xx from other branches of a forked INVITE	[125] clause 8.11 [5] table 7.7.1	64*T1
Timer N	Wait time for receipt of a NOTIFY request upon sending SUBSCRIBE	[20] clause 4.1.2 [5] table 7.7.1	64*T1
NOTE:	As a network option, SIP T1 Timer's value can be extended, along with the necessary modifications of SIP T2 and SIP T4 Timer values, to take into account the specificities of the supported services when the MRFC and the controlling AS are under the control of the same operator and the controlling AS knows, based on local configuration, that the MRFC implements a longer value of SIP T1 Timer.		

7 User plane Interconnection

7.1 Media and Codec

For "end-to-end" media session involving the II-NNI, the SIP/SDP codec negotiation procedure can be applied between IM CN subsystems using different media codecs. It is possible that the end-to-end codec negotiation could fail because no common codec could be supported by the UEs, in particular for voice services.

To enhance interoperability, the IBCF, the MRFC, or other IMS network entities can interfere with the end-to-end codec negotiation to offer additional codec(s) available via transcoding, or to remove codecs. The IBCF can configure an attached TrGW to transcode, and the MRFC can configure an attached MRFP to transcode.

Codecs applicable at the II-NNI may be a subject of interworking agreements.

NOTE 1: Possible codecs which could be used at the II-NNI are described in 3GPP TS 26.114 [11] and ETSI TS 181 005 [12].

NOTE 2: As described in 3GPP TS 24.229 [5], the IETF RFC 4733 [157] is used to encode DTMF events and a payload type number associated with the MIME subtype "telephone-event" is included in a SDP message.

However, to avoid that transcoding is performed several times, applicable codecs at the II-NNI should be restricted as little as possible in the inter-operator agreements. It is not recommended to set only codecs which are not agreed to use by the inter-operator agreement into the SDP of the SIP message at the II-NNI. Whether it is allowed to offer codecs which are not included in the applicable codec list made by inter-operator agreements over the II-NNI is also determined by the inter-operator agreement if necessary.

NOTE 3: Transcoding can be performed in an IMS network serving an SDP offerer or in an IMS network serving an SDP answerer. To avoid that transcoding is performed multiple times, inter-operator agreements can clarify if it is preferred that IMS network serving an SDP offerer or IMS network serving an SDP answerer modify an SDP offer to offer transcoding.

If the IBCF performs media transcoding control, the IBCF shall apply the related procedures in 3GPP TS 24.229 [5].

7.2 User Plane Transport

The user plane transport of the II-NNI may use the protocols listed in table 7.2.1. Protocols that use UDP, RTP, SCTP or TCP as the underlying transport protocol may be used based on agreements between operators. The used protocols to transport media are negotiated by means of the SDP offer/answer procedure specified in IETF RFC 3264 [146].

Table 7.2.1: Supported transport-level RFCs to be described in SIP/SDP messages

Item	RFC	Title	Support
1	IETF RFC 3550 [151]	RTP: A Transport Protocol for Real-Time Applications	Mandatory
2	IETF RFC 768 [152]	User Datagram Protocol	Mandatory
3	IETF RFC 3551 [153]	RTP Profile for Audio and Video Conferences with Minimal Control	Mandatory
4	IETF RFC 3556 [154]	Session Description Protocol (SDP) Bandwidth Modifiers for RTP Control Protocol (RTCP) Bandwidth	Mandatory
5	IETF RFC 4585 [155]	Extended RTP Profile for Real-time Transport Control Protocol (RTCP) - Based Feedback (RTP/AVPF)	Optional (NOTE 1)
6	IETF RFC 793 [156]	Transmission Control Protocol	Optional (NOTE 2)
7	IETF draft-ietf-mmusic-sctp-sdp [190]	Session Description Protocol (SDP) Offer/Answer Procedures For Stream Control Transmission Protocol (SCTP) over Datagram Transport Layer Security (DTLS) Transport	Optional (NOTE 3)
NOTE 1: Used by MTSI, as indicated in 3GPP TS 26.114 [11].			
NOTE 2: Used for MSRP service.			
NOTE 3: Used for data channel in telepresence using IMS, as indicated in 3GPP TS 24.103 [189].			

8 Numbering, Naming and Addressing

8.1 Numbering, Naming and Addressing for SIP message

The following URI formats in SIP messages may be applied at the Ici as standardized in 3GPP TS 24.229 [5]:

- SIP URI defined in IETF RFC 3261 [13];
- tel URI defined in IETF RFC 3966 [14];
- IM URI defined in IETF RFC 3860 [15]; and
- PRES URI defined in IETF RFC 3859 [16].

According to 3GPP TS 24.229 [5], the IBCF acting as an exit or entry point in the IMS network supports these URI formats. These URI formats shall be supported at the roaming II-NNI. The SIP URI format shall be supported at the non-roaming II-NNI. For the loopback traversal scenario both the SIP URI and the tel URI shall be supported. The tel URI, IM URI and PRES URI formats may be supported at the non-roaming II-NNI based on agreement between operators. For the loopback traversal scenario the IM URI and PRES URI may be supported based on agreement between operators. Other URI formats may be supported over the II-NNI depending on the operator agreements.

A global number as defined in IETF RFC 3966 [14] shall be used in a tel URI or in the user portion of a SIP URI with the user=phone parameter when conveyed via a non-roaming II-NNI or for the loopback traversal scenario in the Request-URI and in the P-Asserted-Identity header field, except when agreement exists between the operators to also allow other kinds of numbers.

- NOTE 1: In a SIP URI the user portion of the Request-URI represents a telephone number only if the SIP URI includes the user=phone parameter.
- NOTE 2: Agreements can exist between operators to allow non-global number (e.g. national service numbers, business trunking numbers, or private numbers) at a non-roaming II-NNI or for the loopback traversal scenario. A SIP URI with such a number, a user=phone parameter, and a phone-context parameter agreed between the operators can then be used.
- NOTE 3: 3GPP TS 24.229 [5] allows to restrict the number within a SIP Request-URI with user=phone parameter at a non-roaming II-NNI or for the loopback traversal scenario to be a global number (i.e. E.164 in international format) via an appropriate Application Server. Suitable configuration by the operator is needed to achieve the desired modification of the format.
- NOTE 4: The allowed phone number formats in the P-Asserted-Identity header field of a served user are configured by the operator. According to 3GPP TS 23.003 [35], international E.164 format is used within a P-Asserted-Identity header field.
- NOTE 5: The global number format usage within a SIP Request-URI with the user=phone parameter at a non-roaming II-NNI or for the loopback traversal scenario allows the terminating network to find the called subscriber, via HSS interrogation, without any further number translation and thus improves the success of the interconnection between IMS operators.
- NOTE 6: According to 3GPP TS 23.003 [35] and 3GPP TS 24.229 [5], public user identity takes the form of either SIP URI or tel URI.

The optional "oli" and "cpc" tel URI parameters associated with a tel URI or a SIP URI with user=phone are described in 3GPP TS 24.229 [5] clause 7.2A.12 and can be part of the P-Asserted-Identity header field. Depending on operator agreements, those URI parameters may be supported at the non-roaming II-NNI or for the loopback traversal scenario.

The "sos" SIP URI parameter associated with a URI in the Contact header field of a REGISTER request or a 200 (OK) response to REGISTER request is described in 3GPP TS 24.229 [5]. The "sos" SIP URI parameter shall be supported at the roaming II-NNI.

The "sos" SIP URI parameter associated with the Request-URI for all dialogs and standalone SIP requests described in clause 5.2.10.3 of 3GPP TS 24.229 [5] and shall be supported at the roaming II-NNI.

The "rn" and "npdi" number portability parameters for the tel URI and the SIP URI with user=phone as described within IETF RFC 4694 [75] can be part of the Request-URI. Depending on operator agreements these parameters may be exchanged over the non-roaming II-NNI or for the loopback traversal scenario.

NOTE 7: The "rn" and "npdi" parameters can be used to address the entry point of the terminating operator depending on national rules for number portability.

The "isub" tel URI parameter for the tel URI and the SIP URI with user=phone as described within IETF RFC 3966 [14] can be part of the Request-URI, To header field and P-Asserted-Identity header field. Depending on operator agreements, this URI parameter may be exchanged over the II-NNI.

The "premium-rate" tel URI parameter for the tel URI and the SIP URI with user=phone as described within 3GPP TS 24.229 [5] clause 7.2A.17 can be part of the Request-URI. Depending on operator agreements, this URI parameter may be exchanged at the roaming II-NNI.

The public service identity (PSI) that takes a form of a SIP URI without including a port number as described in clause 13.5 of 3GPP TS 23.003 [35] may be exchanged over the II-NNI depending on operator agreements.

8.2 Numbering, Naming and Addressing for SDP

The following URI format in the SDP exchange may be applied at the Ici as standardized in 3GPP TS 24.229 [5]:

- MSRP URI for a session of instant messages defined in IETF RFC 4975 [17].

This URI format shall be supported at the roaming II-NNI and may be supported at the non-roaming II-NNI and for the loopback traversal scenario based on agreement between operators. Other URI formats may be supported over the II-NNI depending on the operator's agreements.

9 IP Version

The network elements interconnected by means of the II-NNI may support IPv4 only, IPv6 only or both.

The support of one or both of the IP versions is an operator option and should be based on bilateral agreement.

In case IPv4 and IPv6 networks are interconnected, the involved IBCFs and TrGWs shall apply the IP version interworking procedures as indicated in 3GPP TS 29.162 [8].

10 Security

The supported security mechanisms for IP signalling transport over II-NNI interfaces are described in 3GPP TS 33.210 [10].

11 Charging

11.1 General

The accounting information to be supported over the Ici is described in 3GPP TS 32.260 [29] and 3GPP TS 32.240 [183]. It shall be configurable by the operator to use or not the accounting mechanisms provided by the IBCF.

11.2 Inter-operator accounting

For inter-operator accounting, the procedures related to the P-Charging-Vector header field specified in 3GPP TS 24.229 [5] shall be supported over the II-NNI as further specified below.

NOTE 1: The "icid-value" header field parameter identifying a dialog or a transaction outside a dialog is included in the P-Charging-Vector header field as specified in 3GPP TS 24.229 [5]. The "icid-value" header field parameter value of a SIP response to a SIP request is identical to the "icid-value" of the SIP request.

For the roaming II-NNI:

- the P-Charging-Vector header field in the REGISTER requests, initial SIP requests and stand-alone SIP requests, containing the type 1 "orig-ioi" with the entry which identifies the visited network; and
- the P-Charging-Vector header field in the REGISTER responses, SIP responses to initial SIP requests and SIP stand-alone requests, containing type 1 "orig-ioi" and type 1 "term-ioi" header field parameters with the entries which identify the visited network and the home network respectively;

shall be supported.

NOTE 2: Operator network identifiers populated in the type 1 "orig-ioi" and type 1 "term-ioi" header field parameters need to be exchanged by inter-operator agreements in advance.

For the II-NNI between IMS home networks:

- the P-Charging-Vector header field in the SIP requests containing the type 2 "orig-ioi" with the entry which identifies the home originating network; and
- the P-Charging-Vector header field in the SIP responses containing the type 2 "orig-ioi" and type 2 "term-ioi" header field parameters with the entries which identify the home originating network and the home terminating network respectively;

may be supported based on inter-operator agreements.

If the roaming architecture for voice over IMS with local breakout is used, for the II-NNI between the caller's visited network and the callee's home network except for the roaming II-NNI:

- the P-Charging-Vector header field in the SIP requests containing the type 2 "orig-ioi" with the entry which identifies the visited originating network; and
- the P-Charging-Vector header field in the SIP responses containing the type 2 "orig-ioi" and type 2 "term-ioi" header field parameters with the entries which identify the visited originating network and the home terminating network respectively;

may be supported based on inter-operator agreements.

NOTE 3: Operator network identifiers populated in the type 2 "orig-ioi" and type 2 "term-ioi" header field parameters need to be exchanged by inter-operator agreements in advance.

For the II-NNI for the transit scenario:

- the P-Charging-Vector header field in the SIP requests and responses containing the "transit-ioi" header field parameter with the entry(ies) which identify the transit network(s);

may be supported based on inter-operator agreements.

NOTE 4: Operator network identifiers populated in the value(s) of "transit-ioi" header field parameter need to be exchanged by inter-operator agreements in advance.

11.3 Transfer of IP multimedia service tariff information

In order to assure the end-to-end service interoperability through the Inter-IMS Network to Network Interface (II-NNI), transfer of IP multimedia service tariff information as specified in 3GPP TS 29.658 [186] may be supported on the II-NNI between two IMS networks. The support of transfer of IP multimedia service tariff information is based on agreement between operators.

If transfer of IP multimedia service tariff information is supported, the "application/vnd.etsi.sci+xml" MIME body with the Content-Disposition header field set to either "render" with the "handling" parameter set to "optional" or to "signal" with the "handling" parameter set to "required" or "optional" based on operator agreement in 18x responses to the INVITE request and in the INFO request shall be supported at the II-NNI.

12 Supplementary services associated with the IMS multimedia telephony communication service

12.1 General

In order to assure the end-to-end service interoperability through the Inter-IMS Network to Network Interface (II-NNI), the associated supplementary services of the multimedia telephony communication service may be supported on the II-NNI between the two IMS networks.

The MMTEL communication service is identified by means of the "urn:urn-7:3gpp-service.ims.icsi.mmotel" URN. The "urn:urn-7:3gpp-service.ims.icsi.mmotel" can appear in:

- the media feature tag "g.3gpp.icsi-ref" (specified in 3GPP TS 24.229 [5] clause 7.2A.8) in the Contact header field and the Accept-Contact header field;
- the feature-capability indicator "g.3gpp.icsi-ref" (specified in 3GPP TS 24.229 [5] clause 7.9A.2) in the Feature-Caps header field; and
- the P-Asserted-Service header field.

The support of each associated supplementary service is based on agreement between operators.

If a supplementary service is supported, the related procedures from the 3GPP TS 22.173 [30], the protocol details from the 3GPP TS 24.173 [31] and specifications referenced in the 3GPP TS 24.173 [31] shall be applied with the requirements in the relevant clause below due to the crossing of the II-NNI.

A classification of the importance of supplementary services applicable over the II-NNI is available in the informative annex Db of 3GPP TS 22.173 [30].

NOTE: Agreeing on interworking of entire class of services according to this classification can simplify the cooperation between interconnecting networks but remains optional.

12.2 Malicious Communication IDentification (MCID)

Service specific requirements in accordance with 3GPP TS 24.616 [33] shall be supported over the II-NNI.

The P-Asserted-Identity header field shall be supported at the II-NNI.

The INFO request and the 200 (OK) response to the INFO request containing the "application/vnd.etsi.mcid+xml" MIME body defined in 3GPP TS 24.616 [33] may be supported at the II-NNI.

If a network terminating the dialog supports MCID, the terminating network shall only deliver the MCID request in the "application/vnd.etsi.mcid+xml" MIME body, as specified in the 3GPP TS 24.616 [33], if an agreement to use the MCID supplementary service according to the 3GPP TS 24.616 [33] exists with the network originating the dialog and if the INVITE request received by the terminating network does not contain the information of the originating party.

NOTE: The IBCF and the AS in the terminating network interact to deliver the MCID request only if an agreement to use the MCID supplementary service exists, as specified in 3GPP TS 24.616 [33] and 3GPP TS 24.229 [5].

The originating network and the terminating network shall have a bilateral agreement to support transportation of the minimum information specified in clause 4.5.2.5.0 of the 3GPP TS 24.616 [33] between the networks.

12.3 Originating Identification Presentation (OIP) and Originating Identification Restriction (OIR)

Service specific requirements in accordance with 3GPP TS 24.607 [32] and 3GPP TS 24.229 [5] shall be supported over the II-NNI.

The P-Asserted-Identity header field and the Privacy header field with values "id", "user", "none", "header" and "critical" shall be supported at the II-NNI.

NOTE 1: P-Asserted-Identity header fields are intended for end-to-end operation. Removal of such header fields will impact the intended end-to-end operation between the end users. Where a trust relationship exists on the P-Asserted-Identity header field between the two IMS networks, this header field cannot be altered when passing through the II-NNI according to 3GPP TS 24.229 [5]. Where no trust relationship exists on the P-Asserted-Identity header field between the two IMS networks, the IBCF determines whether to remove the P-Asserted-Identity header field according to procedures described in 3GPP TS 24.229 [5] clause 4.4.2 referencing IETF RFC 3325 [44] and local policy rules for using additional screening capabilities as defined in 3GPP TS 24.229 [5] clause 5.10.6.

NOTE 2: Where a trust relationship exists with the remote domain the From header field will be passed transparently by the IBCF. If a SIP request is received by the terminating network and the application of the OIR service is required with the value "user" for the Privacy header field then the From header field will be anonymised in accordance with IETF RFC 3323 [34] by the terminating network. Where no trust relationship exists with the remote domain, the From header field can be, based on local policy rules, anonymised by the IBCF of the originating network prior passing through the II-NNI using screening capabilities defined in 3GPP TS 24.229 [5] clause 5.10.6 and clause 5.10.8.

NOTE 3: The privacy level "session" and "critical" are not used in the OIP/OIR service as described in 3GPP TS 24.607 [32].

SIP based user configuration as described in 3GPP TS 24.238 [100] shall be supported at the roaming II-NNI.

12.4 Terminating Identification Presentation (TIP) and Terminating Identification Restriction (TIR)

Service specific requirements in accordance with 3GPP TS 24.608 [113] shall be supported over the II-NNI.

The P-Asserted-Identity header field and the Privacy header field with values "id", "user", "none", "header" and "critical" shall be supported at the II-NNI.

NOTE: P-Asserted-Identity header fields are intended for end-to-end operation. Removal of such header fields will impact the intended end-to-end operation between the end users. Where a trust relationship exists on the P-Asserted-Identity header field between the two IMS networks, this header field will be passed transparently through the II-NNI according to 3GPP TS 24.229 [5]. Where no trust relationship exists on the P-Asserted-Identity header field between the two IMS networks, the IBCF determines whether to remove the P-Asserted-Identity header field according to procedures described in 3GPP TS 24.229 [5] clause 4.4.2, referencing IETF RFC 3325 [44] and local policy rules for using additional screening capabilities as defined in 3GPP TS 24.229 [5] clause 5.10.6.

The option tag "from-change" defined in IETF RFC 4916 [158], in the Supported header field should be supported at II-NNI.

12.5 Anonymous Communication Rejection (ACR)

Service specific requirements in accordance with 3GPP TS 24.611 [114] shall be supported over the II-NNI.

The P-Asserted-Identity header field and the Privacy header field shall be supported at the II-NNI.

Procedures as described in clause 12.21.4 are used to provide announcements.

The response code 433 (Anonymity Disallowed) shall be supported at the II-NNI.

SIP based user configuration as described in 3GPP TS 24.238 [100] shall be supported at the roaming II-NNI.

12.6 Communication DIVersion (CDIV)

Service specific requirements in accordance with 3GPP TS 24.604 [117] shall be supported over the II-NNI.

NOTE 1: The support of the Diversion header field not adopted in 3GPP TS 24.604 [117] requires bilateral agreement between the operators.

Procedures as described in clause 12.21.2 are used to provide announcements.

The Privacy header field with a priv-value set to "history" included in the hi-targeted-to-uri or as a standalone header field shall be supported at the II-NNI.

The History-Info header field as described by 3GPP TS 24.604 [117] containing an "mp" header field parameter as defined by IETF RFC 7044 [25] and a "cause" SIP URI parameter with cause values as defined by the IETF RFC 4458 [58] shall be supported over the II-NNI.

NOTE 2: The networks can have an internal limit in the number of allowed diversions, as described in 3GPP TS 24.604 [117], clause 4.5.2.6.1. To ensure efficiency of this control operators can indicate in their bilateral agreements their own number of allowed communication diversions, the parameter that is used for counting, and the network behavior when the internal limit is reached.

The response code 181 (Call Is Being Forwarded) shall be supported at the II-NNI.

The MESSAGE request procedure for indication of communication diversion to the diverting user as specified in 3GPP TS 24.604 [117] and 3GPP TS 24.229 [5] should be supported at the roaming II-NNI.

NOTE 3: The content of the MESSAGE request is operator specific.

SIP based user configuration as described in 3GPP TS 24.238 [100] shall be supported at the roaming II-NNI.

12.7 Communication Waiting (CW)

Service specific requirements in accordance with 3GPP TS 24.615 [37] shall be supported over the II-NNI.

The "application/vnd.3gpp.cw+xml" MIME body defined in 3GPP TS 24.615 [37] in the INVITE request shall be supported at the roaming II-NNI.

The Alert-Info header field set to "urn:alert:service:call-waiting" in a 180 (Ringing) response shall be supported at the II-NNI.

As a network option, in case of expiry of the CW timer, the response code 480 (Temporarily Unavailable) including a Reason header field containing the protocol value "Q.850" and the "cause" header field parameter set to "19" shall be supported at the non-roaming II-NNI and for the loopback traversal scenario.

Procedures as described in clause 12.21.2 are used to provide announcements.

12.8 Communication HOLD (HOLD)

Service specific requirements in accordance with 3GPP TS 24.610 [36] shall be supported over the II-NNI.

NOTE: The support of an alternative method not adopted in 3GPP TS 24.610 [36] requires bilateral agreement between the operators and is outside the scope of the present document.

Procedures as described in clause 12.21.3 are used to provide announcements.

12.9 Message Waiting Indication (MWI)

Service specific requirements in accordance with 3GPP TS 24.606 [112] shall be supported over the II-NNI.

The event package name "message-summary" in the Event header field according to IETF RFC 6665 [20] and 3GPP TS 24.229 [5] in the SUBSCRIBE request shall be supported at the roaming II-NNI.

The "application/simple-message-summary" MIME body described in 3GPP TS 24.606 [112] in the NOTIFY request shall be supported at the roaming II-NNI.

12.10 Communication Barring (CB)

12.10.1 Incoming Communication Barring (ICB)

Service specific requirements in accordance with 3GPP TS 24.611 [114] shall be supported over the II-NNI.

Procedures as described in clause 12.21.4 are used to provide announcements.

The response code 603 (Decline) including a Reason header field containing the protocol value set to "SIP" and the "cause" header field parameter set to value "603" as described in 3GPP TS 24.611 [114] shall be supported at the II-NNI.

A Reason header field containing the protocol value set to "SIP" and the "cause" header field parameter set to value "603" as described in 3GPP TS 24.611 [114] included in the BYE request shall be supported at the II-NNI.

SIP based user configuration as described in 3GPP TS 24.238 [100] shall be supported at the roaming II-NNI.

If the option IIFC (Inhibition of Incoming Forwarded Calls) is supported the transparency of information related to communication diversion (see clause 12.6) shall be supported at II-NNI.

12.10.2 Outgoing Communication Barring (OCB)

Service specific requirements in accordance with 3GPP TS 24.611 [114] shall be supported over the II-NNI.

Procedures as described in clause 12.21.4 are used to provide announcements.

The response code 603 (Decline) including a Reason header field containing the protocol value set to "SIP" and the "cause" header field parameter set to "603" as described in 3GPP TS 24.611 [114] shall be supported at the roaming II-NNI.

SIP based user configuration as described in 3GPP TS 24.238 [100] shall be supported at the roaming II-NNI.

12.11 Completion of Communications to Busy Subscriber (CCBS)

Service specific requirements in accordance with 3GPP TS 24.642 [109] shall be supported over the II-NNI.

The response code 486 (Busy Here) containing a Call-Info header field with a "purpose" header field parameter set to "call-completion" and the "m" parameter set to "BS" shall be supported at the non-roaming II-NNI and for the loopback traversal scenario.

For invoking and revoking of the CCBS supplementary service, announcement procedures shall be used to provide announcements and inband-interaction procedures as described in clause 12.21.3 and clause 12.21.4 shall be supported at the roaming II-NNI.

The response code 199 (Early Dialog Terminated) shall be supported at the roaming II-NNI.

Basic call procedures and in case of a call-completion recall initiated by a REFER request, normal REFER method handling procedures according to 3GPP TS 24.229 [5] shall be supported at the roaming II-NNI.

As a network option the special REFER request handling procedures according to 3GPP TS 24.628 [38] should be supported at the roaming II-NNI.

NOTE 1: 3rd party call control procedures can be used when the REFER request is not supported at the II-NNI.

NOTE 2: A REFER request can be rejected by IBCF based on operator policy as specified by 3GPP TS 24.229 [5].

The SUBSCRIBE and NOTIFY methods according to IETF RFC 6665 [20] and 3GPP TS 24.229 [5] containing the event package name "call-completion" in the Event header field and the Call-Info header field with a purpose parameter set to 'call-completion' and the m parameter set to "BS" shall be supported at the non-roaming II-NNI and for the loopback traversal scenario.

The NOTIFY request containing the "application/call-completion" MIME body as defined in IETF RFC 6910 [208] shall be supported at the non-roaming II-NNI.

The Request-URI with the "m" SIP URI parameter with a value set to "BS" and the Call-Info header field with a purpose parameter set to 'call-completion' and the "m" parameter set to "BS" in the INVITE method shall be supported at the non-roaming II-NNI and for the loopback traversal scenario.

The Date header field in the 486 (Busy Here) response to the INVITE request shall be supported at the roaming II-NNI.

SIP based user configuration as described in 3GPP TS 24.238 [100] shall be supported at the roaming II-NNI.

12.12 Completion of Communications by No Reply (CCNR)

Service specific requirements in accordance with 3GPP TS 24.642 [109] shall be supported over the II-NNI.

The response code 180 (Ringing) containing a Call-Info header field with a purpose parameter set to 'call-completion' and the "m" parameter set to "NR" shall be supported at the non-roaming II-NNI and for the loopback traversal scenario.

For invoking and revoking of the CCNR supplementary service, announcement procedures shall be used to provide announcements and inband-interaction procedures as described in clause 12.21.3 and clause 12.21.4 shall be supported at the roaming II-NNI.

The response code 199 (Early Dialog Terminated) shall be supported at the roaming II-NNI.

Basic call procedures and in case of a call-completion recall initiated by a REFER request, normal REFER method handling procedures according to 3GPP TS 24.229 [5] shall be supported at the roaming II-NNI.

As a network option the special REFER request handling procedures according to 3GPP TS 24.628 [38] should be supported at the roaming II-NNI.

NOTE 1: 3rd party call control procedures can be used when the REFER request is not supported at the II-NNI.

NOTE 2: A REFER request can be rejected by IBCF based on operator policy as specified by 3GPP TS 24.229 [5].

The SUBSCRIBE and NOTIFY methods according to IETF RFC 6665 [20] and 3GPP TS 24.229 [5] containing the event package name "call-completion" in the Event header field and the Call-Info header field with a purpose parameter set to 'call-completion' and the m parameter set to "NR" shall be supported at the non-roaming II-NNI and for the loopback traversal scenario.

The NOTIFY request containing the "application/call-completion" MIME body as defined in IETF RFC 6910 [208] shall be supported at the non-roaming II-NNI.

The Request-URI with the "m" SIP URI parameter with a value set to "NR" and the Call-Info header field with a purpose parameter set to 'call-completion' and the "m" parameter set to "NR" in the INVITE method shall be supported at the non-roaming II-NNI and for the loopback traversal scenario.

The Date header field in the 480 (Temporarily Unavailable) response to the INVITE request shall be supported at the roaming II-NNI.

SIP based user configuration as described in 3GPP TS 24.238 [100] shall be supported at the roaming II-NNI.

12.13 Explicit Communication Transfer (ECT)

12.13.1 Consultative and blind transfer

Service specific requirements in accordance with 3GPP TS 24.629 [116] shall be supported over the II-NNI.

The REFER method, the Referred-By header field and the Replaces header field as specified in 3GPP TS 24.629 [116] and the NOTIFY method containing an "application/sipfrag" MIME body shall be supported at the II-NNI for call transfer without third party call control.

The REFER method, the Referred-By header field and the Replaces header field as specified in 3GPP TS 24.629 [116] and the NOTIFY method containing an "application/sipfrag" MIME body shall be supported at the roaming II-NNI for call transfer with third party call control.

The Refer-To URI header parameter in the REFER request containing the Require header field set to "replaces" shall be supported at the roaming II-NNI.

The Replaces header field in the INVITE request shall be supported at the non-roaming II-NNI and for the loopback traversal scenario.

12.13.2 Assured transfer

The requirements for the assured transfer are the same as in clause 12.13.1 with the additional requirements in this subclause.

An Expires header field parameter in the Refer-To URI of the REFER Request shall be supported at the II-NNI for call transfer without third party call control.

An Expires header field parameter in the Refer-To URI of the REFER Request shall be supported at the roaming II-NNI for call transfer with third party call control.

The Refer-To header field in the REFER request containing the method parameter set to "CANCEL" shall be supported at the II-NNI for call transfer without third party call control.

The Refer-To header field in the REFER request containing the method parameter set to "CANCEL" shall be supported at the roaming II-NNI with third party call control.

12.14 Customized Alerting Tone (CAT)

Service specific requirements in accordance with 3GPP TS 24.182 [129] shall be supported over the II-NNI.

The P-Early-Media header field as described in 3GPP TS 24.182 [129] shall be supported at the II-NNI.

The response code 180 (Ringing) and the response code 183 (Session Progress) including a P-Early-Media header field shall be supported over the II-NNI.

The response code 199 (Early Dialog Terminated) shall be supported over the II-NNI.

The Supported header field and the Require header field with "early-session" option-tag shall be supported at the II-NNI, if the early session model is supported.

An "application/sdp" MIME body with the Content-Disposition header field set to "early-session" as specified in IETF RFC 3959 [96] shall be supported at II-NNI, if the early session model is supported.

A SDP "a=content" attribute with a "g.3gpp.cat" value in the 18x responses shall be supported at the II-NNI.

The SIP INFO mechanism for DTMF transport, as defined in 3GPP TS 24.229 [5] may be supported at the roaming II-NNI.

NOTE 1: For telephone-event based DTMF transport, the DTMF digits are sent as media and not visible in the control plane.

NOTE 2: Multiple methods for DTMF transport are defined in 3GPP TS 24.182 [129].

SIP based user configuration as described in 3GPP TS 24.238 [100] shall be supported at the roaming II-NNI.

12.15 Customized Ringing Signal (CRS)

Service specific requirements in accordance with 3GPP TS 24.183 [98] shall be supported over the II-NNI.

An Alert-Info header field in the initial INVITE request containing an URI followed by a URN "urn:alert:service:crs" shall be supported at the II-NNI.

An "application/vnd.3gpp.crs+xml" MIME body in the initial INVITE request shall be supported at the II-NNI.

A SDP "a=content" attribute with a "g.3gpp.crs" value in the PRACK request or the re-INVITE request may be supported at the II-NNI.

The Supported header field and the Require header field with "early-session" option-tag may be supported at the II-NNI.

An "application/sdp" MIME body with the Content-Disposition header field set to "early-session" as specified in IETF RFC 3959 [96] may be supported at II-NNI.

The SIP INFO mechanism for DTMF transport, as defined in 3GPP TS 24.229 [5] may be supported at the II-NNI.

NOTE: For telephone-event based DTMF transport, the DTMF digits are sent as media and not visible in the control plane.

SIP based user configuration as described in 3GPP TS 24.238 [100] shall be supported at the roaming II-NNI.

12.16 Closed User Group (CUG)

Service specific requirements in accordance with 3GPP TS 24.654 [103] shall be supported over the II-NNI.

The "application/vnd.etsi.cug+xml" MIME body as specified 3GPP TS 24.654 [103] shall be supported in INVITE requests at the II-NNI.

NOTE: If no agreement between the originating network and the terminating network exists to support the CUG supplementary service the INVITE request is rejected as described in IETF RFC 5621 [89] when the "handling" parameter in the Content-Disposition header field of the " application/vnd.etsi.cug+xml" MIME body is set to "required".

The 403 (Forbidden) response, the 603 (Decline) response and the 500 (Server Internal Error) response shall be supported at II-NNI.

SIP based user configuration as described in 3GPP TS 24.238 [100] shall be supported at the roaming II-NNI.

12.17 Personal Network Management (PNM)

Service specific requirements in accordance with 3GPP TS 24.259 [99] shall be supported over the II-NNI.

A "g.3gpp.iari_ref" feature tag with the value "urn:urn-7:3gpp-application.ims.iari.pnm-controller" in the Contact header field of the REGISTER request shall be supported at the roaming II-NNI.

A "g.3gpp.iari_ref" feature tag with the value "urn:urn-7:3gpp-application.ims.iari.pnm-controller" in the Accept-Contact header field shall be supported at the II-NNI.

The History-Info header field shall be supported at II-NNI.

A "histinfo" option tag as described by 3GPP TS 24.259 [99] in the Supported header field shall be supported at II-NNI.

12.18 Three-Party (3PTY)

Service specific requirements in accordance with 3GPP TS 24.605 [105] shall be supported over the II-NNI.

NOTE 1: The requirements below can be relaxed by bilateral agreements between operators.

The requirements for the 3PTY supplementary service are the same as for the CONF supplementary service specified in clause 12.19 with the following additional requirement:

- If a REFER request is supported at the II-NNI, a Replaces header field in the header portion of the SIP URI of the Refer-to header field of the REFER request shall also be supported at II-NNI.

NOTE 2: Clause 12.19 describes the conditions for the support of the REFER request.

12.19 Conference (CONF)

Service specific requirements in accordance with 3GPP TS 24.605 [105] and 3GPP TS 24.147 [106] shall be supported over the II-NNI.

NOTE 1: The requirements below can be relaxed by bilateral agreements between operators.

The REFER request shall be supported at the roaming II-NNI in the direction from visited to home network. Based on inter-operator agreement, the REFER request may be supported at the non-roaming II-NNI, for the loopback traversal scenario, and at the roaming II-NNI in the direction from home network to visited network.

NOTE 2: If the REFER request is not supported at the non-roaming II-NNI, for the loopback traversal scenario, or at the roaming II-NNI in the direction from home network to visited network, an attempt of an UE to send the REFER directly to peers to invite them to a conference without involvement of the conference focus can fail over such an II-NNI. However such failures can also occur if a peer is located in a circuit switched network, or if a peer does not support the REFER method. An operator can avoid such failures by configuring an AS to convert the REFER to an INVITE, as detailed in 3GPP TS 24.628 [38]. Information on security risks associated with the REFER request is provided within the "security consideration" of IETF RFC 3515 [22].

NOTE 3: A REFER request can be rejected by IBCF based on operator policy as specified by 3GPP TS 24.229 [5].

The "application/resource-lists+xml" MIME body in the INVITE request shall be supported at the roaming II-NNI.

The Referred-By header field in the INVITE request shall be supported at the II-NNI.

The "isfocus" feature parameter indicated in Contact header field of the INVITE request and in the 200 (OK) response shall be supported at the II-NNI.

The SUBSCRIBE request including the "conference" event package name in the Event header field and the Accept header field containing an "application/conference-info+xml" MIME type shall be supported at the II-NNI.

The NOTIFY request including an "application/conference-info+xml" MIME body shall be supported at the II-NNI.

NOTE 4: The subscription to "conference event" package does not apply at the roaming II-NNI between the MSC Server enhanced for ICS/MSC Server enhanced for SRVCC/MSC server enhanced for dual radio and the IMS network where the communication is anchored.

The Allow-Events header field in the INVITE request with the value "conference" shall be supported at the roaming II-NNI and may be supported at the non-roaming II-NNI and for the loopback traversal scenario.

12.20 Flexible Alerting (FA)

Service specific requirements in accordance with 3GPP TS 24.239 [101] shall be supported over the II-NNI.

The 486 (Busy Here) response code shall be supported at the II-NNI.

SIP based user configuration as described in 3GPP TS 24.238 [100] shall be supported at the roaming II-NNI.

12.21 Announcements

12.21.1 General

Announcements may be provided during the establishment of a communication session, during an established communication session or when a communication request is rejected. All of them shall be managed over the II-NNI.

12.21.2 Providing announcements during the establishment of a communication session

Procedures as described in 3GPP TS 24.628 [38] are used to provide announcements during the establishment of a communication session.

There are two methods defined in 3GPP TS 24.628 [38] to provide the announcement:

- 1) sending an announcement as an early media; and

NOTE 1: There are two methods to use early media for sending the announcement in-band. First method is the gateway model defined by IETF RFC 3960 [150] and 3GPP TS 24.628 [38] annex G, second method is described in 3GPP TS 24.628 [38] annex D.

- 2) sending an Alert-Info header field in 180 (Ringing) response to the INVITE request.

The P-Early-Media header field authorizing early media as defined in IETF RFC 5009 [74] during the establishment of a communication shall be supported at the II-NNI.

The Alert-Info header field in the 180 (Ringing) response to the INVITE request during the establishment of a communication, should be supported at the II-NNI.

NOTE 2: The IBCF can decide to remove the Alert-Info header field if required by local policy.

12.21.3 Providing announcements during an established communication session

Procedures as described in 3GPP TS 24.628 [38] are used to provide announcements during an established communication session.

In case of provision of an announcement to a user over the II-NNI during an established communication, the Call-Info header field in a re-INVITE request should be supported at the II-NNI.

NOTE 1: An alternative method to provide announcements is to use the existing media stream.

NOTE 2: The IBCF can decide to remove the Call-Info header field if required by local policy.

12.21.4 Providing announcements when communication request is rejected

Procedures as described in 3GPP TS 24.628 [38] are used to provide announcements when a communication request is rejected.

There are three methods defined in 3GPP TS 24.628 [38] to provide the announcement:

- 1) sending an announcement as an early media;

NOTE 1: There are two methods to use early media for sending the announcement in-band. First method is the gateway model defined by IETF RFC 3960 [150] and 3GPP TS 24.628 [38] annex G, second method is described in 3GPP TS 24.628 [38] annex D.

- 2) sending an Error-Info header field in the 3xx, 4xx, 5xx or 6xx response to the INVITE request; and
- 3) accept the communication request and then provide the announcement.

NOTE 2: The II-NNI requirements for accepting the communication request and then provide the announcement is not within the scope of this subclause.

The P-Early-Media header field authorizing early media as defined in IETF RFC 5009 [74] and the Reason header field with the proper cause value shall be supported at the II-NNI.

The Error-Info header field in the 3xx, 4xx, 5xx or 6xx response to the INVITE request when rejecting the communication request, should be supported at the II-NNI.

NOTE 3: The IBCF can decide to remove the Error-Info header field if required by local policy.

12.22 Advice Of Charge (AOC)

Service specific requirements in accordance with 3GPP TS 24.647 [122] shall be supported over the II-NNI.

The Accept header field with "application/vnd.etsi.aoc+xml" shall be supported at the roaming II-NNI.

The INVITE method containing an "application/vnd.etsi.aoc+xml" MIME body shall be supported at the roaming II-NNI.

Non-100 provisional responses and the 200 (OK) response to the initial INVITE request containing an "application/vnd.etsi.aoc+xml" MIME body shall be supported at the roaming II-NNI.

The INFO method containing an "application/vnd.etsi.aoc+xml" MIME body shall be supported at the roaming II-NNI.

The response code 504 (Server Time-out) shall be supported at the II-NNI.

A Reason header field containing the protocol value set to "SIP" and the "cause" header field parameter set to "504" or containing the protocol value set to "Q.850" and the "cause" header field parameter set to "31" in the BYE method shall be supported at the II-NNI.

An "application/vnd.etsi.aoc+xml" MIME body in the BYE request or the final response to the BYE request shall be supported over the roaming II-NNI.

12.23 Completion of Communications on Not Logged-in (CCNL)

Service specific requirements in accordance with 3GPP TS 24.642 [109] shall be supported over the II-NNI.

The response code 480 (Temporarily unavailable) containing a Call-Info header field with a purpose parameter set to 'call-completion' and the "m" parameter set to "NL" shall be supported at the non-roaming II-NNI and for the loopback traversal scenario.

For invoking and revoking of the CCNL supplementary service, announcement procedures shall be used to provide announcements and inband-interaction procedures as described in clause 12.21.3 and clause 12.21.4 shall be supported at the roaming II-NNI.

The response code 199 (Early Dialog Terminated) shall be supported at the roaming II-NNI.

Basic call procedures and in case of a call-completion recall initiated by a REFER request, normal REFER method handling procedures according to 3GPP TS 24.229 [5] shall be supported at the roaming II-NNI.

As a network option the special REFER request handling procedures according to 3GPP TS 24.628 [38] should be supported at the roaming II-NNI.

NOTE: 3rd party call control procedures can be used when the REFER request is not supported at the II-NNI.

The SUBSCRIBE and NOTIFY methods according to IETF RFC 6665 [20] and 3GPP TS 24.229 [5] containing the event package name "call-completion" in the Event header field and the Call-Info header field with a purpose parameter set to 'call-completion' and the "m" parameter set to "NL" shall be supported at the non-roaming II-NNI and for the loopback traversal scenario.

The NOTIFY request containing the "application/call-completion" MIME body as defined in IETF RFC 6910 [208] shall be supported at the non-roaming II-NNI.

The Request-URI with the "m" SIP URI parameter with a value set to "NL" and the Call-Info header field with a purpose parameter set to 'call-completion' and the "m" parameter set to "NL" in the INVITE method shall be supported at the non-roaming II-NNI and for the loopback traversal scenario.

The Date header field in the 480 (Temporarily Unavailable) response to the INVITE request shall be supported at the roaming II-NNI.

SIP based user configuration as described in 3GPP TS 24.238 [100] shall be supported at the roaming II-NNI.

12.24 Unstructured Supplementary Service Data (USSD)

Service specific requirements in accordance with 3GPP TS 24.390 [163] shall be supported over the II-NNI.

The Recv-Info header field containing the "g.3gpp.ussd" info package name and the "application/vnd.3gpp.ussd" MIME body as described in annex B of 3GPP TS 24.390 [163] in the INVITE request shall be supported at the roaming II-NNI.

The Recv-Info header field containing the "g.3gpp.ussd" info package name in the 200 (OK) response to the INVITE request shall be supported at the roaming II-NNI.

The INFO request containing "application/vnd.3gpp.ussd" MIME body and the Info-Package header field containing the "g.3gpp.ussd" info package name shall be supported at the roaming II-NNI.

The "application/vnd.3gpp.ussd" MIME body in the BYE request shall be supported at the roaming II-NNI.

13 Interoperability of IMS Centralized Services (ICS) over II-NNI

13.1 General

In order to assure the end-to-end service interoperability through the Inter-IMS Network to Network Interface (II-NNI), the associated service of the IMS Centralized Services (ICS) may be supported on the II-NNI between two IMS networks. The support of ICS is based on agreement between operators.

If ICS is supported, the related procedures from the 3GPP TS 24.292 [121] and 3GPP TS 29.292 [130] shall be applied with the requirements in the clause 13.2 due to the crossing of the II-NNI.

13.2 IMS Centralized Services (ICS)

Service specific requirements in accordance with 3GPP TS 24.292 [121] and 3GPP TS 29.292 [130] shall be supported over the II-NNI.

The "g.3gpp.ics" media feature tag in the Contact header field as specified in annex B of 3GPP TS 24.292 [121] shall be supported at the roaming II-NNI.

The "g.3gpp.accesstype" media feature tag in the Contact header field as specified in annex B of 3GPP TS 24.292 [121] shall be supported at the roaming II-NNI.

The "g.3gpp.icsi-ref" media feature tag as specified in 3GPP TS 24.229 [5] the value for the IMS Multimedia Telephony Communication Service as specified in 3GPP TS 24.173 [31] shall be supported at the roaming II-NNI.

An Accept-Contact header field and a Reject-Contact header field including the media feature tag "g.3gpp.accesstype" and the media feature tag "g.3gpp.ics" in any combination in the INVITE request shall be supported at the roaming II-NNI.

The Target-Dialog header field in the INVITE request shall be supported at the roaming II-NNI.

The P-Early-Media header field in the INVITE request and in non-100 provisional responses to the INVITE request shall be supported on the roaming II-NNI.

The Reason header field containing the protocol value "Q.850" and the header field parameter "cause" with a various set of values in the CANCEL request, the BYE request and in 4xx responses and 6xx responses to the INVITE request shall be supported at the roaming II-NNI.

The REFER request with the "method" SIP URI parameter set to the value "BYE" or "INVITE" or without the "method" SIP URI parameter in the Refer-To header field as specified in 3GPP TS 24.292 [121] shall be supported at the roaming II-NNI.

The Event header field containing the event package name "conference" and the Accept header field with "application/conference-info+xml" in a SUBSCRIBE request shall be supported at the roaming II-NNI.

The Allow-Event header field with "application/conference-info+xml" in an INVITE request shall be supported at the roaming II-NNI.

The "application/conference-info+xml" MIME body and the Event header field containing the event package name "conference" in a NOTIFY request shall be supported at the roaming II-NNI.

NOTE: Supplementary services as specified in clause 12 can be supported based on agreement between operators.

14 Interoperability of IMS Service Continuity over II-NNI

14.1 General

In order to assure the end-to-end service interoperability through the Inter-IMS Network to Network Interface (II-NNI), the associated services of the IMS Service Continuity may be supported on the II-NNI between two IMS networks. The support of each service is based on agreement between operators.

If a service is supported, the related procedures from the 3GPP TS 24.237 [131] shall be applied with the requirements in the relevant clause below due to the crossing of the II-NNI.

14.2 PS to CS Single Radio Voice Call Continuity (SRVCC) and Single Radio Video Call Continuity (vSRVCC)

14.2.1 Basic PS to CS SRVCC

Service specific requirements in accordance with 3GPP TS 24.237 [131] shall be supported over the roaming II-NNI.

Media type "video" in SDP m-lines may be supported at the roaming II-NNI. Related SDP can appear in SDP offer answer exchanges within INVITE dialogues at the roaming II-NNI, and in responses to OPTIONS requests at the roaming II-NNI. If media type "video" is supported within INVITE dialogues at the roaming II-NNI, it shall also be supported within responses to OPTIONS requests at the roaming II-NNI.

The "+g.3gpp.srvcc" header field parameter (specified in 3GPP TS 24.237 [131] annex C) in the Feature-Caps header field of the INVITE request and in non-100 provisional responses or the 2xx response should be supported at the roaming II-NNI.

The Reason header field containing the protocol value set to "SIP" and "cause" header field parameter set to "487" in the re-INVITE request shall be supported at the roaming II-NNI.

The Reason header field containing the protocol value set to "SIP" and "cause" header field parameter set to "503" in the BYE request shall be supported at the roaming II-NNI.

Procedures as described in clause 14.4 are used to provide MSC server assisted mid-call features.

14.2.2 PS to CS SRVCC for calls in alerting phase

The requirements for the PS to CS transfer for alerting calls are the same as in clause 14.2.1 with the following additional requirements:

The "g.3gpp.srvcc-alerting" media feature tag (described in 3GPP TS 24.237 [131] annex C) in a Contact header field of the INVITE request and in non-100 provisional responses and the 2xx response to the INVITE request shall be supported at the roaming II-NNI.

The "+g.3gpp.srvcc-alerting" header field parameter (described in 3GPP TS 24.237 [131] annex C) included in a Feature-Caps header field as described in IETF RFC 6809 [143] in an INVITE request and in non-100 provisional responses and the 2xx response to the INVITE request or in the UPDATE request and in the 2xx response to the UPDATE request shall be supported at the roaming II-NNI.

The Target-Dialog header field in the INVITE request shall be supported at the roaming II-NNI.

An INFO request containing the Info-Package header field as specified in IETF RFC 6086 [39] with "3gpp.state-and-event" info package name and an "application/vnd.3gpp.state-and-event-info+xml" XML body shall be supported at the roaming II-NNI.

14.2.3 Using the ATCF based architecture

The requirements for the ATCF based architecture is the same as in clause 14.2.1 with the following additional requirements:

The "+g.3gpp.atcf", the "+g.3gpp.atcf-mgmt-uri" and the "+g.3gpp.atcf-path" header field parameters (specified in 3GPP TS 24.237 [131] annex C) in the Feature-Caps header field of the REGISTER request as described in IETF RFC 6809 [143] shall be supported at the roaming II-NNI.

A MESSAGE request containing the "application/vnd.3gpp.srvcc-info+xml" MIME body as defined in annex D of 3GPP TS 24.237 [131] shall be supported at the roaming II-NNI.

The URIs of SCC ASs authorised to provide PS to CS SRVCC information in the MESSAGE request need to be specified in the roaming agreement.

The Target-Dialog header field in the INVITE request shall be supported at the roaming II-NNI.

14.2.4 PS to CS SRVCC for originating calls in pre-alerting phase

The requirements for the PS to CS transfer for originating calls in pre-alerting phase are the same as in clause 14.2.1 and in clause 14.2.2 with the additional requirements in this subclause.

NOTE: If PS to CS transfer for originating calls in pre-alerting phase is supported also PS to CS SRVCC for calls in alerting phase specified in clause 14.2.2 is supported.

The "g.3gpp.ps2cs-srvcc-orig-pre-alerting" media feature tag described in 3GPP TS 24.237 [131] annex C in a Contact header field of the REGISTER request and in the INVITE request shall be supported at the roaming II-NNI.

The "g.3gpp.ps2cs-srvcc-orig-pre-alerting" feature-capability indicator as described in 3GPP TS 24.237 [131] annex C in the Feature-Caps header field as described in IETF RFC 6809 [143] in non-100 provisional responses and the 2xx response to the INVITE request and in any target refresh request and in non-100 provisional responses or the 2xx response to target refresh request shall be supported at the roaming II-NNI.

14.2.5 PS to CS SRVCC with the MSC server assisted mid-call feature

The requirements for the PS to CS SRVCC with the assisted mid-call feature are the same as in clause 14.2.1 and in clause 14.4.

14.3 Inter UE Transfer (IUT)

IUT is described in clause 18.

14.4 MSC server assisted mid-call feature

Service specific requirements in accordance with 3GPP TS 24.237 [131] shall be supported over the roaming II-NNI.

The Contact header field of the REGISTER request and the 200 (OK) response containing "g.3gpp.mid-call" media feature tag as described in annex C of 3GPP TS 24.237 [131] shall be supported at the roaming II-NNI.

The Feature-Cap header field of the REGISTER request and the 200 (OK) response containing "+g.3gpp.mid-call" header field parameter specified in annex C of 3GPP TS 24.237 [131] shall be supported at the roaming II-NNI.

The media feature tag "g.3gpp.accesstype" in the Contact header field of the REGISTER request shall be supported at roaming II-NNI.

A Contact header field of the INVITE request and the 200 (OK) response containing the "g.3gpp.mid-call" media feature tag as described in annex C of 3GPP TS 24.237 [131] shall be supported at the roaming II-NNI.

The "g.3gpp.mid-call" feature-capability indicator according to 3GPP TS 24.237 [131] annex C included in the Feature-Caps header field of the INVITE request, in responses to the INVITE request and in any target refresh request and in non-100 provisional responses or the 2xx response to target refresh request shall be supported at the roaming II-NNI.

The Recv-Info header field containing the "g.3gpp.mid-call" package name in the INVITE request as specified in annex D of 3GPP TS 24.237 [131] shall be supported at the roaming II-NNI.

An Accept header field in the INVITE request containing the MIME type "application/vnd.3gpp.mid-call+xml" as specified in clause D.1 of 3GPP TS 24.237 [131] shall be supported at the roaming II-NNI.

The "application/vnd.3gpp.mid-call+xml" MIME body described in clause D.1.3 of 3GPP TS 24.237 [131] in the INVITE request shall be supported at the roaming II-NNI.

The SUBSCRIBE request containing a "g.3gpp.mid-call" media feature tag in the Contact header field shall be supported at the roaming II-NNI.

NOTE: The "g.3gpp.mid-call" media feature tag in the Contact header field of the SUBSCRIBE request may appear if the CONF supplementary service is supported at roaming II-NNI as described in clause 12.9.

An INFO request containing the Info-Package header field as specified in IETF RFC 6086 [39] with "3gpp.state-and-event" info package name and an "application/vnd.3gpp.state-and-event-info+xml" XML body shall be supported at the roaming II-NNI.

A REFER request sent inside an existing SIP dialog containing the "application/vnd.3gpp.mid-call+xml" MIME body specified in the clause D.1.3 of 3GPP TS 24.237 [131] shall be supported at the roaming II-NNI.

The Contact header field of the REFER request and the 2xx response to the request containing "g.3gpp.mid-call" media feature tag as described in annex C of 3GPP TS 24.237 [131] shall be supported at the roaming II-NNI.

The Target-Dialog header field in the INVITE request shall be supported at the roaming II-NNI.

The communication HOLD supplementary service as specified in clause 12.8 for the roaming II-NNI shall be supported.

The Allow-Event header field with "application/conference-info+xml" in an INVITE request shall be supported at the roaming II-NNI.

The Event header field containing the event package name "conference" and the Accept header field with "application/conference-info+xml" in a SUBSCRIBE request shall be supported at the roaming II-NNI.

The "application/conference-info+xml" MIME body and the Event header field containing the event package name "conference" in a NOTIFY request shall be supported at the roaming II-NNI.

The REFER request with the "method" header field parameter set to the value "BYE" sent in the Refer-To header field shall be supported at the roaming II-NNI.

14.5 CS to PS Single Radio Voice Call Continuity (SRVCC)

14.5.1 Basic CS to PS SRVCC

Service specific requirements in accordance with 3GPP TS 24.237 [131] shall be supported over the roaming II-NNI.

Requirements for the ATCF based architecture at II-NNI as described in clause 14.2.3 shall be supported at the roaming II-NNI.

Requirements for IMS Centralized Services (ICS) at II-NNI as described in clause 13 shall be supported at the roaming II-NNI.

The "g.3gpp.cs2ps-srvcc" and "g.3gpp.path" media feature tags in the Contact header field of the REGISTER request shall be supported at the roaming II-NNI.

The Feature-Caps header field with the "g.3gpp.cs2ps-srvcc" feature-capability indicator in the REGISTER request shall be supported at the roaming II-NNI.

The MESSAGE request containing the Accept-Contact header field with the "g.3gpp.path" media feature tag and the "application/vnd.3gpp.srvcc-ext+xml" MIME body shall be supported at the roaming II-NNI.

The URIs of SCC ASs authorised to provide CS to PS SRVCC information in the MESSAGE request need to be specified in the roaming agreement.

14.5.2 CS to PS SRVCC for calls in alerting phase

The requirements for the CS to PS SRVCC for calls in alerting phase are the same as in clause 14.5.1 with the following additional requirement:

The "g.3gpp.cs2ps-srvcc-alerting" media feature tag in the Contact header field of the REGISTER request shall be supported at the roaming II-NNI.

The REFER request sent inside an existing SIP dialog with the Refer-Sub header field and the "application/vnd.3gpp.state-and-event-info+xml" MIME body shall be supported at the roaming II-NNI.

The INFO request with the Info-Package header field containing the "g.3gpp.state-and-event" package name and the "application/vnd.3gpp.state-and-event-info+xml" MIME body shall be supported at the roaming II-NNI.

14.5.3 CS to PS SRVCC with the assisted mid-call feature

The requirements for the CS to PS SRVCC with the assisted mid-call feature are the same as in clause 14.5.1 with the following additional requirement:

The "application/vnd.3gpp.access-transfer-events+xml" MIME body in the REFER request shall be supported at the roaming II-NNI.

14.6 PS to CS dual radio voice call continuity (DRVCC)

14.6.1 Basic PS to CS DRVCC

Service specific requirements in accordance with 3GPP TS 24.237 [131] shall be supported over the roaming II-NNI.

The "g.3gpp.dynamic-stn" media feature tag according to 3GPP TS 24.237 [131] annex C included in the Contact header field of the INVITE request and in responses to the INVITE request shall be supported at the roaming II-NNI.

The "g.3gpp.dynamic-stn" feature-capability indicator according to 3GPP TS 24.237 [131] annex C included in the Feature-Caps header field of the INVITE request, in responses to the INVITE request and in any target refresh request and in non-100 provisional responses or the 2xx response to target refresh request shall be supported at the roaming II-NNI.

NOTE 1: The g.3gpp.dynamic-stn feature capability indicator from the home network contains an STN. The STN is a tel URI that the UE will use when establishing the call in CS. If the STN is known by the visited network the STN can also be used to identify that a call from a UE is a PS to CS dual radio access transfer allowing the visited network to suppress services and announcement that otherwise is executed during the CS call setup. The value of the tel URI STN needs to be communicated between operators when DRVCC is supported.

The requirements for providing IMS Centralized Services (ICS) as described in clause 13.2 should be supported at the roaming II-NNI.

NOTE 2: The support of IMS Centralized Services (ICS) as described in clause 13.2 is only needed if MSC servers in the visited network are enhanced for ICS.

14.6.2 PS to CS DRVCC with the assisted mid-call feature

The requirements for the PS to CS DRVCC with the assisted mid-call feature are the same as in clause 14.6.1 and in clause 14.4.

NOTE: Transfer of an additional call requires the use of IMS Centralized Services (ICS).

14.6.3 PS to CS DRVCC for calls in alerting phase

The requirements for the PS to CS DRVCC for calls in alerting phase are the same as in clause 14.6.1 with the additional requirements in this subclause.

The "g.3gpp.drvcc-alerting" media feature tag according to 3GPP TS 24.237 [131] annex C and IETF RFC 3840 [56] included in the Contact header field of the INVITE request and in responses to the INVITE request shall be supported at the roaming II-NNI.

The "g.3gpp.drvcc-alerting" feature-capability indicator according to 3GPP TS 24.237 [131] annex C included in the Feature-Caps header field of the INVITE request, in responses to the INVITE request and in any target refresh request and in non-100 provisional responses or the 2xx response to target refresh request shall be supported at the roaming II-NNI.

A 488 (Not Acceptable Here) response to the INVITE request without an SDP body shall be supported at the roaming II-NNI.

14.6.4 PS to CS DRVCC for originating calls in pre-alerting phase

The requirements for the PS to CS DRVCC for originating calls in pre-alerting phase are the same as in clause 14.6.1 and in clause 14.6.3 with the additional requirements in this subclause.

The "g.3gpp.ps2cs-drvcc-orig-pre-alerting" media feature tag according to 3GPP TS 24.237 [131] annex C and IETF RFC 3840 [56] in the Contact header field of the INVITE request shall be supported at the roaming II-NNI.

The "g.3gpp.ps2cs-drvcc-orig-pre-alerting" feature-capability indicator according to 3GPP TS 24.237 [131] annex C included in the Feature-Caps header field of the INVITE request, in responses to the INVITE request and in any target refresh request and in non-100 provisional responses or the 2xx response to target refresh request shall be supported at the roaming II-NNI.

14.7 CS to PS Dual Radio Voice Call Continuity (DRVCC)

14.7.1 Basic CS to PS DRVCC

Service specific requirements in accordance with 3GPP TS 24.237 [131] shall be supported over the roaming II-NNI.

The requirements for providing IMS Centralized Services (ICS) as described in clause 13.2 should be supported at the roaming II-NNI.

NOTE: The support of IMS Centralized Services (ICS) as described in clause 13.2 is only needed if MSC servers in the visited network are enhanced for ICS.

14.7.2 CS to PS DRVCC with the assisted mid-call feature

The requirements for the PS to CS DRVCC with the assisted mid-call feature are the same as in clause 14.7.1 and in clause 14.4.

14.7.3 CS to PS DRVCC for calls in alerting phase

The requirements for the CS to PS DRVCC for calls in alerting phase are the same as in clause 14.7.1 with the additional requirements in this subclause.

The "g.3gpp.cs2ps-drvcc-alerting" media feature tag as described included in the Contact header field of the INVITE request and in responses to the INVITE request shall be supported at the roaming II-NNI.

The "g.3gpp.cs2ps-drvcc-alerting" feature-capability indicator according to 3GPP TS 24.237 [131] annex C included in the Feature-Caps header field of the INVITE request, in responses to the INVITE request and in any target refresh request and in non-100 provisional responses or the 2xx response to target refresh request shall be supported at the roaming II-NNI.

A 488 (Not Acceptable Here) response to the INVITE request without an SDP body shall be supported at the roaming II-NNI.

14.7.4 CS to PS DRVCC for originating calls in pre-alerting phase

The requirements for the CS to PS DRVCC for originating calls in pre-alerting phase are the same as in clause 14.7.1 and in clause 14.7.3 with the following additional requirements:

The "g.3gpp.cs2ps-drvcc-orig-pre-alerting" media feature tag according to 3GPP TS 24.237 [131] annex C and IETF RFC 3840 [56] in the Contact header field of the INVITE request shall be supported at the roaming II-NNI.

The "g.3gpp.cs2ps-drvcc-orig-pre-alerting" feature-capability indicator according to 3GPP TS 24.237 [131] annex C included in the Feature-Caps header field of the INVITE request, in responses to the INVITE request and in any target refresh request and in non-100 provisional responses or the 2xx response to target refresh request shall be supported at the roaming II-NNI.

14.8 PS to PS access transfer

Service specific requirements in accordance with 3GPP TS 24.237 [131] clause 10 shall be supported over the roaming II-NNI.

The "g.3gpp.pstops-sti" media feature tag in the Contact header field of the REGISTER request shall be supported at the roaming II-NNI.

The INVITE request containing:

- a) the "g.3gpp.ics" media feature tag; and
- b) either:
 - the Replaces header field and the option tag value "replaces" in the Require header field; or
 - the Target-Dialog header field and the option tag value "tdialog" in the Require header field,

shall be supported at the roaming II-NNI.

A Recv-Info header field containing the "g.3gpp.state-and-event" info package name in the 183 (Session Progress) response shall be supported at the roaming II-NNI.

The INFO request containing the Info-Package header field as specified in IETF RFC 6086 [39] with the "g.3gpp.state-and-event" info package name and the "application/vnd.3gpp.state-and-event-info+xml" XML body shall be supported at the roaming II-NNI.

15 Presence service

15.0 General

In order to assure the end-to-end service interoperability through the Inter-IMS Network to Network Interface (II-NNI), the associated functions of the Presence service may be supported on the II-NNI between two IMS networks. The support of each function is based on agreement between operators.

If a function is supported, the related procedures from the 3GPP TS 24.141 [132] shall be applied with the requirements in the relevant clause below due to the crossing of the II-NNI.

15.1 Subscription of presence information

Service specific requirements in accordance with 3GPP TS 24.141 [132] shall be supported over the II-NNI.

A PUBLISH request identifying the presentity using a SIP URI, a tel URI or a PRES URI and the Event header field with the value "presence" and containing an "application/pidf+xml" MIME body shall be supported at the roaming II-NNI.

Additionally to the above and in any combination, a Content-Type header field with the value "multipart/related" and an "application/pidf-diff+xml" MIME body can be included in the PUBLISH request and shall be supported at the roaming II-NNI.

A SUBSCRIBE request with a Request-URI containing a SIP URI, a tel URI or a pres URI, the Event header field set to "presence" and Accept header fields with values "application/pidf+xml" and "multipart/related" shall be supported at the II-NNI.

Additionally to the above an "application/simple-filter+xml" MIME body can appear in the SUBSCRIBE request and shall be supported at the II-NNI.

Additionally to the above and in any combination a Content-Type header field with the value "multipart/mixed" and an "application/resource-lists" MIME body can appear in the SUBSCRIBE request and shall be supported at the roaming II-NNI.

A NOTIFY request including an Event header field with the value "presence" and an "application/pidf" MIME body shall be supported at the II-NNI.

NOTE: The NOTIFY request can contain substantial amount of data and TCP is expected to be used as the transport protocol.

The Allow-Events header field with the value "presence" shall be supported at the roaming II-NNI and may be supported at the non-roaming II-NNI.

15.2 Watcher subscribing to Presence List

Service specific requirements in accordance with 3GPP TS 24.141 [132] shall be supported over the II-NNI.

The requirements for the watcher subscribing to the Presence List are the same as subscribing to presence information as specified in clause 15.1 with the following additional requirement:

- The SUBSCRIBE request containing a Supported header field with the value "eventlist" shall also be supported at the roaming II-NNI;
- The SUBSCRIBE request containing a Accept header field with the value "application/rfmi+xml" shall be supported at the roaming II-NNI;
- A response code 200 (OK) to the SUBSCRIBE request containing the Require header field with the value "eventlist" shall be supported at the roaming II-NNI; and
- A NOTIFY message containing the "multipart/related" content type and an "application/rfmi+xml" MIME body shall be supported at the roaming II-NNI.

NOTE: The NOTIFY request can contain substantial amount of data and TCP is expected to be used as the transport protocol.

15.3 Subscription to Watcher Information

Service specific requirements in accordance with 3GPP TS 24.141 [132] shall be supported over the II-NNI.

A SUBSCRIBE request containing an Event header field with the value "presence.wininfo" and an Accept header field with value "application/watcherinfo+xml" shall be supported at the roaming II-NNI.

A NOTIFY request containing the Event header field with the value "presence.wininfo" and an "application/watcherinfo+xml" MIME body shall be supported at the roaming II-NNI.

NOTE: The NOTIFY request can contain substantial amount of data and TCP is expected to be used as the transport protocol.

The Allow-Events header field with the value "presence.wininfo" shall be supported at the roaming II-NNI and may be supported at the non-roaming II-NNI.

15.4 Subscription to state changes in XML documents

Service specific requirements in accordance with 3GPP TS 24.141 [132] shall be supported over the II-NNI.

A SUBSCRIBE request containing the Event header field with the value "xcap-diff" and parameters specified in IETF RFC 5875 [134], using the updated procedures from IETF RFC 6665 [20], shall be supported at the roaming II-NNI.

A NOTIFY request containing the Event header field with the value "xcap-diff", the Content-Type header field with the value "multipart/mixed" and any MIME body shall be supported at the roaming II-NNI.

NOTE: The NOTIFY request can contain substantial amount of data and TCP is expected to be the transport protocol.

The Allow-Events header field with the value "xcap-diff" shall be supported at the roaming II-NNI and may be supported at the non-roaming II-NNI.

For backward compatible reasons the Event header field with the value "ua-profile" should be supported at the roaming II-NNI.

15.5 Presence enhancements specified in Open Mobile Alliance (OMA) Release 1.1

15.5.1 General

In order to assure the end-to-end service interoperability through the Inter-IMS Network to Network Interface (II-NNI), the associated functions of the OMA Presence service may be supported on the II-NNI between two IMS networks. The support of each function is based on agreement between operators.

If a function of the OMA Presence Release 1.1 is supported, the related procedures from the OMA-TS-Presence_SIMPLE-V1_1_1 [142] shall be applied with the requirements in the relevant clause below due to the crossing of the II-NNI.

15.5.2 OMA subscription of presence information

The requirements for the OMA subscription of presence information are the same as clause 15.1.

15.5.3 OMA watcher subscribing to Presence List

The requirements for the OMA watcher subscribing to Presence List are the same as clause 15.2.

15.5.4 OMA subscription to Watcher Information

The requirements for the OMA subscription to Watcher Information are the same as clause 15.3.

15.6 Presence enhancements specified in Open Mobile Alliance (OMA) Release 2.0

15.6.1 General

In order to assure the end-to-end service interoperability through the Inter-IMS Network to Network Interface (II-NNI), the associated functions of the OMA Presence service may be supported on the II-NNI between two IMS networks. The support of each function is based on agreement between operators.

If a function of the OMA Presence Release 2.0 is supported, the related procedures from the OMA-TS-Presence_SIMPLE-V2_0 [138] shall be applied with the requirements in the relevant clause below due to the crossing of the II-NNI.

15.6.2 OMA subscription of presence information

The requirements for the OMA subscription of presence information are the same as clause 15.5.2 with the following additional requirement:

- An Allow header field containing the value "REFER" in a PUBLISH request shall be supported at the II-NNI.
- A Policy-Contact header field defined in IETF RFC 6794 [133] in a 488 (Not Acceptable Here) response to a PUBLISH request shall be supported at the II-NNI.

NOTE: Conveyance of this header field in a 488 response to a PUBLISH request is not supported by IETF RFC 6794 [133] but is required to support Presence services according to OMA specifications OMA-TS-Presence_SIMPLE-V2_0 [138].

- A Suppress-If- Match header field in a SUBSCRIBE request shall be supported at the II-NNI.
- An Accept-Encoding header field containing the value "gzip" in a SUBSCRIBE request shall be supported at the II-NNI.
- An "application/vnd.oma.suppnot+xml" MIME body in a SUBSCRIBE request shall be supported at the II-NNI.
- A Content-Encoding header field containing the value "gzip" in a NOTIFY request shall be supported at the II-NNI.

- A Content-Type header field with the value "multipart/mixed" in a SUBSCRIBE request shall be supported at the II-NNI.
- A Refer-To header field with the value "method=PUBLISH?event=presence", a Refer-Sub header field and a SIP-If-Match header field in a REFER request shall be supported at the II-NNI.

15.6.3 OMA watcher subscribing to Presence List

The requirements for the OMA watcher subscribing to Presence List are the same as clause 15.5.3 with the following additional requirements:

- A Suppress-If-Match header field in a SUBSCRIBE request shall be supported at the II-NNI.
- An Accept-Encoding header field containing the value "gzip" in a SUBSCRIBE request shall be supported at the II-NNI.
- An "application/vnd.oma.suppnot+xml" MIME body in a SUBSCRIBE request shall be supported at the II-NNI.
- An "application/resource-lists+xml" MIME body in a SUBSCRIBE request shall be supported at the II-NNI.
- A Content-Type header field with the value "multipart/mixed" in a SUBSCRIBE request shall be supported at the II-NNI.
- A NOTIFY request with a Content-Encoding header field containing the value "gzip" shall be supported at the II-NNI.

15.6.4 OMA subscription to Watcher Information

The requirements for the OMA subscription to Watcher Information are the same as clause 15.5.4 with the following additional requirements:

- Indicating support for "multipart/mixed" and "application/simple-filter+xml" in the Accept header field of the SUBSCRIBE request shall be supported at the II-NNI.
- Multiple "application/simple-filter+xml" MIME bodies in the NOTIFY request shall be supported at the II-NNI.
- A Suppress-If-Match header field in a SUBSCRIBE request shall be supported at the II-NNI.
- An Accept-Encoding header field containing the value "gzip" in the SUBSCRIBE request shall be supported at the II-NNI.
- A Content-Type header field with the value "multipart/mixed" in a NOTIFY request shall be supported at the II-NNI.
- A Content-Encoding header field with the value "gzip" in a NOTIFY request shall be supported at the II-NNI.
- A Refer-To header field with the value "method=SUBSCRIBE?Event=presence.winfo" and a Refer-Sub header field in a REFER request sent to a Watcher Information Subscriber shall be supported at the II-NNI.

15.6.5 Subscription to state changes in XML documents

The requirements for the OMA watcher subscribing to Presence List are the same as clause 15.4 with the following additional requirements:

- An Accept header field indicating the support for "application/xcap-diff+xml", "application/rfmi+xml" and "multipart/related" in a SUBSCRIBE request shall be supported at the II-NNI.
- An Accept-Encoding header field with the value "gzip" in a SUBSCRIBE request shall be supported at the II-NNI.
- A Content-Encoding header field containing the value "gzip" in a NOTIFY request shall be supported at the II-NNI.
- Multiple "multipart/related" MIME bodies in a NOTIFY request shall be supported at the II-NNI.
- An "application/rfmi+xml" MIME bodies in a NOTIFY request shall be supported at the II-NNI.

15.6.6 Void

15.6.7 Void

16 Messaging service

16.1 General

In order to assure the end-to-end service interoperability through the Inter-IMS Network to Network Interface (II-NNI), the associated function of the messaging service may be supported on the II-NNI between two IMS networks.

If a function is supported, the related procedures from the 3GPP TS 24.247 [139] shall be applied with the requirements in the relevant clause below due to the crossing of the II-NNI.

16.2 Page-mode messaging

Service specific requirements in accordance with clause 5 of 3GPP TS 24.247 [139] shall be supported over the II-NNI.

A MESSAGE request containing the "application/recipient-list" MIME body specified in IETF RFC 5365 [67], a Required header field with the 'recipient-list-message' option-tag; and a body carrying payload shall be supported at the roaming II-NNI.

A MESSAGE request containing:

- a body that carrying payload; or
- the "application/im-iscomposing+xml" MIME body,

shall be supported at the II-NNI.

The response code 415 (Unsupported Media Type) and the response code 202 (Accepted) shall be supported at the II-NNI.

16.4 Session-mode messaging

Service specific requirements in accordance with clause 6 of 3GPP TS 24.247 [139] shall be supported over the II-NNI.

No restrictions at the II-NNI identified.

16.5 Session-mode messaging conferences

Service specific requirements in accordance with clause 7 of 3GPP TS 24.247 [139] and 3GPP TS 24.147 [106] shall be supported over the II-NNI.

The "application/resource-lists+xml" MIME body included in the INVITE request shall be supported at the roaming II-NNI.

The media feature tag "isfocus" in the Contact header field of the INVITE request and responses to the INVITE request shall be supported at the II-NNI.

The SUBSCRIBE request including the "conference" event package name in the Event header field and the Accept header field containing an "application/conference-info+xml" MIME type shall be supported at the II-NNI.

The NOTIFY request including an "application/conference-info+xml" MIME body shall be supported at the II-NNI.

The REFER request containing a Referred-By header field and NOTIFY requests procedures shall be supported at the II-NNI.

The REFER request containing the BYE method URI parameter in the Refer-To header field shall be supported at the II-NNI.

The Referred-By header field in the INVITE request shall be supported at the II-NNI.

The Allow-Events header field in the INVITE request with the value "conference" shall be supported at the roaming II-NNI and may be supported at the non-roaming II-NNI.

17 Optimal Media Routeing

17.1 General

Based on inter-operator agreement, the Optimal Media Routeing (OMR) procedures may be supported over the II-NNI.

If OMR procedures are supported, the procedures in 3GPP TS 29.079 [148] shall be applied and the capabilities below shall be provided at the II-NNI.

17.2 OMR related SDP attributes

The "visited-realm", "secondary-realm", "omr-codecs", "omr-m-att", "omr-s-att", "omr-m-bw", "omr-s-bw", "omr-s-cksum", and "omr-m-cksum" SDP attributes defined in 3GPP TS 24.229 [5] shall be supported at the II-NNI.

17.3 IP realm names

Operators need to agree on unique names for IP realms (as defined in 3GPP TS 29.079 [148]) used in their own and interconnecting networks to avoid a collision of IP realm names. Operators may choose to share an IP realm, and shall then also assign a single unique name to that realm. As defined in 3GPP TS 24.229 [5], a public IPv4 or IPv6 address reachable from the open internet is associated with the special realm "IN".

18 Inter-UE transfer (IUT)

18.1 General

Inter-UE transfer may be supported over the II-NNI. The IUT consist of several functional blocks, as described in the clauses below. The support of each of these functional blocks is based on agreement between operators.

If a function is supported, the related procedures from the 3GPP TS 24.337 [149] shall be applied with the requirements in the relevant clause below.

18.2 IUT without establishment of a collaborative session

Service specific requirements in accordance with 3GPP TS 24.337 [149] shall be supported over the II-NNI.

The REFER request shall be supported at the roaming II-NNI.

The Refer-To header field containing a body parameter including a Replaces header field and the Require header field set to "replaces" shall be supported at the roaming II-NNI.

The Refer-To header field containing a body parameter including a Target-Dialog header field and the Require header field set to "tdialog" shall be supported at the roaming II-NNI.

The Refer-To header field containing a body parameter including an Accept-Contact header field with the "g.3gpp.icsi-ref" media feature tag and a P-Preferred-Service header field set to the IMS communication service identifier shall be supported at the roaming II-NNI.

The Contact header field of the REFER request containing a public GRUU or temporary GRUU as specified in 3GPP TS 24.229 [5] shall be supported at the roaming II-NNI.

The "g.3gpp.icsi-ref" media feature tag in the Accept-Contact header field of the REFER request shall be supported at the roaming II-NNI.

NOTIFY requests containing a "sipfrag" MIME body as specified in IETF RFC 3515 [22], using the updated procedures from IETF RFC 6665 [20], shall be supported at the roaming II-NNI.

18.3 IUT using a collaborative session

18.3.1 Collaborative session of participants of the same subscription

This clause describes the requirements at the II-NNI for an ongoing session. Service specific requirements in accordance with 3GPP TS 24.337 [149] shall be supported over the II-NNI.

The "g.3gpp.iut-controller" media feature tag in the Accept-Contact header field in the REGISTER request shall be supported.

A REFER request sent outside an existing dialog shall be supported at the roaming II-NNI with the following additional requirements:

- The Refer-To header field containing a body parameter including a MIME sdp body and no method parameter, the method parameter set to "INVITE" or "BYE" shall be supported at the roaming II-NNI.
- The Accept header field containing the MIME type "message/sipfrag" in the REFER request shall be supported at the roaming II-NNI.
- The Target-Dialog header field in the REFER request shall be supported at the roaming II-NNI.
- The Contact header field in the REFER request containing the "g.3gpp.iut-controller" media feature tag as described in annex B of 3GPP TS 24.337 [149] shall be supported at the roaming II-NNI.
- The Contact header field in the REFER request containing the "g.3gpp.current-iut-controller" media feature tag as described in annex B of 3GPP TS 24.337 [149] shall be supported at the roaming II-NNI.
- The "g.3gpp.iut-controller" media feature tag in the Accept-Contact header field shall be supported at the roaming II-NNI.
- The Referred-By header field shall be supported at the roaming II-NNI at the roaming II-NNI.

The NOTIFY request containing a "sipfrag" MIME body as specified in IETF RFC 3515 [22], using the updated procedures from IETF RFC 6665 [20], shall be supported at the roaming II-NNI.

Initial INVITE requests and re-INVITE requests as follows:

- The Referred-By header field included in initial INVITE requests and re-INVITE requests shall be supported at the roaming II-NNI;
- The "g.3gpp.iut-controller" media feature tag as described in annex B of 3GPP TS 24.337 [149] in the Contact header field shall be supported at the roaming II-NNI.

The "g.3gpp.iut-controller" media feature tag in responses to the INVITE request shall be supported at the roaming II-NNI.

The SUBSCRIBE request including the Event header field with the "dialog" event package; and including the Accept-Contact header field with the "g.3gpp.iut-focus" media feature shall be supported at the roaming II-NNI.

The "dialog-info+xml" MIME body in NOTIFY requests shall be supported at the roaming II-NNI.

18.3.2 Establishment of a collaborative session during session setup

Service specific requirements in accordance with 3GPP TS 24.337 [149] shall be supported over the II-NNI.

The Accept header field containing the MIME type "application/vnd.3gpp.iut+xml" in initial INVITE requests shall be supported at the roaming II-NNI.

A Content-Type header field containing the MIME type "application/vnd.3gpp.iut+xml" and an "application/vnd.3gpp.iut+xml" MIME body in the 300 (Multiple Choices) response shall be supported at the roaming II-NNI.

18.3.3 Assignment and transfer of control of a collaborative session

Service specific requirements in accordance with 3GPP TS 24.337 [149] shall be supported over the II-NNI.

The "g.3gpp.current-iut-controller" media feature tag in the Contact header field of the 200 (OK) response to INVITE request shall be supported at the roaming II-NNI.

A "multipart/mixed" MIME body containing the "application/vnd.3gpp.iut+xml" and the "application/sdp" MIME bodies in the INVITE request shall be supported at the roaming II-NNI.

18.3.4 Collaborative session of participants of different subscriptions

Service specific requirements in accordance with 3GPP TS 24.337 [149] shall be supported over the II-NNI.

In addition to the requirements in clause 18.3.1, 18.3.2 or 18.3.3 the following applies:

- The "g.3gpp.iut-focus" media feature tag (specified in 3GPP TS 24.337 [149] annex B) in the Contact header field shall be supported at the non-roaming II-NNI and for the loopback traversal scenario.
- The "+g.3gpp.iut-focus" header field parameter (specified in 3GPP TS 24.337 [149] annex B) in the Feature-Caps header field as described in IETF RFC 6809 [143] shall be supported at the non-roaming II-NNI and for the loopback traversal scenario.

18.4 Session replication / media replication

18.4.1 Pull mode

Service specific requirements in accordance with 3GPP TS 24.337 [149] shall be supported over the II-NNI.

The Target-Dialog header field and the Accept-Contact header field containing the "g.3gpp.iut-focus" media feature tag of the INVITE request shall be supported at the roaming II-NNI.

A REFER request including:

- the method parameter set to "MESSAGE" in the Refer-To header field;
- the In-Reply-To header field;
- the Target-Dialog header field;
- the Require header field populated with the option tag value "tdialog"; and
- the "application/vnd.3gpp.replication+xml" MIME body,

shall be supported at the roaming II-NNI.

A MESSAGE request including the In-Reply-To header field and the "application/vnd.3gpp.replication+xml" MIME body shall be supported at the roaming II-NNI.

18.4.2 Push mode

Service specific requirements in accordance with 3GPP TS 24.337 [149] shall be supported over the II-NNI.

A REFER request including:

- the Accept-Contact header field containing the "g.3gpp.iut-focus" media feature tag with explicit and require tags;
- the Target-Dialog header field; and
- the Refer-To header field containing the Accept-Contact header field, the P-Preferred-Service header field and the "application/sdp" MIME body,

shall be supported at the roaming II-NNI.

The "application/vnd.3gpp.replication+xml" MIME body of the REFER request shall be supported at the roaming II-NNI.

19 Roaming Architecture for Voice over IMS with Local Breakout

Based on inter-operator agreement, the roaming architecture for voice over IMS with local breakout procedure may be supported over the II-NNI.

If the roaming architecture for voice over IMS with local breakout procedure is supported, the procedures in 3GPP TS 24.229 [5] shall be applied and the capabilities below shall be provided at the II-NNI.

The "+g.3gpp.trf" header field parameter (defined in 3GPP TS 24.229 [5] clause 7.9A.3) with a TRF address included in a Feature-Caps header field as described in IETF RFC 6809 [143] in the INVITE request or in the UPDATE request and in the 2xx response to the UPDATE request shall be supported at the roaming II-NNI.

The "+g.3gpp.loopback" header field parameter (defined in 3GPP TS 24.229 [5] clause 7.9A.4) with the identity of the caller's home network included in the Feature-Caps header field as described in IETF RFC 6809 [143] in the INVITE request or in the UPDATE request and in the 2xx response to the UPDATE request shall be supported for the loopback traversal scenario.

The "loopback-indication" header field parameter (defined in 3GPP TS 24.229 [5] subclause 7.2A.5) included the P-Charging-Vector header field in 18x and 2xx responses to the INVITE request, in subsequent requests and in responses to subsequent requests shall be supported for the loopback traversal scenario and at the roaming II-NNI.

The procedures in clause 17 shall be supported at the II-NNI.

20 Delivery of Media Resource Broker address information

Based on inter-operator agreement, the procedure to deliver MRB address information may be supported over the roaming II-NNI.

NOTE: Subsequent interaction between home network MRB and visited network MRB is outside the scope of this document.

If the procedure to enable optimised allocation of media resources is supported, the procedures in 3GPP TS 24.229 [5] shall be applied and the capabilities below shall be provided at the roaming II-NNI.

The "g.3gpp.mrb" feature-capability indicator (defined in 3GPP TS 24.229 [5] clause 7.9A.6) with the MRB address included in the Feature-Caps header field as described in IETF RFC 6809 [143] in the INVITE request or in the UPDATE request and in the 2xx response to the UPDATE request shall be supported at the roaming II-NNI.

21 Overload control

21.1 General

Based on inter-operator agreement, overload control may be supported over the II-NNI.

The overload control defines two optional mechanisms:

- a feedback based mechanism;
- and a load filter mechanism.

The support of either one of the mechanism is based on operator agreements.

If a mechanism is supported, the related procedures from the 3GPP TS 24.229 [5] shall be applied with the requirements in the relevant clause below.

Based on regional/national requirements and inter-operator agreement, Multimedia Priority Service (MPS), as specified in 3GPP TS 22.153 [187], shall be exempted from SIP overload controls across II-NNI up to the point where further exemption would cause network instability.

21.2 Feedback based mechanism

The procedures in 3GPP TS 24.229 [5] shall be applied and the capabilities below shall be provided at the II-NNI.

The feedback based mechanism, defined in IETF RFC 7339 [165], requires no additional support at the II-NNI as it is supported using header field parameters within existing header fields supported at the II-NNI.

NOTE: An algorithm will need to be selected. The IETF RFC 7339 [165] also defines the default algorithm for usage of the feedback based mechanism in the IM CN subsystem. Additional algorithms are either already defined, e.g. the rate-based scheme defined in IETF RFC 7415 [166], or can also be defined in the future.

21.3 The load filter mechanism

The procedures in 3GPP TS 24.229 [5] shall be applied and the capabilities below shall be provided at the II-NNI.

A SUBSCRIBE request containing the Event header field "load-control" and, optionally, an Accept header field containing the "application/load-control+xml" MIME type as defined in IETF RFC 7200 [167] shall be supported on the II-NNI.

NOTE: The addresses to targets that can be supervised need to form part of the service level agreement.

A NOTIFY request containing the "application/load-control+xml" MIME body defined in IETF RFC 7200 [167] shall be supported on the II-NNI.

22 Delivery of original destination identity

Based on inter-operator agreement, the procedure to deliver original identity may be supported over the II-NNI.

NOTE: Service requirement related to the procedure is available in 3GPP TS 22.228 [9].

If the procedure to enable delivery of original destination identity is supported, the procedures in 3GPP TS 24.229 [5] shall be supported as further specified below.

The "mp" header field parameter in the History-Info header field of the initial INVITE request, as defined in IETF RFC 7044 [25], shall be supported over the II-NNI.

23 Telepresence using IMS

Based on inter-operator agreement, the procedure to support telepresence using IMS may be supported over the II-NNI.

NOTE: Service requirement related to the procedure is available in clause 7.10.2.2 of 3GPP TS 22.228 [9].

If the telepresence using IMS is supported, the procedures in 3GPP TS 24.103 [189] shall be applied and the capabilities below shall be provided at the II-NNI.

The "+sip.clue" header field parameter included in a Contact header field as described in 3GPP TS 24.103 [189] in the INVITE request or in the UPDATE request and in the 2xx response to the UPDATE request shall be supported at the II-NNI.

24 Barring of premium rate numbers

Based on inter-operator agreement, barring of premium rate numbers as described in 3GPP TS 24.315 [191] may be supported over the II-NNI.

If barring of premium rate numbers is supported, the "premium-rate" tel URI parameter defined in 3GPP TS 24.229 [5] clause 7.2A.17 shall be supported at the roaming II-NNI.

25 P-CSCF restoration

25.1 General

Based on inter-operator agreement, P-CSCF restoration may be supported over the II-NNI.

The P-CSCF restoration defines two optional mechanisms:

- a PCRF based mechanism; and
- an HSS based mechanism.

The support of either one of the mechanisms is based on operator agreements.

If a mechanism is supported, the related procedures from the 3GPP TS 24.229 [5] shall be applied with the requirements in the relevant clause below.

25.2 PCRF based P-CSCF restoration

The procedures in 3GPP TS 24.229 [5] shall be applied and the capabilities below shall be provided at the II-NNI.

The Restoration-Info header field containing IMSI information defined in 3GPP TS 24.229 [5] in the home-to-visited initial INVITE request shall be supported on the roaming II-NNI.

25.3 HSS based P-CSCF restoration

The procedures in 3GPP TS 24.229 [5] shall be applied and the capabilities below shall be provided at the II-NNI.

The Restoration-Info header field containing information about failed node defined in 3GPP TS 24.229 [5] in the 408 (Request Timeout) response to the home-to-visited initial INVITE request and in the 504 (Server Time-out) response to the MESSAGE request, NOTIFY request, OPTIONS request, PUBLISH request, REFER request and the SUBSCRIBE request shall be supported on the roaming II-NNI.

26 Resource sharing

Based on inter-operator agreement, resource sharing may be supported over the II-NNI.

If resource sharing is supported, the related procedures from the 3GPP TS 24.229 [5] shall be applied with the requirements in this clause.

The Resource-Share header field shall be supported on the roaming II-NNI in the following SIP requests and SIP responses:

- the ACK request, the INVITE request, the PRACK request, the REGISTER and UPDATE;
- 18x responses to the INVITE request; and
- 2xx responses to the PRACK request, INVITE request and the UPDATE request.

27 Service access number translation

Based on inter-operator agreement, service access number translation may be supported over the II-NNI.

If service access number translation is supported, the related procedures in 3GPP TS 24.229 [5] shall be applied with the requirements in this clause.

The Request-URI containing a "cause" SIP URI parameter, defined in IETF RFC 4458 [58], set to the value "380" defined in IETF RFC 8119 [193] shall be supported at the II-NNI.

The History-Info header field containing a "cause" SIP URI parameter, defined in IETF RFC 4458 [58], set to the value "380" defined in IETF RFC 8119 [193] shall be supported at the II-NNI.

28 Mission critical services

28.1 General

In order to assure the end-to-end service interoperability through the II-NNI, the associated services of the Mission Critical communication may be supported on the II-NNI. The support of mission critical services is based on the business relationships defined in 3GPP TS 23.280 [200] clause 6.

II-NNI requirements for SIP signalling related to mission critical services interface SIP-1 and SIP-3 (see figure 7.3.1-2 in 3GPP TS 23.280 [200]) are addressed in the present specification as follows:

- Apart from differences specified in the present clause 28, the SIP-1 interface is identical to the roaming II-NNI.
- Apart from differences specified in the present clause 28, the SIP-3 interface is identical to the non-roaming II-NNI.

SIP signalling traversing the NNI between an mission critical services server and a SIP core (interface SIP-2 in figure 7.3.1-2 in 3GPP TS 23.280 [200]) is not considered in the present release of this specification.

The mission critical services are identified by means of the following IMS Communication Service Identifiers:

- 1) for MCPTT, the "urn:urn-7:3gpp-service.ims.icsi.mcptt" URN (defined in annex E of 3GPP TS 24.379 [201]) ;
- 2) for mission critical video communications, the "urn:urn-7:3gpp-service.ims.icsi.mcvideo" URN (defined in annex E of 3GPP TS 24.281 [210]); and
- 3) for mission critical data communications, the "urn:urn-7:3gpp-service.ims.icsi.mcdata" URN (defined in annex C of 3GPP TS 24.282 [211]) and additionally:
 - for Short Data Service (SDS), the "urn:urn-7:3gpp-service.ims.icsi.mcdata.sds" URN (defined in annex C of 3GPP TS 24.282 [211]); and
 - for File Distribution (FD), the "urn:urn-7:3gpp-service.ims.icsi.mcdata.fd" URN (defined in annex C of 3GPP TS 24.282 [211]).

The IMS Communication Service Identifiers listed above can appear in:

- the media feature tag "g.3gpp.icsi-ref" (specified in 3GPP TS 24.229 [5] subclause 7.9.2) in the Contact header field and the Accept-Contact header field;
- the P-Asserted-Service header field; and
- the P-Preferred-Service header field.

If the mission critical services are supported, the related procedures from 3GPP TS 24.379 [201], 3GPP TS 24.380 [202], 3GPP TS 24.281 [210], 3GPP TS 24.581 [212], 3GPP TS 24.282 [211] and 3GPP TS 24.582 [213] shall be applied with the requirements in the clauses below due to the crossing of the II-NNI.

28.2 Interoperability of mission critical services for communication over II-NNI

28.2.1 Mission Critical services session establishment

Service specific requirements in accordance with 3GPP TS 22.179 [199], 3GPP TS 22.280 [209], 3GPP TS 24.379 [201], 3GPP TS 24.281 [210] and 3GPP TS 24.282 [211] shall be supported over the II-NNI.

The INVITE request including:

A) For MCPTT:

- 1) the "g.3gpp.mcptt" media feature tag (defined in annex C of 3GPP TS 24.379 [201]) in the Contact header field;

- 2) the media feature tag "isfocus" (defined in IETF RFC 3840 [56]) in the Contact header field;
 - 3) the Content-Type header field with the value "multipart/mixed"; and
 - 4) the "application/vnd.3gpp.mcptt-info+xml" MIME body;
- B) For MCVideo:
- 1) the "g.3gpp.mcvideo" media feature tag (defined in annex D of 3GPP TS 24.281 [210]) in the Contact header field;
 - 2) the media feature tag "isfocus" (defined in IETF RFC 3840 [56]) in the Contact header field;
 - 3) the Content-Type header field with the value "multipart/mixed"; and
 - 4) the "application/vnd.3gpp.mcvideo-info+xml" MIME body;
- C) For MCDATA:
- 1) the:
 - a) "g.3gpp.mcdata.sds" media feature tag; or
 - b) "g.3gpp.mcdata.fd" media feature tag,
(defined in annex B of 3GPP TS 24.282 [211]) in the Contact header field;
 - 2) the media feature tag "isfocus" (defined in IETF RFC 3840 [56]) in the Contact header field;
 - 3) the Content-Type header field with the value "multipart/mixed";
 - 4) the "application/vnd.3gpp.mcdata-info+xml" MIME body; and
 - 5) the "application/vnd.3gpp.mcdata-signalling" MIME body;

shall be supported at the II-NNI.

Responses to the INVITE request including:

- 1) the:
 - a) "g.3gpp.mcptt";
 - b) "g.3gpp.mcvideo";
 - c) "g.3gpp.mcdata.sds"; or
 - d) "g.3gpp.mcdata.fd"media feature tag in the Contact header field;
- 2) the media feature tag "isfocus" in the Contact header field;
- 3) the Content-Type header field with the value "multipart/mixed";
- 4) the "application/vnd.3gpp.mcptt-info+xml" for MCPTT or "application/vnd.3gpp.mcvideo-info+xml" for MCVideo or "application/vnd.3gpp.mcdata-info+xml" for MCDATA MIME body; and
- 5) the Warning header field with the warn-code set to "399" and with the warn-text set to a quoted-string as specified in 3GPP TS 24.379 [201] clause 4.4.2 and 3GPP TS 24.281 [210] clause 4.4.2 and 3GPP TS 24.282 [211] clause 4.9;

shall be supported at the II-NNI.

The initial INVITE request including the Priority-Share header field (defined in 3GPP TS 24.229 [5]), the Resource-Share header field (defined in 3GPP TS 24.229 [5]) and the "application/resource-lists+xml" MIME body shall be supported at the roaming II-NNI.

The Resource-Share header field and the Priority-Share header field in 18x and 2xx responses to the INVITE request shall be supported at the roaming II-NNI.

The Resource-Share header field and the Priority-Share header field in the PRACK requests, the UPDATE requests, the ACK requests and in 2xx responses to the PRACK requests and the UPDATE requests shall be supported at the roaming II-NNI.

The REFER request containing an "application/vnd.3gpp.mcptt-info+xml" MIME body in the headers portion in the Refer-To header field shall be supported at the roaming II-NNI.

NOTE: How the "application/vnd.3gpp.mcptt-info+xml" MIME body is included in the headers portion is described in IETF RFC 3261 [13] section 19.1.1.

The "m=" line set to "application <portnumber> UDP MCPTT" and associated parameters in the "a=fmpt:MCPTT" media line attribute shall be supported at the II-NNI.

An "i=" line set to "speech" in the audio media definition in the SDP offer and SDP answer shall be supported at the II-NNI.

28.2.2 MBMS transmission usage and location procedures

Service specific requirements in accordance with 3GPP TS 24.379 [201] clauses 13 and 14 shall be supported over the II-NNI.

The MESSAGE request containing the "application/vnd.3gpp.mcptt-info+xml" MIME body shall be supported over the roaming II-NNI.

The MESSAGE request containing the "application/vnd.3gpp.mcptt-location-info+xml" MIME body shall be supported over the roaming II-NNI.

The MESSAGE request containing the "application/vnd.3gpp.mcptt-mbms-usage-info+xml" MIME body shall be supported over the roaming II-NNI.

The P-Preferred-Service header field with the value "urn:urn-7:3gpp-service.ims.icsi.mcptt" of the MESSAGE request shall be supported at the roaming II-NNI.

The "g.3gpp.mcptt" media feature tag in the Accept-Contact header field of the MESSAGE request shall be supported from the home network to the visited network at the roaming II-NNI.

The "g.3gpp.icsi-ref" media feature tag with the value "urn:urn-7:3gpp-service.ims.icsi.mcptt" in the Accept-Contact header field of the MESSAGE request shall be supported at the roaming II-NNI.

28.2.3 Affiliation procedure

28.2.3.1 General

The affiliation consists of two procedures. One mandatory mode procedure and one negotiated mode procedure.

Both procedures shall be supported over the II-NNI.

28.2.3.2 Mandatory mode

Service specific requirements in accordance with 3GPP TS 24.379 [201] clause 9, 3GPP TS 24.281 [210] clause 8 and 3GPP TS 24.282 [211] clause 8 shall be supported over the II-NNI.

The SIP PUBLISH request including:

- 1) an Event header field set to the value "presence";
- 2) an "application/vnd.3gpp.mcptt-info+xml" for MCPTT, "application/vnd.3gpp.mcvideo-info+xml" for MCVideo or "application/vnd.3gpp.mcdata-info+xml" for MCDData MIME body; and
- 3) an "application/pdf+xml" MIME body;

shall be supported at the II-NNI.

A SUBSCRIBE request including:

- 1) an Event header field set to the value "presence";
- 2) an "application/vnd.3gpp.mcptt-info+xml" for MCPTT or "application/vnd.3gpp.mcvideo-info+xml" for MCVideo or "application/vnd.3gpp.mcdata-info+xml" for MCDData MIME body;
- 3) an Accept header field containing the "application/pdf+xml" MIME type; and
- 4) an "application/simple-filter+xml" MIME body according to IETF RFC 4661 [176];

shall be supported at the II-NNI.

An NOTIFY request including:

- 1) an Event header field set to the value "presence"; and
- 2) an "application/pdf+xml" MIME body

shall be supported at the II-NNI.

28.2.3.3 Negotiated mode

Service specific requirements in accordance with 3GPP TS 24.379 [201] clause 9, 3GPP TS 24.281 [210] clause 8 and 3GPP TS 24.282 [211] clause 8 shall be supported over the II-NNI.

A MESSAGE request including:

- 1) an "application/vnd.3gpp.mcptt-info+xml" for MCPTT, "application/vnd.3gpp.mcvideo-info+xml" for MCVideo or "application/vnd.3gpp.mcdata-info+xml" for MCDData MIME body; and
- 2) an "application/vnd.3gpp.mcptt-affiliation-command+xml" for MCPTT, "application/vnd.3gpp.mcvideo-affiliation-command+xml" for MCVideo or "application/vnd.3gpp.mcdata-affiliation-command+xml" for MCDData MIME body;

shall be supported at the II-NNI.

28.2.4 Conference event package subscription

Service specific requirements in accordance with 3GPP TS 24.379 [201] clause 10.1.3 shall be supported over the II-NNI.

The SUBSCRIBE request including:

- 1) a "conference" event package name in the Event header field;
- 2) an Accept header field containing the "application/conference-info+xml" MIME type; and
- 3) an "application/vnd.3gpp.mcptt-info+xml" for MCPTT or "application/vnd.3gpp.mcvideo-info+xml" for MCVideo MIME body;

shall be supported at the II-NNI.

The NOTIFY request including:

- 1) the "conference" event package name in the Event header field;
- 2) the Content-Type header field with the value "multipart/mixed";
- 3) an "application/vnd.3gpp.mcptt-info+xml" for MCPTT or "application/vnd.3gpp.mcvideo-info+xml" for MCVideo MIME body; and
- 4) an "application/conference-info+xml" MIME body;

shall be supported at the II-NNI.

28.2.5 Mission critical services settings

Service specific requirements in accordance with 3GPP TS 24.379 [201] clause 7, 3GPP TS 24.281 [210] clause 7 and 3GPP TS 24.282 [211] clause 7 shall be supported over the roaming II-NNI.

A PUBLISH request including:

- 1) an Event header field set to the "poc-settings" value;
- 2) one of the following sets of MIME bodies:
 - an "application/vnd.3gpp.mcptt-info+xml" for MCPTT;
 - an "application/vnd.3gpp.mcvideo-info+xml" MIME body and an "application/vnd.3gpp.mcptt-signed+xml" for MCVideo MIME body; or
 - an "application/vnd.3gpp.mcddata-info+xml" MIME body and an "application/vnd.3gpp.mcptt-signed+xml"; MIME body for MCDData and
- 3) an "application/poc-settings+xml" MIME body according to IETF RFC 4354 [205];

shall be supported at the roaming II-NNI.

28.2.6 Registration procedures

Service specific requirements in accordance with 3GPP TS 24.379 [201] clause 7 shall be supported over the roaming II-NNI.

The REGISTER request including:

- 1) the:
 - a) "g.3gpp.mcptt";
 - b) "g.3gpp.mcvideo";
 - c) "g.3gpp.mcddata.sds"; or
 - d) "g.3gpp.mcddata.fd"media feature tag in the Contact header field;
- 2) the Content-Type header field with the value "multipart/mixed";
- 3) the application/mikey MIME body;
- 4) one of the following sets of MIME bodies:
 - an "application/vnd.3gpp.mcptt-info+xml" for MCPTT;
 - an "application/vnd.3gpp.mcvideo-info+xml" MIME body and an "application/vnd.3gpp.mcptt-signed+xml" for MCVideo MIME body; or
 - an "application/vnd.3gpp.mcddata-info+xml" MIME body and an "application/vnd.3gpp.mcptt-signed+xml" MIME body for MCDData;
- 5) the Resource-Share header field (defined in 3GPP TS 24.229 [5]); and
- 6) the "g.3gpp.priority-share" feature-capability indicator (defined in 3GPP TS 24.229 [5] clause 7.9A.10) in the Feature-Caps header field;

shall be supported at the roaming II-NNI.

28.2.7 Group regrouping

Service specific requirements in accordance with 3GPP TS 24.379 [201] clause 10 shall be supported over the non-roaming II-NNI.

In addition to the requirements in subclause 28.2.1 the 403 (Forbidden) response to the INVITE request including a P-Refused-URI-List header field and an "application/resource-lists+xml" MIME body shall be supported at the non-roaming II-NNI.

The MESSAGE request including:

- 1) a Content-Type header field with the value "multipart/mixed";
- 2) an "application/vnd.3gpp.mcptt-info+xml" MIME body; and
- 3) an "application/vnd.3gpp.mcptt-floor-request+xml" MIME body;

shall be supported at the non-roaming II-NNI.

28.2.8 Signalling plane messages for mission critical data

Service specific requirements in accordance with 3GPP TS 24.282 [211] subclause 9.2.2 shall be supported over the II-NNI.

A MESSAGE request including:

- 1) an "application/vnd.3gpp.mcdata-info+xml" MIME body; and
- 2) an "application/vnd.3gpp.mcdata-signalling" MIME body or an "application/vnd.3gpp.mcdata-payload" MIME body or both;

shall be supported at the II-NNI.

29 Calling number verification

Based on inter-operator agreement, "Calling number verification" functionality, as described in IETF RFC 8224 [206], may be supported over the II-NNI.

If the calling number verification is supported, the related procedures in 3GPP TS 24.229 [5] shall be applied with the requirements in this clause.

A 200 (OK) response to a REGISTER request including a "g.3gpp.verstat" feature-capability indicator (defined in 3GPP TS 24.229 [5] clause 7.9A.11) and a "sip.607" feature-capability indicator (defined in IETF RFC 8197 [207]) in a Feature-Caps header field shall be supported at the roaming II-NNI.

An initial INVITE request and a MESSAGE request containing a P-Asserted-Identity header field and a From header field with a "verstat" tel URI parameter (defined in 3GPP TS 24.229 [5] clause 7.2A.20) in a tel URI or in a SIP URI with a "user=phone" parameter shall be supported at the roaming II-NNI.

An initial INVITE request and a MESSAGE request containing an Identity header field (defined in IETF RFC 8224 [206]) shall be supported at the non-roaming II-NNI.

A 607 (Unwanted) response (defined in IETF RFC 8197 [207]) to an initial INVITE request and a MESSAGE request shall be supported at the II-NNI.

A Reason header field with a protocol value set to "SIP" and a "cause" header field parameter set to "607" in a BYE request shall be supported at the II-NNI.

30 IMS emergency service

30.1 IMS emergency registration

See subclause 8.1 for the signalling requirements of IMS emergency registration regarding the "sos" URI parameter on the roaming II-NNI.

30.2 IMS emergency session

Based on inter-operator agreements or national requirements, IMS emergency session may be supported over the non-roaming II-NNI.

NOTE 1: The details of the SIP signalling requirements for IMS emergency session on the non-roaming II-NNI can be defined by inter-operator agreements or national requirements.

If the IMS emergency session is supported, the related procedures in 3GPP TS 24.229 [5] shall be applied with the requirements in this clause.

The Request-URI containing a uniform resource name (URN) for emergency services, defined in IETF RFC 5031 [61] and 3GPP TS 24.229 [5], shall be supported for the IMS emergency session traversal scenario on the non-roaming II-NNI.

NOTE 2: The emergency service URN(s) to use can be defined by inter-operator agreements or national requirements.

Annex A (informative): Summary of SIP header fields

A summary of the SIP header fields to be used in case of interconnection by using II-NNI is proposed in table A.1.

The starting point is the sending behaviour described for proxy and UA roles in annex A of 3GPP TS 24.229 [5]:

- In case of misalignment between table A.1 and the behaviour described in 3GPP TS 24.229 [5], the behaviour in 3GPP TS 24.229 [5] has the precedence.
- In case a header field is not described in table A.1 and it is described in 3GPP TS 24.229 [5], the description in 3GPP TS 24.229 [5] is applicable over II-NNI.
- If a header field is not described in 3GPP TS 24.229 [5], the description in table A.1 is applicable over II-NNI.

The definition of the notation codes used in table A.1 is provided in table A.2.

Table A.1: Supported header fields

Item	Header field	Ref.	II-NNI
1	Accept	[5]	m
2	Accept-Contact	[5]	m
3	Accept-Encoding	[5]	m
4	Accept-Language	[5]	m
4a	Accept-Resource-Priority	[5]	o
5	Alert-Info	[5]	o
6	Allow	[5]	m
7	Allow-Events	[5]	m on roaming II-NNI, else o
8	Authentication-Info	[5]	m on roaming II-NNI, else n/a
9	Authorization	[5]	m on roaming II-NNI, else n/a
9a	Answer-Mode	[5]	o
10	Call-ID	[5]	m
11	Call-Info	[5]	m
11a	Cellular-Network-Info	clause 6.1.1.3.1 (table 6.2, item 21)	o
12	Contact	[5]	m
13	Content-Disposition	[5]	m
14	Content-Encoding	[5]	m
15	Content-Language	[5]	m
16	Content-Length	[5]	m
17	Content-Type	[5]	m
18	CSeq	[5]	m
19	Date	[5]	m
20	Error-Info	[5]	o
21	Expires	[5]	m
21a	Flow-Timer	[5]	m on roaming II-NNI, else o
21b	Feature-Caps	clause 6.1.1.3.1 (table 6.2, item 13)	o
22	Event	[5]	m
23	From	[5]	m
24	Geolocation	[5]	m
24a	Geolocation-Error	[5]	m
24b	Geolocation-Routing	[5]	m
25	History-Info	clause 6.1.1.3.1 (table 6.2, item 4)	o
25b	Identity	[206] and clause 29	o on non-roaming II-NNI, else n/a
25a	Info-Package	[5]	o
26	In-Reply-To	[5]	o
27	Join	[5]	o
27a	Max-Breadth	[5]	m
28	Max-Forwards	[5]	m
29	Min-Expires	[5]	m
30	MIME-Version	[5]	m
31	Min-SE	[5]	m
32	Organization	[5]	m
33	P-Access-Network-Info	clause 6.1.1.3.1 (table 6.2, item 2)	m in case of a trust relationship between the interconnected networks, else n/a
33a	P-Answer-state	[5]	o
34	P-Asserted-Identity	clause 6.1.1.3.1 (table 6.2, item 1)	m in case of a trust relationship between the interconnected networks, else n/a
35	P-Asserted-Service	clause 6.1.1.3.1 (table 6.2, item 5)	o
35a	P-Associated-URI	[5]	m on roaming II-NNI, else n/a
36	P-Called-Party-ID	[5]	m on roaming II-NNI, else n/a
37	P-Charging-Function-Addresses	clause 6.1.1.3.1 (table 6.2, item 7)	n/a
38	P-Charging-Vector	clause 6.1.1.3.1 (table 6.2, item 6)	m on roaming II-NNI, else o
39	P-Early-Media	clause 6.1.1.3.1 (table 6.2, item 12)	m in case of a trust relationship between the interconnected networks, else n/a
40	P-Media-Authorization	[5]	n/a
41	P-Preferred-Identity	[5]	n/a
42	P-Preferred-Service	[5]	m on roaming II-NNI, else n/a

Item	Header field	Ref.	II-NNI
43	P-Private-Network-Indication	clause 6.1.1.3.1 (table 6.2, item 9)	m on roaming II-NNI, else o
44	P-Profile-Key	clause 6.1.1.3.1 (table 6.2, item 8)	o on roaming II-NNI, else n/a
44a	P-Refused-URI-List	[5]	o on non-roaming II-NNI, else n/a
45	P-Served-User	clause 6.1.1.3.1 (table 6.2, item 10)	m on roaming II-NNI, else n/a
46	P-User-Database	[5]	n/a
47	P-Visited-Network-ID	[5]	m on roaming II-NNI, else n/a
47a	Path	[5]	m on roaming II-NNI, else n/a
47b	Permission-Missing	[5]	o
47c	Policy-Contact	[133] and clause 15.6.2	o
48	Priority	clause 6.1.1.3.1 (table 6.2, item 14)	o
48b	Priority-Share	[5] clause 7.2.16	o on roaming II-NNI, else n/a
48a	Priv-Answer-Mode	[5]	o
49	Privacy	[5]	m
50	Proxy-Authenticate	[5]	m on roaming II-NNI, else n/a
51	Proxy-Authorization	[5]	m on roaming II-NNI, else n/a
52	Proxy-Require	[5]	m
52a	RAck	[5]	m
53	Reason	[5] and clause 6.1.1.3.1 (table 6.2, item 11)	o when in a request. When in a response, m in case of a trust relationship between the interconnected networks, else n/a
54	Record-Route	[5]	m
54a	Recv-Info	[5]	o
55	Referred-By	[5]	m
55a	Refer-Sub	[5]	m in the case the REFER request is supported, else n/a
55b	Refer-To	[5]	m in the case the REFER request is supported, else n/a
56	Reject-Contact	[5]	m
56a	Relayed-Charge	clause 6.1.1.3.1 (table 6.2, item 19)	n/a
57	Replaces	[5]	o
58	Reply-To	[5]	o
59	Request-Disposition	[5]	m
60	Require	[5]	m
61	Resource-Priority	clause 6.1.1.3.1 (table 6.2, item 3)	o
61c	Resource-Share	[5] clause 7.2.13	o on roaming II-NNI, else n/a
61d	Response-Source	[5]	o in case of a trust relationship between the interconnected networks, else n/a
61b	Restoration-Info	clause 6.1.1.3.1 (table 6.2, item 18)	o on roaming II-NNI, else n/a
61a	Retry-After	[5]	o
62	Route	[5]	m
62a	RSeq	[5]	m
63	Security-Client	[5]	n/a
63a	Security-Server	[5]	n/a
64	Security-Verify	[5]	n/a
65	Server	[5]	o
65c	Service-Interact-Info	clause 6.1.1.3.1 (table 6.2, item 20)	o
65a	Service-Route	[5]	m on roaming II-NNI, else n/a
65b	Session-ID	[5]	o
66	Session-Expires	[5]	m
66a	SIP-ETag	[5]	m in the case the PUBLISH request is supported, else n/a
66b	SIP-If-Match	[5]	m in the case the PUBLISH request is supported, else n/a
67	Subject	[5]	o

Item	Header field	Ref.	II-NNI
67a	Subscription-State	[5]	m in the case the NOTIFY request is supported, else n/a
67b	Suppress-If-Match	[144] and clause 15.6.4	o
68	Supported	[5]	m
68a	Target-Dialog	[5]	o
69	Timestamp	[5]	m
70	To	[5]	m
71	Trigger-Consent	[5]	m
71a	Unsupported	[5]	m
72	User-Agent	[5]	m
73	User-to-User	[5]	o
74	Via	[5]	m
75	Warning	[5]	o
76	WWW-Authenticate	[5]	m on roaming II-NNI, else n/a

Editor's note: The Service-Interact-Info header field impact on message tables in Annex B is for further study.

Table A.2: Key to notation codes for SIP header fields

Notation code	Meaning
m	The SIP header field is applicable at II-NNI. Supporting a SIP header field at the II-NNI means that this header field is passed through the IBCF. It does not imply that network elements inside the serving and served networks or user equipment connected to these networks shall support this header field, where 3GPP TS 24.229 [5] is applied. If specified in 3GPP TS 24.229 [5], the IBCF modifies the SIP header field.
o	The applicability of SIP header field at II-NNI depends on bilateral agreement between the operators.
n/a	It is impossible to use the SIP header field at the II-NNI. This header field could be discarded by the IBCF.

Annex B (informative): Dynamic view of SIP header fields within SIP messages

B.1 Scope

This annex provides the applicability of SIP header fields in SIP messages over II-NNI by using the methodology of a so-called "dynamic view", as used in IETF RFC 3261 [13] and other SIP related RFCs. This methodology documents the presence of SIP header fields in SIP messages over the II-NNI and also takes into account dynamic conditions, for instance the presence of a SIP header field in a SIP request message as condition for the SIP header field in the corresponding SIP response message.

Specific information about the applicability of SIP header fields in SIP messages in a dynamic view is also provided for cases where an MMTEL supplementary service is supported over the II-NNI between operators.

The applicability of SIP header fields described in this annex is based on the procedures described in 3GPP TS 24.229 [5] and the list of SIP header fields in annex A of 3GPP TS 24.229 [5].

B.2 Methodology

The meaning of the notation codes used in the tables in subsequent clauses is as follows:

In the "RFC status" column, the notation codes defined in IETF RFC 3261 [13] clause 20 are applied.

In the "II-NNI condition" column the notation codes defined in table B.2.1 are used. If a capability of a SIP header field is specified as either optional or conditional in table 6.1.3.1, then "II-NNI condition" of the SIP header field is described with conditional expression.

In each request-related table, the order of SIP header fields inherits that of clause A.2.2 of 3GPP TS 24.229 [5].

In each response-related table, the SIP status code for which the header field is applicable is described in the "SIP status code" column. The notation codes for the "where" column as defined in IETF RFC 3261 [13] clause 20 are applied. The notation code "r" in "SIP status code" column corresponds to any SIP status code which is described in annex A of 3GPP TS 24.229 [5] for the corresponding method. Any SIP header field not listed in a table is not applicable for the corresponding SIP message.

Table B.2.1: Key to notation codes for SIP header fields in dynamic view for II-NNI

Notation code (NOTE 1)	Meaning
dc	The SIP header field is required to be present in a SIP message over II-NNI according to the procedures specified in other specifications e.g. 3GPP TS 24.229 [5].
dm	The SIP header field shall be always present in a SIP message over II-NNI, and if received, it must be handled according to 3GPP TS 24.229 [5].
dm*	The SIP header field should be present in a SIP message over II-NNI, but the IMS network need to be prepared to receive a SIP message without that header field.
do	The SIP header field can be present in a SIP message over II-NNI, and if received, it must be handled according to 3GPP TS 24.229 [5]. (NOTE 2)
dt	The header field should be present in a SIP message over II-NNI, but the IMS network need to be prepared to receive a SIP message without that header field. If TCP is used as a transport, then the header field must be present in a SIP message.
d*	The SIP header field is required to be present in a SIP message if the message body is not empty.
dn/a	The SIP header field shall not be present in a SIP message over II-NNI. (NOTE 3)
dc<integer>	The condition for the presence of the SIP header field. <integer> is the identifier of the condition. This notation code is applied only in each request-related or response-related table.
NOTE 1: The meaning of the notation codes is same as in IETF RFC 3261 [13] clause 20 and "d" is used to emphasise the dynamic view.	
NOTE 2: If specified by local policy rules, the IBCF acting as entry point may omit or modify any received SIP header fields prior to forwarding SIP messages as specified in 3GPP TS 24.229 [5] clause 5.10.6.2.	
NOTE 3: The SIP header field can be removed at the IBCF acting as exit point by using screening functionality defined in 3GPP TS 24.229 [5] clause 5.10.6.2.	

B.3 ACK method

The table B.3.1 lists the supported header fields within the ACK request.

Table B.3.1: Supported header fields within the ACK request

Item	Header field	Ref.	RFC status	II-NNI condition
1	Accept-Contact	[51]	o	do
2	Allow-Events	[20]	o	IF table 6.1.3.1/23 THEN do (NOTE)
3	Authorization	[13]	o	IF table 6.1.3.1/7 THEN do (NOTE)
4	Call-ID	[13]	m	dm
5	Cellular-Network-Info	[5]	n/a	IF table 6.1.3.1/117 THEN do (NOTE)
6	Content-Disposition	[13]	o	do
7	Content-Encoding	[13]	o	do
8	Content-Language	[13]	o	do
9	Content-Length	[13]	t	dt
10	Content-Type	[13]	*	d*
11	CSeq	[13]	m	dm
12	Date	[13]	o	do
13	From	[13]	m	dm
14	Max-Breadth	[79]	o	do
15	Max-Forwards	[13]	m	dm
16	MIME-Version	[13]	o	do
17	P-Access-Network-Info	[24], [24A], [24B]	o	IF table 6.1.3.1/36 THEN do (NOTE)
18	Priority-Share	[5]	n/a	IF home-to-visited request on roaming II-NNI AND table 6.1.3.1/118 THEN do (NOTE)
19	Privacy	[34]	o	do
20	P-Charging-Vector	[24], [24A]	o	IF table 6.1.3.1/38 THEN do (NOTE)
21	Proxy-Authorization	[13]	o	IF table 6.1.3.1/7 THEN do (NOTE)
22	Proxy-Require	[13]	n/a	dn/a
23	Reason	[48]	o	IF table 6.1.3.1/40 THEN do (NOTE)
24	Record-Route	[13]	o	do
25	Recv-Info	[39]	n/a	dn/a
26	Reject-Contact	[51]	o	do
27	Relayed-Charge	[5]	n/a	dn/a
28	Request-Disposition	[51]	o	do
29	Require	[13]	n/a	dn/a
30	Resource-Priority	[78]	o	IF table 6.1.3.1/73 THEN do (NOTE)
31	Resource-Share	[5]	n/a	IF (home-to-visited request on roaming II-NNI OR visited-to-home request on roaming II-NNI) AND table 6.1.3.1/116 THEN do (NOTE)
32	Route	[13]	c	dc
33	Session-ID	[124]	m	IF table 6.1.3.1/94 THEN dm (NOTE)
34	Timestamp	[13]	o	do
35	To	[13]	m	dm
36	User-Agent	[13]	o	do
37	Via	[13]	m	dm
NOTE:	If the capability specified in table 6.1.3.1 is not supported over the II-NNI, the IBCF in the receiving network can omit or modify the SIP header fields in the received SIP message prior to forwarding the SIP message as specified in 3GPP TS 24.229 [5] clause 5.10.6.2.			

B.4 BYE method

The table B.4.1 lists the supported header fields within the BYE request.

Table B.4.1: Supported header fields within the BYE request

Item	Header field	Ref.	RFC status	II-NNI condition
1	Accept	[13]	o	IF dc1 (AOC: clause 12.22) THEN dm ELSE do
2	Accept-Contact	[51]	o	do
3	Accept-Encoding	[13]	o	do
4	Accept-Language	[13]	o	do
5	Allow	[13]	o	do
6	Allow-Events	[20]	o	IF table 6.1.3.1/23 THEN do (NOTE)
7	Authorization	[13]	o	IF table 6.1.3.1/7 THEN do (NOTE)
8	Call-ID	[13]	m	dm
9	Cellular-Network-Info	[5]	n/a	IF table 6.1.3.1/117 THEN do (NOTE)
10	Content-Disposition	[13]	o	IF dc2 (AOC: clause 12.22) THEN dm ELSE do
11	Content-Encoding	[13]	o	do
12	Content-Language	[13]	o	do
13	Content-Length	[13]	t	dt
14	Content-Type	[13]	*	d*
15	CSeq	[13]	m	dm
16	Date	[13]	o	do
17	From	[13]	m	dm
18	Geolocation	[68]	o	do
19	Geolocation-Routing	[68]	o	do
20	Max-Breadth	[79]	o	do
21	Max-Forwards	[13]	m	dm
22	MIME-Version	[13]	o	do
23	P-Access-Network-Info	[24], [24B]	o	IF table 6.1.3.1/36 THEN do (NOTE)
24	P-Asserted-Identity	[44]	o	IF table 6.1.3.1/27 THEN do (NOTE)
25	P-Charging-Function-Addresses	[24]	o	dn/a
26	P-Charging-Vector	[24]	o	dn/a
27	P-Preferred-Identity	[44]	o	dn/a
28	Privacy	[34]	o	do
29	Proxy-Authorization	[13]	o	IF table 6.1.3.1/7 THEN do (NOTE)
30	Proxy-Require	[13]	o	do
31	Reason	[48]	o	IF dc3 (ICB: clause 12.10.1) THEN dm ELSE IF table 6.1.3.1/40 THEN do (NOTE)
32	Record-Route	[13]	o	do
33	Referred-By	[53]	o	do
34	Reject-Contact	[51]	o	do
35	Relayed-Charge	[5]	n/a	dn/a
36	Request-Disposition	[51]	o	do
37	Require	[13]	c	dc
38	Resource-Priority	[78]	o	IF table 6.1.3.1/73 THEN do (NOTE)
39	Route	[13]	c	dc
40	Security-Client	[47]	o	dn/a
41	Security-Verify	[47]	o	dn/a
42	Session-ID	[124]	m	IF table 6.1.3.1/94 THEN dm (NOTE)
43	Supported	[13]	o	do
44	Timestamp	[13]	o	do
45	To	[13]	m	dm
46	User-Agent	[13]	o	do
47	User-to-User	[83]	o	IF table 6.1.3.1/79 THEN do (NOTE)
48	Via	[13]	m	dm
dc1:	request invoked due to AOC AND visited-to-home request on roaming II-NNI			
dc2:	request invoked due to AOC AND home-to-visited request on roaming II-NNI			
dc3:	request invoked due to "dynamic ICB" on a confirmed status			
NOTE:	If the capability specified in table 6.1.3.1 is not supported over the II-NNI, the IBCF in the receiving network can omit or modify the SIP header fields in the received SIP message prior to forwarding the SIP message as specified in 3GPP TS 24.229 [5] clause 5.10.6.2.			

The table B.4.2 lists the supported header fields within the BYE response.

Table B.4.2: Supported header fields within the BYE response

Item	Header field	SIP status code	Ref.	RFC status	II-NNI condition
1	Accept	415	[13]	c	dc
2	Accept-Encoding	415	[13]	c	dc
3	Accept-Language	415	[13]	c	dc
4	Accept-Resource-Priority	2xx 417	[78]	o	IF table 6.1.3.1/73 THEN do (NOTE 2)
5	Allow	405	[13]	m	dm
		others		o	do
6	Allow-Events	2xx	[20]	o	IF table 6.1.3.1/23 THEN do (NOTE 2)
7	Authentication-Info	2xx	[13]	o	IF table 6.1.3.1/7 THEN do (NOTE 2)
8	Call-ID	100	[13]	m	dm
		others			
9	Cellular-Network-Info	r	[5]	n/a	IF table 6.1.3.1/117 THEN do (NOTE 2)
10	Contact	3xx 485	[13]	o	do
11	Content-Disposition	r	[13]	o	IF dc1 (AOC: clause 12.22) THEN dm ELSE do
12	Content-Encoding	r	[13]	o	do
13	Content-Language	r	[13]	o	do
14	Content-Length	100	[13]	t	dt
		others			
15	Content-Type	r	[13]	*	d*
16	CSeq	100	[13]	m	dm
		others			
17	Date	100 others	[13]	o	do
18	Error-Info	3xx-6xx	[13]	o	IF table 6.1.3.1/13 THEN do (NOTE 2)
19	From	100 others	[13]	m	dm
20	Geolocation-Error	424	[68]	m	dm
		others		o	do
21	MIME-version	r	[13]	o	do
22	P-Access-Network-Info	r	[24], [24A], [24B]	o	IF table 6.1.3.1/36 THEN do (NOTE 2)
23	P-Asserted-Identity	r	[44]	o	IF table 6.1.3.1/27 THEN do (NOTE 2)
24	P-Charging-Function-Addresses	r	[24], [24A]	o	dn/a
25	P-Charging-Vector	r	[24], [24A]	o	dn/a
26	P-Preferred-Identity	r	[44]	o	dn/a
27	Privacy	r	[34]	o	do
28	Proxy-Authenticate	401 (NOTE 1)	[13]	o	do
		407 (NOTE 1)		m	dm
29	Record-Route	2xx	[13]	o	do
30	Relayed-Charge	r	[5]	n/a	dn/a
31	Require	r	[13]	c	dc
32	Response-Source	3xx-6xx	[5]	n/a	IF table 6.1.3.1/121 THEN do (NOTE 2)
33	Retry-After	404	[13]	o	do
		413			
		480			
		486			
		500			
		503			
		600			
603					

Item	Header field	SIP status code	Ref.	RFC status	II-NNI condition
34	Security-Server	421 494	[47]	o	dn/a
35	Server	r	[13]	o	do
36	Session-ID	r	[124]	m	IF table 6.1.3.1/94 THEN dm (NOTE 2)
37	Supported	2xx	[13]	o	do
38	Timestamp	r	[13]	o	do
39	To	100 others	[13]	m	dm
40	Unsupported	420	[13]	m	dm
41	User-Agent	r	[13]	o	do
42	User-to-User	r	[83]	o	IF table 6.1.3.1/79 THEN do (NOTE 2)
43	Via	100 others	[13]	m	dm
44	Warning	r	[13]	o	do
45	WWW-Authenticate	401 (NOTE 1)	[13]	m	dm
		407 (NOTE 1)		o	do
dc1:	200 (OK) response invoked due to AOC AND home-to-visited response on roaming II-NNI				
NOTE 1: The SIP status code is only applicable over the roaming II-NNI.					
NOTE 2: If the capability specified in table 6.1.3.1 is not supported over the II-NNI, the IBCF in the receiving network can omit or modify the SIP header fields in the received SIP message prior to forwarding the SIP message as specified in 3GPP TS 24.229 [5] clause 5.10.6.2.					

B.5 CANCEL method

The table B.5.1 lists the supported header fields within the CANCEL request.

Table B.5.1: Supported header fields within the CANCEL request

Item	Header field	Ref.	RFC status	II-NNI condition
1	Accept-Contact	[51]	o	do
2	Authorization	[13]	o	IF table 6.1.3.1/7 THEN do (NOTE)
3	Call-ID	[13]	m	dm
4	Content-Length	[13]	t	dt
5	Content-Type	[13]	*	IF table 6.1.3.1/20 THEN do (NOTE)
6	CSeq	[13]	m	dm
7	Date	[13]	o	do
8	From	[13]	m	dm
9	Max-Breadth	[79]	o	do
10	Max-Forwards	[13]	m	dm
11	Privacy	[34]	o	do
12	Reason	[48]	o	IF dc1 (CW: clause 12.7) THEN dm ELSE IF table 6.1.3.1/40 THEN do (NOTE)
13	Record-Route	[13]	o	do
14	Reject-Contact	[51]	o	do
15	Request-Disposition	[51]	o	do
16	Resource-Priority	[78]	o	IF table 6.1.3.1/73 THEN do (NOTE)
17	Route	[13]	c	dc
18	Session-ID	[124]	m	IF table 6.1.3.1/94 THEN dm (NOTE)
19	Supported	[13]	o	do
20	Timestamp	[13]	o	do
21	To	[13]	m	dm
22	User-Agent	[13]	o	do
23	Via	[13]	m	dm
dc1:	request invoked due to CW at the expiry of the "CW timer"			
NOTE:	If the capability specified in table 6.1.3.1 is not supported over the II-NNI, the IBCF in the receiving network can omit or modify the SIP header fields in the received SIP message prior to forwarding the SIP message as specified in 3GPP TS 24.229 [5] clause 5.10.6.2.			

The table B.5.2 lists the supported header fields within the CANCEL response.

Table B.5.2: Supported header fields within the CANCEL response

Item	Header field	SIP status code	Ref.	RFC status	II-NNI condition
1	Accept-Resource-Priority	2xx 417	[78]	o	IF table 6.1.3.1/73 THEN do (NOTE)
2	Call-ID	r	[13]	m	dm
3	Content-Length	r	[13]	t	dt
4	CSeq	r	[13]	m	dm
5	Date	r	[13]	o	do
6	Error-Info	3xx-6xx	[13]	o	IF table 6.1.3.1/13 THEN do (NOTE)
7	From	r	[13]	m	dm
8	Privacy	r	[34]	o	do
9	Record-Route	2xx	[13]	o	do
10	Response-Source	3xx-6xx	[5]	n/a	IF table 6.1.3.1/121 THEN do (NOTE)
11	Retry-After	404 413 480 486 500 503 600 603	[13]	o	do
12	Session-ID	r	[124]	m	IF table 6.1.3.1/94 THEN dm (NOTE)
13	Supported	2xx	[13]	o	do
14	Timestamp	r	[13]	o	do
15	To	r	[13]	m	dm
16	User-Agent	r	[13]	o	do
17	Via	r	[13]	m	dm
18	Warning	r	[13]	o	do
NOTE: If the capability specified in table 6.1.3.1 is not supported over the II-NNI, the IBCF in the receiving network can omit or modify the SIP header fields in the received SIP message prior to forwarding the SIP message as specified in 3GPP TS 24.229 [5] clause 5.10.6.2.					

B.6 INFO method

As described in table 6.1, the support of INFO method over the II-NNI is based on bilateral agreement between the operators.

The table B.6.1 lists the supported header fields within the INFO request.

Table B.6.1: Supported header fields within the INFO request

Item	Header field	Ref.	RFC status	II-NNI condition
1	Accept	[13], [39]	o	do
2	Accept-Encoding	[13], [39]	o	do
3	Accept-Language	[13], [39]	o	do
4	Allow	[13], [39]	o	do
5	Allow-Events	[20]	o	IF table 6.1.3.1/23 THEN do (NOTE)
6	Authorization	[13], [39]	o	IF table 6.1.3.1/7 THEN do (NOTE)
7	Call-ID	[13], [39]	m	dm
8	Call-Info	[13], [39]	o	do
9	Cellular-Network-Info	[5]	n/a	IF table 6.1.3.1/117 THEN do (NOTE)
10	Content-Disposition	[13], [39]	o	IF dc1 (AOC: clause 12.22) THEN dm ELSE do
11	Content-Encoding	[13], [39]	o	do
12	Content-Language	[13], [39]	o	do
13	Content-Length	[13], [39]	o	do
14	Content-Type	[13], [39]	*	d*
15	CSeq	[13], [39]	m	dm
16	Date	[13], [39]	o	do
17	From	[13], [39]	m	dm
18	Geolocation	[68]	o	do
19	Geolocation-Routing	[68]	o	do
20	Info-Package	[39]	m*	IF table 6.1.3.1/17 THEN do (NOTE)
21	Max-Breadth	[79], [39]	n/a	dn/a
22	Max-Forwards	[13], [39]	o	do
23	MIME-Version	[13], [39]	o	do
24	P-Access-Network-Info	[24], [24B]	o	IF table 6.1.3.1/36 THEN do (NOTE)
25	P-Charging-Function-Addresses	[24]	o	dn/a
26	P-Charging-Vector	[24]	o	IF table 6.1.3.1/38 THEN do (NOTE)
27	Privacy	[34], [39]	o	do
28	Proxy-Authorization	[13], [39]	o	IF table 6.1.3.1/7 THEN do (NOTE)
29	Proxy-Require	[13], [39]	o	do
30	Reason	[48], [39]	o	IF table 6.1.3.1/40 THEN do (NOTE)
31	Record-Route	[13], [39]	o	do
32	Referred-By	[53], [39]	o	do
33	Relayed-Charge	[5]	n/a	dn/a
34	Request-Disposition	[51], [39]	o	do
35	Require	[13], [39]	o	do
36	Resource-Priority	[78], [39]	o	IF table 6.1.3.1/73 THEN do (NOTE)
37	Route	[13], [39]	o	do
38	Security-Client	[47], [39]	o	dn/a
39	Security-Verify	[47], [39]	o	dn/a
40	Session-ID	[124]	m	IF table 6.1.3.1/94 THEN dm (NOTE)
41	Subject	[13], [39]	o	do
42	Supported	[13], [39]	o	do
43	Timestamp	[13], [39]	o	do
44	To	[13], [39]	m	dm
45	User-Agent	[13], [39]	o	do
46	Via	[13], [39]	m	dm
dc1:	request invoked due to AOC AND home-to-visited request on roaming II-NNI			
NOTE:	If the capability specified in table 6.1.3.1 is not supported over the II-NNI, the IBCF in the receiving network can omit or modify the SIP header fields in the received SIP message prior to forwarding the SIP message as specified in 3GPP TS 24.229 [5] clause 5.10.6.2.			

The table B.6.2 lists the supported header fields within the INFO response.

Table B.6.2: Supported header fields within the INFO response

Item	Header field	SIP status code	Ref.	RFC status	II-NNI condition
1	Accept	2xx 415	[13], [39]	o	do
2	Accept-Encoding	2xx 415	[13], [39]	o c	do dc
3	Accept-Language	2xx 415	[13], [39]	o	do
4	Accept-Resource-Priority	2xx 417	[78], [39]	o	IF table 6.1.3.1/73 THEN do (NOTE 2)
5	Allow	405 others	[13], [39]	m o	dm do
6	Allow-Events	2xx	[20]	o	IF table 6.1.3.1/23 THEN do (NOTE 2)
7	Authentication-Info	2xx	[13], [39]	o	IF table 6.1.3.1/7 THEN do (NOTE 2)
8	Call-ID	100 others	[13], [39]	m	dm
9	Call-Info	r	[13], [39]	o	do
10	Cellular-Network-Info	r	[5]	n/a	IF table 6.1.3.1/117 THEN do (NOTE 2)
11	Content-Disposition	r	[13], [39]	o	do
12	Content-Encoding	r	[13], [39]	o	do
13	Content-Language	r	[13], [39]	o	do
14	Content-Length	100 others	[13], [39]	o	do
15	Content-Type	r	[13], [39]	*	d*
16	CSeq	100 others	[13], [39]	m	dm
17	Date	100 others	[13], [39]	o	do
18	Error-Info	3xx-6xx	[13], [39]	o	IF table 6.1.3.1/13 THEN do (NOTE 2)
19	From	100 others	[13], [39]	m	dm
20	Geolocation-Error	424 others	[68], [39]	m o	dm do
21	MIME-version	r	[13], [39]	o	do
22	Organization	r	[13], [39]	n/a	dn/a
23	P-Access-Network-Info	r	[24], [24A], [24B]	o	IF table 6.1.3.1/36 THEN do (NOTE 2)
24	P-Charging-Function-Addresses	r	[24], [24A]	o	dn/a
25	P-Charging-Vector	r	[24], [24A]	o	IF table 6.1.3.1/38 THEN do (NOTE 2)
26	Privacy	r	[34], [39]	o	do
27	Proxy-Authenticate	401 (NOTE 1)	[13], [39]	o	do
28	Record-Route	2xx	[13], [39]	o	do
29	Relayed-Charge	r	[5]	n/a	dn/a
30	Require	r	[13], [39]	o	do
31	Response-Source	3xx-6xx	[5]	n/a	IF table 6.1.3.1/121 THEN do (NOTE 2)

Item	Header field	SIP status code	Ref.	RFC status	II-NNI condition
32	Retry-After	404 413 480 486 500 503 600 603	[13], [39]	o	do
33	Security-Server	421 494	[47], [39]	o	dn/a
34	Server	r	[13], [39]	o	do
35	Session-ID	r	[124]	m	IF table 6.1.3.1/94 THEN dm (NOTE 2)
36	Supported	2xx	[13], [39]	o	do
37	Timestamp	r	[13], [39]	o	do
38	To	100 others	[13], [39]	m	dm
39	Unsupported	420	[13], [39]	o	do
40	User-Agent	r	[13], [39]	o	do
41	Via	100 others	[13], [39]	m	dm
42	Warning	r	[13], [39]	o	do
43	WWW-Authenticate	401 (NOTE 1)	[13], [39]	m	dm
NOTE 1: The SIP status code is only applicable over the roaming II-NNI.					
NOTE 2: If the capability specified in table 6.1.3.1 is not supported over the II-NNI, the IBCF in the receiving network can omit or modify the SIP header fields in the received SIP message prior to forwarding the SIP message as specified in 3GPP TS 24.229 [5] clause 5.10.6.2.					

B.7 INVITE method

The table B.7.1 lists the supported header fields within the INVITE request.

Table B.7.1: Supported header fields within the INVITE request

Item	Header field	Ref.	RFC status	II-NNI condition
1	Accept	[13]	o	IF dc1 (AOC: clause 12.22) THEN dm ELSE do
2	Accept-Contact	[51]	o	IF dc2 (PNM: clause 12.17) THEN dm ELSE do
3	Accept-Encoding	[13]	o	do
4	Accept-Language	[13]	o	do
5	Alert-Info	[13]	o	IF dc3 (CRS: clause 12.15) THEN dm ELSE IF table 6.1.3.1/10 THEN do (NOTE 3)
6	Allow	[13]	o	do
7	Allow-Events	[20]	o	IF table 6.1.3.1/23 THEN do (NOTE 3)
8	Answer-Mode	[94]	o	IF table 6.1.3.1/90 THEN do (NOTE 3)
9	Authorization	[13]	o	IF table 6.1.3.1/7 THEN do (NOTE 3)
10	Call-ID	[13]	m	dm
11	Call-Info	[13]	o	IF dc4 (CCBS/CCNR/CCNL: clause 12.11/12.12/12.23) OR dc5 (announcements: clause 12.21) THEN dm ELSE do
12	Cellular-Network-Info	[5]	n/a	IF table 6.1.3.1/117 THEN do (NOTE 3)
13	Contact	[13]	m	dm
14	Content-Disposition	[13]	o	IF dc6 (AOC: clause 12.22) THEN dm ELSE do
15	Content-Encoding	[13]	o	do
16	Content-Language	[13]	o	do
17	Content-Length	[13]	t	dt
18	Content-Type	[13]	*	d*
19	CSeq	[13]	m	dm
20	Date	[13]	o	do
21	Expires	[13]	o	do
22	Feature-Caps	[143]	o	IF table 6.1.3.1/103 THEN do (NOTE 3)
23	From	[13]	m	dm
24	Geolocation	[68]	o	do
25	Geolocation-Routing	[68]	o	do
26	History-Info	[25]	o	IF dc7 (CDIV: clause 12.6) OR dc2 (PNM: clause 12.17) THEN dm ELSE IF table 6.1.3.1/50 AND initial request THEN do (NOTE 1, NOTE 3)
27	Identity	[206]	o	IF (non-roaming II-NNI OR loopback traversal scenario) AND table 6.1.3.1/119 THEN do (NOTE 3)
28	In-Reply-To	[13]	o	do
29	Join	[55]	o	IF table 6.1.3.1/48 THEN do (NOTE 3)
30	Max-Breadth	[79]	o	do
31	Max-Forwards	[13]	m	dm
32	MIME-Version	[13]	o	do
33	Min-SE	[52]	o	do
34	Organization	[13]	o	do
35	P-Access-Network-Info	[24], [24B]	o	IF table 6.1.3.1/36 THEN do (NOTE 3)
36	P-Asserted-Identity	[44]	o	IF table 6.1.3.1/27 AND initial request THEN dm (NOTE 2, NOTE 3)
37	P-Asserted-Service	[26]	o	IF (non-roaming II-NNI OR loopback traversal scenario OR home-to-visited request on roaming II-NNI) AND table 6.1.3.1/77 AND initial request THEN do (NOTE 3)
38	P-Called-Party-ID	[24]	o	IF home-to-visited request on roaming II-NNI AND table 6.1.3.1/34 THEN do (NOTE 3)
39	P-Charging-Function-Addresses	[24]	o	dn/a
40	P-Charging-Vector	[24]	o	IF table 6.1.3.1/38 AND initial request THEN dm (NOTE 3)
41	P-Early-Media	[74]	o	IF table 6.1.3.1/69 THEN do (NOTE 3)
42	P-Media-Authorization	[42]	o	dn/a
43	P-Preferred-Identity	[44]	o	dn/a
44	P-Preferred-Service	[26]	o	IF visited-to-home request on roaming II-NNI AND table 6.1.3.1/77 AND initial request THEN do (NOTE 3)
45	P-Private-Network-Indication	[84]	o	IF table 6.1.3.1/80 AND initial request THEN do (NOTE 3)

Item	Header field	Ref.	RFC status	II-NNI condition
46	P-Profile-Key	[64]	o	IF table 6.1.3.1/59 AND initial request THEN do (NOTE 3)
47	P-Served-User	[85]	o	IF visited-to-home request on roaming II-NNI AND initial request being sent from "privileged sender" THEN dm (NOTE 3)
48	P-User-Database	[60]	o	dn/a
49	P-Visited-Network-ID	[24]	o	dn/a
50	Priority	[13]	o	do
51	Priority-Share	[5]	n/a	IF home-to-visited request on roaming II-NNI AND table 6.1.3.1/118 THEN do (NOTE 3)
52	Privacy	[34]	o	IF dc8 (OIP/OIR: clause 12.3) THEN dm ELSE do
53	Priv-Answer-Mode	[94]	o	IF table 6.1.3.1/90 THEN do (NOTE 3)
54	Proxy-Authorization	[13]	o	IF table 6.1.3.1/7 THEN do (NOTE 3)
55	Proxy-Require	[13]	o	do
56	Reason	[48]	o	IF table 6.1.3.1/40 AND subsequent request THEN do (NOTE 3)
57	Record-Route	[13]	o	do
58	Recv-Info	[39]	m	IF table 6.1.3.1/17 THEN dm (NOTE 3)
59	Referred-By	[53]	o	IF dc9 (ECT: clause 12.13) OR dc10 (CONF: clause 12.19) THEN dm ELSE do
60	Reject-Contact	[51]	o	do
61	Relayed-Charge	[5]	n/a	dn/a
62	Replaces	[54]	o	IF dc11 (ECT: clause 12.13) OR dc12 (CONF: clause 12.19) THEN dm ELSE IF table 6.1.3.1/47 THEN do (NOTE 3)
63	Reply-To	[13]	o	do
64	Request-Disposition	[51]	o	do
65	Require	[13]	c	IF dc11 (ECT: clause 12.13) THEN dm ELSE dc
66	Resource-Priority	[78]	o	IF table 6.1.3.1/73 THEN do (NOTE 3)
67	Resource-Share	[5]	n/a	IF (home-to-visited request on roaming II-NNI OR visited-to-home request on roaming II-NNI) AND table 6.1.3.1/116 THEN do (NOTE 3)
68	Restoration-Info	[5]	n/a	IF home-to-visited request on roaming II-NNI AND initial request AND table 6.1.3.1/113 THEN do (NOTE 3)
69	Route	[13]	c	dc
70	Security-Client	[47]	o	dn/a
71	Security-Verify	[47]	o	dn/a
72	Session-Expires	[52]	o	do
73	Session-ID	[124]	m	IF table 6.1.3.1/94 THEN dm (NOTE 3)
74	Subject	[13]	o	do
75	Supported	[13]	m*	IF dc2 (PNM: clause 12.17) THEN dm ELSE dm*
76	Target-Dialog	[140]	o	IF table 6.1.3.1/102 THEN do (NOTE 3)
77	Timestamp	[13]	o	do
78	To	[13]	m	dm
79	Trigger-Consent	[82]	o	IF table 6.1.3.1/78 THEN do (NOTE 3)
80	User-Agent	[13]	o	do
81	User-to-User	[83]	o	IF table 6.1.3.1/79 THEN do (NOTE 3)
82	Via	[13]	m	dm

Item	Header field	Ref.	RFC status	II-NNI condition
dc1:				request invoked due to AOC AND visited-to-home request on roaming II-NNI
dc2:				initial request invoked due to PNM in case of ("PN UE redirection" OR "PN access control") AND (non-roaming II-NNI OR loopback traversal scenario OR home-to-visited request on roaming II-NNI)
dc3:				initial request invoked due to CRS AND (non-roaming II-NNI OR loopback traversal scenario OR home-to-visited request on roaming II-NNI)
dc4:				initial request invoked due to CCBS/CCNR/CCNL AND "CC call" request AND (non-roaming II-NNI OR loopback traversal scenario OR home-to-visited request on roaming II-NNI)
dc5:				subsequent request invoked due to announcements using the Call-info header field AND (non-roaming II-NNI OR loopback traversal scenario OR home-to-visited request on roaming II-NNI)
dc6:				request invoked due to AOC AND home-to-visited request on roaming II-NNI
dc7:				initial request towards the network serving "the diverted-to user" AND CFU/CFB/CFNR/CFNRc/CD/CFNL AND (non-roaming II-NNI OR loopback traversal scenario OR home-to-visited request on roaming II-NNI)
dc8:				(initial request invoked due to OIP/OIR AND "override the default setting" in temporary mode AND visited-to-home request on roaming II-NNI) OR (initial request invoked due to OIP/OIR AND "presentation of the public user identity is restricted" AND (non-roaming II-NNI OR loopback traversal scenario OR home-to-visited request on roaming II-NNI))
dc9:				initial request invoked due to ECT AND (non-roaming II-NNI OR loopback traversal scenario OR home-to-visited request on roaming II-NNI)
dc10:				(initial request from "conference participant" receiving REFER request with Referred-By header field AND (visited-to-home request on roaming II-NNI OR non-roaming II-NNI OR loopback traversal scenario)) OR (initial request from "conference focus" receiving REFER request AND (non-roaming II-NNI OR loopback traversal scenario OR home-to-visited request on roaming II-NNI))
dc11:				"Consultative transfer" due to ECT AND (non-roaming II-NNI OR loopback traversal scenario OR home-to-visited request on roaming II-NNI)
dc12:				initial request from "conference focus" receiving REFER request with Replaces header field escaped in Refer-To header field AND (non-roaming II-NNI OR loopback traversal scenario OR home-to-visited request on roaming II-NNI)
NOTE 1: The Privacy header field can be escaped in the header field for CDIV.				
NOTE 2: The header field is not included in some exceptional cases. (e.g. when an incoming call from a circuit-switched network has not included the required information to be mapped into the header field)				
NOTE 3: If the capability specified in table 6.1.3.1 is not supported over the II-NNI, the IBCF in the receiving network can omit or modify the SIP header fields in the received SIP message prior to forwarding the SIP message as specified in 3GPP TS 24.229 [5] clause 5.10.6.2.				

The table B.7.2 lists the supported header fields within the INVITE response.

Table B.7.2: Supported header fields within the INVITE response

Item	Header field	SIP status code	Ref.	RFC status	II-NNI condition
1	Accept	2xx	[13]	o	do
		415		c	dc
2	Accept-Encoding	2xx	[13]	o	do
		415		c	dc
3	Accept-Language	2xx	[13]	o	do
		415		c	dc
4	Accept-Resource-Priority	2xx 417	[78]	o	IF table 6.1.3.1/73 THEN do (NOTE 3)
5	Alert-Info	180	[13]	o	IF dc1 (CW: clause 12.7) OR dc2 (announcements: clause 12.21) THEN dm ELSE IF table 6.1.3.1/10 THEN do (NOTE 3)
6	Allow	2xx	[13]	m*	dm*
		405		m	dm
		others		o	do
7	Allow-Events	2xx	[20]	o	IF table 6.1.3.1/23 THEN do (NOTE 3)
8	Answer-Mode	2xx	[94]	o	IF table 6.1.3.1/90 THEN do (NOTE 3)
9	Authentication-Info	2xx	[13]	o	IF table 6.1.3.1/7 THEN do (NOTE 3)
10	Call-ID	100 others	[13]	m	dm
11	Call-Info	r	[13]	o	IF dc3 (CCBS: clause 12.11) OR dc4 (CCNR: clause 12.12) OR dc5 (CCNL: clause 12.23) THEN dm ELSE do
12	Cellular-Network-Info	r	[5]	n/a	IF table 6.1.3.1/117 THEN do (NOTE 3)
13	Contact	18x 199	[13]	o	do
		2xx		m	dm
		3xx 485		o	do
14	Content-Disposition	r	[13]	o	IF dc6 (AOC: clause 12.22) THEN dm ELSE do
15	Content-Encoding	r	[13]	o	do
16	Content-Language	r	[13]	o	do
17	Content-Length	100 others	[13]	t	dt
18	Content-Type	r	[13]	*	IF dc7 (CCBS: clause 12.11) OR dc8 (CCNR/CCNL: clause 12.12/12.23) THEN dm ELSE d*
19	CSeq	100 others	[13]	m	dm
20	Date	100 others	[13]	o	IF dc7 (CCBS: clause 12.11) OR dc8 (CCNR/CCNL: clause 12.12/12.23) THEN dm ELSE do
21	Error-Info	3xx-6xx	[13]	o	IF dc9 (announcements: clause 12.21) THEN dm ELSE IF table 6.1.3.1/13 THEN do (NOTE 3)
22	Expires	r	[13]	o	do
23	Feature-Caps	18x 2xx	[143]	o	IF table 6.1.3.1/103 THEN do (NOTE 3)
24	From	100 others	[13]	m	dm
25	Geolocation-Error	424	[68]	m	dm
		others		o	do
26	History-Info	r	[25]	o	IF dc10 (CDIV: clause 12.6) THEN dm ELSE IF table 6.1.3.1/50 AND response to initial request THEN do (NOTE 2, NOTE 3)

Item	Header field	SIP status code	Ref.	RFC status	II-NNI condition
27	MIME-version	r	[13]	o	do
28	Min-SE	422	[52]	m	dm
29	Organization	r	[13]	o	do
30	P-Access-Network-Info	r	[24], [24A], [24B]	o	IF table 6.1.3.1/36 THEN do (NOTE 3)
31	P-Answer-State	18x 2xx	[73]	o	IF table 6.1.3.1/68 THEN do (NOTE 3)
32	P-Asserted-Identity	r	[44]	o	IF dc11 (TIP/TIR: clause 12.4) THEN dm ELSE IF table 6.1.3.1/27 AND response to initial request THEN do (NOTE 3)
33	P-Charging-Function-Addresses	r	[24], [24A]	o	dn/a
34	P-Charging-Vector	r	[24], [24A]	o	IF dc12 (CONF: clause 12.19) OR (table 6.1.3.1/38 AND response to initial request) THEN dm (NOTE 3)
35	P-Early-Media	18x	[74]	o	IF dc13 (CAT: clause 12.14) OR dc14 (announcements: clause 12.21) THEN dm ELSE IF table 6.1.3.1/69 THEN do (NOTE 3)
36	P-Media-Authorization	18x 2xx	[42]	o	dn/a
37	P-Preferred-Identity	r	[44]	o	dn/a
38	P-Refused-URI-List	403	[141]	o	IF (non-roaming II-NNI OR loopback traversal scenario) AND table 6.1.3.1/101 THEN do (NOTE 3)
39	Permission-Missing	470	[82]	o	IF table 6.1.3.1/78 THEN do (NOTE 3)
40	Priority-Share	18x 2xx	[5]	n/a	IF home-to-visited response on roaming II-NNI AND table 6.1.3.1/118 THEN do (NOTE 3)
41	Privacy	r	[34]	o	IF dc15 (TIP/TIR: clause 12.4) THEN dm ELSE do
42	Priv-Answer-Mode	2xx	[94]	o	IF table 6.1.3.1/90 THEN do (NOTE 3)
43	Proxy-Authenticate	401 (NOTE 1)	[13]	o	do
		407 (NOTE 1)		m	dm
44	Reason	18x 199 3xx-6xx	[48]	o	IF dc16 (CW: clause 12.7) OR dc17 (ICB: clause 12.10.1) OR dc18 (announcements: clause 12.21) THEN dm ELSE IF table 6.1.3.1/40 THEN do (NOTE 3)
45	Record-Route	18x 199 2xx	[13]	o	do
46	Recv-Info	18x 199 2xx	[39]	c	IF table 6.1.3.1/17 THEN dc (NOTE 3)
47	Relayed-Charge	r	[5]	n/a	dn/a
48	Reply-To	r	[13]	o	do
49	Require	r	[13]	c	IF dc19 (CAT: clause 12.14) THEN dm ELSE dc
50	Resource-Share	18x 2xx	[5]	n/a	IF (home-to-visited response on roaming II-NNI OR visited-to-home response on roaming II-NNI) AND table 6.1.3.1/116 THEN do (NOTE 3)
51	Response-Source	3xx-6xx	[5]	n/a	IF table 6.1.3.1/121 THEN do (NOTE 3)

Item	Header field	SIP status code	Ref.	RFC status	II-NNI condition
52	Restoration-Info	408	[5]	n/a	IF table 6.1.3.1/114 AND response to initial request AND visited-to-home response on roaming II-NNI THEN do (NOTE 3)
53	Retry-After	404 413 480 486 500 503 600 603	[13]	o	do
54	RSeq	18x 199	[18]	o	do
55	Security-Server	421 494	[47]	o	dn/a
56	Server	r	[13]	o	do
57	Session-Expires	2xx	[52]	o	do
58	Session-ID	r	[124]	m	IF table 6.1.3.1/94 THEN dm (NOTE 3)
59	Supported	2xx	[13]	m*	dm*
60	Timestamp	r	[13]	o	do
61	To	100 others	[13]	m	dm
62	Unsupported	420	[13]	m	dm
63	User-Agent	r	[13]	o	do
64	User-to-User	r	[83]	o	IF table 6.1.3.1/79 THEN do (NOTE 3)
65	Via	100 others	[13]	m	dm
66	Warning	r	[13]	o	IF dc20 (CDIV: clause 12.6) THEN dm ELSE do
67	WWW-Authenticate	401 (NOTE 1)	[13]	m	dm
		407 (NOTE 1)		o	do

Item	Header field	SIP status code	Ref.	RFC status	II-NNI condition
dc1:					response invoked due to CW AND (non-roaming II-NNI OR loopback traversal scenario OR home-to-visited response on roaming II-NNI)
dc2:					response to initial request invoked due to announcements using the Alert-Info header field AND (non-roaming II-NNI OR loopback traversal scenario OR home-to-visited response on roaming II-NNI)
dc3:					486 (Busy Here) response invoked due to CCBS AND (non-roaming II-NNI OR loopback traversal scenario OR home-to-visited response on roaming II-NNI)
dc4:					180 (Ringing) response invoked due to CCNR AND (non-roaming II-NNI OR loopback traversal scenario)
dc5:					480 (Temporarily Unavailable) response invoked due to CCNL AND (non-roaming II-NNI OR loopback traversal scenario OR home-to-visited response on roaming II-NNI)
dc6:					non-100 provisional response /200 (OK) response invoked due to AOC AND home-to-visited response on roaming II-NNI
dc7:					486 (Busy Here) response invoked due to CCBS AND home-to-visited response on roaming II-NNI
dc8:					480 (Temporarily Unavailable) response invoked due to CCNR/CCNL AND home-to-visited response on roaming II-NNI
dc9:					response to initial request invoked due to announcements using the Error-Info header field AND (non-roaming II-NNI OR loopback traversal scenario OR home-to-visited response on roaming II-NNI)
dc10:					180 (Ringing)/181 (Call Is Being Forwarded)/200 (OK) response to initial request AND CFU/CFB/CFNR/CFNRc/CD/CFNL AND (non-roaming II-NNI OR loopback traversal scenario OR home-to-visited response on roaming II-NNI)
dc11:					(TIP/TIR AND 2xx response to initial request AND (visited-to-home response on roaming II-NNI OR non-roaming II-NNI OR loopback traversal scenario)) OR (TIP/TIR AND response to initial request AND "presentation is allowed" AND home-to-visited response on roaming II-NNI)
dc12:					first response from "conference focus" to initial request AND (non-roaming II-NNI OR loopback traversal scenario OR home-to-visited response on roaming II-NNI)
dc13:					reliable 18x response to initial request invoked due to CAT using ("forking model" OR "gateway model") AND (non-roaming II-NNI OR loopback traversal scenario OR home-to-visited response on roaming II-NNI)
dc14:					18x response to initial request invoked due to announcements authorizing early media AND (non-roaming II-NNI OR loopback traversal scenario OR home-to-visited response on roaming II-NNI)
dc15:					(TIP/TIR AND non-100 response to initial request AND "override the default setting" in temporary mode AND visited-to-home response on roaming II-NNI) OR (TIP/TIR AND 2xx response to initial request AND "presentation of the network asserted identity is restricted" AND (non-roaming II-NNI OR loopback traversal scenario OR home-to-visited response on roaming II-NNI))
dc16:					480 (Temporarily Unavailable) response invoked due to CW at the expiry of the "CW timer"
dc17:					603 (Decline) response invoked due to "dynamic ICB" on an early dialog
dc18:					183 (Session Progress) response to initial request invoked due to announcements authorizing early media when rejecting a communication request AND (non-roaming II-NNI OR loopback traversal scenario OR home-to-visited response on roaming II-NNI)
dc19:					first 18x response to initial request invoked due to CAT using "early session model" AND (non-roaming II-NNI OR loopback traversal scenario OR home-to-visited response on roaming II-NNI)
dc20:					480 (Temporarily Unavailable)/486 (Busy Here) response to initial request AND CFU/CFB/CFNR/CFNRc/CD/CFNL in case "maximum number of diversions" exceeds AND (non-roaming II-NNI OR loopback traversal scenario OR home-to-visited response on roaming II-NNI)
NOTE 1: The SIP status code is only applicable over the roaming II-NNI.					
NOTE 2: The Privacy header field can be escaped in the header field for CDIV.					
NOTE 3: If the capability specified in table 6.1.3.1 is not supported over the II-NNI, the IBCF in the receiving network can omit or modify the SIP header fields in the received SIP message prior to forwarding the SIP message as specified in 3GPP TS 24.229 [5] clause 5.10.6.2.					

B.8 MESSAGE method

As described in table 6.1, the support of MESSAGE method over the II-NNI is based on bilateral agreement between the operators.

The table B.8.1 lists the supported header fields within the MESSAGE request.

Table B.8.1: Supported header fields within the MESSAGE request

Item	Header field	Ref.	RFC status	II-NNI condition
1	Accept-Contact	[51]	o	IF dc1 (PNM: clause 12.17) THEN dm ELSE do
2	Allow	[13], [19]	o	do
3	Allow-Events	[20]	o	IF table 6.1.3.1/23 THEN do (NOTE)
4	Authorization	[13], [19]	o	IF table 6.1.3.1/7 THEN do (NOTE)
5	Call-ID	[13], [19]	m	dm
6	Call-Info	[13], [19]	o	do
7	Cellular-Network-Info	[5]	n/a	IF table 6.1.3.1/117 THEN do (NOTE)
8	Content-Disposition	[13], [19]	o	do
9	Content-Encoding	[13], [19]	o	do
10	Content-Language	[13], [19]	o	do
11	Content-Length	[13], [19]	t	dt
12	Content-Type	[13], [19]	*	d*
13	CSeq	[13], [19]	m	dm
14	Date	[13], [19]	o	do
15	Expires	[13], [19]	o	do
16	Feature-Caps	[143]	o	IF table 6.1.3.1/103 AND request outside an existing dialog THEN do (NOTE)
17	From	[13], [19]	m	dm
18	Geolocation	[68]	o	do
19	Geolocation-Routing	[68]	o	do
20	History-Info	[25]	o	IF dc1 (PNM: clause 12.17) THEN dm ELSE IF table 6.1.3.1/50 AND request outside an existing dialog THEN do (NOTE)
21	Identity	[206]	o	IF (non-roaming II-NNI OR loopback traversal scenario) AND table 6.1.3.1/119 THEN do (NOTE)
22	In-Reply-To	[13], [19]	o	do
23	Max-Breadth	[79]	o	do
24	Max-Forwards	[13], [19]	m	dm
25	MIME-Version	[13]	o	do
26	Organization	[13], [19]	o	do
27	P-Access-Network-Info	[24], [24B]	o	IF table 6.1.3.1/36 THEN do (NOTE)
28	P-Asserted-Identity	[44]	o	IF table 6.1.3.1/27 AND request outside an existing dialog THEN dm (NOTE)
29	P-Asserted-Service	[26]	o	IF (non-roaming II-NNI OR home-to-visited request on roaming II-NNI) AND table 6.1.3.1/77 AND request outside an existing dialog THEN do (NOTE)
30	P-Called-Party-ID	[24]	o	IF home-to-visited request on roaming II-NNI AND table 6.1.3.1/34 THEN do (NOTE)
31	P-Charging-Function-Addresses	[24]	o	dn/a
32	P-Charging-Vector	[24]	o	IF table 6.1.3.1/38 AND request outside an existing dialog THEN dm (NOTE)
33	P-Preferred-Identity	[44]	o	dn/a
34	P-Preferred-Service	[26]	o	IF visited-to-home request on roaming II-NNI AND table 6.1.3.1/77 AND request outside an existing dialog THEN do (NOTE)
35	P-Private-Network-Indication	[84]	o	IF table 6.1.3.1/80 AND request outside an existing dialog THEN do (NOTE)
36	P-Profile-Key	[64]	o	IF table 6.1.3.1/59 AND request outside an existing dialog THEN do (NOTE)
37	P-Served-User	[85]	o	IF visited-to-home request on roaming II-NNI AND request outside an existing dialog being sent from "privileged sender" THEN dm (NOTE)
38	P-User-Database	[60]	o	dn/a
39	P-Visited-Network-ID	[24]	o	dn/a
40	Priority	[13], [19]	o	do
41	Privacy	[34]	o	IF dc2 (OIP/OIR: clause 12.3) THEN dm ELSE do
42	Proxy-Authorization	[13], [19]	o	IF table 6.1.3.1/7 THEN do (NOTE)
43	Proxy-Require	[13], [19]	o	do
44	Reason	[48]	o	IF table 6.1.3.1/40 AND request inside an existing dialog THEN do (NOTE)
45	Referred-By	[53]	o	do

Item	Header field	Ref.	RFC status	II-NNI condition
46	Reject-Contact	[51]	o	do
47	Relayed-Charge	[5]	n/a	dn/a
48	Reply-To	[13], [19]	o	do
49	Request-Disposition	[51]	o	do
50	Require	[13], [19]	c	dc
51	Resource-Priority	[78]	o	IF table 6.1.3.1/73 THEN do (NOTE)
52	Route	[13], [19]	c	dc
53	Security-Client	[47]	o	dn/a
54	Security-Verify	[47]	o	dn/a
55	Session-ID	[124]	m	IF table 6.1.3.1/94 THEN dm (NOTE)
56	Subject	[13], [19]	o	do
57	Supported	[13]	o	IF dc1 (PNM: clause 12.17) THEN dm ELSE do
58	Timestamp	[13], [19]	o	do
59	To	[13], [19]	m	dm
60	Trigger-Consent	[82]	o	IF table 6.1.3.1/78 THEN do (NOTE)
61	User-Agent	[13], [19]	o	do
62	Via	[13], [19]	m	dm
dc1:	request outside an existing dialog invoked due to PNM in case of ("PN UE redirection" OR "PN access control") AND (non-roaming II-NNI OR home-to-visited request on roaming II-NNI)			
dc2:	(request outside an existing dialog invoked due to OIP/OIR AND "override the default setting" in temporary mode AND visited-to-home request on roaming II-NNI) OR (request outside an existing dialog invoked due to OIP/OIR AND "presentation of the public user identity is restricted" AND (non-roaming II-NNI OR home-to-visited request on roaming II-NNI))			
NOTE:	If the capability specified in table 6.1.3.1 is not supported over the II-NNI, the IBCF in the receiving network can omit or modify the SIP header fields in the received SIP message prior to forwarding the SIP message as specified in 3GPP TS 24.229 [5] clause 5.10.6.2.			

The table B.8.2 lists the supported header fields within the MESSAGE response.

Table B.8.2: Supported header fields within the MESSAGE response

Item	Header field	SIP status code	Ref.	RFC status	II-NNI condition
1	Accept	415	[13], [19]	m*	dm*
2	Accept-Encoding	415	[13], [19]	m*	dm*
3	Accept-Language	415	[13], [19]	m*	dm*
4	Accept-Resource-Priority	2xx 417	[78]	o	IF table 6.1.3.1/73 THEN do (NOTE 2)
5	Allow	405	[13], [19]	m	dm
		others		o	do
6	Allow-Events	2xx	[20]	o	IF table 6.1.3.1/23 THEN do (NOTE 2)
7	Authentication-Info	2xx	[13], [19]	o	IF table 6.1.3.1/7 THEN do (NOTE 2)
8	Call-ID	100	[13], [19]	m	dm
		others			
9	Call-Info	r	[13], [19]	o	do
10	Cellular-Network-Info	r	[5]	n/a	IF table 6.1.3.1/117 THEN do (NOTE 2)
11	Contact	3xx 485	[13], [19]	o	do
12	Content-Disposition	r	[13], [19]	o	do
13	Content-Encoding	r	[13], [19]	o	do
14	Content-Language	r	[13], [19]	o	do
15	Content-Length	100	[13], [19]	t	dt
		others			
16	Content-Type	r	[13], [19]	*	d*
17	CSeq	100	[13], [19]	m	dm
		others			
18	Date	100 others	[13], [19]	o	do
19	Error-Info	3xx-6xx	[13], [19]	o	IF table 6.1.3.1/13 THEN do (NOTE 2)
20	Expires	r	[13], [19]	o	do
21	Feature-Caps	2xx	[143]	o	IF table 6.1.3.1/103 AND response to request outside an existing dialog THEN do (NOTE 2)
22	From	100	[13], [19]	m	dm
		others			
23	Geolocation-Error	424	[68]	m	dm
		others		o	do
24	History-Info	r	[25]	o	IF table 6.1.3.1/50 AND response to request outside an existing dialog THEN do (NOTE 2)
25	MIME-version	r	[13]	o	do
26	Organization	r	[13], [19]	o	do
27	P-Access-Network-Info	r	[24], [24A], [24B]	o	IF table 6.1.3.1/36 THEN do (NOTE 2)
28	P-Asserted-Identity	r	[44]	o	IF dc1 (TIP/TIR: clause 12.4) THEN dm ELSE IF table 6.1.3.1/27 AND response to request outside an existing dialog THEN do (NOTE 2)
29	P-Charging-Function-Addresses	r	[24], [24A]	o	dn/a
30	P-Charging-Vector	r	[24], [24A]	o	IF table 6.1.3.1/38 AND response to request outside an existing dialog THEN dm (NOTE 2)
31	P-Preferred-Identity	r	[44]	o	dn/a
32	Permission-Missing	470	[82]	o	IF table 6.1.3.1/78 THEN do (NOTE 2)
33	Privacy	r	[34]	o	IF dc2(TIP/TIR: clause 12.4) THEN dm ELSE do
34	Proxy-Authenticate	401 (NOTE 1)	[13], [19]	o	do
		407 (NOTE 1)		m	dm

Item	Header field	SIP status code	Ref.	RFC status	II-NNI condition
35	Relayed-Charge	r	[5]	n/a	dn/a
36	Reply-To	r	[13], [19]	o	do
37	Require	r	[13], [19]	c	dc
38	Response-Source	3xx-6xx	[5]	n/a	IF table 6.1.3.1/121 THEN do (NOTE 2)
39	Restoration-Info	504	[5]	n/a	IF table 6.1.3.1/114 AND visited-to-home response on roaming II-NNI THEN do (NOTE 2)
40	Retry-After	404 413 480 486 500 503 600 603	[13], [19]	o	do
41	Security-Server	421 494	[47]	o	dn/a
42	Server	r	[13], [19]	o	do
43	Session-ID	r	[124]	m	IF table 6.1.3.1/94 THEN dm (NOTE 2)
44	Supported	2xx	[13]	o	do
45	Timestamp	r	[13], [19]	o	do
46	To	100 others	[13], [19]	m	dm
47	Unsupported	420	[13], [19]	o	do
48	User-Agent	r	[13], [19]	o	do
49	Via	100 others	[13], [19]	m	dm
50	Warning	r	[13], [19]	o	do
51	WWW-Authenticate	401 (NOTE 1)	[13], [19]	m	dm
		407 (NOTE 1)		o	do
dc1:	(TIP/TIR AND 2xx response to request outside an existing dialog AND (visited-to-home response on roaming II-NNI OR non-roaming II-NNI)) OR (TIP/TIR AND response to request outside an existing dialog AND "presentation is allowed" AND home-to-visited response on roaming II-NNI)				
dc2:	(TIP/TIR AND non-100 response to request outside an existing dialog AND "override the default setting" in temporary mode AND visited-to-home response on roaming II-NNI) OR (TIP/TIR AND 2xx response to request outside an existing dialog AND "presentation of the network asserted identity is restricted" AND (non-roaming II-NNI OR home-to-visited response on roaming II-NNI))				
NOTE 1: The SIP status code is only applicable over the roaming II-NNI.					
NOTE 2: If the capability specified in table 6.1.3.1 is not supported over the II-NNI, the IBCF in the receiving network can omit or modify the SIP header fields in the received SIP message prior to forwarding the SIP message as specified in 3GPP TS 24.229 [5] clause 5.10.6.2.					

B.9 NOTIFY method

As described in table 6.1, the support of NOTIFY method over the non-roaming II-NNI is based on bilateral agreement between the operators.

The table B.9.1 lists the supported header fields within the NOTIFY request.

Table B.9.1: Supported header fields within the NOTIFY request

Item	Header field	Ref.	RFC status	II-NNI condition
1	Accept	[13], [20]	o	do
2	Accept-Contact	[51]	o	do
3	Accept-Encoding	[13], [20]	o	do
4	Accept-Language	[13], [20]	o	do
5	Allow	[13], [20]	o	do
6	Allow-Events	[20]	o	do
7	Authorization	[13], [20]	o	IF table 6.1.3.1/7 THEN do (NOTE)
8	Call-ID	[13], [20]	m	dm
9	Call-Info	[13]	o	do
10	Cellular-Network-Info	[5]	n/a	IF table 6.1.3.1/117 THEN do (NOTE)
11	Contact	[13], [20]	m	dm
12	Content-Disposition	[13], [20]	o	do
13	Content-Encoding	[13], [20]	o	do
14	Content-Language	[13], [20]	o	do
15	Content-Length	[13], [20]	t	dt
16	Content-Type	[13], [20]	*	d*
17	CSeq	[13], [20]	m	dm
18	Date	[13], [20]	o	do
19	Event	[20]	m	dm
20	Feature-Caps	[143]	o	IF table 6.1.3.1/103 THEN do (NOTE)
21	From	[13], [20]	m	dm
22	Geolocation	[68]	o	do
23	Geolocation-Routing	[68]	o	do
24	History-Info	[25]	o	IF table 6.1.3.1/50 THEN do (NOTE)
25	Max-Breadth	[79]	o	do
26	Max-Forwards	[13], [20]	m	dm
27	MIME-Version	[13], [20]	o	do
28	P-Access-Network-Info	[24], [24B]	o	IF table 6.1.3.1/36 THEN do (NOTE)
29	P-Asserted-Identity	[44]	o	IF table 6.1.3.1/27 THEN do (NOTE)
30	P-Charging-Function-Addresses	[24]	o	dn/a
31	P-Charging-Vector	[24]	o	IF table 6.1.3.1/38 THEN dm (NOTE)
32	P-Preferred-Identity	[44]	o	dn/a
33	Privacy	[34]	o	do
34	Proxy-Authorization	[13], [20]	o	IF table 6.1.3.1/7 THEN do (NOTE)
35	Proxy-Require	[13], [20]	o	do
36	Reason	[48]	o	IF table 6.1.3.1/40 THEN do (NOTE)
37	Record-Route	[13], [20]	o	do
38	Referred-By	[53]	o	do
39	Reject-Contact	[51]	o	do
40	Relayed-Charge	[5]	n/a	dn/a
41	Request-Disposition	[51]	o	do
42	Require	[13], [20]	o	do
43	Resource-Priority	[78]	o	IF table 6.1.3.1/73 THEN do (NOTE)
44	Route	[13], [20]	c	dc
45	Security-Client	[47]	o	dn/a
46	Security-Verify	[47]	o	dn/a
47	Session-ID	[124]	m	IF table 6.1.3.1/94 THEN dm (NOTE)
48	Subscription-State	[20]	m	dm
49	Supported	[13], [20]	o	do
50	Timestamp	[13], [20]	o	do
51	To	[13], [20]	m	dm
52	User-Agent	[13], [20]	o	do
53	Via	[13], [20]	m	dm
54	Warning	[13], [20]	o	do
NOTE:	If the capability specified in table 6.1.3.1 is not supported over the II-NNI, the IBCF in the receiving network can omit or modify the SIP header fields in the received SIP message prior to forwarding the SIP message as specified in 3GPP TS 24.229 [5] clause 5.10.6.2.			

The table B.9.2 lists the supported header fields within the NOTIFY response.

Table B.9.2: Supported header fields within the NOTIFY response

Item	Header field	SIP status code	Ref.	RFC status	II-NNI condition
1	Accept	415	[13], [20]	o	do
2	Accept-Encoding	415	[13], [20]	o	do
3	Accept-Language	415	[13], [20]	o	do
4	Accept-Resource-Priority	2xx 417	[78]	o	IF table 6.1.3.1/73 THEN do (NOTE 2)
5	Allow	405	[13], [20]	m	dm
		others		o	do
6	Allow-Events	2xx	[20]	o	do
		489		m	dm
7	Authentication-Info	2xx	[13], [20]	o	IF table 6.1.3.1/7 THEN do (NOTE 2)
8	Call-ID	100 others	[13], [20]	m	dm
9	Cellular-Network-Info	r	[5]	n/a	IF table 6.1.3.1/117 THEN do (NOTE 2)
10	Contact	2xx	[13], [20]	o	do
		3xx		m	dm
		485		o	do
11	Content-Disposition	r	[13], [20]	o	do
12	Content-Encoding	r	[13], [20]	o	do
13	Content-Language	r	[13], [20]	o	do
14	Content-Length	100 others	[13], [20]	t	dt
15	Content-Type	r	[13], [20]	*	d*
16	CSeq	100 others	[13], [20]	m	dm
17	Date	100 others	[13], [20]	o	do
18	Error-Info	3xx-6xx	[13], [20]	o	IF table 6.1.3.1/13 THEN do (NOTE 2)
19	Feature-Caps	2xx	[143]	o	IF table 6.1.3.1/103 THEN do (NOTE 2)
20	From	100 others	[13], [20]	m	dm
21	Geolocation-Error	424	[68]	m	dm
		others		o	do
22	MIME-version	r	[13], [20]	o	do
23	P-Access-Network-Info	r	[24], [24A], [24B]	o	IF table 6.1.3.1/36 THEN do (NOTE 2)
24	P-Asserted-Identity	r	[44]	o	IF table 6.1.3.1/27 THEN do (NOTE 2)
25	P-Charging-Function-Addresses	r	[24], [24A]	o	dn/a
26	P-Charging-Vector	r	[24], [24A]	o	IF table 6.1.3.1/38 THEN do (NOTE 2)
27	P-Preferred-Identity	r	[44]	o	dn/a
28	Privacy	r	[34]	o	do
29	Proxy-Authenticate	401 (NOTE 1)	[13], [20]	o	do
		407 (NOTE 1)		m	dm
30	Record-Route	2xx	[13], [20]	o	do
31	Relayed-Charge	r	[5]	n/a	dn/a
32	Require	r	[13], [20]	o	do
33	Response-Source	3xx-6xx	[5]	n/a	IF table 6.1.3.1/121 THEN do (NOTE 2)
34	Restoration-Info	504	[5]	n/a	IF table 6.1.3.1/114 AND visited-to-home response on roaming II-NNI THEN do (NOTE 2)

Item	Header field	SIP status code	Ref.	RFC status	II-NNI condition
35	Retry-After	404 413 480 486 500 503 600 603	[13], [20]	o	do
36	Security-Server	421 494	[47]	o	dn/a
37	Server	r	[13], [20]	o	do
38	Session-ID	r	[124]	m	IF table 6.1.3.1/94 THEN dm (NOTE 2)
39	Supported	2xx	[13], [20]	o	do
40	Timestamp	r	[13], [20]	o	do
41	To	100 others	[13], [20]	m	dm
42	Unsupported	420	[13], [20]	o	do
43	User-Agent	r	[13], [20]	o	do
44	Via	100 others	[13], [20]	m	dm
45	Warning	r	[13], [20]	o	do
46	WWW-Authenticate	401 (NOTE 1)	[13], [20]	m	dm
		407 (NOTE 1)		o	do
NOTE 1: The SIP status code is only applicable over the roaming II-NNI.					
NOTE 2: If the capability specified in table 6.1.3.1 is not supported over the II-NNI, the IBCF in the receiving network can omit or modify the SIP header fields in the received SIP message prior to forwarding the SIP message as specified in 3GPP TS 24.229 [5] clause 5.10.6.2.					

B.10 OPTIONS method

The table B.10.1 lists the supported header fields within the OPTIONS request.

Table B.10.1: Supported header fields within the OPTIONS request

Item	Header field	Ref.	RFC status	II-NNI condition
1	Accept	[13]	m*	dm*
2	Accept-Contact	[51]	o	IF dc1 (PNM: clause 12.17) THEN dm ELSE do
3	Accept-Encoding	[13]	o	do
4	Accept-Language	[13]	o	do
5	Allow	[13]	o	do
6	Allow-Events	[20]	o	IF table 6.1.3.1/23 THEN do (NOTE)
7	Authorization	[13]	o	IF table 6.1.3.1/7 THEN do (NOTE)
8	Call-ID	[13]	m	dm
9	Call-Info	[13]	o	do
10	Cellular-Network-Info	[5]	n/a	IF table 6.1.3.1/117 THEN do (NOTE)
11	Contact	[13]	o	do
12	Content-Disposition	[13]	o	do
13	Content-Encoding	[13]	o	do
14	Content-Language	[13]	o	do
15	Content-Length	[13]	t	dt
16	Content-Type	[13]	*	d*
17	CSeq	[13]	m	dm
18	Date	[13]	o	do
19	Feature-Caps	[143]	o	IF table 6.1.3.1/103 AND request outside an existing dialog THEN do (NOTE)
20	From	[13]	m	dm
21	Geolocation	[68]	o	do
22	Geolocation-Routing	[68]	o	do
23	History-Info	[25]	o	IF (dc1 (PNM: clause 12.17) THEN dm ELSE IF table 6.1.3.1/50 AND request outside an existing dialog THEN do (NOTE)
24	Max-Breadth	[79]	o	do
25	Max-Forwards	[13]	m	dm
26	MIME-Version	[13]	o	do
27	Organization	[13]	o	do
28	P-Access-Network-Info	[24], [24B]	o	IF table 6.1.3.1/36 THEN do (NOTE)
29	P-Asserted-Identity	[44]	o	IF table 6.1.3.1/27 AND request outside an existing dialog THEN dm (NOTE)
30	P-Asserted-Service	[26]	o	IF (non-roaming II-NNI OR home-to-visited request on roaming II-NNI) AND table 6.1.3.1/77 AND request outside an existing dialog THEN do (NOTE)
31	P-Called-Party-ID	[24]	o	IF home-to-visited request on roaming II-NNI AND table 6.1.3.1/34 THEN do (NOTE)
32	P-Charging-Function-Addresses	[24]	o	dn/a
33	P-Charging-Vector	[24]	o	IF table 6.1.3.1/38 AND request outside an existing dialog THEN dm (NOTE)
34	P-Preferred-Identity	[44]	o	dn/a
35	P-Preferred-Service	[26]	o	IF visited-to-home request on roaming II-NNI AND table 6.1.3.1/77 AND request outside an existing dialog THEN do (NOTE)
36	P-Private-Network-Indication	[84]	o	IF table 6.1.3.1/80 AND request outside an existing dialog THEN do (NOTE)
37	P-Profile-Key	[64]	o	IF table 6.1.3.1/59 AND request outside an existing dialog THEN do (NOTE)
38	P-Served-User	[85]	o	IF visited-to-home request on roaming II-NNI AND request outside an existing dialog being sent from "privileged sender" THEN dm (NOTE)
39	P-User-Database	[60]	o	dn/a
40	P-Visited-Network-ID	[24]	o	dn/a
41	Privacy	[34]	o	IF dc2 (OIP/OIR: clause 12.3) THEN dm ELSE do
42	Proxy-Authorization	[13]	o	IF table 6.1.3.1/7 THEN do (NOTE)
43	Proxy-Require	[13]	o	do
44	Reason	[48]	o	IF table 6.1.3.1/40 AND request inside an existing dialog THEN do (NOTE)
45	Record-Route	[13]	o	do
46	Recv-Info	[39]	n/a	dn/a
47	Referred-By	[53]	o	do

Item	Header field	Ref.	RFC status	II-NNI condition
48	Reject-Contact	[51]	o	do
49	Relayed-Charge	[5]	n/a	dn/a
50	Request-Disposition	[51]	o	do
51	Require	[13]	c	dc
52	Resource-Priority	[78]	o	IF table 6.1.3.1/73 THEN do (NOTE)
53	Route	[13]	c	dc
54	Security-Client	[47]	o	dn/a
55	Security-Verify	[47]	o	dn/a
56	Session-ID	[124]	m	IF table 6.1.3.1/94 THEN dm (NOTE)
57	Supported	[13]	o	IF dc1 (PNM: clause 12.17) THEN dm ELSE do
58	Timestamp	[13]	o	do
59	To	[13]	m	dm
60	User-Agent	[13]	o	do
61	Via	[13]	m	dm
dc1:	request outside an existing dialog invoked due to PNM in case of ("PN UE redirection" OR "PN access control") AND (non-roaming II-NNI OR home-to-visited request on roaming II-NNI)			
dc2:	(request outside an existing dialog invoked due to OIP/OIR AND "override the default setting" in temporary mode AND visited-to-home request on roaming II-NNI) OR (request outside an existing dialog invoked due to OIP/OIR AND "presentation of the public user identity is restricted" AND (non-roaming II-NNI OR home-to-visited request on roaming II-NNI))			
NOTE:	If the capability specified in table 6.1.3.1 is not supported over the II-NNI, the IBCF in the receiving network can omit or modify the SIP header fields in the received SIP message prior to forwarding the SIP message as specified in 3GPP TS 24.229 [5] clause 5.10.6.2.			

The table B.10.2 lists the supported header fields within the OPTIONS response.

Table B.10.2: Supported header fields within the OPTIONS response

Item	Header field	SIP status code	Ref.	RFC status	II-NNI condition
1	Accept	2xx	[13]	m*	dm*
		415		c	dc
2	Accept-Encoding	2xx	[13]	m*	dm*
		415		c	dc
3	Accept-Language	2xx	[13]	m*	dm*
		415		c	dc
4	Accept-Resource-Priority	2xx 417	[78]	o	IF table 6.1.3.1/73 THEN do (NOTE 2)
5	Allow	2xx	[13]	m*	dm*
		405		m	dm
		others		o	do
6	Allow-Events	2xx	[20]	o	IF table 6.1.3.1/23 THEN do (NOTE 2)
7	Authentication-Info	2xx	[13]	o	IF table 6.1.3.1/7 THEN do (NOTE 2)
8	Call-ID	100 others	[13]	m	dm
9	Call-Info	r	[13]	o	do
10	Cellular-Network-Info	r	[5]	n/a	IF table 6.1.3.1/117 THEN do (NOTE 2)
11	Contact	2xx 3xx 485	[13]	o	do
12	Content-Disposition	r	[13]	o	do
13	Content-Encoding	r	[13]	o	do
14	Content-Language	r	[13]	o	do
15	Content-Length	100 others	[13]	t	dt
16	Content-Type	r	[13]	*	d*
17	CSeq	100 others	[13]	m	dm
18	Date	100 others	[13]	o	do
19	Error-Info	3xx-6xx	[13]	o	IF table 6.1.3.1/13 THEN do (NOTE 2)
20	Feature-Caps	2xx	[143]	o	IF table 6.1.3.1/103 AND response to request outside an existing dialog THEN do (NOTE 2)
21	From	100 others	[13]	m	dm
22	Geolocation-Error	424	[68]	m	dm
		others		o	do
23	History-Info	r	[25]	o	IF table 6.1.3.1/50 AND response to request outside an existing dialog THEN do (NOTE 2)
24	MIME-version	r	[13]	o	do
25	Organization	r	[13]	o	do
26	P-Access-Network-Info	r	[24], [24A], [24B]	o	IF table 6.1.3.1/36 THEN do (NOTE 2)
27	P-Asserted-Identity	r	[44]	o	IF dc1 (TIP/TIR: clause 12.4) THEN dm ELSE IF table 6.1.3.1/27 AND response to request outside an existing dialog THEN do (NOTE 2)
28	P-Charging-Function-Addresses	r	[24], [24A]	o	dn/a
29	P-Charging-Vector	r	[24], [24A]	o	IF table 6.1.3.1/38 AND response to request outside an existing dialog THEN dm (NOTE 2)
30	P-Preferred-Identity	r	[44]	o	dn/a
31	Privacy	r	[34]	o	IF dc2 (TIP/TIR: clause 12.4) THEN dm ELSE do
32	Proxy-Authenticate	401 (NOTE 1)	[13]	o	do

Item	Header field	SIP status code	Ref.	RFC status	II-NNI condition
		407 (NOTE 1)		m	dm
33	Record-Route	2xx	[13]	o	do
34	Recv-Info	2xx others	[39]	n/a	dn/a
35	Relayed-Charge	r	[5]	n/a	dn/a
36	Require	r	[13]	c	dc
37	Response-Source	3xx-6xx	[5]	n/a	IF table 6.1.3.1/121 THEN do (NOTE 2)
38	Restoration-Info	504	[5]	n/a	IF table 6.1.3.1/114 AND visited-to-home response on roaming II-NNI THEN do (NOTE 2)
39	Retry-After	404 413 480 486 500 503 600 603	[13]	o	do
40	Security-Server	421 494	[47]	o	dn/a
41	Server	r	[13]	o	do
42	Session-ID	r	[124]	m	IF table 6.1.3.1/94 THEN dm (NOTE 2)
43	Supported	2xx	[13]	m*	dm*
44	Timestamp	r	[13]	o	do
45	To	100 others	[13]	m	dm
46	Unsupported	420	[13]	m	dm
47	User-Agent	r	[13]	o	do
48	Via	100 others	[13]	m	dm
49	Warning	r	[13]	o	do
50	WWW-Authenticate	401 (NOTE 1)	[13]	m	dm
		407 (NOTE 1)		o	do
dc1:	(TIP/TIR AND 2xx response to request outside an existing dialog AND (visited-to-home response on roaming II-NNI OR non-roaming II-NNI)) OR (TIP/TIR AND response to request outside an existing dialog AND "presentation is allowed" AND home-to-visited response on roaming II-NNI)				
dc2:	(TIP/TIR AND non-100 response to request outside an existing dialog AND "override the default setting" in temporary mode AND visited-to-home response on roaming II-NNI) OR (TIP/TIR AND 2xx response to request outside an existing dialog AND "presentation of the network asserted identity is restricted" AND (non-roaming II-NNI OR home-to-visited response on roaming II-NNI))				
NOTE 1: The SIP status code is only applicable over the roaming II-NNI.					
NOTE 2: If the capability specified in table 6.1.3.1 is not supported over the II-NNI, the IBCF in the receiving network can omit or modify the SIP header fields in the received SIP message prior to forwarding the SIP message as specified in 3GPP TS 24.229 [5] clause 5.10.6.2.					

B.11 PRACK method

The table B.11.1 lists the supported header fields within the PRACK request.

Table B.11.1: Supported header fields within the PRACK request

Item	Header field	Ref.	RFC status	II-NNI condition
1	Accept	[13], [18]	o	do
2	Accept-Contact	[51]	o	do
3	Accept-Encoding	[13], [18]	o	do
4	Accept-Language	[13], [18]	o	do
5	Allow	[13], [18]	o	do
6	Allow-Events	[20]	o	IF table 6.1.3.1/23 THEN do (NOTE)
7	Authorization	[13], [18]	o	IF table 6.1.3.1/7 THEN do (NOTE)
8	Call-ID	[13], [18]	m	dm
9	Cellular-Network-Info	[5]	n/a	IF table 6.1.3.1/117 THEN do (NOTE)
10	Content-Disposition	[13], [18]	o	do
11	Content-Encoding	[13], [18]	o	do
12	Content-Language	[13], [18]	o	do
13	Content-Length	[13], [18]	t	dt
14	Content-Type	[13], [18]	*	d*
15	CSeq	[13], [18]	m	dm
16	Date	[13], [18]	o	do
17	From	[13], [18]	m	dm
18	Max-Breadth	[79]	o	do
19	Max-Forwards	[13], [18]	m	dm
20	MIME-Version	[13], [18]	o	do
21	P-Access-Network-Info	[24], [24B]	o	IF table 6.1.3.1/36 THEN do (NOTE)
22	P-Charging-Function-Addresses	[24]	o	dn/a
23	P-Charging-Vector	[24]	o	dn/a
24	P-Early-Media	[74]	o	IF dc1 (CAT: clause 12.14) THEN dm ELSE IF table 6.1.3.1/69 THEN do (NOTE)
25	Priority-Share	[5]	n/a	IF home-to-visited request on roaming II-NNI AND table 6.1.3.1/118 THEN do (NOTE)
26	Privacy	[34]	o	do
27	Proxy-Authorization	[13], [18]	o	IF table 6.1.3.1/7 THEN do (NOTE)
28	Proxy-Require	[13], [18]	o	do
29	RAck	[18]	m	dm
30	Reason	[48]	o	IF table 6.1.3.1/40 THEN do (NOTE)
31	Record-Route	[13], [18]	o	do
32	Recv-Info	[39]	o	IF table 6.1.3.1/17 THEN do (NOTE)
33	Referred-By	[53]	o	do
34	Reject-Contact	[51]	o	do
35	Relayed-Charge	[5]	n/a	dn/a
36	Request-Disposition	[51]	o	do
37	Require	[13], [18]	c	dc
38	Resource-Priority	[78]	o	IF table 6.1.3.1/73 THEN do (NOTE)
39	Resource-Share	[5]	n/a	IF (home-to-visited request on roaming II-NNI OR visited-to-home request on roaming II-NNI) AND table 6.1.3.1/116 THEN do (NOTE)
40	Route	[13], [18]	c	dc
41	Session-ID	[124]	m	IF table 6.1.3.1/94 THEN dm (NOTE)
42	Supported	[13], [18]	o	do
43	Timestamp	[13], [18]	o	do
44	To	[13], [18]	m	dm
45	User-Agent	[13], [18]	o	do
46	Via	[13], [18]	m	dm
dc1:	request invoked due to CAT to first 18x response with P-Early-Media header field cancelling "CAT service" provided by terminating AS AND (non-roaming II-NNI OR loopback traversal scenario OR home-to-visited request on roaming II-NNI)			
NOTE:	If the capability specified in table 6.1.3.1 is not supported over the II-NNI, the IBCF in the receiving network can omit or modify the SIP header fields in the received SIP message prior to forwarding the SIP message as specified in 3GPP TS 24.229 [5] clause 5.10.6.2.			

The table B.11.2 lists the supported header fields within the PRACK response.

Table B.11.2: Supported header fields within the PRACK response

Item	Header field	SIP status code	Ref.	RFC status	II-NNI condition
1	Accept	415	[13], [18]	c	dc
2	Accept-Encoding	415	[13], [18]	c	dc
3	Accept-Language	415	[13], [18]	c	dc
4	Accept-Resource-Priority	2xx 417	[78]	o	IF table 6.1.3.1/73 THEN do (NOTE 2)
5	Allow	405	[13], [18]	m	dm
		others		o	do
6	Allow-Events	2xx	[20]	o	IF table 6.1.3.1/23 THEN do (NOTE 2)
7	Authentication-Info	2xx	[13], [18]	o	IF table 6.1.3.1/7 THEN do (NOTE 2)
8	Call-ID	100 r	[13], [18]	m	dm
9	Cellular-Network-Info	r	[5]	n/a	IF table 6.1.3.1/117 THEN do (NOTE 2)
10	Contact	3xx 485	[13], [18]	o	do
11	Content-Disposition	r	[13], [18]	o	do
12	Content-Encoding	r	[13], [18]	o	do
13	Content-Language	r	[13], [18]	o	do
14	Content-Length	100 others	[13], [18]	t	dt
15	Content-Type	r	[13], [18]	*	d*
16	CSeq	100	[13], [18]	m	dm
		others			
17	Date	100 others	[13], [18]	o	do
18	Error-Info	3xx-6xx	[13], [18]	o	IF table 6.1.3.1/13 THEN do (NOTE 2)
19	From	100 others	[13], [18]	m	dm
20	MIME-version	r	[13], [18]	o	do
21	P-Access-Network-Info	r	[24], [24A], [24B]	o	IF table 6.1.3.1/36 THEN do (NOTE 2)
22	P-Charging-Function-Addresses	r	[24], [24A]	o	dn/a
23	P-Charging-Vector	r	[24], [24A]	o	dn/a
24	P-Early-Media	2xx	[74]	o	IF table 6.1.3.1/69 THEN do (NOTE 2)
25	Priority-Share	2xx	[5]	n/a	IF home-to-visited response on roaming II-NNI AND table 6.1.3.1/118 THEN do (NOTE 2)
26	Privacy	r	[34]	o	do
27	Proxy-Authenticate	401 (NOTE 1)	[13], [18]	o	do
		407 (NOTE 1)		m	dm
28	Record-Route	2xx	[13], [18]	o	do
29	Recv-Info	2xx	[39]	c	IF table 6.1.3.1/17 THEN dc (NOTE 2)
		others		o	IF table 6.1.3.1/17 THEN do (NOTE 2)
30	Relayed-Charge	r	[5]	n/a	dn/a
31	Require	r	[13], [18]	c	dc
32	Resource-Share	2xx	[5]	n/a	IF (home-to-visited response on roaming II-NNI OR visited-to-home response on roaming II-NNI) AND table 6.1.3.1/116 THEN do (NOTE 2)

Item	Header field	SIP status code	Ref.	RFC status	II-NNI condition
33	Response-Source	3xx-6xx	[5]	n/a	IF table 6.1.3.1/121 THEN do (NOTE 2)
34	Retry-After	404 413 480 486 500 503 600 603	[13], [18]	o	do
35	Security-Server	421 494	[47]	n/a	dn/a
36	Server	r	[13], [18]	o	do
37	Session-ID	r	[124]	m	IF table 6.1.3.1/94 THEN dm (NOTE 2)
38	Supported	2xx	[13], [18]	o	do
39	Timestamp	r	[13], [18]	o	do
40	To	100 others	[13], [18]	m	dm
41	Unsupported	420	[13], [18]	m	dm
42	User-Agent	r	[13], [18]	o	do
43	Via	100 others	[13], [18]	m	dm
44	Warning	r	[13], [18]	o	do
45	WWW-Authenticate	401 (NOTE 1)	[13], [18]	m	dm
		407 (NOTE 1)		o	do
NOTE 1: The SIP status code is only applicable over the roaming II-NNI.					
NOTE 2: If the capability specified in table 6.1.3.1 is not supported over the II-NNI, the IBCF in the receiving network can omit or modify the SIP header fields in the received SIP message prior to forwarding the SIP message as specified in 3GPP TS 24.229 [5] clause 5.10.6.2.					

B.12 PUBLISH method

As described in table 6.1, the support of PUBLISH method over the non-roaming II-NNI is based on bilateral agreement between the operators.

The table B.12.1 lists the supported header fields within the PUBLISH request.

Table B.12.1: Supported header fields within the PUBLISH request

Item	Header field	Ref.	RFC status	II-NNI condition
1	Accept-Contact	[51]	o	IF dc1 (PNM: clause 12.17) THEN dm ELSE do
2	Allow	[13], [21]	o	do
3	Allow-Events	[20]	o	IF table 6.1.3.1/23 THEN do (NOTE)
4	Authorization	[13], [21]	o	IF table 6.1.3.1/7 THEN do (NOTE)
5	Call-ID	[13], [21]	m	dm
6	Call-Info	[13], [21]	o	IF dc2 (CCBS/CCNR/CCNL: clause 12.11/12.12/12.23) THEN dm ELSE do
7	Cellular-Network-Info	[5]	n/a	IF table 6.1.3.1/117 THEN do (NOTE)
8	Contact	[13], [21]	n/a	dn/a
9	Content-Disposition	[13], [21]	o	do
10	Content-Encoding	[13], [21]	o	do
11	Content-Language	[13], [21]	o	do
12	Content-Length	[13], [21]	t	dt
13	Content-Type	[13], [21]	*	d*
14	CSeq	[13], [21]	m	dm
15	Date	[13], [21]	o	do
16	Event	[20]	m	dm
17	Expires	[13], [21]	o	IF dc2 (CCBS/CCNR/CCNL: clause 12.11/12.12/12.23) THEN dm ELSE do
18	Feature-Caps	[143]	o	IF table 6.1.3.1/103 AND request outside an existing dialog THEN do
19	From	[13], [21]	m	dm
20	Geolocation	[68]	o	do
21	Geolocation-Routing	[68]	o	do
22	History-Info	[25]	o	IF dc1 (PNM: clause 12.17) THEN dm ELSE IF table 6.1.3.1/50 AND request outside an existing dialog THEN do (NOTE)
23	In-Reply-To	[13], [21]	n/a	dn/a
24	Max-Breadth	[79]	o	do
25	Max-Forwards	[13], [21]	m	dm
26	MIME-Version	[13], [21]	o	do
27	Organization	[13], [21]	o	do
28	P-Access-Network-Info	[24], [24B]	o	IF table 6.1.3.1/36 THEN do (NOTE)
29	P-Asserted-Identity	[44]	o	IF dc2 (CCBS/CCNR/CCNL: clause 12.11/12.12/12.23) OR table 6.1.3.1/27 AND request outside an existing dialog THEN dm (NOTE)
30	P-Asserted-Service	[26]	o	IF (non-roaming II-NNI OR home-to-visited request on roaming II-NNI) AND table 6.1.3.1/77 AND request outside an existing dialog THEN do (NOTE)
31	P-Called-Party-ID	[24]	o	IF home-to-visited request on roaming II-NNI AND table 6.1.3.1/34 THEN do (NOTE)
32	P-Charging-Function-Addresses	[24]	o	dn/a
33	P-Charging-Vector	[24]	o	IF table 6.1.3.1/38 AND request outside an existing dialog THEN dm (NOTE)
34	P-Preferred-Identity	[44]	o	dn/a
35	P-Preferred-Service	[26]	o	IF visited-to-home request on roaming II-NNI AND table 6.1.3.1/77 AND request outside an existing dialog THEN do (NOTE)
36	P-Private-Network-Indication	[84]	o	IF table 6.1.3.1/80 AND request outside an existing dialog THEN do (NOTE)
37	P-Profile-Key	[64]	o	IF table 6.1.3.1/59 AND request outside an existing dialog THEN do (NOTE)
38	P-Served-User	[85]	o	IF visited-to-home request on roaming II-NNI AND request outside an existing dialog being sent from "privileged sender" THEN dm (NOTE)
39	P-User-Database	[60]	o	dn/a
40	P-Visited-Network-ID	[24]	o	dn/a
41	Priority	[13], [21]	o	do
42	Privacy	[34]	o	IF dc3 (OIP/OIR: clause 12.3) THEN dm ELSE do
43	Proxy-Authorization	[13], [21]	o	IF table 6.1.3.1/7 THEN do (NOTE)
44	Proxy-Require	[13], [21]	o	do

Item	Header field	Ref.	RFC status	II-NNI condition
45	Reason	[48]	o	IF table 6.1.3.1/40 AND request inside an existing dialog THEN do (NOTE)
46	Referred-By	[53]	o	do
47	Reject-Contact	[51]	o	do
48	Relayed-Charge	[5]	n/a	dn/a
49	Reply-To	[13], [21]	n/a	dn/a
50	Request-Disposition	[51]	o	do
51	Require	[13], [21]	o	do
52	Resource-Priority	[78]	o	IF table 6.1.3.1/73 THEN do (NOTE)
53	Route	[13], [21]	c	dc
54	Security-Client	[47]	o	dn/a
55	Security-Verify	[47]	o	dn/a
56	Session-ID	[124]	m	IF table 6.1.3.1/94 THEN dm (NOTE)
57	SIP-If-Match	[21]	o	do
58	Subject	[13], [21]	o	do
59	Supported	[13], [21]	o	IF dc1 (PNM: clause 12.17) THEN dm ELSE do
60	Timestamp	[13], [21]	o	do
61	To	[13], [21]	m	dm
62	User-Agent	[13], [21]	o	do
63	Via	[13], [21]	m	dm
dc1:	request outside an existing dialog invoked due to PNM in case of ("PN UE redirection" OR "PN access control") AND (non-roaming II-NNI OR home-to-visited request on roaming II-NNI)			
dc2:	(request inside an existing dialog invoked due to CCBS/CCNR/CCNL suspending the "CC request" AND (non-roaming II-NNI OR loopback traversal scenario) OR (request inside an existing dialog invoked due to CCBS/CCNR/CCNL resuming the "CC request" AND (non-roaming II-NNI OR loopback traversal scenario))			
dc3:	(request outside an existing dialog invoked due to OIP/OIR AND "override the default setting" in temporary mode AND visited-to-home request on roaming II-NNI) OR (request outside an existing dialog invoked due to OIP/OIR AND "presentation of the public user identity is restricted" AND (non-roaming II-NNI OR home-to-visited request on roaming II-NNI))			
NOTE:	If the capability specified in table 6.1.3.1 is not supported over the II-NNI, the IBCF in the receiving network can omit or modify the SIP header fields in the received SIP message prior to forwarding the SIP message as specified in 3GPP TS 24.229 [5] clause 5.10.6.2.			

The table B.12.2 lists the supported header fields within the PUBLISH response.

Table B.12.2: Supported header fields within the PUBLISH response

Item	Header field	SIP status code	Ref.	RFC status	II-NNI condition
1	Accept	415	[13], [21]	m*	dm*
2	Accept-Encoding	415	[13], [21]	m*	dm*
3	Accept-Language	415	[13], [21]	m*	dm*
4	Accept-Resource-Priority	200 417	[78]	o	IF table 6.1.3.1/73 THEN do (NOTE 2)
5	Allow	405	[13], [21]	m	dm
		others		o	do
6	Allow-Events	489	[20]	m	dm
7	Authentication-Info	2xx	[13], [21]	o	IF table 6.1.3.1/7 THEN do (NOTE 2)
8	Call-ID	100	[13], [21]	m	dm
		others			
9	Call-Info	r	[13], [21]	o	do
10	Cellular-Network-Info	r	[5]	n/a	IF table 6.1.3.1/117 THEN do (NOTE 2)
11	Contact	3xx	[13], [21]	o	do
		485			
12	Content-Disposition	r	[13], [21]	o	do
13	Content-Encoding	r	[13], [21]	o	do
14	Content-Language	r	[13], [21]	o	do
15	Content-Length	100	[13], [21]	t	dt
		others			
16	Content-Type	r	[13], [21]	*	d*
17	CSeq	100	[13], [21]	m	dm
		others			
18	Date	100	[13], [21]	o	do
		others			
19	Error-Info	3xx-6xx	[13], [21]	o	IF table 6.1.3.1/13 THEN do (NOTE 2)
20	Expires	2xx	[13], [21]	m	dm
		others		o	do
21	Feature-Caps	2xx	[143]	o	IF table 6.1.3.1/103 AND response to request outside an existing dialog THEN do
22	From	100	[13], [21]	m	dm
		others			
23	Geolocation-Error	424	[68]	m	dm
		others		o	do
24	History-Info	r	[25]	o	IF table 6.1.3.1/50 AND response to request outside an existing dialog THEN do (NOTE 2)
25	MIME-version	r	[13], [21]	o	do
26	Min-Expires	423	[13], [21]	m	dm
27	Organization	r	[13], [21]	o	do
28	P-Access-Network-Info	r	[24], [24A], [24B]	o	IF table 6.1.3.1/36 THEN do (NOTE 2)
29	P-Asserted-Identity	r	[44]	o	IF dc1 (TIP/TIR: clause 12.4) THEN dm ELSE IF table 6.1.3.1/27 AND response to request outside an existing dialog THEN do (NOTE 2)
30	P-Charging-Function-Addresses	r	[24], [24A]	o	dn/a
31	P-Charging-Vector	r	[24], [24A]	o	IF table 6.1.3.1/38 AND response to request outside an existing dialog THEN dm (NOTE 2)
32	P-Preferred-Identity	r	[44]	o	dn/a
33	Privacy	r	[34]	o	IF dc2 (TIP/TIR: clause 12.4) THEN dm ELSE do
34	Proxy-Authenticate	401 (NOTE 1)	[13], [21]	o	do
		407 (NOTE 1)		m	dm

Item	Header field	SIP status code	Ref.	RFC status	II-NNI condition
35	Relayed-Charge	r	[5]	n/a	dn/a
36	Require	r	[13], [21]	o	do
37	Response-Source	3xx-6xx	[5]	n/a	IF table 6.1.3.1/121 THEN do (NOTE 2)
38	Restoration-Info	504	[5]	n/a	IF table 6.1.3.1/114 AND visited-to-home response on roaming II-NNI THEN do (NOTE 2)
39	Retry-After	404 413 480 486 500 503 600 603	[13], [21]	o	do
40	Security-Server	421 494	[47]	o	dn/a
41	Server	r	[13], [21]	o	do
42	Session-ID	r	[124]	m	IF table 6.1.3.1/94 THEN dm (NOTE 2)
43	SIP-Etag	2xx	[21]	m	dm
44	Supported	2xx	[13], [21]	o	do
45	Timestamp	r	[13], [21]	o	do
46	To	100 others	[13], [21]	m	dm
47	Unsupported	420	[13], [21]	o	do
48	User-Agent	r	[13], [21]	o	do
49	Via	100 others	[13], [21]	m	dm
50	Warning	r	[13], [21]	o	do
51	WWW-Authenticate	401 (NOTE 1) 407 (NOTE 1)	[13], [21]	m o	dm do
dc1:	(TIP/TIR AND 2xx response to request outside an existing dialog AND (visited-to-home response on roaming II-NNI OR non-roaming II-NNI)) OR (TIP/TIR AND response to request outside an existing dialog AND "presentation is allowed" AND home-to-visited response on roaming II-NNI)				
dc2:	(TIP/TIR AND non-100 response to request outside an existing dialog AND "override the default setting" in temporary mode AND visited-to-home response on roaming II-NNI) OR (TIP/TIR AND 2xx response to request outside an existing dialog AND "presentation of the network asserted identity is restricted" AND (non-roaming II-NNI OR home-to-visited response on roaming II-NNI))				
NOTE 1:	The SIP status code is only applicable over the roaming II-NNI.				
NOTE 2:	If the capability specified in table 6.1.3.1 is not supported over the II-NNI, the IBCF in the receiving network can omit or modify the SIP header fields in the received SIP message prior to forwarding the SIP message as specified in 3GPP TS 24.229 [5] clause 5.10.6.2.				

B.13 REFER method

As described in table 6.1, the support of REFER method over the II-NNI is based on bilateral agreement between the operators.

The table B.13.1 lists the supported header fields within the REFER request.

Table B.13.1: Supported header fields within the REFER request

Item	Header field	Ref.	RFC status	II-NNI condition
1	Accept	[13], [22]	o	do
2	Accept-Contact	[51]	o	IF dc1 (PNM: clause 12.17) THEN dm ELSE do
3	Accept-Encoding	[13], [22]	o	do
4	Accept-Language	[13], [22]	o	do
5	Allow	[13], [22]	o	do
6	Allow-Events	[20]	o	IF table 6.1.3.1/23 THEN do (NOTE)
7	Authorization	[13], [22]	o	IF table 6.1.3.1/7 THEN do (NOTE)
8	Call-ID	[13], [22]	m	dm
9	Cellular-Network-Info	[5]	n/a	IF table 6.1.3.1/117 THEN do (NOTE)
10	Contact	[13], [22]	m	dm
11	Content-Disposition	[13], [22]	o	do
12	Content-Encoding	[13], [22]	o	do
13	Content-Language	[13], [22]	o	do
14	Content-Length	[13], [22]	o	do
15	Content-Type	[13], [22]	*	d*
16	CSeq	[13], [22]	m	dm
17	Date	[13], [22]	o	do
18	Expires	[13], [22]	o	do
19	Feature-Caps	[143]	o	IF table 6.1.3.1/103 AND request outside an existing dialog THEN do (NOTE)
20	From	[13], [22]	m	dm
21	Geolocation	[68]	o	do
22	Geolocation-Routing	[68]	o	do
23	History-Info	[25]	o	IF dc1 (PNM: clause 12.17) THEN dm ELSE IF table 6.1.3.1/50 AND request outside an existing dialog THEN do (NOTE)
24	Max-Breadth	[79]	o	do
25	Max-Forwards	[13], [22]	m	dm
26	MIME-Version	[13], [22]	o	do
27	Organization	[13], [22]	o	do
28	P-Access-Network-Info	[24], [24B]	o	IF table 6.1.3.1/36 THEN do (NOTE)
29	P-Asserted-Identity	[44]	o	IF table 6.1.3.1/27 AND request outside an existing dialog THEN dm (NOTE)
30	P-Asserted-Service	[26]	o	IF (non-roaming II-NNI OR home-to-visited request on roaming II-NNI) AND table 6.1.3.1/77 AND request outside an existing dialog THEN do (NOTE)
31	P-Called-Party-ID	[24], [24A]	o	IF home-to-visited request on roaming II-NNI AND table 6.1.3.1/34 THEN do (NOTE)
32	P-Charging-Function-Addresses	[24]	o	dn/a
33	P-Charging-Vector	[24]	o	IF table 6.1.3.1/38 AND request outside an existing dialog THEN dm (NOTE)
34	P-Preferred-Identity	[44]	o	dn/a
35	P-Preferred-Service	[26]	o	IF visited-to-home request on roaming II-NNI AND table 6.1.3.1/77 AND request outside an existing dialog THEN do (NOTE)
36	P-Private-Network-Indication	[84]	o	IF table 6.1.3.1/80 AND request outside an existing dialog THEN do (NOTE)
37	P-Profile-Key	[64]	o	IF table 6.1.3.1/59 AND request outside an existing dialog THEN do (NOTE)
38	P-Served-User	[85]	o	IF visited-to-home request on roaming II-NNI AND request outside an existing dialog being sent from "privileged sender" THEN dm (NOTE)
39	P-User-Database	[60]	o	dn/a
40	P-Visited-Network-ID	[24]	o	dn/a
41	Privacy	[34]	o	IF dc2 (OIP/OIR: clause 12.3) OR dc3 (ECT: clause 12.13) THEN dm ELSE do
42	Proxy-Authorization	[13], [22]	o	IF table 6.1.3.1/7 THEN do (NOTE)
43	Proxy-Require	[13], [22]	o	do
44	Reason	[48]	o	IF table 6.1.3.1/40 AND request inside an existing dialog THEN do (NOTE)
45	Record-Route	[13], [22]	o	do
46	Refer-Sub	[135]	o	do
47	Refer-To	[22]	dm	dm

Item	Header field	Ref.	RFC status	II-NNI condition
48	Referred-By	[53]	o	IF dc4 (ECT: clause 12.13) THEN dm ELSE do
49	Reject-Contact	[51]	o	do
50	Relayed-Charge	[5]	n/a	dn/a
51	Request-Disposition	[51]	o	do
52	Require	[13], [22]	c	dc
53	Resource-Priority	[78]	o	IF table 6.1.3.1/73 THEN do (NOTE)
54	Route	[13], [22]	c	dc
55	Security-Client	[47]	o	dn/a
56	Security-Verify	[47]	o	dn/a
57	Session-ID	[124]	m	IF table 6.1.3.1/94 THEN dm (NOTE)
58	Supported	[13], [22]	o	IF dc1 (PNM: clause 12.17) THEN dm ELSE do
59	Target-Dialog	[140]	o	IF table 6.1.3.1/102 THEN do (NOTE)
60	Timestamp	[13], [22]	o	do
61	To	[13], [22]	m	dm
62	Trigger-Consent	[82]	o	IF table 6.1.3.1/78 THEN do (NOTE)
63	User-Agent	[13], [22]	o	do
64	Via	[13], [22]	m	dm
dc1:	request outside an existing dialog invoked due to PNM in case of ("PN UE redirection" OR "PN access control") AND (non-roaming II-NNI OR home-to-visited request on roaming II-NNI)			
dc2:	(request outside an existing dialog invoked due to OIP/OIR AND "override the default setting" in temporary mode AND visited-to-home request on roaming II-NNI) OR (request outside an existing dialog invoked due to OIP/OIR AND "presentation of the public user identity is restricted" AND (non-roaming II-NNI OR home-to-visited request on roaming II-NNI))			
dc3:	request inside an existing dialog invoked due to ECT including Referred-By header field with privacy requested in the "original communication"			
dc4:	request inside an existing dialog invoked due to ECT AND (non-roaming II-NNI OR loopback traversal scenario OR home-to-visited request on roaming II-NNI)			
NOTE:	If the capability specified in table 6.1.3.1 is not supported over the II-NNI, the IBCF in the receiving network can omit or modify the SIP header fields in the received SIP message prior to forwarding the SIP message as specified in 3GPP TS 24.229 [5] clause 5.10.6.2.			

The table B.13.2 lists the supported header fields within the REFER response.

Table B.13.2: Supported header fields within the REFER response

Item	Header field	SIP status code	Ref.	RFC status	II-NNI condition
1	Accept	415	[13], [22]	c	dc
2	Accept-Encoding	415	[13], [22]	c	dc
3	Accept-Language	415	[13], [22]	c	dc
4	Accept-Resource-Priority	2xx 417	[78]	o	IF table 6.1.3.1/73 THEN do (NOTE 2)
5	Allow	405	[13], [22]	m	dm
		others		o	do
6	Allow-Events	2xx	[20]	o	IF table 6.1.3.1/23 THEN do (NOTE 2)
7	Authentication-Info	2xx	[13], [22]	o	IF table 6.1.3.1/7 THEN do (NOTE 2)
8	Call-ID	100	[13], [22]	m	dm
		others			
9	Cellular-Network-Info	r	[5]	n/a	IF table 6.1.3.1/117 THEN do (NOTE 2)
10	Contact	2xx	[13], [22]	m	dm
		3xx-6xx		o	do
11	Content-Disposition	r	[13], [22]	o	do
12	Content-Encoding	r	[13], [22]	o	do
13	Content-Language	r	[13], [22]	o	do
14	Content-Length	100 others	[13], [22]	t	dt
15	Content-Type	r	[13], [22]	*	d*
16	CSeq	100	[13], [22]	m	dm
		others			
17	Date	100 others	[13], [22]	o	do
18	Error-Info	3xx-6xx	[13], [22]	o	IF table 6.1.3.1/13 THEN do (NOTE 2)
19	Feature-Caps	2xx	[143]	o	IF table 6.1.3.1/103 AND response to request outside an existing dialog THEN do (NOTE 2)
20	From	100 others	[13], [22]	m	dm
21	Geolocation-Error	424	[68]	m	dm
		others		o	do
22	History-Info	r	[25]	o	IF table 6.1.3.1/50 AND response to request outside an existing dialog THEN do (NOTE 2)
23	MIME-version	r	[13], [22]	o	do
24	Organization	r	[13], [22]	o	do
25	P-Access-Network-Info	r	[24], [24A], [24B]	o	IF table 6.1.3.1/36 THEN do (NOTE 2)
26	P-Asserted-Identity	r	[44]	o	IF dc1 (TIP/TIR: clause 12.4) THEN dm ELSE IF table 6.1.3.1/27 AND response to request outside an existing dialog THEN do (NOTE 2)
27	P-Charging-Function-Addresses	r	[24], [24A]	o	dn/a
28	P-Charging-Vector	r	[24], [24A]	o	IF dc2 (CONF: clause 12.19) OR (table 6.1.3.1/38 AND response to request outside an existing dialog) THEN dm (NOTE 2)
29	P-Preferred-Identity	r	[44]	o	dn/a
30	Permission-Missing	470	[82]	o	IF table 6.1.3.1/78 THEN do (NOTE 2)
31	Privacy	r	[34]	o	IF dc3 (TIP/TIR: clause 12.4) THEN dm ELSE do
32	Proxy-Authenticate	401 (NOTE 1)	[13], [22]	o	do
		407 (NOTE 1)		m	dm
33	Record-Route	2xx	[13], [22]	o	do

Item	Header field	SIP status code	Ref.	RFC status	II-NNI condition
34	Refer-Sub	2xx	[135]	o	IF table 6.1.3.1/98 THEN do (NOTE 2)
35	Relayed-Charge	r	[5]	n/a	dn/a
36	Require	r	[13], [22]	c	dc
37	Response-Source	3xx-6xx	[5]	n/a	IF table 6.1.3.1/121 THEN do (NOTE 2)
38	Restoration-Info	504	[5]	n/a	IF table 6.1.3.1/114 AND visited-to-home response on roaming II-NNI THEN do (NOTE 2)
39	Retry-After	404 413 480 486 500 503 600 603	[13], [22]	o	do
40	Security-Server	421 494	[47]	o	dn/a
41	Server	r	[13], [22]	o	do
42	Session-ID	r	[124]	m	IF table 6.1.3.1/94 THEN dm (NOTE 2)
43	Supported	2xx	[13], [22]	o	do
44	Timestamp	r	[13], [22]	o	do
45	To	100 others	[13], [22]	m	dm
46	Unsupported	420	[13], [22]	o	do
47	User-Agent	r	[13], [22]	o	do
48	Via	100 others	[13], [22]	m	dm
49	Warning	r	[13], [22]	o	do
50	WWW-Authenticate	401 (NOTE 1)	[13], [22]	m	dm
		407 (NOTE 1)		o	do
dc1:	(TIP/TIR AND 2xx response to request outside an existing dialog AND (visited-to-home response on roaming II-NNI OR non-roaming II-NNI)) OR (TIP/TIR AND response to request outside an existing dialog AND "presentation is allowed" AND home-to-visited response on roaming II-NNI)				
dc2:	first response from "conference focus" to request outside an existing dialog AND (non-roaming II-NNI OR home-to-visited response on roaming II-NNI)				
dc3:	(TIP/TIR AND non-100 response to request outside an existing dialog AND "override the default setting" in temporary mode AND visited-to-home response on roaming II-NNI) OR (TIP/TIR AND 2xx response to request outside an existing dialog AND "presentation of the network asserted identity is restricted" AND (non-roaming II-NNI OR home-to-visited response on roaming II-NNI))				
NOTE 1:	The SIP status code is only applicable over the roaming II-NNI.				
NOTE 2:	If the capability specified in table 6.1.3.1 is not supported over the II-NNI, the IBCF in the receiving network can omit or modify the SIP header fields in the received SIP message prior to forwarding the SIP message as specified in 3GPP TS 24.229 [5] clause 5.10.6.2.				

B.14 REGISTER method

As described in table 6.1, the REGISTER method is supported only over the roaming II-NNI.

The table B.14.1 lists the supported header fields within the REGISTER request.

Table B.14.1: Supported header fields within the REGISTER request

Item	Header field	Ref.	RFC status	II-NNI condition
1	Accept	[13]	o	do
2	Accept-Encoding	[13]	o	do
3	Accept-Language	[13]	o	do
4	Allow	[13]	o	do
5	Allow-Events	[20]	o	IF table 6.1.3.1/23 THEN do (NOTE)
6	Authorization	[13]	o	IF using IMS AKA OR using SIP digest THEN dm ELSE do
7	Call-ID	[13]	m	dm
8	Call-Info	[13]	o	do
9	Cellular-Network-Info	[5]	n/a	IF table 6.1.3.1/117 THEN do (NOTE)
10	Contact	[13]	o	dm
11	Content-Disposition	[13]	o	do
12	Content-Encoding	[13]	o	do
13	Content-Language	[13]	o	do
14	Content-Length	[13]	t	dt
15	Content-Type	[13]	*	d*
16	CSeq	[13]	m	dm
17	Date	[13]	o	do
18	Expires	[13]	o	do
19	Feature-Caps	[143]	o	IF table 6.1.3.1/103 THEN do (NOTE)
20	From	[13]	m	dm
21	Geolocation	[68]	o	do
22	Geolocation-Routing	[68]	o	do
23	History-Info	[25]	o	IF table 6.1.3.1/50 AND request outside an existing dialog THEN do (NOTE)
24	Max-Breadth	[79]	o	do
25	Max-Forwards	[13]	m	dm
26	MIME-Version	[13]	o	do
27	Organization	[13]	o	do
28	P-Access-Network-Info	[24]	o	IF table 6.1.3.1/36 THEN do (NOTE)
29	P-Charging-Function-Addresses	[24], [24B]	o	dn/a
30	P-Charging-Vector	[24]	o	dm
31	P-User-Database	[60]	o	dn/a
32	P-Visited-Network-ID	[24]	o	dm
33	Path	[43]	o	dm
34	Privacy	[34]	o	dn/a
35	Proxy-Authorization	[13]	o	do
36	Proxy-Require	[13]	o	do
37	Reason	[48]	o	IF table 6.1.3.1/40 THEN do (NOTE)
38	Recv-Info	[39]	o	IF table 6.1.3.1/17 THEN do (NOTE)
39	Referred-By	[53]	o	do
40	Relayed-Charge	[5]	n/a	dn/a
41	Request-Disposition	[51]	o	do
42	Require	[13]	c	dm
43	Resource-Priority	[78]	o	IF table 6.1.3.1/73 THEN do (NOTE)
44	Resource-Share	[5]	n/a	IF visited-to-home request on roaming II-NNI AND table 6.1.3.1/116 THEN do (NOTE)
45	Route	[13]	c	dn/a
46	Security-Client	[47]	o	dn/a
47	Security-Verify	[47]	o	dn/a
48	Session-ID	[124]	m	IF table 6.1.3.1/94 THEN dm (NOTE)
49	Supported	[13]	o	dm
50	Timestamp	[13]	o	do
51	To	[13]	m	dm
52	User-Agent	[13]	o	do
53	Via	[13]	m	dm
NOTE:	If the capability specified in table 6.1.3.1 is not supported over the II-NNI, the IBCF in the receiving network can omit or modify the SIP header fields in the received SIP message prior to forwarding the SIP message as specified in 3GPP TS 24.229 [5] clause 5.10.6.2.			

The table B.14.2 lists the supported header fields within the REGISTER response.

Table B.14.2: Supported header fields within the REGISTER response

Item	Header field	SIP status code	Ref.	RFC status	II-NNI condition
1	Accept	2xx	[13]	o	do
		415		c	dc
2	Accept-Encoding	2xx	[13]	o	do
		415		c	dc
3	Accept-Language	2xx	[13]	o	do
		415		c	dc
4	Accept-Resource-Priority	2xx 417	[78]	o	IF table 6.1.3.1/73 THEN do (NOTE)
5	Allow	405	[13]	m	dm
		others		o	do
6	Allow-Events	2xx	[20]	o	IF table 6.1.3.1/23 THEN do (NOTE)
7	Authentication-Info	2xx	[13]	o	do
8	Call-ID	100 others	[13]	m	dm
9	Call-Info	r	[13]	o	do
10	Contact	2xx	[13]	o	dm
		3xx		o	do
		485			
11	Content-Disposition	r	[13]	o	do
12	Content-Encoding	r	[13]	o	do
13	Content-Language	r	[13]	o	do
14	Content-Length	100 others	[13]	t	dt
15	Content-Type	r	[13]	*	d*
16	CSeq	100	[13]	m	dm
		others			
17	Date	100	[13]	o	do
		others			
18	Error-Info	3xx-6xx	[13]	o	IF table 6.1.3.1/13 THEN do (NOTE)
19	Feature-Caps	2xx	[143]	o	IF table 6.1.3.1/103 THEN do (NOTE)
20	Flow-Timer	2xx	[65]	o	do
21	From	100	[13]	m	dm
		others			
22	Geolocation-Error	424	[68]	m	dm
		others		o	do
23	History-Info	r	[25]	o	IF table 6.1.3.1/50 AND response to request outside an existing dialog THEN do (NOTE)
24	MIME-version	r	[13]	o	do
25	Min-Expires	423	[13]	m	dm
26	Organization	r	[13]	o	do
27	P-Access-Network-Info	r	[24], [2 4A], [2 4B]	o	IF table 6.1.3.1/36 THEN do (NOTE)
28	P-Associated-URI	2xx	[24]	o	dm
29	P-Charging-Function-Addresses	r	[24], [2 4A]	o	dn/a
30	P-Charging-Vector	r	[24], [2 4A]	o	dm
31	Path	2xx	[43]	o	dm
32	Privacy	r	[34]	o	do
33	Proxy-Authenticate	401	[13]	o	do
		407		m	dm
34	Relayed-Charge	r	[5]	n/a	dn/a
35	Require	r	[13]	c	dc

Item	Header field	SIP status code	Ref.	RFC status	II-NNI condition
36	Response-Source	3xx-6xx	[5]	n/a	IF table 6.1.3.1/121 THEN do (NOTE)
37	Retry-After	404 413 480 486 500 503 600 603	[13]	o	do
38	Security-Server	2xx 401	[47]	n/a	dn/a
		421 494		o	dn/a
39	Server	r	[13]	o	do
40	Service-Route	2xx	[45]	o	dm
41	Session-ID	r	[124]	m	IF table 6.1.3.1/94 THEN dm (NOTE)
42	Supported	2xx	[13]	o	do
43	Timestamp	r	[13]	o	do
44	To	100	[13]	m	dm
		others			
45	Unsupported	420	[13]	m	dm
46	User-Agent	r	[13]	o	do
47	Via	100	[13]	m	dm
		others			
48	Warning	r	[13]	o	do
49	WWW-Authenticate	401	[13]	m	dm
		407		o	do
NOTE: If the capability specified in table 6.1.3.1 is not supported over the II-NNI, the IBCF in the receiving network can omit or modify the SIP header fields in the received SIP message prior to forwarding the SIP message as specified in 3GPP TS 24.229 [5] clause 5.10.6.2.					

B.15 SUBSCRIBE method

As described in table 6.1, the support of SUBSCRIBE method over the non-roaming II-NNI is based on bilateral agreement between the operators.

The table B.15.1 lists the supported header fields within the SUBSCRIBE request.

Table B.15.1: Supported header fields within the SUBSCRIBE request

Item	Header field	Ref.	RFC status	II-NNI condition
1	Accept	[13], [20]	o	do
2	Accept-Contact	[51]	o	IF dc1 (PNM: clause 12.17) THEN dm ELSE do
3	Accept-Encoding	[13], [20]	o	do
4	Accept-Language	[13], [20]	o	do
5	Allow	[13], [20]	o	do
6	Allow-Events	[20]	o	do
7	Authorization	[13], [20]	o	IF table 6.1.3.1/7 THEN do (NOTE)
8	Call-ID	[13], [20]	m	dm
9	Call-Info	[13], [20]	o	IF dc2 (CCBS/CCNR/CCNL: clause 12.11/12.12/12.23) THEN dm ELSE dn/a
10	Cellular-Network-Info	[5]	n/a	IF table 6.1.3.1/117 THEN do (NOTE)
11	Contact	[13], [20]	m	dm
12	Content-Disposition	[13], [20]	o	do
13	Content-Encoding	[13], [20]	o	do
14	Content-Language	[13], [20]	o	do
15	Content-Length	[13], [20]	t	dt
16	Content-Type	[13], [20]	*	d*
17	CSeq	[13], [20]	m	dm
18	Date	[13], [20]	o	do
19	Event	[20]	m	dm
20	Expires	[13], [20]	o	IF dc2 (CCBS/CCNR/CCNL: clause 12.11/12.12/12.23) OR using reg event package THEN dm ELSE do
21	Feature-Caps	[143]	o	IF table 6.1.3.1/103 THEN do (NOTE)
22	From	[13], [20]	m	dm
23	Geolocation	[68]	o	do
24	Geolocation-Routing	[68]	o	do
25	History-Info	[25]	o	IF dc1 (PNM: clause 12.17) THEN dm ELSE IF table 6.1.3.1/50 AND initial request THEN do (NOTE)
26	Max-Breadth	[79]	o	dn/a
27	Max-Forwards	[13], [20]	m	dm
28	MIME-Version	[13], [20]	o	do
29	Organization	[13], [20]	o	do
30	P-Access-Network-Info	[24], [24B]	o	IF table 6.1.3.1/36 THEN do (NOTE)
31	P-Asserted-Identity	[44]	o	IF dc2 (CCBS/CCNR/CCNL: clause 12.11/12.12/12.23) OR table 6.1.3.1/27 AND initial request THEN dm (NOTE)
32	P-Asserted-Service	[26]	o	IF (non-roaming II-NNI OR home-to-visited request on roaming II-NNI) AND table 6.1.3.1/77 AND initial request THEN do (NOTE)
33	P-Called-Party-ID	[24]	o	IF home-to-visited request on roaming II-NNI AND table 6.1.3.1/34 THEN do (NOTE)
34	P-Charging-Function-Addresses	[24]	o	dn/a
35	P-Charging-Vector	[24]	o	IF table 6.1.3.1/38 AND initial request THEN dm (NOTE)
36	P-Preferred-Identity	[44]	o	dn/a
37	P-Preferred-Service	[26]	o	IF visited-to-home request on roaming II-NNI AND table 6.1.3.1/77 AND initial request THEN do (NOTE)
38	P-Private-Network-Indication	[84]	o	IF table 6.1.3.1/80 AND initial request THEN do (NOTE)
39	P-Profile-Key	[64]	o	IF table 6.1.3.1/59 AND initial request THEN do (NOTE)
40	P-Served-User	[85]	o	IF visited-to-home request on roaming II-NNI AND initial request being sent from "privileged sender" THEN dm (NOTE)
41	P-User-Database	[60]	o	dn/a
42	P-Visited-Network-ID	[24]	o	dn/a
43	Priority	[13], [20]	o	do
44	Privacy	[34]	o	IF dc3 (OIP/OIR: clause 12.3) THEN dm ELSE do

Item	Header field	Ref.	RFC status	II-NNI condition
45	Proxy-Authorization	[13], [20]	o	IF table 6.1.3.1/7 THEN do (NOTE)
46	Proxy-Require	[13], [20]	o	do
47	Reason	[48]	o	IF table 6.1.3.1/40 AND subsequent request THEN do (NOTE)
48	Record-Route	[13], [20]	o	do
49	Referred-By	[53]	o	do
50	Reject-Contact	[51]	o	do
51	Relayed-Charge	[5]	n/a	dn/a
52	Request-Disposition	[51]	o	do
53	Require	[13], [20]	o	do
54	Resource-Priority	[78]	o	IF table 6.1.3.1/73 THEN do (NOTE)
55	Route	[13], [20]	c	dc
56	Security-Client	[47]	o	dn/a
57	Security-Verify	[47]	o	dn/a
58	Session-ID	[124]	m	IF table 6.1.3.1/94 THEN dm (NOTE)
59	Supported	[13], [20]	o	IF dc1 (PNM: clause 12.17) THEN dm ELSE do
60	Target-Dialog	[140]	o	IF table 6.1.3.1/102 THEN do (NOTE)
61	Timestamp	[13], [20]	o	do
62	To	[13], [20]	m	dm
63	Trigger-Consent	[82]	o	IF table 6.1.3.1/78 THEN do (NOTE)
64	User-Agent	[13], [20]	o	do
65	Via	[13], [20]	m	dm
dc1:	initial request invoked due to PNM in case of ("PN UE redirection" OR "PN access control") AND (non-roaming II-NNI OR home-to-visited request on roaming II-NNI)			
dc2:	("CC invocation request" due to CCBS/CCNR/CCNL AND non-roaming II-NNI) OR ("CC revocation request" due to CCBS/CCNR/CCNL AND non-roaming II-NNI)			
dc3:	(initial request invoked due to OIP/OIR AND "override the default setting" in temporary mode AND visited-to-home request on roaming II-NNI) OR (initial request invoked due to OIP/OIR AND "presentation of the public user identity is restricted" AND (non-roaming II-NNI OR home-to-visited request on roaming II-NNI))			
NOTE:	If the capability specified in table 6.1.3.1 is not supported over the II-NNI, the IBCF in the receiving network can omit or modify the SIP header fields in the received SIP message prior to forwarding the SIP message as specified in 3GPP TS 24.229 [5] clause 5.10.6.2.			

The table B.15.2 lists the supported header fields within the SUBSCRIBE response.

Table B.15.2: Supported header fields within the SUBSCRIBE response

Item	Header field	SIP status code	Ref.	RFC status	II-NNI condition
1	Accept	415	[13], [20]	o	do
2	Accept-Encoding	415	[13], [20]	o	do
3	Accept-Language	415	[13], [20]	o	do
4	Accept-Resource-Priority	2xx 417	[78]	o	IF table 6.1.3.1/73 THEN do (NOTE 2)
5	Allow	405	[13], [20]	m	dm
		others		o	do
6	Allow-Events	2xx	[20]	o	do
		489		m	dm
7	Authentication-Info	2xx	[13], [20]	o	IF table 6.1.3.1/7 THEN do (NOTE 2)
8	Call-ID	100	[13], [20]	m	dm
		r			
9	Call-Info	r	[13], [20]	o	do
10	Cellular-Network-Info	r	[5]	n/a	IF table 6.1.3.1/117 THEN do (NOTE 2)
11	Contact	2xx	[13], [20]	m	dm
		3xx			
		485		o	do
12	Content-Disposition	r	[13], [20]	o	do
13	Content-Encoding	r	[13], [20]	o	do
14	Content-Language	r	[13], [20]	o	do
15	Content-Length	100	[13], [20]	t	dt
		others			
16	Content-Type	r	[13], [20]	*	d*
17	CSeq	100	[13], [20]	m	dm
		others			
18	Date	100 others	[13], [20]	o	do
19	Error-Info	3xx-6xx	[13], [20]	o	IF table 6.1.3.1/13 THEN do (NOTE 2)
20	Expires	2xx	[13], [20]	m	dm
21	Feature-Caps	2xx	[143]	o	IF table 6.1.3.1/103 THEN do (NOTE 2)
22	From	100 others	[13], [20]	m	dm
23	Geolocation-Error	424	[68]	m	dm
		others		o	do
24	History-Info	r	[25]	o	IF table 6.1.3.1/50 AND response to initial request THEN do (NOTE 2)
25	MIME-version	r	[13], [20]	o	do
26	Min-Expires	423	[13], [20]	m	dm
27	Organization	r	[13], [20]	o	do
28	P-Access-Network-Info	r	[24], [24A], [24B]	o	IF table 6.1.3.1/36 THEN do (NOTE 2)
29	P-Asserted-Identity	r	[44]	o	IF dc1 (TIP/TIR: clause 12.4) THEN dm ELSE IF table 6.1.3.1/27 AND response to initial request THEN do (NOTE 2)
30	P-Charging-Function-Addresses	r	[24], [24A]	o	dn/a
31	P-Charging-Vector	r	[24], [24A]	o	IF table 6.1.3.1/38 AND response to initial request THEN dm (NOTE 2)
32	P-Preferred-Identity	r	[44]	o	dn/a
33	Permission-Missing	470	[82]	o	IF table 6.1.3.1/78 THEN do (NOTE 2)
34	Privacy	r	[34]	o	IF dc2 (TIP/TIR: clause 12.4) THEN dm ELSE do
35	Proxy-Authenticate	401 (NOTE 1)	[13], [20]	o	do
		407 (NOTE 1)		m	dm
36	Record-Route	2xx	[13], [20]	o	do
37	Relayed-Charge	r	[5]	n/a	dn/a
38	Require	r	[13], [20]	o	do

Item	Header field	SIP status code	Ref.	RFC status	II-NNI condition
39	Response-Source	3xx-6xx	[5]	n/a	IF table 6.1.3.1/121 THEN do (NOTE 2)
40	Restoration-Info	504	[5]	n/a	IF table 6.1.3.1/114 AND visited-to-home response on roaming II-NNI THEN do (NOTE 2)
41	Retry-After	404 413 480 486 500 503 600 603	[13], [20]	o	do
42	Security-Server	421 494	[47]	o	dn/a
43	Server	r	[13], [20]	o	do
44	Session-ID	r	[124]	m	IF table 6.1.3.1/94 THEN dm (NOTE 2)
45	Supported	2xx	[13], [20]	o	do
46	Timestamp	r	[13], [20]	o	do
47	To	100 others	[13], [20]	m	dm
48	Unsupported	420	[13], [20]	o	do
49	User-Agent	r	[13], [20]	o	do
50	Via	100 others	[13], [20]	m	dm
51	Warning	r	[13], [20]	o	do
52	WWW-Authenticate	401 (NOTE 1)	[13], [20]	m	dm
		407 (NOTE 1)		o	do
dc1:	(TIP/TIR AND 2xx response to initial request AND (visited-to-home response on roaming II-NNI OR non-roaming II-NNI)) OR (TIP/TIR AND response to initial request AND "presentation is allowed" AND home-to-visited response on roaming II-NNI)				
dc2:	(TIP/TIR AND non-100 response to initial request AND "override the default setting" in temporary mode AND visited-to-home response on roaming II-NNI) OR (TIP/TIR AND 2xx response to initial request AND "presentation of the network asserted identity is restricted" AND (non-roaming II-NNI OR home-to-visited response on roaming II-NNI))				
NOTE 1: The SIP status code is only applicable over the roaming II-NNI.					
NOTE 2: If the capability specified in table 6.1.3.1 is not supported over the II-NNI, the IBCF in the receiving network can omit or modify the SIP header fields in the received SIP message prior to forwarding the SIP message as specified in 3GPP TS 24.229 [5] clause 5.10.6.2.					

B.16 UPDATE method

The table B.16.1 lists the supported header fields within the UPDATE request.

Table B.16.1: Supported header fields within the UPDATE request

Item	Header field	Ref.	RFC status	II-NNI condition
1	Accept	[13], [23]	o	do
2	Accept-Contact	[51]	o	do
3	Accept-Encoding	[13], [23]	o	do
4	Accept-Language	[13], [23]	o	do
5	Allow	[13], [23]	o	do
6	Allow-Events	[20]	n/a	dn/a
7	Authorization	[13], [23]	o	IF table 6.1.3.1/7 THEN do (NOTE)
8	Call-ID	[13], [23]	m	dm
9	Call-Info	[13], [23]	o	do
10	Cellular-Network-Info	[5]	n/a	IF table 6.1.3.1/117 THEN do (NOTE)
11	Contact	[13], [23]	m	dm
12	Content-Disposition	[13], [23]	o	do
13	Content-Encoding	[13], [23]	o	do
14	Content-Language	[13], [23]	o	do
15	Content-Length	[13], [23]	t	dt
16	Content-Type	[13], [23]	*	d*
17	CSeq	[13], [23]	m	dm
18	Date	[13], [23]	o	do
19	Feature-Caps	[143]	o	IF table 6.1.3.1/103 THEN do (NOTE)
20	From	[13], [23]	m	dm
21	Geolocation	[68]	o	do
22	Geolocation-Routing	[68]	o	do
23	Max-Breadth	[79]	o	dn/a
24	Max-Forwards	[13], [23]	m	dm
25	MIME-Version	[13], [23]	o	do
26	Min-SE	[52]	o	do
27	Organization	[13], [23]	o	do
28	P-Access-Network-Info	[24], [24B]	o	IF table 6.1.3.1/36 THEN do (NOTE)
29	P-Charging-Function-Addresses	[24]	o	dn/a
30	P-Charging-Vector	[24]	o	IF table 6.1.3.1/38 THEN do (NOTE)
31	P-Early-Media	[74]	o	IF dc1 (CAT: clause 12.14) OR dc2 (announcements: clause 12.21) THEN dm ELSE IF table 6.1.3.1/69 THEN do (NOTE)
32	Priority-Share	[5]	n/a	IF home-to-visited request on roaming II-NNI AND table 6.1.3.1/118 THEN do (NOTE)
33	Privacy	[34]	o	do
34	Proxy-Authorization	[13], [23]	o	IF table 6.1.3.1/7 THEN do (NOTE)
35	Proxy-Require	[13], [23]	o	do
36	Reason	[48]	o	IF table 6.1.3.1/40 THEN do (NOTE)
37	Record-Route	[13], [23]	o	do
38	Recv-Info	[39]	o	IF table 6.1.3.1/17 THEN do (NOTE)
39	Referred-By	[53]	o	do
40	Reject-Contact	[51]	o	do
41	Relayed-Charge	[5]	n/a	dn/a
42	Request-Disposition	[51]	o	do
43	Require	[13], [23]	c	dc
44	Resource-Priority	[78]	o	IF table 6.1.3.1/73 THEN do (NOTE)
45	Resource-Share	[5]	n/a	IF (home-to-visited request on roaming II-NNI OR visited-to-home request on roaming II-NNI) AND table 6.1.3.1/116 THEN do (NOTE)
46	Route	[13], [23]	c	dc
47	Security-Client	[47]	o	dn/a
48	Security-Verify	[47]	o	dn/a
49	Session-Expires	[52]	o	do
50	Session-ID	[124]	m	IF table 6.1.3.1/94 THEN dm (NOTE)
51	Supported	[13], [23]	o	do
52	Timestamp	[13], [23]	o	do
53	To	[13], [23]	m	dm
54	User-Agent	[13], [23]	o	do
55	Via	[13], [23]	m	dm
dc1:	request invoked due to stopping or restarting CAT early media on an existing dialog AND (non-roaming II-NNI OR loopback traversal scenario OR home-to-visited response on roaming II-NNI)			
dc2:	request invoked due to stopping or restarting announcement early media AND (non-roaming II-NNI OR loopback traversal scenario OR home-to-visited response on roaming II-NNI)			

Item	Header field	Ref.	RFC status	II-NNI condition
NOTE:	If the capability specified in table 6.1.3.1 is not supported over the II-NNI, the IBCF in the receiving network can omit or modify the SIP header fields in the received SIP message prior to forwarding the SIP message as specified in 3GPP TS 24.229 [5] clause 5.10.6.2.			

The table B.16.2 lists the supported header fields within the UPDATE response.

Table B.16.2: Supported header fields within the UPDATE response

Item	Header field	SIP status code	Ref.	RFC status	II-NNI condition
1	Accept	2xx	[13], [23]	o	do
		415		c	dc
2	Accept-Encoding	2xx	[13], [23]	o	do
		415		c	dc
3	Accept-Language	2xx	[13], [23]	o	do
		415		c	dc
4	Accept-Resource-Priority	2xx 417	[78]	o	IF table 6.1.3.1/73 THEN do (NOTE 2)
5	Allow	405	[13], [23]	m	dm
		others		o	do
6	Allow-Events	2xx	[20]	n/a	dn/a
7	Authentication-Info	2xx	[13], [23]	o	IF table 6.1.3.1/7 THEN do (NOTE 2)
8	Call-ID	100 others	[13], [23]	m	dm
9	Call-Info	r	[13], [23]	o	do
10	Cellular-Network-Info	r	[5]	n/a	IF table 6.1.3.1/117 THEN do (NOTE 2)
11	Contact	2xx	[13], [23]	m	dm
		3xx		o	do
		485			
		others		o	do
12	Content-Disposition	r	[13], [23]	o	do
13	Content-Encoding	r	[13], [23]	o	do
14	Content-Language	r	[13], [23]	o	do
15	Content-Length	100	[13], [23]	t	dt
		others			
16	Content-Type	r	[13], [23]	*	d*
17	CSeq	100	[13], [23]	m	dm
		others			
18	Date	100 others	[13], [23]	o	do
19	Error-Info	3xx-6xx	[13], [23]	o	IF table 6.1.3.1/13 THEN do (NOTE 2)
20	Feature-Caps	2xx	[143]	o	IF table 6.1.3.1/103 THEN do (NOTE 2)
21	From	100	[13], [23]	m	dm
		others			
22	Geolocation-Error	424	[68]	m	dm
		others		o	do
23	MIME-version	r	[13], [23]	o	do
24	Min-SE	422	[52]	m	dm
25	Organization	r	[13], [23]	o	do
26	P-Access-Network-Info	r	[24], [24A], [24B]	o	IF table 6.1.3.1/36 THEN do (NOTE 2)
27	P-Charging-Function-Addresses	r	[24], [24A]	o	dn/a
28	P-Charging-Vector	r	[24], [24A]	o	IF table 6.1.3.1/38 THEN do (NOTE 2)
29	P-Early-Media	2xx	[74]	o	IF table 6.1.3.1/69 THEN do (NOTE 2)
30	Priority-Share	2xx	[5]	n/a	IF home-to-visited response on roaming II-NNI AND table 6.1.3.1/118 THEN do (NOTE 2)
31	Privacy	r	[34]	o	do
32	Proxy-Authenticate	401 (NOTE 1)	[13], [23]	o	do
		407 (NOTE 1)		m	dm
33	Record-Route	2xx	[13], [23]	o	do
34	Recv-Info	2xx	[39]	c	IF table 6.1.3.1/17 THEN dc (NOTE 2)

Item	Header field	SIP status code	Ref.	RFC status	II-NNI condition
		others		o	IF table 6.1.3.1/17 THEN do (NOTE 2)
35	Relayed-Charge	r	[5]	n/a	dn/a
36	Require	r	[13], [23]	c	dc
37	Resource-Share	2xx	[5]	n/a	IF (home-to-visited response on roaming II-NNI OR visited-to-home response on roaming II-NNI) AND table 6.1.3.1/116 THEN do (NOTE 2)
38	Response-Source	3xx-6xx	[5]	n/a	IF table 6.1.3.1/121 THEN do (NOTE 2)
39	Retry-After	404 413 480 486 500 503 600 603	[13], [23]	o	do
40	Security-Server	421 494	[47]	o	dn/a
41	Server	r	[13], [23]	o	do
42	Session-Expires	2xx	[52]	o	do
43	Session-ID	r	[124]	m	IF table 6.1.3.1/94 THEN dm (NOTE 2)
44	Supported	2xx	[13], [23]	o	do
45	Timestamp	r	[13], [23]	o	do
46	To	100 others	[13], [23]	m	dm
47	Unsupported	420	[13], [23]	m	dm
48	User-Agent	r	[13], [23]	o	do
49	Via	100 others	[13], [23]	m	dm
50	Warning	r	[13], [23]	o	do
51	WWW-Authenticate	401 (NOTE 1)	[13], [23]	m	dm
		407 (NOTE 1)		o	do
NOTE 1: The SIP status code is only applicable over the roaming II-NNI.					
NOTE 2: If the capability specified in table 6.1.3.1 is not supported over the II-NNI, the IBCF in the receiving network can omit or modify the SIP header fields in the received SIP message prior to forwarding the SIP message as specified in 3GPP TS 24.229 [5] clause 5.10.6.2.					

Annex C (informative): The list of option items for II-NNI

C.1 Scope

This annex provides a list of items that are recommended to be selected by inter-operator agreements for the interconnection between IMS operators using the II-NNI. The items in this annex have an influence on the service interconnection.

For the purposes of this annex, these items are called "option items". The option items are extracted from the present document other than this annex, and are categorized from the aspect of service provisioning by IMS operators.

If an option item is used based on inter-operator agreements, then relating capabilities described in the references are used over the II-NNI. In case of misalignment between the normative part of the present document and this annex, the normative part of the present document takes precedence.

C.2 Format of option item table

The format of option item table used in the subsequent clauses is as follows:

- The 2nd column "Option item" shows the option item.
- The 3rd column "References" shows the relevant clauses of the present document for each option item.
- The 4th column "Applicability at the II-NNI" shows the selectable patterns for each option item.
- The 5th column "Details for operator choice" shows the details for the inter-operator agreements in case the corresponding pattern is chosen. This column intends to be used to exchange each detailed conditions of the II-NNI by means of filling the conditions in the columns corresponding to the selected pattern. Blank row intends to be used as a place holder for describing additional detailed II-NNI conditions specific to the operator network not associated with the explicit descriptions in this annex.

C.3 Option item table

C.3.0 Supported II-NNI traversal scenarios

In this clause the table C.3.0.1 shows the supported II-NNI traversal scenarios option items.

Table C.3.0.1: Supported II-NNI traversal scenarios

No.	Option item	References	Applicability at the II-NNI	Details for operator choice
1	Roaming II-NNI support	entire present specification	Yes	Option items in clauses C.3.1 and C.3.2. Applicability of "Roaming Architecture for Voice over IMS with Local Breakout" (Clause 19). If "Roaming Architecture for Voice over IMS with Local Breakout" is applicable: + option items in clause C.3.3; and + the default TRF address to use when not included in the "g.3gpp.trf" feature-capability indicator.
			No	
2	Non-roaming II-NNI support	entire present specification	Yes	Option items in clauses C.3.1 and C.3.3.
			No	

C.3.1 Option item table common to roaming, non-roaming II-NNI and loopback traversal scenario

This clause describes the option item tables common to the roaming II-NNI, the loopback traversal scenario, and the non-roaming II-NNI as follows:

- Table C.3.1.1 shows the common SIP methods option items.
- Table C.3.1.1A shows the SIP overload control option items.
- Table C.3.1.2 shows the SIP negotiation of resource reservation option item.
- Table C.3.1.2A shows the periodic refresh of SIP sessions option item.
- Table C.3.1.3 shows the replacing of SIP dialogs option item.
- Table C.3.1.4 shows the session participation option item.
- Table C.3.1.5 shows the conveying capabilities of UE option item.
- Table C.3.1.5A shows the authorization of early media option item.
- Table C.3.1.6 shows the asserting the service of authenticated users option item.
- Table C.3.1.7 shows the mode of signalling.
- Table C.3.1.7A shows the SIP message bodies option item.
- Table C.3.1.7B shows the SIP message body size option item.
- Table C.3.1.8 shows the control plane transport option item.
- Table C.3.1.9 shows the user plane transport, media, and codec option items.
- Table C.3.1.10 shows the dual tone multi frequency (DTMF) option item.
- Table C.3.1.10A shows the common numbering, naming and addressing option item.
- Table C.3.1.11 shows the IP version option item.
- Table C.3.1.12 shows the common supplementary services option items.

- Table C.3.1.13 shows the common additional functions option items.
- Table C.3.1.14 shows the SDP lines option items.
- Table C.3.1.15 shows the emergency services option items.
- Table C.3.1.16 shows indicating the II-NNI traversal scenario option items.
- Table C.3.1.17 shows the MCPTT option items.
- Table C.3.1.18 shows the Calling number verification option items.

Table C.3.1.1: SIP method (Common)

No.	Option item	References	Applicability at the II-NNI	Details for operator choice
1	INFO method	table 6.1/5A table 6.1/5B	Yes	Info package name to use.
			No	
2	MESSAGE method	table 6.1/9A table 6.1/9B	Yes	Inside or outside existing dialog, and content of MESSAGE request.
			No	
3	REFER method	table 6.1/16 table 6.1/17	Yes	Inside or outside existing dialog.
			No	

Table C.3.1.1A: SIP overload control

No.	Option item	References	Applicability at the II-NNI	Details for operator choice
1	SIP overload control	table 6.1.3.1/106 clause 21.1	Yes	Mechanisms to be used. Whether to exempt MPS from SIP overload controls.
			No	
2	Feedback control	table 6.1.3.1/107 clause 21.2	Yes	Algorithm to be used if not default (see clause 21.2).
			No	
3	Event control	table 6.1.3.1/108 clause 21.3	Yes	Addresses to targets that can be supervised.
			No	

Table C.3.1.2: Negotiation of resource reservation

No.	Option item	References	Applicability at the II-NNI	Details for operator choice
1	Negotiation of resource reservation (precondition)	table 6.1.3.1/20	Yes	
			No	

Table C.3.1.2A: Periodic refresh of SIP sessions

No.	Option item	References	Applicability at the II-NNI	Details for operator choice
1	SIP session timer (timer)	table 6.1.3.1/45	Yes	Use conditions (Possible restriction on range of times and whether SIP session timer is applied in all sessions).

Table C.3.1.3: Replacing of SIP dialogs

No.	Option item	References	Applicability at the II-NNI	Details for operator choice
1	Replacing of SIP dialogs (replaces)	table 6.1.3.1/47	Yes	
			No	

Table C.3.1.4: Session participation

No.	Option item	References	Applicability at the II-NNI	Details for operator choice
1	Session participation (join)	table 6.1.3.1/48	Yes	
			No	

Table C.3.1.5: Conveying capabilities of UE

No.	Option item	References	Applicability at the II-NNI	Details for operator choice
1	Conveying capabilities of UE	table 6.1.3.1/49	Yes	
			No	

Table C.3.1.5A: Authorization of early media

No.	Option item	References	Applicability at the II-NNI	Details for operator choice
1	Authorization of early media	table 6.1.3.1/69	Yes	Whether to use authorization request of early media generated by the entity outside the IMS network.
			No	

Table C.3.1.6: Asserting the service of authenticated users

No.	Option item	References	Applicability at the II-NNI	Details for operator choice
1	Managing the indication of the asserted service (P-Asserted-Service header field)	table 6.1.3.1/77	Yes	Service identifier values to use.
			No	

Table C.3.1.7: Mode of signalling

No.	Option item	References	Applicability at the II-NNI	Details for operator choice	
1	Overlap signalling	clause 6.1.1.5	In-dialog method	Yes	
			Multiple-INVITE method	No	
				Yes	
			No		

Table C.3.1.7A: SIP message bodies

No.	Option item	References	Applicability at the II-NNI	Details for operator choice
1	MIME type	clause 6.1.4	Yes	MIME types to use. Applicable characteristics of the SIP message body MIMEs (i.e. the value(s) of Content-Disposition header field and Content-Language header field) if necessary.

Table C.3.1.7B: SIP message body size

No.	Option item	References	Applicability at the II-NNI	Details for operator choice
1	Limitation on maximum length of a SIP message body	clause 6.1.4	Yes	Maximum length accepted.
			No	

Table C.3.1.8: Control plane transport

No.	Option item	References	Applicability at the II-NNI	Details for operator choice
1	TCP	clause 6.2	Yes	Use conditions (e.g. port number to accept, number of simultaneous connections in case of reuse of the existing connections).
			No	
2	UDP	clause 6.2	Yes	Use conditions (e.g. port number to accept).
			No	
3	SCTP	clause 6.2	Yes	Use conditions (e.g. port number to accept).
			No	

Table C.3.1.9: User plane transport, media, and codec

No.	Option item	References	Applicability at the II-NNI	Details for operator choice
1	Speech media (m=audio)	clause 7.1	Yes	Names of speech codecs to use. (NOTE 1, NOTE 2)
			No	
2	Video media (m=video)	clause 7.1	Yes	Names of video codecs to use. (NOTE 1, NOTE 2)
			No	
3	Other media	clause 7.1	Yes	Media type (m=line of SDP) to use (e.g. application, image, message).
			No	
4	RTP/AVPF	clause 7.2	Yes	Media type (m=line of SDP) that uses the protocol.
			No	
5	Transmission Control Protocol	clause 6.1.2.1 clause 7.2	Yes	Media type (m=line of SDP) that uses the protocol.
			No	
6	Other user plane protocols	clause 7.2	Yes	Protocols to use (e.g. udptl, TCP/MSRP) and media types (m=line of SDP) that describe the protocols.
			No	

NOTE 1: Codecs which are included in the applicable codec list made by inter-operator agreements are guaranteed to be supported at the II-NNI by the peer operators.

NOTE 2: Whether it is allowed to offer codecs which are not included in the applicable codec list made by inter-operator agreements over the II-NNI is also determined by the inter-operator agreement if necessary.

Table C.3.1.10: Dual tone multi frequency (DTMF)

No.	Option item		References	Applicability at the II-NNI	Details for operator choice
1	DTMF transport	"telephone-event" based DTMF transport	clause 7.1 table 6.1/5A table 6.1/5B clause 12.14 clause 12.15	Yes	
				No	
	The SIP INFO mechanism	Yes			
		No			

Table C.3.1.10A: Numbering, naming and addressing (Common)

No.	Option item	References	Applicability at the II-NNI	Details for operator choice
1	Subaddress ("isub" tel URI parameter)	clause 8.1	Yes	
			No	

Table C.3.1.11: IP version

No.	Option item	References	Applicability at the II-NNI	Details for operator choice
1	IPv4	clause 9	Yes	Use conditions (e.g. for control plane, for user plane).
			No	
2	IPv6	clause 9	Yes	Use conditions (e.g. for control plane, for user plane).
			No	

Table C.3.1.12: Supplementary services (Common)

No.	Option item		References	Applicability at the II-NNI	Details for operator choice
1	Malicious Communication Identification (MCID)		clause 12.2	Yes	Minimum information exchanged over the II-NNI.
				No	
2	Originating Identification Presentation (OIP) and Originating Identification Restriction (OIR)		clause 12.3	Yes	
				No	
3	Terminating Identification Presentation (TIP) and Terminating Identification Restriction (TIR)		clause 12.4	Yes	
				No	
4	Anonymous Communication Rejection (ACR)		clause 12.5	Yes	
				No	
5	Communication DIVersion (CDIV)		clause 12.6	Yes	
				No	
6	Communication Waiting (CW)		clause 12.7	Yes	
				No	
7	Communication HOLD (HOLD)		clause 12.8	Yes	
				No	
8	Message Waiting Indication (MWI)		clause 12.9	Yes	
				No	
9	Incoming Communication Barring (ICB)		clause 12.10.1	Yes	
				No	
10	Completion of Communications to Busy Subscriber (CCBS)		clause 12.11	Yes	
				No	
11	Completion of Communications by No Reply (CCNR)		clause 12.12	Yes	
				No	
12	Explicit Communication Transfer (ECT)		clause 12.13	Yes	Type of explicit communication transfer to support.
				No	
13	Customized Alerting Tone (CAT)		clause 12.14	Yes	CAT model to use (Gateway model, forking model and early session model).
				No	
14	Customized Ringing Signal (CRS)		clause 12.15	Yes	
				No	
15	Closed User Group (CUG)		clause 12.16	Yes	
				No	
16	Personal Network Management (PNM)		clause 12.17	Yes	
				No	
17	Three-Party (3PTY)		clause 12.18	Yes	
				No	
18	Conference (CONF)		clause 12.19	Yes	
				No	
19	Flexible Alerting (FA)		clause 12.20	Yes	
				No	
20	Announcements	During the establishment of a session	clause 12.21.2	Yes	Methods for sending announcement.
		No			
		During an established communication session	clause 12.21.3	Yes	Methods for sending announcement.
		No			
		Providing announcements when communication request is rejected	clause 12.21.4	Yes	Methods for sending announcement.
		No			
21	Advice Of Charge (AOC)		clause 12.22	Yes	
				No	

No.	Option item	References	Applicability at the II-NNI	Details for operator choice	
22	Completion of Communications on Not Logged-in (CCNL)	clause 12.23	Yes		
			No		
23	Presence service	clause 15	Yes	Presence services to use (TS 24.141 [132], OMA 1.1 [142] or OMA 2.0 [138]).	
			No		
24	Messaging service	Page-mode messaging	clause 16.2	Yes	
		Session-mode messaging	clause 16.4	No	
		Session-mode messaging conferences	clause 16.5	Yes	
				No	
24A	Delivery of original destination identity	clause 22	Yes	Services to apply the function.	
			No		
24B	Service access number translation	table 6.1.3.1/52A clause 27	Yes		
			No		
25	Other additional service using other SIP extensions	clause 6.1.1.3.2 clause 12.6	Yes	The SIP extensions to use and the service that uses the extensions.	
			No		

Table C.3.1.13: Additional functions (Common)

No.	Option item	References	Applicability at the II-NNI	Details for operator choice
1	Optimal Media Routeing	clause 17	Yes	
			No	
2	Applying forking (NOTE 1)	table 6.1.3.1/5	Yes	Usage of Request-Disposition header field with value "no-fork". (NOTE 3)
			No (NOTE 2)	
3	Transfer of IP multimedia service tariff information	clause 11.3	Yes	The value of the Content-Disposition header field.
			No	
4	Telepresence using IMS	clause 23	Yes	The value of "+sip.clue" media feature tag in Contact header field.
			No	
NOTE 1: Support of handling of several responses due to forking and of the Request-Disposition header field, is mandated on the II-NNI.				
NOTE 2: In case the operator interconnects with IMS non-compliant networks, and wishes to use the II-NNI anyway, then the operators might want to negotiate if the forking procedures are applicable.				
NOTE 3: The Request-Disposition header field with value "no-fork" can be used to suppress that forking occurs. However, a peer operator might require the usage of forking e.g. to implement certain services.				

Table C.3.1.14: SDP lines

No.	Option item	References	Applicability at the II-NNI	Details for operator choice
1	m=line	clause 6.1.2	Yes	Used static RTP payload type numbers.
2	b=line	clause 6.1.2	Yes	Used bandwidth modifier types.
3	a=line	clause 6.1.2	Yes	Used attributes. For the "rtptime" attribute, used "encoding names".

Table C.3.1.15: Emergency services

No.	Option item	References	Applicability at the II-NNI	Details for operator choice
1	Public Safety Answering Point (PSAP) Callback	table 6.1.3.1/110	Yes	Used PSAP callback indicator.
			No	

Table C.3.1.16: Indicating the II-NNI traversal scenario

No.	Option item	References	Applicability at the II-NNI	Details for operator choice
1	Support of the "iotl" SIP URI parameter indicating the II-NNI traversal scenario	table 6.1.3.1/112 clause 5.3	Yes	
			No	

Table C.3.1.17: MCPTT

No.	Option item	References	Applicability at the II-NNI	Details for operator choice
1	Support of MCPTT	clause 28.2.2	Yes	MBMS transmission usage and location procedures support.
			No	

Table C.3.1.18: Calling number verification

No.	Option item	References	Applicability at the II-NNI	Details for operator choice
1	Calling number verification	table 6.1.3.1/119 table 6.1.3.1/120 clause 29	Yes	
			No	

C.3.2 Option item table specific to roaming II-NNI

This clause describes the option item tables specific to roaming II-NNI as follows:

- Table C.3.2.1 shows mechanism for authentication option items.
- Table C.3.2.1A shows roaming II-NNI charging option items.
- Table C.3.2.2 shows the key of service profile for HSS query option item.
- Table C.3.2.3 shows the roaming II-NNI numbering, naming and addressing option items.
- Table C.3.2.4 shows the roaming II-NNI supplementary services option items.
- Table C.3.2.5 shows the roaming II-NNI access transfer services option items.

- Table C.3.2.6 shows the roaming II-NNI registration of bulk number contacts option items.
- Table C.3.2.7 shows the roaming II-NNI P-CSCF restoration option items.
- Table C.3.2.8 shows the roaming II-NNI resource sharing option items.
- Table C.3.2.9 shows the roaming II-NNI Priority sharing option items.

Table C.3.2.1: Mechanism for authentication

No.	Option item	References	Applicability at the II-NNI	Details for operator choice
1	IMS AKA plus Ipsec ESP	table 6.1.3.1/7	Yes	
			No	
2	SIP digest plus check of IP association	table 6.1.3.1/7	Yes	
			No	
3	SIP digest plus Proxy Authentication	table 6.1.3.1/7	Yes	
			No	
4	SIP digest with TLS	table 6.1.3.1/7	Yes	
			No	

Table C.3.2.1A: Charging (roaming II-NNI)

No.	Option item	References	Applicability at the II-NNI	Details for operator choice
1	Inter-operator accounting	table 6.1.3.1/38 clause 11.2	Yes	Operator network identifiers populated in the type 1 "orig-ioi" and "term-ioi" header field parameters of the P-Charging-Vector header field.
2	Inter-operator accounting for the transit scenario	clause 11.2	Yes	Operator network identifiers populated in the "transit-ioi" header field parameters of the P-Charging-Vector header field.
			No	

Table C.3.2.2: The key of service profile for HSS query

No.	Option item	References	Applicability at the II-NNI	Details for operator choice
1	The key of service profile for HSS query (P-Profile-Key header field)	table 6.1.3.1/59	Yes	
			No	

Table C.3.2.3: Numbering, naming and addressing (roaming II-NNI)

No.	Option item	References	Applicability at the II-NNI	Details for operator choice
1	Dial string ("user=dialstring" SIP URI parameter)	table 6.1.3.1/67	Yes	
			No	
2	Barring of premium numbers ("premium-rate" tel URI parameter)	clause 8.1, clause 24	Yes	
			No	

Table C.3.2.4: Supplementary services (roaming II-NNI)

No.	Option item	References	Applicability at the II-NNI	Details for operator choice
1	Outgoing Communication Barring (OCB)	clause 12.10.2	Yes	
			No	
2	Unstructured Supplementary Service Data	clause 12.24	Yes	
			No	

Table C.3.2.5: Access transfer services (roaming II-NNI)

No.	Option item	References	Applicability at the II-NNI	Details for operator choice
1	IMS Centralized Services (ICS)	clause 13	Yes	
			No	
2	PS to CS Single Radio Voice Call Continuity (SRVCC)	clause 14	Yes	Additional use conditions (PS to CS SRVCC for calls in alerting phase, support of ATCF architecture, PS to CS SRVCC for calls in pre-alerting phase and PS to CS SRVCC with the MSC server assisted mid-call feature). If the ATCF architecture applies, the URIs of SCC ASs authorised to provide PS to CS SRVCC information in the MESSAGE request.
			No	
3	Single Radio Video Call Continuity (vSRVCC)	clause 14	Yes	Additional use condition (transfer in alerting phase).
			No	
4	Inter UE Transfer (IUT)	clause 18	Yes	
			No	
5	CS to PS Single Radio Voice Call Continuity (SRVCC)	clause 14.5	Yes	The URIs of SCC ASs authorised to provide CS to PS SRVCC information in the MESSAGE request. Additional use conditions (support of CS to PS SRVCC for calls in alerting phase and support of CS to PS SRVCC with the assisted mid-call feature).
			No	
6	PS to CS Dual Radio Voice Call Continuity (DRVCC)	clause 14.6	Yes	Additional use conditions (PS to CS DRVCC for calls in alerting phase, PS to CS DRVCC for originating calls in pre-alerting phase, PS to CS DRVCC with the MSC server assisted mid-call feature and the use of IMS Centralized Services (ICS) and the tel URI in STN).
			No	
7	CS to PS Dual Radio Voice Call Continuity (DRVCC)	clause 14.7	Yes	Additional use conditions (CS to PS DRVCC for calls in alerting phase, CS to PS DRVCC for originating calls in pre-alerting phase, CS to PS DRVCC with the MSC server assisted mid-call feature) and the use of IMS Centralized Services (ICS).
			No	

Table C.3.2.6: Registration of bulk number contacts (roaming II-NNI)

No.	Option item	References	Applicability at the II-NNI	Details for operator choice
1	Registration of bulk number contacts	table 6.1.3.1/104	Yes	
			No	

Table C.3.2.7: P-CSCF restoration (roaming II-NNI)

No.	Option item	References	Applicability at the II-NNI	Details for operator choice
1	PCRF based P-CSCF restoration	clause 25.2	Yes	
			No	
2	HSS based P-CSCF restoration	clause 25.3	Yes	
			No	

Table C.3.2.8: Resource sharing (roaming II-NNI)

No.	Option item	References	Applicability at the II-NNI	Details for operator choice
1	Resource sharing	clause 26	Yes	
			No	

Table C.3.2.9: Priority sharing (roaming II-NNI)

No.	Option item	References	Applicability at the II-NNI	Details for operator choice
1	Priority sharing	clause 28, table 6.1.3.1/118	Yes	
			No	

C.3.3 Option item table specific to non-roaming II-NNI and loopback traversal scenario

This clause describes the option item tables specific to the non-roaming II-NNI and the loopback traversal scenario as follows:

- Table C.3.3.1 shows the non-roaming II-NNI and loopback traversal scenario SIP method option items.
- Table C.3.3.2 shows the non-roaming II-NNI and loopback traversal scenario charging option items.
- Table C.3.3.3 shows the GRUU option items.
- Table C.3.3.4 shows the media feature tags option items.
- Table C.3.3.5 shows the ISDN interworking option items.
- Table C.3.3.6 shows the corporate network option items.
- Table C.3.3.7 shows the non-roaming II-NNI and loopback traversal scenario numbering, naming and addressing option items.
- Table C.3.3.8 shows the non-roaming II-NNI and loopback traversal scenario additional functions option item.
- Table C.3.3.9 shows IMS emergency session traversal scenario option item.

Table C.3.3.1: SIP method (non-roaming II-NNI and loopback traversal scenario)

No.	Option item	References	Applicability at the II-NNI	Details for operator choice
1	NOTIFY method	table 6.1/10 table 6.1/11	Yes	Event package name to use.
			No	
2	SUBSCRIBE method	table 6.1/20 table 6.1/21	Yes	Event package name to use.
			No	
3	PUBLISH method	table 6.1/15A table 6.1/15B	Yes	Event package name to use.
			No	

Table C.3.3.2: Charging (non-roaming II-NNI and loopback traversal scenario)

No.	Option item	References	Applicability at the II-NNI	Details for operator choice
1	Inter-operator accounting	table 6.1.3.1/38 clause 11.2	Yes	Operator network identifiers populated in the type 2 "orig-ioi" and "term-ioi" header field parameters of the P-Charging-Vector header field.
			No	
2	Inter-operator accounting for the transit scenario	clause 11.2	Yes	Operator network identifiers populated in the "transit-ioi" header field parameters of the P-Charging-Vector header field.
			No	

Table C.3.3.3: Globally routable user agent URIs (GRUU)

No.	Option item	References	Applicability at the II-NNI	Details for operator choice
1	Globally Routable User Agent URIs (gruu)	table 6.1.3.1/56	Yes	
			No	

Table C.3.3.4: Media feature tags

No.	Option item	References	Applicability at the II-NNI	Details for operator choice
1	Media feature tags	table 6.1.3.1/76 clause 12 clause 13 clause 14 clause 16 clause 18	Yes	Names of media feature tags to use.
			No	

Table C.3.3.5: ISDN interworking

No.	Option item	References	Applicability at the II-NNI	Details for operator choice
1	User to User Call Control Information in SIP for ISDN Interworking (uui)	table 6.1.3.1/79	Yes	
			No	

Table C.3.3.6: Corporate network

No.	Option item	References	Applicability at the II-NNI	Details for operator choice
1	Private network traffic (P-Private-Network-Indication header field)	table 6.1.3.1/80	Yes	
			No	

Table C.3.3.7: Numbering, naming and addressing (non-roaming II-NNI and loopback traversal scenario)

No.	Option item	References	Applicability at the II-NNI	Details for operator choice
0	SIP URI	clause 8.1	Yes	Any non-global numbers that are allowed in addition to global numbers.
				Domain name(s) and/or IP address(es) of hostportion to accept.
				Applicability of PSI to use.
0A	tel URI (NOTE)	clause 8.1	Yes	Any non-global numbers that are allowed in addition to global numbers.
				Applicability of the URI in P-Asserted-Identity header field and/or Request-URI.
			No	
0B	IM URI	clause 8.1	Yes	
				No
0C	PRES URI	clause 8.1	Yes	
				No
1	Number Portability Routing Number ("rn" and "npdi" tel URI parameters)	clause 8.1	Yes	
				No
2	Calling Party's Category ("cpc" tel URI parameter)	clause 8.1	Yes	cpc-values to use.
				No
3	Originating Line Information ("oli" tel URI parameter)	clause 8.1	Yes	oli-values to use.
				No
NOTE: The option item is only for the non-roaming II-NNI.				

Table C.3.3.8: Additional functions (non-roaming II-NNI and loopback traversal scenario)

No.	Option item	References	Applicability at the II-NNI	Details for operator choice
1	Support of out-of-dialog OPTIONS method	table 6.1/12 table 6.1/13	Yes	The purpose of the method.
				No

Table C.3.3.9: IMS emergency session traversal scenario

No.	Option item	References	Applicability at the II-NNI	Details for operator choice
1	IMS emergency session traversal scenario	table 6.1.3.1/55 clause 30	Yes	The emergency service URN(s) to use.
				The PSAP URI to use in the Route header field, if applicable.
			No	

Annex D (informative): Change history

Change history							
Date	TSG #	TSG Doc.	CR	Rev	Subject/Comment	Old	New
03/2015	CT-67	CP-150129	736	1	Addition of an optional capability regarding a new cause-param value for service number translation	12.7.0	13.0.0
03/2015	CT-67	CP-150130	719		Correction of a minor error in subclause C.3.1	12.7.0	13.0.0
03/2015	CT-67	CP-150130	723		Annex A corrections	12.7.0	13.0.0
03/2015	CT-67	CP-150130	726	3	Applying drafting rules	12.7.0	13.0.0
03/2015	CT-67	CP-150130	729	1	Adding missing abbreviations	12.7.0	13.0.0
06/2015	CT-68	CP-150339	0741	-	Reference Update: RFC 7462 (alert-info urns)	13.0.0	13.1.0
06/2015	CT-68	CP-150341	0746	-	Condition on usage of Refer-Sub header field	13.0.0	13.1.0
06/2015	CT-68	CP-150356	0747	3	Introducing resource sharing	13.0.0	13.1.0
06/2015	CT-68	CP-150346	0749	1	Correcting errors in annex B	13.0.0	13.1.0
06/2015	CT-68	CP-150347	0751	-	draft-holmberg-dispatch-iotl-parameter-04 updated to RFC 7549	13.0.0	13.1.0
06/2015	CT-68	CP-150350	0753	1	Additional RFC 6665 related IETF drafts added	13.0.0	13.1.0
06/2015	CT-68	CP-150357	0754	1	Correcting inconsistencies in the major capability table	13.0.0	13.1.0
06/2015	CT-68	CP-150364	0756	1	Correction of Record-Route header field applicability in annex B	13.0.0	13.1.0
06/2015	CT-68	CP-150364	0758	-	Correction of applicable SIP status code for SIP header fields in PUBLISH response in annex B	13.0.0	13.1.0
06/2015	CT-68	CP-150364	0760	-	Addition of missing text referring to an option item table in annex C	13.0.0	13.1.0
06/2015	CT-68	CP-150364	0762	1	Correction of the P-Charging-Vector header field in annex B	13.0.0	13.1.0
06/2015	CT-68	CP-150364	0763	1	Correction of the P-Early-Media header field within the PRACK response in annex B	13.0.0	13.1.0
06/2015	CT-68	CP-150364	0765	-	Correction of the Server header field within the SUBSCRIBE response in annex B	13.0.0	13.1.0
06/2015	CT-68	CP-150364	0766	-	Correction of the Allow header field in annex B	13.0.0	13.1.0
06/2015	CT-68	CP-150364	0767	-	Clarifications on NNI impacts due to CAT service	13.0.0	13.1.0
06/2015	-	-	-	-	MCC Correction of implementation of CR0765	13.1.0	13.1.1
09/2015	CT-69	CP-150486	0768	3	The privacy level "session" and "critical" are not used in OIP/OIR	13.1.1	13.2.0
09/2015	CT-69	CP-150479	0769	1	Service access number translation	13.1.1	13.2.0
09/2015	CT-69	CP-150471	0771	1	Reference update: draft-ietf-mmusic-sctp-sdp	13.1.1	13.2.0
09/2015	CT-69	CP-150475	0773	-	Missing SIP request in HSS based P-CSCF restoration	13.1.1	13.2.0
09/2015	CT-69	CP-150479	0774	-	draft-mohali-dispatch-cause-for-service-number updated to latest version	13.1.1	13.2.0
09/2015	CT-69	CP-150486	0775	1	The Service-Interact-Info header field	13.1.1	13.2.0
09/2015	CT-69	CP-150478	0776	1	Plain text message body missing in table 6.1.4.1	13.1.1	13.2.0
09/2015	CT-69	CP-150478	0777	1	application/x-www-form-urlencoded missing in table 6.1.4.1	13.1.1	13.2.0
09/2015	CT-69	CP-150486	0778	1	application/vnd.3gpp.crs+xml MIME body missing in CRS	13.1.1	13.2.0
09/2015	CT-69	CP-150478	0779	-	message/sip MIME body missing in table 6.1.4.1	13.1.1	13.2.0
09/2015	CT-69	CP-150478	0780	-	Applicability of SIP header fields on a roaming II-NNI	13.1.1	13.2.0
09/2015	CT-69	CP-150469	0783	-	Reference update: RFC 7415	13.1.1	13.2.0
09/2015	CT-69	CP-150465	0787	1	Correction for the II-NNI conditions	13.1.1	13.2.0
12/2015	CT-70	CP-150796	0790	2	Clarification on the II-NNI specifications of announcement	13.2.0	13.3.0
12/2015	CT-70	CP-150796	0791	2	Updating for annex B	13.2.0	13.3.0
12/2015	CT-70	CP-150654	0795	-	Telepresence IETF draft update	13.2.0	13.3.0
12/2015	CT-70	CP-150659	0796	3	Introducing MCPTT	13.2.0	13.3.0
12/2015	CT-70	CP-150657	0797	2	Reference update of draft-mohali-dispatch-cause-for-service-number	13.2.0	13.3.0
12/2015	CT-70	CP-150664	0800	2	Adding the "loopback-indication" to RAVEL	13.2.0	13.3.0
12/2015	CT-70	CP-150731	0804	1	ICS and the conference service	13.2.0	13.3.0
12/2015	CT-70	CP-150660	0805	-	SRVCC and subscription to conference package	13.2.0	13.3.0
12/2015	CT-70	CP-150660	0806	1	ICS and subscription to conference package	13.2.0	13.3.0
12/2015	CT-70	CP-150656	0807	1	Clarification of applicable URI formats for public user identity	13.2.0	13.3.0
12/2015	CT-70	CP-150796	0808	-	Miscellaneous editorial modification	13.2.0	13.3.0
12/2015	CT-70	CP-150671	0810	1	Update of UP6665 references	13.2.0	13.3.0
12/2015	CT-70	CP-150662	0812	1	P-CSCF restoration corrections	13.2.0	13.3.0
Change history							
Date	TSG #	TSG Doc.	CR	Rev	Cat	Subject/Comment	New
03/2016	CT-71	CP-160088	0813	2	B	Adding MBMS usage info and location info procedure	13.4.0
03/2016	CT-71	CP-160088	0814	2	F	Adding "application/vnd.3gpp.mcptt-info" MIME body	13.4.0
03/2016	CT-71	CP-160088	0815	2	B	Adding MCPTT as option item in annex C	13.4.0
03/2016	CT-71	CP-160088	0816	1	B	Adding affiliation	13.4.0
03/2016	CT-71	CP-160098	0817	1	F	Adding "Timer N" in the timer table	13.4.0
03/2016	CT-71	CP-160096	0819	1	A	Updating "Details for operator choice" in DRVCC to include the STN	13.4.0
03/2016	CT-71	CP-160088	0821	1	F	Addressed MCPTT SIP interfaces	13.4.0

06/2016	CT-72	CP-160262	0822	2	F	Some error corrections and removing an editor's note	13.5.0
06/2016	CT-72	CP-160262	0823	2	F	Group regrouping	13.5.0
06/2016	CT-72	CP-160262	0824	1	F	Conference event package subscription	13.5.0
06/2016	CT-72	CP-160262	0825	1	F	MCPTT service settings	13.5.0
06/2016	CT-72	CP-160262	0826	-	F	Clarifying the Accept-Contact header field in MBMS usage info	13.5.0
06/2016	CT-72	CP-160262	0827	2	F	The affiliation procedure update	13.5.0
06/2016	CT-72	CP-160259	0828	1	F	Adding the Cellular-Network-Info header field	13.5.0
06/2016	CT-72	CP-160258	0834	1	A	Adding draft-mohali-dispatch-originating-cdiv-parameter	13.5.0
06/2016	CT-72	CP-160258	0840	1	A	Updates to RFC 7315 P-header extensions usage in SIP requests/responses	13.5.0
06/2016	CT-72	CP-160258	0843	1	A	P-Access-Network-Info ABNF Update	13.5.0
06/2016	CT-72	CP-160261	0844	1	F	Update ref to draft-mohali-dispatch-cause-for-service-number-06	13.5.0
06/2016	CT-72	CP-160273	0830	1	F	Clarification of the note about forking	14.0.0
06/2016	CT-72	CP-160273	0831	-	F	Changing content type to correct terminology	14.0.0
06/2016	CT-72	CP-160273	0835	1	F	Clarification of Public Service Identitiy at II-NNI	14.0.0
06/2016	CT-72	CP-160273	0836	1	F	Correcting the subscription to the conference package for CONF and the session-mode messaging service	14.0.0
06/2016	CT-72	CP-160273	0837	1	F	Clarification on the applicability of P-Early-Media header field and early media over the II-NNI	14.0.0
09/2016	CT-73	CP-160446	0846	1	A	Usage of the Resource-Share header field	14.1.0
09/2016	CT-73	CP-160447	0852	1	A	Reference update: RFC 7913	14.1.0
09/2016	CT-73	CP-160449	0855	1	A	Updated ref to draft-mohali-dispatch-cause-for-service-number-07	14.1.0
12/2016	CT-74	CP-160624	0857	1	A	Updated ref to draft-mohali-dispatch-cause-for-service-number-09	14.2.0
12/2016	CT-74	CP-160620	0861	1	A	Updated ref to draft-mohali-dispatch-originating-cdiv-parameter-02	14.2.0
12/2016	CT-74	CP-160620	0865	-	A	Reference update: RFC 7976	14.2.0
12/2016	CT-74	CP-160621	0875	-	A	Reference update: RFC 7989	14.2.0
12/2016	CT-74	CP-160623	0877	2	A	Missing support of priority sharing	14.2.0
12/2016	CT-74	CP-160631	0878	-	F	Additional routing functionality at the IBCF	14.2.0
03/2017	CT-75	CP-170087	0882	1	A	Correction on PSAP callback indicator option item	14.3.0
03/2017	CT-75	CP-170087	0883	1	A	Correction on the architecture diagram of II-NNI	14.3.0
03/2017	CT-75	CP-170087	0884	1	A	Addition of application/call-completion MIME Type	14.3.0
03/2017	CT-75	CP-170080	0886	1	A	Update ref to draft-mohali-dispatch-cause-for-service-number	14.3.0
03/2017	CT-75	CP-170078	0890	2	A	Update ref to draft-mohali-dispatch-originating-cdiv-parameter	14.3.0
03/2017	CT-75	CP-170079	0894	-	A	Reference update: RFC 8055	14.3.0
03/2017	CT-75	CP-170077	0896	-	A	Applicability of Resource-Share header field	14.3.0
03/2017	CT-75	CP-170085	0897	1	B	Support of "Calling number verification"	14.3.0
06/2017	CT-76	CP-171134	0872	5	F	Clarification of II-NNI for IMS emergency session	14.4.0
06/2017	CT-76	CP-171130	0898	2	B	Addition of the location parameter	14.4.0
06/2017	CT-76	CP-171128	0900	-	A	MIME body types used by MCPTT	14.4.0
06/2017	CT-76	CP-171126	0901	-	F	Modifying references to align with rel-14 MCPTT stage 1 and stage 2 restructuring	14.4.0
06/2017	CT-76	CP-171134	0902	1	F	Missing support of Response-Source header field	14.4.0
06/2017	CT-76	CP-171124	0904	1	A	Reference Update RFC8119	14.4.0
06/2017	CT-76	CP-171123	0908	1	A	Update ref to new naming of draft-mohali-sipcore-originating-cdiv-parameter	14.4.0
06/2017	CT-76	CP-171131	0909	2	F	Support of feature capability indicator "sip.607"	14.4.0
06/2017	CT-76	CP-171122	0913	-	A	Reference update: draft-ietf-mmusic-sctp-sdp	14.4.0
06/2017	CT-76	CP-171131	0914	-	F	Reference update: draft-ietf-stir-rfc4474bis	14.4.0
06/2017	CT-76	CP-171125	0915	3	B	IMS Trace (ISAT) Procedures	14.4.0
06/2017	CT-76	CP-171127	0916	3	B	Adding other Mission Critical services	14.4.0
06/2017	CT-76					Editorial changes by MCC	14.4.1
09/2017	CT-77	CP-172045	0921	1	F	Reference Update for the ISUP location parameter	14.5.0
09/2017	CT-77	CP-172049	0924	-	F	Reference update from draft-ietf-sipcore-status-unwanted-06 to RFC 8197	14.5.0
09/2017	CT-77	CP-172049	0926	-	F	Added the profile status in proxy role regarding "A SIP Response Code for Unwanted Calls"	14.5.0
12/2017	CT-78	CP-173095	0923	2	F	Adding MCDATA related MIME bodies	14.6.0
12/2017	CT-78	CP-173099	0927	-	F	Reference Update for the ISUP location parameter	14.6.0
12/2017	CT-78	CP-173091	0932	1	A	Update draft ref for Originating-CDIV param in P-Served-User	14.6.0
12/2017	CT-78	CP-173098	0937	1	A	Correction of II-NNI condition related to P-Early-Media header field	14.6.0
12/2017	CT-78	CP-173102	0939	-	F	Correction of II-NNI condition related to P-Early-Media header field	14.6.0
12/2017	CT-78	CP-173096	0942	-	A	Addition of sign XML MIME body	14.6.0
03/2018	CT-79	CP-180042	0949	-	F	Reference Update for the ISUP location parameter	14.7.0
03/2018	CT-79	CP-180044	0952	-	F	Reference update: RFC 8224	14.7.0

History

Document history		
V14.3.0	April 2017	Publication
V14.4.1	July 2017	Publication
V14.5.0	October 2017	Publication
V14.6.0	January 2018	Publication
V14.7.0	June 2018	Publication