

# ETSI TS 129 165 V10.16.0 (2014-07)



**Digital cellular telecommunications system (Phase 2+);  
Universal Mobile Telecommunications System (UMTS);  
LTE;  
Inter-IMS Network to Network Interface (NNI)  
(3GPP TS 29.165 version 10.16.0 Release 10)**



---

**Reference**

RTS/TSGC-0329165vag0

---

**Keywords**

GSM,LTE,UMTS

**ETSI**

650 Route des Lucioles  
F-06921 Sophia Antipolis Cedex - FRANCE

---

Tel.: +33 4 92 94 42 00 Fax: +33 4 93 65 47 16

Siret N° 348 623 562 00017 - NAF 742 C  
Association à but non lucratif enregistrée à la  
Sous-Préfecture de Grasse (06) N° 7803/88

---

**Important notice**

The present document can be downloaded from:

<http://www.etsi.org>

The present document may be made available in electronic versions and/or in print. The content of any electronic and/or print versions of the present document shall not be modified without the prior written authorization of ETSI. In case of any existing or perceived difference in contents between such versions and/or in print, the only prevailing document is the print of the Portable Document Format (PDF) version kept on a specific network drive within ETSI Secretariat.

Users of the present document should be aware that the document may be subject to revision or change of status. Information on the current status of this and other ETSI documents is available at

<http://portal.etsi.org/tb/status/status.asp>

If you find errors in the present document, please send your comment to one of the following services:

[http://portal.etsi.org/chaicor/ETSI\\_support.asp](http://portal.etsi.org/chaicor/ETSI_support.asp)

---

**Copyright Notification**

No part may be reproduced or utilized in any form or by any means, electronic or mechanical, including photocopying and microfilm except as authorized by written permission of ETSI.

The content of the PDF version shall not be modified without the written authorization of ETSI.

The copyright and the foregoing restriction extend to reproduction in all media.

© European Telecommunications Standards Institute 2014.

All rights reserved.

**DECT™**, **PLUGTESTS™**, **UMTS™** and the ETSI logo are Trade Marks of ETSI registered for the benefit of its Members. **3GPP™** and **LTE™** are Trade Marks of ETSI registered for the benefit of its Members and of the 3GPP Organizational Partners.

**GSM®** and the GSM logo are Trade Marks registered and owned by the GSM Association.

---

## Intellectual Property Rights

IPRs essential or potentially essential to the present document may have been declared to ETSI. The information pertaining to these essential IPRs, if any, is publicly available for **ETSI members and non-members**, and can be found in ETSI SR 000 314: *"Intellectual Property Rights (IPRs); Essential, or potentially Essential, IPRs notified to ETSI in respect of ETSI standards"*, which is available from the ETSI Secretariat. Latest updates are available on the ETSI Web server (<http://ipr.etsi.org>).

Pursuant to the ETSI IPR Policy, no investigation, including IPR searches, has been carried out by ETSI. No guarantee can be given as to the existence of other IPRs not referenced in ETSI SR 000 314 (or the updates on the ETSI Web server) which are, or may be, or may become, essential to the present document.

---

## Foreword

This Technical Specification (TS) has been produced by ETSI 3rd Generation Partnership Project (3GPP).

The present document may refer to technical specifications or reports using their 3GPP identities, UMTS identities or GSM identities. These should be interpreted as being references to the corresponding ETSI deliverables.

The cross reference between GSM, UMTS, 3GPP and ETSI identities can be found under <http://webapp.etsi.org/key/queryform.asp>.

---

## Modal verbs terminology

In the present document "**shall**", "**shall not**", "**should**", "**should not**", "**may**", "**may not**", "**need**", "**need not**", "**will**", "**will not**", "**can**" and "**cannot**" are to be interpreted as described in clause 3.2 of the [ETSI Drafting Rules](#) (Verbal forms for the expression of provisions).

"**must**" and "**must not**" are **NOT** allowed in ETSI deliverables except when used in direct citation.

# Contents

Intellectual Property Rights .....	2
Foreword.....	2
Modal verbs terminology.....	2
Foreword.....	6
1 Scope .....	7
2 References .....	7
3 Definitions, symbols and abbreviations .....	13
3.1 Definitions .....	13
3.2 Symbols.....	14
3.3 Abbreviations .....	14
4 Overview .....	15
5 Reference model for interconnection between IM CN subsystems .....	16
5.1 General .....	16
5.2 Functionalities performed by entities at the edge of the network.....	16
5.2.1 Interconnection Border Control Function (IBCF).....	16
5.2.2 Transition Gateway (TrGW).....	17
6 Control plane interconnection .....	17
6.1 Definition of Inter-IMS Network to Network Interconnection.....	17
6.1.1 SIP methods and header fields.....	17
6.1.1.1 General .....	17
6.1.1.2 SIP methods .....	17
6.1.1.3 SIP header fields .....	18
6.1.1.3.0 General .....	18
6.1.1.3.1 Trust and no trust relationship .....	18
6.1.1.3.2 Derivation of applicable SIP header fields from 3GPP TS 24.229 [5].....	19
6.1.1.3.3 Applicability of SIP header fields on a roaming II-NNI.....	20
6.1.1.3.4 Applicability of SIP header fields on a non-roaming II-NNI .....	20
6.1.1.4 Notations of the codes.....	20
6.1.1.5 Modes of signalling.....	21
6.1.2 SDP protocol.....	21
6.1.2.1 General .....	21
6.1.3 Major capabilities .....	21
6.1.4 SIP message bodies.....	26
6.2 Control Plane Transport .....	27
6.2.1 General.....	27
7 User plane Interconnection.....	27
7.1 Media and Codec.....	27
7.2 User Plane Transport.....	27
8 Numbering, Naming and Addressing .....	28
8.1 Numbering, Naming and Addressing for SIP message .....	28
8.2 Numbering, Naming and Addressing for SDP .....	29
9 IP Version.....	29
10 Security.....	29
11 Charging .....	29
11.1 General .....	29
11.2 Inter-operator accounting .....	30
11.3 Transfer of IP multimedia service tariff information.....	30
12 Supplementary services associated with the IMS multimedia telephony communication service.....	30

12.1	General .....	30
12.2	Malicious Communication IDentification (MCID) .....	31
12.3	Originating Identification Presentation (OIP) and Originating Identification Restriction (OIR) .....	31
12.4	Terminating Identification Presentation (TIP) and Terminating Identification Restriction (TIR) .....	32
12.5	Anonymous Communication Rejection (ACR) .....	32
12.6	Communication DIVersion (CDIV) .....	32
12.7	Communication Waiting (CW) .....	33
12.8	Communication HOLD (HOLD) .....	33
12.9	Message Waiting Indication (MWI) .....	33
12.10	Communication Barring (CB) .....	33
12.10.1	Incoming Communication Barring (ICB) .....	33
12.10.2	Outgoing Communication Barring (OCB) .....	33
12.11	Completion of Communications to Busy Subscriber (CCBS) .....	34
12.12	Completion of Communications by No Reply (CCNR) .....	34
12.13	Explicit Communication Transfer (ECT) .....	35
12.14	Customized Alerting Tone (CAT) .....	35
12.15	Customized Ringing Signal (CRS) .....	35
12.16	Closed User Group (CUG) .....	36
12.17	Personal Network Management (PNM) .....	36
12.18	Three-Party (3PTY) .....	36
12.19	Conference (CONF) .....	37
12.20	Flexible Alerting (FA) .....	37
12.21	Announcements .....	37
12.21.1	General .....	37
12.21.2	Providing announcements during the establishment of a communication session .....	37
12.21.3	Providing announcements during an established communication session .....	38
12.21.4	Providing announcements when communication request is rejected .....	38
12.22	Advice of Charge (AOC) .....	38
12.23	Completion of Communications on Not Logged-in (CCNL) .....	39
13	Interoperability of IMS Centralized Services (ICS) over II-NNI .....	39
13.1	General .....	39
13.2	IMS Centralized Services (ICS) .....	39
14	Interoperability of IMS Service Continuity over II-NNI .....	40
14.1	General .....	40
14.2	Single Radio Voice Call Continuity (SRVCC) .....	40
14.2.1	Basic SRVCC .....	40
14.2.2	Transfer of calls in alerting phase .....	40
14.2.3	Using the ATCF based architecture .....	41
14.3	Inter UE Transfer (IUT) .....	41
14.4	MSC server assisted mid-call feature .....	41
15	Presence service .....	42
15.0	General .....	42
15.1	Subscription of presence information .....	42
15.2	Watcher subscribing to Presence List .....	43
15.3	Subscription to Watcher Information .....	43
15.4	Subscription to state changes in XML documents .....	43
15.5	Presence enhancements specified in Open Mobile Alliance (OMA) Release 1.1 .....	44
15.5.1	General .....	44
15.5.2	OMA subscription of presence information .....	44
15.5.3	OMA watcher subscribing to Presence List .....	44
15.5.4	OMA subscription to Watcher Information .....	44
15.6	Presence enhancements specified in Open Mobile Alliance (OMA) Release 2.0 .....	44
15.6.1	General .....	44
15.6.2	OMA subscription of presence information .....	45
15.6.3	OMA watcher subscribing to Presence List .....	45
15.6.4	OMA subscription to Watcher Information .....	45
15.6.5	Subscription to state changes in XML documents .....	46
15.6.6	Void .....	46
15.6.7	Void .....	46

16	Messaging service .....	46
16.1	General .....	46
16.2	Page-mode messaging .....	46
16.4	Session-mode messaging .....	47
16.5	Session-mode messaging conferences .....	47
17	Optimal Media Routeing .....	47
17.1	General .....	47
17.2	OMR related SDP attributes .....	47
17.3	IP realm names .....	47
18	Inter-UE transfer (IUT) .....	48
18.1	General .....	48
18.2	IUT without establishment of a collaborative session .....	48
18.3	IUT using a collaborative session .....	48
18.3.1	Collaborative session of participants of the same subscription .....	48
18.3.2	Establishment of a collaborative session during session setup .....	49
18.3.3	Assignment and transfer of control of a collaborative session .....	49
18.3.4	Collaborative session of participants of different subscriptions .....	49
18.4	Session replication / media replication .....	49
18.4.1	Pull mode .....	49
18.4.2	Push mode .....	50
<b>Annex A (informative): Summary of SIP header fields .....</b>		<b>51</b>
<b>Annex B (informative): Dynamic view of SIP header fields within SIP messages .....</b>		<b>55</b>
B.1	Scope .....	55
B.2	Methodology .....	55
B.3	ACK method .....	57
B.4	BYE method .....	58
B.5	CANCEL method .....	60
B.6	INFO method .....	61
B.7	INVITE method .....	65
B.8	MESSAGE method .....	71
B.9	NOTIFY method .....	75
B.10	OPTIONS method .....	79
B.11	PRACK method .....	83
B.12	PUBLISH method .....	85
B.13	REFER method .....	89
B.14	REGISTER method .....	93
B.15	SUBSCRIBE method .....	96
B.16	UPDATE method .....	101
<b>Annex C: Change history .....</b>		<b>104</b>
History .....		112

---

# Foreword

This Technical Specification has been produced by the 3<sup>rd</sup> Generation Partnership Project (3GPP).

The contents of the present document are subject to continuing work within the TSG and may change following formal TSG approval. Should the TSG modify the contents of the present document, it will be re-released by the TSG with an identifying change of release date and an increase in version number as follows:

Version x.y.z

where:

- x the first digit:
  - 1 presented to TSG for information;
  - 2 presented to TSG for approval;
  - 3 or greater indicates TSG approved document under change control.
- y the second digit is incremented for all changes of substance, i.e. technical enhancements, corrections, updates, etc.
- z the third digit is incremented when editorial only changes have been incorporated in the document.

---

# 1 Scope

The objective of this document is to address the Inter-IMS Network to Network Interface (II-NNI) consisting of Ici and Izi reference points between IMS networks in order to support end-to-end service interoperability.

The present document will address the issues related to control plane signalling (3GPP usage of SIP and SDP protocols, required SIP header fields) as well as other interconnecting aspects like security, numbering/naming/addressing and user plane issues as transport protocol, media and codecs actually covered in a widespread set of 3GPP specifications. A profiling of the Inter-IMS Network to Network Interface (II-NNI) is also provided.

Charging aspects will be addressed as far as SIP signalling is concerned.

---

# 2 References

The following documents contain provisions which, through reference in this text, constitute provisions of the present document.

- References are either specific (identified by date of publication, edition number, version number, etc.) or non-specific.
- For a specific reference, subsequent revisions do not apply.
- For a non-specific reference, the latest version applies. In the case of a reference to a 3GPP document (including a GSM document), a non-specific reference implicitly refers to the latest version of that document in the same Release as the present document.

- [1] 3GPP TR 21.905: "Vocabulary for 3GPP Specifications".
- [2] IETF RFC 791: "Internet Protocol".
- [3] 3GPP TS 23.002: "Network architecture".
- [4] 3GPP TS 23.228: "IP Multimedia Subsystem (IMS); Stage 2".
- [5] 3GPP TS 24.229: "Internet Protocol (IP) multimedia call control protocol based on Session Initiation Protocol (SIP) and Session Description Protocol (SDP); Stage 3".
- [6] 3GPP TR 24.930: "Signalling flows for the session setup in the IP Multimedia core network Subsystem (IMS) based on Session Initiation Protocol (SIP) and Session Description Protocol (SDP); Stage 3".
- [7] IETF RFC 2460: "Internet Protocol, Version 6 (IPv6) Specification".
- [8] 3GPP TS 29.162: "Interworking between the IM CN subsystem and IP networks".
- [9] 3GPP TS 22.228: "Service requirements for the IP multimedia core network subsystem".
- [10] 3GPP TS 33.210: "3G security; Network Domain Security (NDS); IP network layer security".
- [11] 3GPP TS 26.114: "IP Multimedia Subsystem (IMS); Multimedia Telephony; Media handling and interaction".
- [12] ETSI TS 181 005 1.1.1: "Telecommunications and Internet converged Services and Protocols for Advanced Networking (TISPAN); Services and Capabilities Requirements".
- [13] IETF RFC 3261: "SIP: Session Initiation Protocol".
- [14] IETF RFC 3966: "The tel URI for Telephone Numbers".
- [15] IETF RFC 3860: "Common Profile for Instant Messaging (CPIM)".



- [16] IETF RFC 3859: "Common Profile for Presence (CPP)".
- [17] IETF RFC 4975: "The Message Session Relay Protocol (MSRP)".
- [18] IETF RFC 3262: "Reliability of provisional responses in Session Initiation Protocol (SIP)".
- [19] IETF RFC 3428: "Session Initiation Protocol (SIP) Extension for Instant Messaging".
- [20] IETF RFC 3265: "Session Initiation Protocol (SIP) Specific Event Notification".
- [21] IETF RFC 3903: "An Event State Publication Extension to the Session Initiation Protocol (SIP)".
- [22] IETF RFC 3515: "The Session Initiation Protocol (SIP) REFER method".
- [23] IETF RFC 3311: "The Session Initiation Protocol (SIP) UPDATE method".
- [24] IETF RFC 3455: "Private Header (P-Header) Extensions to the Session Initiation Protocol (SIP) for the 3rd-Generation Partnership Project (3GPP)".
- [25] IETF RFC 4244: "An Extension to the Session Initiation Protocol (SIP) for Request History Information".
- [26] IETF RFC 6050: "A Session Initiation Protocol (SIP) Extension for the Identification of Services".
- [27] IETF RFC 4168: "The Stream Control Transmission Protocol (SCTP) as a Transport for the Session Initiation Protocol (SIP)".
- [28] Void.
- [29] 3GPP TS 32.260: "Telecommunication management; Charging management; IP Multimedia Subsystem (IMS) charging".
- [30] 3GPP TS 22.173: "IP Multimedia Core Network Subsystem (IMS); Multimedia Telephony Service and supplementary services; Stage 1".
- [31] 3GPP TS 24.173: "IMS multimedia telephony communication service and supplementary services; Stage 3".
- [32] 3GPP TS 24.607: "Originating Identification Presentation (OIP) and Originating Identification Restriction (OIR) using IP Multimedia (IM); Core Network (CN) subsystem".
- [33] 3GPP TS 24.616: "Malicious Communication Identification (MCID) using IP Multimedia (IM) Core Network (CN) subsystem".
- [34] IETF RFC 3323: "A Privacy Mechanism for the Session Initiation Protocol (SIP)".
- [35] 3GPP TS 23.003: "Numbering, addressing and identification".
- [36] 3GPP TS 24.610: "Communication HOLD (HOLD) using IP Multimedia (IM) Core Network (CN) subsystem".
- [37] 3GPP TS 24.615: "Communication Waiting (CW) using IP Multimedia (IM) Core Network (CN) subsystem".
- [38] 3GPP TS 24.628: "Common Basic Communication procedures using IP Multimedia (IM) Core Network (CN) subsystem".
- [39] IETF RFC 6086: "Session Initiation Protocol (SIP) INFO Method and Package Framework".
- [40] IETF RFC 3312: "Integration of resource management and Session Initiation Protocol (SIP)".
- [41] IETF RFC 4032: "Update to the Session Initiation Protocol (SIP) Preconditions Framework".
- [42] IETF RFC 3313: "Private Session Initiation Protocol (SIP) Extensions for Media Authorization".
- [43] IETF RFC 3327: "Session Initiation Protocol Extension Header Field for Registering Non-Adjacent Contacts".

- [44] IETF RFC 3325: "Private Extensions to the Session Initiation Protocol (SIP) for Network Asserted Identity within Trusted Networks".
- [45] IETF RFC 3608: "Session Initiation Protocol (SIP) Extension Header Field for Service Route Discovery During Registration".
- [46] IETF RFC 3486: "Compressing the Session Initiation Protocol (SIP)".
- [47] IETF RFC 3329: "Security Mechanism Agreement for the Session Initiation Protocol (SIP)".
- [48] IETF RFC 3326: "The Reason Header Field for the Session Initiation Protocol (SIP)".
- [49] IETF RFC 6432: "Carrying Q.850 Codes in Reason Header Fields in SIP (Session Initiation Protocol) Responses".
- [50] IETF RFC 3581: "An Extension to the Session Initiation Protocol (SIP) for Symmetric Response Routing".
- [51] IETF RFC 3841: "Caller Preferences for the Session Initiation Protocol (SIP)".
- [52] IETF RFC 4028: "Session Timers in the Session Initiation Protocol (SIP)".
- [53] IETF RFC 3892: "The Session Initiation Protocol (SIP) Referred-By Mechanism".
- [54] IETF RFC 3891: "The Session Initiation Protocol (SIP) 'Replaces' Header".
- [55] IETF RFC 3911: "The Session Initiation Protocol (SIP) 'Join' Header".
- [56] IETF RFC 3840: "Indicating User Agent Capabilities in the Session Initiation Protocol (SIP)".
- [57] IETF RFC 5079: "Rejecting Anonymous Requests in the Session Initiation Protocol (SIP)".
- [58] IETF RFC 4458: "Session Initiation Protocol (SIP) URIs for Applications such as Voicemail and Interactive Voice Response (IVR)".
- [59] IETF RFC 4320: "Actions Addressing Identified Issues with the Session Initiation Protocol's (SIP) Non-INVITE Transaction".
- [60] IETF RFC 4457: "The Session Initiation Protocol (SIP) P-User-Database Private-Header (P-header)".
- [61] IETF RFC 5031: "A Uniform Resource Name (URN) for Emergency and Other Well-Known Services".
- [62] IETF RFC 5627: "Obtaining and Using Globally Routable User Agent (UA) URIs (GRUU) in the Session Initiation Protocol (SIP)".
- [63] Void
- [64] IETF RFC 5002: "The Session Initiation Protocol (SIP) P-Profile-Key Private Header (P-Header)".
- [65] IETF RFC 5626: "Managing Client-Initiated Connections in the Session Initiation Protocol (SIP)".
- [66] IETF RFC 5768: "Indicating Support for Interactive Connectivity Establishment (ICE) in the Session Initiation Protocol (SIP)".
- [67] IETF RFC 5365: "Multiple-Recipient MESSAGE Requests in the Session Initiation Protocol (SIP)".
- [68] IETF RFC 6442: "Location Conveyance for the Session Initiation Protocol".
- [69] IETF RFC 5368: "Referring to Multiple Resources in the Session Initiation Protocol (SIP)".
- [70] IETF RFC 5366: "Conference Establishment Using Request-Contained Lists in the Session Initiation Protocol (SIP)".

- [71] IETF RFC 5367: "Subscriptions to Request-Contained Resource Lists in the Session Initiation Protocol (SIP)".
- [72] IETF RFC 4967: "Dial String Parameter for the Session Initiation Protocol Uniform Resource Identifier".
- [73] IETF RFC 4964: "The P-Answer-State Header Extension to the Session Initiation Protocol for the Open Mobile Alliance Push to Talk over Cellular".
- [74] IETF RFC 5009: "Private Header (P-Header) Extension to the Session Initiation Protocol (SIP) for Authorization of Early Media".
- [75] IETF RFC 4694: "Number Portability Parameters for the 'tel' URI".
- [76] Void.
- [77] IETF RFC 4411: "Extending the Session Initiation Protocol (SIP) Reason Header for Preemption Events".
- [78] IETF RFC 4412: "Communications Resource Priority for the Session Initiation Protocol (SIP)".
- [79] IETF RFC 5393: "Addressing an Amplification Vulnerability in Session Initiation Protocol (SIP) Forking Proxies".
- [80] IETF RFC 5049: "Applying Signaling Compression (SigComp) to the Session Initiation Protocol (SIP)".
- [81] IETF RFC 5688: "A Session Initiation Protocol (SIP) Media Feature Tag for MIME Application Sub-Types".
- [82] IETF RFC 5360: "A Framework for Consent-Based Communications in the Session Initiation Protocol (SIP)".
- [83] draft-ietf-cuss-sip-uu-06 (May 2012): "A Mechanism for Transporting User to User Call Control Information in SIP".

**Editor's note:** The above document cannot be formally referenced until it is published as an RFC.

- [83A] draft-ietf-cuss-sip-uu-isdn-04 (May 2012): "Interworking ISDN Call Control User Information with SIP".

**Editor's note:** The above document cannot be formally referenced until it is published as an RFC.

- [84] draft-vanelburg-dispatch-private-network-ind-07 (April 2014): "The Session Initiation Protocol (SIP) P-Private-Network-Indication Private-Header (P-Header)".

**Editor's note:** The above document cannot be formally referenced until it is published as an RFC.

- [85] IETF RFC 5502: "The SIP P-Served-User Private-Header (P-Header) for the 3GPP IP Multimedia (IM) Core Network (CN) Subsystem".
- [86] Void.
- [87] Void.
- [88] IETF RFC 6228: "Response Code for Indication of Terminated Dialog".
- [89] IETF RFC 5621: "Message Body Handling in the Session Initiation Protocol (SIP)".
- [90] IETF RFC 6223: "Indication of support for keep-alive".
- [91] IETF RFC 5552: "SIP Interface to VoiceXML Media Services".
- [92] IETF RFC 3862: "Common Presence and Instant Messaging (CPIM): Message Format".
- [93] IETF RFC 5438: "Instant Message Disposition Notification".

- [94] IETF RFC 5373: "Requesting Answering Modes for the Session Initiation Protocol (SIP)".
- [95] Void.
- [96] IETF RFC 3959: "The Early Session Disposition Type for the Session Initiation Protocol (SIP)".
- [97] Void.
- [98] 3GPP TS 24.183: "Customized Ringing Signal (CRS) using IP Multimedia (IM) Core Network (CN) subsystem".
- [99] 3GPP TS 24.259: "Personal Network Management (PNM) using IP Multimedia (IM) Core Network (CN) subsystem".
- [100] 3GPP TS 24.238: "Session Initiation Protocol (SIP) based user configuration".
- [101] 3GPP TS 24.239: "Flexible Alerting (FA) using IP Multimedia (IM) Core Network (CN) subsystem".
- [102] Void.
- [103] 3GPP TS 24.654: "Closed User Group (CUG) using IP Multimedia (IM) Core Network (CN) subsystem".
- [104] Void.
- [105] 3GPP TS 24.605: "Conference (CONF) using IP Multimedia (IM) Core Network (CN) subsystem".
- [106] 3GPP TS 24.147: "Conferencing using the IP Multimedia (IM) Core Network (CN) subsystem".
- [107] Void.
- [108] Void.
- [109] 3GPP TS 24.642: "Completion of Communications to Busy Subscriber (CCBS) Completion of Communications by No Reply (CCNR) using IP Multimedia (IM) Core Network (CN) subsystem".
- [110] Void.
- [111] Void.
- [112] 3GPP TS 24.606: "Message Waiting Indication (MWI) using IP Multimedia (IM) Core Network (CN) subsystem".
- [113] 3GPP TS 24.608: "Terminating Identification Presentation (TIP) and Terminating Identification Restriction (TIR) using IP Multimedia (IM); Core Network (CN) subsystem".
- [114] 3GPP TS 24.611: "Anonymous Communication Rejection (ACR) and Communication Barring (CB) using IP Multimedia (IM) Core Network (CN) subsystem".
- [115] Void.
- [116] 3GPP TS 24.629: "Explicit Communication Transfer (ECT) using IP Multimedia (IM) Core Network (CN) subsystem".
- [117] 3GPP TS 24.604: "Communication DIVersion (CDIV) using IP Multimedia (IM) Core Network (CN) subsystem".
- [118] Void.
- [119] Void.
- [120] 3GPP TS 23.292: "IP Multimedia Subsystem (IMS) Centralized Services; Stage 2".
- [121] 3GPP TS 24.292: "IP Multimedia Core Network subsystem Centralized Services (ICS); Stage 3".

- [122] 3GPP TS 24.647: "Advice Of Charge (AOC) using IP Multimedia (IM) Core Network (CN) subsystem".
- [123] Void.
- [124] draft-kaplan-insipid-session-id-03 (August 2013): "A Session Identifier for the Session Initiation Protocol (SIP)".

**Editor's note: The above document cannot be formally referenced until it is published as an RFC.**

- [125] IETF RFC 6026: "Correct Transaction Handling for 2xx Responses to Session Initiation Protocol (SIP) INVITE Requests".
- [126] IETF RFC 5658: "Addressing Record-Route issues in the Session Initiation Protocol (SIP)".
- [127] IETF RFC 5954: "Essential correction for IPv6 ABNF and URI comparison in RFC3261".
- [128] Void.
- [129] 3GPP TS 24.182: "IP Multimedia Subsystem (IMS) Customized Alerting Tones (CAT)".
- [130] 3GPP TS 29.292: "Interworking between the IP Multimedia (IM) Core Network (CN) subsystem and MSC Server for IMS Centralized Services (ICS)".
- [131] 3GPP TS 24.237: "IP Multimedia (IM) Core Network (CN) subsystem; IP Multimedia Subsystem (IMS) Service Continuity".
- [132] 3GPP TS 24.141: "Presence service using the IP Multimedia (IM) Core Network (CN) subsystem".
- [133] IETF RFC 6794: "A Framework for Session Initiation Protocol (SIP) Session Policies".
- [134] IETF RFC 5875: "An Extensible Markup Language (XML) Configuration Access Protocol (XCAP) Diff Event Package".
- [135] IETF RFC 4488: "Suppression of Session Initiation Protocol (SIP) REFER Method Implicit Subscription".
- [136] draft-ietf-salud-alert-info-urns-09 (October 2013): "URNs for the Alert-Info Header Field of the Session Initiation Protocol (SIP)".

**Editor's note: The above document cannot be formally referenced until it is published as an RFC.**

- [137] Void.
- [138] OMA-TS-Presence\_SIMPLE-V2\_0-20120710-A: "Presence SIMPLE Specification".
- [139] 3GPP TS 24.247: "Messaging service using the IP Multimedia (IM) Core Network (CN) subsystem".
- [140] IETF RFC 4538: "Request Authorization through Dialog Identification in the Session Initiation Protocol (SIP)".
- [141] IETF RFC 5318: "The Session Initiation Protocol (SIP) P-Refused-URI-List Private-Header (P-Header)".
- [142] OMA-TS-Presence\_SIMPLE-V1\_1\_1-20100225-A: "Presence SIMPLE Specification".
- [143] IETF RFC 6809: "Mechanism to Indicate Support of Features and Capabilities in the Session Initiation Protocol (SIP)".
- [144] IETF RFC 5839: "An Extension to Session Initiation Protocol (SIP) Events for Conditional Event Notification".
- [145] Void.
- [146] IETF RFC 3264: "An Offer/Answer Model with the Session Description Protocol (SDP)".

- [147] IETF RFC 4566: "SDP: Session Description Protocol".
- [148] 3GPP TS 29.079: "Optimal Media Routeing within the IP Multimedia Subsystem; Stage 3".
- [149] 3GPP TS 24.337: "IP Multimedia Subsystem (IMS) inter-UE transfer".
- [150] IETF RFC 3960: "Early Media and Ringing Tone Generation in the Session Initiation Protocol (SIP)".
- [151] IETF RFC 3550: "RTP: A Transport Protocol for Real-Time Applications".
- [152] IETF RFC 768: "User Datagram Protocol".
- [153] IETF RFC 3551: "RTP Profile for Audio and Video Conferences with Minimal Control".
- [154] IETF RFC 3556: "Session Description Protocol (SDP) Bandwidth Modifiers for RTP Control Protocol (RTCP) Bandwidth".
- [155] IETF RFC 4585: "Extended RTP Profile for Real-time Transport Control Protocol (RTCP)-Based Feedback (RTP/AVPF)".
- [156] IETF RFC 793: "Transmission Control Protocol".
- [157] IETF RFC 4733: "RTP Payload for DTMF Digits, Telephony Tones, and Telephony Signals".
- [158] IETF RFC 4916: "Connected Identity in the Session Initiation Protocol (SIP)".
- [159] 3GPP TS 23.237: "IP Multimedia Subsystem (IMS) Service Continuity".
- [160] IETF RFC 4145: "TCP-Based Media Transport in the Session Description Protocol (SDP)".
- [161] 3GPP TS 32.240: "Telecommunication management; Charging management; Charging architecture and principles".
- [162] Void.
- [163] 3GPP TS 29.658: "SIP Transfer of IP Multimedia Service Tariff Information".

---

## 3 Definitions, symbols and abbreviations

### 3.1 Definitions

For the purposes of the present document, the terms and definitions given in 3GPP TR 21.905 [1] and the following apply. A term defined in the present document takes precedence over the definition of the same term, if any, in 3GPP TR 21.905 [1].

**example:** text used to clarify abstract rules by applying them literally.

**IM CN subsystem:** (IP Multimedia CN subsystem) comprises of all CN elements for the provision of IP multimedia applications over IP multimedia sessions, as specified in 3GPP TS 22.228 [9].

**IP multimedia session:** as specified in 3GPP TS 22.228 [9] an IP multimedia session is a set of multimedia senders and receivers and the data streams flowing from senders to receivers. IP multimedia sessions are supported by the IP multimedia CN Subsystem and are enabled by IP connectivity bearers (e.g. GPRS as a bearer). A user can invoke concurrent IP multimedia sessions.

**non-roaming II-NNI:** the II-NNI between IMS home networks.

**roaming II-NNI:** the II-NNI between a visited IMS network and the IMS home network.

**home-to-visited request on roaming II-NNI:** SIP request being sent from the home network to the visited network.

**visited-to-home request on roaming II-NNI:** SIP request being sent from the visited network to the home network.

**home-to-visited response on roaming II-NNI:** SIP response being sent from the home network to the visited network.

**visited-to-home response on roaming II-NNI:** SIP response being sent from the visited network to the home network.

For the purposes of the present document, the following terms and definitions given in 3GPP TS 23.292 [120] apply:

#### **MSC Server enhanced for ICS**

For the purposes of the present document, the following terms and definitions given in 3GPP TS 23.237 [159] apply:

#### **MSC server enhanced for SRVCC**

## 3.2 Symbols

For the purposes of the present document, the following symbols apply:

I2	Reference point between the MSC Server enhanced for ICS and the home IMS
Ici	Reference Point between an IBCF and another IBCF belonging to a different IM CN subsystem network
Izi	Reference Point between a TrGW and another TrGW or media handling node belonging to a different IM CN subsystem network
Mi	Reference Point between a BGCF and CSCF
Mm	Reference Point between a CSCF/BGCF/IMS ALG and an IP multimedia network.
Mw	Reference Point between a CSCF and another CSCF
Mx	Reference Point between a CSCF/BGCF/MSC Server enhanced for ICS/ MSC Server enhanced for SRVCC and IBCF

## 3.3 Abbreviations

For the purposes of the present document, the abbreviations given in 3GPP TR 21.905 [1] and the following apply. An abbreviation defined in the present document takes precedence over the definition of the same abbreviation, if any, in 3GPP TR 21.905 [1].

ACR	Anonymous Communication Rejection
ATCF	Access Transfer Control Function
B2BUA	Back 2 Back User Agent
BGCF	Breakout Gateway Control Function
CAT	Customized Alerting Tone
CB	Communication Barring
CCBS	Completion of Communications to Busy Subscriber
CCNR	Communication Completion on No Reply
CDIV	Communication Diversion
CRS	Customized Ringing Signal
ECT	Explicit Communication Transfer
FA	Flexible Alerting
HOLD	Communication HOLD
CW	Communication Waiting
IBCF	Interconnection Border Control Function
ICB	Incoming Communication Barring
ICID	IMS Charging Identifier
ICS	IMS Centralized Services
I-CSCF	Interrogating CSCF
II-NNI	Inter-IMS Network to Network Interface
IM	Instant Messaging
IMS-ALG	IMS Application Level Gateway
MCID	Malicious Communication IDentification
MRFC	Media Resource Function Controller
MSRP	Message Session Relay Protocol
MWI	Message Waiting Indication
NA(P)T-PT	Network Address (Port-Multiplexing) Translation-Protocol Translation
NNI	Network to Network Interface
OCB	Outgoing Communication Barring
OIP	Originating Identification Presentation

OIR	Originating Identification Restriction
OMA	Open Mobile Alliance
OMR	Optimal Media Routing
P-CSCF	Proxy CSCF
PNM	Personal Network Management
PRES	Presence
TIP	Terminating Identification Presentation
TIR	Terminating Identification Restriction
TrGW	Transition Gateway
SRVCC	Single Radio Voice Call Continuity
IOI	Inter Operator Identifier
IUT	Inter UE Transfer

## 4 Overview

Interconnection between two different IM CN subsystems shall be guaranteed in order to support end-to-end service interoperability. For this purpose, Inter-IMS Network to Network Interface (II-NNI) between two IM CN subsystem networks is adopted, according to the assumptions coming from 3GPP TS 23.002 [3] and 3GPP TS 23.228 [4].

**NOTE:** The end-to-end service interoperability within one IM CN subsystem over the Mi, Mm, Mw and I2 reference points not passing over the Mx reference point as defined in 3GPP TS 23.228 [4] is outside the scope of this document.

Aiming to support the delivery of IMS services between two separated IM CN subsystems, protocol interconnection has to occur:

- at a control plane level, in order that IMS procedures can be supported. In this case the adopted reference point is the Ici; and
- at a user plane level, where media streams are exchanged over the Izi reference point.

IP multimedia sessions are managed by SIP. The transport mechanism for both SIP session signalling and media transport is IPv4 (IETF RFC 791 [2]) or IPv6 (IETF RFC 2460 [7]). The 3GPP profile of SIP defining the usage of SIP within the IM CN subsystem is specified in 3GPP TS 24.229 [5]. Example call flows are provided in 3GPP TR 24.930 [6].

The general interconnection model is shown in Figure 4.1.

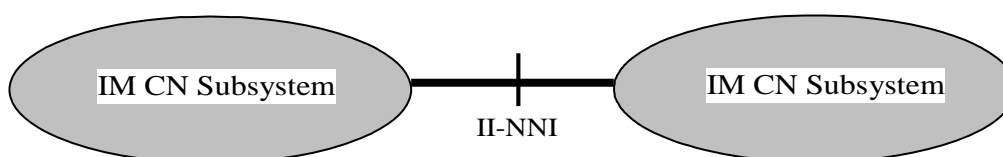

**Figure 4.1: Interconnection Model for IM CN subsystems**

The possible functional entities involved in the signalling plane interconnection (IBCF, I-CSCF, P-CSCF, ATCF, S-CSCF, BGCF, MSC Server enhanced for ICS and MSC server enhanced for SRVCC) and in the user plane interconnection (TrGW) are specified in 3GPP TS 24.229 [5], in 3GPP TS 24.292 [121], 3GPP TS 29.292 [130], 3GPP TS 29.162 [8] and in 3GPP TS 24.237 [131].

IP Version interworking is described within 3GPP TS 29.162 [8].



## 5 Reference model for interconnection between IM CN subsystems

### 5.1 General

Figure 5.1 illustrates the architecture diagram given in 3GPP TS 23.228 [4] showing the Inter-IMS Network to Network Interface (II-NNI) between two IM CN subsystem networks.

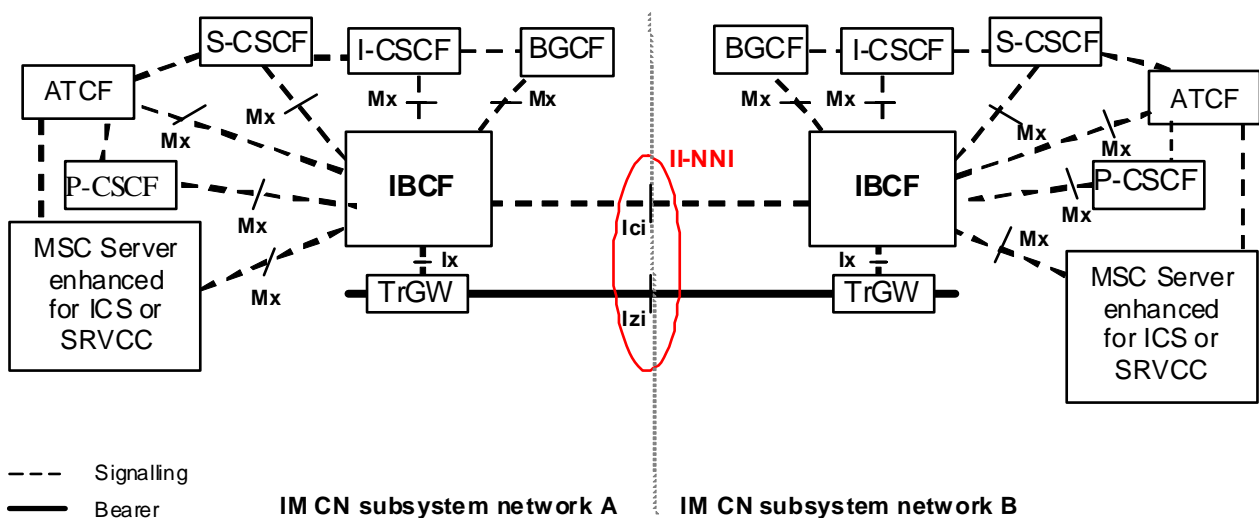

**Figure 5.1.1: Inter-IMS Network to Network Interface between two IM CN subsystem networks**

The protocols over the two reference points Ici and Izi make up the Inter-IMS Network to Network Interface.

The Ici reference point allows IBCFs to communicate with each other in order to provide the communication and forwarding of SIP signalling messaging between IM CN subsystem networks. The Izi reference point allows TrGWs to forward media streams between IM CN subsystem networks.

IMS roaming performed by using II-NNI is considered, when the IBCFs are inserted at the network borders. The applicability of roaming scenario by using II-NNI is based on agreement between the operators.

Whenever the Inter-IMS Network to Network Interface is used to interconnect two IM CN subsystem networks belonging to different security domains, security procedures apply as described in 3GPP TS 33.210 [10].

## 5.2 Functionalities performed by entities at the edge of the network

### 5.2.1 Interconnection Border Control Function (IBCF)

An IBCF provides application specific functions at the SIP/SDP protocol layer in order to perform interconnection between IM CN subsystem networks by using Ici reference point. According to 3GPP TS 23.228 [4], IBCF can act both as an entry point and as an exit point for a network.

The functionalities of IBCF are indicated in the 3GPP TS 23.228 [4] and specified in 3GPP TS 24.229 [5]. They include:

- network topology hiding;
- application level gateway (for instance enabling communication between IPv6 and IPv4 SIP applications, or between a SIP application in a private IP address space and a SIP application outside this address space);
- controlling transport plane functions;

- controlling media plane adaptations;
- screening of SIP signalling information;
- selecting the appropriate signalling interconnect;
- generation of charging data records; and
- privacy protection.

Based on local configuration, the IBCF performs transit routing functions as specified in 3GPP TS 24.229 [5].

The IBCF acts as a B2BUA when it performs IMS-ALG functionality.

## 5.2.2 Transition Gateway (TrGW)

According to 3GPP TS 23.002 [3], the TrGW is located at the network borders within the media path and is controlled by an IBCF. Forwarding of media streams between IM CN subsystem networks is applied over Izi reference point.

The TrGW provides functions like network address/port translation and IPv4/IPv6 protocol translation. NAT-PT binds addresses in IPv6 network with addresses in IPv4 network and vice versa to provide transparent routing between the two IP domains without requiring any changes to end points. NA(P)T-PT provides additional translation of transport identifier (TCP and UDP port numbers). The approach is similar to that one described also in 3GPP TS 29.162 [8].

Further details are described in 3GPP TS 23.228 [4].

---

# 6 Control plane interconnection

## 6.1 Definition of Inter-IMS Network to Network Interconnection

### 6.1.1 SIP methods and header fields

#### 6.1.1.1 General

The functional entity closest to the border of an II-NNI (see reference model in clause 5) shall provide the capabilities specified for that network element in Annex A.2 of 3GPP TS 24.229 [5] with modifications as described in the following sub clauses.

#### 6.1.1.2 SIP methods

3GPP TS 24.229 [5] defines the methods allowing an IBCF to interconnect to an IBCF placed in another IM CN subsystem.

The following SIP methods are supported on the II-NNI as defined in table 6.1.

The following table is based on table A.5 and table A.163 of 3GPP TS 24.229 [5] and endorsed for this document:

**Table 6.1: Supported SIP methods**

Item	Method	Ref.	II-NNI	
			Sending	Receiving
1	ACK request	IETF RFC 3261 [13]	m	m
2	BYE request	IETF RFC 3261 [13]	m	m
3	BYE response	IETF RFC 3261 [13]	m	m
4	CANCEL request	IETF RFC 3261 [13]	m	m
5	CANCEL response	IETF RFC 3261 [13]	m	m
5A	INFO request	IETF RFC 6086 [39]	o	o
5B	INFO response	IETF RFC 6086 [39]	o	o
8	INVITE request	IETF RFC 3261 [13]	m	m
9	INVITE response	IETF RFC 3261 [13]	m	m
9A	MESSAGE request	IETF RFC 3428 [19]	o	o
9B	MESSAGE response	IETF RFC 3428 [19]	o	o
10	NOTIFY request	IETF RFC 3265 [20]	c1	c1
11	NOTIFY response	IETF RFC 3265 [20]	c1	c1
12	OPTIONS request	IETF RFC 3261 [13]	m	m
13	OPTIONS response	IETF RFC 3261 [13]	m	m
14	PRACK request	IETF RFC 3262 [18]	m	m
15	PRACK response	IETF RFC 3262 [18]	m	m
15A	PUBLISH request	IETF RFC 3903 [21]	c1	c1
15B	PUBLISH response	IETF RFC 3903 [21]	c1	c1
16	REFER request	IETF RFC 3515 [22]	o	o
17	REFER response	IETF RFC 3515 [22]	o	o
18	REGISTER request	IETF RFC 3261 [13]	c2	c2
19	REGISTER response	IETF RFC 3261 [13]	c2	c2
20	SUBSCRIBE request	IETF RFC 3265 [20]	c1	c1
21	SUBSCRIBE response	IETF RFC 3265 [20]	c1	c1
22	UPDATE request	IETF RFC 3311 [23]	m	m
23	UPDATE response	IETF RFC 3311 [23]	m	m
c1:	In case of roaming scenario, the support of the method is m, else o.			
c2:	In case of roaming scenario, the support of the method is m, else n/a.			
NOTE:	In the above table, m, o and c and n/a have the meanings indicated in table 6.3			

### 6.1.1.3 SIP header fields

#### 6.1.1.3.0 General

The IBCF shall provide the capabilities to manage and modify SIP header fields according to subclause 5.10 and Annex A of 3GPP TS 24.229 [5] with modifications as described in the following subclauses.

#### 6.1.1.3.1 Trust and no trust relationship

The IBCF acting as exit point applies the procedures described in subclause 5.10.2 of 3GPP TS 24.229 [5] before forwarding the SIP signalling to the IBCF acting as entry point. The IBCF acting as entry point applies the procedures described in subclause 5.10.3 of 3GPP TS 24.229 [5].

Additionally, in case there is no trust relationship between the two IM CN subsystems connected by II-NNI, the IBCF applies the procedures described in subclause 4.4 of 3GPP TS 24.229 [5], before forwarding the SIP signalling.

These procedures may be utilized on a per header field basis to realize overall trust as well as per service level screening of header fields. Trust relationships and trust domains may be defined by inter-operator agreements for individual services and/or individual SIP header fields.

The management of the SIP header fields (if present) over II-NNI in case of a presence or not of a trust relationship between the two interconnected IM CN subsystems is wrapped up in the following table.

**Table 6.2: Management of SIP header fields over II-NNI in presence or not of a trust relationship**

Item	Header field	Reference	Trust relationship	Not trust relationship
1	P-Asserted-Identity	IETF RFC 3325 [44]	As specified in 3GPP TS 24.229 [5], subclause 4.4 (NOTE 5)	As specified in 3GPP TS 24.229 [5], subclause 4.4 (NOTE 5)
2	P-Access-Network-Info	IETF RFC 3455 [24]	As specified in 3GPP TS 24.229 [5], subclause 4.4	As specified in 3GPP TS 24.229 [5], subclause 4.4
3	Resource-Priority	IETF RFC 4412 [78]	As specified in 3GPP TS 24.229 [5], subclause 4.4	As specified in 3GPP TS 24.229 [5], subclause 4.4
4	History-Info	IETF RFC 4244 [25]	As specified in 3GPP TS 24.229 [5], subclause 4.4	As specified in subclause 4.3.3 of RFC 4244 [25] and in 3GPP TS 24.229 [5], subclause 4.4
5	P-Asserted-Service	IETF RFC 6050 [26]	As specified in 3GPP TS 24.229 [5], subclause 4.4 (NOTE 3)	As specified in 3GPP TS 24.229 [5], subclause 4.4 (NOTE 3)
6	P-Charging-Vector	IETF RFC 3455 [24]	As specified in 3GPP TS 24.229 [5], subclause 5.10	As specified in 3GPP TS 24.229 [5], subclause 5.10
7	P-Charging-Function-Addresses (NOTE 4)	IETF RFC 3455 [24]	As specified in 3GPP TS 24.229 [5], subclause 5.10	As specified in 3GPP TS 24.229 [5], subclause 5.10
8	P-Profile-Key (NOTE 2)	IETF RFC 5002 [64]	As specified in 3GPP TS 24.229 [5], subclause 4.4	As specified in 3GPP TS 24.229 [5], subclause 4.4
9	P-Private-Network-Indication (NOTE 1)	draft-vanelburg-dispatch-private-network-ind [84]	As specified in 3GPP TS 24.229 [5], subclause 4.4	As specified in 3GPP TS 24.229 [5], subclause 4.4
10	P-Served-User (NOTE 1, NOTE 2)	IETF RFC 5502 [85]	As specified in 3GPP TS 24.229 [5], subclause 4.4	As specified in 3GPP TS 24.229 [5], subclause 4.4
11	Reason (in a response)	IETF RFC 6432 [49]	As specified in 3GPP TS 24.229 [5], subclause 4.4	As specified in 3GPP TS 24.229 [5], subclause 4.4
12	P-Early-Media	IETF RFC 5009 [74]	As specified in 3GPP TS 24.229 [5], subclause 4.4	As specified in 3GPP TS 24.229 [5], subclause 4.4
13	Feature-Caps	IETF RFC 6809 [143]	As specified in 3GPP TS 24.229 [5], subclause 4.4	As specified in 3GPP TS 24.229 [5], subclause 4.4
<p>NOTE 1: For a roaming II-NNI, a trust relationship with respect to this header field is required.</p> <p>NOTE 2: This header field is only applicable on a roaming II-NNI.</p> <p>NOTE 3: In addition, value-dependent operator policies may be applied.</p> <p>NOTE 4: This header field is not applicable at II-NNI.</p> <p>NOTE 5: The handling of the URI parameters "cpc" and "oli", defined in 3GPP TS 24.229 [5] subclause 7.2A.12, is specified in 3GPP TS 24.229 [5], subclause 4.4.</p>				

### 6.1.1.3.2 Derivation of applicable SIP header fields from 3GPP TS 24.229 [5]

For any method in table 6.1, the SIP header fields applicable on the II-NNI are detailed in the corresponding method tables for the UA role and proxy role sending behaviour in annex A of 3GPP TS 24.229 [5]. Unless other information is specified in the normative part of the present specification, the applicability of header fields at the II-NNI can be derived for each method from the corresponding tables in annex A of 3GPP TS 24.229 [5] as follows:

- All header fields not present in the corresponding tables in annex A of 3GPP TS 24.229 or marked as "n/a" in both the "RFC status" and "profile status" columns for the UA role and proxy role sending behaviour of that tables are not applicable at the II-NNI.

NOTE 1: Operators could choose to apply header fields for other SIP extensions on an II-NNI based on bilateral agreements, but this is outside the scope of the present specification.

- All header fields which are marked as "o" in at least one of the "RFC status" or the "profile status" profile columns for the sending behaviour in the corresponding UA role and proxy role tables in annex A of 3GPP TS

24.229 [5] and as "n/a" or "o" in the other such columns are applicable at II-NNI based on bilateral agreement between operators.

- All header fields which are marked as "m" in at least one of the "RFC status" or the "profile status" columns for the sending behaviour in the corresponding UA role or proxy role table in annex A of 3GPP TS 24.229 [5] and as "n/a", "o", or "m" in the other such columns are applicable at the II-NNI.
- If conditions are specified, they are also applicable at the II-NNI and the above rules are applicable to the "n/a", "o" and "m" values within the conditions.

NOTE 2: In the above rules, the RFC profile columns are taken into account in order to enable interworking with non-3GPP networks,

An informative summary of SIP header fields to be used over the II-NNI is proposed in annex A.

#### 6.1.1.3.3 Applicability of SIP header fields on a roaming II-NNI

The following SIP header fields are only applicable on a roaming II-NNI:

- Authentication-Info
- Authorization
- P-Associated-URI
- P-Called-Party-ID
- P-Preferred-Service
- P-Profile-Key
- P-Served-User
- P-Visited-Network-ID
- Path
- Proxy-Authenticate
- Proxy-Authorization
- Service-Route
- WWW-Authenticate

#### 6.1.1.3.4 Applicability of SIP header fields on a non-roaming II-NNI

The following SIP header fields are only applicable on a non-roaming II-NNI:

- P-Refused-URI-List

#### 6.1.1.4 Notations of the codes

In the table 6.1 the status codes "m", "o", "c" and "n/a" have the following meanings:

**Table 6.3: Key to notation codes for SIP messages**

Notation code	Notation name	Sending side	Receiving side
m	mandatory	The message shall be supported at II-NNI. Supporting sending a SIP message at the II-NNI means that this message shall be sent over the II-NNI if received from the serving network. It does not imply that network elements inside the serving network or user equipment connected to this network shall support this message.	Supporting receiving a SIP message at the II-NNI means that this message shall be forwarded to the serving network unless the operator's policy is applied as defined in subclause 5.10.1 of 3GPP TS 24.229 [5]. It does not imply that network elements inside the served network or user equipment connected to this network are supporting this message.
o	optional	The message may or may not be supported at II-NNI. The support of the message is provided based on bilateral agreement between the operators.	Same as for sending side.
n/a	not applicable	It is impossible to use/support the message.	It is impossible to use/support the message. This message will be discarded by the IBCF.
c <integer>	conditional	The requirement on the message ("m", "o" or "n/a") depends on the support of other optional or conditional items. <integer> is the identifier of the conditional expression.	Same as for sending side.

### 6.1.1.5 Modes of signalling

Overlap signalling may be used if agreement exists between operators to use overlap and which method to be used, otherwise enbloc shall be used at the II-NNI.

## 6.1.2 SDP protocol

### 6.1.2.1 General

The functional entity closest to the border of an II-NNI (see reference model in clause 5) shall provide the capabilities specified for that network element in Annex A.3 of 3GPP TS 24.229 [5].

The SDP bodies shall be encoded as described in IETF RFC 3261 [13] and in IETF RFC 4566 [147].

The offer/answer model with the SDP as defined in IETF RFC 3264 [146] shall be applied.

The procedures and the SDP rules as defined in IETF RFC 4145 [160] may be applied if media streams with TCP is used.

## 6.1.3 Major capabilities

This subclause contains the major capabilities to be supported over the II-NNI.

The table 6.1.3.1 specifies which capabilities are applicable for II-NNI. The profile status codes within table 6.1.3.1 are defined in table 6.1.3.2.

For the "Basic SIP" capabilities part of table 6.1.3.1, the last column "Profile status over II-NNI" specifies the general status of applicability of the IETF RFC 3261 [13] main mechanisms described in the 2<sup>nd</sup> column "Capability over the Ici".

For the "Extensions to basic SIP" capabilities part, the last column "Profile status over II-NNI" specifies the general status of applicability of the RFC referenced in the 2<sup>nd</sup> column "Capability over the Ici".

If necessary, the applicability of RFCs at the II-NNI level is further detailed in the present Technical Specification.

The columns "Reference item in 3GPP TS 24.229 [5] for the profile status" provide informative references for comparison purposes into the UA and Proxy role major capabilities tables in 3GPP TS 24.229 [5], where the capabilities are defined via additional references.

Table 6.1.3.1: Major capabilities over II-NNI

Item	Capability over the ICI	Reference item in 3GPP TS 24.229 [5] for the profile status		Profile status over II-NNI
		UA Role (NOTE 1)	Proxy role (NOTE 2)	
	<b>Basic SIP (IETF RFC 3261 [13])</b>			
1	registrations	1, 2, 2A	-	c2
2	initiating a session	2B, 2C, 3, 4	-	m
3	terminating a session	5	3	m
4	General proxy behaviour	-	4, 5, 14, 15	n/a
5	Managing several responses due to forking	9,10	6	m
6	support of indication of TLS connections in the Record-Route header	-	7, 8	n/a
7	Support of authentication	7, 8, 8A	8A	c2
8	Timestamped requests (Timestamp header field)	6	-	m
9	Presence of date in requests and responses (Date header field)	11	9	m
10	Presence of alerting information data (Alert-info header field)	12	10	o
11	Support and handling of the Require header field for REGISTER and other requests or responses for methods other than REGISTER	-	11, 12, 13	m
12	Support and reading of the Supported and Unsupported header fields	-	16, 17, 18	m
13	Support of the Error-Info header field in 3xx - 6xx responses	-	19	o
14	Support and handling of the Organization header field	-	19A, 19B	m
15	Support and handling of the Call-Info header field	-	19C, 19D	m
16	Support of the Contact header field in 3xx response	-	19E	m
16A	Proxy reading the contents of a body or including a body in a request or response	-	19F	n/a
	<b>Extensions to basic SIP</b>			
16B	3GPP TS 24.237 [131]: proxy modifying the content of a body	-	19G	n/a
17	IETF RFC 6086[39]: SIP INFO method and package framework	13	20	o
17A	IETF RFC 6086 [39]: legacy INFO usage	13A	20A	o
18	IETF RFC 3262 [18]: reliability of provisional responses in SIP (PRACK method)	14	21	m
19	IETF RFC 3515 [22]: the SIP REFER method	15	22	o
20	IETF RFC 3312 [40] and RFC 4032 [41]: integration of resource management and SIP (Preconditions framework)	16	23	o
21	IETF RFC 3311 [23]: the SIP UPDATE method	17	24	m
22	IETF RFC 3313 [42]: SIP extensions for media authorization (P-Media-Authorization header field)	19	26	n/a
23	IETF RFC 3265 [20]: SIP specific event notification (SUBSCRIBE/NOTIFY methods)	20, 21, 22, 23	27, 28	c1
24	IETF RFC 3327 [43]: session initiation protocol extension header field for registering non-adjacent contacts (Path header field)	24	29	c2
25	IETF RFC 3325 [44]: private extensions to the Session Initiation Protocol (SIP) for network asserted identity within trusted networks	25	30	c4
26	IETF RFC 3325 [44]: the P-Preferred-Identity header field extension	-	-	n/a
27	IETF RFC 3325 [44]: the P-Asserted-Identity header field extension	-	-	c4
28	IETF RFC 3323 [34]: a privacy mechanism for the Session Initiation Protocol (SIP) (Privacy header field)	26, 26A, 26B, 26C, 26D, 26E, 26F, 26G, 26H	31, 31A, 31B, 31C, 31D, 31E, 31F, 31G, 31H	m
29	IETF RFC 3428 [19]: a messaging mechanism for the Session Initiation Protocol (SIP) (MESSAGE method)	27	33	o
30	IETF RFC 3608 [45]: session initiation protocol extension header field for service route discovery during registration (Service-Route header field)	28	32	c2



31	IETF RFC 3486 [46]: compressing the session initiation protocol	29	34	n/a
32	IETF RFC 3455 [24]: private header extensions to the session initiation protocol for the 3rd-Generation Partnership Project (3GPP)	30	35	o
32A	IETF RFC 3325 [44]: act as first entity within the trust domain for asserted identity	30A	30A	n/a
32B	IETF RFC 3325 [44]: act as entity within trust network that can route outside the trust network	30B	30B	n/a
32C	IETF RFC 3325: act as entity passing on identity transparently independent of trust domain	30C	30C	n/a
33	IETF RFC 3455 [24]: the P-Associated-URI header field extension	31	36	c2
34	IETF RFC 3455 [24]: the P-Called-Party-ID header field extension	32	37	c2
35	IETF RFC 3455 [24]: the P-Visited-Network-ID header field extension	33	38, 39	c2
36	IETF RFC 3455 [24]: the P-Access-Network-Info header field extension	34	41, 42, 43	c4
37	IETF RFC 3455 [24]: the P-Charging-Function-Addresses header field extension	35	44, 44A	n/a
38	IETF RFC 3455 [24]: the P-Charging-Vector header field extension	36	45, 46	c1
39	IETF RFC 3329 [47]: security mechanism agreement for the session initiation protocol	37	47	n/a
39A	3GPP TS 24.229 [5] subclause 7.2A.7: Capability Exchange for Media Plane Security	37A	47A	n/a
40	IETF RFC 3326 [48]: the Reason header field for the session initiation protocol	38	48	o
41	IETF RFC 6432 [49]: carrying Q.850 codes in reason header fields in SIP (Session Initiation Protocol) responses	38A	48A	c4
42	IETF RFC 3581 [50]: an extension to the session initiation protocol for symmetric response routing	39	49	o
43	IETF RFC 3841 [51]: caller preferences for the session initiation protocol (Accept-Contact, Reject-Contact and Request-Disposition header fields)	40, 40A, 40B, 40C, 40D, 40E, 40F	50, 50A, 50B, 50C, 50D, 50E, 50F	m
44	IETF RFC 3903 [21]: an event state publication extension to the session initiation protocol (PUBLISH method)	41	51	c1
45	IETF RFC 4028 [52]: SIP session timer (Session-Expires and Min-SE headers)	42	52	m
46	IETF RFC 3892 [53]: the SIP Referred-By mechanism	43	53	m
47	IETF RFC 3891 [54]: the Session Initiation Protocol (SIP) "Replaces" header	44	54	o
48	IETF RFC 3911 [55]: the Session Initiation Protocol (SIP) "Join" header	45	55	o
49	IETF RFC 3840 [56]: the callee capabilities	46	56	o
50	IETF RFC 4244 [25]: an extension to the session initiation protocol for request history information (History-Info header field)	47	57	o
51	IETF RFC 5079 [57]: Rejecting anonymous requests in the session initiation protocol	48	58	o
52	IETF RFC 4458 [58]: session initiation protocol URIs for applications such as voicemail and interactive voice response (NOTE 3)	49	59	o
53	IETF RFC 4320 [59]: Session Initiation Protocol's (SIP) non-INVITE transactions	50	61	m
54	IETF RFC 4457 [60]: the P-User-Database private header field extension	51	60	n/a
55	IETF RFC 5031 [61]: A Uniform Resource Name (URN) for Emergency and Other Well-Known Services	52	62	n/a
56	IETF RFC 5627 [62]: obtaining and using GRUUs in the Session Initiation Protocol (SIP)	53	63	c1
57	Void			
58	IETF RFC 4168 [27]: the Stream Control Transmission Protocol (SCTP) as a Transport for the Session Initiation Protocol (SIP)	55	65	o

59	IETF RFC 5002 [64]: the SIP P-Profile-Key private header field extension	56	66, 66A, 66B	c3
60	IETF RFC 5626 [65]: managing client initiated connections in SIP	57	67	c1
61	IETF RFC 5768 [66]: indicating support for interactive connectivity establishment in SIP	58	68	n/a
62	IETF RFC 5365 [67]: multiple-recipient MESSAGE requests in the session initiation protocol	59	69	o if 29, else n/a
63	IETF RFC 6442 [68]: Location Conveyance for the Session Initiation Protocol	60	70, 70A, 70B	m
64	IETF RFC 5368 [69]: referring to multiple resources in the session initiation protocol	61	71	o if 19, else n/a
65	IETF RFC 5366 [70]: conference establishment using request-contained lists in the session initiation protocol	62	72	o
66	IETF RFC 5367 [71]: subscriptions to request-contained resource lists in the session initiation protocol	63	73	o if 23, else n/a
67	IETF RFC 4967 [72]: dialstring parameter for the session initiation protocol uniform resource identifier	64	74	c2
68	IETF RFC 4964 [73]: the P-Answer-State header extension to the session initiation protocol for the open mobile alliance push to talk over cellular	65	75	o
69	IETF RFC 5009 [74]: the SIP P-Early-Media private header field extension for authorization of early media	66	76	c4
70	IETF RFC 4694 [75]: number portability parameters for the "tel" URI	67, 67A, 67B	77, 77A, 77B	o
72	IETF RFC 4411 [77]: extending the session initiation protocol Reason header for preemption events	69	79	o
73	IETF RFC 4412 [78]: communications resource priority for the session initiation protocol (Resource-Priority header field)	70, 70A, 70B	80, 80A, 80B	o
74	IETF RFC 5393 [79]: addressing an amplification vulnerability in session initiation protocol forking proxies	71	81	m
75	IETF RFC 5049 [80]: the remote application identification of applying signalling compression to SIP	72	82	n/a
76	IETF RFC 5688 [81]: a session initiation protocol media feature tag for MIME application sub-types	73	83	c1
77	IETF RFC 6050 [26]: Identification of communication services in the session initiation protocol	74	84, 84A	o
78	IETF RFC 5360 [82]: a framework for consent-based communications in SIP	75, 75A, 75B	85	o
79	draft-ietf-cuss-sip-uu [83]: a mechanism for transporting user to user call control information in SIP	76	86	c1
79A	draft-ietf-cuss-sip-uu-isdn [83A]: Interworking ISDN Call Control User Information with SIP	76A	-	c1
80	draft-vanelburg-dispatch-private-network-ind [84]: The SIP P-Private-Network-Indication private-header (P-Header)	77	87	c1
81	IETF RFC 5502 [85]: the SIP P-Served-User private header	78	88	c2
83	Void			
84	IETF RFC 6228 [88]: the 199 (Early Dialog Terminated) response code	81	91	m
85	IETF RFC 5621 [89]: message body handling in SIP	82	92	m
86	IETF RFC 6223 [90]: indication of support for keep-alive	83	93	o
88	IETF RFC 3862 [92]: common presence and instant messaging (CPIM): message format	85	95	o
89	IETF RFC 5438 [93]: instant message disposition notification	86	96	o
90	IETF RFC 5373 [94]: requesting answering modes for SIP (Answer-Mode and Priv-Answer-Mode header fields)	87	97, 97A	o
	Void			
92	IETF RFC 3959 [96]: the early session disposition type for SIP	89	99	o
93	Subclause 7.2A.16 of 3GPP TS 24.229 [5]: delivery of Request-URI targets to user agents	90	100	o
94	draft-kaplan-insipid-session-id [124]: The Session-ID header	91	101	o
95	IETF RFC 6026 [125]: correct transaction handling for 200 responses to Session Initiation Protocol INVITE requests	92	102	m
96	IETF RFC 5658 [126]: addressing Record-Route issues in the Session Initiation Protocol (SIP)	93	103	o
97	IETF RFC 5954 [127]: essential correction for IPv6 ABNF	94	104	m

	and URI comparison in IETF RFC 3261 [13]			
98	IETF RFC 4488 [135]: suppression of session initiation protocol REFER method implicit subscription	95	105	m if 19, else n/a
99	draft-ietf-salud-alert-info-urns [136]: Alert-Info URNs for the Session Initiation Protocol	96	106	o
100	Subclause 3.1 of 3GPP TS 24.229: multiple registrations	97	107	c2
101	IETF RFC 5318 [141]: the SIP P-Refused-URI-List private-header	98	108	c5
102	IETF RFC 4538 [140]: request authorization through dialog Identification in the session initiation protocol (Target-Dialog header field)	99	109	o
103	IETF RFC 6809 [143]: Mechanism to indicate support of features and capabilities in the Session Initiation Protocol (SIP)	100	110	o
c1: m in case of roaming II-NNI, else o c2: m in case of roaming II-NNI, else n/a c3: o in case of roaming II-NNI, else n/a c4: m in case of trust relationship between the interconnected networks, else n/a c5: o in case of non-roaming II-NNI, else n/a				
NOTE 1: The item numbering corresponds to the one provided in table A.4 in [5]. NOTE 2: The item numbering corresponds to the one provided in table A.162 in [5]. NOTE 3: A common URI namespace is required to apply this feature on the II-NNI.				

Table 6.1.3.2: Key to notation codes for major capabilities

Notation code	Notation name	Explanation
m	mandatory	The capability shall be supported at II-NNI. SIP message relating to this capability shall be sent over the II-NNI if received from the serving network, unless they also make use of other unsupported capabilities. SIP headers or other information elements relating to this capability shall be passed over the II-NNI if received from the sending side. This does not imply that network elements inside the serving network or served network or user equipment connected to these networks shall support this capability.
o	optional	The capability may or may not be supported at II-NNI. The support of the capability is provided based on bilateral agreement between the operators.
n/a	not applicable	It is impossible to use/support the capability at the II-NNI.
c<integer>	conditional	The support of the capability ("m", "o" or "n/a") depends on the support of other optional or conditional items. <integer> is the identifier of the conditional expression.

## 6.1.4 SIP message bodies

The MIME type "application/sdp" and multipart message bodies shall be supported over the II-NNI. Other MIME types may be supported over the II-NNI based on agreement between operators.

The SDP message bodies contained in the INVITE request shall not be encrypted over the II-NNI.

NOTE 1: Some MIME types in SIP requests and responses are listed in Annex A of 3GPP TS 24.229 [5].

NOTE 2: The multipart message bodies are used for carrying two or more message body types as described in IETF RFC 5621 [89].

NOTE 3: In the INVITE request, the SDP message body is present over the II-NNI, except when the INVITE request without SDP message body is required to provide services (e.g. 3rd party call control).

Applicable characteristics of the SIP message body MIMEs (i.e. the value(s) of Content-Disposition header field and Content-Language header field) over the II-NNI may be a subject of operator agreements.

## 6.2 Control Plane Transport

### 6.2.1 General

The control plane transport of the II-NNI shall comply with subclause 4.2A of 3GPP TS 24.229 [5].

Support of SCTP as specified in IETF RFC 4168 [27] is optional for an IBCF connected by II-NNI. Nevertheless this option is favourable if the operators would like to improve reliability over the Ici.

---

## 7 User plane Interconnection

### 7.1 Media and Codec

For "end-to-end" media session involving the II-NNI, the SIP/SDP codec negotiation procedure can be applied between IM CN subsystems using different media codecs. It is possible that the end-to-end codec negotiation could fail because no common codec could be supported by the UEs, in particular for voice services.

To enhance interoperability, the IBCF, the MRFC, or other IMS network entities can interfere with the end-to-end codec negotiation to offer additional codec(s) available via transcoding, or to remove codecs. The IBCF can configure an attached TrGW to transcode, and the MRFC can configure an attached MRFP to transcode.

Codecs applicable at the II-NNI may be a subject of interworking agreements.

NOTE 1: Possible codecs which could be used at the II-NNI are described in 3GPP TS 26.114 [11] and ETSI TS 181 005 [12].

NOTE 2: As described in 3GPP TS 24.229 [5], the IETF RFC 4733 [157] is used to encode DTMF events and a payload type number associated with the MIME subtype "telephone-event" is included in a SDP message.

However, to avoid that transcoding is performed several times, applicable codecs at the II-NNI should be restricted as little as possible.

NOTE 3: Transcoding can be performed in an IMS network serving an SDP offerer or in an IMS network serving an SDP answerer. To avoid that transcoding is performed multiple times, inter-operator agreements can clarify if it is preferred that IMS network serving an SDP offerer or IMS network serving an SDP answerer modify an SDP offer to offer transcoding.

If the IBCF performs media transcoding control, the IBCF shall apply the related procedures in 3GPP TS 24.229 [5].

### 7.2 User Plane Transport

The user plane transport of the II-NNI may use the protocols listed in table 7.2.1. Protocols that use UDP, RTP or TCP as the underlying transport protocol may be used based on agreements between operators. The used protocols to transport media are negotiated by means of SDP offer/answer.

**Table 7.2.1: Supported transport-level RFCs to be described in SIP/SDP messages**

Item	RFC	Title	Support
1	IETF RFC 3550 [151]	RTP: A Transport Protocol for Real-Time Applications	Mandatory
2	IETF RFC 768 [152]	User Datagram Protocol	Mandatory
3	IETF RFC 3551 [153]	RTP Profile for Audio and Video Conferences with Minimal Control	Mandatory
4	IETF RFC 3556 [154]	Session Description Protocol (SDP) Bandwidth Modifiers for RTP Control Protocol (RTCP) Bandwidth	Mandatory
5	IETF RFC 4585 [155]	Extended RTP Profile for Real-time Transport Control Protocol (RTCP) - Based Feedback (RTP/AVPF)	Optional (NOTE 1)
6	IETF RFC 793 [156]	Transmission Control Protocol	Optional (NOTE 2)
NOTE 1: used by MTSI, as indicated in 3GPP TS 26.114 [11]			
NOTE 2: used for MSRP service			

## 8 Numbering, Naming and Addressing

### 8.1 Numbering, Naming and Addressing for SIP message

The following URI formats in SIP messages may be applied at the ICI as standardized in 3GPP TS 24.229 [5]:

- SIP URI defined in IETF RFC 3261 [13];
- tel URI defined in IETF RFC 3966 [14];
- IM URI defined in IETF RFC 3860 [15];
- PRES URI defined in IETF RFC 3859 [16].

According to 3GPP TS 24.229 [5], the IBCF acting as an exit or entry point in the IMS network supports these URI formats. These URI formats shall be supported at the roaming II-NNI. The SIP URI format shall be supported at the non-roaming II-NNI. The tel URI, IM URI and PRES URI formats may be supported at the non-roaming II-NNI based on agreement between operators. Other URI formats may be supported over the II-NNI depending on the operator agreements.

A global number as defined in IETF RFC 3966 [14] shall be used in a tel URI or in the user portion of a SIP URI with the user=phone parameter when conveyed via a non-roaming II-NNI in the Request-URI and in the P-Asserted-Identity header field, except when agreement exists between the operators to also allow other kinds of numbers.

NOTE 1: In a SIP URI the user portion of the Request-URI represents a telephone number only if the SIP URI includes the user=phone parameter.

NOTE 2: Agreements can exist between operators to allow non-global number (e.g. national service numbers, business trunking numbers, or private numbers) at a non-roaming II-NNI. A SIP URI with such a number, a user=phone parameter, and a phone-context parameter agreed between the operators can then be used.

NOTE 3: 3GPP TS 24.229 [5] allows to restrict the number within a SIP Request-URI with user=phone parameter at a non-roaming II-NNI to be a global number (i.e. E.164 in international format) via an appropriate Application Server. Suitable configuration by the operator is needed to achieve the desired modification of the format.

NOTE 4: The allowed phone number formats in the P-Asserted-Identity header field of a served user are configured by the operator. According to 3GPP TS 23.003 [35], international E.164 format is used within a P-Asserted-Identity header field.

NOTE 5: The global number format usage within a SIP Request-URI with the user=phone parameter at a non-roaming II-NNI allows the terminating network to find the called subscriber, via HSS interrogation, without any further number translation and thus improves the success of the interconnection between IMS operators.

The optional "oli" and "cpc" tel URI parameters associated with a tel URI or a SIP URI with user=phone are described in 3GPP TS 24.229 [5] and can be part of the P-Asserted-Identity header field. Depending on operator agreements, those URI parameters may be supported at the non-roaming II-NNI.

The "sos" SIP URI parameter associated with a URI in the Contact header field of a REGISTER request or 200 OK response to REGISTER request is described in 3GPP TS 24.229 [5]. The "sos" SIP URI parameter shall be supported at the roaming II-NNI.

The "sos" SIP URI parameter associated with the Request-URI for all dialogs and standalone SIP requests described in subclause 5.2.10.3 of 3GPP TS 24.229 [5] shall be supported at the roaming II-NNI.

The "rn" and "npdi" number portability parameters for the tel URI and the SIP URI with user=phone as described within IETF RFC 4694 [75] can be part of the Request-URI. Depending on operator agreements these parameters may be exchanged over the non-roaming II-NNI.

NOTE 6: The "rn" and "npdi" parameters can be used to address the entry point of the terminating operator depending on national rules for number portability.

The "isub" tel URI parameter for the tel URI and the SIP URI with user=phone as described within IETF RFC 3966 [14] can be part of the Request-URI, To header field and P-Asserted-Identity header field. Depending on operator agreements, this URI parameter may be exchanged over the II-NNI.

## 8.2 Numbering, Naming and Addressing for SDP

The following URI format in the SDP exchange may be applied at the Ici as standardized in 3GPP TS 24.229 [5]:

- MSRP URI for a session of instant messages defined in IETF RFC 4975 [17].

This URI format shall be supported at the roaming II-NNI and may be supported at the non-roaming II-NNI based on agreement between operators. Other URI formats may be supported over the II-NNI depending on the operators' agreements.

---

# 9 IP Version

The network elements interconnected by means of the II-NNI may support IPv4 only, IPv6 only or both.

The support of one or both of the IP versions is an operator option and should be based on bilateral agreement.

In case IPv4 and IPv6 networks are interconnected, the involved IBCFs and TrGWs shall apply the IP version interworking procedures as indicated in 3GPP TS 29.162 [8].

---

# 10 Security

The supported security mechanisms for IP signalling transport over II-NNI interfaces are described in 3GPP TS 33.210 [10].

---

# 11 Charging

## 11.1 General

The accounting information to be supported over the Ici is described in 3GPP TS 32.260 [29] and 3GPP TS 32.240 [161]. It shall be configurable by the operator to use or not the accounting mechanisms provided by the IBCF.

## 11.2 Inter-operator accounting

For inter-operator accounting, the procedures related to the P-Charging-Vector header field specified in 3GPP TS 24.229 [5] shall be supported over the II-NNI as further specified below.

NOTE 1: The "icid-value" header field parameter identifying a dialog or a transaction outside a dialog is included in the P-Charging-Vector header field as specified in 3GPP TS 24.229 [5].

For the roaming II-NNI:

- the P-Charging-Vector header field in the REGISTER requests containing the type 1 "orig-ioi" with the entry which identifies the visited network; and
- the P-Charging-Vector header field in the REGISTER responses containing type 1 "orig-ioi" and type 1 "term-ioi" header field parameters with the entries which identify the visited network and the home network respectively;

shall be supported.

NOTE 2: Operator network identifiers populated in the type 1 "orig-ioi" and type 1 "term-ioi" header field parameters need to be exchanged by inter-operator agreements in advance.

For the non-roaming II-NNI:

- the P-Charging-Vector header field in the SIP requests containing the type 2 "orig-ioi" with the entry which identifies the home originating network; and
- the P-Charging-Vector header field in the SIP responses containing the type 2 "orig-ioi" and type 2 "term-ioi" header field parameters with the entries which identify the home originating network and the home terminating network respectively;

may be supported based on inter-operator agreements.

NOTE 3: Operator network identifiers populated in the type 2 "orig-ioi" and type 2 "term-ioi" header field parameters need to be exchanged by inter-operator agreements in advance.

## 11.3 Transfer of IP multimedia service tariff information

In order to assure the end-to-end service interoperability through the Inter-IMS Network to Network Interface (II-NNI), transfer of IP multimedia service tariff information as specified in 3GPP TS 29.658 [163] may be supported on the II-NNI between two IMS networks. The support of transfer of IP multimedia service tariff information is based on agreement between operators.

If transfer of IP multimedia service tariff information is supported, the "application/vnd.etsi.sci+xml" MIME body in 18x responses to the INVITE request and in the INFO request shall be supported at the II-NNI.

---

# 12 Supplementary services associated with the IMS multimedia telephony communication service

## 12.1 General

In order to assure the end-to-end service interoperability through the Inter-IMS Network to Network Interface (II-NNI), the associated supplementary services of the multimedia telephony communication service may be supported on the II-NNI between the two IMS networks.

The MMTel communication service is identified by means of the media feature tag +g.3gpp.icsi-ref set to "urn:urn-7:3gpp-service.ims.icsi.mmtel". The media feature tag can appear in the Contact header field, the Accept-Contact header field and the P-Asserted-Service header field.

The support of each associated supplementary service is based on agreement between operators.

If a supplementary service is supported, the related procedures from the 3GPP TS 22.173 [30], the protocol details from the 3GPP TS 24.173 [31] and specifications referenced in the 3GPP TS 24.173 [31] shall be applied with the requirements in the relevant subclause below due to the crossing of the II-NNI.

A classification of the importance of supplementary services applicable over the II-NNI is available in the informative Annex Db of 3GPP TS 22.173 [30].

**NOTE:** Agreeing on interworking of entire class of services according to this classification can simplify the cooperation between interconnecting networks but remains optional.

## 12.2 Malicious Communication IDentification (MCID)

Service specific requirements in accordance with 3GPP TS 24.616 [33] shall be supported over the II-NNI.

The P-Asserted-Identity header field shall be supported at the II-NNI.

The INFO request and the 200 (OK) response to the INFO request containing the "application/vnd.etsi.mcid+xml" MIME body defined in 3GPP TS 24.616 [33] may be supported at the II-NNI.

If a network terminating the dialog supports MCID, the terminating network shall only deliver the MCID request in the "application/vnd.etsi.mcid+xml" MIME body, as specified in the 3GPP TS 24.616 [33], if an agreement to use the MCID supplementary service according to the 3GPP TS 24.616 [33] exists with the network originating the dialog and if the INVITE request received by the terminating network does not contain the information of the originating party.

**NOTE:** The IBCF and the AS in the terminating network interact to deliver the MCID request only if an agreement to use the MCID supplementary service exists, as specified in 3GPP TS 24.616 [33] and 3GPP TS 24.229 [5].

The originating network and the terminating network shall have a bilateral agreement to support transportation of the minimum information specified in subclause 4.5.2.5.0 of the 3GPP TS 24.616 [33] between the networks.

## 12.3 Originating Identification Presentation (OIP) and Originating Identification Restriction (OIR)

Service specific requirements in accordance with 3GPP TS 24.607 [32] shall be supported over the II-NNI.

The P-Asserted-Identity header field and the Privacy header field with values "id", "user", "none", "header" and "critical" shall be supported at the II-NNI.

**NOTE 1:** P-Asserted-Identity header fields are intended for end-to-end operation. Removal of such header fields will impact the intended end-to-end operation between the end users. Where a trust relationship exists on the P-Asserted-Identity header field between the two IMS networks, this header field cannot be altered when passing through the II-NNI according to 3GPP TS 24.229 [5]. Where no trust relationship exists on the P-Asserted-Identity header field between the two IMS networks, the IBCF determines whether to remove the P-Asserted-Identity header field according to procedures described in 3GPP TS 24.229 [5] subclause 4.4.2 referencing IETF RFC 3325 [44] and local policy rules for using additional screening capabilities as defined in 3GPP TS 24.229 [5] subclause 5.10.6.

**NOTE 2:** Where a trust relationship exists with the remote domain the From header field will be passed transparently by the IBCF. If a request is received by the terminating network and the application of the OIR service is required with the value "user" for the Privacy header field then the From header field will be anonymised in accordance with IETF RFC 3323 [34] by the terminating network. Where no trust relationship exists with the remote domain, the From header field can be, based on local policy rules, anonymised by the IBCF of the originating network prior passing through the II-NNI using screening capabilities defined in 3GPP TS 24.229 [5] subclause 5.10.6 and subclause 5.10.8.

SIP based user configuration as described in 3GPP TS 24.238 [100] shall be supported at the roaming II-NNI.



## 12.4 Terminating Identification Presentation (TIP) and Terminating Identification Restriction (TIR)

Service specific requirements in accordance with 3GPP TS 24.608 [113] shall be supported over the II-NNI.

The P-Asserted-Identity header field and the Privacy header field with values "id", "user", "none", "header" and "critical" shall be supported at the II-NNI.

NOTE: P-Asserted-Identity header fields are intended for end-to-end operation. Removal of such header fields will impact the intended end-to-end operation between the end users. Where a trust relationship exists on the P-Asserted-Identity header field between the two IMS networks, this header field will be passed transparently through the II-NNI according to 3GPP TS 24.229 [5]. Where no trust relationship exists on the P-Asserted-Identity header field between the two IMS networks, the IBCF determines whether to remove the P-Asserted-Identity header field according to procedures described in 3GPP TS 24.229 [5] clause 4.4.2, referencing IETF RFC 3325 [44] and local policy rules for using additional screening capabilities as defined in 3GPP TS 24.229 [5] subclause 5.10.6.

The option tag "from-change" defined in IETF RFC 4916 [158], in the Supported header field should be supported at II-NNI.

## 12.5 Anonymous Communication Rejection (ACR)

Service specific requirements in accordance with 3GPP TS 24.611 [114] shall be supported over the II-NNI.

The P-Asserted-Identity header field and the Privacy header field shall be supported at the II-NNI.

Procedures as described in subclause 12.21.4 are used to provide announcements.

The response code 433 (Anonymity Disallowed) shall be supported at the II-NNI.

SIP based user configuration as described in 3GPP TS 24.238 [100] shall be supported at the roaming II-NNI.

## 12.6 Communication DIVersion (CDIV)

Service specific requirements in accordance with 3GPP TS 24.604 [117] shall be supported over the II-NNI.

NOTE 1: The support of the Diversion header field not adopted in 3GPP TS 24.604 [117] requires bilateral agreement between the operators.

Procedures as described in subclause 12.21.2 are used to provide announcements.

The Privacy header field with value "history" shall be supported at the II-NNI.

The History-Info header field as described by 3GPP TS 24.604 [117] and the Cause-Codes as defined by the IETF RFC 4458 [58] shall be supported over the II-NNI.

NOTE 2: The networks can have an internal limit in the number of allowed diversions, as described in 3GPP TS 24.604 [117], subclause 4.5.2.6.1. To ensure efficiency of this control operators can indicate in their bilateral agreements their own number of allowed communication diversions, a parameter that is used for counting, and the network behavior when the internal limit is reached.

The response code 181 (Call Is Being Forwarded) shall be supported at the II-NNI.

The MESSAGE request procedure for indication of communication diversion to the diverting user as specified in 3GPP TS 24.604 [117] and 3GPP TS 24.229 [5] should be supported at the roaming II-NNI.

NOTE 3: The content of the MESSAGE request is operator specific.

SIP based user configuration as described in 3GPP TS 24.238 [100] shall be supported at the roaming II-NNI.

## 12.7 Communication Waiting (CW)

Service specific requirements in accordance with 3GPP TS 24.615 [37] shall be supported over the II-NNI.

The "application/vnd.3gpp.cw+xml" MIME body defined in 3GPP TS 24.615 [37] in the INVITE request shall be supported at the roaming II-NNI.

The Alert-Info header field set to "urn:alert:service:call-waiting" in a 180 (Ringing) response shall be supported at the II-NNI.

As a network option, in case of expiry of the CW timer, the response code 480 (Temporarily Unavailable) including a Reason header field set to cause 19 shall be supported at the non-roaming II-NNI.

Procedures as described in subclause 12.21.2 are used to provide announcements.

## 12.8 Communication HOLD (HOLD)

Service specific requirements in accordance with 3GPP TS 24.610 [36] shall be supported over the II-NNI.

NOTE: The support of an alternative method not adopted in 3GPP TS 24.610 requires bilateral agreement between the operators and is outside the scope of the present document.

Procedures as described in subclause 12.21.3 are used to provide announcements.

## 12.9 Message Waiting Indication (MWI)

Service specific requirements in accordance with 3GPP TS 24.606 [112] shall be supported over the II-NNI.

The event package name "message-summary" in the Event header field according to IETF RFC 3265 [20] and 3GPP TS 24.229 [5] in the SUBSCRIBE request shall be supported at the roaming II-NNI.

The "application/simple-message-summary+xml" MIME body described in 3GPP TS 24.606 [112] in the NOTIFY request shall be supported at the roaming II-NNI.

## 12.10 Communication Barring (CB)

### 12.10.1 Incoming Communication Barring (ICB)

Service specific requirements in accordance with 3GPP TS 24.611 [114] shall be supported over the II-NNI.

Procedures as described in subclause 12.21.4 are used to provide announcements.

The response code 603 (Decline) including a Reason header field as described in 3GPP TS 24.611 [114] shall be supported at the II-NNI.

A Reason header field as described in 3GPP TS 24.611 [114] included in the BYE request shall be supported at the II-NNI.

SIP based user configuration as described in 3GPP TS 24.238 [100] shall be supported at the roaming II-NNI.

If the option IIFC (Inhibition of Incoming Forwarded Calls) is supported the transparency of information related to communication diversion (see subclause 12.6) shall be supported at II-NNI.

### 12.10.2 Outgoing Communication Barring (OCB)

Service specific requirements in accordance with 3GPP TS 24.611 [114] shall be supported over the II-NNI.

Procedures as described in subclause 12.21.4 are used to provide announcements.

The response code 603 (Decline) including a Reason header field as described in 3GPP TS 24.611 [114] shall be supported at the roaming II-NNI.

SIP based user configuration as described in 3GPP TS 24.238 [100] shall be supported at the roaming II-NNI.

## 12.11 Completion of Communications to Busy Subscriber (CCBS)

Service specific requirements in accordance with 3GPP TS 24.642 [109] shall be supported over the II-NNI.

The response code 486 (Busy Here) containing a Call-Info header field with a "purpose" header field parameter set to "call-completion" and the m parameter set to "BS" shall be supported at the non-roaming II-NNI.

For invoking and revoking of the CCBS supplementary service, announcement procedures shall be used to provide announcements and inband-interaction procedures as described in subclause 12.21.3 and subclause 12.21.4 shall be supported at the roaming II-NNI.

The response code 199 (Early Dialog Terminated) shall be supported at the roaming II-NNI.

Basic call procedures and in case of a call-completion recall initiated by a REFER request, normal REFER method handling procedures according to 3GPP TS 24.229 [5] shall be supported at the roaming II-NNI.

As a network option the special REFER request handling procedures according to 3GPP TS 24.628 [38] should be supported at the roaming II-NNI.

NOTE 1: 3<sup>rd</sup> party call control procedures can be used when the REFER request is not supported at the II-NNI.

NOTE 2: A REFER request can be rejected by IBCF based on operator policy as specified by 3GPP TS 24.229 [5].

The SUBSCRIBE and NOTIFY methods according to IETF RFC 3265 [20] and 3GPP TS 24.229 [5] containing the event package name "call-completion" in the Event header field and the Call-Info header field with a purpose parameter set to 'call-completion' and the m parameter set to "BS" shall be supported at the non-roaming II-NNI.

The Request-URI with the "m" SIP URI parameter with a value set to "BS" and the Call-Info header field with a purpose parameter set to 'call-completion' and the "m" parameter set to "BS" in the INVITE method shall be supported at the non-roaming II-NNI.

The Date header field in the 486 (Busy Here) response to the INVITE request shall be supported at the roaming II-NNI.

SIP based user configuration as described in 3GPP TS 24.238 [100] shall be supported at the roaming II-NNI.

## 12.12 Completion of Communications by No Reply (CCNR)

Service specific requirements in accordance with 3GPP TS 24.642 [109] shall be supported over the II-NNI.

The response code 180 (Ringing) containing a Call-Info header field with a purpose parameter set to 'call-completion' and the m parameter set to "NR" shall be supported at the non-roaming II-NNI.

For invoking and revoking of the CCNR supplementary service, announcement procedures shall be used to provide announcements and inband-interaction procedures as described in subclause 12.21.3 and subclause 12.21.4 shall be supported at the roaming II-NNI.

The response code 199 (Early Dialog Terminated) shall be supported at the roaming II-NNI.

Basic call procedures and in case of a call-completion recall initiated by a REFER request, normal REFER method handling procedures according to 3GPP TS 24.229 [5] shall be supported at the roaming II-NNI.

As a network option the special REFER request handling procedures according to 3GPP TS 24.628 [38] should be supported at the roaming II-NNI.

NOTE 1: 3<sup>rd</sup> party call control procedures can be used when the REFER request is not supported at the II-NNI.

NOTE 2: A REFER request can be rejected by IBCF based on operator policy as specified by 3GPP TS 24.229 [5].

The SUBSCRIBE and NOTIFY methods according to IETF RFC 3265 [20] and 3GPP TS 24.229 [5] containing the event package name "call-completion" in the Event header field and the Call-Info header field with a purpose parameter set to 'call-completion' and the m parameter set to "NR" shall be supported at the non-roaming II-NNI.

The Request-URI with the "m" SIP URI parameter with a value set to "NR" and the Call-Info header field with a purpose parameter set to 'call-completion' and the "m" parameter set to "NR" in the INVITE method shall be supported at the non-roaming II-NNI.

The Date header field in the 480 (Temporarily Unavailable) response to the INVITE request shall be supported at the roaming II-NNI.

SIP based user configuration as described in 3GPP TS 24.238 [100] shall be supported at the roaming II-NNI.

## 12.13 Explicit Communication Transfer (ECT)

Service specific requirements in accordance with 3GPP TS 24.629 [116] shall be supported over the II-NNI.

The REFER method, the Referred-By header field and the Replaces header field as specified in 3GPP TS 24.629 [116] and the NOTIFY method containing an "application/sipfrag" MIME body shall be supported at the II-NNI for call transfer without third party call control.

The REFER method, the Referred-By header field and the Replaces header field as specified in 3GPP TS 24.629 [116] and the NOTIFY method containing an "application/sipfrag" MIME body shall be supported at the roaming II-NNI for call transfer with third party call control.

The Refer-To URI header parameter in the REFER request containing the Require header field set to "replaces" shall be supported at the roaming II-NNI.

The Replaces header field in the INVITE request shall be supported at the non-roaming II-NNI.

## 12.14 Customized Alerting Tone (CAT)

Service specific requirements in accordance with 3GPP TS 24.182 [129] shall be supported over the II-NNI.

The P-Early-Media header field in as described in 3GPP TS 24.182 [129] shall be supported at the II-NNI.

The response code 183 (Session Progress) including a P-Early-Media header field shall be supported over the II-NNI.

The response code 199 (Early Dialog Terminated) shall be supported over the II-NNI.

The Supported header field and the Require header field with "early-session" option-tag may be supported at the II-NNI.

An "application/sdp" MIME body with the Content-Disposition set to "early-session" as specified in IETF RFC 3959 [96] may be supported at II-NNI.

The SIP INFO mechanism for DTMF transport, as defined in 3GPP TS 24.229 [5] may be supported at the II-NNI.

NOTE 1: For telephone-event based DTMF transport, the DTMF digits are sent as media and not visible in the control plane.

NOTE 2: Multiple methods for DTMF transport are defined in 3GPP TS 24.182 [129].

SIP based user configuration as described in 3GPP TS 24.238 [100] shall be supported at the roaming II-NNI.

## 12.15 Customized Ringing Signal (CRS)

Service specific requirements in accordance with 3GPP TS 24.183 [98] shall be supported over the II-NNI.

An Alert-Info header field in the initial INVITE request containing an URI followed by a URN "urn:alert:service:crs" shall be supported at the II-NNI.

A SDP "a=content" attribute with a "g.3gpp.crs" value in the PRACK request or the re-INVITE request may be supported at the II-NNI.

The Supported header field and the Require header field with "early-session" option-tag may be supported at the II-NNI.

An "application/sdp" MIME body with the Content-Disposition header field set to "early-session" as specified in IETF RFC 3959 [96] may be supported at II-NNI.

The SIP INFO mechanism for DTMF transport, as defined in 3GPP TS 24.229 [5] may be supported at the II-NNI.

NOTE: For telephone-event based DTMF transport, the DTMF digits are sent as media and not visible in the control plane.

SIP based user configuration as described in 3GPP TS 24.238 [100] shall be supported at the roaming II-NNI.

## 12.16 Closed User Group (CUG)

Service specific requirements in accordance with 3GPP TS 24.654 [103] shall be supported over the II-NNI.

The "application/vnd.etsi.cug+xml" MIME body as specified 3GPP TS 24.654 [103] shall be supported in INVITE requests at the II-NNI.

NOTE: If no agreement between the originating network and the terminating network exists to support the CUG supplementary service the INVITE request is rejected as described in IETF RFC 5621 [89] when the "handling" parameter in the Content-Disposition of the " application/vnd.etsi.cug+xml" MIME body is set to "required".

The 403 (Forbidden) response, the 603 (Decline) response and the 500 (Server Internal Error) response shall be supported at II-NNI.

SIP based user configuration as described in 3GPP TS 24.238 [100] shall be supported at the roaming II-NNI.

## 12.17 Personal Network Management (PNM)

Service specific requirements in accordance with 3GPP TS 24.259 [99] shall be supported over the II-NNI.

A g.3gpp.iari\_ref feature tag with the value urn:urn-7:3gpp-application.ims.iari.pnm-controller in the Contact header field of the REGISTER request shall be supported at the roaming II-NNI.

A g.3gpp.iari\_ref feature tag with the value urn:urn-7:3gpp-application.ims.iari.pnm-controller in the Accept-Contact header field shall be supported at the II-NNI.

The History-Info header field shall be supported at II-NNI.

A "histinfo" option tag as described by 3GPP TS 24.259 [99] in the Supported header field shall be supported at II-NNI.

## 12.18 Three-Party (3PTY)

Service specific requirements in accordance with 3GPP TS 24.605 [105] shall be supported over the II-NNI.

NOTE 1: The requirements below can be relaxed by bilateral agreements between operators.

The requirements for the 3PTY supplementary service are the same as for the CONF supplementary service specified in subclause 12.19 with the following additional requirement:

- If a REFER request is supported at the II-NNI, a Replaces header field in the header portion of the SIP URI of the Refer-to header field of the REFER request shall also be supported at II-NNI.

NOTE 2: Subclause 12.19 describes the conditions for the support of the REFER request.

## 12.19 Conference (CONF)

Service specific requirements in accordance with 3GPP TS 24.605 [105] shall be supported over the II-NNI.

NOTE 1: The requirements below can be relaxed by bilateral agreements between operators.

The REFER request shall be supported at the roaming II-NNI in the direction from visited to home network. Based on inter-operator agreement, the REFER request may be supported at the non-roaming II-NNI, and at the roaming II-NNI in the direction from home network to visited network.

NOTE 2: If the REFER request is not supported at the non-roaming II-NNI, or at the roaming II-NNI in the direction from home network to visited network, an attempt of an UE to send the REFER directly to peers to invite them to a conference without involvement of the conference focus can fail over such an II-NNI. However such failures can also occur if a peer is located in a circuit switched network, or if a peer does not support the REFER method. An operator can avoid such failures by configuring an AS to convert the REFER to an INVITE, as detailed in 3GPP TS 24.628 [38]. Information on security risks associated with the REFER request is provided within the "security consideration" of IETF RFC 3515 [22].

NOTE 3: A REFER request can be rejected by IBCF based on operator policy as specified by 3GPP TS 24.229 [5].

The application/resource-lists+xml MIME body shall be supported at the roaming II-NNI.

The Referred-By header field in the INVITE request shall be supported at the II-NNI.

The "isfocus" feature parameter indicated in Contact header field of the INVITE request and in the 200 (OK) response shall be supported at the II-NNI.

The SUBSCRIBE request including the "conference" event package name in the Event header field and the NOTIFY request procedures according to 3GPP TS 24.147 [106] shall be supported at the II-NNI.

NOTE 4: The subscription to "conference event" package does not apply at the roaming II-NNI between the MSC Server enhanced for ICS/MSC Server enhanced for SRVCC and the IMS network where the communication is anchored.

The Allow-Events header field with the value "conference" shall be supported at the roaming II-NNI and may be supported at the non-roaming II-NNI.

## 12.20 Flexible Alerting (FA)

Service specific requirements in accordance with 3GPP TS 24.239 [101] shall be supported over the II-NNI.

The 486 (Busy Here) response code shall be supported at the II-NNI.

SIP based user configuration as described in 3GPP TS 24.238 [100] shall be supported at the roaming II-NNI.

## 12.21 Announcements

### 12.21.1 General

Announcements may be provided during the establishment of a communication session, during an established communication session or when a communication request is rejected. All of them shall be managed over the II-NNI.

### 12.21.2 Providing announcements during the establishment of a communication session

Procedures as described in 3GPP TS 24.628 [38] are used to provide announcements.

The P-Early-Media header field authorizing early media as defined in IETF RFC 5009 [74] during the establishment of a communication shall be supported at the II-NNI.

The Alert-Info header field in the 180 (Ringing) response to the INVITE request during the establishment of a communication, should be supported at the II-NNI.

NOTE: The IBCF can decide to remove the Alert-Info header field if required by local policy.

### 12.21.3 Providing announcements during an established communication session

Procedures as described in 3GPP TS 24.628 [38] are used to provide announcements.

In case of provision of an announcement to a user over the II-NNI during an established communication, the Call-Info header field in a re-INVITE request should be supported at the II-NNI.

NOTE 1: An alternative method to provide announcements is to use the existing media stream.

NOTE 2: The IBCF can decide to remove the Call-Info header field if required by local policy.

### 12.21.4 Providing announcements when communication request is rejected

Procedures as described in 3GPP TS 24.628 [38] are used to provide announcements when a communication request is rejected.

There are three methods defined in 3GPP TS 24.628 [38] to provide the announcement:

- 1) sending an announcement as an early media;
- 2) return an Error-Info header field; and
- 3) accept the communication request and then provide the announcement.

NOTE 1: The II-NNI requirements for accepting the communication request and then provide the announcement is not within the scope of this subclause.

The P-Early-Media header field authorizing early media as defined in IETF RFC 5009 [74] and the Reason header field with the proper cause value shall be supported at the II-NNI.

NOTE 2: There are 2 methods to use early media for sending the announcement in-band. First method is the gateway model defined by IETF RFC 3960 [150], second method is described in 3GPP TS 24.628 [38] Annex D.

The Error-Info header field in the 3xx, 4xx, 5xx or 6xx response to the INVITE request when rejecting the communication request, should be supported at the II-NNI.

NOTE 3: The IBCF can decide to remove the Error-Info header field if required by local policy.

## 12.22 Advice of Charge (AOC)

Service specific requirements in accordance with 3GPP TS 24.647 [122] shall be supported over the II-NNI.

The Accept header field with "application/vnd.etsi.aoc+xml" shall be supported at the roaming II-NNI.

The INVITE method containing an "application/vnd.etsi.aoc+xml" MIME body shall be supported at the roaming II-NNI.

1xx provisional responses and the 200 (OK) response to the initial INVITE request containing an "application/vnd.etsi.aoc+xml" MIME body shall be supported at the roaming II-NNI.

The INFO method containing an application/vnd.etsi.aoc+xml MIME body shall be supported at the roaming II-NNI.

The response code 504 (Server Time-out) shall be supported at the II-NNI.

A Reason header field with a reason value with the protocol set to "SIP" and the cause set to "504" and a reason value with the protocol set to "Q.850" and the cause set to "31" in the BYE method shall be supported at the II-NNI.

An "application/vnd.etsi.aoc+xml" MIME body in the BYE request or the final response to the BYE request shall be supported over the roaming II-NNI.

## 12.23 Completion of Communications on Not Logged-in (CCNL)

Service specific requirements in accordance with 3GPP TS 24.642 [109] shall be supported over the II-NNI.

The response code 480 (Temporarily unavailable) containing a Call-Info header field with a purpose parameter set to 'call-completion' and the m parameter set to "NL" shall be supported at the non-roaming II-NNI.

For invoking and revoking of the CCNL supplementary service, announcement procedures shall be used to provide announcements and inband-interaction procedures as described in subclause 12.21.3 and subclause 12.21.4 shall be supported at the roaming II-NNI.

The response code 199 (Early Dialog Terminated) shall be supported at the roaming II-NNI.

Basic call procedures and in case of a call-completion recall initiated by a REFER request, normal REFER method handling procedures according to 3GPP TS 24.229 [5] shall be supported at the roaming II-NNI.

As a network option the special REFER request handling procedures according to 3GPP TS 24.628 [38] should be supported at the roaming II-NNI.

NOTE: 3<sup>rd</sup> party call control procedures can be used when the REFER request is not supported at the II-NNI.

The SUBSCRIBE and NOTIFY methods according to IETF RFC 3265 [20] and 3GPP TS 24.229 [5] containing the event package name "call-completion" in the Event header field and the Call-Info header field with a purpose parameter set to 'call-completion' and the m parameter set to "NL" shall be supported at the non-roaming II-NNI.

The Request-URI with the "m" SIP URI parameter with a value set to "NL" and the Call-Info header field with a purpose parameter set to 'call-completion' and the "m" parameter set to "NL" in the INVITE method shall be supported at the non-roaming II-NNI.

The Date header field in the 480 (Temporarily Unavailable) response to the INVITE request shall be supported at the roaming II-NNI.

SIP based user configuration as described in 3GPP TS 24.238 [100] shall be supported at the roaming II-NNI.

---

# 13 Interoperability of IMS Centralized Services (ICS) over II-NNI

## 13.1 General

In order to assure the end-to-end service interoperability through the Inter-IMS Network to Network Interface (II-NNI), the associated service of the IMS Centralized Services (ICS) may be supported on the II-NNI between two IMS networks. The support of ICS is based on agreement between operators.

If ICS is supported, the related procedures from the 3GPP TS 24.292 [121] and 3GPP TS 29.292 [130] shall be applied with the requirements in the subclause 13.2 due to the crossing of the II-NNI.

## 13.2 IMS Centralized Services (ICS)

Service specific requirements in accordance with 3GPP TS 24.292 [121] and 3GPP TS 29.292 [130] shall be supported over the II-NNI.

The "g.3gpp.ics" media feature tag in the Contact header field as specified in annex B of 3GPP TS 24.292 [121] shall be supported at the roaming II-NNI.

The "g.3gpp.accesstype" media feature tag in the Contact header field as specified in annex B of 3GPP TS 24.292 [121] shall be supported at the roaming II-NNI.



The "g.3gpp.icsi-ref" media feature tag as specified in 3GPP TS 24.229 [5] the value for the IMS Multimedia Telephony Communication Service as specified in 3GPP TS 24.173 [31] shall be supported at the roaming II-NNI.

An Accept-Contact header field and a Reject-Contact header field including the media feature tag "g.3gpp.accesstype" and the media feature tag g.3gpp.ics in any combination in the INVITE request shall be supported at the roaming II-NNI.

The Target-Dialog header field in the INVITE request shall be supported at the roaming II-NNI.

The P-Early-Media header field in the INVITE request and in 1xx responses to the INVITE request shall be supported on the roaming II-NNI.

The Reason header field with Q.850 cause values in the CANCEL request, the BYE request and in 4xx responses and 6xx responses to the INVITE request shall be supported at the roaming II-NNI.

NOTE: Supplementary services as specified in clause 12 can be supported based on agreement between operators.

---

## 14 Interoperability of IMS Service Continuity over II-NNI

### 14.1 General

In order to assure the end-to-end service interoperability through the Inter-IMS Network to Network Interface (II-NNI), the associated services of the IMS Service Continuity may be supported on the II-NNI between two IMS networks. The support of each service is based on agreement between operators.

If a service is supported, the related procedures from the 3GPP TS 24.237 [131] shall be applied with the requirements in the relevant subclause below due to the crossing of the II-NNI.

### 14.2 Single Radio Voice Call Continuity (SRVCC)

#### 14.2.1 Basic SRVCC

Service specific requirements in accordance with 3GPP TS 24.237 [131] shall be supported over the II-NNI.

The "+g.3gpp.srvcc" header field parameter (specified in 3GPP TS 24.237 [131] annex C) in the Feature-Caps header field of the INVITE request and in 1xx or 2xx responses to the INVITE request or in the UPDATE request and in the 2xx response to the UPDATE request should be supported at the roaming II-NNI.

The Reason header field containing protocol "SIP" and reason parameter "cause" with value "487" in the re-INVITE request shall be supported at the roaming II-NNI.

The Reason header field containing a SIP 503 (Service Unavailable) response in the SIP BYE request shall be supported at the roaming II-NNI.

Procedures as described in subclause 14.4 are used to provide MSC server assisted mid-call features.

#### 14.2.2 Transfer of calls in alerting phase

The requirements for the transfer of calls in alerting phase are the same as in subclause 14. 2.1 with the following additional requirements:

The g.3gpp.srvcc-alerting media feature tag (described in 3GPP TS 24.237 [131] annex C) in a Contact header field of the INVITE request and of the 180 (Ringing) response shall be supported at the roaming II-NNI.

The "+g.3gpp.srvcc-alerting" header field parameter (described in 3GPP TS 24.237 [131] annex C) included in a Feature-Caps header field as described in IETF RFC 6809 [143] in a SIP INVITE request and in a 180 (Ringing) response to the INVITE request or in the UPDATE request and in the 2xx response to the UPDATE request shall be supported at the roaming II-NNI.

The Target-Dialog header field in the INVITE request shall be supported at the roaming II-NNI.

An INFO request containing the Info-Package header field as specified in IETF RFC 6086 [39] with 3gpp.state-and-event-info package name and an "application/vnd.3gpp.state-and-event-info+xml" XML body shall be supported at the roaming II-NNI.

### 14.2.3 Using the ATCF based architecture

The requirements for the ATCF based architecture is the same as in subclause 14.2.1 with the following additional requirements:

The "+g.3gpp.atcf", the "+g.3gpp.atcf-mgmt-uri" and the "+g.3gpp.atcf-path" header field parameters (specified in 3GPP TS 24.237 [131] annex C) in the Feature-Caps header field of the REGISTER request as described in IETF RFC 6809 [143] shall be supported at the roaming II-NNI.

A MESSAGE request containing the "application/vnd.3gpp.SRVCC-info+xml" MIME body as defined in annex D of 3GPP TS 24.237 [131] shall be supported at the roaming II-NNI.

The URIs of SCC ASs authorised to provide PS to CS SRVCC information in the MESSAGE request need to be specified in the roaming agreement.

The Target-Dialog header field in the INVITE request shall be supported at the roaming II-NNI.

## 14.3 Inter UE Transfer (IUT)

IUT is described in clause 18.

## 14.4 MSC server assisted mid-call feature

Service specific requirements in accordance with 3GPP TS 24.237 [131] shall be supported over the II-NNI.

The Contact header field of the REGISTER request and the 200 (OK) response containing g.3gpp.mid-call media feature tag as described in annex C of 3GPP 24.237 [131] shall be supported at the roaming II-NNI.

The P-Visited-Network-Id header field and the P-Access-Network-Info header field of the REGISTER request shall be supported at the roaming II-NNI.

NOTE 1: The P-Visited-Network-Id header field and the P-Access-Network-Info header field of the REGISTER request is used by the Home IMS network to identify the network where a UE is registered.

The media feature tag g.3gpp.accesstype in the Contact header field of the REGISTER request shall be supported at roaming II-NNI.

A Contact header field of the INVITE request and the 200 (OK) response containing "g.3gpp.mid-call" media feature tag as described in annex C of 3GPP 24.237 [131] shall be supported at the roaming II-NNI.

The Recv-Info header field containing the g.3gpp.mid-call package name in the INVITE request as specified in annex D of 3GPP 24.237 [131] shall be supported at the roaming II-NNI.

An Accept header field in the INVITE request containing the MIME type "application/vnd.3gpp.mid-call+xml" as specified in annex D.1 of 3GPP TS 24.237 [131] shall be supported at the roaming II-NNI.

The "application/vnd.3gpp.mid-call+xml" MIME body described in annex D.1.3 of 3GPP TS 24.237 [131] in the INVITE request shall be supported at the roaming II-NNI.

The SUBSCRIBE request containing a g.3gpp.mid-call media feature tag in the Contact header field shall be supported at the roaming II-NNI.

NOTE 2: The g.3gpp.mid-call media feature tag in the Contact header field of the SUBSCRIBE request may appear if the CONF supplementary service is supported at roaming II-NNI as described in subclause 12.9.

An INFO request containing the Info-Package header field as specified in IETF RFC 6086 [39] with 3gpp.state-and-event info package name and an "application/vnd.3gpp.state-and-event-info+xml" XML body shall be supported at the roaming II-NNI.

A REFER request sent inside an existing SIP dialog containing:

- the "application/vnd.3gpp.mid-call+xml" MIME body specified in the annex D.1.3 of 3GPP TS 24.237 [131] ;
- the Refer-Sub header field; and
- the Supported header field containing "norefersub" value.

shall be supported at the roaming II-NNI.

The Refer-To header field in the REFER request containing:

- a Target-Dialog URI header field;
- a Require URI header field populated with the option tag value "tdialog";
- a To URI header field;
- a From URI header field;
- a Content-Type header field with "application/sdp"; and
- a "body" URI header field populated with an SDP MIME body

shall be supported at the roaming II-NNI.

The Contact header field of the REFER request and 2xx response to the request containing "g.3gpp.mid-call" media feature tag as described in annex C of 3GPP 24.237 [131] shall be supported at the roaming II-NNI.

The Target-Dialog header field in the INVITE request shall be supported at the roaming II-NNI.

The communication HOLD supplementary service as specified in subclause 12.8 for the roaming II-NNI shall be supported.

---

## 15 Presence service

### 15.0 General

In order to assure the end-to-end service interoperability through the Inter-IMS Network to Network Interface (II-NNI), the associated functions of the Presence service may be supported on the II-NNI between two IMS networks. The support of each function is based on agreement between operators.

If a function is supported, the related procedures from the 3GPP TS 24.141 [132] shall be applied with the requirements in the relevant subclause below due to the crossing of the II-NNI.

#### 15.1 Subscription of presence information

Service specific requirements in accordance with 3GPP TS 24.141 [132] shall be supported over the II-NNI.

A PUBLISH request identifying the Presentity using a SIP URI, a tel URI or a PRES URI and the Event header field with the value "presence" and containing an "application/pidf+xml" MIME body shall be supported at the roaming II-NNI.

Additionally to the above and in any combination, a "multipart/related" content type and an "application/pidf-diff+xml" MIME body can be included in the PUBLISH request and shall be supported at the roaming II-NNI.

A SUBSCRIBE request with a Request-URI containing a SIP URI, a TEL URI or a pres URI, the Event header field set to "presence" and Accept header fields with values "application/pidf+xml" and "multipart/related" shall be supported at the II-NNI.

Additionally to the above an "application/simple-filter+xml" MIME body can appear in the SUBSCRIBE request and shall be supported at the II-NNI.

Additionally to the above and in any combination a "multipart/mixed" content type and an "application/resource-lists" MIME body can appear in the SUBSCRIBE request and shall be supported at the roaming II-NNI.

A NOTIFY request including an Event header field with the value "presence" and an "application/pidf" MIME body shall be supported at the II-NNI.

NOTE: The NOTIFY request can contain substantial amount of data and TCP is expected to be used as the transport protocol.

The Allow-Events header field with the value "presence" shall be supported at the roaming II-NNI and may be supported at the non-roaming II-NNI.

## 15.2 Watcher subscribing to Presence List

Service specific requirements in accordance with 3GPP TS 24.141 [132] shall be supported over the II-NNI.

The requirements for the watcher subscribing to the Presence List are the same as subscribing to presence information as specified in subclause 15.1 with the following additional requirement:

- The SUBSCRIBE request containing a Supported header field with the value "eventlist" shall also be supported at the roaming II-NNI;
- The SUBSCRIBE request containing a Accept header field with the value "application/rfmi+xml" shall be supported at the roaming II-NNI;
- A response code 200 (OK) to the SUBSCRIBE request containing the Require header field with the value "eventlist" shall be supported at the roaming II-NNI; and,
- A NOTIFY message containing the "multipart/related" content type and an "application/rfmi+xml" MIME body shall be supported at the roaming II-NNI.

NOTE: The NOTIFY request can contain substantial amount of data and TCP is expected to be used as the transport protocol.

## 15.3 Subscription to Watcher Information

Service specific requirements in accordance with 3GPP TS 24.141 [132] shall be supported over the II-NNI.

A SUBSCRIBE request containing an Event header field with the value "presence.wininfo" and an Accept header field with value "application/watcherinfo+xml" shall be supported at the roaming II-NNI.

A NOTIFY request containing the Event header field with the value "presence.wininfo" and an "application/watcherinfo" MIME body shall be supported at the roaming II-NNI.

NOTE: The NOTIFY request can contain substantial amount of data and TCP is expected to be used as the transport protocol.

The Allow-Events header field with the value "presence.wininfo" shall be supported at the roaming II-NNI and may be supported at the non-roaming II-NNI.

## 15.4 Subscription to state changes in XML documents

Service specific requirements in accordance with 3GPP TS 24.141 [132] shall be supported over the II-NNI.

A SUBSCRIBE request containing the Event header field with the value "xcap-diff" and parameters specified in IETF RFC 5875 [134] shall be supported at the roaming II-NNI.

A NOTIFY request containing the Event header field with the value "xcap-diff", the multipart/mixed content type and any MIME body shall be supported at the roaming II-NNI.

NOTE: The NOTIFY request can contain substantial amount of data and TCP is expected to be the transport protocol.

The Allow-Events header field with the value "xcap-diff" shall be supported at the roaming II-NNI and may be supported at the non-roaming II-NNI.

For backward compatible reasons the Event header field with the value "ua-profile" should be supported at the roaming II-NNI.

## 15.5 Presence enhancements specified in Open Mobile Alliance (OMA) Release 1.1

### 15.5.1 General

In order to assure the end-to-end service interoperability through the Inter-IMS Network to Network Interface (II-NNI), the associated functions of the OMA Presence service may be supported on the II-NNI between two IMS networks. The support of each function is based on agreement between operators.

If a function of the OMA Presence Release 1.1 is supported, the related procedures from the OMA-TS-Presence\_SIMPLE-V1\_1\_1 [142] shall be applied with the requirements in the relevant subclause below due to the crossing of the II-NNI.

### 15.5.2 OMA subscription of presence information

The requirements for the OMA subscription of presence information are the same as subclause 15.1

### 15.5.3 OMA watcher subscribing to Presence List

The requirements for the OMA watcher subscribing to Presence List are the same as subclause 15.2.

### 15.5.4 OMA subscription to Watcher Information

The requirements for the OMA subscription to Watcher Information are the same as subclause 15.3

## 15.6 Presence enhancements specified in Open Mobile Alliance (OMA) Release 2.0

### 15.6.1 General

In order to assure the end-to-end service interoperability through the Inter-IMS Network to Network Interface (II-NNI), the associated functions of the OMA Presence service may be supported on the II-NNI between two IMS networks. The support of each function is based on agreement between operators.

If a function of the OMA Presence Release 2.0 is supported, the related procedures from the OMA-TS-Presence\_SIMPLE-V2\_0 [138] shall be applied with the requirements in the relevant subclause below due to the crossing of the II-NNI.

## 15.6.2 OMA subscription of presence information

The requirements for the OMA subscription of presence information are the same as subclause 15.5.2 with the following additional requirement:

- An Allow header field containing the value "REFER" in a PUBLISH request shall be supported at II-NNI.
- A Policy-Contact header field defined in IETF RFC 6794 [133] in a 488 (Not Acceptable Here) response to a PUBLISH request shall be supported at II-NNI.

NOTE: Conveyance of this header field in a 488 response to a PUBLISH request is not supported by IETF RFC 6794 [133] but is required to support Presence services according to OMA specifications OMA-TS-Presence\_SIMPLE-V2\_0 [138].

- A Suppress-If-Match header field in a SUBSCRIBE request shall be supported at II-NNI.
- An Accept-Encoding header field containing the value "gzip" in a SUBSCRIBE request shall be supported at II-NNI.
- An "application/vnd.oma.suppnot+xml" MIME body in a SUBSCRIBE request shall be supported at II-NNI.
- A Content-Encoding header field containing the value "gzip" in a NOTIFY request shall be supported at II-NNI.
- A "multipart/mixed" content type in a SUBSCRIBE request shall be supported at II-NNI.
- A Refer-To header field with the value "method=PUBLISH?event=presence", a Refer-Sub header field and a SIP-If-Match header field in a REFER request shall be supported at II-NNI.

## 15.6.3 OMA watcher subscribing to Presence List

The requirements for the OMA watcher subscribing to Presence List are the same as subclause 15.5.3 with the following additional requirements;

- A Suppress-If- Match header field in a SUBSCRIBE request shall be supported at II-NNI.
- An Accept-Encoding header field containing the value "gzip" in a SUBSCRIBE request shall be supported at II-NNI.
- A body containing an "application/vnd.oma.suppnot+xml" content type in a SUBSCRIBE request shall be supported at II-NNI.
- A body containing an "application/resource-lists+xml" content type in a SUBSCRIBE request shall be supported at II-NNI.
- A "multipart/mixed" content type in a SUBSCRIBE request shall be supported at II-NNI.
- A NOTIFY request with a Content-Encoding header field containing the value "gzip" shall be supported at II-NNI.

## 15.6.4 OMA subscription to Watcher Information

The requirements for the OMA subscription to Watcher Information are the same as subclause 15.5.4 with the following additional requirement:

- Indicating support for "multipart/mixed" and "application/simple-filter+xml" in the Accept header field of the SUBSCRIBE request shall be supported at II-NNI
- Multiple "application/simple-filter+xml" MIME bodies in the NOTIFY request shall be supported at II-NNI.
- A Suppress-If-Match header field in a SUBSCRIBE request shall be supported at II-NNI.
- An Accept-Encoding header field containing the value "gzip" in the SUBSCRIBE request shall be supported at II-NNI.

- A body with multiple content of the multipart/mixed content type in a NOTIFY request shall be supported at II-NNI.
- A Content-Encoding header field with the value "gzip" in a NOTIFY request shall be supported at II-NNI.
- A Refer-To header field with the value "method=SUBSCRIBE?Event=presence.winfo" and a Refer-Sub header field in a REFER request sent to a Watcher Information Subscriber shall be supported at II-NNI.

### 15.6.5 Subscription to state changes in XML documents

The requirements for the OMA watcher subscribing to Presence List are the same as subclause 15.4 with the following additional requirements

- An Accept header field indicating the support for "application/xcap-diff+xml", "application/rlmi+xml" and "multipart/related" in a SUBSCRIBE request shall be supported at II-NNI.
- An Accept-Encoding header field with the value "gzip" in a SUBSCRIBE request shall be supported at II-NNI.
- A Content-Encoding header field containing the value "gzip" in a NOTIFY request shall be supported at II-NNI.
- mMultiple "multipart/related" MIME bodies in a NOTIFY request shall be supported at II-NNI.
- An "application/rlmi+xml" MIME bodies in a NOTIFY request shall be supported at II-NNI.

### 15.6.6 Void

### 15.6.7 Void

---

## 16 Messaging service

### 16.1 General

In order to assure the end-to-end service interoperability through the Inter-IMS Network to Network Interface (II-NNI), the associated function of the messaging service may be supported on the II-NNI between two IMS networks.

If a function is supported, the related procedures from the 3GPP TS 24.247 [139] shall be applied with the requirements in the relevant subclause below due to the crossing of the II-NNI.

### 16.2 Page-mode messaging

Service specific requirements in accordance with clause 5 of 3GPP TS 24.247 [139] shall be supported over the II-NNI.

A MESSAGE request containing the "application/recipient-list" MIME body specified in IETF RFC 5365 [67], a Required header field with the 'recipient-list-message' option-tag; and a body carrying payload shall be supported at the roaming II-NNI.

A MESSAGE request containing:

- a body that carrying payload; or
- the "application/im-iscomposing+xml" MIME body.

shall be supported at II-NNI.

The response code 415 (Unsupported Media Type) and the response code 202 (Accepted) shall be supported at the II-NNI.

## 16.4 Session-mode messaging

Service specific requirements in accordance with clause 6 of 3GPP TS 24.247 [139] shall be supported over the II-NNI.

No restrictions at II-NNI identified.

## 16.5 Session-mode messaging conferences

Service specific requirements in accordance with clause 7 of 3GPP TS 24.247 [139] shall be supported over the II-NNI.

The "application/resource-lists+xml" MIME body included in the INVITE request shall be supported at the roaming II-NNI.

The media feature tag isfocus in the Contact header field of the INVITE request and responses to the INVITE request shall be supported at the II-NNI.

The SUBSCRIBE request including the "conference" event package name in the Event header field and the NOTIFY request procedures according to 3GPP TS 24.147 [106] shall be supported at the II-NNI.

The REFER request containing a Referred-By header field and NOTIFY requests procedures according to 3GPP TS 24.147 [106] shall be supported at the II-NNI.

The REFER request containing the BYE method URI parameter in the Refer-To header shall be supported at the II-NNI.

The Referred-By header field in the INVITE request shall be supported at the II-NNI.

The Allow-Events header field with the value "conference" shall be supported at the roaming II-NNI and may be supported at the non-roaming II-NNI.

---

# 17 Optimal Media Routeing

## 17.1 General

Based on inter-operator agreement, the Optimal Media Routeing (OMR) procedures may be supported over the II-NNI,

If OMR procedures are supported, the procedures in 3GPP TS 29.079 [148] shall be applied and the capabilities below shall be provided at the II-NNI.

## 17.2 OMR related SDP attributes

The "visited-realm", "secondary-realm", "omr-codecs", "omr-m-att", "omr-s-att", "omr-m-bw", "omr-s-bw", "omr-s-cksum", and "omr-m-cksum" SDP attributes defined in 3GPP TS 24.229 [5] shall be supported at the II-NNI.

## 17.3 IP realm names

Operators need to agree on unique names for IP realms (as defined in 3GPP TS 29.079 [148]) used in their own and interconnecting networks to avoid a collision of IP realm names. Operators may choose to share an IP realm, and shall then also assign a single unique name to that realm. As defined in 3GPP TS 24.229 [5], a public IPv4 or IPv6 address reachable from the open internet is associated with the special realm "IN".



## 18 Inter-UE transfer (IUT)

### 18.1 General

Inter-UE transfer may be supported over the II-NNI. The IUT consist of several functional blocks, as described in the subclauses below. The support of each of these functional blocks is based on agreement between operators.

If a function is supported, the related procedures from the 3GPP TS 24.337 [149] shall be applied with the requirements in the relevant subclause below.

### 18.2 IUT without establishment of a collaborative session

Service specific requirements in accordance with 3GPP TS 24.337 [149] shall be supported over the II-NNI.

The REFER request shall be supported at the roaming II-NNI.

The Refer-To header field containing a body parameter including a Replaces header field and the Require header field set to "replaces" shall be supported at the roaming II-NNI.

The Refer-To header field containing a body parameter including a Target-Dialog header field and the Require header field set to "tdialog" shall be supported at the roaming II-NNI.

The Refer-To header field containing a body parameter including an Accept-Contact header field with the "g.3gpp.icsi-ref" media feature tag and a P-Preferred-Service header field set to the IMS communication service identifier shall be supported at the roaming II-NNI.

The Contact header field of the REFER request containing a public GRUU or temporary GRUU as specified in 3GPP TS 24.229 [5] shall be supported at the roaming II-NNI.

The g.3gpp.icsi-ref media feature tag in the Accept-Contact header field of the REFER request shall be supported at the roaming II-NNI.

NOTIFY requests containing a "sipfrag" MIME body as specified in RFC 3515 [22] shall be supported at the roaming II-NNI.

### 18.3 IUT using a collaborative session

#### 18.3.1 Collaborative session of participants of the same subscription

This subclause describes the requirements at the II-NNI for an ongoing session. Service specific requirements in accordance with 3GPP TS 24.337 [149] shall be supported over the II-NNI.

The "g.3gpp.iut-controller" media feature tag in the Accept-Contact header field in the REGISTER request shall be supported.

A REFER request sent outside an existing dialog shall be supported at the roaming II-NNI with the following additional requirements:

- The Refer-To header field containing a body parameter including a MIME sdp body and no method parameter, the method parameter set to "INVITE" or "BYE" shall be supported at the roaming II-NNI.
- The Accept header field containing the MIME type "message/sipfrag" in the REFER request shall be supported at the roaming II-NNI.
- The Target-Dialog header field in the REFER request shall be supported at the roaming II-NNI.
- The Contact header field in the REFER request containing the "g.3gpp.iut-controller" media feature tag as described in annex B of 3GPP TS 24.337 [149] shall be supported at the roaming II-NNI.
- The Contact header field in the REFER request containing the "g.3gpp.current-iut-controller" media feature tag as described in annex B of 3GPP TS 24.337 [149] shall be supported at the roaming II-NNI.

- The "g.3gpp.iut-controller" media feature tag in the Accept-Contact header field shall be supported at the roaming II-NNI.
- The Referred-By header field shall be supported at the roaming II-NNI at the roaming II-NNI.

The NOTIFY request containing a "sipfrag" MIME body as specified in IETF RFC 3515 [22] shall be supported at the roaming II-NNI.

Initial INVITE requests and re-INVITE requests as follows:

- The Referred-By header field included in initial INVITE requests and re-INVITE requests shall be supported at the roaming II-NNI;
- The g.3gpp.iut-controller media feature tag as described in annex B of 3GPP TS 24.337 [149] in the Contact header field shall be supported at the roaming II-NNI.

The g.3gpp.iut-controller media feature tag in SIP responses to the INVITE request shall be supported at the roaming II-NNI.

The SUBSCRIBE request including the Event header field with the "dialog" event package; and including the Accept-Contact header field with the g.3gpp.iut-focus media feature shall be supported at the roaming II-NNI.

The "dialog-info+xml" MIME body in NOTIFY requests shall be supported at the roaming II-NNI.

### 18.3.2 Establishment of a collaborative session during session setup

Service specific requirements in accordance with 3GPP TS 24.337 [149] shall be supported over the II-NNI.

The Accept header field containing the MIME type application/vnd.3gpp.iut+xml in initial INVITE requests shall be supported at the roaming II-NNI.

A SIP 300 (Multiple Choices) response a Content-Type header field containing the MIME type "application/vnd.3gpp.iut+xml" and an "application/vnd.3gpp.iut+xml" MIME body shall be supported at the roaming II-NNI.

### 18.3.3 Assignment and transfer of control of a collaborative session

Service specific requirements in accordance with 3GPP TS 24.337 [149] shall be supported over the II-NNI.

The g.3gpp.current-iut-controller in the Contact header of the SIP 200 (OK) response to INVITE request shall be supported at the roaming II-NNI.

A "multipart/mixed" MIME body containing the "application/vnd.3gpp.iut+xml" and the "application/sdp" MIME bodies in the INVITE request shall be supported at the roaming II-NNI.

### 18.3.4 Collaborative session of participants of different subscriptions

Service specific requirements in accordance with 3GPP TS 24.337 [149] shall be supported over the II-NNI.

In addition to the requirements in subclause 18.3.1, 18.3.2 or 18.3.3 the following applies:

- The g.3gpp.iut-focus media feature tag (specified in 3GPP TS 24.337 [149] annex B) in the Contact header field shall be supported at the non-roaming II-NNI.
- The "+g.3gpp.iut-focus" header field parameter (specified in 3GPP TS 24.337 [149] annex B) in the Feature-Caps header field as described in IETF RFC 6809 [143] shall be supported at the non-roaming II-NNI.

## 18.4 Session replication / media replication

### 18.4.1 Pull mode

Service specific requirements in accordance with 3GPP TS 24.337 [149] shall be supported over the II-NNI.

The Target-Dialog header field and the Accept-Contact header field containing the g.3gpp.iut-focus media feature tag of the INVITE request shall be supported at roaming II-NNI.

A REFER request including:

- the method parameter set to "MESSAGE" in the Refer-To header field;
- the In-Reply-To header field;
- the Target-Dialog header field;
- the Require header field populated with the option tag value "tdialog"; and
- the "application/vnd.3gpp.replication+xml" MIME body,

shall be supported at the roaming II-NNI.

A MESSAGE request the In-Reply-To header field and the "application/vnd.3gpp.replication+xml" MIME body shall be supported at the roaming II-NNI.

## 18.4.2 Push mode

Service specific requirements in accordance with 3GPP TS 24.337 [149] shall be supported over the II-NNI.

A REFER request as including:

- the Accept-Contact header field containing the g.3gpp.iut-focus media feature tag with explicit and require tags;
- the Target-Dialog header field; and
- the Refer-To header field containing the Accept-Contact header field, the P-Preferred-Service header field and the "application/sdp" body shall be supported at the roaming II-NNI,

shall be supported at the roaming II-NNI.

The "application/vnd.3gpp.replication+xml" MIME body of the SIP REFER request shall be supported at the roaming II-NNI.

---

## Annex A (informative): Summary of SIP header fields

A summary of the SIP header fields to be used in case of interconnection by using II-NNI is proposed in table A.1.

The starting point is the sending behaviour described for proxy and UA roles in annex A of 3GPP TS 24.229 [5]:

- In case of misalignment between table A.1 and the behaviour described in 3GPP TS 24.229 [5], the behaviour in 3GPP TS 24.229 [5] has the precedence.
- In case a header field is not described in table A.1 and it is described in 3GPP TS 24.229 [5], the description in 3GPP TS 24.229 [5] is applicable over II-NNI.
- If a header field is not described in 3GPP TS 24.229 [5], the description in table A.1 is applicable over II-NNI.

The notation of the codes used for the SIP headers listed in table A.1 has a different meaning to the one proposed for the SIP messages. The definition of these terms is provided in table A.2.

Table A.1: Supported header fields

Item	Header field	Ref.	II-NNI
1	Accept	[5]	m
2	Accept-Contact	[5]	m
3	Accept-Encoding	[5]	m
4	Accept-Language	[5]	m
4a	Accept-Resource-Priority	[5]	o
5	Alert-Info	[5]	o
6	Allow	[5]	m
7	Allow-Events	[5]	m on roaming II-NNI, else o
8	Authentication-Info	[5]	m on roaming II-NNI, else n/a
9	Authorization	[5]	m on roaming II-NNI, else n/a
9a	Answer-Mode	[5]	o
10	Call-ID	[5]	m
11	Call-Info	[5]	m
12	Contact	[5]	m
13	Content-Disposition	[5]	m
14	Content-Encoding	[5]	m
15	Content-Language	[5]	m
16	Content-Length	[5]	m
17	Content-Type	[5]	m
18	Cseq	[5]	m
19	Date	[5]	m
20	Error-Info	[5]	o
21	Expires	[5]	m
21a	Flow-Timer	[5]	m on roaming II-NNI, else o
21b	Feature-Caps	[5]	o
22	Event	[5]	m
23	From	[5]	m
24	Geolocation	[5]	m
24a	Geolocation-Error	[5]	m
24b	Geolocation-Routing	[5]	m
25	History-Info	subclause 6.1.1.3.1 (Table 6.2, item 4)	o
25a	Info-Package	[5]	o
26	In-Reply-To	[5]	o
27	Join	[5]	o
27a	Max-Breadth	[5]	m
28	Max-Forwards	[5]	m
29	Min-Expires	[5]	m
30	MIME-Version	[5]	m
31	Min-SE	[5]	m
32	Organization	[5]	m
33	P-Access-Network-Info	subclause 6.1.1.3.1 (Table 6.2, item 2)	m in case of a trust relationship between the interconnected networks, else n/a
33a	P-Answer-state	[5]	o
34	P-Asserted-Identity	subclause 6.1.1.3.1 (Table 6.2, item 1)	m in case of a trust relationship between the interconnected networks, else n/a
35	P-Asserted-Service	subclause 6.1.1.3.1 (Table 6.2, item 5)	o
35a	P-Associated-URI	[5]	m on roaming II-NNI, else n/a
36	P-Called-Party-ID	[5]	m on roaming II-NNI, else n/a
37	P-Charging-Function-Addresses	subclause 6.1.1.3.1 (Table 6.2, item 7)	n/a

Item	Header field	Ref.	II-NNI
38	P-Charging-Vector	subclause 6.1.1.3.1 (Table 6.2, item 6)	m on roaming II-NNI, else o
39	P-Early-Media	subclause 6.1.1.3.1 (Table 6.2, item 12)	m in case of a trust relationship between the interconnected networks, else n/a
40	P-Media-Authorization	[5]	n/a
41	P-Preferred-Identity	[5]	n/a
42	P-Preferred-Service	[5]	m on roaming II-NNI, else n/a
43	P-Private-Network-Indication	subclause 6.1.1.3.1 (Table 6.2, item 9)	m on roaming II-NNI, else o
44	P-Profile-Key	subclause 6.1.1.3.1 (Table 6.2, item 8)	o on roaming II-NNI, else n/a
44a	P-Refused-URI-List	[5]	o on non-roaming II-NNI else n/a
45	P-Served-User	subclause 6.1.1.3.1 (Table 6.2, item 10)	m on roaming II-NNI, else n/a
46	P-User-Database	[5]	n/a
47	P-Visited-Network-ID	[5]	m on roaming II-NNI, else n/a
47a	Path	[5]	m on roaming II-NNI, else n/a
47b	Permission-Missing	[5]	o
47c	Policy-Contact	[133] and subclause 15.6.2	o
48	Priority	[5]	o
48a	Priv-Answer-Mode	[5]	o
49	Privacy	[5]	m
50	Proxy-Authenticate	[5]	m on roaming II-NNI, else n/a
51	Proxy-Authorization	[5]	m on roaming II-NNI, else n/a
52	Proxy-Require	[5]	m
52a	RAck	[5]	m
53	Reason	[5] and subclause 6.1.1.3.1 (Table 6.2, item 11)	o when in a request. When in a response, m in case of a trust relationship between the interconnected networks, else n/a
54	Record-Route	[5]	m
54a	Recv-Info	[5]	o
55	Referred-By	[5]	m
55a	Refer-Sub	[5]	m in the case the REFER request is supported, else n/a
55b	Refer-To	[5]	m in the case the REFER request is supported, else n/a
56	Reject-Contact	[5]	m
57	Replaces	[5]	o
58	Reply-To	[5]	o
59	Request-Disposition	[5]	m
60	Require	[5]	m
61	Resource-Priority	subclause 6.1.1.3.1 (Table 6.2, item 3)	o
61a	Retry-After	[5]	o
62	Route	[5]	m
62a	RSeq	[5]	m
63	Security-Client	[5]	n/a
63a	Security-Server	[5]	n/a
64	Security-Verify	[5]	n/a
65	Server	[5]	o

Item	Header field	Ref.	II-NNI
65a	Service-Route	[5]	m on roaming II-NNI, else n/a
65b	Session-ID	[5]	o
66	Session-Expires	[5]	m
66a	SIP-ETag	[5]	m in the case the PUBLISH request is supported, else n/a
66b	SIP-If-Match	[5]	m in the case the PUBLISH request is supported, else n/a
67	Subject	[5]	o
67a	Subscription-State	[5]	m in the case the NOTIFY request is supported, else n/a
67b	Suppress-If-Match	[144] and subclause 15.6.4	o
68	Supported	[5]	m
68a	Target-Dialog	[5]	o
69	Timestamp	[5]	m
70	To	[5]	m
71	Trigger-Consent	[5]	m
71a	Unsupported	[5]	m
72	User-Agent	[5]	m
73	User-to-User	[5]	o
74	Via	[5]	m
75	Warning	[5]	o
76	WWW-Authenticate	[5]	m on roaming II-NNI, else n/a

**Table A.2: Key to notation codes for SIP header fields**

Notation code	Meaning
m	The SIP header field is applicable at II-NNI. Supporting a SIP header field at the II-NNI means that this header field is passed through the IBCF. It does not imply that network elements inside the serving and served networks or user equipment connected to these networks shall support this header field, where 3GPP TS 24.229 [5] is applied. If specified in 3GPP TS 24.229, the IBCF modifies the SIP header field.
o	The applicability of SIP header field at II-NNI depends on bilateral agreement between the operators.
n/a	It is impossible to use the SIP header field at the II-NNI. This header field could be discarded by the IBCF.

---

## Annex B (informative): Dynamic view of SIP header fields within SIP messages

### B.1 Scope

This annex provides the applicability of SIP header fields in SIP messages over II-NNI by using the methodology of a so-called "dynamic view", as used in IETF RFC 3261 [13] and other SIP related RFCs. This methodology documents the presence of SIP header fields in SIP messages over the II-NNI and also takes into account dynamic conditions, for instance the presence of a SIP header field in a SIP request message as condition for the SIP header field in the corresponding SIP response message.

Specific information about the applicability of SIP header fields in SIP messages in a dynamic view is also provided for cases where an MMTEL supplementary service is supported over the II-NNI between operators.

The applicability of SIP header fields described in this annex is based on the procedures described in 3GPP TS 24.229 [5] and the list of SIP header fields in annex A of 3GPP TS 24.229 [5].

### B.2 Methodology

The meaning of the notation codes used in the tables in subsequent clauses is as follows:

In the "RFC status" column, the notation codes defined in IETF RFC 3261 [13] clause 20 are applied.

In the "II-NNI condition" column the notation codes defined in Table B.2.1 are used. If a capability of a SIP header field is specified as either optional or conditional in Table 6.1.3.1, then "II-NNI condition" of the SIP header field is described with conditional expression.

In each request-related table, each "Item" number for a SIP header field inherits that of annex A of 3GPP TS 24.229 [5].

In each response-related table, the SIP status code for which the header field is applicable is described in the "SIP status code" column. The notation codes for the "where" column as defined in IETF RFC 3261 [13] clause 20 are applied. The notation code "r" in "SIP status code" column corresponds to any SIP status code which is described in annex A of 3GPP TS 24.229 [5] for the corresponding method. Any SIP header field not listed in a table is not applicable for the corresponding SIP message.



**Table B.2.1: Key to notation codes for SIP header fields in dynamic view for II-NNI**

<b>Notation code (NOTE1)</b>	<b>Meaning</b>
dc	The SIP header field is required to be present in a SIP message over II-NNI according to the procedures specified in other specifications e.g. 3GPP TS 24.229 [5].
dm	The SIP header field shall be always present in a SIP message over II-NNI, and if received, it must be handled according to 3GPP TS 24.229 [5].
dm*	The SIP header field should be present in a SIP message over II-NNI, but the IMS network need to be prepared to receive a SIP message without that header field.
do	The SIP header field can be present in a SIP message over II-NNI, and if received, it must be handled according to 3GPP TS 24.229 [5]. (NOTE 2)
dt	The header field should be present in a SIP message over II-NNI, but the IMS network need to be prepared to receive a SIP message without that header field. If TCP is used as a transport, then the header field must be present in a SIP message.
d*	The SIP header field is required to be present in a SIP message if the message body is not empty.
dn/a	The SIP header field is shall not be present in a SIP message over II-NNI. (NOTE 3)
dc<integer>	The condition for the presence of the SIP header field. <integer> is the identifier of the condition. This notation code is applied only in each request-related or response-related table.
NOTE 1: The meaning of the notation codes is same as IETF RFC 3261 [13] clause 20, and "d" is used to emphasise the dynamic view.	
NOTE 2: If specified by local policy rules, the IBCF acting as entry point may omit or modify any received SIP header fields prior to forwarding SIP messages as specified in 3GPP TS 24.229 [5] subclause 5.10.6.2.	
NOTE 3: The SIP header field can be removed at the IBCF acting as exit point by using screening functionality defined in 3GPP TS 24.229 [5] subclause 5.10.6.2.	

## B.3 ACK method

**Table B.3.1: Supported header fields within the ACK request**

Item	Header field	Ref.	RFC status	II-NNI condition
1	Accept-Contact	[51]	o	do
2	Allow-Events	[20]	o	IF Table 6.1.3.1/23 THEN do (NOTE)
3	Authorization	[13]	o	IF Table 6.1.3.1/7 THEN do (NOTE)
4	Call-ID	[13]	m	dm
6	Content-Disposition	[13]	o	do
7	Content-Encoding	[13]	o	do
8	Content-Language	[13]	o	do
9	Content-Length	[13]	t	dt
10	Content-Type	[13]	*	d*
11	Cseq	[13]	m	dm
12	Date	[13]	o	do
13	From	[13]	m	dm
13B	Max-Breadth	[79]	o	do
14	Max-Forwards	[13]	m	dm
15	MIME-Version	[13]	o	do
15B	Privacy	[34]	o	do
16	Proxy-Authorization	[13]	o	IF Table 6.1.3.1/7 THEN do (NOTE)
17	Proxy-Require	[13]	n/a	dn/a
17A	Reason	[48]	o	IF Table 6.1.3.1/40 THEN do (NOTE)
17B	Recv-Info	[39]	n/a	dn/a
17C	Reject-Contact	[51]	o	do
17D	Request-Disposition	[51]	o	do
18	Require	[13]	n/a	dn/a
18A	Resource-Priority	[78]	o	IF Table 6.1.3.1/73 THEN do (NOTE)
19	Route	[13]	c	dc
19A	Session-ID	[124]	m	IF Table 6.1.3.1/94 THEN dm (NOTE)
20	Timestamp	[13]	o	do
21	To	[13]	m	dm
22	User-Agent	[13]	o	do
23	Via	[13]	m	dm
NOTE:	If the capability specified in Table 6.1.3.1 is not supported over the II-NNI, the IBCF in the receiving network can omit or modify the SIP header fields in the received SIP message prior to forwarding as specified in 3GPP TS 24.229 [5] subclause 5.10.6.2.			

## B.4 BYE method

Table B.4.1: Supported header fields within the BYE request

Item	Header field	Ref.	RFC status	II-NNI condition
1	Accept	[13]	o	IF dc1 (AOC: subclause 12.22) THEN dm ELSE do
1A	Accept-Contact	[51]	o	do
2	Accept-Encoding	[13]	o	do
3	Accept-Language	[13]	o	do
3A	Allow	[13]	o	do
4	Allow-Events	[20]	o	IF Table 6.1.3.1/23 THEN do (NOTE)
5	Authorization	[13]	o	IF Table 6.1.3.1/7 THEN do (NOTE)
6	Call-ID	[13]	m	dm
7	Content-Disposition	[13]	o	IF dc2 (AOC: subclause 12.22) THEN dm ELSE do
8	Content-Encoding	[13]	o	do
9	Content-Language	[13]	o	do
10	Content-Length	[13]	t	dt
11	Content-Type	[13]	*	d*
12	Cseq	[13]	m	dm
13	Date	[13]	o	do
14	From	[13]	m	dm
14A	Geolocation	[68]	o	do
14AA	Geolocation-Routing	[68]	o	do
14B	Max-Breadth	[79]	o	do
15	Max-Forwards	[13]	m	dm
16	MIME-Version	[13]	o	do
16A	P-Access-Network-Info	[24]	o	IF Table 6.1.3.1/36 THEN do (NOTE)
16B	P-Asserted-Identity	[44]	o	IF Table 6.1.3.1/27 THEN do (NOTE)
16C	P-Charging-Function-Addresses	[24]	o	dn/a
16D	P-Charging-Vector	[24]	o	dn/a
16F	P-Preferred-Identity	[44]	o	dn/a
16G	Privacy	[34]	o	do
17	Proxy-Authorization	[13]	o	IF Table 6.1.3.1/7 THEN do (NOTE)
18	Proxy-Require	[13]	o	do
18A	Reason	[48]	o	IF dc3 (ICB: subclause 12.10.1) THEN dm ELSE IF Table 6.1.3.1/40 THEN do (NOTE)
19	Record-Route	[13]	o	do
19A	Referred-By	[53]	o	do
19B	Reject-Contact	[51]	o	do
19C	Request-Disposition	[51]	o	do
20	Require	[13]	c	dc
20A	Resource-Priority	[78]	o	IF Table 6.1.3.1/73 THEN do (NOTE)
21	Route	[13]	c	dc
21A	Security-Client	[47]	o	dn/a
21B	Security-Verify	[47]	o	dn/a
21C	Session-ID	[124]	m	IF Table 6.1.3.1/94 THEN dm (NOTE)
22	Supported	[13]	o	do
23	Timestamp	[13]	o	do
24	To	[13]	m	dm
25	User-Agent	[13]	o	do
25A	User-to-User	[83]	o	IF Table 6.1.3.1/79 THEN do (NOTE)
26	Via	[13]	m	dm
dc1:	request invoked due to AOC AND visited-to-home request on roaming II-NNI			
dc2:	request invoked due to AOC AND home-to-visited request on roaming II-NNI			
dc3:	request invoked due to "dynamic ICB" on a confirmed status			
NOTE:	If the capability specified in Table 6.1.3.1 is not supported over the II-NNI, the IBCF in the receiving network can omit or modify the SIP header fields in the received SIP message prior to forwarding as specified in 3GPP TS 24.229 [5] subclause 5.10.6.2.			

Table B.4.2: Supported header fields within the BYE response

Item	Header field	SIP status code	Ref.	RFC status	II-NNI condition
1	Accept	415	[13]	c	dc
2	Accept-Encoding	415	[13]	c	dc
3	Accept-Language	415	[13]	c	dc
4	Accept-Resource-Priority	2xx 417	[78]	o	IF Table 6.1.3.1/73 THEN do (NOTE 2)
5	Allow	2xx	[13]	o	do
		405		m	dm
		others		o	do
6	Allow-Events	2xx	[20]	o	IF Table 6.1.3.1/23 THEN do (NOTE 2)
7	Authentication-Info	2xx	[13]	o	IF Table 6.1.3.1/7 THEN do (NOTE 2)
8	Call-ID	100 others	[13]	m	dm
9	Contact	3xx 485	[13]	o	do
10	Content-Disposition	r	[13]	o	IF dc1 (AOC: subclause 12.22) THEN dm ELSE do
11	Content-Encoding	r	[13]	o	do
12	Content-Language	r	[13]	o	do
13	Content-Length	100 others	[13]	t	dt
14	Content-Type	r	[13]	*	d*
15	Cseq	100 others	[13]	m	dm
16	Date	100 others	[13]	o	do
17	Error-Info	3xx-6xx	[13]	o	IF Table 6.1.3.1/13 THEN do (NOTE 2)
18	From	100 others	[13]	m	dm
19	Geolocation-Error	424	[68]	m	dm
		others		o	do
20	MIME-version	r	[13]	o	do
21	P-Access-Network-Info	r	[24]	o	IF Table 6.1.3.1/36 THEN do (NOTE 2)
22	P-Asserted-Identity	r	[44]	o	IF Table 6.1.3.1/27 THEN do (NOTE 2)
23	P-Charging-Function-Addresses	r	[24]	o	dn/a
24	P-Charging-Vector	r	[24]	o	dn/a
26	P-Preferred-Identity	r	[44]	o	dn/a
27	Privacy	r	[34]	o	do
28	Proxy-Authenticate	401 (NOTE 1)	[13]	o	do
		407 (NOTE 1)		m	dm
29	Record-Route	2xx	[13]	o	do
30	Require	r	[13]	c	dc
31	Retry-After	404 413 480 486 500 503 600 603	[13]	o	do
32	Security-Server	421 494	[47]	o	dn/a
33	Server	r	[13]	o	do
34	Session-ID	r	[124]	m	IF Table 6.1.3.1/94 THEN dm

Item	Header field	SIP status code	Ref.	RFC status	II-NNI condition
					(NOTE 2)
35	Supported	2xx	[13]	o	do
36	Timestamp	r	[13]	o	do
37	To	100 others	[13]	m	dm
38	Unsupported	420	[13]	m	dm
39	User-Agent	r	[13]	o	do
40	User-to-User	r	[83]	o	IF Table 6.1.3.1/79 THEN do (NOTE 2)
41	Via	100 others	[13]	m	dm
42	Warning	r	[13]	o	do
43	WWW-Authenticate	401 (NOTE 1)	[13]	m	dm
		407 (NOTE 1)		o	do
dc1:	200 (OK) response invoked due to AOC AND home-to-visited response on roaming II-NNI				
NOTE 1: The SIP status code is only applicable over the roaming II-NNI.					
NOTE 2: If the capability specified in Table 6.1.3.1 is not supported over the II-NNI, the IBCF in the receiving network can omit or modify the SIP header fields in the received SIP message prior to forwarding as specified in 3GPP TS 24.229 [5] subclause 5.10.6.2.					

## B.5 CANCEL method

Table B.5.1: Supported header fields within the CANCEL request

Item	Header field	Ref.	RFC status	II-NNI condition	
1	Accept-Contact	[51]	o	do	
5	Authorization	[13]	o	IF Table 6.1.3.1/7 THEN do (NOTE)	
6	Call-ID	[13]	m	dm	
8	Content-Length	[13]	t	dt	
9	Cseq	[13]	m	dm	
10	Date	[13]	o	do	
11	From	[13]	m	dm	
11A	Max-Breadth	[79]	o	do	
12	Max-Forwards	[13]	m	dm	
14	Privacy	[34]	o	do	
15	Reason	[48]	o	IF dc1 (CW: subclause 12.7) THEN dm ELSE IF Table 6.1.3.1/40 THEN do (NOTE)	
16	Record-Route	[13]	o	do	
17	Reject-Contact	[51]	o	do	
17A	Request-Disposition	[51]	o	do	
17B	Resource-Priority	[78]	o	IF Table 6.1.3.1/73 THEN do (NOTE)	
18	Route	[13]	c	dc	
18A	Session-ID	[124]	m	IF Table 6.1.3.1/94 THEN dm (NOTE)	
19	Supported	[13]	o	do	
20	Timestamp	[13]	o	do	
21	To	[13]	m	dm	
22	User-Agent	[13]	o	do	
23	Via	[13]	m	dm	
dc1:	request invoked due to CW at the expiry of the "CW timer"				
NOTE: If the capability specified in Table 6.1.3.1 is not supported over the II-NNI, the IBCF in the receiving network can omit or modify the SIP header fields in the received SIP message prior to forwarding as specified in 3GPP TS 24.229 [5] subclause 5.10.6.2.					

**Table B.5.2: Supported header fields within the CANCEL response**

Item	Header field	SIP status code	Ref.	RFC status	II-NNI condition
1	Accept-Resource-Priority	2xx 417	[78]	o	IF Table 6.1.3.1/73 THEN do (NOTE)
2	Call-ID	r	[13]	m	dm
3	Content-Length	r	[13]	t	dt
4	Cseq	r	[13]	m	dm
5	Date	r	[13]	o	do
6	Error-Info	3xx-6xx	[13]	o	IF Table 6.1.3.1/13 THEN do (NOTE)
7	From	r	[13]	m	dm
9	Privacy	r	[34]	o	do
10	Record-Route	2xx	[13]	o	do
11	Retry-After	404 413 480 486 500 503 600 603	[13]	o	do
12	Session-ID	r	[124]	m	IF Table 6.1.3.1/94 THEN dm (NOTE)
13	Supported	2xx	[13]	o	do
14	Timestamp	r	[13]	o	do
15	To	r	[13]	m	dm
16	User-Agent	r	[13]	o	do
17	Via	r	[13]	m	dm
18	Warning	r	[13]	o	do
NOTE:	If the capability specified in Table 6.1.3.1 is not supported over the II-NNI, the IBCF in the receiving network can omit or modify the SIP header fields in the received SIP message prior to forwarding as specified in 3GPP TS 24.229 [5] subclause 5.10.6.2.				

## B.6 INFO method

As described in Table 6.1, the support of INFO method over the II-NNI is based on bilateral agreement between the operators.

**Table B.6.1: Supported header fields within the INFO request**

Item	Header field	Ref.	RFC status	II-NNI condition
1	Accept	[13], [39]	o	do
2	Accept-Encoding	[13], [39]	o	do
3	Accept-Language	[13], [39]	o	do
4	Allow	[13], [39]	o	do
5	Allow-Events	[20]	o	IF Table 6.1.3.1/23 THEN do (NOTE)
6	Authorization	[13], [39]	o	IF Table 6.1.3.1/7 THEN do (NOTE)
7	Call-ID	[13], [39]	m	dm
7A	Call-Info	[13], [39]	o	do
9	Content-Disposition	[13], [39]	o	IF dc1 (AOC: subclause 12.22) THEN dm ELSE do
10	Content-Encoding	[13], [39]	o	do
11	Content-Language	[13], [39]	o	do
12	Content-Length	[13], [39]	o	do
13	Content-Type	[13], [39]	*	d*
14	Cseq	[13], [39]	m	dm
15	Date	[13], [39]	o	do
16	From	[13], [39]	m	dm
17	Geolocation	[68]	o	do
17A	Geolocation-Routing	[68]	o	do
18	Info-Package	[39]	m*	IF Table 6.1.3.1/17 THEN do (NOTE)
19	Max-Breadth	[79], [39]	n/a	dn/a
20	Max-Forwards	[13], [39]	o	do
21	MIME-Version	[13], [39]	o	do
22	P-Access-Network-Info	[24]	o	IF Table 6.1.3.1/36 THEN do (NOTE)
23	P-Charging-Function-Addresses	[24]	o	dn/a
24	P-Charging-Vector	[24]	o	IF Table 6.1.3.1/38 THEN do (NOTE)
26	Privacy	[34], [39]	o	do
27	Proxy-Authorization	[13], [39]	o	IF Table 6.1.3.1/7 THEN do (NOTE)
28	Proxy-Require	[13], [39]	o	do
29	Reason	[48], [39]	o	IF Table 6.1.3.1/40 THEN do (NOTE)
30	Record-Route	[13], [39]	o	do
31	Referred-By	[53], [39]	o	do
33	Request-Disposition	[51], [39]	o	do
34	Require	[13], [39]	o	do
35	Resource-Priority	[78], [39]	o	IF Table 6.1.3.1/73 THEN do (NOTE)
36	Route	[13], [39]	o	do
37	Security-Client	[47], [39]	o	dn/a
38	Security-Verify	[47], [39]	o	dn/a
38A	Session-ID	[124]	m	IF Table 6.1.3.1/94 THEN dm (NOTE)
39	Subject	[13], [39]	o	do
40	Supported	[13], [39]	o	do
41	Timestamp	[13], [39]	o	do
42	To	[13], [39]	m	dm
43	User-Agent	[13], [39]	o	do
44	Via	[13], [39]	m	dm
dc1:	request invoked due to AOC AND home-to-visited request on roaming II-NNI			
NOTE:	If the capability specified in Table 6.1.3.1 is not supported over the II-NNI, the IBCF in the receiving network can omit or modify the SIP header fields in the received SIP message prior to forwarding as specified in 3GPP TS 24.229 [5] subclause 5.10.6.2.			

Table B.6.2: Supported header fields within the INFO response

Item	Header field	SIP status code	Ref.	RFC status	II-NNI condition
1	Accept	2xx 415	[13], [39]	o	do
2	Accept-Encoding	2xx	[13], [39]	o	do
		415		c	dc
3	Accept-Language	2xx 415	[13], [39]	o	do
4	Accept-Resource-Priority	2xx 417	[78], [39]	o	IF Table 6.1.3.1/73 THEN do (NOTE 2)
5	Allow	405	[13], [39]	m	dm
		others		o	do
6	Allow-Events	2xx	[20]	o	IF Table 6.1.3.1/23 THEN do (NOTE 2)
7	Authentication-Info	2xx	[13], [39]	o	IF Table 6.1.3.1/7 THEN do (NOTE 2)
8	Call-ID	100	[13], [39]	m	dm
		others			
9	Call-Info	r	[13], [39]	o	do
10	Content-Disposition	r	[13], [39]	o	do
11	Content-Encoding	r	[13], [39]	o	do
12	Content-Language	r	[13], [39]	o	do
13	Content-Length	100	[13], [39]	o	do
		others			
14	Content-Type	r	[13], [39]	*	d*
15	Cseq	100	[13], [39]	m	dm
		others			
16	Date	100	[13], [39]	o	do
		others			
17	Error-Info	3xx-6xx	[13], [39]	o	IF Table 6.1.3.1/13 THEN do (NOTE 2)
18	From	100	[13], [39]	m	dm
		others			
19	Geolocation-Error	424	[68]	m	dm
		others		o	do
20	MIME-version	r	[13], [39]	o	do
21	Organization	r	[13], [39]	n/a	dn/a
22	P-Access-Network-Info	r	[24]	o	IF Table 6.1.3.1/36 THEN do (NOTE 2)
23	P-Charging-Function-Addresses	r	[24]	o	dn/a
24	P-Charging-Vector	r	[24]	o	IF Table 6.1.3.1/38 THEN do (NOTE 2)
26	Privacy	r	[34], [39]	o	do
27	Proxy-Authenticate	401 (NOTE 1)	[13], [39]	o	do
28	Require	r	[13], [39]	o	do
29	Retry-After	404	[13], [39]	o	do
		413			
		480			
		486			
		500			
		503			
		600 603			
30	Security-Server	421	[47], [39]	o	dn/a
		494			
31	Server	r	[13], [39]	o	do
32	Session-ID	r	[124]	m	IF Table 6.1.3.1/94 THEN dm (NOTE 2)
33	Supported	2xx	[13], [39]	o	do
34	Timestamp	r	[13], [39]	o	do



Item	Header field	SIP status code	Ref.	RFC status	II-NNI condition
35	To	100 others	[13], [39]	m	dm
36	Unsupported	420	[13], [39]	o	do
37	User-Agent	r	[13], [39]	o	do
38	Via	100 others	[13], [39]	m	dm
39	Warning	r	[13], [39]	o	do
40	WWW-Authenticate	401 (NOTE 1)	[13], [39]	m	dm
NOTE 1: The SIP status code is only applicable over the roaming II-NNI.					
NOTE 2: If the capability specified in Table 6.1.3.1 is not supported over the II-NNI, the IBCF in the receiving network can omit or modify the SIP header fields in the received SIP message prior to forwarding as specified in 3GPP TS 24.229 [5] subclause 5.10.6.2.					

## B.7 INVITE method

**Table B.7.1: Supported header fields within the INVITE request**

Item	Header field	Ref.	RFC status	II-NNI condition
1	Accept	[13]	o	IF dc1 (AOC: subclause 12.22) THEN dm ELSE do
1A	Accept-Contact	[51]	o	IF dc2 (PNM: subclause 12.17) THEN dm ELSE do
2	Accept-Encoding	[13]	o	do
3	Accept-Language	[13]	o	do
4	Alert-Info	[13]	o	IF dc3 (CRS: subclause 12.15) THEN dm ELSE IF Table 6.1.3.1/10 THEN do (NOTE 3)
5	Allow	[13]	o	do
6	Allow-Events	[20]	o	IF Table 6.1.3.1/23 THEN do (NOTE 3)
7	Answer-Mode	[94]	o	IF Table 6.1.3.1/90 THEN do (NOTE 3)
8	Authorization	[13]	o	IF Table 6.1.3.1/7 THEN do (NOTE 3)
9	Call-ID	[13]	m	dm
10	Call-Info	[13]	o	IF dc4 (CCBS/CCNR/CCNL: subclause 12.11/12.12/12.23) OR dc5 (announcements: subclause 12.21) THEN dm ELSE do
11	Contact	[13]	m	dm
12	Content-Disposition	[13]	o	IF dc6 (AOC: subclause 12.22) THEN dm ELSE do
13	Content-Encoding	[13]	o	do
14	Content-Language	[13]	o	do
15	Content-Length	[13]	t	dt
16	Content-Type	[13]	*	d*
17	Cseq	[13]	m	dm
18	Date	[13]	o	do
19	Expires	[13]	o	do
19A	Feature-Caps	[143]	o	IF Table 6.1.3.1/103 THEN do (NOTE 3)
20	From	[13]	m	dm
20A	Geolocation	[68]	o	do
20AA	Geolocation-Routing	[68]	o	do
20B	History-Info	[25]	o	IF dc7 (CDIV: subclause 12.6) OR dc2 (PNM: subclause 12.17) THEN dm ELSE IF Table 6.1.3.1/50 THEN do (NOTE 1, NOTE 3)
21	In-Reply-To	[13]	o	do
21A	Join	[55]	o	IF Table 6.1.3.1/48 THEN do (NOTE 3)
21B	Max-Breadth	[79]	o	do
22	Max-Forwards	[13]	m	dm
23	MIME-Version	[13]	o	do
23A	Min-SE	[52]	o	do
24	Organization	[13]	o	do
24A	P-Access-Network-Info	[24]	o	IF Table 6.1.3.1/36 THEN do (NOTE 3)
24B	P-Asserted-Identity	[44]	o	IF Table 6.1.3.1/27 AND initial request THEN dm (NOTE 2, NOTE 3)
24C	P-Asserted-Service	[26]	o	IF (non-roaming II-NNI OR home-to-visited request on roaming II-NNI) AND Table 6.1.3.1/77 AND initial request THEN do (NOTE 3)
24D	P-Called-Party-ID	[24]	o	IF home-to-visited request on roaming II-NNI AND Table 6.1.3.1/34 THEN do (NOTE 3)
24E	P-Charging-Function-Addresses	[24]	o	dn/a
24F	P-Charging-Vector	[24]	o	IF Table 6.1.3.1/38 THEN do (NOTE 3)
24H	P-Early-Media	[74]	o	IF Table 6.1.3.1/69 THEN do (NOTE 3)
25	P-Media-Authorization	[42]	o	dn/a
25A	P-Preferred-Identity	[44]	o	dn/a
25B	P-Preferred-Service	[26]	o	IF visited-to-home request on roaming II-NNI AND Table 6.1.3.1/77 AND initial request THEN do (NOTE 3)
25C	P-Private-Network-Indication	[84]	o	IF Table 6.1.3.1/80 AND initial request THEN

Item	Header field	Ref.	RFC status	II-NNI condition
				do (NOTE 3)
25D	P-Profile-Key	[64]	o	IF Table 6.1.3.1/59 AND initial request THEN do (NOTE 3)
25E	P-Served-User	[85]	o	IF visited-to-home request on roaming II-NNI AND initial request being sent from "privileged sender" THEN dm (NOTE 3)
25F	P-User-Database	[60]	o	dn/a
25G	P-Visited-Network-ID	[24]	o	dn/a
26	Priority	[13]	o	do
26A	Privacy	[34]	o	IF dc8 (OIP/OIR: subclause 12.3) THEN dm ELSE do
26B	Priv-Answer-Mode	[94]	o	IF Table 6.1.3.1/90 THEN do (NOTE 3)
27	Proxy-Authorization	[13]	o	IF Table 6.1.3.1/7 THEN do (NOTE 3)
28	Proxy-Require	[13]	o	do
28A	Reason	[48]	o	IF Table 6.1.3.1/40 AND subsequent request THEN do (NOTE 3)
29	Record-Route	[13]	o	do
29A	Recv-Info	[39]	m	IF Table 6.1.3.1/17 THEN dm (NOTE 3)
30	Referred-By	[53]	o	IF dc9 (ECT: subclause 12.13) OR dc10 (CONF: subclause 12.19) THEN dm ELSE do
31	Reject-Contact	[51]	o	do
31A	Replaces	[54]	o	IF dc11 (ECT: subclause 12.13) OR dc12 (CONF: subclause 12.19) THEN dm ELSE IF Table 6.1.3.1/47 THEN do (NOTE 3)
31B	Reply-To	[13]	o	do
31C	Request-Disposition	[51]	o	do
32	Require	[13]	c	IF dc11 (ECT: subclause 12.13) THEN dm ELSE dc
32A	Resource-Priority	[78]	o	IF Table 6.1.3.1/73 THEN do (NOTE 3)
33	Route	[13]	c	dc
33A	Security-Client	[47]	o	dn/a
33B	Security-Verify	[47]	o	dn/a
33D	Session-Expires	[52]	o	do
33E	Session-ID	[124]	m	IF Table 6.1.3.1/94 THEN dm (NOTE 3)
34	Subject	[13]	o	do
35	Supported	[13]	m*	IF dc2 (PNM: subclause 12.17) THEN dm ELSE dm*
35A	Target-Dialog	[140]	o	IF Table 6.1.3.1/102 THEN do (NOTE 3)
36	Timestamp	[13]	o	do
37	To	[13]	m	dm
37A	Trigger-Consent	[82]	o	IF Table 6.1.3.1/78 THEN do (NOTE 3)
38	User-Agent	[13]	o	do
38A	User-to-User	[83]	o	IF Table 6.1.3.1/79 THEN do (NOTE 3)
39	Via	[13]	m	dm
dc1:	request invoked due to AOC AND visited-to-home request on roaming II-NNI			
dc2:	initial request invoked due to PNM in case of ("PN UE redirection" OR "PN access control") AND (non-roaming II-NNI OR home-to-visited request on roaming II-NNI)			
dc3:	initial request invoked due to CRS AND (non-roaming II-NNI OR home-to-visited request on roaming II-NNI)			
dc4:	initial request invoked due to CCBS/CCNR/CCNL AND "CC call" request AND (non-roaming II-NNI OR home-to-visited request on roaming II-NNI)			
dc5:	subsequent request invoked due to announcements using the Call-info header field AND (non-roaming II-NNI OR home-to-visited request on roaming II-NNI)			
dc6:	request invoked due to AOC AND home-to-visited request on roaming II-NNI			
dc7:	initial request towards the network serving "the diverted-to user" AND CFU/CFB/CFNR/CFNRc/CD/CFNL AND (non-roaming II-NNI OR home-to-visited request on roaming II-NNI)			
dc8:	(initial request invoked due to OIP/OIR AND "override the default setting" in temporary mode AND visited-to-home request on roaming II-NNI) OR (initial request invoked due to OIP/OIR AND "presentation of the public user identity is restricted" AND (non-roaming II-NNI OR home-to-visited request on roaming II-NNI))			
dc9:	initial request invoked due to ECT AND (non-roaming II-NNI OR home-to-visited request on roaming II-NNI)			
dc10:	(initial request from "conference participant" receiving REFER request with Referred-By header field AND (visited-to-home request on roaming II-NNI OR non-roaming II-NNI)) OR (initial request from "conference focus" receiving REFER request AND (non-roaming II-NNI OR home-to-visited request on roaming II-NNI))			
dc11:	"Consultative transfer" due to ECT AND (non-roaming II-NNI OR home-to-visited request on roaming II-NNI)			
dc12:	initial request from "conference focus" receiving REFER request with Replaces header escaped in Refer-To			

Item	Header field	Ref.	RFC status	II-NNI condition
	header field AND (non-roaming II-NNI OR home-to-visited request on roaming II-NNI)			
NOTE 1:	The Privacy header can be escaped in the header field for CDIV.			
NOTE 2:	The header field is not included in some exceptional cases. (e.g. when an incoming call from a circuit-switched network has not included the required information to be mapped into the header field)			
NOTE 3:	If the capability specified in Table 6.1.3.1 is not supported over the II-NNI, the IBCF in the receiving network can omit or modify the SIP header fields in the received SIP message prior to forwarding as specified in 3GPP TS 24.229 [5] subclause 5.10.6.2.			

Table B.7.2: Supported header fields within the INVITE response

Item	Header field	SIP status code	Ref.	RFC status	II-NNI condition
1	Accept	2xx	[13]	o	do
		415		c	dc
2	Accept-Encoding	2xx	[13]	o	do
		415		c	dc
3	Accept-Language	2xx	[13]	o	do
		415		c	dc
4	Accept-Resource-Priority	2xx 417	[78]	o	IF Table 6.1.3.1/73 THEN do (NOTE 3)
5	Alert-Info	180	[13]	o	IF dc1 (CW: subclause 12.7) OR dc2 (announcements: subclause 12.21) THEN dm ELSE IF Table 6.1.3.1/10 THEN do (NOTE 3)
6	Allow	2xx	[13]	m*	dm*
		405		m	dm
		others		o	do
7	Allow-Events	2xx	[20]	o	IF Table 6.1.3.1/23 THEN do (NOTE 3)
8	Answer-Mode	2xx	[94]	o	IF Table 6.1.3.1/90 THEN do (NOTE 3)
9	Authentication-Info	2xx	[13]	o	IF Table 6.1.3.1/7 THEN do (NOTE 3)
10	Call-ID	r	[13]	m	dm
11	Call-Info	r	[13]	o	IF dc3 (CCBS: subclause 12.11) OR dc4 (CCNR: subclause 12.12) OR dc5 (CCNL: subclause 12.23) THEN dm ELSE do
12	Contact	18x 199	[13]	o	do
		2xx		m	dm
		3xx 485		o	do
13	Content-Disposition	r	[13]	o	IF dc6 (AOC: subclause 12.22) THEN dm ELSE do
14	Content-Encoding	r	[13]	o	do
15	Content-Language	r	[13]	o	do
16	Content-Length	100 others	[13]	t	dt
17	Content-Type	r	[13]	*	IF dc7 (CCBS: subclause 12.11) OR dc8 (CCNR/CCNL: subclause 12.12/12.23) THEN dm ELSE d*
18	Cseq	100 others	[13]	m	dm
19	Date	100 others	[13]	o	IF dc7 (CCBS: subclause 12.11) OR dc8 (CCNR/CCNL: subclause 12.12/12.23) THEN dm ELSE do
20	Error-Info	3xx-6xx	[13]	o	IF dc9 (announcements: subclause 12.21) THEN dm ELSE IF Table 6.1.3.1/13 THEN do (NOTE 3)
21	Expires	r	[13]	o	do
21A	Feature-Caps	18x 2xx	[143]	o	IF Table 6.1.3.1/103 THEN do (NOTE 3)
22	From	100 others	[13]	m	dm
23	Geolocation-Error	424	[68]	m	dm
		others		o	do
24	History-Info	r	[25]	o	IF dc10 (CDIV: subclause 12.6) THEN dm ELSE IF Table 6.1.3.1/50 THEN do (NOTE 2, NOTE 3)

Item	Header field	SIP status code	Ref.	RFC status	II-NNI condition
25	MIME-version	r	[13]	o	do
26	Min-SE	422	[52]	m	dm
27	Organization	r	[13]	o	do
28	P-Access-Network-Info	r	[24]	o	IF Table 6.1.3.1/36 THEN do (NOTE 3)
29	P-Answer-State	18x 2xx	[73]	o	IF Table 6.1.3.1/68 THEN do (NOTE 3)
30	P-Asserted-Identity	r	[44]	o	IF dc11 (TIP/TIR: subclause 12.4) THEN dm ELSE IF Table 6.1.3.1/27 AND response to initial request THEN do (NOTE 3)
31	P-Charging-Function-Addresses	r	[24]	o	dn/a
32	P-Charging-Vector	r	[24]	o	IF dc12 (CONF: subclause 12.19) THEN dm ELSE IF Table 6.1.3.1/38 THEN do (NOTE 3)
34	P-Early-Media	18x	[74]	o	IF dc13 (CAT: subclause 12.14) OR dc14 (announcements: subclause 12.21) THEN dm ELSE IF Table 6.1.3.1/69 THEN do (NOTE 3)
35	P-Media-Authorization	18x 2xx	[42]	o	dn/a
36	P-Preferred-Identity	r	[44]	o	dn/a
36A	P-Refused-URI-List	403	[141]	o	IF non-roaming II-NNI AND Table 6.1.3.1/101 THEN do (NOTE 3)
37	Permission-Missing	470	[82]	o	IF Table 6.1.3.1/78 THEN do (NOTE 3)
38	Privacy	r	[34]	o	IF dc15 (TIP/TIR: subclause 12.4) THEN dm ELSE do
39	Priv-Answer-Mode	2xx	[94]	o	IF Table 6.1.3.1/90 THEN do (NOTE 3)
40	Proxy-Authenticate	401 (NOTE 1)	[13]	o	do
		407 (NOTE 1)		m	dm
41	Reason	18x 199 3xx-6xx	[48]	o	IF dc16 (CW: subclause 12.7) OR dc17 (ICB: subclause 12.10.1) OR dc18 (announcements: subclause 12.21) THEN dm ELSE IF Table 6.1.3.1/40 THEN do (NOTE 3)
42	Record-Route	18x 199 2xx	[13]	o	do
43	Recv-Info	18x 199 2xx	[39]	c	IF Table 6.1.3.1/17 THEN dc (NOTE 3)
44	Reply-To	r	[13]	o	do
45	Require	r	[13]	c	IF dc19 (CAT: subclause 12.14) THEN dm ELSE dc
46	Retry-After	404 413 480 486 500 503 600 603	[13]	o	do
47	Rseq	18x 199	[18]	o	do
48	Security-Server	421 494	[47]	o	dn/a
49	Server	r	[13]	o	do
50	Session-Expires	2xx	[52]	o	do
51	Session-ID	r	[124]	m	IF Table 6.1.3.1/94 THEN dm

Item	Header field	SIP status code	Ref.	RFC status	II-NNI condition
					(NOTE 3)
52	Supported	2xx	[13]	m*	dm*
53	Timestamp	r	[13]	o	do
54	To	100 others	[13]	m	dm
55	Unsupported	420	[13]	m	dm
56	User-Agent	r	[13]	o	do
57	User-to-User	r	[83]	o	IF Table 6.1.3.1/79 THEN do (NOTE 3)
58	Via	100 others	[13]	m	dm
59	Warning	r	[13]	o	IF dc20 (CDIV: subclause 12.6) THEN dm ELSE do
60	WWW-Authenticate	401 (NOTE 1)	[13]	m	dm
		407 (NOTE 1)		o	do
dc1:	response invoked due to CW AND (non-roaming II-NNI OR home-to-visited response on roaming II-NNI)				
dc2:	response to initial request invoked due to announcements using the Alert-Info header field AND (non-roaming II-NNI OR home-to-visited response on roaming II-NNI)				
dc3:	486 (Busy Here) response invoked due to CCBS AND (non-roaming II-NNI OR home-to-visited response on roaming II-NNI)				
dc4:	180 (Ringing) response invoked due to CCNR AND non-roaming II-NNI				
dc5:	480 (Temporarily Unavailable) response invoked due to CCNL AND (non-roaming II-NNI OR home-to-visited response on roaming II-NNI)				
dc6:	1xx/200 (OK) response invoked due to AOC AND home-to-visited response on roaming II-NNI				
dc7:	486 (Busy Here) response invoked due to CCBS AND home-to-visited response on roaming II-NNI				
dc8:	480 (Temporarily Unavailable) response invoked due to CCNR/CCNL AND home-to-visited response on roaming II-NNI				
dc9:	response to initial request invoked due to announcements using the Error-Info header field AND (non-roaming II-NNI OR home-to-visited response on roaming II-NNI)				
dc10:	180 (Ringing)/181 (Call Is Being Forwarded)/200 (OK) response to initial request AND CFU/CFB/CFNR/CFNRc/CD/CFNL AND (non-roaming II-NNI OR home-to-visited response on roaming II-NNI)				
dc11:	(TIP/TIR AND 2xx response to initial request AND (visited-to-home response on roaming II-NNI OR non-roaming II-NNI)) OR (TIP/TIR AND response to initial request AND "presentation is allowed" AND home-to-visited response on roaming II-NNI)				
dc12:	first response from "conference focus" to initial request AND (non-roaming II-NNI OR home-to-visited response on roaming II-NNI)				
dc13:	reliable response to initial request invoked due to CAT using "forking model" AND (non-roaming II-NNI OR home-to-visited response on roaming II-NNI)				
dc14:	183 (Session Progress) response to initial request invoked due to announcements authorizing early media AND (non-roaming II-NNI OR home-to-visited response on roaming II-NNI)				
dc15:	(TIP/TIR AND non-100 response to initial request AND "override the default setting" in temporary mode AND visited-to-home response on roaming II-NNI) OR (TIP/TIR AND 2xx response to initial request AND "presentation of the network asserted identity is restricted" AND (non-roaming II-NNI OR home-to-visited response on roaming II-NNI))				
dc16:	480 (Temporarily Unavailable) response invoked due to CW at the expiry of the "CW timer"				
dc17:	603 (Decline) response invoked due to "dynamic ICB" on an early dialog				
dc18:	183 (Session Progress) response to initial request invoked due to announcements authorizing early media when rejecting a communication request AND (non-roaming II-NNI OR home-to-visited response on roaming II-NNI)				
dc19:	first 18x response to initial request invoked due to CAT using "early session model" AND (non-roaming II-NNI OR home-to-visited response on roaming II-NNI)				
dc20:	480 (Temporarily Unavailable)/486 (Busy Here) response to initial request AND CFU/CFB/CFNR/CFNRc/CD/CFNL in case "maximum number of diversions" exceeds AND (non-roaming II-NNI OR home-to-visited response on roaming II-NNI)				
NOTE 1:	The SIP status code is only applicable over the roaming II-NNI.				
NOTE 2:	The Privacy header can be escaped in the header field for CDIV.				
NOTE 3:	If the capability specified in Table 6.1.3.1 is not supported over the II-NNI, the IBCF in the receiving network can omit or modify the SIP header fields in the received SIP message prior to forwarding as specified in 3GPP TS 24.229 [5] subclause 5.10.6.2.				

## B.8 MESSAGE method

As described in Table 6.1, the support of MESSAGE method over the II-NNI is based on bilateral agreement between the operators.



Table B.8.1: Supported header fields within the MESSAGE request

Item	Header field	Ref.	RFC status	II-NNI condition
1	Accept-Contact	[51]	o	IF dc1 (PNM: subclause 12.17) THEN dm ELSE do
1A	Allow	[13], [19]	o	do
2	Allow-Events	[20]	o	IF Table 6.1.3.1/23 THEN do (NOTE)
3	Authorization	[13], [19]	o	IF Table 6.1.3.1/7 THEN do (NOTE)
4	Call-ID	[13], [19]	m	dm
5	Call-Info	[13], [19]	o	do
6	Content-Disposition	[13], [19]	o	do
7	Content-Encoding	[13], [19]	o	do
8	Content-Language	[13], [19]	o	do
9	Content-Length	[13], [19]	t	dt
10	Content-Type	[13], [19]	*	d*
11	Cseq	[13], [19]	m	dm
12	Date	[13], [19]	o	do
13	Expires	[13], [19]	o	do
13A	Feature-Caps	[143]	o	IF Table 6.1.3.1/103 AND request outside an existing dialog THEN do (NOTE)
14	From	[13], [19]	m	dm
14A	Geolocation	[68]	o	do
14AA	Geolocation-Routing	[68]	o	do
14B	History-Info	[25]	o	IF dc1 (PNM: subclause 12.17) THEN dm ELSE IF Table 6.1.3.1/50 THEN do (NOTE)
15	In-Reply-To	[13], [19]	o	do
15A	Max-Breadth	[79]	o	do
16	Max-Forwards	[13], [19]	m	dm
17	MIME-Version	[13]	o	do
18	Organization	[13], [19]	o	do
18A	P-Access-Network-Info	[24]	o	IF Table 6.1.3.1/36 THEN do (NOTE)
18B	P-Asserted-Identity	[44]	o	IF Table 6.1.3.1/27 AND request outside an existing dialog THEN dm (NOTE)
18C	P-Asserted-Service	[26]	o	IF (non-roaming II-NNI OR home-to-visited request on roaming II-NNI) AND Table 6.1.3.1/77 AND request outside an existing dialog THEN do (NOTE)
18D	P-Called-Party-ID	[24]	o	IF home-to-visited request on roaming II-NNI AND Table 6.1.3.1/34 THEN do (NOTE)
18E	P-Charging-Function-Addresses	[24]	o	dn/a
18F	P-Charging-Vector	[24]	o	IF Table 6.1.3.1/38 THEN do (NOTE)
18H	P-Preferred-Identity	[44]	o	dn/a
18I	P-Preferred-Service	[26]	o	IF visited-to-home request on roaming II-NNI AND Table 6.1.3.1/77 AND request outside an existing dialog THEN do (NOTE)
18J	P-Private-Network-Indication	[84]	o	IF Table 6.1.3.1/80 AND request outside an existing dialog THEN do (NOTE)
18K	P-Profile-Key	[64]	o	IF Table 6.1.3.1/59 AND request outside an existing dialog THEN do (NOTE)
18L	P-Served-User	[85]	o	IF visited-to-home request on roaming II-NNI AND request outside an existing dialog being sent from "privileged sender" THEN dm (NOTE)
18M	P-User-Database	[60]	o	dn/a
18N	P-Visited-Network-ID	[24]	o	dn/a
19	Priority	[13], [19]	o	do
19A	Privacy	[34]	o	IF dc2 (OIP/OIR: subclause 12.3) THEN dm ELSE do
20	Proxy-Authorization	[13], [19]	o	IF Table 6.1.3.1/7 THEN do (NOTE)
21	Proxy-Require	[13], [19]	o	do
21A	Reason	[48]	o	IF Table 6.1.3.1/40 AND request inside an existing dialog THEN do (NOTE)
22	Record-Route	[13], [19]	n/a	dn/a
22A	Referred-By	[53]	o	do
23	Reject-Contact	[51]	o	do

Item	Header field	Ref.	RFC status	II-NNI condition
23A	Reply-To	[13], [19]	o	do
23B	Request-Disposition	[51]	o	do
24	Require	[13], [19]	c	dc
24A	Resource-Priority	[78]	o	IF Table 6.1.3.1/73 THEN do (NOTE)
25	Route	[13], [19]	c	dc
25A	Security-Client	[47]	o	dn/a
25B	Security-Verify	[47]	o	dn/a
25C	Session-ID	[124]	m	IF Table 6.1.3.1/94 THEN dm (NOTE)
26	Subject	[13], [19]	o	do
27	Supported	[13]	o	IF dc1 (PNM: subclause 12.17) THEN dm ELSE do
28	Timestamp	[13], [19]	o	do
29	To	[13], [19]	m	dm
29A	Trigger-Consent	[82]	o	IF Table 6.1.3.1/78 THEN do (NOTE)
30	User-Agent	[13], [19]	o	do
31	Via	[13], [19]	m	dm
dc1:	request outside an existing dialog invoked due to PNM in case of ("PN UE redirection" OR "PN access control") AND (non-roaming II-NNI OR home-to-visited request on roaming II-NNI)			
dc2:	(request outside an existing dialog invoked due to OIP/OIR AND "override the default setting" in temporary mode AND visited-to-home request on roaming II-NNI) OR (request outside an existing dialog invoked due to OIP/OIR AND "presentation of the public user identity is restricted" AND (non-roaming II-NNI OR home-to-visited request on roaming II-NNI))			
NOTE:	If the capability specified in Table 6.1.3.1 is not supported over the II-NNI, the IBCF in the receiving network can omit or modify the SIP header fields in the received SIP message prior to forwarding as specified in 3GPP TS 24.229 [5] subclause 5.10.6.2.			

Table B.8.2: Supported header fields within the MESSAGE response

Item	Header field	SIP status code	Ref.	RFC status	II-NNI condition
1	Accept	415	[13], [19]	m*	dm*
2	Accept-Encoding	415	[13], [19]	m*	dm*
3	Accept-Language	415	[13], [19]	m*	dm*
4	Accept-Resource-Priority	2xx 417	[78]	o	IF Table 6.1.3.1/73 THEN do (NOTE 2)
5	Allow	2xx	[13], [19]	o	do
		405		m	dm
		others		o	do
6	Allow-Events	2xx	[20]	o	IF Table 6.1.3.1/23 THEN do (NOTE 2)
7	Authentication-Info	2xx	[13], [19]	o	IF Table 6.1.3.1/7 THEN do (NOTE 2)
8	Call-ID	100 others	[13], [19]	m	dm
9	Call-Info	r	[13], [19]	o	do
10	Contact	3xx 485	[13], [19]	o	do
11	Content-Disposition	r	[13], [19]	o	do
12	Content-Encoding	r	[13], [19]	o	do
13	Content-Language	r	[13], [19]	o	do
14	Content-Length	100 others	[13], [19]	t	dt
15	Content-Type	r	[13], [19]	*	d*
16	Cseq	100 others	[13], [19]	m	dm
17	Date	100 others	[13], [19]	o	do
18	Error-Info	3xx-6xx	[13], [19]	o	IF Table 6.1.3.1/13 THEN do (NOTE 2)
19	Expires	r	[13], [19]	o	do
19A	Feature-Caps	2xx	[143]	o	IF Table 6.1.3.1/103 AND response to request outside an existing dialog THEN do (NOTE 2)
20	From	100 others	[13], [19]	m	dm
21	Geolocation-Error	424	[68]	m	dm
		others		o	do
22	History-Info	r	[25]	o	IF Table 6.1.3.1/50 THEN do (NOTE 2)
23	MIME-version	r	[13]	o	do
24	Organization	r	[13], [19]	o	do
25	P-Access-Network-Info	r	[24]	o	IF Table 6.1.3.1/36 THEN do (NOTE 2)
26	P-Asserted-Identity	r	[44]	o	IF dc1 (TIP/TIR: subclause 12.4) THEN dm ELSE IF Table 6.1.3.1/27 AND response to request outside an existing dialog THEN do (NOTE 2)
27	P-Charging-Function-Addresses	r	[24]	o	dn/a
28	P-Charging-Vector	r	[24]	o	IF Table 6.1.3.1/38 THEN do (NOTE 2)
30	P-Preferred-Identity	r	[44]	o	dn/a
31	Permission-Missing	470	[82]	o	IF Table 6.1.3.1/78 THEN do (NOTE 2)
32	Privacy	r	[34]	o	IF dc2(TIP/TIR: subclause 12.4) THEN dm ELSE do
33	Proxy-Authenticate	401 (NOTE 1)	[13], [19]	o	do
		407 (NOTE 1)		m	dm
34	Record-Route	2xx	[13], [19]	n/a	dn/a
35	Reply-To	r	[13], [19]	o	do

Item	Header field	SIP status code	Ref.	RFC status	II-NNI condition
36	Require	r	[13], [19]	c	dc
37	Retry-After	404 413 480 486 500 503 600 603	[13], [19]	o	do
38	Security-Server	421 494	[47]	o	dn/a
39	Server	r	[13], [19]	o	do
40	Session-ID	r	[124]	m	IF Table 6.1.3.1/94 THEN dm (NOTE 2)
41	Supported	2xx	[13]	o	do
42	Timestamp	r	[13], [19]	o	do
43	To	100 others	[13], [19]	m	dm
44	Unsupported	420	[13], [19]	o	do
45	User-Agent	r	[13], [19]	o	do
46	Via	100 others	[13], [19]	m	dm
47	Warning	r	[13], [19]	o	do
48	WWW-Authenticate	401 (NOTE 1)	[13], [19]	m	dm
		407 (NOTE 1)		o	do
dc1:	(TIP/TIR AND 2xx response to request outside an existing dialog AND (visited-to-home response on roaming II-NNI OR non-roaming II-NNI) OR (TIP/TIR AND response to request outside an existing dialog AND "presentation is allowed" AND home-to-visited response on roaming II-NNI))				
dc2:	(TIP/TIR AND non-100 response to request outside an existing dialog AND "override the default setting" in temporary mode AND visited-to-home response on roaming II-NNI) OR (TIP/TIR AND 2xx response to request outside an existing dialog AND "presentation of the network asserted identity is restricted" AND (non-roaming II-NNI OR home-to-visited response on roaming II-NNI))				
NOTE 1:	The SIP status code is only applicable over the roaming II-NNI.				
NOTE 2:	If the capability specified in Table 6.1.3.1 is not supported over the II-NNI, the IBCF in the receiving network can omit or modify the SIP header fields in the received SIP message prior to forwarding as specified in 3GPP TS 24.229 [5] subclause 5.10.6.2.				

## B.9 NOTIFY method

As described in Table 6.1, the support of NOTIFY method over the non-roaming II-NNI is based on bilateral agreement between the operators.

Table B.9.1: Supported header fields within the NOTIFY request

Item	Header field	Ref.	RFC status	II-NNI condition
1	Accept	[13], [20]	o	do
1A	Accept-Contact	[51]	o	do
2	Accept-Encoding	[13], [20]	o	do
3	Accept-Language	[13], [20]	o	do
3A	Allow	[13], [20]	o	do
4	Allow-Events	[20]	o	do
5	Authorization	[13], [20]	o	IF Table 6.1.3.1/7 THEN do (NOTE)
6	Call-ID	[13], [20]	m	dm
6A	Call-Info	[13]	o	do
6B	Contact	[13], [20]	m	dm
7	Content-Disposition	[13], [20]	o	do
8	Content-Encoding	[13], [20]	o	do
9	Content-Language	[13], [20]	o	do
10	Content-Length	[13], [20]	t	dt
11	Content-Type	[13], [20]	*	d*
12	Cseq	[13], [20]	m	dm
13	Date	[13], [20]	o	do
14	Event	[20]	m	dm
14A	Feature-Caps	[143]	o	IF Table 6.1.3.1/103 THEN do (NOTE)
15	From	[13], [20]	m	dm
15A	Geolocation	[68]	o	do
15AA	Geolocation-Routing	[68]	o	do
15B	History-Info	[25]	o	IF Table 6.1.3.1/50 THEN do (NOTE)
15C	Max-Breadth	[79]	o	do
16	Max-Forwards	[13], [20]	m	dm
17	MIME-Version	[13], [20]	o	do
17A	P-Access-Network-Info	[24]	o	IF Table 6.1.3.1/36 THEN do (NOTE)
17B	P-Asserted-Identity	[44]	o	IF Table 6.1.3.1/27 THEN do (NOTE)
17C	P-Charging-Function-Addresses	[24]	o	dn/a
17D	P-Charging-Vector	[24]	o	dn/a
17F	P-Preferred-Identity	[44]	o	dn/a
17G	Privacy	[34]	o	do
18	Proxy-Authorization	[13], [20]	o	IF Table 6.1.3.1/7 THEN do (NOTE)
19	Proxy-Require	[13], [20]	o	do
19A	Reason	[48]	o	IF Table 6.1.3.1/40 THEN do (NOTE)
20	Record-Route	[13], [20]	o	do
20A	Referred-By	[53]	o	do
20B	Reject-Contact	[51]	o	do
20C	Request-Disposition	[51]	o	do
21	Require	[13], [20]	o	do
22	Route	[13], [20]	c	dc
22A	Resource-Priority	[78]	o	IF Table 6.1.3.1/73 THEN do (NOTE)
22B	Security-Client	[47]	o	dn/a
22C	Security-Verify	[47]	o	dn/a
22D	Session-ID	[124]	m	IF Table 6.1.3.1/94 THEN dm (NOTE)
23	Subscription-State	[20]	m	dm
24	Supported	[13], [20]	o	do
25	Timestamp	[13], [20]	o	do
26	To	[13], [20]	m	dm
27	User-Agent	[13], [20]	o	do
28	Via	[13], [20]	m	dm
29	Warning	[13], [20]	o	do
NOTE:	If the capability specified in Table 6.1.3.1 is not supported over the II-NNI, the IBCF in the receiving network can omit or modify the SIP header fields in the received SIP message prior to forwarding as specified in 3GPP TS 24.229 [5] subclause 5.10.6.2.			

Table B.9.2: Supported header fields within the NOTIFY response

Item	Header field	SIP status code	Ref.	RFC status	II-NNI condition
1	Accept	415	[13], [20]	o	do
2	Accept-Encoding	415	[13], [20]	o	do
3	Accept-Language	415	[13], [20]	o	do
4	Accept-Resource-Priority	2xx 417	[78]	o	IF Table 6.1.3.1/73 THEN do (NOTE 2)
5	Allow	405	[13], [20]	m	dm
		others		o	do
6	Allow-Events	2xx	[20]	o	do
		489		m	dm
7	Authentication-Info	2xx	[13], [20]	o	IF Table 6.1.3.1/7 THEN do (NOTE 2)
8	Call-ID	100 others	[13], [20]	m	dm
9	Contact	2xx	[13], [20]	o	do
		3xx		m	dm
		485		o	do
10	Content-Disposition	r	[13], [20]	o	do
11	Content-Encoding	r	[13], [20]	o	do
12	Content-Language	r	[13], [20]	o	do
13	Content-Length	100 others	[13], [20]	t	dt
14	Content-Type	r	[13], [20]	*	d*
15	Cseq	100 others	[13], [20]	m	dm
16	Date	100 others	[13], [20]	o	do
17	Error-Info	3xx-6xx	[13], [20]	o	IF Table 6.1.3.1/13 THEN do (NOTE 2)
17A	Feature-Caps	2xx	[143]	o	IF Table 6.1.3.1/103 THEN do (NOTE 2)
18	From	100 others	[13], [20]	m	dm
19	Geolocation-Error	424	[68]	m	dm
		others		o	do
20	MIME-version	r	[13], [20]	o	do
21	P-Access-Network-Info	r	[24]	o	IF Table 6.1.3.1/36 THEN do (NOTE 2)
22	P-Asserted-Identity	r	[44]	o	IF Table 6.1.3.1/27 THEN do (NOTE 2)
23	P-Charging-Function-Addresses	r	[24]	o	dn/a
24	P-Charging-Vector	r	[24]	o	dn/a
26	P-Preferred-Identity	r	[44]	o	dn/a
27	Privacy	r	[34]	o	do
28	Proxy-Authenticate	401 (NOTE 1)	[13], [20]	o	do
		407 (NOTE 1)		m	dm
29	Record-Route	2xx	[13], [20]	o	do
30	Require	r	[13], [20]	o	do
31	Retry-After	404 413 480 486 500 503 600 603	[13], [20]	o	do
32	Security-Server	421 494	[47]	o	dn/a
33	Server	r	[13], [20]	o	do

Item	Header field	SIP status code	Ref.	RFC status	II-NNI condition
34	Session-ID	r	[124]	m	IF Table 6.1.3.1/94 THEN dm (NOTE 2)
35	Supported	2xx	[13], [20]	o	do
36	Timestamp	r	[13], [20]	o	do
37	To	100 others	[13], [20]	m	dm
38	Unsupported	420	[13], [20]	o	do
39	User-Agent	r	[13], [20]	o	do
40	Via	100 others	[13], [20]	m	dm
41	Warning	r	[13], [20]	o	do
42	WWW-Authenticate	401 (NOTE 1)	[13], [20]	m	dm
		407 (NOTE 1)		o	do
NOTE 1: The SIP status code is only applicable over the roaming II-NNI.					
NOTE 2: If the capability specified in Table 6.1.3.1 is not supported over the II-NNI, the IBCF in the receiving network can omit or modify the SIP header fields in the received SIP message prior to forwarding as specified in 3GPP TS 24.229 [5] subclause 5.10.6.2.					

## B.10 OPTIONS method

**Table B.10.1: Supported header fields within the OPTIONS request**

Item	Header field	Ref.	RFC status	II-NNI condition
1	Accept	[13]	m*	dm*
1A	Accept-Contact	[51]	o	IF dc1 (PNM: subclause 12.17) THEN dm ELSE do
2	Accept-Encoding	[13]	o	do
3	Accept-Language	[13]	o	do
3A	Allow	[13]	o	do
4	Allow-Events	[20]	o	IF Table 6.1.3.1/23 THEN do (NOTE)
5	Authorization	[13]	o	IF Table 6.1.3.1/7 THEN do (NOTE)
6	Call-ID	[13]	m	dm
7	Call-Info	[13]	o	do
8	Contact	[13]	o	do
9	Content-Disposition	[13]	o	do
10	Content-Encoding	[13]	o	do
11	Content-Language	[13]	o	do
12	Content-Length	[13]	t	dt
13	Content-Type	[13]	*	d*
14	Cseq	[13]	m	dm
15	Date	[13]	o	do
15A	Feature-Caps	[143]	o	IF Table 6.1.3.1/103 AND request outside an existing dialog THEN do (NOTE)
16	From	[13]	m	dm
16A	Geolocation	[68]	o	do
16AA	Geolocation-Routing	[68]	o	do
16B	History-Info	[25]	o	IF (dc1 (PNM: subclause 12.17) THEN dm ELSE IF Table 6.1.3.1/50 THEN do (NOTE)
16C	Max-Breadth	[79]	o	do
17	Max-Forwards	[13]	m	dm
18	MIME-Version	[13]	o	do
19	Organization	[13]	o	do
19A	P-Access-Network-Info	[24]	o	IF Table 6.1.3.1/36 THEN do (NOTE)
19B	P-Asserted-Identity	[44]	o	IF Table 6.1.3.1/27 AND request outside an existing dialog THEN dm (NOTE)
19C	P-Asserted-Service	[26]	o	IF (non-roaming II-NNI OR home-to-visited request on roaming II-NNI) AND Table 6.1.3.1/77 AND request outside an existing dialog THEN do (NOTE)
19D	P-Called-Party-ID	[24]	o	IF home-to-visited request on roaming II-NNI AND Table 6.1.3.1/34 THEN do (NOTE)
19E	P-Charging-Function- Addresses	[24]	o	dn/a
19F	P-Charging-Vector	[24]	o	IF Table 6.1.3.1/38 THEN do (NOTE)
19H	P-Preferred-Identity	[44]	o	dn/a
19I	P-Preferred-Service	[26]	o	IF visited-to-home request on roaming II-NNI AND Table 6.1.3.1/77 AND request outside an existing dialog THEN do (NOTE)
19J	P-Private-Network-Indication	[84]	o	IF Table 6.1.3.1/80 AND request outside an existing dialog THEN do (NOTE)
19K	P-Profile-Key	[64]	o	IF Table 6.1.3.1/59 AND request outside an existing dialog THEN do (NOTE)
19L	P-Served-User	[85]	o	IF visited-to-home request on roaming II-NNI AND request outside an existing dialog being sent from "privileged sender" THEN dm (NOTE)
19M	P-User-Database	[60]	o	dn/a
19N	P-Visited-Network-ID	[24]	o	dn/a
19O	Privacy	[34]	o	IF dc2 (OIP/OIR: subclause 12.3) THEN dm ELSE do
20	Proxy-Authorization	[13]	o	IF Table 6.1.3.1/7 THEN do (NOTE)
21	Proxy-Require	[13]	o	do
21A	Reason	[48]	o	IF Table 6.1.3.1/40 AND request inside an



Item	Header field	Ref.	RFC status	II-NNI condition
				existing dialog THEN do (NOTE)
22	Record-Route	[13]	o	do
22A	Recv-Info	[39]	n/a	dn/a
22B	Referred-By	[53]	o	do
22C	Reject-Contact	[51]	o	do
22D	Request-Disposition	[51]	o	do
23	Require	[13]	c	dc
23A	Resource-Priority	[78]	o	IF Table 6.1.3.1/73 THEN do (NOTE)
24	Route	[13]	c	dc
24A	Security-Client	[47]	o	dn/a
24B	Security-Verify	[47]	o	dn/a
24C	Session-ID	[124]	m	IF Table 6.1.3.1/94 THEN dm (NOTE)
25	Supported	[13]	o	IF dc1 (PNM: subclause 12.17) THEN dm ELSE do
26	Timestamp	[13]	o	do
27	To	[13]	m	dm
28	User-Agent	[13]	o	do
29	Via	[13]	m	dm
dc1:	request outside an existing dialog invoked due to PNM in case of ("PN UE redirection" OR "PN access control") AND (non-roaming II-NNI OR home-to-visited request on roaming II-NNI)			
dc2:	(request outside an existing dialog invoked due to OIP/OIR AND "override the default setting" in temporary mode AND visited-to-home request on roaming II-NNI) OR (request outside an existing dialog invoked due to OIP/OIR AND "presentation of the public user identity is restricted" AND (non-roaming II-NNI OR home-to-visited request on roaming II-NNI))			
NOTE:	If the capability specified in Table 6.1.3.1 is not supported over the II-NNI, the IBCF in the receiving network can omit or modify the SIP header fields in the received SIP message prior to forwarding as specified in 3GPP TS 24.229 [5] subclause 5.10.6.2.			

Table B.10.2: Supported header fields within the OPTIONS response

Item	Header field	SIP status code	Ref.	RFC status	II-NNI condition
1	Accept	2xx	[13]	m*	dm*
		415		c	dc
2	Accept-Encoding	2xx	[13]	m*	dm*
		415		c	dc
3	Accept-Language	2xx	[13]	m*	dm*
		415		c	dc
4	Accept-Resource-Priority	2xx 417	[78]	o	IF Table 6.1.3.1/73 THEN do (NOTE 2)
5	Allow	2xx	[13]	m*	dm*
		405		m	dm
		others		o	do
6	Allow-Events	2xx	[20]	o	IF Table 6.1.3.1/23 THEN do (NOTE 2)
7	Authentication-Info	2xx	[13]	o	IF Table 6.1.3.1/7 THEN do (NOTE 2)
8	Call-ID	100 others	[13]	m	dm
9	Call-Info	r	[13]	o	do
10	Contact	2xx 3xx 485	[13]	o	do
11	Content-Disposition	r	[13]	o	do
12	Content-Encoding	r	[13]	o	do
13	Content-Language	r	[13]	o	do
14	Content-Length	100 others	[13]	t	dt
15	Content-Type	r	[13]	*	d*
16	Cseq	100 others	[13]	m	dm
17	Date	100 others	[13]	o	do
18	Error-Info	3xx-6xx	[13]	o	IF Table 6.1.3.1/13 THEN do (NOTE 2)
18A	Feature-Caps	2xx	[143]	o	IF Table 6.1.3.1/103 AND response to request outside an existing dialog THEN do (NOTE 2)
19	From	100 others	[13]	m	dm
20	Geolocation-Error	424	[68]	m	dm
		others		o	do
21	History-Info	r	[25]	o	IF Table 6.1.3.1/50 THEN do (NOTE 2)
22	MIME-version	r	[13]	o	do
23	Organization	r	[13]	o	do
24	P-Access-Network-Info	r	[24]	o	IF Table 6.1.3.1/36 THEN do (NOTE 2)
25	P-Asserted-Identity	r	[44]	o	IF dc1 (TIP/TIR: subclause 12.4) THEN dm ELSE IF Table 6.1.3.1/27 AND response to request outside an existing dialog THEN do (NOTE 2)
26	P-Charging-Function-Addresses	r	[24]	o	dn/a
27	P-Charging-Vector	r	[24]	o	IF Table 6.1.3.1/38 THEN do (NOTE 2)
29	P-Preferred-Identity	r	[44]	o	dn/a
30	Privacy	r	[34]	o	IF dc2 (TIP/TIR: subclause 12.4) THEN dm ELSE do
31	Proxy-Authenticate	401 (NOTE 1)	[13]	o	do
		407 (NOTE 1)		m	dm
32	Record-Route	2xx	[13]	o	do

Item	Header field	SIP status code	Ref.	RFC status	II-NNI condition
33	Recv-Info	2xx others	[39]	n/a	dn/a
34	Require	r	[13]	c	dc
35	Retry-After	404 413 480 486 500 503 600 603	[13]	o	do
36	Security-Server	421 494	[47]	o	dn/a
37	Server	r	[13]	o	do
38	Session-ID	r	[124]	m	IF Table 6.1.3.1/94 THEN dm (NOTE 2)
39	Supported	2xx	[13]	m*	dm*
40	Timestamp	r	[13]	o	do
41	To	100 others	[13]	m	dm
42	Unsupported	420	[13]	m	dm
43	User-Agent	r	[13]	o	do
44	Via	100 others	[13]	m	dm
45	Warning	r	[13]	o	do
46	WWW-Authenticate	401 (NOTE 1)	[13]	m	dm
		407 (NOTE 1)		o	do
dc1: (TIP/TIR AND 2xx response to request outside an existing dialog AND (visited-to-home response on roaming II-NNI OR non-roaming II-NNI)) OR (TIP/TIR AND response to request outside an existing dialog AND "presentation is allowed" AND home-to-visited response on roaming II-NNI)					
dc2: (TIP/TIR AND non-100 response to request outside an existing dialog AND "override the default setting" in temporary mode AND visited-to-home response on roaming II-NNI) OR (TIP/TIR AND 2xx response to request outside an existing dialog AND "presentation of the network asserted identity is restricted" AND (non-roaming II-NNI OR home-to-visited response on roaming II-NNI))					
NOTE 1: The SIP status code is only applicable over the roaming II-NNI.					
NOTE 2: If the capability specified in Table 6.1.3.1 is not supported over the II-NNI, the IBCF in the receiving network can omit or modify the SIP header fields in the received SIP message prior to forwarding as specified in 3GPP TS 24.229 [5] subclause 5.10.6.2.					

## B.11 PRACK method

**Table B.11.1: Supported header fields within the PRACK request**

Item	Header field	Ref.	RFC status	II-NNI condition
1	Accept	[13], [18]	o	do
1A	Accept-Contact	[51]	o	do
2	Accept-Encoding	[13], [18]	o	do
3	Accept-Language	[13], [18]	o	do
3A	Allow	[13], [18]	o	do
4	Allow-Events	[20]	o	IF Table 6.1.3.1/23 THEN do (NOTE)
5	Authorization	[13], [18]	o	IF Table 6.1.3.1/7 THEN do (NOTE)
6	Call-ID	[13], [18]	m	dm
7	Content-Disposition	[13], [18]	o	do
8	Content-Encoding	[13], [18]	o	do
9	Content-Language	[13], [18]	o	do
10	Content-Length	[13], [18]	t	dt
11	Content-Type	[13], [18]	*	d*
12	Cseq	[13], [18]	m	dm
13	Date	[13], [18]	o	do
14	From	[13], [18]	m	dm
14A	Max-Breadth	[79]	o	do
15	Max-Forwards	[13], [18]	m	dm
16	MIME-Version	[13], [18]	o	do
16A	P-Access-Network-Info	[24]	o	IF Table 6.1.3.1/36 THEN do (NOTE)
16B	P-Charging-Function-Addresses	[24]	o	dn/a
16C	P-Charging-Vector	[24]	o	dn/a
16E	P-Early-Media	[74]	o	IF dc1 (CAT: subclause 12.14) THEN dm ELSE IF Table 6.1.3.1/69 THEN do (NOTE)
16F	Privacy	[34]	o	do
17	Proxy-Authorization	[13], [18]	o	IF Table 6.1.3.1/7 THEN do (NOTE)
18	Proxy-Require	[13], [18]	o	do
19	RAck	[18]	m	dm
19A	Reason	[48]	o	IF Table 6.1.3.1/40 THEN do (NOTE)
20	Record-Route	[13], [18]	o	do
20A	Recv-Info	[39]	o	IF Table 6.1.3.1/17 THEN do (NOTE)
20B	Referred-By	[53]	o	do
20C	Reject-Contact	[51]	o	do
20D	Request-Disposition	[51]	o	do
21	Require	[13], [18]	c	dc
21A	Resource-Priority	[78]	o	IF Table 6.1.3.1/73 THEN do (NOTE)
22	Route	[13], [18]	c	dc
22A	Session-ID	[124]	m	IF Table 6.1.3.1/94 THEN dm (NOTE)
23	Supported	[13], [18]	o	do
24	Timestamp	[13], [18]	o	do
25	To	[13], [18]	m	dm
26	User-Agent	[13], [18]	o	do
27	Via	[13], [18]	m	dm
dc1:	request invoked due to CAT to first 18x response with P-Early-Media header field cancelling "CAT service" provided by terminating AS AND (non-roaming II-NNI OR home-to-visited request on roaming II-NNI)			
NOTE:	If the capability specified in Table 6.1.3.1 is not supported over the II-NNI, the IBCF in the receiving network can omit or modify the SIP header fields in the received SIP message prior to forwarding as specified in 3GPP TS 24.229 [5] subclause 5.10.6.2.			

Table B.11.2: Supported header fields within the PRACK response

Item	Header field	SIP status code	Ref.	RFC status	II-NNI condition
1	Accept	415	[13], [18]	c	dc
2	Accept-Encoding	415	[13], [18]	c	dc
3	Accept-Language	415	[13], [18]	c	dc
4	Accept-Resource-Priority	2xx 417	[78]	o	IF Table 6.1.3.1/73 THEN do (NOTE 2)
5	Allow	2xx	[13], [18]	o	do
		405		m	dm
		others		o	do
6	Allow-Events	2xx	[20]	o	IF Table 6.1.3.1/23 THEN do (NOTE 2)
7	Authentication-Info	2xx	[13], [18]	o	IF Table 6.1.3.1/7 THEN do (NOTE 2)
8	Call-ID	100 r	[13], [18]	m	dm
9	Contact	3xx 485	[13], [18]	o	do
10	Content-Disposition	r	[13], [18]	o	do
11	Content-Encoding	r	[13], [18]	o	do
12	Content-Language	r	[13], [18]	o	do
13	Content-Length	100 others	[13], [18]	t	dt
14	Content-Type	r	[13], [18]	*	d*
15	Cseq	100 others	[13], [18]	m	dm
16	Date	100 others	[13], [18]	o	do
17	Error-Info	3xx-6xx	[13], [18]	o	IF Table 6.1.3.1/13 THEN do (NOTE 2)
18	From	100 others	[13], [18]	m	dm
19	MIME-version	r	[13], [18]	o	do
20	P-Access-Network-Info	r	[24]	o	IF Table 6.1.3.1/36 THEN do (NOTE 2)
21	P-Charging-Function-Addresses	r	[24]	o	dn/a
22	P-Charging-Vector	r	[24]	o	dn/a
24	P-Early-Media	2xx	[74]	o	IF Table 6.1.3.1/69 THEN do (NOTE 2)
		others		n/a	dn/a
25	Privacy	r	[34]	o	do
26	Proxy-Authenticate	401 (NOTE 1)	[13], [18]	o	do
		407 (NOTE 1)		m	dm
27	Record-Route	2xx	[13], [18]	o	do
28	Recv-Info	2xx	[39]	c	IF Table 6.1.3.1/17 THEN dc (NOTE 2)
		others		o	IF Table 6.1.3.1/17 THEN do (NOTE 2)
29	Require	r	[13], [18]	c	dc
30	Retry-After	404 413 480 486 500 503 600 603	[13], [18]	o	do
31	Security-Server	421 494	[47]	n/a	dn/a
32	Server	r	[13], [18]	o	do
33	Session-ID	r	[124]	m	IF Table 6.1.3.1/94 THEN dm

Item	Header field	SIP status code	Ref.	RFC status	II-NNI condition
					(NOTE 2)
34	Supported	2xx	[13], [18]	o	do
35	Timestamp	r	[13], [18]	o	do
36	To	100 others	[13], [18]	m	dm
37	Unsupported	420	[13], [18]	m	dm
38	User-Agent	r	[13], [18]	o	do
39	Via	100 others	[13], [18]	m	dm
40	Warning	r	[13], [18]	o	do
41	WWW-Authenticate	401 (NOTE 1)	[13], [18]	m	dm
		407 (NOTE 1)		o	do
NOTE 1: The SIP status code is only applicable over the roaming II-NNI.					
NOTE 2: If the capability specified in Table 6.1.3.1 is not supported over the II-NNI, the IBCF in the receiving network can omit or modify the SIP header fields in the received SIP message prior to forwarding as specified in 3GPP TS 24.229 [5] subclause 5.10.6.2.					

## B.12 PUBLISH method

As described in Table 6.1, the support of PUBLISH method over the non-roaming II-NNI is based on bilateral agreement between the operators.

Table B.12.1: Supported header fields within the PUBLISH request

Item	Header field	Ref.	RFC status	II-NNI condition
1	Accept-Contact	[51]	o	IF dc1 (PNM: subclause 12.17) THEN dm ELSE do
2	Allow	[13], [21]	o	do
3	Allow-Events	[20]	o	IF Table 6.1.3.1/23 THEN do (NOTE)
4	Authorization	[13], [21]	o	IF Table 6.1.3.1/7 THEN do (NOTE)
5	Call-ID	[13], [21]	m	dm
6	Call-Info	[13], [21]	o	IF dc2 (CCBS/CCNR/CCNL: subclause 12.11/12.12/12.23) THEN dm ELSE do
6A	Contact	[13], [21]	n/a	dn/a
7	Content-Disposition	[13], [21]	o	do
8	Content-Encoding	[13], [21]	o	do
9	Content-Language	[13], [21]	o	do
10	Content-Length	[13], [21]	t	dt
11	Content-Type	[13], [21]	*	d*
12	Cseq	[13], [12]	m	dm
13	Date	[13], [21]	o	do
14	Event	[20]	m	dm
15	Expires	[13], [21]	o	IF dc2 (CCBS/CCNR/CCNL: subclause 12.11/12.12/12.23) THEN dm ELSE do
15A	Feature-Caps	[143]	o	IF Table 6.1.3.1/103 AND request outside an existing dialog THEN do
16	From	[13], [21]	m	dm
16A	Geolocation	[68]	o	do
16AA	Geolocation-Routing	[68]	o	do
16B	History-Info	[25]	o	IF dc1 (PNM: subclause 12.17) THEN dm ELSE IF Table 6.1.3.1/50 THEN do (NOTE)
17	In-Reply-To	[13], [21]	n/a	dn/a
17A	Max-Breadth	[79]	o	do
18	Max-Forwards	[13], [21]	m	dm
19	MIME-Version	[13], [21]	o	do
20	Organization	[13], [21]	o	do
21	P-Access-Network-Info	[24]	o	IF Table 6.1.3.1/36 THEN do (NOTE)
22	P-Asserted-Identity	[44]	o	IF dc2 (CCBS/CCNR/CCNL: subclause 12.11/12.12/12.23) OR Table 6.1.3.1/27 AND request outside an existing dialog THEN dm (NOTE)
22A	P-Asserted-Service	[26]	o	IF (non-roaming II-NNI OR home-to-visited request on roaming II-NNI) AND Table 6.1.3.1/77 AND request outside an existing dialog THEN do (NOTE)
23	P-Called-Party-ID	[24]	o	IF home-to-visited request on roaming II-NNI AND Table 6.1.3.1/34 THEN do (NOTE)
24	P-Charging-Function-Addresses	[24]	o	dn/a
25	P-Charging-Vector	[24]	o	IF Table 6.1.3.1/38 THEN do (NOTE)
26	P-Preferred-Identity	[44]	o	dn/a
26A	P-Preferred-Service	[26]	o	IF visited-to-home request on roaming II-NNI AND Table 6.1.3.1/77 AND request outside an existing dialog THEN do (NOTE)
26B	P-Private-Network-Indication	[84]	o	IF Table 6.1.3.1/80 AND request outside an existing dialog THEN do (NOTE)
26C	P-Profile-Key	[64]	o	IF Table 6.1.3.1/59 AND request outside an existing dialog THEN do (NOTE)
26D	P-Served-User	[85]	o	IF visited-to-home request on roaming II-NNI AND request outside an existing dialog being sent from "privileged sender" THEN dm (NOTE)
26E	P-User-Database	[60]	o	dn/a
27	P-Visited-Network-ID	[24]	o	dn/a
28	Priority	[13], [21]	o	do
29	Privacy	[34]	o	IF dc3 (OIP/OIR: subclause 12.3) THEN dm

Item	Header field	Ref.	RFC status	II-NNI condition
				ELSE do
30	Proxy-Authorization	[13], [21]	o	IF Table 6.1.3.1/7 THEN do (NOTE)
31	Proxy-Require	[13], [21]	o	do
32	Reason	[48]	o	IF Table 6.1.3.1/40 AND request inside an existing dialog THEN do (NOTE)
33	Reject-Contact	[39]	o	do
33A	Referred-By	[53]	o	do
34	Request-Disposition	[54]	o	do
35	Reply-To	[13], [21]	n/a	dn/a
36	Require	[13], [21]	o	do
36A	Resource-Priority	[78]	o	IF Table 6.1.3.1/73 THEN do (NOTE)
37	Route	[13], [21]	c	dc
38	Security-Client	[47]	o	dn/a
39	Security-Verify	[47]	o	dn/a
39A	Session-ID	[124]	m	IF Table 6.1.3.1/94 THEN dm (NOTE)
40	SIP-If-Match	[21]	o	do
41	Subject	[13], [21]	o	do
42	Supported	[13], [21]	o	IF dc1 (PNM: subclause 12.17) THEN dm ELSE do
43	Timestamp	[13], [21]	o	do
44	To	[13], [21]	m	dm
45	User-Agent	[13], [21]	o	do
46	Via	[13], [21]	m	dm
dc1:	request outside an existing dialog invoked due to PNM in case of ("PN UE redirection" OR "PN access control") AND (non-roaming II-NNI OR home-to-visited request on roaming II-NNI)			
dc2:	(request inside an existing dialog invoked due to CCBS/CCNR/CCNL suspending the "CC request" AND non-roaming II-NNI) OR (request inside an existing dialog invoked due to CCBS/CCNR/CCNL resuming the "CC request" AND non-roaming II-NNI)			
dc3:	(request outside an existing dialog invoked due to OIP/OIR AND "override the default setting" in temporary mode AND visited-to-home request on roaming II-NNI) OR (request outside an existing dialog invoked due to OIP/OIR AND "presentation of the public user identity is restricted" AND (non-roaming II-NNI OR home-to-visited request on roaming II-NNI))			
NOTE:	If the capability specified in Table 6.1.3.1 is not supported over the II-NNI, the IBCF in the receiving network can omit or modify the SIP header fields in the received SIP message prior to forwarding as specified in 3GPP TS 24.229 [5] subclause 5.10.6.2.			



Table B.12.2: Supported header fields within the PUBLISH response

Item	Header field	SIP status code	Ref.	RFC status	II-NNI condition
1	Accept	415	[13], [21]	m*	dm*
2	Accept-Encoding	415	[13], [21]	m*	dm*
3	Accept-Language	415	[13], [21]	m*	dm*
4	Accept-Resource-Priority	2xx 417	[78]	o	IF Table 6.1.3.1/73 THEN do (NOTE 2)
5	Allow	405	[13], [21]	m	dm
		r		o	do
6	Allow-Events	2xx	[20]	o	IF Table 6.1.3.1/23 THEN do (NOTE 2)
		489		m	dm
7	Authentication-Info	2xx	[13], [21]	o	IF Table 6.1.3.1/7 THEN do (NOTE 2)
8	Call-ID	100 others	[13], [21]	m	dm
9	Call-Info	r	[13], [21]	o	do
10	Contact	3xx 485	[13], [21]	o	do
11	Content-Disposition	r	[13], [21]	o	do
12	Content-Encoding	r	[13], [21]	o	do
13	Content-Language	r	[13], [21]	o	do
14	Content-Length	100 others	[13], [21]	t	dt
15	Content-Type	r	[13], [21]	*	d*
16	Cseq	100 others	[13], [21]	m	dm
17	Date	100 others	[13], [21]	o	do
18	Error-Info	3xx-6xx	[13], [21]	o	IF Table 6.1.3.1/13 THEN do (NOTE 2)
19	Expires	2xx	[13], [21]	m	dm
		r		o	do
19A	Feature-Caps	200	[143]	o	IF Table 6.1.3.1/103 AND response to request outside an existing dialog THEN do
20	From	100 others	[13], [21]	m	dm
21	Geolocation-Error	424	[68]	m	dm
		others		o	do
22	History-Info	r	[25]	o	IF Table 6.1.3.1/50 THEN do (NOTE 2)
23	MIME-version	r	[13], [21]	o	do
24	Min-Expires	423	[13], [21]	m	dm
25	Organization	r	[13], [21]	o	do
26	P-Access-Network-Info	r	[24]	o	IF Table 6.1.3.1/36 THEN do (NOTE 2)
27	P-Asserted-Identity	r	[44]	o	IF dc1 (TIP/TIR: subclause 12.4) THEN dm ELSE IF Table 6.1.3.1/27 AND response to request outside an existing dialog THEN do (NOTE 2)
28	P-Charging-Function-Addresses	r	[24]	o	dn/a
29	P-Charging-Vector	r	[24]	o	IF Table 6.1.3.1/38 THEN do (NOTE 2)
31	P-Preferred-Identity	r	[44]	o	dn/a
32	Privacy	r	[34]	o	IF dc2 (TIP/TIR: subclause 12.4) THEN dm ELSE do
33	Proxy-Authenticate	401 (NOTE 1)	[13], [21]	o	do
		407 (NOTE 1)		m	dm
34	Require	r	[13], [21]	o	do

Item	Header field	SIP status code	Ref.	RFC status	II-NNI condition
35	Retry-After	404 413 480 486 500 503 600 603	[13], [21]	o	do
36	Security-Server	421 494	[47]	o	dn/a
37	Server	r	[13], [21]	o	do
38	Session-ID	r	[124]	m	IF Table 6.1.3.1/94 THEN dm (NOTE 2)
39	SIP-Etag	2xx	[21]	m	dm
40	Supported	2xx	[13], [21]	o	do
41	Timestamp	r	[13], [21]	o	do
42	To	100 others	[13], [21]	m	dm
43	Unsupported	420	[13], [21]	o	do
44	User-Agent	r	[13], [21]	o	do
45	Via	100 others	[13], [21]	m	dm
46	Warning	r	[13], [21]	o	do
47	WWW-Authenticate	401 (NOTE 1)	[13], [21]	m	dm
		407 (NOTE 1)		o	do
dc1:	(TIP/TIR AND 2xx response to request outside an existing dialog AND (visited-to-home response on roaming II-NNI OR non-roaming II-NNI)) OR (TIP/TIR AND response to request outside an existing dialog AND "presentation is allowed" AND home-to-visited response on roaming II-NNI)				
dc2:	(TIP/TIR AND non-100 response to request outside an existing dialog AND "override the default setting" in temporary mode AND visited-to-home response on roaming II-NNI) OR (TIP/TIR AND 2xx response to request outside an existing dialog AND "presentation of the network asserted identity is restricted" AND (non-roaming II-NNI OR home-to-visited response on roaming II-NNI))				
NOTE 1:	The SIP status code is only applicable over the roaming II-NNI.				
NOTE 2:	If the capability specified in Table 6.1.3.1 is not supported over the II-NNI, the IBCF in the receiving network can omit or modify the SIP header fields in the received SIP message prior to forwarding as specified in 3GPP TS 24.229 [5] subclause 5.10.6.2.				

## B.13 REFER method

As described in Table 6.1, the support of REFER method over the II-NNI is based on bilateral agreement between the operators.

Table B.13.1: Supported header fields within the REFER request

Item	Header field	Ref.	RFC status	II-NNI condition
0A	Accept	[13], [22]	o	do
0B	Accept-Contact	[51]	o	IF dc1 (PNM: subclause 12.17) THEN dm ELSE do
0C	Accept-Encoding	[13], [22]	o	do
1	Accept-Language	[13], [22]	o	do
1A	Allow	[13], [22]	o	do
2	Allow-Events	[20]	o	IF Table 6.1.3.1/23 THEN do (NOTE)
3	Authorization	[13], [22]	o	IF Table 6.1.3.1/7 THEN do (NOTE)
4	Call-ID	[13], [22]	m	dm
5	Contact	[13], [22]	m	dm
5A	Content-Disposition	[13], [22]	o	do
5B	Content-Encoding	[13], [22]	o	do
5C	Content-Language	[13], [22]	o	do
6	Content-Length	[13], [22]	o	do
7	Content-Type	[13], [22]	*	d*
8	Cseq	[13], [22]	m	dm
9	Date	[13], [22]	o	do
10	Expires	[13], [22]	o	do
10A	Feature-Caps	[143]	o	IF Table 6.1.3.1/103 AND request outside an existing dialog THEN do (NOTE)
11	From	[13], [22]	m	dm
11A	Geolocation	[68]	o	do
11AA	Geolocation-Routing	[68]	o	do
11B	History-Info	[25]	o	IF dc1 (PNM: subclause 12.17) THEN dm ELSE IF Table 6.1.3.1/50 AND request outside an existing dialog THEN do (NOTE)
11C	Max-Breadth	[79]	o	do
12	Max-Forwards	[13], [22]	m	dm
13	MIME-Version	[13], [22]	o	do
14	Organization	[13], [22]	o	do
14A	P-Access-Network-Info	[24]	o	IF Table 6.1.3.1/36 THEN do (NOTE)
14B	P-Asserted-Identity	[44]	o	IF Table 6.1.3.1/27 AND request outside an existing dialog THEN dm (NOTE)
14C	P-Asserted-Service	[26]	o	IF (non-roaming II-NNI OR home-to-visited request on roaming II-NNI) AND Table 6.1.3.1/77 AND request outside an existing dialog THEN do (NOTE)
14D	P-Called-Party-ID	[24]	o	IF home-to-visited request on roaming II-NNI AND Table 6.1.3.1/34 THEN do (NOTE)
14E	P-Charging-Function-Addresses	[24]	o	dn/a
14F	P-Charging-Vector	[24]	o	IF Table 6.1.3.1/38 THEN do (NOTE)
14H	P-Preferred-Identity	[44]	o	dn/a
14I	P-Preferred-Service	[26]	o	IF visited-to-home request on roaming II-NNI AND Table 6.1.3.1/77 AND request outside an existing dialog THEN do (NOTE)
14J	P-Private-Network-Indication	[84]	o	IF Table 6.1.3.1/80 AND request outside an existing dialog THEN do (NOTE)
14K	P-Profile-Key	[64]	o	IF Table 6.1.3.1/59 AND request outside an existing dialog THEN do (NOTE)
14L	P-Served-User	[85]	o	IF visited-to-home request on roaming II-NNI AND request outside an existing dialog being sent from "privileged sender" THEN dm (NOTE)
14M	P-User-Database	[60]	o	dn/a
14N	P-Visited-Network-ID	[24]	o	dn/a
14O	Privacy	[34]	o	IF dc2 (OIP/OIR: subclause 12.3) OR dc3 (ECT: subclause 12.13) THEN dm ELSE do
15	Proxy-Authorization	[13], [22]	o	IF Table 6.1.3.1/7 THEN do (NOTE)
16	Proxy-Require	[13], [22]	o	do
16A	Reason	[48]	o	IF Table 6.1.3.1/40 AND request inside an existing dialog THEN do (NOTE)

Item	Header field	Ref.	RFC status	II-NNI condition
17	Record-Route	[13], [22]	o	do
17A	Refer-Sub	[135]	o	do
18	Refer-To	[22]	dm	dm
18A	Referred-By	[53]	o	IF dc4 (ECT: subclause 12.13) THEN dm ELSE do
18B	Reject-Contact	[51]	o	do
18C	Request-Disposition	[51]	o	do
19	Require	[13], [22]	c	dc
19A	Resource-Priority	[78]	o	IF Table 6.1.3.1/73 THEN do (NOTE)
20	Route	[13], [22]	c	dc
20A	Security-Client	[47]	o	dn/a
20B	Security-Verify	[47]	o	dn/a
20C	Session-ID	[124]	m	IF Table 6.1.3.1/94 THEN dm (NOTE)
21	Supported	[13], [22]	o	IF dc1 (PNM: subclause 12.17) THEN dm ELSE do
21A	Target-Dialog	[140]	o	IF Table 6.1.3.1/102 THEN do (NOTE)
22	Timestamp	[13], [22]	o	do
23	To	[13], [22]	m	dm
23A	Trigger-Consent	[82]	o	IF Table 6.1.3.1/78 THEN do (NOTE)
24	User-Agent	[13], [22]	o	do
25	Via	[13], [22]	m	dm
dc1:	request outside an existing dialog invoked due to PNM in case of ("PN UE redirection" OR "PN access control") AND (non-roaming II-NNI OR home-to-visited request on roaming II-NNI)			
dc2:	(request outside an existing dialog invoked due to OIP/OIR AND "override the default setting" in temporary mode AND visited-to-home request on roaming II-NNI) OR (request outside an existing dialog invoked due to OIP/OIR AND "presentation of the public user identity is restricted" AND (non-roaming II-NNI OR home-to-visited request on roaming II-NNI))			
dc3:	request inside an existing dialog invoked due to ECT including Referred-By header field with privacy requested in the "original communication"			
dc4:	request inside an existing dialog invoked due to ECT AND (non-roaming II-NNI OR home-to-visited request on roaming II-NNI)			
NOTE:	If the capability specified in Table 6.1.3.1 is not supported over the II-NNI, the IBCF in the receiving network can omit or modify the SIP header fields in the received SIP message prior to forwarding as specified in 3GPP TS 24.229 [5] subclause 5.10.6.2.			

Table B.13.2: Supported header fields within the REFER response

Item	Header field	SIP status code	Ref.	RFC status	II-NNI condition
1	Accept	415	[13], [22]	c	dc
2	Accept-Encoding	415	[13], [22]	c	dc
3	Accept-Language	415	[13], [22]	c	dc
4	Accept-Resource-Priority	2xx 417	[78]	o	IF Table 6.1.3.1/73 THEN do (NOTE 2)
5	Allow	405	[13], [22]	m	dm
		others		o	do
6	Allow-Events	2xx	[20]	o	IF Table 6.1.3.1/23 THEN do (NOTE 2)
7	Authentication-Info	2xx	[13], [22]	o	IF Table 6.1.3.1/7 THEN do (NOTE 2)
8	Call-ID	100 others	[13], [22]	m	dm
9	Contact	1xx	[13], [22]	n/a	dn/a
		2xx		m	dm
		3xx-6xx		o	do
10	Content-Disposition	r	[13], [22]	o	do
11	Content-Encoding	r	[13], [22]	o	do
12	Content-Language	r	[13], [22]	o	do
13	Content-Length	100 others	[13], [22]	t	dt
14	Content-Type	r	[13], [22]	*	d*
15	Cseq	100 others	[13], [22]	m	dm
16	Date	100 others	[13], [22]	o	do
17	Error-Info	3xx-6xx	[13], [22]	o	IF Table 6.1.3.1/13 THEN do (NOTE 2)
17A	Feature-Caps	2xx	[143]	o	IF Table 6.1.3.1/103 AND response to request outside an existing dialog THEN do (NOTE 2)
18	From	100 others	[13], [22]	m	dm
19	Geolocation-Error	424	[68]	m	dm
		others		o	do
20	History-Info	r	[25]	o	IF Table 6.1.3.1/50 THEN do (NOTE 2)
21	MIME-version	r	[13], [22]	o	do
22	Organization	r	[13], [22]	o	do
23	P-Access-Network-Info	r	[24]	o	IF Table 6.1.3.1/36 THEN do (NOTE 2)
24	P-Asserted-Identity	r	[44]	o	IF dc1 (TIP/TIR: subclause 12.4) THEN dm ELSE IF Table 6.1.3.1/27 AND response to request outside an existing dialog THEN do (NOTE 2)
25	P-Charging-Function-Addresses	r	[24]	o	dn/a
26	P-Charging-Vector	r	[24]	o	IF dc2 (CONF: subclause 12.19) THEN dm ELSE IF Table 6.1.3.1/38 THEN do (NOTE 2)
28	P-Preferred-Identity	r	[44]	o	dn/a
29	Permission-Missing	470	[82]	o	IF Table 6.1.3.1/78 THEN do (NOTE 2)
30	Privacy	r	[34]	o	IF dc3 (TIP/TIR: subclause 12.4) THEN dm ELSE do
31	Proxy-Authenticate	401 (NOTE 1)	[13], [22]	o	do
		407 (NOTE 1)		m	dm
32	Record-Route	2xx	[13], [22]	o	do
33	Refer-Sub	2xx	[135]	o	IF Table 6.1.3.1/83 THEN do (NOTE 2)

Item	Header field	SIP status code	Ref.	RFC status	II-NNI condition
34	Require	r	[13], [22]	c	dc
35	Retry-After	404 413 480 486 500 503 600 603	[13], [22]	o	do
36	Security-Server	421 494	[47]	o	dn/a
37	Server	r	[13], [22]	o	do
38	Session-ID	r	[124]	m	IF Table 6.1.3.1/94 THEN dm (NOTE 2)
39	Supported	2xx	[13], [22]	o	do
40	Timestamp	r	[13], [22]	o	do
41	To	100 others	[13], [22]	m	dm
42	Unsupported	420	[13], [22]	o	do
43	User-Agent	r	[13], [22]	o	do
44	Via	100 others	[13], [22]	m	dm
45	Warning	r	[13], [22]	o	do
46	WWW-Authenticate	401 (NOTE 1)	[13], [22]	m	dm
		407 (NOTE 1)		o	do
dc1:	(TIP/TIR AND 2xx response to request outside an existing dialog AND (visited-to-home response on roaming II-NNI OR non-roaming II-NNI)) OR (TIP/TIR AND response to request outside an existing dialog AND "presentation is allowed" AND home-to-visited response on roaming II-NNI)				
dc2:	first response from "conference focus" to request outside an existing dialog AND (non-roaming II-NNI OR home-to-visited response on roaming II-NNI)				
dc3:	(TIP/TIR AND non-100 response to request outside an existing dialog AND "override the default setting" in temporary mode AND visited-to-home response on roaming II-NNI) OR (TIP/TIR AND 2xx response to request outside an existing dialog AND "presentation of the network asserted identity is restricted" AND (non-roaming II-NNI OR home-to-visited response on roaming II-NNI))				
NOTE 1:	The SIP status code is only applicable over the roaming II-NNI.				
NOTE 2:	If the capability specified in Table 6.1.3.1 is not supported over the II-NNI, the IBCF in the receiving network can omit or modify the SIP header fields in the received SIP message prior to forwarding as specified in 3GPP TS 24.229 [5] subclause 5.10.6.2.				

## B.14 REGISTER method

As described in Table 6.1, the REGISTER method is supported only over the roaming II-NNI.

Table B.14.1: Supported header fields within the REGISTER request

Item	Header field	Ref.	RFC status	II-NNI condition
1	Accept	[13]	o	do
2	Accept-Encoding	[13]	o	do
3	Accept-Language	[13]	o	do
3A	Allow	[13]	o	do
4	Allow-Events	[20]	o	IF Table 6.1.3.1/23 THEN do (NOTE)
5	Authorization	[13]	o	IF using IMS AKA OR using SIP digest THEN dm ELSE do
6	Call-ID	[13]	m	dm
7	Call-Info	[13]	o	do
8	Contact	[13]	o	dm
9	Content-Disposition	[13]	o	do
10	Content-Encoding	[13]	o	do
11	Content-Language	[13]	o	do
12	Content-Length	[13]	t	dt
13	Content-Type	[13]	*	d*
14	Cseq	[13]	m	dm
15	Date	[13]	o	do
16	Expires	[13]	o	do
16A	Feature-Caps	[143]	o	IF Table 6.1.3.1/103 THEN do (NOTE)
17	From	[13]	m	dm
17A	Geolocation	[68]	o	do
17AA	Geolocation-Routing	[68]	o	do
17B	History-Info	[25]	o	IF Table 6.1.3.1/50 THEN do (NOTE)
17C	Max-Breadth	[79]	o	do
18	Max-Forwards	[13]	m	dm
19	MIME-Version	[13]	o	do
20	Organization	[13]	o	do
20A	P-Access-Network-Info	[24]	o	IF Table 6.1.3.1/36 THEN do (NOTE)
20B	P-Charging-Function-Addresses	[24]	o	dn/a
20C	P-Charging-Vector	[24]	o	dm
20E	P-User-Database	[60]	o	dn/a
20F	P-Visited-Network-ID	[24]	o	dm
20G	Path	[43]	o	dm
20H	Privacy	[34]	o	dn/a
21	Proxy-Authorization	[13]	o	do
22	Proxy-Require	[13]	o	do
22A	Reason	[48]	o	IF Table 6.1.3.1/40 THEN do (NOTE)
22B	Recv-Info	[39]	o	IF Table 6.1.3.1/17 THEN do (NOTE)
22C	Referred-By	[53]	o	do
22D	Request-Disposition	[51]	o	do
23	Require	[13]	c	dm
23A	Resource-Priority	[78]	o	IF Table 6.1.3.1/73 THEN do (NOTE)
24	Route	[13]	c	dc
24A	Security-Client	[47]	o	dn/a
24B	Security-Verify	[47]	o	dn/a
24C	Session-ID	[124]	m	IF Table 6.1.3.1/94 THEN dm (NOTE)
25	Supported	[13]	o	dm
26	Timestamp	[13]	o	do
27	To	[13]	m	dm
28	User-Agent	[13]	o	do
29	Via	[13]	m	dm
NOTE:	If the capability specified in Table 6.1.3.1 is not supported over the II-NNI, the IBCF in the receiving network can omit or modify the SIP header fields in the received SIP message prior to forwarding as specified in 3GPP TS 24.229 [5] subclause 5.10.6.2.			

Table B.14.2: Supported header fields within the REGISTER response

Item	Header field	SIP status code	Ref.	RFC status	II-NNI condition
1	Accept	2xx	[13]	o	do
		415		c	dc
2	Accept-Encoding	2xx	[13]	o	do
		415		c	dc
3	Accept-Language	2xx	[13]	o	do
		415		c	dc
4	Accept-Resource-Priority	2xx 417	[78]	o	IF Table 6.1.3.1/73 THEN do (NOTE)
5	Allow	2xx	[13]	o	do
		405		m	dm
		others		o	do
6	Allow-Events	2xx	[20]	o	IF Table 6.1.3.1/23 THEN do (NOTE)
7	Authentication-Info	2xx	[13]	o	do
8	Call-ID	100	[13]	m	dm
		others			
9	Call-Info	r	[13]	o	do
10	Contact	2xx	[13]	o	dm
		3xx		o	do
		485			
11	Content-Disposition	r	[13]	o	do
12	Content-Encoding	r	[13]	o	do
13	Content-Language	r	[13]	o	do
14	Content-Length	100	[13]	t	dt
		others			
15	Content-Type	r	[13]	*	d*
16	Cseq	100	[13]	m	dm
		others			
17	Date	100 others	[13]	o	do
18	Error-Info	3xx-6xx	[13]	o	IF Table 6.1.3.1/13 THEN do (NOTE)
18A	Feature-Caps	2xx	[143]	o	IF Table 6.1.3.1/103 THEN do (NOTE)
19	Flow-Timer	2xx	[65]	o	do
20	From	100	[13]	m	dm
		others			
21	Geolocation-Error	424	[68]	m	dm
		others		o	do
22	History-Info	r	[25]	o	IF Table 6.1.3.1/50 THEN do (NOTE)
23	MIME-version	r	[13]	o	do
24	Min-Expires	423	[13]	m	dm
25	Organization	r	[13]	o	do
26	P-Access-Network-Info	r	[24]	o	IF Table 6.1.3.1/36 THEN do (NOTE)
27	P-Associated-URI	2xx	[24]	o	dm
28	P-Charging-Function-Addresses	r	[24]	o	dn/a
29	P-Charging-Vector	r	[24]	o	dm
31	Path	2xx	[43]	o	dm
32	Privacy	r	[34]	o	do
33	Proxy-Authenticate	401	[13]	o	do
		407		m	dm
34	Require	r	[13]	c	dc
35	Retry-After	404	[13]	o	do
		413			
		480			
		486			
		500			
		503			
		600			
603					
36	Security-Server	2xx	[47]	n/a	dn/a
		401			



Item	Header field	SIP status code	Ref.	RFC status	II-NNI condition
		421 494		o	dn/a
37	Server	r	[13]	o	do
38	Service-Route	2xx	[45]	o	dm
39	Session-ID	r	[124]	m	IF Table 6.1.3.1/94 THEN dm (NOTE)
40	Supported	2xx	[13]	o	do
41	Timestamp	r	[13]	o	do
42	To	100 others	[13]	m	dm
43	Unsupported	420	[13]	m	dm
44	User-Agent	r	[13]	o	do
45	Via	100 others	[13]	m	dm
46	Warning	r	[13]	o	do
47	WWW-Authenticate	401	[13]	m	dm
		407		o	do
NOTE: If the capability specified in Table 6.1.3.1 is not supported over the II-NNI, the IBCF in the receiving network can omit or modify the SIP header fields in the received SIP message prior to forwarding as specified in 3GPP TS 24.229 [5] subclause 5.10.6.2.					

## B.15 SUBSCRIBE method

As described in Table 6.1, the support of SUBSCRIBE method over the non-roaming II-NNI is based on bilateral agreement between the operators.

Table B.15.1: Supported header fields within the SUBSCRIBE request

Item	Header field	Ref.	RFC status	II-NNI condition
1	Accept	[13], [20]	o	do
1A	Accept-Contact	[51]	o	IF dc1 (PNM: subclause 12.17) THEN dm ELSE do
2	Accept-Encoding	[13], [20]	o	do
3	Accept-Language	[13], [20]	o	do
3A	Allow	[13], [20]	o	do
4	Allow-Events	[20]	o	do
5	Authorization	[13], [20]	o	IF Table 6.1.3.1/7 THEN do (NOTE)
6	Call-ID	[13], [20]	m	dm
6A	Call-Info	[13], [20]	o	IF dc2 (CCBS/CCNR/CCNL: subclause 12.11/12.12/12.23) THEN dm ELSE dn/a
6B	Contact	[13], [20]	m	dm
7	Content-Disposition	[13], [20]	o	do
8	Content-Encoding	[13], [20]	o	do
9	Content-Language	[13], [20]	o	do
10	Content-Length	[13], [20]	t	dt
11	Content-Type	[13], [20]	*	d*
12	Cseq	[13], [20]	m	dm
13	Date	[13], [20]	o	do
14	Event	[20]	m	dm
15	Expires	[13], [20]	o	IF dc2 (CCBS/CCNR/CCNL: subclause 12.11/12.12/12.23) OR using reg event package THEN dm ELSE do
15A	Feature-Caps	[143]	o	IF Table 6.1.3.1/103 THEN do (NOTE)
16	From	[13], [20]	m	dm
16A	Geolocation	[68]	o	do
16AA	Geolocation-Routing	[68]	o	do
16B	History-Info	[25]	o	IF dc1 (PNM: subclause 12.17) THEN dm ELSE IF Table 6.1.3.1/50 AND initial request THEN do (NOTE)
16C	Max-Breadth	[79]	o	dn/a
17	Max-Forwards	[13], [20]	m	dm
18	MIME-Version	[13], [20]	o	do
18A	Organization	[13], [20]	o	do
18B	P-Access-Network-Info	[24]	o	IF Table 6.1.3.1/36 THEN do (NOTE)
18C	P-Asserted-Identity	[44]	o	IF dc2 (CCBS/CCNR/CCNL: subclause 12.11/12.12/12.23) OR Table 6.1.3.1/27 AND initial request THEN dm (NOTE)
18D	P-Asserted-Service	[26]	o	IF (non-roaming II-NNI OR home-to-visited request on roaming II-NNI) AND Table 6.1.3.1/77 AND initial request THEN do (NOTE)
18E	P-Called-Party-ID	[24]	o	IF home-to-visited request on roaming II-NNI AND Table 6.1.3.1/34 THEN do (NOTE)
18F	P-Charging-Function-Addresses	[24]	o	dn/a
18G	P-Charging-Vector	[24]	o	IF Table 6.1.3.1/38 THEN do (NOTE)
18I	P-Preferred-Identity	[44]	o	dn/a
18J	P-Preferred-Service	[26]	o	IF visited-to-home request on roaming II-NNI AND Table 6.1.3.1/77 AND initial request THEN do (NOTE)
18K	P-Private-Network-Indication	[84]	o	IF Table 6.1.3.1/80 AND initial request THEN do (NOTE)
18L	P-Profile-Key	[64]	o	IF Table 6.1.3.1/59 AND initial request THEN do (NOTE)
18M	P-Served-User	[85]	o	IF visited-to-home request on roaming II-NNI AND initial request being sent from "privileged sender" THEN dm (NOTE)
18N	P-User-Database	[60]	o	dn/a
18O	P-Visited-Network-ID	[24]	o	dn/a
18P	Privacy	[34]	o	IF dc3 (OIP/OIR: subclause 12.3) THEN dm

Item	Header field	Ref.	RFC status	II-NNI condition
				ELSE do
19	Proxy-Authorization	[13], [20]	o	IF Table 6.1.3.1/7 THEN do (NOTE)
20	Proxy-Require	[13], [20]	o	do
20A	Reason	[48]	o	IF Table 6.1.3.1/40 AND subsequent request THEN do (NOTE)
21	Record-Route	[13], [20]	o	do
21A	Referred-By	[53]	o	do
21B	Reject-Contact	[51]	o	do
21C	Request-Disposition	[51]	o	do
22	Require	[13], [20]	o	do
22A	Resource-Priority	[78]	o	IF Table 6.1.3.1/73 THEN do (NOTE)
23	Route	[13], [20]	c	dc
23A	Security-Client	[47]	o	dn/a
23B	Security-Verify	[47]	o	dn/a
23E	Session-ID	[124]	m	IF Table 6.1.3.1/94 THEN dm (NOTE)
24	Supported	[13], [20]	o	IF dc1 (PNM: subclause 12.17) THEN dm ELSE do
24A	Target-Dialog	[140]	o	IF Table 6.1.3.1/102 THEN do (NOTE)
25	Timestamp	[13], [20]	o	do
26	To	[13], [20]	m	dm
26A	Trigger-Consent	[82]	o	IF Table 6.1.3.1/78 THEN do (NOTE)
27	User-Agent	[13], [20]	o	do
28	Via	[13], [20]	m	dm
dc1:	initial request invoked due to PNM in case of ("PN UE redirection" OR "PN access control") AND (non-roaming II-NNI OR home-to-visited request on roaming II-NNI)			
dc2:	("CC invocation request" due to CCBS/CCNR/CCNL AND non-roaming II-NNI) OR ("CC revocation request" due to CCBS/CCNR/CCNL AND non-roaming II-NNI)			
dc3:	(initial request invoked due to OIP/OIR AND "override the default setting" in temporary mode AND visited-to-home request on roaming II-NNI) OR (initial request invoked due to OIP/OIR AND "presentation of the public user identity is restricted" AND (non-roaming II-NNI OR home-to-visited request on roaming II-NNI))			
NOTE:	If the capability specified in Table 6.1.3.1 is not supported over the II-NNI, the IBCF in the receiving network can omit or modify the SIP header fields in the received SIP message prior to forwarding as specified in 3GPP TS 24.229 [5] subclause 5.10.6.2.			

Table B.15.2: Supported header fields within the SUBSCRIBE response

Item	Header field	SIP status code	Ref.	RFC status	II-NNI condition
1	Accept	415	[13], [20]	o	do
2	Accept-Encoding	415	[13], [20]	o	do
3	Accept-Language	415	[13], [20]	o	do
4	Accept-Resource-Priority	2xx 417	[78]	o	IF Table 6.1.3.1/73 THEN do (NOTE 2)
5	Allow	405	[13], [20]	m	dm
		others		o	do
6	Allow-Events	2xx	[20]	o	do
		489		m	dm
7	Authentication-Info	2xx	[13], [20]	o	IF Table 6.1.3.1/7 THEN do (NOTE 2)
8	Call-ID	100 r	[13], [20]	m	dm
8A	Call-Info	r	[13], [20]	o	do
9	Contact	2xx	[13], [20]	m	dm
		3xx			
		485		o	do
10	Content-Disposition	r	[13], [20]	o	do
11	Content-Encoding	r	[13], [20]	o	do
12	Content-Language	r	[13], [20]	o	do
13	Content-Length	100 others	[13], [20]	t	dt
14	Content-Type	r	[13], [20]	*	d*
15	Cseq	100 others	[13], [20]	m	dm
16	Date	100 others	[13], [20]	o	do
17	Error-Info	3xx-6xx	[13], [20]	o	IF Table 6.1.3.1/13 THEN do (NOTE 2)
18	Expires	2xx	[13], [20]	m	dm
18A	Feature-Caps	2xx	[143]	o	IF Table 6.1.3.1/103 THEN do (NOTE 2)
19	From	100 others	[13], [20]	m	dm
20	Geolocation-Error	424	[68]	m	dm
		others		o	do
21	History-Info	r	[25]	o	IF Table 6.1.3.1/50 THEN do (NOTE 2)
22	MIME-version	r	[13], [20]	o	do
23	Min-Expires	423	[13], [20]	m	dm
24	Organization	r	[13], [20]	o	do
25	P-Access-Network-Info	r	[24]	o	IF Table 6.1.3.1/36 THEN do (NOTE 2)
26	P-Asserted-Identity	r	[44]	o	IF dc1 (TIP/TIR: subclause 12.4) THEN dm ELSE IF Table 6.1.3.1/27 AND response to initial request THEN do (NOTE 2)
27	P-Charging-Function-Addresses	r	[24]	o	dn/a
28	P-Charging-Vector	r	[24]	o	IF Table 6.1.3.1/38 THEN do (NOTE 2)
30	P-Preferred-Identity	r	[44]	o	dn/a
31	Permission-Missing	470	[82]	o	IF Table 6.1.3.1/78 THEN do (NOTE 2)
32	Privacy	r	[34]	o	IF dc2 (TIP/TIR: subclause 12.4) THEN dm ELSE do
33	Proxy-Authenticate	401 (NOTE 1)	[13], [20]	o	do
		407 (NOTE 1)		m	dm
34	Record-Route	2xx	[13], [20]	o	do
35	Require	r	[13], [20]	o	do

Item	Header field	SIP status code	Ref.	RFC status	II-NNI condition
36	Retry-After	404 413 480 486 500 503 600 603	[13], [20]	o	do
37	Security-Server	421 494	[47]	o	dn/a
38	Server	415 others	[13], [20]	o	do
39	Session-ID	r	[124]	m	IF Table 6.1.3.1/94 THEN dm (NOTE 2)
40	Supported	2xx	[13], [20]	o	do
41	Timestamp	r	[13], [20]	o	do
42	To	100 others	[13], [20]	m	dm
43	Unsupported	420	[13], [20]	o	do
44	User-Agent	r	[13], [20]	o	do
45	Via	100 others	[13], [20]	m	dm
46	Warning	r	[13], [20]	o	do
47	WWW-Authenticate	401 (NOTE 1)	[13], [20]	m	dm
		407 (NOTE 1)		o	do
dc1:	(TIP/TIR AND 2xx response to initial request AND (visited-to-home response on roaming II-NNI OR non-roaming II-NNI)) OR (TIP/TIR AND response to initial request AND "presentation is allowed" AND home-to-visited response on roaming II-NNI)				
dc2:	(TIP/TIR AND non-100 response to initial request AND "override the default setting" in temporary mode AND visited-to-home response on roaming II-NNI) OR (TIP/TIR AND 2xx response to initial request AND "presentation of the network asserted identity is restricted" AND (non-roaming II-NNI OR home-to-visited response on roaming II-NNI))				
NOTE 1: The SIP status code is only applicable over the roaming II-NNI.					
NOTE 2: If the capability specified in Table 6.1.3.1 is not supported over the II-NNI, the IBCF in the receiving network can omit or modify the SIP header fields in the received SIP message prior to forwarding as specified in 3GPP TS 24.229 [5] subclause 5.10.6.2.					

## B.16 UPDATE method

**Table B.16.1: Supported header fields within the UPDATE request**

Item	Header field	Ref.	RFC status	II-NNI condition
1	Accept	[13], [23]	o	do
1A	Accept-Contact	[51]	o	do
2	Accept-Encoding	[13], [23]	o	do
3	Accept-Language	[13], [23]	o	do
4	Allow	[13], [23]	o	do
5	Allow-Events	[20]	n/a	dn/a
6	Authorization	[13], [23]	o	IF Table 6.1.3.1/7 THEN do (NOTE)
7	Call-ID	[13], [23]	m	dm
8	Call-Info	[13], [23]	o	do
9	Contact	[13], [23]	m	dm
10	Content-Disposition	[13], [23]	o	do
11	Content-Encoding	[13], [23]	o	do
12	Content-Language	[13], [23]	o	do
13	Content-Length	[13], [23]	t	dt
14	Content-Type	[13], [23]	*	d*
15	Cseq	[13], [23]	m	dm
16	Date	[13], [23]	o	do
16A	Feature-Caps	[143]	o	IF Table 6.1.3.1/103 THEN do (NOTE)
17	From	[13], [23]	m	dm
17A	Geolocation	[68]	o	do
17AA	Geolocation-Routing	[68]	o	do
17B	Max-Breadth	[79]	o	dn/a
18	Max-Forwards	[13], [23]	m	dm
19	MIME-Version	[13], [23]	o	do
19A	Min-SE	[52]	o	do
20	Organization	[13], [23]	o	do
20A	P-Access-Network-Info	[24]	o	IF Table 6.1.3.1/36 THEN do (NOTE)
20B	P-Charging-Function-Addresses	[24]	o	dn/a
20C	P-Charging-Vector	[24]	o	IF Table 6.1.3.1/38 THEN do (NOTE)
20E	P-Early-Media	[74]	o	IF Table 6.1.3.1/69 THEN do (NOTE)
20F	Privacy	[34]	o	do
21	Proxy-Authorization	[13], [23]	o	IF Table 6.1.3.1/7 THEN do (NOTE)
22	Proxy-Require	[13], [23]	o	do
22A	Reason	[48]	o	IF Table 6.1.3.1/40 THEN do (NOTE)
23	Record-Route	[13], [23]	o	do
23A	Recv-Info	[39]	o	IF Table 6.1.3.1/17 THEN do (NOTE)
23B	Referred-By	[53]	o	do
23C	Reject-Contact	[51]	o	do
23D	Request-Disposition	[51]	o	do
24	Require	[13], [23]	c	dc
24A	Resource-Priority	[78]	o	IF Table 6.1.3.1/73 THEN do (NOTE)
25	Route	[13], [23]	c	dc
25A	Security-Client	[47]	o	dn/a
25B	Security-Verify	[47]	o	dn/a
25C	Session-Expires	[52]	o	do
25D	Session-ID	[124]	m	IF Table 6.1.3.1/94 THEN dm (NOTE)
26	Supported	[13], [23]	o	do
27	Timestamp	[13], [23]	o	do
28	To	[13], [23]	m	dm
29	User-Agent	[13], [23]	o	do
30	Via	[13], [23]	m	dm
NOTE:	If the capability specified in Table 6.1.3.1 is not supported over the II-NNI, the IBCF in the receiving network can omit or modify the SIP header fields in the received SIP message prior to forwarding as specified in 3GPP TS 24.229 [5] subclause 5.10.6.2.			

Table B.16.2: Supported header fields within the UPDATE response

Item	Header field	SIP status code	Ref.	RFC status	II-NNI condition
1	Accept	2xx	[13], [23]	o	do
		415		c	dc
2	Accept-Encoding	2xx	[13], [23]	o	do
		415		c	dc
3	Accept-Language	2xx	[13], [23]	o	do
		415		c	dc
4	Accept-Resource-Priority	2xx 417	[78]	o	IF Table 6.1.3.1/73 THEN do (NOTE 2)
5	Allow	2xx	[13], [23]	o	do
		405		m	dm
		others		o	do
6	Allow-Events	2xx	[20]	n/a	dn/a
7	Authentication-Info	2xx	[13], [23]	o	IF Table 6.1.3.1/7 THEN do (NOTE 2)
8	Call-ID	100 others	[13], [23]	m	dm
9	Call-Info	r	[13], [23]	o	do
10	Contact	2xx	[13], [23]	m	dm
		3xx		o	do
		485			
		others		o	do
11	Content-Disposition	r	[13], [23]	o	do
12	Content-Encoding	r	[13], [23]	o	do
13	Content-Language	r	[13], [23]	o	do
14	Content-Length	100 others	[13], [23]	t	dt
15	Content-Type	r	[13], [23]	*	d*
16	Cseq	100	[13], [23]	m	dm
		others			
17	Date	100 others	[13], [23]	o	do
18	Error-Info	3xx-6xx	[13], [23]	o	IF Table 6.1.3.1/13 THEN do (NOTE 2)
18A	Feature-Caps	2xx	[143]	o	IF Table 6.1.3.1/103 THEN do (NOTE 2)
19	From	100	[13], [23]	m	dm
		others			
20	Geolocation-Error	424	[68]	m	dm
		others		o	do
21	MIME-version	r	[13], [23]	o	do
22	Min-SE	422	[52]	m	dm
23	Organization	r	[13], [23]	o	do
24	P-Access-Network-Info	r	[24]	o	IF Table 6.1.3.1/36 THEN do (NOTE 2)
25	P-Charging-Function-Addresses	r	[24]	o	dn/a
26	P-Charging-Vector	r	[24]	o	IF Table 6.1.3.1/38 THEN do (NOTE 2)
28	P-Early-Media	2xx	[74]	o	IF Table 6.1.3.1/69 THEN do (NOTE 2)
29	Privacy	r	[34]	o	do
30	Proxy-Authenticate	401 (NOTE 1)	[13], [23]	o	do
		407 (NOTE 1)		m	dm
31	Recv-Info	2xx	[39]	c	IF Table 6.1.3.1/17 THEN dc (NOTE 2)
		others		o	IF Table 6.1.3.1/17 THEN do (NOTE 2)
32	Require	r	[13], [23]	c	dc

Item	Header field	SIP status code	Ref.	RFC status	II-NNI condition
33	Retry-After	404 413 480 486 500 503 600 603	[13], [23]	o	do
34	Security-Server	421 494	[47]	o	dn/a
35	Server	r	[13], [23]	o	do
36	Session-Expires	2xx	[52]	o	do
37	Session-ID	r	[124]	m	IF Table 6.1.3.1/94 THEN dm (NOTE 2)
38	Supported	2xx	[13], [23]	o	do
39	Timestamp	r	[13], [23]	o	do
40	To	100 others	[13], [23]	m	dm
41	Unsupported	420	[13], [23]	m	dm
42	User-Agent	r	[13], [23]	o	do
43	Via	100 others	[13], [23]	m	dm
44	Warning	r	[13], [23]	o	do
45	WWW-Authenticate	401 (NOTE 1)	[13], [23]	m	dm
		407 (NOTE 1)		o	do
NOTE 1: The SIP status code is only applicable over the roaming II-NNI.					
NOTE 2: If the capability specified in Table 6.1.3.1 is not supported over the II-NNI, the IBCF in the receiving network can omit or modify the SIP header fields in the received SIP message prior to forwarding as specified in 3GPP TS 24.229 [5] subclause 5.10.6.2.					



## Annex C: Change history

Change history							
Date	TSG #	TSG Doc.	CR	Rev	Subject/Comment	Old	New
4/05/2008					TS Skeleton (C3-080779)	-	0.0.0
07/07/2008					Added agreed text of C3-080991, C3-081158 and C3-081208	0.0.0	0.1.0
28/08/2008					Added agreed text of C3-081282 and C3-081672	0.1.0	0.2.0
01/09/2008					Version 1.0.0 created for presentation to TSG by MCC	0.2.0	1.0.0
17/10/2008					Added agreed text of C3-081721 and C3-082105	1.0.0	1.1.0
20/11/2008					Added agreed text of C3-082303, C3-082446, C3-082447 and C3-082611	1.0.0	1.2.0
26/11/2008					v 2.0.0 was produced by MCC for Approval in CT#42	1.2.0	2.0.0
13/12/2008	TSG#42				V 8.0.0 was produced by MCC	2.0.0	8.0.0
03/2008	TSG#43	CP-090087	002	3	Charging requirements on II-NNI	8.0.0	8.1.0
03/2008	TSG#43	CP-090087	004	1	Modification of the REFER method status	8.0.0	8.1.0
03/2008	TSG#43	CP-090087	007	2	NNI header tables	8.0.0	8.1.0
05/2009	TSG#44	CP-090341	008	4	Use of E.164 number at the II-NNI	8.1.0	8.2.0
05/2009	TSG#44	CP-090341	009	4	Correction to SIP headers table	8.1.0	8.2.0
09/2009	TSG#45	CP-090576	017	1	Removal of left-over text from TS drafting phase and update of a reference	8.2.0	8.3.0
09/2009	TSG#45	CP-090576	018	2	Applicability of SIP headers for roaming II-NNI	8.2.0	8.3.0
09/2009	TSG#45	CP-090576	019	1	Application level gateway usage to enable communication from private IP address space	8.2.0	8.3.0
09/2009	TSG#45	CP-090576	020	3	Codecs at the NNI	8.2.0	8.3.0
09/2009	TSG#45	CP-090584	011	4	Major capabilities on II-NNI	8.3.0	9.0.0
09/2009	TSG#45	CP-090584	013	4	Management of SIP headers over II-NNI in presence of trust or no trusted relationship (V1)	8.3.0	9.0.0
09/2009	TSG#45	CP-090584	015	4	Requirements for the end-to-end interoperability of supplementary services	8.3.0	9.0.0
09/2009	TSG#45	CP-090584	016	3	Deletion of the note about the normalization of phone numbers	8.3.0	9.0.0
12/2009	TSG#46	CP-090854	021	5	Requirements for HOLD service over II-NNI	9.0.0	9.1.0
12/2009	TSG#46	CP-090854	022	5	Requirements for CW service over II-NNI	9.0.0	9.1.0
12/2009	TSG#46	CP-090844	024	3	Aligning references to P-Asserted-Service	9.0.0	9.1.0
12/2009	TSG#46	CP-090844	026		Annex A header updated with Answer-Mode, Priv-Answer-Mode and P-Answer-State	9.0.0	9.1.0
12/2009	TSG#46	CP-090854	031	6	Filling of the table about major capabilities on II-NNI	9.0.0	9.1.0
12/2009	TSG#46	CP-090854	032	1	Customized Ringing Signal (CRS) modification	9.0.0	9.1.0
12/2009	TSG#46	CP-090854	033	2	Completing the Personal Network Management (PNM) supplementary service	9.0.0	9.1.0
12/2009	TSG#46	CP-090854	034	1	Aligning existing supplementary services	9.0.0	9.1.0

12/2009	TSG#46	CP-090854	035	1	Completing the Flexible Alerting (FA) supplementary service	9.0.0	9.1.0
12/2009	TSG#46	CP-090854	036	1	Completing the Closed User Group (CUG) supplementary service	9.0.0	9.1.0
12/2009	TSG#46	CP-090854	037	3	Completing the Three-Party (3PTY) and Conference (CONF) supplementary services	9.0.0	9.1.0
12/2009	TSG#46	CP-090854	038	3	Completing the Anonymous Communication Rejection (ACR) supplementary service	9.0.0	9.1.0
12/2009	TSG#46	CP-090854	039	3	Completing Completion of Communications to Busy Subscriber (CCBS) and Completion of Communications by No Reply (CCNR) supplementary services	9.0.0	9.1.0
12/2009	TSG#46	CP-090854	040		Completing Message Waiting Indication (MWI) supplementary service	9.0.0	9.1.0
12/2009	TSG#46	CP-090854	041	1	Completing the Terminating Identification Presentation (TIP) and Terminating Identification Restriction (TIR) needs to be completed.	9.0.0	9.1.0
12/2009	TSG#46	CP-090854	042	3	Completing the Communication Barring (CB) supplementary service	9.0.0	9.1.0
12/2009	TSG#46	CP-090854	043	2	Completing Explicit Communication Transfer (ECT)	9.0.0	9.1.0
12/2009	TSG#46	CP-090854	044	3	Completing Communication DIVersion (CDIV) supplementary services	9.0.0	9.1.0
12/2009	TSG#46	CP-090854	046	2	Deletion of an editors note on OIR service	9.0.0	9.1.0
12/2009	TSG#46	CP-090844	047	3	Annex A header updated	9.0.0	9.1.0
03/2010	TSG#47	CP-100077	051	2	Format of Request URI	9.1.0	9.2.0
03/2010	TSG#47	CP-100077	055	2	MSC Server enhanced for ICS missing in architecture	9.1.0	9.2.0
03/2010	TSG#47	CP-100087	058		AOC added to supplementary services	9.1.0	9.2.0
03/2010	TSG#47	CP-100087	059		CPC and OLI IETF reference update	9.1.0	9.2.0
03/2010	TSG#47	CP-100087	060	3	CPC and OLI and trust domain	9.1.0	9.2.0
03/2010	TSG#47	CP-100087	061	1	Modifying CUG interactions	9.1.0	9.2.0
03/2010	TSG#47	CP-100087	062		Correcting minor errors	9.1.0	9.2.0
03/2010	TSG#47	CP-100087	063	4	Updating Major Capability according to latest 24.229	9.1.0	9.2.0
03/2010	TSG#47	CP-100087	064	1	Major Capabilities revision 2	9.1.0	9.2.0
03/2010	TSG#47	CP-100087	067	1	Table 6.2 update	9.1.0	9.2.0
03/2010	TSG#47	CP-100087	068	1	Modification of OIP/OIR paragraph description (R9 29.165)	9.1.0	9.2.0
03/2010	TSG#47	CP-100087	071	1	References numbers update (R9 29.165)	9.1.0	9.2.0
06/2010	TSG#48	CP-100319	073	1	The Session-ID added to annex A	9.2.0	9.3.0
06/2010	TSG#48	CP-100319	077	2	Correcting incorrect interface name	9.2.0	9.3.0
06/2010	TSG#48	CP-100319	079	2	Supported URI formats also based on operator agreements	9.2.0	9.3.0
06/2010	TSG#48	CP-100319	080	2	Customized Alerting Tone (CAT)	9.2.0	9.3.0
06/2010	TSG#48	CP-100319	081	2	Customized Ringing Signal (CRS)	9.2.0	9.3.0
06/2010	TSG#48	CP-100319	082	1	Correcting miscellaneous errors	9.2.0	9.3.0
06/2010	TSG#48	CP-100319	084	2	Applicability of "critical" privacy value	9.2.0	9.3.0
06/2010	TSG#48	CP-100319	085		Making Alert-Info not mandatory	9.2.0	9.3.0

06/2010	TSG#48	CP-100319	086	1	Draft-johnston-sipping-cc-uii reference updated to new version	9.2.0	9.3.0
06/2010	TSG#48	CP-100319	087	2	Correcting references for removal of P-Asserted-Identity	9.2.0	9.3.0
06/2010	TSG#48	CP-100319	091	2	Correction of Mayor Capabilities	9.2.0	9.3.0
06/2010	TSG#48	CP-100319	093	2	Usage of "Refer" for conferencing and 3PTY	9.2.0	9.3.0
06/2010	TSG#48	CP-100325	083	4	ICS, SRVCC, IUT and MSC Server mid-call assisted feature interoperability	9.3.0	10.0.0
09/2010	TSG#49	CP-100614	094	1	Presence service at II-NNI	10.0.0	10.1.0
09/2010	TSG#49	CP-100553	096	2	Support of REFER checked by entry IBCF	10.0.0	10.1.0
09/2010	TSG#49	CP-100545	099	2	Removing unnecessary normative text	10.0.0	10.1.0
09/2010	TSG#49	CP-100553	101	1	CCBS and CCNR and the m-parameter	10.0.0	10.1.0
09/2010	TSG#49	CP-100559	102	2	CCNL support in the II-NNI	10.0.0	10.1.0
09/2010	TSG#49	CP-100553	104	1	Correcting references	10.0.0	10.1.0
09/2010	TSG#49	CP-100553	106		Adding missing "history" privacy value to CDIV	10.0.0	10.1.0
09/2010	TSG#49	CP-100553	109	3	MCID and identity information transfer clarification	10.0.0	10.1.0
09/2010	TSG#49	CP-100553	111	2	Correcting name of the Authenticate header field and the applicability over II-NNI	10.0.0	10.1.0
09/2010	TSG#49	CP-100553	113	2	Aligning Major Capabilities Table with 24.229	10.0.0	10.1.0
09/2010	TSG#49	CP-100614	114	2	SRVCC additions and reference to subclause 14.2	10.0.0	10.1.0
12/2010	TSG#50	CP-100781	118	2	Aligning annex A with Major Capabilities Table	10.1.0	10.2.0
12/2010	TSG#50	CP-100775	121		Release version added to ETSI specification	10.1.0	10.2.0
12/2010	TSG#50	CP-100785	123		Privacy protection in IBCF	10.1.0	10.2.0
12/2010	TSG#50	CP-100775	126		Correcting errors in SIP method subclause	10.1.0	10.2.0
12/2010	TSG#50	CP-100781	128		Duplications of rows in Major capability table	10.1.0	10.2.0
12/2010	TSG#50	CP-100785	129	1	Editorial corrections	10.1.0	10.2.0
12/2010	TSG#50	CP-100785	130		Missing reference to 24.229 in major capability table	10.1.0	10.2.0
12/2010	TSG#50	CP-100775	133	1	IBCF and URI formats	10.1.0	10.2.0
12/2010	TSG#50	CP-100775	136	1	Roaming and non-roaming definition added	10.1.0	10.2.0
12/2010	TSG#50	CP-100886	137	3	Clarification of relevance of restrictions over II-NNI	10.1.0	10.2.0
12/2010	TSG#50	CP-100775	140	2	Refer-Sub and Refer-To missing in annex A	10.1.0	10.2.0
12/2010	TSG#50	CP-100781	142	2	Supplementary services corrections	10.1.0	10.2.0
12/2010	TSG#50	CP-100785	143	2	OMA presence additions to 3GPP	10.1.0	10.2.0
12/2010	TSG#50	CP-100785	144	1	Instant messaging	10.1.0	10.2.0
12/2010	TSG#50	CP-100785	145	3	adding references to table 6.2	10.1.0	10.2.0
12/2010	TSG#50	CP-100785	146	1	Editors change of major capability n98	10.1.0	10.2.0
12/2010	TSG#50	CP-100785	147	2	ICB	10.1.0	10.2.0
12/2010	TSG#50	CP-100785	148	2	Service OIP/OIR, TIP/TIR	10.1.0	10.2.0
12/2010	TSG#50	CP-100781	149	1	MCID and ACR	10.1.0	10.2.0
12/2010	TSG#50	CP-100785	150	1	Clarifications of operator option items	10.1.0	10.2.0

03/2011	TSG#51	CP-110113	156		Correction on Major Capabilities over II-NNI	10.2.0	10.3.0
03/2011	TSG#51	CP-110113	158	1	Addition of the Target-Dialog header field to the table of major capabilities and Annex A	10.2.0	10.3.0
03/2011	TSG#51	CP-110113	160	2	Correcting major capabilities related to trust domain	10.2.0	10.3.0
03/2011	TSG#51	CP-110116	161	1	RFC 5318 in the Major capability table	10.2.0	10.3.0
03/2011	TSG#51	CP-110116	162	2	Updating OMA presence requirements	10.2.0	10.3.0
03/2011	TSG#51	CP-110113	164	3	Reference clause updates	10.2.0	10.3.0
03/2011	TSG#51	CP-110116	165		Introduction of ATCF	10.2.0	10.3.0
03/2011	TSG#51	CP-110116	166	2	Interoperability of IMS Service Continuity over II-NNI updates	10.2.0	10.3.0
03/2011	TSG#51	CP-110113	168	2	Updates of the Major capability table	10.2.0	10.3.0
03/2011	TSG#51	CP-110116	169	3	Adding new header fields Annex A	10.2.0	10.3.0
03/2011	TSG#51	CP-110107	172	1	Correcting header table in annex A	10.2.0	10.3.0
03/2011	TSG#51	CP-110113	174		Reference update: RFC 6086	10.2.0	10.3.0
03/2011	TSG#51	CP-110116	175	1	Reference points Mi, Mm, Mw and I2	10.2.0	10.3.0
03/2011	TSG#51	CP-110107	178		Adding MMTel feature tag in clause 12	10.2.0	10.3.0
03/2011	TSG#51	CP-110116	179		Minor corrections to 3GPP TS 29.165	10.2.0	10.3.0
03/2011	TSG#51	CP-110116	180		Alignment with 23.228 Ici reference point	10.2.0	10.3.0
03/2011	TSG#51	CP-110116	181	1	Miscellaneous error corrections to 3GPP TS 29.165	10.2.0	10.3.0
03/2011	TSG#51	CP-110129	182	5	New annex for dynamic view of SIP messages	10.2.0	10.3.0
03/2011	TSG#51	CP-110129	183	3	Summary of notation codes in dynamic view (ACK method)	10.2.0	10.3.0
03/2011	TSG#51	CP-110129	184	5	Summary of notation codes in dynamic view (BYE method)	10.2.0	10.3.0
03/2011	TSG#51	CP-110129	185	3	Summary of notation codes in dynamic view (CANCEL method)	10.2.0	10.3.0
03/2011	TSG#51	CP-110129	186	5	Summary of notation codes in dynamic view (INVITE method)	10.2.0	10.3.0
03/2011	TSG#51	CP-110129	187	5	Summary of notation codes in dynamic view (MESSAGE method)	10.2.0	10.3.0
03/2011	TSG#51	CP-110129	188	5	Summary of notation codes in dynamic view (OPTIONS method)	10.2.0	10.3.0
03/2011	TSG#51	CP-110129	189	5	Summary of notation codes in dynamic view (PRACK method)	10.2.0	10.3.0
03/2011	TSG#51	CP-110129	190	5	Summary of notation codes in dynamic view (PUBLISH method)	10.2.0	10.3.0
03/2011	TSG#51	CP-110129	191	3	Summary of notation codes in dynamic view (REGISTER method)	10.2.0	10.3.0
03/2011	TSG#51	CP-110129	192	5	Summary of notation codes in dynamic view (UPDATE method)	10.2.0	10.3.0
03/2011	TSG#51	CP-110113	194	4	Alignment of INFO support for DTMF transport with TS 24.182	10.2.0	10.3.0
03/2011	TSG#51	CP-110116	197	2	Addition of normative references for in band DTMF and SDP messages	10.2.0	10.3.0
03/2011	TSG#51	CP-110113	199	1	Correcting the management of SIP header field relating to trust relationship	10.2.0	10.3.0
03/2011	TSG#51	CP-110116	206	1	Correcting related to references	10.2.0	10.3.0
03/2011	TSG#51	CP-110113	212	1	Updating references in TS29.165	10.2.0	10.3.0

03/2011	TSG#51	CP-110116	213		Minor correction on reference in table 6.2 of TS 29.165	10.2.0	10.3.0
03/2011	TSG#51	CP-110116	214	1	Updating references in TS29.16 release 10	10.2.0	10.3.0
03/2011	TSG#51	CP-110113	217	3	Removal av draft-patel-dispatch-cpc-oli-parameter from references	10.2.0	10.3.0
03/2011	TSG#51	CP-110113	219	1	Removal of draft-patel-ecrit-sos-parameter	10.2.0	10.3.0
03/2011	TSG#51	CP-110129	224	2	Summary of notation codes in dynamic view (INFO method)	10.2.0	10.3.0
03/2011	TSG#51	CP-110129	225	2	Summary of notation codes in dynamic view (NOTIFY method)	10.2.0	10.3.0
03/2011	TSG#51	CP-110129	226	2	Summary of notation codes in dynamic view (REFER method)	10.2.0	10.3.0
03/2011	TSG#51	CP-110129	227	2	Summary of notation codes in dynamic view (SUBSCRIBE method)	10.2.0	10.3.0
03/2011	TSG#51	CP-110117	228	2	OMR	10.2.0	10.3.0
03/2011	TSG#51	CP-110116	234		Unification of the words and phrases in clause 12	10.2.0	10.3.0
03/2011	TSG#51				Editorial changes made by MCC	10.3.0	10.3.1
06/2011	TSG#52	CP-110403	238	2	Reference section updates (II-NNI)	10.3.1	10.4.0
06/2011	TSG#52	CP-110415	240	2	CPC/OLI and trust domain	10.3.1	10.4.0
06/2011	TSG#52	CP-110523	241	2	Completing SRVCC by removing one EN	10.3.1	10.4.0
06/2011	TSG#52	CP-110407	242		Completing MSC assisted mid call	10.3.1	10.4.0
06/2011	TSG#52	CP-110407	243	2	Completing and restructuring IUT	10.3.1	10.4.0
06/2011	TSG#52	CP-110407	244		Reference section updates (II-NNI2)	10.3.1	10.4.0
06/2011	TSG#52	CP-110419	245	1	Modification of the terminology related to roaming II-NNI	10.3.1	10.4.0
06/2011	TSG#52	CP-110419	246	2	The addition of an notation code for SIP header fields in dynamic view for II-NNI	10.3.1	10.4.0
06/2011	TSG#52	CP-110419	247	1	The addition of the conditions for the presence of SIP header fields in SIP messages for supplementary services	10.3.1	10.4.0
06/2011	TSG#52	CP-110403	263	1	Allow-Event header field (II-NNI)	10.3.1	10.4.0
06/2011	TSG#52	CP-110407	264	1	Allow-Event header field (II-NNI2)	10.3.1	10.4.0
06/2011	TSG#52	CP-110403	266		Max-Breadth header field correction	10.3.1	10.4.0
06/2011	TSG#52	CP-110401	269	1	SIP headers alignment in II-NNI	10.3.1	10.4.0
06/2011	TSG#52	CP-110406	271	1	Removal of dial around indicator	10.3.1	10.4.0
06/2011	TSG#52	CP-110403	276	1	Forking definition on II-NNI	10.3.1	10.4.0
06/2011	TSG#52	CP-110407	279	1	Services at II-NNI R10	10.3.1	10.4.0
09/2011	TSG#53	CP-110621	282		CDIV History-Info header field correction	10.4.0	10.5.0
09/2011	TSG#53	CP-110621	284	1	P-Served-User correction in annex b	10.4.0	10.5.0
09/2011	TSG#53	CP-110612	286		Date header field missing in CCBS and CCNR	10.4.0	10.5.0
09/2011	TSG#53	CP-110615	287		Date header field missing in CCNL	10.4.0	10.5.0
09/2011	TSG#53	CP-110612	289		Support of replaces missing in ECT	10.4.0	10.5.0
09/2011	TSG#53	CP-110612	291	1	Error-Info missing in announcements	10.4.0	10.5.0
09/2011	TSG#53	CP-110616	293		ICS error corrections	10.4.0	10.5.0
09/2011	TSG#53	CP-110616	294		SRVCC Target-Dialog corrections	10.4.0	10.5.0

09/2011	TSG#53	CP-110616	297	1	Reference section update (II-NNI2)	10.4.0	10.5.0
09/2011	TSG#53	CP-110619	298	1	Table error corrections	10.4.0	10.5.0
09/2011	TSG#53	CP-110621	299		Correction on descriptions related to CONF in Dynamic View.	10.4.0	10.5.0
09/2011	TSG#53	CP-110621	300		Minor correction on REFER request in Dynamic View	10.4.0	10.5.0
12/2011	TSG#54	CP-110837	302	3	Correction on dynamic view of SIP message	10.5.0	10.6.0
12/2011	TSG#54	CP-110837	304		Adding SIP header fields to dynamic view tables	10.5.0	10.6.0
12/2011	TSG#54	CP-110824	308		Aligning the references with Supported transport-level RFCs	10.5.0	10.6.0
12/2011	TSG#54	CP-110833	310	1	Correcting the references	10.5.0	10.6.0
12/2011	TSG#54	CP-110837	312		Minor correction on PUBLISH request in Dynamic View	10.5.0	10.6.0
12/2011	TSG#54	CP-110829	315	1	Reference updates	10.5.0	10.6.0
12/2011	TSG#54	CP-110833	317	1	MSC server enhanced for SRVCC	10.5.0	10.6.0
12/2011	TSG#54	CP-110829	320		Reference to wrong RFC for INFO method	10.5.0	10.6.0
12/2011	TSG#54	CP-110833	322	3	Indication of features supported by proxy	10.5.0	10.6.0
12/2011	TSG#54	CP-110833	324	1	SRVCC updates	10.5.0	10.6.0
12/2011	TSG#54	CP-110833	326		Removal of draft-ietf-sip-session-policy-framework	10.5.0	10.6.0
12/2011	TSG#54	CP-110833	329	3	"ua-profile" replaced with "xcap-diff"	10.5.0	10.6.0
12/2011	TSG#54	CP-110829	333	2	Reference update: Reason header in SIP responses	10.5.0	10.6.0
12/2011	TSG#54	CP-110829	347	2	RFC4694 passing of rn parameter	10.5.0	10.6.0
03/2012	TSG#55	CP-120205	342	5	Updating of UUS references	10.6.0	10.7.0
03/2012	TSG#55	CP-120067	349		Missing correction for SIP message in dynamic view tables	10.6.0	10.7.0
03/2012	TSG#55	CP-120060	352	1	Clarification on URI formats in SIP message	10.6.0	10.7.0
03/2012	TSG#55	CP-120064	366		Indication of features supported by proxy updates	10.6.0	10.7.0
03/2012	TSG#55	CP-120060	369	3	IETF draft update - Location Conveyance	10.6.0	10.7.0
03/2012	TSG#55	CP-120060	372		Removing draft-rosenberg-sipcore-target-uri-delivery	10.6.0	10.7.0
03/2012	TSG#55	CP-120064	377	1	SRVCC updates and corrections	10.6.0	10.7.0
03/2012	TSG#55	CP-120064	385	1	Clarification of user plane transport with operator agreement	10.6.0	10.7.0
03/2012	TSG#55	CP-120060	389	2	CDIV limitation 29.165r10	10.6.0	10.7.0
06/2012	TSG#56	CP-120340	392	1	Reference update: draft-salud-alert-info-urns	10.7.0	10.8.0
06/2012	TSG#56	CP-120342	403	3	Clarification on SIP message bodies over II-NNI	10.7.0	10.8.0
06/2012	TSG#56	CP-120340	407	2	Usage of isub parameter over II-NNI	10.7.0	10.8.0
06/2012	TSG#56	CP-120342	414		The sos URI parameter in Request-URIs	10.7.0	10.8.0
06/2012	TSG#56	CP-120340	418		Updating of UUS references	10.7.0	10.8.0
06/2012	TSG#56	CP-120332	423	2	The description of notation code for SIP message	10.7.0	10.8.0
09/2012	TSG#57	CP-120519	426		P-Refused-URI-List header field	10.8.0	10.9.0
09/2012	TSG#57	CP-120518	429		Correction on the description of "g.3gpp.crs"	10.8.0	10.9.0
09/2012	TSG#57	CP-120518	432		Correction on the description of "application/vnd.etsi.mcid+xml" MIME body	10.8.0	10.9.0
09/2012	TSG#57	CP-120519	436	1	Clarification on the SDP rules for transporting media streams	10.8.0	10.9.0

					with TCP		
09/2012	TSG#57	CP-120518	439	1	Correcting reference	10.8.0	10.9.0
09/2012	TSG#57	CP-120519	449	1	draft-ietf-sipcore-proxy-feature: reference update and technical changes	10.8.0	10.9.0
09/2012	TSG#57	CP-120519	452		Feature-Caps added to trust domain - CT CR CORRELATION NEEDED	10.8.0	10.9.0
09/2012	TSG#57	CP-120519	458		IUT reference update	10.8.0	10.9.0
09/2012	TSG#57	CP-120519	460		MIME body name update	10.8.0	10.9.0
09/2012	TSG#57	CP-120519	462		CDIV corrections	10.8.0	10.9.0
09/2012	TSG#57	CP-120519	464		Missing the Event header in MWI	10.8.0	10.9.0
09/2012	TSG#57	CP-120519	466		Event header field missing in CC services	10.8.0	10.9.0
09/2012	TSG#57	CP-120519	471		Correcting minor errors	10.8.0	10.9.0
12/2012	TSG#58	CP-120826	473	2	Clarification of SDP setting condition over the II-NNI	10.9.0	10.10.0
12/2012	TSG#58	CP-120825	477	4	Removal of draft-dawes-dispatch-mediasec-parameter draft	10.9.0	10.10.0
12/2012	TSG#58	CP-120825	481	1	Trust domain error corrections	10.9.0	10.10.0
12/2012	TSG#58	CP-120826	488		Reference update: draft-ietf-sipcore-proxy-feature	10.9.0	10.10.0
12/2012	TSG#58	CP-120826	498	3	Description of charging correlation over II-NNI	10.9.0	10.10.0
12/2012	TSG#58	CP-120826	502	3	Policy-Contact in OMA	10.9.0	10.10.0
12/2012	TSG#58	CP-120829	504		The deletion of Security-Server header from dynamic view tables	10.9.0	10.10.0
03/2013	TSG#59	CP-130061	507	1	IMS debug removal of feature	10.10.0	10.11.0
03/2013	TSG#59	CP-130070	515		Reference update: RFC 6809	10.10.0	10.11.0
03/2013	TSG#59	CP-130070	517		Reference update: Draft-ietf-sip-session-policy-framework	10.10.0	10.11.0
03/2013	TSG#59	CP-130069	526	3	Correcting announcement when communication is rejected	10.10.0	10.11.0
03/2013	TSG#59	CP-130070	529	1	Clarifying IOI types	10.10.0	10.11.0
03/2013	TSG#59	CP-130070	531		Reference update: Presence SIMPLE specification	10.10.0	10.11.0
03/2013	TSG#59	CP-130069	534	1	Clarification for CDIV NNI description	10.10.0	10.11.0
06/2013	TSG#60	CP-130320	544	2	Correction on the status of the major capability related to History-Info header field	10.11.0	10.12.0
06/2013	TSG#60	CP-130320	547	1	Operator agreements for the applicable characteristics of the SIP message body MIMEs	10.11.0	10.12.0
06/2013	TSG#60	CP-130320	553	2	ATCF SRVCC - URIs of authorized SCC ASes	10.11.0	10.12.0
06/2013	TSG#60	CP-130320	555	1	ICS corrections	10.11.0	10.12.0
09/2013	TSG#61	CP-130544	564		Reference update of draft-vanelburg-dispatch-private-network-ind	10.12.0	10.13.0
09/2013	TSG#61	CP-130547	567		Clarification of operator agreements for SIP message body MIMEs	10.12.0	10.13.0
09/2013	TSG#61	CP-130547	578	2	Transfer of IP Multimedia Service Tariff Information	10.12.0	10.13.0
09/2013	TSG#61	CP-130547	581	1	Feature-capabilities in target refresh	10.12.0	10.13.0
09/2013	TSG#61	CP-130544	586	2	draft-avasara-dispatch-comm-div-notification ref update	10.12.0	10.13.0
12/2013	TSG#62	CP-130666	594		Reference update of draft-vanelburg-dispatch-private-network-	10.13.0	10.14.0

					ind		
12/2013	TSG#62	CP-130666	598		Reference update: draft-kaplan-insipid-session-id	10.13.0	10.14.0
12/2013	TSG#62	CP-130668	607	1	Removal of debug feature	10.13.0	10.14.0
12/2013	TSG#62	CP-130666	611	1	Reference Update: draft-ietf-salud-alert-info-urns	10.13.0	10.14.0
04/2014	TSG#63	CP-140064	620	1	Reference update of draft-vanelburg-dispatch-private-network-ind	10.14.0	10.15.0
04/2014	TSG#63	CP-140068	623	1	Notation codes for the dynamic view table	10.14.0	10.15.0
2014-06	CP#64	CP-140358	630	-	Correcting the indication of communication diversion to the diverting user	10.15.0	10.16.0
2014-06	CP#64	CP-140359	650	-	Removal of CDIVN	10.15.0	10.16.0
2014-06	CP#64	CP-140360	644	1	Reference update of draft-vanelburg-dispatch-private-network-ind	10.15.0	10.16.0
2014-06	CP#64	CP-140361	661	1	Reference update for "mp" header field parameter in History-Info header field	10.15.0	10.16.0



---

## History

<b>Document history</b>		
V10.3.1	April 2011	Publication
V10.4.0	June 2011	Publication
V10.5.0	October 2011	Publication
V10.6.0	January 2012	Publication
V10.7.0	March 2012	Publication
V10.8.0	July 2012	Publication
V10.9.0	October 2012	Publication
V10.10.0	January 2013	Publication
V10.11.0	April 2013	Publication
V10.12.0	July 2013	Publication
V10.13.0	September 2013	Publication
V10.14.0	January 2014	Publication
V10.15.0	March 2014	Publication
V10.16.0	July 2014	Publication