

# ETSI TS 129 165 V9.1.0 (2010-01)

---

*Technical Specification*

**Digital cellular telecommunications system (Phase 2+);  
Universal Mobile Telecommunications System (UMTS);  
LTE;  
Inter-IMS Network to Network Interface (NNI)  
(3GPP TS 29.165 version 9.1.0 Release 9)**

---



---

**Reference**RTS/TSGC-0329165v910

---

---

**Keywords**GSM, LTE, UMTS

---

**ETSI**

---

650 Route des Lucioles  
F-06921 Sophia Antipolis Cedex - FRANCE

---

Tel.: +33 4 92 94 42 00 Fax: +33 4 93 65 47 16

Siret N° 348 623 562 00017 - NAF 742 C  
Association à but non lucratif enregistrée à la  
Sous-Préfecture de Grasse (06) N° 7803/88

---

**Important notice**

---

Individual copies of the present document can be downloaded from:

<http://www.etsi.org>

The present document may be made available in more than one electronic version or in print. In any case of existing or perceived difference in contents between such versions, the reference version is the Portable Document Format (PDF). In case of dispute, the reference shall be the printing on ETSI printers of the PDF version kept on a specific network drive within ETSI Secretariat.

Users of the present document should be aware that the document may be subject to revision or change of status. Information on the current status of this and other ETSI documents is available at

<http://portal.etsi.org/tb/status/status.asp>

If you find errors in the present document, please send your comment to one of the following services:

[http://portal.etsi.org/chaicor/ETSI\\_support.asp](http://portal.etsi.org/chaicor/ETSI_support.asp)

---

**Copyright Notification**

---

No part may be reproduced except as authorized by written permission.  
The copyright and the foregoing restriction extend to reproduction in all media.

© European Telecommunications Standards Institute 2010.  
All rights reserved.

**DECT™**, **PLUGTESTS™**, **UMTS™**, **TIPHON™**, the TIPHON logo and the ETSI logo are Trade Marks of ETSI registered for the benefit of its Members.

**3GPP™** is a Trade Mark of ETSI registered for the benefit of its Members and of the 3GPP Organizational Partners.

**LTE™** is a Trade Mark of ETSI currently being registered

for the benefit of its Members and of the 3GPP Organizational Partners.

**GSM®** and the GSM logo are Trade Marks registered and owned by the GSM Association.

---

## Intellectual Property Rights

IPRs essential or potentially essential to the present document may have been declared to ETSI. The information pertaining to these essential IPRs, if any, is publicly available for **ETSI members and non-members**, and can be found in ETSI SR 000 314: *"Intellectual Property Rights (IPRs); Essential, or potentially Essential, IPRs notified to ETSI in respect of ETSI standards"*, which is available from the ETSI Secretariat. Latest updates are available on the ETSI Web server (<http://webapp.etsi.org/IPR/home.asp>).

Pursuant to the ETSI IPR Policy, no investigation, including IPR searches, has been carried out by ETSI. No guarantee can be given as to the existence of other IPRs not referenced in ETSI SR 000 314 (or the updates on the ETSI Web server) which are, or may be, or may become, essential to the present document.

---

## Foreword

This Technical Specification (TS) has been produced by ETSI 3rd Generation Partnership Project (3GPP).

The present document may refer to technical specifications or reports using their 3GPP identities, UMTS identities or GSM identities. These should be interpreted as being references to the corresponding ETSI deliverables.

The cross reference between GSM, UMTS, 3GPP and ETSI identities can be found under <http://webapp.etsi.org/key/queryform.asp>.

# Contents

Intellectual Property Rights .....	2
Foreword.....	2
Foreword.....	5
1 Scope .....	6
2 References .....	6
3 Definitions, symbols and abbreviations .....	11
3.1 Definitions .....	11
3.2 Symbols.....	12
3.3 Abbreviations .....	12
4 Overview .....	12
5 Reference model for interconnection between IM CN subsystems .....	13
5.1 General .....	13
5.2 Functionalities performed by entities at the edge of the network .....	13
5.2.1 Interconnection Border Control Function (IBCF).....	13
5.2.2 Transition Gateway (TrGW).....	14
6 Control plane interconnection .....	14
6.1 Definition of Inter-IMS Network to Network Interconnection.....	14
6.1.1 SIP methods and headers .....	14
6.1.1.1 General .....	14
6.1.1.2 SIP methods .....	14
6.1.1.3 SIP headers.....	15
6.1.1.3.0 General .....	15
6.1.1.3.1 Trust and no trust relationship .....	15
6.1.1.3.2 Derivation of applicable SIP headers from TS 24.229 .....	16
6.1.1.3.3 Applicability of SIP headers on a roaming II-NNI between home IMS and visited IMS .....	17
6.1.1.3.4 Applicability of SIP headers on an II-NNI between home IMS networks .....	17
6.1.1.4 Notations of the codes.....	17
6.1.1.5 Modes of signalling.....	17
6.1.2 SDP protocol.....	18
6.1.2.1 General .....	18
6.1.3 Major capabilities .....	18
6.2 Control Plane Transport .....	22
6.2.1 General.....	22
7 User plane Interconnection.....	22
7.1 Media and Codec.....	22
7.2 User Plane Transport.....	23
8 Numbering, Naming and Addressing .....	23
9 IP Version.....	24
10 Security.....	24
11 Charging .....	24
12 Supplementary services associated with the IMS multimedia telephony communication service.....	24
12.1 General .....	24
12.2 Malicious Communication IDentification (MCID).....	24
12.3 Originating Identification Presentation (OIP) and Originating Identification Restriction (OIR) .....	24
12.4 Terminating Identification Presentation (TIP) and Terminating Identification Restriction (TIR) .....	25
12.5 Anonymous Communication Rejection (ACR).....	25
12.6 Communication DIVersion (CDIV).....	25
12.7 Communication Waiting (CW) .....	26

12.8	Communication HOLD (HOLD) .....	26
12.9	Message Waiting Indication (MWI).....	26
12.10	Communication Barring (CB).....	26
12.10.1	Incoming Communication Barring (ICB).....	26
12.10.2	Outgoing Communication Barring (OCB).....	26
12.11	Completion of Communications to Busy Subscriber (CCBS).....	27
12.12	Completion of Communications by No Reply (CCNR).....	27
12.13	Explicit Communication Transfer (ECT).....	27
12.14	Customized Alerting Tone (CAT).....	28
12.15	Customized Ringing Signal (CRS).....	28
12.16	Closed User Group (CUG).....	28
12.17	Personal Network Management (PNM) .....	28
12.18	Three-Party (3PTY).....	28
12.19	Conference (CONF) .....	28
12.20	Flexible Alerting (FA).....	29
12.21	Announcements.....	29
12.21.1	General.....	29
12.21.2	Providing announcements during the establishment of a communication session.....	29
12.21.3	Providing announcements during an established communication session.....	29
<b>Annex A (informative): Summary of SIP headers.....</b>		<b>30</b>
<b>Annex B: Change history .....</b>		<b>34</b>
History .....		35

---

# Foreword

This Technical Specification has been produced by the 3<sup>rd</sup> Generation Partnership Project (3GPP).

The contents of the present document are subject to continuing work within the TSG and may change following formal TSG approval. Should the TSG modify the contents of the present document, it will be re-released by the TSG with an identifying change of release date and an increase in version number as follows:

Version x.y.z

where:

- x the first digit:
  - 1 presented to TSG for information;
  - 2 presented to TSG for approval;
  - 3 or greater indicates TSG approved document under change control.
- y the second digit is incremented for all changes of substance, i.e. technical enhancements, corrections, updates, etc.
- z the third digit is incremented when editorial only changes have been incorporated in the document.

---

# 1 Scope

The objective of this document is to address the Inter-IMS Network to Network Interface (II-NNI) consisting of Ici and Izi reference points between IMS networks in order to support end-to-end service interoperability.

The present document will address the issues related to control plane signalling (3GPP usage of SIP and SDP protocols, required SIP headers) as well as other interconnecting aspects like security, numbering/naming/addressing and user plane issues as transport protocol, media and codecs actually covered in a widespread set of 3GPP specifications. A profiling of the Inter-IMS Network to Network Interface (II-NNI) is also provided.

Charging aspects will be addressed as far as SIP signalling is concerned.

---

# 2 References

The following documents contain provisions which, through reference in this text, constitute provisions of the present document.

- References are either specific (identified by date of publication, edition number, version number, etc.) or non-specific.
- For a specific reference, subsequent revisions do not apply.
- For a non-specific reference, the latest version applies. In the case of a reference to a 3GPP document (including a GSM document), a non-specific reference implicitly refers to the latest version of that document *in the same Release as the present document*.

- [1] 3GPP TR 21.905: "Vocabulary for 3GPP Specifications".
- [2] IETF RFC 791: "Internet Protocol"
- [3] 3GPP TS 23.002: "Network architecture".
- [4] 3GPP TS 23.228: "IP Multimedia Subsystem (IMS); Stage 2".
- [5] 3GPP TS 24.229: "Internet Protocol (IP) multimedia call control protocol based on Session Initiation Protocol (SIP) and Session Description Protocol (SDP); Stage 3".
- [6] 3GPP TR 24.930: "Signalling flows for the session setup in the IP Multimedia core network Subsystem (IMS) based on Session Initiation Protocol (SIP) and Session Description Protocol (SDP); Stage 3".
- [7] IETF RFC 2460: "Internet Protocol, Version 6 (IPv6) Specification".
- [8] 3GPP TS 29.162: 'Interworking between the IM CN subsystem and IP networks'.
- [9] 3GPP TS 22.228: "Service requirements for the IP multimedia core network subsystem".
- [10] 3GPP TS 33.210: "3G security; Network Domain Security (NDS); IP network layer security".
- [11] 3GPP TS 26.114: " IP Multimedia Subsystem (IMS); Multimedia Telephony; Media handling and interaction".
- [12] ETSI TS 181 005: "Telecommunications and Internet converged Services and Protocols for Advanced Networking (TISPAN); Services and Capabilities Requirements"
- [13] IETF RFC 3261: "SIP: Session Initiation Protocol".
- [14] IETF RFC 3966: "The tel URI for Telephone Numbers".
- [15] IETF RFC 3860: "Common Profile for Instant Messaging (CPIM)".
- [16] IETF RFC 3859: "Common Profile for Presence (CPP)".

- [17] IETF RFC 4975: "The Message Session Relay Protocol (MSRP)."
- [18] IETF RFC 3262: "Reliability of provisional responses in Session Initiation Protocol (SIP)".
- [19] IETF RFC 3428: "Session Initiation Protocol (SIP) Extension for Instant Messaging".
- [20] IETF RFC 3265: "Session Initiation Protocol (SIP) Specific Event Notification".
- [21] IETF RFC 3903: "An Event State Publication Extension to the Session Initiation Protocol (SIP)".
- [22] IETF RFC 3515: "The Session Initiation Protocol (SIP) REFER method".
- [23] IETF RFC 3311: "The Session Initiation Protocol (SIP) UPDATE method".
- [24] IETF RFC 3455: "Private Header (P-Header) Extensions to the Session Initiation Protocol (SIP) for the 3rd-Generation Partnership Project (3GPP)".
- [25] IETF RFC 4244: "An Extension to the Session Initiation Protocol (SIP) for Request History Information".
- [26] IETF draft-drage-sipping-service-identification-03 (March 2009): "A Session Initiation Protocol (SIP) Extension for the Identification of Services".

**Editor's note: The above document cannot be formally referenced until it is published as an RFC.**

- [27] IETF RFC 4168: "The Stream Control Transmission Protocol (SCTP) as a Transport for the Session Initiation Protocol (SIP)".
- [28] IETF RFC 2976: "The SIP INFO Method".
- [29] 3GPP TS 32.260: " Telecommunication management; Charging management; IP Multimedia Subsystem (IMS) charging ".
- [30] 3GPP TS 22.173: "IP Multimedia Core Network Subsystem (IMS); Multimedia Telephony Service and supplementary services;Stage 1".
- [31] 3GPP TS 24.173: "IMS multimedia telephony communication service and supplementary services;Stage 3".
- [32] 3GPP TS 24.607: "Originating Identification Presentation (OIP) and Originating Identification Restriction (OIR) using IP Multimedia (IM); Core Network (CN) subsystem".
- [33] 3GPP TS 24.616: "Malicious Communication Identification (MCID) using IP Multimedia (IM) Core Network (CN) subsystem".
- [34] IETF RFC 3323: "A Privacy Mechanism for the Session Initiation Protocol (SIP)".
- [35] 3GPP TS 23.003: "Numbering, addressing and identification".
- [36] 3GPP TS 24.610: "Communication HOLD (HOLD) using IP Multimedia (IM) Core Network (CN) subsystem".
- [37] 3GPP TS 24.615: "Communication Waiting (CW) using IP Multimedia (IM) Core Network (CN) subsystem".
- [38] 3GPP TS 24.628: " Common Basic Communication procedures using IP Multimedia (IM) Core Network (CN) subsystem".
- [39] draft-ietf-sipcore-info-events-01 (September 2009): "Session Initiation Protocol (SIP) INFO Method and Package Framework".

**Editor's note: The above document cannot be formally referenced until it is published as an RFC.**

- [40] IETF RFC 3312 (October 2002): "Integration of resource management and Session Initiation Protocol (SIP)".



- [41] IETF RFC 4032 (March 2005): "Update to the Session Initiation Protocol (SIP) Preconditions Framework".
- [42] IETF RFC 3313 (January 2003): "Private Session Initiation Protocol (SIP) Extensions for Media Authorization".
- [43] IETF RFC 3327 (December 2002): "Session Initiation Protocol Extension Header Field for Registering Non-Adjacent Contacts".
- [44] IETF RFC 3325 (November 2002): "Private Extensions to the Session Initiation Protocol (SIP) for Network Asserted Identity within Trusted Networks".
- [45] IETF RFC 3608 (October 2003): "Session Initiation Protocol (SIP) Extension Header Field for Service Route Discovery During Registration".
- [46] IETF RFC 3486 (February 2003): "Compressing the Session Initiation Protocol (SIP)".
- [47] IETF RFC 3329 (January 2003): "Security Mechanism Agreement for the Session Initiation Protocol (SIP)".
- [48] IETF RFC 3326 (December 2002): "The Reason Header Field for the Session Initiation Protocol (SIP)".
- [49] draft-jesske-sipping-etsi-ngn-reason-04 (October 2008): "Use of the Reason header field in Session Initiation Protocol (SIP) responses"

**Editor's note:** The above document cannot be formally referenced until it is published as an RFC.

- [50] IETF RFC 3581 (August 2003): "An Extension to the Session Initiation Protocol (SIP) for Symmetric Response Routing".
- [51] IETF RFC 3841 (August 2004): "Caller Preferences for the Session Initiation Protocol (SIP)".
- [52] IETF RFC 4028 (April 2005): "Session Timers in the Session Initiation Protocol (SIP)".
- [53] IETF RFC 3892 (September 2004): "The Session Initiation Protocol (SIP) Referred-By Mechanism".
- [54] IETF RFC 3891 (September 2004): "The Session Initiation Protocol (SIP) "Replaces" Header".
- [55] IETF RFC 3911 (October 2004): "The Session Initiation Protocol (SIP) "Join" Header".
- [56] IETF RFC 3840 (August 2004): "Indicating User Agent Capabilities in the Session Initiation Protocol (SIP)".
- [57] IETF RFC 5079 (December 2007): "Rejecting Anonymous Requests in the Session Initiation Protocol (SIP)".
- [58] IETF RFC 4458 (January 2006): "Session Initiation Protocol (SIP) URIs for Applications such as Voicemail and Interactive Voice Response (IVR)".
- [59] IETF RFC 4320 (January 2006): "Actions Addressing Identified Issues with the Session Initiation Protocol's (SIP) Non-INVITE Transaction".
- [60] IETF RFC 4457 (April 2006): "The Session Initiation Protocol (SIP) P-User-Database Private-Header (P-header)".
- [61] IETF RFC 5031 (January 2008): "A Uniform Resource Name (URN) for Services".
- [62] draft-ietf-sip-gruu-15 (October 2007): "Obtaining and Using Globally Routable User Agent (UA) URIs (GRUU) in the Session Initiation Protocol (SIP)".

**Editor's note:** The above document cannot be formally referenced until it is published as an RFC.

- [63] draft-mahy-iptel-cpc-06 (March 2007): "The Calling Party's Category tel URI Parameter".

**Editor's note:** The above document cannot be formally referenced until it is published as an RFC.

- [64] IETF RFC 5002 (August 2007): "The Session Initiation Protocol (SIP) P-Profile-Key Private Header (P-Header)"
- [65] IETF RFC 5626: "Managing Client-Initiated Connections in the Session Initiation Protocol (SIP)".
- [66] draft-ietf-sip-ice-option-tag-02 (June 2007): "Indicating Support for Interactive Connectivity Establishment (ICE) in the Session Initiation Protocol (SIP)".

**Editor's note: The above document cannot be formally referenced until it is published as an RFC.**

- [67] IETF RFC 5365 (October 2008): "Multiple-Recipient MESSAGE Requests in the Session Initiation Protocol (SIP)".
- [68] draft-ietf-sip-location-conveyance-13 (March 2009): "Location Conveyance for the Session Initiation Protocol".

**Editor's note: The above document cannot be formally referenced until it is published as an RFC.**

- [69] IETF RFC 5368 (October 2008): "Referring to Multiple Resources in the Session Initiation Protocol (SIP)".
- [70] IETF RFC 5367 (October 2008): "Conference Establishment Using Request-Contained Lists in the Session Initiation Protocol (SIP)".
- [71] draft-ietf-sip-uri-list-subscribe-02: "Subscriptions to Request-Contained Resource Lists in the Session Initiation Protocol (SIP)".

**Editor's note: The above document cannot be formally referenced until it is published as an RFC.**

- [72] IETF RFC 4967 (July 2007): "Dial String Parameter for the Session Initiation Protocol Uniform Resource Identifier".
- [73] IETF RFC 4964 (September 2007): "The P-Answer-State Header Extension to the Session Initiation Protocol for the Open Mobile Alliance Push to Talk over Cellular".
- [74] IETF RFC 5009 (September 2007): "Private Header (P-Header) Extension to the Session Initiation Protocol (SIP) for Authorization of Early Media".
- [75] IETF RFC 4694 (October 2006): "Number Portability Parameters for the 'tel' URI".
- [76] draft-yu-tel-dai-07 (July 2009): "DAI Parameter for the 'tel' URI".

**Editor's note: The above document cannot be formally referenced until it is published as an RFC.**

- [77] IETF RFC 4411 (February 2006): "Extending the Session Initiation Protocol (SIP) Reason Header for Preemption Events".
- [78] IETF RFC 4412 (February 2006): "Communications Resource Priority for the Session Initiation Protocol (SIP)".
- [79] IETF RFC 5393 (December 2008): "Addressing an Amplification Vulnerability in Session Initiation Protocol (SIP) Forking Proxies".
- [80] IETF RFC 5049 (December 2007): "Applying Signaling Compression (SigComp) to the Session Initiation Protocol (SIP)".
- [81] draft-rosenberg-sip-app-media-tag-02 (November 2007): "A Session Initiation Protocol (SIP) Media Feature Tag for MIME Application Sub-Types".

**Editor's note: The above document cannot be formally referenced until it is published as an RFC.**

- [82] IETF RFC 5360 (October 2008): "A Framework for Consent-Based Communications in the Session Initiation Protocol (SIP)".
- [83] draft-johnston-sipping-cc-uu-08 (July 2009): "Transporting User to User Information in SIP for ISDN interworking".

Editor's note: The above document cannot be formally referenced until it is published as an RFC.

[84] draft-vanelburg-sipping-private-network-indication-03 (February 2009): "The Session Initiation Protocol (SIP) P-Private-Network-Indication Private-Header (P-Header)".

Editor's note: The above document cannot be formally referenced until it is published as an RFC.

[85] IETF RFC 5502 (April 2009): "The SIP P-Served-User Private-Header (P-Header) for the 3GPP IP Multimedia (IM) Core Network (CN) Subsystem".

[86] draft-dotson-sip-mutual-auth-03 (June 2008): "Proxy Mutual Authentication in SIP".

Editor's note: The above document cannot be formally referenced until it is published as an RFC.

[87] draft-dawes-sipping-debug-01 (July 2009): "Private Extension to the Session Initiation Protocol (SIP) for Debugging".

Editor's note: The above document cannot be formally referenced until it is published as an RFC.

[88] draft-ietf-sip-199-08 (April 2009): "Response Code for Indication of Terminated Dialog".

Editor's note: The above document cannot be formally referenced until it is published as an RFC.

[89] draft-ietf-sip-body-handling-06 (March 2009): "Message Body Handling in the Session Initiation Protocol (SIP)".

Editor's note: The above document cannot be formally referenced until it is published as an RFC.

[90] draft-holmberg-sip-keep-04 (March 2009): "Indication of support for keep-alive".

Editor's note: The above document cannot be formally referenced until it is published as an RFC.

[91] IETF RFC 5552 (May 2009): "SIP Interface to VoiceXML Media Services".

[92] IETF RFC 3862 (August 2004): "Common Presence and Instant Messaging (CPIM): Message Format".

[93] IETF RFC 5438 (December 2008): "Instant Message Disposition Notification".

[94] IETF RFC 5373 (November 2008): "Requesting Answering Modes for the Session Initiation Protocol (SIP)"

[95] draft-patel-ecrit-sos-parameter-06 (May 2009): "SOS Uniform Resource Identifier (URI) parameter for marking of Session Initiation Protocol (SIP) requests related to emergency services".

Editor's note: The above document cannot be formally referenced until it is published as an RFC.

[96] IETF RFC 3959 (December 2004): "The Early Session Disposition Type for the Session Initiation Protocol (SIP)".

[97] draft-rosenberg-sip-target-uri-delivery-01 (March 2009): "Delivery of Request-URI Targets to User Agents".

Editor's note: The above document cannot be formally referenced until it is published as an RFC.

[98] 3GPP TS 24.183: "Customized Ringing Signal (CRS) using IP Multimedia (IM) Core Network (CN) subsystem".

[99] 3GPP TS 24.259: "Personal Network Management (PNM) using IP Multimedia (IM) Core Network (CN) subsystem".

[100] 3GPP TS TS 24.238: "Session Initiation Protocol (SIP) based user configuration".

[101] 3GPP TS 24.239: "Flexible Alerting (FA) using IP Multimedia (IM) Core Network (CN) subsystem".

- [102] 3GPP TS 24.238: "Session Initiation Protocol (SIP) based user configuration".
- [103] 3GPP TS 24.654: "Closed User Group (CUG) using IP Multimedia (IM) Core Network (CN) subsystem".
- [104] 3GPP TS 24.238: "Session Initiation Protocol (SIP) based user configuration".
- [105] 3GPP TS 24.605: "Conference (CONF) using IP Multimedia (IM) Core Network (CN) subsystem".
- [106] 3GPP TS 24.147: "Conferencing using the IP Multimedia (IM) Core Network (CN) subsystem "
- [107] 3GPP TS 24.611 "Anonymous Communication Rejection (ACR) using IP Multimedia (IM); Core Network (CN) subsystem".
- [108] 3GPP TS 24.238: "Session Initiation Protocol (SIP) based user configuration".
- [109] 3GPP TS 24.642: "Completion of Communications to Busy Subscriber (CCBS) Completion of Communications by No Reply (CCNR) using IP Multimedia (IM) Core Network (CN) subsystem".
- [110] 3GPP TS 24.628: "Common Basic Communication procedures using IP Multimedia (IM) Core Network (CN) subsystem".
- [111] 3GPP TS 24.238: "Session Initiation Protocol (SIP) based user configuration".
- [112] 3GPP TS 24.606: "Message Waiting Indication (MWI) using IP Multimedia (IM) Core Network (CN) subsystem".
- [113] 3GPP TS 24.608: "Terminating Identification Presentation (TIP) and Terminating Identification Restriction (TIR) using IP Multimedia (IM); Core Network (CN) subsystem".
- [114] 3GPP TS 24.611: "Communication Barring (CB) using IP Multimedia (IM); Core Network (CN) subsystem".
- [115] 3GPP TS 24.238: "Session Initiation Protocol (SIP) based user configuration".
- [116] 3GPP TS 24.629: "Explicit Communication Transfer (ECT) using IP Multimedia (IM) Core Network (CN) subsystem".
- [117] 3GPP TS 24.604: "Communication DIVersion (CDIV) using IP Multimedia (IM) Core Network (CN) subsystem".
- [118] IETF RFC 4458: "Session Initiation Protocol (SIP) URIs for Applications such as Voicemail and Interactive Voice Response (IVR)".
- [119] 3GPP TS 24.238: "Session Initiation Protocol (SIP) based user configuration".

---

## 3 Definitions, symbols and abbreviations

### 3.1 Definitions

For the purposes of the present document, the terms and definitions given in 3GPP TR 21.905 [1] and the following apply. A term defined in the present document takes precedence over the definition of the same term, if any, in 3GPP TR 21.905 [1].

**example:** text used to clarify abstract rules by applying them literally.

**IM CN subsystem:** (IP Multimedia CN subsystem) comprises of all CN elements for the provision of IP multimedia applications over IP multimedia sessions, as specified in 3GPP TS 22.228 [9].

**IP multimedia session:** as specified in 3GPP TS 22.228 [9] an IP multimedia session is a set of multimedia senders and receivers and the data streams flowing from senders to receivers. IP multimedia sessions are supported by the IP

multimedia CN Subsystem and are enabled by IP connectivity bearers (e.g. GPRS as a bearer). A user may invoke concurrent IP multimedia sessions.

## 3.2 Symbols

For the purposes of the present document, the following symbols apply:

Ici	Reference Point between an IBCF and another IBCF or I-CSCF belonging to a different IM CN subsystem network
Izi	Reference Point between a TrGW and another TrGW or media handling node belonging to a different IM CN subsystem network
Mi	Reference Point between a BGCF and CSCF
Mm	Reference Point between a CSCF/BGCF/IMS ALG and an IP multimedia network.
Mw	Reference Point between a CSCF and another CSCF
Mx	Reference Point between a CSCF/BGCF and IBCF

## 3.3 Abbreviations

For the purposes of the present document, the abbreviations given in 3GPP TR 21.905 [1] and the following apply. An abbreviation defined in the present document takes precedence over the definition of the same abbreviation, if any, in 3GPP TR 21.905 [1].

IBCF	Interconnection Border Control Function
II-NNI	Inter-IMS Network to Network Interface
NA(P)T-PT	Network Address (Port-Multiplexing) Translation-Protocol Translation
TrGW	Transition Gateway

---

## 4 Overview

Interconnection between two different IM CN subsystems shall be guaranteed in order to support end-to-end service interoperability. For this purpose, Inter-IMS Network to Network Interface (II-NNI) between two IM CN subsystem networks is adopted, according to the assumptions coming from 3GPP TS 23.002 [3] and 3GPP TS 23.228 [4].

Aiming to support the delivery of IMS services between two separated IM CN subsystems, protocol interconnection has to occur:

- at a control plane level, in order that IMS procedures can be supported. In this case the adopted reference point is the Ici;
- at a user plane level, where media streams are exchanged over the Izi reference point.

The management of IP multimedia sessions is acted by using SIP. The transport mechanism for both SIP session signalling and media transport is IPv4 (IETF RFC 791 [2]) or IPv6 (IETF RFC 2460 [7]). The 3GPP profile of SIP defining the usage of SIP within the IM CN subsystem is specified in 3GPP TS 24.229 [5]. Example call flows are provided in 3GPP TR 24.930 [6].

The general interconnection model is shown in Figure 4.1.

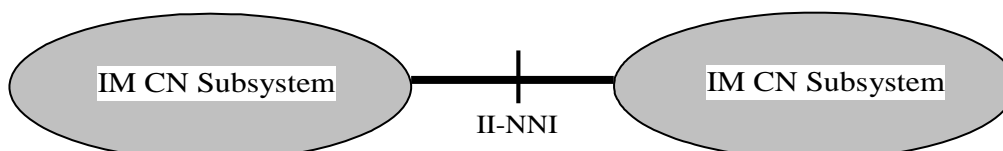

**Figure 4.1: Interconnection Model for IM CN Subsystems**

The possible functional entities involved in the signalling plane interconnection (IBCF, I-CSCF, BGCF) and in the user plane interconnection (TrGW) are specified in 3GPP TS 24.229 [5] and in 3GPP TS 29.162 [8].

IP Version interworking is described within 3GPP TS 29.162 [8].

## 5 Reference model for interconnection between IM CN subsystems

### 5.1 General

Figure 5.1 illustrates the architecture diagram given in 3GPP TS 23.228 [4] showing the Inter-IMS Network to Network Interface (II-NNI) between two IM CN subsystem networks.

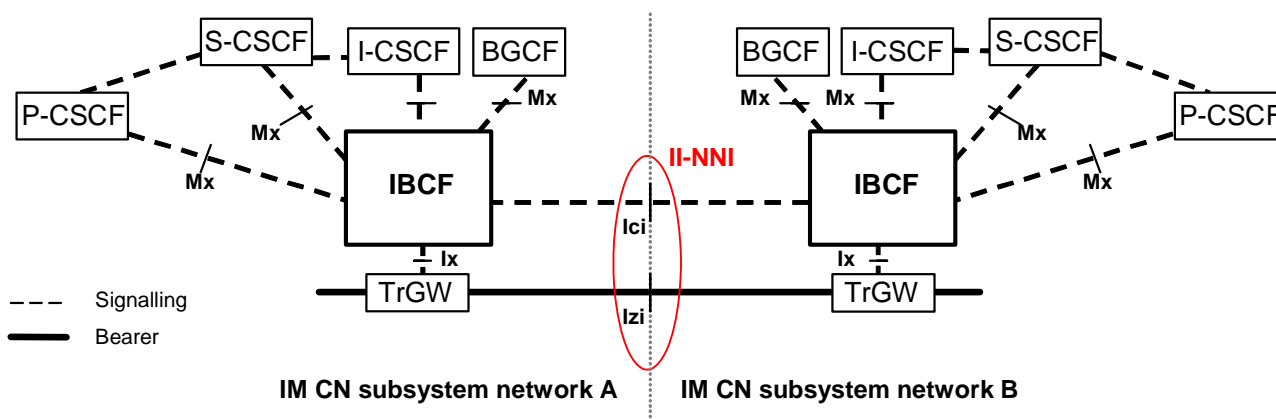

**Figure 5.1.1: Inter-IMS Network to Network Interface between two IM CN subsystem networks**

The protocols over the two reference points Ici and Izi make up the Inter-IMS Network to Network Interface.

The Ici reference point allows IBCFs to communicate with each other in order to provide the communication and forwarding of SIP signalling messaging between IM CN subsystem networks. The Izi reference point allows TrGWs to forward media streams between IM CN subsystem networks.

IMS roaming performed by using II-NNI is considered, when the IBCFs are inserted at the network borders.

Whenever the Inter-IMS Network to Network Interface is used to interconnect two IM CN subsystem networks belonging to different security domains, security procedures apply as described in 3GPP TS 33.210 [10].

## 5.2 Functionalities performed by entities at the edge of the network

### 5.2.1 Interconnection Border Control Function (IBCF)

An IBCF provides application specific functions at the SIP/SDP protocol layer in order to perform interconnection between IM CN subsystem networks by using Ici reference point. According to 3GPP TS 23.228 [4], it may act both as an entry point and as an exit point for a network.

The functionalities of IBCF are indicated in the 3GPP TS 23.228 [4] and specified in 3GPP TS 24.229 [5]: they include:

- network topology hiding;
- application level gateway (for instance enabling communication between IPv6 and IPv4 SIP applications, or between a SIP application in a private IP address space and a SIP application outside this address space);

- controlling transport plane functions;
- controlling media plane adaptations;
- screening of SIP signalling information;
- selecting the appropriate signalling interconnect;
- generation of charging data records;

Based on local configuration, the IBCF may perform transit routing functions [5].

The IBCF acts as a B2BUA when it performs IMS-ALG functionality.

## 5.2.2 Transition Gateway (TrGW)

According to 3GPP TS 23.002 [3], the TrGW is located at the network borders within the media path and is controlled by an IBCF. Forwarding of media streams between IM CN subsystem networks is applied over Izi reference point.

The TrGW provides functions like network address/port translation and IPv4/IPv6 protocol translation. NAT-PT binds addresses in IPv6 network with addresses in IPv4 network and vice versa to provide transparent routing between the two IP domains without requiring any changes to end points. NA(P)T-PT provides additional translation of transport identifier (TCP and UDP port numbers). The approach is similar to that one described also in 3GPP TS 29.162 [8].

Further details are described in 3GPP TS 23.228 [4].

---

# 6 Control plane interconnection

## 6.1 Definition of Inter-IMS Network to Network Interconnection

### 6.1.1 SIP methods and headers

#### 6.1.1.1 General

The functional entity closest to the border of an IMS network towards an Inter-IMS Network to Network Interconnection (see reference model in Clause 5) shall provide the capabilities specified for that network element in Annex A.2 of TS 24.229 [5] with modifications as described in the following sub-clauses.

#### 6.1.1.2 SIP methods

3GPP TS 24.229 [5] defines the methods allowing an IBCF to interconnect to an IBCF placed in another IM CN subsystem.

The following SIP Methods are supported on the II-NNI as defined in table 6.1.

The following table is based on Table A.5 and Table A.163 of TS 24.229 [5] and endorsed for this document:

**Table 6.1: Supported methods**

Item	Method	Ref.	II-NNI	
			Sending	Receiving
1	ACK request	[13]	m	m
2	BYE request	[13]	m	m
3	BYE response	[13]	m	m
4	CANCEL request	[13]	m	m
5	CANCEL response	[13]	m	m
5A	INFO request	[28]	o	o
5B	INFO response	[28]	o	o
8	INVITE request	[13]	m	m
9	INVITE response	[13]	m	m
9A	MESSAGE request	[19]	o	o
9B	MESSAGE response	[19]	o	o
10	NOTIFY request	[20]	c1	c1
11	NOTIFY response	[20]	c1	c1
12	OPTIONS request	[13]	m	m
13	OPTIONS response	[13]	m	m
14	PRACK request	[18]	m	m
15	PRACK response	[18]	m	m
15A	PUBLISH request	[21]	c1	c1
15B	PUBLISH response	[21]	c1	c1
16	REFER request	[22]	o	o
17	REFER response	[22]	o	o
18	REGISTER request	[13]	c2	c2
19	REGISTER response	[13]	c2	c2
20	SUBSCRIBE request	[20]	c1	c1
21	SUBSCRIBE response	[20]	c1	c1
22	UPDATE request	[23]	m	m
23	UPDATE response	[23]	m	m
c1:	In case of roaming scenario, the support of the method is m, else o.			
c2:	In case of roaming scenario, the support of the method is m, else n/a.			
NOTE:	In the above table, m, o and c and n/a have the meanings indicated in Table 6.3			

The methods described in Table 6.1 shall be passed transparently on the II-NNI.

### 6.1.1.3 SIP headers

#### 6.1.1.3.0 General

The IBCF shall provide the capabilities to manage and modify SIP headers according to section 5.10 and Annex A of TS 24.229 [5] with modifications as described in the following sub-clauses.

#### 6.1.1.3.1 Trust and no trust relationship

The IBCF acting as exit point shall apply the procedures described in clause 5.10.2 of TS 24.229 [5] before forwarding the SIP signalling to the IBCF acting as entry point; this one shall apply the procedures described in clause 5.10.3 of TS 24.229 [5].

Additionally, in case there is no trust relationship between the two IM CN subsystems connected by II-NNI, the IBCF acting as exit point shall apply the procedures described in clause 4.4 of TS 24.229 [5], before forwarding the SIP signalling to the next IBCF.

These procedures may be utilized on a per header basis to realize overall trust as well as per service level screening of headers. Trust relationships and trust domains may be defined by inter-operator agreements for individual services and/or individual SIP headers.

The management of the SIP headers (if present) over II-NNI in case of a presence or not of a trust relationship between the two interconnected IM subsystems is wrapped up in the following table.



**Table 6.2: Management of SIP headers over II-NNI in presence or not of a trust relationship**

Item	Header	Trust relationship	Not trust relationship
1	P-Asserted-Identity	As specified in 3GPP TS 24.229 [5], clause 4.4	As specified in 3GPP TS 24.229 [5], clause 4.4
2	P-Access-Network-Info	As specified in 3GPP TS 24.229 [5], clause 4.4	As specified in 3GPP TS 24.229 [5], clause 4.4
3	Resource-Priority	As specified in 3GPP TS 24.229 [5], clause 4.4	As specified in 3GPP TS 24.229 [5], clause 4.4
4	History-Info	As specified in 3GPP TS 24.229 [5], clause 4.4	As specified in Clause 4.3.3 of RFC 4244 [25] and in 3GPP TS 24.229 [5], clause 4.4
5	P-Asserted-Service	As specified in 3GPP TS 24.229 [5], clause 4.4 (NOTE 3)	As specified in 3GPP TS 24.229 [5], clause 4.4 (NOTE 3)
6	P-Charging-Vector (see RFC 3455 [24])	As specified in 3GPP TS 24.229 [5], clause 5.10	As specified in 3GPP TS 24.229 [5], clause 5.10
7	P-Charging-Function-Addresses (see RFC 3455 [24])	As specified in 3GPP TS 24.229 [5], clause 5.10	As specified in 3GPP TS 24.229 [5], clause 5.10
8	P-Profile-Key (NOTE 2)	As specified in 3GPP TS 24.229 [5], clause 4.4	As specified in 3GPP TS 24.229 [5], clause 4.4
9	P-Private-Network-Indication (NOTE 1)	As specified in 3GPP TS 24.229 [5], clause 4.4	As specified in 3GPP TS 24.229 [5], clause 4.4
10	P-Served-User (NOTE 1, NOTE 2)	As specified in 3GPP TS 24.229 [5], clause 4.4	As specified in 3GPP TS 24.229 [5], clause 4.4
11	Reason (in a response)	As specified in 3GPP TS 24.229 [5], clause 4.4	As specified in 3GPP TS 24.229 [5], clause 4.4
NOTE 1: For a roaming II-NNI between a home IMS and a visited IMS, a trust relationship with respect to this header is required.			
NOTE 2: This header is only applicable on an II-NNI between a home IMS and a visited IMS.			
NOTE 3: In addition, value-dependent operator policies may be applied.			

### 6.1.1.3.2 Derivation of applicable SIP headers from TS 24.229

For any method in Table 6.1, the SIP headers applicable on the II-NNI are detailed in the corresponding method tables for the UA role and proxy role sending behaviour in Annex A of 3GPP TS 24.229 [5]. Unless other information is specified in the normative part of the present specification, the applicability of headers at the II-NNI can be derived for each method from the corresponding tables in Annex A of 3GPP TS 24.229 [5] as follows:

- All headers not present in the corresponding tables in Annex A of 3GPP TS 24.229 or marked as 'n/a' in both the 'RFC status' and 'profile status' columns for the UA role and proxy role sending behaviour of that tables are not applicable at the II-NNI.

Note: Operators could choose to apply headers for new SIP extensions on an II-NNI based on bilateral agreements, but this is outside the scope of the present specification.

- All headers which are marked as 'o' in at least one of the 'RFC status' or the 'profile status' profile columns for the sending behaviour in the corresponding UA role and proxy role tables in Annex A of 3GPP TS 24.229 and as 'n/a' or 'o' in the other such columns are applicable at II-NNI based on bilateral agreement between operators.
- All headers which are marked as 'm' in at least one of the 'RFC status' or the 'profile status' columns for the sending behaviour in the corresponding UA role or proxy role table in Annex A of 3GPP TS 24.229 and as 'n/a', 'o', or 'm' in the other such columns are applicable at the II-NNI.
- If conditions are specified, they are also applicable at the II-NNI and the above rules are applicable to the 'n/a', 'o' and 'm' values within the conditions.

Note: In the above rules, the RFC profile columns are taken into account in order to enable interworking with non-3GPP networks,

An informative summary of SIP headers to be used over the II-NNI is proposed in Annex A.

#### 6.1.1.3.3 Applicability of SIP headers on a roaming II-NNI between home IMS and visited IMS

The following SIP headers are not applicable on a roaming II-NNI between a home IMS and a visited IMS:

- Proxy-Authentication
- Proxy-Authorization

#### 6.1.1.3.4 Applicability of SIP headers on an II-NNI between home IMS networks

The following SIP headers are not applicable on an II-NNI between home IMS networks:

- P-Called-Party-ID
- P-Preferred-Service
- P-Profile-Key
- P-Served-User
- P-Visited-Network-ID
- WWW-Authenticate

#### 6.1.1.4 Notations of the codes

In the table 6.1 the status codes m, o, c, i and n/a have the following meanings:

**Table 6.3: Key to notation codes for SIP messages**

Notation code	Notation name	Sending side	Receiving side
m	mandatory	The message shall be supported at II-NNI. Supporting sending a SIP message at the II-NNI means that this message shall be sent over the II-NNI if received from the serving network. It does not imply that network elements inside the serving network or user equipment connected to this network shall support this message.	Supporting receiving a SIP message at the II-NNI means that this message shall be forwarded to the serving network. It does not imply that network elements inside the served network or user equipment connected to this network are supporting this message.
o	optional	The message may or may not be supported at II-NNI. The support of the method is provided based on bilateral agreement between the operators.	Same as for sending side.
n/a	not applicable	It is impossible to use/support the message.	It is impossible to use/support the message. This element will be discarded by the IBCF.
c <integer>	conditional	The requirement on the message ("m", "o" or "n/a") depends on the support of other optional or conditional items. <integer> is the identifier of the conditional expression.	Same as for sending side.

#### 6.1.1.5 Modes of signalling

Overlap signalling may be used if agreement exists between operators to use overlap and which method to be used, otherwise enbloc shall be used at the NNI.

## 6.1.2 SDP protocol

### 6.1.2.1 General

The functional entity closest to the border of an IMS network towards an Inter-IMS Network to Network Interconnection (see reference model in Clause 5) shall provide the capabilities specified for that network element in Annex A.3 of TS 24.229 [5].

## 6.1.3 Major capabilities

This subclause contains the major capabilities to be supported over the II-NNI.

The following table 6.1.3.1 specifies which capabilities are applicable for II-NNI. The profile status codec within table 6.1.3.1 are defined in table 6.1.3.2.

For the "Basic SIP" capabilities part of table 6.1.3.1, the last column "Profile status over II-NNI" specifies the general status of applicability of the IETF RFC 3261 [13] main mechanisms described in the 2<sup>nd</sup> column "Capability over the Ici". For the "Extensions to basic SIP" capabilities part, the last column "Profile status over II-NNI" specifies the general status of applicability of the RFC referenced in the 2<sup>nd</sup> column "Capability over the Ici". If necessary, the applicability of this RFC at the II-NNI level is further detailed in the present Technical Specification.

The columns "Reference item in 3GPP TS 24.229 [5] for the profile status" provide informative references for comparison purposes into the UA and Proxy role major capabilities tables in 3GPP TS 24.229 [5], where the capabilities are defined via additional references.

Table 6.1.3.1: Major capabilities over II-NNI

Item	Capability over the ICI	Reference item in 3GPP TS 24.229 [5] for the profile status		Profile status over II-NNI
		UA Role (NOTE 1)	Proxy role (NOTE 2)	
	<b>Basic SIP (IETF RFC 3261 [13])</b>			
1	registrations	1, 2, 2A	-	c2
2	initiating a session	2B, 2C, 3, 4	-	m
3	terminating a session	5	3	m
4	General proxy behavior	-	4, 5, 14, 15, 19F	n/a
5	Forking of initial requests	9,10	6	m
6	support of indication of TLS connections in the Record-Route header	-	7, 8	n/a
7	usage of http authentication	7, 8, 8A	8A	c2
8	Timestamped requests (Timestamp header)	6	-	m
9	Presence of date in requests and responses (Date header)	11	9	m
10	Presence of alerting information data (Alert-info header)	12	10	o
11	Support and handling of the Require header for REGISTER and other requests or responses for methods other than REGISTER	-	11, 12, 13	m
12	Support and reading of the Supported and Unsupported headers	-	16, 17, 18	m
13	Support of the Error-Info header in 3XX, 4XX, 5XX, 6XX responses	-	19	o
14	Support and handling of the Organization header	-	19A, 19B	m
15	Support and handling of the Call-Info header	-	19C, 19D	m
16	Support of the Contact header in 3XX response	-	19E	m
	<b>Extensions to basic SIP</b>			
17	draft-ietf-sipcore-info-events-01 [39]: SIP INFO method and package framework	13	20	o
18	IETF RFC 3262 [18]: reliability of provisional responses in SIP (PRACK method)	14	21	m
19	IETF RFC 3515 [22]: the SIP REFER method	15	22	o
20	IETF RFC 3312 [40] and RFC 4032 [41]: integration of resource management and SIP (Preconditions framework)	16	23	o
21	IETF RFC 3311 [23]: the SIP UPDATE method	17	24	m
22	IETF RFC 3313 [42]: SIP extensions for media authorization (P-Media-Authorization header)	19	26	n/a
23	IETF RFC 3265 [20]: SIP specific event notification (SUBSCRIBE/NOTIFY methods)	20, 21, 22, 23	27, 28	c1
24	IETF RFC 3327 [43]: session initiation protocol extension header field for registering non-adjacent contacts (Path header)	24	29	c2
25	IETF RFC 3325 [44]: private extensions to the Session Initiation Protocol (SIP) for network asserted identity within trusted networks	25	30, 30A, 30B, 30C	c4
26	IETF RFC 3325 [44]: the P-Preferred-Identity header extension	-	-	n/a
27	IETF RFC 3325 [44]: the P-Asserted-Identity header extension	-	-	c4
28	IETF RFC 3323 [34]: a privacy mechanism for the Session Initiation Protocol (SIP) (Privacy header)	26, 26A, 26B, 26C, 26D, 26E, 26F, 26G, 26H	31, 31A, 31B, 31C, 31D, 31E, 31F, 31G, 31H	m
29	IETF RFC 3428 [19]: a messaging mechanism for the Session Initiation Protocol (SIP) (MESSAGE Method)	27	33	o
30	IETF RFC 3608 [45]: session initiation protocol extension header field for service route discovery during registration (Service-Route header)	28	32	c2
31	IETF RFC 3486 [46]: compressing the session initiation protocol	29	34	n/a
32	IETF RFC 3455 [24]: private header extensions to the session initiation protocol for the 3rd-Generation Partnership	30	35	o

	Project (3GPP)			
33	IETF RFC 3455 [24]: the P-Associated-URI header extension	31	36	c2
34	IETF RFC 3455 [24]: the P-Called-Party-ID header extension	32	37	c2
35	IETF RFC 3455 [24]: the P-Visited-Network-ID header extension	33	38, 39	c2
36	IETF RFC 3455 [24]: the P-Access-Network-Info header extension	34	41, 42, 43	c4
37	IETF RFC 3455 [24]: the P-Charging-Function-Addresses header extension	35	44, 44A	n/a
38	IETF RFC 3455 [24]: the P-Charging-Vector header extension	36	45, 46	c2
39	IETF RFC 3329 [47]: security mechanism agreement for the session initiation protocol	37	47	n/a
40	IETF RFC 3326 [48]: the Reason header field for the session initiation protocol	38	48	o
41	draft-jesske-sipping-etsi-ngn-reason-04 [49]: use of the Reason header field in Session Initiation Protocol (SIP) responses	38A	48A	c4
42	IETF RFC 3581 [50]: an extension to the session initiation protocol for symmetric response routing	39	49	
43	IETF RFC 3841 [51]: caller preferences for the session initiation protocol (Accept-Contact, Reject-Contact and Request-Disposition headers)	40, 40A, 40B, 40C, 40D, 40E, 40F	50, 50A, 50B, 50C, 50D, 50E, 50F	m
44	IETF RFC 3903 [21]: an event state publication extension to the session initiation protocol (PUBLISH method)	41	51	c1
45	IETF RFC 4028 [52]: SIP session timer (Session-Expires and Min-SE headers)	42	52	m
46	IETF RFC 3892 [53]: the SIP Referred-By mechanism	43	53	m
47	IETF RFC 3891 [54]: the Session Initiation Protocol (SIP) "Replaces" header	44	54	o
48	IETF RFC 3911 [55]: the Session Initiation Protocol (SIP) "Join" header	45	55	o
49	IETF RFC 3840 [56]: the callee capabilities	46	56	o
50	IETF RFC 4244 [25]: an extension to the session initiation protocol for request history information (History-Info header)	47	57	c4
51	IETF RFC 5079 [57]: Rejecting anonymous requests in the session initiation protocol	48	58	o
52	IETF RFC 4458 [58]: session initiation protocol URIs for applications such as voicemail and interactive voice response (NOTE 3)	49	59	o
53	IETF RFC 4320 [59]: Session Initiation Protocol's (SIP) non-INVITE transactions	50	61	m
54	IETF RFC 4457 [60]: the P-User-Database private header extension	51	60	n/a
55	IETF RFC 5031 [61]: a uniform resource name for services	52	62	n/a
56	draft-ietf-sip-gruu-15 [62]: obtaining and using GRUUs in the Session Initiation Protocol (SIP)	53	63	
57	draft-mahy-iptel-cpc-06 [63]: an extension to the session initiation protocol for request cpc information	54	64	c4
58	IETF RFC 4168 [27]: the Stream Control Transmission Protocol (SCTP) as a Transport for the Session Initiation Protocol (SIP)	55	65	o
59	IETF RFC 5002 [64]: the SIP P-Profile-Key private header extension	56	66, 66A, 66B	c3
60	IETF RFC 5626 [65]: managing client initiated connections in SIP	57	67	
61	draft-ietf-sip-ice-option-tag-02 [66]: indicating support for interactive connectivity establishment in SIP	58	-	n/a
62	IETF RFC 5365 [67]: multiple-recipient MESSAGE requests in the session initiation protocol	59	69	o if 29, else n/a
63	draft-ietf-sip-location-conveyance-13 [68]: SIP location conveyance (Geolocation header)	60	70, 70A, 70B	m
64	IETF RFC 5368 [69]: referring to multiple resources in the session initiation protocol	61	71	o if 19, else n/a
65	IETF RFC 5367 [70]: conference establishment using request-contained lists in the session initiation protocol	62	72	o

66	draft-ietf-sip-uri-list-subscribe-02 [71]: subscriptions to request-contained resource lists in the session initiation protocol	63	73	o if 23, else n/a
67	IETF RFC 4967 [72]: dialstring parameter for the session initiation protocol uniform resource identifier	64	74	c2
68	IETF RFC 4964 [73]: the P-Answer-State header extension to the session initiation protocol for the open mobile alliance push to talk over cellular	65	75	o
69	IETF RFC 5009 [74]: the SIP P-Early-Media private header extension for authorization of early media	66	76	m
70	IETF RFC 4694 [75]: number portability parameters for the "tel" URI	67, 67A, 67B	77, 77A, 77B	o
71	draft-yu-tel-dai-07 [76]: DAI Parameter for the "tel" URI	68	78	o
72	IETF RFC 4411 [77]: extending the session initiation protocol Reason header for preemption events	69	79	o
73	IETF RFC 4412 [78]: communications resource priority for the session initiation protocol? (Resource-Priority header)	70, 70A, 70B, 70C, 70D, 70E, 70F, 70G	80, 80A, 80B, 80C, 80D, 80E, 80F, 80G	c4
74	IETF RFC 5393 [79]: addressing an amplification vulnerability in session initiation protocol forking proxies	71	81	
75	IETF RFC 5049 [80]: the remote application identification of applying signalling compression to SIP	72	82	
76	draft-rosenberg-sip-app-media-tag-02 [81]: a session initiation protocol media feature tag for MIME application sub-types	73	83	
77	draft-drage-sipping-service-identification-03 [26]: Identification of communication services in the session initiation protocol	74	84, 84A	
78	IETF RFC 5360 [82]: a framework for consent-based communications in SIP?	75, 75A, 75B	85	
79	draft-johnston-sipping-cc-uu-08 [83]: transporting user to user information for call centers using SIP?	76	86	
80	draft-vanelburg-sipping-private-network-indication-03 [84]: The SIP P-Private-Network-Indication private-header (P-Header)	77	87	c1
81	IETF RFC 5502 [85]: the SIP P-Served-User private header	78	88	c2
82	draft-dotson-sip-mutual-auth-03 [86]: proxy mutual authentication in SIP	79	n/a	
83	draft-dawes-sipping-debug-01[87]: the P-Debug-ID header extension	80	90	o
84	draft-ietf-sip-199-08 [88]: the 199 (Early Dialog Terminated) response code)	81	91	
85	draft-ietf-sip-body-handling-06 [89]: message body handling in SIP	82	92	
86	draft-holmberg-sip-keep-04 [90]: indication of support for keep-alive	83	93	
87	IETF RFC 5552 [91]: SIP Interface to VoiceXML Media Services	84	94	
88	IETF RFC 3862 [92]: common presence and instant messaging (CPIM): message format	85	95	
89	IETF RFC 5438 [93] : instant message disposition notification	86	96	
90	IETF RFC 5373 [94]: requesting answering modes for SIP (Answer-Mode and Priv-Answer-Mode headers)	87	97, 97A	o
91	draft-patel-ecrit-sos-parameter-06 [95]: SOS URI parameter for marking SIP requests related to emergency calls	88	98	
92	IETF RFC 3959 [96]: the early session disposition type for SIP	89	99	
93	draft-rosenberg-sip-target-uri-delivery-01 [97]: delivery of Request-URI targets to user agents	90	100	
c1: m in case of roaming NNI between home and visited IMS, else o c2: m in case of roaming NNI between home and visited IMS, else n/a c3: o in case of roaming NNI between home and visited IMS, else n/a c4: m in case of trust relationship between the interconnected networks, else n/a				
NOTE 1: the item numbering corresponds to the one provided in Table A.4 in [5] NOTE 2: the item numbering corresponds to the one provided in Table A.162 in [5] NOTE 3: a common URI namespace is required to apply this feature on the II-NN				

Editor's Note: Profile status over II-NNI will be defined in this Release

**Table 6.1.3.2: Key to notation codes for major capabilities**

Notation code	Notation name	Explanation
m	mandatory	The capability shall be supported at II-NNI. SIP message relating to this capability shall be sent over the II-NNI if received from the serving network, unless they also make use of other unsupported capabilities. SIP headers or other information elements relating to this capability shall be passed over the II-NNI if received from the sending side. This does not imply that network elements inside the serving network or served network or user equipment connected to these networks shall support this capability.
o	optional	The capability may or may not be supported at II-NNI. The support of the capability is provided based on bilateral agreement between the operators.
n/a	not applicable	It is impossible to use/support the capability at the II-NNI.
c <integer>	conditional	The support of the capability ("m", "o" or "n/a") depends on the support of other optional or conditional items. <integer> is the identifier of the conditional expression.

## 6.2 Control Plane Transport

### 6.2.1 General

The control plane transport of the IMS Inter-Operator Service Interconnection Interface shall comply with Clause 4.2A of TS 24.229 [5].

Support of SCTP as specified in RFC 4168 [27] is optional for an IBCF connected by II-NNI. Nevertheless this option is favourable if the operators would like to improve reliability over the Icf.

---

## 7 User plane Interconnection

### 7.1 Media and Codec

For "end-to-end" media session involving the II-NNI, the SIP/SDP codec negotiation procedure can be applied between IM CN subsystems using different media codecs. It is possible that the end-to-end codec negotiation could fail because no common codec could be supported by the UEs, in particular for voice services.

To enhance interoperability, the IBCF, the MRFC, or other IMS network entities can interfere with the end-to-end codec negotiation to offer additional codec(s) available via transcoding, or to remove codecs. The IBCF can configure an attached TrGW to transcode, and the MRFC can configure an attached MRFP to transcode.

Codecs applicable at the NNI may be a subject of interworking agreements.

NOTE: Possible codecs which could be used at the II-NNI are described in 3GPP TS 26.114 [11] and ETSI TS 181 005 [12].

However, to avoid that transcoding is performed several times, applicable codecs at the NNI should be restricted as little as possible.

NOTE: Transcoding can be performed in an IMS network serving an SDP offerer or in an IMS network serving an SDP answerer. To avoid that transcoding is performed multiple times, inter-operator agreements can clarify if it is preferred that IMS network serving an SDP offerer or IMS network serving an SDP answerer modify an SDP offer to offer transcoding.

If the IBCF performs media transcoding control, it shall apply the related procedures in 3GPP TS 24.229 [5].

## 7.2 User Plane Transport

The user plane transport of the IMS Inter-Operator Service Interconnection Interface may use the protocols listed in Table 7.2.1. The used protocols to transport media are negotiated by means of SDP offer/answer.

**Table 7.2.1: Supported transport-level RFCs to be described in SIP/SDP messages**

Item	RFC	Title	Support
1	RFC 3550	RTP: A Transport Protocol for Real-Time Applications	Mandatory
2	RFC 768	User Datagram Protocol	Mandatory
3	RFC 3551	RTP Profile for Audio and Video Conferences with Minimal Control	Mandatory
4	RFC 3556	Session Description Protocol (SDP) Bandwidth Modifiers for RTP Control Protocol (RTCP) Bandwidth	Mandatory
5	RFC 4585	Extended RTP Profile for Real-time Transport Control Protocol (RTCP) - Based Feedback (RTP/AVPF)	Optional (NOTE 1)
6	RFC 793	Transmission Control Protocol	Optional (NOTE 2)
NOTE 1: used by MTSI, as indicated in 3GPP TS 26.114 [11]			
NOTE 2: used for MSRP service			

---

## 8 Numbering, Naming and Addressing

The following URI formats in SIP messages may be applied at the Ici as standardized in 3GPP TS 24.229 [5]:

- SIP URI defined in IETF RFC 3261 [13];
- tel URI defined in IETF RFC 3966 [14];
- IM URI defined in IETF RFC 3860 [15];
- PRES URI defined in IETF RFC 3859 [16].

Moreover, in case of MSRP sessions passing through the II-NNI, the MSRP URI may be also used at the Ici in the SDP exchange, following the formats defined in IETF RFC 4975 [17].

The IBCF shall support these URI formats. Other URI formats may be supported over the II-NNI depending on the operators' policies.

A global number as defined in RFC 3966 [14] shall be used in a Tel-URI or in the user portion of a SIP URI with the user=phone parameter when conveyed via a non-roaming interface in the Request URI and in the P-Asserted-Identity header.

NOTE 1: In a SIP URI the user portion of the request URI represents a telephone number only if the SIP URI includes user equal phone parameter.

NOTE 2: If bilateral agreements exist between operators non-global number (e.g. national service numbers.) can be transported in local format.

NOTE 3: The IMS entities involved in the modification of the format of the Request-URI header are defined in 3GPP TS 24.229 [5]. Suitable configuration by the operator is needed to achieve the desired modification of the format.

**Editor's note: The involved entities require further checking.**

NOTE 4: The allowed phone numbers format in P-Asserted-Identities of a served user are configured by the operator. According to 3GPP TS 23.003 [35], those P-Asserted-Identities have international E.164 format.



---

## 9 IP Version

The network elements interconnected by means of the II-NNI may support IPv4 only, IPv6 only or both.

The support of one or both of the IP versions is an operator option and should be based on bilateral agreement.

In case IPv4 and IPv6 networks are interconnected, the involved IBCFs and TrGWs shall apply the IP version interworking procedures as indicated in 3GPP TS 29.162 [8].

---

## 10 Security

The supported security mechanisms for IP signalling transport over II-NNI interfaces are described in 3GPP TS 33.210 [10].

---

## 11 Charging

The accounting information to be supported over the Ici is described in 3GPP TS 32.260 [29]. It shall be configurable by the operator to use or not the accounting mechanisms provided by the IBCF.

---

## 12 Supplementary services associated with the IMS multimedia telephony communication service

### 12.1 General

In order to assure the end-to-end service interoperability through the Inter-IMS Network to Network Interface (II-NNI), associated supplementary services of the multimedia telephony communication service may be supported on the II-NNI between the two IMS networks. If they are supported, the related procedures from the 3GPP TS 22.173 [30], the protocol details from the 3GPP TS 24.173 [31] and specifications referenced in the later specification shall be applied with the following restrictions due to the crossing of the II-NNI.

### 12.2 Malicious Communication IDentification (MCID)

Service specific requirements in accordance with 3GPP TS 24.616 [33] shall be supported over the II-NNI.

The INFO request and the 200 (OK) response to the INFO request containing the application/vnd.etsi.mcid+xml body defined in 3GPP TS 24.616 [33] may be supported at the II-NNI.

If a network terminating the dialog supports MCID, the terminating network shall only deliver the MCID request in the mcid+xml body, as specified in the 3GPP TS 24.616 [33], if an agreement to use the MCID supplementary service according to the 3GPP TS 24.616 [33] exists with the network originating the dialog and if the INVITE request received by the terminating network does not contain the information of the originating party.

**NOTE:** The IBCF and the AS in the terminating network interact to deliver the MCID request only if an agreement to use the MCID supplementary service exists, as specified in 3GPP TS 24.616 [33] and 3GPP TS 24.229 [5].

### 12.3 Originating Identification Presentation (OIP) and Originating Identification Restriction (OIR)

Service specific requirements in accordance with 3GPP TS 24.607 [32] shall be supported over the II-NNI.

The P-Asserted-Identity header and the Privacy header with values "id", "user", "none" and "header" shall be supported at the II-NNI.

**Editor's Note:** The handling of the "critical" value of the Privacy header field is ffs.

NOTE 1: Where a trust relationship exists on the P-Asserted-Identity header between the two IMS networks, this header cannot be altered when passing through the II-NNI according to 3GPP TS 24.229 [5]. Where no trust relationship exists on the P-Asserted-Identity header between the two IMS networks, the P-Asserted-Identity header will be removed by the IBCF of the originating network prior passing through the II-NNI according to the 3GPP TS 24.229 [5].

NOTE 2: The From header cannot be altered when passing through the II-NNI and will be passed transparently by the IBCF. If a request is received by the terminating network and the application of the OIR service is required with the value "user" for the Privacy header then the From header will be anonymised in accordance with RFC 3323 [34] by the terminating network.

SIP based user configuration as described in 3GPP TS 24.238 [100] shall be supported at the roaming II-NNI.

## 12.4 Terminating Identification Presentation (TIP) and Terminating Identification Restriction (TIR)

Service specific requirements in accordance with 3GPP TS 24.608 [113] shall be supported over the II-NNI.

The P-Asserted-Identity header and the Privacy header with values "id", "user", "none" and "header" shall be supported at the II-NNI.

**Editor's Note:** The handling of the "critical" value of the Privacy header field is ffs.

## 12.5 Anonymous Communication Rejection (ACR)

Service specific requirements in accordance with 3GPP TS 24.611 [107] shall be supported over the II-NNI.

Procedures as described in subclause 12.21.2 are used to provide announcements.

The response code 433 (Anonymity Disallowed) shall be supported at the II-NNI.

SIP based user configuration as described in 3GPP TS 24.238 [108] shall be supported at the roaming II-NNI.

## 12.6 Communication DIVersion (CDIV)

Service specific requirements in accordance with 3GPP TS 24.604 [117] shall be supported over the II-NNI.

NOTE 1: The support of the Diversion header not adopted in 3GPP TS 24.604 requires bilateral agreement between the operators. Procedures as described in subclause 12.21.2 are used to provide announcements.

The History-Info header as described by 3GPP TS 24.604 [117] and the Cause-Codes as defined by the IETF RFC 4458 [118] shall be supported over the II-NNI.

The response code 181 (Call Is Being Forwarded) shall be supported at the II-NNI. The SUBSCRIBE requests with the event package name "comm-div-info" and the NOTIFY request procedure as specified in IETF RFC 3265 [20] and 3GPP TS 24.229 [5] shall be supported at the roaming II-NNI if CDIVN is provided.

The MESSAGE request procedure as specified in IETF RFC 3428 [19] and 3GPP TS 24.229 [5] should be supported at the roaming II-NNI if CDIVN is provided.

NOTE 2: The content of the MESSAGE request is operator specific.

SIP based user configuration as described in 3GPP TS 24.238 [119] shall be supported at the roaming II-NNI.

## 12.7 Communication Waiting (CW)

Service specific requirements in accordance with 3GPP TS 24.615 [37] shall be supported over the II-NNI.

The INVITE method containing the application/vnd.3gpp.cw+xml body defined in 3GPP TS 24.615 [37] shall be supported at the roaming II-NNI.

The Alert-Info header set to "urn:alert:service:call-waiting" in a 180 (Ringing) response shall be supported at the II-NNI.

As a network option, in case of expiry of the CW timer, the response code 480 (Temporarily Unavailable) including a Reason header field set to cause 19 shall be supported at the non-roaming II-NNI.

Procedures as described in subclause 12.21.2 are used to provide announcements.

## 12.8 Communication HOLD (HOLD)

Service specific requirements in accordance with 3GPP TS 24.610 [36] shall be supported over the II-NNI.

NOTE: The support of an alternative method not adopted in 3GPP TS 24.610 requires bilateral agreement between the operators and is outside the scope of the present document.

Procedures as described in subclause 12.21.3 are used to provide announcements.

## 12.9 Message Waiting Indication (MWI)

Service specific requirements in accordance with 3GPP TS 24.606 [112] shall be supported over the II-NNI.

The SUBSCRIBE request with the event package name "message-summary" and NOTIFY request procedures according to IETF RFC 3265 [20] and 3GPP TS 24.229 [5] shall be supported at the roaming II-NNI.

The "simple-message-summary+xml" body described in 3GPP TS 24.606 [112] in the NOTIFY request shall be supported at the roaming II-NNI.

## 12.10 Communication Barring (CB)

### 12.10.1 Incoming Communication Barring (ICB)

Service specific requirements in accordance with 3GPP TS 24.611 [114] shall be supported over the II-NNI.

Procedures as described in subclause 12.21.2 are used to provide announcements.

The response code 603 (Decline) including a Reason header as described in 3GPP TS 24.611 [114] shall be supported at the II-NNI.

The BYE request including a Reason header as described in 3GPP TS 24.611 [114] shall be supported at the II-NNI.

SIP based user configuration as described in 3GPP TS 24.238 [115] shall be supported at the roaming II-NNI.

### 12.10.2 Outgoing Communication Barring (OCB)

Service specific requirements in accordance with 3GPP TS 24.611 [114] shall be supported over the II-NNI.

Procedures as described in subclause 12.21.2 are used to provide announcements.

The response code 603 (Decline) including a Reason header as described in 3GPP TS 24.611 [114] shall be supported at the roaming II-NNI.

SIP based user configuration as described in 3GPP TS 24.238 [115] shall be supported at the roaming II-NNI.

## 12.11 Completion of Communications to Busy Subscriber (CCBS)

Service specific requirements in accordance with 3GPP TS 24.642 [109] shall be supported over the II-NNI.

The response code 486 (Busy Here) containing a Call-Info header field with a "purpose" header field parameter set to "call-completion" shall be supported at the non-roaming II-NNI.

For invoking and revoking of the CCBS supplementary service, announcement procedures shall be used to provide announcements and inband-interaction procedures as described in subclause 12.21.2 shall be supported at the roaming II-NNI.

The response code 199 (Early Dialog Terminated) shall be supported at the roaming II-NNI.

Basic call procedures and in case of a call-completion recall initiated by a REFER request, normal REFER method handling procedures according to 3GPP TS 24.229 [5] shall supported at the roaming II-NNI.

As a network option the special REFER request handling procedures according to 3GPP TS 24.628 [110] should be supported at the roaming II-NNI.

NOTE: 3<sup>rd</sup> party call control procedures can be used when the REFER request is not supported at the II-NNI.

The SUBSCRIBE and NOTIFY methods according to IETF RFC 3265 [20] and 3GPP TS 24.229 [5] containing the event package name "call-completion" shall be supported at the non-roaming interface II-NNI.

SIP based user configuration as described in 3GPP TS 24.238 [111] shall be supported at the roaming II-NNI.

## 12.12 Completion of Communications by No Reply (CCNR)

Service specific requirements in accordance with 3GPP TS 24.642 [109] shall be supported over the II-NNI.

The response code 180 (Ringing) containing a Call-Info header with a purpose parameter set to 'call-completion' shall be supported at the non-roaming interface.

For invoking and revoking of the CCNR supplementary service, announcement procedures shall be used to provide announcements and inband-interaction procedures as described in subclause 12.21.2 shall be supported at the roaming II-NNI.

The response code 199 (Early Dialog Terminated) shall be supported at the roaming II-NNI.

Basic call procedures and in case of a call-completion recall initiated by a REFER request, normal REFER method handling procedures according to 3GPP TS 24.229 [5] shall supported at the roaming II-NNI.

As a network option the special REFER request handling procedures according to 3GPP TS 24.628 [110] should be supported at the roaming II-NNI.

NOTE: 3<sup>rd</sup> party call control procedures can be used when the REFER request is not supported at the II-NNI.

The SUBSCRIBE and NOTIFY methods according to IETF RFC 3265 [20] and 3GPP TS 24.229 [5] containing the event package name "call-completion" shall be supported at the non-roaming interface II-NNI.

SIP based user configuration as described in 3GPP TS 24.238 [111] shall be supported at the roaming II-NNI.

## 12.13 Explicit Communication Transfer (ECT)

Service specific requirements in accordance with 3GPP TS 24.629 [116] shall be supported over the II-NNI.

The REFER method, the Referred-By header and the Replaces header as specified in 3GPP TS 24.629 [116] shall be supported at the II-NNI for call tranfer without third party call control.

The REFER method, the Referred-By header and the Replaces header as specified in 3GPP TS 24.629 [116] shall only be supported at the roaming II-NNI for call tranfer with third party call control.

## 12.14 Customized Alerting Tone (CAT)

Editor's Note: To be completed

## 12.15 Customized Ringing Signal (CRS)

Service specific requirements in accordance with 3GPP TS 24.183 [98] shall be supported over the II-NNI.

Editor's Note: To be completed when the 3GPP TS 24.183 [98] is a TSG approved document under change control.

## 12.16 Closed User Group (CUG)

Service specific requirements in accordance with 3GPP TS 24.654 [103] shall be supported over the II-NNI.

The application/vnd.etsi.cug+xml MIME as specified 3GPP TS 24.654 [103] shall be supported in INVITE requests at the II-NNI.

The 403 (Forbidden) response, the 603 (Decline) response and the 500 (Server Internal Error) response shall be supported at II-NNI.

SIP based user configuration as described in 3GPP TS 24.238 [104] shall be supported at the roaming II-NNI.

## 12.17 Personal Network Management (PNM)

Service specific requirements in accordance with 3GPP TS 24.259 [99] shall be supported over the II-NNI.

The Contact header of the REGISTER request containing g.3gpp.iari\_ref feature tag with the value urn:urn-7:3gpp-application.ims.iari.pnm-controller shall be supported at the roaming II-NNI.

The Accept-Contact header containing a g.3gpp.iari\_ref feature with the value urn:urn-7:3gpp-application.ims.iari.pnm-controller shall be supported at the II-NNI.

The History-Info header and Supported header containing the "histinfo" option tag as described by 3GPP TS 24.259 [99] shall be supported at II-NNI.

## 12.18 Three-Party (3PTY)

Service specific requirements in accordance with 3GPP TS 24.605 [105] shall be supported over the II-NNI.

NOTE: The requirements below can be relaxed by bilateral agreements between operators.

The requirements for the 3PTY supplementary service are the same as for the CONF supplementary service specified in subclause 12.19 with the following additional requirement:

- A Replaces header in the header portion of the SIP URI of the Refer-to header of the REFER request shall be supported at II-NNI.

## 12.19 Conference (CONF)

Service specific requirements in accordance with 3GPP TS 24.605 [105] shall be supported over the II-NNI.

NOTE: The requirements below can be relaxed by bilateral agreements between operators.

The REFER request and NOTIFY request procedures according to 3GPP TS 24.229 [5] shall be supported at II-NNI.

The application/resource-lists+xml body shall be supported at II-NNI.

The Referred-By header in the INVITE request shall be supported at the II-NNI.

The "isfocus" feature parameter indicated in Contact header of the INVITE request and in the 200 (OK) response shall be supported at the II-NNI.

The SUBSCRIBE request including the "conference" event package name in the Event header and the NOTIFY request procedures according to 3GPP TS 24.147 [106] shall be supported at the II-NNI.

The REFER including the "method" parameter set to "BYE" according to 3GPP TS 24.147 [106] shall be supported in the II-NNI.

## 12.20 Flexible Alerting (FA)

Service specific requirements in accordance with 3GPP TS 24.239 [101] shall be supported over the II-NNI.

The 486 (Busy Here) response code shall be supported at the II-NNI.

SIP based user configuration as described in 3GPP TS 24.238 [102] shall be supported at the roaming II-NNI.

## 12.21 Announcements

### 12.21.1 General

Announcements may be provided during the establishment of a communication session or during an established communication session. Both of them shall be managed over the II-NNI.

### 12.21.2 Providing announcements during the establishment of a communication session

Procedures as described in 3GPP TS 24.628 [38] are used to provide announcements.

In case of provision of an announcement to a user over the II-NNI during the establishment of a communication, one of the following headers shall be supported at the II-NNI:

- the Alert-Info header in the 180 (Ringing) response to the INVITE request; or.
- the P-Early-Media header authorizing early media as defined in IETF RFC 5009 [12]

NOTE: The IBCF can decide to remove the Alert-Info header if required by local policy.

### 12.21.3 Providing announcements during an established communication session

Procedures as described in 3GPP TS 24.628 [38] are used to provide announcements.

In case of provision of an announcement to a user over the II-NNI during an established communication, the Call-Info header in a re-INVITE request should be supported at the II-NNI.

NOTE 1: An alternative method to provide announcements is to use the existing media stream.

NOTE 2: The IBCF can decide to remove the Call-Info header if required by local policy.

---

## Annex A (informative): Summary of SIP headers

A summary of the SIP headers to be used in case of interconnection by using II-NNI is proposed in Table A.1.

The starting point is the sending behaviour described for proxy and UA roles in Annex A of TS 24.229 [5]. In case of misalignment between Table A.1 and the behaviour described in [5], the [5] has the precedence. In case a header is not described in Table A.1 and it is described in [5], description in [5] is applicable over II-NNI.

The notation of the codes used for the SIP headers listed in table A.1 has a different meaning to the one proposed for the SIP messages. The definition of these terms is provided in table A.2.

Table A.1: Supported headers

Item	Header	Ref.	II-NNI
1	Accept	[5]	m
2	Accept-Contact	[5]	m
3	Accept-Encoding	[5]	m
4	Accept-Language	[5]	m
5	Alert-Info	[5]	o
6	Allow	[5]	m
7	Allow-Events	[5]	m
8	Authentication-Info	[5]	m
9	Authorization	[5]	m
9a	Answer-Mode	[5]	o
10	Call-ID	[5]	m
11	Call-Info	[5]	m
12	Contact	[5]	m
13	Content-Disposition	[5]	m
14	Content-Encoding	[5]	m
15	Content-Language	[5]	m
16	Content-Length	[5]	m
17	Content-Type	[5]	m
18	Cseq	[5]	m
19	Date	[5]	m
20	Error-Info	[5]	o
21	Expires	[5]	m
22	Event	[5]	m
23	From	[5]	m
24	Geolocation	[5]	m
25	History-Info	sub-clause 6.1.1.3.1 (Table 6.2, item 4)	m in case of a trust relationship between the interconnected networks, else n/a
26	In-Reply-To	[5]	o
27	Join	[5]	o
27a	Max-Breadth	[5]	n/a
28	Max-Forwards	[5]	m
29	Min-Expires	[5]	m
30	MIME-Version	[5]	m
31	Min-SE	[5]	m
32	Organization	[5]	m
33	P-Access-Network-Info	sub-clause 6.1.1.3.1 (Table 6.2, item 2)	m in case of a trust relationship between the interconnected networks, else n/a
33a	P-Answer-state	[5]	o
34	P-Asserted-Identity	sub-clause 6.1.1.3.1 (Table 6.2, item 1)	m in case of a trust relationship between the interconnected networks, else n/a
35	P-Asserted-Service	sub-clause 6.1.1.3.1 (Table 6.2, item 5)	m in case of a trust relationship between the interconnected networks, else n/a
35a	P-Associated-URI	[5]	m on roaming NNI between home and visited IMS, else n/a
36	P-Called-Party-ID	[5]	m on roaming NNI between home and visited IMS, else n/a
37	P-Charging-Function-Addresses	sub-clause 6.1.1.3.1 (Table 6.2, item 7)	n/a
38	P-Charging-Vector	sub-clause 6.1.1.3.1 (Table 6.2, item 6)	m in case of a trust relationship between the interconnected networks, else n/a
38a	P-Debug-Id	[5]	o
39	P-Early-Media	[5]	m



Item	Header	Ref.	II-NNI
40	P-Media-Authorization	[5]	n/a
41	P-Preferred-Identity	[5]	n/a
42	P-Preferred-Service	[5]	m on roaming NNI between home and visited IMS, else n/a
43	P-Private-Network-Indication	sub-clause 6.1.1.3.1 (Table 6.2, item 9)	m on roaming NNI between home and visited IMS, else o
44	P-Profile-Key	sub-clause 6.1.1.3.1 (Table 6.2, item 8)	o on roaming NNI between home and visited IMS, else n/a
45	P-Served-User	sub-clause 6.1.1.3.1 (Table 6.2, item 10)	m on roaming NNI between home and visited IMS, else n/a
46	P-User-Database	[5]	n/a
47	P-Visited-Network-ID	[5]	m on roaming NNI between home and visited IMS, else n/a
47a	Path	[5]	m on roaming NNI between home and visited IMS, else n/a
48	Priority	[5]	o
48a	Priv-Answer-Mode	[5]	o
49	Privacy	[5]	m
50	Proxy-Authentication	[5]	m on NNI between home IMS A and home IMS B, else n/a
51	Proxy-Authorization	[5]	m on NNI between home IMS A and home IMS B, else n/a
52	Proxy-Require	[5]	m
53	Reason	[5] and sub-clause 6.1.1.3.1 (Table 6.2, item 11)	o when in a request. When in a response, m in case of a trust relationship between the interconnected networks, else n/a
54	Record-Route	[5]	m
55	Referred-By	[5]	m
56	Reject-Contact	[5]	m
57	Replaces	[5]	o
58	Reply-To	[5]	o
59	Request-Disposition	[5]	m
60	Require	[5]	m
61	Resource-Priority	sub-clause 6.1.1.3.1 (Table 6.2, item 3)	m in case of a trust relationship between the interconnected networks, else n/a
62	Route	[5]	m
63	Security-Client	[5]	n/a
64	Security-Verify	[5]	n/a
65	Server	[5]	o
65a	Service-Route	[5]	m on roaming NNI between home and visited IMS, else n/a
66	Session-Expires	[5]	m
67	Subject	[5]	o
68	Supported	[5]	m
69	Timestamp	[5]	m
70	To	[5]	m
71	Trigger-Consent	[5]	m
71a	Unsupported	[5]	m
72	User-Agent	[5]	m
73	User-to-User	[5]	o
74	Via	[5]	m
75	Warning	[5]	o
76	WWW-Authenticate	[5]	m on roaming NNI between home and visited IMS, else n/a

**Table A.2: Key to notation codes for SIP headers**

<b>Notation code</b>	<b>Meaning</b>
m	The SIP header is applicable at II-NNI. Supporting a SIP header at the II-NNI means that this header is passed through the IBCF. It does not imply that network elements inside the serving and served networks or user equipment connected to these networks shall support this header, where 3GPP TS 24.229 [5] is applied. If specified in 3GPP TS 24.229, an IBCF modifies the SIP header.
o	The applicability of SIP header at II-NNI depends on bilateral agreement between the operators.
n/a	It is impossible to use the SIP header at the II-NNI. This header could be discarded by the IBCF.

## Annex B: Change history

Change history							
Date	TSG #	TSG Doc.	CR	Rev	Subject/Comment	Old	New
4/05/2008					TS Skeleton (C3-080779)	-	0.0.0
07/07/2008					Added agreed text of C3-080991, C3-081158 and C3-081208	0.0.0	0.1.0
28/08/2008					Added agreed text of C3-081282 and C3-081672	0.1.0	0.2.0
01/09/2008					Version 1.0.0 created for presentation to TSG by MCC	0.2.0	1.0.0
17/10/2008					Added agreed text of C3-081721 and C3-082105	1.0.0	1.1.0
20/11/2008					Added agreed text of C3-082303, C3-082446, C3-082447 and C3-082611	1.0.0	1.2.0
26/11/2008					v 2.0.0 was produced by MCC for Approval in CT#42	1.2.0	2.0.0
13/12/2008	TSG#42				V 8.0.0 was produced by MCC	2.0.0	8.0.0
03/2008	TSG#43	CP-090087	002	3	Charging requirements on II-NNI	8.0.0	8.1.0
03/2008	TSG#43	CP-090087	004	1	Modification of the REFER method status	8.0.0	8.1.0
03/2008	TSG#43	CP-090087	007	2	NNI header tables	8.0.0	8.1.0
05/2009	TSG#44	CP-090341	008	4	Use of E.164 number at the II-NNI	8.1.0	8.2.0
05/2009	TSG#44	CP-090341	009	4	Correction to SIP headers table	8.1.0	8.2.0
09/2009	TSG#45	CP-090576	017	1	Removal of left-over text from TS drafting phase and update of a reference	8.2.0	8.3.0
09/2009	TSG#45	CP-090576	018	2	Applicability of SIP headers for roaming II-NNI	8.2.0	8.3.0
09/2009	TSG#45	CP-090576	019	1	Application level gateway usage to enable communication from private IP address space	8.2.0	8.3.0
09/2009	TSG#45	CP-090576	020	3	Codecs at the NNI	8.2.0	8.3.0
09/2009	TSG#45	CP-090584	011	4	Major capabilities on II-NNI	8.3.0	9.0.0
09/2009	TSG#45	CP-090584	013	4	Management of SIP headers over II-NNI in presence of trust or no trusted relationship (V1)	8.3.0	9.0.0
09/2009	TSG#45	CP-090584	015	4	Requirements for the end-to-end interoperability of supplementary services	8.3.0	9.0.0
09/2009	TSG#45	CP-090584	016	3	Deletion of the note about the normalization of phone numbers	8.3.0	9.0.0
12/2009	TSG#46	CP-090854	021	5	Requirements for HOLD service over II-NNI	9.0.0	9.1.0
12/2009	TSG#46	CP-090854	022	5	Requirements for CW service over II-NNI	9.0.0	9.1.0
12/2009	TSG#46	CP-090844	024	3	Aligning references to P-Asserted-Service	9.0.0	9.1.0
12/2009	TSG#46	CP-090844	026		Annex A header updated with Answer-Mode, Priv-Answer-Mode and P-Answer-State	9.0.0	9.1.0
12/2009	TSG#46	CP-090854	031	6	Filling of the table about major capabilities on II-NNI	9.0.0	9.1.0
12/2009	TSG#46	CP-090854	032	1	Customized Ringing Signal (CRS) modification	9.0.0	9.1.0
12/2009	TSG#46	CP-090854	033	2	Completing the Personal Network Management (PNM) supplementary service	9.0.0	9.1.0
12/2009	TSG#46	CP-090854	034	1	Aligning existing supplementary services	9.0.0	9.1.0
12/2009	TSG#46	CP-090854	035	1	Completing the Flexible Alerting (FA) supplementary service	9.0.0	9.1.0
12/2009	TSG#46	CP-090854	036	1	Completing the Closed User Group (CUG) supplementary service	9.0.0	9.1.0
12/2009	TSG#46	CP-090854	037	3	Completing the Three-Party (3PTY) and Conference (CONF) supplementary services	9.0.0	9.1.0
12/2009	TSG#46	CP-090854	038	3	Completing the Anonymous Communication Rejection (ACR) supplementary service	9.0.0	9.1.0
12/2009	TSG#46	CP-090854	039	3	Completing Completion of Communications to Busy Subscriber (CCBS) and Completion of Communications by No Reply (CCNR) supplementary services	9.0.0	9.1.0
12/2009	TSG#46	CP-090854	040		Completing Message Waiting Indication (MWI) supplementary service	9.0.0	9.1.0
12/2009	TSG#46	CP-090854	041	1	Completing the Terminating Identification Presentation (TIP) and Terminating Identification Restriction (TIR) needs to be completed.	9.0.0	9.1.0
12/2009	TSG#46	CP-090854	042	3	Completing the Communication Barring (CB) supplementary service	9.0.0	9.1.0
12/2009	TSG#46	CP-090854	043	2	Completing Explicit Communication Transfer (ECT)	9.0.0	9.1.0
12/2009	TSG#46	CP-090854	044	3	Completing Communication DIVersion (CDIV) supplementary services	9.0.0	9.1.0
12/2009	TSG#46	CP-090854	046	2	Deletion of an editors note on OIR service	9.0.0	9.1.0
12/2009	TSG#46	CP-090844	047	3	Annex A header updated	9.0.0	9.1.0

---

# History

<b>Document history</b>		
V9.1.0	January 2010	Publication