

# ETSI TS 129 007 V3.12.0 (2003-06)

---

*Technical Specification*

**Digital cellular telecommunications system (Phase 2+);  
Universal Mobile Telecommunications System (UMTS);  
General requirements on interworking between  
the Public Land Mobile Network (PLMN) and  
the Integrated Services Digital Network (ISDN) or  
Public Switched Telephone Network (PSTN)  
(3GPP TS 29.007 version 3.12.0 Release 1999)**

---



---

Reference

RTS/TSGN-0329007v3c0

---

Keywords

GSM, UMTS

**ETSI**

650 Route des Lucioles  
F-06921 Sophia Antipolis Cedex - FRANCE

Tel.: +33 4 92 94 42 00 Fax: +33 4 93 65 47 16

Siret N° 348 623 562 00017 - NAF 742 C  
Association à but non lucratif enregistrée à la  
Sous-Préfecture de Grasse (06) N° 7803/88

---

**Important notice**

Individual copies of the present document can be downloaded from:

<http://www.etsi.org>

The present document may be made available in more than one electronic version or in print. In any case of existing or perceived difference in contents between such versions, the reference version is the Portable Document Format (PDF). In case of dispute, the reference shall be the printing on ETSI printers of the PDF version kept on a specific network drive within ETSI Secretariat.

Users of the present document should be aware that the document may be subject to revision or change of status. Information on the current status of this and other ETSI documents is available at

<http://portal.etsi.org/tb/status/status.asp>

If you find errors in the present document, send your comment to:

[editor@etsi.org](mailto:editor@etsi.org)

---

**Copyright Notification**

No part may be reproduced except as authorized by written permission.  
The copyright and the foregoing restriction extend to reproduction in all media.

© European Telecommunications Standards Institute 2003.  
All rights reserved.

**DECT**<sup>TM</sup>, **PLUGTESTS**<sup>TM</sup> and **UMTS**<sup>TM</sup> are Trade Marks of ETSI registered for the benefit of its Members.  
**TIPHON**<sup>TM</sup> and the **TIPHON logo** are Trade Marks currently being registered by ETSI for the benefit of its Members.  
**3GPP**<sup>TM</sup> is a Trade Mark of ETSI registered for the benefit of its Members and of the 3GPP Organizational Partners.

---

## Intellectual Property Rights

IPRs essential or potentially essential to the present document may have been declared to ETSI. The information pertaining to these essential IPRs, if any, is publicly available for **ETSI members and non-members**, and can be found in ETSI SR 000 314: *"Intellectual Property Rights (IPRs); Essential, or potentially Essential, IPRs notified to ETSI in respect of ETSI standards"*, which is available from the ETSI Secretariat. Latest updates are available on the ETSI Web server (<http://webapp.etsi.org/IPR/home.asp>).

Pursuant to the ETSI IPR Policy, no investigation, including IPR searches, has been carried out by ETSI. No guarantee can be given as to the existence of other IPRs not referenced in ETSI SR 000 314 (or the updates on the ETSI Web server) which are, or may be, or may become, essential to the present document.

---

## Foreword

This Technical Specification (TS) has been produced by ETSI 3rd Generation Partnership Project (3GPP).

The present document may refer to technical specifications or reports using their 3GPP identities, UMTS identities or GSM identities. These should be interpreted as being references to the corresponding ETSI deliverables.

The cross reference between GSM, UMTS, 3GPP and ETSI identities can be found under <http://webapp.etsi.org/key/queryform.asp>.

# Contents

Intellectual Property Rights .....	2
Foreword.....	2
Foreword.....	6
1 Scope .....	7
2 References .....	7
3 Definitions and abbreviations.....	10
3.1 Abbreviations .....	11
4 Introduction .....	11
5 Void.....	12
6 Network Characteristics .....	12
6.1 Key Characteristics of Networks Concerned.....	12
6.1.1 Characteristics of PLMNs.....	12
6.1.2 Characteristics of PSTNs .....	12
6.1.3 Characteristics of ISDN .....	13
7 Interworking classifications .....	13
7.1 Service interworking .....	13
7.2 Network interworking .....	13
7.3 Signalling interworking .....	14
7.4 Numbering.....	14
7.5 Supplementary service interworking .....	14
8 Compatibility and subscription checking.....	15
9 Interworking to PSTN .....	15
9.1 Speech Calls .....	15
9.1.1 Interworking indications to PLMN terminal.....	15
9.1.2 Transmission aspects .....	15
9.1.3 Generation of In-band Tones and Announcements (PLMN-PSTN).....	15
9.2 Data Calls .....	15
9.2.1 Network interworking mobile originated.....	16
9.2.1.1 Selection of interworking function.....	16
9.2.1.2 Modem Selection .....	16
9.2.1.3 Mapping of BC-IE from PLMN to ISUP (or other).....	17
9.2.2 Network Interworking Mobile terminated PSTN Originated .....	17
9.2.2.1 Multi-numbering Scheme.....	17
9.2.2.2 Single-numbering Scheme .....	19
9.2.3 Transparent service support .....	20
9.2.3.1 Structure of the MSC/IWF for UMTS .....	21
9.2.3.2 Structure of the MSC/IWF for GSM.....	21
9.2.3.3 Mapping of signalling MS/MSC/IWF to modem interface requirements .....	21
9.2.3.4 Establishment of end-to-end terminal synchronizations .....	22
9.2.3.4.1 Terminating side (towards the MS / UE).....	23
9.2.3.4.1.1 GSM Traffic channel types TCH/F4.8 and TCH/F9.6.....	23
9.2.3.4.1.2 GSM Traffic channel type TCH/F14.4 .....	23
9.2.3.4.2 Transit side (towards the fixed network) .....	23
9.2.3.5 Network Independent Clocking (NIC).....	24
9.2.4 Non-transparent service support .....	24
9.2.4.1 Structure of the MSC/IWF for UMTS .....	25
9.2.4.2 Structure of the MSC/IWF for GSM.....	25
9.2.4.3 Re-constitution of user data.....	25
9.2.4.4 Layer 2 relay functionality .....	25
9.2.4.5 In band signalling mapping flow control .....	25

9.2.4.5.1	Conditions requiring flow control towards the fixed network.....	26
9.2.4.5.2	Conditions requiring flow control towards the MS .....	26
9.2.4.6	Data buffers.....	26
9.2.4.6.1	Transmit buffers (towards MS) .....	26
9.2.4.6.2	Receive buffers (from MS).....	26
9.2.4.7	Transportation of the Break condition.....	27
9.2.4.8	In band signalling mapping modem status information .....	27
9.2.4.9	Support of out-band flow control.....	28
9.2.4.10	Establishment of end-to-end terminal synchronizations .....	28
9.2.4.10.1	Terminating side (towards the MS / UE).....	28
9.2.4.10.2	Transit side (towards the fixed network) .....	28
9.2.4.11	Data compression.....	29
9.2.4.12	Service level up and down grading .....	29
9.2.5	DTE/DCE interface (Filtering) .....	29
9.3	Interworking Alternate Speech / Facsimile Group 3 Calls .....	30
9.3.1	General.....	30
9.3.2	Mobile originated PSTN terminated calls.....	31
9.3.3	PSTN originated mobile terminated calls .....	31
9.4	3G-H.324/M calls over 3,1kHz audio .....	31
9.4.1	Mobile originated multimedia call.....	31
9.4.1.1	Call setup .....	31
9.4.1.2	Fallback to speech after setup .....	32
9.4.2	Mobile terminated multimedia call.....	32
9.4.2.1	Call setup .....	32
9.4.2.2	Fallback to speech after setup .....	33
9.4.3	Seamless data rate change.....	33
10	Interworking to the ISDN.....	33
10.1	Speech Calls .....	33
10.2	Data Calls .....	33
10.2.1	Network interworking mobile originated.....	34
10.2.2	Network interworking mobile terminated.....	34
10.2.2.1	General .....	34
10.2.2.2	Functions in GMSC.....	34
10.2.2.3	Functions in HLR.....	35
10.2.2.4	Functions in VMSC.....	36
10.2.2.5	Call Flows .....	37
10.2.2.6	Mapping Functions .....	38
10.2.3	Transparent service support .....	55
10.2.3.1	Structure of the MSC/IWF for UMTS .....	55
10.2.3.2	Structure of the MSC/IWF for GSM.....	56
10.2.3.3	Mapping of signalling MS/MSC/IWF to modem or ISDN (V.110) TA-function interface requirements.....	56
10.2.3.4	Establishment of end-to-end terminal synchronizations .....	57
10.2.3.4.1	Terminating side (towards the MS / UE).....	57
10.2.3.4.1.1	GSM Traffic channel types TCH/F4.8 and TCH/F9.6.....	57
10.2.3.4.1.2	GSM Traffic channel type TCH/F14.4 .....	58
10.2.3.4.1.3	UMTS User Plane.....	58
10.2.3.4.2	Transit side (towards the fixed network) .....	58
10.2.3.5	Network independent Clocking (NIC) .....	58
10.2.4	Non-transparent service support .....	58
10.2.4.1	Structure of the MSC/IWF for UMTS .....	59
10.2.4.2	Structure of the MSC/IWF for GSM.....	59
10.2.4.3	Re-constitution of user data.....	60
10.2.4.4	Layer 2 relay functionality .....	60
10.2.4.5	In band signalling mapping flow control .....	60
10.2.4.5.1	Conditions requiring flow control - if flow control is provided - towards the fixed network.....	60
10.2.4.5.2	Conditions requiring flow control towards the MS .....	61
10.2.4.6	Data buffers.....	61
10.2.4.6.1	Transmit buffers (towards MS) .....	61
10.2.4.6.2	Receive buffers (from MS).....	61
10.2.4.7	BREAK Indication .....	61

10.2.4.8	Signalling mapping of modem or ISDN (V.110, V.120 or PIAFS) TA-function status information.....	61
10.2.4.9	Support of out-band flow control.....	62
10.2.4.10	Synchronizations.....	62
10.2.4.10.1	V.110 and V.120 Frame synchronizations.....	62
10.2.4.10.2	RLP Frame start indication.....	62
10.2.4.10.3	L2R Frame synchronizations.....	63
10.2.4.10.4	Establishment of end-to-end terminal synchronizations.....	63
10.2.4.10.4.1	Terminating side (towards the MS).....	63
10.2.4.10.4.2	Transit side (towards the fixed network).....	63
10.2.4.11	Data compression.....	63
10.2.4.12	Additional aspects of V.120 Interworking.....	63
10.2.4.12.1	V.120 Signalling parameters.....	64
10.2.4.12.2	V.120 Protocol parameters.....	64
10.2.4.12.3	Data compression on the ISDN.....	64
10.2.4.12.4	Use of the V.120 Control State (header extension) octet.....	64
10.2.4.13	Interworking with restricted 64 kbit/s networks.....	64
10.2.4.13.1	Rate adaptation.....	64
10.2.4.13.2	MSC - ISDN signalling.....	64
10.2.4.14	Service level up and down grading.....	65
10.2.4.15	Interworking in Frame Tunneling Mode.....	65
10.2.4.16	Additional aspects of PIAFS Interworking.....	65
10.2.5	DTE/DCE interface (Filtering).....	65
10.3	Interworking Alternate speech facsimile group 3 calls.....	66
10.3.1	Alternate speech data bearer interworking.....	66
10.3.1.1	General.....	66
10.3.1.2	Mobile originated ISDN terminated.....	66
10.3.1.3	ISDN originated mobile terminated.....	66
10.4	3G-H.324/M calls over UDI/RDI.....	66
11	Interworking between GSM and UMTS.....	67
11.1	Handover from UMTS to GSM.....	67
11.2	Handover from GSM to UMTS.....	67
11.2.1	Frame layout for the different transparent user rates.....	67
11.2.2	A-TRAU' frame format.....	68
11.3	Handover within 3G PLMNs.....	70
11.4	Handover for 56kbit/s.....	70
12	Frame Synchronization.....	70
12.1	Initial frame synchronization.....	71
12.1.1	Terminating side (towards the MS / UE).....	71
12.1.2	Transit side (towards the fixed network).....	71
12.1.2.1	Interworking to the PSTN.....	71
12.1.2.2	Interworking to the ISDN.....	71
12.2	Action on loss of frame synchronization.....	71
12.2.1	Loss on the transit side (towards the fixed network).....	71
12.2.2	Loss on the terminating side (towards the MS).....	71
13	Call Clearing.....	72
<b>Annex A (informative): SDLs.....</b>		<b>73</b>
<b>Annex B (informative): General mapping of V.24 circuits to channel status bits.....</b>		<b>75</b>
<b>Annex C (informative): Change history.....</b>		<b>76</b>
History.....		77

---

# Foreword

This Technical Specification (TS) has been produced by the 3<sup>rd</sup> Generation Partnership Project (3GPP).

The present document identifies the Mobile-services Switching Centre/Interworking functions (MSC/IWFs) and requirements to support interworking between:

- i) PLMN and PSTN;
- ii) PLMN and ISDN;

within the 3GPP system.

The contents of the present document are subject to continuing work within the TSG and may change following formal TSG approval. Should the TSG modify the contents of the present document, it will be re-released by the TSG with an identifying change of release date and an increase in version number as follows:

Version x.y.z

where:

- x the first digit:
  - 1 presented to TSG for information;
  - 2 presented to TSG for approval;
  - 3 or greater indicates TSG approved document under change control.
- y the second digit is incremented for all changes of substance, i.e. technical enhancements, corrections, updates, etc.
- z the third digit is incremented when editorial only changes have been incorporated in the document.

---

# 1 Scope

The present document identifies the Mobile-services Switching Centre/Interworking Functions (MSC/IWFs) and requirements to support interworking between:

- a) PLMN and PSTN;
- b) PLMN and ISDN;

for circuit switched services in the PLMN. It is not possible to treat ISDN and PSTN as one type of network, even when both ISDN and PSTN subscribers are served by the same exchange because of the limitations of the PSTN subscribers access i.e. analogue connection without D-channel signalling.

Within the present document, the requirements for voice and non-voice (data) calls are considered separately.

From GSM R99 onwards the following services are no more required to be provided by a GSM PLMN:

- the dual Bearer Services "alternate speech/data" (BS 61) and "speech followed by data" (BS 81);
- the dedicated services for PAD (BS 4x) and Packet access (BS 5x);
- the single asynchronous and synchronous Bearer Services (BS 21..26, BS 31..34).

If a PLMN network still provides these services it shall fulfil the specification of GSM R98.

The present document is valid for a 2<sup>nd</sup> generation PLMN (GSM) as well as for a 3<sup>rd</sup> generation PLMN (UMTS). If text applies only for one of these systems it is explicitly mentioned by using the terms "GSM" and "UMTS". If text applies to both of the systems, but a distinction between the ISDN/PSTN and the PLMN is necessary, the term "PLMN" is used.

Descriptions related to facsimile are not applied to UMTS but to GSM.

---

# 2 References

The following documents contain provisions which, through reference in this text, constitute provisions of the present document.

- References are either specific (identified by date of publication, edition number, version number, etc.) or non-specific.
- For a specific reference, subsequent revisions do not apply.
- For a non-specific reference, the latest version applies. In the case of a reference to a 3GPP document (including a GSM document), a non-specific reference implicitly refers to the latest version of that document *in the same Release as the present document*.

- [1] ITU-T Recommendation G.711: "Pulse code modulation (PCM) of voice frequencies".
- [2] ITU-T Recommendation I.460: "Multiplexing, rate adaption and support of existing interfaces".
- [3] ITU-T Recommendation I.464: "Multiplexing, rate adaption and support of existing interfaces for restricted 64 kbit/s transfer capability".
- [4] ITU-T Recommendation Q.922 (1992): "DSS 1 Data link layer: ISDN data link layer specification for frame mode bearer services".
- [5] ITU-T Recommendation Q.931 (05/98): "DSS 1 - ISDN user network interface layer 3 specification for basic call control".
- [6] ITU-T Recommendation V.22: "1200 bits per second duplex modem standardized for use in the general switched telephone network and on point-to-point 2-wire leased telephone-type circuits".



- [7] ITU-T Recommendation V.24: "List of definitions for interchange circuits between data terminal equipment (DTE) and data circuit-terminating equipment (DCE)".
- [8] ITU-T Recommendation V.25: "Automatic answering equipment and/or parallel automatic calling equipment on the general switched telephone network including procedures for disabling of echo control devices for both manually and automatically established calls".
- [9] ITU-T Recommendation V.32: "A family of 2-wire, duplex modems operating at data signalling rates of up to 9600 bit/s for use on the general switched telephone network and on leased telephone-type circuits".
- [10] ITU-T Recommendation V.32bis: "A duplex modem operating at data signalling rates of up to 14 400 bit/s for use on the general switched telephone network and on leased point-to-point 2-wire telephone-type circuits".
- [11] ITU-T Recommendation V.34: "A modem operating at data signalling rates of up to 33 600 bit/s for use on the general switched telephone network and on leased point-to-point 2-wire telephone-type circuits".
- [12] ITU-T Recommendation V.42: "Error-correcting procedures for DCEs using asynchronous-to-synchronous conversion".
- [13] ITU-T Recommendation V.42bis: "Data Compression for Data Circuit Terminating Equipment (DCE) using Error Correction Procedures".
- [14] ITU-T Recommendation V.90: "A digital modem and analogue modem pair for use on the Public Switched Telephone Network (PSTN) at data signalling rates of up to 56 000 bit/s downstream and up to 33 600 bit/s upstream".
- [15] ITU-T Recommendation V.110: "Support of data terminal equipments (DTEs) with V-Series interfaces by an integrated services digital network".
- [16] ITU-T Recommendation V.120: "Support by an ISDN of data terminal equipment with V-Series type interfaces with provision for statistical multiplexing".
- [17] ETR 018: "Integrated Services Digital Network (ISDN); Application of the Bearer Capability (BC), High Layer Compatibility (HLC) and Low Layer Compatibility (LLC) information elements by terminals supporting ISDN services".
- [18] ETS 300 102-1 Edition 1 (1990): "Integrated Services Digital Network (ISDN); User-network interface layer 3 Specifications for basic call control".
- [19] EN 300 403-1 V1.2.2 (1998-04): "Integrated Services Digital Network (ISDN); Digital Subscriber Signalling System No. One (DSS1) protocol; Signalling network layer for circuit-mode basic call control; Part 1: Protocol specification".
- [20] 3GPP TS 01.01: "GSM Release 1999 Specifications".
- [21] 3GPP TS 01.04: "Abbreviations and acronyms".
- [22] 3GPP TS 02.01: "Principles of telecommunication services supported by a GSM Public Land Mobile Network (PLMN)".
- [23] 3GPP TS 02.03: "Teleservices supported by a GSM Public Land Mobile Network (PLMN)".
- [24] 3GPP TR 03.10: "GSM PLMN Connection types".
- [25] 3GPP TS 03.45: "Technical realization of facsimile group 3 transparent".
- [26] 3GPP TS 03.50: "Transmission planning aspects of the speech service in the GSM Public Land Mobile Network (PLMN) system".
- [27] 3GPP TS 04.21: "Rate adaption on the Mobile Station - Base Station System (MS - BSS) interface".

- [28] 3GPP TS 08.20: "Rate adaption on the Base Station System - Mobile-services Switching Centre (BSS - MSC) interface".
- [29] 3GPP TS 08.60: "Inband control of remote transcoders and rate adaptors for Enhanced Full Rate (EFR) and full rate traffic channels".
- [30] 3GPP TS 09.02: "Mobile Application Part (MAP) specification".
- [31] 3GPP TS 09.03: "Signalling requirements on interworking between the Integrated Services Digital Network (ISDN) or Public Switched Telephone Network (PSTN) and the Public Land Mobile Network (PLMN)".
- [32] 3GPP TS 21.101: "Release 1999 Specifications".
- [33] 3GPP TS 22.002: "Bearer Services (BS) supported by a GSM Public Land Mobile Network (PLMN)".
- [34] 3GPP TS 22.004: "General on supplementary services".
- [35] 3GPP TS 23.003: "Numbering, addressing and identification".
- [36] 3GPP TS 23.008: "Organization of subscriber data".
- [37] 3GPP TS 23.011: "Technical realization of supplementary services".
- [38] Void.
- [39] Void.
- [40] 3GPP TS 24.008: "Mobile radio interface layer 3 specification".
- [41] 3GPP TS 24.022: "Radio Link Protocol (RLP) for data and telematic services on the Mobile Station - Base Station System (MS - BSS) interface and the Base Station System - Mobile-services Switching Centre (BSS - MSC) interface".
- [42] 3GPP TS 25.415: "Iu Interface CN-UTRAN User Plane Protocols".
- [43] 3GPP TS 27.001: "General on Terminal Adaptation Functions (TAF) for Mobile Stations (MS)".
- [44] 3GPP TS 27.002: "Terminal Adaptation Functions (TAF) for services using asynchronous bearer capabilities".
- [45] 3GPP TS 27.003: "Terminal Adaptation Functions (TAF) for services using synchronous bearer capabilities".
- [46] 3GPP TS 29.002: "Mobile Application Part (MAP) specification".
- [47] 3GPP TS 29.006: "Interworking between a Public Land Mobile Network (PLMN) and a Packet Switched Public Data Network/Integrated Services Digital Network (PSPDN/ISDN) for the support of packet switched data transmission services".
- [48] ISO/IEC 3309: "Telecommunications and information exchange between systems - High-level data link control (HDLC) procedures - Frame structure".
- [49] IETF RFC 1662: "PPP in HDLC-like framing".
- [50] Mobile Internet Access Forum: "PIAFS Specification Ver. 1.1, 2.1".
- [51] ITU-T Recommendation V.8: "Procedures for starting sessions of data transmission over the public switched telephone network".
- [52] 3GPP TS 26.111: "Codec for Circuit Switched Multimedia Telephony Service; Modifications to H.324".
- [53] 3GPP TR 23.910: " Circuit Switched Data Bearer Services".

- [54] ITU-T Recommendation H.223: "Multiplexing protocol for low bit rate multimedia communication".
- [55] ITU-T Recommendation H.223, Annex A: "Multiplexing protocol for low bit rate multimedia communication over low error-prone channels".
- [56] ITU-T Recommendation H.223, Annex B: "Multiplexing protocol for low bit rate multimedia communication over moderate error-prone channels".
- [57] ITU-T Recommendation H.223, Annex C: "Multiplexing protocol for low bit rate multimedia communication over highly error-prone channels".
- [58] ITU-T Recommendation H.324: "Terminal for low bit-rate multimedia communication".

---

## 3 Definitions and abbreviations

Use is made of the following terms within the present document. These terms refer to information requirements necessary to support interworking functions, some of these terms will be identifiable with their use in other GSM specifications.

**bearer capability information:** specific information defining the lower layer characteristics required within the network.

**low layer compatibility information:** information defining the lower layer characteristics of the terminal.

**high layer compatibility information:** information defining the higher layer characteristics of the terminal.

**compatibility information:** this term subsumes the entirety of Bearer Capability, Low Layer Compatibility, High Layer Compatibility, Progress Indicator and Address Information conveyed out-of-band prior to call establishment for the support of compatibility checking and terminal/function/service selection at the ISDN-type user-network interface.

**protocol identifier:** information defining the specific protocols utilized for the support of data transfer by a terminal.

**progress indicator:** information supplied to indicate to the terminal that network interworking has taken place.

**out-of-band parameter exchange:** information exchanged via an associated or non-associated signalling link e.g. SS No 7.

**PSTN:** subscriber to network interface supports only analogue terminals.

**ISDN:** subscriber to network interface supports digital or analogue terminals, plus a standardized user to network associated signalling system and a standardized internetwork signalling system.

**autobauding type 1:** this information element value may be contained in the setup or call confirm messages from the MS in association with a non transparent data service. This implies that the MSC/IWF may select any speed and modem type according to what it can negotiate with the remote modem on the PSTN/ISDN. The parameters User Rate and FNUR (Fixed Network User Rate), if present, has no meaning when Modem Type is autobauding type 1.

**multi self selecting speed modem:** this term applies to V series modems capable of handling one or more lower speeds as a fall back position. When such a modem is requested in the call setup or call confirm message from the MS in association with a non transparent service, the MSC/IWF may select any of the speeds supported according to the negotiation with the remote modem on the PSTN/ISDN. The parameters User Rate and FNUR (Fixed Network User Rate), if present, has no meaning when Modem Type is autobauding type 1.

**unrestricted 64 kbit/s network:** a digital network which has 64 kbit/s octet-structured Information Transfer Capability (ITC) with no restrictions on the contents of each octet.

**restricted 64 kbit/s network:** ITU-T I.464 defines "restricted 64 kbit/s transfer capability" as "64 kbit/s octet-structured capability with the exception that an all-zero octet is not permitted". In the present document, the term "restricted 64 kbit/s network" refers not only to networks with the I.464 restriction but also to those in which the 8th bit of each octet is unusable for data transmission.

**directly connected restricted 64 kbit/s network:** restricted 64 kbit/s network which is connected directly to the MSC/IWF.

**indirectly connected restricted 64 kbit/s network:** restricted 64 kbit/s network which is connected to the MSC/IWF via an unrestricted 64 kbit/s network.

**EDGE channel:** general term referring to channels based on 8PSK modulation; i.e. TCH/F28.8, TCH/F32.0, and TCH/F43.2.

## 3.1 Abbreviations

In addition to the following, abbreviations used in the present document are listed in 3GPP TS 01.04 [21].

ADPCM	Adaptive Differential Pulse Coded Modulation
DP	Dial Pulse
DSS1	Digital Subscriber Signalling 1
FTM	Frame Tunnelling Mode
ITC	Information Transfer Capability
LE	Local Exchange
NT	Network Termination
PABX	Private Automatic Branch Exchange
PIAFS	PHS Internet Access Forum Standard
PPP	Point to Point Protocol
SPC	Stored Program Control
SS No.7	Signalling System No.7
TE	Terminal Equipment
TA	Terminal Adaptor
TUP	Telephone User Part (of Signalling System No.7)
UNI	User Network Interface

---

## 4 Introduction

Since the numbering plan for the ISDN era (E.164) includes the numbering plan for the telephone network (E.163), it is not possible to distinguish by the number whether a given subscriber is a PSTN or ISDN subscriber. Further, in some countries both PSTN and ISDN subscribers will be connected to the same exchange, so the only difference for this type of combined network will be in the nature of the customer access. In the present document a PSTN is considered to support only an analogue interface towards the subscriber. An ISDN shall be considered to support digital interface towards the subscriber. In addition, the ISDN is considered to support a standardized outband signalling protocol both between the subscriber and the network and within the network, i.e. DSS1 and ISUP, thus enabling the generation and transport of Compatibility Information for compatibility checking and terminal/function/service selection at the user-network interface as well as for MSC/IWF selection.

There now exist networks which do not fall into either of these categories in that they provide for digital connectivity from subscriber to subscriber through the network. The subscribers have access to a wide range of services by a limited set of standard multi-purpose user network interfaces. However, these networks do not support the standardized inter-exchange signalling protocol throughout, in that they are e.g. using TUP or National User Part (NUP). These types of network support 64 kbit/s connections, so in service support are comparable to ISDN, however, the signalling system provided may not support transport of all Compatibility Information allowed for in the standardized ISDN signalling. The present document will therefore identify interworking to PSTN and ISDN on the principle of the network characteristics as identified in the previous paragraph. The aforementioned existing networks then constitute one particular case in the ISDN interworking scenarios. These cases will be itemized when the implication of the various degrees of exhaustiveness of the Compatibility Information - delivered via the ISDN - used for deducting a GSM Basic Service needs to be set forth.

When two dissimilar networks are required to interwork in order to support a communication between two subscribers, one on each network, a number of Interworking Functions (MSC/IWFs) are required to support the communication. Some of these are related to the differences in signalling and are dealt with in 3GPP TS 09.03.

Examples of other aspects of interworking are:

- a) the need or otherwise of echo control devices;
- b) the need or otherwise of modem pools and network-based rate adaptation.

For the purposes of determining the required MSC/IWFs, it is necessary, however, to consider separately each type of interworking (i.e. PLMN-ISDN and PLMN-PSTN) since, in the worst case, "PSTN" could refer to an essentially analogue network with electromechanical switching not controlled by software and without common-channel signalling.

Some facilities associated with alternate speech and facsimile group 3 may not be available with version 1 of the MAP (3GPP TS 09.02). Version 1 of the Mobile Application Part (MAP) does not support in-call modification and channel mode modification following an inter-MSC handover.

## 5 Void

## 6 Network Characteristics

### 6.1 Key Characteristics of Networks Concerned

**Table 1: Key Characteristics of Networks Concerned**

Characteristic	PLMN	ISDN	PSTN
Subscriber Interface	Digital	Digital	Analogue
User-network signalling	3GPP TS 24.008	DSS1, other UNIs	loop-disconnect and DTMF
User-terminal equipment supported	for GSM see 3GPP TS 04.02 for UMTS see 3GPP TS 27.001	Digital TE (ISDN NT, TE1 or TE2+TA) see e.g. I.411	Analogue TE (e.g. dial pulse telephones PABXs modem equipped DTEs)
Inter-exchange signalling	SS No.7 ISUP TUP+, MAP	SS No.7 ISUP TUP+, TUP, NUP	Channel associated (e.g. R2, No.4, No.5) or common channel (e.g. No.6)
Transmission facilities	Digital	Digital	Analogue
Exchange types	Digital	Digital	Analogue/digital
Information transfer mode	Circuit/Packet	Circuit/Packet	Circuit
Information transfer capability	Speech, digital unrestricted, alternate speech/ group 3 fax etc.	Speech, digital unrestricted, 3,1 kHz audio, video etc.	3,1 kHz audio (voice/voice- band data)

#### 6.1.1 Characteristics of PLMNs

The PLMN is fully defined in the Technical Specifications summarised in 3GPP TS 01.01 for a 2<sup>nd</sup> generation PLMN (GSM) or in 3GPP TS 21.101 for a 3<sup>rd</sup> generation PLMN (UMTS).

#### 6.1.2 Characteristics of PSTNs

Because of the efforts at an early stage to standardize ISDNs in different countries, the differences between any two ISDNs will be small compared with the differences between PSTNs, which have evolved in different ways in different countries. In some cases the evolution has occurred over many decades, and therefore each PSTN is distinct, and for a recommendation on interworking, it is necessary to make certain assumptions about a generalized PSTN.

Whilst the key characteristics of PSTNs are given in table 1 above, the specific MSC/IWFs needed to allow interworking between a PLMN and a PSTN will depend on the nature of the PSTN concerned.

Table 2 below gives a number of categories that can be used to classify PSTNs and a number of possibilities within each category.

**Table 2: Characteristics of PSTNs**

Category	Possibilities within Category
Type of subscriber signalling	a) PSTN with loop disconnect subscriber signalling (10 pps) b) PSTN with DTMF subscriber signalling
Type of interexchange signalling	a) PSTN with channel-associated signalling b) PSTN with common-channel signalling
Type of interexchange transmission	a) Analogue b) Digital
Type of exchange switching	a) PSTN with electro-mechanical switching b) PSTN with electronic (non-digital) switching c) PSTN with electronic digital switching
Type of exchange control	a) Non-SPC b) SPC
NOTE:	Under each category, it is possible that a PSTN will have a combination of the possibilities rather than only one.

### 6.1.3 Characteristics of ISDN

For the "standardized ISDN" in principle taken into account here, these are defined in the ETS/ITU-T-series.

---

## 7 Interworking classifications

### 7.1 Service interworking

Service interworking is required when the Teleservices at the calling and called terminals are different. No service interworking, except for facsimile group 3 (Teleservice 61 or 62 interworking with standard facsimile group 3 service), has been identified as a requirement of the PLMN system for PSTN/ISDN network based services.

### 7.2 Network interworking

Network interworking is required whenever a PLMN and a non-PLMN together are involved to provide an end to end connection and may be required in instances of PLMN to PLMN connections.

The concept of Bearer Services was developed for the ISDN and has been extended to the PLMN. A bearer service is defined (in 3GPP TS 02.01) as.

A type of telecommunication service that provides the capability for the transmission of signals between user-network interfaces.

Bearer services are described by a number of attributes, where an attribute is defined as a specified characteristic of an object or element whose values distinguish that object or element from others.

For the purpose of the present document, a PSTN is assumed to provide a bearer service which equates to an ISDN 3,1 kHz audio bearer service.

Refer to 3GPP TS 22.002 for complete list of bearer services. Refer to 3GPP TS 24.008 for coding of Bearer Capabilities. Refer to 3GPP TS 27.001 for the allowed combinations of parameter value settings.

**Table 3: Bearer Service Interworking**

Bearer service category in PLMN	Bearer Service in PLMN	Bearer service in ISDN	Service in PSTN
Circuit mode unstructured with unrestricted digital capability Transparent and Non transparent	Asynchronous Data general	Cct mode structured 64 kbit/s unrestricted	Not Applicable
Circuit mode unstructured with unrestricted digital capability Transparent	Synchronous Data general		
Circuit mode unstructured with unrestricted digital capability. Non-transparent	Packet Services see 3GPP TS 29.006	Packet Services see 3GPP TS 29.006	
3,1 kHz Audio Ex PLMN Transparent and Non-transparent	Asynchronous Data general	Cct Mode 3,1 kHz Audio	Cct Mode 3,1 kHz Audio
3,1 kHz Audio Ex PLMN Transparent	Synchronous Data general		
3,1 kHz Audio Ex PLMN Non Transparent	See 3GPP TS 29.006	See 3GPP TS 29.006	

**Table 4: Network interworking of Teleservices**

Teleservice in PLMN	Lower layer capabilities addressed in the PLMN Bearer Capabilities IE	Bearer service in ISDN	Service in PSTN
Telephony	Unstructured with speech capability	Speech or Cct mode	Cct Mode 3,1 kHz audio
Emergency calls	Unstructured with speech capability	3,1 kHz audio	
Alternate speech/ facsimile group 3	Data Cct duplex synchronous access alternate speech group 3 fax	Cct mode 3,1 kHz audio	
Automatic Facsimile group 3	Data Cct duplex synchronous access group 3 fax	Cct mode 3,1 kHz audio	

This table does not identify any relationship between Teleservices in the PLMN with those in the ISDN/PSTN, it is merely to identify the interworking of the lower network layers of that teleservice with the network layers i.e. bearer service in the ISDN/PSTN.

## 7.3 Signalling interworking

See 3GPP TS 09.03.

## 7.4 Numbering

See 3GPP TS 23.003

## 7.5 Supplementary service interworking

For general aspects of supplementary services refer to 3GPP TS 22.004 and 23.011.

Not every supplementary service may be used in combination with each basic service. The applicability of each supplementary service for a basic service is defined in 3GPP TS 22.004.

---

## 8 Compatibility and subscription checking

Compatibility checking is carried out on the following items:

- a) Low layer compatibility - utilizing low layer compatibility and bearer capability information elements.
- b) High layer compatibility - utilizing high layer compatibility information element.

The use of the progress indicator for compatibility checking is outside the scope of the present document.

Indication of compatibility requirements is carried out as described in subclauses 9.2.2 and 10.2.2.

For subscription checking, relevant for the interworking described in clauses 9 and 10 of the present document, refer to 3GPP TS 02.01.

---

## 9 Interworking to PSTN

### 9.1 Speech Calls

#### 9.1.1 Interworking indications to PLMN terminal

An indication to inform the PLMN terminal that:

- i) instead of receiving out-of-band indications for certain types of failure conditions, a tone or announcement will be received in-band from the PSTN.
- ii) the available compatibility information will be not exhaustive for deducing a PLMN Basic Service and there will be a limitation on address - the terminal may be required to accept the call on the basis of indicating its compatibility requirements.
- iii) (if a DTE) in-band handshaking signals should be anticipated.

#### 9.1.2 Transmission aspects

Includes control of Speech Processing and Echo Control Devices, see 3GPP TS 03.50.

#### 9.1.3 Generation of In-band Tones and Announcements (PLMN-PSTN)

In-band tones and announcements shall be provided for all speech and 3,1 kHz audio bearer services between a PLMN and a PSTN.

### 9.2 Data Calls

Low Layer Compatibility Checking on the received PLMN bearer capability information element will be carried out by the MSC/IWF to check if the call setup is compatible to the bearer service (3,1 kHz audio) provided by a PSTN and to the IWFs provided by the PLMN.

In case the call setup does not conform to these requirements (e.g. an information transfer capability value "unrestricted digital information" is requested), the call shall fail with an error cause indicating that the network is unable to support the service requested.

As well as compatibility checking subscription checking shall be performed. If the subscription check fails the call setup shall be rejected.

For the case where the MS offers negotiable values in the PLMN bearer capability information element (e.g. both transparent and non-transparent connection element) refer to the definitions specified in 3GPP TS 27.001.



For interworking of data calls between a PLMN and a PSTN a modem will be utilized to provide the interworking function.

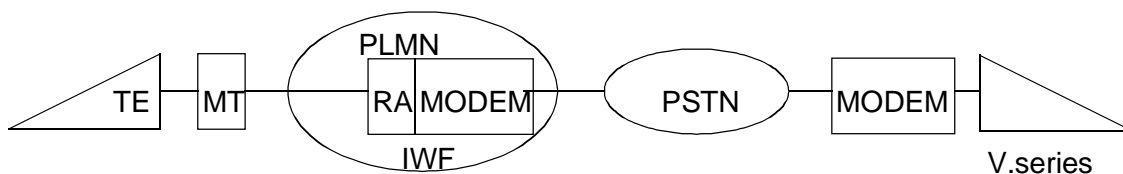

**Figure 1: PLMN PSTN interworking for circuit switched calls**

## 9.2.1 Network interworking mobile originated

### 9.2.1.1 Selection of interworking function

The interworking function will need to negotiate with the user to establish the appropriate modem selection e.g. data rate, modulation scheme, etc. In addition, it will also be required to convert the signalling format, from a combination of out of band and in band, to that suitable for controlling the modem and the autocalling line procedure function where applicable. In the following modem selection procedures it is assumed that the interworking function and modems will be associated with each MSC.

For a data call originated by a circuit mode data terminal on the PLMN, the modem selection is done by using the element "modem type" in the call set-up message (bearer capability).

In addition, other elements of the call setup will indicate the user rate, etc. to be used via that modem. The use of this information however means that the network is only able to select a modem from the modem pool which conforms to the speed which the terminal is utilizing at the DTE/DCE interface at the MS (e.g. V.22 for 1 200 bps). The exception to this is where the user has selected the non transparent service in which case either an autobauding or multi self selecting speed modem (e.g. V.32) may be used.

In case the PLMN-BC(s) received with the set-up message indicated a multislot, 14.4kbit/s, and EDGE-operation (refer to 3GPP TS 27.001) and the network does not support any of the required such services, the PLMN-BC(s) sent with the call proceeding message shall not contain the "fixed network user rate", "other modem type" and "user initiated modification indicator" parameters - the MSC shall discard the multislot or 14.4kbit/s and/or EDGE-related parameters and use the fall-back bearer service indicated by the remaining parameters of the PLMN-BS(s) on a singleslot configuration (refer to 3GPP TS 08.20 and 3GPP TS 04.21) on the MSC/IWF-BSS link. The MSC/IWF shall modify the relevant parameters in a possibly present LLC accordingly.

If the MSC supports the multislot, 14.4kbit/s and/or EDGE-operation, the PLMN-BC(s) shall include the "fixed network user rate", "other modem type" and if applicable the "user initiated modification indicator" parameters. The MSC shall apply on the MSC/IWF-BSS link a singleslot or multislot configuration according to the rules defined in 3GPP TS 04.21, 3GPP TS 08.20 and 3GPP TS 24.022. In case the MS signals an ACC containing TCH/F4.8 only and the network does not support TCH/F4.8 channel coding, then the MSC may act as if TCH/F9.6 were included in the ACC.

In case the PLMN-BC(s) received with the set-up message did not indicate a multislot, 14.4kbit/s or EDGE-operation, the MSC shall not include the "fixed network user rate", "other modem type" and "user initiated modification indicator" parameters in the PLMN-BC(s) of the call proceeding message - the MSC shall use a singleslot configuration on the MSC/IWF-BSS link.

The MSC may negotiate parameters with the MS according to the rules defined in 3GPP TS 27.001. For multislot, 14.4 kbit/s, EDGE and Iu Mode operations the MSC/IWF shall modify the relevant parameters in a possibly present LLC accordingly.

### 9.2.1.2 Modem Selection

In general terms the indication of the bearer capability parameter "Information Transfer Capability" will be utilized in the call set-up message to determine when the modem should be selected in the call.

In case of single calls, the modem function shall operate in the calling mode in case of mobile originated calls and in the answering mode in case of mobile terminated calls.

In case of dual data calls (alternate speech/facsimile group 3) the operation mode of the modem (working in calling or answering mode) depend on the initial call setup direction and on the optional parameter "Reverse Call Setup Direction" information element of the MODIFY message. If this information element is omitted the direction is derived from the initial call setup direction, i.e. the mode is the same as in case of single calls.

For the attribute value "3,1 kHz audio Ex PLMN" and "facsimile group 3", the modem will be selected immediately. The line procedure according to V.25 will then be carried out using the appropriate modem functions.

For the Teleservice 61 "Alternate speech/facsimile group 3", (if speech is selected as the first service), the modem is made available but not selected until the subscriber indicates the change of service request (see subclause 9.3).

For "alternate speech/facsimile group 3" calls refer to 3GPP TS 03.45 and 03.46 (GSM).

### 9.2.1.3 Mapping of BC-IE from PLMN to ISUP (or other)

As it cannot be determined from the called address whether the distant network is a PSTN or an ISDN the same mapping takes place as for ISDN calls (see table 7A), if ISDN signalling is used between different MSCs (e.g. on the link VMSC - GMSC).

## 9.2.2 Network Interworking Mobile terminated PSTN Originated

This subclause describes the interworking of calls where the calling subscriber cannot generate or communicate Compatibility Information exhaustive for deducing a PLMN Basic Service to a PLMN (gateway MSC/interrogating node) because of lack of ISDN signalling capability. Thus the HLR is relieved from any compatibility checking for such calls.

Two methods of allocating MS International ISDN Numbers (MSISDNs) are allowed: Firstly, a separate MSISDN may be allocated for each service, or service option, which a subscriber uses for incoming calls; or, alternatively, a single number, applicable for all incoming calls is used.

It should be noted that it is possible for both schemes to co-exist within the PLMN and that they are not mutually exclusive.

- a) Multiple MSISDNs are used ("The Multi-numbering Scheme"). See figure 2.
- b) A single MSISDN is used ("The Single-numbering Scheme"). See figure 3.

### 9.2.2.1 Multi-numbering Scheme

In this scheme, the HPLMN will allocate a number of MSISDNs to a subscriber and associate with each of these numbers a Bearer Capability to identify a Bearer or a Teleservice. This Bearer Capability comprises a complete PLMN Bearer Capability (PLMN BC) information element with contents according to 3GPP TS 27.001 and coded as per 3GPP TS 24.008. In either case, when the HLR receives an interrogation relating to an incoming call (i.e. the MAP "Send Routing Information" procedure), it requests a roaming number (MSRN) from the VLR. This request will contain the PLMN BC reflecting the service associated with the called MSISDN, i.e. the PLMN BC is passed to the VLR within the MAP parameter "GSM Bearer Capability" of the message "Provide Roaming Number".

At the VMSC, when the incoming call arrives, the PLMN BC associated with the MSRN are retrieved from the VLR and sent to the MS at call set-up.

Where the PLMN specific parameters "connection element" and "radio channel" requirements contained in the retrieved PLMN BC-IE, indicate dual capabilities then the VMSC shall set them according to its capabilities/preferences. Additionally the parameters correlated to those mentioned above shall be modified in accordance with 3GPP TS 27.001.

The same applies to the parameter modem type if "autobauding type 1" is indicated but the IWF does not support this feature. The parameter "data compression" may also be modified according to the capabilities of the IWF.

Where single capabilities are indicated then the VMSC shall use the requested values if it is able to support the service requested. If it is unable to support the requested service then it shall set them according to its capabilities/preferences.

Where the Compatibility Information is provided in a degree exhaustive to deduce a PLMN Basic Service (see application rules in subclause 10.2.2), then the VMSC in providing the PLMN BC IE in the setup message shall set the PLMN specific parameters to its capabilities/preferences.

On receipt of a Set-up message containing the compatibility information, the MS will analyse the contents to decide whether the service can be supported (with or without modification, see 3GPP TS 27.001) and the call will be accepted or rejected as appropriate.

These negotiable parameters in the PLMN BC-IE are: Connection Element (Transparent/non-transparent), Data Compression, number of data bits, number of stop bits and parity as well as the correlated parameters Structure, Intermediate Rate, Modem Type and User Information Layer 2 Protocol. Additionally, for multislot, 14.4 kbit/s and EDGE operations the parameters Fixed Network User Rate, Other Modem Type and User Initiated Modification Indicator, and for Iu Mode operations the parameters Fixed Network User Rate and Other Modem Type, can be negotiated. For FTM, PIAFS and Multimedia, Rate adaption/Other rate adaption can be negotiated. For FTM and PIAFS, Synchronous/asynchronous can be negotiated, see 3GPP TS 27.001. This negotiation takes place by means of the MS reflecting back to the MSC a complete bearer capability information element in the call confirm message, with the relevant parameters changed. If this does not take place (i.e. if there is no PLMN BC present in the call confirmed message), then the MSC will assume that the values originally transmitted to the MS are accepted.

In case the PLMN-BC sent with the set-up message contained the "fixed network user rate", "other modem type" and "user initiated modification parameter" parameters and no multislot, 14.4 kbit/s, and/or EDGE related parameters (refer to 3GPP TS 27.001) are received in the PLMN-BC of the call confirmed message or no PLMN-BC is received, the MSC shall discard the "fixed network user rate", "other modem type" and "user initiated modification parameter" parameters - the MSC shall use the fall-back bearer service indicated by the remaining parameters of the PLMN-BC on a singleslot configuration (refer to 3GPP TS 08.20 and 3GPP TS 04.21) on the MSC/IWF-BSS link.

On the other hand, if the PLMN-BC received with the call confirmed message contain(s) multislot, 14.4kbit/s or EDGE-related parameters the MSC shall apply on the MSC/IWF-BSS link a singleslot or multislot configuration according to the rules defined in 3GPP TS 04.21, 3GPP TS 08.20 and 3GPP TS 24.022. In case the MS signals an ACC containing TCH/F4.8 only and the network does not support TCH/F4.8 channel coding, then the MSC may act as if TCH/F9.6 were included in the ACC.

In addition the MS may propose to the network to modify the User Rate as well as the correlated parameters Modem Type and Intermediate Rate in the CALL CONFIRMED message. The network may accept or release the call. For multislot, 14.4kbit/s, EDGE and Iu Mode operations, the MS may also propose to the network to modify the Fixed Network User Rate and Other Modem Type parameters (see 3GPP TS 27.001).

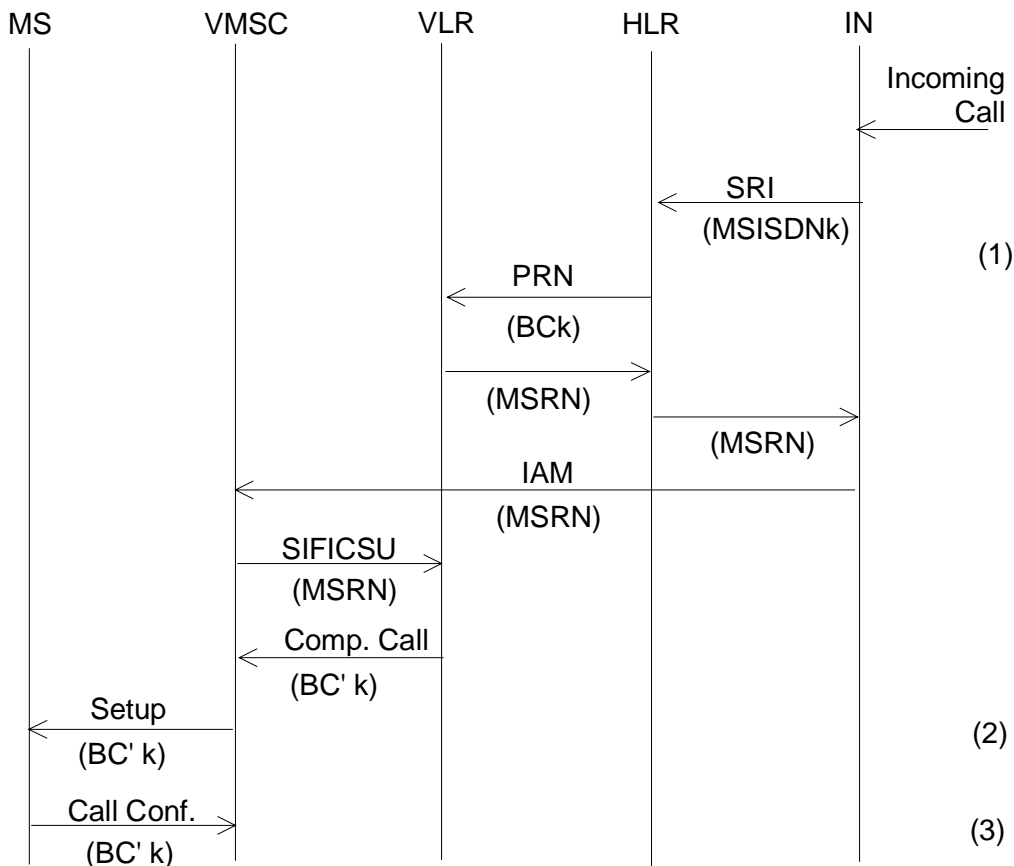

- NOTES: (1) The HLR translates the received MSISDN\_ called address (MSISDNk) into the relevant bearer capability information (Bck).  
 (2) Some parameters of BCK may be provided/modified according to the MSC's capabilities/preferences. See subclause 9.2.2.  
 (3) In the "Call Confirm" message, the MS may modify some parameters of the BC. See subclause 9.2.2.

Abbr.: SRI - Send Routing Information.  
 PRN - Provide Roaming Number.  
 MSRN - Mobile Station Roaming Number.  
 IAM - Initial Address Message.  
 SIFICSU - Send Information For Incoming Call Set Up.

**Figure 2: Call Flow for a mobile terminated, PSTN originated call where the compatibility information provided are not exhaustive for deducing a PLMN Bearer Service; HLR uses multiple MSISDN numbers with corresponding BCs**

### 9.2.2.2 Single-numbering Scheme

In the single-numbering scheme, the HPLMN will allocate one MSISDN to a subscriber, applicable to all services.

In this case, when the HLR receives an interrogation relating to an incoming call without compatibility information exhaustive for deducing a PLMN Basic Service (i.e. the MAP "Send Routing Information" procedure), the request to the VLR for a roaming number will not contain compatibility information i.e. a PLMN BC.

At the VLR, when the incoming call arrives, there is no PLMN BC associated with the MSRN and so the call set-up to the mobile will not contain the PLMN BC element.

In this case, the MS will return a complete single or dual PLMN BC in the Call Confirmed message, indicating the service required by the mobile subscriber. The VMSC will analyse this PLMN BC and optionally perform subscription checking (see 3GPP TS 02.01). If the requested PLMN BC can be supported the call is established, otherwise the call will be released.

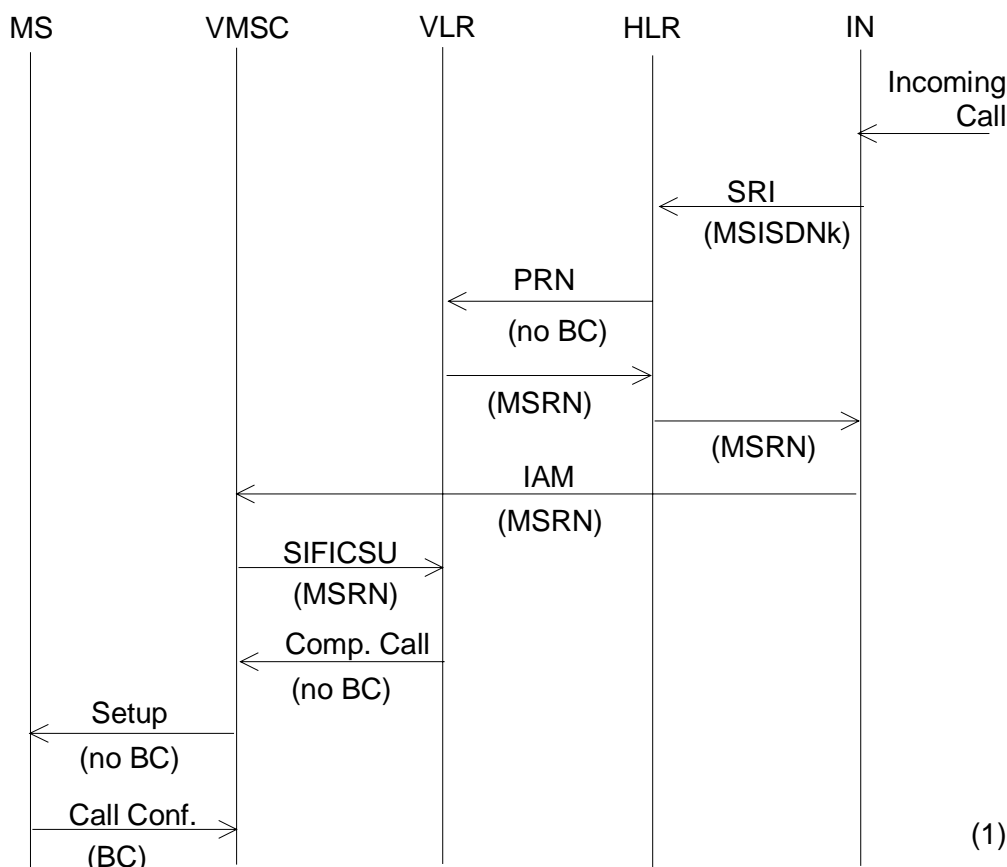

NOTE: (1) This BC is derived from information stored in the MS, according to its configuration.  
 (2) Abbreviations: see figure 2.

**Figure 3: Call Flow for a mobile terminated, PSTN originated call where the compatibility information provided are not exhaustive for deducing a PLMN Bearer Service; HLR uses single MSISDN numbers (no corresponding BC stored). Per call MSRN allocation**

### 9.2.3 Transparent service support

The protocol stacks for transparent services are specified in 3GPP TR 03.10 (GSM) and in 3GPP TR 23.910 (UMTS).

In UMTS, the transparent services are based in the Iu User Plane protocol specified in 3GPP TS 25.415.

In GSM the rate adaptation scheme shall be utilized on the BSS to MSC link as identified in 3GPP TS 08.20. The transcoding function will generate the 64 kbit/s rate adapted format utilizing the 8 and 16 kbit/s intermediate data rates. The MSC to MSC/IWF link (e.g. in the case of handover) will utilize the same 64 kbit/s rate adaptation scheme as that indicated in 3GPP TS 08.20.

For the transparent service support the MSC/IWF will select the modem and speed based on the Compatibility information contained in either the call set-up or call confirmed message reference subclause 9.2.1 and 9.2.2. Where the modem type indicated is one of the multi-speed versions, e.g. V.32, then the MSC/IWF will restrict the modem to the speed indicated in the call set-up and call confirmed message, respectively, i.e. will inhibit the modem from changing speed, irrespective of the conditions, error rate, encountered on the PSTN link. This scenario is also applicable for the use of "autobauding" modems, in that only the specifically requested modem type and speed will be selected at the MSC/IWF (however Facsimile Group 3 can use channel mode modify).

### 9.2.3.1 Structure of the MSC/IWF for UMTS

The transmission towards the RNC is based on AAL2. The Iu UP is used in the transparent mode.

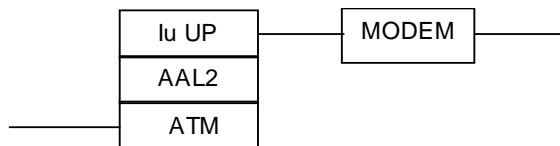

Figure 4: Structure of MSC/IWF

### 9.2.3.2 Structure of the MSC/IWF for GSM

The rate adaptation process is a reverse of that provided in the Terminal Adaptation function of the MS. The rate adaptation RA1 is based on the ITU-T V.110 80 bit frame for TCH/F2.4, TCH/F4.8 and TCH/F9.6 and on A-TRAU frame for TCH/F14.4. 3GPP TS 04.21 and 08.20, respectively, refer to the rate adaptation mechanisms to be provided. For multislot configurations refer to 3GPP TR 03.10.

NOTE: From MSC/IWF's perspective a TCH/F28.8 EDGE configuration is identical to a multislot 2xTCH/F14.4 configuration.

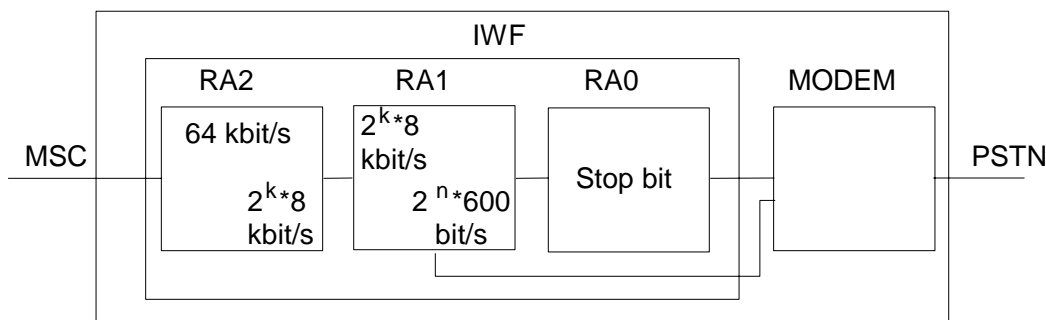

Figure 5: Rate adaptation schematic

In case of asynchronous bearer services and the facsimile teleservices in the transparent mode, the IWF shall disregard the value of bits E4, E5, E6 and E7 in the data transmission phase.

### 9.2.3.3 Mapping of signalling MS/MSC/IWF to modem interface requirements

This process also is a reverse of the function provided in the Terminal Adaptation function of the MS for the mapping of DTE/DCE signalling information to Dm channel and in band signalling information. 3GPP TS 27.002, and 3GPP TS 27.003 refer.

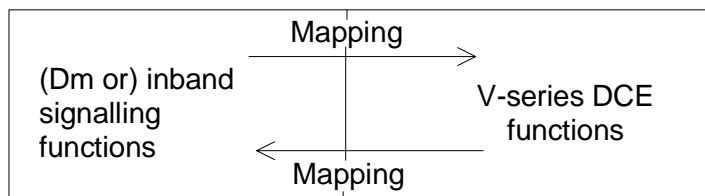

Figure 6: Signalling mapping schematic

Status bits SA, SB and X can be used to convey channel control information associated with the data bits in the data transfer state. Table 5 shows the mapping scheme between the V.24 circuit numbers corresponding to the V-series DCE functions and the status bits for the transparent mode. It also shows how the unused status bits should be handled. It is derived from the General Mapping scheme described in annex B. A binary 0 corresponds to the ON condition, a binary 1 to the OFF condition.

The transport of these status bits by the various channel codings is described in 3GPP TS 04.21 and 08.20 for GSM. For UMTS refer to 3GPP TR 23.910.

NOTE Although the interface to the modem is described in terms of V.24 interchange circuit functions, this does not imply that such circuits need to be physically realised.

**Table 5: Mapping scheme at the IWF for the transparent mode**

Mapping direction: MS to IWF	Mapping direction: IWF to MS	Signal at IWF modem interface or condition within the IWF
always ON (note 1)		CT 105
	to status bit X	CT 106
	not mapped (note 5)	CT 107
not mapped (note 6)		CT 108
	to status bit SB	CT 109
always ON (note 2)		CT 133
from status bit SA (note 3)		ignored by IWF
from status bit SB (note 1)		ignored by IWF
from status bit X (note 4)		ignored by IWF
	to status bit SA (note 3)	always ON
<p>NOTE 1: The SB bit towards the IWF, according to the General Mapping (annex B), could be used to carry CT 105 from the mobile DTE to the modem in the IWF. However, CT 105 should always be ON at the DTE interface in the data transfer state since only duplex operation is supported. Also, many DTEs use the connector pin assigned to CT 105 for CT 133. Therefore, CT 105 shall always be set to ON at the IWF modem during the data transfer state.</p> <p>NOTE 2: CT 133 is not mapped since there is no flow control in transparent mode.</p> <p>NOTE 3: The SA bits in both directions are available only with certain channel codings. Therefore, for maximum compatibility, they should not be mapped.</p> <p>NOTE 4: The X bit towards the IWF is not mapped since there is no flow control in transparent mode.</p> <p>NOTE 5: CT 107 is not used by the IWF.</p> <p>NOTE 6: CT 108 is used in the call setup and answering processes.</p>		

In general it is not required for the modem in the MSC/IWF to support a "remote looping" request from a modem in the PSTN. In addition the invocation of a "remote looping" request from the mobile subscriber to a modem in the PSTN need not be supported (see also 3GPP TS 27.001). Specific test loops for mobile subscribers to contact may be provided at the network operators discretion.

#### 9.2.3.4 Establishment of end-to-end terminal synchronizations

Prior to exposing the traffic channel of a PLMN connection to transmission of user data, the controlling entities of the connection shall assure of the availability of the traffic channel. This is done by a so called synchronizations process:

- starting on the indication of "physical connection established" resulting from the PLMN-inherent outband signalling procedure. This indication is given on sending the message CONNECT in case of MOC, CONNECT ACKNOWLEDGEMENT in case of MTC and MODIFY COMPLETE (which is sent after reception of the ASSIGN COMPLETE message) in case of in-call modification;
- ending by indicating the successful execution of this process to the controlling entity, which then takes care of the further use of the inband information (data, status).

Network interworking within an MSC/IWF is concerned with the terminating side (to the MS / UE) and the transit side (to the fixed network) of a connection. Both sides have to be treated individually related to the synchronizations process.

#### 9.2.3.4.1 Terminating side (towards the MS / UE)

##### 9.2.3.4.1.1 GSM Traffic channel types TCH/F4.8 and TCH/F9.6

With respect to the terminating side the procedure is as follows:

- sending of synchronizations pattern 1/OFF (all data bits "1"/all status bits "OFF") to the MS using the RA1/RA2 rate adaptation function. In multislot transparent operation, the synchronisation pattern sent is 1/OFF with the exception of the bit positions S1, first X, S3, and S4 which contain the substream number and multiframe alignment pattern (Ref. 3GPP TS 04.21);
- searching for detection of the synchronizations pattern from the MS within valid V.110 frames, and in multislot operation, also searching for the multiframe alignment pattern "0000 1001 0110 0111 1100 0110 1110 101" (Ref. to 3GPP TS 04.21) in bit position S4 and substream numbers in bit positions S1, first X, and S3. This implies that the E1, E2 and E3 bit of the V.110 frame shall be checked for the appropriate user rate in order to distinguish the synchronization pattern from the BSS idle data frame;
- timer T (= 500 ms) is started for each of the allocated traffic channel(s) of the call on receipt of the synchronizations pattern from the MS;
- when the frame alignment pattern and, in case of multislot operation, the multiframe alignment pattern have been recognized as a steady state, the MSC/IWF continues sending the synchronizations patterns to the MS until a timer T expires.

##### 9.2.3.4.1.2 GSM Traffic channel type TCH/F14.4

With respect to the terminating side the procedure is as follows:

- sending A-TRAU frames with the data rate set in the bits C1-C4 (TS 08.20) and data bits set to one, sending the multiframe structure with the alignment pattern (bit M1) and with the status bits OFF (bit M2) and, in a multislot case, sending substream numbers (bit M2);
- searching for the detection of the multiframe alignment pattern "0000 1001 0110 0111 1100 0110 1110 101" (TS 04.21) in the bit M1 and, in a multislot case, searching for substream numbers in the bit M2. (Any 5 bit sequence in the multiframe alignment pattern is unique, i.e. the multiframe alignment can take place by recognition of five successive M1 bits);
- timer T (= 500 ms) is started for each of the allocated traffic channel(s) of the call on receipt of the synchronizations pattern from the MS;
- when the frame alignment pattern and the multiframe alignment pattern have been recognized as a steady state, the MSC/IWF continues sending the synchronizations patterns to the MS until a timer T expires.

##### 9.2.3.4.1.3 UMTS User Plane

The IWF does not send any frame down link until the modem connection has been established and the modems have synchronised. Thereafter the IWF through connects, mapping data from the fixed network side onto frames that are sent toward the MS, and mapping data in the received frames to the fixed network side.

#### 9.2.3.4.2 Transit side (towards the fixed network)

With respect to the transit side the procedure is as follows:

- at the start of timer T for each of the allocated traffic channel(s) of the call, circuit 108 to the selected modem associated with the connection will be switched from the "OFF" to "ON" condition, thus initiating the establishment of the modem connection. In the case of mobile originated calls, this initiates the auto calling sequence and after signalling, calling tone according to V.25 shall be generated by the modem in the IWF;
- the interchange circuits towards the modem (with the exception of CT108) are held in the OFF condition until timer T expires, when they are switched to ON;



- from this time, after the expiration of the timer T of every allocated traffic channel, the information on CT106 and CT109 from the IWF Modem are directly mapped to the SB and X bits toward the MS. For TCH/F14.4 the SB and X bits are mapped to the M2 multiframe bits according to 3GPP TS 04.21. The IWF is allowed to map CT104 to the data bits sent towards the MS and to map data bits received from the MS to CT103.

### 9.2.3.5 Network Independent Clocking (NIC)

The network independent clocking function applies only to GSM. It is invoked by the VMSC/IWF when the service requested (MO or MT) is 3,1 kHz Ex PLMN and synchronous. The above rule applies irrespective of the information contained in the 3GPP TS 24.008 setup message regarding NIC. For all other services NIC is not used.

Within the GSM network the coding of the values for bits associated with NIC is specified in 3GPP TS 04.21/08.20. In the forward (transmitting) direction the multiframes shall be coded in exact accordance with that specified in those GSM specifications. Bit E6 is set to "1" in alternate modified V.110 frames at the transmitter. However, the use of this bit at the receiver for monitoring frame synchronization, or any other purpose, is not specified and is left to the discretion of the implementer.

A "perfect linear block Code" is used in C1-C5, whose error correction properties may be utilized in the receiver, in order to ensure reliable operation of NIC.

The NIC sending function shall recognize when the difference between the applicable clock speed of the GSM network and the interface speed generates a positive or negative whole bit requirement. When this positive or negative condition occurs, the NIC codewords specified in 3GPP TS 04.21 are used to transport this condition to the receiving NIC function. Transmission of the codeword shall clear the positive or negative condition related to that codeword at the sending function. The sending function shall not send more than one positive or negative compensation within a contiguous period of time corresponding to 10 000 user data bits minus the maximum NIC code framing delay (e.g. in the case of TCH/F2.4, TCH/F4.8 or TCH/F9.6, the number of user data bits necessary to make up an even number of V.110 frames between compensation). NIC compensation is coded in two V.110 frames in the case of TCH/F2.4, TCH/F4.8 or TCH/F9.6 and in one multiframe in the case of TCH/F14.4. This results from the requirements to compensate for maximum clock differences of  $\pm 100$  parts per million. If the receiving function receives NIC compensations in the average more often than a contiguous period of time corresponding to 10000 user data bits, there is no guarantee that data will not be lost.

The NIC receiving function shall provide the capability to support the compensation requirements of the sending function. This compensation is managed by manipulating the clock speed of the interface, within the standard constraints of that interface.

Overall, the compensation functions shall be capable of managing clock tolerances of  $\pm 100$  parts per million.

Action on loss of synchronization.

If five consecutive NIC multiframes in the V.110 frame have incorrect framing bit values in E7 or if the A-TRAU multiframe synchronisation is lost, the receiver shall stop applying clocking compensation to the received data. Resynchronization will be attempted and compensation will resume when synchronization is achieved.

### 9.2.4 Non-transparent service support

The protocol stacks for non-transparent services are specified in 3GPP TR 03.10 (GSM) and in 3GPP TR 23.910 (UMTS). Both of the systems use the Radio Link Protocol (RLP) specified in 3GPP TS 24.022.

In UMTS, the non-transparent services are based in the Iu User Plane protocol specified in 3GPP TS 25.415.

In GSM the corresponding necessary support concerning the rate adaptation scheme shall be utilized on the BSS-MSC link as identified in 3GPP TS 08.20.

For the non-transparent service support the MSC/IWF will select the modem and speed based on the Compatibility information contained in either the call set-up or call confirmed message, reference subclauses 9.2.1 and 9.2.2. Where the Modem Type indicated is autobauding type 1, the MSC/IWF may select any speed and modem type according to what it can negotiate with the remote modem. In this case User Rate and Fixed Network User Rate, if present, has no meaning.

#### 9.2.4.1 Structure of the MSC/IWF for UMTS

The transmission towards the RNC is based on AAL2. The Iu UP is used in the support mode. The RLP/L2R extends to the MS.

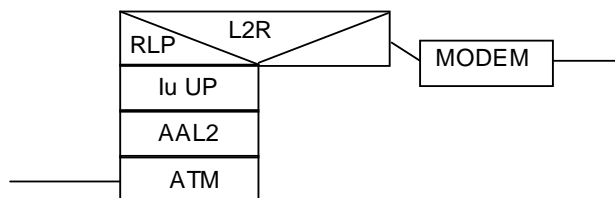

**Figure 7: Structure of MSC/IWF**

#### 9.2.4.2 Structure of the MSC/IWF for GSM

The rate adaptation process will be the same as for the transparent case (see figure 5), except that a TCH/F43.2 channel coding is also supported. From MSC/IWF's perspective a TCH/F43.2 EDGE configuration is identical to a multislot 3×TCH/F14.4 configuration.

3GPP TR 03.10 identifies the protocol layer structures for the non-transparent case, the physical layer to the PSTN is provided by means of a modem.

#### 9.2.4.3 Re-constitution of user data

3GPP TS 24.022 refers to the frame of user data in the radio link protocol. The layer 2 relay functions in the MS and the MSC/IWF (identified in 3GPP TR 03.10) contain the mechanism for packing and unpacking the user data into the L2R protocol data units.

#### 9.2.4.4 Layer 2 relay functionality

Specific functionality is required of the L2R dependant upon the service which is being requested to be supported. The selection of the appropriate L2R function will be determined by the MSC/IWF on the basis of the bearer capability information signalled in either the call set-up request, or call confirmation messages. The prime information element being transparent or non transparent service indication. In addition the particular L2R function will be selected on the basis of the users layer 2 indication - type of protocol to be terminated and mode of flow control to be applied (see appropriate clauses of the 3GPP TS 27 series).

The specific interaction between the L2R function and the RLP function and the L2R frame structure will be the same as that detailed in the annex to the appropriate 3GPP TS 27 series.

#### 9.2.4.5 In band signalling mapping flow control

This entails the L2R function providing the means of controlling and responding to flow control functions of the modem plus any synchronization requirements related to flow control. For synchronous services flow control is covered by the protocol indicated, whereas for asynchronous services a specific rule applies for flow control (see 3GPP TS 27.001).

The flow control function chosen will be dependent upon the information contained or not contained in the "user information layer 2" information element of the PLMN BC received from the MS.

If flow control is provided, irrespective of the type used the L2R function shall:

- (a) provide immediate indication of flow control to the fixed network on receipt of flow control request from the MS; and/or
- (b) provide immediate indication of flow control to the MS on receipt of flow control request from the fixed network i.e. in the next available L2R status octet to be transmitted.

Where in-band (X-on/X-off) flow control is in use, then the X-on/X-off characters will not be passed across the radio interface.

For outband flow control refer to subclause 9.2.4.9.

If no flow control is provided, the involved end systems are responsible for performing in-band flow control on their own by taking into account the buffer capacity of the MSC/IWF stated below.

#### 9.2.4.5.1 Conditions requiring flow control towards the fixed network

The L2R function will initiate flow control - if flow control is present - in the following circumstances:

- 1) the transmit buffer reaches a preset threshold (BACK PRESSURE);
- 2) the L2R function receives an explicit "flow control active" indication.

No flow control initiation/removal will take place at the L2R function and loss of data may occur if no flow control is provided.

On removal of buffer congestion or receipt of L2R "flow control inactive" the flow control will be removed.

#### 9.2.4.5.2 Conditions requiring flow control towards the MS

The L2R function will transmit to the MS an explicit "flow control active indication" if flow control is provided in the following circumstances:

- 1) if the receive buffer from the radio side reaches a preset threshold (BACK PRESSURE);
- 2) if a flow control indication is received from the fixed network customer. On receipt of this flow control indication, transmission of data from the receive buffers towards the fixed network terminal is halted.

On removal of the buffer congestion or fixed network flow control indication, the L2R function will send a "flow control inactive" indication towards the MS. In addition, for the fixed network indication, transmission of data from the receive buffers will be restarted.

If no flow control is provided at the L2R function, no flow control initiation/removal will take place by the MSC/IWF. Data might be lost without any indication by the MSC/IWF to the end systems involved.

### 9.2.4.6 Data buffers

#### 9.2.4.6.1 Transmit buffers (towards MS)

Incoming data from the fixed network customer shall be buffered such that if the MSC/IWF is unable to transfer data over the radio path the data is not lost.

The buffer shall be capable of holding the data. Its size is up to the implementers. When the buffer is half full flow control towards the fixed network shall be initiated if flow control is provided as per subclause 9.2.4.5.1.

#### 9.2.4.6.2 Receive buffers (from MS)

Incoming data from the MS is buffered such that if the fixed network terminal is unable to accept the data then it is not lost.

The buffer shall be capable of holding the data. Its size is up to the implementers. When the buffer becomes half full, the L2R function will send a "flow control active" indication towards the MS if flow control is provided at the L2R function, as per subclause 9.2.4.5.2.

### 9.2.4.7 Transportation of the Break condition

The "BREAK" condition shall be recognized by the L2R function and passed immediately to the MS. The L2R will generate a "BREAK" condition towards the fixed network on receipt of a break indication from the MS. The action of the "BREAK" on the L2R transmit and receive and the length of the "BREAK" signal to be generated towards the fixed network is described in 3GPP TS 27.002.

### 9.2.4.8 In band signalling mapping modem status information

Status information is carried between the modem in the IWF and the terminal adaptation function in the MS by the L2R function. The L2RCOP entity transfers interface status information between L2Rs via the status octets SA, SB and X in L2RCOP-PDUs (3GPP TS 27.002). Table 6 shows the mapping scheme between the V.24 circuit numbers corresponding to the V-series DCE functions and the status bits for the non-transparent mode. It also shows how the unused status bits should be handled. It is derived from the general mapping scheme described in annex B. A binary 0 corresponds to the ON condition, a binary 1 to the OFF condition.

NOTE Although the interface to the modem is described in terms of V.24 interchange circuit functions, this does not imply that such circuits need to be physically realised.

**Table 6: Mapping scheme at the IWF for the non-transparent mode**

Mapping direction: MS to IWF	Mapping direction: IWF to MS	Signal at IWF modem interface or condition within the IWF
always ON (note 1)		CT 105
	to status bit X (notes 4, 7)	CT 106 (note 7)
	not mapped (note 5)	CT 107
not mapped (note 6)		CT 108
	to status bit SB	CT 109
from status bit X (note 8)		CT 133 (notes 3, 8)
from status bit SA (note 2)		ignored by IWF
from status bit SB (note 1)		ignored by IWF
	to status bit SA (note 2)	always ON
NOTE 1: The SB bit towards the IWF, according to the General Mapping (annex B), could be used to carry CT 105 from the mobile DTE to the modem in the IWF. However, CT 105 should always be ON at the DTE interface in the data transfer state since only duplex operation is supported. Also, many DTEs use the connector pin assigned to CT 105 for CT 133. Therefore, CT 105 shall always be set to ON at the IWF modem during the data transfer state.		
NOTE 2: The SA bits (both directions) are not mapped since CTs 107 and 108 are handled locally (notes 5 and 6).		
NOTE 3: The condition of CT 133 (or other flow control mechanism) may also be affected by the state of the L2R transmit buffer (towards the MS) in the IWF and the state of RLP (RR/RNR).		
NOTE 4: The condition of status bit X towards the MS may also be affected by the state of the L2R receive buffer (from the MS) in the IWF.		
NOTE 5: CT 107 is not used by the IWF.		
NOTE 6: CT 108 is used in the call setup and answering processes.		
NOTE 7: For inband flow control, CT 106 is not mapped and the status bit X towards the MS is controlled by the reception of XON and XOFF characters from the modem.		
NOTE 8: For inband flow control, changes in the condition of the status bit X from the MS result in the sending of XON or XOFF to the modem. CT 133 is always set to ON.		

#### 9.2.4.9 Support of out-band flow control

Out-band flow control in case of the asynchronous bearer service requires V.42 functionality in the modems in the MSC/IWF and the fixed network.

If this functionality is requested by the MS but cannot be provided by the MSC/IWF or the remote (fixed network) modem for any reason, the call shall be supported without V.42 functionality (fall back to the non-error correction mode according to V.42).

This implies that no flow control initiation/removal (refer to subclause 9.2.4.5.1) is possible towards the fixed network. In this case the L2R transmit buffers in the IWF (towards the MS, refer to subclause 9.2.4.6.1) shall overbridge temporary throughput problems on the radio interface and the case where the MS initiates flow control. The IWF however shall release the connection if an overflow of these buffers occurs.

#### 9.2.4.10 Establishment of end-to-end terminal synchronizations

Prior to exposing the traffic channel of a PLMN connection to transmission of user data, the controlling entities of the connection shall assure of the availability of the traffic channel. This is done by a so called synchronization process:

- starting on the indication of "physical connection established" resulting from the PLMN-inherent outband signalling procedure. This indication is given on sending the message CONNECT in case of MOC, CONNECT ACKNOWLEDGEMENT in case of MTC and MODIFY COMPLETE (which is sent after reception of the ASSIGN COMPLETE message) in case of in-call modification;
- ending by indicating the successful execution of this process to the controlling entity, which then takes care of the further use of the in-band information (data, status).

Network interworking within an MSC/IWF is concerned with the terminating side (to the MS) and the transit side (to the fixed network) of a connection. Both sides shall be treated individually related to the synchronization process.

##### 9.2.4.10.1 Terminating side (towards the MS / UE)

With respect to the terminating side the procedure in GSM is as follows:

- reception of V.110 or A-TRAU frames on all allocated traffic channels for the call is required before the MSC/IWF shall reply with an RLP-UA frame to the MT's RLP link establishment request (if the MSC/IWF initiates the RLP link establishment, reception of V.110 frames or A-TRAU on all allocated traffic channels for the call shall be detected first);
- waiting for the RLP link establishment by the MT (in addition the MSC/IWF may initiate the RLP establishment).

In UMTS at the IWF, the synchronisation of modems on the transit network is performed after establishment of the physical connection. The RLP establishment may be initiated by the IWF, but is normally initiated by the MS. If the modems synchronise before the RLP has been established, the IWF stores the information received from the other modem in the L2R buffers.

##### 9.2.4.10.2 Transit side (towards the fixed network)

Depending upon implementation - CT108 will be turned ON to enable the autocalling/autoanswering function of the selected modem either when the RLP has been established or in parallel to RLP establishment. If CT 108 is turned ON in parallel to the RLP establishment, the modem connection may be established before the RLP is established. In this case, data received from the transit side during RLP establishment shall be stored within the L2R buffers until the RLP establishment at the terminating side has been finished. When the RLP has been established, the information from/to the RLP including status changes will be mapped by the L2R entity applicable to the particular bearer capability. After signalling, for MO calls, calling tone according to V.25 shall be generated by the modem in the IWF.

### 9.2.4.11 Data compression

When data compression is invoked within a non-transparent bearer service, interworking to the fixed network is realized as follows.

The PLMN BC is used to indicate the interworking modem type and user rate. The modems shall try to negotiate data compression and flow control. If negotiation of data compression fails in the fixed network, the call continues with data compression between MS and IWF only.

### 9.2.4.12 Service level up and down grading

Service level up and down grading is only applicable for GSM. If the value of the RLP parameter "UP signalling" is negotiated to 1, the IWF shall send a suggestion to the MS to initiate an upgrading whenever the following condition holds:

The IWF:

- 1) is receiving user data from the fixed network side at a higher rate than the current AIUR; or
- 2) in symmetrical calls only, can send user data towards the fixed network side at a higher rate than the current AIUR.

When the above condition does not hold, the IWF sets the value of the UP bit continuously to 0. When the condition above does hold, the IWF indicates the number of traffic channels to upgrade by, by sending that number of 1s between two consecutive 0s in the UP bit sequence. This indication is not repeated since the FCS protects it. For instance, if the current number of traffic channels is two and an upgrading to four traffic channels is suggested, the UP bit sequence shall be ..01100... How the IWF detects the condition and additional details for setting and resetting of the UP bit, e.g., hysteresis levels, may depend on implementation. NOTE: From MSC/IWF's perspective a TCH/F28.8 or TCH/F43.2 EDGE configuration is identical to a multislot 2×TCH/F14.4 or 3×TCH/F14.4 configuration. In this case, rather than suggesting the number of channels to add, the IWF suggests a number of 14.4 substreams to add and therefore a factor of 1/2 or 1/3 shall be applied to the suggested increase when the assigned up link channel is TCH/F28.8 or TCH/F43.2 respectively.

## 9.2.5 DTE/DCE interface (Filtering)

The DTEs taken into account for the PLMN at the MS side conform to ITU-T's DTE/DCE interface specifications, which assume basically an error-free environment, i.e.:

- limited distance, point-to-point local interconnection of the interface circuits for data and status;
- steady state signalling.

The envisaged use of these DTE's in the PLMN environment leads to the exposure of these "interconnections" - which may, in the ISDN case, lead to the ISDN Rate Adaptation rather than to a Modem in the MSC/IWF - to the PLMN Radio Channel. To assure proper operation even under these conditions appropriate measures shall be taken. In the "non-transparent case" the RLP satisfies the requirement for both data and status lines. In the "transparent" case, the:

- data line aspects shall be dealt with end-to-end between the users; while
- status line aspects are of concern to the network which are dealt with in the following.

The use of the channel control information for the remote control of the DTE/DCE control interchange-circuits between the MS and the MSC/IWF (the conveyance of which is supported by the rate adaptation scheme adopted for PLMN application) requires alignment to the particular transmission occurrences in the traffic channel to be taken into account within the PLMN. In principle this can be best achieved by:

- relying only on the PLMN outband signalling as far as connection control is concerned;
- eliminating the dependence upon the transmission of channel control information via the radio link.

Support for this strategy is given to a certain extent by the confinement of PLMN data connections to:

- full duplex operation (no turning round of the connection is required);

- switched service (demand access);
- mapping of connection-control relevant conditions of the DTE/DCE control interchange-circuits to/from outband PLMN signalling according to 3GPP TS 24.008 after successful traffic channel synchronization;
- flow control by a network entity supported only in non-transparent mode;
- support of connections with the same user data rate only (no TA to TA end-to-end flow control in case of transparent mode).

The only DTE/DCE control interchange-circuit conditions, which actually are not covered by the above confinements, are the indications of readiness for data transmission, i.e. CT106/109 in case of V.-series interface and I-circuit of X.-series interface. As the effect of a condition change of the afore-mentioned DTE/DCE interchange-circuits depends on the:

- phase within the course of the connection;
- direction of change (ON-OFF or OFF-ON).

The required precaution to be applied (Filtering) shall be determined individually in view of:

- function deduced from the change;
- resilience of the connection needed;
- error condition possibly invoked due to a delay in performing the condition change of the control interchange circuit;
- potential loss of performance in connection usage.

The details of the filtering function are laid down in 3GPP TS 27- series. Filtering of channel control information is only relevant at the MS side in the transparent mode of operation.

## 9.3 Interworking Alternate Speech / Facsimile Group 3 Calls

### 9.3.1 General

The procedure for the alternate speech/facsimile group 3 services is invoked at MS-MS network link during the call set-up phase. This service is invoked by indication of repeated bearer capability information elements in the setup message and/or call confirmed message respectively (preceded by a repeat indicator "circular"), one indicating speech and the other indicating facsimile group 3. The facsimile service requested will be indicated by the information transfer capability "facsimile group 3", as for a normal single call. The bearer capability first indicated i.e. speech or facsimile group 3 determines the first selection required of the network by the subscriber. Depending on the type of service requested and direction of call establishment (MO/MT, see relevant clauses of 3GPP TS 27 series) low layer and high layer capabilities may also be included. The MSC/IWF will perform both compatibility checking and subscription checking on both sets of capabilities as for normal data calls. If either the subscription check or the compatibility check fails then the call will be rejected. The only exception to this is when TS61/TS62 negotiation takes place, see 3GPP TS 27.001.

The applicable rules for provision of supplementary services are laid down in 3GPP TS 22.004.

The "speech" phase of the call, when invoked is handled by the transcoder and will utilize normal telephony teleservice interworking requirements and mobile network capabilities. This includes any requirements for echo cancellers etc. as indicated in subclause 9.1. The "facsimile group 3" phase of the call, when invoked, will utilize the appropriate data interworking capability (IWF including modem) and may use either the transparent or non-transparent mobile network capability in the case of GSM.

The network shall provide, for service and operational reasons, a rapid and reliable changeover of capability upon request from the mobile user. This changeover may involve the disabling, by-passing or introduction of particular network functions (e.g. speech coder, modem etc.) and change of the channel configuration on the radio interface. This changeover is initiated on the receipt of the "MODIFY" message (see 3GPP TS 24.008) from the MS. The network itself will not initiate a changeover.

## 9.3.2 Mobile originated PSTN terminated calls

The call is set up in the normal manner (but with repeated bearer capability information elements as described in subclause 9.3.1 and handled by the MSC/IWF as indicated in the general clause.

## 9.3.3 PSTN originated mobile terminated calls

The call set up request for this particular service is performed in a similar manner to that indicated in subclause 9.2 for normal PSTN originated calls.

When multiple MSISDNs are used by the HLR ("Multi-numbering scheme"), one PLMN BC-IE with the ITC value set to "alternate speech/facsimile group 3, starting with speech" is passed to the VLR in the MAP operation "provide roaming number". The VLR stores this information against the MSRN.

When the call arrives at the visited MSC this information is retrieved from the VLR and sent to the MS in the setup message as defined in 3GPP TS 27.001.

If the ITC of the PLMN BC-IE retrieved from the VLR has the value "alternate speech/facsimile group 3, starting with speech" this PLMN BC-IE shall be mapped to two PLMN BC-IEs (preceded by a repeat indicator "circular"), one representing speech, the other representing facsimile group 3. The order in which these two PLMN BC-IEs are sent towards the MS, in the setup message, is a network option.

In order to allow auto answering mode for the facsimile phase (i.e. the call starts automatically with the facsimile phase), the MS can reflect back to MSC the dual Bearer Capability in the Call Confirm message with the BC elements interchanged to those in the original Call Set-up message (i.e. facsimile element first or negotiate to facsimile only, see subclause 9.2.2 and 3GPP TS 27.001). In all other aspects it is handled as indicated for mobile originated.

NOTE: However, the PLMN specific parameters "connection element" and "radio channel requirements" of the retrieved PLMN BC-IE may be modified, or added in line with the principles identified in subclause 9.2.2.

When a single MSISDN is allocated to the subscriber ("single numbering scheme"), the call is handled as described in case b) of subclause 9.2.2. In the "call confirmed" message, however, two PLMN BC-IEs are preceded by a repeat indicator "circular", with the first PLMN BC-IE indicating the initial phase of the connection.

## 9.4 3G-H.324/M calls over 3,1kHz audio

In case of 3G-H.324/M calls over 3.1kHz audio, the IWF shall provide the V.34 modem modulation and the V.8 procedure with the indication of H.324 support in the call function category of the V.8 handshaking. H.223 & H.245 flow is not terminated in the modem function.

The performance of V.8bis by the modem function is FFS.

### 9.4.1 Mobile originated multimedia call

#### 9.4.1.1 Call setup

The setup message sent by the MS contains either a multimedia BC-IE indicating a multimedia only call request (i.e. no fallback to speech allowed) or both a speech BC-IE and a 3.1kHz multimedia BC-IE to indicate the support of a fallback to speech (ref. to TS 27.001 and TS 24.008).

The MSC shall not accept a requested service to which the user has no subscription. On the condition the user has the required subscriptions (i.e. to multimedia and/or speech) the following applies:

- in case of a multimedia only BC-IE the MSC may accept the setup as such or with modifications sent to the MS in the call proceeding message (ref. to TS 27.001);
- in case of both a speech BC-IE and a 3.1kHz multimedia BC-IE the MSC may either accept the possibility of a fallback to speech by responding with two BC-IEs or with no BC-IEs or turn the call to a speech call by sending only a speech BC-IE in the call confirm message or turn the call to a multimedia only call by sending only a multimedia BC-IE in the call confirm message (Ref. to TS 27.001).



The IWF V.34 modem shall initiate the ITU-T V.8 handshaking and indicate the support of H.324/M in the call function category of the V.8 handshaking. If the called party's modem does not indicate a H.324 support in its V.8 inband signalling response, the IWF may clear the call. If the called party responds with a modem answering tone but there is no V.8 response at all, the IWF shall clear the call.

If FNUR = 33.6 kbit/s is agreed on in the setup, the IWF shall configure its V.34 modem to operate in automode with an upper data rate limit of 33.6 kbit/s and a lower data rate limit of 28.8 kbit/s. If the modems handshake to 31.2 or 28.8 kbit/s, the MSC shall initiate a MODIFY message (ref. to TS 24.008) to indicate the new data rate to the MS. HDLC flag stuffing or the stuffing mode defined in ITU-T recommendation H.223 (Annexes A, B and C) shall be used to adapt the 31.2 or 28.8 kbit/s data rate to the 33.6 kbit/s traffic channel between the MS and the IWF. In order to be able to use the correct stuffing pattern, the IWF shall detect the stuffing mode patterns exchanged between the multimedia terminals after the traffic channel setup (ref. to ITU-T recommendation H.324). The IWF may start the stuffing immediately after the detection of the used method. In downlink stuffing the IWF inserts stuffing patterns between the H.223 frames. In uplink stuffing the IWF removes stuffing patterns from between the H.223 frames received from the MS. If the MS responds with a MODIFY REJECT message, the MSC shall clear the call.

#### 9.4.1.2 Fallback to speech after setup

If the MSC has accepted the possibility of a fallback to speech and the IWF modem does not recognize the answering tone of the called modem within the expiration of a timer started at the reception of the answer message, the MSC IWF shall initiate an In Call Modification procedure (ref. to TS 24.008) in order to fall back to a speech mode. As a result of the procedure the IWF resource shall be released and a speech channel shall be set up between the calling MS and the fixed network. If the fallback fails e.g. due to a failing In Call Modification procedure, the IWF shall clear the call.

A recommended minimum value for the timer is 3 seconds (ref. to the ITU-T V.25 recommendation).

### 9.4.2 Mobile terminated multimedia call

#### 9.4.2.1 Call setup

If the user has a subscription to both the multimedia bearer service and the speech teleservice and if the network supports both services and the fallback functionality, the MSC shall send both a multimedia BC-IE and a speech BC-IE in the setup message to the mobile station. If the user has a subscription only to the multimedia bearer service the MSC shall send only a multimedia BC-IE.

In case of both a speech BC-IE and a 3,1 kHz multimedia BC-IE in the setup the mobile station may either accept the possibility of a fallback to speech by responding with two BC-IEs or with no BC-IEs or turn the call to a speech call by sending only a speech BC-IE in the call confirm message or to a multimedia only call (i.e. no fallback to speech allowed) by sending only a multimedia BC-IE in the call confirm message. In case of a multimedia only BC-IE in the setup the MS may accept the setup as such or with modifications sent to the MSC in the call confirm message.

If no service definition is available in the network, the MSC shall send no BC-IE(s) to the mobile station in the call setup. The MSC shall analyse the received BC-IE(s) and optionally perform a subscription check to the multimedia and/or speech service(s) requested by the mobile station in the call confirm message and shall not accept a requested service rejected by the subscription check.

The IWF V.34 modem shall await the ITU-T V.8 handshaking to be initiated by the calling party's modem and shall recognize the support of H.324 in the call function category of the incoming V.8 handshaking. If the calling party's modem does not indicate a H.324 support in its V.8 inband signalling, the IWF may clear the call. If the calling modem tries to handshake another than V.34 modem scheme, the IWF shall clear the call.

If FNUR = 33.6 kbit/s is agreed on in the setup, the IWF shall configure its V.34 modem to operate in automode with an upper data rate limit of 33.6 kbit/s and a lower data rate limit of 28.8 kbit/s. If the modems handshake to 31.2 or 28.8 kbit/s, the MSC shall initiate a MODIFY message (ref. to TS 24.008) to indicate the new data rate to the MS. HDLC flag stuffing or the stuffing mode defined in ITU-T recommendation H.223 (Annexes A, B and C) shall be used to adapt the 31.2 or 28.8 kbit/s data rate to the 33.6 kbit/s traffic channel between the MS and the IWF. In order to be able to use the correct stuffing pattern, the IWF shall detect the stuffing mode patterns exchanged between the multimedia terminals after the traffic channel setup (ref. to ITU-T recommendation H.324). The IWF may start the stuffing immediately after the detection of the used method. In downlink stuffing the IWF inserts stuffing patterns between the H.223 frames. In uplink stuffing the IWF removes stuffing patterns from between the H.223 frames received from the MS. If the MS responds with a MODIFY REJECT message, the MSC shall clear the call.

### 9.4.2.2 Fallback to speech after setup

If the MSC supports a fallback to speech and the user has a subscription to the speech service and the mobile station accepts the possibility of a fallback to speech in the call confirm message and the IWF modem does not recognize a call tone nor a V.8 Call Indication nor a V.8 Call Menu within the expiration of a timer started at the sending of the ANSam answer tone (i.e. the calling party is not a V.34 modem), the IWF shall initiate an In Call Modification procedure (ref. to TS 24.008) in order to fall back to a speech mode. As a result of the procedure the IWF resource shall be released and a speech channel shall be set up between the called MS and the fixed network. If the fallback fails e.g. due to a missing subscription to speech or a failing In Call Modification procedure, the IWF shall clear the call.

A recommended minimum timer value is 3 seconds (ref. to the ITU-T V.8 recommendation).

### 9.4.3 Seamless data rate change

If the modems change the data rate during an ongoing multimedia call (using the ITU-T V.34 seamless data rate change mechanism), the MSC shall initiate a MODIFY message (ref. to TS 24.008) to indicate the new data rate to the MS. HDLC flag stuffing or the stuffing mode defined in ITU-T recommendation H.223 (Annexes A, B and C) shall be used to adapt the 31.2 or 28.8 kbit/s data rate to the 33.6 kbit/s traffic channel between the MS and the IWF. The stuffing pattern found out during the traffic channel setup (ref. to subclauses Call setup) is used. The IWF may start the stuffing immediately after the detection of the data rate change by the modems.

---

## 10 Interworking to the ISDN

The interworking to the ISDN is specified on the principle of the network supporting standardized associated signalling protocol as outlined in clause 6, i.e. DSS1 and ISUP. An ISDN not complying with this definition differs - for the purpose of the present document - in that it does not support the compatibility information to that degree necessary for deducing a PLMN Basic Service. These networks will find their reflection in the following where those implications are to be set out.

The calling address sent in a mobile originated call to the ISDN is always the basic MSISDN even if the ISDN user shall use a different MSISDN (multi numbering scheme, see 9.2.2 case a) for a mobile terminated call (call back) as only the basic MSISDN is available at the VLR (see 3GPP TS 29.002).

The scope of this clause is to describe the handling of the content of the Information Elements where "content" is understood to be the value of the parameter fields of the Information Elements, namely BC-IE, HLC and LLC, after the length indicator. For the transport of these Information Elements within the PLMN refer to 3GPP TS 29.002.

The handling of multislot, 14.4kbit/s, EDGE and Iu Mode related parameter of the call control signalling and the applicability of single- or multislot configurations (refer to 3GPP TS 08.20 and 3GPP TS 04.21) is the same as for the PSTN interworking cases. For multislot, 14.4kbit/s, EDGE and Iu Mode operations, the MS may also propose to the network to modify the Fixed Network User Rate and Other Modem Type parameters (see 3GPP TS 27.001). In case a transparent service is used, the call shall be released. For a non-transparent service with flow control, the MSC/IWF shall use towards the fixed network the unmodified "fixed network user rate" and shall use the "wanted air interface user rate" towards the mobile station.

### 10.1 Speech Calls

Since at the interworking point the transcoder provides for A-law or  $\mu$ -law (PCS-1900) PCM at 64 kbit/s, no particular interworking is required. It is anticipated that the ISDN Teleservice Telephony and ISDN Bearer Service speech, respectively would be used. Transmission aspects are covered in 3GPP TS 03.50. Any further requirements are a national matter.

### 10.2 Data Calls

In this case it is assumed that the ISDN bearer service 3,1 kHz audio shall only be interworked by means of a modem pool in the PLMN. If a network operator provides this facility, then the MSC/IWF operation will be similar to that described for interworking to the PSTN.

Where the bearer capability information indicates that the call is a circuit switched unrestricted digital call, then the MSC/IWF shall select the appropriate rate adapted ISDN and PLMN bearer services.

The mobile network offers only Bm channel access for the packet mode service. The ISDN offers both B and D channel access for the packet mode service. The interworking of mobile packet service calls is described in 3GPP TS 29.006.

## 10.2.1 Network interworking mobile originated

Low layer compatibility checking of the mobile originated call is carried out by the MSC/IWF to determine the appropriate bearer service selection in the ISDN. This will entail the MSC/IWF in mapping appropriately the PLMN BC-IE to the ISDN BC-IE (bearer capability information element). If it is not possible for the MSC/IWF to provide a bearer service match, then the MSC/IWF shall fail the call and indicate the reason to the user.

The MS shall provide further compatibility information (LLC/HLC-IEs) if required for defining end-to-end compatibility.

As well as compatibility checking, subscription checking should be performed.

The selection of the MSC/IWF will be by means of the bearer capability information within the call set up message. The mobile subscriber shall be able to select the unrestricted digital capability, which the MSC/IWF will map to the same capability in the ISDN call set up message. If an interworking point is encountered within the ISDN which does not support this service request, then either a call release message including an appropriate error cause or progress message is returned to the PLMN, indicating that the ISDN network is unable to support the service requested. In the case of a call release message the network shall release the call. In the case of progress message the network releases the call or forwards it (see 3GPP TS 24.008) to the mobile which will release the call.

## 10.2.2 Network interworking mobile terminated

### 10.2.2.1 General

This subclause describes the interworking of calls where the calling subscriber can communicate ISDN compatibility information with exhaustive contents for deducing a PLMN Basic Service to a PLMN (gateway MSC/interrogating node) i.e. by means of ISDN signalling.

The GMSC shall perform a mapping of the received Basic Service Information for the transport to the HLR, for details of this transport refer to 3GPP TS 29.002.

Compatibility checking of the low layers of the ISDN originated call is carried out by the MSC/IWF to determine the appropriate bearer service selection in the PLMN. This will entail the MSC/IWF in mapping appropriately the ISDN BC/LLC-IE to the PLMN BC-IE.

As well as compatibility checking, subscription checking should be performed. If either the subscription check or the compatibility check fails then the call will be rejected.

For ISDN originated calls it will not be possible to signal mobile specific requirements e.g. transparent/non transparent, full/half rate channel. Therefore the MSC/IWF shall select a default setting appropriate to the visited PLMN's network capabilities. In general it will be beneficial, where a network supports both full and half rate channels and transparent/non transparent capabilities, to indicate so in the appropriate PLMN BC field of 3GPP TS 24.008. The mobile subscriber has the option to indicate in the call confirmation message a change to this default setting according to the rules specified in 3GPP TS 27.001. The appropriate MSC/IWF shall be selected on the basis of this requirement.

### 10.2.2.2 Functions in GMSC

At call Set-up, the interrogating node passes in the "send routing information" to the HLR, the ISDN BC, LLC and HLC received in the initial address message. The coding of these parameters shall comply with Q.931 (05/98). For MT calls, and for backward compatibility purposes only, the mapping of the modem type according to ETS 300-102-1 (12/90) shall also be accepted, see note 12 of table 7B.

### 10.2.2.3 Functions in HLR

According to the contents of the Compatibility Information, i.e. the ISDN BC, LLC and HLC received, the HLR applies one of the following alternatives:

- 1) no ISDN BC is received, or one from which a PLMN Basic Service cannot be deduced with the information Transfer Capability field set to "3,1 kHz audio" but without any associated modem type<sup>1</sup> in the ISDN BC and LLC, or without HLC indication of group 3 facsimile. Two cases shall be considered:
  - a) the called MSISDN has a corresponding PLMN BC-IE stored in the HLR (see option a) of 9.2.2); then the service attached to this number in the HLR tables is applicable and the corresponding PLMN BC-IE is passed to the VLR in "provide roaming number". See figure 6;
  - b) the called MSISDN has no corresponding PLMN BC-IE stored in the HLR (see option b in 9.2.2). In this case no PLMN BC is passed to the VLR in the "provide roaming number" message.
- 2) compatibility Information is received from which a PLMN Basic Service can be deduced, i.e. the ITC field in the ISDN BC received is "unrestricted digital" and the fields for the applicable user layer 1 protocol and user rate (except for the 64kbit/s case, see Note 22 Table 7B) are available (either in the ISDN BC or LLC), or the ITC field is "3,1 kHz audio", and a modem type, user rate, etc. is indicated but the HLC does not indicate "facsimile group 3". The received ISDN BC (and possibly LLC plus HLC) is then considered applicable regardless of the kind of MSISDN received (PLMN BC associated or not) and either the equivalent PLMN BC or the original ISDN BC/LLC is sent to the VLR. Additionally in both cases the originally received HLC may also be sent to the VLR, see figure 7.

In exception to this the BC stored in the HLR is regarded valid if one of the following cases applies:

- If ITC = UDI/RDI and User Rate = 32 kbit/s /56 kbit/s and User information layer 1 protocol = V.110, I.460/X.30 and the stored BC indicates FTM, PIAFS or Multimedia.
- If ITC = 3,1 kHz audio and User Rate = 28.8 kbit/s and Modem Type = V.34 and the stored BC indicates Multimedia.

When the HLR interworks with a phase 1 GSM VPLMN (VLR/VMSC), then the HLR shall convert the ISDN BC to the equivalent GSM BC, and forward to the VLR. In this case however no LLC can be forwarded.

- 3) Compatibility Information is received from which the PLMN Teleservice category Facsimile transmission can be deduced i.e. the ITC field in the ISDN BC received is "3,1kHz audio" and the HLC indicates "facsimile group 3" (see figure 7), the following two cases shall be considered:
  - a) the called MSISDN has a corresponding PLMN BC stored in the HLR (either stating TS 61 or TS 62). In this case the service attached to the MSISDN in the HLR tables is applicable and the corresponding PLMN BC is passed to the VLR in the "provide roaming number" message, see also subclause 10.3.1.3;
  - b) the called MSISDN has no corresponding PLMN BC stored in the HLR. In this case the HLR shall forward the appropriate PLMN BC to the VLR in line with the subscribers subscription to Teleservice TS 61 or 62.

For TS 61 the value of the PLMN BC-IE parameter "Information Transfer Capability" shall be set to "alternate speech/facsimile group 3, starting with speech".

In both cases the HLC IE should be passed to the VLR in the "provide roaming number" message.

Alternatively the HLR may forward the originally received ISDN/LLC/HLC, when interworking with a phase 2 GSM VLR or a UMTS VLR, respectively.

- 4) In the case where Compatibility Information received does not allow for deducing a PLMN Bearer Service but an ISDN BC is received with the ITC field indicating "unrestricted digital", but without the fields indicating applicable "user layer 1 protocol", user rate, etc., neither in the ISDN BC or the ISDN LLC then the following shall apply. The call is managed as for an udi call according to subclause 9.2.2, i.e. either the "multi numbering" or "single numbering" scenario is applied depending on which capability is provided by home PLMN/HLR.

<sup>1</sup> "Modem type" in connection with the ITC value "3,1 kHz audio" means hereafter that either an ISDN BC modem type value is present or the autobauding modem function is indicated (see note 16 of table 7B)

#### 10.2.2.4 Functions in VMSC

At the VMSC, when the incoming call arrives, the LLC/HLC and the PLMN or ISDN BC associated with the MSRN is retrieved from the VLR. LLC and HLC are sent with the PLMN BC in general to the MS at call set-up. In particular, however the following rules apply:

- 1) If the Initial Address Message (IAM) contains no ISDN BC and there is no PLMN or ISDN BC/LLC/HLC retrieved from the VLR, the call is handled as subclause 9.2.2 case b.
- 2) If there is no ISDN BC in the IAM but a PLMN or ISDN BC/LLC/HLC was signalled in the "provide roaming number" message, the retrieved PLMN or ISDN BC/LLC/HLC applies.
- 3) If there is an ISDN BC in the IAM with the ITC field set to "3,1 kHz audio" but without any associated modem type or indication of facsimile group 3 in the HLC, the PLMN or ISDN BC/LLC/HLC retrieved from the VLR is considered as applicable when it exists. If no PLMN or ISDN BC is retrieved from the VLR, the call is handled as in subclause 9.2.2 case b.
- 4) If the ISDN BC received in the IAM has the ITC field set to the value "unrestricted digital information" and the fields for the applicable "user layer 1 protocol" and "user rate" (except for the 64kbit/s case, see note 22 table 7B) are available (either in the ISDN BC or ISDN LLC), or if 3,1 kHz audio and a modem type is indicated, this ISDN BC is applicable regardless of what has been retrieved from the VLR. In this case the ISDN BC shall be mapped to an appropriate PLMN BC (refer to table 7B).

In exception to this the BC stored in the VLR is retrieved and send to the MS if one of the following cases applies:

If ITC = UDI/RDI and User Rate = 32 kbit/s /56 kbit/s and User information layer 1 protocol = V.110, I.460/X.30 and the stored BC indicates FTM, PIAFS or Multimedia.

If ITC = 3,1 kHz audio and User Rate = 28,8 kbit/s and Modem Type = V.34 and the stored BC indicates Multimedia.

- 5) If the ISDN BC received in the IAM has the ITC field set to the value "3,1kHz audio" and a HLC "facsimile group 3" is indicated, the PLMN BC retrieved from the VLR is applicable when it exists. If a PLMN BC-IE with the parameter "information transfer capability" set to "alternate speech/facsimile group 3, starting with speech" (stating TS61) is retrieved from the VLR, this shall be mapped to two PLMN BC-IE preceded by a repeat indicator, one representing speech, the other representing facsimile group 3.

When no PLMN BC is retrieved from the VLR, either two PLMN BCs preceded by a repeat indicator (stating Teleservice TS 61), or a single PLMN BC-IE (stating TS 62), are sent in the setup message, depending whether TS 61 or TS 62 is subscribed (see also subclause 10.3.1.3).

In case of TS 61, the order in which the two PLMN BC-IEs are sent towards the MS, in the setup message, is a network option.

- 6) If the ISDN BC received in the IAM has a ITC value "unrestricted digital information" but without applicable "user layer 1 protocol" and "user rate", etc. fields, neither in the ISDN BC nor ISDN LLC, then the PLMN or ISDN BC/LLC retrieved from the VLR is applicable, if available otherwise subclause 9.2.2 case b applies.

In case of an ISDN BC/LLC/HLC was attached to the MSRN this shall be mapped to an appropriate PLMN BC (refer to table 7B). However in both cases (PLMN or ISDN BC attached) the PLMN specific parameters of the PLMN BC-IEs may be added/modified in line with procedures identified in subclause 9.2.2.

- 7) If the ISDN BC received in the IAM has the ITC field set to the value "Speech" and the ITC field of the ISDN BC received with the IAM differs from the ITC field of the BC stored in the VLR for this call, the VLR BC/LLC/HLC is considered applicable. If no PLMN or ISDN BC is retrieved from the VLR, the call is handled as in subclause 9.2.2 case b.

In all cases when no PLMN or ISDN BC is retrieved from the VLR and no ISDN Compatibility information allowing deduction of a PLMN Bearer Service is available, then no PLMN BC is inserted by the VMSC and subclause 9.2.2 case b applies.

The mapping between PLMN and ISDN BCs is shown in table 7.

10.2.2.5 Call Flows

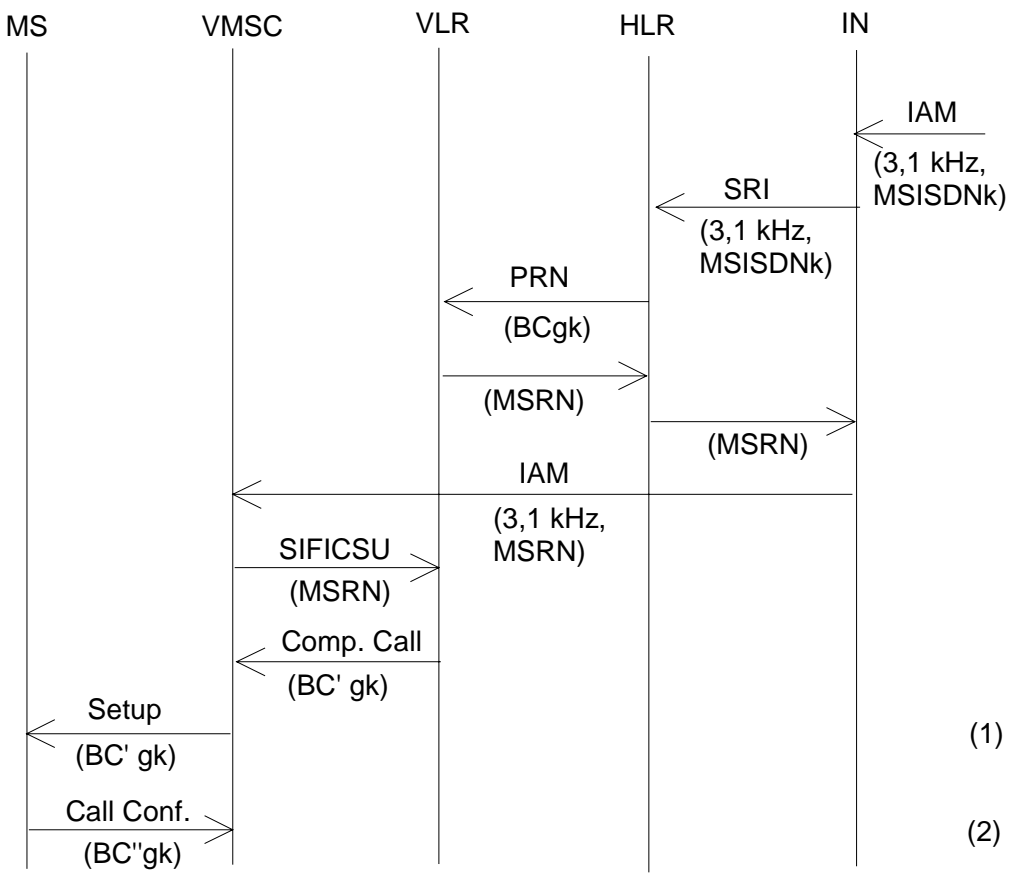

Abbreviations: see figure 2.

- NOTE: (1) Some parameters of BCgk may be provided/modified according to the MSC's capabilities/preferences. See subclause 9.2.2.  
 (2) In the "Call Confirm" message, the MS may modify some parameters of the PLMN BC. See subclause 9.2.2.

**Figure 8: Call Flow for a mobile terminated, ISDN originated call where compatibility information provided are not exhaustive for deducing a PLMN Bearer Service, but Information Transfer Capability = 3,1 kHz audio, no modem type and no HLC IE indicating facsimile group 3 HLR stores PLMN BC against MSISDN number multi-numbering scheme**

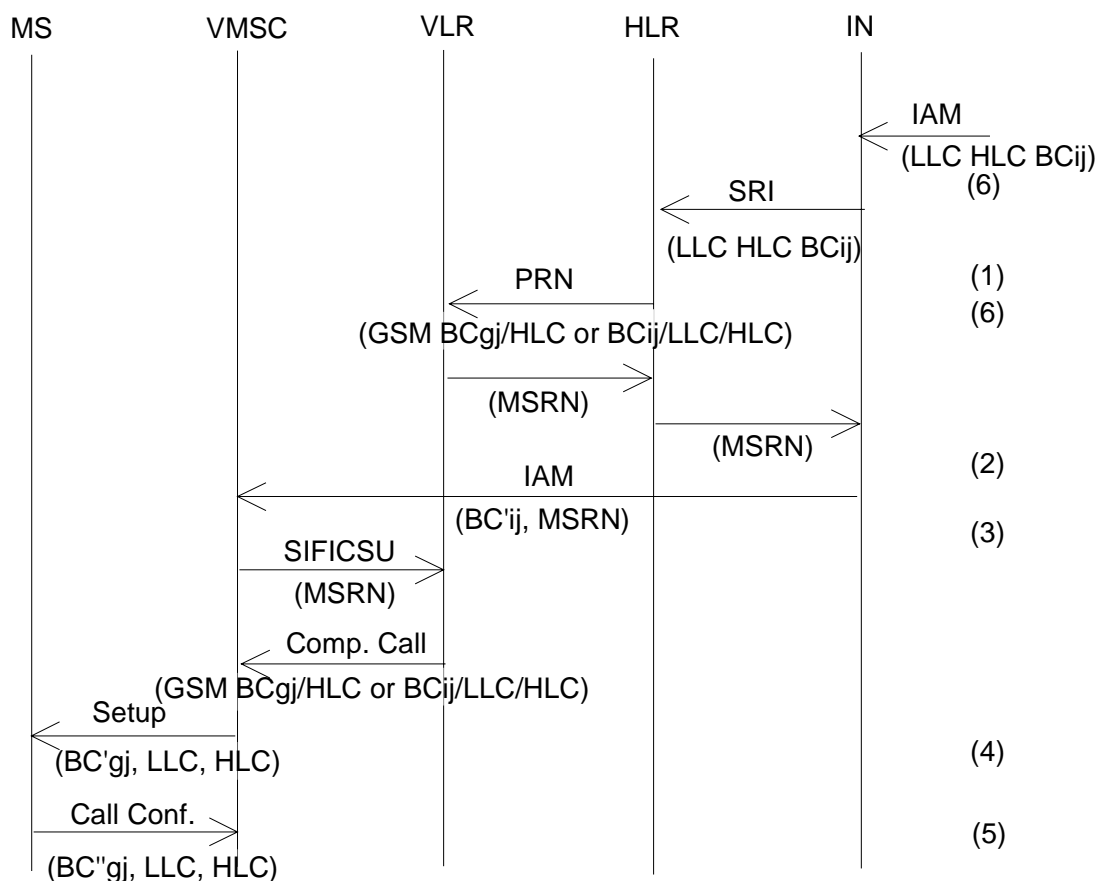

- NOTES:
- (1) BCij denotes ISDN BC\*; BCgj is the corresponding PLMN BC.
  - (2) Assumes signalling capabilities permit the transfer of BC between IN and VMSC. If this is not the case, the VLR uses the stored BC/LLC/HLC.
  - (3) BC'ij denotes BCij as maybe modified by intervening networks.
  - (4) Some parameters of BCgj may be provided/modified according to the MSC's capabilities/preferences. See subclause 9.2.2.
  - (5) In the "Call Confirm" message, the MS may modify some parameters of the BC. See subclause 9.2.2.
  - (6) For details on how the BC, HLC, and LLC are transported, refer to 3GPP TS 29.002.
  - \* HLC and LLC refers to ISDN values.
  - (7) Abbreviations: see figure 2.

**Figure 9: Call Flow for a mobile terminated, ISDN originated call where compatibility information provided are sufficient information to deduce a PLMN Bearer Service or Information Transfer Capability = 3,1 kHz audio with HLC IE indicating facsimile group 3**

### 10.2.2.6 Mapping Functions

The following tables (7A + 7B) show that only the ISDN BC is used for mapping (exceptions are indicated).

NOTE: The ISDN/ PLMN BC-IE mapping shall be performed as specified in tables 7A and 7B. This shall be done to allow setup of a compatible end-to-end connection between two MSs or one MS and an ISDN terminal.

In the following tables 7A and 7B the comparison is drawn between parameters in the PLMN call set up request message and that of the ISDN call set up request message. In some cases no comparable values are available and these will be marked as such. In these cases reference will need to be made to the table of network interworking in 3GPP TS 29.007 to identify the appropriate choice. In some cases it is not necessary to support a particular option, and in this case those parameters will be annotated appropriately.

The PLMN parameters and values are as in 3GPP TS 24.008 in combination as in 3GPP TS 27.001. The ISDN parameters and values are as in Q.931 (05/98).

Table 7A: Comparable setting of parameters in PLMN and ISDN: Mobile Originated

Octet	PLMN BC parameter value	Octet	ISDN BC parameter value
1	<b>Bearer Capability IEI</b>	1	<b>Bearer Capability IEI</b>
2	<b>Length of BC contents</b>	2	<b>Length of BC contents</b>
3 #7..6	<b>Radio channel requirement</b> half rate channel full rate channel dual, full, rate preferred dual, half rate preferred		No comparable field
3 #5	<b>Coding Standard</b> GSM standard coding	3 #7..6	<b>Coding Standard</b> ITU-T standardized coding
3 #4	<b>Transfer mode</b> circuit mode packet mode (note7)	4 #7..6	Transfer mode circuit mode packet mode
3 #3..1	<b>Information transfer capability</b> speech unrestricted digital 3,1 kHz audio ex PLMN facsimile group 3 (note 1) other ITC (see octet 5a)	3 #5..1	<b>Information transfer capability</b> speech unrestricted digital 3,1 kHz audio 3,1 kHz audio no comparable value
5a #7..6	<b>Other ITC</b> restricted digital		(note 18)
4 #7	<b>Compression</b> (note 14) data compression allowed data compression not allowed		No comparable field
4 #6..5	<b>Structure</b> SDU integrity unstructured	4a #7..5	<b>Structure</b> (note 4)
4 #4	<b>Duplex mode</b> half duplex full duplex	5d #7	<b>Duplex mode</b> half duplex full duplex
4 #3	<b>Configuration</b> point to point	4a #4..3	<b>Configuration</b> (note 4)
4 #1	<b>Establishment</b> demand	4a #2..1	<b>Establishment</b> (note 4)
4	<b>NIRR</b> (note 12) no meaning Data ≤ 4.8kbit/s, FR nt, 6kbit/s radio interface is requested		No comparable field

(continued)



Table 7A (continued): Comparable setting of parameters in PLMN and ISDN: Mobile Originated

Octet	PLMN BC parameter value	Octet	ISDN BC parameter value
5 #5..4	<b>Rate adaptation</b> no rate adaptation (note 2) V.110, I.460/X.30 rate adaptation  ITU-T X.31 flag stuffing (note 25)  No comparable value(note 11) No comparable value(note 11)  No comparable value(note 11)  other rate adaptation (see octet 5a)	5 #5..1	<b>User information layer 1 protocol</b> no comparable value ITU-T standardized rate adaption V.110, I.460/X.30 ITU-T standardized rate adaption X.31 flag stuffing Recommendation G.711 $\mu$ -law Recommendation G.711 A-law (note 3) Recommendation G.721 32 kbit/s ADPCM and I.460 No comparable value  No comparable value  H.223 & H.245 (note 26)
5a #5..4	<b>Other rate adaptation</b> V.120 (note 17) PIAFS (note 27) H.223 & H.245		
5 #3..1	<b>Signalling access protocol</b> I.440/I.450 X.21 X.28, ded.PAD, indiv.NUI (note 24) X.28, ded PAD, univ.NUI (note 24) X.28, non-ded PAD X.32		No comparable field
6 #1	<b>Synchronous/asynchronous</b> synchronous asynchronous	5a #7	<b>Synchronous/asynchronous</b> synchronous asynchronous
6 #5..2	<b>User info. layer 1 protocol</b> default layer 1 protocol	5 #5..1	<b>User info. layer 1 protocol</b> see section under rate adaptation for 3GPP TS 24.008 above
6a #7	<b>Number of stop bits</b> 1 bit 2 bits	5c #7..6	<b>Number of stop bits</b> 1 bit 2 bits
6a #6	<b>Negotiation</b> In band neg. not possible no comparable value	5a #6	<b>Negotiation</b> In band neg. not possible In band neg. possible (note 10)
6a #5	<b>Number of data bits</b> 7 bits 8 bits	5c #5..4	<b>Number of data bits excluding parity if present</b> 7 bits 8 bits
6a #4..1	<b>User rate</b> 0.3 kbit/s 1.2 kbit/s 2.4 kbit/s 4.8 kbit/s 9.6 kbit/s 12 kbit/s (note 7) 1.2 kbit/s / 75 bit/s (note 24) any value no comparable value	5a #5..1	<b>User rate</b> 0.3 kbit/s 1.2 kbit/s 2.4 kbit/s 4.8 kbit/s 9.6 kbit/s 12 kbit/s 75 bit/s / 1.2 kbit/s 19.2 kbit/s (note 14) Ebits or inband negotiation (note 10)

(continued)

Table 7A (continued): Comparable setting of parameters in PLMN and ISDN: Mobile Originated

Octet	PLMN BC parameter value	Octet	ISDN BC parameter value
6b #7..6	<b>Intermediate rate</b> 8 kbit/s 16 kbit/s any value	5b #7..6	<b>Intermediate rate</b> (note 13) 8 kbit/s or not used 16 kbit/s or not used 32 kbit/s or not used (note 14)
6b #5	<b>NIC on Tx</b> does not require requires (note7)	5b #5b	<b>NIC on Tx</b> does not require requires (note 8)
6b #4	<b>NIC on Rx</b> cannot accept can accept (note 7)	5b #4	<b>NIC on Rx</b> cannot accept can accept (note 8)
6b #3..1	<b>Parity information</b> odd even none forced to 0 forced to 1	5c #3..1	<b>Parity information</b> odd even none forced to 0 forced to 1
6c #7..6	<b>Connection element</b> transparent non-transparent (RLP) both, transp. preferred both, non-transp. preferred		No comparable field
6c #5..1	<b>Modem type</b> none V.21 V.22 V.22bis V.23 (note 24) V.26ter V.32 modem for undef. interface autobauding type 1	5d #6..1	<b>Modem type</b> no comparable value (note 5) V.21 V.22 V.22bis V.23 V.26ter V.32 No comparable value (note 5) No comparable value (note 5, note 10)
7 #5..1	<b>User info. layer 2 protocol</b> X.25 link level ISO 6429, codeset 0 COPnoFICt videotex profile 1 (note 7) X.75 layer 2 modified (CAPI)	6	<b>User info. layer 2 prot.</b> (note 6) X.25 link level no comparable value no comparable value no comparable value X.25 link level
6d #5..1	<b>Fixed network user rate</b> (note 15) FNUR not applicable (note 7) 9,6 kbit/s 12 kbit/s (note 7) 14,4 kbit/s 19,2 kbit/s 28,8 kbit/s 32,0 kbit/s 33,6 kbit/s 38,4 kbit/s 48,0 kbit/s 56,0 kbit/s 64,0 kbit/s	5a #5..1	<b>User rate</b> no comparable value 9,6 kbit/s 12 kbit/s 14,4 kbit/s 19,2 kbit/s 28,8 kbit/s 32,0 kbit/s no comparable value 38,4 kbit/s 48,0 kbit/s 56,0 kbit/s no comparable value (note 16)
(continued)			

Table 7A (concluded): Comparable setting of parameters in PLMN and ISDN: Mobile Originated

Octet	PLMN BC parameter value	Octet	ISDN BC parameter value
6e #3..1	<b>Maximum number of traffic channels</b> 1 TCH 2 TCH 3 TCH 4 TCH 5 TCH 6 TCH 7 TCH (note 7) 8 TCH (note 7)		No comparable field
6f #4..1	<b>Wanted air interface user rate (note 23)</b> air interface user rate not applicable (note 7) 9,6 kbit/s 14,4 kbit/s 19,2 kbit/s 28,8 kbit/s 38,4 kbit/s 43,2 kbit/s 57,6 kbit/s interpreted by the network as 38.4 kbit/s (note 7)		No comparable field
6d #7..6	<b>Other modem type</b> (note 15) No other modem type V.34	5d #6..1	<b>Modem type</b> no comparable value V.34
6e #7..4	<b>Acceptable channel coding(s)</b> TCH/F4.8 acceptable (note 19) TCH/F9.6 acceptable TCH/F14.4 acceptable		No comparable field
6f #7..5	<b>User initiated modification indicator (note 23)</b> User initiated modification not required User initiated modification upto 1 TCH/F may be requested User initiated modification upto 2 TCH/F may be requested User initiated modification upto 3 TCH/F may be requested User initiated modification upto 4 TCH/F may be requested		No comparable field
6g #7..5	<b>Acceptable channel coding(s) (note 20)</b> TCH/F28.8 acceptable TCH/F32.0 acceptable TCH/F43.2 acceptable (note 22)		No comparable field
6g #4..3	<b>Asymmetry preference indication (Note 23)</b> no preference up link biased asymmetry preference down link biased asymmetry preference		No comparable field

The application rules for coding the information elements ISDN-BC/LLC/HLC as set out in ETR 018 and Q.931 (05/98) shall apply.

Other field values in the ISDN BC-IE not supported in 3GPP TS 24.008 are:

- Information transfer rate: In this case default 64 kbit/s is selected.
- Flow control on transmission: This shall be selected if outband flow control applies.
- Flow control on reception: This shall be selected if outband flow control applies.

NOTE 0: Outband flow control is indicated by the absence of the UIL2P parameter for non-transparent connections.

User information layer 3 protocol: Octet 7 shall not be sent unless specific application rules are given for particular cases (to be defined by PLMN). End-to-end significant User Information layer 3 protocol shall be sent by LLC.

NOTE 1: In the case where PLMN BC "Information Transfer Capability" indicates "Facsimile group 3" and only a single PLMN BC is contained in the call set-up request then this shall be mapped to an ISDN BC with:

- coding standard: ITU-T;
- information transfer capability: 3,1 kHz audio;
- transfer mode: circuit;
- information transfer rate: 64 kbit/s;
- user layer 1 protocol: G711 A-law or  $\mu$ -law (PCS-1900); and
- if an HLC is not present, the network will insert a "Facsimile group 2/3" HLC;
- if an HLC element is present, the network will pass it through unmodified.

In the case where PLMN BC "Information Transfer Capability" indicates "Facsimile group 3" and two PLMN BCs are contained in the call set-up request, then the same ISDN BC as mentioned above is created. If the first PLMN BC indicates "facsimile group 3" an HLC "facsimile group 2/3" will be inserted by the network (if not received from the MS). However if the first PLMN BC indicates "speech", the network will not send a HLC, irrespective where a HLC was received from the MS or not.

NOTE 2: This value is present in combination with information transfer capability parameter value "3,1 kHz audio Ex PLMN" or "facsimile group 3" and will therefore be mapped to the value "Recommendation G.711 A-law" or Recommendation G.711  $\mu$ -law" (PCS-1900) of the Q.931 (05/98) parameter user layer 1 protocol (see note 3).

NOTE 3: The value "Recommendation G.711 A-law" or "Recommendation G.711  $\mu$ -law" (PCS-1900) applies only when the Q.931 (05/98) parameter information transfer capability indicates "3,1 kHz audio" or "speech".

NOTE 4: When interworking with an ISDN according to ETS 300 102-1 octets 4a and 4b shall not be included because default values apply. In an ISDN according to Q.931 (05/98) these octets no more exist.

NOTE 5: In this case octet 5d shall not be included.

NOTE 6: Octet 6 shall not be sent unless specific application rules are given for a particular case (PLMN specified). End-to-end significant user information layer 2 protocol shall be sent by LLC.

NOTE 7: Not used for currently defined Bearer Services and Teleservices.

NOTE 8: These values will only be set if the "Information Transfer Capability" indicates "3,1 kHz audio", synchronous data transmission is used and octet 5b of the ISDN BC is present.

NOTE 9: (VOID).

NOTE 10: The PLMN BC-IE parameter value "autobauding modem type 1" will be mapped to the ISDN BC-IE parameter values "inband negotiation possible" and "user rate indicated by E-bits specified in ITU-T Recommendation I.460 or may be negotiated inband" (octet 5a of ISDN BC-IE). In case of data compression high speed modems, like V.32bis, V.34 and/or V.90 may be used in the IWF. Autobauding may also be used to support user rates less than 9.6 kbit/s towards the PSTN.

NOTE 11: The ITC value of the PLMN BC-IE "speech", "3,1 kHz audio Ex PLMN" will indicate these requirements.

NOTE 12: For the use of NIRR see 3GPP TS 27.001.

NOTE 13: The value of the Intermediate Rate field of the ISDN Bearer Capability information element shall only depend on the values of the User Rate and the Information Transfer Capability in the same information element. The correspondence is:

Intermediate Rate = not used if User Rate > than 19.2 kbit/s.  
 Intermediate Rate = 32 kbit/s if User Rate = 19,2 kbit/s or 14.4 kbit/s.  
 Intermediate Rate = 16 kbit/s if User Rate = 9,6 kbit/s.  
 Intermediate Rate = 8 kbit/s otherwise.

In case of Audio calls the value of the Intermediate Rate may be set to "not used".

NOTE 14: If compression is supported by the MSC and "data compression allowed" is indicated, then the ISDN user rate for UDI calls shall be set as follows. If the parameter "FNUR" is present the ISDN user rate shall be set to this value. Otherwise the PLMN user rate shall be mapped to an equal or any higher ISDN user rate value (in case of V.110 the highest ISDN user rate shall be 19,2 kbit/s). The Intermediate Rate shall be set to an appropriate value.(see subclause 10.2.4.11).

In case of "3,1 kHz audio" the modem shall try to negotiate data compression and flow control (see subclause 9.2.4.11). In case of "autobauding type 1" high speed modems may be used (see note 10).

NOTE 15: User rate of the PLMN -BC is overridden by the fixed network user rate of the PLMN BC-IE if available. When the MT indicates „autobauding“, „modem for undefined interface“ or „none“, the other modem type shall be set to „no other modem type“; any other value of the modem type is overridden by the other modem type value (see 3GPP TS 27.001). In UMTS, if octet 6d is not present in the PLMN BC, the MSC shall reject the call. The support of user rates lower than 9.6 kbit/s in UMTS are only possible in the scope of autobauding (see note 10).

NOTE 16: In the case other rate adaptation = H.223 & H.245 the ISDN BC-IE shall be coded as follows:

Coding standard:	ITU-T
Information Transfer capability:	UDI
Transfer mode:	circuit
Information transfer rate:	64 kbit/s
User information layer 1 protocol:	H.223 & H.245

In all the other cases the ISDN-BC will consist of the octets 1 to 4 only, coded:

Coding standard:	ITU-T
Information Transfer capability:	UDI
Transfer mode:	circuit
Information transfer rate:	64 kbit/s

NOTE 17: V.120 interworking is selected.

If an LLC element is not present, the network will insert an LLC. If an LLC is present it may be modified. The PLMN -BC parameters negotiated with the MS shall be mapped to the LLC parameters. The LLC parameter Rate Adaptation will be set to "V.120".

When interworking with unrestricted 64 kbit/s networks the ISDN BC shall be coded according to note 16.

NOTE 18: When the MSC is directly connected to a restricted 64 kbit/s network, the ISDN BC-IE is coded with an ITC = RDI.

When indirectly interworking with a restricted 64 kbit/s network the ISDN BC-IE shall be coded according to ETR 018, as shown below:

Coding standard:	ITU-T
Information Transfer capability:	UDI
Transfer mode:	circuit
Information transfer rate:	64 kbit/s
User information layer 1 protocol:	V.110/X.30
Synchronous/Asynchronous:	synchronous
Negotiation:	In-band negotiation not possible
User rate:	56 kbit/s

If an LLC element is not present, the network will insert an LLC. If an LLC is present it may be modified. The PLMN -BC parameters negotiated with the MS shall be mapped to the LLC parameters according to the rules in this table. The LLC parameter Information Transfer Capability will be set to „restricted digital“

NOTE 19: In case the MS signals an ACC containing TCH/F4.8 only and the network does not support TCH/F4.8 channel coding, then the MSC may act as if TCH/F9.6 were included in the ACC.

NOTE 20: Extension of the 'Acceptable channel codings' field in octet 6e in case EDGE channel codings are supported.

NOTE 21: Void

NOTE 22: Only applicable for non-transparent services.

NOTE 23: This parameter shall be included if EDGE channel codings are indicated in ACC. In cases where this parameter would not otherwise be included, the value is set to 'Air interface user rate not applicable' or 'User initiated modification not requested' or 'No preference'.

NOTE 24: This value was used by services defined for former GSM releases and does not need to be supported.

NOTE 25: The case of FTM is identified by Rate adaptation in the PLMN BC-IE set to "ITU-T X.31 flag stuffing", Connection element set to "non-transparent", and Synchronous/asynchronous set to "asynchronous". The MSC applies one of the following alternatives:

- 1) In the case FNUR=64 kbit/s  
- the ISDN BC-IE shall be coded as follows:

Coding standard:	ITU-T
Information Transfer capability:	UDI
Transfer mode:	circuit
Information transfer rate:	64 kbit/s

- the LLC-IE shall be coded according to ETR 018 as follows:

Coding standard:	ITU-T
Information Transfer capability:	UDI
Transfer mode:	circuit
Information transfer rate:	64 kbit/s
User information layer 1 protocol:	(CCITT standardized rate adaptation X.31 HDLC flag stuffing) (note: the absence of octet 5 indicates that HDLC flag stuffing applies)
User information layer 2 protocol:	Recommendation X.25, link layer
User information layer 3 protocol:	Recommendation X.25, packet layer

If user information layer 1 protocol is indicated by absence of octet 5 user information layer 2/3 protocol are also absent.

- 2) In the case FNUR=56 kbit/s and the MSC is directly connected to a restricted 64 kbit/s network,  
- the ISDN BC-IE shall be coded as follows:

Coding standard:	ITU-T
Information Transfer capability:	RDI
Transfer mode:	circuit
Information transfer rate:	64 kbit/s

- the LLC-IE shall be coded as follows:

Coding standard:	ITU-T
Information Transfer capability:	RDI
Transfer mode:	circuit
Information transfer rate:	64 kbit/s
User information layer 1 protocol:	(CCITT standardized rate adaptation X.31 HDLC flag stuffing) (note: the absence of octet 5 indicates that HDLC flag stuffing applies)
User information layer 2 protocol:	Recommendation X.25, link layer
User information layer 3 protocol:	Recommendation X.25, packet layer

If user information layer 1 protocol is indicated by absence of octet 5 user information layer 2/3 protocol are also absent.

3) In the case FNUR=56 kbit/s and the MSC is indirectly interworking with a restricted 64 kbit/s network,

- the ISDN BC-IE shall be coded according to ETR 018, as shown below:

Coding standard:	ITU-T
Information Transfer capability:	UDI
Transfer mode:	circuit
Information transfer rate:	64 kbit/s
User information layer 1 protocol:	V.110/X.30
Synchronous/Asynchronous:	synchronous
Negotiation:	In-band negotiation not possible
User rate:	56 kbit/s

- If an LLC element is not present, the network will insert an LLC. If an LLC is present it may be modified. The PLMN -BC parameters negotiated with the MS shall be mapped to the LLC parameters according to the rules in this table. The LLC parameter Information Transfer Capability will be set to „restricted digital" and the LLC parameter User information layer 1 protocol will be set to "X.31 flag stuffing".

NOTE 26: In the case FNUR=64 kbit/s the ISDN BC-IE shall be coded as follows:

Coding standard:	ITU-T
Information Transfer capability:	UDI
Transfer mode:	circuit
Information transfer rate:	64 kbit/s
User information layer 1 protocol:	H.223 and H.245

In the case FNUR=56 kbit/s the ISDN BC-IE shall be coded as in note 18.

In the case FNUR=32 kbit/s the ISDN BC-IE shall be coded as follows:

Coding standard:	ITU-T
Information Transfer capability:	UDI
Transfer mode:	circuit
Information transfer rate:	64 kbit/s
User information layer 1 protocol:	V.110, I.460 & X.30
Synchronous/Asynchronous:	synchronous
Negotiation:	In-band negotiation not possible
User rate:	32 kbit/s

In the case FNUR=28.8 kbit/s the ISDN BC-IE shall be coded as follows:

Coding standard:	ITU-T
Information Transfer capability:	3,1 kHz Audio
Transfer mode:	circuit
Information transfer rate:	64 kbit/s
User information layer 1 protocol:	G.711 A-law or $\mu$ -law
Synchronous/Asynchronous:	synchronous
Negotiation:	In-band negotiation not possible
Modem type:	V.34
User rate:	28.8 kbit/s

In the case FNUR=33.6 kbit/s the ISDN BC-IE shall be coded as follows:

Coding standard:	ITU-T
Information Transfer capability:	3,1 kHz Audio
Transfer mode:	circuit
Information transfer rate:	64 kbit/s
User information layer 1 protocol:	G.711 A-law or $\mu$ -law

NOTE 27: In the case the FNUR=32 kbit/s the ISDN BC-IE shall be coded for PIAFS as follows:

Coding standard:	ITU-T
Information Transfer capability:	UDI
Transfer mode:	circuit
Information transfer rate:	64 kbit/s
User information layer 1 protocol:	V.110, I.460 and X.30
Synchronous/Asynchronous:	synchronous
Negotiation:	In-band negotiation not possible
User rate:	32 kbit/s

In the case of a FNUR=64 kbit/s the ISDN BC-IE shall be coded for PIAFS as in note 16.



Table 7B: Comparable setting of parameters in PLMN and ISDN: Mobile Terminated

Octet	ISDN BC parameter value	Octet	PLMN BC parameter value
1	<b>Bearer Capability IEI</b>	1	<b>Bearer Capability IEI</b>
2	<b>Length of BC contents</b>	2	<b>Length of BC contents</b>
	no comparable field	3 #7..6	<b>Radio channel requirement</b> (note 1) half rate channel full rate channel both, half rate preferred both, full rate preferred
3 #7..6	<b>Coding standard</b> ITU-T standardized coding	3 #5	<b>Coding standard</b> GSM standardized coding
3 #5..1	<b>Information transfer capability</b> speech unrestricted digital 3,1 kHz audio no comparable value no comparable value 7 kHz audio video  (note 23)	3 #3..1	<b>Information transfer capability</b> speech unrestricted digital 3,1 kHz audio ex PLMN (note2) facsimile group 3 (note 3) other ITC (see octet 5a) not supported not supported
		5a #7..6	<b>Other ITC</b> restricted digital
4 #7..6	<b>Transfer mode</b> circuit mode packet mode	3 #4	<b>Transfer mode</b> circuit mode circuit mode
4 #5..1	<b>Information transfer rate</b> 64 kbit/s		no comparable field
	No comparable field	4 #7	<b>Compression</b> (note 18) data compression possible data compression not possible
	No comparable field (note 4)	(4) 4 #6..5	<b>Structure</b> (note 9) SDU integrity unstructured
4a #4..3	No comparable field (note 4)	4 #3	<b>Configuration</b> point-to-point (note 5)
	No comparable field	4 #2	<b>NIRR</b> (note 17) No meaning Data ≤ 4.8 kbit/s, FR nt, 6 kbit/s radio interface requested
4a #2..1	No comparable field (note 4)	4 #1	<b>Establishment</b> demand (note 5)
4b #7..6			
4b #5..1			

(continued)

Table 7B (continued): Comparable setting of parameters in PLMN and ISDN: Mobile Terminated

Octet	ISDN BC parameter value	Octet	PLMN BC parameter value
5 #5..1	<b>User information layer 1 protocol</b> no comparable value ITU-T V.110, I.460 / X.30 G.711 A-law ITU-T X.31 flag stuffing no comparable value	5 #5..4	<b>Rate adaption</b> no rate adaption (note 11) V.110, I.460/X.30 rate adaption no comparable value ITU-T X.31 flag stuffing other rate adaption (see octet 5a)
	No comparable value  H.221 & H.242(note 28) H.223 & H.245	5a #5..4	<b>Other rate adaptation</b> V.120 (note 24) PIAFS H.223 & H.245 H.223 & H.245
	no comparable field	5 #3..1	<b>Signalling access protocol</b> I.440/I.450 X.21 X.28, ded.PAD, indiv.NUI (note 26) X.28, ded.PAD, univ.NUI (note 26) X.28, non-ded.PAD X.32
	see above	6 #5..2	<b>User information layer 1 protocol</b> default layer 1 protocol
5a #7	<b>Synchronous / asynchronous</b> synchronous asynchronous	6 #1	<b>Synchronous/asynchronous</b> synchronous asynchronous
5a #6	<b>Negotiation</b> not possible inband neg, possible (note 16)	6a #6	<b>Negotiation</b> not possible no comparable value

(continued)

Table 7B (continued): Comparable setting of parameters in PLMN and ISDN: Mobile Terminated

Octet	ISDN BC parameter value	Octet	PLMN BC parameter value
5a #5..1	<b>User rate</b> 0,3 kbit/s 1,2 kbit/s 2,4 kbit/s 4,8 kbit/s 9,6 kbit/s 12 kbit/s rate is indicated by Ebit as specified in rec. I.460 0,6 kbit/s 3,6 kbit/s 7,2 kbit/s 8 kbit/s 14,4 kbit/s 16 kbit/s 19,2 kbit/s 28,8 kbit/s 32 kbit/s 38,4 kbit/s 48 kbit/s 56 kbit/s 57,6 kbit/s 0,1345 kbit/s 0,1 kbit/s 75 bit/s / 1,2 kbit/s 1,2 kbit/s / 75 bit/s 0,110 kbit/s 0,2 kbit/s	6a #4..1	<b>User rate (note 18 and 29)</b> 0,3 kbit/s 1,2 kbit/s 2,4 kbit/s 4,8 kbit/s 9,6 kbit/s 12 kbit/s (note 13) (note 16)  not supported not supported not supported not supported (note 20) not supported (note 20) (note 20) (note 20) (note 20) (note 20) (note 20) not supported not supported not supported not supported not supported not supported
5b #7..6	<b>Intermediate rate</b> not used (note 19) 8 kbit/s 16 kbit/s 32 kbit/s	6b #7..6	<b>Intermediate rate</b> (note 6) (note 18) 8 or 16 kbit/s 8 kbit/s 16 kbit/s
5b #5	<b>NIC on Tx</b> (note 14) does not require requires	6b #5	<b>NIC on Tx</b> does not require requires (note 13)
5b #4	<b>NIC on Rx</b> (note 14) cannot accept can accept	6b #4	<b>NIC on Rx</b> cannot accept can accept (note 13)
5b #3	<b>Flow control on Tx</b> (note 15) Not Required Required		no comparable field
5b #2	<b>Flow control on Rx</b> (note 15) Cannot Accept Accept		no comparable field
5c #7..6	<b>Number of stop bits</b> 1 bit 2 bits not used 1.5 bits	6a #7	<b>Number of stop bits</b> 1 bit 2 bits no comparable value not supported

(continued)

Table 7B (continued): Comparable setting of parameters in PLMN and ISDN: Mobile Terminated

Octet	ISDN BC parameter value	Octet	PLMN BC parameter value
5c #5..4	<b>Number of data bits</b> 7 bits 8 bits not used 5 bits	6a #5	<b>Number of data bits</b> 7 bits 8 bits no comparable value not supported
5c #3..1	<b>Parity information</b> odd even none forced to 0 forced to 1	6b #3..1	<b>Parity information</b> odd even none forced to 0 forced to 1
	no comparable field	6c #7..6	<b>Connection element</b> (note 1) transparent non-transparent (RLP) both, transp. preferred both, non-transp preferred
5d #7	<b>Duplex mode</b> half duplex full duplex	4 #4	<b>Duplex mode</b> half duplex (note 13) full duplex (note 5)
5d #6..1	<b>Modem type</b> reserved V.21 V.22 V.22bis V.23 V.26ter V.32 V.26 V.26bis V.27 V.27bis V.29  no comparable value	6c #5..1	<b>Modem type</b> (note 12) none (note 7) V.21 V.22 V.22bis not supported V.26ter V.32 not supported not supported not supported not supported not supported  autobauding type 1 (note 16)
5a #5..1	<b>User rate</b> no comparable value 9,6 kbit/s 14,4 kbit/s 19,2 kbit/s 28,8 kbit/s 32,0 kbit/s 38,4 kbit/s 48 kbit/s 56 kbit/s no comparable value	6d #5..1	<b>Fixed network user rate</b> (note 20) FNUR not applicable 9,6 kbit/s 14,4 kbit/s 19,2 kbit/s 28,8 kbit/s 32,0 kbit/s (note 27) 38,4 kbit/s 48,0 kbit/s 56,0 kbit/s 64,0 kbit/s (note 22)
	<b>Modem type</b> no comparable value (note 21) V.34	6d #7..6	<b>Other modem type</b> No other modem type V.34

(continued)

**Table 7B (concluded): Comparable setting of parameters in PLMN and ISDN: Mobile Terminated**

Octet	ISDN BC parameter value	Octet	PLMN BC parameter value
	No comparable field	6f #7..5	<b>User initiated modification indicator (note 1) (note 25)</b> User initiated modification not required User initiated modification upto 1 TCH/F may be requested User initiated modification upto 2 TCH/F may be requested User initiated modification upto 3 TCH/F may be requested User initiated modification upto 4 TCH/F may be requested
6 #5..1	<b>User information layer 2 protocol (note 10)</b> Q.921 (I.441) X.25, link level no comparable value	7	<b>User information layer 2 protocol (note 8)</b> no comparable value X.25, link level ISO 6429, codeset 0
7	<b>User information layer 3 protocol (note 10)</b> Q.931 (I.451) X.25, packet level		not supported not supported

## General notes:

- 1) Other ISDN BC parameter values than those listed in the table, if indicated in the BC-IE, will be rejected by clearing the call, exception see mapping note 4.
- 2) Only the PLMN BC parameter values listed in the table may be generated (comparable values) during a mobile-terminated call by mapping the ISDN BC parameter values, exception see (10).
- 3) According to Q.931 (05/98) and 3GPP TS 24.008, respectively, the octets are counted from 1 to n onwards; the bit position in a particular octet is indicated by #x..y, with {x,y} = 1..8 (bit 1 is the least and bit 8 the most significant bit).
- 4) If octets 5 to 5d of the ISDN BC are absent but present in the LLC, the LLC octets should apply for the mapping as indicated above. In the case of V.120 interworking (see note 24) these LLC octets shall apply.
- 5) If within the ISDN BC the parameters information transfer capability indicates "3,1 kHz audio" and user layer 1 protocol indicates "G711 A-law" or "G.711  $\mu$ -law" (PCS-1900) but no modem type is available and the HLC does not indicate "facsimile group 3", octets 5 to 5d of the LLC, if available, apply for the above mapping procedure.
- 6) The number of octets which shall be encoded for the PLMN BC-IE must comply to encoding rules in 3GPP TS 24.008 and the combination of the different parameter values shall be in accordance to 3GPP TS 27.001.

## NOTES regarding the mapping:

- 1) This PLMN parameter value is inserted according to user rate requirements and network capabilities / preferences.
- 2) This PLMN parameter value is inserted, if the information transfer capability in ISDN BC is "3,1kHz audio" and a comparable modem type is specified.
- 3) This PLMN parameter value is inserted, if the information transfer capability is "3,1 kHz audio" and the content of the HLC-IE, if any, indicates "facsimile group 2/3", (for details refer to subclause 10.2.2 case 3 for HLR action and case 5 for VMSC action). Note that via MAP the value "alternate speech/facsimile group 3 - starting with speech" shall be used, when TS 61 applies.
- 4) When interworking with an ISDN according to ETS 300 102-1, octets 4a and 4b may be present. The values are ignored and PLMN values are set according to notes 5 and 9.
- 5) This PLMN parameter value is inserted if the comparable ISDN parameter value is missing.

- 6) The value of the Intermediate Rate field of the GSM Bearer Capability information element shall only depend on the values of the user rate or the radio channel requirement in the same information element. If the connection element is "transparent", the value is 16 kbit/s, if the user rate is 9.6 or 12 kbit/s, and 8 kbit/s otherwise. For any other connection element setting the value is 16 kbit/s, if the radio channel requirements are "full rate" or "dual, full rate preferred", or "dual, half rate preferred", and 8 kbit/s, if the radio channel requirements is "half rate".
- 7) This PLMN BC parameter value is inserted, if the PLMN BC parameter "Information Transfer Capability" indicates "Unrestricted digital information", "facsimile group 3" or "alternate speech/facsimile group 3, starting with speech".
- 8) Where the network indicates "asynchronous" and connection elements "non-transparent", "both, transparent preferred" or "both, non-transparent preferred", then the GSM BC should be forwarded without parameter user information layer 2 protocol, see also (10).
- 9) The PLMN parameter value shall be set to "unstructured" where the network indicates connection element "transparent". Where the network indicates connection elements "non transparent" "both, transparent preferred" or "both, non transparent preferred" the value of the parameter structure shall be set to "SDU Integrity".
- 10) Mapping of parameter values of this octet to PLMN BC parameters and values are subject to specific application rules, i.e. unless otherwise explicitly stated in an appropriate TS mapping to PLMN BC parameters shall not take place.
- 11) This value shall be used when the value of the PLMN BC parameter "Information Transfer Capability" indicates the value "3,1 kHz audio ex PLMN", "facsimile group 3" or "alternate speech/facsimile group 3, starting with speech" which is reserved for MAP operations.
- 12) The modem encoding of both Q.931 (05/98) and ETS 300 102-1 version 1 shall be accepted and mapped according to 3GPP TS 24.008.
- 13) Value not used for currently defined bearer services and Teleservices.
- 14) NIC is only supported in GSM for "3,1 kHz Ex PLMN audio" interworking with synchronous data transmission.
- 15) Because the required flow control mechanism can not be indicated to the MS (refer to 3GPP TS 27.001), the network shall check if the flow control mechanism selected by the MS and indicated in the CALL CONFIRMED message suits to the requirements requested by the ISDN terminal adaptor. In case of a mismatch the call shall be released in the IWF.

Because an asymmetric flow control mechanism (with respect to transmitting and receiving side) is not supported in the PLMN, the different values of the ISDN BC-IE parameters "flow control on Tx" and "flow control on Rx" shall be interpreted in the following way:

- "Flow control on Rx" set to "accepted" matches with "outband flow control", irrespective of the value of the parameter "flow control on Tx".
  - "Flow control on Rx" set to "not accepted" and "flow control on Tx" set to "not required" matches with "inband flow control" and "no flow control".
  - where "Flow control on Rx" is set to "not accepted" and "flow control on Tx" to "required" the call shall be released by the IWF.
- 16) If in case of 3,1 kHz audio interworking "inband negotiation possible" is indicated and the parameter user rate is set to "rate is indicated by E bits specified in Recommendation I.460 or may be negotiated inband" the user rate in the PLMN BC-IE shall be set according to a network preferred value, whereas the preferred value of the Radio Channel Requirement shall be considered. If ISDN-BC parameter modem type is present, its value shall be ignored. The PLMN-BC parameter modem type shall be set according to the user rate in case of connection element "transparent" and to "autobauding type 1" in case of connection element "non transparent", "both, transparent preferred" or "both, non transparent preferred". In case of data compression high speed modems, like V.32bis, V.34 and/or V.90 may be used in the IWF. Autobauding may also be used to support user rates less than 9.6 kbit/s towards the PSTN.

For unrestricted digital interworking the call shall be rejected if these values are indicated. If the PLMN-BC parameter modem type indicates "autobauding type 1" or "none", then the PLMN-BC parameter other modem type shall be set to "no other modem type".

- 17) For the use of NIRR see 3GPP TS 27.001. The VMSC shall set this parameter dependent upon its capabilities and preferences.
- 18) If compression is supported by the MSC, the value "data compression possible" may be set. Depending on the capabilities of the MSC, the user rate value and the intermediate rate value is set to an appropriate value.
- 19) Only applicable if the parameter ISDN-BC ITC indicates "3,1 kHz audio" and for "UDI" calls if User Rate > "19,2 kbit/s".
- 20) The user rate of the PLMN BC is set to the value for the fall-back bearer service. In case the mobile station does not support the fixed network user rate (i.e. the call confirmation message does not contain the fixed network user rate parameter), the network may release the call for a transparent connection element.
- 21) The modem type parameter of the PLMN -BC is taken into account, only.
- 22) In the case no LLC is received and the ISDN-BC received consists of octets 1 to 4 only, coded:

Coding standard:	ITU-T
Information Transfer capability:	UDI
Transfer mode:	circuit
Information transfer rate:	64kbit/s

the following PLMN -BC parameters, shall be set to:

fixed network user rate:	64 kbit/s
connection element:	transparent bothNT or bothT (If IWF supports PIAFS)

The other parameters of the PLMN -BC shall be set to values indicating a fall-back service.

In the case an LLC indicating UIL1P=X.31 (either explicitly or implicitly by octet 5 missing) is received and the ISDN-BC received consists of 1 to 4 only, coded:

Coding standard:	ITU-T
Information Transfer capability:	UDI
Transfer mode:	circuit
Information transfer rate:	64kbit/s

the following PLMN BC parameters, shall be set to:

fixed network user rate:	64 kbit/s
connection element:	non-transparent
Synchronous/Asynchronous	asynchronous

all other parameters shall be set according to 3GPP TS 27.001 to indicate FTM.

In the case an LLC indicating UIL1P=X.31 (either explicitly or implicitly by octet 5 missing) is received and the ISDN-BC received consists of 1 to 4 only, coded:

Coding standard:	ITU-T
Information Transfer capability:	RDI
Transfer mode:	circuit
Information transfer rate:	64kbit/s

the following PLMN BC parameters, shall be set to:

fixed network user rate:	56 kbit/s
connection element:	non-transparent
Synchronous/Asynchronous	asynchronous

all other parameters shall be set according to 3GPP TS 27.001 to indicate FTM.

- 23) When the MSC is directly connected to a restricted 64 kbit/s network, the ISDN BC-IE is coded with an ITC = RDI.

An ISDN BC-IE, as specified in ETR 018 and shown below, shall be taken to indicate that interworking with an indirectly connected restricted 64 kbit/s network is required:

Coding standard:	ITU-T
Information Transfer capability:	UDI
Transfer mode:	circuit
Information transfer rate:	64 kbit/s
User information layer 1 protocol:	V.110/X.30
Synchronous/Asynchronous:	synchronous
Negotiation:	In-band negotiation not possible
User rate:	56 kbit/s

In this case the PLMN BC parameter Information Transfer Capability is set to „Other ITC" and Other ITC parameter is set to „restricted digital". If ISDN LLC exists, all the corresponding fields in the PLMN BC shall be derived from the ISDN LLC. Otherwise, the corresponding fields in the UMTS BC shall be derived from the ISDN BC. In the above both case, Connection element is set as follows.

Connection element:	transparent bothNT or bothT (If IWF supports FTM) and LLC does not indicate User information layer 1 protocol = "X.31 flag stuffing") non-transparent (if IWF supports FTM and LLC indicates User information layer 1 protocol = "X.31 flag stuffing")
---------------------	--

24) V.120 interworking is required if the ISDN LLC parameter User Information Layer 1 Protocol is set to „V.120". In this case the PLMN BC parameter Rate Adaptation is set to „Other rate adaptation" and Other Rate Adaptation parameter is set to „V.120". All the corresponding fields in the GSM BC shall be derived from the ISDN LLC.

25) This parameter is only included in case of non-transparent multislot connections.

26) This value was used by services defined for former GSM releases and does not need to be supported.

27) Following BC parameters in SETUP message shall be set to:

Fixed network user rate	32 kbit/s
Connection element	transparent (for multimedia) bothNT or bothT (If IWF supports PIAFS, UMTS only)

28) UIL1P is set to "H.221 & H.242" or "H.223 & H.245" by H.324/I. In the case where UIL1P is set to "H.221 and H.242", this should be mapped to "H.223 & H.245".

29) In UMTS, if the User Rate of the ISDN BC is less than 9,6 kbit/s and the Connection Element is mapped to "NT", then FNUR is fixed to 9,6 kbit/s.

### 10.2.3 Transparent service support

The protocol stacks for transparent services are specified in 3GPP TR 03.10 (GSM) and in 3GPP TR 23.910 (UMTS).

In UMTS, the transparent services are based in the Iu User Plane protocol specified in 3GPP TS 25.415.

In GSM identifies the rate adaptation scheme shall be utilized on the BSS to MSC link as identified in 3GPP TS 08.20. The transcoding function will generate the 64 kbit/s rate adapted format utilizing the 8 and 16 kbit/s intermediate data rates. The MSC - MSC/IWF will utilize the same rate adaptation scheme as that indicated in 3GPP TS 08.20, i.e. adapted to 64 kbit/s.

#### 10.2.3.1 Structure of the MSC/IWF for UMTS

The transmission towards the RNC is based on AAL2. The Iu UP is used in the transparent mode.



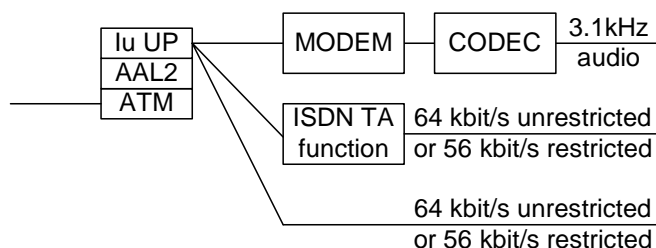

Figure 10: Structure of the MSC/IWF (transparent)

### 10.2.3.2 Structure of the MSC/IWF for GSM

When interworking to the unrestricted digital bearer service rate adaptation according to ITU-T V.110 will be necessary within the MSC/IWF. For multislots, TCH/F14.4 or EDGE operations MSC/IWF shall adapt the data stream as defined in 3GPP TS 04.21 and 3GPP TS 08.20.

NOTE: From the perspective of MSC/IWF, a TCH/F28.8 EDGE configuration is identical to a multislots 2×TCH/F14.4 configuration.

When interworking to the 3,1 kHz audio service, then the same process as for the PSTN case is necessary (section 9.2.3.2).

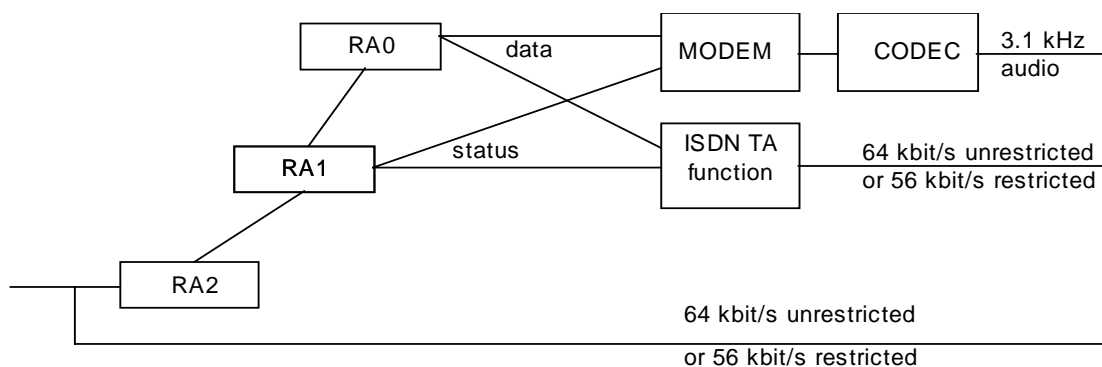

Figure 11: Structure of the MSC/IWF (transparent)

### 10.2.3.3 Mapping of signalling MS/MSC/IWF to modem or ISDN (V.110) TA-function interface requirements

For the 3,1 kHz audio interworking case see subclause 9.2.3.3.

Status bits SA, SB and X can be used to convey channel control information associated with the data bits in the data transfer state. Table 8 shows the mapping scheme between the V.24 circuit numbers corresponding to the V-series DCE functions and the status bits for the transparent mode. It also shows how the unused status bits should be handled. It is derived from the General Mapping scheme described in annex B. A binary 0 corresponds to the ON condition, a binary 1 to the OFF condition.

The transport of these status bits by the various channel codings is described in 3GPP TS 04.21 and 08.20 for GSM. For UMTS refer to 3GPP TR 23.910.

NOTE Although the interface to the ISDN TA function is described in terms of V.24 interchange circuit functions, this does not imply that such circuits need to be physically realised.

**Table 8: Mapping scheme at the IWF for the transparent mode**

Mapping direction: MS to IWF	Mapping direction: IWF to MS	Signal at IWF ISDN TA interface or condition within the IWF
always ON (note 1)		CT 105
	to status bit X	CT 106
	not mapped (note 5)	CT 107
not mapped (note 6)		CT 108
	to status bit SB	CT 109
always ON (note 2)		CT 133
from status bit SA (note 3)		ignored by IWF
from status bit SB (note 1)		ignored by IWF
from status bit X (note 4)		ignored by IWF
	to status bit SA (note 3)	always ON
<p>NOTE 1: The SB bit towards the IWF, according to the General Mapping (annex B), could be used to carry CT 105 from the mobile DTE to the ISDN TA function in the IWF. However, CT 105 should always be ON at the DTE interface in the data transfer state since only duplex operation is supported. Also, many DTEs use the connector pin assigned to CT 105 for CT 133. Therefore, CT 105 shall always be set to ON at the IWF ISDN TA function during the data transfer state.</p> <p>NOTE 2: CT 133 is not mapped since there is no flow control in transparent mode.</p> <p>NOTE 3: The SA bits in both directions are available only with certain channel codings. Therefore, for maximum compatibility, they should not be mapped.</p> <p>NOTE 4: The X bit towards the IWF is not mapped since there is no flow control in transparent mode.</p> <p>NOTE 5: CT 107 is not used by the IWF.</p> <p>NOTE 6: CT 108 is used in the call setup and answering processes.</p>		

### 10.2.3.4 Establishment of end-to-end terminal synchronizations

Prior to exposing the traffic channel of a PLMN connection to transmission of user data, the controlling entities of the connection shall assure of the availability of the traffic channel. This is done by a so called synchronizations process:

- starting on the indication of "physical connection established" resulting from the PLMN-inherent outband signalling procedure This indication is given on sending the message CONNECT in case of MOC, CONNECT ACKNOWLEDGEMENT in case of MTC and MODIFY COMPLETE (which is sent after reception of the ASSIGN COMPLETE message) in case of in-call modification;
- ending by indicating the successful execution of this process to the controlling entity, which then takes care of the further use of the inband information (data, status).

Network interworking within an MSC/IWF is concerned with the terminating side (to the MS / UE) and the transit side (to the fixed network) of a connection. Both sides shall be treated individually related to the synchronizations process.

#### 10.2.3.4.1 Terminating side (towards the MS / UE)

##### 10.2.3.4.1.1 GSM Traffic channel types TCH/F4.8 and TCH/F9.6

With respect to the terminating side the procedure is as follows:

- sending of synchronizations pattern 1/OFF (all data bits "1"/all status bits "OFF") to the MS using the RA1/RA2 rate adaptation function. In multislot transparent operation, the synchronisation pattern sent is 1/OFF with the exception of the bit positions S1, first X, S3, and S4 which contain the substream number and multiframe alignment pattern (Ref. 3GPP TS 04.21);
- searching for detection of the synchronizations pattern from the MS within valid V.110 frames, and in multislot operation, also searching for the multiframe alignment pattern "0000 1001 0110 0111 1100 0110 1110 101" (Ref. to 3GPP TS 04.21) in bit position S4 and substream numbers in bit positions S1, first X, and S3. This implies that the E1, E2 and E3 bit of the V.110 frame shall be checked for the appropriate user rate in order to distinguish the synchronization pattern from the BSS idle data frame.

- Timer T (= 500 ms) is started for each of the allocated traffic channel(s) of the call on receipt of the synchronizations pattern from the MS.
- When the frame alignment pattern and, in case of multislot operation, the multiframe alignment pattern have been recognized as a steady state, the MSC/IWF continues sending the synchronizations patterns to the MS until a timer T expires.

#### 10.2.3.4.1.2 GSM Traffic channel type TCH/F14.4

With respect to the terminating side the procedure is as follows:

- Sending A-TRAU frames with the data rate set in the bits C1-C4 (TS 08.20) and data bits set to one, sending the multiframe structure with the alignment pattern (bit M1) and with the status bits OFF (bit M2) and, in a multislot case, sending substream numbers (bit M2).
- Searching for the detection of the multiframe alignment pattern „0000 1001 0110 0111 1100 0110 1110 101" (TS 04.21) in the bit M1 and, in a multislot case, searching for substream numbers in the bit M2. (Any 5 bit sequence in the multiframe alignment pattern is unique, i.e. the multiframe alignment can take place by recognition of five successive M1 bits).
- Timer T (= 500 ms) is started for each of the allocated traffic channel(s) of the call on receipt of the synchronizations pattern from the MS.
- When the frame alignment pattern and the multiframe alignment pattern have been recognized as a steady state, the MSC/IWF continues sending the synchronizations patterns to the MS until a timer T expires.

#### 10.2.3.4.1.3 UMTS User Plane

The procedures are the same as for the modem case, but, depending on implementation, the IWF may through connect before the fixed network leg has been synchronised.

#### 10.2.3.4.2 Transit side (towards the fixed network).

In case of interworking to the ISDN "3,1 kHz audio" bearer service the synchronization process is as for the PSTN interworking case (see subclause 9.2.3.4.2).

In case of V.110 interworking to the ISDN unrestricted digital bearer service the following synchronization process shall be performed.

The interchange circuits towards the V.110 ISDN TA function are held in the OFF condition until timer T expires, when they are switched to ON.

From this time, after the expiration of the timer T of every allocated traffic channel, the information on CT106 and CT109 from the IWF V.110 ISDN TA function are directly mapped to the X and SB bits, respectively, towards the MS. For TCH/F14.4 the X and SB bits are mapped to the M2 multiframe bits according to 3GPP TS 04.21. Circuit 108 to the selected V.110 ISDN TA function associated with the connection will be switched from the "OFF" to "ON" condition, thus initiating the synchronization process on the fixed network according to ITU-T V.110. The IWF is allowed to map CT 104 to the data bits sent towards the MS and to map data bits received from the MS to CT 103.

#### 10.2.3.5 Network independent Clocking (NIC)

Due to the incompatibility between the ISDN and the GSM requirements for NIC interworking is not provided between these two formats. As such no NIC function is required in providing interworking to the ISDN. In this case, the IWF shall disregard the value of bits E4, E5, E6 and E7 in the data transmission phase.

### 10.2.4 Non-transparent service support

The protocol stacks for non-transparent services are specified in 3GPP TR 03.10 (GSM) and in 3GPP TR 23.910 (UMTS). Both of the systems use the Radio Link Protocol (RLP) specified in 3GPP TS 24.022.

In UMTS, the non-transparent services are based in the Iu User Plane protocol specified in 3GPP TS 25.415.

In GSM the corresponding necessary support concerning the rate adaptation scheme shall be utilized on the BSS-MSC link as identified in 3GPP TS 08.20.

For the non-transparent service support the MSC/IWF will select the modem and speed based on the Compatibility information contained in either the call set-up or call confirmed message, reference subclauses 9.2.1 and 9.2.2. Where the Modem Type indicated is autobauding type 1, the MSC/IWF may select any speed and modem type according to what it can negotiate with the remote modem. In this case User Rate and Fixed Network User Rate, if present, has no meaning.

### 10.2.4.1 Structure of the MSC/IWF for UMTS

The transmission towards the RNC is based on AAL2. The Iu UP is used in the support mode. The RLP/L2R extends to the MS.

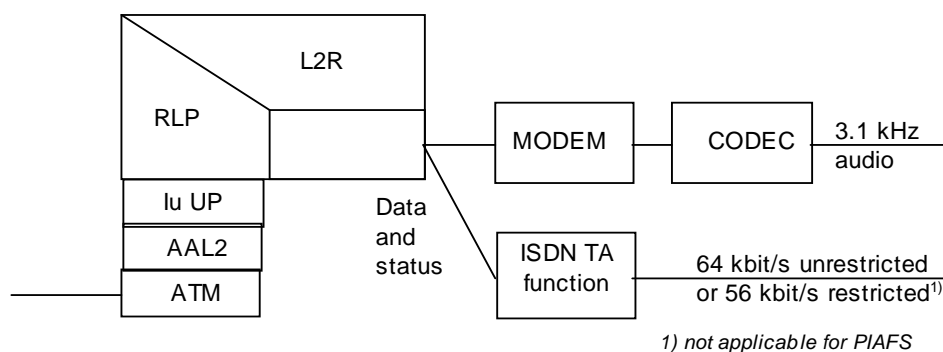

Figure 12: Structure of the MSC/IWF (non-transparent)

### 10.2.4.2 Structure of the MSC/IWF for GSM

The rate adaptation process will be the same as for the transparent case, except that a TCH/F43.2 channel coding is also supported. From MSC/IWF's perspective a TCH/F43.2 EDGE configuration is identical to a multislot 3×TCH/F14.4 configuration.

3GPP TR 03.10 identifies the protocol layer structure for the non-transparent case, the MSC/IWF provides the inverse of the action in the MS terminal adaptation function. For a multislot configuration refer to 3GPP TR 03.10.

The V.110, V.120 and PIAFS ISDN TA (terminal adapter) functions provide the same functionality and operational behaviour as fixed ISDN terminal adapters that conform to the corresponding ITU-T Recommendations (V.110 or V.120).

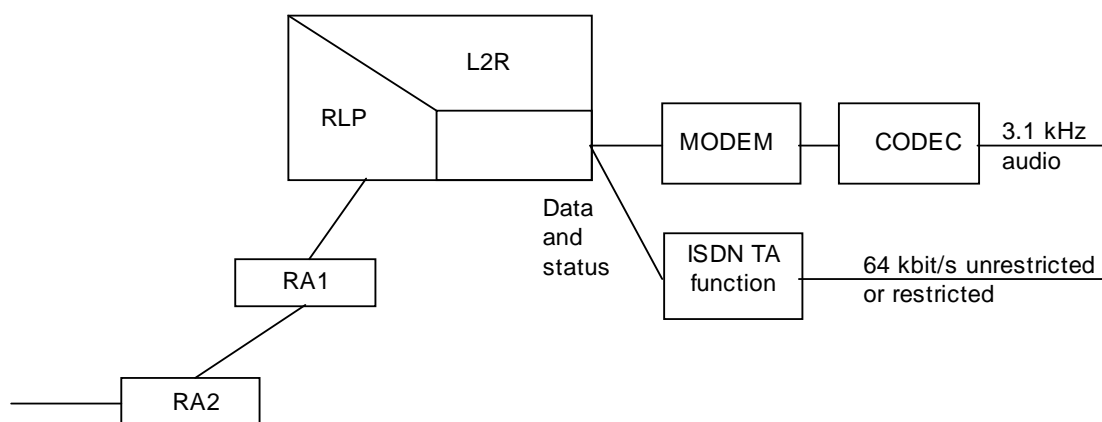

Figure 13: Structure of the MSC/IWF (non-transparent)

### 10.2.4.3 Re-constitution of user data

3GPP TS 24.022 refers to the frame of user data in the radio link protocol. The layer 2 relay functions in the MS and the MSC/IWF (identified in 3GPP TR 03.10 and 3GPP TS 23.910) contain the mechanism for packing and unpacking the user data into the L2R protocol data units.

### 10.2.4.4 Layer 2 relay functionality

Specific functionality is required on the L2R dependant upon the service which is being requested to be supported. The selection of the appropriate L2R function will be determined by the MSC/IWF on the basis of the bearer capability information signalled in the call set-up request, or call confirmation message. The prime information element being transparent or non transparent service indication. In addition the particular L2R function - type of protocol to be terminated and mode of flow control to be applied (see appropriate subclauses in 3GPP TS 27 series) - will be selected on the basis of the user's layer 2 indication.

The specific interaction between the L2R function and the RLP function and the L2R frame structure will be the same as that detailed in the Annex to the appropriate 3GPP TS 27 series.

### 10.2.4.5 In band signalling mapping flow control

This entails the L2R function providing the means of controlling and responding to flow control function of the modem (or in the rate adapted frame) plus any synchronizations requirements related to flow control. for synchronous services flow control is covered by the protocol indicated whereas for asynchronous services a specific rule applies for flow control (see 3GPP TS 27.001).

In case of interworking to the ISDN "3,1kHz audio" bearer service the flow control process is as for the PSTN interworking case (see subclause 9.2.4.5). In case of interworking to the ISDN unrestricted digital bearer service the following procedures apply:

The flow control function chosen will be dependent upon the availability of the "user information layer 2" information element of the GSM BC and if available its value.

For V.110 interworking, outband flow control will be by means of the "X" bit in the V.110 frame to the ISDN.

For V.120 interworking, outband flow control shall be as follows. In Multiple frame acknowledged mode the functions of the data link control sublayer (send RNR or withhold update of the sequence state variable V(R)) shall be used. In Unacknowledged mode the RR bit in the Control State octet shall be used.

For PIAFS interworking, outband flow control shall be as follows. The functions of the data link control sublayer (withhold update of the frame number) shall be used.

If flow control is provided irrespective of the type used, the L2R function shall:

- a) provide immediate indication of flow control to the fixed network on receipt of flow control request from the MS; and/or
- b) provide immediate indication of flow control to the MS on receipt of flow control request from the fixed network i.e. in the next available L2R status octet to be transmitted.

Where in band (X-on/X-off) flow control is in use, then the X-on/X-off characters will not be passed across the radio interface.

If no flow control is provided the involved end systems are responsible for performing in-band flow control on their own by taking into account the buffer capacity of the MSC/IWF as stated below.

#### 10.2.4.5.1 Conditions requiring flow control - if flow control is provided - towards the fixed network

The L2R function will initiate flow control in the following circumstances:

- 1) the transmit buffer to the radio side reaches a preset threshold (BACK PRESSURE);
- 2) the L2R function receives a "flow control active" indication.

On removal of buffer congestion or receipt of L2R "flow control inactive" the flow control will be removed.

No flow initiation/removal will take place at the L2R function and loss of data may occur, if no flow control is provided.

#### 10.2.4.5.2 Conditions requiring flow control towards the MS

The L2R function will transmit to the MS a "flow control active indication", if flow control is provided, in the following circumstances:

- 1) if the receive buffer from the radio side reaches a preset threshold (BACK PRESSURE);
- 2) if a flow control indication is received from the fixed network customer. On receipt of this flow control indication, transmission of data from the receive buffers towards the fixed network terminal is halted.

On removal of the buffer congestion or fixed network flow control indication, the L2R function will send a "flow control inactive" indication towards the MS. In addition, for the fixed network indication, transmission of data from the receive buffers will be restarted.

If no flow control is provided at the L2R function, no flow control initiation/removal will take place by the MSC/IWF. Data might be lost without any indication by the MSC/IWF to the end systems involved.

#### 10.2.4.6 Data buffers

##### 10.2.4.6.1 Transmit buffers (towards MS)

Incoming data from the fixed network customer shall be buffered such that if the MSC/IWF is unable to transfer data over the radio path the data is not lost.

The buffer shall be capable of holding the data. Its size is up to the implementers. When the buffer is half full flow control towards the fixed network shall be initiated if flow control is provided as per subclause 10.2.4.5.1.

##### 10.2.4.6.2 Receive buffers (from MS)

Incoming data from the MS is buffered such that if the fixed network terminal is unable to accept the data then it is not lost.

The buffer shall be capable of holding the data. Its size is up to the implementers. When the buffer becomes half full, the L2R function will send a "flow control active" indication towards the MS if flow control is provided at the L2R function, as per subclause 10.2.4.5.2.

#### 10.2.4.7 BREAK Indication

The BREAK indication is managed as detailed in subclause 9.2.4.7.

When V.120 rate adaptation is being used in protocol sensitive asynchronous mode on the ISDN, the L2R break condition shall map on to the BR bit of the V.120 header octet.

#### 10.2.4.8 Signalling mapping of modem or ISDN (V.110, V.120 or PIAFS) TA-function status information

Status information is carried between the modem or ISDN (V.110, V.120 or PIAFS) TA-function in the IWF and the terminal adaptation function in the MS by the L2R function. The L2RCOP entity transfers interface status information between L2Rs via the status octets SA, SB and X in L2RCOP-PDUs (3GPP TS 27.002). Table 9 shows the mapping scheme between the V.24 circuit numbers corresponding to the V-series DCE functions and the status bits for the non-transparent mode. It also shows how the unused status bits should be handled. It is derived from the General Mapping scheme described in annex B. A binary 0 corresponds to the ON condition, a binary 1 to the OFF condition.

NOTE. Although the interface to the ISDN TA function is described in terms of V.24 interchange circuit functions, this does not imply that such circuits need to be physically realised.

**Table 9: Mapping scheme at the IWF for the non-transparent mode**

Mapping direction: MS to IWF	Mapping direction: IWF to MS	Signal at IWF ISDN TA interface or condition within the IWF
always ON (note 1)		CT 105
	to status bit X (notes 4, 7)	CT 106 (note 7)
	not mapped (note 5)	CT 107
not mapped (note 6)		CT 108
	to status bit SB	CT 109
from status bit X (note 8)		CT 133 (notes 3, 8)
from status bit SA (note 2)		ignored by IWF
from status bit SB (note 1)		ignored by IWF
	to status bit SA (note 2)	always ON
<p>NOTE 1: The SB bit towards the IWF, according to the General Mapping (annex B), could be used to carry CT 105 from the mobile DTE to the ISDN TA function in the IWF. However, CT 105 should always be ON at the mobile DTE interface in the data transfer state since only duplex operation is supported. Also, many DTEs use the connector pin assigned to CT 105 for CT 133. Therefore, CT 105 shall always be set to ON at the ISDN TA function during the data transfer state.</p> <p>NOTE 2: The SA bits (both directions) are not mapped since CTs 107 and 108 are handled locally (notes 5, 6).</p> <p>NOTE 3: The condition of CT 133 (or other flow control mechanism) may also be affected by the state of the L2R transmit buffer (towards the MS) in the IWF and the state of RLP (RR/RNR).</p> <p>NOTE 4: The condition of status bit X towards the MS may also be affected by the state of the L2R receive buffer in the IWF (from the MS).</p> <p>NOTE 5: CT 107 is not used by the IWF.</p> <p>NOTE 6: CT 108 is used in the call setup and answering processes.</p> <p>NOTE 7: For inband flow control, CT 106 is not mapped and the status bit X towards the MS is controlled by the reception of XON and XOFF characters from the ISDN TA function.</p> <p>NOTE 8: For inband flow control, changes in the condition of the status bit X from the MS result in the sending of XON or XOFF to the ISDN TA function. CT 133 is always set to ON.</p>		

#### 10.2.4.9 Support of out-band flow control

Out-band flow control in the case of V.110 rate adaption requires V.110 TA to TA "end-to-end flow control" as defined therein. If this functionality is requested by MS but cannot be supported by the MSC/IWF for any reason (refer also to note 15 of table 7B) the call pending shall be released.

For V.120 interworking, outband flow control shall be as follows. In Multiple frame acknowledged mode the functions of the data link control sublayer (send RNR or withhold update of the sequence state variable V(R)) shall be used. In Unacknowledged mode the RR bit in the Control State octet shall be used.

#### 10.2.4.10 Synchronizations

In case of interworking to the ISDN "3,1kHz audio" bearer service the synchronization process is as for the PSTN interworking case (see subclause 9.2.3.4). In case of interworking to the ISDN unrestricted digital bearer service the following synchronization process shall be performed:

##### 10.2.4.10.1 V.110 and V.120 Frame synchronizations

The ISDN frame synchronizations will need to be mapped to the frame synchronizations utilized on the MSC/IWF to MSC link.

##### 10.2.4.10.2 RLP Frame start indication

The frame start indication is defined in 3GPP TS 08.20. Link establishment and frame error recovery are defined in 3GPP TS 24.022.

### 10.2.4.10.3 L2R Frame synchronizations

The synchronizations of user data and its interaction between the L2R function and RLP function are defined in 3GPP TS 27 series.

### 10.2.4.10.4 Establishment of end-to-end terminal synchronizations

Prior to exposing the traffic channel of a PLMN connection to transmission of user data, the controlling entities of the connection shall assure of the availability of the traffic channel. This is done by a so called synchronization process:

- starting on the indication of "physical connection established" resulting from the PLMN-inherent outband signalling procedure This indication is given on sending the message CONNECT in case of MOC, CONNECT ACKNOWLEDGEMENT in case of MTC and MODIFY COMPLETE (which is sent after reception of the ASSIGN COMPLETE message) in case of in-call modification;
- ending by indicating the successful execution of this process to the controlling entity, which then takes care of the further use of the in-band information (data, status).

Network interworking within an MSC/IWF is concerned with the terminating side (to the MS) and the transit side (to the fixed network) of a connection. Both sides shall be treated individually related to the synchronization process.

#### 10.2.4.10.4.1 Terminating side (towards the MS)

The procedures are the same as for the modem case.

#### 10.2.4.10.4.2 Transit side (towards the fixed network)

Depending upon implementation, the synchronization of the V.110 or V.120 rate adaptation protocol on the ISDN transit network may be performed either after RLP establishment or in parallel to the RLP establishment. In case of the parallel establishment, data received from the transit side during RLP establishment shall be stored within the L2R buffers until the RLP establishment at the terminating side has been finished. When the RLP has been established and on recognizing frame alignment the information from/to the RLP is mapped by the L2R entity applicable to this particular bearer capability.

For V.110 rate adaptation on the ISDN, the synchronization process consists of sending the V.110 frame structure and looking for incoming frame synchronization according to the procedures in ITU-T V.110.

For V.120 rate adaptation the following applies. In Multiple frame acknowledged mode, data (I frames) may be sent following an exchange of SABME and UA in the traffic channel. In Unacknowledged mode, data (UI frames) may be sent immediately after an ISUP CONNECT or CONNECT COMPLETE message has been received on the ISDN signalling channel. Optionally, an XID exchange may take place in the traffic channel to verify link integrity.

Note. V.120 allows UI frames to be sent in Multiple frame acknowledged mode at any time in addition to I frames. Whilst the IWF shall not follow this procedure when sending frames, such a sequence of I and UI frames may be received by the IWF. Although not specified in V.120, it is recommended that the IWF should deliver to the MS, the contents of the sequence of I and UI frames in the order in which they are received.

For PIAFS rate adaptation the following applies. Data frame is sent following an exchange of initial negotiation and control frame in the traffic channel.

### 10.2.4.11 Data compression

When data compression is invoked within a non-transparent bearer service, interworking to the ISDN is realized by mapping the PLMN user rate to at least the same user rate in the ISDN. When the ISDN user rate is the same flow control will ensure data integrity, but the overall performance will be slow. When the ISDN user rate is higher the overall performance may be faster.

### 10.2.4.12 Additional aspects of V.120 Interworking

V.120 rate adaptation may be invoked with either synchronous or asynchronous services. V.120 is applicable to both UDI and RDI connections.



#### 10.2.4.12.1 V.120 Signalling parameters

The signalling parameters relevant to V.120 will be carried in the ISDN LLC and PLMN BC and PLMN LLC information elements. The mapping of the parameter values takes place in the MSC/IWF.

For mobile terminated calls both single-numbering and multi-numbering scenarios may apply, as defined in subclause 9.2.2. The HLR shall not store an ISDN LLC with the MSISDN.

#### 10.2.4.12.2 V.120 Protocol parameters

The following restrictions apply for the parameters relevant for V.120:

- BS 20 NT will use the protocol sensitive asynchronous mode. BS 30 NT will use the protocol sensitive synchronous mode. As a consequence, the rate adaption header shall always be present.
- Only the default logical link will be established, i.e. the LLI negotiation value is "Default, LLI=256 only".
- V.120 recommends the use of the multiple frame acknowledged information transfer procedure for the protocol sensitive mode of operation.
- The IWF shall use the default value for the V.120 window size and the default value for the maximum transmit information field size. It shall be able to receive frames with the default maximum size.

NOTE: V.120 does not specify the values for these and other HDLC-related parameters directly. They are specified in Q.922 (1992) section 5.9. The information field includes the V.120 terminal adaption data field, the rate adaption header and the header extension (Control State octet), if present.

#### 10.2.4.12.3 Data compression on the ISDN

Whilst V.110 rate adaptation does not support standardized data compression, V.42bis data compression may be used with V.120 protocol sensitive asynchronous mode. This is described in V.120 (10/96) annex C.

#### 10.2.4.12.4 Use of the V.120 Control State (header extension) octet

The bits in the V.120 Control State octet are not used for the control of V.24 interface circuits. In unacknowledged mode the RR bit in the Control State octet is used to carry flow control information between the peer terminal adaption protocol entities. In acknowledged mode the Control State octet is not required.

### 10.2.4.13 Interworking with restricted 64 kbit/s networks

#### 10.2.4.13.1 Rate adaptation

Both V.110 and V.120 rate adaption protocols may be used on a restricted 64 kbit/s network.

For V.110 rate adaption, the procedure is described in ITU-T Rec. I.464. The RA2 function shall set the 8th bit of each octet in the 64 kbit/s stream to binary 1. A consequence of this is that the highest permitted intermediate rate is 32 kbit/s. At the receiver, the 8th bit shall be ignored.

Rec. V.120 states that the user data shall be rate adapted to 56 kbit/s by using only the first 7 bits of each octet in the 64 kbit/s stream. The 8th bit shall be set to binary 1. At the receiver, the 8th bit shall be ignored.

#### 10.2.4.13.2 MSC - ISDN signalling

When interworking indirectly with restricted 64 kbit/s networks the ISDN BC information element shall be coded according to ETR 018 (as shown in the notes to tables 7A and 7B). The information corresponding to the GSM BC-IE shall be communicated in the ISDN LLC-IE which shall be provided by the MS for mobile originated calls.

In the case of direct interworking, an ITC = RDI in the GSM BC-IE maps on to an ITC = RDI in the ISDN BC-IE for both MO and MT calls.

#### 10.2.4.14 Service level up and down grading

Text in 9.2.4.13 applies here as well.

#### 10.2.4.15 Interworking in Frame Tunneling Mode

Figure 14 below shows the protocol stack used for FTM. The interface between the two asynchronous-synchronous conversion functions in the IWF and the remote terminal adapter (TA) is a 64 kbit/s UDI or a 56 kbit/s RDI connection. X.31 flag stuffing is used to adapt the rate between the two conversion functions. Data transparency is provided through bit stuffing.

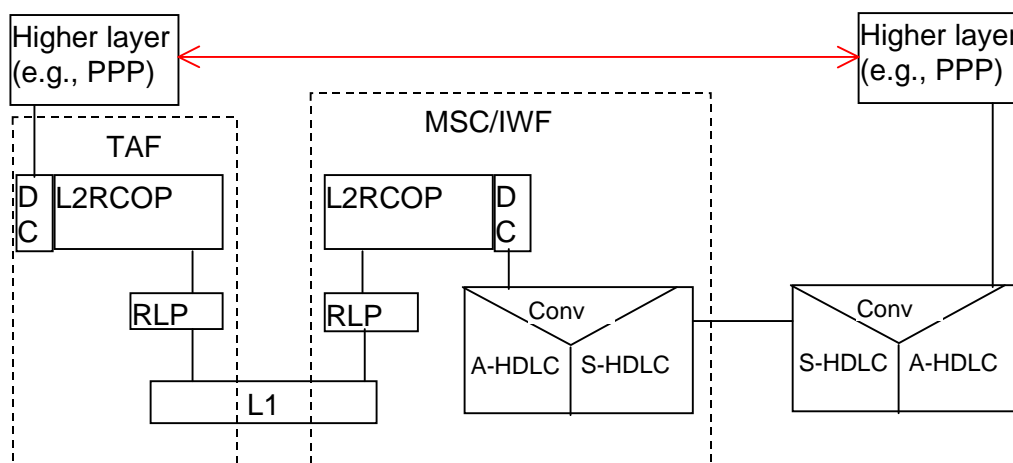

**Figure 14: The FTM protocol stack**

Data compression between the TAF and the IWF is optionally applied. The asynchronous to synchronous HDLC conversion follows from ISO 3309[48].

A particular aspect of the asynchronous HDLC protocol is the provision of control character transparency. This means that flags (0x7E) and the control escape character (0x7D) are escaped, by insertion of the control escape character in front of the character to be escaped, and that the 6<sup>th</sup> bit of the escaped character is complemented (i.e., the escaped character is XOR'ed with 0x20). ISO 3309 allows additional control characters to be escaped by prior agreement or negotiation between the peer entities. For instance, in PPP [49], a negotiation procedure is defined using an Asynchronous Control Character Map (ACCM). By examining the contents of the HDLC frames that pass through it, the IWF shall identify whether the higher layer protocol is PPP, in which case, it shall detect and interpret the ACCM negotiation result. If PPP is used, the conversion function in the IWF shall apply a default ACCM until another is negotiated.

#### 10.2.4.16 Additional aspects of PIAFS Interworking

PIAFS has several U-Plane protocol suites, but "Data Transmission Protocol (fixed rate)"[50] is only applied for UMTS R'99 in consideration of simplicity. Details of frame structure and retransmission procedure etc. conform to reference [50].

In case of 32kbit/s mode, IWF performs rate adaptation based on I.460 for fixed network.

In case of 64 kbit/s mode, restriction on throughput may be caused by co-ordination with GSM (maximum frame length of RLP is 572bits in UMTS).

### 10.2.5 DTE/DCE interface (Filtering)

This is described in section 9.2.5.

## 10.3 Interworking Alternate speech facsimile group 3 calls

### 10.3.1 Alternate speech data bearer interworking

#### 10.3.1.1 General

The procedure for the alternate speech/facsimile group 3 service is invoked at the MS-MSC link during the call set-up phase. This service is invoked by indication of repeated bearer capability information elements in the setup message and/or call confirmed message, respectively (preceded by a repeat indicator "circular"), one indicating speech and the other indicating "facsimile group 3" plus user rate etc., as for normal single calls. The bearer capability first indicated i.e. speech or facsimile determines the first selection required of the network by the subscriber. Depending on the type of service requested and direction of call establishment (MO/MT, see relevant clauses of the 3GPP TS 27 series) low layer and high layer capabilities may also be included. The MSC/IWF will perform both compatibility checking and subscription checking for mobile originated calls and optionally for mobile terminated calls (single numbering scheme) on both sets of capabilities as for normal data calls. If either the subscription check or the compatibility check fails then the call shall be rejected. The only exception to this is when TS61/TS62 negotiation takes place, see 3GPP TS 27.001.

As regards the supplementary services the application rules are laid down in 3GPP TS 22.004.

The speech phase of the call, when invoked, is handled by the transcoder and will utilize the normal telephony teleservice interworking requirements and mobile network capabilities. The Facsimile group 3 phase of the call, when invoked, will utilize the appropriate data interworking capability (e.g. IWF) and may use either the transparent or non-transparent mobile network capability.

The network shall provide, for service and operational reasons, a rapid and reliable changeover of capability upon request from the mobile user. This changeover may involve the disabling, by-passing or introduction of particular network functions (e.g. speech coder, modem etc.) and change of the channel configuration on the radio interface. This changeover is initiated on the receipt of the "MODIFY" message (see 3GPP TS 24.008) from the MS. The network itself will not initiate a changeover.

#### 10.3.1.2 Mobile originated ISDN terminated

If one bearer capability information element indicates the ITC value "facsimile group 3", the call set up is as for the PSTN case. Interworking is provided to the ISDN bearer service 3,1 kHz audio for the whole connection, including the speech phase. The MODIFY message (see 3GPP TS 24.008) will be generated by the mobile subscriber. This message is not transmitted to the ISDN, i.e. no outband correlation between the user on the fixed network and the mobile user will be possible. In this instance it is necessary for change of network capabilities to be carried out in the mobile network.

#### 10.3.1.3 ISDN originated mobile terminated

In principle this is handled as for normal ISDN originated call.

When the calling user however indicates an ISDN BC-IE with an ITC value "3,1 kHz audio" and a HLC "facsimile group 3", i.e. the call arrives at the GSM with compatibility information allowing for deducing the Teleservice "Facsimile transmission", the call setup is as described in subclause 10.2.2 (case 3 in HLR, case 5 in VMSC).

In the information transfer phase the call is dealt with as indicated in the previous paragraph.

## 10.4 3G-H.324/M calls over UDI/RDI

3G-H.324/M calls provide UDI/RDI (e.g. 32 kbit/s transparent data, 56 kbit/s transparent data or 64 kbit/s transparent data). H.223 and H.245 flow is not terminated in the MSC.

3G-H.324 calls over 64 kbit/s transparent data and 56 kbit/s transparent data can be connected to H.324/I calls over UDI/RDI. H.223 protocol is transparent to IWF.

In case of 3G-H.324M calls over 32 kbit/s, IWF which performs rate adaptation between 64 kbit/s and 32 kbit/s is used. Rate adaptation is based on ITU-T I.460.

The support of IWF which transcodes the multiplexes and the content of control, audio, video and data in MSC is FFS.

## 11 Interworking between GSM and UMTS

### 11.1 Handover from UMTS to GSM

After a handover from UMTS to GSM the user plane between the anchor MSC and the visited MSC shall comply to the standard GSM A-interface protocols, i.e:

- A-TRAU or modified V.110 frames as defined in 3GPP TS 04.21 [27] and 3GPP TS 08.20 [28];
- up to four 16kbit/s substreams are multiplexed in one 64kbit/s channel (Split/Combine function and Multiplexing function as defined in 3GPP TS 04.21 [27] and 3GPP TS 08.20 [28]).

### 11.2 Handover from GSM to UMTS

After a handover from GSM to UMTS the user plane between the anchor MSC and the visited MSC shall comply to the A-TRAU' protocol except for FNUR = 56 kbit/s (ITC=RDI) and FNUR = 64 kbit/s (ITC=UDI). For both exceptions a plain 64 kbit/s channel is used between the MSCs.

The A-TRAU' protocol is defined as follows:

- A-TRAU' frames are transmitted in regular intervals of 10ms;
- an A-TRAU' frame consists of two consecutive A-TRAU frames (as defined in 3GPP TS 08.20 [28]) each with a length of 320 bit;
- the A-TRAU' protocol is used on a plain 64 kbit/s channel without substreams;
- the same A-TRAU' format is used for the transparent and non-transparent transmission mode;
- in transparent mode the number of data bits in an A-TRAU' frame depend on the user rate only, each user rate corresponds to a fixed number of data bits (see below);
- in non-transparent mode A-TRAU' frames contain always complete RLP frames, rate adaptation is performed by means of the M2 bit;
- the M1-bit is used to identify 1<sup>st</sup> and 2<sup>nd</sup> frame in both transmission modes.

#### 11.2.1 Frame layout for the different transparent user rates

The number of data bits in an A-TRAU' frame depend on the user rate only, each user rate corresponds to a fixed number of data bits in an A-TRAU' frame.

**Table 10: A-TRAU' frame layout for transparent user rate**

Date Rate	Number of data bits per A-TRAU' frame
33.6 kbit/s	336
28.8 kbit/s	288

The data bits are inserted in the A-TRAU' frame starting with D1 of Data field 1 of the first A-TRAU frame. The unused bits are filled with binary '1'.

### 11.2.2 A-TRAU' frame format

One A-TRAU' frame consists of two consecutive A-TRAU frames. Figure 15 shows the format of one A-TRAU frame.

Octet number	bit number							
	0	1	2	3	4	5	6	7
0	0	0	0	0	0	0	0	0
1	0	0	0	0	0	0	0	0
2	1	<b>C1</b>	<b>C2</b>	<b>C3</b>	<b>C4</b>	<b>C5</b>	<b>M1</b>	<b>M2</b>
3	<b>Z1</b>	D1	D2	D3	D4	D5	D6	D7
4	D8	D9	D10	D11	D12	D13	D14	D15
5	D16	D17	D18	D19	D20	D21	D22	D23
6	D24	D25	D26	D27	D28	D29	D30	D31
7	D32	D33	D34	D35	D36	<b>Z2</b>	D1	D2
8	D3	D4	D5	D6	D7	D8	D9	D10
9	D11	D12	D13	D14	D15	D16	D17	D18
10	D19	D20	D21	D22	D23	D24	D25	D26
11	D27	D28	D29	D30	D31	D32	D33	D34
12	D35	D36	<b>Z3</b>	D1	D2	D3	D4	D5
13	D6	D7	D8	D9	D10	D11	D12	D13
14	D14	D15	D16	D17	D18	D19	D20	D21
15	D22	D23	D24	D25	D26	D27	D28	D29
16	D30	D31	D32	D33	D34	D35	D36	<b>Z4</b>
17	D1	D2	D3	D4	D5	D6	D7	D8
18	D9	D10	D11	D12	D13	D14	D15	D16
19	D17	D18	D19	D20	D21	D22	D23	D24
20	D25	D26	D27	D28	D29	D30	D31	D32
21	D33	D34	D35	D36	<b>Z5</b>	D1	D2	D3
22	D4	D5	D6	D7	D8	D9	D10	D11
23	D12	D13	D14	D15	D16	D17	D18	D19
24	D20	D21	D22	D23	D24	D25	D26	D27
25	D28	D29	D30	D31	D32	D33	D34	D35
26	D36	<b>Z6</b>	D1	D2	D3	D4	D5	D6
27	D7	D8	D9	D10	D11	D12	D13	D14
28	D15	D16	D17	D18	D19	D20	D21	D22
29	D23	D24	D25	D26	D27	D28	D29	D30
30	D31	D32	D33	D34	D35	D36	<b>Z7</b>	D1
31	D2	D3	D4	D5	D6	D7	D8	D9
32	D10	D11	D12	D13	D14	D15	D16	D17
33	D18	D19	D20	D21	D22	D23	D24	D25
34	D26	D27	D28	D29	D30	D31	D32	D33
35	D34	D35	D36	<b>Z8</b>	D1	D2	D3	D4
36	D5	D6	D7	D8	D9	D10	D11	D12
37	D13	D14	D15	D16	D17	D18	D19	D20
38	D21	D22	D23	D24	D25	D26	D27	D28
39	D29	D30	D31	D32	D33	D34	D35	D36

Figure 15: A-TRAU 320 bit frame

**Data Bits (Dxx):**

The 288 data bits of an A-TRAU frame are divided in eight fields of 36 bits.

**Control bits (C Bits):**

**C1 to C4:**

The Control bits C1 to C4 define the used data rate. C1 to C4 in the first A-TRAU frame indicate the data rate in send direction.

C1 to C4 in the second A-TRAU frame indicate the used data rate in backward direction. This is required for Rate Control that is required in uplink direction. For details on Rate Control see 3GPP TS 25.415 [42].

**Table 11: A-TRAU' control bits**

C1	C2	C3	C4	Radio Interface User Rate
1	0	1	1	57,6 kbit/s
1	0	1	0	33,6 kbit/s
1	0	0	0	28,8 kbit/s
0	1	1	1	14,4 kbit/s

**C5:**

C5 is not used, it is set to binary '1'.

**Bit M1:**

An A-TRAU' frame is made of two consecutive A-TRAU which build the transport container for 576 data bits. Bit M1 is used to determine the order of the A-TRAU frames within an A-TRAU' frame.

The two M1 bits are referred to as the Frame Start Identifier. The FSI value is 01. These values are assigned to the M1 bit as shown below:

**Table 12: Frame Start Identifier**

	M1 bit
First A-TRAU frame	0
Second A-TRAU frame	1

**Bit M2:**

The M2 bit is used to indicate 'valid' A-TRAU' frames. The M2 bit in both of the two consecutive A-TRAU frames relating to an A-TRAU' frame shall have the same value.

Transparent mode:

In transparent mode M2 is clamped to binary '0'.

Non-transparent mode:

In non-transparent mode M2 is used for DTX. If DTX is applied, M2 is set to binary '1'. If DTX is not to be applied, M2 bit is set to binary '0'. The DTX handling is used in both directions for rate adaptation purpose. This means that the sending entity will insert 'fill RLP-frames' with DTX set to binary '1' in case no RLP-frame is available.

Fill frames are also sent in order to adapt the RLP transmission frequency to the AIUR. The ratio between RLP frames and 'fill' RLP frames is defined in the following table:

**Table 13: RLP transmission frequency**

AIUR	Ratio between RLP and 'fill' RLP frames
57.6 kbit/s	Only valid frames
28.8 kbit/s	1 valid frame followed by 1 'fill' frame
14.4 kbit/s	1 valid frame followed by 3 'fill' frames

**Z bits:**

The bits Zi are used for Framing Pattern Substitution mechanism. This mechanism is defined in 3GPP TS 08.20 [28].

**Mapping of A-TRAU' frames to PCM time slots:**

A-TRAU' frames shall be mapped octet aligned to PCM time slots. I.e. bit number 0 to 7 of each octet of an A-TRAU' frame shall be mapped to bit number 0 to 7 of the PCM time slot.

## 11.3 Handover within 3G PLMNs

After a handover from a 3G MSC to another 3G MSC the user plane between the anchor MSC and the visited MSC shall comply to:

- the Iu UP protocol if both MSC are connected via an ATM interface;
- the A-TRAU' protocol if both MSC are connected via a TDM interface except for the transparent case FNUR = 32 kbit/s (ITC = UDI or RDI), FNUR = 56 kbit/s (ITC=RDI) and FNUR = 64 kbit/s (ITC=UDI). For these exceptions a plain 64 kbit/s channel is used between the MSCs. The rate adaptation between 64 kbit/s and 32 kbit/s is based on ITU-T I.460 [2].

## 11.4 Handover for 56kbit/s

The FNUR = 56 kbit/s in transparent mode can be supported in GSM by two configurations:

1. without IWF with the following channel codings
  - 2\*TCH/F32.0
  - 5\*TCH/F9.6
2. with IWF with the following channel coding
  - 4\*TCH/F14.4

The FNUR = 56 kbit/s in transparent mode is supported in UMTS by a configuration without IWF only. Therefore handover for 56kbit/s in transparent mode between UMTS and GSM can be supported only for configurations without IWF.

**Note:** Handover between configurations with and without IWF are also not supported within GSM.

---

# 12 Frame Synchronization

Potentially two links are involved in the MSC/IWF regarding the need for frame synchronization, i.e the link towards the MS and the link towards the fixed network. The links towards the MS are covered by 3GPP TS 08.20 and 08.60 for GSM and 3GPP TS 25.415 for UMTS. For the link towards the fixed network, the appropriate sections of ITU-T V-series modem, V.110, V.120 and PIAFS Recommendations apply.

## 12.1 Initial frame synchronization

### 12.1.1 Terminating side (towards the MS / UE)

In UMTS, the terminating side is not synchronous.

In GSM, for transparent/non-transparent and interworking to the PSTN or ISDN the interface to the BSS is managed as follows. As soon as the outband signalling exchange indicates that the traffic channel is available the MSC/IWF will start sending frames with the frame contents set as indicated in subclause 9.2.3.4.1 towards the BSS. The MSC/IWF will seek to attain V.110 or A-TRAU frame synchronization on the incoming data from the BSS. V.110 synchronization will be considered to be completed in line with the procedures described in subclause 9.2.3.4.1.1. A-TRAU frame synchronization will be considered to be completed in line with the procedures described in subclause 9.2.3.4.1.2. The incoming data will only be considered valid once the frame synchronization procedure defined in subclause 9.2.3.4.1 is complete. For non-transparent interworking to the PSTN or ISDN, the procedures described in subclause 9.2.4.10.1 shall be followed.

### 12.1.2 Transit side (towards the fixed network)

#### 12.1.2.1 Interworking to the PSTN

In the case of interworking to the PSTN the procedures for initial synchronization for the transparent services are covered in subclause 9.2.3.4.2 and the non-transparent services in subclause 9.2.4.10.2.

#### 12.1.2.2 Interworking to the ISDN

In the case of interworking to the ISDN the procedures for initial synchronization for the transparent services are covered in subclause 10.2.3.4.2 and the non-transparent services in subclause 10.2.4.10.4.2.

## 12.2 Action on loss of frame synchronization

The IWF should attempt to recover synchronization as described in the following subsections. If the resynchronization attempt fails, the IWF may clear the call.

### 12.2.1 Loss on the transit side (towards the fixed network)

If loss of frame synchronization is detected from the fixed network in line with the procedures specified in the ITU-T or PIAFS recommendation applicable to the type of interworking (V.110, V.120, PIAFS or V-series modem), then re-synchronization is initiated in line with the procedures specified in that recommendation. No change of behaviour of the MSC/IWF on the BSS/MSC link is necessary.

### 12.2.2 Loss on the terminating side (towards the MS)

In UMTS, the terminating side is not synchronous, so loss of synchronisation is not possible. For T services, frames may be lost or arrive irregularly, which handling is implementation dependent.

In GSM, if the MSC/IWF detects a loss of frame synchronisation on one or more substreams on the BSS/MSC link, the MSC/IWF initiates a re-synchronisation on the substreams in question as specified in the following.

The MSC/IWF shall detect a loss of V.110 frame synchronisation in line with the rules specified in ITU-T V.110. The MSC/IWF shall detect a loss of A-TRAU frame synchronisation when an A-TRAU frame has been received with at least one error in the synchronisation pattern (ref 3GPP TS 08.20).

If loss of synchronization is detected on the BSS/MSC link then a re-synchronization process should be initiated. However for this link to the BSS it is only necessary to search for the frame alignment pattern incoming from the BSS. In the case of A-TRAU the synchronisation shall take care of the multiframe alignment according to subclause 9.2.3.4.1.2 and the MSC/IWF shall set the control bit UFE (Uplink Frame Error, see 3GPP TS 08.20) in the next downlink A-TRAU frame to indicate the framing error to the BSS.



There shall be no action regarding the outgoing frame towards the BSS, other than to continue sending the rate adapted frames made up of the incoming data from the fixed network. During the re-synchronization process data shall continue to be sent towards the fixed network via the modem or ISDN (V.110, V.120, or PIAFS) TA-function as if the frame synchronization were still available. The mapping of the status bits is unchanged during re-synchronization.

Once synchronization has been re-attained the RLP will recover any possible loss of data on the BSS/MS link in the case of non-transparent services. The indication of UFE will be stopped in the case of A-TRAU.

---

## 13 Call Clearing

When a call is to be cleared, the MSC/IWF shall handle both the links, towards the MS as well as towards the fixed network.

At the link towards the MS out-band (3GPP TS 24.008) signalling shall be used. Changes in the in-band status bits shall not be used to signal call clearing.

At the link towards the fixed network, the clearing procedures appropriate to the fixed network shall be used, together with any additional procedures described in the ITU-T recommendation applicable to the type of interworking (V.110, V.120, PIAFS or V-series modem).

# Annex A (informative): SDLs

The following SDLs are intended to assist in the interpretation of the text in subclause 10.2.2 and are not intended to indicate implementation requirements. Therefore these SDLs are informative only.

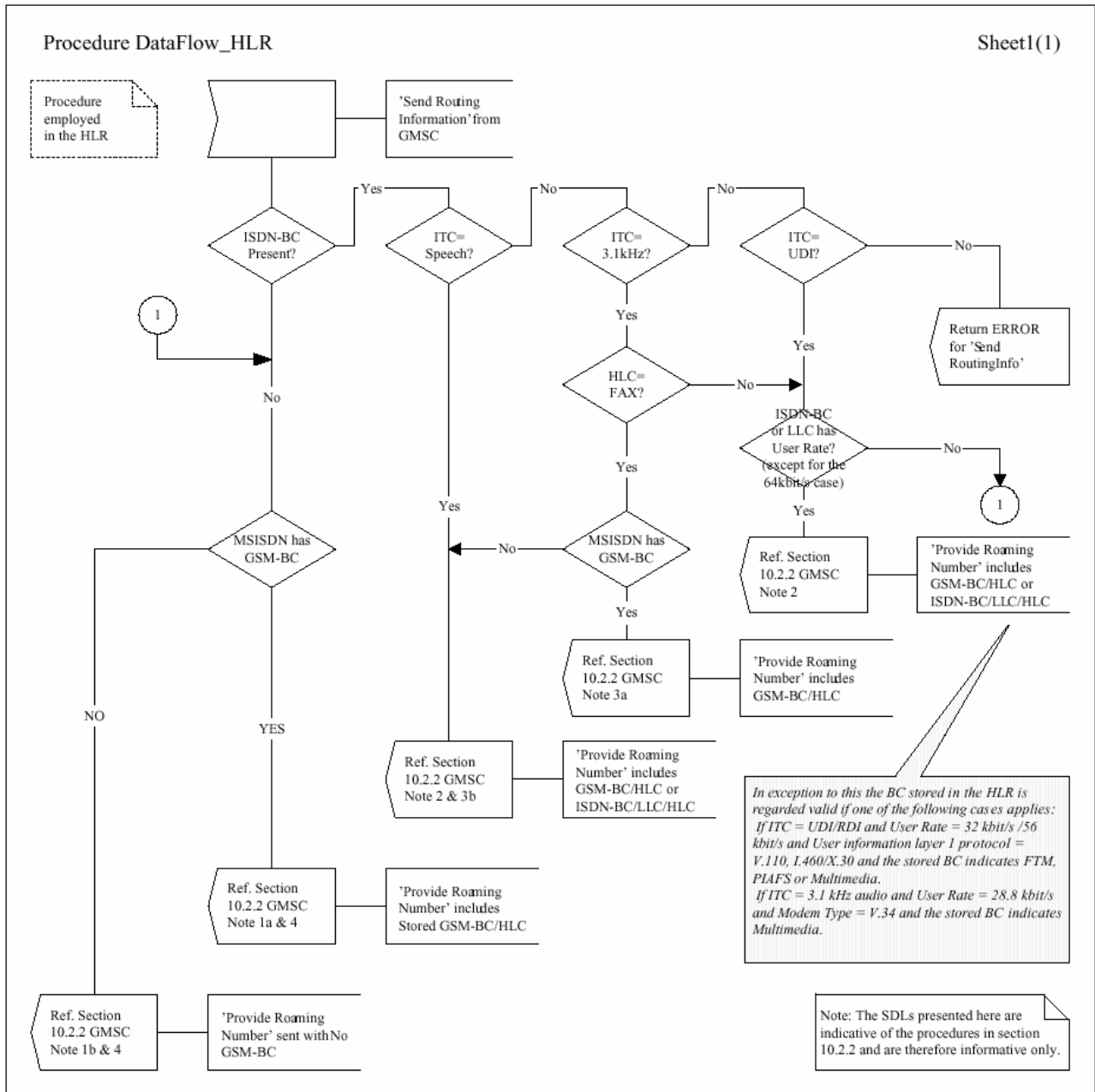

Figure A.1 (Sheet 1 of 1): Procedures in the HLR

Procedure DataFlow\_MSC\_VLR

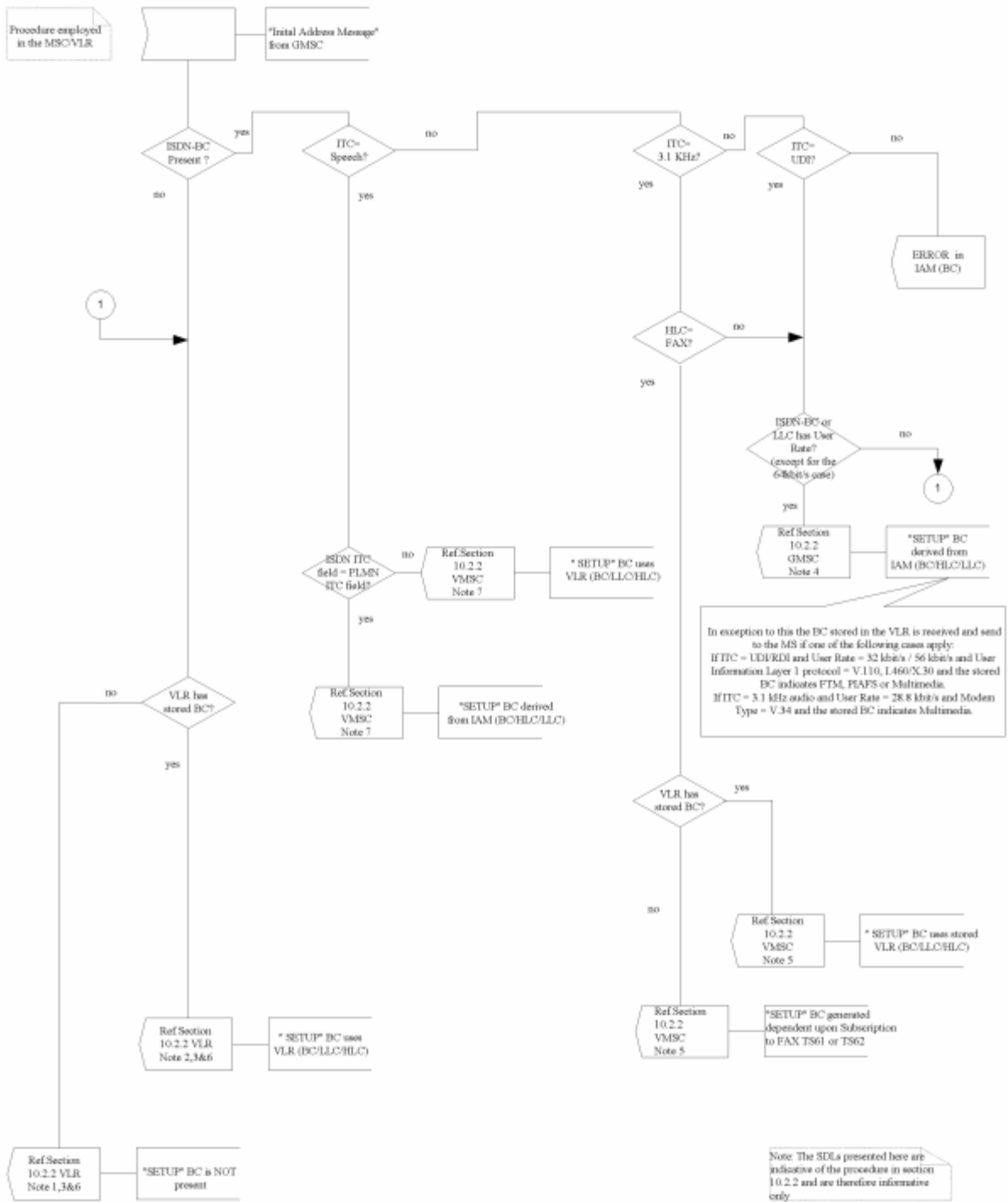

Figure A.2 (Sheet 1 of 1): Procedures in the MSC/VLR

## Annex B (informative): General mapping of V.24 circuits to channel status bits

In the data transfer state, status bits SA, SB and X can be used to convey channel control information associated with the data bits. Table C1 shows the general mapping scheme between the V.24 circuit numbers and the status bits in the IWF. A binary 0 corresponds to the ON condition, a binary 1 to the OFF condition. The specific mappings for the various GSM bearer types are given elsewhere in the present document.

Since the V.24 circuits that are outputs from a DCE are inputs to a DTE (and vice versa), this mapping is the reverse of that used in the MT (3GPP TS 27.002, 3GPP TS 27.003).

For example, CT 109 is an output from the modem in the IWF and maps on to SB towards the MT. In the MT, SB is mapped on to CT 109 which is an input to the attached DTE.

**Table B1: General mapping scheme at the IWF**

Status bit direction: MS to IWF	Status bit direction: IWF to MS	Signal at IWF modem interface
SB		105 (note 3)
	X (note 1)	106
	SA	107
SA		108
	SB	109
X		133 (notes 2 and 3)
NOTE 1: The condition of X towards the MS may also be affected by the state of any transmit buffer in the IWF. NOTE 2: The condition of CT 133 towards the modem may also be affected by the state of any receive buffer in the IWF or layer 2 flow control condition between the MT and IWF. NOTE 3: CT105 and CT133 are assigned to the same connector pin on both the standard 25 pin connector (ISO 2110) and the commonly used 9 pin connector (annex B). When this pin is used for CT133 at the DTE/MT interface then on the MT side of the interface CT 105 is treated as being always in the ON condition. SB towards the IWF will therefore also always be ON. Similarly, when this pin is being used for CT105 then on the MT side of the interface CT 133 is treated as being always in the ON condition. X towards the IWF will therefore also always be ON. As circuit 133 is used only in duplex operation and circuit 105 is used only in half duplex operation (which is not supported by GSM/UMTS) there should be no conflict.		

## Annex C (informative): Change history

Change history						
TSG CN#	Spec	Version	CR	<Phase>	New Version	Subject/Comment
Apr 1999	GSM 09.07	7.1.0				Transferred to 3GPP CN3
CN#03	29.007				3.0.0	Approved at CN#03
CN#04	29.007	3.0.0	001	R99	3.1.0	Introduction of EDGE channel codings into the specifications
CN#05	29.007	3.1.0	002	R99	3.2.0	R99 Service Clean-up
CN#05	29.007	3.1.0	003	R99	3.2.0	EDGE related corrections
CN#05	29.007	3.1.0	004	R99	3.2.0	EDGE Asymmetric channel coding
CN#06	29.007	3.2.0	006	R99	3.3.0	R99 service clean up
CN#06	29.007	3.2.0	007	R99	3.3.0	Correction of intermediate rate values
CN#06	29.007	3.2.0	008	R99	3.3.0	Introduction of Frame Tunnelling Mode
CN#06	29.007	3.2.0	009	R99	3.3.0	Updates for UMTS
CN#06	29.007	3.2.0	010	R99	3.3.0	Introduction of PIAFS and enhancement of processing at mobile terminated call
CN#06	29.007	3.2.0	011	R99	3.3.0	Multimedia call
CN#07	29.007	3.3.0	012	R99	3.4.0	Change of reference from ETS 300102-1 to Q.931
CN#07	29.007	3.3.0	013	R99	3.4.0	Handover between GSM and UMTS
CN#07	29.007	3.3.0	014	R99	3.4.0	Changes to support fallback to speech in a circuit switched multimedia call set-up
CN#08	29.007	3.4.0	015	R99	3.5.0	Handover between 3G MSCs
CN#08	29.007	3.4.0	016	R99	3.5.0	Rejection of lower user rates
CN#08	29.007	3.4.0	017	R99	3.5.0	Fax
CN#08	29.007	3.4.0	018	R99	3.5.0	Clarification of the VMSC behaviour in case of interworking
CN#08	29.007	3.4.0	019	R99	3.5.0	Handover between 3G MSCs (Clarification for 56 and 64 kbit/s)
CN#08	29.007	3.4.0	020	R99	3.5.0	ISDN TA function in case of bit transparent 56 kbit/s (RDI) and 64 kbit/s (UDI)
CN#08	29.007	3.4.0	021	R99	3.5.0	33.6 kbit/s for multimedia
CN#09	29.007	3.5.0	023	R99	3.6.0	Deletion of UMTS NT-RT FAX from R99
CN#09	29.007	3.5.0	024	R99	3.6.0	Transparent 32 kbit/s data rate with 1.460 rate adaptation
CN#09	29.007	3.5.0	027	R99	3.6.0	3.1 kHz multimedia at 33.6 kbit/s
CN#09	29.007	3.5.0	030	R99	3.6.0	32 kbit/s UDI/RDI multimedia
CN#10	29.007	3.6.0	031	R99	3.7.0	Handover for 56Kbit/s
CN#11	29.007	3.7.0	034	R99	3.8.0	A-TRAU' Correction
CN#11	29.007	3.7.0	036	R99	3.8.0	A-TRAU' Synchronization
CN#14	29.007	3.8.0	042	R99	3.9.0	Removal of Shared IWF
CN#16	29.007	3.9.0	050r2	R99	3.10.0	Signalling of FTM calls
CN#18	29.007	3.10.0	062	R99	3.11.0	Correction on mapping of BC-IE
CN#20	29.007	3.11.0	076	R99	3.12.0	Use of single or multislot configurations
CN#20	29.007	3.11.0	078	R99	3.12.0	Subscription check after Call Confirmed
CN#20	29.007	3.11.0	068	R99	3.12.0	Negotiation of fixed network user rate (FNUR)

---

## History

<b>Document history</b>		
V3.3.0	January 2000	Publication
V3.4.0	March 2000	Publication
V3.5.0	June 2000	Publication
V3.6.0	September 2000	Publication
V3.7.0	December 2000	Publication
V3.8.0	March 2001	Publication
V3.9.0	December 2001	Publication
V3.10.0	June 2002	Publication
V3.11.0	December 2002	Publication
V3.12.0	June 2003	Publication