

ETSI TS 128 536 V16.0.0 (2020-07)



**LTE;
5G;
Management and orchestration;
Management services for communication service assurance;
Stage 2 and stage 3
(3GPP TS 28.536 version 16.0.0 Release 16)**



Reference

DTS/TSGS-0528536vg00

Keywords

5G,LTE

ETSI

650 Route des Lucioles
F-06921 Sophia Antipolis Cedex - FRANCE

Tel.: +33 4 92 94 42 00 Fax: +33 4 93 65 47 16

Siret N° 348 623 562 00017 - NAF 742 C
Association à but non lucratif enregistrée à la
Sous-Préfecture de Grasse (06) N° 7803/88

Important notice

The present document can be downloaded from:

<http://www.etsi.org/standards-search>

The present document may be made available in electronic versions and/or in print. The content of any electronic and/or print versions of the present document shall not be modified without the prior written authorization of ETSI. In case of any existing or perceived difference in contents between such versions and/or in print, the prevailing version of an ETSI deliverable is the one made publicly available in PDF format at www.etsi.org/deliver.

Users of the present document should be aware that the document may be subject to revision or change of status.

Information on the current status of this and other ETSI documents is available at

<https://portal.etsi.org/TB/ETSIDeliverableStatus.aspx>

If you find errors in the present document, please send your comment to one of the following services:

<https://portal.etsi.org/People/CommiteeSupportStaff.aspx>

Copyright Notification

No part may be reproduced or utilized in any form or by any means, electronic or mechanical, including photocopying and microfilm except as authorized by written permission of ETSI.

The content of the PDF version shall not be modified without the written authorization of ETSI.

The copyright and the foregoing restriction extend to reproduction in all media.

© ETSI 2020.

All rights reserved.

DECT™, **PLUGTESTS™**, **UMTS™** and the ETSI logo are trademarks of ETSI registered for the benefit of its Members.

3GPP™ and **LTE™** are trademarks of ETSI registered for the benefit of its Members and of the 3GPP Organizational Partners.

oneM2M™ logo is a trademark of ETSI registered for the benefit of its Members and of the oneM2M Partners.

GSM® and the GSM logo are trademarks registered and owned by the GSM Association.

Intellectual Property Rights

Essential patents

IPRs essential or potentially essential to normative deliverables may have been declared to ETSI. The information pertaining to these essential IPRs, if any, is publicly available for **ETSI members and non-members**, and can be found in ETSI SR 000 314: "*Intellectual Property Rights (IPRs); Essential, or potentially Essential, IPRs notified to ETSI in respect of ETSI standards*", which is available from the ETSI Secretariat. Latest updates are available on the ETSI Web server (<https://ipr.etsi.org/>).

Pursuant to the ETSI IPR Policy, no investigation, including IPR searches, has been carried out by ETSI. No guarantee can be given as to the existence of other IPRs not referenced in ETSI SR 000 314 (or the updates on the ETSI Web server) which are, or may be, or may become, essential to the present document.

Trademarks

The present document may include trademarks and/or tradenames which are asserted and/or registered by their owners. ETSI claims no ownership of these except for any which are indicated as being the property of ETSI, and conveys no right to use or reproduce any trademark and/or tradename. Mention of those trademarks in the present document does not constitute an endorsement by ETSI of products, services or organizations associated with those trademarks.

Legal Notice

This Technical Specification (TS) has been produced by ETSI 3rd Generation Partnership Project (3GPP).

The present document may refer to technical specifications or reports using their 3GPP identities. These shall be interpreted as being references to the corresponding ETSI deliverables.

The cross reference between 3GPP and ETSI identities can be found under <http://webapp.etsi.org/key/queryform.asp>.

Modal verbs terminology

In the present document "**shall**", "**shall not**", "**should**", "**should not**", "**may**", "**need not**", "**will**", "**will not**", "**can**" and "**cannot**" are to be interpreted as described in clause 3.2 of the [ETSI Drafting Rules](#) (Verbal forms for the expression of provisions).

"**must**" and "**must not**" are **NOT** allowed in ETSI deliverables except when used in direct citation.

Contents

Intellectual Property Rights	2
Legal Notice	2
Modal verbs terminology.....	2
Foreword.....	4
Introduction	5
1 Scope	6
2 References	6
3 Definitions of terms, symbols and abbreviations	6
3.1 Terms.....	6
3.2 Symbols.....	6
3.3 Abbreviations	7
4 Communication service assurance service	7
4.1 Stage 2	7
4.1.1 Overview of interfaces.....	7
4.1.2 Model.....	8
4.1.2.1 Imported and associated information entities.....	8
4.1.2.1.1 Imported information entities and local labels	8
4.1.2.2 Class diagram.....	8
4.1.2.2.1 Relationships.....	8
4.1.2.2.2 Inheritance.....	8
4.1.2.3 Class definitions.....	9
4.1.2.3.1 AssuranceControlLoop	9
4.1.2.2.3 AssuranceGoalStatus	9
4.1.2.3.3 AssuranceControlLoopGoal <<ProxyClass>>.....	10
4.1.2.3.4 ObservationTimePeriod <<dataType>>.....	10
4.1.2.4 Attribute definitions	10
4.1.2.4.1 Attribute properties.....	10
4.1.2.4.2 Constraints.....	11
4.1.2.4.3 Notifications	11
4.1.2.5 Common notifications.....	12
4.1.2.5.1 Alarm notifications.....	12
4.1.2.5.2 Configuration notifications.....	12
4.1.3 Procedures.....	12
4.1.3.1 SLS Assurance Procedure	12
4.2 Stage 3	13
4.2.1 Solution Set (SS) for JSON/YAML.....	13
Annex A (informative): Control loop deployed in different layers	14
A.1 Introduction	14
A.2 Control loop in communication service layer.....	14
A.3 Control loop in network slice layer	14
A.4 Control loop in network slice subnet layer.....	15
A.5 Control loop in NF layer	15
Annex B (normative): OpenAPI definition of the COSLA NRM.....	16
B.1 General	16
B.2 Solution Set (SS) definitions	16
B.2.1 OpenAPI document "coslaNrm.yml"	16
Annex C (informative): Change history	19
History	20

Foreword

This Technical Specification has been produced by the 3rd Generation Partnership Project (3GPP).

The contents of the present document are subject to continuing work within the TSG and may change following formal TSG approval. Should the TSG modify the contents of the present document, it will be re-released by the TSG with an identifying change of release date and an increase in version number as follows:

Version x.y.z

where:

- x the first digit:
 - 1 presented to TSG for information;
 - 2 presented to TSG for approval;
 - 3 or greater indicates TSG approved document under change control.
- y the second digit is incremented for all changes of substance, i.e. technical enhancements, corrections, updates, etc.
- z the third digit is incremented when editorial only changes have been incorporated in the document.

In the present document, modal verbs have the following meanings:

- shall** indicates a mandatory requirement to do something
- shall not** indicates an interdiction (prohibition) to do something

The constructions "shall" and "shall not" are confined to the context of normative provisions, and do not appear in Technical Reports.

The constructions "must" and "must not" are not used as substitutes for "shall" and "shall not". Their use is avoided insofar as possible, and they are not used in a normative context except in a direct citation from an external, referenced, non-3GPP document, or so as to maintain continuity of style when extending or modifying the provisions of such a referenced document.

- should** indicates a recommendation to do something
- should not** indicates a recommendation not to do something
- may** indicates permission to do something
- need not** indicates permission not to do something

The construction "may not" is ambiguous and is not used in normative elements. The unambiguous constructions "might not" or "shall not" are used instead, depending upon the meaning intended.

- can** indicates that something is possible
- cannot** indicates that something is impossible

The constructions "can" and "cannot" are not substitutes for "may" and "need not".

- will** indicates that something is certain or expected to happen as a result of action taken by an agency the behaviour of which is outside the scope of the present document
- will not** indicates that something is certain or expected not to happen as a result of action taken by an agency the behaviour of which is outside the scope of the present document
- might** indicates a likelihood that something will happen as a result of action taken by some agency the behaviour of which is outside the scope of the present document

might not indicates a likelihood that something will not happen as a result of action taken by some agency the behaviour of which is outside the scope of the present document

In addition:

is (or any other verb in the indicative mood) indicates a statement of fact

is not (or any other negative verb in the indicative mood) indicates a statement of fact

The constructions "is" and "is not" do not indicate requirements.

Introduction

The present document describes closed loop assurance solution enabling a service provider or an operator to continuously deliver the requested level of communication service quality to the customer and is part of a TS-family covering the 3rd Generation Partnership Project Technical Specification Group Services and System Aspects Management and orchestration of networks, as identified below:

TS 28.535: Management Services for Communication Service Assurance; Requirements

TS 28.536: Management Services for Communication Service Assurance; Stage 2 and stage 3

The solution described builds upon the management services specifications as identified below:

TS 28.530: Management and orchestration; Concepts, use cases and requirements

TS 28.533: Management and orchestration; Architecture framework

TS 28.532: Management and orchestration; Generic management services.

TS 28.540: Management and orchestration; 5G Network Resource Model (NRM); Stage 1

TS 28.541: Management and orchestration; 5G Network Resource Model (NRM); Stage 2 and stage 3

TS 28.531: Management and orchestration; Provisioning

TS 28.545: Management and orchestration; Fault Supervision (FS)

TS 28.550: Management and orchestration; Performance assurance

TS 28.552: Management and orchestration; 5G performance measurements

TS 28.554: Management and orchestration; 5G End to end Key Performance Indicators (KPI)

1 Scope

The present document describes the management services for communication service assurance and specifies stage 2 and stage 3 for closed loop communication service assurance solution that adjusts and optimizes the services provided by NG-RAN and 5GC.

2 References

The following documents contain provisions which, through reference in this text, constitute provisions of the present document.

- References are either specific (identified by date of publication, edition number, version number, etc.) or non-specific.
- For a specific reference, subsequent revisions do not apply.
- For a non-specific reference, the latest version applies. In the case of a reference to a 3GPP document (including a GSM document), a non-specific reference implicitly refers to the latest version of that document *in the same Release as the present document*.

- [1] 3GPP TR 21.905: "Vocabulary for 3GPP Specifications".
- [2] ETSI GS ZSM 002 (V1.1.1) (2019-08): "Zero-touch network and Service Management (ZSM); Reference Architecture".
- [3] 3GPP TS 28.550: "Management and orchestration; Performance assurance".
- [4] 3GPP TS 28.545: "Management and orchestration; Fault Supervision (FS)".
- [5] 3GPP TS 28.622: "Telecommunication management; Generic Network Resource Model (NRM) Integration Reference Point (IRP); Information Service (IS)".
- [6] 3GPP TS 28.541: "Management and orchestration; 5G Network Resource Model (NRM); Stage 2 and stage 3".
- [7] 3GPP TS 28.532: "Management and orchestration; Generic management services".
- [8] 3GPP TS 32.302: "Telecommunication management; Configuration Management (CM); Notification Integration Reference Point (IRP); Information Service (IS)".
- [9] 3GPP TS 28.531: "Management and orchestration; Provisioning".
- [10] 3GPP TS 32.160: "Management and orchestration; Management service template".

3 Definitions of terms, symbols and abbreviations

3.1 Terms

For the purposes of the present document, the terms given in TR 21.905 [1] and the following apply. A term defined in the present document takes precedence over the definition of the same term, if any, in TR 21.905 [1].

3.2 Symbols

Void.

3.3 Abbreviations

For the purposes of the present document, the abbreviations given in TR 21.905 [1] and the following apply. An abbreviation defined in the present document takes precedence over the definition of the same abbreviation, if any, in TR 21.905 [1].

4 Communication service assurance service

4.1 Stage 2

4.1.1 Overview of interfaces

Communication service assurance relies on a set of management services that together provide the CSP with the capability to assure the communication service as per agreement with a CSC (e.g. enterprise). The overall solution and information flows between management services and control steps [2] are shown in Figure 4.1.1.1.

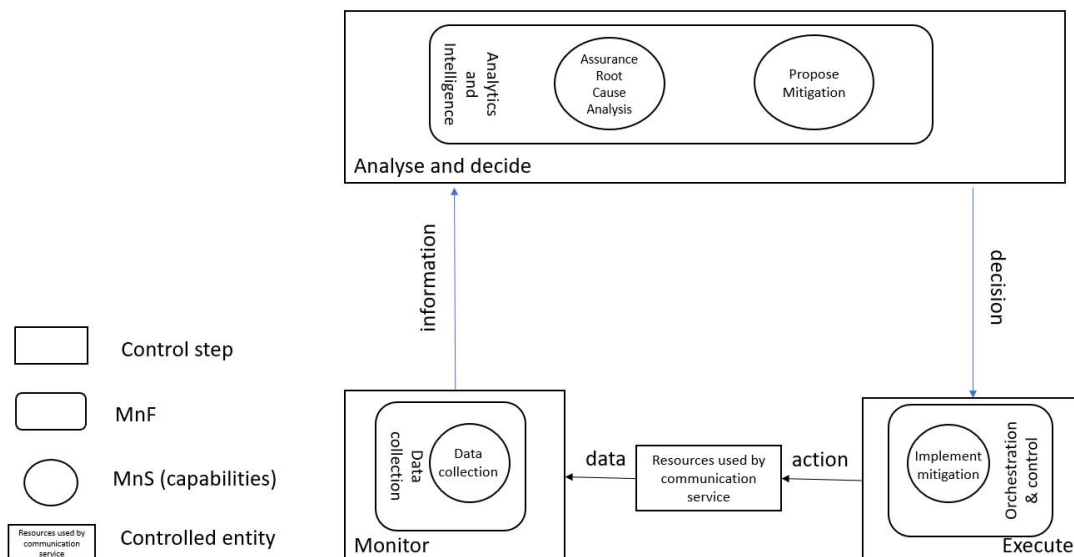

Figure 4.1.1.1: Overview of information flows

In Figure 4.1.1.1 the controlled entity represents the resources used by a communication service and the assurance of this communication service is provided by the loop between the different management services provided by the management system. The input to the loop is the data concerning the resources used by the communication service which is monitored by the control step Monitor and the output of the step "Analysis and Decide" may be a possible action from the control step "Execute", when for example the service experience degrades, the resources used by a communication service have to be adjusted. The data associated with the communication service is monitored by the management services for data collection and threshold monitoring, the management service provides information to the assurance root cause analysis management service and based on that information the assurance root cause analysis takes place followed by propose mitigation or suggestion to solve the problem. The mitigation or problem-solving suggestion is executed to bring the behaviour of the communication service within the requested boundaries of the metrics (SLS goals) that are controlled by the loop.

NOTE: The interface for interaction between the capabilities in the Analyse and decide step is not addressed in this release.

The management services available between the control step for "Monitor" and "Analyse" as well as "Decide" are based on file transfer described in TS 28.550 [3], or data streaming described in TS 28.550 [3] and notifications described in TS 28.545 [4].

Editor's Note: Further details including the relationship between the content of the figure "Overview of information flows", Trace as well as MDT are FFS

4.1.2 Model

4.1.2.1 Imported and associated information entities

4.1.2.1.1 Imported information entities and local labels

Label reference	Local label
TS 28.622 [5], IOC, Top	Top
TS 28.622 [5], IOC, SubNetwork	SubNetwork
TS 28.622 [6], ProxyClass, ManagedEntity	ManagedEntity
TS 28.541 [6], dataType, ServiceProfile	ServiceProfile
TS 28.541 [6], dataType, SliceProfile	SliceProfile

4.1.2.2 Class diagram

4.1.2.2.1 Relationships

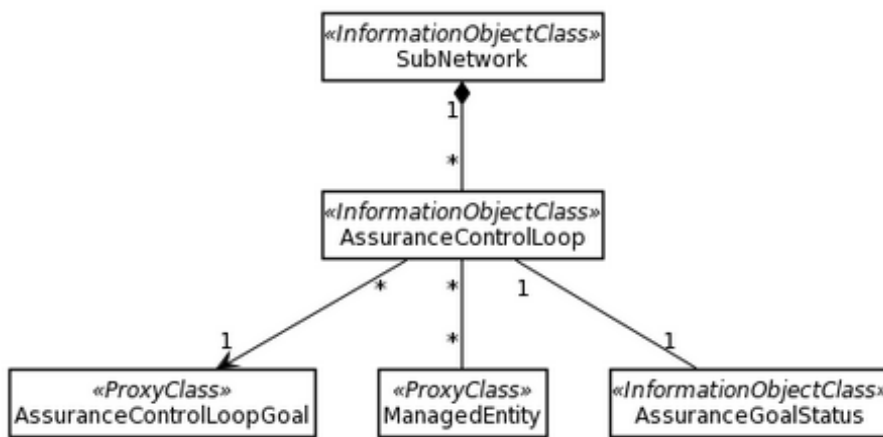

Figure 4.1.2.2.1.1: Assurance management NRM fragment

4.1.2.2.2 Inheritance

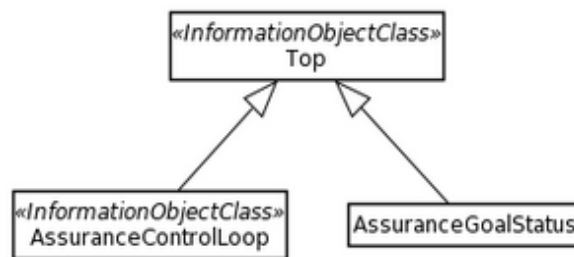

Figure 4.1.2.2.2.1: Assurance management inheritance relationships

4.1.2.3 Class definitions

4.1.2.3.1 AssuranceControlLoop

4.1.2.3.1.1 Definition

This IOC represents the capabilities of a control loop, these include:

- to automatically adjust a ManagedEntity (for example a network slice) to meet the objective described in AssuranceControlLoopGoal
- to report the effectiveness of an AssuranceControlLoop
- state management of an AssuranceControlLoop
- to keep track of the lifecycle of an AssuranceControlLoop

4.1.2.3.1.2 Attributes

Attribute name	Support Qualifier	isReadable	isWritable	isInvariant	isNotifiable
operationalState	M	T	F	F	T
administrativeState	M	T	T	F	T
controlLoopLifeCyclePhase	M	T	T	F	T
observationTimePeriod	M	T	T	F	T
assuranceGoalStatus	M	T	F	F	T

4.1.2.3.1.3 Constraints

No constraints have been defined for this release.

4.1.2.3.1.4 Notifications

The common notifications defined in clause 4.1.2.5 are valid for this IOC, without exceptions or additions.

4.1.2.2.3 AssuranceGoalStatus

4.1.2.2.3.1 Definition

This class represents the status of the controlLoopGoal at the end of an observationPeriod. The status can be reported as actual status and predicted status. Data that is monitored by an assuranceControlLoop and includes measurements [x] and KPI's [y] and predictions that are applicable to the assuranceControlLoopGoals.

An assuranceGoalStatus holds the value of the observation and where applicable the value of a prediction. Depending on the AssuranceGoal the type of the AssuranceGoalStatusObserved and AssuranceGoalStatusPredicted can be different for different AssuranceGoalStatus MOIs.

4.1.2.2.3.2 Attributes

Attribute name	Support Qualifier	isReadable	isWritable	isInvariant	isNotifiable
AssuranceGoalStatusObserved	M	T	T	F	T
AssuranceGoalStatusPredicted	O	T	T	F	T

4.1.2.2.3.3 Attribute constraints

No constraints have been defined for this release.

4.1.2.2.3.4 Notifications

The common notifications defined in subclause 4.1.2.5 are valid for this IOC, without exceptions or additions.

4.1.2.3.3 AssuranceControlLoopGoal <<ProxyClass>>

4.1.2.3.3.1 Definition

This IOC represents the <<dataType>> *ServiceProfile* and <<dataType>> *SliceProfile*, defined in network slice NRM in [6].

4.1.2.3.3.2 Attributes

The attributes are defined in network slice NRM in [6].

4.1.2.3.3.3 Attribute constraints

The attribute constraints are defined in network slice NRM in [6].

4.1.2.3.3.4 Notifications

The notifications of IOCs using the <<dataType>> *ServiceProfile* or <<dataType>> *SliceProfile* are defined in network slice NRM in [6].

4.1.2.3.4 ObservationTimePeriod <<dataType>>

4.1.2.3.4.1 Definition

This datatype represents the time that a goal is observed which can be specified in seconds, minutes, hours or days depending on the goal that is being observed.

4.1.2.3.4.2 Attributes

Attribute name	Support Qualifier	isReadable	isWritable	isInvariant	isNotifyable
observationTime	M	T	T	F	T
timeUnit	M	T	T	F	T

4.1.2.3.3.3 Attribute constraints

No constraints have been defined for this release.

4.1.2.3.3.4 Notifications

The common notifications defined in subclause 4.1.2.5 are valid for this IOC, without exceptions or additions.

4.1.2.4 Attribute definitions

4.1.2.4.1 Attribute properties

The following table defines the properties of attributes that are specified in the present document.

Table 4.1.2.4.1.1

Attribute Name	Documentation and Allowed Values	Properties
controlLoopLifeCyclePhase	It indicates the lifecycle phase of the ControlLoop. AllowedValues: Preparation, Commissioning, Operation and Decommissioning.	type: Enum multiplicity: 1 isOrdered: N/A isUnique: N/A defaultValue: None isNullable: False
observationTimePeriod	It indicates the time duration over which a controlLoopGoal is observed. During the observation period various observation data is collected to assess if the controlLoopGoal has been met The observation time is expressed in timeUnits.	type: Integer multiplicity: 1 isOrdered: N/A isUnique: N/A defaultValue: None isNullable: False
timeUnit	It indicates the unit of time used to express the observationTime AllowedValues: second, minute, hour, day	type: Enum multiplicity: 1 isOrdered: N/A isUnique: N/A defaultValue: None isNullable: False
observationTime	It indicates the observation time expressed in number of timeUnit.	type: Integer multiplicity: 1 isOrdered: N/A isUnique: N/A defaultValue: None isNullable: False
assuranceGoalStatus	It reports the status of the controlLoopGoal at the end of an observationPeriod. The status can be reported as actual status or predicted status.	type: <<dataType>> multiplicity: 1 isOrdered: N/A isUnique: N/A defaultValue: None isNullable: False
assuranceGoalStatusObserved	It indicates the actual value of the controlLoopGoal at the end of an observation period	type: AssuranceGoalStatusObserved multiplicity: 1 isOrdered: N/A isUnique: N/A defaultValue: None isNullable: False
assuranceGoalStatusPredicted	It indicates the predicted value of the controlLoopGoal at the end of an observation period see note 1, or of a future observation period, see note 2.	type: AssuranceGoalStatusPredicted multiplicity: 1 isOrdered: N/A isUnique: N/A defaultValue: None isNullable: False
NOTE 1: The predictive capability is provided by using a different population for assessment than the population for which measurements are available.		
NOTE 2: The predictive capability is provided by using a method for predicting the most likely status in the future.		

4.1.2.4.2 Constraints

No constraints have been identified for this release

4.1.2.4.3 Notifications

This subclause presents a list of notifications, defined in [7], that provisioning management service consumer can receive. The notification parameter objectClass/objectInstance, defined in [10], would capture the DN of an instance of an IOC defined in the present document.

4.1.2.5 Common notifications

4.1.2.5.1 Alarm notifications

This clause presents a list of notifications, defined in TS 28.532 [7], that an MnS consumer may receive. The notification header attribute `objectClass/objectInstance`, defined in TS 32.302 [8], shall capture the DN of an instance of a class defined in the present document.

4.1.2.5.2 Configuration notifications

This clause presents a list of notifications, defined in TS 28.532 [7], that an MnS consumer may receive. The notification header attribute `objectClass/objectInstance`, defined in TS 32.302 [8], shall capture the DN of an instance of a class defined in the present document.

4.1.3 Procedures

4.1.3.1 SLS Assurance Procedure

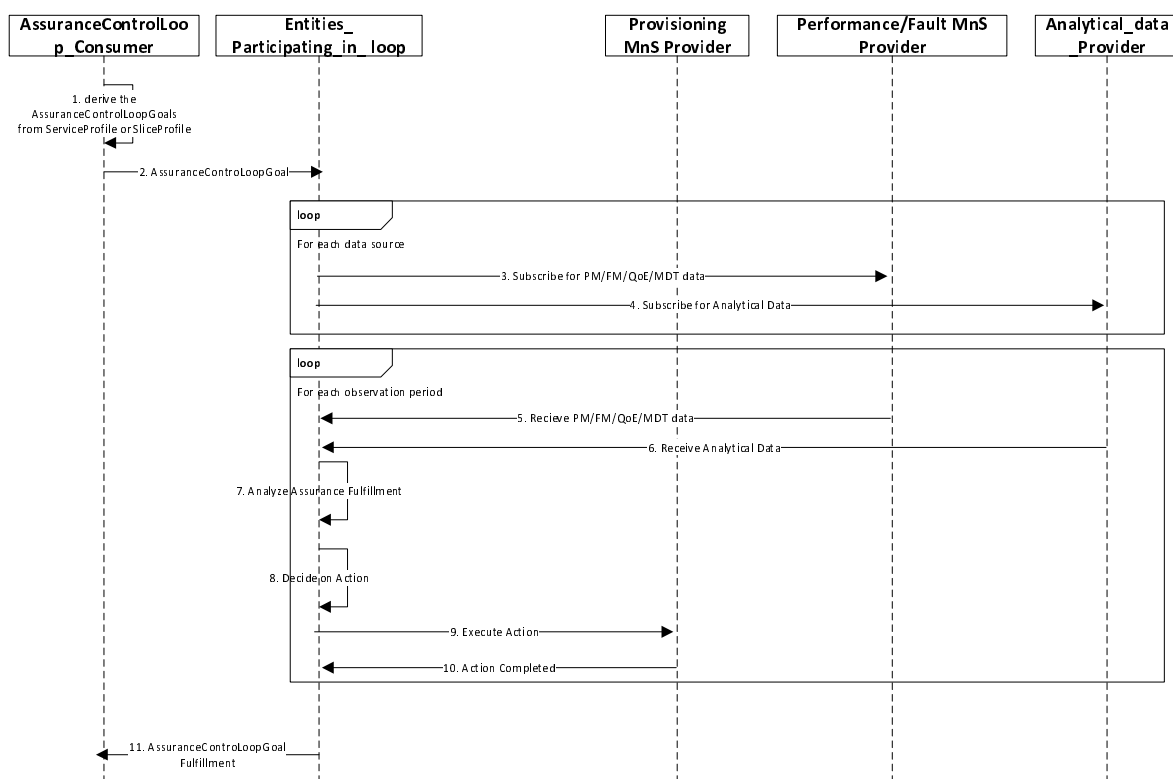

Figure 4.1.3.1.1

1. AssuranceControlLoop_consumer derives AssuranceControlLoopGoal from the ServiceProfile or SliceProfile.
2. AssuranceControlLoop_consumer provides the AssuranceControlLoopGoal to Entities_Participating_in_loop by utilizing the provision management services defined in as defined in clause 11.1.1.3 of TS 28.532 [7].

NOTE 1: In case the Entities_Participating_in_loop represents CrossDomain_Entities_Participating_in_loop, the AssuranceControlLoopGoal is the attribute(s) of the ServiceProfile. In case the Entities_Participating_in_loop represents Domain_Entities_Participating_in_loop, the AssuranceControlLoopGoal is the attribute(s) of the SliceProfile.

3. Entities_Participating_in_loop subscribes the related performance data (e.g., the packet delay related measurements), fault data, QoE data (e.g., buffer level) and MDT data from respective sources by utilizing the Operation establishStreamingConnection as defined in clause 6.2.1 of TS 28.550 [3].

4. Entities_Participating_in_loop, optionally, subscribes the related analytical data from MDAS or network functions, e.g., NWDAF. In case of NWDAF as a provider, Nnwdaf_EventsSubscription Service as defined in clause 4.2 is used.
 5. Entities_Participating_in_loop collects the related performance, fault, QoE and MDT data (e.g., the packet delay related measurements), fault data, QoE data (e.g., buffer level) and MDT data from respective sources by utilizing the Operation establishStreamingConnection as defined in clause 6.2.1 of TS 28.550 [3].
 6. Entities_Participating_in_loop, optionally, collects the related analytical data from MDAS or network functions, e.g., NWDAF. In case of NWDAF as a provider, Nnwdaf_EventsSubscription Service as defined in clause 4.2 of TS 29.520 [y] is used.
 7. Entities_Participating_in_loop assesses if the AssuranceControlLoopGoal has been fulfilled.
 8. Entities_Participating_in_loop assesses if and which action to take in case the AssuranceControlLoopGoal has not been fulfilled.
 9. As per the mitigation action (e.g., scale out) resources are changed, the generic provisioning management service as defined in clause 11.1 of TS 28.532 [7] is utilized for the same.
 10. Action completed.
- NOTE 2: The Entities_Participating_in_loop continues to monitor and analyse the performance and perform the adjustment until the attribute(s) of SliceProfile is assured.
11. AssuranceControlLoop_consumer receives the confirmation of assurance fulfilment from Entities_Participating_in_loop by utilizing the provision management services defined in as defined in clause 11.1.1.3 of TS 28.532 [7].

4.2 Stage 3

4.2.1 Solution Set (SS) for JSON/YAML

The JSON/YAML solution set is documented in clause B.2.

Annex A (informative): Control loop deployed in different layers

A.1 Introduction

This example gives a high-level view of control loops deployed in different layers, which consists of control loop in communication service layer, control loop in network slice layer, control loop in network slice subnet layer and control loop in NF layer, as described as Figure A.1.1, where the analytic could be leverage MDAS, and different control loops can provide input (interact with) to other control loops (in the same layer or different layers) and obtain the output from other control loops (in the same layer or different layers).

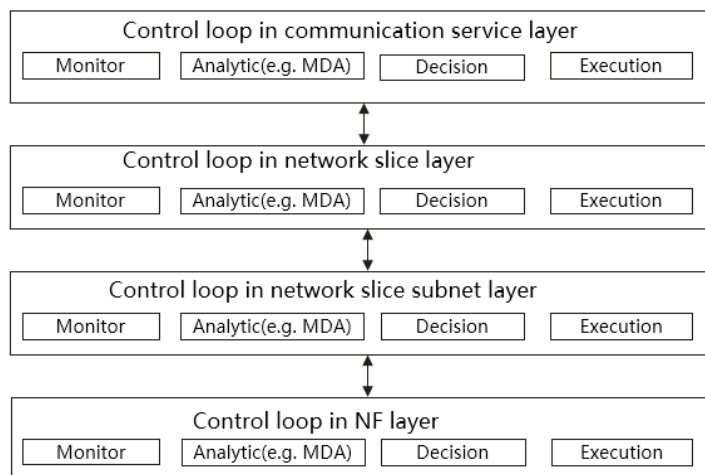

Figure A.1.1: Control loop in different layers

A.2 Control loop in communication service layer

SLA/SLS requirements provided from CSC are translated into serviceProfile, which represents the requirements for communication service assurance to the CSP. Coordination between control loop in communication service layer and control loop in network slice layer is needed to calculate the communication service resource requirements and to assure the communication service SLA/SLS requirements.

When the communication service is active, network slice performance is monitored and analysed for the communication service according to end user service experiences.

If service degradation occurs or it is predicted, the 3GPP management system could take actions, i.e. the allocated resources are scaled up or the SLS is adjusted based on pre-agreement/interaction between CSP and CSC.

A.3 Control loop in network slice layer

After the network slice provisioning, the network slice performance (e.g. KPI, QoE) are monitored and reported. When network slice performance is not met, the 3GPP management system identifies the root cause and may reconfigure the resources according to analytical report from MDAS producer. The network slice resources are also modified accordantly in case the network slice performance requirement needs to be changed based on communication service requirement adjustment.

A.4 Control loop in network slice subnet layer

The 3GPP management system could have the capability of service observation (e.g., the supervision to the NSSI) based on MDAS. Based on such observation, management actions on the NSSI might be performed if NSSI performance requirements fulfillment indicates a problem. Another possible scenario is that, when the NSSI performance requirement is changed because of the network slice modification management action, the NSSI resources might be also reconfigured.

A.5 Control loop in NF layer

Editor's note: the control loop in NF layer is FFS.

Annex B (normative): OpenAPI definition of the COSLA NRM

B.1 General

This annex contains the OpenAPI definition of the COSLA NRM in YAML format.

The Information Service (IS) of the COSLA NRM is defined in clause 3.

Mapping rules to produce the OpenAPI definition based on the IS are defined in TS 32.160 [10].

B.2 Solution Set (SS) definitions

B.2.1 OpenAPI document "coslaNrm.yml"

```
openapi: 3.0.3

info:
  title: coslaNrm
  version: 16.4.0
  description:
    OAS 3.0.1 specification of the Cosla NRM
    © 2020, 3GPP Organizational Partners (ARIB, ATIS, CCSA, ETSI, TSDSI, TTA, TTC).
    All rights reserved.

externalDocs:
  description: 3GPP TS 28.536 V16.4.0; 5G NRM, Slice NRM
  url: http://www.3gpp.org/ftp/Specs/archive/28_series/28.536/

paths: {}

components:
  schemas:

#----- Type definitions -----

  ControlLoopLifeCyclePhase:
    anyOf:
      - type: string
      enum:
        - PREPARATION
        - COMMISSIONING
        - OPERATION
        - DECOMMISSIONING
      - type: string

  TimeUnit:
    anyOf:
      - type: string
      enum:
        - SECOND
        - MINUTE
        - HOUR
        - DAY
      - type: string

  OperationalState:
    anyOf:
      - type: string
      enum:
        - ENABLED
        - DISABLED
      - type: string

  AdministrativeState:
```

```

    anyOf:
      - type: string
        enum:
          - LOCKED
          - SHUTTING_DOWN
          - UNLOCKED
      - type: string

ObservationTime:
  type: integer

ObservationTimePeriod:
  type: object

AssuranceControlLoopGoal:
  type: object

AssuranceGoalStatus:
  type: object

AssuranceGoalStatusObserved:
  type: object

AssuranceGoalStatusPredicted:
  type: object

#----- Definition of concrete IOCs -----

AssuranceControlLoop-Single:
  allOf:
    - $ref: 'genericNrm.yaml#/components/schemas/SubNetwork-Attr'
    - type: object
      properties:
        operationalState:
          $ref: '#/components/schemas/OperationalState'
        administrativeState:
          $ref: '#/components/schemas/AdministrativeState'
        controlLoopLifeCyclePhase:
          $ref: '#/components/schemas/ControlLoopLifeCyclePhase'
        observationTimePeriod:
          allOf:
            - $ref: '#/components/schemas/ObservationTimePeriod'
            - type: object
              properties:
                observationTime:
                  $ref: '#/components/schemas/ObservationTime'
                timeUnit:
                  $ref: '#/components/schemas/TimeUnit'
        AssuranceGoalStatus:
          allOf:
            - $ref: '#/components/schemas/AssuranceGoalStatus'
            - type: object
              properties:
                assuranceGoalStatusObserved:
                  $ref: '#/components/schemas/AssuranceGoalStatusObserved'
                assuranceGoalStatusPredicted:
                  $ref: '#/components/schemas/AssuranceGoalStatusPredicted'
        managedEntity-Multiple:
          $ref: '#/components/schemas/ManagedEntity-Multiple'
        assuranceControlLoopGoal:
          $ref: '#/components/schemas/AssuranceControlLoopGoal'

ManagedEntity-Single:
  oneOf:
    - $ref: 'sliceNrm.yaml#/components/schemas/NetworkSlice'
    - $ref: 'sliceNrm.yaml#/components/schemas/NetworkSliceSubnet'
    - $ref: 'genericNrm.yaml#/components/schemas/ManagedFunction-Attr'
    - $ref: 'genericNrm.yaml#/components/schemas/ManagedElement-Attr'

#----- Definition of JSON arrays for name-contained IOCs -----

AssuranceControlLoop-Multiple:
  type: array
  items:
    $ref: '#/components/schemas/AssuranceControlLoop-Single'

ManagedEntity-Multiple:
  type: array

```

items:

\$ref: '#/components/schemas/ManagedEntity-Single'

Annex C (informative): Change history

Change history							
Date	Meeting	TDoc	CR	Rev	Cat	Subject/Comment	New version
2019-09	SA5#126					Skeleton	0.0.0
2019-10	SA5#127	S5-196741				pCR 28.536 Add scope	0.1.0
2019-10	SA5#127	S5-196742				pCR 28.536 Add introduction	0.1.0
2019-10	SA5#127	S5-196744				pCR 28.536 Introduce table of content	0.1.0
2019-11	SA5#128	S5-197788				pCR 28.536 Add Overview of interfaces	0.2.0
2020-04	SA5#130e	S5-202341				pCR TS 28.536 Move and update Annex A Management control loop in different later from TS 28.535	0.3.0
2020-04	SA5#130e	S5-202399				pCR TS 28.536 Communication service assurance stage 2 solution	0.3.0
2020-06	SA5#131e	S5-203432				pCR 28.536 Generic SLS Assurance Procedure	0.4.0
2020-06	SA5#131e	S5-203433				TS 28.536 Add attributes to assurance control loop	0.4.0
2020-06	SA5#131e	S5-203428				pCR TS 28.536 Remove CSI from clause 4.1.1	0.4.0
2020-06	SA5#131e	S5-203434				pCR TS 28.536 Add stage 3 solution	0.4.0
2020-06	SA#88-e	SP-200479				EditHelp review Presented for information and approval	1.0.0
2020-07	SA#88e					Upgrade to change control version	16.0.0

History

Document history		
V16.0.0	July 2020	Publication