

ETSI TS 128 311 V17.0.0 (2022-04)



**5G; LTE;  
Management and orchestration;  
Network policy management for mobile networks based on  
Network Function Virtualization (NFV) scenarios  
(3GPP TS 28.311 version 17.0.0 Release 17)**



---

**Reference**

RTS/TSGS-0528311vH00

---

**Keywords**

5G,LTE

**ETSI**

650 Route des Lucioles  
F-06921 Sophia Antipolis Cedex - FRANCE

---

Tel.: +33 4 92 94 42 00 Fax: +33 4 93 65 47 16

Siret N° 348 623 562 00017 - APE 7112B  
Association à but non lucratif enregistrée à la  
Sous-Préfecture de Grasse (06) N° w061004871

---

**Important notice**

---

The present document can be downloaded from:

<http://www.etsi.org/standards-search>

The present document may be made available in electronic versions and/or in print. The content of any electronic and/or print versions of the present document shall not be modified without the prior written authorization of ETSI. In case of any existing or perceived difference in contents between such versions and/or in print, the prevailing version of an ETSI deliverable is the one made publicly available in PDF format at [www.etsi.org/deliver](http://www.etsi.org/deliver).

Users of the present document should be aware that the document may be subject to revision or change of status.

Information on the current status of this and other ETSI documents is available at

<https://portal.etsi.org/TB/ETSIDeliverableStatus.aspx>

If you find errors in the present document, please send your comment to one of the following services:

<https://portal.etsi.org/People/CommitteeSupportStaff.aspx>

If you find a security vulnerability in the present document, please report it through our  
Coordinated Vulnerability Disclosure Program:

<https://www.etsi.org/standards/coordinated-vulnerability-disclosure>

---

**Notice of disclaimer & limitation of liability**

---

The information provided in the present deliverable is directed solely to professionals who have the appropriate degree of experience to understand and interpret its content in accordance with generally accepted engineering or other professional standard and applicable regulations.

No recommendation as to products and services or vendors is made or should be implied.

No representation or warranty is made that this deliverable is technically accurate or sufficient or conforms to any law and/or governmental rule and/or regulation and further, no representation or warranty is made of merchantability or fitness for any particular purpose or against infringement of intellectual property rights.

In no event shall ETSI be held liable for loss of profits or any other incidental or consequential damages.

Any software contained in this deliverable is provided "AS IS" with no warranties, express or implied, including but not limited to, the warranties of merchantability, fitness for a particular purpose and non-infringement of intellectual property rights and ETSI shall not be held liable in any event for any damages whatsoever (including, without limitation, damages for loss of profits, business interruption, loss of information, or any other pecuniary loss) arising out of or related to the use of or inability to use the software.

---

**Copyright Notification**

---

No part may be reproduced or utilized in any form or by any means, electronic or mechanical, including photocopying and microfilm except as authorized by written permission of ETSI.

The content of the PDF version shall not be modified without the written authorization of ETSI.

The copyright and the foregoing restriction extend to reproduction in all media.

© ETSI 2022.  
All rights reserved.

---

# Intellectual Property Rights

## Essential patents

IPRs essential or potentially essential to normative deliverables may have been declared to ETSI. The declarations pertaining to these essential IPRs, if any, are publicly available for **ETSI members and non-members**, and can be found in ETSI SR 000 314: "*Intellectual Property Rights (IPRs); Essential, or potentially Essential, IPRs notified to ETSI in respect of ETSI standards*", which is available from the ETSI Secretariat. Latest updates are available on the ETSI Web server (<https://ipr.etsi.org/>).

Pursuant to the ETSI Directives including the ETSI IPR Policy, no investigation regarding the essentiality of IPRs, including IPR searches, has been carried out by ETSI. No guarantee can be given as to the existence of other IPRs not referenced in ETSI SR 000 314 (or the updates on the ETSI Web server) which are, or may be, or may become, essential to the present document.

## Trademarks

The present document may include trademarks and/or tradenames which are asserted and/or registered by their owners. ETSI claims no ownership of these except for any which are indicated as being the property of ETSI, and conveys no right to use or reproduce any trademark and/or tradename. Mention of those trademarks in the present document does not constitute an endorsement by ETSI of products, services or organizations associated with those trademarks.

**DECT™**, **PLUGTESTS™**, **UMTS™** and the ETSI logo are trademarks of ETSI registered for the benefit of its Members. **3GPP™** and **LTE™** are trademarks of ETSI registered for the benefit of its Members and of the 3GPP Organizational Partners. **oneM2M™** logo is a trademark of ETSI registered for the benefit of its Members and of the oneM2M Partners. **GSM®** and the GSM logo are trademarks registered and owned by the GSM Association.

---

# Legal Notice

This Technical Specification (TS) has been produced by ETSI 3rd Generation Partnership Project (3GPP).

The present document may refer to technical specifications or reports using their 3GPP identities. These shall be interpreted as being references to the corresponding ETSI deliverables.

The cross reference between 3GPP and ETSI identities can be found under <http://webapp.etsi.org/key/queryform.asp>.

---

# Modal verbs terminology

In the present document "**shall**", "**shall not**", "**should**", "**should not**", "**may**", "**need not**", "**will**", "**will not**", "**can**" and "**cannot**" are to be interpreted as described in clause 3.2 of the [ETSI Drafting Rules](#) (Verbal forms for the expression of provisions).

"**must**" and "**must not**" are **NOT** allowed in ETSI deliverables except when used in direct citation.

# Contents

Intellectual Property Rights .....	2
Legal Notice .....	2
Modal verbs terminology.....	2
Foreword.....	6
1 Scope .....	8
2 References .....	8
3 Definitions of terms, symbols and abbreviations .....	8
3.1 Terms.....	8
3.2 Symbols.....	8
3.3 Abbreviations .....	8
4 Overview .....	9
5 Policy management architecture .....	9
6 Business level requirements .....	10
6.1 Requirements.....	10
6.2 Actor roles .....	10
6.3 Telecommunication resources .....	10
6.4 High-level use cases .....	10
6.4.1 Deploy the network function .....	10
7 Specification level requirements .....	10
7.1 Requirements.....	10
7.2 Actor roles .....	11
7.3 Telecommunications resources .....	11
7.4 Use cases .....	11
7.4.1 Create a policy in the context of NFV .....	11
7.4.2 Delete a policy in the context of NFV .....	12
7.4.3 Update a policy in the context of NFV .....	12
7.4.4 Query a policy in the context of NFV .....	13
7.4.5 Activate a policy in the context of NFV .....	13
7.4.6 Deactivate a policy in the context of NFV .....	14
7.4.7 Reporting policy conflicts in the context of NFV .....	14
8 Policy management procedures.....	14
8.1 General description for policy management procedures .....	14
8.2 Policy Creation .....	15
8.3 Policy Deletion .....	15
8.4 Policy Update .....	15
8.5 Policy Query.....	15
8.6 Policy Activation.....	16
8.7 Policy Deactivation .....	16
8.8 Policy Conflicts Notification.....	16
9 Information Object Classes .....	16
9.1 Information entities imported and local label.....	16
9.2 Class diagram .....	17
9.2.1 Attributes and relationships .....	17
9.2.2 Inheritance .....	17
9.3 Information object classes definition.....	17
9.3.1 Policy.....	17
9.3.1.1 Definition .....	17
9.3.1.2 Attributes.....	18
9.3.2 PolicyList .....	18
9.3.2.1 Definition .....	18

9.3.2.2	Attributes.....	18
9.3.3	PolicyManagementIRP .....	18
9.3.3.1	Definition .....	18
9.3.3.2	Attribute .....	18
9.3.3.3	Notifications.....	18
9.4	Information relationship definitions .....	18
9.4.1	relation-PolicyManagementIRP-PolicyList (M).....	18
9.4.1.1	Definition .....	18
9.4.1.2	Role .....	18
9.4.1.3	Constraint .....	19
9.4.2	relation-PolicyList-Policy (M).....	19
9.4.2.1	Definition .....	19
9.4.2.2	Role .....	19
9.4.2.3	Constraint .....	19
9.5	Information attribute definitions.....	19
9.5.0	Introduction.....	19
9.5.1	Definitions and legal values.....	20
10	Interface definition .....	20
10.1	Class diagram .....	20
10.2	PolicyManagementIRPOperations_Interface (M).....	21
10.2.1	Operation createPolicy (M).....	21
10.2.1.1	Input parameters.....	21
10.2.1.2	Output parameters .....	21
10.2.1.3	Results.....	21
10.2.2	Operation deletePolicy (M).....	21
10.2.2.1	Input parameters.....	21
10.2.2.2	Output parameters .....	21
10.2.2.3	Results.....	21
10.2.3	Operation updatePolicy (M) .....	22
10.2.3.1	Input parameters.....	22
10.2.3.2	Output parameters .....	22
10.2.3.3	Results.....	22
10.2.4	Operation queryPolicy (M).....	22
10.2.4.1	Input parameters.....	22
10.2.4.2	Output parameters .....	22
10.2.4.3	Results.....	23
10.2.5	Operation activatePolicy (M).....	23
10.2.5.1	Input parameters.....	23
10.2.5.2	Output parameters .....	23
10.2.5.3	Results.....	23
10.2.6	Operation deactivatePolicy (M).....	23
10.2.6.1	Input parameters.....	23
10.2.6.2	Output parameters .....	23
10.2.6.3	Results.....	23
10.2.7	Operation queryPolicyList (M).....	24
10.2.7.1	Input parameters.....	24
10.2.7.2	Output parameters .....	24
10.2.7.3	Results.....	24
10.3	PolicyManagementIRPNotification_Interface (M) .....	24
10.3.1	policyConflictNotification .....	24
10.3.1.1	Input parameters.....	24
10.3.1.2	Triggering Event .....	24
10.3.1.2.1	From-state.....	24
10.3.1.2.2	To-state.....	24
11	Solution Set (SS) definitions .....	24
<b>Annex A (normative): XML definitions .....</b>		<b>26</b>
A.1	General .....	26
A.2	Architectural features .....	26

A.3	Mapping .....	26
A.3.1	General mapping .....	26
A.3.2	Information Object Class (IOC) mapping .....	26
A.4	Solution Set definitions .....	26
A.4.1	XML definition structure.....	26
A.4.2	Graphical Representation .....	26
A.4.3	XML Schema “PolicyManagement.xsd” .....	26
<b>Annex B (normative): SOAP Solution Set .....</b>		<b>30</b>
B.1	General .....	30
B.2	Architectural features .....	30
B.3	Mapping .....	30
B.3.1	Operation and notification mapping .....	30
B.3.2	Operation parameter mapping .....	30
B.3.2.0	General.....	30
B.3.2.1	Operation createPolicy.....	31
B.3.2.1.1	Input parameters.....	31
B.3.2.1.2	Output parameters .....	31
B.3.2.2	Operation deletePolicy.....	31
B.3.2.2.1	Input parameters.....	31
B.3.2.2.2	Output parameters .....	31
B.3.2.3	Operation updatePolicy.....	32
B.3.2.3.1	Input parameters.....	32
B.3.2.3.2	Output parameters .....	32
B.3.2.4	Operation queryPolicy .....	32
B.3.2.4.1	Input parameters.....	32
B.3.2.4.2	Output parameters .....	33
B.3.2.5	Operation activatePolicy.....	33
B.3.2.5.1	Input parameters.....	33
B.3.2.5.2	Output parameters .....	33
B.3.2.6	Operation deactivatePolicy .....	33
B.3.2.6.1	Input parameters.....	33
B.3.2.6.2	Output parameters .....	33
B.3.2.7	Operation queryPolicyList.....	34
B.3.2.7.1	Input parameters.....	34
B.3.2.7.2	Output parameters .....	34
B.3.2.8	Operation policyConflictNotification .....	34
B.3.2.8.1	Input parameters.....	34
B.3.2.8.2	Output parameters .....	34
B.4	Solution Set definitions .....	34
B.4.1	WSDL definition structure .....	34
B.4.2	Graphical Representation .....	34
B.4.3	WSDL specification “PolicyManagementIRPSystem.wsdl” .....	35
<b>Annex C (informative): Change history .....</b>		<b>40</b>
History .....		41

---

# Foreword

This Technical Specification has been produced by the 3<sup>rd</sup> Generation Partnership Project (3GPP).

The contents of the present document are subject to continuing work within the TSG and may change following formal TSG approval. Should the TSG modify the contents of the present document, it will be re-released by the TSG with an identifying change of release date and an increase in version number as follows:

Version x.y.z

where:

- x the first digit:
  - 1 presented to TSG for information;
  - 2 presented to TSG for approval;
  - 3 or greater indicates TSG approved document under change control.
- y the second digit is incremented for all changes of substance, i.e. technical enhancements, corrections, updates, etc.
- z the third digit is incremented when editorial only changes have been incorporated in the document.

In the present document, modal verbs have the following meanings:

- shall** indicates a mandatory requirement to do something
- shall not** indicates an interdiction (prohibition) to do something

The constructions "shall" and "shall not" are confined to the context of normative provisions, and do not appear in Technical Reports.

The constructions "must" and "must not" are not used as substitutes for "shall" and "shall not". Their use is avoided insofar as possible, and they are not used in a normative context except in a direct citation from an external, referenced, non-3GPP document, or so as to maintain continuity of style when extending or modifying the provisions of such a referenced document.

- should** indicates a recommendation to do something
- should not** indicates a recommendation not to do something
- may** indicates permission to do something
- need not** indicates permission not to do something

The construction "may not" is ambiguous and is not used in normative elements. The unambiguous constructions "might not" or "shall not" are used instead, depending upon the meaning intended.

- can** indicates that something is possible
- cannot** indicates that something is impossible

The constructions "can" and "cannot" are not substitutes for "may" and "need not".

- will** indicates that something is certain or expected to happen as a result of action taken by an agency the behaviour of which is outside the scope of the present document
- will not** indicates that something is certain or expected not to happen as a result of action taken by an agency the behaviour of which is outside the scope of the present document
- might** indicates a likelihood that something will happen as a result of action taken by some agency the behaviour of which is outside the scope of the present document

**might not** indicates a likelihood that something will not happen as a result of action taken by some agency the behaviour of which is outside the scope of the present document

In addition:

**is** (or any other verb in the indicative mood) indicates a statement of fact

**is not** (or any other negative verb in the indicative mood) indicates a statement of fact

The constructions "is" and "is not" do not indicate requirements.



---

# 1 Scope

The present document contains the architecture, requirements, use cases, procedures and definitions of interfaces for policy management for 4G networks.

---

# 2 References

The following documents contain provisions which, through reference in this text, constitute provisions of the present document.

- References are either specific (identified by date of publication, edition number, version number, etc.) or non-specific.
- For a specific reference, subsequent revisions do not apply.
- For a non-specific reference, the latest version applies. In the case of a reference to a 3GPP document (including a GSM document), a non-specific reference implicitly refers to the latest version of that document *in the same Release as the present document*.

- [1] 3GPP TR 21.905: "Vocabulary for 3GPP Specifications".
- [2] ETSI GR NFV-IFA 023 (V3.1.1): "Network Function Virtualisation (NFV); Management and Orchestration; Report on Policy Management in MANO; Release 3".
- [3] 3GPP TS 32.312: "Telecommunication management; Generic Integration Reference Point (IRP) management: Information Service (IS)".

---

# 3 Definitions of terms, symbols and abbreviations

## 3.1 Terms

Void.

## 3.2 Symbols

Void.

## 3.3 Abbreviations

For the purposes of the present document, the abbreviations given in 3GPP TR 21.905 [1] and the following apply. An abbreviation defined in the present document takes precedence over the definition of the same abbreviation, if any, in 3GPP TR 21.905 [1].

EM	Element Management
IRP	Integration Reference Point
NE	Network Element
NFVI	Network Functions Virtualization Infrastructure
NFVO	Network Functions Virtualization Orchestrator
NM	Network Management
PAF	Policy Administration Function
PF	Policy Function
VIM	Virtualized Infrastructure Manager
VNF	Virtualized Network Function
VNFM	VNF Manager

## 4 Overview

NFV policy management system may have policy conflict problem, which is a newly created policy may be conflict with an existing policy.

There are two potential policy conflict detection approaches, one is policy conflict detection in the Policy Function (PF), which makes the policy execution decisions, and the other one is policy conflict detection in the Policy Administration Function (PAF), which defines the network policy. There are multiple scenarios for policy conflict. For example, if the events are the same and the same condition are triggered (e.g. scaling policy on a VNF), but two policies have different actions, the conflict should be detected and resolved. It is not easy for one PF to resolve all of scenarios of the policy conflict. Hence, it is reasonable to enable PAF to resolve policy conflict, while the conflict detected by PAF or PF based on different specific scenarios, and the present document try to resolve the problem.

## 5 Policy management architecture

In order to delegate the support of policy control for virtualized NFs such as automatic scale in/out under certain condition , 3GPP management system would use the ETSI NFV defined related policy features/services. Consequently, two important logical functions are needed for the definition of the 3GPP policy management architecture.

- 1) Policy Administration Function (PAF) provides the services as follows:
  - Allows the operator to define and administrate the network policy
- 2) Policy Function (PF) makes the decision for policy execution and provides the services as follows:
  - Activating/deactivating the network policy
  - Event subscription/notification of the network policy execution
  - Providing relevant data and parameters during the process of policy execution (e.g. execution time consuming)

The 3GPP global policy management system would affect the behavior of all 3GPP defined nodes and would delegate the support of policy for virtualized NFs in ETSI MANO systems [2]. For NFV related policy management, 3GPP mainly focus on NM acting as PAF and EM acted as PF, and the interface between the NM and EM can be updated to support policy related operations. Hence, 3GPP policy management architecture under NFV scenario is as follows.

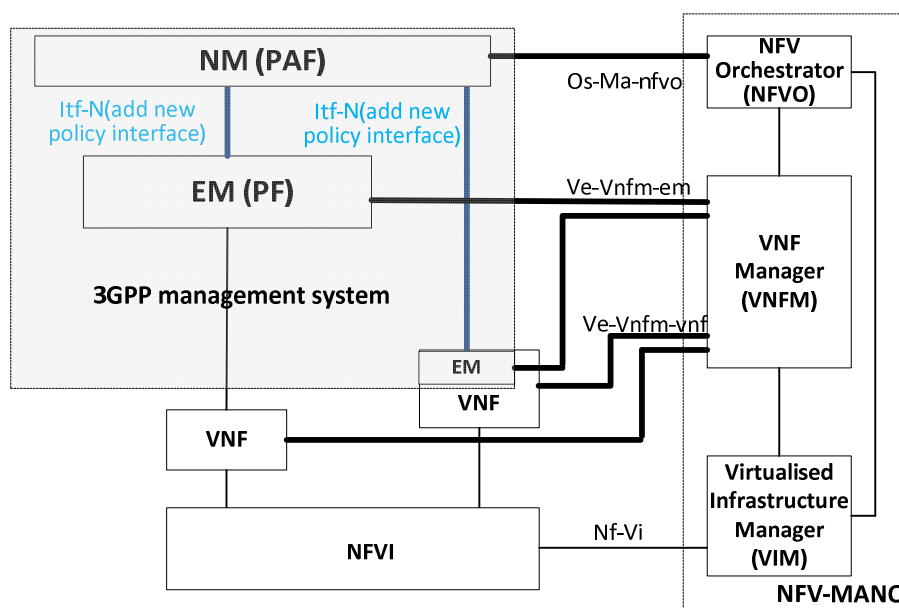

Figure 5-1: NFV policy management architecture in reference point presentation

NFV related policy interfaces between 3GPP management system and MANO such as Os-Ma-nfvo and Ve-Vnfm-em have been defined by ETSI.

---

## 6 Business level requirements

### 6.1 Requirements

**REQ-POM\_PO-CON-1** 3GPP management system should be able to support the capability about the network policy.

### 6.2 Actor roles

See detailed actors and roles for each use case in clause 6.4.

### 6.3 Telecommunication resources

See detailed telecommunication resources for each use case in clause 6.4.

### 6.4 High-level use cases

#### 6.4.1 Deploy the network function

Use Case Stage	Evolution / Specification	<<Uses>> Related use
Goal	According to the network deployment policy, 3GPP system use the policy to deploy the corresponding network.	
Actors and Roles	NM create/delete/update/query/activate/deactivate the network deployment policy, EM execute the NM's policy operation request, and notifies NM policy conflict, if exist.	
Telecom resources	3GPP management system (EM, NM)	
Assumptions	3GPP management system want to deploy a network	
Pre conditions	The operator designs the network deployment requirement and need deploy the network based on the requirement.	
Begins when	There is a new network policy about the network deployment.	
Step 1 (M)	The operator sets up the network deployment policy through NM.	
Step 2 (M)	The NM activates the policy and notifies related EM.	
Step 3 (M)	The EM follows the policy to design the network then the network is instantiated by the management system.	
Ends when	The EM informs the NM that the policy has been executed.	
Exceptions	One of the steps identified above fails.	
Post Conditions	The network is correctly configured and normally running	
Traceability	REQ-POM_PO-CON-1	

---

## 7 Specification level requirements

### 7.1 Requirements

#### **REQ-POM-FUN-01**

The IRPAgent shall provide the capability to allow the IRPManager to create the network policy.

#### **REQ-POM-FUN-02**

The IRPAgent shall provide the capability to allow the IRPManager to delete the network policy.

**REQ-POM-FUN-03**

The IRPAgent shall provide the capability to allow the IRPManager to update the network policy.

**REQ-POM-FUN-04**

The IRPAgent shall provide the capability to allow the IRPManager to query the network policy.

**REQ-POM-FUN-05**

The IRPAgent shall provide the capability to allow the IRPManager to activate the network policy.

**REQ-POM-FUN-06**

The IRPAgent shall provide the capability to allow the IRPManager to deactivate the network policy.

**REQ-POM-FUN-07**

The IRPAgent should notify the IRPManager when there is a network policy conflict.

## 7.2 Actor roles

See detailed actors and roles for each use case in clause 7.4.

## 7.3 Telecommunications resources

See detailed telecommunication resources for each use case in clause 7.4.

## 7.4 Use cases

### 7.4.1 Create a policy in the context of NFV

Use Case Stage	Evolution / Specification	<<Uses>> Related use
Goal	To create a policy such as deploying the SBC from IMS and P-GW from EPC in the same Data Centre.	
Actors and Roles	IRPManager as user	
Telecom resources	3GPP management system (NM, EM).	
Assumptions	3GPP management systems are running normally, scenarios and policy requirements are clearly defined.	
Pre conditions	The systems is correctly configured and normally running.	
Begins when	The IRPManager decides to create a policy.	
Step 1 (M)	The IPRManager makes a decision to create a network policy according to the network requirements, such as deploying the SBC.	
Step 2 (M)	After the completion of the policy creation process, the IRPAgent informs the IRPManager on the result of the process.	
Ends when	Ends when all mandatory steps identified above are successfully completed or when an exception occurs.	
Exceptions	One of the steps identified above fails.	
Post Conditions	The policy is created and stored in the IRPAgent.	
Traceability	REQ-POM-FUN -01	

## 7.4.2 Delete a policy in the context of NFV

Use Case Stage	Evolution / Specification	<<Uses>> Related use
Goal	To delete a policy such as deploying the SBC from IMS and P-GW from EPC in the same Data Center.	
Actors and Roles	IRPManager as user	
Telecom resources	3GPP management system (NM, EM).	
Assumptions	3GPP management systems are running normally, scenarios and policy requirements are clearly defined.	
Pre conditions	The systems is correctly configured and normally running. There is a network policy stored in the IRPAgent.	
Begins when	The IRPManager decides to delete a policy.	
Step 1 (M)	The IPRManager makes a decision to delete the existing policy.	
Step 2 (M)	After the completion of the policy deletion process, the IRPAgent informs the IRPManager on the result of the process.	
Ends when	Ends when all mandatory steps identified above are successfully completed or when an exception occurs.	
Exceptions	One of the steps identified above fails.	
Post Conditions	The policy is deleted in the IRPAgent.	
Traceability	REQ-POM-FUN -02	

## 7.4.3 Update a policy in the context of NFV

Use Case Stage	Evolution / Specification	<<Uses>> Related use
Goal	To update an existing network policy.	
Actors and Roles	IRPManager as user	
Telecom resources	3GPP management system (NM, EM).	
Assumptions	3GPP management systems are running normally, scenarios and policy requirements are clearly defined.	
Pre conditions	The systems is correctly configured and normally running. There is a network policy stored in the IRPAgent.	
Begins when	The IRPManager decides to update a policy.	
Step 1 (M)	The IPRManager makes a decision to update the existing policy.	
Step 2 (M)	After the completion of the policy update process, the IRPAgent informs the IRPManager on the result of the process.	
Ends when	Ends when all mandatory steps identified above are successfully completed or when an exception occurs.	
Exceptions	One of the steps identified above fails.	
Post Conditions	The policy is updated and stored in the IRPAgent.	
Traceability	REQ-POM-FUN -03	

#### 7.4.4 Query a policy in the context of NFV

Use Case Stage	Evolution / Specification	<<Uses>> Related use
Goal	To query an existing network policy.	
Actors and Roles	IRPManager as user	
Telecom resources	3GPP management system (NM, EM).	
Assumptions	3GPP management systems are running normally, scenarios and policy requirements are clearly defined.	
Pre conditions	The systems is correctly configured and normally running. There is a network policy stored in the IRPAgent.	
Begins when	The IRPManager decides to query a policy.	
Step 1 (M)	The IPRManager makes a decision to query the existing policy.	
Step 2 (M)	After the completion of the policy query process, the IRPAgent informs the IRPManager on the result of the process.	
Ends when	Ends when all mandatory steps identified above are successfully completed or when an exception occurs.	
Exceptions	One of the steps identified above fails.	
Post Conditions	The policy information is returned to the IPRManager.	
Traceability	REQ-POM-FUN -04	

#### 7.4.5 Activate a policy in the context of NFV

Use Case Stage	Evolution / Specification	<<Uses>> Related use
Goal	To activate an existing network policy.	
Actors and Roles	IRPManager as user	
Telecom resources	3GPP management system (NM, EM).	
Assumptions	3GPP management systems are running normally, scenarios and policy requirements are clearly defined.	
Pre conditions	The systems is correctly configured and normally running. There is a network policy stored in the IRPAgent.	
Begins when	The IRPManager decides to activate a policy.	
Step 1 (M)	The IPRManager makes a decision to activate the existing policy.	
Step 2 (M)	After the completion of the policy activation process, the IRPAgent informs the IRPManager on the result of the process.	
Ends when	Ends when all mandatory steps identified above are successfully completed or when an exception occurs.	
Exceptions	One of the steps identified above fails.	
Post Conditions	The policy is activated in the IRPAgent.	
Traceability	REQ-POM-FUN -05	

## 7.4.6 Deactivate a policy in the context of NFV

Use Case Stage	Evolution / Specification	<<Uses>> Related use
Goal	To query an existing network policy.	
Actors and Roles	IRPManager as user	
Telecom resources	3GPP management system (NM, EM).	
Assumptions	3GPP management systems are running normally, scenarios and policy requirements are clearly defined.	
Pre conditions	The systems is correctly configured and normally running. There is an active network policy stored in the IRPAgent.	
Begins when	The IRPManager decides to deactivate a policy.	
Step 1 (M)	The IPRManager makes a decision to deactivate the existing policy.	
Step 2 (M)	After the completion of the policy deactivation process, the IRPAgent informs the IRPManager on the result of the process.	
Ends when	Ends when all mandatory steps identified above are successfully completed or when an exception occurs.	
Exceptions	One of the steps identified above fails.	
Post Conditions	The policy is deactivated in the IRPAgent.	
Traceability	REQ-POM-FUN -06	

## 7.4.7 Reporting policy conflicts in the context of NFV

Use Case Stage	Evolution / Specification	<<Uses>> Related use
Goal	To query an existing network policy.	
Actors and Roles	IRPManager as user	
Telecom resources	3GPP management system (NM, EM).	
Assumptions	3GPP management systems are running normally, scenarios and policy requirements are clearly defined.	
Pre conditions	The systems is correctly configured and normally running. There is a network policy stored in the IRPAgent.	
Begins when	The IRPManager decides to update a policy.	
Step 1 (M)	The IPRManager makes a decision to query the existing policy.	
Step 2 (M)	After the completion of the policy conflicts notification process, the IRPAgent informs the IRPManager on the result of the process.	
Ends when	Ends when all mandatory steps identified above are successfully completed or when an exception occurs.	
Exceptions	One of the steps identified above fails.	
Post Conditions	The policy conflicts notification is returned to the IRPManager.	
Traceability	REQ-POM-FUN -07	

# 8 Policy management procedures

## 8.1 General description for policy management procedures

There are two kinds of management procedures. The first kind includes those operations that allow the NM to invoke policy management operations towards the EM.

- Policy Creation
- Policy Deletion
- Policy Update
- Policy Query
- Policy Activation

- Policy Deactivation

The second kind includes the operation that the EM notifies NM policy conflicts found in EM.

- Policy Conflicts Notification.

## 8.2 Policy Creation

After the NM (IRP Manager) decides to create a policy (ies), it will send the create request to the EM (IRP Agent).

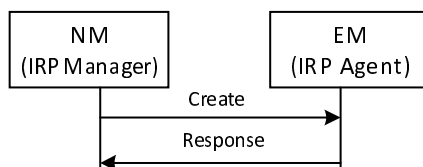

Figure 8.2: policy creation message flow

## 8.3 Policy Deletion

After the NM (IRP Manager) decides to delete a policy (ies), it will send the delete request to the EM (IRP Agent).

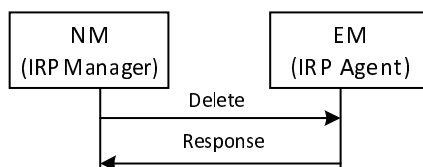

Figure 8.3: policy deletion message flow

## 8.4 Policy Update

After the NM (IRP Manager) decides to update a policy (ies), it will send the update request to the EM (IRP Agent).

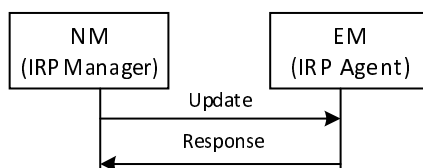

Figure 8.4: policy update message flow

## 8.5 Policy Query

After the NM (IRP Manager) decides to query a policy, it will send the query request to the EM (IRP Agent). For the query request, the EM (IRP Agent) sends back the response with the policy to the NM (IRP Manager).

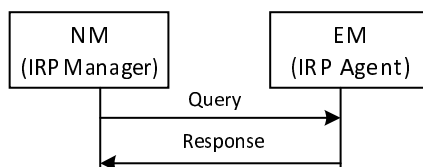

Figure 8.5: policy query message flow



## 8.6 Policy Activation

After the NM (IRP Manager) decides to activate a policy (ies), it will send the policy activation request to the EM (IRP Agent).

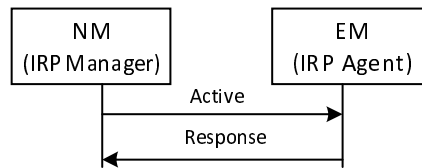

Figure 8.6: policy activation message flow

## 8.7 Policy Deactivation

After the NM (IRP Manager) decides to deactivate a policy (ies), it will send the policy deactivation request to the EM (IRP Agent).

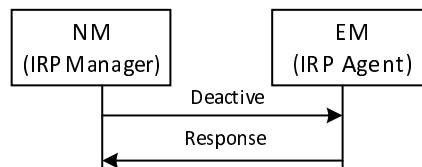

Figure 8.7: policy deactivation message flow

## 8.8 Policy Conflicts Notification

When the EM (IRP Agent) receives new or updated policy (ies) from NM (IRP Manager), it will check whether the each received policy is conflicts with the previous storage policy. If the conflict is detected, the EM (IRP Agent) will notify the information to the NM (IRP Manager).

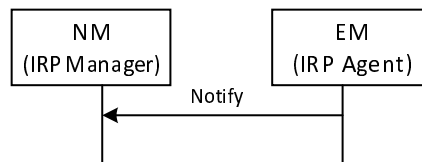

Figure 8.8: policy conflicts notification message flow

---

## 9 Information Object Classes

### 9.1 Information entities imported and local label

Label reference	Local label
TS 32.312 [3], information object class, ManagedGenericIRP	ManagedGenericIRP

## 9.2 Class diagram

### 9.2.1 Attributes and relationships

This clause introduces the set of Information Object Classes (IOCs) that encapsulate capabilities contained within the IRP. This clause provides the overview of all support object classes in UML. Subsequent clauses provide more detailed specification of various aspects of these support object classes.

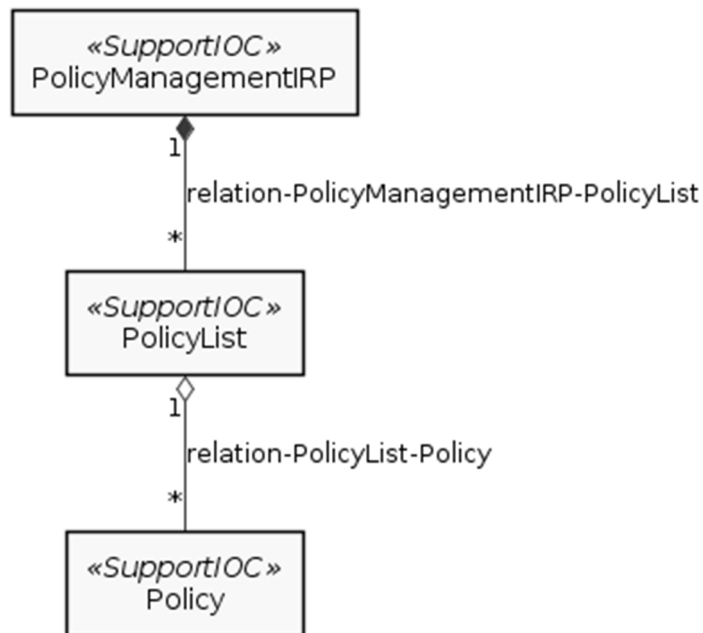

Figure 9.2.1: Information Object Class UML Diagram

### 9.2.2 Inheritance

This IOC inherits from ManagedGenericIRP IOC specified in TS.32.312 [3].

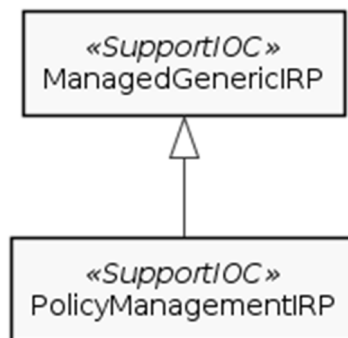

Figure 9.2.2: Information Object Class UML Diagram

## 9.3 Information object classes definition

### 9.3.1 Policy

#### 9.3.1.1 Definition

This IOC represents a network policy.

### 9.3.1.2 Attributes

Attribute name	Support Qualifier	isReadable	isWriteable	isInvariant	isNotifiable
policyId	M	T	F	T	T
policyPriority	M	T	T	F	T
policyStatus	M	T	T	F	T
policyType	M	T	T	F	T
policyContent	M	T	T	F	T

## 9.3.2 PolicyList

### 9.3.2.1 Definition

PolicyList is the representation of the list of Policy.

### 9.3.2.2 Attributes

Attribute name	Support Qualifier	isReadable	isWriteable	isInvariant	isNotifiable
policyListId	M	T	F	T	T
policyIdList	M	T	F	T	T

## 9.3.3 PolicyManagementIRP

### 9.3.3.1 Definition

PolicyManagementIRP is the representation of the policy management capabilities specified by the present document. This Support IOC inherits from ManagedGenericIRP Support IOC specified in 3GPP TS 32.312 [x].

### 9.3.3.2 Attribute

There is no additional attribute defined for this IOC besides those inherited.

### 9.3.3.3 Notifications

Name	Qualifier	Notes
policyConflictNotification	M	If there is network policy conflict(s), then the IRP Agent may send this notification to the IPRmanager

## 9.4 Information relationship definitions

### 9.4.1 relation-PolicyManagementIRP-PolicyList (M)

#### 9.4.1.1 Definition

This represents the relationship between PolicyManagementIRP and PolicyList.

#### 9.4.1.2 Role

Name	Definition
thePolicyList	It represents the PolicyList.
thePolicyManagementIRP	It represents the PolicyManagementIRP.

### 9.4.1.3 Constraint

Name	Definition
uniquePolicyListId	The policyListIds playing the role of thePolicyList are unique within a particular PolicyManagementIRP.

## 9.4.2 relation-PolicyList-Policy (M)

### 9.4.2.1 Definition

This represents the relationship between PolicyList and Policy.

### 9.4.2.2 Role

Name	Definition
thePolicy	It represents the Policy.
thePolicyList	It represents the PolicyList.

### 9.4.2.3 Constraint

Name	Definition
uniquePolicyId	The policyIds of all Policys, playing the role of the Policy, are unique within a particular PolicyManagementIRP and PolicyList.

## 9.5 Information attribute definitions

### 9.5.0 Introduction

This clause defines the semantics of the attributes used in SupportIOCs.

### 9.5.1 Definitions and legal values

Attribute Name	Definition	Legal Values
policyId	It identifies the Policy instance (and distinguishes it from all other existing and stopped Policy instances of the PolicyManagementIRP Agent).	Any identifier. Value type is string.
policyPriority	It specifies the priority of Policy	Its value should be one of the following: Low, Medium, High
policyStatus	It specifies the status of Policy. If a policy is activated, and then its status is active. If it is deactivated, then its status is deactivated	Its value should be one of the following: Activated, Deactivated
policyType	It identifies a name of one policy type	Its value is network operator specific. Value type is string.
policyContent	It identifies the content of a network policy	Its value is network operator specific. Value type is string.
policyListId	It identifies the singleton PolicyList of the PolicyManagementIRP Agent.	Any identifier. Value type is string.
policyIdList	It is an array list of Policy.policyId.	Value type is array.
policyConflictNotification	It specifies which policies conflict.	Its value is vendor specific. Value type is string.

## 10 Interface definition

### 10.1 Class diagram

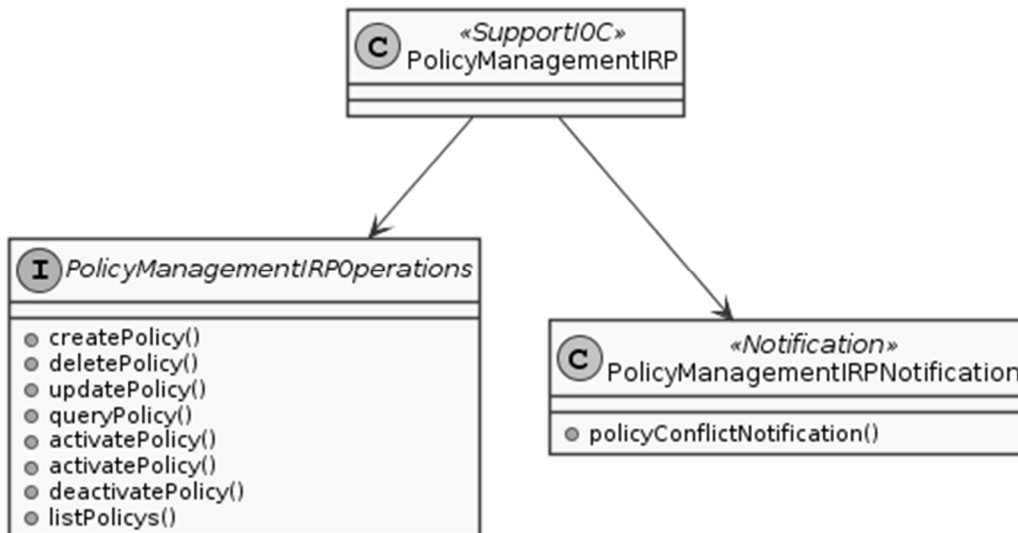

Figure 10.1: Class Diagram

## 10.2 PolicyManagementIRPOperations\_Interface (M)

### 10.2.1 Operation createPolicy (M)

#### 10.2.1.1 Input parameters

Parameter Name	Qualifier	Matching Information	Comment
designer	M	Policy.designer	See clause 9.5.1 (definitions and legal values).
name	M	Policy.name	See clause 9.5.1 (definitions and legal values).
policyPriority	M	Policy.policyPriority	See clause 9.5.1 (definitions and legal values).
policyStatus	M	Policy.policyStatus	See clause 9.5.1 (definitions and legal values).
policyType	M	Policy.policyType	See clause 9.5.1 (definitions and legal values).
policyContent	M	Policy.policyContent	See clause 9.5.1 (definitions and legal values).

#### 10.2.1.2 Output parameters

Parameter Name	Qualifier	Matching Information	Comment
designer	M	Policy.designer	See clause 9.5.1 (definitions and legal values).
name	M	Policy.name	See clause 9.5.1 (definitions and legal values).
policyId	M	Policy.policyId	See clause 9.5.1 (definitions and legal values).
policyPriority	M	Policy.policyPriority	See clause 9.5.1 (definitions and legal values).
policyStatus	M	Policy.policyStatus	See clause 9.5.1 (definitions and legal values).
policyType	M	Policy.policyType	See clause 9.5.1 (definitions and legal values).
policyContent	M	Policy.policyContent	See clause 9.5.1 (definitions and legal values).

#### 10.2.1.3 Results

In case of success, the corresponding policy information is created by the EM (IRP Agent). In case of failure, appropriate error information is returned.

### 10.2.2 Operation deletePolicy (M)

#### 10.2.2.1 Input parameters

Parameter Name	Qualifier	Matching Information	Comment
policyId	M	Policy.policyId	See clause 9.5.1 (definitions and legal values).

#### 10.2.2.2 Output parameters

Parameter Name	Qualifier	Matching Information	Comment
designer	M	Policy.designer	See clause 9.5.1 (definitions and legal values).
name	M	Policy.name	See clause 9.5.1 (definitions and legal values).
policyId	M	Policy.policyId	The policyId of the deleted policy. See clause 9.5.1 (definitions and legal values).
policyPriority	M	Policy.policyPriority	See clause 9.5.1 (definitions and legal values).
policyStatus	M	Policy.policyStatus	See clause 9.5.1 (definitions and legal values).
policyType	M	Policy.policyType	See clause 9.5.1 (definitions and legal values).
policyContent	M	Policy.policyContent	See clause 9.5.1 (definitions and legal values).

#### 10.2.2.3 Results

In case of success, the policy information are deleted by the EM (IRP Agent), and the corresponding deleted policy information is returned to the NM (IRP Manager). In case of failure, appropriate error information is returned.

## 10.2.3 Operation updatePolicy (M)

### 10.2.3.1 Input parameters

Parameter Name	Qualifier	Matching Information	Comment
designer	O	Policy.designer	See clause 9.5.1 (definitions and legal values).
name	O	Policy.name	See clause 9.5.1 (definitions and legal values).
policyId	M	Policy.policyId	See clause 9.5.1 (definitions and legal values). This parameter's value is not allowed to be updated.
policyPriority	O	Policy.policyPriority	See clause 9.5.1 (definitions and legal values). This parameter's value is allowed to be updated.
policyStatus	M	Policy.policyStatus	See clause 9.5.1 (definitions and legal values). This parameter's value is allowed to be updated.
policyType	O	Policy.policyType	See clause 9.5.1 (definitions and legal values). This parameter's value is allowed to be updated.
policyContent	O	Policy.policyContent	See clause 9.5.1 (definitions and legal values). This parameter's value is allowed to be updated.

### 10.2.2.2 Output parameters

Parameter Name	Qualifier	Matching Information	Comment
designer	M	Policy.designer	See clause 9.5.1 (definitions and legal values).
name	M	Policy.name	See clause 9.5.1 (definitions and legal values).
policyId	M	Policy.policyId	The policyId of the deleted policy. See clause 9.5.1 (definitions and legal values).
policyPriority	M	Policy.policyPriority	See clause 9.5.1 (definitions and legal values).
policyStatus	M	Policy.policyStatus	See clause 9.5.1 (definitions and legal values).
policyType	M	Policy.policyType	See clause 9.5.1 (definitions and legal values).
policyContent	M	Policy.policyContent	See clause 9.5.1 (definitions and legal values).

### 10.2.2.3 Results

In case of success, the corresponding policy information is updated by the EM (IRP Agent). In case of failure, appropriate error information is returned.

## 10.2.4 Operation queryPolicy (M)

### 10.2.4.1 Input parameters

Parameter Name	Qualifier	Matching Information	Comment
policyId	M	Policy.policyId	See clause 9.5.1 (definitions and legal values).

### 10.2.4.2 Output parameters

Parameter Name	Qualifier	Matching Information	Comment
designer	M	Policy.designer	See clause 9.5.1 (definitions and legal values).
name	M	Policy.name	See clause 9.5.1 (definitions and legal values).
policyId	M	Policy.policyId	The policyId of the deleted policy. See clause 9.5.1 (definitions and legal values).
policyPriority	M	Policy.policyPriority	See clause 9.5.1 (definitions and legal values).
policyStatus	M	Policy.policyStatus	See clause 9.5.1 (definitions and legal values).
policyType	M	Policy.policyType	See clause 9.5.1 (definitions and legal values).
policyContent	M	Policy.policyContent	See clause 9.5.1 (definitions and legal values).

### 10.2.4.3 Results

In case of success, the corresponding policy information is returned by the EM (IRP Agent). In case of failure, appropriate error information is returned.

## 10.2.5 Operation activatePolicy (M)

### 10.2.5.1 Input parameters

Parameter Name	Qualifier	Matching Information	Comment
policyId	M	Policy.policyId	See clause 9.5.1 (definitions and legal values).

### 10.3.5.2 Output parameters

Parameter Name	Qualifier	Matching Information	Comment
designer	M	Policy.designer	See clause 9.5.1 (definitions and legal values).
name	M	Policy.name	See clause 9.5.1 (definitions and legal values).
PolicyId	M	Policy.policyId	See clause 9.5.1 (definitions and legal values). Identifier of the activated Policy.
policyPriority	M	Policy.policyPriority	See clause 9.5.1 (definitions and legal values).
policyStatus	M	Policy.policyStatus	See clause 9.5.1 (definitions and legal values).
policyType	M	Policy.policyType	See clause 9.5.1 (definitions and legal values).
policyContent	M	Policy.policyContent	See clause 9.5.1 (definitions and legal values).

### 10.3.5.3 Results

In case of success, the policy(ies) information are activated by the EM (IRP Agent) , and the activated policy information is returned to the NM (IRP Manager). In case of failure, appropriate error information is returned.

## 10.2.6 Operation deactivatePolicy (M)

### 10.2.6.1 Input parameters

Parameter Name	Qualifier	Matching Information	Comment
policyId	M	Policy. policyId	See clause 9.5.1 (definitions and legal values).

### 10.2.6.2 Output parameters

Parameter Name	Qualifier	Matching Information	Comment
designer	M	Policy.designer	See clause 9.5.1 (definitions and legal values).
name	M	Policy.name	See clause 9.5.1 (definitions and legal values).
PolicyId	M	Policy. policyId	See clause 9.5.1 (definitions and legal values). Identifier of the activated Policy.
policyPriority	M	Policy. policyPriority	See clause 9.5.1 (definitions and legal values).
policyStatus	M	Policy. policyStatus	See clause 9.5.1 (definitions and legal values).
policyType	M	Policy. policyType	See clause 9.5.1 (definitions and legal values).
policyContent	M	Policy. policyContent	See clause 9.5.1 (definitions and legal values).

### 10.2.6.3 Results

In case of success, the policy(ies) information are deactivated by the EM (IRP Agent), and the deactivated policy information is returned to the NM (IRP Manager). In case of failure, appropriate error information is returned.



## 10.2.7 Operation queryPolicyList (M)

### 10.2.7.1 Input parameters

Parameter Name	Qualifier	Matching Information	Comment
policyListId	M	PolicyList.policyListId	See clause 9.5.1 (definitions and legal values).

### 10.2.7.2 Output parameters

Parameter Name	Qualifier	Matching Information	Comment
policyListId	M	PolicyList.policyListId	See clause 9.5.1 (definitions and legal values).
policyIdList	M	PolicyList.policyIdList	See clause 9.5.1 (definitions and legal values).

### 10.2.7.3 Results

In case of success, the EM (IRP Agent) returns the corresponding policy information. In case of failure, appropriate error information is returned.

## 10.3 PolicyManagementIRPNotification\_Interface (M)

### 10.3.1 policyConflictNotification

#### 10.3.1.1 Input parameters

Parameter Name	Qualifier	Matching Information	Comment
activatedPolicyList	M	List of <PolicyList.policyListId> and their corresponding policy is activated.	See clause 9.5.1 (definitions and legal values). Identifier(s) of the activated Policy.

#### 10.3.1.2 Triggering Event

##### 10.3.1.2.1 From-state

internalProblem

Assertion Name	Definition
internalProblem	Because of a network policy conflict's problem, PolicyManagementIRP Agent decides that it no longer can maintain the policy in any policyStatus but "deactivated".

##### 10.3.1.2.2 To-state

policyConflictNotification

Assertion Name	Definition
policyConflictNotification	There is network policyconflict(s).

## 11 Solution Set (SS) definitions

The present document defines the following policy management Solution Set Definitions:

- Annex A provides the XML Definitions.
- Annex B provides the SOAP Solution Set.

---

# Annex A (normative): XML definitions

## A.1 General

This annex contains the XML definitions for the policy management Integration Reference Point.

---

## A.2 Architectural features

The overall architectural feature of policy management IRP is specified, this clause specifies features that are specific to the Schema definitions.

The present document provides the main part of the XML file format definition for the policy management IRP IS.

The other parts of this XML definition are NRM-specific parts. All NRM IRPs that include SS-level XML definition are in the scope of the policy management IRP.

---

## A.3 Mapping

### A.3.1 General mapping

An IOC maps to an XML element of the same name as the IOC's name in the Information Model. An IOC attribute maps to a sub-element of the corresponding IOC's XML element, and the name of this sub-element is the same as the attribute's name in the Information Model.

### A.3.2 Information Object Class (IOC) mapping

The mapping is not present in the current version of the present document.

---

## A.4 Solution Set definitions

### A.4.1 XML definition structure

Clause A.4.2 provides a graphical representation of the XML elements.

Clause A.4.3 provides the schema fragment for policy management (policy creation/deletion/update/query/activation/deactivation/conflicts notification) XML files.

### A.4.2 Graphical Representation

The graphical representation is not present in the current version of the present document.

### A.4.3 XML Schema "PolicyManagement.xsd"

```
<?xml version="1.0" encoding="UTF-8"?>
<!--
  3GPP TS 28.311 policy management XML Schema
  PolicyOperation.xsd
-->
```

```

<schema xmlns:xb="http://www.3gpp.org/ftp/specs/archive/28_series/28.311#PolicyManagement"
xmlns:xe="http://www.3gpp.org/ftp/specs/archive/28_series/28.311#PolicyManagement "
xmlns="http://www.w3.org/2001/XMLSchema"
targetNamespace="http://www.3gpp.org/ftp/specs/archive/28_series/28.311#PolicyManagement"
elementFormDefault="qualified" attributeFormDefault="unqualified">

```

```

<!--createPolicy Request -->
<element name="createPolicy">
  <complexType>
    <sequence>
      <element name="designer" type="string"/>
      <element name="name" type="string"/>
      <element name="policyPriority" type="string"/>
      <element name="policyStatus" type="string"/>
      <element name="policyType" type="string"/>
      <element name="policyContent" type="string"/>
    </sequence>
  </complexType>
</element>

<!-- createPolicy Response -->
<element name="createPolicyResponse">
  <complexType>
    <sequence>
      <element name="designer" type="string"/>
      <element name="name" type="string"/>
      <element name="policyId " type="Identifier"/>
      <element name="policyPriority" type="string"/>
      <element name="policyStatus" type="string"/>
      <element name="policyType" type="string"/>
      <element name="policyContent" type="string"/>
    </sequence>
  </complexType>
</element>

<!-- deletePolicy Request -->
<element name="deletePolicy">
  <complexType>
    <sequence>
      <element name="policyId" type="string"/>
    </sequence>
  </complexType>
</element>

<!-- deletePolicy Response -->
<element name="deletePolicyResponse">
  <complexType>
    <sequence>
      <element name="designer" type="string"/>
      <element name="name" type="string"/>
      <element name="policyId " type="Identifier"/>
      <element name="policyPriority" type="string"/>
      <element name="policyStatus" type="string"/>
      <element name="policyType" type="string"/>
      <element name="policyContent" type="string"/>
    </sequence>
  </complexType>
</element>

<!-- updatePolicy Request -->
<element name="updatePolicy">
  <complexType>
    <sequence>
      <element name="designer" type="string"/>
      <element name="name" type="string"/>
      <element name="policyId " type="Identifier"/>
      <element name="policyPriority" type="string"/>
      <element name="policyStatus" type="string"/>
      <element name="policyType" type="string"/>
      <element name="policyContent" type="string"/>
    </sequence>
  </complexType>
</element>

<!-- updatePolicy Response -->
<element name="updatePolicy">
  <complexType>
    <sequence>

```

```

        <element name="designer" type="string"/>
        <element name="name" type="string"/>
        <element name="policyId " type="Identifier"/>
        <element name="policyPriority" type="string"/>
        <element name="policyStatus" type="string"/>
        <element name="policyType" type="string"/>
        <element name="policyContent" type="string"/>
    </sequence>
</complexType>
</element>

<!-- queryPolicy Request -->
<element name="queryPolicy">
    <complexType>
        <sequence>
            <element name="policyId " type="Identifier"/>
        </sequence>
    </complexType>
</element>

<!-- queryPolicy Response -->
<element name="queryPolicyResponse">
    <complexType>
        <sequence>
            <element name="designer" type="string"/>
            <element name="name" type="string"/>
            <element name="policyId " type="Identifier"/>
            <element name="policyPriority" type="string"/>
            <element name="policyStatus" type="string"/>
            <element name="policyType" type="string"/>
            <element name="policyContent" type="string"/>
        </sequence>
    </complexType>
</element>

<!-- activatePolicy Request -->
<element name="activatePolicy">
    <complexType>
        <sequence>
            <element name="policyId " type="Identifier"/>
        </sequence>
    </complexType>
</element>

<!-- activatePolicy Response -->
<element name=" activatePolicyResponse">
    <complexType>
        <sequence>
            <element name="designer" type="string"/>
            <element name="name" type="string"/>
            <element name="policyId " type="Identifier"/>
            <element name="policyPriority" type="string"/>
            <element name="policyStatus" type="string"/>
            <element name="policyType" type="string"/>
            <element name="policyContent" type="string"/>
        </sequence>
    </complexType>
</element>

<!-- deactivatePolicy Request -->
<element name="deactivatePolicy">
    <complexType>
        <sequence>
            <element name="policyId" type="Identifier"/>
        </sequence>
    </complexType>
</element>

<!-- deactivatePolicy Response -->
<element name=" deactivatePolicyResponse">
    <complexType>
        <sequence>
            <element name="designer" type="string"/>
            <element name="name" type="string"/>
            <element name="policyId " type="Identifier"/>
            <element name="policyPriority" type="string"/>
            <element name="policyStatus" type="string"/>
            <element name="policyType" type="string"/>

```

```
        <element name="policyContent" type="string"/>
      </sequence>
    </complexType>
  </element>

  <!-- queryPolicyList Request -->
  <element name="queryPolicyList">
    <complexType>
      <sequence>
        <element name="policyListId" type="Identifier"/>
      </sequence>
    </complexType>
  </element>

  <!-- queryPolicyList Response -->
  <element name="queryPolicyList">
    <complexType>
      <sequence>
        <element name="policyListId" type="Identifier"/>
        <element name="policyIdList" type="array"/>
      </sequence>
    </complexType>
  </element>

  <!-- policyConflictNotification Request -->
  <element name="policyConflictNotification">
    <complexType>
      <sequence>
        <element name="activatedPolicyList" type="Identifier"/>
      </sequence>
    </complexType>
  </element>
</schema>
```

---

## Annex B (normative): SOAP Solution Set

### B.1 General

This annex contains the XML definitions for the policy management Integration Reference Point.

---

### B.2 Architectural features

The overall architectural feature of the policy management IRP is specified in the present document. This clause specifies features that are specific to the SOAP Solution Set.

The present document uses "document" style in the WSDL description.

The present document uses "literal" encoding style in the WSDL description.

---

### B.3 Mapping

#### B.3.1 Operation and notification mapping

Policy management IRP management: Clause 9 defines semantics of operation visible across the Itf-N. Table B.3 indicates mapping of these operations to their equivalents defined in this SS.

**Table B.3: Mapping from IS Operation to SS Equivalent**

IS Operation	SS Operation	Qualifier
createPolicy	createPolicy	M
deletePolicy	deletePolicy	M
updatePolicy	updatePolicy	M
queryPolicy	queryPolicy	M
activatePolicy	activatePolicy	M
deactivatePolicy	deactivatePolicy	M
queryPolicyList	queryPolicyList	M
policyConflictNotification	policyConflictNotification	M

#### B.3.2 Operation parameter mapping

##### B.3.2.0 General

The clause 10 defines semantics of parameters carried in operations. The tables below show the mapping of these parameters, as per operation, to their equivalents defined in this SS.

## B.3.2.1 Operation createPolicy

### B.3.2.1.1 Input parameters

**Table B.3.2.1.1: Mapping from IS createPolicy input parameters to SS equivalents**

IS Operation parameter	SS Operation parameter	Qualifier
designer	designer	M
name	name	M
policyPriority	policyPriority	M
policyStatus	policyStatus	M
policyType	policyType	M
policyContent	policyContent	M

### B.3.2.1.2 Output parameters

**Table B.3.2.1.2: Mapping from IS createPolicy output parameters to SS equivalents**

IS Operation parameter	SS Operation parameter	Qualifier
designer	designer	M
name	name	M
policyId	policyInfoId	M
policyPriority	policyPriority	M
policyStatus	policyStatus	M
policyType	policyType	M
policyContent	policyContent	M

## B.3.2.2 Operation deletePolicy

### B.3.2.2.1 Input parameters

**Table B.3.2.2.1: Mapping from IS deletePolicy input parameters to SS equivalents**

IS Operation parameter	SS Operation parameter	Qualifier
policyId	policyInfoId	M

### B.3.2.2.2 Output parameters

**Table B.3.2.2.2: Mapping from IS deletePolicy output parameters to SS equivalents**

IS Operation parameter	SS Operation parameter	Qualifier
designer	designer	M
name	name	M
policyId	policyInfoId	M
policyPriority	policyPriority	M
policyStatus	policyStatus	M
policyType	policyType	M
policyContent	policyContent	M



### B.3.2.3 Operation updatePolicy

#### B.3.2.3.1 Input parameters

**Table B.3.2.3.1: Mapping from IS updatePolicy input parameters to SS equivalents**

IS Operation parameter	SS Operation parameter	Qualifier
designer	designer	O
name	name	O
policyId	policyInfoId	M
policyPriority	policyPriority	O
policyStatus	policyStatus	M
policyType	policyType	O
policyContent	policyContent	O

#### B.3.2.3.2 Output parameters

**Table B.3.2.3.2: Mapping from IS updatePolicy output parameters to SS equivalents**

IS Operation parameter	SS Operation parameter	Qualifier
designer	designer	M
name	name	M
policyId	policyInfoId	M
policyPriority	policyPriority	M
policyStatus	policyStatus	M
policyType	policyType	M
policyContent	policyContent	M

### B.3.2.4 Operation queryPolicy

#### B.3.2.4.1 Input parameters

**Table B.3.2.4.1: Mapping from IS queryPolicy input parameters to SS equivalents**

IS Operation parameter	SS Operation parameter	Qualifier
policyId	policyInfoId	M

### B.3.2.4.2 Output parameters

**Table B.3.2.4.2: Mapping from IS queryPolicy input parameters to SS equivalents**

IS Operation parameter	SS Operation parameter	Qualifier
designer	designer	M
name	name	M
policyId	policyInfoId	M
policyPriority	policyPriority	M
policyStatus	policyStatus	M
policyType	policyType	M
policyContent	policyContent	M

### B.3.2.5 Operation activatePolicy

#### B.3.2.5.1 Input parameters

**Table B.3.2.5.1: Mapping from IS activatePolicy input parameters to SS equivalents**

IS Operation parameter	SS Operation parameter	Qualifier
policyId	policyInfoId	M

#### B.3.2.5.2 Output parameters

**Table B.3.2.5.2: Mapping from IS startSession input parameters to SS equivalents**

IS Operation parameter	SS Operation parameter	Qualifier
designer	designer	M
name	name	M
policyId	policyInfoId	M
policyPriority	policyPriority	M
policyStatus	policyStatus	M
policyType	policyType	M
policyContent	policyContent	M

### B.3.2.6 Operation deactivatePolicy

#### B.3.2.6.1 Input parameters

**Table B.3.2.6.1: Mapping from IS deactivatePolicy input parameters to SS equivalents**

IS Operation parameter	SS Operation parameter	Qualifier
policyId	policyInfoId	M

#### B.3.2.6.2 Output parameters

**Table B.3.2.6.2: Mapping from IS deactivatePolicy input parameters to SS equivalents**

IS Operation parameter	SS Operation parameter	Qualifier
designer	designer	M
name	name	M
policyId	policyInfoId	M
policyPriority	policyPriority	M
policyStatus	policyStatus	M
policyType	policyType	M
policyContent	policyContent	M

### B.3.2.7 Operation queryPolicyList

#### B.3.2.7.1 Input parameters

**Table B.3.2.7.1: Mapping from IS listPolicys input parameters to SS equivalents**

IS Operation parameter	SS Operation parameter	Qualifier
policyListId	policyListId	M

#### B.3.2.7.2 Output parameters

**Table B.3.2.7.2: Mapping from IS listPolicys output parameters to SS equivalents**

IS Operation parameter	SS Operation parameter	Qualifier
policyListId	policyListId	M
policyIdList	policyIdList	M

### B.3.2.8 Operation policyConflictNotification

#### B.3.2.8.1 Input parameters

**Table B.3.2.8.1: Mapping from IS policyConflictNOtification output parameters to SS equivalents**

IS Operation parameter	SS Operation parameter	Qualifier
activatedPolicyList	activatedPolicyList	M

#### B.3.2.8.2 Output parameters

Void.

---

## B.4 Solution Set definitions

### B.4.1 WSDL definition structure

The present document defines the main part of what are supported by the policy management IRP agent.

### B.4.2 Graphical Representation

The graphical representation is not present in the current version of the present document.

### B.4.3 WSDL specification "PolicyManagementIRPSystem.wsdl"

```

<?xml version="1.0" encoding="UTF-8"?>
<definitions xmlns="http://schemas.xmlsoap.org/wsdl/"
xmlns:soap="http://schemas.xmlsoap.org/wsdl/soap/" xmlns:PolicyManagement
IRPSystem=http://www.3gpp.org/ftp/Specs/archive/28_series/28.311/schema/28311/PolicyManagementIRPSys
tem
xmlns:xs="http://www.w3.org/2001/XMLSchema"
targetNamespace="http://www.3gpp.org/ftp/Specs/archive/28_series/28.311/schema/28311/GenericIRPSyste
m">
  <types>
    <!--createPolicy Request -->
    <element name="createPolicy">
      <complexType>
        <sequence>
          <element name="designer" type="string"/>
          <element name="name" type="string"/>
          <element name="policyPriority" type="string"/>
          <element name="policyStatus" type="string"/>
          <element name="policyType" type="string"/>
          <element name="policyContent" type="string"/>
        </sequence>
      </complexType>
    </element>

    <!-- createPolicy Response -->
    <element name="createPolicyResponse">
      <complexType>
        <sequence>
          <element name="designer" type="string"/>
          <element name="name" type="string"/>
          <element name="policyId " type="Identifier"/>
          <element name="policyPriority" type="string"/>
          <element name="policyStatus" type="string"/>
          <element name="policyType" type="string"/>
          <element name="policyContent" type="string"/>
        </sequence>
      </complexType>
    </element>

    <!-- deletePolicy Request -->
    <element name="deletePolicy">
      <complexType>
        <sequence>
          <element name="policyId" type="string"/>
        </sequence>
      </complexType>
    </element>

    <!-- deletePolicy Response -->
    <element name="deletePolicyResponse">
      <complexType>
        <sequence>
          <element name="designer" type="string"/>
          <element name="name" type="string"/>
          <element name="policyId " type="Identifier"/>
          <element name="policyPriority" type="string"/>
          <element name="policyStatus" type="string"/>
          <element name="policyType" type="string"/>
          <element name="policyContent" type="string"/>
        </sequence>
      </complexType>
    </element>

    <!-- updatePolicy Request -->
    <element name="updatePolicy">
      <complexType>
        <sequence>
          <element name="designer" type="string"/>
          <element name="name" type="string"/>
          <element name="policyId " type="Identifier"/>
          <element name="policyPriority" type="string"/>
          <element name="policyStatus" type="string"/>
          <element name="policyType" type="string"/>
          <element name="policyContent" type="string"/>
        </sequence>
      </complexType>
    </element>
  </types>

```

```

</element>

<!-- updatePolicy Response -->
<element name="updatePolicy">
  <complexType>
    <sequence>
      <element name="designer" type="string"/>
      <element name="name" type="string"/>
      <element name="policyId " type="Identifier"/>
      <element name="policyPriority" type="string"/>
      <element name="policyStatus" type="string"/>
      <element name="policyType" type="string"/>
      <element name="policyContent" type="string"/>
    </sequence>
  </complexType>
</element>

<!-- queryPolicy Request -->
<element name="queryPolicy">
  <complexType>
    <sequence>
      <element name="policyId " type="Identifier"/>
    </sequence>
  </complexType>
</element>

<!-- queryPolicy Response -->
<element name="queryPolicyResponse">
  <complexType>
    <sequence>
      <element name="designer" type="string"/>
      <element name="name" type="string"/>
      <element name="policyId " type="Identifier"/>
      <element name="policyPriority" type="string"/>
      <element name="policyStatus" type="string"/>
      <element name="policyType" type="string"/>
      <element name="policyContent" type="string"/>
    </sequence>
  </complexType>
</element>

<!-- activatePolicy Request -->
<element name="activatePolicy">
  <complexType>
    <sequence>
      <element name="policyId " type="Identifier"/>
    </sequence>
  </complexType>
</element>

<!-- activatePolicy Response -->
<element name=" activatePolicyResponse">
  <complexType>
    <sequence>
      <element name="designer" type="string"/>
      <element name="name" type="string"/>
      <element name="policyId " type="Identifier"/>
      <element name="policyPriority" type="string"/>
      <element name="policyStatus" type="string"/>
      <element name="policyType" type="string"/>
      <element name="policyContent" type="string"/>
    </sequence>
  </complexType>
</element>

<!-- deactivatePolicy Request -->
<element name="deactivatePolicy">
  <complexType>
    <sequence>
      <element name="policyId " type="Identifier"/>
    </sequence>
  </complexType>
</element>

<!-- deactivatePolicy Response -->
<element name=" deactivatePolicyResponse">
  <complexType>
    <sequence>

```

```

        <element name="designer" type="string"/>
        <element name="name" type="string"/>
        <element name="policyId " type="Identifier"/>
        <element name="policyPriority" type="string"/>
        <element name="policyStatus" type="string"/>
        <element name="policyType" type="string"/>
        <element name="policyContent" type="string"/>
    </sequence>
</complexType>
</element>

<!-- queryPolicyList Request -->
<element name="queryPolicyList">
    <complexType>
        <sequence>
            <element name="policyListId" type="Identifier"/>
        </sequence>
    </complexType>
</element>

<!-- queryPolicyList Response -->
<element name="queryPolicyList">
    <complexType>
        <sequence>
            <element name="policyListId" type="Identifier"/>
            <element name="policyIdList" type="array"/>
        </sequence>
    </complexType>
</element>

<!-- policyConflictNotification Request -->
<element name="policyConflictNotification">
    <complexType>
        <sequence>
            <element name="activatedPolicyList" type="Identifier"/>
        </sequence>
    </complexType>
</element>

</types>

<message name="createPolicy Request">
    <part name="parameter" element="createPolicy"/>
</message>
<message name="createPolicy Response">
    <part name="parameter" element="createPolicyResponse"/>
</message>
<message name="deletePolicy Request ">
    <part name="parameter" element="deletePolicy"/>
</message>
<message name="deletePolicy Response">
    <part name="parameter" element="deletePolicyResponse"/>
</message>
<message name="updatePolicy Request ">
    <part name="parameter" element="PolicyUpdate"/>
</message>
<message name="updatePolicy Response">
    <part name="parameter" element="updatePolicyResponse"/>
</message>
<message name="queryPolicyRequest ">
    <part name="parameter" element="queryPolicy"/>
</message>
<message name="queryPolicyResponse">
    <part name="parameter" element="queryPolicyResponse"/>
</message>
<message name="activePolicyRequest ">
    <part name="parameter" element="ActivePolicy"/>
</message>
<message name="activePolicyResponse">
    <part name="parameter" element="ActivePolicyResponse"/>
</message>
<message name="deactivePolicyRequest ">
    <part name="parameter" element="deactivePolicy"/>
</message>
<message name="deactivePolicyResponse">
    <part name="parameter" element="deactivePolicyResponse"/>
</message>
<message name="queryPolicyListRequest">

```

```

    <part name="parameter" element="queryPolicyList" />
  </message>
<message name="queryPolicyListResponse">
  <part name="parameter" element="queryPolicyListResponse" />
</message>
<message name="policyConflictNotificaitonRequest">
  <part name="parameter" element="policyConflictsNotificaiton" />
</message>
<portType name="PolicyMangementIRPPortType">
  <operation name="createPolicy">
    <input message="PolicyMangementIRPSystem:createPolicyRequest" />
    <output message="PolicyMangementIRPSystem:createPolicyResponse" />
  </operation>
  <operation name="deletePolicy">
    <input message="PolicyMangementIRPSystem:deletePolicyRequest" />
    <output message="PolicyMangementIRPSystem:deletePolicyResponse" />
  </operation>

  <operation name="updatePolicy">
    <input message="PolicyMangementIRPSystem:updatePolicyRequest" />
    <output message="PolicyMangementIRPSystem:updatePolicyResponse" />
  </operation>
  <operation name="queryPolicy">
    <input message="PolicyQueryIRPSystem:queryPolicyRequest" />
    <output message="PolicyQueryIRPSystem:queryPolicyResponse" />
  </operation>
  <operation name="activePolicy">
    <input message="PolicyMangementIRPSystem:activePolicyRequest" />
    <output message="PolicyMangementIRPSystem:activePolicyResponse" />
  </operation>
  <operation name="deactivePolicy">
    <input message="PolicyMangementIRPSystem:deactivePolicyRequest" />
    <output message="PolicyMangementIRPSystem:deactivePolicyResponse" />
  </operation>
  <operation name="queryPolicyList">
    <input message="PolicyMangementIRPSystem:queryPolicyListRequest" />
    <output message="PolicyMangementIRPSystem:queryPolicyListResponse" />
  </operation>

  <operation name="PolicyConflictNotification">
    <input message="PolicyMangementIRPSystem:policyConflictNotificationRequest" />
  </operation>
</portType>
<binding name="PolicyManagementIRPBinding" type="PolicyManagementIRPSystem:
PolicyManagementIRPPortType">
  <soap:binding style="document" transport="http://schemas.xmlsoap.org/soap/http" />
  <operation name="createPolicy">
    <soap:operation soapAction="http://www.3gpp.org/ftp/specs/archive/28_series/28.311#
createPolicy" style="document" />
    <input>
      <soap:body use="literal" />
    </input>
    <output>
      <soap:body use="literal" />
    </output>
  </operation>
  <operation name="deletePolicy">
    <soap:operation soapAction="http://www.3gpp.org/ftp/specs/archive/28_series/28.311#
deletePolicy" style="document" />
    <input>
      <soap:body use="literal" />
    </input>
    <output>
      <soap:body use="literal" />
    </output>
  </operation>
  <operation name="updatePolicy">
    <soap:operation soapAction="http://www.3gpp.org/ftp/specs/archive/28_series/28.311#
updatePolicy" style="document" />
    <input>
      <soap:body use="literal" />
    </input>
    <output>
      <soap:body use="literal" />
    </output>
  </operation>
  <operation name="queryPolicy">

```

```

    <soap:operation soapAction="http://www.3gpp.org/ftp/specs/archive/28_series/28.311#
queryPolicy" style="document"/>
    <input>
      <soap:body use="literal"/>
    </input>
    <output>
      <soap:body use="literal"/>
    </output>
  </operation>
  <operation name="activePolicy">
    <soap:operation soapAction="http://www.3gpp.org/ftp/specs/archive/28_series/28.311#
activePolicy" style="document"/>
    <input>
      <soap:body use="literal"/>
    </input>
    <output>
      <soap:body use="literal"/>
    </output>
  </operation>
  <operation name="deactivePolicy">
    <soap:operation soapAction="http://www.3gpp.org/ftp/specs/archive/28_series/28.311#
deactivePolicy" style="document"/>
    <input>
      <soap:body use="literal"/>
    </input>
    <output>
      <soap:body use="literal"/>
    </output>
  </operation>
  <operation name="queryPolicyList">
    <soap:operation soapAction="http://www.3gpp.org/ftp/specs/archive/28_series/28.311#
queryPolicyList" style="document"/>
    <input>
      <soap:body use="literal"/>
    </input>
    <output>
      <soap:body use="literal"/>
    </output>
  </operation>

  <operation name="policyConflictNofitication">
    <soap:operation
soapAction="http://www.3gpp.org/ftp/specs/archive/28_series/28.311#PolicyConflictNofitication"
style="document"/>
    <input>
      <soap:body use="literal"/>
    </input>
    <output>
      <soap:body use="literal"/>
    </output>
  </operation>
</binding>
<service name="PolicyMangementIRPService">
  <port name="PolicyMangementIRPPort" binding="PolicyMangementIRPSystem:
PolicyMangementIRPBinding">
    <soap:address
location="http://www.3gpp.org/ftp/specs/archive/28_series/28.311#BulkCMIRP"/>
  </port>
  <port name="GenericIRPPort" binding="genericIRPSystem:GenericIRPBinding">
    <soap:address
location="http://www.3gpp.org/ftp/specs/archive/28_series/28.311#GenericIRP"/>
  </port>
</service>
</definitions>

```



## Annex C (informative): Change history

Change history							
Date	Meeting	TDoc	CR	Rev	Cat	Subject/Comment	New version
2018-09						Skeleton	0.0.0
2018-10	SA5#121	S5-186398 S5-186468				Update to implement the agreed pCRs in SA5#121: S5-186398 pCR 28.311 Add Scope S5-186468 Rel-16 draft TS Skeleton 28.311	0.1.0
2018-11	SA5#122	S5-187385 S5-187386				Update to implement the agreed pCRs in SA5#122: S5-187385 Add Policy management architecture S5-187386 Add Business level requirements	0.2.0
2019-06	SA5#125 Adhoc	S5-194428 S5-194429 S5-194430 S5-194431 S5-194432 S5-194433 S5-194434 S5-194435				Update to implement the agreed pCRs in SA5#125Adhoc: S5-194428 Policy Management Procedures S5-194429 Policy Creation S5-194430 Policy Deletion S5-194431 Policy Update S5-194432 Policy Query S5-194433 Policy Activation S5-194434 Policy Deactivation S5-194435 Policy Conflicts Notification	0.3.0
2019-08	SA5#126	S5-195179 S5-195843 S5-195845 S5-195846 S5-195847				Update to implement the agreed pCRs in SA5#126: S5-195179 Add abbreviations S5-195843 Add references S5-195845 Add overview S5-195846 Rewrite business level requirements S5-195847 Add specification level requirements	0.4.0
2019-10	SA5#127	S5-196658				Update to implement the agreed pCRs in SA5#127: S5-196658 Add Solution Set(SS) definitions	0.5.0
2019-11	SA5#128	S5-197763 S5-197764 S5-197765 S5-197766				Update to implement the agreed pCRs in SA5#128: S5-197763 pCR 28.311 Add Information Object Classes S5-197764 pCR 28.311 Add XML definition S5-197765 pCR 28.311 Add SOAP Solution Set S5-197766 pCR 28.311 Rewrite interface	0.6.0
2019-12	SA#86	SP-191185				Presented for information and approval	1.0.0
2019-12	SA#86					Change control version	16.0.0
2022-03	-	-	-	-	-	Update to Rel-17 version (MCC)	17.0.0

---

# History

<b>Document history</b>		
V17.0.0	April 2022	Publication