

ETSI TS 128 302 V15.0.0 (2018-07)



**LTE;
Telecommunication management;
Licensed Shared Access (LSA) Controller (LC)
Integration Reference Point (IRP);
Information Service (IS)
(3GPP TS 28.302 version 15.0.0 Release 15)**



Reference

RTS/TSGS-0528302vf00

Keywords

LTE

ETSI

650 Route des Lucioles
F-06921 Sophia Antipolis Cedex - FRANCE

Tel.: +33 4 92 94 42 00 Fax: +33 4 93 65 47 16

Siret N° 348 623 562 00017 - NAF 742 C
Association à but non lucratif enregistrée à la
Sous-Préfecture de Grasse (06) N° 7803/88

Important notice

The present document can be downloaded from:

<http://www.etsi.org/standards-search>

The present document may be made available in electronic versions and/or in print. The content of any electronic and/or print versions of the present document shall not be modified without the prior written authorization of ETSI. In case of any existing or perceived difference in contents between such versions and/or in print, the only prevailing document is the print of the Portable Document Format (PDF) version kept on a specific network drive within ETSI Secretariat.

Users of the present document should be aware that the document may be subject to revision or change of status.

Information on the current status of this and other ETSI documents is available at

<https://portal.etsi.org/TB/ETSIDeliverableStatus.aspx>

If you find errors in the present document, please send your comment to one of the following services:

<https://portal.etsi.org/People/CommiteeSupportStaff.aspx>

Copyright Notification

No part may be reproduced or utilized in any form or by any means, electronic or mechanical, including photocopying and microfilm except as authorized by written permission of ETSI.

The content of the PDF version shall not be modified without the written authorization of ETSI.

The copyright and the foregoing restriction extend to reproduction in all media.

© ETSI 2018.

All rights reserved.

DECT™, **PLUGTESTS™**, **UMTS™** and the ETSI logo are trademarks of ETSI registered for the benefit of its Members.

3GPP™ and **LTE™** are trademarks of ETSI registered for the benefit of its Members and of the 3GPP Organizational Partners.

oneM2M logo is protected for the benefit of its Members.

GSM® and the GSM logo are trademarks registered and owned by the GSM Association.

Intellectual Property Rights

Essential patents

IPRs essential or potentially essential to normative deliverables may have been declared to ETSI. The information pertaining to these essential IPRs, if any, is publicly available for **ETSI members and non-members**, and can be found in ETSI SR 000 314: *"Intellectual Property Rights (IPRs); Essential, or potentially Essential, IPRs notified to ETSI in respect of ETSI standards"*, which is available from the ETSI Secretariat. Latest updates are available on the ETSI Web server (<https://ipr.etsi.org/>).

Pursuant to the ETSI IPR Policy, no investigation, including IPR searches, has been carried out by ETSI. No guarantee can be given as to the existence of other IPRs not referenced in ETSI SR 000 314 (or the updates on the ETSI Web server) which are, or may be, or may become, essential to the present document.

Trademarks

The present document may include trademarks and/or tradenames which are asserted and/or registered by their owners. ETSI claims no ownership of these except for any which are indicated as being the property of ETSI, and conveys no right to use or reproduce any trademark and/or tradename. Mention of those trademarks in the present document does not constitute an endorsement by ETSI of products, services or organizations associated with those trademarks.

Foreword

This Technical Specification (TS) has been produced by ETSI 3rd Generation Partnership Project (3GPP).

The present document may refer to technical specifications or reports using their 3GPP identities, UMTS identities or GSM identities. These should be interpreted as being references to the corresponding ETSI deliverables.

The cross reference between GSM, UMTS, 3GPP and ETSI identities can be found under <http://webapp.etsi.org/key/queryform.asp>.

Modal verbs terminology

In the present document "**shall**", "**shall not**", "**should**", "**should not**", "**may**", "**need not**", "**will**", "**will not**", "**can**" and "**cannot**" are to be interpreted as described in clause 3.2 of the [ETSI Drafting Rules](#) (Verbal forms for the expression of provisions).

"**must**" and "**must not**" are **NOT** allowed in ETSI deliverables except when used in direct citation.

Contents

Intellectual Property Rights	2
Foreword.....	2
Modal verbs terminology.....	2
Foreword.....	6
Introduction	6
1 Scope	7
2 References	7
3 Definitions and abbreviations.....	7
3.1 Definitions	7
3.2 Abbreviations	7
4 System overview	8
4.1 System Context	8
4.1.1 System Context for scenario 1	8
4.1.2 System Context for scenario 2	8
5 Model	9
5.1 Imported and associated information entities	9
5.1.1 Imported information entities and local labels.....	9
5.1.1 Associated information entities and local labels.....	9
5.2 Class diagram	9
5.2.1 Relationships.....	9
5.2.1.1 Relationships for scenario 1	9
5.2.1.2 Relationships for scenario 2	10
5.2.2 Inheritance	10
5.2.2.1 Inheritance for scenario 1	10
5.2.2.2 Inheritance for scenario 2	10
5.3 Class definitions	10
5.3.1 Class definitions for scenario 1	10
5.3.1.1 LSRAIContextLC	10
5.3.1.1.1 Definition.....	10
5.3.1.1.2 Attributes	11
5.3.1.2 ZoneLC	11
5.3.1.2.1 Definition.....	11
5.3.1.2.2 Attributes	11
5.3.1.3 LSRAIContextNM.....	11
5.3.1.3.1 Definition.....	11
5.3.1.3.2 Attributes	11
5.3.1.4 ZoneNM.....	11
5.3.1.4.1 Definition.....	11
5.3.1.4.2 Attributes	11
5.3.2 Class definitions for scenario 2.....	11
5.3.2.1 LSACell	11
5.3.2.1.1 Definition	11
5.3.2.1.2 Attributes.....	12
5.3.2.1.3 Attribute constraints	12
5.3.2.1.4 Notifications.....	12
5.3.2.2 LSACellConstraints	12
5.3.2.2.1 Definition	12
5.3.2.2.2 Attributes.....	12
5.3.2.2.3 Attribute constraints	12
5.3.2.2.4 Notifications.....	12
5.4 Attribute definitions	13
5.4.1 Attribute definitions for scenario 1	13
5.4.1.1 Attribute properties	13

5.4.1.2	Constraints	15
5.4.2	Attribute definitions for scenario 2	15
5.4.2.1	Attribute properties	15
5.4.2.2	Constraints	16
6	Interface Definition	16
6.1	Class diagram representing interfaces	16
6.1.1	Class diagram representing interfaces for scenario 1	16
6.1.2	Class diagram representing interfaces for scenario 2	17
6.3	OperationsInvokedByNM Interface (M)	18
6.3.1	OperationsInvokedbyNM Interface (M) for scenario 1	18
6.3.1.1	Operation requestLcRegistration (M)	18
6.3.1.1.1	Definition.....	18
6.3.1.1.2	Input parameters	18
6.3.1.1.3	Output parameters	18
6.3.1.2	Operation requestLcDeregistration (M).....	18
6.3.1.2.1	Definition.....	18
6.3.1.2.2	Input parameters	19
6.3.1.2.3	Output parameters	19
6.3.1.3	Operation getLSRAI (M)	19
6.3.1.3.1	Definition.....	19
6.3.1.3.2	Input parameters	19
6.3.1.3.3	Output parameters	19
6.3.2	OperationsInvokedByNM Interface (M) for scenario 2	19
6.3.2.1	Operation cellsUpdate (M).....	19
6.3.2.1.1	Definition	19
6.3.2.1.2	Input parameters.....	20
6.3.2.1.3	Output parameters	20
6.3.2.2	Operation cellsConstraintsSatisfied (M).....	20
6.3.2.2.1	Definition	20
6.3.2.2.2	Input parameters.....	21
6.3.2.2.3	Output parameters	21
6.4	OperationsInvokedByLC Interface (M)	21
6.4.1	OperationsInvokedByLC Interface (M) for scenario 1	21
6.4.1.1	Operation getLSRAIConfirmation (M).....	21
6.4.1.1.1	Input parameters	21
6.4.1.1.2	Output parameters	21
6.4.2	OperationsInvokedByLC Interface (M) for scenario 2	21
6.4.2.1	Operation cellsConstraintsUpdate (M).....	21
6.4.2.1.1	Definition	21
6.4.2.1.2	Input parameters.....	22
6.4.2.1.3	Output parameters	22
6.5	NotificationsEmittedByNM Interface (M)	22
6.5.1	NotificationsEmittedByNM Interface (M) for scenario 1	22
6.5.1.1	Notification notifyLSRAIConfirmation (M)	22
6.5.1.1.1	Definition.....	22
6.5.1.1.2	Input parameters	22
6.5.2	NotificationsEmittedByNM Interface (M) for scenario 2	22
6.6	NotificationsEmittedByLC Interface (M)	23
6.6.1	NotificationsEmittedByLC Interface (M) for scenario 1	23
6.6.1.1	Notification notifyLCRegistration.....	23
6.6.1.1.1	Definition.....	23
6.6.1.1.2	Input parameters	23
6.6.1.2	Notification notifyLCDeRegistration.....	23
6.6.1.2.1	Definition.....	23
6.6.1.2.2	Input parameters	23
6.6.1.3	Notification notifyZoneCreation (M)	23
6.6.1.3.1	Definition.....	23
6.6.1.3.2	Input parameters	23
6.6.1.4	Notification notifyZoneDeletion (M)	24

6.6.1.4.1	Definition.....	24
6.6.1.4.2	Input parameters	24
6.6.1.5	Notification notifyZoneModification (M).....	24
6.6.1.5.1	Definition.....	24
6.6.1.5.2	Input parameters	24
6.6.2	NotificationsEmittedByLC Interface (M) for scenario 2.....	24
6.6.2.1	Notification notifyLCRegistration (M).....	24
6.6.2.1.1	Definition.....	24
6.6.2.1.2	Input parameters	24
6.6.2.2	Notification notifyLCDeRegistration (M).....	25
6.6.2.2.1	Definition.....	25
6.6.2.2.2	Input parameters	25
Annex A (informative):	Change history	26
History		27

Foreword

This Technical Specification has been produced by the 3rd Generation Partnership Project (3GPP).

The contents of the present document are subject to continuing work within the TSG and may change following formal TSG approval. Should the TSG modify the contents of the present document, it will be re-released by the TSG with an identifying change of release date and an increase in version number as follows:

Version x.y.z

where:

- x the first digit:
 - 1 presented to TSG for information;
 - 2 presented to TSG for approval;
 - 3 or greater indicates TSG approved document under change control.
- y the second digit is incremented for all changes of substance, i.e. technical enhancements, corrections, updates, etc.
- z the third digit is incremented when editorial only changes have been incorporated in the document.

Introduction

The present document is part of a TS-family covering the 3rd Generation Partnership Project Technical Specification Group Services and System Aspects, Telecommunication Management; as identified below:

- TS 28.301: Telecommunication management; LSA controller (LC) Integration Reference Point (IRP); Requirements
- TS 28.302: Telecommunication management; LSA controller (LC) Integration Reference Point (IRP); Information Service (IS)**
- TS 28.303: Telecommunication management; LSA controller (LC) Integration Reference Point (IRP); Solution Set (SS) definitions

1 Scope

The present document specifies the LSA controller (LC) Integration Reference Point (IRP) management operations and notifications that can be communicated between an IRP Agent and one or several IRP Managers.

The present document specifies the semantics and behaviour of operations, notifications and their parameters visible across the reference point in a protocol and technology neutral way. It does not define their syntax and encoding.

2 References

The following documents contain provisions which, through reference in this text, constitute provisions of the present document.

- References are either specific (identified by date of publication, edition number, version number, etc.) or non-specific.
- For a specific reference, subsequent revisions do not apply.
- For a non-specific reference, the latest version applies. In the case of a reference to a 3GPP document (including a GSM document), a non-specific reference implicitly refers to the latest version of that document *in the same Release as the present document*.

- [1] 3GPP TR 21.905: "Vocabulary for 3GPP Specifications".
 - [2] ETSI TS 103 379 (V1.1.1): "Reconfigurable Radio Systems (RRS); Information elements and protocols for the interface between LSA Controller (LC) and LSA Repository (LR) for operation of Licensed Shared Access (LSA) in the 2300 MHz-2400 MHz band".
 - [3] 3GPP TS 25.105: "Base Station (BS) radio transmission and reception (TDD)".
 - [4] 3GPP TS 23.032: "Technical Specification Group Services and System Aspects; Universal Geographical Area Description (GAD)".
 - [5] 3GPP TS 28.668: "Telecommunication management; Radio Planning Tool Access (RPTA) Integration Reference Point (IRP); Information Service (IS)".
 - [6] ETSI TS 103 235 (V1.1.1): "Reconfigurable Radio Systems (RRS); System architecture and high level procedures for operation of Licensed Shared Access (LSA) in the 2300 MHz-2400 MHz band".
 - [7] 3GPP TS 28.301: "Telecommunication Management; Licensed Shared Access (LSA) Controller (LC) Integration Reference Point (IRP); Requirements".
-

3 Definitions and abbreviations

3.1 Definitions

For the purposes of the present document, the terms and definitions given in 3GPP TR 21.905 [1] and the following apply. A term defined in the present document takes precedence over the definition of the same term, if any, in 3GPP TR 21.905 [1].

LSRAI Context: See definition in ETSI TS 103 379 [2].

LSA₁: See definition in ETSI TS 103 235 [6].

3.2 Abbreviations

For the purposes of the present document, the abbreviations given in 3GPP TR 21.905 [1] and the following apply. An abbreviation defined in the present document takes precedence over the definition of the same abbreviation, if any, in 3GPP TR 21.905 [1].

EIRP Equivalent Isotropic Radiated Power

LC	LSA Controller
LR	LSA Repository
LSRAI	LSA Spectrum Resource Availability Information
NM	Network Manager

4 System overview

4.1 System Context

4.1.1 System Context for scenario 1

Figure 4.1.1.1 shows the System Context for scenario 1. The LC and NM can play both the roles of IRPAgent and IRPManager for operations and notifications of the LSA IRP.

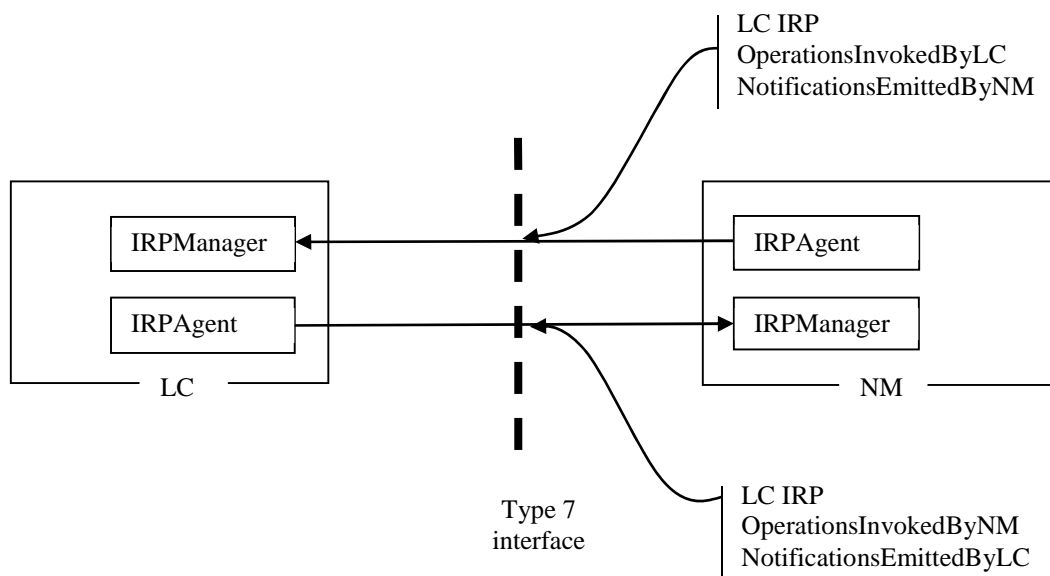

Figure 4.1.1.1: System Context for LC IRP (scenario 1)

4.1.2 System Context for scenario 2

Figure 4.1.2.1 shows the System Context for scenario 1. The LC and NM can play both the roles of IRPAgent and IRPManager for operations and notifications of the LSA IRP.

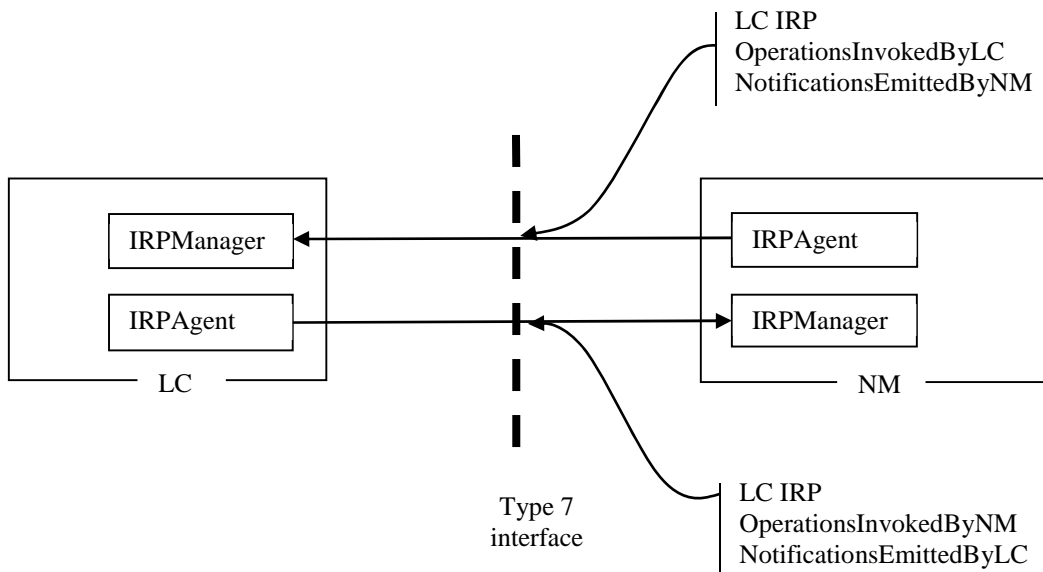

Figure 4.1.2.1: System Context for LC IRP (scenario 2)

5 Model

5.1 Imported and associated information entities

5.1.1 Imported information entities and local labels

None.

5.1.1 Associated information entities and local labels

None.

5.2 Class diagram

5.2.1 Relationships

5.2.1.1 Relationships for scenario 1

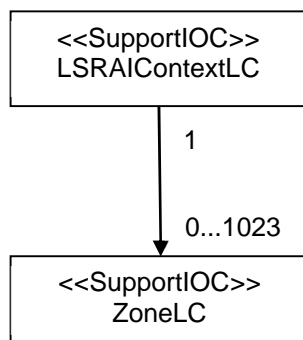

Figure 5.2.1.1.1: Information Model of the LSA controller IRP for the interface OperationsInvokedByNM and the interface NotificationsEmittedByLC (scenario 1)

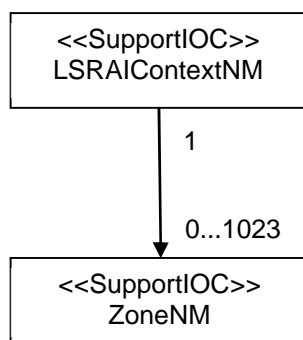

Figure 5.2.1.1.2: Information Model of the LSA controller IRP for the interface OperationsInvokedByLC and the interface NotificationsEmittedByNM (scenario 1)

An instance of this model is always related to a particular instance of the Type 7 interface between a LC and a LR. Identifiers are unique within this scope. In case the NM has multiple instances of the Type 7 interface to multiple LCs, identifiers for zones as allocated by the LR may be overlapping. The NM may have to add prefixes to identifiers of zones, whose value depends on the interface instance on which information is exchanged with the LC, to integrate these (extended) identifiers into its namespace or make them globally unique.

5.2.1.2 Relationships for scenario 2

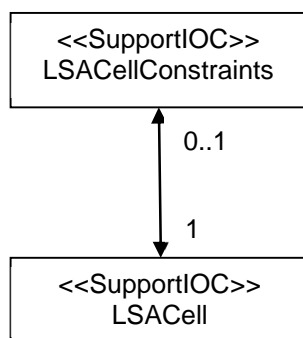

Figure 5.2.1.2.1: Information Model of the LSA controller IRP (scenario 2)

5.2.2 Inheritance

5.2.2.1 Inheritance for scenario 1

There is no inheritance.

5.2.2.2 Inheritance for scenario 2

There is no inheritance.

5.3 Class definitions

5.3.1 Class definitions for scenario 1

5.3.1.1 LSRAIContextLC

5.3.1.1.1 Definition

This Support IOC represents the LSRAI context as seen by the NM in the LC.

5.3.1.1.2 Attributes

Attribute name	Support Qualifier	isReadable	isWritable	isInvariant	isNotifiable
licenseeId	M	M	-	-	M
lRId	M	M	-	-	M
lCId	M	M	-	-	M

5.3.1.2 ZoneLC

5.3.1.2.1 Definition

This Support IOC represents a zone as seen by the NM in the LC.

5.3.1.2.2 Attributes

Attribute name	Support Qualifier	isReadable	isWritable	isInvariant	isNotifiable
zoneId	M	M	-	-	M
zoneType	M	M	-	-	M
frequency	M	M	-	-	M
radioConstraints	M	M	-	-	M
space	M	M	-	-	M
time	M	M	-	-	M

5.3.1.3 LSRAIContextNM

5.3.1.3.1 Definition

This Support IOC represents the LSRAI context as seen by the LC in the NM.

5.3.1.3.2 Attributes

Attribute name	Support Qualifier	isReadable	isWritable	isInvariant	isNotifiable
licenseeId	M	M	-	-	M
lRId	M	M	-	-	M
lCId	M	M	-	-	M

5.3.1.4 ZoneNM

5.3.1.4.1 Definition

This Support IOC represents a zone as seen by the LC in the NM.

5.3.1.4.2 Attributes

Attribute name	Support Qualifier	isReadable	isWritable	isInvariant	isNotifiable
zoneId	M	M	-	-	M
zoneStatus	M	M	-	-	M

5.3.2 Class definitions for scenario 2

5.3.2.1 LSACell

5.3.2.1.1 Definition

This Support IOC represents a cell.

Referenced TS	Requirement label	Comment
3GPP TS 28.301	REQ-LC-IRP-SC2-FUN-002	

5.3.2.1.2 Attributes

Attribute name	Support Qualifier	isReadable	isWritable	isInvariant	isNotifyable
cellId	M	M	O	-	-
geographicalArea	M	M	O	-	-
maxAllowedEIRP	M	M	O	-	-
minAllowedEIRP	M	M	O	-	-
maxAllowedAntennaAltitude	O	M	O	-	-
minAllowedAntennaAltitude	O	M	O	-	-
maxAllowedAntennaTilt	O	M	O	-	-
minAllowedAntennaTilt	O	M	O	-	-
antennaPatternLabel	O	M	O	-	-
antennaType	O	M	O	-	-

5.3.2.1.3 Attribute constraints

None.

5.3.2.1.4 Notifications

None.

5.3.2.2 LSACellConstraints

5.3.2.2.1 Definition

This SupportIOC represents constraints on parameters of a cell operating on LSA frequencies.

Referenced TS	Requirement label	Comment
3GPP TS 28.301 [7]	REQ-LC-IRP-SC2-FUN-001	

5.3.2.2.2 Attributes

Attribute name	Support Qualifier	isReadable	isWritable	isInvariant	isNotifyable
cellId	M	M	M	-	-
maxAllowedEIRP	M	M	M	-	-
maxLeadTime	O	M	M	-	-

5.3.2.2.3 Attribute constraints

None.

5.3.2.2.4 Notifications

None.

5.4 Attribute definitions

5.4.1 Attribute definitions for scenario 1

5.4.1.1 Attribute properties

Attribute Name	Documentation and Allowed Values	Properties
lCid	Identifier of the LC used on LSA1, as defined in ETSI TS 103 379 [2] allowedValues: N/A	type: Integer multiplicity: 1 isOrdered: N/A isUnique: False defaultValue: No default value isNullable: False
lRId	Identifier of the LR used on LSA1, as defined in ETSI TS 103 379 [2] allowedValues: N/A	type: Integer multiplicity: 1 isOrdered: N/A isUnique: False defaultValue: No default value isNullable: False
frequency	The frequency range of the zone. The type is a structure with the following fields <ul style="list-style-type: none"> • lowerFrequency • upperFrequency The fields are defined in ETSI TS 103 379 [2]. allowedValues: N/A	type: <<dataType>> multiplicity: 1 isOrdered: N/A isUnique: False defaultValue: No default value isNullable: False
licenseeId	Identifier of the licensee used on LSA1, as defined in ETSI TS 103 379 [2] allowedValues: N/A	type: Integer multiplicity: 1 isOrdered: N/A isUnique: False defaultValue: No default value isNullable: False
radioConstraints	The description of the radio constraints applying to a zone. The type is a structure with the following fields: <ul style="list-style-type: none"> • radioConstraintsProfileIdentifier • protectionHeightAboveGround • maximumFieldStrength • frequencyInterval • maximumApplicableAntennaHeight • EIRPRestriction • ACS The fields are defined in ETSI TS 103 379 [2]. allowedValues: N/A	type: <<dataType>> multiplicity: 1 isOrdered: N/A isUnique: False defaultValue: No default value isNullable: False
space	The description of the geographical area of a zone. The type is a structure with the following fields: <ul style="list-style-type: none"> • switch • circle • polygon • area descriptor The value of switch indicates if the information in circle, polygon or area descriptor shall be used. Circle, polygon and area descriptor are defined in ETSI TS 103 379 [2]. allowedValues: N/A	type: <<dataType>> multiplicity: 1 isOrdered: N/A isUnique: False defaultValue: No default value isNullable: False

Attribute Name	Documentation and Allowed Values	Properties
time	<p>The description of when the zone is operational. The type is a structure with the following fields:</p> <ul style="list-style-type: none"> switch periodicSchedule aperiodicSchedule <p>The value of the switch indicates if the information periodicSchedule or aperiodicSchedule shall be used.</p> <p>The schedule types are defined in ETSI TS 103 379 [2].</p> <p>allowedValues: N/A</p>	<p>type: <<dataType>> multiplicity: 1 isOrdered: N/A isUnique: False defaultValue: No default value isNullable: False</p>
zoneId	<p>The identifier of a zone, as defined in ETSI TS 103 379 [2].</p> <p>allowedValues: N/A</p>	<p>type: Integer multiplicity: 1 isOrdered: N/A isUnique: False defaultValue: No default value isNullable: False</p>
zoneStatus	<p>The conformation status of a zone, as defined in ETSI TS 103 379 [2]. In a confirmed zone, configuration changes in the MFCN (if needed) have been applied according to previously received LSRAI.</p> <p>allowedValues: confirmed, notConfirmed</p>	<p>type: <<enumeration>> multiplicity: 1 isOrdered: N/A isUnique: False defaultValue: notConfirmed isNullable: False</p>
zoneType	<p>The type of a zone as defined in ETSI TS 103 379 [2]. The following values shall be used:</p> <p>"0" - Exclusion Zone. "1" - Restriction Zone. "2" - Protection Zone.</p> <p>allowedValues: 0,1,2</p>	<p>type: Integer multiplicity: 1 isOrdered: N/A isUnique: False defaultValue: No default value isNullable: False</p>

5.4.1.2 Constraints

None.

5.4.2 Attribute definitions for scenario 2

5.4.2.1 Attribute properties

The following table defines the attributes that are present in the Support Object Classes of the present document.

Attribute Name	Documentation and Allowed Values	Properties
cellId	<p>NM defined cell identifier.</p> <p>allowedValues: N/A</p>	<p>type: String multiplicity: 1 isOrdered: N/A isUnique: True defaultValue: None isNullable: False</p>
geographicalArea	<p>Geographical area, as defined in TS 23.032 [4]. It describes the area in which the antenna is located. The antenna can be located in any point inside this area.</p>	<p>type: Set types multiplicity: 1 isOrdered: N/A isUnique: N/A defaultValue: None isNullable: False</p>

Attribute Name	Documentation and Allowed Values	Properties
maxAllowedEIRP	Maximum EIRP allowed, expressed in dBm. allowedValues: N/A For EIRP reference: TS 25.105 [3]	type: Integer multiplicity: 1 isOrdered: N/A isUnique: N/A defaultValue: None isNullable: False
minAllowedEIRP	Minimum EIRP allowed, expressed in dBm. allowedValues: N/A For EIRP reference: TS 25.105 [3]	type: Integer multiplicity: 1 isOrdered: N/A isUnique: N/A defaultValue: None isNullable: False
maxAllowedAntennaAltitude	The max elevation of the antenna above sea level. allowedValues: An integral value representing a number of meters in 0.1 meter increments. Reference: TS 28.668 [5]	type: Integer multiplicity: 1 isOrdered: N/A isUnique: N/A defaultValue: None isNullable: False
minAllowedAntennaAltitude	The min elevation of the antenna above sea level. allowedValues: An integral value representing a number of meters in 0.1 meter increments. Reference: TS 28.668 [5]	type: Integer multiplicity: 1 isOrdered: N/A isUnique: N/A defaultValue: None isNullable: False
maxAllowedAntennaTilt	The max tilt of the antenna allowedValues: (0..360) Max value for antennaMechanicalOffset as described in TS 28.668 [5]	type: Integer multiplicity: 1 isOrdered: N/A isUnique: N/A defaultValue: None isNullable: False
minAllowedAntennaTilt	The min tilt of the antenna allowedValues: (0..360) Min value for antennaMechanicalOffset as described in TS 28.668 [5]	type: Integer multiplicity: 1 isOrdered: N/A isUnique: N/A defaultValue: None isNullable: False
antennaPatternLabel	The radiation pattern of the antenna, also referred to as antenna pattern. allowedValues: N/A Reference: TS 28.668 [5]	type: String multiplicity: 1 isOrdered: N/A isUnique: N/A defaultValue: None isNullable: False
antennaType	The type of the antenna. Types are e.g. repeaters, remote antennas, power dividers. allowedValues: N/A Reference: TS 28.668 [5]	type: String multiplicity: 1 isOrdered: N/A isUnique: N/A defaultValue: None isNullable: False

5.4.2.2 Constraints

None.

6 Interface Definition

6.1 Class diagram representing interfaces

6.1.1 Class diagram representing interfaces for scenario 1

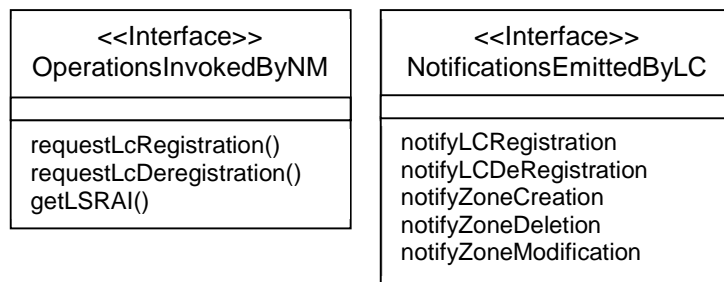

Figure 6.1.1-1: Class diagram representing the interface OperationsInvokedByNM and the interface NotificationsEmittedByLC (scenario 1)

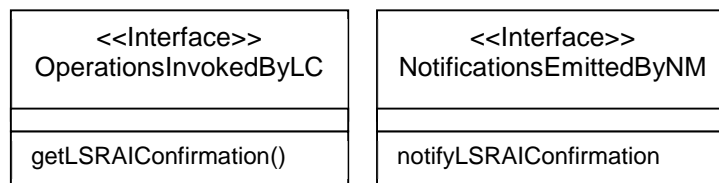

Figure 6.1.1-2: Class diagram representing the interface OperationsInvokedByLC and the interface NotificationsEmittedByNM (scenario 1)

6.1.2 Class diagram representing interfaces for scenario 2

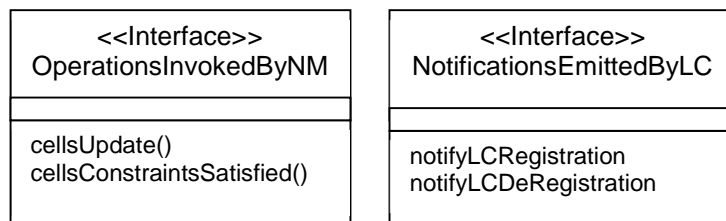

Figure 6.1.2-1: Class diagram representing the interface OperationsInvokedByNM and the interface NotificationsEmittedByLC (scenario 2)

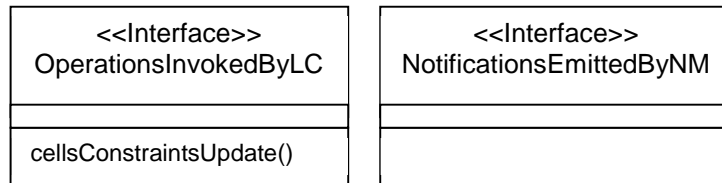

Figure 6.1.2-2: Class diagram representing the interface OperationsInvokedByLC and the interface NotificationsEmittedByNM (scenario 2)

6.3 OperationsInvokedByNM Interface (M)

6.3.1 OperationsInvokedbyNM Interface (M) for scenario 1

6.3.1.1 Operation requestLcRegistration (M)

6.3.1.1.1 Definition

The NM invokes this operation to request the LC to register with the LR.

Referenced TS	Requirement label	Comment
3GPP TS 28.301 [7]	REQ-LC-IRP-SC1-FUN-001	

6.3.1.1.2 Input parameters

Parameter Name	Support Qualifier	Information Type / Legal Values	Comment
licenseeId	M	LSRAIContextNM.licenseeId	Uniquely identifies the LSA Licensee
lCId	M	LSRAIContextNM.lCId	Uniquely identifies the LC
lRId	M	LSRAIContextNM.lRId	Uniquely identifies the LR

6.3.1.1.3 Output parameters

Parameter Name	Support Qualifier	Matching Information / Information Type / Legal Values	Comment
licenseeId	M	LSRAIContextLC.licenseeId	Uniquely identifies the LSA Licensee
lCId	M	LSRAIContextLC.lCId	Uniquely identifies the LC
lRId	M	LSRAIContextLC.lRId	Uniquely identifies the LR
cause	O	INTEGER	Indicates cause of registration failure. Cause values are specified in ETSI TS 103 379 [2].
result	M	ENUM (OperationSucceeded, OperationFailed)	Indicates success or failure

6.3.1.2 Operation requestLcDeregistration (M)

6.3.1.2.1 Definition

The NM invokes this operation to request the LC to deregister from the LR.

Referenced TS	Requirement label	Comment
3GPP TS 28.301 [7]	REQ-LC-IRP-SC1-FUN-003	

6.3.1.2.2 Input parameters

Parameter Name	Support Qualifier	Information Type / Legal Values	Comment
lCId	M	LSRAIContextNM.lCId	Uniquely identifies the LC
lRId	M	LSRAIContextNM.lRId	Uniquely identifies the LR

6.3.1.2.3 Output parameters

Parameter Name	Support Qualifier	Matching Information / Information Type / Legal Values	Comment
lCId	M	LSRAIContextLC.lCId	Uniquely identifies the LC
lRId	M	LSRAIContextLC.lRId	Uniquely identifies the LR
cause	O	INTEGER	Indicates cause of deregistration failure. Cause values are specified in ETSI TS 103 379 [2].
result	M	ENUM (OperationSucceeded, OperationFailed)	Indicates success or failure

6.3.1.3 Operation getLSRAI (M)

6.3.1.3.1 Definition

The NM invokes this operation to get LSRAI for the scoped subset of zones in an LSRAI context.

Referenced TS	Requirement label	Comment
3GPP TS 28.301 [7]	REQ-LC-IRP-SC1-FUN-005	

6.3.1.3.2 Input parameters

Parameter Name	Support Qualifier	Information Type / Legal Values	Comment
scope	M	LIST OF zoneId	This parameter defines the subset of zones to be returned. The absence of an input parameter is equivalent to all zones under LSRAI.

6.3.1.3.3 Output parameters

Parameter Name	Support Qualifier	Matching Information / Information Type / Legal Values	Comment
lSRAl	M	LIST OF zone instances	This parameter returns the scoped zone instances under LSRAI. The data structure is described by the information model specified in subclause 5.
status	M	ENUM (OperationSucceeded, OperationFailed)	If allScopedPlannedDataReturned is true, status = OperationSucceeded. If operation_failed is true, status = OperationFailed.

6.3.2 OperationsInvokedByNM Interface (M) for scenario 2

6.3.2.1 Operation cellsUpdate (M)

6.3.2.1.1 Definition

The NM invokes this operation to provide the LC with information about created, deleted or modified cells operating on LSA frequencies.

NOTE: it is assumed that prior to invoking this operation:

- cells operating on LSA frequencies have been identified by the operator, and
- the LC is connected to the LR and has received up-to-date LSRAI information from the LR.

Referenced TS	Requirement label	Comment
3GPP TS 28.301 [7]	REQ-LC-IRP-SC2-FUN-006	

6.3.2.1.2 Input parameters

Parameter Name	Support Qualifier	Information Type / Legal Values	Comment
addedLSACells	O	LIST OF LSACell	This parameter contains a list of instances of the LSACell class.
modifiedLSACells	O	LIST OF LSACell	This parameter contains a list of instances of the LSACell class. Each LSACell instance within this list contains only the parameters and corresponding values that need to be updated by the LC, and the attribute cellId.
removedLSACells	O	LIST OF LSACell.cellId	This parameter contains a list of cellId(s), indicating which cells to delete.

6.3.2.1.3 Output parameters

Parameter Name	Support Qualifier	Matching Information / Information Type / Legal Values	Comment
status	M	ENUM (OperationSucceeded, OperationFailed)	The LC returns OperationSucceeded if all requested changes have been executed by the LC. Otherwise (e.g., in case of a missing parameter or of an unknown cellId), the LC returns OperationFailed. In that case, the LC has not modified, added or deleted any LSACell.

6.3.2.2 Operation cellsConstraintsSatisfied (M)

6.3.2.2.1 Definition

The NM invokes this operation to indicate to the LC that the constraints on cells parameters provided in the message cellsConstraintsUpdate are accepted and satisfied.

For each confirmed cell, the NM shall include a LSACellConstraints instance in the cellsConstraintsUpdate operation. After receiving a response to this operation with the status parameter set to OperationSucceeded, the NM is allowed to activate each confirmed cell.

NOTE 1: The NM may invoke this operation multiple times to confirm constraints on different cells at different points in time.

NOTE 2: The NM does not need to invoke this operation for cells on which the LC did not provide any constraint.

6.3.2.2.2 Input parameters

Parameter Name	Support Qualifier	Information Type / Legal Values	Comment
cellsConstraints	M	LIST OF LSACellConstraints	This parameter contains a list of instances of the LSACellConstraints class.

6.3.2.2.3 Output parameters

Parameter Name	Support Qualifier	Matching Information / Information Type / Legal Values	Comment
status	M	ENUM (OperationSucceeded, OperationFailed)	The LC returns <code>OperationSucceeded</code> if the operation was successfully handled. Otherwise (e.g., in case of a missing parameter or of an unknown <code>cellId</code>), the LC returns <code>OperationFailed</code> .

6.4 OperationsInvokedByLC Interface (M)

6.4.1 OperationsInvokedByLC Interface (M) for scenario 1

6.4.1.1 Operation `getLSRAIConfirmation` (M)

The LC invokes this operation to get confirmation from the NM that configuration changes in the MFCN (if needed) have been applied according to previously received LSRAI.

Referenced TS	Requirement label	Comment
3GPP TS 28.301 [8]	REQ-LC-IRP-SC1-FUN-007	

6.4.1.1.1 Input parameters

Parameter Name	Support Qualifier	Information Type / Legal Values	Comment

6.4.1.1.2 Output parameters

Parameter Name	Support Qualifier	Matching Information / Information Type / Legal Values	Comment
confirmedZoneList	M	LIST OF LSRAIContextNM. <code>zoneId</code>	This parameter contains a list of <code>zoneId</code> 's with confirmed LSRAI.

6.4.2 OperationsInvokedByLC Interface (M) for scenario 2

6.4.2.1 Operation `cellsConstraintsUpdate` (M)

6.4.2.1.1 Definition

The LC invokes this operation to provide the NM with constraints on parameters of cells operating on LSA frequencies.

The LC shall initiate a `cellsConstraintsUpdate` operation upon one of the following events:

- a change in LSA spectrum resource availability (e.g., LSRAI received from the LR), or
- a successful `cellUpdate` operation.

Following a successful `cellUpdate` operation, the LC shall provide constraints for all cells that were added or modified by the NM. In case the LC does not define any constraints on a given cell, the `LSACellConstraints` instance associated with this cell only includes the attribute `cellId`. This information enables the NM to know that this given cell can be activated.

If the parameter `maxLeadTime` is included in a given `LSACellConstraints` instance, the NM shall confirm that the constraints provided in this instance are satisfied within `maxLeadTime` seconds.

Referenced TS	Requirement label	Comment
3GPP TS 28.301 [7]	REQ-LC-IRP-SC1-FUN-005	

6.4.2.1.2 Input parameters

Parameter Name	Support Qualifier	Information Type / Legal Values	Comment
<code>cellsConstraints</code>	M	LIST OF <code>LSACellConstraints</code>	This parameter contains a list of instances of the <code>LSACellConstraints</code> class.

6.4.2.1.3 Output parameters

Parameter Name	Support Qualifier	Matching Information / Information Type / Legal Values	Comment
<code>status</code>	M	ENUM (<code>OperationSucceeded</code> , <code>OperationFailed</code>)	The NM returns <code>OperationSucceeded</code> if all requested changes have been executed by the NM. Otherwise (e.g., in case of a missing parameter or an unknown <code>cellId</code>), the NM returns <code>OperationFailed</code> . In that case the NM has not modified any constraints.

6.5 NotificationsEmittedByNM Interface (M)

6.5.1 NotificationsEmittedByNM Interface (M) for scenario 1

6.5.1.1 Notification `notifyLSRAIConfirmation` (M)

6.5.1.1.1 Definition

The NM emits this notification to notify the LC that configuration changes in the MFCN (if needed) have been applied according to previously received LSRAI. Each notification can carry information about one or more confirmed zones. Information about a confirmed zone is sent only once in a notification. It is up to the implementation of the `IRPAgent` to decide how to group information about confirmed zones in notifications.

Referenced TS	Requirement label	Comment
3GPP TS 28.301 [7]	REQ-LC-IRP-SC1-FUN-007	

6.5.1.1.2 Input parameters

Parameter Name	Support Qualifiers	Matching Information / Information Type / Legal Values	Comment
<code>confirmedZoneList</code>	M	LIST OF <code>LSRAIContextNM.zoneId</code>	This parameter contains a list of <code>zoneId</code> 's with confirmed LSRAI.

6.5.2 NotificationsEmittedByNM Interface (M) for scenario 2

None.

6.6 NotificationsEmittedByLC Interface (M)

6.6.1 NotificationsEmittedByLC Interface (M) for scenario 1

6.6.1.1 Notification notifyLCRegistration

6.6.1.1.1 Definition

The LC emits this notification to notify the NM about the completion of the registration of the LC with the LR.

Referenced TS	Requirement label	Comment
3GPP TS 28.301 [7]	REQ-LC-IRP-SC1-FUN-002	

6.6.1.1.2 Input parameters

Parameter Name	Support Qualifier	Matching Information / Information Type / Legal Values	Comment
licenseeId	M	LSRAIContextLC.licenseeId	Uniquely identifies the LSA Licensee
lCId	M	LSRAIContextLC.lCId	Uniquely identifies the LC
lRId	M	LSRAIContextLC.lRId	Uniquely identifies the LR

6.6.1.2 Notification notifyLCDeRegistration

6.6.1.2.1 Definition

The LC emits this notification to notify the NM about the completion of the de-registration of the LC with the LR.

Referenced TS	Requirement label	Comment
3GPP TS 28.301 [7]	REQ-LC-IRP-SC1-FUN-004	

6.6.1.2.2 Input parameters

Parameter Name	Support Qualifier	Matching Information / Information Type / Legal Values	Comment
licenseeId	M	LSRAIContextLC.licenseeId	Uniquely identifies the LSA Licensee
lCId	M	LSRAIContextLC.lCId	Uniquely identifies the LC
lRId	M	LSRAIContextLC.lRId	Uniquely identifies the LR

6.6.1.3 Notification notifyZoneCreation (M)

6.6.1.3.1 Definition

The LC emits this notification to notify the NM about created ZoneLC instances. Each notification can carry information about one or more ZoneLC instances. Information about a created ZoneLC instance is sent only once in a notification. It is up to the implementation of the IRP Agent to decide how to group information about Zone instances in notifications.

Referenced TS	Requirement label	Comment
3GPP TS 28.301 [7]	REQ-LC-IRP-SC1-FUN-006	

6.6.1.3.2 Input parameters

Parameter Name	Support Qualifier	Matching Information / Information Type / Legal Values	Comment
lSRAI	M	LIST OF ZoneLC instances	This parameter contains information about Zone instances that have been created.

6.6.1.4 Notification `notifyZoneDeletion` (M)

6.6.1.4.1 Definition

The LC emits this notification to notify the NM about deleted `ZoneLC` instances. Each notification can carry information about one or more `Zone` instances. Information about a deleted `ZoneLC` instance is sent only once in a notification. It is up to the implementation of the IRPAgent to decide how to group information about `ZoneLC` instances in notifications.

Referenced TS	Requirement label	Comment
3GPP TS 28.301 [7]	REQ-LC-IRP-SC1-FUN-006	

6.6.1.4.2 Input parameters

Parameter Name	Support Qualifier	Matching Information / Information Type / Legal Values	Comment
<code>lSRAI</code>	M	LIST OF <code>ZoneLC</code> instances	This parameter contains information about <code>Zone</code> instances that have been deleted.

6.6.1.5 Notification `notifyZoneModification` (M)

6.6.1.5.1 Definition

The LC emits this notification to notify the NM about modified `ZoneLC` instances. Each notification can carry information about one or more `Zone` instances. Information about a modified `ZoneLC` instance is sent only once in a notification. It is up to the implementation of the IRPAgent to decide how to group information about `ZoneLC` instances in notifications.

Referenced TS	Requirement label	Comment
3GPP TS 28.301 [7]	REQ-LC-IRP-SC1-FUN-006	

6.6.1.5.2 Input parameters

Parameter Name	Support Qualifier	Matching Information / Information Type / Legal Values	Comment
<code>lSRAI</code>	M	LIST OF <code>ZoneLC</code> instances	This parameter contains information about <code>Zone</code> instances that have been modified.

6.6.2 NotificationsEmittedByLC Interface (M) for scenario 2

6.6.2.1 Notification `notifyLCRegistration` (M)

6.6.2.1.1 Definition

The LC emits this notification to notify the NM about the completion of the registration of the LC with the LR.

Referenced TS	Requirement label	Comment
3GPP TS 28.301 [7]	REQ-LC-IRP-SC2-FUN-002	

6.6.2.1.2 Input parameters

Parameter Name	Support Qualifier	Matching Information / Information Type / Legal Values	Comment
<code>licenseeId</code>	M	<code>licenseeId</code>	Uniquely identifies the LSA Licensee
<code>lCId</code>	M	<code>lCId</code>	Uniquely identifies the LC
<code>lRId</code>	M	<code>lRId</code>	Uniquely identifies the LR

6.6.2.2 Notification notifyLCDeRegistration (M)

6.6.2.2.1 Definition

The LC emits this notification to notify the NM about the completion of the de-registration of the LC with the LR.

Referenced TS	Requirement label	Comment
3GPP TS 28.301 [7]	REQ-LC-IRP-SC2-FUN-004	

6.6.2.2.2 Input parameters

Parameter Name	Support Qualifier	Matching Information / Information Type / Legal Values	Comment
licenseeId	M	licenseeId	Uniquely identifies the LSA Licensee
lCId	M	lCId	Uniquely identifies the LC
lRId	M	lRId	Uniquely identifies the LR

Annex A (informative): Change history

Change history							
Date	Meeting	TDoc	CR	Rev	Cat	Subject/Comment	New version
2017-06	SA#76	SP-170470				Presented for information and approval	1.0.0
2017-06	SA#76					Upgrade to change control version	14.0.0
2018-06	-	-	-	-	-	Update to Rel-15 version (MCC)	15.0.0

History

Document history		
V15.0.0	July 2018	Publication