

# ETSI TS 128 202 V17.1.0 (2023-09)



**5G;  
Charging management;  
Network slice management charging in the 5G System (5GS);  
Stage 2  
(3GPP TS 28.202 version 17.1.0 Release 17)**



---

**Reference**

RTS/TSGS-0528202vh10

---

**Keywords**

5G

**ETSI**

---

650 Route des Lucioles  
F-06921 Sophia Antipolis Cedex - FRANCE

Tel.: +33 4 92 94 42 00 Fax: +33 4 93 65 47 16

Siret N° 348 623 562 00017 - APE 7112B  
Association à but non lucratif enregistrée à la  
Sous-Préfecture de Grasse (06) N° w061004871

---

**Important notice**

The present document can be downloaded from:

<https://www.etsi.org/standards-search>

The present document may be made available in electronic versions and/or in print. The content of any electronic and/or print versions of the present document shall not be modified without the prior written authorization of ETSI. In case of any existing or perceived difference in contents between such versions and/or in print, the prevailing version of an ETSI deliverable is the one made publicly available in PDF format at [www.etsi.org/deliver](http://www.etsi.org/deliver).

Users of the present document should be aware that the document may be subject to revision or change of status.

Information on the current status of this and other ETSI documents is available at

<https://portal.etsi.org/TB/ETSIDeliverableStatus.aspx>

If you find errors in the present document, please send your comment to one of the following services:

<https://portal.etsi.org/People/CommitteeSupportStaff.aspx>

If you find a security vulnerability in the present document, please report it through our  
Coordinated Vulnerability Disclosure Program:

<https://www.etsi.org/standards/coordinated-vulnerability-disclosure>

---

**Notice of disclaimer & limitation of liability**

The information provided in the present deliverable is directed solely to professionals who have the appropriate degree of experience to understand and interpret its content in accordance with generally accepted engineering or other professional standard and applicable regulations.

No recommendation as to products and services or vendors is made or should be implied.

No representation or warranty is made that this deliverable is technically accurate or sufficient or conforms to any law and/or governmental rule and/or regulation and further, no representation or warranty is made of merchantability or fitness for any particular purpose or against infringement of intellectual property rights.

In no event shall ETSI be held liable for loss of profits or any other incidental or consequential damages.

Any software contained in this deliverable is provided "AS IS" with no warranties, express or implied, including but not limited to, the warranties of merchantability, fitness for a particular purpose and non-infringement of intellectual property rights and ETSI shall not be held liable in any event for any damages whatsoever (including, without limitation, damages for loss of profits, business interruption, loss of information, or any other pecuniary loss) arising out of or related to the use of or inability to use the software.

---

**Copyright Notification**

No part may be reproduced or utilized in any form or by any means, electronic or mechanical, including photocopying and microfilm except as authorized by written permission of ETSI.

The content of the PDF version shall not be modified without the written authorization of ETSI.

The copyright and the foregoing restriction extend to reproduction in all media.

© ETSI 2023.  
All rights reserved.

---

# Intellectual Property Rights

## Essential patents

IPRs essential or potentially essential to normative deliverables may have been declared to ETSI. The declarations pertaining to these essential IPRs, if any, are publicly available for **ETSI members and non-members**, and can be found in ETSI SR 000 314: "*Intellectual Property Rights (IPRs); Essential, or potentially Essential, IPRs notified to ETSI in respect of ETSI standards*", which is available from the ETSI Secretariat. Latest updates are available on the ETSI Web server (<https://ipr.etsi.org/>).

Pursuant to the ETSI Directives including the ETSI IPR Policy, no investigation regarding the essentiality of IPRs, including IPR searches, has been carried out by ETSI. No guarantee can be given as to the existence of other IPRs not referenced in ETSI SR 000 314 (or the updates on the ETSI Web server) which are, or may be, or may become, essential to the present document.

## Trademarks

The present document may include trademarks and/or tradenames which are asserted and/or registered by their owners. ETSI claims no ownership of these except for any which are indicated as being the property of ETSI, and conveys no right to use or reproduce any trademark and/or tradename. Mention of those trademarks in the present document does not constitute an endorsement by ETSI of products, services or organizations associated with those trademarks.

**DECT™**, **PLUGTESTS™**, **UMTS™** and the ETSI logo are trademarks of ETSI registered for the benefit of its Members. **3GPP™** and **LTE™** are trademarks of ETSI registered for the benefit of its Members and of the 3GPP Organizational Partners. **oneM2M™** logo is a trademark of ETSI registered for the benefit of its Members and of the oneM2M Partners. **GSM®** and the GSM logo are trademarks registered and owned by the GSM Association.

---

# Legal Notice

This Technical Specification (TS) has been produced by ETSI 3rd Generation Partnership Project (3GPP).

The present document may refer to technical specifications or reports using their 3GPP identities. These shall be interpreted as being references to the corresponding ETSI deliverables.

The cross reference between 3GPP and ETSI identities can be found under <https://webapp.etsi.org/key/queryform.asp>.

---

# Modal verbs terminology

In the present document "**shall**", "**shall not**", "**should**", "**should not**", "**may**", "**need not**", "**will**", "**will not**", "**can**" and "**cannot**" are to be interpreted as described in clause 3.2 of the [ETSI Drafting Rules](#) (Verbal forms for the expression of provisions).

"**must**" and "**must not**" are **NOT** allowed in ETSI deliverables except when used in direct citation.

# Contents

Intellectual Property Rights .....	2
Legal Notice .....	2
Modal verbs terminology.....	2
Foreword.....	5
1 Scope .....	7
2 References .....	7
3 Definitions of terms, symbols and abbreviations .....	8
3.1 Terms.....	8
3.2 Symbols.....	8
3.3 Abbreviations .....	8
4 Architecture considerations .....	8
4.1 High level architecture .....	8
4.2 Network Slice Management converged charging architecture .....	9
4.2.1 High level architecture network slice charging.....	9
4.2.2 Converged charging architecture .....	9
5 Network Slice Management charging principles and scenarios.....	10
5.1 Network Slice Management charging principles.....	10
5.1.1 General.....	10
5.1.2 Requirements .....	10
5.1.3 Network Slice Management charging information .....	11
5.1.4 CHF selection .....	12
5.2 Network Slice Management charging scenarios.....	12
5.2.1 Basic principles.....	12
5.2.1.1 General .....	12
5.2.1.2 Applicable triggers in Network Slice Management charging.....	12
5.2.2 Message flows .....	13
5.2.2.1 General .....	13
5.2.2.2 NSI Creation - PEC.....	13
5.2.2.3 NSI Modification - PEC.....	16
5.2.2.4 NSI Termination - PEC.....	18
5.2.3 CDR generation .....	20
5.2.3.1 Introduction.....	20
5.2.3.2 Triggers for CHF CDR.....	20
5.2.3.2.1 General .....	20
5.2.3.2.2 Triggers for CHF CDR generation .....	20
5.2.4 Ga record transfer flows .....	20
5.2.5 Bns CDR file transfer .....	20
6 Definition of charging information .....	20
6.1 Data description for network slice management charging.....	20
6.1.1 Message contents .....	20
6.1.1.1 General .....	20
6.1.1.2 Charging Data Request message .....	21
6.1.1.3 Charging data response message.....	21
6.1.2 Ga message contents.....	21
6.1.3 CDR description on the B <sub>ns</sub> interface.....	21
6.1.3.1 General .....	21
6.1.3.2 Network Slice Management charging CHF CDR data.....	22
6.2 Network Slice management charging specific parameters .....	22
6.2.1 Definition of Network Slice management charging information.....	22
6.2.1.1 General .....	22
6.2.1.2 Definition of Network Slice Management charging information.....	23
6.2.1.3 Definition of Service profile charging information.....	23

6.2.2 Formal Network Slice management charging parameter description .....24  
6.2.2.1 Network Slice management charging CHF CDR parameters .....24  
6.2.2.2 Network Slice management charging resources attributes .....24  
**Annex A (informative): Change history .....25**  
History .....26

---

# Foreword

This Technical Specification has been produced by the 3rd Generation Partnership Project (3GPP).

The contents of the present document are subject to continuing work within the TSG and may change following formal TSG approval. Should the TSG modify the contents of the present document, it will be re-released by the TSG with an identifying change of release date and an increase in version number as follows:

Version x.y.z

where:

- x the first digit:
  - 1 presented to TSG for information;
  - 2 presented to TSG for approval;
  - 3 or greater indicates TSG approved document under change control.
- y the second digit is incremented for all changes of substance, i.e. technical enhancements, corrections, updates, etc.
- z the third digit is incremented when editorial only changes have been incorporated in the document.

In the present document, modal verbs have the following meanings:

- shall** indicates a mandatory requirement to do something
- shall not** indicates an interdiction (prohibition) to do something

The constructions "shall" and "shall not" are confined to the context of normative provisions, and do not appear in Technical Reports.

The constructions "must" and "must not" are not used as substitutes for "shall" and "shall not". Their use is avoided insofar as possible, and they are not used in a normative context except in a direct citation from an external, referenced, non-3GPP document, or so as to maintain continuity of style when extending or modifying the provisions of such a referenced document.

- should** indicates a recommendation to do something
- should not** indicates a recommendation not to do something
- may** indicates permission to do something
- need not** indicates permission not to do something

The construction "may not" is ambiguous and is not used in normative elements. The unambiguous constructions "might not" or "shall not" are used instead, depending upon the meaning intended.

- can** indicates that something is possible
- cannot** indicates that something is impossible

The constructions "can" and "cannot" are not substitutes for "may" and "need not".

- will** indicates that something is certain or expected to happen as a result of action taken by an agency the behaviour of which is outside the scope of the present document
- will not** indicates that something is certain or expected not to happen as a result of action taken by an agency the behaviour of which is outside the scope of the present document
- might** indicates a likelihood that something will happen as a result of action taken by some agency the behaviour of which is outside the scope of the present document

**might not** indicates a likelihood that something will not happen as a result of action taken by some agency the behaviour of which is outside the scope of the present document

In addition:

**is** (or any other verb in the indicative mood) indicates a statement of fact

**is not** (or any other negative verb in the indicative mood) indicates a statement of fact

The constructions "is" and "is not" do not indicate requirements.

---

# 1 Scope

The present document specifies the Converged Charging description for network slice management charging in the 5G System (5GS). The present document specifies the charging aspects for management of network slicing in mobile networks.

The following management operations are within the scope:

- Network Slice Instance creation, modification and termination;
- Network Slice Instance activation and deactivation.

---

# 2 References

The following documents contain provisions which, through reference in this text, constitute provisions of the present document.

- References are either specific (identified by date of publication, edition number, version number, etc.) or non-specific.
- For a specific reference, subsequent revisions do not apply.
- For a non-specific reference, the latest version applies. In the case of a reference to a 3GPP document (including a GSM document), a non-specific reference implicitly refers to the latest version of that document *in the same Release as the present document*.

- [1] 3GPP TS 32.240: "Telecommunication management; Charging management; Charging architecture and principles".
- [2] - [14] Void
- [15] 3GPP TS 32.255: "Telecommunication management; Charging management; 5G Data connectivity domain charging; stage 2".
- [16] - [49] Void
- [50] 3GPP TS 32.290: "Telecommunication management; Charging management; 5G system; Services, operations and procedures of charging using Service Based Interface (SBI)".
- [51] 3GPP TS 32.291: "Telecommunication management; Charging management; 5G system; Charging service, stage 3".
- [52] - [54] Void.
- [55] 3GPP TS 32.295: "Telecommunication management; Charging management; Charging Data Record (CDR) transfer".
- [56] 3GPP TS 32.297: "Telecommunication management; Charging management; Charging Data Record (CDR) file format and transfer".
- [57] 3GPP TS 32.298: "Telecommunication management; Charging management; Charging Data Record (CDR) parameter description".
- [58] - [99] Void.
- [70] 3GPP TS 28.201: "Charging management; Network slice performance and analytics charging in the 5G System (5GS); Stage 2".
- [71] - [99] Void.
- [100] 3GPP TR 21.905: "Vocabulary for 3GPP Specifications".
- [101] - [199] Void.



[200] - [249]	Void.
[250]	3GPP TS 28.533: "Management and orchestration; Architecture framework".
[251]	3GPP TS 28.530: "Management and orchestration; Concepts, use cases and requirements".
[252]	3GPP TS 28.531: "Management and orchestration; Provisioning".
[253]	3GPP TS 28.532: "Management and orchestration; Generic management services".
[254]	3GPP TS 28.541: "Management and orchestration; 5G Network Resource Model (NRM); Stage 2 and stage 3".
[255] - [299]	Void.
[300] - [399]	Void.
[400] - [499]	Void.
[500] - [599]	Void.

---

## 3 Definitions of terms, symbols and abbreviations

### 3.1 Terms

For the purposes of the present document, the terms given in 3GPP TR 21.905 [100] and the following apply. A term defined in the present document takes precedence over the definition of the same term, if any, in 3GPP TR 21.905 [100].

### 3.2 Symbols

For the purposes of the present document, the following symbols apply:

Bns	Reference point for the CDR file transfer from the Network slice CGF to the BD.
Ga	Reference point for CDR transfer between a CDF and the CGF.
Nchf	Service based interface exhibited by CHF.

### 3.3 Abbreviations

For the purposes of the present document, the abbreviations given in 3GPP TR 21.905 [100] and the following apply. An abbreviation defined in the present document takes precedence over the definition of the same abbreviation, if any, in 3GPP TR 21.905 [100].

CEF	Charging Enablement Function
MnS	Management Service
NSI	Network Slice Instance
NSM	Network Slice Management
NSSAI	Network Slice Selection Assistance Information
S-NSSAI	Single Network Slice Selection Assistance Information
SLS	Service Level Specification

---

## 4 Architecture considerations

### 4.1 High level architecture

The high level service based management architecture for Network Slicing management is specified in TS 28.533 [250] clause 4, with Management Services (MnS) produced by MnS Producer and consumed by MnS Consumer.

## 4.2 Network Slice Management converged charging architecture

### 4.2.1 High level architecture network slice charging

The scope of the present document is network slice management charging, the details for other types of network slice charging are defined in TS 32.255 [15] and TS 28.201 [70].

### 4.2.2 Converged charging architecture

Network Slice Management converged charging can be achieved under the alternatives:

- Charging Trigger Function (CTF) based, as depicted in figure 4.2.2.1.
- Charging Enablement Function (CEF) based, as depicted in figure 4.2.2.2.

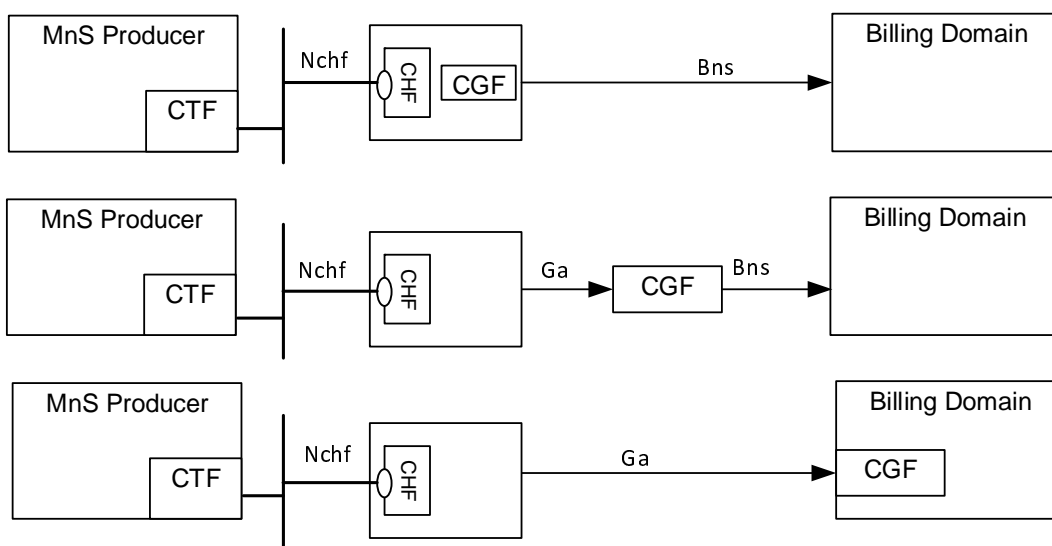

Figure 4.2.2.1: Network Slice Management converged charging architecture (CTF)

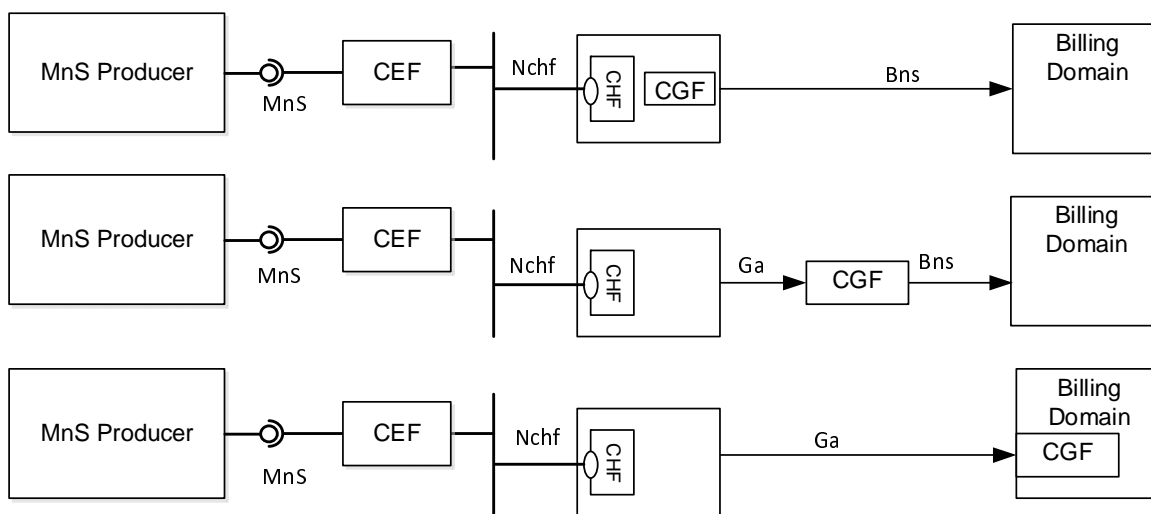

Figure 4.2.2.2: Network Slice Management converged charging architecture (CEF)

The Charging Trigger Function (CTF) is specified in TS 32.240 [1].

The Charging Enablement Function (CEF) is defined in TS 32.240 [1]: charging information addressed by the CEF in the present document, are related to provisioning for network slices.

The MnS producer is defined in TS 28.533 [250]: the MnS producer in the present document is the producer of provisioning MnS.

For network slice management converged charging the CEF is a consumer of both:

- provisioning service (MnS) for network slice exposed by the MnS Producer, specified in TS 28.532 [253];
- charging (Nchf) service.

Details on the interfaces and functions can be found in TS 32.240 [1] for the general architecture components. Ga is described in clause 5.2.4 and Bns in clause 5.2.5 of the present document, and Nchf is described in TS 32.290 [50].

---

## 5 Network Slice Management charging principles and scenarios

### 5.1 Network Slice Management charging principles

#### 5.1.1 General

The charging functions for the Network Slice Management charging, are based on provisioning management services used for provisioning of network slice.

The management services are specified under TS 28.533 [250], TS 28.532 [253] and TS 28.541 [254]. Management services and procedures for provisioning are described TS 28.531 [252].

How a MnS consumer consumes and is authorized to consume provisioning MnS produced by the MnS producer, are out of the scope of the present document.

The network slice subscriber is the tenant, i.e. the party for which the network slice instance(s) is(are) created, satisfying the requirements of subscribed-to service(s).

NOTE 1: these service(s) requirements may take the form of Service Level Specification (SLS) per TS 28.530 [251] definition, supplied by external service providers (e.g. MVNO, Verticals, enterprises), in which case the tenant is the external service provider.

NOTE 2: these service(s) requirements may be built by a MNO for its own operational needs, in which case the tenant is the MNO itself, and the tenant id may not be present.

Depending on the relationship and deployment model between the tenant and the party owning the MnS producer, the MnS consumer of the provisioning MnS may be the tenant.

The following provisioning of network slice procedures of clause 7 in TS 28.531 [252] are considered for Network Slice Management charging:

- Network Slice Instance (NSI) Creation.
- Network Slice Instance (NSI) Modification.
- Network Slice Instance (NSI) Termination.

Network Slice Instance (NSI) is defined in TS 28.530 [251].

#### 5.1.2 Requirements

The following are high-level charging requirements specific to the Network Slice Management charging:

- The CEF shall support converged charging.

- The CEF shall collect charging information per NSI Creation, Modification and Termination.
- The Service Producer (CTF) shall support converged charging.
- The Service Producer (CTF) shall collect charging information per NSI Creation, Modification and Termination.

### 5.1.3 Network Slice Management charging information

The charging information for Network Slice Management charging are defined under the following list:

- identity of the MnS consumer of provisioning MnS.
- identity of the tenant, i.e. viewed as the network slice subscriber.
- operation type invoked by MnS consumer of provisioning MnS.
- identifier of the Network Slice Instance.
- network slice related requirements identified by a service profile as defined in TS 28.530 [251] clause 4.6.2 and detailed in TS 28.541 [254] clause 6.3.3.

The following non-exhaustive list of information elements of the service profile are identified for Network Slice Management charging:

- Service Profile identifier.
- S-NSSAI(s).
- SST.
- Latency.
- Resource Sharing Level.
- Availability.
- Jitter.
- Reliability.
- Maximum Number of UEs.
- Coverage Area.
- Max Number of PDU sessions,
- UE mobility Level.
- Delay Tolerance.
- UL/DL Throughput Per UE.
- UL/DL Throughput Per UE.
- UL/DL Throughput Per Slice.
- KPI Monitoring.
- Supported Access Technology.
- V2X Communication Mode.

## 5.1.4 CHF selection

The CHF selection by the MnS Producer (CTF)/CEF is based on the following options and with this priority order (highest to lowest):

- NRF based discovery;
- pre-configured CHF address(s).

## 5.2 Network Slice Management charging scenarios

### 5.2.1 Basic principles

#### 5.2.1.1 General

Network Slice Management charging is performed by the Service Producer (CTF) of provisioning MnS or the CEF interacting with CHF using Nchf specified in TS 32.290 [50] and TS 32.291 [51]. In order to provide the data required for the charging management activities outlined in TS 32.240 [1], the Service Producer (CTF) or CEF shall be able to perform converged charging for provisioning MnS when consumed by MnS consumer for NSI allocation, modification and deallocation.

The Service Producer (CTF) of provisioning MnS or CEF shall be able to perform converged charging by interacting with CHF, for charging data related to Network Slice Management. The Charging Data Request and Charging Data Response are exchanged between the Service Producer (CTF) and the CHF or between the CEF and the CHF, based on PEC scenarios specified in TS 32.290 [50]. The Charging Data Request is issued by the Service Producer (CTF) or CEF towards the CHF when certain conditions (chargeable events) are met.

The CEF shall be able to consume services related to provisioning MnS events, defined in TS 28.531 [252], for collecting charging information related to Network Slice Management.

The contents and purpose of each charging event that triggers interaction with CHF, as well as the chargeable events that trigger them, are described in clauses 5.2.2.

A detailed formal description of the converged charging parameters to CHF defined in the present document can be found in TS 32.291 [51].

A detailed formal description of the CDR parameters defined in the present document can be found in TS 32.298 [57].

Whether network slice management charging is active is configured in MnS producer or CEF.

#### 5.2.1.2 Applicable triggers in Network Slice Management charging

A set of trigger conditions are defined for the CEF or Service Producer (CTF) to invoke a Charging Data Request [Event] towards the CHF.

Table 5.2.1.2.1 summarizes the set of default trigger conditions and their category which shall be supported by the Service Producer (CTF).

**Table 5.2.1.2.1: Default Trigger conditions in CEF or Service Producer (CTF)**

Trigger Conditions	Trigger level	Default category	CHF allowed to change category	CHF allowed to enable and disable	Message when "immediate reporting" category
NSI Allocated	-	Immediate	Not Applicable	Not Applicable	Charging Data Request [Event]
NSI Modified	-	Immediate	Not Applicable	Not Applicable	Charging Data Request [Event]
NSI Terminated	-	Immediate	Not Applicable	Not Applicable	Charging Data Request [Event]

The CDR generation mechanism processed by the CHF upon receiving Charging Data Request [Event] issued by the CEF or Service Producer (CTF) for these chargeable events, is specified in clause 5.2.3.

## 5.2.2 Message flows

### 5.2.2.1 General

The management services for network slice provisioning, specified in TS 28.531 [252], enables its consumer to request allocating, deallocating or modifying an NSI. The following operations are defined to enable this: createMOI, deleteMOI, getMOIAttributes, modifyMOIAttributes, allocateNsi and deallocateNsi. Use of any of these operations, with the exception of getMOIAttributes, can be subscribed to for charging purposes.

The CEF shall use this subscription possibility to get notifications based on the operations used and filtered for network slice.

The flows in the present document specify the interaction between an MnS producer with a CTF and the CHF for Network Slice Management charging functionality, in some scenarios, based on TS 28.531 [252] clause 7 procedures and flows.

The table 5.2.2.1.1 describes the mapping between the messages used in the flows, and the Operations specified in TS 28.531 [252].

**Table 5.2.2.1.1: Messages mapping to Operations**

Message	Operations
NSI Creation Request/Response	createMOI allocateNsi
NSI Modification Request/Response	modifyMOIAttributes
NSI Termination Request/Response	deleteMOI deallocateNsi
Notification (NSI created)/Notification Ack	notifyMOICreation
Notification (NSI modified)/Notification Ack	notifyMOIAttributeValueChanges
Notification (NSI terminated)/Notification Ack	notifyMOIDeletion

### 5.2.2.2 NSI Creation - PEC

The scenario where a NSI Creation request is invoked towards a Service Producer is described for the two architecture options in PEC mode.

Figure 5.2.2.2.1 describes the message flows with CTF internal to Service Producer.

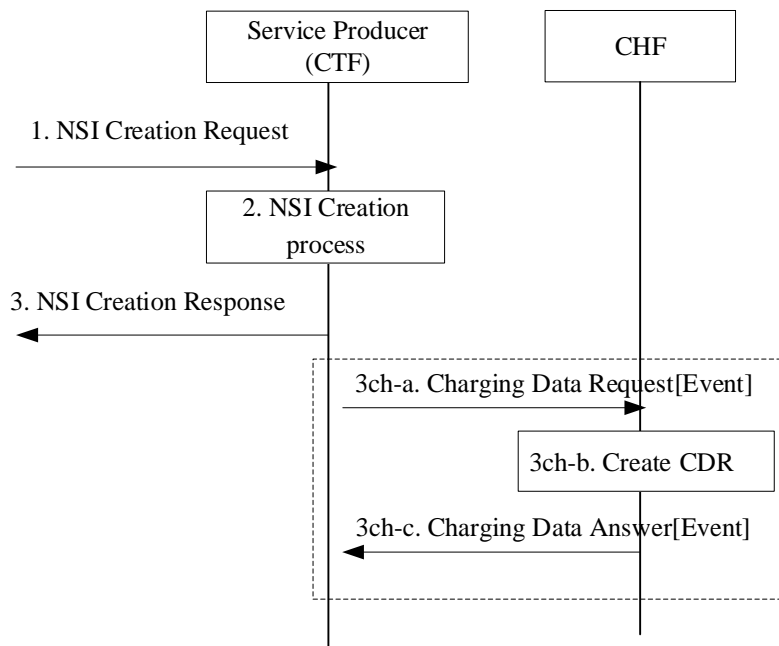

**Figure 5.2.2.2.1: NSI Creation - Internal CTF - PEC**

1. The Service Producer (CTF) receives an NSI Creation Request from an MnS consumer.
  2. The Service Producer (CTF) performs NSI Creation process by creating a new NSI or using an existing NSI.
  3. The Service Producer (CTF) sends the NSI Creation Response with appropriate result.
- 3ch-a. The Service Producer (CTF) sends Charging Data Request [Event] to CHF associated to the NSI Creation transaction.
- 3ch-b. The CHF creates a CDR for this NSI Creation transaction.
- 3ch-c. The CHF acknowledges by sending Charging Data Response [Event] to the Service Producer (CTF).

Figure 5.2.2.2.2 describes the message flows with CEF.

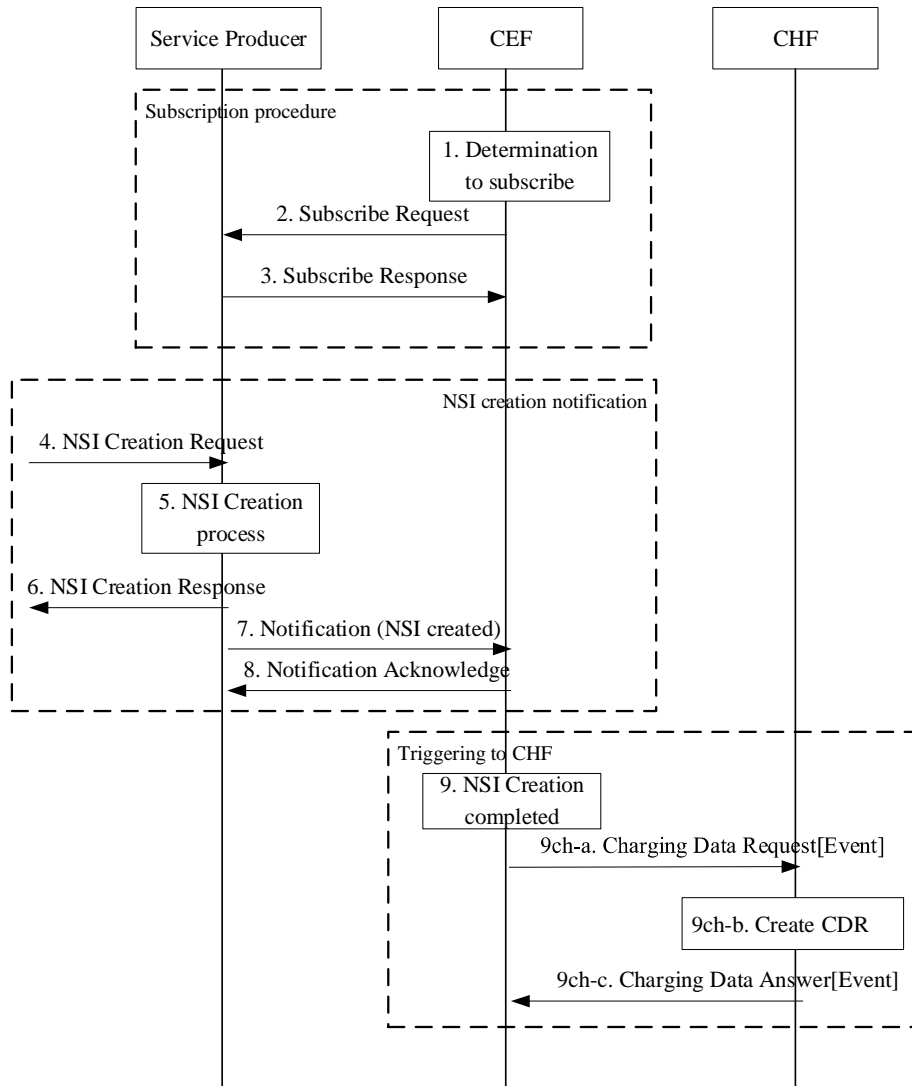

**Figure 5.2.2.2.2: NSI creation - CEF - PEC**

1. Determination by CEF to subscribe to any new NSI creation using MnS provisioning.
  2. Subscribe Request: the CEF subscribes to new NSI creation using MnS provisioning.
  3. Subscribe Response: the Service Producer sends successful subscription response.
  4. The Service Producer receives an NSI Creation Request from an MnS consumer.
  5. The Service Producer performs NSI Creation process by creating a new NSI or using an existing NSI.
  6. The Service Producer sends the NSI Creation Response with appropriate result.
  7. Notification: the Service Producer notifies the CEF that a new NSI has been created using MnS provisioning.
  8. Notification Acknowledge sent by the CEF.
- Steps 4 to 8 can be repeated.
9. NSI Creation completed
- 9ch-a. The CEF sends Charging Data Request [Event] to CHF associated to the NSI Creation transaction.
- 9ch-b. The CHF creates a CDR for this NSI Creation transaction.
- 9ch-c. The CHF acknowledges by sending Charging Data Response to the CEF.



Steps 9 to 9ch-c can be repeated.

### 5.2.2.3 NSI Modification - PEC

The scenario where a NSI Modification request is invoked towards a Service Producer (CTF) is described for the two architecture options in PEC mode.

Figure 5.2.2.3.1 describes the message flows with CTF internal to Service Producer.

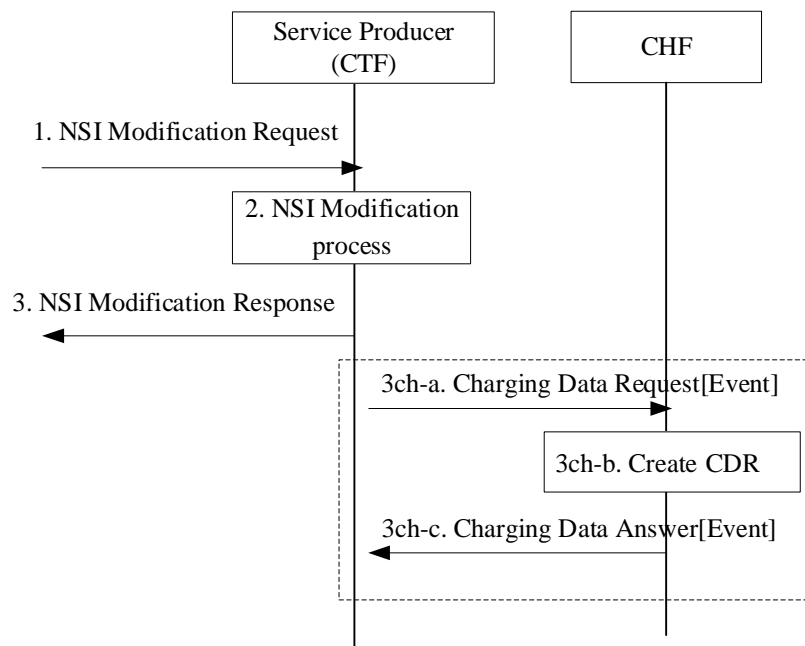

**Figure 5.2.2.3.1: NSI Modification - internal CTF - PEC**

1. The Service Producer (CTF) receives an NSI Modification Request from an MnS consumer.
  2. The Service Producer (CTF) performs NSI Modification process.
  3. The Service Producer (CTF) sends the NSI Modification Response with appropriate result.
- 3ch-a. The Service Producer (CTF) sends Charging Data Request [Event] to CHF associated to the NSI Modification transaction.
- 3ch-b. The CHF creates a CDR for this NSI Modification transaction.
- 3ch-c. The CHF acknowledges by sending Charging Data Response [Event] to the Service Producer (CTF).

Figure 5.2.2.3.2 describes the message flows with CEF.

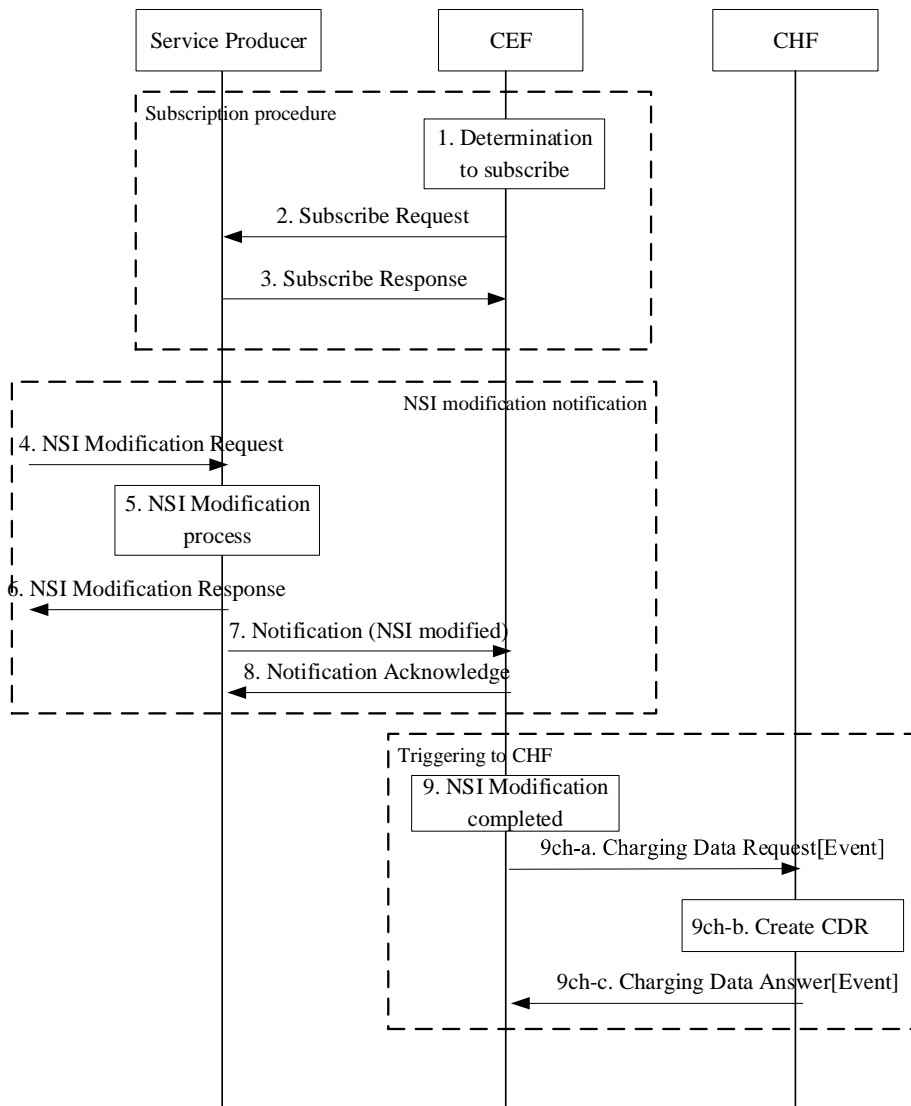

**Figure 5.2.2.3.2: NSI Modification - CEF - PEC**

1. Determination by CEF to subscribe to NSI modification.
2. Subscribe Request: the CEF subscribes to NSI modification using MnS provisioning.
3. Subscribe Response: the Service Producer sends successful response.
4. The Service Producer receives an NSI Modification Request from an MnS consumer for this particular NSI.
5. The Service Producer performs NSI Modification process.
6. The Service Producer sends the NSI Modification Response with appropriate result.
7. Notification: the Service Producer notifies the CEF by using MnS provisioning, that the particular NSI has been modified.
8. Notification Acknowledge sent by the CEF.

Steps 4 to 8 can be repeated.

9. NSI Modification completed

9ch-a. The CEF sends Charging Data Request [Event] to CHF associated to the NSI Modification transaction.

9ch-b. The CHF creates a CDR for this NSI Modification transaction.

9ch-c. The CHF acknowledges by sending Charging Data Response [Event] to the CEF.

Steps 9 to 9ch-c can be repeated.

### 5.2.2.4 NSI Termination - PEC

The scenario where a NSI Termination request is invoked towards a Service Producer (CTF) is described for the two architecture options in PEC mode.

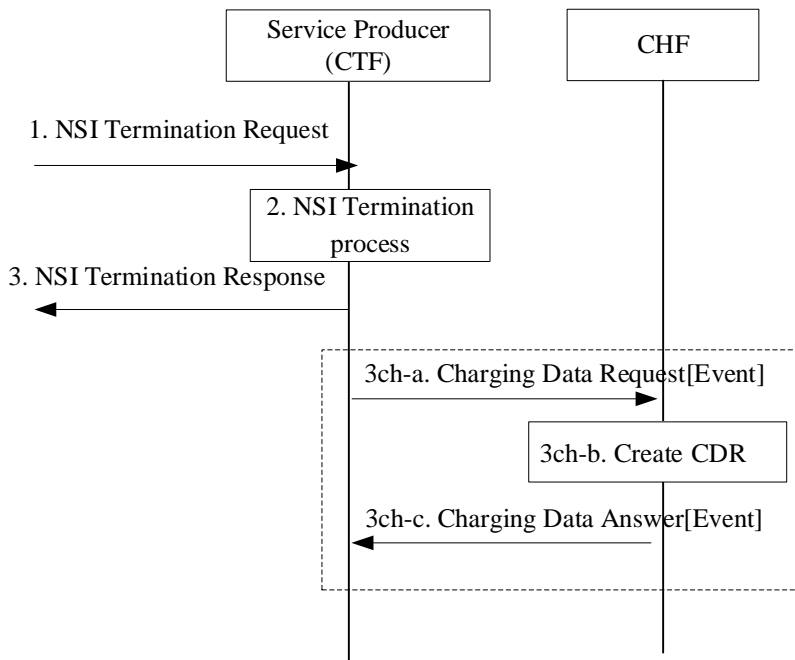

**Figure 5.2.2.4.1: NSI Termination - internal CTF - PEC**

1. The Service Producer (CTF) receives an NSI Termination Request from an MnS consumer.
2. The Service Producer (CTF) performs the NSI Termination process.
3. The Service Producer (CTF) sends the NSI Termination Response.
- 3ch-a. The Service Producer (CTF) sends Charging Data Request [Event] to CHF associated to the NSI Termination transaction.
- 3ch-b. The CHF creates a CDR for this NSI Termination transaction.
- 3ch-c. The CHF acknowledges by sending Charging Data Response [Event] to the Service Producer (CTF).

Figure 5.2.2.4.2 describes the message flows with CEF.

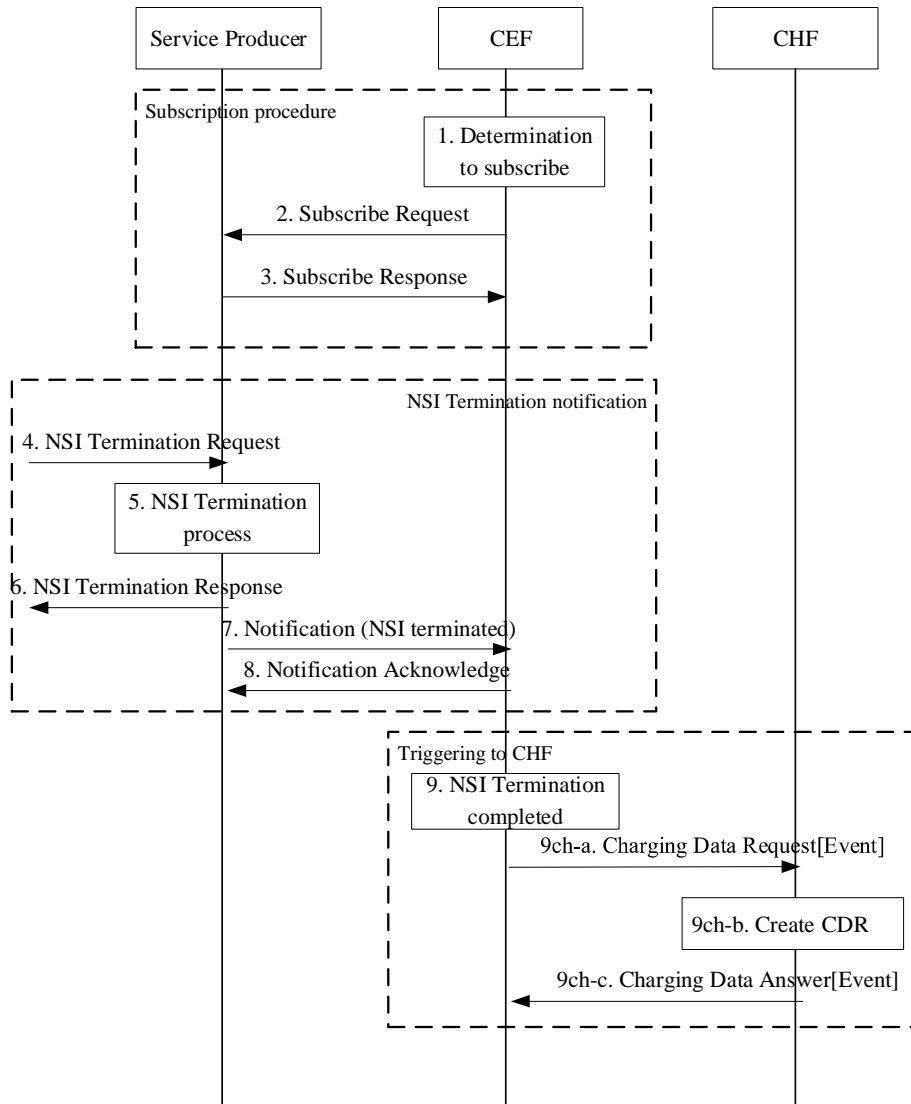

**Figure 5.2.2.4.2: NSI Termination - CEF - PEC**

1. Determination by CEF to subscribe to NSI termination.
2. Subscribe Request: the CEF subscribes to NSI Termination using MnS provisioning.
3. Subscribe Response: the Service Producer sends successful response.
4. The Service Producer receives an NSI Termination Request from an MnS consumer for this particular NSI.
5. The Service Producer performs NSI Termination process.
6. The Service Producer sends the NSI Termination Response with appropriate result.
7. Notification: the Service Producer notifies the CEF by using MnS provisioning, that the particular NSI has been terminated.
8. Notification Acknowledge sent by the CEF.

Steps 4 to 8 can be repeated.

9. NSI Termination completed

9ch-a. The CEF sends Charging Data Request [Event] to CHF associated to the NSI Termination transaction.

9ch-b. The CHF creates a CDR for this NSI Termination transaction.

9ch-c. The CHF acknowledges by sending Charging Data Response [Event] to the CEF.

Steps 9 to 9ch-c can be repeated.

## 5.2.3 CDR generation

### 5.2.3.1 Introduction

The CHF CDRs for Network slice management charging are generated by the CHF to collect charging information that they subsequently transfer to the Charging Gateway Function (CGF).

The following clauses describe in detail the conditions for generating the CHF CDR, which shall be supported by the CHF.

### 5.2.3.2 Triggers for CHF CDR

#### 5.2.3.2.1 General

A Network slice management charging CHF CDR is used to capture charging information related to Network slice management chargeable events.

#### 5.2.3.2.2 Triggers for CHF CDR generation

A Network slice management charging CHF CDR is generated by the CHF for each received Charging Data Request [Event].

## 5.2.4 Ga record transfer flows

Details of the Ga protocol application are specified in TS 32.295 [55].

## 5.2.5 Bns CDR file transfer

Details of the Bns protocol application are specified in TS 32.297 [56].

---

# 6 Definition of charging information

## 6.1 Data description for network slice management charging

### 6.1.1 Message contents

#### 6.1.1.1 General

The Charging Data Request and Charging Data Response are specified in subclause 5.1.2.2.1 of TS 32.290 [50].

Table 6.1.1.1.1 describes the use of these messages for network slice management charging.

**Table 6.1.1.1.1: Network slice management charging messages reference table**

Message	Source	Destination
Charging Data Request	MnS producer/ CEF	CHF
Charging Data Response	CHF	MnS producer/ CEF

The following clauses describe the different fields used in the Charging Data messages and the category in the tables is used according to the charging data configuration defined in clause 5.4 of TS 32.240 [1].

### 6.1.1.2 Charging Data Request message

Table 6.1.1.2.1 illustrates the basic structure of a Charging Data Request message from the CEF or MnS producer as used for Network slice management charging.

**Table 6.1.1.2.1: Charging Data Request message contents**

Information Element	Category for converged charging	Description
Session Identifier	O <sub>C</sub>	Described in TS 32.290 [57]
Subscriber Identifier	-	This field is not applicable.
Tenant Identifier	O <sub>M</sub>	This fields holds the identifier of the tenant the network slice instance is created for.
MnS Consumer Identifier	O <sub>M</sub>	This fields holds the identifier of the MnS Consumer of Provisioning MnS.
NF Consumer Identification	M	Described in TS 32.290 [57] and holds the identifier of the CEF or MnS producer.
Invocation Timestamp	M	Described in TS 32.290 [57]
Invocation Sequence Number	M	Described in TS 32.290 [57]
One-time Event	O <sub>C</sub>	Described in TS 32.290 [57]
One-time Event Type	O <sub>C</sub>	Described in TS 32.290 [57]
Notify URI	-	This field is not applicable.
Service Specification Information	O <sub>C</sub>	Described in TS 32.290 [57]
Triggers	-	This field is not applicable.
Multiple Unit Usage	-	This field is not applicable.
NSM Charging information	O <sub>M</sub>	This field holds NSM specific information described in clause 6.2.1.2

### 6.1.1.3 Charging data response message

Table 6.1.1.3.1 illustrates the basic structure of a Charging Data Response message from the CHF to the MnS producer or CEF as used for Network slice management charging.

**Table 6.1.1.3.1: Charging Data Response message contents**

Information Element	Category for converged charging	Description
Session Identifier	O <sub>C</sub>	Described in TS 32.290 [57]
Invocation Timestamp	M	Described in TS 32.290 [57]
Invocation Result	O <sub>C</sub>	Described in TS 32.290 [57]
Invocation Sequence Number	M	Described in TS 32.290 [57]
Session Failover	-	This field is not applicable.
Triggers	-	This field is not applicable.
Multiple Unit Information	-	This field is not applicable.

## 6.1.2 Ga message contents

See clause 5.2.4.

## 6.1.3 CDR description on the B<sub>ns</sub> interface

### 6.1.3.1 General

This clause describes the CDR content and format generated for Network Slice Management charging.

The following tables provide a brief description of each CDR parameter. The category in the tables is used according to the charging data configuration defined in clause 5.4 of TS 32.240 [1]. Full definitions of the CDR parameters, sorted by the name in alphabetical order, are provided in TS 32.298 [57].

### 6.1.3.2 Network Slice Management charging CHF CDR data

If enabled, CHF CDRs for Network Slice Management charging shall be produced for each Network Slice Management operations.

The fields of Network Slice Management charging CHF CDR are specified in table 6.1.3.2.1.

**Table 6.1.3.2.1: Network Slice Management charging CHF record data**

Field	Category	Description
Record Type	M	CHF record.
Recording Network Function ID	O <sub>M</sub>	This field holds the name of the recording entity, i.e. the CHF id.
Subscriber Identifier	-	This field is not applicable.
Tenant Identifier	O <sub>M</sub>	This field holds the identifier of the tenant the network slice instance is created for.
MnS Consumer Identifier	O <sub>M</sub>	This fields holds the identifier of the MnS Consumer of Provisioning MnS.
NF Consumer Information	M	This field holds the information of the entity that used the charging service (i.e. Service Producer (CTF), CEF).
NF Functionality	M	This field contains the function of the entity: Service Producer (CTF) or CEF
NF Name	O <sub>C</sub>	This field holds the name of the entity.
NF Address	O <sub>C</sub>	This field holds the IP Address of the entity
NF PLMN ID	O <sub>C</sub>	This field holds the PLMN identifier (MCC MNC) of the entity.
Record Opening Time	M	Described in TS 32.298 [57]
Duration	M	Described in TS 32.298 [57]
Record Sequence Number	C	Described in TS 32.298 [57]
Cause for Record Closing	M	Described in TS 32.298 [57]
Diagnostics	O <sub>M</sub>	Described in TS 32.298 [57]
Local Record Sequence Number	O <sub>M</sub>	Described in TS 32.298 [57]
Record Extensions	O <sub>C</sub>	Described in TS 32.298 [57]
NSM Charging information	O <sub>M</sub>	This field holds the Network Slice Management Charging information defined in clause 6.2.1.2.

## 6.2 Network Slice management charging specific parameters

### 6.2.1 Definition of Network Slice management charging information

#### 6.2.1.1 General

The Charging Information parameter used for Network Slice management charging is provided in the following clauses.

### 6.2.1.2 Definition of Network Slice Management charging information

Specific charging information used for Network Slice Management charging is provided within the NSM Charging Information.

The detailed structure of the NSM Charging Information can be found in table 6.2.1.2.1.

**Table 6.2.1.2.1: Structure of NSM Charging Information**

Information Element	Category	Description
Management operation	M	This field holds the management operation associated to with the provisioning.
Identifier of NetworkSlice Instance	O <sub>M</sub>	This field holds the identifier of the Network Slice Instance as defined in TS 28.530 [251] .
List of Service profile charging information	O <sub>M</sub>	This field holds the list of service profile charging information supported by the Network Slice instance and is defined in clause 6.2.1.3.
Management operation status	O <sub>C</sub>	This field holds the status of the management operation (Succeeded or Failed), as defined in TS 28.532 [253] clause 11.1.1.1.3.
Operational state	O <sub>C</sub>	This field indicates the operational state of the network slice instance (enabled or disabled), as defined in TS 28.541 [254] clause 6.4.1.
Administrative state	O <sub>C</sub>	This indicates the administrative state of the network slice instance (locked, unlocked or shuttingdown), as defined in TS 28.541 [254] clause 6.4.1.

### 6.2.1.3 Definition of Service profile charging information

The service profile is defined in TS 28.541 [254], clause 6.3.3. Service profile specific charging information used for Network Slice Management charging is provided within the Service profile charging information.

The detailed structure of the Service profile charging information can be found in table 6.2.1.3.1.

**Table 6.2.1.3.1: Structure of Service profile Charging Information**

Information Element	Category	Description
Service Profile Id	O <sub>M</sub>	Described in TS 28.541 [254] clause 6.4 serviceProfileId attribute
S-NSSAIs List	O <sub>M</sub>	Described in TS 28.541 [254] clause 6.4 sNSSAIsList attribute
SST	O <sub>M</sub>	Described in TS 28.541 [254] clause 6.4 sST attribute
Latency	O <sub>C</sub>	Described in TS 28.541 [254] clause 6.4 latency attribute
Availability	O <sub>C</sub>	Described in TS 28.541 [254] clause 6.4 availability attribute
Resource Sharing Level	O <sub>C</sub>	Described in TS 28.541 [254] clause 6.4 serviceProfile.resourceSharingLevel attribute
Jitter	O <sub>C</sub>	Described in TS 28.541 [254] clause 6.4 jitter attribute
Reliability	O <sub>C</sub>	Described in TS 28.541 [254] clause 6.4 d reliability attribute
Maximum Number of UEs	O <sub>C</sub>	Described in TS 28.541 [254] clause 6.4 maxNumberOfUEs attribute
Coverage Area	O <sub>C</sub>	Described in TS 28.541 [254] clause 6.4 coverageArea attribute
UE Mobility Level	O <sub>C</sub>	Described in TS 28.541 [254] clause 6.4 uEMobilityLevel attribute
Delay Tolerance	O <sub>C</sub>	Described in TS 28.541 [254] clause 6.4 delayTolerance attribute
DL Throughput Per Slice	O <sub>C</sub>	Described in TS 28.541 [254] clause 6.4 dLThptPerSlice attribute
DL Throughput Per UE	O <sub>C</sub>	Described in TS 28.541 [254] clause 6.4 dLThptPerUE attribute
UL Throughput Per Slice	O <sub>C</sub>	Described in TS 28.541 [254] clause 6.4 uLThptPerSlic attribute
UL Throughput Per UE	O <sub>C</sub>	Described in TS 28.541 [254] clause 6.4 uLThptPerUE attribute
Max Number of PDU sessions	O <sub>C</sub>	Described in TS 28.541 [254] clause 6.4 maxNumberOfConns.nOofConn attribute
KPIs Monitoring list	O <sub>C</sub>	Described in TS 28.541 [254] clause 6.4 kPIMonitoring attribute
Supported Access Technology	O <sub>C</sub>	Described in TS 28.541 [254] clause 6.4 SupportedAccessTech.accTechList attribute
V2X Communication Mode	O <sub>C</sub>	Described in TS 28.541 [254] clause 6.4 V2XCommMode.v2XMode attribute
Additional service profile charging information	O <sub>C</sub>	This fields holds additional attributes of the service profile.



## 6.2.2 Formal Network Slice management charging parameter description

### 6.2.2.1 Network Slice management charging CHF CDR parameters

The detailed definitions, abstract syntax and encoding of Network Slice management charging CHF CDRs parameters are specified in TS 32.298 [57].

### 6.2.2.2 Network Slice management charging resources attributes

The detailed definitions of resources attributes used for Network Slice management charging are specified in TS 32.291 [51].

---

## Annex A (informative): Change history

Change history							
Date	Meeting	TDoc	CR	Rev	Cat	Subject/Comment	New version
2020-09	SA#89e					Upgrade to change control version, including EditHelp review	16.0.0
2020-12	SA#90e	SP-201044	0001	1	F	Correction of Abbreviation NSM	16.1.0
2020-12	SA#90e	SP-201044	0002	1	F	Correction of the Category of Subscriber Identifier	16.1.0
2022-03	-	-	-	-	-	Update to Rel-17 version (MCC)	<b>17.0.0</b>
2023-09	SA#101	SP-230944	0003		F	Correction on references	17.1.0
2023-09	SA#101	SP-230944	0004	1	F	Correction on triggers for CEF based architecture	17.1.0

---

# History

<b>Document history</b>		
V17.0.0	April 2022	Publication
V17.1.0	September 2023	Publication