

ETSI TS 126 502 V17.4.0 (2023-04)



**5G;
5G multicast-broadcast services;
User service architecture
(3GPP TS 26.502 version 17.4.0 Release 17)**



Reference

RTS/TSGS-0426502vh40

Keywords

5G

ETSI

650 Route des Lucioles
F-06921 Sophia Antipolis Cedex - FRANCE

Tel.: +33 4 92 94 42 00 Fax: +33 4 93 65 47 16

Siret N° 348 623 562 00017 - APE 7112B
Association à but non lucratif enregistrée à la
Sous-Préfecture de Grasse (06) N° w061004871

Important notice

The present document can be downloaded from:

<https://www.etsi.org/standards-search>

The present document may be made available in electronic versions and/or in print. The content of any electronic and/or print versions of the present document shall not be modified without the prior written authorization of ETSI. In case of any existing or perceived difference in contents between such versions and/or in print, the prevailing version of an ETSI deliverable is the one made publicly available in PDF format at www.etsi.org/deliver.

Users of the present document should be aware that the document may be subject to revision or change of status.

Information on the current status of this and other ETSI documents is available at

<https://portal.etsi.org/TB/ETSIDeliverableStatus.aspx>

If you find errors in the present document, please send your comment to one of the following services:

<https://portal.etsi.org/People/CommitteeSupportStaff.aspx>

If you find a security vulnerability in the present document, please report it through our
Coordinated Vulnerability Disclosure Program:

<https://www.etsi.org/standards/coordinated-vulnerability-disclosure>

Notice of disclaimer & limitation of liability

The information provided in the present deliverable is directed solely to professionals who have the appropriate degree of experience to understand and interpret its content in accordance with generally accepted engineering or other professional standard and applicable regulations.

No recommendation as to products and services or vendors is made or should be implied.

No representation or warranty is made that this deliverable is technically accurate or sufficient or conforms to any law and/or governmental rule and/or regulation and further, no representation or warranty is made of merchantability or fitness for any particular purpose or against infringement of intellectual property rights.

In no event shall ETSI be held liable for loss of profits or any other incidental or consequential damages.

Any software contained in this deliverable is provided "AS IS" with no warranties, express or implied, including but not limited to, the warranties of merchantability, fitness for a particular purpose and non-infringement of intellectual property rights and ETSI shall not be held liable in any event for any damages whatsoever (including, without limitation, damages for loss of profits, business interruption, loss of information, or any other pecuniary loss) arising out of or related to the use of or inability to use the software.

Copyright Notification

No part may be reproduced or utilized in any form or by any means, electronic or mechanical, including photocopying and microfilm except as authorized by written permission of ETSI.

The content of the PDF version shall not be modified without the written authorization of ETSI.

The copyright and the foregoing restriction extend to reproduction in all media.

© ETSI 2023.
All rights reserved.

Intellectual Property Rights

Essential patents

IPRs essential or potentially essential to normative deliverables may have been declared to ETSI. The declarations pertaining to these essential IPRs, if any, are publicly available for **ETSI members and non-members**, and can be found in ETSI SR 000 314: "*Intellectual Property Rights (IPRs); Essential, or potentially Essential, IPRs notified to ETSI in respect of ETSI standards*", which is available from the ETSI Secretariat. Latest updates are available on the ETSI Web server (<https://ipr.etsi.org/>).

Pursuant to the ETSI Directives including the ETSI IPR Policy, no investigation regarding the essentiality of IPRs, including IPR searches, has been carried out by ETSI. No guarantee can be given as to the existence of other IPRs not referenced in ETSI SR 000 314 (or the updates on the ETSI Web server) which are, or may be, or may become, essential to the present document.

Trademarks

The present document may include trademarks and/or tradenames which are asserted and/or registered by their owners. ETSI claims no ownership of these except for any which are indicated as being the property of ETSI, and conveys no right to use or reproduce any trademark and/or tradename. Mention of those trademarks in the present document does not constitute an endorsement by ETSI of products, services or organizations associated with those trademarks.

DECT™, **PLUGTESTS™**, **UMTS™** and the ETSI logo are trademarks of ETSI registered for the benefit of its Members. **3GPP™** and **LTE™** are trademarks of ETSI registered for the benefit of its Members and of the 3GPP Organizational Partners. **oneM2M™** logo is a trademark of ETSI registered for the benefit of its Members and of the oneM2M Partners. **GSM®** and the GSM logo are trademarks registered and owned by the GSM Association.

Legal Notice

This Technical Specification (TS) has been produced by ETSI 3rd Generation Partnership Project (3GPP).

The present document may refer to technical specifications or reports using their 3GPP identities. These shall be interpreted as being references to the corresponding ETSI deliverables.

The cross reference between 3GPP and ETSI identities can be found under <https://webapp.etsi.org/key/queryform.asp>.

Modal verbs terminology

In the present document "**shall**", "**shall not**", "**should**", "**should not**", "**may**", "**need not**", "**will**", "**will not**", "**can**" and "**cannot**" are to be interpreted as described in clause 3.2 of the [ETSI Drafting Rules](#) (Verbal forms for the expression of provisions).

"**must**" and "**must not**" are **NOT** allowed in ETSI deliverables except when used in direct citation.

Contents

Intellectual Property Rights	2
Legal Notice	2
Modal verbs terminology.....	2
Foreword.....	6
1 Scope	8
2 References	8
3 Definitions of terms, symbols and abbreviations	9
3.1 Terms.....	9
3.2 Symbols.....	10
3.3 Abbreviations	10
4 Reference architecture for 5G Multicast–Broadcast User Services	10
4.1 General	10
4.2 System description	11
4.2.1 Network architecture.....	11
4.2.2 User Services network architecture	11
4.2.3 User Services Distribution methods.....	12
4.2.4 User Service Announcement.....	13
4.2.5 User Services Reception Reporting	13
4.2.6 Object Repair.....	13
4.3 Functional entities	14
4.3.1 General.....	14
4.3.2 MBSF.....	14
4.3.3 MBSTF	15
4.3.3.1 General	15
4.3.3.2 MBSTF subfunctions to support Object Distribution Method	16
4.3.3.3 MBSTF subfunctions to support Packet Distribution Method	17
4.3.3A MBS AF.....	17
4.3.4 MBS AS	18
4.3.4A MBSSF	18
4.3.5 MBS Client	18
4.3.6 MBS-Aware Application	18
4.4 Reference points and interfaces	19
4.4.1 Overview	19
4.5 Domain model	19
4.5.1 User Services domain model	19
4.5.2 Static information model	21
4.5.3 MBS User Service parameters	24
4.5.4 MBS Reception Reporting Configuration parameters	24
4.5.5 MBS User Data Ingest Session parameters.....	25
4.5.6 MBS Distribution Session parameters	25
4.5.7 MBS User Service Announcement parameters.....	29
4.5.8 MBS Distribution Session Announcement parameters	30
4.5.9 Mapping of MBS Distribution Session to MBS Session Context.....	31
4.6 Dynamic model	31
4.6.1 MBS Distribution Session life-cycle	31
4.6.2 Notification events.....	34
4.7 QoS model.....	34
4.8 Security	34
4.9 Interworking with eMBMS	35
5 Procedures for 5G Multicast–Broadcast User Services.....	36
5.1 General	36
5.2 High-level baseline procedures	37
5.3 Procedures for User Service provisioning.....	39

5.4	Procedures for User Service advertisement/discovery	42
5.5	Procedures for User Service data transfer	43
5.6	Procedure for User Service data repair.....	45
6	MBS User Services distribution methods.....	45
6.1	Object Distribution Method.....	45
6.2	Packet Distribution Method.....	46
7	Network Function services	47
7.1	General	47
7.2	MBSF Services.....	47
7.2.1	General.....	47
7.2.2	Nmbssf MBS User Service operations	47
7.2.2.1	Nmbssf_MBSUserService_Create service operation	47
7.2.2.2	Nmbssf_MBSUserService_Retrieve service operation	47
7.2.2.3	Nmbssf_MBSUserService_Update service operation	48
7.2.2.4	Nmbssf_MBSUserService_Destroy service operation	48
7.2.3	Nmbssf MBS User Data Ingest Session operation	48
7.2.3.1	Nmbssf_MBSUserDataIngestSession_Create service operation	48
7.2.3.2	Nmbssf_MBSUserDataIngestSession_Retrieve service operation.....	48
7.2.3.3	Nmbssf_MBSUserDataIngestSession_Update service operation.....	48
7.2.3.4	Nmbssf_MBSUserDataIngestSession_Destroy service operation.....	49
7.2.3.5	Nmbssf_MBSUserDataIngestSession_StatusSubscribe operation	49
7.2.3.6	Nmbssf_MBSUserDataIngestSession_StatusUnsubscribe operation	49
7.2.3.7	Nmbssf_MBSUserDataIngestSession_StatusNotify operation	49
7.2.3.8	Nmbssf_MBSUserDataIngestSession_StatusSubscribeMod operation.....	49
7.3	MBSTF Services	50
7.3.1	General.....	50
7.3.2	Nmbstf_MBSDistributionSession service	50
7.3.2.1	Nmbstf_MBSDistributionSession_Create service operation	50
7.3.2.2	Nmbstf_MBSDistributionSession_Retrieve service operation	50
7.3.2.3	Nmbstf_MBSDistributionSession_Update service operation	50
7.3.2.4	Nmbstf_MBSDistributionSession_Destroy service operation.....	50
7.3.2.5	Nmbstf_MBSDistributionSession_StatusSubscribe operation.....	51
7.3.2.6	Nmbstf_MBSDistributionSession_StatusUnsubscribe operation	51
7.3.2.7	Nmbstf_MBSDistributionSession_StatusNotify operation	51
7.3.2.8	Nmbstf_MBSDistributionSession_StatusSubscribeMod operation	51
Annex A (informative): Deployment and Collaboration Models		52
A.1	Group Communication	52
A.2	5G Media Streaming	52
A.3	MBS Application Provider (AF/AS) in Trusted DN.....	53
A.4	MBS Application Provider (AF/AS) in external DN	54
A.5	MBSF/MBSTF-like functions in External DN.....	54
Annex B (informative): Nmb8 User Plane ingest examples.....		56
B.1	General	56
B.2	Object Distribution Method.....	56
B.2.1	Object Distribution Method with pull-based ingest.....	56
B.2.2	Object Distribution Method with push-based ingest	57
B.3	Packet Distribution Method.....	58
B.3.1	Proxy mode	58
B.3.2	Forward-only mode	59
Annex C (informative): Data model examples		60
C.1	General	60
C.2	Object Distribution Method with push-based ingest	60

C.2.1	DASH content distribution with push-based ingest.....	60
C.2.2	DASH content distribution with push-based ingest using separate MBS Distribution Sessions for audio and video	62
C.2.3	Generic object distribution with push-based ingest.....	64
C.3	Object Distribution Method with pull-based ingest	65
C.3.1	DASH content distribution with pull-based ingest.....	65
C.3.2	DASH content distribution with pull-based ingest using separate MBS Distribution Sessions for audio and video	66
C.3.3	Generic object distribution with pull-based ingest	67
C.4	Location-dependent Object Distribution Method using push-based ingest.....	68
C.4.1	Location-dependent DASH content distribution using push-based ingest	68
C.4.2	Location-dependent generic object distribution with push-based ingest.....	69
Annex D (informative):	Change history	70
History		71

Foreword

This Technical Specification has been produced by the 3rd Generation Partnership Project (3GPP).

The contents of the present document are subject to continuing work within the TSG and may change following formal TSG approval. Should the TSG modify the contents of the present document, it will be re-released by the TSG with an identifying change of release date and an increase in version number as follows:

Version x.y.z

where:

- x the first digit:
 - 1 presented to TSG for information;
 - 2 presented to TSG for approval;
 - 3 or greater indicates TSG approved document under change control.
- y the second digit is incremented for all changes of substance, i.e. technical enhancements, corrections, updates, etc.
- z the third digit is incremented when editorial only changes have been incorporated in the document.

In the present document, modal verbs have the following meanings:

- shall** indicates a mandatory requirement to do something
- shall not** indicates an interdiction (prohibition) to do something

The constructions "shall" and "shall not" are confined to the context of normative provisions, and do not appear in Technical Reports.

The constructions "must" and "must not" are not used as substitutes for "shall" and "shall not". Their use is avoided insofar as possible, and they are not used in a normative context except in a direct citation from an external, referenced, non-3GPP document, or so as to maintain continuity of style when extending or modifying the provisions of such a referenced document.

- should** indicates a recommendation to do something
- should not** indicates a recommendation not to do something
- may** indicates permission to do something
- need not** indicates permission not to do something

The construction "may not" is ambiguous and is not used in normative elements. The unambiguous constructions "might not" or "shall not" are used instead, depending upon the meaning intended.

- can** indicates that something is possible
- cannot** indicates that something is impossible

The constructions "can" and "cannot" are not substitutes for "may" and "need not".

- will** indicates that something is certain or expected to happen as a result of action taken by an agency the behaviour of which is outside the scope of the present document
- will not** indicates that something is certain or expected not to happen as a result of action taken by an agency the behaviour of which is outside the scope of the present document
- might** indicates a likelihood that something will happen as a result of action taken by some agency the behaviour of which is outside the scope of the present document

might not indicates a likelihood that something will not happen as a result of action taken by some agency the behaviour of which is outside the scope of the present document

In addition:

is (or any other verb in the indicative mood) indicates a statement of fact

is not (or any other negative verb in the indicative mood) indicates a statement of fact

The constructions "is" and "is not" do not indicate requirements.

1 Scope

The present document defines an architecture and high-level procedures for User Services conveyed using the 5G multicast–broadcast capabilities of the 5G System defined in TS 23.501 [2], TS 23.502 [3] and TS 23.247 [5].

2 References

The following documents contain provisions which, through reference in this text, constitute provisions of the present document.

- References are either specific (identified by date of publication, edition number, version number, etc.) or non-specific.
- For a specific reference, subsequent revisions do not apply.
- For a non-specific reference, the latest version applies. In the case of a reference to a 3GPP document (including a GSM document), a non-specific reference implicitly refers to the latest version of that document *in the same Release as the present document*.

- [1] 3GPP TR 21.905: "Vocabulary for 3GPP Specifications".
- [2] 3GPP TS 23.501: "System architecture for the 5G System (5GS)".
- [3] 3GPP TS 23.502: "Procedures for the 5G System (5GS)".
- [4] 3GPP TS 23.503: "Policy and charging control framework for the 5G System (5GS); Stage 2".
- [5] 3GPP TS 23.247: "Architectural enhancements for 5G multicast-broadcast services; Stage 2".
- [6] 3GPP TS 26.348: "Northbound Application Programming Interface (API) for Multimedia Broadcast/Multicast Service (MBMS) at the xMB reference point".
- [7] 3GPP TS 26.501: "5G Media Streaming (5GMS); General description and architecture".
- [8] IETF RFC 3550: "RTP: A Transport Protocol for Real-Time Applications".
- [9] IETF RFC 2250: "RTP Payload Format for MPEG1/MPEG2 Video".
- [10] 3GPP TS 26.247: "Transparent end-to-end Packet-switched Streaming Service (PSS); Progressive Download and Dynamic Adaptive Streaming over HTTP (3GP-DASH)".
- [11] 3GPP TS 26.531: "Data Collection and Reporting; General Description and Architecture".
- [12] 3GPP TS 23.468: "Group Communication System Enablers for LTE (GCSE_LTE)".
- [13] 3GPP TS 26.517: "5G Multicast–Broadcast User Services; Protocols and Formats".
- [14] 3GPP TS 23.468: "Group Communication System Enablers for LTE (GCSE_LTE)".
- [15] 3GPP TS 29.522: "5G System; Network Exposure Function Northbound APIs; Stage 3".
- [16] OMA: "OMNA BCAST Service Class Registry",
<https://technical.openmobilealliance.org/OMNA/bcast/bcast-service-class-registry.html>.
- [17] IANA: "Reliable Multicast Transport (RMT) FEC Encoding IDs and FEC Instance IDs",
<https://www.iana.org/assignments/rmt-fec-parameters/rmt-fec-parameters.xhtml#rmt-fec-parameters-1>.
- [18] 3GPP TS 33.501: "Security architecture and procedures for 5G system".

3 Definitions of terms, symbols and abbreviations

3.1 Terms

For the purposes of the present document, the terms given in 3GPP TR 21.905 [1], TS 23.501 [2], TS 23.502 [3], TS 23.247 [5] and the following apply. A term defined in the present document takes precedence over the definition of the same term, if any, in 3GPP TR 21.905 [1].

Broadcast MBS session: an MBS session to deliver the broadcast communication service, as defined in TS 23.247 [4].

distribution method: a mechanism (comprising the Object Distribution Method and Packet Distribution Method) used by the MBSTF to deliver data to the MBS Client as part of a User Service.

MBS Application Data Session: time, protocols and protocol state (i.e. parameters) provided by the MBSTF Client to the MBS-Aware Application.

MBS Distribution Session Announcement: metadata entity consumed by the MBSTF Client that is used to advertise the current or imminent availability of an MBS Distribution Session in the MBS System that provides parameters needed by the MBSTF Client to receive it.

MBS Application Service: an end-user service for which parts or all of the data are accessible by activating the reception of an MBS User Service.

MBS-Aware Application: a UE-based application that consumes User Services by invoking with MBS Client APIs.

MBS Client: the UE function that consumes User Services defined in the present document.

MBS Distribution Session: time, protocols and protocol state (i.e. parameters) which define sender and receiver configuration and which use an MBS Session for the delivery of an MBS User Data Ingest Session.

MBS Session: a multicast session or a broadcast session, as defined in TS 23.247 [4].

MBS User Service: an abstract transport-level service configured by the MBSF and using one or more MBS Distribution Sessions, possibly in combination with unicast, for the purpose of supporting an MBS-Aware Application via a set of APIs that allows the MBS Client to activate and deactivate reception of the MBS Session.

MBS User Data Ingest Session: time, protocols and protocol state (i.e. parameters) provided by an MBS Application Provider for distribution over an MBS User Service, and provided to the MBS-Aware Application as an MBS Application Data Session.

MBS User Service Announcement: metadata entity consumed by the MBSF Client composed of one or more MBS Distribution Session Announcements.

MBS User Service Announcement Channel: MBS Distribution Session generated by the MBSF to carousel MBS User Service Announcements to the MBS Client using the Object Distribution Method.

MBS User Service Control: control of an MBS User Service by an MBS-Aware Application interacting with an MBSF Client.

MBS User Service Provisioning: provisioning of an MBS User Service in the MBSF by an MBS Application Provider.

MBS User Service Session: an instance of an MBS User Service.

Multicast MBS session: an MBS session to deliver the multicast communication service, as defined in TS 23.247 [4].

Object Distribution Method: the distribution method supporting real-time and non-real-time distribution of discrete binary objects, including media segments, to MBS Clients as part of an MBS Session.

Packet Distribution Method: the distribution method supporting transparent delivery of Application Data Units to MBS Clients as part of an MBS Session.

3.2 Symbols

Void.

3.3 Abbreviations

For the purposes of the present document, the abbreviations given in 3GPP TR 21.905 [1], TS 23.501 [2], TS 23.502 [3], TS 23.247 [4] and the following apply. An abbreviation defined in the present document takes precedence over the definition of the same abbreviation, if any, in 3GPP TR 21.905 [1].

5QI	5G QoS Identifier
AL-FEC	Application Level FEC
DN	Data Network
FEC	Forward Erasure Correction
MBS	Multicast–Broadcast Services
MB-SMF	Multicast–Broadcast Session Management Function
MB-UPF	Multicast–Broadcast User Plane Function
MBSF	Multicast–Broadcast Service Function
MBSTF	Multicast–Broadcast Service Transport Function
LTE	Long Term Evolution
NEF	Network Exposure Function
PCF	Policy and Charging Function
PDU	Protocol Data Unit
QoS	Quality of Service
SDU	Service Data Unit
UE	User Equipment

4 Reference architecture for 5G Multicast–Broadcast User Services

4.1 General

This clause defines a reference architecture for 5G Multicast–Broadcast User Services, including the logical functions involved and the logical reference points between them.

Interworking with LTE is specified in clause 5.2 of TS 23.247 [5] and its use in the context of MBS User Services is further specified in clauses 4.9 and A.1 of the present document.

4.2 System description

4.2.1 Network architecture

Figure 4.2.1-1 depicts the MBS network architecture defined in clause 5.1 of TS 23.247 [5] using the reference point representation.

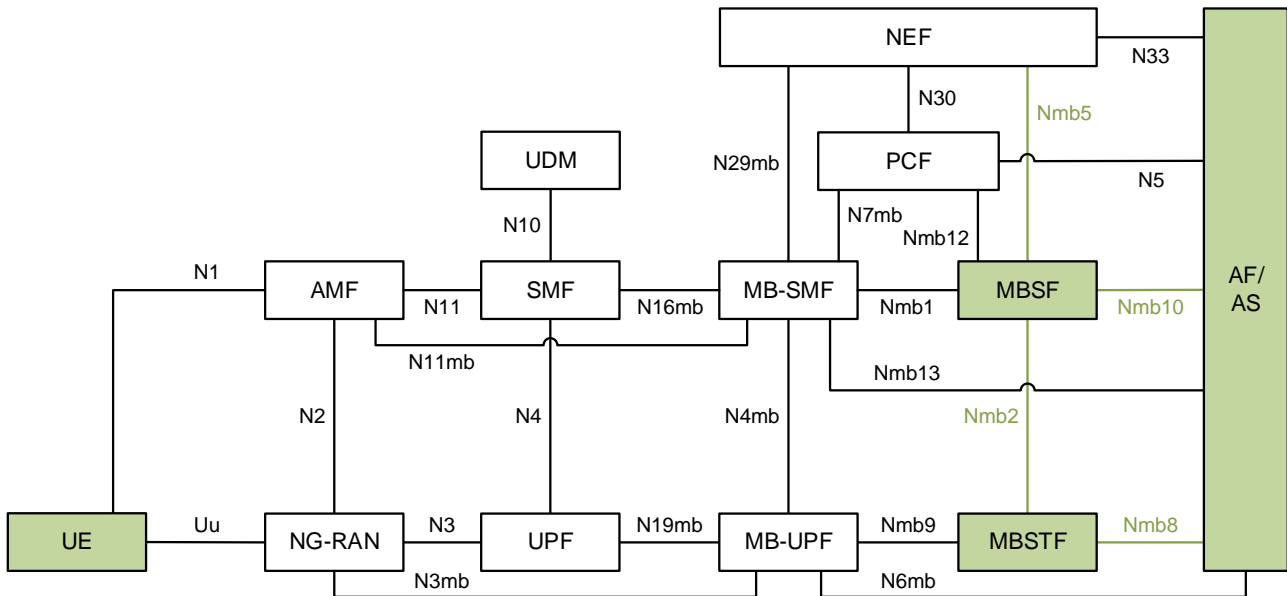

Figure 4.2.1-1: Network architecture for MBS User Services delivery and control

The functions and reference points involved in providing MBS User Services within the MBS System are highlighted in green. In particular:

- Reference point Nmb10 is used by the AF/AS to provision MBS User Services in the MBSF by invoking the *Nmbfsf* service defined in clause 7.2.
- Reference point Nmb2 is used by the MBSF to configure and control MBS User Services distribution methods in the MBSTF by invoking the *Nmbstf* service defined in clause 7.3. Additionally, Nmb2 may be used by the MBSTF to ingest User Service Announcement objects from the MBSF via either the pull-based or push-based object ingest method (see clause 6.1) for subsequent delivery to the MBS Client via a suitable MBS Distribution Session (see clause 4.2.4).
- Reference point Nmb8 is used by the MBSTF to ingest content from the AF/AS.

4.2.2 User Services network architecture

MBS User Services enable high-level applications to make use of the low-level features of the MBS System. An MBS User Service is provided by the MBSF and MBSTF working in combination to support configuration option 2 and configuration option 3 defined in annex A of TS 23.247 [5]. In addition to the Network Functions defined in [5]:

- The MBS AF provides unicast User Service Announcement in the user plane.
- The MBS AS provides unicast services such as Object Repair.
- The MBSSF supports the User Plane security procedure according to clause W.4.1.3 of TS 33.501 [18].

Together, these functions enable a complete service offering to an end-user, via a set of APIs that allows the MBS Client to activate or deactivate reception of MBS User Services.

The MBS User Services architecture depicted in figure 4.2.2-1 shows the MBS-related entities involved in providing MBS User Services delivery and control. These are described in the following clauses. The MBS Application Provider plays the role of the AF/AS.

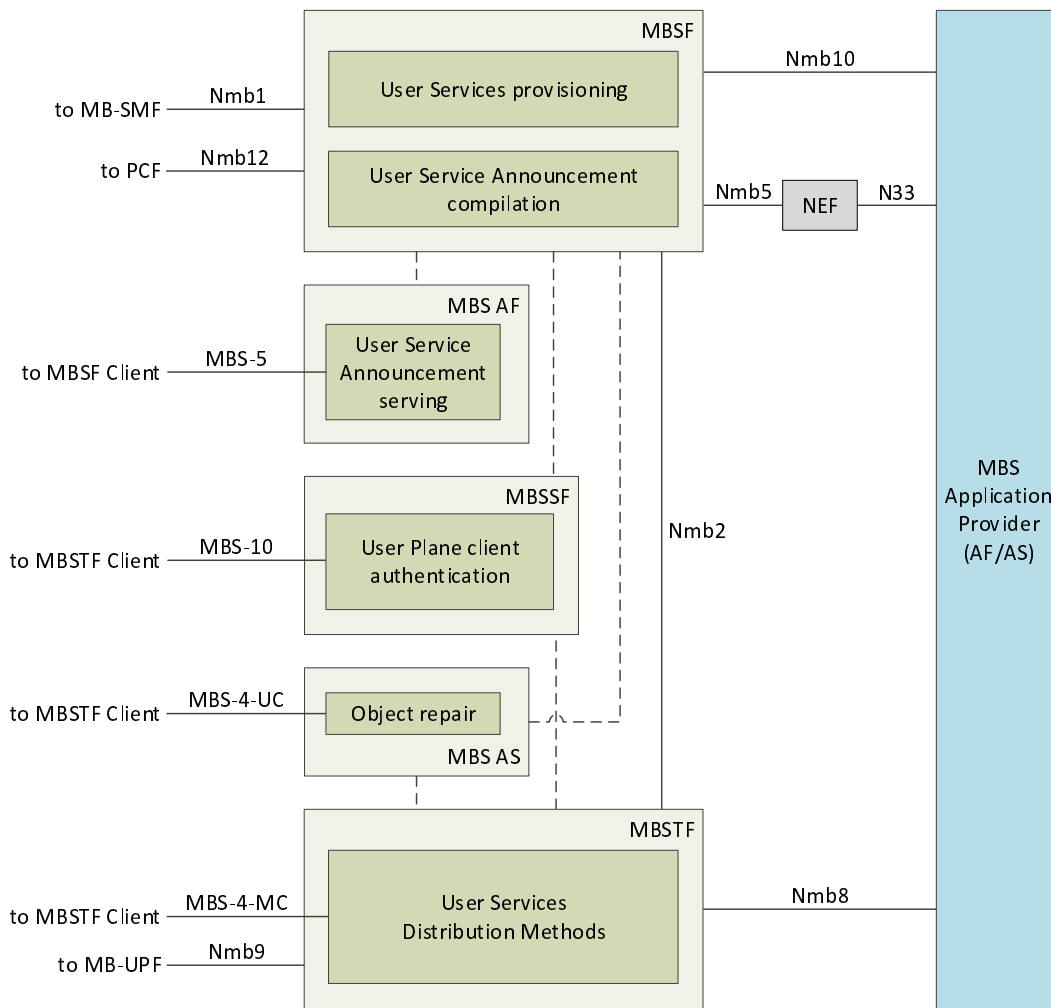

Figure 4.2.2-1:

MBS User Services network architecture

4.2.3 User Services Distribution methods

The distribution methods defined for use by MBS User Services in clause 6 of the present document make use of MBS Sessions (see clause 4.1 of TS 23.247 [5]) to deliver MBS data packets to the MBS Client. The distribution methods may use either a multicast MBS Session or a broadcast MBS Session. A set of MBS distribution methods is provided by the MBSTF. These provide functionality such as security and key distribution, reliability control (by means of FEC techniques) and associated delivery procedures.

- **Object Distribution Method:** A distribution method that delivers discrete binary objects over an MBS Session. This may be used to support real-time distribution of media segments (as special objects) including Low-Latency CMAF segments.

The use of MBS Sessions by the Object Distribution Method is specified in clause 6.1.

- **Packet Distribution Method:** A distribution method that supports streaming of packetized media data over an MBS Session where Service Data Units (SDUs) are conveyed to the UE as part of Protocol Data Units (PDUs) or IP flows. Examples of upper layer SDUs are generic IP/UDP datagrams.

The use of MBS Sessions by the Packet Distribution Method is specified in clause 6.2.

The above distribution methods may use either a multicast MBS Session or a broadcast MBS Session to distribute content to an MBS Client and may also make use of the Object Repair feature, as defined in clause 4.2.5 below.

4.2.4 User Service Announcement

The User Service Announcement provides service access information needed by the MBS Client to discover and activate the reception of one or more MBS User Services. User Service Announcements may be delivered via MBS Distribution Sessions using the Object Distribution Method (either in the same MBS Distribution Session as the advertised content, or else via a dedicated MBS Distribution Session provisioned and managed by the MBSF called the *MBS User Service Announcement Channel*) at reference point MBS-4-MC or via a regular unicast PDU Session at reference point MBS-5.

The baseline information conveyed in User Service Announcements is defined in clause 4.5.7.

4.2.5 User Services Reception Reporting

Reporting by the MBS Client to the MBSF is for further study and may be realised by instantiating the data collection and reporting architecture specified in TS 26.531 [11]. This may include, for example, dynamically adjusting the Application Layer FEC redundancy level in the MBSTF according to the Packet Error Rate (PER) reported by the MBS Client.

4.2.6 Object Repair

When using the Object Distribution Method, Object Repair may be provisioned by the MBS Application Provider. This feature allows an MBS Client to retrieve from the MBS AS (via reference point MBS-4-UC) missing portions of objects not received intact from the MBSTF at reference point MBS-4-MC.

Two types of Object Repair are defined by the present document:

- *Object Repair during the MBS Distribution Session.*
- *Object Repair after the completion of the MBS Distribution Session*, including a randomized back-off period for different MBS Clients in order to avoid overloading the MBS AS.

The functions of the MBS AS are defined in clause 4.3.4.

4.3 Functional entities

4.3.1 General

The MBSF and MBSTF offer service layer functionality for sending data via MBS Sessions. The MBSF (clause 4.3.2) offers control plane functionality while the MBSTF (clause 4.3.3) offers user plane functionality. The MBSTF acts as a User Plane anchor when it sources IP multicast traffic. Reference point Nmb2 provides the means for the MBSF to configure the delivery methods in the MBSTF, and supports Object ingest at the MBSTF of User Service Announcements for delivery to the MBS Client via reference point MBS-4-MC (as described in clause 4.2.4).

Figure 4.3.1-1 shows the complete set of functional entities involved in supporting MBS User Services when the MBS Application Provider is deployed in the Trusted DN, including client functions in the UE.

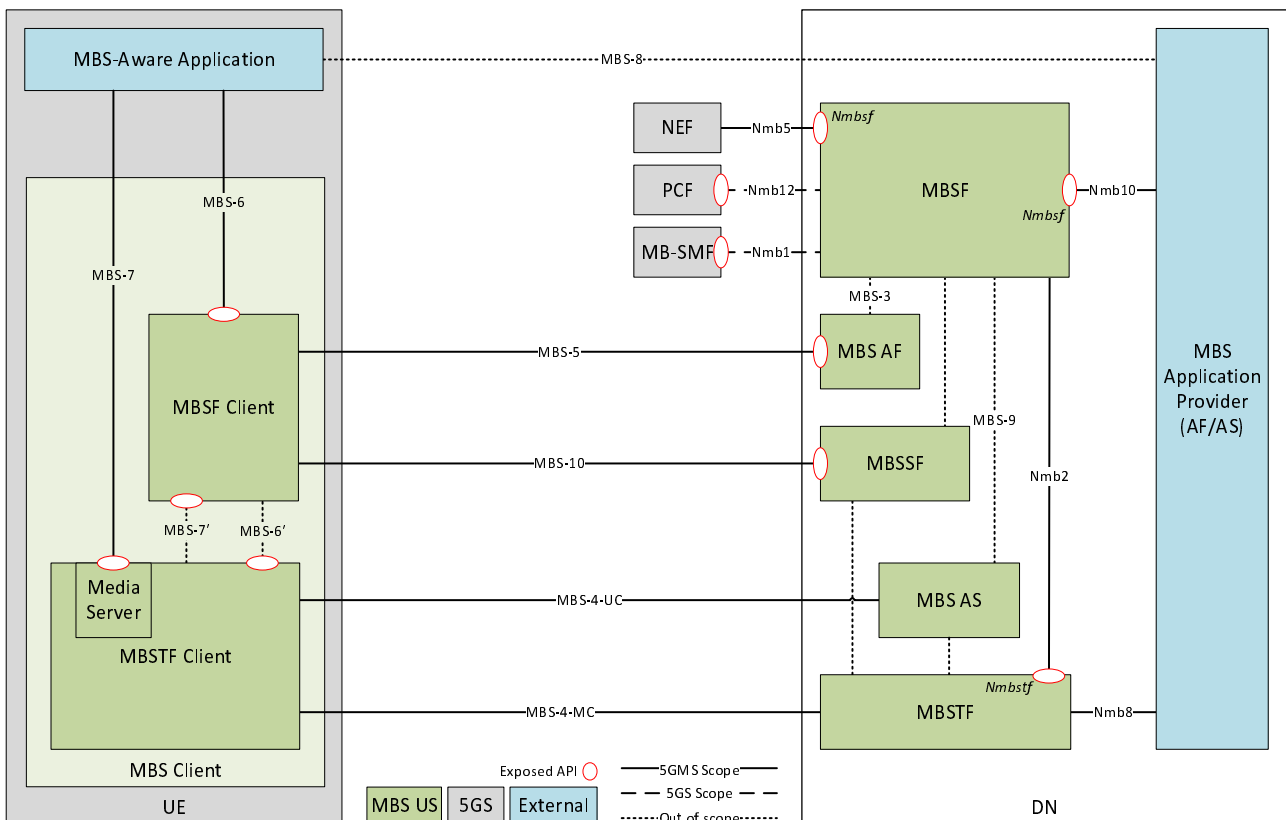

NOTE: When the MBS Application Provider is deployed outside the Trusted DN, it interacts with the MBSF via the NEF at reference point N33, as shown in figure 4.2.2-1, instead of via Nmb10.

Figure 4.3.1-1 MBS User Service reference architecture

In the above architecture, MBS-specific functions such as the MBS AS and MBSF are shown as independent and standalone. In deployments, they may be co-located on physical devices with other functions. As an example, the MBS AS may be hosted in the MBS Application Provider domain, or it may be hosted in a 5GMS AS.

4.3.2 MBSF

The functionality of the MBSF is defined in clause 5.3.2.11 of TS 23.247 [5]. It receives provisioning and control commands either directly at reference point Nmb10 or at reference point Nmb5 (via the NEF). The MBSF invokes MBS Session operations on the MB-SMF at reference point Nmb1. The MBSF configures the MBSTF at reference point Nmb2.

The User Service Announcement function of the MBSF provides session access information which is consumed by the MBS Client and subsequently used to discover and initiate the reception of one or multiple MBS User Services. The session access information may contain information for presentation to the end-user, as well as application parameters used in generating service content for consumption by the MBS Client.

The present document defines additional Control Plane functionalities of the MBSF to support MBS User Services including:

1. Generating the User Service Announcement for each MBS Session.
2. Managing User Service Announcement updates.
3. Providing the User Service Announcement information to the MBS Client in a timely manner using one or more of the following mechanisms:
 - a) Unicast User Service Announcement delivered by the MBS AF via reference point MBS-5, including the possible use of push- or notification-based update mechanisms.
 - b) User Service Announcement via an MBS Distribution Session delivered by the MBSTF at reference point MBS-4-MC, optionally in the same MBS Distribution Session as the content it is advertising, or else via a dedicated MBS Distribution Session managed by the MBSF called the *MBS User Service Announcement Channel*.
 - c) User Service Announcement via application-private means at reference point MBS-8.

4.3.3 MBSTF

4.3.3.1 General

The functionality of the MBSTF is defined in clause 5.3.2.12 of TS 23.247 [5]. It receives User Plane data traffic at reference point Nmb8 and sends MBS data packets to the MB-UPF via reference point Nmb9.

NOTE: The MBSTF may not be present in all deployments of the MBS System. However, the MBSTF is an integral and necessary component of MBS User Services and the present document is not concerned with deployments in which it is absent.

The present document defines additional User Plane functionalities of the MBSTF to support MBS User Services as follows:

1. Receiving MBS Distribution Session configurations from the MBSF at reference point Nmb2.
2. Sending notification events to the MBSF, e.g. data ingest failure, session terminated, delivery started via reference point Nmb2.
3. Based on the MBS Distribution Session configuration:
 - a) MBS delivery of ingested objects or sequences of objects to the MBS Client using the Object Distribution Method (see clause 6.1). This may be used to support real-time distribution of media segments (as special objects) including CMAF segments.
 - b) MBS delivery of ingested packet streams to the MBS Client using the Packet Distribution Method (see clause 6.2).
 - c) Delivery of MBS User Service Announcement information (including updates as necessary) within the MBS Session.

4.3.3.2 MBSTF subfunctions to support Object Distribution Method

The MBSTF subfunctions supporting the Object Distribution Method are depicted in figure 4.3.3.2-1 below.

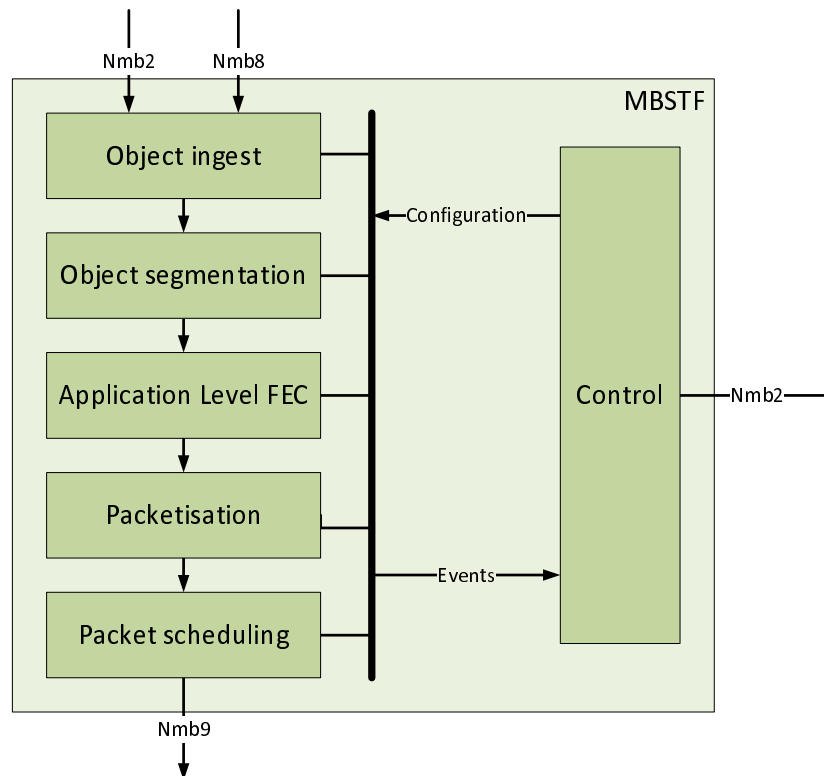

Figure 4.3.3.2-1: MBSTF architecture overview for Object Distribution Method

The *Object ingest* subfunction supports:

- Pull-based ingest at reference point Nmb2: The Object ingest subfunction in this case fetches one or more objects from the MBSF using HTTPS for inclusion in the MBS User Service Announcement Channel.
- Push-based ingest at reference point Nmb2: The Object ingest subfunction receives one or more objects from the MBSF using HTTPS for inclusion in the MBS User Service Announcement Channel.
- Pull-based ingest at reference point Nmb8: The Object ingest subfunction in this case fetches one or more objects from the MBS Application Provider (AF/AS) using HTTPS.
- Push-based ingest at reference point Nmb8: The Object ingest subfunction receives one or more objects from the MBS Application Provider (AF/AS) using HTTPS.

Object ingest procedures at reference point Nmb2 shall be a subset of those at reference point Nmb8.

The *Object segmentation* subfunction supports the partitioning of an object into payload units suitable for MBS transmission.

The optional *Application Layer FEC* subfunction supports object recovery when some packets are not received by the MBMS Client.

The *Packetisation* subfunction places the payload units (and, optionally, the FEC data) into Nmb9 transmission packets according to clause 6.1.

The *Packet scheduling* subfunction schedules the outgoing packet stream according to target bit rate configuration.

The *Control* subfunction offers support for MBSTF service configuration, status query and notifications at reference point Nmb2.

4.3.3.3 MBSTF subfunctions to support Packet Distribution Method

The MBSTF subfunctions supporting the Packet Distribution Method are depicted in figure 4.3.3.3-1 below.

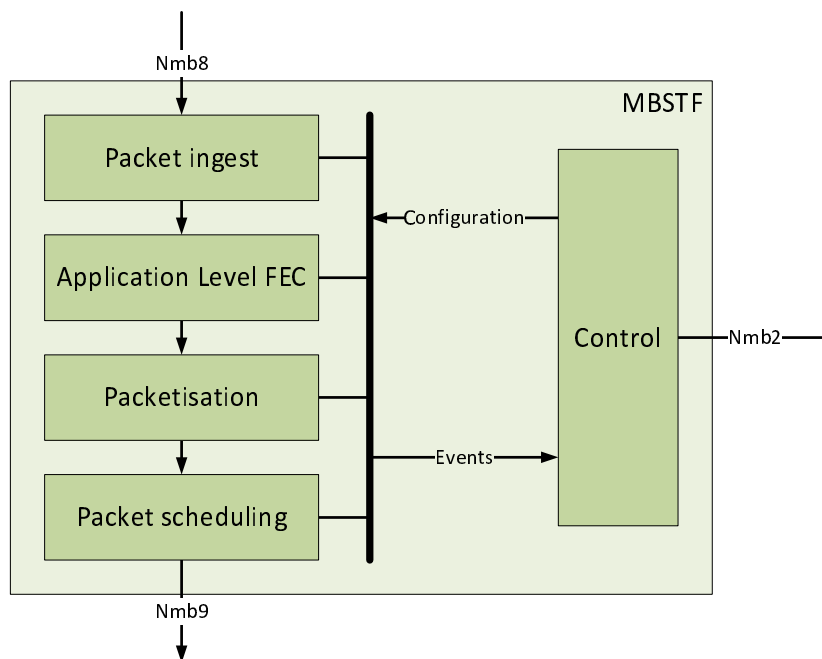

Figure 4.3.3.3-1: MBSTF architecture overview for Packet Distribution Method

The *Packet ingest* subfunction supports the reception of a packet sequence at reference point Nmb2 from authorized sources.

The optional *Application Layer FEC* subfunction to support object recovery when some packets are not received by the MBMS Client.

The *Packetisation* subfunction places the ingested packets (and, optionally, the FEC data) into Nmb9 transmission packets. Depending on the transmission mode, ingested packets may be reformatted suitable for MBS transmission.

The *Packet scheduling* subfunction schedules the outgoing data stream according to target bit rate configuration.

The *Control subfunction* offers support for MBSTF service configuration and service notifications at reference point Nmb2.

4.3.3A MBS AF

The MBS AF is an optional entity that performs the following functions to support MBS User Services:

- Delivering unicast User Service Announcements to the MBSF Client via reference point MBS-5.

The MBS AF is configured by the MBSF at reference point MBS-3. This interaction is not further defined by the present document.

The MBS AF may be deployed as a standalone entity, or its functions may be co-located with other Network Functions such as the MBSF (see clause 4.3.2), or the 5GMS AF defined in TS 26.501 [7].

4.3.4 MBS AS

The MBS AS is an optional entity that performs the following functions to support MBS User Services:

- Providing a byte-range file repair service to the MBSTF Client (via reference point MBS-4-UC) for use with the Object Distribution Method.

The MBS AS is configured by the MBSF at reference point MBS-9. The MBS AS may acquire content from the MBSTF. These interactions are not further defined by the present document.

The MBS AS may be deployed as a standalone entity, or its functions may be co-located with other Network Functions such as the MBSTF (see clause 4.3.3) or the 5GMS AS defined in TS 26.501 [7].

4.3.4A MBSSF

The MBS Security Function (MBSSF) is an optional logical entity defined in clause 6.13 of TS 23.247 [5] and TS 33.501 [18] that performs the following functions to support MBS User Services:

- Providing a security anchor to the MBSTF Client (see clause 4.3.5) via reference point MBS-10, realising the User Plane security procedure defined in clause W.4.1.3 of TS 33.501 [18].

In deployment, the MBSSF may be co-located with the MBSF or with the MBSTF, as described in clause 6.13 of TS 23.247 [5]. Interactions and procedures between these three functions are not defined in the present document.

4.3.5 MBS Client

The MBS Client function is part of the UE. The functionality of the UE is defined in clause 5.3.2.8 of TS 23.247 [5].

The MBS Client is further divided into the following subfunctions:

- *MBSF Client*: Communicates with the MBS AF at reference point MBS-5 on MBS User Service control aspects. Communicates with the MBSSF at reference point MBS-10 to authenticate access to security-protected MBS data (see clause W.4 of TS 33.501 [18]) that it has received from reference point MBS-4-MC.
- *MBSTF Client*: Communicates with the MBSTF at reference point MBS-4-MC and/or with the MBS AS at reference point MBS-4-UC in order to provide an MBS Application Data Session to the MBS-Aware Application.

The MBS Client performs the following functions to support MBS User Services:

- Acquisition of MBSF-compiled User Service Announcements from the MBS AF at reference point MBS-5 and/or from the MBSTF at reference point MBS-4-MC.
- Authorisation of access to security-protected MBS data by invoking the User Plane security procedure defined in clause W.4.1.3 of TS 33.501 [18] at reference point MBS-10.
- Reception of MBS data via reference point MBS-4-MC from either a Multicast MBS Session or a Broadcast MBS Session.
- Exposure of MBS Application Data Sessions towards an MBS-Aware Application.
- Using AL-FEC to recover packets or objects, if this optional feature is provisioned for the MBS Session.
- Unicast recovery via reference point MBS-4-UC of the application payload data carried in multicast/broadcast packets that are not successfully received via MBS-4-MC, if unicast repair is provisioned for the MBS Session.

NOTE: Roaming of the MBS Client is for further study.

4.3.6 MBS-Aware Application

The MBS Client is typically controlled by an external application which triggers the establishment of an MBS User Services session. The MBS-Aware Application is not defined within the present document, but the function makes use

of the MBS Client and (indirectly) the Network Functions supporting MBS User Services (MBSF, MBSTF and MBS AS) via reference points MBS-6 and MBS-7.

4.4 Reference points and interfaces

4.4.1 Overview

The following reference points defined in clause 5.1 of TS 23.247 [5] are relevant to MBS User Services architecture: Nmb1, Nmb2, Nmb5, Nmb8, Nmb9, Nmb10 and Nmb12.

The following additional reference points are defined by the present document:

- **MBS-3:** Used by the MBSF to configure the MBS AF and to publish User Service Announcements to it. This reference point is not described further in the present document.
- **MBS-4-MC:** Unidirectional multicast distribution of content from the MBSTF to the MBS Client.
- **MBS-4-UC:** User Plane interactions between the MBSTF Client and the MBS AS for the purpose of file-based unicast repair.
- **MBS-5:** User Plane interactions between the MBSF Client and the MBS AF for the purpose of MBS control plane and service handling.
- **MBS-6:** API exposed by the MBSF Client and used by the MBS-Aware Application to manage and control MBS User Services.
- **MBS-7:** API exposed by the MBSTF Client and used by the MBS-Aware Application to receive user data information distributed using MBS User Services.
- **MBS-8:** Announcement of MBS User Services to the MBS-Aware Application by the MBS Application Provider. The procedures at this reference point are beyond the scope of 3GPP specification.
- **MBS-9:** Used by the MBSF to configure the MBS AS. This reference point is not described further in the present document.
- **MBS-10:** User Plane interactions between the MBSF Client and the MBSSF for the purpose of authorising access to security-protected MBS data by means of the User Plane security procedure specified in clause W.4.1.3 of TS 33.501 [18].

In addition, the following reference points are defined inside the MBS Client function:

- **MBS-6':** API exposed by the MBSTF Client and used by the MBSF Client to (de)activate reception of an MBS Session by the MBSTF. The reception parameters are supplied by the MBSF Client.

This reference point is outside the scope of MBS User Services and is not described further in the present document.

- **MBS-7':** API exposed by the MSTF Client and used by the MBSTF to supply MBS Session configuration information that has been received from reference point MBS-4-MC.

This reference point is outside the scope of MBS User Services and is not described further in the present document.

4.5 Domain model

4.5.1 User Services domain model

The domain model for MBS User Services addresses different service and session concepts that are established between the different functional entities of the MBS User Services architecture, as shown in figure 4.5.1-1.

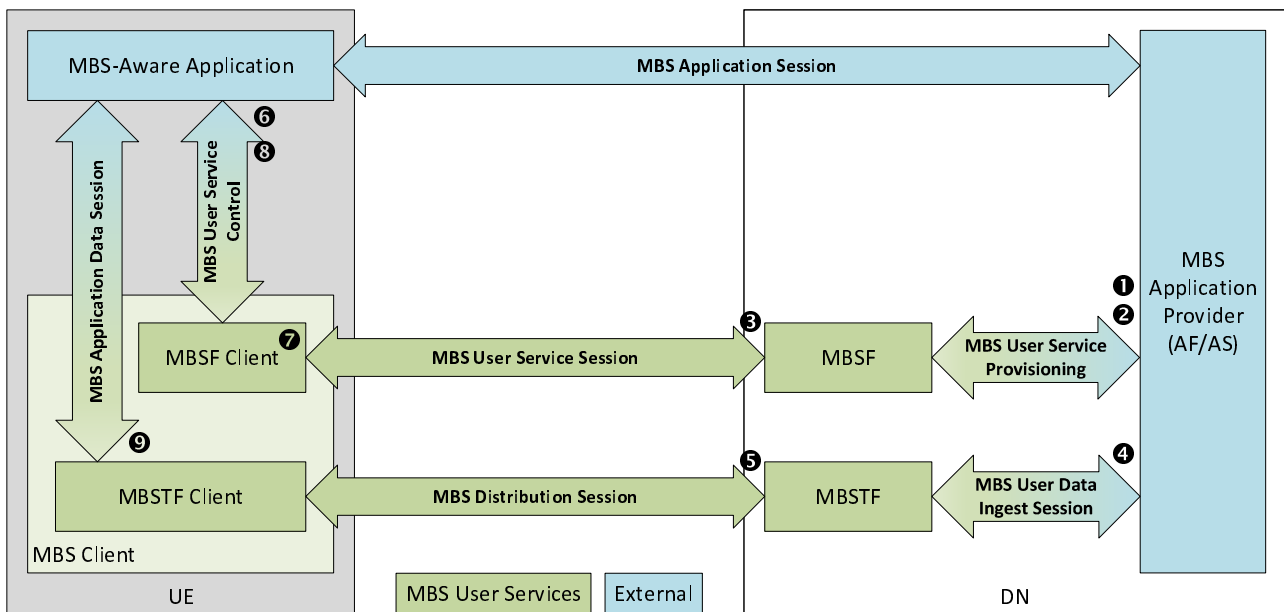

Figure 4.5.1-1: MBS User Services domain model

In the above figure:

1. The MBS Application Provider initiates *MBS User Service Provisioning* with the MBSF to provision an *MBS User Service*.
2. Subsequently, the MBS Application Provider provisions a number of time-bound *MBS User Data Ingest Sessions* within the scope of the newly provisioned *MBS User Service*, also by means of *MBS User Service Provisioning*.

When the current time enters the time window of a provisioned *MBS User Data Ingest Session*:

3. The MBSF establishes an *MBS User Service Session* of the parent *MBS User Service* by establishing an *MBS Session* in the MBS System. The reception parameters of the *MBS Session* are advertised in an *MBS User Service Announcement*, as defined in clause 4.5.2 below. The *MBS User Service Announcement* is optionally passed back to the MBS Application Provider by means of *MBS User Service Provisioning* (see step 7bis).
4. The MBSTF establishes an *MBS User Data Ingest Session* between itself and the MBS Application Provider for the purpose of ingesting objects or packets, according to the type of distribution method provisioned.
5. The MBSTF establishes an *MBS Distribution Session* and begins to transmit objects or packets on it according to the configured distribution method as and when they are available from the *MBS User Data Ingest Session*.

When an *MBS User Service* is established:

6. The MBS-Aware Application instructs the MBSF Client to activate an *MBS User Service* by means of *MBS User Service Control*.
7. The MBSF Client may acquire the *MBS User Service Announcement* from the MBSF via the *MBS User Service* [or via the *MBS Distribution Session*] and pass selected application-facing parameters (such as the service class and service names) up to the MBS-Aware Application by means of *MBS User Service Control*.
- 7bis. Alternatively, the *MBS User Service Announcement* may be made available to the MBS Application Provider, in which case the MBS-Aware Application obtains it via an application-private *MBS Application Service* and then provides it to the MBSF Client by means of *MBS User Service Control*.
8. The MBS-Aware Application selects the announced *MBS User Service* via *MBS User Service Control* and, as a result, the MBSF Client activates reception of the corresponding *MBS Distribution Session* in the MBSTF Client.
9. An *MBS Application Data Session* is established between the MBSTF Client and the MBS-Aware Application to supply the latter with received (and possibly repaired) user data.

4.5.2 Static information model

Figure 4.5.2-1 shows how the different service and session concepts depicted in figure 4.5.1-1 above relate to each other. In this figure:

1. The MBS Application Provider provisions the parameters of a new MBS User Service by invoking the *Nmbsf* service either directly, or via the NEF. This specifies which of the *Service announcement modes* are to be used to advertise the MBS User Service, as well as descriptive metadata for inclusion in the MBS User Service Announcement.
2. The MBS Application Provider provisions a number of time-bound MBS User Data Ingest Sessions within the scope of the MBS User Service by invoking the *Nmbsf* service either directly, or via an equivalent *Nnef* service provided by the NEF. Each MBS User Data Ingest Session includes the details of one or more MBS Distribution Sessions.
 - To indicate that it has a restricted MBS service area (i.e. corresponding to a local MBS Service, as defined in clause 6.2.2 of TS 23.247 [5]), an MBS Distribution Session may specify one or more *Target service areas*. In line with [5], MBS data is not transmitted outside the MBS service area derived from the indicated *Target service areas*.
 - To provision location-dependent variants of an MBS User Service (see clause 6.2.3 of TS 23.247 [5]), a number of MBS Distribution Sessions conveying different MBS data may be provisioned within the scope of the same MBS User Service by setting the *Location-dependent service flag* on the MBS Distribution Sessions of each variant. Location-dependent MBS Distribution Session variants shall have the same *MBS Session Identifier*, but they shall have disjoint *Target service areas*.
 - When the *Multiplexed service flag* is set on the MBS Distribution Session, all MBS Distribution Sessions with an identical (or empty) set of *Target service areas* shall be multiplexed onto the same MBS Session. The *MBS Session Identifier* shall be the same for all MBS Distribution Sessions within the multiplex. This feature may be combined with the *Location-dependent service flag*, in which case each location-dependent multiplex of MBS Distribution Sessions is mapped into a separate MBS Session.

The MBSF provisions additional MBS Distribution Session parameters (denoted in table 4.5.6-1 as assigned by the MBSF) and exposes some of them back to the MBS Application Provider (as indicated by the NOTE to table 4.5.6-1).

NOTE 1: The MBSF typically allocates an *MBS Session Identifier*, such as a Temporary Mobile Group Identity (TMGI) for each MBS Distribution session (see step 4 below) as a side-effect of provisioning, but it is also possible for the *Nmbsf* service invoker to nominate a particular value during this provisioning step if TMGI allocations are managed externally to the MBSF.

3. The MBS Application Provider may additionally provision an MBS Consumption Reporting Configuration within the scope of the MBS User Service by invoking the *Nmbsf* service either directly, or via the NEF.

NOTE 2: Reception reporting for MBS User Services is for future study.

Shortly before the current time enters the time window of a provisioned MBS User Data Ingest Session:

4. The MBSF provisions an MBS Session in the MBS System by invoking the *Nmbsmf* service on the MB-SMF (see clause 9 of TS 23.247 [5]) to allocate a TMGI (if one has not already been allocated) for each MBS Distribution Session and to create an MBS Session Context for each one. The parameters of the MBS Session Context shall be populated as specified in clause 4.5.9. In response, the MB-SMF provides the MB-UPF ingest information (specifically, the MB-UPF tunnel endpoint address and traffic flow information to be used by the MBSTF) to the MBSF.
5. The MBSF provisions an MBS Distribution Session in the MBSTF by invoking the *Nmbstf* service at reference point Nmb2 using the parameters from the newly created MBS Session Context.
6. Using the parameters from the MBS Distribution Session and from the newly created MBS Session Context, the MBSF compiles an MBS User Service Announcement to advertise the availability of the MBS User Service and makes this service access information available by one or more of the *Service announcement modes* provisioned in the MBS User Service.

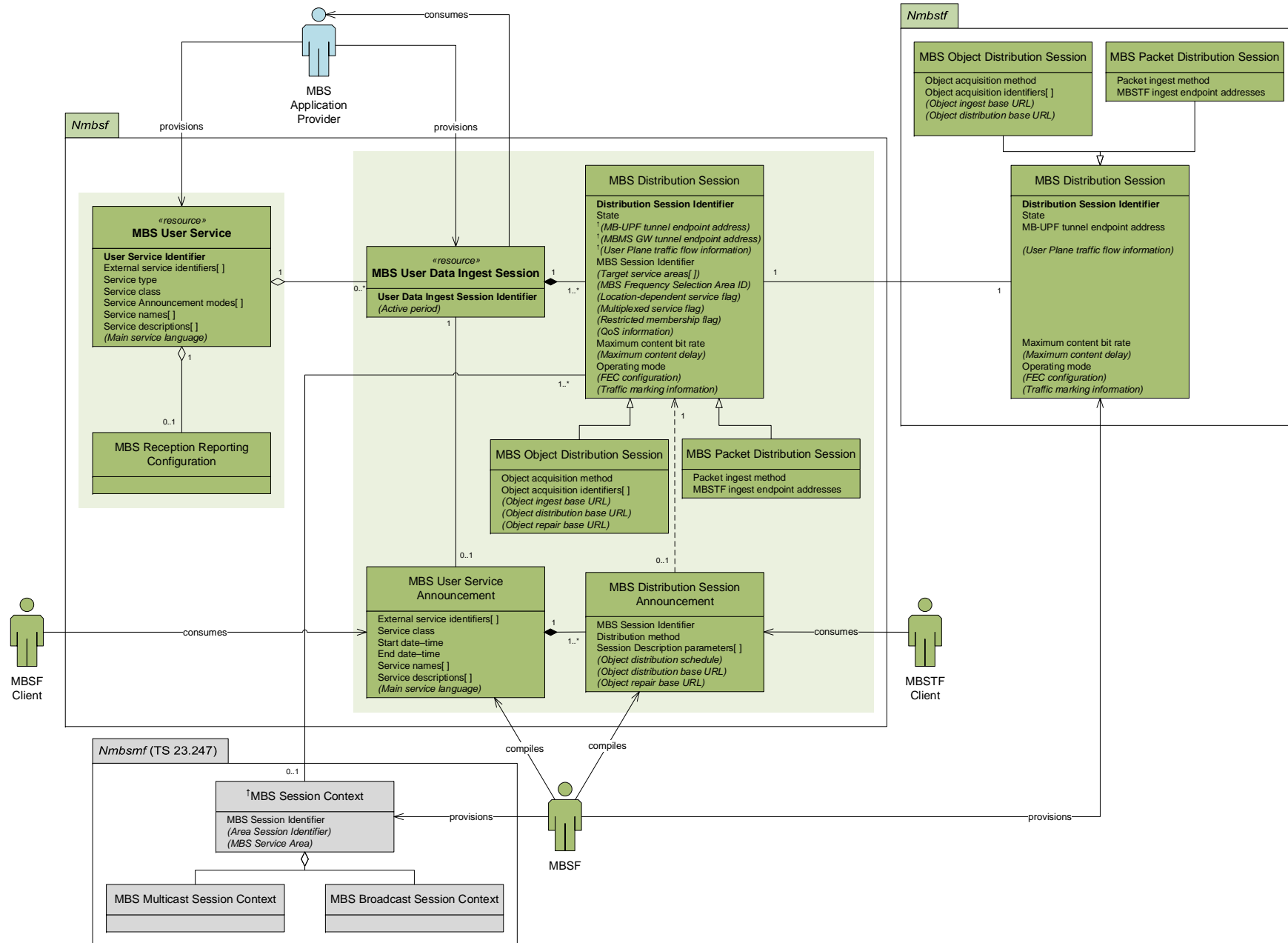

- NOTE 1 Square brackets after a parameter name indicate multiplicity; parameter names rendered in italics with parentheses are optional. See the following clauses for details.
- NOTE 2: Parameters and entities not exposed to the MBS Application Provider via the *Nmbssf* service at reference point Nmb10 are annotated with the dagger symbol †.
- NOTE 3: MBS Session Identifier is defined by clause 6.5.1 of TS 23.247 [5] as a Temporary Mobile Group Identity (TMGI) or a Source-Specific Multicast (SSM) IP address.

Figure 4.5.2-1: MBS User Services static information model

4.5.3 MBS User Service parameters

This entity models an MBS User Service, as provisioned by the MBS Application Provider and as managed by the MBSF. The baseline parameters of an MBS User Service are listed in table 4.5.3-1 below:

With the exception of *Service type*, which is an immutable property of an MBS User Service, any of the parameters assigned by the MBS Application Provider may be updated by the MBS Application Provider at any time.

NOTE 1: Propagation of modified parameter values to the MBS Client in an updated MBS User Service Announcement is subject to implementation-dependent and operational latencies.

Table 4.5.3-1: Baseline parameters of MBS User Service entity

Parameter	Cardinality	Assigner	Description
User Service Identifier	1..1	MBSF	A unique identifier for this MBS User Service in the MBSF.
External service identifiers	1..*	MBS Application Provider	A unique identifier for this MBS User Service that is also present in the MBS User Service Announcement. If assigned in a globally unique manner, this identifier may be useful in correlating this MBS User Service with the same service delivered by a different system.
Service type	1..1		Indicates whether this MBS User Service is distributed via Multicast MBS Session(s) or Broadcast MBS Session(s)
Service class	1..1		The class of this MBS User Service, expressed as a fully-qualified term identifier from a controlled vocabulary such as the OMNA BCAST Service Class [16], e.g. <i>urn:oma:bcast:oma_bsc:st:1.0</i> .
Service announcement modes	1..*		Determines whether the MBS User Service Announcement compiled by the MBSF is advertised to the MBSF Client at reference point MBS-5 and/or advertised to the MBSF Client via the MBS Distribution Session and/or passed back to the MBS Application Provider via reference point Nmb10.
Service names	1..*		A set of distinguishing names for this MBS User Service, one per language.
Service descriptions	1..*		A set of descriptions of this MBS User Service, one per language.
Main service language	0..1		The main language of this MBS User Service.

MBS User Data Ingest Sessions (see clause 4.5.5) are separately provisioned within the scope of an MBS User Service. It is valid for an MBS User Service to have no MBS User Data Ingest Sessions currently provisioned.

An MBS Reception Reporting Configuration (see clause 4.5.4 below) may be separately provisioned within the scope of an MBS User Service.

NOTE 2: Reception reporting for MBS User Services is for future study.

4.5.4 MBS Reception Reporting Configuration parameters

Reception reporting for MBS User Services is for future study.

4.5.5 MBS User Data Ingest Session parameters

This entity models an MBS User Data Ingest Session, as provisioned by the MBS Application Provider and as managed by the MBSF. The baseline parameters for an MBS User Data Ingest Session are listed in table 4.5.5-1 below.

NOTE: A linkage from the MBS User Data Ingest Session to its parent MBS User Service is additionally required at stage 3. The *User Service identifier* defined in table 4.5.3-1 serves this purpose.

The set of active periods may be updated by the MBS Application Provider at any time. The state of constituent MBS Distribution Sessions (and their corresponding MBS Distribution Session Announcements) may need to change as a consequence.

Table 4.5.5-1: Baseline parameters of MBS User Data Ingest Session entity

Parameter	Cardinality	Assigner	Description
User Data Ingest Session Identifier	1..1	MBSF	An identifier for this MBS User Data Ingest Session that is unique in the scope of the parent MBS User Service (see clause 4.5.3).
MBS User Service Announcement	0..1	MBSF	The MBS User Service Announcement (see clause 4.5.7) currently associated with this MBS User Data Ingest Session. Present only if all constituent MBS Distribution Sessions are in the <i>ESTABLISHED</i> or <i>ACTIVE</i> state.
Active periods	0..*	MBS Application Provider	Periods of time during which the MBS User Data Ingest Session is active in the MBS System. If omitted, the MBS User Data Ingest session is intended to be active until further notice.

The MBS User Data Ingest Session is composed of one or more MBS Distribution Sessions (see clause 4.5.6 below) and these shall be provisioned in the same operation as the enclosing MBS User Data Ingest Session. It is not valid for an MBS User Data Ingest Session to have no MBS Distribution Sessions defined.

MBS Distribution Sessions may be added to or removed from an MBS User Data Ingest Session by the MBS Application Provider at any time, subject to the minimum number specified above. The MBS User Service Announcement may need to change as a consequence to refer to a revised set of corresponding MBS Distribution Session Announcements.

4.5.6 MBS Distribution Session parameters

This entity models an MBS Distribution Session, as provisioned by the MBS Application Provider and as managed by the MBSF. This MBSF subsequently uses this information to provision a corresponding MBS Distribution Session in the MBSTF.

The following parameters assigned by the MBS Application Provider may be updated by the MBS Application Provider at any time:

- Target service areas,
- MBS Frequency Selection Area (FSA) Identifier (applicable only to broadcast Service type)
- QoS information.

With the exception of the *MBS Session Identifier* (which is immutable after initial assignment) and the *Location-dependent service flag* (which is immutable after creation), all other parameters assigned by the MBS Application Provider may be updated by the MBS Application Provider when the MBS Distribution Session is in the *INACTIVE* state.

The baseline parameters for an MBS Distribution Session that are common to all distribution methods are listed in table 4.5.6-1 below. All parameters are exposed to the MBS Application Provider except where noted otherwise.

Table 4.5.6-1: Common baseline parameters of MBS Distribution Session entity

Parameter	Cardinality	Assigner	Description
Distribution Session Identifier	1..1	MBSF	An identifier for this MBS Distribution Session that is unique within the scope of the MBS User Service (see clause 4.5.3).
State	1..1		The current state of the MBS Distribution Session: <i>INACTIVE</i> , <i>ESTABLISHED</i> , <i>ACTIVE</i> or <i>DEACTIVATING</i> (see clause 4.6.1).
MBS Session Context	1..*		As defined in clause 6.9 of TS 23.247 [5] (see NOTE 1). There shall be one MBS Session Context associated with the MBS Distribution Session unless multiple <i>Target service areas</i> are specified (see below).
MB-UPF tunnel endpoint address	0..1		The tunnel endpoint address of the MB-UPF that supports this MBS Distribution Session at reference point Nmb9 (see NOTE 1, NOTE 4).
MBMS GW tunnel endpoint address	0..1		The tunnel endpoint address of the MBMS GW that supports this MBS Distribution Session at reference point SGI-mb (see NOTE 1, NOTE 4).
User Plane traffic flow information	0..1		Details of the MBS-4-MC User Plane traffic flow to be used by the MBSTF for this MBS Distribution Session, including the multicast group destination address and port number to be used inside the unicast tunnel at reference point Nmb9 (see NOTE 1). This parameter is mandatory except in the case of Packet Distribution Method operating in Forward-only mode, in which case multicast-addressed packets ingested at reference point Nmb8 are relayed to Nmb9 without changing their address.
MBS Session Identifier	0..1	MBSF or MBS Application Provider	The Temporary Mobile Group Identity (TMGI) or Source-Specific Multicast (SSM) IP address of the MBS Session supporting this MBS Distribution Session (see NOTE 2). Multiple MBS Distribution Sessions within the scope of the same MBS User Service may share the same value if they are location-dependent MBS Services, as defined in clause 6.2.3 of TS 23.247[5]. TMGI values are allocated by the MBSF in conjunction with the MB-SMF unless supplied by the MBS Application Provider at the time of provisioning.
Target service areas	0..*	MBS Application Provider	The set of regions comprising the MBS service area in which this MBS Distribution Session is to be made available (see NOTE 2). The provided set of regions shall be disjoint with that of every other MBS Distribution Session sharing the same MBS Session Identifier. A unique MBS Session Context shall be associated with the MBS Distribution Session for each declared service area, distinguishable by its Area Session Identifier.
MBS Frequency Selection Area (FSA) Identifier	0..1		(Applicable only to broadcast <i>Service type</i> .) Identifies a preconfigured area within which, and in proximity to, the cell(s) announce the MBS FSA ID and the associated frequency corresponding to this MBS Distribution Session (see NOTE 3).
Location-dependent service flag	0..1		An indication that this MBS Distribution Session corresponds to a location-dependent MBS Session. If the flag is unset or omitted, the MBS Distribution Session is not location-dependent.

Multiplexed service flag	0..1		If set, all MBS Distribution Sessions in the scope of the same parent MBS User Data Ingest Session with identical or empty sets of <i>Target service areas</i> shall be multiplexed onto the same MBS Session. All MBS Distribution Sessions in the multiplex shall be assigned the same MBS Session Identifier.
Restricted membership flag	0..1		(Applicable only to multicast <i>Service type</i> .) An indication that this MBS Distribution Session is restricted to a set of UEs according to their current subscription status in the MBS System. If the flag is set, only UEs in the restricted set are permitted to join this MBS Distribution Session; otherwise, any UE is permitted to join.
QoS information	0..1		A 5G QoS Identifier (5QI) [2] to be applied to the traffic flow for this MBS Distribution Session (see NOTE 2). The 5QI information is used by the MBSF to set the Quality of Service for the MBS Session by interacting with the PCF at reference point Nmb12.
Maximum content bit rate	1..1		The maximum bit rate for content in this MBS Distribution Session.
Maximum content delay	0..1		The maximum end-to-end content distribution delay that is tolerated for this MBS Distribution Session by the MBS Application Provider.
Distribution method	1..1		The distribution method for this MBS Distribution Session, as defined in clause 6.
Operating mode	0..1		The operating mode in the case where multiple modes are defined in clause 6 for the indicated distribution method.
FEC configuration	0..1		Configuration for Application Level FEC (AL-FEC) information added by the MBSTF to protect this MBS Distribution Session. The AL-FEC scheme shall be identified using a term from the Reliable Multicast Transport (RMT) controlled vocabulary of FEC Encoding IDs [17] expressed as a fully-qualified URI, e.g. <i>urn:ietf:rmt:fec:encoding:0</i> . The overhead of AL-FEC protection shall be specified as a proportion of the (unprotected) MBS data, e.g. 1.1 for 10% overhead. Additional scheme-specific parameters may be signalled in the form of uncontrolled name–value pairs.
Traffic marking information	0..1	MBS Application Provider or MBSF	Information (e.g. a Differentiated Services Code Point) used by the MBSTF to mark the multicast packets that it conveys to the MB-UPF at reference point Nmb9.
NOTE 1: Internal parameter not exposed to the MBS Application Provider.			
NOTE 2: Parameter not relevant to the MBSTF.			
NOTE 3: Used to guide frequency selection by the UE for a broadcast MBS Session.			
NOTE 4: At least one of <i>MB-UPF tunnel endpoint address</i> or <i>MBMS GW tunnel endpoint address</i> shall be present.			

An MBS Distribution Session Announcement (see clause 4.5.8 below) shall be associated with an MBS Distribution Session when the latter is in the *ESTABLISHED* or *ACTIVE* state.

The following MBS Distribution Session parameters are additionally relevant when the distribution method is the Object Distribution Method:

Table 4.5.6-2: Additional MBS Distribution Session parameters for Object Distribution Method

Parameter	Cardinality	Assigner	Description
Object acquisition method	1..1	MBS Application Provider	Indicates whether the object(s) are to be pushed into the MBSTF by the MBS Application Provider or whether they are to be pulled from the MBS Application Provider by the MBSTF as part of the corresponding MBS User Data Ingest Session. In the latter case, the <i>Object acquisition method</i> indicates whether the object(s) are to be retrieved once from the MBS Application Provider at the start of each active period of the corresponding MBS User Data Ingest Session, or whether the MBSTF is required to check their validity periodically, for example once per rotation of an object carousel.
Object acquisition identifiers	1..*		Identifies the object(s) to be ingested and distributed by the MBSTF during this MBS Distribution Session. This could be the ingest URL of the object, or the ingest URL of a manifest describing a set of objects, or a reference into a manifest describing a set of objects.
Object ingest base URL	0..1	MBS Application Provider or MBSF	A URL prefix substituted by the MBSTF with the <i>Object distribution base URL</i> prior to distribution of ingested objects. Assigned by the MBS Application Provider for the pull-based <i>Object acquisition method</i> . Assigned by the MBSF for push-based object acquisition. If omitted, nothing is removed from the content ingest URL when forming the object distribution URL
Object distribution base URL	0..1	MBS Application Provider	A URL prefix substituted by the MBSTF in place of the <i>Object ingest base URL</i> prior to distribution of ingested objects. If present, the optional <i>Object ingest base URL</i> shall also be present. If omitted, the object distribution URL is the same as the object ingest URL.
Object repair base URL	0,,1	MBSF	A URL prefix substituted by the MBSTF Client in place of the <i>Object distribution base URL</i> when repairing objects not received completely intact from this MBS Distribution Session (see NOTE). The value shall point to the MBS AS. Present only when object repair is provisioned for this MBS Distribution Session.
NOTE: Parameter not relevant to the MBSTF.			

The following MBS distribution session are additionally relevant when the distribution method is the Packet Distribution Method:

Table 4.5.6-3: Additional MBS Distribution Session parameters for Packet Distribution Method

Parameter	Cardinality	Assigner	Description
Packet ingest method	1..1	MBS Application Provider	Indicates whether packets are to be ingested using multicast ingest or unicast ingest. Multicast ingest is valid for Proxy mode only. In this case, the MBSTF shall join a Source-Specific Multicast (SSM) group indicated in <i>MBSTF ingest endpoint addresses</i> parameter. Unicast ingest is valid for Proxy mode and Forward-only mode. In this case, the MBSTF shall allocate a listening IP address and port number for packet ingest and shall return it to the MBSF in the <i>MBSTF ingest endpoint addresses</i> parameter below.
MBSTF ingest endpoint addresses	1..1	MBS Application Provider, MBSF, MBSTF	The endpoint addresses used by the MBS Application Provider and MBSTF to establish a connection at reference point Nmb8 prior to the commencement of this MBS User Data Ingest Session. In the case of Proxy mode, this shall be the Source-Specific Multicast (SSM) endpoint addresses (including the source IP address, destination multicast group address and destination UDP port) nominated by the MBS Application Provider or else by the MBSF. In the case of Forward-only mode, this shall be the IP addresses and UDP port numbers at the source and destination ends of the content ingest tunnel, nominated respectively by the MBS Application Provider and the MBSTF.

4.5.7 MBS User Service Announcement parameters

This entity models an MBS User Service Announcement, which is compiled by the MBSF and used to advertise the current or imminent availability of an MBS User Service in the MBS System. The baseline parameters for an MBS User Service Announcement are listed in table 4.5.7-1 below:

Table 4.5.7-1: Baseline parameters of MBS User Service Announcement entity

Parameter	Cardinality	Assigner	Description
External service identifiers	1..*	MBS Application Provider	A unique identifier used by the MBSF Client to distinguish between MBS User Services. If assigned in a globally unique manner, this identifier may be useful to the MBSF Client in correlating the MBS User Service with the same service delivered by a different system.
Service class	1..1		The class of the MBS User Service, expressed as a term identifier from a controlled vocabulary.
Start date–time	0..1		The point in time from which this MBS User Service Announcement is valid. If not present, the announcement is already valid.
End date–time	0..1		The point in time after which this MBS User Service Announcement is no longer valid. If not present, the announcement is valid indefinitely.
Service names	1..*		A set of distinguishing names for the MBS User Service, one per language.
Service descriptions	1..*		A set of descriptions of the MBS User Service, one per language.
Main service language	0..1		The main language of the MBS User Service.
MBS Distribution Session Announcements	1..*	MBSF	The set of MBS Distribution Session Announcements (see clause 4.5.8) currently associated with this MBS User Service Announcement.

4.5.8 MBS Distribution Session Announcement parameters

This entity models an MBS Distribution Session Announcement, which is compiled by the MBSF and used to advertise the current or imminent availability of an MBS Distribution Session in the MBS System. The baseline parameters for an MBS Distribution Session Announcement are listed in table 4.5.8-1 below:

Table 4.5.8-1: Baseline parameters of MBS Distribution Session Announcement entity

Parameter	Cardinality	Assigner	Description
MBS Session Identifier	1..1	MB-SMF	The Temporary Mobile Group Identity (TMGI) or Source-Specific Multicast (SSM) IP address of the MBS Distribution Session from which this announcement is derived.
MBS Frequency Selection Area (FSA) Identifier	0..1	MBS Application Provider or MB-SMF	(Broadcast MBS Session only.) Identifies a preconfigured area within which, and in proximity to, the cell(s) are announcing the MBS FSA ID and the associated frequency corresponding to this MBS Distribution Session Announcement. (see NOTE)
Distribution method	1..1	MBS Application Provider	The distribution method (as defined in clause 6) of the MBS Distribution Session from which this announcement is derived.
Session Description parameters	1..*	MBSF	Additional parameters needed to receive the MBS Distribution Session from which this announcement is derived, including relevant User Plane traffic flow parameters.
Transport security protection parameters	0..1		The security parameters for the MBS Distribution Session, including the address of the key management server (FQDN of the MBSSF).
NOTE: Used to guide frequency selection by the UE for a broadcast MBS Session.			

The following session announcement parameters are additionally relevant when *Distribution method* above indicates the Object Distribution Method:

Table 4.5.8-2: Additional MBS Distribution Session Announcement parameters for Object Distribution Method

Parameter	Cardinality	Assigner	Description
Object distribution schedule	0..1	MBS Application Provider	A schedule indicating when individual objects are to be delivered on the corresponding MBS Distribution Session. Present only when this information has been provided in the <i>Object acquisition identifiers</i> of the corresponding MBS Distribution Session (see table 4.5.6-2).
Object distribution base URL	0..1		A URL prefix substituted by the MBSTF Client with the <i>Object repair base URL</i> when repairing objects not received completely intact from the corresponding MBS Distribution Session. Present only when object repair is provisioned for the corresponding MBS Distribution Session.
Object repair base URL	0..1	MBSF	The base URL of the MBS AS to be used for object repair of the corresponding MBS Distribution Session. Present only when object repair is provisioned for the corresponding MBS Distribution Session.

4.5.9 Mapping of MBS Distribution Session to MBS Session Context

Except when it is in the *INACTIVE* state, an MBS Distribution Session in the MBSF is associated with an MBS Session Context in the MB-SMF. When the MBSF invokes the *Nmb-smf_MBSSession* service, the parameters defined in clause 6.9 of TS 23.247 [5] shall be populated as indicated in table 4.5.9-1 below.

Table 4.5.9-1: Mapping of baseline parameters to MBS Session Context parameters

MBS Session Context parameter	Source	Clause	Source parameter
State	MBS Distribution Session.	4.5.6	State.
Source-Specific Multicast (SSM) IP address	MBS Distribution Session.	4.5.6	MBS Session Identifier
TMGI			
MBS Service Area	MBS Distribution Session.	4.5.6	Target service area (see NOTE 2)
Area Session Identifier	Assigned by MB-SMF.	4.5.6	Location-dependent service flag
MBS Frequency Selection Area (FSA) ID (see NOTE 1)	MBS Distribution Session.	4.5.6	MBS Frequency Selection Area
MB-SMF	Not applicable to MB-SMF.	N/A	Not applicable.
AMF	Discovered by MB-SMF	N/A	Not applicable.
SMF	Selected by AMF.	N/A	Not applicable.
PCF	[Selected by MBSF or MB-UPF.]	N/A	Not applicable.
QoS (flow) information	MBS Distribution Session.	4.5.6	QoS information
Tunnel Endpoint Identifier (TEID) for distribution	Assigned by MB-SMF.	N/A	Not applicable.
IP multicast and source address for data distribution	?	N/A	Not applicable.
NG-RAN IP address for data distribution	Selected by MB-SMF.	N/A	Not applicable.
NG-RAN Node ID(s)	Not applicable to MB-SMF.	N/A	Not applicable.
UE IDs	Not applicable to MB-SMF.	N/A	Not applicable.
NOTE 1: Applicable to Broadcast MBS Session only.			
NOTE 2: Mapping to Tracking Area Identifier (TAI) list and/or Cell ID list performed by MBSF as required.			

In addition, the following parameters to the *Nmb-smf_MBSSession_Create* service operation defined in clause 9.1.3.6 of TS 23.247 [5] shall be populated as indicated in table 4.5.9-2 below.

Table 4.5.9-2: Mapping of baseline parameters to Nmb-smf_MBSSession_Create parameters

MBSSessionCreate input parameter	Source	Clause	Source parameter
MBS Service type	MBS User Service	4.5.3	Service type
MBS activation time	MBS User Data Ingest Session	4.5.5	Active period
MBS termination time			
Indication that any UE may join (see NOTE)	MBS Distribution Session	4.5.6	Restricted membership flag
[MBS Service requirements or MBS Session information]	MBS Distribution Session	4.5.3	QoS information
Data Network Name (DNN)	Selected by MBSF based on	N/A	Not applicable.
Single-Network Slice Selection Assistance Information (S-NSSAI)	MBS Application Provider authorisation.	N/A	Not applicable.
NOTE: Applicable to Multicast MBS Session only.			

4.6 Dynamic model

4.6.1 MBS Distribution Session life-cycle

The life-cycle model for the MBS Distribution Session is depicted in figure 4.6.1-1 below. The current state of a provisioned MBS Distribution Session is reflected in the *state* parameter of the information entities maintained by the MBSF and the MBSTF, and is exposed to the MBS Application Provider via the *Nmb-smf* service.

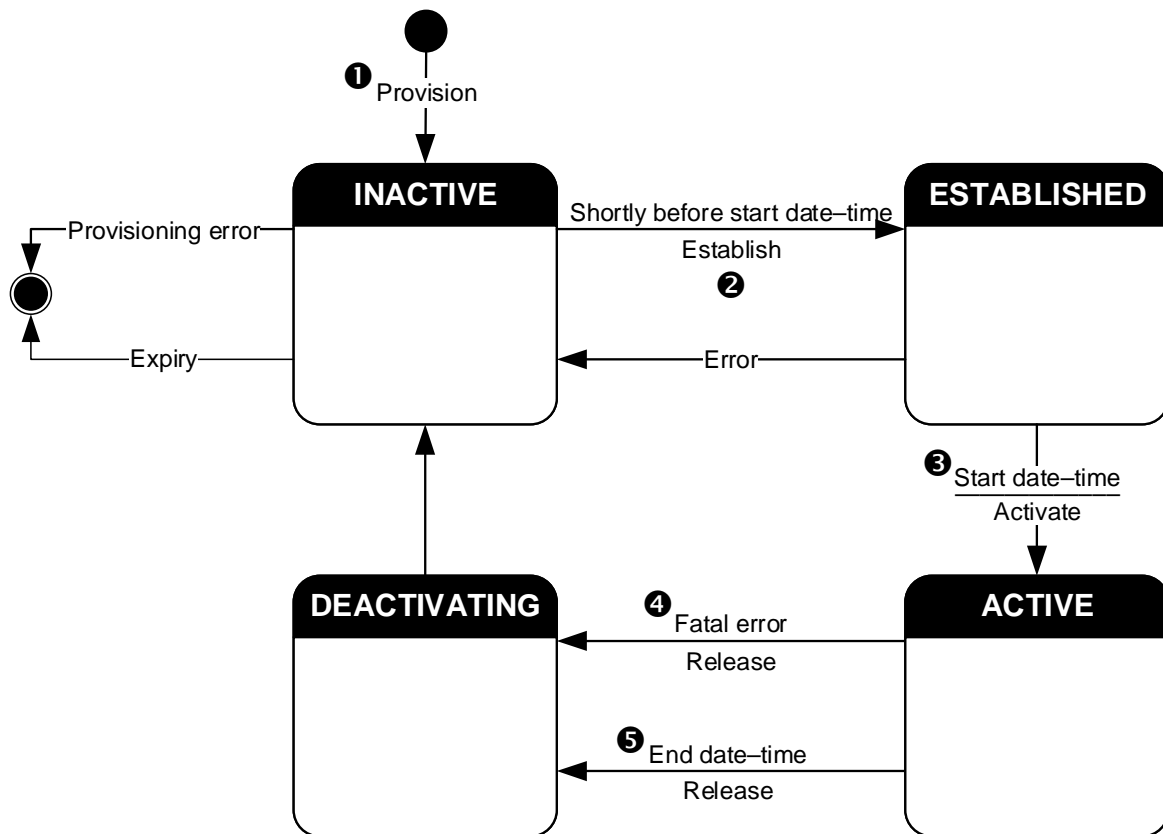

Figure 4.6.1-1: Life-cycle model for MBS Distribution Session

1. An MBS Distribution Session shall be in the *INACTIVE* state when it is first provisioned in the MBSF by the MBS Application Provider. The MBSF shall provision a corresponding MBS Distribution Session entity in the MBSTF. This replica of the MBS Distribution Session shall also be in the *INACTIVE* state.

If the provisioned end date–time of the parent MBS User Data Ingest Session is in the past, the MBS Distribution Session shall immediately expire and shall transition to a state in which it is no longer provisioned.

It is an error for the end date–time of the parent MBS User Data Ingest Session to be prior to the start date–time. The MBSF shall reject such a configuration at the time of provisioning.

2. Shortly before the provisioned start date–time of the parent MBS User Data Ingest Session (or immediately if the start date–time is in the past at the point of provisioning) the MBS Distribution Session shall transition into the *ESTABLISHED* state.

At this point:

- a. The MBSF shall reserve resources for the MBS Distribution Session in the MBS System by interacting with the MB-SMF at reference point Nmb1 using the procedures defined in clause 7.1.1 of TS 23.247 [5].
- b. The MBSF shall establish the MBS Distribution Session in the MBSTF by invoking the MBS Distribution Session establishment procedure on the *Nmbstf* service at reference point Nmb2 using the procedures defined in clause 5.4 of the present document. As a result, the MBSTF shall attempt to establish an MBS User Data Ingest Session with the upstream data source at reference point Nmb8 and may commence ingesting data (but not distributing it).

NOTE: Successfully establishing the MBS User Data Ingest Session requires, in the case of the Object Distribution Method, successful retrieval of at least an initial object from the MBS Application Provider via reference point Nmb8. In the case of the Packet Distribution Method, successful establishment of the MBS User Data Ingest Session may require a data ingest tunnel to be established successfully with the MBS Application Provider at reference point Nmb8 and receipt of at least one data packet through that tunnel.

If either of these procedures fail, a suitable error shall be returned to the MBSF. Any successfully reserved resources in the MBS System shall be released and the MBS Distribution Session shall return to the *INACTIVE* state.

Otherwise, the MBSF shall advertise the successfully established MBS Distribution Session to MBSF Clients (either directly via MBS-5, or indirectly via MBS-8, depending on the provisioned advertisement mode) by means of an MBS User Service Announcement that it has compiled. An MBS Client in receipt of this advertisement may activate reception of the established MBS Distribution Session at this point (but will not yet receive any MBS data packets).

3. At the provisioned start date–time of the parent MBS User Data Ingest Session (or immediately if the start date–time is in the past at the point of provisioning) the MBS Distribution Session shall transition into the *ACTIVE* state.

The MBSF shall inform the MBSTF of this state transition by invoking the MBS Distribution Session activation procedure on the *Nmbstf* service at reference point Nmb2, as specified in clause 5.4 of the present document. As a result, the MBSTF shall commence sending MBS data packets to the MB-UPF at reference point Nmb9, and any MBS Clients that have activated reception of the previously advertised MBS Distribution Session in step 2 above may start to receive MBS data packets at reference point MBS-4-MC.

4. If the MBSTF encounters any error conditions when the MBS Distribution Session is in the *ACTIVE* state it shall notify the MBSF by invoking the MBS Distribution Session notification procedure defined by the *Nmbstf* service at reference point Nmb2 per clause 5.4.

If the MBSF determines that the error is of such a severity that the MBS Distribution Session cannot continue, it shall transition to the *DEACTIVATING* state.

- a. The MBSF shall stop advertising the MBS Distribution Session by means of an MBS User Service Announcement.
- b. The MBSF shall inform the MBSTF of this state transition by invoking the MBS Distribution Session deactivation procedure on the *Nmbstf* service at reference point Nmb2 using the procedures defined in clause 5.4 of the present document. As a result, the MBSTF shall cease sending MBS data packets to the MB-UPF at reference point Nmb9.
- c. The MBSF shall release the MBS Distribution Session in the MBSTF by invoking the MBS Distribution Session release procedure on the *Nmbstf* service at reference point Nmb2 using the procedures defined in clause 5.4 of the present document. As a result, the MBSTF shall stop ingesting data at reference point Nmb8 from the upstream data source. As a result of this procedure, the MBSTF shall automatically transition to the *INACTIVE* state.
- d. The MBSF shall release resources in the MBS System associated with the MBS Distribution Session by interacting with the MB-SMF at reference point Nmb1 using the procedures defined in clause 7.1.1 of TS 23.247 [5]. As a result of this procedure, the MBSF shall automatically transition to the *INACTIVE* state.
5. At the provisioned end date–time of the parent MBS User Data Ingest Session (or immediately if the MBS Distribution Session or its parent MBS User Data Ingest Session are destroyed by the MBS Application Provider earlier than the provisioned end date–time) an MBS Distribution Session in the *ACTIVE* state shall transition into the *DEACTIVATING* state and the deactivation procedure described in steps 4a to 4d inclusive shall be followed.

Once the deactivation procedure is complete, the expired MBS Distribution Session shall transition automatically to a state in which it is no longer provisioned.

4.6.2 Notification events

During the lifecycle of a MBS User Service Session, a number of notification messages may be sent by different Network Functions. The MBSF may modify event information when passing on notifications from other Network Functions to the MBS Application Provider (AF/AS) at reference point Nmb10 or (via the NEF) at reference point Nmb5.

The events may originate from different sources:

- If the event originates in the MB-SMF at reference point Nmb1 or in the PCF at reference point Nmb12, it is propagated to the MBS Application Provider (AF/AS) at reference point Nmb10 (or via the NEF at reference point Nmb5). The MBSF conditions the event payload for external usage.
- If the event originates in the MBSTF at reference point Nmb2, it is propagated to the MBS Application Provider (AF/AS) at reference point Nmb10 (or via the NEF at reference point Nmb5). The MBSF conditions the event payload for external usage.
- If the event originates in the MBSF itself, it is propagated directly to the MBS Application Provider (AF/AS) at reference point Nmb10 (or via the NEF at reference point Nmb5).

The notification events listed in table 4.6.2-1 below are used by the MBSF to notify the MBS Application Provider (AF/AS) or NEF. The relevant stimulating reference point is indicated in brackets in the final column of the table.

Table 4.6.2-1: Notification events

Event	Description	Applicable reference point(s)
Distribution Session established	The MBS Distribution Session is established.	Nmb10/Nmb5
Distribution Session service management failure	The MBS Distribution Session could not be started, for example because the necessary resources could not be allocated by the MBS System.	(Nmb1), (Nmb2), Nmb10/Nmb5
Distribution Session policy control failure	The MBS Distribution Session could not be started because of a policy authorization/control failure or rejection.	(Nmb12), Nmb10/Nmb5
Distribution Session activated	The MBS Distribution Session is activated successfully.	(Nmb2), Nmb10/Nmb5
Distribution Session deactivated	The MBS Distribution Session is deactivated.	(Nmb2), Nmb10/Nmb5
Distribution Session data ingest failure	The MBSTF is expecting ingest data for an active MBS Distribution session, but is not receiving data.	(Nmb2), Nmb10/Nmb5

4.7 QoS model

How MBS User Services make use of the network Quality of Service primitives defined in TS 23.247 [5] is for further study.

4.8 Security

How MBS User Services makes use of the security primitives studied in TR 33.850 is for further study.

4.9 Interworking with eMBMS

Interworking between MBS and eMBMS is described in clause 5.2 of TS 23.247 [5] and applies at the service layer in cases where the same Multicast/Broadcast service is provided simultaneously via eMBMS and MBS. Figure 4.9-1 depicts a combined network architecture based on figure 4.2.1-1 in the present document and figure 5.2-1 in TS 23.247 [5].

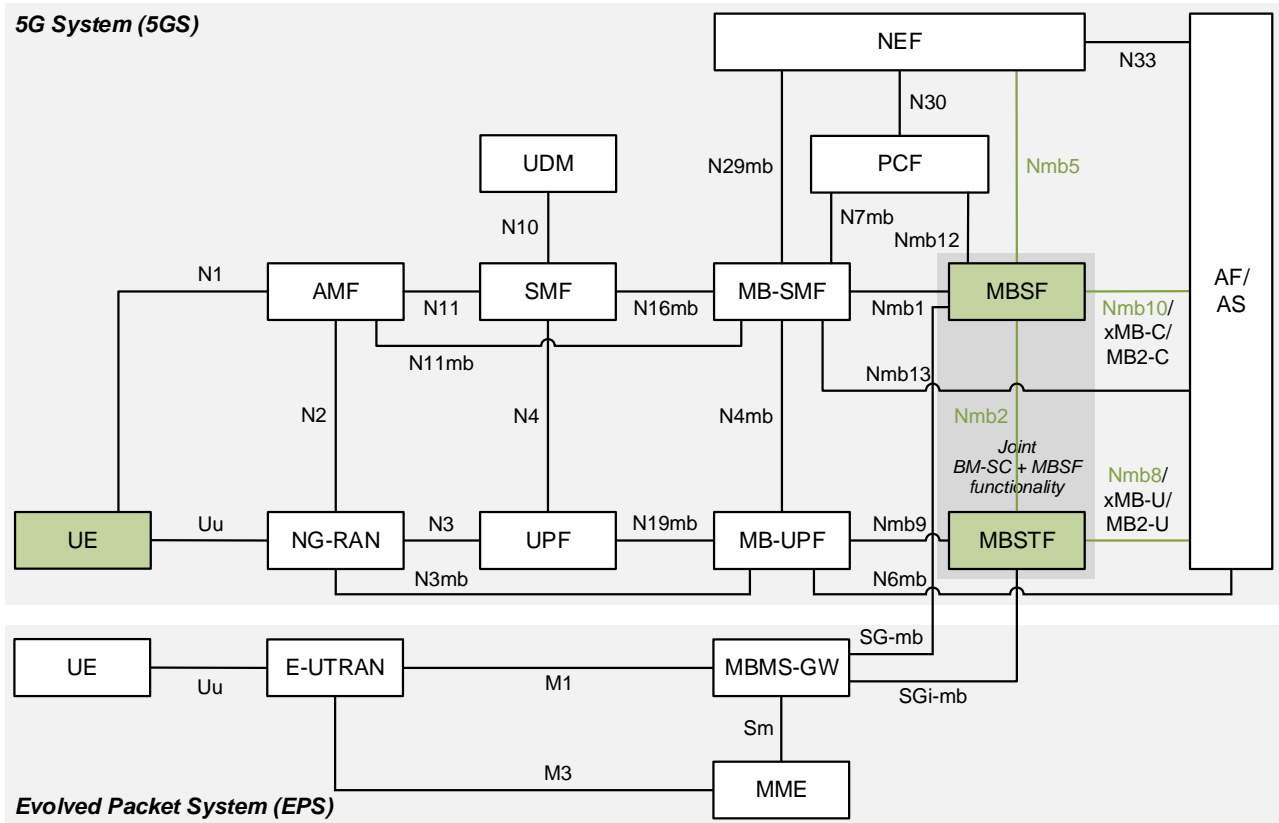

Figure 4.9-1: MBS-eMBMS interworking system architecture

To support MBS-eMBMS interworking according to the description in clause 5.2 of TS 23.247 [5], the MBS User Services architecture supports the following functionality:

1. MBS User Services are provisioned via reference point Nmb8 per the present document. eMBMS User Services are separately provisioned at xMB-C per TS 26.348 [6] or MB2-C per TS 23.468 [12]. A common TMGI is used in the MBS System and in the eMBMS System. The two User Services should be provisioned to ingest the same content if service continuity between the MBS System and the eMBMS System is required.
2. Signalling from the MBSF to the MBS Client is present in the MBS User Service Announcement indicating that the equivalent User Service is also available via eMBMS. By this, a UE that implements both an MBS Client and an eMBMS Client may choose to receive the service from either network, and may dynamically switch between them according to varying reception conditions. Such an architecture is shown in figure 4.9-2.
3. Content for the provisioned MBS User Service is ingested logically by the MBTSF at reference point Nmb8 per the present document. Content for the provisioned eMBMS User Service is ingested logically by the MBSTF at reference point xMB-U per TS 26.348 [6] or MB-2 per TS 23.468 [12]. If these reference points are compatible, the content is ingested once to satisfy both logical ingests.
4. MBS User Services distribution methods are compatible with eMBMS delivery methods such that the same ingested content can be delivered to an MBS Client and to an eMBMS Client. UEs only supporting only eMBMS are served by this architecture as well.

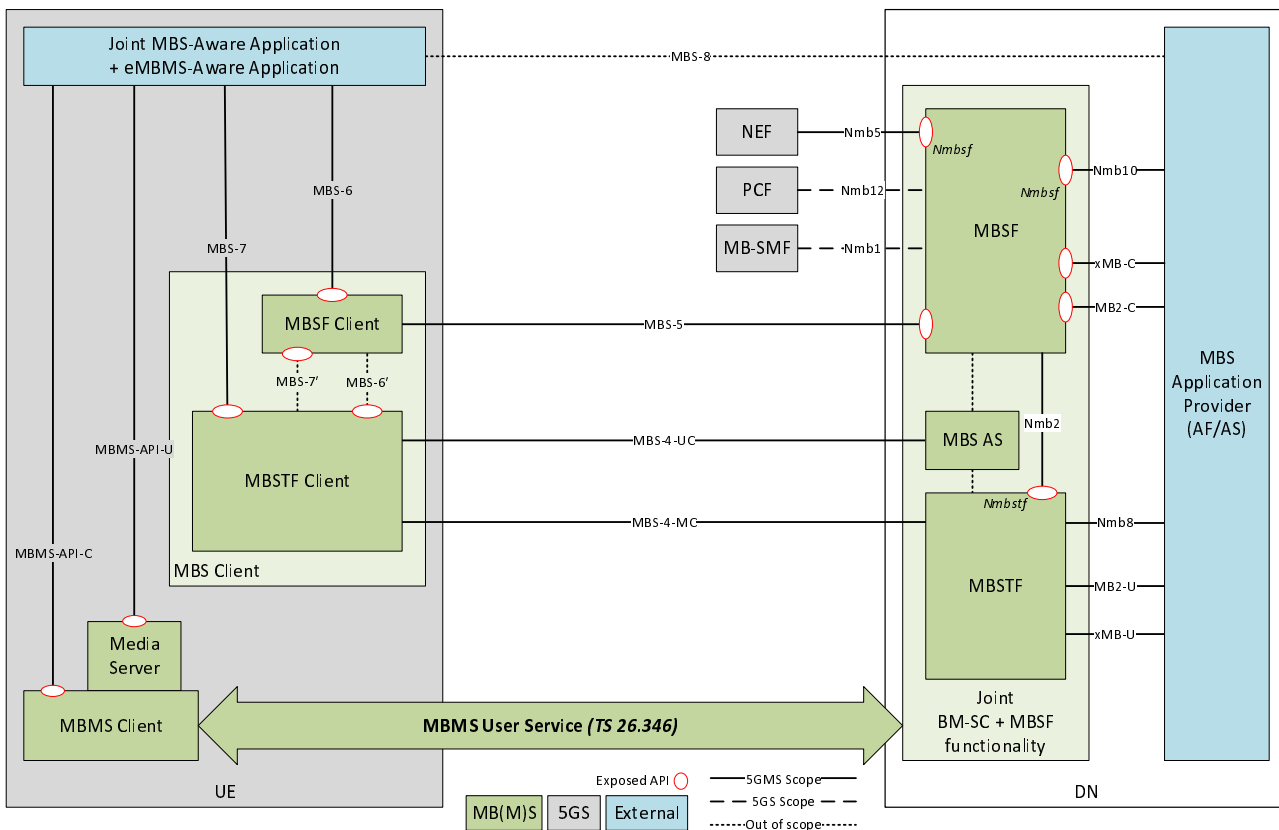

Figure 4.9-2: MBS-eMBMS interworking reference architecture

5 Procedures for 5G Multicast-Broadcast User Services

5.1 General

This clause defines the high-level procedures for 5G Multicast-Broadcast User Services.

5.2 High-level baseline procedures

The high-level baseline procedures for MBS User Services are shown in figure 5.2-1.

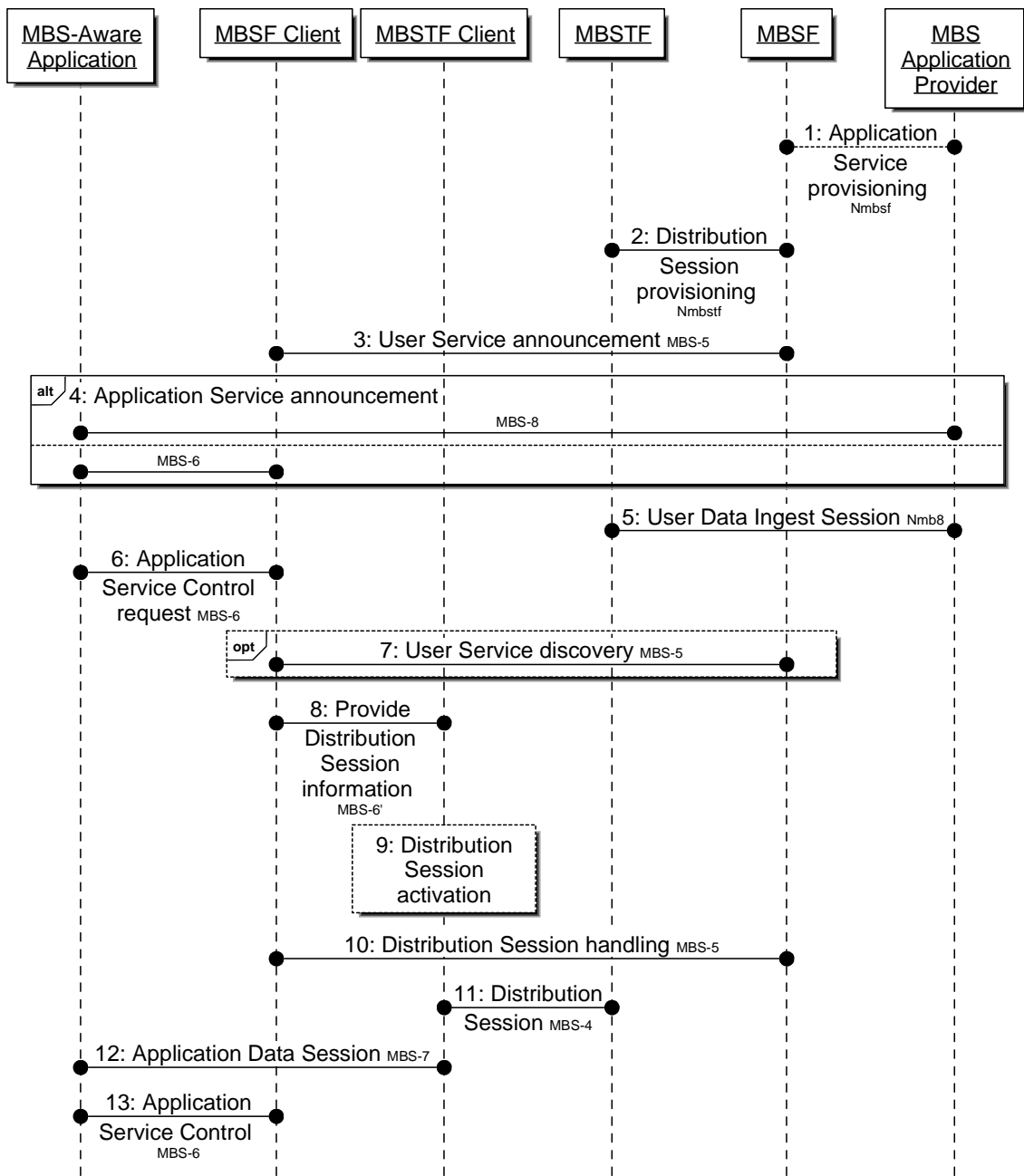

<http://msc-generator.sourceforge.net v6.3.7>

NOTE: In the interests of brevity, the prefix MBS is omitted from the numbered steps in the figure.

Figure 5.2-1: MBS User Service high-level baseline procedures

The basic procedures are as follows:

1. The MBS Application Provider provisions an Application Service as an MBS User Service by invoking the *Nmbssf* service on the MBSF.
2. The MBSF provisions one or more MBS Distribution Session by invoking the *Nmbstf* on the MBSTF.
3. The MBSF creates a User Service Announcement that may be accessed by the MBS Client of interested UEs.

4. The MBS Application Provider informs the MBS-Aware Application via MBS-8 that the specific Application Service can be accessed via an MBS User Service by means of an Application Service Announcement.

[Alternatively, the MBSF Client synthesises the Application Service Announcement from the User Service Announcement received in step 3 and informs the MBS-Aware Application via MBS-6 that the Application Service can be accessed via an MBS User Service.]
5. The MBS Application Provider creates an MBS User Data Ingest Session with the MBSTF (via the MBSF) and the latter ingests the user data via Nmb8.
6. The MBS-Aware Application requests the MBS Client to access a specific MBS User Service by invoking procedures at MBS-6.
7. Optional: If it has not already been received in step 3 above, the MBSF Client may discover additional access information about this MBS User Service by querying the MBSF via MBS-5.
8. The MBSF Client provides the MBS Distribution Session information acquired as part of the User Service Announcement information to the MBSTF Client via MBS-6'.
9. The MBSTF Client activates reception of the MBS Distribution Session.
10. The MBSF Client continuously handles the MBS Distribution Session data based on updates received via MBS-5.
11. The MBSTF Client receives MBS Distribution Session data via MBS-4-MC as part of the MBS Distribution Session.
12. The MBSTF provides the MBS Distribution Session data to the MBS-Aware Application via MBS-7 in an MBS Application Data Session.
13. The MBS-Aware Application controls the MBS User Service by invoking MBS Application Service Control procedures on the MBSF Client via MBS-6.

5.3 Procedures for User Service provisioning

The procedure begins with the MBS Application Provider provisioning an MBS User Service and, within its scope, a set of MBS User Data Ingest Sessions, as shown in figures 5.3-1 and 5.3-2 below.

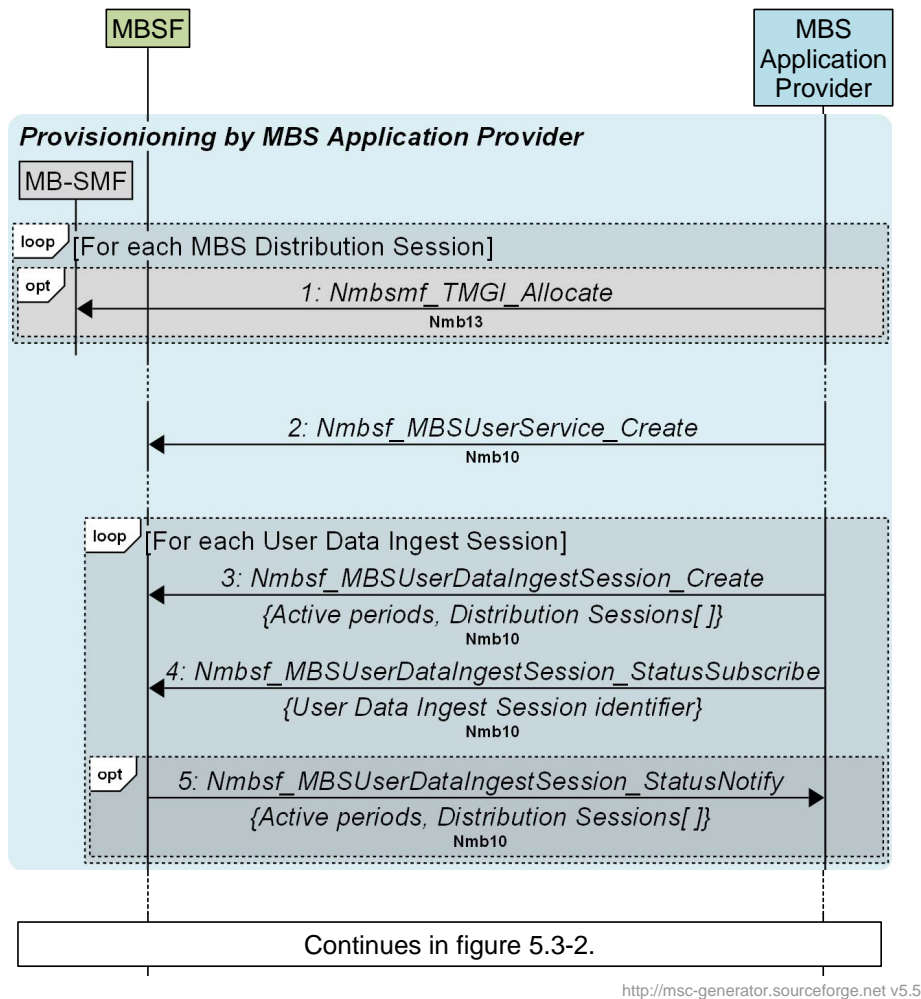

Figure 5.3-1: Call flow for MBS User Service provisioning by MBS Application Provider

First, the MBS Application Provider provisions a new MBS User Service Session in the MBS System:

1. To support Use Cases (e.g. Group Communication) where there is a requirement for TMGI allocation to be managed outside the MBS System, the MBS Application Provider may pre-allocate a TMGI for some or all of the MBS Distribution Sessions declared in step 3 below by invoking the *Nmbsmf_TMGI_Allocate* service operation on the MB-SMF at reference point Nmb13 (or N33+N29mb, if invoked via the NEF), as specified in clause 9.1.2.2 of TS 23.247 [5].
2. The MBS Application Provider invokes the *Nmbsf_MBSUserService_Create* service operation at reference point Nmb10 (or N33+Nmb5 if invoking via the NEF) to create a new MBS User Service, as defined in clause 4.5.3.

Immediately, or at some later time, the MBS Application Provider creates at least one MBS User Data Ingest Session (as defined in clause 4.5.5) within the scope of the MBS User Service created in step 2 above:

3. The MBS Application Provider creates an MBS User Data Ingest Session by invoking the *Nmbsf_MBSUserDataIngestSession_Create* service operation at reference point Nmb10 (or N33+Nmb5, if invoked via the NEF).

The MBS User Data Ingest Session optionally includes a schedule of start and end times referred to as *active periods*.

The MBS User Data Ingest Session comprises the details of one or more MBS Distribution Session(s), as defined in clause 4.5.6. Each such MBS Distribution Session fully specifies one of the distribution methods defined in clause 6 and may optionally nominate a TMGI to be used if one was pre-allocated in step 1 above.

4. The MBS Application Provider subscribes to status events from the MBSF relating to the MBS User Data Ingest Session just created by invoking *Nmbssf_MBSUserDataIngestSession_StatusSubscribe* service operation at reference point Nmb10 (or N33+Nmb5, if invoked via the NEF).
5. The MBSF may notify the status of each created MBS User Data Ingest Session to the MBS Application Provider by invoking the *Nmbssf_MBSUserDataIngestSession_StatusNotify* callback service operation at reference point Nmb10 (or N33+Nmb5, if invoked via the NEF).

Shortly before a provisioned MBS User Data Ingest session is scheduled to become active (see clause 4.5.5), or immediately if no schedule of active periods is provisioned, the MBSF establishes in the MBSTF all MBS Distribution Sessions comprising that MBS User Data Ingest Session as shown in figure 5.3-2 below.

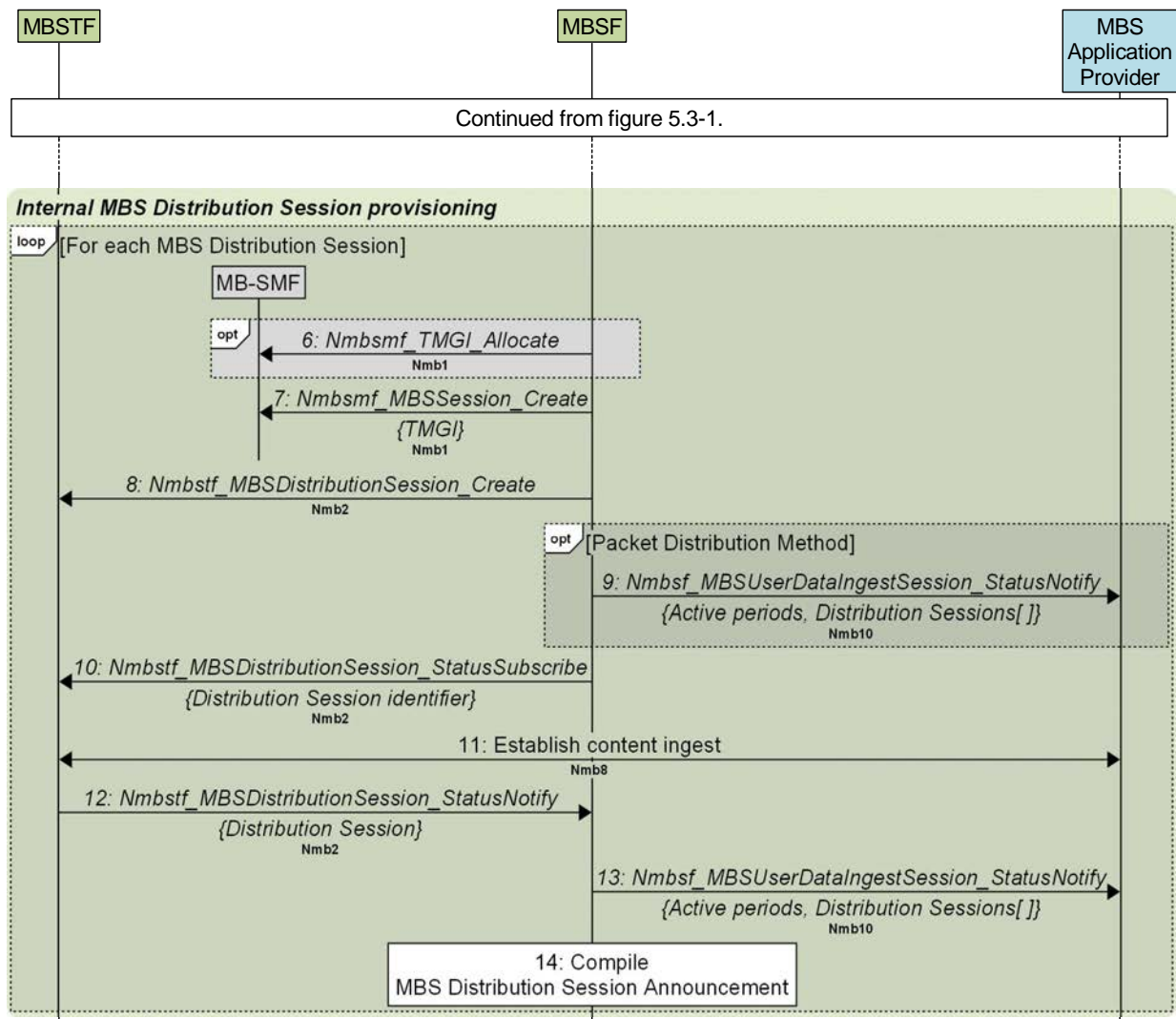

<http://msc-generator.sourceforge.net v5.5>

Figure 5.3-2: Call flow for MBS User Service internal provisioning

For each such MBS Distribution Session:

6. If no MBS Session ID was nominated by the MBS Application Provider in step 1 above, the MBSF may allocate a TMGI for it at this point by invoking the *Nmbsmf_TMGI_Allocate* service operation on the MB-SMF at reference point Nmb1, as specified in clause 9.1.2.2 of TS 23.247 [5].
7. The MBSF creates an MBS Session to reserve resources in the MBS System for the MBS Distribution Session by invoking the *Nmbsmf_MBSSession_Create* service operation on the MB-SMF at reference point Nmb1, as

specified in clause 9.1.3.6 of TS 23.247 [5]). The MBS Session ID provided for the MBS Distribution Session in step 1 or reserved in step 6 above is provided as an input parameter, if available. If needed, the MB-SMF allocates a TMGI as a side-effect of this operation. The MBSF determines the other input parameters as specified in clause 4.5.9.

8. The MBSF creates the MBS Distribution Session in the MBSTF by invoking the *Nmbstf_MBSDistributionSession_Create* service operation at reference point Nmb2. This is a mirror of the entity in the MBSF (see clause 4.5.6). In the case of the Packet Distribution Method, the response may include additional content ingest parameters chosen by the MBSTF for this MBS Distribution Session (see *MBSTF ingest endpoint addresses* in table 4.5.6-3).
9. In the case of the Packet Distribution Method, the MBSF invokes the *Nmbstf_MBSUserDataIngestSession_StatusNotify* callback service operation at reference point Nmb10 (or Nmb5+N33, if invoked via the NEF) to inform the MBS Application Provider of the content ingest parameters that have been chosen for this MBS Distribution Session (see *MBSTF ingest endpoint addresses* in table 4.5.6-3).
10. The MBSF subscribes to status events from the MBSTF relating to the MBS Distribution Session just created by invoking the *Nmbstf_MBSDistributionSessionStatusSubscribe* service operation at reference point Nmb2.
11. The MBSTF attempts to establish content ingest from the MBS Application Provider at reference point Nmb8 according to the ingest parameters and distribution method provisioned for the MBS Distribution Session in question (see table 4.5.6-1).

On success, the state of the MBS Distribution Session in the MBSTF becomes *ESTABLISHED*; on failure, it remains *INACTIVE* (see step 2 in clause 4.6.1).

NOTE: Success of this step varies according to the provisioned distribution method and its configuration. Success may, for example, be defined as establishing a network association with the MBS Application Provider (using the additional parameters defined in table 4.5.6-3), or it may require successful ingest of an initial object from the MBS Application Provider (using the additional parameters defined in table 4.5.6-2).

12. The MBSTF invokes the *Nmbstf_MBSDistributionSession_StatusNotify* callback service operation at reference point Nmb2 to inform the MBSF of the (un)successful establishment of content ingest.

On success, the state of the MBS Distribution Session in the MBSF becomes *ESTABLISHED*; on failure, it remains *INACTIVE* (see step 2 in clause 4.6.1).

13. The MBSF invokes the *Nmbstf_MBSUserDataIngestSession_StatusNotify* callback service operation at reference point Nmb10 (or Nmb5+N33, if invoked via the NEF) to inform the MBS Application Provider of the (un)successful establishment of content ingest for the MBS Distribution Session in the context of its parent MBS User Data Ingest Session.
14. If content ingest was established successfully in step 11 above, the MBSF compiles the metadata relating to this MBS Distribution Session into an MBS Distribution Session Announcement, as defined in clause 4.5.8.

5.4 Procedures for User Service advertisement/discovery

At this point, the MBS User Service Session is advertised to the MBSF Client, as shown in figure 5.4-1 below.

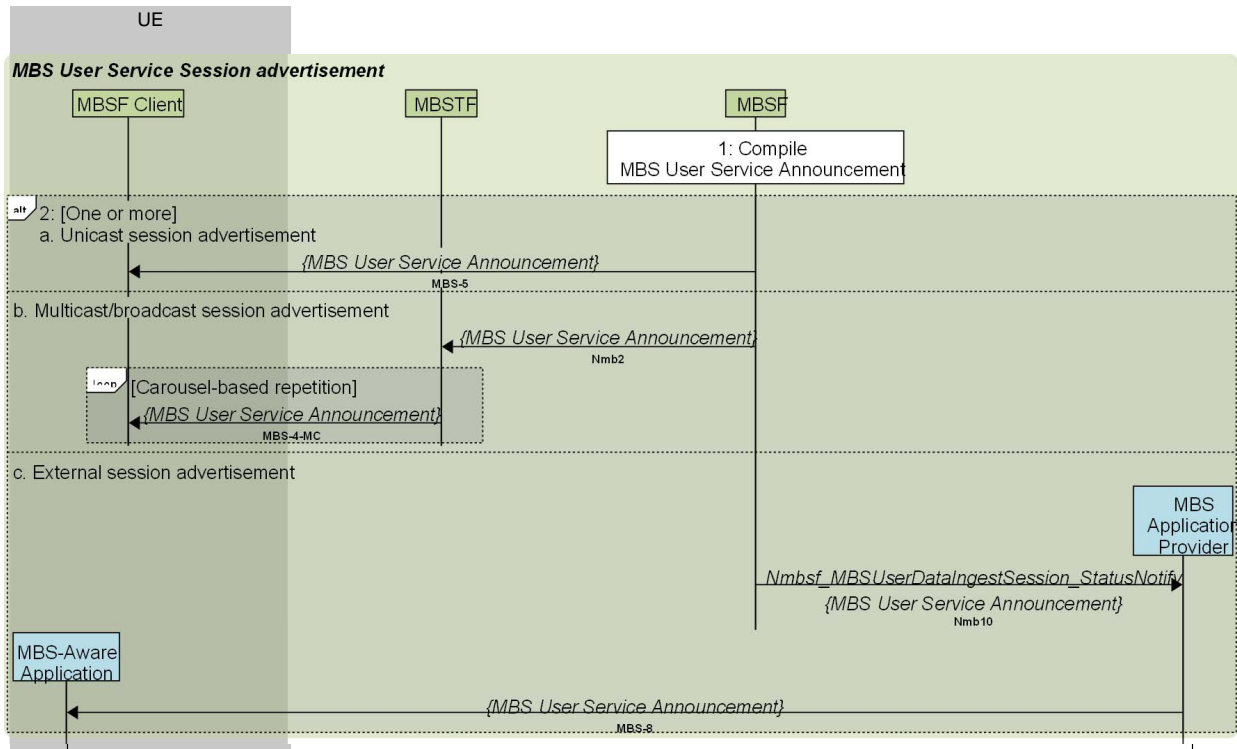

Figure 5.4-1: Call flow for MBS User Service advertisement/discovery

The steps are as follows:

1. The MBSF compiles a composite MBS User Service Announcement from the set of individual MBS Distribution Session Announcements compiled in step 14 of clause 5.3. The compiled MBS User Service Announcement describes the current set of MBS Distribution Sessions that comprise the active MBS User Data Ingest Session. The advertised start date–time is the next start time indicated in the MBS User Data Ingest Session schedule of active periods, or the current date–time if no schedule is provisioned.
2. The MBS User Service Announcement is distributed using one or more of the following mechanisms:
 - a. The MBS User Service Announcement is made available for unicast retrieval by the MBSF Client at reference point MBS-5.
 - b. The MBS User Service Announcement is made available to the MBSTF via reference point Nmb2 for ingest as defined in clause 4.3.3.2. Depending on the object acquisition method configured for the intended MBS Distribution Session, the MBS User Service Announcement is either pulled from the MBSF by the MBSTF or pushed to the MBSTF by the MBSF.

As a result, the MBS User Service Announcement is delivered (optionally repeatedly) via a suitable MBS Distribution Session at reference point MBS-4-MC using the Object Distribution Method. As specified in clause 4.2.4, this may be the same MBS Distribution Session as that carrying the advertised MBS Application Service content and/or a separate and dedicated MBS Distribution Session (i.e., the MBS User Service Announcement Channel).

- c. The MBS User Service Announcement is passed back to the MBS Application Provider by invoking the *Nmbssf_MBSUserDataIngestSession_StatusNotify* callback service operation at reference point Nmb10 (or Nmb5+N33, if invoked via the NEF).

As a result, the MBS Application Provider advertises the MBS User Service Announcement to the MBS-Aware Application by private means at reference point MBS-8.

The MBSF may rescind an MBS User Service Announcement at any time for operational reasons.

5.5 Procedures for User Service data transfer

At the next start time indicated in the MBS User Data Ingest Session schedule of active periods, or immediately if no schedule is provisioned, the MBSF activates all MBS Distribution Sessions comprising that MBS User Data Ingest Session, as shown in figures 5.5-1 and 5.5-2 below.

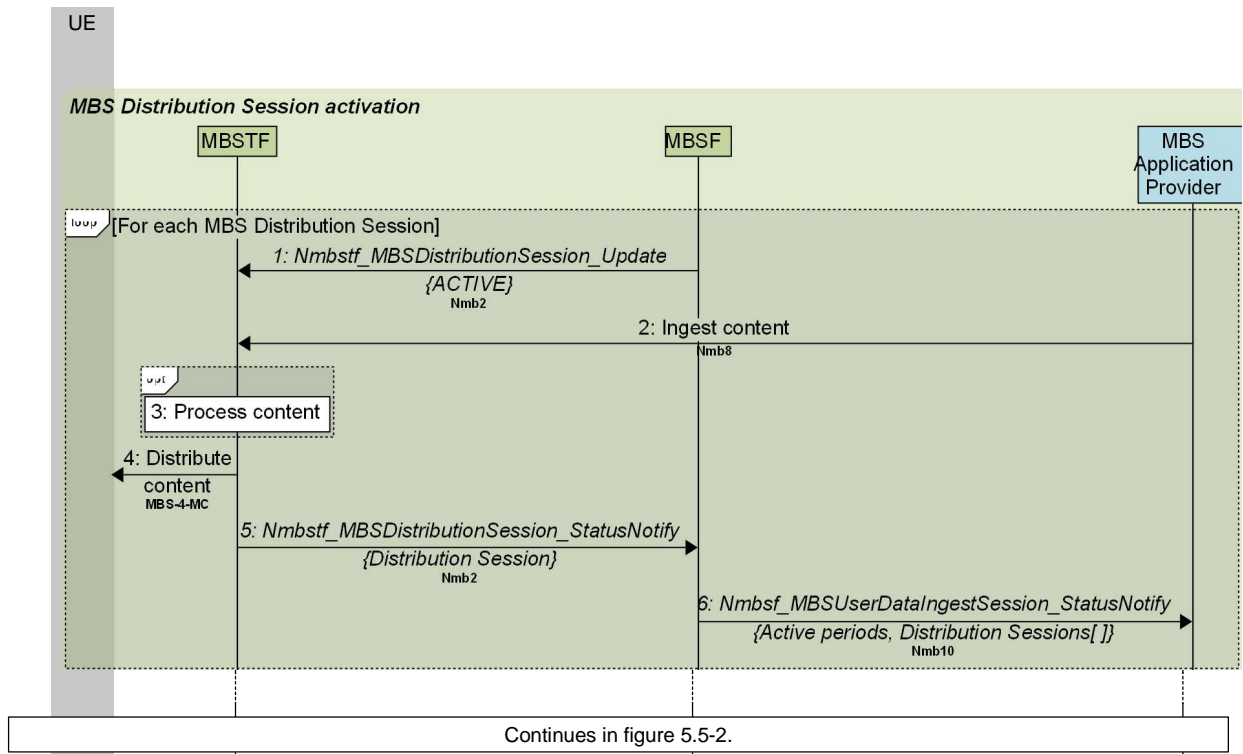

<http://msc-generator.sourceforge.net v5.5>

Figure 5.5-1: Call flow for MBS Distribution Session activation by MBSF

For each such MBS Distribution Session:

1. The MBSF invokes the *Nmbstf_MBSDistributionSession_Update* service operation on the MBSTF at reference point Nmb2, updating the current state of the MBS Distribution Session to *ACTIVE* (see step 3 in clause 4.6.1).
2. As a direct result of the previous step, the MBSTF begins to ingest content from the MBS Application Provider.
3. The MBSTF processes the ingested content according to the provisioned distribution method, as defined in clause 4.3.3. This may optionally include the computation of Application Level FEC (AL-FEC) information.
4. The MBSTF distributes the resulting MBS data at reference point MBS-4-MC. This is achieved by passing the MBS data to the MB-UPF at reference point Nmb9, according to the protocol stacks defined in clause 8.2 of TS 23.247 [5].
5. On successful content ingest and MBS data distribution, the state of the MBS Distribution Session in the MBSTF becomes and remains *ACTIVE* (see step 3 in clause 4.6.1); on failure, it transitions through *DEACTIVATING* to *INACTIVE* (see step 4 in clause 4.6.1).

The MBSTF invokes the *Nmbstf_MBSDistributionSession_StatusNotify* callback service operation at reference point Nmb2 to inform the MBSF of any changes to the state of the MBS Distribution Session.

6. The MBSF invokes the *Nmbstf_MBSDistributionSession_StatusNotify* callback service operation at reference point Nmb10 (or Nmb5+N33, if invoked via the NEF) to inform the MBS Application Provider of any changes to the state of the MBS Distribution Session in the context of its parent MBS User Data Ingest Session.

The MBS Client in the UE activates reception of an MBS User Service by establishing an MBS User Service Session between the MBSF Client and the MBSF, and consequently activating reception of one or more MBS Distribution Sessions by the MBSTF Client that are currently being distributed by the MBSTF. This call flow is shown in figure 5.5-2 below:

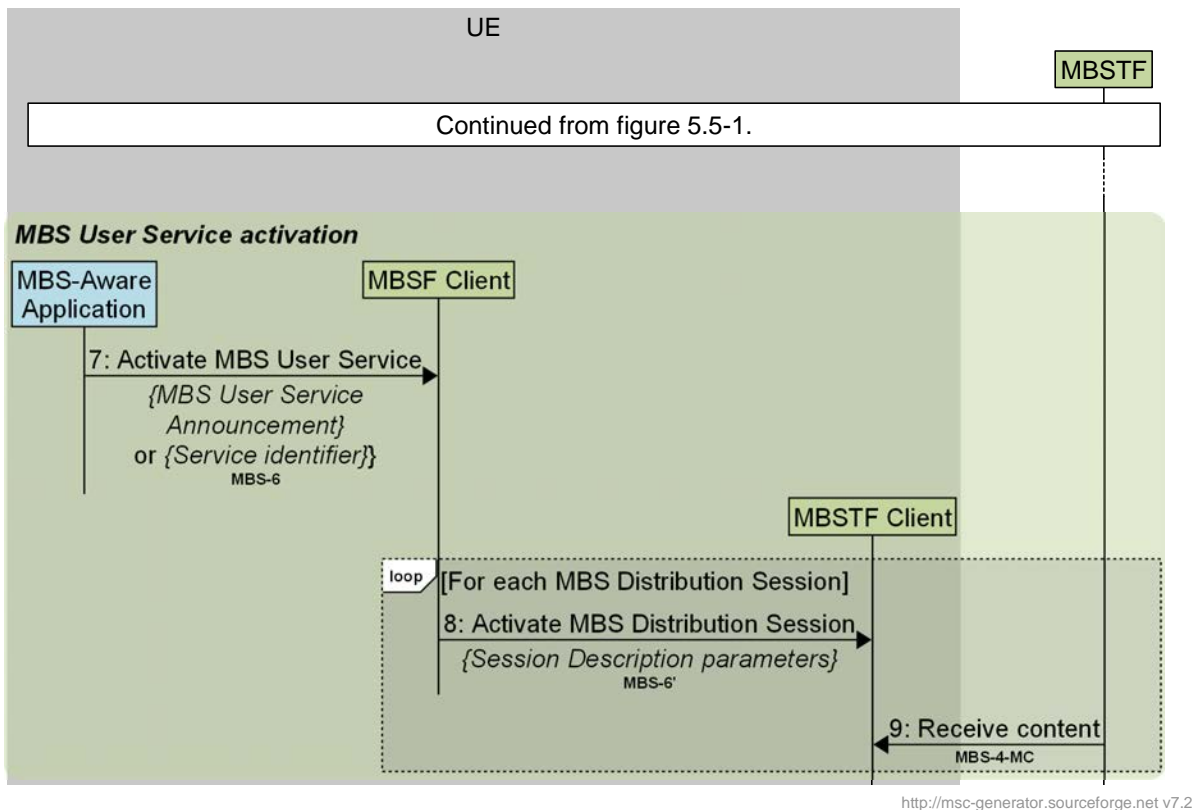

Figure 5.5-2: Call flow for MBS User Service activation by MBS Client

The steps are as follows:

7. The MBS-Aware Application invokes a client API exposed by the MBSF Client at reference point MBS-6 to activate the MBS User Service Session.

If the MBS User Service Announcement was received by the MBS-Aware Application in step 2c in clause 5.4, this is passed as one of the parameters in the API call.

Otherwise, the target service is identified by one of the service identifiers in the MBS User Service entity (see clause 4.5.3) and this identifier is used by the MBSF Client to locate an MBS User Service Announcement obtained according to step 2a or step 2b in clause 5.4.

For each MBS Distribution Session listed in the composite MBS User Service Announcement:

8. The MBSF Client invokes a client API exposed by the MBSTF Client at reference point MBS-6' to activate reception of the MBS Distribution Session in question. The Session Description parameters needed to receive the MBS Distribution Session are taken from the relevant MBS Distribution Session Announcement which, in turn, is extracted from the composite MBS User Service Announcement.
9. MBS data from the MBSTF is received by the MBSTF Client at reference point MBS-4-MC.

5.6 Procedure for User Service data repair

In the case of the Object Distribution Method (as defined in clause 6.1), the MBSTF Client may collaborate with the MBS AS at reference point MBS-4-UC to recover lost portions of content corresponding to MBS data that was not successfully received by the MBSTF Client at reference point MBS-4-MC (see step 9 in clause 5.5).

The procedure for data repair is illustrated in figure 5.6-1 below:

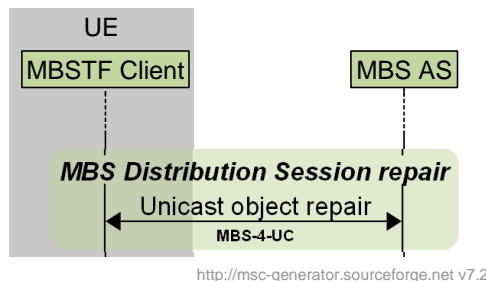

Figure 5.6-1: Call flow for MBS User Service data repair

6 MBS User Services distribution methods

6.1 Object Distribution Method

The Object Distribution Method is used to deliver binary objects to the MBS Client over an MBS Session that have been received from the MBS Application Provider over reference point Nmb8.

The following Use Cases are supported:

- Single file delivery.
- Delivering a root object and its dependent objects as a collection, e.g. a web page and all the assets needed to render it.
- Object carouseling for file delivery, including updates of files.
- Real-time object streaming, for example for regular-latency or low-latency streaming delivery. In the latter case, the objects distributed may be CMAF segments as defined by the 5G Media Streaming DASH Interoperability Point specified in clause 7.3.11 of TS 26.247 [10].

The operating modes for the Object Distribution Method are summarised in table 6.1-1 below.

Table 6.1-1: Summary of operating modes for Object Distribution Method

Distribution method	Operating mode	Description
OBJECT	OBJECT_SINGLE	Each object ingested by the MBSTF is distributed once.
	OBJECT_COLLECTION	A set of objects described by a manifest (see NOTE) is ingested by the MBSTF and distributed once.
	OBJECT_CAROUSEL	A set of one or more objects described by a manifest (see NOTE) is ingested by the MBSTF and distributed according to a repetition pattern specified in the manifest. Any change to an object during the course of the MBS Distribution Session is reflected in the distribution at the next available opportunity.
	OBJECT_STREAMING	A sequence of objects is ingested by the MBSTF and streamed in real time, for example according to a schedule described in a presentation manifest (e.g. DASH MPD).
NOTE: The manifest format is specified in TS 26.517 [13].		

Based on the configuration received from the MBSF via reference point Nmb2, the objects are ingested by the MBSTF from the MBS Application Provider via the pull-based or push-based object ingest method. As defined in clause 4, the MBSTF segments the objects into appropriate payloads, adds the FEC redundancy and schedule packet transmission to the MBS Client.

NOTE: Pull-based object ingest may occur once at the start of each active period of the associated MBS User Data Ingest Session, or the pulled objects may be revalidated (and possibly re-ingested) periodically, for example once per rotation of an object carousel.

File repair functionality may be utilized to repair object fragments transmitted by the MBSTF using the Object Distribution Method but lost or corrupted in transit. In such cases, the MBS Client may request the missing object fragments from the MBS AS. File repair may be done during an ongoing MBS User Services Session or after an MBS User Services Session.

6.2 Packet Distribution Method

The Packet Distribution Method is used to deliver packet streams to the MBS Client over an MBS Session that have been received from the MBS Application Provider over reference point Nmb8. This distribution method is particularly useful for multicast and broadcast of IP-based services for which the content delivery protocols are defined outside the scope of the MBS specification.

The MBSTF receives packet streams from the MBS Application Provider, typically in the form of UDP/IP packets, and sends them to the configured MBS Session. Optionally, packet sequence numbering and/or FEC redundancy may be added by the MBSTF.

The Packet Distribution Session may be operated in one of two different modes:

- In *Forward-only mode*, the transport protocol on top of IP is opaque to the MBS System, as described in clause B.3.1. The User Service Announcement may be handled by the MBS Application Provider via external means at reference point MBS-8.
- In *Proxy mode*, the UDP packet payload of the UDP streams is opaque to the MBS Session, as described in clause B.3.2. An MBS Client is expected to make the UDP Payloads available directly to the MBS-Aware Application, without further knowledge of the content carried.

The operating modes for the Packet Distribution Method are summarised in table 6.2-1 below.

Table 6.2-1: Summary of operating modes for Packet Distribution Method

Distribution method	Operating mode	Description
PACKET	PACKET_FORWARD_ONLY	The payloads of IP packets ingested by the MBSTF are forwarded to the MB-UPF in new IP packets (Layer 3 proxying).
	PACKET_PROXY	The payloads of UDP packets ingested by the MBSTF are forwarded to the MB-UPF in new UDP packets (Layer 4 proxying).
NOTE 1: RTP packets formatted according to RFC 3550 [8] can be distributed using either of the above operating modes.		
NOTE 2: The MBSTF is not required to inspect or otherwise act on the payload of ingested UDP packets.		

7 Network Function services

7.1 General

The Network Function Services exposed by the MBSF and the MBSTF are defined in this clause.

7.2 MBSF Services

7.2.1 General

The following table illustrates the set of Network Function services exposed by the MBSF.

Table 7.2-1: NF services provided by MBSF

Service name	Service operation name	Operation semantics	Example consumer(s) (see NOTE)
<i>Nmbfsf_MBSUserService</i>	<i>Create</i>	Request/Response	AF, NEF
	<i>Retrieve</i>	Request/Response	AF, NEF
	<i>Update</i>	Request/Response	AF, NEF
	<i>Destroy</i>	Request/Response	AF, NEF
<i>Nmbfsf_MBSUserDataIngestSession</i>	<i>Create</i>	Request/Response	AF, NEF
	<i>Retrieve</i>	Request/Response	AF, NEF
	<i>Update</i>	Request/Response	AF, NEF
	<i>Destroy</i>	Request/Response	AF, NEF
	<i>StatusSubscribe</i>	Subscribe/Notify	AF, NEF
	<i>StatusUnsubscribe</i>		AF, NEF
	<i>StatusNotify</i>		AF, NEF
	<i>StatusSubscribeMod</i>		AF, NEF
NOTE: When the MBS Application Provider (AF/AS) lies outside the trusted DN, these services shall be exposed via the NEF (N33+Nmb5) as <i>Nnef_MBSUserService</i> and <i>Nnef_MBSUserDataIngestSession</i> respectively, as specified in clauses 4.4.29.5 and 4.4.29.6 respectively of TS 29.522 [15].			

7.2.2 Nmbfsf MBS User Service operations

7.2.2.1 Nmbfsf_MBSUserService_Create service operation

Service operation name: *Nmbfsf_MBSUserService_Create*

Description: Provision a new MBS User Service. The general data model is illustrated in figure 4.5.2-1.

Input parameters (Required): Parameters in table 4.5.3-1 assigned by the MBS Application Provider.

Output parameters: Result indication. MBS User Service identifier assigned by the MBSF.

7.2.2.2 Nmbfsf_MBSUserService_Retrieve service operation

Service operation name: *Nmbfsf_MBSUserService_Retrieve*

Description: Used by the NF/NEF to retrieve the properties of an existing MBS User Service.

Input parameters (Required): MBS User Service Identifier in request URL.

Output parameters: Result indication. MBS User Service resource entity, including parameters in table 4.5.3-1.

7.2.2.3 Nmbf_MBSUserService_Update service operation

Service operation name: *Nmbf_MBSUserService_Update*

Description: Update the properties of an existing MBS User Service.

Input parameters (Required, Optional): MBS User Service Identifier. Parameters in table 4.5.3-1 assigned by the MBS Application Provider.

Output parameters (Required): Result indication.

Output parameters (Optional): MBS User Service resource entity, including parameters in table 4.5.3-1.

7.2.2.4 Nmbf_MBSUserService_Destroy service operation

Service operation name: *Nmbf_MBSUserService_Destroy*

Description: Release the resources of the associated MBS User Service.

Input parameters (Required): MBS User Service Identifier.

Output parameters: Result indication.

7.2.3 Nmbf MBS User Data Ingest Session operation

7.2.3.1 Nmbf_MBSUserDataIngestSession_Create service operation

Service operation name: *Nmbf_MBSUserDataIngestSession_Create*

Description: Create an MBS User Data Ingest Session, including a set of subordinate MBS Distribution Session(s).

Input parameters (Required, Optional): Parameters in table 4.5.5-1 and table 4.5.6-1, and either table 4.5.6-2 or table 4.5.6-3 assigned by the MBS Application Provider, depending on the distribution method.

Output parameters: Result indication. MBS User Data Ingest Session Identifier assigned by the MBSF.

7.2.3.2 Nmbf_MBSUserDataIngestSession_Retrieve service operation

Service operation name: *Nmbf_MBSUserDataIngestSession_Retrieve*

Description: Used by the AF/NEF to retrieve the properties of an existing MBS User Data Ingest Session.

Input parameters (Required): User Data Ingest Session Identifier in request URL.

Output parameters: Result indication. MBS User Data Ingest Session resource entity, including parameters in table 4.5.5-1 and table 4.5.6-1, and either table 4.5.6-2 or table 4.5.6-3, depending on the distribution method.

7.2.3.3 Nmbf_MBSUserDataIngestSession_Update service operation

Service operation name: *Nmbf_MBSUserDataIngestSession_Update*

Description: Update the properties of an existing MBS User Data Ingest Session and its set of subordinate MBS Distribution Session(s).

Input parameters (Required, Optional): MBS User Data Ingest Session Identifier. Parameters in table 4.5.5-1 and table 4.5.6-1, and either table 4.5.6-2 or table 4.5.6-3, depending on the distribution method.

Output parameters (Required): Result indication.

Output parameters (Optional): MBS User Data Ingest Session resource entity, including subordinate MBS Distribution Session data entities(s).

7.2.3.4 Nmbf_MBSUserDataIngestSession_Destroy service operation

Service operation name: *Nmbf_MBSUserDataIngestSession_Destroy*

Description: Destroy an MBS User Data Ingest Session along with its subordinate MBS Distribution Session(s).

Input parameters (Required): MBS User Data Ingest Session Identifier.

Output parameters: Result indication.

7.2.3.5 Nmbf_MBSUserDataIngestSession_StatusSubscribe operation

Service operation name: *Nmbf_MBSUserDataIngestSession_StatusSubscribe*

Description: Invoked by AF/NEF on the MBSF when it needs to create a subscription to monitor at least one event relevant to the MBS User Data Ingest Session. The AF may subscribe to multiple events in a subscription.

Input parameters (Required): MBS User Data Ingest Session Identifier, Event ID(s) as described in table 4.6.2-1, notification target address.

Output parameters (Required, Optional): When the subscription is accepted: Subscription correlation ID.

7.2.3.6 Nmbf_MBSUserDataIngestSession_StatusUnsubscribe operation

Service operation name: *Nmbf_MBSUserDataIngestSession_StatusUnsubscribe*

Description: Remove an existing subscription.

Input parameters (Required): Subscription correlation ID.

Output parameters: Result Indication.

7.2.3.7 Nmbf_MBSUserDataIngestSession_StatusNotify operation

Service operation name: *Nmbf_MBSUserDataIngestSession_StatusNotify*

Description: Used by the MBSF to notify the MBS Application Provider (AF/AS) or NEF about the status change of the MBS User Data Ingest Session.

Input parameters (Required): MBS User Data Ingest Session Identifier, Event ID(s) as described in table 4.6.2-1, informative message.

Output parameters: Result indication.

7.2.3.8 Nmbf_MBSUserDataIngestSession_StatusSubscribeMod operation

Service operation name: *Nmbf_MBSUserDataIngestSession_StatusSubscribeMod*

Description: Invoked by an MBS Application Provider (AF/AS) or NEF on the MBSF to modify an existing status subscription.

Input parameters (Required): Subscription correlation ID.

Input parameters (Optional): Event ID(s) as described in table 4.6.2-1, notification target address, subscription expiration time.

Output parameters (Required, Optional): Result indication.

7.3 MBSTF Services

7.3.1 General

The following table illustrates the set of NF services exposed by the MBSTF.

Table 7.3-1: NF services provided by MBSTF

Service name	Service operation name	Operation semantics	Example consumer(s)
<i>Nmbstf_MBSDistributionSession</i>	<i>Create</i>	Request/Response	MBSF
	<i>Retrieve</i>	Request/Response	MBSF
	<i>Update</i>	Request/Response	MBSF
	<i>Destroy</i>	Request/Response	MBSF
	<i>StatusSubscribe</i>	Subscribe/Notify	MBSF
	<i>StatusUnsubscribe</i>		MBSF
	<i>StatusNotify</i>		MBSF
	<i>StatusSubscribeMod</i>		MBSF

7.3.2 Nmbstf_MBSDistributionSession service

7.3.2.1 Nmbstf_MBSDistributionSession_Create service operation

Service operation name: *Nmbstf_MBSDistributionSession_Create*

Description: Create a new MBS Distribution Session within the MBSTF.

Input parameters (Required, Optional): Parameters in table 4.5.6-1 and either table 4.5.6-2 or table 4.5.6-3, depending on the distribution method.

Output parameters: Result indication.

7.3.2.2 Nmbstf_MBSDistributionSession_Retrieve service operation

Service operation name: *Nmbstf_MBSDistributionSession_Retrieve*

Description: Retrieve the parameters of an existing MBS Distribution Session.

Input parameters (Required): Distribution Session Identifier in request URL.

Output parameters: MBS Distribution Session resource entity, including parameters in table 4.5.6-1 and either table 4.5.6-2 or table 4.5.6-3, depending on the distribution method.

7.3.2.3 Nmbstf_MBSDistributionSession_Update service operation

Service operation name: *Nmbstf_MBSDistributionSession_Update*

Description: Update an existing MBS Distribution Session, for example to change the session stop time, object delivery session, application session, packets delivery session, files, and ancillary information.

Input parameters (Required, Optional): MBS Distribution Session Identifier. Parameters in table 4.5.6-1 and either table 4.5.6-2 or table 4.5.6-3, depending on the distribution method.

Output parameters (Required): Result indication.

Output parameters (Optional): MBS Distribution Session resource entity.

7.3.2.4 Nmbstf_MBSDistributionSession_Destroy service operation

Service operation name: *Nmbstf_MBSDistributionSession_Destroy*

Description: Destroy an existing MBS Distribution Session.

Input parameters (Required): MBS Distribution Session Identifier.

Output parameters: Result indication.

7.3.2.5 Nmbstf_MBSDistributionSession_StatusSubscribe operation

Service operation name: *Nmbstf_MBSDistributionSession_StatusSubscribe*

Description: Invoked by MBSF on the MBSTF when it needs to monitor at least one event relevant to the MBS Distribution session. The MBSF may subscribe to multiple events in a subscription.

Input parameters (Required): MBS Distribution Session Identifier, Event ID(s) as described in table 4.6.2-1, notification target address.

Output parameters: When the subscription is accepted: Subscription correlation ID.

7.3.2.6 Nmbstf_MBSDistributionSession_StatusUnsubscribe operation

Service operation name: *Nmbstf_MBSDistributionSession_StatusUnsubscribe*

Description: Remove an existing subscription.

Input parameters (Required): Subscription correlation ID.

Output parameters: Result indication.

7.3.2.7 Nmbstf_MBSDistributionSession_StatusNotify operation

Service operation name: *Nmbstf_MBSDistributionSession_StatusNotify*

Description: Used by the MBSTF to notify the MBSF about the status change of the MBS Distribution Session.

Input parameters (Required): MBS Distribution Session Identifier, Event ID(s) as described in table 4.6.2-1, informative message.

Output parameters: Result indication.

7.3.2.8 Nmbstf_MBSDistributionSession_StatusSubscribeMod operation

Service operation name: *Nmbstf_MBSDistributionSession_StatusSubscribeMod*

Description: Invoked by the MBSF on the MBSTF to modify an existing status subscription.

Input parameters (Required): Subscription correlation ID.

Input parameters (Optional): Event ID(s) as described in table 4.6.2-1, notification target address, subscription expiration time.

Output parameters (Required, Optional): Result indication.

Annex A (informative): Deployment and Collaboration Models

A.1 Group Communication

The Group Communication (GC) Service is defined for use with LTC/EPC in TS 23.468 [14]. In order to allow GC Services to interwork with an MBS System, the MBSF also supports reference point MB2-C and the MBSTF also supports reference point MB2-U, as defined in clause 5.2 and annex C of TS 23.247 [5].

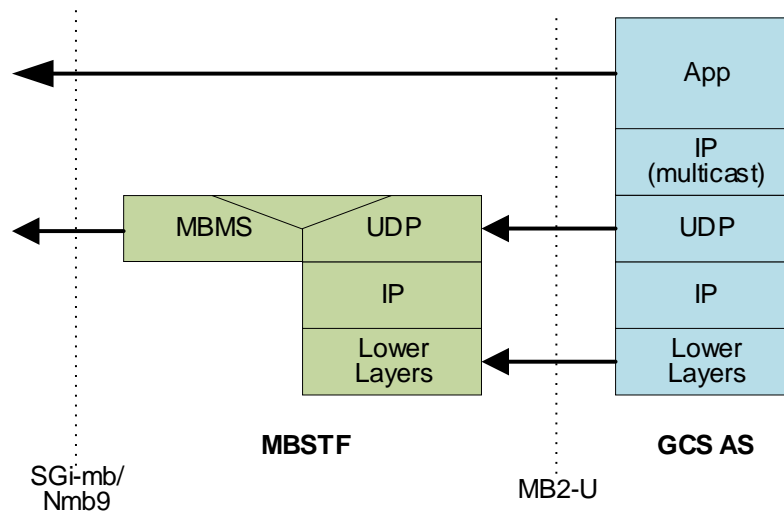

Figure A.1-1: User Plane protocol stack for Group Communication services

The following MBS Distribution Session properties (see clause 4.5.6) are used by the MBSF at reference point Nmb2 to provision this setup in the MBSTF:

- Distribution method is set to Packet.
- Operating mode is set to Forward-only.
- Packet ingest method is set to Unicast.
- User plane traffic flow information is omitted because ingested multicast packets are not modified.
- The tunnel endpoint addresses of the MBMS-GW (SGi-mb) and/or MB-UPF (Nmb9).
- FEC configuration information is provided if AL-FEC protection was requested by the GCS AS in the MBMS bearer allocation request at MB2-C.
- The MBSTF provides the MBSTF ingest endpoint addresses (representing the BM-SC address and BM-SC port) via the MBSF to the GCS AS at reference point MB2-C so that the GCS AS can establish a UDP/IP tunnel with the MBSTF at MB2-U and start sending tunnelled IP packets.
- The MBSTF provides forward error protection according to the FEC configuration for downlink IP packets ingested from GCS AS, and then sends the source packets and any FEC packets to the MBMS GW at reference point SGI-mb.

A.2 5G Media Streaming

The use of MBS User Services in collaboration with the 5G Media Streaming architecture [7] is for further study.

A.3 MBS Application Provider (AF/AS) in Trusted DN

Figure A.3-1 depicts a collaboration in which the MBS Application Provider (AF/AS) is deployed within the Trusted DN.

1. The AF/AS uses the *Nmbssf* service directly at reference point Nmb10.
2. The MBSTF injects packets into the MB-UPF via reference point Nmb9.

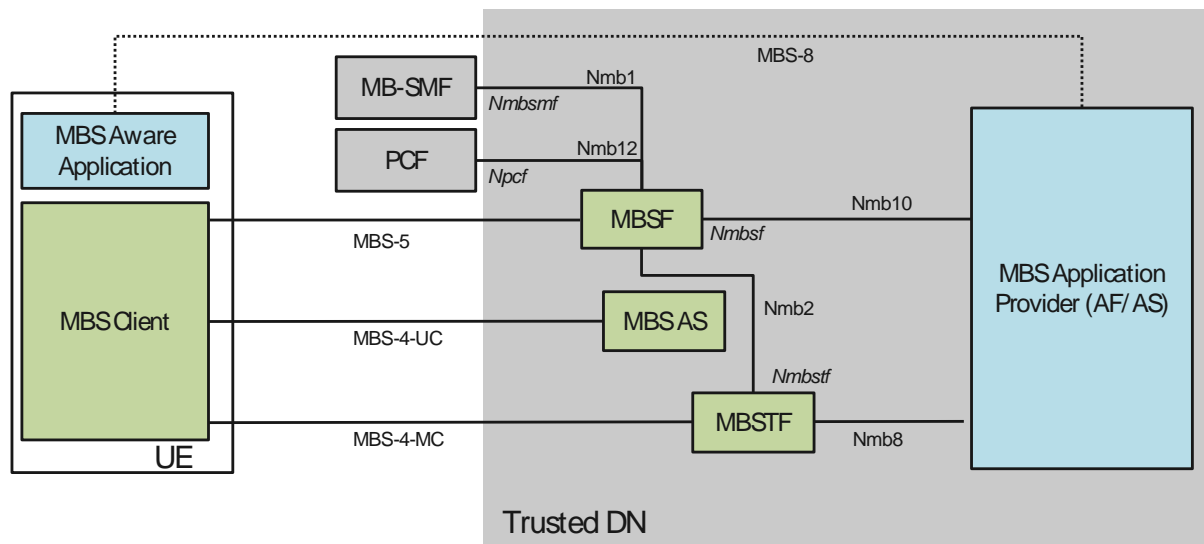

NOTE: Italic type is used to annotate service-based interactions.

Figure A.3-1: Deployment with MBS Application Provider (AF/AS) in Trusted DN

A.4 MBS Application Provider (AF/AS) in external DN

Figure A.4-1 depicts a collaboration in which the MBS Application Provider (AF/AS) is deployed within the External DN.

1. The AF/AS invokes the *Nnef* service at reference point N33 to access the MBSF via the NEF. The NEF, in turn, invokes the *Nmbssf* service on the MBSF at reference point Nmb5 on behalf of the AF/AS.
2. The MBSTF injects packets into the MB-UPF via reference point Nmb9.

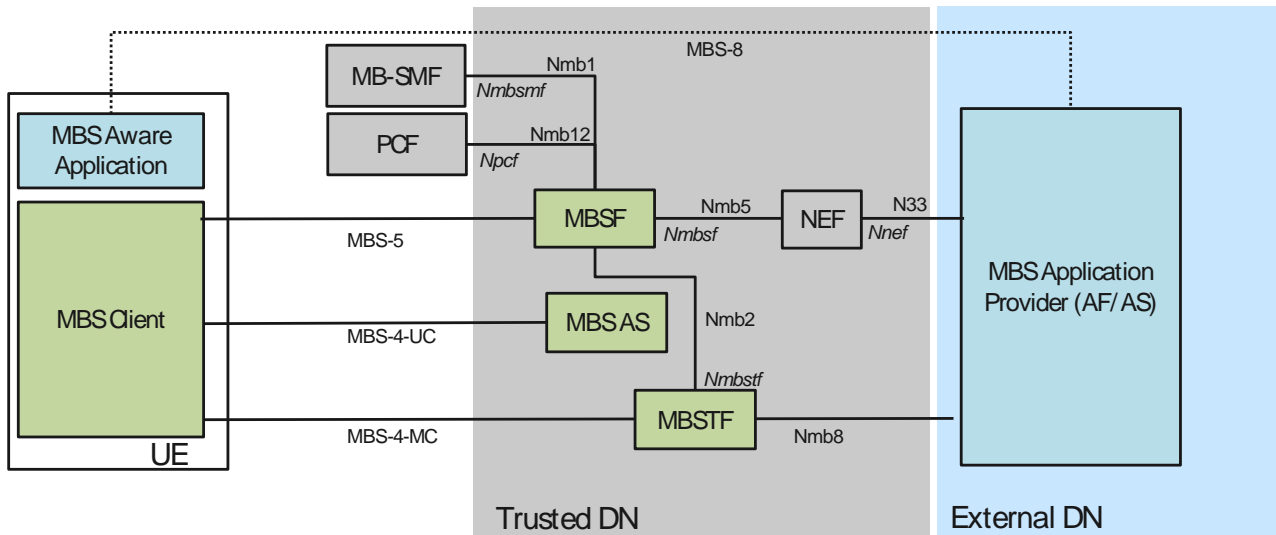

NOTE: Italic type is used to annotate service-based interactions.

Figure A.4-1: Deployment with MBS Application Provider (AF/AS) in External DN

A.5 MBSF/MBSTF-like functions in External DN

Figure A.5-1 depicts a transport-only deployment in which the MBS Application Provider (AF/AS) hosts an "MBSF-like" function that mimics the MBSF at reference point MBS-5 and an "MBSTF-like" function that mimics the MBSTF at reference point MBS-4-MC. The "MBSF-like", "MBSTF-like" and "MBS AS-like" functions produce data streams which are compliant with the present document. Although the 5G System sets up a Transport-only Mode (see configuration option 1 in annex A of TS 23.247 [5]), the MBS Client in the UE follows the procedures defined in the present document.

1. The MBSF-like function provisions MBS Services in the MB-SMF via the *Nnef* service at reference point N33.
2. The MBS Application Provider (AF/AS) uses an MBSTF-like function to produce packet data compliant with reference point MBS-4-MC. The packets are injected directly into the MB-UPF at reference point N6mb (not shown).
3. An MBS Application Provider (AF/AS) in an External DN uses an MBSF-like function to generate a Service Announcement for MBS User Services.
4. The MBS Application Provider (AF/AS) makes object repair available from an MBS AS-like function that is compliant with reference point MBS-4-UC.

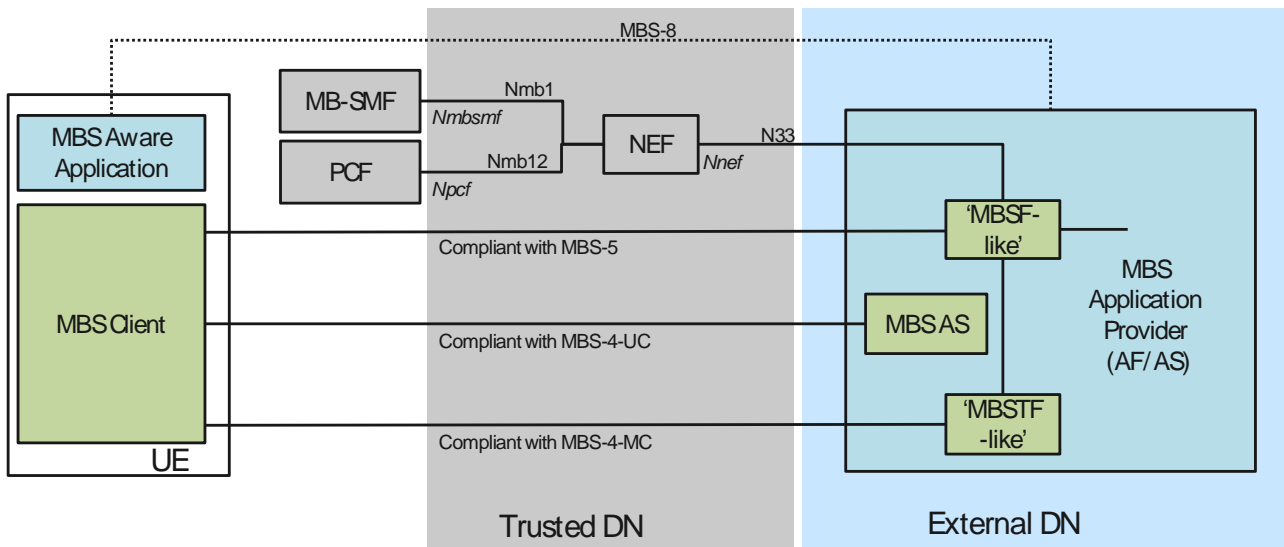

NOTE: Italic type is used to annotate service-based interfaces.

Figure A.5-1: Deployment with MBSF/MBSTF-like functions in External DN

Annex B (informative): Nmb8 User Plane ingest examples

B.1 General

This annex provides an overview of the different Nmb8 User Plane protocol stacks for the distribution methods defined in clause 6. The distribution method is selected and configured at reference point Nmb2 based on Nmb10 provisioning.

B.2 Object Distribution Method

B.2.1 Object Distribution Method with pull-based ingest

Figure B.2.1-1 illustrates a setup in which the MBS Application Provider (AF/AS) provides an object manifest to the MBSF listing the URLs of objects to be ingested and distributed. This is passed to the MBSTF at reference point Nmb2, and the MBSTF then fetches these objects using HTTP. The MBSTF handles all MBS-related complexity, e.g. converting the HTTP message payload into an IP multicast suitable protocol, adding AL-FEC, etc. The AF/AS delegates to the MBSF the delivery of MBS Service Announcement metadata to the MBS Client (i.e. IP multicast protocol details, etc).

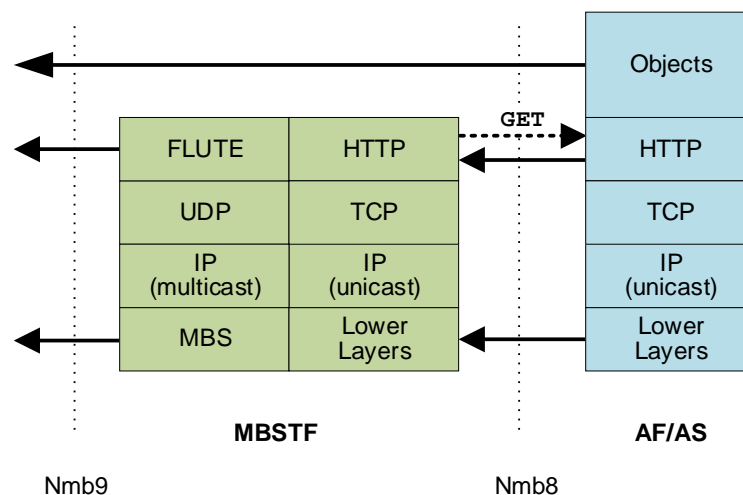

Figure B.2.1-1: Object Distribution Method using Pull ingest mode (HTTP GET)

The following Parameters are used by the MBS Application Provider (AF/AS) at reference point Nmb10 to provision this setup:

- *Distribution method* is set to *Object*.
- *Object acquisition method* (property specific to the distribution method) is set to *Pull*.
- *Operating mode* is set to *OBJECT_SINGLE* or *OBJECT_COLLECTION* or *OBJECT_CAROUSEL* or *OBJECT_STREAMING*, as appropriate.
 - *OBJECT_SINGLE*: *Object acquisition identifiers* refers to a single object.
 - *OBJECT_COLLECTION*: *Object acquisition identifiers* refers to a manifest describing the set of objects to be distributed once.
 - *OBJECT_CAROUSEL*: *Object acquisition identifiers* refers to a manifest describing the set of objects and their repetition and update pattern.

- *OBJECT_STREAMING*: *Object acquisition identifiers* refers to a presentation manifest such as a DASH MPD. The MBSTF pulls the objects according to the presentation manifest.

B.2.2 Object Distribution Method with push-based ingest

Figure B.2.2-1 illustrates a setup in which the MBS Application Provider (AF/AS) pushes objects directly into the MBSTF at Nmb8 using HTTP PUT. The MBSTF handles all MBS-related complexity, e.g. converting the HTTP message payload into an IP multicast suitable protocol, adding AL-FEC, etc. The AF/AS delegates MBS delivery of Service Announcement metadata destined for the MBS Client (i.e. DASH MPD, IP multicast protocol details, etc.) to the MBSTF via MBSF.

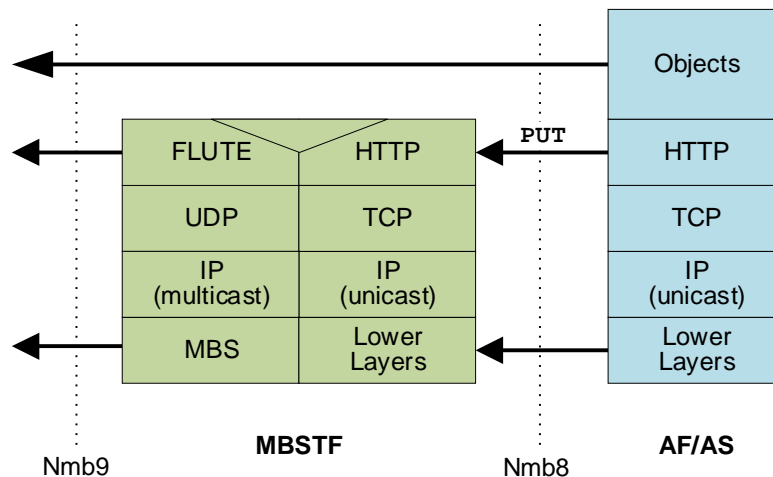

Figure B.2.2-1: Object Distribution Method using Push ingest mode (HTTP PUT)

The following MBS Distribution Session properties are used by the MBS Application Provider (AF/AS) at reference point Nmb10 to provision this setup:

- *Distribution method* is set to *Object*.
- *Object acquisition method* is set to *Push*.
- *Operating mode* is set to *OBJECT_SINGLE* or *OBJECT_STREAMING*, as appropriate.
 - *OBJECT_SINGLE*: Each pushed object is distributed once.
 - *OBJECT_COLLECTION*: Not used.
 - *OBJECT_CAROUSEL*: Not used.
 - *OBJECT_STREAMING*: Each pushed object is distributed once.
- *Distribution operating mode* is set to *File* or *Collection* or *Carousel* or *Real-time*, as appropriate.
- *Object acquisition identifiers* contains the Push base URL used to ingest objects. The MBSF provides the *Push base URL* (property specific to the distribution method) to the MBS Application Provider (AF/AS).
- *Distribution base URL* contains the base URL for the objects. The MBSF replaces the Push base URL part of the object ingest URL with the value of the *Distribution base URL* for inclusion in FLUTE FDT instance(s) and (in some cases) in the Service Announcement.

B.3 Packet Distribution Method

B.3.1 Proxy mode

Figure B.3.1-1 illustrates a setup in which the MBS Application Provider (AF/AS) injects UDP datagrams directly into the MBSTF at reference point Nmb8. The MBSTF handles all MBS-related complexity, e.g. restamping the UDP datagram headers and/or the IP packet headers, as required for distribution. The MBSTF is not required to process the UDP payload of packets ingested at reference point Nmb8.

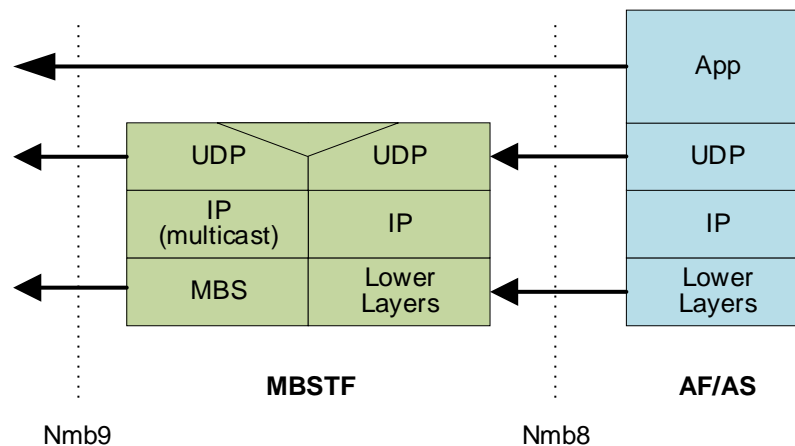

Figure B.3.1-1: Packet Distribution Method using Proxy mode

The following MBS Distribution Session properties are used by the MBS Application Provider (AF/AS) at reference point Nmb10 to provision this setup:

- *Distribution method* is set to *Packet*.
- *Operating mode* is set to *PACKET_PROXY*.
- *Packet ingest method* is set to *Multicast* or *Unicast*.
- When the *Packet ingest method* indicates *Multicast ingest*, then either the MBS Application Provider (AF/AS) nominates the multicast IP address and UDP port(s) to be used for reception at reference point Nmb8, or else the MBSF allocates these values.
- When the *Packet ingest method* indicates *Unicast ingest*, the MBSTF allocates a UDP reception port for use at reference point Nmb8 and provides the reception UDP port together with the reception IP address to the MBS Application Provider (AF/AS) via the MBSF.

A unicast ingest packet delivery protocol is established at reference point Nmb8 that allows the control of the unicast stream.

The MBSTF processes the UDP packet payloads received by the Packet ingest subfunction and creates MBS-4-MC packets as described in clause 4.3.3.3. The MBSTF encapsulates these packets into the Nmb9 tunnel.

- The MBSF nominates the MBS-4-MC multicast group destination IP address and UDP ports to be used inside the Nmb9 unicast tunnel in the *User plane traffic flow information*.

B.3.2 Forward-only mode

Figure B.3.2-1 illustrates a setup in which the MBS Application Provider (AF/AS) injects multicast IP packets encapsulated in a unicast UDP/IP tunnel directly into the MBSTF. The MBSTF decapsulates the multicast IP packets from the tunnel and forwards them unmodified to the MBS Session at reference point Nmb9.

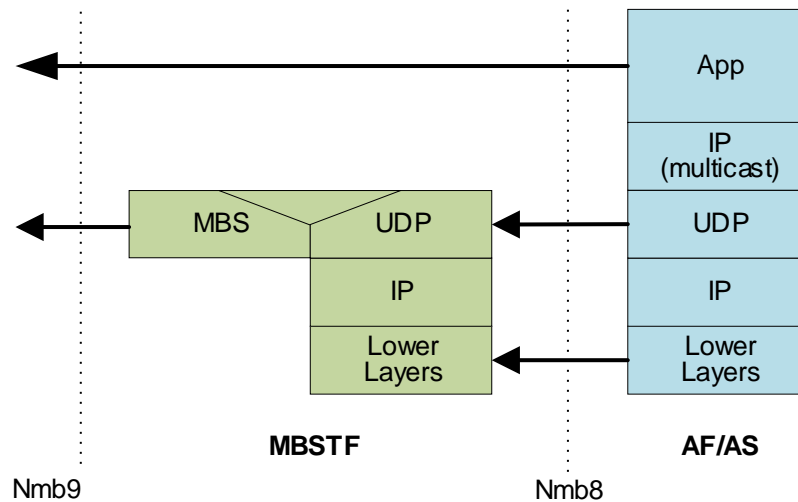

Figure B.3.2-1: Packet Distribution Method using Forward-only mode

The following MBS Distribution Session properties are used by the MBS Application Provider (AF/AS) at reference point Nmb10 to provision this setup:

- *Distribution method* is set to *Packet*.
- *Operating mode* is set to *PACKET_FORWARD_ONLY*.
- *Packet ingest method* is set to *Unicast*.
- *User plane traffic flow information* is omitted because ingested multicast packets are not modified.

The MBSTF provides the *MBSTF ingest endpoint addresses* via the MBSF to the MBS Application Provider (AF/AS) so that it can establish the UDP/IP tunnel with the MBSTF and start sending tunnelled IP packets.

A unicast ingest packet delivery protocol is established at reference point Nmb8 that allows the control of the unicast stream.

The MBSTF Packet ingest subfunction receives ready-made multicast UDP/IP packets from the MBS Application Provider (AF/AS) at reference point Nmb8.

- When no *FEC configuration* is provided, the MBSTF pushes the packets into the Packet scheduling subfunction (see clause 4.3.3.3). The MBSTF encapsulates these packets into the Nmb9 tunnel for transmission to the MB-UPF.
- When an *FEC configuration* is provided, the MBSTF parses deep into the UDP payload to create AL-FEC redundancy. Source block marking is appended to source packets and the packet length fields are adjusted in UDP and IP headers. AL-FEC redundancy is inserted into the stream according to the *FEC configuration*. The resulting packets are handled by the Packet scheduling subfunction (see clause 4.3.3.3). The MBSTF encapsulates these packets into the Nmb9 tunnel.

Annex C (informative): Data model examples

C.1 General

This annex contains a set of examples of the MBS User Services data model as defined in clause 4.5.

C.2 Object Distribution Method with push-based ingest

C.2.1 DASH content distribution with push-based ingest

This example focuses on DASH content distribution with push-based ingest. The DASH segment packager continuously publishes media segments to the MBSTF as they become available. Media segments from all relevant DASH Adaptation Sets and Representations are multiplexed into the same MBS Distribution session. The data model parameters are provided in Figure C.2.1-1.

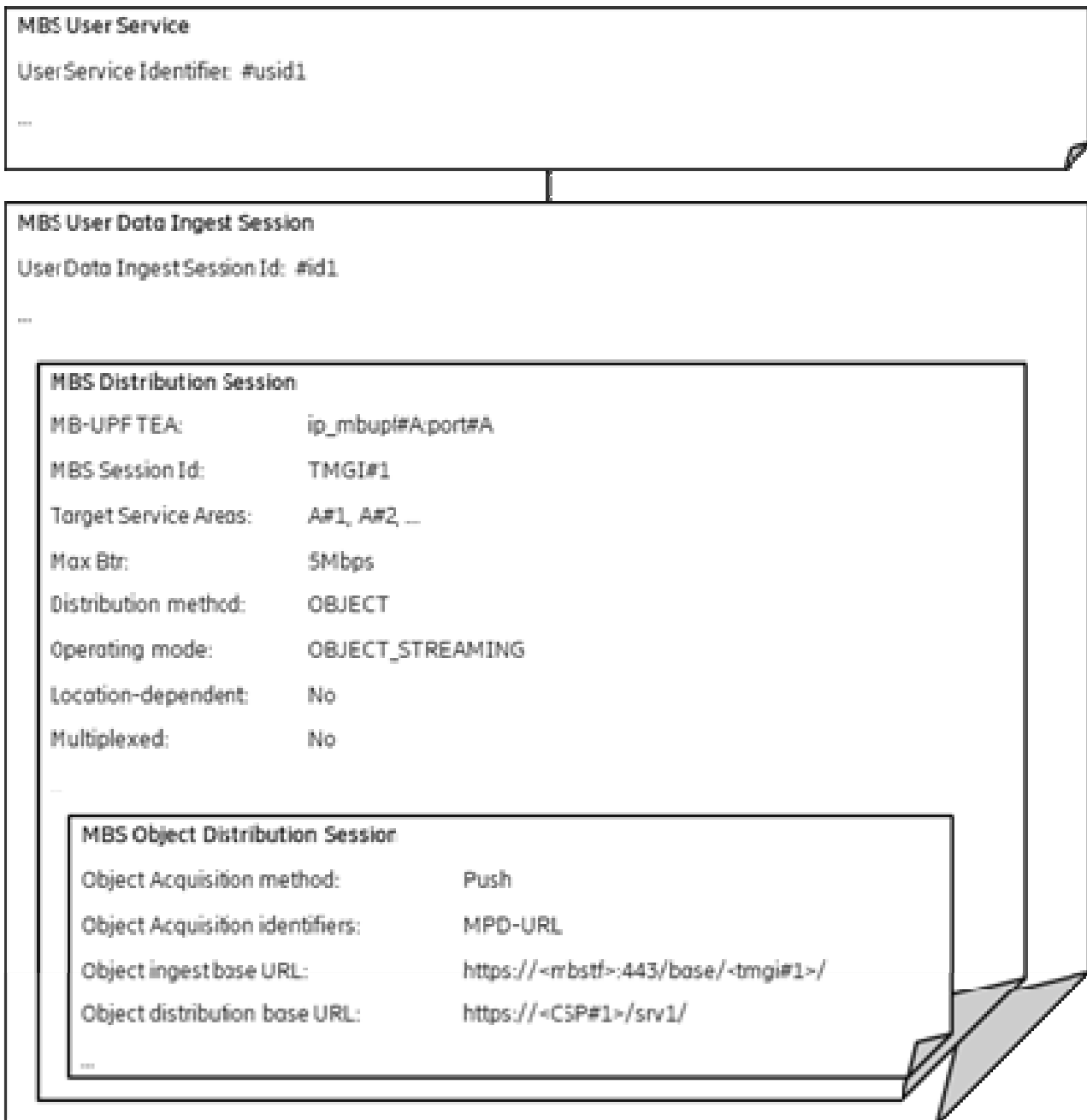

Figure C.2.1-1: DASH content distribution with push-based ingest

The DASH segment packager is configured to use the *Object ingest base URL* to upload media segments using HTTP. Each segment is identified by a unique URL relative to this base. The distribution URL generated by the MBSTF is formed by replacing the *Object ingest base URL* prefix with the value of *Object distribution base URL*.

EXAMPLE:

URL of ingested object: `https://<mbstf>:443/base/<tmgi#1>/video/segment_1000.m4s`

URL of distributed object: `https://<CSP#1>/srv1/video/segment_1000.m4s`

where:

- The string *ip_mbupf##A:port##A* refers to the IP address and port for the tunnel at which the MB-UPF expects the data for the MBS Session.
- The string *<mbstf>* refers to the IP address or the hostname of the MBSTF function.
- The string *<tmgi##1>* refers to the TMGI, which is assigned to the MBS Session.

NOTE: The TMGI of the MBS Session is used in this example to make the ingest URL unique within the 5G System. Other solutions to ensure uniqueness are possible.

- The term *<CSP##1>* refers to a fully qualified domain name of the CSP.

The MBSF needs access to the MPD URL in order to compile the MBS Distribution Session Announcement. The MBSF may also modify the contents of the MPD ("conditioning") before compiling it into the Session Announcement and/or publishing it for retrieval at reference point MBS-4-UC.

The MBSTF does not need to inspect the contents of the DASH MPD.

The MBSTF uses a unicast tunnel to inject the generated MBS data into the MB-UPF at reference point Nmb9, using the *Maximum bit rate* parameter to pace these packets.

C.2.2 DASH content distribution with push-based ingest using separate MBS Distribution Sessions for audio and video

This example focuses on DASH content distribution with push-based ingest. The DASH segment packager continuously publishes media segments to the MBSTF as they become available. In this case, media segments from the video and audio Adaptation Sets are multiplexed into different MBS Distribution Sessions. In this case, the MBS User Service is provisioned to distribute the audio and video segments on separate MBS Distribution Sessions, with the two resulting MBS Distribution Sessions multiplexed onto the same MBS Session.

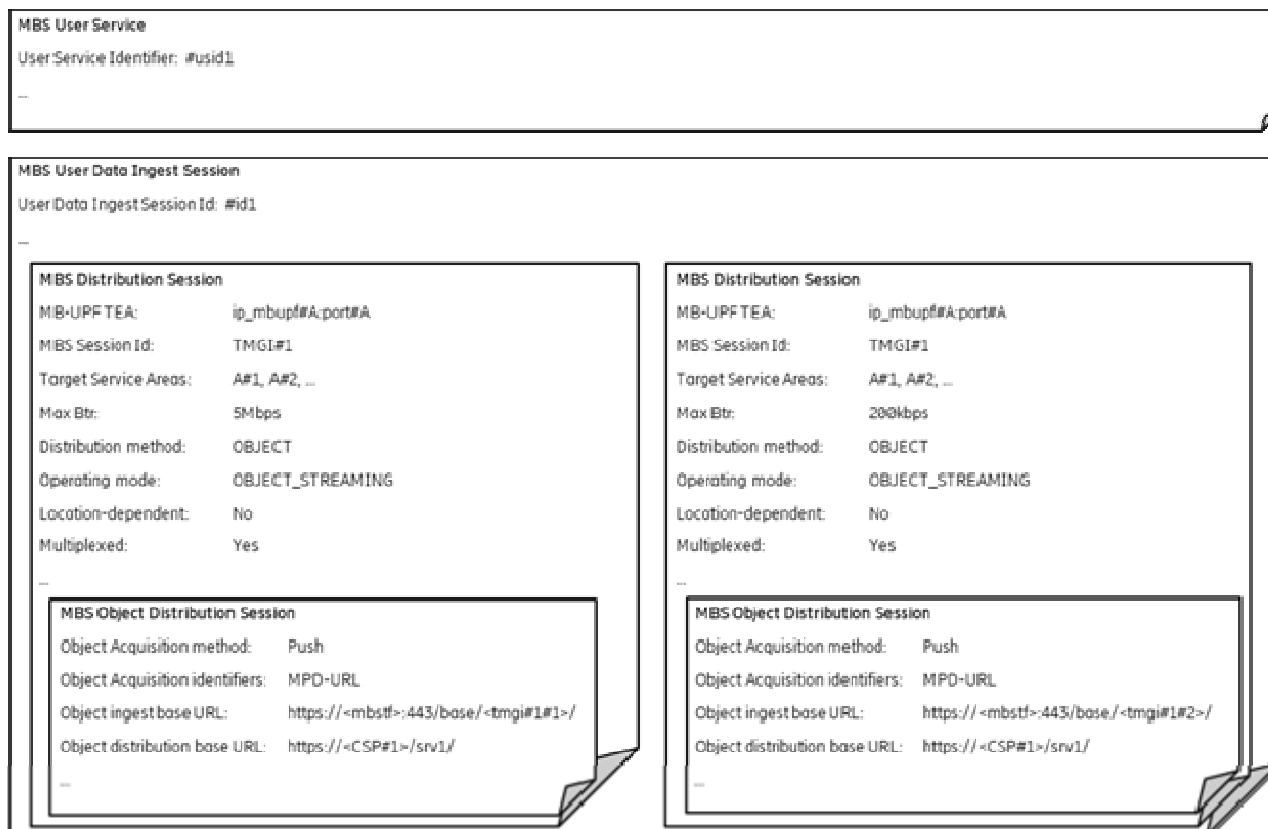

Figure C.2.2-1: DASH content distribution with push-based ingest using separate MBS Distribution Sessions for audio and video

For each MBS Session, the MBSTF uses a specific *Maximum bit rate* parameter to pace the packets towards the MB-UPF (here 5 Mbps for video segments and 200 kbps for audio segments). For the ingest session, two separate Object ingest base URLs are provided, namely:

<https://<mbstf>:443/base/<tmgi#1#1>/> and

<https://<mbstf>:443/base/<tmgi#1#2>/>

The strings *<tmgi#1#1>* and *<tmgi#1#2>* are used to make the ingest URLs unique within the 5G System. The last portion is a suffix for the individual MBS Distribution Session. The usage of the TMGI of the MBS Session is one example to make the ingest URL unique within the 5G System.

The MBSTF uses the same unicast tunnel to inject the data into the MB-UPF at reference point Nmb9, so that the data is distributed via the same MBS Session.

C.2.3 Generic object distribution with push-based ingest

This example focuses on generic object distribution using push-based ingest. In this case, a series of objects are pushed by the MBS Application Provider (AF/AS) into the MBSTF where an MBS Distribution Session is provisioned to use the *OBJECT_SINGLE* operating mode, which requires no manifest.

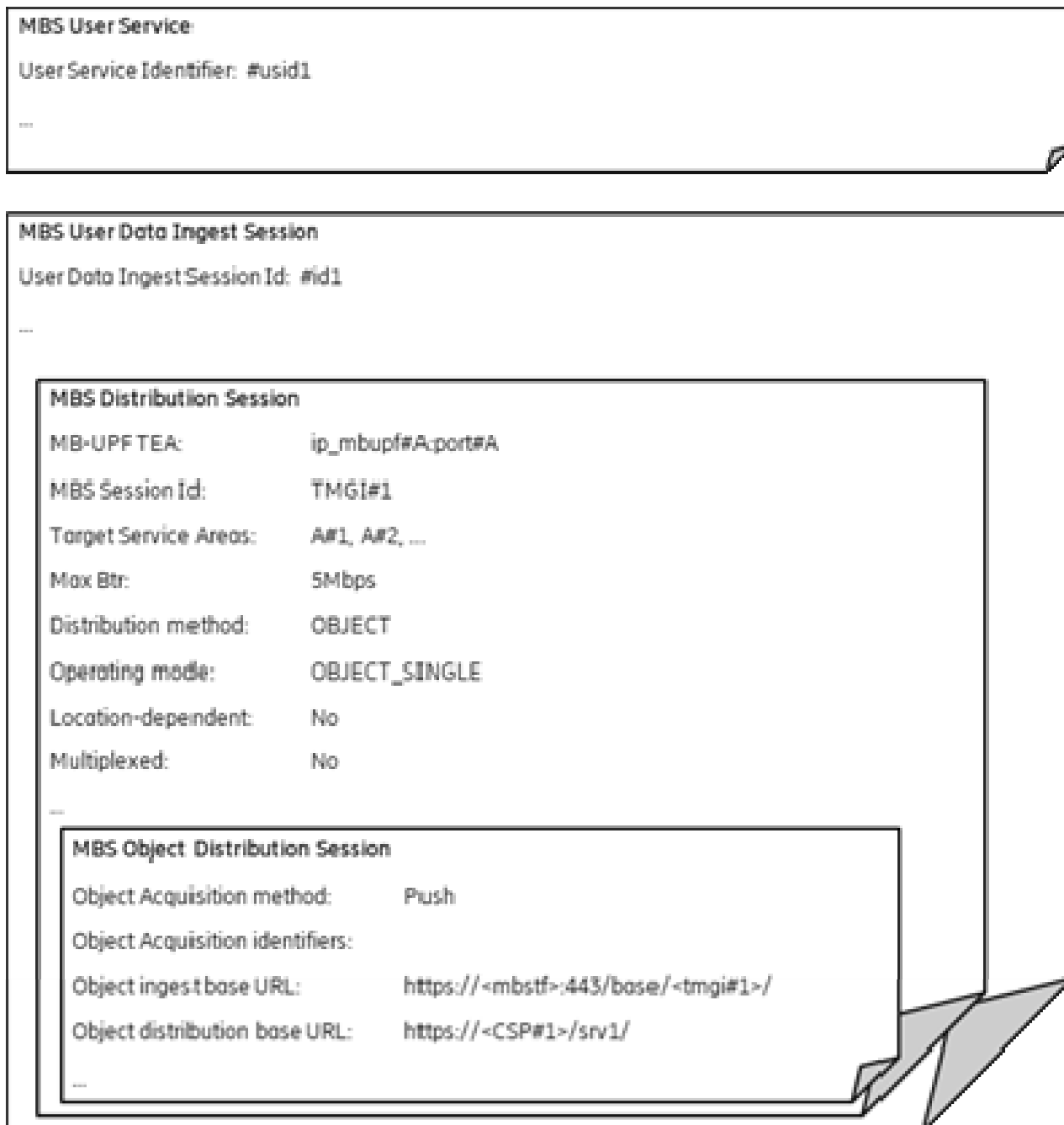

Figure C.2.3-1: Generic object distribution with push-based ingest

The case is very similar to the previous DASH content distribution cases, with the difference that no *Object acquisition identifiers* are provisioned. Any object pushed to the *Object ingest base URL* nominated by the MBSF is distributed in the MBS Distribution Session by the MBSTF after substituting the *Object ingest base URL* prefix with the *Object distribution base URL*.

C.3 Object Distribution Method with pull-based ingest

C.3.1 DASH content distribution with pull-based ingest

This example focuses on DASH content distribution with pull-based ingest. The DASH segment packager publishes media segments to an external origin server and the MBSTF pulls them according to the timing model of a DASH presentation specified in an MPD.

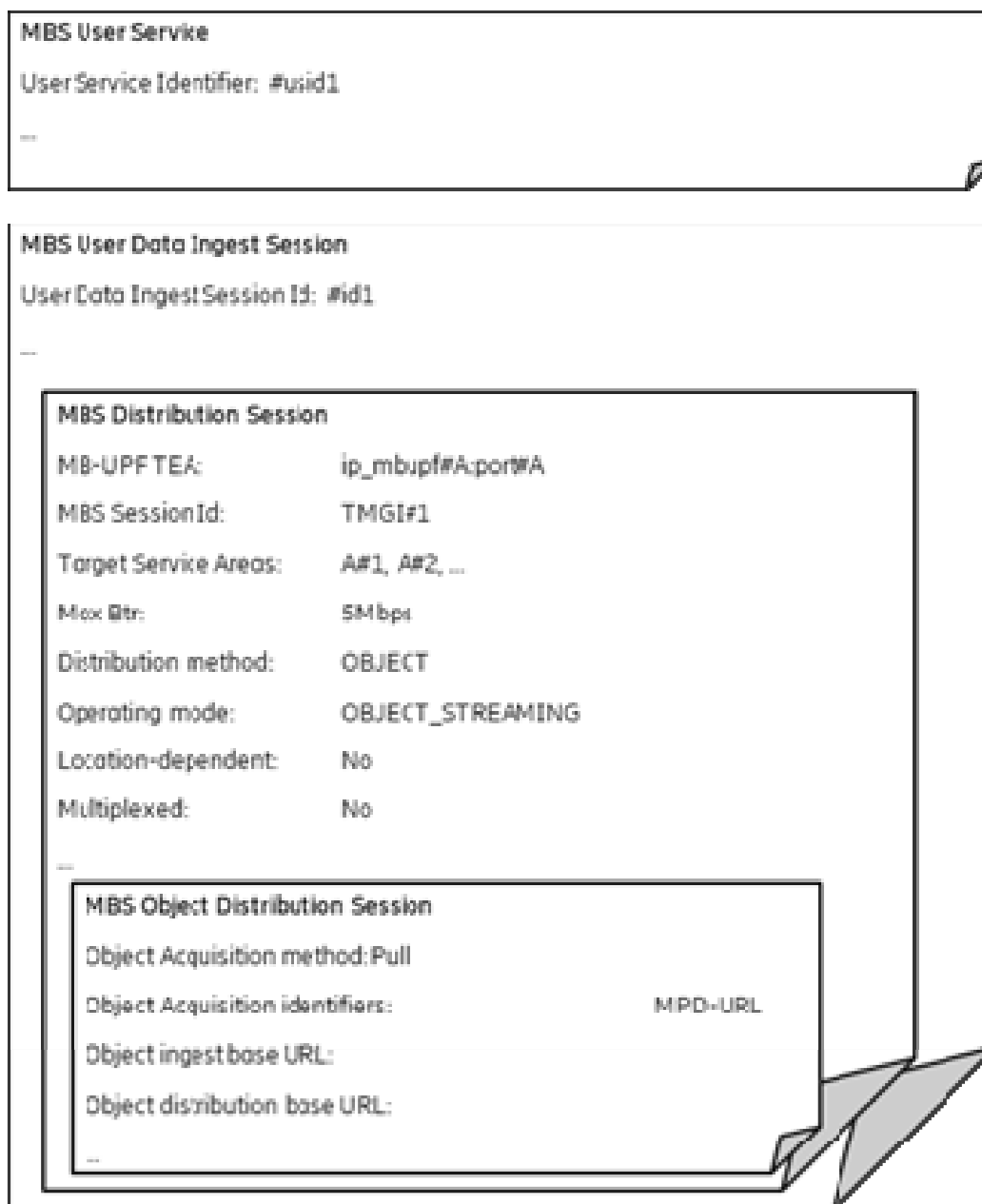

Figure C.3.1-1: DASH content with pull-based ingest

The *Object ingest base URL* remains empty, since the DASH media segments are fetched according to the DASH presentation manifest referenced by the *Object Acquisition identifiers* property.

In this example, the *Object ingest base URL* and *Object distribution base URL* are both omitted, resulting in the same URL used for fetching each media segment being used for its distribution.

C.3.2 DASH content distribution with pull-based ingest using separate MBS Distribution Sessions for audio and video

This example focuses on DASH content distribution with pull-based ingest. The DASH segment packager publishes media segments to an external origin server and the MBSTF pulls them according to the timing model of a DASH presentation specified in an MPD. In this case, the MBS User Service is provisioned to distribute the audio and video segments on separate MBS Distribution Sessions, which are multiplexed onto the same MBS Session.

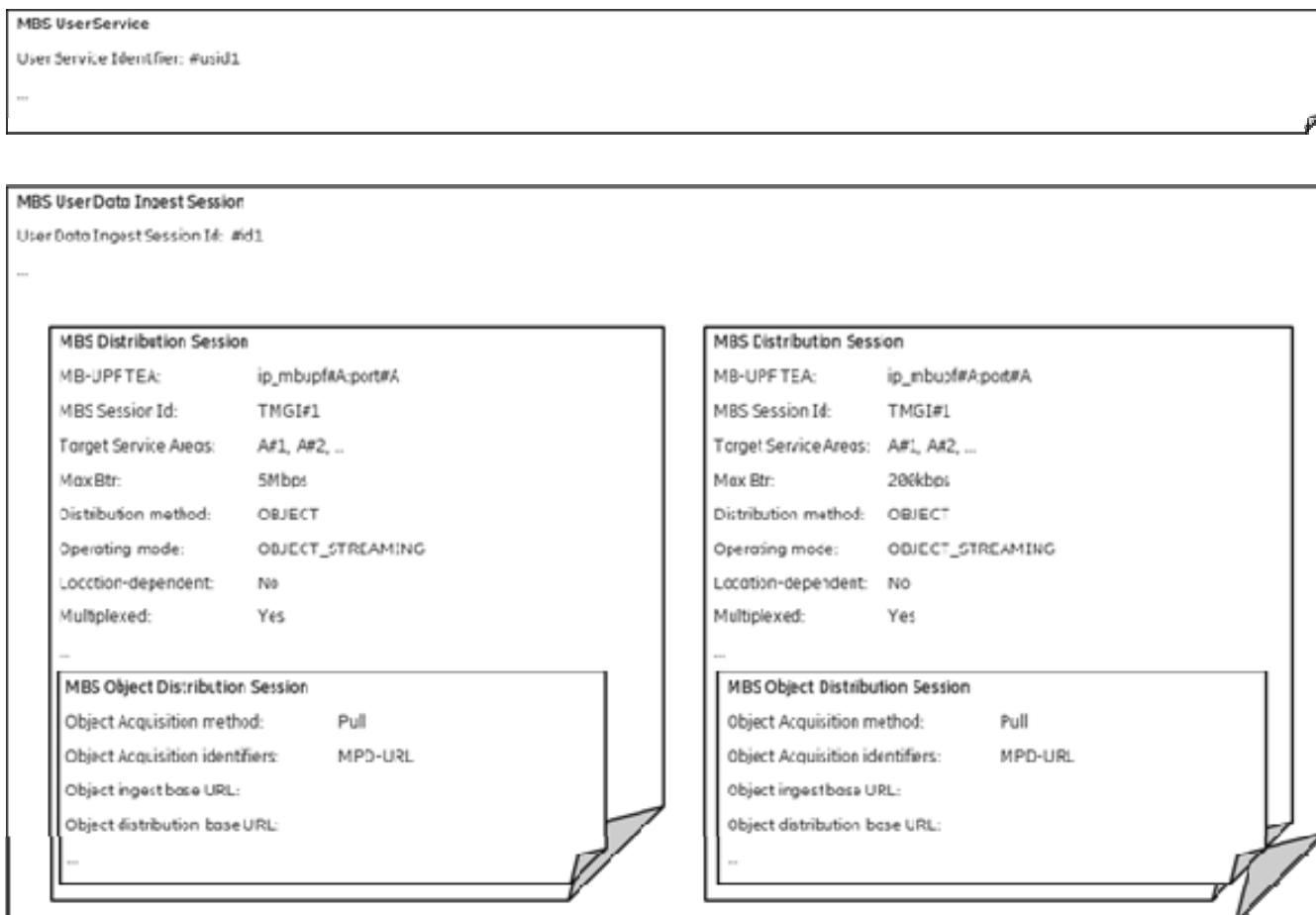

Figure C.3.2-1: DASH content distribution with pull-based ingest using separate MBS Distribution Sessions for audio and video

The *Object ingest base URL* is ignored in this case because the media segments are fetched according to the DASH MPD referenced by the *Object acquisition identifiers* property.

In this example, the *Object distribution base URL* is also omitted, resulting in the same URL used for fetching each media segments being used for its distribution.

C.3.3 Generic object distribution with pull-based ingest

This example focuses on generic object distribution using pull-based ingest. In this case, objects are pulled into the MBSTF according to an object manifest.

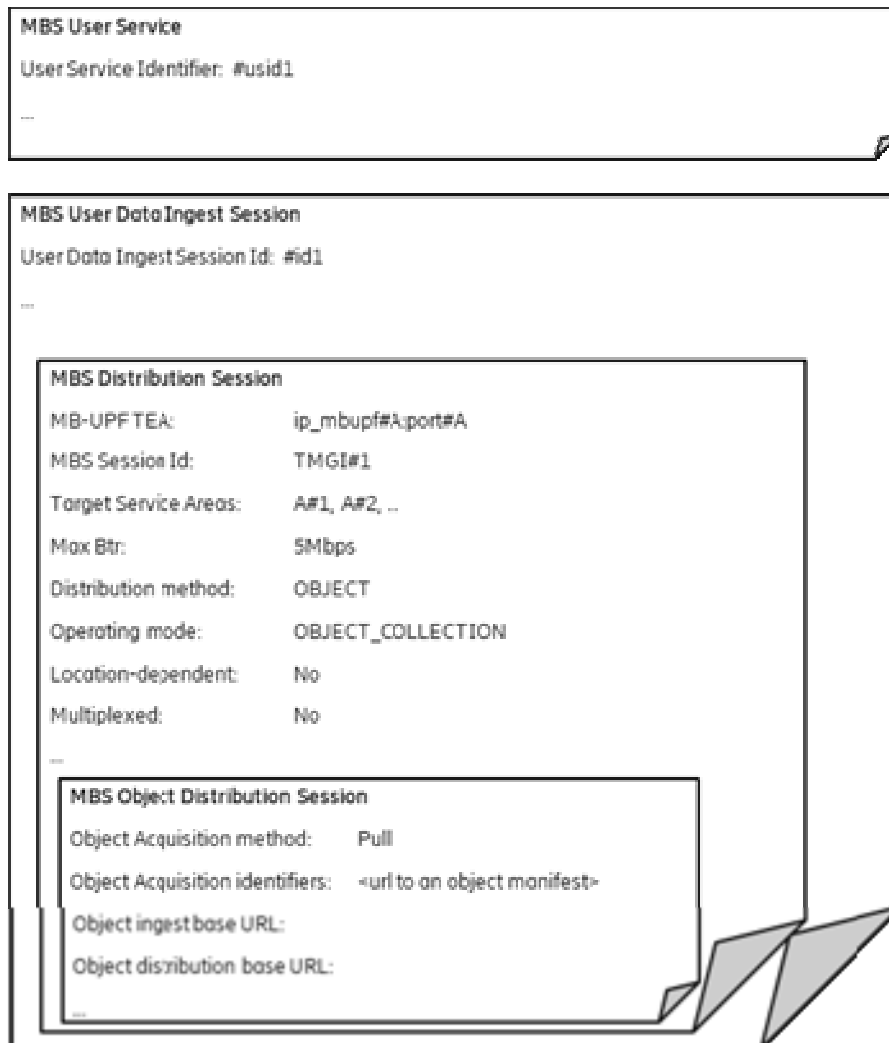

Figure C.3.3-1: Generic object distribution with pull-based ingest

The URL of the object manifest is provisioned by the MBS Application Provider using the *Object acquisition identifiers* parameter.

In this example, the *Object ingest base URL* and *Object distribution base URL* are both omitted, resulting in the same URL used for fetching each object being used for its distribution.

C.4 Location-dependent Object Distribution Method using push-based ingest

C.4.1 Location-dependent DASH content distribution using push-based ingest

A location-dependent MBS Service allows regional content variants to be distributed to different MBS Service Areas within the scope of a common MBS Session. The UE receives the content variant appropriate to its current location. This feature allows realization of MBS User Services such as local traffic information.

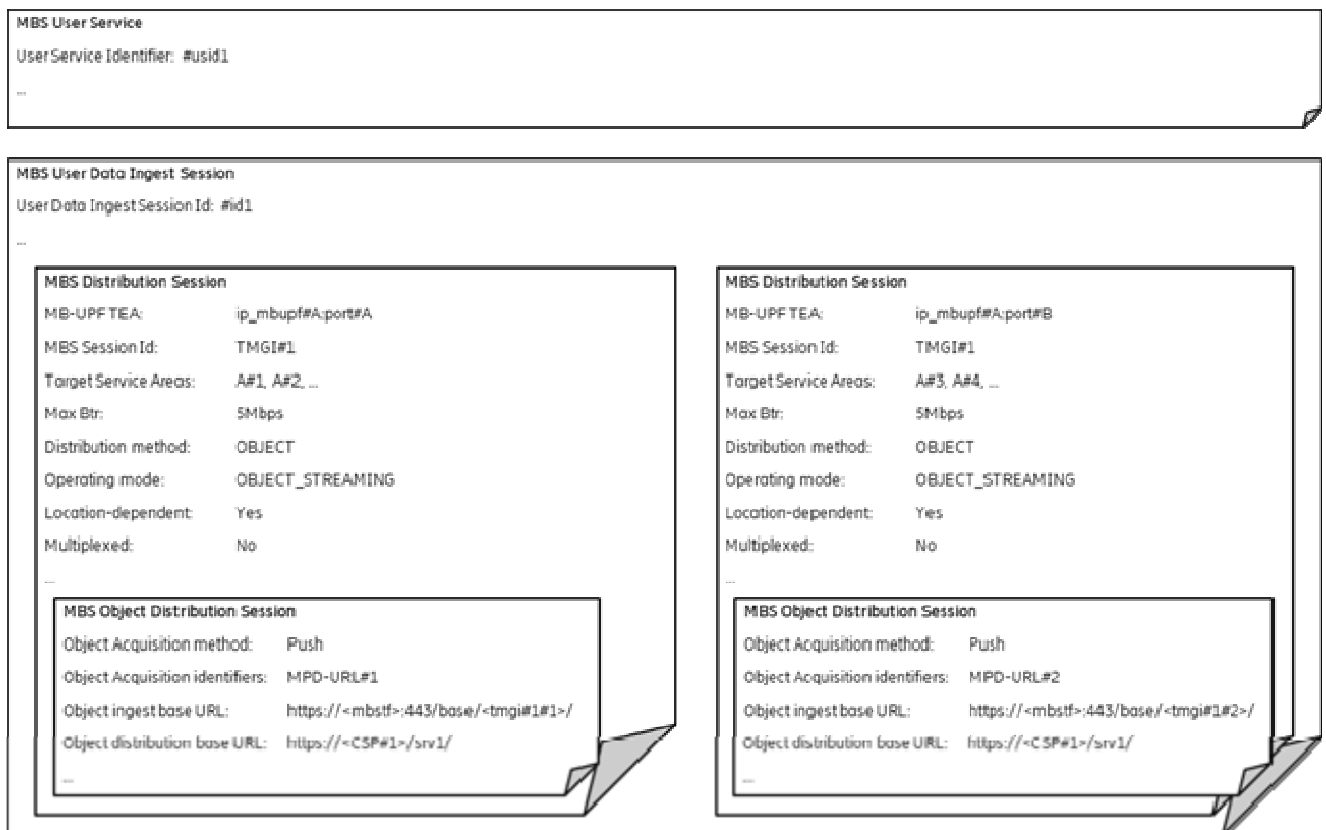

Figure C.4.1-1: Location-dependent DASH content distribution using push-based ingest

Two MBS Distribution Sessions with different *Target service areas* are provisioned. Each MBS Distribution Session has a different *Object ingest base URL* so that two content sources can push different media objects to the two MBS Distribution Sessions. Each content source uses a different DASH presentation manifest.

The MBSF provisions a different MBS Session in the MB-SMF for each MBS Distribution Session and arranges for the user plane traffic of each one to be distributed to the correct MBS Service Area.

The MBSTF uses a separate tunnel to inject the MBS data for each MBS Distribution Session into the MB-UPF.

The MB-UPF listens on two separate UDP ports (*port#A* and *port#B*) for the location-specific MBS data streams.

C.4.2 Location-dependent generic object distribution with push-based ingest

The location-dependent MBS Service described in this clause is very similar to that in clause C.4.1. The difference is the distribution of a generic object stream which is not described by a manifest.

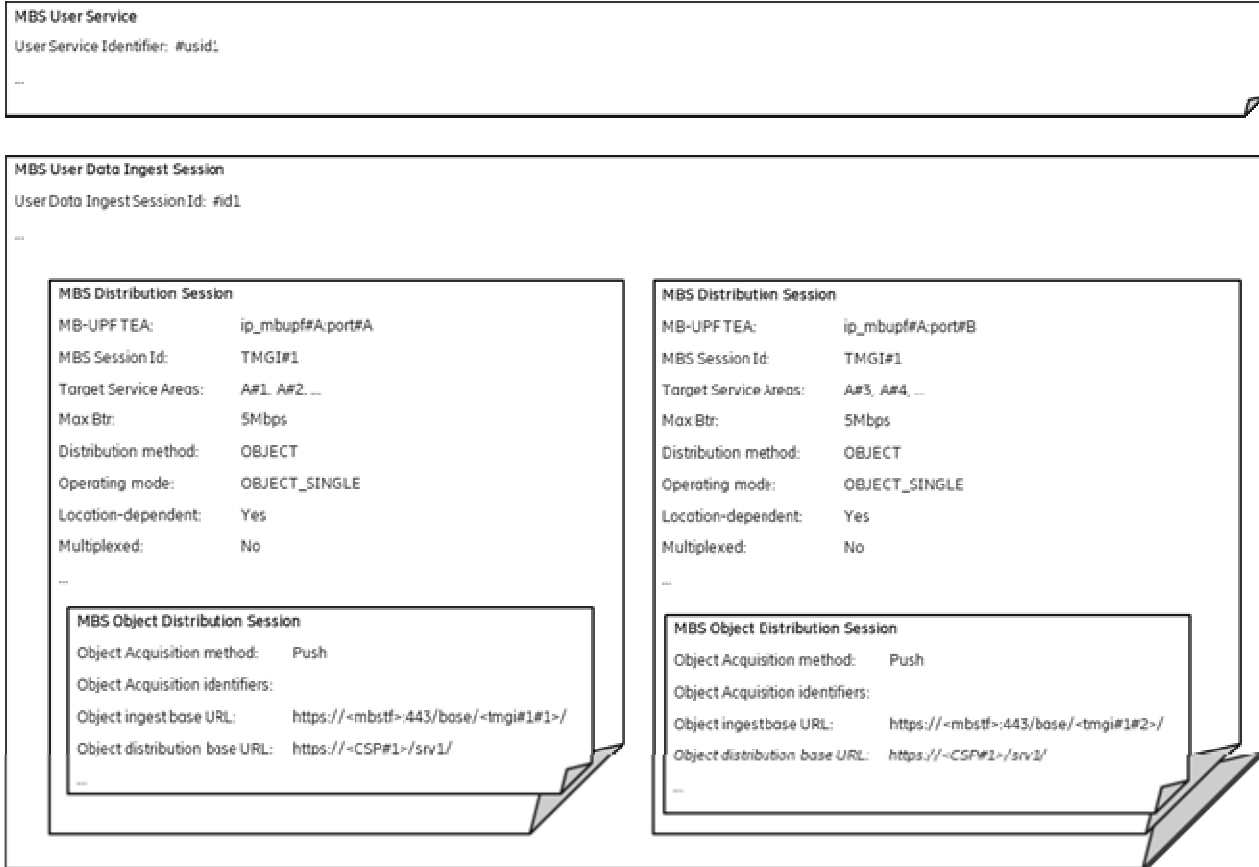

Figure C.4.2-1: Location-dependent generic object distribution with push-based ingest

As in clause C.2.3, no *Object acquisition identifiers* are provisioned. Any object pushed to one of the *Object ingest base URLs* nominated by the MBSF is distributed to the corresponding MBS Distribution Session by the MBSTF after substituting the relevant *Object ingest base URL* prefix with the corresponding *Object distribution base URL*.

Annex D (informative): Change history

Change history							
Date	Meeting	TDoc	CR	Rev	Cat	Subject/Comment	New version
2021-07	Post-SA4#114-e ad hoc	S4al211206				Initial skeleton document.	0.0.1
2021-08	SA4#115-e	S4-211270				Implemented agreements at SA4#115-e	0.1.0
2021-11	SA4#116-e	S4-211663				Implemented agreements at SA4#115-e: S4-211588: Service/session model and high-level procedures. S4-211597: Reference architecture and reference points. S4-211657: Definitions of functional entities. S4-211661: Definitions of two distribution methods. S4-211662: Collaboration scenarios.	0.2.0
2021-12	SA#94-e	SP-211343				Presentation to plenary for information	1.0.0
2022-02	SA4#117-e	S4-220235				Implemented agreements at SA4#115-e: S4-220056r05: Static domain model and baseline parameters. S4-220057: MBS Distribution Session life-cycle model. S4-220149r01: Network Function services. S4-220150r03: Nmb8 User Plane ingest examples. S4-220112r03: Interworking with eMBMS and updates on User Service Announcement carriage. S4-220123r08: Support of interworking with LTE-MBMS.	1.1.0
2022-03	SA#95-e	SP-220297				Presentation to SA for approval	2.0.0
2022-03	SA#95-e					Under change control	17.0.0
2022-06	SA#96	SP-220621	0001	1	F	[5MBUSA] MBS User Service procedures	17.1.0
2022-06	SA#96	SP-220621	0002	1	F	[5MBUSA] Additional stage 2 detail	17.1.0
2022-06	SA#96	SP-220621	0003	1	F	CR support of Group Communication Service	17.1.0
2022-06	SA#96	SP-220621	0004	1	F	[5MBUSA]: Various corrections around File Repair, Consumption Reporting and Reception Reporting	17.1.0
2022-06	SA#96	SP-220621	0005	1	F	[5MBUSA]: Clarification of Nmb8 Protocol stacks wrt Unicast or Multicast usage.	17.1.0
2022-06	SA#96	SP-220621	0006		F	Service-based operand details	17.1.0
2022-06	SA#96					Editorials	17.1.1
2022-09	SA#97-e	SP-220760	0007	1	F	[5MBUSA] Modifications to MBS User Services architecture	17.2.0
2022-09	SA#97-e	SP-220760	0008		F	[5MBUSA] New Annex on Data Model example instantiations	17.2.0
2022-12	SA#98-e	SP-221045	0010	1	F	CR to TS 26.502 Correction of FSA ID	17.3.0
2022-12	SA#98-e	SP-221045	0011	2	F	[5MBUSA] Correction of interworking for Group Communication	17.3.0
2022-12	SA#98-e	SP-221045	0012	2	F	[5MBUSA] Correction of Nmb2 Events	17.3.0
2023-03	SA#99	SP-230255	0009	4	F	[5MBUSA] Modifications to reference architecture	17.4.0
2023-03	SA#99	SP-230255	0014	2	F	[5MBUSA] Corrections to domain model and procedures	17.4.0
2023-03	SA#99	SP-230255	0017	1	F	[5MBUSA] Corrections to MBS Architecture and User Service Announcement Procedures	17.4.0

History

Document history		
V17.0.0	May 2022	Publication
V17.1.0	July 2022	Publication (withdrawn)
V17.1.1	August 2022	Publication
V17.2.0	October 2022	Publication
V17.3.0	January 2023	Publication
V17.4.0	April 2023	Publication