

ETSI TS 126 501 V16.4.1 (2020-09)



**5G;  
5G Media Streaming (5GMS);  
General description and architecture  
(3GPP TS 26.501 version 16.4.1 Release 16)**



---

**Reference**

DTS/TSGS-0426501vg41

---

**Keywords**

5G

**ETSI**

650 Route des Lucioles  
F-06921 Sophia Antipolis Cedex - FRANCE

---

Tel.: +33 4 92 94 42 00 Fax: +33 4 93 65 47 16

Siret N° 348 623 562 00017 - NAF 742 C  
Association à but non lucratif enregistrée à la  
Sous-Préfecture de Grasse (06) N° 7803/88

---

**Important notice**

---

The present document can be downloaded from:

<http://www.etsi.org/standards-search>

The present document may be made available in electronic versions and/or in print. The content of any electronic and/or print versions of the present document shall not be modified without the prior written authorization of ETSI. In case of any existing or perceived difference in contents between such versions and/or in print, the prevailing version of an ETSI deliverable is the one made publicly available in PDF format at [www.etsi.org/deliver](http://www.etsi.org/deliver).

Users of the present document should be aware that the document may be subject to revision or change of status.

Information on the current status of this and other ETSI documents is available at

<https://portal.etsi.org/TB/ETSIDeliverableStatus.aspx>

If you find errors in the present document, please send your comment to one of the following services:

<https://portal.etsi.org/People/CommitteeSupportStaff.aspx>

---

**Copyright Notification**

---

No part may be reproduced or utilized in any form or by any means, electronic or mechanical, including photocopying and microfilm except as authorized by written permission of ETSI.

The content of the PDF version shall not be modified without the written authorization of ETSI.

The copyright and the foregoing restriction extend to reproduction in all media.

© ETSI 2020.

All rights reserved.

**DECT™**, **PLUGTESTS™**, **UMTS™** and the ETSI logo are trademarks of ETSI registered for the benefit of its Members.

**3GPP™** and **LTE™** are trademarks of ETSI registered for the benefit of its Members and of the 3GPP Organizational Partners.

**oneM2M™** logo is a trademark of ETSI registered for the benefit of its Members and of the oneM2M Partners.

**GSM®** and the GSM logo are trademarks registered and owned by the GSM Association.

---

## Intellectual Property Rights

### Essential patents

IPRs essential or potentially essential to normative deliverables may have been declared to ETSI. The information pertaining to these essential IPRs, if any, is publicly available for **ETSI members and non-members**, and can be found in ETSI SR 000 314: *"Intellectual Property Rights (IPRs); Essential, or potentially Essential, IPRs notified to ETSI in respect of ETSI standards"*, which is available from the ETSI Secretariat. Latest updates are available on the ETSI Web server (<https://ipr.etsi.org/>).

Pursuant to the ETSI IPR Policy, no investigation, including IPR searches, has been carried out by ETSI. No guarantee can be given as to the existence of other IPRs not referenced in ETSI SR 000 314 (or the updates on the ETSI Web server) which are, or may be, or may become, essential to the present document.

### Trademarks

The present document may include trademarks and/or tradenames which are asserted and/or registered by their owners. ETSI claims no ownership of these except for any which are indicated as being the property of ETSI, and conveys no right to use or reproduce any trademark and/or tradename. Mention of those trademarks in the present document does not constitute an endorsement by ETSI of products, services or organizations associated with those trademarks.

---

## Legal Notice

This Technical Specification (TS) has been produced by ETSI 3rd Generation Partnership Project (3GPP).

The present document may refer to technical specifications or reports using their 3GPP identities. These shall be interpreted as being references to the corresponding ETSI deliverables.

The cross reference between 3GPP and ETSI identities can be found under <http://webapp.etsi.org/key/queryform.asp>.

---

## Modal verbs terminology

In the present document "**shall**", "**shall not**", "**should**", "**should not**", "**may**", "**need not**", "**will**", "**will not**", "**can**" and "**cannot**" are to be interpreted as described in clause 3.2 of the [ETSI Drafting Rules](#) (Verbal forms for the expression of provisions).

"**must**" and "**must not**" are **NOT** allowed in ETSI deliverables except when used in direct citation.

# Contents

Intellectual Property Rights .....	2
Legal Notice .....	2
Modal verbs terminology.....	2
Foreword.....	5
1 Scope .....	6
2 References .....	6
3 Definition of terms, symbols and abbreviations.....	7
3.1 Terms.....	7
3.2 Symbols.....	8
3.3 Abbreviations .....	9
4 Media Streaming General Service Architecture.....	10
4.1 Overall Media Architecture .....	10
4.2 5G Unicast Downlink Media Streaming Architecture.....	12
4.2.1 Standalone – Non-Roaming.....	12
4.2.2 UE 5GMSd Functions.....	15
4.2.3 Service Access Information for Downlink Media Streaming .....	17
4.3 5G Uplink Media Streaming Architecture.....	18
4.3.1 Media Architecture .....	18
4.3.2 UE Media Functions .....	21
4.4 Network Slicing for Downlink Media Streaming.....	22
5 Procedures for Downlink Media Streaming .....	23
5.1 General .....	23
5.2 Baseline procedure for Unicast Downlink Media Streaming Session establishment .....	25
5.2.1 General.....	25
5.2.2 Progressive Download of On-Demand Content.....	25
5.2.3 DASH Streaming .....	27
5.3 Provisioning Session for Media Streaming .....	28
5.3.1 Domain model .....	28
5.3.2 Baseline provisioning procedure.....	30
5.4 Content Hosting Configuration for Downlink Media Streaming .....	32
5.4.1 General.....	32
5.4.2 Media ingest procedure.....	33
5.5 Metrics collection and reporting .....	34
5.5.1 General.....	34
5.5.2 Out-of-band-controlled reporting procedure.....	34
5.5.3 In-band-controlled reporting procedure.....	36
5.5.4 Metrics collection configuration parameters.....	37
5.6 Consumption reporting.....	38
5.6.1 Consumption reporting procedure .....	38
5.6.2 Consumption reporting parameters.....	40
5.6.3 Triggering consumption reporting .....	40
5.7 Establishing a Unicast Downlink Media Streaming Session with 5GMSd AF interactions for dynamic policy updates.....	40
5.7.1 General.....	40
5.7.2 Provisioning.....	41
5.7.3 Progressive Download of On-Demand Content.....	42
5.7.4 DASH Streaming .....	45
5.7.5 Parameters for dynamic policy invocation configuration .....	47
5.8 Dynamic Policy based on Network Slicing for Downlink Media Streaming .....	48
5.9 Downlink Network Assistance .....	49
5.9.1 Introduction.....	49
5.9.2 5GMSd AF-based downlink Network Assistance .....	49
5.9.3 ANBR-based downlink Network Assistance .....	50

6	Procedures for Uplink Media Streaming.....	51
6.1	General .....	51
6.2	Preparing for Uplink Media Streaming .....	53
6.2.1	Introduction.....	53
6.2.2	Sink Configuration at the 5GMSu AF/AS .....	53
6.2.3	Source Configuration at the UE.....	53
6.3	Establishment of an Uplink Media Streaming Session.....	55
6.4	Termination of an Uplink Media Streaming Session .....	56
6.5	Providing 5GMSu AF-based Network Assistance .....	57
6.6	Providing Remote Control.....	57
6.7	RAN Signalling based Support for Uplink Network Assistance.....	58
7	5GMS Network Media Processing.....	59
7.1	General .....	59
7.2	Media Processing Procedures for Downlink .....	59
7.3	Media Processing Procedures for Uplink .....	61
7.4	Edge Computing.....	61
<b>Annex A (informative): Usage Guidelines for collaboration scenarios.....</b>		<b>62</b>
A.0	General .....	62
A.1	Collaboration 1 .....	62
A.2	Collaboration 2 .....	63
A.3	Collaboration 3 .....	63
A.4	Collaboration 4 .....	64
A.5	Collaboration 5 .....	64
A.6	Collaboration 6 .....	65
A.7	Collaboration 7 .....	65
A.8	Collaboration 8 .....	66
A.9	Collaboration 9 .....	67
<b>Annex B (informative): MNO-specific Service Access Information acquisition.....</b>		<b>68</b>
B.1	General .....	68
B.2	Deployment with DNS-based resolution .....	68
B.3	Deployment with HTTPS-based resolution.....	70
<b>Annex C (informative): Change history .....</b>		<b>72</b>
History .....		73

---

# Foreword

This Technical Specification has been produced by the 3rd Generation Partnership Project (3GPP).

The contents of the present document are subject to continuing work within the TSG and may change following formal TSG approval. Should the TSG modify the contents of the present document, it will be re-released by the TSG with an identifying change of release date and an increase in version number as follows:

Version x.y.z

where:

- x the first digit:
  - 1 presented to TSG for information;
  - 2 presented to TSG for approval;
  - 3 or greater indicates TSG approved document under change control.
- y the second digit is incremented for all changes of substance, i.e. technical enhancements, corrections, updates, etc.
- z the third digit is incremented when editorial only changes have been incorporated in the document.

---

# 1 Scope

The present document specifies the 5G Media Streaming (5GMS) architecture. The 5GMS supported services include MNO and third-party Downlink Media Streaming Services, and MNO and third-party Uplink Media Streaming Services. The 5GMS architecture supports related network and UE functions and APIs, backwards compatible functions for EUTRAN deployments (with and without MBMS) and 5G specific features.

NOTE: Support of 5G Media Streaming over MBMS with 5GC is not considered in the current version of the present document.

The 5GMS architecture is functionally divided into independent components enabling different deployments with various degrees of integration between 5G MNOs and Content Providers. It is specified as a set of extensions to TS 23.501 "System Architecture for the 5G System".

---

# 2 References

The following documents contain provisions which, through reference in this text, constitute provisions of the present document.

- References are either specific (identified by date of publication, edition number, version number, etc.) or non-specific.
- For a specific reference, subsequent revisions do not apply.
- For a non-specific reference, the latest version applies. In the case of a reference to a 3GPP document (including a GSM document), a non-specific reference implicitly refers to the latest version of that document *in the same Release as the present document*.

- [1] 3GPP TR 21.905: "Vocabulary for 3GPP Specifications".
- [2] 3GPP TS 23.501: "System architecture for the 5G System (5GS)".
- [3] 3GPP TS 23.502: "Procedures for the 5G System (5GS)".
- [4] 3GPP TS 23.503: "Policy and charging control framework for the 5G System (5GS); Stage 2".
- [5] 3GPP TS 26.238: "Uplink streaming".
- [6] 3GPP TS 26.307: "Presentation layer for 3GPP services".
- [7] 3GPP TS 26.247: "Transparent end-to-end Packet-switched Streaming Service (PSS); Progressive Download and Dynamic Adaptive Streaming over HTTP (3GP-DASH)".
- [8] 3GPP TS 26.234: "Transparent end-to-end Packet-switched Streaming Service (PSS); Protocols and codecs".
- [9] 3GPP TS 23.003: "Technical Specification Group Core Network and Terminals; Numbering, addressing and identification".
- [10] 3GPP TS 28.530: "Management and orchestration; Concepts, use cases and requirements".
- [11] 3GPP TS 28.531: "Management and orchestration; Provisioning".
- [12] 3GPP TS 28.541: "Management and orchestration; 5G Network Resource Model (NRM); Stage 2 and stage 3".
- [13] 3GPP TS 23.222: "Common API Framework for 3GPP Northbound APIs".
- [14] IETF RFC 1034: "Domain names – concepts and facilities".

## 3 Definition of terms, symbols and abbreviations

### 3.1 Terms

For the purposes of the present document, the terms given in TR 21.905 [1] and the following apply. A term defined in the present document takes precedence over the definition of the same term, if any, in TR 21.905 [1].

**5GMS System:** An assembly of Application Functions, Application Servers and interfaces from the 5G Media Streaming architecture that support either downlink media streaming services or uplink media streaming services, or both.

NOTE 1: The components of a 5GMS System may be provided by an MNO as part of a 5GS and/or by a 5GMS Application Provider.

**5GMS Application Provider:** A party that interacts with functions of the 5GMS System and supplies a 5GMS-Aware Application that interacts with functions of the 5GMS System.

**5GMS-Aware Application:** Application in the UE, provided by the 5GMS Application Provider, that contains the service logic of the 5GMS application service, and interacts with other 5GMS Client and Network functions via the interfaces and APIs defined in the 5GMS architecture.

NOTE 2: Functionality of the 5GMS-Aware Application is outside the scope of this specification.

NOTE 3: A 5GMS-Aware Application associated with the delivery of either a downlink or uplink related 5GMS service is referred to as a 5GMSd-Aware Application or a 5GMSu-Aware Application, respectively.

**5GMS Client:** A UE function that is either a 5GMSd Client or a 5GMSu Client, or both.

**5G Media Streaming Client for downlink (5GMSd Client):** UE function that includes at least a 5G Media Streaming Player and a Media Session Handler for downlink streaming and that may be accessed through well-defined interfaces/APIs.

**5G Media Streaming Client for uplink (5GMSu Client):** Originator of 5GMSu service that may be accessed through well-defined interfaces/APIs.

**5GMSu Media Streamer:** UE function that enables uplink delivery of streaming media content to an Application Server function of the 5GMS Application Provider, and which interacts with both the 5GMSu-Aware Application for media capture and subsequent streaming, and the Media Session Handler for media session control.

NOTE 4: The 5GMSu Media Streamer receives a Media Streamer Entry to initiate an uplink streaming session.

NOTE 5: The 5GMSu Media Streamer captures the media on the provided input devices. The 5GMSu Media Streamer exposes some basic controls such as capture, pause, and stop to the 5GMSu-Aware Application.

**Dynamic policy:** A Dynamic PCC Rule (c.f. TS 23.503[4]) for an uplink or downlink application flow during a media session.

**Egest Session:** An uplink media streaming session from the 5GMSu AS towards the 5GMSu Application Provider.

**Ingest Session:** A session to upload the media content into a 5GMSd AS.

**Policy Template:** A collection of (semi-static) PCF/NEF API parameters which are specific to the 5GMS Application Provider and also the resulting PCC Rule.

**Policy Template Id:** Identifies the desired policy template, which is used by 5GMSd AF to select the appropriate PCF/NEF API towards the 5G System so that the PCF can compile the desired PCC Rule.

**Media Player Entry:** a document or a pointer to a document that defines a media presentation e.g. MPD for DASH content or URL to a video clip file.

**Media Streamer Entry:** A pointer (e.g. in the form of a URL) that defines an entry point of an uplink media streaming session.



**presentation entry:** A document or a pointer to a document that defines an application presentation e.g. an HTML5 document as defined in e.g. TS 26.307 [6].

**Provisioning Session:** a data structure supplied at interface M1d by a 5GMSd Application Provider that configures the 5GMSd features relevant to a set of 5GMSd-Aware Applications.

**5GMSd Media Player:** UE function that enables playback and rendering of a media presentation based on a media player entry and exposing some basic controls such as play, pause, seek, stop to the 5GMSd-Aware Application.

NOTE 6: A 5GMSd Media Player is expected to include a Media Access Client, Media Decoders, Media rendering/presentation, and possibly also DRM Client and Metrics Collection and Reporting. The 5GMSd Media Player's Media Access Client receives a Media Player Entry. The 5GMSd Media Player renders the media on the provided output devices, such as a display in case of video.

NOTE 7: The 5GMSd Media Player is functionally similar to the combination of a TS 26.247 [7] 3GP-DASH client and a TS 26.234 [8] PSS media decoder and renderer.

**Service Access Information:** Set of parameters and addresses (including 5GMSd AF and 5GMSd AS addresses), which are needed to activate the reception of a streaming session.

**Service and Content Discovery:** Functionality and procedures provided by a 5GMSd Application Provider to a 5GMS-Aware Application that enables the end user to discover the available streaming service and content offerings and select a specific service or content item for access.

NOTE 8: The Service and Content Discovery functionality and procedures are outside the scope of this specification.

**Service Announcement:** Procedures conducted between the 5GMS-Aware Application and the 5GMS Application Provider such that the 5GMS-Aware Application is able to obtain 5GMS Service Access Information, either directly or in the form of a reference to that information.

**third party player:** Part of an application that uses APIs to exercise selected 5GMSd functions to play back media content.

NOTE 9: Such APIs are for example defined in TS 26.307 [6] when using the Media Source Extensions for media playback. This type of player is downloaded by or built into an application, or it is downloaded with the Presentation Entry (e.g. as a JavaScript library).

**third party uplink streamer:** Part of an application that uses APIs to exercise selected 5GMSu functions to capture and stream media content.

NOTE 10: This type of streamer is typically implemented as downloadable software.

## 3.2 Symbols

Void.

### 3.3 Abbreviations

For the purposes of the present document, the abbreviations given in TR 21.905 [1] and the following apply. An abbreviation defined in the present document takes precedence over the definition of the same abbreviation, if any, in TR 21.905 [1].

5GC	5G Core Network
5GMS	5G Media Streaming
5GMSd	5G Media Streaming downlink
5GMSu	5G Media Streaming uplink
5GS	5G Systems
AF	Application Function
ABR	Adaptive Bit Rate
AMF	Access and Mobility Function
API	Application Programming Interface
App	Application
AS	Application Server
CAPIF	Common API Framework
CDN	Content Delivery Network
DASH	Dynamic and Adaptive Streaming over HTTP
DN	Data Network
DNAI	Data Network Application Identifier
DNN	Data Network Name
DRM	Digital Rights Management
EPC	Evolved Packet Core
EPS	Evolved Packet System
EUTRAN	Evolved Universal Terrestrial Radio Access Network
FLUS	Framework for Live Uplink Streaming
FQDN	Fully-Qualified Domain Name
GPU	Graphics Processing Unit
GSM	Global System for Mobile communication
HPLMN	Home Public Land Mobile Network
HTTP	HyperText Transfer Protocol
HTTPS	HyperText Transfer Protocol Secure
LTE	Long-Term Evolution
MBMS	Multimedia Broadcast Multicast System
MNO	Mobile Network Operator
MPD	Media Presentation Description
MSISDN	Mobile Station International Subscriber Directory Number
NA	Network Assistance
NEF	Network Exposure Function
NR	New Radio
NSMF	Network Slice Management Function
NSSAI	Network Slice Selection Assistance Information
NSSP	Network Slice Selection Policy
OAM	Operations, Administration and Maintenance
OTT	Over-The-Top
PCC	Policy and Charging Control
PCF	Policy and Charging Function
PDU	Packet Data Unit
PSS	Packet-switched Streaming Service
RAN	Radio Access Network
SBA	Service based Architecture
SLA	Service Level Agreement
TCP	Transmission Control Protocol
URL	Unique Resource Identifier
URSP	UE Route Selection Policy



The 5G Media Services Architecture maps the overall high-level architecture shown in Figure 4.1-1 above to the general architecture shown in Figure 4.1-2 below.

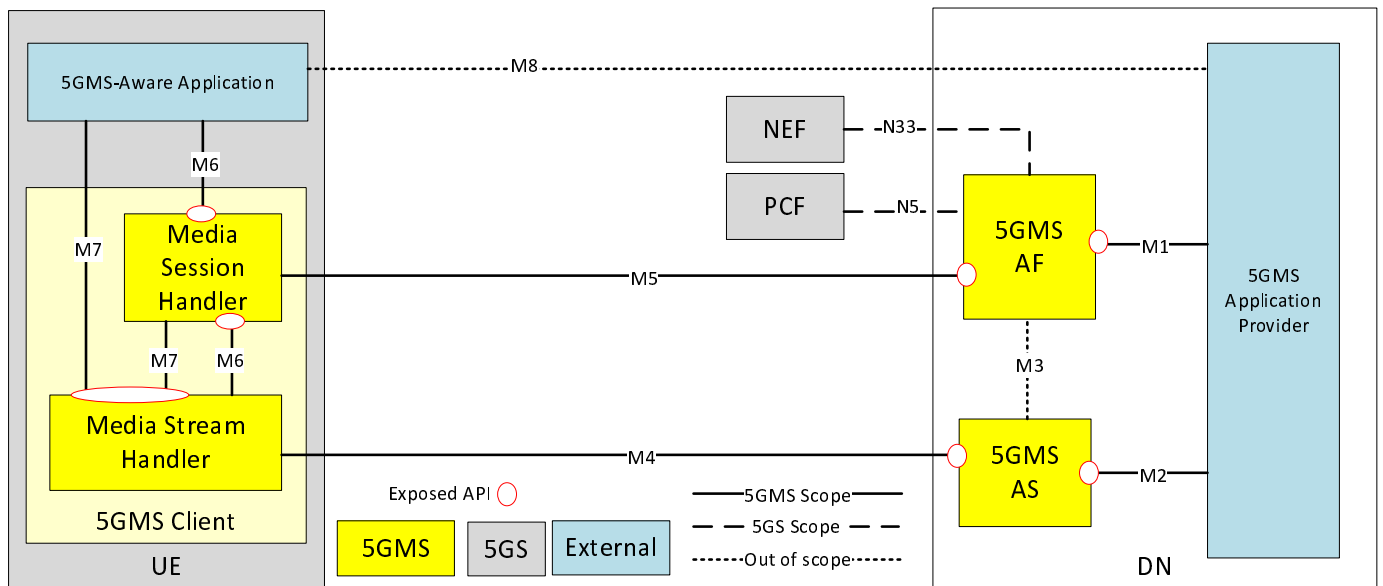

**Figure 4.1-2: 5G Media Streaming General Architecture**

**NOTE:** In Figure 4.1-2 the 5GMS Client in the UE is depicted in the form of a UE that exposes APIs to the constituent functions Media Session Handler and Media Stream Handler in the same way that the same APIs are exposed to 5GMS-aware applications. This UE architecture is not applicable generally; it is just as valid to implement a 5GMS Client that does not expose interfaces M6 and M7 within the 5GMS Client. It is also valid for a 5GMS Client inside a UE to be completely self-contained, such that all functionality typically implemented in the 5GMS-aware application is embedded in the UE and thus interfaces M6 and M7 are not exposed at all.

The remainder of the present document specifies stage 2 aspects of the media streaming functional entities shown in the general architecture of Figure 4.1-2.

This architecture specification addresses two main scenarios as concerns each individual media streaming operation:

- **Downlink streaming:** The network is the origin of the media and the UE acts as the consumption device.
- **Uplink streaming:** The UE is the origin of the media and the network acts as the consumption entity.

The functional entities and interfaces of the media streaming general architecture need to be elaborated with specificities relating to downlink and uplink streaming. For this purpose corresponding descriptions add the suffix “d” for downlink and “u” for uplink functionality as appropriate in each case.

Clause 4.2 introduces the 5G Unicast Downlink Media Streaming architecture.

Clause 4.3 introduces the 5G Unicast Uplink Media Streaming architecture.

## 4.2 5G Unicast Downlink Media Streaming Architecture

### 4.2.1 Standalone – Non-Roaming

The 5GMSd Application Provider uses 5GMSd functions for downlink streaming services. It provides a 5GMSd-Aware Application on the UE the ability to make use of 5GMSd Client and network functions using 5GMSd interfaces and APIs.

The architecture in Figure 4.2.1-1 below represents the specified 5GMSd functions within the 5G System (5GS) as defined in TS23.501 [2]. Three main functions are defined:

- **5GMSd AF:** An Application Function similar to that defined in TS 23.501 [2] clause 6.2.10, dedicated to 5G Downlink Media Streaming.
- **5GMSd AS:** An Application Server dedicated to 5G Downlink Media Streaming.
- **5GMSd Client:** A UE internal function dedicated to 5G Downlink Media Streaming.

5GMSd AF and 5GMSd AS are Data Network (DN) functions and communicate with the UE via N6 as defined in TS 23.501 [2].

Functions in trusted DNs are trusted by the operator's network as illustrated in Figure 4.2.3-5 of TS 23.501 [2]. Therefore, AFs in trusted DNs may directly communicate with relevant 5G Core functions.

Functions in external DNs, i.e. 5GMSd AFs in external DNs, may only communicate with 5G Core functions via the NEF using N33.

NOTE 1: The 5GMS architecture may be applied to an EPS although such an application is not specified in the present document and is left to the discretion of deployments and implementations.

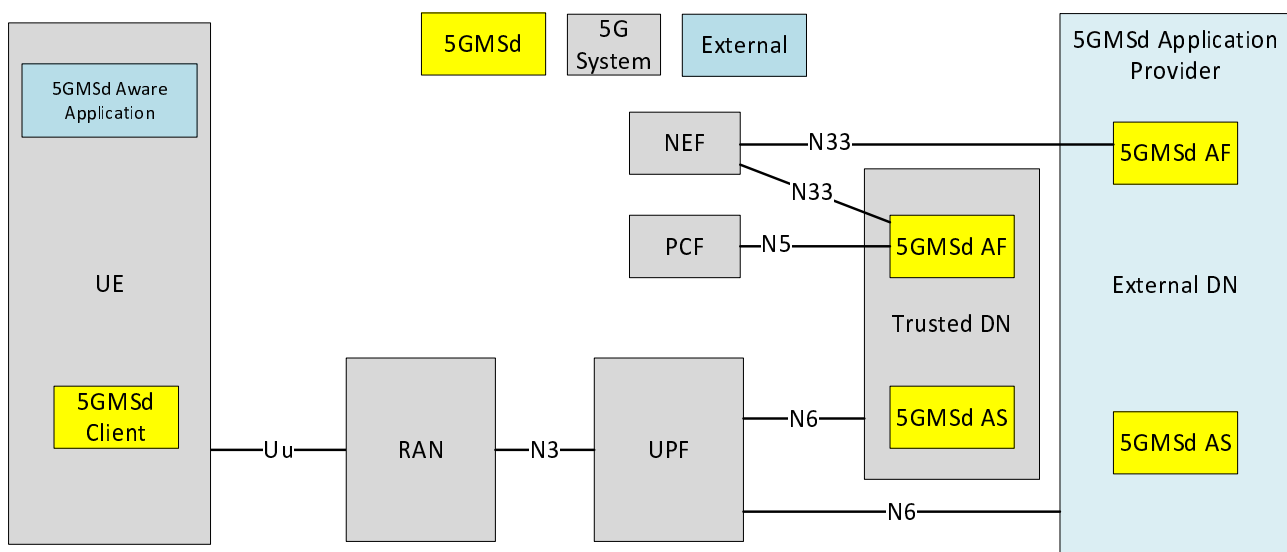
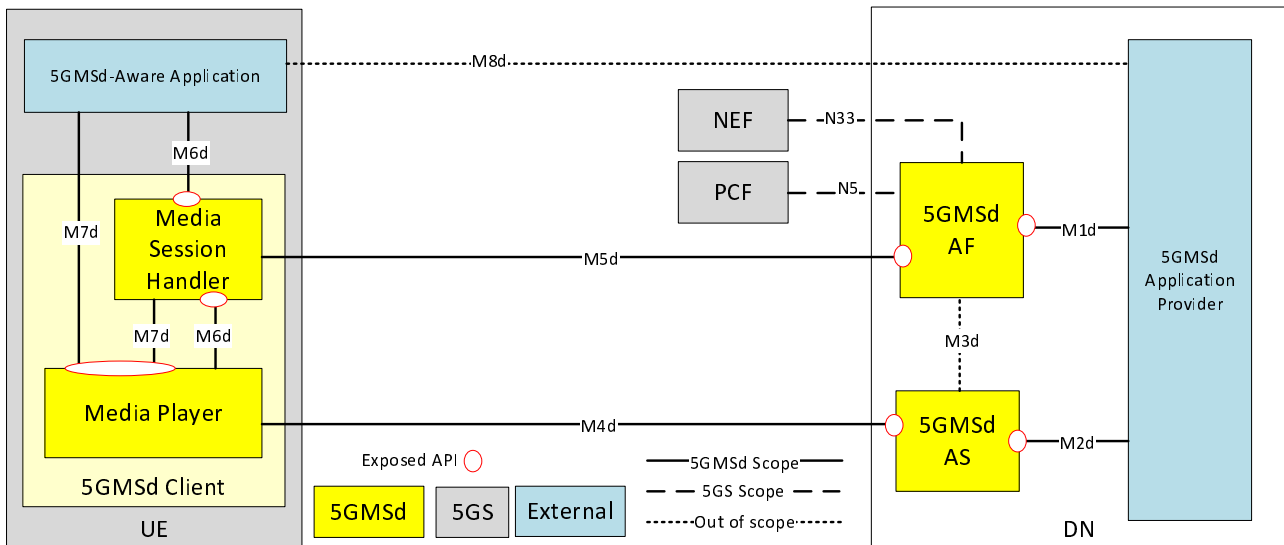

Figure 4.2.1-1: 5G Downlink Media Streaming within 5G System

NOTE 2: The functions indicated by the yellow filled boxes are in scope of stage 3 specifications for 5GMS. The functions indicated by the grey boxes are defined in 5G System specifications. The functions indicated by the blue boxes are neither in scope of 5G Media Streaming nor 5G System specifications.

The architecture in Figure 4.2.1-2 below represents the media architecture connecting UE internal functions and related network functions.



**Figure 4.2.1-2: Media Architecture for unicast downlink media streaming**

NOTE 3: The functions indicated by the yellow filled boxes are in scope of stage 3 for 5GMSd. The functions indicated by the grey boxes are defined in 5GS. The interfaces indicated by solid lines are in scope of stage 3 for 5GMSd. The interfaces indicated by dashed lines are defined in 5GS. The interfaces indicated by dotted lines are neither in scope of 5GS nor 5GMSd, but are considered as part of informative call flows.

NOTE 4: Red ovals indicate API provider functions.

NOTE 5: The 5GMSd AF may also interact with the NEF for NEF-enabled API access. However, within Release 16, the NEF is only used by the 5GMSd AF to interact with the Policy and Charging Function (PCF) in 5GMS specifications.

NOTE 6: Some information might also be exchanged via the OAM, although the OAM is not explicitly shown in the architecture.

The following functions are defined:

- 5G Media Streaming Client for downlink (**5GMSd Client**) on the UE: Receiver of 5GMS downlink media streaming service that may be accessed through well-defined interfaces/APIs. Alternatively, the UE may be implemented in a self-contained manner such that interfaces M6d and M7d are not exposed at all.
- The 5GMSd Client contains two subfunctions:
  - **Media Session Handler:** A function on the UE that communicates with the 5GMSd AF in order to establish, control and support the delivery of a media session. The Media Session Handler may expose APIs that can be used by the 5GMSd-Aware Application.
  - **Media Player:** A function on the UE that communicates with the 5GMSd AS in order to stream the media content and may provide APIs to the 5GMSd-Aware Application for media playback and to the Media Session Handler for media session control.
- **5GMSd-Aware Application:** The 5GMSd Client is typically controlled by an external media application, e.g. an App, which implements external application or content service provider specific logic and enables a media session to be established. The 5GMSd-Aware Application is not defined within the 5G Media Streaming specifications, but the function makes use of 5GMSd Client and network functions using 5GMSd interfaces and APIs.
- **5GMSd AS:** An Application Server which hosts 5G media functions. Note that there may be different realizations of the 5GMSd AS, for example a Content Delivery Network (CDN).

- **5GMSd Application Provider:** External application or content-specific media functionality, e.g., media creation, encoding and formatting that uses 5GMSd to stream media to 5GMSd-Aware applications.
- **5GMSd AF:** An Application Function that provides various control functions to the Media Session Handler on the UE and/or to the 5GMSd Application Provider. It may relay or initiate a request for different Policy or Charging Function (PCF) treatment or interact with other network functions via the NEF.

NOTE 7: There may be multiple 5GMSd AFs residing within the Trusted Media Functions entity, each exposing one or more APIs.

The following interfaces are defined for 5G Downlink Media Streaming:

- M1d (5GMSd Provisioning API): External API, exposed by the 5GMSd AF to provision the usage of the 5G Media Streaming System and to obtain feedback.
- M2d (5GMSd Ingest API): Optional External API exposed by the 5GMSd AS used when the 5GMSd AS in the trusted DN is selected to host content for the streaming service.
- M3d: (Internal and NOT SPECIFIED): Internal API used to exchange information for content hosting on a 5GMSd AS within the trusted DN.
- M4d (Media Streaming APIs): APIs exposed by a 5GMSd AS to the Media Player to stream media content.
- M5d (Media Session Handling API): APIs exposed by a 5GMSd AF to the Media Session Handler for media session handling, control and assistance that also include appropriate security mechanisms, e.g. authorization and authentication.
- M6d (UE Media Session Handling APIs): APIs exposed by a Media Session Handler to the Media Player for client-internal communication, and exposed to the 5GMSd-Aware Application enabling it to make use of 5GMS functions.
- M7d (UE Media Player APIs): APIs exposed by a Media Player to the 5GMSd-Aware Application and Media Session Handler to make use of the Media Player.
- M8d: (Application API): application interface used for information exchange between the 5GMSd-Aware application and the 5GMSd Application Provider, for example to provide Service Access Information to the 5GMSd-Aware Application. This API is external to the 5G System and not specified by 5GMS.

NOTE 8: Non-Standalone, Roaming, Non-3GPP Access and EPC-5GC interworking aspects are FFS.

The following subfunctions are identified as a part of a more detailed breakdown of the 5GMSd AS for stage 3 specifications:

- Adaptive Bit Rate (ABR) Encoder, Encryption and Encapsulator.
- Manifest (e.g. MPD) Generator and Segment (e.g. DASH) Packager.
- Origin Server.
- CDN Server (e.g. Edge Servers).
- DRM Server (e.g. DRM License Server).
- Service Directory.
- Content Guide Server.
- Replacement content server (e.g. Ad content server).
- Manifest Proxy, i.e. MPD modification server.
- App Server.
- Session Management Server.

A breakdown of 5GMSd functions in the UE is provided in clause 4.2.2 below.

## 4.2.2 UE 5GMSd Functions

The UE may include many detailed subfunctions that can be used individually or controlled individually by the 5GMSd-Aware Application. This clause breaks down several relevant identified subfunctions for which stage 3 specification is available.

The 5GMSd-Aware Application itself may include many functions that are not provided by the 5GMSd Client or by the 5G UE. Examples include service and content discovery, notifications and social network integration. The 5GMSd-Aware Application may also include functions that are equivalent to ones provided by the 5GMSd Client and may only use a subset of the 5GMSd client functions. The 5GMSd-Aware Application may act based on user input or may for example also receive remote control commands from the 5GMSd Application Provider through M8d.

With respect to Media Player functions, Figure 4.2.2-1 below shows more detailed functional components of a UE for media player functions to access the 5GMSd AS.

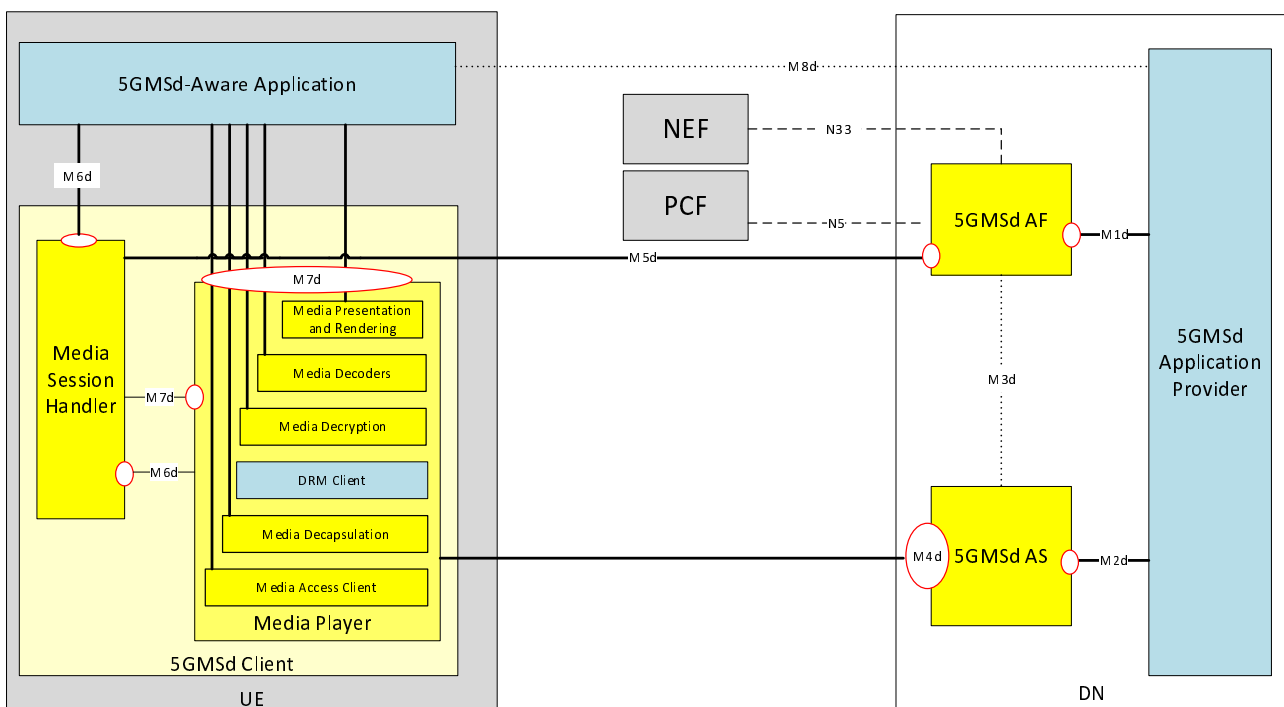

**Figure 4.2.2-1: UE 5G Downlink Media Streaming Functions (Media Player centric)**

The following subfunctions are identified as part of a more detailed breakdown of the Media Player function:

- **Media Access Client:** Accesses media content such as DASH-formatted media segments.
- **Media Decapsulation:** Extracts the elementary media streams for decoding and provides media system related functions such as time synchronization, capability signalling, accessibility signalling, etc.
- **DRM Client** (optional): When present, the DRM client might or might not be a part of the Media Player. It provides a content protection mechanism with its unique key management and key delivery system, authentication/authorization, policy enforcement and entitlement check. The DRM Client is not defined within 5G Media Streaming specifications.
- **Media Decryption** (optional): When present, media decryption is responsible to decrypt the media samples using the keys provided in the DRM license, and further passing to the Media Decoder to enable playback of encrypted media. The media decryption and media decoding could be implemented on a general-purpose processor in software or hardware or, for a more secure and robust architecture, the decryption, decoding and rendering could be implemented on the hardware of secure processors.
- **Media Decoder:** Decodes the media, such as audio or video.
- **Media Presentation and Rendering:** Presents the media using an appropriate output device and enables possible interaction with the media.





### 4.2.3 Service Access Information for Downlink Media Streaming

The Service Access Information is the set of parameters and addresses which are needed by the 5GMSd Client to activate the reception of a downlink streaming session or other 5GMSd network features.

The Service Access Information may be provided together with other service announcement information using M8d. Alternatively, the 5GMSd Client fetches the Service Access Information from the 5GMSd AF. Regardless of how it is provided, the Service Access Information contains different information, depending on the collaboration model between the 5GMS System and the 5GMSd Application Provider, and also depending on offered features. Baseline parameters are listed in Table 4.2.3-1 below:

**Table 4.2.3-1: Parameters of baseline service access information**

Parameters	Description
Media Player Entry	A document or a pointer to a document that defines a media presentation e.g. MPD for DASH content or URL to a video clip file.
URL signing information	...
Provisioning Session identifier	Unique identification of the M1d Provisioning Session.

When the consumption reporting feature is activated for a downlink streaming session, the parameters from Table 4.2.3-2 below are additionally present.

**Table 4.2.3-2: Parameters for consumption reporting configuration**

Parameters	Description
Reporting interval	Identifies the interval between consumption reports being sent by the Media Session Handler.
Server address	A list of 5GMSd AF addresses where the consumption reports are sent by the Media Session Handler.
Sample percentage	The proportion of clients that shall report media consumption. If not specified, all clients shall send reports.
Location reporting	Identify whether the Media Session Handler provides location data to the 5GMSd AF (in case of MNO or trusted third parties)

When the dynamic policy invocation feature is activated for a downlink streaming session the parameters from Table 4.2.3-3 below are additionally present.

**Table 4.2.3-3: Parameters for dynamic policy invocation configuration**

Parameters	Description
Server address	A list of 5GMSd AF addresses which offer the APIs for dynamic policy invocation sent by the 5GMS Media Session Handler. (Opaque URL, following the 5GMS URL format.)
Policy Template Ids	A list of Policy Template identifiers which the 5GMSd Client is authorized to use.

When the metrics reporting feature is activated for a downlink streaming session the parameters from Table 4.2.3-4 below are additionally present.

**Table 4.2.3-4: Parameters for metrics configuration**

Parameters	Description
Server address	A list of 5GMSd AF addresses to which metric reports shall be sent.
DNN	The DNN which shall be used when sending metrics report. If not specified, the default DN shall be used.
Reporting interval	The sending interval between metrics reports. If not specified, a single final report shall be sent after the streaming session has ended.
Sample percentage	The proportion of streaming sessions that shall report metrics. If not specified, reports shall be sent for all sessions.
Streaming source filter	A list of URL patterns for which metrics reporting shall be done. If not specified, reporting shall be done for all sessions.
Metrics	A list of metrics which shall be reported.

When Network Assistance is activated for a downlink streaming session the parameters from Table 4.2.3-5 below are additionally present.

**Table 4.2.3-5: Parameters for Network Assistance configuration**

Parameters	Description
Server address	5GMSd AF address that offers the APIs for 5GMSd AF-based Network Assistance, accessed by the 5GMSd Media Session Handler. (Opaque URL, following the 5GMS URL format.)

## 4.3 5G Uplink Media Streaming Architecture

### 4.3.1 Media Architecture

The 5GMSu Application Provider uses 5GMSu functions for uplink streaming services. It provides a 5GMSu-Aware Application on the UE the ability to make use of 5GMSu Client and network functions using 5GMSu interfaces and APIs.

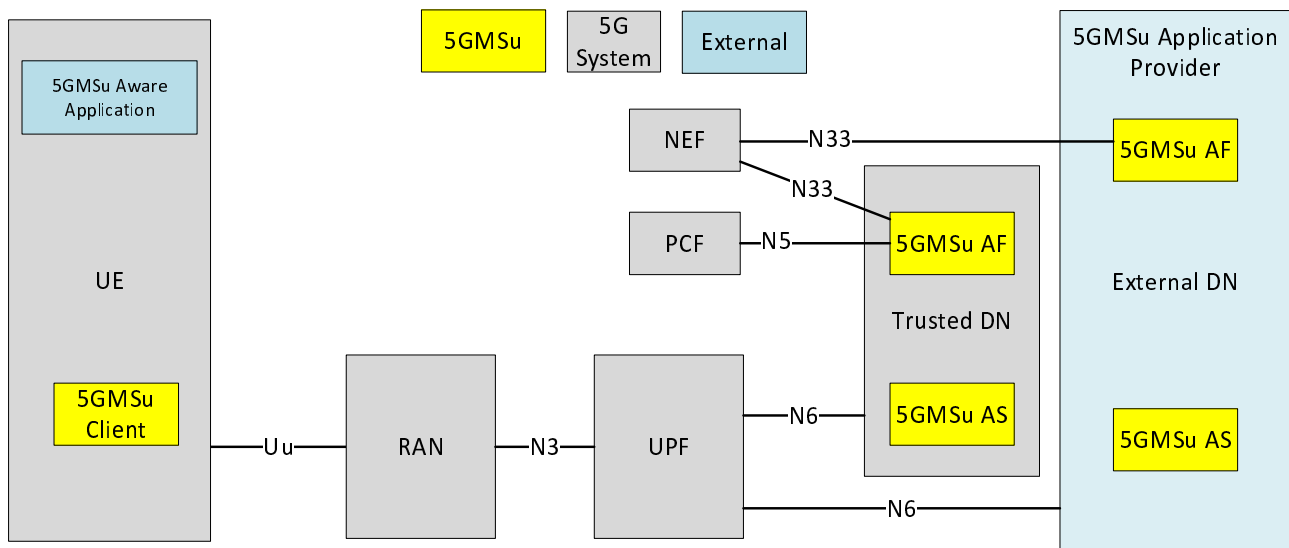

**Figure 4.3.1-1: Media Architecture for unicast uplink media streaming**

NOTE 1: The functions indicated by the yellow filled boxes are in scope of stage 3 specifications for 5GMS. The functions indicated by the grey boxes are defined in 5G System specifications. The functions indicated by the blue boxes are neither in scope of 5G Media Streaming nor 5G System specifications.

The architecture in Figure 4.3.1-1 above represents the specified 5GMSu functions within the 5G System (5GS) as defined in TS23.501 [2]. Three main functions are defined:

- **5GMSu AF:** An Application Function similar to that defined in TS 23.501 [2] clause 6.2.10, dedicated to 5G Uplink Media Streaming.
- **5GMSu AS:** An Application Server dedicated to 5G Uplink Media Streaming.
- **5GMSu Client:** A UE-internal function dedicated to 5G Uplink Media Streaming.

5GMSu AF and 5GMSu AS are Data Network (DN) functions and communicate with the UE via N6 as defined in TS23.501 [2].

Functions in trusted DNs are trusted by the operator’s network as illustrated in Figure 4.2.3-5 of TS 23.501 [2]. Therefore, AFs in trusted DNs may directly communicate with relevant 5G Core functions.

Functions in external DNs, i.e. 5GMSu AFs in external DNs, may only communicate with 5G Core functions via the NEF using N33.

The architecture in Figure 4.3.1-2 below represents the media architecture connecting UE internal functions and related network functions for 5G Uplink Media Streaming.

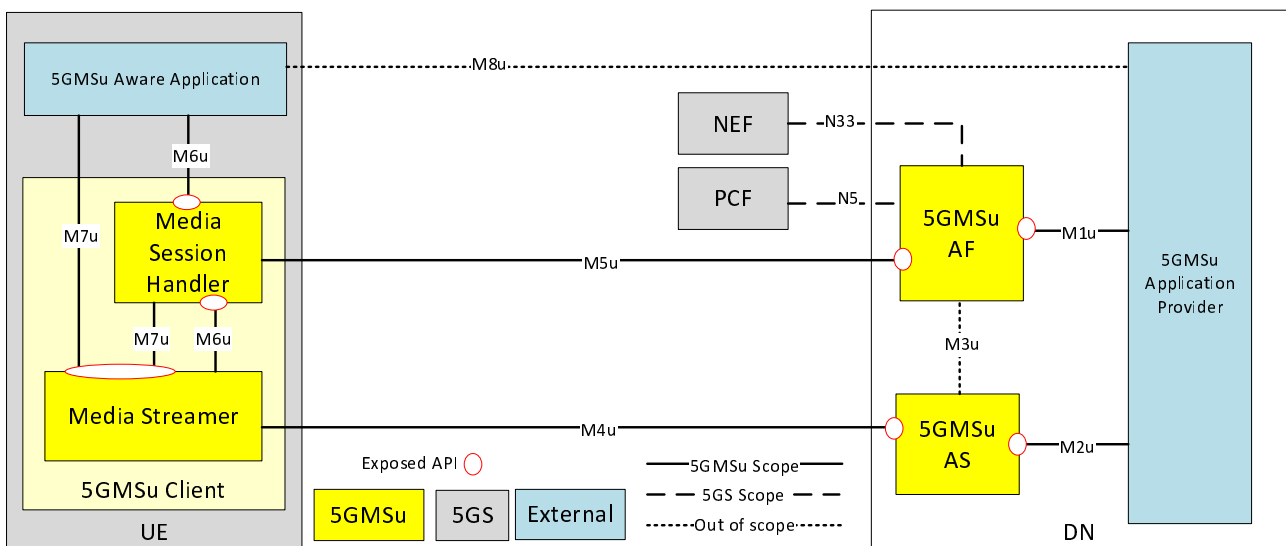

**Figure 4.3.1-2: Media Architecture for unicast uplink media streaming**

NOTE 2: The functions indicated by the yellow filled boxes are in scope of stage 3 for 5GMSu. The functions indicated by the grey boxes are defined in 5GS. The interfaces indicated by solid lines are in scope of stage 3 for 5GMSu. The interfaces indicated by dashed lines are defined in 5GS. The interfaces indicated by dotted lines are neither in scope of 5GS nor 5GMSu , but are considered as part of informative call flows.

NOTE 3: Red ovals indicate API provider functions.

NOTE 4: The 5GMSu AF may also interact with the NEF for NEF-enabled API access. However, within Release 16, the NEF is only used by the 5GMSu AF to interact with the Policy and Charging Function (PCF) in 5GS specifications.

NOTE 5: Some information might also be exchanged via the OAM, although the OAM is not explicitly shown in the architecture.

The following functions are defined:

- 5G Media Streaming Client for uplink (**5GMSu Client**) on UE: Originator of 5GMSu service that may be accessed through well-defined interfaces/APIs. The UE may also be implemented in a self-contained manner such that interfaces M6u and M7u are not exposed at all.
- The 5GMSu Client contains two subfunctions:
  - **Media Session Handler:** A function on the UE that communicates with the 5GMSu AF in order to establish, control and support the delivery of a media session. The Media Session Handler exposes APIs that can be used by the 5GMSu-aware Application.
  - **Media Streamer:** A function on the UE that communicates with the 5GMSu AS in order to stream the media content and provides a service to the 5GMSu-Aware Application for media capturing and streaming and the Media Session Handler for media session control.
- **5GMSu-Aware Application:** The 5GMSu Client is typically controlled by an external media application, e.g. an App, which implements external application or content service provider specific logic and enables a media session to be established. The 5GMSu-Aware Application is not defined within the 5G Media Streaming specifications, but the function makes use of 5GMSu Client and network functions using 5GMSu interfaces and APIs.
- **5GMSu AS:** An Application Server which hosts 5G media functions. Note that there may be different realizations of 5GMSu ASs, for example a Content Delivery Network (CDN).
- **5GMSu Application Provider:** External application or content-specific media functionality, e.g., media storage, consumption, transcoding and redistribution that uses 5GMSu to stream media from 5GMSu Aware applications.
- **5GMSu AF:** An Application Function that provides various control functions to the Media Session Handler on the UE and/or to 5GMSu Application Provider. It may relay or initiate a request for different Policy or Charging Function (PCF) treatment or interact with other network functions via the NEF.

NOTE 6: There may be multiple 5GMSu AFs residing within the Trusted Media Functions entity, each exposing one or more APIs.

The following interfaces are defined for 5G Uplink Media Streaming:

- M1u (5GMSu Provisioning API): External API, exposed by the 5GMSu AF to provision the usage of the 5G Media Streaming Uplink Streaming system and to obtain feedback.
- M2u (5GMSu Publish API): Optional External API exposed by the 5GMSu AS used when the 5GMSu AS in the trusted DN is selected to receive the content for the streaming service.
- M3u: (Internal and NOT SPECIFIED): Internal API used to exchange information for content hosting on a 5GMSu AS within the trusted DN.
- M4u (Uplink Media Streaming APIs): APIs exposed by a 5GMSu AS to the Media Streamer to stream media content.
- M5u (Media Session Handling API): APIs exposed by a 5GMSu AF to the Media Session Handler for media session handling, control and assistance that also include appropriate security mechanisms e.g. authorization and authentication.
- M6u (UE Media Session Handling APIs): APIs that may be exposed by a Media Session Handler to the 5GMSu-Aware Application to make use of 5GMSu functions.
- M7u (UE Media Streamer APIs): APIs that may be exposed by a Media Streamer to the 5GMSu-Aware Application and Media Session Handler to make use of the Media Streamer.
- M8u: (Application API): application interface used for information exchange between the 5GMSu-Aware Application and the 5GMSu Application Provider, for example to provide Service Access Information to the 5GMSu-Aware Application. This API is external and not specified in the 5GMS architecture.

NOTE 7: Non-Standalone, Roaming, Non-3GPP Access and EPC-5GC interworking aspects are FFS.

## 4.3.2 UE Media Functions

The UE may include many detailed subfunctions that can be used individually or controlled individually by the 5GMSu-Aware Application. This clause breaks down several relevant identified subfunctions for which stage 3 specification is available.

The 5GMSu-Aware Application itself may include many functions that are not provided by the 5GMSu Client or to the 5G UE. Examples include peripheral discovery, notifications and social network integration. The 5GMSu-Aware Application may also include functions that are equivalent to ones provided by the 5GMSu Client and may only use a subset of the 5GMSu Client functions.

With respect to the Media Streamer and Media Handler functions, Figure 4.3.2-1 shows more detailed functional components of a 5GMSu Client.

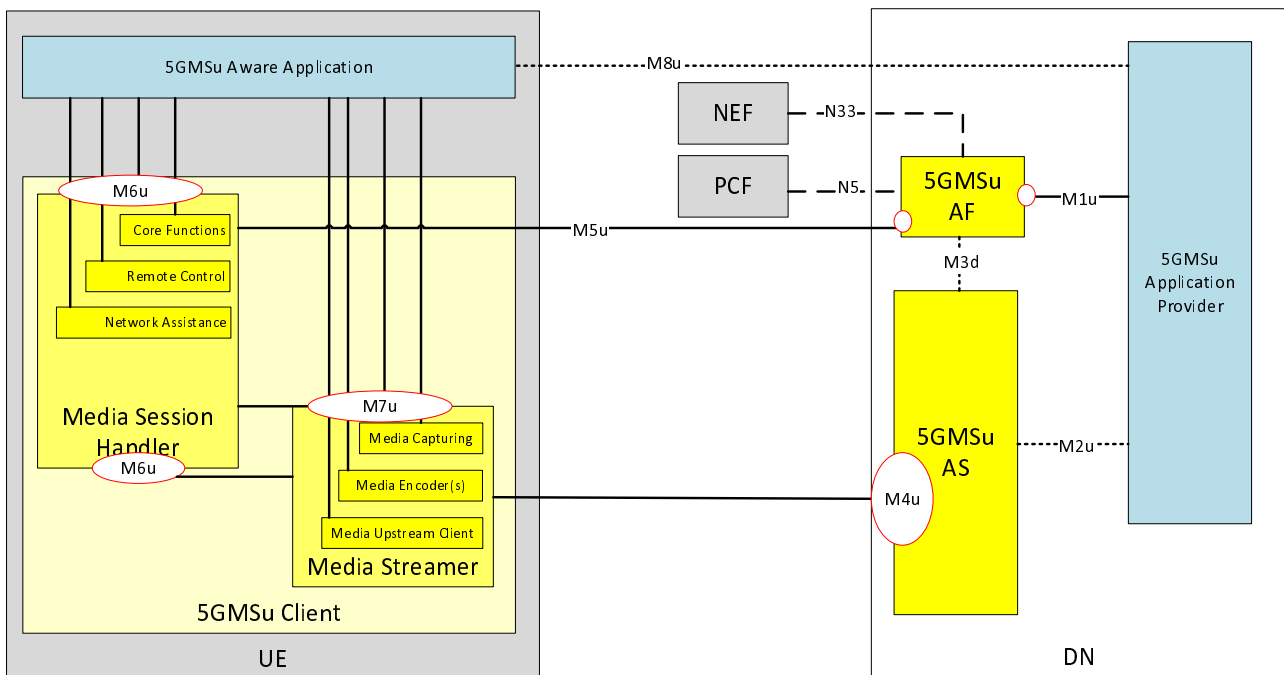

**Figure 4.3.2-1: UE 5G Uplink Media Streaming Functions**

NOTE 1: A UE is a logical device which may correspond to the tethering of multiple physical devices or other types of realizations.

The following subfunctions are identified as part of a more detailed breakdown of the UE 5G Uplink Media Streaming functions:

- **5GMSu-Aware Application:** application which is out of scope of the present specification and which uses the UE 5G Uplink Media Streaming functions and APIs.
- **Media Capturing:** Devices, such as video cameras or microphones, that transform an analog media signal into digital media data.
- **Media Encoder(s):** Compress the media data.
- **Media Upstream Client:** encapsulates encoded media data and pushes it upstream.

NOTE 2: This maps to the FLUS media function in the FLUS Source specified in TS 26.238 Uplink Streaming stage 3 [5].

- **Network Assistance:** requests and/or subscribes to receive assistance information from one or more 5GMSu AF in support of the streaming process.

NOTE 3: This is expected to map to the FLUS Assistance function specified in TS 26.238 Uplink Streaming stage 3 [5].

- **Media Remote Control:** receives control commands from a 5GMSu AF.

NOTE 4: This is expected to map to the FLUS Remote control function specified in TS 26.238 Uplink Streaming stage 3 [5].

- **Core Function:** configures the 5GMSu AS for uplink streaming reception.

NOTE 5: This maps to the FLUS control function in the FLUS source specified in TS 26.238 Uplink Streaming stage 3 [5].

Here are the roles of the different APIs of the UE 5G Uplink Media Streaming functions:

- M6u: API used to control the Core Functions, Remote Control and Network Assistance functions.
- M7u: API used to configure, activate and stop the Media Capturing, Media Encoding(s) and Media Upstream Client functions.

## 4.4 Network Slicing for Downlink Media Streaming

The 5GMS architecture offers the option to create a Content Hosting Configuration for external 5GMSd AS(s) through a provisioning interface, as described in clause 5.4. A Content Hosting Configuration is a 5GMS-optimized configuration that is tailored to a third-party content or service provider to leverage the capabilities of the 5G System to achieve optimized delivery of media content.

Upon successful setup of a Content Hosting Configuration, the 5GMSd AF uses the NSaaS to create or use an existing corresponding network slice, and assigns the Content Hosting Configuration domain as the network slice selection assistance information rule. This allows any traffic to and from the Content Hosting Configuration domain to be mapped to the correct network slice instance.

The concept of Network Slice as a Service (NSaaS) is defined in TS 28.530 [10]. NSaaS can be offered by an MNO to third-party providers in the form of a service. This service allows the providers to use the network slice instance as the end user and to manage the network slice instance via a management interface exposed by the MNO. In turn, these providers offer their own services, e.g. OTT service, on top of the network slice instance obtained from the MNO.

The NSaaS offered by the MNO can be characterized by certain properties (capabilities to satisfy service level requirements), e.g.

- radio access technology,
- bandwidth,
- end-to-end latency,
- reliability,
- mobility,
- density,
- guaranteed / non-guaranteed QoS,
- security level, etc.

The interface that is used for the creation and management of network slices is defined in TS 28.531 [11] and the information elements are defined in TS 28.541 [12].

The network (HPLMN) may provision the UE with Network Slice Selection Policy (NSSP) as part of the UE Route Selection Policy rules as described in TS 23.503 [4]. This ensures that the UE will request a particular network slice when establishing the PDU session. Note that this mapping can also be established through associating an Application with the Content Hosting Configuration and the network slice, which in turn will be associated with a PDU session that includes the Content Hosting Configuration domain as a matching domain.

Once the PDU session is established using the network slice instance that corresponds to the Content Hosting Configuration, the media distribution to the UE may start. The network slice instance may be provisioned to support processing and edge computing in addition to the appropriate QoS allocation. The 5GMSd AF is responsible for

ensuring appropriate traffic routing, e.g. request the routing of traffic to a local access to a Data Network (identified by a DNAI) that hosts the media processing compute instances.

## 5 Procedures for Downlink Media Streaming

### 5.1 General

The downlink streaming procedures follow the general high-level workflow depicted in Figure 5.1-1 below, starting from provisioning and ingest session preparation to the actual content streaming sessions. The **Ingest Session** refers to the time interval during which media content is uploaded to the 5GMSd AS. The **Provisioning Session** refers to the time interval during which the 5GMSd Client can access the media content and the 5GMSd Application Provider can control and monitor the media content and its delivery. Interactions between the 5GMSd AF and the 5GMSd Application Provider may occur at any time while the Provisioning Session is active.

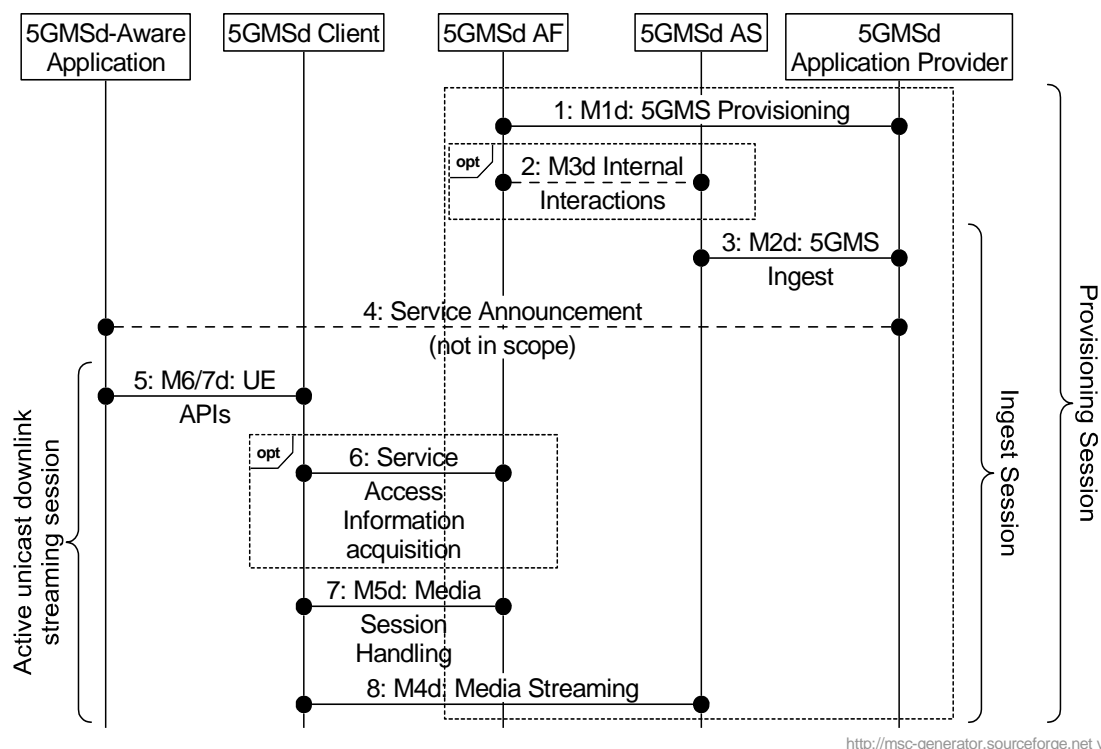

**Figure 5.1-1: High Level Procedure for downlink streaming**

The 5GMSd provisioning API at M1d allows selection of media session handling (M5d) and media streaming (M4d) options, including whether the media content is hosted on trusted 5GMSd ASs. The selection is identified by a Provisioning Session identifier. The 5GMSd AF selects the M5d interface features according to the provisioning option. The Media Session Handling interface can be used for core session handling, consumption reporting, metrics reporting, requesting different policy and charging treatments or other network assistance services.

When the media content is hosted by trusted Media ASs, then the 5GMSd AF selects and configures the 5GMSd AS. Interactions between a 5GMSd AF and a 5GMSd AS (M3d interactions) take place for 5GMS Ingest (M2d) and Media Streaming (M4d) resource reservations. The 5GMSd AS allocates M2d and M4d resources and communicates resource identifiers back to the 5GMSd AF. The 5GMSd AF provides information about the provisioned resources (in form of resource identifiers) for Media Session Handling (M5d), the 5GMSd Ingest (M2d) and the Media Streaming (M4d), to the 5GMSd Application Provider. The resource identifiers for Media Session Handling and Media Streaming are needed by the 5GMSd Client to access the 5GMSd functions.

When Content Hosting is provided by a 5GMSd AS in the external DN, then the M3d interface is not used and the 5GMSd AF does not provide 5GMS Ingest (M2d) and Media Streaming (M4d) resource reservations. M3d procedures are not standardized.



5GMSd Clients can (in principle) start streaming media as soon as the corresponding content is ingested by activating a unicast downlink streaming session. However, it may take some time until the media content is available for Media Streaming (via the Media Streaming API) or the distribution availability might be based on a provisioned schedule. The unicast downlink streaming session for a given UE (or "for each UE") is active from the time, at which the 5GMSd-Aware Application activates the reception of a streaming service until its termination.

The 5GMSd-Aware Application receives application data from the 5GMSd Application Provider before receiving the downlink streaming media. The application data contains Service Access Information, which acts as an entry point for the 5GMSd Client to start the downlink streaming session. The 5GMSd Client may either receive a reference to that Service Access Information or the full Service Access Information from the 5GMSd Application Provider.

Steps:

1. The 5GMSd Application Provider creates a Provisioning Session and starts provisioning the usage of the 5G Media Streaming System. During the establishment phase, the used features are negotiated and detailed configurations are exchanged. The 5GMSd Application Provider receives Service Access Information for M5d (Media Session Handling) and, where media content hosting is negotiated, Service Access Information for M2d (Ingestion) and M4d (Media Streaming) as well. This information is needed by the 5GMSd Client to access the service. Depending on the provisioning, only a reference to the Service Access Information may be supplied.
2. When Content Hosting is offered and selected there may be interactions between the 5GMSd AF and the 5GMSd AS, e.g. to allocate 5GMSd content ingest and distribution resources. The 5GMSd AS provides resource identifiers for the allocated resources to the 5GMSd AF, which then provides the information to the 5GMSd Application Provider. The M3d procedures between 5GMSd AF and 5GMSd AS are not specified.
3. The 5GMSd Application Provider starts the Ingest Session by ingesting content. In case of live services, the content is continuously ingested. In case of on-demand streaming services, the content may be uploaded once and then updated later on.

NOTE 1: A 5GMSd AS in the external Data Network may provide the Content Hosting.

4. The 5GMSd Application Provider provides the Service Announcement Information to the 5GMSd-Aware Application. The service announcement includes either the whole Service Access Information (i.e. details for Media Session Handling (M5d) and for Media Streaming access (M4d)) or a reference to the Service Access Information or pre-configured information. When only a reference is included, the 5GMSd Client fetches (in step 6) the Services Access Information when needed.
5. When the 5GMSd-Aware Application decides to begin streaming, the Service Access Information (all or a reference) is provided to the 5GMSd Client. The 5GMSd Client activates the unicast downlink streaming session.
6. When the 5GMSd Client received only a reference to the Service Access Information, then it acquires the Service Access Information.

NOTE 2: Pre-caching of Service Access Information may also be supported by the 5GMS Client to speed up the activation of the service.

7. The 5GMSd Client uses the Media Session Handling API towards the 5GMSd AF. The Media Session Handling API is used for consumption reporting, metrics reporting, requesting different policy and charging treatments or other network assistance services. The actual time of API usage depends on the feature and interactions that may be used during the media content reception.
8. The 5GMSd Client activates reception of the media content.

## 5.2 Baseline procedure for Unicast Downlink Media Streaming Session establishment

### 5.2.1 General

This clause describes the baseline procedure for establishing a unicast downlink media streaming session. This baseline procedure assumes that the 5GMSd AF and the 5GMSd AS both reside in the external DN and that there are no interactions between the 5GMSd AF and the 5G System.

### 5.2.2 Progressive Download of On-Demand Content

This baseline procedure describes the establishment of a unicast downlink streaming session. A streaming session may use 3GP File Format (Progressive Download), 3GP Timed Text or other (potentially non-3GPP defined) formats.

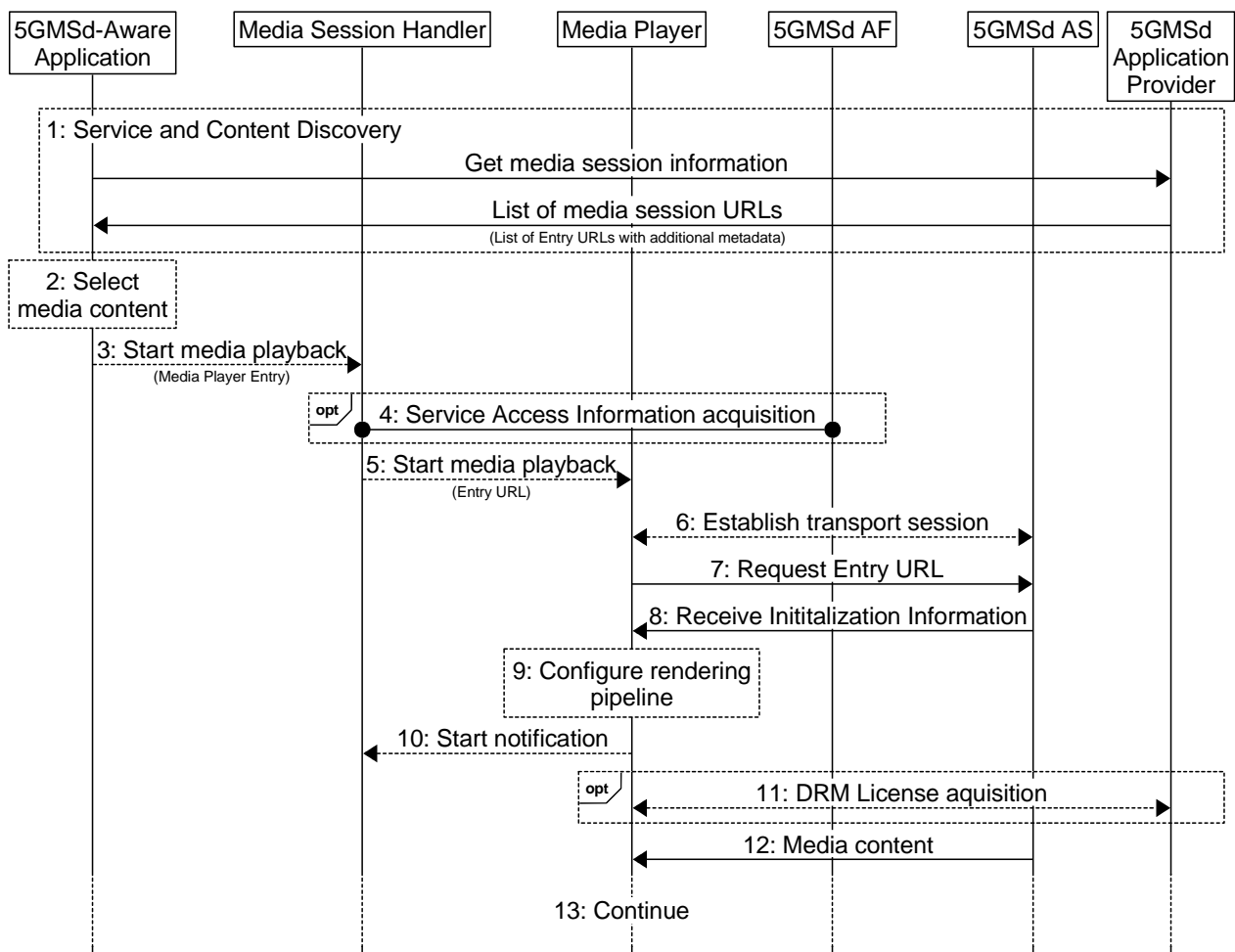

<http://msc-generator.sourceforge.net v6.3.8>

**Figure 5.2-1: High Level Procedure for progressive download for on-demand media**

Prerequisites:

- The 5GMSd Application Provider has provisioned the 5G Media Streaming System and has set up content ingest.
- The 5GMSd-Aware Application has received the service announcement from the 5GMSd Application Provider.

## Steps:

1: The 5GMSd-Aware Application triggers the Service Announcement and Service and Content Discovery procedure. The Service Announcement includes either the whole Service Access Information (i.e. details for Media Session Handling (M5d) and for Media Streaming access (M4d)) or a reference to the Service Access Information.

NOTE: The Service and Content Discovery procedure only involves the 5GMSd-Aware Application and the 5GMSd Application Provider and hence is out of scope of the present document.

2: A Media Player Entry is selected.

3: The 5GMSd-Aware Application triggers the Media Session Handler to start the playback. The Media Player Entry is provided to the Media Session Handler.

4: When the 5GMS-Aware Application has received only a reference to the Service Access Information (see step 1), the Media Session Handler interacts with the 5GMSd AF to acquire the whole Service Access Information.

5: The Media Session Handler triggers the Media Player to start the session.

6: The Media Player establishes the transport session.

7: The Media Player sends the request for the progressive download content.

8: The Media Player receives the initialization information of the progressive download content. The initialization information contains configuration parameters for reception of the media and, optionally, also DRM information.

9: The Media Player configures the rendering pipeline for media playback.

10: The Media Player notifies the Media Session Handler, providing the transport session information and some media content related information.

11: Optional: The Media Player acquires a DRM License from the 5GMSd Application Provider.

12: The Media Player receives media content and puts it into the rendering pipeline.

13: The Media Player continuously receives and plays back the media content.

### 5.2.3 DASH Streaming

It is assumed here that the key information to initialize the media decoding and rendering pipeline is present in the Media Player Entry (or referenced by the Media Player Entry). The intention is to provide the 5GMSd Client with information to set up the media decoding and rendering pipeline in such a way that no pipeline reset is needed during the session. Implementations need to consider that parts of the information are provided with the initialization segments.

It is assumed that the client is enabled to use the same media decoding and rendering pipeline during the session.

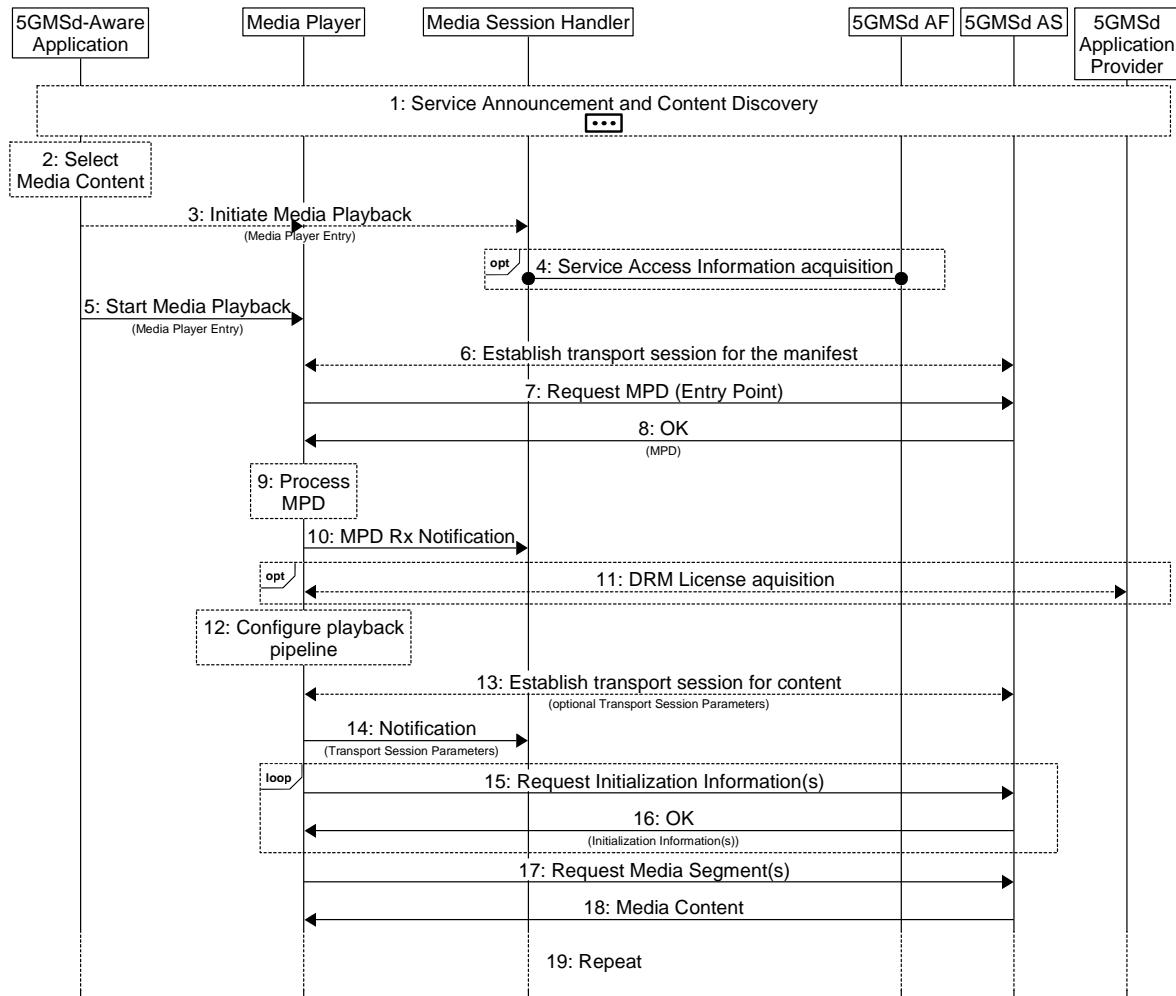

Figure 5.2-2: High Level Procedure for DASH content

Prerequisites:

- The 5GMSd Application Provider has provisioned the 5G Media Streaming System and has setup content ingest.
- The 5GMSd Aware Application has received the service announcement from the 5GMS Application Provider.

Steps:

- 1: The 5GMSd Aware Application triggers the Service Announcement and Service and Content Discovery procedure. The Service and Content Discovery procedure only involves the App and the external Application Server. The Service Announcement includes either the whole Service Access Information (i.e. details for Media Session Handling (M5d) and for Media Streaming access (M4d)) or a reference to the service access information.
- 2: A media content item is selected.
- 3: The 5GMSd-Aware Application triggers the 5GMSd Client to start media playback. The Media Player Entry is provided to the 5GMSd Client.

- 4: When the 5GMS-Aware Application has received only a reference to the Service Access Information (see step 1), the Media Session Handler interacts with the 5GMSd AF to acquire the whole Service Access Information.
- 5: In parallel, the Media Player is invoked to start media access and playback.
- 6: The Media Player establishes the transport session for acquiring the MPD referenced by the Media Player Entry.
- 7: The Media Player requests the MPD.
- 8: The Media Player receives the MPD.
- 9: The Media Player processes the MPD. It determines for example the number of needed transport sessions for media acquisition. The Media Player should be able to use the MPD information to initialize the media pipelines for each media stream. The MPD should also contain information to initialize the DRM client, when DRM is used.
- 10: The Media Player notifies the Media Session Handler about the MPD. The notification may contain parameters from the MPD.
- 11: Optional: the Media Player acquires the necessary DRM information, for example a DRM License.
- 12: The Media Player configures the media playback pipeline.
- 13: The Media Player establishes the necessary transport sessions for the content. For example, the Media Player may establish one transport session for each media component (audio, video, etc) and possibly additional transport sessions for other media representations.
- 14: The Media Player notifies the Media Session Handler that it is ready to commence playback and optionally provides transport session parameters.
- 15: The Media Player requests initialization information. The Media Player repeats this step for each required initialization segment.
- 16: The Media Player receives the initialization information.
- 17: The Media Player requests media segments according to the MPD.
- 18: the Media Player receives media segments and puts the information into the appropriate media rendering pipeline.
- 19: Previous steps are repeated according to the MPD information.

NOTE: The Media Player can interact with multiple instances of the 5GMSd AS. The Media Player can be made aware of the 5GMSd AS instances via the manifest.

## 5.3 Provisioning Session for Media Streaming

### 5.3.1 Domain model

The M1d baseline domain model is depicted in Figure 5.3.1-1 overleaf. It consists of a Provisioning Session, which contains at least one of the following:

- A Content Hosting Configuration,
- A Consumption Reporting Configuration,
- A Policy Template, or
- A Metrics Reporting Configuration.

Each Provisioning Session is uniquely identified within the 5GMS System by a Provisioning Session identifier.

When a certain 5GMS feature is selected, the 5GMSd AF compiles the resulting Service Access Information so that the 5GMSd Client can access the services via M4d and/or M5d.

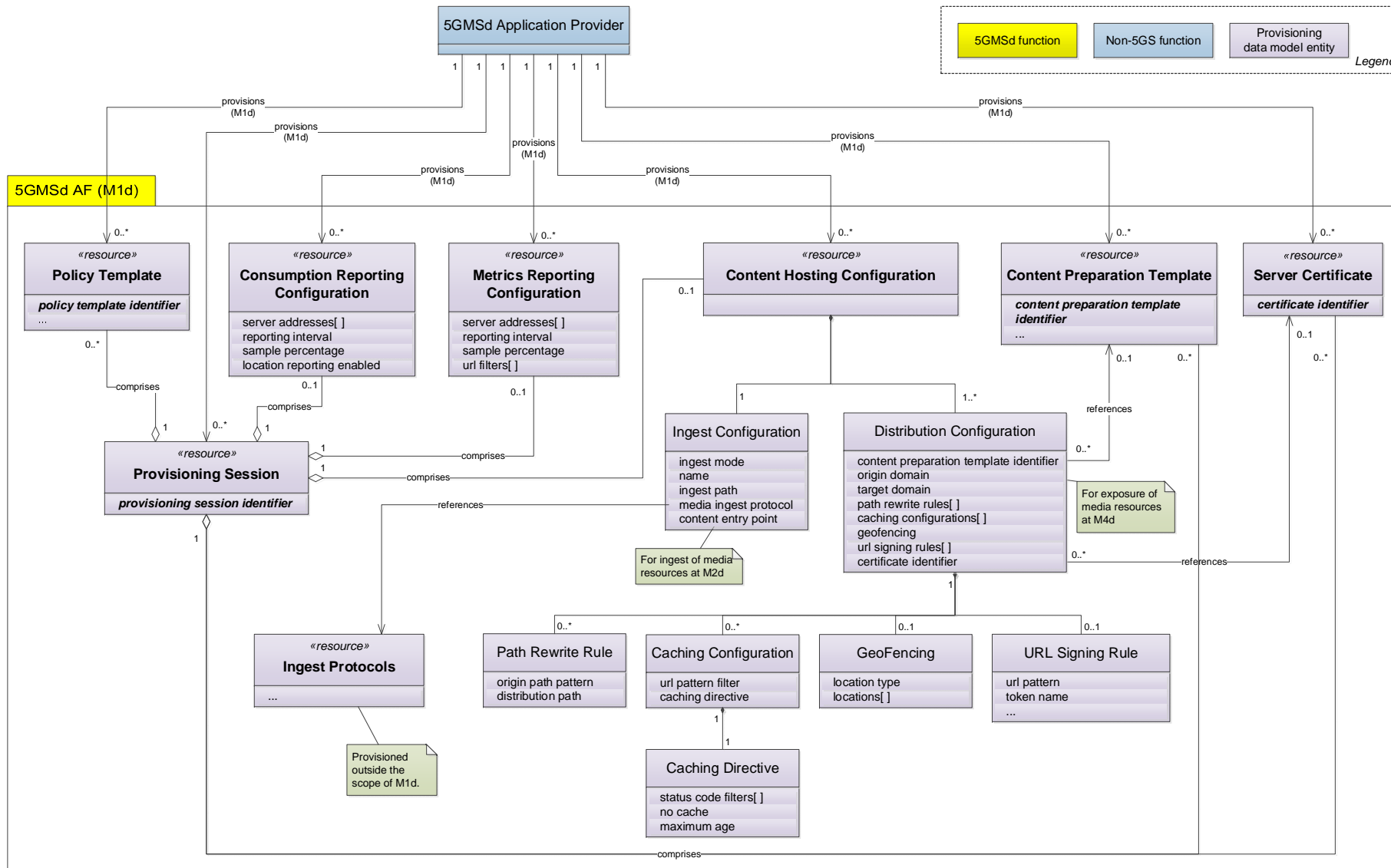
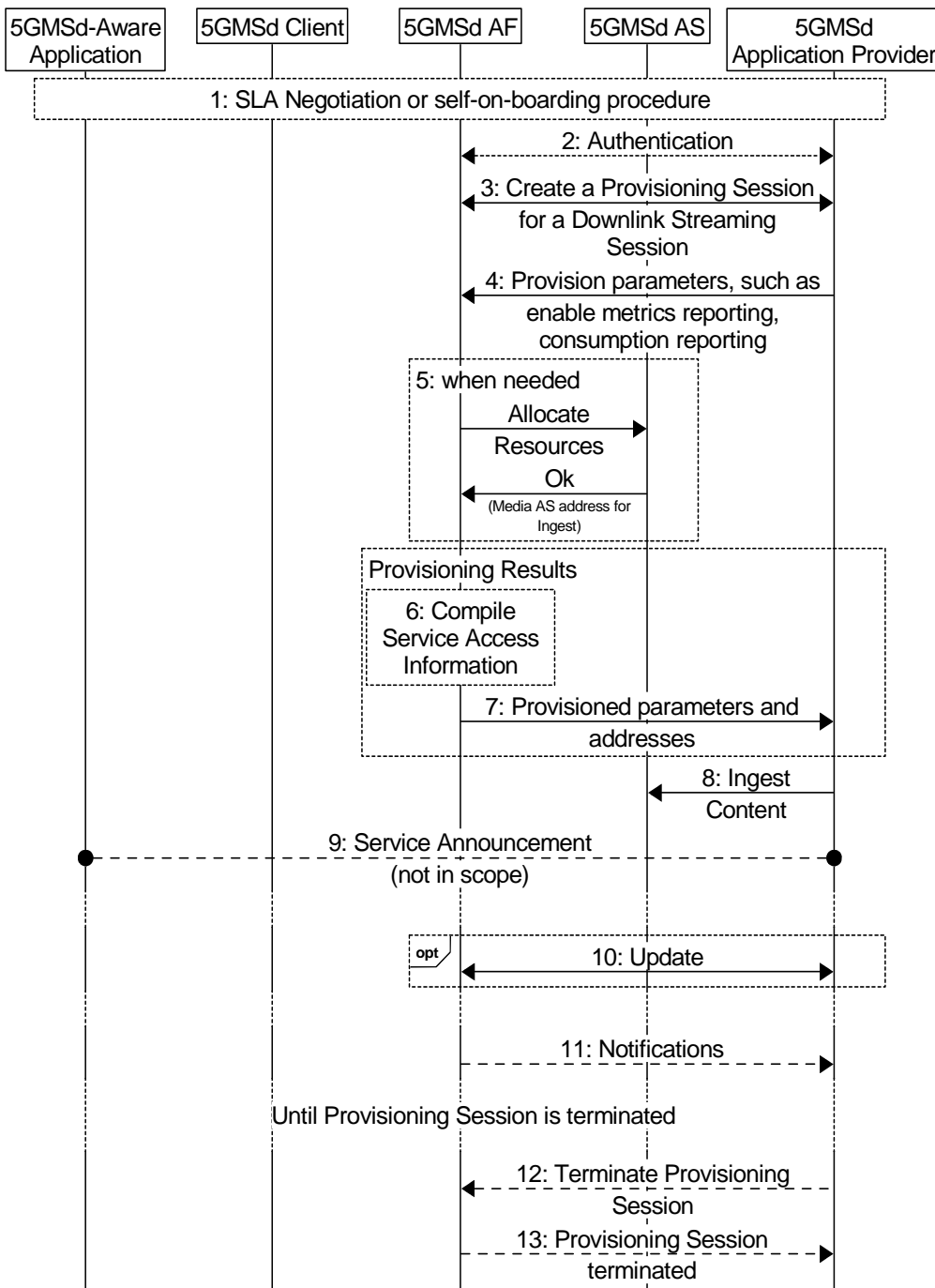

Figure 5.3.1-1: M1d provisioning domain model

### 5.3.2 Baseline provisioning procedure

The present clause describes the baseline procedure to provision the features using the 5GMS System.

NOTE 1: SLA negotiations between the 5GMSd Application Provider and the 5GMS System provider are outside the scope of the present specification and are included in the figure below for illustrative purposes only.



<http://msc-generator.sourceforge.net> v6.3.8

Figure 5.3-1: High Level Procedure for provisioning the 5GMS System for downlink streaming sessions

## Steps:

1. The 5GMSd Application Provider discovers the address (URL) of the 5GMSd AF (M1d) for Session Provisioning.
2. The 5GMSd Application Provider authenticates itself with the system. This procedure reuses existing authentication/authorization procedures, e.g. as defined for CAPIF [13].
3. The 5GMSd Application Provider creates a Provisioning Session, providing its 5GMSd Application Provider identifier as input. 5GMSd Application Provider queries the capabilities and authorized features.
4. The 5GMSd Application Provider specifies one or more 5GMSd features in the Provisioning Session. A set of authorized features is activated, such as consumption reporting, metrics reporting, dynamic policy, network assistance and content hosting (including ingest).

When the content hosting feature is offered and selected, the 5GMS Application Provider configures the content hosting behaviour of the 5GMSd AS. This Content Hosting Configuration is specified in clause 5.4 and includes selecting the ingest protocol and format, caching and proxying of media objects, content preparation, access protection (e.g. URL signing) and indicating a target distribution area (e.g. through geofencing).

When the dynamic policy feature is offered and selected, the 5GMSd Application Provider specifies a set of policies which can be invoked for the unicast downlink streaming session. The UE becomes aware of the selected policies in the form of a list of valid Policy Template Ids.

When the consumption reporting feature is offered and selected, the 5GMSd Application Provider indicates the desired reporting interval. When the 5GMSd Application Provider has delegated Service Access Information handling to the 5GMS System, then location reporting is also selected or de-selected.

When the metrics reporting feature is offered and selected, the 5GMSd Application Provider provides configuration input on the QoE post processing. When the 5GMSd Application Provider has delegated Service Access Information handling to the 5GMS System, then more detailed metrics reporting is configured.

5. When content hosting is desired, the 5GMSd AF interacts with the 5GMSd AS to allocate M2d resources and configure the ingest format. Then the 5GMSd AS responds with the M2d address. The 5GMSd AF selects the desired ingest format.
6. The 5GMSd AF compiles the Service Access Information. The Service Access Information contains access details and options such as the Provisioning Session identifier, M5d (Media Session Handling) addresses for consumption reporting, metrics reporting, dynamic policy, network assistance, etc. When content hosting is offered and has been selected in step 4, then also M4d (Media Streaming) information such as the DASH MPD is included.
7. The 5GMSd AF provides the results to the 5GMSd Application Provider.
  - a. When the 5GMSd Application Provider has selected full Service Access Information, then the results are provided in the form of addresses and configurations for M2d (Ingest), M5d (Media Session Handling) and M4d (Media Streaming).
  - b. When the 5GMSd Application Provider delegated the service access information handling to the 5GMS System, then a reference to the Service Access Information (e.g. an URL) is provided. The Media Session Handler fetches the full Service Access Information later from the 5GMSd AF.
8. When content hosting is offered and has been selected in step 4, the 5GMSd Application Provider can start supplying content at the M2d ingest interface. In the case of progressive download or on-demand DASH sessions, the 5GMSd Application Provider makes the content assets available. In the case of Live DASH streaming sessions, the 5GMSd Application Provider starts supplying the live content.
9. The 5GMSd Application Provider executes Service Announcement and updates the UEs (during the lifetime of the Provisioning Session).

## Optional:

10. The 5GMSd Application Provider may update the Provisioning Session.



Depending on the parameters of the Provisioning Session:

11. The 5GMSd AF may send event-related or periodic notifications to the 5GMSd Application Provider.

According to schedule, or upon request:

12. The 5GMSd Application Provider may manually terminate the Provisioning Session (at any time). All associated resources are released. Content may be removed from the 5GMSd AS. The 5GMSd Application Provider may configure a schedule for Provisioning Session termination.
13. The 5GMSd AF sends a notification upon Provisioning Session termination.

The 5GMSd AF may request the creation or reuse of one or more network slices for distributing the content of the provisioned session. If more than one network slice is provisioned for the distribution of the content of a session, the list of allowed S-NSSAIs shall be conveyed to the target UEs (e.g. through URSP or through M5d or M8d).

NOTE 2: The 5GMSd AS(s) serving the content are only accessible through the DNN(s) used by the network slice(s) provisioned for the distribution of that content.

## 5.4 Content Hosting Configuration for Downlink Media Streaming

### 5.4.1 General

The 5G Media Streaming architecture defines an interface (M2d) for provisioning which offers the procedures to configure content ingest for downlink media streaming over 5G. Once a Provisioning Session is established using the API at interface M1d, content hosting can be configured. The control part of the ingest interface may be performed through the NEF. Ingested content is accessible from the 5GMSd AS at interface M4d through a new location identifier.

The M2d interface supports the ingest of the following types of content:

- Live streaming content.
- On-demand streaming content.
- Static files such as images, scene descriptions, etc.

The 5GMSd AF provides an API at interface M1d that allows a 5GMSd Application Provider to create/update/delete an Content Hosting Configuration. A Content Hosting configuration contains all the parameters for a particular content ingest and distribution setup.

NOTE: In the current version of the present document, the M2d ingest interface only supports Unicast downlink streaming.

## 5.4.2 Media ingest procedure

The media ingest procedure is as follows:

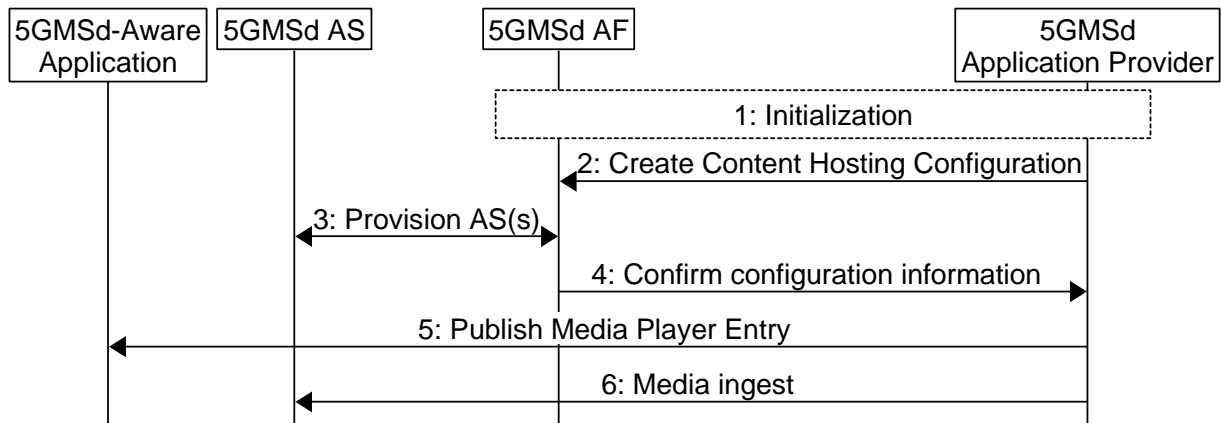

<http://msc-generator.sourceforge.net> v6.3.8

**Figure 5.4-1: Media Ingest procedure**

The steps are as follows:

- 1: Initialization:** the 5GMSd Application Provider discovers the entry point and authenticates itself with the 5GMSd AF.
- 2: Create Content Hosting Configuration:** the 5GMSd Application Provider creates a new Content Hosting Configuration for its content through the 5GMSd AF. The configuration specifies a domain name, supplies a certificate for HTTPS access to the content, sets the caching rules per media type, indicates the distribution area (e.g. through geofencing), distribution protocol, the desired content preparation, URL signing, etc. Upon successful configuration, the 5GMSd AF responds with a Content Hosting Configuration identifier, and the location of the 5GMSd AS to which to send the content (if using the push mode).
- 3: Provision 5GMSd AS(s):** The 5GMSd AF configures the related 5GMSd AS(s) to prepare for media ingest for that particular Content Hosting Configuration. This step may involve instructing the 5GMSd AS(s) to set appropriate caching rules, to perform URL signature validation and to limit access through geofencing. The 5GMSd AS(s) will respond whether the configuration is successful or not.
- 4: Confirm configuration information:** The 5GMSd AF communicates the Content Hosting Configuration of the 5GMSd AS(s) back to the 5GMSd Application Provider for further media push or pull.
- 5: Publish Media Player Entry:** The 5GMSd Application Provider shall then publish the Media Player Entry to the 5GMSd-Aware Application to enable access to the content.
- 6: Media ingest:** The 5GMSd AS(s) may start pulling or receiving content (if using push mode) from the 5GMSd Application Provider. The 5GMSd AS performs the requested content preparation prior to providing access to the content.

**NOTE:** Pull of media content from the external 5GMSd AS(s) may be triggered by a request from the 5GMSd Client.

The 5GMSd Application Provider may update a Content Hosting Configuration subsequently to modify some of its parameters. The subset of parameters that can be updated may be limited by the 5GMSd AF.

## 5.5 Metrics collection and reporting

### 5.5.1 General

Metrics collection and reporting can be done in different ways, depending on the relationship between the Service Provider and the Network Operator. The following clauses show simplified signalling examples for two different use-cases.

### 5.5.2 Out-of-band-controlled reporting procedure

In the first use-case, shown in Figure 5.5.2-1 below, the MNO is controlling the metrics reporting using the out-of-band configuration and reporting option. In this case the metrics are configured via the RAN and the 5G control plane.

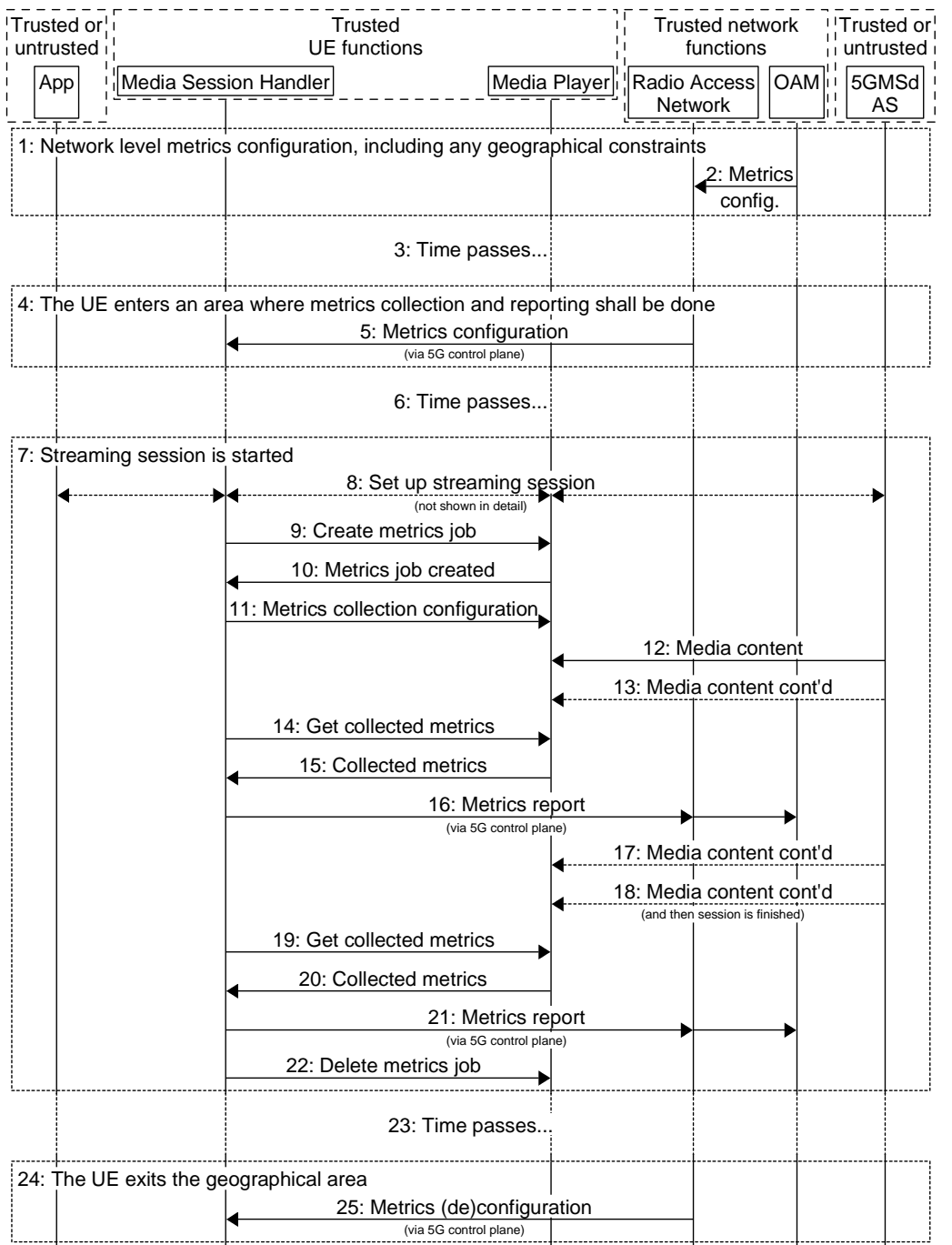

<http://msc-generator.sourceforge.net v6.3.8>

Figure 5.5.2-1: Metrics collection using the out-of-band 5G control plane option

The different steps are explained below:

- 1: Overall metrics configuration is done on the network level, for instance defining which geographical areas that shall have metrics collection active, and how often metrics shall be reported.
- 2: The metrics configuration(s) is/are sent from the OAM to the RAN, which does not forward that information to the UE at this stage.
- 3: Time passes, and it is assumed that the UE moves around during that period.
- 4: The UE enters an area (cell, location area, etc.,) which is inside the geographical constraint. This is discovered by the RAN, and it now needs to activate metrics reporting for the UE.
- 5: The actual metrics configuration is sent from the RAN to the Media Session Handler, via the 5G control plane.
- 6: Additional time passes, and the UE has a metrics configuration, but no streaming session has started.
- 7: A streaming session is started.
- 8: The session setup is done in conjunction with signalling transactions (not shown here).
- 9: A new metrics collection job is created in the Media Player.
- 10: A reference to the new metrics collection job is returned.
- 11: The configuration for the metrics collection job is sent to the Media Player (i.e. which metrics should be measured).
- 12: Media is delivered and rendered, and...
- 13: ...more media is delivered...
- 14: The configured metrics reporting interval has passed, and the Media Session Handler now requests the collected metrics from the Media Player.
- 15: The Media Player returns the collected metrics.
- 16: The metrics are reported via the 5G control plane.
- 17: The session continues...
- 18: more media is delivered, and then the session is finished.
- 19: The Media Session Handler requests the final metrics collected.
- 20: The Media Player returns the final collected metrics.
- 21: The metrics are reported to the OAM via the 5G control plane.
- 22: The metrics collection job is deleted.
- 23: Time passes, the UE moves around.
- 24: The UE leaves the geographical area specified by the metrics configuration.
- 25: The RAN sends metrics (de)configuration to the UE, to stop future metrics collection.

### 5.5.3 In-band-controlled reporting procedure

The second use-case, shown in figure 5.5.3-1 below, illustrates a scenario where the metrics collection is configured in-band. Thus, together with the media, there are metadata which describe how metrics shall be collected and how they shall be reported. The Media OAM and 5GMSd AS functions can both be either trusted or untrusted (but not mixed).

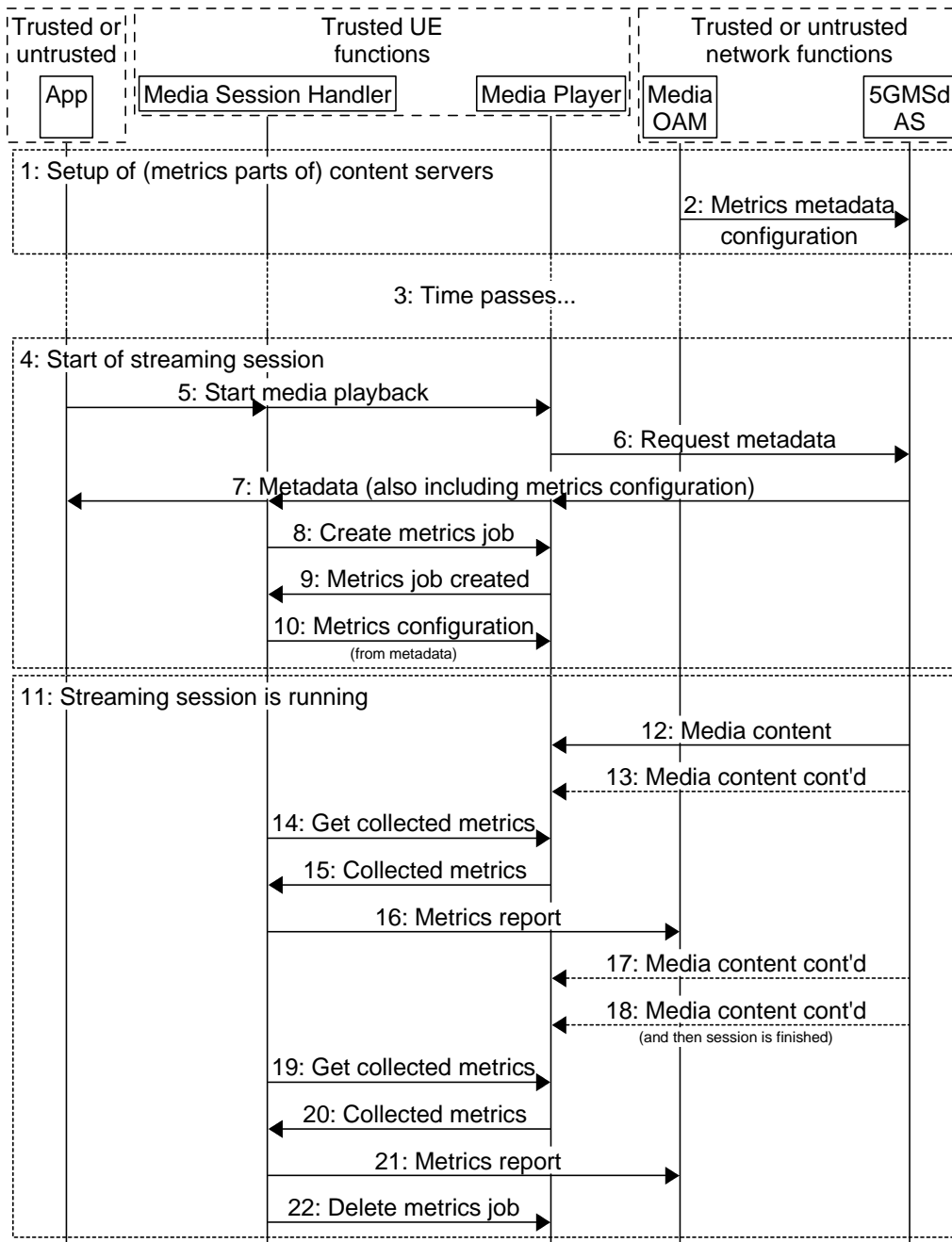

<http://msc-generator.sourceforge.net> v6.3.8

**Figure 5.5.3-1: Metrics collection using the in-band metadata option**

The different steps are explained below:

- 1: The content servers are set up, including any metrics configuration.
- 2: If the Media OAM and 5GMSd AS are located in a trusted domain, metadata regarding the metrics collection and reporting are sent to the 5GMSd AS.

NOTE: The procedure for configuring the 5GMSd AS in the case when the Media OAM and 5GMSd AS reside in an untrusted domain is unspecified.

- 3: Time passes during which no streaming session is active...
- 4: A streaming session starts.
- 5: The App and the Media Session Handler initialize a new session.
- 6: The Media Player requests any metadata from the 5GMSd AS which is needed for downloading the media content.
- 7: Metadata is returned to the Media Player and also forwarded to the Media Session Handler and (potentially) to the App.
- 8: A new metrics job is created in the Media Player.
- 9: A reference to the new metrics job is returned.
- 10: Based on the metadata, the configuration for the metrics collection job is sent to the Media Player (i.e. specifying which metrics should be measured).
- 11: The streaming session is running.
- 12: Media is delivered and rendered, and...
- 13: more media is delivered...
- 14: The configured metrics reporting interval has passed, and the Media Session Handler now requests the collected metrics from the Media Player.
- 15: The Media Player returns the collected metrics.
- 16: The metrics are reported according to the reporting method defined in the configuration, for instance HTTP upload.
- 17: The session continues...
- 18: more media is delivered, and then the session is finished.
- 19: The Media Session Handler requests the final metrics collected.
- 20: The Media Player returns the final collected metrics.
- 21: The metrics are reported.
- 22: The metrics collection job is deleted.

## 5.5.4 Metrics collection configuration parameters

Table 4.2.3-4 in clause 4.2.3 describes the metrics collection configuration parameters used in step 5 of Figure 5.5.2-1 and step 7 of Figure 5.5.3-1. Note that some of the parameters are only relevant for a specific reporting option, as shown in Table 5.5.4-1 below.

**Table 5.5.4-1: Metrics collection configuration parameters and options**

Parameters	Out-of-band-controlled reporting	In-band-controlled reporting
Server address		X
DNN		X
Reporting interval	X	X
Sample percentage	X	X
Streaming source filter	X	
Metrics	X	X

## 5.6 Consumption reporting

### 5.6.1 Consumption reporting procedure

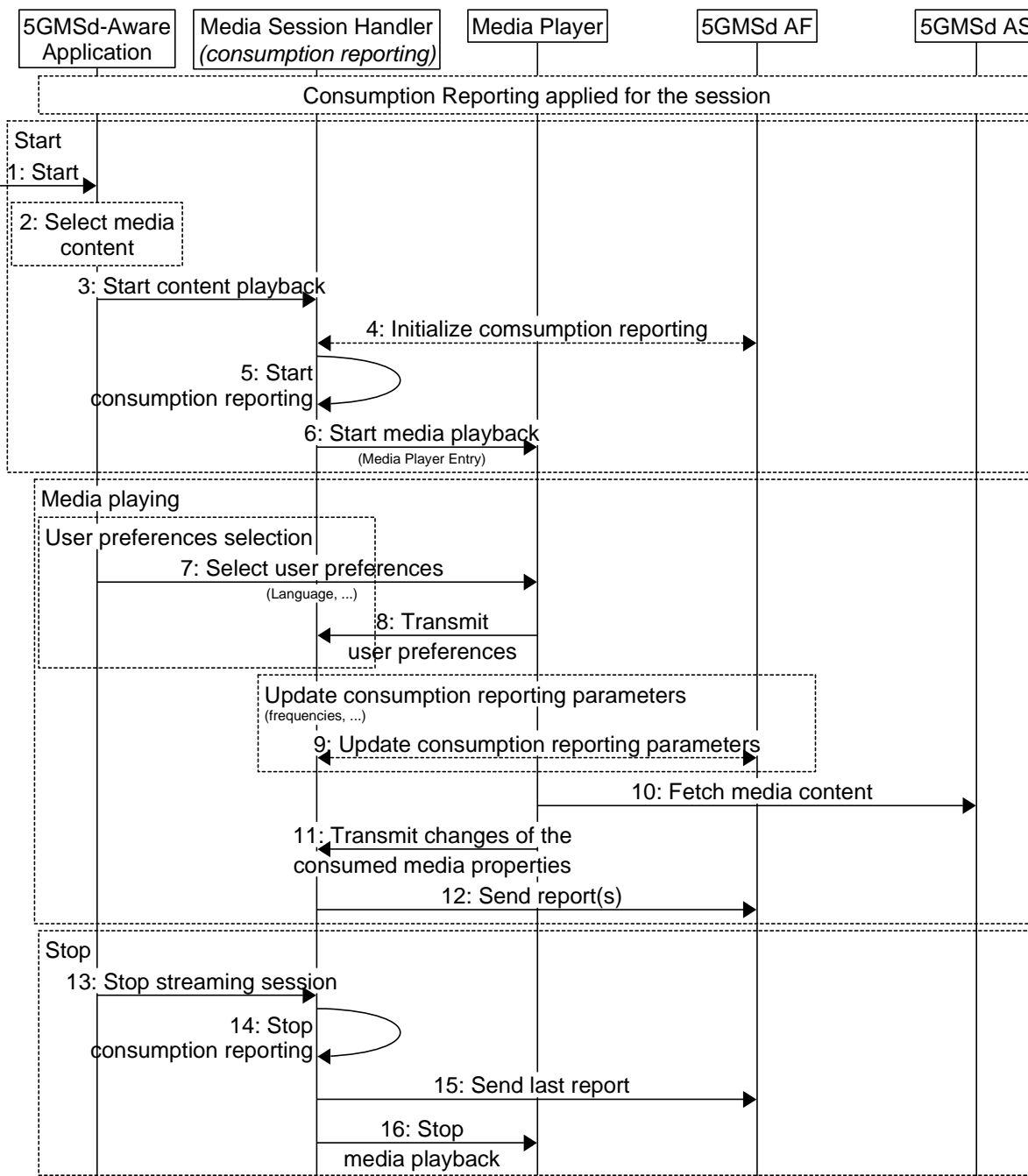

<http://msc-generator.sourceforge.net> v6.3.8

Figure 5.6-1: Consumption reporting

Steps:

The first phase is the initialisation phase:

- 1: The 5GMSd-Aware Application is started.
- 2: A media content item is selected.
- 3: The 5GMSd-Aware Application triggers the Media Session Handler to start content playback. The Media Player Entry is provided.
- 4: The 5GMSd AF initializes the parameters for the consumption reporting configuration (e.g. frequency).
- 5: The Media Session Handler triggers consumption reporting.
- 6: The Media Session Handler starts the Media Player with the Media Player Entry.

The second phase is media playback:

The user preferences may be changed:

- 7: The 5GMSd-Aware Application selects/changes the user preferences.
- 8: The Media Player transmits consumption reporting user preferences to the Media Session Handler.

When media is playing, the consumption reporting parameters may be updated.

- 9: The 5GMSd AF updates the consumption reporting parameters.

When media is playing:

- 10: The Media Player regularly accesses to the media content.
- 11: In case of changes to the consumed media properties, the Media Player transmits the changes to the Media Session Handler.
- 12: The Media Session Handler regularly sends report(s) to the 5GMSd AF.

The last phase is to stop the media:

- 13: The 5GMSd-Aware Application triggers the Media Session Handler to stop content playback.
- 14: The Media Session Handler stops consumption reporting.
- 15: The Media Session Handler may send final consumption report(s) to the 5GMSd AF.
- 17: The Media Session Handler stops the Media Player.



## 5.6.2 Consumption reporting parameters

Table 4.2.3-2 describes the parameters used in step 4 of clause 5.6.1.

Table 5.6.2-2 below describes the additional parameters used in steps 13 or 16 of clause 5.6.1.

**Table 5.6.2-2: Additional consumption reporting parameters**

Parameters	Description
Media Player Entry pointer	Identify the Media Player Entry. In the case of DASH, the Media Player Entry pointer can be a URL of the MPD.
Consumption reporting client ID	Identify the identifier of the UE that consumes the data.
Location type	Identify the UE location type. This parameter is only used when the location reporting is enabled for the UE or for the Downlink Streaming session with a condition that the UE allows to share its location within operator's trust domain. The location type can be CGI, ECGI or NCGI as defined in TS 23.003 [9].
Location	Identify the UE location. This parameter is only used when location reporting is enabled for the UE or for the Downlink Streaming session, and when the UE allows its location to be shared within the Network Operator's trust domain.
Media consumed	Identifies the media consumed. In the case of DASH, the AdaptationSet@id may be used.
Start time	The time when media consumption started.
Duration	The duration of media consumption relative to the start time.

## 5.6.3 Triggering consumption reporting

If consumption reporting is supported and activated, the 5GMSd Client shall send a consumption report when any of the following conditions is met:

- Start of 5GMS consumption of a Downlink Streaming session;
- Stop of 5GMS consumption of a Downlink Streaming session;
- Upon determining the need to report ongoing 5GMS consumption
  - Reports are sent at periodic intervals determined by the reporting interval attribute of the consumption reporting configuration specified in Table 4.2.3-2.
- Upon determining a location change if location reporting is requested by the 5GMSd AF and is allowed to be reported by the UE.

**NOTE:** Whenever a consumption report is sent, the 5GMSd Client is expected to reset its corresponding reporting interval timer to the value of that attribute and begin countdown of the timer. Whenever the 5GMSd Client stops consumption of the same session, it is expected to disable its corresponding reporting interval timer.

## 5.7 Establishing a Unicast Downlink Media Streaming Session with 5GMSd AF interactions for dynamic policy updates

### 5.7.1 General

This clause describes the provisioning for dynamic policy invocation and the establishment of a unicast downlink streaming session using the dynamic policy API. The establishment of the unicast downlink media streaming session uses 5GMSd AF interactions, as described in Steps 4 to 8 of clause 5.1. The dynamic policy API allows separate handling of application flows within the same PDU Session. The Media Session Handler provides a Policy Template Id

together with a Flow Description when requesting a dynamic policy. An example Policy Template Id value is “background\_data”.

The Media Session Handler provides needed information to the 5GMSd AF, so that the 5GMSd AF can combine the semi-static parameters from a Policy Template (which is associated with the Policy Template Id) with the API parameters to trigger a dynamic PCC rule update using the NEF or PCF.

The 5GMSd AF may trigger, for example, the “AF session with required QoS procedure” (see TS 23.502 [3] clause 4.15.6.6) for updating QoS related dynamic PCC rules. For changing charging related rules, the 5GMSd AF may trigger the “Change the chargeable party during the session” procedure (see TS 23.502 [3] clause 4.15.6.5).

### 5.7.2 Provisioning

The provisioning for the dynamic policy procedure follows generally the procedure from clause 5.3. Specifically, the Dynamic Policy feature is activated and, as result, the 5GMSd Application Provider is able to provision one or more Policy Templates.

The domain model of M1d and M5d APIs is depicted in Figure 5.7.2-1. Realization of the dependencies between M1d and M5d data entries are up to implementation.

NOTE: Multiple M5d 5GMSd AF nodes may reference the same M1d resource.

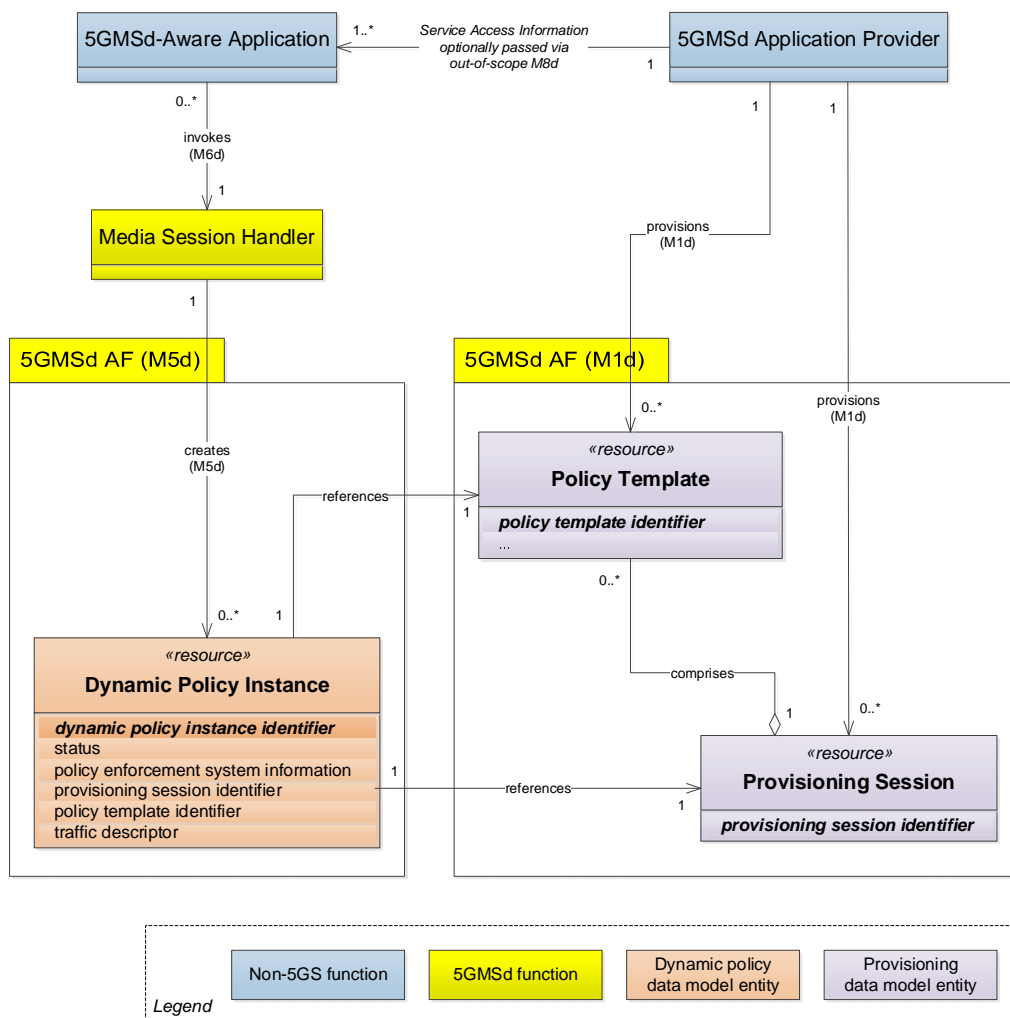

Figure 5.7.2-1: Domain model for dynamic policies

A Policy Template is identified by a Policy Template Id and contains semi-static parameters, including the API entry for the PCF/NEF interactions. The list of provisioned Policy Template Ids is communicated as valid Policy Template

Ids to the Media Session Handler. The Media Session Handler uses one of the valid Policy Template Ids when invoking a dynamic policy.

### 5.7.3 Progressive Download of On-Demand Content

This procedure describes the establishment of a unicast downlink media media streaming session with 5GMSd AF interactions for dynamic policy updates. A streaming session may use 3GP File Format (Progressive Download), 3GP Timed Text or other (potentially non-3GPP defined) formats.

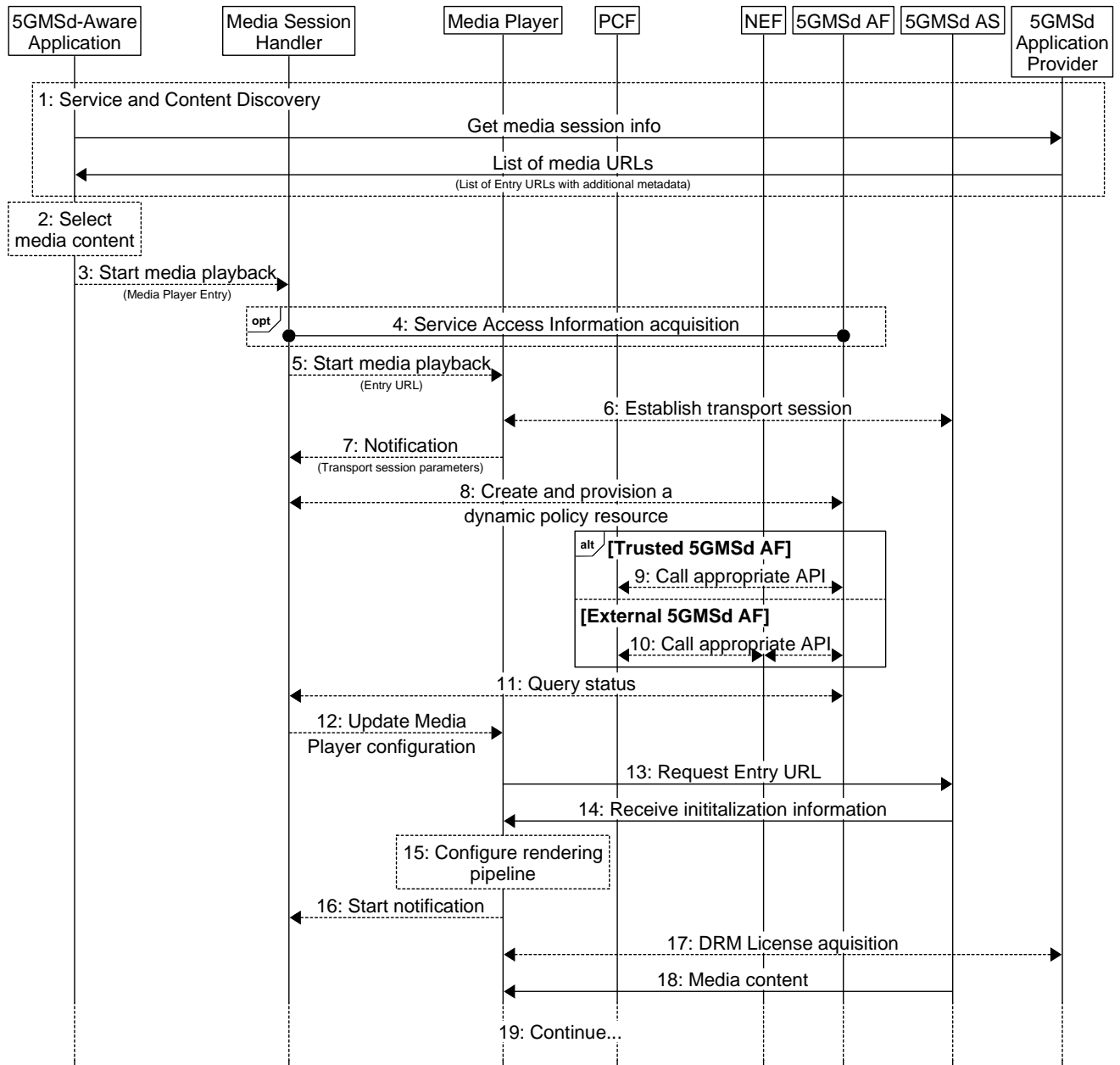

<http://msc-generator.sourceforge.net v6.3.8>

Figure 5.7-1: High Level Procedure for progressive download for on-demand media

## Prerequisites:

- The 5GMSd Application Provider has provisioned the 5G Media Streaming System and has set up content ingest.
- The 5GMSd-Aware Application has received the Service Announcement from the 5GMSd Application Provider.
- The Service Access Information contains detailed information for the policy related interactions. Specifically, the information includes URL(s) for the 5GMSd AF, an identifier of the 5GMS Provisioning Session and a list of authorized Policy Type indications for that specific application.
- The 5GMSd Application Provider has agreed an SLA with the Network Operator defining the possible QoS levels and their charging rates (see TS 23.503 [4] clause 6.1.3.22). The PCF is configured with the corresponding QoS parameters and charging information.

## Steps:

- 1: The 5GMSd-Aware Application triggers the Service Announcement and Content Discovery procedure. The Service Announcement includes either the whole Service Access Information (i.e. details for Media Session Handling (M5d) and for Media Streaming access (M4d)) or a reference to the Service Access Information. The configuration parameters are listed in Table 5.7.4-1.

NOTE: The Service and Content Discovery procedure only involves the App and the external Application Server, and hence is out of scope of the present document.

- 2: A Media Player Entry is selected.
- 3: The 5GMSd-Aware Application triggers the Media Session Handler to start media playback. The Media Player Entry is provided to the Media Session Handler.
- 4: When the 5GMSd-Aware Application has received a reference to the Service Access Information (see step 1), the Media Session Handler interacts with the 5GMSd AF to acquire the whole Service Access Information.
- 5: The Media Session Handler triggers the Media Player to start the session.
- 6: The Media Player establishes the transport session, e.g. a TCP connection.
- 7: The Media Player notifies the Media Session Handler about the Flow description(s) of the transport session established in the previous step (see TS 23.502 [3]), e.g. the 5-tuple.
- 8: The Media Session Handler requests that a dynamic policy be applied to the media session. The request includes at least the Provisioning Session identifier, the Flow description(s) and the Policy Template identifier (see Table 5.7.4-1) to be applied to the described transport session. The 5GMSd AF uses the Policy Template indication for the related procedure and to identify the related network function.
- 9: This step applies when the 5GMSd AF resides in the trusted Data Network. Depending on the Policy Template, the step is executed either:
  - a. When the Policy Template relates to QoS, the 5GMSd AF may either directly interact with the PCF or may use a NEF service:
    - when directly interacting with the PCF, the 5GMSd AF uses the Npcf\_PolicyAuthorization Service as defined in TS 23.502 [3] clause 5.2.5.3).
    - when interacting via the NEF with the PCF, continue at step 10a.
  - b. When the Policy Template relates to a different charging scheme, the 5GMSd AF may either directly interact with the PCF or may use a NEF service:
    - when directly interacting with the PCF, the 5GMSd AF uses the Npcf\_PolicyAuthorization Service as defined in TS 23.502 [3] clause 5.2.5.3).
    - when interacting via the NEF with the PCF, continue at step 10b.

- 10: This step applies when the 5GMSd AF resides in the external Data Network. Depending on the Policy Template, the step is executed either:
- a. When the Policy Template relates to QoS, the 5GMSd AF may use the Nnef\_AFsessionWithQoS service as defined in TS 23.502 [3] clause 5.2.6.9. (The complete call flow is described in TS 23.502 clause 4.15.6.6.)
  - b. When the Policy Template relates to a different charging scheme, the 5GMSd AF may use the Nnef\_ChargeableParty service as defined in TS 23.502 [3] clause 5.2.6.8. (The complete call flow is described in TS 23.502 clause 4.15.6.4 and clause 4.15.6.5.) The Policy Template may contain the Sponsor Information (values, based on SLA negotiation) and Background Data Transfer Reference ID. The Flow description is provided by the Media Session Handler at API invocation.
- 11: The Media Session Handler queries the status of the dynamic policy invocation. The response contains status information (policy accepted, rejected, etc) and information on policy enforcement.
- 12: The Media Session Handler notifies the Media Player according to the response from the 5GMSd AF (see Table 5.6.4-2).
- 13: The Media Player sends the request for the progressive download content.
- 14: The Media Player receives the initialization information of the progressive download content. The initialization information contains configuration parameters for reception of the media, and optionally also DRM information.
- 15: The Media Player configures the rendering pipeline for media playback.
- 16: The Media Player notifies the Media Session Handler, providing the transport session information and some media content related information.
- 17: Optional: Media Player acquires a DRM License from as the 5GMSd Application Provider.
- 18: The Media Player receives media content and puts it into the rendering pipeline.
- 19: The Media Player continues to receive and play back the media content.

### 5.7.4 DASH Streaming

It is assumed here that the key information to initialize the media decoding and rendering pipeline is present in the Media Player Entry (or referenced by the Media Player Entry). The intention is to provide the client with information to setup the media decoding and rendering pipeline in such a way that no pipeline reset is needed during the session. Implementations need to consider that parts of the information are provided with the initialization segments.

It is assumed that the client is enabled to use the same media decoding and rendering pipeline during the session.

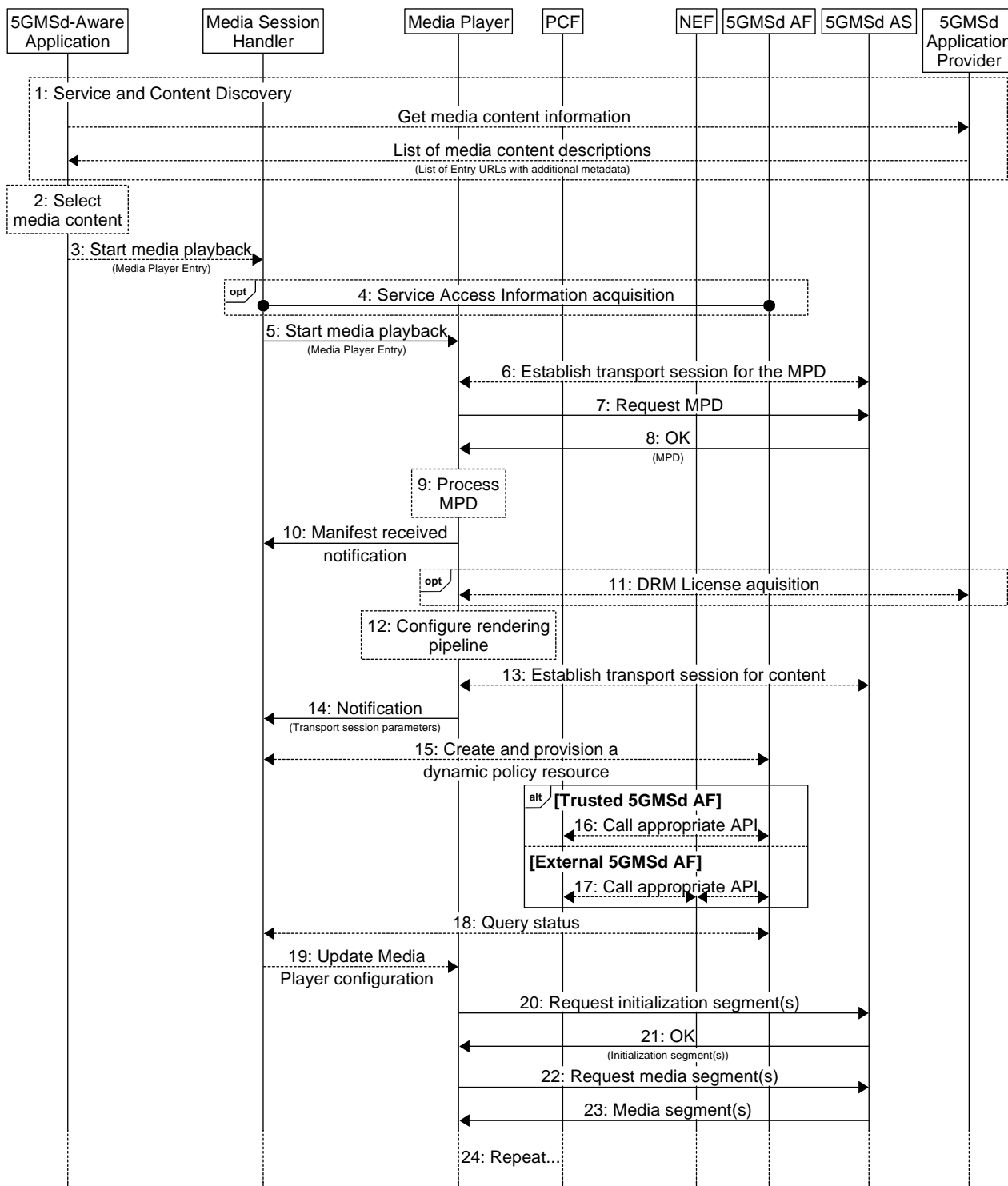

<http://msc-generator.sourceforge.net v6.3.8>

Figure 5.7-2: High Level Procedure for DASH content

## Prerequisites:

- The 5GMSd Application Provider has provisioned the 5G Media Streaming System and has set up content ingest.
- The 5GMSd-Aware Application has received the service announcement from the 5GMSd Application Provider.
- The Service Announcement Information contains detailed information for the policy related interactions. Specifically, the information includes URLs for the 5GMSd AF, an identifier of the Provisioning Session and a list of authorized Policy Type indications for that specific application.
- The 5GMSd Application Provider has agreed an SLA with the Network Operator defining the possible QoS levels and their charging rates (see TS 23.503 [4] clause 6.1.3.22). The PCF is configured with the corresponding QoS parameters and charging information.

## Steps:

- 1: The 5GMSd-Aware Application triggers the Service Announcement and Content Discovery procedure. The Content Discovery procedure only involves the App 5GMSd-Aware Application and the 5GMSd Application Provider. The Service Announcement includes either the whole Service Access Information (i.e. details for Media Session Handling (M5d) and for Media Streaming access (M4d)) or a reference to the Service Access Information. The configuration parameters are listed in Table 5.7.4-1.
- 2: A media content item is selected.
- 3: The 5GMSd-Aware Application triggers the Media Session Handler to start media playback. The Media Player Entry is provided to the Media Session Handler.
- 4: When the 5GMS-Aware Application has received only a reference to the Service Access Information (see step 1), the Media Session Handler interacts with the 5GMSd AF to acquire the whole Service Access Information.
- 5: The Media Session Handler triggers the Media Player to start the session.
- 6: The Media Player establishes a transport session for acquiring the MPD referenced by the Media Player Entry.
- 7: The Media Player requests the MPD.
- 8: The Media Player receives the MPD.
- 9: The Media Player processes the MPD. It determines, for example, the number of needed transport sessions for media acquisition. The Media Player should be able to use the MPD information to initialize the media pipelines for each media stream. The MPD should also contain information to start the DRM client initialization, when DRM is used.
- 10: The Media Player notifies the Media Session Handler about the MPD. The notification may contain parameters from the MPD.
- 11: (Optional) the Media Player acquires the necessary DRM information, for example a DRM License.
- 12: The Media Player configures the media rendering pipeline.
- 13: The Media Player establishes the necessary transport session(s) for acquiring the content. For example, the Media Player may establish one transport session for each media component (audio, video, etc) and possibly additional transport sessions for other media representations.
- 14: The Media Session Handler is notified about the established transport session(s) for the content by providing the description of the application flows e.g. 5-tuples.
- 15: The Media Session Handler requests that a dynamic policy be applied to the media session. The request includes at least the Provisioning Session identifier, the Flow description(s) and the Policy Template identifier (see Table 5.7.4-1), to be applied to the described transport session. The 5GMSd AF uses the Policy Template for the related procedure and to identify the related network function.

- 16: This step applies when the 5GMSd AF resides in the trusted Data Network. Depending on the Policy Template, the step is executed either:
- a. When the Policy Template relates to QoS, the 5GMSd AF may either directly interact with the PCF or may use a NEF service:
    - when directly interacting with the PCF, the 5GMSd AF uses the Npcf\_PolicyAuthorization Service as defined in TS 23.502 [3] clause 5.2.5.3).
    - when interacting via the NEF with the PCF, continue at step 17a.
  - b. When the Policy Template relates to a different charging scheme, the 5GMSd AF may either directly interact with the PCF or may use a NEF service:
    - when directly interacting with the PCF, the 5GMSd AF uses the Npcf\_PolicyAuthorization Service as defined in TS 23.502 [3] clause 5.2.5.3).
    - when interacting via the NEF with the PCF, continue at step 17b.
- 17: This step applies when the 5GMSd AF resides in the external Data Network. Depending on the Policy Template, the step is executed either:
- a. When the Policy Template relates to QoS, the 5GMSd AF may use the Nnef\_AFsessionWithQoS service as defined in TS 23.502 [3] clause 5.2.6.9. (The complete call flow is described in TS 23.502 clause 4.15.6.6.)
  - b. When the Policy Template relates to a different charging scheme, the 5GMSd AF may use the Nnef\_ChargeableParty service as defined in TS 23.502 [3] clause 5.2.6.8. (The complete call flow is described in TS 23.502 clause 4.15.6.4 and clause 4.15.6.5.) The Policy Template may contain the Sponsor Information (values, based on SLA negotiation) and Background Data Transfer Reference ID. The Flow Description is provided by the Media Session Handler at API invocation.
- 18: The Media Session Handler queries the status of the dynamic policy invocation. The response contains status information (policy accepted, rejected, etc) and information on policy enforcement.
- 19: The Media Session Handler updates the configuration of the Media Player according to the response from the 5GMSd AF (See Table 5.6.4-2).
- 20: The Media Player requests a DASH initialization segment. The Media Player repeats this step for each required initialization segment.
- 21: The Media Player receives the initialization segments.
- 22: The Media Player requests DASH media segments according to the MPD.
- 23: The Media Player receives media segments and feeds them into the appropriate media rendering pipeline.
- 24: Previous steps are repeated according to the MPD information.

## 5.7.5 Parameters for dynamic policy invocation configuration

**Table 5.7.5-1: Status information dynamic policy**

Parameters	Description
Status	Status of a dynamic policy. A dynamic policy has the status granted or rejected. The status of a policy may change while the streaming session is active.
Policy Enforcement	Information about the policy enforcement system.



## 5.8 Dynamic Policy based on Network Slicing for Downlink Media Streaming

### 5.8.1 Procedure

The 5GMSd Application Provider requests the assignment of more than one network slice for the distribution of the service. The 5GMSd Application Provider indicates the desired network slice features that correspond to the Service Access Information. Upon successful assignment of the network slices for the service, the 5GMSd AF shall respond with the list of allowed S-NSSAIs to the 5GMSd Application Provider.

Figure 5.8.1-1 is the flowchart diagram for this procedure.

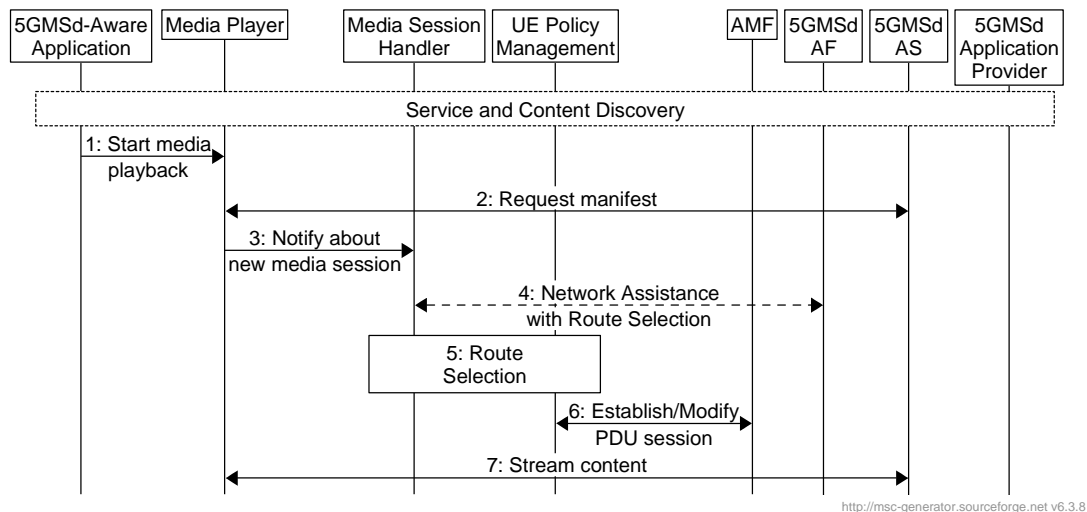

**Figure 5.8.1-1 Dynamic Policy based on Network Slicing for Downlink Streaming**

Pre-requisites:

1. The UE knows how to access the network slice(s) associated with a particular Provisioning Session.
2. The 5GMSd AS(s) serving the content for the particular Provisioning Session shall be accessible through the DNN(s) associated to the network slice(s) provisioned for the distribution of that content.

The steps are as follows:

1. The 5GMSd-Aware Application triggers media playback by invoking the Media Player with the Media Player Entry for the selected content.
2. The Media Player requests the manifest from the 5GMSd AS.
3. The Media Player notifies the Media Session Handler about the upcoming media session and may request specific network assistance for that session, when not already established.
4. The Media Session Handler retrieves information from the 5GMSd AF to assist with the route selection for the session. This may include information about the network slices, the DNNs, any pre-authorized QoS guarantees for that Provisioning Session. The Media Session Handler gets information about the operation selection from the Media Player as described in step 4.
5. The Media Session Handler and the UE Policy Management in the UE perform the route selection procedure using information such as the playback operation point, the traffic descriptors. The UE Policy Management will use the matching filter to retrieve the Route Selection descriptor, which provides the DNN, and the S-NSSAI(s), identifying the network slice(s) to be used for this Provisioning Session.
6. The UE reuses an existing PDU session with the selected S-NSSAI and DNN from step 5, or requests the establishment of a new PDU session with the identified parameters, if one doesn't exist already.
7. The streaming of the media content at the target operation point starts.

## 5.9 Downlink Network Assistance

### 5.9.1 Introduction

The Network Assistance (NA) feature enables a UE that is receiving a downlink media stream to improve the QoE of the media streaming session, by being able to make use of two distinct facilities.

The first facility is **throughput estimation**. This enables the UE to start a downlink streaming session at the most appropriate bit rate for the network conditions at hand, or to obtain a recommendation from the network for an upcoming nominal time period during a media streaming session. This function is provided as an additional tool to support the UE, in addition to the common approach of the UE performing its own estimation based on measurement of the downlink traffic in the past.

The second facility is the **delivery boost**. The 5GMS Client uses this function to indicate to the network that a temporary boost, i.e. a temporary increase of network throughput for this client, would be needed in order to avoid the risk of media playback stalling due to buffer under-run, which could otherwise occur during the next media segment or soon after. Throughput boosting may also be used at the start of a playback session to shorten the time to start media playback, giving a better experience for the user.

Network Assistance may be offered to the UE in one of two ways:

- Based on interaction between the UE and the 5GMSd AF, with a subsequent interaction between the 5GMSd AF and the PCF (or the NEF);
- Based on interaction between the UE and the RAN, re-using the ANBR RAN-layer signalling.

The UE shall not use both approaches on the same network assistance session.

Figure 5.9.1-1 depicts the Network Assistance feature in the context of the 5GMS architecture, showing the scope of both approaches.

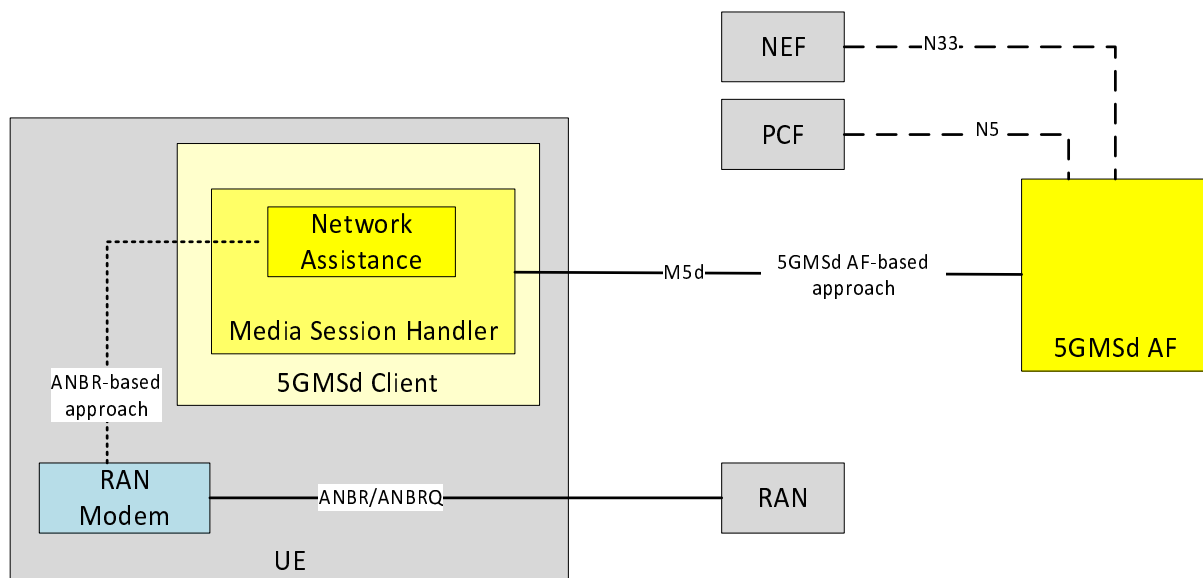

**Figure 5.9.1-1: Downlink Network Assistance alternative approaches**

### 5.9.2 5GMSd AF-based downlink Network Assistance

The Network Assistance (NA) feature enables a UE to receive a bit rate recommendation from the 5GMSd AF that provides the NA server function. The 5GMSd AF provides the response with an estimation of throughput, or the recommendation of a bit rate, for the ensuing nominal time period. The UE uses this estimation to derive the most suitable bit rate for its downlink content session from the versions that might be available. The network is expected to commit resources to be able to fulfill the recommendation, although no guarantee for the bandwidth estimation can be

assumed. The 5GMSd Client may provide additional information, such as available media versions, in terms of the required bit rates, to the 5GMSd AF.

The second facility is the delivery boost. The 5GMSd Client uses this function to indicate to the network that a temporary boost, i.e. a temporary increase of network throughput for this client, is needed.

Each interaction for the 5GMSd AF-based downlink Network Assistance procedures consists of two steps in sequence:

1. Between the UE (Media Session Handler) and the 5GMSd AF using a 5GMS API at interface M5d;
2. Between the 5GMSd AF and the PCF (or the NEF):
  - using the Npcf\_PolicyAuthorization procedure or Nnef\_AFSessionWithQoS procedure to request modification of the PDU session with the requested QoS information.
  - using the Npcf\_PolicyAuthorization notification service or Nnef Monitoring Event procedure to receive QoS changes. The 5GMSd AF receives these policy change notifications asynchronously.

Network Assistance is performed within dedicated NA sessions that are a part of the Media Session Handler procedures. Only 5GMSd Clients that have been granted an NA session by the 5GMSd AF may execute the NA bit rate recommendation and boost request procedures. This enables the 5GMSd AF to enforce policies that could include the access to NA by certain 5GMSd Clients only, such that authorisation to use NA facilities can be verified once at the granting of an NA session, and does not need to be verified for each NA request from the 5GMSd Client.

The procedures for 5GMSd AF-based downlink Network Assistance are:

1. NA session initiation. The 5GMSd Client requests to initiate an NA session with the 5GMSd AF. If the request fulfils any pre-requisites for access to NA functionality, for example policy and charging, then the 5GMSd AF responds with a confirmation that the NA session has been established.
2. NA throughput estimation. The 5GMSd Client requests a throughput estimation for a downlink media session from the 5GMSd AF. A unique identifier for the downlink media session is provided by the 5GMSd Client.

If the set of available bit rates in the downlink media session is provided with the request then the 5GMSd AF responds with the recommended bit rate based on its throughput estimation. If the throughput estimation is lower than the lowest value from the set of available bit rates, then the actual throughput estimation is provided.

If no set of available bit rates is provided with the request then the 5GMSd AF responds with the throughput estimation.

3. NA delivery boost. The 5GMSd Client requests from the AF a downlink delivery boost. A unique identifier for the downlink media session is provided by the 5GMSd Client.
4. NA session termination. The 5GMSd Client requests to terminate an NA session with the 5GMSd AF. The unique identifier of the NA session to be terminated is provided by the 5GMSd Client.

The AF responds positively if the indicated session could be terminated, and negatively otherwise.

### 5.9.3 ANBR-based downlink Network Assistance

This approach for the downlink Network Assistance feature is based upon the exchange of the bit rate recommendation message and bit rate recommendation query message between the RAN and UE as described in TS 38.321 [9]. In this case the Network Assistance function in the 5GMSd Client utilises a UE-internal facility to access the RAN modem driver to access ANBR signalling operations and to receive corresponding responses from the network. Hence, this control interface is outside the scope of the 5GMS architecture.

The RAN in this architecture contains control plane and user plane entities that interact with peer control plane and user plane entities in the UE.

- The control plane interactions involve the sending by the RAN of downlink bit rate recommendations to the UE, which may occur either independently, or in response to a boost request from the UE, via the exchange of the bit rate recommendation message and bit rate recommendation query message between the RAN and UE as described in TS 38.321 [9]. This control interface is outside the scope of the 5GMS architecture.
- The user plane interaction pertains to downlink streaming media transport over interface M4d.

---

## 6 Procedures for Uplink Media Streaming

### 6.1 General

The procedures for uplink media streaming allow a system user to create, modify, establish and delete sessions. Uplink media streaming sessions exist between a 5GMSu Client and a 5GMSu AS. The term **Sink Configuration** refers to the provisioned parameters of a 5GMSu AS. The term **Source Session** refers to the provisioned parameters in the 5GMSu Client.

The uplink streaming procedures follow a general high-level workflow, starting from provisioning to the actual uplink streaming sessions. The egest session refers to the time during which media content is uplink streamed into the 5GMSu AS. The provisioning session refers to the time period during which the 5GMSu Client is permitted to uplink stream media content. Interactions between the 5GMSu AF and the 5GMSu Application Provider may occur at any time while the Provisioning Session is active.

The 5GMSu Provisioning API allows selection of Media Session Handling (M5u) and Uplink Streaming (M4u) options, including whether the media content is published to trusted 5GMSu ASs. The 5GMSu AF selects the M5u interface according to the provisioning option. The Media Session Handling interface can be used for remote control, metrics reporting, requesting different policy and charging treatments or other Network Assistance services.

When the 5GMSu AF and AS are in the same DN, then the 5GMSu AF selects the 5GMSu AS. Interactions between a 5GMSu AF and a 5GMSu AS (M3u interactions) take place for 5GMS Egest (M2u) and Uplink Streaming (M4u) resource reservations. The 5GMSu AS allocates M2u and M4u resources and communicates resource identifiers back to the 5GMSu AF. The 5GMSu AF provides information about the provisioned resources (in the form of resource identifiers) for Media Session Handling, Egest and Uplink Streaming to the 5GMSu Application Provider. The resource identifiers for Media Session Handling and Uplink Streaming are needed by the 5GMSu Client to access the selected features.

When 5GMSu AF and 5GMSu AS are operated by different providers, then the M3u interface is not used and the 5GMSu AF does not provide 5GMS Egest (M2u) and Uplink Streaming (M4u) resource reservations. M3u procedures are not specified.

5GMSu Client can (in principle) start the uplink streaming by activating its uplink streaming session. The uplink streaming session for a given UE (or for each UE) is active from the time at which the 5GMSu-Aware Application activates the transmission of an uplink streaming service until its termination.

The 5GMSu-Aware Application receives application metadata from the 5GMSu Application Provider before transmitting the uplink streaming media. The application metadata contains Service Access Information, which acts as an entry point for the 5GMSu Client to start the uplink streaming session. The 5GMSu Client may either receive the Service Access Information from the 5GMSu Application Provider (using a not standardized interface) or instructions for a remote control session. When remote control is activated, then the 5GMSu Client is remotely configured and controlled by a 5GMSu AF.

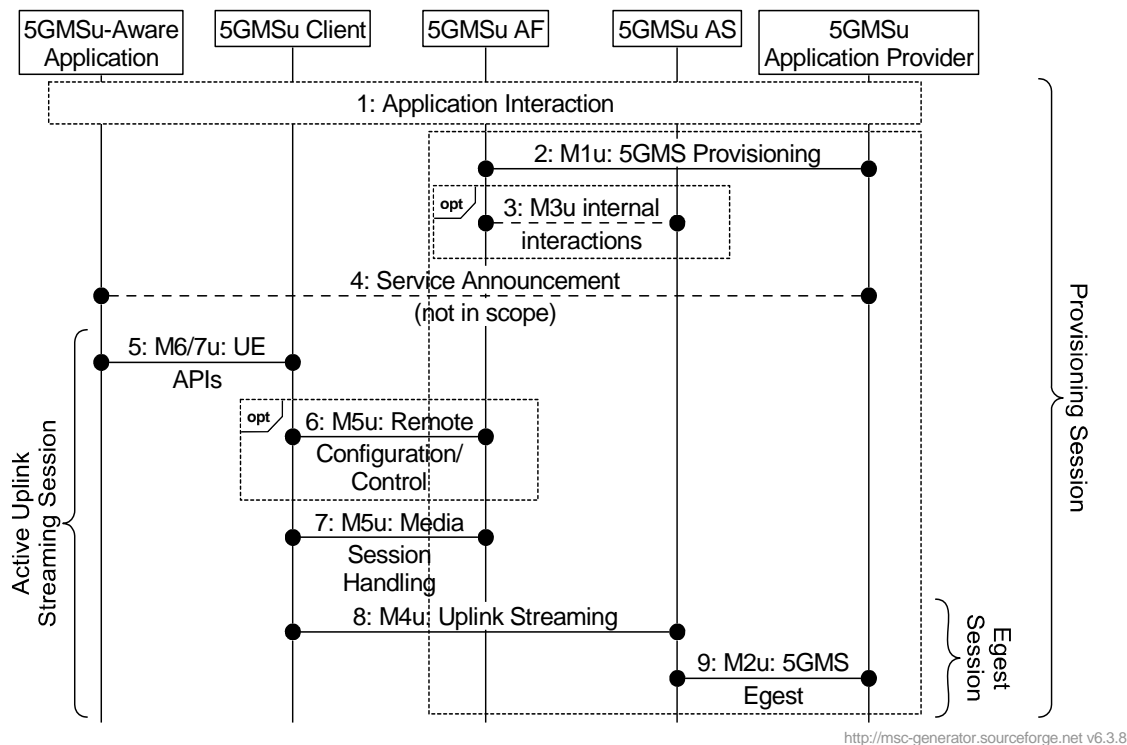

**Figure 6.1-1: High Level Procedure for uplink streaming**

Steps:

1. The 5GMSu Application Provider creates a Provisioning Session and starts provisioning the usage of the 5G Media Streaming System. During the establishment phase, the used features are negotiated and detailed configurations are exchanged. The 5GMSu Application Provider receives Service Access Information for M5u (Media Session Handling) and, when media content reception is negotiated, Service Access Information for M2u (Egest) and M4d (Uplink Streaming). This information is needed by the 5GMSu Client to access the service. Depending on the provisioning, only Remote Configuration information may be provided.
2. When the 5GMSu AF and the 5GMSu AS are operated by the same provider (e.g. the MNO), there may be interactions between the 5GMSu AF and 5GMSu AS, e.g. to allocate 5GMSu egest and uplink streaming resources. The 5GMSu AS provides resource identifiers for the allocated resources to the 5GMSu AF, which then provides the information to the 5GMSu Application Provider. The M3u procedures between 5GMSu AF and 5GMSu AS are not specified.
3. The 5GMSu Application Provider provides the Service Announcement Information to the 5GMSu-Aware Application.

NOTE: This may include manual entering of parameters.

The Service Announcement includes either the whole Service Access Information (i.e. details for Media Session Handling (M5u) and for Media Streaming access (M4u)) or only a remote configuration and control address (5GMSu AF URL). In the latter case, the 5GMSu Client retrieves the Services Access Information in a later step.

4. The 5GMSu-Aware Application configures and starts the 5GMSu Client.
5. When the 5GMSu-Aware Application decides to activate the streaming service transmission, the Service Access Information is provided to the 5GMSu Client. When remote configuration and control is activated, then the 5GMSu AF configures and controls the 5GMSu Client remotely.
6. Depending on the configurations, the 5GMSu Client uses the Media Session Handling API towards the 5GMSu AF. The Media Session Handling API is used for requesting different policy and charging treatments or other Network Assistance services.
7. The 5GMSu Client starts the Egest Session by activating the uplink streaming session.
8. The 5GMSu AS publishes the content towards the 5GMSu Application Provider.

## 6.2 Preparing for Uplink Media Streaming

### 6.2.1 Introduction

Before streaming media data in the uplink direction, a set of parameters are provisioned at the 5GMSu AF/AS and at the 5GMSu Client. On the UE side, the M8u API is used for local provisioning and the M5u API for remote control. On the 5GMSu AF/AS, the M1u API is used for session provisioning.

### 6.2.2 Sink Configuration at the 5GMSu AF/AS

The procedure allows the configuration of a 5GMSu AS for media reception. A Sink Session is created and updated. One or more media sessions are associated with a sink session.

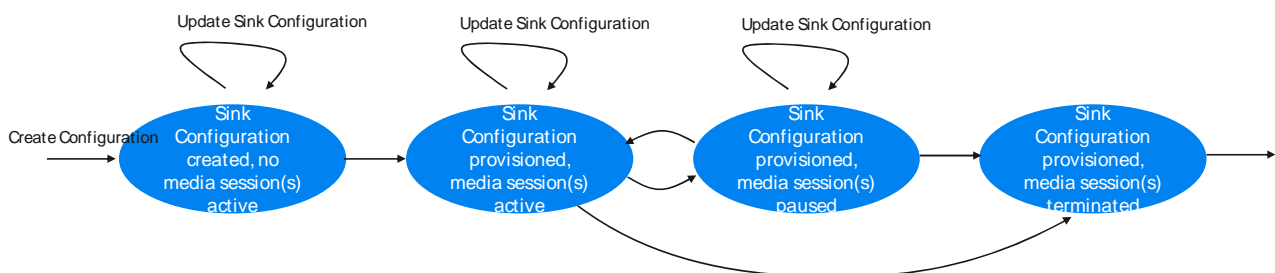

**Figure 6.2.2-1: Sink Configuration states**

The states describe the Sink Configuration and the relation to the media session:

- Sink Configuration created, no media session(s) active: The Sink Configuration entry is created at the 5GMSu AF and may be updated/modified before any media session(s) start.
- Sink Configuration Provisioned, media session(s) active: The 5GMSu AS is receiving uplink media data. Some properties of the Sink Configuration may be updated while receiving media data.
- Sink Configuration Provisioned, media session(s) paused: The 5GMSu AS is temporarily not receiving uplink media data. Some properties of the Sink Configuration may be updated.
- Sink Configuration Provisioned, media session(s) terminated: The 5GMSu AS is not receiving uplink media data anymore.

### 6.2.3 Source Configuration at the UE

The procedure allows the (remote) configuration of a UE for media transmission. When remote control is used, the application authorizes remote control e.g. by providing the remote control server address. It is assumed that a 5GMSu Client can have only a single Source Configuration at a time, which can be remotely configured. One or more media sessions are associated with the Source Configuration.

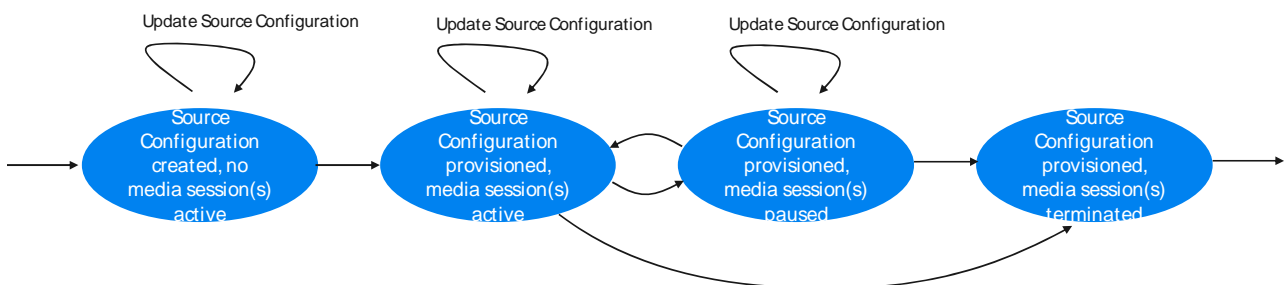

**Figure 6.2.3-1: Source Configuration states**

The states describe the Source Configuration and the relation to the media session.

- Source Configuration created, no media session(s) active: The Source Configuration entry is created and may be updated/modified before any media session(s) start. When remote control is enabled, the connection to the remote control function is established.
- Source Configuration Provisioned, media session(s) active: The 5GMSu Client is sending uplink media data. Some properties of the Source Configuration may be updated while sending media data.
- Source Configuration Provisioned, media session(s) paused: The 5GMSu Client is temporarily not sending uplink media data. Some properties of the Source Configuration may be updated.
- Source Configuration Provisioned, media session(s) terminated: The 5GMSu Client is not receiving uplink media data anymore.

## 6.3 Establishment of an Uplink Media Streaming Session

The procedure allows a Media Streamer to establish an uplink streaming session with a 5GMSu AS.

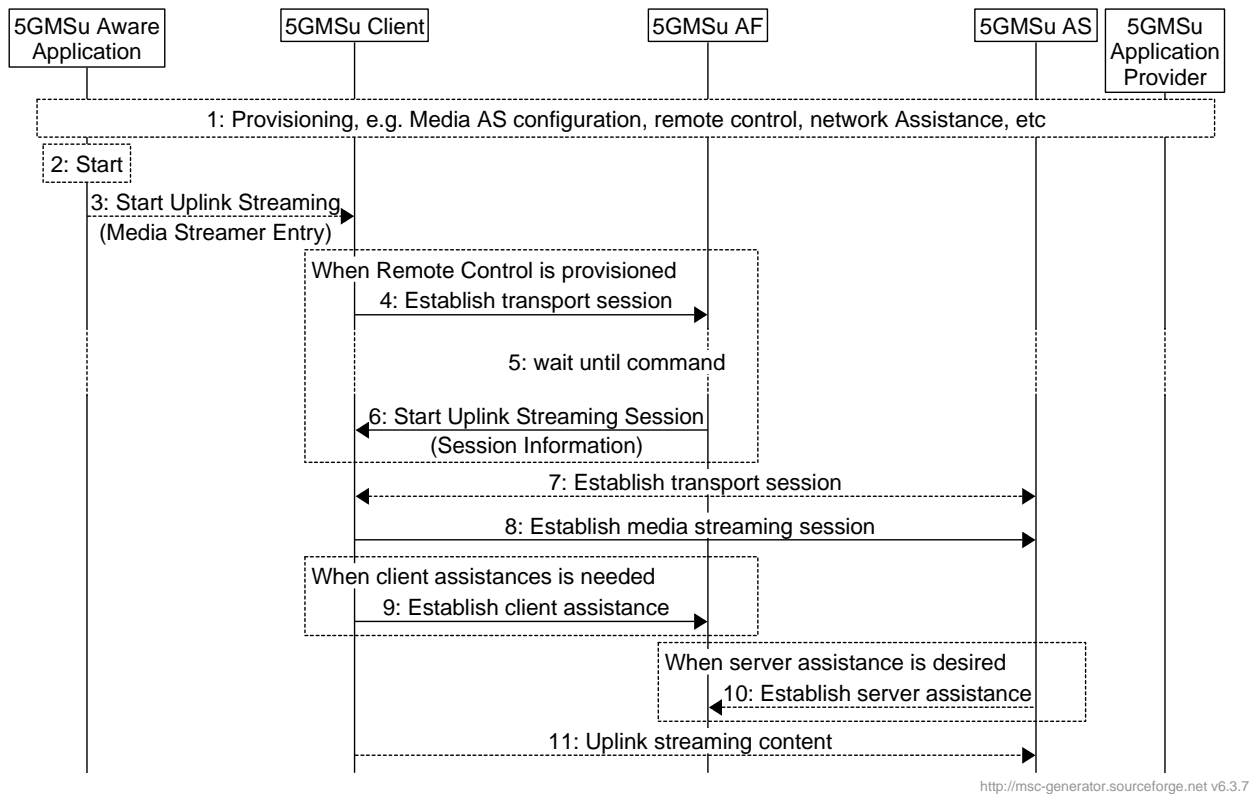

<http://msc-generator.sourceforge.net/v6.3.7>

**Figure 6.3-1: Uplink Streaming Session Establishment**

Steps:

- 1: During provisioning, the Media Streamer component of the 5GMSu Client is provisioned with basic information, such as the 5GMSu AF and 5GMSu AS addresses. For some devices, only the remote control information is provisioned and all additional parameters are retrieved from Remote Controller.
- 2: The 5GMSu-Aware Application starts uplink media streaming.
- 3: The 5GMSu-Aware Application instructs the 5GMSu Client to provide a Media Streaming Entry.

When remote control is provisioned in step 1:

- 4: The transport session for remote control is established.
- 5: The 5GMSu Client starts waiting for incoming remote control commands.
- 6: The 5GMSu Client receives a remote control command to start uplink streaming (either now or with a timestamp). The Remote control command may contain details of the 5GMSu AS, etc.
- 7: The 5GMSu Client establishes the uplink transport session.
- 8: The 5GMSu Client establishes the uplink media streaming session.

When client assistance is provisioned:

- 9: The 5GMSu Client establishes the assistance channel to the provisioned 5GMSu AF(s).

When server assistance is desired (e.g. for QoS or charging):

- 10: The 5GMSu AS establishes an assistance session with the 5GMSu AF.



## 6.4 Termination of an Uplink Media Streaming Session

The procedure defines the termination of an uplink media streaming session.

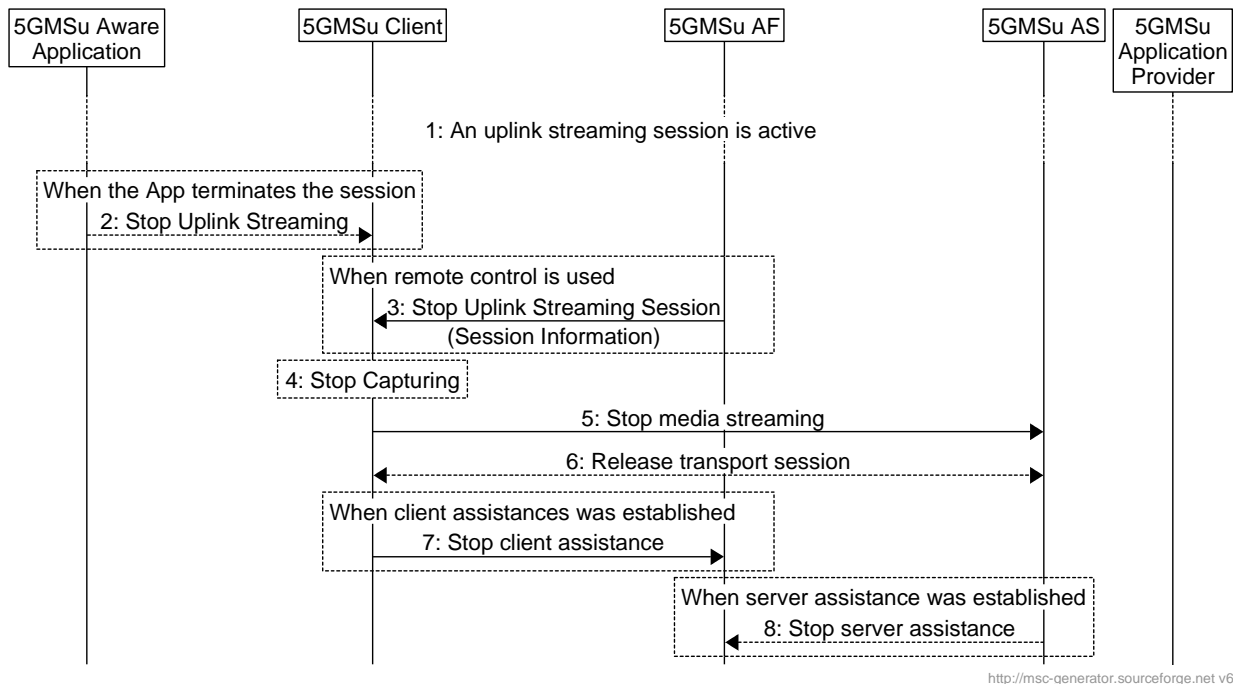

<http://msc-generator.sourceforge.net v6.3.7>

**Figure 6.4-1: Uplink Streaming Session Teardown**

Steps:

1: An uplink media streaming session is active and should be terminated.

When the 5GMSu-Aware Application terminates the session, e.g. triggered by user input:

2: The 5GMSu-Aware Application sends a Stop commands to the 5GMSu Client.

When remote control is used and the remote control session is established:

3: The 5GMSu Client receives a stop command.

4: The 5GMSu Client stops the capturing process.

5: The uplink media streaming process is terminated.

6: The uplink transport session is released.

When client assistance was established:

7: The 5GMSu AF is notified that the uplink media streaming session is terminated

When server assistance was established:

8: The 5GMSu AS is notified the 5GMSu AF that the uplink media streaming session is terminated

## 6.5 Providing 5GMSu AF-based Network Assistance

The procedure defines the network assistance from a 5GMSu AF.

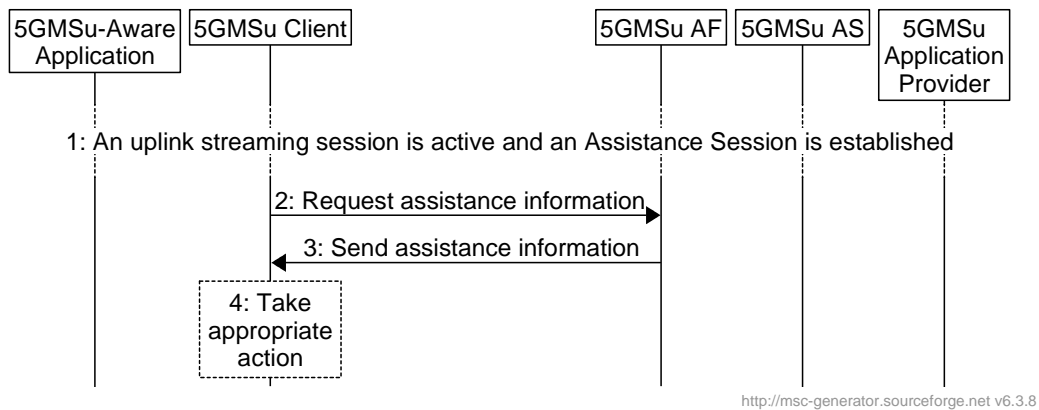

Figure 6.5-1: Providing Network Assistance

Steps:

- 1: An uplink streaming session is active. The Assistance Session is established with the 5GMSu AF.
- 2: The 5GMSu Client requests assistance information from the 5GMSu AF.
- 3: The assistance message is sent.
- 4: The Media Streamer takes an appropriate action to the message.

## 6.6 Providing Remote Control

The procedure defines the remote control from a 5GMSu AF. Note that the 5GMSu AF for remote control may be deployed as a network based function or a UE-based function.

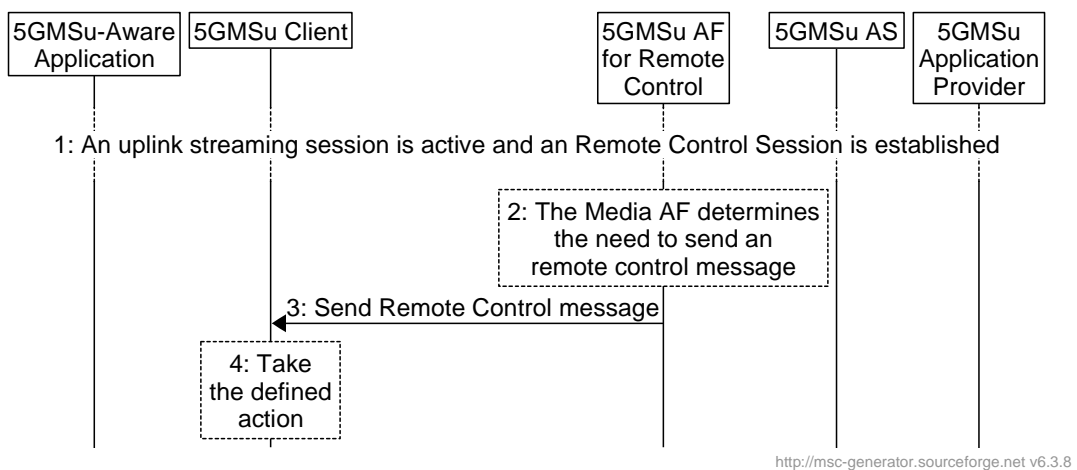

Figure 6.6-1: Uplink Streaming Session Establishment

Steps:

- 1: An uplink streaming session is active. The Remote Control Session is established with the 5GMSu AF.
- 2: The 5GMSu AF for Remote Control determines the need to send a remote control message.
- 3: The remote control message is sent to the 5GMSu Client.
- 4: The 5GMSu Client takes the defined action specified in the remote control message.

## 6.7 RAN Signalling based Support for Uplink Network Assistance

Figure 6.7-1 depicts an uplink streaming architecture where RAN signalling is employed to support uplink Network Assistance functionality.

The RAN in the architecture contains control plane and user plane entities that interact with peer control and user plane entities in the UE, in the request/response for boost of the uplink streaming data rate, and subsequent media transport. The user plane functionality as shown in Figure 6.7-1 (solid line going from UE to RAN to 5GMSu AS) illustrates the scheduling/passthrough functionality associated with user plane communications, governed by the RAN, as result of the uplink assistance messaging over the control plane (shown by dotted line between the UE and RAN). It is assumed in this case that application-level Network Assistance, i.e., as represented by the "NA AF sub-function" of the "UL 5GMSu AF" is not utilized.

It should be noted that although the NA AF is not utilized when RAN signaling based network assistance is performed, it is assumed that there is a higher level network entity which coordinates and tracks network assistance performed using RAN signaling versus application signaling for individual UEs.

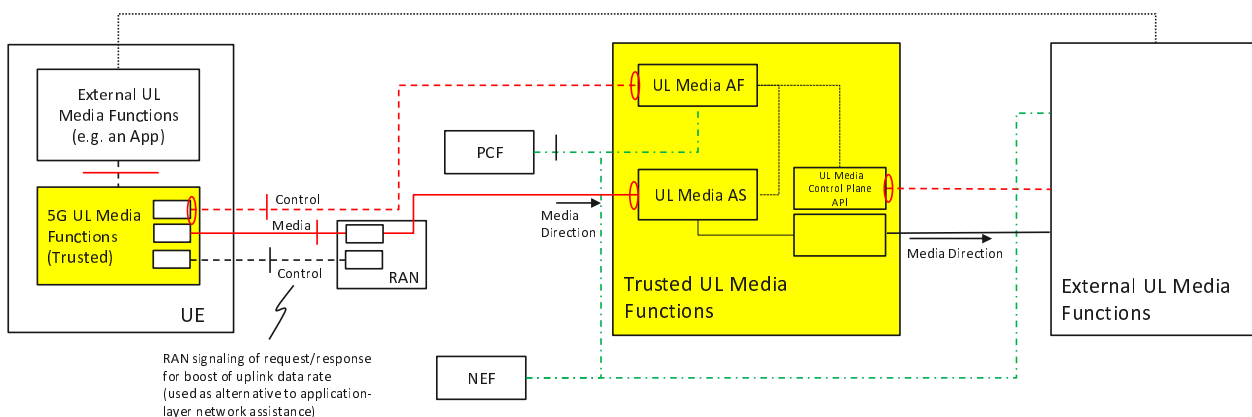

**Figure 6.7-1: RAN Signaling based Uplink Network Assistance**

# 7 5GMS Network Media Processing

## 7.1 General

A 5GMS Application Provider may request media processing to be performed on its media data. This can be instantiated as part of the Uplink or Downlink streaming. For uplink, FLUS TS 26.238 [5] provides measures to describe the required media processing as part of the FLUS session creation request. For downlink media distribution, the 5GMSd Application Provider may wish to execute some media processing functions within the MNO network infrastructure.

The media processing is performed by a set of 5GMS AS(s), which may be combined together to build complex media processing workflows. A 5GMS AF coordinates the media processing and ensures that the appropriate QoS and traffic handling for the session are provided.

## 7.2 Media Processing Procedures for Downlink

As part of setting up a Content Hosting Configuration for downlink media streaming, a 5GMSd Application Provider may request custom processing to be performed.

The following processing operations may be available:

- Adaptive Bit Rate (ABR) Encoding, Encryption and Encapsulation.
- MPD (e.g. MPD) Generator and Segment (e.g. DASH) Packager.
- Content Replacement (e.g. Ad insertion, blackouts, regional content):
  - MPD (e.g. MPD) modification.
- App Server: other content enrichment functions such as Closed Caption insertion, object detection, content filtering, etc.

The procedures are as follows:

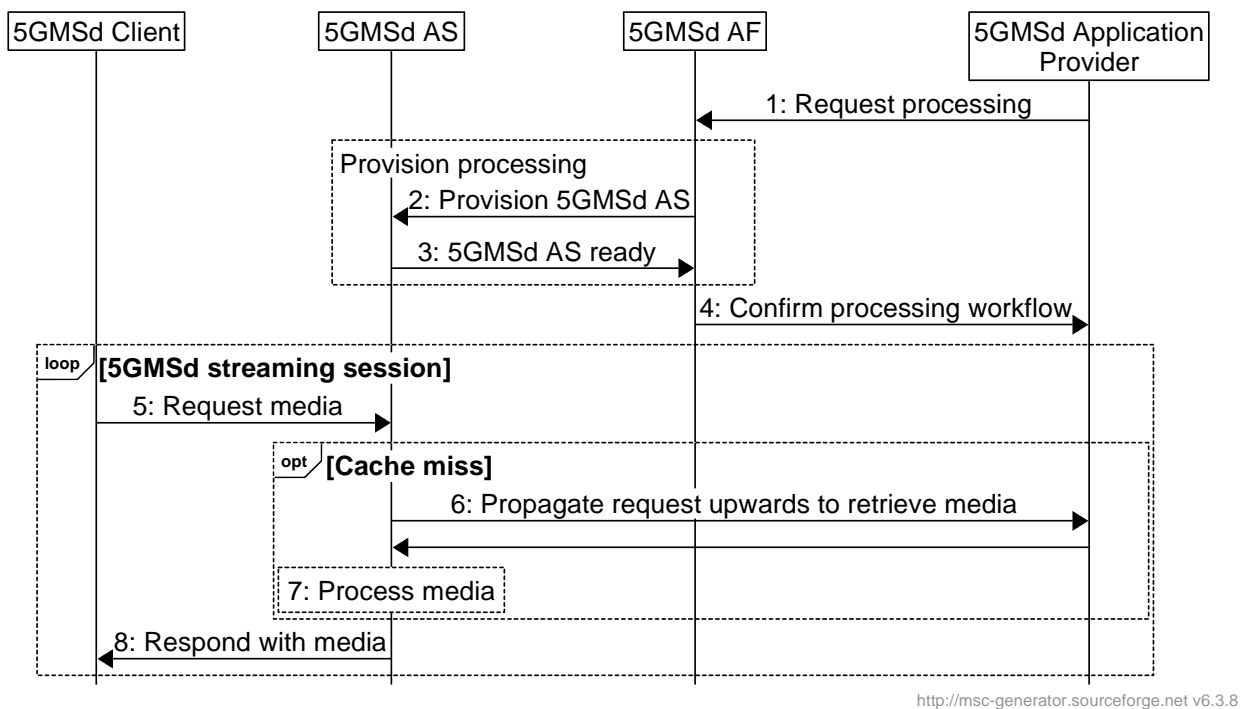

<http://msc-generator.sourceforge.net> v6.3.8

Figure 7.2-1: Media Processing Procedures for Downlink

The steps are as follows:

1. Upon setting up a Content Hosting Configuration, the 5GMSd Application Provider requests media processing to be set up. The 5GMSd Application Provider provides a description of the type and placement of the processing. The 5GMS System may only allow a shortlisted set of media processing functions to be used by the 5GMSd Application Provider.
2. The 5GMSd AF provisions a selected set of 5GMSd AS(s) to fulfil the requested media processing in the appropriate placement. Depending on the configuration, one or multiple AS(s) may be involved.
3. The 5GMSd AS(s) confirm successful provisioning to the 5GMSd AF.
4. The 5GMSd AF confirms the successful creation of the Content Hosting Configuration with the requested media processing to the external Media application server.
5. A 5GMSd Client sends a request for media content to one of the 5GMSd AS(s) listed in the provisioned Content Hosting Configuration (see clause 5.4).
6. If it does not already have a copy of the requested media cached, the 5GMSd AS fetches the media from the 5GMSd Application Provider.
7. The 5GMSd AS processes the ingested media based on the provisioned media processing workflow.
8. The 5GMSd AS serves the requested media to the 5GMSd Client after successful media processing.

Different variants of these procedures may be possible, depending on the type of processing, the placement of the processing, and the characteristics of the Content Hosting Configuration.

## 7.3 Media Processing Procedures for Uplink

FLUS TS 26.238 [5] allows for the provisioning of media processing by the FLUS Source to the FLUS Sink. In such a scenario, the FLUS Sink will consist of a FLUS 5GMSu AF and a FLUS 5GMSu AS. The 5GMSu AF instructs the 5GMSu AS to perform processing of the media according to the provided media processing document. Alternatively, it can share the media processing load among multiple 5GMSu AS(s).

The procedure is defined as follows:

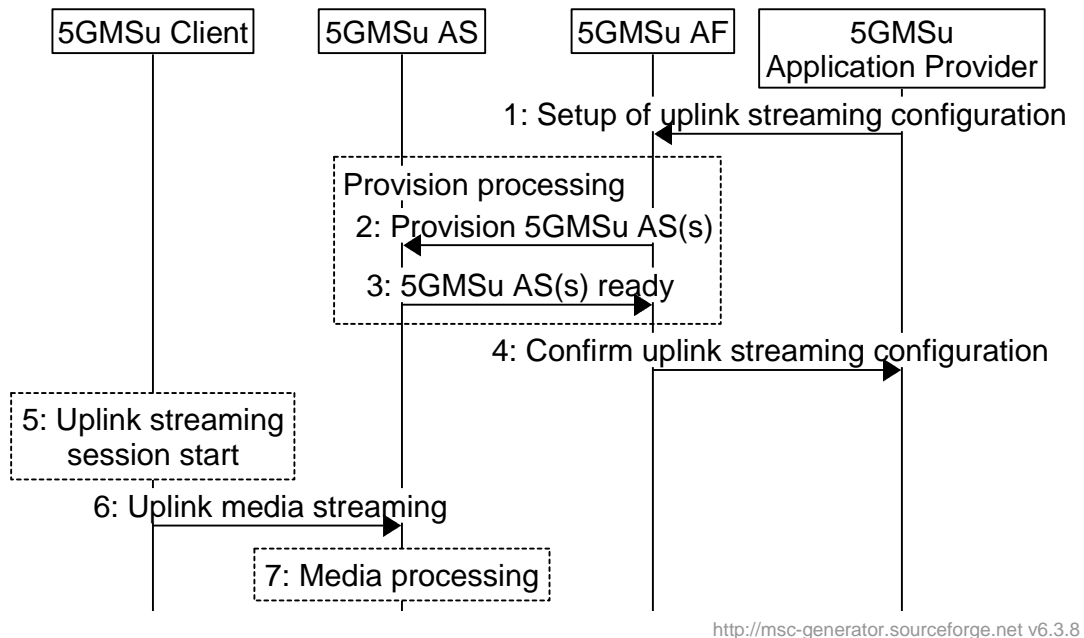

<http://msc-generator.sourceforge.net> v6.3.8

**Figure 7.3-1: Media Processing Procedures for Uplink**

The steps are as follows:

- 1: Setup of uplink streaming configuration:** The 5GMSu Application Provider sends a request to start a FLUS session to the 5GMSu AF. The request contains a description of the media processing that is to be performed by the 5GMSu AS. Depending on the configuration one or multiple 5GMSu AS(s) may be involved.
- 2: Provision 5GMSu AS(s):** The 5GMSu AF parses the media processing description and provisions the 5GMSu AS(s) that will perform the requested processing. If the requested processing is not accepted, the session creation fails.
- 3: 5GMSu AS(s) ready:** The 5GMSu AS(s) confirm(s) correct configuration and inform(s) the 5GMSu AF that it is ready to receive and process media as requested.
- 4: Confirm uplink streaming configuration:** The 5GMSu AF confirms the successful creation of the uplink streaming configuration to the 5GMSu Application Provider.
- 5: Uplink streaming session start:** the session is triggered in the 5GMSu Client.
- 6: Uplink media streaming:** Media content is streamed from the 5GMSu Client to the 5GMSu AS(s).
- 7: The 5GMSu AS(s) process(es) the received media based on the provisioned media processing.**

## 7.4 Edge Computing

NOTE: This clause is FFS.

# Annex A (informative): Usage Guidelines for collaboration scenarios

## A.0 General

This annex describes a set of collaboration scenarios and deployment options of the 5G Media Streaming architecture. The intention is to illustrate different deployment options.

Note that the scenarios focus on the ownership of the functions. Scalability realizations such as a CDN are not illustrated. As result of the scalability considerations, the M4d-serving 5GMSd AS and/or M5d-serving 5GMSd AF may:

- Consist of multiple (physical) servers, which may be addressed using a single FQDN. A load balancer forwards client requests to one of these servers. Forwarding may be via HTTP redirects or transparent towards the client.
- Consist of multiple (physical) servers, where different servers, or different groups of servers, may be addressed with different FQDNs. The client may be made aware of this via the manifest (i.e. listing multiple base URLs).

NOTE: In this case the servers may be managed by the same or different parties (e.g. MNO and/or 5GMSd Application Provider).

- Be addressed with a single FQDN. For example, the MNO AS is mostly transparent and acts as a proxy/cache.

## A.1 Collaboration 1

This collaboration scenario represents a typical OTT collaboration scenario, where the 5GMSd AF and 5GMSd AS are deployed in an external Data Network.

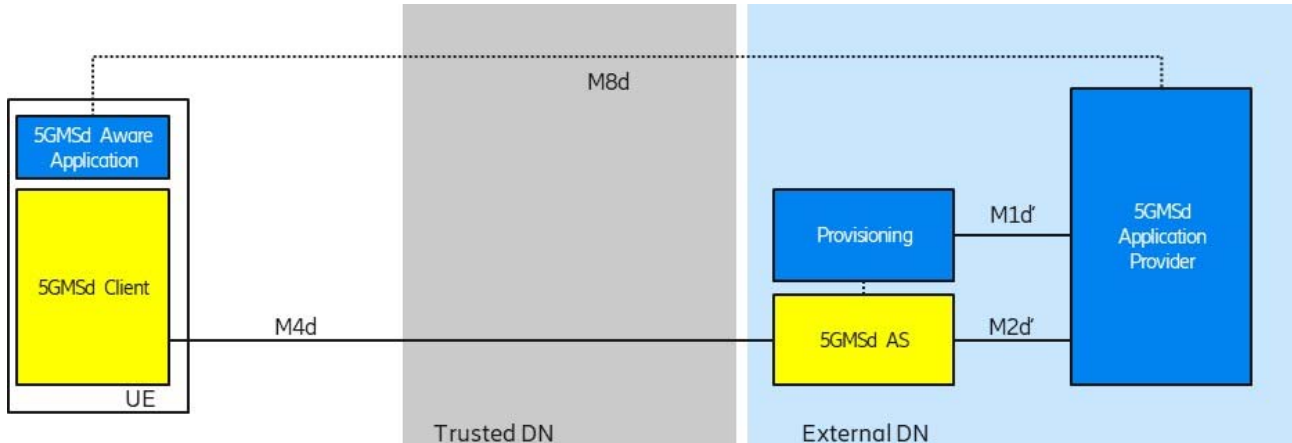

**Figure A.1-1: Collaboration 1**

The interfaces M1d' and M2d' may be similar to interfaces M1d and M2d respectively. Interface M4d follows 3GPP specifications.

NOTE: Although a single logical 5GMSd AS exposes both the M2d' (Ingest) and M4d (Downlink Streaming) interfaces, these APIs may, in a real deployment, be implemented on different physical servers (with different FQDNs). Furthermore, a large number of serving nodes, each with its own FQDN may offer the M4d service, following CDN scaling principles.

## A.2 Collaboration 2

This collaboration scenario represents a MNO CDN scenario, where the CDN is used for ingest and delivery of the content.

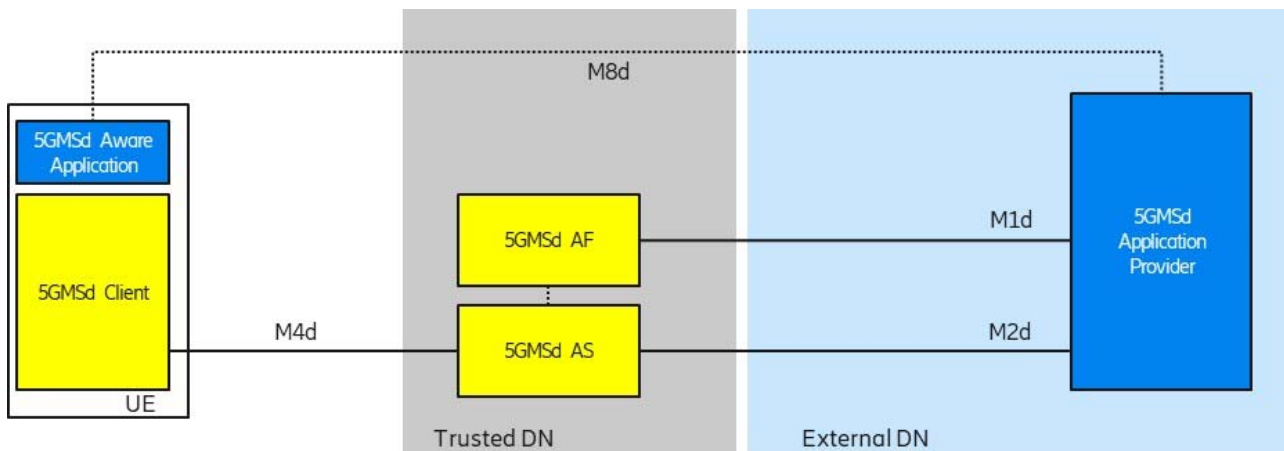

Figure A.2-1: Collaboration 2

## A.3 Collaboration 3

This collaboration scenario represents a typical OTT collaboration scenario, where the 5GMSd AF and 5GMSd AS are deployed in an external Data Network. The 5GMSd AF interacts with the NEF via N33.

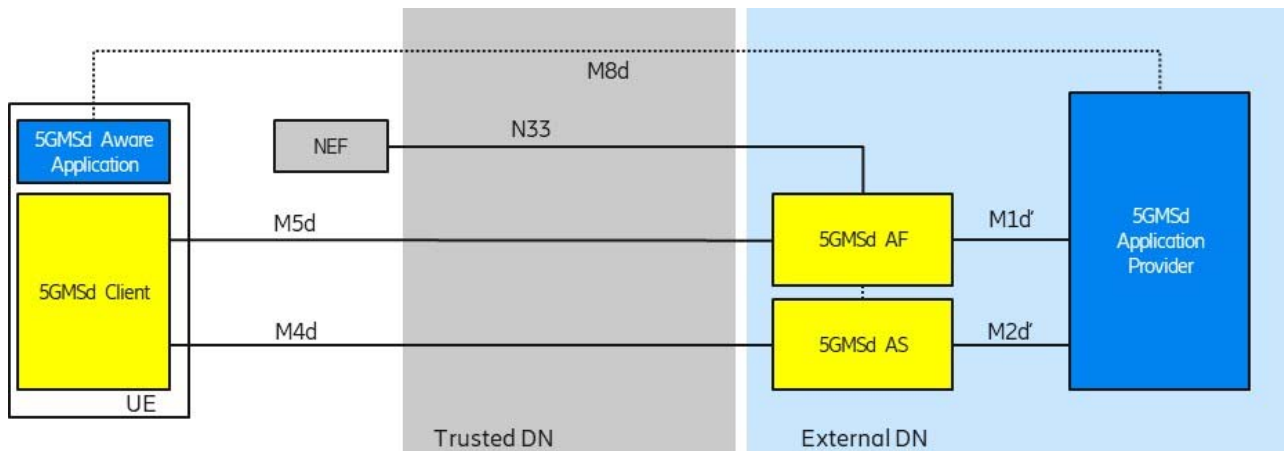

Figure A.3-1: Collaboration 3

NOTE 1: The M5d API may be exposed using a different FQDN than the M1d' API exposing function.

NOTE 2: The M5d API may be exposed using several FQDNs, e.g. for different M5d assistance services.



## A.4 Collaboration 4

This collaboration scenario depicts a content hosting function in the external Data Network, e.g. using a third-party CDN in collaboration with MNO offered assistance and network services. The Provisioning API (M1d') and Ingest API (M2d') may follow 5GMS specifications.

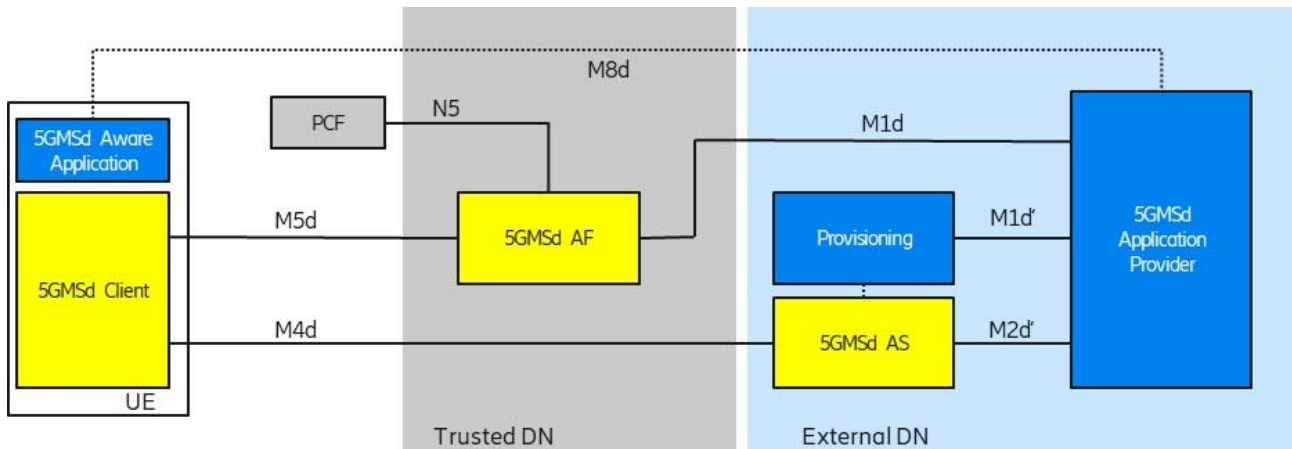

Figure A.4-1: Collaboration 4

Interfaces M1d' and M2d' may be similar to interfaces M1d and M2d respectively. Interface M4d follows 5GMS specifications.

## A.5 Collaboration 5

This collaboration scenario is similar to Collaboration 4 with the difference that the external content hosting function (5GMSd AS) is provisioned from a 5GMSd AF which is located in a trusted Data Network. It is expected that a 5GMSd AF and 5GMSd AS from different providers are interconnected using an M3d interface.

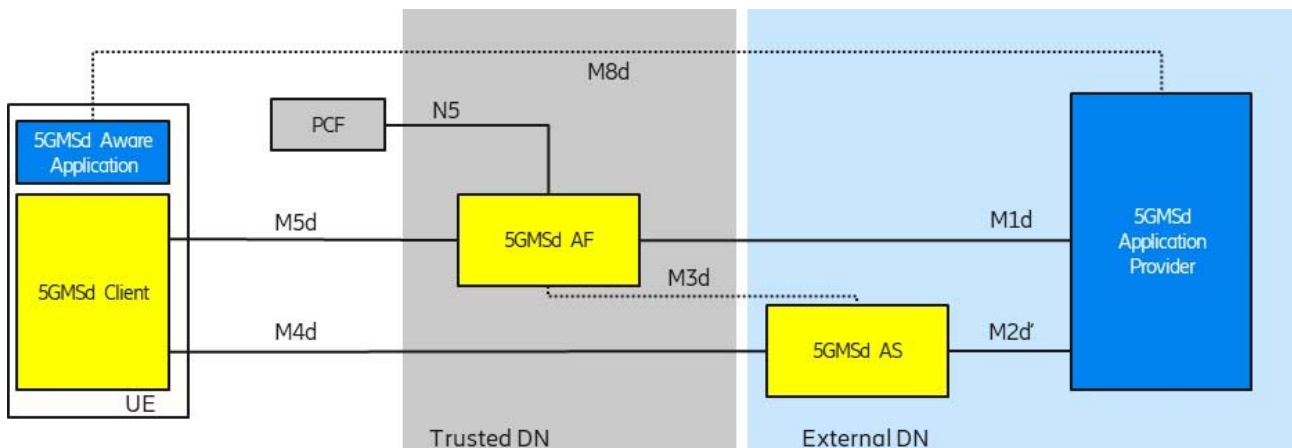

Figure A.5-1: Collaboration 5

Interface M2d' may be similar to interface M2d. All other interfaces depicted follow 3GPP specifications.

## A.6 Collaboration 6

This collaboration scenario is similar to Collaboration 4 and Collaboration 5 with the difference that the trusted content hosting function (5GMSd AS) is provisioned from an external 5GMSd AF. It is expected that a 5GMSd AF and 5GMSd AS from different providers are interconnected using an M3d interface.

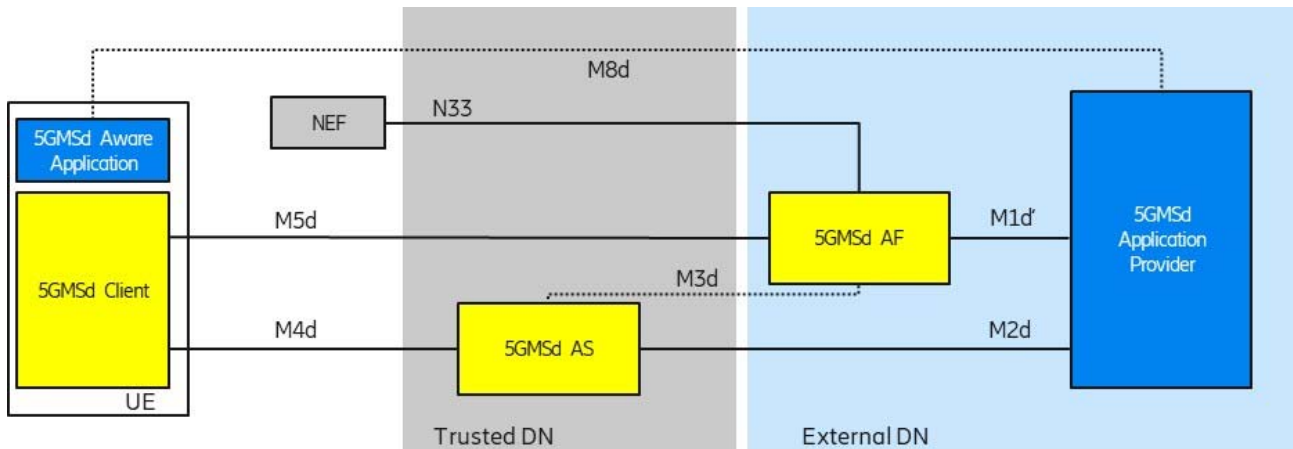

Figure A.6-1: Collaboration 6

Interface M1d' may be similar to interface M1d. All other interfaces depicted follow 3GPP specifications.

## A.7 Collaboration 7

This collaboration scenario represents a MNO CDN scenario (like in Collaboration 2) where the CDN is used for ingest and delivery of the content. Additional 5GMS features are used which require interaction with the PCF.

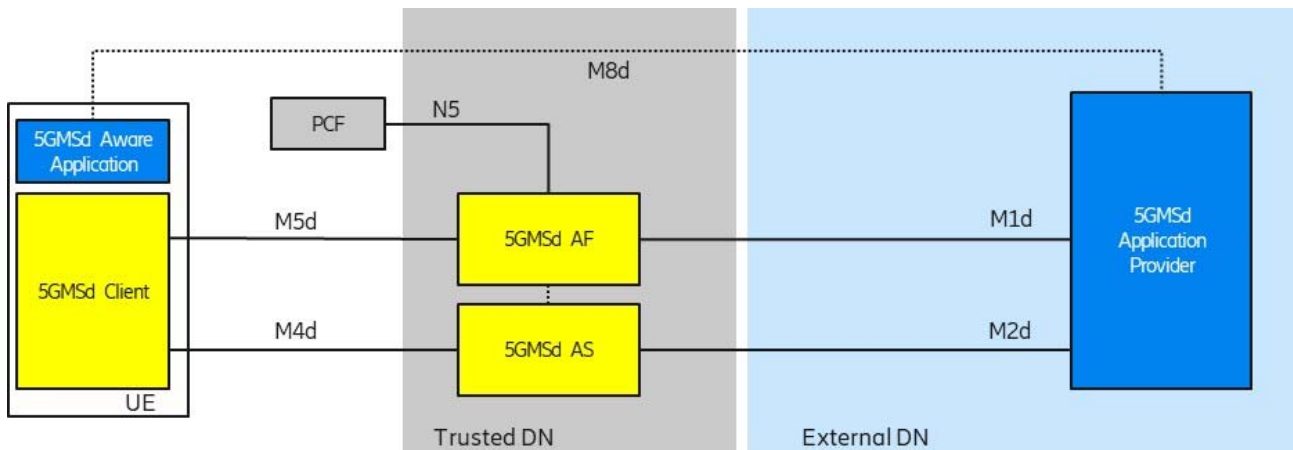

Figure A.7-1: Collaboration 7

## A.8 Collaboration 8

This collaboration scenario represents a multi-MNO distribution scenario where an external CDN (5GMSd AS) is used to deliver content through multiple 5GMSd capable PLMNs. Additional 5GMSd features are used from the serving 5GMS System which need interactions with the PCF of the serving PLMN.

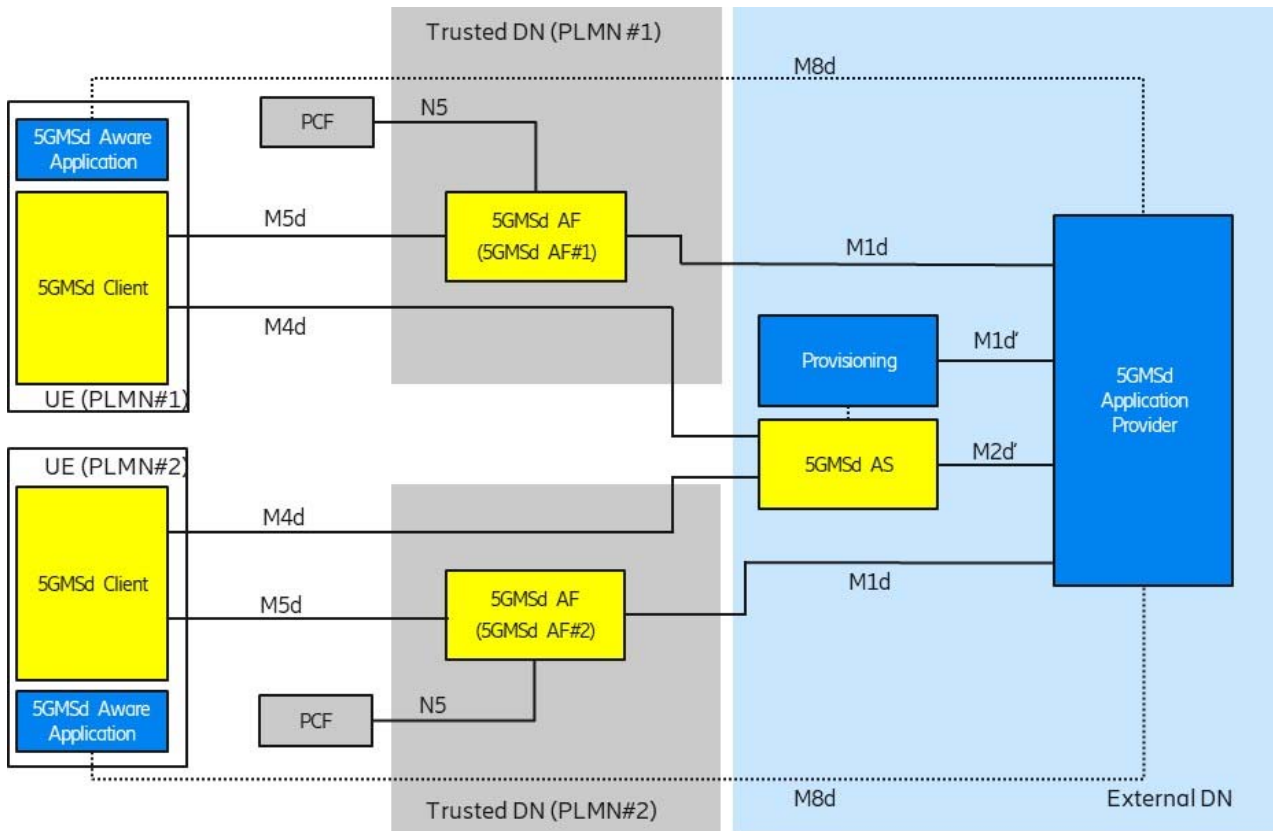

Figure A.8-1: Collaboration 8

## A.9 Collaboration 9

This collaboration scenario represents a multi-MNO distribution scenario where an external CDN (5GMSd AS) is used to deliver content through multiple 5GMSd-capable PLMNs. Additional 5GMSd features are used from the serving 5GMSd system which need interactions with the NEF of the serving PLMN.

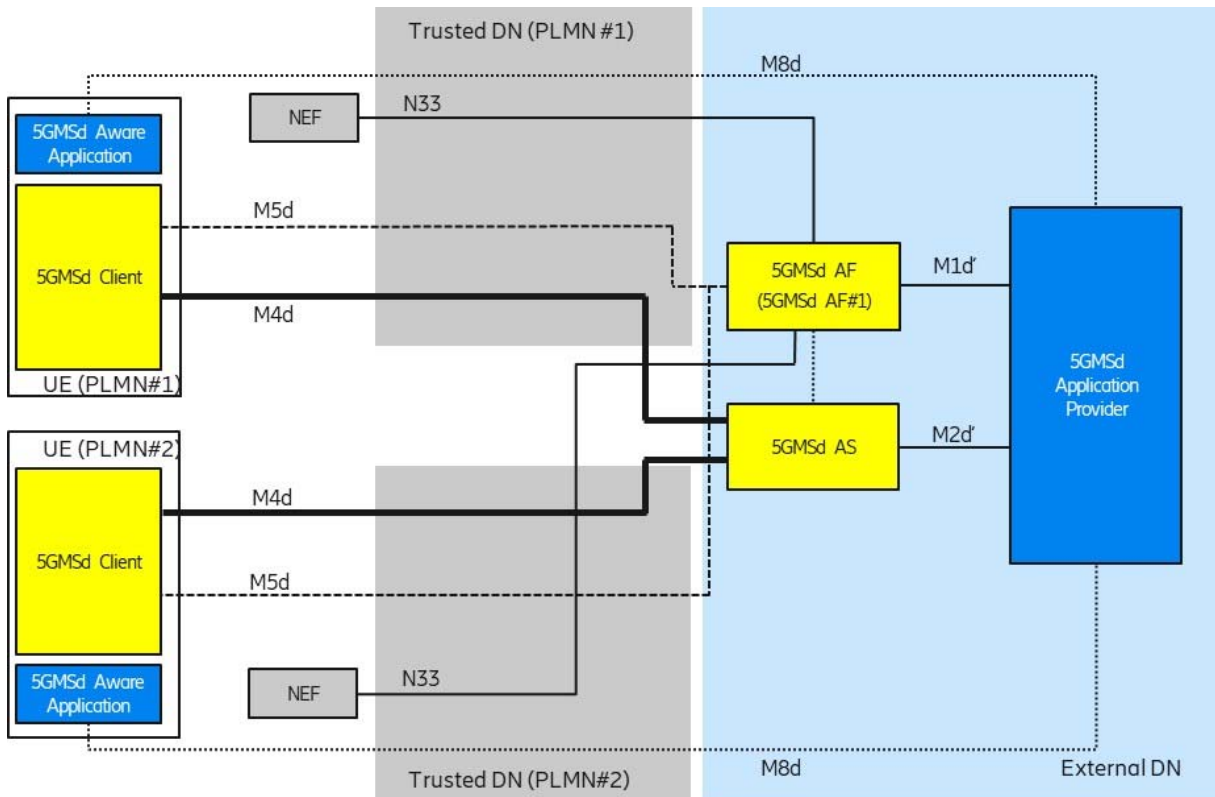

Figure A.9-1: Collaboration 9

## Annex B (informative): MNO-specific Service Access Information acquisition

### B.1 General

A 5GMSd Application Provider may offer its content via multiple Access Networks from different operators. Each access network can consist of a 5G System and one or more 5G Media Streaming Architecture components, in particular its own 5GMSd AFs. The 5GMSd AFs of that access network use their own FQDNs and potentially their own URL root path elements. When a 5GMSd-Aware Application is deployed in different 5G Systems the 5GMSd Client needs to acquire Service Access Information that resolves to the 5GMSd AF endpoint address(es) appropriate for the serving 5G System. The Service Access Information contains the URLs and API parameters of the configured 5GMSd AFs and ASs of that 5G Media Streaming System.

There are different ways to resolve the matching service access information. This annex focuses on two solutions where the 5GMSd Client fetches the Service Access Information from a 5GMSd AF within the Trusted DN of the serving mobile network.

### B.2 Deployment with DNS-based resolution

Figure B.2-1 depicts the deployment for DNS-based resolution of the 5GMSd AF in the Trusted DN of the MNO which is currently providing connectivity to the 5GMSd Client. The DNS functions are defined in RFC 1034 [14].

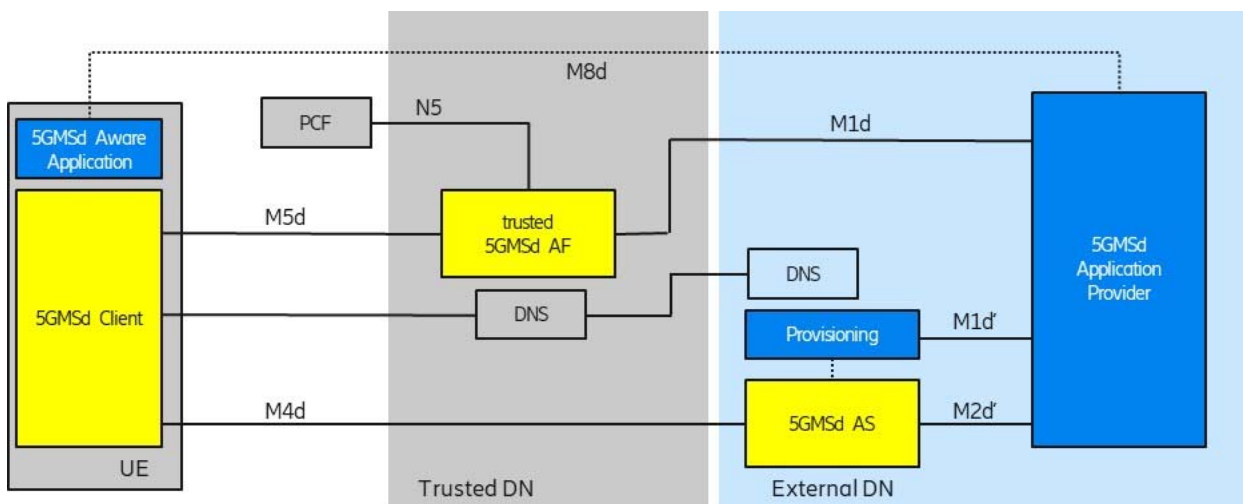

**Figure B.2-1: DNS based resolution of 5GMSd AF in trusted DN**

For the DNS-based resolution mechanism, the 5GMSd Client is provisioned with a Service Access Information URL, for example dynamically via M8d or statically within the code of the 5GMSd-Aware Application. The Service Access Information URL contains an FQDN from the 5GMSd Application Provider or a global URL in the GSMA domain (i.e. in the “3gppnetworks.org” domain).

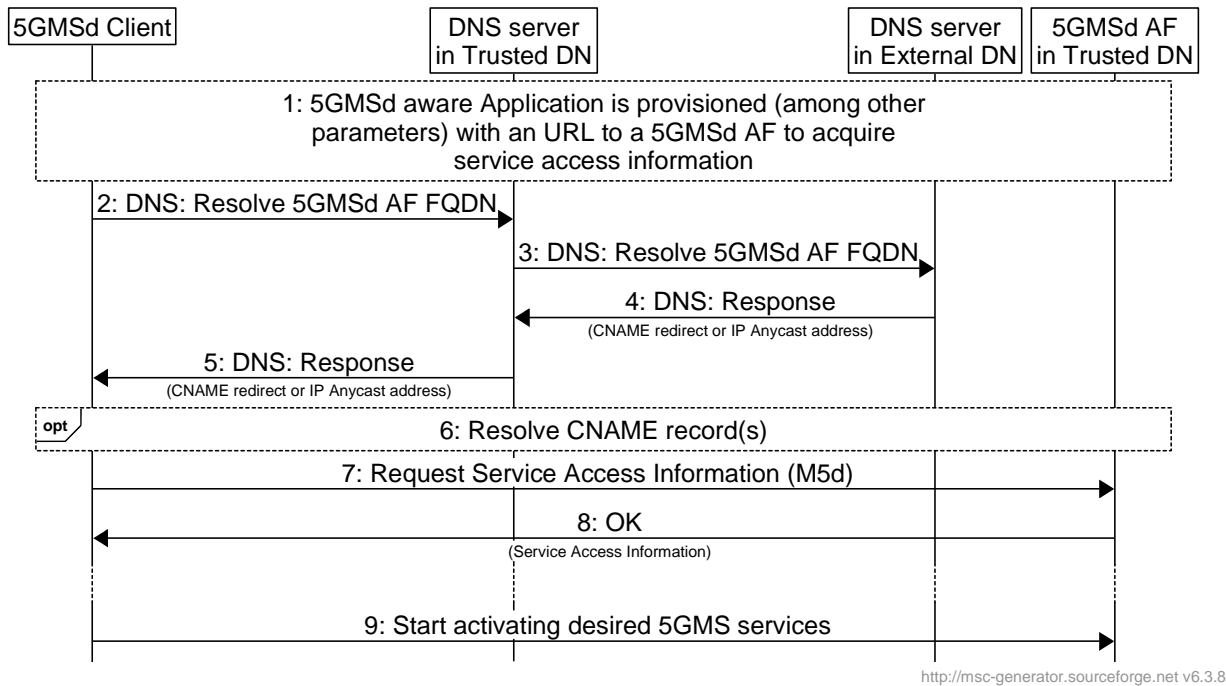

**Figure B.2-2: Message Sequence Chart for DNS-based resolution**

Steps:

- 1: The 5GMSd-Aware Application is provisioned (among other parameters) with a URL of the 5GMSd AF from which to acquire Service Access Information. The 5GMSd-Aware Application provides this URL to the 5GMSd Client upon start.
- 2: The 5GMSd Client uses DNS to resolve the FQDN of the URL. The 5GMSd Client sends a DNS request to the DNS server in the Trusted DN.
- 3: The DNS server in the trusted DN is not responsible for the FQDN and the DNS server forwards the DNS request to a DNS server in the external DN responsible for the FQDN. This may be the DNS server of the 5GMSd Application Provider or a GSMA DNS server.
- 4: Based on information from the originating network, the external DNS creates a response. The response may be a *CNAME* redirect (i.e. FQDN from the serving mobile network responsibility) or an IP address (preferably an IP Anycast Address).
- 5: The DNS server forwards the DNS response to the 5GMSd Client.
- 6: When the 5GMSd Client received another FQDN with the response (i.e. a *CNAME* DNS record), then the 5GMSd Client resolves the FQDN to an IP address. The resolved IP address should be an IP address of an 5GMSd AF in the Trusted DN.
- 7: The 5GMSd Client issues a request to the resolved 5GMSd AF in order to acquire the Service Access Information.
- 8: The 5GMSd AF provides the Service Access Information in its response to the 5GMSd Client. The Service Access Information contains URLs and parameters according to provisioned 5GMS features.
- 9: When needed, the 5GMSd Client uses the acquired Service Access Information to activate the needed 5GMSd feature(s).

### B.3 Deployment with HTTPS-based resolution

Figure B.3-1 depicts the deployment for HTTPS-based resolution of the 5GMSd AF in the Trusted DN of the MNO which is currently providing connectivity to the 5GMSd Client.

NOTE: The process of resolving IP addresses from FQDNs is not depicted in this deployment architecture.

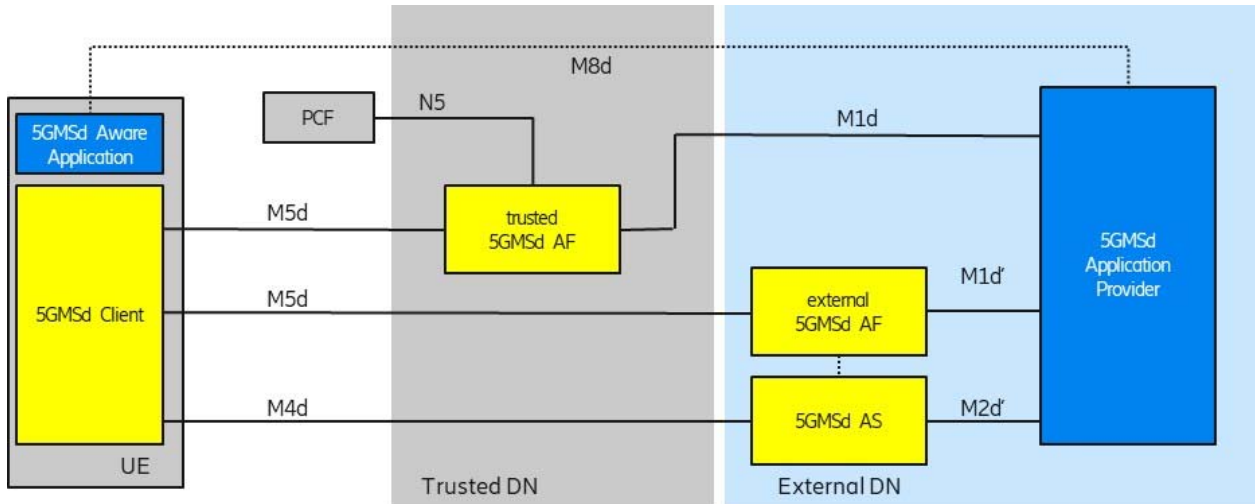

**Figure B.3-1: HTTPS based resolution of 5GMSd AF in Trusted DN**

For the HTTPS-based resolution mechanism, the 5GMSd Client is provisioned with a Service Access Information URL, for example dynamically via M8d or statically within the code of the 5GMSd-Aware Application. The Service Access Information URL contains an FQDN of a 5GMSd AF within the 5GMSd Application Provider domain, which acts as a request redirector.

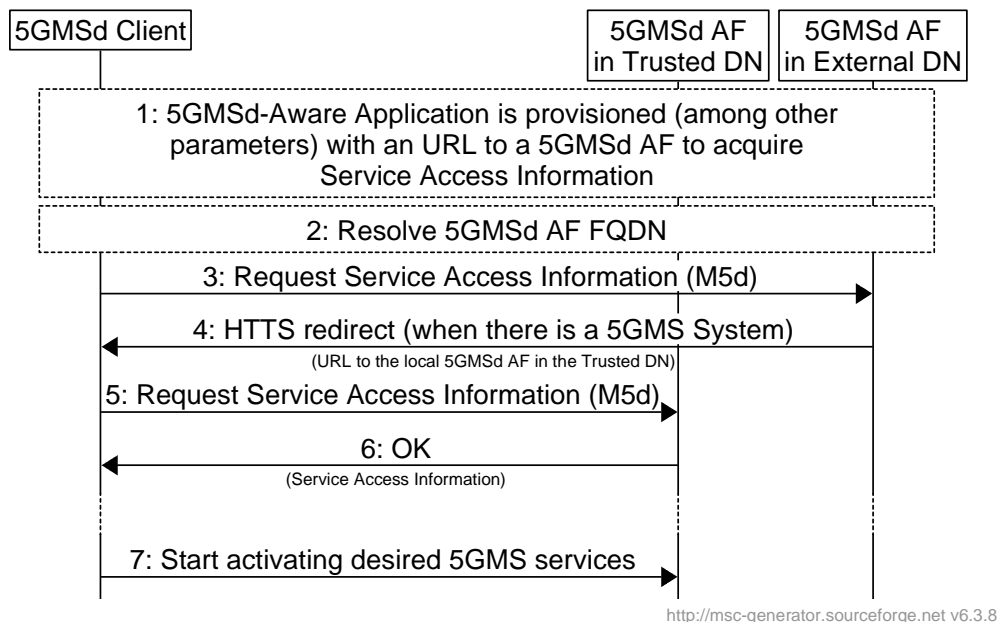

<http://msc-generator.sourceforge.net v6.3.8>

**Figure B.3-2: Message Sequence Chart for HTTPS based resolution**

Steps:

- 1: The 5GMSd-Aware Application is provisioned (among other parameters) with a URL of the 5GMSd AF from which to acquire Service Access Information. The 5GMSd-Aware Application passes this URL to the 5GMSd Client upon start.
- 2: The 5GMSd Client uses DNS to resolve the FQDN of the URL.

- 3: The 5GMSd Client issues a request to the resolved 5GMSd AF in order to acquire the Service Access Information.
- 4: Based on information from the originating network (e.g. visible IP of the 5GMSd Client), the 5GMSd AF in the External DN creates an HTTPS redirection response. The 5GMSd AF looks up the according FQDN of the 5GMSd AF in the trusted DN and sends an HTTPS redirection response to the 5GMSd Client.

When the 5GMSd AF in the External DN does not offer 5GMS features, or if the 5GMS features are not provisioned it instead provides a response containing an HTTP error message.

**NOTE:** Instead of redirecting a 5GMSd Client to the 5GMSd AF in the Trusted DN, the External 5GMSd AF may directly provide the Service Access Information in the above step. In this case, the 5GMSd Application Provider needs to update its 5GMSd AF according to changes within the Trusted DN, e.g. changes of FQDNs.

- 5: The 5GMSd Client issues a request to the resolved 5GMSd AF in order to acquire the Service Access Information.
- 6: The 5GMSd AF provides the Service Access Information in its response to the 5GMSd Client. The Service Access Information contains URLs and parameters according to provisioned 5GMS features.
- 7: When needed, the 5GMSd Client uses the acquired Service Access Information to activate the needed 5GMSd feature(s).



## Annex C (informative): Change history

Change history							
Date	Meeting	TDoc	CR	Rev	Cat	Subject/Comment	New version
2019-03	SA#83	SP-190037				Presented to TSG SA#83 (for information)	1.0.0
2019-06	SA#84	SP-190333				Presented to TSG SA#84 (for approval)	2.0.0
2019-06	SA#84					Approved at TSG SA#84	16.0.0
2019-09	SA#85	SP-190654	0001	2	F	Clarification of configuration updates when not streaming media data	16.1.0
2019-09	SA#85	SP-190654	0002	3	F	Correction of Architecture, Unicast Streaming Procedure, QoE metrics reporting, Consumption reporting and Session Handling for 5GMS	16.1.0
2019-12	SA#86	SP-190999	0003	-	F	Correction to architecture and procedures	16.2.0
2020-03	SA#87-e	SP-200040	0004	1	B	Triggering conditions for Consumption Reporting	16.3.0
2020-03	SA#87-e	SP-200040	0005		F	Correction on downlink media streaming establishment	16.3.0
2020-03	SA#87-e	SP-200040	0006	1	F	Collaboration Scenarios for 5G Media Streaming	16.3.0
2020-03	SA#87-e	SP-200040	0007	1	F	Correction on Provisioning procedures	16.3.0
2020-03	SA#87-e	SP-200040	0008	1	F	Corrections and clarifications for Dynamic Policy Procedures	16.3.0
2020-03	SA#87-e	SP-200040	0009	1	C	Metrics collection parameters	16.3.0
2020-03	SA#87-e	SP-200040	0010		C	UE-internal interfaces	16.3.0
2020-03	SA#87-e	SP-200040	0011		F	Procedures for Unicast Downlink Streaming with 5GMSd AS interactions	16.3.0
2020-03	SA#87-e	SP-200040	0012		F	Network Assistance	16.3.0
2020-03	SA#87-e					Editorial	16.3.1
2020-04	SA4#108-e					Working draft following SA4#108-e as baseline for SA4#109-e draft CRs.	
2020-06	SA#88-e	SP-200388	0018		F	Consolidated changes from SA4#108-e and SA4#109-e	16.4.0
2020-06	SA#88-e	SP-200388	0015		F	Corrections on network slicing	16.4.0
2020-06	SA#88-e					Editorial Corrections	16.4.1

---

# History

<b>Document history</b>		
V16.4.1	September 2020	Publication