

ETSI TS 126 269 V14.1.0 (2018-01)



**Digital cellular telecommunications system (Phase 2+) (GSM);
Universal Mobile Telecommunications System (UMTS);
eCall data transfer;
In-band modem solution;
Conformance testing
(3GPP TS 26.269 version 14.1.0 Release 14)**



Reference

RTS/TSGS-0426269ve10

Keywords

GSM,UMTS

ETSI

650 Route des Lucioles
F-06921 Sophia Antipolis Cedex - FRANCE

Tel.: +33 4 92 94 42 00 Fax: +33 4 93 65 47 16

Siret N° 348 623 562 00017 - NAF 742 C
Association à but non lucratif enregistrée à la
Sous-Préfecture de Grasse (06) N° 7803/88

Important notice

The present document can be downloaded from:

<http://www.etsi.org/standards-search>

The present document may be made available in electronic versions and/or in print. The content of any electronic and/or print versions of the present document shall not be modified without the prior written authorization of ETSI. In case of any existing or perceived difference in contents between such versions and/or in print, the only prevailing document is the print of the Portable Document Format (PDF) version kept on a specific network drive within ETSI Secretariat.

Users of the present document should be aware that the document may be subject to revision or change of status.

Information on the current status of this and other ETSI documents is available at

<https://portal.etsi.org/TB/ETSIDeliverableStatus.aspx>

If you find errors in the present document, please send your comment to one of the following services:

<https://portal.etsi.org/People/CommiteeSupportStaff.aspx>

Copyright Notification

No part may be reproduced or utilized in any form or by any means, electronic or mechanical, including photocopying and microfilm except as authorized by written permission of ETSI.

The content of the PDF version shall not be modified without the written authorization of ETSI.

The copyright and the foregoing restriction extend to reproduction in all media.

© ETSI 2018.

All rights reserved.

DECT™, **PLUGTESTS™**, **UMTS™** and the ETSI logo are trademarks of ETSI registered for the benefit of its Members.

3GPP™ and **LTE™** are trademarks of ETSI registered for the benefit of its Members and of the 3GPP Organizational Partners.

oneM2M logo is protected for the benefit of its Members.

GSM® and the GSM logo are trademarks registered and owned by the GSM Association.

Intellectual Property Rights

Essential patents

IPRs essential or potentially essential to the present document may have been declared to ETSI. The information pertaining to these essential IPRs, if any, is publicly available for **ETSI members and non-members**, and can be found in ETSI SR 000 314: "*Intellectual Property Rights (IPRs); Essential, or potentially Essential, IPRs notified to ETSI in respect of ETSI standards*", which is available from the ETSI Secretariat. Latest updates are available on the ETSI Web server (<https://ipr.etsi.org/>).

Pursuant to the ETSI IPR Policy, no investigation, including IPR searches, has been carried out by ETSI. No guarantee can be given as to the existence of other IPRs not referenced in ETSI SR 000 314 (or the updates on the ETSI Web server) which are, or may be, or may become, essential to the present document.

Trademarks

The present document may include trademarks and/or tradenames which are asserted and/or registered by their owners. ETSI claims no ownership of these except for any which are indicated as being the property of ETSI, and conveys no right to use or reproduce any trademark and/or tradename. Mention of those trademarks in the present document does not constitute an endorsement by ETSI of products, services or organizations associated with those trademarks.

Foreword

This Technical Specification (TS) has been produced by ETSI 3rd Generation Partnership Project (3GPP).

The present document may refer to technical specifications or reports using their 3GPP identities, UMTS identities or GSM identities. These should be interpreted as being references to the corresponding ETSI deliverables.

The cross reference between GSM, UMTS, 3GPP and ETSI identities can be found under <http://webapp.etsi.org/key/queryform.asp>.

Modal verbs terminology

In the present document "**shall**", "**shall not**", "**should**", "**should not**", "**may**", "**need not**", "**will**", "**will not**", "**can**" and "**cannot**" are to be interpreted as described in clause 3.2 of the [ETSI Drafting Rules](#) (Verbal forms for the expression of provisions).

"**must**" and "**must not**" are **NOT** allowed in ETSI deliverables except when used in direct citation.

Contents

Intellectual Property Rights	2
Foreword.....	2
Modal verbs terminology.....	2
Foreword.....	4
1 Scope	5
2 Normative references	5
3 Definitions and abbreviations.....	5
3.1 Definitions	5
3.2 Abbreviations	6
4 General	6
5 Conformance	7
5.1 Bit-exactness	7
5.2 Minimum performance requirements	8
5.2.1 MSD transmission time	8
5.2.1.1 Full campaign (all AMR-FR codec modes plus GSM-FR)	9
5.2.1.2 Error-free case for AMR 12.2 and FR.....	9
5.2.1.3 GSM-HR codec.....	9
5.2.1.4 Noisy conditions	9
5.2.1.5 Scaling of PCM signals.....	10
5.2.2 CRC check quality.....	10
5.2.3 Transmission failures.....	10
5.2.4 False detection due to signalling tones	11
5.2.5 Push messages	11
5.2.6 HLACK messages.....	11
6 IMS eCall Conformance of In-band Modem.....	11
6.1 General	11
6.2 Initial Settings	11
6.3 No Time-Warping Conformance Test.....	12
6.4 Time-Warping Conformance Test.....	12
Annex A (normative): Test sequences and scripts for testing bit-exact implementation of eCall in-band modem.....	13
A.1 Testing a bit-exact implementation of the IVS transmitter function	13
A.2 Testing a bit-exact implementation of the PSAP transmitter function.....	14
A.3 Testing a bit-exact implementation of the IVS receiver function	15
A.4 Testing a bit-exact implementation of the PSAP receiver function	15
Annex B (normative): Test set-up and sequences for testing minimum performance of eCall in-band modem receivers	17
B.1 Modem Transmission Performance.....	17
B.1.2 Test Tone Sensitivity.....	18
Annex C (normative): Additional Performance Requirements	19
Annex D (informative): Change history	20
History	21

Foreword

The present document has been produced by the 3rd Generation Partnership Project (3GPP).

The contents of the present document are subject to continuing work within the TSG and may change following formal TSG approval. Should the TSG modify the contents of the present document, it will be re-released by the TSG with an identifying change of release date and an increase in version number as follows:

Version x.y.z

where:

- x the first digit:
 - 1 presented to TSG for information;
 - 2 presented to TSG for approval;
 - 3 or greater indicates TSG approved document under change control.
- y the second digit is incremented for all changes of substance, i.e. technical enhancements, corrections, updates, etc.
- z the third digit is incremented when editorial only changes have been incorporated in the document.

1 Scope

This Technical Specification (TS) specifies minimum performance requirements, test procedures and digital test sequences to be used for conformance testing of implementations of the eCall in-band modem.

The eCall in-band modem PSAP and IVS transmitters and receivers are specified in TS 26.267 [1]. The reference fixed point ANSI-C implementation for the specified eCall modem is provided in TS 26.268 [2].

The eCall in-band modem is a technology that transmits data reliably over the speech channel of the cellular and PSTN networks. It is specifically designed for transmission of the Minimum Set of Data (MSD) from IVS to PSAP for the Pan-European eCall initiative. For the purpose of the present specification, conformance is determined for the transmission of one single MSD of length 140 bytes. Other applications of the eCall in-band modem are out of scope of this document.

2 Normative references

The following documents contain provisions which, through reference in this text, constitute provisions of the present document.

- References are either specific (identified by date of publication, edition number, version number, etc.) or non-specific.
- For a specific reference, subsequent revisions do not apply.

For a non-specific reference, the latest version applies. In the case of a reference to a 3GPP document (including a GSM document), a non-specific reference implicitly refers to the latest version of that document *in the same Release as the present document*.

- [1] 3GPP TR 26.267: "eCall Data Transfer; In-band modem solution; General Description".
- [2] 3GPP TS 26.268: "eCall Data Transfer; In-band modem solution; ANSI-C reference code".
- [3] 3GPP TR 26.969: "eCall data transfer; In-band modem solution; Characterization report".
- [4] 3GPP TS 46.001: "Full rate speech; Processing functions".
- [5] 3GPP TS 26.071: "Mandatory speech CODEC speech processing functions; AMR speech Codec; General description".
- [6] 3GPP TR 21.905: "Vocabulary for 3GPP Specifications".
- [7] 3GPP TS 23.167: "IP Multimedia Subsystem (IMS) emergency sessions".
- [8] 3GPP TS 24.229: "IP multimedia call control protocol based on Session Initiation Protocol (SIP) and Session Description Protocol (SDP); Stage 3 "

3 Definitions and abbreviations

3.1 Definitions

For the purposes of the present document, the terms and definitions given in TR 21.905 [6] and the following apply. A term defined in the present document takes precedence over the definition of the same term, if any, in TR 21.905 [6].

eCall: manually or automatically initiated emergency call (TS12) from a vehicle, supplemented with a minimum set of emergency related data (MSD), as defined under the EU Commission's eSafety initiative.

eCall In-band Modem: modem pair (consisting of transmitters and receivers at IVS and PSAP) that operates full-duplex and allows reliable transmission of eCall Minimum Set of Data from IVS to PSAP via the voice channel of the emergency voice call through cellular and PSTN networks.

eSafety: European Commission sponsored forum to improve safety aspects of European citizens.

feedback frame: downlink signal transmission interval containing feedback data - corresponds to a time interval of 180 ms or 1 440 samples at an 8 kHz sampling rate

frame: time interval equal to 20 ms (corresponding to one AMR or FR speech frame, represented by 160 samples at an 8 kHz sampling rate)

Minimum Set of Data (MSD): forming the data component of an eCall sent from a vehicle to a Public Safety Answering Point or other designated emergency call centre. The MSD has a maximum size of 140 bytes and includes, for example, vehicle identity, location information and time-stamp.

3.2 Abbreviations

For the purposes of the present document, the following abbreviations apply.

ACK	ACKnowledgement
AMR	Adaptive Multi-Rate (speech codec)
CRC	Cyclic Redundancy Check
CTM	Cellular Text Telephone Modem
eIM	eCall In-band Modem
EU	European Union
FEC	Forward Error Correction
FoM	Figure of Merit
FR	Full Rate (speech codec)
GSM	Global System for Mobile communications
IVS	In-Vehicle System
MSD	Minimum Set of Data
NACK	Negative ACKnowledgement
PCM	Pulse Code Modulation
PSAP	Public Safety Answering Point
PSTN	Public Switched Telephone Network
UMTS	Universal Mobile Telecommunications Systems
VAD	Voice Activity Detection

4 General

This specification provides minimum performance requirements and test procedures that are necessary to test implementations of the eCall in-band modem for correctness. Correctness in this context means that the tested eCall modem implementation works within the performance parameter range defined in this document.

The eCall modem set consists of four main functional entities, i.e., the transmitter and receiver functions within the IVS and PSAP eCall modems. These functional entities are illustrated in Figure 1.

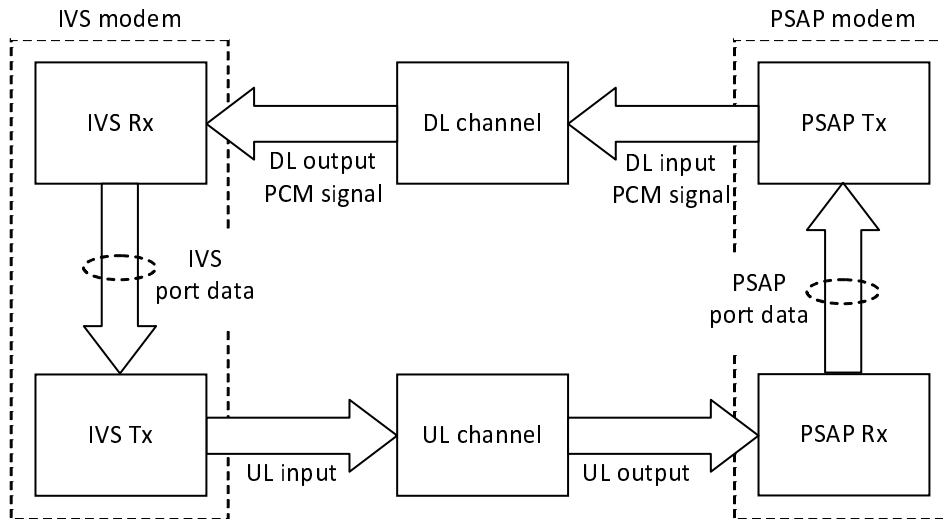

Figure 1: Functional components of the IVS and PSAP eCall modems

Clause 5 contains the procedures for conformance testing as well as the detailed performance requirements.

Annex A explains the digital test sequences and scripts to be executed for conformance testing of bit-exact eCall in-band modem implementations. The test sequences and scripts are attached to this specification.

Annex B describes the eCall test set-up to be used for minimum performance testing of eCall in-band modem implementations.

5 Conformance

Conformance testing of the fixed-point IVS and PSAP **transmitters shall be** performed by demonstrating bit-exactness to the fixed-point reference C-code implementation (given in TS 26.268 [2]).

Bit-exactness means that given a specific input sequence, the corresponding digital output sequence of the component under test shall exactly match the time-aligned output sequence of the reference implementation [2] of that component. The delay of the output sequence shall not exceed a certain specified limit.

Conformance testing of the IVS and PSAP **receiver** implementations **shall be** performed by either demonstrating bit-exactness to the reference C-code, or by testing against a set of minimum performance requirements by means of objective measures. The bit-exact approach should be preferred over the application of objective measures if the implementation of the IVS and PSAP receivers follows the one given in the reference C-code.

The MSDs, codecs and channel conditions to be used in the testing for bit-exactness as well as for minimum performance requirements are further described in Annexes A and B. Annex B also specifies the procedures for evaluating the conformance of a receiver implementation with respect to the minimum performance requirements.

5.1 Bit-exactness

To guarantee interoperability and data integrity, the implementation of PSAP and IVS **transmitters shall be** bit-exact.

For the IVS and PSAP **receivers**, the conformance of the implementation **may** be tested by showing bit-exactness.

For bit-exact fixed-point implementations, test sequences and scripts are used for conformance testing. The test cases consist of input and output reference MSDs, control sequences, and PCM data files.

For testing transmitters, input control sequences are fed into the IVS/PSAP transmitter and the corresponding PCM data output of the IVS/PSAP transmitter is recorded. To meet the bit exactness criterion, all test cases must yield bit-exact results for the durations of the reference sequences, compared to the provided reference IVS/PSAP PCM output files, starting from the first non-zero output sample.

The maximum delay, measured as the number of zero-valued output samples of the IVS transmitter, as a reaction to any of the reference input sequences, shall not exceed 160 samples.

The maximum delay, measured as the number of zero-valued output samples of the PSAP transmitter, as a reaction to any of the reference input sequences, shall not exceed 320 samples.

For testing receivers, input PCM data files are fed into the IVS/PSAP receiver and the sequence of control states of the IVS/PSAP receiver is recorded after the processing of each received frame (duration 20 ms). To meet the conformance requirements, the control state sequence must be identical to the provided reference control sequence within a tolerable timing difference of one frame.

5.2 Minimum performance requirements

Objective measures are used for testing the fulfilment of minimum performance requirements. These measures are the same for all implementations. They shall be met by all non-bit exact fixed-point receiver implementations of the IVS and PSAP, and may also be used as an additional check for receiver implementations which have been shown to meet conformance by demonstrating bit-exactness.

The following minimum performance requirements apply to transmissions of single MSDs of length 140 bytes.

5.2.1 MSD transmission time

The average MSD transmission times serve as a performance indicator for the signal waveform demodulator and FEC decoder implementation. The MSD transmission time can be defined by five different metrics as described in Annex D of 3GPP TR 26.969 [3]:

- 1) As the interval from the time instant when the IVS transmitter writes the first non-zero sample onto the uplink channel until the MSD message has been correctly decoded at the PSAP. This metric was used during the initial eCall selection tests and is called "Figure-of-Merit" (FoM).
- 2) As the interval from the time instant of call connect state at PSAP side until the MSD message has been correctly decoded. This metric can assess the complete round-trip-time (RTT) of the PSAP in PUSH mode and is called PSAP-PUSH-RTT.
- 3) As the interval from the time instant when PSAP begins sending of first START message until the MSD message has been correctly decoded. This metric can assess the complete round-trip-time (RTT) of the PSAP in PULL mode and is called PSAP-PULL-RTT.
- 4) As the interval from the time instance when IVS detects call is connected until it detects the first HLACK message. This metric can assess the complete round-trip-time (RTT) of the PSAP in PUSH mode from IVS perspective and is called IVS-PUSH-RTT.
- 5) As the interval from the time instance when IVS detects the first START message from PSAP until it detects the first HLACK message. This metric can assess the complete round-trip-time (RTT) of the PSAP in PULL mode from IVS perspective and is called IVS-PULL-RTT.

The FoM metric for the full test campaign given in Annex B was also used in the eCall selection tests.. In the FoM, for each single transmission simulation, the transmission time is limited to a value of 200 s, i.e., if the MSD has not been correctly received after 200 s, the transmission attempt is aborted and the transmission time is counted as 200 s. The respective transmission attempt is recorded as a failure (and this constitutes a violation of the minimum performance requirement "Transmission failures" in clause 5.2.3).

All RTT metrics are suitable also for performance tests over-the-air or in lab environments as they require only measurement instances at either PSAP or IVS side. They do not require exact time synchronization between IVS and PSAP clocks as would be required for the FoM metric.

The following subsections refer to the minimum requirements for the FoM metric, which can be easily obtained through simulative assessment of the in-band modem implementation. Additional minimum requirements for the RTT metrics are listed in Annex C.

5.2.1.1 Full campaign (all AMR-FR codec modes plus GSM-FR)

For the specified full campaign given in Annex B, the average MSD transmission time (Figure of Merit) shall not exceed 2.90 s.

5.2.1.2 Error-free case for AMR 12.2 and FR

For the subset of error-free test cases in the AMR 12.2 and FR codecs of the full campaign, the average MSD transmission time shall not exceed 2.00 s.

5.2.1.3 GSM-HR codec

In the GSM-HR codec, the average MSD transmission time shall not exceed 18.00 s for the set of channel conditions comprising a C/I of 10, 7, and 4 dB as well as the error free case. 100 test cases per channel conditions shall be carried out.

5.2.1.4 Noisy conditions

For the specified full campaign in Annex B, the average MSD transmission time shall not exceed 3.20 s if white Gaussian noise (AWGN) of 10 dB SNR is added both to the PSAP transmitter output and at the PSAP receiver input signals.

Noise shall be added to the PCM data that is fed into the PSAP receiver and to the PCM data that is output from the PSAP transmitter. This reflects noise that could occur on an analogue line in a PSTN.

The noise power shall be set to yield 10 dB SNR. At the PSAP receiver, the reference signal power shall be obtained by averaging over all incoming signal intervals while the PSAP receiver is in NACK state, which is the case when it receives the data part of the MSD message. A separate reference signal power shall be computed for each codec and channel condition as an average of the 100 test cases of the attached official test campaign `official_test_configuration_file.txt`.

At the PSAP transmitter, the reference signal power shall be calculated by averaging over an entire feedback message [1] consisting of 20 frames.

For information, the standard deviations of the PSAP receiver input PCM signals are given in Table 1 for the reference implementation [2]. The average PSAP transmitter PCM output standard deviation is 2056.

Table 1: Standard deviations of PSAP input signals

Codec, channel condition	Standard deviation	Codec, channel condition	Standard deviation
Full Rate, 7 dB	1223	AMR 7.95, 7 dB	1067
Full Rate, 10 dB	1190	AMR 7.95, 10 dB	1059
Full Rate, 13 dB	1167	AMR 7.40, 7 dB	988
Full Rate, 16 dB	1156	AMR 7.40, 10 dB	971
Full Rate, clean	1181	AMR 6.70, 7 dB	954
Full Rate, RSSI	1149	AMR 5.90, 4 dB	931
AMR 12.20, 7 dB	1112	AMR 5.90, 7 dB	953
AMR 12.20, 10 dB	1129	AMR 5.15, 4 dB	836
AMR 12.20, 13 dB	1092	AMR 5.15, 7 dB	854
AMR 12.20, clean	1130	AMR 4.75, 1 dB	737
AMR 10.20, 7 dB	1045	AMR 4.75, 4 dB	762
AMR 10.20, 10 dB	1052	AMR 4.75, 7 dB	770
AMR 10.20, 13 dB	994	AMR 4.75, RSSI	771

The following C code fragment illustrates the application of noise (and a possible subsequent clipping) onto the PSAP input or output signals:

```
temp = (int) pcm + (int)((double)sigma)*randn();
    if (temp > 32767) {
```

```

        noisy_pcm = 32767;
    } else if (temp < -32768) {
        noisy_pcm = -32768;
    } else {
        noisy_pcm = (short) temp;
    }

```

5.2.1.5 Scaling of PCM signals

For the specified full campaign, the average MSD transmission times indicated in Table 2 shall not be exceeded for the given channel gains (caused, e.g., by different AGC settings), applied to the signals before the IVS and PSAP receivers.

Before being fed to the IVS and PSAP receivers, the signed 16-bit PCM data shall be amplified/attenuated by a constant gain factor and then be mapped on PCM values again. More specifically, the PCM values shall be multiplied with the amplitude scaling factors given in the second column of Table 2. Signal amplitudes exceeding the signed 16-bit PCM range (-32768 to +32767) shall be clipped. Testing shall be carried out with the gain factors in the range from -12 dB to +12 dB as given in Table 2. For the specified full campaign, the average MSD transmission times (FoM) shall not exceed the values given in the third column of Table 2 for the respective gains.

Table 2: Gains and maximum MSD transmission times for different scaling factors

Gain	Amplitude scaling factor	Maximum FoM
-12 dB	0.25	2.95 s
-6 dB	0.5	2.95 s
+6 dB	2.0	2.95 s
+12 dB	4.0	3.30 s

The following C code fragment illustrates the scaling and a possible subsequent clipping of PCM signals:

```

pcmScaled = (double) pcm * (double) AGC_UL_SCALE_FACTOR;
if (pcmScaled >= 0.0) {
    if (pcmScaled > (double) 32767)
        pcm = 32767;
    else
        pcm = (short) (pcmScaled + 0.5);
} else {
    if (pcmScaled < (double) -32768)
        pcm = -32768;
    else
        pcm = (short) (pcmScaled - 0.5);
}

```

5.2.2 CRC check quality

The CRC on the uplink shall be evaluated. No incorrect MSD shall pass the CRC check in any test case of the specified full test campaign.

5.2.3 Transmission failures

No transmission failures shall occur with any test case of the full test campaign, i.e. no single MSD transmission time shall exceed 200 s.

5.2.4 False detection due to signalling tones

The IVS modem receiver shall not falsely detect eCall communication at any instance, when the tone test file (see Annex B) is used as modem input.

5.2.5 Push messages

This minimum performance requirement is only applicable for the case that IVS and PSAP in-band modems are configured to work in *push* mode.

It shall take a maximum of five SEND messages to trigger the PSAP eCall modem receiver in push mode. The test shall be carried out for the test conditions given in the official test campaign `official_test_configuration_file.txt`.

5.2.6 HLACK messages

The IVS receiver shall reliably detect a higher-layer ACK (HLACK) with no more than five transmitted HLACK messages. This test shall be carried out for the conditions given in the official test campaign. `official_test_configuration_file.txt`.

6 IMS eCall Conformance of In-band Modem

6.1 General

When supported by the IVS, mobile network, and PSAP, IMS eCall uses SIP signalling to send the MSD to the PSAP as this provides a compact and reliable means to transfer the information without interrupting the voice conversation between the motorist and the PSAP operator. During the deployment of IMS eCall, there may be temporary scenarios where the mobile network does not support a circuit-switch bearer and the network or PSAP do not support the IMS eCall protocol. In such scenarios, the IVS has no reliable means to send the MSD to the PSAP. As a solution of “last-resort” clause 7.7.2 of 3GPP TS 23.167 [7] and clause 5.1.6.11.2 of 3GPP TS 24.229 [8] require that the IVS attempt to transfer the MSD via the in-band modem sending the voice-band signals through the Voice-Over-IP bearer.

As ETSI and 3GPP determined that the operation of the in-band modem over the VoIP bearer cannot guarantee reliable transmission of the MSD, the deployment scenario that requires use of this “last-resort” solution must be avoided as much as possible. Furthermore, the testing of this mode of operation in the IVS does not require testing of reliability. The testing only focuses on conformance as follows:

- 1) The in-band modem conformance shall be tested separately from the VoIP bearer using the tests specified in clause 5.
- 2) To test that the in-band modem conforming to clause 5 is operating over the VoIP bearer in the IVS, the test described in clause 6.3 should be used.

To avoid the effects of jitter and time-warping interfering with the testing of the in-band modem, the test set-up should not introduce any time-warping when decoding the VoIP packets encoding the in-band modem signals. Therefore the test specified in clause 6.3 is recommended.

If the test set-up is not able to prevent time-warping in any adaptive de-jitter buffers at the IVS, PSAP, or intermediate nodes (e.g., media gateway) then the test in clause 6.3 can not be used to reliably test the in-band modem. The test in clause 6.4 shall only be used if the test in clause 6.3 can not be used.

6.2 Initial Settings

Following are the initial settings to be used before starting the test:

- 1) Place the PSAP simulator into PULL mode so that it sends START signaling ([1] and [2]) once the voice bearer is connected with the IVS under test

- 2) Negotiate use of the AMR 12.2 speech codec for encoding the in-band modem signal
- 3) Use an error free channel model in the channel simulator
- 4) Set-up the IMS eCall session so that it triggers the “last-resort” condition in the IVS that requires the in-band modem operation over the VoIP bearer.

6.3 No Time-Warping Conformance Test

If the test set-up can prevent time-warping of the decoded VoIP signal (i.e., it does not introduce jitter or the de-jitter buffers in the IVS and PSAP do not perform time-warping) then the following test procedures shall be used:

- 1) When the IVS detects the START messages sent by the PSAP (after the voice bearer is established), the IVS is expected to send the MSD.
- 2) If the PSAP simulator detects that the IVS has started sending the MSD then the IVS PASSES conformance. Detecting the start of MSD transmission does not require decoding the entire MSD correctly. The PSAP simulator could detect the sync ([1] and [2]) from the IVS that precedes the MSD information.
- 3) If the test fails, i.e., the PSAP simulator does not detect the sync or the MSD within 20s, the call is terminated.
 - a) If the IVS has failed five consecutive tests then it FAILS conformance.
 - b) Otherwise the test is re-run starting with the triggering event in step 4 of clause 6.2.

6.4 Time-Warping Conformance Test

If the test set-up can not prevent time-warping of the decoded VoIP signal (i.e., it could introduce jitter and the de-jitter buffers in the IVS and PSAP could perform time-warping) then the following test procedures shall be used:

- 1) When the IVS detects the START messages sent by the PSAP (after the voice bearer is established), the IVS is expected to send the MSD.
- 2) If the PSAP simulator detects that the IVS has started sending the MSD then the IVS PASSES conformance. Detecting the start of MSD transmission does not require decoding the entire MSD correctly. The PSAP simulator could detect the sync ([1] and [2]) from the IVS that precedes the MSD information.
- 3) If the test fails, i.e., the PSAP simulator does not detect the sync or the MSD within 20s, the call is terminated.
 - a) If the IVS has failed 50 consecutive tests then it FAILS conformance.
 - b) Otherwise the jitter-model of the channel simulator is re-randomized to ensure that the same jitter profile is not re-used and the test is re-run starting with the triggering event in step 4 of clause 6.2.

Annex A (normative): Test sequences and scripts for testing bit-exact implementation of eCall in-band modem

This Annex describes the test set-up, test sequences, and scripts designed to evaluate the bit-exact implementation of the eCall in-band modem [2].

For the purpose of conformance testing, the control sequences at the receiver-transmitter interfaces of the IVS and PSAP are defined as the content of certain state variables at the end of the receiver processing stage after each frame. The IVS and PSAP input/output data signals are standard PCM data signals with 16 bits per sample and 8 kHz sampling rate. Three sets of state variables and PCM data signals are provided to carry out the bit-exactness tests for the eCall core, the eCall push trigger, and the eCall HLACK transmission. The eCall core is defined as a transmission that is initiated by the PSAP and terminated by the transmission of lower layer ACK (LLACK) messages after the successful reception of the MSD by the PSAP. The push trigger test files are intended to test an IVS initiated eCall transmission, which starts with the transmission of SEND messages and is terminated by the transmission of lower layer ACK messages after the successful reception of the MSD by the PSAP. The HLACK transmission test files are intended to test the transmission of HLACK messages, which starts with an PSAP initiated MSD transmission and terminates with the successful reception of the HLACK by the IVS. The three data sets are distinguished by their 'basename' which is to be replaced by 'core', 'corepush', or 'corehlack' in the tables below, respectively.

Note that the number of LLACK and HLACK messages to be transmitted is a configuration parameter of the in-band modem [2]. It is up to higher-layer protocol requirements whether link-layer and/or higher-layer ACK messages are transmitted. From a modem protocol perspective [1], at least five ACK messages of one type (either link-layer or higher-layer) shall be transmitted consecutively for security. For conformance testing, the modem shall be configured to send four LLACK and then five HLACK messages.

The attached test campaign file `campaign_conformance_test.txt` specifies the MSDs, delays, codecs and channel conditions to be used according to Tables A.1 to A.4.

The test scripts `confptest.bat` (for Windows) and `confptest.sh` (for Linux) are provided in order to perform all tests according to clauses A.1 to A.4. Note that these are exemplary test scripts for the case that the IVS and PSAP implementations exhibit the same output signal delays as the reference implementation [2]. For other signal output delays within the limits specified in clause 5.1, the scripts should be adapted.

The test setup included in [2] automatically records input/output PCM data, as well as the contents of the state variables at the transmitter/receiver interface. The test setup also checks for the correct reception of the MSD. It is required for the execution of the above test scripts.

A.1 Testing a bit-exact implementation of the IVS transmitter function

The set-up illustrated in Figure A.1 is used to test the bit-exact compliance of an IVS transmitter implementation.

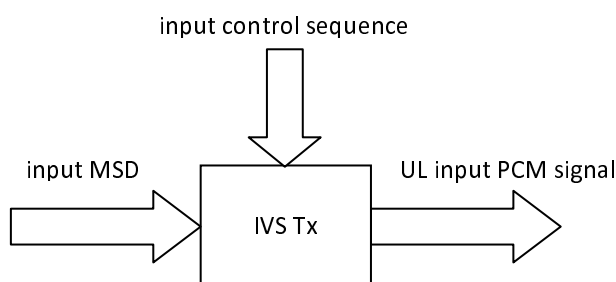

Figure A.1: Set-up for testing bit-exact eCall modem IVS transmitter function

The set of test input control sequences listed in Table A.1 are input into the IVS Tx. Each test sequence specifies the series of control messages and the time at which each is to be input into the IVS Tx.

Table A.1: Input control sequences and output PCM files for testing bit-exact IVS transmitter - The sequences are attached electronically

Sequence	Characteristics	Input Control Sequence Filename	Output PCM Data Filename
1	AMR-FR 12.2 Error Free	{basename}_portivstx1.txt	{basename}_pcmulin1.pcm
2	GSM_FR, C/I = 7dB	{basename}_portivstx2.txt	{basename}_pcmulin2.pcm
3	AMR-FR 12.2, C/I = 7dB	{basename}_portivstx3.txt	{basename}_pcmulin3.pcm
4	AMR-FR 5.9, C/I = 4dB	{basename}_portivstx4.txt	{basename}_pcmulin4.pcm
5	AMR-FR 5.15, C/I = 4dB	{basename}_portivstx5.txt	{basename}_pcmulin5.pcm
6	AMR-FR 4.75, C/I = 1dB	{basename}_portivstx6.txt	{basename}_pcmulin6.pcm
7	GSM-HR, C/I = 4dB	{basename}_portivstx7.txt	{basename}_pcmulin7.pcm
8	GSM_FR, C/I = 7dB	{basename}_portivstx8.txt	{basename}_pcmulin8.pcm

For each test input control sequence, the output PCM data from the IVS Tx function is recorded and the initial series of zero-valued PCM samples shall be checked to not exceed the maximum allowable delay specified in clause 5.1. The initial series of zero samples are then removed and the remaining PCM output data shall be bit-exact identical to the output PCM data files listed in Table A.1.

A.2 Testing a bit-exact implementation of the PSAP transmitter function

The set-up illustrated in Figure A.2 is used to test the bit-exact compliance of a PSAP transmitter implementation.

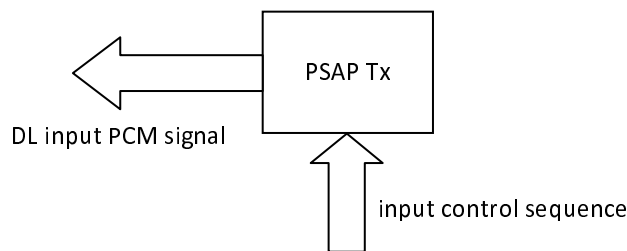

Figure A.2: Set-up for testing bit-exact eCall modem PSAP transmitter function

The set of test input control sequences listed in Table A.2 are input into the PSAP Tx. Each test sequence specifies the series of control message and the time at which each is to be input into the PSAP Tx.

Table A.2: Input control sequences and output PCM files for testing bit-exact PSAP transmitter - The sequences are attached electronically

Sequence	Characteristics	Input Control Sequence Filename	Output PCM Data Filename
1	AMR-FR 12.2 Error Free	{basename}_portpsaptx1.txt	{basename}_pcmdlin1.pcm
2	GSM_FR, C/I = 7dB	{basename}_portpsaptx2.txt	{basename}_pcmdlin2.pcm
3	AMR-FR 12.2, C/I = 7dB	{basename}_portpsaptx3.txt	{basename}_pcmdlin3.pcm
4	AMR-FR 5.9, C/I = 4dB	{basename}_portpsaptx4.txt	{basename}_pcmdlin4.pcm
5	AMR-FR 5.15, C/I = 4dB	{basename}_portpsaptx5.txt	{basename}_pcmdlin5.pcm
6	AMR-FR 4.75, C/I = 1dB	{basename}_portpsaptx6.txt	{basename}_pcmdlin6.pcm
7	GSM-HR, C/I = 4dB	{basename}_portpsaptx7.txt	{basename}_pcmdlin7.pcm
8	GSM_FR, C/I = 7dB	{basename}_portpsaptx8.txt	{basename}_pcmdlin8.pcm

For each test input control sequence, the output PCM data from the PSAP Tx function is recorded and the initial series of zero-valued PCM samples shall be checked to not exceed the maximum allowable delay specified in clause 5.1. The initial series of zero samples are then removed and the remaining PCM output data shall be bit-exact identical to the output PCM data files listed in Table A.2.

A.3 Testing a bit-exact implementation of the IVS receiver function

The set-up illustrated in Figure A.3 is used to test the bit-exact compliance of an IVS receiver implementation.

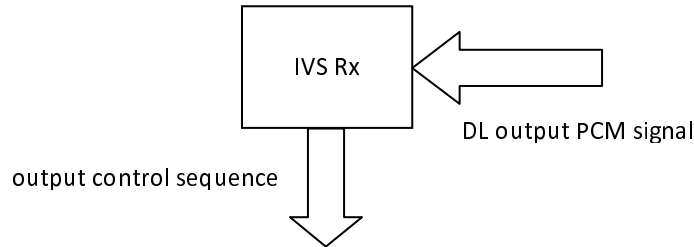

Figure A.3: Set-up for testing bit-exact eCall modem IVS receiver function

The set of test input PCM data files listed in Table A.3 are input into the IVS Rx. For each test input PCM data file, the output control sequence from the IVS Rx function is recorded with a time stamp for each control message.

The sequence of recorded output control messages from IVS Rx shall be identical to the output control sequence listed in Table A.3. The absolute value difference in time stamps of a message in the recorded and attached sequence file shall not exceed one frame.

Table A.3: Input PCM files and output control sequences for testing bit-exact IVS receiver - The sequences are attached electronically.

Sequence	Characteristics	Output Control Sequence Filename	Input PCM Data Filename
1	AMR-FR 12.2 Error Free	{basename}_portivsrx1.txt	{basename}_pcmdlout1.pcm
2	GSM_FR, C/I = 7dB	{basename}_portivsrx2.txt	{basename}_pcmdlout2.pcm
3	AMR-FR 12.2, C/I = 7dB	{basename}_portivsrx3.txt	{basename}_pcmdlout3.pcm
4	AMR-FR 5.9, C/I = 4dB	{basename}_portivsrx4.txt	{basename}_pcmdlout4.pcm
5	AMR-FR 5.15, C/I = 4dB	{basename}_portivsrx5.txt	{basename}_pcmdlout5.pcm
6	AMR-FR 4.75, C/I = 1dB	{basename}_portivsrx6.txt	{basename}_pcmdlout6.pcm
7	GSM-HR, C/I = 4dB	{basename}_portivsrx7.txt	{basename}_pcmdlout7.pcm
8	GSM_FR, C/I = 7dB	{basename}_portivsrx8.txt	{basename}_pcmdlout8.pcm

A.4 Testing a bit-exact implementation of the PSAP receiver function

The set-up illustrated in Figure A.4 is used to test the bit-exact compliance of a PSAP receiver implementation.

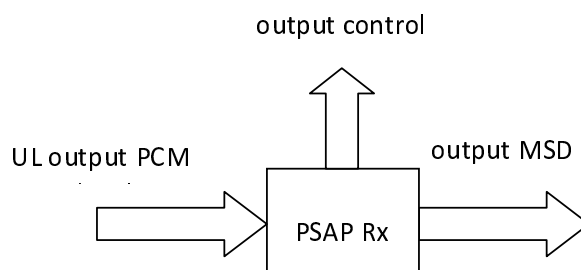

Figure A.4: Set-up for testing bit-exact eCall modem PSAP receiver function

The set of test input PCM data files listed in Table A.4 are input into the PSAP Rx. For each test input PCM data file the following are recorded and tested:

1. The output control sequence from the PSAP Rx function is recorded with a time stamp for each control message. The sequence of recorded output control messages from PSAP Rx shall be identical to the output control sequence listed in Table A.4. The absolute value difference in time stamps of a message in the recorded and attached sequence file shall not exceed one frame.
2. The output MSD from the PSAP Rx function is evaluated. The output MSD shall be equal to the MSD indicated in the attached campaign file `campaign_conformance_test.txt`.

Table A.4: Input PCM files and output control sequences for testing bit-exact PSAP receiver - The sequences are attached electronically.

Sequence	Characteristics	Output Control Sequence Filename	Input PCM Data Filename
1	AMR-FR 12.2 Error Free	{basename}_portpsaprx1.txt	{basename}_pcmulout1.pcm
2	GSM_FR, C/I = 7dB	{basename}_portpsaprx2.txt	{basename}_pcmulout2.pcm
3	AMR-FR 12.2, C/I = 7dB	{basename}_portpsaprx3.txt	{basename}_pcmulout3.pcm
4	AMR-FR 5.9, C/I = 4dB	{basename}_portpsaprx4.txt	{basename}_pcmulout4.pcm
5	AMR-FR 5.15, C/I = 4dB	{basename}_portpsaprx5.txt	{basename}_pcmulout5.pcm
6	AMR-FR 4.75, C/I = 1dB	{basename}_portpsaprx6.txt	{basename}_pcmulout6.pcm
7	GSM-HR, C/I = 4dB	{basename}_portpsaprx7.txt	{basename}_pcmulout7.pcm
8	GSM_FR, C/I = 7dB	{basename}_portpsaprx8.txt	{basename}_pcmulout8.pcm

Annex B (normative): Test set-up and sequences for testing minimum performance of eCall in-band modem receivers

This annex specifies how modem receiver implementations can be tested to determine if they conform to the minimum performance requirements.

The MSDs, codecs, and channel conditions to be used for minimum performance testing are given in the attached full campaign file `official_test_configuration_file.txt`.

B.1 Modem Transmission Performance

The transmission performance of an eCall modem receiver shall be evaluated using the eCall test set-up and the attached full campaign test file, including the input test MSDs.

The eCall test set-up configuration illustrated in Figure B.1 is used to test the minimum performance compliance of an IVS receiver implementation. For all of the other modem functions not being tested, i.e., IVS Tx, PSAP Rx, and PSAP Tx, the ANSI-C reference code or a bit-exact implementation of them shall be used.

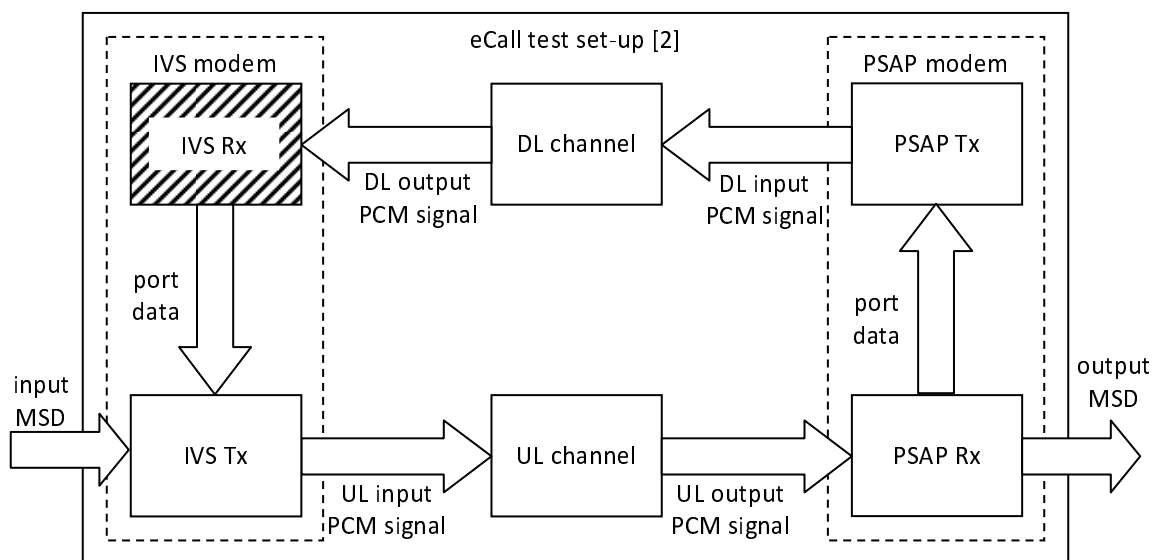

Figure B.1: Set-up for testing the minimum performance compliance of the eCall modem IVS receiver function

The performance of the above set-up over the entire test campaign shall meet the requirements in clauses 5.2.1 to 5.2.3.

The eCall test set-up configuration illustrated in Figure B.2 is used to test the minimum performance compliance of an PSAP receiver implementation. For all of the other modem functions not being tested, i.e., IVS Rx, IVS Tx, and PSAP Tx, the ANSI-C reference code or a bit-exact implementation of them shall be used.

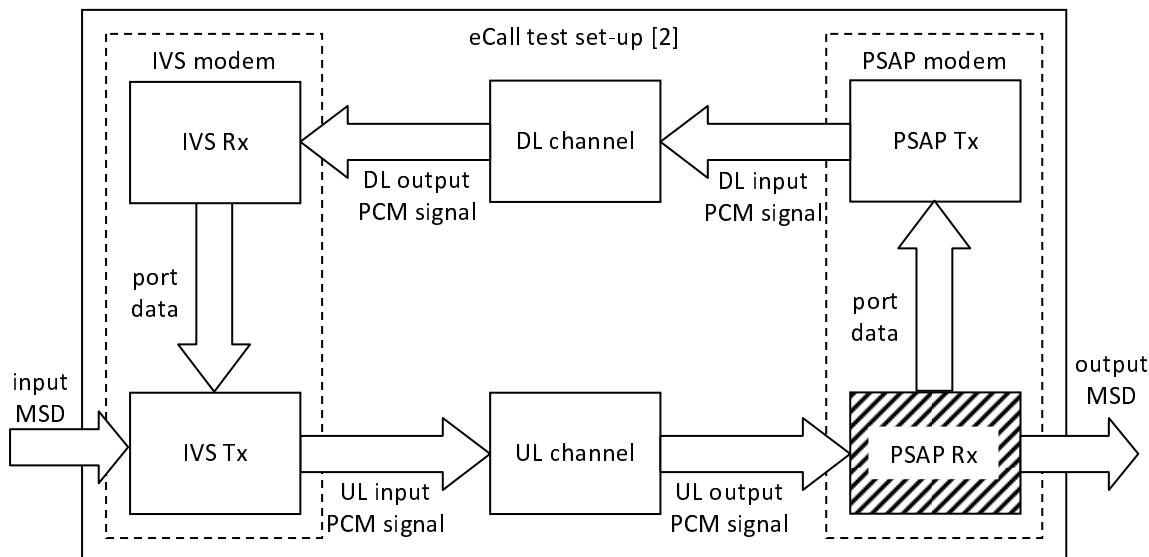

Figure B.2: Set-up for testing the minimum performance compliance of the eCall modem PSAP receiver function

The performance of the above set-up over the entire test campaign must meet the requirements in clauses 5.2.1 to 5.2.3. Furthermore, the output MSD from the PSAP Rx function shall be equal to the input MSD.

B.1.2 Test Tone Sensitivity

The set-up illustrated in Figure B.3 shall be used to test the sensitivity of the IVS Rx implementation. When the test tone PCM data provided in the attached file `EU_DTMF_tones.rawpcm` is input into the IVS Rx function, the IVS Rx function shall not indicate that it has detected any of the eCall modem messages.

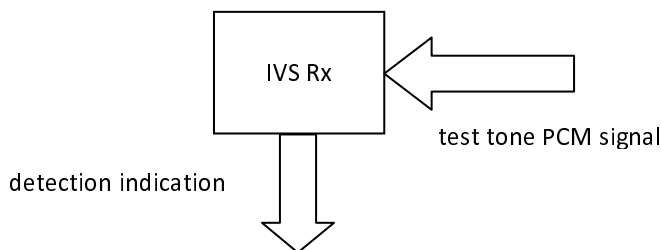

Figure B.3: Set-up for testing test tone sensitivity of eCall modem IVS receiver function

This test can be performed in a similar way as described in clause A.3. The detection indication can be evaluated by analyzing the output control sequence file according to Figure A.3.

Annex C (normative): Additional Performance Requirements

In order to allow for readily testable performance assessments in over-the-air and lab environments, additional RTT performance indicator metrics were defined in Section 5.2.1 and [3] for the MSD transmission time. Table C.1 compares the corresponding performance requirements for the average MSD transmission time, when these metrics are used instead of the FoM.

Note that these requirements assume that the IVS immediately starts sending the SEND message as soon as it receives the CALL CONNECTED indication from the network. If there is a delay between these two events this difference should be considered when comparing the measured time to the requirements.

Table C.1: Additional performance requirements for different definitions of MSD transmission time

Test Case	FoM [s]	PSAP-PUSH-RTT [s]	PSAP-PULL-RTT [s]	IVS-PUSH-RTT [s]	IVS-PULL-RTT [s]
Full Campaign	2.90	5.8	4.7	7.5	4.7
Error Free	2.00	4.8	3.7	6.5	3.7

Annex D (informative): Change history

Change history							
Date	TSG SA#	TSG Doc.	CR	Rev	Subject/Comment	Old	New
2009-06	44	SP-090252			Approved at TSG SA#44	2.0.0	8.0.0
2009-09	45	SP-090565	0001		Introduction of HL-ACK test cases	8.0.0	8.1.0
2009-09	45	SP-090625	0002	3	Introduction of test cases for IVS-initiated signalling	8.0.0	8.1.0
2009-09	45	SP-090565	0003	1	Clarification of conformance testing requirements and correction of a figure	8.0.0	8.1.0
2009-12	46				Version for Release 9	8.1.0	9.0.0
2010-09	49	SP-100462	0005		Update of conformance testing reference sequences	9.0.0	9.1.0
2010-12	50	SP-100844	0007	2	Correction of eCall conformance test sequences	9.1.0	9.2.0
2011-03	51				Version for Release 10	9.2.0	10.0.0
2012-09	57				Version for Release 11	10.0.0	11.0.0
2014-09	65				Version for Release 12	11.0.0	12.0.0
2015-09	69	SP-150455	0008	1	Round trip time measurements	12.0.0	13.0.0

Change history							
Date	Meeting	TDoc	CR	Rev	Cat	Subject/Comment	New version
2017-03	75					Version for Release 14	14.0.0
2017-12	78	SP-170822	0009	1	B	IMS eCall In-band Modem Conformance Test	14.1.0

History

Document history		
V14.0.0	April 2017	Publication
V14.1.0	January 2018	Publication